

Electronics[®]

Integrated circuits replace the servo: page 90

Improving diode lasers: page 95

Electronics markets for 1966: page 111

January 10, 1966

75 cents

A McGraw-Hill Publication

Below: Production of color tv races to keep up with demand: page 117

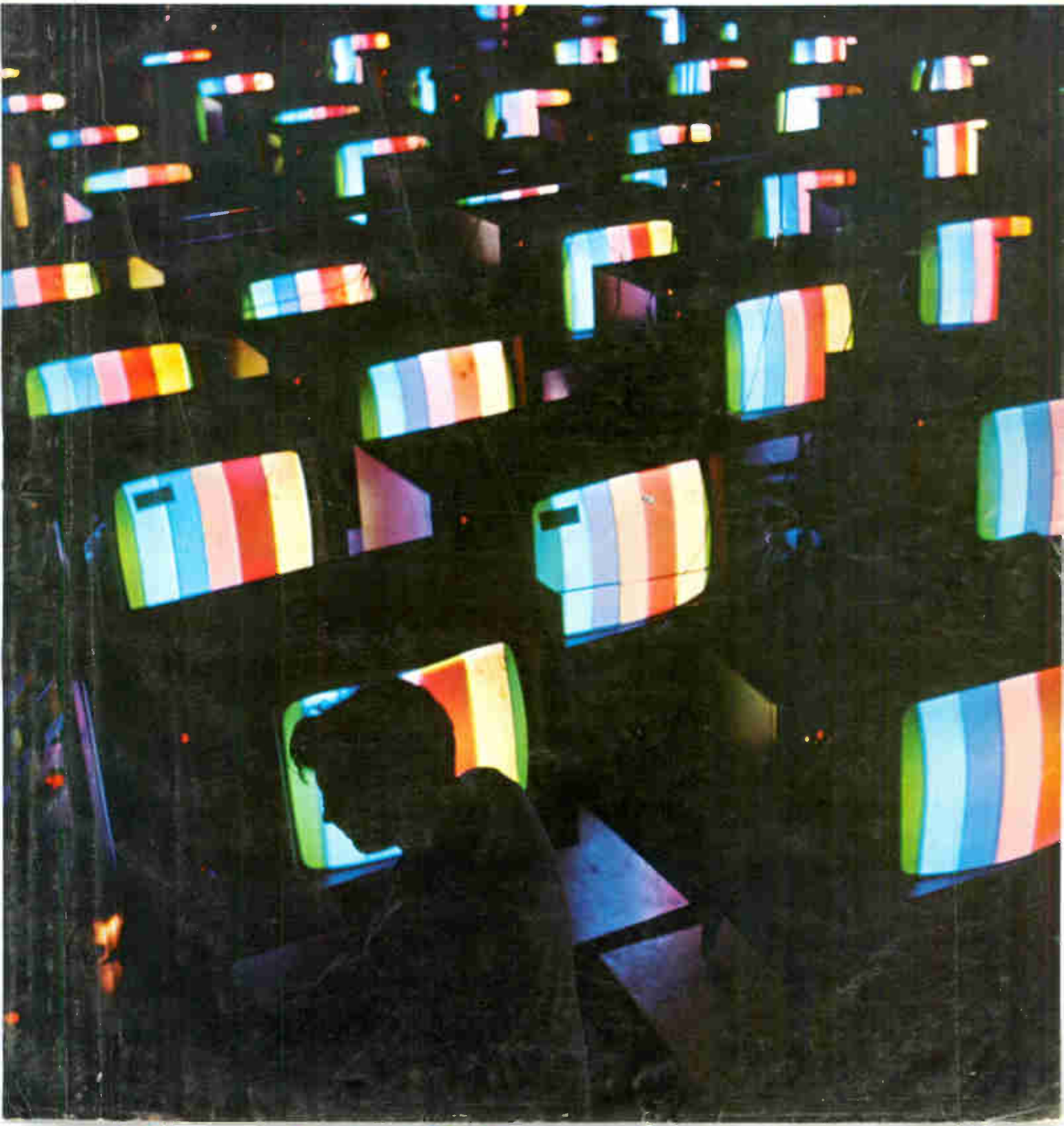



**“SPECIAL”
CUSTOM BUILT**

POWER TRANSFORMERS & INDUCTORS

**TO YOUR
SPECIFICATIONS**

Exceptional quality and reliability is provided in all UTC designs. Over 30 years of engineering knowledge and experience backed by complete environmental testing and life testing facilities assure the highest standard in the industry. Full analysis and evaluation of materials are conducted in UTC's Material and Chemical Laboratories. Rigid quality control measures coordinated with exhaustive statistical findings and latest production procedures results in the industry's highest degree of reliability. Range covered in Power Transformers is from milliwatts to 100 KVA. Some typical applications include: Current Limiting, Filament, Isolation, Plate, Transistor Inverter, Transistor Supply.

**MILITARY AND COMMERCIAL TYPES FOR
EVERY PHASE OF THE ELECTRONICS ART**

POWER TRANSFORMERS • AUDIO TRANSFORMERS • INDUCTORS • PULSE TRANSFORMERS • ELECTRIC WAVE FILTERS • LUMPED CONSTANT DELAY LINES • HIGH Q COILS • MAGNETIC AMPLIFIERS • SATURABLE REACTORS • REFERENCE UNITS

Write for catalog of over
1,300 UTC HIGH RELIABILITY
STOCK ITEMS
IMMEDIATELY AVAILABLE
from your local distributor.



<p>Low capacity current limiting filament transformer. Primary 118 V. 60 cycles to 6.3 V. at 3 A., 8 A. at short circuit. 25 MMFD capacity. 30 KV hipot and 200:1 capacity divider; 5 x 3 3/4 x 4 1/2", 9 lbs.</p>	<p>MIL-T-27B ultraminiature Scott connected power transformer, 5/16 Dia. x 13/32" H., 1/10 Oz. Primary 28 V 400 — with taps @ 50% & 86.6%. Two units provide 28 V two phase from three phase source.</p>	<p>Molded Power Transformer 3 Phase. Input 200V, 380-420 cps. Electrostatic Shield, 8 output windings, 26 terminals. MIL-T-27B, Grade 2 Class S. Max. Alt. 50K Ft. Size 6 x 2 1/2 x 5", 8 lbs.</p>
<p>Commercial type molded power transformer. Primary 115/230 V., 50/420 cycles to 680 VCT.-015 A., 6.3 VCT.-1.2 A., 6.3 V.-.6A. Size: 2 1/2 x 3 x 2 7/8", weight: 1.6 lbs.</p>	<p>Three phase high voltage power transformer. Primary jumper hardware for easy conversion from delta to wye inputs. Made to MIL-T-27B specifications. Primary: 440 V 60 cycles delta or wye 3 phase input. Secondary: 2100 V line to line or 1215 V line to line @ 242 ma.</p>	<p>High current filament transformer. Primary 140/156 V., 47/63 cycles to 1.8 V.-1070 A. Current limiting through separate primary reactor, MIL-T-27B; 10 x 10 x 11 1/2", 150 lbs.</p>

UNITED TRANSFORMER CORP.

150 VARICK STREET, NEW YORK 13, N. Y.

PACIFIC MFG. DIVISION: 3630 EASTHAM DRIVE, CULVER CITY, CALIF.
EXPORT DIVISION: 13 EAST 40th STREET, NEW YORK 16, N. Y. CABLE: "ARLAB"

Circle 900 on reader service card

MATCH THIS TO YOUR



New hp 3300A Function Generator

APPLICATION

3302A Trigger Phase Lock Plug-in

*First Plug-in
Function Generator to offer variable phase, phase-lock
capability... plus these useful features:*



- Accurate sine, square, triangular waveform output, amplitude controlled
- Test signals 0.01 Hz (cps) to 100 kHz (kc), constant amplitude
- Linear voltage programmability
- Single-cycle, multi-cycle, free-run modes, with external trigger capability
- Dual output amplifiers, uniquely isolated for maximum versatility
- Sync pulse output for scope or recorder
- Available this for just \$760... and plug-in capability to let you buy what you need, add extra versatility later

Versatility finds a real definition in the new hp 3300A Function Generator, \$570, with its 3301A Operational Plug-in, \$20, and its 3302A Trigger/Phase Lock Plug-in, \$190... with more plug-ins to come!

Any two of the three waveforms selectable by a front-panel switch, amplitude individually adjustable, over the entire frequency range. Frequency adjustable by front-panel dial ($\pm 1\%$) or by external voltage (+0.3 to 10 V will control frequency approximately 50:1). With the 3302A Plug-in, you also get single- and multiple-cycle operation with variable start/stop phase. Trigger input lets you phase lock onto fundamentals, harmonics, lock indicated by front-panel meter.

Output is dc coupled, fully floating, with an internal shield that reduces radiated interference and provides high CMR. Apply any dc offset voltage, up to ± 250 V, using circuit, shield and power line rear-terminal grounds. You can use Channel B to invert the signal from Channel A, useful for driving balanced systems and other applications. 40 DB dynamic range, each amplifier, up to 35 V p-p into an open circuit, output impedance 600 ohms.

Here is an instrument that has to be seen to be appreciated: ideal for servo, medical, analog simulation, geophysical, subsonic and audio, vibration and frequency response applications. Explain your requirement to your Hewlett-Packard field engineer... and ask him for a demonstration. Or write for complete specifications: Hewlett-Packard, Palo Alto, California 94304, Tel. (415) 326-7000; Europe: 54 Route des Acacias, Geneva.

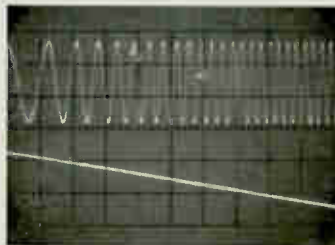

Voltage programming; frequency upper trace, programming voltage below.

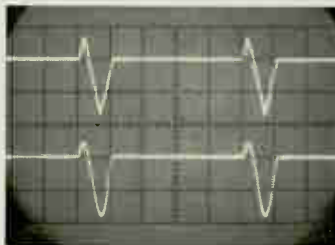
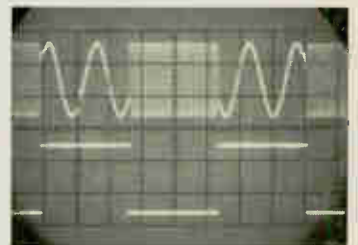

Single cycle—simultaneous triangular and sine outputs.

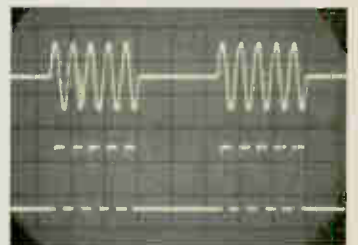

Multiple cycle—bursts of simultaneous sine and square-wave outputs.

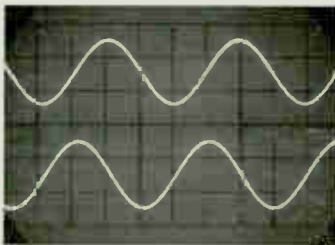

Phase lock; output from function generator (upper trace) locked to external fundamental (lower trace).

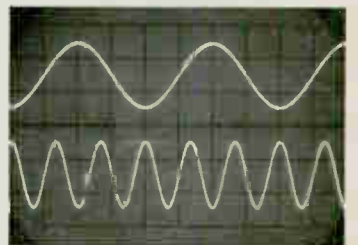

Phase lock; output from function generator (upper trace) locked to external harmonic (lower trace).

Data subject to change without notice. Prices f.o.b. factory.

861

INSTRUMENTATION SPECS in 250 KC tape recording

...now start at under \$9966

(7 CHANNELS, 6 SPEEDS, DIRECT MODE)

The design approach that yields superior frequency response performance at 250 KC in the bandwidth tape recording is now available in a remarkably low-priced Sanborn Model 3900 and 3901 7- and 14-channel systems based on 7 channels with up to 250 or 500 cps wideband FM mode. Fully automatic digital modulation is used as a means of frequency modulation and synchronization. A complete 2-speed motor drive system recording/reproduction mode allows for 7 channels, 100% or 50% bandwidth. 100% bandwidth may be selected with speed change. (Speed change at various intervals.)

These new systems have the same performance in performance, reliability and operating ease as the low impedance mode. The high-frequency tape recording with complete FM compatibility. The tape transport, based on superior design techniques, is a rugged and precise Hewlett-Packard design which utilizes both automatic and manual tape motion. The tape motion is controlled by a motor-driven 12 to 100 cps without filter or system change. Other standard features include provision for tape heads for "non-synchronous" utilization in adjacent levels, built-in filter stages, variable speed to 100% and over-stamped reel loading. The transport needs no lubrication except occasional cleaning of the tape path.

Check the system specifications here and call the H-P Field Engineer in your locale for complete technical data and application engineering assistance. Offices in 48 U.S. and Canadian cities, and major areas overseas. Bureau Division, Hewlett-Packard Company, Waltham, Massachusetts 01981, Europe: Hewlett-Packard S.A., 14 Route des Ardoles, Geneva, Switzerland.



representative specifications

DIRECT MODE

Tape Speed	Bandwidth	Frequency Response	S/N Ratio Filtered	Minimum RMS Unfiltered
60 ips	300-250 KC	±3 db	35 db	29 db
15 ips	100-62.5 KC 300-44 KC	±3 db	32 db 38 db	27 db
1 7/8 ips	50-7 KC 300-5 KC	±3 db	30 db 39 db	26 db

^aMeasured with bandpass filter at output with an 18 db/octave rolloff

FM MODE

Tape Speed	Bandwidth	Frequency Response	FM Carrier Frequency (Nominal)	S/N Ratio* Without Flutter Comp.	Total Harmonic Distortion
60 ips	0-20 KC	+0, -1db	108 KC	45 db	1.5%
15 ips	0-5 KC	+0, -1db	27.0 KC	45 db	1.5%
1 7/8 ips	0-625 cps	+0, -1db	3.38 KC	40 db	1.8%

^aNoise measured over full bandwidth, min. rms at zero freq. dev., with lowpass filter placed at output. Filter has 18 db/octave rolloffs.

TAPE TRANSPORT

Maximum Interchannel Time Displacement Error: ±1 microsecond at 60 IPS, between two adjacent tracks on same head.

Tape Speeds: 60, 30, 15, 7 1/2, 3 3/4, 1 7/8 ips standard; 0.3 to 120 ips optionally available.

Tape: 3600 feet, 1.0 mil, 1/2" (7 channel), 1" (14 channel).

Controls: Line (Power), Stop, Play, Reverse, Forward (fast) and Record are pushbutton relays. A receptacle at the rear of the transport is provided for remote control operation.

Drive Speed Accuracy: ±.25%.

FLUTTER

Speed	Bandwidth	Flutter (p-p)
60 ips	0-200 cps	0.2 %
	0-10 KC	0.6 %
30 ips	0-200 cps	0.2 %
	0-5 KC	0.8 %
15 ips	0-200 cps	0.25%
	0-2.5 KC	0.6 %
7 1/2 ips	0-200 cps	0.5 %
	0-1.25 KC	0.65%
3 3/4 ips	0-200 cps	0.5 %
	0-625 cps	0.8 %
1 7/8 ips	0-200 cps	0.8 %
	0-312 cps	1.2 %

**HEWLETT
PACKARD**  **SANBORN
DIVISION**

Electronics

January 10, 1966
Volume 39, Number 1

Page	4	Readers Comment
	8	People
	14	Meetings
	16	Meeting Preview
	23	Editorial
	25	Electronics Newsletter
	57	Washington Newsletter
	80	Reprints
	181	New Products
	225	New Books
	226	Technical Abstracts
	237	New Literature

Electronics Review

Page	43	Steady job for Tiros	48	Less from LES-4
	44	Extension phone	48	Self-diagnosis in flight
	45	Yokeless color tv	48	Early Bird's successors
	45	Bedside computer	50	Solar-cell circuit
	46	Air Force shopping list	52	Electronics notes

Probing the News

149	Bird-watching on rise at Vandenberg
156	Silicon's new wonder drug
167	Television in Eastern Europe

Electronics Abroad

239	A better PAL	241	Boost for computers
240	Low-cost Nadge	241	The biggest order
240	Broader communications	242	Contraband market
		243	Around the world

Technical Articles

Computers	90	Integrated circuits replace the electro-mechanical resolver In analog computers, IC resolvers are smaller lighter and consume 90% less power Hermann Schmid, General Electric Co.
Advanced technology	95	Diode lasers that operate continuously By refining material and improving fabrication researchers expect to get continuous-wave operation of gallium arsenide lasers within a year Michael F. Lamorte, RCA
Circuit design	100	Designer's casebook <ul style="list-style-type: none">• Two unijunction transistors produce three-state circuit• Electronic thermostat controls temperature to within 0.1°C.• Breadboarding IC systems with color-coded modules• Curves speed design of multiplier circuits
Communications	105	Tunnel-diode oscillator expands f-m system's channel capacity With high-speed devices, the voltage-controlled oscillator performs at frequencies to 200 Mc
Marketing	111	Electronics markets 1966 A statistical analysis of estimated electronics consumption in 1965, 1966 and 1969
	117	Faster growth in 1966 Electronics' editors examine the technological trends and market opportunities in 1966

Title R registered
U.S. Patent Office;
© copyright 1966
by McGraw-Hill, Inc.
All rights reserved,
including the right to
reproduce the contents
of this publication,
in whole or in part.

Electronics

Editor: Lewis H. Young

Senior editors

Technical: Samuel Weber

News: Kemp Anderson Jr.

Senior associate editors: John F. Mason, George Sideris

Department editors

Advanced technology: Joan Blum

Avionics: W.J. Evanzia

Circuit design: Michael Elia

Computers: Wallace B. Riley

Consumer electronics: Richard Lipkin

Electronics review: Stanley Zarowin

Instrumentation: Carl Moskowitz

Manufacturing: George Sideris

Military electronics: John F. Mason

New products: William P. O'Brien

Solid state: Jerome Eimbinder

Space electronics: Peter R. Sigmund

Regional editors

Bonn: John Gosch

Boston: Thomas Maguire, editor; Robin Carlson

London: Derek Barlow

Los Angeles: William B. Wallace, Walter Barney, editors; June Ranill

San Francisco: Laurence D. Shergalis, Edmond G. Addeo, editors; Mary Jo Jadin

Tokyo: Charles Cohen

Copy editors

Howard Rausch, Sally Powell, Kenneth Munn, James J. Moran

Graphic design

Art director: Saul Sussman

Assistant art director: Donna M. Griffiths

Editorial production: Ann Mella

Production editor: Arthur C. Miller

Editorial secretaries: Claire Benell, Mary D'Angelo, Lynn Emery, Lorraine Fabry, Kay Fontana, Lorraine Longo, Carolyn Michnowicz

McGraw-Hill News Service

Director: John Wilhelm; **Atlanta:** Fran Ridgway; **Chicago:** Reck Johnson;

Cleveland: Arthur Zimmerman; **Dallas:** Marvin Reid;

Detroit: N. Hunter; **Houston:** Ron Lovell; **Los Angeles:** Michael Murphy, Gerald Parkinson;

San Francisco: Margaret Ralston;

Seattle: Ray Bloomberg; **Washington:** Arthur L. Moore, Charles Gardner,

Herbert W. Cheshire, Seth Payne, Warren Burkett, Warren Kornberg

McGraw-Hill World News Service

Bonn: John Johnsrud; **Brussels:** Arthur Erikson; **London:** John Shinn;

Mexico City: Bruce Cross; **Milan:** Bruce Bendow;

Moscow: Donald Winston; **Paris:** Dan Smith;

Rio de Janeiro: Leslie Perry; **Tokyo:** Marvin Petal

Circulation manager: Hugh J. Quinn

Reprints: T.M. Egan

Publisher: C.C. Randolph

Electronics: January 10, 1966, Vol. 39, No. 1

Printed at 99 North Broadway, Albany, N.Y., 12207
Second class postage paid at Albany, N.Y.

Subscriptions are solicited only from those actively engaged in the field of the publication. Position and company connection must be indicated on orders. Subscription prices: United States and Possessions and Canada, \$6.00 one year, \$9.00 two years, \$12.00 three years. All other countries \$20.00 one year. Single copies, United States and Possessions and Canada 75¢. Single copies all other countries \$1.50.

Published every other Monday by McGraw-Hill Inc. 330 West 42nd Street, New York, N.Y. 10036. Founder: James H. McGraw, 1860-1948.

Subscribers: The Publisher, upon written request to our New York office from any subscriber, agrees to refund that part of the subscription price applying to copies not yet mailed. Please send change of address notices, subscription orders or complaints to Fulfillment Manager, Electronics, at the address below. Change of address notices should provide old as well as new address, including postal zone number if any. If possible, attach address label from recent issue. Allow one month for change to become effective.

Postmaster: Please send Form 3579 to Fulfillment Manager, Electronics, P.O. Box 430, Hightstown, New Jersey 08520

Readers Comment

A minute error

To the Editor:

You said that the Perkin-Elmer Corp.'s laser tv scanner [Nov. 29, p. 29] uses a prism rotating at "60,000 revolutions per second." Didn't you mean 60,000 revolutions per minute? The latter figure equates to 1,000 rps, which, when multiplied by 16, yields the correct line rate.

Besides, a point on the periphery of a two-inch diameter cylinder rotating at 60,000 rps, would be subjected to an acceleration of 366 million G's. If your statement is correct, your headline should read, "Perkin-Elmer develops new super-strength prism material."

Warren E. Dion

Bristol, Conn.

■ Reader Dion is right. The figure should have been 60,000 rpm, not rps. In fact, any known material would be torn apart long before it reached 60,000 rps.

In case of accident

To the Editor:

In the voltage regulator with short-circuit protection, [Nov. 1, p. 68] I question if this "protection" will be in time. First, it must be noted that the output voltage must drop to approximately 1.5 volts before Q_4 will go out of saturation sufficiently to turn on Q_5 and turn off the regulator. As the output drops toward the approximate 1.5 volt turn-off output voltage, the base drives for the Q_1 and Q_2 regulator transistors increase very rapidly in an attempt to maintain the output voltage.

By the time the 1.5-volt limit is reached, the pulse current ratings of both Q_1 and Q_2 will probably be exceeded. If the output short circuit is not of sufficiently low resistance (~ 0.2 ohms) to cause the output to fall below the turn-off voltage level with this increased regulator current, then no turn-off will occur and Q_1 and Q_2 may easily burn up due to excessive power dissipation.

Further, for space applications I would expect that the failure mode for this circuit would be un-

Now from Sprague!

DIFFERENTIAL AMPLIFIERS IN FLAT PACKS!

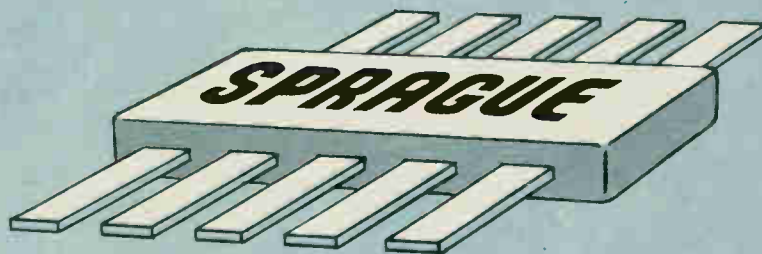

2N3043	2N3044	2N3046	2N3047	2N3049
2N3050	2N3051	2N3052	2N3520	2N3524

PNP or NPN • BETA MATCHING to 10%

V_{BE} MATCHING to 3mV • VOLTAGE CAPABILITY to 60 VOLTS

TEMPERATURE COEFFICIENTS to $5\mu\text{V}/^\circ\text{C}$

ALSO AVAILABLE IN 6-LEAD TO-5 OUTLINE PACKAGES!

For complete information, write to Technical Literature Service, Sprague Electric Company, 35 Marshall Street, North Adams, Mass. 01248

SPRAGUE COMPONENTS

TRANSISTORS
CAPACITORS
RESISTORS
INTEGRATED CIRCUITS
THIN-FILM MICROCIRCUITS

PULSE TRANSFORMERS
INTERFERENCE FILTERS
PULSE-FORMING NETWORKS
TOROIDAL INDUCTORS
ELECTRIC WAVE FILTERS

CERAMIC-BASE PRINTED NETWORKS
PACKAGED COMPONENT ASSEMBLIES
BOBBIN and TAPE WOUND MAGNETIC CORES
SILICON RECTIFIER GATE CONTROLS
FUNCTIONAL DIGITAL CIRCUITS



Sprague and ® are registered trademarks of the Sprague Electric Co.



Just
add a
scope . . .



and you have everything you need for
Quantitative Frequency-Response Measurements

The Type 1025-A Standard Sweep-Frequency Generator is both a sweep generator and a CW generator, with a marker generator, attenuator, and output meter . . . all wrapped up in a single package • it can be switched instantly from swept to CW mode without readjusting, recalibrating, or reconnecting • it covers 0.7 to 230 Mc/s in 10 overlapping octave ranges • has two bandspread ranges (400 to 500 kc/s and 10.4 to 11 Mc/s) • has a “perfect marker” . . . continuously adjustable and accurately calibrated both in frequency and amplitude, which allows you to take accurate quantitative data *directly* from a scope display • output is calibrated, 0.3 μ V to 1 V behind 50 ohms • frequency can be monitored by an external counter through a connector provided specifically for that purpose • price is \$3450, far less than the total cost of the separate instruments you would need for comparable performance.

Write for complete information or a demonstration.



An experimental 5-stage, single-tuned, 30-Mc i-f strip with 1-Mc bandwidth being aligned with the Type 1025-A Standard Sweep-Frequency Generator. Data measured includes center frequency, 6- and 60-dB bandwidths, and gain. The generator can be accurately set to both the 10 μ V signal level at the front end as well as to 100 mV at the last stage.

GENERAL RADIO COMPANY

WEST CONCORD, MASSACHUSETTS

BOSTON • NEW YORK • CHICAGO • PHILADELPHIA • WASHINGTON, D.C. • SYRACUSE • DALLAS • SAN FRANCISCO • LOS ANGELES • DRIANDO • CLEVELAND — TORONTO • MONTREAL
GENERAL RADIO COMPANY (overseas), ZURICH, SWITZERLAND; GENERAL RADIO COMPANY (U.K.) Ltd., BOURNE END, ENGLAND

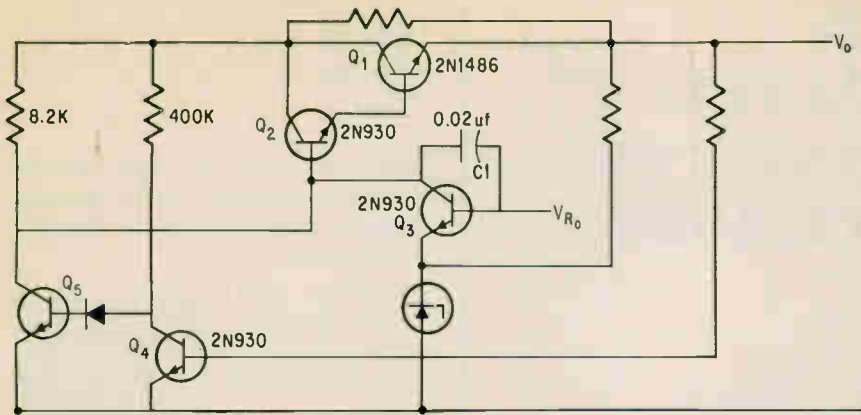

Protection against accidental short circuits.

acceptable, as the normal Q_1 and Q_2 failure mode would be a collector-emitter short using excessive power and losing regulating and turn-off capabilities.

A. E. Terpening
Rochester, N. Y.

The author replies:

As stated in the article, the circuit will protect against accidental short circuits. It was designed for flight hardware where the expected mode of failure is an accidental short circuit across the load during the many preflight tests or during flight. It will not protect against overload or against internal shorts. The use of high gain-bandwidth transistors for Q_4 and Q_5 , with a minimum amount of biasing, enables the short circuit sensing network to turn off Q_1 and Q_2 before large currents can build up when the output is suddenly shorted.

Reader Terpening may reason that overload protection will protect against both short circuits and overload—and rightfully so; however, if protection only against output short circuits is desired, then the circuit in question is more de-

sirable as it will consume less power than a circuit which will furnish overload protection. On some flight packages only the lesser amount of protection is specified while on others overload protection is required which would preclude the use of this circuit.

Gary A. Chunn
Chrysler Corp.
Huntsville, Ala.

Right credit

To the Editor:
The article "Page one," [June 28, p. 156] contains a good description of the Dutch-Belgian Semaphore system. It states that the system was developed by Philips Gloeilampenfabrieken. However, only the receiver was developed by Philips, in cooperation with PTT, Posterijsen Telefon en Telegraph, the Dutch agency that governs the post office, telephone and telegraph systems. The system and central computer control were developed solely by PTT.

Ir. G.M. Uitermark
Netherlands Postal and
Telecommunications Services
The Hague, Netherlands

maintenance

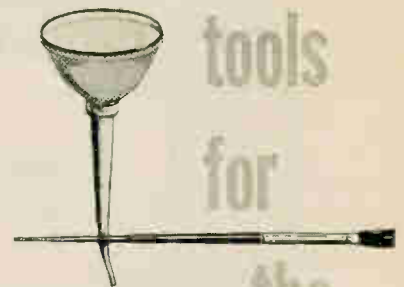

tools
for
the

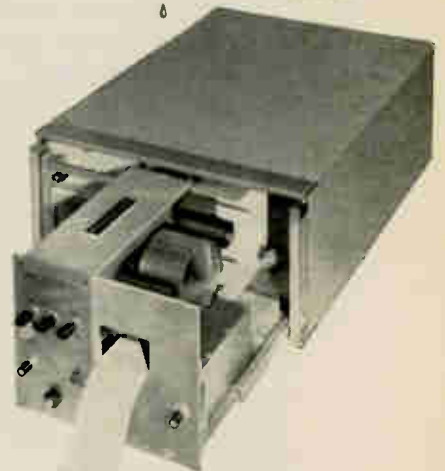

World's Fastest, Low-Cost Digital Printer

Apply several drops of oil to the drive-motor shaft-ends each year (or every fifty-million lines). Brush out any accumulated dust or lint. Clean the air filter periodically.

That's the extent of maintenance for a Franklin Model 1000 . . . the only digital printer that offers a printing rate of 40 lines per second (or less) at low, low, OEM prices.

REQUEST BULLETIN 2301



East Fourth St. • Bridgeport, Pa. 19405
A Division of the Anelex Corporation

SUBSCRIPTION SERVICE

Please include an Electronics Magazine address label to insure prompt service whenever you write us about your subscription.

Mail to: Fulfillment Manager
Electronics
P.O. Box 430
Hightstown, N.J. 08520

To subscribe mail this form with your payment and check new subscription renew my present subscription

Subscription rates: in the U.S.: 1 year, \$6; two years, \$9; three years, \$12. Subscription rates for foreign countries available on request

CHANGE OF ADDRESS

ATTACH LABEL HERE

If you are moving, please let us know five weeks before changing your address. Place magazine address label here, print your new address below.

name _____
address _____
city _____ state _____ zip code _____

NEED SOPHISTICATED COMPONENTS SUCH AS THESE?

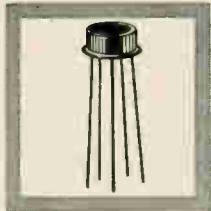

THIS?

Most circuit designers do.

OR THIS?

Integrated circuit packages are critical in use by just about any standard.

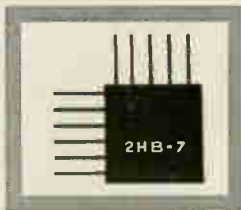

**AND HOW
ABOUT**

**THIS TWO TERMINAL
DEVICE**—*a small but critically important Resistor?*

After perusing the following details, more circuit designers and component-reliability engineers than ever before will realize that **SAGE SILICOHM**[®] miniature power resistors stand out above all others in providing:

- ① smallest size vs wattage rating
- ② fully welded construction using precision wire elements
- ③ Sage IMPERVOHM[®] silicone encapsulation, designed for 1000 volt body insulation and operating temperature extremes -65°C to 350°C
- ④ close tolerance, 1%, .5%, .25%, .1%, .05%
- ⑤ close TC, ± 20 ppm/ $^{\circ}\text{C}$
- ⑥ Copper leads standard, weldable nickel or Dumet when specified



- ⑦ non-inductive windings when specified
- ⑧ low values to $.05\Omega$, specials even lower
- ⑨ millions of unit-hours reliability documentation under Polaris and Improved Minuteman programs

Request Catalog R-62 for more details.



SAGE

SAGE ELECTRONICS CORP.
P.O. Box 3926 Rochester, N. Y. 14610



People

Clyde Bothmer has been named executive secretary of the Defense Industry Advisory Council (DIAC), a 22-man industry-group that advises the Pentagon on major procurement policy.



Bothmer will direct studies on the effects of military operations on the defense industries.

Typical of the problems he will tackle is the question of when and to what extent new components, such as advanced electronics, can be added to a system in development without drastically altering final design or passing cost limits.

Bothmer says his objective is "that delicate balance" between too much and too little control over design and component changes.

Bothmer takes over DIAC from Samuel W. Crosby, who resigned Sept. 1.

The new director, 41, is no stranger to problems encountered by defense contractors.

A lawyer by training, he first worked in procurement and logistics management for the Air Force before becoming the Pentagon's director for small business shortly after Robert S. McNamara became Secretary of Defense.

In 1962, he joined the National Aeronautics and Space Administration to become director of management for manned space flight and later, became director of NASA's Office of Industry Affairs.

"People have knocked lasers for various reasons," says Morris Katzman, the new manager of the Optical Radar section of the Xerox Corp.'s Pasadena, Calif., subsidiary, Electro-Optical Systems, Inc. "There was a need for a large power supply, efficiency was low, there were problems with atmos-



When Pete Balthasar concentrates on Bendix silicon power transistors...

Scott hears music!

Whenever you listen to an H. H. Scott stereo amplifier, you'll realize how Pete's concentration has paid off. The difference is the new Bendix silicon power transistors in the audio output.

Just take a look at what Pete, our Applications Engineering Manager, has to work with: I_C to 15 A, V_{CB} to 200 V, P_C to 175 W. Excellent beta stability over the entire operating range of -65°C to $+200^\circ\text{C}$. High voltage capabilities and diffused construction for fast switching. Outstanding thermal resistance characteristics, too.

Some of the more popular 2N performers? 2N3055, 2N3232 and 2N3235. Also the 2N1487-2N1490 that meet military specification MIL-S-19500/208 (EL).

Pete's defined SOAR (Safe Operating Area) for these types, too, with still more on the way. (That's a "first" for silicon power.) With SOAR, secondary breakdown is virtually impossible. There are also additional new commercial grades and lower cost types. (Our 2N3055 often proves more economical than germanium, for example.)

Now you can begin to see how you might put these powerful silicon mesas to work: for hi-fi and audio, of course. Voltage and current regulators, choppers, inverters, relay and solenoid actuating circuits and high power switching, too.

Like more information? Just write or phone our nearest sales office. Then sit back and enjoy the sound of Bendix.

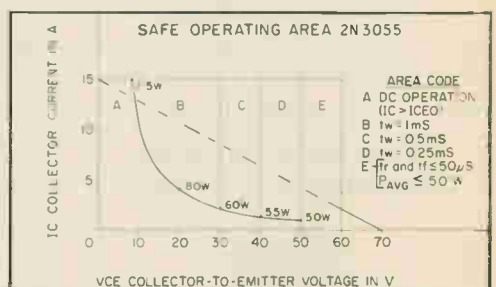
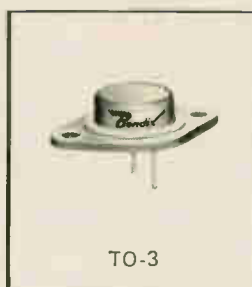

Bendix Semiconductor Division
HOLMDEL, NEW JERSEY



Baltimore, Md.—(301) 828-6877; Chicago—(312) 637-6929; Dallas—(214) 357-1972; Detroit—(313) JO 6-1420; Holmdel, N. J.—(201) 747-5400; Los Angeles—(213) 776-4100; Miami—(305) 887-5521; Minneapolis—(612) 926-4633; Redwood City, Calif.—James S. Heaton Co., (415) 369-4671; Seattle—Ray Johnston Co., Inc., (206) LA 4-5170; Syracuse, N. Y.—(315) 474-7531; Waltham, Mass.—(617) 899-0770; Export—(212) 973-2121; Cable: "Bendixint." 605 Third Ave., N. Y.; Ottawa, Ont.—Computing Devices of Canada, P.O. Box 508—(613) TA 8-2711.

Did You Know Sprague Makes 32 Types of Foil Tantalum Capacitors?

125 C TUBULAR TANTALEX® CAPACITORS



- Type 120D polarized plain-foil
- Type 121D non-polarized plain-foil
- Type 122D polarized etched-foil
- Type 123D non-polarized etched-foil

ASK FOR BULLETIN 3602C

Circle 332 on reader service card

85 C TUBULAR TANTALEX® CAPACITORS



- Type 110D polarized plain-foil
- Type 111D non-polarized plain-foil
- Type 112D polarized etched-foil
- Type 113D non-polarized etched-foil

ASK FOR BULLETIN 3601C

Circle 333 on reader service card

RECTANGULAR TANTALEX® CAPACITORS



- Type 300D polarized plain-foil
- Type 301D non-polarized plain-foil
- Type 302D polarized etched-foil
- Type 303D non-polarized etched-foil

ASK FOR BULLETIN 3650

Circle 334 on reader service card

TUBULAR TANTALUM CAPACITORS TO MIL-C-3965C



- CL20, CL21 125 C polarized etched-foil
- CL22, CL23 125 C non-polarized etched-foil
- CL24, CL25 85 C polarized etched-foil
- CL26, CL27 85 C non-polarized etched-foil
- CL30, CL31 125 C polarized plain-foil
- CL32, CL33 125 C non-polarized plain-foil
- CL34, CL35 85 C polarized plain-foil
- CL36, CL37 85 C non-polarized plain-foil

Circle 335 on reader service card

RECTANGULAR TANTALUM CAPACITORS TO MIL-C-3965C



- CL51 polarized plain-foil
- CL52 non-polarized plain-foil
- CL53 polarized etched-foil
- CL54 non-polarized etched-foil

Circle 336 on reader service card

For comprehensive engineering bulletins on the capacitor types in which you are interested, write to:

Technical Literature Service
Sprague Electric Company
35 Marshall Street
North Adams, Mass. 01248

45C-5161

SPRAGUE®
THE MARK OF RELIABILITY

*Sprague and ® are registered trademarks of the Sprague Electric Co.

People

pheric attenuation and the signal was not clean. But the skeptics are beginning to change their minds. The problems are being overcome; lasers are spreading out in all directions, and in all wavelengths. Out here we're working on a carbon-dioxide laser that develops 100 watts, continuous wave, and is about 8% efficient. In five years, you'll see all kinds of field equipment, such as laser radars, welders and surgical devices."

Katzman, 42, is interested specifically in laser radar; he believes it will be two to three years before field equipment is ready, but expects to confirm the techniques his four-man group at Electro-Optical is using by the end of 1966.

The breaking up of the wavefront, he says, is a more serious problem than atmospheric attenuation. Electro-Optical's technique is to try to compensate for phase changes so that only the attenuation problem is left.

There are two complementary approaches, he adds: a mode-locking operation that uses the laser's whole spectrum, and a technique that allow only one mode to oscillate.

[The approaches resemble the frequency-modulated and super-mode lasers described in *Electronics*, Sept. 20, p. 102].

Using the whole spectrum would be useful for multiple targets, Katzman says, while the single frequency would work better for a single target. Ideally, the radar would have a switch to change from mode to mode.

The Katzman group is working with neodymium-doped glass and neodymium yttrium-aluminum-garnet lasers, at frequencies in the near-infrared.

Katzman came to Electro-Optical from the Army Electronics Laboratory at Fort Monmouth, N. J. He likes the Los Angeles area, even to the smog. "In fact," he adds, "the smog comes in handy when we're studying attenuation factors" at the company's three-mile range in Pasadena.

He received his bachelor's degree in engineering from New York University.

**Powerful Machlett
tetrode delivers
330 kW plate output
with .7 kW drive**

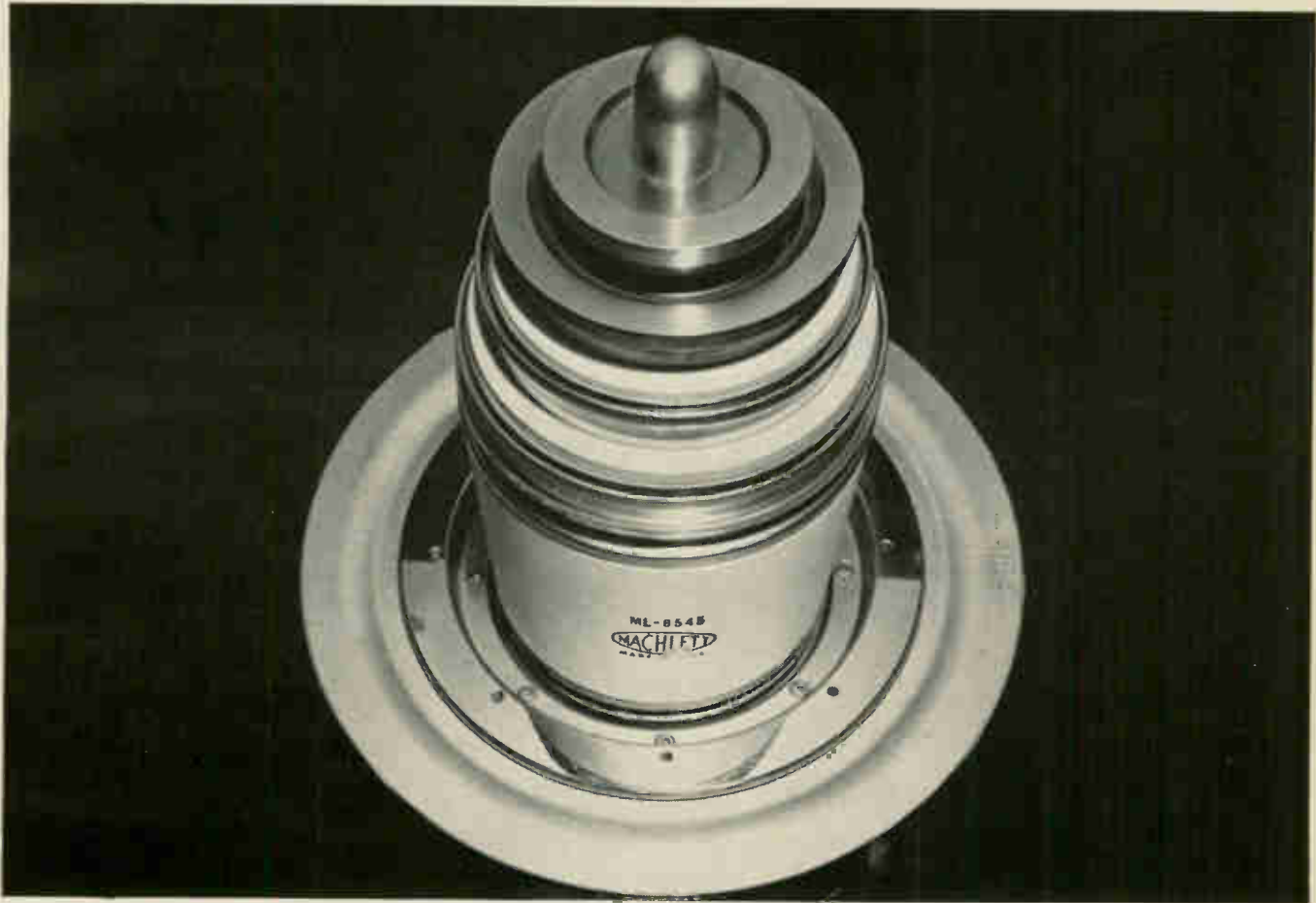

This vapor-cooled ML-8545, the world's most powerful tetrode, is designed for high power broadcast and communications, rf generators and particle acceleration applications. It delivers 16% more power with 25% less plate voltage (plate modulation service) than its closest competitor.

As a Class C amplifier or oscillator, it is capable of over 300 kW continuous output at frequencies to 50 Mc. Maximum plate input is 450 kW.

For full details on the vapor-cooled ML-8545 or the water-cooled ML-8546, write to The Machlett Laboratories, Inc., Springdale, Conn. 06879. An affiliate of Raytheon Company.



ELECTRON TUBE SPECIALIST

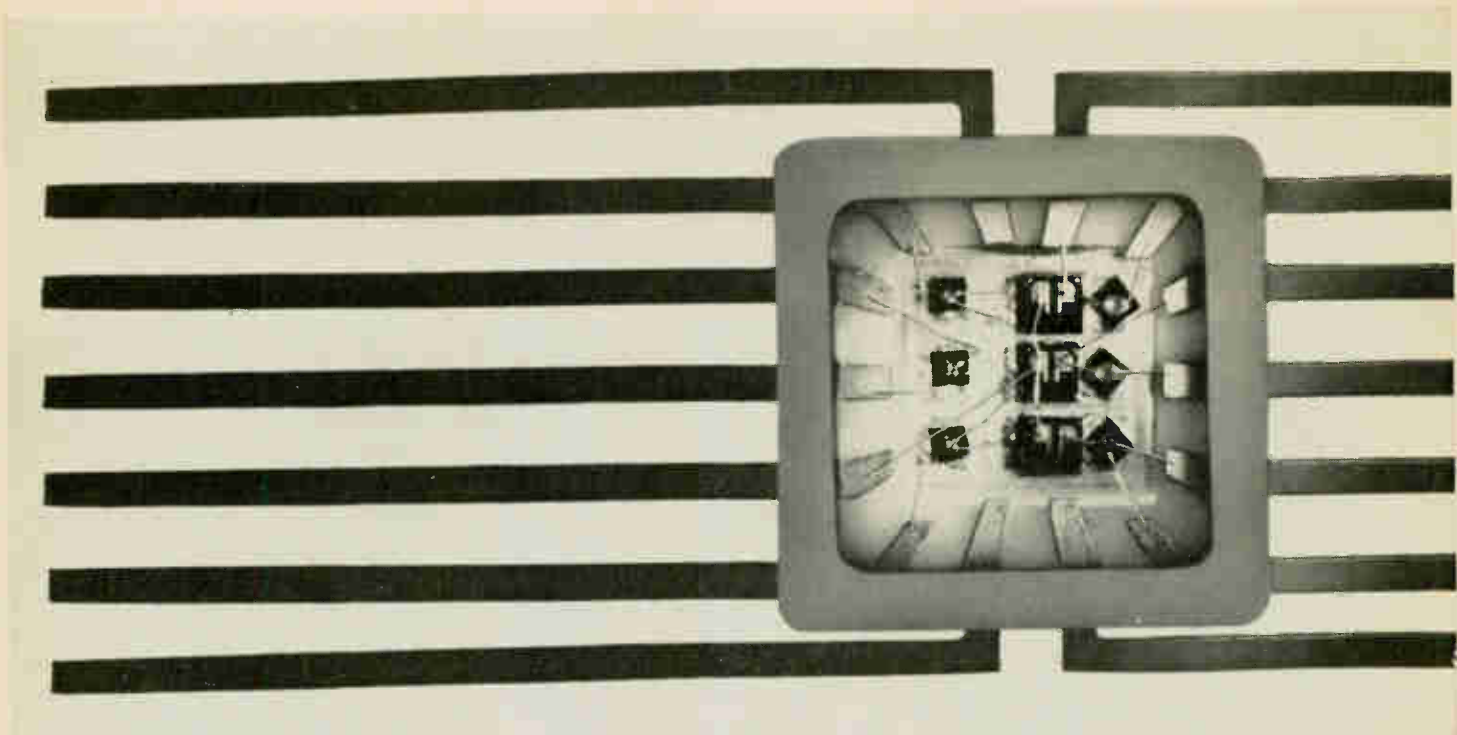

Reasons for buying Fairchild Hybrids, magnified 100 times.

What we have to offer:

Pick from the widest line of transistors, diodes, and integrated circuits in the industry.

Integrated circuits: A complete line of logic functions in μL^* standard resistor-transistor integrated circuits, $\text{F}\mu\text{L}^*$ industrial integrated circuits, $\text{MW}\mu\text{L}^*$ milliwatt integrated circuits, and $\text{DT}\mu\text{L}^*$ diode-transistor logic circuits.

Transistors and diodes: Our complete catalog of high-performance transistors and diodes. Anything our factory makes we will put in a hybrid circuit for you.

Resistors: We use nichrome thin-film resistors in all RETMA values from 20Ω to $500\text{k}\Omega$. Tolerances from 10% to 2%.

Capacitors: MOS capacitors from 20pf to 1000pf.

Packaging: TO-5 (8, 10 or 12 leads) or FlatPak (12 or 14 leads).

We're geared for action:

We have a complete staff devoted to hybrid work. This means you get immediate answers, quotes and delivery on your custom orders. Fast. We also offer assistance in converting your schematic to a hybrid design. Write for details on our Technicon (specifications delineation), our Hybrid Design Handbook, and our Design Kit. Or, if you're not in the market for a custom design, write for data sheets on our standard hybrid circuits.

FAIRCHILD
SEMICONDUCTOR

* μL , $\text{F}\mu\text{L}$, $\text{MW}\mu\text{L}$ and $\text{DT}\mu\text{L}$ are Fairchild trademarks.

DUAL OUTPUT POWER SUPPLIES



Dual output power supplies are housed in one case 3-5/16" x 4-5/32" x 4-11/16" high. Identical or different output voltages from 1.5 to 75 are available in 1 volt increments for each of the DC outputs. The graph below furnishes maximum current corresponding to output voltage. Select the two outputs needed and telephone Acopian for all the details — plus guaranteed 3-day shipment after receipt of your order.

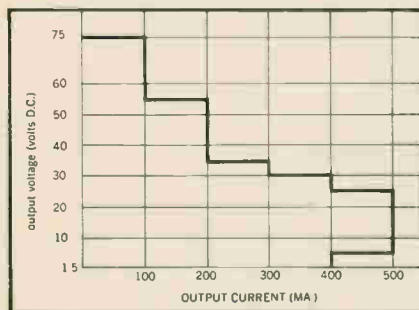

TYPICAL SPECIFICATIONS

Input Voltage: 105 to 125 VAC
 Line Regulation: ± 0.5 to $\pm 0.05\%$
 (depending on model)
 Load Regulation: ± 1.0 to $\pm 0.05\%$
 (depending on model)
 Ripple: 5 to 1 mv (depending on model)
 No additional external heat sinking required.

Write for Acopian's 16-page catalog and price list to: Acopian Corp., Easton, Penna., or call collect (215) 258-5441.



Meetings

Instrumentation for Process Industries Conference, Texas A&M University; College Station, Tex., Jan. 19-21.

Conference on Symmetry Principles at High Energy, AFOSR, AEC, NASA; University of Miami, Coral Gables, Fla., Jan. 20-22.

Phonon Interaction in Solids Conference, Princeton University; Princeton, N. J., Jan. 20-21.

Helicopter Conference, Helicopter Association of America; Inn of Six Flags, Arlington, Tex., Jan. 23-26.

Aerospace Sciences Conference, Statler Hilton Hotel, New York, Jan. 24-26.

AE-4 Electromagnetic Compatibility Conference, SAE; General Dynamics/Convair, San Diego, Calif., Jan. 25-26.

National Electronic Representatives Association Marketing Conference, ERA; Riviera Hotel, Palm Springs, Calif., Jan. 26-30.

American Society of Testing and Materials Spring Meeting, ASTM; Shoreham and Sheraton Park Hotels, Washington, D.C., Jan. 30-Feb. 4.

International Symposium on Information Theory, AFOSR, IEEE; University of California, Los Angeles, Jan. 31-Feb. 2.

Integrated Circuits Seminar, IEEE, Basic Sciences Committee; Stevens Institute of Technology, Hoboken, N.J., Feb. 2.

Winter Convention on Aerospace & Electronics Systems, IEEE; International Hotel, Los Angeles, Feb. 2-4.

International Salon of Electronic Components, Federation National des Industries Electroniques; Parc des Expositions, Paris, Feb. 3-8.*

Solid State Circuits Conference, IEEE, University of Pennsylvania; Sheraton Hotel, Philadelphia, Feb. 9-11.

Radioisotope Applications in Aerospace, AFSC and Atomic Energy Commission; Sheraton-Dayton Hotel, Dayton, Ohio, Feb. 22-24.

Offshore Exploration Conference, OECON; Lafayette Hotel, Long Beach, Calif., Feb. 22-24.

Symposium on Manufacturing In-Process Control and Measuring Techniques, Air Force Materials Laboratory and Motorola Semiconductor Products Division; Hiway House, Phoenix, Ariz., Mar. 9-11.

International ISA Aerospace Instrumentation Symposium, ISA, College of Aeronautics; College of Aeronautics, Cranfield, England, Mar. 21-24.

International Convention and Exhibition of the IEEE; New York Hilton Hotel and the Coliseum, New York City, Mar. 21-25.

Seminar on Computers and Automation in Europe, Lomond Systems, Inc.; Washington, D.C. and European tour, Mar. 21-Apr. 7.

Call for papers

National Symposium on Biomedical Sciences Instrumentation, ISA; Disneyland Hotel, Anaheim, Calif., May 16-19. Feb. 15 is deadline for submission of 200-word abstract on aerospace biomedical instrumentation, interdisciplinary teaching of biomedical and measurement techniques for the engineer and physician, and electronics in patient monitoring systems, to Dr. Thomas B. Weber, Program Cochairman, Beckman Instruments, Inc., 2500 Harbor Blvd., Fullerton, Calif. 92632.

Symposium on Hydrogen Thyratrons and Modulators, U.S. Army Electronics Command Advisory Group on Electron Devices; Hexagon Building, Fort Monmouth, N.J., May 10-12. Mar. 1 is deadline for submission of abstracts on the design of tubes and active components used in the design of pulse modulators to Sol Schneider, Cochairman, Hydrogen Thyatron and Modulator Symposium, Electronic Components Laboratory, US Army Electronics Command, Fort Monmouth, N.J. 07703.

* Meeting preview on page 16

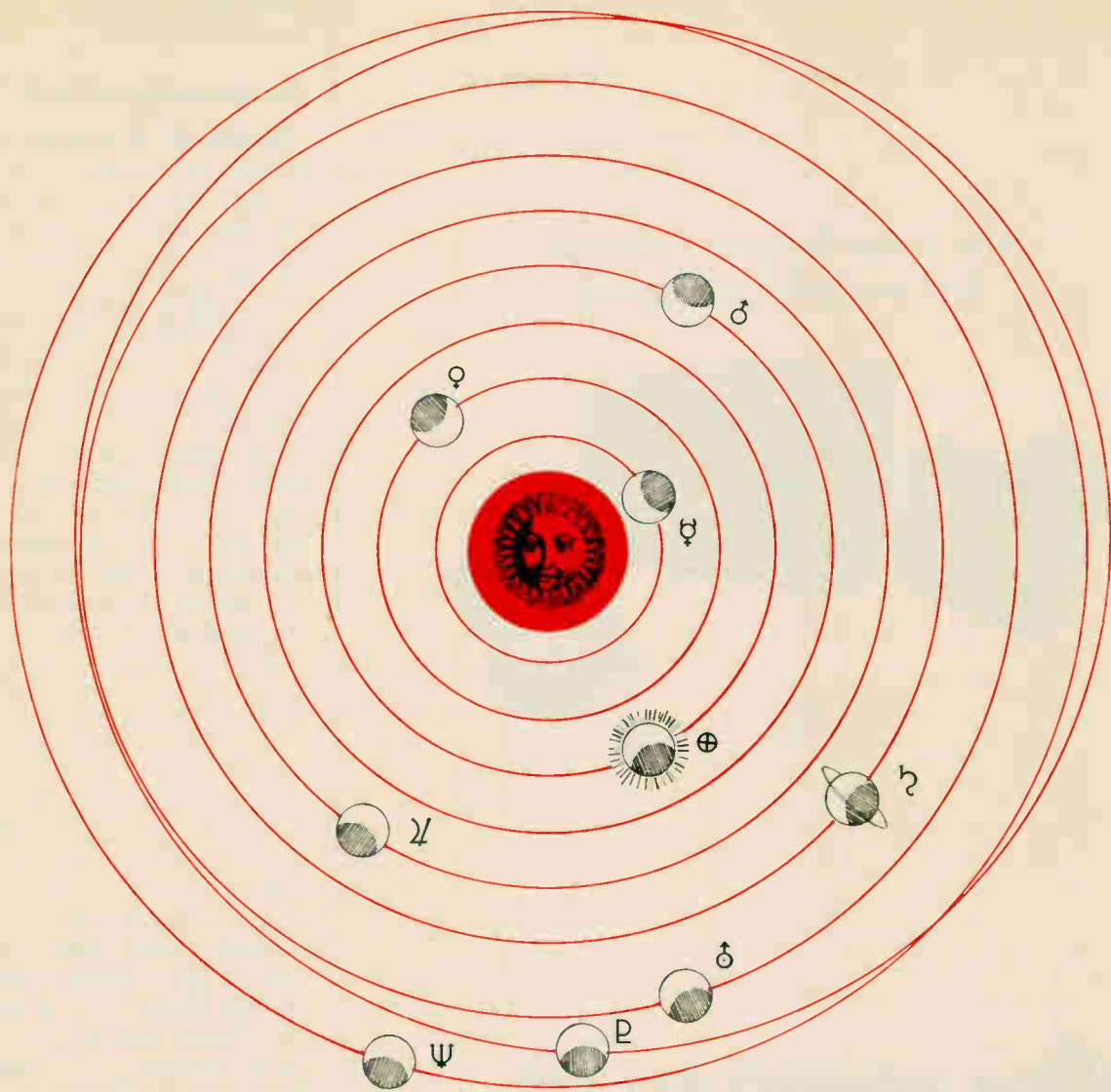

Chances are 9999999 to 1 this system's **on the air**

A new target figure for reliable uptime (.9999999) is now being demonstrated with an Astrodata system in one of this nation's key defense communications networks. Unlike other instruments and equipment with high reliability for limited intervals, Astrodata's Model 6600 Timing System is designed to be up and available around the clock.

Chances that it will be off the air even momentarily are one in 10^{-7} . This outstanding availability is the result of several design concepts:

Triple redundancy and majority logic ensure that the 6600 will continue functioning before, during and after component failure. Triple redundancy is designed into power, oscillation, and all other functional components. Majority logic (best two out of three) is used for all

divider circuitry at every stage of the system.

The 6600 need not go off the air for maintenance. Alarms, both audible and visible, are energized upon failure of any component. Localized error condition lights on each circuit card enable the operator to pinpoint any malfunction immediately. And the test point of any circuit card may be accessed from the front without making another circuit card inaccessible.

Whether redundant or non-redundant design, Astrodata has supplied well over 50 percent of the free world's timing instrumentation.

For more information concerning timing, data acquisition, processing, telemetry, hybrid, or analog computer techniques, please write for our timing and/or systems experience brochures.



ASTRODATA

P.O. Box 3003 ■ 240 E. Palais Road, Anaheim, California ■ 92803

This is the build-in concept
that trio/lab[®] pioneered.



Why come to us now that 12 others are doing it?

We do it better, faster, at lowest cost:

1. We've been doing it longer—11 years of build-in experience must count for something. 90% of all build-in electronic voltmeters are trio/lab.

2. The chances are good that we've already solved your build-in problem or one like it.

We have 50,000 case histories to draw on. Therefore, a "special" is not always a "special" to us. When it is...there's our experience again.

Plus (don't forget) all the basic rea-

sons for *designing-in* in the first place: to customize test systems, set-ups and instruments; save space; save time with at-a-glance monitoring; save money by excluding unneeded functions; make monitoring go/no-go; improve systems reliability; increase design freedom.

Write or call for design help or a free copy of our handbook/catalog.

Trio Laboratories, Inc., Plainview, L.I., New York. (516) OV-1-0400. TWX: (510) 221-1861.



© 1966, TRIO LABORATORIES, INC. • ORIGINAL CONCEPTS IN INSTRUMENTATION

Meeting preview

Components in Paris

The growth of Europe as a rich market for the electronics industry is reflected in the huge, sprawling, bustling, technical Tower of Babel known as the International Salon of Electronic Components.

Scheduled in Paris from Feb. 3 to 8, the Salon is billed as an excellent meeting ground for technical people to discuss new ideas and keep up with the latest technical advances. But visitors to the Salon should not expect to hear any major scientific papers during the show. The real purpose of the meeting is to line up new customers, tighten distribution lines, and see what the competition is up to.

For a broad view of where world electronics is heading, the Salon is of incomparable value.

In 1965, the Salon had 859 exhibitors and 125,000 visitors. This year nearly 900 firms are expected to show wares, which will include every category of electronic component and instruments, from attenuators to zoom lenses. The show is truly international—more than half of the exhibitors come from outside France, led by firms from the United States, Germany and Great Britain. Much interest will focus on the Japanese, who exhibited at the Salon for the first time in 1965, and are showing increasing aggressiveness in the European market.

Delegations and exhibitors from Eastern Bloc nations such as Poland, East Germany, Yugoslavia and Hungary are expected back. Teams of Russian and Communist Chinese technicians will surely make the rounds.

Begun in 1934, the Salon is sponsored by the FNIE (Electronic Industries Association of France) and Sipare (Radioelectric and Electronic Components and Accessories Manufacturers Association). The second International Exhibition of Audio Equipment will be in a hall adjacent to the Salon. This features consumer electronic equipment such as radios, television sets and tape recorders.

The Salon returns to its traditional February schedule after an experimental trial in April last year.

...NOW IN A NEW MINIATURIZED SIZE

Hermetically Sealed ERIE BUTTON® MICA capacitors

designed for
-55° to +200°C at 2000 Mc.



Featuring 508 MECHANICAL VARIATIONS TO SUIT
ANY HIGH TEMPERATURE—HIGH FREQUENCY CAPACITOR APPLICATION

With the addition of these new miniatures, Erie further broadens the most complete selection of Button Mica Capacitors in the industry. These new miniaturized micas provide 33% reduction in mounting area.

Erie Button Mica Capacitors are designed for use in radio frequency circuits for tuning, bypassing and coupling. The outstanding properties of metallized mica dielectric combined with the radial current pattern, make Erie Button Capacitors ideal for low inductance, high frequency applications.

These high quality capacitors are designed for microwave and filter applications, for use in carrier equipment, parametric and RF amplifiers, oscilloscopes... any application where high temperature and high frequency are factors.

The welded hermetic seal of these excellent broad frequency Gold Seal® capacitors for military and commercial use is 100% tested under pressure steam/salt water during production to guarantee a positive moisture seal.

Consider the advantages of Erie Button Mica Capacitors in the equipment you are designing. Write for Gold Seal Bulletin 500-2 or Resin Seal Bulletin 318-3.

GENERAL SPECIFICATIONS

Capacitance:	5 pf. thru 2500 pf.	Frequency Range:	to 2Gc and beyond
Tolerance:	1% or .25 pf thru ±20%	Operating Temp.:	-55°C to +200°C
Working Voltage:	500 WVDC for 1/2" dia. units 250 WVDC for 3/8" dia. units		-55°C to +150°C -55°C to +85°C

Q: per MIL-C-10950

TYPES AVAILABLE

HERMETICALLY SEALED (GOLD SEAL®)	RESIN SEALED
.410" O. D. or .505" O. D.	.375", .447" or .657" O. D.



MINIATURE BYPASS CAPACITOR SYSTEMS FOR TRANSMITTING TUBES...



Designed for the 10 to 3,000 megacycles range—and beyond

Erie now provides effective capacitive bypassing and coupling or filtering of all RFI signals in the range of 10 to 3,000 megacycles. Variety of systems to meet your requirements.

Write for Bulletin 525-R

Formerly Erie Resistor Corporation

Another Series of Components in Erie's Project "ACTIVE"
Advanced Components Through Increased Volumetric Efficiency

ERIE

TECHNOLOGICAL

PRODUCTS, INC.



644 West 12th Street
Erie, Pennsylvania



LOOK TO THE LEADER
IN INTEGRATED CIRCUITS

Here's a New Way to

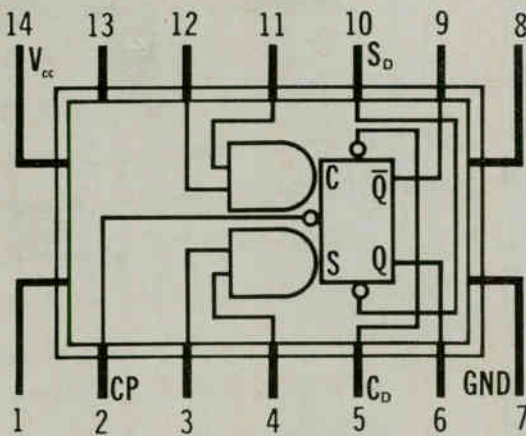

NEW

SN54 948
T²L Flip-flop
... replaces 931, 945 and 948 DTL

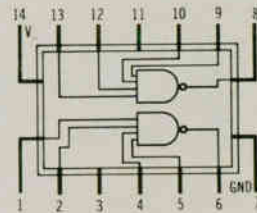

SN54 930
Dual 4-input Gate
... replaces 930 DTL

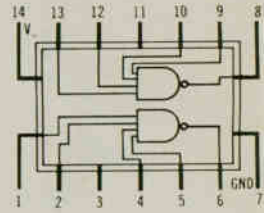

SN54 932
Dual 4-input Buffer
... replaces 932 DTL

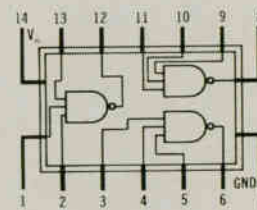

SN54 962
Triple 3-input Gate
... replaces 962 DTL

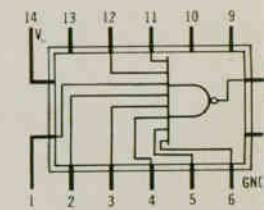

SN54 965
8-input Gate
No DTL circuit yet

T²L integrated circuits from TI replace 930-series DTL . . .

Upgrade 930-series DTL performance in your present systems *without* costly and time-consuming redesign. How? Simply replace the DTL circuits with new Series 54 930 T²L integrated circuits from Texas Instruments — now including a new flip-flop. No change in circuit boards or power supplies is necessary. Series 54 T²L offers 48% higher speed, 25% higher fan-out and 15% higher noise margin than DTL — *at competitive or lower prices!*

New Series 54 930 T²L circuits are now available with pin configurations that make them *direct electrical and mechanical replacements* for their older

DTL equivalents in most applications. These circuits are logically compatible with 930-series DTL, and can replace all or part of DTL-designed systems.

The new Series 54 930 circuits with DTL-type pin configurations are an expansion of TI's regular Series 54 line. They are identical in every respect with standard Series 54 circuits, except for pin configurations.

Series 54 Transistor-Transistor Logic (T²L) fully exploits the inherent capabilities of integrated semiconductor structures. The multiple-emitter transistor input provides a faster turn-off time than other logic forms, thereby minimizing

propagation delay. Because of unique circuit characteristics and exacting production control, propagation delays are almost independent of temperature and load.

The output stage of the Series 54 circuit provides low line-termination impedance in both logical "0" (12 ohms) and logical "1" (100 ohms) states. This contributes to low propagation delays, preserves undistorted waveforms when driving large-capacitance loads. The low line-termination impedance also accounts for low susceptibility to capacitively coupled noise.

Typical noise margin for Series 54 integrated circuits is one volt. Guaranteed

Upgrade Your DTL System

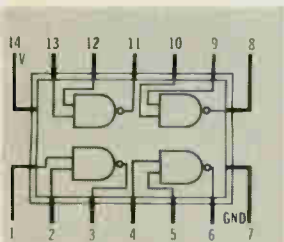

SN54 946
Quad 2-input Gate
... replaces 946 DTL

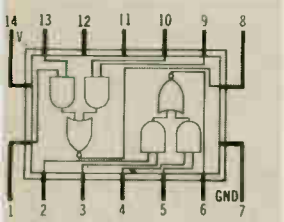

SN54 966
Dual EXCLUSIVE-OR
No DTL circuit yet

Logic	Propagation Delay (Typical)	Fan-Out	D-c Noise Margin (Guaranteed)
Series 54 930 T ² L	13 nsec	10	400 mV
930-series DTL	25 nsec	8	350 mV

Series 54 930 T²L offers higher speed, higher fan-out and higher noise margin than 930-series DTL gates.

Oscilloscope traces compare speed degradation of 930-series DTL and Series 54 930 T²L as capacitance load is increased. Turn-off times for 50-pf and 100-pf loading conditions are shown at the 1.5-volt point.

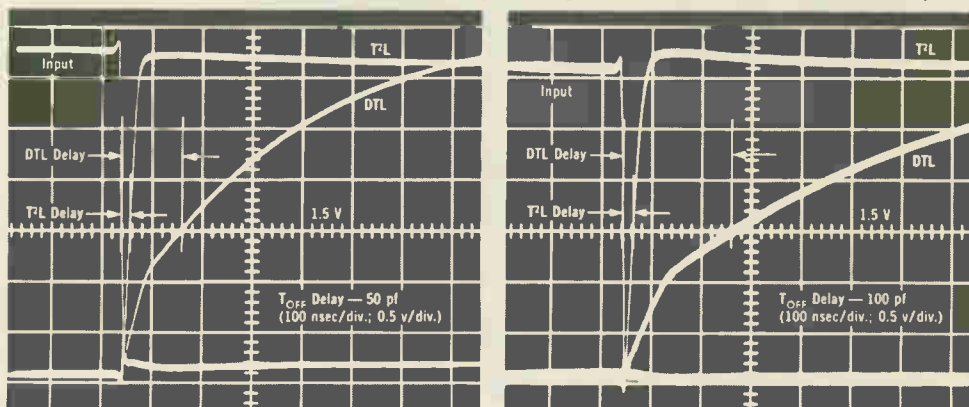

Give you higher speed, higher fan-out, higher noise margin

1 worst-case noise margin is 400 millivolts for both logical "1" and logical "0" conditions.

TI's standard 1/4" by 1/8" flat package (D-84) is used for all Series 54 circuits. This package — proved by more than 1,000,000 hours of controlled tests and 10 years of field use — features all-metal construction with hermetic glass-metal seals.

Why not try replacing DTL circuits with Series 54 T²L in your present system? See for yourself the improvement in performance. For evaluation quantities from stock, contact your local TI Sales Engineer or Distributor.



TEXAS INSTRUMENTS
INCORPORATED
13500 N. CENTRAL EXPRESSWAY
P. O. BOX 5012 • DALLAS 22, TEXAS

SEMICONDUCTOR PLANTS IN BEDFORD, ENGLAND • NICE, FRANCE • DALLAS, TEXAS

what's in a spec?

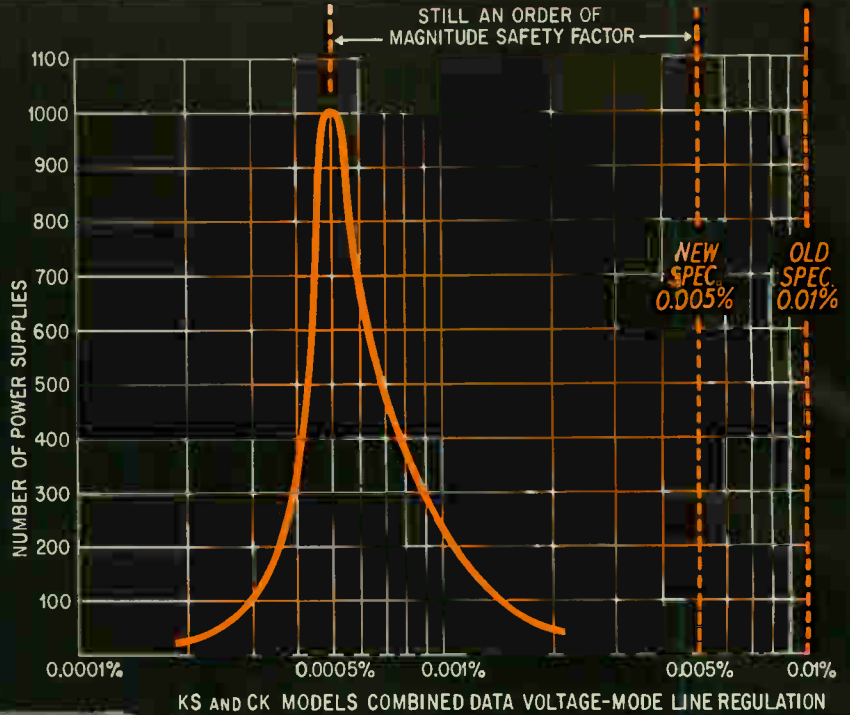

KS AND CK MODELS COMBINED DATA VOLTAGE-MODE LINE REGULATION



Model KS 36-5M



Model CK 40-0.8M

NOW!

0.005% LINE REGULATION SPECIFIED FOR 26 MODELS

What's in a spec? Lots more than just wishful thinking! For example, the line regulation specification of our popular CK and KS models has been 0.01% for some years. Recently we compiled statistical performance data on thousands of production instruments, and discovered that a 0.005% specification would still leave a generous order-of-magnitude safety margin. As a result, Kepco will rewrite the book on voltage line regulation specifications (the amount of the output voltage change when power line input varies from 105 to 125V AC). The new line regulation specification will be 0.005% starting with 1966 production models. As the above figure shows, however, 100% of all delivered KS/CK Power Supplies already meet this spec. So you can rewrite the book, too . . . on existing as well as new equipment.

What's in a spec? A Kepco spec is made up of a whole lot of experience, painstaking attention to detail, a no-nonsense Quality Control attitude and a healthy dose of conservatism.

Applicable Patent Nos.
furnished on request



OUR NEW CATALOG
CONTAINING COMPLETE
SPECIFICATIONS AND
APPLICATIONS NOTES
IS NOW AVAILABLE

WRITE FOR YOUR
FREE COPY!



KEPCO K S GROUP

MODEL	DC OUTPUT RANGE		DIMENSIONS			PRICE
	VOLTS	AMPS	H"	W"	D"	
KS 8-15M	0-8	0-15	3½	19	14¾	\$625
KS 8-25M	0-8	0-25	5¼	19	16	760
KS 8-50M	0-8	0-50	7	19	16	1,050
KS 8-100M	0-8	0-100	8¾	19	20	1,450
KS 18-10M	0-18	0-10	3½	19	14¾	575
KS 18-15M	0-18	0-15	5¼	19	16	725
KS 18-25M	0-18	0-25	7	19	16	970
KS 18-50M	0-18	0-50	8¾	19	20	1,360
KS 36-5M	0-36	0-5	3½	19	14¾	525
KS 36-10M	0-36	0-10	5¼	19	16	625
KS 36-15M	0-36	0-15	7	19	16	730
KS 36-30M	0-36	0-30	8¾	19	20	1,150
KS 60-2M	0-60	0-2	3½	19	14¾	525
KS 60-5M	0-60	0-5	5¼	19	16	645
KS 60-10M	0-60	0-10	7	19	16	895
KS 60-20M	0-60	0-20	8¾	19	20	1,350
KS 120-1M	0-120	0-1	3½	19	14¾	550
KS 120-2.5M	0-120	0-2.5	5¼	19	16	695
KS 120-5M	0-120	0-5	7	19	16	970
KS 120-10M	0-120	0-10	8¾	19	20	1,450

KEPCO C K GROUP

CK 2-8M	0-2	0-8	4¼	8¾	13¾	\$345
CK 8-5M	0-8	0-5	4¼	8¾	13¾	345
CK 18-3M	0-18	0-3	4¼	8¾	13¾	305
CK 36-1.5M	0-36	0-1.5	4¼	8¾	13¾	305
CK 40-0.8M	0-40	0-0.8	4¼	8¾	13¾	267
CK 60-0.5M	0-60	0-0.5	4¼	8¾	13¾	305

CK GROUP: 19" rack adapters available for single (RA 5) or dual (RA 4) mounting . . . \$15.00 each.

WRITE FOR COMPLETE SPECIFICATIONS

Editorial

Rosy 1966: a time to plan?

A happy new year seems assured for most of the electronics industry.

Our annual survey (pps. 111 to 140) predicts the industry will grow 7.6% in 1966, more than three times the growth predicted in 1965. Unemployment among electronics engineers has nearly vanished, and in many geographic areas—like Los Angeles and San Francisco—the frantic recruiting drives of a few years ago are being repeated. Sharp economic pickups have benefited electronics firms and engineers in Boston and Philadelphia, two areas that were hurting this time last year.

With nearly everybody enjoying the rosy glow of good business, the temptation is to sit back and relax.

However, the good business of last year—much better than anybody expected on Jan. 1, 1965—and the prospects for even better in 1966—haven't erased some fundamental industry problems.

- Too many companies depend too much on military spending for a livelihood. There is no question that additional military buying caused by escalation of the fighting in Vietnam breathed new life into many electronics firms last year. But an armistice will end this boom. Pressure around the world is building to end the fighting. If it does end, electronics firms which supply military gear would feel the pinch quickly because most of the additional funds are going for production of equipment already developed, rather than for new developments. Such production can be quickly shut off.

- Competition from Japan, Hong Kong and Europe is slashing away at U. S. markets for consumer goods, components and semiconductors. U. S. companies can't hope to match the low labor

rates of the competition. The hope lies in automating production to the point where it matches the cost of manufacture by cheap labor, or in stepping up research activities to increase the U. S. technological lead, or in expanding development to create new products that use advanced technology or in invading areas that have never before used electronics equipment.

- Integrated circuits will replace discrete components in more applications than most people expect—and faster. Some component makers have to face the hard facts that giant markets they have cultivated for years are going to disappear overnight, unless they develop products that fall into the broad category of microelectronics. The facing of harsh facts is never easy. For years the manufacturers of vacuum tubes refused to recognize the growth of transistor suppliers until the makers of solid state devices had won most of the tube makers' choicest markets. Component makers could make the same mistake as IC makers grow.

Although solving any one of these problems is a gigantic task—and if a company has to face all three, its job is truly herculean—the time was never better for starting on them. In a study of diversification, for example, the Denver Research Institute concluded that the best time to diversify is when things are going well, not when business is bad. Similarly, for conducting long-range planning, introducing new research projects, and launching product-development programs, the best time is when a company is making money.

The reasons are simple. One is plain psychology. When business is good, everybody—executives and engineers—are optimistic. They have a strong motivation to start—and finish satisfactorily—new projects. Another is economic. When business turns down suddenly or sharply, only the stoutest heart will fail to slash R&D funds, thus crippling what could be a company's main line of recovery.

Clearly 1966 will be a good year for the electronics industry. The prosperity offers the best opportunity in some time for companies to diversify activities and products and to step up research and development work. And the same aura of well being gives engineers a chance to do some solid career planning, to find a niche in which they can fully employ their talents and to look forward to improvement and advancement.

1966 can be a turning point for the industry.

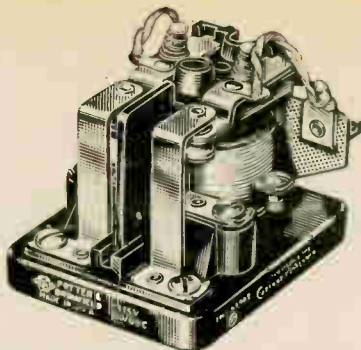

Here's why engineers have specified this heavy duty 25 amp relay by P&B for over 30 years

This is the granddaddy of all P&B relays. Our very first design. Many millions are in use throughout the world . . . starting motors, controlling elevators, switching high current and voltage loads, doing a multitude of heavy duty jobs, reliably. Year after year, the PR Series remains high on our best-seller list. Here are some reasons why.

EXCELLENT CONTACT WIPE ACHIEVED WITH FLOATING CONTACT CARRIER

PR relays are designed with a full floating carrier for the movable contacts. Beside providing sufficient contact pressures, the floating carrier builds-in an abundance of wipe to keep the contacts scrubbed on every operation. Large, $\frac{3}{16}$ " diameter contacts switch 25 ampere non-inductive loads or 1 HP at 115/230 VAC, single phase. A phenolic barrier between the contacts of multipole relays prevent flash-over between contacts.

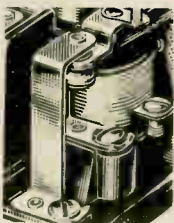

SELECT FROM A VARIETY OF CONTACT ARRANGEMENTS

PR reliability is available in relays having the following contact arrangements: SPST-NO, SPST-NC, SPST-NO-DB, SPST-NC-DB, SPDT, DPST-NO, DPST-NC, and DPDT. Coil voltages range from 6 to 440 volts A.C., and 6 to 110 volts D.C. A vast number of special variations of these standard parameters have been engineered over the years.



AUXILIARY CONTACTS ADD TO VERSATILITY OF PR RELAYS

A single set of auxiliary contacts (Form A, B or C) can be supplied when the application demands. They are rated at 5 amperes at 115 VAC, 60 cycle resistive. Standard models of PR relays with auxiliary contacts are available from leading electronic parts distributors.

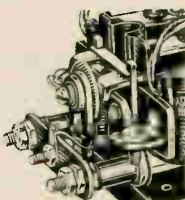

MANY STANDARD RELAYS ARE LISTED BY U/L AND CSA

A wide range of standard PR relays is listed by Underwriters' Laboratories (File E22575) and Canadian Standards Association (File 15734). CSA listing covers AC relays only. These listings can often save you time and extra expense when obtaining UL or CSA qualification for your products.

MAGNETIC ARC-QUENCHERS FURNISHED ON SOME MODELS

For DC loads over 28 VDC, PR relays with normally open contacts can be furnished with permanent magnets to quench arcs. These magnets increase the DC voltage rating to 220 volts resistive . . . and often increase the life of contacts handling DC inductive loads.

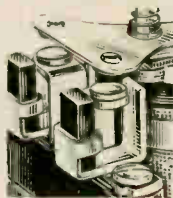

PR SERIES SPECIFICATIONS

GENERAL:

- Mechanical Life:** Single-pole, 1,000,000 (cycles); double-pole 10,000,000 (cycles).
- Contacts:** 100,000 cycles at rated load. Contact life increases at smaller loads or with appropriate arc suppression.
- Breakdown Voltage:** 1 500 volts rms minimum between all elements and ground.
- Ambient Temperature Range:** DC: -55 to +80° C. AC: -55 to +45° C.
- Weight:** Approximately 10 ozs.
- Pull-in** DC: 75% of nominal voltage (approx.) AC: 78% of nominal voltage (approx.)
- Terminals:** Heavy-duty screw type terminals are standard for coil and contacts. Available with printed circuit, plug-in, $\frac{1}{4}$ " quick connect and terminals for rear panel wiring.
- Enclosure:** PR dust cover.

CONTACTS:

- Arrangements:** Up to 2 Form C (DPDT.)
- Material:** $\frac{3}{16}$ " dia. silver standard. Other materials available for special applications.
- Load:** 25 amps non-inductive or 1 HP @ 115/230 volts AC, single phase. Special version—30 amp. non-inductive at 115/230 VAC; single phase available. (Consult factory)

COIL:

- Voltage:** AC: 6 to 440 volts. DC: 6 to 110 volts.
- Power:** DC: 2.0 watts nominal. AC: 9.8 volt-amps.
- Resistance:** 63,800 ohms maximum.
- Duty:** Continuous, AC or DC (DC coils will withstand 8 watts @ +25° C.)
- Mounting:** Two $\frac{3}{16}$ " diameter holes on $1\frac{1}{2}$ " centers.

LEADING ELECTRONIC PARTS DISTRIBUTORS STOCK 44 DIFFERENT PR RELAYS

Immediate delivery at factory prices.

Ask your distributor for a copy of Stock Catalog 100



POTTER & BRUMFIELD

Division of American Machine & Foundry Company, Princeton, Indiana
Export: AMF International, 261 Madison Avenue, New York, N.Y.

Electronics Newsletter

January 10, 1966

Westinghouse plans IC's for auto voltage regulator

The Westinghouse Electric Corp. says it is producing a prototype of an integrated circuit voltage regulator for automobiles. The IC regulator will be competitively priced with mechanical voltage regulators now used on all autos.

The IC has a 4-ampere power transistor in series with the field of the car's alternator. The device's input circuit compares the battery voltage with a zener reference in the control circuit. When the battery voltage is too low, the power transistor is switched on; when the battery voltage is higher than the reference, the transistor is switched off.

The IC is a single 90-mil-square monolithic chip made by the silicon-planar-epitaxial process. In an earlier model, two standard chips were used, but temperature compensation became a problem and it cost more to produce.

400-loop DDC unit for British Esso

A direct digital control (DDC) system that operates more than 400 feedback loops and 12 different oil refinery processes is being built by the Foxboro Co., Foxboro, Mass. The DDC system is being designed to run an Esso Petroleum, Ltd., complex in Fawley, England. Esso is the British subsidiary of the Standard Oil Co. (N.J.).

The only other DDC system of comparable size is the Monsanto Co.'s chemical complex in Chocolate Bayou, La., but there is doubt that it has as many computer-controlled feedback loops.

The \$1.2-million Foxboro system will be made up of several computers. If one or more computers fail, others on the line will be able to provide backup service for critical controls.

Air Force balloons relay messages over the horizon

The Air Force is continuing tests on high-soaring balloons as a poor man's satellite communications system for the military.

The use of balloons as relay stations for over-the-horizon communications at ultrahigh frequencies has been successfully demonstrated by the Air Force Cambridge Research Laboratories, Bedford, Mass. At the lab's balloon-launch facility at Holloman Air Force Base, N.M., a balloon reached an altitude of 80,000 feet and stayed there for several hours, relaying voice and teletype messages between Fort Huachuca, Ariz., and Reese Air Force Base near Lubbock, Texas, a distance of 500 miles.

The balloon relay system operated like an active communications satellite. In the tests, a compact repeater, which operates at 225 to 400 megacycles, was installed in the balloon, receiving signals from one station and retransmitting them to the other.

Further tests of both tethered and free-floating balloons will be made this year. The lab says the maximum distance over which ground stations can communicate using a single balloon is about 780 miles.

Instrument makers and doctors form new organization

An organization formed in Boston seeks to close the communications gap between doctors and the instrumentation industry.

"Groups like the IEEE [Institute of Electrical and Electronic Engineers] and the ISA [Instrument Society of America] have failed to set up the necessary communications," says John Abele, vice president of Advanced Instruments, Inc., Newton, Mass. Abele is chairman of the manufacturers advisory board of the Association for the Advancement of Medical Instrumentation (AAMI).

Electronics Newsletter

AAMI will oppose such bills as the Medical Devices Bill that was introduced in Congress last year; the aim of the bill is to put new electronic instruments through the same kind of examination that the Federal Drug Administration requires for new drugs. AAMI will take what Abele describes as a positive approach, providing a code of ethics and industry standards for medical instrumentation.

In July AAMI will sponsor a medical equipment meeting.

U. S. data network blocked by panel

Development of a nationwide system for storage and retrieval of technical information still seems to be a long way off, primarily because a White House panel that is investigating the problem is opposed to centralized control of such a system. Government spending on computer-operated systems is expected to rise to \$500 million next year from the current \$400-million annual level.

The Committee on Scientific and Technical Information (Cosati) prefers a program in which the government contributes funds to private technical libraries, engineering societies and other organizations so they can develop their own information system.

In a recent study paid for by Cosati, the Systems Development Corp., a research company, urged that a single federal agency be established to coordinate all storage and retrieval activities.

More international ventures in space?

President Johnson seems ready for more international cooperation in space. Near the end of 1965 he invited West Germany to join in programs to send spacecraft past the sun and the planet Jupiter. Early this year he will send James E. Webb, administrator of the National Aeronautics and Space Administration, to Europe to discuss joint space ventures with other countries.

The United States already is studying joint use with France of a launch site being built in French Guiana.

ESRO plans labs and school in Italy

The European Space Research Organization plans to start construction this year of three large laboratories and a university in Frascati, near Rome. The space research facility will conduct "laboratory and theoretic research on the physical and chemical bases necessary to understand past space research and to plan new space research." The 10-nation organization coordinates Europe-wide space research.

U. S. guide due on computer sales to Red nations

This year the Commerce Department is expected to draft a single set of regulations governing the sales of American-made computers to Eastern European countries. At the moment, no single agency or rule of thumb guides U.S. computer makers on such sales. Each export-license application is considered by itself, with the departments of State, Defense and Commerce all having veto power.

Many U.S. computer companies simply won't sell to the communists because of the red tape and the lack of a single guide.

The Commerce Department's Office of Export Control is considering two factors as guides: memory size and computation speed. A top permissible size of a million bits is favored, as long as the computer isn't too fast. In the past, "too fast" meant memory-cycle time of less than six microseconds. Some computer manufacturers favor lowering the limit to less than three microseconds.

Component
and
Circuit
Design

IDEAS

from SYLVANIA Electronic Components Group

INTEGRATED CIRCUITS

100mc linear amplifier for high-gain wide bandwidth information transmission

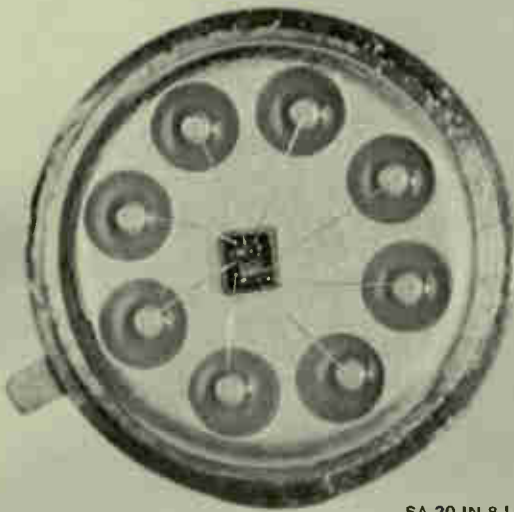

SA-20 IN 8-LEAD TO-5

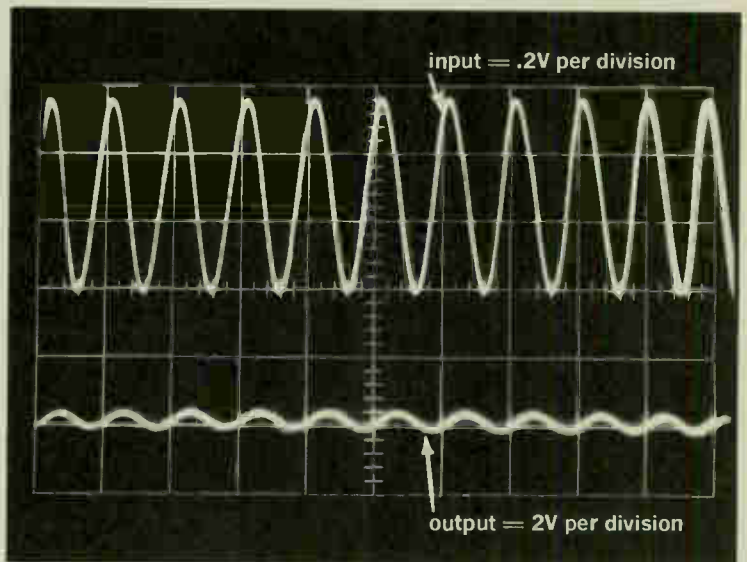

Introduction of the IC linear amplifier, with 20 db typical gain, immediately follows earlier announcement of Sylvania's unusually effective SA-10 sense amplifier. News on further additions to Sylvania's line of amplifiers will be forthcoming shortly.

Now there's an integrated circuit amplifier with broad problem-solving versatility. Whether the problem is in driving low impedance loads, avoiding large signal clipping or cross-talk, or in achieving a broad frequency response with flat gain, Sylvania's SA-20 can well be the logical solution.

The strong capabilities of this wideband linear amplifier lie in the device's outstanding combination of features. These include -65 db intermodulation (harmonic) distortion, externally variable gain-bandwidth and phase shift, 1.6k input impedance, output voltage 14Vp-p swing, and less than 10ns pulse response.

Apropos of this point, one of the possible uses of the Sylvania wide-band amplifier is as a pulse 10-times amplifier. The scope trace shown here indicates the fast pulse response that the SA-20 makes possible.

There are several practical instances where this device can be the answer: *Avoiding cross-talk* between information channels is now possible with the Sylvania wideband linear amplifier. Because of its -60 db second harmonic, -75 db third harmonic intermodulation product, cross-talk can be sufficiently reduced to avoid the problem, especially critical in multiplexing and telemetry applications.

Driving low impedance loads is a special capability of the SA-20, the result of its own low output impedance of less than 5 ohms. Examples of this might be in driving a 50-ohm cable or a transformer. For matching

higher impedance loads for maximum power transfer, the output impedance
(continued)

This issue in capsule

Counter Tubes—How a remarkable cold cathode tube that counts, clocks and displays is now used in slot car racing.

Diodes—News of a versatile diode line for choppers, clippers, logic circuits and high-frequency detectors.

CRTs—Preadjusted high-resolution assemblies that save downtime, trouble and time.

Photoconductors—How a rugged T-4 line withstands impact shocks of 300-g's.

Microwave Diodes—Announcing a new gallium arsenide unit that oscillates.

Readouts—Now you can build an EL power supply with off-the-shelf components.

GAIN VS FREQUENCY WITH VARIOUS FEEDBACK CAPACITANCE

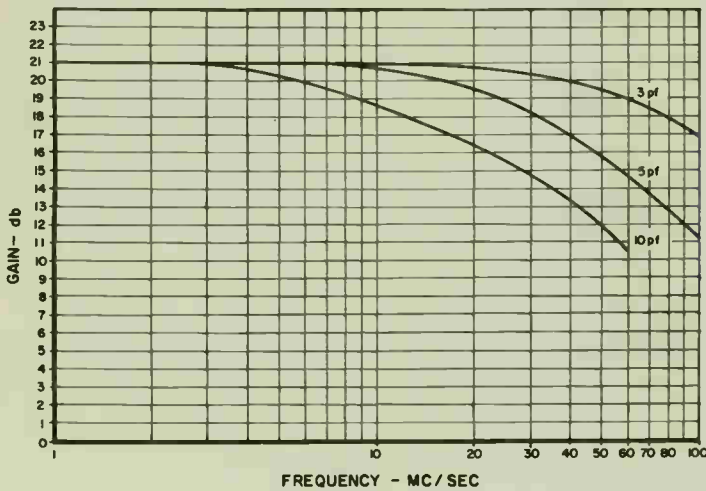

PHASE RESPONSE VS FREQUENCY FOR VARIOUS FEEDBACK CAPACITANCE

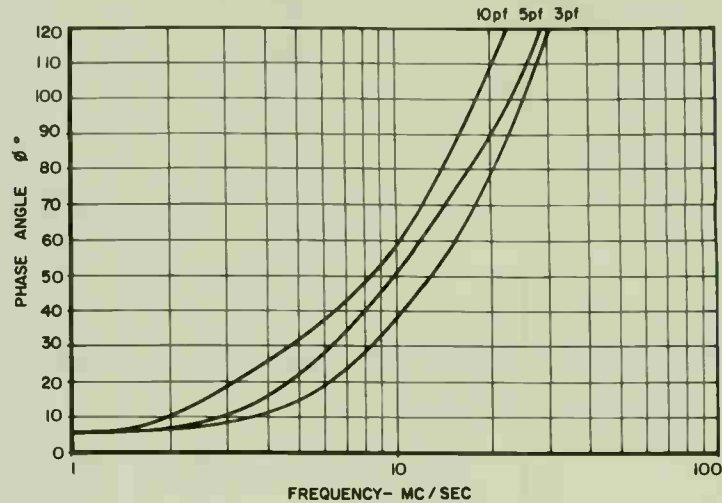

can be varied with an external resistor. This is a desirable feature since the total output impedance then depends on a passive component which will remain stable over frequency and temperature excursions.

Large signal clipping can be avoided because this Sylvania amplifier circuit is designed for 14Vp-p output signal swing. The SA-20 answers the need in large signal amplifying to know beforehand just how large a signal may be produced.

Attaining a broad frequency response with flat gain is simplified with this linear amplifier. The fre-

quency response of a wideband linear amplifier limits the frequency range over which the amplifier may be used. The -3 db frequency of Sylvania's SA-20 is largely determined by the size of the external feedback capacitor placed between the collector and the base of the second stage, as shown on this page. Since the frequency and phase response of the amplifier may be altered with external feedback networks, it is possible to make the amplifier frequency selective, simply by replacing the feedback capacitor with a suitable bandpass filter.

CIRCLE NUMBER 300

SA-20 Typical Electrical Characteristics

Power Supply	+24 volts
Voltage Gain	21 db
Input Impedance	1.6K
Output Impedance	5 ohms
Max. Output Voltage Swing	14 volts p-to-p
3 db Frequency Response	100 mc: 17 db 30 mc: 20 db
2nd order Intermodulation Product Po = 0 dbm	-65 db
3rd order Intermodulation Product Po = 0 dbm	-75 db

SYLVANIA WIDEBAND LINEAR AMPLIFIER

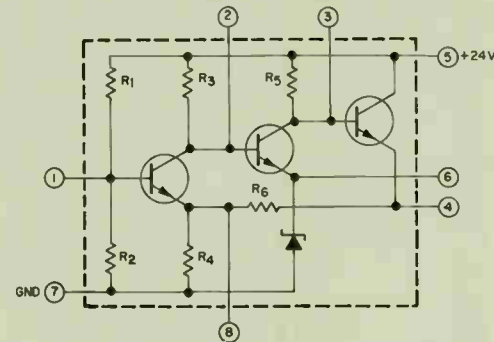

COUNTER TUBES

A tube that counts, clocks and displays —perfect for slot car tracking

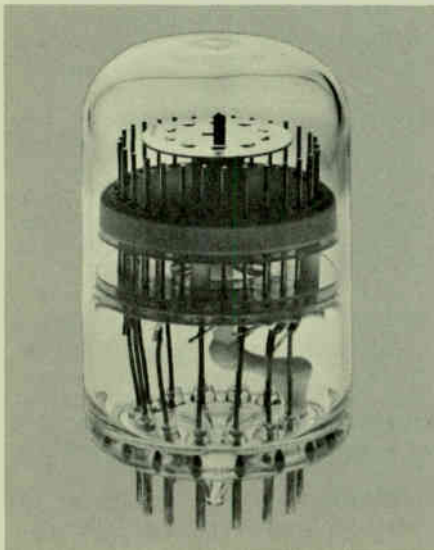

The axiom that a manufacturer knows all there is to know about his products isn't always true. He may be in for a surprise when he sees how a design engineer has interpreted a product's capabilities. Here's an instance where Sylvania was surprised to find that one of its electron tubes has actually furthered a fad.

The type 8353 is a remarkable cold cathode tube. It's a bidirectional decade counter tube that reads out from the top. It can compute, scale, count, frequency divide, code, modulate. And it matrixes, indexes, multiplies, adds and subtracts.

Now these long-life tubes also

count laps in slot car races, clock the cars and rank them as they cross the finish line. Sylvania counter tubes do this as vital parts of a new economical high-reliability computer used at several Miniature Grand Prix Racing Centers. The unit is connected to both the power supply and the track. Then as soon as the race begins, the timer with Sylvania's Type 8353 tubes begins to record the performance of as many as eight competing scale model racing cars as they zip through races of as many as 999 laps.

At the end of the race the counter tubes indicate the elapsed time in hundredths of a second for each car,

the number of laps per car and the sequence of the cars as they cross the finish line. The tubes can continue to display the information in a bright yellow-red until the race master decides it's time for the next race.

This new computer is a large advancement over older types that required considerably more circuitry, needed a separate scoreboard, and cost considerably more to manufacture. This highly efficient, more economical version reads out directly from the unit while working from simplified solid-state circuitry.

The Type 8353 tube that simulta-

neously counts and reads out is designed to operate at inputs up to 4000 pulses per second. Its 10 cathodes are brought out to individual base pins. Readout is done by observing the position of the glow.

Sylvania's counter tube designs provide for operation rates up to 100 Kpps. These include low-speed types having an operating frequency range of 0-4 Kpps and high-speed types which operate at 0-100 Kpps.

Since the actual counting is done by the counter tube, all associated circuitry is relatively simple, limited to whatever may be required for shap-

ing and amplifying the input signal.

The Type 8353 tube is an extremely reliable device that offers hundreds of hours of trouble-free operation. The tube reads out in a pleasing yellow-orange, not the dark orange associated with older-style counter tubes. This improved readability is the result of a new gas additive within its glass envelope. The same new inert gas mixture also improves the tube's standby life, i.e. its ability to operate on a single segment for a prolonged period of time.

CIRCLE NUMBER 301

CRTs

How preadjusted high-resolution CRT saves downtime, trouble and man hours



sists of the tube, deflection coil, alignment magnets and mu-metal shield. A front-end mounting plate is also provided.

Like other self-contained units in the product line, this complete plug-in assembly unit is suited to any application requiring high-resolution flying spot scanning, photographic recording or video recording. And all units are equally useful to display designers as well as users.

Installation and servicing are easy with these preassembled devices. They're installed by nontechnical personnel quickly and easily. Without any further alignment or adjustment necessary, they just need to be plugged in. That's all.

If servicing is ever needed, the assembly is disconnected and removed just as quickly. To save downtime, another unit can be inserted in a matter of minutes. Engineering time and costs are cut to the absolute minimum. And because components are prealigned, there's the quickest possible optimum resolution.

Other Sylvania packaged assemblies include the AT-SK-6000, designed for use with electrostatic focus tubes such as the 5ZP, another 5" high-resolution CRT.

Still another, the AT-SK-5053 assembly is supplied with the 10" SC-3890 or any of these 5" CRTs: 5CEP, 5ZP, SC-2782, SC-2809 or SC-3168.

CIRCLE NUMBER 302

An engineer with a large manufacturer of electronic equipment told us that he learned a valuable lesson last month. Seems the 5" cathode ray tube in his department's video recording apparatus was obviously on its last legs. Having a spare 5CEP tube on the shelf, he had a couple of technicians and a tube engineer make the replacement. "Much more than we bargained for," he told us. "By the time we disassembled, replaced, reassembled, focused and aligned, al-

most a full day was shot. If we hadn't had a tube engineer on hand, it would've taken another 2 or 3 hours." With a minimum of expense and a little foresight they could easily have saved a lot of trouble, downtime and man hours.

One of Sylvania's preadjusted, prealigned, high-resolution CRT assemblies is especially designed, manufactured and packaged with a 5CEP (5") tube. The complete plug-in assembly, the AT-SK-6003/5CEP, con-

A versatile line for choppers, clippers, logic circuits and high-frequency detectors

The many types that make up Sylvania's silicon epitaxial diode (DF-22) product line are all high-conductance, fast-switching devices with characteristics that especially suit them for logic circuits, high-frequency detectors, clippers and choppers. They're available now for use in the industrial, military computer and consumer product fields.

The design engineer's major reason for specifying a silicon diode from the DF-22 family is the combination of reliability with high-performance levels over a long period of time. DF-22 reliability is enhanced by the solid silver sphere which Sylvania deposits on every epitaxial chip to assure forward current stability.

Using stringent in-process controls, Sylvania is able to provide silicon epitaxial diodes that meet, and often exceed, MIL tests which include constant acceleration, temperature cycling and moisture resistance. In addition, Sylvania subjects DF-22's to a 4500-g shock test, far beyond usual MIL test requirements.

These same silicon epitaxial units must also surpass MIL requirements for ion drift testing, a reverse bias test at considerably elevated temperatures. All lots showing any evidence of free ions on the surface which might conceivably move about and upset delicate systems are rejected. This is an important additional evidence of reliability in Sylvania diodes.

Some random examples of QA-approved DF-22 units and the specs they meet are: Jan 1N251 (MIL-S-19500/188A), Jan 1N662 (-/256B), Jan 1N663 (-/256B), and USN 1N3064 (-/144A).

Another significant reason why there's reliability throughout Sylvania's entire DF-22 family is batch processing. Here thousands of compatible diodes are fabricated simultaneously assuring a uniformity of characteristics from product to product.

All units are supplied with either dumet stud for high current requirements or with a continuous dumet lead for lower current applications.

CIRCLE NUMBER 303

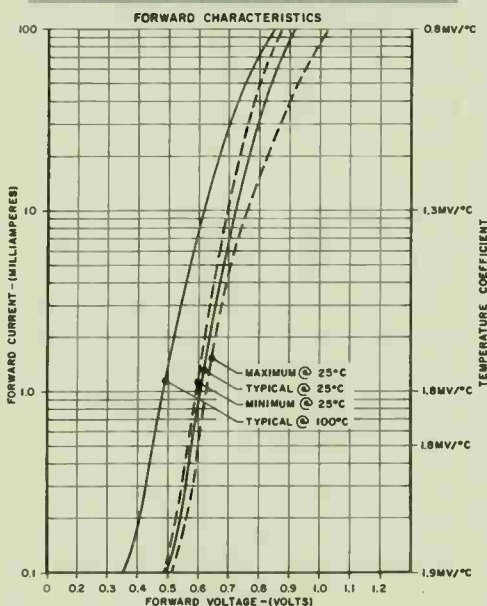
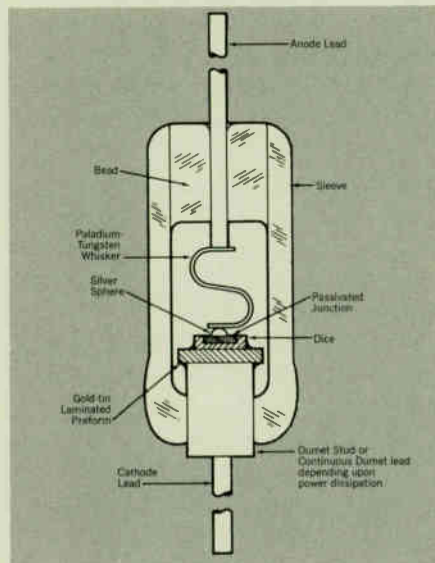

Type	Maximum Peak Reverse (volts)	Forward Current @ 1.0V (ma)	Maximum Reverse Current		V _R V	Temp °C	Reverse Recovery Time Recover to 1 ma @ I _F =I _R =10 ma (ns max.)	Cap. @ 0 V (pf)	
			I _R @ 25°C and V _R μA	I _R @ Temp and V _R μA					
*1N251	30	5	.1	10	10	10	125	150	1
1N252	20	10	.1	5	10	5	125	150	1
1N659	60	6	5	60	25	60	100	300	5
1N815	15	100 @ 1.5V	.5	5	10	5	125	250	3
1N903	50	10	.1	40	10	40	100	4	1.5
1N903A	50	20	.1	40	10	40	100	4	1.5
1N904	50	10	.1	30	10	30	100	4	1.5
1N904A	50	20	.1	30	10	30	100	4	1.5
1N905	25	10	.1	20	10	20	100	4	1.5
1N905A	25	20	.1	20	10	20	100	4	1.5
1N906	25	10	.1	20	10	20	100	4	3
1N906A	25	10	.1	20	10	20	100	4	3
1N907	40	10	.1	30	10	30	100	4	3
1N907A	40	20	.1	30	10	30	100	4	3
1N908	50	10	.1	40	10	40	100	4	3
1N908A	50	20	.1	40	10	40	100	4	3
1N914	100	10	.025	20	50	20	150	4	4
1N914A	100	20	.025	20	50	20	150	4	4
1N914B	100	100	.025	20	50	20	150	4	4
1N916	100	10	.025	20	50	20	150	4	2
1N916A	100	20	.025	20	50	20	150	4	2
1N916B	100	30	.025	20	50	20	150	4	2
1N3062	75	20	.1	50	100	50	150	2	1
1N3063	75	10 @ .85V	.1	50	100	50	150	4	2
*1N3064	75	10	.1	50	100	50	150	4	2
1N3070	200	100	.1	175	100	175	150	50	5
1N3069	65	50	.1	50	100	50	150	5	
1N3600	75	200	.1	50	100	50	150	4	3
1N3605	40	20 @ .88V	.05	30	50	30	150	4	2
1N3669	80	40 @ 1.1V	.05	50				200	10
1N3771	100	100	.05	50	50	50	150	3	2
1N4009	35	30	.1	25	100	25	150	120	25
1N4086	80	200	.25	70				200	1
1N625	30	4 @ 1.5V	1	30	20		150	1000	
1N626	50	4 @ 1.5V	1	30	35		150	1000	
1N627	100	4 @ 1.5V	1	30	75		150	1000	
*1N662	80	10	1	20	10	10	150	.5	
*1N663	80	100	5	5	50	75	150	.5	
1N799	100	50	5	5	25	25	100	600	
1N409Z	50	5	5	5	5	20	70	1000	

*Types available to Mil Spec

ABSOLUTE MAXIMUM RATINGS	
Average Rectified Current, I ₀	75 ma
Peak Forward Current, I _{PK}	225 ma
Forward Surge Current (8.3 μ sec)	500 ma
Power Dissipation, P _T	250 mw
Storage Temperature, T _A	-65°C to +200°C

How a rugged T-4 line withstands 300-g impact shocks

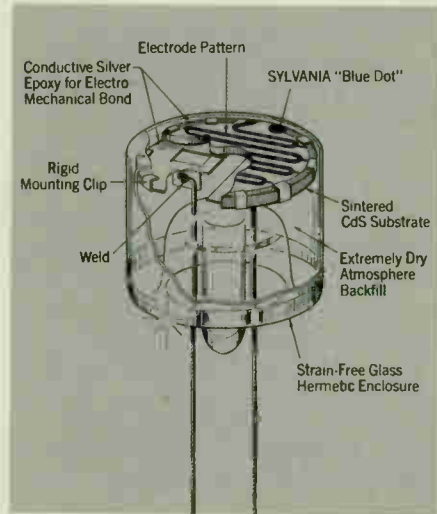

Ruggedness, a characteristic not always associated with photoconductors, can indeed be built into these devices. Sylvania has proved it. What had often disenchanted many design engineers previously was not merely performance, but mechanical weaknesses like inherent glass fragility, insufficient hermeticity or poorly supported internal construction. Here's news on the industry's first truly ruggedized T-4 photocell line.

Now there's a line of T-4 photoconductors that withstands 300-g impact shocks and 2.5-g vibrations over extended periods. This high degree of immunity to outside strain has enabled industrial equipment manufacturers to mount Sylvania 1/2-inch cells directly on machines where other devices had been short-lived.

It also qualifies them for aviation and aerospace applications where similar products had been below acceptable standards.

A combination of features makes for this ruggedness. First, all Sylvania glass envelopes are both strain-free and hermetically sealed. Vital too, is the tightness of the entire structure inside the glass, a factor that contributes heavily toward the cell's ability to remain highly immune to shock and vibration in g-level situations.

In addition, Sylvania builds a strong epoxy bond between the cell's wafer and supporting clip. Electrodes are also epoxied to the leads. This is a high-conductivity epoxy with a high silver content.

Sylvania cells are subjected to polariscopic tests for tension and com-

pression to insure that reliability will be present over a broad range of mechanical and thermal conditions.

Hermeticity of these rugged units is assured by the famous Sylvania Blue Dot, applied to the edge of the light-sensitive wafer. With only 0.02% moisture the dot turns pink thus forewarning of degradation in performance before the trouble starts.

These 1/2-inch-diameter end-view cells combine high sensitivity with a power dissipation capability of 300 milliwatts and maximum rated operating voltage of 400 volts. Thus it is understandable why they have already solved many power-handling problems. And they meet power dissipation requirements in light-controlled relay usage where the light sensor directly operates a relay.

The Sylvania Type 8345 photoconductor, for example, can safely handle a current of 38 milliamperes at a

light level of 10 foot-candles. This is several times the current required to actuate a relay of medium sensitivity. The comparatively low resistance of the photoconductor when illuminated permits it to be used with a power source of only a few volts in many applications. The operating voltage may be either ac or dc.

The standard line of high-sensitivity cells consists of five basic types, each of which is available in three different physical configurations (see outline drawings). The circuit designer can choose from light resistance values covering the range from 750 ohms to 16,000 ohms (at 2 foot-candles). The corresponding dark resistances are 75,000 ohms to 1.6 megohms, a 100-to-1 ratio.

All of the five basic types in the Sylvania T-4 line use cadmium sulfide as the light-sensitive material.

CIRCLE NUMBER 304

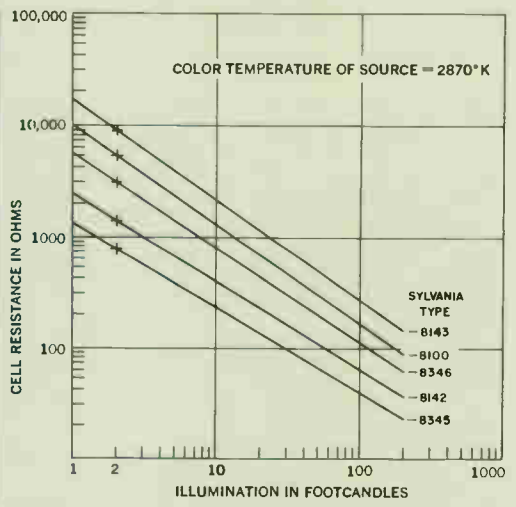
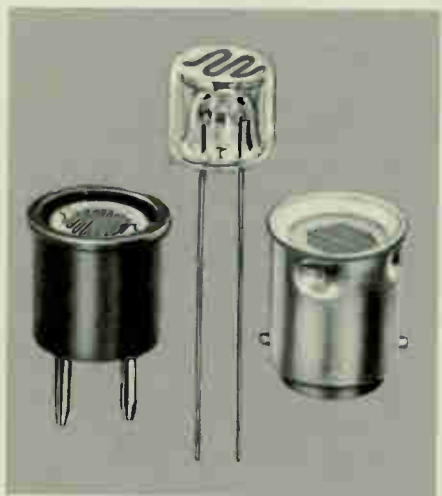

T-4 PHOTOCONDUCTOR DATA

Type	Cell Voltage (Volts) ^{1,2}	Light Resistance (Ohms) ³	Dark Resistance (Megohms) ⁴	Cell Dissipation (Milliwatts at 25°C)	Shock Impact Acceleration (G) ^{1,5}	Vibration Fatigue (G) ^{1,6}
8100 8100-1 8100-7	400	5000	0.5	300	300	2.5
8142 8142-1 8142-7	400	1500	0.2	300	300	2.5
8143 8143-1 8143-7	400	9000	0.9	300	300	2.5
8345 8345-1 8345-7	400	750	0.075	300	300	2.5
8346 8346-1 8346-7	400	3000	0.3	300	300	2.5

- NOTES: 1. Absolute maximum values.
 2. Measured with cell in complete darkness at a pulse rate of 100 pps, 100 μsec. duration. Voltage in excess of the rated value may damage the cell. Max. DC voltage is limited by max. dissipation and min. dark resistance rating.
 3. Illumination 2 FC. Color temperature 2870°K for all. Measured after 60 minutes minimum exposure to approximately 50 FC illumination (ambient room light).
 4. Minimum. Measured in complete darkness at least 10 seconds after removal of 2 FC illumination.
 5. 1 micro sec. duration (MIL-E-IE-Method 1041).
 6. Vibration acceleration for extended periods (MIL-E-IE-Method 1031).

Announcing a GaAs microwave oscillator

The gallium arsenide varactor has been long considered a "conventional" microwave device. But now here's news of an exciting new mode of varactor operation that will be of special interest to microwave design engineers.

You can now get microwave energy from a varactor diode using dc power inputs. Sound impossible? It seemed that way until Sylvania's recent announcement of a new gallium arsenide unit, the D-5540, a reverse breakdown oscillator diode. Sylvania has named this varactor the MOD (microwave oscillator diode).

The MOD, the first diffused junction GaAs microwave diode of its type, actually can generate microwave power in Ku-band between 12 GHz and 14 GHz with 0.2 to 2 percent efficiency with more than 1 mw

output power. The unit is biased in the avalanche breakdown region of the I-V characteristics. Sylvania is now making the D-5540 available in sample quantities as an experimental device.

Among the unit's known areas of application are local oscillators for microwave receivers, low-power beacons, signal and noise generators.

Test circuits used by Sylvania for rapid screening of diodes for oscillation and for accurate output power measurements and analysis are shown on this page. The test diode was driven by a reverse biasing 60 Hz half-sine-wave voltage into the avalanche breakdown. Oscillation of the diode was detected by a crystal detector, the output voltage of which was connected to the vertical deflection of an oscilloscope.

Horizontal deflection was supplied by the voltage across the 1K series resistor. Voltage was proportionate to the bias current of the diode. The resulting display on the oscilloscope gave the output power of the diode oscillator versus bias current. The output power was displayed as function of V_S , the bias voltage across the test diode.

There will be more news on oscillating varactors from Sylvania in future issues of IDEAS.

TENTATIVE CHARACTERISTICS

- Breakdown voltage: 20-40V @ $-10 \mu\text{A}$
- Total capacitance: 0.4-1.5 pf @ 0 volts
- Minimum output as oscillator: 1 milliwatt at 12-14 GHz
- Maximum power dissipation: 300 milliwatts
- Maximum reverse current: 10 milliamperes if maximum P_{DISS} is not exceeded.
- Threshold current (typ): 5 milliamperes (Somewhat dependent upon tuning)

CIRCLE NUMBER 306

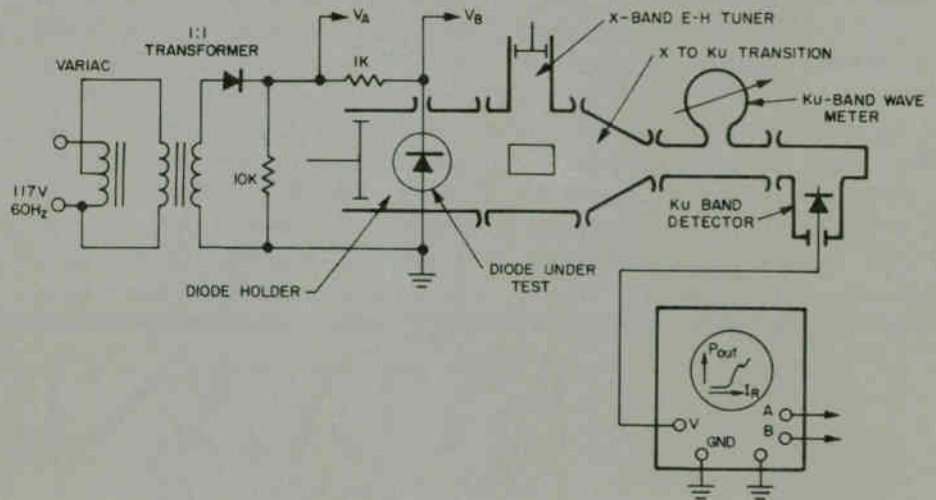
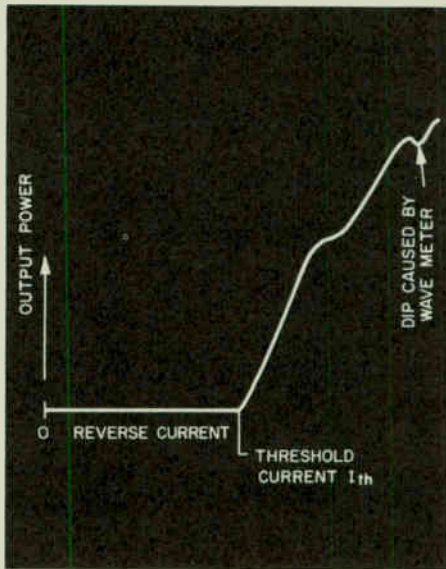

HOT LINE INQUIRY SERVICE

Use Sylvania's "Hot Line" inquiry service, especially if you require full particulars on integrated circuits in a hurry. Simply fill in the required information. We'll do the rest and see that your request gets immediate attention.

BUSINESS REPLY MAIL

No Postage Stamp Necessary if Mailed in the United States

POSTAGE WILL BE PAID BY

SYLVANIA ELECTRONIC COMPONENTS GROUP

Sylvania Electric Products Inc.
1100 Main Street
Buffalo, New York 14209

Dept. A-111

FIRST CLASS
Permit No. 2833
Buffalo, N. Y.

Some questions and answers

What is Marketing Services? Where does it fit in the complexity of today's marketing activity? For the sake of quick definition, its role can best be defined as one of coordination—the interrelationship of advertising, public relations, man-power development, market research and planning. This interrelationship evolves not necessarily for the company under whose auspices such a function exists, but more for the customer to whom the company has an obligation and responsibility.

What's in MS for me? At Sylvania, the role of Marketing Services is a very important adjunct to overall customer-oriented planning. Recently, Bob Lynch, our Vice President of Marketing, discussed the philosophy behind the Sylvania ECG concept and the customer advantages of offering multiple product lines and technical assistance. The mantle of direction for engineering and production facilities falls to the Marketing Services group to have, in advance of customer requirements, the right product at the right place and at the right price.

What about new products? Marketing Services anticipates through analysis and study, both in semiconductors and vacuum tubes, the future needs of customers, the life span of

individual product lines, and the emergence of new products. All factors involving application and cost are considered.

How does this apply to integrated circuits, for instance? New markets, the vitality in this dynamic electronics industry, are carefully appraised and their rate of acceleration and maturing evaluated. Integrated Circuits is a prime example. Careful evaluation is made of where this product line is going, what components it will replace, as well as what the market applicability will be and how fast the maturing process will take.

What about color TV? Sylvania has been vitally interested in color television right along. We must know what the rate of transition from black and white to color television will be next year, five years hence, and beyond. We have to calculate accurately what future generations, 10, 15, 20 years from now will require in the way of electronic technology on all levels. Each of these problems must be carefully evaluated, analyzed and conclusions made by the Marketing Services Group. Management must be provided with the necessary tools of judgment to permit planning and effective implementation of facilities to meet demands that today do not exist.

Does my opinion count? At Sylvania, perhaps one of our prime sources of input data is the customer. An effective Marketing Services operation cannot be generated, maintained, or long remain effective without the proper attitude. What is best for the customer? We recognize that to retain a position of leadership requires sensitivity to the needs of customers even before the customer recognizes that need.

Where do R&D and Production fit into the picture? Engineering and research facilities are constantly dedicated to the future demands of products yet unborn and to improving specifications and existing designs. The results of these analyses have their corresponding effects in the manufacturing area where conclusions of Marketing Services must be transformed into concrete production facilities—the factories that will be necessary, the locations to best serve distribution requirements, and the capability and capacity to produce a product when it is needed.



Bob Lynch

R. A. STAREK

This information in Sylvania Ideas is furnished without assuming any obligations.

SYLVANIA

SUBSIDIARY OF
GENERAL TELEPHONE & ELECTRONICS **GTE**

NEW CAPABILITIES IN: ELECTRONIC TUBES • SEMICONDUCTORS • MICROWAVE DEVICES • SPECIAL COMPONENTS • DISPLAY DEVICES

NAME _____
 TITLE _____
 COMPANY _____
 ADDRESS _____
 CITY _____ STATE _____

Circle Numbers Corresponding to Product Item

300 301 302 303 304
 305 306

Please have a Sales Engineer call



HOT LINE INQUIRY SERVICE

Need information in a hurry? Clip the card and mail it. Be sure to fill in all information requested. We'll rush you full particulars on any item indicated.

You can also get information using the publication's card elsewhere in this issue. Use of the card shown here will simplify handling and save time.



Hearing aid designers needed a battery so small it would fit inside your ear.

Mallory made it.

What can we do for you?



Actual size RM-212 hearing aid battery

Just how big can a battery be when it fits inside a hearing aid small enough to fit entirely inside the ear? Mallory's answer: 0.130" high by 0.225" diameter, the world's smallest primary cell actually in production. It

uses Mallory's mercuric oxide—potassium hydroxide—zinc system to produce 16 milli-ampere hours at 1.35 volts. If you're looking for extremely small power sources, this is it. Or perhaps this breakthrough in size suggests entirely new designs impossible until this battery existed. In any case, it might be a good idea to check into past projects that couldn't be accomplished because of size limitations upon the power source.

Manganese-alkaline standard size cells gain improved performance at low temperatures and high current drains. Now, all standard size Mallory manganese-alkaline batteries have completely new performance ratings when operating at low temperatures or under high current drains.

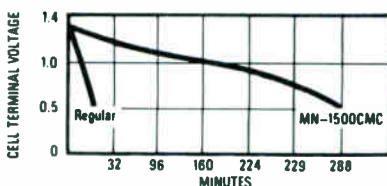

For example, the graph compares the new Mallory MN-1500 (Size "AA") versus the old when both cells are operated in parallel through a PR-4 bulb at 31°F. The dramatic difference in battery life depicted in the graph was accomplished by changes in the battery's internal design. Anode surface area was increased and conductivity greatly improved. The new Mallory manganese-alkaline batteries are ideal for motor driven applications and other services that demand relatively heavy drains over extended periods of time.

New low temperature performance for standard size mercury cells. The same research that led to improved internal structure and performance for Mallory manganese-alkaline batteries has paid off

with new low temperature characteristics and performance for Mallory mercury batteries. Now Mallory can offer designers standard size mercury batteries. (RM-1, RM-502, RM-12) with low temperature performance comparable to performance at ambient temperatures. For more information write us about our new RM-1CMC, RM-502CMC, RM-12CMC (our new designations) mercury cells. We can give you some data

that will change your mind about mercury cells and low temperature performance. And remember, Mallory is currently producing over 100 batteries of all sizes and capacities. If we're not actually producing the battery you need, we'll be happy to work with you in designing a new one. Just write us at the Application Engineering Dept., Mallory Battery Company, a division of P. R. Mallory & Co. Inc., S. Broadway, Tarrytown, N.Y. Or call us at 914-591-7000.



It's good business to do business with Mallory

MALLORY

**Who cares about
component innovations?**



At General Electric, engineering is the most important factor in electronics. This engineering excellence means you get the best in component reliability and performance.

**Who cares if you improve
your circuit designs?**



Constant attention to new and improved electronic circuit designs results in better quality, lower price, and new market growth for your business and ours.

Who cares about all your component needs?

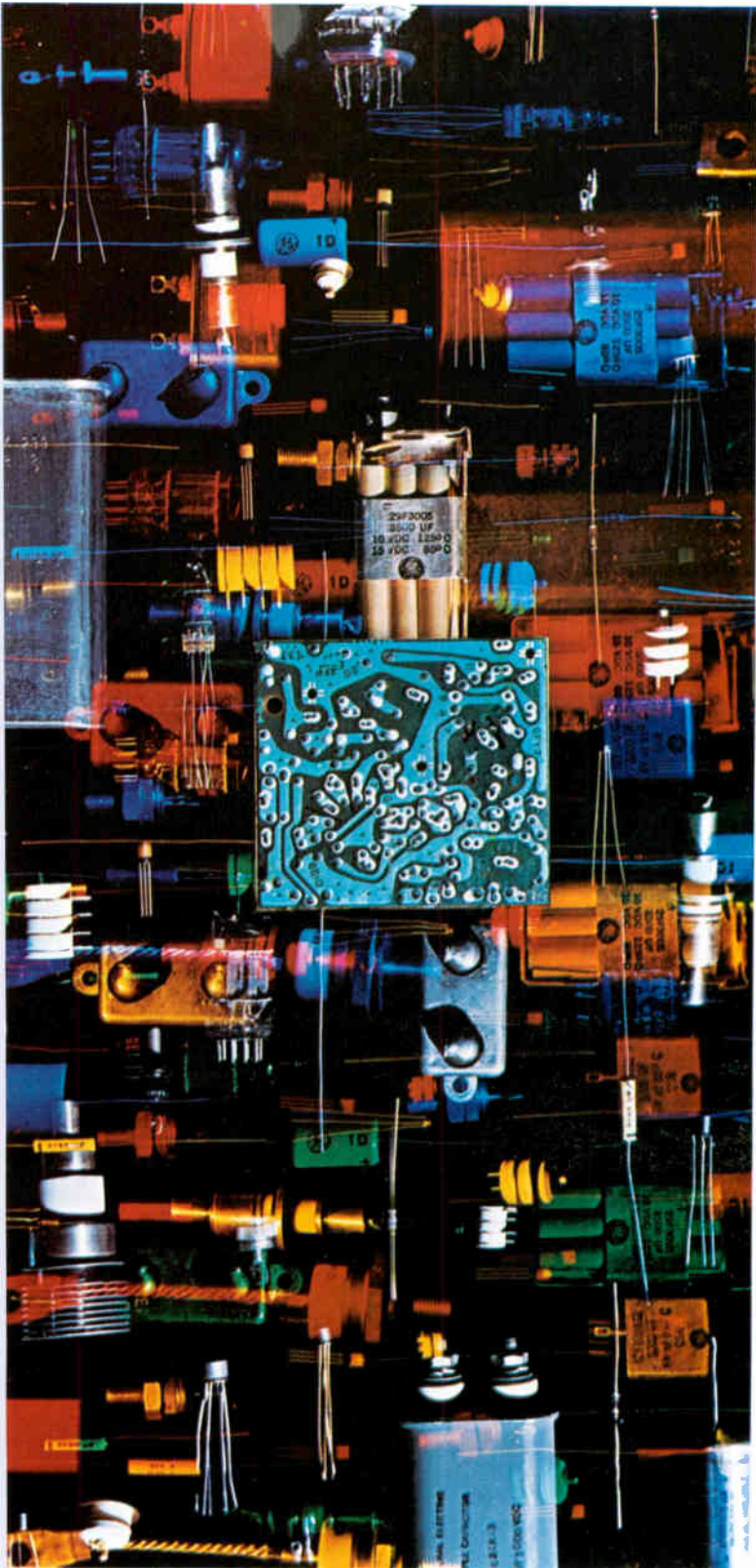

You can choose from more than 6,000 different G-E electronic components from capacitors, semiconductors and tubes to instruments, batteries and integrated circuits.

General Electric cares

(so do you; that's why
we're out to do
things your way)

We may not offer everything you want from one supplier. But, we do come a little closer than anyone else.

This means more than just being your number one source for a full range of electronic components. Our experience, facilities, and engineering competence—both as a producer and major user—combine to give you unmatched design capability and component reliability.

You're also assured of continuing product innovation—like Triac, the new low-cost SCR, Compactrons, Blackhawk capacitors, and nickle-cadmium batteries, just to name a few.

How do you benefit from this continuing partnership in electronics? Ask the people who represent us, your G-E engineer/salesman or distributor.

900-02

Progress Is Our Most Important Product

GENERAL  ELECTRIC

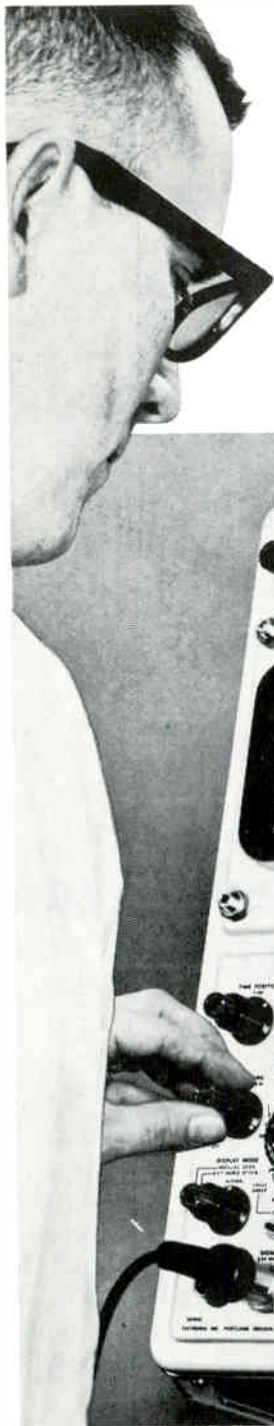

DC-to-30 MHz performance AND THE versatility of 20 plug-ins with split-screen storage



Type 549

split screen permits simultaneous operation as a storage and conventional oscilloscope

Split-screen storage offers a distinct advantage to the user in waveform-comparison applications — by permitting quick comparison of dynamic signals appearing on one half of the crt with a reference trace stored on the other half, or the Type 549 can be used for full screen storage or full screen conventional displays.

SAMPLING AND STORAGE

The storage capacity of the Type 549 provides easy-to-study displays—and with a Type 1S1 Plug-In adds new convenience to sampling applications. With this new dc-to-1 GHz sampling unit, you need no pretriggers or external delay lines—the 1S1 has internal triggering with a built-in delay line. The Type 549/1S1 combination gives a stored display that is steady and, because more samples can be displayed, there is high resolution of the sampled information.

storage features:

Unparalleled Writing Speed — up to 5 cm/ μ s, with enhancement.

2 Independent 3x10 cm Display Areas — with separate upper half and lower half controls.

Bistable Storage.

Automatic Erase — with selectable viewing times from 0.5 seconds to 5 seconds. Erase can be selected for re-current or after-sweep operation.

Erase-and-Reset — with push-button control for erasing display and rearming single sweep. Erase-and-Reset can be controlled remotely, if desired.

other features:

Precision Sweep Delay—from 1 microsecond to 10 seconds.

Wide Sweep Range — 5 s/cm to 0.1 μ s/cm (Time Base A) and 1 s/cm to 2 μ s/cm (Time Base B). 5X Magnifier extends fastest sweeps to 20 ns/cm (Time Base A) and to 0.4 μ s/cm (Time Base B).

Single Sweep — manually, automatically, or remotely.

Full-Passband Triggering — with flexible, easy-to-use facilities.

Simplified Trigger Logic — with lever control of trigger functions.

Size and Weight — dimensions are 17" high x 13" wide x 24" deep; net weight is \approx 67 lbs.

Type 549 Oscilloscope \$2375 (without plug-ins)

The plug-in units range in price from \$145 (B high-gain unit, K fast-rise unit) to \$1100 (1S1 sampling unit, illustrated).

U.S. Sales Prices f.o.b. Beaverton, Oregon

For a demonstration call your Tektronix Field Engineer.

Tektronix, Inc.

GRC[®]

tiny die castings
and plastic moldings
add value to
products you
use every day



HONEYWELL Thermostat



GE Electric Toothbrush



MALLORY TIMER
for Washing Machines



DICTAPHONE Dictating Machine



Parts shown approx. 5/8 actual size



SHOUP Voting Machine



Almost everything you do, every step you take, brings you into contact with a product that uses Gries' small parts. Designers at thousands of companies — America's best known, plus a lot of smaller "blue chips" — have discovered the positive advantage of using GRC HIGHER VALUE *tiny* zinc alloy die castings and engineering thermoplastic moldings. It all adds up very simply and logically to a bonus of broader design latitude—reflected right down to your production line—in easier, faster final assembly... and a brighter profit picture.

GRC SPECIAL METHODS produce tiny zinc alloy die castings and plastic moldings in engineering thermoplastics by exclusive totally automatic patented high-speed machines. Parts have great design flexibility, are highly uniform and precise.

Write today for helpful guides to achieving higher value in small parts... full information, demonstration samples.

Maximum sizes: Zinc Alloy—2" long; 1/2 oz. Plastics—1 3/4" long; .05 oz.

No minimum sizes



GRIES REPRODUCER CO.
Division of Coats & Clark Inc.

GRIES

world's foremost producer of small die castings & plastic moldings • 151 Beechwood Ave., New Rochelle, N. Y. • (914) NEW Rochelle 3-8600

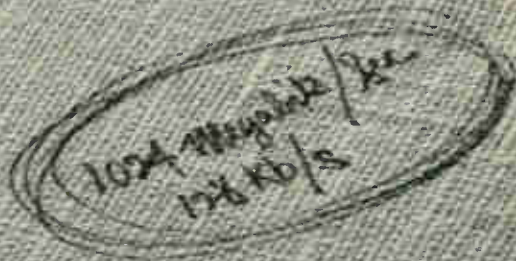
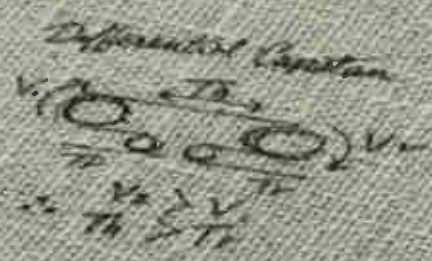

to bits per second
Capacity

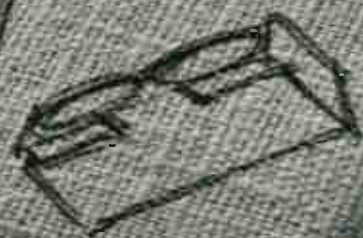



**We can't keep our
guys from working on
the MOL recorders.**

**All we need now is
the purchase order.**

MOL's tough requirements present the kind of challenge our guys can't pass up. They're geared to taking on the big ones. That's why 80% of all satellite recorders are Leach-built and why Leach recording systems have logged more flight time than all other manufacturers' recorders combined.

To give you a little insight into our capabilities, we've taken excerpts from some of our past proposals and put them together in a 36-page technical abstract. You'll get a quick look at some of the contracts that are presently in the works.

Contracts like the high reliability unit for the Apollo, the low signal to noise system for sonar recording, the high data capacity system for the LEM, the high environmental unit for the PRIME and long orbit life recorders for satellite applications.

Like the MOL, each of these projects offered a challenge. This abstract will give you an idea of how we handle it. Your copy of the abstract is ready to mail. Just let us know where to send it.

Leach Corporation, Controls Division; 717 North Coney Avenue,
Azusa, California; Phone (213) 334-8211,
Export: LEACH INTERNATIONAL S. A.

LEACH

System 360, also made by the International Business Machines Corp.

Eventually, the center hopes to build computer models of the human physiological system, although this is "still pretty far out," Hill says. Such models, for example, would enable a doctor to obtain information about a patient's reaction to a drug by trying it out on the computer model first.

Military electronics

Shopping list

The Air Force will spend millions of dollars over the next two years for new battlefield radar and communications equipment to replace

as the TPS-43, will replace the MPS-11 and 16 that are now in the field.

The contract will be awarded by the Air Force Electronic Systems division, Hanscom Field, Mass., through the 407L program office. The 407L program, a \$50-million-a-year operation, is currently developing the Tactical Air Control System (TACS) under Colonel George A. Guy.

The overhaul. This year, the program will concentrate on overhauling the tactical aircraft control and warning system. "It's more than a Baby Sage," says Col. Guy. "We call it airspace management, and it includes directing our own planes for offense, defending against enemy planes and controlling air traffic in any battlefield areas."

In fiscal 1965, the 407L program

\$30 million, will represent the largest single procurement in 407L's two-year history. The Data Systems division of Litton Industries, Inc., and the Ground Systems group of Hughes Aircraft have been awarded six-month study contracts to come up with technical proposals for the tactical air control operating centers. A hardware contract is expected next fall. The centers will consist of data processing equipment and displays and will be used to aid radar surveillance and control and handle weather, logistics and intelligence data.

Linking 3-D. Still being debated is the method of linking 3-D radars to these data centers in a tactical war area. Cable links have been proposed, but some commanders in the field reportedly favor microwave links.

In the next three months, two or more contractors will be chosen to compete in a contract definition phase for lightweight tactical ground-controlled approach (GCA) radar. "We're interested in both the precision approach and the area-control problem," says Col. Guy. "We hope to come up with a new family of GCA's. Everything available today is an upgraded version of World War II equipment, using mechanical scan. We want to exploit new technologies, such as solid state circuits and electronic scanning."

The new GCA equipment will replace items like the L-band TPS-35.

The GCA program is expected to involve expenditures of about \$15 million. Also in radar, the Air Force will replace the UPS-1 with a forward-area radar surveillance sensor designated the TPS-44. This is now being built as a 2-D radar, and it may later be redesigned for 3-D. Cardion Electronics, Inc., has a \$3-million contract to build 26 of the radars for forward air control posts as part of the aircraft control and warning system.

'Little Bell System.' In the next three or four months, the 407L organization will go to industry for proposals on new communications complexes for battlefield conditions. "We really need a little Bell



Tactical communications systems, like this AN/TRC-97, are being sought by the Pentagon to provide the military with "a little Bell System" on the battlefield.

upgraded versions of World War II equipment.

Due in the next two weeks is a \$15-million to \$20-million production contract for a lightweight three-dimensional radar designed for tactical forces in a forward air-control post. The contract will be given to either the Westinghouse Electric Corp. or the Hughes Aircraft Co., successful bidders for the study phase [Electronics, Dec. 27, 1965, p. 25]. The radar, to be known

stressed urgent, off-the-shelf procurement with minimum engineering. In fiscal 1966 to 1968 there will be limited development efforts and the emphasis will be on buying systems packages. "We will not be trying to create new technology," says Col. Guy, "But we will be exploiting industry's technology to the fullest for tactical needs."

The contemplated purchase this year of 43 data-collection centers for battle areas, for an estimated

TRW ANNOUNCES

10 W 400 mc 60% η

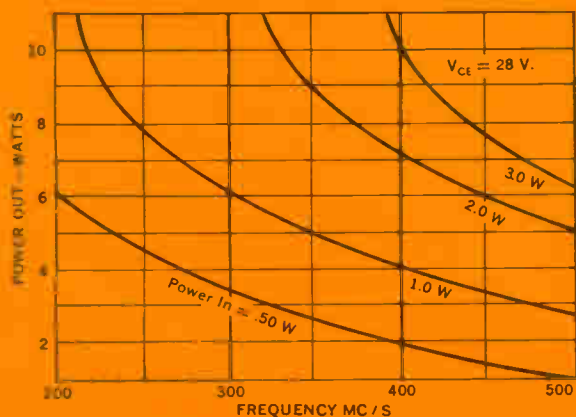

NEW UHF POWER TRANSISTOR

The new TRW 10W/400Mc (2N4040) UHF Power Transistor provides full rated performance in conventional circuits...no need to resort to emitter tuning or other techniques which contribute to circuit instability. TRW 2N4040 is available now at competitive prices.

For detailed technical information phone, write or wire: TRW Semiconductors, Transistor Plant, 14520 Aviation Blvd., Lawndale, Calif. 90260. Phone: (213) 679-4561, Ext. 477 TWX: 213 647-5113

TRW designs and manufactures high performance transistors for the communications industry and specialized types for military and industrial applications.

TRW SEMICONDUCTORS

System," says Col. Guy. The basic equipment in the tactical communications setup is the AN/TRC-97, a tactical wideband communications system built for the Marine Corps by the Radio Corp. of America. It provides full duplex multichannel voice, data and teletype communications in the 4400-5000-megacycle band, using line-of-sight, diffraction or tropospheric scatter. Range is about 100 miles.

The Air Force is buying a modified version, called the TRC-97A, in which channel capacity is doubled to 24 and the size and weight of the equipment is reduced. A preproduction model is now under test at Eglin Air Force Base, Fla. It is expected that the equipment will replace the TRC-66's and 66A's now being used in Vietnam.

The Air Force will also buy modified versions of the TSW-6 towers for air traffic control in battlefield areas [Electronics, Oct. 5, 1964, p. 114] designed by RCA. This portable control tower in "the best thing to come out of the 482L program," says Col. Guy. The 482L program, called emergency mission support, has been merged into the 407L. The final 407L procurements planned for fiscal 1966-68 include base command and control radios such as the FRC-110's and 116's.

Less from LES-4

It was a pleasant Christmas-Sunday surprise for the space communications researchers at Lincoln Laboratory of the Massachusetts Institute of Technology, who traveled to a field site on Millstone Hill in Westford, Mass., to see if they could salvage some routine telemetry from the Lincoln Experimental Satellite, LES-4. The military communications satellite had gone into a crazy orbit when a Titan 3C transtage misfired after a flawless six-hour flight [Electronics, Dec. 27, 1965, p. 26].

It worked. Surprisingly, the bus voltage had gone up. The men turned on the X-band equipment and found that the transponder on LES-4 was working. About an hour of satisfactory tone and voice com-

munications came through that afternoon as the team worked with frequency-modulation techniques and the 60-foot Millstone Hill parabolic reflector.

Monday morning, they tried out the Vocoder circuits, tying the Lincoln Experimental Terminal into the 6-foot dish [Electronics, June 14, 1965, p. 136]. The circuits worked beautifully.

The research group acknowledges that the experiments aboard LES-4 will never work perfectly. Tailored to a quasisynchronous circular orbit at 18,200 miles, the experiments ended up in a highly elliptical orbit ranging from 100 nautical miles up to 18,000.

Analysis indicates that LES-3, also hurtled into the wrong orbit, will probably accomplish its major objectives. It is a signal generator, designed to measure properties of the communications path between the satellite and various receiving terminals.

The LES program calls for at least one more experimental satellite, to be launched on a Titan 3C rocket.

Communications

Flock of Birds . . .

By late 1969 a series of giant multipurpose communications satellites, each with the capacity of at least 20 Early Birds, may be providing global communications links. The new birds will also have enough power to beam domestic television signals directly to local tv stations.

Proposals for the global relays were sent out to industry late last month by the Communications Satellite Corp.; responses are expected by mid-February [Electronics, Dec. 27, p. 48].

The new satellites each weighing about 2,300 pounds, will be versatile as well as powerful. Each will carry at least four separate transponders so it can simultaneously handle television, radio and telephone, messages, digital data and conversations between ground stations and planes and ships.

Multiplexing, too. What will make the giant bird so powerful and versatile is its sophisticated electronics.

The craft will use frequency-division multiplexing, allowing more than one message to be transmitted on a single frequency band. Also, some of the transponders would contain wideband quasilinear equipment; the output power of such transponders increases linearly as the power input from a ground station increases. Hence, the strength of the satellite's radiated signal can be directed from the ground; some signals can be stepped up for direct reception by small ground stations, and other signals can be lowered for reception by large ground stations. Early Bird's output power, in contrast, is constant no matter how strong the input signal may be.

In addition, the new bird's antennas will be despun, either electronically or mechanically, to focus the radiated signals toward specific areas.

Each satellite's capacity is expected to be between 4,800 and 6,000 two-way voice channels, or up to 10 television channels, or a combination.

Comsat engineers want the bird's output power to be about 40 decibels above 1 watt (dbw), compared with only 10 dbw for Early Bird. Total bandwidth of the new craft would be about 500 megacycles, compared with Early Bird's 25-Mc capacity.

Small antennas. Dishes as small as 30 feet in diameter would be able to pick up tv signals, Comsat engineers say, making it economical for a local station to use the satellite's tv relay rather than microwave or coaxial links that are currently provided by the American Telephone & Telegraph Co.

The decision to develop the giant bird follows a request by the American Broadcasting Co. for its own domestic communications satellite. The request is still being studied by the Federal Communications Commission.

ABC argued that it could save \$6 million a year if it were able to loft its own domestic bird.

Under Comsat's proposal, however, all tv stations around the



Low-cost digital frequency meters for mobile communications

Communications engineers who must now have more accurate measurements can get them with Beckman Models 6120 and 6121 Frequency Meters. These 25-mc and 50-mc instruments are the lowest cost digital frequency meters available employing direct counting techniques... 6120—\$1,750; 6121—\$1,950. They give you the benefits of direct digital display, simple controls, data logging (with option for printer), plus accuracy that can't be had in an analog device. For aircraft, marine, and surface mobile communications, these solid-state instruments have four plug-in extenders: a 400-mc prescaler, 1-gc heterodyne, DVM, and

preamplifier. Your Beckman Berkeley sales engineer has the full story on the Models 6120 and 6121 and how they can help you solve frequency measuring problems... with more accuracy at the lowest possible cost. For complete details, call or write today.

Beckman®

INSTRUMENTS, INC.

BERKELEY DIVISION

RICHMOND, CALIFORNIA • 94804

INTERNATIONAL SUBSIDIARIES: GENEVA; MUNICH;
GLENROTHES, SCOTLAND; TOKYO; PARIS; CAPETOWN; LONDON



another BURR-BROWN innovation



a small operational amplifier with FET chopper

Model 1538 is a new solid-state operational amplifier that uses a Field Effect chopper for maximum stability. But, the big news is its size... a module 0.6" x 1.8" x 2.4". It's really a slimmed-down version of our popular 1608A rack-mount unit, designed especially for engineers faced with space problems. Don't let the size fool you though, it's still a tiger when it comes to performance. And, the 1538 is immediately available at a single unit price of \$165.00.

MODEL 1538

Voltage Output	± 10 volts
Current Output	± 20 ma
Voltage Gain	160 db
Voltage Drift	$\pm 0.5 \mu\text{V}/^\circ\text{C}$
Current Drift	$\pm 2.5 \text{ pA}/^\circ\text{C}$
Temperature Range	
Operating	-40 to +85°C
Storage	-55 to +100°C

FOR COMPLETE TECHNICAL INFORMATION, or prompt assistance with your operational amplifier applications, wire, write or phone Burr-Brown, today.

BURR-BROWN

RESEARCH CORPORATION
INTERNATIONAL AIRPORT INDUSTRIAL PARK
BOX 11400, TUCSON, ARIZONA 85706

Electronics Review

country could be served by the giant satellite.

... for radio, too?

Industry proposals are due next week on the feasibility of orbiting a large satellite to relay f-m radio signals directly to home receivers. The satellite that would be needed for such a job would weigh between 2,000 and 3,000 pounds and have at least 100 kilowatts of effective radiated power (ERP).

The program is sponsored by the National Aeronautics and Space Administration.

NASA won't say when, if ever, it will build the direct-broadcast radio satellite, but the agency thinks jumping to 100-kw ERP is within today's state of the art.

Ideas wanted. NASA has asked companies to submit proposals on the money and technology required for such a system. Then, two companies will be selected to conduct six-month detailed studies under contracts running about \$125,000 each. Once these studies are completed, the agency will decide if it wants to proceed into the project-definition and design phase of the program and ultimately to develop and launch a satellite.

Officially, NASA cites its responsibility to push space technology on all fronts as the reason for going into the program. Unofficially, however, it is known that there is strong interest in the satellite by a number of government agencies. The U.S. Information Agency, which beams propaganda radio programs to all parts of the world, is one. Also, the military could use the direct-broadcast radio satellite to communicate with troops all over the world. The system would have civil defense value, and commercial broadcasters are also interested in the proposal.

Technically, NASA thinks that most inexpensive home receiving sets would need an outside antenna to receive the broadcasts. Outside antennas probably would not be needed for more expensive sets, with better noise sensitivity, or sets in areas with little electromagnetic "pollution."

Power needed. Broadcasting is envisioned in the low-frequency range—20 to 30 megacycles—or in the 100-Mc region. NASA believes a bank of solar cells capable of putting out about 5 kw to insure 2-kw transmitter output, would be required. Then, assuming a 17-decibel antenna gain for full global coverage, the ERP should reach about 100 kw. This, however, would require about a 30-foot parabolic antenna.

Approximately 500 square feet of solar cells would be needed to generate the 5-kw power supply. NASA thinks this could be accomplished by using a satellite similar in design to the large paddle-wheel Pegasus satellites it launched in 1965.

Space electronics

Supply on demand

The solar cell and the rechargeable battery seem to be natural partners: the inexhaustible, though cyclical, supply of light energy from the sun is converted into electrical energy and stored in the battery until needed. But in some respects the partners are incompatible: a solar cell's efficiency steadily degrades as the sun heats it and the battery offers a higher resistance to recharging as the storage level builds up.

Gulton Industries, Inc., of Metuchen, N. J., says it has found a way to coordinate the supply and demand of a solar cell-nickel cadmium battery. Gulton claims the design, developed for the National Aeronautics and Space Administration, can be used to build a power-supply system that weighs 20% less than a conventional system and recharges a battery 25% faster.

Cycle speeded. Engineers at Gulton's Engineered Magnetic division decided first to speed the charging cycle. The engineers aimed at achieving the most rapid recharging pace early in the cycle, when the solar cells are cool and produce the highest power and when the battery's appetite for power is

greatest, offering the least resistance to recharging.

During the early part of the cycle, the cell's high voltage and low current output is converted to a high current and low voltage output. Later in the charge cycle, when the battery offers resistance to the buildup of electricity, the balance is shifted: voltage is stepped up and current is lowered, in effect boosting the solar cell's pumping action.

Safety valve. The Gulton system provides other advantages: it eliminates the shunt regulator found in conventional systems and provides sensors to detect overcharging and undercharging. Since a surge of high voltage can damage the battery, designers of conventional systems use a shunt regulator to limit the flow. Although the regulator acts as a safety valve, it also wastes power, contributing to the slowness of the charge cycle.

Two electronic sensors are in-battery is nearing the point where too great a power drain could damage the battery and the other to detect when the battery is nearing the fully charged state. Overcharging is just as damaging to a battery as excessive draining.

Basic to the system is a series of comparator circuits, which act like a computer. The circuits decide when to turn on power, turn it off and adjust the component parts, current and voltage.

To determine the state of the battery, the Gulton engineers designed an ampere-hour meter that integrates the current in and out of the battery.

Aside from detecting the state of the battery, sensors also check the temperature of the solar cell's arrays, thus monitoring another variable that affects the charging cycle.

Avionics

Self-diagnosis in flight

In addition to delivering passengers and the mail, airliners in 1967 may

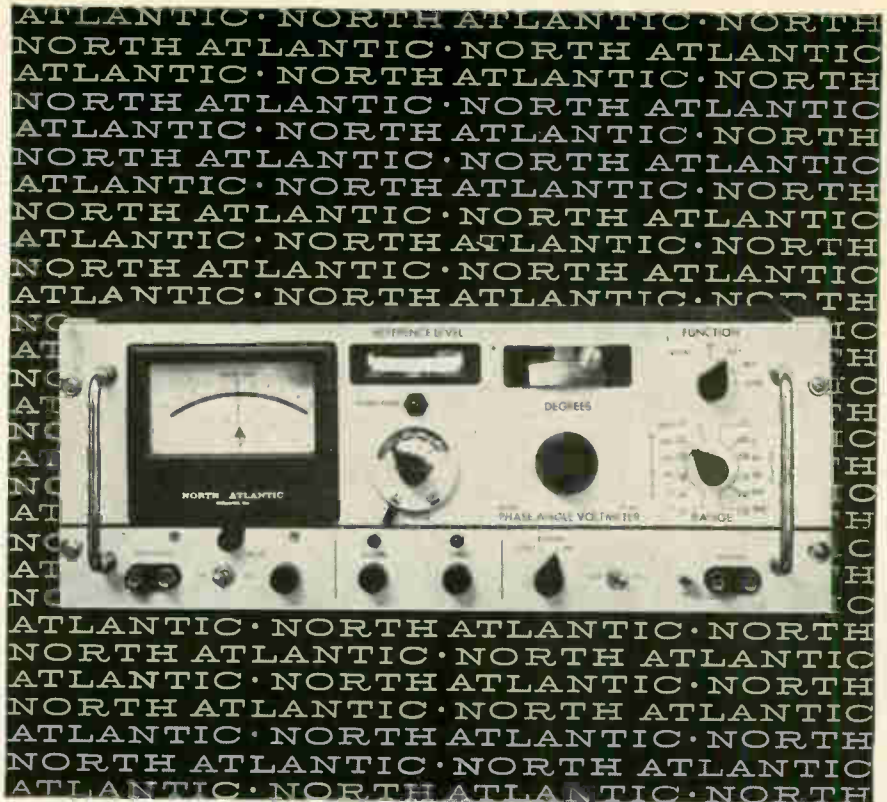

how to measure in-phase, quadrature and angle while sweeping frequency to 100 kc

North Atlantic's latest addition to the PAV line of Phase Angle Voltmeters* enables you to make measurements while frequency is varying over half-decades without recalibration. The VM-301 Broadband Phase Angle Voltmeter* provides complete coverage from 10 cps to 100 kc, and incorporates plug-in filters to reduce the effects of harmonics in the range of 50 cps to 10 kc with only 16 sets of filters. Vibration analysis and servo analysis are only two of the many applications for this unit. Abridged specifications are listed below:

Voltage Range.....	1 mv to 300 volts full scale
Voltage Accuracy.....	2% full scale
Phase Dial Range.....	0° to 90° with 0.1° resolution (plus 4 quadrants)
Phase Accuracy.....	0.25°
Input Impedance.....	10 megohms, 30μf for all ranges (signal and reference inputs)
Reference Level Range.....	0.15 to 130 volts
Harmonic Rejection.....	50 db
Nulling Sensitivity.....	less than 2 microvolts
Size.....	19" x 7" x 10" deep
Price.....	\$2290.00 plus \$160.00 per set of filters

North Atlantic's sales representative in your area can tell you all about this unit as well as other Phase Angle Voltmeters* for both production test and ground support applications. Send for our data sheet today.

*Trademark



NORTH ATLANTIC industries, inc.
TERMINAL DRIVE, PLAINVIEW, L. I., NEW YORK • OVERbrook 1-8600

VOLTROL* STABILIZERS

provide custom-built
regulation

AT STANDARD
STOCK PRICES

Most commercially available electronic equipment, machines, devices or control systems whose performance may be affected by low voltage, high voltage or fluctuating voltage, do not require voltage regulation more precise than that provided by a standard stock model Voltrol Stabilizer.

An inherent advantage of the Voltrol core design permits a close realization of the rated nominal output voltage. With the output voltage precisely adjusted, voltage regulation of $\pm 1\%$ is usually adequate for most applications.

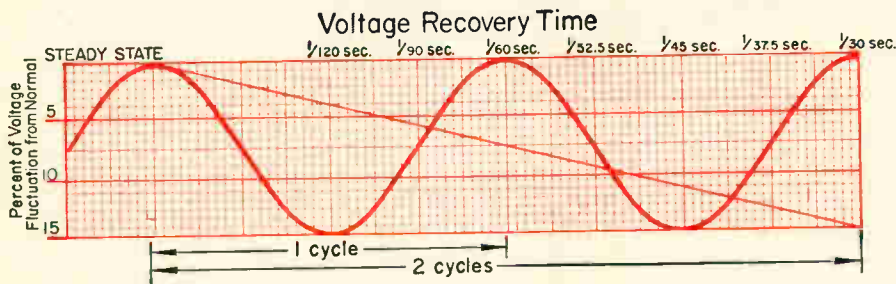

The Voltrol Stabilizer is extremely sensitive and quickly responsive to line voltage fluctuations. In two cycles or one-thirtieth of a second, correction is made to a voltage fluctuation of plus or minus 15% nominal voltage caused by an inductive surge, switching, arc over or other momentary voltage variation. The recovery time on voltage fluctuations of less amplitude is proportionately faster. A 10% variation would recover in less than one-fortieth of a second, a 5% variation would recover in approximately one-sixtieth of a second.

All units are normally supplied to operate with output voltage stabilized at $\pm 1\%$ of nominal rating when operating under full load in an ambient temperature of 77-80°F.

SEND FOR BULLETIN 09

Full specifications, dimensions and performance features fully explained in this free Bulletin 09.

SAA-3931-3229

*Voltrol is a trademark of Acme Electric

Acme ACME Electric

Engineers and Builders of...

311 WATER STREET, CUBA, NEW YORK

Canadian Representative: Polygon Services Ltd.,
50 Northline Rd., Toronto 16, Ont.

REGULATED POWER SUPPLIES
STATIC POWER RECTIFIERS
VOLTAGE STABILIZERS
VOLTAGE REGULATORS

deliver analyses of their own mechanical and electronic systems so airports' ground crews can make repairs speedily.

The in-flight analysis, already being tested on an Eastern Airlines plane, would eliminate a lot of wasted time on the ground. More than one-third of all components removed on suspicion of failure are found to be in good working order, according to Eastern.

Eastern's system, being developed jointly with the International Business Machines Corp., records 40 engine parameters. Eventually the system will measure 296 parameters of the aircraft, its engine and subsystems. The Air Force is working on an in-flight automatic test system, developed by the Douglas Aircraft Co. for its proposed C-5A transport plane.

Signaling the faults. The commercial system places sensors at strategic locations throughout the aircraft. These sensors transmit signals, through a premultiplexer, to signal conditioners that make the signals acceptable to the main multiplexer.

At the main multiplexer, a converter changes each sensor's signal voltage into a number. Next, a formatter puts the digital value into computer form and records it on magnetic tape.

The recorder will scan one channel five times a second, 95 channels once a second, and the remaining 200 channels every 10 seconds. The higher scanning rates will be applied to fast-changing measurements such as acceleration, vibration, air condition, engine pressure and fuel flow.

At present, test tapes are being processed in Miami by an IBM 7074 computer. Next September an airborne digital data-processor, built with integrated circuits, is scheduled to be installed in Eastern planes. Quantity production of the system is due early in 1967.

Electronics notes

▪ **Airline computer.** The Burroughs Corp. has sold a D830 computer system to Trans World

The 4 rectifiers used
in this 10-amp bridge
cost \$4.57* — the bridge
takes 6 minutes to build...

This Motorola 10-amp
bridge costs \$3.65† —
takes only 75 seconds
to install!

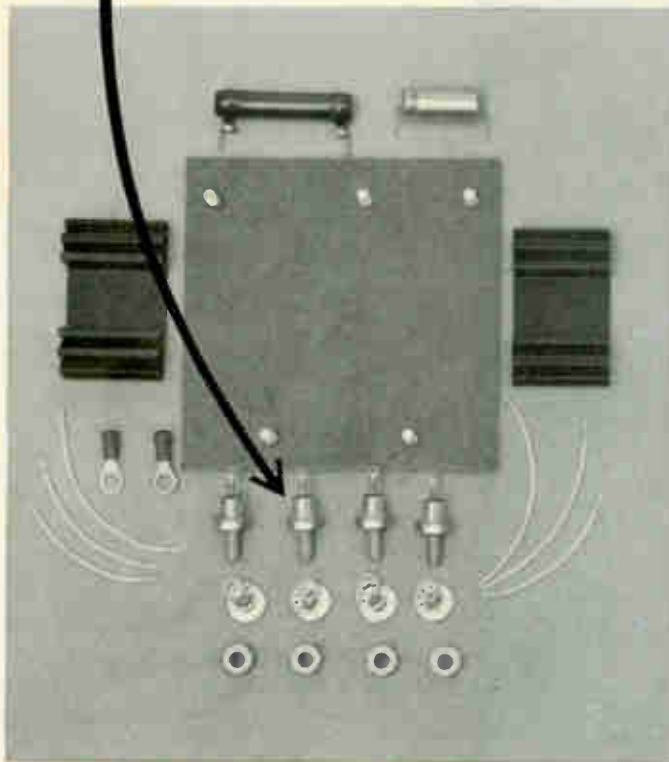

You, too, can simplify your designs, reduce costs and increase the reliability of your circuits with Motorola Molded Rectifier Bridges. They provide these advantages:

■ reduction of assembly-steps by up to 75%. ■ elimination of bridging "heat-sinks", mounting hardware, and intercomponent connections. ■ no dirt and grime-catching corners and crevices common to unencapsulated or "finned-type" assemblies. ■ 3-step "source-tested" — (1) individual rectifiers tested and matched before assembly (2) bridge assembly tested before encapsulation (3) final molded bridge tested before shipment.

Now, with the addition of the MDA972 series, Motorola offers a complete molded bridge line up to

16-Amps, covering all your applications down to 1-amp, in a variety of case sizes, shapes and terminal configurations.

44 types immediately available in any quantity

- MDA920 series: 1A, 25-600 V
- MDA942 series: 1.5A, 50-600 V
- MDA952 series: 6A, 50-600 V
- MDA962 series: 10A, 50-600 V
- *New* MDA972 series: 16A, 50-600 V

Contact your franchised Motorola distributor now for evaluation units from his "off-the-shelf" stock — determine for yourself how these ready-to-use, easy-to-install rectifier bridges can save you **TIME AND MONEY.**

*Estimated average cost for 4 stud-rectifiers per current major manufacturers' published prices.

†Price for MDA962-3, 200 volts, in 100-up quantities.

POWER UP WITH . . .

MOTOROLA Semiconductor Products Inc.

BOX 955, PHOENIX, ARIZONA 85001

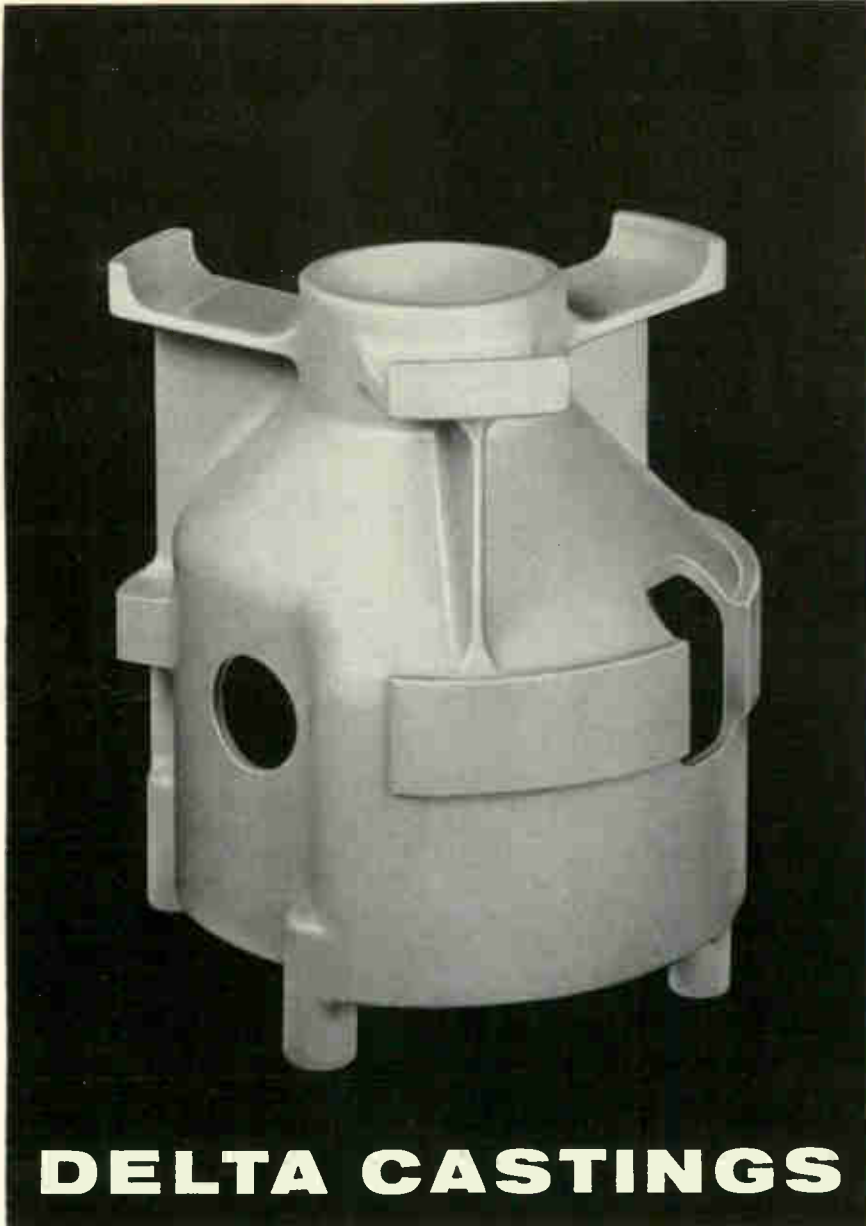

DELTA CASTINGS

We investment cast this part . . . already finished. This complex, thin-walled helicopter part is produced by Delta requiring no further operations to achieve the specified surface finish.

Over five inches across, the part consists of two conical sections with different radii on different centers. Delta engineers, highly experienced in complex tooling, designed a die to produce one-piece patterns for greater dimensional accuracy. A typical example of the design flexibility and economies possible with Delta investment castings.

Don't be chained to the high-cost machining habit. Send us a print of a part as you want it produced. Forget restrictions of other metalforming methods. Frequently, all you will have to do to a Delta casting is unwrap and install.

Delta specializes in non-ferrous investment castings meeting the most stringent dimensional and structural requirements for both commercial and military applications.



DELTA

MICROWAVE CORPORATION

HACKENSACK, NEW JERSEY 07601

Tel. (201) 343-2484

a subsidiary of HITCHINER MANUFACTURING CO., INC.

Electronics notes

Airlines to handle passenger reservations and management information. The D830 is an advanced design of the D825, a system developed several years ago for the military. Several weeks ago United Air Lines placed a \$39-million order for a computer system to be built by the Sperry Rand Corp.

▪ **Nike X contracts.** Although no orders for the production of the Nike X antimissile system are being issued, the Pentagon continues to award contracts for further research and preproduction activity. The Western Electric Co., the manufacturing arm of the Bell System, received a \$92.8 million order for R&D on the system.

▪ **Color tv boom.** The Zenith Radio Corp. has announced its \$17-million expansion program intended to boost color television tube production 50% by year-end. Zenith's current output is about 900,000 color tubes a year. By the end of 1967, Zenith estimates, color tube production will reach 2 million annually.

▪ **Patient robot.** The University of Southern California's School of Medicine and the Aerojet-General Corp. are developing a computer-operated model of a human being to help train hospital residents in anesthesiology. The mannikin will simulate pulse, muscle and skin-color changes in response to dosages of 10 anesthetics. It will take 22 months to build under a \$280,000 grant by the Department of Health, Education and Welfare.

▪ **Laser drill.** Add another production chore to the growing list of laser uses: drilling diamond dies for wire-drawing machines at the Buffalo, N. Y., plant of the Western Electric Co. The plant manufactures 160 billion feet of wire a year. About 30,000 diamond dies are made or reworked annually. By vaporizing, the laser has reduced drilling time per die to two minutes. Grinding techniques take two or three days.

ENVIRONMENTAL PROOF
is what we call it . . .



 **Stackpole Rotary Switches**
Specially Designed to Guard Against
EXPOSURE—CONTACT CONTAMINATION—PRODUCTION DAMAGE

COMPETITIVELY PRICED—This completely enclosed, rugged switch costs no more than the open clip type.

SAMPLES IN 3 DAYS—to your exact specifications. Send your drawing and prove it to yourself.

ORDERS IN 2 TO 3 WEEKS—On-time delivery of uniform, high quality production quantities to meet your schedule.

SEND YOUR DRAWING FOR A QUOTATION AND SAMPLE. Take advantage of Stackpole quality, price and service. For additional information and technical data write: Electro-Mechanical Products Division, Stackpole Carbon Company, St. Marys, Pennsylvania 15857. Phone: 814-834-1521. TWX: 510-693-4511.

 **STACKPOLE**
ELECTRO-MECHANICAL
PRODUCTS DIVISION

Announcing another tailored solvent from Du Pont: FREON[®] T-P 35

Gives you safer cleaning of reactive metals plus improved water-drying properties.

FREON T-P 35—Du Pont's exclusive, new solvent—is one of the safest commercial cleaning and drying agents known. It is compatible with active metals such as aluminum, magnesium, zinc and magnesium-lithium alloys. And because it holds up to 9% water, FREON T-P 35 is an excellent drying agent for cleaning residual water traces.

This patented blend of FREON-TF and isopropanol is specifically tailored to remove rosin flux from all kinds of electronic and electromechanical assemblies, from printed circuit

boards to potentiometers... from hearing aids to missile guidance systems. In addition, FREON T-P 35 is ideal for flushing hydraulic piping.

New FREON T-P 35 is completely safe for most plastics, elastomers or wire coatings. It has low surface tension for complete wetting of the smallest pores and crevices...high density to loosen and float away particulate matter. Because FREON T-P 35 is nonflammable and virtually nontoxic, extra precautions on the production line are rarely needed.

Find out more about DuPont's new FREON T-P 35—a unique, selective solvent that offers ex-

cellent cleaning and drying properties, and is safe with the most sensitive components. For further information, mail the coupon today.

Du Pont Co., Room 3363, A
Wilmington, Delaware 19898.
Please send me more information on FREON T-P 35. (Bulletin FST-5F).



Name _____

Company _____

Address _____

City _____ State _____ Zip _____

(In Europe, mail to: E. I. du Pont de Nemours International S.A., "Freon" Products Div., 81, Route de l'Aire, 1211 Geneva 24, Switzerland.)



Better Things for Better Living
... through Chemistry

Washington Newsletter

January 10, 1966

Military spending continues to rise despite peace bids

Despite the United States' renewed efforts for a settlement of the Vietnam war, the Johnson Administration remains committed to further expansion of defense spending. Current estimates for fiscal 1967's military budget have been put at between \$57 billion and \$60 billion. Estimates for this year's budget range from \$52 billion to \$54 billion. For fiscal 1968, Pentagon spokesmen predict a further rise in defense outlays—as much as \$3 billion to \$5 billion.

Nothing less than the complete cessation of hostilities in Vietnam could reduce current defense spending by any noticeable amount. Plans for fiscal 1967 are virtually set and there's a strong feeling in Washington that signs of indifference to U.S. peace gestures by Hanoi would indicate that the Viet Cong isn't ready to come to the conference table.

In any case, the Administration learned a lesson from the war in Vietnam and will keep spending for high-level preparedness. The military doesn't want to risk being caught flatfooted by any other outbreaks in the Far East.

Pentagon changes cost-report rules

The Pentagon's new comptroller, Robert N. Anthony, will soon issue a revision of the cost-reporting system that defense contractors must follow when submitting bids. Contractors had criticized the old regulations, drawn up by Anthony's predecessor, Charles J. Hitch, contending they were written without regard to contractors' suggestions.

The new rules were circulated in advance among defense contractors and Anthony's changes are said to overcome most of their objections.

The cost information reported by bidding contractors gives the Defense Department data on past weapons costs and is used to judge new bids.

White House pushing satellite for 3 R's

A proposal for a worldwide educational television system by satellite [Electronics, Oct. 18, 1965, p. 65] has cleared all preliminary hurdles and is now in the hands of a top-level White House committee headed by Leonard Marks, former director of the Communications Satellite Corp. and now head of the U. S. Information Agency. The committee's job is to work out details of the proposal. A \$20-million to \$30-million pilot program is likely to be unveiled for Congress by President Johnson this year, for possible funding in 1967.

The plan is a response to the President's request for ways to spread education in backward parts of the world. The proposal recently cleared the desk of Secretary of State Dean Rusk and has been screened by Comsat, the Federal Communications Commission and Johnson himself. Comsat has asked electronics companies to submit ideas for a huge, synchronous multipurpose satellite [for details see p. 48], not specifically for this project but with it in mind. And several key congressmen have indicated congressional acceptance.

To avoid accusations of propagandizing by satellite, an international group would prepare the courses and the receiving countries would own and maintain the receiving stations. Comsat would probably own the satellites; most of the money and technical assistance would be supplied by the U. S.

Washington Newsletter

Wanted by FBI: automated file for fingerprints

The Federal Bureau of Investigation says it's in the market for a computer-operated optical system for reading, classifying, sorting and retrieving fingerprints, but wants electronics companies to pay for development. In addition, the FBI says it will only buy a system that is "nothing less than perfect." The present generation of optical readers is no more than 95% accurate. If a perfect system were to be developed, the FBI says it would still back it up with manual techniques—to double-check the machine.

In the past, producers of optical scanning and computing systems—such as the International Business Machines Corp., the Radio Corp. of America and Rabinow Electronics, Inc.—have approached the bureau with proposals, but without success.

Some 15 years ago the FBI experimented with punched cards and mechanical sorters for its fingerprint file, but junked the plan when it proved less efficient than manual searching. The FBI has the fingerprints of 80 million people.

Air Force tries 200-number battle phone

The Air Force begins this week to evaluate technical proposals for a rugged, versatile radiotelephone that can be air-dropped to forward battle areas and operated within minutes under severe weather conditions.

The AN/TRC-124 will handle up to 14 simultaneous conversations with up to 200 addresses over a five-mile area. Each handset will weigh 15 pounds, without battery, and the repeater will weigh about 100 pounds. The transmitter will automatically seek a vacant channel and sound the called station's tone.

The Electronic Systems division at Hanscom Field, Mass., is evaluating proposals submitted by the Martin Marietta Co., the Electronics division of the General Dynamics Corp., the Sylvania Electronic Systems division of the General Telephone and Electronics Corp. and the International Telephone and Telegraph Corp.

The prototype equipment will include nine transceivers and two repeaters, using state-of-the-art equipment with rugged circuitry and packaging. Delivery is scheduled for December.

If the new system passes field tests, it will be produced for the Tactical Air Command and may become part of the 407L system. [For more details on procurement for the 407L program, see p. 46].

Revised Mariner may replace Voyager

The National Aeronautics and Space Administration is proposing a revised four-year, \$160-million Mariner interplanetary program. The program would replace a \$1.2-billion effort to orbit a pair of Voyager satellites around Mars by 1970. Instead of developing the new three-to-five-ton Voyagers, NASA would put the 500-to-600-pound Mariners on a Venus mission in 1967, and a Mars mission in early 1969. NASA hopes the Mariner program will fill the gap in interplanetary exploration left by budget tightening. The agency still proposes, however, to come back to Voyager later, with a Mars shot possible by 1973.

Mariner's prime contractor has been the Jet Propulsion Laboratory of the California Institute of Technology, with more than 60 subcontractors contributing equipment.

3 AU 8 FEVRIER 1966 - PORTE DE VERSAILLES - PARIS

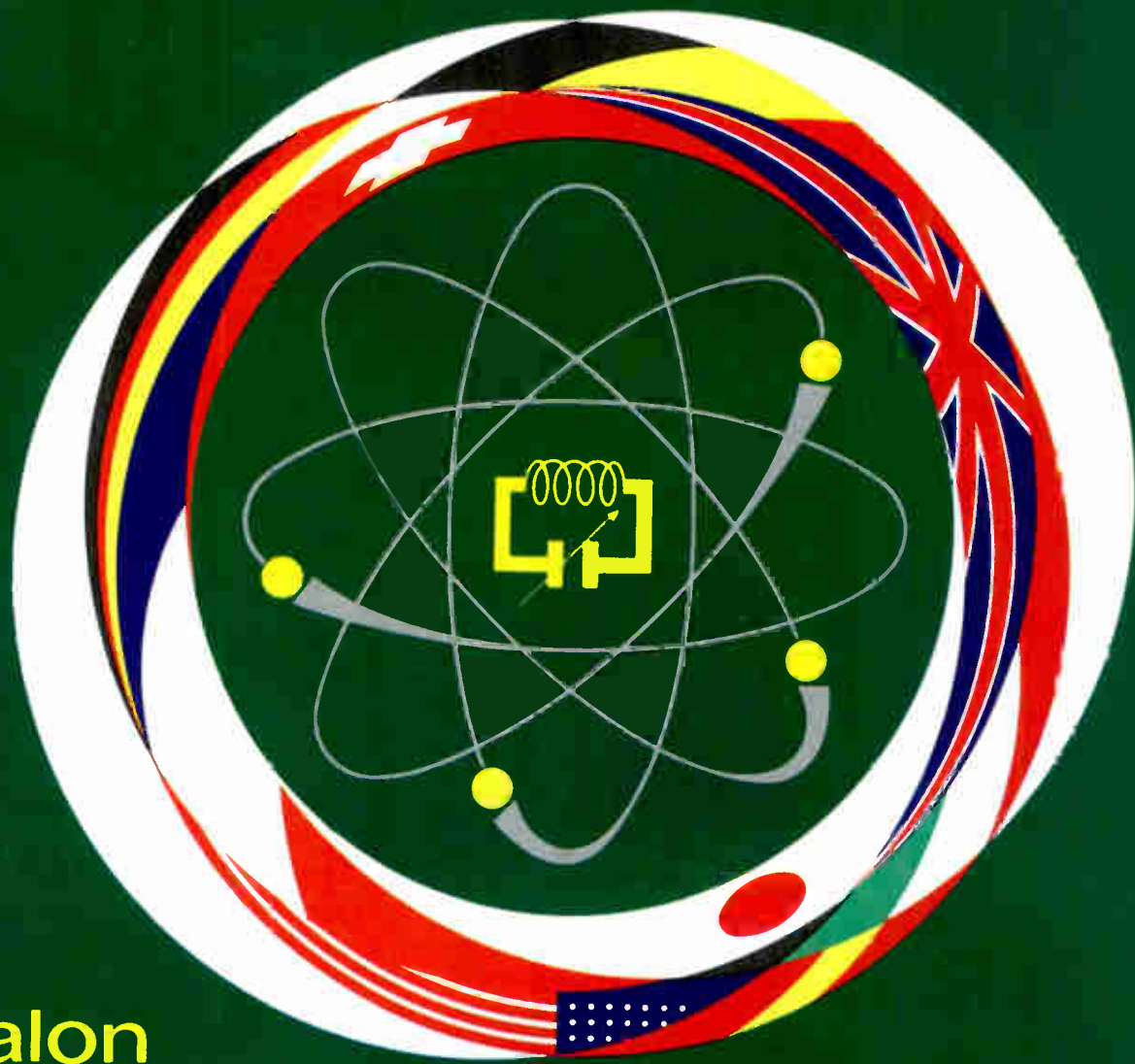

salon
international des

COMPOSANTS ELECTRONIQUES

salon international de

L'ELECTROACOUSTIQUE

RENSEIGNEMENTS S.D.S.A. 16 RUE DE PRESLES PARIS 15

the very first components exhibition

Founded in 1934 and raised to international status in 1958, the International Exhibition of Electronic Components, reserved for manufacturers alone, opens its doors every year to firms specializing in electronics throughout the world.

the most comprehensive exhibition

This is the largest world exhibition of electronic parts and accessories and is more successful each year...

It is a display centre for world production in electronic components where manufacturers and engineers from all countries can meet to compare techniques and equipment and jointly work out future developments.

In February 1966 the Exhibition will be held on a wider scale than ever before and will be the first international meeting of the year where the latest discoveries in electronics will be on display.

900 exhibitors will have their stands in the new showrooms on the Exhibition Grounds at the Porte de Versailles in Paris.

the most internationalized

Visited by the Specialists of 60 nations, it groups 450 foreign firms featuring 20 nations' production. Half of the exhibitors attending this great Paris Show have come from all over the world to do so, bringing the best Electronics engineers and technicians along with them.

The International Exhibition of Audio Equipment will be held next to it at the same time, bringing together specialists from this rapidly expanding branch of electronics.

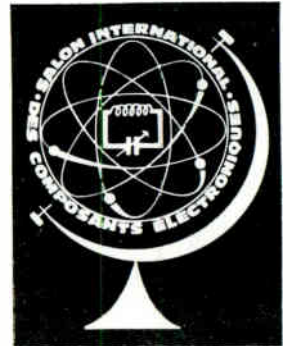



INTERNATIONAL EXHIBITION OF
ELECTRONIC COMPONENTS
PARIS 3rd to 8th FEBRUARY



ELECTRONIC COMPONENTS

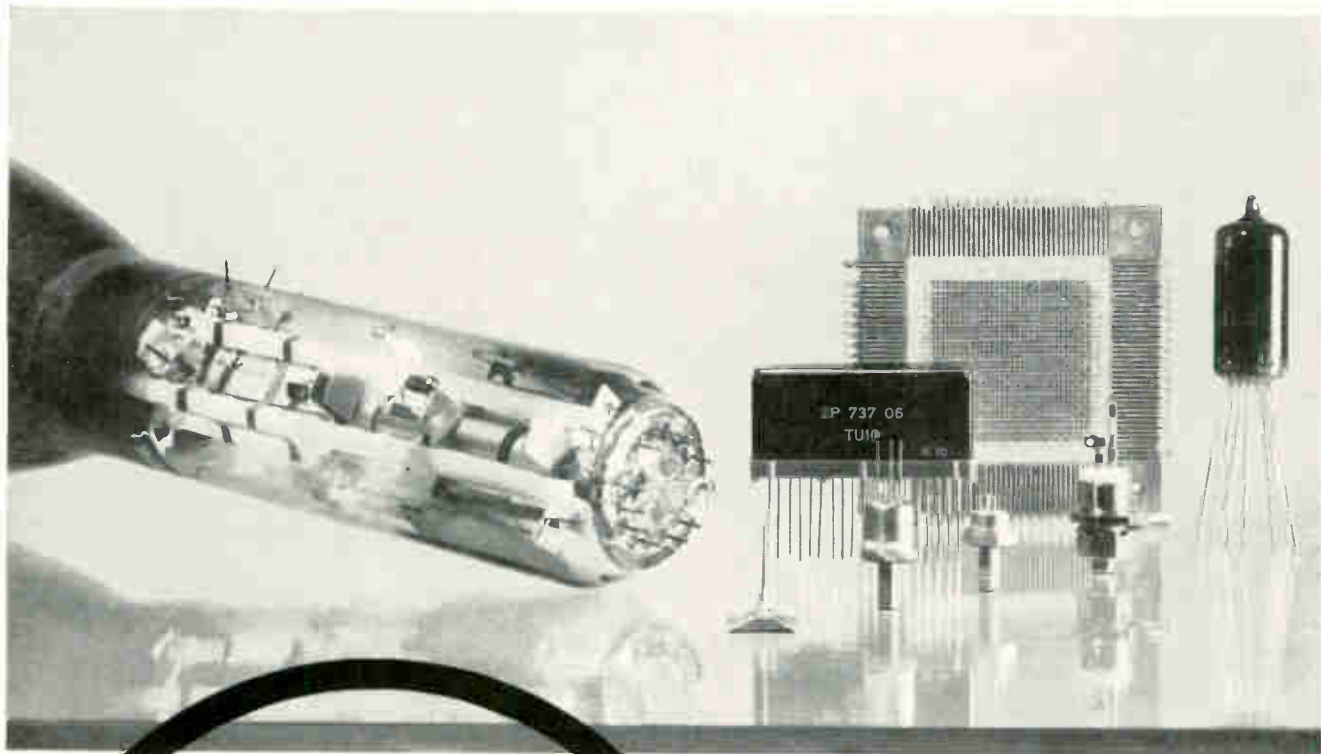

RELIABILITY

ADVANCED TECHNIQUES

Semiconductor Crystals
(Ga As — In As — GaP — Epitaxy)
Special Semiconductor Devices
Integrated Circuits
Thin film circuits
Magnetic memories
Photomultipliers
Electronic Tubes

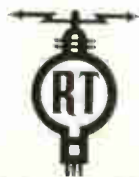

LA RADIOTECHNIQUE-COPRIM

130, Avenue Ledru-Rollin - PARIS (France)



INTERNATIONAL EXHIBITION OF ELECTRONIC COMPONENTS

PARIS 3rd to 8th FEBRUARY



Go to the 9th International Exhibition of Electronic Components from Feb. 3-8.



(It's held in Paris.)



F 9103

IONIZATION GAUGES

for measurement of gas
pressure in the range
from 10^{-3} to 10^{-10} torr

PUBLIC SERVICE
PARIS

Travel on Air France.



(It flies to Paris... and it's the Official Airline for the Exhibition.)

TYPES	Ic at 10^{-5} torr	Vg volts	Vc volts	Ig mA
-------	-------------------------	-------------	-------------	----------

IONIZATION GAUGES - Pressure range : 10^{-3} - 10^{-6} torr

J A 10	0,4 μ A	+ 250	- 30	10
F 9117	1,6 μ A	+ 200	- 80	10
8418	1,4 μ A	+ 250	- 30	10

BAYARD-ALPERT GAUGES - Pressure range : 10^{-4} - 10^{-10} torr

F 9101	1 μ A	} + 200 - 50 10 2 separate filaments		
F 9102	1,3 μ A			
F 9103	1,2 μ A			



**COMPAGNIE INDUSTRIELLE
FRANÇAISE
DES TUBES ÉLECTRONIQUES**

Write
for information :

C.I.F.T.É.
50 rue J.P. Timbaud, 92-COURBEVOIE
FRANCE

Telephone 333.37-50

Telegram CIFTE-COURBEVOIE

Better yet, do both.



AIR FRANCE

THE WORLD'S LARGEST AIRLINE
Overseas Trade Show Department
Box 707
New York, N.Y. 10011

E-1

I've been thinking about going to the Electronic Components Exhibition. I've also been thinking about going to Paris. Please send me your brochure on combining the two. Please include your "specific commodity" cargo rates, too.

Name _____

Company _____

Address _____

City _____ State _____ Zip _____

VALUE ENGINEERED FOR LOWER COST THRU SIMPLIFIED DESIGN

4 New 1/2" x 13/32"

High Performance Trimmers with Solder or Pin Terminals

Infinite resolution. Excellent high frequency performance characteristics. No catastrophic failures.

These four new additions to the extensive CTS trimmer line have many applications in High Performance Industrial and Military fields: computers, instruments, medical electronics, communications equipment, electronic machine controls, aerospace electronics, microwave transmission, etc.

Series 330



80¢

in production quantities
Priced lower than comparable wirewound trimmers.

Series 330P



85¢

- Proven Reliable CTS Carbon-Ceramic Resistance Element
- Far Exceeds Environmental Performance Spec of MIL-R-94B, Char. Y
- ± 8% Humidity Stability
- 100 Ohms to 2.5 Megohms
- 3/8 Watt @ 70°C Derated to Zero Load @ 150°C
- Grounded Construction Available on Model 330

Series 330 Has Solder Terminals. Series 330P Has Pin Terminals on .100" Grid Configuration and Standoffs to Insulate Metal Cover From P. C. Board.

Write for Data Sheet 2330A

Series 630



\$1.50

in production quantities
Priced lower than comparable wirewound trimmers.

Series 630P



\$1.60

- Famous CTS CERMET Resistance Element
- Extreme Stability Under Severe Environmental Conditions
- ± 4% Humidity Stability
- 20 Ohms to 2.5 Megohms
- 1/2 Watt @ 85°C Derated to Zero Load @ 150°C
- Low Noise—Long Life
- Extreme Overload Capacity
- Grounded Construction Available on Model 630

Series 630 Has Solder Terminals. Series 630P Has Pin Terminals on .100" Grid Configuration and Standoffs to Insulate Metal Cover From P. C. Board.

Write for Data Sheet 3630A



Founded 1896

CTS CORPORATION
Elkhart, Indiana

Sales Offices and Representatives Conveniently Located Throughout the World.

Principal Products

Variable Resistors
Selector Switches
Loudspeakers
Trimming Potentiometers
Microminiature Components
& Circuit Packages
Crystals, Filters,
Oscillators & Ovens

Subsidiaries

CTS of Asheville, Inc., Skyland, N. C.
CTS of Berne, Inc., Berne, Indiana
CTS of Paducah, Inc., Paducah, Ky.
Chicago Telephone of California, Inc.,
South Pasadena, Calif.
CTS of Canada, Ltd., Streetsville, Ontario
CTS Microelectronics, Inc., Ridgefield, Conn.
CTS Research, Inc., Lafayette, Ind.
CTS Knights, Inc., Sanowich, Ill.

TODAY'S HIGHEST ACCURACY MOST VERSATILE SWEEPS EASIEST OPERATION...

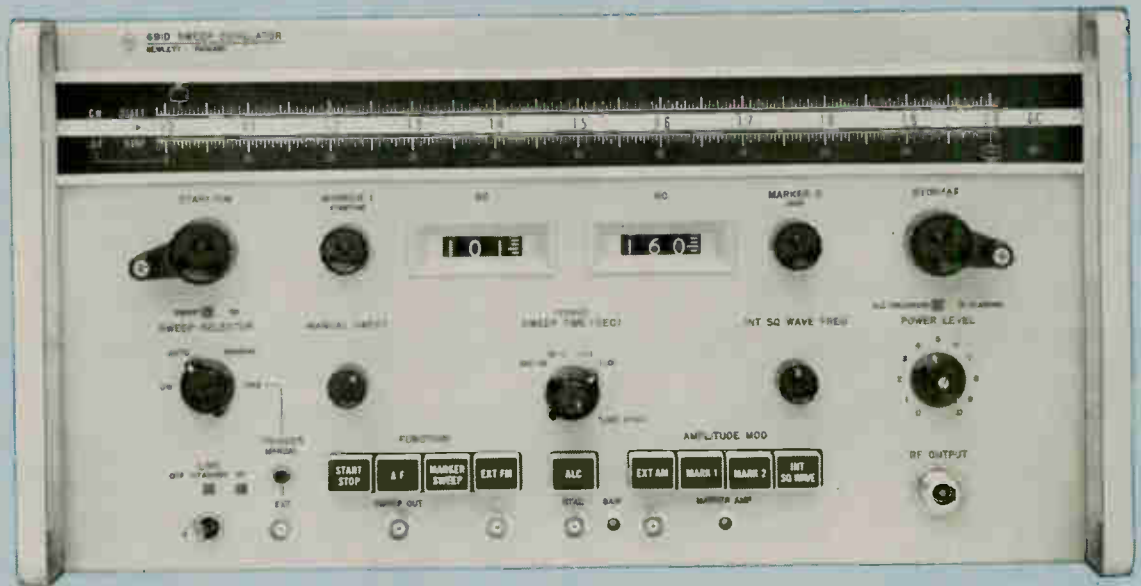

The Hewlett-Packard 690 Sweep Oscillators give you superior performance in terms of accuracy and flexibility through exclusive features such as PIN diode leveling and modulation, plus the convenience of easy x-y recording capability, clear marker visibility, push-button operating convenience, easy-to-understand front panel and compact construction. The unique PIN diode attenuators permit all AM functions, including leveling, to be performed independent of the BWO tube, thus virtually eliminating frequency pulling and providing the high frequency accuracy and linearity.

*from the complete line of
hp 690 Sweep Oscillators
1 to 40 GC:*

For maximum flexibility, the 690's give you these independent sweep modes:

Start-Stop Sweep: Set end points anywhere in the frequency range on slide rule scale. Sweep up or down just by pushing the Start-Stop button. Markers appear on rf output.

Marker Sweep: Expand any small area of the major sweep merely by setting independent Marker controls and pushing the Marker Sweep button. End points set on error-free digital readouts. Sweep up or down the Marker range.

Delta F Sweep: A symmetrical sweep about a center frequency, useful for calibrating narrow-band devices. Just press the ΔF button and get the industry's only accurately calibrated narrow sweeps.

Manual Sweep: The useful Manual Sweep permits detailed investigation of a localized area. For x-y recording, tedious set-up time becomes a thing of the past.

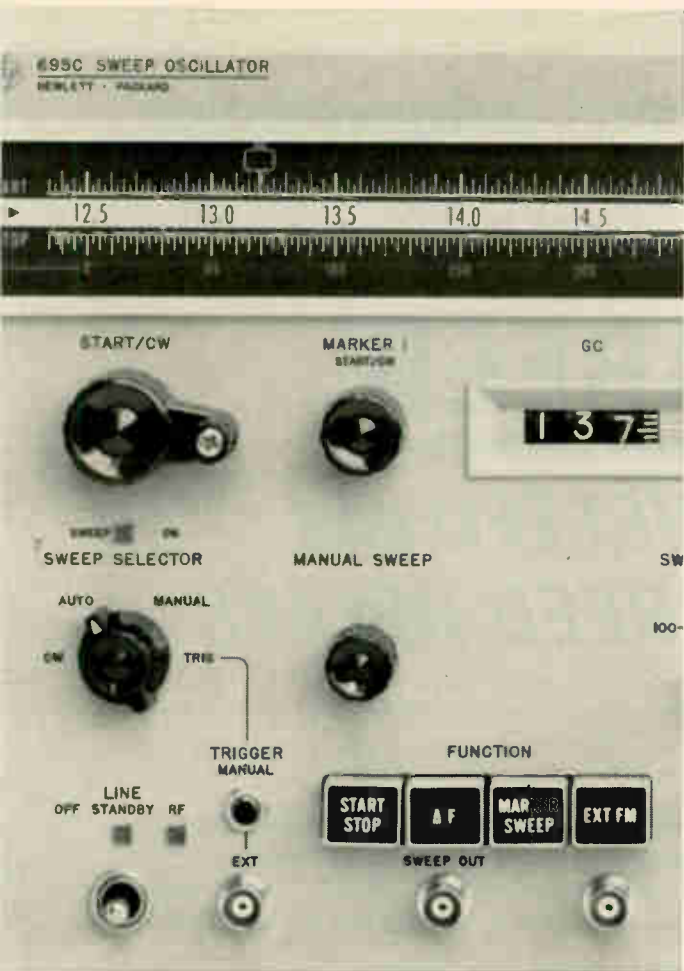

A variety of sweep speeds are offered in the 690's, too: With the Sweep Selector in Automatic, you get recurrent sweeps, continuously adjustable in 4 ranges, 0.01 to 100 seconds. Or you can sync the sweep with line frequency. For use with a scope, output power can be blanked during retrace to provide a zero baseline, yet there are no transients at the start or end of sweep. Automatic pen lift circuit on the two slowest speeds permits easy x-y recorder use. Sweep voltages for both scope and recorder are provided concurrent with swept rf.

Pushbutton selection of sweep mode is standard, as is modulation selection: external AM or FM or internal square wave modulation, 950-1050 cps. And you add sharp, distinct markers merely by pushing buttons.

Two leveling options are offered: external closed loop, which eliminates transmission line problems and delivers leveled power where you need it, or internal leveling for less critical applications. Your leveling can be derived from crystal detector or power meter. Maximum usefulness of leveling capabilities is demonstrated in your ability to use reflectometer techniques with direct scope or x-y recorder readout. More information on these techniques is contained in Application Note 65, yours for the asking.

Your Hewlett-Packard field engineer can give you a demonstration of a 690 on your bench, where it can prove itself. Or write for complete specifications on the entire series: Hewlett-Packard, Palo Alto, California 94304. Tel. (415) 326-7000; Europe: 54 Route des Acacias, Geneva.

Data subject to change without notice. Prices f.o.b. factory.

SUMMARY OF SPECIFICATIONS				
Model	Frequency range	Max. leveled power output	Frequency Accuracy	Price
691D	1 - 2 gc	≥70 mw	± 10 mc	\$3550*
692D	2 - 4 gc	≥40 mw	± 10 mc	3350*
HO1-692D	1.7 - 4.2 gc	≥15 mw	± 13 mc	3650
693D	4 - 8 gc	≥15 mw	± 20 mc	3350*
HO1-693D	3.7 - 8.3 gc	≥ 5 mw	± 25 mc	3650
694D	8 - 12.4 gc	≥30 mw	± 30 mc	3450*
HO1-694D	7 - 12.4 gc	≥15 mw	± 40 mc	3750*
695C	12.4 - 18 gc	≥40 mw	± 1 %	3500
696C	18 - 26.5 gc	≥10 mw	± 1 %	4500
697C	26.5 - 40 gc	≥ 5 mw	± 1 %	6500

*Grid leveled "C" models \$350 less

The chart, listing brief specs on some of the available models, includes three "specials" (HO1 models) designed for popular extended range applications. "D" models offer PIN diode modulators, while "C" models use BWO grid modulation and offer slightly increased power output and lower price. Other models with a choice of modulation techniques and special frequency ranges are available. All BWO's have 2500-hour warranty. The specified accuracy of each model covers all sweeps, plus rf in cw mode.



For industrial and military control, instrumentation and communications switching you now get more contact capability...more versatility...with

NEW CLAREED[®]

MERCURY-WETTED and HIGH VOLTAGE REED RELAYS

Clare's newest innovations in Clareed contacts provide more design flexibility...more application versatility than ever before possible with any reed-contact relay. For instance:

New Power Output Capability—You can handle up to 50 va power output loads . . . and be assured of good low level performance, too, with the mercury-wetted Clareed.

New Voltage Stand-off Capability—You can perform hi-pot functions at 1500 v stand-off with the new high voltage Clareed relay... up to 5000 v peak with special assemblies.

New Bounce-Free Contacts—You are assured of faster response time. No waiting with bounce-free mercury-wetted Clareed contacts.

New Low and Consistent Contact Resistance—You can depend on mercury-wetted Clareed relays to hold original contact resistance to within ± 2 milliohms throughout life.

New Longer Life Ratings—You can specify mercury-wetted Clareed contacts and be sure of millions of operations at rated load over the life of your system . . . *billions* of operations at low level.

CLAREED Relay Versatility Meets Every Packaging Requirement



***... for printed
circuit boards***
Types CRT, CRTN,
CHT, CHTN,
CRM, CHM

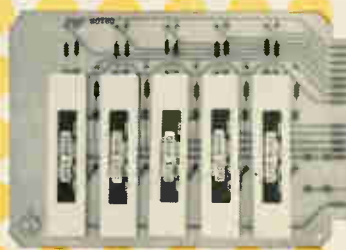

***... as functional
pcb assemblies***
combining Clareed
relays and other
components



***... for wired
assemblies***
Types CRA, CHA,
CRB, CHB

CLAREED RELAY CHARACTERISTICS	For WIRED ASSEMBLIES	For PRINTED CIRCUIT BOARDS	
	Type CRA, CHA, CRB, CHB	Type CRT, CHT	Type CRM, CHM
Contact Arrangements (Maximum)	12 Form A 6 Form B 2 Form C 6 Form A and 6 Form B	12 Form A 6 Form B 4 Form C	3 Form A 2 Form B 1 Form C
Operating Voltages	.5 vdc to 340 vdc	1 vdc to 550 vdc	1 vdc to 145 vdc
Coil Resistances	2 ohms to 27,500 ohms	7.3 ohms to 35,500 ohms	10 ohms to 12,700 ohms
Operate Times* (Nom. coil power)	.6 to 9 ms	.6 to 3.4 ms	.6 to 2.8 ms
Must Operate Sensitivities*	80 mw to 2.3 watts	110 mw to 1.8 watts	110 mw to 750 mw
*Depending upon number of contacts.			
CONTACT CHARACTERISTICS (All Contacts Are Available In Any Assembly Shown Above.)			
	GENERAL PURPOSE	HIGH VOLTAGE	MERCURY-WETTED
Contact Rating Switched Load	15 va max, non-inductive 1 amp max, 250 v max	15 va max, non-inductive 1 amp max, 250 v max	50 watts DC resistive 25 watts AC resistive 3 amps max, 500 v max 5 amps max, not switched
Carry Load	5 amps max, not switched	5 amps max, not switched	5 amps max, not switched
Life Expectancy Full Rated Load Low Level	20 x 10 ⁶ operations 100 x 10 ⁶ operations	20 x 10 ⁶ operations 100 x 10 ⁶ operations	100 x 10 ⁶ operations 1 x 10 ⁹ operations
Stand-Off Voltage	500 v rms	1500 v rms, standard 5000 v peak, special	1000 v rms, standard 3000 v peak, special

Clareed relays help to assure that your system will operate dependably . . . to its design characteristics . . . over its planned life. Here's how:

Inherent Reliability—You can optimize your system design and depend on it to perform. Fully defined Clareed initial and life ratings allow you to design optimum performance into your system. Maintenance-free switches are sealed in glass and are not subject to environmental contamination or mis-adjustment.

Ample Speed for Most Applications—You'll realize ample switching speeds for most industrial control functions—particularly for applications having electromechanical input and output devices where solid state microsecond switching speeds are impractical . . . and expensive. Clareed relay switching speeds in the high microsecond and low millisecond range are entirely compatible with your system requirements.

Immunity to Transient Noise—Your Clareed relay system is not subject to inadvertent switching by ambient or line transients. No need to buffer or use special logic levels. And, by the way, you need only one power source . . . 24 vdc \pm 5% does the job.

Special Design Capability—You're not confined to standard relay ratings and packages. If your system demands special requirements, turn your problem over to the switching experts—Clare's Application Engineers. They have more experience than anyone else in providing effective time and money saving solutions for special switching problems.

Added Bonus! Clareed switches and relays are built by Clare from start to finish to one high quality standard. Careful production control procedures pay off in longer life, consistent performance and greater reliability for you.

Combine these new contact developments with the basic Clareed capabilities. Add the variety of packages available. You'll discover a relay line that meets the switching needs for practically any control function.

For complete information contact your nearest CLARE Sales Engineer

CALL—NEEDHAM (Mass.): (617) 444-4200 • GREAT NECK, L. I. (N.Y.): (516) 466-2100 • SYRACUSE: (315) 422-0347 • PHILADELPHIA: (215) 386-3385 • BALTIMORE: (202) 393-1337 • ORLANDO: (305) 424-9508 • CHICAGO: (312) 262-7700 • MINNEAPOLIS: (612) 920-3125 • CLEVELAND: (216) 221-9030 • XENIA (Ohio): (513) 426-5485 • CINCINNATI: (513) 891-3827 • COLUMBUS (Ohio): (614) 486-4046 • MISSION (Kansas): (913) 722-2441 • DALLAS: (214) 741-4411 • HOUSTON: (713) 528-3811 • SEATTLE: (206) 725-9700 • SAN FRANCISCO: (415) 982-7932 • VAN NUYS (Calif.): (213) 787-2510 • TORONTO, CANADA: C. P. Clare Canada Ltd. • TOKYO, JAPAN: Westrex Co., Orient • IN EUROPE: C. P. Clare International N. V., TONGEREN, BELGIUM • Clare-Elliott, Ltd., LONDON, ENGLAND

Write Group 01N9 C. P. CLARE & CO.
3101 Pratt Boulevard Chicago, Illinois 60645



relays and related control components

**MOTOROLA PNP/NPN
SILICON ANNULAR**

Twins^{*}

**MULTIPLE-DEVICE
TRANSISTORS**

the *full* line from low-level 
to high-current  transistors
...with built-in *design flexibility*
to meet many special applications—

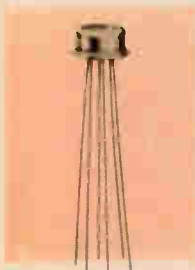

LOW-PROFILE
TO-5 PACKAGE

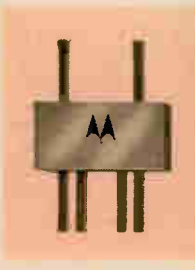

CERAMIC 6-LEAD
FLAT PACKAGE

Motorola TWINS^{*} let you make maximum use of space.

Motorola Twins put two transistors in the space of one. Each compact device—in 6-lead, low-profile TO-5, TO-18, or ceramic flat pack—holds dual PNP, NPN, or complementary transistors in one common environment, permitting better parameter uniformity during wide temperature swings.

Motorola's Annular Process Achieves New Performance Characteristics, New Levels of Reliability



^{*}Trademarks of Motorola Inc.

The unique Motorola annular process has made it possible to design and produce the broadest available range of PNP or NPN silicon transistor and complementary pairs. For the annular process permits true silicon oxide surface passivation—thus eliminating uncontrolled "channeling" and leakage to the edges of the transistor die.

FOR HIGH-SPEED SWITCHING CIRCUITS AND DC TO VHF AMPLIFIER APPLICATIONS: DUAL TRANSISTORS

LOW-LEVEL AND HIGH-FREQUENCY

Dual PNP MD3250 and 51, featuring minimum f_T of up to 250 MHz and C_{obo} of 6 pf maximum; current gain specified from 10 μ A to 50 mA; high breakdown voltage — up to 50 V minimum; wide band noise figures as low as 3 db maximum.

LOW-NOISE/LOW-LEVEL/HIGH-GAIN AT μ A LEVELS

Dual PNP 2N3800-01 and 2N3806-07, featuring noise characteristics as low as 1.5 db maximum at $f=1$ kc and 10 kc; wide band noise figures as low as 2.5 db; high breakdown voltage $BV_{CE0}=60$ Vdc minimum; high beta guaranteed from 10 μ A to 10 mAdc.

LOW-LEVEL AND LOW-NOISE

Dual NPN 2N2913-14 and 2N2972-73, featuring high breakdown voltage $BV_{CE0}=45$ Vdc minimum; very high beta guaranteed from 10 μ Adc to 1.0

mAdc — h_{FE} up to 150 minimum at 10 μ Adc; excellent noise characteristics — as low as 3.0 db maximum at $f=1$ kc.

HIGH SPEED SWITCHING AND DC TO VHF AMPLIFICATION

Dual PNP Stars* MD2904/A-05/A, featuring high-voltage rating — BV_{CE0} to 60 Vdc minimum; high uniform beta over the current range from 0.1 mA to 300 mA; high current-gain bandwidth product — $f_T=200$ MHz minimum; low saturation voltage — 0.4 volt maximum at 150 mA.

Dual NPN Stars MD2218/A-19/A, featuring current gain specified from 0.1 to 300 mAdc; high current-gain bandwidth product — $f_T=300$ MHz minimum for MD2219/A; switching limits specified — t_d, t_r, t_s, t_f ; all leads electrically isolated.

COMPLEMENTARY PAIRS

HIGH SPEED SWITCHING / DC TO VHF AMPLIFICATION AND COMPLEMENTARY CIRCUITRY

Dual Stars NPN/PNP MD6001-02 (NPN type similar to the 2N2218 and 2N2219; PNP type similar to the 2N2904 and 2N2905), featuring beta specified at five current levels from 0.1 mAdc to 300 mAdc; switching limits specified — t_d, t_r, t_s, t_f ; all leads electrically isolated.

FOR APPLICATIONS REQUIRING A MATCHED PAIR OF DEVICES WITH HIGH UNIFORMITY UNDER VARYING CONDITIONS:

DIFFERENTIAL AMPLIFIERS

LOW-LEVEL AND HIGH-FREQUENCY

Dual PNP MD3250A and MD3251A, featuring minimum f_T of up to 250 MHz and C_{obo} of 6 pf maximum; current gain specified from 10 μ A to 50 mA; high breakdown voltage — $BV_{CB0}=50$ V minimum; low base voltage differential — 3 mV maximum at $I_C=100$ μ Adc — held within 1.8 mV from -55° C to $+125^\circ$ C; wide-band noise figures as low as 3 db maximum.

LOW-LEVEL AND LOW-NOISE

Dual NPN 2N2915-20 and 2N2974-79, featuring high breakdown voltage $BV_{CE0}=45-60$ Vdc minimum; very high beta guaranteed from 10 μ Adc to 1.0 mAdc; beta match as tight as 0.9 to 1; base voltage differential as low as 3 mV maximum at $I_C=100$ μ Adc; excellent noise characteristics — as low as 3.0 db maximum at $f=1$ kc.

LOWEST NOISE/LOW-LEVEL/HIGH GAIN AT μ A LEVELS

Dual PNP 2N3802-05 and 2N3808-11, featuring minimum gains as high as 300 at 100 μ A; noise characteristics as low as 1.5 db maximum at $f=1$ kc and 10 kc; wide-band noise figures as low as 2.5 db; device-to-device V_{BE} (base voltage differential) as low as 5 mV over complete current range from 10 μ A to 10 mA; differential changes with temperature as low as 10 μ V/ $^\circ$ C from -55° C to $+125^\circ$ C.

HIGH UNIFORMITY OVER WIDE TEMPERATURE RANGE

Dual NPN Stars 2N2060/A, 2N2223/A and 2N2480/A, featuring BV_{CB0} as high as 100 V; $\Delta(V_{BE1}-V_{BE2})$ as low as 0.9 mVdc = 100 μ Adc from -55° C to $+125^\circ$ C; maximum base-emitter voltage differential as low as 3 mVdc; low capacitance values ($C_{ob}=8$ pf typical; $C_{ib}=20$ pf typical); all leads electrically isolated.

FOR SPECIAL APPLICATIONS CUSTOM-TAILORED TO SPECIFIC OEM REQUIREMENTS:

DARLINGTON AMPLIFIERS

Motorola has a complete custom capability for fabricating "one-of-a-kind" Darlington amplifiers to go with any given circuit.

GET IN TOUCH with your Motorola field sales representative or local Motorola semiconductor distributor to get sample devices for testing. For complete technical details, write: Motorola Semiconductor Products Inc., Technical Information Center, Box 955, Phoenix, Arizona 85001. Act today.



MOTOROLA
Semiconductors

INTERNATIONAL RECTIFIER

PROUDLY PRESENTS A CONTROLLED RECTIFIER FAMILY

Proven performance backed by years of intensive research and environmental testing

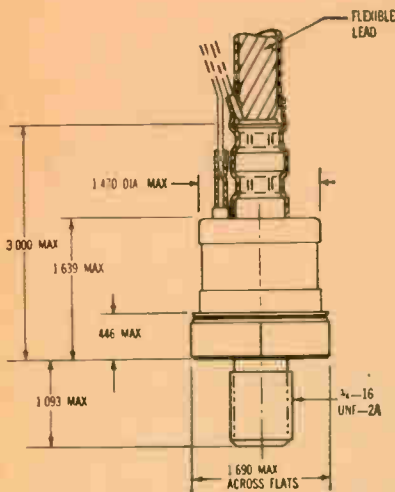

For more complete technical information, write for these bulletins—

- 350 Amps—Bulletin A-116
- 300 Amps (standard)—Bulletin A-114
- 300 Amps (fast switching)—Bulletin A-115
- 250 Amps—Bulletin A-113

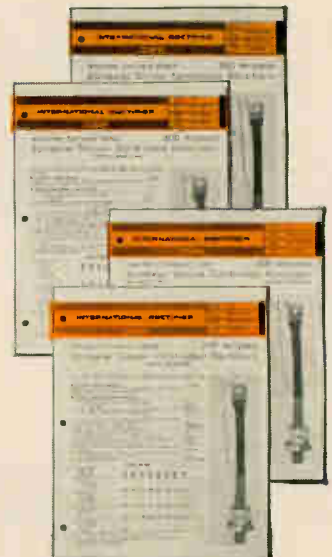

CALL MR. RECTIFIER

He is your local International Rectifier Sales Engineer. He's experienced. He understands your problem. He has the answers. He works closely with you. His sole purpose is to serve you. You can deal in confidence with "Mr. Rectifier"—your rectifier specialist from IR. Call him.

WITH RATINGS UP TO

350 AMPS*

UP TO 1200 VOLTS PRV EPITAXIAL SCR

1,000,000 to 1 RATIO, FIRING POWER to RATED POWER

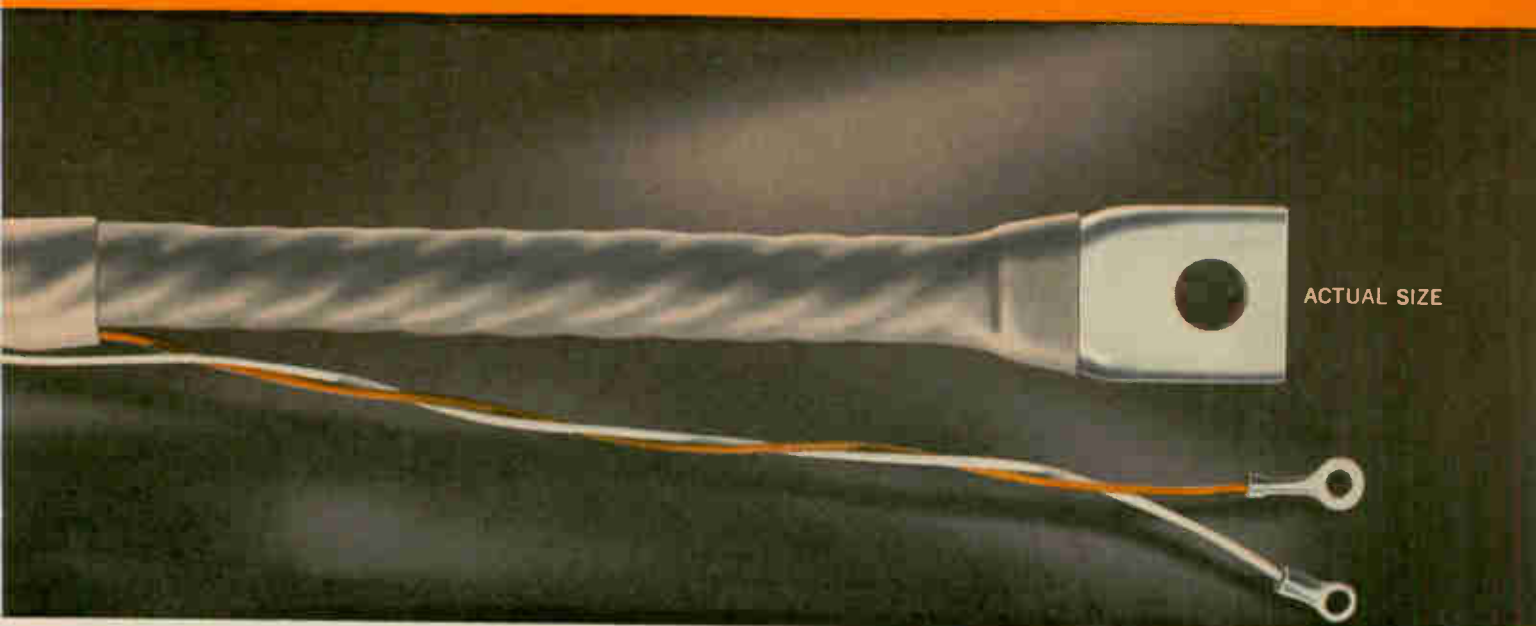

*Average DC amperes

World's most advanced line of **HIGH POWER EPITAXIAL SCRs...UP TO 1200 VOLTS PRV**

- 350 Amps epitaxial SCR
- 300 Amps epitaxial SCR (standard)
- 300 Amps epitaxial SCR (fast switching)
- 250 Amps epitaxial SCR

IR opens new vistas in the field of power control and conversion with a complete family of silicon controlled rectifiers. They are indispensable tools of the engineer in meeting demanding design requirements for higher performance. Increased efficiency, increased reliability, reduced size and reduced weight are merely a few of the advantages engineered into IR's high power SCR line. The inherent capabilities in the design of these devices, combined with the application experience of our engineering staff offers you an opportunity to utilize the most advanced SCR technology available today in the design of your high power equipment. Only IR manufactures a full spectrum of epitaxial SCRs—35 amps to 350 amps, 200 volts to 1200 volts. For full facts and technical assistance, call in a power rectifier specialist: your IR sales engineer. You'll find he is "Mr. Rectifier" himself when it comes to sizing up your problems...and solving them fast. Or write: International Rectifier, El Segundo, California 90246.

WORLD'S LARGEST RECTIFIER SPECIALISTS



INTERNATIONAL RECTIFIER

INTERNATIONAL RECTIFIER, EL SEGUNDO, CALIF. PHONE (213) OR 8 6281 • CABLE RECTUSA • REGIONAL OFFICES IN NEW YORK CITY, (212) CH 4 0748 • FORT LEE, N.J., (201) WI 7 3311 • SYRACUSE, N.Y., (315) HE 7 8495 • CAMBRIDGE, MASS. (617) UN 4 6520 • AROMORE, PA., (215) MI 9 3666, (215) GR 3 3931 • SILVER SPRING, MO. (301) JU 9 3305 • MIAMI, FLA. (305) 445 5201 • CHICAGO, ILL. (312) OR 6 4090 • CLEVELAND, OHIO, (216) 734 4100 • DAYTON, OHIO, (513) 223 7691 • HUNTINGTON WOODS, MICH., (313) LI 8 1144 • ST LOUIS, MO., (314) TE 8 6333 • MINNEAPOLIS, MINN., (612) 920 1200 RICHARDSON, TEX., (214) AO 1 2504 • SAN MATEO, CALIF., (415) 349 2373 • LOS ANGELES, CALIF. (213) 678 2181 • IN CANADA: TORONTO, ONT. (416) 421 5970 • MONTREAL, QUEBEC. (514) 861 0562
EUROPEAN GENERAL SALES OFFICE: 38 AVENUE OES ARTS, BRUSSELS, 4, BELGIUM • TELEPHONE 111774

EAGLE ELECTRIC COUNTER

Batch count a predetermined number. Shut off or actuate a machine or machines.

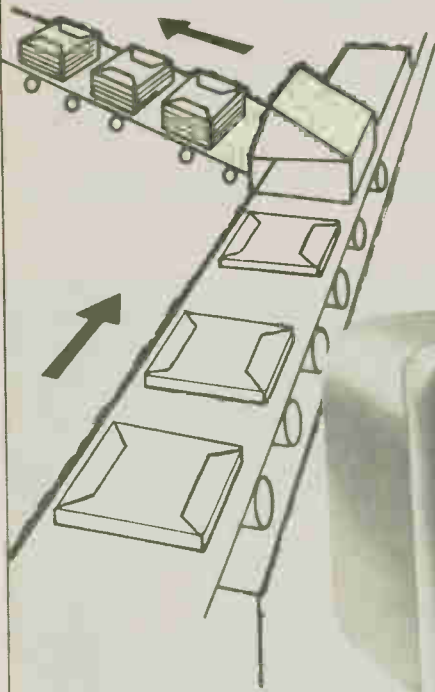

Meter fluids by flowmeter. Control a shut-off or a mixing valve or valves.

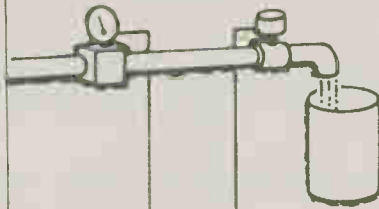

Add-subtract count. Control of parking lot, hopper or conveyor section capacity.

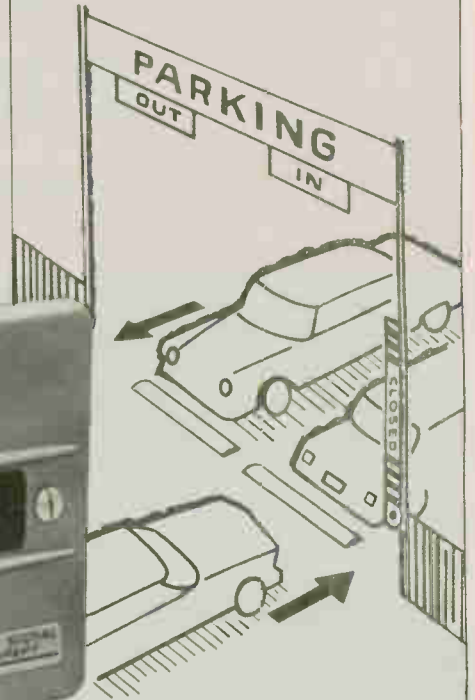

COUNTS...THEN CONTROLS

The HZ760 performs in three ways...as a batch counter... a continuous count counter... an add-subtract counter. Whether you count pills or automobile bodies, this is the unit for the job.

Functionally, the HZ760 registers counts by electric impulse from a limit switch, photoelectric cell, flow meter or similar device. At the preselected number of counts, *adjustable up to 9999*, the unit's control switch turns electronically or electrically controlled equipment on or off. **THERE IS NO RESET TIME.**

The HZ760 is a rugged counter designed for precise, industrial control. Among its outstanding features: pushbuttons to set count...keylock to prevent tampering...large, easy-to-read numerals...10 amp. load switches...counting speeds to 500 per minute...AC coils. HZ762 shaft driven units for revolution counting also available. Compare. You'll choose Eagle.

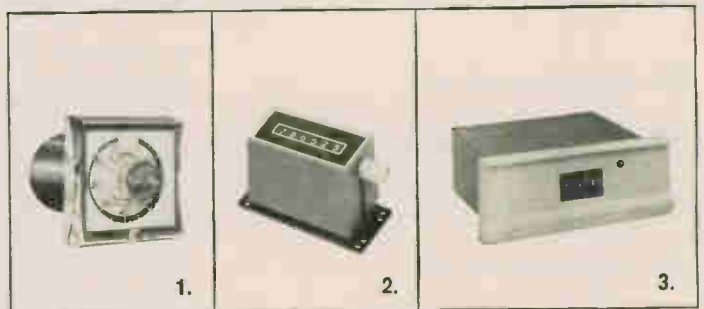

EAGLE's family of counters offers you a wide selection for your most exacting control problems: 1. 80 count plug-in automatic reset counter. 2. 6 digit electric count totalizer. 3. 3 digit electronic counter for high speed counting.

Contact Eagle Signal Division, E. W. Bliss Company, Federal Street, Davenport, Iowa.



A DIVISION OF THE E. W. BLISS COMPANY

Electro-Mechanical, Electronic, Solid State Timing/Counting/Programming Controls General Purpose, Medium Power Relays

NEW EAGLE RELAYS

COMPARE
Better Life Characteristics

COMPARE
Higher Reliability

COMPARE
Fewer Parts

COMPARE
More Design Flexibility

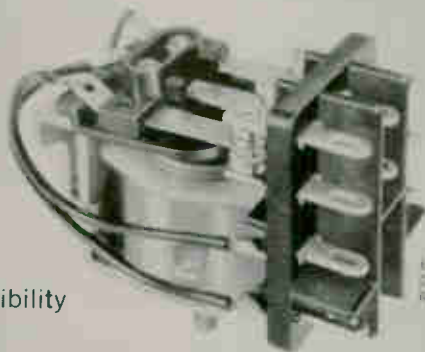

Eagle 25A2
General Purpose
Relay (Actual Size)

COMPARE
Lower Pull-in Voltages

COMPARE THEM!

New Eagle relays... more than 3,000 types... are the best you can get anywhere. Be crafty. Check the specs and the product. Convince yourself.

One example: Gold-plated contacts are *standard* on every general purpose Eagle relay. And on medium power relays, silver cadmium oxide contacts are standard, since they deliver the best possible current-bearing characteristics in this power range.

Check some more. Note the sturdy designs... the ratings that exceed all other competitively-priced units... the precise engineering and inventive use of materials. They're all what you'd expect from Eagle—leaders in time/count control devices.

If you've ever dealt with Eagle you'll expect more, and you'll get it. We're talking about unequalled service... service that frankly has never before been available from any relay manufacturer.

Compare. You'll choose Eagle.



Part of the "big" picture... more than 3,000 types: plug-in with dust covers; dual latching; hermetically sealed; custom-engineered styles.

Get full details in our new, 16-page color catalog. Send for your free copy to Eagle Signal Division, E. W. Bliss Company, Federal Street, Davenport, Iowa.

BLISS  **EAGLE SIGNAL**

A DIVISION OF THE E. W. BLISS COMPANY

Electro-Mechanical, Electronic, Solid State Timing/Counting/Programming Controls □ General Purpose, Medium Power Relays

Check
your
lacing
tape
requirements
here 

- HIGH TEMPERATURE**
General use Gudebrod Tapes are unaffected by temperatures to 250°F.; specially designed tapes are essentially stable in excess of 1500°F.
- LOW TEMPERATURES**
Most popular Gudebrod Tapes are stable down to -67°F., others are designed to take temperatures as low as -100°F.
- BURNPROOF**
Gudebrod has lacing tapes of completely fireproof materials, others will not support a flame.
- OUTER SPACE**
Gudebrod has a tape that won't outgas in outer space—especially suitable for space, or industrial applications in vacuum.
- FUNGISTATIC**
Whenever possible with the material of construction Gudebrod guarantees its tapes to be fungistatic or fungicidal.
- MIL-T-713A**
Gudebrod's Gudalace 18 meets all requirements of specification MIL-T-713A, type P, class two. Other Gudebrod Tapes meet or surpass these specs.
- TENSILE STRENGTH**
All Gudebrod Tapes are available in a number of widths and thicknesses to meet varying size requirements.
- CUT LENGTHS**
Gudebrod Tapes can be supplied in handy dispenser packs of cut lengths to suit your harnessing needs.
- COMPATIBLE MATERIALS**
From the wide range of basic materials and finishes used in Gudebrod Tapes the selection of a tape compatible to your insulation is easy.
- COLOR CODED TAPES**
For complicated circuitry, color coding with Gudebrod Lacing Tapes makes assembly and tracing easy.
- SPECIAL APPLICATIONS**
Gudebrod will work with your engineers to develop a special tape to meet sophisticated requirements.

THEN GET THE RIGHT TAPE FROM **GUDEBROD!**

Perhaps you are regularly using Gudebrod Gudalace 18, the standard, wax impregnated nylon tape that's known round-the-world for its non-slip knotting (meets MIL-T-713A specs, too). You are doing well then—with the finest tape and saving money on harnesses, too!

But when you are making gear for tropic or arctic use, if you are involved with outer space or

special industrial applications—come to Gudebrod. Here is your one best source for lacing tape information. Ask for a copy of our Product Data Book describing the more than 200 different tapes in our regular stock. In it you'll probably find the tape that fits your requirements—but if you don't, inquire about having one made to your particular specifications.



GUDEBROD BROS. SILK CO., INC.

FOUNDED IN 1870

Electronics Division

12 SOUTH 12th STREET, PHILADELPHIA, PENNSYLVANIA 19107

Area Code 215, WA 2-1122

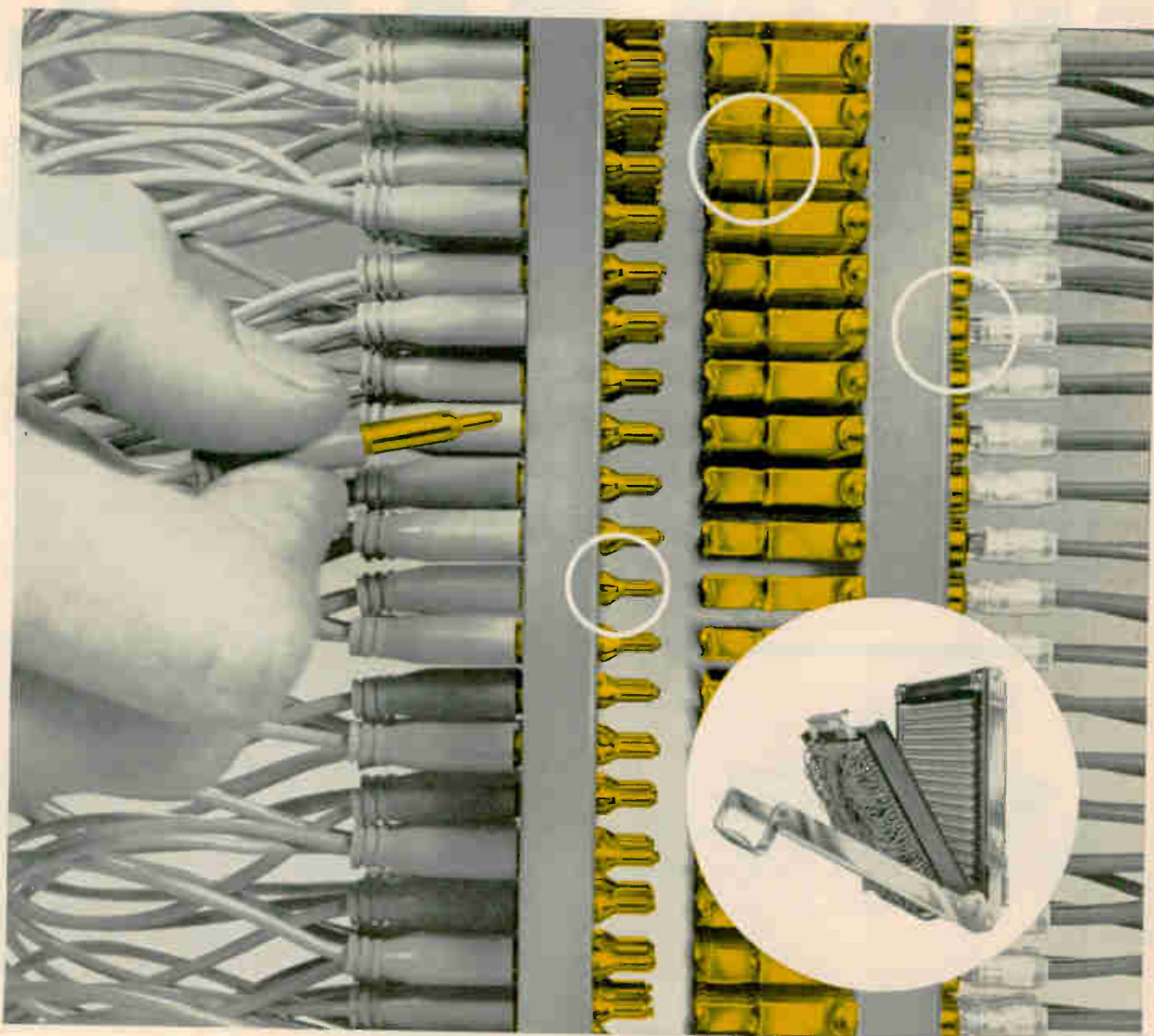

Zero in on quality

There's not even the hint of a "miss" in this A-MP* Patchcord Programming System!

Patchcord Programming Systems are comprised of a series of metallic contact junctions. The electrical performance of these systems is determined by the sum of the mechanical properties of these junctions.

Check ours out . . . feature by feature . . . and one fact is outstanding: it's quality-built at *every point* for overall *reliable* performance.

Ours is a modern, compact, lightweight system designed with fewer moving mechanical parts and is quality-controlled to maintain precision tolerances, resulting in increased reliability.

All contacts are gold-over-nickel plated. This, coupled with our patented double-wiping action that pre-cleans contact springs and patchcord pins, assures positive, reliable connections everytime.

Twin-Detent Patchcords, in manual or semi-permanent types, incorporate a specially designed, wholly contained spring-member that

locks the cord to board and prevents program failure by accidental dislodgement. Patchcords can be easily hand-removed to facilitate program changes.

As for rear board wiring, precision crimped LANCELOK* contacts provide maximum electrical performance and positive retention in the board through a unique locking lance design.

These are just highlights. All of them add up to the quality you look for to assure reliable performance. Get all the details you need by writing today for complete information.

*Trademark of AMP INCORPORATED



A-MP* products and engineering assistance are available through subsidiary companies in: Australia • Canada • England • France • Holland • Italy • Japan • Mexico • West Germany

SIGNALITE

COMPLETE LINE OF GAS DISCHARGE DEVICES



Spark Gaps — Two Electrode

Used for protection of electronic components . . . transfer of high energy. Use them singly or in various combinations. Select from a standard line of spark gaps that fit 400 volt to 50,000 volt applications.

Signalite recently purchased the entire Gas Discharge Tube Product Line of the Bendix Red Bank Division and now offers *Complete Engineering Capabilities* in the production, design, and application of gas discharge devices for your requirements. Feel free to contact us for any special design work. Our engineering staff will be pleased to serve you.

Signalite's high production capabilities insure that every standard gas discharge item in the catalog will be in stock — in quantity. Further, many specially fabricated assemblies can be supplied to you on short notice.



Triggered Spark Gaps

Switch high levels of energy faster and easier with low-energy-controlled triggered spark gaps. Hundreds of types are available covering the applied voltage range of 1,000 to 40,000 volts.



Miniature Gas Discharge Microwave Noise Generators

Reliable, inexpensive references for establishment of system receiver sensitivity levels. These small size and light weight units are ideal for system applications where space and power are limited. A full range of microwave noise generators is available. Specials can be supplied to individual requirements.

Gas Discharge Microwave Noise Source Tubes



Used in waveguide from L-band to Ka-band and with coaxial noise generators. Standard tubes are available for use in frequencies from 200 Mc to 40 Gc. Specials in the 40 Gc to 90 Gc range can be supplied.

Experimental He-Ne Laser

Output is 6328Å at approximately 1mW. All components are visible and unit is portable. Its use in basic physical optics experiments insures easier measurements and superior end results.



Circle 76 on reader service card



If there is a Gas Discharge Device or Glow Lamp to meet your needs, We'll have it.

For an introduction to Signalite's Gas Discharge Products Line . . .

Your Single Source for Gas Discharge Tubes and Glow Lamps

VOLTAGE REGULATING TUBES WITH ± 1 VOLT TOLERANCE

These specifications cover only 2 of the 19 different voltage regulator tubes presently available. Reference voltages of 82, 91, 100, 103, 105, 115, 139, and 143 are in stock. All of them have that significant ± 1 volt tolerance. For more detailed specifications, write for Signalite Application Newsletter Supplement #1 or contact us and describe your particular applications.

Typical Characteristics

	Z82R10	Z100R12
BREAKDOWN VOLTAGE (in Dark or Light) MAX	115	150
REFERENCE VOLTAGE (measured at)	82 ± 1 (2.0 MA)	100 ± 1 (3.0 MA)
VOLTAGE REGULATION (variation in reference voltage exhibited by individual tube) LESS THAN 1 VOLT CHANGE FROM	0.3 to 10.0 MA	0.6 to 12.0 MA
TEMPERATURE COEFFICIENT (TYPICAL)	-2mv/°C	-9mv/°C
LIFE EXPECTANCY (hours)	30,000 hours	30,000 hours

Tentative specifications subject to change without notice.

Some Proven Applications

Reference Voltage Sources
Regulated Power Supplies
Oscilloscope Calibrators
Photo Multipliers
Zener Diode Voltage Sources
Digital Voltmeters
Timing Circuits
Overvoltage Protection
Suppressed 0 Voltmeters
Frequency Dividers
Indicating Voltmeters

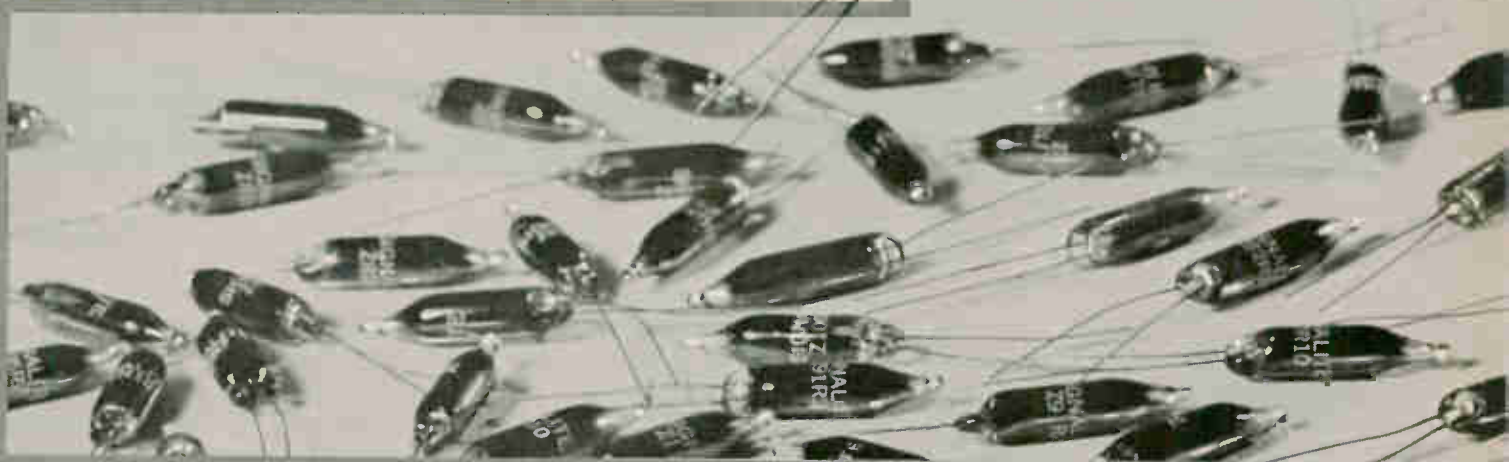

Circle 77 on reader service card

If there isn't, We'll Design it!



For your copy
of the
Signalite Application
Newsletter,
Supplement #1 . . .

Signalite

NEPTUNE, NEW JERSEY — 201-775-2490 — TWX 201-775-2255

INCORPORATED

**GET
THE
FULL
PICTURE**

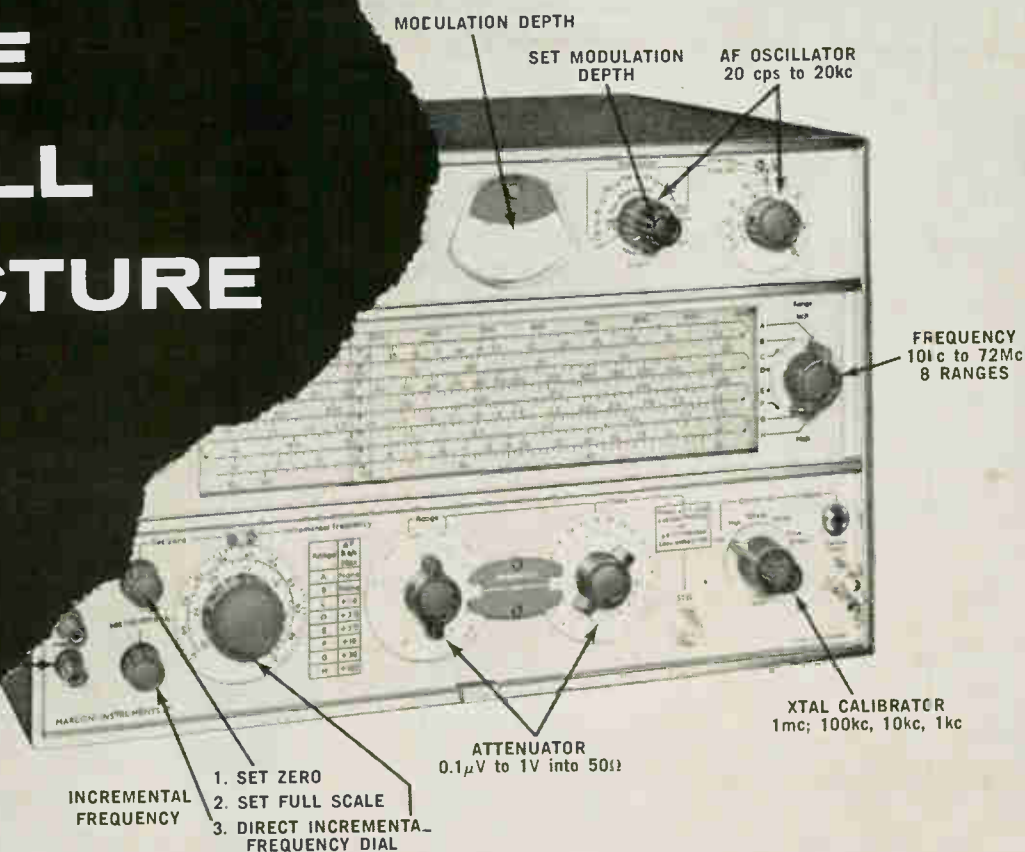

THE FIRST SOLID STATE SIGNAL GENERATOR



Get the full picture plus complete technical literature.

Circle Reader Service 68



Free! Marconi Instrumentation, a quarterly, technical information bulletin.

Circle Reader Service 78

FREQUENCY RANGE

- 10kc to 72 mc on fundamentals
- Fine tuning discrimination 300 p.p.m

MODULATION AM — 20 cps to 20kc, 0 to 100%.

Other — may be used for manual or automatic frequency control, f.m., phase mod. or sweeping above 100kc.

**MARCONI
INSTRUMENTS**

Division of English Electric Corp.

111 CEDAR LANE, ENGLEWOOD, NEW JERSEY

IS A PHOTO-CHOPPER BETTER?

PART NINE of a series on the state of the chopper art

Maybe. Us engineer types never get a decent clear cut decision. Still, if the Old Man said don't use them damn choppers maybe you'd better go photo-chopper. If you just ignore the neon bulbs you could say all solid state and get away with it.

It's like this. You'll get 1500 to 2500 ohms conducting resistance if you leave the neon lamp on. If you switch it at 60 cycles you get maybe 20 K. Dark resistance gets pretty good, about 10^9 .

The response time is not so hot. The flaw is turn-off time. The cells turn on quick and off slow. You use two, which helps, one in series with the load, one in shunt.

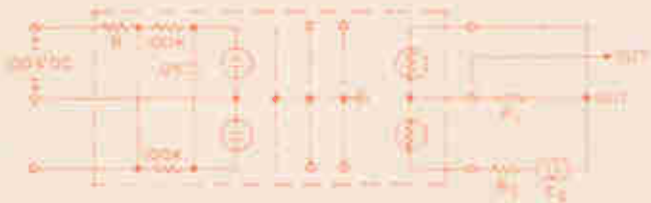

Type 5514 in a modulator circuit

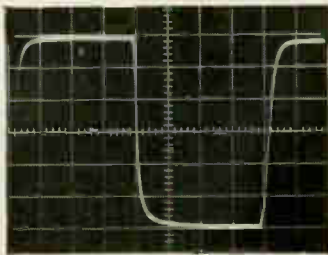

Output waveform
60 cycle square wave drive

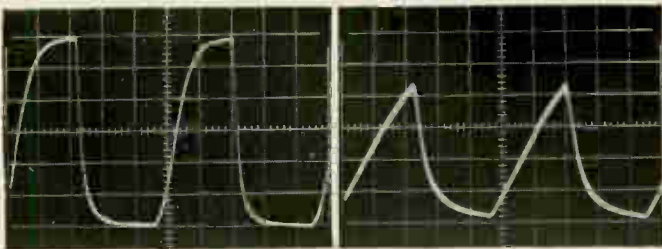

Output waveform
400 cycle square wave drive

Output waveform
1000 cycle square wave drive

You really need a square wave drive for best performance. Or you can supply DC at about 200 volts and get the neon bulbs to operate as relaxation oscillators. That's Airpax part 5514. The chopping rate will vary directly as the DC voltage.

So — sorry about that. It's still your headache. The life seems pretty good, we dunno how good yet, but it's probably up to the neon bulb if the photo-resistors are any good.

We will cheerfully sell you a couple thousand.

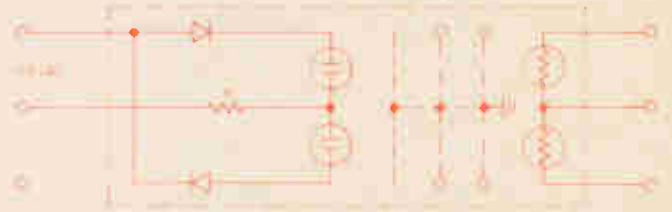

Internal schematic of AC Drive Type 5510,
60 to 400 cps. R = Limiting resistor.

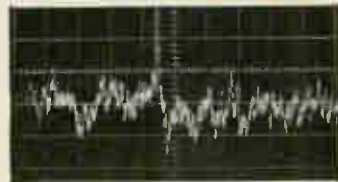

3 microvolt RMS, 50 microvolt
peak noise across 1 megohm.

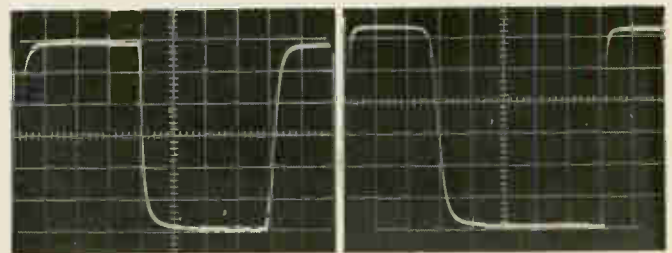

60 cps square wave drive
showing maximum efficiency.

60 cps sine wave drive
showing reduced time efficiency.

AIRPAX ELECTRONICS incorporated CAMBRIDGE DIVISION, Cambridge, Maryland

Phone: 301 228-4600 • TWX: 301-228-3558 • TELEX: 8-7715

(advertisement)

How to extend measurements past the limits of present instruments:

**Use the Below Coupon To
Order Editorial Reprints
From Electronics!**

Fill in, cut out the coupon, insert in envelope
and mail to:

Electronics Reprint Department
330 West 42nd Street, New York, N.Y. 10036

Reprints Available:

(Price: 50¢ each unless otherwise noted.)

- Key no. **R-83** **A Look at Japanese Electronics Technology**, 36 pages.
- Key no. **R-82** **Computer Time Sharing**, 20 pages
- Key no. **R-80** **The Packaging Revolution In Microelectronics** (2 part series, 32 pages.) \$1.00.
- Key no. **R-79** **MOS Integrated Circuits Save Space and Money**, 16 pages.
- Key no. **R-78** **The Overlay Transistor**, 4 color special feature, 15 pages.
- Key no. **R-77** **Cold Cathode Tubes** (3 part series, 28 pages).
- Key no. **R-76** **Automated Trains: Who's On The Right Track?** 16 pages.
- Key no. **R-74** **Unijunction Transistors**, 24 pages.

Reprint order form

(See the above list, please order by key number.)

To help expedite mailing of your reprints, please send cash, check, or money order when you order.

Send me reprint(s) of key no(s) at ¢ each.

Name

Number & Street

City, State, Zip Code

Get the extra capability, greater reliability, and longer useful life of Rohde & Schwarz!

Since 1933, Rohde & Schwarz' group of unusually creative engineers have been designing electronic instruments that are truly unique. These instruments are constantly ahead of what is considered to be the state-of-the-art. They are more precise. They are easier to use and read. Many perform extra functions. Some do jobs never done before. All are constructed with uncompromising quality—drastically reducing maintenance requirements. As a result, they do not become obsolete as fast as ordinary instruments—they provide more years of useful life. As you might expect, you pay a little more initially for some of these—but an investment in Rohde & Schwarz saves you plenty in the long run!

Get extreme accuracy with these
new solid state FREQUENCY SYNTHESIZERS!



TYPE ND 30M
For more information, CIRCLE 80 ON READER SERVICE CARD

A line of signal generators providing unusually high accuracy and ease of operation. Continuously variable over its range, each model provides a direct digital read-out, with no tuning required. Perfect for bridge measurement, work with filters, networks, nuclear magnetic resonance, and as a source of reference frequencies for standards labs. All are fully transistorized and designed for AC or battery operation.

FREQUENCY RANGES: Type ND30M... 300 Hz to 31 MHz
Type ND1M... 300 Hz to 1.1 MHz
Type ND99K... 0 to 110 kHz

FEATURES:

- Built-in 1 MHz crystal has proportional oven and $5 \times 10^{-7}/^{\circ}\text{C}$ stability
- Spurious and noise suppression better than 80 dB
- Decade tuning
- Modular construction
- Completely transistorized
- High resolution search oscillator—130 divisions

**A Crystal Measuring Set
Built to IEC, IEEE &
DIN Recommendations!**

The Rohde & Schwarz RQZ Crystal Measuring Set provides a truly uniform method of measuring equivalent circuit parameters of oscillator or filter crystals. Frequency range is 0 to 300 MHz, and measuring head will work over a range of -20° to $+70^{\circ}\text{C}$. Provision is made for remote measuring.

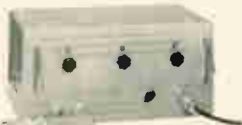

FEATURES:

- Measures motional capacitance, resistance, and inductance, and series resonance frequency.
- Measures crystals over wide range of drive levels
- Ranges of motional resistance 0 to 17 k Ω
- Built-in load capacitances of 12, 30, and 50 pF

For more information, CIRCLE 81 ON READER SERVICE CARD

**Make rapid, reliable measurements
of semiconductor
parameters**



TYPE TYM
For more information,
CIRCLE 82 ON READER
SERVICE CARD

The Rohde & Schwarz Transistor-Y Meter is a transistorized precision instrument which provides a complete measuring system for both dynamic and static parameters associated with diodes, transistors and other semiconductor devices and circuits. Also suitable for impedance measurements on other components, it is designed for low power consumption, thus reducing operating temperatures and increasing reliability.

FEATURES:

- Directly measures Y_{11e} , Y_{22e} , $|Y_{21e}|$, d_{12}
- Measurements at 8 switchable fixed frequencies from 20 kHz to 37 MHz
- Test jigs for TO-5 and TO-18 packages; others available
- Output provided for measurement of phase (R&S Phasemeter Type PDF available as option)

**Use this Microvoltmeter
for applications
never before possible!**

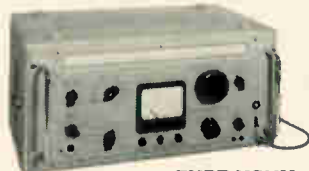

TYPE USVH
For more information,
CIRCLE 83 ON READER SERVICE CARD

Rohde & Schwarz's USVH Selective Microvoltmeter features unusual sensitivity and sharpness in tuning that permits measurement of • selective attenuation and frequency response on 4-terminal networks • RF distortion and waveform analysis • depth of modulation • receiver and amplifier inter- and cross-modulation • RF leakage • spurious frequencies and noise—all without the need for additional equipment!

FEATURES:

- 10 kHz to 30 MHz frequency range
- Full scale deflections of $1\mu\text{V}$ to 1V
- Selectable bandwidth of 500 Hz or 5 kHz
- Six input impedances from 50 Ω to 500 k Ω
- Expanded scale with suppressed zero for 3 dB point measurements

Rohde & Schwarz, 111 Lexington Ave., Passaic, N.J., 07056 Phone: PRescott 3-8010

Inquiries outside the U.S.A. should be directed to: Rohde & Schwarz, Muehldorfstrasse 15, Munchen 8, West Germany.

DESIGNER'S

P. R. MALLORY & CO. INC., INDIANAPOLIS, INDIANA 46206

New miniature tantalum capacitor for microcircuits

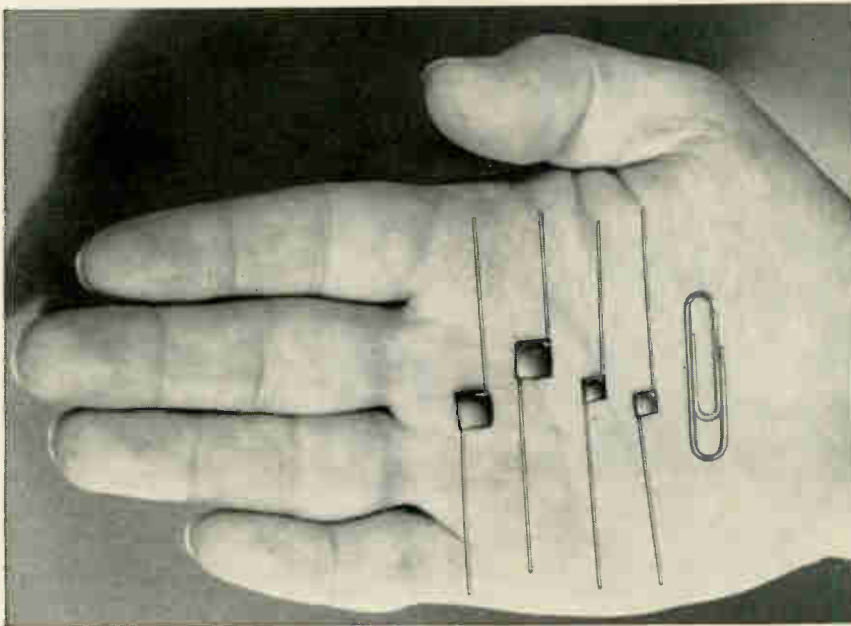

The Mallory TUR is a miniature solid electrolyte tantalum capacitor designed for use with integrated circuits, thin film and other micro-electronic circuits. It is supplied un-encapsulated to provide extremely small size per rating. It is intended for use with microcircuits where it will be encapsulated after assembly.

The TUR has a new configuration which provides maximum capacity per unit volume. It's a square chip, only .225" to .325" square, and .04" to .170" thick depending on rating. It is supplied with an electrically insulating coating on the positive side of the case, so it can be stacked or placed directly on the circuit chip or board prior to encapsulation. When properly pre-dried and encapsulated, it withstands MIL environments.

CV (capacity x voltage) product is extremely high. Ratings range from

47 mfd., 6 VDC to 15 mfd., 50 VDC. Temperature rating is -55°C to $+85^{\circ}\text{C}$, de-rated linearly to $\frac{2}{3}$ voltage at 125°C . DC leakage is low. Three configurations keyed to lead position are available. Standard units are polarized; non-polarized units on special order. Leads are gold-plated ribbons, can be welded or soldered.

DIMENSIONS

Case Size	A Max.	B Max.	C Max.
A	.225	.225	.040
B	.225	.225	.050
C	.225	.225	.060
D	.225	.225	.075
E	.225	.225	.110
F	.325	.325	.060
G	.325	.325	.075
H	.325	.325	.110
J	.325	.325	.125
K	.325	.325	.170

CIRCLE 105 ON READER SERVICE CARD

Reducing costs with Mallory packaged rectifier circuits

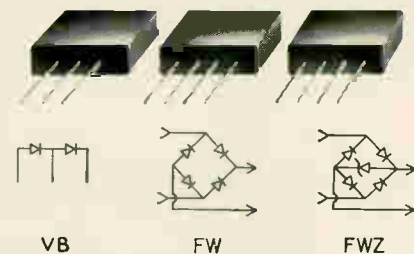

You can save both on component costs and on assembly costs, with Mallory rectifier packages. Each of these factory-connected circuits costs less than what you would pay for an equivalent number of separate rectifiers. The four-rectifier bridge package costs less than four separate rectifiers, and the full-wave and doubler packages cost less than a pair of rectifiers.

Savings in assembly come from reduction in number of soldered connections which you need to make . . . one less on a doubler or full-wave circuit, two less on a bridge. You can figure it out for your own conditions, but here's a typical analysis. At a labor rate of \$1.60 per hour, the saving is about \$300 per 25,000 doubler packages, or \$600 per 25,000 bridge packages. Extra reliability due to fewer solder joints is a plus value.

Cold-case encapsulated circuits include Type FW full wave bridge, Type VB voltage doubler, Type CT full-wave center tap with either positive or negative polarity . . . all rated for 100°C , in PRV values from 50 to 600 volts. Bridge circuits, Type FWZ, are also supplied with an integral, factory-connected zener diode across DC output terminals; all standard zener voltage ratings are available in this configuration.

CIRCLE 106 ON READER SERVICE CARD

Improved heavy-duty performance now provided by Mallory Alkaline Batteries

Recent refinements in Mallory Alkaline Batteries increase their ability to deliver long life at higher values of current drain, and further improve their advantage over conventional zinc-carbon batteries both in service dependability and cost per hour.

This added capability is the result of new internal construction which increases the effective anode area in relation to cell volume. Internal impedance of the cell is reduced, particularly at low temperatures. At 70°F ambient, the Mallory alkaline system delivers up to 7 times more hours of service on continuous heavy drain than ordinary batteries (see chart). At 32°F, the improvement in performance is even better.

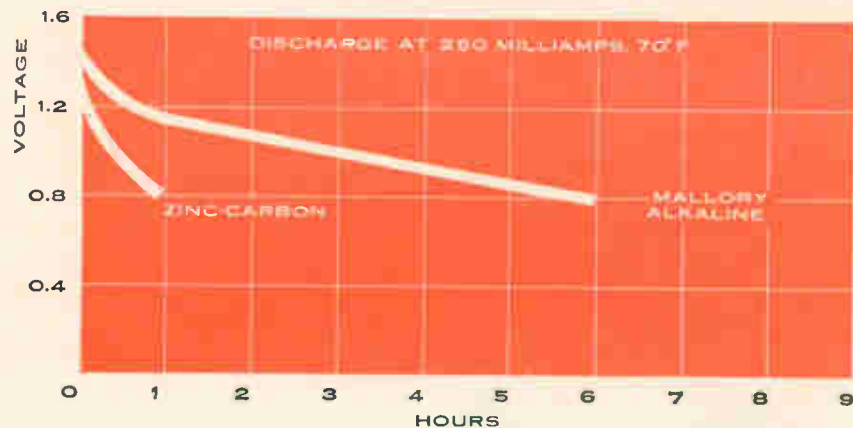

Added refinements in case and seal construction have also been made to insure reliability of the seal under even the most severe vibration.

Mallory Alkaline Batteries with the new construction are available in a broad range of standard cell configurations.

CIRCLE 107 ON READER SERVICE CARD

Circuit breaker-switch now available on Mallory controls

The OCB breaker-switch eliminates the need for a separate circuit breaker by combining overload protection and line switch into a single, compact unit. It's an extra convenience idea for television and stereo equipment, for instruments and any products which require overload breakers under 5 amperes.

To reset the breaker after it trips, you simply turn the switch back to OFF, then to ON. You cannot hold the breaker closed against an overload.

Holding current is factory-set to your specifications; standard range is 1.25 to 1.9 amperes, with special models available up to 5 amperes.



OCB breaker switch attached to volume control.

Break current is 50% higher than holding current. The OCB switch will withstand a 10% overload for 4 hours at 65°C ambient. It will take a 50 ampere surge, peaking in 1.6 millise and decaying to normal in 3 millise, without opening or being damaged.

The OCB is supplied attached to standard Mallory volume controls as a rotary on-off switch, or can be supplied as a separate breaker switch. As a combination control-switch-breaker, it offers savings in total component and assembly cost.

CIRCLE 108 ON READER SERVICE CARD

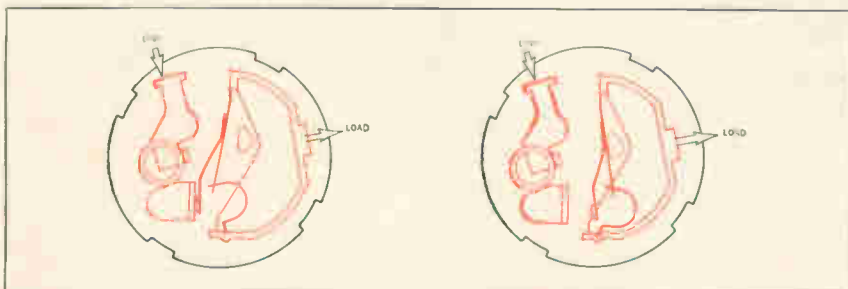

Diagrams show operation of breaker mechanism: at left, in MAKE position; at right, in BREAK position.

EIMAC

introduces a new family of magnetically shielded VTM's for microwave oscillator circuits.

Eimac's voltage tunable magnetrons are now magnetically shielded against degaussing effects of other permanent-magnet devices, dynamic magnetic fields, and stray radiation. A unique magnetic circuit design results in negligible external magnetic field and allows the tubes to contact ferromagnetic materials without degrading performance. If you're working on radar receivers, telemetry, or other sophisticated systems—any space-limited package which requires the small size, tuning linearity, high efficiency, and high-speed frequency modulation of VTM's—you'll want to know more about our new family of magnetically shielded voltage tunable magnetrons. Write for complete technical data.

MAGNETICALLY SHIELDED VTM'S

Type	Frequency range (Mc)	P ₀ (Min)
EM 1300	250-500	50 mW
EM 1310	500-1000	100 mW
EM 1311	980-1020	50 W
EM 1320	1000-2000	100 mW
EM 1331	2200-2300	35 W
EM 1332	2000-3000	100 mW
EM 1333	2900-3200	75 W

EIMAC
San Carlos, California 94070
A Division of Varian Associates

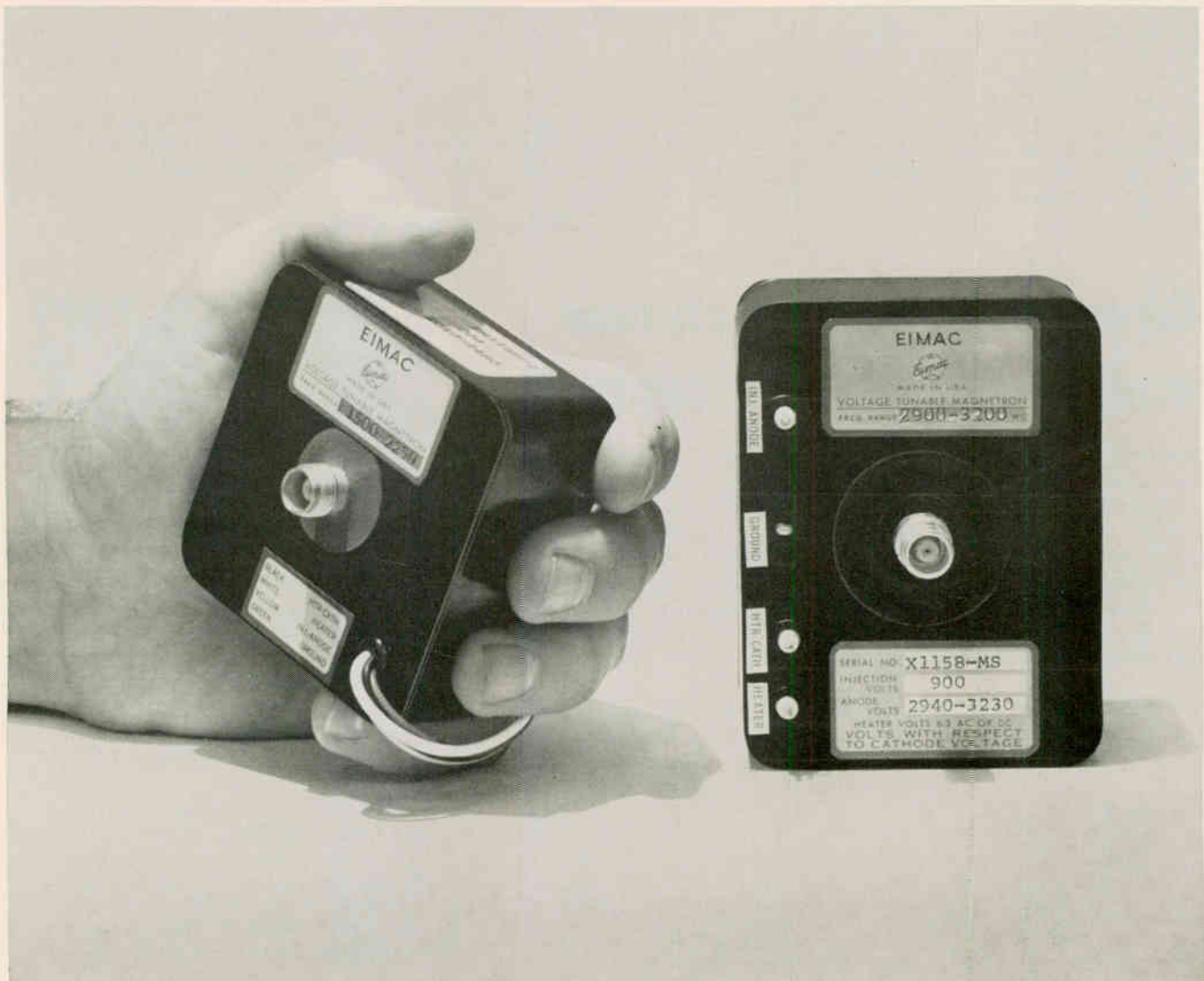

GENERAL PURPOSE Control

Dunco 219 Frame relays in three stock contact arrangements



Single Coil

SEQUENCE

NEW! — Dunco Frame 211 relays provide thousands of control sequences

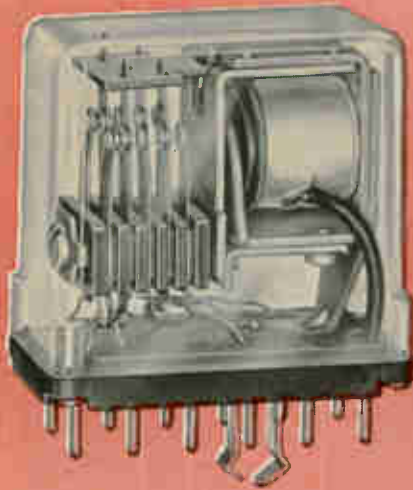

2-Coil

"MEMORY"

NEW! — mechanical latch electrical reset Frame 255 relays



A COMPLETE RELAY LINE FOR Simplified, Economical Industrial Control

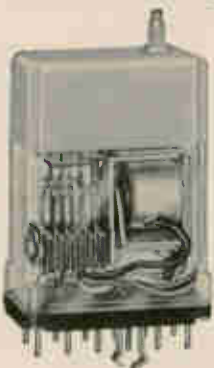

Operates directly from 115 volts, 60 cycles

TIME DELAY CONTROL RELAY

Combines a high quality RC network triggering a 4-level transistor with the Dunco general-purpose control relay. Timing is adjustable over a 90:1 scale in two standard ranges: 0.2 to 18 seconds; or 2 to 180 seconds. Write for Data Bulletin 6235.

These four Dunco industrial control relays simplify and economize control panels which, in the past, have often been "over-relayed" with larger, more costly types or types entailing more complicated circuitry. All four relays are in matched designs using 12-pin plugs and heavy-duty industrial sockets. Contacts are conservatively rated 10 amperes. Standard 150 volt electrical spacings are used throughout. Write for Data Bulletin on any type to STRUTHERS-DUNN, Inc., Pitman, N. J.

STRUTHERS-DUNN

WORLD'S LARGEST ASSORTMENT OF RELAY TYPES

SALES ENGINEERING OFFICES IN: Albuquerque • Atlanta • Belmont, Calif. • Boston • Buffalo • Charlotte • Cincinnati • Clearwater, Fla. • Cleveland • Clifton • Dallas • Encino • Englewood • Glen Ellyn, Ill. • Houston • Kansas City • Las Vegas • Memphis • New York • Phoenix • Pittsburgh • St. Louis • St. Paul • Salt Lake City • Richardson, Tex. • Seattle • Southfield • Wichita • Wilmette. Canadian Licensee: Renfrew Electric Co., Ltd., Toronto. Export Department: 1505 Race St., Phila., Penna. 19102, U.S.A.



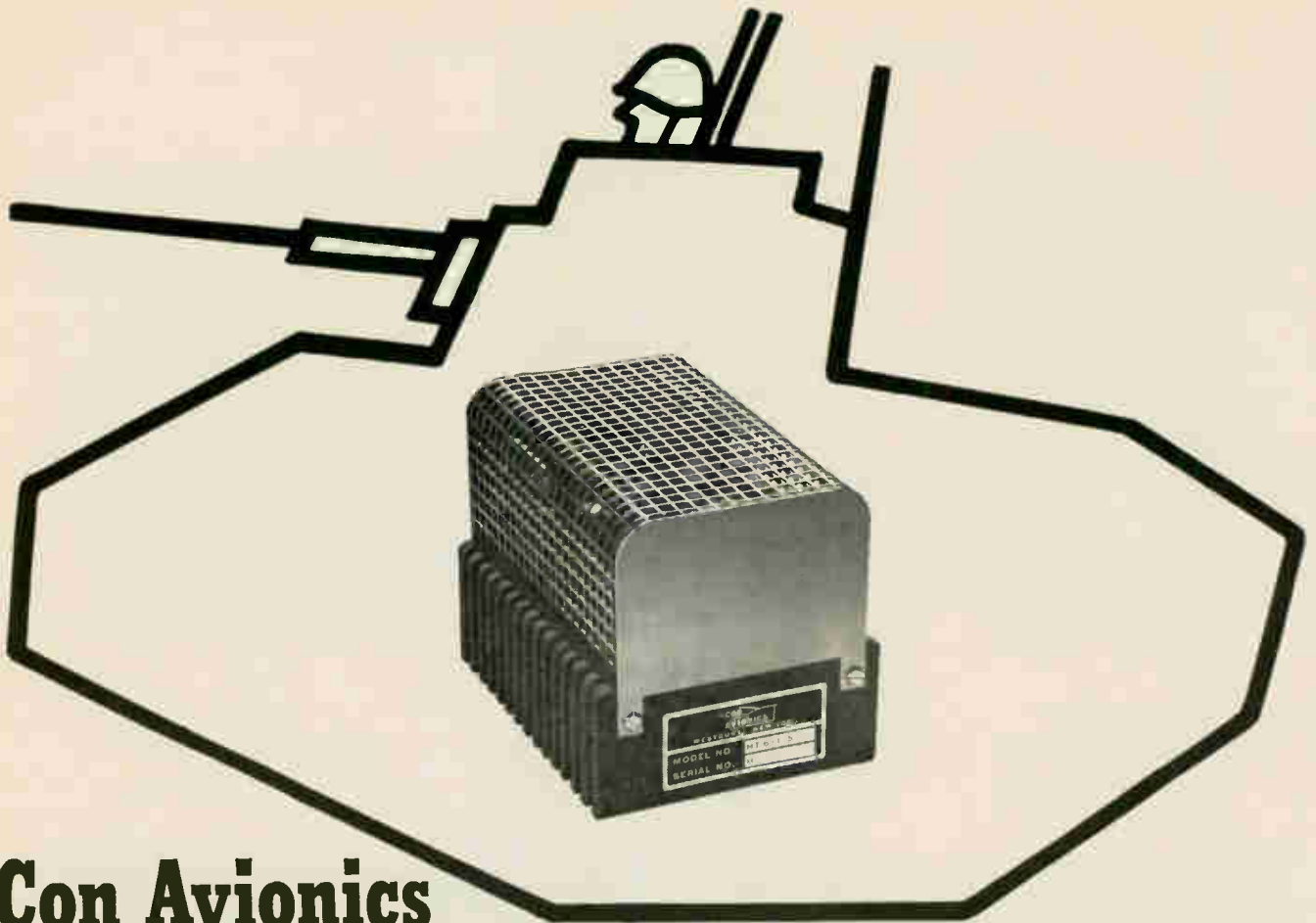

Con Avionics \$65 power supplies meet military specs

Made With Silicon Transistors, They Are Unconditionally Guaranteed For 5 Years

These dc regulated power supplies are available in nearly 200 different voltage-current combinations. Silicon transistors are used throughout and the units operate in ambients as high as 75°C, with a small external heat sink.

The Mean Time Between Failure of the modules is 100,000 hours, calculated according to Mil Handbook 217. They are certified to meet the environmental tests of Mil-E-5272, and most of the requirements of three other mil specs. In addition, they meet the RFI requirements of Mil-I-6181.

Prices start at \$65. Every time you specify one of these supplies, instead of a comparable germanium unit, you save considerable money. If you're using commercial supplies, typical savings-per-unit are about \$40. For military supplies it's much more.

The fastest way to get complete technical information and prices is to write, call, TWX or wire Gerry Albers at Con Avionics.

SPECIFICATIONS		
	STANDARD MODEL	"A" MODEL
Total Regulation (Line and Load)	±0.5%	±0.05%
Ripple (rms max.)	10 mv	1 mv
Temperature Coefficient	0.07%/°C	0.03%/°C
ALL MODELS		
Input	105-125 v ac, 47 to 440 cps	
Temperature	75°C ambient max. 90°C base plate max.	
Response Time	10 microseconds	
Military Specifications	Certified to meet the environmental requirements of MIL-E-5272 and the RFI requirements of MIL-I-6181	

CONSOLIDATED AVIONICS A DIVISION OF **CONDEC** CORPORATION

800 SHAMES DRIVE / WESTBURY, L.I., NEW YORK / 516 ED 4-8400



Soliton

*announces a family
of NPN Silicon Planar
Power Transistors
featuring*

TO-46 Package

*2 Amps I_C max
4 watts at
100°C!*

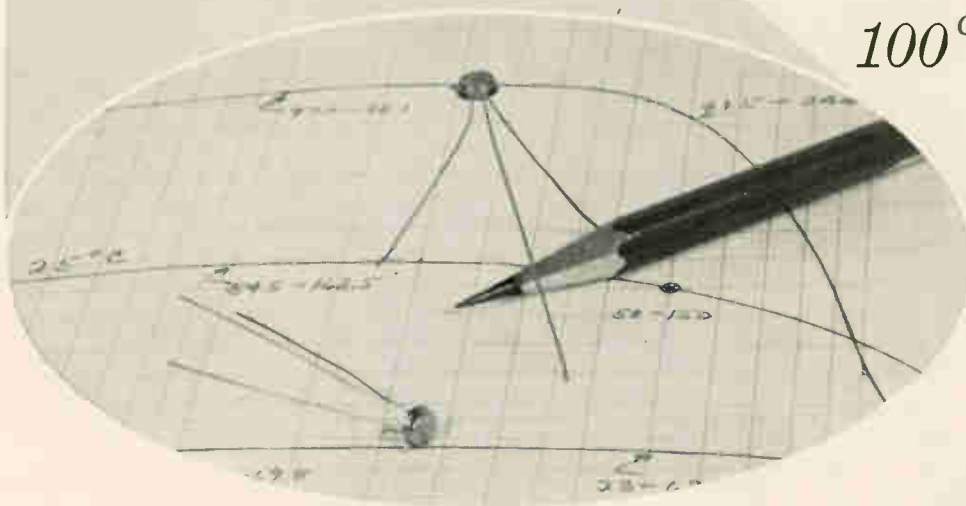

Type Number	Pkg Size	DESIGN LIMITS							PERFORMANCE SPECIFICATIONS					
		T_J	θ	P_T	BV_{CBO}	V_{CE0} (SUS)	BV_{EBO}	h_{FE}	V_{BE} (sat)	V_{CE} (sat)	I_{CBO}		f_T	
		°C	°C/W	Watts	Volts	Volts	Volts	Min. Max.	Volts	Volts	μA		mc	
		Max.	Max.	Max.	Min.	Min.	Min.	Min. Max.	Max.	Max.	Max.	Max.	Min.	
MHT5001	TO-46	200	25	4	60	40	8	50	150	1.2	0.35	0.1		50
MHT5002	TO-46	200	25	4	80	60	8	50	150	1.2	0.35	0.1		50
MHT5003	TO-46	200	25	4	100	80	8	50	150	1.2	0.35		0.1	50
MHT5004	TO-46	200	25	4	140	100	8	50	150	1.2	0.35		0.1	50
MHT5005	TO-46	200	25	4	180	120	8	50	150	1.2	0.35		0.1	50

Soliton TRANSISTOR DIVISION
DEVICES, INC.

1177 BLUE HERON BLVD. / RIVIERA BEACH, FLORIDA / (305) 848-4311

Leader in Germanium and Silicon Power Transistors, Cryogenic Thermometers, High Voltage Rectifiers, Temperature Compensated Zeners, Voltage Variable Capacitors, Random/White Noise Components and Microelectronic Components.

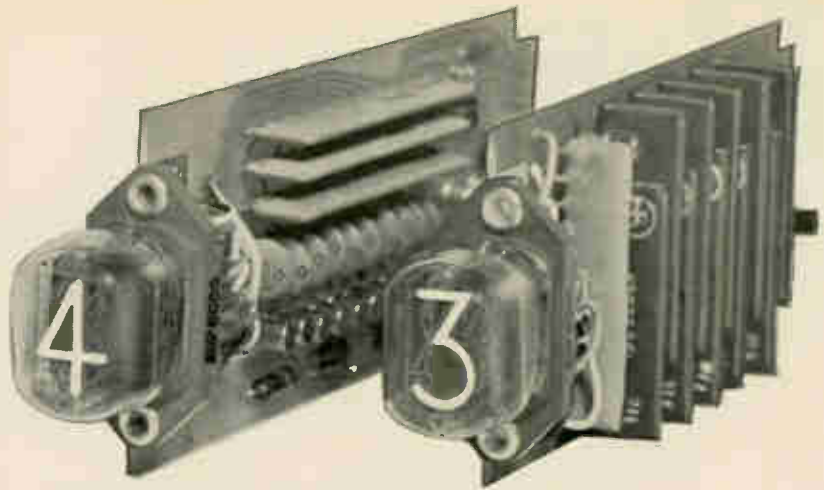

Silicon Controlled Switch Decade Counters
BIP-8055 Uni-Directional • BIP-8054 Bi-directional

Is this SCS decade counter the logical choice for direct-digital control?

Many users seem to think so.

They've taken our uni- and bi-directional SCS decade counters and designed them into scores of direct-digital control applications: N/C machine tools, Depth/Flow/Dimension measurement, Continuous/Discrete process control, just plain counting.

Function is one big reason. Together with their complementary logic and control modules, the counters can be packaged as a complete decimal accumulator that provides integral visual readout (provided by our ultra-reliable NIXIE® tube). Or, use the 10-wire output to drive a printer, or for other control purposes. You can have uni-directional or bi-directional counting, and the counter's

carry output lets you cascade up to six modules for multi-decade operation.

Convenience is another reason. There's the flexible form factor of modular packaging. And the design freedom of modular function: *pre-amplifier* accepts three primary types of count input, buffers the input of bi-directional counters; *polarity indicator* discriminates "plus" from "minus" counts; *pre-set/re-set* with multi-mode capability. And finally there's **reliability** and **economy**. All solid-state, plug-in PC board construction. Dependable operation in high-noise environments. Compatible design and interconnection that assure performance and respect your budget!

Delivery? From stock. Call or write for full information.



Burroughs Corporation

ELECTRONIC COMPONENTS DIVISION

PLAINFIELD, NEW JERSEY 07061

Circle 88 on reader service card

Technical Articles

Integrated circuits replace the electromechanical resolver: page 90

With off-the-shelf digital integrated circuits, engineers have designed a time-based analog circuit that could replace electromechanical resolvers and servo drivers in analog computers. The microelectronic device is smaller, lighter, consumes 90% less power and is 10 times as reliable as the conventional gear it replaces.

Making semiconductor lasers operate continuously: page 95

By refining the material and improving fabrication techniques, researchers say they can make the gallium-arsenide laser generate continuous-wave coherent light. They predict such operation at room temperature within a year.

Tunnel-diode oscillator expands f-m system's channel capacity: page 105

Performance of an f-m telemetry system depends on the characteristics of the voltage-controlled oscillator (vco). By using the unique characteristics of tunnel diodes, a newly designed oscillator can perform at frequencies to 200 Mc and can accommodate 600 channels.

Electronics markets in 1966: page 111



Everything is coming up roses for the electronics industry in 1966. Electronics' annual statistical survey of the industry starts on page 111 and includes 30 additional categories. Then, starting on page 117, the editors examine the technological trends and market opportunities in the major segments of the industry. The cover scene photographed at a Zenith Corp. plant, where color tv sets are being life tested, is being duplicated at color tv plants across the country as set producers strive to keep up with demand. In 1966, color tv will again set the pace for makers of consumer products and components.

**Coming
January 24, 1966**

- Mass-producing a new beam-lead diode
- Using feedback in amplifier design
- More approaches to time sharing

Integrated circuits replace the electromechanical resolver

Electronic analog resolver is smaller, lighter, consumes 90% less power and is 10 times as reliable as mechanical devices solving trigonometric problems in analog computers

By Hermann Schmid,

General Electric Co., Johnson City, N. Y.

A two-cubic-inch package containing 17 off-the-shelf integrated circuits and a few discrete components promises to do the computation job now being performed in analog computers by bulky electromechanical resolvers and servo drivers.

The time-based analog circuit, for which a patent application has been filed, is called an electronic analog resolver (EAR). With one-tenth the size, weight and power consumption, it solves trigonometric equations and performs coordinate transformations and rotations with the accuracy, 0.1%, of the electromechanical resolver—and is 10 times as reliable.

The electronic analog resolver, with full-temperature-range devices, costs about \$500—the price of a size 11 electromechanical resolver and servo drive. With temperature-restricted devices and oven control, the price would be lower.

The resolver's job

In an electromechanical resolver, rotation of a constant-magnitude vector R is accomplished by physically turning the rotor and its magnetic field with respect to the stator. The amplitudes of the a-c voltages generated in the two stator windings are proportional to the x and y components of R .

In EAR, vector R rotates at a constant velocity for a time proportional to the desired angle of rota-

The author



Hermann Schmid of GE's armament and control products section is the designer of the electronic analog resolver. He has been creating analog computing circuits ever since he received his bachelor's degree in Germany in 1950.

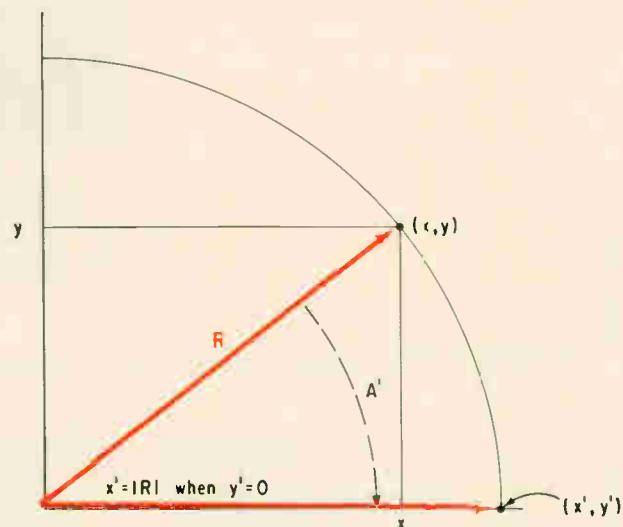
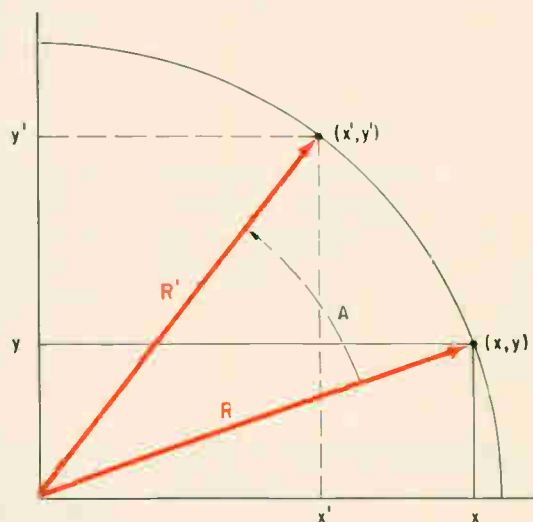

Trigonometric operations which rotate coordinates through an angle A (top) and transform coordinates from rectangular to polar form (bottom).

tion. During this rotation, the EAR solves the differential equation $A\ddot{X} = -CX$ as a function of time, where the input signals set the initial conditions and the output signals represent the solution.

Coordinate rotation and coordinate transformation—the two basic functions of resolvers—are shown graphically on page 90.

In coordinate rotation, vector R is rotated through an angle A from its initial position x, y to x', y' . The new coordinates, in terms of the initial conditions and the angle of rotation, are

$$x' = x \cos A - y \sin A$$

$$y' = y \cos A + x \sin A$$

To transform from rectangular to polar coordinates, the initial position x, y is rotated to the X axis through some angle A' so that $y' = 0$ and $x' = |R|$

the magnitude of the polar coordinate. The polar coordinates, in terms of the initial rectangular coordinates, are

$$|R| = x' = \sqrt{x^2 + y^2}$$

$$A' = \arctan y/x$$

Other trigonometric functions (such as transformation of polar to rectangular coordinates) can be derived from these equations by cascading two or more operations, by setting x or y equal to zero, or by using different criteria for determining the amount of rotation.

Harmonic oscillator

A harmonic oscillator, two integrators and an inverter connected in a closed loop, are shown in the figure just below. They are the basis of the

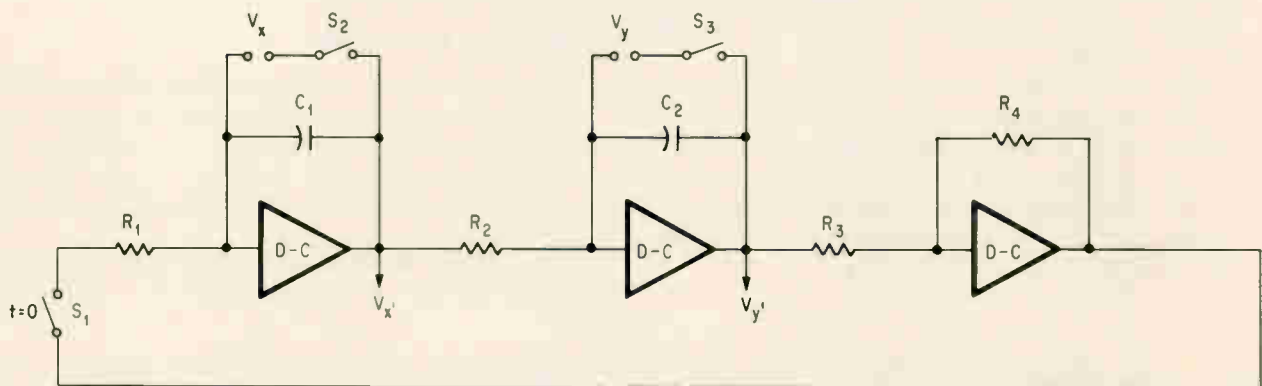

Harmonic oscillator with two integrators and an inverter connected in a closed loop can perform the functions of an electromechanical resolver. This is the basis for the EAR.

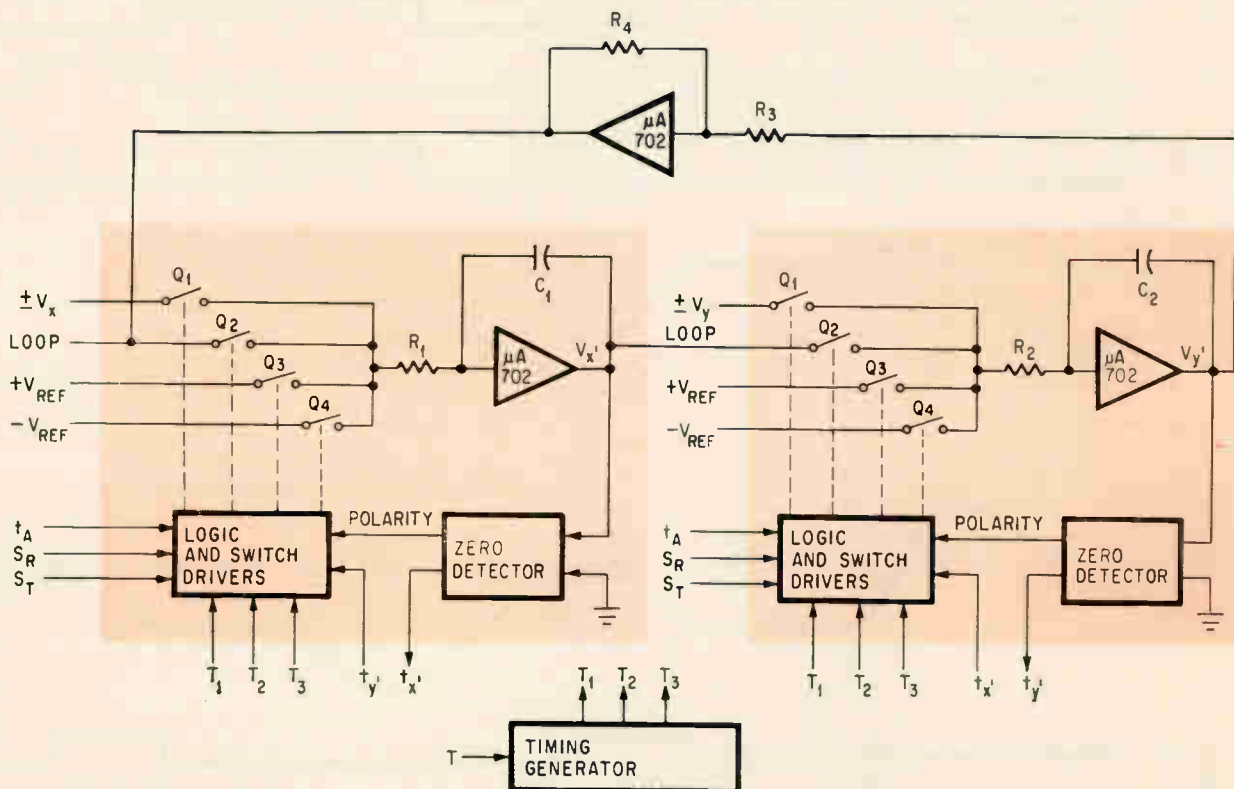

Electronic analog resolver contains two pulse-width modulators shown in color panels. Modulator at left is for x component; modulator at right is for y component. With the exception of the transistor switches, all the circuits are standard linear and digital integrated.

electronic analog resolver. The harmonic oscillator operation is defined by the differential equation:

$$\ddot{X} = \frac{-R_1/R_3}{(R_1C_1R_2C_2)^{1/2}} X$$

The solutions, which appear at the outputs of the two integrators, are

$$V_{x'} = M \cos(\omega t + p)$$

$$V_{y'} = M \sin(\omega t + p)$$

where amplitude $M = \sqrt{V_x^2 + V_y^2}$

frequency $\omega = 1/(R_1C_1R_2C_2)^{1/2}$

phase shift $p = \arctan(V_y/V_x)$

V_x and V_y are the integrating capacitor voltages on C_1 and C_2 at $t = 0$, or the initial condition voltages. This determines the amplitude and phase of the output voltages $V_{x'}$ and $V_{y'}$. Note that amplitude and phase are independent of the time constants R_1C_1 and R_2C_2 .

The frequency of the sine and cosine waves is only a function of the integrator time constants and independent of the initial conditions. $V_{x'}$ and $V_{y'}$ can be considered the x and y components of vector \mathbf{R} , which rotates with angular velocity $k\omega$.

The two output voltages, in terms of the initial voltages on the capacitors, are

$$V_{x'} = V_x \cos \omega t - V_y \sin \omega t$$

$$V_{y'} = V_y \cos \omega t + V_x \sin \omega t$$

Notice the parallel between these equations and the graphically derived equations for coordinate rotation. To rotate a coordinate using the harmonic oscillator, S_2 and S_3 are closed long enough to charge C_1 and C_2 to voltages V_x and V_y , which are analogous to some initial rectangular coordinates. Vector \mathbf{R} rotates at some constant velocity when S_1 is closed so that the desired angle of rotation is directly proportional to time. After rotation, the new coordinates are determined from the values of voltages $V_{x'}$ and $V_{y'}$.

To change the rectangular coordinates represented by V_x and V_y to polar coordinates, S_1 is closed for time t until $V_{y'}$ is zero. $V_{x'}$ is then proportional to the polar coordinate's amplitude, and ωt is proportional to its angle.

Controlling the resolver

In the electronic analog resolver, the harmonic oscillator switching is controlled by logic, zero detectors and timing circuits. In addition, the outputs of the harmonic oscillator, $V_{x'}$ and $V_{y'}$, are converted to pulses whose widths represent solutions.

Two basic functions—rotation and coordinate transformation—are accomplished by controlling

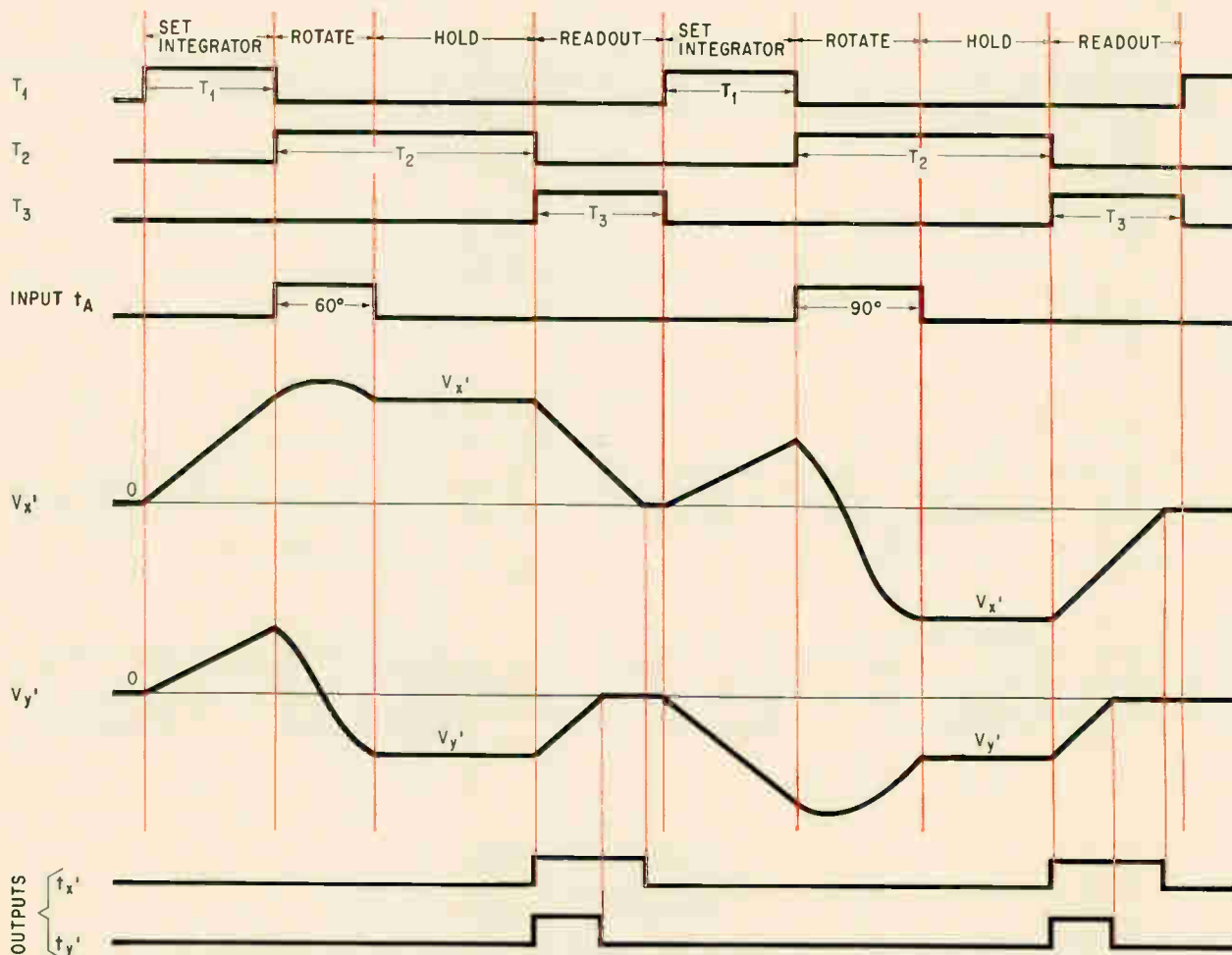

Operational sequence for coordinate rotation. At top are timing pulses. Representing the outputs of the integrators are $V_{x'}$ and $V_{y'}$. The final coordinates are given by the width of the pulses at the bottom.

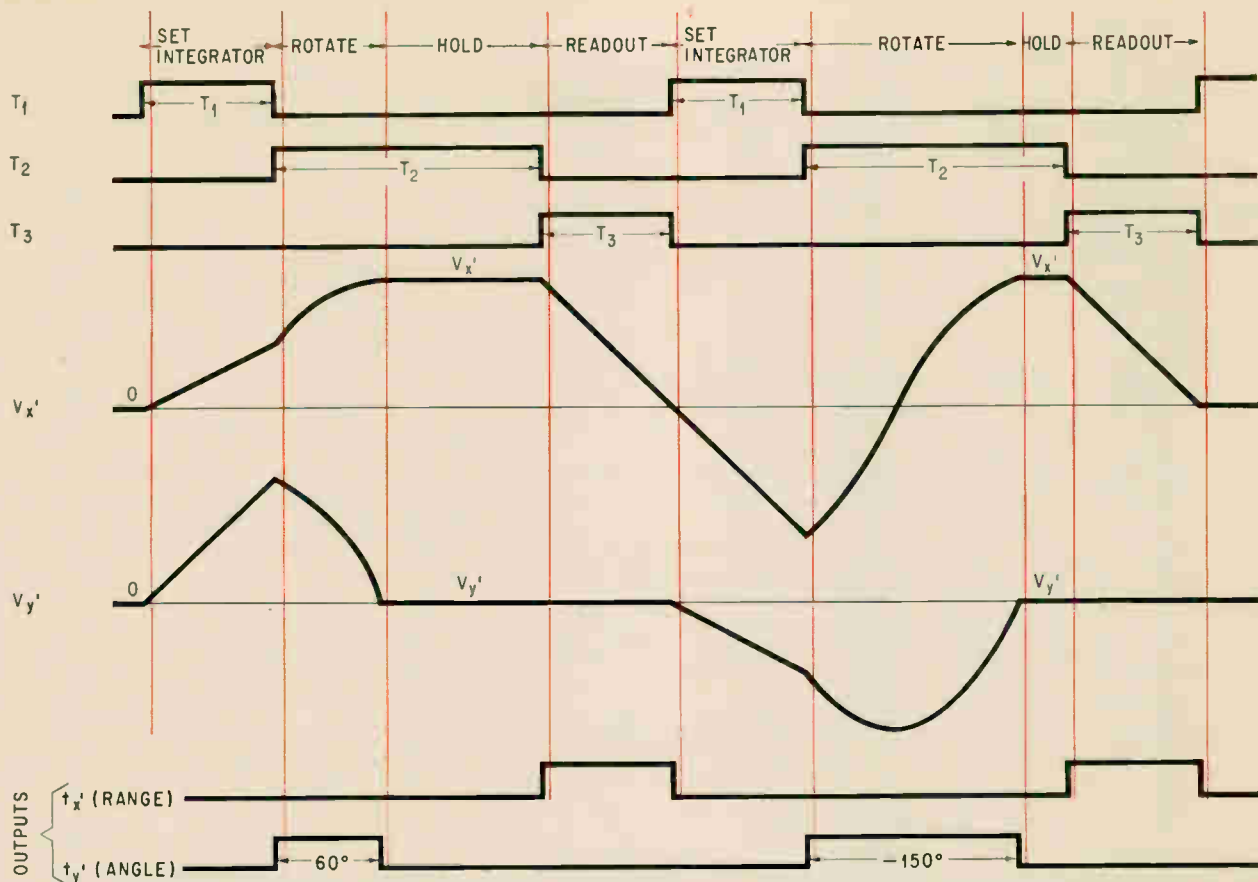

Operational sequence for coordinate transformation. Note that one of the output pulses starts at T_2 , the other at T_3 .

the integrator initial conditions and the time during which the harmonic oscillator loop is closed, as shown in the block diagram at the bottom of page 91. Three timing intervals are provided:

During T_1 , initial conditions are set by integrating voltages V_x and V_y representing the initial position of R . During T_2 , R is rotated by closing the harmonic oscillator loop. Lastly, during T_3 , information is read out as pulses t_x and t_y with widths proportional to the values of the final coordinates of R .

Two sets of analog switches connect input or reference voltages to the integrator or connect the integrators and the inverter into a closed loop. Each set of switches is controlled by a logic circuit which combines command signals— S_r for rotation or S_t for transformation—zero-detector signals and the three timing pulses.

The resolver's operation during two successive coordinate rotations is illustrated by the waveforms in the figure at the left. V_x and V_y represent the outputs of the two integrators.

The initial conditions are set by integrating the input voltages during T_1 . During T_2 , R is rotated through an angle A for a time, t_A . Outputs V_x and V_y are sine and cosine waves; the phases are determined by the integrations of T_1 . From the end of t_A to the end of T_2 , V_x and V_y are held constant by opening the harmonic generator loop and removing the inputs to the integrators.

During T_3 , reference voltage $\pm V_{ref}$ is applied to the input of each integrator. These reference voltages are integrated until V_x and V_y go to zero. The length of pulses t_x and t_y starting at T_3 are analogous to the final rotated coordinates x' and y' .

The reference voltage V_{ref} , used on each integrator during T_3 , is in opposite polarity to V_x and V_y , the d-c voltage present at the end of T_2 .

With a change in logic, the resolver transforms rectangular coordinates to polar coordinates. Two such transformations are shown by the waveforms in the diagram on this page. As before, the initial voltages representing coordinates x and y are integrated during T_1 . But rotation during T_2 continues until V_y is zero because then V_x represents the magnitude of the polar coordinate. This voltage is then held at the output of the integrator for the remainder of T_2 and then reduced to zero during T_3 as the reference voltage is applied to the integrator input. The time needed for V_x to reach zero from time T_3 is again the length of pulse t_x , but this time t_x represents the magnitude of the polar coordinate. Its angle is represented by pulse t_y , which starts at time T_2 and continues until V_y is zero. Pulse t_y is also the zero-detecting pulse that terminates the rotation during T_2 .

Pulse-width modulator

In the EAR are two identical pulse-width modulators. The one to be described and shown in the

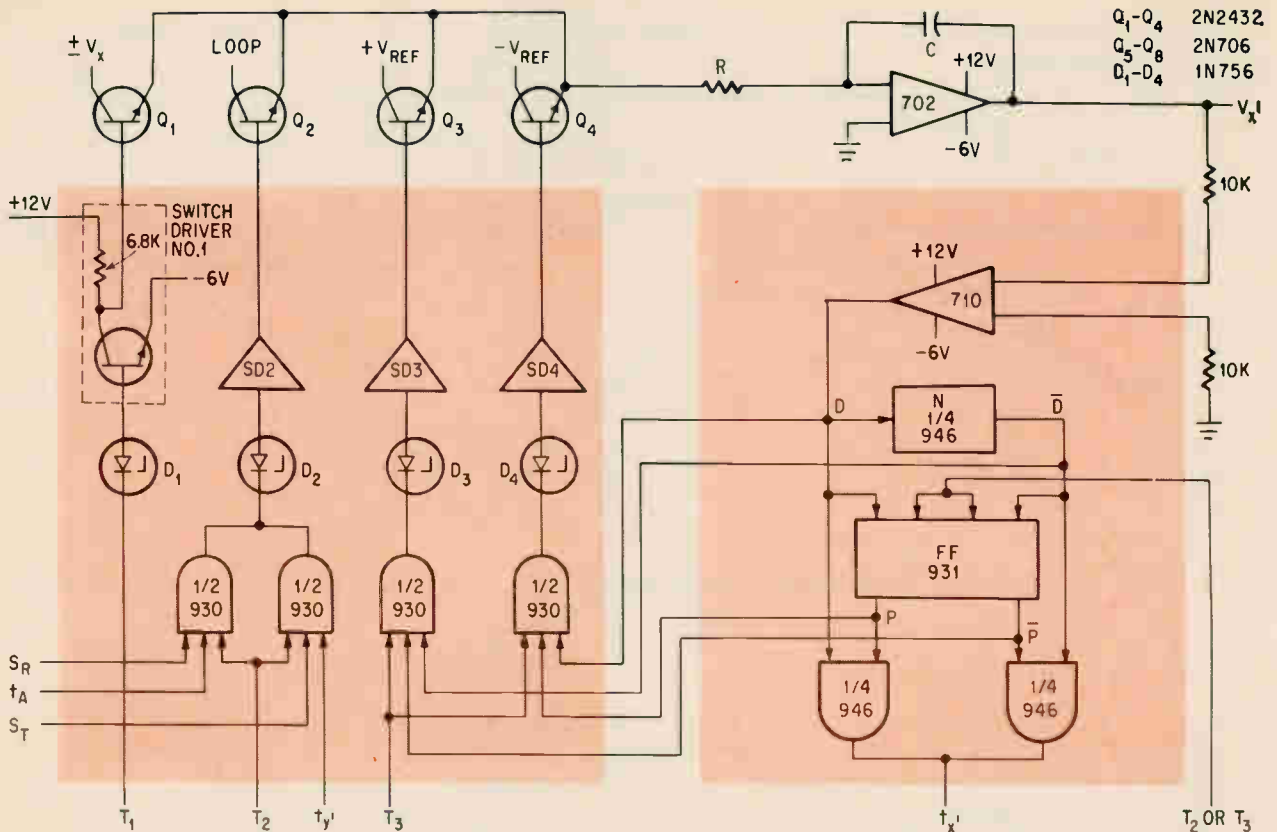

One of the two identical pulse-width modulators shown on page 91. Both use Fairchild, standard integrated circuits. Switch drivers and logic are shown in color panel at left. Zero detector is shown in the color panel at right.

schematic above is for the x-component. The other is for the y-component. Though the circuit was built with standard digital NAND/NOR-gate integrated circuits manufactured by the Semiconductor division of the Fairchild Camera & Instrument Corp., the equivalent AND/OR-gate logic is shown to simplify understanding of the operation.

The analog integrator is of conventional design with resistance R in the input and capacitance C in the feedback path of an IC operational amplifier (Fairchild μA 702).

The zero detector contains one analog comparator (Fairchild μA 710). It compares integrator output voltage V_x with ground to produce an on/off control signal (designated D)—positive when V_x is more than +2 millivolts, zero when V_x is less than -2 millivolts. From D , a logic inverter generates \bar{D} , which is zero when D is positive and positive when D is zero.

Next, a flip-flop operating as a one-bit shift register, produces signal P and \bar{P} , which have the same respective polarities as D and \bar{D} after the flip-flop has been triggered by the leading edge of T_2 or T_3 . The presence of both P and D or \bar{P} and \bar{D} during T_2 or T_3 generates the pulse t_x . The type of operation determines whether the pulse originates during T_2 or T_3 .

Only one of the transistors Q_1 through Q_4 is switched on at any one time to connect the appropriate analog voltage to the integrator. The zero

diode and switchdrivers boost the logic voltage to a level high enough to operate the switching transistors. The various logic functions of the electronic analog resolver are defined by these Boolean equations in terms of the "on" states of the transistors Q_1 through Q_4 and the logic inputs:

$$\begin{aligned}
 Q_1 &= T_1 \\
 Q_2 &= T_2 \cdot S_r \cdot t_A + T_2 \cdot S_t \cdot t_y \\
 Q_3 &= \bar{P} \cdot \bar{D} \cdot T_3 \\
 Q_4 &= P \cdot D \cdot T_3 \\
 t_x &= P \cdot D \cdot (T_2 + T_3) + \bar{P} \cdot \bar{D} \cdot (T_2 + T_3)
 \end{aligned}$$

Bibliography

- A.S. Robinson, "An Electronic Analog Computing Technique for the Solution of Trigonometric Problems," IRE Transactions on Electronic Computers, September, 1955, pp. 96-101.
- G.A. Korn, "Electronic Analog Computers," McGraw-Hill, N. Y., 1956.
- R.M. Howe and E.G. Gilbert, "Trigonometric Resolution in Analog Computers by Means of Multiplier Elements," IRE Transactions on Electronic Computers, June, 1957, pp. 86-92.
- H. Schmid, "A Transistorized Time Division Multiplier," IRE Transactions on Electronic Computers, March, 1958, pp. 43-47.
- H. Schmid, "Function Generator for Sines and Cosines," Electronics, Jan. 23, 1959.
- C.C. Ritchie and R.W. Young, "The Design of Biased Diode Function Generators," Electronic Engineering, June, 1959 pp. 347-351.
- J.E. Volder, "The Cordic Trigonometric Computing Technique," IRE Transactions on Electronic Computers, September, 1959, pp. 330-335.
- "An Electronic Sine/Cosine Former for Fast Resolution," Speaking with Ease, Beckman Instruments, Inc., Publication C11-1, 1959.
- H. Schmid, "Four Quadrant All-Electronic Pulse Time Multiplier," General Electric Co., TIS Report 62APJ43, October, 1962, pp. 11-13.
- "Molecular Optoelectronic Multiplex/Chopper," Texas Instruments Incorporated's Product News Release, Mar. 23, 1964.
- H. Schmid, "Sequential Analog/Digital Computer," Paper presented at the Fall Joint Computer Conference, Las Vegas, Nev., Dec. 1, 1965.

Continuous operation is near for uncooled diode lasers

Researchers are refining the material and improving fabrication techniques for GaAs lasers; they predict c-w operation at room temperature within a year

By Michael F. Lamorte

Radio Corp. of America, Electronic Components and Devices Division, Somerville, N.J.

This may be the year in which continuous-wave operation of a laser diode at room temperature is achieved.

One obstacle bars the way: the heat produced within the semiconductor by its threshold current—the minimum needed to initiate laser action. Boosting the current to the level needed to achieve lasing is self-defeating because the higher the current the higher the temperature of the diode, and the higher the temperature, the lower the efficiency of the diode. Ultimately, if the heat rises too high, the diode is destroyed.

The obvious solution to the heat problem—cryogenic cooling of the semiconductor—is too cumbersome and impractical. For the past few years, researchers at the Radio Corp. of America, among others, have been investigating diode lasers, specifically gallium arsenide injection lasers, and three directions have been under study in an effort to lower the threshold: improvement of the diode itself, improvement of the pn junction and reduction of the diode's thermal resistance.

Purer, more uniform semiconductor material is expected to result in higher power and better efficiency. The improvement in the pn junction is being accomplished through the use of epitaxial tech-

niques, which produces uniform, planar junctions; this alone is likely to lower threshold current density by factors of 10 to 100. And reduction of thermal resistance is being accomplished by making the material very thin.

A prediction and a goal

Results to date indicate c-w operation at room temperature will be achieved during 1966. Recently, RCA reported levels as low as 4 amperes at room temperature (300°K). The goal is about 0.5 ampere. At liquid nitrogen temperatures, however, threshold has been reduced to as low as 0.1 to 0.7 amperes.

Why turn to the diode in the first place? Can't the gas laser do the job without worrying about heat and threshold current?

To be sure, gas lasers have their place, but several unique features of the diode laser^{1, 2, 3} make it the perfect choice for many applications. For example, it is relatively cheap, potentially rugged, small, efficient, easy to modulate internally, and compatible with both transistor pulse-forming circuits and microcircuit fabrication techniques.

Aside from less heat, the lowering of the threshold level results in another advantage: the elimination of the complex and expensive pulse-forming circuits needed to pump the diode. At levels below 10 amperes the laser can be pumped by pulse-forming circuits with inexpensive power transistors.

But why center the investigation on GaAs?

For one thing, the wavelength of GaAs lasers corresponds to the wavelength at which many common photodetectors are most efficient—a handy feature if the laser is to be used for communications or for radar and ranging. In addition, researchers have accumulated a wealth of knowledge about the material because of its use in transistors⁴, varactor

The author



In 1959, Michael F. Lamorte joined the RCA semiconductor and materials division. He has been a project leader in advanced development, responsible for research and development of varactor diodes and GaAs solar cells. Presently he is in charge of electro-optical devices.

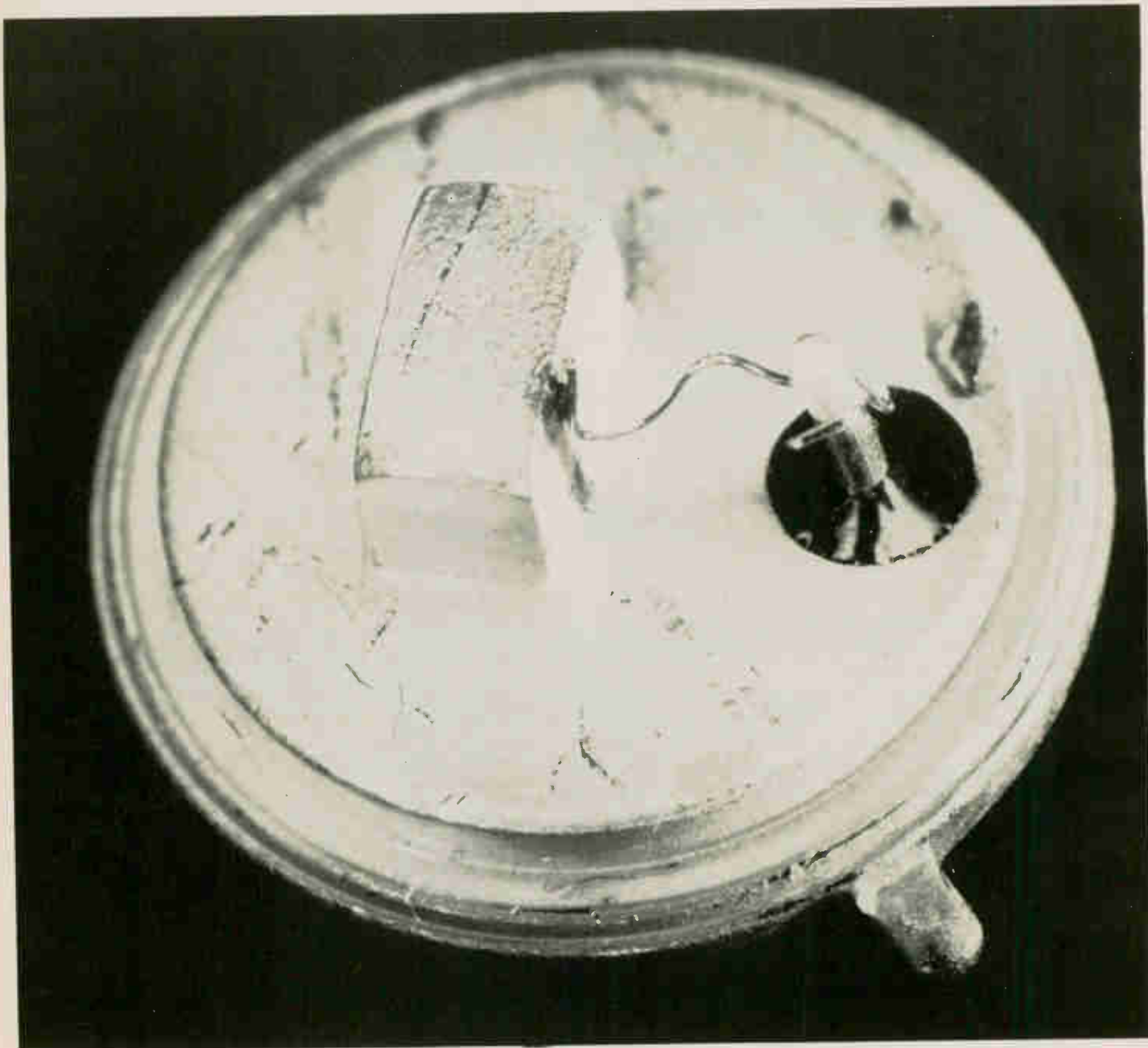

Room-temperature GaAs injection laser is the black speck between the wire lead and the molybdenum block. It is alloyed to a specially designed transistor header. The laser's radiation is directed perpendicular to the plane of the header.

diodes⁵, solar cells⁶ and tunnel diodes⁷, making much of the present investigation easier.

Lengthening the pulses

To be sure, not all of RCA's investigation has been directed toward c-w operation. For example, using GaAs, peak outputs of 60 watts have been achieved for 30-nanosecond pulses—about twice the level reported anywhere, and 20 watts for microsecond pulses—about 10 times the level previously reported. Efficiency in both cases was 40%. Additionally, at liquid nitrogen temperatures (77°K), threshold current has been lowered to 0.1 ampere—about a tenth of the previously reported level. Moreover, this performance has been accomplished

with pulses of microsecond lengths.

This reduction in threshold has been accomplished with a combination of exceptionally pure material and careful fabrication. First, gallium arsenide ingots of high purity and uniformity are used to obtain the diode wafers. The material is then made highly degenerate, that is, heavily doped. Finally, the use of epitaxial growth techniques makes possible the formation of highly planar junctions, free from irregularities.

The basic principles

A schematic of a pn junction, GaAs laser diode is shown on page 97. One end is coated with a totally reflective material and the other, the emit-

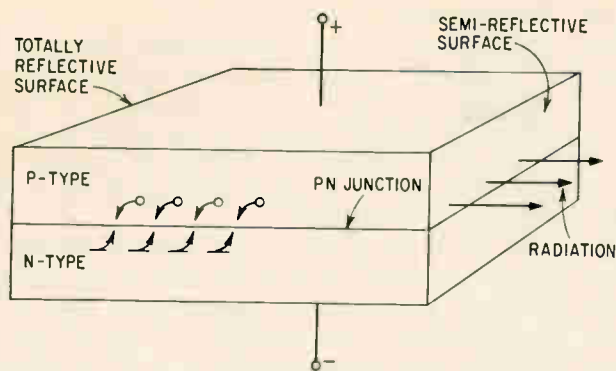

Forward-biased gallium arsenide laser diode. Holes from the p semiconductor material and electrons from the n material are injected into the space-charge region on either side of the junction. Upon recombination of the carriers, radiation is emitted from the diode.

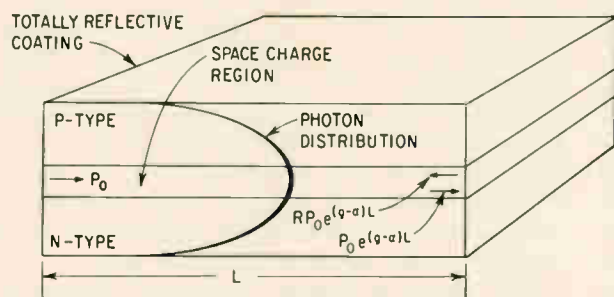

After passing through the diode once, the relative power remaining in it must be equal to or greater than unity for positive feedback to exist. When the power is greater than unity, the population-inversion condition in the space-charge region gives rise to laser oscillations.

ting end, with a semireflective material. The diode is forward biased so that minority carriers (holes from the p-section, electrons from the n-section) are injected into the space-charge region. When the carriers recombine, the diode emits radiation, which is incoherent, or spontaneous, at low current densities, and has a line width of several hundred angstroms. However, if the current density is increased to about 30,000 amperes per square centimeter at 300°K, it produces population inversion—a condition in which the normal energy-level distribution of electrons is reversed (that is, more electrons are in high energy levels than in low energy levels). At this threshold current density, coherent radiation occurs. If the temperature is reduced, lower threshold current densities will produce emission.

Recombination occurs only when excess hole-electron pairs are present in the semiconductor material. Electrons at the conduction-band edge drop down into the valence-band edge, there recombine with holes, and give up energy in the form of either photons, phonons, or both. The mechanism of recombination, although influenced by temperature, injection level and crystalline perfection, is an inherent property of the semiconductor material. GaAs is a direct-band-gap, or direct-transition, semiconductor. In this case, an electron makes a

transition to the top of the valence band and gives up its energy as a photon without a change in crystal momentum. For the indirect-transition materials, such as silicon and germanium, a transition will occur only if at least one phonon is involved in the necessary dynamic process to conserve crystal momentum. Because a transition involving only a hole and an electron is more probable than one in which one or more phonons are also required, the radiative recombination process is more efficient, by several orders of magnitude, in direct-transition semiconductors.

The pn junction

Both spontaneous and stimulated emission occur in the space-charge region surrounding the pn junction; laser radiation oscillation also takes place in this region. The quantum efficiency depends in part on the degree to which the radiation extends into the inactive (absence of inverted population) n- and p-regions.

Positive feedback must be present to produce oscillation in the semiconductor material cavity. Consider the cavity at the left; if L is the length, P_0 is the power at one end, the power incident to the other end after one pass is $P_0 e^{(g-\alpha)L}$, where g is the gain from stimulated emission per unit length and α is the sum of cavity losses per unit length. Upon reflection from the end of the diode, the relative power remaining in the cavity must be equal to or greater than unity for positive feedback, i.e., $R e^{(g-\alpha)L} > 1$, where R is the reflectance. When this quantity is greater than unity, the population inversion condition in the space-charge region causes oscillations. At threshold, this relationship equals unity, and the gain per unit length is given by

$$g = \alpha + \frac{1}{L} \ln \frac{1}{R}$$

Thus, for a longer cavity with increased reflectance and reduced optical losses, the gain required for threshold is reduced and lasing occurs sooner.

At the high injection levels required for coherent radiation, the width of the space-charge region is probably less than a micron. However, photons cannot be restricted to a region equal to or less than their wavelength. Although the stimulated emission takes place between energy levels in a region one micron wide or less, the photons are distributed over a distance of 10 microns. Usually this is also the width of the light-emitting region surrounding the junction. Thus, some of the photons' energy is unavoidably dissipated through the inactive portion of the diode.

The spreading of the photon distribution into the inactive regions of the junction hurts laser performance. The inactive region does not contribute to gain from stimulated emission; it may, in fact possess a strong absorption characteristic that would reduce cavity Q , increase threshold and decrease external efficiency. It has been shown⁸ that increased absorption in the inactive p-region is re-

sponsible for increasing threshold and decreasing external efficiency at between 77°K and 300°K. This suggests that the internal efficiency of gallium arsenide is constant in this temperature range.

Spectra of a laser diode

How does temperature affect the spectra of a GaAs laser? Typical spectra are shown at the right. These spectra are resolved in time at one microsecond intervals and are obtained by scanning the output pulse.⁹ The obvious shift in laser radiation with time is caused by a junction temperature rise that occurs while the input pulse is applied. The line width for some typical lasers at 77°K is always less than 1 angstrom and generally less than 0.5 angstrom. As room temperature is approached, the line width increases to about 5 angstroms.¹⁰ At room temperature the laser radiation has a wavelength of approximately 9,000 angstroms; the separation between the discrete frequencies produced by the laser is 5 angstroms and increases slightly at room temperature with increased line width.

Many modes, or discrete frequencies, persist for four microseconds; however, the number decreases because of a rise in junction temperature. The higher the rate of temperature rise, the sooner the number of modes decreases. For some applications only a single mode containing all the laser's power is desirable. In that case, a very narrow band filter can be used with the laser and a high signal-to-noise ratio obtained from it.

Power vs. temperature

The figure on page 99 shows typical curves of power output as a function of input current over the temperature range of 100°K to 300°K.⁸ These data show that the power remains high, with only a decrease of 10% or less between 100°K and 150°K. Between 77°K (not shown) and 100°K there is no essential change in output.

The appreciable decrease observed from 150°K to 200°K is typical of most laser diodes. From 100°K to 200°K, the decrease is 35% for a current density of 21×10^4 amperes per square centimeter, but the drop rises to 75% at 4×10^4 amperes per square centimeter. The greater change at the lower current density is caused by the threshold offset at the higher temperature, not by a decrease in gain from stimulated emission. For the laser diode used in these measurements, the greatest decrease in output occurs between 200°K and 245°K; however, this behavior is not typical. In other diodes the decrease is considerably smaller in this temperature range; the greatest decrease occurs between 250°K and 300°K.

The slope $dP/d(J - J_{th})$ is proportional to the gain from stimulated emission, where P is the power, J is the current density and J_{th} is the threshold current density, i.e., the point on the curve at which the slope sharply increases. For this diode, the slope is nearly constant in the temperature range 100°K to 200°K. However, in other laser diodes this relatively constant slope is observed up

to a temperature of 250°K.

It has not yet been determined why this slope is relatively constant at these temperatures, but the effect is probably due to the degree of junction planarity. A small change in junction planarity can result in a nonuniform stimulated emission gain, and may even cause attenuation of the laser radiation due to absorption.

At lower temperatures, the laser oscillation may not be seriously affected because of the small absorption coefficient. At temperatures approaching 300°K, however, the absorption is greater and may influence the power output as well as threshold. Data have been presented¹⁰ which show that the line width and cavity undergo pronounced changes in the range 250°K to 300°K.

Effects of junction heating

Junction heating under d-c conditions either prevents coherent radiation or destroys the laser. Under pulse conditions the only pronounced limiting effect is a maximum pulse length over which coherent radiation can be observed. The major effects of junction temperature rise under pulse conditions are increase of threshold current, decrease in efficiency, shift of laser radiation line to longer wavelengths, increase in the line width over the temperature range 77°K to 300°K and increase in mode spacing in the same temperature range.

The figure at bottom shows the typical linear line shift with time caused by junction heating. For low current values the shift is proportional to

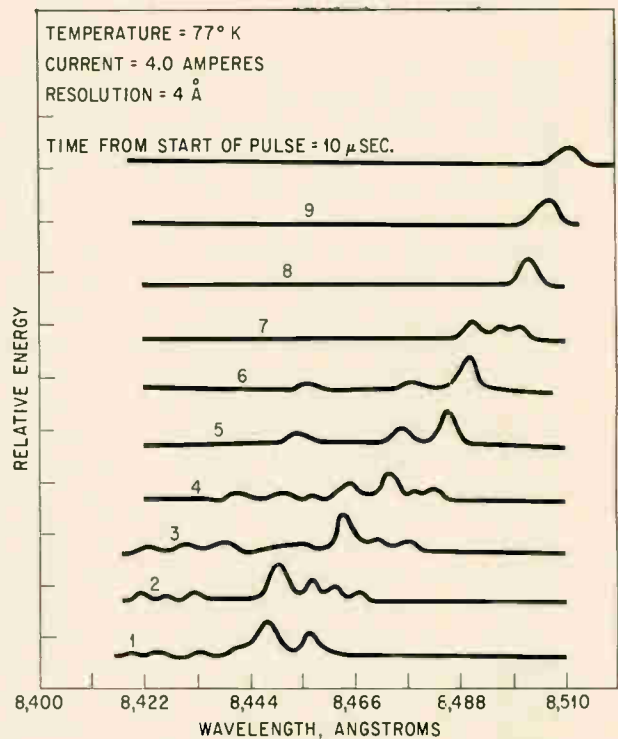

Spectra of a gallium arsenide laser are resolved in time at one microsecond intervals. When the input pulse is applied to the junction, temperature rises, causing the shift in wavelength of the radiation with time.

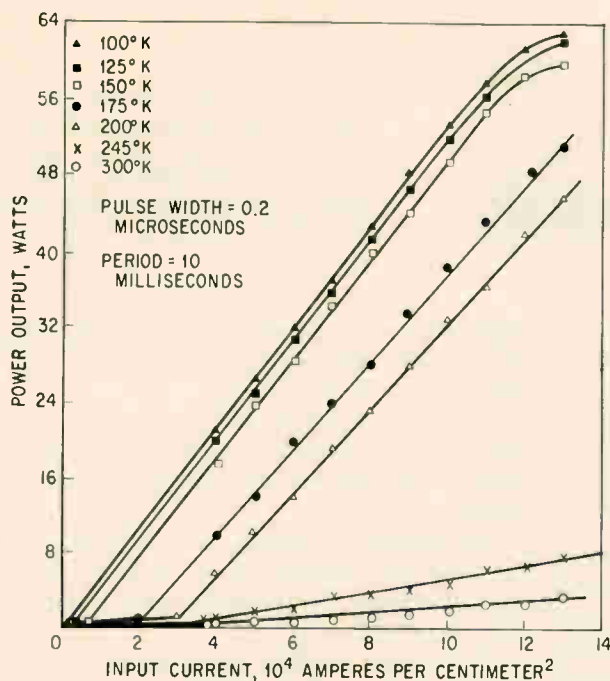

Curves of power output as a function of input current from 100°K to 300°K. For the diode whose characteristics are illustrated by the graph, the greatest decrease in output occurs between 200°K and 245°K, but other diodes show a much smaller power decrease at these temperatures. Most diodes show the greatest power decrease at 250°K to 300°K.

current, whereas for high current values it is proportional to the square of current.

If the detector has a slow response, the laser output cannot be resolved in time, and a single spectrum is obtained that essentially represents the envelope of the time-resolved spectra series. A slow detector, such as a resistance-capacitance integrating circuit, responds to energy, while a fast-response detector, such as a multiplier phototube, detects power.

Radiation pattern

Because of the small emitting region from which the laser radiation exits, the radiation from laser diodes is diffraction limited, i.e., it spreads a relatively large amount, and power density along the axis of the laser decreases. The best lasers have a beam spread of 1° parallel to the junction plane and 5° perpendicular to it. In some cases the spread is as large as 2° and 10°, respectively. Since very small beam spread is desired, the diameters of focusing lenses used with the laser must be relatively large—larger than the laser itself. But the size of the optics is still small compared with that for solid crystal and gas lasers.

Thermal resistance

Thermal resistance is mainly responsible for the laser's performance characteristics. Semiconductor materials exhibit smaller thermal conductivity than do most metals. To reduce their resistance, the junction area could be made large and the pellet

thinner. However, increasing the junction area results in a proportional increase in the required threshold current. It is difficult to handle pellets less than 3-mils thick without breaking them, so processing such pellets would result in higher costs. The problems encountered are similar to those which arise in power transistors.

Imperfect contact between the alloyed region and the GaAs crystal also contributes to the thermal resistance problem. Better contact would increase the thermal path for heat flux. And, since alloys usually have lower thermal conductivity than metals, the alloyed regions of the diode also add thermal resistance.

The thermal resistance of the semiconductor pellet is so high, that the package in which the laser is mounted, however small, does not add significantly to it at room temperature. Thus, laser diodes can be mounted in small packages which are desirable when used in conjunction with microwave modulators.

On the other hand, at reduced temperatures, the thermal conductivity of semiconductors is much higher, so a package with lower thermal resistance must be used to keep the over-all resistance low. Thus, a large, bulky package is usually required for optimum performance at low temperatures.

New technologies which will permit the laser to be constructed entirely by epitaxial growth should reduce thermal resistance by an order of magnitude.

Pressure contacts vs. solder

The low threshold currents reported in this article were achieved with the laser diode soldered to its contacts on a transistor header. This is particularly significant because other researchers have reported that laser action is degraded, if not destroyed, by the use of solder contacts. According to author Lamorte, the usual laboratory laser diode is designed with pressure contacts. A pressure contact, he says, is not suitable for commercial use because of poor reliability.

If injection lasers are ever to capture a significant portion of the laser market, Lamorte holds, they must be mass-produced with solder contacts, much like transistors.

References

1. R.N. Hall, G.E. Fenner, J.D. Kingsley, T.J. Soltys and R.O. Carlson, *Physical Review Letters* 9, 366, November 1962.
2. M.I. Nathan, W.P. Dumke, G. Burns, F.H. Dill, Jr. and G. Lasher, *Applied Physics Letters* 1, 62, November 1962.
3. T.M. Quist, R.H. Rediker, R.J. Keyes, W.E. Krag, B. Lax, A.I. McWhorter and H.J. Zeiger, *Applied Physics Letters* 1, 91, December 1962.
4. H. Becker, D. Flatley and D. Stolnitz, *Solid-State Electronics*, 8, 255 (1964).
5. L.H. Gibbons, Jr., M.F. Lamorte and A.E. Widmer, *RCA Review*, XXIV, 199-213 (June 1963).
6. M.F. Lamorte, *Proceedings of the 16th Annual Power Sources Conference*, 1962.
7. N. Holonyak, Jr., and I. Leask, *Proceedings of the IEEE* 48, 1405-9, August 1960.
8. T. Gonda, H. Junker, M.F. Lamorte and P. Nyul, *IEEE 1964 Electron Devices Meeting*, Washington, D.C., October 29-31.
9. T. Gonda, H. Junker, M.F. Lamorte and R. Liebert, *IEEE 1964 Electron Devices Meeting*, Washington, D.C., October 29-31.
10. M.F. Lamorte, H. Junker and T. Gonda, to be published in *Journal of Quantum Electronics*.

Designer's casebook

Designer's casebook is a regular feature in Electronics. Readers are invited to submit novel circuit ideas, packaging schemes, or other unusual solutions to design problems. Descriptions should be short. We'll pay \$50 for each item published.

Two unijunction transistors produce three-state circuit

By Steven F. Summer

City College Research Foundation, New York

Logic circuits are normally binary elements which store information by assuming either of two states. However, it is sometimes possible to reduce the number of components in a logic circuit by using trinary elements, which can assume three different states. In the circuit shown below an inexpensive trinary module has been designed by using the latching characteristics of unijunction transistors.

The three possible states are:

1. Terminal A at zero volts and terminal B at 1.5 v.
2. Terminals A and B both at 1.5 v.
3. Terminals A and B both at zero v.

These correspond to the absence of an input pulse or the arrival of positive or negative input pulse. Input pulses are ± 12 volts in amplitude and 300 microseconds in duration. A 12-volt, positive pulse at the reset terminal restores the circuit to state one.

A voltage divider consisting of R_3 and R_4 biases transistor Q_1 at 85% of its minimum peak-point or firing voltage. Transistor Q_2 is similarly biased by a divider consisting of R_5 and R_6 . In state one, Q_1 is off and terminal A is at zero volts; Q_2 is conducting and terminal B is at 1.5 volts.

If a positive input pulse appears, the peak-point current of Q_1 is exceeded and Q_1 turns on,

and the circuit enters state two. If the input pulse is negative, Q_2 is back-biased and is turned off. This produces state three.

The reset pulse turns off Q_1 by reverse-biasing the base-emitter junction and turns on Q_2 by making the emitter current rise above the peak-point value.

Temperature changes will shift the peak-point voltages and current of Q_1 and Q_2 . Resistors R_1 and R_7 reduce the variations over a moderate temperature range.

The trinary module was used as the basic building block for coding the dash, dot and space of Morse code symbols from a standard typewriter keyboard. Six circuits were triggered in parallel to form the code for any one symbol. The outputs of each module were connected to AND gates and were read out sequentially by the system's clock.

If binary circuits were used, 12 flip-flop circuits would be needed.

Electronic thermostat controls temperature to within 0.1°C

By Gerrit H. P. Köhnke

Natuurkundig Laboratorium der Rijks-Universiteit, Groningen, Netherlands

Accurate temperature control requires that both the sensing device and the control circuitry respond to small changes in temperature. The electronic

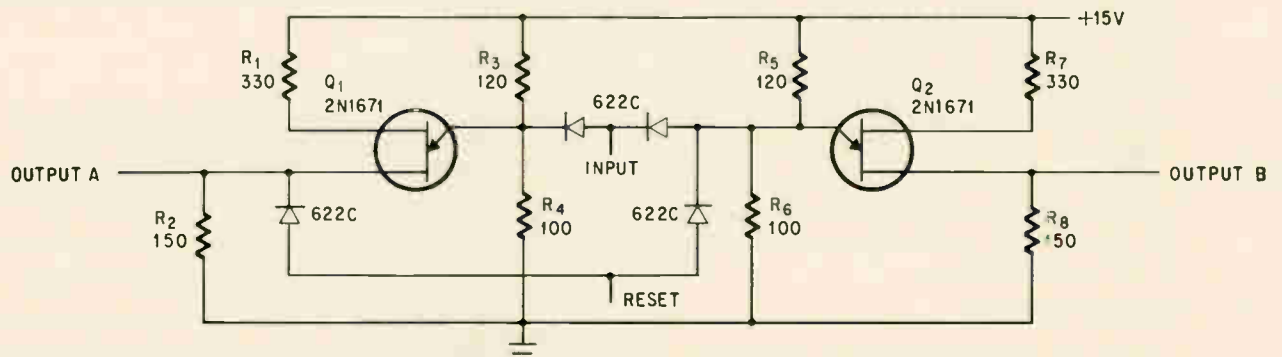

Trinary logic element uses two inexpensive unijunction transistors to store information in three different states. Because unijunction transistors can be constructed from a bar of silicon, the trinary module may be easily converted into an integrated circuit.

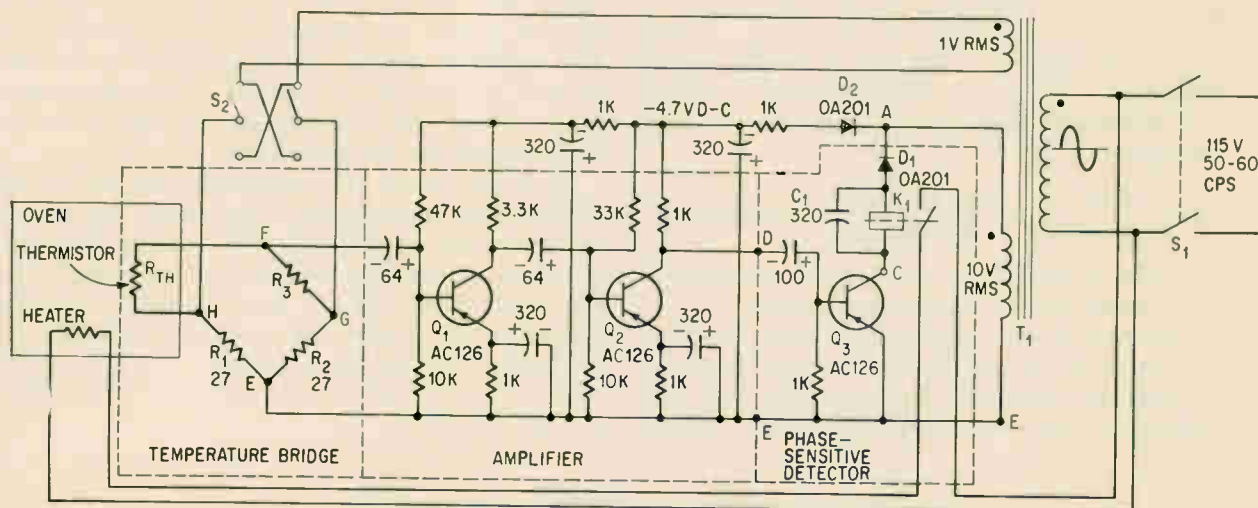

Thermostat senses an unbalanced voltage across the Wheatstone bridge terminals FE, when the resistance of the thermistor R_{th} , changes with temperature. The amplified error signal actuates a relay which controls the heater voltage.

thermostat shown above, though relatively simple in design, can maintain the temperature T_o of a device to within 0.1°C between -25° and 200°C . The temperature T_o is fixed by the resistance of R_3 in the Wheatstone bridge at the left in the schematic. Continuous control over the entire temperature range may be obtained by replacing R_3 with a calibrated precision-potentiometer.

The circuit is shown with the phase-reversing switch, S_2 , in position to control an oven temperature above the ambient temperature. Thermistor R_{th} , which is placed in the oven and is part of the Wheatstone bridge, senses the change in temperature. The bridge's voltage source is a 60 cycles-per-second voltage obtained from the step-down winding on transformer T_1 . When the oven is at the desired temperature, the voltage $V_{FE} = 0$, where V_{FE} is the bridge-output voltage. This implies that $R_3 = R_{th}$. If the temperature decreases, the bridge is unbalanced and a 60 cps voltage, ΔV_{FE} , in phase with the line voltage appears across terminals FE. ΔV_{FE} is amplified by a factor of G in Q_1 and Q_2 and appears in phase with the line voltage at the base of Q_3 . Transistor Q_3 will conduct if both its base and collector are negative with respect to the emitter. This occurs on the negative half-cycle of the line voltage. If $G \Delta V_{FE}$ is large enough, relay K_1 in the collector of Q_3 is energized and closes a contact to apply heater-voltage to the oven. The relay is held in its energized position during the positive portions of the line voltage by capacitor C_1 . As the temperature of the oven rises to the temperature specified, the bridge becomes more balanced and the current through the relay decreases. Eventually the relay opens, removing power from the heaters. If the bridge passes through the balance point, the unbalanced voltage becomes out of phase with the line voltage and Q_3 no longer conducts. Therefore

Q_3 is a phase-sensitive detector in which the power line waveform is the phase reference.

If the temperature of a refrigerated unit is to be controlled, the relay would energize a solenoid-operated valve connected to the refrigerant. Switch S_2 is placed in its other position to maintain the proper phase relationships for operating the relay. In this instance the relay would be activated above the temperature T_o established by R_3 .

The circuit may be analyzed in the following manner. Near balance,

$$R_{th} \approx R_3 \quad \text{and} \quad (1)$$

$$\Delta V_{FE} \approx \frac{R_{th} - R_3}{4 R_{th}} V_{GH} = \frac{\Delta R_{th}}{4 R_{th}} V_{GH} \quad (2)$$

The resistance of the thermistor used in this circuit varied with temperature according to the relation

$$R_{th} T_o = R_{th} 25^\circ\text{C} \exp K(25^\circ - T_o) \quad (3)$$

where $R_{th} 25^\circ\text{C} = 1,000$ ohms and $K = 0.023$ per $^\circ\text{C}$ (4)

Therefore the ratio of the increase in the thermistor's resistance, caused by the drop in temperature, to the resistance R_{th} at the temperature T_o is approximately

$$\frac{\Delta R_{th} T_o - \Delta T}{R_{th} T_o} \approx K(\Delta T) \quad (5)$$

where ΔT is the drop in temperature and ΔR_{th} is the incremental increase in the resistance of the thermistor. Thus

$$\Delta V_{FE} \approx \frac{K(\Delta T)}{4} V_{GH} \quad (6)$$

This signal is amplified by Q_1 and Q_2 . Therefore, at the base of Q_3

$$V_{DE} \approx \frac{GK(\Delta T)}{4} V_{GH} \quad (7)$$

The sensitivity of the detector is such that the

relay is energized when $V_{DE} = 0.25$ volts root mean square (rms) and deenergized when $V_{DE} = 0.12$ volts rms. The gain $G = 300$, and the bridge supply voltage $V_{GH} = 1$ volt rms. Therefore from equation 7, the difference in temperature at which the relay is energized is

$$\Delta T = \frac{4 \Delta V_{DE}}{G K V_{GH}} = \frac{4(0.25 - 0.12)}{300(.023)(1)} = 0.075^{\circ}\text{C}$$

It can also be shown that the relay is deenergized 0.07°C before bridge balance is reached.

All resistors in the bridge should have 1% tolerances. Resistors R_1 and R_2 are the same type and value and are mounted closely together, so that temperature variations will not affect their relative

values. As a result, R_3 has the major influence over the temperature at which the thermostat operates. For maximum accuracy the temperature of R_3 must be held as constant as possible. The temperature range of the unit is determined by the allowable temperatures for the thermistor.

In the schematic, the transistors and diodes are of European manufacture. The diodes are silicon and must operate with 150 milliamperes. The transistors are germanium and have low-frequency current gains (β) of 150 at 1 ma. Npn transistors may be used if the diodes and polarized capacitors are reversed. The relay has a winding resistance of 130 ohms. A current of 15 milliamperes is required to actuate the relay.

Breadboarding IC systems with color-coded modules

By Eugene L. Field

Sylvania Electronic Systems, Williamsville, N.Y.

Integrated circuit packages, such as flatpacks, require special handling to prevent damage from excessive heat during soldering operations or lead breakage during testing. The problem is especially severe when breadboarding with flatpacks because interconnections are changed many times in the process of achieving the final design.

To reduce these problems, a technique has been developed that not only permits repeated changes in interconnections, but also saves a great deal of time in the design of new circuitry. It has also been useful and economical for integration of subsystems, for trouble shooting equipment, and for evaluation tests.

The photograph at the right shows a typical breadboard arrangement with 144 integrated circuit modules plugged into power-supply strips that are mounted across the face of a standard 19-inch rack. Each integrated circuit is mounted on its own printed circuit module with provisions for such additional discrete components as timing resistors, diodes or coupling capacitors. Integrated circuit packages and discrete components are mounted on the back of the modules and are not visible in the photograph. All modules are color-coded with decals that identify the pin connections and the logic function. Interconnections between modules are made with wires that have small pin-plugs on each end. The plugs mate with pin jacks mounted on the modules.

The reverse side of four modules can be seen in the top photograph on p. 103. The first board on the left shows the printed circuit wiring for a ten-lead, integrated-circuit package. The next board shows a standard TO-5 transistor and other discrete components mounted on the printed circuit. The third and fourth boards are wired for TO-5 case- and flat-package versions of the same integrated circuit logic element. All boards use the same printed circuit.

One basic etched circuit may be used for logic elements manufactured by a number of companies. The only changes required are in the pin connections and the decal on the front of the board. Pin connections may be changed by removing portions of the etched conductor and by wiring between points. For example, the same basic printed circuit layout may be used for Sylvania's SUHL line, for

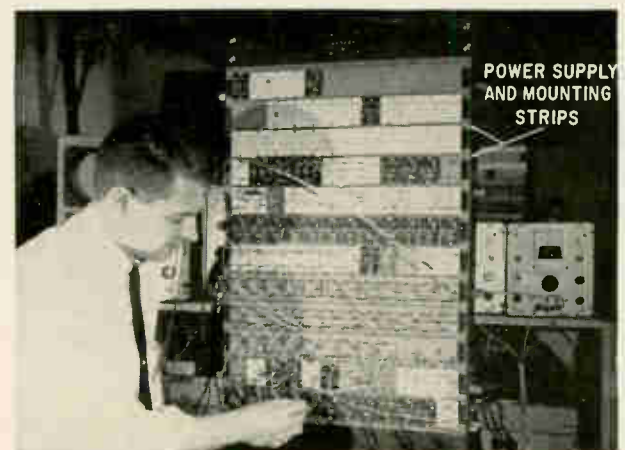

Integrated circuit packages are mounted on individual modules and are interconnected to set up a breadboard circuit. Power is supplied through a printed circuit board that is sandwiched between insulator strips mounted along the face of the rack.

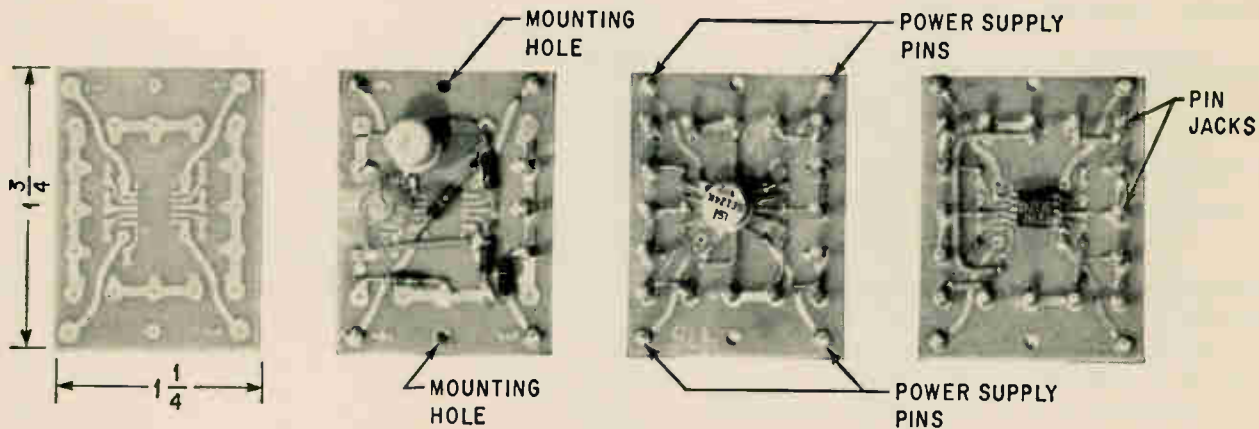

Modules are supplied with mounting holes for inserting a thumb-screw that engages a threaded hole on the mounting strips. Terminals are miniature pin jacks which accept pin plugs for interconnecting the modules. In each of the four corners is a pin for a pressure connection to the power-supply strips.

Signetics' SE100 line and for Texas Instruments' Series 53. Decals are easily and inexpensively made from "Scotch-Cal," a product of the Minnesota Mining and Manufacturing Corp. Three boards using the same etched circuit for different logic functions are shown in the photograph at the right.

Special purpose modules can be constructed for testing and for mounting other devices such as miniature relays and crystals. As an example, read-out circuits are mounted on the bottom row of the rack in the photograph on page 102. The lamp driver circuit and a small incandescent bulb provide a very useful indicator module for showing logic levels at various points in a digital system.

The modules are mounted on aluminum angle-brackets. On the surface of each angle bracket is a sandwich assembly consisting of a strip of circuit board between two strips of insulation. Four etched conductors on each printed circuit strip are used as power lines. Holes are drilled in the outer insulator strip to allow the power-supply pins on the module to make contact with the etched conductors. To insure good contact, small "fuzz buttons" made of copper wire-mesh are trapped between the conductor and the outer layer of insulation. The modules are firmly mounted to the strips by small thumb screws which engage tapped holes regularly spaced on the aluminum angle-bracket. This procedure for obtaining power connections by standardized pin-layouts minimizes wiring errors that cause damaged circuits.

In working with the system a variety of modules are "plugged" into the rack and are automatically supplied with power by the power-supply printed circuit board. Interconnections are then made for the circuit that is to be breadboarded. Entire systems of counters, shift registers, gating circuitry, line drivers and readout indicators can be interconnected and tested as a complete unit. Voltages from external power supplies and input signal

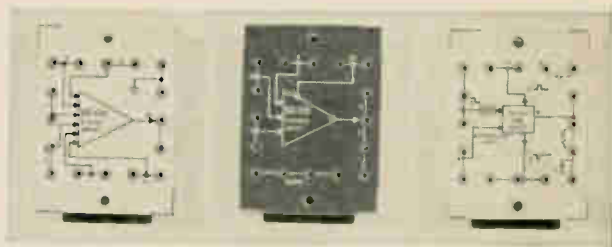

Color-coded decals, affixed to boards using the same printed circuit, differentiate the various logic functions. The decals also indicate the interconnection terminals and the discrete components mounted on the boards.

generators can be varied readily for worst-case analysis effects.

Breadboard systems such as the one in the photograph have been used at Sylvania in the design of Minuteman ground-support equipment. The technique has been used successfully at frequencies as high as 2.5 megacycles per second. If the breadboard is laid out and interconnected carefully, the frequency range may be extended.

The circuit modules are extremely sturdy and can be used over and over again. Also, the test setups can be used in many phases of developing deliverable hardware. Certain breadboard circuits like multielement shift registers are needed so often that they are kept mounted on a strip and ready to use. Some functions have been assembled to serve as simulators or special test devices during evaluation test programs.

Another feature of the technique is that a draftsman can derive a logic diagram directly from the breadboard. When time is critical, close-up photographs can record all the information required for a drawing. On the other hand, once a logic drawing exists and the modules are available, a relatively inexperienced technician can easily put together a complicated breadboard system.

Curves speed design of multiplier circuits

By D. Bruce Swartz

Sperry Microwave Electronics Co., Clearwater, Fla.

Frequency multipliers are circuits that permit current flow at several different frequencies. A varactor frequency-doubler circuit shown below is a typical example of a multiplier. Parallel resonant circuits or traps consisting of an inductance, L , in parallel with a capacitance, C , are used at the output of the doubler to reject the fundamental current. Similarly, a trap in the input circuit keeps second harmonic voltage from appearing across the generator terminals.

The usual design procedure for such a stage begins with the selection of components of a resonant trap circuit to stop current flow at one frequency, followed by calculation of the equivalent reactance of this trap at other frequencies of interest. In many cases, this reactance is used as part of the matching circuit. The equivalent reactance for various ratios of L and C can be determined by the relatively complex impedance-equation given by

$$Z = \frac{(j\omega L) \left(\frac{-j}{\omega C} \right)}{j \left(\omega L - \frac{1}{\omega C} \right)} \quad (1)$$

However, calculations by this method are tedious and time consuming.

The graph at the right enables the impedance to be determined easily from the ratio L/C . The reactance of the parallel resonant circuit is shown at frequencies f , which are either higher or lower than the resonant frequency f_0 . The left hand ordinate is the inductive reactance, X_L , of the tuned circuit when the frequency, f , is less than f_0 . The right hand ordinate is the capacitive reactance, X_C , of the circuit when the frequency, f , is greater than f_0 . The graph is based on the relationship

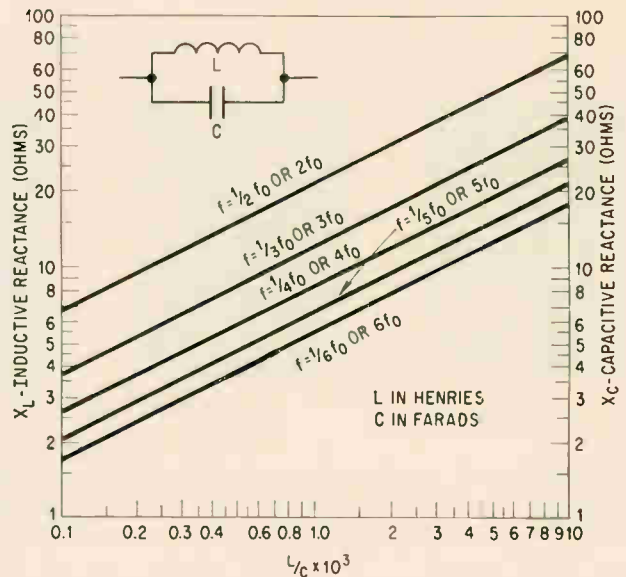

Reactance curves show the impedance of a lossless parallel-resonant circuit as a function of the L/C ratio.

$$\log Z = - \log \left| \frac{(f/f_0)^2 - 1}{f/f_0} \right| + \frac{1}{2} \log \frac{L}{C} \quad (2)$$

which is derived from equation 1.

An example illustrates the use of the curves. Assume that $L/C = 400$. To determine the reactance at a frequency $f_0/2$, the graph is entered on the ordinate at the point marked 0.4 which corresponds to $L/C = 400$. A vertical line drawn upward crosses the line $f = \frac{1}{2} f_0$, at $X_L = 13$ ohms.

If the L/C ratio falls outside the range of the graph, the values of L/C are multiplied by 10^2 and the reactances are multiplied by 10. If the L/C ratios are multiplied by 10^{-2} the reactances are multiplied by 10^{-1} . Using the same example as before, except with $L/C = 40 \times 10^3$, the inductive reactance at $f = \frac{1}{2} f_0$ would be about 130 ohms. If in the same example, $L/C = 4$, the inductive reactance of the circuit would be 1.3 ohms. In most practical applications the L/C ratio will fall within the range shown on the graph.

The graph is derived by assuming that the resistance in the resonant circuit is zero. For most experimental work, the small error introduced by this assumption can be ignored.

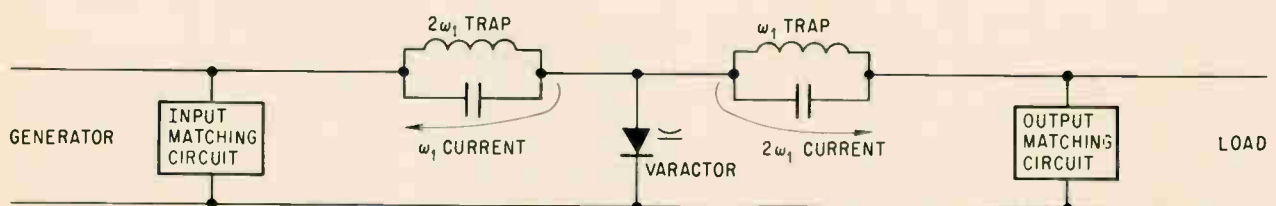

Varactor doubler uses traps for filtering and for matching the diode impedance. The traps are resonant at radian frequencies ω_1 and ω_2 .

Tunnel-diode oscillator expands f-m system's channel capacity

Voltage-controlled oscillator performs well at frequencies up to 200 Mc, accommodates 600 channels with less power, improves linearity and sensitivity, and is easy to build

By Frederick H. Lefrak

Radio Corp. of America,
Defense Electronic Products Communications Systems Division, New York

In wideband frequency-modulation systems for telemetry, satellite communications and other applications that require a large number of information channels, performance depends mainly on the characteristics of the voltage-controlled oscillator (vco). The vco, in the modulators or demodulators, produces the necessary frequency deviation. The most important requirement is that the vco produce a wide frequency swing relative to the center frequency—and in a highly linear fashion—when a small control voltage is applied.

With tunnel diodes, which can switch at high speed, as the oscillating elements, a new vco circuit works excellently at frequencies to at least 200 megacycles per second and is simple to build. Its simplicity is an added advantage over more complex competitors like the varactor-controlled oscillator and the klystron.

The two tunnel diodes in this vco are located in an astable multivibrator circuit designed to produce a symmetrical square-wave output.

If the multivibrator had been built with transis-

tors—say a pair of 1-gigacycle devices—the multivibrator might have a 30-Mc center frequency and a sensitivity of 25 Mc per volt. At frequencies above 70 Mc, switching in nanoseconds—the kind of speed delivered by a tunnel diode—is required. The resulting tunnel diode circuit is simple, with little phase shift, and requires a minimum of adjustment; high sensitivity to control voltage is obtained with this circuit.

The only disadvantage is that the tunnel diode has a low-output power which has to be amplified to drive a phase detector or mixer.

Tunnel-diode vco analysis

The multivibrator oscillates when the tunnel diodes alternately switch between their high- and low-voltage states.

In the circuit diagram, page 106, top, the tunnel diodes are identical and resistance R is less than the minimum negative resistance r_d of either tunnel diode. Although the circuit has a baseband input current, it is more conveniently analyzed through voltage $E_{bi} = RI_{bi}$.

To understand how the circuit oscillates, assume that because of the circuit symmetry, the diode voltages are equal—corresponding to zero voltage across inductor L —and the diodes are biased in the negative-resistance region. Because this is an unstable condition, the operating points of both diodes will shift so that one is at high voltage and the other at low voltage with initially equal currents through them. The voltage induced across inductor L decays toward zero at a rate determined by four values: L , R , the positive dynamic resistance of the diodes, and the final current through L . All of these

The author



Frederick H. Lefrak, holder of a master's degree in electrical engineering, has worked with advanced analog communication techniques, on stereophones, video tape recording and color television at the Radio Corp. of America.

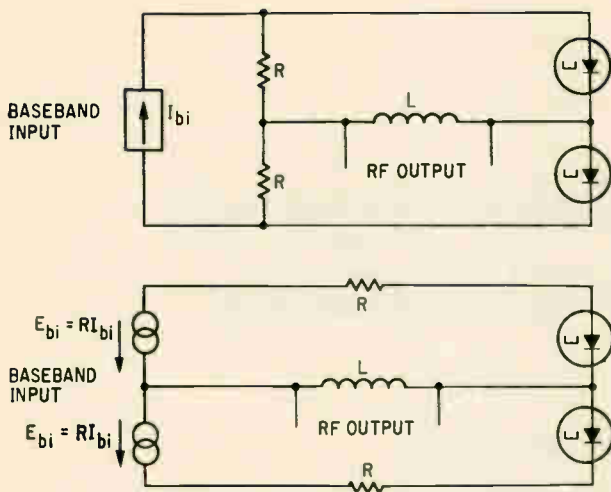

Basic circuit of a tunnel-diode oscillator with constant-current drive, top, and its equivalent circuit, bottom. The circuit oscillates because the tunnel diodes alternately switch between their high- and low-voltage regions.

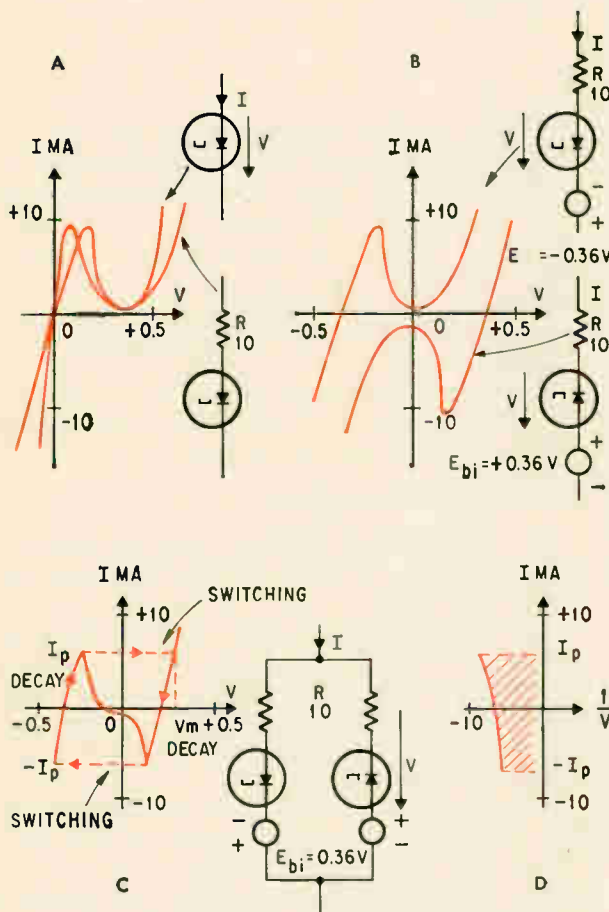

Graphic analysis of the vco's composite characteristic is obtained by adding the effect of the series resistance to the tunnel diode's V-I curves (A), then adding the effect of the series voltage and plotting the resulting curves for both branches on the same coordinates (B), and finally adding these curves (C). The shaded area (D) represents the integral of $(1/V)di$ evaluated between $-I_p$ and $+I_p$. This area is used to calculate the period.

values affect the operating frequency. When the current through L brings the diodes into the negative resistance regions of their characteristics, switching takes place and the diodes become biased in opposite directions.

The symmetry of the circuit produces a nearly square output voltage waveshape with a slight tilt, caused by the decay of voltage across L during each half cycle.

To facilitate analysis, the vco with a current-source baseband input I_{bi} may be replaced by an equivalent voltage-source baseband input E_{bi} as in the equivalent circuit diagram at the left. Because the tunnel diode V-I characteristic is non-linear, the vco's frequency versus voltage characteristic is most conveniently derived by graphic methods illustrated in the diagram below. For this analysis, $R = 10$ ohms, $E_{bi} = 0.36$ volt, and the V-I characteristic is measured for an RCA IN3858 germanium tunnel diode.

This analysis is done to construct the V-I characteristics of the entire vco circuit measured at the inductor terminals. This is accomplished in four steps. First, as shown in A, the series resistance R is added to the tunnel diode and the combined V-I characteristic is plotted. Second, the effect of E_{bi} is added to the resulting characteristic. Third, on the same coordinates, the curves for the series combination of tunnel diode, R and E_{bi} for both circuit branches are plotted. These curves are shown by B. Fourth, these curves, point by point, are added to obtain the composite V-I characteristic for the entire circuit represented by the solid line in C.

The multivibrator action in the vco is shown by the circulating arrows on the composite characteristic for the total vco circuit. An exponential decay in voltage across the inductor alternates with switching across the negative-resistance region. Switching time is negligible compared with the decay time, so the decay time is essentially half the radio-frequency period of the voltage-controlled-oscillator.

From the defining equation for the voltage across

$$\text{an inductor, } V = -L \frac{di}{dt},$$

the half-wave period is

$$\frac{T}{2} = -L \int_{-I_p}^{+I_p} \frac{1}{V} di$$

The integral is evaluated graphically by replotting the left-hand portion of the composite characteristic between

$$-I_p \text{ and } +I_p \text{ as a function of } \frac{1}{V}$$

and calculating the area under the curve, as shown in figure D.

From this graphic analysis, curves for frequency versus current and waveshape amplitude versus current were calculated from composite characteristics obtained for different values of I_{bi} . These

curves are for two values of R in the top and middle diagrams shown at the right. The abscissa is baseband input current times resistance R . In the frequency diagram, the ordinate is the product of frequency times inductance L .

Frequency curves

The amplitude curves show little variation over most of the range of I_{bi} . The frequency curves consist of three regions:

1. Frequency decreases rapidly as I_{bi} increases;
2. Frequency increases gradually with I_{bi} ;
3. Frequency increases rapidly with I_{bi} .

The composite characteristics of page 106 are related to these regions.

In region 1, an increase in I_{bi} causes a large increase in I_p while the positive dynamic resistance of the vco circuit decreases. The increase in I_p extends the range of current decay and the decrease in resistance retards the rate of decay. Both effects increase the half-wave period.

In region 2, as I_{bi} increases, I_p remains nearly constant and the circuit's dynamic resistance continues to decrease. The result is a moderate positive slope in the frequency-voltage characteristic in this region.

In region 3, I_p decreases rapidly with an increase in I_{bi} while the circuit's dynamic resistance remains nearly constant. So, frequency increases rapidly as a function of voltage.

In region 3, if L is chosen so that a frequency of 70 Mc corresponds to the center of this region, then the useful frequency swing is about plus or minus 15 Mc. The sensitivity is 7.3 Mc/milliampere for $R = 5.6$ ohms and 10.4 Mc/milliampere for $R = 10$ ohms. Frequency sensitivity is rated in terms of current for convenience, although it could also be rated in terms of voltage.

Region 1 was not used because tests showed that quiescent I_{bi} required critical adjustment and the amplitude of the output waveshape varies too much. The linear portion of region 2 could have been used, but it has marginal range for a ± 10 -Mc deviation at 70 Mc.

Testing the vco

The performance of a tunnel-diode vco designed with $R = 10$ ohms and $L = 0.1$ microhenry was measured at a 70-Mc center frequency. This value of R was less than r_d , but large enough to provide high current sensitivity with a moderate quiescent drive requirement. The frequency-response curves at the right and on page 108, top, were measured with the vco fed by the collector of a transistor, which in turn was driven by an emitter follower. For the frequency-current characteristic, the current I_{bi} was derived by measuring the voltage across a 22-ohm resistor in the emitter circuit of the transistor feeding the oscillator. For the frequency-voltage characteristic, the voltage E_{be} —the sum of the diode voltages—was measured directly across the input terminals.

With current drive, shown in the first curve, re-

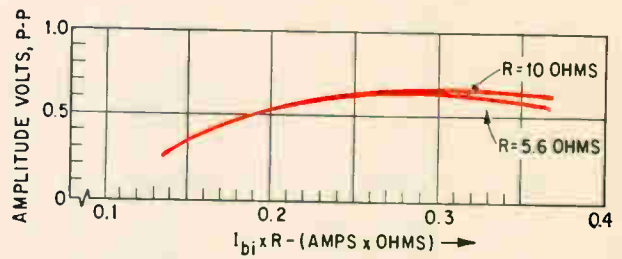

Vco's output waveshape amplitude characteristics are calculated from the graphic analysis of composite characteristics obtained from different baseband input current values. The amplitude varies little over most of the range of input currents.

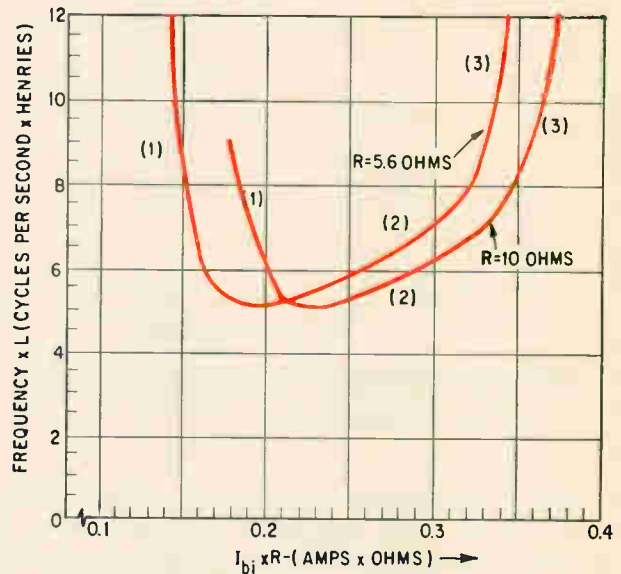

Vco's frequency characteristics, as calculated from the graphic analysis, consists of three regions. Of these, region 3 is the most useful because it has a frequency swing of about ± 15 Mc about a 70-Mc center frequency, and sensitivities of 7.3 Mc/ma for $R = 5.6$ ohms and 10.4 Mc/ma for $R = 10$ ohms. Region 2 has a frequency swing of only ± 10 Mc and region 1 is not generally useful because quiescent I_{bi} requires critical adjustment.

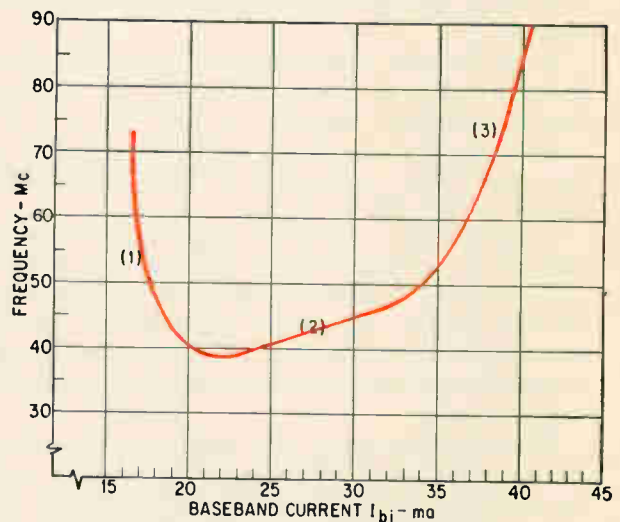

Measured frequency-baseband current characteristics. Region 3 has a 40% bandwidth with respect to 74-Mc center frequency.

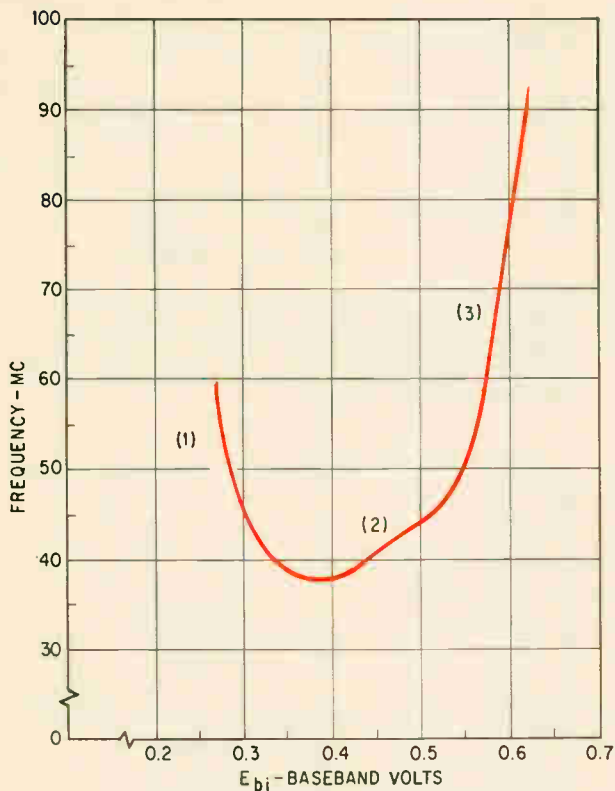

Vco frequency characteristics measured as a function of voltage drive results in better linearity in the useful region than from current drive.

Region 3 corresponds to a frequency range of 59 to 89 Mc—a 40% bandwidth with respect to the center frequency of 74 Mc. Measured sensitivity at 74 Mc is 10.3 Mc per ma and agrees closely with the sensitivity of 10.4 Mc per milliamperere calculated from the curves on page 106. Although region 2 of this curve is more linear, it extends only from 37.5 Mc to 44 Mc—a 16% bandwidth about a center frequency of 41 Mc—and the sensitivity is only 0.92 Mc per milliamperere. If region 2 were centered at 70 megacycles by decreasing the value of the inductor L, the sensitivity would be proportionately greater.

Better linearity is obtained with constant-voltage drive in region 3. Sensitivity is 580 Mc per volt. Region 2 extends from 37.5 to 43.5 Mc, a 14.8% bandwidth, and sensitivity is 60 Mc per volt. If this region were centered at 70 Mc, the sensitivity would be 104 Mc per volt.

Unfortunately, constant-voltage drive is more difficult to produce because the vco is a low-impedance circuit, requiring about 40 milliamperes. At this current, the output impedance of several cascaded emitter followers should be low enough to approximate the output impedance of a constant-voltage source.

Characteristics for a vco with constant-voltage drive can be calculated by a graphic analysis similar to that for the current drive. The circuit diagrams shown above represent a voltage-driven vco and a two-mesh equivalent circuit used in the analysis.

Spurious oscillations suppressed

Care must be taken to prevent spurious oscillations in a vco circuit. Because of its high-frequency capabilities, a tunnel diode tends to oscillate at frequencies determined by the parasitic parameters of a circuit, such as shunt capacitance and the inductance of the lead wires. In the experimental model of the vco, ultrahigh-frequency oscillations were suppressed by inserting ferrite beads in series with the baseband input leads. The beads have

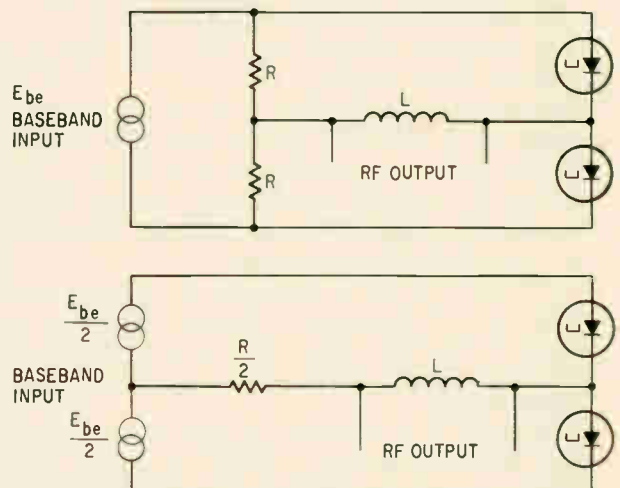

Constant-voltage drive provides better linearity in region 3 than constant-current drive, although it may be difficult to build the circuit because of the vco's low input impedance. The actual circuit, top, can also be analyzed graphically using its equivalent circuit, bottom.

about 25 ohms resistance and thus lower the Q of the lead inductance. One or two beads connected in each lead allows stable, noise-free modulation of the vco.

Spurious oscillation also occurs from shunt capacitance in the circuit in combination with the total resistance and inductance L. For the circuit shown above these oscillations occur at 120 Mc. To suppress them, the vco capacitance loading was minimized and a wire holding 3 ferrite beads connected from the ends of inductor L to the base of an emitter-degenerated stage with an input impedance of 7.5 picofarads and 300 ohms in parallel at 70 Mc.

With constant-current drive as in the diagram on page 109, one baseband lead to the vco is effectively grounded. Little signal loss results from taking the output between one side of L and ground, instead of directly across L.

Phase-locked detector

In a phase-locked, f-m threshold detector for several hundred frequency-division multiplexed channels, the vco's loop delay is as important as the need for high linearity and sensitivity. Wide frequency range is also necessary for the high deviation ratios required for satellite communications systems.

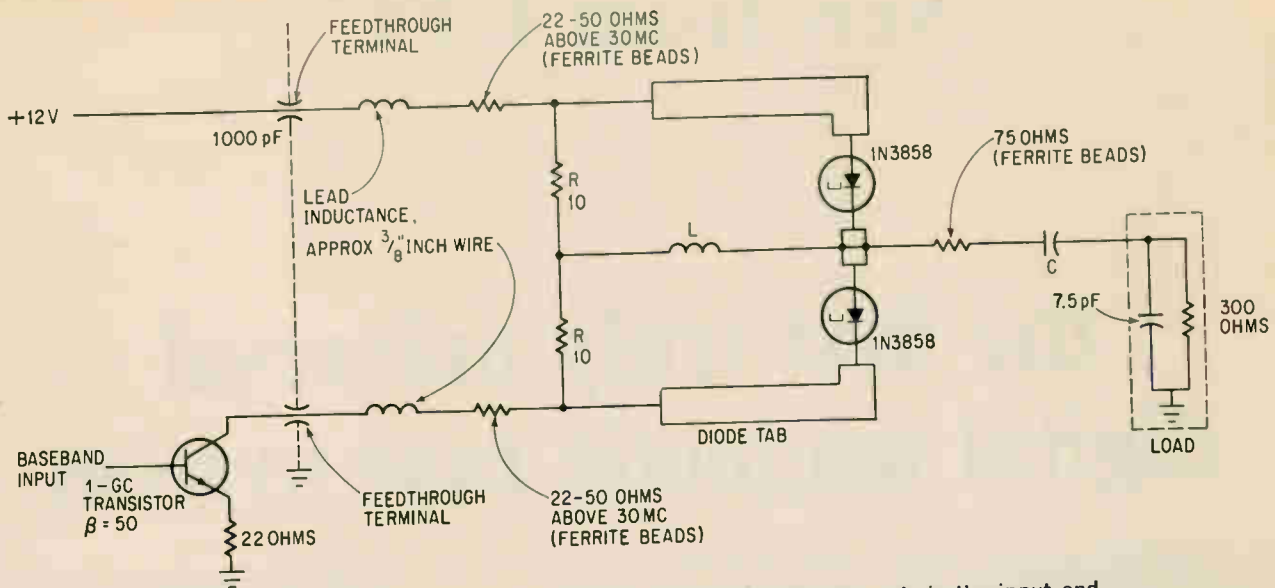

Spurious oscillations are suppressed in the tunnel diode vco by inserting ferrite beads in the input and output connections to reduce the Q of the inductance in the leads.

The baseband frequency response of vco, with a 70-Mc center frequency, has a measured low-frequency cutoff at 5 Mc. This causes a 30° excess phase shift at 2.66 Mc—the maximum frequency of a 600-channel baseband—and is the main reason for the measured phase shift of 40° for the entire discriminator feedback loop. Excess phase shift limits the amount of feedback that can be applied to obtain optimum threshold performance or to reduce the distortions caused by the nonlinearity of loop components.

What produces the low-pass response is undetermined. However, since L must be involved, the baseband cutoff frequency should increase proportionally with the center frequency. For example, if the center frequency were 120 Mc, the excess phase shift at 2.5 Mc would be approximately 17° .

Noise power ratio (npr) of the detector was measured with the vco operating in region 3 at a 70-Mc center frequency and with constant-current drive. The npr is the ratio of the power in an occupied channel to the power spilling over from adjacent channels. With a 552-kc baseband frequency—corresponding to 120 channels—and ± 2.5 -Mc vco frequency deviation, a npr of 43 db was measured in the highest channel and 57 db in the lowest channel. These npr values correspond to signal-to-noise ratios of 58 and 72 db.

The tunnel diode circuit showed a 6.5 db threshold improvement over open loop detectors with the same 600-channel baseband capacity.

Flexible signal-to-noise ratio

With the growing trend toward greater deviations and wider basebands in f-m systems, the voltage-controlled oscillator described in this article should prove useful.

One result of this trend would be an increase in information capacity, such as the number of telephone channels that can be transmitted as fre-

quency-division multiplex. Another result would be further utilization of the noise-suppressing properties of frequency modulation. Frequency modulation permits the transmitter's peak power to be received with less noise. Compared with single-sideband amplitude modulation, for example, f-m also provides a certain amount of design flexibility in improving signal-to-noise ratio by permitting adjustment of the deviation ratio. The deviation ratio is the ratio of the maximum frequency excursion of the carrier to the highest frequency in the baseband signal. Above the system's noise threshold, the output signal-to-noise ratio is proportional to the carrier-to-noise ratio at the demodulator. However, signal-to-noise ratio is also proportional to the square of the deviation ratio.

Thus, while satellite transmitter output power is severely limited by the space allowed for the power supply, the signal-to-noise ratio can be maintained at a high value by increasing the deviation ratio. Therefore, a system able to accommodate wide-deviation signals is especially valuable when reduced threshold demodulators are used, such as would be necessary for a satellite communications system.

Bibliography

- CCIR, "Radio-Relay Systems for Telephony Using Frequency-Division Multiplex," Recommendation No. 287, Documents of the 9th Plenary Assembly, vol. 1, p. 258, Note 8, Los Angeles, 1959.
- C.S. Weaver, "Thresholds and Tracking Ranges in Phase-Locked Loops," IRE Transactions on Space Electronics and Telemetry, vol. SET-7, pp. 60-70, September, 1961.
- R.C. Boonton Jr., "Demodulation of Wideband Frequency Modulation Utilizing Phase-Lock Technique," 1962 Proceedings of the National Telemetry Conference, vol. 2, paper 6-4, Washington, D.C., May 23-25, 1962.
- J.J. Gibson, "An Analysis of the Effects of Reactances on the Performance of the Tunnel Diode Balanced Pair Logic Circuit," RCA Review, vol. 23, p. 460, December, 1962.
- A. Benjaminson, "Phase-Locking Microwave Oscillators to Improve Stability and Frequency Modulation," Microwave Journal, vol. 6, pp. 88-92, January, 1963.

New from CEC...

the first truly universal digital magnetic tape system



The new DR-3000 offers unequalled versatility and performance — at the lowest cost of any comparable digital tape system available today.

Check the following advantages, and you will see why the DR-3000 is the obvious answer for so many digital data processing requirements.

1 Compatibility. The DR-3000 will guarantee complete machine-to-machine compatibility with any other DR-3000, or with any IBM-compatible tape system operating within IBM specifications.

2 Versatility. Both high or low speed applications. The most com-

pact system made, it will mount 2 or 3 to a rack — even fit through a submarine hatch. It is available in horizontal or vertical cabinets. Ruggedized for semi-mobile or extreme environments, it provides a complete selection of input/output logic levels. It is the ideal unit for most commercial or laboratory data processing systems.

3 Operator convenience. The DR-3000 is the easiest of all to load due to a straight tape loading path which requires no threading. The entire operation takes less than 10 seconds. Front access only is required for all normal maintenance. In addition, a complete selection of IBM-compatible accessories is available.

4 Formats. 7 channel 729 series or 9 channel 360 series formats are standard, reading and writing at 200, 556, or 800 bpi — plus 1600 bpi phase-encoded format available on special order.

5 Reliability. Only field-proven design concepts are used. Dual capacitors with rugged drive actuators provide positive drive. There are no belts or mechanical linkages to cause tape slippage or creep. Air bearings virtually eliminate tape friction. CEC-built all-metal-front-surface read/write heads have achieved over 12,000 hours operational life in field environments. All electronics are modular and solid-state.

6 Performance. The DR-3000 assures the most performance per dollar available today. Fast start/stop characteristics provide complete unrestricted programming up to 200 commands per second. There are 84 inches of tape buffering. Tape speed variation is less than $\pm 0.5\%$.



Transport Specifications:

Standard $\frac{1}{2}$ " tape, 7 or 9 channels • Tape speeds — $37\frac{1}{2}$ or 75 ips standard IBM formats • Operates at 200, 556, 800 bpi NRZ or 1600 bpi phase-encoded • Start time — less than 4 msec • Stop time — less than 3 msec • Rewind — 2400 feet in $2\frac{1}{2}$ minutes • Bit dropout rate less than 1 in 10^7 • Maximum total skew — within full IBM machine-to-machine compatibility at all speeds • Average tape speed accuracy — within $\pm 0.5\%$ of absolute • Cycling rate — 200 commands-per-second without programming restrictions • Power — 1 kva • Size — $19" \times 24\frac{1}{2}" \times 13\frac{1}{2}"$ • Weight — 135 lbs.

For all the rewarding facts about the DR-3000, call CEC or write for Bulletin 3000-X5.

CEC

Data Recorders Division

CONSOLIDATED ELECTRODYNAMICS

A SUBSIDIARY OF BELL & HOWELL/PASADENA, CALIF. 91109
INTERNATIONAL SUBSIDIARIES: WOKING, SURREY, ENGLAND
AND FRIEDBERG (HESSEN), W. GERMANY

Electronics Markets 1966

TOTAL ELECTRONICS INDUSTRY

(millions of dollars)

	1965	1966	1969
ELECTRONICS INDUSTRY, TOTAL	18,065.0	19,430.8	23,826.0
Consumer electronics	3,079.5	3,291.5	3,586.3
Industrial-commercial electronics	5,083.5	5,837.3	7,918.7
Federal, (including military and government non-military, adjusted for calendar years)	9,551	10,190	11,600
Replacement components	702	712	721

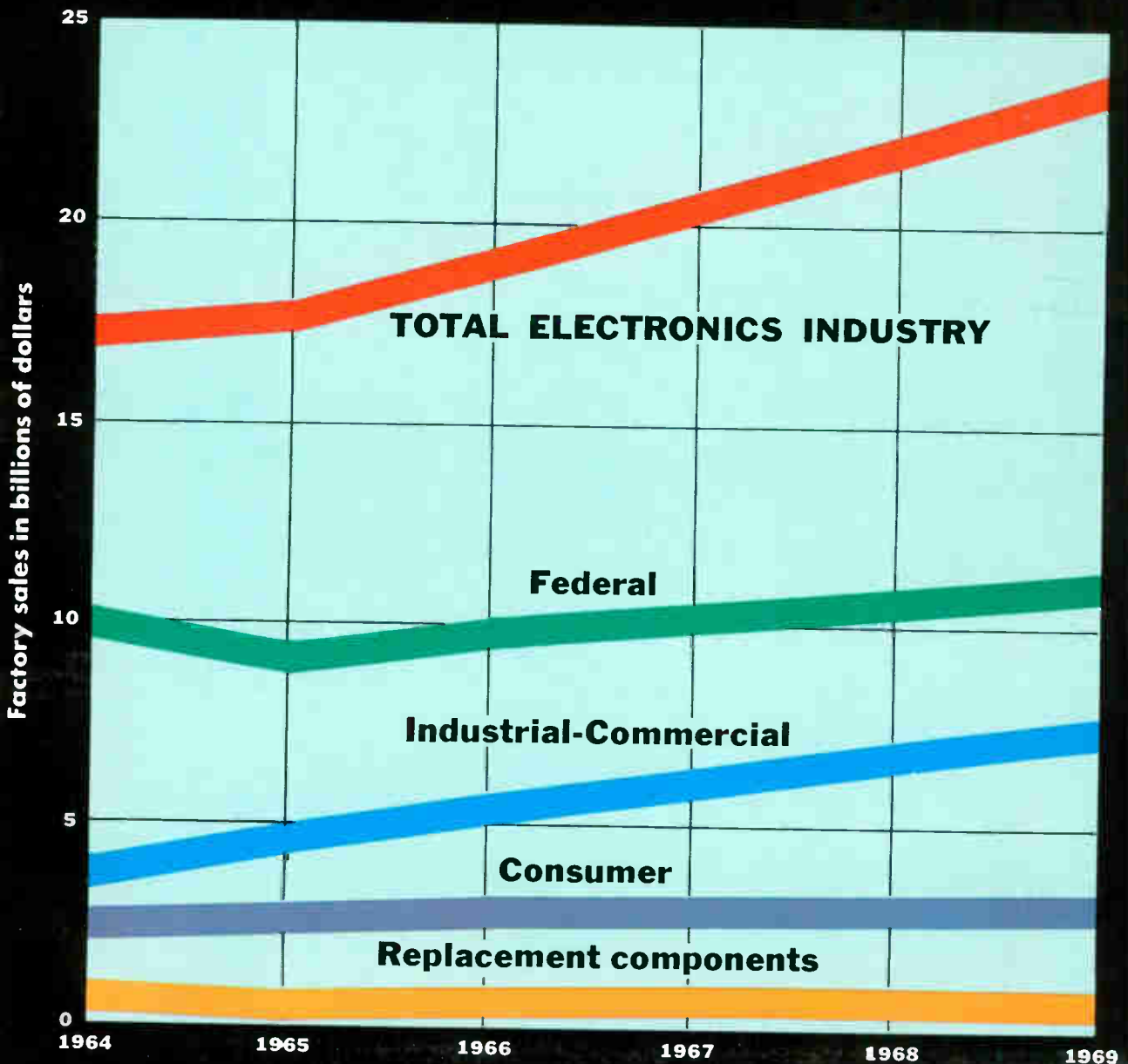

COMPONENTS

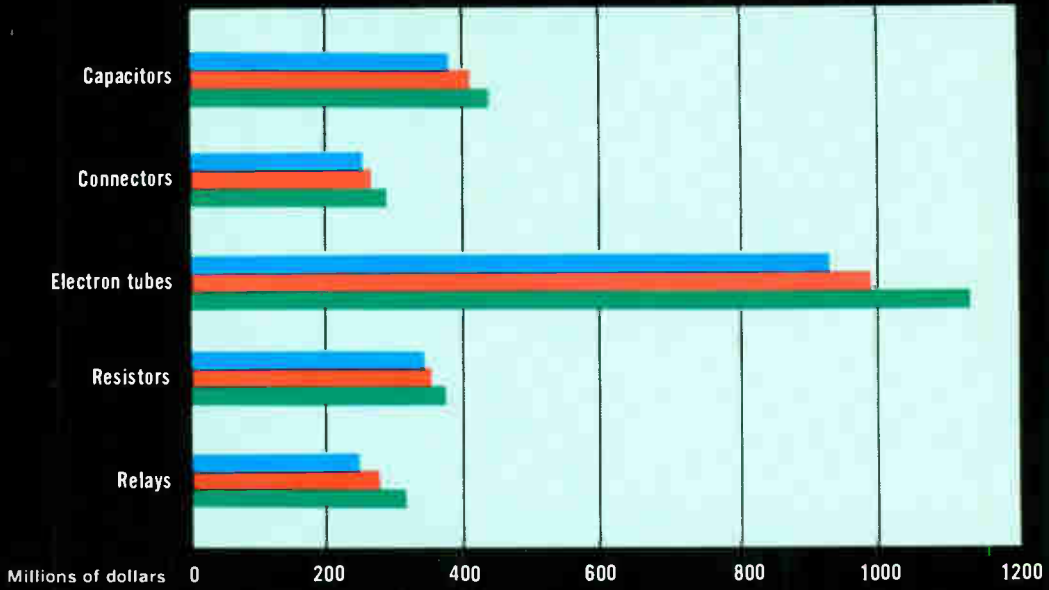

SEMICONDUCTORS, TOTAL

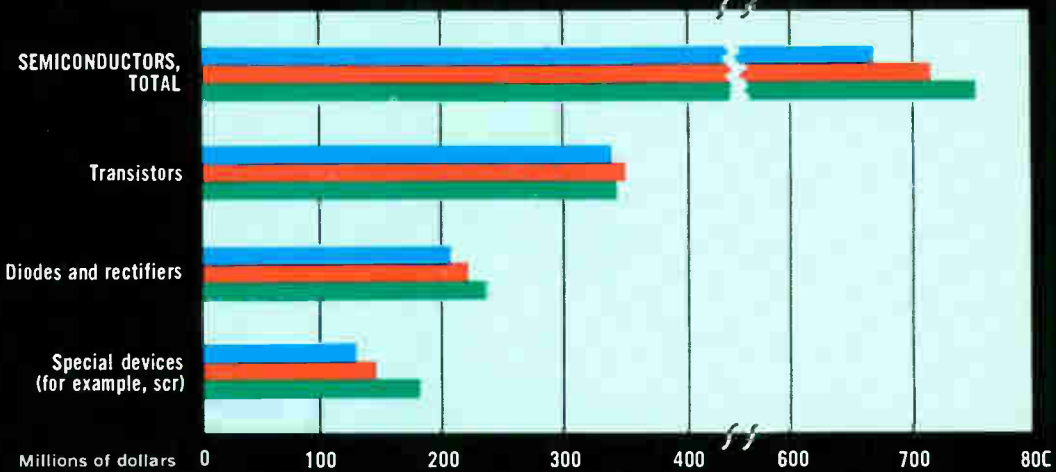

COMPLEX COMPONENTS

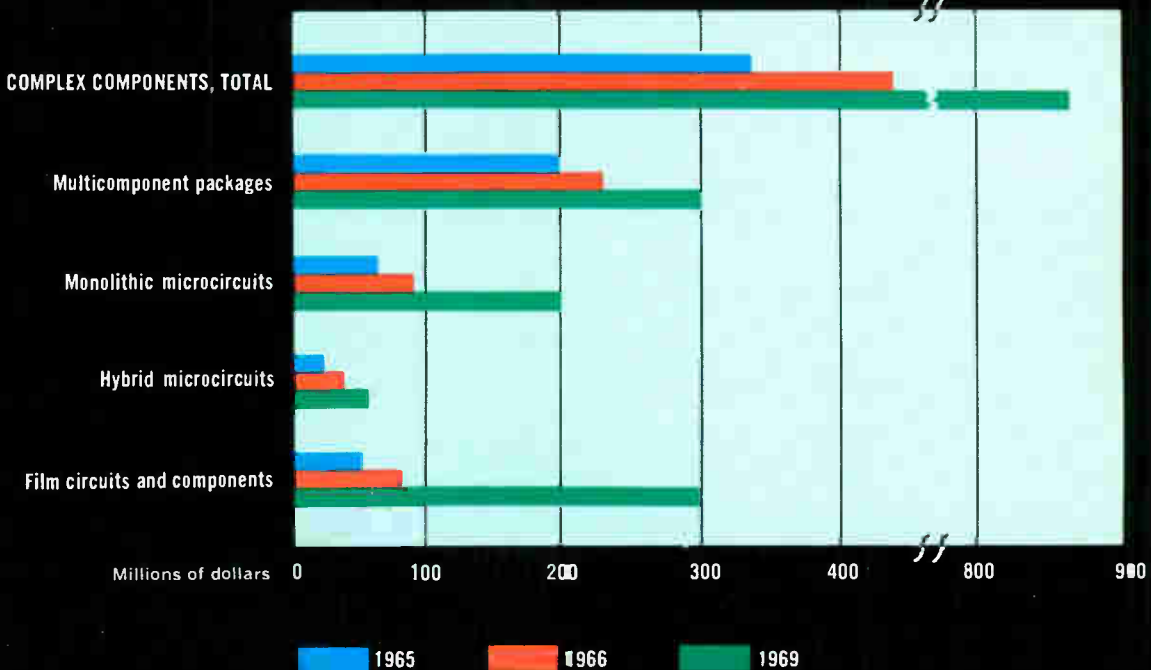

Electronics markets: Faster growth in 1966

Page 118 Vietnam war stimulates military procurement

121 Lid held on space projects

125 New applications in industrial markets

126 Demand for color tv still outstrips supply

135 Appliance makers discover the scr

Everything is coming up roses for the electronics industry in 1966. In every major segment of the industry, companies expect significant sales gains. In fact, the end of 1966 should see the industry in its healthiest condition since the boom years of 1959 and 1960.

These are the conclusions of Electronics' annual study of the industry's outlook for the new year.

Sales are expected to leap ahead 7.8% this year to \$19.40 billion from \$18.06 billion in 1965. In contrast, last year's survey predicted that the industry's growth in 1965 would slow to only 2.13%. Last year, electronics companies did much better than most executives had expected; the improvement over predicted growth resulted from stepped-up military procurement for the armed forces in Vietnam.

Increased buying to support the growing number of United States troops in Vietnam will boost federal spending for electronics this year to \$9.59 billion from last year's \$9.20 billion. Many plans for nonmilitary spending on social and health programs will probably be curtailed as President Johnson strives to keep total spending down.

Consumer electronics will be spearheaded by a continued boom in color television. Most suppliers expect demand to outstrip supply through 1966, even though almost every company will have additional production capacity for sets and color tubes.

More arms purchases are anticipated but R&D outlays will hold at '65 level

Acceleration of the war in Vietnam transformed proposed cutbacks into sharp increases in military spending last year and will have the same effect well into 1967. For electronics companies, the big increases in fiscal 1967 will be in equipment sales; military spending for research, development, test and evaluation will probably remain at the \$7-billion level of fiscal 1966, which ends June 30.

Last January, the Defense Department estimated its budget for fiscal 1966 at \$49 billion. It has received an additional \$1.7-billion appropriation, and is expected to ask for \$2.3 billion more; it also has drawn on Army depots for supplies that will have to be replaced.

The budget for fiscal 1967 is expected to be between \$57 billion and \$60 billion, probably closer to the higher amount.

Most of the new funds will be for salaries, operations and maintenance, but some of it will also go for helicopters for the Army and Marines, and fighters for the Navy's aircraft carriers; also being purchased is avionics and ground-communications equipment.

The armed services are also continuing to develop and test new ways to beat the problem of radio-signal attenuation in jungle foliage. And they are still seeking lighter long-range radios; more durable avionics gear that does not need frequent overhauling; more rugged data-processing equipment; improved sound ranging; surveillance equipment, both ground and air; and systems to warn ground forces of enemy intrusion into their camp.

For strategic warfare

Research and development will continue this year on the Navy's Poseidon submarine-launched ballistic missile. During fiscal 1966, \$35 million is being spent. Before the missile is ready for production, development costs will total \$900 million. The total cost of developing and producing the missile, also of equipping Polaris submarines to handle the new missile, is estimated at \$2.6 billion.

Work on the Air Force's Minuteman II missile will be designed to improve its accuracy and survivability after attack. Accuracy will be improved by continuing development of inertial guidance systems. Survivability can be sought in several ways: increasing the number of missiles, modifying the Minuteman so it can be launched from railroad flatcars, and developing an antimissile system such as Nike X. Although \$400 million was budgeted to continue R&D on the Nike X in fiscal 1966, full production is likely to be deferred again.

To keep the program alive, R&D will be prolonged with minimal appropriations.

By the end of this year, the Air Force will probably have formulated a concept for a follow-on to Minuteman II, which would then get under way in 1967. Procurement will continue this year for more Polaris A-3 and Minuteman II ballistic missiles.

Penetration aids—electronic countermeasures and counter-countermeasures that help a missile get through an enemy's defenses—reached the billion-dollar level last year and will continue to be a big, active R&D effort, for tactical as well as ballistic missiles.

Defense Secretary Robert S. McNamara announced last month that the B-52 and B-58 bombers will be phased out and that a new version of the F-111, called the FB-111, will be produced to fill the gap. This may make the F-111 the most versatile plane in history. Twelve million dollars was set aside recently to build a reconnaissance version, called the FR-111. If the British decide to buy the plane, it will probably be modified again. The bomber version, 210 of which will be built, will cost \$1.8 billion. The first will be operational in 1968.

Development of Sram, the short-range air-to-surface missile that is being designed to be launched from a bomber 50 or 60 miles from the target, will continue. It will be used on the remaining B-52's and on the FB-111; \$37 million was spent on this missile this year. Development is expected to cost \$100 million or \$150 million.

The announcement that the Soviet Union has built an orbital nuclear bomb that can be brought down on any target in the world will not, apparently, spur the United States Defense Department to follow suit. McNamara said last year that orbiting bombs were not as efficient as intercontinental missiles, and there is no sign that he has changed his mind.

Approximately 60% of the Manned Orbiting Laboratory program will concern the electronics industry. This year \$150 million is being spent, with a similar amount expected in fiscal year 1967. The Air Force wanted \$300 million for next year, but \$150 million is more likely because of the budgetary pressure caused by acceleration of the war in Vietnam.

The military-satellite communications system will be pushed vigorously this year. Work will continue on permanent and air-transportable ground terminals for the strategic system. Work also will

begin on small transportable terminals for tactical use by each military service. Aircraft will use the satellites as relays to communicate over long distances by ultrahigh frequency instead of high frequency, ships will use them to communicate with other ships, and Army jeeps in a jungle in Southeast Asia might use them to communicate with headquarters 100 miles away.

Air and missile defense

The Air Force will sit tight with its space-surveillance radars—such as the big phased-array radar being rebuilt at Eglin Air Force Base, Fla., after it burned down last year. While no new techniques are planned, R&D will continue on ways to improve the resolution and accuracy of the present generation of phased-array equipment.

The program to modify aircraft-warning radars along the United States' coastline to detect missiles launched from submarines will continue actively throughout the year. R&D on over-the-horizon radar will pick up.

General-purpose forces

In fiscal 1966, twice as much R&D money is being spent on tactical weapons as on strategic weapons. This trend will continue, with emphasis on electronic countermeasures, a V/STOL (vertical or short take-off and landing) aircraft, air-to-surface missiles, better tactical command-and-control equipment, and the long-range airlift capabilities that started with plans for the C-5A military transport plane.

The Air Force will push research on better, faster surveillance data and on efforts to find targets more accurately. Guidance techniques for air-

What's in the marketing report

Avionics	Page 124
Communications	132
Computers	133
Consumer electronics	126
Educational electronics	130
Industrial electronics	125
Instrumentation	138
Medical electronics	128
Microelectronics	137
Microwave	139
Military electronics	118
Oceanology	124
Solid state	135
Space electronics	121

to-surface missiles will receive increased attention this year. Radar, infrared, optical devices and radio will be explored further. The precision inherent in radio navigation systems looks promising, the Air Force says. A missile might be able to find its target by using a hyperbolic grid system similar to loran D.

Much of the Army's R&D will go for the development of better night vision and ground surveillance equipment—tactical equipment that field units can use to spot enemy troops and materiel in the surrounding area by day or night. Present equipment needs to be improved in several ways: higher target-discrimination ability in clutter, faster decision capability, and pattern recognition. The Night Vision Laboratory established by the Army in

The F-111 may become the most versatile military aircraft in history. Designed first as a fighter plane for the Air Force with a modified version for the Navy, it was later given another role as a reconnaissance plane, the FR-111. Now Defense Secretary Robert McNamara says still another version will be built, designated the FB-111, to satisfy the Air Force's need for a bomber.

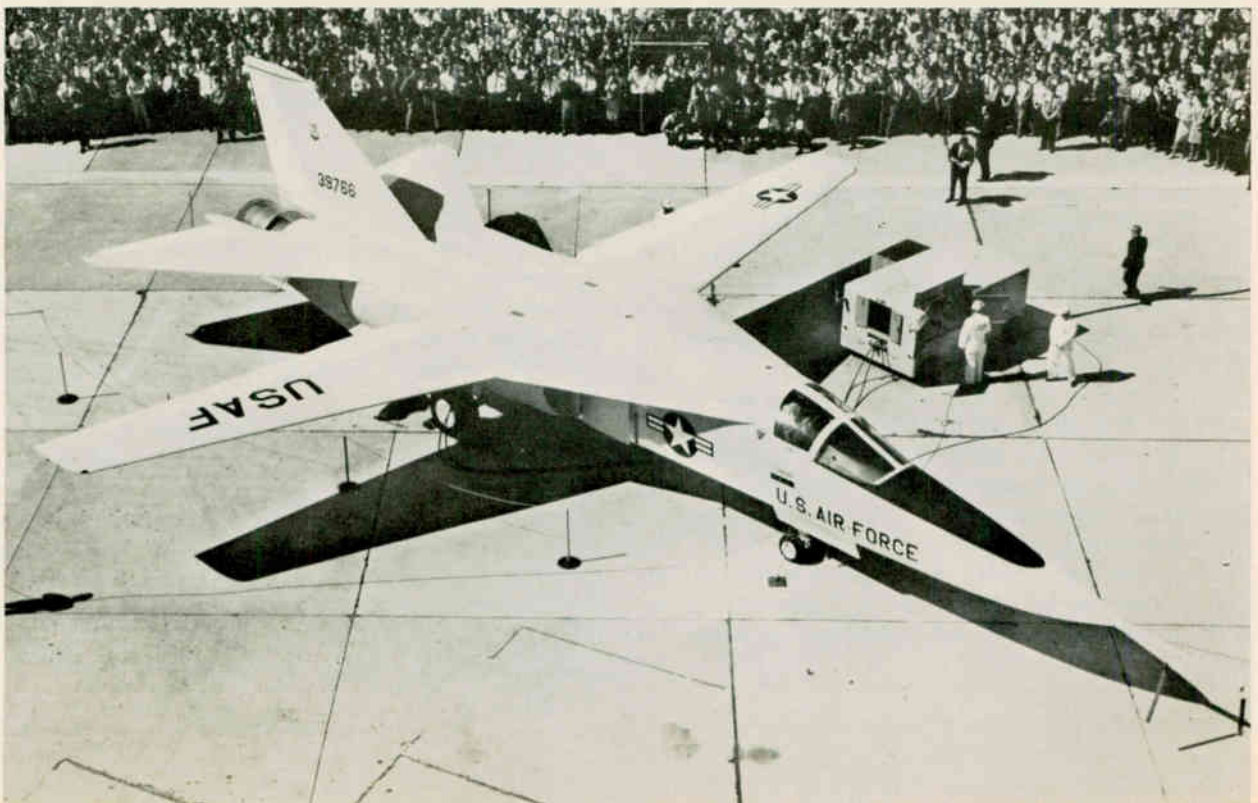

November at Fort Belvoir, Va., employs 200 specialists and engineers. The Army will spend about \$20 million in 1966 on R&D in these two areas—ground surveillance and night vision—but there will be little procurement of systems.

Money is already pouring into facilities to produce more tactical planes for Vietnam, and for long-lead-time equipment for them. How many planes will be bought has not yet been decided. Additional orders probably will be placed for the F-4, built by the McDonnell Aircraft Corp., also for the Douglas Aircraft Co.'s A-4E and the Grumman Aircraft Engineering Corp.'s A-6.

The A-7A fighter, being built by Ling-Temco-Vought, Inc., should be a big seller this year. The Navy is buying it, and the Air Force is considering it to fill a need for a new close-support fighter.

Work on the giant C-5A Air Force transport will get under way in 1966. The Air Force has contracted for 28 of the huge planes at a cost of about \$5 billion, and more orders are expected. About 10% of the total will go for avionics.

McNamara's satisfaction with the air-cavalry division in Vietnam and his decision to create another one will increase procurement of helicopters and avionics, and speed development of the next generation of aerial firing platforms and of their fire-control and avionics systems.

Bright outlook for avionics

The Army has joined the Air Force and the Navy in their pursuit of advanced avionics. Aside from test equipment, the Navy has two avionics programs, the Air Force one, and the Army two.

The Navy programs are ILAAS, which stands for integrated light-attack avionics system, and IHAS, for integrated helicopter avionics system. The Air Force's second-generation avionics package (Mark II) for the F-111 is being delayed until the Navy makes more progress with ILAAS. When this is done, and when all the elements in the Mark II are selected, the program will be big and will move quickly.

The Army will award a large contract for the avionics package for a light observation helicopter (LOH) some time this month. It will consist of vhf, uhf, f-m and intercommunication radio transceivers, an f-m monitor receiver for the pilot, and an automatic direction-finder for navigation. The uhf radio represents a new generation; the unit will be 40% lighter than previous ones, and the purchase will be big. The radio may also be used in other Army planes besides the LOH.

The Army's next big avionics program is for AAFSS, the advanced aerial fire-support system. The Army paid for 40% of the Navy's IHAS program and is watching it closely. Besides the usual electronic subsystems, the package will include station-keeping equipment. The Army would like terrain-avoidance radar, but plans for the aircraft have gone too far to include it. Tests on terrain-avoidance equipment will continue, however, so

the next generation—STAAS, for surveillance and target acquisition aircraft system—will be able to use it. STAAS is the follow-on to the fixed-wing Mohawk aircraft.

This year is expected to be the biggest for automatic test equipment, and the military is expected to be the best customer. Sales to the Army and Air Force should top \$80 million; the Navy will spend between \$10 million and \$20 million, most of it on versatile avionics system test equipment, called VAST.

Automatic test gear should continue to increase, at least through 1970. Eventually all three military services plan to equip all their maintenance depots with such equipment. The Army has already begun installing automatic test equipment at its Tobyhanna, Pa., depot and has scheduled general-purpose test gear for several other depots. The Navy has begun installing VAST aboard aircraft carriers.

The shift to integrated circuits

All the services are looking forward to the glories of integrated circuits—more elaborate systems, more sophisticated solutions, high reliability, reduced weight, and ultimately lower cost. The Air Force, experienced with IC's in its Minuteman missile, is probably the most enthusiastic. "We'll be able to do much more daring things," one high official says.

The Air Force is ready to move into third-generation solid state equipment. Transistors were the first generation, present integrated circuits the second. The third generation will see many more active elements—perhaps 1,000—on a single chip. Cost will be greatly reduced, and reliability will reach new heights.

The Navy is going full-steam ahead with IC's, but one official expresses concern. "It may turn out that a number of design, maintenance and logistics problems should have been solved before we jumped into designing IC's in so much equipment," he says. "Maybe the top echelon in the military has accepted IC's too quickly."

The Army, with less experience with IC's than the other two services, is showing the most apprehension. How will IC's change equipment design? Will their reliability be overestimated, resulting in equipment that cannot be repaired at all? Can IC's be used in throwaways? How will maintenance be handled—with replacement plug-ins or duplicate equipment? And how will maintenance crews be trained [Electronics, Oct. 18, 1965, p. 72]? The Army has to answer these questions soon, because the LOH avionics package will probably contain IC's.

Both the Army and the Air Force are looking for a follow-on to loran D, the transportable hyperbolic grid system now being tested at Eglin. The goal is a system that won't be vulnerable to jamming and that will be a hyperbolic type, using low frequency—100 to 300 kilocycles per second—with antennas much lower than those required for loran D.

The Army wants an air-transportable air-traffic regulation system that is easy to set up and compatible with systems the other services use; it would regulate the Army's helicopters and fixed-wing planes.

The three services are working together on terminal phase equipment to control planes from the time they approach the traffic pattern until they land. The decision on this system is important; it will be bought by all three services, and is intended to remain standard equipment for several years.

Although the Army will buy large quantities of radio equipment this year, it will not initiate much R&D for communications. It will continue studies on ways to digitize communications—a goal set for the mid-1970's—and buy only the most tempting R&D gear that comes from unsolicited proposals such as the Pico terminal, or a microwave communications system, built with hybrid integrated circuits and small enough to be carried by hand. The microwave system is built by the International Telephone and Telegraph Corp.

The Army needs an answer to a pressing new problem: how to locate mortar fire that might come from any direction. The "front line" in Vietnam, for example, is usually a circle. Counter-mortar radar now covers only one-quarter of a circle. Also, Army aviation urgently needs a small, light-

weight single-sideband radio which would operate from levels of 100 watts to 1 kilowatt peak effective power at both uhf and vhf.

A three-service effort will begin this year to develop a universal data link to get reconnaissance and target position data to the ground quickly from aircraft and drones. On the ground, a tactical image photoprocessing system will be needed to process television, infrared and photographic pictures obtained by aerial survey.

Spending on antisubmarine warfare will increase this year to about \$3 billion; it will be a little more than one-fourth of the Navy's budget. Sonar again will be the biggest item. The Navy will ask industry to put more effort this year on signal-processing and noise-discrimination techniques.

The Navy's deep-submergence-systems program [Electronics, Feb. 22, 1965, p. 123] will be accelerated; electronics companies have been asked to submit bids on the deep-level rescue submarine. And Autec, the Atlantic undersea test and evaluation center off Andros Island in the Bahamas [Electronics, April 6, 1964, p. 105], will be ready for operation in 1967. The Navy's underwater programs are the most promising in oceanology (p. 124).

A big communications project that will move faster this year is the Navy's Southern Cross—a program to upgrade basic equipment and techniques in the fleet.

Space electronics

Spending will remain the same but NASA's demands will be stiffer

Nineteen sixty-five was the year when Mars became a television star and two spaceships met in space to fly five laps around the earth in close formation. Despite these successes, however, the United States will spend no more for space electronics in fiscal 1967 than in the fiscal year that ends June 30, 1966—between \$1.6 billion and \$2 billion.

But longer, more complex missions will require smaller, more reliable electronic gear, with increasing emphasis on components designed specifically for use in space. In addition to systems for navigation, communications, tracking, instrumentation, data processing and such, NASA will continue to sponsor a broad research program concentrating principally on navigation, data processing and circuit performance.

Smaller circuits for longer missions

Late this year, the space agency plans to award the first contracts for experimental gear to be carried on 14-day missions on the surface of the moon in the Apollo Applications program, which

S-band communications equipment like this antenna will get its first big test in the Apollo program.

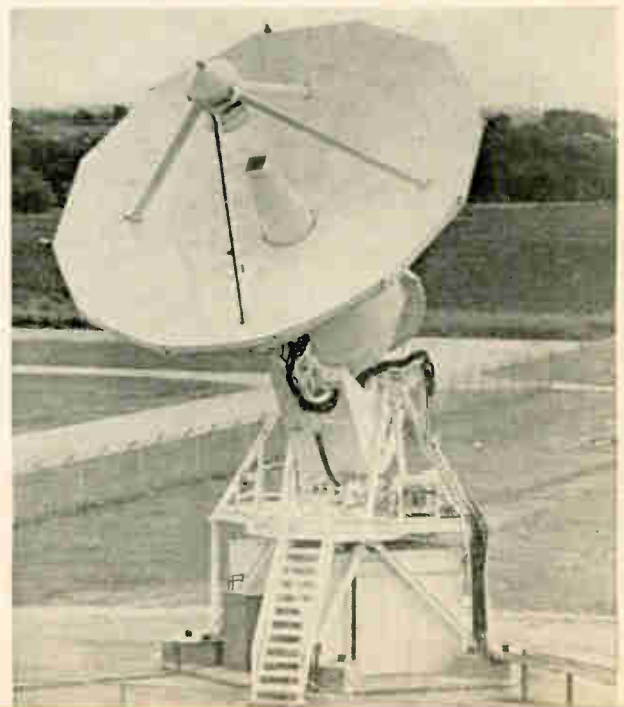

Scientific instruments in the Lunar Excursion Module portion of the Apollo program are contained in packages which can be removed easily from the space craft. Package in foreground contains devices to measure soil temperature and impact of micrometeorites and a seismograph. The instrument package behind the antenna contains an atmosphere analyzer, magnetometer and gravitometer.

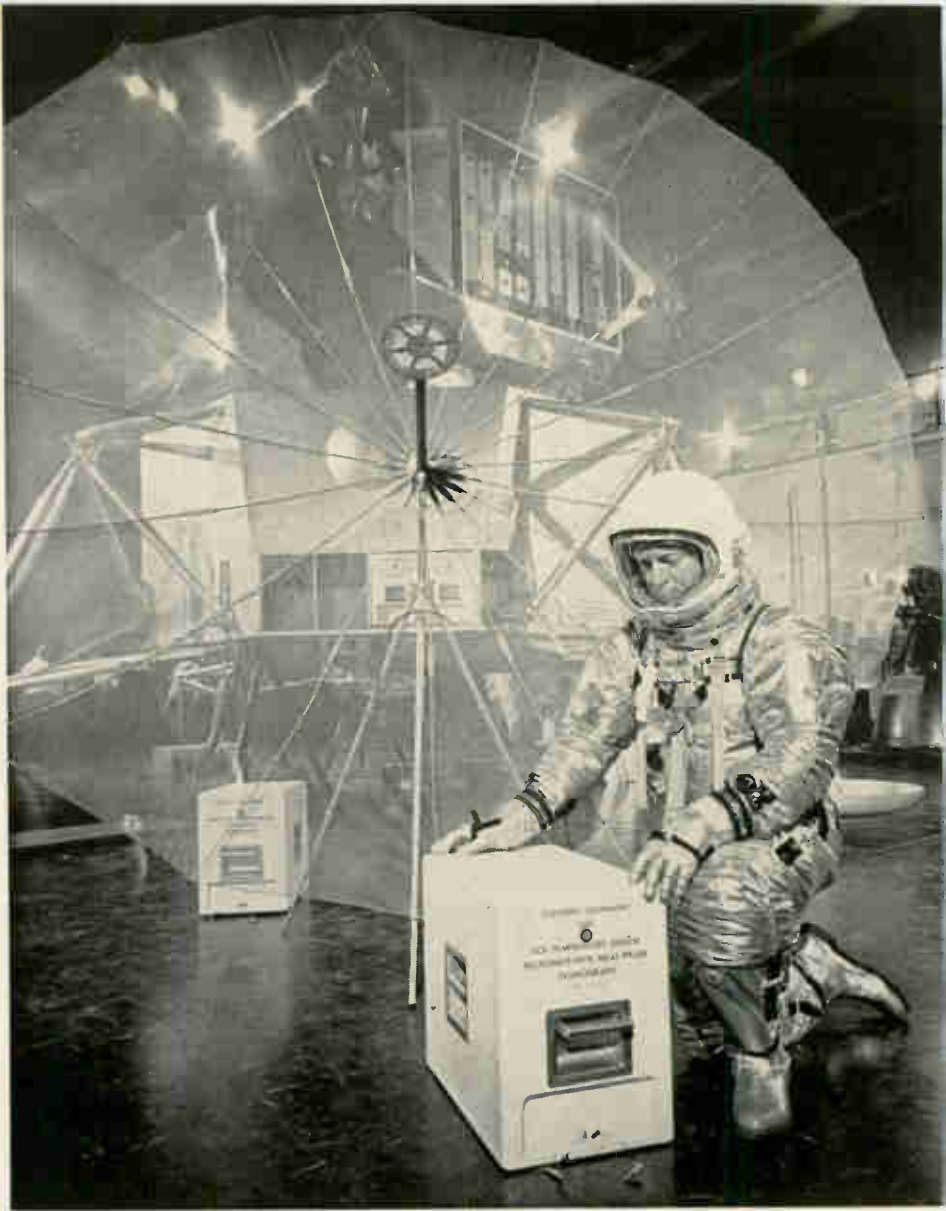

will run concurrently with Project Apollo's effort to land men on the moon by 1970. NASA will also fund further research for the Voyager missions which are to land capsules on Mars in the 1970's. Both projects will stress microminiaturization.

Early contracts in Apollo Applications will be for development of refined instrumentation for experiments, also better ways to record, process and transmit data aboard a spacecraft, and improved life-support systems. Future procurement also will include hardware for 90 days in earth orbit and 28 days in orbit of the moon.

For the Voyager flights, electronic systems will have to be designed to last seven months and later as long as two years. Contracts could total more than \$2 billion. NASA may need S-band power-amplifier tubes that can operate at up to 500 watts, also solid state amplifiers with up to 100 watts of power. Other needs will include data-processing equipment that can handle 40,000 bits per second, and sterilizable components that can withstand impacts of more than 1,000 gravities.

Specifications will reflect the increasing length and hazard of missions. A failure rate of only one part in a million hours was specified for Apollo, and NASA wants to improve this by one order of mag-

nitude for later missions. To meet such requirements, the space agency will not be satisfied with modifications of equipment that was designed for other uses.

Many integrated circuits already are specified for the Advanced Orbiting Solar Observatory, which is to be launched in 1969. In the lunar excursion module (LEM), where every pound of electronics requires 400 pounds of launch fuel, IC's in cordwood modules will be used extensively.

"Within a year or two," says Clyde M. Singleton, test director for LEM at the Grumman Aircraft Engineering Corp., "the majority of satellites and space vehicles will be designed with IC's."

IC's made with metal oxide semiconductors will make their debut in space this summer in the encoder of the anchored Interplanetary Monitoring Platform (IMP), which will orbit the moon and gather data about the moon's surroundings in space. NASA's Goddard Space Flight Center says use of MOS IC's will reduce the components in the four-pound encoder to 3,000 from 10,000.

Toward global communications

Communications gear will continue to constitute a big chunk of the space electronics market. This

year the Communications Satellite Corp. will begin to buy equipment for satellites designed to be part of a worldwide communications network in 1968. The first big award will be to TRW, Inc., for development of the satellites themselves; each will be capable of carrying more than 1,000 channels.

Components of the operational system will include specialized, custom-made equipment such as wideband transponders to carry hundreds of channels simultaneously, traveling-wave tubes for multiple access, and tunnel-diode front-end receivers.

"The most important parameter is reliability," says Sidney Metzger, Comsat's manager of engineering. "We are shooting for a five-year operating lifetime for the satellites. Rather than looking for new types of transmitters or resistors, we hope to achieve this level by proper design and test of existing equipment."

U. S. producers of ground-station equipment are expected to find more customers this year among members of the consortium that owns Comsat. Sales of ground stations, with 85-foot antennas, are expected in Switzerland, Nigeria, Ethiopia, Australia, India, Japan and Scandinavia. The price of each station will be at least \$5 million, including antennas and auxiliary equipment for functions such as multiple access.

Communications equipment also will be needed for ground stations, broadcasting stations and telephone companies.

Comsat's interim system will be established this fall with the orbiting of two satellites, one over the Atlantic and another over the Pacific. Satellites are expected to be used increasingly for television and data transmission as well as voice, and Comsat is trying to attract more customers by substantial reductions in rates for channels.

More efficient solid state amplifiers also are needed for satellites, also better threshold-extension demodulators and low-noise amplifiers for ground stations.

Farther in the future, a market is expected to develop in equipment for direct-broadcast satellites. "Within 5 or 10 years, high-power broadcasting satellites will be capable of transmitting television and radio directly into the home," predicts David A. Sarnoff, chairman of the Radio Corp. of America. This would be possible, Sarnoff continues, with nuclear-powered synchronous satellites capable of radiating up to 30 kilowatts to home receivers within a million-square-mile range. Sarnoff also believes home antennas can be modified easily to receive such transmission which would be in the ultrahigh-frequency band.

Officials of the National Aeronautics and Space Administration have already asked the communications industry for proposals on studies for construction of a direct-broadcast satellite.

More immediate is the need for a worldwide communications system for aircraft in flight. Such a system may evolve from NASA's Applications Technology Satellite-B, to be launched late this year. The practicality of such a system will be eval-

uated from tests in which voice and data will be relayed from the ground to aircraft by the ATS-B's 30-watt vhf transponder. Comsat, meanwhile, plans to include aircraft communications on an all-purpose satellite, which would also be used for weather studies and for domestic tv. A prime contractor is expected to be selected this year for this satellite, which may be launched in about three years.

The space agency will continue its steady move toward higher frequencies to gain broader bandwidths and more exclusive operating regions. Next year it will complete the augmentation of its manned spaceflight network with S-band equipment. It will continue to sponsor studies of the possibility of moving into the X band portion of the spectrum for earth-orbital scientific research, but this won't happen before 1980. NASA will also consider moving into millimeter wavelengths, for certain types of space research. A promising market also is developing for electronic gear of the future, such as laser transmitters, which can meet the stiff new requirements of reliability, long life and light weight.

There will be no big new electronic procurement for NASA's tracking and communications network this year, however. The tracking stations already contain most of the equipment they will need for the next few years, says C. R. Morrison, director of systems planning and development at NASA's Office of Tracking and Data Acquisition. "In fiscal 1966," he says, "our budget was 55% for equipment and 45% for operation; next year it will swing to 45% equipment and 55% operations."

NASA will continue to study methods of automating ground-station functions to eliminate costly manual operations. The major cost of such systems would be for electronic interface equipment between computers and other checkout equipment. More automatic checkout gear also would be bought.

Depending on next year's budget, NASA may begin buying late in 1966 for two more 210-foot antenna stations, which would be used in the 1971 Voyager mission to Mars. Sometime later, other equipment will have to be developed, including new gear for data-processing and -storage and for handling large amounts of data during planetary missions in the 1970's.

NASA is still seeking expandable antennas that can be compressed into small areas on spacecraft.

Advanced research

One good clue to what's beyond 1966 is NASA's electronics research program. Still relatively modest, it includes many projects vital to operational systems 5 to 15 years from now.

NASA's new Electronics Research Center in Cambridge, Mass., will fund \$15 million in outside research during fiscal 1967 compared with \$8 million in fiscal '66. This will increase to \$50 million in 1969, when the center is fully operational.

A big field for outside research this year will be

for better data-processing systems for future space vehicles. The goal is to reduce the amount of data that must be transmitted to earth during long space missions, or to increase the significance of each bit of data. Research will continue on compact short-access-time memory systems and on associated microelectronic circuitry.

The research center may also finance work on holograms which put three-dimensional information on a two dimensional plane—for possible applica-

tion in planetary surveys. Research also is expected in adaptive circuitry, MOS field effect transistors for data-processing on spacecraft, electrostatic and cryogenic gyroscope systems, hybrid thin-film space-charge-limited triodes, microelectronic circuit modules that can operate in radiation and temperature environments beyond the limit for silicon, improved silicon reliability, and solid state hot-electron devices for Gunn-effect diodes with frequencies over 12 gigacycles per second.

Commercial avionics

Searching for airport automation

As the skies become more crowded with civilian airplanes, the need for automatic equipment increases—and so does the avionics market. Spending for commercial avionics is expected to climb to \$265 million this year from \$205 million in 1965.

The biggest research-and-development efforts are in two fields: automation for airports and automatic landing systems for planes. In all, the Federal Aviation Agency will spend about \$105 million for electronic systems this year, up slightly from \$100 million last year. Of this amount, R&D will receive about \$35 million, the same as last year. In addition, aircraft builders will spend about \$100 million for avionics on the \$1.8 billion worth of planes that will be delivered to commercial airlines this year. And avionics in the general aviation category, which includes business and private aircraft, is expected to total \$60 million.

Of the \$70 million that the FAA will spend for equipment, the biggest chunk will go for semi-automatic air-traffic controls. Other major categories are radar, communications and navigation equipment.

The most important research is in all-weather landing. Late this year or early in 1967 the FAA probably will give full certification to a Category

II landing system—one that operates when visibility is only 1,600 feet along the runway and the ceiling is only 100 feet. The agency and the Air Force are cooperating in further studies toward the development of an all-weather, zero-zero landing system.

The FAA has awarded a contract for about \$1 million to Lear-Siegler, Inc., for testing of all-weather landing systems; the contract runs to March, 1967. Zero-zero landing systems are being studied by Pan American World Airways, Trans World Airlines and United Airlines. And the Air Force has awarded a contract of about \$1 million to Lear-Siegler, Inc., to test all-weather landing systems for the C-5A military transport. Two Category II systems already have the FAA's conditional certification, which means they can be used, but not for passenger flights.

The effort to develop a workable all-weather landing system has resulted in improvements in other avionic equipment. United Airlines is installing a pulsed-radar type of altimeter—the AL-101 made by the Collins Radio Co.—in 164 of its jet planes. The altimeter measures terrain clearance from 2,500 feet to touchdown. Altitude error must not be greater than ± 5 ft. ($\pm 5\%$ over 100 ft.)

Oceanology

Interest is high, expenditures low

Electronics companies will continue to look cautiously before leaping into oceanology. They are watching the activities of the federal government and of some big oil companies, currently the big spenders of the deep [Electronics, Sept. 20, 1965, p. 129 and Oct. 18, 1965, p. 123].

Despite the increasing fascination with the sea, and the increasing awareness of its riches, expenditures in exploring its depths only total a few hun-

dred million dollars a year. The expenditure is not known accurately because much of the government's activity consists of classified work on anti-submarine warfare. Unofficial estimates put the cost of the antisub work at \$110 million for fiscal 1967, which begins July 1.

The government will spend \$140 million on unclassified projects, about half of it for study programs such as Sealab, in which men lived at the

bottom of the ocean off California for weeks.

The oil industry, which has spent more than \$1 billion on undersea oil exploration and research in the past decade, is expected to move into deeper water in the next two or three years, into depths that require complex, reliable instruments—the kind that is best built electronically.

Needed: better communications

The most pressing need is for a communications system that is reliable over a five-mile range at least 6,000 feet below the surface of the sea. As submersibles are built that can explore deeper, these ranges and depth requirements will increase.

One major problem is slant range: the deeper a submersible goes, the more difficult it is to maintain vertical communications with surface vessels such as tenders. As the slant angle increases, so does

the problem of multiple communications paths. Multiple paths result from underwater phenomena such as thermoclines—temperature gradients—and deep scattering layers.

Another requirement is a method, better than sonar, for measuring depth with instruments at the surface. Sonar is least effective under ice, because the junction of ice and water has practically no reflectivity, unlike the air-water interface. Yet precise measurements of the thickness of ice or of the depth of water below ice are particularly important in the accurate firing of Polaris missiles.

The development of such electronic systems may depend on the start of projects of which they would be part. But the converse may also be true: undersea projects still undreamed-of may be triggered by the knowledge that better electronic equipment is available.

Industrial electronics

Numerical control sales to rise 25%; process controls will climb 60%

With orders backed up 24 months, producers of numerical controls will not introduce many big changes this year. It's all they can do to meet the present demand for existing equipment. Sales are expected to top \$50 million, up 25% from \$40 million last year; associated machinery cost an additional \$120 million in 1965.

The market for process-control computers will expand even faster, largely because it is newer

and smaller than the NC market. Sales of process controls this year are expected to climb 60%, to \$40 million, from \$25 million in 1965; associated instrumentation should add \$11 million in sales compared with \$7.5 million last year. Here, too, little technological innovation is expected; the reason is that existing systems are considered quite adequate.

One technological advance will be the use of

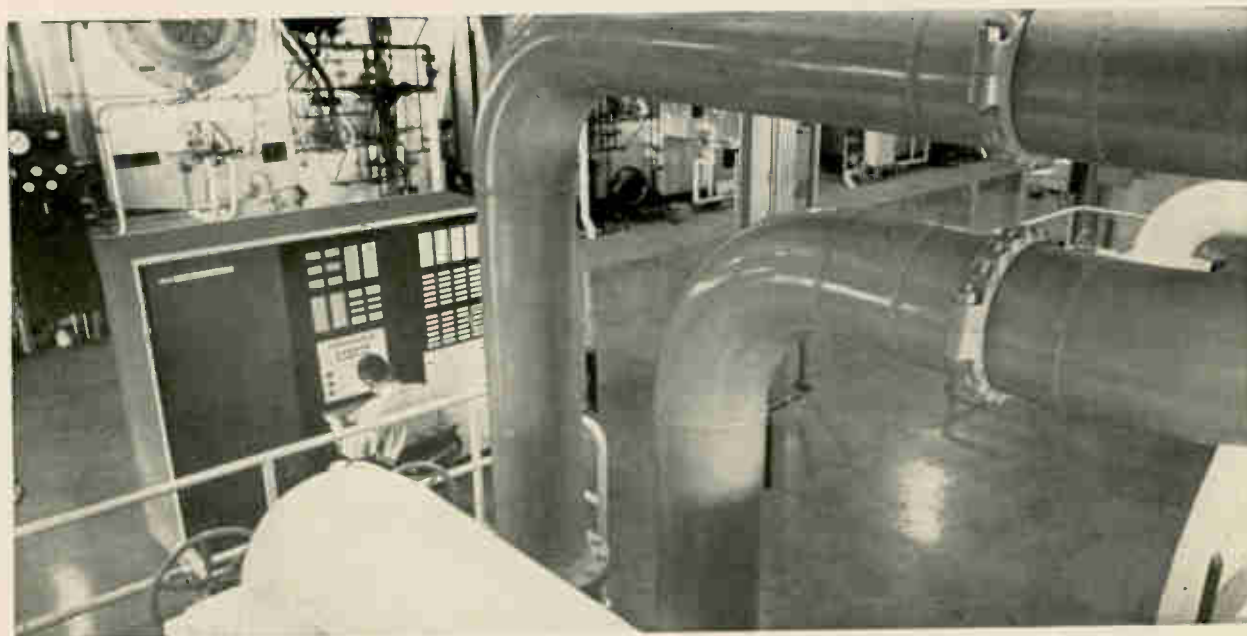

Model 1800 computer, made by International Business Machines Corp., is designed specifically for direct digital control of industrial processes such as electric utilities' steam generating plants.

integrated circuits. The Westinghouse Electric Corp. recently introduced a numerical control system, model 20, whose logic section is built entirely with IC's.

Process control will continue to expand into "manufacturing control"—regulating of mass production—which constituted 20% of the field last year. For example, one computer made by Honeywell, Inc., constantly monitors and controls production at a completely automated bakery in the Midwest. And a producer of integrated circuits is using a computer to automate the testing of its IC's; the testing system not only checks the condition of circuits and rejects faulty ones, but also supplies statistical analyses of such factors as the most prevalent type of defect and the time of day at which most defects are found.

Major users of process control will continue to be electric utilities and the chemical and petroleum refining industries, with steelmaking not far behind. But control computers will find increasing applications in many other industries, such as smelting and refining, textiles, electronics manufacturing and automobile assembly.

Controlling city traffic

Two areas of long-range promise are computer controls for mass transit systems and for street and highway traffic. The whole transit industry is

watching the experiments at San Francisco's Bay Area Rapid Transit District [Electronics, July 26, 1965, p. 71]. Although computerized traffic control is not new, many cities are just beginning to consider it seriously. Computerized facilities costing \$5 million will eventually control traffic in sections of four of New York City's five boroughs. The first stage in its installation, expected to be completed late this year, will control 1,200 intersections in central Manhattan and several major traffic arteries in Queens.

The move to direct digital control—real-time control of an analog process by a digital computer—will continue to accelerate. A. L. Rogers, marketing director of the computer control department at Honeywell, Inc., says bluntly, "Simple supervisory control is headed for obsolescence."

But major technical advances are unlikely, simply because computers are considered good enough now. "What's the use of having a millisecond response time in the instrumentation," asks Charles Schwarzler, a marketing official at the Foxboro Co., "if the mechanics of the process itself can't react in less than one-tenth of a second—or tens of seconds in some cases?"

Despite the trend to DDC, many open-loop systems will be sold this year. Design improvements include new remote communication equipment and improved peripheral devices.

Consumer electronics

Continued gains seen: color tv ahead, and scr's move into new markets

With color television again in the vanguard, consumer electronics companies seem to be marching into another spectacular year. Sales of color sets in 1965 totaled 2.6 million, but 3.5 million could have been sold if plants could have produced them. This year, added facilities probably will boost output to between 4 million and 4.5 million receivers, but still will not match the demand.

Of the eight manufacturers of color picture tubes, four entered the field late in 1965. One of these, the Admiral Corp., has invested \$18 million in its tube facility and says its annual production of shadow-mask tubes should reach 600,000 by the end of 1966.

The Philco Corp., is now producing 2000 tubes a week at its new assembly line in Lansdale, Pa., after only a few-months of production.

The General Electric Co. is in full production on the industry's smallest and only different shadow-mask color tube. The 11-inch Porta-Color tube uses a straight-line configuration for its three electron guns, rather than the conventional delta

arrangement. GE, which now buys standard tubes for its larger color sets, is considering production of a larger version of its new tube.

GE claims that those who are ordering its \$249.50 Porta-Color, represent a completely new market. Many people, GE says, just don't have room at home for a large set. But GE may not have this market to itself for long. The Radio Corp. of America will start pilot production of a 15-inch shadow-mask tube this month. Color sets with these tubes will not reach the dealers before September.

Tube-hungry makers of color sets, seeking additional sources of supply, have turned to Japan; but Japanese tube exports this year will be insignificant. Japanese manufacturers, suffering from a recession, would rather export completed sets. Some Japanese companies are working on small-screen color sets that could hit the American market this year. Half a dozen manufacturers also have announced that they will export large-screen color sets to the United States in 1966, but the

total will be under 200,000.

The color-tv boom is also creating a shortage of equipment for broadcasting studios. RCA alone has a \$25-million backlog in orders for its newest color camera and color film pickup. The company manufacturers 30 of its new \$75,000 TK-42 camera chains a month, and is taking orders for delivery in late 1966. GE's popular 4V color-film pickup has a similar backlog.

The North American Philips Co., whose Norelco Plumbicon camera has been heralded as the most important development in color television since the shadow-mask tube, reports a backlog extending into the summer of 1967. The Norelco camera is manufactured in the United States with Plumbicon tubes made in the Netherlands by Norelco's parent company, Philips Gloeilampenfabrieken, N.V. In about eight months, however, Norelco's subsidiary, the Amperex Electronics Corp., plans to produce the tube in the United States. Norelco will supply the tube to at least three other makers of color cameras this year.

The Selenicon, RCA's answer to the sensitive and linear Plumbicon, will go into production this year. RCA has designed its TK-42 camera, which now uses three vidicons and an image orthicon, so it can be converted easily to use the newer Selenicons.

Across-the-board increases

Color television will be only one facet of the

How U. S. tv sales will go . . .

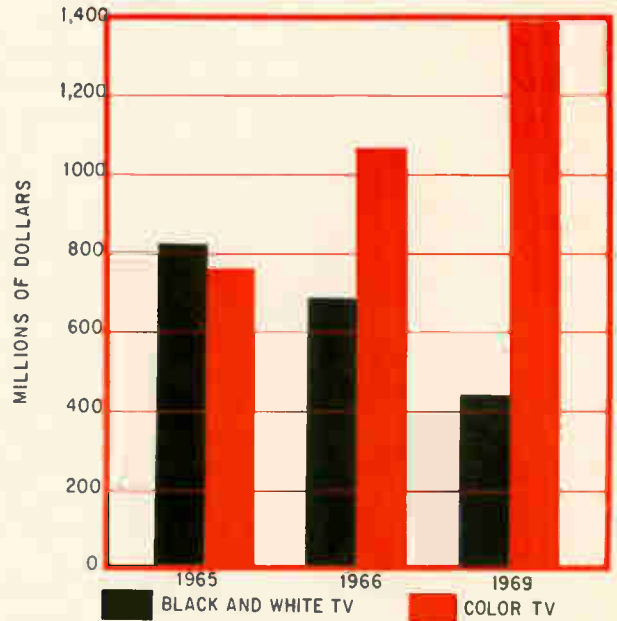

boom in consumer electronics. According to Electronics' survey, factory sales of consumer electronics products will increase 6.9% in 1966 and 16% by 1969, from \$3.0 billion in 1965. Only black and white tv is headed for a decline (see chart above).

Sales increases are expected in tv sets, radios, phonographs, tape recorders, electronic musical in-



Color-tube assembly line at Philco's Lansdale division, after several months of production, is producing 2,000 tubes per week. Total production of color tubes from eight manufacturers will be over 4.5 million this year.

struments and other major equipment for the home. In addition, breakthroughs in microcircuits will permit the introduction of many new products.

Some of the gains in these areas will be balanced elsewhere, however. As production of color tubes reaches 7.5 million a year in 1970, production of black-and-white tubes is expected to drop to 6.8 million from a 1964 high of 9.5 million. Production of monochrome tv tubes for 1966 will be 9.0 million. The number of vacuum tubes produced, 390 million in 1965, will drop to 320 million in 1966 and 200 million by 1970, but sales of semiconductors and integrated circuits will double by 1970.

The EIA expects the sale of 24.2 million domestically produced radios in 1966 and 25.9 million in 1970, 39% of which will be for automobiles; this compares with 23.5 million radios produced in 1965. Production of phonographs in 1966 is expected to reach 5.5 million, and by 1970 it should climb to 7 million units, compared with the estimated 1965 total of 5.3 million.

After color tv, the fastest-selling consumer product is the audio tape recorder. The EIA predicts that yearly sales of American-made recorders will increase 7% this year, and 33% by 1970 from about 524,000 sold in 1965.

As for home video recorders, William E. Roberts president of the Ampex Corp., predicts that sales will total \$10 million in 1966 and \$100 million in 1970. Sales in 1965 were negligible. Ampex plans to start deliveries this month. A Japanese company, the Sony Corp., already has begun deliveries of home video recorders.

Stereo on the road

The prediction for tape-recorder sales does not include the stereo tape-playback system for auto-

mobiles, which looks like the hottest new automobile accessory. About 18 companies are offering tape-playback units that can be installed under the dashboard. The units, which use prerecorded eight- or four-track tape cartridges, are priced from \$130. The Ford Motor Co. alone expects to sell 100,000 sets this year.

Several tape-cartridge systems are competing for the lush automotive market, but the eight-track cartridge developed by the Lear Jet Corp. seems to have the lead. Lear, whose cartridge has been chosen by both Ford and the Chrysler Corp. for their own brands of tape players, expects to sell 20 million cartridges this year.

Scr's enter the appliance field

Since the advent of the silicon controlled rectifier as an inexpensive way to control electrical power, electronics has expanded its role in the appliance field. Just about every type of hand tool and small appliance is available with the option of speed or temperature controls with scr's (see page 135).

This year for the first time, large appliances also will have solid state controls. The Hotpoint division of the General Electric Co. has, in its most expensive clothes washer, scr controls with which the housewife can choose any speed of agitation and spin, to suit the fabric she is washing. The washer has a tachometer mounted on its capacitor-start, capacitor-run motor; the tachometer serves as a feedback loop to the transistorized speed control. The washer will run at the selected speed regardless of the size of the wash load. Hotpoint and other companies are confident that customers will pay for the added electronics; the solid-state control package on the new Hotpoint washer adds \$60 to its retail price.

Medical electronics

Continued slow progress toward a big future

Medical electronics continued to expand slowly in 1965 toward what everybody agrees is a big future. Its growth, 7%, was even slower than expected, but the pace probably will quicken a bit to 10% this year.

With few exceptions, applications are still exploratory; the biggest fields for practical applications are patient-monitoring equipment in hospitals, where sales are expected to rise 40% this year to \$5 million, and clinical instrumentation that can make routine chemical analyses automatically in two or three hours.

The biggest drawback remains the language barrier between physicians and engineers. Engineers don't know what doctors want, and the doctors

don't know what engineering can do for them. To remedy this situation, the National Institutes of Health will give nearly \$20 million this year to schools where engineers will be trained in the life sciences. Private companies, such as the Smith Kline Instrument Co.—a division of Smith Kline & French Laboratories—conduct courses for physicians in the use of medical-electronics equipment. Hospitals are trying to solve the problem by adding engineers to their staffs.

Walter Tolles, head of the medical and biological physics department at the Airborne Instruments Laboratory, says his company's automated chemical-analysis station is more accurate than standard laboratories', at comparable cost.

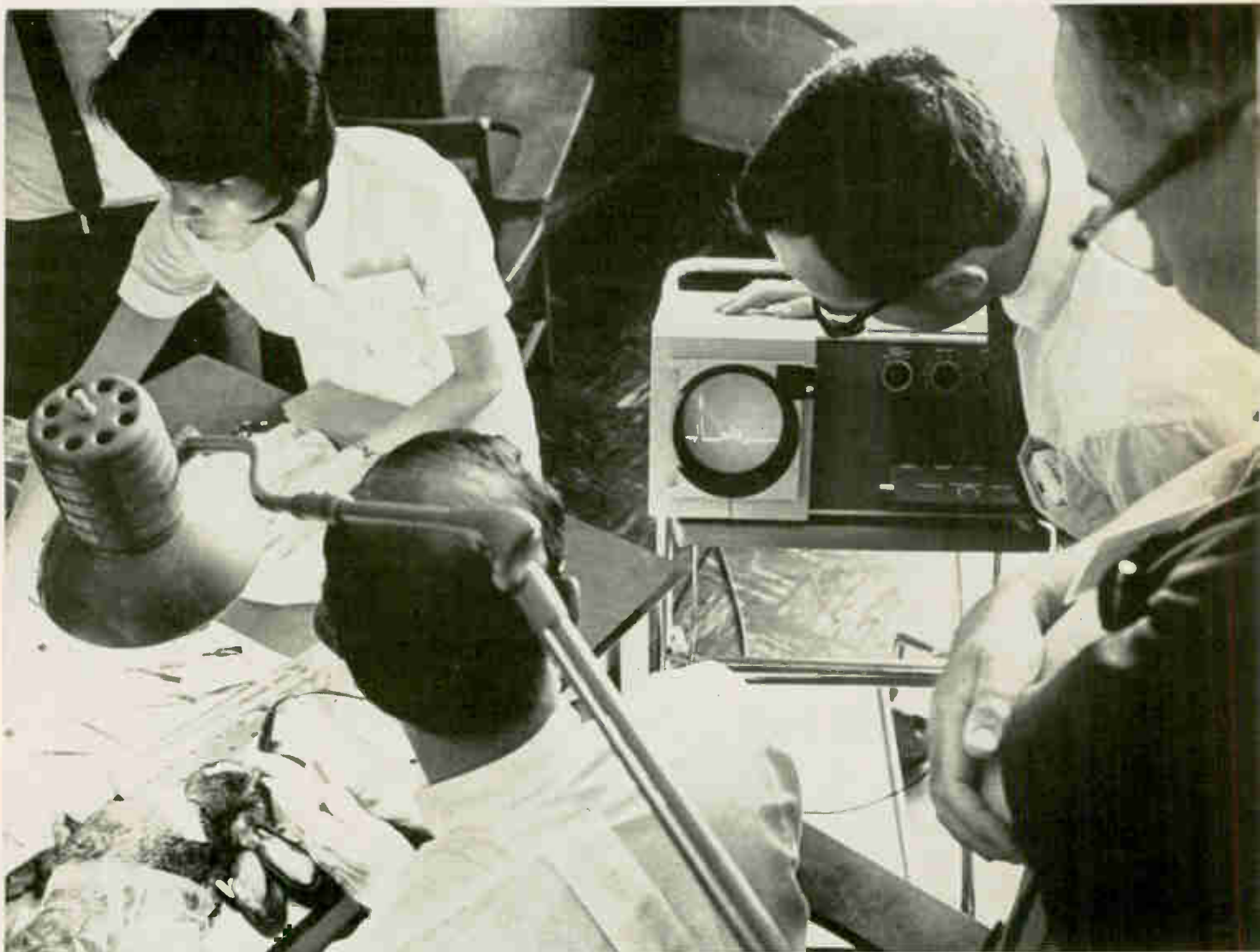

Teaching electronic techniques to doctors is the purpose of such seminars as Smith Kline Instrument Co.'s latest on ultrasonics in medicine. An ophthalmologist uses the company's Ekoline 20 Ultrasonoscope to locate a small foreign body in the eye of a rabbit before performing surgery.

Electronic monitor

Electronic monitoring has a strong supporter in Dr. J.D. Michenfelder of the Mayo Clinic in Rochester, Minn. Such a system, installed by IBM and operated by a physician in the operating room, has kept patients alive during critical neurosurgical procedures, Michenfelder says. Previous monitoring systems had to be operated by several skilled technicians; this requirement limited their usefulness.

Computers also hold great promise for medicine and biology. Applications range from diagnostics to administration. The missile division of the Lockheed Aircraft Corp. has developed a computer that diagnoses heart troubles from electrocardiograms more accurately than a cardiologist can, and in less time, the company says. Access to the computer can be through standard telephone connections, and no special transmission lines are required.

For biomedical research, the Digital Equipment Corp. has designed a computer called Linc, for laboratory instrument computer. It is a multipurpose system that performs tasks usually assigned to assistants.

Entering its third year of seeking ways in which the computer can serve a hospital is a broad project at the Massachusetts General Hospital. Administrators expect this study to find ways to store and transmit information faster and more accurately, and to reduce the amount of routine paper work that consumes much of a professional staff's time.

Further progress is expected this year in electronic aids for the disabled: pacemakers to stimulate damaged kidneys and other organs, as well as hearts; prosthetic limbs for amputees and paralytics; and electronic detours for broken neural circuits to help paralytics move arms and legs.



Called the talking typewriter, this machine, developed by the Edison Laboratory division of the McGraw-Edison Co., helped preschool children learn to read, write and touch-type. It contains computer-controlled keyboard, random-access audio storage and slide projector.

Educational electronics

Ready to reap rewards of the Great Society

As the Great Society takes shape and its directors are ready to buy equipment, it is expected to cause a surge in sales of electronic hardware for education. Many of the final decisions will be made by thousands of state and municipal officials across the country—unless increased military spending causes the budgetary brakes to be applied to civilian programs.

The Elementary and Secondary Education Act of 1965, for example, will provide \$100 million for teaching retarded, disadvantaged and gifted children. A sizable portion of this money is likely to go for such electronic aids as language laboratories, educational television, and programed teaching machines.

In teaching languages, the lab has become as important as the blackboard. The language lab consists of batteries of tape recorders, which allow students to listen to their own pronunciation and compare it with a master tape made by the instructor. Sales of these labs in 1966 are expected to exceed the \$15-million record set last year.

Educational television

A close second to language labs in sales, and moving up fast in the educational electronics market, is educational television. Sales of studio equipment and receiver sales in 1965 totaled \$8 million to \$10 million, they should reach \$13 million to \$15 million this year.

From professor ...



Lecturer Howard F. Fehr at Columbia University in New York speaks into headset while writing on an Electrowriter. Both voice and writing are carried by phone lines.

Robert N. Veneland, sales manager of the Conrac division of the Giannini Controls Corp., the largest producer of tv monitors, predicts a 25% annual increase in educational-tv sales.

The most important recent development in educational tv is 2,500-megacycle transmission, which allows school districts to broadcast to their schools without resorting to expensive coaxial-cable networks or hard-to-get commercial channel allocations. Some industry specialists are predicting that, because of 2,500-Mc transmission, each of the 50,000 school districts in the United States will eventually be part of a multichannel tv network.

With such a system a low-power omnidirectional microwave signal—10 watts maximum—is sent out from a transmitting tower and picked up at each participating school by a dish-type microwave antenna. The received signal is then changed back to vhf so that ordinary tv sets can be used in the classrooms.

The market for such 2,500-Mc microwave equipment is expected to reach \$10 million a year soon; it is now under \$2 million.

Long-distance teaching need not be limited to tv. A less costly technique called "blackboard-by-wire" permits college students all over the country to "attend" lectures by leaders in their field, who may be hundreds of miles away (see photos below). The technique uses the Victor Comptometer Corp.'s Electrowriter, to transmit handwriting.

Teaching machines

Teaching machines may be a simple mechanical
... to classroom by wire

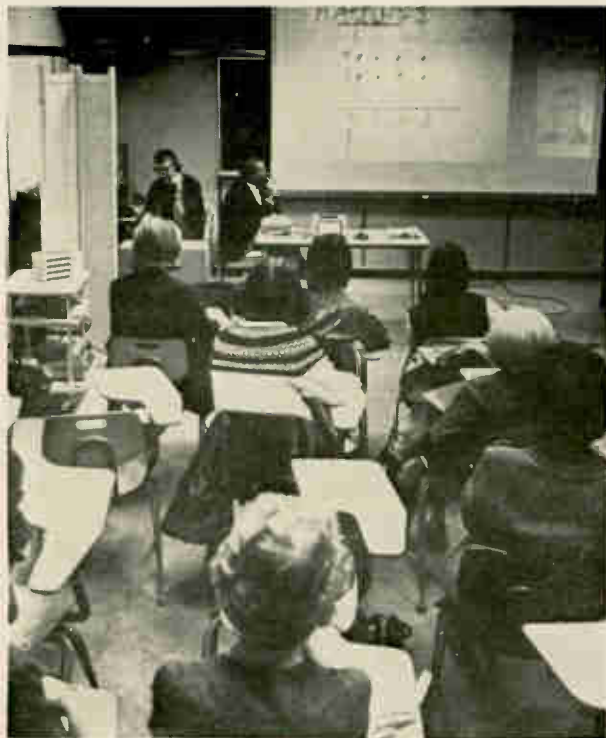

Students at Stephens College look and listen in a classroom in Columbia, Mo. Long distance phone line connects students and lecturer Howard Fehr.

device that costs \$10 and is little more than a textbook. Or it may be an elaborate, computer-based system costing tens of thousands of dollars, which almost duplicates the function of a private tutor.

There is a great deal of experimentation by colleges, textbook publishers and computer companies. The goals are to learn which types of machines best fill the needs of certain classroom situations, and to write programed course material. As educators learn to use them, these machines will become important classroom tools and a big market for electronics companies.

The teaching machine of the future probably will be computer-based, because of the computer's almost limitless memory and its inherent flexibility. Because the computer can be programed to read answers typed onto it, instruction can take the form of a question-and-answer dialogue.

The International Business Machines Corp., which is doing a great deal of experimentation in computer-assisted instruction, has set up computerized learning laboratories in about a dozen universities, and is itself studying the presentation of complex material by computer [Electronics, June 28, 1965, p. 34].

Recent innovations

One relatively inexpensive educational aid, which has recently been offered by several companies, is the student-response monitor. With this system, the teacher intersperses his lecture with questions, offering as many as four possible answers. Each student then presses one of four buttons on his own desk-top response unit, corresponding to his answer. Meters on the teacher's console tell him what percentage of the class selected each answer. With the flick of a switch, the teacher can light an indicator at each response station to let each student know whether his choice was correct. In this way, the teacher is always aware of a student's comprehension without testing and without having to call on each student frequently.

One such system, Telesponder, made by TelePro Industries, Inc., provides a paper-tape puncher for each student. The punched tapes can be collected at the end of each session and graded in seconds with a tape reader.

TelePro expects to sell 5,000 units this year and 25,000 in 1967. Thirty-six student stations and a teacher's monitor cost \$2,095; the tape reader sells for \$2,500.

In a system developed by the New York Institute of Technology through a grant from the Carnegie Corp., the student answers questions by forcing a probe through a card onto a conducting surface. The punched cards are collected and fed to an IBM 1620 computer and a 1622 card reader for scoring. The computer then prints out a class report showing each student's errors, a grading curve based on the standard deviation of the class, and individual lesson assignments based on how well the students answered the questions.

Electronic switching promotes boom in data-sending gear

By 1970, data transmission will exceed voice traffic over telephone lines, Leslie H. Warner, president of the General Telephone and Electronics Corp. predicts. Sales of data-transmission equipment this year are expected to increase to \$55.6 million from \$43.6 million in 1965.

One factor contributing to increased telephone traffic is electronic switching and the additional services it makes available. Both the GT&E and the Bell System have electronic switching centers in operation. In addition to the center operating for seven months in Succasunna, N. J., Bell will start operating electronic switching equipment in Chase, Md., Beverly Hills, Calif., and one exchange in New York City early this year. A spokesman for the parent company, the American Telephone and Telegraph Co., says \$85 million of electronic switching equipment will be installed this year.

The Bell System has two factories producing electronic equipment. All of it is built with discrete components; Ray W. Ketchledge, director of the Switching Laboratory at the Bell Telephone Laboratories, says he won't consider redesigning the system with integrated circuits until the cost and reliability of IC's are demonstrably better than can be obtained with discrete components.

On the other hand, the Automatic Electric Co. division of GT&E, which installed an experimental electronic switching center late last year in Portage, Ind., is not yet in production, and is therefore still flexible enough to be able to test IC's. Frank Reese, Automatic's president, says that if costs are low enough, IC's will be used. In the next three years, however, GT&E will install several electronic switching systems with discrete components for further tests and evaluation.

Both GT&E and Bell estimate that it will be at least 40 years before all the telephones in the country will be electronically switched. But that doesn't mean that the additional services of electronic switching won't be available to all telephone subscribers until then. W. S. Brown, product marketing supervisor for the AT&T, says that one Bell System company, in Sioux City, Iowa, is adding equipment, compatible with the electro-mechanical switches, to provide such additional services as abbreviated dialing and rerouting of calls. This equipment will go into trial operation in 1966.

Digital communications

Hall McKinley, who is responsible for marketing the International Business Machines Corp.'s commercial products for data processing, sees a new market opening this year halfway between the

simple and the complex on-line data-processing equipment currently available. Companies whose needs are too sophisticated for simple equipment, yet not great enough to warrant a complex system such as the reservations system IBM built for American Airlines or the one Sperry Rand Co. will build for United Airlines will be able to acquire terminal equipment for handling on-line data to be processed by a computer at a remote location.

This new market will demand more and faster digital communications. To meet these needs, Bell Labs is developing techniques for increasing the rates of transmitting digital data over high-quality and ordinary voice-grade telephone lines. With the high-quality line, says R. W. Lucky, head of the data-theory department at Bell Labs, transmission at 9,600 bits per second has been obtained under ideal conditions in the laboratory; but in practice, 7,200 bits seems more reasonable in commercial service. Lucky's group is trying to increase the digital transmission rate over voice-grade telephone lines from the present 2,000 bits per second to at least 4,000 bits.

These increased rates are obtained by using multilevel transmission techniques, error control, and equalizers at the terminals of the line. Bell developed the equalizers to maintain the signal's phase and amplitude despite changes in the characteristics of the line.

Pulse-code modulation

Another important trend is the increasing use of pulse-code modulation (pcm), which enables analog signals to be transmitted in digital form. Bell Labs is experimenting with a pcm system for transmitting signals, such as television, which require broad bandwidths. R. A. Kelley, director of the digital transmission lab at Bell Labs, says Bell has nearly completed basic tests on a pcm system capable of transmitting 224 million bits per second over coaxial cable. A cable 4,000 miles long was simulated in the laboratory to show that two tv signals, or more than 3,000 voice signals, can be transmitted with high quality over transcontinental distances. This year, Kelley says, the system will be refined further. Bell will attempt to implement the system with high-speed integrated circuits. The present model uses integrated circuits only in the low-speed portions.

Sven H. Dodington, vice president of research and development at the International Telephone and Telegraph Corp.'s Federal Laboratories, expects microcircuits and digital techniques to be used increasingly in the development and production of pcm systems.

Military communications

Increased emphasis on tactical and survivable communications is what the Westinghouse Electric Corp.'s surface division expects from the military this year. Westinghouse will use microcircuits to develop mobile tactical equipment for tropospheric scatter, microwave line-of-sight, and high-frequency communications systems. Such equipment is needed in areas like Vietnam, where it must be set up quickly, drain little power, and be rugged and reliable and easy to maintain.

Fulfilling the same needs is the Defense Elec-

tronic Communications products division of the Radio Corp. of America, which is developing solid state f-m equipment that is highly mobile.

Westinghouse's surface division is also developing survivable communications systems for operation in the low and very-low frequency bands, for surface, shipborne and airborne applications. These systems will be designed in modules so that basic components can be applied in many system configurations. The equipment will be solid state in the r-f signal-generating stages, as well as in the amplifying stages.

Computers

A time for time-sharing . . . and the used computer dealer

In Raleigh, N.C. and in Boulder, Colo., the International Business Machines Corp. is building facilities to increase its production of computers. In Camden, N.J., the Radio Corp. of America will return a plant to computer production. In Oklahoma City, Okla., the General Electric Co. is converting a military-products plant to a computer factory. And in Blue Bell, Pa., and St. Paul, Minn., the Univac division of the Sperry Rand Corp. is planning to expand computer-building facilities.

These are just a few efforts to meet the surging demand for computers. The value of computer installations in the United States is expected to increase this year at the same half-billion-dollar rate as in 1965, to \$3.5 billion. These prices are sales values, even though most computers are leased rather than sold.

The most significant developments in hardware this year will be the refinement of time-sharing, new bulk-memory devices with new forms of organization for large and small memories, and new system concepts. In marketing, the field may be ready for a new entrepreneur—the used-computer dealer.

Time-sharing comes into its own

Nineteen sixty-five was a year of experimentation with time-sharing; 1966 will be the year in which time-sharing comes into use, according to Harlan Anderson, vice president of the Digital Equipment Corp. The first big application will be by service bureaus that offer computer access on a time-shared basis. They will have new remote equipment available, designed specifically for time-shared computers; the teleprinter now used will be gradually replaced.

As the investment in remote equipment increases, central processors will constitute an ever-decreasing portion of the field—as little as 30% eventually, some specialists predict, compared with 50% to

60% at present. This decline will start in 1966.

Toward larger memories

A time-shared computer system requires large storage. Memory is arranged in hierarchies of increasing size and decreasing speed, organized so that a user need not worry about memory limitations when writing his program. Present hierarchies consist of arrays of ferrite cores, backed up by a high-speed magnetic drum, and supported further by high-capacity magnetic disks. In 1966, there will be further developments in the technology and organization of very large bulk storage, although few of these will reach the market this year. Photographic recording of data may be one area of development; IBM has already announced that one such system will be installed at the Lawrence Radiation Laboratory of the University of California.

Large computer systems, particularly those used

The computer market grows . . .

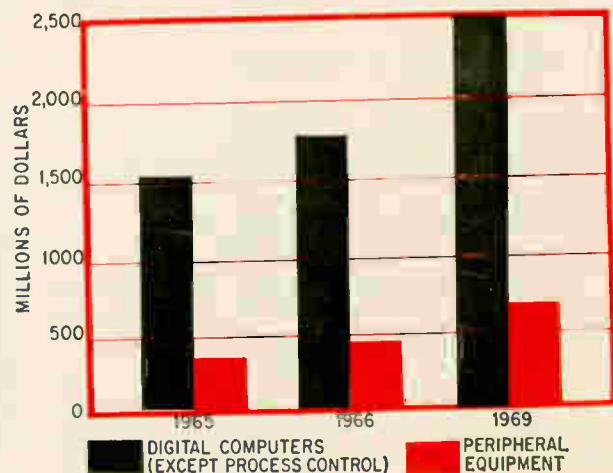

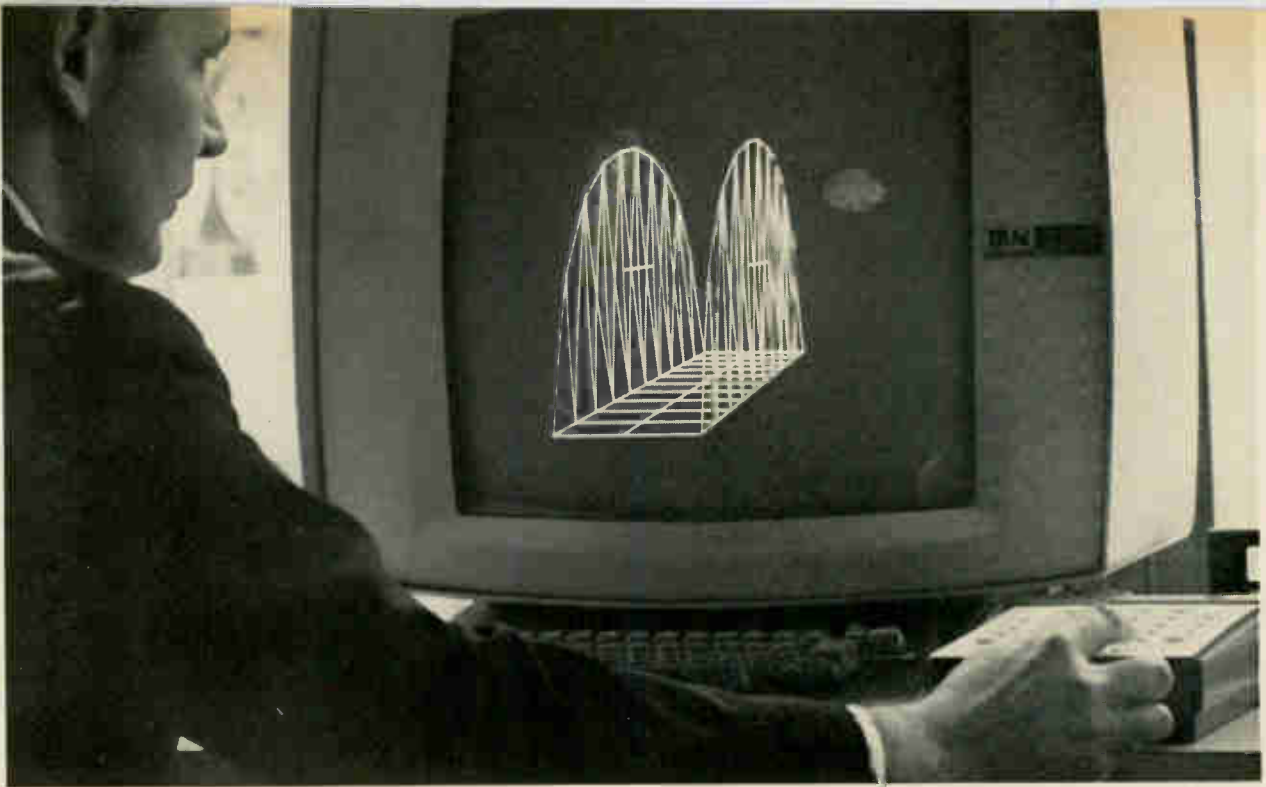

Three-dimensional image of a bridge—generated by a mathematical model stored in an IBM System 360 computer—can be examined and manipulated by instructions to the computer. Using the keyboard at right, the operator can display the bridge from different angles and can make the image—or parts of it—larger or smaller.

in multiprogramming and multiprocessing, require complex controls. These controls are often designed efficiently around scratch-pad memories—small, fast memories that back up the main ferrite-core memory array by storing intermediate results of computations or by temporarily holding a small block of data or instructions obtained from the main memory. Electrically nonalterable, or read-only, memories are also used to contain the specific sequence of steps for executing each instruction in the computer's repertoire. Both types of small memories will appear more and more frequently in 1966.

New memories organized to resemble associative memories, will appear in 1966 together with further development of true associative memories. An associative or content-addressable memory may be considered an extreme example of a true random-access file, in which data may be stored with total disregard of its size or location. However, no radically new technology will appear on the market in 1966.

System concepts and developments

The capabilities of third-generation technology will permit old tasks to be done in new ways. From these capabilities will come new ways to organize computer systems, including processors and peripheral gear. Computers in widely separate locations, linked by telephone lines, will communicate with each other through remote consoles, says Claude H. Smith, vice president, marketing, at the data-processing division of Honeywell, Inc.

New peripheral devices will be developed for sensing and controlling various processes. These will promote direct computer control of all kinds of industrial and business processes, closing the

loop that now requires human intervention between the computer's calculation and the adjustment of physical processes. One application might be controlling electrical power-generating and distributing equipment; such computer controls might prevent power failures such as the one that blacked out the Northeast last fall.

Sharing the market

In 1967, the computer field will still be dominated



The tiny plastic cell in the girl's hand stores 4.5 million words on tiny chips of film, the same information found in three volumes of an encyclopedia. It was built by IBM.

by IBM, but that company's leadership position seems to have been eroding slowly, and this process may continue.

General Electric, for instance, has done well with its 600 series, largely at IBM's expense, based primarily on its short delivery schedule. A GE 625 ordered today can be in operation in 12 months, whereas the best IBM can do with its System 360, Model 75 is 24 months. IBM recently lengthened its delivery schedules by two to four months.

Honeywell, Inc., has aimed at IBM's 1400 series for some time with its Series 200, and is now sniping at the smaller models of System 360. The 200's can be made compatible with System 360 in the

same way that the 1400-series machines are. About half of Honeywell's sales replace former IBM installations, according to Smith.

As the number of computers increases, and as computers are replaced by more powerful machines, there arises a market for second-hand machines. This market so far has been relatively small; most producers have been taking back their old machines and either disposing of them or reconditioning them for further use. But when there are enough used machines to attract independent used-computer dealers, the market for new machines is bound to be affected. This trend could begin to take shape in 1966.

Solid state

Ladies' home companion: the silicon controlled rectifier

While solid state components continue to whittle away at vacuum-tube markets, they are also branching out into fields that never required tubes—or electronics of any kind. This year many companies in industrial control and in consumer fields will receive calls for the first time from salesmen of discrete semiconductor devices. Prime consumer targets will be producers of household appliances, business machines, cameras and slide projectors.

Electronic's survey predicts 1966 sales of discrete components—all semiconductors except integrated circuits—at \$714.5 million, a healthy gain from last year's \$669 million. By 1969, the survey estimates that sales will total \$752 million. IC figures are included in another section of this report (p. 137).

Banner year for the scr

The healthiest growth is expected in silicon controlled rectifiers, or thyristors as they are sometimes called in Europe. These will widen their applications in industrial speed and power controls, such as in steel, paper and textile mills. They will also make their first appearances in such household appliances as sewing machines, and slide projectors, and will continue to make inroads in washers and dryers and in heating and in home lighting systems. "By 1970," says Leonard C. Maier, general manager of the General Electric Co.'s semiconductor operations, "half of the consumer electric appliances made in the United States will contain silicon controlled rectifiers."

Sales of scr's should climb to \$39 million this year from \$33 million in 1965, and by 1969 the total should reach \$59 million.

More power transistors

A scramble is shaping up for the high-frequency

power-transistor business. The targets are markets such as aircraft communications, citizens band, community-antenna television systems, radar transponders, radio relays, radiosondes, rescue beacons for life rafts and parachutes, tactical communications, telemetry and troposcatter systems.

Demand for transistorized sonobuoys may be huge, possibly calling for several hundred thousand transistors. Sonobuoys contain two to nine transistors each. When they sense the presence of a ship, their transmitters turn on and the position of the vessel is fixed by triangulation. Sonobuoys sink when their batteries are exhausted, usually from a few hours to a few days after they are dropped. During the Cuban missile crisis of 1962, about 10,000 sonobuoys a day were dropped.

The battle is already on for the community antenna television (CATV) market. Class A-operated transistors with high, linear gain over wide frequency bands are needed. The chief contenders are the overlay transistor, which contains many emitters tied in parallel by aluminum metallization, and an interdigitated-geometry device whose emitters look like pairs of interlocked combs; this device has complete transistors, known as cells, in parallel. The overlay transistor was introduced commercially in 1964 by the Radio Corp. of America. The parallel-cell device was brought out last year by TRW Semiconductors, Inc., a division of TRW, Inc.

Field-effect transistors

Further gains also are expected for field effect transistors which, despite their cost, have already penetrated the high-fidelity market. Work is under way to increase their operating speeds and power-handling capabilities. Texas Instruments Incorpo-

Big scr's for industrial applications . . .

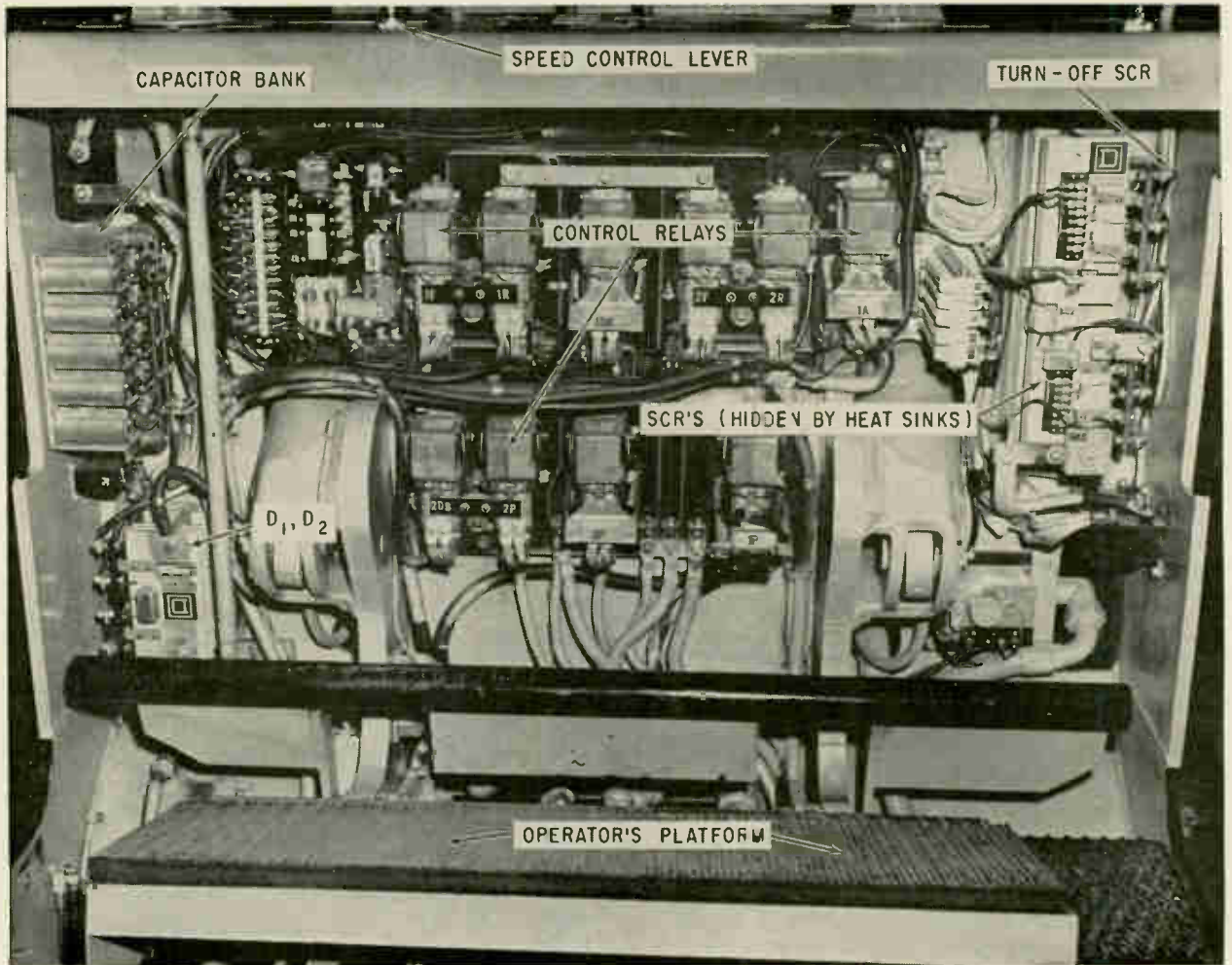

As the capacity of scr's has increased, new applications have developed like this control for a giant 15-ton electric lift truck which uses four 235-ampere scr's. Increased capacity has come from the fabrication of bigger devices and the development of new techniques such as paralleling scr's.

rated is studying a developmental field effect transistor that can provide outputs of several watts at hundreds of megacycles. Several companies, including the Union Carbide Corp. and Texas Instruments Incorporated, have already built experimental field effect transistors that can operate as amplifiers at up to one gigacycle.

Unijunction transistors

Despite a drop in prices, sales of unijunction transistors will climb to about \$2.5 million in 1966 from 1.6 million last year. This gain will move them ahead of tunnel diodes (about \$2 million) in sales.

The increased demand for unijunction transistors will result largely from greater use of industrial circuitry, which requires unijunction transistors to trigger silicon controlled rectifiers. Plastic-packaged planar unijunctions will bite into the market now dominated by metal-case types built with bar and cube unijunction construction.

The only bad news in the forecast for solid-state suppliers is that Japanese producers will increase their share of the business in 1966, the result of aggressive marketing and low prices.

. . . and little scr's in housewares



Whirlpool Corp. will supply an scr motor control for this home vacuum sweeper which Sears Roebuck and Co. will sell in 1966.

A 60% sales spurt expected this year

When the **Signetics Corp.** opened its new 100,000-square-foot plant in Sunnyvale, Calif., last October, it considered selling its old facilities, encompassing 17,000 square feet, in the same town. Fortunately the company, a subsidiary of the Corning Glass Works, decided to keep the older plant; today both are busy producing integrated circuits.

Signetics' experience is typical of the rapid growth in IC's, which spurted ahead from a standing start in 1964 to sales of \$70 million last year. Sales this year are expected to climb 60% to \$112 million, and a spokesman for Texas Instruments Incorporated predicts \$1 billion in annual sales within a decade.

At Motorola, Inc., C. Lester Hogan, vice president and general manager of semiconductor operations, declares, "One of the industry's biggest problems for the immediate future will be how to keep up with the skyrocketing demand." The Radio Corp. of America seems to agree; RCA is doubling its IC-production capacity, but even after the new facilities are in operation, RCA still will rely heavily on other companies' IC's for its Spectra 70 computers.

Gains for linear and thick-film IC's

Linear IC's will gain more widespread use this year as video and audio amplifiers—also as d-c, i-f and r-f amplifiers. Particularly competitive will be integrated circuits for operational amplifiers. Linear IC's also will appear in cameras, organs and adding machines.

Circuits combining thick-film passive components with silicon chips also are expected to find more applications, almost entirely in custom IC's. Practical circuits already are being made entirely of thin films with active and passive devices deposited on glass or sapphire substrates.

The scramble for the entertainment market will begin in earnest. The biggest early plums may be in automobile radios and television sets. The military also is expected to increase its purchases, reducing temperature specifications to make less expensive IC's, both monolithic and hybrid, acceptable for many applications.

In addition, microwave IC's will become available; multichip construction with thin-film passive components will be used in amplifiers capable of operating at three gigacycles per second. Faster transistor-transistor logical circuits also will be introduced, and more companies will produce this type of circuit. For the future, more companies will begin to design into IC's such devices as tunnel diodes and Schottky hot-electron transistors. There will be increased use of controlled rectifiers in

custom-built integrated circuits.

Strong demand is expected for IC's in dual in-line plug-in packages. Many manufacturers will sell more IC's in this package than in flat-pack and TO-5 cases combined.

As the trend to second-sourcing continues, more companies will adopt type numbers assigned by the EIA instead of their own designations.

Competition in complex IC's

The three approaches to complex monolithic integrated circuits will come in for close competitive scrutiny this year. Metal-oxide semiconductor (MOS) IC's, multilayer IC's and large-chip IC's will be competing with each other in many areas.

"Systems built with MOS IC's will make large inroads," predicts Donald E. Farina, general manager of the subsystems division at General Microelectronics, Inc., "because they will be able to duplicate the functions of systems using conventional monolithic IC's but will cost less to build.

Gordon E. Moore, research director at the Fairchild Camera & Instrument Corp., predicts increased applications of MOS circuits in analog switching and digital systems where high speed is not essential.

Earl Gregory, marketing manager of General Microelectronics, Inc., says more than half of the MOS IC's sold in 1966 will go into military equipment. Industry sales, he predicts, will climb from \$2 million last year to \$15 million in 1966.

Frank W. Wanlass, director of integrated-circuit operations for the semiconductor division of the General Instrument Corp., expects MOS IC's to constitute a \$140-million market by 1970. "Over-all system speeds" says Wanlass, "will be obtained with MOS integrated circuits that are faster than

Sales of IC's boom . . .

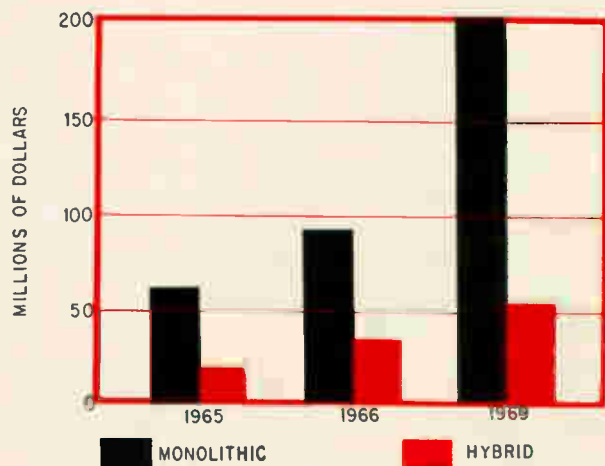

the fastest speeds now being obtained with digital systems."

Not everybody shares Wanlass's optimism. "In the long run," says Alvin B. Phillips, general manager of the integrated circuits department of Sylvania Electric Products, Inc., a subsidiary of the General Telephone & Electronics Corp., "two- or three-oxide-layer integrated circuits, with chips slightly larger than those now being used, will be predominant."

Multiple-oxide-layer IC's contain monolithic chips on top of which alternate layers of metal (interconnections) and oxide are placed. Stewart-Warner Microcircuits, Inc., a division of the Stewart-Warner Corp., is currently using this technique (three oxide and three metal layers) to put more than 2,000 components on a single 100-by-100-mil chip. Frances Hugle, director of research and engineering at Stewart-Warner Microcircuits, expects wider use of multioxide-layer construction this year in high-density systems that require high operating speeds but do not have severe power-handling requirements. For complex low-speed systems, where low battery drain is important, William Martin, marketing engineer for Texas Instruments, expects MOS IC's to be most prevalent.

Large-chip IC's may be approaching the limit of their popularity. C. Robert Cooke, Jr., director of research and development at the Semiconductor

division of the International Telephone and Telegraph Corp., says monolithic chip sizes should reach 250-by-250 mils in two or three years, but adds that "applications for chip sizes this large will probably be limited." The large number of pins required will be a restricting factor, Cooke explains.

"We can produce 180-by-180-mil chips," says Richard J. Hanschen, assistant vice president of TI's Semiconductor Components division, "but we don't see a widespread need for them." Hanschen points out that current chip sizes, such as 100-by-100 mils, are sufficient to meet most present and anticipated requirements. Chips 70-by-200 mils were in the IC's that TI introduced in 1960.

The General Instrument Corp. is developing a line of MOS IC's that will use 100-by-150-mil chips. Wanlass says the bigger chips are being used to permit the use of larger MOS transistors for greater power-handling capability, rather than to put more transistors onto a single chip.

And if present methods for producing complex integrated circuits cannot provide enough component density, Frances Hugle of Stewart-Warner has a suggestion: "Diffusing components into both sides of the chip is possible," she says. "For example, an optoelectronic integrated circuit could have a light detector on one side and output circuitry on the other side of the same chip."

Instrumentation

Market becoming richer . . . and more competitive

Although sales will cross the \$600-million mark this year, up from \$535 million in 1965, electronic instrumentation is rapidly becoming a buyer's market. Competition is stronger and specifications more stringent. The customer is no longer willing to compromise; if his supplier cannot provide an instrument tailored closely to his needs, another supplier will.

For example, the Fairchild Camera & Instrument Corp. last year developed an oscilloscope that captures high-speed transients that occur only once; the instrument has fiber optics in the faceplate to increase brightness of the traces so they can be recorded photographically. And the Hewlett-Packard Co. supplied the Bell System with a television waveform monitor that displays short-duration pulses with low duty cycle in a brightly lit tv room.

Seeking civilian markets

Remembering the effects of cutbacks in defense spending last year, instrument manufacturers are seeking industrial customers. Gulton Industries, Inc., is one of an increasing number of companies

that operate on the principle that selling to industry is different from selling to the military. "They buy to specifications and accept no deviations," says Leslie K. Gulton, president of the company, which derives about half of its income from civilian sales.

Companies that offer a full line of test and measuring equipment usually fare best in the civilian market. That's why many small companies in the instrument field are rounding out their product lines through acquisition or merger.

Many innovations in 1966 will result from the continuing trend toward automation. Many more automatic test and production facilities can be built, and for less money, if conventional instruments can become the bases for complete, more exotic lines.

To provide better interface with computers, measuring instruments and power supplies are being made with remote readout and programing capabilities. Fairchild's instrumentation division, for example, introduced a laboratory dual-power source in 1965 that is externally programable. Such instruments, usable in more than one ap-

plication, are becoming more common.

Event and strip-chart recorders, along with x-y plotters, are also receiving a boost from automation. Sales of these devices should exceed \$52 million. These items are needed to provide a permanent record of what has occurred. Manufacturers are building into these devices more accuracy, broader bandwidths and greater flexibility. Magnetic tape instrumentation recorders have usually been considered too expensive to be practical for these applications, but that situation seems to have changed; Hewlett-Packard has introduced a low-cost instrumentation tape recorder for industry. In some applications, this new device may replace the graphic recorder.

Other innovations are aimed at increasing versatility and simplifying operation. In line with this, says a General Radio Co. spokesman, is the trend to automatic instruments such as component measuring bridges, which reduce by 90% the time the best technician takes to make a measurement. In addition, incorporating printout devices with these instruments makes it unnecessary for the operator to stop and record the results manually. At present, however, some accuracy has to be sacrificed to accomplish this. General Radio's automatic capacitor bridge has an accuracy of 0.1% while the best available bridges are an order of magnitude better.

With plug-ins, oscilloscope makers are increas-

ing versatility and sophistication. At the same time, they are working toward devices that are easier to use. Advances in semiconductors are making high-accuracy oscilloscopes available as portable instruments for field use. Many scopes now have outputs for digital printout or a graphic recorder.

Even with all these innovations, advances in instrumentation are becoming harder to achieve. "Whereas previous developments may have resulted in accuracy being increased from 10% to 1%," says Kenneth Halvorsen, technical director of Beckman Instruments, Inc., "it is much harder to increase the accuracy of a 1% instrument by an order of magnitude." Although accuracy is important to the user, he now considers many other specifications when considering the purchase of an instrument.

"Applications of instrumentation are limitless," Halvorsen declares. "The fields of medicine and education, along with the automobile and chemical industries, are all increasing their reliance upon instrumentation. However, many problems must be solved before these opportunities can be pursued profitably. The user-instrument interface must be smoothed over. And we need engineers trained in the areas in instrument design and application. There just aren't enough of these people around," he added wistfully.

Microwave

Leveling off forecast for '66 after the unexpected rebound of '65

The microwave industry confounded the experts last year. They had predicted a continuation of the 1963-64 decline, but sales rebounded to about \$500 million—the 1963 level. This year, those willing to hazard a guess are split between those who think business will continue to rise and those who predict about the same level as in 1965. Electronics' survey predicts an increase in sales of both microwave systems (from \$80 million to \$84 million) and instruments (from \$62.6 million to \$72.8 million).

About 25% of the sales will be for tubes. Other major segments will include radio relay, radar, telemetry and microwave measuring equipment, each of which is expected to account for 12% to 16% of the market.

The government will continue to be the biggest customer. "Let us not deceive ourselves," says John Minck, marketing manager of the Hewlett-Packard Co.'s microwave division, "the bulk of the big money in microwaves is coming from the government." Hal Tenney, marketing manager at Western Microwave Laboratories, Inc., agrees: "There isn't enough commercial business to support the industry. It has to be supported by the military."

The war in Vietnam has taught the military the need for more sophisticated systems, Tenney says. Minck sees 1966 as a year of proposals rather than of sales. "The big contracts aren't going to break," he says. "The government is going to demand tighter specs because it knows they can be achieved. Bidding is going to be tougher because the government is going to award contracts only to the firms that understand advanced techniques. Thus, the technical leaders are going to get bigger at the expense of the laggards."

Technical advances

Hewlett-Packard is trying to extend the capabilities of present microwave equipment to meet users' tighter specifications.

For instance, the spacing of mobile communications channels is now being decreased from 100 kilocycles per second at 100 megacycles to 50 kc and perhaps even to 25 kc. This requires very stable signal generators, so H-P has developed a disciplining oscillator which, when used with its standard signal generators, improves frequency stability by two orders of magnitude. The device,

called the 8708, is an adjustable stable crystal oscillator using a phase-lock sampling technique. It is untuned, with the front end wide open and phase locks with zero frequency offset. The 20-Mc output of a crystal oscillator is counted down to a 2-kc sampling frequency; the d-c correction signal is fed back to the signal generator.

The market for microwave tubes will be strong for several reasons. For one thing, existing radar communications systems will continue to require spares. And although solid state circuits are making inroads into the microwave signal-source area, it will be a long time before they replace traveling-wave tubes entirely; twt's have broad bandwidths, and so far nothing in solid state can do a comparable job.

Finally, there are still many areas in electronics where adequate performance can be achieved only with tubes. New areas for sophisticated, high-performance tubes are still opening up. Some are spin-offs from aerospace requirements; others are caused by the crowded conditions of the spectrum below X band; still others result from the need to increase capabilities of existing systems. But Dean Watkins, president of Watkins-Johnson Co., expects no big developments in microwave tubes; he does predict continued, steady improvement in tube technology, however.

The market for electronic tubes in 1966 should be about \$120 million, up from \$117 million last year.

Eimac, a division of Varian Associates, has developed a "window" twt that can remain in the system, turned off, with an insertion loss of only one decibel. When turned on, it provides a gain of 10 db. Eimac's first such tube is rated at 1.5-kilowatts peak power output; the goal is 5-kw peak power output, with efficiency of 40% over the 2.5- to 5.8-Gc range.

Although it wasn't his intention to compete with twt's, R. P. Wadhwa of Litton Industries, Inc., has developed a low-noise crossed-field amplifier. Crossed-field tubes, he says, are more efficient than twt's and have greater bandwidth at high power, good saturation characteristics and better phase linearity. Wadhwa's first experimental amplifier has 12 watts output with only 3.5 db of noise in the 3-Gc range; a twt with comparable output, he says, has a noise figure of about 30 db. His goal is a 2-kw amplifier with noise of only 30 db in the same frequency range.

Further improvements in magnetrons are expected this year. Eimac soon will announce a magnetically shielded magnetron for use in systems where packaging density requires tubes to be close together; magnetic shielding prevents the tubes from degaussing each other, or from adversely affecting other ferromagnetic devices. Eimac's magnetrons range in power from 50 milliwatts to 75 watts, over a range of 250 to 3,200 Mc.

The ferrite market is continuing to grow, says Tenney of Western Microwave. Most microwave systems for the government require ferrite devices,

he says, including radar, communications, reconnaissance and electronic countermeasures systems from 1.2 to 12 Gc. Pulse-latched ferrite switches developed by Western Microwave make it possible to talk about large phased-array radars with many channels. Pulse-latching requires no holding power and makes a very efficient system.

Yttrium-iron-garnet (YIG) devices will become increasingly important. Watkins-Johnson, for instance, has developed techniques to make YIG filters in large quantities. In addition, says Watkins, the company has learned how to reduce size and weight by a factor of 10 in some models, with no loss in performance. Some time this year, the company will introduce YIG-tuned transistor oscillators—a new application of YIG's and transistors. And the company is setting up new facilities for work in microwave integrated circuits. Mainly this will involve tying YIG devices in with other microwave elements. Using this concept, says Watkins, it may be possible to make an entire receiver front end in an IC package.

In microwave antennas, a new approach to achieving high scanning rates is needed, according to Mike Apar, marketing manager for the Dalmo-Victor Co. The eventual goal, says Apar, is the electronically steerable array; all long-range development programs are aimed in this direction. Antenna designers feel, however, that phase shifters are not yet reliable enough to achieve this goal. Thus, they say, there has to be an interim design. Most promising is the Cassegrain technique, with which high scanning rate can be achieved because a relatively low-mass, small-size element is displaced through a small amplitude.

Industrial microwave heating will be another growth area in 1966. The most promising new technique seems to be the use of microwaves to process cloth for permanent-press garments.

New classifications

Readers will note that this year's Electronic survey differs, in composition, from Electronics market reports of the past, with the result that all totals for 1966 are slightly higher. Electronics has enlarged the survey to include 30 additional categories (see gatefold, p. 111). In previous surveys, some of these categories were included in other larger classifications; others were too small to be included.

The new categories are: timers, panel meters, noise measuring equipment, impedance measuring equipment, microwave oscilloscopes, microwave measuring equipment, microwave spectrum analyzers, microwave sweep generators, microwave pulse generators, nuclear personal dosimeters, nuclear tube detectors, nuclear scintillation detectors, nuclear ionization chambers, nuclear industrial gauging, optoelectronic instruments and equipment, data transmission equipment, data acquisition equipment, cryogenic equipment, ultrasonic equipment, machine tool controls, consumer tape recorders, light dimmers, consumer antennas, batteries, microwave components, fractional horsepower motors, film circuits, solder, and manual switches.

At last— a production laser welder that really works:

the *Linde* LWM-1



See and try the LWM-1 at the IEEE Show.

This is the first practical laser welder that makes precise, reproducible welds on a *production basis*—the LINDE LWM-1.

Another important thing: it's easy to use. Almost anyone can learn to operate it in about five minutes. The 25:1 ratio micro-manipulator makes positioning a snap. And the operator has a continuous right-side-up image in the binocular viewer, even *during welding*.

The LWM-1 Laser Micro-Welder is manufactured by Korad Corporation to LINDE specifications. Want complete details? Contact the nearest Linde Division office, or send the coupon.

"Linde" is a registered trade mark of Union Carbide Corporation.
Korad Corporation is a subsidiary of Union Carbide Corporation.

FILL IN — CLIP TO BUSINESS LETTERHEAD — MAIL

Union Carbide Corporation
Linde Division, Dept. E-12
270 Park Avenue, New York 10017

Please send me details of the LINDE LWM-1
Laser Micro-Welder.

Name _____

Title _____



a pot
is a pot
is a pot...



No it's not!

It's not true that everyone's precision pots are the same... not even when the specs and the prices look alike. A Spectrol precision pot stands apart.

We give you a potentiometer with: (1) the best possible accuracies for linear and non-linear functions that only our own in-house designed winding equipment is capable of providing, (2) high reliability built-in to meet the most demanding environmental conditions, and (3) standard designs that assure positive contact under the most severe shock and vibration.

In addition, we continue to offer exceptional responsiveness to customer requirements for special designs, a service which has firmly established our reputation as a quality custom house.

Therefore, a pot is a pot is a pot—unless it's a Spectrol precision pot. Its superior quality sets it apart. If you don't agree, you probably haven't tried one. If you would like to, contact us. We'll make it easy for you. Ask for our new eight-page short form catalog.

Spectrol Electronics Corporation
17070 East Gale Avenue
City of Industry, Calif. 91745

spectrol

Boiling water in an atomic teapot!

This 30-ton bottom portion of an atomic reactor vessel for Wisconsin's first atomic power plant being developed by Allis-Chalmers Atomic Energy Division, Bethesda, Maryland, looks like a giant teapot. Additional nozzles will be welded to the 4-inch-thick steel shell. Eventually this section will be connected to two other parts to form a reactor vessel 45 feet tall and weighing about 100 tons. When finished, it will supply power for the LaCrosse Boiling Water Reactor near Genoa, Wisconsin. Boiling huge volumes of water for power in atomic reactors is quite different from boiling water for a cup of tea. Each weld is critical and the smallest flaw could halt or delay the \$18.5 million reactor's operation. That's why the integrity of each weld was tested by radiography. Allis-Chalmers used KODAK Industrial X-ray Film, Type M (ESTAR Base).

The atomic age has created some of the most exacting and extensive assignments radiography has ever had, helping in the expansion of nuclear technology. Perhaps radiography can save time and money in your business. Why not talk to a Kodak x-ray dealer? Or write us to have a representative from Kodak's Radiography Markets Division call.

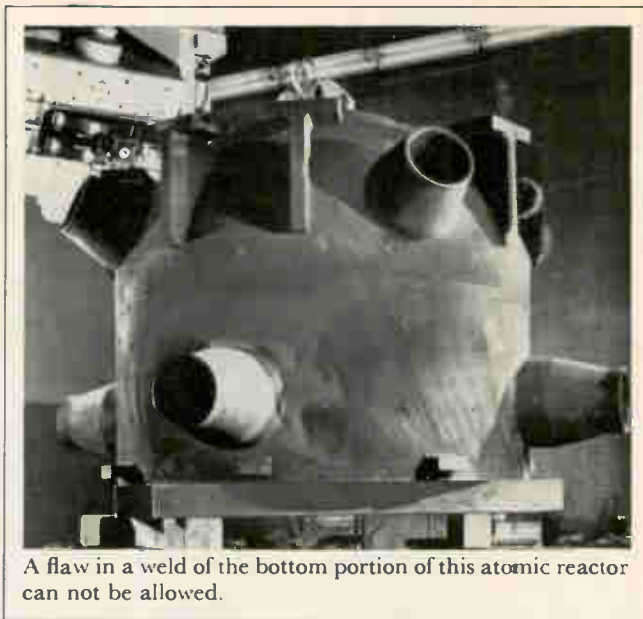

A flaw in a weld of the bottom portion of this atomic reactor can not be allowed.

Three outstanding KODAK Industrial X-ray Films

- Type AA—Fast, fine grain with high contrast. A widely used film, for most purposes.
- Type M—Extra-fine grain. High contrast. Used for highest quality, production radiography.
- Type R—Ultrafine grain. Very high contrast. Used for highest quality, critical radiography.

EASTMAN KODAK COMPANY. Radiography Markets Division, Rochester, N.Y. 14650

Radiography certifies the integrity of each weld; enables correction of imperfection *before* operation.

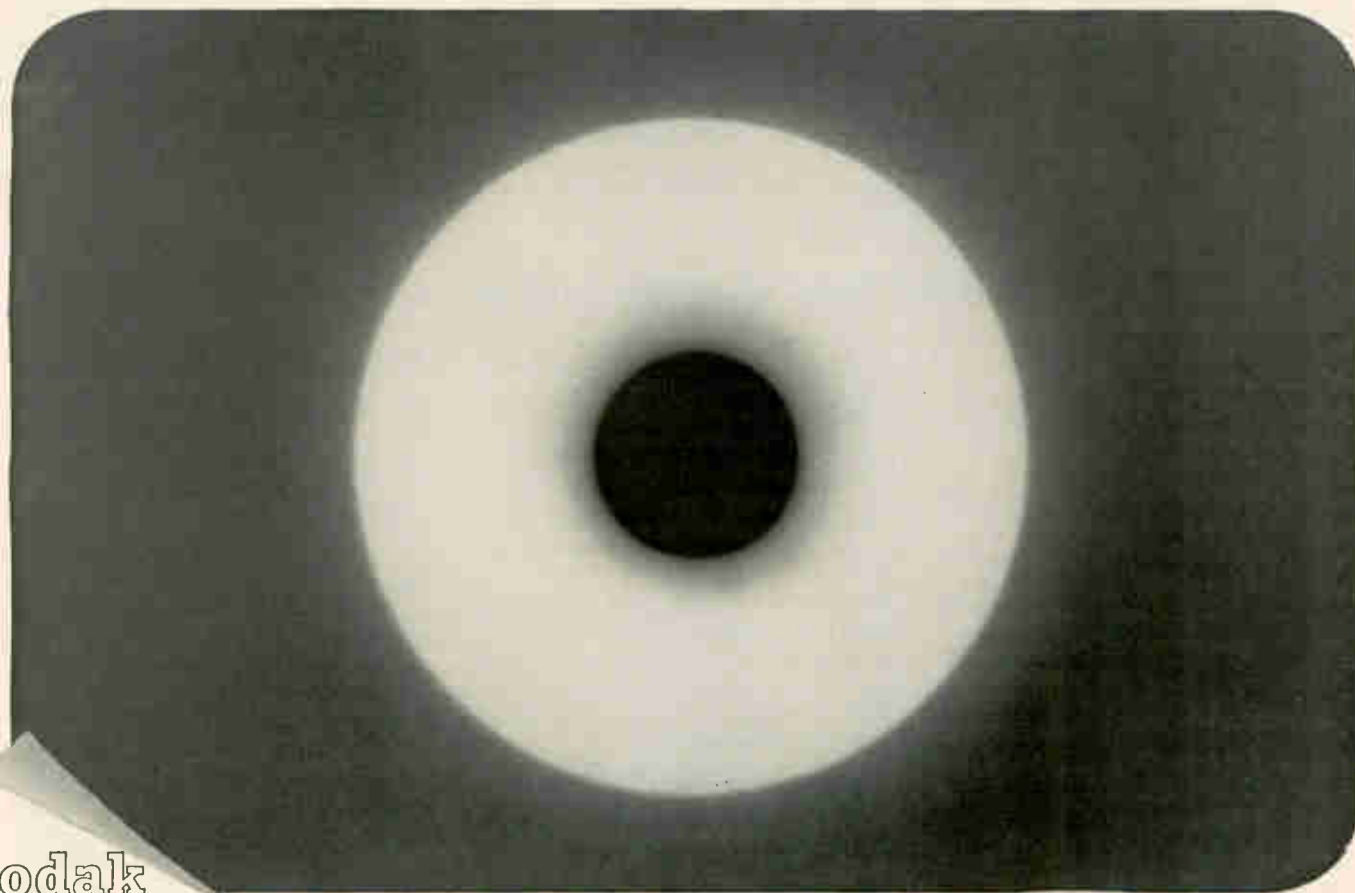

Kodak
MARK

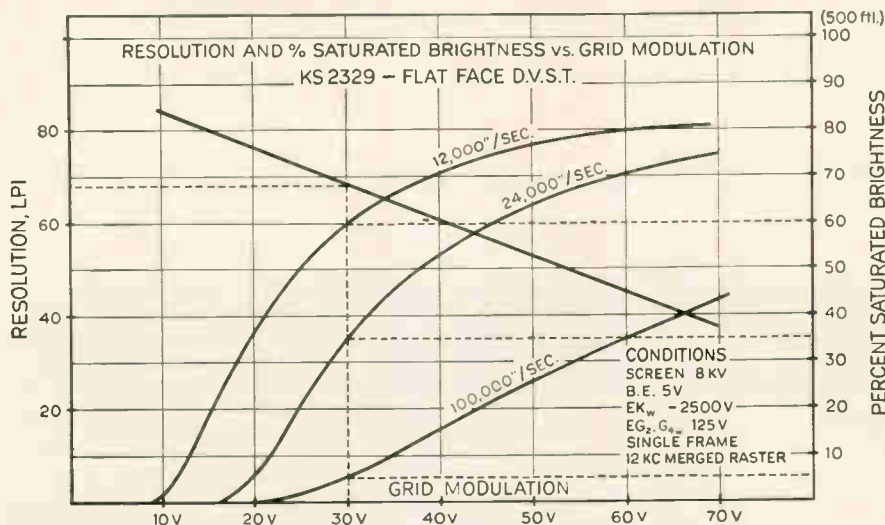

NEW STORAGE TUBE SHARPENS TRACKING SYSTEM'S VISION

The newest generation of tracking and radar systems demands a new generation of direct view storage tubes with improved dynamic display uniformity and resolution capabilities. Du Mont engineers have taken on this problem with marked success.

Case in point: the storage tube originally specified for the PPI of a certain missile tracking system (not Du Mont) lacked center-to-edge uniformity of writing, erasing and brightness. The area at the center of the screen built up a disproportionately high signal charge level. This increased background brightness to the point of obscuring nearby targets. The condition could be partially compensated by increasing storage electrode bias, but this reduced sensitivity to remote weak targets displayed in the peripheral area. Another alternative, equally unsatisfactory, was to erase the image completely every two or three minutes. This left the system blind during the interval required for a complete antenna rotation.

The problem was eliminated by the storage tube Du Mont designed and built for this application. This tube, Type KS2329, achieves substantially uniform dynamic characteristics over the entire storage surface. Resolution capability—600 TV lines in the useful diameter—is 60% greater than that of the original tube. And, with no increase in length, a 12% increase in useful diameter (to 9") was achieved.

Reliability in severe environments was another requirement. So, with its integral mu-metal shield, the Type KS2329 is potted in a resilient, fungus-resistant compound, and is fitted with multiple pin locking connectors and rugged mounting lugs.

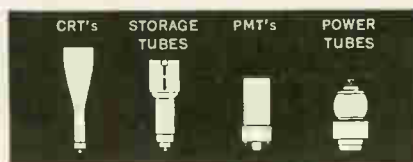

The final result was a significant advance in storage tube technology—or, from the customer's viewpoint, a tracking system with greatly improved vision. Now both strong and weak targets are displayed with excellent resolution, persistence and brightness. Additional features include internal feedback correction electrodes for high pattern geometry accuracy and zero DP current operation to overcome deflection non-linearities resulting from unpredictable collection of writing beam current and reflected flood beam current.

COMPACT PACKAGING

Another new storage tube developed by Du Mont packs unusual performance into a small envelope—and even that is designed to provide extra space for circuitry in the area around the yoke. This tube has a screen diameter of 5", overall length of only 8". Resolution is better than 125 lines/in.; writing speed is 300,000 in./sec. Since the tube has the same excellent integration characteristics as the KS2329, it is expected to find wide application as an indicator in airborne radars, or as a radar indicator and TV display monitor.

Other Du Mont storage tube developments include an on-axis writing gun. This considerable feat, never successfully accomplished in larger tubes, hinged on locating the flood gun or guns off-axis while retaining uniform illumination. The Du Mont tube does not depend on physical alignment to do this. Instead, three off-axis guns are used with split anodes which direct the beam from each toward or away from the tube axis. Uniform illumination is achieved, the write gun is located on-axis—and the DVST can replace a CRT with no change in deflection components.

CUSTOM DESIGN OR OFF-THE-SHELF

Over the years, the solution of many individual tube problems has resulted in the availability of more than 4,000 types of Du Mont tubes. These fall into four general categories: Cathode-ray Tubes, Photomultiplier Tubes, Power Tubes and Storage Tubes. The latter includes both direct view and electrical output tubes. If you need a special purpose tube, you'll probably find it listed in the latest Du Mont tube catalog. If it isn't, we will design and build it for you. For your copy of the catalog, write (letterhead, please) to Fairchild's Du Mont Electron Tube Division, 750 Bloomfield Avenue, Clifton, New Jersey.

FAIRCHILD
DU MONT ELECTRON TUBES
A DIVISION OF FAIRCHILD CAMERA
AND INSTRUMENT CORPORATION

Bowmar: emphasis on digital displays, assemblies

This time of year is one of looking ahead, evaluating past performance and considering new possibilities for growth in the future. Bowmar Instrument Corporation served many new customers during the year past and contributed substantially to their growth with an influx of new products and expanded assembly capabilities, some of which are highlighted below.

Bowmar is known as a manufacturer of one of the industry's most complete lines of precision servo components. From design to final test, the firm offers a most complete service to major prime contractors.

Having one of the best backgrounds in precision military displays, the company produced a data annotation system, the AN/UAS-7, last year for use in the Army Mohawk in Viet Nam. Major display assemblies are a Bowmar specialty.

Much of Bowmar's growth has been predicated on new display products for many years. In 1955, the company designed seventeen types of counters which are still standard in such systems as the B58 Hustler. Other latitude, longitude, variation and various types of navigational counters created by Bowmar have been used extensively in such systems as Polaris, Apollo, Ihas, F-4, F-111, Hawkeye, and commercially in the Boeing 707 and the Douglas DC-9.

The growing need for electrically-pulsed displays to be used on a time-shared basis with computers prompted the company to create displays with sufficient response time and small sizes to fulfill applications where space is critical.

Bowmar has become the only firm to offer both seven-bar incandescent and magnetically-detented readouts, called Opticator® and Logicator®, respectively. The fast-acting, miniature displays are easily read by pilots and ground station operators, and are adaptable for various ambient light conditions for legible annotation on film. "Plug-in commonality" is designed in to allow common usage throughout a system, eliminating the need to replace the complete conversion and logic portions of a system.

One packaged control device, the two or three axes joystick, has become the standard in many industries. The units produce a potentiometric output when the stick is turned in any direction. Offered in packages as small as 1¼ inch cube, the Bowmar joysticks are used for precision positioning, tracking, servo

control and correction, slewing, aiming, tuning, guidance and many other remote functions.

Many Bowmar products find their beginnings in new material processes and techniques in the company's chemical and metallurgical test lab. The firm's comprehensive quality assurance program also begins here, if the product is being researched and developed in house, or at the production line in the case of an existing, qualified product. Quality assurance maintains its vigil every step of the way, even to the installation in the customer's system, if necessary.

Bowmar was among the first firms of its size to adopt and activate a Zero Defects program. Initial goals for the first year in eliminating defects were exceeded by the company's employees in a matter of months, and it appears the company will register one of the industry's best records of success in producing defect-free products.

That fairly well summarizes what you can expect from Bowmar today: a wide range of components, a complete digital display capability, in-depth experience in all types of assembly production backed by quality, ZD performance and service in the field and at the plant. Career opportunities in most technical disciplines are available. We welcome your further inquiry for product and career information. Bowmar-Fort Wayne Division, 8000 Bluffton Road, Fort Wayne, Indiana 46809.

Representative Precision Bowmar Products

- Mechanical counters and indicators
- Opticator® displays
- Logicator® displays
- Servo gearheads, speed reducers
- Servo and stepper motors
- Motor tachometers
- Synchros
- Digital elapsed time and events indicators
- Electroshift® gearchangers
- Data handling and conversion equipment
- Data display assemblies
- Analog and digital servomechanisms
- Servo potentiometers
- Vari(function)® pot-clutch modules
- Phase meters and standards
- Delay measurement sets
- Analytical instruments
- Scientific instruments

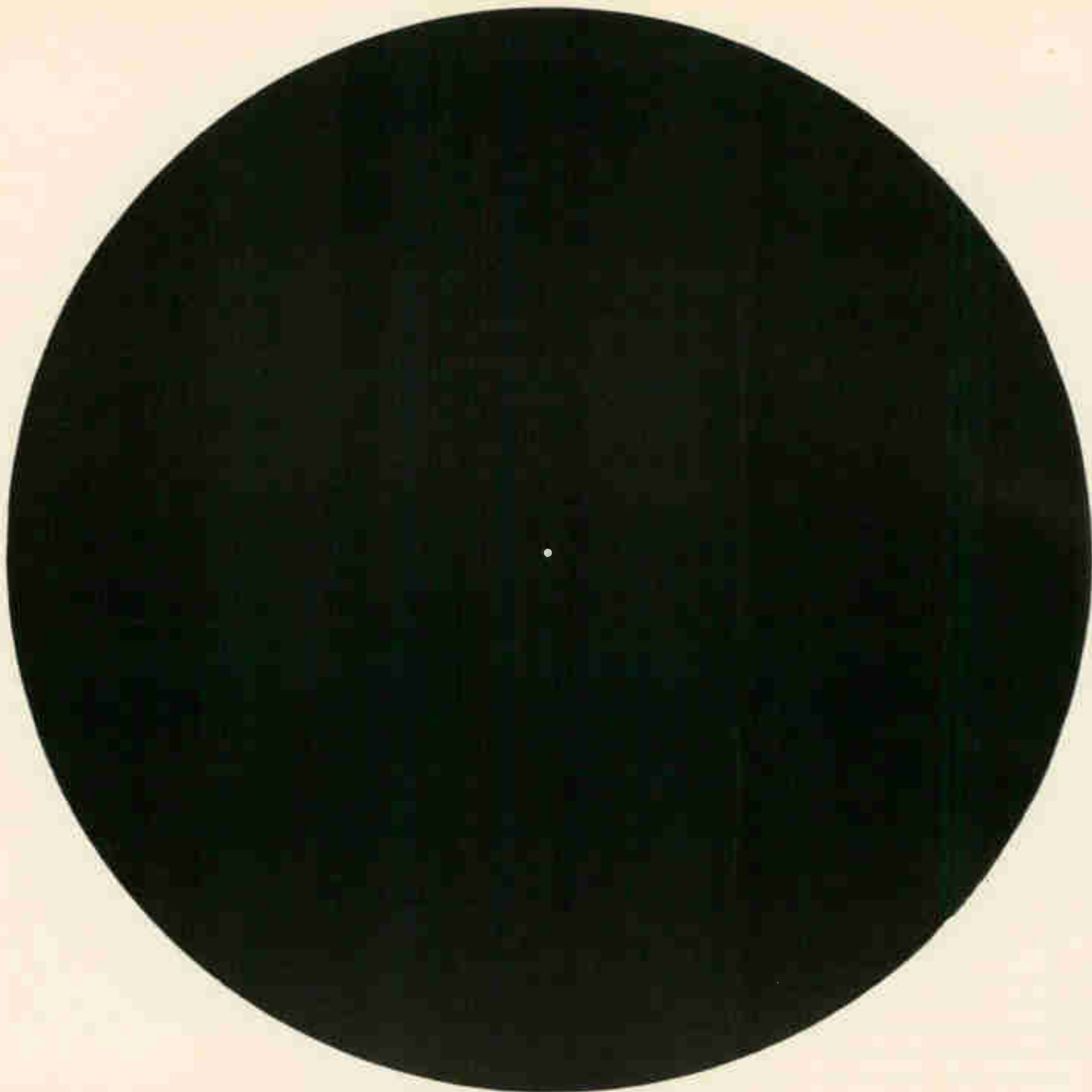

The small pin hole in the center of this circle is more than enough light for MTI Image Orthicon Television Cameras.

MTI is the world's largest manufacturer of low light level TV systems. This simply means that low light levels are our specialty. Specifically, at 1×10^{-5} foot candles of ambient light (approaching total darkness) MTI image Orthicon TV cameras will produce high resolution pictures. So the amount of light illustrated by the pin hole is more than enough.

There are hundreds of applications for MTI low light level equipment. Here are just a few: viewing nocturnal animals performing tasks, observing stars, examining small components such as transistors, diodes, capacitors and relays for minute flaws, and so on. In any application where low light levels are of prime importance, MTI can solve your problems.

Seven different line scan frequencies are available "off the shelf". Specific details available on request. If you have an application problem, call us. We can help.

mti MARYLAND TELECOMMUNICATIONS, INC.

York & Video Roads, Cockeysville, Maryland / Area code 301, 666-2727

WORLD'S LARGEST MANUFACTURER of low light level image Orthicon cameras



NEW



INTEGRATED CIRCUIT 1 μ SEC CORE MEMORY

New ICM-40 microcircuit, coincident current, random access core memories feature full cycle operation in 1 μ SEC (less than 500 nsec access time). ICM-40s feature price, size and reliability advantages of integrated circuit μ -PAC[™] logic.* Word capacities to 16,384 in a 5 $\frac{1}{4}$ " high unit for mounting in a standard relay rack. Design permits pull out front of rack access. Operating temperatures from 0°C to +50°C, with broad margins. Clear/Write, Read/Restore and Read/Modify/Write are standard modes of operation. ICM-40 interfaces comfortably with both discrete component and integrated circuit systems. Low power dissipation.

*More than 20 months of in-house funded research went into development of the standard μ -PAC line of 5 mc silicon monolithic integrated circuit modules.

3C SALES OFFICES: NEEDHAM, MASS.; FOREST HILLS, N.Y.;
LEVITTOWN, PA.; SYRACUSE, N.Y.; SILVER SPRING, MD.; HOUSTON,
TEXAS; HUNTSVILLE, ALA.; ORLANDO, FLA.; DES PLAINES, ILL.;
DETROIT, MICH.; CENTERVILLE, OHIO; LOS ANGELES, CALIF.;
PALO ALTO, CALIF.; RENT, WASH.; ALBUQUERQUE, N.M.



COMPUTER CONTROL COMPANY, INC.
OLD CONNECTICUT PATH, FRAMINGHAM, MASSACHUSETTS 01702

LOW MICROWAVE NOISE?



Model SE-200

WHY NOT PROVE IT?

SPECTRA Microwave Noise Measuring Instruments are the only equipments yet devised that can give you the FM and AM noise content of conventional and solid state microwave sources — to accuracies as high as ± 1 DB. Proof? Maybe not, but close to it.

SPECTRA-EXCLUSIVES:

- RF Frequency Ranges: 1.0 Gc/s to 32 Gc/s
- Self-Calibrating for both AM & FM noise measurements
- Broad Video Frequency Coverage: 1 Kc/s to 150 Kc/s
- Residual FM Monitor: 10 cps to 1 Kc/s
- Dual Bandwidth Spectrum Analyzer: 100 cps and 1 Kc/s
- High Sensitivity: AM 135 DB below carrier level; FM .0032 cps rms deviation
- Minimum RF Input Power: 1.5 milliwatts
- Self-Contained Microwave Spectrum Analyzer
- Phase-Locked Local Oscillator

NEW MEASUREMENT SERVICE

A custom Noise Measurement Service is now operated by Spectra to provide accurate noise measurements of X-band sources in the frequency range from 8.5 Gc/s to 10.5 Gc/s. Readout: X-Y recordings of FM or AM noise vs. video frequency. Write today for technical data and complete details.

SPECTRA  **ELECTRONICS**

P.O. Box 85
Los Altos, Calif. 94023 • (415) 948-4998

vent a firing at any time up to the final, automatic countdown. That time varies from missile to missile; in the solid-fuel Minuteman, for instance, it is 30 seconds. After lift-off, information is fed from a number of sources to an IBM 7094 computer, which in turn commands a series of X-Y plot boards arranged so that the safety officer can tell at a glance whether the booster is sufficiently off course to menace land areas.

If the booster has a beacon aboard, the computer gets information from the ground up; but in most cases the computer must rely on radar skin tracking and on telemetered data on pitch, yaw, and roll. Vandenberg has two correlated tracking and range (Cotar) systems for boosters equipped with beacons; Cotar is a passive system which externally looks like a half-acre field of six-inch stumps. The stumps are dipole antennas, and the Cotar determines range by measuring a signal's difference in phase at different antennas. Cotar is ultrahigh frequency; the range also uses the General Electric Co. Range Tracking System (Gerts), a passive I-band system.

The Strategic Air Command, to preserve realism, does not want anyone hanging beacons on its birds, so the range must follow ICBM's by skin tracking. The first radar to pick up the missile is the M-33, but this pulse system is for short range only, and two FPS-16's on Vandenberg's Mount Tranquillon take over when the missile is at their own altitude, 2,000 feet. The

WTR's single TPQ-18, the most advanced form of pulse tracking radar operating at 5,400 to 5,900 megacycles, is also at Vandenberg; this set is essential when the FPS-16's at the base and at Pillar Point and the Navy's San Nicholas Island lose contact. With the help of "ducting" in the troposphere, which acts like a big waveguide in the sky, the TPQ-18 can track out to 2,500 miles.

Once an ICBM has left Vandenberg's control, it is watched by a cooperative network that includes elements from the Army, Navy, NASA, and the Air Force.

III. Updating the range

Vandenberg's range distance will be expanded as budgets grow. "But we plan to buy only what is needed," says Col. R. W. Hoffman, the director of range engineering. And, in fact, there are no plans to dress up the WTR with continuous-wave radar systems such as Mistran and Udop in the Eastern Range. Nevertheless, the expansion of Vandenberg and the budget increase spell the end of minimum instrumentation.

NASA is switching much of its unmanned launch activity to the base. The Air Force's Start project, a four-step program to develop a space ferry that can fly into orbit and supply manned space stations, is centered there. The maneuvering reentry vehicles in the Air Force's Advanced Ballistic Reentry System (Abres) will require that the WTR cover a greater range of the Pacific. Scramjet will be



Stanley R. Radom, civilian technical director, says new programs at Western Test Range will require new equipment.

“We demand minimum size plus maximum reliability. That’s why we use capacitors of Mylar®”

says Worthington C. Lent, Vice President,
Telephone Development & Operations,
Lear Siegler, Inc.

Central telephone office equipment must be designed as compactly as possible. At the same time, this equipment must be reliable for a service life of many years. So Lear Siegler uses capacitors of MYLAR®. And nothing but capacitors of MYLAR in the R-635 Voice-Frequency Repeater. The extremely high dielectric strength of MYLAR means smaller capacitors. The extremely high stability of MYLAR means long-term reliability.

Other dielectric materials could have been used but anything else that would meet specifications would cost much more than capacitors of MYLAR, according to Lear-Siegler, Inc.

If size, reliability and price are important to you, check the ways capacitors of MYLAR could help you improve your designs. For some interesting technical data, write Du Pont Co., Room 3241-A, Wilmington, Delaware 19898. (In Canada, write Du Pont of Canada Ltd., P. O. Box 660, Montreal, Quebec.)

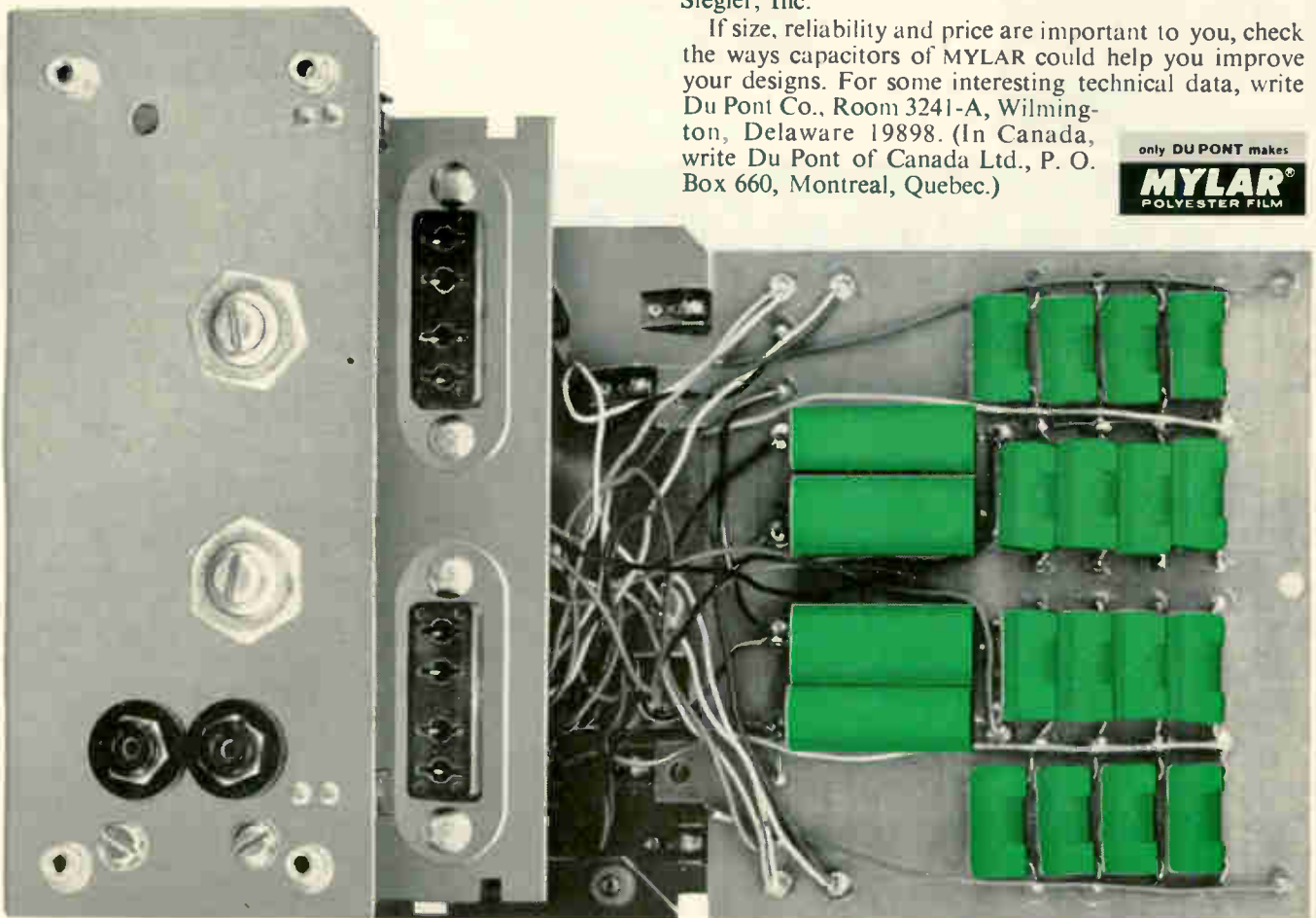

20 capacitors of MYLAR® polyester film are used in the R-635 Voice-Frequency Repeater manufactured by the Electronic Instrumentation Division of Lear Siegler, Anaheim, California.

*Du Pont's registered trademark for its polyester film.



BETTER THINGS FOR BETTER LIVING... THROUGH CHEMISTRY

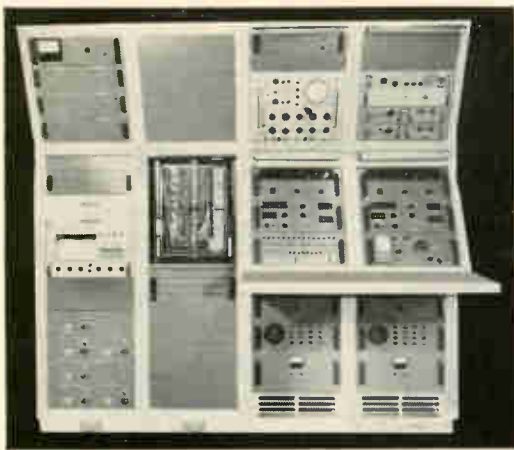

U. S. Navy
(AUTECH)
Master Timing
System

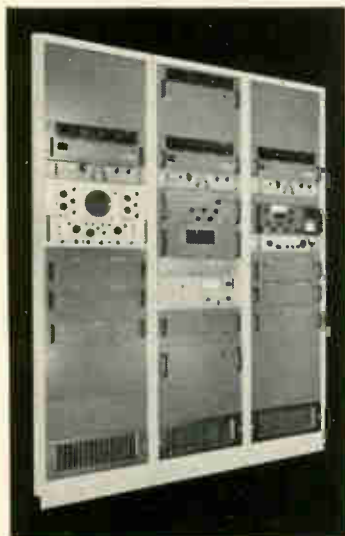

NASA
Mississippi
Test Facility
(MTF) Master
Timing System

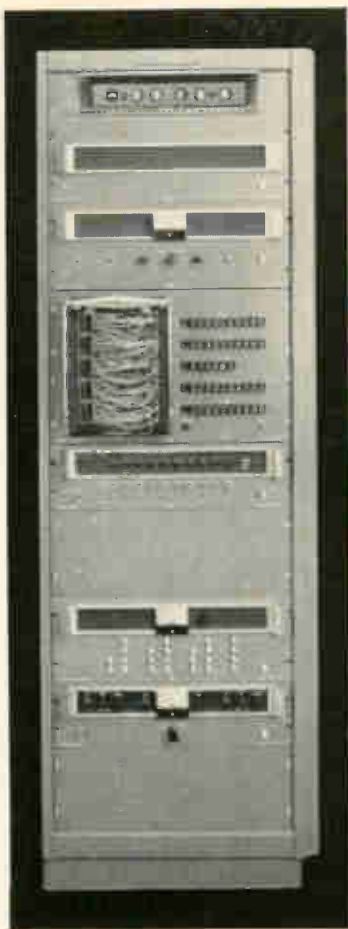

NASA Wallops Island
Terminal Time Systems

Hyperion

the name for Precision Time Indexing and Automatic Search Equipment and Systems

Hyperion's Timing Equipments are being used on many major Range Facilities including NASA, Mississippi Test Facility (MTF), U. S. Navy Underwater Range (AUTECH), NASA, Wallops Island, etc.

Hyperion's Technical Staff represents 100-man years of technical experience in the field of Precision Timing and a broad background in the field of Ultra-Stable Oscillators, Automatic Time Synchronization with LORAN-C, VLF, and WWV Time Transmission Equipment, Precision Time Equipment includes Precision Time Code Generators and Countdown Clocks, and Fully Automatic Tape Search Equipments for Ground and Airborne environments.

Write or call Hyperion for your precision range time indexing and search requirements

Hyperion



INDUSTRIES CORPORATION

• DIGITAL PRODUCTS DIVISION

134 COOLIDGE AVENUE, WATERTOWN, MASSACHUSETTS 02172
TWXN: 617-924-9272 TEL: 617-WA6-0140

tested at Vandenberg, and the Army is testing the Nike-X missile defense system at Kwajalein. The MOL program alone will demand the addition of one or more systems to the range equipment.

New switches. Within a year, the range will have automatic switching equipment installed so that communications and data channels between control consoles and the various launch pads can be changed quickly and easily. At present, the channels must be hand-patched, a process that takes hours—sometimes days. With the new equipment, for which the Western Electric Co. is the prime contractor, changing channels will be a matter of dialing. The equipment is necessary if the range is to handle dissimilar launches from different complexes in a short time—if, say, it must send an Atlas-Agena on its way, then turn quickly to a Minuteman.

An IBM 7044 computer is now being debugged; when it is operational, late in 1966, it will be used for real-time processing of tracking data for range safety, freeing the 7094 for full-time data reduction. A new safety control room is being built. It will double present equipment, so that two missiles or boosters may be watched simultaneously.

For better impact prediction, the Radio Corp. of America is working on a trilateration system using the FPS-16 radars at Mount Tranquillon and San Nicholas Island, and the TPQ-18 at Vandenberg. The Pillar Point FPS-16 and one aboard a ship may be added later.

The WTR already supports more than 60 programs. "With the advent of new ones, we are going to have to refine our equipment," Radom says. "There are bound to be difficulties; for one thing, the instruments must now be man-rated, for manned launches. For another, we can't be sure that the switch to S-band telemetry won't give trouble. Will there be a drop-out problem because of different antenna patterns? We don't know yet; S band has worked well with large vehicles, but hasn't been tried with small ones."

The switch, of course, will require new equipment—antennas, r-f and hardline "plumbing" to receivers, and receiver components.

**a termination
for every
application....
wire lead,
printed circuit,
or shaft type
trimming potentiometers**

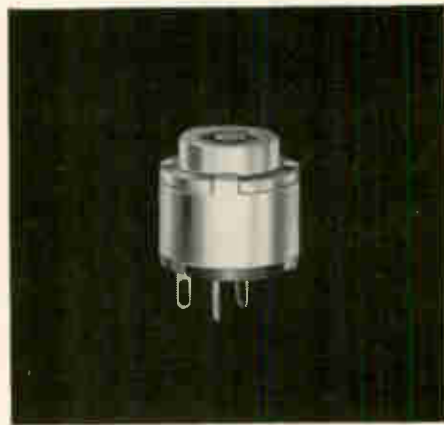

CLAROSTAT SERIES 63

COMPOSITION ELEMENT TRIMMING POTENTIOMETERS

One of the great things about this great series of trimmer pots is the choice of configurations which lets you mate the same electrical performance and mechanical quality to several requirements. Whether you need the Series 63 specs for a printed circuit, wired circuit, or with a shaft, you still know you're getting the best there is. Available in resistance ranges from 100 ohms to up to 1 megohm, the Series 63 pots are rated for .25 watts dissipation at 70°C. Working voltage is 350VAC, and breakdown voltage is 750VAC (terminals to ground). Mechanical construction of the Series 63 pot trimmers includes features such as carbon-to-carbon and metal-to-metal contacts for increased reliability, longer life, and lower noise. Gold plated mounting terminals are located for a .1" grid configuration, and mechanical and electrical rotation are 295°. Write for prices or further information.

CLAROSTAT

CLAROSTAT MFG. CO., INC., DOVER, NEW HAMPSHIRE, U.S.A.

Silicon's new wonder drug

Silicon-nitride coatings are expected to produce healthier field effect transistors, higher-voltage planar components, and, ultimately, microwave-frequency planar germanium circuits

By Thomas Maguire

Boston Regional Editor

Is another revolution brewing in semiconductor technology?

Developers of a new process for coating silicon think they've made an advance that will significantly improve the performance of solid-state components. Instead of silicon oxide, the old standby coating for diffusion masking, junction passivation and dielectric insulation, scientists at the Sperry Rand Corp. Research Center are using silicon nitride.

The switch from oxide to nitride seems a simple change, because there is little change in the rest of the silicon-planar process, the one used today to make most silicon

transistors, diodes and rectifiers, all of the monolithic integrated circuits and the metal-oxide-semiconductor (MOS) devices and circuits.

But the new process cures the instability ailments of MOS transistors. It will probably boost the speed of MOS computer circuits five times and double or triple the voltage of planar transistors and diodes, Sperry Rand researchers say.

And because the nitride is deposited, not grown by oxidizing the silicon crystal, it should be applicable to other semiconductors, including germanium, gallium arsenide and indium arsenide. Hopes

are that planar germanium devices operating at microwave frequencies can be built with the process.

A metal-nitride-semiconductor, insulated-gate, field effect transistor (MNS-Igfet) has already been built and tested at the research center in Sudbury, Mass. It reportedly is markedly better in stability than MOS-Igfet's and has a lower threshold voltage and higher voltage-handling capability. Sperry Rand has already installed nitride processing equipment at its Semiconductor division plant in Norwalk, Conn., and plans to be selling MNS devices in a year.

IBM experiments. Sperry began

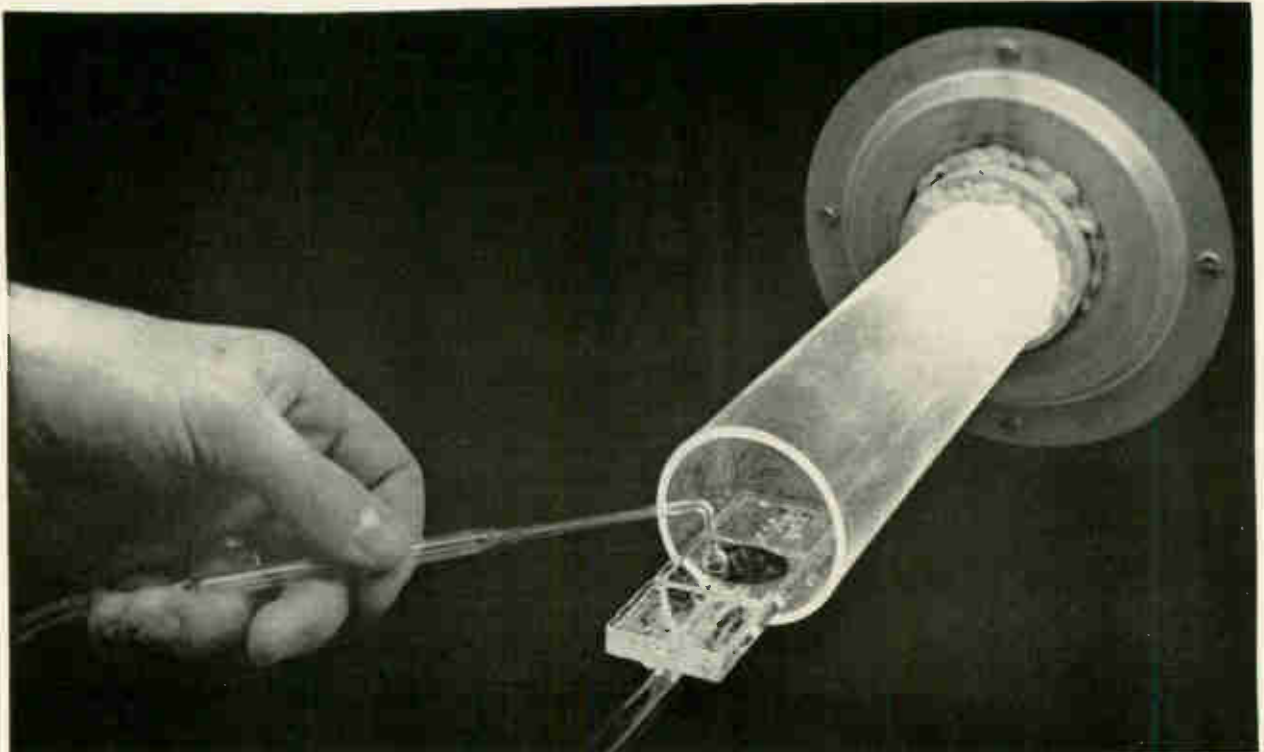

Into a diffusion furnace goes a silicon wafer coated with silicon nitride, which researchers claim is a better diffusion mask and dielectric coating than oxide.

REMI*

(REmovable, REEntrancy, MIniature)
sleeve-fitted closed-entry crimp-type
contact connectors.



U.S.C. REMI sleeve-fitted closed entry crimp-type contact connectors snap in—snap out quickly, simply and surely. Contacts do not ride in bare plastic of the connector body. Both male and female spring phosphor bronze contacts snap into and out of heat-treated beryllium copper sleeves for positive solid connection. Mechanical stresses are confined between metallic elements. ■ No. of Contacts: 7, 14, 18, 20, 21, 26, 34, 41, 42, 50, 75, 104, 123, 150, 225. ■ Wire Sizes Accommodated: AWG #14 to #30 and MIL-W-16878A #16 to #32. REMI contacts are ordered separately. Crimping by MIL-T-22520A (WEP) ■ Class I or II tools ■ Military Specifications: (Contacts) MIL-C-23216, MIL-C-26636, MS3190. (Connectors) MIL-C-8384, and MIL-C-25955. [Latest Revisions] U.S. Patent Nos. 2,761,108; 2,979,689 & Five International Patents ■ Write for REMI catalog.

Golden RUMI

(Removable Ultra-Miniature)
Crimp-Contact Series



Adds removable crimp-contact connector versatility to any micro-miniature system—now. Can be incorporated immediately into any established or advanced system. Interchanges with any other Ultra-Miniature connectors—positively and economically. Contacts are machined of top quality spring temper phosphor bronze per Federal specification QQ-B-750. RUMI contacts are ordered separately. U.S. Pat. No. 2,761,108. ■ Write for RUMI catalog. ■ No. of Contacts: 7, 11, 14, 20, 26, 29, 34, 44 and 50. Wire Sizes Accommodated: AWG #24, 26 and 28 ■ Current Rating: 5 amps

Take Your Choice of These REMOVABLE CRIMP-CONTACT CONNECTOR SERIES from U.S.C.

Here, from one source is a complete family of performance-proved removable crimp-contact connectors. Whether you select the REMI*, RUMI, URC or REPC series you get extra reliability plus the highest possible performance-to-size ratio.

URC Series



Developed especially for compact marine, aircraft, missile and computer electronic packages. Saves replacement and installation time. Removable contacts facilitate replacement of defective contacts and circuit changes without disruption. Contacts can be replaced with standard hand crimping tool or automatic type in seconds. (URC contacts are ordered separately.) U.S. Pat. No. 2,761,108 ■ Write for URC catalog. No. of Contacts: 14, 20, 34, 42, 50, 66, 75 and 104. Wire Sizes Accommodated: AWG #14 thru #30. ■ Current Rating: 13 amps. ■ Military Specifications: MIL-C-22857C & related drawings. ■ Also Available: Four other pairs of size 16 contacts, from AWG #14 through #28. Also, complete series of 6 pairs of size 20 contacts from AWG #16 through #30.

REPC

(REmovable, REEntrancy, Printed Circuit)
removable crimp-contact connectors.

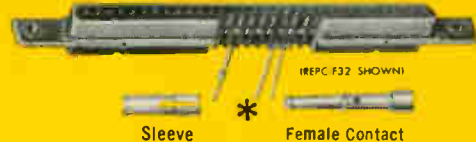

Another first from U.S.C. Meet tri-service specs MIL-C-23353/9 and MIL-C-23353/10 ■ Uses the unique REMI concept that confines mechanical stresses between metallic elements only. REMI sleeves are now specified as MS18135 (per MIL-C-23216) with U.S.C. Part No. 1242-9 (female crimp-barrel socket contact MS18134 per MIL-C-23216), on both new military specifications sheets. ■ U.S. Pat. 2,979,689 & five international patents. ■ Write for UPCC-REPC catalog. ■ REPC-F SERIES ■ No. of Contacts: 7, 11, 15, 19, 23, and 32 ■ Wire Sizes Accommodated: AWG #14 to #30. Current Rating: 7.5 amps ■ Military Specifications: MIL-C-23353/9 ■ REPC-SGF SERIES ■ No. of Contacts: 11, 17, 23, 29, 35 ■ Wire Sizes Accommodated: # 14 to #30 ■ Current Rating: 7.5 amps ■ Military Specifications: Connector—MIL-C-23353/10 ■ Contacts per MIL-C-23216 ■ REPC contacts are ordered separately.

TODAY—JOIN AMERICA'S LEADING COMPANIES WHO
RELY ON U.S.C. FOR CO-RELIABILITY!



U. S. COMPONENTS, INC.

1320 ZEREGA AVENUE, BRONX, N. Y. 10462

TEL. 212 TA 4-1600

Cable Address: COMPONENTS NYK.

TELEX: 1-2411TWX—212-824-6990

This energy-storage CAPACITOR has the characteristics YOU NEED

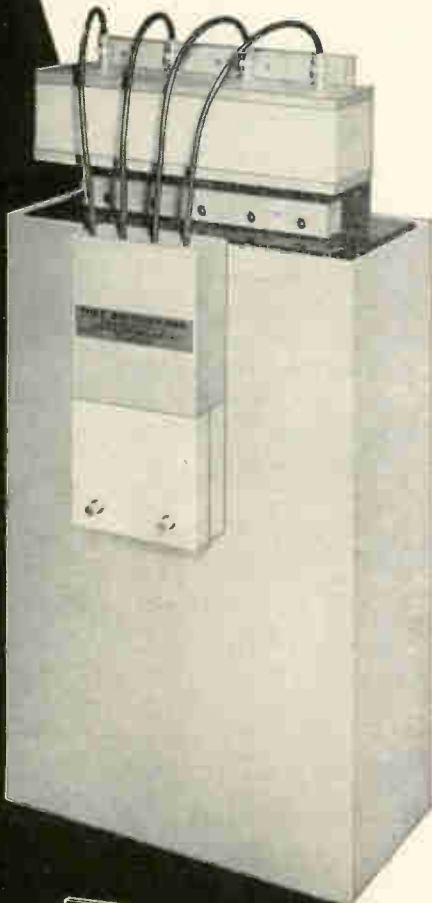

- 5 nanohenries
- 3000 joules
- 20 kilovolts
- 10,000 discharges
- Auxiliaries to suit your application-requirements.

Capacitor is pictured with TOBE Model SBG-5 five-nanohenry discharge-switch and trigger assembly.

The Model ESC-248A capacitor is one of a series comprising units rated at 10 to 25 kilovolts, 900 to 3000 joules, 4.5 to 60 microfarads—with maximum self-inductance of 5 nanohenries.

All units in this series have life expectancy of 10,000 discharges at rated voltage and 95% voltage-reversal.

A 10-inch, parallel-plate terminal-header—standard on all units—fits the mating discharge-switch, as shown in the photograph.

The unique performance and life characteristics of this capacitor have been proved in many research installations.

Ask for Bulletin No. EB365-10; it gives detailed information about physical structure, electrical characteristics, and test standards.

And write or call us whenever you have a special or unusual requirement for capacitors, discharge switches, or low-impedance pulse-forming lines.

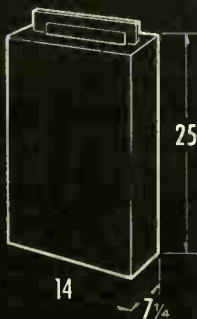

pursuing the MNS process two years ago, when it says it decided that it couldn't overcome basic flaws in MOS. Another company on the nitride-process trail is the International Business Machines Corp.

Researchers at the IBM labs in East Fishkill, N. Y., have been experimenting with nitride coatings as a way to obtain smaller, better isolated integrated-circuit devices. Small size and dielectric isolation are two ways to boost the speed of logic circuits. IBM found that nitride is more durable than oxide and more impervious to silicon-diffusion materials than oxide. Thus, thinner nitride layers can be used as diffusion masks. The thinner the layer, the smaller the masks that can be etched—IBM has etched stripes as narrow as 0.0001 inch, at last report. Alone, or in combination with deposited oxide, the nitride also makes a dandy isolation structure around devices diffused into little islands of silicon crystal. IBM has been dividing the islands with oxide and polycrystalline silicon [Electronics, June 14, 1965, p. 40].

IBM first reported on the deposition process last October. Since then it has used the process to make experimental devices and isolation structures. It won't identify the devices, except to say that they aren't all for logic circuits. IBM has also noted the high-voltage capability of nitride—in the isolation experiments, films thinner than a micron withstood 200 volts without breakdown.

I. Something for everybody

The nitride process "is the first significantly different development in silicon technology since the planar-epitaxial breakthrough of 1960-61," claims Roger Newman, manager of solid-state sciences at the Sperry lab in Sudbury.

"It may well become the dominant silicon planar technology," adds Arthur M. Cappon, applications engineering manager at Sperry's Norwalk plant.

"Silicon-nitride devices will be in our product line within a year," emphasizes Richard S. Mandelkorn, general manager of the Semiconductor division and a Sperry Rand vice president.

Newman sees MNS as fulfilling

TOBE DEUTSCHMANN

LABORATORIES

CANTON, MASSACHUSETTS 02021 Telephone (617) 828-3366 TWX 617-828-2567
TERRITORIES OPEN FOR QUALIFIED SALES REPRESENTATIVES

Now! All the Features of Larger Size Potentiometers—Except Larger Size!

- (1) Dimensions: $\frac{1}{4}$ " x $\frac{1}{4}$ " x 0.17"
- (2) Multi-turn adjustment
- (3) Damage-proof clutch action
- (4) Indestructible SILVERWELD[®] termination
- (5) Standard resistances from 10 Ω to 20K
- (6) 20 ppm wire



New TRIMPOT[®] Potentiometer Model 3260
ACTUAL SIZE

Write today for complete technical data

If it's TRIMPOT[®], it's BOURNS

TRIMPOT is a registered trademark of Bourns, Inc.

MANUFACTURER: TRIMPOT[®] & PRECISION POTENTIOMETERS, RELAYS: TRANSDUCERS FOR PRESSURE, POSITION, ACCELERATION. PLANTS: RIVERSIDE, CALIFORNIA; AMES, IOWA; TORONTO, CANADA



BOURNS, INC., TRIMPOT DIVISION
1200 COLUMBIA AVE., RIVERSIDE, CALIF.
PHONE 684-1700 • TWX: 714-682 9582
CABLE: EDURNSINC.

CRYSTAL FILTERS



BAND PASS FILTER

A filter of this type permits the transmission of a specified frequency band only. Fig. (1) shows a typical response curve. The information needed for the design of a bandpass filter is as follows:

- Center frequency of passband
- Permissible variation in passband attenuation
- Minimum tolerance bandwidth
- Maximum bandwidth at _____ db.
- Minimum attenuation in the stopband
- Maximum insertion loss
- Load and source impedances.

Low pass and high pass filters are special types of bandpass filters where the pass band extends to zero or infinite frequency, respectively. Sideband filters have asymmetrical response curves and are characterized by the sharp attenuation rise on the carrier side and a more gradual rise on the opposite side.

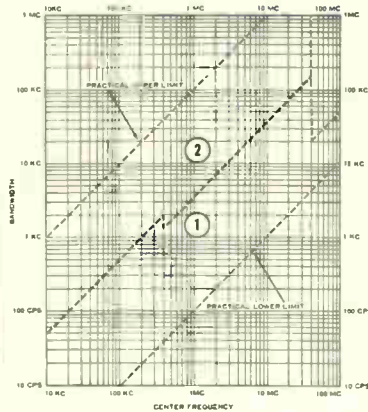

GUIDE TO PRACTICAL LIMITS

This chart is meant as a guide only and indicates the practical limits of crystal filters and discriminators. Filters within region (1) can be made with crystals and capacitors only and can, hence, be made in very small packages. Filters within region (2) must include inductors as well and are, therefore, slightly larger.



DELAY LINES
QUARTZ CRYSTAL PRODUCTS

the promise of reduced size and lower cost promised by the MOS technique [Electronics, Oct. 4, 1965, p. 84]. The use of MOS, he claims, has been retarded by the "uncertain stability" of the oxide now used as the insulation.

MNS will also permit high-performance complementary arrays of Igfet's—"good n- and p-channels on the same substrate," Cappon says. Nobody else has reported good n-channel devices because oxide favors p-channel devices, he claims. Because both types can be made well, he sees a five-to-one improvement in integrated-circuit speed or frequency—5 megacycles for MNS as against 1 megacycle average propagation time for MOS.

The Sperry lab's chief device developer, H. A. Richard Wegener, is more bullish. With complementary transistors and sharply reduced device size, he thinks, MNS circuits can be pushed to 10 megacycles. Among the first applications expected are computer logic and memory arrays.

Because nitride is a better barrier against diffusants, Cappon says, the dielectric layer can be thinner, eliminating the need for special trimming during processing.

Mandelkorn expects the nitride process to be applied soon to integrated circuits. In addition, he thinks the process will permit production of planar diodes and double-diffused transistors with two or three times their present voltage-handling capacity.

On television. Cappon agrees. "In the transistorization of television," he says, the sweep-amplifier circuit poses a real problem. A high-voltage, moderate-current transistor is needed, and this process should be able to supply it at a reasonable price."

Cappon sees an important role for the MNS process in production of planar-type cathode-ray-tube drivers, high-voltage rectifiers and silicon controlled rectifiers, as well.

Meanwhile, at Sudbury, the researchers are trying the nitride on other semiconductors. Newman plans to test it on gallium arsenide and indium arsenide, promising, but little-used intermetallics.

"We have had preliminary success with germanium," Newman says. Wegener says the process shows definite promise in the fab-

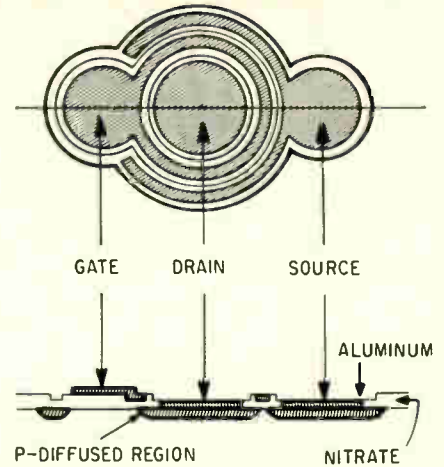

Igfet structure. Sketch of an insulated gate field effect transistor indicates where Sperry Rand researchers use silicon nitride for diffusion masking, p-n junction passivation, and as a dielectric.

rication of germanium microwave devices. IBM has also reported successful application of nitride to germanium. At least one company, Texas Instruments Incorporated, has made microwave-frequency germanium devices with a planar process. However, TI deposits silicon dioxide as the diffusion mask and insulation [Electronics, April 6, 1964, p. 62].

II. The MNS-Igfet

A report on Sperry's experiments with the MNS-Igfet is being published this month in the Proceedings of the IEEE by the Sperry team of Newman, Wegener, Nigel C. Tombs, Bradley T. Kenney and Anthony J. Coppola.

The Igfet is a p-channel, enhancement-mode device with a geometry (shown above) identical to that of an MOS transistor. Its average gate diameter is 125 microns, its width is 12.5 microns, distance between source and drain is 10 microns, and the thickness of the silicon nitride layer under the gate is 1,000 angstroms.

In prolonged tests, the threshold voltages remained below 5 volts. No measurable changes occurred in the electrical characteristics, the team says, during a temperature-bias test in which unencapsulated devices were stored at 150° C with 30 volts positive applied to the gate.

A MOS device is often unstable under these conditions, the researchers say, because it is afflicted



WE'VE BROKEN THE \$20 BARRIER

Now, for the first time, you can buy an encapsulated, solid-state operational amplifier for less than \$20

We hate to keep harping on price. We'd much rather talk strong NEXUS product advantages like reliability and performance.

But what can you do when you have news like this to break?

Because recent orders and production have substantially exceeded expectations, we have been able to drop the price of the NEXUS SQ-10 general-purpose operational amplifier to \$19*. Likewise, the price of the premium Q-10 is now only \$29*. And to top it off, we have actually improved the performance of both these units by increasing the gain, reducing the offset current and increasing the output current.

Both the SQ-10 and the Q-10 are moderately high-gain units primarily designed for closed-loop operation with negative feedback in most analog configurations. They may also be used open-loop as voltage crossing detectors, etc. Each provides up to 0.1 megohm differential input impedance (10 megohms common mode). They also provide input offset temperature coefficients typically $\pm 20\mu\text{V}/^\circ\text{C}$ and $\pm 2\text{na}/^\circ\text{C}$.

The commercial SQ-10, fully encapsulated, offers a quality and re-

liability comparable to that of many premium amplifiers. The premium Q-10 which features metal-can, hermetic-seal transistors, can withstand storage temperatures of -65° to $+125^\circ\text{C}$.

For excellent d-c stability, small size, high reliability, versatility, and low price too, your best buy in operational amplifiers is NEXUS.

Write today for full details on the NEXUS SQ-10 and Q-10, together with our new price list, showing many new reductions, and NEXUS' new short form catalog.

*UNIT PRICE, GENEROUS DISCOUNTING FEACHING \$19 OF SQ-10 AND \$16 ON Q-10 IN QUANTITIES OF 10,000. ALL PRICES ARE F.O.B. CAMTON, MASS., U.S.A.

NEXUS
RESEARCH LABORATORY, INC.
460 NEPONSET STREET, CAMTON MASS. 02027
TEL: (617) 828-9000 TWX (617) 828-1022



D CASE



K CASE

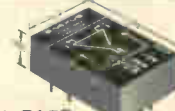

L CASE



Q CASE



JB CASE

Fiberfil High-Performance FRTP's In Action

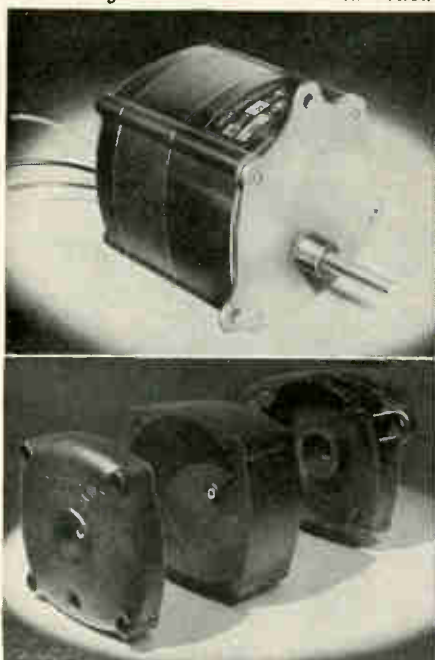

Polycarbafil Instrument Motor Housing molded for Hurst by Lenco, Inc., Jackson, Mo.

A better motor housing at lower cost with Polycarbafil®

Hurst Mfg. Corp., Princeton, Indiana chose fiberglass reinforced polycarbonate.

For the new Model GA 600 inch-ounce, Synchronous Hysteresis Instrument Motor, Hurst chose Polycarbafil (fiberglass reinforced polycarbonate). Hurst research and tests proved that the FRTP adds performance characteristics for the user. It has lighter weight, reduced noise level, high impact strength, dimensional stability and heat resistance. Flexural and Tensile strength of Polycarbafil is higher than many common aluminum alloys. The company found that they gained a cost advantage because the Polycarbafil housing needs no finishing and painting, as aluminum housings would.

Compare Physical Properties

Property	Unit	Unreinforced Polycarbonate	Polycarbafil G-50/20
Tensile Strength @ 73°F.	PSI	8,000	18,500
Flexural Strength @ 73°F.	PSI	13,500	25,000
Coef. Linear Thermal Expansion	°F./In./In.	3.75 x 10 ⁻⁵	1.07 x 10 ⁻⁵
Heat Distortion Temp. @ 66 PSI	°F.	285	308
Water Absorption 24 Hrs.	%	0.15	0.4

Polycarbafil is just one of several fiberglass reinforced thermoplastics pioneered and patented by Fiberfil. Only Fiberfil can give you complete technical data, practical experience and a full line of reinforced materials. Send for your free copy of the FRTP engineering manual. Fiberfil, Inc., Evansville, Indiana 47717.



Fiberglass Reinforced Thermoplastics ©

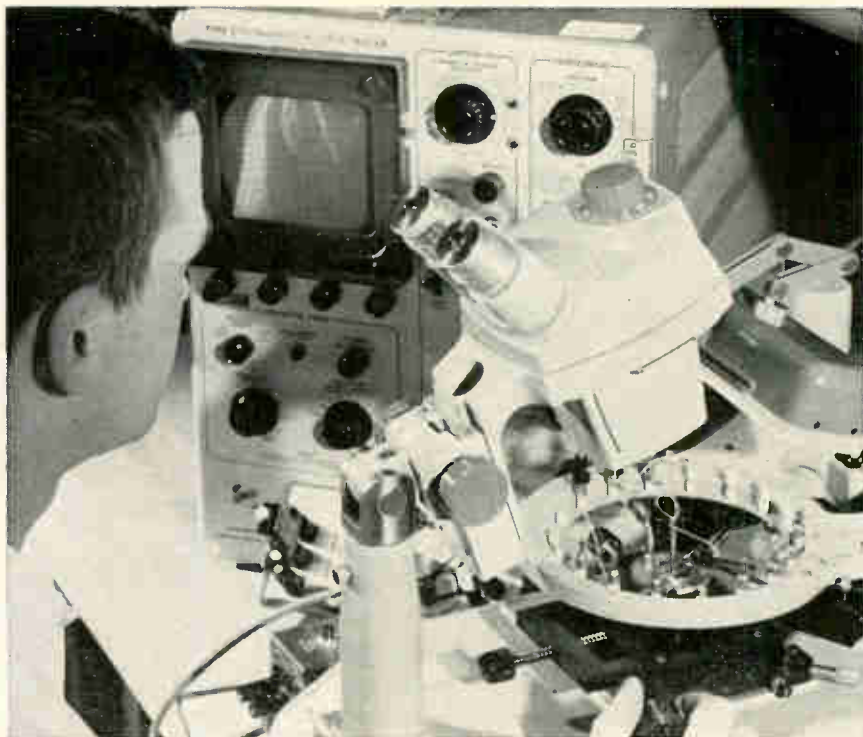

Hundreds of experimental metal-nitride-semiconductor transistors, made in a silicon wafer, are tested with needle probes and a transistor-curve tracer.

with electrostatic interactions between the oxide layer and the silicon. At 100° C, the gate's operating point can be shifted by more than 70 volts, they report, blaming the displacement on the drifting of ions through the oxide layer under the influence of the applied field.

III. The physics of dirt

What makes the MNS more stable than MOS? The answer is a complicated one, which Wegener unfolds in this way:

"Semiconductor technology has been referred to as the physics of dirt." Planar processing solved most of the early problems of unwanted materials, but the "interface between the silicon and the outside world" is still a problem.

"The better this interface is controlled, the better the surface is tailored, the better will be the device structure and performance."

The MNS process, he continues, improves the interface.

Ionic drift. MOS is all right at room temperature, Wegener says, but ionic drift—a form of dirt—sets in above 80° or 90°. Mobile ions trapped in the dielectric build up a static charge which changes the device characteristics. The charge takes days or weeks to dissipate. Cleaner processing and the

addition of a gettering layer—a layer that attracts and holds contaminants—have only alleviated the problems, says the Sperry team.

The MNS experiments showed that ionic drift was much slower in nitride than oxide. The nitride, Sperry reports, also gives better control over surface charges caused by the redistribution of bulk impurities during oxidation and from chemical reactions between the dielectric and the silicon. Nitride deposition avoids the first problem and should avoid the second, because it is very inert to chemicals.

Tombs, the chemist who developed Sperry's process, emphasizes the importance of not oxidizing the silicon.

"In the conventional technique," he explains, "the silicon oxide is grown by eating up the silicon interface."

The nitride process does not depend on reaction with the silicon surface, so the "interfacial situation" can be better controlled," Tombs concludes.

Except for this difference, planar processing with nitride and with oxide are similar. The crystal is first coated with nitride, which is etched to open up diffusion windows. The windows are closed with more nitride and the diffusants are

Low Cost Test Signals

10 MHz to 1000 MHz



—with the 3200B VHF OSCILLATOR

Using the new Frequency Doubler Probe 13515A

Features:

±0.002% Frequency
Stability

External AM and
Pulse Modulation

Waveguide-Below-
Cutoff Output
Attenuator

Solid-State Power
Supply

Data subject to change
without notice.

The VHF Oscillator Model 3200B is designed for general purpose laboratory use including receiver and amplifier testing, driving bridges, slotted lines, antenna and filter networks, and as a local oscillator for heterodyne detector systems in the frequency range from 10 to 500 mc.

The push-pull oscillator is housed in a rugged aluminum casting for maximum stability and extremely low leakage; six frequency ranges are provided for adequate bandsread on the slide-rule dial. Internal CW operation is provided; AM and pulse modulation may be obtained through the use of a suitable external source. The RF output is coupled through a waveguide-below-cutoff variable attenuator; in addition, an electrical RF level vernier is included as a front panel control.

An optional accessory Frequency Doubler Probe, Model 13515A incorporates a solid-state doubler circuit and provides additional frequency coverage from 500 to 1000 mc.

SPECIFICATIONS 3200B

Frequency range: 10 to 500 Mc (MHz)
in six bands: 10 to 18.8 Mc; 18.5 to 35 Mc;
35 to 68 Mc; 68 to 130 Mc; 130 to 260 Mc;
260 to 500 Mc.

Frequency accuracy: within ±2% after
½ hour warmup (under 0.2 mw load).

Frequency calibration: increments of
less than 4%.

**Frequency stability (after 4-hour warmup under
0.2 mw load):** short term (5 minutes)
±0.002%; long term (1 hour) ±0.02%;
line voltage (5-volt change) ±0.001%.

RF output:

Maximum power (across 50-ohm external load):

>200 mw (10 to 130 Mc);
>150 mw (130 to 260 Mc);
>25 mw (260 to 500 Mc).

Range: 0 to >120 db attenuation from
maximum output.

Load impedance: 50 ohms nominal.

RF leakage: sufficiently low to permit
measurements at 1µv.

Amplitude modulation: externally modulated.

Range: 0 to 30%.

Distortion: <1% at 30% AM.

External requirements: approximately 15 volts
rms into 600 ohms for 30% AM,
200 cps to 100 Kc.

Pulse modulation: externally modulated.

External requirements: 1 volt peak pulse
into 2000 ohms. 5-volt rms sine wave will
provide useable square-wave modulation.

Power: 105 to 125 v or 210 to 250 v,
50 or 60 cps, 30 w.

Dimensions: 7½" wide, 6½" high,
12½" deep (198 x 165 x 318 mm.)

Weight: net 15 lbs. (6, 8 kg),
shipping 19 lbs. (8, 6 kg).

Accessories available: 13515A Frequency
Doubler Probe; 501B, 514B, 517B Output
Cables; 502B, 506B Patching Cables.

Price: Model 3200B, \$475.
F.o.b. factory.

13515A FREQUENCY DOUBLER PROBE

Frequency range: 500 to 1000 Mc (MHz) with
the 3200A/B operating at 250 to 500 Mc.

Harmonic suppression: (at 4 mw output):
fundamental: >16 db down;
higher order: >16 db down (500 to 800 Mc);
>14 db down (800 to 1000 Mc).

RF output: more than 4 mw across external
50-ohm load, controlled by probe depth.

Weight: net 4 oz. (110 gms),
shipping 8 oz. (220 gms).

Price: Model 13515A, \$95.
F.o.b. factory.

For more information contact your local Hewlett-Packard field engineer or write Hewlett-Packard, Green Pond Road, Rockaway, N. J. 07866; Europe: 54 Route des Acacias, Geneva.

HEWLETT  PACKARD

An extra measure of quality

draw yourself a circuit to control **SPEED**

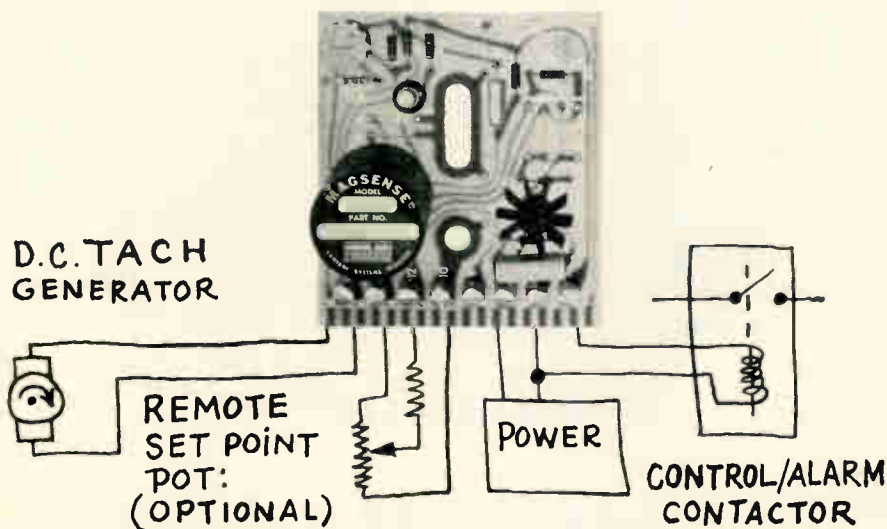

PUT MAGSENSE® IN THE MIDDLE

Connect your D.C. tach generator to one side of a MAGSENSE controller/alarm and a relay or power contactor to the other. It's just about that simple to control *speed* accurately and reliably. Solid-state MAGSENSE controllers have a 100-billion power gain and will accept the output of the transducers directly *without amplifiers*. Set point or dual set points are adjustable. Transducer excitation voltage is available from the MAGSENSE where transducers require it. Examine these specifications for the Model 70. Versions to meet Mil E-5272 and a variety of special application controllers are also available. Prices are from \$60 up, with quantity discounts.

BRIEF SPECIFICATIONS FOR MODEL 70

RESPONSE TIME:	100 ms max., 50 ms typical (10 ms max. available)
POWER REQUIRED:	10 to 14 V DC at approx. 30 ma exclusive of load current.
OUTPUT:	Non-latching for inputs with ranges of 100 μ a, 1 ma, 10 ma or 100 ma. Latching or pulse outputs also available.
SIZE:	3" x 3.35" x 1.25"
WEIGHT:	Approx. 3 ounces
DELIVERY:	From stock



FOR INFORMATION about the complete line of MAGSENSE products for military and industrial applications, circle the inquiry number below or contact MAGSENSE Products, Dept. 115, La Jolla Division, Control Data Corporation, 4455 Miramar Rd., La Jolla, California (Area code 714, 453-2500)

CONTROL DATA
CORPORATION

4455 Miramar Road, La Jolla, Calif.

driven into the crystal at high temperature. Then the nitride is etched again, so metal film contacts can be applied to the MNS devices.

IV. Deposit it, don't grow it

One of the significant advantages of nitride deposition, reports Sperry, is that it can be applied 10 times as fast as oxide can be grown, and at lower temperatures than the 1,000° C required for oxide growth. Therefore, junctions that were diffused before a coating step aren't likely to be rediffused, thus altering the device's junction profile and operating characteristics, during deposition. Oxidation, they claim, can cause this type of flaw.

Furthermore, Sperry adds, the nitride layers can be deposited in controlled thicknesses from angstroms to mils, while it is impossible to get oxide layers that are thicker than a few microns (a mil is 0.001 inch, a micron is 0.000039 inch and an angstrom is 0.0001 micron). The oxide layers, the research team contends, are not always thick enough for adequate isolation of the silicon devices and metallic layers or other materials deposited on the oxide. Nor can the oxide layers always prevent long-term effects due to changes in the atmosphere around the device.

Sperry is closemouthed on details of its deposition method but IBM described one of its deposition techniques last October in a series of papers that Yen V. Doo and other IBM scientists presented at the Electrochemical Society and Electron Devices meetings.

The nitride was pyrolytically deposited by IBM. That is, silane and ammonia were reacted with excess hydrogen while the substrate was heated to between 750° and 1,100° C. The hotter the substrate, the faster the deposition. At 800° C, the deposition rate is 30 angstroms a minute.

However, Doo said that layers thicker than 1 micron tended to crack, apparently because of stresses at the silicon-silicon nitride interface. IBM says it hasn't worried about that, because it is mainly interested in thinner films. Tombs, of Sperry, claims that the thermal expansion of the silicon and the nitride are so closely matched that the thickest films do not crack.



Exclusive design...supported by infinite care

4-POINTED TEMPRESS DIAMOND SCRIBERS HAVE 4 TO 6 TIMES THE LIFE OF CONVENTIONAL SCRIBING TOOLS . . . COST LITTLE MORE. Infinite care in every phase of production, from raw material through precision manufacture to delivery, guarantees you the full advantage of the exclusive Tempress design. If tool is used at proper angle and pressure, assured every time with a Tempress Scribing Machine, it will produce a totally unchipped scribe line, even on oxide coated semiconductor

materials. Scribers can be delivered immediately from stock, as can the full line of Tempress lead-bonding tools, diamond lapping points, and other miniature semiconductor manufacturing tools. Write for complete information on Tempress diamond scribers and the new Tempress Scribing Machine with selective electronic controls.



TEMPRESS

Tempress Research Co., 566 San Xavier Ave., Sunnyvale, California



$\frac{\Delta x}{\Delta i}$ on a flat face CRT increases center to edge

Want to measure it precisely? — elegantly?

Get the Two-Slit Linearity Micro-Scanner.



Constantine Engineering Laboratories Company

YOKES FOCUS COILS DEFLECTION AMPLIFIERS

Mahwah, N. J. 201-327-1123

Upland, Cal. 714-982-0215

Television ready to take forward step in Eastern European-bloc countries

Increased freedom, trade and audience demand are causing tv broadcasters in Eastern Europe to overhaul their facilities

By Joseph Roizen*

International Video Consultant
Ampex Corp., Redwood City, Calif.

There is new life stirring in television land in the Communist countries of Eastern Europe.

Long handicapped by old studio and transmitter equipment and limited to single-channel operation, Communist-bloc broadcasters are busy drawing up plans for new tv production centers; they are shopping for new studio equipment; and they plan to buy a number of new transmitters.

Within two or three years, they hope to introduce some second-channel operations and expand programming time. All of this requires substantial investments in equipment and an increase in technical manpower.

Several developments are behind the changes. Greater independence from Moscow is permitting television to become more national—and hence more vital. The audience is growing; it's becoming more sophisticated, and it is more demanding. Although sets cost more compared to income in Communist countries, they are, nevertheless, good, available, and can even be bought "on time." Another factor is that travel and trade between East and West Europe have made Communist-bloc broadcasters realize how antiquated their equipment is. While the lag in developmental equipment is only three to five years, its effect is considerable because of the rapid rate of new

developments in western Europe.

Where will the new equipment come from? Many of the telecasters in Eastern Europe would like to buy American equipment—especially video tape recorders—but the U. S. Department of Commerce does not permit American companies to sell them such gear.

I. Soviet recorders

To satisfy the demand for recorders, the Russians designed a video recorder, put it in production, and are offering delivery by June 1966.

In addition, the Soviets are still

using a 50-millimeter tape recorder which came into use in 1961. Four of them are reportedly in use in Moscow, and a few in other major cities. Vladivostok used one to record tv pictures beamed recently from the Soviet communications satellite. They are compatible with Western machines.

The new one, already operating in Moscow and Leningrad, used a 70-mm-wide tape. This requires a larger head assembly. So, even though the rotational speed is the same as that of the old machine, a higher writing rate results. The



Some tv broadcast engineers in Eastern European countries are women. Here two girls monitor a broadcast in a well-equipped Polish studio.

* Joseph Roizen travels the world over studying broadcasting and telecasting facilities and teaching engineers how to operate video and audio tape recorders. This report is based on his latest trip to Eastern Europe.

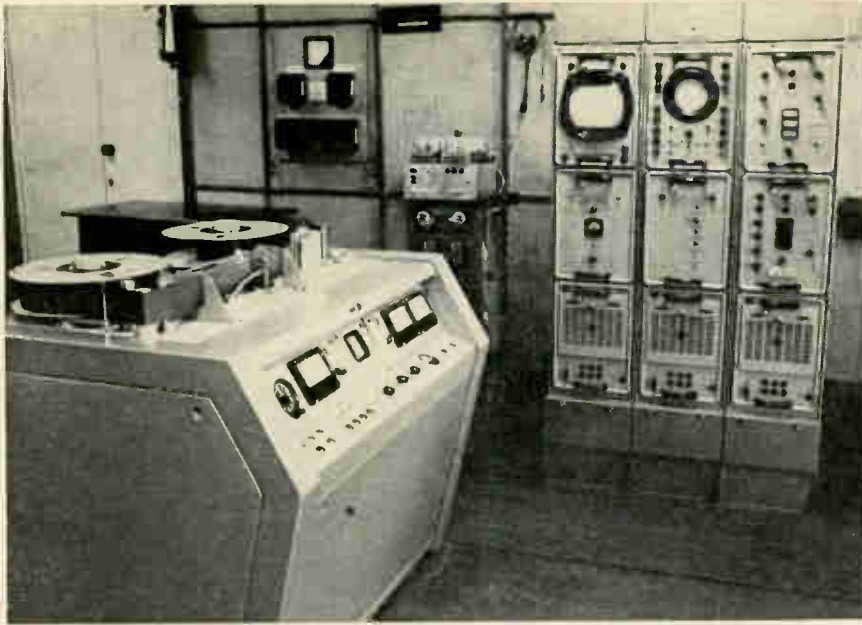

New Soviet video tape recorder in Leningrad studios is similar to Ampex VR-1000.

speed of the tape past the head has also been altered.

The new machine uses a heterodyne modulator operating on frequencies between 6.5 and 10 megacycles. These frequencies which resemble closely the high-band operation of the most advanced Ampex Corp. machines, were selected to provide a wider bandwidth on the Russian OIRT standard. OIRT is an Eastern European radio and television organization. The wider tape also permits three audio tracks and a control track. The drum is slotted for mechanical quadrature adjustment, although delay lines are also used for quadrature correction.

A first-hand examination of the recorder revealed that the stability of the capstan and drum servos is good and recovery from disturbances is reasonably fast—one to two seconds. The designer of the machine claims a bandwidth of 6.5 Mc with a 38- to 39-db signal-to-noise ratio. Whether the performance is actually this good or not is not known.

New components. At the time the machine was examined, in August, 1965, there was no time-base correction accessory on the machine. Experiments, it is believed, are being carried out to compensate for the accessory. Synchronizing systems had been constructed, tested, and were being installed.

There were problems with the new machines. Using a British magnetic tape, the head life was

only 50 to 70 hours. With Russian-made tape, this was further reduced to 40 hours. In addition, the tape deteriorated after only 40 passes through the machine.

II. Polish recorder

Within the bloc, competition with the Soviet machines is weak, but it is beginning. When Polish Television in Warsaw needed a recorder, it did not buy the Soviet machine, but asked its research department to build one. The objective was to get a recorder for its own use, not to go into business.

The machine the tv station turned out is a completely operational transverse-track magnetic video recorder that, when examined in August, appeared to be interchangeable with the Ampex 625-line VR-1000 series machine.

Although the quality of pictures was less than might be expected from the latest American transverse video recorders, it was fully acceptable. The nontechnical observer would probably not be aware of its small pictorial defects. The recorder was built as an experimental prototype for training technical personnel and for occasional on-the-air operation. Its bandwidth was said to be between 3 and 3.5 Mc.

It consists of a VR-1000 type console and two racks with all-tube circuitry. Unlike American machines, no air cooling or air cleaning is used on the head assembly. The four heads are on a solid drum

MOSFET KITS are now available at your authorized GI distributor.



ALABAMA
 BIRMINGHAM—M.G. Electronics, (205) FA 8-4525
 HUNTSVILLE—M.G. Electronics, (205) 837-0350

ARIZONA—PHOENIX
 R.V. Weatherford Co., (602) 272-7144

CALIFORNIA—NORTHERN
 MOUNTAIN VIEW—Avnet Corp., (415) 961-7700
 Kierulff Electronics, Inc., (415) 968-6292
 OAKLAND—Elmar Electronics, (415) 834-3311
 PALO ALTO—Pencor Electronics, (415) DA 6-3366

CALIFORNIA—SOUTHERN
 CULVER CITY—Avnet, (213) 870-6140
 INGLEWOOD—Liberty Electronics, Inc., (213) OR 8-8111
 LOS ANGELES—Kierulff Electronics, Inc., (213) 685-5511
 SAN DIEGO—Milo of California, Inc., (714) BE 2-8951

COLORADO—DENVER
 Industrial Electronic Sales Co., (303) 757-1261

FLORIDA
 MELBOURNE—Electronic Wholesalers, Inc., (305) PA 3-1441
 MIAMI—Electronic Wholesalers, Inc., (305) OX 6-1620

GEORGIA—ATLANTA
 Southeastern Radio Parts Co., (401) JA 4-7536

ILLINOIS
 CHICAGO—Newark Electronics Corp., (312) ST 2-2944
 SCHILLER PARK—Pace Electronic Supplies Inc., (312) 678-6310

INDIANA—INDIANAPOLIS
 Graham Electronic Supply, Inc., (317) ME 4-8486

IOWA—CEDAR RAPIDS
 Deeco, Inc., (319) EM 5-7551

LOUISIANA—NEW ORLEANS
 Southern Radio Supply Co., (504) 524-2345

MARYLAND—WASHINGTON, D. C.
 BALTIMORE—Radio Electric Service Co. of Baltimore, Inc., (301) LE 9-3835

BETHESDA—Empire Electronics Supply Co., (301) OL 6-3300

HYATTSVILLE—Milgray Washington, Inc., (301) UN 4-6330

MASSACHUSETTS
 BURLINGTON—Avnet Corp., (617) 272-3060
 CAMBRIDGE—R & D Electronics Supply Co., Inc., (617) UN 8-6644

NEWTON—The Greene-Shaw Co., (617) WO 9-8900

MICHIGAN—KALAMAZOO
 Electronic Supply Corp., (616) WO 5-1241

MINNESOTA—ST. PAUL
 Gopher Electronics, (612) 645-0241

MISSOURI
 KANSAS CITY—Walters Radio Supply Co., Inc., (816) VA 1-7015
 UNIVERSITY CITY—Olive Industrial Electronics, Inc., (314) VO 3-4051

NEW MEXICO—ALBUQUERQUE
 Electronic Parts Co., Inc., Albuquerque, (505) AL 6-0946

NEW YORK (METROPOLITAN AREA)
 YONKERS—Delburn Electronics, (914) 423-2800
 NEW YORK—Milgray Electronics, Inc., (212) YU 9-1600
 Terminal Hudson Electronics, Inc., (212) CH 3-5200

NEW YORK STATE
 BINGHAMTON—Stack Industrial Electronics, (607) RA 3-6326
 BUFFALO—Summit Distributors, (716) TT 4-3450

OHIO—CINCINNATI
 The Mytronic Co., (513) 961-4600

OKLAHOMA
 OKLAHOMA CITY—Trice Wholesalers, (405) JA 4-4411
 TULSA—Radio, Inc., (918) LU 7-9124

PENNSYLVANIA—SOUTH JERSEY
 PHILADELPHIA—Herbach & Rademan, Inc., (215) LO 7-4309
 Milgray Delaware Valley, Inc., (215) BA 8-2000

TENNESSEE
 KNOXVILLE—McClung Appliances, (615) 524-1811
 NASHVILLE—Electra Distributing Co., (615) AL 5-8444

TEXAS
 ARLINGTON—Beta Electronics, Inc., (214) TA 1-1120
 DALLAS—Contact Electronics, Inc., (214) ME 1-9530
 Solid State Electronics, (214) 352-2601
 EL PASO—McNicol, Inc., (915) 566-2936
 FT. WORTH—Scooters Radio Supply Co., (817) ED 6-7448
 HOUSTON—Busacker Electronic Equipment Co., (713) JA 6-4661

UTAH—SALT LAKE CITY
 Kimball Electronics, Inc., (810) 328-2075

VIRGINIA
 CHARLOTTESVILLE—Virginia Radio Supply Co., Inc., (703) 296-4184
 NORFOLK—Priest Electronics, Inc., (703) 855-0141

WASHINGTON—OREGON—SEATTLE
 Seattle Radio Supply, Inc., (206) MA 4-2341

WISCONSIN—MILWAUKEE
 Electronic Expeditors, Inc., (414) UP 1-3000

Can You Top This?

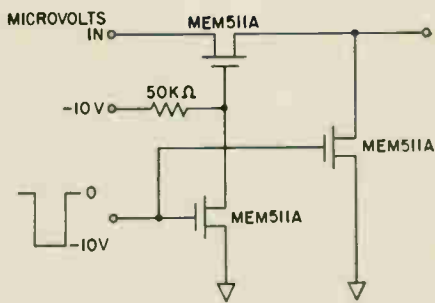

SERIES SHUNT CHOPPER CIRCUIT

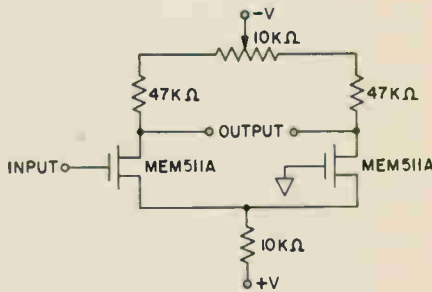

DIFFERENTIAL AMPLIFIER CIRCUIT

Here are just two ways MOS field effect transistors provide unique advantages like these: high input impedance, high on-to-off resistance, and isolation of gate drive. Care to try your hand at a few more? We have an attractive prize for the six best circuit ideas.

If you can, you may win a handsome 15-volume McGraw-Hill Encyclopedia of Science and Technology



Return the coupon below for an official contest Entry Form and helpful design data on General Instrument's MEM 511A MOSFET. The contest begins immediately and ends March 31, 1966. Six winners will be chosen. You may enter as many circuits as you wish, covering any function in any field of electronics . . . but the MEM 511A must be central to your design.

MEM 511A offers:

- P-channel, enhancement mode operation, plus . . .
- Protective diode in the gate to prevent electrostatic destruction
- High input impedance ($10^{10}\Omega$ Typ.)
- Interdigitated geometry

**YOU DON'T NEED THIS KIT TO ENTER THE CONTEST
(BUT YOU'RE APT TO WANT IT ANYWAY!)**

YOU NEEDN'T buy this kit — or anything else — to be eligible for the big GI MOSFET CIRCUIT DESIGN CONTEST . . .

But it's such a bargain (and limited to the duration of the contest) that it's hard to see how you can resist. Here's what you get:

- 25 Type MEM 511A MOSFETS (normally priced at \$10. each).
- MOS CIRCUIT DIGEST, with full information on designing with MOSFETS . . . 12 circuit diagrams . . . and complete specs on GI MOS Devices. Contains all you've wanted to know about MOS, and maybe a bit more.

This unit is ideal for you or your staff to test experimental MOS circuits; or merely to put GI MOSFETS through their paces to see how much they'll take. Please order through your authorized GI Distributor — and remember: this offer expires with the contest on March 31, 1966.

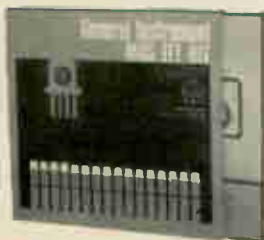

Special
**MOSFET CIRCUIT
DESIGNER'S KIT**
\$250. VALUE
Only **79.50**

MAIL THIS COUPON NOW

General Instrument Corporation • Technical Service Center
600 West John Street, Hicksville, New York 11802

Please rush me my Entry Blank, Contest Rules, and MEM 511A Data Sheet for the General Instrument MOSFET CIRCUIT DESIGN CONTEST.

NAME _____ TITLE _____

COMPANY _____

ADDRESS _____



GENERAL INSTRUMENT CORPORATION / SEMICONDUCTOR PRODUCTS GROUP

600 West John Street, Hicksville, New York

THINK RATS

... for electrical power.

Garrett-AiResearch Ram Air Turbine Systems (RATS) give you auxiliary electrical power from 150 watts to 30 kw.

Externally or internally stored RATS provide power on demand—full-time or intermittent loading—speed control within $\pm 5\%$ of the rated electrical frequency.

Think RATS for reliable electrical power for countermeasures, communications, control, guidance, weapons systems, and other aircraft and missile needs. Operate over a broad environmental range. Low weight. Low drag. Backed by AiResearch single-source responsibility and service.

For design and application data on RATS for electrical, hydraulic, pneumatic, and mechanical power, write: AiResearch Manufacturing Company, 9851 Sepulveda Blvd., Los Angeles, California 90009.

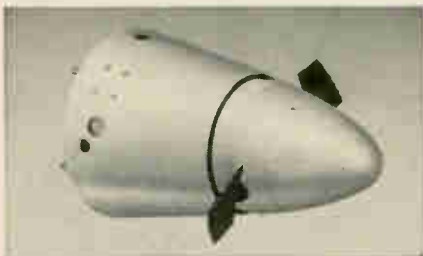
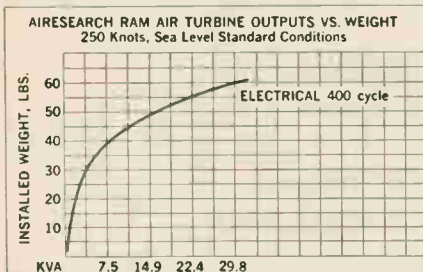

**AIRESEARCH
RAM AIR TURBINE
SYSTEMS**



The Warsaw Television Factory, Poland's sole manufacturer of studio equipment, can completely equip a television studio. Nevertheless, many studios buy British, French, Russian and Czechoslovakian equipment.

without quadrature adjustment. Mechanical and quadrature errors are compensated for with electrical delay lines.

III. East German competition

The research department of East Berlin's telephone and telegraph organization has constructed two prototypes of a video recorder that appear to be more sophisticated than either the Soviet or Polish recorders and may, in the long run, compete with recorders from the West.

Using both tubes and transistors, the hybrid machine, called the Mavicord QR-300, has been offered to other Eastern European countries on a built-to-order basis. The price is comparable to that of American equipment.

West Berlin tv engineers have seen the machine on the air and report that it makes adequate pictures. No attempts have been made

yet, however, to record color. The East German engineers said they have successfully duplicated two of the latest control devices used in American tape recorders. One matches the synchronizing information from a tape recorder with other studio sources, such as Ampex's Intersync and the Radio Corp. of America's Pixlock. The other device is a variable-voltage delay line that corrects for any geometric errors in the playback system. The American equivalent is Ampex's Amtec and RCA's ATC, for automatic time correction.

The East Germans are also developing another recorder, using only transistors.

While tv is improving in all East European countries, there are differences in each.

IV. Soviet Union

In the major Soviet cities, such as Moscow and Leningrad, the

Tv standards in Eastern Europe and in the U. S.

	OIRT standard	FCC standard
Number of lines per picture	625	525
Channel width	8 Mc	6 Mc
Video bandwidth	6 Mc	4.25 Mc
Picture carrier frequency above low end of band	1.25 Mc	1.25 Mc
Sound carrier frequency above picture carrier	6.5 Mc	4.5 Mc
Guard band between sound carrier and upper end of channel	0.25 Mc	0.25 Mc
Picture frequency	25 cps	30 cps
Field frequency	50 cps	60 cps

black box or polka dotted

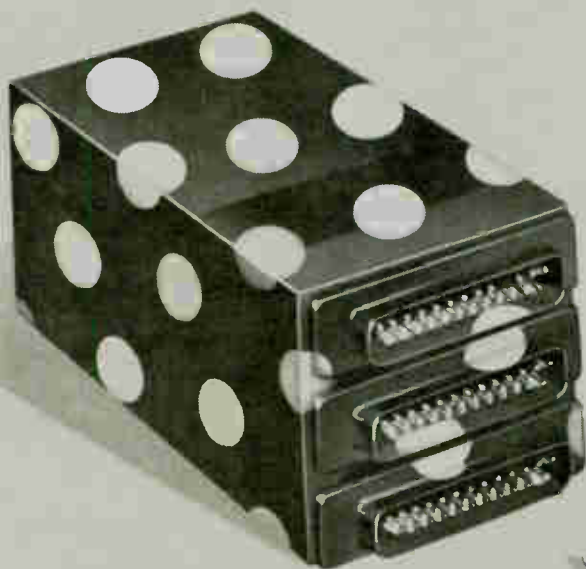

no matter how different your design
It's Better with Sperry in it.

To whatever you direct your design talents whether military or industrial. Sperry semiconductors will complement it. Take our new line of Epitaxial Base Oxide Passivated Silicon Transistors for example (and we hope you do). Through planar technology, these Epi-Base units exhibit high emitter to base breakdown voltage – tighter leak-

age current, improved offset voltage and higher forward and inverse betas.

More good news. The industry's largest line of alloy transistors will be available in Epi-Base also. Only Sperry can offer a no-axe-to-grind choice between Epi-Base and Alloy Transistors.

SPERRY SEMICONDUCTOR,
Norwalk, Connecticut 06852.

Sperry Europe Continental, 7 Avenue de l'Opera, Paris 1, France

SPERRY

DIVISION OF
SPERRY RAND
CORPORATION

NEW

For LEM-MOL-APOLLO-SATURN

BIT ERROR RATE MONITOR

Compares serial data bits, DC to 2 MC
Accumulates, stores, and displays bit errors
Direct 3 or 4 digit display of bit error rate
Internal data delay compensation: 0 to 5 bits
Printer output: 1-2-4-8 BCD
Bit matches selectable in place of bit errors
Wide application as general purpose comparator



The DEI Bit Error Rate Monitor provides a means of comparing two serial NRZ data bit streams on a bit by bit basis. It accumulates the number of negative or positive comparisons over a bit interval selectable 10^3 to 10^7 bits or on a continuous basis. Provision is made for processing code forms other than NRZ. The number of bit errors (or bit matches) are presented on a visual digital display while simultaneously presented in BCD form as a printer output.

The BA-102 Series can be used in conjunction with PCM serial simulators to measure bit error rate of PCM processing systems. Operation is provided at bit rates from DC to 2 megacycles with data I/O threshold adjustable from +7 to -7 volts.

The power supply is self-contained and input/output connections are provided on both the front and the rear of the unit. A built-in delay to compensate for delay of the processing system under measurement is also provided.

For additional information write for Bulletin BA-102.



DEI
RESEARCH
DEVELOPMENT
MANUFACTURING

Defense Electronics, Inc.

Rockville, Maryland

(301)762-5700

TWX: 710-828-9783



Mobile units, like this Hungarian van used for on-the-spot news coverage, transmit to the studio by microwave relay.

number of tv receivers per capita is comparable to that of Paris, London and other West European capitals. Throughout the whole country there are 15 million sets and the number is growing fast.

The Soviet citizen, who does not have to pay a fee for his tv set, has a choice of three channels: two provide general programs, and one education programs. Programs on one of the general channels are transmitted by microwaves between major cities. The other two are produced locally.

In 1965, the Soviet television system produced 5,330 hours of programs, of which 67% were live and 33% film.

Broadcasters. There are, throughout the Soviet Union, 116 program centers, each equipped with live studio-production facilities, and over 80 mobile units. Coverage of the huge country is achieved with 52 high-powered transmitters and more than 300 low-power secondary transmitters linked to a vast microwave and coaxial cable network.

The studio in Moscow is in an antiquated building that is slowly being equipped with modern facilities. Leningrad has a new building with extensive monochrome and color facilities and good studios for local production.

The color equipment in Leningrad is similar to the NTSC (National Television Standards Committee) type used in the United States and Canada, and is still experimental.

Engineers in the Soviet Union do not agree on the kind of color tv that should be adopted. In Mos-

cow, they appear to favor Secam, the French system, while Leningrad engineers like NTSC.

V. Czechoslovakia

Czechoslovakia has the most extensive tv system in Eastern Europe and it continues to grow. Soon, there will be a second tv channel, making Czechoslovakia the only Eastern European Communist country outside of the Soviet Union with more than one channel.

There are now over 2 million tv receivers for the approximately 14 million inhabitants, the highest per capita density outside of a few Western countries. In use are 20 transmitters, and more than 220 repeater stations. This yields a population coverage of over 90%, rivaling any tv system in the world.

The single Czechoslovakian tv channel that operates from five tv centers around the country in Prague, Bratislava, Ostravo, Brno and Kosice has eight studios and 12 mobile units. Fixed radio relay links extending over 2,100 miles throughout the country connect the studios. Also, with mobile units and mobile relay links, direct transmission is possible from practically any spot in Czechoslovakia. Considering the mountainous terrain, this is a real achievement.

Almost all of the tv equipment used in Czechoslovakia, including receivers, is made by a local firm known as Tesla. Czechoslovakia has in operation more than 90 Tesla camera and film-camera chains. Experimental work with transistorized tv equipment has started.

The major task confronting Czechoslovakian tv is to improve

recording techniques and program production. Two new tv centers are being planned in Prague and Bratislava. Each will provide regional programming in its own language in addition to feeding the national network.

A local research center in Prague does development work on all phases of tv equipment and has even developed its own version of an NTSC color system. However, there are no immediate plans for color tv.

Prague is the switching center for Intervision, the Eastern European network, and also connects with the West European tv network, Eurovision. More than 100 transmissions with approximately 200 hours of program material were taken from the Intervision or Eurovision networks last year, while approximately 150 hours were fed into these networks from Czechoslovakian production centers.

VI. Poland

Poland also has a very highly developed tv system, with eight major tv centers containing 10 live studio production facilities and five mobile units. There are 13 tv transmitters and a comprehensive microwave and coaxial cable system which could serve 77% of the population, though only 7% of the people own sets.

Sets are locally produced in three different factories. The monthly subscription fee for the ownership of a tv set, which is paid to the post telephone and telegraph organization is 40 zloty, or \$1.

All Polish studio equipment is made in the Warsaw Television Factory, known as WZT, but many studios also use English, French, Russian and Czechoslovakian equipment.

Polish cameras. Polish technicians have, on their own, produced an excellent 4½-inch image-orthicon camera. They are planning to produce a number of these cameras for their new television center now under construction in Warsaw.

All the equipment purchased for this center will be suitable for conversion to color by 1970; however, no decision has been made on which color system to use. The Poles hope to have a second television channel operating by 1967.

Polish tv presents approximately



HOW TO FORM STRONGER BOXES FAST!

1

Shear up to 160 blanks per minute with lowest cost, high speed, precision shear on the market! Di-Acro Power Shear No. 36 — only \$1,350 complete!

2

Notch blanks on a Di-Acro Power Tab Notcher. Extra strong tabbed corners are self-aligning. And easier to fasten.

3

No wasted motion. Form box on a Di-Acro Hand or Power Press Brake or Di-Acro Leaf Type Brake. Read the full story in Di-Acro's newest catalog. See your distributor or write us.



DI-ACRO

A Division of Houdaille Industries, Inc.
431 Eighth Ave., Lake City, Minn. 55041

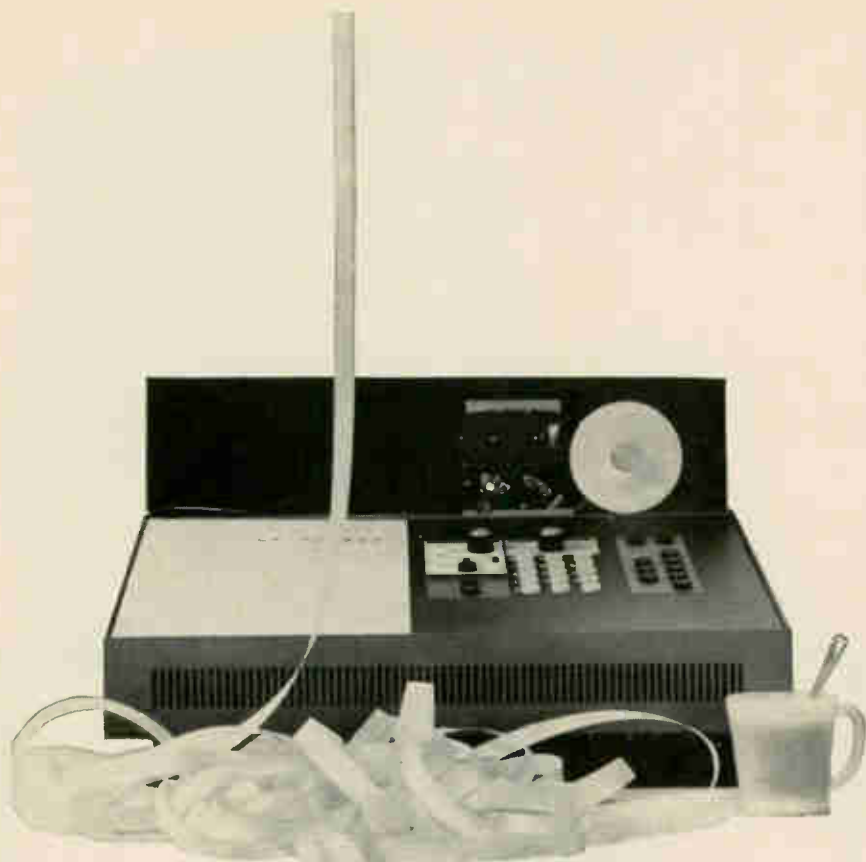

*This
\$5,000
Mathatron digital computer
uses a new
computer language...
...algebra*

Tap in the problem, digit by digit, sign by sign, with decimal points and parentheses and power of 10 exponents, just as if you were writing it out. The Mathatron prints the problem on paper tape, then prints out the answer. As simple as that.

Four or eight independent storage registers, 24 or 48 step ferrite core memory, 100 column number capacity, 8 to 9 significant digit accuracy, automatic decimal placement, electronic speeds, optional pre-wired programs, all solid state logic and circuitry. It won't solve everything, of course.

If you already have a large data processor, consider this: 80% of the Mathatron owners have big computers, too.

But they can't stand the time lag, or the hourly cost, or the gaff. The Mathatron is twice the size of a typewriter and is accessible, immediately, to the whole department.

Write for further information.

MATHATRONICS, INC.

257 Crescent St., Waltham, Mass. 02154 (617) 894-0835

... the Poles watch Bonanza and Disneyland ...

63 hours of programing each week —40% live and 60% film. The Poles utilize the greatest proportion of American film material of all Eastern European countries, especially tv film series, such as Dr. Kildare, Disneyland and Bonanza. They also show United States Information Agency material, mainly in the area of televised news.

Polish program production people have visited the United States on various State Department grants and are familiar with American tv techniques and programing. American materials put on the air are translated either through the medium of subtitles or dubbing.

VII. Rumania

Rumania's radio broadcasting system is extensive and modern. Housed in a new building in Bucharest, its studios and technical facilities are equipped with up-to-date distribution, switching and transmission equipment.

Television in Rumania, however, is another story. The equipment, built in the Soviet Union, is antiquated. It is housed in a small building that was not designed for tv production.

The system consists of nine transmitters, ranging in output from two to 11 kilowatts, and 18 low-power secondary transmitters. This network covers an area in which 55% of the population live. It broadcasts on one channel 28 hours a week.

About seven hours of the weekly total are live studio productions. U.S. programs on film are available to Rumania, but their high cost keeps such programs to a minimum.

There are about 400,000 receivers in the country, most of which are Hungarian; others are imported from East Germany, Czechoslovakia, Poland and Japan.

Microwave. Rumania has five vans. The newest is for mobile tv operations. All vans transmit to the studios by microwave relay. Microwave is also used to distribute programs throughout the country.

Oddly enough, Rumania has tv commercials. Set owners pay a monthly charge to support pro-

Kodak advertises:

high-speed bibliography . . . photorecording a 100 mc carrier . . . neck-saving information from harried men

Collaboration with Mary Sarah

We approached a young lady of incredible beauty whose boss had gone out late to lunch and had left her with too light a work load. "Mary Sarah," said we, "please think of any ten numbers between 1 and 538 that come into your head and say them. In order, please."

Mary Sarah replied, "6, 71, 162, 210, 304, 396, 408, 479, 513, 535."

We did this for the following reason.

The 7th International Congress on High-Speed Photography met in Zürich this past September. To commemorate that event we put together a bibliography on high-speed photography for the period 1960-1964. On its cover appears the following frame from a high-speed motion picture study of explosion phenomena:

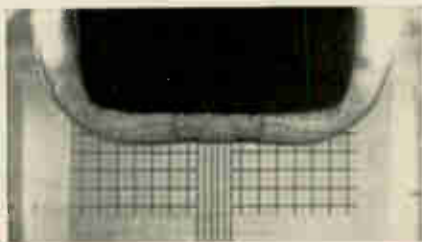

You may not fully understand its significance. Neither do we. That's the trouble with virtually all significant high-speed movies. They look pretty blah until the guys who planned and took them explain everything. Then your eyes may light up.

Some investigations with high-speed movies are brilliant engineering or brilli-

ant applied physics or brilliant bio-science. Some are not very brilliant. Who are we to say which are which? Therefore we approached Mary Sarah. Of the 538 entries in the bibliography, here are the ones she picked:

- 6 Research Directed Toward the Attainment and Utilization of High Temperature (Multi-Frame High Speed Camera, Exploding Wire Phenomena and Plasma Acceleration). L.L. Bohn, F.H. Nadig, and T. Korneff, Temple U. Mar., 1958, 109p. (PB 138 435). — Exploding wires; Framing cameras; Plasmas; Rotating-mirror cameras; Image converters.
- 71 Study of the Process of Cutting Metals by High-Speed Cinematography (In Russian). C.P. Tambovtsev. *Usp.Nauchn.Fotogr.* 6, 174 (1959). — Cinematography; Metals; Photomicrography.
- 162 The Astracon Tube and Its Application to High-Speed Photography. A.E. Anderson, G.W. Goetze, and H. Kanter. *J. Soc. Mot. Pict. Telev. Engrs.* 70, 440-42 (1961). — Image intensifiers; Cameras.
- 210 An Electronic Flash Adapter for Photomicrography. J.J. Lee and B. Freidman. *J. Biol. Phot. Assoc.* 29, 93-7 (1961). — Photomicrography; Flash tubes; Electronic flash.
- 304 Brit. P. 886, 829. High-Speed Camera Having Improved Kerr Cell Shutter Assembly. A.E. Huston. To United Kingdom Atomic Energy Authority, 9/24/58, 5p. — Framing cameras; Kerr cell; Shutters; Electro-optical devices.
- 396 The Use of High Speed Cameras for Metric Photography. L.L. Endelman. *Soc. Phot. Instr. Engrs. J.* 1, 128-30 (1963). — Framing cameras; Missile photography.

- 408 The LER-1 Recording Lux-Meter (In Russian). I. M. Gurevich, V. G. Baryshnikov, L. E. Finkel'shtein. *Svetotekhnika* No. 5, 16-19 (1963). — Oscillograph recording; Photometers; Light sources.
- 479 Twenty-Thousand Frames Per Sec. Amateur Cine World 8, 241 (1964). — Oscilloscope Photography; Flash synchronization; Motion-picture cameras.
- 513 A High-Speed Camera for High Frequency Electrocardiography. F.T. Mansure, P.H. Langner. *Am. Heart J.* 67, 88-91 (Jan. 1964). — Streak cameras; Streak photography; Medical photography; Oscillograph recording.
- 535 Brit. P. 961,441. Improvements in Optical Image Transmission Devices. J. N. Whyte. To Secretary of State for the War Department, London, 7/12/60-6/24/64. — Streak cameras; Rotating-prism cameras.

This will give you an idea of whether or not to send for a free copy of the 1960-64 high-speed bibliography from Eastman Kodak Company, Publications Service, Rochester, N. Y. 14650.

How to write with a fine pencil

To the surprise of some, a 100-megacycle carrier turns out to be not beyond photographic recording at gratifyingly high density. The secret is to do it with a pencil of electrons and avoid phosphors and lenses. Various arrangements are being worked out to supply unusual sensitized goods for this purpose.

Inquiries of more than casual motivation on this subject are welcomed by Eastman Kodak Company, Special Applications, Rochester, N. Y. 14650.

They attenuate

These are a random sampling of radiation attenuators other than the famous spectrally selective KODAK WRATTEN Light Filters. Just to know they can be had can save one's neck when devising instrumentation. They include straight and circular wedges, uniform densities, stepped densities. Some attenuate by evaporated metal, some by dispersed carbon, and some by photographic silver. Some need to be handled with cotton gloves. Some will stand the toughest aerospace duty. Some serve as beam-splitters. Some transmit to 200m μ in the ultraviolet. Some transmit to 20 μ in the infrared. Some we alone make. Some other companies can make just as well. Some of those companies can seem less than eager for the business. Some of the business we ourselves are less than eager for. Some of our reserve conceals shame for the prices and deliveries that would have to be quoted. Some conceals fear that the comptroller will ask where in the charter it says that we are a charitable institution.

To determine whether what you need we can supply, phone (716)-325-2000, Ext. 2339. A harried man may answer. If he is too harried to answer, try Ext. 2415. The man there is harried also. The two work in different departments but know each other's business fairly well. If phone tolls mean much, write a letter to Eastman Kodak Company, Special Applications, Rochester, N. Y. 14650.

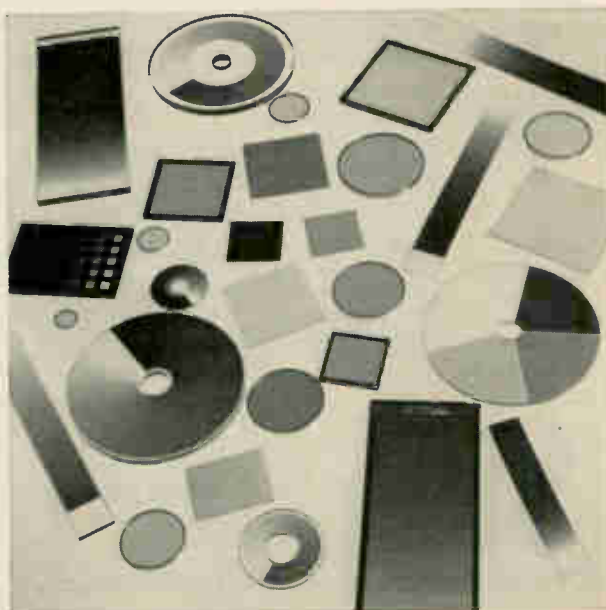

there are only two ways of looking at Transistor Sockets

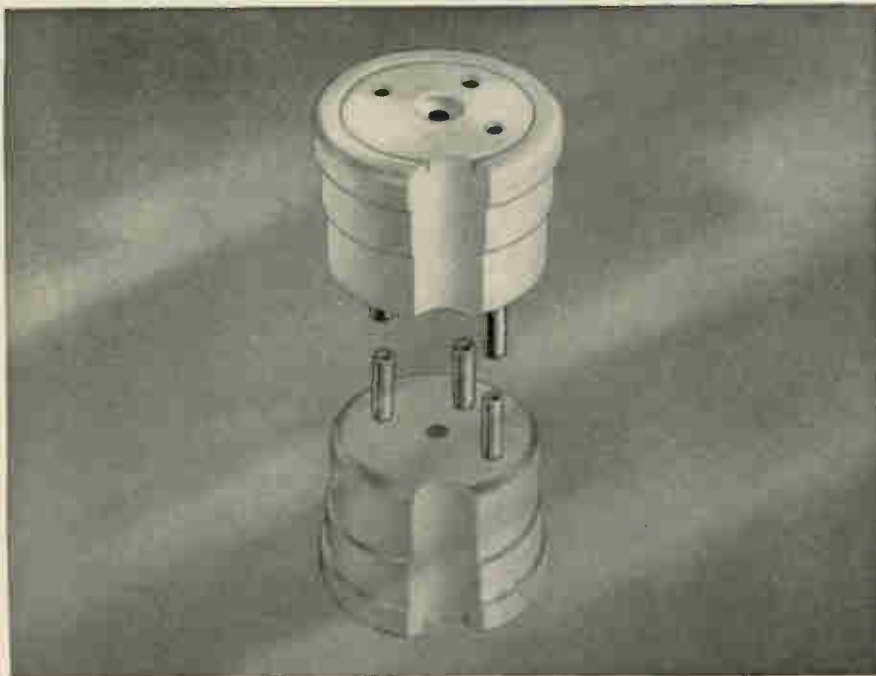

PRICE & PRECISION



Sealectro has broken the price barrier for precision Teflon Transistor and IC Sockets! New mass production techniques result in higher contact reliability at lower prices . . . while retaining the famous Sealectro 'Press-Fit' installation. One operation and they're in the chassis for good. Gold-plate plus unique contact construction assures minimum contact resistance and positive holding action, even after hundreds of insertions.

* REGISTERED TRADEMARK
E. I. DUPONT DE NEMOURS & CO

Transistor Sockets		Integrated Circuit Sockets*	
3 Lead TO-18	TS-365-1	8 Lead, .200" Pitch Circle	TS-860
3 Lead TO-5	TS-366	10 Lead, .230" Pitch Circle	TS-1060
4 Lead TO-18	TS-461-1	10 Lead, .230" Pitch Circle	TS-1061
4 Lead TO-5	TS-461	12 Lead, .250" Pitch Circle	TS-1260

* For TO-5 Packages

Write today for complete details!



CIRCUIT HARDWARE DIVISION

SEALECTRO CORPORATION

HOYT STREET • MAMARONECK • NEW YORK
PHONE: 914 698-5600 TWX: 914-3180

Sealectro Ltd., Portsmouth, Hants, England

. . . in Rumania, advertisers want more commercials . . .

graming—as the British do—but with the relatively low number of sets, income from state licensing is limited and the additional revenue from advertising is useful. Restaurants, wines and other commodities are advertised between regular broadcasts. Since there is not enough time to accommodate all of the potential advertisers, pressure is growing for more broadcast time and more commercials.

More programs. Rumania is connected to Intervision, the Eastern European tv network, through Kiev, Moscow, Prague and Bulgaria. After the Hungarian tv relay links now under construction are completed, there will be more exchange of programs between Hungary, Rumania and Yugoslavia.

To meet the increasing need for tv facilities, the Tv Planning Bureau has a comprehensive schedule up to 1970. A new center is under construction in Bucharest that will be completed and equipped by 1966. The basic equipment will be bought with an eye toward color compatibility, although no decision on the color system to be used has been made. Color and a second tv channel will not be considered before 1970.

VIII. Hungary

The studio center in Budapest is in an old government office building. It has three studios and a few mobile units that can be connected directly or by microwave to the center. While its 10 transmitters can reach more than 80% of the population, service is still limited to single channel operation for five days a week. There are approximately 700,000 sets in the country, mostly Hungarian. Border residents in the country can pick up direct transmissions from Czechoslovakia, Austria, Yugoslavia and the Soviet Union. Home tv receivers are licensed by the state and a monthly fee of 50 forints (about \$1) is charged.

The studios have home-built equipment, such as switchers, but the camera chains are British, made by EMI, Ltd. and Marconi, Ltd. Kinescope recordings are made on a Fernseh GmbH tele-recorder. Hungary has no video recorders.



**Should you waste time
second guessing IC specs and delivery
when you could be
designing systems**



**Signetics Guaranteed Worst Case Design Limits
assure highest performance levels for HI REL DTL integrated circuits.
And you can be sure of "off the shelf" delivery.**



Now you can design without calculating or worrying about any additional safety factors or guard bands. Signetics new J series data sheets for DTL circuits provide systems designers with complete clarity of worst case design limits. No foggy "typical characteristics" talk. Each data sheet is also a model procurement document for component and reliability engineers. They

are complete down to details of acceptance, quality assurance, and environmental test methods, and limits in accordance with all applicable MIL specifications. You design the system, directly from the data Signetics provides for optimum performance. Don't waste time second-guessing. Write today for complete specification sheets with guaranteed worst case design limits.

SIGNETICS INTEGRATED CIRCUITS

A subsidiary of Corning Glass Works,
811 East Arques Avenue, Sunnyvale, California
Tel: (408) 739-7700 TWX: (910) 737-9965



Signetics complete line of MIL Temperature Range DTL Circuits includes 34 elements to assure flexibility, performance, reliability and economy. And the full line is available "off the shelf."

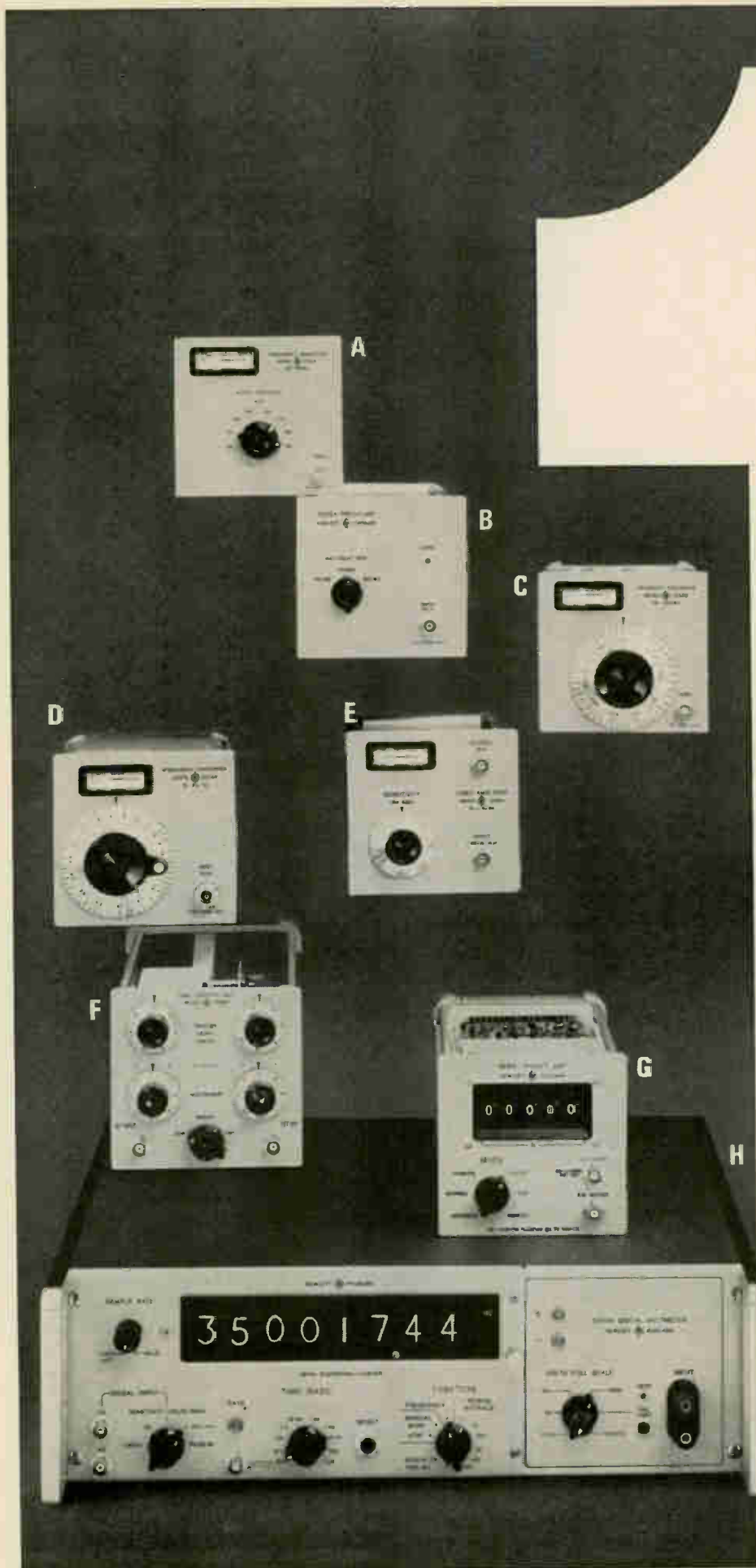

Plug-ins of your choice—to meet your need:

- A** 20-100 MHz frequency converter, to increase the basic 50 MHz counting rate of the 5245L; 5251A, \$300.
- B** DC to 350 MHz prescaler, direct readout, no tuning, multiple scale factors for faster readings in lower ranges; 5252A, \$685.
- C** 50 MHz to 500 MHz frequency converter, to increase the basic counting rate of the 5245L; 5253B, \$500.
- D** 300 MHz to 3000 MHz frequency converter; as with other hp converters, just add the tuning indication to the counter measurement; 5254A, \$825.
- E** 1 mv to 300 mv rms video amplifier, to increase counter sensitivity; 5261A, \$325.
- F** Time interval unit, measure time interval 1 μ sec to 10⁸ sec, resolution of 0.1 μ sec; 5262A, \$300.
- G** Preset unit, normalizes measurements to engineering units, divides input frequency by N, counts N events (1 to 100,000); 5264A, \$650.
- H** Digital voltmeter, 6-digit measurement of 10, 100 and 1000 v full scale, 0.1% accuracy, 5% overranging; 5265A, \$575.

Accessories to increase usefulness, value:

- *2590B Transfer Oscillator for reliable, rapid measurement to 15 GHz, \$1900
- *580A, 581A Digital-to-Analog Converters, for conversion of output for x-y recording, \$525
- *562A Digital Recorder, about \$1600, depending on options
- *2514A Digital Scanner, for systems applications, \$2500
- *2545 Tape Punch Set, \$3900
- *2526 Card Punch Set, \$3100
- *2546 Magnetic Tape Recorder Set, \$8565

Data subject to change without notice. Prices f.o.b. factory.

ONE COUNTER FOR ALL YOUR NEEDS:

hp 5245L!

Can't be obsoleted—just plug in new capabilities as you need them

Today! direct counting to 350 MHz, converter measurements to 3000 MHz!

Eight plug-ins, available now!

More plug-ins to come!

Convenient, easy-to-read controls!

Superior readability, electrical output!

Value-priced at \$2950!

The Hewlett-Packard 5245L 50 MHz Electronic Counter is unmatched in performance capabilities, convenience features and plug-in versatility. Your \$2950 investment in the basic counter gives you the measuring capability you need today, an investment in your expanding needs for greater frequency range, sensitivity and special measurements, plus a guarantee that new state-of-the-art measurements will be available as they're developed.

The basic 5245L gives you a highly stable time base for accuracy, BCD output for recorders and accessories, capability for fre-

quency, period, multiple period average, ratio and multiples of ratio measurements, plus the ability to scale a signal by decades. Such hp features as display storage, rectangular digital readout tubes for measurements at-a-glance, solid-state modular construction for reliability and easy maintenance . . . are standard.

The plug-ins tell their own stories. Ask your Hewlett-Packard field engineer for a demonstration or write for complete specifications to Hewlett-Packard, Palo Alto, California 94304, Tel. (415) 326-7000; Europe: 54 Route des Acacias, Geneva.

HEWLETT  **PACKARD**
An extra measure of quality

IRG

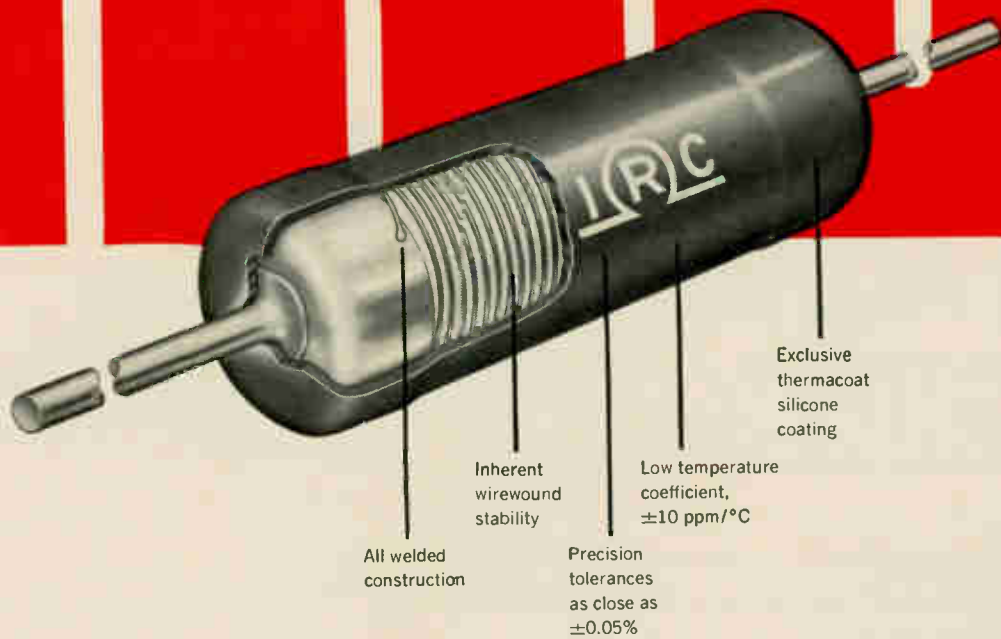

Miniature precision power resistors

±10 ppm TC plus tolerances to 0.05%

Add versatility and economy to your circuits with IRC type AS resistors. They offer all the advantages you want—small size, economy, precision tolerances, high dielectric strength, high heat capability and superior construction. Hot side temperature coefficient is an assured maximum of ± 10 ppm/°C in standard ranges above 50 ohms.

SAVE SPACE. These precision wirewound resistors offer an economical approach to miniaturization and upgraded performance.

CUT DESIGN COSTS. AS resistors offer impressive cost savings where tolerances under 1% and temperature coefficient lower than ± 10 ppm/°C are needed. Save as much as 20% to 45% compared to MIL-R-10509 metal film types.

REPLACE VITREOUS ENAMEL. At comparable prices you can replace axial-lead vitreous enamel types with space and performance advantages.

Special AS resistors are available for use as squib fuses. Special inductive designs are also available for fixed rise time applications. For information send resistance, wattage, frequency and rise time requirements to: IRC, Inc., 401 N. Broad St., Philadelphia, Pennsylvania 19108.

CAPSULE SPECIFICATIONS

POWER:	1, 2, 3, 5, 7, 10, 15 watts @ 25°C ½, 1, 2, 3, 5, 7, 10 watts @ 125°C
TOLERANCES:	±0.05%, 0.1%, 0.25%, 0.5%, 1%, 3%, 5%
RESISTANCE:	0.1 ohm to 175K ohms
TEMPERATURE COEFFICIENT:	±20 ppm/°C below 50 ohms ±10 ppm/°C above 50 ohms
MIL-R-26:	Characteristics G and V. Withstands 350°C hot spot.
MIL-R-23379:	RWP 18, 20, 21
LEADS:	Alloy-coated copperweld. Special types available.



Precision multimeter costs under \$200

Solid state instrument has a stable, direct-coupled, chopperless amplifier with three silicon transistors and one field effect transistor

Laboratory-quality performance in the field at low cost is a goal of all instrument designers. The Hewlett-Packard Co. has taken a long step in that direction with the introduction of its multifunction voltmeter, model 427A. This solid state instrument has a resolution of one millivolt in measurement of both negative and positive d-c voltages from 100 mv full scale to 1,000 v full scale; it will measure a-c voltage from 10 mv full scale to 300 v full scale with a minimum reading of 0.3 mv. It measures resistance from 10 ohms center scale to 10 megohms center scale with a minimum reading of 0.2 ohm. Temperature drift on d-c measurements is only 0.5 mv per ° C. The price is \$195.

The secret of its low-cost performance is the design of a stable, direct-coupled amplifier without a chopper. In most d-c voltmeters, sensitivity at the 100-mv level with good stability is achieved either with expensive chopper stabilization or by using large amounts of feedback. The latter requires expensive hybrid circuits and related power supplies.

The d-c amplifier in the model

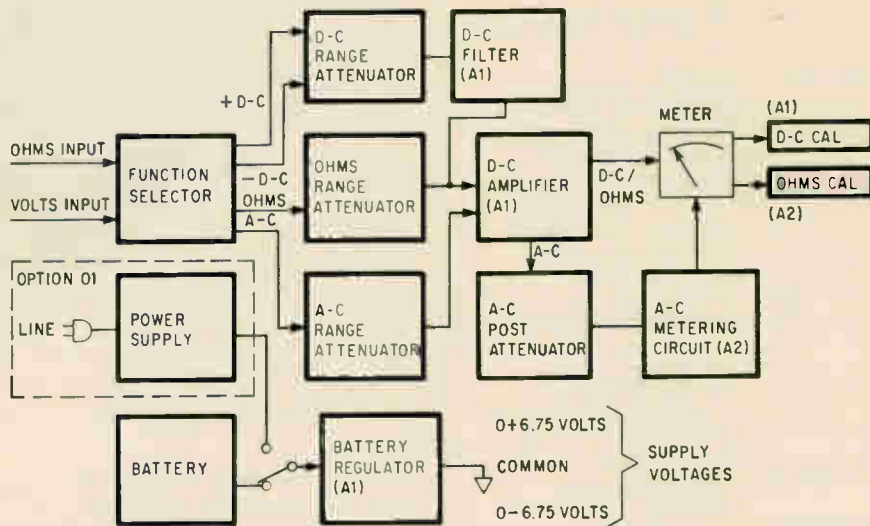

Circuit arrangement of the multifunction voltmeter.

427A is solid state, direct coupled, and temperature stabilized, yet uses only three silicon transistors and one field effect transistor. The FET temperature coefficient is exploited to counter the silicon transistor's temperature characteristics, reducing the amount of feedback required and thus cutting the number and cost of other components. Also, the FET eliminates the need for vacuum tubes to achieve high input resistance, again decreasing the power supply.

In combination, this design results in a stable circuit with the required gain from fewer, less critical and less costly components.

The 427A has instant turn-on in all modes of operation. A front panel zero set is provided, which is suppressed on the ranges above one volt.

The meter movement is the taut band type with an individually calibrated meter face. Accuracy of voltage measurement is $\pm 2\%$. Re-

sistance measurements are accurate to within $\pm 5\%$.

Power can be supplied from an internal 22.5 v battery, or from an optional line operation. Battery life is about 300 hours.

Specifications

D-c voltage ranges	± 100 mv to $\pm 1,000$ v full scale in 9 ranges
Accuracy	$\pm 2\%$ of full scale
Input resistance	10 megohms on all ranges
A-c voltage ranges	10 mv to 300 v rms full scale in 10 ranges
Frequency range	10 cps to 1 Mc
Accuracy	$\pm 2\%$
Input impedance	10 megohms shunted by 40 pf on 10-mv to 1-v ranges and 20 pf on 3-v to 300-v ranges
Ohmmeter ranges	From 10 ohms center scale to 10 megohms center scale
Accuracy	$\pm 5\%$ of reading at mid-scale
Floating input	May be operated up to 500 v d-c above ground
Power	22½-v dry battery (Eveready 763 or RCA VS 102) Optional line operation
Weight	5¼ pounds

Hewlett-Packard Co., 1501 Page Mill Rd., Palo Alto, Calif.
Circle 350 on reader service card.



Bulova can supply the crystal you need



to match your specs!

Many years of supplying crystal control units for the most advanced military and space programs enable Bulova to offer a full line encompassing virtually the entire frequency spectrum—2 kc to 125 Mc for oscillator and filter applications. We can supply every type of packaging—including koldweld and glass sealed. Our military crystals meet latest MIL-C-3098D specifications. All reasons why you should make Bulova your single source of supply.

HIGH PRECISION GLASS SEALED CRYSTALS 1 Mc to 125Mc. Available in vacuum sealed, glass enclosures of the HC-26/U and HC-27/U type.

Example: Precision SSB Crystals



Frequency: 1 Mc to 5 Mc
Holder: HC-27/U
Tolerance: $\pm .0025\%$ from -55°C to $+90^{\circ}\text{C}$, or to specification
Aging: 3×10^{-8} per week after one week stabilization at 75°C

KOLDWELD SEALED CRYSTALS—low aging, high reliability, 1 Mc to 125 Mc. Now available in TO-5, HC-6/U and HC-18/U type cans sealed by the koldweld process to eliminate effects of heat and to reduce contamination.

Example: TO-5

Frequency: 15 Mc to 125 Mc
Tolerance: $\pm .0025\%$ from -55°C to $+105^{\circ}\text{C}$, or to specification
Aging: 1×10^{-7} per week after one week stabilization at 75°C



Write or call for specifications on Bulova's complete line of crystals. Address: Dept. E-17.

BULOVA

FREQUENCY CONTROL PRODUCTS

ELECTRONICS DIVISION OF BULOVA WATCH COMPANY, INC.

61-20 WOODSIDE AVENUE WOODSIDE, N.Y. 11377, (212) DE 5-6000

New Components and Hardware

IBM markets modular packages

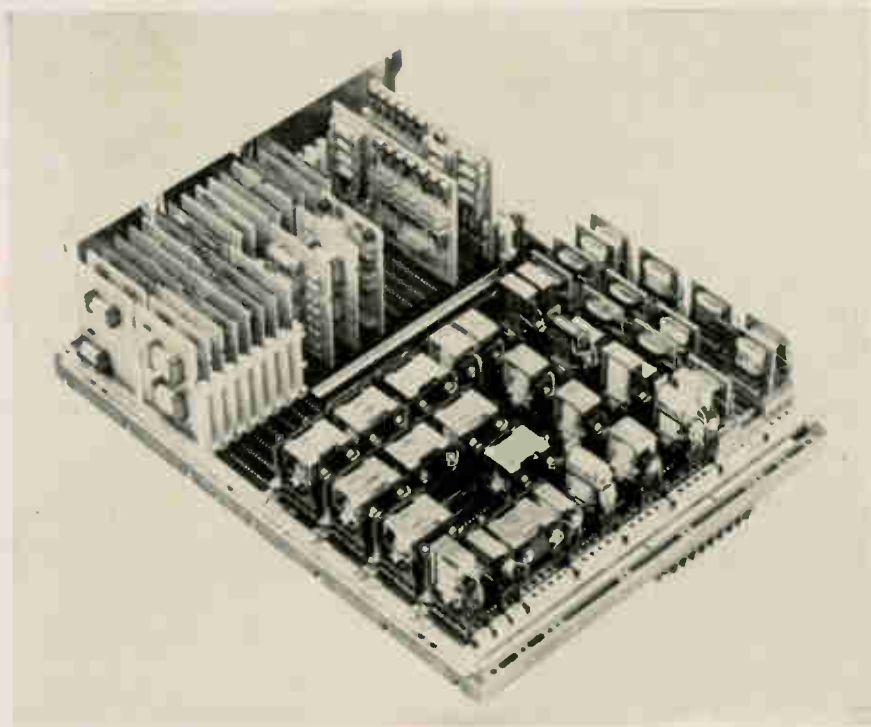

A complete line of hardware that can be used for packaging electronic circuits, subsystems and systems is being offered by the International Business Machines Corp. The line, called SMS for standard modular systems, has been used by IBM in over 15,000 computer installations since 1959.

Why is IBM concentrating on this market? With the advent of the System 360, the firm has adapted a smaller packaging technique, basically incompatible with SMS. But IBM believes that the versatility and flexibility of the packaging technique will meet the requirements of designers of data processing, testing, controlling and telemetry systems.

SMS includes rectangular mounting frames in two sizes, individual and multiple sockets that fit in the frames, printed-circuit card blanks and cable connectors that fit the sockets, sockets and connectors for wire-contact, permissive-make, or reed relays, back-panel wiring cards, ground planes and voltage chains. The voltage chains supply voltages to entire rows of sockets. A cooling fan and plenum assem-

bly is available for attachment to the smaller of the two rectangular mounting frames.

The printed-circuit paper-epoxy cards used by IBM have had wiring printed on one side and transistors and other discrete components mounted on the other. In some cases printed wiring has been used on both sides. Presumably hybrid or integrated circuits could also be used on the cards except where specific electrical and mechanical characteristics of the card—dimensional stability for instance—are unfavorable. Printed-circuit wiring is brought out to a row of contacts along one edge of the card; these contacts mate with prongs inside the socket when the card is plugged in. The prongs extend through the back of the socket as pins. Wires may be attached to the pins either by soldering or by wire-wrapping.

This kind of packaging scheme is particularly well suited to the development of automatic packaging techniques. Indeed, the manufacturing side of IBM's method of design automation was built around SMS. Wire connections

Can we make better resistors, switches and attenuators in Manchester, New Hampshire, than we can in Livingston, New Jersey?

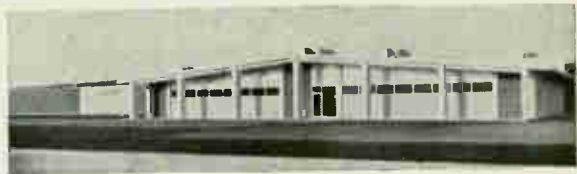

Our new 70,000' plant

We sure can.

Unlike our customers, we at Daven have spent the last 40 years being dissatisfied with our products. We always want to do better. Which is why Daven is moving its personnel, equipment and know-how from Livingston, New Jersey, to Manchester, New Hampshire.

Our reasons are simple: we want to make a better product, to make it more economically, to provide a better working environment for ourselves.

After careful study, we think Manchester is the place to do it.

Daven is no stranger to Manchester. We've had a plant in this handsome New England community for years. So we

know whereof we speak. It was up here that American craftsmanship and precision were born. And we are looking forward to great things once the entire operation gets settled.

When you're in the neighborhood, drop in. They tell us the fishing and skiing is superb.

DAVEN 

Grenier Field, Municipal Airport, Manchester, N. H.
(603) 669-0940 • TWX 603 623-4938 • Cable: Daven Manchester NH

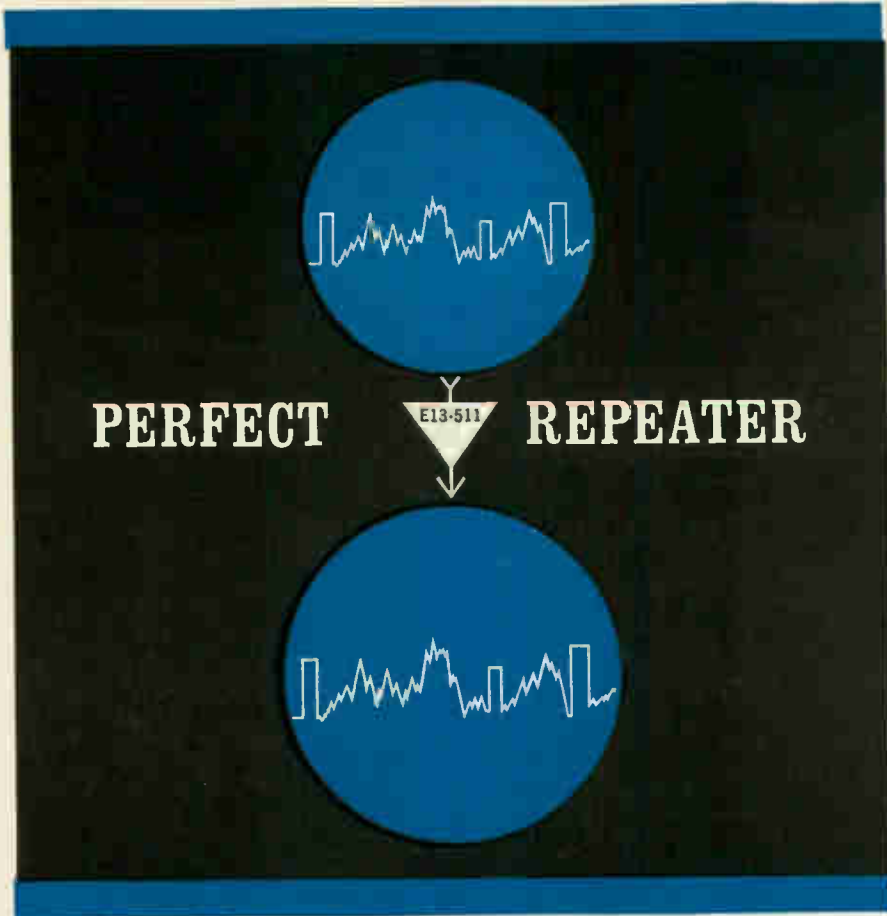

NEW - \$12.00
INTEGRATED VIDEO AMPLIFIER BY AMELCO
HAS HIGH STABILITY!

AMELCO's new E13-511 wideband video amplifier features high stability from -55°C to $+125^{\circ}\text{C}$ at a cost of only \$12.00 in one to 99 quantities! ▲ This monolithic integrated circuit amplifies from DC to over 50 mc (-3 db) with an essentially flat gain characteristic to 40 mc. ▲ Constructed by silicon planar techniques using high resolution photoetching and epitaxial material, exceptional isolation between circuit parts and uniformity of characteristics are achieved. The E13-511 simplifies inspection, shortens assembly time, and increases reliability with no sacrifice in performance and, at a remarkably low price!

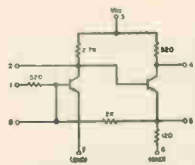

KEY SPECIFICATIONS:

- ▲ Voltage Gain 24 db
- ▲ Bandwidth (-3 db) 50 mc
- ▲ Gain Variation (-55°C to $+125^{\circ}\text{C}$) $\pm 0.3\text{ db}$
- ▲ Limits of Gain Variation (DC to 10 mc) $\pm 0.5\text{ db}$
- ▲ Dynamic Range 7.0 Volts



AMELCO
SEMICONDUCTOR

DIVISION OF TELEDYNE, INC.
 1300 TERRA BELLA AVE., MOUNTAIN VIEW, CALIFORNIA

Mail Address: P. O. Box 1030, Mountain View, Calif./Phone: (415) 968-9241/TWX: (415) 969-9112/Telex: 033-914

REGIONAL OFFICES

Southwest
 3216 West El Segundo Blvd.
 Hawthorne, California
 (213) 772-6341

Northwest
 1300 Terra Bella Avenue
 Mountain View, California
 (415) 968-9241

East
 P. O. Box 1927
 Paterson, New Jersey 07509
 (516) 334-7997

Northeast
 543 High Street
 Westwood, Massachusetts
 (617) 326-6600

Midwest
 650 West Algonquin Road
 Des Plaines, Illinois
 (312) 439-3250

2428 West 22nd Street
 Minneapolis, Minnesota
 (612) 374-1969

New Components

called for in the engineering design of an electronic assembly are first translated by a computer into connections in a particular order. This order minimizes wire length and noise pickup, and optimally satisfies other design criteria. These connections are recorded on magnetic tape, which then controls an automatic wire-wrapping machine that does most of the back-panel wiring on a frame. The longest wires and those with the most difficult routing are added later by hand.

Specifications

P/C card sizes, single	4.500 x 2.600 x 0.093 inches
double	4.500 x 5.250 x 0.093 inches
Socket sizes, single	0.500 x 2.375 inches
multiple	4.000 x 2.375 inches
Overall height of card in socket	5.635 inches from pin to edge of card
Frame dimensions, Module I	14 x 18 inches
Module II	15 x 29 inches
Frame capacity, Module I	156 single cards, or 78 double cards, or 152 relays (may be intermixed)
Module II	280 single cards, or 140 double cards (may be intermixed)
Component height on card	0.350 inch maximum
Prices—	
Module I frames	\$8.25
Module II frames	11.50
Single sockets	.65
Multiple sockets	3.95
Card blanks, single	1.50 (copper clad one side)
double	3.95 (copper clad one side)
Sockets for wire-contact relays	.40 (4-pole) .75 (6-pole) 1.50 (12-pole)
Delivery	30 days from receipt of order

International Business Machines Corp., Industrial Products Division, 1000 Westchester Avenue, White Plains, N.Y. 10604 [351]

Multiturn pot offers infinite resolution



A line of multiturn potentiometers now available is said to be the first of its kind in high resistance

Brand **NEW** FROM **HICKOK**

DMS-3200 Digital Measuring System



DMS-3200 Main Frame **\$320**
(shown with DP-100)

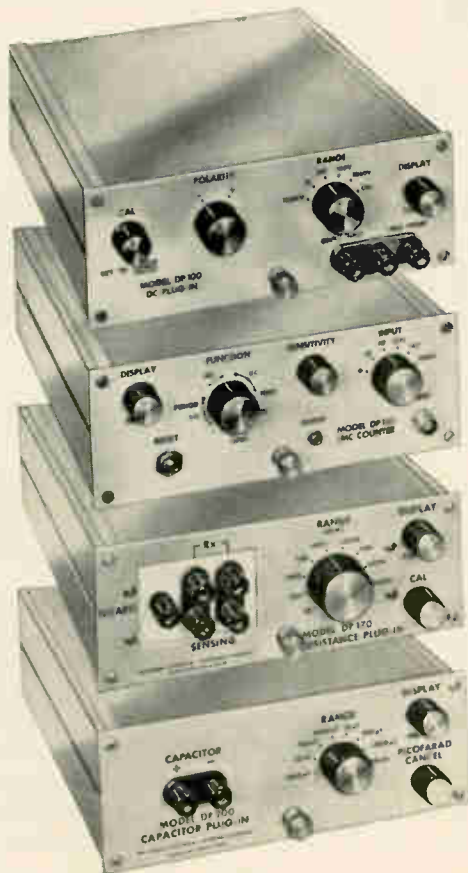

DP-100
DC Voltmeter
Plug-in
\$175

DP-150
1 MC Counter
Plug-in
\$175

DP-170
Ohmmeter
Plug-in
\$240

DP-200
Capacity
Meter
Plug-in
\$240

HIGHLIGHT FEATURES

- 3-digit Biquinary Tube Read-out
- Plug-in Flexibility
- All-electronic
- Fully-transistorized
- Modular Design
- Fully Field-tested
- Automatic Polarity Indication
- Automatic Decimal Point Indication

AS A DIGITAL DC VOLTMETER (DP100 Plug-in)

- Range 0.1 millivolts to 1000 volts
- Accuracy $\pm 0.1\%$ FS, $\pm 0.1\%$ of reading
- True integrating voltmeter design
- 10 megohms input impedance at all times

AS A DIGITAL 1 MC COUNTER (DP150 Plug-in)

- $\pm 0.005\%$ accuracy: Resolution 1 part in 10^7
- (Overrange capability with sector read-out permits 3-digit display to be equivalent of a 7-digit instrument)
- Frequency measurement range 0.1 cps to 1 mc
- Period measurement range 0.1 ms to 999 seconds

AS A DIGITAL OHMMETER (DP170 Plug-in)

- Range 0.01 ohm to 1,000 megohms
- Accuracy $\pm 0.1\%$ FS, $\pm 0.2\%$ of reading

AS A DIGITAL CAPACITY METER (DP200 Plug-in)

- Range 1.0 picofarad to 10,000 microfarads
- Accuracy $\pm 0.1\%$ FS, $\pm 0.2\%$ of reading

The DMS-3200 is designed for rugged industrial and laboratory applications. By utilizing a design which has the optimum combination of accuracy capability and number of digit display, the DMS-3200 meets the general purpose measurement needs of industry for reliable, precision digital measurement equipment in the \$400-\$500 price range.

MAGNETIC SHIELDING MADE EASY

APPLIED IN SECONDS

**Cut to any size or outline
with ordinary scissors**



Co-Netic and Netic foils are ideal for initial laboratory or experimental evaluation . . . also for production applications and automated operations. Dramatically enhance component performance by stopping degradation from unpredictable magnetic fields. When grounded, foils also shield electrostatically. They are not significantly affected by dropping, vibration or shock, and do not require periodic annealing. Available in thicknesses from .002" in rolls 4", 15", and 19-3/8" wide. High attenuation to weight ratio possibilities. Every satellite and virtually all guidance devices increase reliability with Netic and Co-Netic alloys, saving valuable space, weight, time, and money.

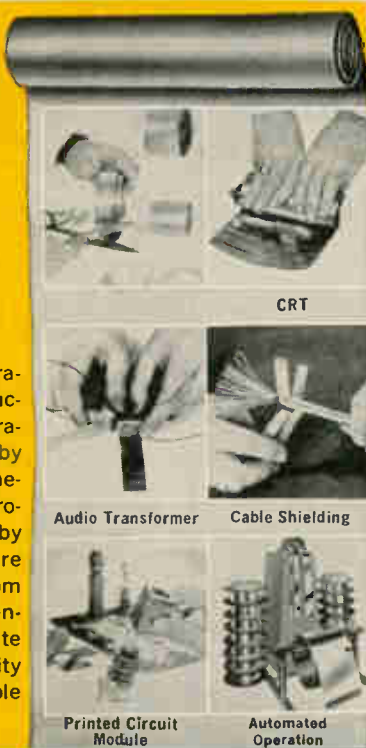

MAGNETIC SHIELD DIVISION

Perfection Mica Company

1322 N. ELSTON AVENUE, CHICAGO 22, ILLINOIS

ORIGINATORS OF PERMANENTLY EFFECTIVE NETIC CO-NETIC MAGNETIC SHIELDING

Circle 254 on reader service card

IMMEDIATE IN-STOCK DELIVERY 1200-POINT CROSSBAR SWITCHES

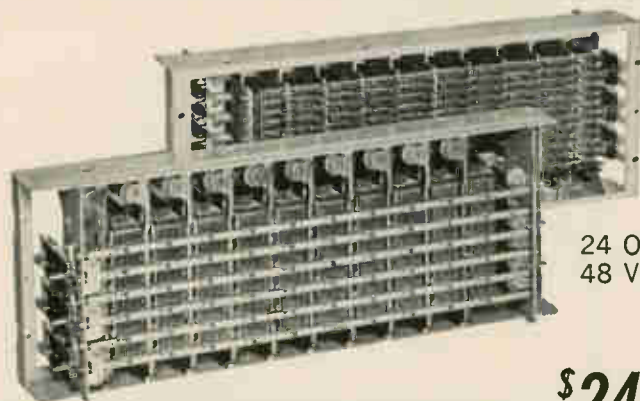

24 OR
48 VOLT

LOTS OF 100 OR MORE (SILVER CONTACTS) . . . **\$240 EACH**
PRE-WIRED \$45 ADDITIONAL

Renown for unique flexibility, extreme reliability and economical long-life. Crafted by L. M. Ericsson, world leader in telecommunications. Mechanical life—25 million operations per vertical, 60 million per horizontal select bar. Electrical life—70 million operations per contact; 400 million, off-normal contacts. Typical crosspoint operate times from select to hold, 20 to 35 ms. Pre-wired horizontal multiple. Silver-alloy contacts. Gold-plated contacts and other size pre-wired or non-wired switches available. For immediate delivery of 1200-point switches call or write components manager.

THE ERICSSON CORPORATION

100 PARK AVENUE / NEW YORK, N. Y. 10017 / 212-685-4030

New Components

ranges. The wiper rotates around the periphery of the resistance wire helix, and follows each turn as does a nut on a screw. As the contact essentially travels with the axis of the resistance wire, instead of across the turns as with conventional potentiometers, an unusually high resolution is achieved with a low noise level.

Resistance ranges from 25 to 100,000 ohms are available, with a resistance tolerance of 1% standard. Linearity is 0.01%, and temperature coefficient is 10 ppm/°C to 125°C.

According to the manufacturer, 1/2 degree of shaft rotation provides a typical resolution of 0.17 ohm in the 25,000-ohm unit. There are 150,000 degrees of shaft rotation in this model.

Dimensions are 1/2 x 1/2 x 3/4 in. Units are encapsulated, and panel bushing and several printed-circuit board mounts are available. Elliott Industries, 23987 Craftsman Rd., Calabasas, Calif. [352]

Square-trimming pot for panel mounting

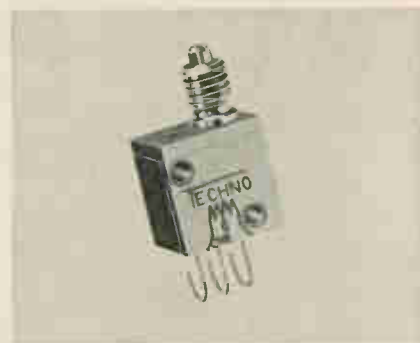

A panel mounting, miniature, square-trimming potentiometer has been developed with solder hook terminations. Model 160 features a heat dissipator as an integral part of the solder hook design. In addition, both the panel-mounting bushing and the terminating solder hooks are molded into the plastic case for rugged, dependable mechanical bonds.

The wirebound unit measures 0.453 x 0.468 x 0.282 in., and is available in resistance ranges from 10 to 50,000 ohms. Power rating is

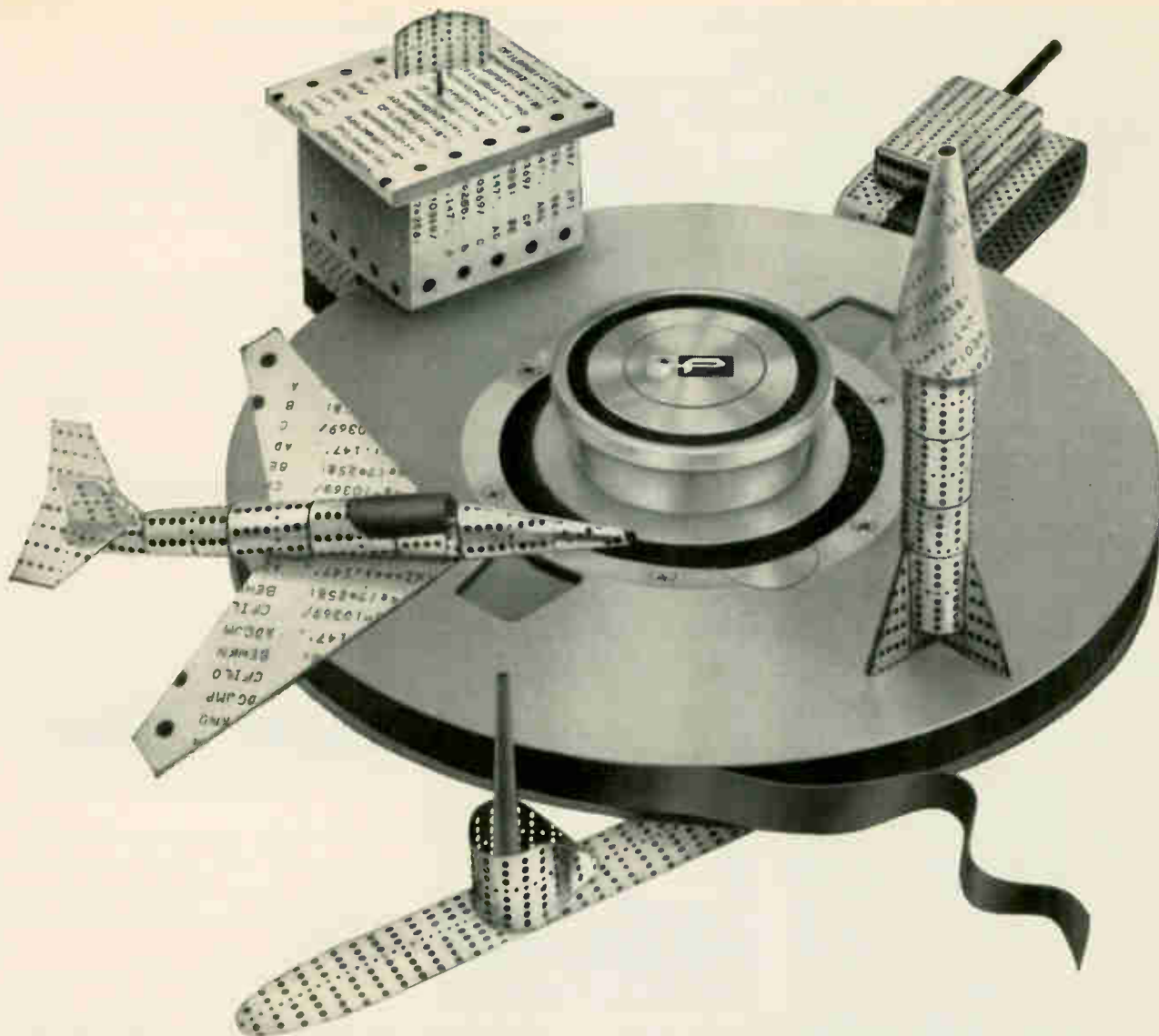

Do your military EDP systems need peripherals? Read what **POTTER®** capability can do for you

POTTER INSTRUMENT COMPANY, the nation's leading supplier of high speed printers and perforated tape readers for military use, also produces the industry's broadest line of tape transports in use by military contractors.

Pioneering in HIGH-SPEED PRINTERS, Potter introduced the first transistorized military units. Today Potter supplies military printers with such advanced features as fully integrated logic packages, double-column hammers, multiple four-copy printout and immediate visibility of the last printed line. The 5½-inch wide series printers are available with quick-change, 64-character type fonts in up to 26-column formats. They have a MTR of 15 minutes and a MTBF exceeding 2,500 hours.

Potter's military PERFORATED TAPE READERS provide a MTBF of 3,000 hours and operate at dual speeds up to 500 characters per second with program-free operation from -25°F to +135°F. Their design simplicity allows replacement of all functional assemblies without adjustment providing a MTR of 15 minutes.

The company's newest military edp contributions include the world's most advanced single capstan MAGNETIC TAPE TRANSPORT, the SC-1150M. This rugged unit operates at speeds up to 150 ips and can withstand 50 g's shock. It has the simplest tape path made. Incremental read/write transports, field transports and a wide variety of conventional and special magnetic tape transports are available from Potter.

The newest concept in RANDOM ACCESS MEMORY is also a Potter product: the **RAM**, which for the first time provides a complete random access system using magnetic tape. Offering freedom at last from the easily damaged, delicate disc storage system, Potter's new, rugged 50.2 million-bit **RAM** is ideally suited for the tough demands of military service.

If your military system needs peripherals, why not contact Potter's Military Products Manager, and see what Potter capability can do for you.

Visit booths 537-539 at FJCC



POTTER® INSTRUMENT CO. INC.

151 Sunnyside Blvd. • Plainview, N.Y. 11803 • 516 OV 1-3200 • TWX (516) 433-9320 • Cable-PICO



the
BEST
all-purpose
**MICROVOLT-
AMMETER...**
KEITHLEY
model 153

- 5 μ V to 1000 V f. s. voltage range
- 5×10^{-12} to 0.1 ampere f. s. current range
- 40 db ac line rejection assures less than 0.5% error
- less than 0.06 μ V rms noise
- 2 microvolts drift per day
- only \$550, including input leads

☑ Use versatile zero-center and zero-left voltage ranges on the 153 Microvolt-Ammeter for measuring 0.2 μ V to 1000 volts. Switch selectable input resistances from 200 megohms down to 2 megohms. Read measurements directly with 1% accuracy on most ranges. Pinpoint resolution with less than 0.06 μ V rms noise. Measure long term with under 2 μ V per day zero drift and recorder output adjustable between 0 and ± 1 volt. And . . . forget about extraneous signals with the 153's 40 db ac rejection.

☑ As a direct-reading ammeter, the 153 provides 42 f.s. ranges measuring 5×10^{-12} to 10^{-1} ampere. 2% accuracy and less than 2 second rise time, 10%-90%, are featured for most ranges.

☑ Any way you use it, this photo-modulator type microvoltmeter fills the bill for low noise, high input resistance microvolt measurements. Try this laboratory giant . . . an in-plant demonstration is yours for the asking. Be sure to ask for four-page Model 153 technical engineering note, too.



**KEITHLEY
INSTRUMENTS**

12415 Euclid Ave. • Cleveland, Ohio 44106

electrometers / differential voltmeters / picoammeters / calibration devices

New Components

1 w at 50°C, derating to 0 at 175°C, over an operating range of -65°C to 175°C. Styles are available for continuous or clutch-stop wiper rotation. The unit meets applicable MIL specs.

The trimmer has the manufacturer's exclusive two-half-case construction for 100% inspection before and after final assembly. Techno-Components Corp., 7803 Lemon Ave., Van Nuys, Calif. [353]

Miniature connectors have keyed shells



Keyed shells permit users of miniature rack and panel connectors to mount many identical units on a single frame without danger of mismatching.

The Micro-Ribbon 57 series connectors are available with as many as 50 contacts in a mating face area approximately 2.4 x 0.61 in. Four different keying positions are possible on each connector in the line. Combinations of these basic keying positions further increase the number of like connectors that can be used on the same panel without danger of mismatching.

Three types are available: cable-to-chassis units with sturdy spring-type latches on the receptacle which are guided and held by cut-outs in the plug flanges; cable-to-cable units; and right-angle shell units.

The 57 series connectors have smooth, easy insertion and extraction. Each contact is self-wiping and self-cleaning, due to double-sided flexing of both mating and contact members. These features result in increased reliability and considerable saving in space and weight, particularly important in airborne electronics and computer applications.

Connector bodies are molded of

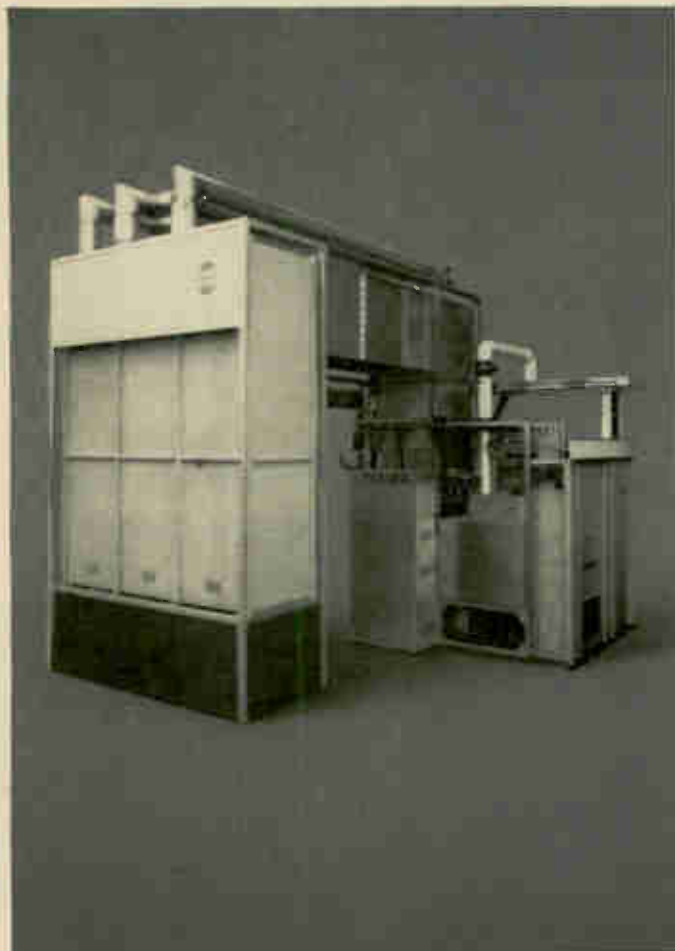

250 KW Transmitter Achieves Extremely High Tank Circuit Efficiency With Jennings Vacuum Capacitors

Two of the most significant features of Collins Radio Company's 821A 250 KW transmitter are the unusually high efficiency of the tank circuits in the final amplifier and the completely automatic tuning techniques. The output network employs large coaxial line sections which are automatically resonated by new internally forced-air cooled Jennings vacuum variable capacitors. It also utilizes the wide capacity range, high frequency response, and high voltage rating of Jennings capacitors to aid in automatic tuning anywhere in the frequency range of 3.95 to 26.5 megacycles.

This permits completely automatic tuning in a maximum of 20 secs and avoids the loss of valuable air time, usually 5 to 15 minutes, consumed by conventional transmitters.

In addition to the low loss dielectric and lowest inductance of any other capacitor Jennings new vacuum capacitors offer (1) highest maximum to minimum capacity change ratios (2) long life (3) high current capability (4) light weight (5) built-in corona rings on many models (6) shock resistant glazed ceramic envelope (7) wide variety to solve most desired combinations of capacitance, voltage, and current.

Whether it's 250 KW or 5 KW, Jennings vacuum capacitors will contribute more to superior transmitter performance than any other capacitor known. A brief examination of our new line of ceramic vacuum capacitors will suggest many new ways in which circuit design can be improved. We will be pleased to send complete details at your request.



JENNINGS TYPE
CVHP 650

Capacitance Range: 30-650 pf
Voltage Rating: 45 kv peak
Current Rating: 250 amps rms



JENNINGS TYPE
CFHP 1000

Capacity: 1000 pf
Voltage Rating: 45 kv peak
Current Rating: 215 amps rms

RELIABILITY MEANS VACUUM-
VACUUM MEANS

ITT Jennings

JENNINGS RADIO MFG. CORPORATION • Subsidiary
of International Telephone and Telegraph Corporation
970 McLAUGHLIN AVE., SAN JOSE, CALIF. 95108 • PHONE 292-4025

DIVIDE POWER

4 WAYS / 8 WAYS



Improve system performance and save significant space and weight with these new 4-way, 8-way hybrid, binary power dividers. A single 8-H unit does the work of SEVEN transmission line hybrids. A 4-H unit replaces THREE hybrids. No two ways about them . . . but 4-ways and 8-ways to split and add power with excellent isolation (30 db minimum from 2 to 400 Mc).

Beam forming in large, ground-based antenna arrays plus power splitting into balanced coherent signals and multiplexing are several uses. That's why clever systems designers are joining a unique 4-H Club. Direct your application for membership to attention of:

Earl Russell,
4-H Club Program Director,
(617) 899-3145.

*and Subtract bulk, Add reliability, Multiply efficiency.

ADAMS-RUSSELL CO., INC.

280 BEAR HILL RD., WALTHAM, MASS. 02154
(617) 899-3145



International Sales:
TECHNICAL RESOURCES, INC.
600 MAIN ST., WALTHAM, MASS.

SPECIFICATIONS		
(Model No. indicates characteristic impedance)		
4H-50	8H-50	2-32 Mc
4H-75	8H-75	2-32 Mc
4V-50	8V-50	20-200 Mc
4U-50	8U-50	200-400 Mc
Isolation	30 db (min.)	
Insertion Loss	0.5 db (4-way), 1.0 db (8-way)	
VSWR	1.3 (max.)	
Phase Bal.†	1.0° max.	
Amplitude Bal.†	0.2 db max.	
Weight	4-H Series — 4 oz., 8-H Series — 8 oz.	
Size	1½ and 2 cubic inches respectively	
†measured between isolated ports		

New Components

high-impact-strength diallyl phthalate with excellent dielectric features. Standard shells are cadmium-plated brass with clear chromate treatment. Contacts are rated 5 amp 700 v d-c at sea level; 200 v d-c at 70,000 ft. Contact material is gold-plated silver.

Amphenol Connector Division, 1830 S. 54th Ave., Chicago, Ill., 60650. [354]

Solid-state a-c relay is fast switching



This a-c relay provides the function of the electromechanical type yet offers solid-state reliability, noiseless operation, fast switching, extremely long life, and a low-power sensitive control circuit. It eliminates contact contamination and contact welding problems.

The solid-state relay has a control circuit and contact circuit similar to any standard relay. It can be used to switch resistive loads, inductive loads, and tungsten lamp loads. Present models available are single-pole normally-open. Contact ratings are 5 to 15 amps inductive or resistive at 120, 240 or 440 v at 60 cycles. Control circuit ratings are 24, 120 or 240 v a-c.

The heart of the relay features the Quadrac, a symmetrical a-c silicon semiconductor developed for this application. The electronics are packaged into an easy-to-mount enclosed metal housing. Quick-connect or lead-wire terminals are offered.

The compact, 5-amp relay package measures 2½ x 1¾ x 1¾ in. Price is under \$4 in quantity. Electronic Control Corp., 1010 Pamela Drive, Euless, Texas. [355]

i/c's and modules tested...

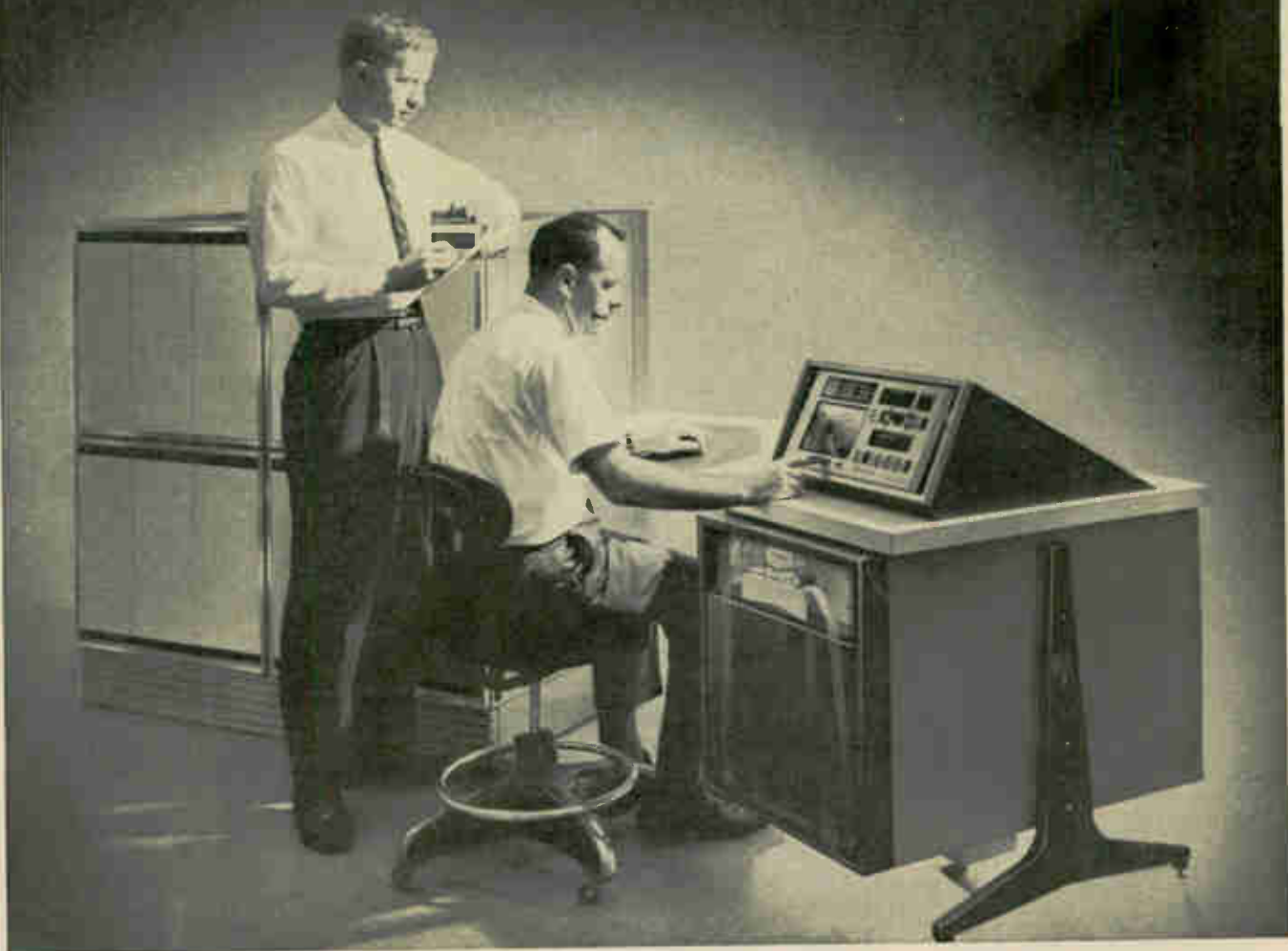

DYNAMICALLY!

Now you can perform important *dynamic* tests in addition to ordinary static (dc) tests with TI's Model 553 *Dynamic Test System*. Measure propagation delay and noise feed-through; *dynamically* determine "fan-in"/"fan-out" ratios, and noise immunity; assess the effects of transients. Now, measure switching times in terms of percentage or absolute values. You save money by performing more tests at high speed with handling reduced by single-socket testing.

The 553 *Dynamic Test System* is designed for integrated circuits, transistors, diodes, thin films, logic cards, other circuit elements with 10, 20, 50, or more active leads. Testing can be done from dc to 50 mc, thereby simu-

lating actual operating speeds. Time or voltage is measured anywhere *on* or *between* pulses (widths from 10 ns to 1 ms) with a resolution of .000001%. Jitter is less than 50 ps; accuracies better than 2%.

Modular design and variable word-length program logic provide for infinite system expansion. Simplified programming language allows operators to learn to program in 45 minutes. Data as well as double-ended hi-lo limits can be produced at test rates faster than go/no-go systems with a wide variety of output recording techniques available.

For detailed information about the 553, contact your TI Field Office or the Test Equipment department, Houston.

INDUSTRIAL
PRODUCTS
GROUP



TEXAS INSTRUMENTS

INCORPORATED

P. O. BOX 66027 HOUSTON, TEXAS 77006
118 RUE du RHONE GENEVA, SWITZERLAND

**ONLY FROM
TEXAS INSTRUMENTS**



**NEW EPITAXIAL
GALLIUM PHOSPHIDE
AND GALLIUM
ARSENIDE PHOSPHIDE**

New purities . . . new forms . . . new composition control mean broader capabilities for light-emitting diodes, and optoelectronics generally. TI's exclusive epitaxial processes are now supplying for production, as well as R&D requirements, high purity single crystal gallium phosphide (GaP), gallium arsenide-phosphide ($\text{GaAs}_x\text{P}_{(1-x)}$), and gallium arsenide (GaAs).

Individual epitaxial layers of each material are produced on gallium arsenide substrates in thicknesses from two microns to 0.025 inches. Multiple layers are produced as combinations of GaAs, $\text{GaAs}_x\text{P}_{(1-x)}$ and GaP, or as separately doped deposits of any desired composition.

Precise material composition is maintained without variation both across the deposits and throughout thick deposits.

Gallium arsenide substrates are P-type, N-type, or semi-insulating, as required.

**FOR VISIBLE GREEN
LIGHT SOURCES**

Gallium phosphide epitaxial slices with (1-1-1) or (1-0-0) orientations. N-type and P-type dopings available. Thick deposits with or without substrates removed.

**FOR INFRARED, VISIBLE
RED, OR ORANGE
LIGHT SOURCES**

Gallium arsenide-phosphide slices: Epitaxial material of any composition intermediate between GaAs and GaP. N-type and P-type dopings available. Orientation (1-1-1) or (1-0-0).

**FOR INFRARED
LIGHT SOURCES**

Gallium arsenide epitaxial slices have (1-1-1) or (1-0-0) orientations. N-type and P-type dopings available. Thick deposits with or without substrates removed.



For complete data, write Manager, New Product Development, MCRD

**TEXAS INSTRUMENTS
INCORPORATED**

MATERIALS & CONTROLS DIVISION
P. O. Box 5303
Dallas, Texas

New Semiconductors

IC simulates four-layer diode

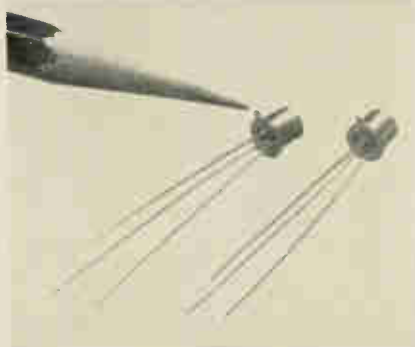

Inexpensive monolithic integrated circuits that do the job usually done by four-layer diodes have been developed by the General Electric Co. The devices have lower breakover voltages than most diodes, and are temperature-stabilized.

Most conventional four-layer diodes—p-n-p-n devices—do not conduct until the voltage across terminals is at least 20 volts. Furthermore, this breakover voltage, though fairly stable in the center of the operating temperature range, varies widely at extreme temperatures. The new IC's not only conduct at 8 volts, but the temperature coefficient of this breakover voltage is only 0.01% per degree centigrade over the range of -65° to 100° . That means the maximum variation in breakover voltage is less than 0.2 volt over the range.

The low breakover voltage of the new IC's permits operation in low-voltage transistor circuits. And their low temperature coefficient allows stable solid state switching for maintaining the frequency stability of relaxation types of circuits, such as monostable multivibrators, and for accurately controlling the power supplied by phase-controlled thyristor circuits, such as light dimmers. The IC's may be used in many other switching applications that previously used four-layer diodes or in circuits that require the latching feature of these devices.

The new IC's come in two models: one allows only unidirectional

current flow and is designated as a silicon unilateral switch (SUS); the other, called a silicon bilateral switch (SBS), can break over in either direction, providing bidirectional current flow. When either device is conducting, the voltage drop across its terminals is less than 1.4 volts at 200 ma.

The circuit of the basic unidirectional device, the SUS, is shown below; it consists of two complementary transistors, a resistor, and an 8-volt zener diode, all fabricated on a single chip. Except for the zener diode, the circuit is the simple two-transistor analog of a conventional p-n-p-n device such as the thyristor. The zener diode gives it the characteristics of a

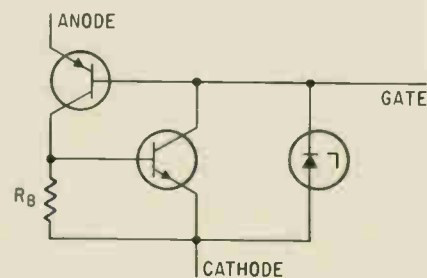

The silicon unilateral switch, developed by the General Electric Co., has a lower breakover voltage than most diodes.

four-layer diode. The anode and cathode terminals correspond to the terminals of a diode. A switching current of less than 500 microamperes is required from the external circuit if the gate is not used. The holding current—the minimum current at which the circuit will remain in conduction—is about 250 microamperes. (Holding currents of four-layer diodes are generally in excess of 1 milliampere.) If the gate is biased to supply some current to the zener, the switching current may be reduced.

The bilateral SBS switch is produced by combining two similar SUS circuits on the same chip. The SBS will conduct when the anode-to-cathode voltage is ± 8

standard rheostat variations

pre-engineered for better delivery

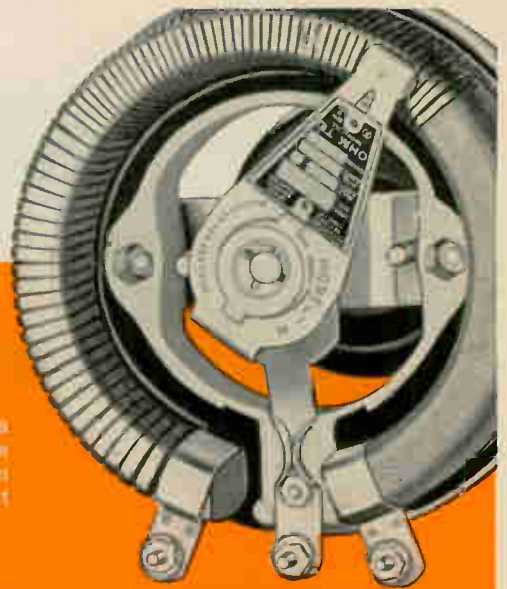

Tapered Windings—Wound in sections of diminishing wire sizes. Permits use of a physically smaller rheostat for the same load than a rheostat wound with just one wire size; allows more nearly linear control. Widely used where change from maximum to minimum currents is large, or where a specific variation of current with resistance is required.



Locking Bushings—Prevents tampering or accidental shifting of the rheostat setting. Choose from several types of clamping arrangements for wrench or finger locking.



Shaft Variations—A big selection of round, flattened, and screwdriver slotted shafts in different lengths and materials. Also for extension from both sides of rheostat.



Gangs—Supplied assembled in gangs (or "landems") of two or more rheostats of the same or different sizes. Coupling kits are also available for do-it-yourself ganging.



Enclosures—Take your choice of general purpose ventilated or dust-proof types; lightweight sealed; explosion-proof; weather-resistant; drip-proof; gastight; gas or fluid-filled.



Off-Positions and Auxiliary Switches—Three basic types of off-positions; also toggle and sensitive switches to operate in conjunction with the rheostat circuit or to control external circuits.



Motor Driven—Factory assembled with single or ganged rheostats. Motor modules also available separately for fast assembly by the customer.

■ Where you have a special application which requires rheostats with nonstandard or auxiliary features, an Ohmite pre-engineered variation may be a quick answer to your problem. Besides those pictured above, Ohmite supplies such features as: less-than-standard winding angles; taps; 360° rotation; concentric shafts; special stops; low or high torque rotation; flexible shunts; screw termi-

nals; "sequence-coupled" gangs; and ganged combinations with other controls. For additional versatility, add to this the world's most complete selection of industrial and military rheostats.

■ *Stock* rheostats are listed in Catalog 30. Your local Ohmite representative will help on *special* requirements. His name and address will be sent with your literature.

RHEOSTATS • POWER RESISTORS • PRECISION RESISTORS • VARIABLE TRANSFORMERS • RELAYS
TAP SWITCHES • TANTALUM CAPACITORS • SEMICONDUCTOR DIODES • R.F. CHOKES

OHMITE

MANUFACTURING COMPANY
3610 Howard Street • Skokie, Illinois 60076
Phone: (312) ORchard 5-2600



BLOCKS FOR BUSS FUSES

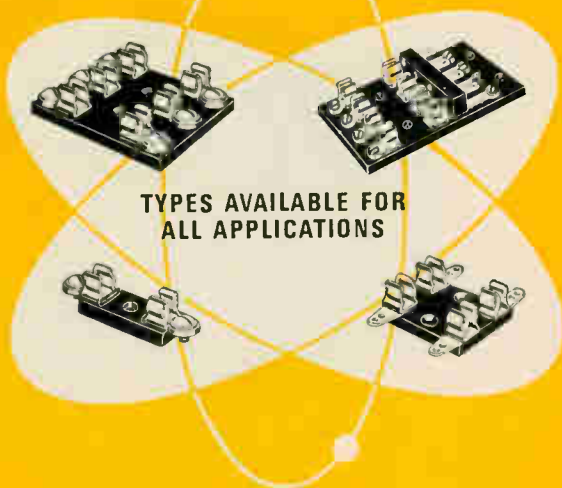

TYPES AVAILABLE FOR ALL APPLICATIONS

Single pole, multiple pole, small base, full base, molded base, laminated base, porcelain base for fuses from $\frac{1}{4}$ x $\frac{5}{16}$ inches up. Also signal type fuse blocks and special blocks of all types.

Tell us what you need or...

Insist On
BUSS

QUALITY
Fuse Blocks

BUSSMANN MFG. DIVISION, McGraw-Edison Co., St. Louis, Mo. 63107

Write for
BUSS
Bulletin SFB

TRON SUB-MINIATURE PIGTAIL FUSES



VISUAL INDICATING

BODY SIZE ONLY
.145 x .300 INCHES

For use on miniaturized devices, or on gigantic space tight multi-circuit electronic devices.

Glass tube construction permits visual inspection of element.

Smallest fuses available with wide ampere range. Twenty-three ampere sizes from 1/100 thru 15 amps.

Hermetically sealed for potting without danger of sealing material affecting operation. Extremely high resistance to shock or vibration. Operate without exterior venting.

Insist On
BUSS

QUALITY
Fuses

BUSSMANN MFG. DIVISION, McGraw-Edison Co., St. Louis, Mo. 63107

Write for
BUSS
Bulletin SFB

BUSS: The Complete Line of Fuses and ...

Circle 195 on reader service card

Circle 195 on reader service card

To order reprints from Electronics

Fill in, cut coupon below, insert in envelope and mail to:

Electronics reprint dept.

330 West 42nd Street, New York, N. Y. 10036

Reprint order form

For listing of reprints available see the reader service card

To help expedite mailing of your reprints please send cash, check, or money order with your order.

U.S. Electronics Markets 1966

Send me _____ copies of Key no. R-85 at 50¢ each.

For reprints of previous special reports fill in below:

Send me _____ reprints of Key no. (s) _____ @ _____ ¢ each

For prices see the reader service card.

Name

Number and Street

City, Zone No., State

New Semiconductors

volts. In all other respects, including the low voltage drop when conducting, its operation and characteristics are similar to those of the SUS.

Development models of the SUS and SBS are available in hermetically sealed TO-18 packages.

Specifications

Type number	
Undirectional (SUS)	D13D1
Bidirectional (SBS)	D13E1
Breakover voltages	
SUS	+8 volts
SBS	±8 volts
Temperature coefficient of breakover voltage	0.01% per degree centigrade
Operating temperature	-65°C to 100°C
dv/dt rating	>50 volts/microsecond
Switching speed	0.5 μsec.
Turn-off time	2 μsec.
Recovery time	25 μsec.
Switching current	<500 μa
Holding current	250 μa

General Electric Co., Schenectady, N.Y. [361]

Planar passivated phototransistor

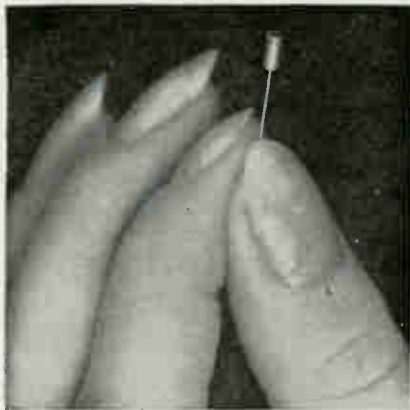

A miniature photosensor has been developed for use in tape and card readers, optically coupled circuits, encoder-decoders, character-recognition devices and process-control applications. The silicon device features planar passivation for long-term stability.

The FPM-100 phototransistor has a special response extending from 0.4 to 1.1 microns and features a maximum power dissipation of 75 mw at 25°C.

Collector current rises from a maximum dark value of 0.1 μa to typical values in the range 1.5 to 2.5 ma upon illumination. Typical rise time is 3 microseconds.

The FPM-100 is packaged in a hermetically sealed cylinder with a diameter of 0.08 in. and a length of 0.18 in., and "reads" at the top end of the cylinder through a flat polished window.

By using a flat window, company engineers have realized a divergence angle of 70°. The avoidance of any optical magnification eliminates the possibility of a hot spot developing to introduce random errors and, since the flat window is flush with the cylinder body, an array of units may be placed in physical contact with a moving tape without abrading the tape. Cross-

Fuseholders of Unquestioned High Quality

BUSS QUALITY

small
dimension
fuses



For protection of all types of electronic and electric devices

The complete line of BUSS and "TRON Family" fuses includes quick-acting, slow-blowing, signal or visual indicating fuses in sizes from 1/500 amperes up.

All standard items are easily obtained through your BUSS distributor, but if you don't find what you want get in touch with us.

Insist On
BUSS

QUALITY
Fuses

Write for
BUSS
Bulletin SFB

BUSSMANN MFG. DIVISION, McGraw-Edison Co., St. Louis, Mo. 63107

VISUAL INDICATING FUSES

FUSE ONLY
.270 x .250
INCHES



GMW FUSE
and HWA
FUSEHOLDER

BUSS
SUB-MINIATURE
FUSEHOLDER COMBINATION

For space-tight applications. Fuse has window for inspection of element. Fuse may be used with or without holder.

Fuse held tight in holder by beryllium copper contacts assuring low resistance.

Holder can be used with or without knob. Knob makes holder water-proof from front of panel.

Military type fuse FM01 meets all requirements of MIL-F-23419. Military type holder FHN42W meets all military requirements of MIL-F-19207A.

Insist On
BUSS

QUALITY
Fuses and Fuseholders

Write for
BUSS
Bulletin SFB

BUSSMANN MFG. DIVISION, McGraw-Edison Co., St. Louis, Mo. 63107

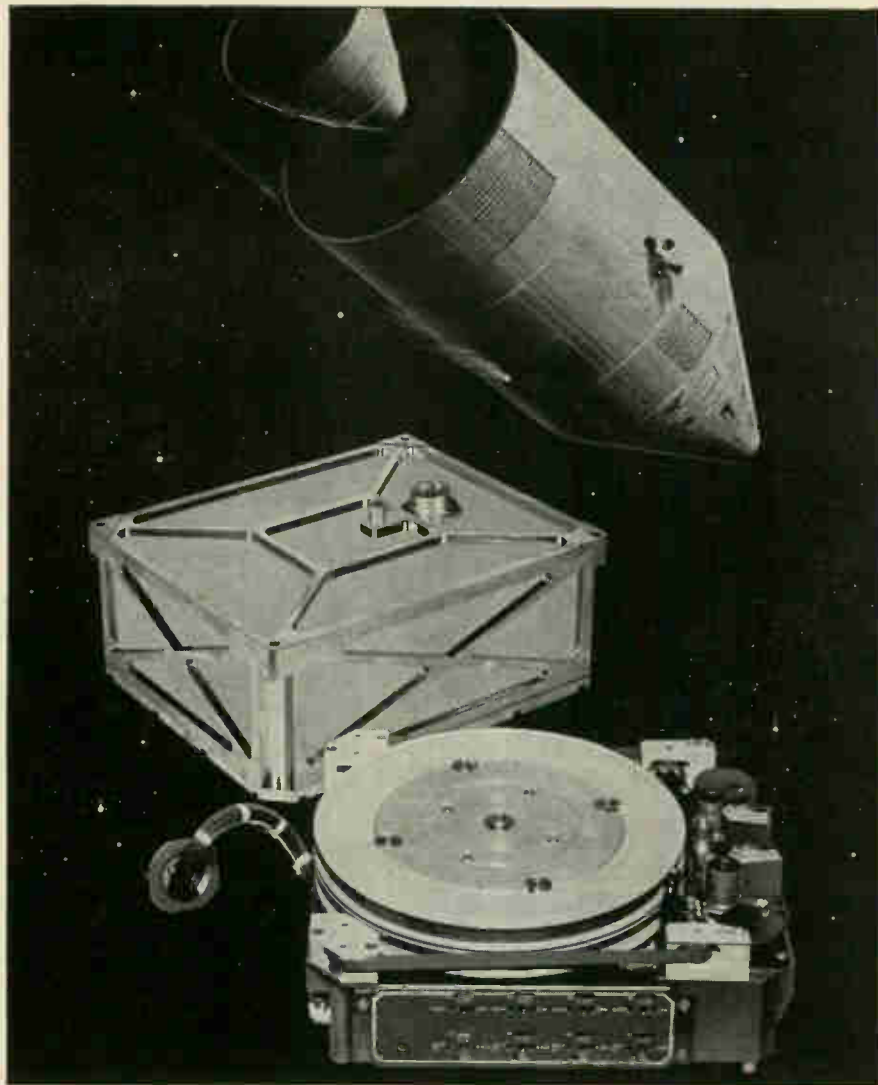

*In outer space...
maximum reliability
at every turn*

PARSONS Type SIR SPACEBORNE RECORDERS

Typical is the SIR-940 recorder-reproducer having a 16:1 reproduce/record ratio and equipped with four tracks of wideband FM electronics, exhibiting an operating MTBF in excess of 8,000 hours. The unit is internally pressurized to ensure operation under vacuum conditions.

To achieve reliability and long life, hysteresis-synchronous capstan motors are used and total power consumption has been maintained *below 5 watts recording and below 10 watts reproducing*. SIR-940 measures 7 $\frac{3}{8}$ " x 9" x 3 $\frac{1}{2}$ " and weighs 7 lbs. 8 oz., complete with electronics.

Other SIR-940 Recorders are available as PCM or analog (direct) recorder-reproducers in a variety of record and reproduce speeds. Write for complete details.



**THE RALPH M. PARSONS
ELECTRONICS COMPANY**

151 S. DE LACEY AVE., PASADENA, CALIF.
A subsidiary of The Ralph M. Parsons Company

LOS ANGELES
NEW YORK
WASHINGTON

OFFICES IN OTHER
PRINCIPAL CITIES
THROUGHOUT
THE WORLD

New Semiconductors

talk is eliminated by this feature.

Price of the FPM-100 is \$8.50 for 1 to 99; \$7.25 for 100 to 999; \$5.50 for 1,000 to 4,999.

Fairchild Semiconductor, a division of Fairchild Camera and Instrument Corp., 313 Fairchild Dr., Mountain View, Calif. [362]

High transconductance tetrode FET

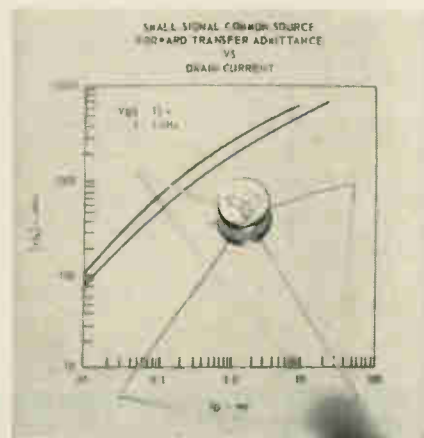

A high-frequency, high-transconductance N-channel tetrode FET has been added to the company's line of junction field-effect transistors. The double-gate TO-12 device, designated TIXS35, is said to offer a two-to-one improvement in transconductance and frequency capability over currently available tetrode FET's. It makes possible the use of a FET in an autodyne mixer circuit, where it can function as both mixer and local oscillator, eliminating one transistor and associated oscillator circuitry. Other principal applications include high-frequency mixers, amplifiers, and choppers. The device is also well suited for use in multiplex and sample-hold circuits.

Transconductance of the front gate with the substrate gate connected to source is typically 8,000 μ mhos. With the front and substrate gates connected together, Y_{fs} is 10,000 μ mhos minimum. This high transconductance allows designers to achieve higher gain than ever before in field-effect circuitry, the manufacturer says.

Texas Instruments Inc., 13500 N. Central Expressway, Dallas, Tex. [363]

REAL MEASURE OF PERFORMANCE:

Exclusive with the 175A Oscilloscope:

20 MHz bandwidth at 1 mv/cm sensitivity, 50 MHz at 10 mv/cm, dual-channel!

4-channel 40 MHz bandwidth plug-in!

Plug-in recorder, pushbutton trace recordings with 30 MHz bandwidth!

Plug-in trace scanner for high resolution recording on external x-y recorder!

Time mark generator plug-in for 0.5% accuracy time measurements!

Mixed sweep for error-free time interval measurements!

Measurement performance is what you get with the 175A 50 MHz Scope, performance not available elsewhere. The performance spotlighted above is yours with the 175A...high sensitivity and bandwidth for dual- or 4-channel broadband measurements, inexpensive recordings of signals (improves signal to noise ratio of noisy signals, plus it gives clear recordings of dim low-duty-cycle signals), the unique benefits of a delay generator plug-in...all exclusive with the 175A. And 14 plug-ins to choose from, for maximum versatility to match your specific application.

And every combination of scope and plug-ins gives you Hewlett-Packard design and manufacturing quality. Backed up, too, by your Hewlett-Packard field engineer, who can help solve your measurement problem with a scope or with other tools from the broad line of high-quality instrumentation he offers.

Give him a call. Take a look at the 175A Scope. A comparison with other scopes will show you the real measure of performance you get exclusively from Hewlett-Packard. Full specifications on the 175A are available by writing Hewlett-Packard, Palo Alto, California 94304, Tel. (415) 326-7000; Europe: 54 Route des Acacias, Geneva.

- 175A Oscilloscope, \$1325
- 1755A 50 MHz Dual-Trace Vertical Amplifier, \$575
- 1754A Four-channel Vertical Amplifier, \$595
- 1784A Recorder Plug-in, \$775
- 1782A Trace Scanner, \$425
- 1783A Time Mark Generator, \$130
- 1781B Delay Generator, \$325

Prices f.o.b. factory.

964

HEWLETT  **PACKARD**
An extra measure of quality

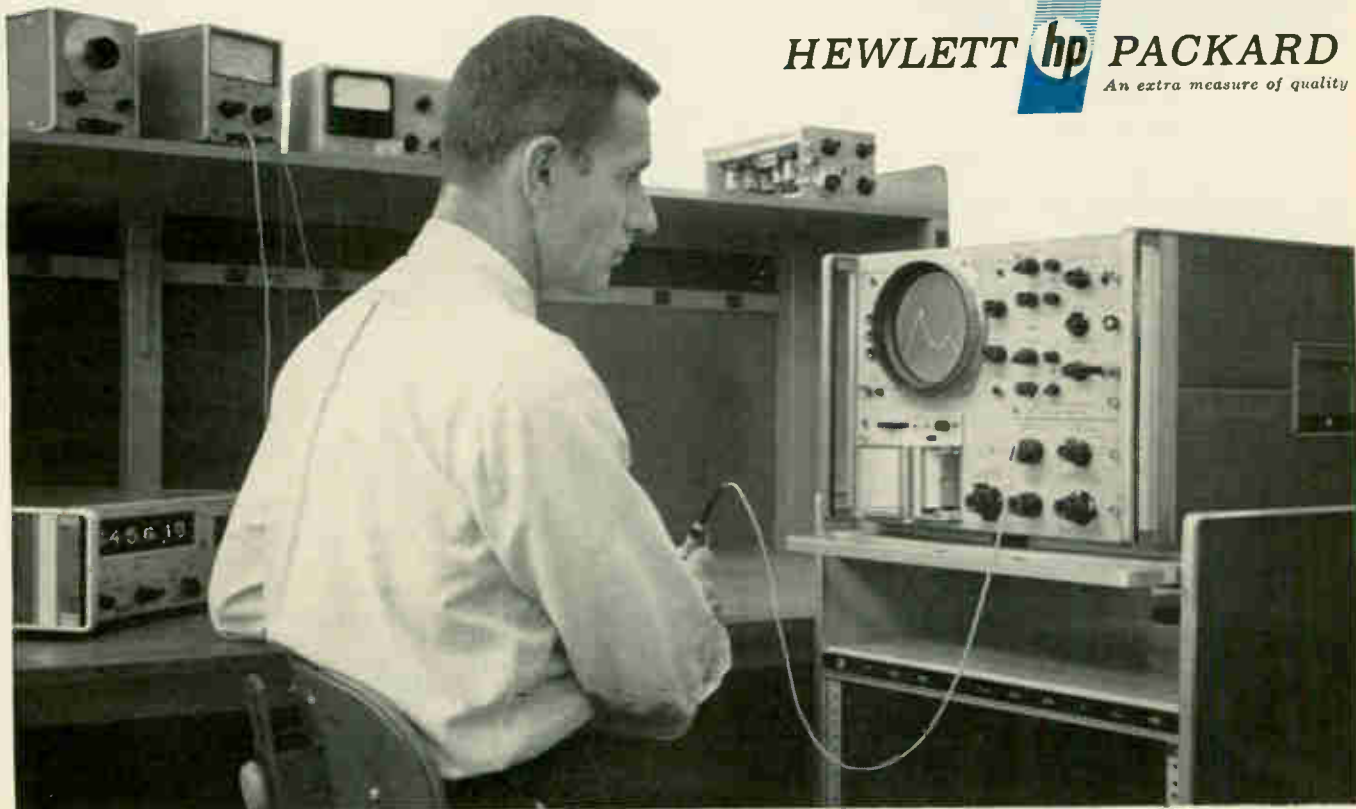

The 175A Scope, 1755A Vertical Amplifier Plug-in and 1781B Sweep Delay Generator give you the exclusive 20 and 50 MHz dual-channel performance listed above—for only \$2225!

Want to . . .

TURN IT ON?

TURN IT OFF?

RECORD IT?

SWITCH IT?

CYCLE IT?

REVERSE IT?

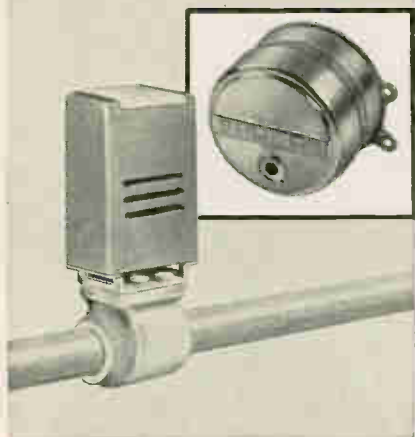

turn the job over to SYNCHRON® MOTORS!

The list above is only the start of the jobs done by Synchron Motors. In every area from time-recording instruments to motion-display drives, Synchron Motors serve you automatically. Whether you're starting a new design now, planning a modification, or just looking for a better component, call on Hansen Manufacturing Co. — for SYNCHRON Motors and for help in your application. Do it before you're in a hurry for the information — write now for specifications on the Synchron Motors that are likely to interest you.



HANSEN REPRESENTATIVES: CAREY & ASSOCIATES, Houston, Tex., R. S. HOPKINS CO., Sherman Oaks, Calif., MELCHIOR & MACPHERSON, INC., San Carlos, Calif., THE FROMM CO., Chicago, Ill., H. C. JOHNSON AGENCY, INC., Rochester, N. Y., WINSLOW ELECTRIC CO., Essex, Conn., Narberth, Pa., and New York, N. Y. EXPORT DEPARTMENT, 64-14 Woodside Ave., Woodside, N. Y.

New Instruments

High-impedance matching amplifiers

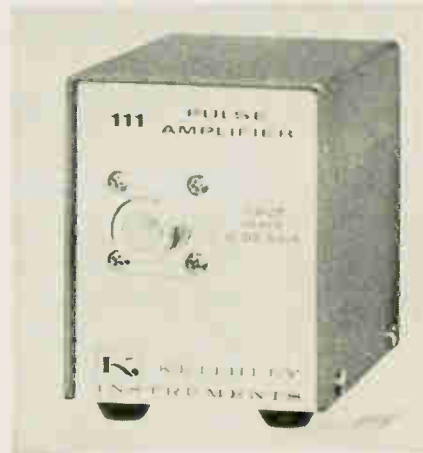

A pair of unity-gain amplifiers, introduced by Keithley Instruments, Inc., provides impedance-matching functions in a variety of instrumentation systems. Designed with an input impedance of 10 megohms and an output impedance of 50 ohms, the Models 110 and 111 are particularly useful in amplifying signals from high-impedance sources such as multiplier phototubes. Properly terminated at the input, they can drive up to 100 feet of coaxial cable with no signal loss. This means the amplifiers may be located at the signal source, while the rest of the instrumentation system may be installed remotely.

Both amplifiers can provide input protection for sampling oscilloscopes because they can withstand overloads of 300 volts peak to peak and 600 volts d-c. Other applications include mass spectrometers, high-speed counters, thermopiles and infrared detectors.

Model 110 is primarily designed to provide constant gain for sinusoidal signals over a wide bandwidth. The amplifier has a frequency response that is flat to within ± 0.5 decibel from 1 kilocycle to 150 Mc. The model 111 is used when faithful waveform reproduction is the main consideration. This model has a rise time of 3 nanoseconds with less than 3% overshoot. Both amplifiers have 10 megohm input impedances shunted by 12 picofarads.

A field effect transistor in the first stage of both amplifiers provides the high input impedance. Two cascaded transistor stages make up the voltage losses in the first stage. Both amplifiers are of conventional RC-coupled cascaded design and have negative feedback. No inductive peaking is used. Wide bandwidth is achieved with selected epitaxial mesa transistors that have a one-gigacycle cutoff frequency.

Point-to-point wiring throughout the amplifiers keeps lead inductance at a minimum. Silver plating on the chassis minimizes ground loops and reduces resistance caused by high-frequency skin effects.

These amplifiers can be placed

Specifications

	Model 110	Model 111
Frequency response (-3 db)	500 cps and 180 Mc	
(+0.5 db) Pulse width for 10% droop	1 kc to 150 Mc	40 micro-seconds
Voltage gain	1 (0 db) $\pm 2\%$ at 10 kc	1 (0 db) $\pm 2\%$ at 10 kc
Maximum output (into 50 ohm load)	700 mv peak to peak	700 mv peak to peak
Maximum RMS noise (50-ohm load)	75 μ v (12 db)	75 μ v (12 db)
Overload recovery time	Less than 50 ns	Less than 50 ns
Line stability	Less than 0.1% for a 10% line voltage change	
Power supply required	+16 v d-c and -12 v d-c or 28 v d-c floating; $\pm 5\%$; 40 ma	

For air/surface/sub-surface environments

Ferranti ADA System:

compatible with any naval fighting force in the world

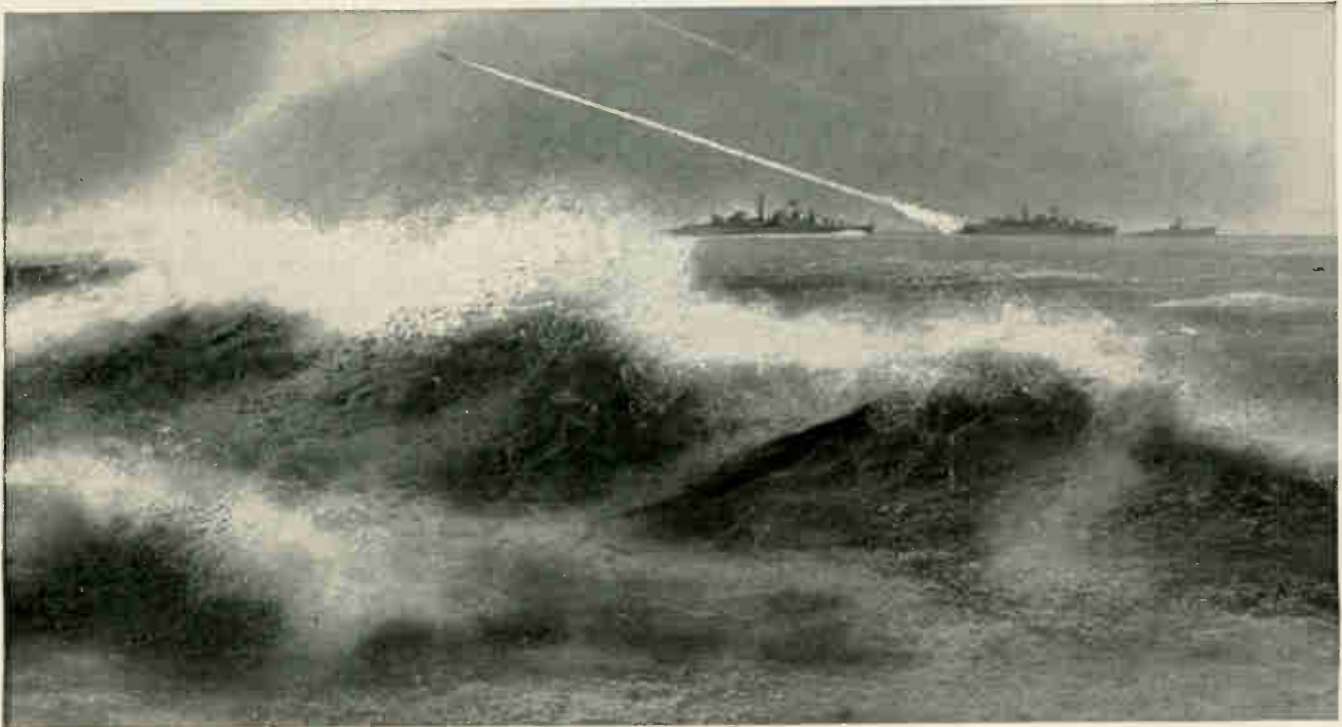

Action Data Automation is based on a series of ship-borne computer systems for command and control of sensor and weapon equipments. The installing of an ADA System greatly enhances the overall effectiveness of weapons already fitted, and—by virtue of its inherent flexibility—enables optimum use to be made of new weapons in any foreseeable situation in the future.

ADA provides Central Command with a comprehensive tactical picture of air, surface and sub-surface situations from all available sources. It recommends the action to be taken against an enemy and supplies immediate solutions to urgent tactical problems. To achieve successful combat it predicts and transmits vital 'kill point' and control data to fighter aircraft, missile complexes and helicopter-borne weapons systems.

ADA computer systems perform all these functions in micro-seconds. Subject to human decision, real-time action can proceed instantly.

The computer systems initially developed by Ferranti DSD in collaboration with the British Admiralty Surface Weapons Establishment for air

defence duties aboard HMS *Eagle*, can be used to maximise the effectiveness of guided missile destroyers, anti-submarine frigates, anti-aircraft frigates and submarines. Utilizing advanced micro-miniaturization techniques the ADA System can be installed in helicopters and fast patrol boats. Ferranti possess the experience to understand and evaluate the most complex defence needs, and—equally important—the large-scale resources to produce computer-based systems to meet specific Service requirements. Having worked closely and successfully with members of NATO, Ferranti are uniquely qualified to undertake national defence projects of vital importance.

FERRANTI

**DIGITAL SYSTEMS FOR
MILITARY APPLICATIONS**

Ferranti Limited, Digital Systems Department, Moston, Manchester 10, England.
DSD Research and Development Laboratories, Bracknell, Berkshire, England.

DST

Versatile!



HYGRADE

Polytube 463 Coated Fiberglass SLEEVING

You get most for your money in Markel's Polytube 463 Sleeving. It is constructed of closely woven fiberglass, thoroughly impregnated and uniformly coated with modified acrylics. It meets all applicable MIL and NEMA standards.

Heat Stability

Polytube 463 is rated for continuous use at Class F temperatures. Even after 1000 hours at 155°C., it will not crack when bent 180° around a mandrel.

Flexibility

Polytube 463 is extremely tough and flexible. It can be flattened, knotted, or twisted into any shape without loss of dielectric (7000 v., Grade A).

Compatibility

Polytube 463 is completely compatible with most wire enamels and encapsulants, and is resistant to transformer oils.

Non-Wicking

The thorough impregnation and coating of Polytube 463 makes it ideal for applications where non-wicking is essential, as in motors and transformers.

Ask for Samples, Data, Prices

FRANK **MARKEL** & SONS

SINCE 1922

NORRISTOWN, PA.



SOURCE FOR EXCELLENCE

Insulating Tubings and Sleeveings
High Temperature Wire and Cable

New Instruments

anywhere in a measuring system, thanks to a variety of available accessories, such as a power supply for up to three amplifiers and special mounting plates.

Keithley Instruments, Inc., 12415 Euclid Ave., Cleveland, Ohio [371]

Charge-discharge battery analyzer



A new circuitry development, which supplies a completely static constant current battery discharge, is utilized in this battery charge-discharge capacity analyzer. The battery analyzer, discharger, and charger, designated ANDAC, provides complete and automatic electrical check-out of such exotic batteries as silver-zinc, silver-cadmium and nickel-cadmium, as well as conventional lead-acid batteries and individual cells of any battery type.

Manual operation is also featured, allowing selection of closely-held constant current charge or constant current discharge at all battery or cell voltages, or constant potential charge with current-limit crossover. An important feature of the unit is ampere-hour read-out in both charge and discharge modes, thus providing indication of battery capacity as well as acceptability.

The advantages of this system are most apparent where accurate battery evaluation is desired, such as in aircraft and missile systems. In the laboratory as well as in field use, the accurate ampere-hour, timing, and cut-off indications and controllability allow a versatile means of determining the best charge method for a battery. On

Mars...a nice place to visit, but...

it takes teamwork to get there.

Following past space successes such as *Mariner's* photographic mission to Mars and the *Ranger Moon* shot, JPL is planning even more ambitious missions; challenges like soft landings on the Moon and Mars.

Thus, having expanded its horizons, JPL needs qualified engineers to keep up with the increasing demand for talent.

Listed below you'll see many of the functions at JPL in which talented engineers are needed. For more information on these particular phases of JPL's operation, check the box opposite those which interest you.

Fill out the coupon at the bottom, send it to us along with your resume, and we'll send you literature about the areas in which you have expressed interest.

- Deep Space Network
- Lunar Program
- Research and Advanced Development
- Space Sciences
- Guidance and Control
- Engineering Mechanics
- Propulsion
- Planetary Program
- Project Engineering
- Systems
- Telecommunications
- Environmental Simulator
- Administrative Support

Dear Sir:

I am interested in the above areas that I have checked. Please send me literature on these operations at JPL. I am also enclosing my resume.

Name _____

Address _____

City _____ State _____ Zip _____

Send to:



**JET PROPULSION
LABORATORY**

4814 Oak Grove Dr., Pasadena, Calif.

Attention: Personnel Dept. 1

"An equal opportunity employer."



half the picture

*When you look at electronic components
are you seeing only half the picture?*

We're the last people to argue with component purchasers who put performance, price and delivery first — meeting these three basic requirements is what keeps us in business. But most engineers are also on the lookout for something more, and many of them find it at Mullard.

Take research and development for instance. Out of Mullard R&D have come outstanding devices such as the travelling wave tubes for the New York—San Francisco and Montreal—Vancouver microwave links. Production resources? Mullard

plants are among the most efficient anywhere, with a reputation for the production of tight-tolerance devices to proved standards of reliability. As for circuit know-how, Mullard has the best equipped applications laboratories in Britain. And when it comes to technical services, you will find that Mullard provides the kind of comprehensive performance specs, survey documents and application reports that are just that much more useful.

If you want to get the *whole* picture, why not ask us to help you with some of your component problems?

DIODES · TRANSISTORS · PHOTO-DEVICES AND RADIATION DETECTORS ·
RECTIFIER DIODES AND STACKS · THYRISTORS AND STACKS · INTEGRATED
CIRCUITS · CATHODE RAY TUBES · RECEIVING TUBES · ELECTRON OPTICAL
DEVICES · PHOTSENSITIVE DEVICES · COLD CATHODE DEVICES · POWER
DEVICES · TRANSMITTING TUBES · MICROWAVE DEVICES · CAPACITORS ·
FERRITE MATERIALS AND ASSEMBLIES · COMPUTER COMPONENTS AND
ASSEMBLIES · MAGNETIC MATERIALS · SPECIAL PURPOSE MAGNETS · VACUUM
DEVICES · WOUND COMPONENTS.

Mullard

where the product is only part of the deal

MULLARD LIMITED · TORRINGTON PLACE · LONDON WC1 · ENGLAND

TRYLON ROTATABLE LOG PERIODIC ANTENNA

Single-layer, horizontally polarized,
for 6.5 to 32 mc. 65° azimuth beamwidth.
6 db gain/std. dipole. Power to 50 kw PEP

**"One cannot continually disappoint a Continent."
We have designed, constructed, and installed
antenna and tower systems in North America,
South America, Europe, Asia, Africa, Antarctica.
We wish someone from Australia would call us.**



Circle 255 on reader service card

JUGGLING YOUR SUPPLIERS ...WHEN ONE CAN DO THE JOB?



Then let's talk availability!! If you have been poring through directories and catalogs for your semi-conductor sources, forget it! Western's nationwide distributors have 6,000... the greatest selection in the industry... more than any other three manufacturers combined. And they are available to you at the lowest prices anywhere. Just add up the savings on manhours lost searching... the answer always comes up "Western!"

Lowest Cost... Highest Quality... Immediate Availability

Your Western Distributor ...

The One Source for All Your Customers' Semi-Conductor Needs!!

WESTERN TRANSISTOR CORPORATION
DEPT. D-4 • 11581 FEDERAL DR. • EL MONTE, CALIF. 91731 • PHONE: 442-5507



New Instruments

battery production lines, a quick controlled and instrumented discharge can be invaluable in check-out procedures.

Input for the unit is 120 v \pm 10%, 1 phase 60 cycles; output, 1-30 amps, 0-32 v. Current or voltage regulation is \pm 1%. Prices for basic unit modules are from \$500 up, depending on ratings and accessories for a particular application. Availability is 6 to 8 weeks after receipt of order.

Macarr, Inc., 4360 Bullard Ave., New York, N.Y., 10466. [372]

Continuous-indicating vacuum gauge



The Thermivac vacuum gauge uses matched thermistors to measure vacuum in the 2,500-micron to 1-micron range with accuracy to 1% of full-scale deflection. A built-in jack for recording the 1,000-mv signal is provided.

The Thermivac eliminates errors found in Pirani gauges. It does not oxidize or corrode; it does not change in calibration; it is not affected by rapid changes from vacuum to ambient or vice-versa; and the probe is virtually unbreakable.

The meter and all components are mounted on the back of the removable front panel for easy installation. The Thermivac is housed in a Bakelite case 7 x 5 x 2 in., with carrying handle. The sensor cable is 10 ft long and the 117 v a-c line cord is 6 ft long. The en-

WEBBER Environmental Chambers

STANDARD AND SPECIAL UNITS • SIX EXCLUSIVE PATENTS

ALL UNITS HAVE
MECHANICAL
REFRIGERATION

For controlled
atmospheric conditions

- TEMPERATURE
- HUMIDITY
- ALTITUDE

Interior: 30' x 10' x 10'.
Range: -100° F to
+250° F with humidity

Altitude chambers
in any size and
combination of
temperatures

Shock test
chamber.
Programmed from
-125° F to +300° F

Chambers
for vibration
devices with
ranges from
-125° F to
+500° F

Temperature ranges
as low as -250° F

Write for new
brochure No. 6600

Forty-four pages of
helpful data on Webber
environmental chambers

phone
317-632-1378

Webber MANUFACTURING CO. INC.

P. O. BOX 217 • Indianapolis, Indiana 46206

Circle 256 on reader service card

NO. 123 ISOMETRIC TEMPLATE

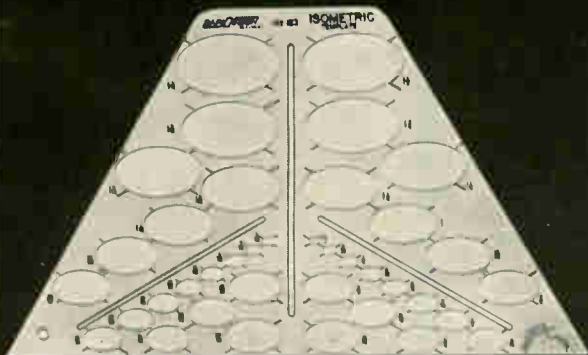

ALL THREE AXES ARE AVAILABLE
WITHOUT TURNING THE TEMPLATE

.040 clear mathematical quality double cured
plastic. All cut-outs are smooth-milled to give
engraving-machine accuracy.

One of more than 35 Rapidesign time-saver
templates—all of which are better made, more
useful and lesser priced.

\$3.00 AT YOUR LOCAL DEALER
CATALOG No. 50 MAILED ON REQUEST

RAPIDESIGN INC.
BOX 592 GLENDALE CALIF.

Circle 257 on reader service card

NIFEGON



servo-
components
with
built-in
quality

Servo components are not all alike, in spite of the fact that international standards dictate identical external appearance. The difference is in the component — reliability and life expectancy — two characteristics which depend solely on quality. The Nifegon trademark symbolizes precision servo components with built-in quality.



SYNCHROS
(for torque applications
and servo system)
Sizes 11, 18 and 23 — 2",
3" and 5" respectively.



RESOLVERS
(compensated and
uncompensated)
Sizes 11 and 18 — 2"



SERVOMOTORS
Size 11



**MOTOR-
GENERATORS**
Size 11



GEARHEADS
Size 11

SVENSKA ACKUMULATOR AKTIEBOLAGET

JUNGER

INSTRUMENTFABRIKEN · STOCKHOLM

Riddargatan 17 • Stockholm 14 • Sweden
Telephone: Sweden 22 23 40 • Cables: NIFE
Telex: 1592

Circle 203 on reader service card

203



EXTENDS

solid state power source capability to

60 Gc

with development of

10-20 Gc DOUBLER	and	20-60 Gc TRIPLER
-----------------------------------	-----	-----------------------------------

These outstanding developments coupled with AEL's highly efficient X-Band Power Source make the following possible . . .

12 WATTS AT 28 VOLTS gives you:

- (a) 200 mw at 10 Gc
- (b) 80 mw at 20 Gc
- (c) 2 mw at 60 Gc

If you have a custom or standard requirement for frequency multipliers and solid state sources — ask AEL for the best solution. Call or write to . . .



American Electronic Laboratories, Inc.
P. O. BOX 552, LANSDALE, PENNSYLVANIA 19446 • (215) 822-2929

New Instruments

tire instrument, including the probe, weighs 2 lb. When necessary, the probe can be washed in alcohol and immediately restored to duty.

Amlab, Inc., 1701 Elizabeth Ave., Rahway, N.J., 07065. [373]

Frequency synthesizer covers wide range

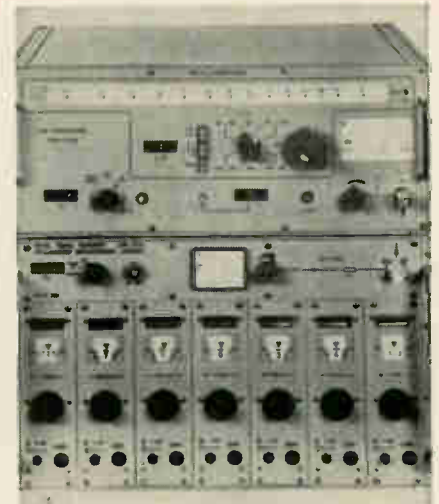

Two solid-state frequency synthesizers are being produced by Schlumberger Overseas GmbH, of Munich, West Germany.

The FS30 unit covers a range from 10 kc to 32 Mc, featuring a crystal stability of 3 parts in 10^9 , 10 cps phase locked crystal accurate steps and incremental tuning of ± 0.05 cps. The FS500 is an extension generator to the FS30 to provide a frequency range up to 470 Mc in 1-Mc phase-locked intervals.

The output signal has a low spurious noise modulation for a-m and f-m (below 80 db). The high performance of the synthesizer system enables operation on critical narrow band f-m systems and filters.

Both units can be supplied with an internal battery having an automatic recharge installation, which makes the system useful for field work. Price of the FS30 is \$5,250; delivery 60 days. The FS500 costs \$4,925; delivery July, 1966.

E.F. Associates, Inc., P.O. Box 477, Westfield, N.J. [374]

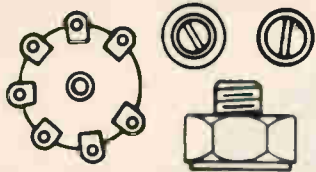

CHICOPEE MANUFACTURING CO. RESEARCH DIVISION MILLTOWN, NEW JERSEY	
TITLE	
DRAWN BY	DATE
CHECKED BY	SCALE
APPROVED BY	DWG. NO.
PROJECT NO.	

The second time you draw these (or any other repetitive element) you're wasting creative time!

Use STANPAT repetitive symbols for any diagram, spec, detail, title block . . . or any other detail you draw. It's like adding another draftsman to your staff. STANPAT will preprint your own symbol. You'll always have it ready for application to your drawings and tracings on any medium. It will be accurate, permanent, reproducible, and . . . most important . . . you will gain creative time!

STANPAT reproduces the drawing you need on top-quality tri-acetate sheets. You simply apply the STANPAT to your tracings whenever you need to, as often as you need to. Adherence is instant. Reproductions are crisp and clean, even when microfilming. There's never ghosting . . . no matter what tracing medium you use!

Send for literature and samples today.

*faithfully serving the engineer
for over two decades*

STANPAT PRODUCTS INC.



Covert and Main Street, Dept. J-1
Port Washington, N.Y. 11050
Telephone: 516 883-8400



Circle 258 on reader service card

Ω

7

NEW
FROM
IEE

μ

+

WORLD'S SMALLEST REAR-
PROJECTION READOUT GIVES
YOU CHARACTERS THIS BIG ▶

W



Shown
actual size

A

+9

The new Series 340 is the smallest rear-projection readout in the world! It's just 3/4" x 1/2" x 2"—yet its 3/8" characters are clear, sharp, and easily read.

Only IEE's patented rear-projection readouts give you your choice of any type face, symbol, color. Anything you can put on film! Use the single-plane Series 340 anywhere you need maximum clarity in minimum space.

Send for complete technical information.

4

8

1
VOLT

GO

IEE

INDUSTRIAL ELECTRONIC ENGINEERS, INC.
7720 Lemona Avenue • Van Nuys, California
Phone: (213) 787-0311 • TWX (213) 781-8115

Representatives in Principal Cities

3

Circle 259 on reader service card

CALL ON hurst-POWER FOR YOUR APPLICATION

NEW hurst 600 IN. OZ. HYSTERESIS REVERSIBLE SYNCHRONOUS INSTRUMENT MOTOR



MODEL GA

- HEAVY DUTY GEARING
- NO LUBRICATION REQUIRED
- CAN BE STALLED WITHOUT OVERHEATING

For long life and higher torque applications. Offers instrument manufacturers high performance and economy. Starting torque is uniform; smoothly, rapidly accelerates into synchronization. Capacitor included.



MODEL EA

150 IN. OZ. OF TORQUE AT 1 RPM (Unidirectional) (EA)

Open frame, shaded pole, extremely cool running. Bronze bearings, brass gears, hardened steel pinions and wheel shafts, stainless steel output shaft. For dependable, low-cost timing applications. Wide range of speeds.

120 IN. OZ. OF TORQUE AT 1 RPM (Reversible) (DA)

Timing accuracy both clockwise and counter-clockwise. SPDT switching. Case 2 1/2" diam., 1 1/4" long. Will not overheat. Capacitor included.

100 IN. OZ. OF TORQUE AT 1 RPM (Reversible) (CA)

Features 1200 rpm rotor speed for quiet performance. Extremely versatile (animated displays, program instruments, outdoor advertising, etc.) Wide range of output speeds. Will not overheat. Capacitor included.



MODEL CA

RATED 40 IN. OZ. OF TORQUE AT 1 RPM (Unidirectional) (SM)

For tough jobs demanding accurate timing. Excellent shock and vibration resistance. Starts instantly at full torque. Will not overheat. Wide range of output speeds.

40 IN. OZ. OF TORQUE AT 1 RPM (Unidirectional) (PC-SM)

120 IN. OZ. OF TORQUE AT 1 RPM (Reversible) (PC-DA)

Both are positive clutch and instantaneous brake motors. For extremely fast starts and stops. Motor runs continuously with clutch and brake controlled by switching actuator only. Clutch starts output shaft within 20 milliseconds; brake stops output shaft within 1/5" at 1 rpm; with 12" at 60 rpm. Motor on AC voltage; actuator AC or DC. Either can be supplied in any voltage combination when motor is AC. Will not overheat.



MODEL SM

100 IN. OZ. OF TORQUE AT 1 RPM (Reversible) (AR-DA)

40 IN. OZ. OF TORQUE AT 1 RPM (Unidirectional) (AR-SM)

Automatic reset. Planetary-type clutch operates directly upon output shaft. When de-energized, shaft is manual or automatic reset. Addition of external return spring to output shaft provides automatic reset on either model. Motor on AC voltage; actuator on AC or DC. Either can be supplied in any voltage combination when motor is AC. Will not overheat. Capacitor included.



MODEL PC-SM MODEL AR-DA
MODEL PC-DA MODEL AR-SM

STANDARD SPEEDS STOCKED BY
YOUR HURST DISTRIBUTOR

hurst

MFG. CORP. • PRINCETON, INDIANA

Circle 205 on reader service card

205

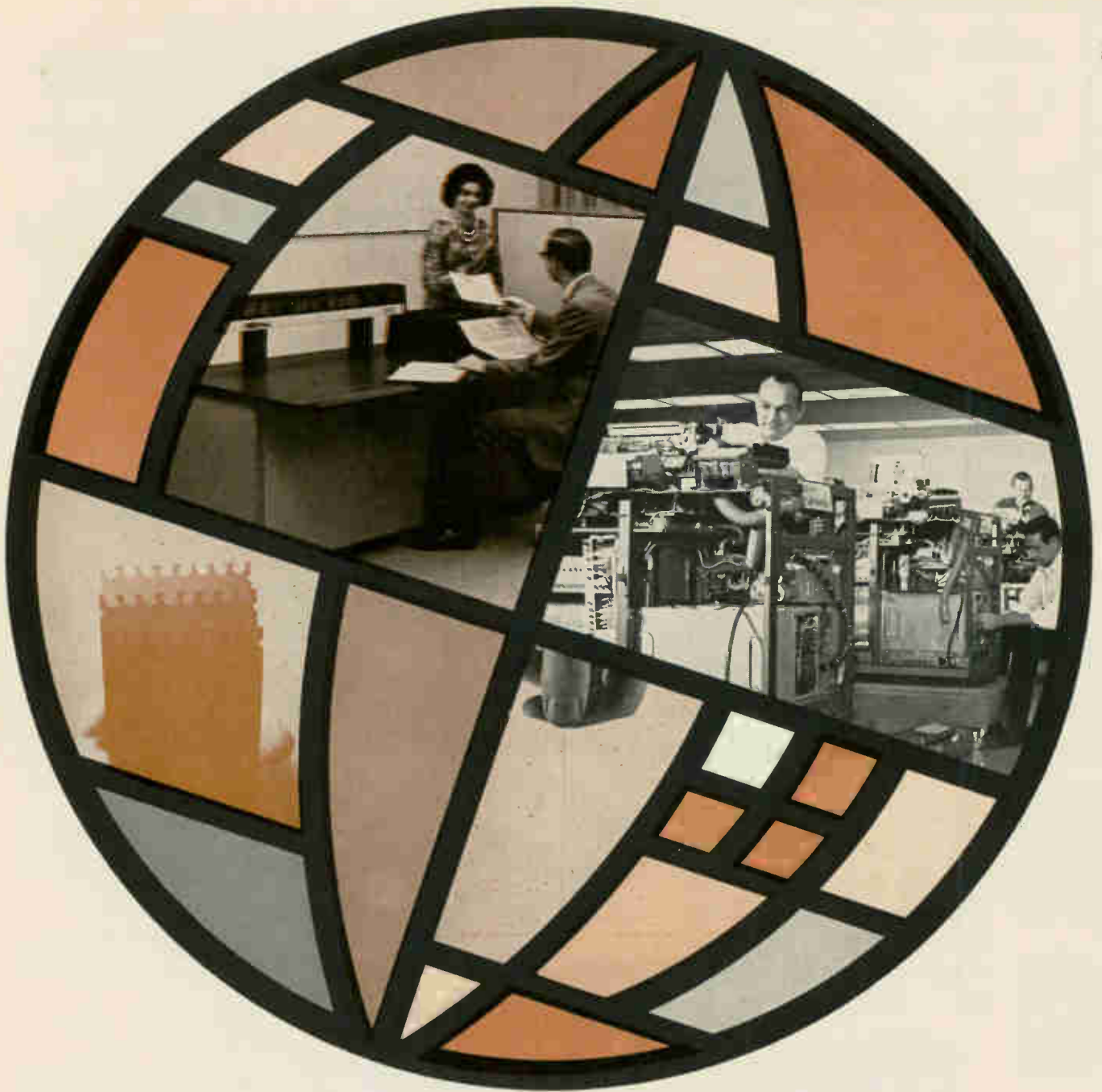

**BUILD
YOUR
FUTURE**

At the NCR Electronics Division, you build your career on hardware — not hope. Advanced developments like CRAM and the NCR 315 RMC Rod Memory Computer — the first commercially available computer with an all-thin-film main memory — are a marketplace reality. (And bear in mind that the NCR marketplace consists of more than 120 countries!) If you want to combine career stability with go-ahead, on-line opportunity... if you want to earn a good living while enjoying the good Southern California life... look into the opportunities on the page at the right.

NCR

ELECTRONICS DIVISION

**IN
WORLD-WIDE
BUSINESS
AUTOMATION
AT NCR,
LOS
ANGELES**

New Subassemblies and Systems

Magnetic core memory uses monolithic IC's



A series of magnetic core memory systems now available uses silicon monolithic integrated circuits for increased reliability. The memories have a full cycle time of 1.50 to 1.75 μ sec, with storage capacities from 128 to 8192 words for the basic unit. Access time is 600 nsec for read or read/restore operation. Date-in time as late as 800 nsec after initiation of the memory cycle speeds up computer operations.

Addressing methods available are random access, sequential, sequential/interlace and combinations of these methods. Standard logic levels are nominally 0 and +2 v.

Packaging features include open construction for ready access to all test points, and plug-in cards.

The following options are available: special input-output voltage levels, split cycle capability, automatic worst-case pattern test, up-down address counting, BCD address, parity check and alarm, indicator lamps, and interface logic for different data levels.

Systems Engineering Laboratories, Inc., Box 9148, Fort Lauderdale, Fla., [381]

Converter preamp has fast response

This converter preamp produces a d-c voltage proportional to the average value of full-wave rectified a-c voltages. The 8807A is useful with sinusoidal inputs in the frequency range of 50 cps to 100 kc with rms values from 3 mv to 500 v. It features a true floating, guarded input which is transformer-coupled and isolated from system ground. The calibrated zero

suppression and variable scale expansion permit detailed observation of small changes in large input voltages. The unit can drive a 1,000-ohm load to ± 3 v or 0 to ± 5 v, and, when used in a recording system, has transient response time of 10 msec (with 400 cps filter 10-90% at small amplitude). Plug-in filters within the unit permit selection of response time.

The compact, all-solid-state 8807A is useful as a bench-top device or data system component as well as for the company's models 7706 and 7708 oscillographic recording systems. A plug-in card is available which permits use of the 8807A as a general-purpose low-gain d-c differential amplifier. Sanborn Division, Hewlett-Packard Co., 175 Wyman St., Waltham, Mass., [382]

Pulsed ruby laser kit is easily assembled



An easily assembled, low-cost, pulsed ruby laser kit, model 21, is a high-quality, portable system intended for general laboratory and experimental use, and is ideal for class-room demonstration. Safety of operation is inherent. The power-supply unit features crowbar switch protection which is interlocked. The laser head is a separate unit, complete with mounting stand and cable.

Power output of the laser is variable, with a peak output approaching 1 joule in a pulse of 600- to 800- μ sec. duration. The ruby rod supplied provides visible radiation at a wavelength of 6,943 angstroms, with beam spread less than 30 milliradians; rods with other output



DIGITAL SYSTEMS OPPORTUNITIES AT NCR, LOS ANGELES

ADVANCED COMPUTER DEVELOPMENT

SYSTEMS DESIGN / Senior-level positions in advanced development and preliminary design of beyond-the-state-of-the-art data processing equipment. Considerable experience required in the over-all system design and integration of commercial computing equipment. BSEE required with advanced degree highly desirable.

MEMORY DEVELOPMENT / Positions will entail analysis and design of advanced thin-film memory systems, both linear select and coincident current. Also advanced random-access development on magnetic-card and disk-file systems. Requires BSEE, with advanced degree desired.

LOGIC AND CIRCUIT DESIGN / Openings are available for design of advanced integrated-circuit computers, buffering systems, on-line computing and transmission systems, and computer peripheral equipment. BSEE and good knowledge of state-of-the-art required.

MECHANISMS DESIGN / Senior-level positions available which entail working with new techniques for development of advanced high-speed random-access memories. Work requires five years' experience in servomechanisms and BSEE or BS in physics; or considerable experience in high-speed mechanisms and BSME and MSEE or BSEE and MSME.

PRODUCT ENGINEERING

ELECTRONIC PRODUCT ENGINEERS / These positions require a BSEE degree with experience in designing digital computer equipment and in maintaining liaison with manufacturing.

PACKAGING / These positions entail layout and design of packaging for computer systems. Applicants must have previous experience with electronic computers or electromechanical devices. Background in miniaturization utilizing thin films and integrated circuits is desirable. BSEE required.

SYSTEMS FORMULATION

Positions available at all levels to study and formulate systems for commercial and industrial on-line computer applications, with emphasis on communications interface. Requires a minimum of two years' experience in specifying or programming real-time systems for banks, airlines or industry. A degree in engineering, business administration or related field is required.

PROGRAMMING DEVELOPMENT

SOFTWARE PROGRAMMERS
DESIGN AUTOMATION PROGRAMMERS

ARRANGE NOW FOR AN INTERVIEW IN YOUR AREA

Confidential interviews will be held soon in various parts of the country. To arrange an appointment, please send a resume immediately, including training, experience, and salary history to Bill Holloway, Technical Placement.

The National Cash Register Company

NCR

ELECTRONICS DIVISION

2816 W. El Segundo Blvd., Hawthorne, Calif.
Telephone: Area Code 213-757-5111

An equal-opportunity employer

**IT'S
A
FACT**

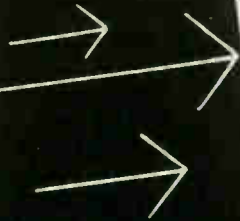

America's principal
defense contractors,
computer builders,
instrumentation
manufacturers and
electronic systems
developers use more
Metal Removal Company
solid carbide circuit
board drills and
routers than all other
makes combined.

For more information,
may we send you our
Catalogs D63 and E65
... and name of
nearest distributor?

**SOLID CARBIDE
CIRCUIT BOARD
TOOLING**

THE METAL REMOVAL COMPANY
1859 West Columbia Avenue • Chicago, Illinois 60626
Plants Located in CHICAGO • LOS ANGELES • SAN JUAN

**MASTER TOOL AND WHEEL MAKERS
FOR THE WORLD**

Circle 208 on reader service card

To order reprints: Fill in, cut out coupon below, insert in envelope and mail to: **Electronics Reprint Dept., 330 W. 42nd Street, New York, N.Y. 10036**

Reprint order form

For listing of reprints available see the Reader Service Card.

The Packaging Revolution In Microelectronics

Send me _____ reprints of Key no. R-80 & 81 at 50¢ each.

For reprints of previous special reports fill in below:

Send me _____ reprints of Key No.(s) @¢ each.

(For prices, see Reader Service Card)

Name

Number of street

City, State, Zip code

New Subassemblies

wavelengths are also available. Total bank energy storage is approximately 375 joules. Meter indicated charging voltage is variable from 0 to 1,000 v. Power requirements are 110 v a-c, 50-60 cps, at 1 amp. Assembled weight is 25 lb.

Each instrument is supplied with assembly, adjustment and operating instructions, a discussion of laser theory, and a description of experiments that may be performed. Price of the complete kit is \$499.50. A factory-assembled unit is also available, at \$560. Delivery is 30 days after receipt of order.

Electro-Optical Systems, Inc., 300 N. Halstead St., Pasadena, Calif. [383]

**Alphanumeric readout
with built-in memory**

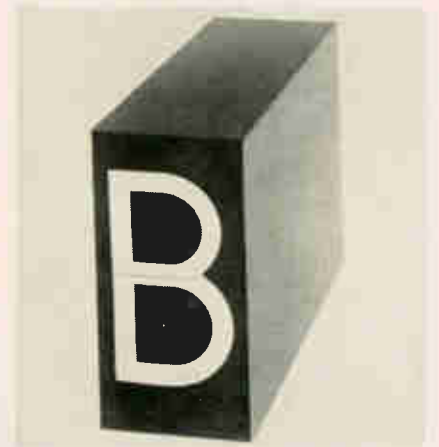

The 404 alphanumeric, 40-position readout uses the new flap principle to display numbers 0-9, alphabet A through Z, 4 in. high and 2 in. wide, with four blank positions that can be used for display of special symbols. Readout characters are of high-contrast white on nonglare black, with unlimited color combination selection optional. Display definition remains constant regardless of ambient light conditions. No bulbs or luminous or projection devices are used.

Model 404, with built-in decoder and memory, does not depend on pulse count to reach correct readout position, which is controlled

KNOW with an AEROCOM MODULATION MONITOR

AEROCOM's Model 906 Modulation Monitor is used for continuous monitoring of percentage of modulation of an AM transmitter operating on Low, Medium, High, and Very High frequencies.



This AEROCOM unit

- Measures percentage of Modulation on either positive or negative peaks.
- Monitors modulation level. Covers carrier frequency range from 200 kc. to 160 mc.
- Handles transmitter power up to one kilowatt. Adjustment provided to meet different carrier powers.
- No power supply required (passive).

Detector unit is installed and left in transmission line and connected to meter panel with RG 58/U coaxial cable. This monitor is available for rack mounting (Model 906-R) and as a portable unit (Model 906-C) in self-contained case.

Additional data on request

WORLD WIDE



SINCE 1946

3090 S.W. 37th Avenue

Miami, Florida 33133

Circle 260 on reader service card

Smallest 3-Phase Electronic Frequency Converters Ever Made!



Now, from CML, comes a series of the smallest 3-phase Electronic Frequency Converters ever made... featuring fixed or adjustable plug-in oscillators at frequencies ranging from 45 to 6,000 cycles. Write today for details on Models T500A through T2500A!

Model	3 ϕ Output VA	Dimensions (For standard 19" relay rack mounting)
T500A	500	8 $\frac{3}{4}$ " h x 21" d
T750A	750	14" h x 21" d
T1200A	1200	14" h x 21" d
T1750A	1750	14" h x 21" d
T2500A	2500	14" h x 21" d

CML **CML, Inc.**
A Subsidiary of Tenney Engineering, Inc.
350 Leland Avenue • Plainfield, New Jersey
Telephone (201) 754-5502 • TWX: 201-756-2064

Circle 261 on reader service card

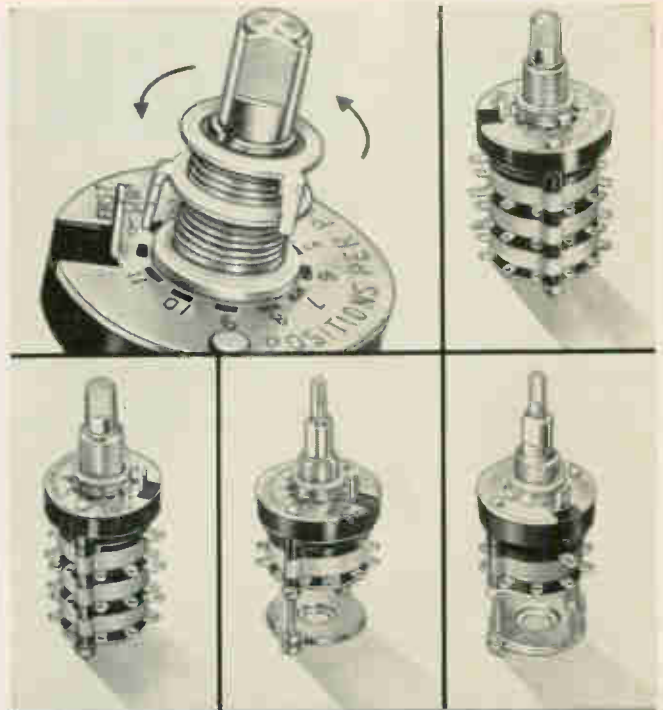

Grayhill®

Miniature
Adjustable Stop
Rotary Switches...

... the Difference Between
Excellent and Adequate ...

Select your own circuitry.
Ideal for prototype and
small production runs.

Select Materials:

- Contacts: Silver Alloy
- Terminals: Brass, Lead-Tin Plated and Fused
- Common Plate: Brass, Silver Plated

Typical Specifications:

- Explosion Proof
- Stop strength: 12 Pound-Inches Minimum
- 1 to 12 Decks
- 1 to 4 Poles per Deck
- 2 to 12 Positions per Pole
- Life Expectancy; 100,000 Operations

... in
Design
Materials
Construction

Send for
Engineering
Data
Book



523 Hillgrove Avenue
LaGrange, Illinois 60526
Area Code 312, Phone 354-1040

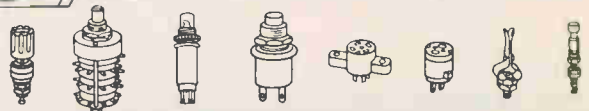

'PIONEERS IN MINIATURIZATION'

Circle 209 on reader service card

209

YOKE SPECIALISTS

FOR INFORMATION DISPLAYS

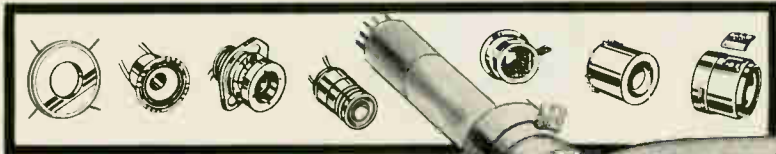

Syntronic's devotion to precision and attention to detail assure skillfully engineered deflection yokes in prototype or full production quantities. A complete line of value engineered yokes offer cost saving solutions to your CRT projects. Consult scientifically oriented Syntronic Yoke Specialists for the right yoke for your display.

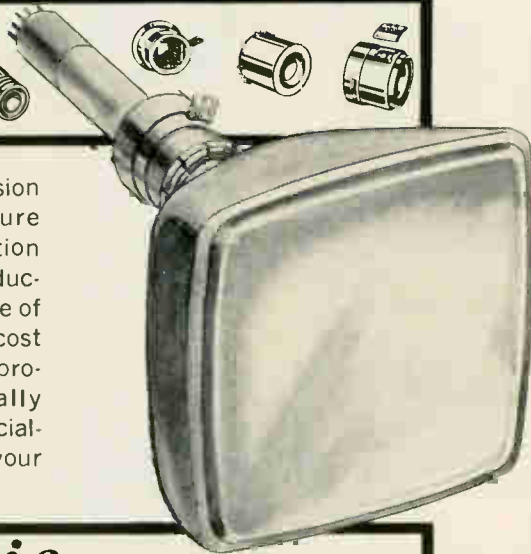

Syntronic INSTRUMENTS, INC.
100 Industrial Road, Addison, Ill.
Phone: Area 312, 543-6444

Circle 262 on reader service card



**LIGHT
TO FIGHT
BY...**

Portable military shelters require a very special kind of interior lighting.

WE MAKE THIS KIND.

Literature on request

BRUCE INDUSTRIES, INC. 1528 West 178th Street, Gardena, California

210 Circle 210 on reader service card

New Subassemblies

positively through self-seeking 8-channel code directly, eliminating need for reset.

Applications include computer readout systems, instrument readout, betting display boards, process control boards, status display boards, etc.

Visiontron Corp., 663 Fifth Ave., New York, N.Y., 10022. [384]

Co-ax recorder offers 14 2-Mc channels

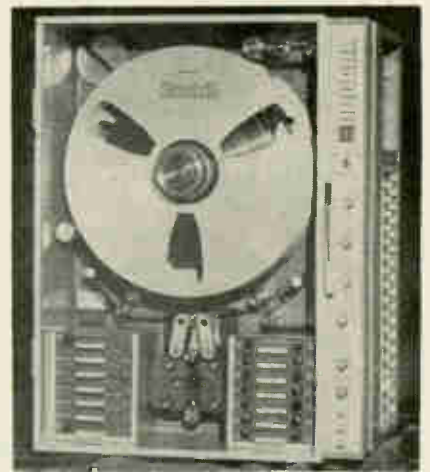

The latest model in the PC-500 portable coaxial recorder series extends its wideband capability to seven or fourteen 2-Mc channels at 120 ips, with two selectable reproduce-monitor tracks. The system is contained in a 4-cu ft package only 24 in. high. It accommodates 10½-, 12½-, or 14-in. NAB standard or precision reels.

The recorder is rfi-shielded to meet the intent of MIL-I-26600, and is IRIG-compatible with all standard playback systems in the same performance category. It offers seven push-button speeds, 178 to 120 ips, in three ranges.

All transport and signal electronics circuitry is solid state. Supply and take-up reels are stack-mounted on a single hub, and both are equipped with photocell sensors for auto stop, auto rewind or auto transfer commands. The unit draws less than 650 w in any operational mode for a complete 14-channel system.

Revere-Mincom Division, 3 M Co., 300 S. Lewis Rd., Camarillo, Calif. [385]

Electronics | January 10, 1966

Schematic to shipment in 60 days proves...

Nobody packages telemetry faster than Space Craft

Do you need uncommon electronic packaging skill combined with quick reaction capability? Space Craft, Inc., is the place to look.

Consider the case of the satellite data system for "Injun IV." Space Craft received a rough schematic, incorporated design changes, and went to work. It took only 60 days to go from the unfinished, unproved schematic to a flight-qualified 61-channel data handling system. The result was a 3.9 pound, 160 cubic inch package containing more than 6000 components.

When you have packaging problems with space electronics and need the fastest, most expert help available, *go where the experience is . . .*

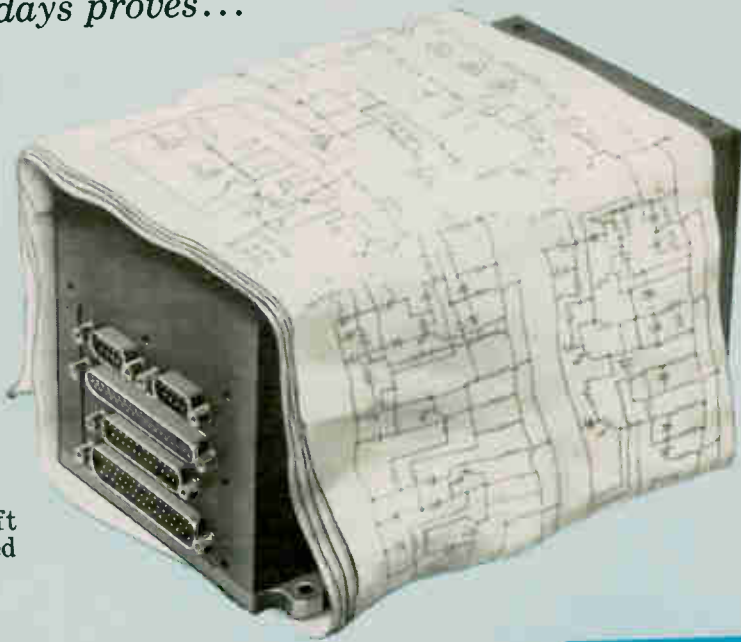

SPACE CRAFT, INC.

8620 SO. MEMORIAL PARKWAY / HUNTSVILLE, ALABAMA 35802
TELEPHONE: (205) 881-1611 TWX: (510) 579-2234



Circle 263 on reader service card

IMPROVED!



NEVER
SO MUCH
OVEN
FOR UNDER
\$300
BLUE M
STABIL-THERM®

ELECTRIC UTILITY OVENS

FULL U.L. APPROVAL . . . EXCLUSIVE "MEMORY" RING TEMPERATURE CALIBRATING DIAL—make one of the most popular (and economical) ovens ever designed even more dependable!

- "Memory" Ring Dial makes pin-point calibration of temperatures fast, easy, sure . . . "remembers" calibration factors for 100% reproducibility. Lock prevents accidental setting change.
- U.L. Approval assures safety.

Wattage automatically controlled for quick, stable working temperatures. Range: +38 C. to +260° C. (+500° F.). Two sizes: 1 or 2.4 cu. ft. All stainless or with enameled steel exteriors. Rugged for years of continuous service in the laboratory or for production.

PRICES, COMPLETE: \$297.50 TO \$429.00.

SEND FOR FULL INFORMATION



BLUE M Electric Company

Corporate Headquarters: BLUE ISLAND, ILLINOIS 60406

Circle 264 on reader service card

How to breadboard microwave circuits in minutes



Use
TRI-PLATE®
Module
Kits

Discover all the advantages of Sanders exclusive TRI-PLATE Module Kits. You can breadboard any kind of microwave circuit, apply power, prove the circuit and de-bug it . . . all in minutes. What's more, you can use TRI-PLATE Modules again and again to test functioning circuits.

Send your breadboarding problems to Sanders . . . get complete technical assistance on the most complex microwave circuits.

Write for your free copy of Sanders 32-page brochure which covers all the practical applications of Sanders L, S and C Band TRI-PLATE Module Kits. Sanders Associates, Inc., Microwave Products Dept., Nashua, New Hampshire 03060.

. . . and for creative employment opportunities write us today.

SANDERS ASSOCIATES, INC.
CREATING NEW DIRECTIONS IN ELECTRONICS

*T.M., Sanders Associates, Inc.



Circle 211 on reader service card

System-285 Recorder

**For
Real-Time
Data
Analysis**



Interstate Electronics' Precision CRT Recorder delivers precise real-time and recorded data in any application where speed, accuracy, and permanency are required—from oceanography to speech analysis; from telemetry to seismology, radar and environmental tests.

Besides making it possible to visually monitor the CRT face while recording, this IEC-designed package records spot image speeds as high as 330,000 inches per second; provides resolution in excess of 75-line pairs per inch, and features video amplification flat to 10 mc—to name a few of the highlights.

System-285 records three variable parameters on light sensitive paper or film as a result of its horizontal sweep, lateral film movement, and intensity-modulated beam. In operation, the trace image is obtained from the CRT beam which is deflected along the horizontal axis. This beam is magnified and focused for projection through a narrow-slot optical aperture on a recording magazine. The recording medium is passed by the aperture where it is exposed to the trace image. Time-coherent video data is correlated on the film and appears as easily seen continuous lines or bands—noise is reduced to non-coherent random dots.

For complete information on the high-speed precision System-285 Recorder—and how it can be applied to your data analysis problems—contact your local Interstate representative or write to Dept. B-1.

**INTERSTATE ELECTRONICS
CORPORATION**
DATA PRODUCTS DIVISION

707 E. VERMONT AVE. 
ANAHEIM, CALIF. 92803

Regional Offices: Atlanta,
Georgia; Washington, D.C.

Subsidiary of

INTERSTATE ENGINEERING CORPORATION



New Microwave

New magnet reduces bwo size



Microwave tube oscillators for airborne and missile applications must be small and light as well as rugged and reliable. The size and weight of these tubes is primarily determined by the magnet structure accompanying the tube for focusing the electron beam.

Now a new magnetic material, called Alnico V-7, has enabled engineers at the Watkins-Johnson Co. to cut both size and weight of a backward-wave oscillator. The redesigned magnet is only one-eighth its former weight and half the size. Other tube elements, such as the gun and collector were also reduced in size. Helix length remained the same.

According to the company, these reductions resulted in the smallest and lightest bwo ever built. Designated WJ-2004, it measures 2 x 2 x 6 inches and weighs less than three pounds.

Other methods of electron-beam focusing such as electrostatic focusing could possibly yield yet a smaller and lighter bwo, but they haven't been successfully implemented outside the laboratory.

The WJ-2004 housing is a double layer of steel shielding to minimize magnetic flux leakage. At the sur-

face of the tube, the flux is about 75 gauss; it reduces to half that value at one inch.

The tube operates in the 9.5- to 13.0-gigacycle frequency range. Power output is 10 milliwatts minimum. The tube is convection air-cooled.

Price upon request. Delivery within 45 days.

Specifications

Frequency	9.5 to 13.0 gigacycles
Tuning voltage	300 to 750 volts
Output power	10 milliwatts minimum
Input power	5 watts maximum, excluding heater
Heater voltage	6.3 volts
Anode voltage	150 volts
Cathode current	6 milliamperes
Output connector	Type TNC

Watkins-Johnson Co., 3333 Hillview Avenue, Palo Alto, Calif. 94304. [391]

Miniature, portable microwave receiver

A miniature microwave receiver, model CMR-312A, which weighs only 4.3 oz and measures 2¼ x 2¼ x 1¼ in., is expected to have applications in monitoring pulsed or a-m modulated r-f signals. It has a wide dynamic range of input power without blocking. Output

signal is a tone that provides the operator with an audible indication of signal activity in the 2- to 12-Gc range.

The solid-state receiver incorporates a high-gain, printed-circuit Archimedes Spiral antenna, and is powered by two small mercury button-type batteries that provide 30 hours of operation. A simple on-off switch places the unit in operation, and an adjustable gain control is available as optional equipment. The unit's "poly-mount" receiver case is designed to provide a variety of mechanical mounting arrangements.

American Electronic Laboratories, Inc.,
P.O. Box 552, Lansdale, Pa. [392]

B-w oscillator spans 10 to 15.5 Gc



The VA-177M backward wave oscillator operates in the 10.0- to 15.5-Gc frequency range. This fully shielded, permanent - magnet - focused tube provides at least 50 mw of output power over the M-band range. Tuning is achieved by adjusting only the helix voltage. The resulting voltage - vs - frequency curve follows an exponential function and exhibits no discontinuities. A nonintercepting negative control grid provides a means for amplitude modulation without drawing current in the modulating circuit.

The unit features magnetic shielding, which not only reduces the stray magnetic field of the bwo to less than 10 gauss at $\frac{1}{2}$ in. from the tube surface, but also allows the bwo to be operated in contact with ferrous materials or in stray magnetic fields typically found in microwave equipment, without performance degradation. This feature simplifies equipment design and layout and eliminates special handling and storage precautions required for nonshielded units.

Other features of the VA-177M include rugged metal-ceramic construction, smooth output character-

high
power:

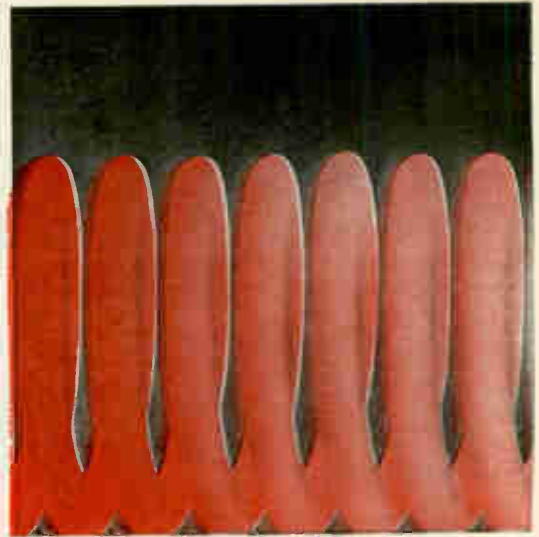

practical new dimension in twt technology

Until recently a number of technical problems (notably cooling and efficiency) irritated users of high power traveling wave tubes. But new techniques developed at MEC have solved these problems. For example:

- MEC's method of cooling the helix support structure directly has overcome the thermal problem in TWTs developing powers in excess of 1 kw CW.
- Contoured support rods minimize dielectric loading on 100 and 200 watt CW amplifiers while still providing proper margins of thermal conductivity to the tube barrel.
- Depressed collector operation increases efficiency of 12 kilowatt CW tubes to 35%. The result: TWTs which match klystrons in efficiency yet provide 7 times the instantaneous bandwidth.

MEC produces high power tubes in four ranges: 20-35 watts, 100-200 watts, 1 kw CW, and 12 kw CW. For complete details, please contact your MEC engineering representative or write to us. Internationally, contact Frazar & Hansen, Bern, Switzerland.



Microwave Electronics

a division of Teledyne

3165 Porter Drive, Palo Alto, California

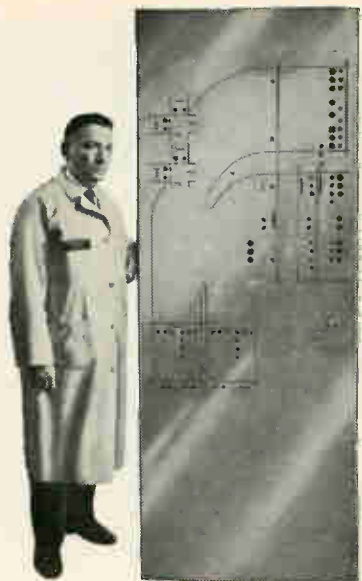

think BIG

(also small)



Now engrave anything from 6 ft. panels to tiny nameplates

Engravograph tackles them all. Right in your own shop, effortlessly, speedily — ideal for unskilled workers. Adjustable ratio engraves 21 different sizes.

Write for illustrated catalog # 114

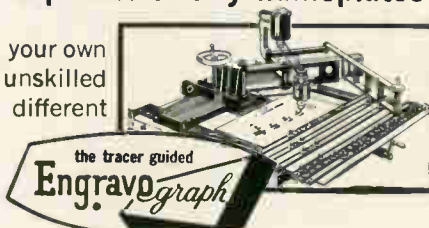

new hermes engraving machine corp.

154 WEST 14th STREET, NEW YORK 11, N. Y. Chicago, Atlanta, Dallas, Los Angeles, Montreal

Circle 224 on reader service card

WE'VE SIMPLIFIED PHOTOCELL- LAMP DESIGN

New Clairex® PHOTOMODS® combine selected photoconductive cells and lamps into one compact module ready for use as noiseless pots, circuit isolators, automatic gain controls and for numerous other control applications. 11 standard PHOTOMODS are now available combining hermetically sealed CdS and CdSe photocells coupled to 5000 hour lamps rated at 6, 12, 24, and 120 volts.

Custom PHOTOMODS are also available based on your specific control and signal circuit parameters.



For additional design data request technical bulletin ITD 465.

CLAIREX

"The LIGHT Touch in Automation and Control"

CL-105

1239 Broadway, New York, N. Y. 10001, 212 MU 4-0940

New Microwave

istics, rapid sweep rate capabilities, excellent a-m, f-m and spurious noise performance, and high reliability. The r-f output connector mates with WR-75 waveguide flange. Cooling is by conduction. Possible applications include local oscillators for use in spectrum analyzers, sweep signal generators, or special test sets.

Delivery is 30 to 60 days.

Varian Associates, Tube Division, 611 Hansen Way, Palo Alto, Calif. [393]

Precision wavemeters span 18 to 40 Gc

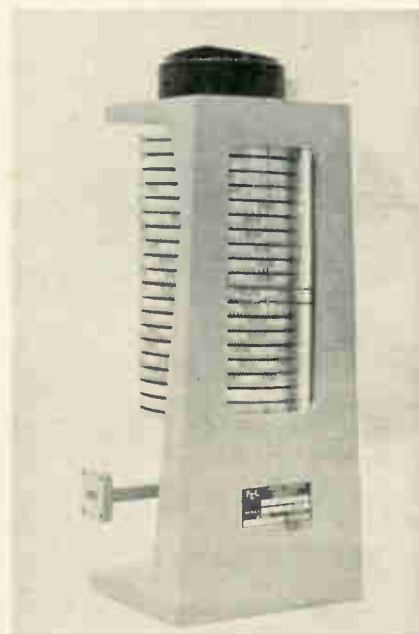

Two new precision wavemeters tune from 18 Gc to 26 Gc, and 26 Gc to 40 Gc, respectively, with an absolute accuracy of $\pm 0.05\%$. Because of their broad tuning range and accuracy they are especially suited for use as frequency markers in conjunction with broadband sweep generators and spectrum analyzers, or in calibrating the frequency of a transmitter, receiver, local oscillator or signal generator.

Spurious signals are a minimum of 20 db down from the main response and absorption dip is 1.5 ± 1 db. Loaded Q is 3,500 and power capacity is 20 watts. The wavemeter retains its accuracy over a temperature range of $22^\circ\text{C} \pm 10^\circ\text{C}$.

Dimensions are 8 in. high x $3\frac{3}{4}$

200 WATT DC SERVO AMPLIFIER

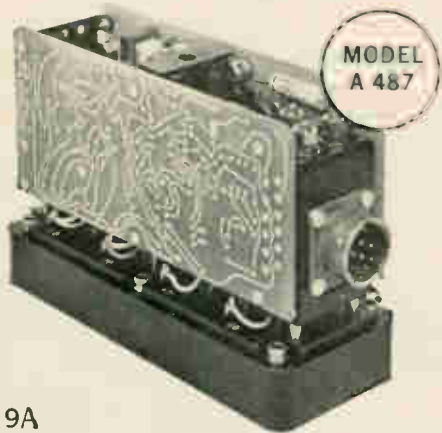

MODEL
A 487

22V @ 9A

**FOR
DC MOTORS
AND
TORQUERS**

- ★ Current feedback
- ★ Three signal inputs
- ★ Small size — 2 3/4" W x 6 L x 4 H
- ★ Gain — 50 amp./volt
- ★ Signal inputs DC isolated from 28VDC pwr.

Servo Amplifiers / Static Inverters / Power Supplies

WESTAMP

SANTA MONICA, CALIFORNIA • 213+393-0401

Circle 265 on reader service card



the latest in Heat Sink Extrusions WAKEFIELD DISTRIBUTOR PRODUCTS CATALOG

Your authorized WAKEFIELD Electronic Distributor stocks a wide variety of Heat Sink Extrusions in 3 ft. ± 1/4" lengths. This catalog will give you the name of your nearest distributor and full product information: milliwatt to high power coolers, circuit board heat sinks, extrusions, thermal joint compound DELTA BOND 152 Thermally Conductive Adhesive.

FOR YOUR COPY, WRITE

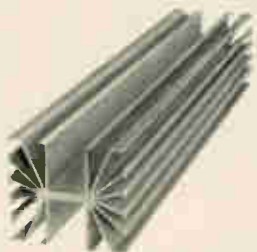

**WAKEFIELD
ENGINEERING, INC.**



139 FOUNDRY ST. / WAKEFIELD, MASS. (617) 245-5900 • TWX 617-245-9213

Circle 266 on reader service card

Tung-Sol Read-Out Lamp Saves Customer Two Operations, Cuts Shrinkage

ACTUAL
SIZE



Our customer's problem stemmed from handling. The bulbs he bought went first to a wiring company to have lead wires attached. (Shrinkage here due to lead wire damage). After the leads were attached the bulbs went to a molder, to have bases added. (More shrinkage due to bulb damage and lead wire breakage). Shrinkage in both operations ran as high as 15 per cent.

Now Tung-Sol does the whole job and the customer has benefitted 4 ways: (1) two processing steps eliminated. (2) valuable production time saved. (3) inventory reduced. (4) gets 1000 usable lamps for every 1000 purchased.

Tung-Sol can harness to any specifications and mold to any configuration. Describe your application to us for free suggestions about how Tung-Sol can solve your problem at a saving.



If your application requires only bulbs, ask for a quotation from Tung-Sol. The Tung-Sol line of miniature and subminiature lamps is extensive. Quality is the best that more than half a century of know-how can produce.

TUNG-SOL

INSTRUMENT LAMPS

Tung-Sol Electric Inc., Newark, N. J. 07104

Circle 215 on reader service card

215

"bugged" BY A PRINTED CIRCUIT PRODUCTION PROBLEM?

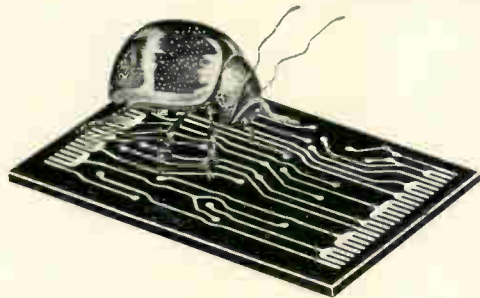

BRING IT TO CHEMCUT

Whether it's a microminiature or mammoth board, Chemcut has the spray etcher to produce it for you—accurately and economically. Chemcut, the pioneer and leader in the spray etching field, has units ranging in size from laboratory models to fully automatic, conveyerized systems for high volume production. (Model 502 horizontal, conveyerized etcher is shown at left.)

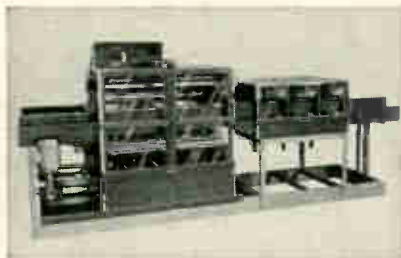

Also available is a complete line of Chemcut equipment for printing, developing, resist removal and other auxiliary functions. There are over 1800 units in use throughout the world. One that will fill your production needs is available through your nearby Chemcut distributor.



HOW ABOUT PART PRODUCTION?

With continued emphasis on miniaturization, manufacturers of electronic devices are finding spray etchers ideally suited to the production of a variety of parts. We welcome the opportunity of exploring your part production problems with you.



CHEMCUT Corporation
1101 North Atherton Street,
State College, Pennsylvania 16801

Circle 216 on reader service card

To order reprints: Fill in, cut out coupon below, insert in envelope and mail to: **Electronics Reprint Dept., 330 W. 42nd Street, New York, N.Y. 10036**

Reprint order form

For listing of reprints available see the Reader Service Card.

A Look at Japanese Electronics Technology

Send me reprints of Key no. R-83 at 50¢ each.

For reprints of previous special reports fill in below:

Send me reprints of Key No.(s) @¢ each.
(For prices, see Reader Service Card)

Name

Number of street

City, State, Zip Code

New Microwave

in. wide; price, \$500; delivery, 30 days.

Frequency Engineering Laboratories, Farmingdale, N.J. [394]

Ferrite circulator spans 8.5 to 9.6 Gc



An ultraminiature, 4-port, ferrite circulator has been developed for X-band. The MA-3066 operates in the 8.5- to 9.6-Gc frequency range with less than 0.25-db insertion loss between ports 1 and 2. Maximum vswr is 1.2:1 with isolation of 20 and 40 db between ports 2 and 1, 3 and 1. The compact unit uses OSM connectors and weighs less than 4 oz.

Microwave Associates, Inc., Burlington, Mass. [395]

Ferrite circulators designed for C-band

A pair of C-band ferrite circulators has been developed for high-power applications. The CCH13 has a frequency range of 5.7 to 5.9 Gc. Peak power is 150 kw while average power (based on 2:1 mismatch) is 2.7 kw. Isolation is 25 db minimum for ports 2 to 1 while other paths offer 20 db minimum. Maximum vswr is 1.15.

Operating in a band between 5.4 and 5.9 Gc, the CCH14 can handle peak power to 1.6 Mw and average power of 10 kw. Isolation is 20 db minimum and vswr is 1.20 maximum.

Each of the assemblies is 23/4 in. long and is fitted with CPR-137F flanges and WR-137 waveguide. Insertion loss for the circulators is 0.5 or less.

Raytheon Co., 130 Second Ave., Waltham, Mass., 02154 [396]

SUBMINIATURE TOGGLE SWITCHES

SERIES 7100/SPDT
subminiature toggle switches
(one of the smallest made in
America!) provide maximum
reliable performance in a tiny
but precisely fabricated com-
ponent!

SERIES 7200/DPDT
subminiature toggle
switches will meet high
reliability standards in a
wide range of ground/aero-
space applications where the
utilization of small space is
a positive requirement!

A competitively priced, made-in-America product. Write for literature today!

C&K quality electro-mechanical products
103 Morse Street, Newton, Massachusetts 02158
Telephone: 617 926-0800
COMPONENTS, INC.

C&K also manufactures a quality line of magnetic code converters, timers and logic elements.
Circle 267 on reader service card

Weld Insulated Wire Fast and Reliably!

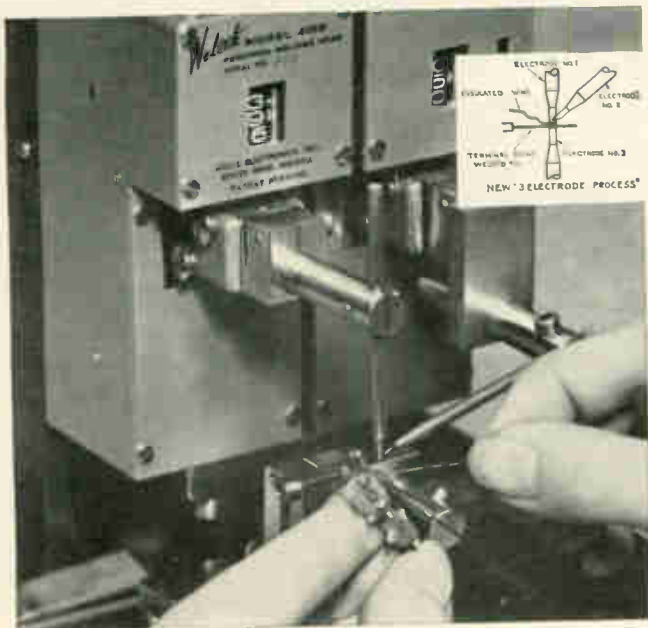

Get rid of costly wire stripping operations...
ask about our new AC-10/410-E system. It
welds through insulated wire (up to .010"
dia.) in less than 1/3 second. Send samples.

Weltek Precision Welders
by **WELLS ELECTRONICS, INC.**
1701 S. Main Street, South Bend, Indiana, U.S.A.

Circle 268 on reader service card

It's new from IMC



How fast do you need a solenoid?

4 milliseconds fast; day after tomorrow fast? That's what's new from IMC—the first factory-stocked broad line of precision solenoids. Twenty-two models, including a 4ms unit. And all for day-after-tomorrow delivery. Diameters from .375" to 2.3". Force from 10 grams to 32 lbs. Single coil. Two coil. Adjustable stroke types. And proven capability (15 years, 675,000 solenoids) to make "specials."

Call your nearest IMC Engineering Rep. or use the coupon, for the new 30-page Linear DC Solenoid Selector. Better still, test us with a fast order!

Check IMC also for: Boxer Fans (Distributor Stocked) / The New Air Bearing Boxer / Step Servo Motors / and many other motors.

ENGINEERING REPRESENTATIVES FOR IMC PRECISION SOLENOIDS
(Not to mention step-servos,
synchros and resolvers, DC synchro indicators)

Albuquerque: J. F. Quirk & Assoc., 256-0884
Dallas: Hillman Enterprises, Inc., LA 1-2070
Georgetown, Tex.: Hillman Enterprises, Inc., UN 3-3780
Los Altos, Calif.: Richard Strassner Co., 948-334
Portland: Shaffer & Nelson, Inc., 234-7437
Salt Lake City: Oscar Salme & Assoc., Inc., AM 2-2343
Seattle: Shaffer & Nelson, Inc., MU 2-0186
Tempe: IMC Magnetics Corp., Ariz. Div., 967-7851
Chicago: Berndt & Klein Assoc., SP 5-3488
Dayton: Bek Assoc., Inc., CR 8-1343
Kansas City: Design & Sales Eng. Co., GR 1-1640
Minneapolis: D. A. Schultz Co., FE 9-7701
St. Louis: Design & Sales Eng. Co., PA 1-6403
Atlanta: Bill Henry Assoc., 255-0920
Charlotte, N. C.: Bill Henry Assoc., 375-8958
Sarasota: Bill Henry Assoc., 955-4637
Binghamton, N.Y.: Engineering Components, RA 3-4197
New Haven: Edcom, Inc., MA 4-7291
Newtonville, Mass.: Edcom, Inc., WO 9-9710
Ottawa, Ontario: M. J. Howard Co., Ltd., PA 8-2991
Philadelphia: Burgin-Kreh Assoc., Inc., OR 7-1646
Syracuse, N.Y.: Engineering Components, HE 7-8181
Towson, Md.: Burgin-Kreh Assoc., Inc., VA 5-3212
Westwood, N. J.: Clarfield-Stollmack Assoc., 666-8989

Manufactured by IMC Western Div., 6058 Walker Ave., May-
wood, Calif. 90270. Tel. (213) LU 3-4785, TWX 213-773-5307.



IMC Magnetics Corporation
Marketing Division: 570 Main Street
Westbury, New York 11591. Telephone:
(516) 334-7070. TWX (516) 333-3319

- Send my Solenoid Catalog, fast
 Send a Rep, faster
 And/or tell me about _____

Name _____

Title or dept. _____

Company _____

Address _____

City _____ State _____ Zip Code _____

Circle 217 on reader service card

217

HERE'S AN OPPORTUNITY

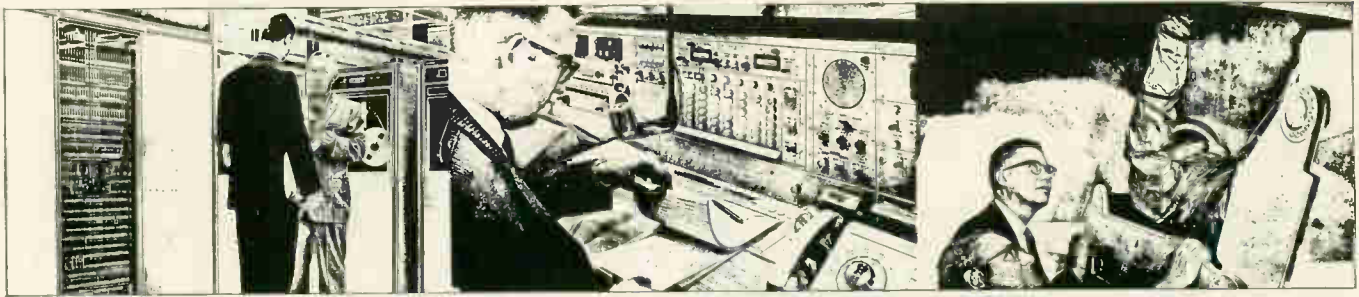

TO IMPROVE YOUR FUTURE

... Both professionally and personally. Every project at Collins is the most demanding in its area of industry, and we need professionals to continue the growth this level of qual-

ity has created. Living and working conditions—and compensation—are commensurate with these standards. These listings are current.

SEND RESUME FOR PROMPT INFORMATION

MICROWAVE SYSTEMS ENGINEERS—Electrical engineers with experience in microwave communication systems, design, or wire line carrier design. B.S.E.E. preferred. Must be willing to travel. (Dallas)

INDUSTRIAL ENGINEERING—These men will have a wide range of industrial engineering experience. They will be involved in standard data application, cost estimating, utilization studies, layout facilities planning, work measurement and cost reduction. (Cedar Rapids and Newport Beach)

INDUSTRIAL ENGINEERING, MECHANICAL ENGINEERING OR INDUSTRIAL MANAGEMENT GRADUATES—Experience in any of the following areas: manufacturing planning and methods, facilities planning, work measurement, cost reduction and control systems and procedures, tool and equipment design, computerized manufacturing techniques, quality engineering. (Dallas and Newport Beach)

FIELD SUPPORT ENGINEERS—Openings for field engineers with installation and

check-out experience in one or more of the following: high density microwave systems, toll terminal equipments, cable and open wire multiplex monopulse tracking techniques, phase locked loop receivers, parametric amplifiers, Cassegrain feeds, tropospheric scatter systems, solid state data systems. Most openings are single status with minimum of one year at location. (Dallas)

MECHANICAL ENGINEERS—B.S.M.E. for equipment and systems design. Duties will include machine design, hydraulic circuit design, stress and dynamic analysis, hydraulic and pneumatic design, electronic packaging and production processes. (Dallas and Newport Beach)

CRYSTAL FILTER ENGINEERS—To work in the challenging field of crystal filter development and/or crystal development. Minimum requirement B.S. degree but prefer M.S. or Ph.D. Two to four years minimum experience. (Newport Beach)

PRODUCTION ENGINEERS—These men

should have a background in flight director systems, gyroscopic devices or general electronics manufacturing. This area involves final development, tooling up and development of processes required for manufacture of newly designed avionics products. (Cedar Rapids and Newport Beach)

ELECTRICAL ENGINEER (Test Equipment)—This supervisory position involves the application of advanced techniques in product testing. Background should include utilization of programmed tape control and real time computer control technology and automatic test stations. (Cedar Rapids and Newport Beach)

RF SYSTEMS ENGINEERS—B.S.E.E. with experience in RF Systems including receivers, transmitters, and antennas in the VHF-UHF frequency range. Of specific interest is experience in phase locked loop receivers, high power transmitters, tracking (monopulse) antenna systems, and tracking system analysis. (Dallas)

COMMUNICATION / COMPUTATION / CONTROL



COLLINS RADIO COMPANY
An equal opportunity employer

New Production Equipment

Machine aligns and inspects IC's

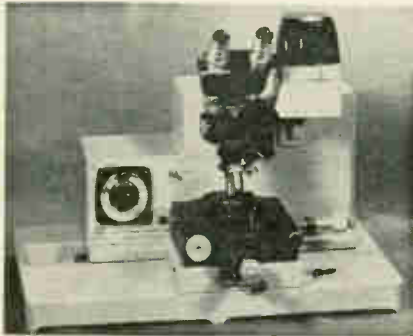

A mechanical alignment and inspection machine for integrated circuits is designed specifically for the semiconductor integrated circuit industry. Model 702 is both a work station for the precise alignment of a glass mask with patterns on a semiconductor wafer, and an inspection station for masks and wafers.

The microscope has a vertical illuminator, x-y motion, and coarse and fine adjustments for accurate focusing. The optics of the model 702 comprise a binocular metalurgical microscope with a revolving-turret triple objective which scans a 2 x 2-in. mask. A variety of eyepieces and objective lenses permit magnifications up to 600 X.

Large thimble micrometers precisely control the horizontal position of each wafer during alignment without the need for special mask holders; another adjustment provides for 360° rotation with either coarse or fine positioning. The vertical motion of the wafer is coincident with the optical axis of the microscope and is free from backlash or vibration.

In operation, the selected mask is inserted and clamped in the mask holder. After the wafer has been placed atop the vertical-motion table, the hinged mask holder is brought down over the wafer and clamped. Movement of the vertical motion lever brings the wafer face into close contact with the mask, and vacuum is applied to lock it into position. Another lever lets the operator separate the wafer from the mask by a mini-

mum distance sufficient to provide clearance, so further alignment can be done without frictional damage to either part. Once the alignment is perfect, the wafer and mask remain fixed in position. The microscope, timer, and exposure light are then slid to the left on frictionless, zero-clearance ball slides. This moves the microscope out of position while the exposure light assumes the position directly over the wafer and mask. The timer then causes the exposure light to expose the photoresist for the proper length of time.

This machine has a sturdy 24 x 15-in. base and weighs 80 lb. Electrical requirements are 120 v \pm 1%, 60 cycle, single phase, 650 w. Westinghouse Scientific Equipment Dept., P.O. Box 8606, Pittsburgh, Pa., 15221. [401]

Solder coating system is fully automatic

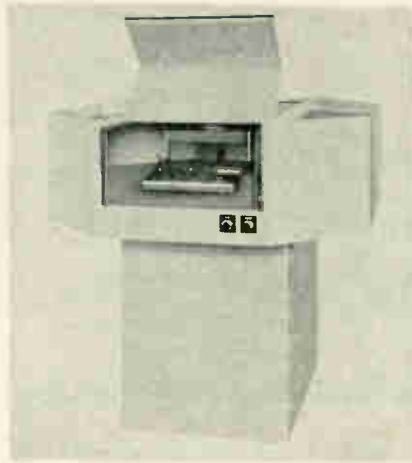

Model 562 is a fully automatic solder coating system that uses centrifugal force to leave a smooth, even solder coating on printed circuit boards. It meets MSFC 154.

Up to 100 individual boards can be coated per hour with excellent quality. Boards smaller than 12 x 12 in. can be ganged for even faster production. Single-sided, two-sided with plated-through holes, and multilayer boards can be processed.

Dip time and spin time can each be varied from 0 to 15 seconds. Total cycle time is 20 seconds plus

"Get Acquainted" Offer

If you'll tell us more about yourself through the confidential resume below, we'll know where to send you this booklet telling more about ourselves.



Send resume to Manager,
Professional Employment,
Collins Radio Company

Cedar Rapids, Iowa
Dallas, Texas
Newport Beach, California

CHECK LISTINGS

Name _____ Home Address _____ Phone _____

City & State _____

Present Position, Company _____

Primary Experience Area _____ No. of years _____

Education: EE _____ ME _____ Math _____ Physics _____ Chemistry _____

Bus. Adm. _____ Other _____ PhD _____

Degree: BS _____ MS _____ school, date _____

_____ school, date _____

Please attach any pertinent information

3



FOR ANALOG TAPE UNITS...

1

**PINPOINT
EVENTS
PRECISELY**



2

**LOCATE
DATA
QUICKLY**



If you want to . . .

- Easily locate and isolate portions of data recorded on tape . . .
- Read time code formats from magnetic tape running forward or backward at fast or slow speeds . . .
- Record real-time or elapsed time on oscillographs during recording or playback of tapes . . .

. . . then, you will want to learn all about **CHRONO-LOG TIME CODE GENERATORS and TIME CODE READERS.**

Each model has many outstanding design and construction features . . . solid state circuitry, front panel test controls, front and rear panel accessibility for checking and servicing, modular design that provides many optional features.

Write now for technical literature . . . or call (215) EL 6-6771.



CHRONO-LOG CORP.

2583 WEST CHESTER PIKE, BROOMALL, PA.

Circle 269 on reader service card

Production Equipment

dip and spin times. Over-all dimensions are 52x53x53 in. For operator safety, the system is entirely enclosed. Electrical interlocks prevent the machine from operating when the access doors are open. The loading door is automatically locked from the inside during the cycle.

Gyrex Corp., 3003 Pennsylvania Ave., Santa Monica, Calif., 90406. [402]

Corrosion-resistant microfeeding device

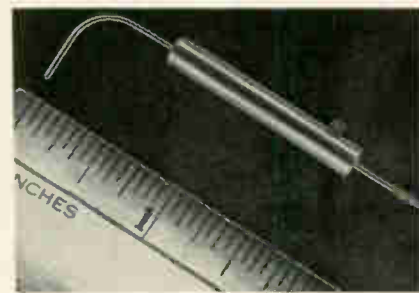

This long-life, glass-tipped microfeeding device is highly corrosion-resistant. It is suitable for any application where it is necessary to eject or apply minute amounts of liquid, powder, air, gas, chemicals or other materials with a high degree of control and accuracy. A typical application is the precision marking of electrically rejected 0.015-in. sections of germanium or silicon wafers. In this application, the microfeeder acts as a marking pen, depositing 0.006-in.-diameter dots of colored ink on rejected die-sections to facilitate visual separation of the rejects.

Body of the new feeder is fabricated of fine-quality polished stainless steel tubing of the type commonly employed for medical syringes. Tips are glass and are mounted in holders that are easily removable for servicing or replacement with any of a variety of styles and sizes. Glass tips are available with orifices ranging from 0.010 in. in diameter down to as small as 0.0005 in. Bores are smooth and stepless and are held to accuracies of ± 0.0001 in. consistently, even on large production runs.

Inquiries are invited regarding possible applications for the glass-

INNOVATION
INNOVATION
INNOVATION
INNOVATION



In Electrical Electronics Engineering

- 80 Technical sessions, 300 papers — all at the New York Hilton
- 4 floors of exhibits — all at the New York Coliseum. Four days only — Monday - Thursday
- Gala IEEE Banquet—Wednesday, 7:15 p.m., New York Hilton Grand Ballroom — \$15.00
- Free shuttle busses between the Hilton and the Coliseum — every few minutes
- Registration — Members \$2.00 — Non-members \$5.00. Ladies \$1.00. Good for all days — Technical Sessions and Exhibits. In and out privileges.

EXHIBITS (4 days only)

Monday through Thursday
11:30 a.m. - 9:30 p.m.

NEW YORK COLISEUM

TECHNICAL SESSIONS

Monday through Friday

NEW YORK HILTON

MARCH 21-25, 1966

Students (over 14) accompanied by adult will be admitted to Exhibits Thursday only. \$2.00. (Not more than 3 per adult)



IEEE EXHIBITION

WHERE CAN MAN GO... IN ELECTRONICS?

Electronics is a discipline unlike any other. For whatever name we give to these fast paced times in which we live—the Age of Space, the Age of Mass Communications, the Age of Transportation—electronics plays a vital role. Through advances in this single key technology, advances in all others are brought nearer to reality. And nowhere is this truth more evident than at Lockheed, where to all programs, electronics is essential. Research. Development. Systems. At Lockheed, those knowledgeable in the nuances of electronics help to further man's achievement upon this planet. They bring practicality to investigative ocean vehicles such as Lockheed's Deep Quest, a two-place research submarine. They permit land vehicles of the future to achieve reality. And they extend the reach of mankind heavenward through spacecraft systems such as Agena. Undersea, on land, and in space environments, Lockheed electronic systems control and guide, communicate and compute. Now, generalists and specialists, experienced and interested in a broad spectrum of electronics assignments, are invited to write Mr. K. R. Kiddoo, Professional Placement Manager, Sunnyvale, California. Lockheed is an equal opportunity employer.

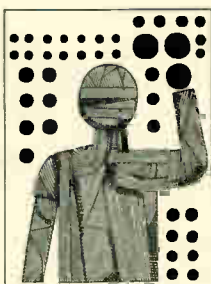

LOCKHEED
MISSILES & SPACE COMPANY
A GROUP DIVISION OF LOCKHEED AIRCRAFT CORPORATION

Champion of Tape Handlers

FACOM 603

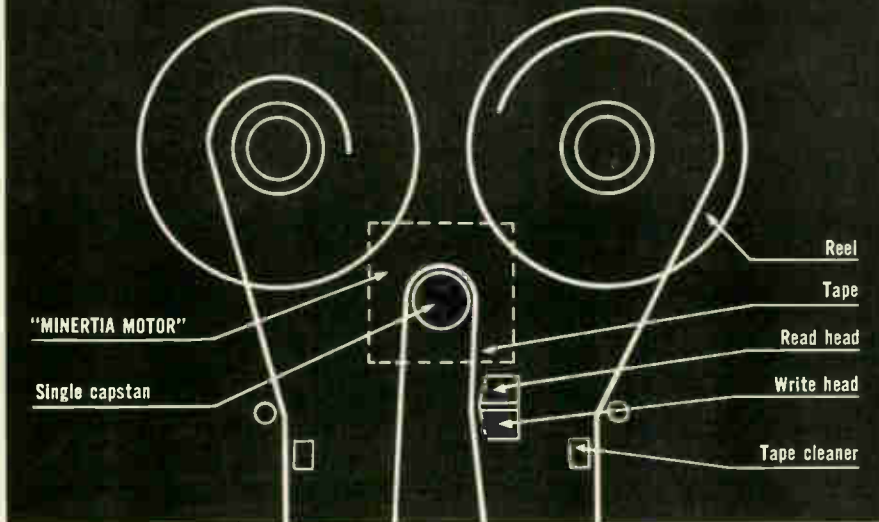

FUJITSU . . . the world's first producer of the single capstan tape handler system . . . FACOM 603

Outstanding Features

- Revolutionary "MINERTIA MOTOR" (minimized inertia motor) is directly coupled with the capstan.
- No clutch, no pinchroller, no pneumatic valve. The most simple and ideal tape-path with a single capstan.
- No scratching of magnetic tape.
 - Only the read/write head and the tape cleaners touch the recording side of the tape.
- Tape life prolonged by over 10 times.
- Also can be used as a highly accurate tester for the quality of magnetic tape.

FACOM 603 Series Performance

- IBM Compatible (IBM 729)
- Density 200, 556 or 800 bits/inch
- Tape speed 45, 75, 120 inch/sec.
- Transfer rate 9,000, 15,000, 24,000, 25,000, 41,700, 60,000, 66,700, 96,000 characters/sec.
- I.R.G. 3/4 inch
- Reverse reading possible

All kinds of inexpensive peripheral equipment are also available.



FUJITSU LIMITED

Communications and Electronics

Marunouchi, Tokyo, Japan

Main Products: Telephone Exchange Equipment Telephone Sets Carrier Transmission Equipment Radio Communication Equipment Remote Control & Telemetering Equipment Data Transmission Systems Computers (FACOM) Automatic Control Equipment (FANUC) Electrical Indicators Electronic Components & Semiconductor Devices

Production Equipment

tipped microfeeding device. Send specifications or description of application.

Specialty Glass Products Inc., 2552 Wyandotte Road, Willow Grove, Pa., 19090. [403]

High-vacuum cart for exhausting tv tubes

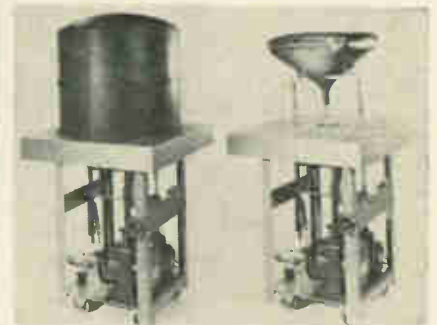

A high-vacuum cart now available is designed to exhaust color and black-and-white tv tubes, and can be made to the dimensional specifications of the customer. It consists basically of a water-cooled header, a 1½-in. low backstreaming water-cooled diffusion pump with solenoid-actuated, quick-quench boiler coil, and a Hyvac 14, two-stage mechanical forepump with water-cooled baffle.

The lever and/or rack-and-pinion mechanisms for elevating the tv tube and diffusion pump are provided according to the customer's specifications. Power pick-up train, r-f pick-up contactors, high current tip-off contactors, tip-off oven, contact switches, control panel, meters, and safety devices are also provided according to the customer's specifications.

The unit can be quickly assembled or disassembled and has low maintenance costs. The cart features a stainless steel, maronite-insulated top.

Ultimate pressure of the system is 2×10^{-7} torr; speed of the diffusion pump is 100 liters/sec; and the forepump speed is 140 liters/min. Power consumption is only 700 watts.

Central Scientific Co., a division of Cenco Instruments Corp., 1700 W. Irving Park Rd., Chicago, Ill., [404]

ENGINEERS AND SCIENTISTS

**Phoenix, HM-99, Syncom, Colidar
Laser Range Finders, ADO - 51,
Surveyor, Maverick, Early Bird,
TOW, Polaris Guidance Systems,
AIM-47, Advanced Technology
Satellites, VATE and more...**

They're all at Hughes.

(Should you be there, too?)

Send your resume to: Mr. Robert A. Martin/Head of Employment/Hughes Aerospace Divisions/11940 West Jefferson Boulevard/Culver City 53, California.

Requirements: Accredited Engineering degree and a minimum of three years of applicable professional experience. U. S. Citizenship.

We promise you a reply within one week.

An equal opportunity employer.

HUGHES

HUGHES AIRCRAFT COMPANY
AEROSPACE DIVISIONS

"ROOM AT THE TOP"

Here are growth opportunities in Communications with TRW Systems in Los Angeles and Houston

There is "room at the top" for your special talents on America's major missile and space programs with TRW Systems' Communication Laboratory in either Los Angeles or Houston. From the beginning of communications via space, this group has played a pre-eminent role in developing communications systems for the nation's major missile and space programs. Major achievements include the first unified carrier tracking, telemetry and command system and the first PCM telemetry system for space. Now is the time for you to investigate these opportunities with this outstanding professional organization.

MAJOR PROGRAMS . . .

- Apollo spacecraft systems
- Advanced Minuteman systems
- Mars mission and spacecraft studies
- Nuclear Detection (Vela) Satellites
- Pioneer interplanetary spacecraft
- Weather satellite systems
- Standardized tracking, telemetry and command system (SGLS)
- Advanced space probes
- Lunar telemetry systems
- Communication satellite systems

Senior Communication Engineers

For design, analysis and management of communication systems and evaluation of scientific and military applications of communication techniques for aircraft, spacecraft and underwater craft use. BSEE, MSEE or PhD.

Communication Equipment Design Engineers

Several years' experience in design and analysis in the following fields: RF filters, duplexers, antennas, phased arrays, feeds, solid-state transmitters, receivers, phase-lock loop techniques, cavity techniques, strip line, very wide and very narrow band circuits, circuit engineering, and modulation techniques. BSEE or MSEE.

Communication System Analysis Engineers

Conceptual design, analysis and synthesis of wide variety of digital and analog communication systems, employing coding, modulation, and statistical communication theory. Systems include integrated coherent-carrier systems, phase lock demodulation (restrictive/non-restrictive), communication satellites and deep space probes. MSEE or PhD.

Signal Processing Engineers

Design and development of sophisticated communication systems and components. Signal conditioners, analog and digital encoding and decoding, modulation tracking and carrier tracking phase lock loops, and multiphase modulation are involved in tracking, telemetry and command equipment which includes but is not limited to space applications. BSEE or MSEE.

Telemetry Circuit Design Engineers

To design a wide variety of analog and digital signal processing circuits for spacecraft digital telemetry equipment. Experience should relate to the design of analog-to-digital converters, analog and digital multiplexers, logic and data storage. Familiarity with micro-electronics desirable. BSEE or MSEE.

Telemetry System Engineers

Experienced in the functional and logical design of analog and digital telemetry systems. Familiarity with design, development, application and evaluation of spacecraft instrumentation systems. Experienced in the design of data systems to interface with a wide variety of data sources including scientific experiments, and engineering measurements.

Please submit resume and salary history in confidence to R. J. Brown, TRW Professional Placement, Dept. LI-1, One Space Park, Redondo Beach, California 90278. TRW is an equal opportunity employer, male and female.

TRW SYSTEMS

New Books

Instrumentation

Telemetry Systems
Leroy E. Foster

John Wiley & Sons, Inc., 308 pp., \$12.75

To keep pace with the swift advances in telemetry, a comprehensive collection of information for analyzing and designing airborne equipment would be helpful to an engineer designing missile or spacecraft telemetry systems. The author has tried to be comprehensive, but has fallen short. Nonetheless, the book will serve well as an introduction to telemetry.

The scope of the material is broad and encompasses areas not normally included in books on telemetry. But precisely because of its scope, the book isn't sufficiently detailed in specific areas to serve as a comprehensive design reference. The author's objectivity is apparently influenced by his own work with pulse code modulation/phase shifting (pcm/ps) telemetry, since he devotes a disproportionate amount of space to this technique.

Perhaps the most impressive chapter in the book is the one dealing with fundamental engineering measurements, in which 70 pages are devoted to a detailed and well-composed discussion of sensors, their measurement techniques and their limitations and advantages. The author carefully stresses practical techniques and establishes a good set of ground rules for the selection of measurements and encoding techniques.

The sections of the book devoted to system multiplexing format selections are neither complete nor comprehensive—which is also true of every other book on the subject. The author himself is aware of this deficiency and points out the fact that criteria for selection of optimum multiplexing techniques are governed by such unmeasurable characteristics as economy, availability, expediency, etc.

The author borrows freely from Nichols and Rausch's "Radio Telemetry," long considered the most authoritative work in the field, yet he ventures some justifiable criticism of that work in light of more recent developments.

Unusual in a book of this sort, but essential to a well-rounded coverage of telemetry, are the chapters devoted to range instrumentation, space television, and spacecraft communication—although here, again, their usefulness is limited by brevity. The book falls short in the coverage of ground equipment with the notable exception of the chapter on data reduction, in which the author develops a typical complete facility for telemetry data reduction.

With respect to radio-frequency links and receiving techniques, the book is not as up-to-date as it might be. There is no mention whatever of such areas as predetection recording, diversity reception techniques, high-density serial pcm recording, constant-bandwidth and extended-band subcarriers, or phase lock discriminators.

Some recent sophisticated space-communication techniques such as pulse frequency modulation (pfn) are not discussed; discussions of phase lock discriminators and recently developed receiving techniques such as phase lock threshold suppression properties, etc., are also entirely absent. Some of the photographs, such as those of the subcarrier discriminator racks, pulse amplitude modulation (pam) decommutator and helical antennas, are of obsolete equipment (some more than 10 years old).

In the author's description of a pcm decommutator, which is the most complex of the various systems discussed, no block diagram is shown and no description is given of the general logic operations required. Operation of such key items as the frame synchronization correlator and the bit synchronizer are not explained at all, and the entire section appears too narrowly directed at some unidentified specific installation.

On the other hand, there are some sections which will be extremely helpful to the practicing engineer. Particularly worthy of mention are those on graphic recorders, digitizing techniques, airborne sensors and the detailed calibration and set-up procedure for synchronization correlator operations in fm/fin systems.

V. A. Ratner

Defense Electronics, Inc.
Rockville, Md.

This new DVM from Trymetrics proves—



**Eleven
(plug-in)
heads are
better
than one!**



Models 103—104—105
Single range plug-in heads
10V, 1V, 100mV

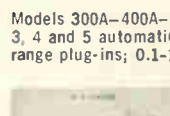

Models 300A—400A—500A
3, 4 and 5 automatic
range plug-ins; 0.1—1000VDC



Models 300M—
400M—500M
3, 4 and 5 manual
range plug-ins;
0.1—1000VDC

Check these Trymetrics features:

- Full 4 digit resolution.
- Accuracy $\pm 0.01\%$ of reading ± 1 count.
- Automatic polarity and overscale indicator.
- High common mode rejection.
- Complete range of plug-in heads for optimum flexibility. All silicon solid state circuitry.
- Operation up to 50°C .
- Sampling speeds up to (10) samples/second.
- Sensitivity to $10\ \mu\text{V}$.
- BCD or decimal printer output.
- Crystal controlled oscillator guarantees ultra stable voltage-to-time conversion system.

Check this Trymetrics price:

Model 4000 DVM \$770 with Model 103 10V Range Plug-In. For complete information and prices, write to:

TRYMETRICS
Corporation

204 Babylon Tpke., Roosevelt, L.I., N.Y.
Phone 516-378-5020 Zip 11575

VITREOSIL®

PURE FUSED
QUARTZ
TAKES
MORE
SHOCK,
HEAT
AND
ACID

THAN GLASS
 OR PORCELAIN —

RESISTS
 TEMPERATURES TO
 1050°C —

HANDLES
 MOST HOT ACIDS
 WITHOUT ETCHING —

WITHSTANDS
 CONSTANT THERMAL
 SHOCK —

EXCELLENT
 ELECTRICAL AND
 OPTICAL
 PROPERTIES —

LABORATORY AND
 INDUSTRIAL WARE —

SPECIAL
 FABRICATION —

SPECTROSIL®
FOR PURITY

ASK FOR
 32 PAGE FREE
 CATALOG —

THERMAL
AMERICAN
FUSED QUARTZ CO.

RT. 202 AND
 CHANGE BRIDGE RD.
 MONTVILLE, N. J.



Technical Abstracts

Solid state microwave generators

Avalanche transit time microwave oscillators and amplifiers
 B.C. De Loach and R.L. Johnston,
 Bell Telephone Laboratories, Inc.,
 Murray Hill, N.J.

Two kinds of avalanche transit time oscillators are described: a simple silicon pn junction and the more complicated silicon p-n-i-n junction, or Read diode. Both structures have been found capable of emitting continuous-wave microwave oscillations, and the pn junction has also demonstrated amplification.

Pn junctions can be made either by single diffusion into a uniformly doped substrate, or by single diffusion into a lightly doped epitaxial layer. It has been found that with increasing frequency, the first method offers higher efficiency than the second method. Diodes made by single diffusion into a uniform material have produced 13 milliwatts of continuous-wave power at 10.5 gigacycles with 0.5% efficiency.

These simple silicon diodes have also exhibited parametric effects. When pumped at 17.49 Gc, one sample simultaneously delivered power at a lower frequency, 8.512 Gc and 8.982 Gc, such that $f_1 + f_2 = f_{\text{pump}}$.

A pn junction amplifier was constructed from the oscillator circuit by replacing the slide screw tuner with a series of tuning screws closer to the diode, and by the addition of a circulator. Stable, negative-resistance amplification occurred in a suitably packaged sample when the circuit was tuned for operation within the range of the circulator. At 20 decibel gain, a 3-db bandwidth of 20 Mc was obtained. The noise figures were in the 50 db to 60 db range. Noise decreased when bias current was increased.

Using a p-n-i-n structure, or Read diode, oscillations from 3.8 Gc to 5.6 Gc were obtained from one sample. Other wafers produced 19 milliwatts of c-w power at 5 Gc with 1.4% efficiency, and 13 mw with 1.5% efficiency.

A 75- by 75-micron sample was

NORTON Magnetic Tape Heads



2507—1" Tape

2504—½" Tape

2502—¼" Tape

SERIES 2500

- CROSSTALK—60DB
- +75°C Temperature Operation

Send now for complete technical literature.

NORTON

ASSOCIATES, INC.

240 Old Country Road, Hicksville, N. Y.

Circle 270 on reader service card

More torque, Less weight



APT-1; 1 cu. in., 3.15 oz.
 (actual size)

in moving coil mechanism

Stable, linear, accurate mechanism for indicating, control or recording systems. 1% linearity over 18-0-18° and greater accuracy assured by coil design with over 75% of winding "working" in high energy, uniform field air gap. Coil system weighs 0.85 gm, develops 26.4 mmg of torque; 31:1 T/W. Vibration resonance negligible; acceleration errors sharply attenuated. Standard pivots and jewels—custom damping—wide range of sensitivities.

AMMON

AMMON INSTRUMENTS, INC.
 345 Kelley Street, Manchester, N. H. 03105

Circle 271 on reader service card

Here are a few of the ways Xerox is working on graphic communications:

DEVELOPMENT of imaging systems, image storage devices, image translation methods, coherent light techniques and materials development.

DESIGN of systems, equipment and components for image sensing, image recording, image display, graphic communications and translation devices.

ENGINEERING studies (theoretical and experimental) for photographic systems, electrostatic systems, evaluation determinations and system simulation.

Here are the kinds of people we'd like to have working with us:

ELECTRONIC DEVELOPMENT ENGINEERS

For experimental design, fabrication and testing of advanced CRT display, character generation, and control equipment. BSEE required, MS preferred, with experience in electronic circuit design, solid state logic, display, communications, and/or packaging.

ELECTRONIC ENGINEERS

To work in the development of peripheral equipment of data processing systems. BSEE with design experience in the area of solid state digital data processing equipment in both systems and circuits.

COMPUTER PERIPHERAL SYSTEMS ENGINEERS

Electrical or mechanical engineers, with experience in the peripheral equipment area for data systems or computer systems including development work on magnetic tape, magnetic drums, punched card equipment, electromechanical printers. Should also have been involved with systems planning and/or systems integration of computer peripherals with computer systems.

These positions are in Rochester, New York. Please send your resume, including salary history, in confidence to Mr. Gerald Swanson, Department EL-1, Xerox Corporation, P.O. Box 1540, Rochester, New York 14603.

XEROX

An Equal Opportunity Employer (M&F)

90% of all Japanese ITV cameras use COSMICAR lenses.



For your vidicon, image orthicon and professional movie cameras, Cosmicar lenses are available in focal lengths from 12.5mm up to 1000mm.

New zoom lenses are now available.



ICHIZUKA OPTICAL CO., LTD.

2-568, SHIMOOCHIAI, SHINJUKU-KU, TOKYO

CABLE ADDRESS: "MOVIEKINO TOKYO"

Circle 272 on reader service card

Technical Abstracts

ultrasonically cut and etched from a slice conventionally diffused with phosphorus and boron, and mounted in a coaxial cavity. Spectrum analyzer displays of the Read oscillator output have shown 3 db points separated by less than 10 kilocycles—much less than that observed with the simple pn junction. Noise figures for practical Read amplifiers are expected to be considerably lower than those for pn junctions.

Presented at the International Electron Devices Meeting, Washington, Oct. 20-22.

Achieving high frequency

Microwave power transistors
Harry F. Cooke, Andrew J. Anderson,
Texas Instruments Incorporated,
Dallas

A transistor capable of delivering two watts at 2.25 gigacycles with a duty cycle of 10% has been developed. The transistor was required in the transmitter of an all solid state radar system which will eventually be built with integrated circuits.

Several intermediate transistors, each with characteristics superior to the preceding one were built first. Development started with a prototype having a 7-stripe base-emitter geometry capable of providing an output of 100 milliwatts at 2 Gc. The base resistance of this device was then lowered by changing the diffusion rate, allowing the construction of a transistor having a power output of 150 milliwatts at 2 Gc. Next, four of these transistors were interconnected to obtain greater power. This device, however, was inefficient and a single transistor with a larger area was substituted. Finally, a device with 65 stripes in a total base area of 100 square mils was fashioned. The emitter and base stripe widths and spacings were equal and were each 0.2 mils. The bonding pads were kept widely separated in order to keep as low as possible the mutual inductance between the leads. The work was supported by Air Force Contract AF33-615-2525.

Presented at the International Electron Devices Meeting, Washington, Oct. 20-22.

For
Production
Efficiency



CRM FINE WIRE
for **ULTRASONIC BONDING —**
ALUMINUM & ALUMINUM ALLOYS
featuring

Cleanliness • Strength • Uniformity

Contact CRM engineers for recommendations
for your application.



Write for Data.

CONSOLIDATED REACTIVE METALS, inc.

115 Hoyt Avenue — Mamaroneck, N. Y. — OWens 8-2300 — TWX 914-835-3380

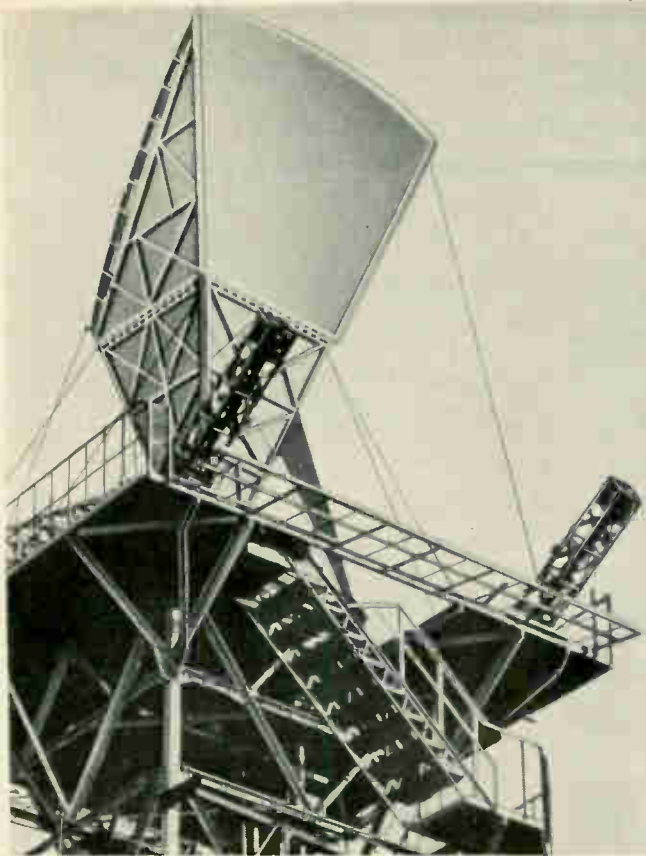

MITSUBISHI MICROWAVE ANTENNAS FOR TELECOMMUNICATIONS

Japan today has the second largest microwave network in the world. Mitsubishi Electric, with the longest microwave antenna experience in Japan, has supplied 90% of the antennas used in the trunk lines of this extensive network. Mitsubishi antenna systems include parabolic, scatter, horn reflector and radar types, as well as a complete line of wave guide components and accessories. Frequencies from 900 Mc. to 24 KMc. are covered. The horn reflector antenna MA 6040HR, shown left and specified below, is typical of the outstanding performance of Mitsubishi microwave antennas. Full technical information on any of these types is available at your request.

Horn Reflector Antenna MA 6040HR

Frequency Range : 3,600 · 4,200Mc and 5,925 · 6,425Mc
 Polarization : Vertical and Horizontal Plane
 Gain over Isotropic Radiator : 41.2dB (H) 3,900Mc
 41.5dB (V) " "
 45.0dB (H) 6,100Mc
 44.9dB (V) " "
 Cross Polarization Discrimination : 65dB minimum
 Front to Back Ratio (over 90 degrees) : 65dB minimum
 Guaranteed Wind Speed : 215Kmph (134 mph)
 Net Weight : 2,000kg. (approx.)
 VSWR : V 1.02 H 1.01 at 4,000Mc band
 V 1.02 H 1.02 at 6,000Mc band
 Waveguide and Fittings : 69mm I.D. Circular Waveguide



MITSUBISHI ELECTRIC CORPORATION

Head Office: Mitsubishi Denki Bldg., Marunouchi, Tokyo. Cable Address: MELCO TOKYO

Circle 273 on reader service card

Help Your Post Office
 To Serve You Better

By

Mailing Early in the Day

Nationwide Improved Mail

Service Program

CHECK

TENSION

QUICKLY

WITH THE
**GENALEX
 TENSION
 GAUGE**



FOR checking the tension of springs or similar resistive forces.

- Most precise
- Easiest to read

Available in six tension ranges from 4 to 2500 grams

for free illustrated leaflet, write to



11 UNIVERSITY ROAD, CAMBRIDGE 38, MASS

QUALIFICATION FORM FOR POSITIONS AVAILABLE

ATTENTION: ENGINEERS, SCIENTISTS, PHYSICISTS

This Qualification Form is designed to help you advance in the electronics industry. It is unique and compact. Designed with the assistance of professional personnel management, it isolates specific experience in electronics and deals only in essential background information. The advertisers listed here are seeking professional experience. Fill in the Qualification Form below.

STRICTLY CONFIDENTIAL: Your Qualification form will be handled as "Strictly Confidential" by Electronics. Our processing system is such that your form will be forwarded within 24 hours to the proper executives in the companies you select. You will be contacted at your home by the interested companies.

WHAT TO DO. (1.) Review the positions in the advertisements. (2.) Select those for which you qualify. (3.) Notice the key numbers. (4.) Circle the corresponding key number below the Qualification Form. (5.) Fill out the form completely. Please print clearly. (6.) Mail to: Classified Advtg. Div., Electronics, Box 12, N. Y. 10036.

COMPANY	PAGE	KEY #
ATOMIC PERSONNEL INC. Phila., Pa.	235	1
BAUSCH & LOMB Rochester, New York	230	2
COLLINS RADIO CO. Cedar Rapids, Iowa	218-219	3
DOUGLAS AIRCRAFT CO. Santa Monica, Calif.	218-219	4
ELDORADO ELECTRONICS Concord, Calif.	230	5

GENERAL DYNAMICS CORP. Rochester, New York	232	6
JET PROPULSION LABORATORY Pasadena, Calif.	200	7
LAWRENCE RADIATION Livermore, Calif.	234	8
LOCKHEED MISSILES & SPACE CO. Sunnyvale, Calif.	221	9
NATIONAL CASH REGISTER CO. Hawthorne, Calif.	206-207	10
PAN AMERICAN WORLD AIRWAYS Cocoa Beach, Fla.	234	11
PHILADELPHIA NAVAL SHIPYARDS Phila., Pa.	232	12
SANDERS ASSOCIATES INC. Nashua, New Hampshire	231	13
TRW SYSTEMS Redondo Beach, Calif.	224	14
XEROX CORP. Rochester, New York	227	15
P-8191	231	16

PERSONAL BACKGROUND

Name
Home Address
City Zone State
Home Telephone

EDUCATION

Professional Degree(s)
Major(s)
University
Date(s)

FIELDS OF EXPERIENCE (Please Check) 1/10/66

- | | |
|---|---|
| <input type="checkbox"/> Aerospace | <input type="checkbox"/> Medicine |
| <input type="checkbox"/> Antennas | <input type="checkbox"/> Microwave |
| <input type="checkbox"/> ASW | <input type="checkbox"/> Navigation |
| <input type="checkbox"/> Circuits | <input type="checkbox"/> Operation Research |
| <input type="checkbox"/> Communications | <input type="checkbox"/> Optics |

- | | |
|--|---------------------------------------|
| <input type="checkbox"/> Components | <input type="checkbox"/> Packaging |
| <input type="checkbox"/> Computers | <input type="checkbox"/> Radar |
| <input type="checkbox"/> ECM | <input type="checkbox"/> Radio-TV |
| <input type="checkbox"/> Electron Tubes | <input type="checkbox"/> Simulators |
| <input type="checkbox"/> Engineering Writing | <input type="checkbox"/> Solid State |
| <input type="checkbox"/> Fire Control | <input type="checkbox"/> Telemetry |
| <input type="checkbox"/> Human Factors | <input type="checkbox"/> Transformers |
| <input type="checkbox"/> Infrared | <input type="checkbox"/> Other |
| <input type="checkbox"/> Instrumentation | |

CATEGORY OF SPECIALIZATION

Please Indicate number of months experience on proper lines.

	Technical Experience (Months)	Supervisory Experience (Months)
RESEARCH (pure, fundamental, basic)
RESEARCH (Applied)
SYSTEMS (New Concepts)
DEVELOPMENT (Model)
DESIGN (Products)
MANUFACTURING (Product)
FIELD (Service)
SALES (Proposals & Products)

CIRCLE KEY NUMBERS OF ABOVE COMPANIES' POSITIONS THAT INTEREST YOU

1	2	3	4	5	6	7	8	9	10	11	12	13	14	15	16
---	---	---	---	---	---	---	---	---	----	----	----	----	----	----	----

Bausch & Lomb has openings for ELECTRONIC ENGINEERS

B.S. or M.S. with one to five years experience in the design of analog and digital circuits and systems. Good theoretical background in math, physics and network analyses desirable. Experience in control systems and low signal level circuit techniques helpful. Projects involve development of sophisticated instruments in bio-medical, chemical, optical and electronic fields at the applied research stage.

Please send resume in confidence, including salary requirements to: E. J. Walter, Employment Specialist, Bausch & Lomb, 620 St. Paul St., Rochester, N.Y. 14602.

BAUSCH & LOMB 
An Equal Opportunity Employer

ELECTRICAL ENGINEER MECHANICAL ENGINEER

Leading company in its field located on Chicago's North Shore, has openings for Electrical Engineer and Mechanical Engineer. B.S. degrees required.

Some experience in electronics, photography and transducers helpful, but not necessary.

Non-military work within small group. Individual effort recognized. Ideal working conditions with all benefits. Salary commensurate with ability.

P-8191, Electronics
645 N. Michigan Ave., Chicago, Ill. 60611

SENIOR ELECTRONIC ENGINEERS

Design and project responsibility for high performance digital commercial instruments. Strong background in design/analysis solid state circuits, switching theory, analog circuits desired. BSEE or Physics. Salary open. Contact D. Condon.

ELDORADO ELECTRONICS

601 Chalomar Road
Concord, Calif. 94520
(415) 686-4200

An Equal Opportunity Employer

Not every engineer can see through our camouflage.



A Sanders engineer looks at things differently. So does his management. □ □ □ The fact that our Nashua, New Hampshire headquarters doesn't resemble a country club—inside or out—doesn't get in their way. □ □ □ Our engineers know that we're in a position to pour a lot of money into interior decoration and morocco bound proposals. (In the last 4 years our sales volume has almost tripled to over \$56 million.) □ □ □ They see it our way—that a couple of million dollars pays for a lot of electronics technology through company funded research and development. □ □ □ They like being adventurers

in an adventuresome company. Why? They're free to create in as many new directions as their ideas lead them. Red tape is out. Mr. Sanders is in. Getting his engineers' ideas into his office is far more important than dwelling on protocol. □ □ □ If you see our point and feel comfortable in a hard-nosed yet flexible systems climate, inquire now. Immediate senior level openings exist in significant research, development and product design in such areas as infrared systems, advanced military communication systems, microwave components and antennas, power supplies, and CRT display circuitry and systems.

Write in confidence to Mr. Lloyd Ware, Staff Engineer.

sanders associates, inc.



NEW DIRECTIONS IN
ELECTRONICS SYSTEMS

NASHUA, NEW HAMPSHIRE

An equal opportunity employer, M & F

Follow the logic of our data communications systems

(It could
lead you to
a better
job.)

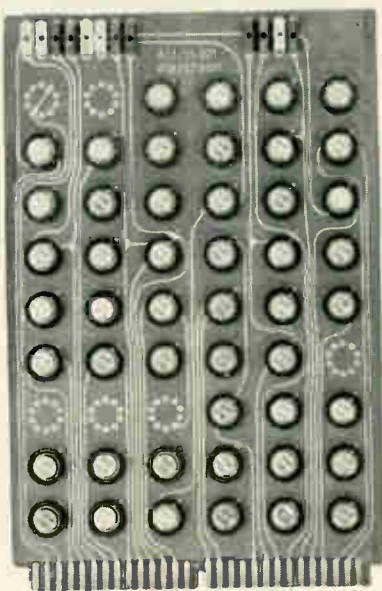

If you're pretty much sold on the idea that data communications is one of the most profound growth areas in the electronics industry today (and for a lot of todays to come), your most important move right now should be a no-nonsense examination of the firms with a commitment like yours.

The trick is to separate pretensions from performance.

You might call the above photo one of our calling cards. It's a multi-layer printed circuit board, mounting integrated circuit submodules for performing digital logic functions. We're devising similar circuits for the systems under development here for AUTODIN at our Data Communications Lab.

Two strong areas of current R&D interest in our Data Communications Lab will give you additional career clues: 1) The application of modulation and coding theory to data communications for transmission via many different media; 2) Development of frequency-differential signalling for high-speed data transmission in the high frequency band, studies of propagation and polarization phenomena at high frequency, and frequency measurements in the microwave band.

If you begin to see the logic behind all this, you may want to add some of your own — especially if you're a Systems or Design Engineer with experience in logic design, input-output devices and MODEMS.

If you're more qualified in radio communications, ASW, space/navigation, AGE, electronic reconnaissance/countermeasures, your move to Electronics Division is just as logical.

Write us and we'll give you more details on the growth picture here. Address Mr. Lewis A. Corwin, Dept. 22.

GENERAL DYNAMICS *Electronics Division*

1400 N. Goodman St., Rochester 1, New York

An Equal Opportunity Employer (M&F)

*Electrical and
Electronic Engineers:*

**Naval expansion
offers you a
career in
ship and shore
system design,
research,
development and
evaluation**

*Starting salaries up to \$10,619
depending on experience.*

Many exciting opportunities for engineers are being created by the expansion of the Philadelphia Naval Shipyard, the major facility for new ship construction on the East Coast, and expansion of the activities of the Office of Industrial Manager, Fourth Naval District. These are career Civil Service positions with regular salary increases and generous benefits including 13-26 days of vacation, 13 days of sick leave, 8 holidays, inexpensive health and life insurance, and an unusually liberal retirement plan.

Electrical and electronic engineers are offered a variety of challenging assignments in every phase of ship and system design ranging from electrical power and light to fire control, communications, radar, and instrumentation, etc. Also offered are laboratory assignments in research and development of stress, sound and vibration, measuring equipment and their application; assurance engineering and reliability engineering covering the field of shipbuilding systems and equipment; and development, design, instrumentation, and installation planning of electronic systems for U. S. Naval activities ashore.

Philadelphia and its suburbs offer housing accommodations for every taste. This historic city has museums, libraries, spacious parks, 27 colleges and universities, and is within an hour's drive of excellent ocean beaches and famous mountain resorts.

If you have a degree in engineering, send a resume or Standard Form 57 (available at any Post Office) to the Industrial Relations Office, Code 175-F



**Philadelphia
Naval Shipyard**
Philadelphia, Pennsylvania 19112

An Equal Opportunity Employer

Give us 30 minutes of your time and we'll give you 2 years of IBM's

How? By using IRIS—IBM's Recruitment Information System—to help you find a new career . . . with IBM.

IRIS could find you a position with IBM that matches your unique talents in a matter of minutes. But if there's nothing open right now, that won't stop IRIS. It keeps right on searching. For two solid years.

All you have to do is fill out the IRIS Data-Pak. That takes about 30 minutes. IRIS takes it from there.

IRIS is tuned to openings in marketing, finance, manufacturing, research and development throughout IBM—from recent college graduates to the most highly experienced professionals. And IRIS may even *widen* your job opportunities. By instantly matching our openings to your unique experience and preferences.

IRIS could even find a new kind of job for you—a job requiring completely new mixes of personal experience—experience you have that may now be going unused and unrewarded.

With IRIS, whenever the computer singles out a job that appears right for you, IBM's experienced staffing people are alerted. They check carefully to be certain that the opening meets your professional goals and offers advancement potential. If it does, you'll be notified immediately of the opportunity. Then arrangements for a personal interview will be made.

Until then, your file remains "on top" and available when an opportunity comes along.

There are plenty of opportunities for professionals with college degrees and appropriate experience. We need qualified Electrical Engineers, Mechanical Engineers, Industrial Engineers and Plant Engineers.

We need qualified professionals in all phases of Development, Manufacturing, Programming, Space Systems and Research.

And there are other immediate openings, too. For Facilities Engineers, Statisticians, Systems Analysts and Sales Engineers.

Once your Data-Pak is returned to IBM and acknowledged, you'll know you're getting a clear shot at developing opportunities throughout IBM—the growth company in *the* growth industry: information handling and control. You'll know you could have the opportunity of a lifetime—the opportunity to work for an exciting company that offers stability and real growth potential. And more importantly, all the accompanying personal rewards.

So, even if you're not contemplating a move right now, let IRIS put your resume "on top" for hundreds of exciting opportunities at IBM.

Who knows what career challenge the next two years—and IRIS—could bring?

IBM is an Equal Opportunity Employer

SEND FOR YOUR IRIS DATA-PAK NOW!

Coleman Mandellblit, Dept. 554N1
Professional Staffing
IBM Corporate Headquarters
Armonk, New York 10504

IBM[®]

I am interested in career opportunities with IBM.
Please send me the IRIS Data-Pak.

Name _____

Address _____

City _____

State _____

Zip Code _____

Degree _____

Present Job Title _____



Last year weeds grew here.

It seems our telemetry pros never have a chance to get used to the scenery on the range. It changes too fast. Next year the skyline will be even more dramatic. It's never been any other way.

What better method of keeping on top of the technology?

Take Tel-4, for example. In order to pick up heartbeats from astronauts on their way to the moon (among other exotic space mission requirements), this advanced telemetry system now being installed incorporates bandwidth and gain characteristics unexcelled in the free world. Its computer controlled switching system will hook all equipment together in 20 seconds, and will be capable of changing from one mission to another in a matter of minutes. Completely automatic, its self-calibrating features will do in 240 seconds the task it would take humans a week to accomplish.

Other current modernization projects in the telemetry area alone include building in advanced capabilities to handle more data generated by more sophisticated space missions...providing more real-time readout for manned missions...receiving all modulations...shifting from very high frequency to ultra high frequency...providing more accuracy and reliability.

If you'd like to benefit from these dramatic and sweeping technological changes, you are invited to write to Manager, Professional Employment, Dept. 28A2



GUIDED MISSILES RANGE DIVISION

PAN AMERICAN WORLD AIRWAYS, INC.
750 S. ORLANDO AVENUE, COCOA BEACH, FLORIDA
An Equal Opportunity Employer M/F

UNIVERSITY OF CALIFORNIA

LAWRENCE RADIATION LABORATORY

ELECTRONICS ENGINEERING POSITIONS

B.S., M.S., Ph.D.

solid state circuit
design
microcircuitry
microwave
digital computers
nuclear instrumenta-
tion

APPLIED RESEARCH PROGRAMS:

- **BIO-MEDICAL**

radiation effects on
the biosphere

- **PLOWSHARE**

peaceful applications
of nuclear explosives

- **Propulsion**

reactors for propulsion
and power in space

- **SHERWOOD**

controlled thermonuclear
fusion

- **WHITNEY**

nuclear weapons for
national defense

For further information about
our programs and a listing of
current openings, write:

B. R. Graf

P. O. Box 808 20-16

LAWRENCE RADIATION LABORATORY

Livermore, California

U. S. Citizenship Required

An Equal Opportunity Employer



E. E.'s
for FEE-PAID Positions
WRITE US FIRST!
Use our confidential application
for professional, individualized
service... a complete national
technical employment agency.
ATOMIC PERSONNEL, INC.
Suite 1207L, 1518 Walnut St., Phila. 2, Pa.

PROFESSIONAL SERVICES

GIBBS & HILL, Inc.
Consulting Engineers
Systems Engineering
Operations Research • Development
Field Studies • Design • Procurement
Power • Transportation • Communications
Water Supply • Waste Treatment
393 Seventh Avenue New York 1, N. Y.

SELLING OPPORTUNITY AVAILABLE

Representatives Wanted—Choice territories
still available. See our ad on page 150. Sensi-
tak Instrument Corp., 531 Front St., Man-
chester, N. H. 03102, Phone (603) 627-1432.

YOU'RE H!RED

Do you need electronics engi-
neers or technical manage-
ment men? Electronics mag-
azine is the way to recruit
them. Electronics is designed
specifically for the working
engineer. 68,000 subscribers
and an additional 133,000
pass-along readers turn to it
to keep up with their indus-
try. You can find the man that
meets your qualifications
with an advertisement in the
Employment Opportunities
Section.

For rates & information
write: Electronics, a McGraw-
Hill Publication. Classified
Advertising Division, Post Of-
fice Box 12, New York 10036.

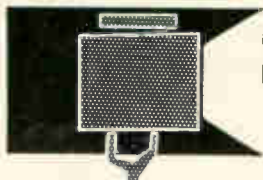

SEARCHLIGHT SECTION

- CLASSIFIED ADVERTISING • BUSINESS OPPORTUNITIES
- USED OR SURPLUS EQUIPMENT

TO SATISFY YOUR ELECTRONIC AND COMMUNICATIONS EQUIPMENT
REQUIREMENTS AND SAVE \$, BUY
U. S. DEPARTMENT OF DEFENSE SURPLUS

176 LOTS OF
PROPERTY
OFFERED **\$1.7** MILLION
ACTUAL
COST

SEALED BID SALE

Tuesday, 25 January— 10:00 a. m.

Bid Room, Bldg. 502, Defense Surplus Sales Office
U.S. Naval Supply Center, Oakland, California

To Be Offered

Communications Equipment
Electronic Tubes
Telephone & Telegraph Equipmt.
Radio Transmitter Sets
Electric Relays
Motors - Switches

Capacitors - Relays
Motor Generator Sets
Coils & Transformers
Magnetron Tubes
Misc. Electrical & Electronic
Components

These Items are Located at 8 Military Installations in Northern & Central California

Inspect Them 5 Jan. To Time of Bid Opening, 8:00 a.m. to 3:00 p.m.

Except Saturdays, Sundays, and Holidays

Mail Coupon to Order your Illustrated Sales Catalog & Bid Form

Defense Surplus Sales Office, Dept. E1
P.O. Box 4000, Bayshore Station
Oakland, California 94623
Phone: A. C. 415/466-6410

Catalog
No. 44-6060



NAME

ADDRESS

CITY

STATE ZIP

I Am Am Not On The DoD National Bidders List.

Send additional information that tells how I can purchase surplus products from the United States Government

CIRCLE 951 ON READER SERVICE CARD

TEST EQUIPMENT

For over 20 years specializing in top brands
only. Write for our latest listing.
We buy complete inventories.



ELECTRONIC SALES
1413 Howard Street, Chicago, Illinois 60626
Telephone Rogers Park 4-0600

CIRCLE 952 ON READER SERVICE CARD

MICROWAVE EQUIPMENT SALE

Signal generators, receivers, slotted lines, coaxial
and waveguide components, klystrons, power sup-
plies etc., covering 2mc to 140,000mc. \$30,000
valuation, all brand names, no surplus.

Write or call for complete list.

P.O. Box 235, Goleta, Calif. 93017
Phone (805) 96 65314

CIRCLE 953 ON READER SERVICE CARD

BIG CATALOG

World's "BEST BUYS"
in GOV'T. SURPLUS
Electronic Equipment

FULL OF TOP QUALITY ITEMS—
Transmitters, Receivers, Power Supplies,
Inverters, Microphones, Filters, Meters,
Cable, Keys, Phones, Antennas, Chokes,
Dynamotors, Blowers, Switches, Test Equip-
ment, Headsets, Amplifiers, etc., etc. SEND
25¢ (stamps or coin) for CATALOG and
receive 50¢ CREDIT on your order. Address
Dept. E-6.

FAIR RADIO SALES
P.O. Box 1105 • LIMA, OHIO • 45802

AUTOTRACK ANTENNA MOUNT

360 degree azimuth, 210 degree elevation sweep with better than 1 mil. accuracy. Missile velocity acceleration and slew rates. Amplify and servo control. Will handle up to 20 ft. dish. Supplied complete with control chassis. In stock—immediate delivery. Used world over by NASA, USAF. TYPE MI-61 B. SCR-584. NIKE AJAX mounts also in stock plus several airborne trackers.

SCR 584 AUTOMATIC TRACKING RADARS

Our 584s in like new condition, ready to go, and in stock for immediate delivery. Ideal for telemetry research and development, missile tracking, satellite tracking, balloon tracking. Used on Atlantic Missile Range, Pacific Missile Range, N.A.S.A. Wallops Island, A.B.M.A. Write us, Fully Desc. MIT Rad. Lab. Series, Vol. 1, pps. 207-210, 228, 284-286. Compl. Inst. Bk. avail. \$25.00 each.

AN/GPG-1

SKYSWEEP TRACKER

3 cm. automatic tracking radar system. Complete package with Indicator system. Full target acquisition and automatic tracking. Input 115 volts 60 cycle. New. In stock for immediate delivery. Entire System 6' long, 3' wide, 10' high. Ideal for Infrared Tracker, Drone Tracker, Missile, Tracker, R & D.

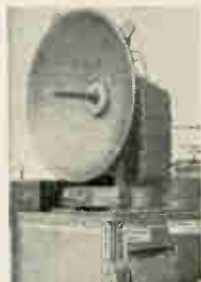

PULSE MODULATORS

MIT MODEL 9 PULSER

1 MEGAWATT—HARD TUBE

Output 25 kv 40 amp. Duty cycle. .002. Pulse lengths .25 to 2 microsec. Also .5 to 5 microsec. and 1 to 5 microsec. Uses 6U21. Input 115 60 cycle AC. Mfr. GE. Complete with driver and high voltage power supply. Ref: MIT Rad. Lab. Series, Vol. 5, pps. 152-160

2 MEGAWATT PULSER

Output 30 kv at 70 amp. Duty cycle .001. Rep rates: 1 microsec 600 pps, 1 or 2 msec 300 pps. Uses 5948 hydrogen thyratron. Input 120/208 VAC 60 cycle. Mfr. GE. Complete with high voltage power supply.

MIT MODEL 3 PULSER

Output: 144 kv (12 kv at 12 amp.) Duty ratio: .001 max. Pulse duration: .5, 1 and 2 microsec. Input: 115 v 400 to 2000 cps and 24 vdc. \$325 ea. Full desc. Vol. 5, MIT Rad. Lab. series, pg. 140.

250KW HARD TUBE PULSER

Output 16 kv 16 amp. duty cycle .002. Pulses can be coded. Uses 5D21, 715C or 4PR60A. Input 115 v 60 cycle ac. Incl. H.V. pwr supply \$1200 ea.

5949 THYRATRON AGING RACK

Compl. Chatham Electronics Console incl. 15 kv power supply & PFN's. \$1800.

MICROWAVE SYSTEMS

E-4 FIRE CONTROL SYSTEM

Hughes Aircraft X Band. Complete. In stock.

C-BAND RADAR

250 KW output, C-band, PPI indicator, 5C22 thyratron modulator. Antenna hi gain paraboloid section. Input 115 volts 60 cycle AC. complete \$2750.00.

300 TO 2400MC RF PKG.

300 to 2400 MC CW Tuneable. Transmitter 10 to 30 Watts. Output. As new \$475.

500KW "L" BAND RADAR

500 kw 1220-1359 mcs. 160 nautical mile search range P.P.I. and A Scopes. MTI, thyratron mod. 5J26 magnetron. Complete system.

PHILCO MICROWAVE LINKS

C Band Microwave Link terminal bays and repeater bays in stock. New \$1500 each or \$2500 per pr.

100—800MC. CW SOURCE

150 watts CW nominal output 115 V 60 Cy AC Input. \$1600

100KW 3CM. RADAR

Complete 100 kw output airborne system with AMTI. 5C22 thyr. mod. 4J52 magnetron. PPI. 360 deg az sweep. 60 deg. elev. sweep. gyro stabilizer, hi-gain revt. Complete with all plugs and cables.

M-33 AUTO-TRACK RADAR SYSTEM

X band with plotting board, automatic range tracking, etc. Complete with 1 megawatt acq. radar.

INFRARED SOURCES

Collimated radiation simulator and transistorized temp. controller. Temp range, 200-600 degree C. Absolute Accuracy ± 3 degree C. Type AN/USM. \$1975 New

3KW RCA PHONE & TELEG XMT

2—30 Mc. 10 Autotone channels plus MO. Input 220 vac. 50/60 cycles.

Radio-Research Instrument Co.
550 5th Ave. New York 38, N.Y.
Tel. JUdaon 6-4891

CIRCLE 954 ON READER SERVICE CARD

Transistorized Packaged Circuits

T-101B Flip Flop...	8.15
T-102A Flip Flop...	6.75
T-103 Flip Flop...	6.40
T-104 Multivibrator...	7.25
T-105A One-Shot...	6.65
T-106 Squaring Amplifier...	5.80
TM-106 Squaring Amplifier...	6.80
T-108 Amplifier...	9.40
T-109 Reset Generator...	6.00
TE-109* Reset Generator...	9.50
T-112 Emitter Follower, Dual...	4.40
T-113 Emitter Follower, Triple...	5.35
T-115 Emitter Follower, Dual...	5.05
T-116 Emitter Follower, Triple...	6.40
T-128 Relay Driver (D-24V)...	9.05
T-129 Reset Generator...	4.75
T-139 Driver 0-30V...	14.30
TM-170* Driver...	9.20
TM-171* Driver...	10.30
TM-411 Pulse Logic...	8.15
TM-620 DC Logic...	8.25
TM-644 Flip Flop...	11.90
TE-648 Flip Flop...	11.05

Actual Size

Prices subject to change without notice. Usual terms to rated Accounts—All others 25% Cash with order—Balance C.O.D. F.O.B. Bay Area. All items subject to prior sale. Minimum order \$10.00

EMMONS ELECTRONIC SUPPLY CO.

405-10th St.,
Oakland 7, California
TWinaks 3-7411

See Our Ad Page 913

1965 ELECTRONICS BUYERS' GUIDE

CIRCLE 955 ON READER SERVICE CARD

Standardized TERMINALS & BUSHINGS

FREE CATALOG

KEYSTONE ELECTRONICS CORP.
49 BLEECKER ST., N.Y., N.Y. 10012

CIRCLE 956 ON READER SERVICE CARD

EDMUND Scientific Co. Catalog 'EX'

Many on-the-job helps... Quality Control Aids! Write for this completely new, 1965 Catalog. New items, new categories, new illustrations. 148 easy-to-read pages packed with hundreds of charts, diagrams, illustrations. A treasure-house of optical and scientific information... unusual bargains galore. Optics for industry, research labs, design engineers, experimenters, hobbyists! Instruments for checking, measuring—to speed work, improve quality, cut production costs. We give you facts: what it is—how it works—where it's used!

COMPARATORS, MAGNIFIERS, MICROSCOPES

Hard-to-get war surplus bargains—ingenious scientific tools—imported—domestic. Thousands of components: lenses, prisms, wedges, mirrors, mounts—accessories of all descriptions. Dozens of instruments: magnifiers, stereo microscopes, telescopes, binoculars, infrared equipment, photo attachments. Shop by mail. No salesman will call. Use the Catalog of America's greatest Optics—Science—Math Mart. Known for reliability. Mail coupon below for catalog "EX". No obligation.

EDMUND SCIENTIFIC CO.
Barrington, N. J.

New VACUUM PENCIL

for picking up miniature parts

\$7.50 ea

Selected Distributors available.

PHILIP FISHERMAN COMPANY
7 CAMERON ST., WELLESLEY, MASSACHUSETTS

ELECTRON TUBES

KLYSTRONS • ATR & TR • MAGNETRONS
SUBMINIATURES • C.R.T. • T.W.T. • 5000-6000 SERIES

• SEND FOR NEW CATALOG A2 •

A & A ELECTRONICS CORP.
1063 PERRY ANNEX
WHITTIER, CALIF.
696-7544

SMALL AD but BIG STOCK

of choice test equipment and surplus electronics

Higher Quality—Lower Costs
Get our advice on your problem

ENGINEERING ASSOCIATES
434 Pottersson Road — Dayton 19, Ohio

GET INSTANT MONEY!!

We want your surplus, obsolete, or excess inventory equipment, components & parts! Need ground & air communication equip., teletype, all GRC, PRC, ARC, ARN—all test equip. What have you? WE PAY TOP DOLLAR! We make deals—now! And we pay freight. Tell us what you have—not tomorrow—today!

COLUMBIA ELECTRONICS—Dept E
4365 W. Pico Blvd.,
Los Angeles, Cal. 90019

DIGITAL RECORDERS

H.P. 561B, never used. \$550 each. Electro Instruments Inc. mod. 500 XY recorder, nuc. detector. Mod. 472, never used. \$600. Misc. tec. plug-ins and p.r. lab equip. Meppo prec. resis. .01%.

W. D. CONTRACTING ENGINEERS
5437 West Division Chicago, Illinois 60651
Phone: (312) 378-7461

WATCH—

the Searchlight Section for Equipment Opportunities

FREE CATALOG!

NEARLY 4,000 BUYS FOR INDUSTRY

OPTICS! SCIENCE! MATH!

GIANT 148 PAGES

MAIL COUPON FOR FREE CATALOG "EX"

EDMUND SCIENTIFIC CO., Barrington, N. J.
Please send FREE Giant 148-page Catalog 'EX'

NAME

ADDRESS

CITYZONE.....STATE.....

CIRCLE 962 ON READER SERVICE CARD

GRAPHIC VISUAL CONTROL

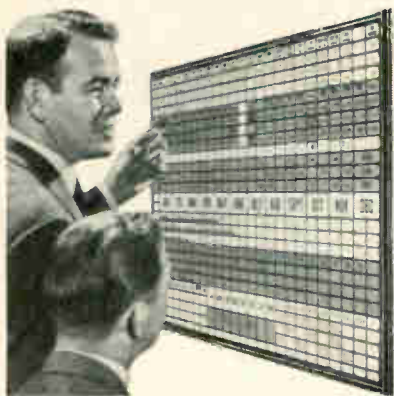

You SEE How To Get Things Done With The BOARDMASTER System

You see a Graphic Picture of your operations, spotlighted in color. You have facts at Eye Level. Saves time, cuts costs and prevents errors.

Ideal for Production, Maintenance, Scheduling, Inventory, Sales, Traffic, Personnel and many other uses.

Simple and flexible tool. You write or type on cards and post on board. All cards are interchangeable.

Compact and Attractive. Made of Aluminum. Over 1,000,000 in use.

Complete Price \$49⁵⁰ Including Cards

FREE 24-Page BOOKLET No. C-10
Mailed Without Obligation

Write Today for Your Copy

GRAPHIC SYSTEMS
925 Danville Road • Yanceyville, N.C.

Circle 274 on reader service card



Reed Relays

Basic
and special
REED RELAYS
and/or **COILS** for
high reliability and
sophisticated switching

Operating Inputs: low as 1mA. and 15mW.
Standard Coil Voltages: 6, 12, 24, 32, 48V in stock
for immediate delivery.

Special Voltage or Resistance, multiple windings for
flip flop, memory and crosspoint selection applica-
tions — to customer specifications.

Relay Contacts in Form A, B, C and latching. Also
high vacuum type 5000V Form A.

Write for Bulletin and Prices

Coto-Coil

COMPANY INC.

Pavilion Ave.
Providence, R. I. 02905
Phone: (401) 941-3355

New Literature

Capacitor selector. Electro Materials Corp., 11620 Sorrento Valley Road, San Diego, Calif., 92121. Case size, tolerance, voltage and capacitance of ceramic capacitors are all easily selected with a new circular slide rule catalog. Circle 420 on reader service card.

Time-delay relays. Airborne Accessories Corp., Electronic Products division, 1414 Chestnut St., Hillside, N.J., 07205. Bulletin PS-13 contains comprehensive information on a versatile new line of solid-state industrial time-delay relays. [421]

D-c microvolt/microammeter. Boonton Electronics Corp., Route 287, Parsippany, N.J., 07054, has issued a technical information sheet providing a general description, circuit discussion and detailed specifications of the model 95A d-c microvolt/microammeter. [422]

Packaging hardware. Scanbe Mfg. Corp., 1161 Monterey Pass Road, Monterey Park, Calif., offers a catalog covering series-T modular electronic packaging hardware, a more flexible approach for individual circuit card support through complete system enclosure. [423]

Tv camera tubes. EMI Electronics Ltd., Hayes, Middlesex, England, has published a brochure containing detailed information on its 4½-in. image orthicon television camera tubes. [424]

Indicator lights. Dialight Corp., 60 Stewart Ave., Brooklyn, N.Y., 11237. A 16-page, illustrated catalog presents a wide array of miniature and large indicator lights (many of which meet or exceed the requirements of MIL-L-3661) for use with neon or incandescent light sources. [425]

Computers in oceanography. Digital Equipment Corp., 146 Main St., Maynard, Mass., 01754. An eight-page brochure discusses the roles computers are playing in studies of the oceans, describes seven specific applications of the company's PDP computers, and lists some of the programing aids available to help the oceanographer. [426]

Power supplies. Deltron Inc., Wissahickon Ave., North Wales, Pa., 19454. Bulletin 101C describes improved specifications and one new model in the series of compact, high-quality power supplies with Duet twin amplifier to control voltage or current with automatic crossover to either mode. [427]

Crystal oscillators. Hill Electronics, Inc., 300 N. Chestnut St., Mechanicsburg, Pa. A four-page booklet covers the selection, specifying and ordering of oven and non-oven oscillators from 1 cps to 100 Mc. [428]

Inertial Guidance Systems Engineers

If you are a Ph.D. or M.S. with 5 years experience, you can be an Electronics Dept. Staff Technical advisor on inertial guidance systems. You should have extensive experience in the detail design of stabilized platforms, as well as a complete knowledge of inertial instruments. Initial assignment will be the analysis of a sub-contractor effort to design and produce an attitude reference unit for tactical missile system. Additional duties will require analysis and design of advanced guidance systems to be used on future Douglas missile and space vehicles.

If you are interested in this opportunity, send your resume in confidence to C. C. MacDonald, Douglas Missile and Space Systems Division, 2700 Ocean Park Blvd., Santa Monica, Calif.

DOUGLAS

MISSILE & SPACE SYSTEMS DIVISION
An equal opportunity employer

Almost everyone asks the same old question. Well, we're not an insurance company, a state hospital, or for that matter anyone in khaki.

Actually, an Indiana General is a 58-year-old veteran corporation. We make magnetic materials of every shape and variety. So you don't have to look very long or hard to find our products in use. Your television set, telephone, and hi-fi equipment probably have some. Even the

electric razor you use in the morning.

Most computers couldn't think without tiny memory cores developed by Indiana General Corporation.

Then there are the big, hefty magnets that lift huge hunks of steel. Or equipment that detects metallic particles that might otherwise drop in a box of cereal.

The company's six divisions produce magnets, ferrites, memory cores and stacks, motors, magnetic separators,

and magnetic handling equipment for consumer, industrial, and military applications.

To put it more simply, Indiana General is the world's largest manufacturer of magnetic materials.

Now you know when somebody asks you.

INDIANA GENERAL 

VALPARAISO, INDIANA • KEASBY, NEW JERSEY • MILWAUKEE, WIS.
OGLESBY, ILLINOIS • KITCHENER, ONTARIO, CANADA

What's an Indiana General?



Electronics Abroad

West Germany

A better PAL

Telefunken AG in West Germany has been refining its color-television system to permit the use of simpler, less expensive receivers that are more reliable than those required a year ago [Electronics, March 22, 1965, p. 106]. Telefunken's system is called PAL, for phase alternation line.

The major changes have been to the chrominance bandwidth and modulation axes, which were previously the same as in the NTSC (National Television Standards Committee) system operating in the United States.

One change is for the color components of the chrominance to be modulated along the color-difference axes, R—Y and B—Y, rather than along the axes of maximum and minimum color acuity, I and Q. The other change does away with dissimilar bandwidths for the two components; the color components now have bandwidths equal to NTSC's larger channel, I.

Out with matrixing. Because NTSC's color bandwidths are unequal, the larger channel is used to modulate the I axis, the axis of color changes to which the eye is most sensitive. I and Q must then be matrixed after detection into

R—Y and B—Y, the signals that ultimately enter the picture tube.

By modulating from the beginning along R—Y and B—Y, PAL eliminates the need for this matrixing in the receiver. There is one additional requirement, however; because the eye has equal sensitivity for R—Y and B—Y, these components must be transmitted with equal bandwidths.

With NTSC, equiband vestigial sideband operation is impossible; full double sidebands are needed in the demodulator to separate the two color channels accurately without color crosstalk. With PAL, which uses delay lines to average out the errors over two lines, the R—Y and B—Y components are separated before demodulation into two separate a-m signals; hence there is no chance for color crosstalk in PAL.

A receiver with such a delay line has been built as deluxe PAL. The simple PAL receiver does not contain the delay lines necessary to separate the two color components over the full bandwidth, but it can be used as a narrow-bandwidth set operating within the double sidebands.

Manufacturers in the United States do not produce full-bandwidth color receivers, considering them too complicated and costly; European manufacturers are likely to follow suit, and simple PAL will probably prevail.

Similar to NTSC. The simple PAL receiver has only one circuit not present in NTSC receivers. This is the switch that keeps the set's R—Y demodulator in step with the R—Y signal, which reverses in phase for every line.

To further simplify the PAL receiver, a new method of R—Y phase identification has been proposed. Previously, phase identification was achieved by a series of subcarrier bursts during a few lines of the vertical retrace period. In the new method of identifica-

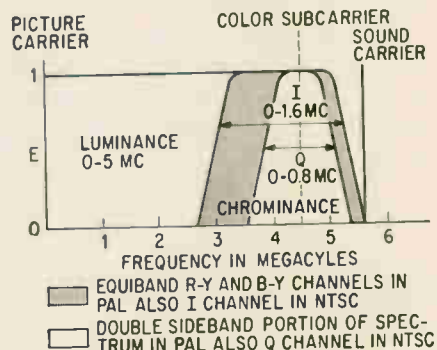

Frequency spectrum for 625-line television used in Europe shows overlapping I and Q channels that are still used in NTSC but eliminated from PAL color-tv system. New PAL has equiband R—Y and B—Y channels.

tion, the subcarrier burst—which is transmitted on the back porch of the horizontal synchronization pulse—is changed in phase 90° on a line-by-line basis. In contrast, the direction of this burst in NTSC and in the old PAL is maintained along the —(B—Y) axis. Now the burst will alternate direction for each line, up 45° and down 45° from the —(B—Y) axis, so that its projection on the —(B—Y) axis will remain the same. However, its projection along the R—Y axis will shift 180° for each line, indicating the phase of the R—Y signal component to follow.

Transcoder. Telefunken engineers have also come up with a transcoder that eliminates all phase errors caused by time-based instability in a color-video recorder. The transcoder, placed in the recorder's output, demodulates and corrects the signal and then remodulates it for transmission. The system could be adapted for NTSC videotape recorders by recording in the PAL form and then remodulating into NTSC. Phase errors in PAL cause desaturation (lightening) of colors; in NTSC these errors cause a change in hue.

The transcoder eliminates phase errors by continuously synchronizing its demodulator directly with the recorded signal subcarrier. In

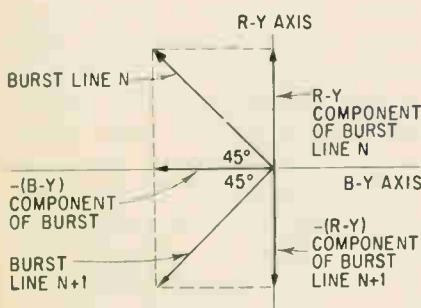

Color phasor diagram shows direction of proposed color burst for lines n and n+1. Alternating position of the burst simplifies receiver design.

this way any instantaneous shift in the phase of the recorded sub-carrier is compensated by a similar shift in the phase of the demodulator. Synchronization usually occurs only at the beginning of each line during the color burst.

The principle of the transcoder system can also be applied easily to a deluxe PAL receiver to eliminate any phase errors picked up in transmission.

France

New approach to Nadge

The North Atlantic Treaty Organization may drop its all-or-nothing approach to awarding of a \$280-million contract for an air-defense ground-environment system called Nadge. NATO has been trying to choose a prime contractor from among three consortiums. Now there are indications that NATO may take bits and pieces from each consortium's proposals.

The competing consortiums are led by the International Telephone and Telegraph Corp., Westinghouse Electric Corp. and Hughes Aircraft Co.

Price has been the big obstacle. All three bids are reported to be well above the \$280-million ceiling. But if the best of each could be combined, the network might be built within the cost limit.

Who'll decide? But who would put the pieces together? NATO obviously cannot be its own systems engineer.

Another problem is apportioning the money to the various countries: the program requires that the industries of each NATO member share the work to the extent of that country's financial contribution to Nadge. The United States' share is 30.8%.

American companies have a big advantage over the Europeans: they can supply most of the off-the-shelf equipment required for Nadge, because development costs have been written off long ago in contracts with the Pentagon.

Belgium

Broader communications

The 75 miles of coaxial telephone lines that link Brussels with Den-dermonde 18 miles away may pre-empt broadband analog communications throughout Western Europe. The 1,200-channel line is field-testing transistorized equipment that is scheduled to expand communications capacity between Brussels and Antwerp by 1967.

Like most telephone systems on the continent, Belgium's Regie des Télégraphes et Téléphones (RTT) is hard pressed to keep up with the rapid increase in communications traffic. The system it is testing was developed by N. V. Philips Telecommunicatie Industrie (PTI), an affiliate of Philips Gloeilampenfabrieken N. V. of the Netherlands.

PTI's family of broadband analog systems does not match the message-carrying capacity of the forthcoming generation of United States systems, but the technology is comparable. Nonregulated repeater amplifiers in the PTI systems, for example, have fixed gain held to a tolerance of plus or minus 0.01 decibel. And the systems meet strict demands for reliability without relying on expensive, brute-force redundancy.

Austere amplifiers. To achieve high reliability and hold down maintenance costs, PTI pared the components in the buried repeater amplifiers. A complete amplifier has only four transistors. Complex circuits, such as equalizers and automatic level-regulating equipment, are concentrated in the main station above ground, where they can be serviced easily.

Throughout the system, components are heavily derated—to one-half the acceptable values specified by their manufacturers, or less. Limits on junction temperatures for transistors, for instance, are kept so low that their expected life matches that of passive components. Based on experience so far, J. F. Lansu, who designed the system, says that no more than two of every 1,000 amplifiers will fail in

a year of continuous operation.

Lansu is especially proud of the system's technique for locating faults. Each buried substation has an oscillator that can inject a 280-kilocycle signal into the station's amplifiers. The oscillators are wired across an interstitial pair of wires in the coaxial cable; by taking advantage of the voltage drop along the pair, the oscillators can be switched on and off in sequence.

When a repeater fails, an alarm sounds at the main station. The operator then switches on the power supply that feeds the oscillators. As he increases the voltage gradually, the first oscillator starts to operate at about 25 volts. A further increase in the voltage switches off the first oscillator and turns on the second oscillator. The operator keeps increasing voltage in this fashion until he gets a return oscillator signal. He can then read off the power-supply voltage control the number of the faulty station.

Two-way stretch. The system is designed so that 32 nonregulated substations and three regulated substations can extend the range of the highest-frequency hardware of the new PTI transistorized line equipment family to 100 miles between main stations. This system has 2,700 channels and operates between 0.3 and 12.5 megacycles per second. The 1,200-channel equipment being tested in Belgium operates between 60 kc and 6 Mc. A third member of the family is a 4-Mc system.

For testing the 6-Mc equipment, RTT laid a 12-tube cable 18.6 miles long and connected the coaxial tubes together in groups of four to get the equivalent of three 75-mile cables. Such mileage between main stations is in a sense too much for a small, densely populated country like Belgium. So RTT and PTI, together with the Dutch Telephone Administration and Philips' Belgian Affiliate, Manufacturing Belge De Lampes et de Material Electroniques put two-way stretch into the system. Channels can be dropped off at way points, with regulating circuits only for the cable pairs involved; ordinarily, all

the pairs in a cable have to be regulated at a dropoff point.

Nonregulated repeater stations along the cable are spaced at 1.8-mile intervals. But since, for the field test, RTT laid "small" cable—1.2 to 4.4 millimeters—with attenuation of 5.3 decibels per kilometer, this is equivalent to 2.9-mile spacing on the 2.6- to 9.5-millimeter cable used in the United States.

U. S. counterpart. The United States' most advanced analog system is being built by the American Telephone and Telegraph Corp. The system, called L-4, is expected to begin operation in 1967. It will contain 3,600 message channels, operate at 564 to 17,548 kilocycles per second, and have a repeater station every two miles. It will carry one television channel (4.2-Mc bandwidth) and 1,320 message channels.

The Philips system also can carry tv. Like AT&T's system, it uses a 4-kv bandwidth for voice channels.

At present, the United States is served by AT&T's L-3 communications network, which operates at 312 to 8,284 kc. It has a repeater station every four miles and can carry 660 message channels plus one tv channel.

Great Britain

New boost for computers

Stepping up its efforts to further the role of computers in Britain, the government plans to finance \$82 million of computer facilities over the next six years.

Anthony Crosland, secretary for education and science, told the Houses of Parliament that the six-year plan would create large regional computing centers at the universities of London, Manchester and Edinburgh, as well as improvements in computing facilities at other universities and research centers. These facilities will be compatible, Crosland said, so the network will form an integrated system.

It is believed that multiaccess, real-time systems will be included, possibly with teledata links between the centers and universities. The program will cost \$9 million a year for the first three years, a dramatic increase from last year's \$3.3 million.

Who will benefit? The installations probably will be made by two companies: International Computers and Tabulators, Ltd. (ICT) and English Electric-Leo-Marconi Computers, Ltd. ICT already has several large installations based on its Atlas computer, with smaller systems ordered or installed at 12 universities.

English Electric's orders and installations in universities are valued at \$6.6 million. The latest is the University of Nottingham's \$600,000 order for a KDF-9 computer for retrieval of legal information and other tasks.

For ICT, Britain's biggest computer company, the news comes at an opportune time. Its financial report for the fiscal year ended Sept. 30, 1965, shows a \$1.42-million loss; the company had a \$7.3-million profit for fiscal 1964.

The loss last year came despite a \$3-million contribution from the government's National Research Development Corp. for research and development.

ICT also has received a \$3-million order in the current fiscal year from the Ministry of Pensions, to set up a computer center that will handle all social-security transactions for the London area. For this real-time system, the computer will be accessible from 120 offices in London. The computer will contain records of 2.5-million people; it will receive details of claims from the local offices, calculate the payments and print out postal drafts for payments at the rate of 50,000 a day.

ICT offers three reasons for its loss last year: the high cost of expanding production facilities for its 1900 series of computers, a decline in deliveries of earlier models after the announcement of the 1900 series, and a failure to produce enough punched-card equipment because of the problems of expanding existing facilities.

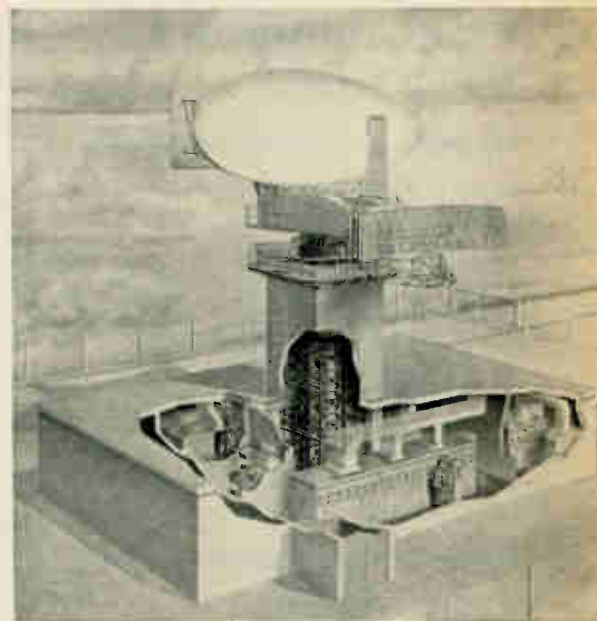

Radar station provides instantaneous 3-D data at altitudes up to 100,000 feet.

The biggest order

Saudi Arabia's \$300-million order for an air-defense network from three British companies will bring \$75 million of business to Associated Electrical Industries, Ltd. (AEI). The other members of the bidding group are the British Aircraft Corp. and Airwork, Ltd. The radar order is believed to be the biggest ever received from abroad by a British electronics company.

AEI is prime contractor for the three-dimensional radar surveillance and control system. The contract also calls for 35 to 40 Lightning supersonic fighter planes and for technical support and training facilities. An additional order has been placed with the Raytheon Co. in Lexington, Mass., for Hawk ground-to-air missile systems. Raytheon says the order is "in excess of \$100 million."

3-D radar. The surveillance system is based on a new radar designed by AEI in conjunction with the British government's Royal Radar Establishment. The system provides instantaneous three-dimensional position data on all planes within an undisclosed coverage area.

Operating in the S band, the sys-

Total production control for top quality in Gold Bonding Wire (99.99%)

Every production step is repeatedly checked to assure Gold Bonding Wire that meets our traditionally high standards...The same critical care is taken with the spooling and packing... The wire is respooled on precision winding equipment especially designed by our plant engineers...Winding tension and pitch are fully controlled so that the single layer winding will not shift or slip... Plastic case with dust-free cushion keeps spool safe in transit.

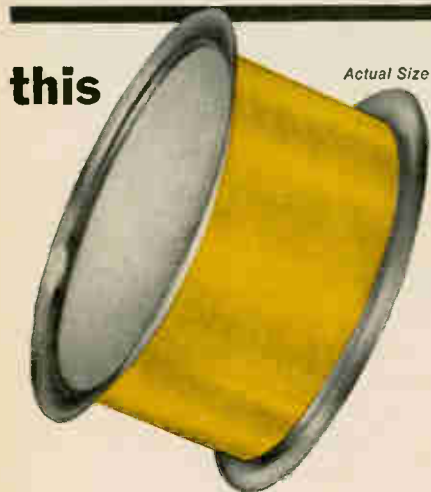

The single layer package
Is designed for:
400 feet of .0007"
400 feet of .0010"
250 feet of .0015"
150 feet of .002"

Write for latest brochure

Sigmund Cohn Corp.

121 So. Columbus Ave., Mt. Vernon, N.Y.



Circle 242 on reader service card

Electronics Abroad

tem contains a receiver for each of 12 stacked beams. Although technical details are secret, the type 40 is believed to achieve instantaneous altitude readings up to 100,000 feet through an electronic scanning system on the stacked beams. Accuracy has not been disclosed.

Between 10 and 15 radar stations are believed necessary to cover Saudi Arabia. Output data from each station, before transmission to the central control unit, is processed by a Myriad computer built by Marconi, Ltd. From the position data, the computer calculates flight paths for the Lightning interceptors. AEI also will supply a communications network to link the radar sites with the control station, where synthesized displays will allow central control of the entire interception pattern.

Deliveries of the system will begin in 1967 and extend until 1970.

International

The contraband market

Cuba has surged ahead of Eastern Europe as the principal destination for contraband goods from the United States, including electronic equipment, according to sketchy information obtained by the Office of Export Control in the United States Commerce Department.

The major reason for the change is the relaxation of American restrictions on sales to Eastern Europe. Nearly everything sold to Cuba, on the other hand, is contraband. And because most of Cuba's industrial equipment was made in the United States, it requires American-made replacements and parts.

The department's export-control division says 55% of its investigations are of reports of goods moving to Cuba. Ten percent are based on reports of goods destined for Communist China and other countries in Asia. Smuggling to China is increasing rapidly, Commerce spokesmen say.

Electronics for Castro. Strict enforcement is accompanied by lenient penalties. When Z&I Aero

Services, Ltd., of London, was caught shipping American-made electronic tubes to China, the company was barred from trading in American goods for only three months and put on probation for 33 more months.

Earlier, the British company had been middleman for five lots of American electronic equipment that found its way into Cuba, according to Commerce Department officials.

Four-way deal. Some cases indicate intricate planning that would do credit to an international spy network. An employee of a legitimate Austrian distributor of electronic equipment ordered two electronic counters and two microvolt ammeters from a Swiss subsidiary of an American company. Then a phony purchase order was submitted by PI-MO K. Pirker & Co. of Austria; that order allowed the distributor to obtain an Austrian import certificate to get the instruments out of bond.

But instead of sending the instruments to PI-MO, the employee transferred them to an Italian company, Socorin, which had been barred from handling American-made goods because of previous allegations of smuggling. The Italian company sent the gear to Vienna for forwarding to Budapest.

For its part in the scheme, PI-MO received only \$250. But there is bigger money to be made in this game of contraband. One lot of 100 small parts for transportation equipment was sold to Cuba a few months ago for \$27,000; the parts cost \$1.67 apiece.

Long way home. One reason for fancy prices is the devious route that contraband shipments must take. U. S. officials recently halted a shipment of machine parts that was sold by an American company to a Toronto distributor, which shipped them to Glasgow for re-routing to Havana.

The direct route can also be expensive. An Austrian father-and-son team successfully airmailed 17 shipments of contraband electronic equipment such as diodes, oscilloscopes and tubes. They were nabbed with three cathode-ray storage tubes, being sent as unaccompanied airline baggage.

Around the world

Great Britain. Merger at home and joint venture abroad are the principal treatments prescribed for Britain's ailing aviation industry by an eight-man government committee headed by Lord Plowden. After a year's study, the panel suggests a merger of activities of the two biggest airframe companies, the British Aircraft Corp. and the aviation operations of the Hawker-Siddeley Group, with the government acquiring a big financial stake in the new organization. Another proposal is for more cooperative ventures with aviation industries in other European countries. Aviation in Britain has declined to 260,000 employees from a peak employment of 311,000 in 1957.

France. The unexpectedly close elections last month are not expected to deter President de Gaulle from continuing to expand the French military, which constitutes about 30% of the domestic electronics market. The military is expected to spend \$380 million for electronics in 1970 compared with \$290 million this year.

Sweden. The pirate radio station, Radio Syd, has branched out into television. The programs, consisting mostly of commercials and old movies beamed to the province of Skaana in southern Sweden, are believed to be the first pirate tv broadcast from shipboard; they originate in international waters between Malmö, Sweden, and Copenhagen, Denmark. Sweden prohibits commercial tv.

Hungary. Like its neighbors in the Soviet bloc, Hungary continues to make agreements with West German companies for cooperative production in electronics and for joint sales to third countries. Czepel, Hungary's biggest industrial complex, is producing numerically controlled lathes in cooperation with the Krupp Works in Essen. Another Hungarian plant, whose identity has not been disclosed, will produce x-ray equipment with help from Siemens & Halske AG, the Hungarian government says.

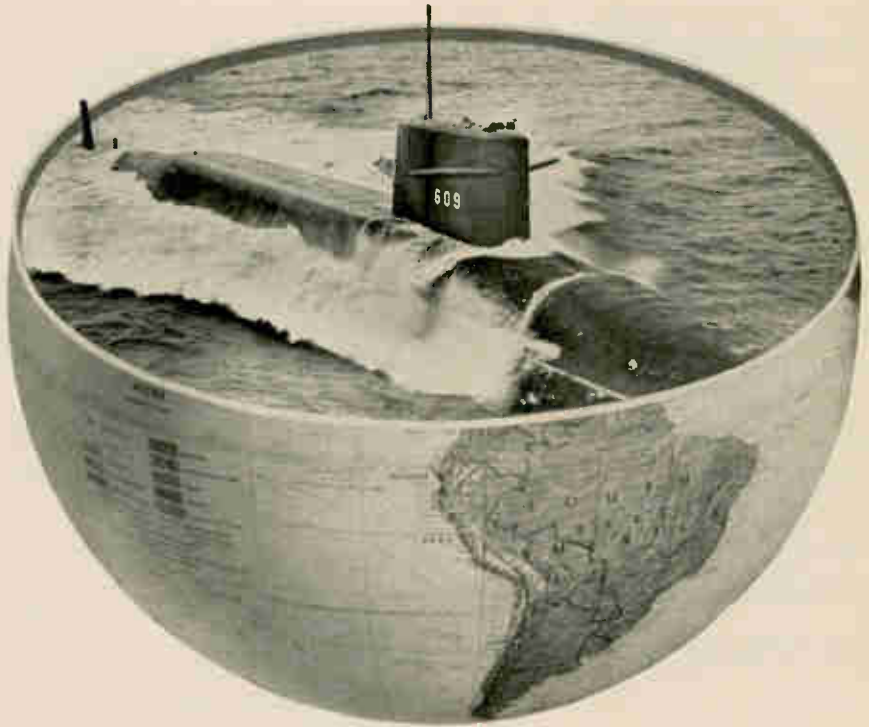

Sub-analyst

From several fathoms down, a roar erupts. It grows, to the accompaniment of a million bubbles, until it reaches the surface of the sea. Then it shrieks away to keep an appointment several hundred miles from where it began.

In the heart of a Polaris submarine, where the roar began, weapon system test instrumentation produced by the prime contractor, Interstate Electronics Corporation, is hard at work. By listening, tracking, evaluating, and analyzing the operation of the system from beginning to end, IEC tests the readiness of the bird and the boat for the defense of our country.

So you see, by analyzing the complexities of a Polaris submarine, the Systems Development Division of Interstate Electronics plays a decisive role in the shaping of our world. If you would like to know more about Interstate's capability, write to Dept. SB-1.

INTERSTATE ELECTRONICS CORPORATION SYSTEMS DEVELOPMENT DIVISION

707 E. VERMONT AVE., ANAHEIM, CALIFORNIA 92803
Regional Offices: Atlanta, Georgia • Washington, D.C.

Subsidiary of

INTERSTATE ENGINEERING CORPORATION



IEC

Electronics advertisers

January 10, 1966



■ AMP Incorporated Garceau, Hargrave & McCullough, Inc.	75	■ Cohn, Sigmund, Corp. William G. Seidenbaum & Co.	242	General Instrument Corp., Semiconductor Products Group	168, 169
Acme Electric Corp. Scheel Adv. Agcy.	52	■ Collins Radio Co. Tracy-Locke Co. Inc.	218, 219	Norman Allen Associates, Inc.	6
Acopian Corp. Mort Barish Associates, Inc.	14	Computer Control Co. Franklin P. Folts, Inc.	147	General Radio Co. K.E. Morang Co.	237
Adams-Russell Co. Inc. Tech/Reps	190	■ Consolidated Avionics Corp. The Stanley Schwartz Co.	86	Graphic Systems, Inc. Caswell Adv. Agcy.	209
Aerocom Grant Advertising, Inc.	209	Consolidated Electrodynamics Corp. Hixson & Jorgensen, Inc.	110	■ Grayhill, Inc. Merchandising Advertisers, Inc.	39
Air France Fuller & Smith & Ross, Inc.	62	Consolidated Reactive Metals, Inc. Charles V. Corbin Associates	228	Gries Reproducer Corp. Harold Marshall Adv. Co. Inc.	74
Airesearch Mfg. Co. J. Walter Thompson Co.	170	Consumers Power District Swanson, Sinkey, Ellis, Inc.	245	Gudebrod Bros. Silk Co. Inc. Ramdsell, Buckley Co.	
Airpax Electronics Welch Mirabile & Company	79	Control Data Corp. Barnes Champ Adv.	164		
Alcatel	F-18	Coto-Coil, Inc. The Williams Co.	237		
Amelco Semiconductor Sturges & Associates	184	■ CTS Corp. Burton Browne Adv.	63		
■ American Electronic Labs. Inc. Benn Associates	204			Hansen Mfg. Co. Inc. Keller-Crescent Co.	198
Amphenol Connector Div. Marsteller, Inc.	18,19	Daven, Div. of McGraw-Edison Keyes, Martin & Co.	183	■ Hewlett-Packard Co. 1, 64, 65, 178, 179, 197, F-17 Lennen & Newell, Inc.	F-17
■ Ammon Instruments, Inc. Culver Advertising, Inc.	226	■ Defense Electronics, Inc. H. Durant Associates	172	Hickok Electrical Instrument Co. Parsells Adv. Service	185
■ Arena	F-7	Delta Microwave S. Gunnar Myrbeck & Co.	54	Holland Electronics Lawrence Peska Associates, Inc.	246
■ Astrodata, Inc. Bonfield Associates, Inc.	15	Di-Acro Corp. Charles E. Brown Adv.	173	■ Hughes Aircraft Co. Foote, Cone & Belding, Inc.	223
		Douglas Missiles & Space Systems Div. J. Walter Thompson	237	Hurst Mfg. Corp. Hathaway Adv. Agcy.	205
Beckman Instruments, Inc. Berkeley Div. Hickson & Jorgensen	49	■ Drusch Voltreg	F-12	■ Hyperelec	F-19
■ Bendix Corp., Semiconductor Products MacManus, John & Adams, Inc.	9	■ DuPont de Nemours & Co. Inc., E.I. Batten, Barton, Durstine & Osborn, Inc.	56, 153	Hyperion Industries, Inc. S. Gunnar Myrbeck & Co.	154
■ Bliss Co., E. W., Eagle Signal Div. Feeley Adv. Agcy. Inc.	72, 73				
■ Blue M Electric Co. South Suburban Advertising	211	Eastman Kodak Co. Inc. The Rumrill Co. Inc.	175	IEEE Exhibition Alpaugh Adv.	220
■ Boonton Div. Hewlett-Packard Co. George Homer Martin Associates	163	Eastman Kodak, X-Ray Div. J. Walter Thompson Co.	143	■ IMC Magnetics Corp. Monad Adv. Design	217
■ Bourns, Inc. Allen, Dorsey & Hatfield, Inc.	159	Eimac Div. of Varian Associates Cunningham & Walsh, Inc.	84	Ichizuka Optical Co. Ltd. Matsushita, Inc.	228
■ Bowmar Instrument Corp. Engineering Writers	145	■ Ela	F-10	■ Imtra Corporation S. Gunnar Myrbeck & Co.	229
Bruce Industries, Inc. Balsam Adv. Inc.	210	Electro Instruments, Inc. Van Der Boom, McCarron Inc.	151	Indiana General Corp. The Griswold Eshleman Co.	238
■ Brush Instruments, Div. of Clevite Corp. Carr Liggett Adv. Inc.	3rd Cover	Ericsson Corp. The Bugli Co.	186	Industrial Electronics Engineers Inc. Gumpertz, Bentley & Dolan Inc.	205
Bulova Watch Co. Electronics Div. Ted Gravenston, Inc.	182	Erie Technological Products Co. Inc. Altman-Hall Associates	17	International Rectifier-Corp. Willard G. Gregory	70, 71
Burr-Brown Research Corp. N. A. Winter Adv. Agcy.	50			International Resistance Co. Gray & Rogers, Inc.	180
Burroughs Corporation Conti Adv. Inc.	88	Fairchild DuMont Electron Tube Div. Conti Adv. Agency	144	Interstate Electronics Corp. Hixson & Jorgenson, Inc.	212, 243
■ Bussmann Mfg. Co. Div. of McGraw-Edison Co. Henderson Adv. Co.	194, 195	■ Fairchild Instrumentation Johnson & Lewis Inc.	148	■ Jennings Div. of ITT L.H. Waldron Adv.	189
		■ Fairchild Semiconductor Corp. Faust/Day Inc.	12, 13	■ ITT Standard Telephones & Cables Ltd. Brockie, Haslam & Co.	F-27
C & K Components, Inc. Van Christo Associates	217	Ferranti Ltd. Rowlinson-Broughton Ltd.	199		
CSF	F-1	Fiberfil, Inc. Tri-State Adv. Co. Inc.	162	Jet Propulsion Labs. Hixson & Jorgenson, Inc.	200
CSF Socapex	F-2	Franklin Electronics, Inc. James J. Cavella Adv.	7	Jungner AB Instrumentfabriken Drevas ABS Gumelius Annonsbyra	203
CSF Dte	F-3	Fujitsu, Limited Fuji Agency	222		
CELCO Stano Advertising	166			Keithley Instruments, Inc. Bayless Kerr Co.	188
Charvin Arnoux	F-11	■ General Electric Co., Electronic Components Sales Div. George R. Nelson Inc.	36, 37	■ Kepco, Inc. Weiss Adv.	22
Chemcut Corp. Adams Associates, Inc.	216				
C.I.F.T.E. Publi-Service	62				
■ Clairex Corp. Michel Cather, Inc.	214				
Clare & Co., C.P. Reincke, Meyer & Finn Adv.	66, 67				
Clarostat Mfg. Co. Inc. Lescarbours Adv. Inc.	155				
■ CML, Inc. Keyes, Martin & Co.	209				

Executive, editorial, circulation and advertising offices: McGraw-Hill Building, 330 West 42nd Street, New York, N. Y. 10036. Telephone (212) 971-3333. Teletype TWX N. Y. 212 640-4646. Cable: McGrawhill, N. Y. Officers of the Publications Division: Joseph H. Allen, President; Vice Presidents: Elton Tuohis, Operations; Robert F. Berger, Administration; John R. Callahan, Editorial; Ervin E. DeGraff, Circulation; Donald C. McGraw, Jr., Advertising Sales; Angelo R. Venezian, Marketing; Officers of the Corporation: Donald C. McGraw, Chairman of the Board; Shelton Fisher, President; L. Keith Goodrich, Hugh J. Kelly and Robert E. Slaughter, Executive Vice Presidents; John J. Cooke, Vice President and Secretary; John L. McGraw, Treasurer; Title R registered U.S. Patent Office; © copyright 1966 by McGraw-Hill, Inc. All rights reserved, including the right to reproduce the contents of this publication, in whole or in part.

Electronics advertisers

January 10, 1966

■ Leach Corp. Jay Chiat & Associates	40, 41	Radio Technique Publi-Service	61
Lockheed Missiles & Space Co. McCann-Erickson, Inc.	221	Rapidesign, Inc. Harry G. Willis & Associates, Inc.	203
		Rohde & Schwarz Inc. Ted Gravenson Adv.	80, 81
		□ Ribet Desjardins Inter-Plans	F-6
		□ Rochar	F-9
Machlett Labs. Inc. Fuller & Smith & Ross, Inc.	11		
■ Magnetic Shield Div., Perfection Mica Co. Burton Browne Adv.	186	SDSA Paris Electronics Show Publi-Service	59, 60
■ Mallory Co., P.R. Aitkin-Kynett Co.	82, 83	■ Sage Electronics Corp. Scrivener & Company Inc.	8
■ Mallory Battery Co. Needham, Harper & Steers, Inc.	35	Sanborn Co., A Div. of Hewlett Packard Co. Culver Advertising Inc.	2
Marconi Instruments, Ltd. Armand Richards Adv. Agcy.	78	■ Sanders Associates Inc. Chirurg & Cairns, Inc.	211
■ Markel & Sons, L. Frank George Moll Adv. Inc.	200	□ Schneider	F-16
Maryland Telecommunications Raymond E. Finn Adv.	146	Sealectro Corporation Lescarboura Adv. Inc.	176
Mathatronics, Inc. Kalb & Schneider, Inc.	174	Sensitak Instrument Corp. Allied Adv. Agency Inc.	150
■ Metal Removal Co. Advertising Producers Associated, Inc.	208	□ SESCO	F-5
■ Microsonic S. Gunnar Myrbeck & Co.	160	Signetics Corporation Cunningham & Walsh Inc.	177
Microwave Electronics Corp. Bonfield Associates, Inc.	213	■ Signalite Incorporated Armand Richards Advertising Agency	76, 77
Mitsubishi Electric Corporation Hakuhodo Inc.	229	□ Silec	F-13
Motorola Semiconductor Products Inc.	53, 68, 69	Soliton Devices Inc. Haselmire & Pearson Adv.	87
Lane and Bird Advertising Inc.		□ Souriau	F-8
Mullard Ltd. Roles & Parker Ltd.	201	Space Craft Inc. Neals & Hickok Incorporated	211
		■ Spectra Electronics Marketing Services	152
		Spectrol Electronics Corporation Jones, Maher, Roberts Adv.	142
National Cash Register Company Allen, Dorsey, & Hatfield Inc.	206, 207	Sperry Semiconductor, Div. of Sperry Rand Corporation Armand Richards Advertising Agency	171
New Hermes Engraving Machine Corp. Doner-Harrison Inc. Adv.	214	Sprague Electric Company The Harry P. Bridge Co.	5, 10
■ Nexus Research Laboratories Larcom Randall Advertising	161	Stackpole Carbon Company Meek and Thomas Inc.	55
Nishimura Musen-Denki Co., Ltd. Nichiden Adv. Ltd.	245	Stanpat Products Inc. Morton Advertising Inc.	205
North Atlantic Industries, Inc. Murray Heyert Associates	51	Struthers-Dunn Inc. The Harry P. Bridge Co.	85
■ Norton Associates J.J. Coppo Co. Inc.	226	Sylvania Electric Products Inc. Tatham, Laird & Kudner Inc.	27 to 34
		■ Syntronic Instruments, Inc. Burton Browne Advertising	210
■ Ohmite Mfg. Company The Fensholt Adv. Agency	193		
		TRW Electronics Fuller & Smith & Ross Inc.	47, 224
Parsons Electronics Company, Ralph M. Hammer & Ormsby Adv.	196	Tektronix Inc. Hugh Dwight Adv. Inc.	38
□ Phillips M.V. Havas International Service	F-20, F-22, F-23	Tempress Research Inc. Hal Lawrence Inc.	165
□ Plessy Potter Instrument Co., Inc. Michel Cather Inc.	F-21, F-24, F-25, F-26	Texas Instruments Incorporated, Industrial Products Group Robinson-Gerrard Inc.	191
■ Potter and Brumfield, Div. of American Machine & Foundry Co. Grant, Schwenck & Baker Inc.	187	Texas Instruments Incorporated, Materials & Controls Division Horton Church & Goff Inc.	192
■ Primo Company Ltd. General Advertising Agcy.	246	Texas Instruments Incorporated, Semiconductor-Components Division Don L. Baxter Inc.	20, 21
Princeton Applied Research Corp. Mort Barish Associates	42	Thermal American Fused Quartz Company Kniep Associates	226
		□ Thomson Varian	F-4
		Tobe Deutschmann Laboratories Engineered Advertising	158
		Trio Laboratories Inc. Zam & Kirshner Inc.	16
Radio Corporation of America Al Paul Lafton Co.	4th Cover	■ Tylon Inc. George Moll Adv. Inc.	202

Transformer for MICROPHONE



Q+Q

YOUR assurance of best quality
and quantity
The secret 2-Q's
behind
every Nishimura products



Nishimura Musen-Denki Co., Ltd.

21, Owada-cho, Shibuya-ku,
Tokyo, Japan

Circle 280 on reader service card

Looking for PROFIT?

The facts favor
NEBRASKA

Sample the
facts in a
free
booklet.



Also ask for *any specific data* on taxes, population, work laws, resources, power, financing. If the information you want about Nebraska is not at hand, we'll research it for you.

CONSUMERS POWER DISTRICT

Community Development Dept.
1401 O Street, Lincoln, Nebraska 68508

Please mail free booklet "Look into Nebraska" to

NAME _____

ADDRESS _____

CITY _____

STATE _____

ZIP _____

(Please attach specific requests for other data)

Precision Test Terminations

FOR PULSE, VIDEO AND RF APPLICATIONS



Type BNC



Type PL 359



Type N

HOLLAND ELECTRONICS Precision Test Terminations provide a simple, convenient method for accurately terminating pulse, video and RF coaxial cables. These terminations eliminate undesirable reflections and provide an easily accessible test terminal for checking waveform and level.

The terminating elements are low noise 1% metal film resistors and can be supplied in any value required.

PRICE LIST	Type BNC	Type PL259	Type N
	0.5 Watt	0.5 Watt	1 Watt
1-9	\$4.85	\$3.30	\$6.75
10-49	4.65	3.00	5.35
50-99	4.30	2.85	4.55
100-240	3.60	2.75	4.25
250-499	3.30	2.45	3.75

DELIVERY Small quantities—standard resistance—stock to one week. Larger quantities—3 to 4 weeks.

Holland Electronics, Inc.

772 East 53rd St. Brooklyn, N.Y.
(212) 451-1123

Circle 279 on reader service card

Primo

Super High Sensitivity
SOUND LEVEL METER MICROPHONE
(DYNAMIC TYPE)



Specifications

- Frequency Response: 20~16,000c/s ± 1.5 dB
- Impedance: 100 Ω $\pm 10\%$
- Sensitivity: -80dB ± 2 dB
- Dimensions: 3.5 ϕ x220mm
- Weight: 7.30gm.

DM-1332

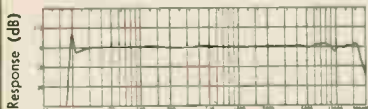

For catalog write to

PRIMO COMPANY LTD.

2043 MURE, MITAKASHI, TOKYO, JAPAN
TEL.0422-3-3121 (Colling from Tokyo)

Trymetrics 225
The Wexton Company, Inc.
■ Tung-Sol Electric Inc. 215
E.M. Freystadt Associates Inc.

Union Carbide Electronics 141
J.M. Mather Adv.
■ U.S. Components Inc. 157
Delphi Adv. Inc.
■ United Transformer Corporation 2nd Cover
Philip Stogel Company Inc.

Wakefield Engineering Inc. 215
Sales Promotion Services
Webber Mfg. Co. 203
Rohr Advertising
Wells Electronics Inc. 217
Weco Adv.
Westamp Inc. 215
Siegmeister/Grant
Western Transistor Corp. 202
Alden Advertising of California Inc.

Xerox Corporation 227
Deutsch & Shea Inc



Advertising sales staff

Gordon Jones [212] 971-2210
Advertising sales manager

Atlanta, Ga. 30309: Gus H. Krimmier,
Michael H. Miller, 1375 Peachtree St. N.E.,
[404] TR 5-0523

Boston, Mass. 02116: William S. Hodgkinson
McGraw-Hill Building, Copley Square.
[617] CO 2-1160

Chicago, Ill. 60611: Robert M. Denmead,
J. Bradley MacKimm
645 North Michigan Avenue,
[312] MO 4-5800

Cleveland, Ohio 44113: Paul T. Fegley, 55
Public Square, [216] SU 1-7000

Dallas, Texas 75201: Richard P. Poole, The
Vaughn Building, 1712 Commerce Street,
[214] RI 7-9721

Denver, Colo. 80202: Joseph C. Page, David
M. Watson, Tower Bldg., 1700 Broadway,
[303] AL 5-2981

Detroit, Michigan 48226: Paul T. Fegley
856 Penobscot Building
[313] 962-1793

Houston, Texas 77002: Kenneth George,
2270 Humble Bldg.,
[713] CA 4-8381

Los Angeles, Calif. 90017: Ashley P.
Hartman, John G. Zisch, 1125 W. 6th St.,
[213] HU 2-5450

Minneapolis, Minn. 55402: J. Bradley
MacKimm 1104 Northstar Center
(612) 332-7425

New York, N. Y. 10036:
Donald R. Furth [212] 971-3615
Frank LeBeau [212] 971-3615
George F. Werner [212] 971-3615
500 Fifth Avenue

Philadelphia, Pa. 19103: William J. Boyle,
Warren H. Gardner, 6 Penn Center Plaza,
[215] LO 8-6161

Pittsburgh, Pa. 15222: Paul T. Fegley,
4 Gateway Center, (412) 391-1314

Portland, Ore. 97204: James T. Hauptli,
Pacific Building, Yamhill Street,
(503) CA3-5118

St. Louis, Mo. 63105: Robert M. Denmead
The Clayton Tower, 7751 Carondelet Ave.
[314] PA5-7285

San Francisco, Calif. 94111:
James T. Hauptli, 255 California Street,
[415] DO 2-4600

London W1: John W. Patten, Edwin S.
Murphy Jr., 34 Dover Street,
Hyde Park 1451

Milan: 1, via
Baracchini Phone: 86-90-617
86-90-656

Frankfurt/Main: Gerd Hinske, 85
Westendstrasse Phone: 77 26 65 and
77 30 59

Geneva: Michael R. Zeynel, Joseph Wuensch,
1, rue du Temple
Phone: 31 95 60

Paris VIII: Denis Jacob, 17 Avenue
Matignon ALMA-0452

Tokyo: Nobuyuki Sato, 1, Kotohiracho
Shiba, Minato-Ku (502) 0656

Osaka: Ryosi Kobayashi, 163, Umegee-cho,
Kita-ku [362] 8771

Hugh J. Quinn: [212] 971-2335
Manager Electronics Buyers' Guide

David M. Tempest: [212] 971-3139
Promotion manager

Milton Drake: [212] 971-3485
Market research manager

Wallace C. Carmichael [212] 971-3191
Business manager

Theodore R. Geipel: [212] 971-2044
Production manager

Classified advertising

F.J. Eberle, Business Mgr.

EMPLOYMENT OPPORTUNITIES 230-235

EQUIPMENT
(Used or Surplus New)
For Sale 235-236

A & Electronics Corp. 236

Atomic Personnel Inc. 235

Bausch & Lomb 230

Columbia Electronics 236

Edmund Scientific Co. 236

Eldorado Electronics 230

Emmons 236

Engineering Associates 236

Fair Radio Sales 235

Fishman Co., Philip 236

General Dynamics
Electronics Div. 232

IBM 233

Keystone Electronics Corp. 236

Lawrence Radiation 234

Norman Electronic Sales 235

Pan Am World Airways
Guided Missiles Range Div. 234

Philadelphia Naval Shipyard 232

Radio Research Instr. Co. 236

Sanders Associates Inc. 231

U.S. Logistics 235

W.D. Contracting Engineers 236

■ For more information on complete product
line see advertisement in the latest Elec-
tronics Buyer's Guide

□ Advertiser in Foreign Edition

Another Brush Innovation in Recording:

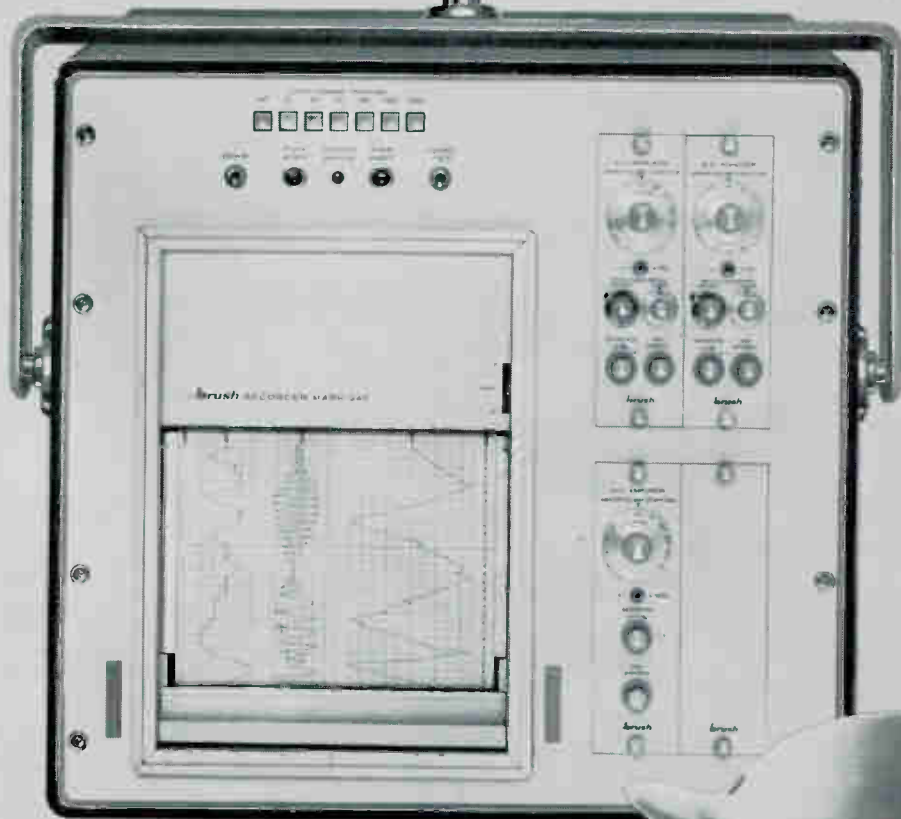

The Brush Mark 240

**If you can't record it
with this recorder,
chances are
it didn't happen!**



What we've done is this:

We took our famous Mark 200 Recorder and made a 'compact' version for general purpose and medical requirements. Performance? The new 240 will do everything the Mark 200 will do. And as Aerospace people will tell you, that's plenty: System linearity better than $\frac{1}{2}\%$. Pressurized fluid writing system assures incredibly crisp traces on low cost chart paper. Presentation is true rectilinear and there's push-button choice of 12 chart speeds.

Cost? The Mark 240 runs about

half as much as a Mark 200. Still, you have a choice of either four 40 mm analog channels, two 80 mm channels, or a combination* of two 40s and one 80. (You can also have 8-channel event-marker modules). There's a choice of 17 plug-in pre-amplifiers, too. High gain d-c units, straight-through couplers and strain-gage and demodulator types. The Mark 240 is just $17\frac{1}{2}$ " high x 19" wide x $20\frac{1}{2}$ " deep. Mount it vertically or horizontally in standard 19" racks to RETMA specs, on table-top carts or you name it!

If your kind of recording calls for the utmost in resolution, precision and recording flexibility, ask your Brush representative for complete details about the new Brush Mark 240. There's nothing else like it . . . anywhere! Brush Instruments Division, Clevite Corporation, 37th & Perkins, Cleveland, Ohio 44114. *Just out! Three information-packed booklets on strain recording, temperature recording and techniques of low-level recording. Write us today for your copies. They're yours for the asking!*

*see photo

brush INSTRUMENTS DIVISION
CLEVITE

Circle 901 on reader service card

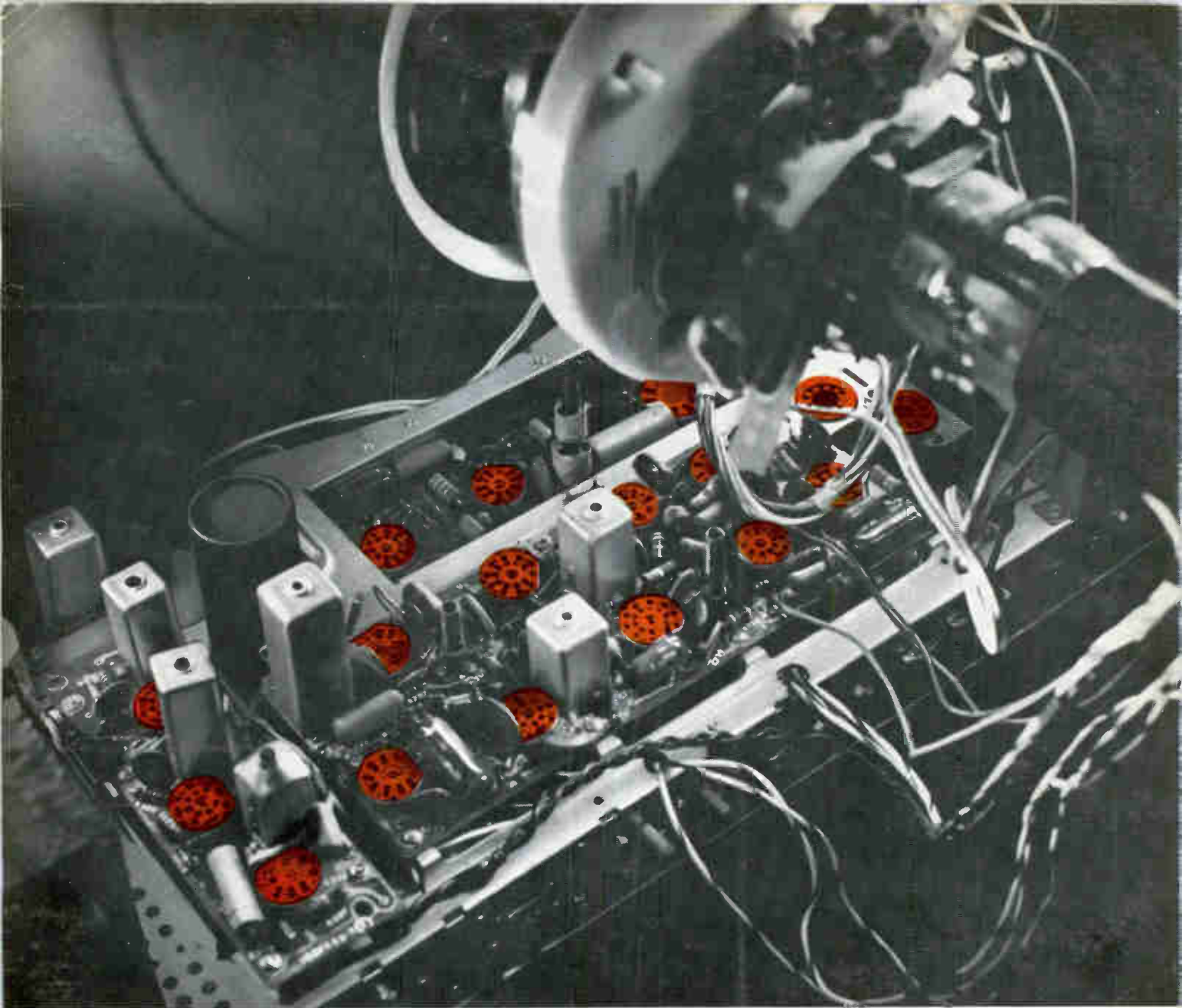

For the best possible color-TV picture

THESE SOCKETS NEED COLOR-TV RECEIVING TUBES BY RCA

In today's growing and highly-competitive color-TV market, your company's reputation rides on the performance of the color sets you manufacture.

That's why it's so important that you specify dependable RCA COLOR-TV RECEIVING TUBES for every socket.

**What's so special about RCA
COLOR-TV RECEIVING TUBES?**

As pioneer of today's compatible color TV, RCA has accumulated knowledge of color-TV circuitry that is unmatched in the industry. This knowledge has enabled us to select and develop the group of receiving tubes that best meet the exacting requirements of today's high-fidelity color TV.

The tubes have been field-proven in thousands of color-TV sets across the nation.

Samples of each week's production of RCA COLOR-TV RECEIVING TUBES are given exhaustive tests, under actual field conditions, in our Tube Reliability Laboratory. The performance of these sample tubes must meet rigid quality standards before their respective production lots are released to the warehouses.

This group of RCA tubes offers color-TV manufacturers the best combination of price, performance and reliability on the market today.

RCA ELECTRONIC COMPONENTS AND DEVICES, HARRISON, N.J.
RCA DISTRICT OFFICES—OEM SALES: EAST, 2075 Millburn Ave., Maplewood, N. J. 07040, (201) 485-3900 • MID-ATLANTIC, 605 Marlton Pike, Haddonfield, N. J. 08034, (609) 428-4802 • MID-CENTRAL, 2511 East 46th St., Bldg. Q2, Atkinson Square, Indianapolis, Ind. 46205, (317) 546-4001 • CENTRAL, 446 East Howard Ave., Des Plaines, Ill. 60018, (312) 827-0033 • WEST, 6363 Sunset Boulevard, Hollywood, Calif. 90028, (213) 461-9171 • INTERNATIONAL OPERATIONS, RCA International Division: Central and Terminal Aves., Clark, N.J. 07066, (201) 382-1000 • 118 Rue du Rhone, Geneva, Switzerland, 35 75 00.



The Most Trusted Name in Electronics