

October 21, 1960

electronics

Infrared width gage (upper left) in steel-rolling mill measures width of fast-moving, red-hot strip within one-eighth inch. See p 65
Telemetry system records automobile performance. See p 57

A McGraw-Hill Publication 75 Cents

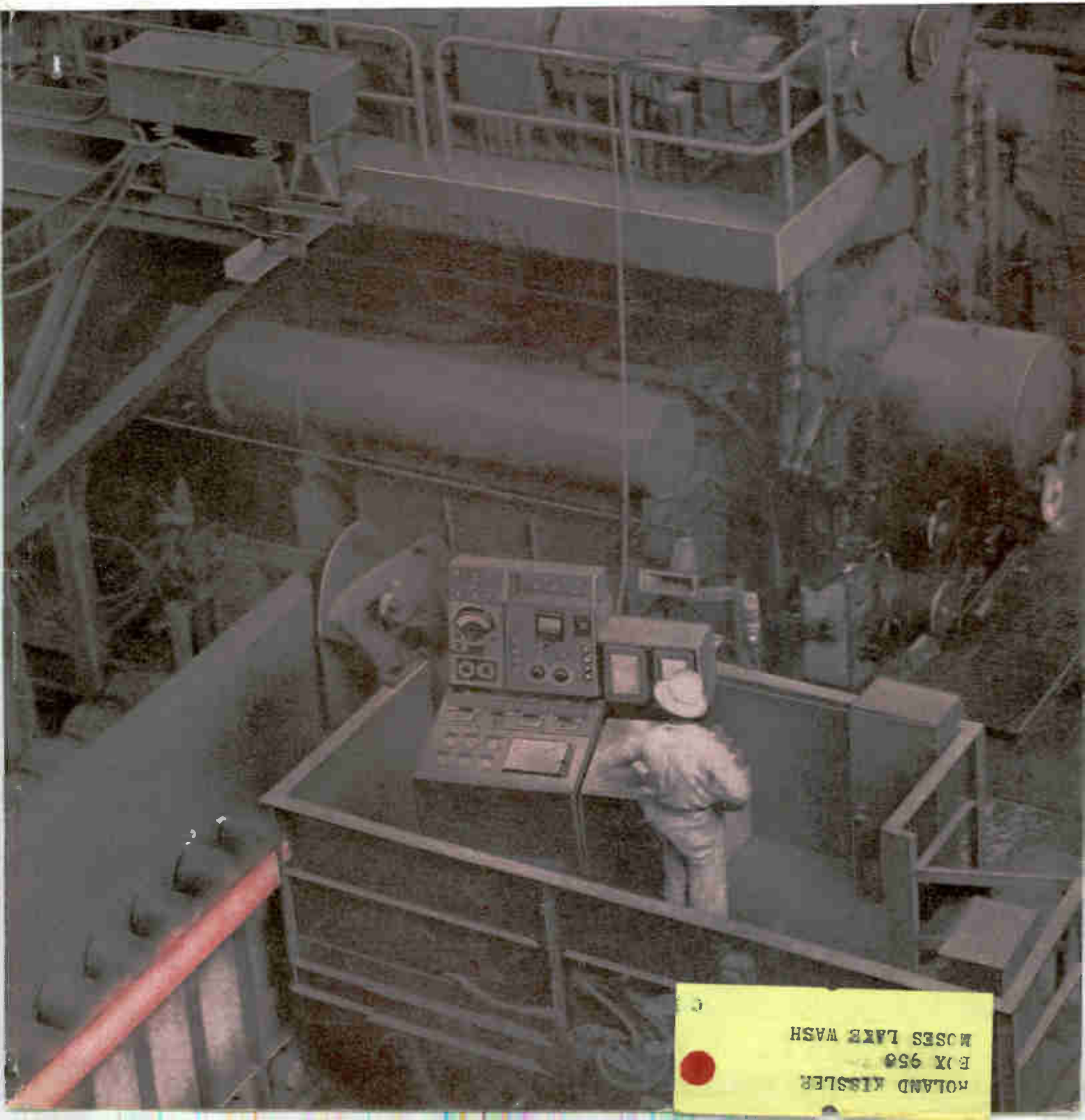

ROLAND KISSLER
BOX 950
MOSES LAKE WASH

Creative Microwave Technology

Published by MICROWAVE AND POWER TUBE DIVISION, RAYTHEON COMPANY, WALTHAM 54, MASS., Vol. 2, No. 4

RAYTHEON KLYSTRON CLOCKS 62,000 HOURS OF SERVICE

--tube retired after seven years of continuous operation

We don't send out 62,000-hour warranties; however, you can expect unusual performance from Raytheon klystrons. Take the tube cited above -- the QK-531 -- a 6,575-6,875 mc reflex klystron which we conservatively warrant for 7,500 hours. As the local oscillator in the Houstonia, Missouri, link of the Panhandle Eastern Pipeline Company's 400-mile microwave system, the tube performed a major function in relaying up to ten channels of information between the Odessa and Boonville stations.

How is this kind of performance built into a tube? Advanced manufacturing techniques and rigorous quality control is the answer.

If you need low-power coverage of government, studio link and common carrier frequency bands, look into the characteristics of Raytheon's complete line of klystrons.

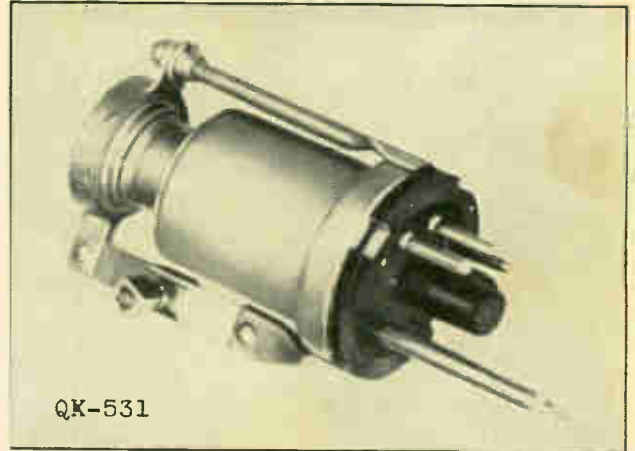

QK-531

The QK-531 is particularly suited for local oscillator service in microwave receivers. It is useful, also, as a local oscillator in microwave spectrum analyzers, as a pulse generator for testing circuit response and as a frequency modulated source in microwave relay links.



Homer Marrs of Motorola presents gold-plated klystron trophy to F. J. McElhatton, Panhandle Eastern Pipeline Co. J. A. Fowler, Supervisor of Communications for Panhandle, is at the left. Prized klystron, the Raytheon QK-531, performed for 62,000 hours.



Close control of product quality and costs at every state of production is responsible, in part, for Raytheon's success in meeting industry and government specifications. Every step of assembly is spot checked by inspectors, each with 10 years or more experience in microwave tube production.

Excellence in Electronics



You can obtain detailed application information and special development services by contacting: Microwave and Power Tube Division, Raytheon Company, Waltham 54, Massachusetts. In Canada: E. Waterloo, Ontario.

A LEADER IN CREATIVE MICROWAVE TECHNOLOGY

electronics

A McGraw-Hill Publication 75 Cents



W. W. MacDONALD, Editor

J. M. CARROLL, Managing Editor
 SENIOR ASSOCIATE EDITORS: Samuel Weber, Roland J. Charest. ASSOCIATE EDITORS: Frank Leary, Michael F. Tomaino, Sylvester P. Carter, William P. O'Brien, John F. Mason, William E. Bushor, Thomas Emma, Sy Vogel, Leslie Solomon, M. M. Perugini, George J. Flynn. ASSISTANT EDITORS: Michael F. Wolff, Nilo Lindgren, Stanley Froud, Stephen B. Gray. REGIONAL EDITORS: Harold C. Hood (Pacific Coast, Los Angeles), Thomas Maguire (New England, Boston), Cletus M. Wiley (Midwest, Chicago). MARKET RESEARCH EDITOR: Edward DeJongh. BUYERS' GUIDE EDITOR: George Sideris. ART DIRECTOR: Harry Phillips; Howard R. Berry. PRODUCTION EDITOR: John C. Wright, Jr. EDITORIAL ASSISTANTS: Gloria J. Filippone, Arlene Rudd, Bernice Duffy, Patricia Martine, Lorraine Rossi, Virginia T. Bastian, Ruth Ayres.

JAMES GIRDWOOD, Publisher

BUSINESS

Europe Is Catching Up. Rapid progress in computers and controls	32
Engineers Form Physical Standards Groups. Labs participating	34
USAF to Get Fast Data Link Net. Forerunner of civilian systems?	37
Scientists Demonstrate Optical Maser. Suits communications	38
Soviets Pushing All Technologies. Electron-beam welding reported	40
Army Develops New Silicon Solar Cell. Resists radiation longer	43
Students Need Good Apparatus. News from educational centers	45
Crosstalk	4
Comment	6
Electronics Newsletter	11
Washington Outlook	14
Financial Roundup	21
25 Most Active Stocks	21
Marketing	24
Current Figures	25
Meetings Ahead	46

ENGINEERING

Electronics engineers come to the assistance of steelmakers to increase efficiency and reduce waste. See p 65	COVER
Telemetry System for Testing Automobiles. Allows measurement of up to 23 parameters. By A. Potton	57
Miniaturized Autopilot System for Missiles. Micromodular construction plus unique programmer cut space and weight requirements. By J. H. Porter	60
Infrared Gage Measures Hot Steel Strip Width. Solving an industry problem. By F. J. Danks	65
Digital Instrumentation for Nuclear Research. How digital techniques speed nuclear data-processing. By E. J. Wade	68
Highly Accurate Phantatron Delay Circuit. Provides one percent accuracy with solid-state components. By S. R. Parris and D. A. Starr	72
Design Chart for Broadband Couplers. Circuit parameters are tabulated. By R. F. Burns	76

DEPARTMENTS

Research and Development. F-M Technique Used in Tracker	82
Components and Materials. Silicon Epitaxial Transistors	86
Production Techniques. Wire Mesh Makes Flexible R-F Shields	90
New On the Market	94
Literature of the Week	114
New Books	116
Thumbnails	117
People and Plants	118
Index to Advertisers	125

GRANGER ASSOCIATES' fast-stepping ionosphere sounder makes possible substantial improvements in long-distance hf radio communications ● it provides instantaneous optimum frequency measurement ● it automatically selects alternate frequency following point-to-point circuit failure ● it observes hf broadcast coverage area by means of backscatter sounding

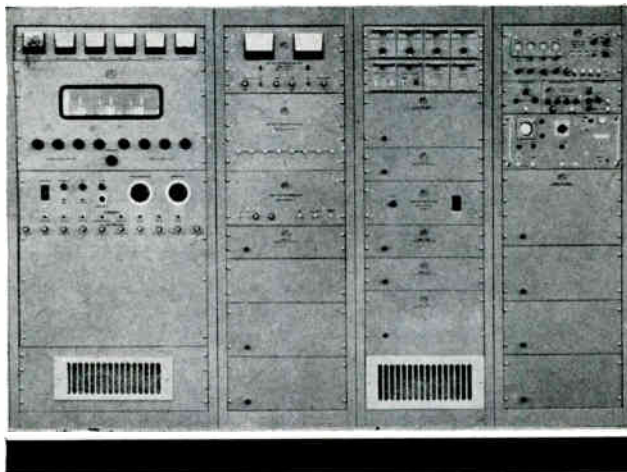

THE PROBLEM:

Long distance hf radio communication depends critically on ionospheric conditions. Under "normal" conditions, gross changes occur between day and night; and solar flares can, and frequently do, cause rapid variations that cannot be predicted. To improve hf communication reliability, major communication centers need the capability to select the *optimum working frequency* based on actual conditions at the time of operation. A related problem: in point-to-point communications it is often necessary for both parties to switch rapidly to an alternate frequency when sudden disturbances cause a circuit failure. This alternate frequency should be selected automatically and instantaneously; and both operators must immediately know what the new frequency is.

THE EFFECTIVE ANSWER is Grangers Associates' high speed step-frequency ionosphere sounder. It scans up to 160 frequencies from 4 to 64 Mc at rates up to 50 channels per second. It can be used for vertical-incidence or backscatter sounding; and two equipments can be remotely synchronized for instantaneous optimum frequency measurement. Operation is entirely electronic—there are no mechanical switches or tuning devices. Special antennas for use with the sounder are available from G/A.

FOR POINT-TO-POINT COMMUNICATIONS: With two sounders operating on a synchronized transponder mode instantaneous measurement of the best working frequency is provided

among the available channels.

Following a circuit failure, operators at each end need only push a single button to place the sounder in operation. Within

minutes a new frequency has been selected, and operators at both ends are informed of the new frequency. Both coordinating orderwires and the need for tedious systematic frequency searches are eliminated. Since the time required for this operation is so brief, a single sounder may suffice for all the circuits served by a communications station.

FOR BROADCAST APPLICATIONS: Backscatter sounders have already been effectively utilized in determining high frequency broadcast coverage. This technique makes it possible to observe broadcast coverage area in detail from the transmitter location. Range information is provided by the time delay of the backscattered signals, and azimuth information may be obtained with a rotating directional antenna. Since the new G/A sounder is extremely flexible, it becomes possible to sound on the broadcast frequency automatically at times when the program material is interrupted for even a fraction of a second. This enables the station operator to observe the skip distance and the propagation conditions during the normal programming period. He will know immediately if abnormal propagation conditions develop, and broadcast listeners can be directly informed at that time of a frequency or band more likely to produce satisfactory reception.

SPECIFICATIONS/STEP-FREQUENCY IONOSPHERE SOUNDER MODEL 902

Frequency Range 4.05 Mc to 63.6 Mc
 Number of Channels Selectable: 160 or 40
 Frequency Increment 100 kc, 200 kc, 400 kc and 800 kc in four octave bands
 Pulses Per Channel Selectable: 1, 2, 5, or 10
 Pulse Length Selectable: 50, 100, 500, or 1000 μ s
 Pulse Repetition Rate Selectable: 2, 5, 10, 20, or 50 pps
 Duty Cycle 2% Max.
 Channel Scan Rate Channels/Scan x Pulses/Channel PRF
 Range Marks Timing comb with markers every 0.2, 1.0, 2.0 and 10.0 milliseconds.
 Frequency Marks Every tenth channel.

Receiver Bandwidth Selectable: 6 or 16 kc
 Receiver Sensitivity 0.5 μ v for 2:1 signal + noise to noise.
 Receiver Dyn. Range Greater than 30 db.
 Power Output 500 watts.
 Operating Controls Pulse length, repetition rate, receiver gain and bandwidth, manual or automatic frequency step.
 Frequency Stability 5×10^{-6} parts per week.

Also Available: Model 903 Step-Freq. Receiver, identical to Model 902 without transmitter section; Model 904 Step-Freq. Transmitter, identical to Model 902 without receiver section. 30, 60, or 100 kw Pulse Distributed Amplifiers, and antennas for Sounder.



Send For Complete Information

GRANGER ASSOCIATES / 974 Commercial Street / Palo Alto, California / Davenport 1-4175

New LAMBDA

Regulated Power Supplies

5 and 10 AMP 0-34 VDC

CONVECTION COOLED



3 1/2" PANEL HEIGHT ON 5 AMP MODELS

- Convection cooled—no internal blowers to wear out
- Guaranteed for a full 5 years
- Ambient temperature 50°C
- Excess ambient thermal protection
- Special, high purity foil, hermetically sealed long-life electrolytic capacitors
- Hermetically sealed transformer designed to MIL-T-27A
- Remote sensing and DC vernier

New LAMBDA LA Series Condensed Data

DC OUTPUT:

(Regulated for line and load)

MODEL	VOLTAGE RANGE ¹	CURRENT RANGE ²	PRICE
LA50-03A	0-34 VDC	0- 5A	\$395
LA50-03AM	0-34 VDC	0- 5A	\$425
LA100-03A	0-34 VDC	0-10A	\$510
LA100-03AM	0-34 VDC	0-10A	\$540

¹ The output voltage for each model is completely covered in four steps by selector switches plus vernier control and is obtained by summation of voltage steps and continuously variable DC vernier as follows:

MODEL	VOLTAGE STEPS
LA 50-03A, LA 50-03AM	—2, 4, 8, 16 and 0-4 volt vernier
LA100-03A, LA100-03AM	—2, 4, 8, 16 and 0-4 volt vernier

² Current rating applies over entire output voltage range

Regulation: Line: Better than 0.15 per cent or 20 millivolts (whichever is greater).
Load: Better than 0.15 per cent or 20 millivolts (whichever is greater).

Transient Response: Line or Load: Output voltage is constant within regulation specifications for step function line voltage change from 100-130 VAC or 130-100 VAC or for step-function load change from 0 to full load or full load to 0 within 50 microseconds after application.

Ripple

and Noise: Less than 1 millivolt rms with either terminal grounded.

AC INPUT:

100-130 VAC, 60 ± 0.3 cycle. This frequency band amply covers standard commercial power lines in the United States and Canada.

OVERLOAD PROTECTION:

Electrical: Magnetic circuit breaker front panel mounted. Special transistor circuitry provides independent protection against transistor complement overload. Fuses provide internal failure protection. Unit cannot be injured by short circuit or overload.

REMOTE SENSING:

Provision is made for remote sensing to minimize effect of power output leads on DC regulation, output impedance and transient response.

PHYSICAL DATA:

Size: LA 50-03A... 3 1/2" H x 19" W x 14 3/8" D
LA100-03A... 7" H x 19" W x 14 3/8" D

Panel Finish: Black ripple enamel (standard). Special finishes available to customers specifications at moderate surcharge. Quotation upon request.

Send today for complete data



LAMBDA ELECTRONICS CORP.

11-11 131 STREET • DEPT. 1 • COLLEGE POINT 56, N. Y. • INDEPENDENCE 1-8500

CIRCLE 3 ON READER SERVICE CARD

CROSSTALK

UPGRADING THE CONSUMER. With the television receiver manufacturing industry bumping its nose every year now with a market saturation of some 90 percent, industry leaders are devoting a lot of time to schemes for expanding the market.

Thinner sets made possible by 110-deg picture tubes, the 19-in. and 23-in. tubes, and remote-control systems have helped but they have not forced anything like the planned obsolescence an industry such as the automobile industry has been able to create. Color television seems still to be around some corner or other.

Another answer is to educate the consumer to how good television can be. A decade of price-cutting design changes has so eroded the performance of the average television receiver that most consumers no longer know what really good television reception looks like. Travelers abroad often return singing the praises of British television when actually the British tv standards technically are inferior to ours.

If the consumer could be taught to want better television reception it would be well within the ability of set manufacturers to design it into new models with only a moderate increase in price. For example, there is d-c restoration; if the consumer knew that the tv picture was supposed to fade to black, not mouse-grey. Also, full 4.5-Mc video bandwidth instead of the 2.5 to 3.5-Mc bandwidth common today; if the consumer knew there was such a thing as grey scale, that pictures didn't have to be just black or white with nothing much in between these extremes. Other improvements could include improved horizontal linearity to reduce picture distortion, video response control not uncommon on European sets and really low-noise front ends using new r-f amplifying devices.

Maybe the consumer forever will buy television strictly on price and cabinet styling alone, content with marginal technical performance of the set. But if the industry can upgrade the consumer's taste, what a wonderful opportunity to resell a large part of the television set market. To us, it seems worth some effort and investigation.

Coming In Our October 28 Issue

NEXT ABLE SPACE PROBE. One day next month, missilemen hope to see the next in the historic series of Able space probes blast off for an orbit about the moon. Largest and most sophisticated of the NASA/USAF Able series, the Able-5 lunar satellite will carry scientific experiments for obtaining data concerning the moon, its immediate environment and the space between earth and moon.

In our next issue, P. F. Glaser and E. R. Spangler of Space Technology Laboratories describe the experiments, instrumentation and temperature control system for Able-5. Their fascinating article tells about the magnetometers, five radiation detectors and micrometeorite detector, as well as the telemetry, power supply and temperature control systems.

IN ADDITION: The variety of interesting feature articles to appear next week includes: an airborne optical beacon by A. Finlay and R. E. DeMuth of Battelle Memorial Institute and W. D. Hail of Grimes Manufacturing Co.; a telemetry system for monitoring jet car performance by A. D. Runnalls of Sir W. G. Armstrong Whitworth Co. Ltd; designing diode AND gates by F. E. Kirkland of Western Electric Co; and communications using groundscatter propagation by R. T. Wolfram of Stanford Research Institute.

electronics

Oct. 21, 1960 Volume 33 Number 43

Published weekly, with Electronics Buyers' Guide and Reference annually, by McGraw-Hill Publishing Company, Inc. Founder: James H. McGraw (1860-1948).

Title registered U.S. Patent Office; Copyright 1960, McGraw-Hill Publishing Company, Inc. All rights reserved, including the right to reproduce the contents of this publication, in whole or in part.

Executive, editorial, circulation and advertising offices McGraw-Hill Building, 330 West 42nd Street, New York 36, N. Y. Telephone Longacre 4-3000. Teletype TWX N.Y. 1-1636. Cable McGraw-Hill, N.Y. Printed in Albany, N. Y.; second class postage paid.

Subscription price U. S. and possessions \$6 per year; single copies 75¢, Buyers' Guide \$3. Other countries, and longer periods, on request. Subscriptions solicited only from those actively engaged in the field of the publication and in a manner served by its contents; position and company should be indicated.

Subscribers: Please address all correspondence, change of address notices, subscription orders or complaints to Fulfillment Manager, Electronics, at above address. Change of address notices should provide old as well as new address, including postal zone number if any. If possible, attach address label from recent issue. Allow one month for change to become effective.

Postmaster: Please send Form 3579.

ALL UNITS ACTUAL SIZE

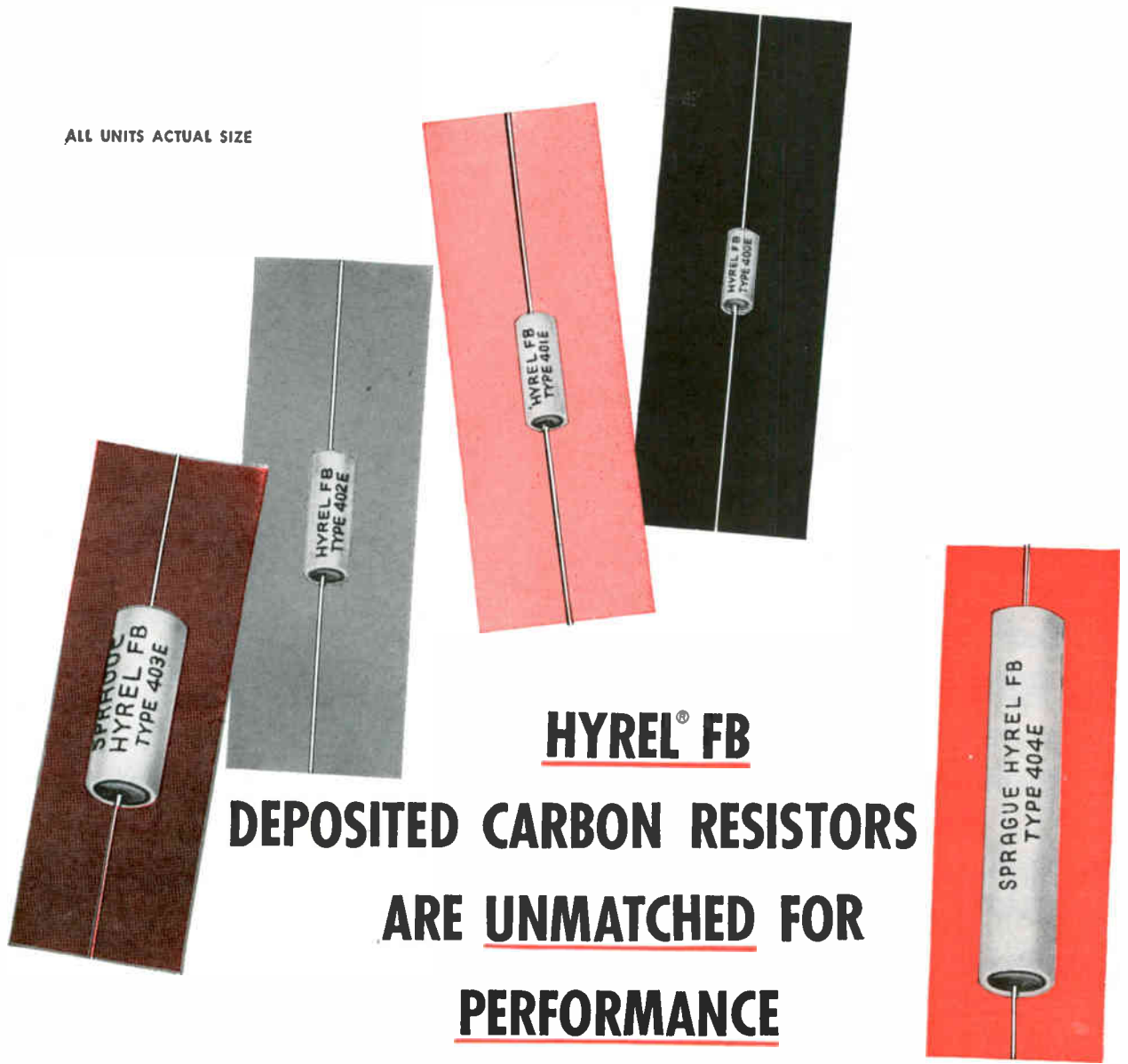

HYREL® FB
DEPOSITED CARBON RESISTORS
ARE UNMATCHED FOR
PERFORMANCE



HYREL® FB DEPOSITED CARBON RESISTORS

are hermetically sealed in ceramic jackets against moisture and vapor... **safely protected** against mechanical abuse.

The Hyrel FB series is intended for applications in military, commercial and telephone equipment where **long life under high humidity, small size, and stability of electrical characteristics** are important.

WRITE FOR ENGINEERING BULLETIN 7010B
SPRAGUE ELECTRIC COMPANY
 35 MARSHALL STREET • NORTH ADAMS, MASS.



Made to far exceed MIL-R-10509C Specifications

SPRAGUE COMPONENTS:

CAPACITORS • RESISTORS • MAGNETIC COMPONENTS • TRANSISTORS • INTERFERENCE FILTERS • PULSE NETWORKS
 HIGH TEMPERATURE MAGNET WIRE • CERAMIC-BASE PRINTED NETWORKS • PACKAGED COMPONENT ASSEMBLIES



a **spot** is a **spot**
is a high
resolution **spot**
with
CELCO YOKES

- **Celco YOKES**
keep spots **smallest**
- **Celco YOKES**
keep spots **roundest**
- **Celco YOKES**
keep spots **sharpest**

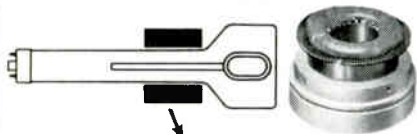

Use a **CELCO DEFLECTION YOKE** for
your high resolution applications.

In a **DISPLAY SPOT?** call **Celco!**

Celco
*Constantine Engineering
Laboratories Co.*

Main Plant: MAHWAN, N. J. DAVIS 7-1123

• Pacific Division - Cucamonga, Calif. - YUkon 2-2688

COMMENT

Down on the Farm

There has been much talk about the farm problem and it seems that modern methods of communication and computation now make it possible to do something about it.

Without subsidy, a farmer will choose to grow the crop which will bring the best price. This price can be predicted in advance by totalizing reports from County Agents all over the country on planned acreage of each crop. Total production compared with demand extrapolated from the previous year will result in a probable unit price for each crop. Then daily transmission to all County Agents of revised commodity prices for all crops will enable each farmer to make an intelligent decision as to which crop is most advisable to plant.

It would be good business for the electronics industry as well as the poor taxpayer if a system of this magnitude were installed in the United States. The present bill for farm subsidy is over \$8 billion annually. The electronics required for this plan would be considerably less than this, but certainly not to be scoffed at. And surely no taxpayer would be against such an improvement.

CHARLES W. GASTON
MONTGOMERY, ALA.

It's not a bad notion, and certainly we need some new ideas on handling our farm surplus. But we feel that few farmers would welcome placing their financial wellbeing at the mercy of a mechanized system. Also, reader Gaston's system would require farmers continually to readjust planting plans right up to plowing time.

Besides, both political parties stand firmly on farm planks that commit the federal government to uncomputerized supports and controls.

The Reinvented Circuit

Reference is made to the article by E. W. Van Winkle ("Circuit Removes D-C from Amplifier Signal Output") in *ELECTRONICS* for Aug. 12, p 150.

I am certainly glad that this cir-

cuit has been "recently declassified"!

I had been totally unaware that I was violating the security regulations by keeping my Vol. 18, MIT Radiation Lab Series on the bookshelf.

On page 486, a circuit by J. W. Gray is described. I call particular attention to the last sentence on the page.

"Recently declassified" indeed!

I appreciate the efforts of engineers who want to propagate new and useful circuitry for the general benefit of others. I think, however, it is a duty to first give a cursory check in the existing literature to see if this information is not already available.

This is a pet peeve of mine, as I constantly see engineers wasting valuable time reinventing solutions to problems already solved, when a few hours spent looking through reference books and technical magazines could save endless days wasted on repeating the brainwork of others.

SERGIO BERNSTEIN-BEVERY
BERNE ELECTRONICS
VALHALLA, N. Y.

Here's how author Van Winkle answers reader Bernstein-Bervery:

The phrase "recently declassified" referred to the circuit discussed in my article. This circuit is covered in patent application 414,911, which was a classified application. The secrecy order was rescinded on Oct. 26, 1959, and the application processing continued. Patent 2,927,164 was granted on Mar. 1, 1960, covering this circuit.

Part of the circuit appears on p 428, Fig. 11.14, and part of the circuit is on p 486, Fig. 11.69, of Vol. 18, MIT Radiation Lab. Series. A similar circuit appears in Chestnut and Mayer, *Servomechanisms and Regulating System Design*. Vol. II, p 173, Fig. 5.6-2.

None of these figures embodies the whole circuit, and the date of the invention preceded the publication of the volumes. References cited in the patent are prior patents 2,369,138; 2,513,354; 2,549,833; 2,554,469; 2,579,633 and 2,763,733. Sufficient differences existed to justify granting patent 2,927,164.

EDGAR W. VAN WINKLE
BENDIX CORP.
TETERBORO, N. J.

EX-CELL-O CONTOUR PROJECTORS GIVE YOU MORE—

1. **LARGEST WORK AREA**—Regardless of magnification there is a constant eight inches of work space from lens to focal plane to accommodate large objects. The Model 30 has a 12" diameter capacity.
2. **UNSURPASSED ACCURACY**—Kodak optics with famed Ektar® lenses guarantee accurate measurements and give clear undistorted images over entire screen. You can depend upon optical decisions made on the Ex-Cell-O.
3. **TRUEST MEASURING PRECISION**—All Ex-Cell-O Contour Projectors read to tenths and measure to tenths. Each Ex-Cell-O contour projector is tested and checked to the highest laboratory standards before shipping.
4. **BRIGHTEST GLARE FREE SCREEN**—Coated lenses and mirrors have been standard on all Ex-Cell-O models for many years. The patented "Fresnel" lens (exclusive with Ex-Cell-O) brings entire screen into clear view from normal operator position. Sharp clear images in normal room light—the brightest and clearest in the contour projector field!
5. **MOST RUGGED CONSTRUCTION**—Built to "stand the gaff." Solid construction with optical system locked into lifetime cabinets. Will withstand factory wear and tear—without getting out of adjustment. Guaranteed by Ex-Cell-O's long experience in the manufacture of precision machine tools.
6. **SIMPLEST OPERATION**—Finger tip controls, cool to the touch lamphouses, simple setting and measuring devices, unreversed images, all add up to comfortable day long operation. A precision machine of great accuracy that can be quickly mastered by average factory inspection personnel.

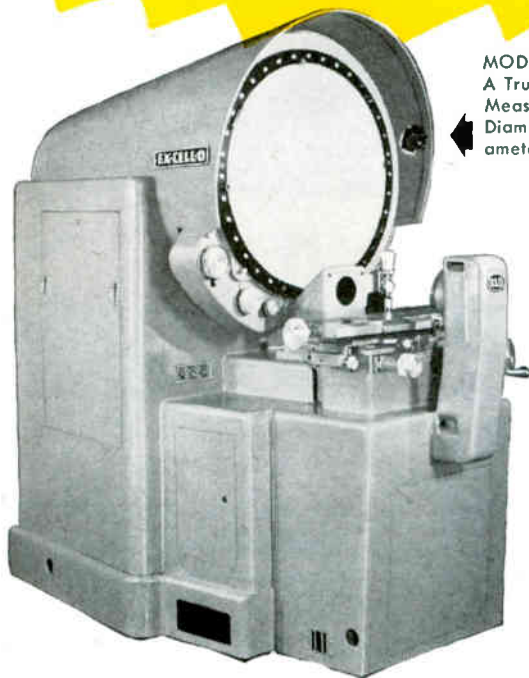

MODEL 30
A True, Heavy Duty Precision
Measuring Projector with 30"
Diameter Screen, and 12" Di-
ameter Capacity.

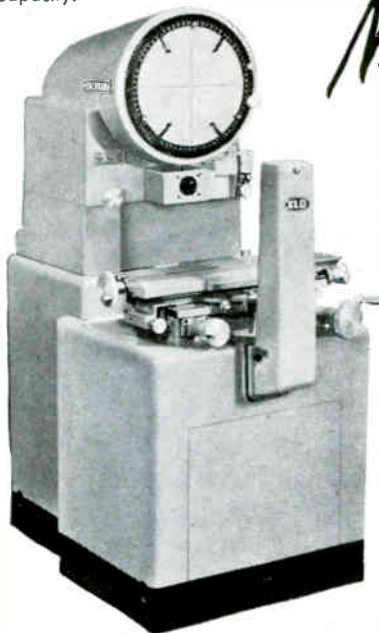

MODEL 14-5
The Finest, Most Versatile, 14"
Screen Contour Projector
Available.

New!

The Ex-Cell-O Mercury Arc Light Source Accessory. A high intensity Accessory light source including Mercury Arc Lamp, special collimator and auxiliary power supply. Quickly adaptable to all Ex-Cell-O Contour Projector Models (except Model 8) to give maximum screen brightness at higher magnifications.

Write for new booklet "See The Savings" which graphically demonstrates time savings through optical gaging over conventional methods.



Manufactured by EX-CELL-O Corporation of Detroit, Mich.

SOLD AND SERVICED BY

OPTICAL GAGING PRODUCTS, INC.

26 FORBES STREET

ROCHESTER 11, N. Y.

(A subsidiary of EX-CELL-O Corporation)

***Now you can monitor
directly, continuously
... on operating***

All-New, Transistorized  344AR Noise Figure Meter



The new  344AR Noise Figure Meter assures you that your radar is continuously operating at peak performance, and you are enjoying maximum range. The instrument's fast meter response lets you optimize or adjust the system during operation or maintenance. Model 344AR is designed for the utmost in dependability—it is militarized, transistorized, very compact and very rugged.



With this new 5¼" high instrument system noise figure is measured on a time-shared basis with the radar scan. The unit has high sensitivity to minimize signal and transmitter losses; the noise source may be decoupled 20 db from the main transmitter line. Two alarm func-

tions give visible and electrical indication when an allowable noise figure is exceeded, or a noise source malfunctions.

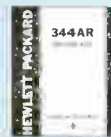
High voltage on antenna slip rings is eliminated with a remote noise source modulator operated with low voltage triggers. Other features include quick, easy front panel calibration, and remote metering and alarms if desired.



**FREE APPLICATION NOTES INCLUDE
CONSIDERATIONS FOR AUTOMATIC
MEASUREMENT OF NOISE FIGURE
ON A CONTINUOUS BASIS**

Write  direct for Application Note 43—"Continuous Monitoring of Radar Noise Frequency". Discussion includes description of  344AR and its application to radar systems.

noise figure and automatically radars!

Separate Modulator, Noise Source

The new Φ 344AR Noise Figure Meter operates on either a 25 or 30 MC IF frequency. It is designed for pulse radars with repetition rates of 90 to 500 pps; also, its high sensitivity and compact design make it very valuable in all radars, including high PRF and CW Types. In its free-run mode it measures receiver noise figure without turning on the transmitter or radar timing circuitry. Thus periodic measurement and maintenance procedures are simplified.

The 344AR's noise source and modulator are separate units which may be mounted on the antenna mast or in an aircraft. In the first case, high voltage connections are short and beyond slip rings. In the second case, you save weight and space and measure noise figure on the ground through low voltage connections.

Operation

The Φ 344AR measures noise figure by operating a standard noise source and comparing the noise output of equipment under test when the noise source is off to the noise output when the noise source is on. Since the Φ 344AR measures in synchronism with the radar, the noise source and measuring circuitry are triggered by a pulse from the radar's timing circuit, occurring at the end of the radar scan.

Φ 340B/342A Noise Figure Meters



General-purpose instruments making possible, in minutes, receiver and component alignment jobs that once took hours. Simplify accurate alignment; encourage better maintenance; better performance.

Φ 340B automatically measures, continuously displays noise figure of IF amplifiers or microwave devices with output at 30 or 60 MC. Other frequencies on special order. Operates both temperature limited diodes or Φ 347 Waveguide Noise Sources. \$715.00 (cabinet) \$700.00 (rack).

Φ 342A, similar, operates on 30, 60, 70, 105, 200 MC. 30 MC and 4 other frequencies between 38 and 200 MC on special order. \$815.00 (cabinet) \$800.00 (rack).

(Note: Models 340B and 342A available only in the U.S.A. and Canada.)

SPECIFICATIONS

Φ 344AR Noise Figure Meter

Input Frequency:	25 or 30 MC, as specified
Bandwidth:	1 MC
Input Sensitivity:	Requires 35 db \pm 5 db gain between noise source and 344AR input
Input Impedance:	75 ohms nominal. Passive termination during radar scan
Return Loss:	20 db from 20 to 40 MC
Accuracy:	\pm 0.5 db, 0 to 12 db; \pm 1 db, 12 to 20 db
Repetition Rate:	90 to 500 pps, as specified
Total Duty Factor:	0.075 + (100 μ sec) \times (PRF)
Input Trigger:	3 v pos. peak, 3 μ sec duration
Output:	100 μ amp into 2,000 or 3,000 ohms
Temperature Range:	0 to 52 $^{\circ}$ C
Humidity:	95%
Power:	115 v \pm 10%, 50/1,000 cps, 20 to 40 watts (depending on noise source and duty cycle)
Dimensions:	5 $\frac{1}{4}$ " high, 19" wide, 8" deep.
Price:	\$1,600.00 approximate. Depends on options and modifications.

Φ 343A vhf Noise Source, temperature limited diode broadband source, 10 to 600 MC, 5.2 db excess noise, \$100.00.

Φ 345B IF Noise Source, 30 or 60 MC (others to order); 4 impedances, 5.2 db excess noise. \$75.00.

Φ 347A Waveguide Noise Source. Argon gas discharge tubes in waveguide sections; for bands S, G, J, H, X, P, 2.6 to 18.0 KMC, 15.2 db excess noise. \$190.00 to \$250.00.

HEWLETT-PACKARD COMPANY

1053A Page Mill Road Palo Alto, California, U.S.A.
Cable "HEWPACK" Davenport 6-7000
Field representatives in all principal areas

HEWLETT-PACKARD, S. A.

Rue du Vieux Billard No. 1, Geneva, Switzerland
Cable "HEWPACKSA" Tel. No. (022) 26.43.36

Data subject to change without notice. Prices f.o.b. factory.

PROVED IN 200°C HEAT

HUGHES 2N1196 & 2N1197 DOUBLE-DIFFUSED MESA SILICON TRANSISTORS

These amplifiers can take it. Hughes 2N1196 & 2N1197 transistors were developed in conjunction with the U.S. Army Signal Corps on an IPS contract for military devices. They meet the exacting requirements of MIL-T-19500-A. ■ Among the ordeals these devices have undergone is a 5000-hour storage test at 200°C. But they re-prove their ruggedness and reliability every time. h_{fe} and leakage currents stay constant and uniform. They're guaranteed to do so. ■ All units are stabilized at 300°C during processing. ■ These PNP double-diffused mesa silicon transistors are outstanding in another way. They have an extraordinary combination of parameters. For instance: High alpha cutoff frequency, low collector shunt capacitance, low power requirements and low signal distortion, high gain at high frequency. And, as proven by the vigorous tests, for high-temperature operation these amplifiers can really take it. ■ For further information contact your nearest Hughes Semiconductor sales office or authorized distributor.

Or write Hughes Semiconductor Div., Marketing Dept., 500 Superior Ave., Newport Beach, Calif. For export, write Hughes International, Culver City, Calif.

SPECIFICATIONS @ 25° C		
ABSOLUTE MAXIMUM RATING	2N1196	2N1197 Units
$V_{CE0} @ I_{C0} = -100 \mu A$	-70	-70 volts max
$V_{CB0} @ I_{CB0} = -100 \mu A$	-70	-70 volts max
$V_{ES0} @ I_{ES0} = -100 \mu A$	-4	-4 volts max
ELECTRICAL CHARACTERISTICS		
$G_r @ V_{CE} = -10V, I_C = mA$	28 @ 4.3Mc	22 @ 12.5Mc db typ
$f_{\alpha 0} @ V_{CE} = -10V, I_C = 2mA$	45	55 Mc typ
$C_{00} @ V_{CB} = -10V, I_C = 0, f = 140Kc$	3	3 pf typ
$I_{CS0} @ -20V, T = 200°C$	-50	-50 μA max

350 mW dissipation in Free Air
Operating temperature range -65°C to +200°C

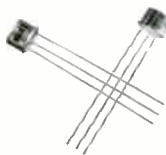

CREATING A NEW WORLD WITH ELECTRONICS

HUGHES

SEMICONDUCTOR DIVISION
HUGHES AIRCRAFT COMPANY

ELECTRONICS NEWSLETTER

Stereo Standards Group Files Field-Test Report

DOCUMENTATION of stereo field-test data—amounting to a half-foot-high pile of paper—is due to be completed this week by the National Stereophonic Radio Committee, the study group set up by Electronic Industries Association to determine standards for stereophonic radio. After evaluating the data, Federal Communications Commission will select a system for broadcast use. With luck, the Commission will make its choice by yearend.

Along with the paperwork are tape recordings of broadcasts received over the air from station KDKA in Pittsburgh, the test site NSRC used. The report will make no recommendations regarding the six systems tested, will merely submit findings of fact to FCC.

Air Force To Set Up Electronics Plans Agency

AIR FORCE general staff is now studying a blueprint for overhauling the Air Force "L" systems (electronic communications, command, and control). The plan results from a 6-month effort by the 140 members of the USAF winter study group at Hanscom AFB, Bedford, Mass. It recommends the creation of a strong central planning and design agency for all electronic command-control systems.

Nucleus of the central planning agency will be the USAF command and control development division at Hanscom AFB; the division is currently headed by Major General K. P. Berquist. The Air Force Scientific Advisory Board will meet at Bedford next Monday for a three-day discussion of command-control problems.

Commercial Communications To Get Help From NASA

NATIONAL AERONAUTICS & Space Administration chief T. K. Glennan says the government will make rockets and launching facilities available to private industry for development of an international

commercial satellite communications system.

Speaking to a state planning group in Oregon, Glennan indicated that the first nongovernmental satellite launching may take place "in the not too distant future," added that reliable satellite communications are "several years" away.

NASA expects to leave commercial developments to industry, will continue research for the present in both active and passive systems. Agency support will be given to "technically promising private proposals on a cost-reimbursable basis." Support will include "vehicles, launching and tracking facilities and technical services," to be made available at cost.

Silicon Carbide Transistors Now Reach for 925 F

TRANSISTOR capable of operating above 650 F was announced last week by two Westinghouse engineers. The device is made from silicon carbide, operates at a temperature above the melting point of lead. It was described at the Fall meeting of the Electrochemical Society in Houston, Tex. The new transistor was developed under sponsorship of the Electronics Research Directorate of the Air Force Cambridge Research Laboratories.

Germanium transistors are currently temperature-limited at about 200 F; silicon units can operate up to 400 F. Lab tests of the SiC device show that it amplifies power up to 670 F; with further development. Westinghouse expects to be able to push its limit up to more than 925 F.

National Alarm Device Tested By OCDM

OFFICE OF CIVIL & Defense Mobilization has successfully tested a simple alarm device that could alert 96 percent of the U.S. population in seconds in case of national emergency.

The device, dubbed NEAR (national emergency alarm repeater) was tested last week in more than

a thousand homes in Charlotte, Mich. Several designs are currently held under OCDM patent; the one tested last week was designed by Midwest Research Institute, built by the AC Spark Plug division of General Motors. It consists of a vibrating reed, a timing motor and a relay sensitive to 240 cps. Only electronic component is a diode rectifier.

The 3x3x2-inch device plugs into an electric outlet. In case of emergency, national attack warning system (NAWAS) would send out a master alarm from its Colorado Springs headquarters to all electric-power companies. These in turn would send out a 1-volt 240-cps signal superimposed on the ordinary 60-cps utility service. After a 70-second delay (to keep the alarm from being triggered by transients), the receiver emits a loud, insistent buzzing.

Outfitting the power companies would cost \$60-70 million. The alarm receivers would probably cost about \$10. OCDM hopes the NEAR system will be a nationwide reality within three years.

Soviets Use Computer For Brain Research

SOVIET LIFE-SCIENCE researches are digging into the operational intricacies of the human brain. M. Livanov of the Soviet Academy's Research Institute of Physiology in Higher Nervous Activity has hooked an electric encephaloscope to a computer in an effort to establish the pattern of cortical connections and find out more about brain conditioning and the learning process.

Livanov's encephaloscope was first exhibited at the Brussels World Fair in 1958. It picks up bioelectric currents by means of 100 electrodes affixed to the head. Livanov is now developing an instrument for simultaneously recording 400 pickoffs.

By hooking the instrument into a computer, Livanov expects to be able to correlate readings to determine close and loose couplings and watch how they change under conditioning. Part of his aim is to aid in diagnosis; he is also interested in pursuing further Pavlov's work in conditioned reflexes.

Palladium Diffusion Purifier removes all impurities from commercial cylinder hydrogen

CHEMICAL
DIVISION

The Engelhard Palladium Diffusion Purifier is used to remove all impurities from commercial cylinder hydrogen. This includes such impurities as oxygen, nitrogen, argon, water vapor, hydrocarbons and any others found in commercially bottled hydrogen.

The hydrogen purity achieved is, without question, the highest obtainable—no trace of impurities are detectable in the purified gas, by any known method.

Electrical circuit interlocks prevent palladium and hydrogen contacting at 150°C to form beta phase Pd-H₂ system which is brittle and impervious. Impurities are not permitted to accumulate within the palladium tubes. Impurities are bled off continuously with a small hydrogen stream which is vented to a hood or a small burner. A check valve located in the pure product line prevents back flow into the tubes.

The Engelhard Hydrogen Palladium Diffusion Purifier is now manufactured in standard sizes for flowrates from 5 scfh up to 1000 scfh. Larger sizes are custom built to meet customer's requirement. Write for literature and price list.

CHEMICAL DIVISION • 113 ASTOR STREET
NEWARK, N. J.

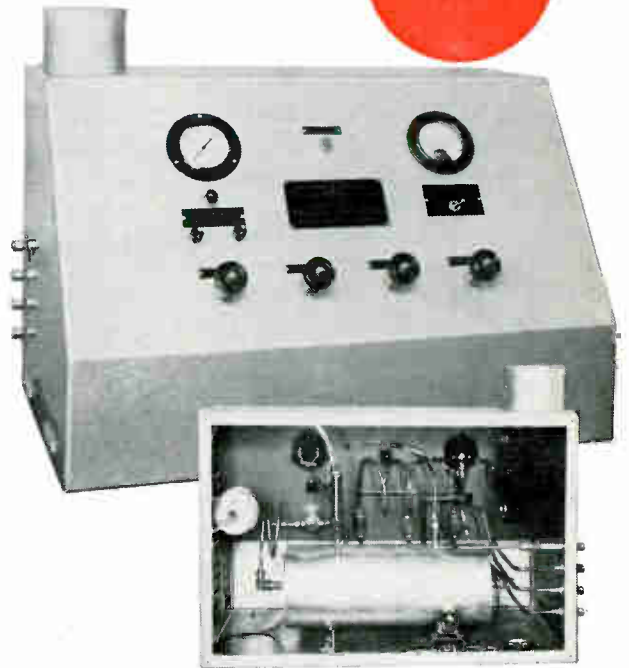

These platinum precision resistance spirals measure temperature by change in electrical resistance.

INSTRUMENTS
AND
SYSTEMS
DIVISION

Here are ideal components for both accuracy and reliability in temperature measuring or controlling equipment. They have an accuracy of $\pm 0.1^\circ\text{C}$.

Three types are available in a full range of sizes. A glass enclosed series affords high precision for temperatures between -220°C and $+500^\circ\text{C}$. Spirals are obtainable as standard products having a resistance of 25, 50 or 100 ohms. The variation in diameters, lengths, etc., are numerous.

High temperature spirals in which suitable ceramic replaces the glass are also available. These are used for measuring temperatures up to 750°C . The accuracy of the ceramic spirals is only slightly less than that obtainable from the glass spiral, but still superior to thermocouples in stability. For extremely precise temperature measurements, a laboratory standard resistance thermometer is available.

Although most spirals are supplied directly to the user as components, we also provide a fabrication service and supply spirals in metal sleeves or other constructions as required. Send for complete literature.

INSTRUMENTS AND SYSTEMS DIVISION • 850 PASSAIC AVENUE
EAST NEWARK, NEW JERSEY



DOMESTIC DIVISIONS: AMERICAN PLATINUM & SILVER DIVISION • AMERSIL QUARTZ DIVISION • BAKER CONTACT DIVISION • BAKER DENTAL DIVISION • BAKER PLATINUM DIVISION • BAKER SETTING DIVISION • CHEMICAL DIVISION • HANOVIA LIQUID GOLD DIVISION • INSTRUMENTS & SYSTEMS DIVISION • IRVINGTON-BAKER REFINING DIVISION • D. E. MAKEPEACE DIVISION • RESEARCH & DEVELOPMENT DIVISION • H. A. WILSON DIVISION. COMPANIES ABROAD: ENGELHARD INDUSTRIES OF CANADA, LTD., TORONTO • ENGELHARD INDUSTRIES LTD., BAKER PLATINUM DIVISION, HANOVIA PRODUCTS DIVISION, LONDON • SOCIEDAD SURAMERICANA DE METALES PRECIOSOS S.A., BO-

PROMPT PRECIOUS METAL SCRAP RECOVERY SERVICE • ENGELHARD PROCEDURES RECOVER

CHEMICAL
DIVISION



gold plating for electrical and electronic components

Atomic Number	79
Atomic Wgt.	197.20
Crystal Structure	Face center cubic 4.07A°
Density	20°C = 19.3 G/CM ³
Melting Point	1063°C
Specific Resistance	13.2 OHMS/MILL/FOOT
Thermal Conductivity	0.71 c g s UNITS (20°C)
Coef. Linear Expansion	14.2 Micro Inches /°C (20°C)
Hardness	Rockwell 15 T Scale = 24
Tensile Strength	P.S.1 x 1000 = 18
Magnetic Susceptibility	.15 x 10 ⁻⁶ C.G.S. Units (18°C)

Recently, the use of gold electroplates have been extended to many new functional applications especially in the field of electronics where the tarnish resistance and low electrical resistivity of gold are most useful. A complete line of precious metal plating solutions for both decorative and functional purposes are available from stock.

ATOMEX is a 24K gold immersion solution that permits the deposition of a thin, dense, uniform layer of 24K gold on printed circuits and metallized plastics by means of a simple bath. Atomex deposits gold by ionic displacement—it is the first practical gold immersion solution containing no free cyanide. The Atomex deposit is more permanent and less expensive than electroplating of comparable thickness. Costly analytical control is unnecessary. Write for literature.

CHEMICAL DIVISION • 113 ASTOR STREET
NEWARK, N. J.

ENGELHARD
INDUSTRIES, INC.

EXECUTIVE OFFICES:

113 ASTOR STREET • NEWARK 2, NEW JERSEY

BAKER
CONTACT
DIVISION



precious metal contacts for high-reliability



For high-reliability and long operating life, precious metal contacts in pure or alloyed forms of silver, platinum, palladium and gold are very definitely indicated. These contacts provide unmatched high resistance to atmospheric corrosion, deformation, arc erosion, binding and metal transfer. Baker precious metal contacts are supplied as wire, rod, sheet and in a complete line of fabricated forms. Facilities are also available for manufacture to your specifications. Write for Baker Contact catalog.

BAKER CONTACT DIVISION • 207 GRANT AVE., E. NEWARK
HARRISON P. O., N. J.

GOTA • ENGELHARD INDUSTRIES S.A.R.L., PARIS • ENGELHARD INDUSTRIES A/S, COPENHAGEN • GLOVER & GOODE PTY., LTD., MELBOURNE • ENGELHARD INDUSTRIES, K.K., TOKYO • ENGELHARD INDUSTRIES, PTY., LTD., MELBOURNE • ENGELHARD INDUSTRIES, LTD., ZURICH • INDUSTRIE ENGELHARD S.P.A., ROME • GIULIANO STACCIOLI—METALLI PREZIOSI S.P.A., ROME • INVERSIONES EN INDUSTRIAS NACIONALES, S.A., BOGOTA. ASSOCIATED COMPANIES: KALIE-CHEMIE-ENGELHARD KATALYSATOREN G.M.B.H., HANOVER

100% OF ASSAYED PRECIOUS METAL CONTENT • IRVINGTON-BAKER REFINING DIVISION

WEINSCHEL

COAXIAL TERMINATIONS

DC to 10 KMC
50 ohms

Connectors: N, C, SC, BNC and TNC
Individual VSWR calibrations supplied at seven frequencies: DC, 4, 1, 2, 4, 7.5 and 10 KMC.

Made with Weinschel Film Resistors for maximum stability.



Weinschel Fixed Coaxial Attenuators cover the frequency range of DC to 12.4 KMC. Write for complete catalog.

Weinschel Engineering
KENSINGTON, MARYLAND

WASHINGTON OUTLOOK

MILITARY ELECTRONICS research and procurement for the years ahead is sure to be affected by the interservice squabble now bubbling up in the Pentagon. The argument is over the nation's deterrent strategy. At stake are decisions on the numbers and types of manned aircraft, missiles and other strategic weapons systems to be added to U. S. retaliatory strength over the next decade.

Air Force strategists on the one side, and the Army and Navy on the other, are arguing about what size nuclear striking forces this country should maintain to deter Soviet aggression. Air Force is putting forth a theory of an evergrowing counter-force; Army and Navy want to stop piling up an over-kill potential and start planning against brushfire wars.

Air Force theorists believe the Soviets could never knock out U. S. retaliatory forces in one big blow. They're concerned, therefore, with our second-strike capabilities. Their theory holds that an all-out nuclear war does not necessarily involve city-busting or genocide. Says one USAF strategist: "Our analysis is that if the Soviets were to attack the U. S., the last thing they would want to attack is our people. Genocide has no military value. Populated cities are hostages and you don't want to kill hostages."

The Air Force envisages that offensive strikes in any possible nuclear war would be aimed at sources of military power—missile sites, bomber bases, and the like; cities would suffer only collateral damage. Air Force's argument is that as the enemy's offensive capacity increases, our own forces must grow to be able to strike at and destroy his more numerous bases of operation.

Implicit in the Air Force theory is a projection of ever-rising military expenditure.

Army and Navy theorists disagree with the argument that strategic forces must continue to grow. They say an all-out nuclear war is unlikely because of its suicidal consequences, that limited local conflicts are a greater threat. Instead of building up an enormous over-kill capacity in heavy bombers and big missiles, the elder services say the U. S. should be putting more money into conventional forces to fight these brushfires as they break out.

Their theory is that we need only enough nuclear striking power, in invulnerable or highly mobile forces, to deter Soviet attack. "Enough" in this view is the relatively stable arsenal of weapons needed to wipe out 150 or so major Soviet strategic centers.

The controversy over strategy takes on new significance as the Presidential election nears. The issue will be one of the key military questions dumped on the new administration. But it's not a question that will be resolved easily, quickly or even permanently. Policy of the Eisenhower administration, for example, has in theory reflected the Air Force opinion; in practice, limitations on defense spending have brought U. S. deterrent strategy more in line with Army-Navy views.

AIR FORCE plans to award a contract for development of a new fighter-bomber within the next six months. At least \$25 million is earmarked in the current budget for initial development.

The plane has been tagged the F-X (also the F-111) and is envisaged as "the most flexible tactical aircraft ever designed." Some Air Force planners also foresee use of the plane as an advanced fighter-interceptor and as a carrier-based craft for the Navy. The F-X is to have short-takeoff-and-landing capability, will be able to operate at both low and extremely high speeds.



**INSIDE
1,000
ERUPTING
VOLCANOS!...**

These are the conditions faced in placing closed-circuit TV cameras within 10 feet of the cluster of eight rocket engines used to power the SATURN space vehicle. The severe heat and vibration generated during a static firing called for a Vidicon having the highest sensitivity characteristics while being of the most rugged construction.

GEC'S 7226A—Ruggedized Vidicon was found capable of meeting these extreme requirements . . . successfully. The engineers and technicians were able to monitor and film the exhaust characteristics in recent static firings of the National Aeronautics and Space Administration's SATURN vehicle because of the dependable performance of four 7226A VIDICONS manufactured by General Electrodynamics. The 7226A GEC Vidicon meets military environmental conditions for shock and vibrations MIL-E-5272A; illumination, 1,000 ft-c; temperature, 71°C.

If you have a project requiring difficult applications for Vidicons, Scan Conversion, Image Conversion, or Display Tubes, contact General Electrodynamics Corporation . . .

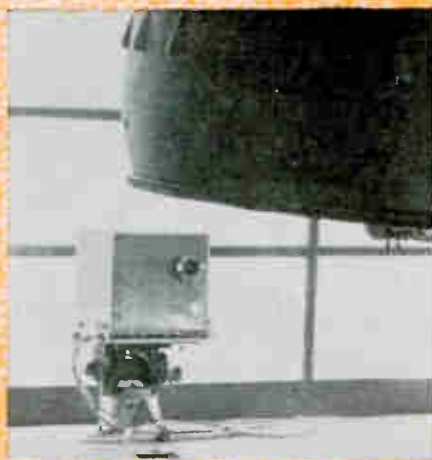

where tube research begins. . . .



GENERAL ELECTRODYNAMICS CORPORATION
4430 FOREST LANE • GARLAND, TEXAS • BROADWAY 6-1161

Here's why the NEW AO TRACE-MASTER is the world's finest 8-channel direct writing recorder!

American Optical Company, famous for precision instrumentation for 138 years, introduces an electronic direct-writing recorder of unique design, in which ultra-precise electromechanics has been combined with advanced electronics to achieve *truly superior performance*.

Finest Writing Method Ever

Unique direct-carbon-transfer writing method. Trace is uniformly black and up to four times thinner than that made by any other recorder. Minute variations in phenomena measured are more faithful, meaningful. Carbon trace cannot fade... may be easily reproduced.

Finest Frequency-Amplitude Performance

TRACE-MASTER'S multiple-feedback wide-range Driver circuitry, combined with the advanced pen-motor design, produces wider frequency response at larger amplitudes than any other recorder. TRACE-MASTER response is flat—with in 1%—from dc to 110 cps at 40 mm!

Band Amplitude Product (i. e. Bandwidth times Amplitude) is 5600...140 cps (3 db point) x 40mm!

Finest Chart-Drive Facilities

TRACE-MASTER provides widest chart-speed range...0.1 to 500 mm/sec...of any direct-writing recorder! Convenient

push-button selection. Take-up reel automatically stores full 1000 ft. record. Writing table tilts for easy chart annotations. Guide rails permit quick, easy paper-roll changes. Low cost chart paper makes practical protracted recording at high speeds.

Finest Resolution, Linearity, Stability

Thin carbon trace (thinner by 4 to 1 over most recorders) and high Band Amplitude Product (higher by 6 to 1 over other recorders) provide up to 24 times the resolving power or ability to detect short, sharp variations in the record. The superior linearity ($\pm 1\%$) and stability in rectilinear presentation permit full use of this unexcelled resolution.

Finest Systems Oriented Compatibility

Fully transistorized circuitry...application of combined dc level and signal multiple feedback...complete interchangeability of modular signal-conditioning elements... are some of the features that make the AO TRACE-MASTER the world's finest 8-channel direct writing recorder.

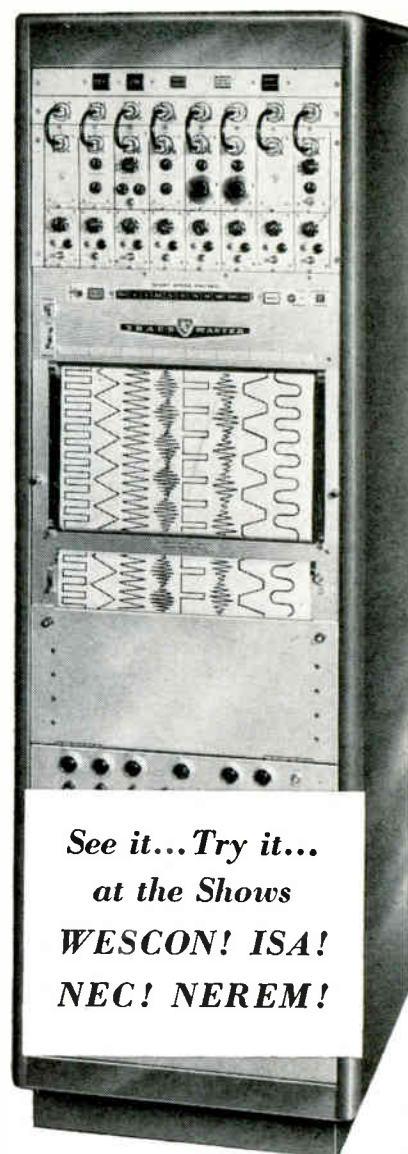

See it... Try it...
at the Shows
WESCON! ISA!
NEC! NEREM!



Entire channel easily accessible and completely interchangeable as single unit.

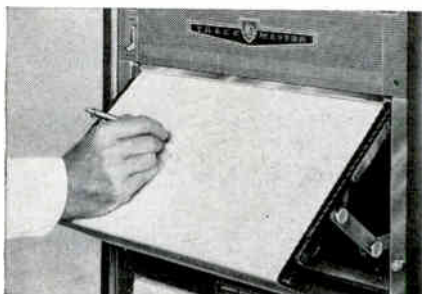

Platen tilts to convenient writing angle.

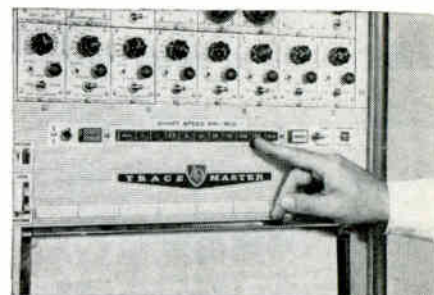

Widest range chart speed... push-button selection through 0.1 mm/sec to 500 mm/sec.

WRITE, WIRE, TELEPHONE TODAY
FOR COMPLETE INFORMATION!

Complete Engineering Bulletins available.
Field Sales Engineers at your service everywhere.

American  Optical
COMPANY

INSTRUMENT DIVISION, BUFFALO 15, NEW YORK

Reliability in volume...



CLEVITE
TRANSISTOR
WALTHAM, MASSACHUSETTS



NEW!

ADVANCED DESIGN POWER TRANSISTORS FROM CLEVITE

Three new lines of germanium power transistors by Clevite feature new advances in controlled gain spread, fully specified collector-to-emitter voltage characteristics and low current leakage — even at maximum voltages and high temperatures.

The new 8 ampere switching series can be used to replace the older, more costly ring-emitter types in 3 to 8 ampere service.

The new 25 ampere switching type offers exceptionally low saturation voltage and is available with either pin terminals or solder lugs.

The new Spacesaver design not only affords important savings in space and weight, but its significantly improved frequency response means higher audio fidelity, faster switching and better performance in regulated

power supply applications. Its low base resistance gives lower input impedance for equal power gain and lower saturation resistance, resulting in lower "switched-on" voltage drop. Lower cut off current results in better temperature stability in direct coupled circuits and a higher "switched-off" impedance.

CLEVITE NOW OFFERS THESE COMPLETE LINES

Switching Types

5 ampere

8 ampere

15 ampere

25 ampere

3 ampere Spacesaver

Amplifier Types

2 watt

4 watt

2 watt Spacesaver

All Clevite germanium power transistors are designed for low thermal resistance, low base input voltage, low saturation voltage and superior current gain.

For latest data and prices or application assistance, write for Bulletin 60 . . .

A DIVISION OF

CLEVITE
CORPORATION

Reliability in volume . . .

CLEVITE TRANSISTOR

254 Crescent Street Waltham 54, Mass. Tel: TWinbrook 4-9330



OZALID NEWSLETTER

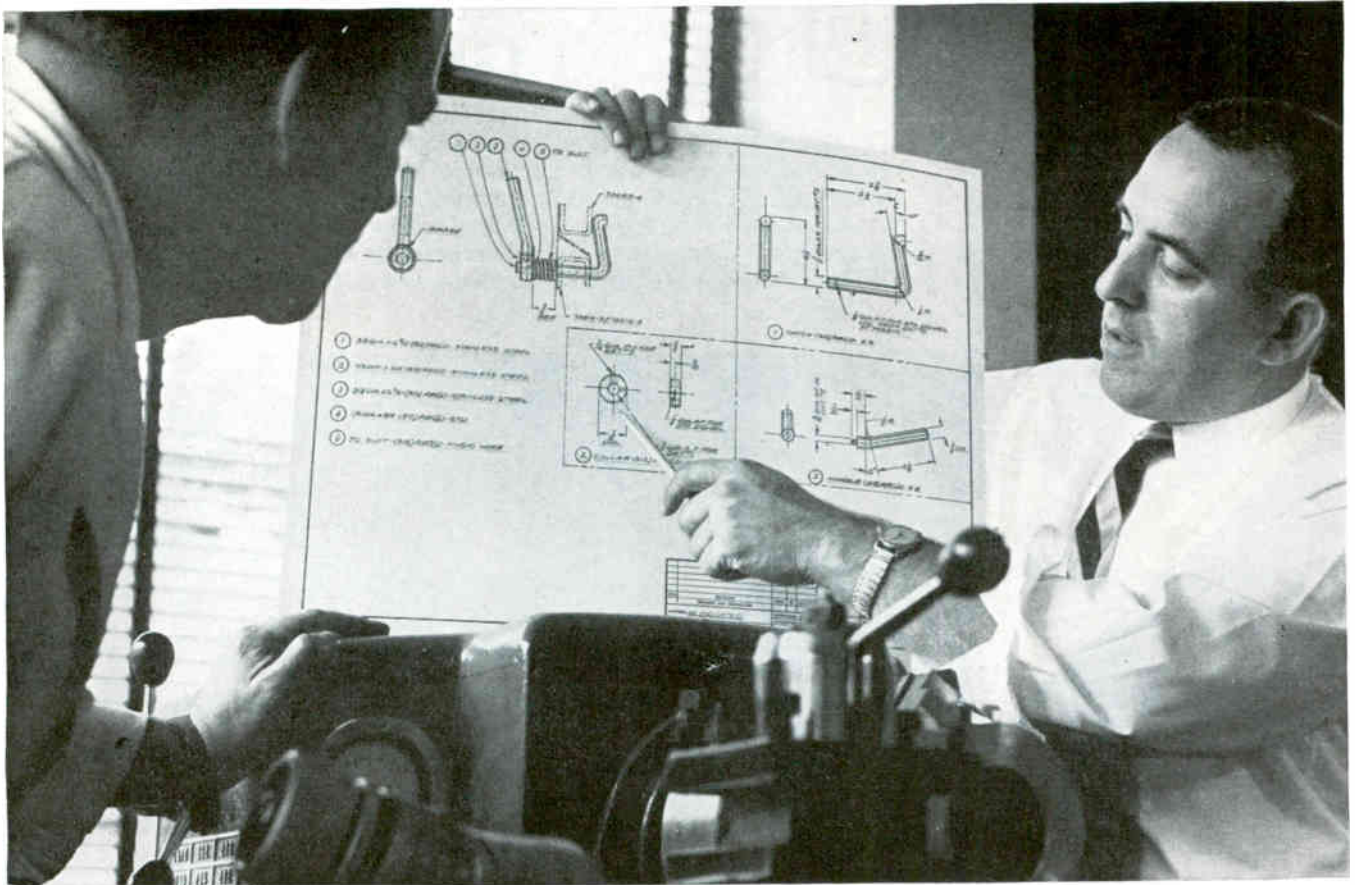

Newest black-line intermediate paper copies fine details ... gives fast, easy-to-read prints

This paper's so new—and so hot—we're still getting plaudits from companies that field-tested it for us. (Top names in Engineering, Chemicals, Electronics, Petroleum, Metals, Retailing, Publishing.)

They found that Ozalid's new black-line 102 ITF picks up fine details, even from faint pencil-line drawings. And its opaque black line gives far more covering power than any comparable intermediate paper, sepia or black—with no letup in speed.

Why black line? A rich image that's a cinch to read, a snap to mass-copy. But that's not all.

The paper has a vellum base—100% rag, for durability and strength. It knows how to handle penciled, penned or typed additions. Also image corrections.

In addition, the base is transparent—gives fast reprints even with age or constant use. And there's no

transference, no damage when you file it with other papers, including Van Dykes and photographic material.

What machines accommodate 102 ITF? Any Ozalid machine with a Teflon screen or stainless steel mesh belt developer section. Or any other machine similarly equipped.

Here are some of the ways you'll benefit from 102 ITF:

You'll prevent damage to valuable original drawings by making fast mass-copies. Make changes without touching your original drawing. Distribute 102 ITF intermediates to branch plants, so they can make prints as needed. Save time in mass printing by using several duplicate originals. Superimpose one drawing on another, and print the composite on 102 ITF.

Chances are you've already thought of a dozen more uses for 102 ITF... or will, as soon as you start working

with it. We'll appreciate it mightily if you'll shoot 'em along to us!

Top-quality, low-cost plastic-coated copy papers

Also from Ozalid—two superior copy papers. *Black* image paper, standard speed, for office use. And *blue* image paper, rapid speed, for engineering drawings.

Both are smooth-surfaced, semi-glossy. Both make crisp prints and copies. The black image paper (105 SZ) reproduces halftones from a film positive with photographic clarity. The blue image paper (208 SZ) is tough enough for shop and field use, and wipes clean with a damp cloth.

Both papers belong in your setup.

For more information, or a demonstration, get in touch with your nearest Ozalid man. His job is to help you do your job even better.

OZALID Johnson City, N. Y. A Division of General Aniline & Film Corp. In Canada: Hughes-Owens Co., Ltd., Montreal

New dimensions in design flexibility

HUDSON PRECISION DRAWN CLOSURES

Leading electronic/electrical manufacturers specify HUDSON closures for *total* reliability in commercial equipment and vital military programs. HUDSON precision-drawing is an industry standard... standardized tooling reduces cost and production time... HUDSON "know-how" turns out specials quickly for unusual applications. Call Hudson for complete, reliable service — *every time!*

**A complete
Range of Standard
Cases and Covers from
Transistor Caps to
Transformer Housings**

Hudson Standardized Closure Designs include —

- RELAY CLOSURES
- TRANSFORMER HOUSINGS
- INSTRUMENT CASES
- TRANSISTOR AND DIODE CLOSURES
- NICKEL-SILVER CRYSTAL CASES
- COVERS WITH INSTALLED TERMINALS

Commercial and Military Closures in —

- MU METAL
- BRASS
- NICKEL-SILVER
- COPPER
- ALUMINUM
- STEEL AND STAINLESS STEEL

— all finishes available

Hudson Tool & Die Company • Inc

18-38 Malvern Street, Newark 5, New Jersey

Precision Metal Components for Electronics, Instruments, Avionics and Machinery

Telephone: Market 4-1802
Teletype: NK 1066

Ask for the
HUDSON
CATALOG
— contains
complete data
on HUDSON
Standard
Closures
including MIL
types. Please
make request
on company
letterhead.



Perkin-Elmer Sales Up 26 Percent

THE PERKIN-ELMER CORP., Norwalk, Conn., reports a rise in net income as a percentage of sales for the fifth consecutive year. In fiscal 1960, ended July 31, this percentage was 5.5, compared with 5.1 the year before. Sales of \$22.4 million were 26 percent ahead of the previous year's \$17.5 million. Earnings of \$1,208,085, equivalent to \$1.05 a share, marked a 34-percent increase over earnings of \$900,799, equal to \$.80 per share, the year before. Backlog is reported at \$11.5 million.

International Rectifier Corp., El Segundo, Calif., announces a sales rise of 21 percent and an increase in earnings after taxes of 37 percent for the fiscal year ended June 30 this year, compared with the same period last year. For this fiscal year, sales were \$13,124,586, compared with \$10,870,038 last year. Earnings after taxes were \$1,206,007 or 52 cents a share, as against \$877,371 or 36.4 cents in the preceding year.

Consolidated net income for The Bendix Corp. for the nine months ended June 30 this year was \$17,359,408, equivalent to \$3.23 a common share. These earnings compare with the higher figure of \$17,745,589, or \$3.48 a share, in the same fiscal period of 1959. Net income for the first nine months of this year is after provision for federal income taxes of \$18,467,601. The comparable figure for the first nine months of last year was \$20,705,693. Consolidated net sales, royalties and other operating income for the first nine months amounted to \$606,009,118, compared with \$504,553,408 reported for the first nine months of last year.

Federal Pacific Electric Co., Newark, N. J., reports net sales of \$100,194,175 for the fiscal year ended June 30, 1960. Net earnings after deducting for minority inter-

ests amounted to \$2,767,815. After deducting for dividend payments of \$267,604 on all outstanding preferred stock, the earnings per share were \$1.72 on 1,454,558 shares of common stock outstanding. These figures incorporate the sales and earnings of Cornell-Dubilier for the 12 months ending June 30, 1960, including the net loss of \$395,543 for the last quarter of C-D's fiscal year which ended Sept. 30, 1960.

Craig Systems, Inc., and its wholly-owned subsidiary, LeFebure Corp., Cedar Rapids, Ia., report sales of \$14,253,755 and net earnings of \$591,298, equal to 77 cents per share on 772,862 shares, for the fiscal year ended July 31, 1960. Sales of the Lawrence, Mass., firm and its subsidiary were \$12,081,619 in the previous year, with net earnings of \$380,887, equal to 50 cents a share on 762,862 shares which were then outstanding.

25 MOST ACTIVE STOCKS

	WEEK ENDING OCTOBER 7, 1960			
	SHARES (IN 100's)	HIGH	LOW	CLOSE
Gen Tel & Elec	876	277½	265½	27¼
Ampex	774	24½	22¾	22¾
RCA	686	55½	52¼	54¾
Gen Elec	664	75¾	71	74¾
Westinghouse	572	51¾	48½	50¾
Elec & Mus Ind	524	6½	6½	6½
Univ Controls	497	17¼	15½	16
Sperry Rand	494	20¾	19½	20
Avco	459	14½	14½	14½
Int'l Tel & Tel	427	37¾	36½	37¾
Gen Dynamics	387	38¾	37	38½
Zenith	377	114¼	107	107¾
Sterling Precis	326	3½	2½	3
Gen Inst	321	36½	33¼	34½
Beckman Inst	317	91¼	87	88½
Raytheon	311	37¾	35½	35¾
Philco	293	21¾	20	20
Litton Ind	289	77¾	72½	75¾
Varian Assoc	264	48¼	44½	45½
Collins Radio	264	51¾	47½	49¾
Motorola	261	73¾	66¼	66¾
Telectro Ind	254	16¼	14¼	15½
Nat'l Cash Register	225	57¾	53¾	53¾
Texas Inst	216	184¾	175¼	180¾
Tung Sol Elec	213	35¾	30¾	33¾

The above figures represent sales of electronics stocks on the New York and American Stock Exchanges. Listings are prepared exclusively for ELECTRONICS by Ira Haupt & Co., investment bankers.



VITREOUS-ENAMEL POWER RESISTORS

Sprague reliability is built-in these dependable Blue Jacket miniature axial lead resistors. New all-welded end-cup construction gives improved reliability under severe environmental conditions.

Blue Jackets are ideal for use in miniature electronic equipment with either conventional wiring or printed wiring boards.

Get complete data on these dependable minified resistors, write for Engineering Bulletin 7410A.

SPRAGUE ELECTRIC COMPANY
35 Marshall Street, North Adams, Mass.



New Subminiature Door Interlock Switch...

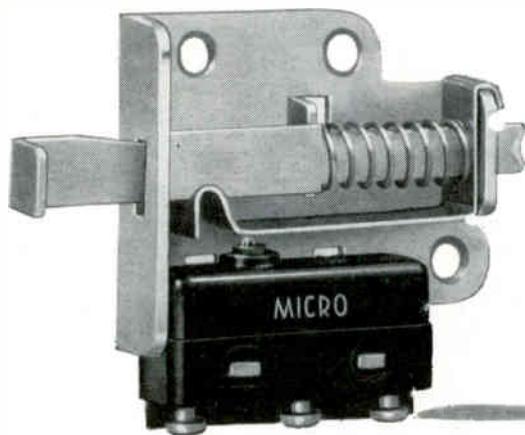

Reliable safeguard even in contaminated atmosphere

Now you can specify reliable protection for electronic equipment with minimum size and weight requirements. This new subminiature door interlock switch can be installed on high voltage cabinets to automatically cut off the power circuit when the door is opened for repairs or testing. It operates reliably in locations subject to the effects of fungus, salt, fog, dirt, dust and high temperatures up to 250°E. Stainless steel is used in all metal parts to resist corrosion, give longer life, greater reliability.

The basic switch conforms with military specification MIL-S-6743.

A "safety" position adds protection during maintenance. By manually pulling the plunger out to the maintained-contact position, you safely close the circuit for checking. When the door closes, the plunger returns automatically to normal operating position. This eliminates dangers in "tying down" or wiring around a conventional switch which may be forgotten after service is completed.

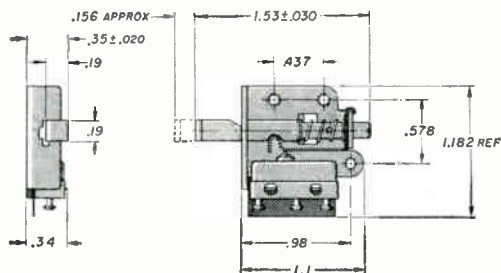

Series "17AC" Door Interlock Switch. Weight of this new switch is only .32 oz. Maximum dimension is only 1.5". Write for full information—ask for Catalog 63.



In Door Interlock Switches . . .

Only MICRO SWITCH Reliability means absolute safety!

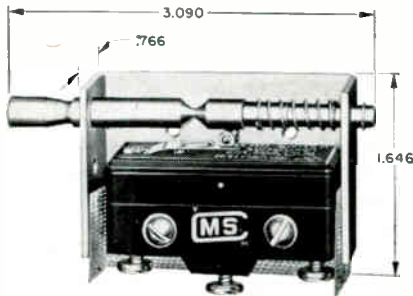

1AC Single-pole double-throw circuit. Basic switch is UL listed for 15 amps. 125, 250 or 460 vac; 1/2 amp. 125 vdc; 1/4 amp. 250 vdc. Operating Force—3 1/2 lb. max. Total Travel—3/12 in. (approx.) each direction.

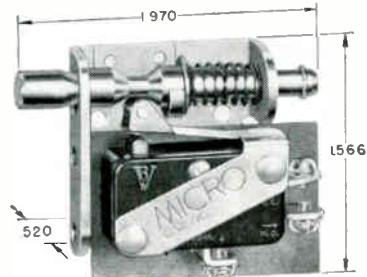

2AC Single-pole double-throw circuit. Basic switch is UL listed for 10 amps. 125 or 250 vac; 1/2 amp. 125 vdc; 1/4 amp. 250 vdc. Operating Force—4 lb. max. Total Travel—1/4 in. (approx.) push. 3/16 in. (approx.) pull.

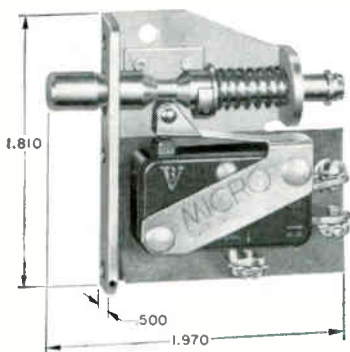

3AC Single-pole double-throw circuit. Basic switch is UL listed for 10 amps. 125 or 250 vac; 1/2 amp. 125 vdc; 1/4 amp. 250 vdc. Operating Force—4 lb. max. Total Travel—1/4 in. (approx.) push. 3/16 in. (approx.) pull.

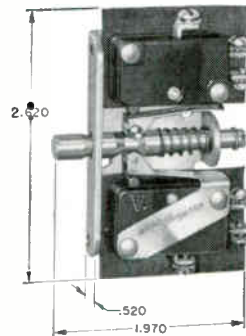

4AC A two switch double-pole double-throw assembly for controlling two circuits simultaneously. Basic switches are UL listed for 10 amps. 125 or 250 vac; 1/2 amp. 125 vdc; 1/4 amp. 250 vdc. Operating Force—3 lb. max. Total Travel—1/4 in. (approx.) push. 3/16 in. (approx.) pull.

Consult the Yellow Pages for the name of the nearby MICRO SWITCH branch office. Engineering assistance is available without obligation.

MICRO SWITCH . . . FREEPORT, ILLINOIS
A division of Honeywell
In Canada: Honeywell Controls Limited, Toronto 17, Ontario

75 YEARS HONEYWELL
PIONEERING THE FUTURE



Honeywell

MICRO SWITCH Precision Switches



RCA POWER TRANSISTORS
are as close as your telephone

CALL YOUR RCA SEMICONDUCTOR DISTRIBUTOR

Just pick up the 'phone and tell him how many and what type you need for your special project or pre-production requirements. He will deliver from local stock—and he also offers these extra advantages:

- ✓ Prompt delivery of the latest RCA types for your evaluation
- ✓ Orders filled from factory-fresh stock
- ✓ Up-to-date, practical product information
- ✓ Valuable RCA technical assistance when you need it
- ✓ "One-stop" service on your orders
- ✓ Specialists who understand your problems and electronic needs

Remember when you want fast delivery, reliable service, always check first with your local RCA Semiconductor Distributor. For the name and address of your nearest RCA Semiconductor Distributor, write RCA, Distributor Products Sales, Harrison, N. J.

For details on RCA Power Transistors, see back cover!



**RADIO CORPORATION
OF AMERICA**

Semiconductor Products-Distributor Sales
Harrison, N. J.

MARKETING

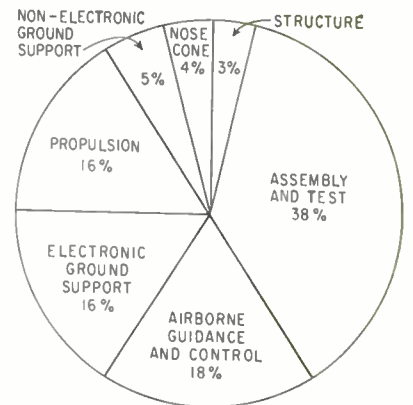
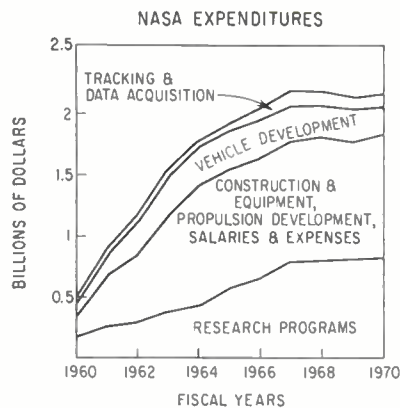

Total Missile Expenditures Fiscal 1960, \$3.5 billion
Source: Comptroller's Div., Department of Defense

Space Complements Missile Growth

SPACE PROGRAM is based in great measure on military missile capability, and missile production is already the fastest-growing segment of military spending, opines Murray Weidenbaum, Boeing Airplane corporate economist.

His rough estimates of total missile and astronautics spending for the three services total approximately \$4 billion for fiscal 1960. Fiscal 1970 spending will rise to about \$8 billion, he indicates, accounting for 58 percent of Air Force procurement expenditures, 53 percent of Army expenditures and 20 percent of Navy expenditures.

Military economists estimate 33½ to 40 percent of missile procurement now goes to the electronics industry. Many say this portion will soon increase to about 50 percent.

Spending by National Aeronautics & Space Administration is expected to rise from less than \$500 million in fiscal 1960 to \$2.2 billion by 1967, Weidenbaum told a recent American Management conference on space technology. Cumulative expenditures through 1970 should total about \$17½ billion, he said.

Electronics' share, about 20 percent in fiscal 1960, will rise to nearly 50 percent in 1970, David R. Hull, past president of Electronic Industries Association, reported some months ago. This expected

trend in NASA expenditures is shown above.

Chart on military research, development, and evaluation test expenditures is a lead indicator of military procurement trends, Weidenbaum believes. Intimations in the mid-1950s of the coming crossover between missiles and aircraft procurement expenditures came into full flower in 1960 when missile RDT&E was three to four times aircraft RDT&E. Missile procurement expenditures will, according to all indications, top aircraft procurement in 1963.

Weidenbaum estimates that about one quarter of all military research and development, test and evaluation is devoted to research and the rest to the testing and developing of weapon systems. A little more than \$100 million a year is spent on basic research, he believes.

First step in constructing Weidenbaum's military and space estimates is a careful analysis of overall economic activity. Four basic factors used in the report to AMA are population growth, consumer demand, total R&D expenditures and nondefense government expenditures.

From analysis of these four factors he arrived at an estimated gross national product of about \$700 billion for 1970. But since defense spending has been a declining

ALLOCATION OF MILITARY RDT & E

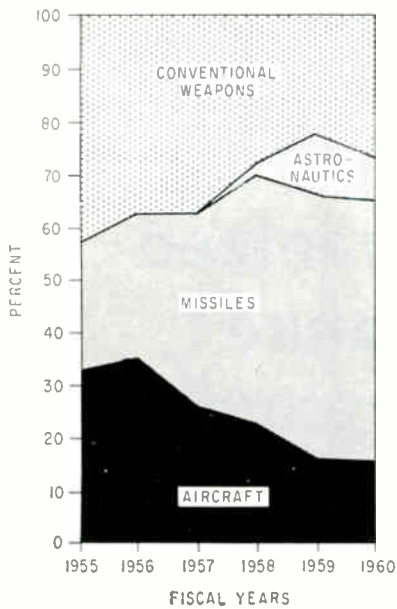

percentage of the GNP ever since the end of the Korean War, and since the most reasonable expectation is for this trend to continue, he says, military spending will rise from \$41 billion today to about \$49 billion in 1970.

Weidenbaum considers this level of military spending is consistent with existing tax rates, large increases in nondefense programs, a balanced budget and a moderate surplus available for tax reduction or debt retirement.

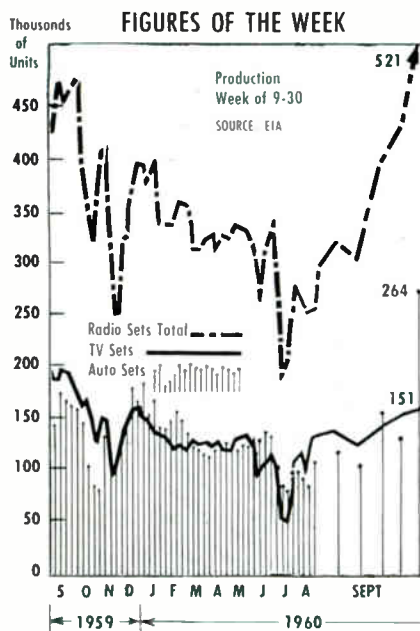

IT FLOATS!

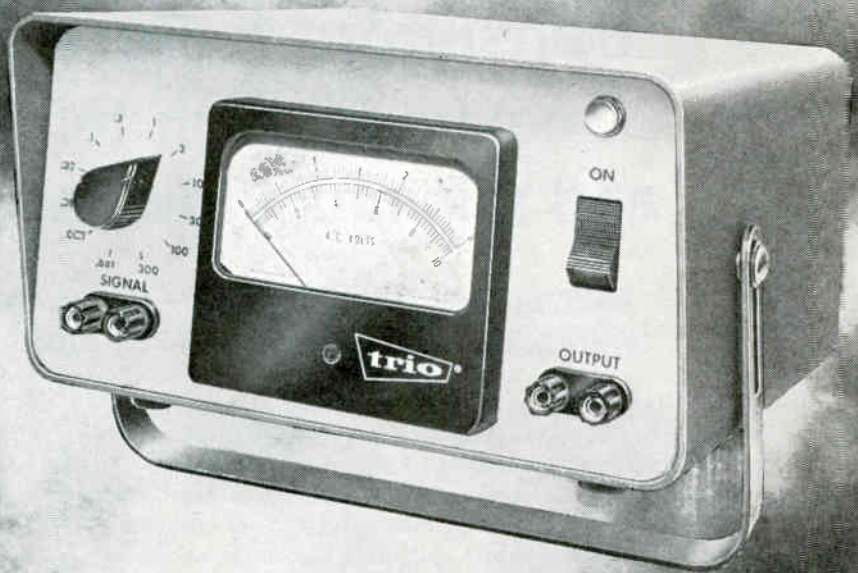

In Trio Labs' new Standard Laboratory AC VTVM... the signal circuits are isolated from case and power circuits, to provide

- floating measurements previously impractical
- accurate voltage measurements to 5 cps
- shock safety: case isolated from circuit under test

The new Model 109-2 has 12 voltage ranges calibrated to RMS value of a sine wave: 0.001 to 300 VAC full scale, with frequency range of 5-200,000 cps. Accuracy is $\pm 2\%$ full scale. Can measure accurately to 20 microvolts. Input impedance 10 megohms. Low distortion amplifier output voltage can be externally shorted without internal damage. Power: 105-125 VAC, 50-420 cps, 25 watts. Price: \$220.00

For free 36-page Engineering Guide, write to Dept. E-8.

Precision electronic instruments for measurement and control.



TRIO LABORATORIES, INC.
Plainview, Long Island, New York
Overbrook 1-0400 • TWX HKVL 1166

© 1960, Trio Laboratories, Inc.

General Electric 2N396A and 2N526 transistors feature guaranteed maximum high temperature I_{CO} and minimum low temperature h_{FE}

A WELL-CHARACTERIZED SWITCH AND AMPLIFIER FOR MILITARY USE WITH EXTREME STABILITY PROVED BY 10,000-HOUR LIFE TESTS

These two do the tough jobs—a fact demonstrated by their use in dozens of different missiles. Reliability and uniformity of parameters are enhanced by a 100°C bake on 100% of all manufactured product. All units also undergo a hydraulic pressure test to insure against leaks. Gettering guards against entrapped moisture and provides unusual stability of parameters.

USN 2N396A

Method B life-test of MIL-S-19500 assures exceptional reliability for General Electric's USN 2N396A. Life-test reliability is the highest for any transistor now covered by military specifications. The G-E USN 2N396A is guaranteed to have extremely low failure rates,

being required to meet acceptance criteria roughly equivalent to 0.65 AQL. Compare this with the AQL's of 4.0 and 6.5 generally used for life assurance in MIL specs.

USN 2N526

The Navy specification for General Electric's 2N526 reflects the outstanding characteristics of this transistor type. Among the features which contribute to its superiority are high dissipation (225 mw), 100°C maximum storage temperature and h_{FE} from 53 to 90.

See your General Electric Semiconductor District Sales Manager for complete specifications. General Electric Company, Semiconductor Products Dept., Electronics Park, Syracuse, New York.

2N396 EXTENDED LIFE TEST STABILITY

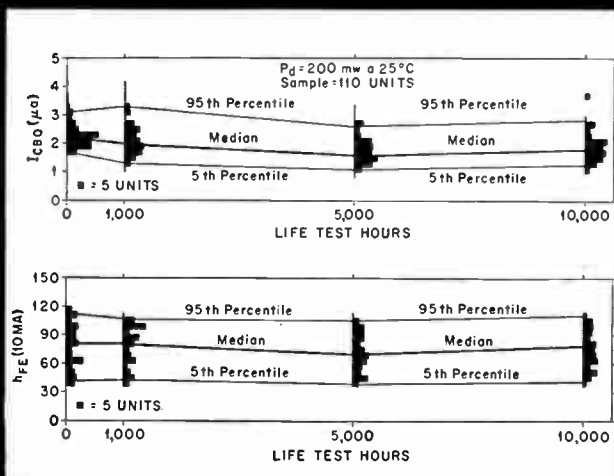

2N526 EXTENDED LIFE TEST STABILITY

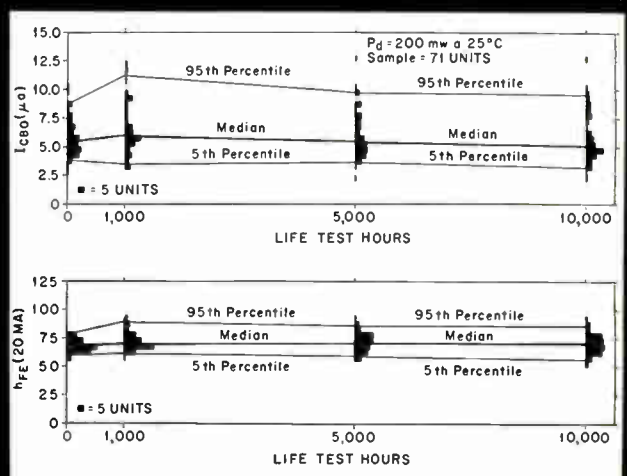

Scope at left shows high-temperature I_{CO} trace with transistor immersed in mineral oil at $+70^{\circ}\text{C}$. Scope at right shows low-temperature h_{FE} with transistor packed in dry ice at approximately -55°C . Scales: I_{CO} — vertical scale 10 microamps./cm., voltage scale 2 volts/cm.; h_{FE} — base drive 50 microamps./step, vertical scale 1 m.lamp./cm., horizontal scale 2 volts/cm.



TYPE	MAXIMUM RATINGS (25°C)				ELECTRICAL CHARACTERISTICS				
	V_{CBO}	V_{CEr}	V_{EBO}	P_T	25°C Max. I_{CO}	70°C Max. I_{CO}	25°C h_{FE}		h_{FE}
							min.	max.	min.
2N526	-45***	-30	-15	225 mw	-10 μa @ -30V	-220 μa @ -30V	53	90	27 (-25°C)
2N396A	-30	-20*	-20	200 mw**	-6 μa @ -20V	-120 μa @ -20V	30	150	20 (-55°C)

* V_{CEO}
 Mil Version 150 mw *Mil Version -30V

For fast delivery at factory low prices, call your authorized General Electric Distributor.



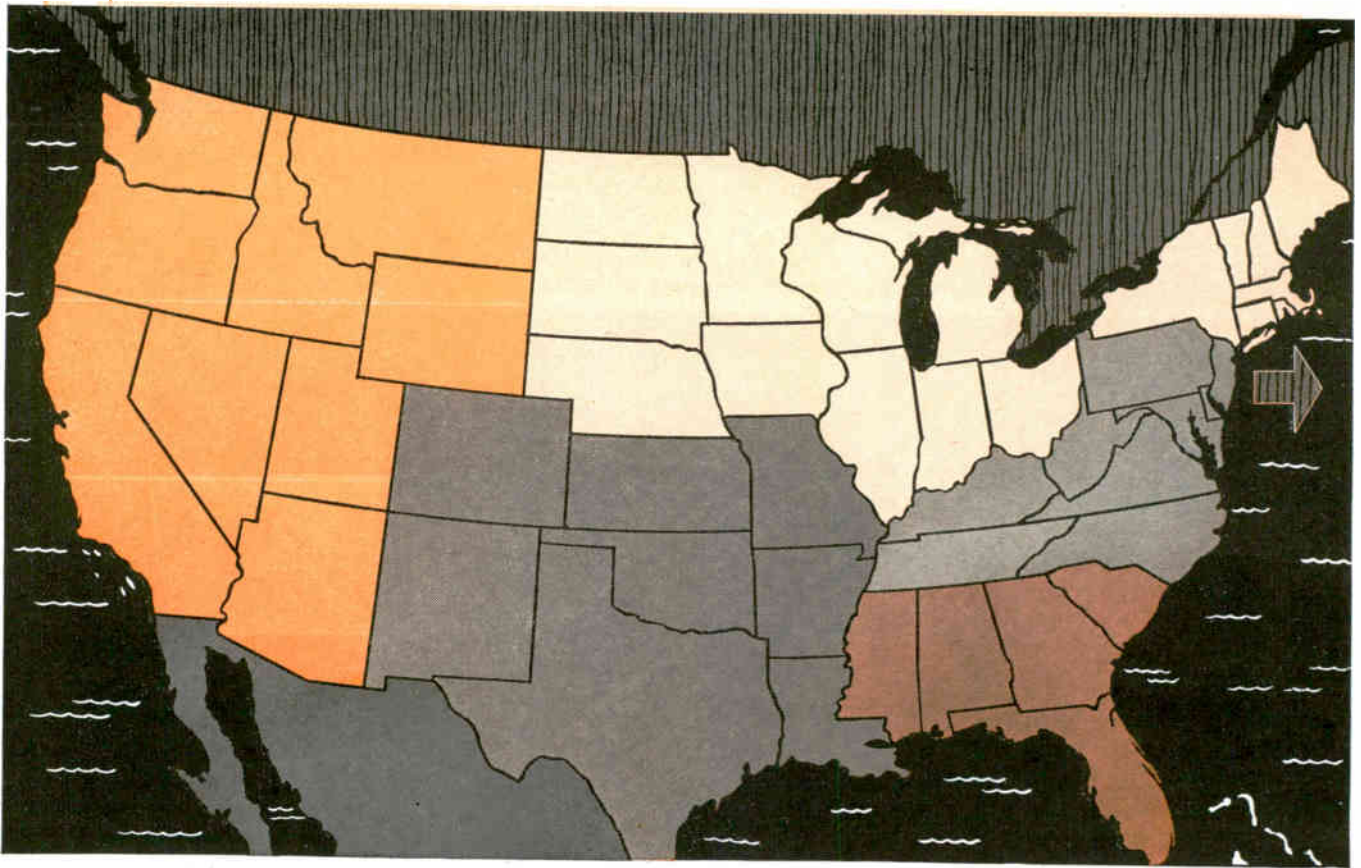

DISTRIBUTION NETWORK OFFERS MAXIMUM SERVICE TO BENDIX CONNECTOR CUSTOMERS

Important Supplement to Factory Facilities:

This distribution network was built to serve you promptly from strategically located stocks—and is, in effect, an extension of the same quality customer service we maintain at our Sidney plant. Rigid factory assembly and quality control standards are observed at all our field locations. Check the appropriate map section for the source nearest you.

WESTERN STATES

DISTRIBUTION CENTERS:

LOS ANGELES 16, CALIFORNIA
Avnet Corporation, 5877 Rodeo Rd.
SUNNYVALE, CALIFORNIA
Avnet Electronic Corporation of Northern California
1262 No. Lawrence Rd. (P. O. Box 568)

SALES OFFICE & FACTORY BRANCH:

LOS ANGELES, CALIFORNIA
117 E. Providencia Ave.
Burbank, Calif.

SALES OFFICE:

SEATTLE, WASHINGTON
8425 First Ave. S.

NORTHEAST & GREAT LAKES STATES

DISTRIBUTION CENTERS:

WESTBURY, LONG ISLAND, N. Y.
Avnet Electronic Corporation
70 State St.
MELROSE PARK, ILL.
Avnet Electronic Corporation of Illinois
2728 No. Mannheim Rd.

SALES OFFICES:

NEW YORK
545 Cedar Lane
Teaneck, N. J.

CHICAGO, ILL.
4104 N. Harlem Ave.

SOUTHEASTERN STATES

DISTRIBUTION CENTER:

MIAMI, FLORIDA
Airwork Corporation
1740 N. W. 69th Ave.

SALES OFFICE:

ORLANDO, FLORIDA
1922 Taylor Ave.
Winter Park, Fla.

SOUTHWESTERN STATES

DISTRIBUTION CENTER:

DALLAS 7, TEXAS
Contact Electronics, Inc.
2403 Farrington St.

SALES OFFICE:

DALLAS 35, TEXAS
2608 Inwood Rd.

MIDDLE ATLANTIC STATES

DISTRIBUTION CENTER:

PHILADELPHIA 3, PA.
Harold H. Powell Company
2102 Market St.

SALES OFFICE:

WASHINGTON 6, D. C.
1701 K St., N. W.

EXPORT AND CANADA

EXPORT:

BENDIX INTERNATIONAL DIVISION,
BENDIX AVIATION CORPORATION
205 E. 42nd St.
New York 17, N. Y.

CANADA:

Aviation Electric Ltd.,
200 Laurentien Blvd.
Montreal 9, Quebec

Scintilla Division

Sidney, N. Y.



New Cubic V-45 Digital Meters

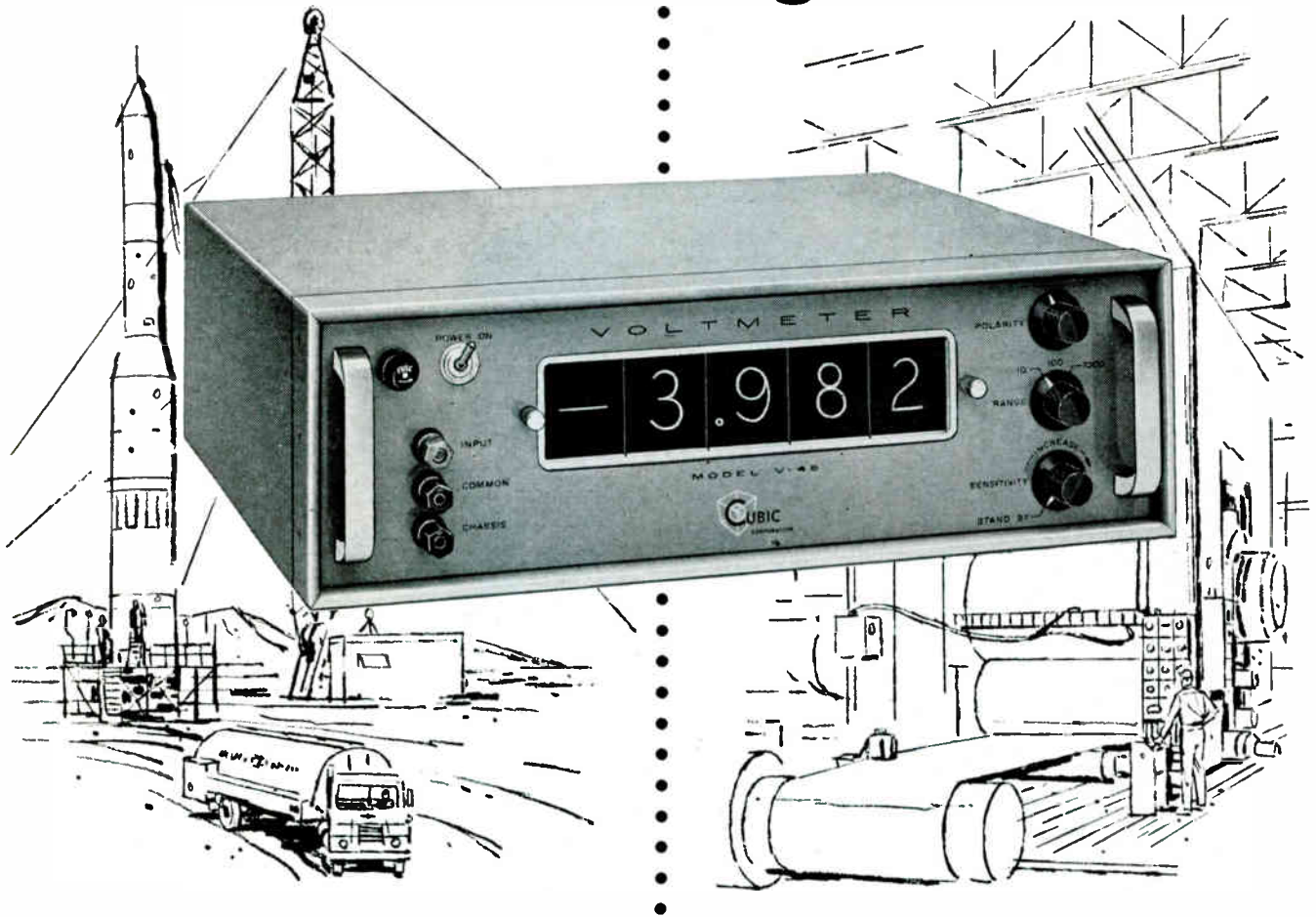

Priced for Industry! Proven for Defense!

SPECIFICATIONS*

Absolute accuracy: 0.02% ± 1 digit
(rms sum of system tolerances)

Input: Floating or grounded, from front panel connections.

Input impedance: 10 megohms at balance

Input filter: 60 cps rejection

Ranges: Manually selected, 10% expanded range

Low ± 0.000 to ± 10.999 vdc

Mid ± 00.00 to ± 109.99 vdc

High ± 000.0 to ± 1099.9 vdc

Sensitivity: 1 millivolt

Sensitivity control: continuous from 1 digit to 10,000 digits, with standby lockout.

Power Input: 105-125 vac, 50-60 cps, 20 watts

Dimensions: 19" wide x 5 $\frac{1}{4}$ " high x 15 $\frac{1}{2}$ " deep, rack or bench mounting, with dust-proof switch and bridge section.

Now, at last, the top quality and dependability of Cubic digital voltmeters are available in a meter priced for the industrial market. It is the new four-digit V-45 Digital Voltmeter, fully transistorized, accurate, economically priced.

The practical manager recognizes the costliness of operator errors through misreading and misinterpretation. These errors occur daily on the production line, in quality control, testing and receiving inspection. Alert managers are continuously seeking instrumentation which will eliminate the human element in measurement procedures.

The new Cubic Model V-45 Voltmeter is the answer. It offers the precision expected from custom-built

equipment and covers the full d-c range from 1 millivolt to 1099.9 volts. It is rugged enough for operation in any industrial environment. Like all Cubic digital voltmeters, the V-45 features the proven reliability and accuracy of transistor-driven stepping switches.

Write for more information to Dept. E-3, Industrial Division, Cubic Corporation, San Diego 11, California.

V-45... the economy meter in a quality line, price \$940.00



To keep electronic "brains"
BECK'S uses **REVERE**

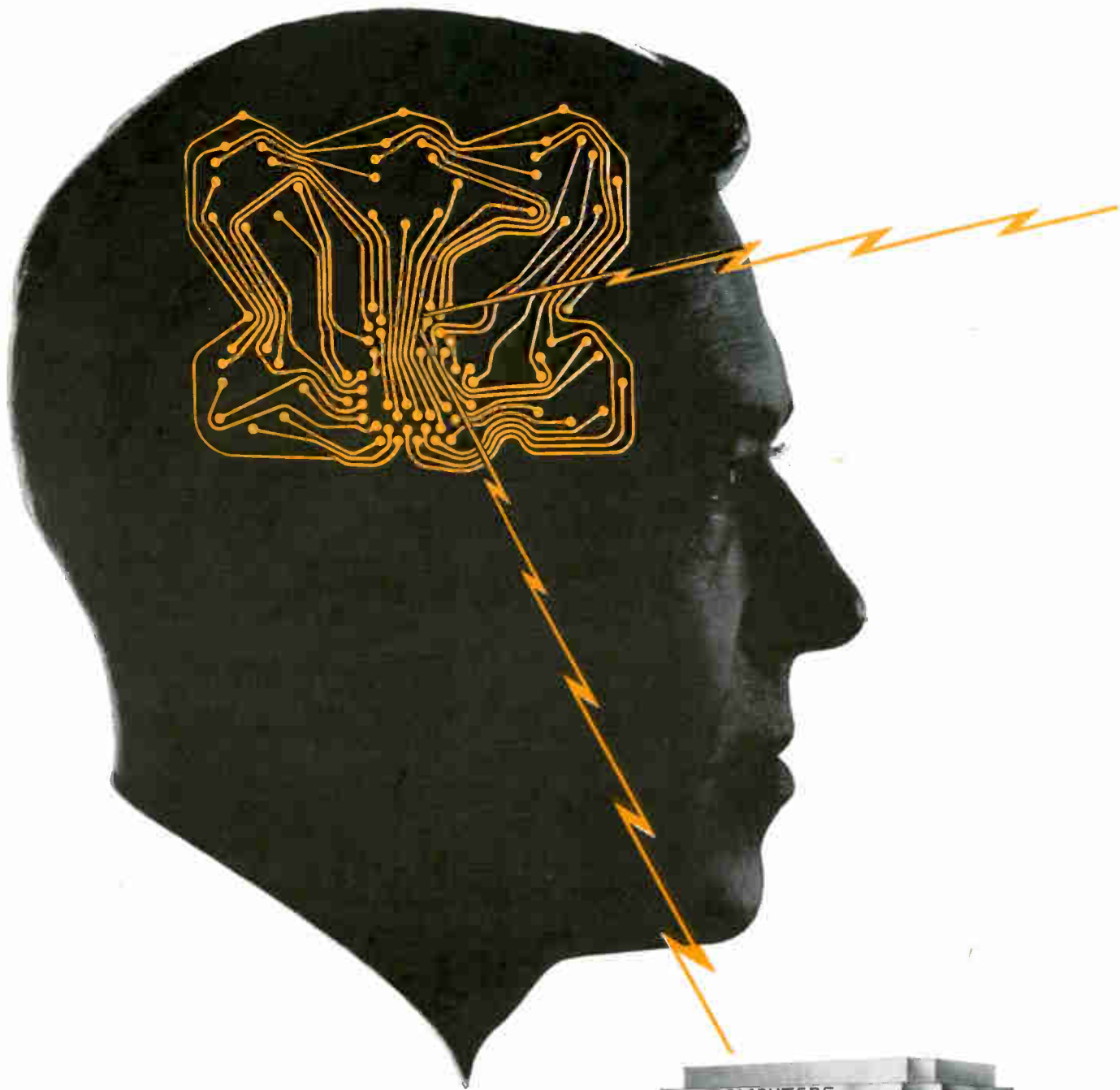

INSIDE THIS "BLACK BOX" the wizardry of electronic circuitry is carried out by Beck Insulated Electronic Circuitry, capable of handling voltages as high as 2500 volts.



operating with peak reliability

ROLLED COPPER...

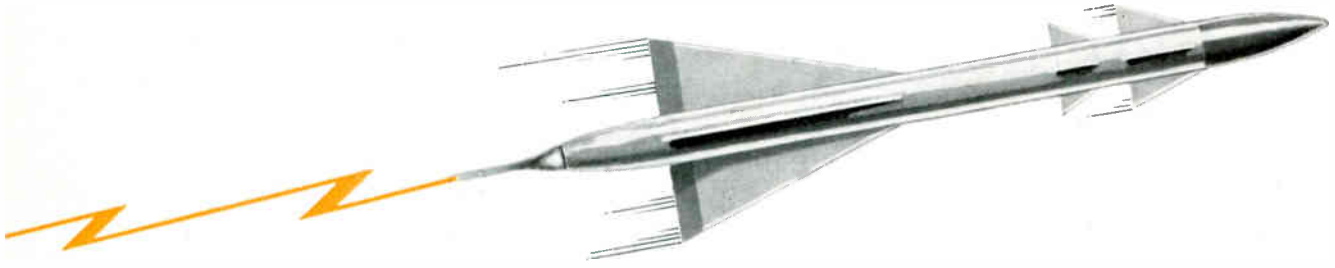

PROBING outer space or plumbing the depths of the sea . . . computing figures or operating TV, Beck Patented Insulated Electronic Circuitry performs with maximum reliability under the most extreme conditions. To make sure that their printed circuits are of the finest quality obtainable, Beck's Incorporated, St. Paul, Minnesota, uses Revere Rolled Copper exclusively. Here's why you, too, should insist that Revere Rolled Copper be used when ordering blanks from your laminator.

1. It has a minimum tensile strength of 55,000 pounds per square inch. This higher tensile strength results in a higher fatigue strength, a factor which has become quite important in critical missile circuitry where roll copper is practically a must.
2. It is more dense and has a harder surface, which is extremely important in switch or other wear applications of circuitry.
3. It is held to closer gauge tolerances. This consistently uniform thickness results in better production rates in the etching process.
4. It is free from oxidation as it comes from the mill and does not contain lead inclusions. It has longer shelf life without the need for major cleaning operation prior to soldering.
5. In 1 oz., it is comparatively freer from pits, pinholes and other imperfections, while in 2 oz. and heavier, it is free of pinholes. (Beck's uses copper in weights ranging from 3 oz. to 25 oz. for their circuitry.)
6. Its smooth, hard surface without peaks or valleys permits the resist to clean off easily and eliminates this problem in the soldering operation.
7. Its clean surface permits fluxes to wet readily and the automatic soldering operation provides a uniform solder coat free of skips or bald spots.
8. Extremely fine-line etching can be accomplished due to more uniform etching qualities.
9. Its close tolerance (10% of gauge) enables the laminator to maintain better gauge control on the finished laminated board as required by the user.
10. It makes it possible for the laminator to realize substantial savings on his copper requirements.

It is available in unlimited quantities in standard coils of 350 lbs. in widths up to 38" and in .0014, .0028 and .0042 gauges, weighing approximately 1 oz. and 2 oz. and 3 oz. per square foot, or heavier if required. Revere Rolled Copper exceeds requirements of standard specifications and meets Electrolytic Tough Pitch Copper ASTM B5 specifications for purity with 99.9% minimum.

Consult your laminator regarding the use of Revere Rolled Copper for your printed circuits, or contact the Revere Representative nearest you through the yellow pages of your local telephone directory.

Revere does no laminating of printed circuit boards, making only the rolled copper. Revere Rolled Copper can also be furnished for coil winding applications.

EXAMPLES OF PATENTED BECK INSULATED CIRCUITRY

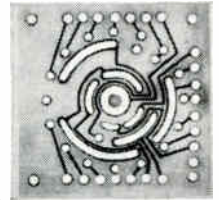
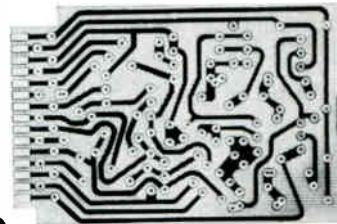

- A Circuit board with edge contacts for slip on connector. Epoxy-fiberglass base with .006 terminals and contacts .003 circuit path. Imbedded type.
- B Combination of imbedded and flush circuit. Switch plate. Switch segments and terminals are flush, circuit paths are imbedded.
- C Standard code drum, used for aerial research, usually made of brass. Contact area is flush, insulated on area showing code.

REVERE COPPER AND BRASS INCORPORATED

Founded by Paul Revere in 1801

Executive Offices: 230 Park Avenue, New York 17, N. Y.

Sales Offices in Principal Cities. Mills: Rome, N. Y.; Baltimore, Md.; Chicago and Clinton, Ill.; Detroit, Mich.; Los Angeles, Riverside and Santa Ana, Calif.; New Bedford and Plymouth, Mass.; Brooklyn, N. Y.; Newport, Ark.; Ft. Calloun, Neb.

Distributors Everywhere.



EUROPE Is Catching Up

Germany's Interkama exhibition, plus reports from returning observers, point up rapid European progress in cybernetic techniques

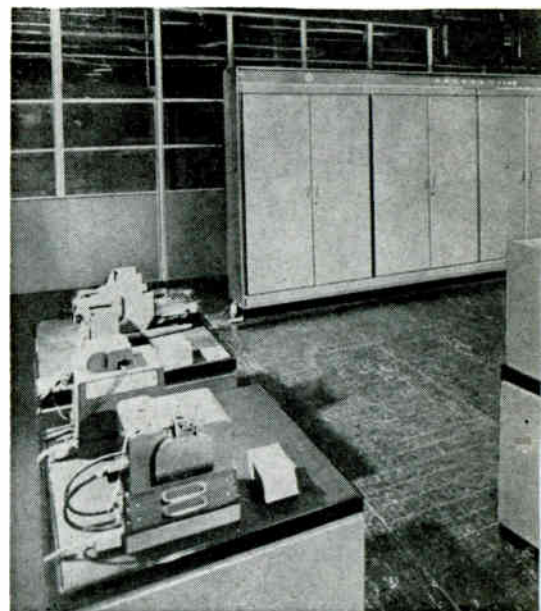

SIGNIFICANCE OF INTERKAMA (International Congress & Exhibition for Instrumentation & Automation) to world market balance in electronics is pointed up by reports reaching *ELECTRONICS* this month of new computer developments throughout Europe.

The 1960 Interkama is being held this week and next in Duesseldorf, Germany, is the second exhibition of its kind; the first was held in 1957. More than 300 exhibitors are showing their wares. A hundred or more came from outside Germany, including several from the U. S.

The congress stresses automatic industrial systems, is also concerned with computers, data-analysis techniques and related areas of the technology. It is more than a trade fair; a hearty schedule of lectures and seminars covers the problems and recent progress in instrumentation and automation. Digital controls and telemetering are receiving considerable attention. One series of discussions looks at man as a model of a biological control system. Among talks on hardware are pneumatic and hydraulic logic, nucleonic instruments, and magnetic and transistor circuits.

Electronic instruments and computing equipment have become increasingly important factors in trade between Western Europe and the U. S. Last year, for example, the U. S. was Germany's best customer for electronic instruments, with total shipments of more than

\$3.6 million. The U. S. was also Germany's largest supplier of such equipment; total shipments the other way were valued at \$4.5 million.

But the favorable trade balances in the fields of computers and instruments may not last too much longer. All over free Europe, a long period of germination in the twin technologies of computers and controls is coming to an end with an explosion of new systems. The British, French and German manufacturers are particularly active; but Sweden, Denmark, the Netherlands, Italy and Austria are also bringing out new systems. (Item: Austria's transistorized Mailuefterl, whose name, an ironic commentary on U. S.-built Typhoons and Whirlwinds, means "a gentle spring breeze.")

Returning U. S. observers comment that men in industry and in the universities are vigorously pursuing basic research and developing new equipment and techniques. In a recent intensive 7-week, 9-country tour for the Office of Naval Research, I. L. Auerbach, president of Auerbach Electronics and of the International Federation of Information Processing Societies, saw some of the work being done, told the Navy several things:

"The U. S. is still in the forefront in both the state of the industry and the state of the art. Lead time varies from one to two years, and results in large measure from R&D expenditures by the Pentagon . . .

"The Europeans follow technological progress in the U. S. in detail. Even the Russians—for example, Soviet engineers know exactly what transistor Bell is using in the Tradic. . . .

"Engineering practice in Europe is efficient and productive. There is a great deal to be gained by taking a few competent people and giving them what they need to solve a problem. The British say that in the U. S. we always hire three times as many people as needed and then trample the problem to death. . . .

"American computermen will begin to experience a tough time in the next three years because of the more competent production capability of European industry. We have no monopoly on ideas; Europe's ideas are just as good. U. S. industry, to compete efficiently with our friends abroad—let alone to compete with monolithic Soviet industry—will need to place greater emphasis on productivity."

Among ideas which European computermen are exploring that depart from U. S. practice, Auerbach cited three areas: fixed high-speed internal memory; novel random-access systems, and hydraulic logic.

Wired-core fixed memories are not new, but have found limited use in the U. S. Bell Labs' Mark VI uses wired cores in the program unit; the Atlas guidance computer also uses them. They are faster than coincident-current memories (as little as 0.1 microsecond access), less expensive to make and non-



destructive on readout. In Europe, they are being engineered into most computers to hold basic machine procedures (such as START or LOAD TAPE) or much-used subroutines (square root, sine, cosine). Emidec (illustrated) Elliott and Leo in Britain, and the Dutch Electrológica, are among systems using wired-core memories for fixed high-speed storage; sizes range from Ferranti's Stretch-class Atlas system, now in development, to Telefunken's small business systems.

Fixed-rod memories were invented by T. Kilburn at the University of Manchester. The system uses ordinary insulated wire woven into a screen with ends connected to form looped pairs. The screen is mounted in soft plastic into which linear-ferrite rods 0.1 mm in diameter and 0.5 mm long are pushed. These rods, magnetized to represent a stored binary ONE, couple the X lines to coincident Y lines. Noncoupling loops are connected with neutral rods representing binary ZEROS for magnetic return. A unit 3 ft wide, 8 ft long and less than an inch thick holds 4,000 48-bit words with an access time of 0.2 microseconds. Major problem: loading the memory; it takes a girl half an hour to plug 256 rods.

Among random-access memories being used, the K-10 of the German firm Standard Electric Lorenz and Swedish Facit's Carousel are particularly unusual.

The K-10 was developed for an

airline reservation system being developed by SEL for Air France and British European Airways. It is a multitape file using 10 loops of tape in a bin, somewhat like a small version of Burroughs' Datafile. A head and drive mechanism is supplied for each tape loop. Electronic circuits select the tape loop; the tape drive passes 100 in. of tape a second, on which data are stored at 250 bits to the inch. Access time averages 10 sec for a block of data; the control mechanism can read and write on 4 simultaneously. Cost is small.

Facit's Carousel is—as its name suggests—a revolving ring containing 64 spools of tape, each about the size of a large spool of thread. Each spool holds 28 ft of 8-channel tape. The spools are indexed to a single reading station; then arms adjust the spool to the head. After the tape is read it is rewound and the spool is returned to its place in the merry-go-round. Capacity is 8,192 40-bit words, stored as 128 blocks of 64 words each. Average access time is less than two seconds to the spool.

IBM Zurich Laboratories are experimenting with hydraulic logic in a move to design a low-speed high-reliability logic element (in the range of 300 to 2,000 cps). Basic hydraulic element has been

devised that performs logical AND, OR and NOT functions by valves connected to high and low pressure points. Bistable elements have also been devised, operating at about 400 cps. Advantage is high reliability and predictability of hydraulic systems. Complete computers are somewhat problematic, since topology would have to be precisely calculated to ensure exact delays.

Observers comment that the hydraulic elements, and pneumatic logic developed and operating in the USSR, are "shockingly" similar. Pneumatic and hydraulic logic elements meet faster acceptance in automatic control fields, where these technologies are better known and understood than electronics is.

Decca, EMI and other European companies are reported to have developed excellent tape units, but many U.S.-made digital tape devices are used and more are needed. The Rank organization has developed a xerographic printer that operates at about 3,000 lines a minute; most big systems use high-speed printers similar to those used in the U.S. Punched-card readers and paper-tape devices are highly advanced in development; one paper-tape reader, built by Facit, uses ferroresonant techniques to read at high speeds by sensing changes in capacitance.

New Moon-Bounce Ear Goes Up In Jersey



This 40-ft dish antenna at ITT will receive radio signals reflected from the moon or passive satellites

Engineers Form Physical Standards Groups

Both individuals and laboratories in instrument calibration field organize to coordinate physical standards work in electronics and other technical fields

By **GEORGE SIDERIS**,
Buyers' Guide Editor

SPECIALISTS in measurement standards, instrument standards and calibration are close to forming a nationwide organization, coordinating standards activities in electronics and other fields.

Two almost parallel groups, one for individuals and one for standards laboratories, held organization meetings during the Instrument Society of America (ISA) conference in New York last month. In physical standards and instruments, these groups would cut across industry lines as the American Standards Association does for written standards and ASTM for materials. Spokesmen pointed out that the U.S. lacks an organization concentrating on measurement standards.

Many professional and trade organizations are concerned with standards, but they generally stay close to their own field. It was estimated that there are 350 organizations with some standards activity and 3,000 standards laboratories.

Both groups want help from other organizations in funneling information to and from a common pool. Once data is organized, efforts would be made to fill in gaps.

The two groups are a new division of ISA and a proposed Association of Standards Laboratories (ASL).

The ISA division will be called division 6H, Measurement Standards. About 50 members attended the organization meeting after an all-day laboratories workshop session.

ASL's steering committee met the day before to draft tentative goals. Another meeting, with an expanded committee, will be held at the American Ordnance Association conference in Albuquerque next February.

Orval Linebrink, of Battelle Memorial Institute, is director of the new ISA division. Ralph Bowen, of the Naval Reference Standards Laboratory, Pensacola, and S. C. Richardson, of General Electric's Electrical Measurements Laboratory, are functioning as associate directors.

Linebrink recommended these goals for ISA division 6H:

- Survey of measurements standards and facilities.
- Establishment of a measurement standards information center and publication of significant developments.
- Quality control of standards laboratories. Linebrink suggested this be handled by ASL with ISA assistance.
- Initiating development of better standards and instruments.
- Organization of working committees such as a long-range planning committee to advise the director; functional committees

handling organization and manpower, education and personnel, liaison with other groups, and semantics and statistics; and technical committees on electrical, electronic, physical and dimensional measurement standards.

ASL got its start in June at the 1960 Conference on Standards and Electronics Measurements, held at the Boulder Laboratories of the National Bureau of Standards. It was suggested by Harvey W. Lance of the NBS Electronic Calibration Center. The steering committee was appointed after a meeting of some 200 representatives from industry, institutions and government agencies.

The steering committee now has 12 members. During its meeting at the ISA conference, it voted to increase its membership to 20. Appointment of new members was left to the discretion of H. C. Biggs, of Sandia Corporation, the chairman. But he was asked to seek representation from IRE, AIEE and large industrial laboratories. The ISA division will be asked to set up liaison with other organizations.

If the steering committee decides in February to formally organize ASL, it will probably be helped by the Department of Defense and the Precision Measurements Association, as well as ISA and NBS.

Objectives drafted by the ASL committee included:

- Setting up a method by which laboratories can qualify themselves according to accuracy of equipment, experience of personnel, environmental control and procedures.
- Realistic accuracy requirements in specifications, especially in the military specifications.
- Faster development of good physical standards.
- Information coordination and publication.
- Assistance in the educating and

Transmission Disk

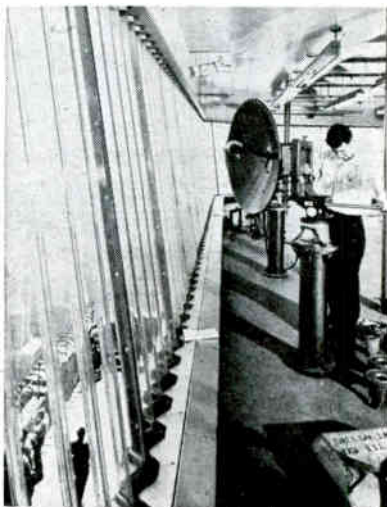

Low energy absorbent Plexiglas acrylicplastic protects New York Telephone Co. microwave relay station on Empire State Building from high winds

training of various personnel.

- Standardization of terminology and test report forms.
- Establishment of arbitrary standards.

Written, as opposed to physical standards, would probably be developed through the American Standards Association, according to ASA's procedures for preparing written standards that affect more than one industry or profession.

Electronics Plays Role In Microscopy Advances

BETHESDA, MD.—Electronics' role in recent advances in microscopy were highlighted at the 10th annual Instrument Symposium and Research Equipment Exhibit at the National Institutes of Health here.

According to O. W. Richards of American Optical Co., fluorescent, phase, interference, and electronic scanning are methods that have recently proven especially helpful for examining specimens too transparent for the brightfield microscope. It is possible to estimate mass with the interference microscope and to do quantitative chemical analysis with absorption spectrophotometric methods.

A paper on "Microscopy for Experimental and Quantitative Studies on Living Cells" by M. J. Kopac of New York University pointed out that useful information is obtained by high-speed electronic image scanning. Closed circuit tv combined with scan line selection and analysis by delayed sweep cathode ray oscillography is an important quantitative approach.

Ultraviolet flying spot microscopy provides a method of studying living cells under ultraviolet without the excessive damage generally produced with ultraviolet illumination.

Latest electronic devices for laboratory and chemical investigations, plus optical and mechanical ones, were exhibited by 120 firms.

Among devices manufacturers representatives demonstrated at instrumentation sessions were an electronic counter, a physiological gas analyzer, a fluorescent microscope, a robot chemist, recording balance, and nitrogen analyzer.

Attendance at the symposium was estimated at 1,500. About 5,500 viewed the exhibits.

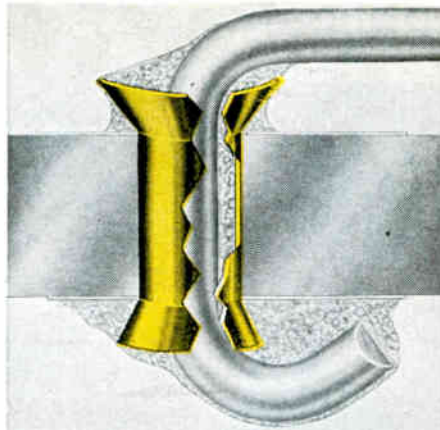

Enlarged cross section of United Funnel Flange Eyelet showing greater soldered area which lends greater strength.

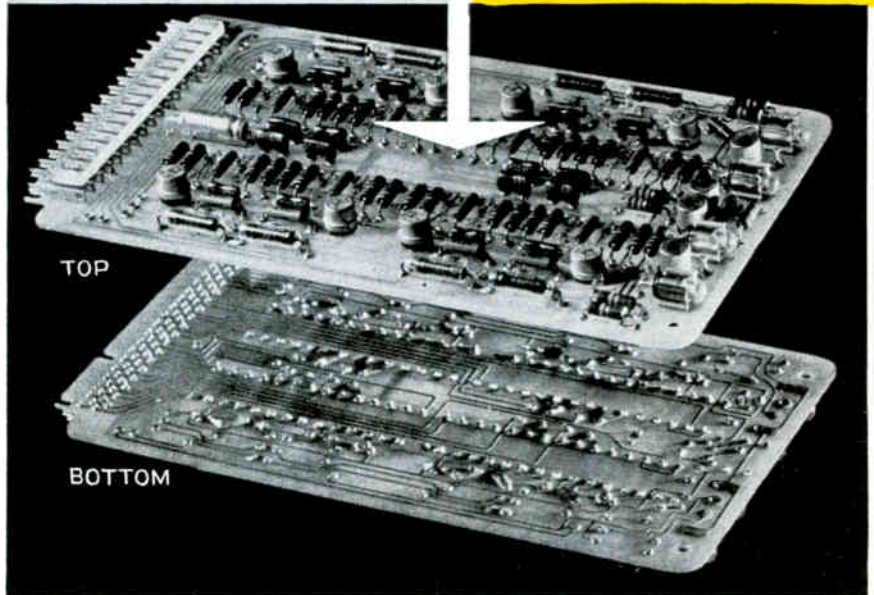

- **New United Funnel Flange design improves reliability of soldered connections**
- **Greater mechanical strength due to greater soldered area of funnel eyelet**

WHY UNITED FUNNEL FLANGE EYELETS ARE SUPERIOR

... The funnel design permits easy insertion of leads. When soldering, the solder fills the funnels and flows around the outside of the eyelet on both sides of the etched circuit. This increases the soldered areas and seals the lead and the funnel eyelet tightly to the circuit. The unique design of the funnel eyelet permits entrapped gases to escape and makes it possible to achieve an unusually solid, dependable connection.

More uniform circuitry is also realized with United Funnel Flange Eyelets which are made from electrolytic copper. This material has a coefficient of expansion in the same order as that of the copper in the etched circuit.

United Funnel Flange Eyelets meet MIL Standard No. 202 for vibration, shock, thermal cycling, and humidity. Wide choice of sizes and lengths meet needs of hole sizes and board thicknesses. Also available in brass. Special plating, and packing to order.

Free: Send us a sample of your board for free insertion of funnel flange eyelets for your testing and evaluation or write for complete specifications of sizes available.

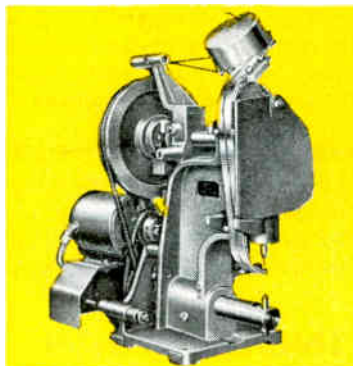

High speed automatic setting of Funnel Flange Eyelets with United Eyeletting Machine Model G.

This Connection STAYS Connected

United

UNITED SHOE MACHINERY CORPORATION

140 Federal Street, Boston, Mass.

Liberty 2-9100

Universal in Application...

E-I

**Glass-to-Metal
SEALS**

Universal in Reliability...



SEMI-CONDUCTOR SEALS
INDIVIDUAL TERMINALS
MULTIPLE-LEAD HEADERS
CONDENSER END SEALS
COLOR CODED TERMINALS
THREADED END SEALS
CUSTOM SEALING SERVICE

Standardized Production

E-I offers designers and engineers the complete flexibility and economy of standardized production on all types of seals from individual terminals to sub-miniature closures. For proven reliability, specify the seals employed by leading manufacturers in both commercial equipment and space age projects.

Nation-wide Field Service

Write today for complete information on standard E-I seals or custom sealing of terminal assemblies of your own manufacture. E-I field engineers will gladly make recommendations on your specific requirements on receipt of your application data.

ELECTRICAL INDUSTRIES

MURRAY HILL, NEW JERSEY

A Division of Philips Electronics & Pharmaceutical Industries Corp.



Patented in Canada, No. 523,390;
in United Kingdom, No. 734,583;
licensed in U.S. under No. 2561520

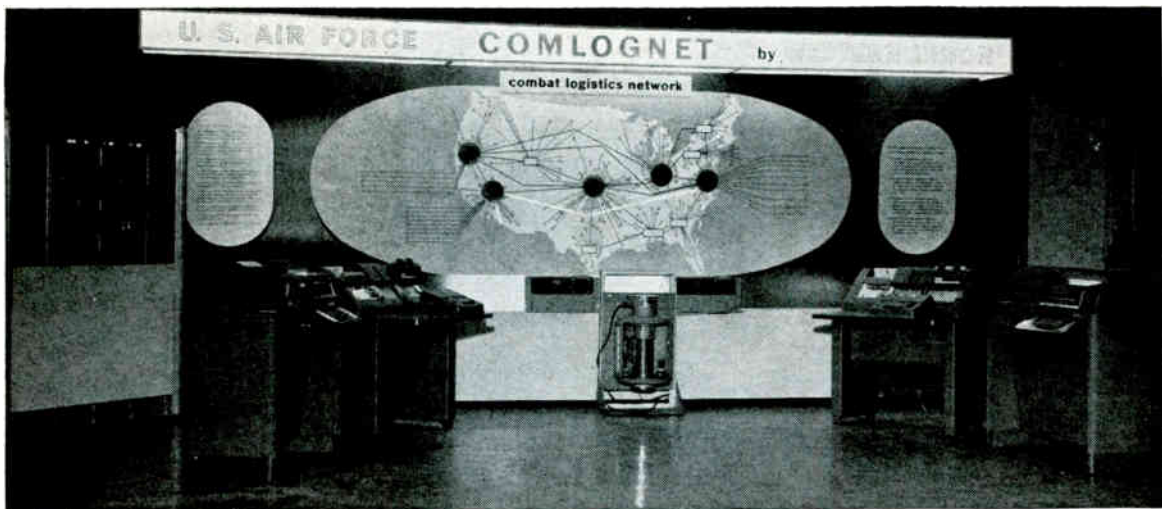

Subcontractor RCA constructed and assembled electronic equipment under \$50 million contract. The Air Force will lease the service from prime contractor Western Union for \$22 million a year

USAF to Get Fast Data Link Net

BY JANUARY 1962, USAF will get "the largest and most sophisticated logistic data and message communications system in the world," it was announced recently by USAF and prime contractor Western Union.

Called Comlognet (Combat Logistic Network), the system will consist of five large automatic switching centers with connecting terminals at 450 air bases, air stations and civilian contractors.

As an integral part of USAF's global communications system Aircom, the new network will interchange traffic on an automatic, compatible basis with other Air Force networks. Data from overseas will be brought into the domestic network by facilities at gateway centers.

The system will ultimately handle many millions of messages concerning aircraft movements, air traffic maintenance, passenger information and flight control data. Plans also call for inclusion of financial, medical, personnel control and statistical reports requiring more than 24 million messages a year. The system will convert data for entry into electronic computers, and distribute the traffic delivered by the computers.

Commercial potential for a system like Comlognet is good, says John L. Burns, president of RCA, major subcontractor for manufacturing and assembling the electronic equipment.

"Comlognet is a forerunner of automatic civilian communications systems which some day will provide a high-speed interflow of data among all the far-flung branches of business and industry," Burns says.

The switching centers, in conjunction with the station terminals, will handle digital information of any type including digitalized voice for graphics. Service for record message traffic by conventional type telegraph apparatus will also be provided.

The system will initially handle about 10 million punched cards (equivalent to 130 million words) daily.

Both "store and forward" (message switching) and direct "user-to-user" (circuit switching) service will be provided at the five leased centers.

The first center will be opened at Norton Air Force Base, Calif., in Nov. 1961.

The system will operate initially at rates of from 100 words per minute (75 bauds or "bits" per second) up to 3,000 words per minute (2400 bauds), and is designed to be capable of handling rates up to 62,500 words per minute (50,000 bauds) as needed, by adding channel termination modules.

All channels, including trunks, will be cryptographically secured, link-by-link, with no loss of transmission synchronism resulting

from tandem interconnection of circuit-switched channels. The system will automatically reject traffic that is classified higher than the security clearance of a destination terminal.

Messages will be interchanged between different terminal devices. The system is designed to accommodate a variety of input and output devices, including punch card readers and punches, magnetic tape transports, digital computers, teletypewriters, paper tape transmitters, perforators of various kinds, and digitalized graphic transceivers and transmitters.

Standard operating channels will be full duplex, providing two-way operation in conjunction with automatic accuracy controls. Switching centers will be capable of high duplex operation for transmission in either direction.

With a few exceptions all channels will operate in a bit-synchronous mode.

The eight-level Fieldata code was chosen as the "common language" code and all originating codes are converted to it.

Line facilities, tributary stations and switching centers incorporate automatic accuracy control features assuring that not more than one error in 10 million characters will go undetected.

Switching centers are fully solid-state design, utilizing transistor and magnetic core circuits.

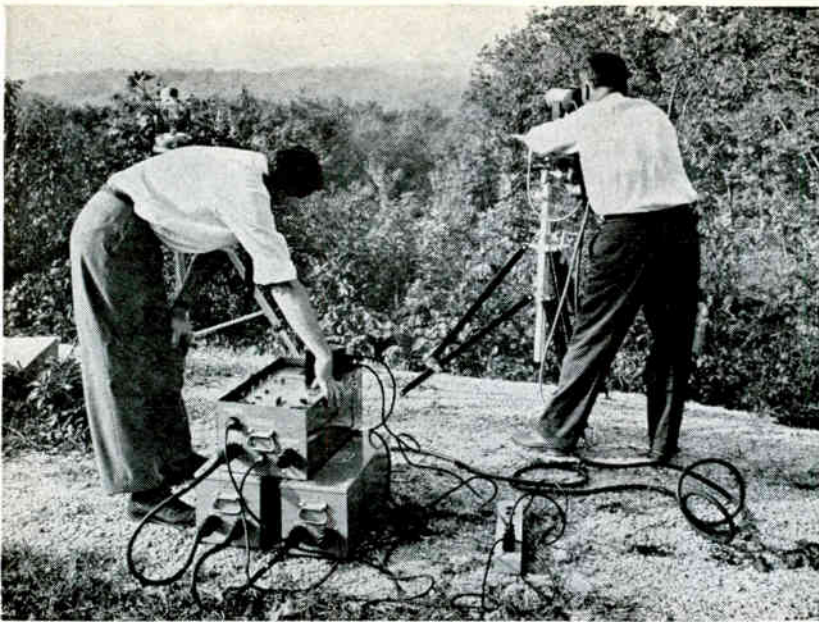

Optical maser is set for firing during twenty-five mile communication test

Scientists Demonstrate Optical Maser

Intense short pulses emitted by optical maser may make possible 10,000,000 simultaneous transmissions

SCIENTISTS at Bell Telephone Labs believe they have experimentally proved the communications feasibility of the Labs' optical maser, it was revealed at a recent demonstration of the device in New York City. The optical maser is similar in principle to the Hughes Aircraft laser (see *ELECTRONICS*, July 22, 1960, p 43).

As with the Hughes laser, the heart of the optical maser is a synthetic ruby rod, which in this instance is $1\frac{1}{2}$ inches long and $\frac{1}{8}$ inch in diameter. As with the laser, the two ends of the rod were polished until extremely flat and parallel, then covered with a reflecting layer of silver thin enough to be slightly transparent. The ruby rod is held in the center of a spiral photoflash lamp that illuminates it with an intense flash of ordinary white light.

Bell Lab investigators found that when flash-lamp power exceeded a certain value, a nearly parallel beam of light having a width of 0.05 degree, was emitted through the silvered ends of the rod. The light beam met the directionality requirement of communications. Like ordinary fluorescent light emitted from ruby, this stimulated light was red, but was sixty times closer to being monochromatic—that is, having a single frequency. This light was also shown to be coherent—of a single phase. By thickening the silver coating at one end of the ruby rod and cutting two fine parallel slits in the coating, an emitted light pattern of constructive

and destructive interference was obtained that proved the in-phase condition.

The coherent light was found to be emitted in short, intense bursts a millionth of a second long. Several hundred of these bursts were observed during the thousandth second of maser action sustained by the flash lamp. Such short pulse bursts rather than a smooth pulse makes eventual modulation of the signal possible so that many telephone conversations or television signals can be transmitted simultaneously over a maser link—perhaps as many as 10,000,000.

Bell Labs scientists feel that there is one way that they might explain the bursts: In the usual fluorescence of ruby, the green component of the source white light excites some of the chromium atoms in the ruby to their highest energy level. The atoms rapidly relax to an intermediate level. Somewhat more slowly, the atoms then relax from the intermediate (metastable) level to the original lowest level, emitting quanta of light in the process. The optical maser causes the atoms to make the last jump more readily by bathing them in light of the emitted frequency—that is, the red light confined within the rod by the silvered ends. This intensifies or stimulates the red light until it is able to pass through the silvered ends. At this point, the metastable level is depopulated so rapidly that the green light component is no longer able to maintain a population of atoms in that state sufficient

for the action to continue. Radiation abruptly dies down until the exciting lamp can restore metastable population. Alternating depletion and restoration of the atom population results in the extremely rapid pulsing of stimulated light.

Practical feasibility of the optical maser was indicated by two Bell Lab experiments: a line-of-sight transmission of the red-light signal pulses over a twenty-five mile distance, and a transmission through a quarter-mile, 2-inch diameter circular waveguide without extraneous reflection.

Now that favorable communication properties of ruby have been determined, scientists are actively exploring means for extending the radio-communication techniques of modulation, amplification and detection to the much higher frequencies of radiation from the optical maser. Maser experimental work is also being performed with gaseous systems in which atomic collisions impart energy.

Possible applications mentioned for the optical maser include control of chemical reactions, high-frequency switching, relativity experiments and accurate measurement of long distances.

Maser's concentration of large amounts of energy would permit it to direct a beam at orbiting satellite with sufficient pressure to maintain the satellite in orbit. Also, maser would, because of its high directionality, permit private communications between satellites, say Bell Labs spokesmen.

NOW...

**RAYTHEON
"PROGRAM 2020"
MEETS YOUR
VOLTAGE
REGULATOR
SPECIFICATIONS
FAST AND AT
LOW COST FROM
STANDARD DESIGNS**

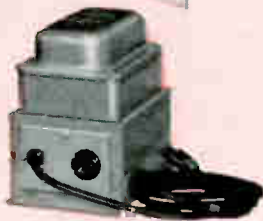

NEW

LOW-COST RAYTHEON REGULATED DC POWER PACKAGES



**SPECIFY A RAYTHEON
"RD" POWER SUPPLY AND ELIMINATE
POWER SUPPLY DESIGN HEADACHES**

**132 different ready-to-operate
models for standard 19-inch rack
installation, 3 to 1,000 volts, 50 to
3,000 watts**

These compact Raytheon "RD" units are the complete low-cost solution to your power supply problems without any sacrifice of the heavy-duty industrial performance your specifications demand.

The new power packages utilize ferroresonant (magnetic) voltage regulation coupled with full-wave silicon diode rectification and

capacitive input filtering. Ripple is reduced to within 0.5 to 1.0% depending on model.

Raytheon assures prompt delivery of your selection from 132 different models in 20 voltage steps and 7 power ratings, 3 to 1,000 volts, 50 to 3,000 watts, all for 19-inch rack mounting.

CHECK THESE BENEFITS OF "RD" POWER SUPPLIES

- Lowest cost consistent with heavy-duty industrial ratings
- 132 models: 3 to 1,000 volts, 50 to 3,000 watts
- Self-protecting; extremely dependable
- DC output filtered and isolated
- Improved load regulation
- 19" rack mounting; 6 sizes, panel heights from 3½" to 28"
- Regulation $\pm 1\%$ for line variation of $\pm 15\%$



RAYTHEON COMPANY

Power Supply and Voltage Regulator Operations
Keeler Avenue, South Norwalk, Connecticut

Send coupon for free
Selection Guide and
Catalog of 2,020
Standard Designs

RAYTHEON COMPANY
Power Supply and Voltage Regulator Operations
Keeler Avenue, South Norwalk, Connecticut
Please send me

- Raytheon "RD" Product Selection Data #4-290
 Raytheon 2020 Regulator Selection Guide and
Catalog #4-265

Name _____
Title _____
Company _____
City _____ State _____

How
to get
very
precise
data...
anywhere



Ampex's new CP-100 ideally balances size and performance in a magnetic tape recorder. It meets laboratory standards in all the critical parameters—cumulative peak-to-peak flutter is well below 0.2% (60 ips, 300 cps cut-off); $\pm 0.25\%$ maximum tape-speed variation; frequency response from DC to over 200 kc. Yet it's compact enough (4.7 cu. ft.) to go virtually anywhere on land, sea or air where you need to recover critical data.

Like the rest of the facts? A full page in **ELECTRONICS** for October 7 tells more, or write us and descriptive literature (plus a copy of the ad) is yours for the asking.

AMPEX

AMPEX DATA PRODUCTS COMPANY
Box 5000 Redwood City, California

Soviets Are Pushing All Technologies

SOVIET TECHNOLOGY continues to increase the speed of its advance.

Electron-beam welding has been successfully reported in the Soviet technical press. Recent reports indicate successful welds on molybdenum and tungsten.

Factories in the Gorky region will soon start production of program-controlled machine tools for export. Speed of the Soviet progress in this field is illustrated by the fact that only last June, USSR experts said that all the Union factories would produce only 60 program-controlled systems this year.

In the Azerbaijan SSR, a young researcher has used high-voltage pulses to alter the internal structure of cottonseed, causing an increase in germination speed and higher cotton yield. Seeds were soaked in water, dried and subjected to 2,500-v fields. Plants sprouted two or three days sooner than usual, had more buds, ovaries and bolls.

Tass reports use of nucleonic instruments in automatic controls for ore extracting and tunneling machines. A gamma source on the cutter head is focused on the ore being cut; absorption by ore directs position and movement of the head.

In the space field, Soviet Academy space expert N. Sisyakian indicated in a recent speech that the USSR is pushing ahead in controlled space probes. He said that flights to Mars and Venus present "new difficulties." The degree of accuracy needed to hit the moon could still have a Mars-bound rocket miss its mark by a million kilometers, he said. He mentioned "fundamentally new guidance systems" that would have to be applied to steer a Mars probe.

Television Brings Classes To Electronics Engineers

CLASSES IN NETWORK THEORY are provided for 1,500 engineers by a special three-way network set up by the University of Wisconsin. The closed-circuit tv network went into operation between Madison and Milwaukee this fall.

Classes originate at the University's main campus in Madison, are piped 80 miles to the suburban Milwaukee plant of AC Sparkplug, the electronics division of General Motors. The University's branch in downtown Milwaukee is the third

Space Radiation Measurement Vehicle



Nuclear emulsion recovery vehicle (NERV), by GE, was recovered after being launched to 1,200-mi altitude to measure radiation

station. Three-way audio permits students in either location to communicate with the professors in Madison.

Courses are televised three mornings a week, use two textbooks, include homework. Successful completion—determined by a tv-administered examination—results in three hours of graduate or undergraduate credit.

Missile-Warning System: One Down, Two to Go

FIRST STATION in the ballistic-missile early-warning system recently went on the air at Thule, Greenland. Immediately after, Sylvania began airlifting parts of the electronic data-processing equipment for the second site at Clear, Alaska.

Computing gear for BMEWS includes detection-radar data takeoff, for estimating target azimuth, range and radial velocity; and missile impact predictor, which uses two IBM computers plus a giant Sylvania storage system. The data takeoff system coordinates a dozen special-purpose computers which analyze returns from the BMEWS radars, excludes noise return, meteor echoes and other natural phenomena.

Third site, at Flyingdales, England, will contain only radar receiving gear and computers, will be the last site of the three to be finished.

Defense circles are currently reviving the idea for a southern BMEWS. Recent international developments—including the Soviet attempt to subvert the Congo—point up the possibility that hostile missiles may come from directions other than the North.

British to Display Fast Printer, Punch

BUSINESS EFFICIENCY exhibition at London's Olympia will this month show a high-speed serial printer designed to operate at 1,000 words a minute, and a tape punch that can put out 5, 6, or 8-track paper tape at 3,000 words a minute.

Both devices, reportedly 10 times faster than existing teletypewriter equipment, were developed by Creed & Co. of Croydon, Surrey.

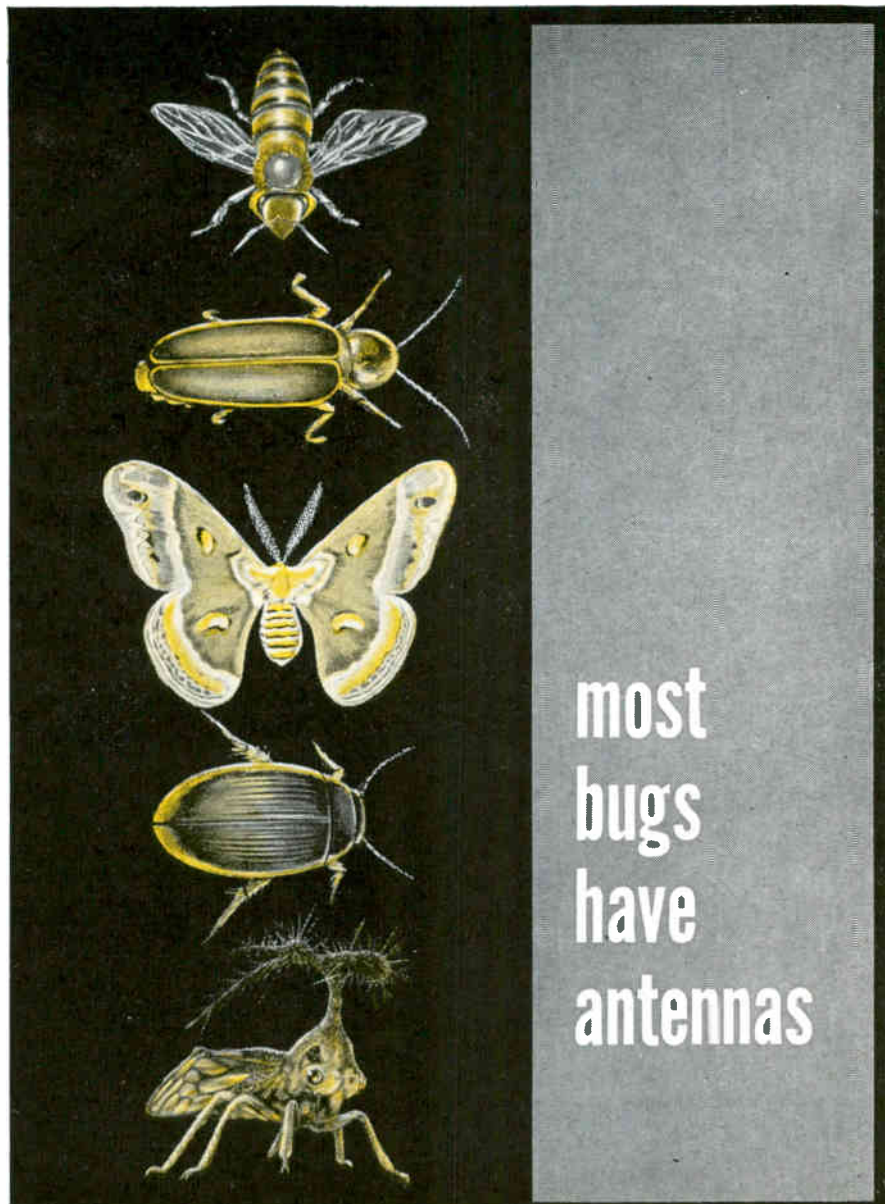

most
bugs
have
antennas

...but the reverse of the above statement is being challenged successfully at Dorne & Margolin, Inc.

It has taken insects thousands of years to evolve countless variations of antennas to suit environmental conditions and adapt them to perform specific functions perfectly. Dorne & Margolin engineers have less time at their disposal, yet they achieve similarly satisfactory end results.

And the insect world has nothing on Dorne & Margolin when it comes to all-out organization to get the job done. Meticulous as bees, determined as ants, more curious than moths... that's the approach to every problem in components or systems... aircraft or missiles, practiced by D & M engineers.

The results have been products in which we can confidently take pride... just ask our customers*. By the way, our engineers still have a healthy and creative curiosity about antenna problems. If there's one plaguing you, no matter how large... or small, drop us a line.

*A customer list is included in our Antenna Catalog. Write for your copy today.



DORNE & MARGOLIN, Inc.

WEST COAST:
1434 Westwood Boulevard
Los Angeles, California

EAST COAST:
29 New York Avenue
Westbury, L. I., New York

If you're an engineer whose creative curiosity is matched by a desire for many organizational benefits, including stock participation, contact R. E. Anderson, Chief Engineer.



OVER AND UNDER THE TOP OF THE WORLD

In early 1950, American craft pierced the North Pole in two elements. Fathoms below solid ice the USS Sargo probed unerringly to "90 North"; miles above, a GAM-77 missile on a B-52 pinpointed the featureless goal. Both used Inertial Navigation systems by Autonetics—where today's results pave the way for tomorrow's breakthroughs.

Electromechanical Systems by **Autonetics**  Division of North American Aviation

Army Develops New Silicon Solar Cell

ARMY SIGNAL CORPS has developed a silicon solar cell that will resist four times more radiation than conventional cells for a period ten times longer.

The new design, Army says, "is perhaps the most important advance in the field since the first solar cell was produced in 1954."

The new cells will be of immediate benefit to space flights. The vulnerability of solar cells to radiation damage limits their operating life under conditions of prolonged exposure to the intense radiation in the Van Allen belts, Army says.

In addition to its importance in space, the discovery may open the way to techniques for producing highly resistant transistors, diodes and other semiconductor devices basic to military and civilian electronic equipment.

The new cells are similar in appearance to present types except that the active layers are reversed. The cells are made by diffusing phosphorous into the surface of a *p*-type silicon crystal. Present cells are made by diffusing boron into an *n*-type silicon crystal.

The new *n-on-p* solar cells are produced at a temperature of 950 C, significantly lower than the temperature employed in producing conventional cells. The milder environment causes less damage to the delicate internal crystal struc-

ture of the silicon, so that fewer are spoiled and rejected. For this reason, cells of higher performance may be produced at lower costs. Scientists now are analyzing the new process to pinpoint the exact mechanism that gives the cells their unique properties.

The new cells were exposed to protons with an energy of 740 million electron volts by the University of California synchrocyclotron. These high energy protons produced an unexpectedly large reduction in power output of conventional cells. This is believed to be related to disintegration of silicon atoms within the solar cell. The resistance to disintegration of new cells was approximately four times greater.

Although it is known that *n-on-p* solar cells are also produced in the Soviet Union, manufacturing processes and radiation damage resistance have not been reported.

The new process was developed by the U. S. Army Signal Corps at Fort Monmouth, N. J. Special characteristics of the cells were measured in radiation exposures by RCA Laboratories, Princeton, N. J. and supported by NASA. Similar measurements have been made by the Transitron Electronic Corp., Measurements of extremely high proton energies have been carried out by STL under a NASA contract.

Electronic Color - Matching

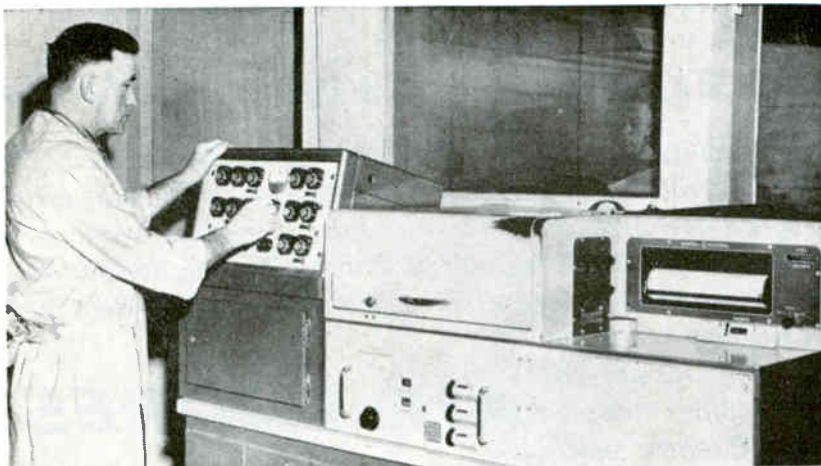

General Electric spectrophotometer (on the right) analyzes colors of Monsanto plastic compounds. The resulting mathematical values are then compared to standard color by Davidson & Hemmendinger computer (left)

Presenting Another New Development from Lindsay Research **Ultra High Purity YTTRIUM OXIDE**

(Codes 1117 and 1118)

Until recently, the best Yttrium Oxide commercially available has been Lindsay Yttrium Oxide Code 1116, designated as 99.99% purity. Continuing progress in rare earth separation technology now makes it possible to produce even higher purity materials.

These new materials are Lindsay Yttrium Oxide Codes 1117 and 1118.

The largest single application for Yttrium Oxide today is in YIGs for microwave use. Although Lindsay Codes 1115 and 1116 are suitable for most polycrystalline applications, the new codes 1117 or 1118 may offer performance improvement, particularly in single crystal YIGs.

The new code 1117 and 1118 materials are "spectrographically pure" and better insofar as rare earth impurities are concerned.

Availability is presently limited to experimental quantities, but production can be increased with adequate lead-time.

Some suggested uses are: electronic ceramic materials, source of high purity yttrium for semiconductor and thermoelectric devices. Your own experimental research may disclose other significant and valuable applications.

Technical data on codes 1117 and 1118 will be found in Lindsay's Technical Data Sheet on "Ultra High Purity Yttrium Salts." It is available to you promptly on letterhead request.



LINDSAY CHEMICAL DIVISION
**American Potash &
Chemical Corporation**

99 Park Avenue, New York 16, N.Y.

3000 West Sixth St., Los Angeles 54, Calif.

America's modern way of doing business



Men and machines of AIR EXPRESS deliver vital missile component with jet speed to Convair test site

Priority service makes Air Express today's best way to ship

At Convair's big Sycamore Canyon Test Facility in California, an Atlas missile stands ready for a static test firing. An eleventh-hour engineering refinement brings AIR EXPRESS service into the picture. AIR EXPRESS is constantly called on to speed new parts. It's all in the day's (or night's) work for this skilled shipping team. Here's what you get when you call AIR EXPRESS: Priority service—first on, first off—on all 35 scheduled U. S. airlines • Kid-glove handling every mile of the way • Door-to-door pickup and delivery via 13,000 trucks (many radio-dispatched for maximum speed) • Teletype confirmation of receipt on request • Service to 20,000 American communities coast to coast • It pays to think fast . . . think AIR EXPRESS first!

AIR EXPRESS



CALL AIR EXPRESS DIVISION OF RAILWAY EXPRESS AGENCY • GETS THERE FIRST VIA U. S. SCHEDULED AIRLINES

Students Need Good Apparatus

NATIONAL SCIENCE FOUNDATION is inviting scientists, engineers, and science teachers in colleges, universities and nonprofit organizations to submit more proposals for development of prototypes of new science equipment for use in the nation's schools and colleges.

Good apparatus to perform good experiments is needed by science students, but modern science equipment is often too expensive for secondary schools and undergraduate colleges, says Alan T. Waterman, Foundation director.

The high caliber of work that scientists, science teachers, and engineers have already done indicates that this program should continue, he said. The program has been sponsored on a limited basis for two years during which grants were awarded for some 50 projects including a low-cost ophthalmoscope, supersonic wind tunnel and mass spectrophotometer.

UNIVERSITY OF CALIFORNIA associate engineer Warren Flock, during research for his Ph.D dissertation, simulated spaceship plasma problem in the laboratory, under supervision of Prof. Robert S. Elliot. Flock found that the degree of distortion in radio signals from spacecraft depends on the thickness of the plasma layer. A higher radio frequency might be a possible solution but this can raise new problems, says Flock.

UNIVERSITY OF WISCONSIN will have a one-million dollar electronic computer installed early in 1961 at the University's Numerical Analysis Laboratory. Funds for the computer are being supplied by the Wisconsin Alumni Research Foundation, the National Science Foundation and the U.S. Army Mathematics Research Center on the Madison campus. Builder of the computer is Control Data Corporation of Minneapolis. Conrad A. Elvekjem, university president, said the new computer would handle 100,000 instructions per second and would store 1,500,000 pieces of information, which it would recall at

a two-millionth of a second rate.

PENNSYLVANIA STATE UNIVERSITY was recently the recipient of the Curtiss-Wright nuclear reactor located at Quehanna, Pa. The reactor is a four megawatt swimming-pool type. With its auxiliary laboratories, it provides complete radiation services required in nuclear programs.

NEWARK COLLEGE OF ENGINEERING has been granted authority by the New Jersey State Board of Education to confer the degree Doctor of Engineering Science in addition to B.S. and M.S. degrees the college now offers in various engineering departments. Initially, the new doctoral program will be offered in chemical and electrical engineering.

ILLINOIS INSTITUTE OF TECHNOLOGY's Armour Research Division will sponsor the 1960 Computer Applications Symposium, next Wednesday and Thursday, to be held in Chicago's Morrison Hotel. Problems to be discussed include common computer programming languages for business and scientific applications, and the development of cooperative computing centers. Business management applications will be discussed on Oct. 26. On Oct 27, engineering and scientific applications topics will be heard.

Electronic Teacher



Student learns foreign language in new electronic language laboratory booth made by Bernco, Inc.

TOUGH



... AS A TURTLE'S BACK



**ARMAG*-PROTECTED
DYNACOR®
BOBBIN CORES
AT NO EXTRA COST!**

Tough-as-tortoise-shell Armag armor is an exclusive Dynacor development. It is a thin, non-metallic laminated jacket for bobbin cores that replaces the defects of nylon materials and polyester tape *with very definite advantages*—and, you pay no premium for Armag extra protection.

Tough Armag is suitable for use with normal encapsulation techniques on both ceramic and stainless steel bobbins. It withstands 180°C without deterioration—is completely compatible with poured potted compounds—has no abrasive effect on copper wire during winding—fabricates easily to close-tolerance dimensions—inner layer is compressible to assure tight fit on bobbin—does not shrink, age or discolor.

Write for Engineering Bulletin DN 1500, DN 1000A, DN 1003 for complete performance and specification data covering the wide range of Dynacor low cost Standard, Special and Custom Bobbin Cores—all available with Armag non-metallic armor.

*TRADEMARK

DYNACOR

DYNACOR, INC.
A SUBSIDIARY OF SPRAGUE ELECTRIC CO.

1006 Westmore Ave.

Rockville, Maryland

MEETINGS AHEAD

Oct. 19-26: International Congress & Exhibition for Instrumentation & Automation, INTERKAMA, Dusseldorf, Germany.

Oct. 24-26: Aero & Nav. Elec. Cong., PGANE of IRE, Lord Baltimore Hotel, Baltimore.

Oct. 26-27: Computer Applications Symposium, Armour Research Foundation & Illinois Inst. of Tech., Morrison Hotel, Chicago.

Oct. 26-28: Non-Linear Magnetics and Magnetic Amplifiers, AIEE, PGIE of IRE, Bellevue-Stratford Hotel, Philadelphia.

Oct. 27-28: Magnetodynamics, Engineering Applications, Engineering Institutes, Univ. of Wisconsin, Madison, Wis.

Oct. 27-28: Electron Devices Meeting, PGED of IRE, Shoreham Hotel, Washington, D. C.

Oct. 31-Nov. 2: Radio Fall Meeting, IRE, EIA, Syracuse Hotel, Syracuse, N. Y.

Oct. 31-Nov. 4: Seventh Institute of Electronics in Management; American University, Wash., D. C.

Oct. 31-Nov. 2: Electronic Techniques in Medicine & Biology, PGME of IRE, AIEE, ISA, Sheraton Park Hotel, Wash., D. C.

Nov. 1-2: Electrical Techniques in Medicine & Biology, AIEE, ISA, IRE, Sheraton Park Hotel, Wash., D. C.

Nov. 4: Automatic Data Processing Systems, Institute of Electronics in Management, American University, Wash., D. C.

Nov. 14-17: Magnetism & Magnetic Materials, AIEE, AIP, ONR, IRE, AIME, Hotel New Yorker, New York City.

Nov. 15: Product Engineering & Production, PGPEP of IRE, Contact D. Ehrenpreis, 325 Spring St., New York City.

Nov. 15-16: Mid-American Elect. Convention, MAECON, Hotel Muehlebach, Kansas City, Mo.

Nov. 15-16: Northeast Electronics Research & Engineering Meeting, NEREM, PGPT of IRE, Commonwealth Armory, Boston.

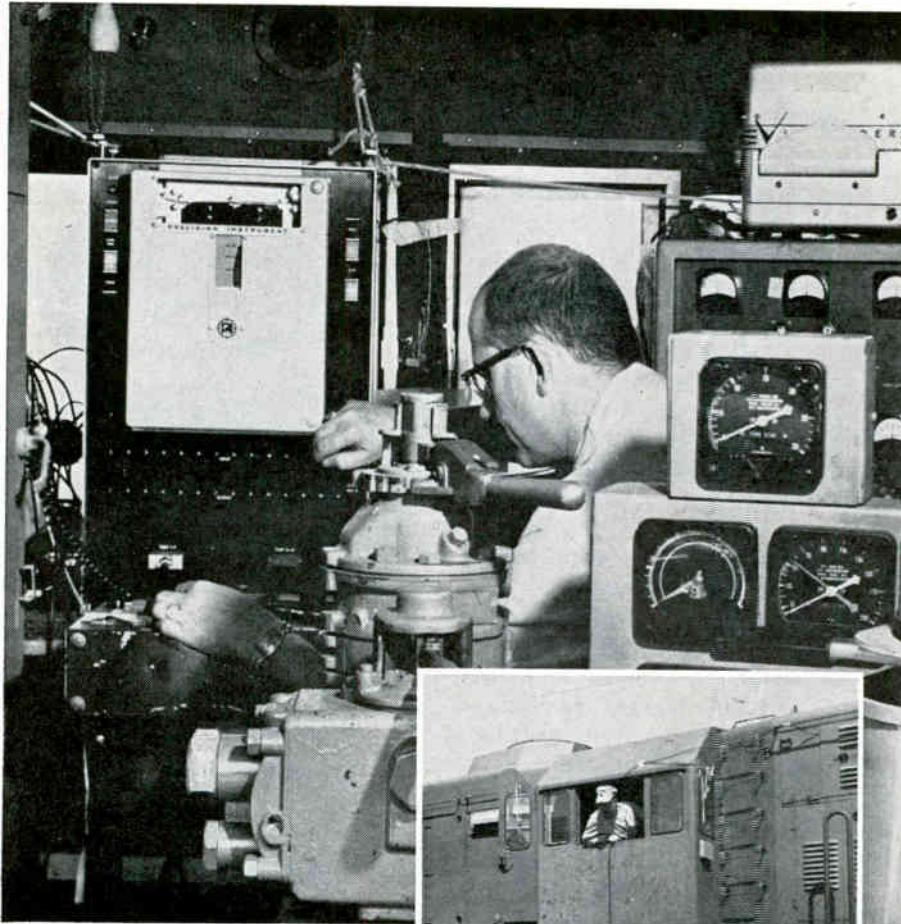

Measurements engineer with General Electric Locomotive and Car Equipment Department checks operation of PI recorder in locomotive cab.

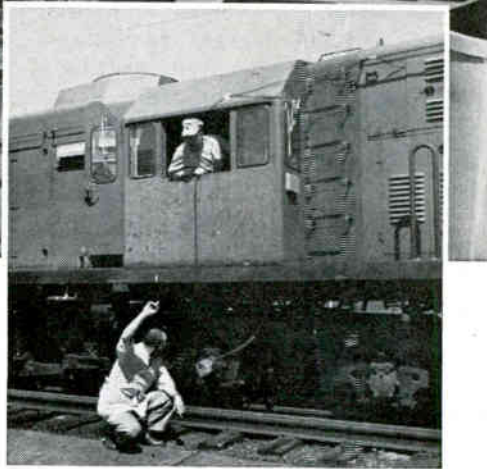

PI Tape Recorder rides the rails - writes 14-track travel report

Even in the pitching, rolling cab of an 1800-horsepower diesel-electric locomotive, it's an easy task for a PI instrumentation magnetic tape recorder to gather data with laboratory accuracy. In special tests recently run by General Electric's Locomotive and Car Equipment Department, their PI 14-track tape recorder was used to measure such parameters as shaft torque, motor-mount movement, strain information, vibration, speed and motor current data. Magnetic tape was chosen for the job because it permits automatic frequency analysis and analog computer processing of quasi-random data.

Such data, when recorded by conventional oscillographic methods, may be extremely difficult and time consuming, if not impossible, to analyze.

For this and other mobile or airborne applications, PI all-solid-state tape recorders offer many unusual advantages which we'd like to tell you about. Drop us a note today, or phone your local Precision representative.

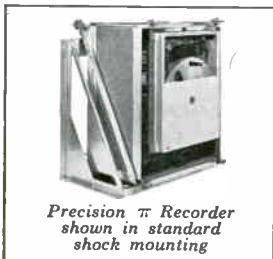

Precision π Recorder shown in standard shock mounting



PRECISION INSTRUMENT COMPANY
1011 Commercial Street • San Carlos, California
Phone: LYtel 1-4441 • TWX: SCAR BEL 30

REPRESENTATIVES IN PRINCIPAL CITIES THROUGHOUT THE WORLD

NEW ... FROM ESC



MINIATURE MODULAR COMPUTER DELAY LINES

... designed for printed board mounting

Module No.	Delay	Size
15-89	100 musec.	$\frac{3}{8}$ " x $\frac{1}{2}$ " x $3\frac{5}{8}$ "
15-90	75 musec.	$\frac{3}{8}$ " x $\frac{1}{2}$ " x $3\frac{5}{8}$ "
15-91	20, 10, 10, 5 musec.	$\frac{3}{8}$ " x $\frac{1}{2}$ " x $3\frac{5}{8}$ "
15-92	50 musec.	$\frac{3}{8}$ " x $\frac{1}{2}$ " x $2\frac{1}{4}$ "
15-93	20, 20 musec.	$\frac{3}{8}$ " x $\frac{1}{2}$ " x $2\frac{1}{4}$ "
15-94	10, 5 musec.	$\frac{3}{8}$ " x $\frac{1}{2}$ " x $2\frac{1}{4}$ "

As a group these miniature, modular, lumped constant delay lines constitute an adjustable delay line. They offer great flexibility in design by providing adjustable delays ranging from 5 musec. to 335 musec. or greater, if additional units are employed.

Impedance — 93 ohms with a maximum pulse attenuation of .5 db and pulse rise time of 30 musec. (max.) for any module.

Modules with variations of rise time, delay or impedance can be supplied upon request.



ESC

WRITE TODAY FOR COMPLETE TECHNICAL DATA.

exceptional employment opportunities for engineers experienced in computer components... excellent profit-sharing plan.

ELECTRONICS CORP. 534 Bergen Boulevard, Palisades Park, New Jersey

Distributed constant delay lines • Lumped constant delay lines • Variable delay networks • Continuously variable delay lines • Step variable delay lines • Shift registers • Video transformers • Filters of all types • Pulse-forming networks • Miniature plug-in encapsulated circuit assemblies

TAF TANTALUM FOIL ... polarized and

*... for high working voltages
in small case sizes*

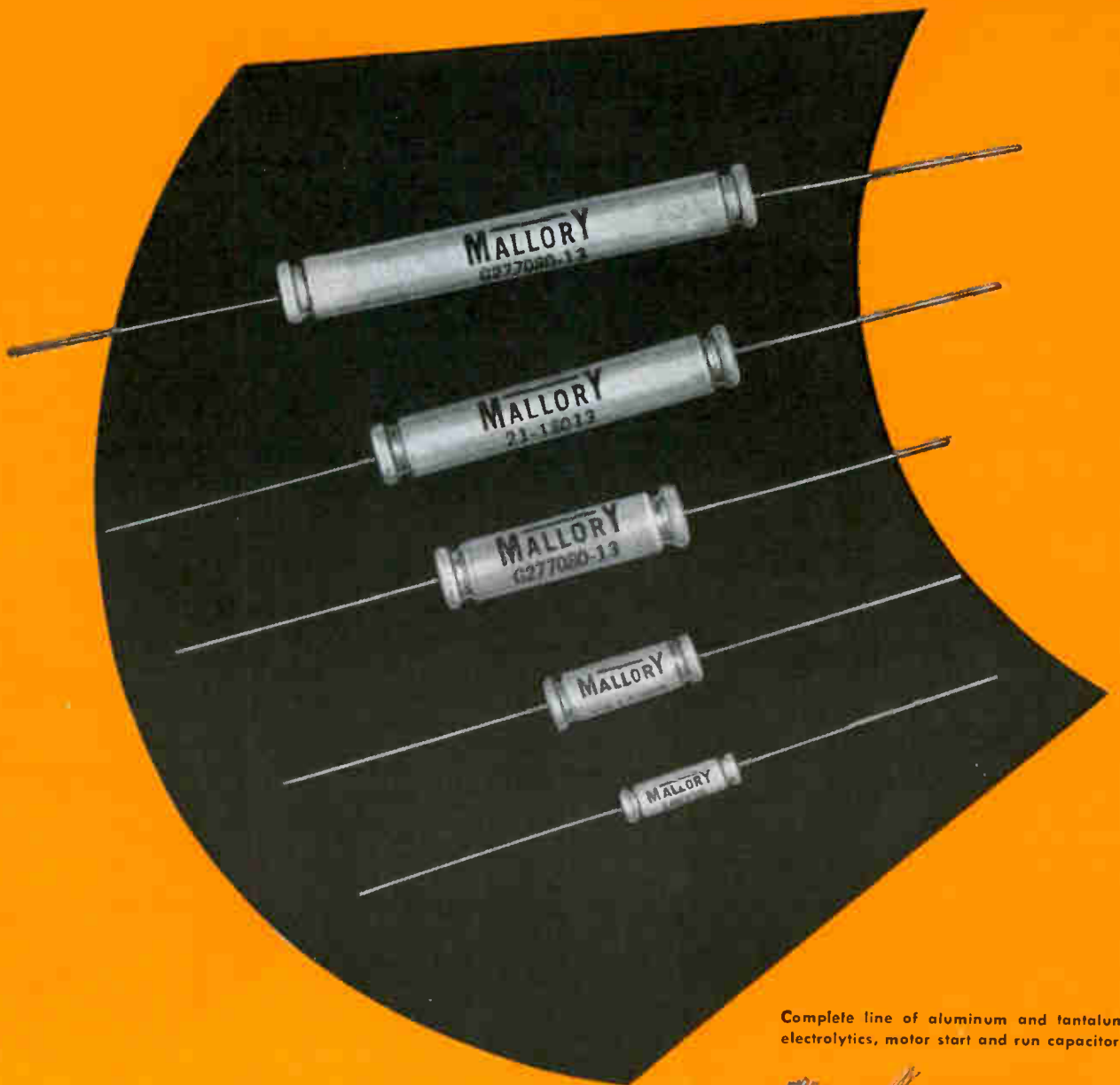

Complete line of aluminum and tantalum electrolytics, motor start and run capacitors



CAPACITORS

non-polarized

Here's a tantalum capacitor that's small in size but large in voltage handling capacity. Mallory TAF Tantalum Foil Capacitors are available in voltage ratings up to 150 WVDC in case sizes as small as $\frac{3}{16}$ " x $\frac{1}{16}$ ". Available in polarized and non-polarized designs, these capacitors are ideal for computers, airborne radar, control systems, and other applications requiring the reliability, stability, low leakage current, and long shelf-life of a quality tantalum foil capacitor.

TAF Plain (unetched) Foil Tantalum Capacitors operate over a temperature range of -55°C to $+85^{\circ}\text{C}$. Standard capacitance tolerance for all units is $\pm 20\%$. TAF capacitors are designed to meet the electrical and environmental characteristics of military specification MIL-C-3965B. Capacitors may be ordered with or without Mylar* insulating sleeves.

IT'S MALLORY FOR TANTALUM CAPACITORS!

... immediate delivery on 13 different types!

The TAF Capacitor Series is just one of the 13 tantalum types now available for immediate delivery—including microminiature to high capacitance, foil and sintered anode, solid and liquid electrolyte, encapsulated and metal case, medium and high temperature. Reliability of these capacitors is firmly established by thousands of test hours and more than a decade of in-service performance.

Write for complete technical data. For expert consultation on your circuit requirements, see a Mallory capacitor specialist.

*Registered trademark—E. I. du Pont de Nemours & Co., Inc.

TYPE TAF PLAIN TANTALUM FOIL CAPACITORS

POLARIZED (150-3 WVDC) CAP. MFD.	NON-POLARIZED (150-6 WVDC) CAP. MFD.	BODY LENGTH	BODY DIAMETER
.5-10	.25-5	$\frac{1}{16}$	$\frac{3}{16}$
1-50	1-25	$\frac{7}{8}$	$\frac{9}{32}$
4-160	3.5-85	$1\frac{1}{16}$	$\frac{3}{8}$
8-350	7-170	$2\frac{1}{8}$	$\frac{3}{8}$
20-440	10-250	$2\frac{3}{4}$	$\frac{3}{8}$

Mallory Capacitor Co. • Indianapolis 6, Indiana

a division of

P. R. MALLORY & CO. Inc.
MALLORY

Mallory
Tantalum
Capacitors
Stocked
by these
distributors



Baltimore, Md.
Radio Electric Service

Binghamton, N.Y.
Stack Electronics

Boston, Mass.
Cramer Electronics, Inc.
DeMambo Radio Supply Co.
Lafayette Radio

Bridgeport, Conn.
Westconn Electronics

Buffalo, N.Y.
Wehle Electronics

Camden, N.J.
General Radio Supply Co.

Chicago, Ill.
Allied Radio Corp.
Newark Electronics Corp.

Cincinnati, Ohio
United Radio

Cleveland, Ohio
Pioneer Electronics

Dallas, Texas
Engineering Supply Co.

Dayton, Ohio
Allied Supply Co.

Denver, Colo.
Denver Electronics

Houston, Texas
Harrison Equipment Co., Inc.
Lenert Company

Indianapolis, Ind.
Graham Electronics

Los Angeles, Calif.
California Electronics
Kierulff Electronics, Inc.
Radio Product Sales

Minneapolis, Minn.
Northwest Radio

Montreal, Que.
Canadian Electrical Supply Co.

Mountainside, N.J.
Federated Purchaser, Inc.

Nashville, Tenn.
Electra Dist. Co.

Newark, N.J.
Lafayette Radio

New York, N.Y.
Harrison Radio Corp.
Harvey Radio Co., Inc.
Hudson Radio & TV Corp.
Lafayette Radio
Terminal Electronics

Oakland, Calif.
Elmar Electronics, Inc.
Zack Radio Supply Co.

Orlando, Fla.
East Coast Radio

Ottawa, Ont.
Wackid Radio-TV Lab.

Palo Alto, Calif.
Zack Radio Supply Co.

Pasadena, Calif.
Electronic Supply Corp.

Perth Amboy, N.J.
Atlas Electronics

Philadelphia, Pa.
Herbach & Rademan
Philadelphia Electronics

Pittsburgh, Pa.
Radio Parts Co.

St. Louis, Mo.
Olive Electronics

Seattle, Wash.
F. B. Connelly Co.

Tampa, Florida
Thurrow Distributors, Inc.

Toronto, Ont.
Alpha Aracon Radio Co.
Electro Sonic Supply
Wholesale Radio & Electronics

Tucson, Ariz.
Standard Radio Parts

Tulsa, Okla.
Engineering Supply Co.

Washington, D.C.
Electronic Industrial Sales

White Plains, N.Y.
Westchester Electric

Winston-Salem, N.C.
Dalton-Hege Radio



from milliwatts

to megawatts

EIMAC OFFERS RF POWER FOR ALL AIR-SPACE SYSTEMS

From miniature microwave devices to the highest power klystron, Eimac offers rf power for every type of air-space system. With tubes designed for airborne communication. For warning systems. For tracking and guidance. You can look to Eimac as the one source of all your rf power needs. ■ For still further progress, new tube types to meet new needs, Eimac continues to forge ahead with the most advanced research facilities available today for power tube development. And its manufacturing program is unmatched in ability to turn blueprint ideas into quantity production. No wonder Eimac tubes power nearly every major air-space system the world over: telemetry, troposcatter, navigational radar, high-power radar—including the recent BMEWS program. Eitel-McCullough, Inc., San Carlos, Calif.



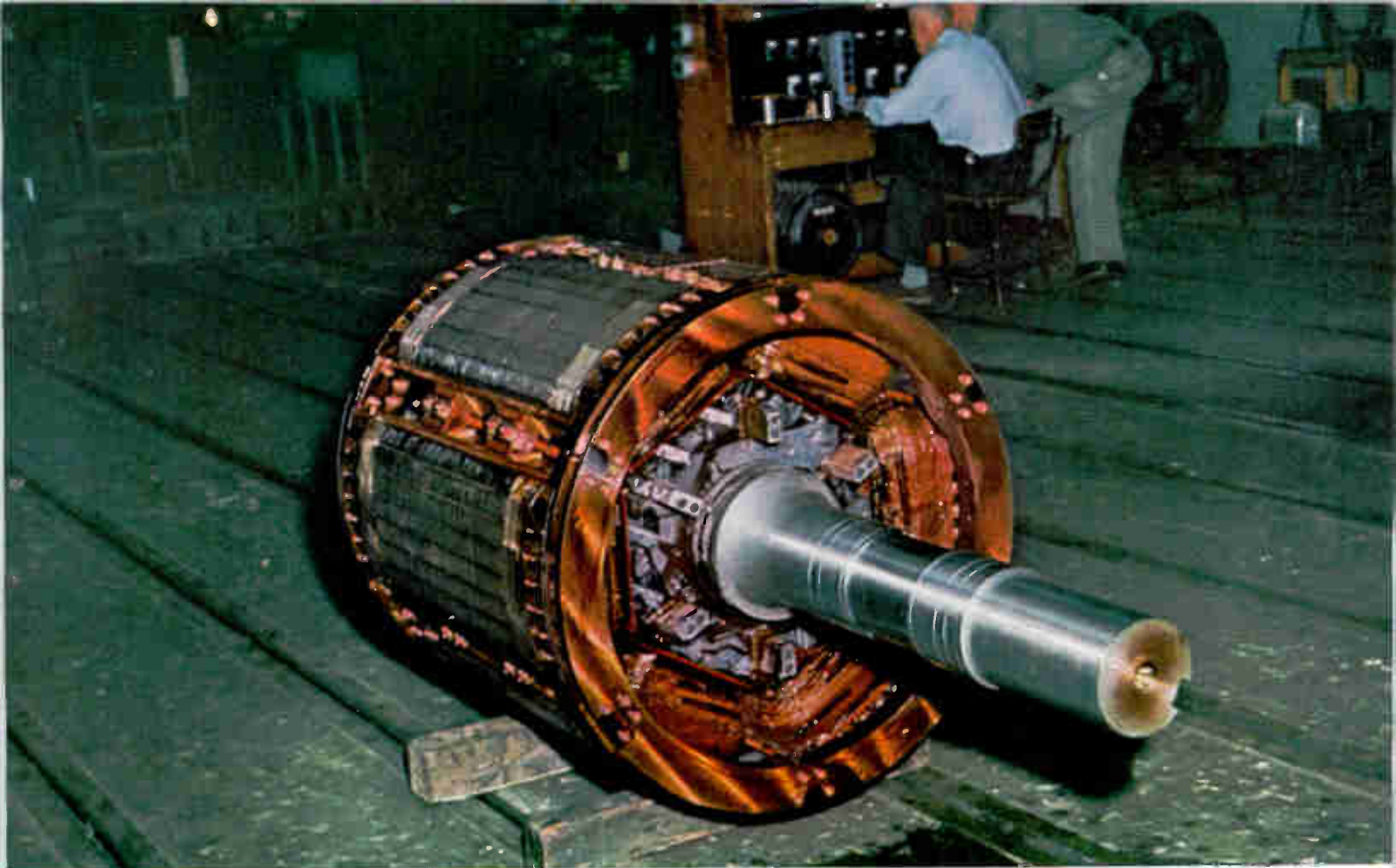

ANACONDA SILOTEX—THE ALL-GLASS-INSULATED CLASS H MAGNET WIRE WITH EXTRA OVERLOAD PROTECTION

300C operation continuously for over 5000 hours before failure—this is the kind of high-temperature punishment withstood by a motor wound with Anaconda Silotex Magnet Wire.

A leading American motor manufacturer conducted these severe thermal-overload tests to find out just what Anaconda's silicone-bonded, all-glass-insulated magnet wire could really do. The winding withstood a 66 per cent overload for over 5000 hours before failure.

Although Silotex is officially rated as a Class H insulation (AIEE), capable of withstanding "hot spot" temperatures of 180C, resistance to high temperatures is only part of the reason why it gives long continuous service. It also has excellent moisture resistance, outstanding dielectric strength.

Where this maximum overload protection is not necessary,

and where mechanical abuse during winding may occur, fused Dacron* fibers are substituted for some of the glass, giving additional abrasion resistance. This *Silotex-D* is manufactured to the same rigid quality requirements as Silotex—and all of Anaconda's other magnet wire products.

Whatever your application, Anaconda has a glass or glass-combination insulation to fit your requirements—and in a full range of sizes—rounds, squares, and rectangulars. The next time you have requirements, contact your nearest Anaconda Wire and Cable Company district office for help in selecting the right glass-insulated magnet wire. Or—for more information, write: The Anaconda Wire and Cable Company, 25 Broadway, New York 4, N. Y.

60256

*duPont registered trademark

ASK THE MAN FROM **ANACONDA**[®] ABOUT GLASS-INSULATED MAGNET WIRE

ANATHERM 155C (AIEE Class F)
high temperature resistance



NYFORM 105C (AIEE Class A)
superior windability



PLAIN ENAMEL 105C (AIEE Class A)
low-cost enameled magnet wire



FORMVAR 105C (AIEE Class A)
proven dependability



ANALAC 105C (AIEE Class A)
so durable magnet wire





STATISTICAL THEORY OF COMMUNICATION By Y. W. LEE, M.I.T. 1960. 509 pages. \$16.75

ELECTROMAGNETIC FIELDS, ENERGY AND FORCES By ROBERT M. FANO, LAN JEN CHU, and RICHARD B. ADLER, all of M.I.T. 1960. 520 pages. \$12.00

ELECTROMAGNETIC ENERGY TRANSMISSION AND RADIATION By RICHARD B. ADLER, LAN JEN CHU, and ROBERT M. FANO, all of M.I.T. 1960. 621 pages. \$14.50

ELECTRONIC CIRCUITS, SIGNALS, AND SYSTEMS By SAMUEL J. MASON and HENRY J. ZIMMERMANN, both of M.I.T. 1960. 616 pages. \$12.50

PHOTOCONDUCTIVITY OF SOLIDS By RICHARD H. BUBE, RCA Laboratories. 1960. 461 pages. \$14.75

THERMOELECTRICITY Edited by PAUL H. EGLI, U. S. Naval Research Laboratory. 1960. 407 pages. \$10.00

DIGITAL COMPUTERS AND NUCLEAR REACTOR CALCULATIONS By WARD C. SANGREN, General Dynamics Corporation. 1960. 208 pages. \$8.50

ELECTRONIC PROCESSES IN SOLIDS By P. R. AIGRAIN, University of Paris, R. J. COELHO, M.I.T., and G. ASCARELLI, Univ. of Illinois. A Technology Press Research Monograph, M.I.T. 1960. 67 pages. \$4.00

FOUNDATIONS FOR A CONTROL THEORY OF MULTIVARIABLE SYSTEMS By MIHAJLO D. MESAROVIC, Case Institute of Technology. A Technology Press Research Monograph, M.I.T. 1960. Approx. 128 pages. Prob. \$3.50

FREQUENCY - POWER FORMULAS By PAUL PENFIELD, JR., M.I.T. A Technology Press Research Monograph, M.I.T. 1960. Approx. 256 pages. Prob. \$4.50

PROGRESS IN DIELECTRICS, Vols. I & II Edited by J. B. BIRKS, Manchester Univ. and J. H. SCHULMAN, U. S. Naval Research Laboratory. 1960. Vol. I, 312 pages. \$11.00. Vol. II, 225 pages, \$9.50

HYDROMAGNETIC CHANNEL FLOWS By LAWSON P. HARRIS, G.E. Research Laboratory. A Technology Press Research Monograph, M.I.T. 1960. 90 pages. \$2.75

INTRODUCTION TO MODERN NETWORK SYNTHESIS By M. E. VAN VALKENBURG, Univ. of Illinois. 1960. 498 pages. \$11.75

MATHEMATICAL METHODS FOR DIGITAL COMPUTERS Edited by ANTHONY RALSTON, Bell Telephone Laboratories, and HERBERT S. WILF, Univ. of Illinois. 1960. 293 pages. \$9.00

FUNDAMENTALS OF ELECTRONICS By NORMAN LURCH, State Univ. of New York. 1960. 631 pages. \$8.25

INDUSTRIAL ELECTRONICS AND CONTROL, 2d Edition By R. G. KLOEFFLER, Kansas State Univ. 1960. 540 pages. \$10.00

DIRECT CONVERSION OF HEAT TO ELECTRICITY Edited by JOSEPH KAYE and JOHN A. WELSH, both of M.I.T. 1960. 388 pages. \$8.75

SELECTED SEMICONDUCTOR CIRCUITS HANDBOOK Edited by SEYMOUR SCHWARTZ, Transistor Applications, Inc. 1960. 506 pages. \$12.00

ALTERNATING - CURRENT CIRCUITS, 4th Edition By R. M. KERCHNER, Kansas State Univ., and GEORGE F. CORCORAN, Univ. of Maryland. 1960. 602 pages. \$8.75

FLUID POWER CONTROL Edited by JOHN F. BLACKBURN, GERHARD REETHOF, and J. L. SHEARER, all of M.I.T. A Technology Press Book, M.I.T. 1960. 710 pages. \$17.50

PRINCIPLES OF SEMICONDUCTOR DEVICE OPERATION By A. K. JONSCHER, General Electric Co., England. \$5.75

THE THEORY AND DESIGN OF INDUCTANCE COILS By V. G. WELSBY, Univ. of Birmingham. 1960. 232 pages. In press

ELECTRONIC EQUIPMENT RELIABILITY By G. W. A. DUMMER and N. B. GRIFFIN. 1960. In press

PROGRESS IN SEMICONDUCTORS, Vol. IV. Edited by ALAN F. GIBSON, Radar Research Establishment, U.K. Co-Editors, R. E. BURGESS and F. A. KROGER. 1960. 292 pages. \$10.50

SEND NOW FOR ON-APPROVAL COPIES

JOHN WILEY & SONS, Inc.

440 PARK AVENUE SOUTH

NEW YORK 16, N. Y.

FIRST PHONE CALL VIA MAN-MADE SATELLITE!

"Project Echo" satellite went into a near-perfect circular orbit 1000 miles high, circling the earth once every two hours. Its orbital path covered all parts of the U. S.

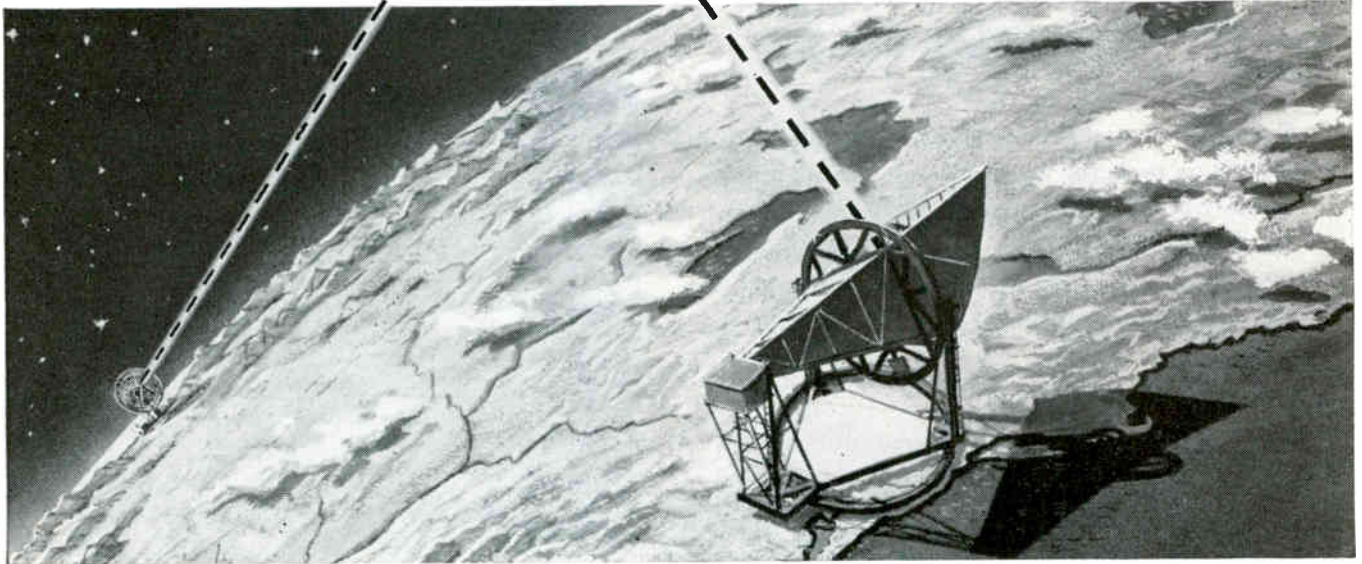

BELL TELEPHONE LABORATORIES BOUNCES VOICE OFF SPHERE PLACED IN ORBIT A THOUSAND MILES ABOVE THE EARTH

Think of watching a royal wedding in Europe by live TV, or telephoning to Singapore or Calcutta—*by way of outer-space satellites!* A mere dream a few years ago, this idea is now a giant step closer to reality.

Bell Telephone Laboratories recently took the step by successfully bouncing a phone call between its Holmdel, N. J., test site and the Jet Propulsion Laboratory of the National Aeronautics and Space Administration (NASA) in Goldstone, California. The reflector was a 100-foot sphere of aluminized plastic orbiting the earth 1000 miles up.

Dramatic application of telephone science

Sponsored by NASA, this dramatic experiment—known as "Project Echo"—relied heavily on telephone science for its fulfillment...

- The Delta rocket which carried the satellite into space was steered into a precise orbit by the Bell Laboratories Command Guidance System. This is the same system which recently guided the remarkable Tiros I weather satellite into its near-perfect circular orbit.
- To pick up the signals, a special horn-reflector antenna was used. Previously perfected by Bell Laboratories for microwave radio relay, it is virtually immune to common radio "noise" interference. The amplifier—also a Laboratories development—was a traveling wave "maser" with very low noise susceptibility. The signals were still further protected from noise by a special FM receiving technique invented at Bell Laboratories.

"Project Echo" foreshadows the day when numerous man-made satellites might be in orbit all around the earth, acting as 24-hour-a-day relay stations for TV programs and phone calls between all nations.

This experiment shows how Bell Laboratories, as part of the Bell System, is working to advance space communication. Just as we pioneered in world-wide telephone service by radio and cable, so we are pioneering now in using outer space to improve communications on earth. It's part of our job, and we are a long way toward the goal.

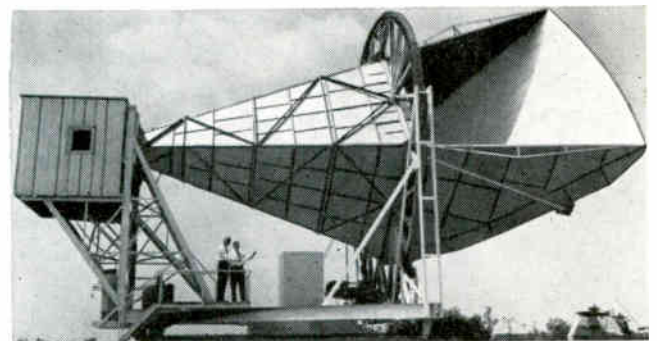

Giant ultra-sensitive horn-reflector antenna which received signals bounced off the satellite. It is located at Bell Telephone Laboratories, Holmdel, New Jersey.



BELL TELEPHONE LABORATORIES

WORLD CENTER OF COMMUNICATIONS RESEARCH AND DEVELOPMENT

population -



Even in the most remote areas, wings aloft are guided on their way by AeroCom's new medium range N.D. Beacon Transmitter. This transmitter was designed and built to provide long, trouble-free service with no attendants...even where the total population is Zero.

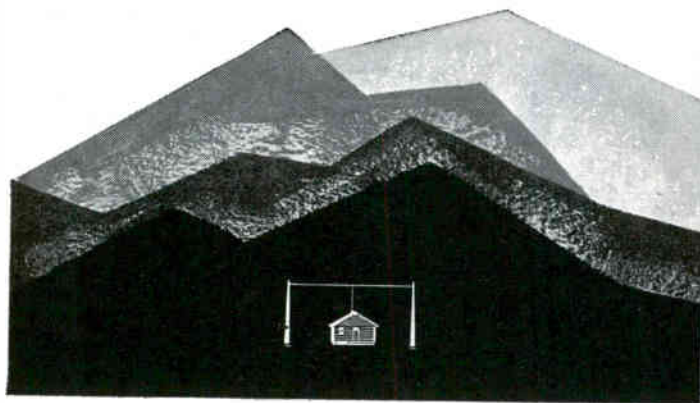

NOW — FCC type accepted — single or dual automatic—for carrier powers of 10, 12, 15, 20, 25, 50 and 100 watts.

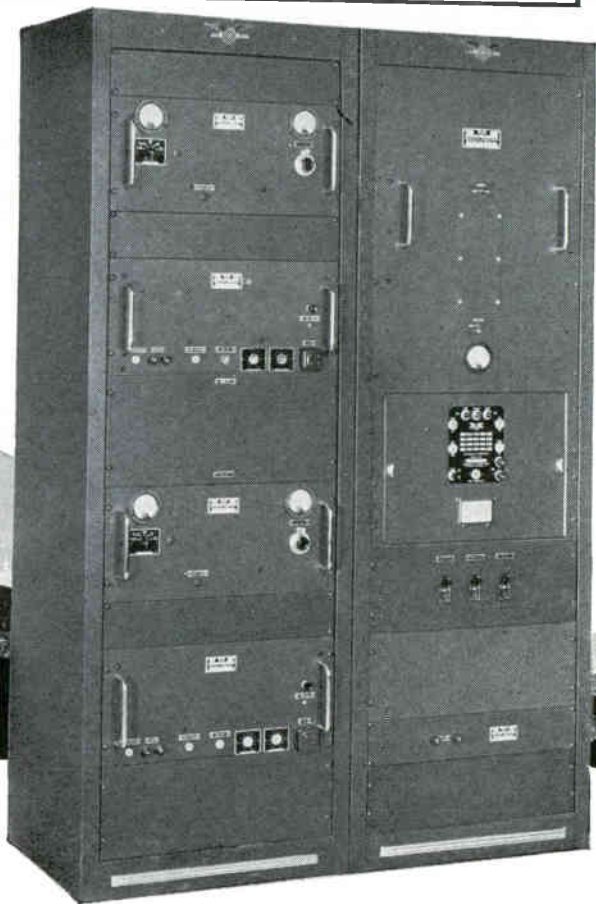

AEROCOM'S **Dual Automatic** **Package-Type Radio Beacon**

for completely unattended service. This N.D. Beacon (illustrated) consists of two 100 watt (or 50 watt) transmitters with 2 keys, automatic transfer and antenna tuner. (Power needed 110 or 220 volts 50/60 cycles, 465 V.A. for 50 watt, 675 V.A. for 100 watt.)

Frequency range 200-500 kcs.: available with either crystal or self excited oscillator coil. High level plate modulation of final amplifier is used, giving 97% tone modulation. Microphone P-T switch interrupts tone, permitting voice operation.

The "stand-by" transmitter is selected when the carrier or modulation level of main transmitter drops 3 db or more, in case of failure to transmit the identification signal or if carrier frequency changes 5 kcs. or more. Audible indication in monitoring receiver tells which transmitter is in operation.

Unit is ruggedly constructed and conservatively rated, providing low operating and maintenance costs.

Also available in 400 watt, 1 K.W. and 4 K.W. Models, 200-415 kcs.



3090 S. W. 37th AVENUE • MIAMI 33, FLORIDA



Polarity Of Aluminum Electrolytic Capacitors

Many electrolytic capacitors have plus and minus terminals, like flashlight batteries, which makes them quite different from other types of capacitors. Polarity becomes necessary because of special construction that provides maximum capacitance for a given volume, weight, and cost.

Aluminum electrolytic capacitors are built around one of the best overall dielectric materials available. Aluminum oxide formed on a high-purity aluminum foil has a dielectric constant of from 7 to 10 and an extremely high dielectric strength of 2.5 million volts per 0.1 inch of thickness.

These unique dielectric characteristics of aluminum oxide can be utilized fully by controlling thickness of the oxide dielectric from a film only a few molecules thick to any depth required for conventional voltage ratings of electrolytic capacitors. Furthermore, aluminum foil can be etched to increase its surface area as much as ten times, increasing capacitance proportionally.

This extremely thin dielectric film offers very high resistance to passage of electrical current as long as the anode is positive with respect to the cathode. If the capacitor is connected with polarity reversed, the oxide film offers very little resistance to current flow and the resulting high currents will cause the capacitor to overheat.

 This is the reason why polar electrolytic capacitors must be properly connected in a d-c circuit. Most electrolytic capacitors for filter, by-pass, and energy storage applications are polar capacitors. That is, they are constructed with the anode covered with dielectric oxide to a thickness capable of withstanding both rated and surge voltage of the capacitors. The negative plate normally has no dielectric oxide other than a thin film formed when aluminum is exposed to air.

 It is possible to adapt the electrolytic principle for a non-polar capacitor to a-c applications. Two anodes are used, each plate having an aluminum-oxide dielectric formed on its surface to a thickness capable of withstanding normal and surge-voltage rating in either direction. When connected to an a-c source, one foil acts as an anode for one-half the cycle while the other functions as an anode on the other half of the cycle. Thus, there is no need to observe polarity with a non-polar capacitor. Because a non-polar capacitor is really two capacitors in series, it will have approximately one-half the capacitance of a polar capacitor of the same voltage rating when read on a bridge. Or, to put it another way,

it will have twice the volume of a polar capacitor for the same capacity and voltage rating.

Non-polar electrolytic capacitors can operate on a-c provided service is intermittent or if reactive currents are low enough to prevent overheating. They cannot operate continuously at a-c potentials higher than 40 volts rms because of their high power factor and small surface area for dissipation of heat.



Type DCM, Polar Energy Storage Type MJ, Non-Polar Motor Starting Type TR, Polar High Reliability Type MT, Polar General Purpose

Motor-starter capacitors are non-polar. They are also used where voltage may reverse on occasion or where a-c current must be passed continuously during the starting period.

 There is another large family of electrolytic capacitors which, for lack of a better name, are called semi-non-polar. As the name implies, oxide is purposely formed on the negative plate, but of a thickness less than that formed on the anode. Most semi-non-polar capacitors are especially designed for particular applications.

Where a-c ripple voltage across semi-non-polar capacitors is high in filter applications, it is desirable to have oxide formed on the cathode capable of withstanding peak-to-peak voltage of the ripple wave — otherwise, oxide will accumulate on the cathode which will reduce capacitance and increase impedance.

Since non-polar and semi-non-polar electrolytic capacitors have more foil area to absorb heat, more parallel paths for current, and larger case sizes with greater area to dissipate heat, they are used where high a-c ripple currents and/or low impedance requirements make polar capacitors impractical.

Sangamo has a complete line of polar and non-polar capacitors for filtering, energy storage, motor starting, by-pass, coupling, and non-critical timing circuit applications. Where semi-non-polar capacitors are required, Sangamo engineers are well qualified to supply the most economical design that will give good service and long life.

SC60-6

SANGAMO ELECTRIC COMPANY, Springfield, Illinois
— designing toward the promise of tomorrow

1940 1941 1942 1943 1944
Certi-Crimp* • A-MP-O-LECTRIC • Plasti-Grip • SOLISTRAND • Plasti-Bond • AMP-O-MATIC • Amplifilm • AM

4 1945 1946 1947 1948 1949
TION • COPALUM • Ampli-Bond • DYNA-CRIMP • TERMALUM • FASTON • AMPLIVAR • CERTI-SEAL • PIDG • A

49 1950 1951 1952 1953 1954
MPOWER • DIAMOND GRIP • AMPORTAPOWER • AMP EDGE • Certi-Crimp • A-MP-O-LECTRIC • Plasti-Grip •

954 1955 1956 1957 1958 1959
SOLISTRAND • Plasti-Bond • Amplifilm • A-MP-O-LECTRIC • Plasti-Bond • DYNA-CRIMP •

1960 1961 1962 1963 1964 1965
RIMP • AMPLIVAR • CERTI-SEAL • AMPORTAPOWER



*Registered U.S. Patent Office

INDUSTRY LEADERS

BECAUSE IT'S THE CRIMP THAT COUNTS!



All connectors may look alike but when faced with the test of performance . . . contact crimp reliability makes them all different. The big difference between other connectors and the AMPin-cert connector is the snap-in design contact attached to the wire by AMP's precision-controlled, compression-crimp technique. Twenty years of intensified research, development and production stand behind the industry-accepted compression technique which produced Solistrand®, Diamond Grip®, Pre-Insulated Diamond Grip®, Plasti-Grip®, Certi-Crimp® and the

more than 15,000 different AMP circuit termination products. This is the common denominator which spells out unquestioned reliability in all our products including the AMPin-cert connector line. ANOTHER AMP FIRST! Now AMP offers tape-fed, automated application of AMPin-cert contacts. Production levels of up to 1,500 terminations per hour can be achieved with standard A-MP-O-LECTRIC® machines. Also, the AMPORTAMATIC crimping tool is available for tape-fed terminations in hard-to-reach locations.

Visit us at the A.E.S. Show, Los Angeles; Oct. 26, 27 and 28, 1960, Booths 313 to 315.

AMP INCORPORATED

GENERAL OFFICES: HARRISBURG, PENNSYLVANIA

AMP products and engineering assistance are available through subsidiary companies in: Australia • Canada • England • France • Holland • Italy • Japan • Mexico • West Germany

Telemetry System for Testing Automobiles



By ALAN POTTON,
Armstrong Whitworth Aircraft Ltd.,
Coventry, England

Author adjusts transmitter (above) that enables tests to be made at various points on a car and transmitted to a recording and monitoring station (below) where it is possible to warn the driver of danger from a part nearing the breaking point

A SATISFACTORY METHOD of measuring temperatures, pressures, and other parameters in a moving vehicle has been needed by automobile industry. Direct recording techniques have been used such as carrying the recording equipment in the vehicle itself, or in a second vehicle attached to the test vehicle by a cable.

A four-channel telemetry system was developed to test the feasibility of a telemetry scheme designed for vehicle designers in the automobile industry. A four-channel unit was chosen as having the minimum number of channels to allow assessment of the scheme, but the addition of more channels involves little further complications.

A block diagram of the transmitter is shown in Fig. 1A. A time multiplex pam/f-m/a-m system having an f-m subcarrier amplitude-modulating a transmitter with a carrier frequency in the decimeter wave band is used. The test vehicle was fitted with four transducers comprising two strain gages, one thermocouple and one thermistor. Strain gages are fitted to one track

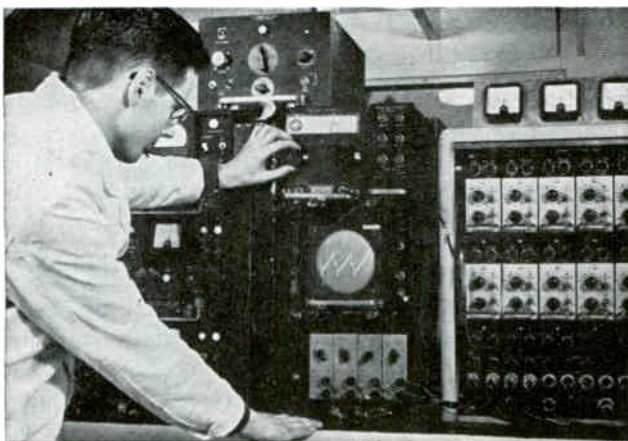

rod and one steering arm in pairs of one active and one passive element to compensate for temperature changes. A thermocouple is fitted to the exhaust manifold, and a thermistor measures the temperature in the oil sump.

Lowlevel transducer outputs from the strain gage and thermocouple circuits are connected to bank 1 of a double-bank 24-channel telemetry sampling switch. The output from bank 1 of the switch is amplified by a heat-stabilized low-drift d-c

amplifier. This signal is then fed to bank 2 of the sampling switch. At this point, a synchronizing voltage source and the thermistor output are connected to the switch.

The output from bank 2 of the switch frequency-modulates the subcarrier oscillator, which in turn is used to amplitude-modulate a uhf transmitter. A monopole antenna fitted to the roof of the vehicle transmits the signal.

A block diagram of the receiver is shown in Fig. 1B. The receiving

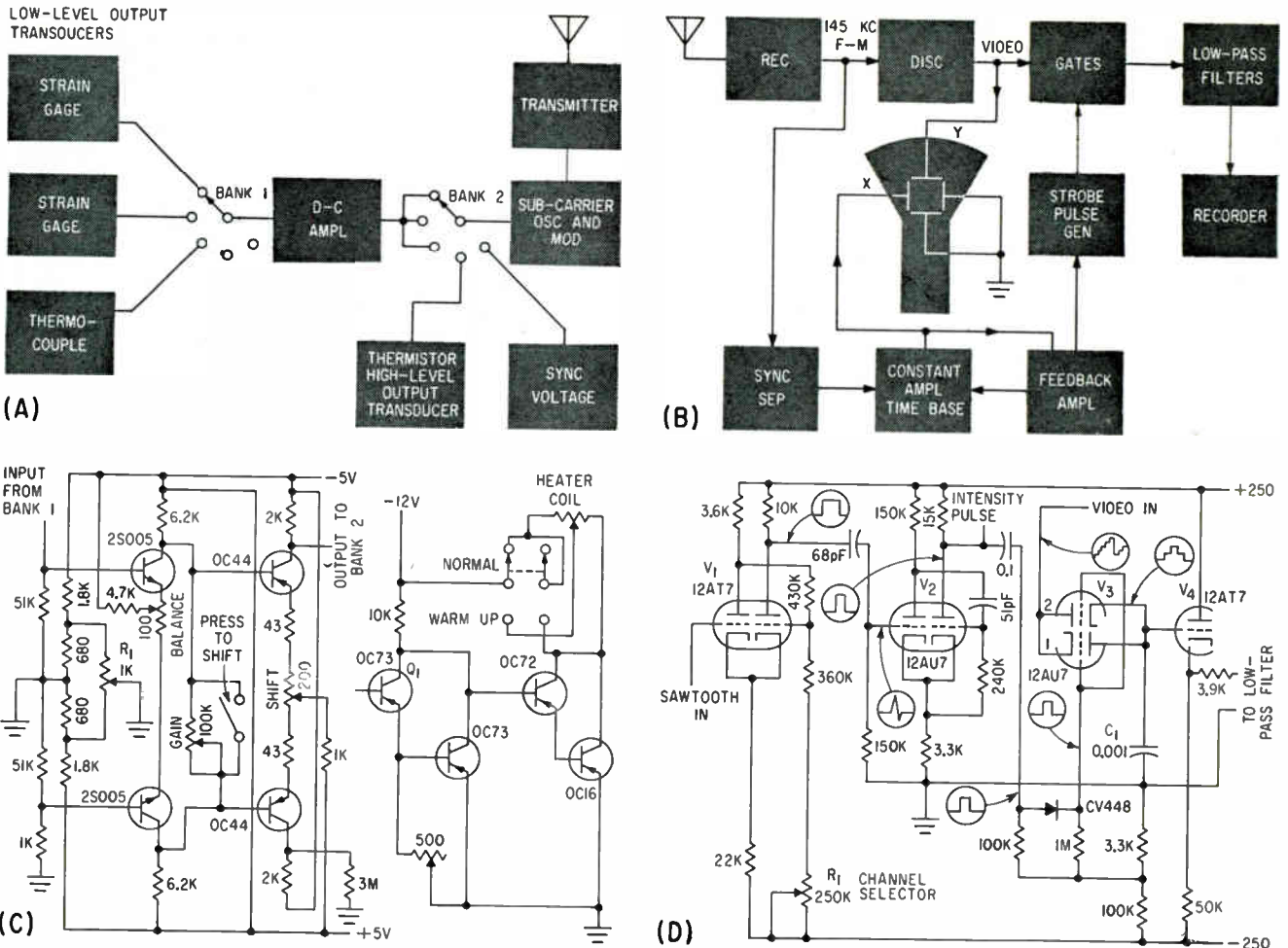

FIG. 1—Block diagrams of transmitter unit (A) and receiving station (B). Transmitter d-c amplifier (C left); temperature control circuit (C right); receiving unit strobe pulse generator (D)

antenna is a folded dipole with a single reflector and is matched to the input impedance of the uhf receiver. The detected signal is then fed to the frequency discriminator. The discriminator output is displayed on a cathode-ray tube. After discrimination, the signal is demultiplexed in the strobing system and the individual channels are recorded by ultra-violet recorders.

Since the transmitter modulator requires a single-ended input going positive and negative about ground, it is necessary that the transducer circuits give this type of output. A further restriction is that to satisfy the bias requirements of the input stage of the d-c amplifier, signals must be presented to a resistance of 1,000 ohms. Voltage supplies for the transducers consist of a +12 v and -12 v stabilized supply.

The transducer circuit is shown in Fig. 2A. The strain gages are connected in half-bridge circuits with one passive and one active element. A variable resistance bal-

ances the system, and in view of the amplifier input requirements, 2,000-ohm strain gages are used. From an estimate of the strains involved, an output from the strain gage circuits of ± 10 mv at maximum strain was expected. A similar output was also anticipated from the thermocouple circuit. The output from the thermistor circuit, however, is ± 1.5 v over the expected temperature range and amplification is therefore not required.

A circuit of the d-c amplifier is shown in Fig. 1C. The amplifier consists of two stages, each stage comprising an emitter-coupled pair. This configuration results in a symmetrical circuit which minimizes effects due to the thermal drift of individual transistor parameters. To further minimize thermal drift, Q_1 is a temperature-sensing element which controls the current through the heater of a temperature-controlled block. The base of Q_1 is left floating. Variations of ambient temperature are reduced by a factor of ten inside the block and the tran-

sistors are maintained at a steady 40 C. Since noise in a mechanical switch depends partly on the current through the contacts, R_1 may be adjusted so that the amplifier draws no current from the input source for zero input level.

The gain of the amplifier is variable with a maximum of 240, and zero level drift is equivalent to 10μ v at the input per degree centigrade change of ambient temperature. The output of the amplifier is 3 db down at 50 Kc. Power supplies are obtained from a 10 v transistorized stabilizer.

The frequency modulator circuit is a conventional reactance tube type. The uhf transmitter is amplitude modulated by feeding the subcarrier output to the grid of a tube in series with the transmitter. The uhf transmitter uses two type A1714 tubes in a push-pull circuit with a quarter-wave lecher line. Loop coupling is used at the output of the transmitter and the signal is fed to a monopole antenna on the roof of the vehicle. Maximum power

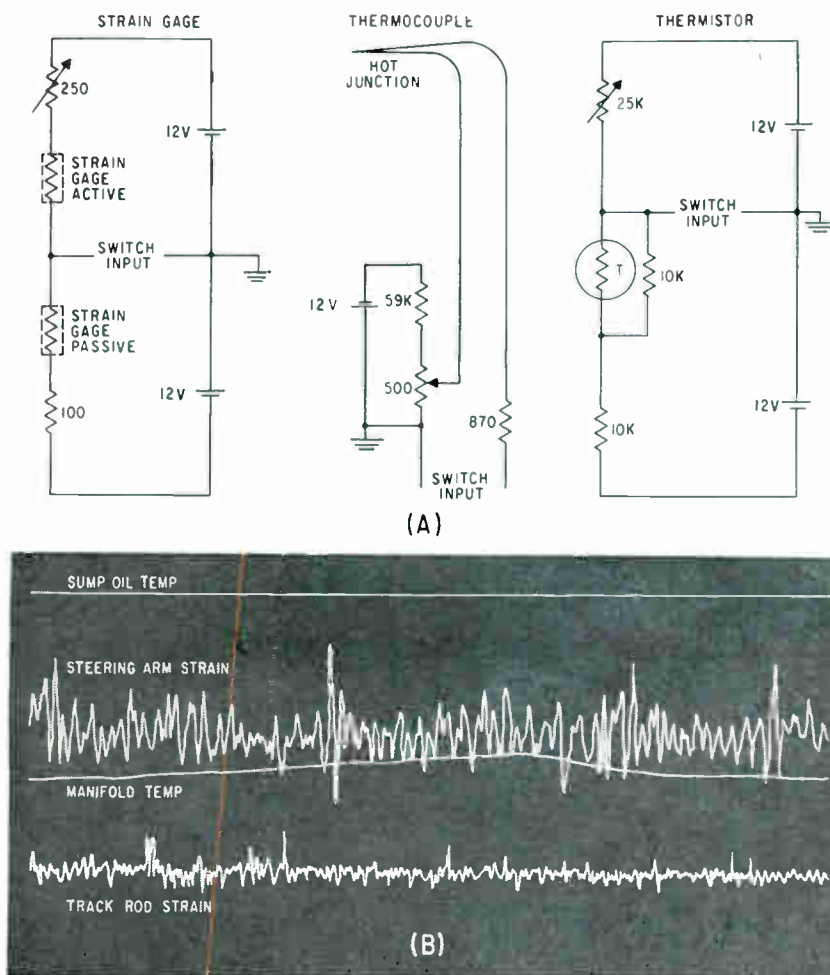

FIG. 2—The transducers (A) measure the temperature and strain parameters shown in a typical record of a test run (B)

output of the transmitter is 1.5 watts, and range with the present antenna is well over two miles. The maximum frequency of the information transmitted is 60 cps with the present design.

The entire transmitter weighs 30 pounds and will fit easily into the front seat next to the driver. An attempt to minimize the effects of vibration is made by mounting the unit on a sheet of rubber and strapping it firmly to the front seat, which has always been satisfactory in practice. When fitted in the front seat in this way, the equipment can easily be operated by the driver and it is therefore unnecessary to carry a second person specifically to operate the sender unit.

A folded dipole with a single reflector is used as a receiving aerial and is matched to the receiver at the carrier frequency. The receiver is a conventional uhf receiver using a type A2521 tube in the grounded-grid configuration as a low-noise amplifier giving an ef-

fective noise temperature of approximately 3,000 K. The bandwidth of the available receiver is 4.5 Mc which, although excessive for the immediate application, is a facility available for high information systems that may come into use.

After detection of the signal, it is passed into a Travis-Round discriminator. This discriminator is of the simple balanced type utilizing two circuits tuned to frequencies above and below the sub-carrier center frequency. The output of the discriminator is a telemetry histogram that is displayed on a cathode-ray tube for visually monitoring the signal before demultiplexing. The display system also separates synchronizing channel from the composite signal and uses it to lock the visual display.

The transitron type of timebase uses a feedback loop to ensure a sawtooth output of constant amplitude. The timebase output is amplified by an EF91 tube and d-c restored by an EB91. Two EF91 pentodes act as a differential ampli-

fier, the output from which is fed to the grid of the sawtooth oscillator EF91 tube. This tube has a $0.002 \mu\text{f}$ capacitor between its plate and the grid resistor. The rate of charge of this capacitor and hence the slope of the timebase is controlled by this feedback voltage. Since the frequency of the timebase is fixed by the synchronizing frequency, the result is a sawtooth output of constant amplitude.

The circuit of the strobing unit is shown in Fig. 1D. The constant amplitude sawtooth from the display unit timebase is fed to the left-hand control grid of V_1 . This tube is connected as a Schmitt trigger circuit, and when the grid reaches a predetermined voltage, the drop in plate voltage causes the second half of the tube to be cut off. Potentiometer R_1 sets the triggering level, which is used to select the channel to be strobed out. The output from the Schmitt trigger is now differentiated, and the differentiated waveform triggers one-shot multivibrator V_2 . A pulse 0.1 msec wide is produced by the multivibrator and the position of the pulse relative to the start of the timebase is controlled by R_1 . The output pulse from the multivibrator acts as a gating pulse and also identifies the strobed channel on the visual display by brightening the trace at that point.

When the strobing pulse is applied to the grids of double-triode gating tube V_3 , the gate will select the required channel from the composite signal applied to cathode 1 and plate 2. The gate is of the sample-and-hold type, since capacitor C_1 holds each gate level until the next gating pulse comes. The gate output is a stepped wave, which is passed through a low-pass filter by way of cathode follower buffer stage V_4 . Since the cutoff frequency of the filter is 60 cps, the output from the filter is no longer a stepped waveform, and all frequency components of the original signal up to 60 cps appear at the output. The maximum output voltage from the filter is $\pm 15 \text{ v}$ across the 30,000-ohm input resistance of the recording unit.

REFERENCE

- (1) H. Kemhadjian, A Simple Temperature Control System for Transistors, *Mullard Technical Communications*, Dec. 1958.

Mockup of micromodular autopilot, complete except for gyros, takes up 0.035 cu ft, weighs slightly over three pounds

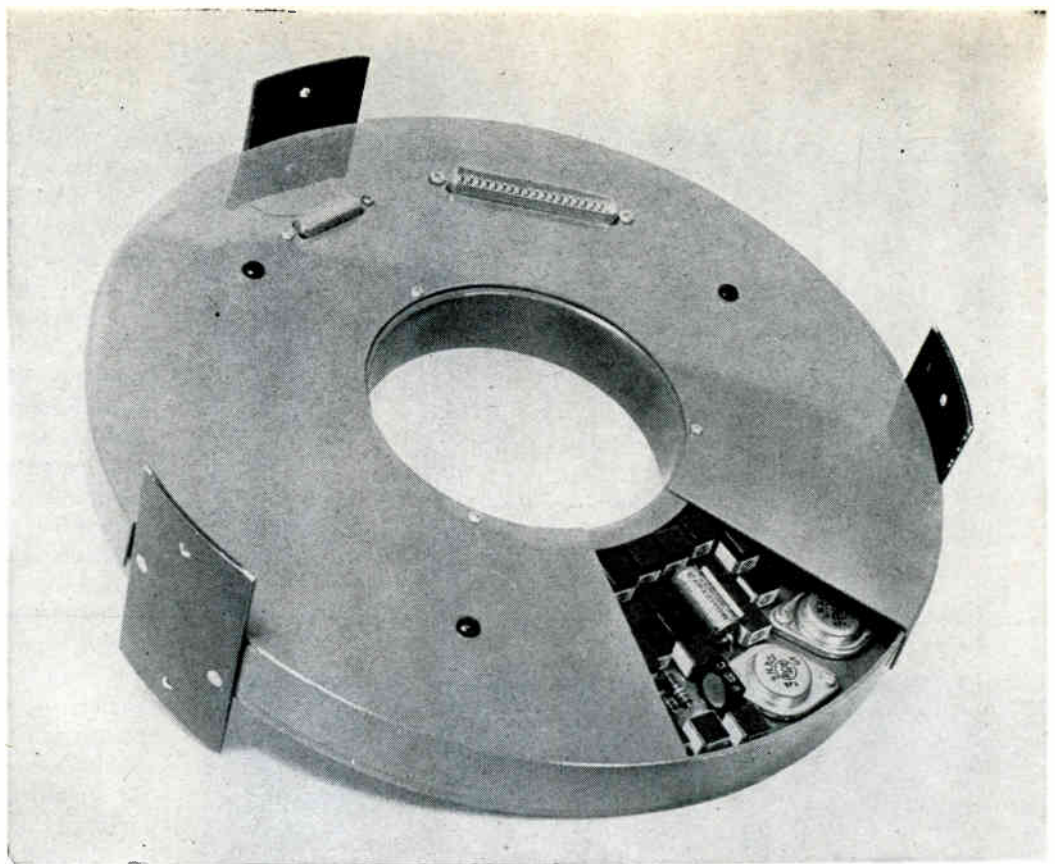

MINIATURIZED

Autopilot System for Missiles

Micromodular construction cuts volume and weight, enables system to be mounted in bulkhead of airframe. Unique magnetic shift register permits simple, versatile programming of inflight operations

By J. H. PORTER, RCA West Coast Missiles and Surface Radar Division, Van Nuys, Calif.

AUTOPILOTS are used to maintain airborne vehicles in a flight path. To alleviate the space and weight problems in missiles, a miniature autopilot system is required. A full-scale mockup of such a system using micromodular fabrication is described.

Each axis of the system consists of rate and position gyros, an a-c amplifier in which the error signals from the gyros are mixed, a caging amplifier, and a demodulator that recovers the sense and amplitude of the error signal. The pitch and yaw demodulator outputs are fed directly to appropriate response shaping networks, while the roll signal is first passed through a phase inverter. Three d-c ampli-

fiers, feedback networks and valve drivers position the pitch and yaw actuators. (See Fig. 1).

A programmer generates a total of 19 discrete pulses occurring at predetermined times for actuation of torquing, gain change and guidance control switches. These times are resolvable to one second intervals and are flexible within a 2,000 sec period. A one-pps clock signal is derived from the stable 400-cps square wave supply by time division techniques. The programmer is held in a nonoperative condition by a reset generator until lift-off or some other initiating signal occurs.

During programmed flight, step levels of 2,400-cps square-wave current are supplied to the torquing

fields of the pitch and roll gyros. At changeover, roll torquing is discontinued, and the pitch and yaw torquing fields are made available for guidance control.

The switches shown in Fig. 1 as functional items are actually electronic devices. Three types of electronic switches are used: one to select levels of current to the torquing fields of the roll and pitch position gyros, one to introduce a gain change in the a-c amplifier, and one to make both the torque and pattern field windings of the gyros available for control by guidance signals. Control of the switches is effected by a flip-flop.

Both d-c and a-c gyro torquing techniques were considered, d-c be-

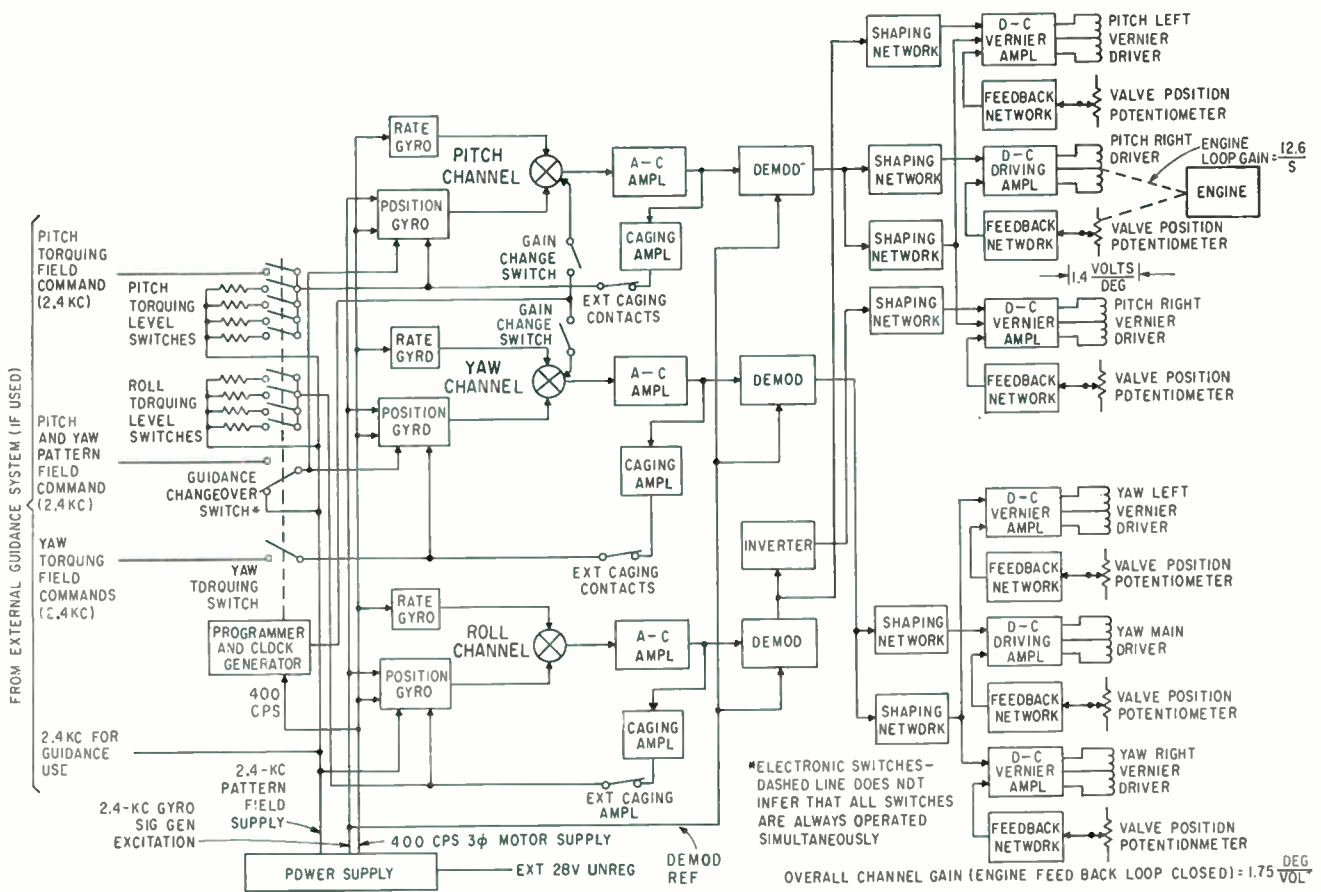

FIG. 1—Missile autopilot system uses wafer semiconductors throughout except for seven silicon power transistors in power supply. Use of magnetic programmer offers ruggedness, low power consumption and memory of stored time despite momentary power failure

ing mandatory for a miniature integrating type gyro such as the MIG. It was decided to adhere to the HIG-4 gyros used in another autopilot and apply torquing current levels only to the torquing fields of the gyros. Separate caging amplifiers are used.

Error signals from the rate and position gyros for the pitch, yaw, and roll channels are resistively summed and fed through a-c amplifiers, demodulators, shaping networks and driving amplifiers to actuate the main pitch and yaw valves. Feedback loops from the valve position potentiometer feed the d-c amplifier through other shaping networks with lead-lag-lag characteristics.

To drive the pitch and yaw vernier engine actuator valves, signals from the demodulators are passed through shaping networks and summed at the input of another d-c amplifier. Feedback signals representing valve positions are shaped and fed to their respective driving amplifier input.

Pitch and yaw channels are

straight through, while roll control is accomplished by differential motions of the pitch vernier engine actuators. A unity-gain inverter provides a signal of opposite sense for the control from the roll demodulator. Gain changing is done by increasing the attenuation of the position and rate gyro coupling networks.

A unique magnetic shift register element is used in both the one-pps clock generator (Fig. 2A) and the 2,000-second counter (Fig. 2B). For both applications, the elements are connected in rings with the output of the last element in a ring connected to the input of the first element in that ring. Each ring has its own driver and all drivers are operated from the same pulse generator. Thus, one generator is required for the 400:1 divider (Fig. 2A) triggered at a 400-pps rate, and one for the 2,000-second counter (Fig. 2B) triggered by the output of the divider at one-pps rate. Prior to lift-off, all elements of all rings contain logic ZERO's; at lift-off, logic ONE's are inserted in

the first element of each ring.

In the clock generator (Fig. 2A), the logic ONE's in each ring are circulated by the pulse generator and driver at the 400-pps rate. The numbers of elements in the four rings were chosen as 3, 4, 5 and 7 so that all but one ring contains a prime number of elements. The product of the number of elements should exceed the desired count by as small an amount as possible, in this case $3 \times 4 \times 5 \times 7$ or 420.

To determine where the ONE is in each ring at any given time, such as 400 pulses after lift-off, divide 400 by 3 to get $133 \frac{1}{3}$ and use the remainder, 1, as the element number desired for the 3-element ring; divide 400 by 4 to get $99 \frac{4}{4}$, and use the remainder, 4, as the element in the 4-element ring; divide 400 by 5 to get $79 \frac{5}{5}$ and use the remainder, 5, as the correct element in the 5-element ring; and divide 400 by 7 to get $57 \frac{1}{7}$, and use the remainder of, 1, as the element desired in the 7-element ring. Another way of saying this, with respect to the 7-element ring, is

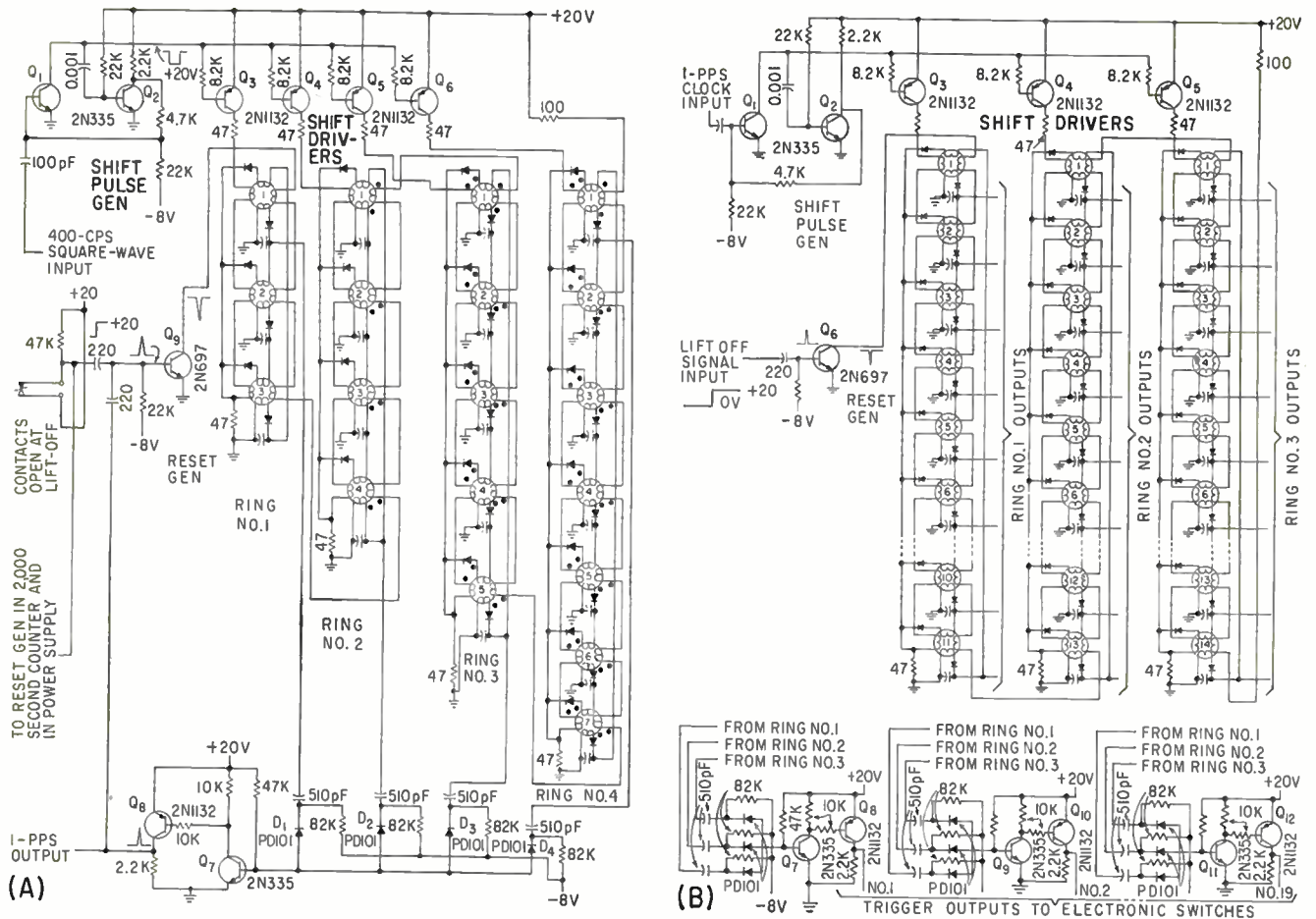

FIG. 2—One-pps output of clock generator (A) is derived from a much higher frequency crystal oscillator, thus any desired clock rate can be obtained with only minor reassembly of modules. As many as 20 AND gate inputs can be supplied by each ring element in 2,000-second counter (B)

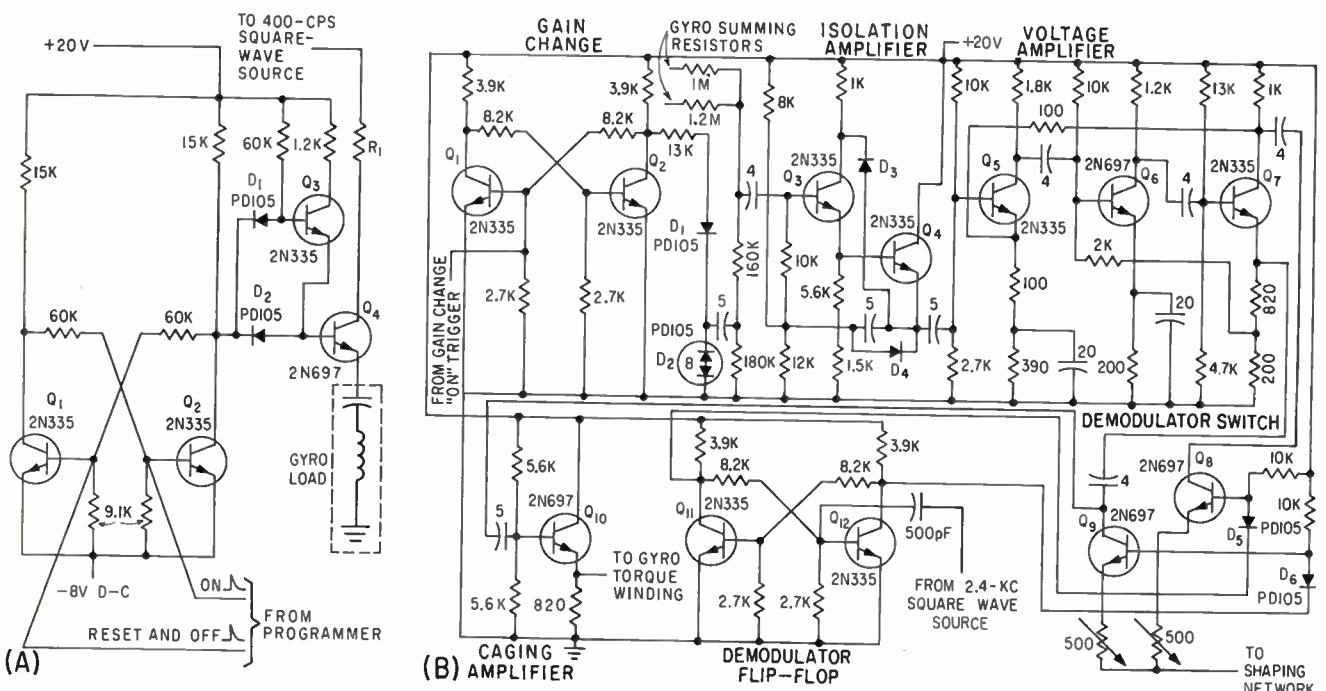

FIG. 3—Typical gyro torquing switch (A) can pass square wave with 10-v peak. Gain change, a-c amplifier-demodulator and caging amplifier circuit (B) can be used in either the pitch or yaw channels; roll channel requires additional phase inverters (see Fig. 4A)

that the original ONE has made 57 complete circuits of the ring and is now in the 1 element.

A 4-leg diode and gate consisting of D_1 , D_2 , D_3 and D_4 determines coincidence of the ONE's in the proper element of each ring and generates a negative pulse in the collector of Q_7 . The negative pulse is inverted by Q_8 , and is used as a trigger for the 2,000-second counter and to reset ONE's into the element number 1 of each ring in the 400:1 divider so that another clock pulse will be generated 800 pulses after lift-off.

The one-pps clock triggers operate the 2,000-second counter pulse generator (Fig. 2B) and associated shift pulse drivers. Just as in the 400:1 divider, closed rings are used, with a total count capacity of 2,002 seconds. Circulation of the ONE's is carried out just as was done in the 400:1 divider. The total capacity is $11 \times 13 \times 14$ or 2,002 sec and, for this application, reset at 2,002 sec is not required.

Element number 1 in each ring is primed with ONE's at lift-off; every second thereafter the ONE's are stepped along. A total of 19 positive-going pulses are required, each suitable for operating flip-flops in the electronic switches.

A typical requirement is a pitch torque change 4 seconds after lift-off. This operation is easy because an output is taken from element number 4 in each ring and, since there are 3 rings, fed to a 3-legged diode AND gate to generate the positive pulse. This pitch torque level might then be switched at 19 seconds to another level, while at 17 seconds a new roll torque level may be required.

For a discrete output at 17 seconds the remainders after dividing 17 by 11, 13, and 14 respectively are used. These remainders or 6, 4, and 3, and these elements will be tied to the inputs of another AND gate. An example may be the operation at 1,999 seconds. Here the elements to be used will be: $1,999/11 = 181 \text{ R}/11$ or 8; $1,999/13 = 153 \text{ R}/13$ or 4; and $1,999/14 = 142 \text{ R}/14$ or 11, for the 3 rings, respectively. To generate positive-going output signals from the programmer, the register elements are polarized to yield positive capacitor potentials. During the ANDing op-

eration and subsequent two-stage amplification, the output signals from the programmer have positive polarity.

A typical gyro torquing switch is shown in Fig. 3A. A flip-flop (Q_1 and Q_2) controls transistor Q_3 driving switching transistor Q_4 . Trigger signals from the programmer control the state of the flip-flop.

A switch closure is initiated by a positive step voltage from the flip-flop applied to diodes D_1 and D_2 connected to the drive transistor. A large base current flow saturates the switching transistor, thus passing the square wave torquing current to the gyro torque field. When the state of the flip-flop is changed, a negative step voltage is applied to the diodes, back-biasing the switching transistor and effectively isolating the square wave source from the gyro torque field. Resistor R_1 determines the level of torquing current.

External guidance control for the pattern and torque fields is done by the same type switch. The flip-flop for the pattern field, however, will drive two switching transistors connected to opposite collectors of the control flip-flop. During autopilot operation, the pattern field will be excited through a normally closed switch. The switches will reverse their state at the proper time for external control and pattern field excitation will be by external guidance.

Gain change is introduced in the pitch and yaw a-c amplifiers after a fixed amount of fuel has been consumed. This is achieved by shorting to ground part of the resistor network of the summing stage. As shown in Fig. 3B, a flip-flop controls the breakdown of the Zener diode, D_2 . At breakdown D_2 exhibits a low impedance, shunting the 180,000-ohm resistor and reducing the input to the a-c amplifier. The pattern and torquing currents provide a maximum torquing rate of approximately 2.5 deg per sec. The gyro signal generator is supplied with square wave excitation at 2.4 Kc on the primary. The higher impedance secondary is resonated to this frequency with a small capacitor. The secondary waveform then becomes a clean sine wave at the same impedance level that it would have had with sine-wave ex-

citation at a lower frequency.

A caging gain of 26 is inherent in the a-c signal amplifier and demodulator while the separate amplifier provides impedance matching to the gyro torquing field. Since the 2.4-Kc and 400-cps supplies are precisely phased together, these separate frequencies could be used for gyro pattern and torquing field excitation. To minimize interaction due to the different frequencies and because the caging loop operates at 2.4 Kc, this frequency is used for both field windings. Prior to guidance control changeover, all position gyro pattern fields are supplied with a fixed level of 2.4 Kc; at changeover the pattern and control fields of the pitch and yaw gyros are made available for guidance control.

The a-c amplifier, shown in Fig. 3B, is a 5-stage circuit: the first two stages (Q_3 and Q_4) as a high-impedance bootstrapped isolation amplifier; the third and fourth stages (Q_5 and Q_6) act as a voltage amplifier; and the last stage (Q_7) acts as a phase splitter supplying equal voltages of opposite phase to the demodulator.

Voltage gain is obtained in the third and fourth stages, and good stability is achieved by two feedback loops. The amplifier operates linearly for inputs up to 0.2 volt peak-to-peak and the overall voltage gain is 27.

The demodulator is composed of a bistable flip-flop (Q_{11} and Q_{12}) and two series switching transistors (Q_8 and Q_9) connected to opposite collectors of a control flip-flop and is designed to give a no-signal d-c output of 9 volts. This level is modulated approximately ± 3 volts for maximum in-phase or out-of-phase error signals from the gyros.

The 2.4-Kc square-wave reference voltage is differentiated and used to trigger the flip-flop ON and OFF at a switching rate of twice the reference frequency. Switching transistors Q_8 and Q_9 will alternately be turned ON and OFF at this frequency. Since the switching transistors are coupled to the two outputs of the phase splitter, the opening and closing of the transistor switches pass half cycles of the error signal. From the switches, the half cycles of the error signal are resistively summed and then

coupled to the shaping network. Since the transistor switches alternately pass half cycles of the error signal that are 180 degrees out of phase, the demodulator gives a full-wave rectified output. The output can be made positive going or negative going, depending on the state of the flip-flop and the connection of the transistor switches to the phase splitter.

The a-c amplifier-demodulator shown is for a single channel and is applicable for either the pitch or yaw channels; however, to provide the differential roll motion, an additional unity gain inverter (Fig. 4A) is required.

The caging amplifier used to null the gyro is shown in Fig. 3B. It is an emitter-follower, Q_{10} , connected to the emitter of the phase splitter and works with the a-c amplifier during caging to give an over-all voltage gain of 30. Output of the caging amplifier is connected to the gyro torquing field through external contacts in the ground equipment prior to missile liftoff.

The networks shown in Fig. 4B provide a current transfer function I_{out}/I_{in} having the desired frequency response when terminated in a low impedance such as the input impedance of the d-c amplifier, which is approximately 200 ohms. Resistor R, at the input of the network from the demodulator provides bias current for the demodulator. The networks isolate their inputs from the amplifier, while permitting the amplifier to be driven by a high impedance, or current source.

The d-c amplifier (Fig. 4B) has a current gain of 4,000 with voltage feedback and a voltage gain of 28,000 to give a power gain of 51 db. It consists of two differential stages (Q_1 and Q_2 , Q_3 and Q_4) driving two emitter followers Q_5 and Q_6 . The first differential stage Q_1 and Q_2 utilizes a 2N1247 which is a low-level, low-leakage transistor.

The second differential amplifier stage (Q_3 and Q_4) uses *pnp* silicon transistors to provide the right polarity for the tandem connections and for I_{cc} cancellation between this stage and the emitter followers. Transistor Q_7 acts as a high impedance while passing a high current to improve the differential action of Q_3 and Q_4 .

Transistors Q_5 and Q_6 drive the valve coils and dissipate a maximum of 72 milliwatts each. The small collector loads permit an isolated output from which to derive voltage feedback for stability. The 2N1132's and the 2N697's are complementary, thus by being connected in tandem they effect mutual leakage current cancellation. To facilitate this cancellation, transistors Q_1 through Q_7 are mounted in the same micromodule. One of the advantages of the micromodule effort is a reduction in system volume. A micromodularized autopilot can be assembled readily in 0.035 cubic foot (weighing slightly over 3 pounds complete with power supply and capable of operating to 100 C) exclusive of gyros and gyro temperature controllers. Using HIG-4 gyros, a total volume of 0.238 cubic foot and a total weight

of 13 pounds can be obtained. Pallets with the wide angle MIG gyros would reduce the total volume and weight to 0.155 cubic foot and 8 pounds, respectively. In most instances, each module contains no more than one silicon transistor which, together with associated components, has less than 0.5 watt dissipation. For some cases, such as in the d-c amplifier, two waferized transistors are mounted in close proximity for thermal equilibrium. This is made possible by backing the metal enclosures of the transistors together. Certain components are not now presently practical on micromodule wafers; for example, a 1-watt resistor would require at least 2 modules of waferized resistances and a 0.01 pF stable capacitor would require at least 10 stacked wafers.

Two cascaded magnetic shift register elements can be assembled on one module. The actual limitation of number of components per module is determined by the power dissipation, and by the number of connections to be made to the module. Likewise, the number of modules which can be laid out on an etched wiring board depends on the number of conductors that can be etched on that board. A suitable design may well be a flat disk approximately 9 inches in diameter and 1-inch thick with a 2-inch diameter hole in the center through which missile cabling and tubing can pass. Connectors will be mounted on the flat side of the disk for the gyro, power and guidance cabling.

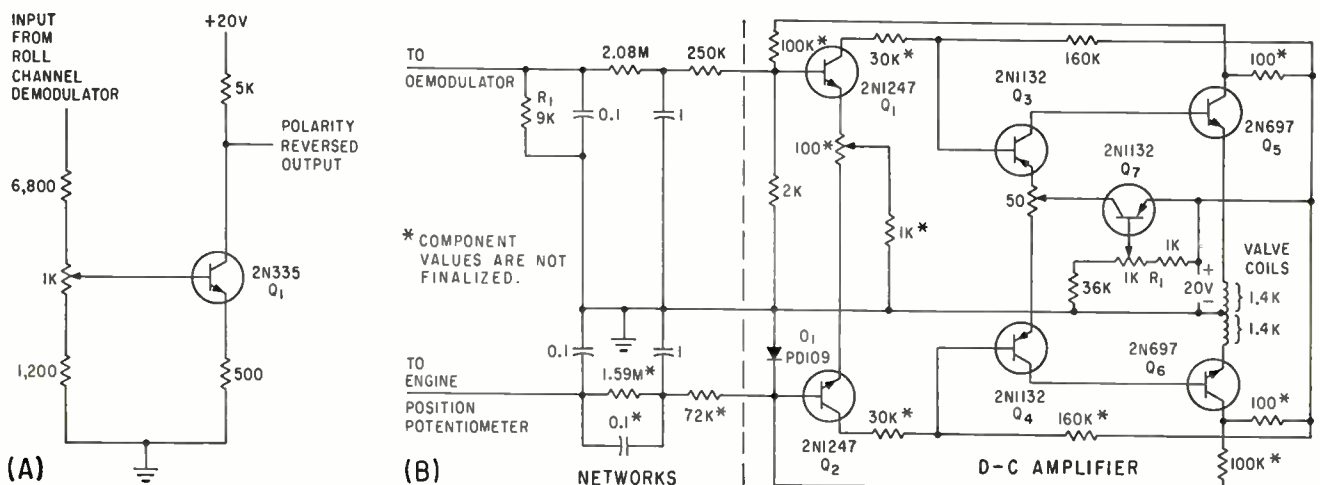
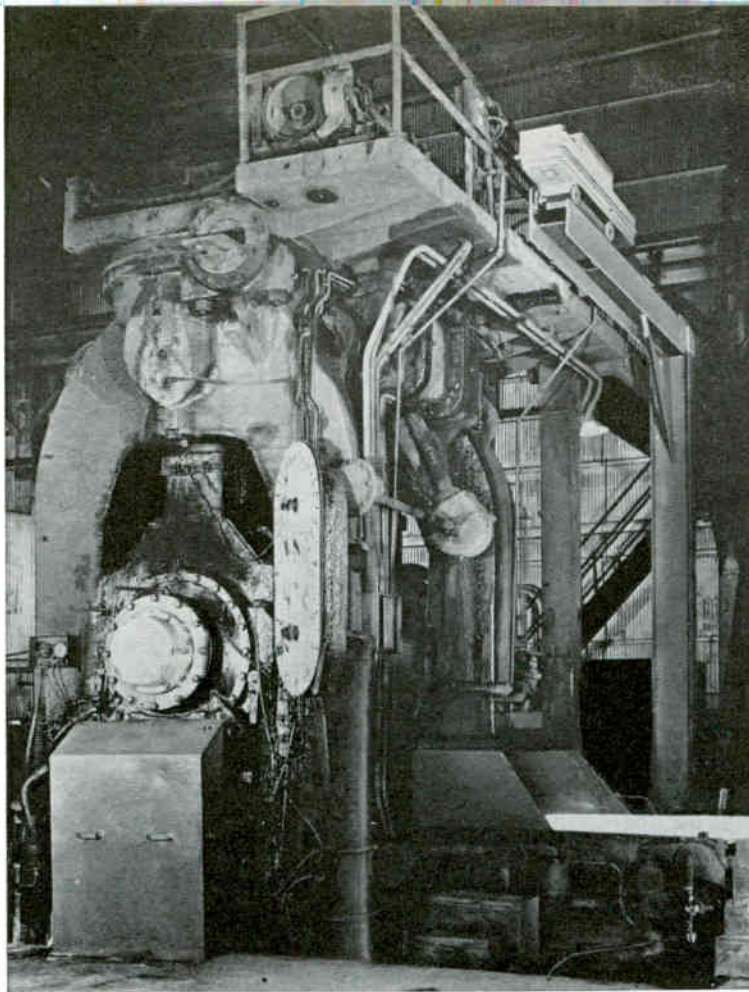
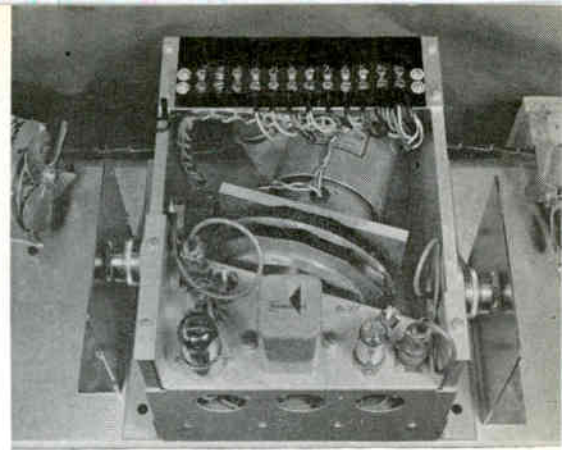

FIG. 4—Differential roll motion is provided for by phase inverter (A). The d-c amplifier and shaping networks (B) are used only in pitch and yaw channels. Networks isolate inputs from the d-c amplifier driving valve coils



(A)



(B)

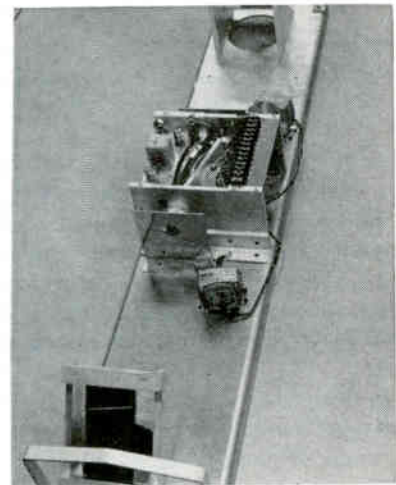

(C)

FIG. 1 Detecting head mounted above moving steel strip (A) consists of rotating scanner (B) operating with a pair of mirrors (C) and infrared-sensitive photocells so that each portion covers half of the mill table

Infrared Gage Measures Hot Steel Strip Width

Measuring the width of strip steel within one-eighth inch when the strip is heated to approximately 2,100 F and moving at speeds up to 3,000 feet per minute is a problem. This gage solves it

By FRED J. DANKS,
Development Engineering Manager,
Daystrom Inc., Poughkeepsie, New York

STRIP STEEL is produced from large slabs by continuous rolling. The slabs are heated to about 2,100 F and rolled through a scale breaker, several roughing mills with edge rolls and finally into a series of five or six finishing mills before being coiled as thin hot-rolled strip. This is a high-volume process with the leading edge of one strip following the tail of another by a few feet.

Rolling speeds are typically 1,000 to 3,000 ft per min at the last finishing stand.

Instrumentation is essential to insure consistently good quality. Temperatures, thickness and width are of prime concern. The width of the strip is set far back in the process by edge rolls working on the width of the slab as it emerges from the furnace. However, if the speeds of the finishing stands are not properly set, they can stretch the strip causing neckdown. If the strip is necked down to where it

does not meet the minimum width tolerance, it must be diverted and stored until it can be used for an order calling for the same alloy, same thickness, same heat treatment but slightly narrower width.

Before the width gage there was no way to measure finished width except by one reading taken by hand on the outer wrap or two of the finished coil long after it left the mill. To increase the yield of the mill, it was common practice to roll the coil $\frac{1}{2}$ - to 1-in. wider than ordered to permit side trimming

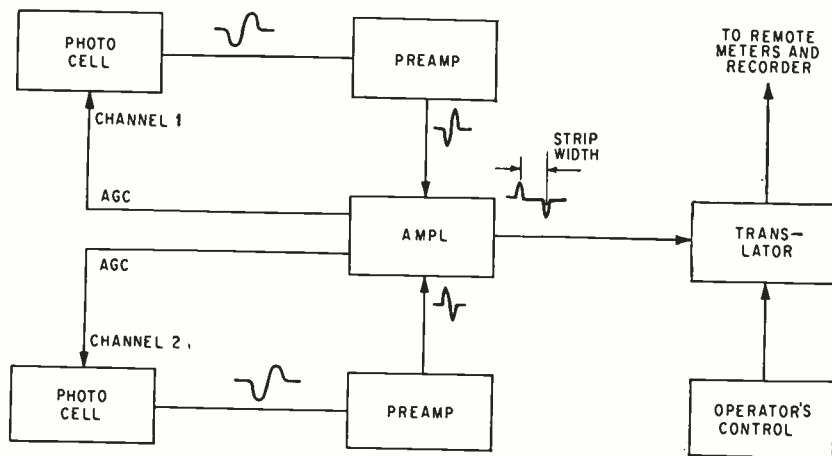

FIG. 2—Automatic gain control maintains photocell output constant over wide range of strip temperatures

later to the specified width. On an average width of 40 inches, $\frac{1}{2}$ -in. is 1.25 percent and 1-in. equals 2.5 percent scrap. With the width gage, these figures have been reduced about 50 percent affecting savings in scrap steel and storage costs.

In designing the gage, the following requirements were set: to cover a range of widths from 20 to 80 inches (since extended down to 10 in. and up to 100 in.); to display on wide-scale meters in several locations as well as record a full-scale deviation of ± 1 in.; to have an accuracy of $\pm \frac{1}{8}$ in. while tolerating vertical strip bounce, side sway of ± 3 in. and temperature variations of the strip from 1,000 to 2,000 F, with reasonable amounts of scale and oxide dust in the air between strip and pickup head; to permit direct setting of nominal width from an operator's control cabinet mounted remote from the head and main console; to maintain calibration for reasonable periods of time such as one week of continuous service and then be easily and completely checked against a standard reference; and the pickup head or sensing unit to be mounted far enough above the strip at the last finishing stand to protect it from cobbles between stands and to permit access by overhead cranes to all operating parts of the mill.

It was decided early in the design to reduce the number of moving parts and approach as nearly as possible an all-electronic solution. The result was a unit with one moving part, a rotating scanner driven by a low-speed ball-bearing motor. The photocells had to respond to the red and near infrared

radiation of the strip to provide maximum efficiency. The speed of response was also important since it was desirable to have a sharp pulse generated by the image of the edge of the strip as it passed the cell. Lead sulphide cells were chosen.

The layout of the scanning system is shown in Fig. 1 and a block diagram is shown in Fig. 2. Each half of the pickup is a 45-degree front-surfaced mirror, lens, 12-sided front-surfaced rotating mirror and photocell behind a 0.020-in. slit aperture. The distance from pickup to strip (typically 12 to 20 ft), the lens focal length and the length of a mirror face are such that a scan covers approximately one-half of the mill table and therefore one-half of the widest strip plus its side weave.

As the scanning mirror rotates, the image of the mill table and strip is swept past the photocell aperture. In channel one (shown in Fig. 3A) as the edge of the hot strip passes, cell D_1 resistance drops and produces a negative-going pulse that remains until the strip image is cut off by the corner of the scanner. This pulse is amplified, differentiated, clipped and differentiated again by V_1 . Clipping diode D_2 eliminates the unwanted pulse generated by the scanner corner cutting off the strip image.

The signal through channel two (also shown in Fig. 3A) is similar except that the first pulse is the unwanted one; the second is indicative of the strip edge. The reversed polarity of diode D_3 accomplishes this selection. Both signals are fed into cathode followers V_2 to provide low-impedance drives

for the shielded cable to the main console.

The original square wave at the photocell does not have an instantaneous rise time due to the response of the cell, the finite width of the aperture and the temperature gradient at the strip edge. By differentiating this signal, a pulse is generated whose peak occurs at the time of maximum rate-of-change of temperature and this time point represents the true strip edge. By a second differentiation the pulse is sharpened but more important the needed point in time is now at the base line or zero amplitude for transmission through the shielded cable to the main amplifier. This approach, together with agc circuits, permits good stability with wide variations in strip temperature.

The two signals from the preamplifier are fed to the main amplifier shown in Fig. 3B. As both circuits are similar, only one will be described.

The input signal is amplified by one triode of V_3 , clipped by grid limiting in the second triode of V_3 and amplified by the first triode of V_4 .

The signals from both channels are combined at the second triode of V_4 . The combined signal fed to the translator consists of a positive-going pulse from channel 1 and a negative-going pulse from channel 2 with the distance between the pulses indicating the strip width.

Each photocell has its own agc system. As shown in Fig. 3B, the signal at the first triode of V_4 is sampled by a differentiator and clamper, inverted and amplified by V_5 and applied to peak detector V_6 . The detected output is amplified by the d-c amplifier portion of V_6 and applied to the photocell circuit in the preamplifier. The agc maintains the photocell output constant over a wide range of strip temperatures (1,000 to 2,000 F).

The combined signal output from the main amplifier is coupled to the translator circuit shown in Fig. 3C and triggers bistable multivibrator V_7 . The output of V_7 is a rectangular pulse whose width is proportional to the steel strip width. The pulse is clamped and amplified by V_8 and passed to comparator V_9 .

The comparator provides an out-

Digital Instrumentation

By E. J. WADE,*

Knolls Atomic Power Laboratory,
General Electric Co.,
Schenectady, N. Y.



Analyzer and readout cabinet is to left of author

NUCLEAR ANALYZERS collect and store data in a form readily available for interpretation and study. An analyzer consists of a scaler, or counter, for temporary storage of pulses from neutrons or other inputs. The pulses are then transferred to a memory. The memory is divided into a number of compartments, or time channels, in each of which data may be stored as a binary number.

The analyzer discussed here is for neutron time-of-flight measurements (Fig. 1A) and neutron measurements (Fig.

In Fig. 1A, the neutron beam is shut off by a mechanical shutter. The analyzer counts neutrons during successive fixed-time periods that are

called channels. The data obtained, which consist of the neutron pulses counted during 256 channels, is valuable in subcritical reactivity measurements.

The analyzer block diagram (Fig. 2) shows the interconnections between the circuit blocks. The count down (C.D.), address overflow (O.F.) memory cycle (M.C.), sync and gate binaries are identical (Fig. 3). Their triggering conditions are controlled by diode gates in coincidence with clock pulses derived from a 200-Kc crystal oscillator. The matrix (Fig. 2) contains core switching circuits and the memory-cycle generators (M.C. GEN) which are blocking oscillators that supply control pulses to the drivers of the ferrite-core memory.

Analyzer functioning will be described for the pulsed-neutron test. After a cycle, the C.D. binaries are in the tripped condition and stopped because of gate B from M.C. 2, which is also tripped as are the sync, gate, O.F. 1, O.F. 2 and O.F. 3 binaries. Data from the last chan-

called channels. The data obtained, which consist of the neutron pulses counted during 256 channels, is valuable in subcritical reactivity measurements.

The analyzer block diagram (Fig. 2) shows the interconnections between the circuit blocks. The count down (C.D.), address overflow (O.F.) memory cycle (M.C.), sync and gate binaries are identical (Fig. 3). Their triggering conditions are controlled by diode gates in coincidence with clock pulses derived from a 200-Kc crystal oscillator. The matrix (Fig. 2) contains core switching circuits and the memory-cycle generators (M.C. GEN) which are blocking oscillators that supply control pulses to the drivers of the ferrite-core memory.

Analyzer functioning will be described for the pulsed-neutron test. After a cycle, the C.D. binaries are in the tripped condition and stopped because of gate B from M.C. 2, which is also tripped as are the sync, gate, O.F. 1, O.F. 2 and O.F. 3 binaries. Data from the last chan-

* Now with Mohawk Development Service, Inc., Schenectady, N. Y.

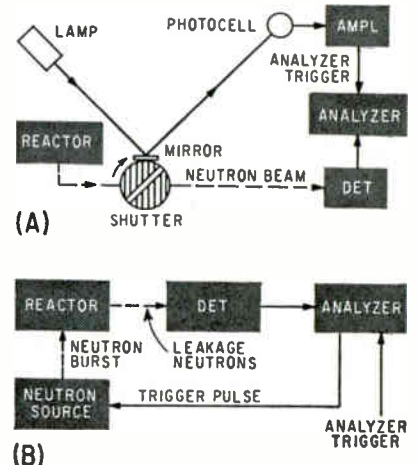

FIG. 1—Setup for time-of-flight test (A). Setup for pulsed neutron test (B)

for Nuclear Research Tests

A detailed account of how digital techniques have been used in a 256-channel neutron analyzer. These channels are time intervals in which nuclear measurements take place

nel are still stored in the arithmetic binaries.

The analyzer trigger, which may be made manually or by a variable-pulse-rate generator, starts a cycle by resetting O.F. 1, O.F. 2 and O.F. 3 and the gate. Since the analyzer trigger is not keyed to the clock pulses (the clock runs continuously), a clock pulse which is delayed $2\frac{1}{2}$ μ sec is used to trip the sync binary after its gate has been opened by resetting O.F. 3.

Tripping of the sync binary drops the potential at its P output, producing a negative signal at N of M.C. 1. This allows the next clock pulse to trigger M.C. 1, flipping all the address binaries to the reset position, which is channel zero, the channel at which background counts are taken.

Output C from M.C. 1 triggers

M.C. Gen 1, which resets the arithmetic binaries and delivers a read signal to the matrix. Assuming that this cycle is not the first in a series of cycles, background counts will have been stored during the previous cycles. Thus the read signal now causes the memory's sense windings to deliver the accumulated background count to the arithmetic binaries. Channel-zero background counts are accumulated from many successive cycles so that a high statistical accuracy can be obtained from the average of the background-count total.

On the next clock pulse, both M.C. 1 and M.C. 2 (M.C. 2 had remained tripped since the previous cycle) are reset through the delay. Gate A of O.F. 2 prevents further triggering of M.C. 1 and 2.

The resetting of M.C. 2 allows the

C.D. and address binaries to start counting background time. The data gate is also opened by the resetting of M.C. 2, allowing background counts to accumulate in the arithmetic binaries. Note that the address binaries now control the time background counts are taken. This time is adjustable from 2 to 256 times the channel length by the background count switch, which selects the address binary that trips O.F. 1.

When O.F. 1 trips, it resets the address and the gate binaries and triggers the neutron source; when the gate resets, it closes the data gate. The C.D. and address binaries now measure the delay, which is adjusted by the delay switch to be between 2 to 256 times the channel length. At the end of this delay time, the output of the delay switch

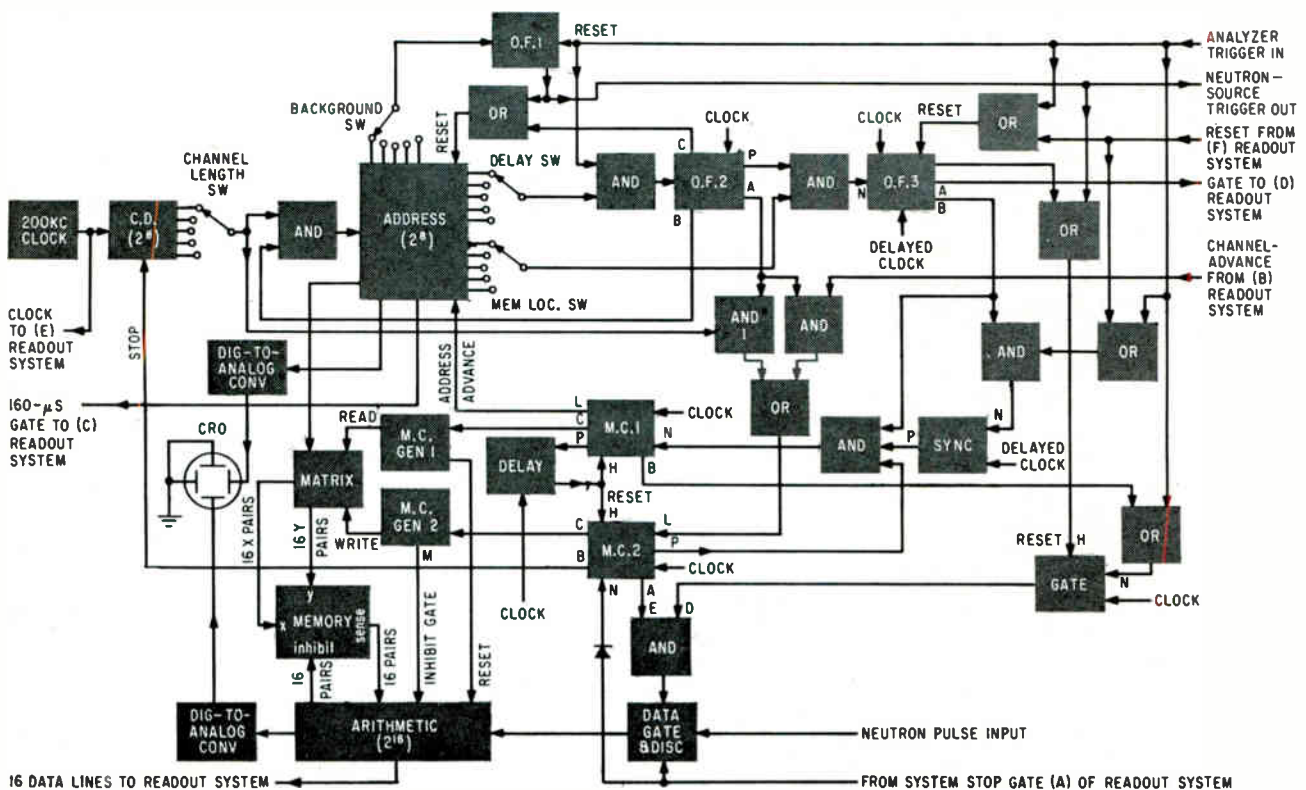

FIG. 2—Neutron analyzer has a cro for showing a spectrum of neutron counts against time channels—the x-axis; display is obtained by using a prf generator to repetitively trigger tests

trips O.F. 2. When O.F. 2 trips, it resets the address binary with its C output. Gate B of O.F. 2 blocks the pulses from the C.D. to the address binaries. Gate A of O.F. 2 allows M.C. 2 to trigger on the next clock pulse. (O.F. 2 remains tripped for rest of cycle.)

Output B from M.C. 2 stops the C.D. during the storage cycle, which lasts 10 μ sec. Output C triggers M.C. GEN 2, which delivers a write signal to the matrix, transferring the background-count data held in the arithmetic binaries to the memory. Triggering M.C. 2 also drops the potential on its P output, allowing the next clock pulse to trigger M.C. 1, which advances the address binaries.

Now M.C. 1 triggers M.C. GEN 1, which resets the arithmetic binaries and delivers a read signal to the matrix. The memory now gives the arithmetic binaries the channel-1 counts that the memory accumulated from previous cycles.

Both M.C. 1 and M.C. 2 are then reset by the next clock pulse through the delay. The C.D. binaries are thus allowed to time the channel length as determined by the channel length switch; this switch adjusts channel durations to 20 to 1,280 μ sec. With resetting of M.C. 2, the data gate opens, admitting neutron counts for channel 1. These counts are added to the count accumulated from previous cycles, which is held in the arithmetic binaries.

Since O.F. 2 is still tripped, the gate to the address binary remains closed but the channel-length-switch gate from C. D. to L of M. C. 2 is open. Thus at the end of channel 1, the memory cycle is again initiated by the triggering of M.C. 2. This starts the cycle that closes the data gate, stores the data, advances the address binary, resets the arith-

metic binaries, reads into the arithmetic binaries the next channel's counts—which were accumulated during previous cycles, and reopens the data gate to start channel 2. This process continues through 63, 127 or 255 data channels, depending upon the setting of the memory location switch, until all the address binaries flip to the tripped position. This drops the potential of the series gate to O.F. 3, which trips 2.5 μ sec early on receiving the delayed clock pulse. Its gate B to M.C. 1 prevents further tripping of M.C. 1, thus preventing triggering of the address binary. Since M.C. 1 is not tripped, M.C. 2 is not reset; therefore, the C.D. remains stopped.

The data-taking cycle is complete, all data having been stored in the ferrite-core memory. Power can be turned off indefinitely with no loss of stored data.

The readout system (Fig. 4) transfers the data to magnetic tap in the form used by an IBM 704 computer. This system is made from units similar to those used in the analyzer, with different interconnections and gates to provide the logic.

The readout cycle is started by tripping the ready binary. If the analyzer has finished taking count data, the readout system AND gate allows the record binary to trip on the next clock pulse. This causes all succeeding readout-cycle operations to be keyed by the 200-Kc clock pulses E.

The record binary starts the tape drive, and after a 50-m sec delay to allow the tape to start, the analyzer is activated by output F, which resets O.F. 3 and sync. (Note that the record binary also produces a stop gate A, which prevents the memory cycle of the analyzer from being operated except from the readout system.) Now M.C. 1 advances the address binary to chan-

nel zero, resets the arithmetic binary and reads the background count data held in the memory into the arithmetic binary. The arithmetic binaries deliver count data to the diode gate matrix of the readout system. The data is transferred to the tape, six bits at a time since there are six writing heads across the tape for data; there is a seventh head for check bits, which are used to make the count in each line odd (only 1's are written on the tape).

A 160 μ sec pulse at C, from the analyzer, triggers the readout-system's shift register transferring the data in groups of six bits to the storage binaries. At each step, gates are successively opened in groups of six. Only three steps are necessary to read the 16 bits from the arithmetic binaries, but since the standard word on the computer contains 36 bits, the remaining 20 bits are used for identification data.

Check bits are also generated and recorded on the tape to detect errors or defects in the tape. The time required to transfer the data from 256 channels to the tape is 0.5 sec.

The computer processes the data so that information is presented in the desired form.

A trigger pulse generator is provided for repetitive tests, which may be varied from 0.06 to 120 cps.

All binaries (the basic type is shown in Fig. 3), except those used in the arithmetic scaler are adapted from a nonsaturated design². The triggering system used with the logic circuits formed by the binaries also produces a series gate system which has negligible propagation time. As logic elements, the N inputs are controlled through diode gates, and when held at +10 v or more, tripping will not occur because the clock pulse cannot override the potential at the base of Q₁. When used as a scaler, diodes are connected between L of one stage and P of the following stage. The scaler will operate at somewhat above 1 Mc with transistors having grounded-emitter cutoff frequencies of 6 to 8 Mc.

The arithmetic binaries³ (Fig. 5) are series triggered, using 2N501 transistors, catching diodes and peaking coils. They will operate at about 30 Mc, but the data input rate is limited to about 15 Mc by the input shaper. The shaper circuit is

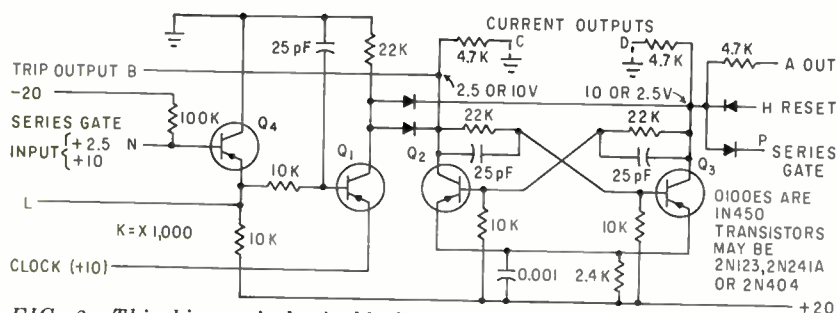

FIG. 3—This binary is basic block used in analyzer and readout system

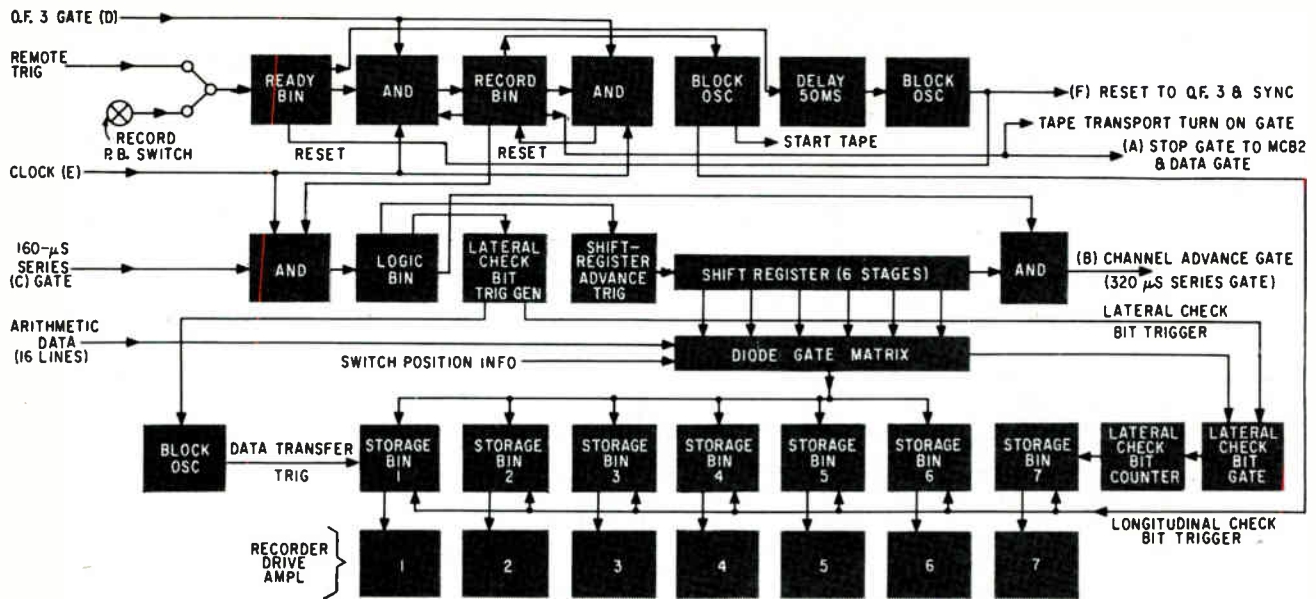

FIG. 4—Readout system. Its output is recorded on tape, which is then processed by a computer

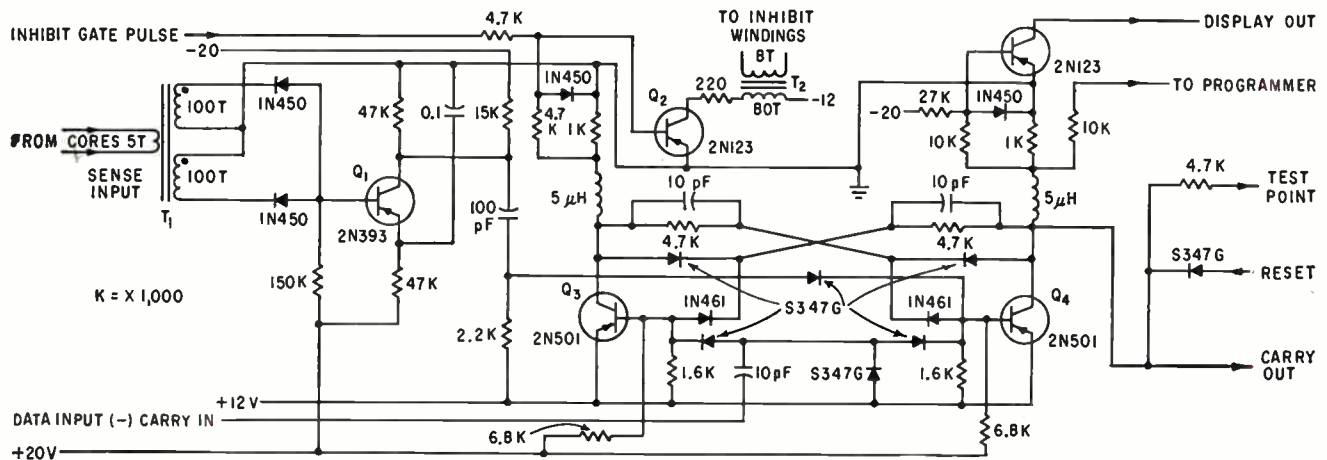

FIG. 5—This circuit is one of the 16 binaries that comprise the arithmetic scaler

similar to Fig. 5, with added gates and a biased-diode amplitude selector.

When data is to be read out from the memory, each arithmetic binary is first reset by a positive 10-v reset pulse from M.C. GEN 1 (Fig. 2), making Q_1 conduct. When the cores are switched by read current, a 50-mv pulse, which indicates the storage of ONES is produced at the input to T_1 . Amplifier Q_1 applies a positive pulse to Q_2 , tripping the binary. (Note that the output from the cores may be of either polarity because the direction of the sense winding is reversed on adjacent cores to reduce pickup.)

When a number is written into the memory, the presence or absence of an inhibit pulse from an arithmetic binary determines whether

the number written into the memory is a ONE or ZERO. Transistor Q_2 gates the inhibit gate pulse, which comes from M.C. GEN 2. When a ONE is stored in this binary it is tripped, that is, Q_3 conducts. Thus, Q_3 is biased positive and prevents current flow to T_2 . This allows the full address current to switch the corresponding core. Each arithmetic-binary inhibit output drives an inhibit winding which threads the cores of one memory plane.

The ferrite-core memory is conventional. There are 16 frames, each containing 256 cores in a 16×16 x-y matrix. Each frame corresponds to one binary digit; since $2^{16} = 65,536$, 65,535 is the largest number that can be stored. The corresponding x lines of the 16 frames

are driven in parallel, as are their y lines. Thus, for the write sequence, the address switches one of the 256 cores in each plane, these 16 cores corresponding to one of the 256 channels.

The work of D. S. Davidson, now vice president of Technical Measurement Corp., was important in the successful design of these analyzers.

REFERENCES

- (1) E. J. Wade and D. S. Davidson, Transistorized Time of Flight Analyzer with Ferrite Core Memory, *IRE Con Record*, 5, Part 9, p 89, Mar. 18, 1957.
- (2) J. J. Suran and F. A. Reibert, Two-terminal Analysis and Synthesis of Junction Transistor Multivibrators, *Trans IRE*, CT-3, p 26, Mar. 1956.
- (3) J. J. Suran and B. K. Eriksen, Design of VHF Asynchronous Pulse Circuit, *GOSAM*, May 1958.
- (4) R. W. Schumann and J. P. McMahon, Argonne 256 Channel Pulse-Height Analyzer and 1024 Channel Neutron Time of Flight Analyzer, *R.S.I.*, 27, No. 9, p 675, Sept. 1956.

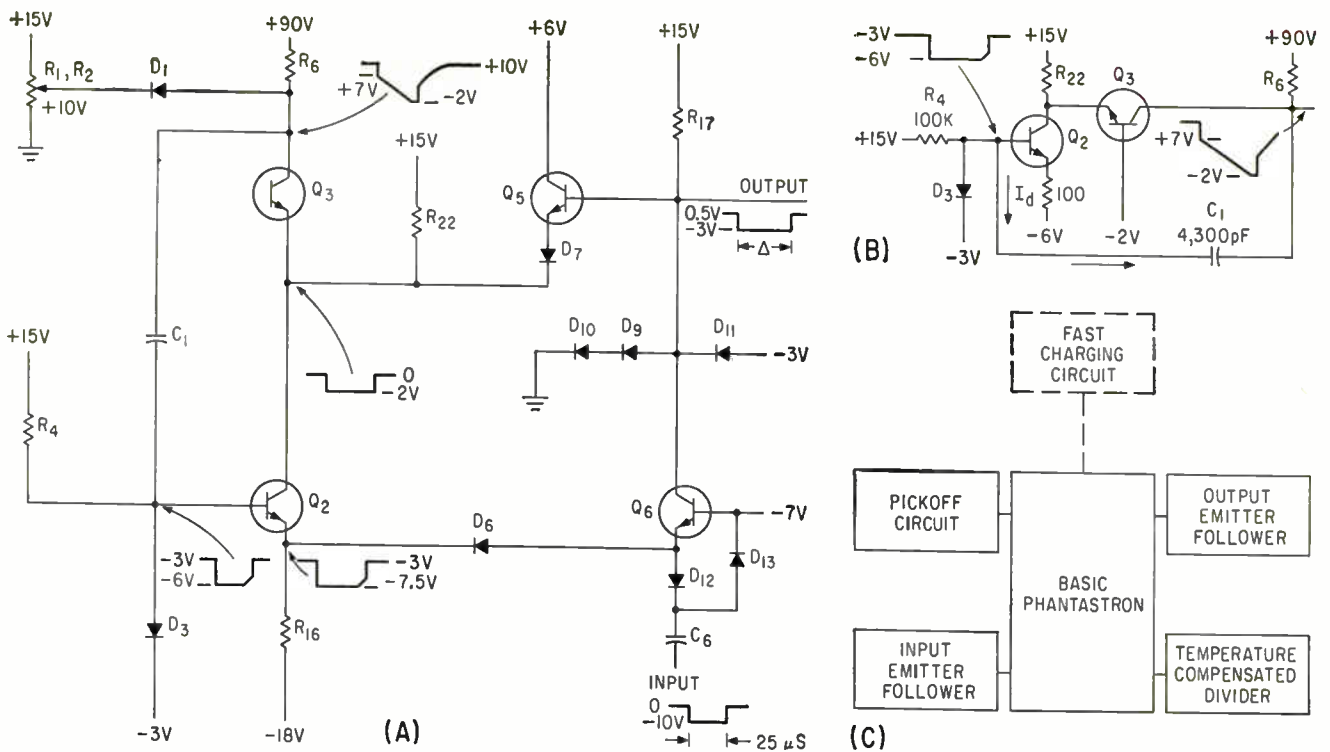

FIG. 1—Phantastron before modifications are introduced (A), basic circuit during the active period, showing the integrating section isolated from the rest of the circuit (B), final block diagram showing where error correcting modifications are needed (C)

HIGHLY ACCURATE

This circuit uses solid-state components throughout and incorporates compensating arrangements to cancel the sources of timing error. Final circuit is designed to provide a delay of 220 microseconds with an accuracy of plus or minus one percent

By S. RALPH PARRIS,
Associate Development Engineer

DAVID A. STAAR,
Senior Development Engineer,
Burroughs Corporation Research Center,
Paoli, Pennsylvania

THE OPERATION of the phantastron can be examined most easily using a simplified circuit as shown in Fig. 1A. In the stable or quiescent state, D_6 is back-biased and transistor Q_6 is OFF since both its base and emitter are at nearly the same voltage. This condition allows the collector of Q_6 and the base of Q_5 to rise to approximately +0.5 v where diodes D_6 and D_{10} in series are clamped by current supplied through R_{17} . The emitter of Q_5 follows its base by emitter follower action and

holds the collector of Q_2 and emitter of Q_3 at about zero volts. Since the base of Q_2 is clamped to about -3 v by current through R_4 and D_3 , the emitter of Q_2 remains at about -3 v with its emitter current causing a 15-v drop across R_{16} . Resistor R_{22} is included to keep Q_2 biased as the desired operating point (high beta) in the active state of circuit operation. Because the base of Q_3 is returned to about -2 v, Q_3 is held OFF by Q_5 and the collector of Q_2 rises to about +10 v, which is the output voltage of the low impedance divider, R_1 and R_2 . During this quiescent state, capacitor C_1 is charged to about 13 v.

The circuit is switched into its active state by a negative trigger pulse which is a-c coupled to the

emitter circuit of Q_3 , causing it to turn ON. The collector of Q_6 falls and is clamped at -3 v by D_{11} , which keeps it from saturating. The positive-going trailing edge of the trigger pulse is blocked by diode D_{12} so that it will not turn Q_6 OFF and diode D_{13} provides an alternate charging path for C_6 . The collector of Q_6 pulls the base of Q_5 to -3 v. The emitter of Q_5 tries to follow and in so doing allows Q_2 to be turned ON when the emitter of Q_3 reaches -2 v. Transistor Q_5 now turns OFF since its emitter junction is back-biased by about 1 volt.

When Q_3 is turned ON D_1 disconnects as current begins to flow through R_6 causing the collector of Q_2 to fall rapidly. Capacitor C_1 couples the collector of Q_2 to the base

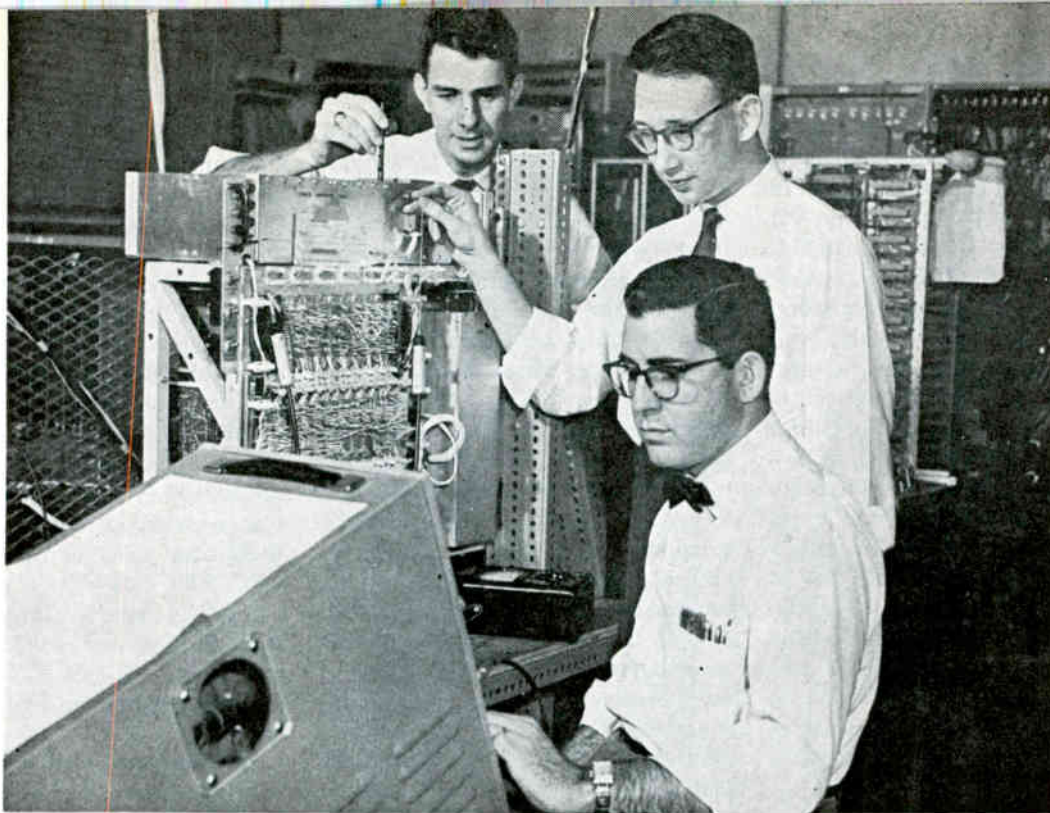

Engineers adjust performance of delay circuit incorporated in Burroughs B-100 Sorter-Reader

PHANTASTRON DELAY CIRCUIT

of Q_2 so that the emitter of Q_2 also falls by emitter follower action. The emitter of Q_2 approaches equilibrium at about -13 v where the level would be established by the currents supplied through R_8 and R_{22} . In actual operation, however, the emitter of Q_2 is clamped at -7.5 v by D_6 and the emitter of Q_6 , which is being held ON by the input pulse at this time.

While the circuit is in its active state, Q_2 cannot supply sufficient current to hold its emitter above -7.5 v so that Q_6 remains ON and acts as an emitter follower even after the input pulse is removed. This provides a low impedance source in the emitter circuit of Q_2 . The circuit operation during the active state can be analyzed by re-drawing part of the circuit as shown in Fig. 1B.

This is basically an operational integrator where Q_2 and Q_3 provide the open-loop gain and R_1 and C_1 are the feedback elements. If the open-loop current gain is large, the error voltage at the base of Q_2 remains nearly constant and the ca-

pacitor is charged by a nearly-constant current (approximately = $[15 - (-6)]/100,000$ amperes). This causes the output to fall linearly with time, since $\partial v/\partial t = I_4/C_1$.

The potential across capacitor C_1 continues to fall until Q_3 bottoms at about -2 v. This short-circuits the feedback loop and allows the voltage at the base of Q_2 to rise toward $+15$ v as capacitor C_1 continues to charge. Current into the base of Q_2 also increases and emitter voltage of Q_2 rises, as current is supplied to R_{10} . When this current reaches about 6 ma, the emitter voltage of Q_2 rises above -7.5 v, D_6 is back-biased, and Q_6 turns OFF. This allows Q_5 to turn ON, which in turn back-biases the emitter junction of Q_3 , turning Q_3 OFF. The base of Q_2 rises rapidly from -7 v and clamped by D_5 at -3 v. This same rise is coupled by C_1 to the collector of Q_3 which is now a high impedance point. The capacitor continues to recharge through R_6 toward $+90$ v and will be clamped by D_1 to the output voltage of the

low impedance divider R_1 — R_2 ($+10$ volts). The circuit is now in its equilibrium condition and can be retriggered. The output pulse may be taken from several points, but in this circuit, the base of Q_2 is used.

There are a number of sources of inaccuracy in the basic circuit illustrated by Figures 1A and 1B; block diagram Fig. 1C shows how some of the inaccuracies are corrected by specific modifications to the parts of the circuit causing the errors.

The operational integrator of Fig. 1B has been modified by the addition on an input emitter follower Q_1 as shown in Fig. 2A. This increases the open-loop current gain of the integrator and provides increased accuracy and linearity since the input current to the base of Q_1 is small compared with the charging current into C_1 . Resistance R_{13} and capacitor C_3 provide a secondary feedback path which shapes the high-frequency response of the amplifier in order to guarantee stable closed-loop operation.

The time required to recharge

C_1 at the end of the cycle may be decreased greatly by the addition of transistor Q_7 and its associated circuitry. This is shown in Fig. 2B. The collector of Q_6 is returned to +15 v through R_7 . Diode D_8 is used as a clamp to +6 so that Q_5 operates as an emitter follower when it is ON. The waveform at the collector of Q_1 is a-c coupled through C_1 to the emitter circuit of Q_7 , the charging transistor. Normally, Q_7 is held OFF by the drop across D_2 . The leading edge of the pulse from Q_6 tends to keep Q_7 OFF and has no effect. The trailing edge turns Q_7 ON at the end of the active period of circuit operation. This provides a high current rapidly charging C_1 and reduces the charging time to 5 to 10 μsec . This circuit is inoperative during all other parts of the cycle, including the quiescent state.

An improved pick-off may be obtained by the addition of transistor Q_4 . The connection is shown in

Fig. 2C. The emitter is grounded, the collector is connected to the base of Q_2 and the base is connected to the collector of Q_3 . Transistor Q_3 is OFF whenever the collector of Q_3 is above ground. During the active state of the basic circuit, the collector voltage of Q_3 falls linearly toward -2 v, where Q_3 bottoms as described previously. With this addition, the emitter of Q_3 maintains the collector of Q_3 near ground potential, thus lifting the base of Q_2 to ground potential. This causes Q_2 to conduct more heavily, which increases the collector current in Q_3 , tending to make the collector voltage of Q_3 fall. This increases the base current of Q_3 and closes a regenerative loop. As soon as Q_2 conducts sufficiently to pull its emitter above -7 v, Q_3 turns OFF and Q_2 turns ON as in the basic circuit. At the same time, Q_7 turns ON and causes the rapid charging of C_1 . The collector of Q_3 charges

rapidly toward its quiescent value.

Emitter follower Q_4 is added as an output buffer between the pulse forming circuits and the load. Adding the buffer allows the phantastron to drive its load without affecting timing accuracy. The timing loop and pick-off circuits are thermally stabilized by the addition of a silicon sensistor in the voltage divider, consisting of R_9 , R_{10} , and R_{11} . This supplies a temperature-dependent reference level which compensates for the changing base-to-emitter voltages of the transistors. The delay time of the final circuit is nearly independent of temperature, and it varies by much less than a microsecond over the ambient temperature range of 25 to 55 C.

ACKNOWLEDGMENTS: We wish to acknowledge the support of D. Moister and H. Caswell for their help in constructing and testing the circuit described herein.

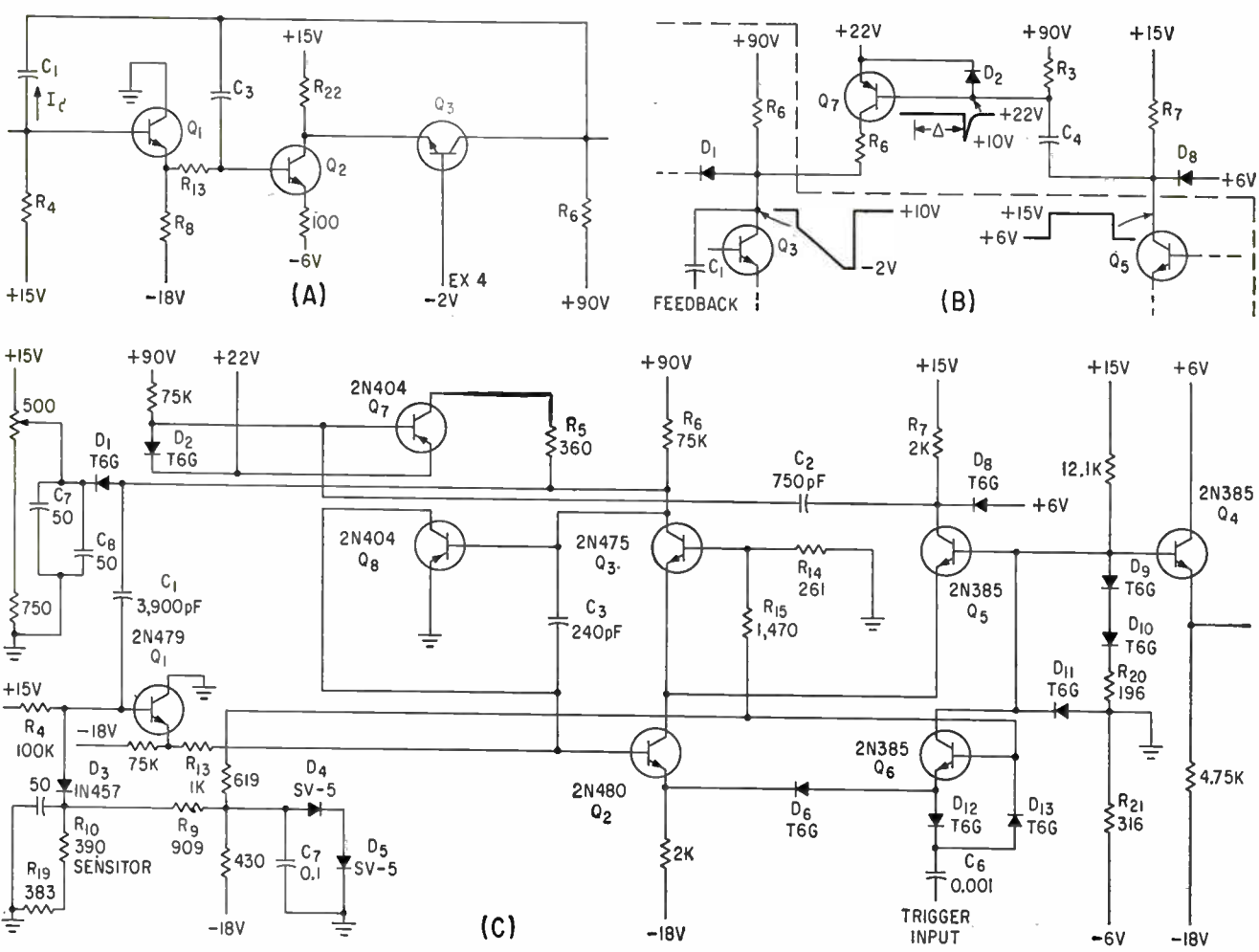

FIG. 2—Open-loop current gain of integrator is increased by addition of emitter follower Q_1 (A), addition of charging transistor Q_7 returns phantastron rapidly to quiescent state at the end of a cycle (B), final circuit with modifications and temperature corrections incorporated (C)

Two completely new, transistorized, differential Data Amplifiers, Types 491 and 492, by Offner Electronics Inc.

Their high precision makes possible an accuracy and simplification of data reduction previously impossible.

Sixteen channels of data reduction (Type 492) requires only $8\frac{3}{4}$ " of rack space. Power supply occupies only $5\frac{1}{4}$ ". The combination of accuracy, stability, fast response, and size is unmatched.

1/100% accuracy

1/100% gain stability

1/100% linearity

OFFNER
Type 491 and 492
Differential
Data Amplifiers

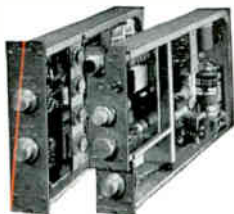

Type 492 Amplifier (left) provides 2 channels of precision amplification per unit. The Type 491 (right) is a single channel unit, with input coupler for added versatility.

featuring

1/100% accuracy

1/100% gain stability—for 1,000 hours at normal ambients

1/100% linearity—for full output

All-transistor construction

1/400th second response—to step input

Very low output impedance—less than 0.1 ohm

Infinite rejection—of common d-c signals

120db rejection—at 60 cps

16 channels in $8\frac{3}{4}$ inches of rack space (Type 492)

Versatile input couplers (Type 491)



OFFNER ELECTRONICS INC.

3906 River Road, Schiller Park, Ill. (Suburb of Chicago)

Design Chart for Broadband Couplers

Tabulation of circuit parameters is useful in designing several types of broadband couplers

By RICHARD F. BURNS, The Hallicrafters Co., Chicago, Ill.

SEVERAL TYPES of broadband couplers can be designed from the circuit parameters tabulated in the table. These include symmetrical and nonsymmetrical circuit configurations using mutual inductance, inductive π , inductive T and capacitive π coupling.

The table is based upon design equations in Beam's paper¹ and eliminates most of the computational work involved in using Dishal's charts.² Filters designed from the table can be expected to have a passband peak-to-valley ratio of less than 1 db for bandwidths as large as 50 percent of the midband frequency.

The circuit parameters for the symmetrical coupler configurations are given in a normalized form in which the input and output terminations are each 1 ohm. The midband frequency, f_m , is 1 cps while bandwidths at the 1-db down points are given in percent of the midband frequency. Fig.

1 shows the response curve for a broadband coupler.

The symmetrical configurations of Fig. 2 are used when the source and load impedances are equal. The nonsymmetrical configurations of Fig. 2 are used when the source and load impedances are unequal. Ratio of the desired output to input resistance is denoted by n . For computing bandwidths at the 10-db, 20-db, and 30-db down points, the following formulas computed from Dishal's charts can be used

$$\begin{aligned} \text{BW}(10\text{-db}) &= 3.3 \times \text{BW}(1\text{-db}) \\ \text{BW}(20\text{-db}) &= 5.8 \times \text{BW}(1\text{-db}) \\ \text{BW}(30\text{-db}) &= 10 \times \text{BW}(1\text{-db}) \end{aligned}$$

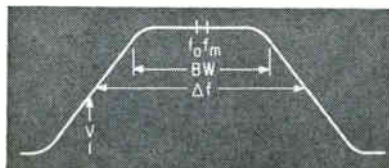

FIG. 1—Broadband coupler response curve

To compute the circuit parameters for a symmetrical coupler similar to those shown in Fig. 2A, through 2D, the following procedure is followed.

1. Determine the midband frequency, f_m , from

$$f_m = (f_1 f_2)^{1/2}$$

where f_1 and f_2 are the passband limits measured at the 1-db down points.

2. Determine the percentage bandwidth required from

$$\%BW = [(f_2 - f_1)/f_m] \times 100$$

Use the next greater tabulated percentage bandwidth.

3. From the table find the normalized parameters required for the circuit selected under the percent bandwidth column in step 2.

4. Convert the normalized circuit parameters to the required denormalized values by multiplying by a denormalizing factor. For inductances the denormalizing factor is R/f_m and for ca-

for
HIGH

LOW

**INSULATION RESISTANCE
 and CAPACITANCE STABILITY**

POWER FACTOR and SOAKAGE



f-c-i

Polystyrene Capacitors

are wound with

NATVAR
Styroflex[®]

Film Capacitors, Inc., New York, manufactures capacitors for critical AC and DC circuitry applications—such as bridge arm elements, filter network components, standards of capacitance, RF tank circuits, storage circuits and computer circuits—where stability and high Q are essential.

Natvar Styroflex film is used as the dielectric in f-c-i polystyrene capacitors because of its uniformly high shock resistance and excellent dielectric properties. Because of its bi-axial orientation during the manufacturing process, it is completely flexible in all thicknesses, and easy to handle.

If you need an insulating material with the desirable characteristics of polystyrene—plus pliability, it will pay you to investigate Natvar Styroflex.

NATVAR CORPORATION

FORMERLY THE NATIONAL VARNISHED PRODUCTS CORPORATION

Telephone

TWX

Cable Address

FULTON 8-8800

RAHWAY, N.J., RAH 1134

NATVAR: RAHWAY, N.J.

201 RANDOLPH AVENUE • WOODBRIDGE, NEW JERSEY

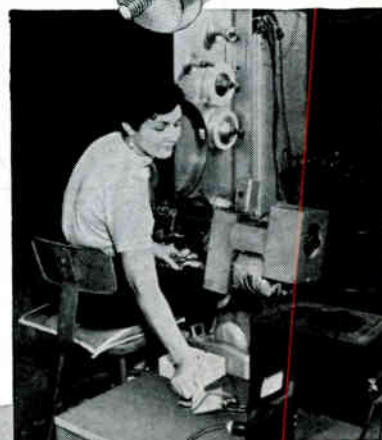

f-c-i polystyrene capacitors are available in hermetically sealed glass tubes, metal shells, bathtub cases, or metal cans. Operators like Styroflex because it winds easily, and testers find a minimum of rejects.



Natvar Products

- Varnished cambric—sheet and tape
- Varnished canvas and duck—sheet and tape
- Varnished silk and special rayon—sheet and tape
- Varnished papers—rope and kraft—sheet and tape
- Varnished, silicone varnished and silicone rubber coated Fiberglas*—sheet and tape
- Slot cell combinations, Aboglas[®]
- Teraglas[®]
- Isoglas[®] sheet and tape
- Isolastane[®] sheet, tape, tubing and sleeving
- Vinyl coated and silicone rubber coated Fiberglas tubing and sleeving
- Extruded vinyl tubing and tape
- Styroflex[®] flexible polystyrene tape
- Extruded identification markers

*TM (Reg. U.S. Pat. Off.) OCF Corp.

We will be very happy to supply information on any of our products on request.

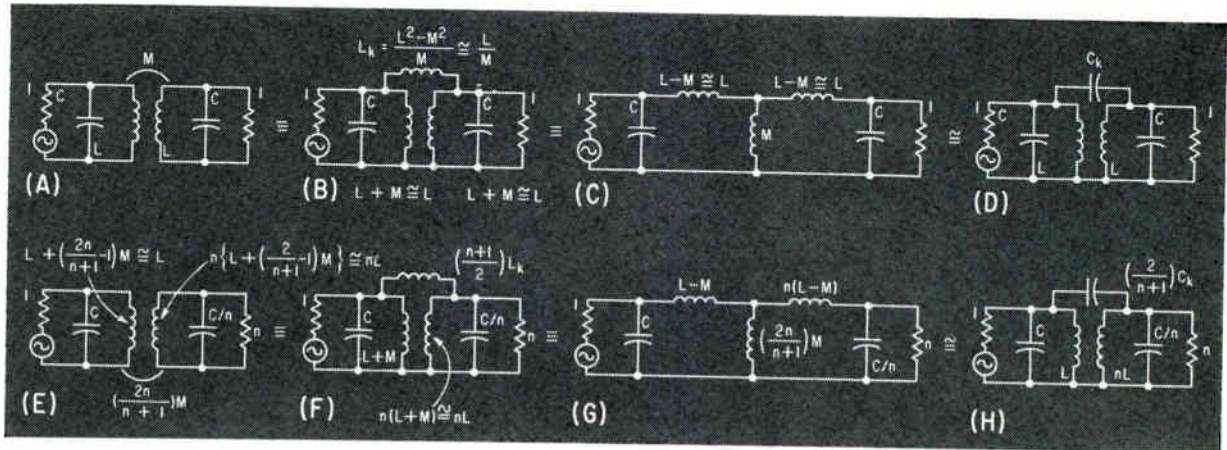

FIG. 2—Equivalent circuits are shown for symmetrical circuit configurations using mutual inductance (A), inductive π (B), inductive T (C) and capacitive π (D) coupling and for nonsymmetrical configurations using mutual inductance (E), inductive π (F), inductive T (G) and capacitive π (H) coupling

Broadband Coupler Circuit Parameters

Percent Bandwidth	1%	5%	10%	20%	30%	40%	50%
l	1.58×10^{-3}	7.94×10^{-3}	1.64×10^{-2}	3.21×10^{-2}	4.91×10^{-2}	6.72×10^{-2}	8.69×10^{-2}
c	1.61×10^1	3.19	1.55	8.05×10^{-1}	5.36×10^{-1}	4.07×10^{-1}	3.28×10^{-1}
m	1.56×10^{-5}	3.96×10^{-4}	1.69×10^{-3}	6.12×10^{-3}	1.11×10^{-2}	2.53×10^{-2}	3.98×10^{-2}
$l - m$	1.56×10^{-3}	7.90×10^{-3}	1.17×10^{-2}	2.57×10^{-2}	3.50×10^{-2}	4.19×10^{-2}	4.71×10^{-2}
l_k	1.60×10^{-1}	1.59×10^{-1}	1.57×10^{-1}	1.56×10^{-1}	1.55×10^{-1}	1.53×10^{-1}	1.50×10^{-1}
c_k	1.59×10^{-1}	1.68×10^{-1}	1.78×10^{-1}	1.78×10^{-1}	1.78×10^{-1}	1.78×10^{-1}	1.78×10^{-1}
k	9.90×10^{-3}	4.99×10^{-2}	1.03×10^{-1}	2.00×10^{-1}	2.91×10^{-1}	3.77×10^{-1}	4.58×10^{-1}
f_0	1.000	1.000	1.000	0.990	0.978	0.962	0.943
$l + m$	1.60×10^{-3}	8.34×10^{-3}	1.81×10^{-2}	3.85×10^{-2}	6.38×10^{-2}	9.25×10^{-2}	1.27×10^{-1}

capacitances it is $1/f_m R$; that is,

$$L = l (R/f_m) \text{ henry}$$

$$C = c (1/f_m R) \text{ farad}$$

where l and c refer to the tabulated normalized inductance and capacitance, respectively, f_m is the midband frequency in cps computed in step 1, R is the value of the desired source resistance in ohms, and L and C are the denormalized inductance and capacitance in henries and farads, respectively. The denormalization procedure is illustrated in Examples 1 and 2.

If it is desired to change the ratio of load-to-source impedances by a factor n , the equivalent circuits shown in Fig. 2E through 2H are used. The procedure is essentially the same as

that used for the symmetrical cases and is illustrated in Example 3.

EXAMPLE 1—Design a bandpass coupler using mutual inductance coupling in the form of a doubly parallel tuned transformer having load and source impedances of 10,000 ohms and a passband extending from 13.650 Mc to 14.350 Mc at the 1-db points. From these specifications

$$f_m = (1.36 \times 10^6 \times 1.43 \times 10^6)^{1/2}$$

$$= 1.4 \times 10^7 \text{ cps}$$

$$R = 10^4 \text{ ohms}$$

$$\% \text{ BW} = \frac{7.00 \times 10^5}{1.40 \times 10^7} \times 10^2 = 5\%$$

$$R/f_m = 7.14 \times 10^{-4} \text{ ohms/cps}$$

$$1/f_m R = 7.14 \times 10^{-12} \text{ 1/cps} \times \text{ohms}$$

Using the mutual inductance equivalent circuit of Fig. 2A and

substituting in the denormalization formulas

$$L = l (R/f_m) = (7.94 \times 10^{-3})(7.14 \times 10^{-4})$$

$$= 5.68 \times 10^{-6} \text{ henry}$$

$$C = c (1/f_m R) = (3.19)(7.14 \times 10^{-12})$$

$$= 2.28 \times 10^{-11} \text{ farad}$$

$$M = m (R/f_m) = (3.96 \times 10^{-4})(7.14 \times 10^{-4})$$

$$= 2.83 \times 10^{-7} \text{ henry}$$

EXAMPLE 2—Design a bandpass coupler equivalent to that of Example 1 but using an inductive π configuration.

Using the inductive π equivalent circuit of Fig. 2B and the circuit parameters computed in Example 1, $f_m = 1.4 \times 10^7$ cps, $R = 10^4$ ohms, $\% \text{ BW} = 5\%$, $C = 2.28 \times 10^{-11}$ farad and $R/f_m = 7.14 \times 10^{-4}$ ohms/cps.

From the table, $(l + m) = 8.34 \times 10^{-3}$ henry and $l_k = 1.59 \times 10^{-1}$ henry.

How to determine high-frequency characteristics of precision film resistors

Specify with confidence from this complete line of time-proved TI resistors

MOLDED†



Ti type number	wattage rating watts	MIL designation	standard resistance ranges	max. recommended voltage volts
CDM 1/4	1/4	RN60B	10 Ohm-1 Meg	350
CDM 1/2	1/2	RN65B	10 Ohm-1 Meg	500
CDM 1	1	RN70B	10 Ohm-5 Meg	750
CDM 2	2	RN75B	10 Ohm-10 Meg	1000
CDM 2	2	RN80B	50 Ohm-50 Meg	2000

MIL-LINE †



Ti type number	wattage rating watts	MIL designation	standard resistance ranges	max. recommended voltage volts
CD 1/4 R	1/4	—	10 Ohm-1 Meg	350
CD 1/2 R	1/2	RN10X	10 Ohm-1 Meg	500
CD 1/2 PR	1/2	RN15X	10 Ohm-3 Meg	650
CD 1/2 MR	1/2	RN20X	10 Ohm-5 Meg	750
CD 1/2 SR	1/2	—	50 Ohm-10 Meg	850
CD1R	1	RN25X	10 Ohm-10 Meg	1000
CD2R	2	RN30X	50 Ohm-50 Meg	2000

HERMETICALLY SEALED LINE †



Ti type number	wattage rating watts	MIL designation	standard resistance ranges	max. recommended voltage volts
CDH 1/4 M	1/4	—	10 Ohm-500K	250
CDH 1/4	1/4	RN60B	10 Ohm-1 Meg	350
CDH 1/2	1/2	RN65B	10 Ohm-1 Meg	500
CDH 1/2 P	1/2	—	10 Ohm-3 Meg	650
CDH 1/2 A	1/2	RN65B	10 Ohm-3 Meg	650
CDH 1/2 M	1/2	RN70B	10 Ohm-5 Meg	750
CDH 1/2 S	1/2	—	50 Ohm-10 Meg	850
CDH 1	1	RN75B	10 Ohm-10 Meg	1000
CDH 2	2	RN80B	50 Ohm-50 Meg	2000

†All values available in 1% tolerance; nominal lead length 1.5 in.

silicon RESISTORS



Standard available resistances @ 25° C:
50, 82, 100, 120, 150, 180, 220, 270, 330, 390, 470, 560, 680, 820, 1000, 1200, 1500, 1800 ohms. †

Type No.	Wattage Rating	Length	Body Diameter	Average Temperature Coefficient	Resistance Tolerance
TM 1/4	1/4	0.345"	0.200"	+0.7	±10
TM 1/2	1/2	0.406"	0.140"	+0.7	±10
TC 1/4	1/4	T0-5	Transistor	+0.7	±10

• TRADEMARK OF TEXAS INSTRUMENTS INCORPORATED
† Other resistance values and tolerances available on special order.



For a more detailed discussion of this subject, contact your nearest TI sales office for a copy of "High-Frequency Characteristics of Precision Film Resistors."

In high frequency applications, precision film resistors are superior to composition or wirewound resistors; skin effect of the thin film is negligible.

OHMIC VALUE vs FREQUENCY

Precision film resistors of a given physical size have the same distributed capacitances regardless of their ohmic value. As the frequency increases, the shunting effect of the distributed capacitance causes the effective parallel resistance to decrease. The reactance of the stray capacitance becomes a relatively good shunt when it approximates the ohmic value of the resistor. The smaller the ohmic value of a precision film resistor (for a given physical size), the higher its usable frequency range.

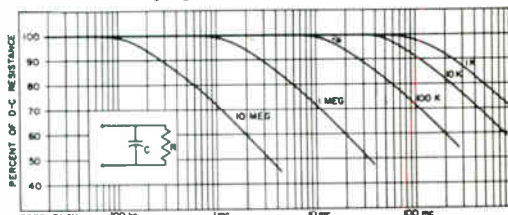

HIGH FREQUENCY RESISTANCE OF PRECISION FILM RESISTORS

INDUCTANCE CONSIDERATIONS

The inductance caused by helixing the higher value resistors is negligible throughout the "useful" range of frequencies at which the resistance is greater than 60% of its d-c value.

When resistors under 500 ohms are measured using high frequency meters, the reactive component of the equivalent parallel circuit appears inductive because of lead and binding post inductance. However, the resistor itself is capacitive.

TI TYPE	SIZE (WATT RATING)				
	1/4	1/2	1	2	5
MIL-LINE (CD)	0.2	0.1	0.25	0.5	0.6
MOLDED (CDM)	0.3	0.25	0.45	0.7	0.7
HERMETICALLY SEALED (CDH)	0.3	0.25	0.45	0.75	0.8

CAPACITANCE IN μMFD OF TI PRECISION FILM RESISTORS

CAPACITANCE CONSIDERATIONS

The average measured capacitance of Texas Instruments Precision Film Resistors is determined primarily by the end cap-to-cap capacitance which is proportional to the dielectric constant of the core and encapsulating material.

MOUNTING

Precision film resistors of 200 ohms or less perform satisfactorily at 5000 mc and higher if placed in a well-designed coaxial mount. A coaxial mount constructed from a standard UG-18B/U Type N plug can be used effectively. In conventional terminals, correct mounting of the body of the resistor off the circuit chassis and the use of short leads will minimize the stray capacitance and lead inductance.

Specify TI precision resistors!

TEXAS  **INSTRUMENTS INCORPORATED**
SEMICONDUCTOR COMPONENTS DIVISION
13500 N. CENTRAL EXPRESSWAY
POST OFFICE BOX 312 • DALLAS, TEXAS

Denormalize by multiplying by appropriate factor

$$(L+M) = (l+m) (R/f_m) \\ = (8.34 \times 10^{-3}) (7.14 \times 10^{-4}) \\ = 5.96 \times 10^{-6} \text{ henry}$$

$$L_k = l_k (R/f_m) \\ = (1.59 \times 10^{-1}) (7.14 \times 10^{-4}) \\ = 1.14 \times 10^{-4} \text{ henry}$$

EXAMPLE 3—Design a bandpass coupler using the double-tuned transformer configuration of Fig. 2A having characteristics identical to those of the coupler of Example 1 except that a 20,000-ohm output termination is required. Using the equivalent circuit for the nonsymmetrical configuration of Fig. 2E and the circuit parameters computed in Example 1, $f_m = 1.4 \times 10^7$ cps, $R = 10^4$ ohms, $C = 2.29 \times 10^{-11}$ farad and $n = 2$.

Thus

$$L + \left(\frac{2n}{n+1} - 1 \right) M = 5.68 \times 10^{-6} \\ + \left(\frac{4}{3} - 1 \right) (2.83 \times 10^{-7}) \\ = 5.77 \times 10^{-6} \text{ henry} \\ n \left\{ L + \left(\frac{2}{n+1} - 1 \right) M \right\} \\ = 11.2 \times 10^{-6} \text{ henry} \\ C/n = 1.14 \times 10^{-11} \text{ farad}$$

The doubly-tuned air core transformer realization of the coupler is usually practical for percentage bandwidths less than 30 percent. Couplers using carbonyl-iron core transformers are practical for percentage bandwidths up to about 50 percent.

The π and T sections are usually the easiest to fabricate although they may be somewhat bulkier and more expensive. The larger percentage bandwidths may be achieved with the inductive π or T sections.

The capacitive π coupler is practical for percentage bandwidths of about 10 percent, however, because of its poor phase response, it is usually not suitable for larger bandwidths⁹.

In the case of the transformer realization of the coupler, the correct spacing of the windings may be determined as follows

1. Adjust each winding to resonate with the design capacitance at f_0 with the other winding open circuited.

2. Determine the terminating resistors by an impedance bridge

or Q-meter remembering that the actual value of the terminating resistor may be several times as large as the design value due to coil loss. The indicated equivalent circuit parallel resistance of each coil with the terminating resistor in parallel when measured at the midband frequency by an impedance bridge should equal the design value.

3. Using the test setup shown in Fig. 3, adjust the mutual inductance by pushing the coils together until the meter peaks. Check band limits and passband flatness.

In the cases of other than the transformer realization of the coupler, it is usually sufficient to adjust the circuit components to the design values on an impedance bridge at the midband frequency.

REFERENCES

- (1) R. Beam, "Doubly Parallel—Tuned Broadband Couplers and Doubly Series-Tuned Broadband Couplers," Hallcrafters Internal Publication, 1960.
- (2) M. Dishal, Exact Design and Analysis of Double and Triple Tuned Bandpass Amplifiers, *Proc. IRE*, 35, p 606, 1947.
- (3) W. Dougharty, The Theory of Broadband Coupler Circuits, *Electronic Engineering*, p 488, Aug. 1959.

BIBLIOGRAPHY

- C. B. Aiken, Two-Mesh-Tuned Coupled Circuit Filters, *Proc. IRE*, 25, p 230, 1937.
- B. D. N. Tellegen, Coupled Circuits, *Phillips Res Rep*, 2, No. 1, 1947.
- V. C. Rideout, Note on Parallel Tuned Transformer Design, *Bell System T. J.*, 27, p 96, Jan. 1948.
- J. B. Rudd, Design for Double-Tuned Transformers, *AWA Tech Rev*, 8, p 147, 1949.
- A. Van Weel, "The Design of Phase-Linear IF Amplifiers," *J. Brit. Inst. of Radio Engrs*, 17, p 275, 1957.
- J. H. Mole, Filter Design Data, (Book, Spon, Ltd, 1952) p 243.
- Valley and Wallman, Vacuum Tube Amplifiers, Rad. Lab. Series, McGraw-Hill, p 201.
- E. Gruen, "A Network Theorem," p 35 *Marconi Review*, xx No. 125, 1957.

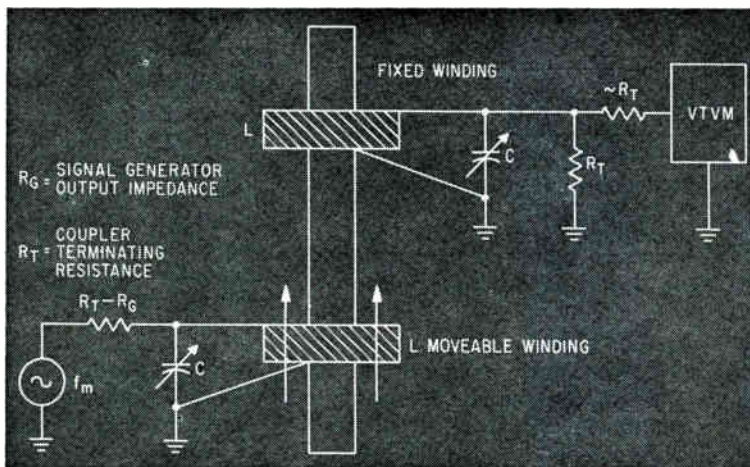

FIG. 3—This setup is used for the tuned transformer coupler alignment procedure



For more than a quarter century, Hallicrafters has worked in close partnership with our armed forces on fast solutions to critical military electronics problems. Out of this priceless experience are emerging startling new ideas and hard-hitting, fast-moving techniques to keep our country one jump ahead in electronic warfare . . .



B-52 and other military aircraft will be protected by the most potent Electronic Countermeasures equipments yet devised. These equipments were developed in close teamwork with the Air Force under Hallicrafters' QRC (Quick Reaction Capability) program. Now qualified to meet full environmental specifications, they are in quantity production.



New levels of speed and efficiency are being reached in equipment modernization, retrofit and technical support programs with Hallicrafters' radical new "Blue Streak" project. Specially-trained Maintenance and Technical Support Teams, close-knit and flexible, can be tactically deployed to accomplish maintenance, installation and testing of electronics weapons systems anywhere in the world.

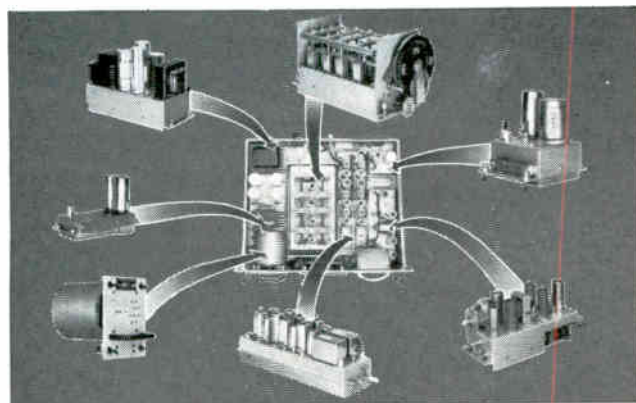

Hallicrafters communications leadership is exemplified by new high frequency Single Sideband receiver, (model no. SX-116). 100% modular design permits simple modification for compatibility with existing and future communications systems. Stability, with proper available plug-ins, is better than one part in 10,000,000 per month. Hallicrafters also offers an existing capability in receiving and transmitting techniques up to frequencies of 50,000 megacycles.



Hallicrafters participation in the Atlas missile project helped to develop capability for many areas of the complex missile field, including code translator data systems; ground support equipment; ECM testing and antenna systems. Current explorations involve latest Infra Red techniques.

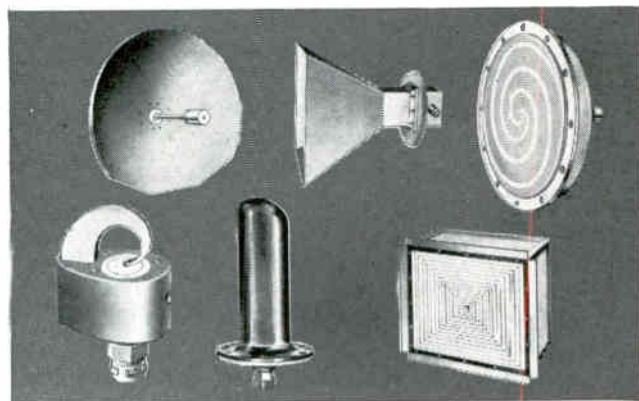

Airborne antennas and micro-wave components with power capability in excess of 1,000 watts, can be made available to solve tomorrow's very high power handling requirements. Testing of microwave components is possible with special high power generators, designed and built by Hallicrafters.

Looking for a challenging new opportunity? We are interested in qualified engineers at all levels. For full details in confidence, contact William F. Frankart, Director of Engineering.

For further information on Hallicrafters facilities and experience in military electronics research, development and production, please write to:

hallicrafters h company

Military Electronics Division,
Chicago 24, Illinois

F-M Is Used in Electro-Optical Tracker

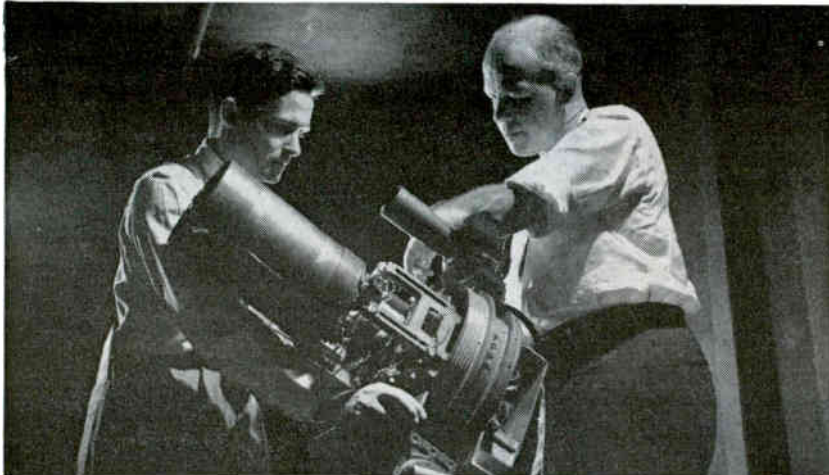

High-accuracy Raytheon tracker for aircraft and space vehicles

INSTANT tracking data for space vehicles is provided by an electro-optical automatic tracking system. It also provides information essential in designing systems to overcome tumbling of satellites.

The portable instrument developed by Raytheon relies on light reflected from the vehicle but can be adapted to respond to infrared energy. In the passive tracker, the expense, bulk and weight of radar equipment is saved. The tracking system, which occupies less than eight cubic feet, can be used in aircraft above cloud cover. In a space vehicle, one unit could track the sun and another a planet to establish relative position of the vehicle and help in making soft landings.

The system has tracked Echo I at 1 000 miles altitude and traveling at 18,000 mph, indicating immediately its position within a fraction of a mile. Plotting information complements photographic plotting, which is available about 45 minutes after photographing.

The high accuracy of the system stems from its reliance on the higher frequencies of light energy. By tracking re-entering vehicles, the system could predict impact areas more accurately than using estimated trajectory.

The cassagranian telescope in the tracker has a 6-inch primary mirror with a one-degree field of view. Light from the target reflected

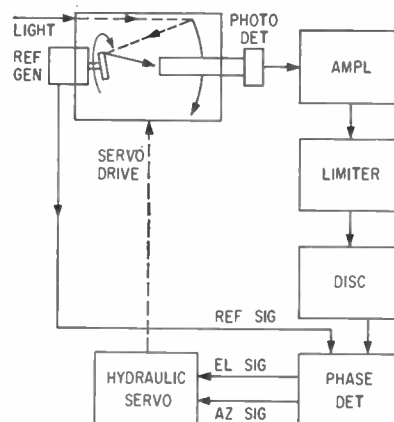

Tracking errors are resolved into azimuth and elevation signals

by a scanning mirror is rotated at about 50 cps over a spoked reticle. The spokes interrupt the light, providing light pulses of about 1 Kc to a multiplier phototube.

The output modulated in frequency at the scan rate is amplified and limited. A discriminator recovers the scan-rate signal, which is compared in phase with a reference from the scan drive motor.

Tracking errors result in a phase-error signal from the phase detector that is resolved into x and y coordinates. These d-c analogs of azimuth and elevation errors control servo valves that cause the hydraulic system to drive the telescope to the correct line of sight.

The 1-Kc carrier with bandwidths of a few hundred cps requires no special filtering techniques. The 50-cps scan rate is convenient for use with transformer-coupled amplifiers.

Automatic tracking rates to 10 deg/sec from -45 to $+45$ degrees in both azimuth and elevation are possible with signal-to-noise ratios exceeding two. Servo velocity in slewing to a target is about 200 deg/sec. The tracker tripod also has two degrees of freedom for manual positioning.

The system is highly sensitive—about 10-15 watts per sq cm. Stars down to about the third magnitude can be locked on and tracked.

Precision potentiometers energized with regulated supplies provide d-c analogs of both angular positions. For an angle of 90 deg, minimum measurement accuracy is about 0.1 deg. For measuring smaller angles about a mean, accuracy is about 0.005 deg. Other apparatus can be slaved to the tracker.

Multiplier phototube output is recorded to indicate light intensity as a function of time. Periodic fluctuations of about 30 seconds were observed in tracking Echo I, believed to result from tumbling.

In laboratory tests, the tracker equipped for infrared detection sensed and followed objects with temperatures as low as 150 C. With longer wavelength detectors, objects at lower temperatures could be detected.

Electronic System for Balancing Gyro Wheels

By F. W. KEAR,

Supervisor, Research and Development,
Lytle Corp., Albuquerque, N. M.

INERTIAL guidance for missiles, navigation equipment and radar fire-control systems are examples of the broad variety of equipment that rely on gyros. Demands placed on these important sensing devices have increased as refinements have

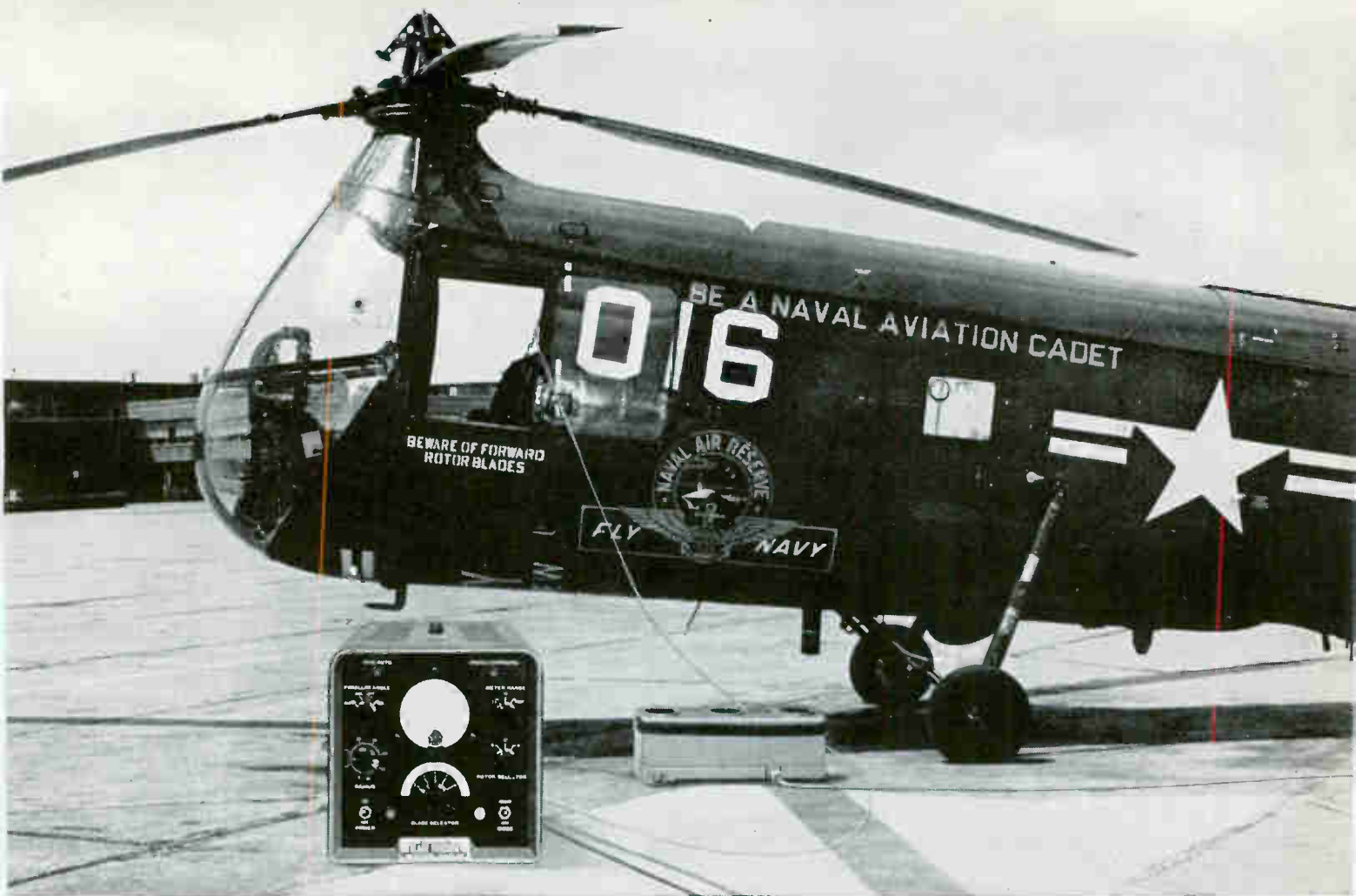

Tung-Sol tubes help **CHICAGO AERIAL** keep 'copter blades on "right track"

Chicago Aerial Industries' automatic Electronic Blade Tracker brings new standards of accuracy to the critical job of tracking helicopter blades to assure that they are all rotating in the same plane, or track. Proper rotation means smoother flight characteristics, minimized vibration, reduced structural stresses and lower maintenance costs. It virtually makes obsolete the manual flag-tracking method.

The Tracker uses range finding principles to triangulate for each successive blade height. Electrical signals generated by photo-cells in the electro-optical pick-up positioned beneath the rotating blades are fed to a computer analyzer. These signals are then converted to dc voltages proportional to blade height, which registers on the front-panel meter.

Because rigid standards of reliability are mandatory for this equipment, Chicago Aerial selected Tung-Sol tubes to handle the vital regulation

function in the conversion network. Tung-Sol 5687 series regulator tubes minimize any variations in output voltage due to load current or line voltage changes. Both tubes maintain 150 volts \pm 1 volt insuring the most precise readings.

CAI adds still another name to the growing list of manufacturers who are calling upon Tung-Sol tubes and semiconductors to deliver top performance reliability. Like CAI, you can get the benefit of Tung-Sol component know-how, too. Tung-Sol makes a component for virtually every industrial and military requirement. Our applications engineers will be glad to make an impartial recommendation for the component complement that will best satisfy your design needs. Tung-Sol Electric Inc., Newark 4, N. J. TWX: NK 193.

Technical assistance is available through the following sales offices: Atlanta, Ga.; Columbus, Ohio; Culver City, Calif.; Dallas, Texas; Denver, Colo.; Detroit, Mich.; Irvington, N. J.; Melrose Park, Ill.; Newark, N. J.; Philadelphia, Pa.; Seattle, Wash. Canada: Toronto, Ontario.



 **TUNG-SOL[®]**

CIRCLE 83 ON READER SERVICE CARD

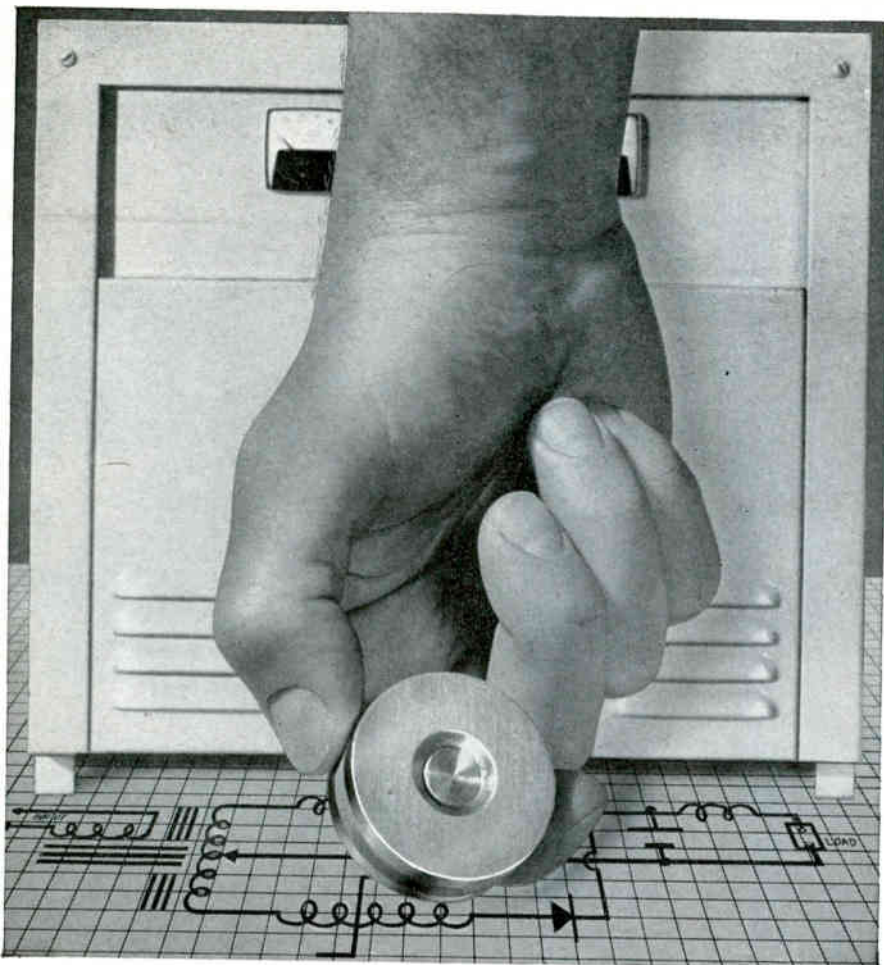

Can a silicon rectifier solve your problem?

It might, if you have a problem in DC power sources. For example, some time ago C & D needed a high efficiency, constant potential, current limiting DC power supply. Output had to be held within $\pm 1\%$ over an AC input variation of $\pm 15\%$. In addition, maintenance would have to be virtually nil.

The answer was found by using a silicon rectifier in combination with simplified components that became the heart of C & D's *AutoReg*® charger. *AutoReg* chargers provide continuous, automatic, unattended charging of industrial storage batteries. With the exception of a timing circuit there are no moving parts. There are no relays to adjust and practically no maintenance is required.

Now, C & D has expanded facilities of the *AutoReg* plant to provide industry with similar DC sources, which incorporate silicon rectifiers and automatic regulation. Final form of these units can supply power in a range from milliwatts to megawatts, depending upon your requirements.

Companies with a problem in DC power sources should write, giving a general outline of their requirements, to: Vice President in Charge of Engineering

AutoReg® Power Sources



Manufacturers of Slyver-Clad® Industrial Batteries • PlastiCell® and PlastiCal® Batteries for Communications, Control, and Auxiliary Power • Producers of AutoReg® Silicon Chargers and AutoCal® Charger-Battery Combinations

been incorporated in the systems in which they are used. An important factor in constructing reliable, high-performance gyros is balance of the gyro wheel.

A sensitive electronic system has been developed to detect imbalance in gyro wheels and to enable determination of the exact point of imbalance from a known reference. The balancing system, which displays results on an oscilloscope, can be readily adapted for many other precision rotating assemblies.

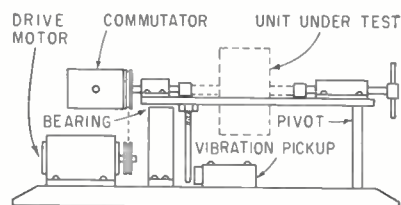

FIG. 1—Balancing fixture triggers oscilloscope reference sweep and detects vibration

The assembly to be balanced is mounted in the test fixture in Fig. 1. A variable-speed d-c motor was found suitable as a source of driving power. Energy is transferred from the motor to the rotating portion of the assembly by a drive belt made of material that will avoid oscillation in rotational velocity of the driven assembly.

Imbalance of the unit under test causes vibration. Construction of the assembly in which the test unit is held restricts movement to the horizontal plane. The support at the right acts as a pivot, while a bearing is installed on the support member immediately to the right of the drive belt to permit horizontal motion.

The rotating part of the setup must provide an output signal at the same instant during each revolution of the assembly under test. An inductive slug mounted in the driven pulley could provide a pulse to an inductive pickup. In the system described, however, a commutator with one segment grounded was found to be a convenient means of providing an output signal.

The base of transistor Q₁ in Fig. 2A is grounded once during each revolution by the grounded commutator segment. As a result, the circuit produces a sharp pulse that is used to trigger an oscilloscope sweep. The display is a sine wave of constant amplitude and starting

at the same instant during each revolution of the unit under test.

Vibration resulting from imbalance is sensed by a transducer that produces another sine wave. An inductive pickup was used in this instance, although a piezoelectric transducer could also be used. Transducer output is amplified by the circuit in Fig. 2B and also displayed on the oscilloscope. Rotational velocity of the assembly being tested is adjusted for mechanical resonance so that the displayed sine wave is at maximum.

The direction of phase difference of the vibration-induced sine wave relative to the reference sine wave indicates the direction of the imbalance from the grounded commutator segment. Actual angular phase displacement of the two sine waves indicates the position of the imbalance with respect to the grounded segment. A protractor can be used to find position of the imbalance on the unit under test.

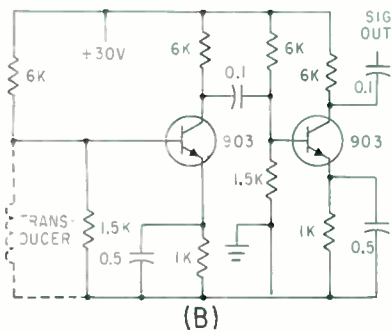
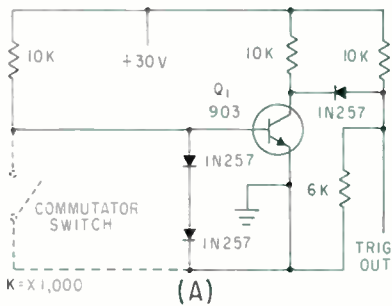

FIG. 2—Grounded commutator segment (A) triggers reference sine wave, while transducer output is amplified (B) for display

When the gyro wheel or other device is in perfect balance, only the reference sine wave and background noise appear on the oscilloscope. Motor speed can be altered to locate resonances where vibration and thus transducer output are at maximum. Thus minor imbalances that might otherwise be overlooked can be detected.

NOW IT'S OFF THE GROUND!

NEXT QUESTION . . .

HOW DOES IT PERFORM?

The RADAR QUANTIZER Provides Answers

By utilizing the RADAR QUANTIZER[®], the Army Ordnance Corps can track the Pershing missile in flight with a position plot resolution of $\pm 2\frac{1}{2}$ feet — a resolution heretofore impossible. The Quantizer, developed under contract of the Army's Diamond Ordnance Fuze Laboratories, is a millimicrosecond time interval meter. It converts the radar electrical signals into digital code format and feeds a storage tape, *as fast as the dynamic data occurs.* As a result, engineers can follow the missile's exact flight path on the ground with the aid of digital computing equipment — making optimum use of the radar equipment's full capability, down to the Quantizer's instantaneous resolution of ± 10 millimicroseconds!

If you have data processing requirements where it is desirable to measure time intervals down to ten millimicroseconds or less, and read the result out in digital format *while the data occurs,* contact Computer Equipment Corp. for full details on how the QUANTIZER can be applied to your system.

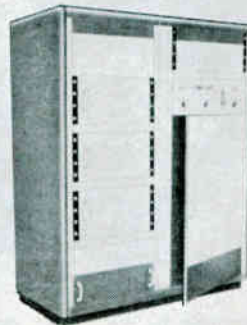

Computer Equipment Corp.

1933 PONTIUS AVENUE, LOS ANGELES 25, CALIFORNIA
GRANITE 8-0464 TWX WLA 6650

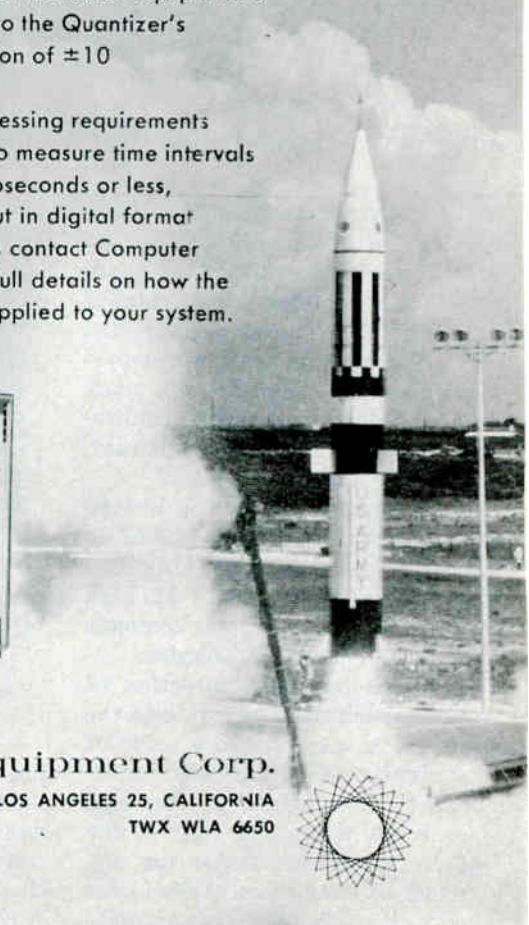
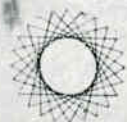

Silicon Epitaxial Transistors On Way

THE AVAILABILITY of developmental samples of a silicon epitaxial transistor was recently announced by E. M. Baldwin, Vice President and General Manager of the Rheem Semiconductor Corp., Mountain View, California, a subsidiary of the Rheem Manufacturing Co. According to Baldwin, the transistor is the first of a line of epitaxial transistors which are being readied for production at Rheem and it is the result of an intensive research and development program.

The development of epitaxial deposition techniques, as used in the fabrication of transistors, has been heralded as a great processing improvement since diffusion techniques were first used for making transistors. The basic process in making epitaxial transistors at Rheem consists of depositing a very thin layer (about one-half mil thick) of high resistivity silicon on a thicker substrate of very low re-

sistivity material. Using this material, transistors are fabricated using the same diffusion techniques as for other high quality mesa transistors. Since the active part of the transistor is all within the high resistivity material, this process, in essence, provides a method for handling one-half mil thick silicon slices.

Two major advantages of epitaxial transistors are the virtual elimination of the collector series resistance and a large decrease in storage and turn-off times, as was indicated in the first public announcement of epitaxial transistors by Bell Telephone Laboratories at the IRE Solid State Devices Research Conference on June 13, 1960. The epitaxial transistors made show both of the above-mentioned effects.

The transistor announced today, RT409, is a 60-v collector breakdown unit and otherwise meets the

general specs of the 2N697 series. The typical collector to emitter saturation voltage at 150 ma has been reduced by a factor of 2, as shown below:

V_{CE} (sat):	RT409	2N697
Typical	0.35	0.7
Max.	0.5	1.5

The storage time for the RT409 transistor is typically less than 100 nanoseconds for the same test conditions which yield 400 nanoseconds in a 2N697. An additional dividend is that, since the power dissipation is low, the transistor may be operated at higher current levels.

Other epitaxial transistors, to be announced soon, include improved versions of other transistors like the 2N699, 2N699A, 2N657, and RT5004. Also, there will be new type numbers to utilize the combined advantages of high breakdown voltage, low saturation voltage, high current and low storage. It will be in these high voltage and high current types that the advantages of epitaxial transistors will be demonstrated most dramatically. These units will be made available at first in the TO-18, TO-5 and the newly-announced MICROBLOC packages. (MICROBLOCs are higher powered, micro-sized replacements for their electrical counterparts in TO-5 and TO-18 packages.)

Developmental samples of transistor RT409 are available six weeks after receipt of order at \$170 each. In order to make the devices most widely available to industry, initial orders are limited to a maximum of ten units.

Portable Kit for Capacitor Standards

RECENT DEVELOPMENT by Arco Electronics, Inc., New York, N. Y. of precision miniature capacitor standards having a tolerance of $\pm 0.1\%$ and over 50 percent smaller and lighter than standards of comparable accuracy, has solved many problems for government calibration centers by providing accuracy, portability and ease in use.

A complete set of 32 plug-in type standards ranging from 0.0001 to 0.5 μf is housed in a carrying case only 12 $\frac{3}{4}$ in. wide by 11 $\frac{1}{2}$ in. high by 4 $\frac{3}{4}$ in. deep, and comes complete with a four position adapter.

By quick and easy insertion of Arco's capacitor standards into the adapter jig, a capacitance value of four significant figures with an accuracy of ± 0.1 percent is obtained.

Contracts were let to Arco by the Dayton Air Force Depot for 202 kits and by Frankford Arsenal for 55 kits for use in all laboratories



Set offered by Arco comes with four-position adapter

and calibration centers. Arco capacitor standards are available direct from the New York plant in individual unit values as well as in kit form, according to Ben Stanley, in charge of standards sales.

Silicon Whiskers for Instrumentation Devices

USE OF SILICON semiconductor whiskers to provide micro-sensitive instrumentation devices, 50 to 60 times more sensitive than their metallic counterparts, was described by W. V. Wright, of Electro-Optical Systems, Inc., of Pasadena. Wright



WESTON CONSOLE PROVIDES HIGHEST SPEED CALIBRATION

- $\pm 0.05\%$ accuracy of indicated value
- only one operator required
- for indicating, recording or digital instruments

One operator can now calibrate or standardize most types of indicating, digital and recording-type instruments in 1/3 the time previously required by *two skilled technicians*. Designed for speed and simplicity, Model 61 Console is an ideal laboratory standard for periodic testing of other instrumentation.

Precisely adjustable calibration points are provided by this compact unit. AC ranges of 1 through 50 amperes may be subdivided into 30 equal parts . . . and up to 1,500 volts is available in 10 ranges with 75 to 300 divisions per range. In DC calibration, all full-scale ranges may be divided automatically into as many as 15,000 equal parts.

Accuracy of $\pm 0.05\%$ is achieved through proved Weston circuitry and high-precision standard cells. Any load variation, drift or deviation in either input or output voltage is instantaneously and automatically corrected. Phasing of AC units permits calibration of wattmeters at unity power-factor. For limited applications, individual units are available separately.

Call your Weston representative for complete details, or write for Catalog 06-101. Daystrom, Incorporated, Weston Instruments Division, Newark 12, New Jersey.

Export: International Sales Division, 100 Empire St. Newark 12, New Jersey.

In Canada: Daystrom Ltd., 840 Caledonia Rd., Toronto 19, Ontario.



Weston Calibration Console consists of: Models 62 AC Ammeter; 63 AC Voltmeter; 64 DC Voltmeter; and 65 DC Ammeter Calibrators. Power requirement: 60 cycle, 110 to 120 volts. Overall size: 5' high x 7' long x 2' deep.

DAYSTROM, INCORPORATED
WESTON INSTRUMENTS DIVISION
Reliability by Design

Malco

solderless terminals



**Speed and simplify wire insertion...
...insure maximum holding power**

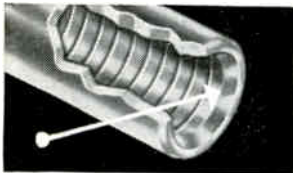

Funnel-edged barrel for fast, easy insertion of wire.

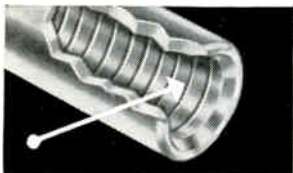

Multiple V-notched internally for better contact and maximum holding power.

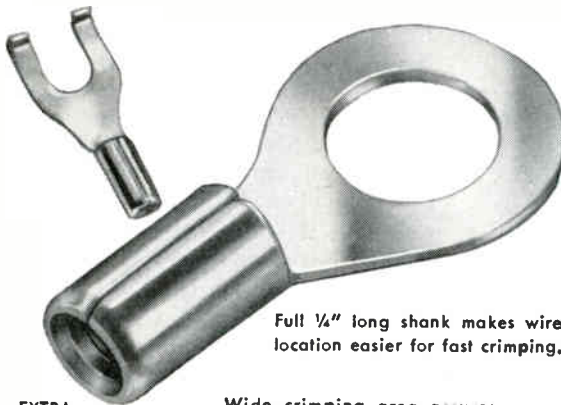

Full 1/4" long shank makes wire location easier for fast crimping.

EXTRA
ADDED
FEATURE
↑
Beveled O.D.

Wide crimping area assures permanent, vibration-free and moisture-proof connections.

other features

- Available in a wide variety of types and styles.
- Made of pure soft copper for high conductivity and electro-tin plated for maximum corrosion resistance.
- Load capacity greater than wire itself.
- Constructed in one piece for economy and strength.
- Quality controlled for dimensional and electrical uniformity.
- Wire ranges clearly marked on all terminals.
- Stocked in 22-16, 16-14, 12-10 wire ranges.

Insulated Solderless Terminals Also Available

Write for new Malco Solderless Terminals Bulletin No. 601



Malco MANUFACTURING COMPANY

4023 WEST LAKE STREET

CHICAGO 24, ILLINOIS

enumerated applications and characteristics of the 1-inch-long, half-a-mil diameter whisker, which is formed either by etching methods or through vapor deposition.

The whisker manifests a piezoresistive effect when strained. By coupling several of these devices to a cantilever beam and hooking up an ordinary bridge circuit, the semiconductor whisker can be used as a strain gage or transducer to measure force, acceleration, vibration, and other forms of physical stress. Low impedance of the silicon whisker, coupled with high output, results in superior signal-to-noise ratio. The device provides a gage factor of approximately 130.

Recently a silicon whisker has been incorporated into a semiconductor strain gage called a Micro-Sensor which is being commercially marketed by Micro Systems, Inc., a subsidiary of Electro-Optical Systems. The Micro-Sensor has a resistance of 350 ohms and an operating temperature ranging from -65 F to 180 F. It consists of a thin silicon element 3/8 inch long, 0.020 inch wide, and 0.0005 inch thick, attached to an epoxy based carrier for application.

Initial development of the whisker element was under contract to the Army Ordnance Corps' Picatinny Arsenal, Dover, New Jersey.

Epoxy, Plus Coal Tar for Electrical Insulation

A COMBINATION of epoxy resins and coal tar derivatives, possessing excellent electrical insulating qualities, has found acceptance in important industrial activities. Low in density, moderate in cost, this product, identified as Epocast H-1338, promises to serve as an important insulation work horse, according to Furane Plastics, LA.

Coal tar products in combination with epoxies have enjoyed important applications to highways and building construction. Following this trend, Furane's research laboratory has distilled the essential insulating qualities of both products into a valuable electrical insulation. Deriving economy from the presence of certain coal tar fractions and the proven excellence of epoxy resins, the research group has developed a good dielectric

which has opened new areas for electrical encapsulation.

Epocast H-1338 systems for impregnating and encapsulating have found application in industrial applications of Class A insulation of transformers, terminal boards and miscellaneous electrical components. Salient properties:

Table of Properties—Epocast's

	H-1338/ 9012-A	H-1338/ 9816
Mixed Viscosity		
At 75 F	1,200 cps	3,100 cps
At 150 F	80 cps	
Pot Life (One Lb.)	5 days	60 minutes
Cure	3 hrs. @ 250 F	Overnite @ 80 F
Cured Spec. Grav.	1.2	1.2
Dissi. Fact.		
Dielec. Const.		
At 10 ⁴ Cycles (75 F)	0.007/3	0.019/3.8
Weight Loss		
1 day at 300 F	-5.3%	-6.3%
7 days at 300 F	-8.0%	-9.9%
Shore D Hardness		
At 75 F	81/79	77/74
At 200 F	35	27
Vol. Resis. (ohm-cm)		
At 75 F	1.0 × 10 ¹⁵	1.8 × 10 ¹⁴
At 200 F	4.8 × 10 ⁹	9.9 × 10 ⁸
Tens. Str.	4,000 psi	1,600 psi
Elongation	20%	20%

Multi-Function Tubes Augur Widespread Use

A NEW low slim look in home radios and television sets seems assured for 1961.

"Several makes of 'Compactronized' (ELECTRONICS, July 8, p 70) radio and television sets are scheduled to appear in the consumer market next year," said Leo T. Bowles, product planning manager of the General Electric Company's Receiving Tube Department. He added:

"At the request of 13 different manufacturers, we presently are developing 37 types of the Compactron components."

"We have firm orders for 50,000 Compactron units per month. We are completing tooling up of plants here in Owensboro, Ky. and in Tell City, Ind., to mass-produce many types of these components. In addition, it is our understanding that at least two other receiving tube manufacturers also are planning to mass produce Compactron devices."

Bowles said this is significant because radio and television manufacturers desire more than one source of supply.

THREE KLEIN PLIERS to make electrical wiring easier

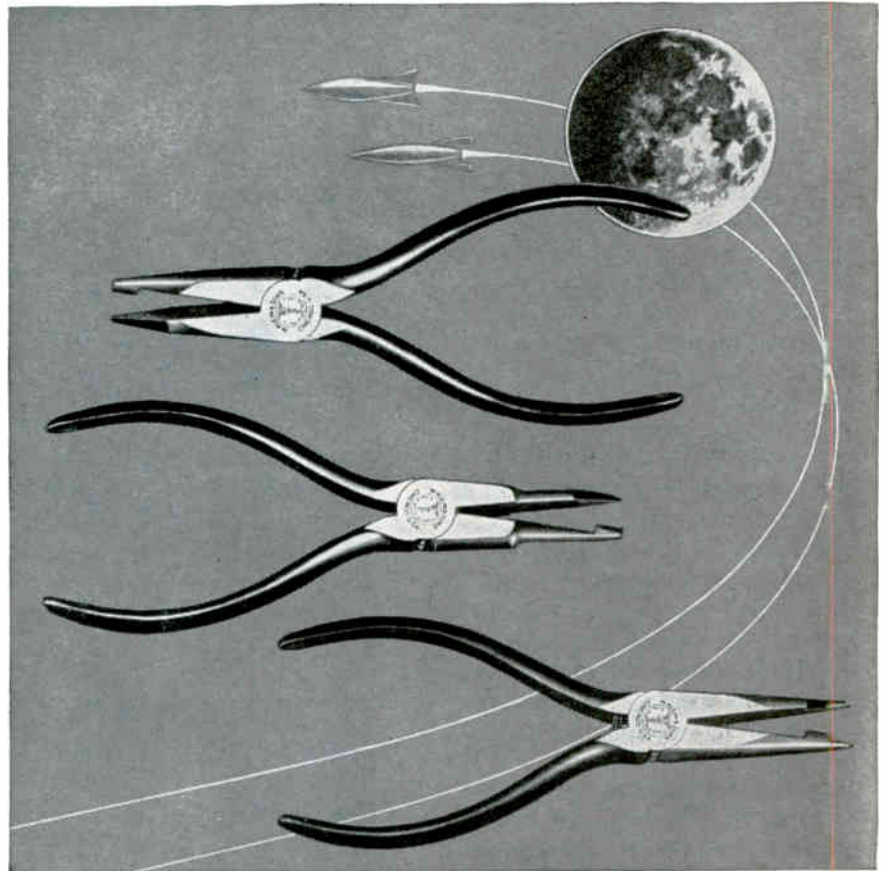

Here are three newly engineered Klein Pliers which will solve difficult problems in the wiring of electronic assemblies. Catalog 103-A describes these and scores of other pliers in the complete Klein line. If you wire electronic assemblies, write for a copy.

ALL-PURPOSE ELECTRONIC PLIER

Patent pending

Shear blade cuts flush and holds clipped end of wire

Requires no sharpening; will cut hard or soft wire. Smooth, continuous action prevents shock which may damage resistors. For bare wire up to 18 gauge.

No. 260-6—length 6 3/8"

No. 260-6C—with coil spring that holds jaws open

NEEDLE-NOSE PLIER

Patent pending

Similar to No. 260-6 but nose has been slimmed down to permit use in confined areas.

No. 261-6—length 6 3/8"

No. 261-6C—with coil spring to hold jaws open

LONG-NOSE PLIER—KNIFE AT TIP

Pat. No. 2,848,724

Jaws behind blade hold clipped wire end firmly

A shear-cutting plier that will cut hard or soft wire. Blade is at the tip of the plier. Supplied with coil spring to keep jaws apart.

No. 208-6PC—length 6 3/8"

Write for
Catalog 103-A,
which shows the
complete line of Klein
Pliers, including 20 pliers
recently developed.



Foreign Distributor: International Standard Electric Corp., New York



Mathias KLEIN & Sons
Established 1857
7200 McCORMICK ROAD • CHICAGO 45, ILLINOIS
Chicago, Ill., U.S.A.

Wire Mesh Makes Flexible R-F Shields

KNITTED WIRE MESH is generally formed into resilient shielding gaskets or r-f weatherstripping. The mesh, made on machines similar to those used to knit stockings, can also be sewed like cloth to form flexible shields in odd shapes.

The sheet shield illustrated is made by Technical Wire Products, Inc., Springfield, N. J., for a military application requiring a shield that will close a gap of varying size. The mesh structure is similar to that previously reported (ELECTRONICS, p 84, Sept. 23, 1960).

The mesh is prepared as several-ply sheets of cloth. The pieces of the pattern are cut with scissors, basted with thread and sewed together on a heavy-duty sewing machine. The pieces are permanently connected by welding with a fine wire type of welding unit and the pattern is installed in the frames.

Large gaskets are made by compressing the knitted stocking into a compact rope. The flat stocking is drawn through a funneling spiral and a series of dies with decreasing diameters. The rope is further compacted and formed to the desired gasket cross section by running it through roller dies in a process similar to calendering.

Sections of the rope are shaped to mate with rubber O-rings or other flexible seals. The rope is fixed to the rubber with adhesive dispensed from a medical syringe. If the cross section of the r-f seal is large, the mesh is formed around a core of rubber or other flexible material. This helps preserve shape and flexibility while conserving materials.

Another method of forming large closure shields is crimping the compressed mesh rope in aluminum strip extrusions. The strip is welded to door frames or housing faces so the mesh is compressed when the door is closed. Welds, or other fastenings, must be closely spaced to prevent leakage of r-f energy through long, hairline cracks.

Small gaskets are die-formed from lengths of stocking bent in



Mesh cloth is sewed into shield that covers a varying gap

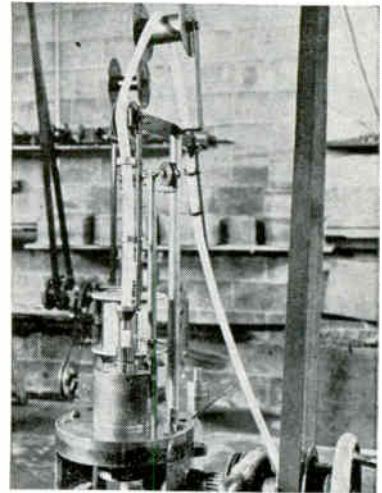

Mesh is prepared on machines similar to stocking knitters

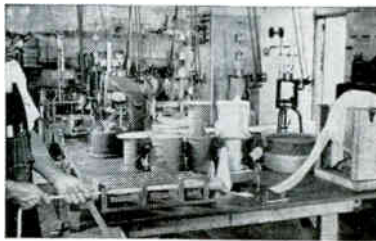

Stocking is spiraled and compressed to form gasketing rope



Rope is cemented to gaskets to form combination seals

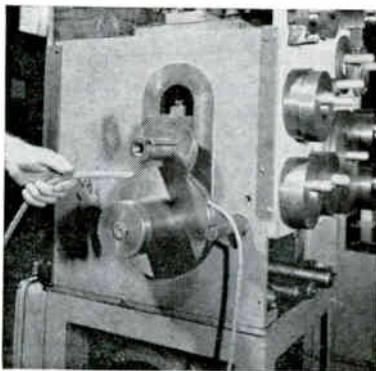

Mesh rope is compressed further and shaped by rollers



Aluminum holding strips facilitate welding to metal closures

donut shape. The donut is placed around the female die and is pressed into shape by the male die. The small gaskets can be cemented inside small O-rings or rectangular gaskets. When they are placed on top of the gaskets, for waveguide joint sealing or similar applications, mounting holes through the

gasket are usually required. The holes in the base material may be punched or molded in beforehand. Holes punched in the mesh could cause discontinuity and fraying. The holes are made by pointed die members which spread the mesh at the hole locations.

Die-pressing is also employed to

New B/A Model NC-1

TESTS POWER TRANSISTORS BY VARYING DUTY CYCLE

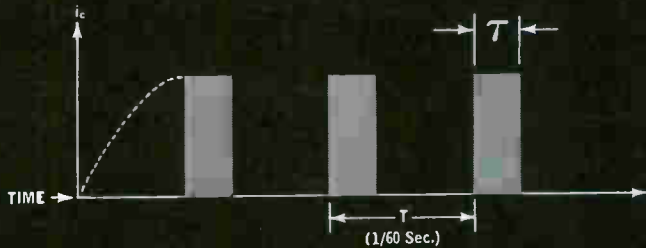

- Minimizes heat sink requirements
- Puts less stress on the transistor
- Permits tests at very high power levels — 750 watts maximum power with maximum current of 50A or maximum voltage of 250V.

The Baird-Atomic NC-1 is the only direct reading, variable duty cycle, medium and high-power transistor test set on the market. This instrument applies suitable pulse drive signals to the transistor under test and then peak detects the resulting current pulses so that they have the same measuring value as steady state DC. The average power in the pulse signals is considerably lower than would be required if steady state DC biases were applied. Thus, measurements can be made at power levels higher than the transistor could survive if normal DC measurement methods were used. At the same time, less stress is put on the transistor itself. Under optimum conditions, the power fed into the transistor is but 6/10ths of 1% of the power used with conventional DC currents.

With the NC-1, tests are conducted under pulse conditions in the common emitter configuration — the meters present DC readings of V_{BE} , I_B , V_{CE} and I_C . The instrument also measures leakage current and floating potential by standard techniques.

EXAMPLE

Here is how the variable duty cycle tests may be used to advantage. Shown below is a typical power transistor C-E set of collector characteristics.

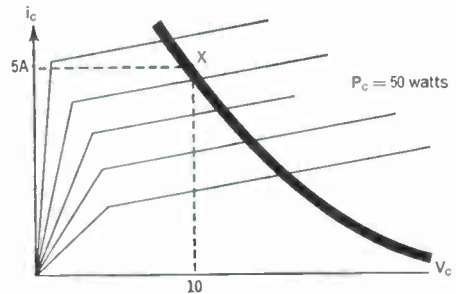

Suppose that we desire to measure the DC current gain at point X. A steady state voltage of 10V and a current of 5A would be required. If conventional DC biases were used, 50W of input power would have to be dissipated by a very large heat sink or auxiliary cooling, such as forced air.

Consider now testing this transistor by the pulse method. We can apply a peak collector voltage of 10V and suitable base drive to produce collector current pulses 5A peak.

For the current pulses 100 μ sec. wide at 1/60 Sec. repetition, the average power is:

$$P = V_c I_c \tau / T$$

$$(10)(5) \frac{(100 \times 10^{-6})}{1/60} = 0.3 \text{ Watt}$$

CURVE TRACER MODEL MW-1

- Designed to display families of characteristic curves for PNP and NPN transistors — either common base or common emitter configurations.
- Both input and/or output current or voltage may be selected as components of the curves displayed.
- Operational range includes the highest maximum current (30 amp collector current continuous duty — 50 amp intermittent, 450 watts maximum available power) and the lowest observable impedance (.001 ohms) now available.
- Maximum input current is 5 amp.
- Automatic overload protection.
- Users say this is the finest, most versatile instrument on the market. (Illustration shows instrument with tube adaptor.)

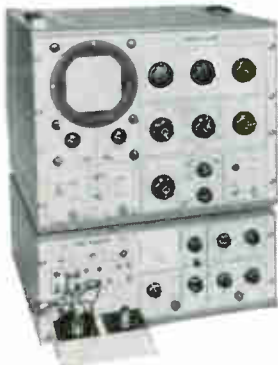

BAIRD-ATOMIC, INC.

33 University Road, Cambridge 38, Mass.

BAIRD-ATOMIC HAS THE MOST COMPLETE LINE OF TRANSISTOR TEST EQUIPMENT

THE **NEW** MARCONI UNIVERSAL BRIDGE

*Gives NEW Simplicity
in LCR Measurements*

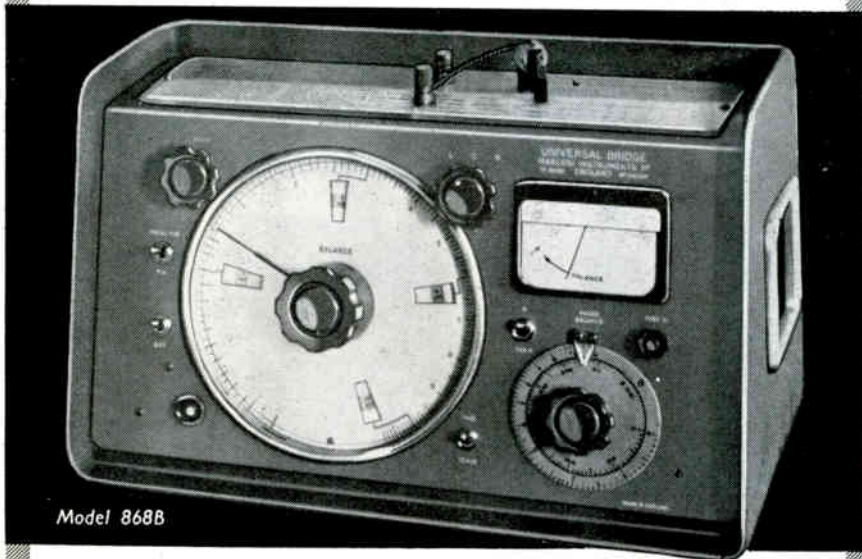

Model 868B

L — 1 μ H to 100 henrys
C — 1 μ F to 100 μ F
R — 0.1 ohm to 100 M Ω

•Direct read-out with no multiplying factors, eliminates operator errors. •Model 868 B also has precision Q and tan δ (D) dials. Inductance and capacitance are measured at 1 or 10 kc/s in an R-C ratio-arm bridge; resistance at d.c. in a Wheatstone bridge. The bridge detector gives positive indication of the direction of balance point even when far off-balance; as a result, components whose values are completely unknown can be evaluated in a few seconds with the minimum of searching. Detector a.g.c. eliminates the need for sensitivity controls. Also available—Low Capacitance Bridge Model 1342: 0.002 μ F to 1,111 μ F; 3-terminal transformer ratio-arm bridge designed for precision measurement of extremely low capacitance. For full details, write for leaflet B171.

MARCONI INSTRUMENTS

111 CEDAR LANE • ENGLEWOOD • NEW JERSEY

TELEPHONE: LOwell 7-0607

Canada: Canadian Marconi Co • Marconi Building • 2442 Trenton Ave • Montreal 16
 Marconi Instruments Ltd • St. Albans • Herts • England



Small shielding gaskets are made by die-forming stockings

make pads for shielding between modules, contact buttons and electron tube shields.

Work Bench Enclosures Boost Lab Efficiency

COMBINATION WORK BENCHES and enclosures have stepped up the efficiency of engineering, research and test personnel, reports Telonic Industries, Inc., of Beech Grove, Beech Grove, Ind. The work benches on which the firm has standardized, incorporating suggestions by the

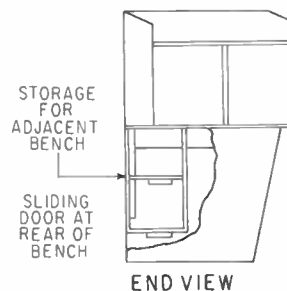
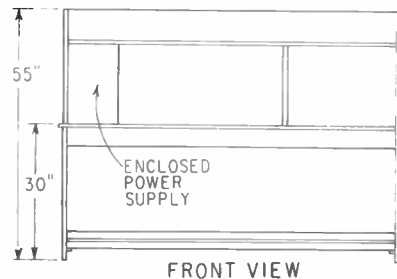
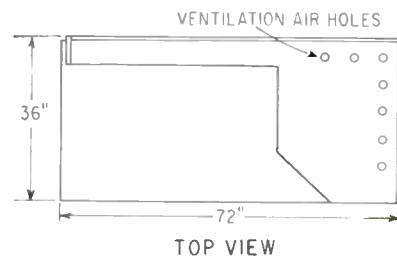

Construction details. Material is plywood

engineering staff, cost about \$100 each when made by a cabinet maker and wired.

The company found that placing men and equipment along the conventional long laboratory bench hampered concentration and lost time through idle conversation, tool borrowing and other time-killers. Development, assembly and testing of the firm's principal product, signal generators, require long periods of attention by employees, making semi-isolation desirable.



Bench helps break up engineering or test areas so employees can concentrate

The enclosures are made of $\frac{3}{4}$ -inch plywood with an overlay of Masonite or Formica on work surfaces. Work surface is about 10 feet square, ample for handling large equipments. Unwieldy test equipment, such as oscilloscopes, are placed in the alcove at the right side. Smaller test equipment, parts and tools are placed on the overhead shelf.

The power supply panel at the left end of the table contains a pilot light, on-off switch, a-c isolation transformer, voltmeter, rheostat and outlets. Below the bench are several cubic feet of storage space and a foot rest running the length of the bench.

Machine Sets Eyelets In Irregular Pattern

CONNECTOR EYELETS are automatically fed and set into small terminal boards in pairs in an irregular pattern by a machine recently developed at United Shoe Machinery Corp., Boston, Mass. The machine is a modification (Model F) of those used to insert terminals and connectors in printed circuit boards.

3-IN-ONE AMCO ENCLOSURE SYSTEM

Provides Cooling, Mounting and Lighting for Electronic Instruments in Any Installation

No one type of enclosure meets all environmental and physical demands. AMCO has developed 3 complete systems integrated into 1 system with interchangeable accessories, applicable for both commercial and military use.

CUSTOM . . . *When space and appearance are critical . . .* 16 ga. double-channel steel frames, based on increments of $19\frac{1}{8}$ " widths, supports in excess of 3000 lbs. Multi-width panels and cowlings give single-unit appearance with series mounted racks. Meets EIA Standards.

SEMI-CUSTOM . . . *Heavy-duty, more internal clearance . . .* 14 ga. box-channel steel frames, 12 ga. gusseting provides exceptional rigidity both front-to-back and side-to-side. Frames based on $22\frac{1}{8}$ " increments provides clearance for recessing 19" wide panels. Meets EIA Standards.

ALUMINUM . . . *Unique! Meets any size . . .* almost any configuration from 6 basic parts . . . 3 castings and 3 extrusions. Any size from 6" to 20 ft.; any slope from 0° to 90° is standard. Mil Specs strength and material (6061-T6 extrusions and 356-T6 castings).

In addition, Amco manufactures all necessary blowers, chassis slides, doors and drawers, writing surfaces, cowlings lights and other accessories. *Check the extra savings you get thru Amco's combined-discount system of racks and accessories, PLUS FREE ASSEMBLY.*

Amco is your one complete source of Modular Instrument Enclosure Systems and Accessories. Write today for catalog of complete specifications.



Aluminum



Semi-Custom



REALISTIC 3 WEEK DELIVERY

Factory trained representatives in principal cities of U.S. and in Canada.

Custom



AMCO ENGINEERING CO.

7333 West Ainslie Street, Chicago 31, Illinois

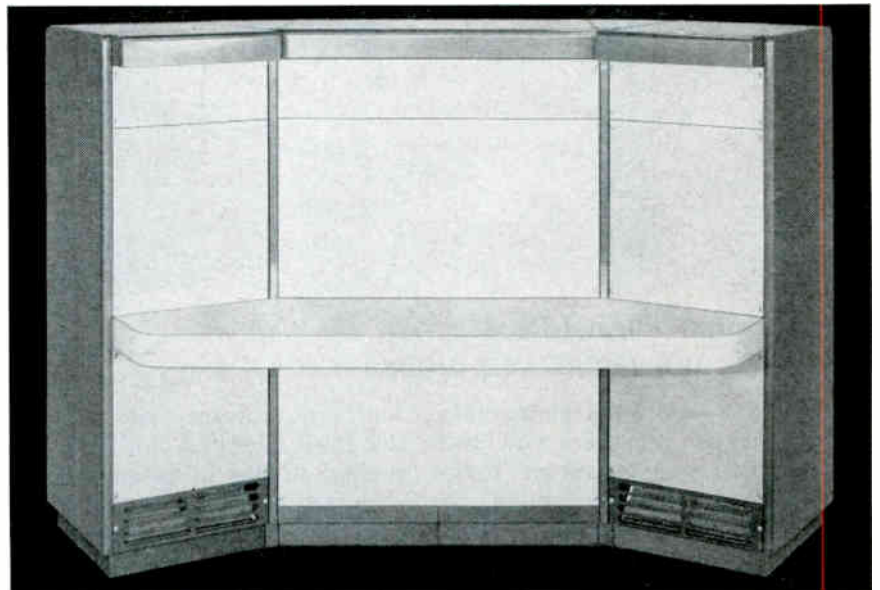

New On The Market

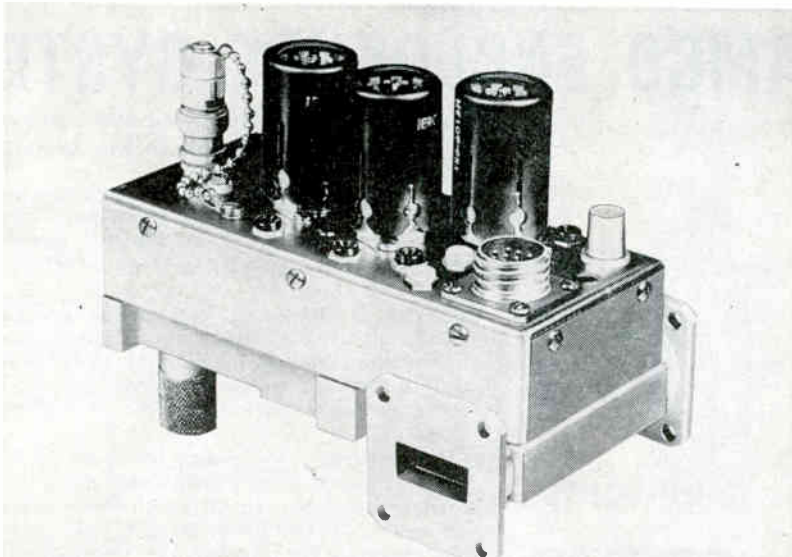

Mixer-Preamplifier

FOR MASERS AND PARAMETRICS

A 9.6 to 10.7 Gc combination mixer-preamplifier for microwave and guidance systems, developed by Microwave Development Laboratories, Inc., Wellesley, Mass., eliminates the problem of variable parameters resulting when separate mixers and preamplifiers are combined.

The model 90MB-361F1 integrated mixer-preamplifier serves as a low-noise, wideband down-converter for maser and parametric r-f

amplifiers. Noise figure of the unit is less than 9.5 db, with a minimum gain of 25 db.

The preamplifier is fix-tuned, with a stabilizing circuit that eliminates need for realignment after replacement of tubes or crystal. Preamplifier output is precisely matched to fifty ohms, allowing the main amplifier to be remotely located.

CIRCLE 301 ON READER SERVICE CARD

tector circuits are other uses for the backward diodes.

Backward diode specifications are pegged at the critical points for computer designs utilizing tunnel diodes. Leakage current is specified at 400 ma, forward voltage at 15 percent of the companion tunnel diode's peak current.

Typical shunt capacitance of the backward diodes is 3 pf, making it possible to drive several from one tunnel diode with little reduction in speed. Forward voltage drop is a maximum of 30 millivolts. Circuit design notes are available from the manufacturer.

Prices for the tunnel diodes in quantities of 100 to 999 range from \$4 to \$9; for backward diodes from \$3 to \$3.80; units are available from factory or from distributors.

CIRCLE 302 ON READER SERVICE CARD

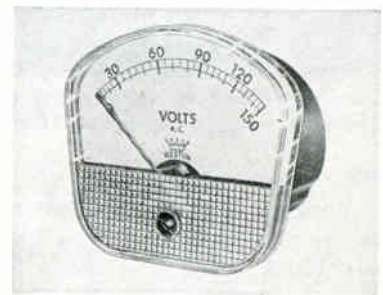

Low Cost Meter

A-C VOLTS AND AMPS

A LOW-COST a-c model in the Weston Crown line of panel instruments, with an accuracy of ± 2 per cent of full scale value, has been announced by Daystrom, Incorporated, Weston Instruments Div., 614 Frelinghuysen Ave., Newark, N. J.

Designated model 1724, the panel meter uses a movable iron vane mechanism and is available as voltmeter, ammeter, and milliammeter. The instrument has a plastic cover and molded Bakelite base. Top and sides of the cover are clear, providing excellent scale illumination and freedom from shadows; a small external bulb will provide adequate illumination for use in dimly lighted areas. Mountings of the instrument are interchangeable with any 2.5-inch MIL Spec meter.

The a-c voltmeter is normally adjusted for use on 25 to 125 cps but can be adjusted for use at desired

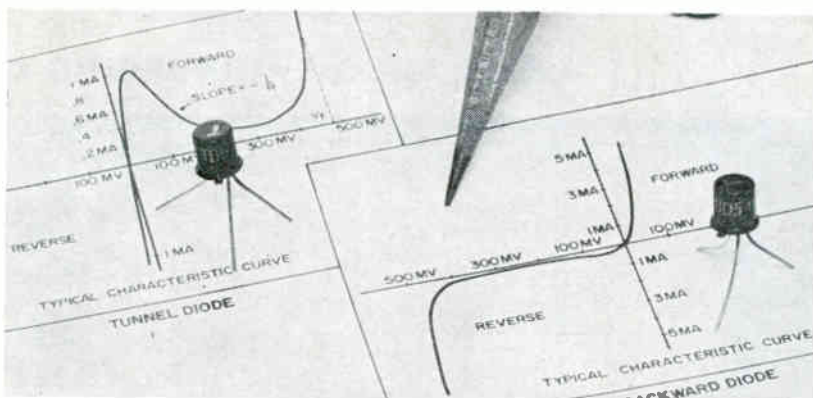

Germanium Tunnel Diodes

& MATCHED BACKWARD DIODES

SERIES of 1- and 5-ma germanium tunnel diodes, together with two complementary germanium backward diodes, are announced by Transatron Electronic Corp., 168 Albion St., Wakefield, Mass.

The tunnel diodes are designed

for high frequency use and have the close tolerance limits in peak current needed in computers. The backward diodes are designed to be used with the tunnel diodes in logic circuits and other computer applications. Low level rectifier and de-

COMPLETE LINE OF VHF TELEMETRY EQUIPMENT

MANY ITEMS AVAILABLE FROM STOCK



TELEMETRY TRANSMITTER, 215 - 265 mc

Improved frequency stability, true frequency modulation, reduced harmonic distortions, and increased power output characterize GEL's VHF Telemetry Transmitter, Type 15A2, specifically designed to meet the exacting requirements of present day telemetry systems.

FEATURES

- *Shock:* 100g, 11 milliseconds
- *Vibration:* 15g, 2000 cps
- *Frequency Stability:* $\pm 0.005\%$
- *Distortion:* Less than 1%
- *Modulation:* FM/FM, PDM/FM, PCM/FM
- *Temperature Range:* -54°C to $+85^{\circ}\text{C}$

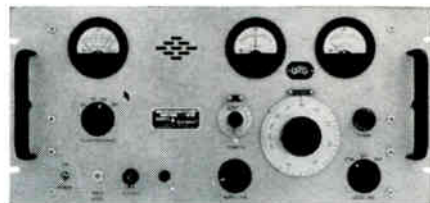

TELEMETRY RECEIVER, 215 - 265 mc

Designed in conformity with IRIG requirements specifically for use in FM/FM, PDM/FM, and PCM/FM Systems, GEL's Telemetry Receiver, Type 11B1, provides a versatility heretofore unobtainable. Other bandwidths than those shown below, or special response characteristics are available on order.

FEATURES

- *IF Bandwidths:* Plug-in type, 100, 300, 500, 750kc
- *OSC Radiation:* Meets MIL - I - 6181
- *VFO or Crystal:* Operation selected by panel switch
- *Image Rejection:* Greater than 60 db
- *Noise Figure:* Less than 7 db

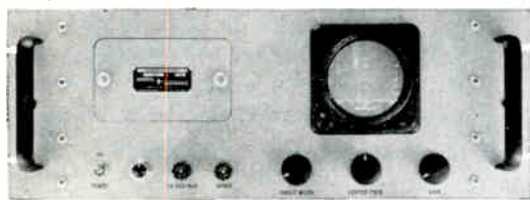

FREQUENCY DISPLAY UNIT, SERIES 14

Accepting signals from GEL Receivers, Frequency Display Unit, Series 14, features good resolution, equalization ± 3 db, low spurious radiation, edge-lighted scale, and 60 db image rejection. A signal as low as 2 microvolts at the Receiver input gives full-scale deflection.

Sweep width, center frequency, and gain control are located below a 3" Cathode Ray Tube. Unit mounts in 19" Relay Rack. Series 14 Frequency Display Units are companion units to GEL VHF Receivers.

FEATURES

- Low Spurious Radiation
- Edge-lighted Scale
- Pentagrid Mixer
- Switch for Multiple Inputs
- 20k resolution
- Adjustable sweep width 0 to 3 mc

GEL Also Designs and Manufactures a Complete Line of Telemetry Equipment for Microwave Applications

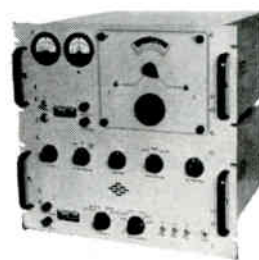

WIDE RANGE RECEIVER, 30 - 260 mc

GEL Wide Range Receiver, Type 17A1, is used in a broad variety of applications, and is designed to receive AM, FM, and Pulse information. This unit is characterized by extreme sensitivity to the reception of weak signals. The tuning head is contained in a completely shielded sub-assembly, and has very low oscillator radiation. Tuning range is covered in two bands selectable from the front panel. Panels are notched for 19" Relay Rack mounting. Power consumption is 225w at 115-230v a-c 50-60 cycles.

FEATURES

- *Input Impedance:* 50 ohm source with separate antenna input for each band
- *Frequency:* Band 1: 30-60 mc; Band 2: 55-260 mc
- *Noise Figures:* Band 1: Less than 5 db; Band 2: Less than 6 db
- *Oscillator Radiation:* 90 db below 1 mw at antenna terminal
- *IF Bandwidths:* 10 kc, 300 kc, 4 mc

Write for Technical Data Sheets on Compatible GEL Telemetry Equipment in the VHF Band.

ADDRESS ALL INQUIRIES TO:
General Electronic Labs, Inc.
8521 Second Avenue
Silver Spring, Maryland



GENERAL ELECTRONIC
LABORATORIES, INC.

CAMBRIDGE 42, MASS SILVER SPRING, MD.

frequencies up to 2,500 cps. Nine voltmeter ranges are available below 500 volts; higher ranges require use of external resistors or potential transformers.

Ammeters and milliammeters are available for use on frequencies

from 25 to 500 cps but can also be obtained for use on higher frequencies. Five ammeter models range 0-1 amp through 0-10 amp; four milliammeters from 0-15 ma through 0-500 ma.

CIRCLE 303 ON READER SERVICE CARD

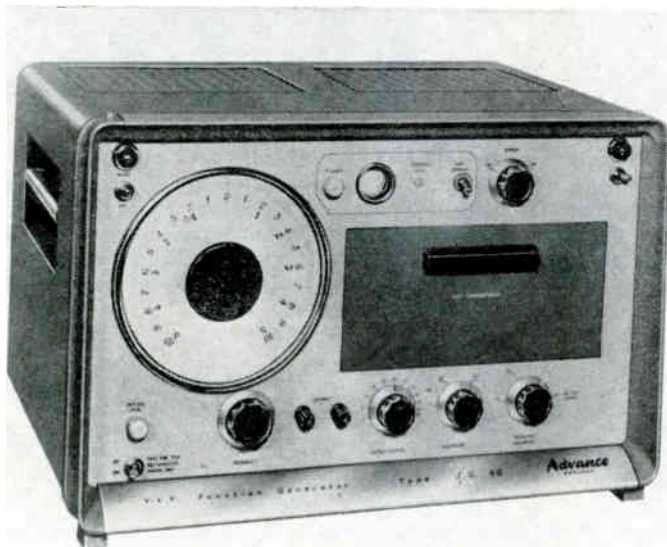

Function Generator

VARIABLE WAVEFORM

A FUNCTION GENERATOR that provides any waveform at repetition rates down to one cycle every 200 seconds has been introduced by Advance Components Limited, Hainault, Ilford, Essex, England.

Called the SG88 V.L.F. Function Generator, it combines accuracy with great flexibility of operation and is designed to fill a gap in the range of laboratory instruments currently available. It can be used for solving many simulation and computer design problems, for servo-system analysis, vibration testing and similar applications.

The generator is also valuable for analysis, performance testing and simulation problems on a variety of electronic, electric, electromechanical, seismographic and medical equipment. It eliminates the need for specially shaped and wound potentiometers and complex electronic wave-shaping circuits.

Further information is available from the exclusive U. S. distributors, General Measurements Company, Inc., 1108 Beacon Street, Newton Highlands, Mass.

CIRCLE 304 ON READER SERVICE CARD

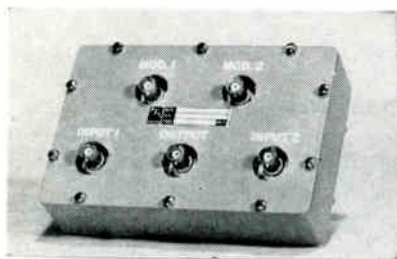

SPDT Crystal Switch

50 DB ISOLATION

A NEW single pole double throw solid state crystal switch, model

SNB203A, has been developed by American Electronic Laboratories, 121 N. 7th St., Philadelphia, Pa. The switch is designed to operate at 25 Mc with a bandwidth of about ± 5 Mc. However, it can be factory tuned to operate from below 10 Mc up to about 75 Mc. Other models can be built for frequencies up to 18 Gc. Closed insertion loss is less than 2 db, with an isolation greater than 50 db.

CIRCLE 305 ON READER SERVICE CARD

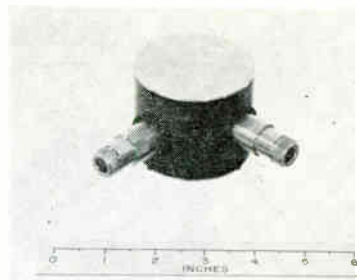

Microwave Filter

ELECTRONICALLY TUNED

WATKINS-JOHNSON COMPANY, 3333 Hillview Ave., Palo Alto, Calif., has announced the commercial availability of its WJ-501, an electronically tuned microwave filter that can be electronically tuned over a wide range of frequencies. The device uses the principle of low-loss gyromagnetic resonance in single crystal yttrium iron garnet (YIG) to achieve a high Q structure whose resonant frequency can be controlled by a d-c magnetic field.

The unit covers the full 2 to 4 Gc band, with a bandwidth of approximately 25 Mc. Insertion losses range from 3 db at 2 Gc to 1 db at 4 Gc. If higher selectivities are required, multiple-tuned structures can be designed but with increased insertion loss at resonance. Band rejection filters of similar characteristics have been built. Bandpass and band rejection filters can be built at frequencies through 30 Gc for specific applications.

The complete filter (15 cubic inches, 2½ pounds) is priced at \$870, with about a four-week delivery date.

CIRCLE 306 ON READER SERVICE CARD

Temperature Recorder

500 TO 2,500 F SPANS

ECONOMICAL miniaturized temperature recorder that operates directly from a thermocouple is announced by Assembly Products, Inc., Chesterland, O.

The Temprint recorder is sensitive enough to permit temperature recording without a signal amplifier. The meter movement, calibrated to match the thermocouple, is essentially the same as the movement used in sensitive panel pyrometers.

The only electrical connections

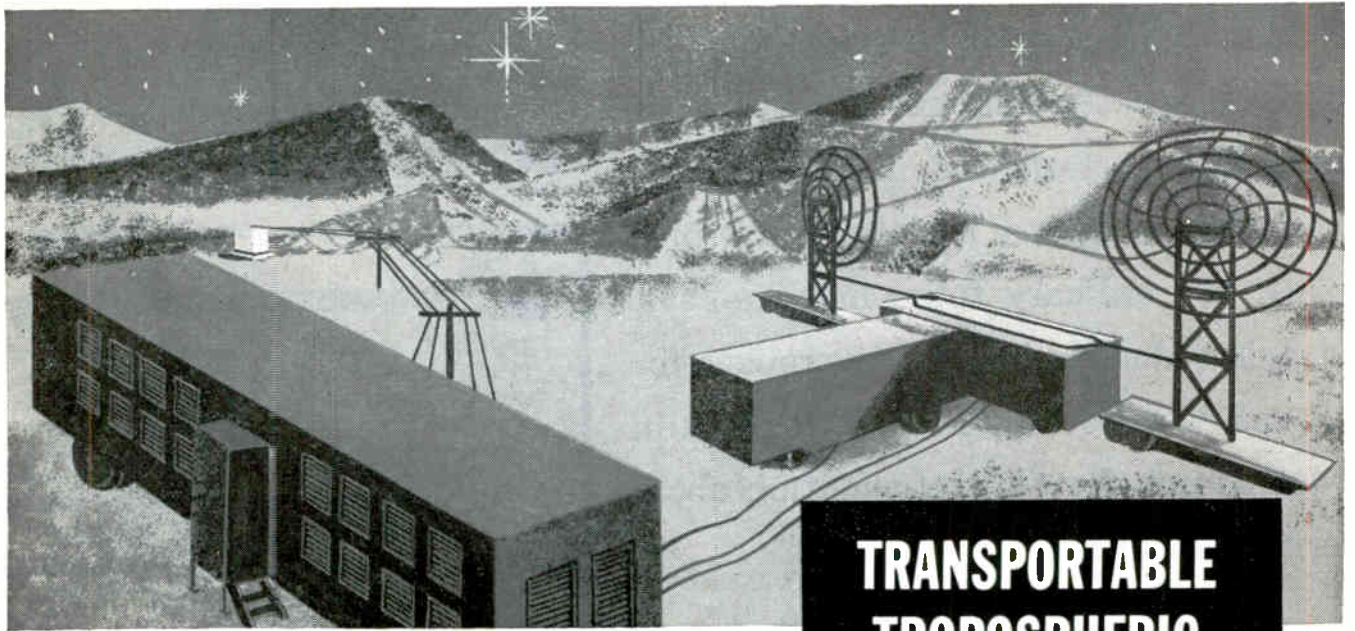

**TRANSPORTABLE
TROPOSPHERIC
SCATTER SYSTEM**

THE BIG **A LEADS THE WAY
TO *INTEGRATED* COMMUNICATIONS SYSTEMS**

A new concept in continent-spanning tropospheric scatter communications soon will be available to the U.S. Air Force. For the first time, the full multichannel capability and reliability of a large, fixed installation will be provided in a compact, air-ground transportable package. The all-environment, 10kw, AN/MRC-85 is being designed and manufactured by ADLER under subcontract to Page Communications.

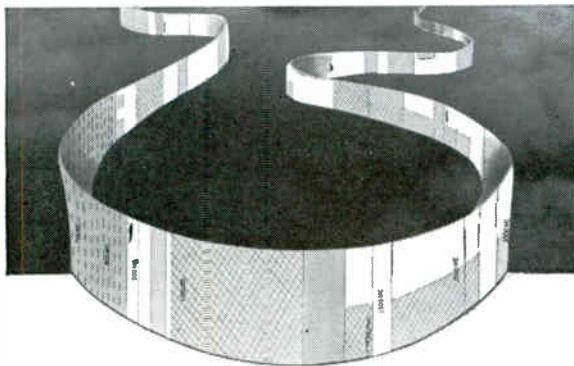

SPECTRUM-STRETCHING COMMUNICATIONS SYSTEM — ADLER heterodyne repeater techniques have opened a wide range of UHF channels for U. S. Army field communications, and prevented obsoleting of millions of dollars of VHF equipment. Developed and manufactured by ADLER, the "F-Head" converter permits the basic AN/TRC-24 VHF system to be used for UHF relaying in areas where VHF spectrum congestion is a problem. Designed for plug-in use, the compact "F-Head" heterodynes the VHF output of the AN/TRC-24 to the available UHF range. ADLER heterodyne techniques also are used in advanced TV microwave and repeater systems, and multichannel communications.

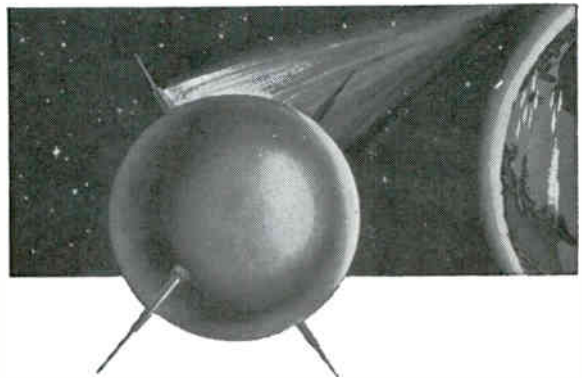

SATELLITE RELAY SYSTEM — A reliable, worldwide network for telegraphy and teletype communications will be realized through PROJECT COURIER of the Advanced Research Projects Agency and U. S. Army Research & Development Laboratories. Each of the Courier's air-ground transportable stations duplex transmit and receive 15 million bits of stored information in the 4-minute contact with the satellite. As subcontractor to ITT Laboratories, ADLER is responsible for design, manufacture and equipment installation of the ground station trailers of this earth-satellite relay system.

Write for all the facts on how ADLER experience can help solve your communications problems.

**A
ADLER**

ADLER ELECTRONICS, INC. New Rochelle, N. Y.

WEIGHT of your system can be cut if you specify components capable of outstanding performance. Example: high output lets *one* Sperry traveling wave tube replace *two* ordinary tubes in Nike-Zeus. If weight reduction is a knotty problem for you, call Gainesville, Florida, FRanklin 2-0411 collect, for full information about Sperry capabilities.

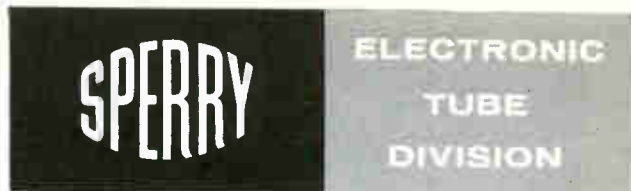

Gainesville, Florida • A Division of Sperry Rand Corporation

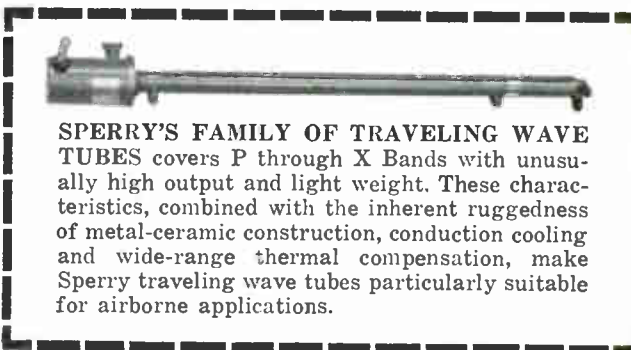

SPERRY'S FAMILY OF TRAVELING WAVE TUBES covers P through X Bands with unusually high output and light weight. These characteristics, combined with the inherent ruggedness of metal-ceramic construction, conduction cooling and wide-range thermal compensation, make Sperry traveling wave tubes particularly suitable for airborne applications.

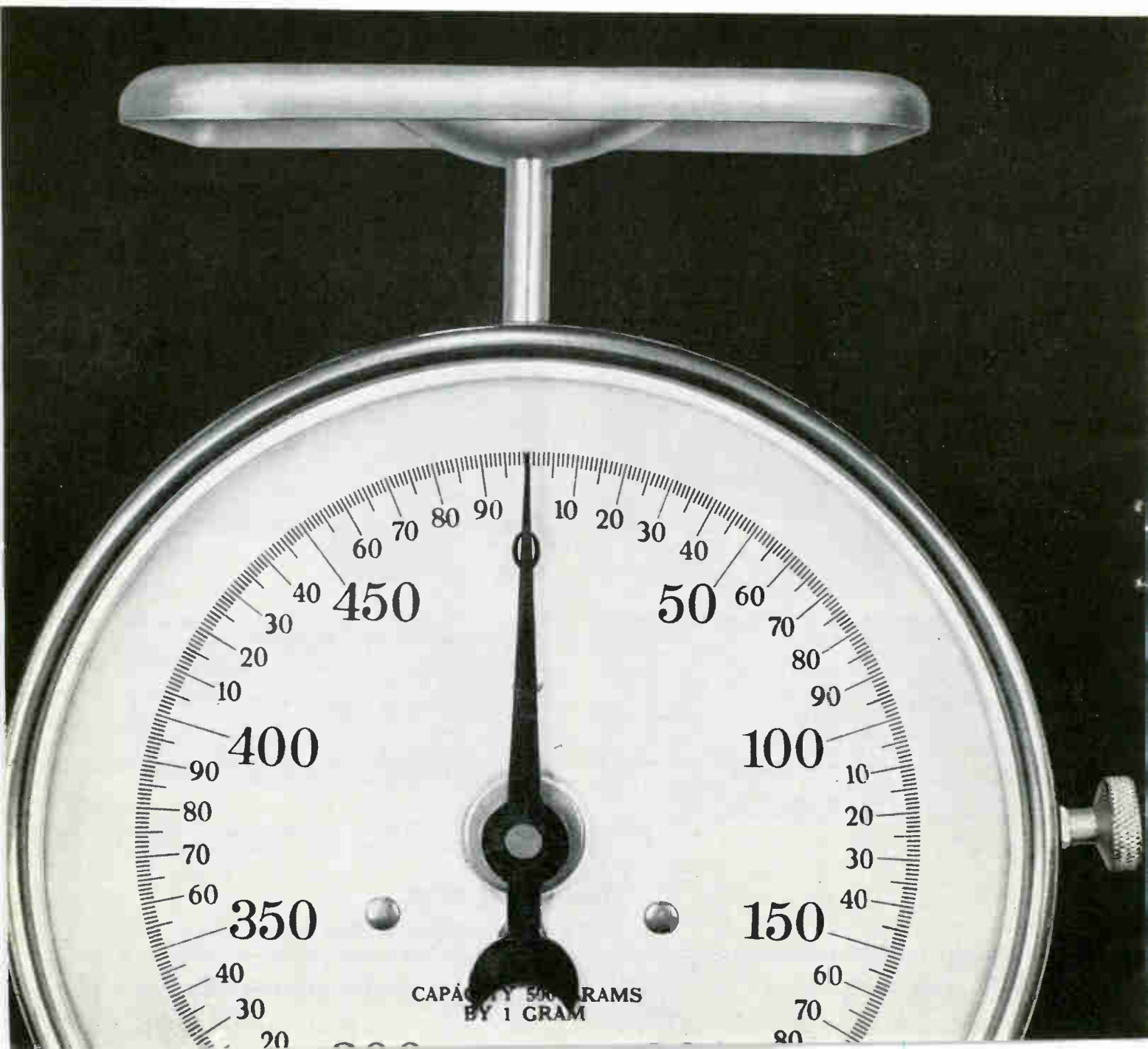

SPECIFY RAPIDLY AND ACCURATELY WITH SPERRY'S SPECI-FILE



Now you can have Sperry's complete family of klystron and traveling wave tubes right at your fingertips for faster, more accurate tube selection. Attractively packaged and comprehensively indexed, the Sperry's Spec-File gives you complete electronic and physical characteristics of every tube in the Sperry line.

TO GET YOUR FREE

Speci-File, use this coupon:

Section C-105
SPERRY
ELECTRONIC TUBE DIVISION
Gainesville, Fla.

Please send me a FREE Sperry
Speci-File:

Name _____
Title _____
Company _____
Address _____
City _____
State _____



GAINESVILLE, FLORIDA
A Division of Sperry Rand Corporation
CIRCLE 200 ON READER SERVICE CARD
← CIRCLE 98 ON READER SERVICE CARD

necessary for operation are the thermocouple and a 115-volt a-c line. A rear mounted knob simplifies adjustment for thermocouple resist-

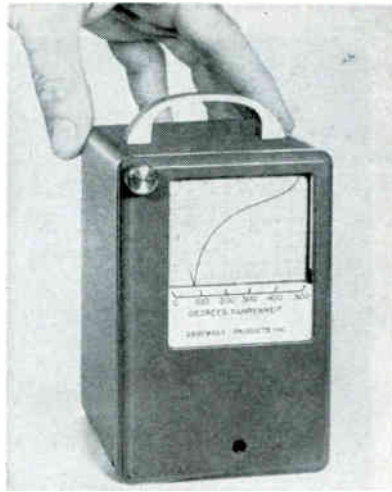

ance, eliminating the need to remove turns of resistor wire.

Minimum temperature span covered by the recorder is 0 to 500 degrees F; maximum span is 0 to 2,500 degrees. Accuracy is ± 2 percent of full scale. Standard chart speed is 1 inch per hour, although other speeds are available.

The recorder operates on the clamped-bar principle. Every four seconds the pointer on the moving coil is clamped briefly. A marker on the pointer then prints the pressure sensitive chart paper. Chart paper is advanced by a synchronous motor drive.

Dimensions of the recorder are $3\frac{1}{2}$ inches wide, $5\frac{1}{2}$ inches high, $4\frac{1}{2}$ inches deep. Weight with paper roll is $3\frac{1}{2}$ pounds.

CIRCLE 307 ON READER SERVICE CARD

Multipurpose Lab Meter HIGH INPUT IMPEDANCE

MODEL 302E Electrosensor has high input impedance of 10^{17} ohms with input capacitance of less than 0.01 pf and precise unity gain amplification. The device is designed to perform with stability, accuracy and extreme sensitivity as an ultra high impedance electrometer, a microammeter, unity gain amplifier, meg-megohmmeter, voltage follower, driver amplifier for d-c systems, micro coulombmeter, precision current follower, feedback amplifier for precise standards, high accuracy analog computer, and

WHAT do you need to know about...

PURE
FERRIC
OXIDES

MAGNETIC
IRON
OXIDES

MAGNETIC
IRON
POWDERS
?

Since final quality of your production of ferrites, electronic cores, and magnetic recording media depends on proper use of 3 specialized groups of magnetic materials... you'll find it mighty helpful to have all the latest, authoritative technical data describing the physical and chemical characteristics of each. This information is available to you just for the asking. Meanwhile, here are highlights of each product group.

PURE FERRIC OXIDES—For the production of ferrite bodies, we manufacture a complete range of high purity ferric oxide powders. These are available in both the spheroidal and acicular shapes, with average particle diameters from 0.2 to 0.8 microns. Impurities such as soluble salts, silica, alumina and calcium are at a minimum.

MAGNETIC IRON OXIDES—For magnetic recording—audio, video, instrumentation etc.—we produce a group of special magnetic oxides with a range of controlled magnetic properties. Both the black ferroso-ferric and brown gamma ferric oxides are available.

MAGNETIC IRON POWDERS—For the fabrication of magnetic cores in high-frequency, tele-communication, and other magnetic applications, we make a series of high purity iron powders.

If you have problems involving any of these materials, please let us go to work for you. We maintain fully equipped laboratories for the development of new and better inorganic materials. Write... stating your problem... to C. K. Williams & Co., Dept. 25, 640 N. 13th St., Easton, Penna.

WILLIAMS

COLORS & PIGMENTS

C. K. WILLIAMS & CO.
EAST ST. LOUIS, ILL. • EASTON, PA.
EMERYVILLE, CAL.

CIRCLE 99 ON READER SERVICE CARD 99

LAPP INSULATION

FOR WATER-COOLED SYSTEMS

For carrying cooling water which must undergo a change in potential, use of Lapp porcelain eliminates trouble arising from water contamination and conductivity, sludging and electrolytic attack of fittings. Permanent cleanness and high resistance of cooling water is assured with the completely vitrified, non-absorbent Lapp porcelain.

PORCELAIN WATER COILS

Twin hole or single hole models to provide flow of cooling water from 2 to 90 gallons per minute. Each assembly includes ceramic coil, aluminum mounting base, nickel plated brass attachment fittings... and is proof-tested to 100 lbs. per square inch water pressure.

PORCELAIN PIPE

Practically any piping layout can be made with these pieces... swivel flanges provide automatic alignment. Straight pipe up to 60" lengths, 90° and 180° elbows, fittings for easy attachment to metal pipe; matching support insulators. Inside diameters $\frac{3}{4}$ " to 3".

WRITE for Bulletin 301 containing complete description and specification data. Lapp Insulator Co., Inc., 172 Sumner Street, Le Roy, New York.

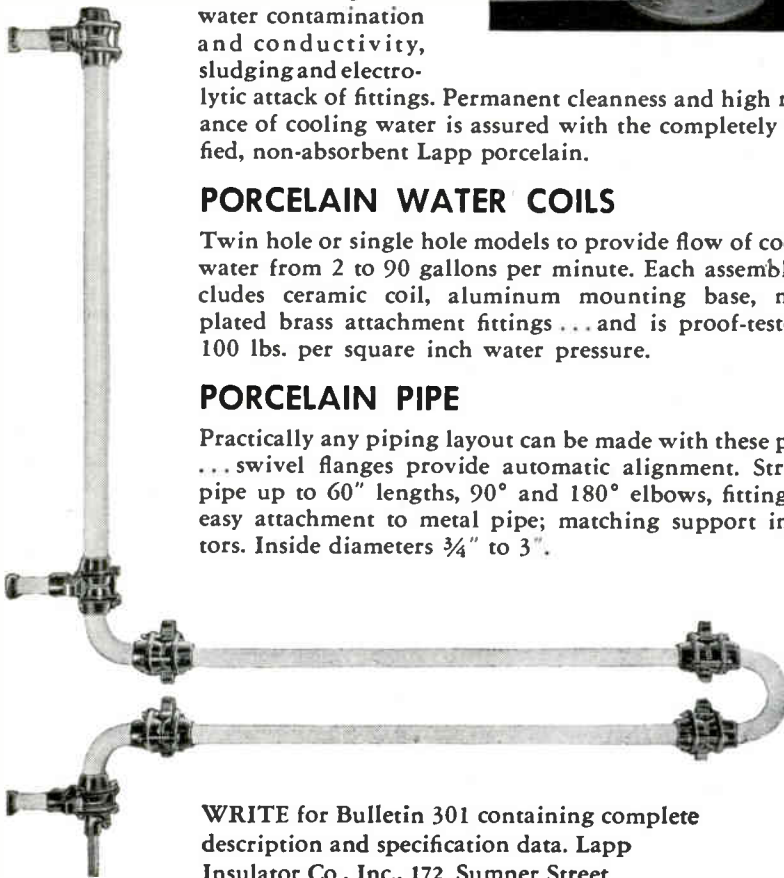

Lapp

semiconductor testing instrument.

Specifications include full voltage ranges on mirror-back meter of 100 mv to 250 volts, d-c follower

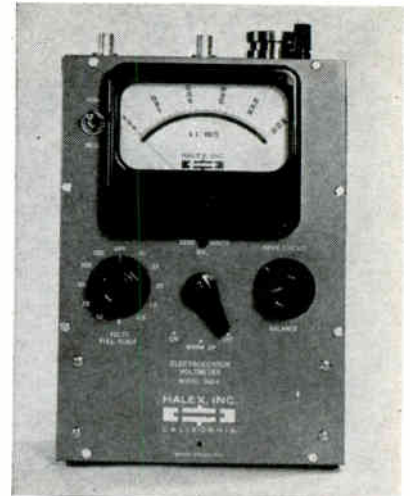

accuracy of 0.02 percent at low terminal and 0.001 percent at high terminal, and a d-c proportionality factor of 0.9995 at low terminal and 0.99997 at high terminal.

Circuits include a precision high impedance unity gain amplifier consisting of an electrometer circuit with transistorized current amplifier, and a precision unity gain transistor-vacuum tube amplifier. Relativistic coupling of these basic components provides extremely precise voltage following characteristics with an input impedance higher than that of the free space surrounding the instrument.

Device is manufactured by Halex, Inc., Box 546, El Segundo, Calif.
CIRCLE 308 ON READER SERVICE CARD

Resin Dispenser VARIABLE RATIO

DELSEN CORP., 719 W. Broadway, Glendale 4, Calif. By providing a greater range of resin-hardener ratios, the model 395 variable ratio resin dispenser provides a much greater flexibility in metering two-component liquid resin systems. By means of a simple lever adjustment, the ratio of resin to hardener can be varied from about 20:1 to 1:1. Use of the dispenser allows rapid change over from one resin-hardener system to another. Changes in resin to hardener ratio can readily be made in order to compensate for changes in ambient temperature. A reference scale is provided so that

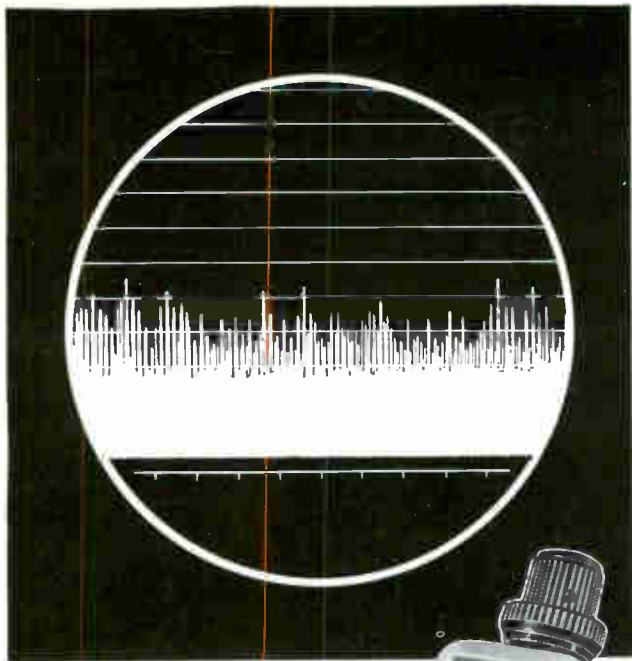

NEW FROM
RAYTHEON...



Wide Band Noise Source

The new transistorized Raytheon Noise Source can generate noise power, flat within ± 2 DB over the spectrum of 30 cps to 300 Kcps, at a level of 0-10 millivolts rms into a 1,000 ohm load. Designers of missile field test equipment, noise simulators, and other laboratory and production test equipment requiring a compact, low power DC-operated noise source module, will find this new Raytheon development a versatile component. For complete data on the Raytheon Wide Band Noise Source, please write to: Raytheon, Industrial Components Div., 55 Chapel St., Newton 58, Mass.



CIRCLE 201 ON READER SERVICE CARD

October 21, 1960

digital simulation

Realistic Tests . . .
mean
Reliable Results



will simulate any digital code

Solid State PCM Simulator ESS-500 by Telemetry

Realistic preliminary checkout of PCM telemetry ground stations assures reliable results in performance. The Electronic Signal Simulator ESS-500 by Telemetry, Inc. gives this assurance . . . simulates the digital output of an airborne or ground multiplexer and digitizer for both calibration and checkout . . . presents serial input data . . . applicable also in research and development of pulse coded systems.

Versatile Signal Simulator provides for word length selection, master sync code, 0-to-full scale coding, and 11 special data codes . . . through use of plug-in units, can generate binary, binary-coded-decimal, excess three, biquinary, or any other digital code. NRZ and RZ output signals are provided at +20 volts and -10 volts for full scale; with zero volts for zero scale. Completely transistorized unit occupies only 5 1/4-inch panel space in standard 19-inch relay rack.

Telemetry, Inc.

12927 S. Budlong Avenue, Gardena, California

CIRCLE 101 ON READER SERVICE CARD 101

HIGH RELIABILITY LONG LIFE

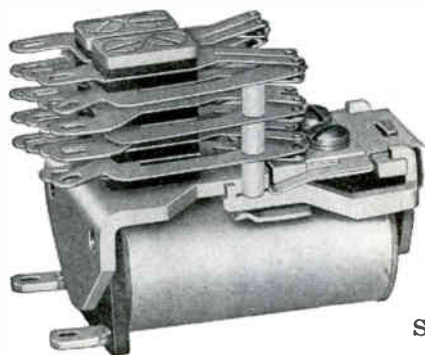

Series 5600
6PDT

PRICE ELECTRIC TELEPHONE TYPE RELAY with BIFURCATED CONTACTS

Small, general-purpose Series 5600 relays are designed to insure increased reliability and longer life in critical applications.

Mechanical design features include a low friction armature hinge for reduced wear, and coil and contact lugs located at the same end of the relay for ease in mounting and wiring.

Coils to 10,000 ohms are available for standard voltages to 120 VDC . . . Coils to 25,000 ohms are available for special applications. Normally fast operate and release operation can be modified, through special relay construction, to provide time delay on operate and/or release.

Combinations of contact forms A, B, C, and D are available to a total of 18 contact springs. Typical ratings for bifurcated contacts are 4 amps at 150 volt-amperes AC or 3 amps at 26.5 volts DC. Other ratings are also available.

Series 5600 relays are available open or hermetically sealed, with plain or bifurcated contacts.

Call Or Write For Additional Information

PRICE ELECTRIC CORPORATION



306 E. Church Street • Frederick, Maryland
MOument 3-5141 • TWX: Fred 565-U

ratios may be accurately reset. The new unit dispenses a reproducible ratio of resin to hardener and is equipped with drip-proof outlet valves. It is available in both hand operated and motor driven models.

CIRCLE 316 ON READER SERVICE CARD



Germanium Transistor MESA CONFIGURATION

TEXAS INSTRUMENTS INCORPORATED, P. O. Box 312, Dallas 21, Texas. The 2N1405 series germanium mesa transistor features low noise figures with f (max.) in excess of 1,000 Mc. They are especially engineered to provide a rugged and reliable device for applications as r-f amplifiers, oscillators or intermediate frequency amplifiers in transceivers and communications equipment. The 2N1405, -6 and -7 are production tested to assure maximum noise figures of 6, 8 and 10 db respectively at 200 Mc. The 2N1405 series has excellent emitter-base diode characteristics which make them useful as mixers, well into the uhf range. The 2N1405 and -6 have typical bandwidth products of 300 Mc which provide excellent characteristics for video amplifier circuits. The 2N1407 is recommended for use in local oscillator circuits, i-f amplifiers or as a general purpose h-f low cost amplifier.

CIRCLE 317 ON READER SERVICE CARD



Delay Line AUDIO TYPE

CONTROL ELECTRONICS CO., INC., 10 Stepar Place, Huntington Station, L. I., N. Y. Model F-483 audio type delay line has a delay of 1,000 μ sec

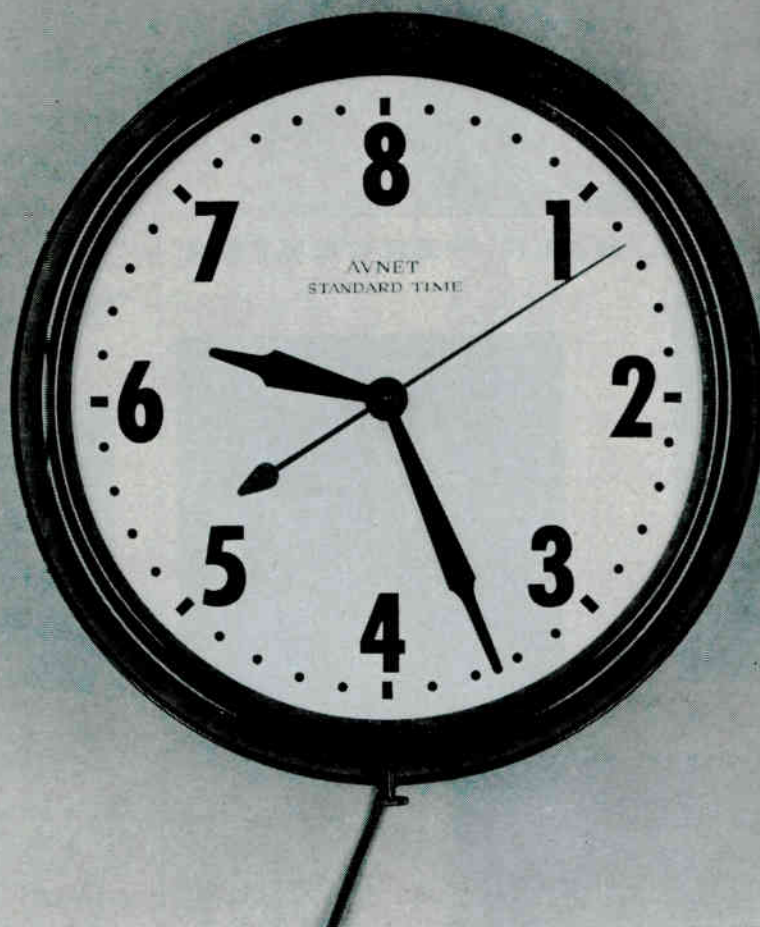

The Avnet System

creates a new Concept of Time

A normally expedient shipping time for your order would be 9:27, as shown by the hands on the clock above. *The Avnet System* would ship at 6:18. The few hour difference (or few day difference) might not be crucial, But if time *is* an important factor, use The Avnet System. Avnet Standard Time and Avnet Standard Procedures ship your order faster than any other major source for electronic components.

This new Concept of Time is one of the many advantages in The Avnet System. *Avnet maintains a network of Sales Engineers traveling the U.S. Each engineer has his counterpart in a Service Center Expediter. Tremendous stocking facilities are maintained strategically throughout the country. Avnet maintains and operates complete assembly facilities for Connector Prototype requirements. Avnet's Concept of Time may gain you minutes, hours, days, money. Contact your nearest Service Center in The Avnet System.*

AVNET



THE AVNET SYSTEM
Men / Methods / Materials / Management
AVNET ELECTRONICS CORP.

Avnet Service Centers and Stocking Facilities are located in Los Angeles, Cal.; Sunnyvale, Cal.; Chicago, Ill.; Dayton, Ohio; Westbury, L. I.; Burlington, Mass.

Avnet distributes from its stocking facilities: BENDIX SCINTILLA CONNECTORS, SPERRY SEMICONDUCTORS, RHEEM SEMICONDUCTORS, ELECTROSNAP AND HETHERINGTON SWITCHES, GREMAR CONNECTORS, CLARE RELAYS, ROBERTSON SPLICE & CONNECTOR CASES, BABCOCK RELAYS, KING SUBMINIATURE HI-TEMP CERAMIC CAPACITORS, TIC PRECISION TRIMMERS, VIBPEX FASTENERS by GENERAL TIRE & RUBBER CO., U. S. SEMCOR SEMICONDUCTORS, SANGAMO CAPACITORS, SPRAGUE CAPACITORS

NB note well...

this may be
the meter
for you!

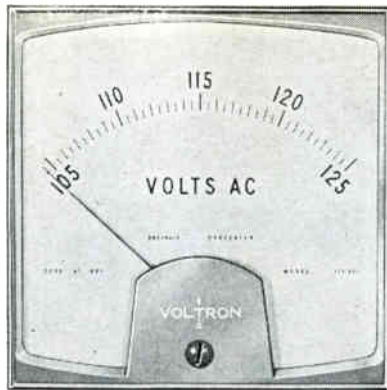

VOLTRON'S ONE/HALF PERCENTER

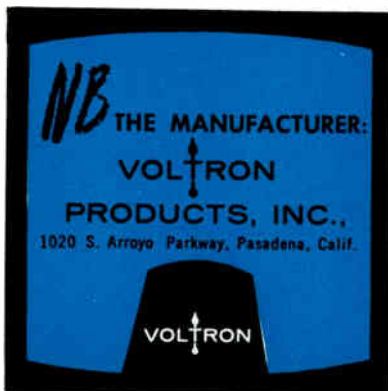
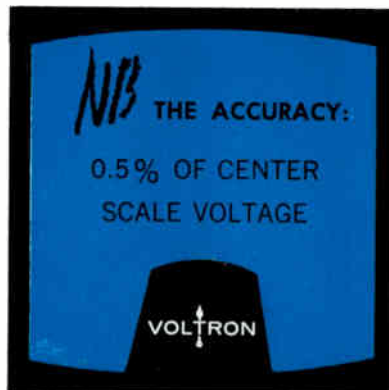

WRITE FOR BULLETIN #608
REPRESENTATIVES IN
PRINCIPAL CITIES

and attenuation of 3 db at 15Kc. Delay is held to 1/2 percent. Impedance is 600 ohms. Unit features a rise time of 40 μ sec and cut-off frequency at 20 Kc. Phase linearity is better than 0.5 percent to 10 Kc. This delay line features standard rack type mounting and measures 19 in. long, 5 1/2 in. deep by 6 in. high. It weighs 30 lb. The line, which can be cascaded, has application in study of special wave forms, sonar returns, sonar ranging as well as survey analysis. Taps are available every 20 μ sec. Availability is 6 weeks.

CIRCLE 318 ON READER SERVICE CARD



High Pot Tester SEMI-AUTOMATIC

TRANS-AMERICA DYNAMICS CORP., 149-A Babylon Turnpike, Roosevelt, L.I., N.Y. Model T-660 is a semi-automatic high potential circuit tester for detecting high resistance leakage breakdown, arcing or shorting on electronic control circuits of all types. It is capable of testing 167 related circuits simultaneously against all others or one nonrelated circuit at a time and can be expanded for programming to customer requirements in multiples of 56 circuits. Features include automatic advancement from one circuit to another and variable peak time adjustment from 1 to 60 sec.

CIRCLE 319 ON READER SERVICE CARD

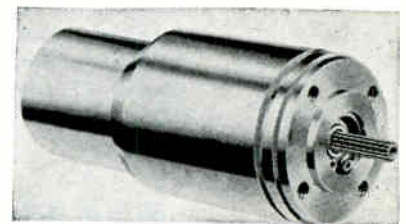

Servo Motor INERTIALLY DAMPED

JOHN OSTER MFG. CO., Avionic Division, Racine, Wisc., offers a new

THERE'S NOTHING INTANGIBLE ABOUT THIS MEASURE OF TRANSFORMER RELIABILITY

Maximum
Failure
Rate:

1 per 100,000,000 part hours



Extraordinarily high reliability is the essential element in the Air Force Minuteman Intercontinental Ballistic Missile program. For example, the transformers used in Minuteman must be of such quality and reliability that they will be able to survive repeated checkout testing and have a failure rate of only 0.001 per cent per 1,000 hours . . . or, to put it another way, one failure per 100,000,000 part hours.

These stringent requirements are demanded by the fact that Minuteman will be left unattended in underground silos for months, or even years, and yet must be ready for instant launching and assure pinpoint target accuracy.

Wheeler Electronic Corp. is proud to have been chosen by Autonetics to develop a program which will result in a continuous supply of transformers that will meet the objective failure rate. As with all electromagnetic products, Wheeler will engineer and design these transformers under the "Systems Concept" . . . as integral parts of the missile's inertial guidance and flight control equipment.

If you need high reliability electromagnetic products, let Wheeler show you how their "Systems Concept" can help you. You will find that Wheeler's team of exceptionally well-qualified engineers can skillfully interpret and develop your specifications, and will translate your special needs into efficient production methods constantly keeping in mind the vital part each component will play in the system.

Transformers — Power Supplies — Current Regulators — Magnetic Amplifiers — Voltage Regulators — Communications Equipment, both VHF and UHF — Special Test and Checkout Equipment — Approved Environmental Test Facilities Available.

**WHEELER
ELECTRONIC**
CORP.

Subsidiary of Sperry Rand Corporation

150 East Aurora Street, Waterbury 20,
Connecticut • Telephone: PLaza 4-5191
Western Sales Office: 2200 East Imperial
Highway, El Segundo, California

IERC TRANSISTOR HEAT DISSIPATOR



actual size

accepts .305 to .335 variations in TO-5 cases!

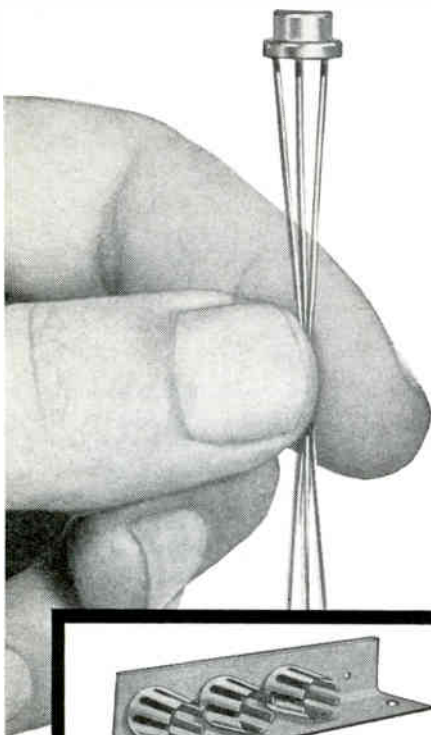

IERC Transistor Heat-dissipating Retainer^c readily accommodate diameter variations up to .030" found in TO-5, TO-9, TO-11, TO-39 transistor cases. This single IERC part saves you time and costs in specifying, stocking and application.

IERC's exclusive design features maximum thermal contact with transistor case for efficient transfer of heat to the dissipator and heat sink. Attaching methods suitable for printed circuit boards, chassis and heat sinks provide thermal benefits and retention in extreme shock and vibration environments.

Installation is a smooth, tension fit—eliminating the possibility of "snap-fit" impact injuries to the transistor!

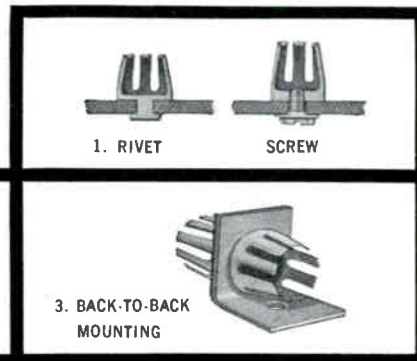

Simplified installation for effective heat dissipation with IERC Transistor Heat Dissipators are illustrated: 1. Parts available in rivet or screw attaching types. 2. Single or multiple mounting on heat sink angle. 3. Back-to-back mounting.

Detailed information, performance graphs, etc. are available in latest IERC Technical Bulletin. Write for a copy today!

IERC DIVISION

INTERNATIONAL ELECTRONIC RESEARCH CORPORATION
135 West Magnolia Boulevard, Burbank, California

Foreign Manufacturers: Europelec, Paris, France. Garrard Mfg. & Eng. Co., Ltd., Swindon, England.

size 11 precision hi temp inertially damped servo motor for high speed and/or high gain servo systems. Inertial damping eliminates the need for a generator amplifier. Type 5752-03 is manufactured completely from corrosion-resistant materials and meets military environmental specifications. No load speed is 5,800 rpm, torque at stall 0.60 oz in., rated voltage 115 rms, 400 cps for fixed phase and 70 for control phase. Other voltages are available. Flywheel magnet inertia is 2.0 gm cm² and flywheel magnet damping factor 80 dyne cm/rad/sec. Corner frequencies are 2.3 cps for F₁, 6.4 cps for F₂ and 23.3 cps for F₃.

CIRCLE 320 ON READER SERVICE CARD



Mixer-Preamplifier LOW NOISE UNIT

LEL, INC., Akron St., Copiague, N.Y. Model MMC-3 coaxial microwave front end provides a low-noise coverage over the 4,000 to 8,000 Mc spectrum. Overall gain is 25 db minimum, typical noise figure is 7.5 db minimum, i-f bandpass is 8 Mc in either 30 or 60 Mc center frequency versions. The MMC-3 supplements the MML-2 and MMC-2 octave coverage coaxial mixer/pre-amplifier units.

CIRCLE 321 ON READER SERVICE CARD

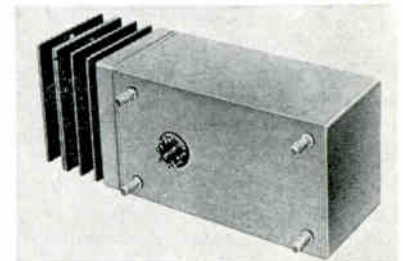

D-C Power Supply IN MODULAR FORM

VIKING INDUSTRIES, INC., 21343 Roscoe Blvd., Canoga Park, Calif. Constructed in modular form, com-

*A new addition
to VARIAN'S G-22
Dual Channel
Potentiometer
Recorder*

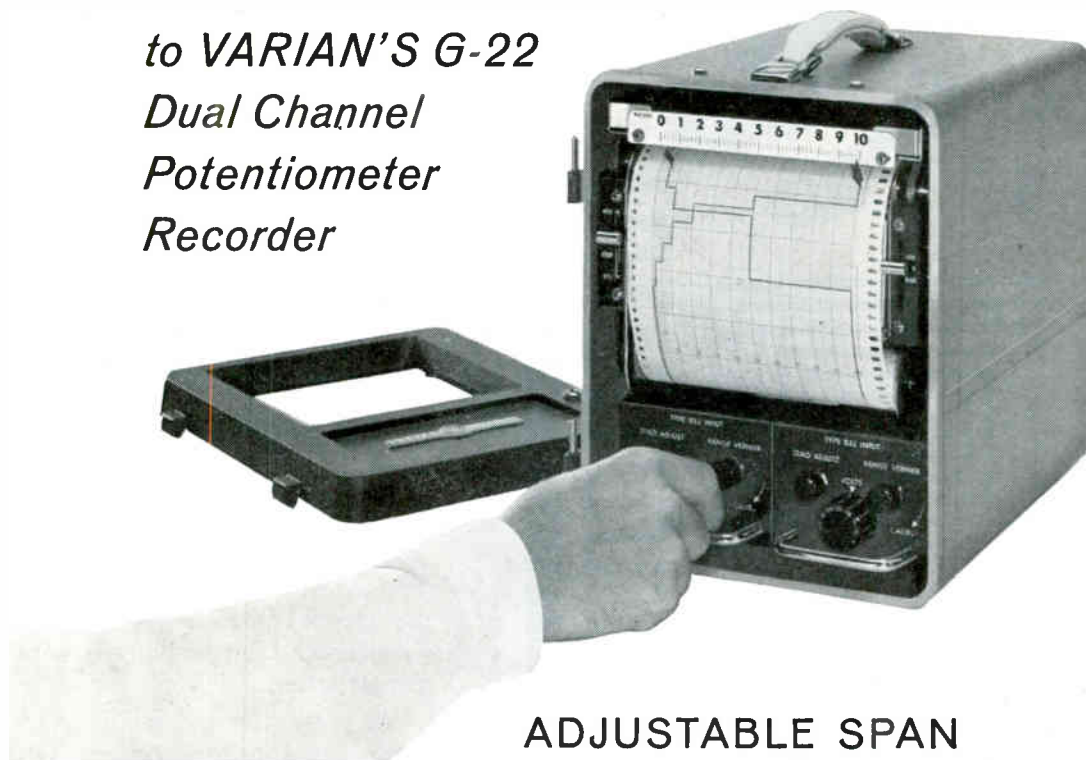

ADJUSTABLE SPAN

0-10 MV TO 0-500 VOLTS

More versatile than ever, the Varian G-22 will now record from sources of almost any likely signal voltage. A newly available plug-in input chassis, the B-22 attenuator type, is easily set as needed from spans as little as 10 millivolts full scale to as high as 500 volts. Front-panel adjustment is continuous in between for optimizing use of the chart's full width in any recording situation.

The G-22 can be your best all-purpose recorder in other ways too. Two channels in themselves also mean versatility—they make the recorder a correlator of simultaneous variables (any two you choose). Two plug-in input chassis mean that each channel's recording characteristics can be quickly changed. And zero can be reset anywhere across the chart from left to right—each channel separately. Last

but not least don't underestimate the value of the handle on top. This recorder goes wherever there is recording to be done.*

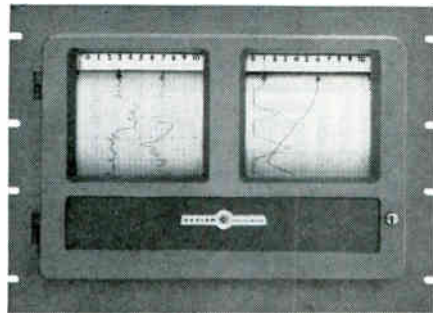

*Varian offers rack mounted versions too—either singles or twins. The latter is pictured, showing how four channels of recording can be fitted within the 19-inch width of a standard rack.

SPECIFICATIONS, OPTIONS, AND ACCESSORIES

One second full-scale balancing time • Accuracy 1% of full scale • Sensitivity 0.25% of full scale • Two chart speeds standard, four speeds optional • Wide selection of chart speeds from $\frac{3}{8}$ " per hour to 16" per minute • Weight 33 pounds • Available accessories include retransmitting slide wires, alarm contacts, event markers, etc.

For full specifications, write the Instrument Division.

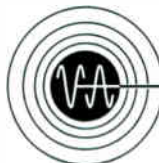

VARIAN associates
PALO ALTO 1, CALIFORNIA

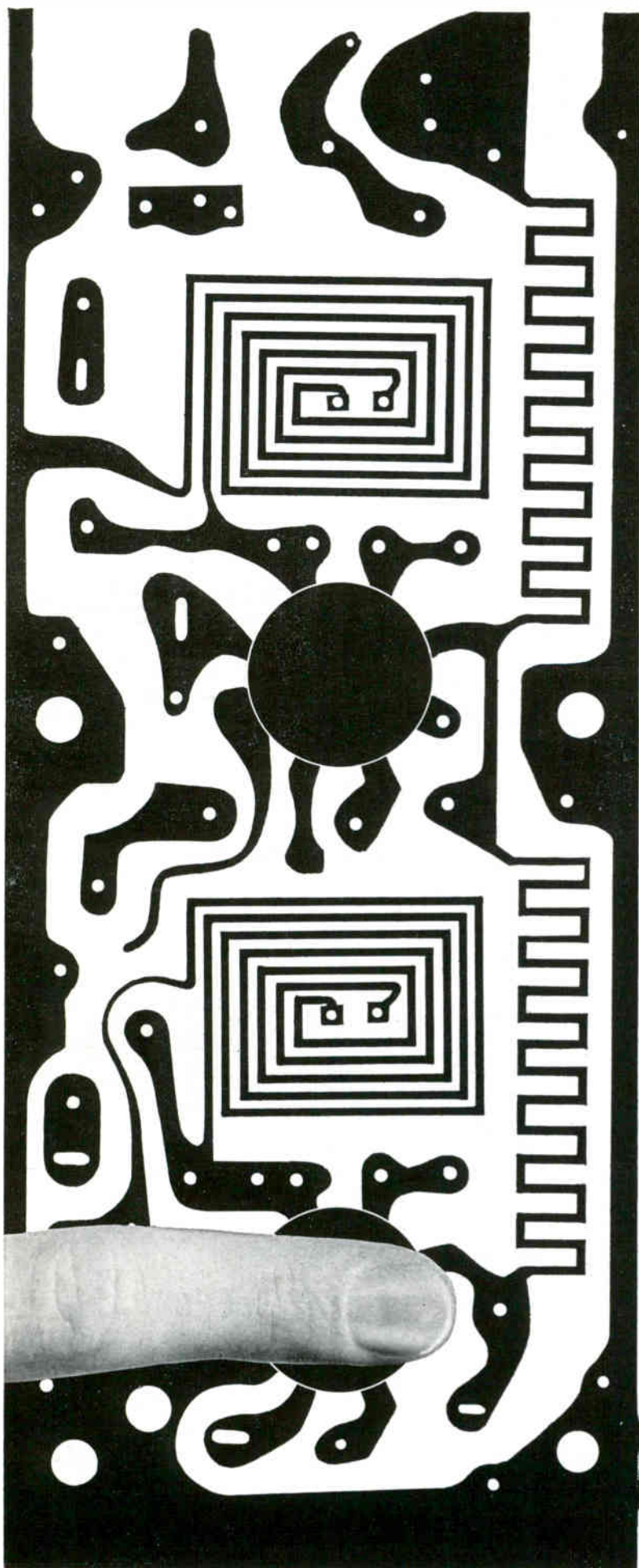

Better base for printed circuits ...Panelyte®

No matter what dramatic new uses you find for printed circuits . . . no matter what requirements you specify . . . count on Panelyte Copper-Clad Laminates for consistently superior construction.

At present, you can choose from a wide range of properties in six different grades. And St. Regis Panelyte is working to perfect structural qualities which will meet your *future* needs, as well.

Whether you're looking for less warp, more flexural strength, shock-resistance, or any special combination of characteristics, bring your copper-clad laminate specifications to Panelyte. We're also equipped to serve you promptly with laminated plastic sheet, rod, or tube in Military and NEMA Grades. The name again: St. Regis Panelyte. For complete information and the address of your nearest Panelyte distributor, write Dept. EL-1021 St. Regis Paper Company, 150 E. 42nd Street, New York 17, New York.



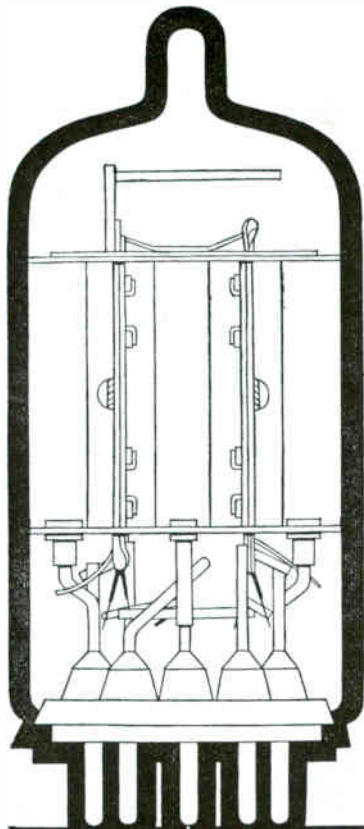

ECC83

12AX7

high gain
double
triode

Double Triode having separate cathodes, primarily intended for use as a resistance-coupled amplifier or phase inverter.

characteristics (each section)

V_a	100	250 V
I_a	0.5	1.2 mA
V_g	-1.0	-2.0 V
g_m	1.25	1.6 mA/V
μ	100	100
r_a	80	62.5 k Ω



Mullard is the trademark of Mullard Ltd.

Mullard

ELECTRONIC TUBES

BRITAIN'S FIRST CHOICE
FOR FIRST EQUIPMENTS

SUPPLIES AVAILABLE FROM
IN THE U.S.A.
International Electronics Corporation
81 Spring Street, New York 12, N.Y.
Worth 6-0790
IN CANADA
Rogers Electronic
Tubes & Components
116 Vanderhoof Avenue,
Toronto 17, Ontario.
Hudson 5-8621

MULLARD OVERSEAS LTD., MULLARD HOUSE,
TORRINGTON PLACE, LONDON, ENGLAND

October 21, 1960

MEV 103

CIRCLE 111 ON READER SERVICE CARD 111

"SPOOLY"
SAYS...



Super-Temp for Fastest Delivery of HIGH TEMPERATURE **MAGNET WIRE**

You get the finest . . . fastest from Super-Temp. Magnet wire insulated with Teflon*, silicone or Isonel films. Ranges to +260°C. Mica films with ranges to +350°C. Complete quality control.

ALSO: Airframe Wire, Hook-up Wire, Tapes
Coaxial Cables, Miniature & Jumbo Cables
Teflon or Silicone Rubber Insulations

*DUPONT'S TFE RESIN



Save Time WITH Super-Temp

American Super-Temperature Wires, Inc.

8W. Canal Street, Winooski, Vermont • UNiversity 2-9636
General Sales Office: 195 Nassau St., Princeton, N. J. • WALnut 4-4450
A Subsidiary of Haveg Industries, Inc., Wilmington, Del.

Free! Send for 1960
Catalog. 88 pages of
valuable data.

CIRCLE 202 ON READER SERVICE CARD

compact, and easy to maintain, the model 101-D solid state power supply features 0.1 percent regulation for any combination of input voltage or load conditions. Ripple is less than 1 mv rms. Input is 100 to 130 v, 50 to 2,000 cps. Temperature stabilization insures a maximum of ± 0.01 percent/deg C drift. An output of 12 v d-c at 1 ampere is available over a temperature range of -25 C to $+45$ C and is capable of operation up to $+71$ C at reduced output current. Size is $2\frac{1}{2}$ in. by $2\frac{3}{4}$ in. by $6\frac{1}{8}$ in.

CIRCLE 322 ON READER SERVICE CARD



Coax Noise Source SMALL AND RUGGED

TUCOR, INC., 18 Marshall St., South Norwalk, Conn. The T44L1D is a double-ended coaxial noise source covering a frequency range of 1,000 to 2,000 Mc with an 18.5 db noise output. It is small in size ($10\frac{1}{4}$ in. long), and rugged enough to meet all severe environmental requirements. A companion to Tucor's T44L1C single-ended coaxial noise source, the new tube is identical in all other respects. Both tubes are used for noise measurement and testing of microwave components. Other aspects of T441D are a 180 v nominal operating voltage, 50 ma operating current and 1,200 v striking voltage.

CIRCLE 323 ON READER SERVICE CARD

Resistors FIXED COMPOSITION

HAMILTON-HALL, INC., 227 N. Water St., Milwaukee 2, Wisc., offers a new, complete line of fixed composition resistors in $\frac{1}{2}$, 1 and 2 watts. 231 resistance values are available in three wattages, and range from 10 ohms to 32 megohms in all standard EIA values. The resistors are made to meet or exceed all requirements specified by MIL-R-11 and RS-172.

CIRCLE 324 ON READER SERVICE CARD

Why it pays to use

NATIONAL Molded Activated Carbon Getters in sealed electronic relays

Instrument Life is extended

by adsorbing vapors generated during normal instrument operation from wire insulation, organic plasticizers and residual solvents which might carbonize on the contact points.

Manufacturing Costs are lowered

by eliminating the need for special insulations and also by reducing the need for "baking-out."

"National" and "Union Carbide" are registered trade-marks for products of

NATIONAL CARBON COMPANY

Division of Union Carbide Corporation
270 Park Avenue, New York 17, New York



FOR
DETAILS WRITE

112 CIRCLE 112 ON READER SERVICE CARD

electronics

KAY Precision RANDOM NOISE GENERATORS

1 KC TO 26,500 MC

COAXIAL NOISE SOURCES

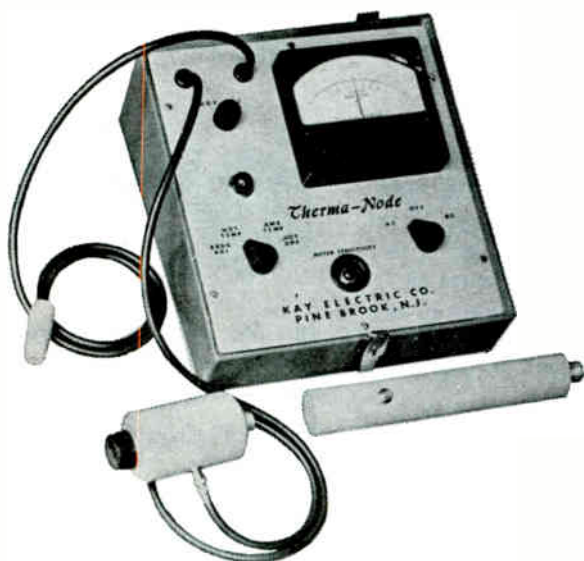

1 MC to 3000 MC . . . THE *Mega-Node*[®] 3000

The Mega-Node 3000 is a calibrated random noise source providing output over a wide frequency and power range. It employs a coaxial-type noise diode with a tungsten filament as a temperature-limited noise generator.

- Noise figure, 0-20 db • Output impedance, 50 ohms unbalanced
- Accuracy ± 0.25 db below 250 mc, ± 1.0 db below 2000 mc, ± 1.5 db at 3000 mc Price \$790.00, f.o.b. factory

1 KC to 1000 MC . . . THE *Therma-Node*
(Illustrated)

The Therma-Node is a basic noise source which provides extremely high accuracy by utilizing a basic noise generation technique—thermal noise from a heated resistive element.

- Noise figure to 10 db • Output impedance, 50 ohms unbalanced
- Accuracy ± 0.1 db • Operates from line or 24 V dc . . . Price \$550.00, f.o.b. factory, 2–1000 mc (1 kc–300 mc, add \$135.00)

3 MC to 500 MC . . . THE *Mega-Node*[®] 403-A

The Mega-Node 403-A is a calibrated random noise source providing precise operation over a more limited frequency range at proportionately lower cost.

- Noise figure, 0-19 db • Output impedance, 50 ohms unbalanced
- Accuracy ± 0.5 db Price \$375.00, f.o.b. factory

WAVEGUIDE NOISE SOURCES

1120 MC to 26,500 MC

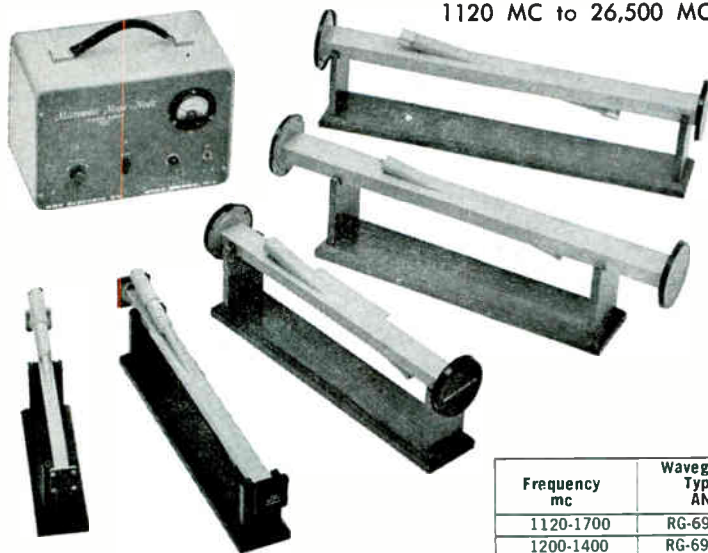

THE

Microwave Mega-Nodes[®]

The Microwave Mega-Nodes are precision machined and plated waveguide fixtures, utilizing argon, fluorescent, or neon gas discharge tubes. Single power supply operates all units. (Power Supply, \$95.00.)

- Noise output of 15.8 ± 0.25 db for fluorescent tubes, 15.45 ± 0.2 db for argon, 18.0 ± 0.2 db for neon. Supplied with power cables and fittings.

Write for Catalog Information

KAY
ELECTRIC COMPANY

Dept. E-10 Maple Avenue, Pine Brook, N.J.
CApital 6-4000

Frequency mc	Waveguide Type AN	Flange AN	Catalog No.			Price*
			Argon	Fluor.	Neon	
1120-1700	RG-69/U	UG-417/U	**	312-A	**	\$595.00
1200-1400	RG-69/U	UG-417/U	311-A	310-A	313-A	\$395.00
1700-2600	RG-104/U	UG-435A/U	**	870-A	**	\$495.00
2200-3300	RG-112/U	UG-553/U	**	880-A	**	\$495.00
2600-3950	RG-48/U	UG-214/U	261-A	260-A	262-A	\$175.00††
3950-5850	RG-49/U	UG-149A/U	271-A	270-A	272-A	\$175.00††
5850-8200	RG-50/U	UG-344/U	281-A	280-A	282-A	\$175.00††
7050-10,000	RG-51/U	UG-51/U	291-A	290-A	292-A	\$175.00††
8200-12,400	RG-52/U	UG-39/U	301-A	300-A	302-A	\$175.00††
12,400-18,000	RG-91/U	UG-419/U	521-A	**	522-A	\$250.00
18,000-26,500	RG-53/U	UG-425/U	531-A	**	532-A	\$250.00

†† Any three plus power supply: \$595.00. Any in excess of three: \$167.00 ea.

** None available.

* All prices f.o.b. factory.

Permanent
Top Position
for Qualified
Electrical Engineer
for

TRANSISTOR CIRCUIT DESIGN

KAMAN AIRCRAFT

largest independent producer
of helicopters and VTOL
aircraft has research and
design assignments open in

- Guidance and recovery
of space vehicles
- Remote control of
drone helicopters
- Automatic stabilization
and electronic
navigational equipment
- Research and design
development for
H43 HUSKIE
HU2K1 SEASPRITE
K16 SHRIKE
- Complete development
of classified contracts

Write or call W. M. Tynan,
Administrative Engineer
Kaman Aircraft Corporation
Bloomfield, Connecticut



Literature of the Week

INDICATOR LIGHTS Dialight Corp., 60 Stewart Ave., Brooklyn 37, N. Y. An 8-page brochure discusses ultraminiature indicator lights (Datalites) and their use either singly or in multiples as a "Data Strip" or "Data Matrix".

CIRCLE 325 ON READER SERVICE CARD

MAGNETIC AMPLIFIERS Airpax Electronics Inc., Seminole Division, Fort Lauderdale, Fla. Bulletin M-24 describes low level FERRAC magnetic amplifiers which provide linear outputs of ± 7.5 v d-c with input signals in the low millivolt range.

CIRCLE 326 ON READER SERVICE CARD

SYNCHRONOUS MOTORS The Superior Electric Co., 83 Laurel St., Bristol, Conn. Slo-Syn folder SE-L2604 contains technical characteristics, specifications, ratings and outline dimensions of new 50, 150 and 250 oz-in. Slo-Syn synchronous motors. Conventional, militarized and explosion-proof types are offered with or without planetary gear speed reduction assemblies.

CIRCLE 327 ON READER SERVICE CARD

PRINTED CIRCUIT RELAYS Executone Inc., Components Division, 47-37 Austell Place, Long Island City 1, N. Y., has available a catalog and specification sheets describing Printact printed contact-permanent magnet relays which save space, money and manhours.

CIRCLE 328 ON READER SERVICE CARD

DIALYL PHTHALATES Mesa Plastics Co., 12270 Nebraska Ave., Los Angeles 25, Calif. A property chart, 11 in. by 13 in., is available listing electrical, structural, thermal and other data on regular and flame-retardant diallyl phthalate and diallyl iso-phthalate plastics.

CIRCLE 329 ON READER SERVICE CARD

CHOPPERS Airpax Electronics Inc., Cambridge Division, Cambridge, Md. Bulletin C-33 describes series 300 choppers for 400 cycle operation. A summary of chopper ratings including electrical charac-

STROMBERG-CARLSON TELEPHONE HANDSETS

MODELS FOR
MANY INDUSTRIAL
APPLICATIONS



No. 26: short, lightweight, sturdy. Comes with capsule-type receiver and transmitter.

No. 27: high-gain version of No. 26 handset.



No. 28: "push-to-talk" handset. Rocker bar switch; various spring combinations.

No. 29: high-gain version of No. 28 handset.

Typical applications: mobile radio • intercom systems • carrier and microwave • aircraft and railroad.

Modern handset cradle for mobile or panel use fits any Stromberg-Carlson handset.

Write to Telecommunication Industrial Sales, 114 Carlson Road, Rochester 3, New York. Or in Atlanta call TRinity 5-7467; Chicago: STate 2-4235; Kansas City: HARRison 1-6618; Rochester: HUBbard 2-2200; San Francisco: OXFord 7-3630.

STROMBERG-CARLSON
A DIVISION OF
GENERAL DYNAMICS

CIRCLE 203 ON READER SERVICE CARD
electronics

reliability

...based
on
experience



ultra-high precision capacitors

Southern Electronics high-precision capacitors are demonstrating their proven reliability today in twelve different missiles, analog computers, and many radar and communications applications.

SEC high-precision capacitors utilize polystyrene, providing .01% tolerances, and mylar and teflon to meet .5% requirements. They show excellent stability characteristics over an extended temperature range, and tolerances are unaffected even at extreme high altitudes.

The unusual accuracy, stability and reliability of SEC capacitors are the result of engineering experience concentrated on the design and manufacture of precision capacitors only, plus rigid quality control standards subjecting each capacitor to seven inspections during manufacture, plus final inspection.

Our engineering experience enables us to meet your size requirements, while holding to exact capacitance and tolerance specifications.

SEC capacitors are manufactured in a wide range of capacitance to meet your needs from 100 mmfd. to any higher value, and meet or exceed the most rigid MIL-SPECS.

Write today for detailed technical data and general catalog.



*Pioneers in custom precision
capacitor engineering*

SOUTHERN ELECTRONICS Corporation

150 WEST CYPRESS AVENUE
BURBANK, CALIFORNIA

CIRCLE 204 ON READER SERVICE CARD
October 21, 1960

teristics, environmental conditions, and mechanical characteristics, and a glossary of chopper terms and definitions are detailed.

CIRCLE 330 ON READER SERVICE CARD

CONTROL CHASSIS Datex Corp., 1307 South Myrtle Ave., Monrovia, Calif. Bulletin DPS/A5 describes the K-111A control chassis which is designed for the acquisition, storage and translation of digital data.

CIRCLE 331 ON READER SERVICE CARD

D-C POWER SUPPLIES Opad Electric Co., 43 Walker St., New York 13, N. Y., has issued a catalog sheet illustrating and describing a new series of low cost transistor regulated d-c power supplies.

CIRCLE 332 ON READER SERVICE CARD

FREQUENCY MEASUREMENT Hewlett-Packard Co., 1501 Page Mill Road, Palo Alto, Calif. Latest techniques and equipment for accurately measuring frequency from vhf up to and above 18,000 Mc are described in a new application note now available.

CIRCLE 333 ON READER SERVICE CARD

VIDEO RECORDING GPL Division, General Precision, Inc., 63 Bedford Road, Pleasantville, N. Y. A four-page illustrated brochure outlines new developments in video recording technique. It covers a new application, tape to film transfer, and two new features now available, spot wobble and the alternate synchronizing generator.

CIRCLE 334 ON READER SERVICE CARD

CONTROLLED TEMPERATURE The Electric Hotpack Co., Inc., 5069 Cottman Ave., Philadelphia 35, Pa. Seven high-low temperature test chambers are featured in the newest controlled temperature bulletin. Included are photographs of all the units, technical data, prices and complete specification.

CIRCLE 335 ON READER SERVICE CARD

POWER SUPPLY Mid-Eastern Electronics, Inc., 32 Commerce St., Springfield, N. J. New two-page bulletin gives complete performance characteristics for the HC40-50 high current transistorized power supply.

CIRCLE 336 ON READER SERVICE CARD

Permanent
Top Position
for Qualified
Electrical Engineer
for

SERVO- MECHANISM DESIGN

KAMAN AIRCRAFT

largest independent producer of helicopters and VTOL aircraft has research and design assignments open in

- Guidance and recovery of space vehicles
- Remote control of drone helicopters
- Automatic stabilization and electronic navigational equipment
- Research and design development for
H43 HUSKIE
HU2K1 SEASPRITE
K16 SHRIKE
- Complete development of classified contracts

Write or call W. M. Tynan, Administrative Engineer
Kaman Aircraft Corporation
Bloomfield, Connecticut



CIRCLE 378 ON READER SERVICE CARD

115

TELREX LABORATORIES

Designers and Manufacturers of

COMMERCIAL SERVICE "BEAMED-POWER" ARRAYS AND TWO-WAY SYSTEMS

Model illustrates a wide-spaced, 12 element circular polarized optimum-tuned skewed dipole "SPIRALRAY" antenna. Provides unusually high gain, even response, in all polarization planes, vertical, horizontal or oblique with unusually high signal-to-noise ratio.

NO OTHER CIRCULAR POLARIZED ARRAY known to the art today can provide the linear high gain and signal-to-noise ratio in all radiation planes.

The ideal antenna for missile tracking, telemetering and no-fade response to mobile (or moving) stations.

Models available to extend the practical range of 2-Way Communication Systems.

Model SY-12-104-11
\$265.00

Model MSY-104-110
\$390.00

(f.o.b. Asbury
Park, N. J.)

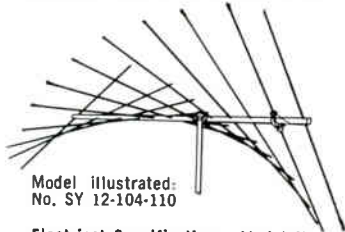

Model illustrated—
No. SY 12-104-110

Electrical Specifications—Model No. SY-12-104-110: Polarization, circular, linear within 1/2 db. Gain 13 db. F/B-Ratio 30 db. V/S/W/R (50 ohm cable) 1.1/1. Beamwidth at half power points 33 degrees. Max. power input 300 w, with "Balun" supplied.

Mechanical Specifications: Boom diameter 2" O.D. x 25 ft. All aluminum boom and elements. Weight approx 25 lbs. Rated wind-load 90 mph. No ice load. Available for 120 mph wind load. (Model No. MSY-104-110).

- Telrex is equipped to design and supply to our specifications or yours, Broad-band or single frequency, fixed or rotary arrays for communications, FM, TV, scatter-propagation, etc.

- Consultants and suppliers to communication firms, universities, propagation laboratories and the Armed Forces.

ANTENNAS

Communication and TV Antennas

SINCE
1921

telrex LABORATORIES

ASBURY PARK 25, NEW JERSEY, U.S.A.

CIRCLE 205 ON READER SERVICE CARD

**GUDELACE
TAKES THE
SLIPS
OUT OF
LACING**

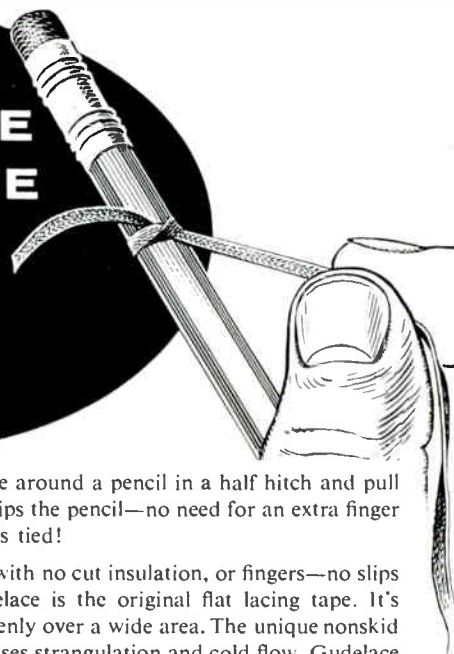

Try this simple test. Tie a piece of Gudelace around a pencil in a half hitch and pull one end. Gudelace's flat, nonskid surface grips the pencil—no need for an extra finger to hold Gudelace in place while the knot is tied!

Gudelace makes lacing easier and faster, with no cut insulation, or fingers—no slips or rejects—and that's *real* economy. Gudelace is the original flat lacing tape. It's engineered to *stay* flat, distributing stress evenly over a wide area. The unique nonskid surface eliminates the too-tight pull that causes strangulation and cold flow. Gudelace is made of sturdy nylon mesh, combined with special microcrystalline wax, for outstanding strength, toughness, and stability.

Write for a free sample and test it yourself. See how Gudelace takes the slips—and the problems—out of lacing.

GUDEBROD

Electronic Division
225 West 34th Street
New York 1, N.Y.

BROS. SILK CO., INC.

Executive Offices
12 South 12th Street
Philadelphia 7, Pa.

116 CIRCLE 116 ON READER SERVICE CARD

NEW BOOKS

Introduction to Statistical Communication Theory

By DAVID MIDDLETON
McGraw-Hill Book Co., Inc., New
York, 1960, 1,140 p, \$25.

THIS remarkable book cannot be recommended as an introduction to its subject since the author's sometimes awkward symbolism and murky exposition would be difficult hurdles for a beginner. For specialists in communication theory the book should prove to be useful and probably worth its considerable price.

The four parts of the book are: Part 1—an introduction to statistical communication theory; Part 2—random noise processes; Part 3—application to special systems; Part 4—a statistical theory of reception. In the first two parts, some topics are very sketchily treated and might better have been omitted; for example, the chapter on information theory. On the other hand, Part 3, dealing with random processes in modulation systems, is reasonably complete and particularly valuable. Part 4 is a thorough discussion of the application of decision theory to reception.

Figures and graphs are plentiful and there seem to be relatively few misprints.—T. M. BURFORD, *Bell Telephone Lab, Murray Hill, N. J.*

Simplified Data Control Systems

By ELIAHU I. JURY.
John Wiley & Sons, New York, \$14.

THIS text presents a rather complete analysis of a relatively new field—that of control systems using time sampled rather than continuous inputs.

The author presents the sampled data system in a simplified open loop form and then proceeds to develop the tools that will be used to analyze the closed loop system. The Z transform and the modified Z transform form the basis for sampled data systems analysis and the presentation of these methods is adequate. Generally, the instructive material in the text is well pre-

sented and well ordered. The lack of illustrative samples is somewhat compensated for by the choice of some very good problems presented at the end of the chapter. It is felt, however, that the addition of answers to the problems would facilitate the students' understanding.

One general criticism of the text is that the author does not give the reader the feel for the application of the analysis, but rather presents one method after another in sequential form. It appears that the author has attempted to concentrate too much analysis within the text, thereby leaving no space for discussion of application. The result is that the reader does not fully appreciate where the analysis will lead. If the subject had dealt with simple circuits, rather than the relatively new and complex field of sampled data systems, then a discussion of application would not have been necessary.

To summarize, the content of the text is good, however, it is felt that had the author reduced the amount of material presented, he could have expounded on the application of the presented material. — RALPH J. MASTRANDREA, *Senior Research Engineer, Columbia University, Electronic Research Lab, New York.*

THUMBNAIL REVIEWS

F-M Simplified. By Milton S. Kiver, D. Van Nostrand Company, Inc., New York, 1960, 384 p, \$7.50. Starting with the basic principles of f-m, the author makes a simplified detailed analysis of the operation of the various types of f-m receivers and transmitters. Besides theory of operation, the book also contains full instructions for receiver alignment. As an additional aid to the student, a set of self-check questions for each chapter is included. An excellent book for the electronics technician or student engineer.

Radiation Counters and Detectors. By C. C. H. Washtell, Philosophical Library, Inc., New York, 1960, 115 p. \$7.50. An introductory survey of radiation-detection devices is given. Geiger, proportional, and scintillation types are discussed in some detail. Emphasis is on detectors; there is little information on circuits. ELECTRONICS readers will find this a bit light in content, but it serves as an easy-to-read orientation to detectors and their applications.

On Target, Because...

B&L optical-electronic-mechanical capabilities help align azimuth on Polaris Submarines

To sharpen the shooting eye of this deadly fish, Bausch & Lomb developed four different instrument systems to convey optical and electronic information between the missile guidance package and the inertial navigation system.

Accuracy of these systems is measured in terms of one second of arc: 1 part in 200,000.

The integrated skills of Bausch & Lomb sped these four Polaris projects through every phase of development: complete original design, BuOrd documentation, fabrication. We'd like to apply the same skills to your project.

WRITE for B&L Capabilities Bulletin . . . and for help in the development and manufacture of optical-electronic-mechanical systems. Bausch & Lomb Incorporated, Military Products Division, 61410 Bausch St., Rochester 2, N. Y.

BAUSCH & LOMB

SINCE 1853



AEL Announces Construction Plans

AMERICAN ELECTRONIC LABORATORIES, INC., of Philadelphia, plans to construct a new plant and development center. The 32,000-sq-ft plant will be situated on a 55-acre tract at Colmar, Pa.

AEL was incorporated in 1950 with a capitalization of \$500. After 10 years of rapid growth, the company now considers itself one of the leaders in the fields of microwave, communication, and medical electronic research and development. The firm now employs 200 people.

Early in 1961, AEL expects to be in full operation at the Colmar site with production of its line of industrial and electromedical products. AEL's Microwave & Communications Center has been operating from there, and it is felt that greater production efficiency will result from the move. The tract provides long test paths for re-

search and development work.

The building is designed for expansion, and AEL expects to double in size within two years.

A special section of the new facility has been assigned to AEL's environmental test unit. New and expanded test facilities are being incorporated to enable the unit to handle a larger volume of work with a greater efficiency.

Eighty percent of AEL production and research is for the government. The company is engaged in countermeasures research, satellite tracking, equipment development, and the uhf and vhf communication fields. A contract has just been signed with the Navy Department Bureau of Ships for \$449,128 for development of special antennas for a technical research ship. AEL will be responsible for all development design and fabrication for the ship's antenna installation.

search, development, and manufacturing of precision electronic equipment.

The new executive vice president joined Colorado Research Corp. in January of this year as manager of the research department, where he has been in charge of the company's digital television development program. He will continue to supervise this phase of company operations.

Prior to his association with Colorado Research, Wendt was chief engineer of the communications and radar section of the Martin Co. He was with RCA for 18 years, pioneering in the development of both black and white and

color television. He was manager of advanced tv development at Sylvania, and held similar positions with Telemeter Magnetics and International Telemeter Corp.

Watkins-Johnson Hires Nelson

J. NORMAN NELSON has joined the technical staff of Watkins-Johnson Co., Palo Alto, Calif., to be primarily concerned with the development of medium-power traveling-wave amplifiers.

Nelson spent the past three years with RCA at Harrison, N. J., where he was responsible for the design and development of low noise and medium power traveling-wave tubes.



Altec Lansing Names Harrison G-M

ALTEC LANSING CORP., Anaheim, Calif., has appointed Ercell B. Harrison general manager of its Peerless Products division.

Harrison, who has been with Peerless for twenty years, will retain his current position as sales manager in addition to assuming his new duties. Peerless designs and manufactures high reliability transformers and power supplies for electronic applications.

Precision Electronics Doubles Capacity

PRECISION ELECTRONICS, INC., Rockville Center, Long Island, N. Y., manufacturer of coils and transformers, recently completed an expansion wherein it has doubled its



Colorado Research Promotes Wendt

KARL R. WENDT has been appointed executive vice president of Colorado Research Corp., Broomfield, Colo. The company specializes in re-

RACAL RADIO-TELETYPEWRITER TERMINAL

FOR AVIATION AUTHORITIES
 METEOROLOGICAL SERVICES
 PRESS RADIO STATIONS
 ARMED FORCES INSTALLATIONS
 THIS IS IDEAL FOR YOUR
 PURPOSES+THE EQUIPMENT
 PROVIDES A FIRST CLASS
 PRINTER SERVICE+
 THE RA129 IS SIMPLE TO
 OPERATE QUICK TO ALIGN
 ACCURATE AND DEPENDABLE
 YET VERY LOW IN COST+

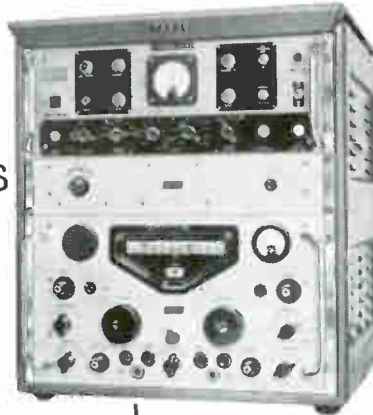

TYPE RA.129
 Single Channel

TYPE RA.103
 Dual Diversity

Frequency Range:
 1—30 Mc/s

Tuning:
 Continuous without
 band-switching

Signalling Speeds:
 Up to 300 bauds

Power Supply:
 100/125 and 200/250
 volts
 45/65 c/s AC. 220 watts

Frequency Shift:
 150 to 1000 cycles total

Output:
 Polarised or neutral
 Suitable for all tele-
 printers

Write for details to:

RACAL'S REPRESENTATIVE in the
 UNITED STATES, Mr. W. J. ZULLO; 104,
 Highland Avenue, Somerville 43, Mass.

CANADIAN AGENT, INSTRONICS LTD. P.O. Box 100, Stittsville, Ontario, Canada

RACAL ENGINEERING LIMITED

WESTERN ROAD, BRACKNELL, BERKS, ENGLAND Tel.: Bracknell 941 Grams, Cables: RACAL BRACKNELL BERKS
Overseas agents in most territories



CIRCLE 206 ON READER SERVICE CARD

The Leaders Specify ALPHLEX® TUBING & SLEEVING

- made to the highest standards • comprehensive variety of colors and put-ups
- immediate delivery from your local Alpha Wire distributor



For these advantages Alphlex Tubing & Sleaving is used by such leaders as Convair, General Electric, Gulton Industries, Polaroid Corporation & Govt. agencies. Write for Alphlex catalog.

TYPE	DESCRIPTION	GRADE	DIELECTRIC STRENGTH V/MIL	TEMP. RATING	LOW TEMP. FLEX.	OIL RESISTANCE	SIZES & COLORS
PVC-.05 PLASTIC TUBING	High resistance to heat, oil, chemicals, corrosion, fungi; no loss in tensile strength or flexibility. Protects irregular objects and snakes well.		800	105°C	-30°C	remains flexible indefinitely	#24-#12 A-I #11-#2 A, B, C, D, G, H #2 1/2-#1 A, B
PVC-744 PLAST. TUBING	Specifically designed for sub-zero temperatures.		550	70°C	-67°C	Good	#24-#0 A
PIF-130 PLASTIC IMPREGNATED FIBERGLASS SLEEVING	Class B insulation for continuous operation to 130°C. Excellent color retention even on prolonged baking at high altitudes.	A-1 B-1 C-1	8000 4500 2500	130°C 130°C 130°C	-30°C -30°C -30°C	Good Good Good	#24-#2 B, C, D, G #1 and larger C, D
VTS-.35 VARNISH IMPREGNATED TUBING & SLEEVING	Class B insulation for general use; high tensile strength, good flexibility, non-peeling cracking, low moisture absorption, acid oil resistant.	A-1 B-1 C-1	7000 4000 2500	135°C 135°C 135°C		Good Good Good	#24-#2 B, C, D, G #2 1/2-#1 B, C
TFT-200 TEFLON EXTRUDED TUBING	Unmatched for electrical application at high temperature frequencies. Thin, flexible, permits miniaturization and compactness.		500-1000	250°C	-90°C	Excellent	#30-#15 B-K #14-#8 B, C, D, F, G, H, I, J #7-#0 J
SRT-250 SILICONE RUBBER EXTRUDED TUBING	Excellent tensile strength, elongation, and tear strength, low water absorption and good oil resistance.		400	200°C	-85°C	Good	#28-#10 H
PVC-80 EXTRUDED PLASTIC TUBING	Excellent snaking, expands to irregular shapes. Dilates under certain conditions and resumes its size if it is the polyvinylchloride type.		800	80°C	-30°C	stiffens slightly	#24-#12 A-I #11-#2 A, B, C, D, G, H #2 1/2-#1 A, B
PLE-70	(Same as PVC-80)		1200	80°C	-70°C	swells slightly	#24-#7 J
SRF 200 SILICONE RUBBER FIBERGLASS TUBING	Class H insulation, excellent for shock resistance, extreme flexibility and freedom from cracking and crazing at extreme temperatures.	A-1 B-1 C-1	7000 4000 2500	200°C 200°C 200°C	-67°C -67°C -67°C	Good Good Good	#24-#15 B-K #14-#2 B, C, D, G, H, J #1-#1/2 B, C, H, J
HTF-1200 HI-TEMPERATURE FIBERGLASS SLEEVING	Class H insulation. Tightly braided sleeving for use up to 650°C. Can be colored for coding. Special constructions up to 1/16" wall thickness and double wall thickness available.		Determined by space factor	650°C	-55°C	Good	#24-#1/2 B, J
SFS-400 SIL CONE IMPREGNATED FIBERGLASS TUBING	Class H insulation for high temperature use. Remains flexible and retains its electrical properties to 205°C.	C-1 C-2 C-3	2500 1500 Space factor	205°C 205°C 205°C	-39°C -39°C -39°C	Good Good Good	#24-#1/2 J

A. CLEAR B. BLACK C. YELLOW D. RED E. BLUE F. BROWN G. GREEN H. WHITE I. ORANGE J. NATURAL K. VIOLET

ALPHA WIRE CORPORATION Subsidiary of LORAL Electronics Corporation
 200 Varick Street, New York 14, N. Y.
 Pacific Division: 1871 So. Orange Dr., Los Angeles 19, Calif.



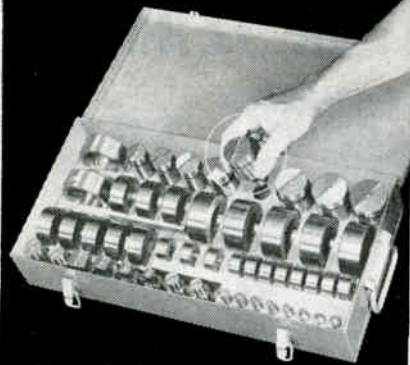

the right punch & die
at your finger tips...

NEW DI-ACRO PUNCH PAKS

Punch Pak No. 1 - \$139.50

Punch Pak No. 2 - \$259.50

- Off the shelf delivery
- Adapters to fit any punch press

Di-Acro Punch-Paks save you money, cut production delays. No time lost looking for the right size or waiting for special orders. Cost is approximately 10 per cent less than individual punch and die sets—with the rugged, steel store-or-carry chest free. All Di-Acro Punches and Dies are precision made of quality tool steel.

PUNCH-PAK NO. 1 contains 30 sizes of round punches and dies from 3/64" to 1/2" in increments of 1/64".

PUNCH-PAK NO. 2 contains round punches and dies from 1/16" to 1/2" in 1/16" increments, round sizes from 1/2" to 2" in 1/8" increments, squares in 1/2", 5/8", 3/4" and 1" sizes, one die holder and two die adapters.

Die Adapter A-2 3/4" diameter—1 1/4" bore, Die Adapter B-2 3/4" diameter—2 1/8" bore.

DIMENSION DATA

All Di-Acro Punches to 1/2" have 1/2" diameter shanks, 2 13/32" length.

All Di-Acro Punches from 1/2" to 2" have 1" diameter shanks, 3 1/8" length.

All Di-Acro Dies to 3/4" are 1 1/4" diameter, 3/8" high.

All Di-Acro Dies from 3/4" to 1 3/8" are 2 1/8" diameter, 7/8" high.

All Di-Acro Dies from 1 1/2" to 2" are 2 3/4" diameter, 1 5/32" high.

PUNCH AND DIE HOLDERS

which adapt Di-Acro Punches and Dies to any punch press are listed in literature on single station punch and die program. Ask for it... also for literature on new Adjustable Punch and Die program.



For full information consult Yellow Pages of your phone book under Machinery-Machine Tools for the name of your Di-Acro distributor or write us.



Pronounced die-ack-ro
**O'NEIL-IRWIN
MFG. CO.**

321 Eighth Avenue
Lake City, Minnesota • U.S.A.

manufacturing capacity.

This move was brought about by the increasing demand for its products by industry, according to Jules Salit, vice president.

Contact Manufacturer To Serve West Coast

GENERAL FINDINGS & SUPPLY CO., Attleboro, Mass., developer and producer of miniature contacts and assemblies for the electronics and electrical industries, now extends its manufacturing facilities across the nation by opening a new plant in North Hollywood, Calif.

In making the announcement, Gerald F. Tucci, General Findings general manager, said that the move establishes the company as the first major Eastern precious metal fabricator to open complete research, development and fabrication facilities to serve the important West Coast electronics field.

Management of the new plant will be made up entirely of experienced staff engineers from the main factory in Attleboro. Peter Microulis, a product division manager in the Attleboro office, has been appointed to head up the new operation.



Establish New Company, Name Vice President

CHEMONICS, INC., a subsidiary of Lancer Industries Inc. of Mineola, N. Y., was recently established in Pasadena, Calif. It will specialize in the development and manufacturing of modular circuits for use in analog and digital computers and other types of electronic equipment.

W. O. Sandberg has been named vice president and will be general manager of the newly formed company. He was formerly general

DYNASERT

Increase
Hourly Output
up to 10 Times Over
Hand Inserting



If you insert only a few hundred components a week, Dynasert component inserting machines should be considered. Big or small boards, long or short runs, Dynasert handles all.

Automatically feeds, trims, bends leads, inserts component, and clinches with uniform results. Little operator training. Highly engineered single or multi-stage production machines available. Write for descriptive 12 page booklet.

United

UNITED SHOE MACHINERY CORPORATION
140 Federal Street, Boston, Mass.

CIRCLE 207 ON READER SERVICE CARD

Which of these Craig skills and services can help you ?

- Systems housing — light weight, high strength aluminum shelters, vans and trailers.
- Systems components — telescoping antenna masts, transit cases, cabinets, equipment racks.
- Systems installation service — layout and installation of transportable systems, through final checkout.
- Systems packaging research — engineering design and development for ground support and electronic equipment protection.
- Complete production facilities — to handle your complete packaging assignment.
- A unique "aluminum-chemical research" service — engineering "brainpower pool" for solving virtually any problem in aluminum and formed plastic fabrication.

WRITE TODAY FOR CRAIG'S
CAPABILITIES BROCHURE



Craig
SYSTEMS, INC.

Dept. F-9, 360 Merrimack St., Lawrence, Mass. - Tel. MURdock 8-6961
Business systems and equipment are another Craig specialty through LeFebvre Corporation, Cedar Rapids, Iowa — a Craig subsidiary.

CIRCLE 208 ON READER SERVICE CARD
electronics

ARE YOU PROPERLY GEARED FOR MINIATURIZATION?

LEVIN® INSTRUMENT LATHES

PRODUCE SMALL INSTRUMENT PARTS BETTER

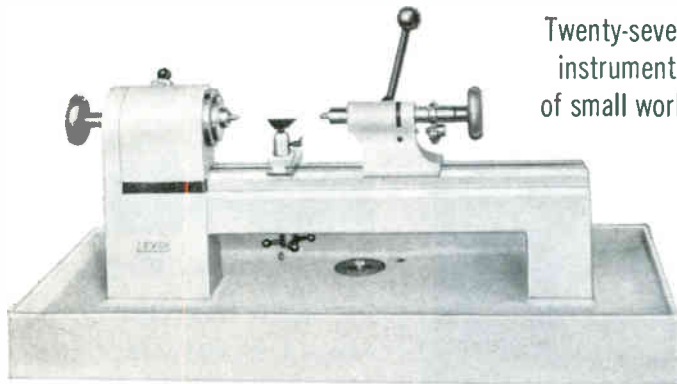

Twenty-seven models of instrument lathes for all types of small work. Collet capacity

5/16" or 3/16". Levin Instrument

Lathes are used wherever fine work is being done. Over 11,000 lathes in use.

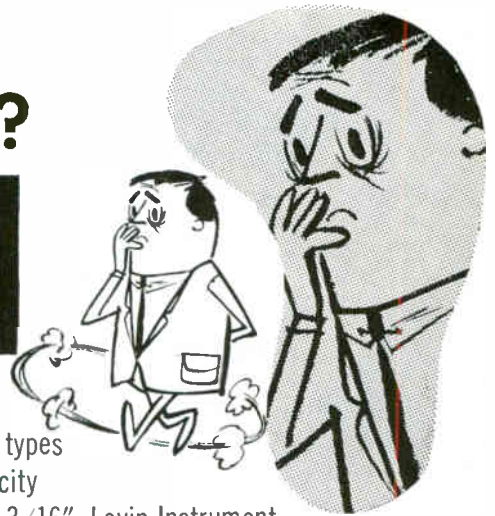

For complete details of Levin Instrument Lathes and accessories send for catalog T.

Louis Levin & Son, Inc., 3610 So. Broadway, Los Angeles 7, Calif.

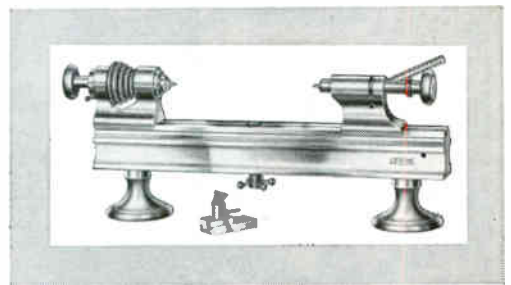

CIRCLE 209 ON READER SERVICE CARD

TESTS CLIPS with ADJUSTABLE TENSION

Grayhill Test Clips, designed for panel mounting, permit faster testing without manual opening and closing of jaws. Tension easily and simply adjusted by turning hex nut. Standard (No. 2-0) projects 1.25" above panel — Miniature (2-20) projects only 3/4". Also available with banana plug, pin jacks or molded board mounting (10 standard variations available.)

Write for Catalog



Grayhill
Tests
Clips

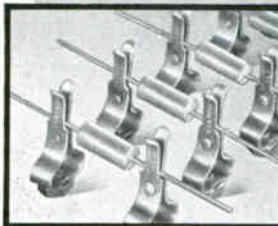

Phone: Fleetwood 4-1040
523 Hillgrove Avenue,
LaGrange, Illinois



PIONEERS IN MINIATURIZATION
CIRCLE 210 ON READER SERVICE CARD

October 21, 1960



Shown actual size

**IDEAL FOR
COMPUTER
PATCHWORK
PANELS**

Take your pick from the large selections of CAMBION miniature jacks and plugs. Varying widely in types, these top quality, precision made units are ideal for quick, tight, space-saving patchwork on panel boards.

The jacks make perfect electrical connections, thanks to their special beryllium copper compression springs, floating D keys and solid fronts. Jacks are available in shank lengths for varying panel thicknesses, pin diameters of the plugs are .080", .062" and .045".

Write Cambridge Thermionic Corporation, 437 Concord Avenue, Cambridge 38, Mass. for full details on these and other products in the wide line of

CAMBION®
The guaranteed electronic components

CIRCLE 121 ON READER SERVICE CARD

121

DON'T MISS THIS



**New, Miniaturized
1-MC PRECISION
CRYSTAL OSCILLATOR**
with transistorized,
proportional-controlled oven

BULLETIN S-1159
contains typical specifications and
characteristics. Write for your copy.

REEVES-HOFFMAN
DIVISION OF DYNAMICS CORPORATION OF AMERICA
CARLISLE, PENNSYLVANIA

CIRCLE 211 ON READER SERVICE CARD

.. . Electrical Coil Windings

... WIRE SIZES #6 TO #56
For 43 Years . . . specializing in all types of coils to customers' specifications. Design or engineering assistance available on request.

COTO-COIL CO., INC.

SINCE 1917
65 Pavilion Avenue Providence 5, Rhode Island

CIRCLE 212 ON READER SERVICE CARD

NEW IDEAS FOR SALE!

Words and pictures tell you about the top new product ideas each week in "On the Market". Who makes 'em and what they'll do for you. Easy way to keep in touch with the latest and best.

Another reason why it will pay you to subscribe to *electronics* (or renew your subscription) right now. Fill in the box on Reader Service Card. Easy to use. Postage free.

**FIND WHAT
YOU NEED IN...**

electronics

manager of the printed circuits division of Consolidated Electro-dynamics Corp. of Pasadena, and is treasurer of the Western Association of Circuit Manufacturers.



Name James Bagnall
Division Director

JAMES J. BAGNALL, JR., former manager of the systems engineering department of the National Co., Inc., Malden, Mass., has been named director of the company's newly created applied research division.

Since joining National in 1954, he has also worked as a supervisor of systems of the engineering department, supervisor of the technical staff, chief engineer of electronic component and parts standardization programs, and project engineer on the AN/APS-54 airborne radar receiver production.

Previously, Bagnall was employed as an engineer by the Press Wireless Laboratories, Inc. and Philco Corp.

Caryotakis Joins Eitel-McCullough

GEORGE CARYOTAKIS recently joined Eitel-McCullough, Inc., San Carlos, Calif., manufacturer of electron-power tubes, as senior project engineer, power klystron laboratory. He is responsible for high-power broadband klystron development in the company's power klystron division at San Bruno, Calif.

Prior to this, Caryotakis was senior engineer, tube research department, at Varian Associates. From 1955 to 1956 he worked on periodic focusing of traveling-wave tubes at Stanford Electronics Research Laboratories as a research associate.

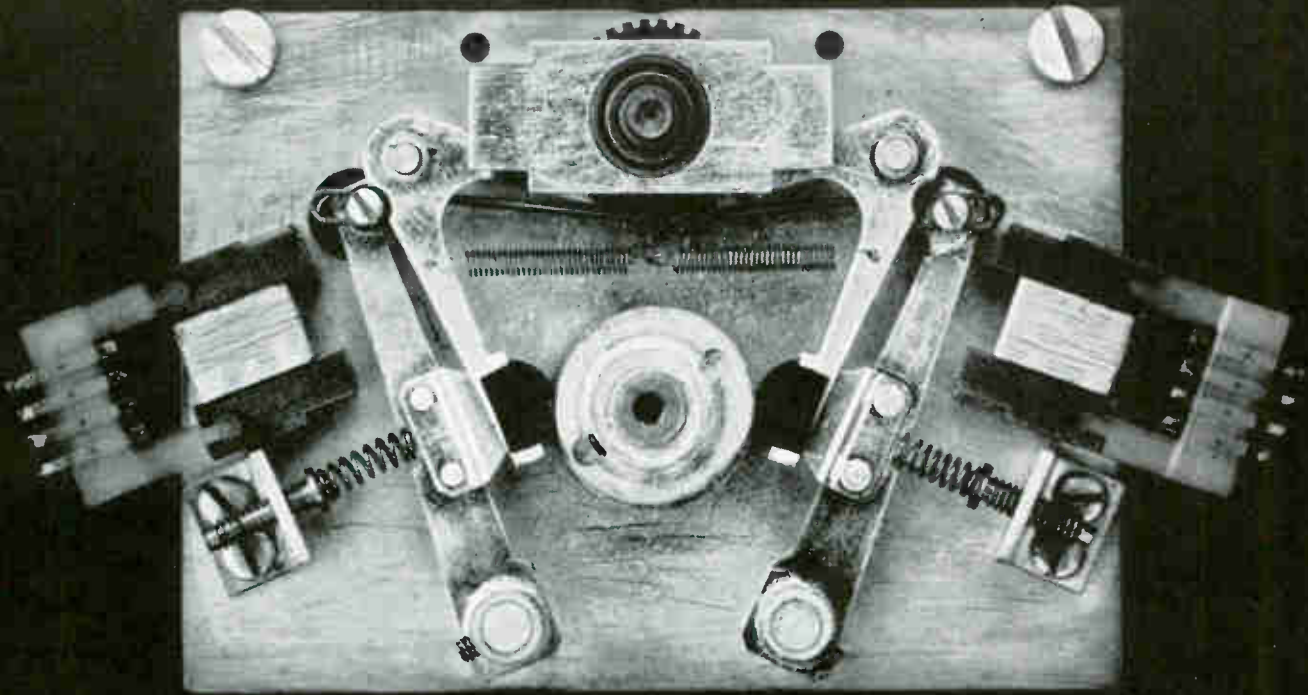

Harnessing a new principle of incremental drive

Here is a new way to convert high-speed shaft motion into precise increments, stepping forward, backward or oscillating alternately. It was developed from scratch by IBM engineers.

This truly clutchable incremental stepper provides precise control of acceleration, runs at high speed, and has great accuracy.

The Method of Attack

IBM engineers tackled the problem of high-speed, start-and-stop motion on a theoretical basis. They analyzed the loads and accelerations involved, and decided

what masses and forces would be practicable. The stepper they developed is not only more versatile and efficient than alternate methods but also gives greater life expectancy, requires no elaborate oil bath, and is easier to package into a machine assembly.

Whether it's a problem in mechanics, electronics or physical science, IBM engineers are encouraged to attack problems from fresh viewpoints. Depending on your field, you might be interested in the advances IBM people are making in magnetics, microwaves, semiconductors and inertial

guidance. In every area of research and development, you will find IBM receptive to the individual who wants to make significant contributions.

How to Start an IBM Career

Right now, there are several key openings in IBM's expanding research and development staff. If you have a degree in engineering, mathematics or one of the sciences—plus experience in your field, write, briefly describing your qualifications, to:

Manager of Technical Employment
IBM Corporation, Dept. 554W3
590 Madison Avenue, New York 22, N. Y.

IBM

INTERNATIONAL BUSINESS MACHINES CORPORATION

Engineers, EE

The Closest Thing to Running Your Own Business

FIELD ENGINEERING at the Light Military
Electronics Dept. of General Electric

To some engineers, being on their own professionally is an all-important factor. Are you one of these individualists who is at his best when working on his own?

The LME Dept. Field Engineer is G.E.'s sole representative at many of the locations and it is his responsibility to give expert professional assistance.

Assignments may be in any of the 50 states. Average is one year at one location.

You will be trained at one of our plant locations in one or more of the following product lines:

**Radar/Countermeasures/
Digital Communications/
Navigation/Armament Systems/
Flight Control/Missile Guidance/
Test Equipment**

Requirements: BS in Electrical Engineering or BS in Mechanical Engineering, Physics or Mathematics with minimum of 2 years electronics experience.

Write today—and by return mail we'll send you a simple application form. Mr. Vernon Wild, Room 69-WP
LIGHT MILITARY ELECTRONICS DEPT.—PRODUCT SERVICE

GENERAL ELECTRIC

831 Broad Street, Utica, N. Y.

THE ELECTRONICS MAN

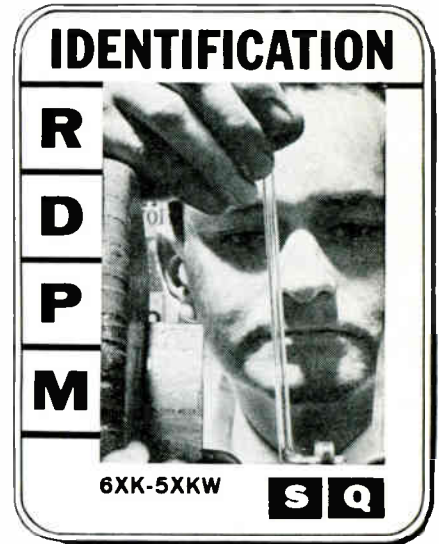

WHERE TO FIND HIM

The electronics man may be found in any or all of the areas of research, design, production, management.

Your problem: sell him (wherever he is) and keep him sold all year long. Here's the simplified key to this job!

Use electronics to arouse his interest and create acceptance for your products in the magazine's weekly issues.

Use the electronics BUYERS' GUIDE and Reference Issue to be there all year long whenever he is ready to buy.

This is the best selling combination in the electronics industry... and the one that carries the most weight!

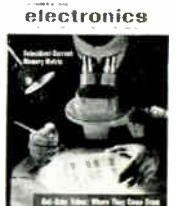

THE ELECTRONICS MAN
"BUYS" WHAT HE READS IN...

electronics

A MCGRAW-HILL PUBLICATION
330 West 42nd Street, New York 36, New York

**COMPUTER PROGRAMMING
SYSTEMS ANALYST . . . \$9,044
DATA PROCESSING SYSTEM
COMPUTER APPLICATIONS . . . \$9,500
BSEE OR MATH
MGR. DIGITAL COMPUTATION
and SIMULATION . . . \$15,000**
Contact Lew Musgrave,
MONARCH PERSONNEL
28 East Jackson Chicago 4, Illinois

CIRCLE 381 ON READER SERVICE CARD

SEARCHLIGHT SECTION

(Classified Advertising)

BUSINESS OPPORTUNITIES
EQUIPMENT - USED or RESALE

OSCILLOSCOPES

Special Sale—Laboratory
Used—Checked Out—
Perfect

TS28 Synchroscope. \$95
TS34 Synchroscope. 100
TS34A Synchroscope. 150
TS239 Oscilloscope. 795
Tektronix 511A. . . 350
Tektronix 511AD. . . 375
Tektronix 514D. . . 425
Tektronix 524D. . . 475

Many other types

Phone:
Walker 5-6000

Cables:
TELSERSUP

See pages 594, 595
of 1960 Electronics
Buyers' Guide for a
more complete listing

LIBERTY
ELECTRONICS
INC.

582 BROADWAY
New York 12, N. Y.

CIRCLE 460 ON READER SERVICE CARD

**LOOKING FOR
USED/SURPLUS ELECTRONIC
EQUIPMENT/COMPONENTS?**

For an up-to-date listing of such equipment
ment see Searchlight Section of Oct. 14th.

CIRCLE 380 ON READER SERVICE CARD

PROJECT ENGINEER . . . \$14,000 Yr.

Will supervise infrared group. Physics degree preferred, and should be familiar with the state of the art on systems, components, techniques, etc. Any experience in noise analysis helpful. Company client assumes all employment expense.

ESQUIRE PERSONNEL, INC.
202 So. State St., Chicago 4, Illinois
Phone HArrison 7-6337

CIRCLE 382 ON READER SERVICE CARD



MANUFACTURERS' REPRESENTATIVES

IN THE ELECTRONIC INDUSTRY

SAMUEL K. MACDONALD, INC.

manufacturers representatives over 25 years
1531 SPRUCE STREET, PHILA. 2, PA.

Territory: Pennsylvania • New Jersey
Delaware • Maryland
Virginia • West Virginia
District of Columbia

Other Offices:
Pittsburgh
Baltimore
Washington, D.C.

CIRCLE 383 ON READER SERVICE CARD

PROFESSIONAL SERVICES

JOHN LESSER & STAFF ENGINEERING—DESIGN— DEVELOPMENT—PRODUCTION

For Edge Light Panels Qualified to MIL-P-7788A
and Instruments Illuminated To MIL-I-25467A
BODNAR PRODUCTS CORP.
236 Huguenot St., New Rochelle, N. Y. NE 6-4664

INDEX TO ADVERTISERS



Audited Paid Circulation

*AMP Incorporated	56	Granger Associates	2
Adler Electronics, Inc.....	97	*Grayhill, Inc.	121
Aeronautical Communications Equipment, Inc.	54	*Gudebrod Bros. Silk Co., Inc.....	116
Air Express	44		
*Alpha Wire Corp.....	119	*Hallicrafters Company, The.....	81
Amco Engineering Co.	93	*Hewlett-Packard Co.	8, 9
*American Optical Company.....	16	*Hudson Tool & Die Company, Inc...	20
American Potash & Chemical Corporation	43	*Hughes Aircraft Co.	10
American Super-Temperature Wires, Inc.	112		
*Ampex Data Products	40	*Instrument Development Laboratories, Inc.	125
Anaconda Wire & Cable Co.....	51	International Electronic Research Corp., ERC Division	106
Autonetics, Division of North American Aviation	42	International Resistance Co... 3rd Cover	
*Avnet Electronics	103		
*Baird-Atomic, Inc.	91	Kamen Aircraft Corp.....	114, 115
Bausch & Lomb Optical Co.....	117	*Kay Electric Co.	113
Bell Telephone Laboratories.....	53	Klein & Sons, Mathias.....	89
*Bendix Corporation Scintilla Division	28		
*Cambridge Thermionic Corp.....	121	*Lambda Electronics Corp.....	3
C&D Batteries	84	*Lapp Insulator Co., Inc.....	100
*Celco-Constantine Engineering Laboratories	6	Levin & Son, Inc., Louis.....	121
*Clevite Transistor, A Division of Clevite Corporation	17, 18		
Computer Equipment Corp.....	85	Malco Mfg. Co.....	88
*Constantine Engineering Laboratories	6	Mallory & Co., Inc., P. R.....	48, 49
*Coto-Coil Co., Inc.....	122	*Marconi Instruments, Ltd.....	92
Craig Systems Inc.....	120	Micro Switch, Division of Honeywell	22, 23
Cubic Corp.	29	*Mullard Ltd.	111
Dorne & Margolin, Inc.....	41	National Carbon Co.....	112
Dynacor, Inc., Subsidiary of Sprague Electric Co.	45	*Natvar Corporation	77
*ESC Electronics Corporation.....	47	Offner Electronics, Inc.....	75
*Eitel-McCullough, Inc.	50	O'Neil-Irwin Mfg. Co.....	120
*Electrical Industries, Inc.....	36	Optical Gaging Products, Inc.....	7
Engelhard Industries, Inc., Baker & Co. Div.	12, 13		
General Aniline & Film Corp. Ozalid Division	19	Precision Instrument Co.....	46
*General Electric Co. Semiconductor Products Dept..	26, 27	*Price Electric Corp.....	102
General Electrodynamics Corp....	15		
General Electronic Laboratories, Inc.	95		

* See Advertisement in the July 20, 1960 issue of Electronics Buyers' Guide for complete line of products or services.

Analog to Digital CONVERTERS



for Linear or Angular Motions

IDL Shaft Angle Converters

are fully qualified per MIL-E-5272 A

for Operation:

At temperatures 0°F to 160°F
per Paragraph 4.1.1 Procedure 1

From 0.55 to 14.7 p.s.i.a.
per Paragraph 4.5.3 Procedure 3

Under vibration 5-5000 cps
per Paragraph 4.7.1 Procedure 1

for Exposure:

To Humidity and Temperature
per Paragraph 4.4.4 Procedure 1

To Sand and Dust
per Paragraph 4.11.1 Procedure 1

To 50 hour Salt Spray
per Paragraph 4.6 through 4.6.13

To Shock
per Paragraph 4.15.1 Procedure 1
and Paragraph 4.15.2.1

To 10 G's Sustained Acceleration
per Paragraph 4.16.2 Procedure 2

For Linear Motions, Model 500206 provides accuracies of 1 part in 1000 counts.

For Angular Motions, Model 500406 provides accuracies of one tenth degree; Model 500407 provides accuracies of a tenth of a minute.

Each unit provides bidirectional rotation for applications in mechanically geared systems. The Gray BCD coding system is easily translated into other digital format for visual readout or for recording.

For specifications on these components, ask IDL for their data sheet, "Shaft Position to Digital Converters" or price information, use your letterhead.

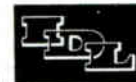

INSTRUMENT DEVELOPMENT LABORATORIES
INCORPORATED
Subsidiary of Royal McBee

51 MECHANIC STREET, ATTLEBORO, MASS.

electronics fills you in on every phase of the electronics industry each week featuring engineering and technical data every issue. Latest economic trends, technically interpreted, to help you make sound plans. Facts you'll want to file and keep. Subscribe now. Mail the reader service card (postpaid) to **electronics**, the magazine that helps you to know and to grow! Rates: three years for \$12, one year for \$6; Canadian, one year for \$10; foreign, one year for \$20. Annual **electronics** BUYERS' GUIDE (single issue price \$3.00) included with every subscription.

it's read
more by
all 4!

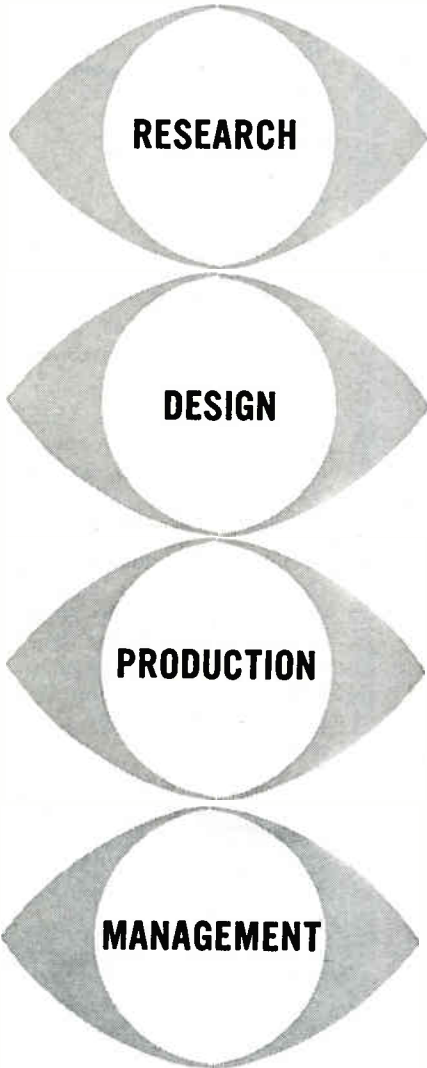

SUBSCRIBE TODAY TO
electronics!

Racal Engineering Ltd.....	119
*Radio Corporation of America... 4th Cover	24
*Raytheon Company 2nd Cover,	39
Industrial Components Division..	101
*Reeves-Hoffman, Division of Dynamics Corporation of America	122
Revere Copper and Brass Corp... 30,	31
St. Regis Paper Company.....	108
Sangamo Electric Co.....	55
*Southern Electronics	115
Sperry Electronic Tube Division, Sperry-Rand Corp.....	98, 99
Sprague Electric Co.....	5, 21
Stromberg-Carlson Electronics, Div. of General Dynamics Corp.....	114
Telemetry Inc.	101
Telrex Laboratories	116
*Texas Instruments Incorporated Semiconductor-Components Division..	79
*Trio Laboratories, Inc.	25
*Tung-Sol Electric, Inc.	83
United Shoe Machinery Corp... 35,	120
*Varian Associates	107
Voltron Products, Inc.	104
*Weinschel Engineering	14
Weston Instruments, A Division of Daystrom, Inc.	87
*Wheeler Electronic, Corp.....	105
Wiley & Sons, Inc., John.....	52
*Williams & Co., C. K.....	99
MANUFACTURERS REPRESENTATIVES	
MacDonald Inc., Samuel K.....	124
PROFESSIONAL SERVICES	
124	
CLASSIFIED ADVERTISING	
F. J. Eberle, Business Mgr.	
EMPLOYMENT OPPORTUNITIES.123-124	
EQUIPMENT	
(Used or Surplus New)	
For Sale	
124	
WANTED	
Equipment	
124	

* See Advertisement in the July 20, 1960 issue of Electronics Buyers' Guide for complete line of products or services.

CLASSIFIED ADVERTISERS

Esquire Personnel Inc.....	124
General Electric Co.....	124
International Business Machines Corp...	123
Liberty Electronics Inc.....	124
Monarch Personnel	124

Our index and our Reader Service Numbers are published as a service. Every precaution is taken to make them accurate, but **ELECTRONICS** assumes no responsibilities for errors or omissions.

electronics



Audited Paid Circulation

BRUCE A. WINNER,
Advertising Sales Manager

R. S. QUINT, Assistant Advertising Sales Manager and Buyers' Guide Manager; FRED STEWART, Promotion Manager; RICHARD J. TOMLINSON, Production Manager; GEORGE E. POMEROY, Classified Manager; HUGH J. QUINN, Circulation Manager.

ADVERTISING REPRESENTATIVES: NEW YORK Donald H. Miller, Henry M. Shaw, George F. Werner; **BOSTON** William S. Hodgkinson, Donald R. Furth; **PITTSBURGH** David M. Watson; **PHILADELPHIA** Warren H. Gardner, William J. Boyle; **CHICAGO** Harvey W. Wernecke, Martin J. Gallay; **CLEVELAND** P. T. Fegley; **SAN FRANCISCO** T. H. Carmody, R. C. Alcorn; **LOS ANGELES** Carl W. Dysinger, D. A. McMillan, Marshall Freeman; **DENVER** J. Patten; **ATLANTA** M. Miller; **DALLAS** Robert T. Wood; **LONDON** Edward E. Schirmer; **FRANKFURT** Stanley R. Kimes; **GENEVA** Michael R. Zeynel.

BRANCH OFFICES: National Press Bldg., Washington 4, D.C.; McGraw-Hill Bldg., Copley Square, Boston 16; Four Gateway Center, Pittsburgh 22; Six Penn Center Plaza, Philadelphia 3; 520 North Michigan Avenue, Chicago 11; 55 Public Square, Cleveland 13; 68 Post Street, San Francisco 4; 1125 West Sixth St., Los Angeles 17; 1740 Broadway, Denver 2; 1301 Rhodes-Haverty Bldg., Atlanta 3; 901 Vaughn Bldg., Dallas 1; McGraw-Hill House, London E.C.4; 85 Westendstrasse, Frankfurt/Main; 2 Place de Port, Geneva.

OFFICERS OF THE PUBLICATIONS DIVISION: Nelson L. Bond, President; Shelton Fisher, Wallace F. Traendly, Senior Vice Presidents; John R. Callahan, Vice President and Editorial Director; Joseph H. Allen, Vice President and Director of Advertising Sales; A. R. Venezian, Vice President and Circulation Coordinator.

OFFICERS OF THE CORPORATION: Donald C. McGraw, President; Joseph A. Gerardi, Hugh J. Kelly, Harry L. Waddell, Executive Vice Presidents; L. Keith Goodrich, Vice President and Treasurer; John J. Cooke, Secretary.

In **PRECISION FILM RESISTORS**

if it's news, expect it first from IRC

NEW ...

exclusive

M* COAT

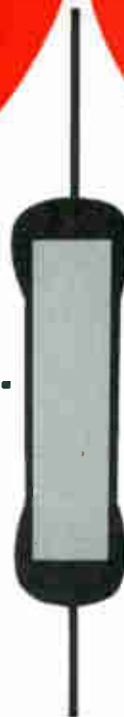

Most moisture-resistant coat ever achieved...
withstands 30 cycles of MIL moisture!

IRC precision film resistors with M Coat take 30 cycles of moisture, 300% of the MIL-R-10509C Characteristic B requirement, tested in accordance with MIL standard 202.

M Coat adds greater protection for the resistance element, eliminates handling and assembly damage. Insulation resistance after 30 cycles of moisture is over 100 megohms.

Rating: $\frac{1}{2}$ watt at 70°C ambient. Standard tolerance: $\pm 1\%$. Range: 10 ohms to 2.49 megohms. Maximum continuous working voltage: 350.

Write for Bulletin AE-15, International Resistance Co., 401 N. Broad St., Philadelphia 8, Pa.

*Trademark exclusive IRC moisture-proof coating



Leading supplier to manufacturers of electronic equipment

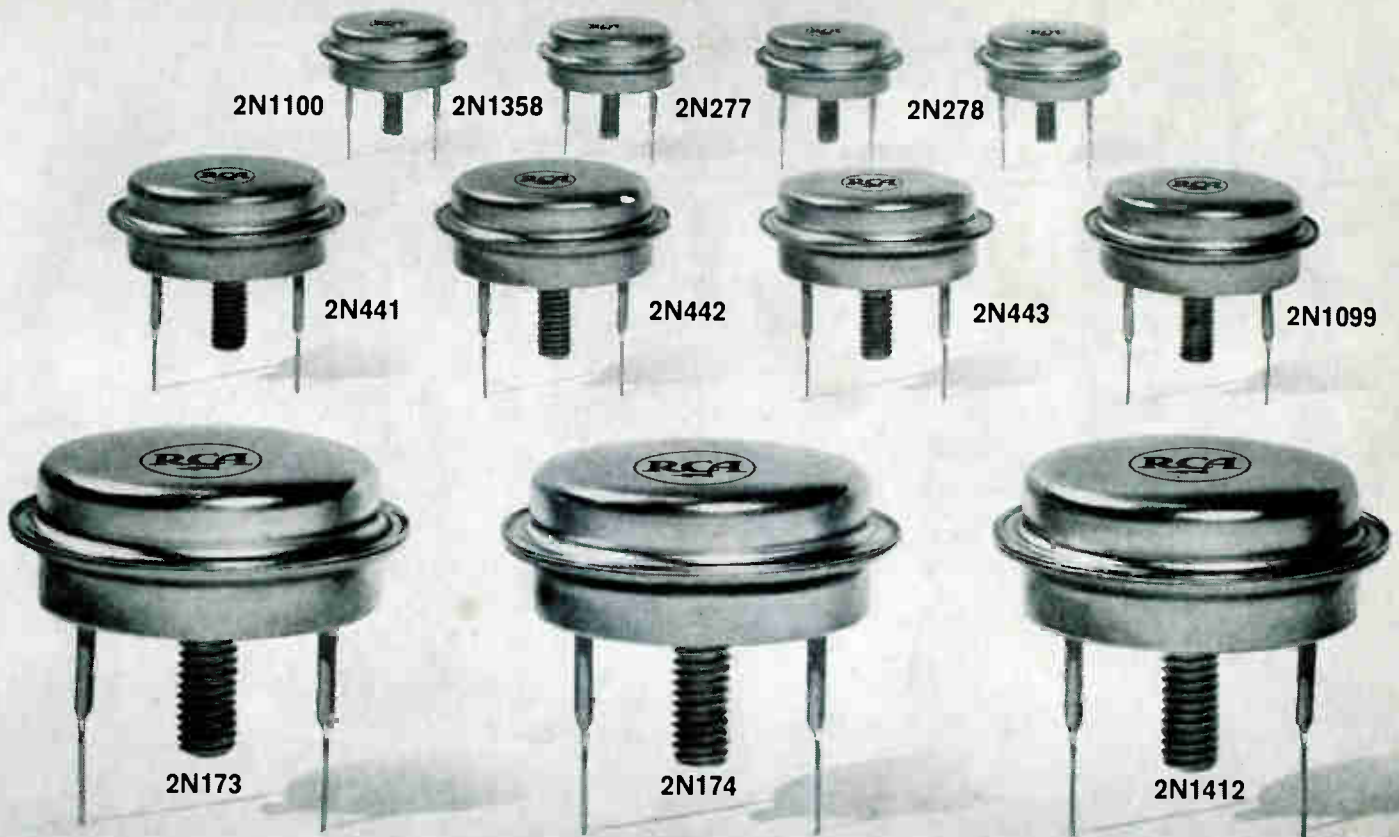

11 NEW RCA INDUSTRIAL POWER TRANSISTORS IN THE TO-36 PACKAGE

These PNP Germanium alloy junction types featuring 100°C maximum junction temperature are broadly applicable for power switching in industrial and military circuits

Now make RCA your source of supply for germanium power transistors in the single ended center stud package. Check out the important design advantages these new RCA types provide:

- Low saturation resistance and low leakage current for high power efficiency.
- Effective heat transfer right at the point where needed, facilitates more compact designs.
- Cold-weld seal, proved by RCA through years of experience, provides extra assurance of uniform hermetic sealing.
- Broad selection of voltage ratings and beta ranges for greater design flexibility.

- Wide application in power switching circuits such as dc-to-dc converters, inverters, choppers, solenoid drivers and relay controls.
- Comprehensive on-the-spot design and application service provided by RCA's growing team of Semiconductor Product Field Engineers.

Call your nearby RCA Semiconductor representative today for additional information on these new transistors. For further technical data, write RCA Commercial Engineering, Section K-19-NN-3, Somerville, N. J.

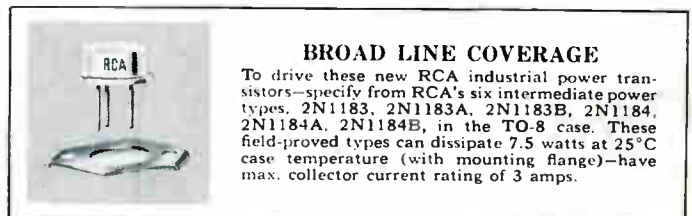

RCA SEMICONDUCTOR & MATERIALS DIVISION FIELD OFFICES ... EAST: 744 Broad Street, Newark, New Jersey, HUmboldt 5-3900 • NORTHEAST: 64 "A" Street, Needham Heights 94, Massachusetts, HIllcrest 4-7200 • EAST CENTRAL: 714 New Center Building, Detroit 2, Michigan, TRinity 5-5600 • CENTRAL: Suite 1154, Merchandise Mart Plaza, Chicago, Illinois, WHitehall 4-2900 • P.O. Box 8406, St. Louis Park Branch, Minneapolis, Minnesota, FEderal 9-1249 • WEST: 6355 East Washington Boulevard, Los Angeles, California, RAymond 3-8361 • 1838 El Camino Real, Burlingame, California, OXFord 7-1620 • SOUTHWEST: 7905 Empire Freeway, Dallas 7, Texas, FLEetwood 7-8167 • GOVERNMENT: 224 North Wilkinson Street, Dayton, Ohio, BAldwin 6-2366 • 1725 "K" Street, N.W., Washington, D. C., FEderal 7-8500.

Available
through your
RCA Distributor



The Most Trusted Name in Electronics
RADIO CORPORATION OF AMERICA