

SEPTEMBER 25, 1959

electronics

A MCGRAW-HILL PUBLICATION

VOL. 32, No. 39

PRICE SEVENTY-FIVE CENTS

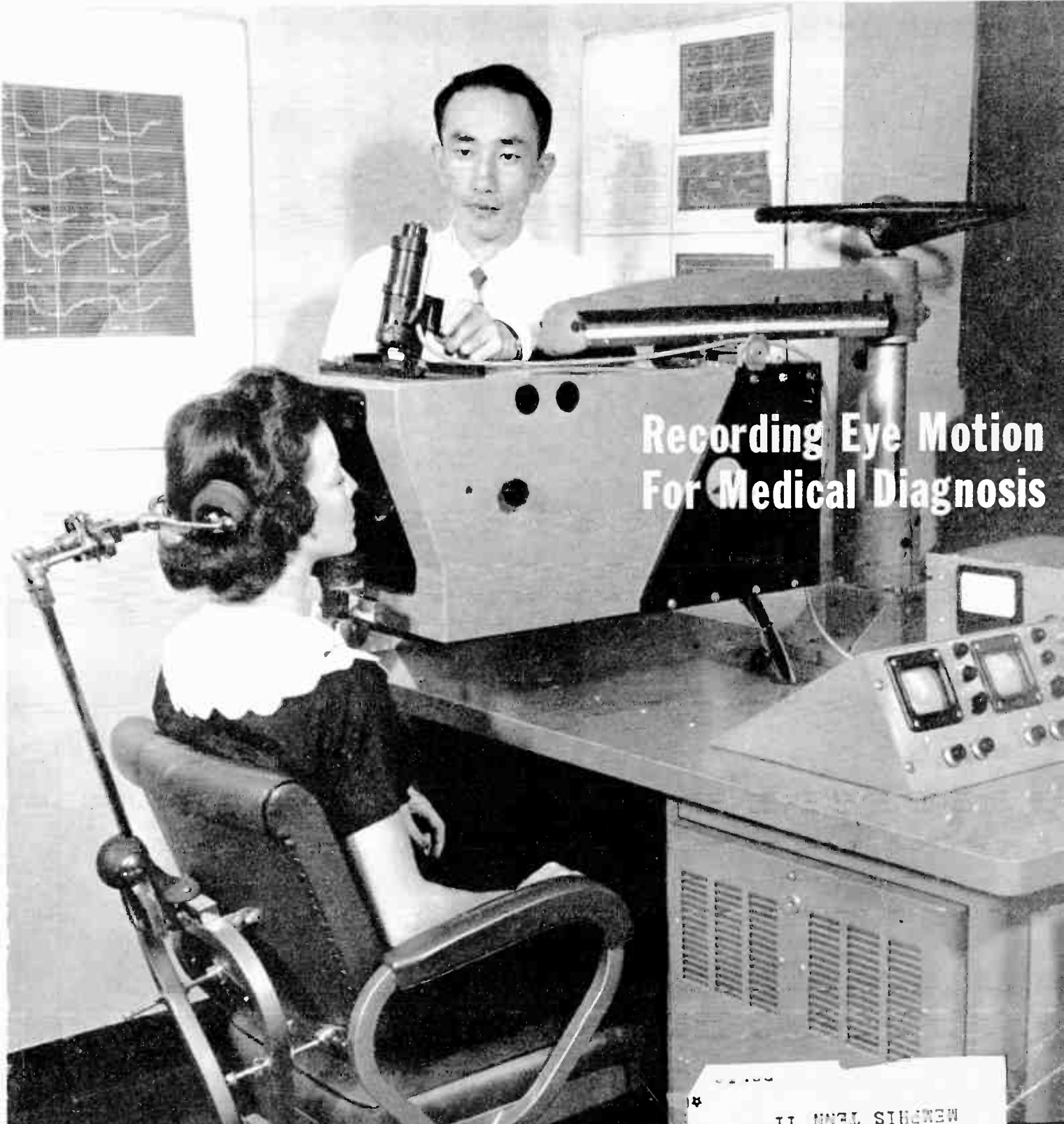

Recording Eye Motion
For Medical Diagnosis

New Trends in Cockpit

1
L E MCGRAW
689 ECHLES ST
MEMPHIS TENN 11

Creative Microwave Technology

Published by MICROWAVE AND POWER TUBE DIVISION, RAYTHEON COMPANY, WALTHAM 54, MASS., Vol. 1, No. 5

NEW RAYTHEON MICROWAVE TUBE DEVELOPMENTS

Miniature pulsed magnetrons for missile beacon applications are ruggedly constructed with integral magnets. The RK-7461 is tunable from 9,300 to 9,500 mc and has minimum peak power output of 60 watts. It is 1 1/4" in diameter and 2 1/2" long, and weighs only 6 ounces.

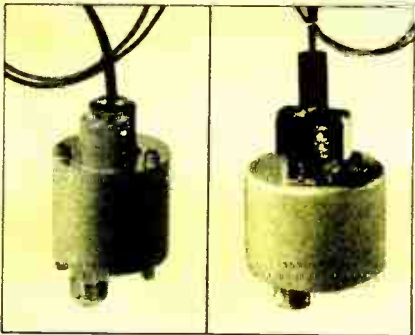

RK-7461

QK-735

The QK-735 is tunable from 5,400 to 5,900 mc with minimum peak power output of 400 watts. 1 1/2" in diameter and 3 1/4" long, it weighs 8 ounces.

CIRCLE 182

Reader Service Card

* * *

Designed for electronic countermeasures and FM/CW operations, the QK-625 BWO provides a minimum CW power output of 180 watts and a nominal CW power output of 250 to 350 watts over the 2,500 to 3,000 mc band. The tube is voltage tunable over the entire range with tuning sensitivity of approximately 0.4 mc/volt. Liquid-cooled, the QK-625 BWO is equipped with an integral

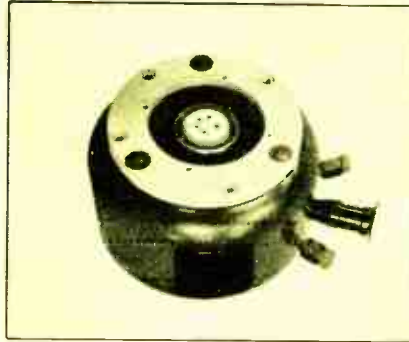

permanent magnet, and can be mounted in any position.

CIRCLE 180

Reader Service Card

* * *

Small-signal gain of up to 35 db in microwave relay links is achieved by means of a new compact traveling wave tube amplifier -- the QK-542. This permanent-magnet focused CW tube has nominal saturated power output of 5 watts over 5,900 to 7,400 mc. An integral UG 344/U waveguide-type flange is supplied as standard. With an optional coaxial output coupler the QK-542 covers 4,000 to 8,000 mc.

CIRCLE 183

Reader Service Card

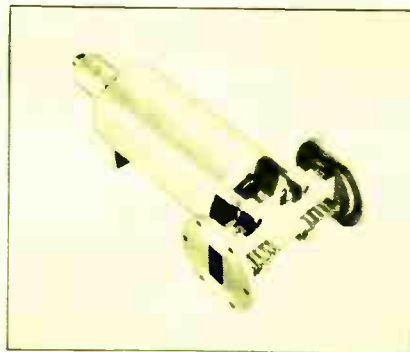

Ideal for linear accelerators and high-power radar systems. The QK-783 and QK-622 Amplitrons operate over the 2,700-2,900 mc and 2,900-3,100 mc bands, respectively, at a peak power of 3 megawatts and a typical efficiency of 75%. Because no heater is required, these tubes are capable of exceptionally long life. RF gain is 8 db under rated conditions, and as high as 12 db at lower peak power outputs. Phase pushing figure is less than 0.5 degrees for a 1% variation of anode current.

CIRCLE 181

Reader Service Card

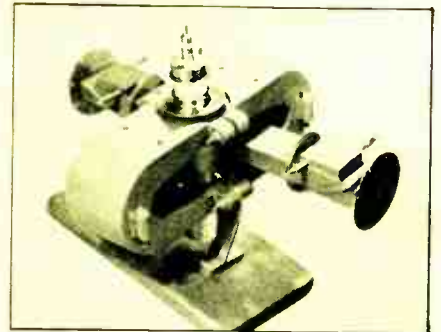

* * *

Compiled as a Raytheon service to the field, new Consolidated Data Booklet contains comprehensive information about principal unclassified magnetrons, klystrons, backward wave oscillators and special purpose tubes manufactured by Raytheon. Characteristics presented include maximum ratings, typical operating values, band or frequency ranges and other essential data for microwave engineers and purchasing departments.

CIRCLE 184

Reader Service Card

A Leader in Creative Microwave Technology



Issue at a Glance

A MCGRAW-HILL PUBLICATION
Vol. 32 No. 39

JAMES GIRDWOOD, *Publisher*

W. W. MacDONALD, *Editor*

JOHN M. CARROLL, *Managing Editor*

Associate Editors: Frank Leary, Michael F. Tomaino, Howard K. Jonis, Sylvester P. Carter, Roland J. Charest, William P. O'Brien, George Sideris, John F. Mason, William E. Bushor, Thomas Emma, Samuel Weber, Sy Vogel, Leslie Solomon, M. M. Perugini, George J. Flynn.

Pacific Coast Editor (Los Angeles) Harold C. Hood; *Midwestern Editor (Chicago)* Harold Harris; *New England Editor (Boston)* Thomas Maguire.

Art Director, Harry Phillips, Roy Thompson.

Production Editor, John C. Wright, Jr., Bernice Duffy.

Market Research, Edward DeJongh.

Editorial Assistants, Gloria J. Filippone, Arlene Schilp, Patricia Landers, Carol Weaver.

BRUCE A. WINNER, *Advertising Sales Manager.* R. S. Quint, *Assistant Advertising Sales Manager and Buyers' Guide Manager.* Fred Stewart, *Promotion Manager.* Frank H. Ward, *Business Manager.* George E. Pomeroy, *Classified Manager.* Hugh J. Quinn, *Circulation Manager.*

New York: Donald H. Miller, Henry M. Shaw, William J. Boyle. *Boston:* Wm. S. Hodgkinson. *Philadelphia:* Warren H. Gardner. *Chicago:* Harvey W. Wernicke, Martin J. Gally. *Cleveland:* P. T. Fegley. *San Francisco:* T. H. Carmody, R. C. Alcorn. *Los Angeles:* Carl W. Dysinger, D. A. McMillan. *Denver:* J. Patten. *Atlanta:* M. Miller. *Dallas:* Gordon L. Jones, Robert T. Wood. *London:* E. E. Schrimmer. *Frankfurt:* Michael R. Zeynel.

Business

- Picture Flying Arrives. An exclusive first-person report.....38
Beacon Extends Radar Range. New York area gets new gear.....43
Magnetic Ink Sorts Checks. Here's how new system operates.....46
'Dead' Town Comes to Life. Electronics paces Danbury revival....53
Shoptalk4 25 Most Active Stocks.....21
Electronics Newsletter11 Market Research28
Washington Outlook14 Current Figures28
Financial Roundup21 Meetings Ahead56

Engineering









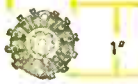

- Changes in pupillary size are measured directly by electronic means.
See p 67.....COVER
Recording Eye Changes for Clinical Diagnosis. Direct-writing instrument has important clinical uses.....By G. W. King 67
Designing Stable Power Supplies. Transistorized power supply drifts less than 40 μ v per hour....By E. Baldinger and W. Czaja 70
Transistor Time Delay for Industrial Control. Adjustable time-delay relay has many applications...By L. Szmaz and H. Bakes 74
Electronic Commutators for Multiplex Telemetry. Specifications and operating principles of available commutators.
By A. S. Kramer 76
Realistic Simulation of Radar Clutter. Field conditions duplicated in laboratory.....By J. Atkin, H. J. Bickel and M. Weiss 78
Binary Circuits Count Backward or Forward. Small transistorized digital building blocks.....By H. J. Weber 82
Unusual Uses for Standard Synchros. Five are described, including a frequency deviation meter.....By D. J. Salonimer 84
Transistor Eyeglass Radio. Music to see by.....By H. F. Cooke 88

Departments

- Research and Development. Locked Oscillator for Color Tv.....90
Components and Materials. Ceramic Wafer Tubes for Modular Units.94
Production Techniques. Ferrules Shield Multiconductor Cable.....98
On the Market.....104 News of Reps.....125
Literature of the Week.....118 Comment126
Plants and People.....122 Index to Advertisers.....135

Widest Option in Low-Power Rotary Switches

SECTIONS

 <p>15/16" 1°</p> <p>THROW: 30°, 36°, 45° INSULATION: stator glass silicone; rotor, KEL-F</p>	 <p>1-9/32" 1-5/16"</p> <p>THROW: 30°, 45°, 60°, 90° INSULATION: phenolic, Mycalex, ceramic</p>	 <p>1-13/32" 1-17/32"</p> <p>THROW: 25.7°, 30°, 36°, 45°, 60° INSULATION: phenolic, ceramic</p>	 <p>1-5/8" 1-7/8"</p> <p>THROW: 18°, 20°, 30°, 36°, 45°, 60°, 90° INSULATION: phenolic, Mycalex, ceramic</p>	 <p>1-7/8" 1-7/8"</p> <p>THROW: 30°, 36°, 45°, 60°, 90° INSULATION: phenolic, Mycalex, ceramic</p>
 <p>1-31/32" 2-5/16"</p> <p>THROW: 20°, 40° INSULATION: phenolic</p>	 <p>1-3/4" 2-5/16"</p> <p>THROW: 15°, 30° INSULATION: phenolic</p>	 <p>2-5/16" 2-5/16"</p> <p>THROW: 20°, 40° INSULATION: phenolic, Mycalex</p>	 <p>1-23/32" 2-17/32" or 2-5/16"</p> <p>THROW: 12.85°, 25.7° INSULATION: phenolic</p>	 <p>2-1/32" 2-17/32"</p> <p>THROW: 12.85°, 18°, 25.7°, 36° INSULATION: phenolic</p>

METAL PARTS AND FINISHES

STANDARD COMMERCIAL—Punched steel parts are lead-coated, cold-rolled steel. Parts such as nuts, lockwashers, etc., are cadmium-plated steel. Shafts may be cadmium-plated steel, brass, or aluminum. Brass parts are unplated.

TROPICAL OR 50-HOUR SALT SPRAY MILITARY SPECIFICATIONS—All steel and brass parts are cadmium-plated and chromate-dipped. Stainless steel parts are passivated.

200-HOUR SALT SPRAY MILITARY SPECIFICATIONS—All brass parts are nickel plated. All stainless steel parts are passivated. Shafts, "C" washers and index springs, balls and plates are stainless steel.

CONTACTS



Famous Oak double wiping, high-pressure design. Riveted or eye-leted in place and keyed from turning. Rotors shorting or nonshorting.

TYPE 1—Contacts are spring brass, silver-plated. Rotors are brass, silver-plated. Temperature limit: 100°C constant ambient.

TYPE 2—Contacts, spring tempered-silver alloy. Rotors, coin-silver alloy. Temperature limit: 100°C constant ambient.

TYPE 3—Contacts and rotor blades made of Oak alloy

CMS-202. This is a special alloy for high temperature operation to 150°C.

GOLD-PLATED CONTACTS—Type 1 or 2 contacts may be gold-plated .0002" thick. Not to be confused with gold flash.
FOR PRINTED CIRCUITS—Standard Oak contacts with a lug extending from the terminal end. Lug inserts in board for dip soldering.

ACCESSORIES



AC SNAP SWITCHES—36 models for use on most switch types. All are UL approved.

POTENTIOMETERS—Customers' choice. Mounts on rear of Oak switches. Operates by switch shaft or separate concentric shaft.

ELECTROSTATIC SHIELDS—Used between sections. Sizes and shapes for all switches.

BEARING STRAPS—Added shaft support on long switches. Steel, brass, and phenolic.

MOUNTING BRACES—Prevents frame twist on long switches due to torsion.

SPECIAL SHAFTS—Hollow, dual-concentric, and triple-concentric for many switches.

OAK MFG. CO.

1260 Clybourn Ave., Dept. D, Chicago 10, Illinois
Phone: MOhawk 4-2222

When your design calls for a low-power rotary switch, you want a unit that matches job requirements exactly—not an "almost" fit. But in the process you don't want the switch to involve a lot of extra tooling and delay either. At Oak, the above options, plus numerous other alternatives in construction, are pretooled for economy, service, and convenience.

Specify your low-power switch has the Oak name—from the smallest diameter, the most "ready-to-go" low available.

Lambda Power Supplies specified for newest radar installation

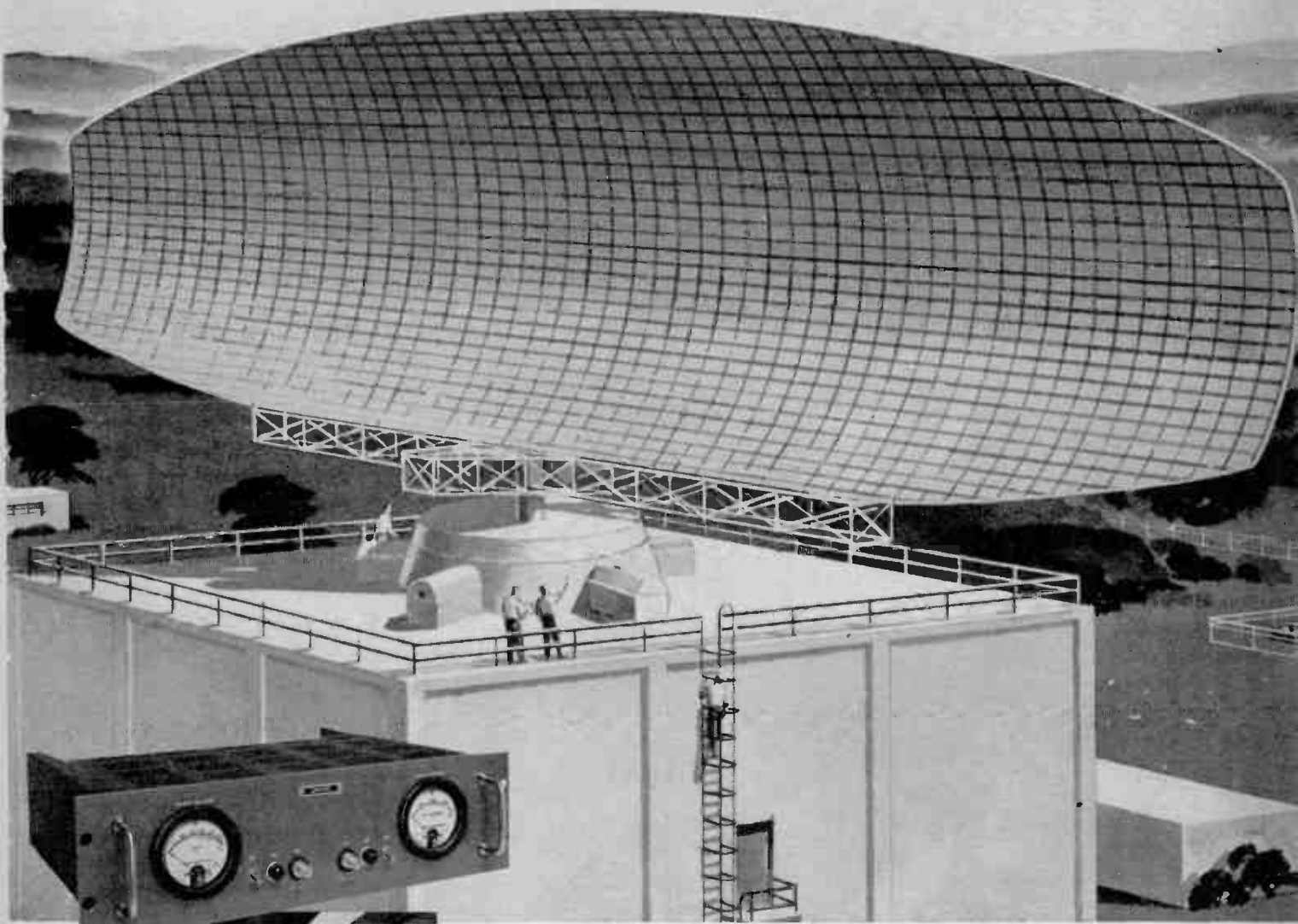

"Off-the-shelf" Lambda power supplies—modified only with special panels, MIL meters and tubes—will be part of the complex radar equipment housed in the 85-foot tower at Thomasville, Alabama, one of four identical installations.

Meet MIL-E 4158 environmental test requirements

Sperry Gyroscope Co., operating under the technical guidance of the Rome (N.Y.) Air Development Center, is producing the new SAGE radar equipment (AN/FPS-35). The power supplies employed to power transmitters and receivers must be able to pass stringent tests.

Sperry's choice: Lambda's COM-PAK[®], already widely used as a component in many rocket and missile programs.

All Lambda stock industrial power supplies are made to MIL quality and *guaranteed for five years*. They are pictured and described in a new 32-page catalog. Write for your copy.



LAMBDA ELECTRONICS CORP.

11-11 131 STREET • COLLEGE POINT 56, NEW YORK
INDEPENDENCE 1-8500 CABLE ADDRESS: LAMBDATRON, NEW YORK

electronics

September 25, 1959 Vol. 32, No. 39

Published weekly, including the ELECTRONICS BUYERS' GUIDE and REFERENCE Issue in mid-June as part of the subscription, by McGraw-Hill Publishing Company, Inc., James H. McGraw (1860-1948) Founder.

Executive, Editorial, Circulation and Advertising Offices: McGraw-Hill Building, 330 W. 42 St., New York 36, N. Y. Longacre 4-3000. Publication Office: 99-129 North Broadway, Albany 1, N. Y.

See panel below for directions regarding subscriptions or change of address. Donald C. McGraw, President; Joseph A. Gerardi, Executive Vice President; L. Keith Goodrich, Vice President and Treasurer; John J. Cooke, Secretary; Nelson L. Bond, President, Publications Division; Shelton Fisher, Senior Vice President; John R. Callahan, Vice President and Editorial Director; Joseph H. Allen, Vice President and Director of Advertising Sales; A. R. Venezian, Vice President and Circulation Coordinator.

Single copies in the United States, U. S. possessions & Canada 75¢; \$1.50 for all other foreign countries. Buyers' Guide in the United States, U. S. possessions & Canada \$3.00; all other foreign \$10.00. Subscription rates—United States and possessions, \$6.00 a year; \$9.00 for two years; \$12.00 for three years. Canada, \$10.00 a year; \$16.00 for two years; \$20.00 for three years. All other countries, \$20.00 a year; \$30.00 for two years; \$40.00 for three years. Second class postage paid at Albany, N. Y. Printed in U.S.A. Copyright 1959 by McGraw-Hill Publishing Co., Inc.—All Rights Reserved. Title registered in U. S. Patent Office. BRANCH OFFICES: 520 North Michigan Avenue, Chicago 11; 68 Post Street, San Francisco 4; McGraw-Hill House, London E. C. 4; 85, Westendstrasse, Frankfurt/Main; National Press Bldg., Washington 4, D. C.; Six Penn Center Plaza, Philadelphia 3; 1111 Henry W. Oliver Bldg., Pittsburgh 22; 55 Public Square, Cleveland 13; 856 Penobscot Bldg., Detroit 26; 3615 Olive St., St. Louis 8; 350 Park Square Bldg., Boston 16; 1301 Rhodes-Haverty Bldg., Atlanta 3; 1125 West Sixth St., Los Angeles 17; 1740 Broadway, Denver 2; 901 Vaughn Bldg., Dallas 1. ELECTRONICS is indexed regularly in The Engineering Index.

Subscription: Address correspondence to: Fulfillment Manager, Electronics, 330 W. 42nd St., New York 36, N. Y. Allow one month for change of address, stating old as well as new address, including postal zone if any. Subscriptions are solicited only from persons engaged in theory, research, design, production, management, maintenance and use of electronics and industrial control components, parts and products. POSITION and COMPANY CONNECTION must be indicated on subscription orders.

Postmaster: please send form 3579 to Electronics, 330 W. 42nd St., New York 36, N. Y.



Member ABP and ABC

COMPONENT RESEARCH & DEVELOPMENT. Fear of some component manufacturers continues to be that they may suddenly find a large portion of their conventional product line made obsolete by radical technological change. How much basis is there for this fear, and what can be done to reduce it?

Three important trends have been slowly but surely gaining ground in the design of electronic equipment: packaged circuits, miniaturization and microminiaturization.

Packaged circuits involve putting several components together in a functional unit. Some manufacturing responsibilities are thus transferred from the equipment manufacturer to the components maker. This approach lends itself well to equipment involving circuit redundancy, as in large-scale digital computers. It lends itself less well, at least at this moment, to some other types of equipment.

Miniaturization involves use of smaller components. By and large, component manufacturers themselves have led the way in this direction, with an assist from the military that has led to increased consumer demand. But the practical limit appears to be the size of the largest component in a piece of equipment, such as the loudspeaker in a radio or the picture tube in a tv set.

In microminiaturization, the newest of the three approaches, the conventional component could disappear entirely. Among the methods of fabrication are vacuum deposition of resistive and conductive films to form passive circuits to which transistors are then joined, and fabrication of monolithic circuits from single semiconductor blocks in a manner that simultaneously provides both passive and active components. And there will be more such approaches, not necessarily limited to semiconductors.

Thus far, microminiaturization has been aimed largely at specialized military and scientific applications. Most developments are still in the laboratory stage. The difficulty of obtaining inductance is one problem to be overcome. Another is the dissipation of heat.

We're obviously talking about a revolution, but not a sudden one. One answer to fear of change, where it exists, is to keep abreast of these new techniques. A solid-state research group is a good investment, and one that pay off in many other ways.

Coming In Our October 2 Issue . . .

HIGH MAGNETIC FIELDS. In electronics and physics research laboratories, equipment for the generation of magnetic fields of high intensity is an indispensable tool. In nuclear resonance measurements, maser research, plasma studies for thermonuclear fusion, investigation of the energy-band structure of semiconductors, and in millimeter and sub-millimeter wave radiation for communications and missile detection, the generation of magnetic fields is essential. According to H. H. Kolm, of MIT's Lincoln Laboratory, activity in these fields has stimulated much interest in the problem of generation of high continuous fields over large volumes. Kolm's survey of the state of the art points up the need for sophisticated instrumentation and complex electronic equipment in this area.

SENSITIVE TRANSDUCER. A crystal oscillator circuit, using only one tube, is described by L. J. Rogers of the special instrumentation division of Union Carbide. This simple yet sensitive device is used in conjunction with a small, nonhazardous sensing head, which can be remote from the oscillator and other parts of the system. Transducers constructed with this system can measure pressure, displacement or temperature in chemical plants or other hazardous locations. Use in medical research or in aircraft and missile guidance appears feasible.

★ SPRAGUE® RELIABILITY in these two dependable wirewound resistors ★

MINIATURE *Blue Jacket*® VITREOUS-ENAMEL POWER RESISTORS

Sprague's new improved construction gives even greater reliability and higher wattage ratings to famous Blue Jacket miniature axial lead resistors.

A look at the small *actual sizes* illustrated, emphasizes how ideal they are for use in miniature

NEW SMALLER SIZE

KOOLOHM®

INSULATED-SHELL POWER RESISTORS

New Koolohm construction features include welded leads and winding terminations—Ceron ceramic-

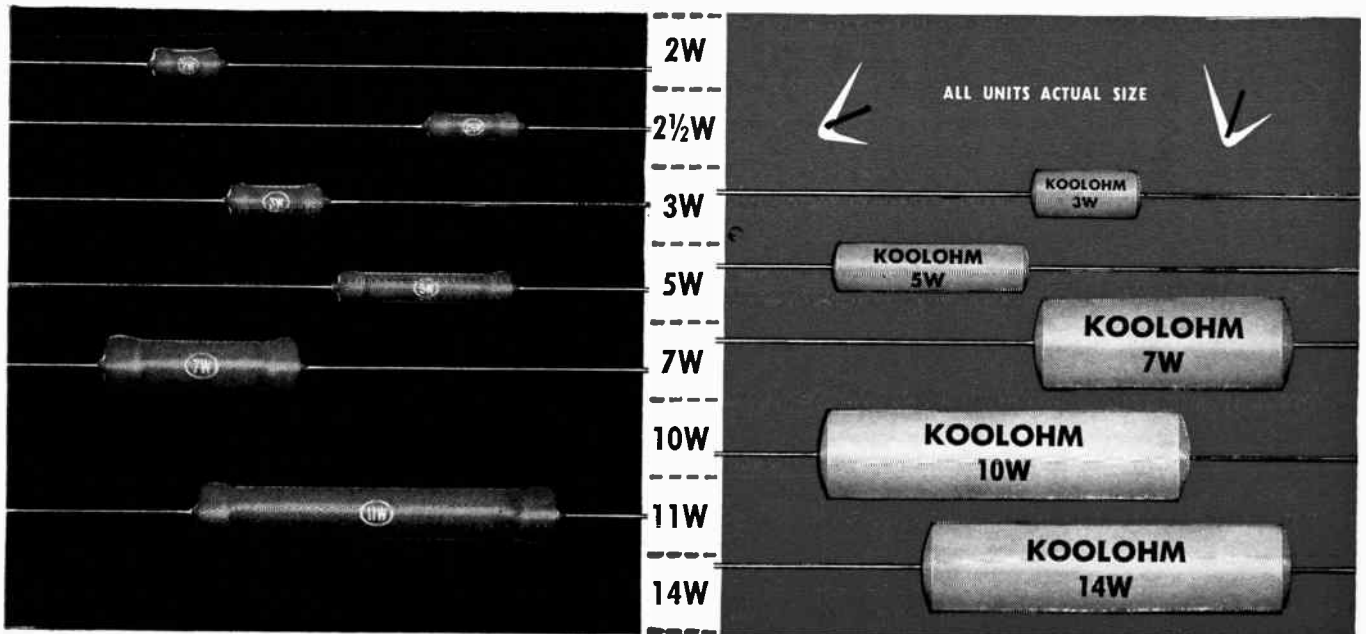

electronic equipment with either conventional wiring or printed wiring boards.

Get complete data on these dependable minified resistors, write for **Engineering Bulletin 7410**.

TAB-TYPE BLUE JACKETS: For industrial applications, a wide selection of wattage ratings from 5 to 218 watts are available in Sprague's famous Tab-Type Blue Jacket close-tolerance, power-type wirewound resistors. Ideal for use in radio transmitters, electronic and industrial equipment, etc. For complete data, send for **Engineering Bulletin 7400A**.

insulated resistance wire, wound on special ceramic core—multi-layer non-inductive windings or high resistance value conventional windings—sealed, insulated, non-porous ceramic outer shells—aged-on-load to stabilize resistance value.

You can depend upon them to carry maximum rated load for any given physical size.

Send for **Engineering Bulletin 7300** for complete technical data.

SPRAGUE ELECTRIC COMPANY

35 MARSHALL STREET • NORTH ADAMS, MASS.

SPRAGUE®
THE MARK OF RELIABILITY

SPRAGUE COMPONENTS: RESISTORS • CAPACITORS • MAGNETIC COMPONENTS • TRANSISTORS
INTERFERENCE FILTERS • PULSE NETWORKS • HIGH TEMPERATURE MAGNET WIRE • PRINTED CIRCUITS

Here are the "basic ingredients" in some of today's most advanced design concepts . . . Norton Ceramic Materials. Exceptionally versatile, these exciting materials are meeting operating requirements of products and processes across industry.

Norton Ceramic Materials offer design engineers a wide range of outstanding physical, chemical, thermal, and electrical properties. What's more, they provide interesting combinations of these properties. For example: CRYSTOLON* silicon carbide provides high thermal conductivity as well as exceptional thermal strength; ALUNDUM* aluminum oxide has excellent chemical stability in addition to good abrasion resistance; MAGNORITE* magnesium oxide offers high purity, thermal and electrical resistance; fused

Dynamic Ideas in Engineering . . .

thrive on Norton ceramic materials

zirconium oxide is today's highest melting point material available in tonnage quantities and it's immune to both reducing and oxidizing atmospheres. And each product has many other invaluable properties.

Think of Norton Ceramic Compositions as essential components in equipment for metal and chemical processing, electrical, electronic, ceramic and nuclear applications . . . as "the answer" to literally hundreds of design problems. They're manufactured to meet highly exacting standards of purity, density, shape, size and wear resistance . . . available in granular and in fabricated form to meet your requirements efficiently and economically. For complete details, write for "Norton REFRACTORY GRAIN". NORTON COMPANY, Refractories Division, 938 New Bond Street, Worcester 6, Mass.

*Trade-Marks Reg. U. S. Pat. Off. and Foreign Countries

NORTON

REFRACTERIES

Engineered . . . R_x . . . Prescribed

Making better products . . . to make your products better

NORTON PRODUCTS Abrasives • Grinding Wheels • Grinding Machines • Refractories • Electrochemicals — BENR-MANNING DIVISION Coated Abrasives • Sharpening Stones • Pressure-Sensitive Tapes



FORMED & SOLID
TAPER PINS



FOR A TIGHT FIT IN A TIGHT SPOT...



MOLDED
TAPER
BLOCKS



INSERTION &
CRIMPING
TOOLS



If miniaturization has put your circuits in a tight spot, you can build reliability right into them with the AMP Taper Technique . . . formed taper pins or new solid, pre-insulated taper pins . . . two-piece or molded one-piece stackable blocks . . . plus a wide assortment of taper receptacles.

The AMP Taper Technique offers the most complete line of taper products available plus many extra features. A three-and-a-half degree taper assures the firmest fit of pin in block. A-MP Pull-Test Insertion Tools assure the proper seating of pins. Hand and Automachine crimping tools assure uniformity of pin attachment to your circuit leads.

And—with the addition to the AMP Taper Technique of the new Solid Pre-Insulated Diamond Grip Taper Pin and the new one-piece warp-free block, you can have the greatest flexibility of product choice for your circuit design and manufacturing operations.

You can concentrate more circuits in a smaller space—and be sure of reliability when you use the AMP Taper Technique. Send for our new catalog today.

AMP INCORPORATED

GENERAL OFFICES: HARRISBURG, PENNSYLVANIA

A-MP products and engineering assistance are available through subsidiary companies in: Australia • Canada • England • France • Holland • Japan

Electronics Progress through
Chemistry and Metallurgy

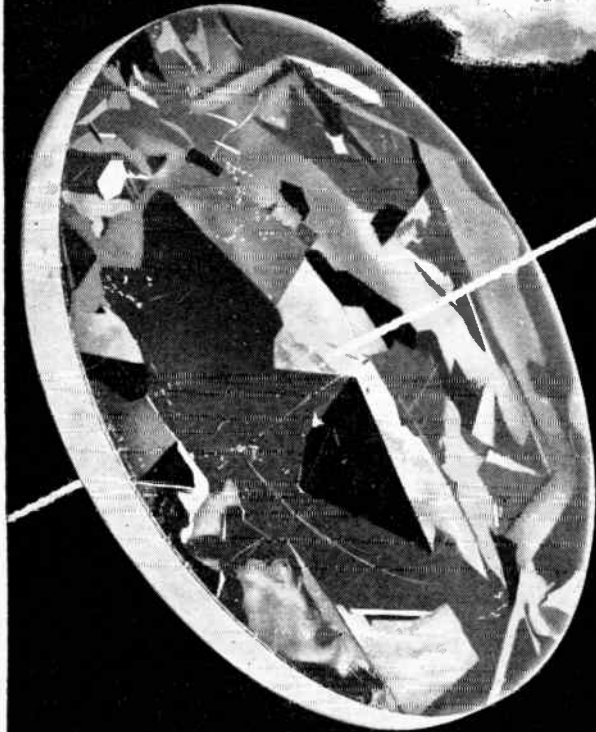

SYLVANIA GERMANIUM CAST LENS DISCS ...

sharpen man's "vision" in the infrared

Scientists have long known that germanium and certain other crystalline materials, though opaque to visible light, are transparent to infrared radiation. These rays now can be focused and directed as readily as light rays . . . by lenses and prisms made from cast germanium blanks.

Sylvania has perfected a process by means of which germanium of high purity is cast in forms suitable for optical purposes . . . in sizes hitherto impracticable to

manufacture (See panel for samples of work already delivered and in process).

Sylvania cast germanium is now in use in vital infrared systems . . . passive radar, missiles, reconnaissance equipment, spectroscopic devices, etc. Its industrial applications are just beginning to be explored.

As a prime supplier of both single crystal and polycrystalline germanium in all its usable forms, *Sylvania invites your inquiries.*

Transparency range
2-15 microns



Discs
to 8½" dia.,
6" thick



Domes
to 8½" dia.,
6" high



Strips—odd shapes
to 16" length

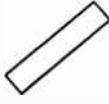

Rods and cylinders
to ½" dia.,
24" length
(Larger diameters
in shorter lengths)



Sheets
to 8" x 16" x ½"

 **SYLVANIA** 
Subsidiary of
GENERAL TELEPHONE & ELECTRONICS

SYLVANIA ELECTRIC PRODUCTS INC.
Chemical & Metallurgical Div.
Towanda, Penna.

Experience—the added alloy in **A-L Electrical Steels**

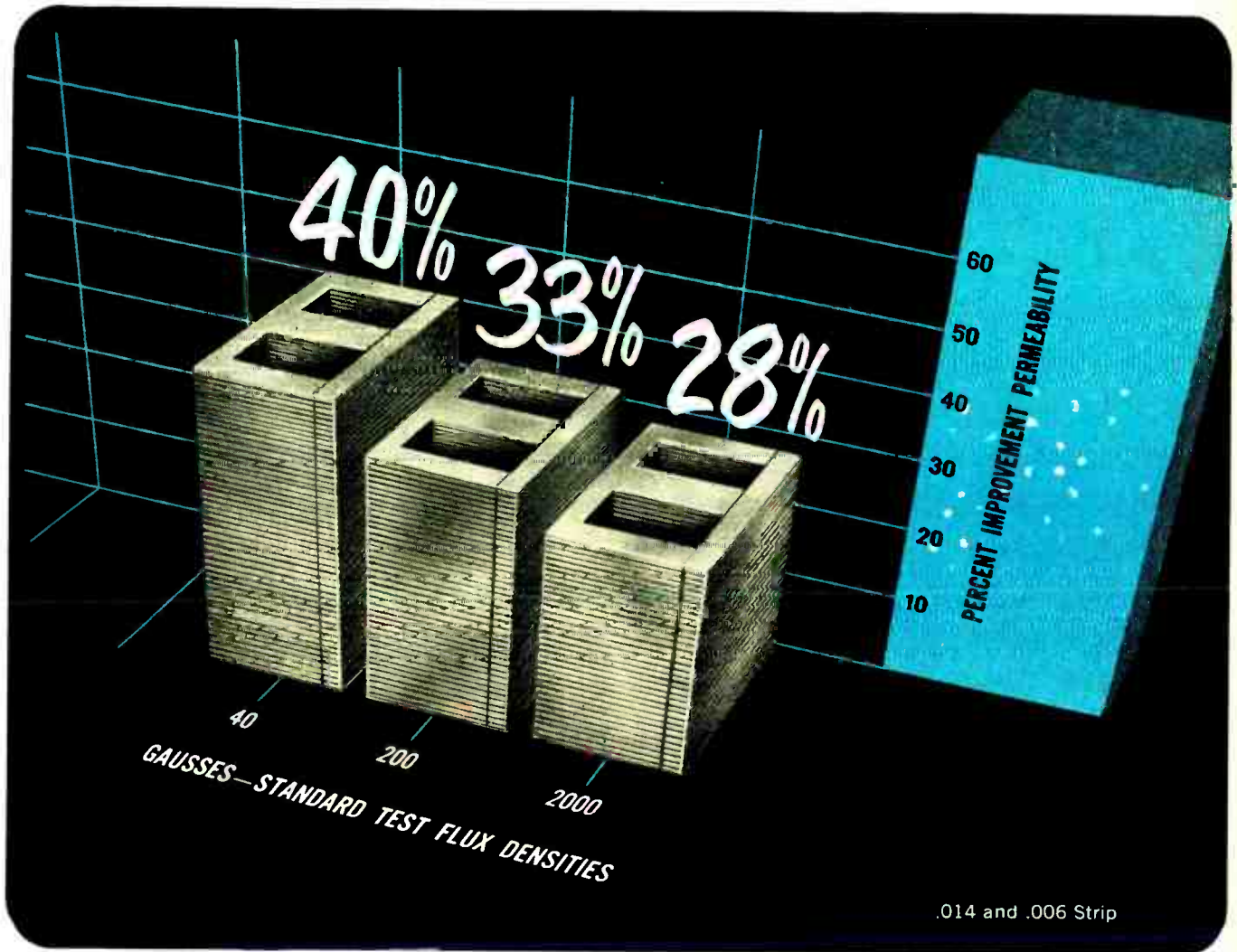

Higher permeability values now guaranteed for Allegheny Ludlum's Moly Permalloy

Means new, consistent and predictable magnetic core performance

Molybdenum Permalloy nickel-iron strip is now available from Allegheny Ludlum, with higher guaranteed permeability values than former typical values. For the buyer, this new high quality means greater uniformity . . . more consistent and predictable magnetic core performance.

This higher permeability is the result of Allegheny Ludlum's intensive research on nickel-bearing electrical alloys. A similar improvement has been made in AL-4750 strip steel. A-L continues its research on silicon steels,

including Silectron, well-known grain-oriented silicon steel, and other magnetic alloys.

Complete facilities for the fabrication and heat treatment of laminations are available from Allegheny Ludlum. In addition, you can be assured of close gage tolerance, uniformity of gage throughout the coil, and minimum spread of gage across the coil-width.

If you have a problem relating to electrical steels, laminations or magnetic materials, call A-L. Prompt technical assistance will be yours. And write for more information on Moly Permalloy. *Allegheny Ludlum Steel Corporation, Oliver Building, Pittsburgh 22, Pa.*

Address Dept. E-21.

WSW 7490

ALLEGHENY LUDLUM

STEELMAKERS TO THE ELECTRICAL INDUSTRY

Export distribution, Electrical Materials: AIRCO INTERNATIONAL INC., NYC 17

Export distribution, Laminations: AD. AURIEMA, NYC 4



World Radio History

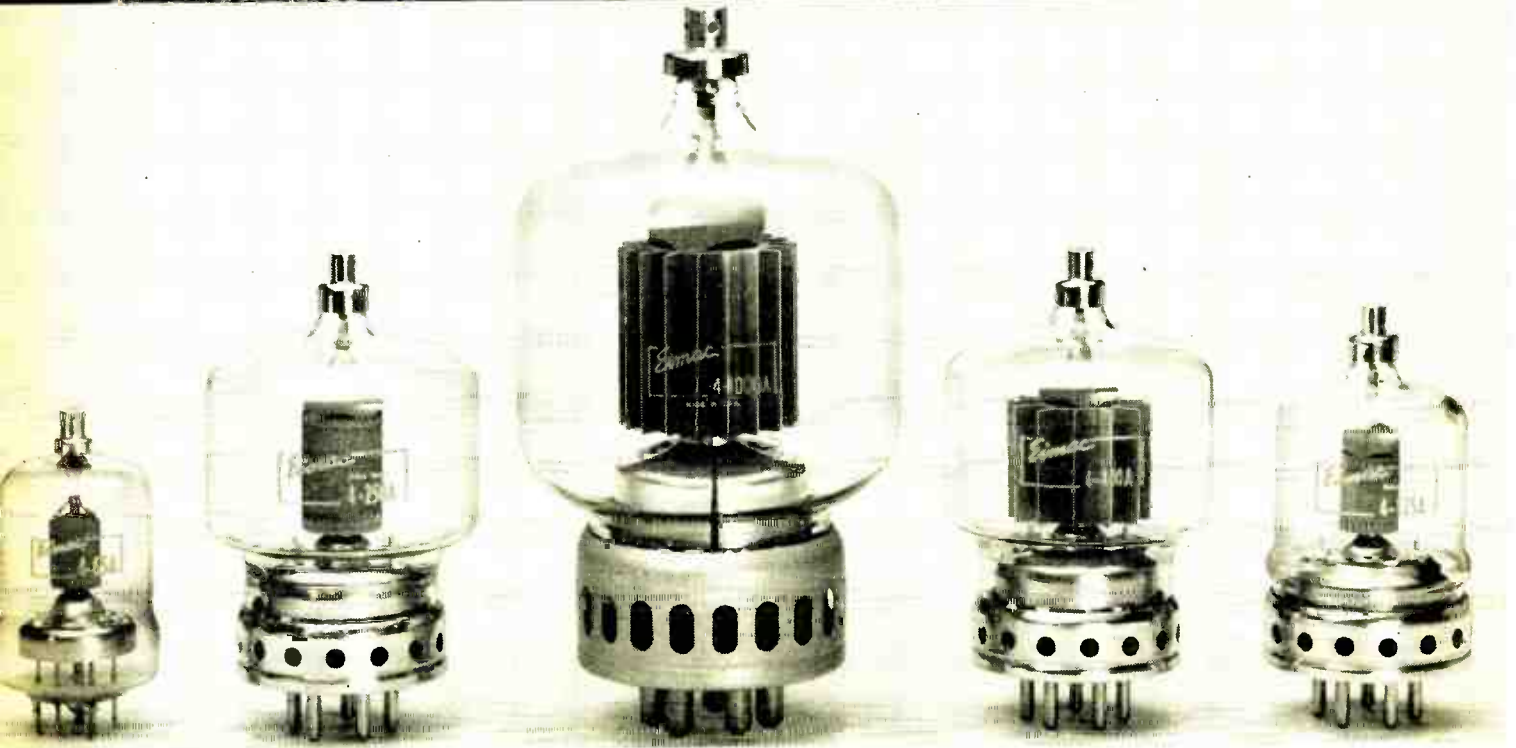
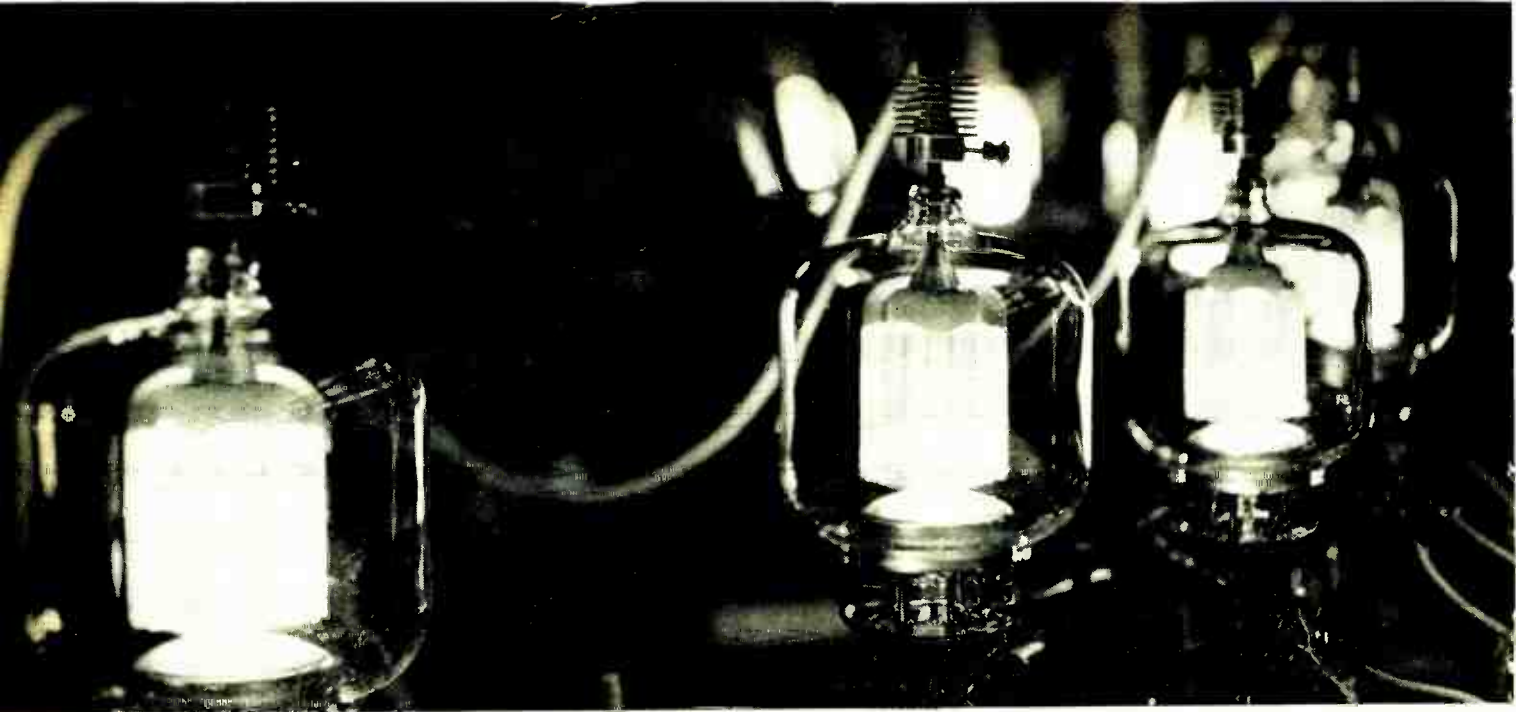

EIMAC PIONEERED INTERNAL-ANODE TETRODES PERFORMANCE LEADERS FOR OVER A DECADE

Developed and introduced to the industry in the mid 1940's, Eimac's line of internal-anode radial-beam tetrodes immediately received widespread and enthusiastic acceptance. Well over a million have been sold since that time. These tubes, quality leaders from the very start, still maintain that position through advanced processing techniques, inherently sound design and continuing concern with production refinements.

Clean electrode design, for example, and the exceptionally hard vacuums achieved on Eimac-developed rotary

vacuum pumps, result in consistently reliable tubes with an exceptional ability to withstand high momentary overloads and peak powers. Rugged filament design with high reserve emission contributes greatly to their reliability and long life.

Stable operation at high frequencies is assured by low inter-electrode capacitances and low lead inductances. Driver requirements and associated circuitry are simplified by the high power gain and low driving power requirements of these tube types.

These features, plus other Eimac

design innovations such as the Pyrovac[®] plate and non-emitting grids make Eimac internal-anode tetrodes your logical choice for new equipment designs, as well as tube replacements, when exceptional performance and reliability are required. Most types available for immediate delivery.

**Registered Trademark*

EITEL-McCULLOUGH, INC.



San Carlos, California

ELECTRONICS NEWSLETTER

COMMUNICATIONS-TRACKING ANTENNAS will be installed for Project Courier—Army Signal Corps' orbiting teletypewriter relay station scheduled to go up this spring (*ELECTRONICS*, p 52, Sept. 11). Hawaii and Puerto Rico are under consideration as locations for antennas. The 28-ft diameter antennas are mounted on a 40-ft steel pedestal built on concrete pads 20 × 20 ft. Housed within each pedestal will be an instrumentation complex that includes four racks of control equipment, a control console, signal tracking display, plus azimuth and elevation indicators. The servo system provides for fast antenna control in local, remote and automatic tracking modes, and for "coasting" at a memorized rate when a temporary signal loss occurs. Other gear may be slaved to the antenna. Sector scan is provided in either remote or local operation modes, and secant correction is supplied for near-zenith tracking. Antenna system was designed and built by Radiation, Inc.

Electronic gear for extracting data from photographs of very low contrast has been devised by the Air Force and described in a report just released by the Office of Technical Services, U. S. Department of Commerce.

RADAR ANTIJAMMING DEVICE developed by Temco Electronics division of Temco Aircraft with its own funds has just been classified by the Defense Department. But this much was already known: The device, attached to a radar, eliminates natural as well as manmade interference, including random white noise. Black box design can be modified to accommodate any radar by a simple change in the final output circuit configuration. Commercial possibilities include clear, close-in presentation of ships on a collision course and the filtering out of noise around air traffic control radars. Jamming caused by proximity of other radar installations is also counteracted.

Strategic Air Command headquarters can now transmit weather maps of the northern hemisphere by facsimile to all SAC facilities in the U. S. in 28 minutes.

MAGNETIC DOMAIN INTERACTION is basis of RV-2 airborne digital computer being developed by an Army-Navy Instrumentation Program (ANIP) team consisting of Douglas Aircraft, Servomechanisms, Varo Mfg. and Litton Industries. Servomechanisms, which has been researching the use of magnetic domain interaction in thin evaporated films, says this approach "should do much to miniaturize digital circuitry and increase its reliability." Magnetic domain memory and logic elements are fabricated by high vacuum thermal evaporation techniques. The RV-2 computer is slated for completion in about two years.

SECOND VENUS RADAR PROBE from MIT Lincoln Laboratory's Millstone Hill installation in Westford, Mass. took place this month. In the latest experiments, a lower sideband up-converter type parametric amplifier using a silicon mesa diode was substituted for the uhf maser which provided the low-noise receiving front end in the first series of interplanetary radar contacts (*ELECTRONICS*, p 35, Apr. 17, '59). Most favorable time in the new series came in first week of September, when Venus passed relatively close to earth. Runs were begun several weeks before, and were continued after the optimum date. Among the new experiments was an attempt at real-time digital processing of the signals. In the first series, signals were directed at Venus in February 1958; it wasn't until March 1959 that success was announced, after cross-correlation studies of the "frozen" data established genuinity of the return signals.

NATIONWIDE CHAIN of large-scale computer service centers is planned by C-E-I-R, Inc., which now operates an independent commercial computing service in Arlington, Va. Firm says it will install \$25 million worth of computer gear in five cities, starting with three IBM 7090's in New York, Houston and Washington; Chicago will get a comparable machine next year, Los Angeles another one in 1961.

During recent war game an IBM 704 computer at Strategic Air Command headquarters made up individual flight plans for 2,100 bombers that took off from 70 bases bound for different targets. The bombers had to fly through varying altitude and weather conditions. Work took 10 man hours, with three men working 3½ hours. Navigators would have needed about 3,000 man hours to do the job.

LABORATORY EQUIPMENT for instructional use in high schools and colleges is being developed by universities, professional scientific organizations and research institutes under new National Science Foundation grants totaling \$189,000. Among the aids: modified research gear for quantitative experiments on the properties of waves for college physics courses; an inexpensive digital computer easily assembled for mathematics courses; a set of about 30 instrument "building blocks" which illustrate fundamental principles involved in complex instrumentation and can be used to build 35 instruments for analytical chemistry; aids for instruction in design and use of analog computers.

MINUTEMAN PCM TELEMETRY responsibility is now claimed by Radiation Inc. with the announcement two weeks apart of two contracts from Boeing totaling \$5.9 million.

ALLIED'S

New

CRYSTAL CAN

5 amp Relay

GENERAL FEATURES

Contact Arrangement:

Two pole double throw.

Contact Rating:

d-c non-inductive—low-level
up to 5 amperes at 29 volts.

a-c non-inductive—low-level
up to 2 amperes at 115 volts.

a-c or d-c inductive—1 ampere
at 29 volts d-c and 115 volts a-c.

Initial Contact Resistance:

.05 ohms maximum.

Minimum Operate Sensitivity

100 milliwatts with a contact
rating of 2 amperes non-inductive.

Ambient Temperature:

-65°C to +125°C.

Dielectric Strength:

1,000 volts rms at sea level.
450 volts rms at 70,000 feet.
350 volts rms at 80,000 feet.

Insulating Resistance:

10,000 megohms minimum.

Vibration:

5-28 cps at 0.5 inch double
amplitude and 28-2000 cps at 20 g.

Shock: 50 g operational. 100 g mechanical.

Operate Time:

10 milliseconds or less at rated voltage at 25°C.

Release Time:

5 milliseconds or less at rated voltage at 25°C.

Maximum Over-all Dimensions:

height 1.0" length 0.8" width 0.4".

Terminals:

0.2 inch grid spaced. Plug-in printed circuit
and hooked type solder terminals.

Weight: 0.8 ounces maximum.

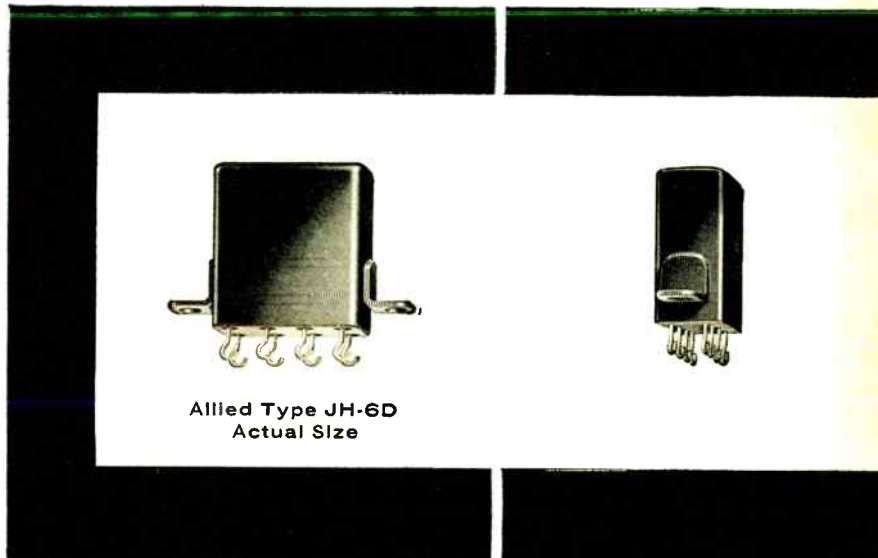

Allied Type JH-6D
Actual Size

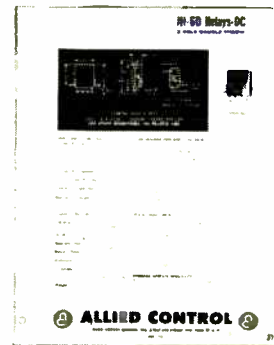

Write
for
Bulletin
JH-6D



ALLIED CONTROL



ALLIED CONTROL COMPANY, INC. 2 EAST END AVENUE, NEW YORK 21, N.Y.

CIRCLE 12 ON READER SERVICE CARD

WEINSCHEL

COAXIAL TERMINATIONS

DC to 10 KMC
50 ohms

Connectors: N, C, SC, BNC and TNC
Individual VSWR calibrations supplied at seven frequencies: DC, .4, 1, 2, 4, 7.5 and 10 KMC.

Made with Weinschel Film Resistors for maximum stability.

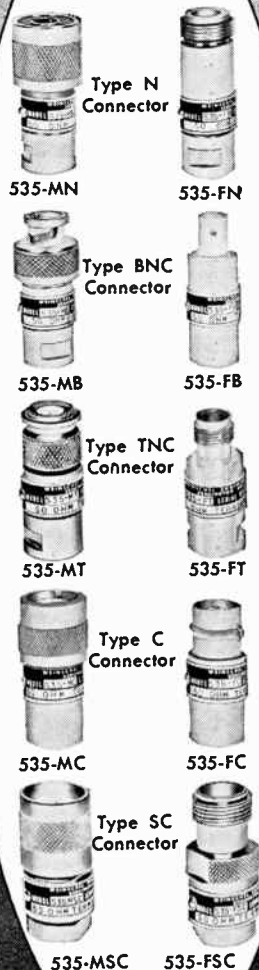

Weinschel Fixed Coaxial Attenuators cover the frequency range of DC to 12.4 KMC. Write for complete catalog.

Weinschel Engineering
KENSINGTON, MARYLAND

WASHINGTON OUTLOOK

WASHINGTON—U. S. SPACE EXPERIMENTATION, still running at a fair head of steam, may be accelerated in the wake of the successful Soviet moon-shot. U.S. scientists acclaim the shot as a major scientific achievement, also hope it will reverse the recent mild trend toward trimming space budgets.

Four major space experiments are planned for the rest of this year by National Aeronautics and Space Administration. First, tentatively set for Sept. 30, is an earth satellite shot that will attempt to put some 91 lbs of instruments into orbit around the earth, primarily to measure radiation.

The U.S. try for a moon satellite—to go around the moon and photograph its hidden face—is scheduled for around Oct. 4. Then in late October or early November an attempt will be made to put a satellite into the same orbit as Venus—not around the planet, but in its orbital path.

Another deep-space probe to go beyond the earth's gravitational pull is planned for later in November. And there will be more tests this year of the vehicles that will carry a man into space next year.

Besides these NASA experiments, the armed services will also be conducting space shots of their own. Late in September a communications satellite is scheduled to be launched. And additional polar-orbit satellites are planned by the Air Force in its Project Discovery series.

Up to now, the U.S. space program has largely been run with makeshift military weapons, mostly modified Atlas, Thor and Jupiter missiles. By mid-1960, however, the first of a series of specially developed space launching craft will be coming into use. Result should be less trial and error, more firm and reliable experiment.

- House Armed Services Investigations subcommittee, under Rep. F. Edward Hebert (D., La.), has completed separate inquiries into defense contracting and into the defense industry's employment of retired military brass. The subcommittee is now hammering out recommendations to be made in January when Congress reconvenes.

On the contracting side, the Hebert committee will probably recommend tougher verification of contractors' cost estimates and tighter military scrutiny of contract performance. Pentagon is already pushing through such measures administratively; legislative action would throw the weight of Congress behind the Defense Department's administrative moves.

The new restrictions were generated by General Accounting Office disclosures that the government was overcharged a total of \$42.2-million during two years in 12 Air Force and 14 Navy contracts.

- On the other issue—that of retired brass in defense industry—the outlook for Congressional action is not as clearcut. The question cannot easily be clarified by statute. Besides, Congressional investigators were unable to come up with specific cases of procurement hanky-pinky involving influence-peddling by retired brass.

Present laws forbid retired officers from selling to the military. Hebert wants to spell out in law just what "selling" constitutes. He also wants to liberalize the rules restricting retired officers from taking civil service jobs. He thinks such action would retain military talents for the government, discourage defense industry recruitment of the retired brass.

Some lawmakers are pushing for rules to bar retired officers from industry contact with military projects with which they were directly responsible while in uniform. But any new curbs are unlikely to discourage industry from hiring retired military men.



CLEVITE

DIFFUSED SILICON RECTIFIERS

TECHNICAL DATA:

Diode Type	Maximum DC Inverse Operating Voltage (volts)	Maximum Average Forward Current @ 25°C (ma)	Maximum Forward Voltage Drop @ 25°C (volts @ ma)
1N645	225	400	1.0 @ 400
1N647	400	400	1.0 @ 400
1N649	600	400	1.0 @ 400
1N677	100	400	1.0 @ 400
1N681	300	200	1.0 @ 200
1N683	400	200	1.0 @ 200
1N685	500	200	1.0 @ 200
1N687	600	200	1.0 @ 200

OTHER CLEVITE DIVISIONS:

- Cleveland Graphite Bronze • Brush Instruments
- Clevite Electronic Components • Clevite Harris Products
- Clevite Ltd. • Clevite Ordnance • Clevite Research Center
- Texas Division • Intermetall G.m.b.H.

Clevite offers silicon rectifiers designed for maximum reliability in the severest military and commercial applications.

Check these features:

- HIGH DISSIPATION — 600 mw
- SUBMINIATURE GLASS PACKAGE
- HIGH VOLTAGE — up to 600 volts
- HERMETICALLY SEALED
- HIGH TEMPERATURE OPERATION — up to 150 ma at 150°C

For details, write for Bulletin B217A-3

A DIVISION OF



CLEVITE

TRANSISTOR PRODUCTS

241 CRESCENT ST., WALTHAM 54, MASS.

Twinbrook 4-9330

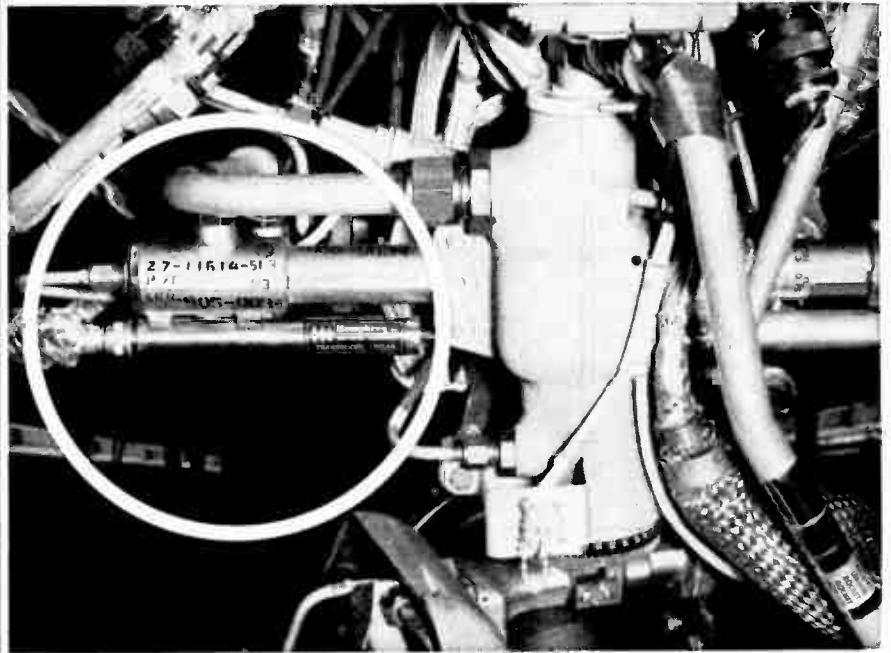

Humphrey potentiometer measures position of vernier rockets on Atlas

The above photograph of a vernier rocket on the Atlas intercontinental ballistic missile shows the installation of the Humphrey RP-23 linear potentiometer. This transducer measures the vernier engine pitch and roll displacement for the telemetry system. The signal is fed to the telemetering package for transmission to the ground, providing an exact record of the operation of the vernier engine pitch-roll motion during missile flight.

The Humphrey RP-23 linear potentiometer offers extremely low resolution, down to less than 1/1000 of an inch. Accuracy is better than .1%. It is completely pressure-sealed in a stainless steel case to withstand tough environmental conditions. Service life of the potentiometer is in excess of one million cycles.

Humphrey makes a complete line of linear and sector potentiometers for severe duty applications. Typical of the environmental conditions they are meeting in current missile applications are vibration 25 G, 10 to 2,000 cps, and shock of 100 G while operating.

Humphrey Potentiometers are available in a wide selection of standard models. Precision pots such as the RP-23 shown here are available for immediate shipment. Specialized types to your specifications can be built on short notice. Development, qualification and production of hardware on the RP-23 all took place in 60 days.

Phone or write today for information on Humphrey ruggedized precision potentiometers. Humphrey, Inc., Dept. E-99, 2805 Canon Street, San Diego 6, Calif.

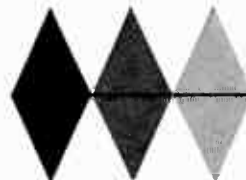

Humphrey Inc.

ELECTRO-MECHANICAL INSTRUMENTS

GYROSCOPES, ACCELEROMETERS, POTENTIOMETERS
WHEN OTHERS CAN'T—HUMPHREY CAN!



One of the earliest and most basic breakthroughs in fastener design was the common safety pin. And, although DOT is not a manufacturer of safety pins, many a DOT industrial fastener has had an equally revolutionary effect on modern fastening technique. Hundreds of different DOT fasteners have created relatively minor revolutions in specific industries.

A DOT fastener may save a few man-minutes of labor. It may save material. Or it may improve product performance and hence saleability. But multiply each small improvement by the number of units in a true mass-production operation and the savings really pile up to impressive proportions.

Rather than spend your own design staff's time on fastening problems, it might pay you well to call in DOT. You'll have at your service a design and production organization with large-scale facilities for genuine mass-production of special-purpose fasteners and self-fastening devices of all kinds.

Supplementing the Carr Fastener Company are a number of other plants which form the United-Carr Fastener group. They are located in the principal production centers of the United States, Canada, England and Australia. Your nearest United-Carr Field office (see below) is no further away than a telephone call from your desk.



CARR FASTENER COMPANY

Cambridge 42, Massachusetts

Offices In:

Atlanta, Boston, Chicago, Cleveland, Dallas, Detroit, Los Angeles, New York, Philadelphia, Syracuse

World Radio History



Here's how to pick the best **DIODES** for your money

Price is no clue when diodes sell for about the same, and just looking at them tells nothing. But if you ask the right questions about the three key factors in the production of quality germanium gold bonded diodes, you have your clues to more long-term reliability for your money. Here they are:

BAKING TIME AND TEMPERATURE

bear a direct relationship to long-term stability. You get a measure of the quality of diodes by asking: "How long do you bake, and at what temperature?" (All GT diodes are baked at 140°C for at least 96 hours—the highest and longest in the industry!)

STRICT, STATISTICAL, HISTORY LOGGING

traces the progress of every single wafer made from each ingot of germanium. At GT, if a few wafers fail to pass the stringent GT quality tests along the way, then all from the ingot are suspect and can be identified and pulled out. There are no "stowaways" in a shipment of GT quality diodes.

LEVEL OF TESTING STANDARDS

reveals the level of quality. Ask about "everyday" test standards. (In the GT Seal Test, diodes are submerged in a penetrant-dye solution for 24 hours under 75 psi. This test is so sensitive that it will reveal a leak so small it would take over 300 years for 1 cc of gas to diffuse through the case.)

All GT quality tests—100% electrical, 100% shock and vibration, and 100% temperature cycling

—are at the highest industry level... and as a final mark of quality, the color bands on GT Germanium Gold Bonded Diodes are baked on to stay.

GT is equipped to supply diodes tested to individual customer requirements, such as JAN Qualification Inspection Tests and many others.

To get the full measure of quality in Germanium Gold Bonded Diodes, see your GT representative; or write directly to the company with know-how **NOW**.

GENERAL TRANSISTOR CORPORATION

91-27 138th Place, Jamaica 35, New York



FOR IMMEDIATE DELIVERY FROM STOCK, CONTACT YOUR NEAREST AUTHORIZED GENERAL TRANSISTOR DISTRIBUTOR OR GENERAL TRANSISTOR DISTRIBUTING CORP., 91-27 138TH PLACE, JAMAICA 35, NEW YORK. FOR EXPORT: GENERAL TRANSISTOR INTERNATIONAL CORP., 91-27 138TH PLACE, JAMAICA 35, NEW YORK. PRECISION MAGNETIC RECORDING HEADS AVAILABLE FROM GENERAL TRANSISTOR WESTERN CORP., 6110 VENICE BLVD., LOS ANGELES, CALIF.

World Radio History

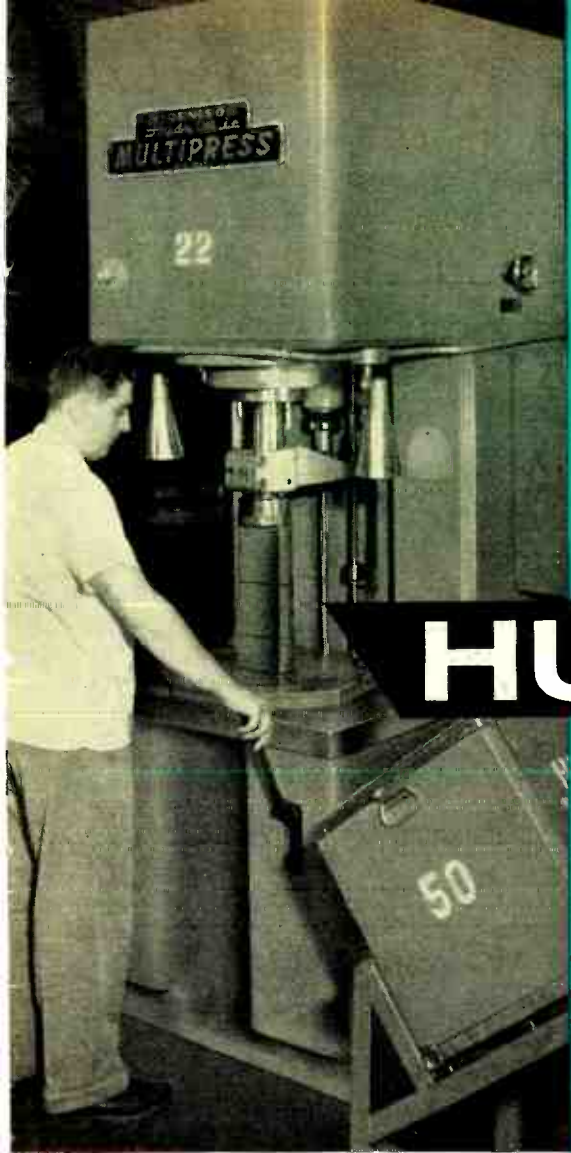

HUDSON

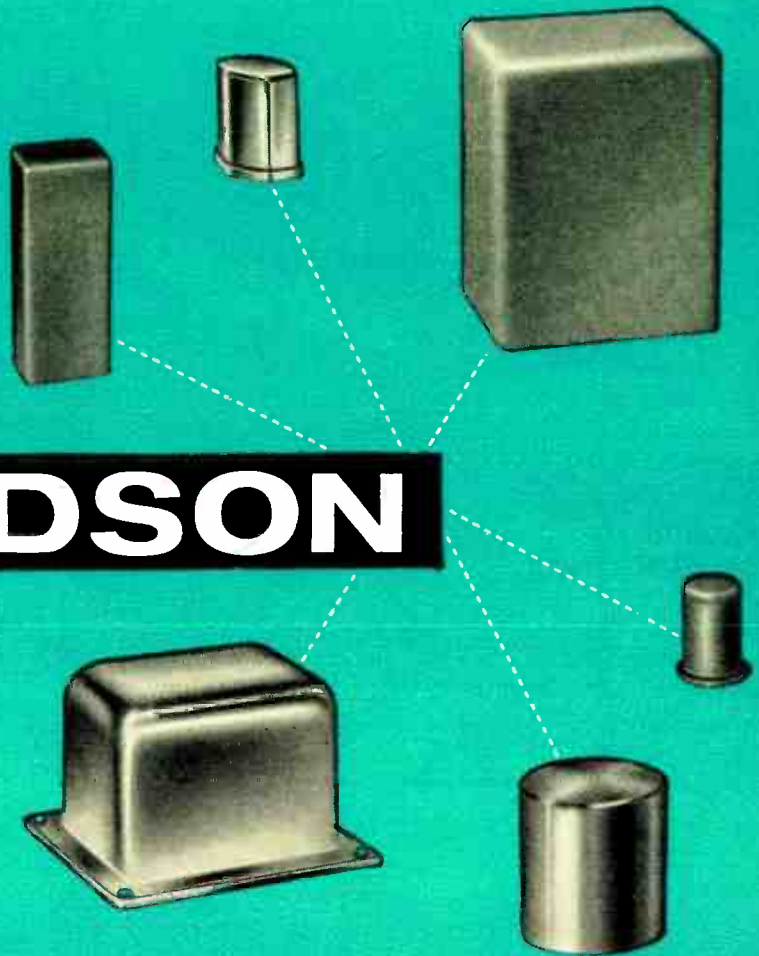

-the Standard Line that's Deep-Drawn to Precision Standards*

DESIGNERS!

For precision quality at commercial prices, consult the new HUDSON catalog. Call or write for this cost and time-saving handbook, today!

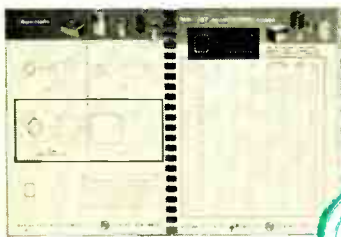

*The Most Complete Line in the Industry, too!

HUDSON STANDARD CASES AND COVERS offer a quick, economical solution to your military and commercial closure problems. Components of mu metal, nickel-silver, aluminum, brass, copper, steel and stainless steel are available in any required finish.

HUDSON STANDARD TOOLING saves you time and money on all but the most unusual closure applications. Check your requirements with HUDSON engineers, now!



Hudson Tool & Die Co. Inc
18-38 Malvern St., Newark 5, New Jersey

Telephone: Market 4-1802
Teletype: NK 1066

Precision Metal Components for Electronics, Nucleonics, Avionics and General Industrial Applications!

3 MODERN PLANTS TO SERVE YOU



World Radio History

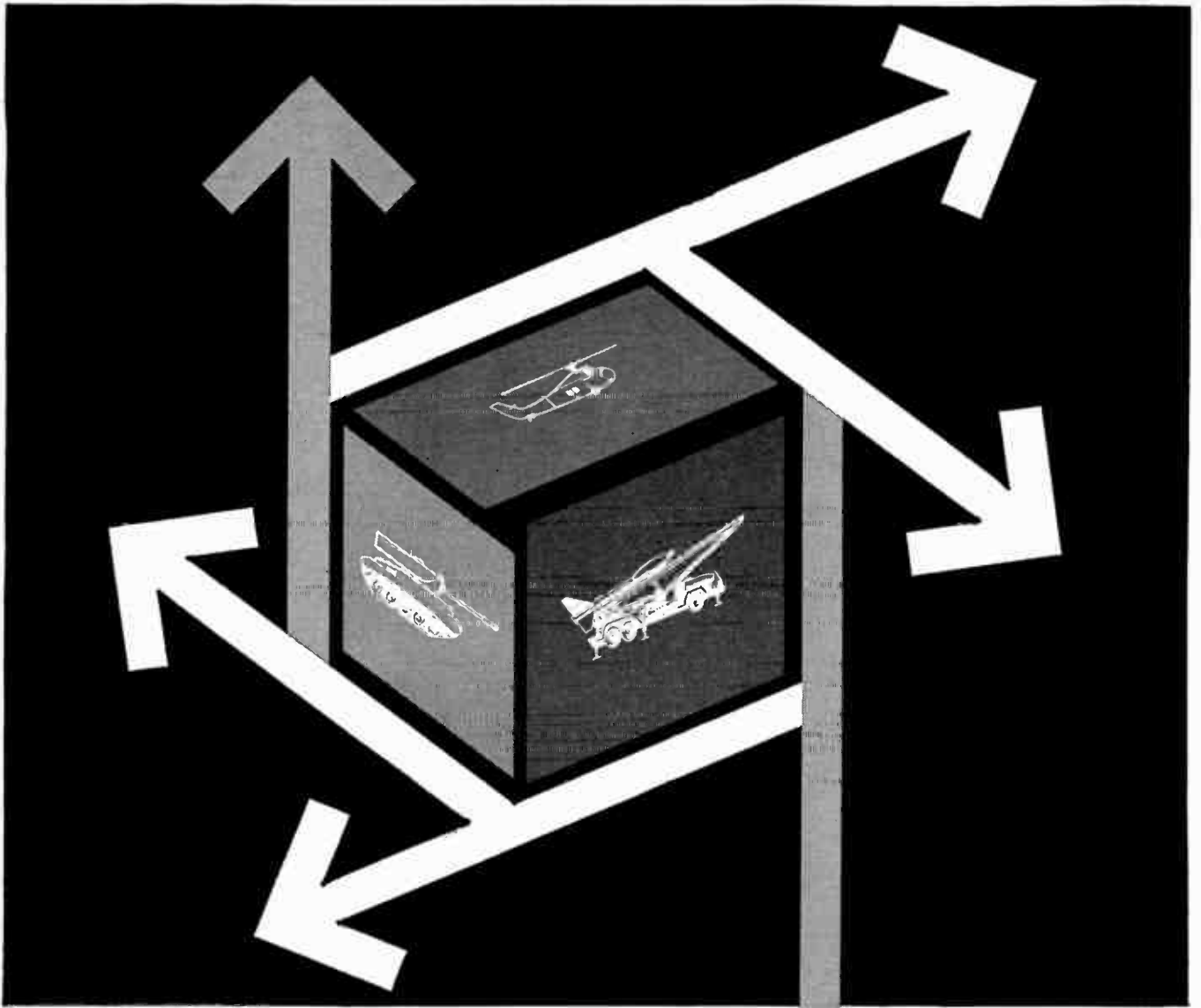

How to put wings on a warehouse

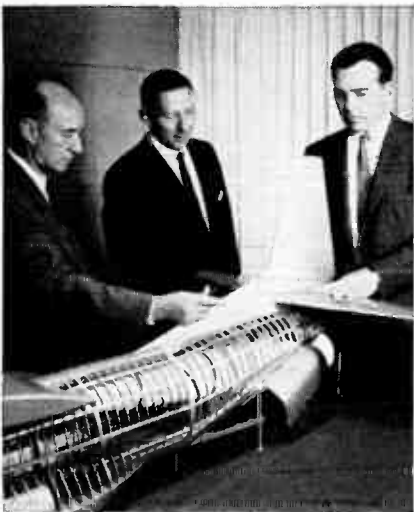

Giving overseas air bases what amounts to local warehouse service on important parts is an Air Force objective. Its present system has slashed delivery schedules up to *20 times*...saved taxpayers several *billion* dollars over the past decade. To improve it further, Douglas has been selected to develop specifications for a comprehensive Material Handling Support System involving better communications, control, cargo handling and loading, packaging and air terminal design. Douglas is well qualified for this program by its more than 20 years in all phases of cargo transport. Air logistics is only one area of extensive Douglas operations in aircraft, missile and space fields in which outstanding openings exist for qualified scientists and engineers. Some are listed on the facing page.

Schuyler Kleinhans and Charles Glasgow, Chief Engineers of the Santa Monica and Long Beach Divisions, go over air transport needs relating to advanced cargo loading techniques with **DOUGLAS**
Donald W. Douglas, Jr., President of

Sales Increases Announced

SALES for Eitel-McCullough, San Carlos, Calif., are up 66 percent for the first half of the firm's fiscal year, compared to the same period last year. Sales for the latest period amounted to \$12,047,746. Earnings were 90 cents a share, as compared with the two cents a share deficit for the initial half of 1958 and the 26-cent total reached last year. Total 1958 sales came to about \$16 million, while company predictions for total 1959 sales are in excess of \$25 million. This prediction is partly based on a backlog of about \$9,700,000, compared with \$7,100,000 a year ago.

• **Smith-Corona Marchant** reports net sales of \$90,411,280 for the fiscal year ended June 30, 1959. Sales in the previous year were \$87,145,774. Net earnings decreased to \$551,396, equal to 30 cents a share, compared with \$2,244,258 or \$1.38 a share for last year. Company officials attribute the dip to building programs and accelerated research and engineering activities which added to operating expenses. As an example, they cite R&D expenditures of \$4.3 million, as compared with \$2.8 million in 1958.

• **Chicago Aerial Industries**, Melrose Park, Ill. manufacturer of drone and manned aircraft reconnaissance systems, airborne data displays and missile guidance systems, reports sales for the first half of this year of \$6,007,478, a 60-percent increase over the first half of 1958. Earnings per share and total earnings were up 80 percent to 76 cents and \$400,525, respectively. Backlog is counted at over \$6 million, mainly in production orders for precision avionics equipment.

• **Industrial Electronic Hardware Corp.**, New York, reports net sales for its fiscal first quarter amounting to \$854,211. This compares with a total of \$547,583 in the similar quarter of 1958, a gain of about 56 percent. Net profits totaled \$33,573, equal to 5½ cents

a share. Net profits in the first quarter of last year were \$8,066 or 1.3 cents a share on the company's 611,568 outstanding shares of common stock.

• **Telemeter Magnetics, Inc.**, Los Angeles, announces acquisition of **Invar Electronics Corp.**, Pasadena, Calif., manufacturer of solid state power supplies and electronic instruments. Company officials say the move will provide Invar with financial support for development of new products and extension of present product lines. No changes in personnel or management are contemplated as a result of the acquisition.

• **Granco Products, Inc.**, New York, reports sales of \$3,070,486 for the fiscal year ended June 30. This represents a 38-percent increase over the previous fiscal year. Net earnings for the period were \$49,152 this year, compared with \$2,812 for last year. The firm makes f-m radio receivers.

25 MOST ACTIVE STOCKS

WEEK ENDING SEPTEMBER 11

	SHARES (IN 100's)	HIGH	LOW	CLOSE
Int'l Tel & Tel	776	33	30¼	32½
Sperry Rand	721	227½	22	22¾
Raytheon	686	48¾	43½	43¾
RCA	647	59½	55¾	58½
Burroughs	607	31¾	30½	30¼
Gen Elec	529	78½	75¾	78¼
Avco Corp	516	137½	13½	13¼
Gen Tel & Elec	443	71½	69¾	70¾
Westinghouse	427	90¼	85¾	88¾
Univ Control	406	17¼	16	16½
Zenith Radio	329	104¼	99¼	100½
Elec & Mus Ind	317	7¼	7	7¼
Texas Inst	314	136¾	126¾	132
Gen Inst	296	23¾	20¾	22¾
Standard Coil	282	16¼	14¾	16½
Litton Ind	265	118¾	110½	114¾
Gen Dynamics	255	49	46¾	47¼
El-Tronics	243	1½	1¾	1½
Reeves Sndrcft	223	77½	7½	7¾
Beckman Inst	214	54¾	50¾	52
Philco Corp	204	25¼	23¾	24
Siegler Corp	193	27¾	25¼	26½
Gen Transistor	190	35½	32½	34¼
Dynamics Corp	173	87½	8¾	8½
Victoreen Inst	172	14¾	13	13¾

The above figures represent sales of electronics stocks on the New York and American Stock Exchanges. Listings are prepared exclusively for ELECTRONICS by Ira Haupt & Co.

STOCK PRICE AVERAGES

	Sept. 9, 1959	Aug. 12, 1959	Change From One Year Ago
Electronic mfrs.	84.58	87.95	+43.9%
Radio & tv mfrs.	103.16	111.15	+82.11%
Broadcasters	91.89	99.29	+33.7%

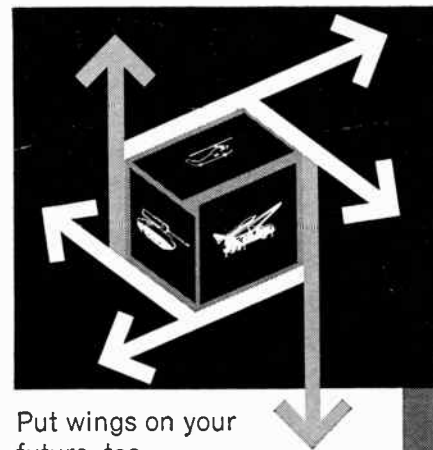

Put wings on your future, too.

DOUGLAS AIRCRAFT COMPANY MISSILES AND SPACE SYSTEMS

has immediate openings in the following fields—

Electrical and Electronics:

- Control System Analysis & Design
- Antenna & Radome Design
- Radar System Analysis and Design
- Instrumentation
- Equipment Installation
- Test Procedures
- Logic Design
- Power System Design

Mechanical Engineering —

Analysis and Design of the following:

- Servo Units
- Hydraulic Power Systems
- Air Conditioning Systems
- Missile Launcher Systems
- Propulsion Units and Systems
- Auxiliary Power Supplies

Aeronautical Engineering:

- Aerodynamic Design
- Advanced Aerodynamic Study
- Aerodynamic Heating
- Structural Analysis
- Strength Testing
- Dynamic Analysis of Flutter and Vibration
- Aeroelasticity
- Design of Complex Structure
- Trajectory Analysis
- Space Mechanics
- Welding
- Metallurgy

Physics and Mathematics:

- Experimental Thermodynamics
- General Advanced Analysis in all fields
- Computer Application Analysis
- Computer Programming and Analysis
- Mathematical Analysis

For full information write to:

Mr. C. C. LaVene

Box F-620

**Douglas Aircraft Company, Inc.
Santa Monica, Calif.**

Helping to keep computers compact...

The space and weight saving characteristics of Gamewell Sinusoidal Potentiometers make them a popular choice for equipment employing sine-cosine operations. Far lighter and more compact than gears, cams, and other complicated mechanisms, they're widely used in analog computers, data converters, Tacan systems, and radar components. Wire wound card and double brushes produce sine-cosine functions with a smoothness and precision unobtainable by other resistive methods... ideal for low frequency sine wave generation.

Solve *your* prototype problems with Gamewell Precision Potentiometers. A wide range of linear and non-linear models including servo, precision, and trimmer types. Emphasis on "specials." Engineering assistance upon request. Write THE GAMEWELL COMPANY, Dept. 13E, Newton Upper Falls 64, Mass.

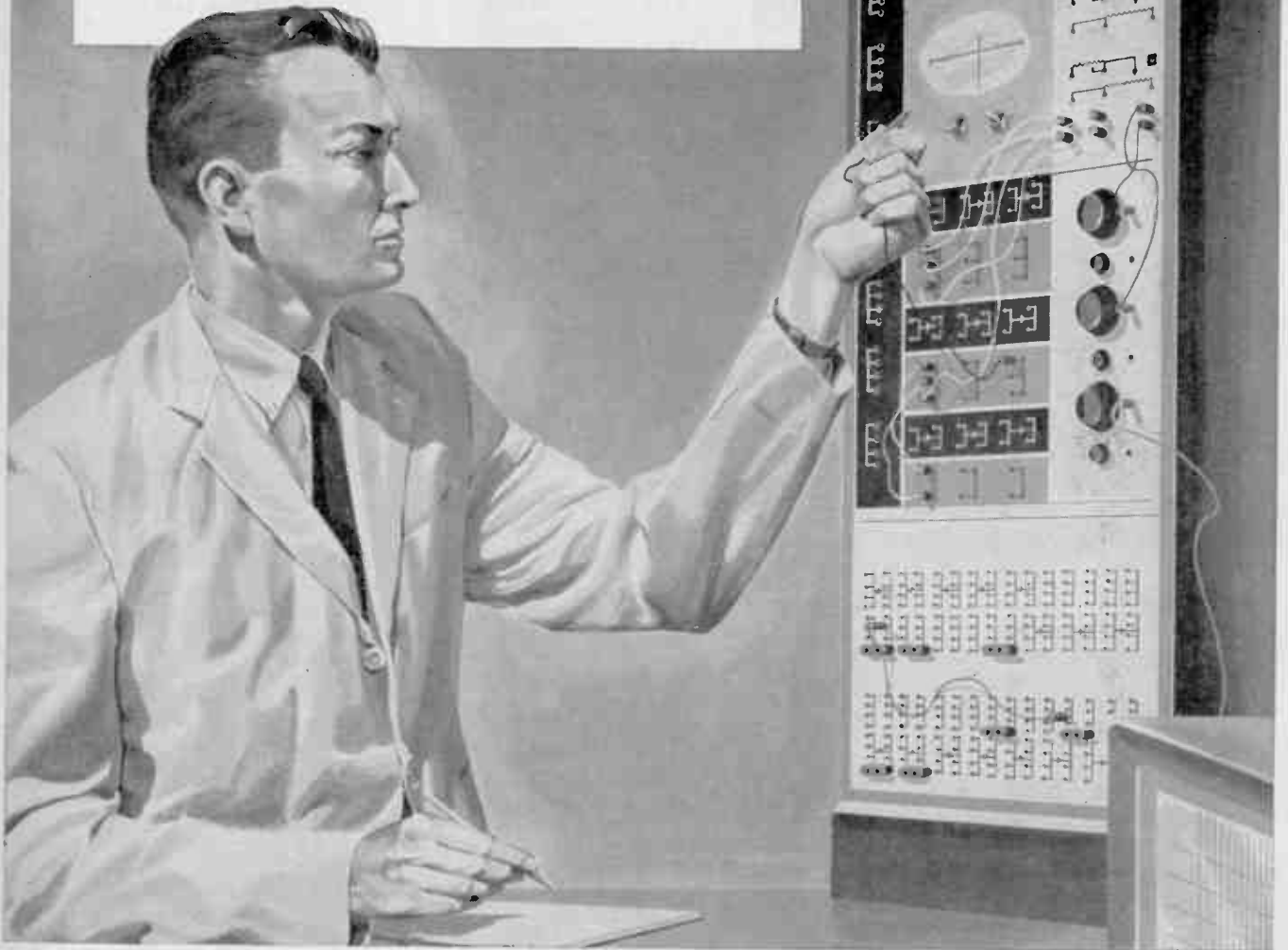

CONDENSED SPEC OF RVG-30XS-4POT

Resistance.....16,000 ohms \pm 5%
 Conformity.....1.0% peak to peak
 Starting Torque.....0.5 oz. in. max.
 Angular Accuracy..... \pm 0.7°
 Weight.....2 oz. max.
 Mechanical Rotation.....Continuous
 Electrical Rotation.....360°
 Nominal Life.....350,000 cycles

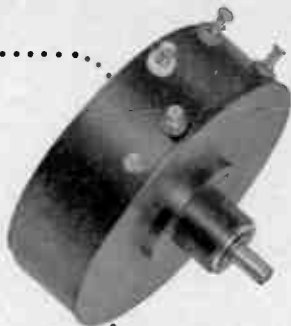

Gamewell®

PRECISION POTENTIOMETERS
 INTEGRALS OF
 HIGH PERFORMANCE



RECTIFIER NEWS

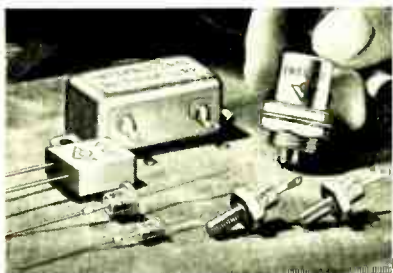

644 Zener Diode Types Offer Advantages to Every Voltage Regulator Circuit

As compared to other voltage reference elements, the silicon diode regulator has a longer life expectancy because of its mechanical ruggedness. It does not deteriorate under storage nor age during its operating life. Small size and light weight make its use in airborne or portable equipment especially desirable from many standpoints.

International Rectifier Corporation now offers an extensive line of zener types numbering 644 in seven basic styles. From the miniature type rated at 750 milliwatts to the precision 1N430 reference element types, all are manufactured to meet the most rigid military requirements. See how these all-welded, hermetically sealed diodes can improve your circuit design. . . .

CIRCLE READER SERVICE CARD NO. 155

Miniature Voltage Reference Packs Maintain Voltage Regulation to within $\pm 0.01\%$!



REF-PAK MODEL 4RV8
Standard MIL Transformer Case

Designed around the highly stable 1N430 silicon reference element, these miniature reference supplies may be considered to be the solid state equivalent of the standard cell. A high degree of stability is attained by maintaining a precise constant current through the reference element, regardless of temperature or line voltage variations.

Ref-Paks will operate directly from



REF-PAK MODEL RV8-PC
Special Housing for insertion into printed circuit boards.

an unregulated power source . . . maintain voltage regulation to within $\pm 0.01\%$! Output voltages of either 8.4 or 16.8 volts dc are available in 5 distinct types that allow operation from 28 or 115 volt dc, 400 and 60 cycle power supplies. Temperature coefficient of these devices is $\pm 0.001\%/^{\circ}\text{C}$ from -55° to $+100^{\circ}\text{C}$.

For complete details ask for SR-401.

CIRCLE READER SERVICE CARD NO. 156

ZENIAC Provides a Shortcut to the Application of Silicon Zener Diodes

A flip of the Zeniac selector switch quickly tells you the exact diode required in complex breadboard circuitry. This unique innovation — the first semiconductor substitution box in history — has been designed specifically to aid system design groups by saving valuable lab time in the application of zener diodes.

Two units are available, each housing 11 diodes in voltage steps from 3.9 thru 27 volts. Model A Zeniac is rated at 1-watt; Model B is rated at 10-watts. Both are now in stock at your Authorized Distributor. Ask for details on this time saver . . .



CIRCLE READER SERVICE CARD NO. 157

Technical Service Provides XY Plot of Reverse Breakdown Characteristics of Each Diode in all Prototype Orders

To eliminate guesswork and tedious testing on your part, every zener diode sent on prototype orders will be accompanied by a specially plotted XY recording of its exact breakdown voltage point! This permanent record can come in mighty handy when it's time to match diodes or reorder to the same specs. This is just one of the many application engineering services we are prepared to extend to you at all times!

Write to the factory for Bulletin SR-250-A, a four page technical article describing the characteristics of zener diodes, how to select them, and application data with circuit schematics.

FOR SALES AND SERVICE ON PRODUCTS INFORMATION—CIRCLE NO. 1 AND VISITATION—CIRCLE NO. 2 AT THE SHOW

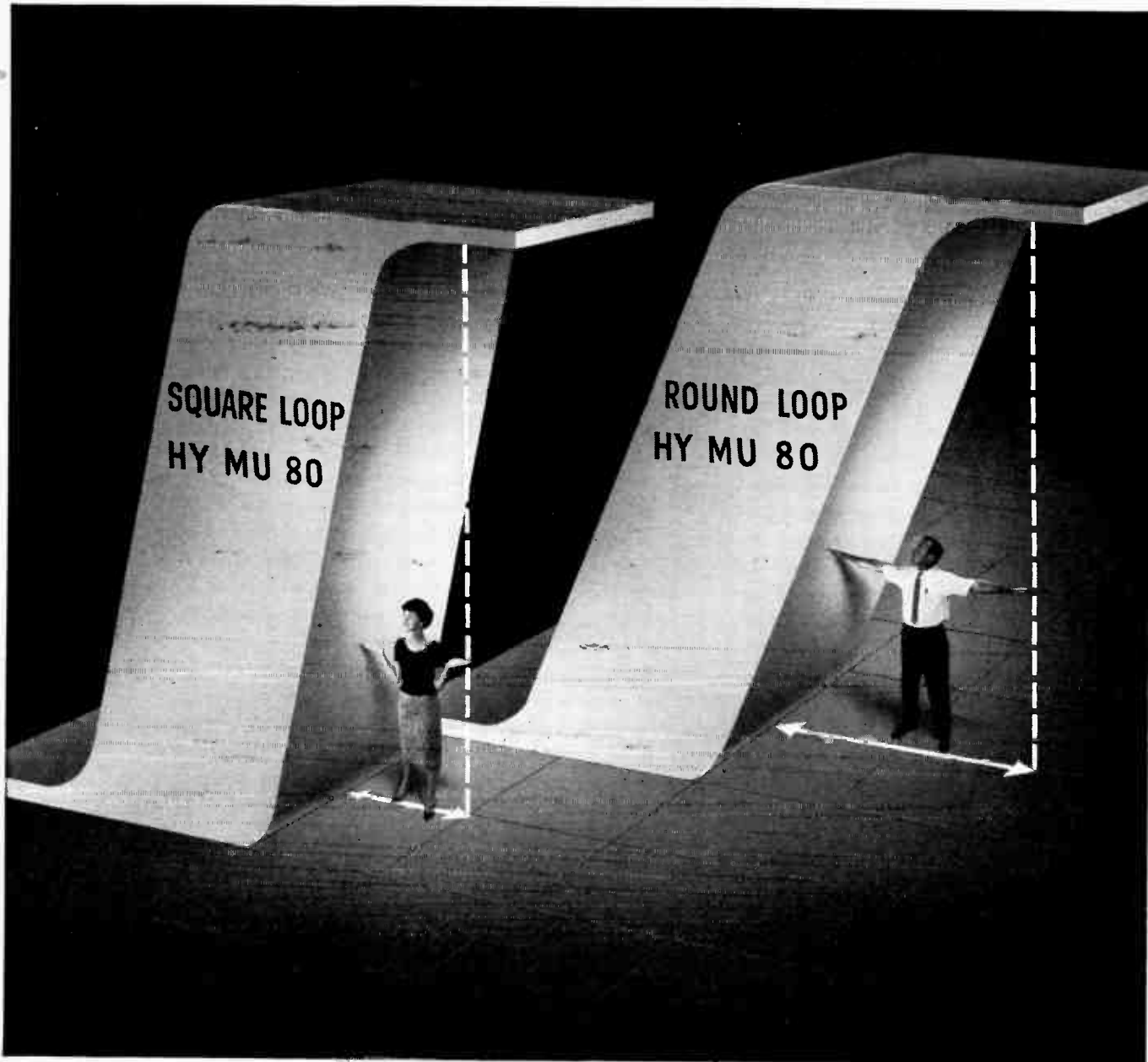

Vive la différence in Hy Mu 80!

For greater sensitivity—Magnetics, Inc. makes Round Hy Mu 80 for more output at low flux densities
For greater gain—Magnetics, Inc. makes Square Hy Mu 80 for more voltage amplification

There's an important difference in the two basic kinds of Hy Mu 80, Round Loop and Square Loop. By taking advantage of it, you design magnetic amplifiers with better performance and efficiency characteristics. We stock standard tape wound cores made of *both*, to be sold at non-premium prices. We want you to order the right kind.

Round Hy Mu 80 is demanded when flux densities are down around the 10 to 50-gauss level. Its high initial permeability results in great sensitivity. It also means fewer windings, thus smaller sizes. Combine higher inductance, great sensitivity and small size, and if you are a designer of devices like low level transformers or thermocouple amplifiers, then you want Round Hy Mu 80 tape cores.

On the other hand, if you design sensitive high gain magnetic amplifiers you need Square Hy Mu 80. The transfer curve is so

linear and so nearly vertical that a minute change in input produces an extremely sharp response. When only a small bias supply is available, you get a lot more amplifier per dollar. Preamplifier designers are among our best customers.

So vive la différence! Order the right Hy Mu 80 for your needs. We'll supply either, and what's more, we'll supply them quickly. Want the full story? Write Magnetics, Inc., Dept. E-71, Butler, Pennsylvania.

MAGNETICS inc.

2N1069 2N1070

HIGH POWER — LOW SATURATION RESISTANCE NPN SILICON TRANSISTORS

Silicon Transistor Corporation is now delivering diffused-junction, NPN silicon mesa transistors. These new high power—low saturation resistance transistors operate in the temperature range of -65°C to 75°C for a wide variety of military and industrial applications where peak reliability and high temperature characteristics are required. Maximum saturation resistance for the 2N1070 is 0.67 ohms at a collector current of 1.5 amps., the 2N1069 is 2 ohms maximum at the same current.

Applications: Since these STC transistors feature low saturation resistance they are ideally suited for switching applications as well as relay replacements and controls, solenoid actuators, power converters, power switches, high level D.C. amplifiers, power supply regulators, and Class A and B power amplifiers.

For complete specifications, request STC Form 1953. Write also for engineering bulletins on STC's full line of silicon glass diodes.

RATINGS

Power Dissipation.....	50 watts
V _{CEO}	60 volts
V _{EB0}	9 volts
V _{CE0}	45 volts
I _C	4 amperes

TYPICAL SATURATION RESISTANCE

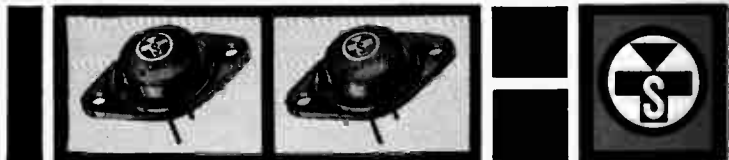
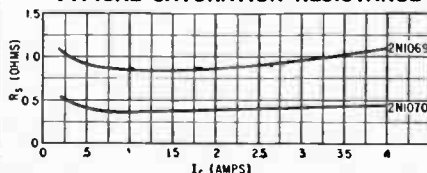

SILICON TRANSISTOR CORPORATION, World Radio History, Carle Place, L. I., New York, Pioneer 2-4100

KLIXON[®]

CIRCUIT BREAKERS, PRECISION THERMOSTATS, SWITCHES and OVERHEAT PROTECTORS

For Electronic, Radar and Radio Equipment, Ground Support Equipment, Missiles and Aircraft Controls

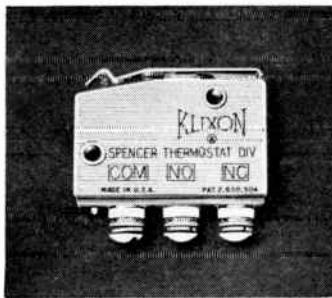

**KLIXON KX-5 SERIES
PRECISION SWITCHES**

Hermetically sealed snap-acting limit switches. Seal uses metalized ceramic terminal inserts and metal diaphragm. Switching element, one-piece sine blade. Steel case withstands high impact and compression loads. High temperature resistance to 375°F. Vibration resistance to 25 g's, 0-2500 cps. Ratings to 10 amperes, 115 VAC or 30 VDC resistive. 25,000 cycles minimum life. Ambient temperatures range, -65°F to +375°F. Weight 1 oz. Variety of actuators available.

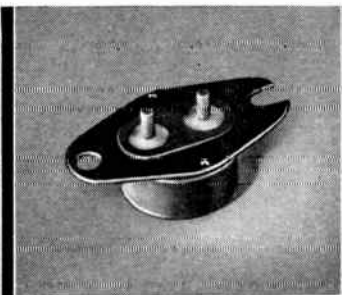

**NEW KLIXON M1
PRECISION THERMOSTAT**

Hermetically sealed, vibration resistant, snap action. Gold plated contacts for dry circuit applications. Conforms with MIL-E-5272A and MIL-T-5574A. Preset and non-adjustable. Temperature settings from -65°F to +400°F. High dielectric strength 1250 VAC. Ratings up to 7 amperes, 30 VAC/DC resistive; or 6 amperes, 125 VAC; or 3 amperes, 250 VAC. Weight 5 grams. Special high-reliability version with low differential (9°F) available.

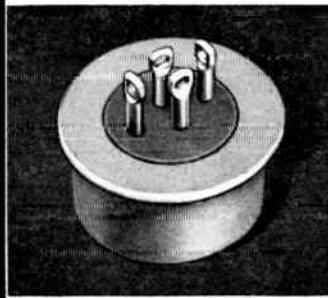

**NEW KLIXON 2862
PRECISION THERMOSTAT**

Positive temperature control for three-phase systems. Hermetically sealed, fixed temperature, snap action. Controls three phases simultaneously. Temperature settings from -65°F to +325°F. Minimum differential: 25°F. Rating 5 amperes, 120 VAC, 60/400 cycles. Variety of mounting brackets available.

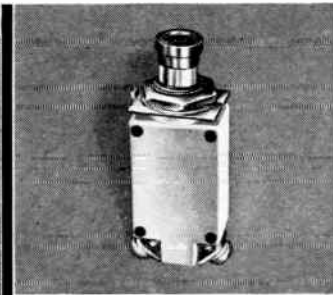

**NEW KLIXON 7274
MICRO-MINIATURE
CIRCUIT BREAKER**

Simple push-pull, trip-free design. Available as shown SPST with 6/32 screw-type terminal or mounting to replace NAF-1357 front-mounted fuse. Also SPDT with N/O auxiliary contacts and 4 solder terminals. Exceptionally small — height 1.420", width 0.744", depth 0.562". Ratings 1/2 to 5 amperes. Ultimate trip @ 77°F, 115-145%. 200% trip, 2-15 seconds. Vibration resistance 10 g's, 10-500 cps. Shock resistance 25 g's. Weight only 0.9 oz.

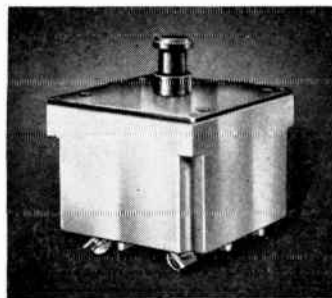

**NEW KLIXON 06760
SIMULTRIP[®] CIRCUIT BREAKER**

Thermal type, three phase. Interrupts high AC short circuits . . . trips quickly . . . provides simultaneous tripping of all three phases should any one phase become overloaded. Phases can be different ratings. Ratings 5 to 60 amperes, 120/208 VAC, 60/400 cycle systems and 220/440 VAC, 60/400 cycle systems. Weight 227 grams. Minimum AC rupture capacity 2500 amperes, 1 φ, 120 VAC, 400 cps. Ultimate trip @ 77°F, 105-130%. 200% trip, 10-65 seconds.
*Trade Mark

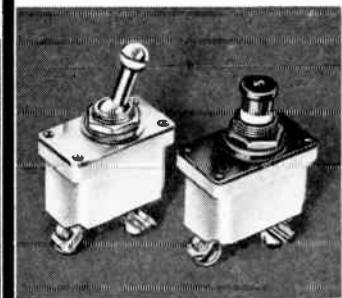

**KLIXON 07270-07271
CIRCUIT BREAKERS**

Two miniature breakers different only in actuators. Simple trip-free design about 1/3 the size of MS25005 and MS25017. Only three moving parts — actuator, slide and thermal disc. Ratings 3 to 35 amperes; weight 1.5 ozs. High rupture capacity 3500 amperes, 120 VAC, 400 cps; 4,000 amperes, 30 VDC.

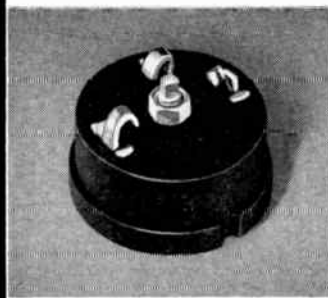

**KLIXON SINGLE-PHASE
INHERENT OVERHEAT
PROTECTORS**

Protect transformers, solenoids, electric motors against excessive temperatures. Responsive to both temperature and current. These types are for single-phase inductive equipment with maximum continuous operating temperatures up to 225°C. Maximum rupture capacity is 750 amperes, 200 VAC, 400 cycle. Available in automatic and non-automatic reset types.

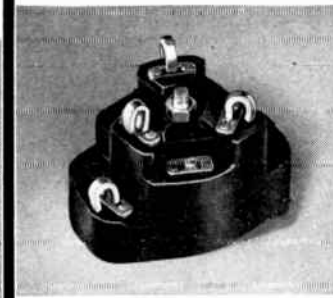

**NEW KLIXON THREE-PHASE
INHERENT OVERHEAT
PROTECTORS**

Designed to match the thermal and electrical characteristics of inductive equipment, they prevent protected components from reaching destructive temperatures without limiting useful output. For 3-phase equipment with maximum continuous operating temperatures up to 225°C. Maximum rupture capacity is 400 amperes, 200 V, 400 cycles. Available in open and hermetically-sealed construction in automatic and non-automatic reset types.

KLIXON Circuit Breakers, Precision Switches, Precision Thermostats and Overheat Protectors are small in size and light in weight; they respond quickly and with accurate repeat performance; they have ample capacity to handle a wide range of electrical loads; their calibrations stand up in the face of severe environmental conditions.

Competent Metals & Controls engineers at the

SPENCER PRODUCTS: Klixon[®] Inherent Overheat Motor Protectors • Motor Starting Relays • Thermostats • Precision Switches • Circuit Breakers

factory and in the field will gladly make test applications of the KLIXON Line. Write for "KLIXON Controls for Electronic Equipment, Aircraft and Guided Missiles" Catalog.

METALS & CONTROLS

5009 FOREST STREET, ATTLEBORO, MASS., U.S.A.

A DIVISION OF TEXAS INSTRUMENTS INCORPORATED

Why compromise on your panel or switchboard instrumentation?

SPECIFY WESTON: The finest instruments available . . . combining long-range economy, lasting quality

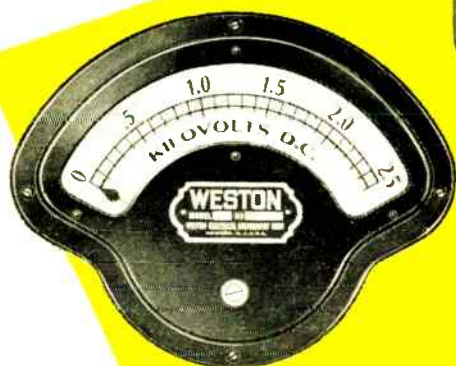

Model 273

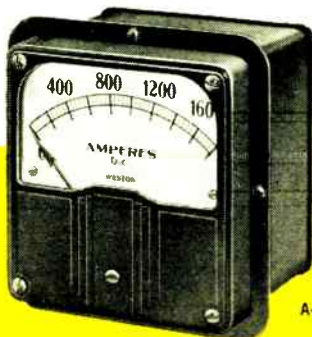

Model 921

	Model 741 Group	Model 640 Group	Model 610 Group	Model 921 Group	Model 273	Model 269	Model 267
A-C voltmeters	X	X	X	X			
A-C ammeters	X	X	X	X			
A-C milliammeters	X	X	X	X			
A-C rectifier-type instruments	X	X	X	X	X	X	X
D-C voltmeters	X	X	X	X	X	X	X
D-C ammeters	X	X	X	X	X	X	X
D-C micro- and milliammeters	X	X	X	X	X	X	X
D-C millivoltmeters	X	X	X	X	X	X	X
Polyphase wattmeters-varmeters		X	X				
D-C & single-phase A-C wattmeters		X	X				
Single & polyphase power factor meters			X	X			
Frequency meters	X	X	X	X			
Thermo instruments	X	X	X	X			
Synchrosopes				X			

The widest range of SHAPES, TYPES and SIZES*

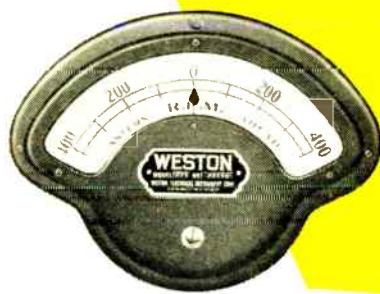

Model 271



Model 610



Model 643



Model 741

Over 70 years' leadership in electrical measurement . . . that's the tradition behind each of these instruments . . . the reason for the world-wide preference they've earned. You'll find just the model to meet your switchboard or panel needs in the Weston Catalog — including all versions of the famous instruments pictured on this page.

For specifications . . . information . . . or the address of your nearest distributor, contact your local Weston representative . . . or write to Weston Instruments, Division of Daystrom, Inc., Newark 12, N. J. In Canada: Daystrom Ltd., 840 Caledonia Rd., Toronto 19, Ont. Export: Daystrom Int'l., 100 Empire St., Newark 12, N. J.

WESTON

Instruments

WORLD LEADER IN MEASUREMENT AND CONTROL



*Weston offers the broadest panel instrument coverage in the industry . . . in terms of shapes, scale lengths, ranges, accuracies, sensitivities and sizes.

NEW WAVEGUIDE FERRITE ISOLATORS

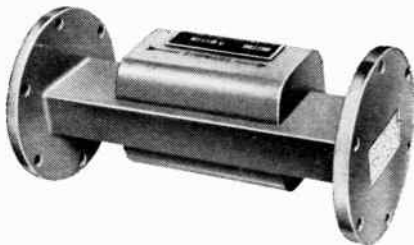

Specially designed to offer maximum isolation with minimum insertion loss, six broadband isolators cover a frequency range of 3.95 to 26.5 KMC/S.

Conservatively rated at 5 watts, these rugged units can dissipate FIVE TIMES as much power with only temporary electrical characteristic degradation.

PRD TYPE	FREQUENCY (KMC/S)	MINIMUM ISOLATION	LENGTH (INCHES)
1205	3.95-5.85	16 db	8¼
1204	5.85-8.20	20 db	6½
1206	7.05-10.0	24 db	5
1203	8.20-12.4	30 db	6¼
1208	12.4-18.0	24 db	6
1209F1	18.0-26.5	24 db	4½

Complete specifications on the PRD Type 1203, 1204, and 1205 are contained on page A-21 of the PRD Catalog E-8. For a copy of this 160 page designers' workbook containing data on hundreds of quality microwave instruments from PRD, the company that's FIRST IN MICROWAVES, send your request on your company letterhead please.

If you want specifications on PRD Waveguide Ferrite Isolators, simply fill out inquiry card in this magazine.

POLYTECHNIC RESEARCH & DEVELOPMENT CO., INC.
 Factory & General Office:
 202 Tillary St., Brooklyn 1, N. Y.
 ULster 2-6800

Western Sales Office:
 2639 So. La Cienega Blvd., Los Angeles 34, Calif.
 TEXas 0-1940

MARKET RESEARCH

New Statistical Facts Coming

WITH THE REVISED Standard Industrial Classification manual unlocking the floodgates, a new stream of electronics industry market statistics will soon be flowing.

Bureau of Census will issue its first preliminary industry report on the 1958 Census of Manufactures in December. All preliminary reports on electronics industry products will be issued between December and the following March, says Clarence Olsen of the Bureau's Industry Division.

Census industry reports, which include value of shipments, number of employees and establishments plus other statistics, are valued for their reliability. They are prepared from data reported to Census by all U. S. manufacturing firms.

Fills Barren Areas

The new Census of Manufactures will fill many statistical areas that have been nearly barren of factual market data since the preceding 1954 Census.

For instance, 1958 Census data on electrical measuring instruments will fall on electronics industry market planners like manna from heaven.

Also, the final 1958 industry reports, which will be issued between May and July of 1960, will supply our industry with more usable data than the 1954 Census. Reason: the final reports will also provide data based on the 1957 revised Standard Industrial Classification manual.

The 1957 revision created a number of new electronics industry statistical groups, including: Radio and TV receiving sets; Radio and TV transmitting-signaling apparatus; Radio and TV receiving tubes—except cathode ray; Cathode ray tubes; Transmitting-industrial electron tubes and Electronic components.

New Look

But this is only part of the story. Both the Bureau and other divisions of the Department of Commerce are looking at the elec-

trical-electronics industry in a new light.

Bureau is becoming increasingly responsive to industry requests for a public source of statistical information in the approximately five-year intervals between issuance of major reports.

It hopes to help plug this five-year gap by adding more electrical-electronics industry surveys to its annual special survey program.

Several new electrical-electronic products may be introduced to the program with surveys of 1959 activities. There are good prospects that other products from our industry will be added in future years.

Other Plans

Also, conversations are now going on among Census, Business and Defense Services Administration, Electronic Production Resources Agency and industry trade associations on ways to provide the industry with more complete and more timely military and industrial electronics statistics.

Government is currently surveying electronic component shipments, backlogs through a joint survey by EPRA and BDSA. Plans have not yet jelled. But new components survey could turn out to be an expansion of the joint survey, or a new survey.

In addition, all government statistical centers have been knee-deep in eorts to penetrate the military electronic statistical barrier.

BDSA is putting finishing touches on its first survey of electronic end-equipment sales. This survey will include separate industrial and military sales totals.

EPRA, which just published a detailed report on military transistor requirements, hopes to follow up this effort with similar reports on other products.

FIGURES OF THE WEEK

LATEST WEEKLY PRODUCTION FIGURES

(Source: EIA)	Sept. 4, 1959	Aug. 7, 1959	Change From One Year Ago
Television sets	141,550	121,581	+25.27%
Radio sets, total	369,035	184,692	+34.39%
Auto sets	125,087	39,219	+36.35%

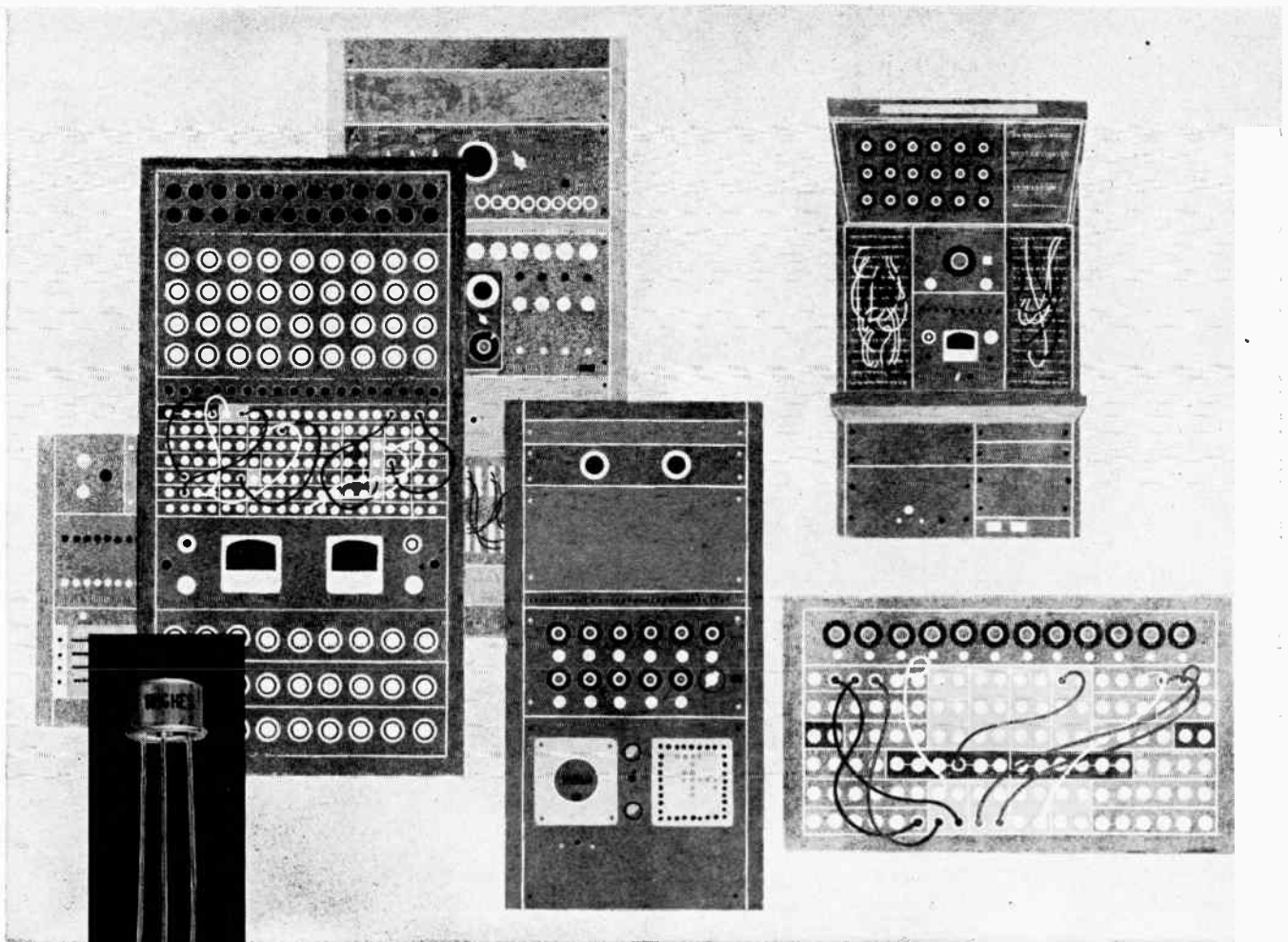

HIGH-SPEED COMPUTER SWITCHING TRANSISTORS

SILICON DDMT—Double Diffused Mesa Transistor . . . now available from Hughes to solve your high-speed

switching problems. This new silicon PNP transistor, which operates at low and medium current levels, gives you a cut-off frequency greater than 50 megacycles. In addition, Beta—as a function of collector current—is flat over 80 per cent of the operating range.

Two other advantages: 1. This Hughes transistor offers you all the desirable characteristics inherent in the solid state diffusion technique. 2. The tiny flexible leads of its gold plated package may be soldered directly into circuits or used with standard plug-in sockets.

This new device, while designed primarily for computers, is also an excellent amplifier and oscillator, lending itself to an unusually broad range of applications.

As in all Hughes semiconductor devices, reliability has been specifically designed into this mesa transistor. They are manufactured in the new multi-million dollar Hughes Semiconductor facility . . . using the finest equipment and newest techniques.

Your inquiry regarding these transistors will be given prompt attention. Just write or call the Hughes sales office nearest you.

They are located in:

*Boston, 4 Federal Street; Woburn, Mass.; WElls 3-4824
 Minneapolis, 6121 Excelsior; Minneapolis 16, Minn.; WEst 9-0461
 Newark, 80 Mulberry Street; Newark 2, N. J.; MArket 3-3520
 San Francisco, 535 Middlefield Road; Palo Alto, Calif.; DA 6-7780
 Syracuse, 224 Harrison Street; Syracuse 2, N. Y.; GRanite 1-0163
 Chicago, 1515 N. Harlem Ave.; Oak Park, Ill.; NAtional 2-0283
 Cincinnati, 816 Swifton Center; Cincinnati, Ohio; ELmhurst 1-5665
 Philadelphia, 1 Bala Avenue; Bala-Cynwyd, Penn.; MOhawk 4-8365
 Los Angeles, 690 N. Sepulveda; El Segundo, Calif.; OR 8-6125*

Or write, Hughes Products, Marketing Department,
 SEMICONDUCTOR DIVISION, NEWPORT BEACH, CALIFORNIA.

For export, write: Hughes International, Culver City, Calif.

SPECIFICATIONS: Absolute Maximum Ratings (25°C)

	2N1254	2N1255	2N1256	2N1257	2N1258	2N1219
V_{CE0}	15V	15V	30V	30V	50V	50V
V_{CB0}	15V	15V	30V	30V	50V	50V
V_{EB0}	5V	5V	5V	5V	50V	3V
Power Dissipation	250 mw					
Ambient Temperature	-65°C + 175°C					

SEMICONDUCTOR DIVISION

Creating a new world with ELECTRONICS

HUGHES PRODUCTS

© 1959, HUGHES AIRCRAFT COMPANY

SEMICONDUCTOR DEVICES • STORAGE TUBES AND DEVICES • MICROWAVE TUBES • VACUUM TUBES AND COMPONENTS • CRYSTAL FILTERS • MEMO-SCOPE® OSCILLOSCOPES • INDUSTRIAL CONTROL SYSTEMS

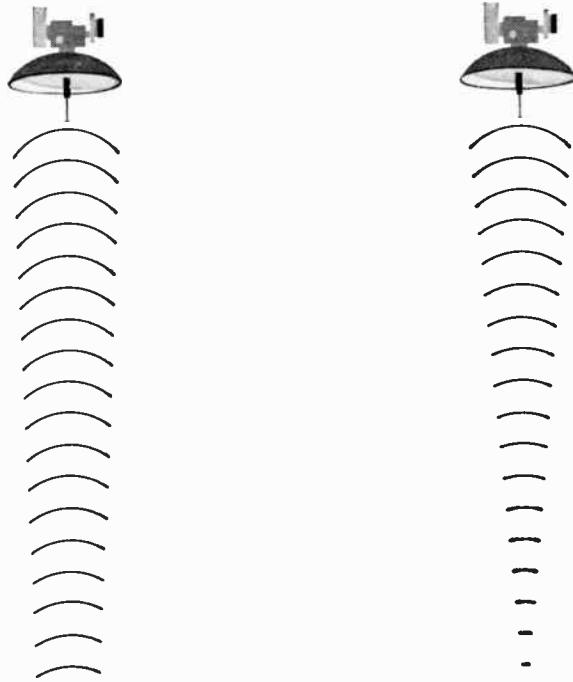

DOUBLE YOUR RANGE!

WITH ONLY ONE CHANGE—ON X-BAND AND S-BAND MICROWAVE SYSTEMS

You can now double the effective range of your X-band or S-band microwave system applications with no change in power requirements, no change in antennas, no change in other system equipment!

How? By using Hughes PAX-1 or PAS-2B backward-wave amplifiers in your microwave systems you will achieve noise characteristics much lower than from any other traveling-wave tube. The lower the noise level, the longer the effective range!

Recent advances in electron gun design (resulting from noise phenomena studies conducted by Hughes R & D laboratories) make possible the extremely low noise characteristics

of the Hughes PAX-1 and PAS-2B tubes.

In your microwave system applications, these amplifiers alone offer you advantages not obtainable by any combination of other low-noise devices.

Only one voltage to vary... Another important feature of the PAX-1 and PAS-2B backward-wave amplifiers is a narrow, electronically tunable passband covering the entire X-band or S-band spectrum. This feature automatically provides image rejection, excellent selectivity and anti-jamming capability. And, once the initial setup has been made, only the tuning voltage needs to be varied for complete operation.

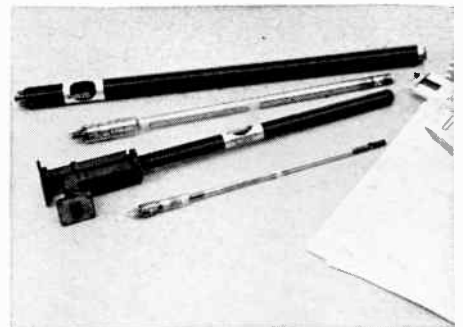

SPECIFICATIONS:

	PAX-1 (X-Band)	PAS-2B (S-Band)
Minimum noise figure	4.5 db	under 4.0 db
Gain	over 20 db	10-25 db
Tuning voltage	420-650 v	180-1150 v
Maximum voltage	1500 v	2750 v
Bandwidth	12 mc	11 mc
Input-output isolation	over 50 db	over 50 db
Filament power	6 w	10 w
Magnetic field	1300 gauss	1000 gauss
Saturation power output	0.2 mw	1 mw

Write now for detailed specifications on the PAX-1 and PAS-2B: HUGHES PRODUCTS, Electron Tube Division, International Airport Station, Los Angeles 45, Calif. For export information, write: HUGHES INTERNATIONAL, Culver City, Calif.

ELECTRON TUBE DIVISION

Creating a new world with ELECTRONICS

HUGHES PRODUCTS

© 1959, HUGHES AIRCRAFT COMPANY

SEMICONDUCTOR DEVICES • STORAGE TUBES AND DEVICES • MICROWAVE TUBES • VACUUM TUBES AND COMPONENTS • CRYSTAL FILTERS • MEMO-SCOPE® OSCILLOSCOPES • INDUSTRIAL CONTROL SYSTEMS

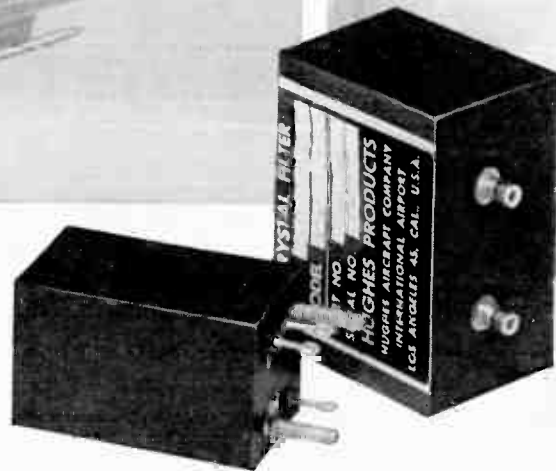
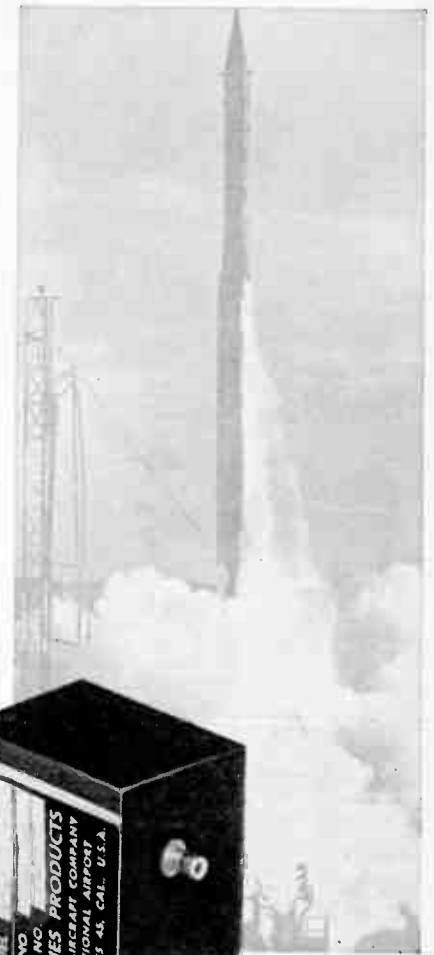

If you're looking for a high-performance crystal filter

At your service is a group of highly talented Hughes Crystal Filter engineers who specialize in solving difficult network problems. These men can design and produce a crystal filter to meet your most exacting requirements! In addition, Hughes offers you tremendous production capacity—over 10,000 filters per month of a single type. With Hughes Crystal Filters you get:

Precise Selectivity—Eliminates cross talk between channels, makes new systems possible.

Small Size—Reduces overall equipment size, makes filter more reliable by eliminating air space, results in higher stress factor.

High Frequency—Saves circuit costs, eliminates the need for double conversion. Center frequencies 30 kc to 40 mc.

Low Passband Ripple—Eliminates errors in information, enables end equipment to be more precise.

Wide Temperature Stability—Provides flexibility of use, contributes to high reliability.

Low Insertion Loss—Enables system to operate on low signal level—thereby combating noise and cutting circuit costs.

To avail yourself of the Hughes applications engineering service, or for additional information concerning performance levels please write: HUGHES PRODUCTS, Industrial Systems Division, Marketing Dept., International Airport Station, Los Angeles 45, California. For Export, write: Hughes International, Culver City, California.

See Crystal Filters and other Hughes Products at WESCON: Booths 3012 18.

Creating a new world with ELECTRONICS

HUGHES PRODUCTS

© 1959, HUGHES AIRCRAFT COMPANY

SEMICONDUCTOR DEVICES • STORAGE TUBES AND DEVICES • MICROWAVE TUBES • VACUUM TUBES AND COMPONENTS • CRYSTAL FILTERS • MEMO-SCOPE® OSCILLOSCOPES • INDUSTRIAL CONTROL SYSTEMS

GENERAL ELECTRIC GL-7398* VOLUME PRODUCTION, AVAILABLE

*formerly designated Z-5300

Voltage-tunable magnetrons now available are indicated by solid areas. Other developments are shown by cross-hatched areas.

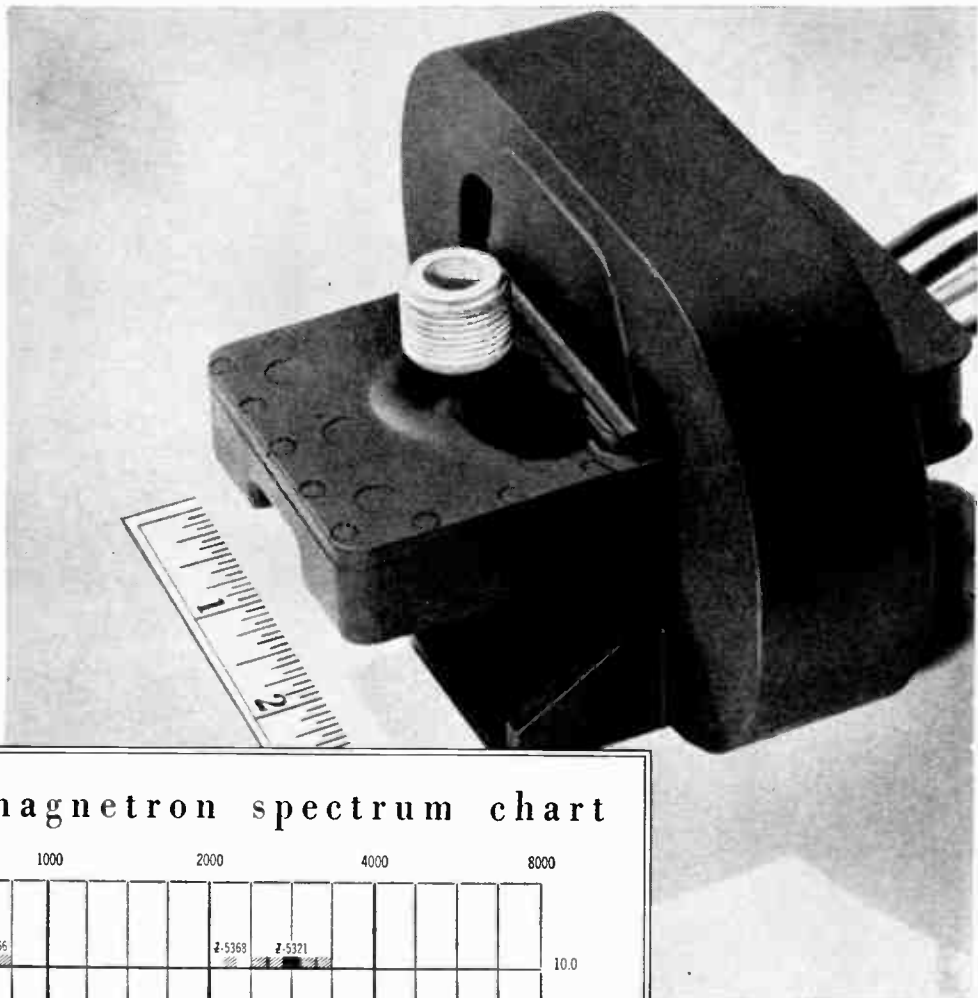

voltage-tunable magnetron spectrum chart

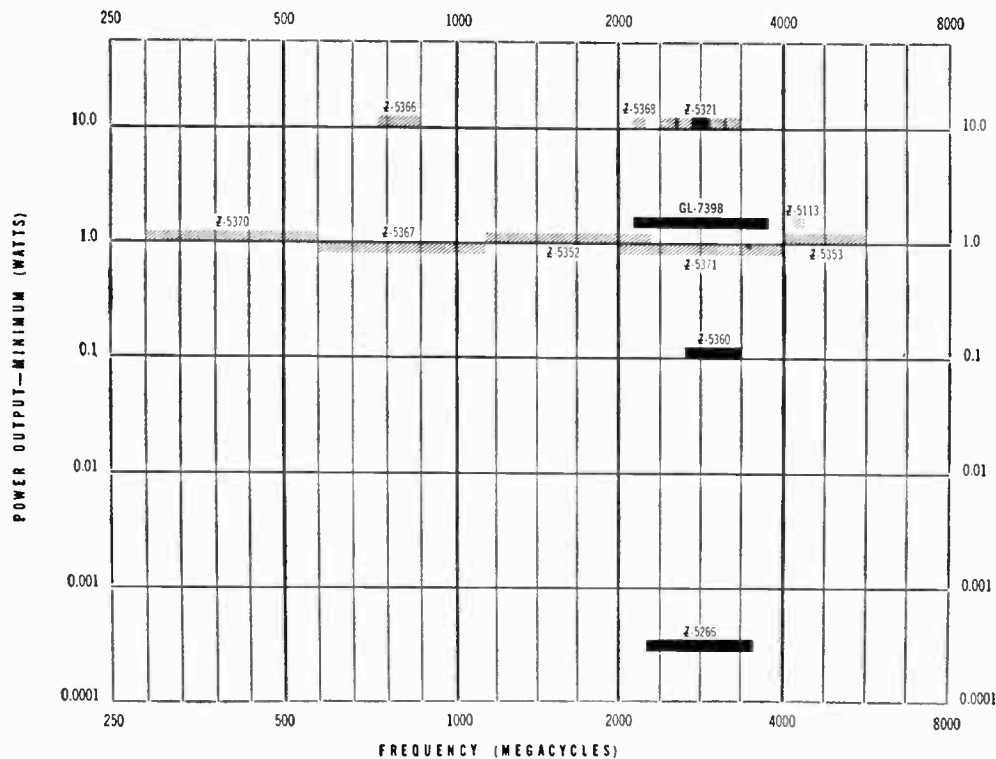

VOLTAGE-TUNABLE MAGNETRON IN FOR IMMEDIATE DELIVERY!

The General Electric GL-7398 voltage-tunable magnetron, a complete RF power source ideal for FM modulation, is now in volume production and available for immediate delivery. Moreover, samples are currently available or can be developed by use of proved technology to meet any need within the frequencies charted on the opposite page. The GL-7398 is designed for use in many applications, such as:

- FM telemetering or video transmission
- Beacon transmitters
- Local oscillators in electronically tunable radars
- Drivers in pulse-to-pulse frequency-shift radars
- FM altimeters
- Broad-band signal generators
- Countermeasure transmitters
- Drivers for countermeasure amplifiers

Output frequency can be varied linearly over a range of nearly 2 to 1 by sweeping

the anode voltage. Power output is relatively flat at a minimum of 2 watts. The GL-7398 is a rugged, compact, packaged unit with these characteristics:

Anode voltage at 3 kmc	— 1250 volts
Anode current	— 10-20 ma
Frequency range	— 2200-3850 mcs
Tuning rate	— approx. 3 mcs/volt
FM rate	— 10 mcs or higher
Weight	— 3.1 lbs.

By use of internal narrow-band circuits, a variation (Z-5321) is available which gives a minimum of 10 watts power over a 200 mc bandwidth at a factory-predetermined centerpoint in the 2 to 4 kmc band. Other variations with built-in attenuators for local oscillator applications can be supplied (Z-5360 and Z-5266). *Power Tube Department, General Electric Company, Schenectady, New York.*

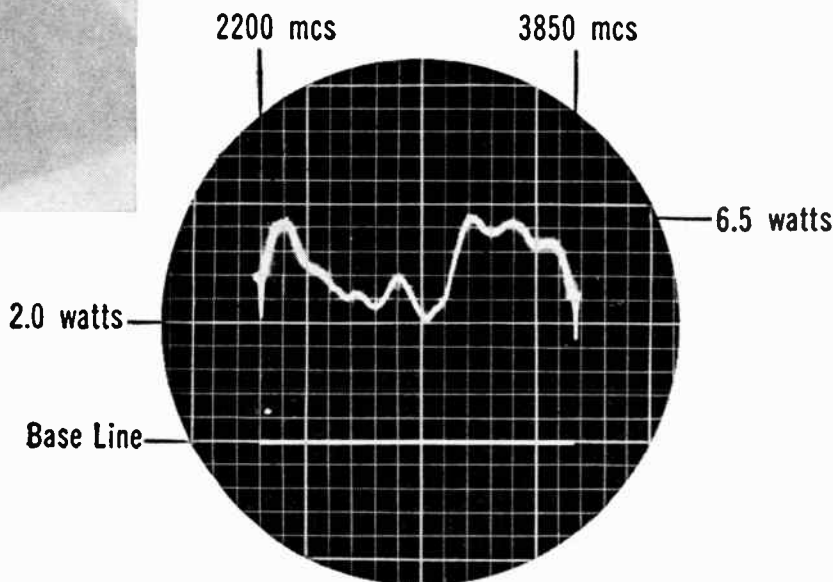

◀ Typical power – frequency of the GL-7398 shows power constant over the full band to within plus-or-minus 3 db.

Progress Is Our Most Important Product

GENERAL  **ELECTRIC**

9545-8481-22

Quality Manufacture depends
on Quality Materials...

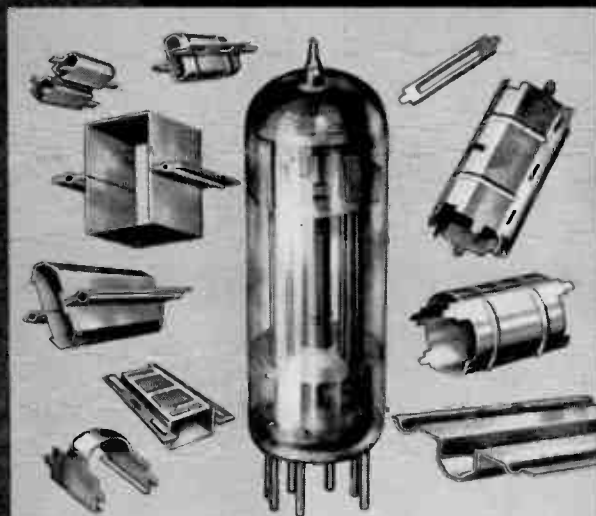

that's why

**MICRO STAMPING
COMPANY**

uses General Plate Clad Metals

Quality radio tube stampings for the nation's leading electron tube manufacturers are fabricated from General Plate Clad Metals by Micro Stamping Company, Maplewood, N. J. . . . one of industry's most reliable suppliers.

Mr. E. A. Ardolina, President of Micro Stamping Company, has this to say about General Plate materials . . . "The General Plate Clad Metals we use are satisfactory in every way. Tolerance and consistency are always excellent."

General Plate Clad Metals for tube applications include:

ALIRON® — aluminum alloy clad to both sides of low-carbon steel. ALIRON is considerably less ex-

pensive than nickel. Its lower density gives approximately 30% more parts per pound of strip. The inner steel layer insures adequate ductility.

ALNIFER® — low-carbon steel clad on one side with aluminum alloy and the other side with grade 330 nickel. Used for close-spaced tubes. Matte finish aluminum blackens during bombardment to provide maximum radiation properties.

NIFER® — Grade 330 nickel clad on both sides of low-carbon steel. Used as an alternate for pure nickel strip.

For detailed information, write for new catalog, "Clad Metals for Semiconductor, Radio Tubes, Spring and High Temperature Applications."

METALS & CONTROLS

1309 FOREST STREET, ATTLEBORO, MASS., U. S. A.

A DIVISION OF TEXAS INSTRUMENTS INCORPORATED

GENERAL PLATE PRODUCTS: Clad Metals • Electrical Contacts • Trufflex® Thermostat Metal • Platinum Metals • Reactor Metals • Radio Tube & Transistor Metals

World Radio History



"Ordered today...
delivered today!"

...and now you can buy at Factory Prices from your

RCA INDUSTRIAL TUBE DISTRIBUTOR

This engineer wanted RCA Industrial Tubes in a hurry. A phone call was placed and he got them in a hurry—locally from his RCA Industrial Tube Distributor.

Fast service, in many cases same day delivery, is a practice of the RCA Industrial Tube Distributor. And now, he can offer the designer and manufacturer of electronic equipment off-the-shelf delivery of industrial tubes at factory prices. That's a combination that's hard to beat—and it only takes a phone call. When the need arises for power and gas tubes, industrial receiving tubes, photosensitive devices, cathode-ray tubes...in fact almost any RCA industrial-type tube...you can get them fast from your RCA Industrial Tube Distributor. Keep him in mind. He's set up to give you "one-stop" service for your small production runs and laboratory requirements.

And you'll be pleased with the extra service this man offers you:

- immediate delivery of new RCA developed types
- orders filled from factory-fresh tube stocks
- practical product information—regularly
- helpful RCA technical assistance
- a specialist who understands your problems and electronic needs

Give your local RCA Industrial Tube Distributor a call today. You'll be glad you did.



RADIO CORPORATION OF AMERICA
Electron Tube Division
Harrison, N. J.



For the name of your nearest
RCA Industrial Tube Distributor
call Western Union by 'phone
and ask for Operator 25.

Only GENERAL CERAMICS offers a complete line of HIGH FREQUENCY FERRITE CORES

Make G-C your single source for a complete line of H-F ferrites ranging in frequency from 300 kc to 220 mc.

Ferramic® Q-1, Q-2 and Q-3 materials, developed and introduced by G-C, feature exceptionally low losses, temperature stability and high permeability. Whether your ferrite requirement is for the commercial entertainment industry, military, ground or air borne communication equipment or industrial electronic applications, G-C will meet your needs with the broadest line of high frequency ferrite materials and in the shapes you require.

This curve demonstrates the exceptional qualities of G.C.'s "Q" family of materials — high permeability and low loss.

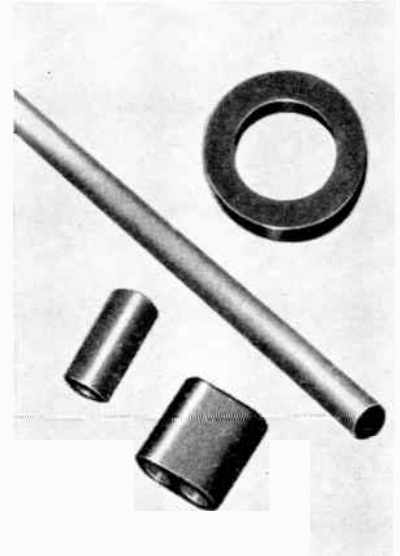
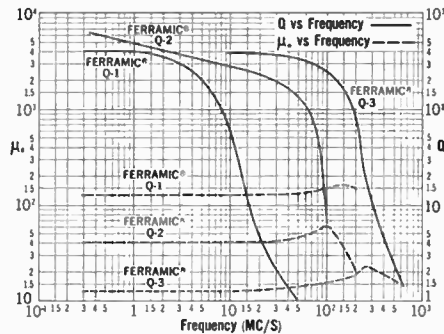

Q-1 Material

Ideally suited for IF transformers at 455 kc and antenna cores from 500 kc to 1700 kc.

Magnetic properties include: Initial permeability at 1 mc/sec. — 125; Maximum permeability — 400; Saturation flux density — 3300 gauss; residual mag. — 1800 gauss; coercive force — 2.1 oersted; temperature coefficient of initial permeability — .10%/°C max; Curie point — 350°C; vol. resistivity — high; loss factor at 1 mcs/sec. — .000020; loss factor at 5 mcs/sec. — .000050.

Standard Ferramic parts in various sizes and shapes offer a dependable, quick solution to design problems. Custom parts can be produced to your specifications. Contact General Ceramics' engineering advisory service. Our staff is ready to discuss your problems and make recommendations.

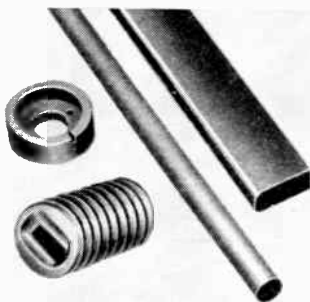

Q-2 Material

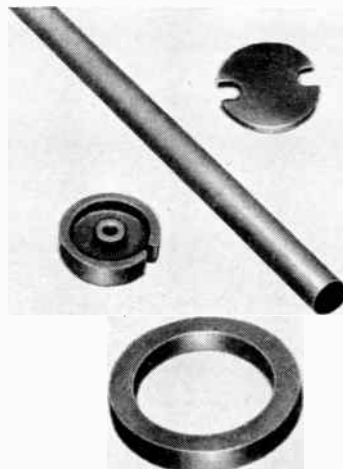

This material produces excellent results in TV receiver IF applications at 45 mc; and FM radio applications at 10.7 mc.

Magnetic properties include: Initial permeability at 1 mc/sec. — 40; Maximum permeability — 115; Saturation flux density — 2400 gauss; residual mag. — 750 gauss; coercive force — 4.7 oersted; temperature coefficient of initial permeability — 0.10%/°C max; Curie point — 450°C; vol. resistivity — high loss factor at 10.0 mc/sec. — 0.000085; loss factor at 50.0 mc/sec. — 0.000017.

Q-3 Material

The exceptionally high Q, excellent temperature stability and high permeability of Q-3 ideally suits it for applications in the 88 mc–108mc FM band and television RF frequencies from 50 mc–216 mc.

Preliminary specifications include: Initial permeability μ_0 — 14; Maximum permeability μ_{max} — 42; Saturation flux density B_s — 2600 gauss; Residual magnetism B_r — 1470 gauss; Coercive Force — 21 oersted; Q at 100 mc — 250; Q at 150 mc — 150; Q at 200 mc — 70; Resistivity high; Curie point 330°C; Temperature coefficient of μ_0 — .09%/°C max.

A New 16-page FERRITE PARTS CATALOG



is available to engineers by request on company letterhead. It contains complete engineering data on stock parts and materials. When requesting your copy, please address Dept. E.

General Ceramics Corporation

KEASBEY, NEW JERSEY (Near Perth Amboy) — Telephone: VALley 6-5100

GENERAL CERAMICS

Industrial Ceramics for Industrial Progress... Since 1906

for an extension in Reliability

engineered...

CANNON PLUG/HARNESS SYSTEMS

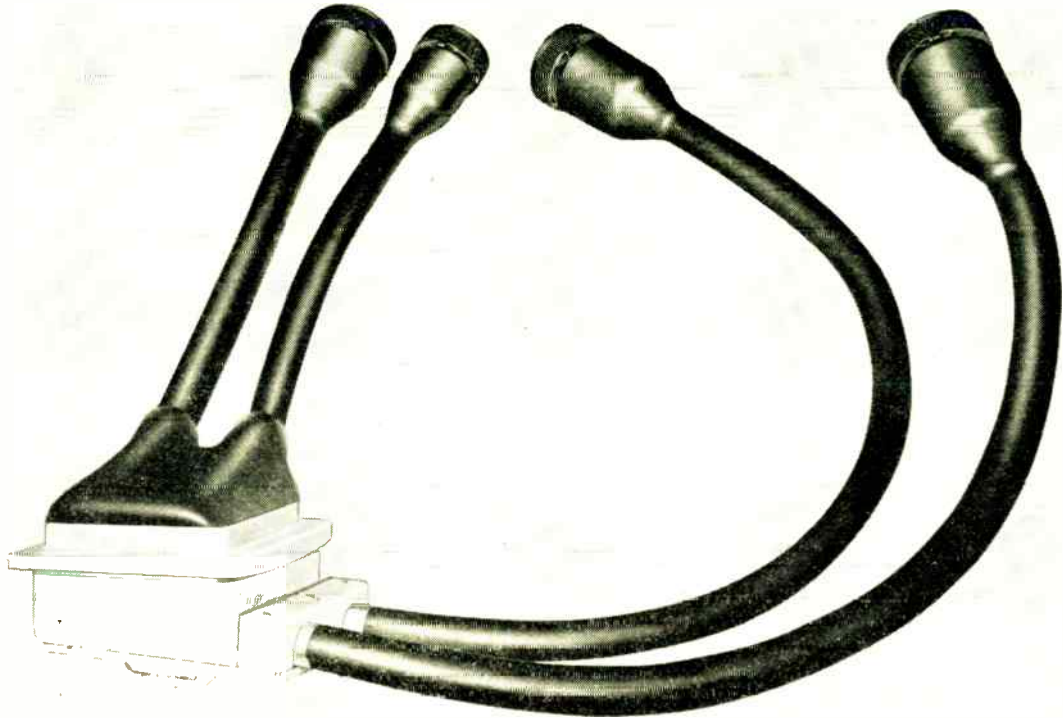

SINGLE RESPONSIBILITY FOR PERFORMANCE OF PLUG/HARNESS SYSTEMS...RELIABILITY GUARANTEED!

■ **CANNON PLUG/HARNESS SYSTEMS** are designed and manufactured under rigid, quality-controlled conditions in a separate, highly specialized facility completely equipped to handle all phases of design, development and manufacture. As a single source supplier for both plugs and harness assemblies, Cannon can assume complete responsibility for the reliability of the "Cannon Plug/Harness System" as a whole.

■ **COMPLETE TESTING FACILITIES:** Extensive testing equipment is also available to duplicate environmental conditions. These include vibration tests, temperature cycling tests, and heat flux tests duplicating heat re-entry conditions. Each system is 100% tested for continuity and for high potential and insulation resistance, shorts or grounds as well as humidity, VSWR, contact retention, etc. Certified test reports are available.

■ **SPECIAL DESIGN SERVICES:** Because Cannon is a single source supplier of the plugs and completes the termination, it is possible to select and recommend cables and termination techniques designed to custom-match the proper plug for the assembly. The complete assembly can thus be manufactured and tested under conditions prohibited to single-source suppliers.

■ **FASTER DELIVERY — NO COST PYRAMIDING:** A special, separate facility devoted to umbilical and harnessing production offers the most up-to-date production techniques to provide the industry's fastest delivery—plus no pyramiding of costs. Customers draw on Cannon's capabilities as the world's largest exclusive manufacturer of electrical plugs.

■ **FIELD TECHNICAL ASSISTANCE:** Experienced specialized sales engineers are available to discuss and assist customers in the technical aspects of plug-harness system requirements prior to manufacture and after installation in the field.

FOR FURTHER INFORMATION on Cannon Plug/Harness Systems write for Cannon Catalog HC-1—Cannon Electric Company, 3208 Humboldt Street, Los Angeles 31, Calif. Please refer to Department 120

CANNON ELECTRIC COMPANY
—Factories in Los Angeles, Santa Ana, Salem, Toronto, London, Paris, Melbourne and Tokyo.

Distributors and Representatives in principal cities of the world.

**CANNON
PLUGS**

Picture Flying Arrives

Integrated instrumentation systems using contact analog display promise safe all-weather flying for both fixed and rotary-wing aircraft

By WILLIAM E. BUSHOR

DALLAS, TEX.—Problems of presenting flight data to aircraft pilots are slowly but surely being solved. Recent advances were shown at the Army-Navy Instrumentation Program (ANIP) symposium held here last month. (See *ELECTRONICS*, p. 21, Sept. 18).

Helicopters

Demonstrations (see photo) of a contact analog system for instrument flying were given by Bell using their experimental RH-1 helicopter. A picture of the external world is presented to the pilot on a trichroic combining glass developed by North American's Autonetics division. The glass acts as a filter capable of reflecting one color while permitting others to pass through. The image projected on the trichroic glass is formed by an optomechanical generator designed by Bell.

The pattern is continuously varied by altitude signals from Bendix-Pacific's sonic altimeter; roll, pitch and heading signals from conventional vertical and directional gyros; and velocity signals from Ryan's Doppler radar. All these motions are shown as an integrated picture. Thus the pilot can judge attitude, altitude, ground speed and compass heading.

During a demonstration flight in the RH-1, I was able at all times to orient myself without reference to the outside world. Although judgment of ground speed was somewhat difficult, experienced helicopter pilots have flown and landed blind. One item needing further development is the altitude display—I found it extremely difficult to detect changes in vertical position of the aircraft.

Bell also displayed the RH-2 helicopter used as a research tool for



Author tries contact analog flying. Special glasses make screen image more distinct

evaluating performance of new instruments, controls and systems. A forward-looking obstacle radar system built by DuMont was shown installed in the RH-2. This system is a pulsed radar in the millimeter wavelength region which permits flight under zero-zero weather conditions at altitudes as low as 20 ft. I noticed that the radar was able to detect with good resolution close-in objects, such as other helicopters parked immediately in front. A narrow beam-width and nearly hemispherical field of view are required.

Sensors

A new technique for air-speed measurement using radar and acoustics was shown by Midwest Research Institute. The system, unlike the conventional pitot tube, will be able to reach out beyond disturbed air mass produced by helicopter rotary wings. An acoustic

wave and a radar beam are sent out. The radar beam is reflected by the acoustic wave; the frequency of the electromagnetic energy returned is automatically interpreted to give the pilot an instantaneous, accurate reading of air-speed. This technique also has meteorological applications.

Displays

Avion division of ACF described a device which automatically correlates information fed into it by navigation computers and instruments, and presents a tv picture in the form of a map of the terrain below the plane. An image of the plane projected over the map corresponds to the exact position of the aircraft.

Another unit shown was a ground-plane generator built by DuMont. Its crt display simulates the earth's surface by coordinate grid lines of uniform spacing. Sys-

tem contains high-speed analog computers capable of solving the equations required to describe the six kinds of helicopter motion: roll, pitch, yaw, change in altitude and translation in two directions relative to the earth. The pattern presented moves with the aircraft.

The radar data converter system developed by DuMont converts radar signals into tv-like displays and allows pilots to perceive depth of surrounding space outside aircraft. System receives antenna pointing angles and target range from a special radar system. This information is stored in two electrostatic storage tubes alternately storing, reading out and erasing on successive antenna scans. Readout is accomplished by tv scan at standard EIA rates. Display appears as standard lap-dissolved picture where the output of one storage tube is dissolved into the output of the other. Apparent target range information is provided through a process of intensity coding of the targets; close targets are brightest; brightness decreases as range increases.

Supporting Research

Varo Manufacturing is exerting research efforts towards developing ultimate microcircuits through optimum utilization of electrical, magnetic and other properties of matter, and through elimination of all superfluous nonfunctional materials. Varo is also striving to obtain a high degree of reliability by reducing process contamination, eliminating mechanical junctions and removing human factors in fabrication and assembly.

Laboratory for Electronics is studying micromagnetic properties of vacuum-evaporated thin films and the dependence of these properties on other controllable or measurable characteristics. Practical objective is a new class of storage and display devices which depend on the detailed properties of domain walls and their motion. Such devices are expected to be extremely compact, rugged and simple.

Servomechanisms, Inc., is researching thermoelectric materials with relatively high conversion effi-

(Continued on p 43)



STRIP CHART RECORDER MODEL 80

 WITH PUSH BUTTON SPEED CONTROL

The Model 80 AUTOGRAF is a completely new laboratory type strip-chart recorder featuring instantaneous control of all operating functions. No gears to change, just push a button to select any one of six different chart speeds. Start or stop chart, raise or lower ink pen, locally or remotely. Glass door protected chart transport is mounted on a roll-out carriage for convenient chart service.

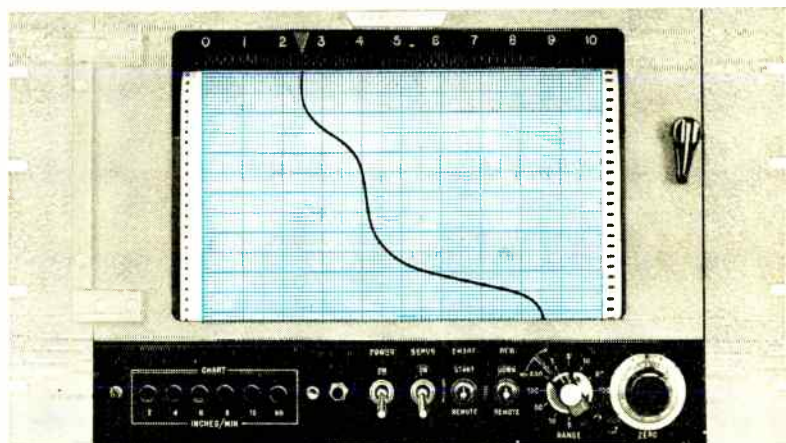

Specifications

Input Ranges:	5 MV to 100 volts in 10 calibrated steps plus transfer switch for stepless control.	Pen Speed:	Up to 1/4 second for full scale pen travel.
Zero Positioning:	Full range zero set and one full scale of suppression.	Standardization:	Continuous precision electronic reference.
Input Resistance:	200,000 ohms/volt through 10 volt range; 2 megohms on all higher ranges.	Chart Speeds:	2, 4, 6, 8, 15, and 60 inches/minute; other speed combinations available.
Sensitivity:	0.05% of full scale.	Chart:	Standard 120 foot roll; approx. 10" x 6" visible area.
Accuracy and Resolution:	0.25%.	Amplifier:	Chopper input type.
		Dimensions:	10 1/2" high; 16 1/2" deep. Standard 19" rack mounting.

Sales representatives in all principal areas

Our catalog includes a complete line of X-Y Recorders and Data Reduction Accessories. We will be glad to send you one.

F. L. MOSELEY CO.

409 N. Fair Oaks Ave., Pasadena, California

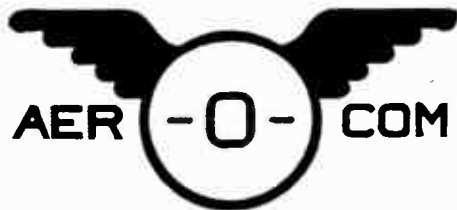

DEFINITELY DEPENDABLE!

Aerocom's Dual Automatic Radio Beacon

Reliability is built into every part of this dual 1000-watt aerophare unit. Ruggedly constructed and conservatively rated, it provides trouble-free unattended service, and at truly low operating and maintenance cost. It operates in the frequency range 200-415 kcs, using plug-in crystal for desired frequency.

Uses single phase power supply, nominal 220 volts, 50 or 60 cycles. Consists of two 1 kw transmitters with 2 keys, automatic transfer unit and weatherproof antenna tuner. Each transmitter housed in separate fan ventilated rack cabinet, with controls in center rack cabinet.

Nominal carrier power is 1000 watts.

High level plate modulation of final amplifier is used, providing any desired level of modulation up to 100%. P-T switch interrupts tone, permitting voice operation. Operates in ambient temperatures from -35°C to 55°C , humidity up to 95%.

Standby transmitter is placed in operation when main transmitter suffers loss (or low level) of carrier power or modulation, or continuous (30 sec.) tone, or carrier frequency change of 5 kcs or more. Audible indication in monitoring receiver tells when standby transmitter is in operation.

Antenna may be either vertical tower or symmetrical T type.

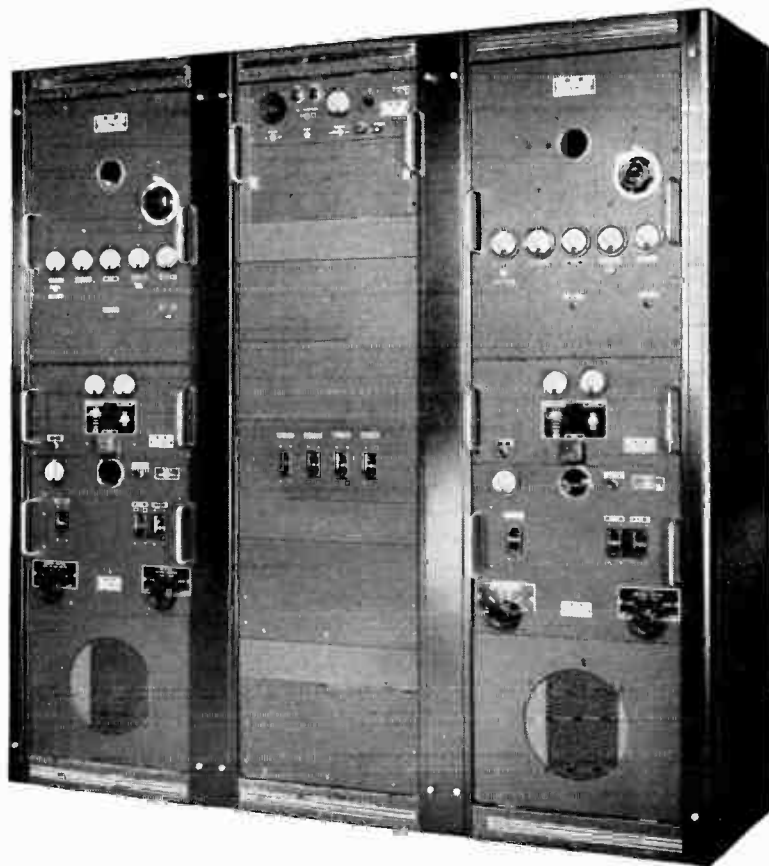

Also available in
50 WATT
100 WATT
400 WATT
and
4 KILOWATT
models

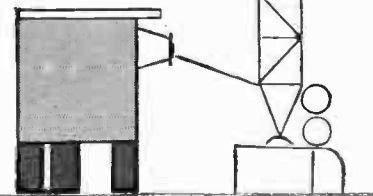

A-101



3090 S.W. 37th AVENUE • MIAMI, FLORIDA

VT2
VT2N



VT2E



VT2F



Popular, small Model VT2 (with overvoltage). Volts output: 0-120/132; amps output: 1.5 . . . Model VT2N (without overvoltage). Volts output: 0-120; amps output: 1.8. This model delivers more current than existing transformers of comparable size and price.

VT4
VT4N

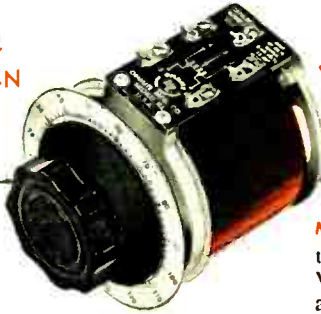

VT4E



VT4F



Models VT4 and VT4N provide output capacity greater than other units of comparable size and price. Model VT4 (with overvoltage). Volts output: 0-120/140; amps output 3.5 . . . Model VT4N (without overvoltage). Volts output: 0-120; amps output: 4.75.



OHMITE®

VARIABLE TRANSFORMERS

Complete Line Now Available
from Stock

VT8
VT8N



VT8E



VT8F



VT8G



Models VT8 and VT8N offer the heavy capacity demanded for general laboratory and industrial applications. Model VT8 (with overvoltage). Volts output: 0-120/140; amps output: 7.5 . . . Model VT8N (without overvoltage). Volts output: 0-120; amps output 10.0. Units available for 240-volt input also.

Now you can get *fast delivery from stock* on 35 different models of Ohmite variable transformers. This newly expanded selection covers a high percentage of industrial needs. In it you will find single and three-phase units, two and three-in-tandem assemblies (not shown above), plus a variety of other cased and uncased models.

Ohmite "v.t." variable transformers combine fresh thinking in design with traditional Ohmite quality. For example,

positive current transfer is achieved with direct brush to slip-ring, pig-tailed connection. Adjustable shafts on sizes VT4 and VT8 extend either to the brush or the base side. These two models also are *interchangeable* with competitive makes of comparable ratings. The "N" types in all three models provide additional current without overvoltage. The next time you need variable transformers, select from the line with advanced design—Ohmite.

Write for NEW Stock Catalog 30.

OHMITE®

QUALITY
Components

OHMITE MANUFACTURING COMPANY

3610 Howard Street, Skokie, Illinois

RHEOSTATS RESISTORS RELAYS
TAP SWITCHES TANTALUM CAPACITORS DIODES
VARIABLE TRANSFORMERS R. F. CHOKES

World Radio History

Measure dc currents 0.3 ma to 1 ampere with

**No Breaking of Leads
No DC Connection
No Circuit Loading**

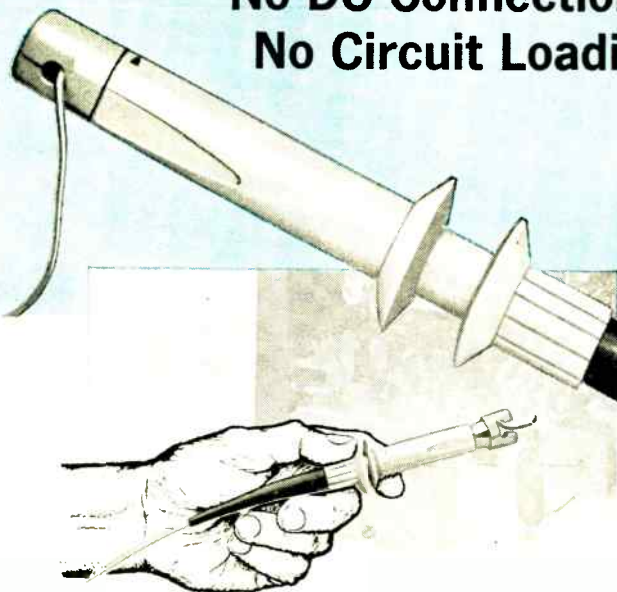

**428A CLIP-ON
MILLIAMMETER.**

Probe clamps AROUND wire; measures by sensing magnetic field!

Think of the measuring convenience, time saved and accuracy gained when you don't have to break into a circuit, solder on a connection, or worry about probe loading.

With the 428A Milliammeter and its new probe, you literally "clamp around" and read! You get maximum accuracy because there is no effective circuit loading from the 428A's dc probe. The instrument easily measures dc currents in the presence of ac. And insulation is more than adequate to insure safe measurements at all normal voltage levels.

For extremely low current level measurement, sensitivity can be increased by looping the conductor through the "jaws" of the 428A probe two or more times.

Brief specifications are given here; for complete details and demonstration *on your bench*, call your representative or write direct.

Specifications

Current Range: Less than 0.3 ma to 1 amp, 6 ranges. Full scale readings from 3 ma to 1 amp: 3 ma, 10 ma, 30 ma, 100 ma, 300 ma, 1 amp.

Accuracy: $\pm 3\% \pm 0.1$ ma.

Probe Inductance: Less than 0.5 μ h maximum.

Probe Induced Voltage: Less than 15 mv peak.

Effects of ac in circuit: Ac with peak value less than full scale affects accuracy less than 2% at frequencies different from the carrier (40 KC) and its harmonics.

Power: 115/230 v $\pm 10\%$, 50-60 cps, 70 watts.

Size: Cabinet mount, 7 $\frac{1}{2}$ " wide, 11 $\frac{1}{2}$ " high, 14 $\frac{1}{4}$ " deep. Weight 19 pounds. Rack mount, 19" wide, 7" high, 12 $\frac{1}{2}$ " deep. Weight 24 pounds.

Probe Tip Size: Approximately $\frac{5}{8}$ " x $\frac{7}{16}$ ". Wire aperture diameter $\frac{3}{16}$ ".

Price: (Cabinet) \$475.00; (Rack) \$480.00.

Data subject to change without notice.

Prices f.o.b. factory.

HEWLETT-PACKARD COMPANY

1005A PAGE MILL ROAD • PALO ALTO, CALIFORNIA, U.S.A.
HEWLETT-PACKARD S.A., RUE VIEUX BILLARD NO. 1,
GENEVA, SWITZERLAND

CABLE "HEWPAKSA" • TEL. NO. (022) 26. 43. 36

CABLE "HEWPACK" • DAVENPORT 5-4451

Field representatives in all principal areas

6058

Test the new  405A DC Digital Voltmeter

Beacon Extends Radar Range

First radar beacon in FAA's plan for positive airways control goes into New York area

IMPORTANT ADVANCE in positive air-traffic control was registered earlier this month with the dedication in New York of Federal Aviation Agency's air-traffic control radar beacon system.

First four beacons, implementing already-installed long-range and airport-surveillance radars, went into the ever-problematical New York complex of airports—one each at Newark, LaGuardia and New York International (Idlewild), and the fourth at the New York Air Route Traffic Control Center, also at Idlewild.

These four cost substantially more than the quarter-million-dollar price tag to be put on the production models of the beacon. The higher initial costs paid for a lot of test, evaluation and R&D, including development of a "defruiter" to keep the clutter from other beacons (called fruit) off the scopes. Airborne Instruments Laboratory division of Cutler-Hammer worked with

FAA staff in the testing, evaluation and R&D.

Coherent Defruiter

The defruiter developed by AIL is a coherence device. The transponder returns a four-bit answer upon interrogation from the ground; the four bits are bracketed by spacing pulses. The bracket pulses are compared against a stored record of the transmitted interrogation pulse. If successive bracket pulses do not match successive interrogation pulses, the response is junked. If they do match, a blip is artificially prepared for the ppi display.

Since there are relatively few transponder-equipped planes flying (aside from military craft), and since many general-aviation craft may never be properly equipped, the system also presents primary radar returns. The primary return signal is delayed suitably to match the delay introduced by the transponder and the two sets of returns are superimposed on a common ppi display.

Secondary returns (beacon signals) are larger and clearer than primary returns from the same distance. Further, the 63 codes permitted by the four-bit answer can be used to communicate information—altitude, identification, position, states of emergency—as the need for this information becomes more clearly established.

Experience to date indicates that range of airport surveillance radars can be extended from 30 to 50 nautical miles by the beacon, and range of terminal-area radars can be extended from 90 to 120 nautical miles at 10,000 ft. The beacon is a lower L-band system.

Joseph Tippets, who runs FAA's Bureau of Facilities, said that his bureau will spend some \$150-to-\$200-million annually during the next few years for buying new con-

trol gear—"principally electronic gear." By the end of fiscal 1961, FAA will have spent upwards of \$1 billion for new facilities, he added, pointing out that by then, spending for sophisticated air-ground communications and navigation aids will have only begun.

Radar beacon systems will be added to all long-range radars (whether FAA's or USAF's) which cover high-altitude flights; they will be working at the 13 air-route control centers before the end of this year. Then, as a second priority, they will be installed at the 180-odd terminal radar locations.

This will mean about 250 beacon installations for FAA, which adds up to about \$70 million for ground stations alone. Airborne transponders cost about \$2,000, and there doesn't seem to be much chance, ELECTRONICS learned, that the price can be substantially reduced.

Few commercial craft are presently equipped with the needed airborne transponder. Eastern Airlines has outfitted its fleet, and a few other flag craft are outfitted, for a total of about 200 transponders thus far. The 600 transponders now on order will outfit about a third of the carrier fleet. New commercial craft will come from factory with transponders installed.

Picture Flying . . .

(Continued from p 39)

ciency. Much effort is directed toward obtaining materials capable of retaining thermoelectric properties at very high temperature. Also being studied is the use of magnetic domain interaction in thin evaporated films as an approach to digital logic and memory elements. Success of such studies should do much to miniaturize digital circuits and increase their reliability.

An ANIP research team made up of Douglas Aircraft, Servomechanisms, Varo and Litton is developing the RV-2 airborne digital computer, which will use principles of magnetic-domain interaction. This computer is scheduled for completion in approximately two years.

King Klystron



Multi-million watt klystron is being placed in new Sage radar system. The tube, developed jointly by GE and the Air Research and Development Command's Rome Air Development Center, will produce hundreds of times more power than the radar used to beam pulses to moon and back in 1946

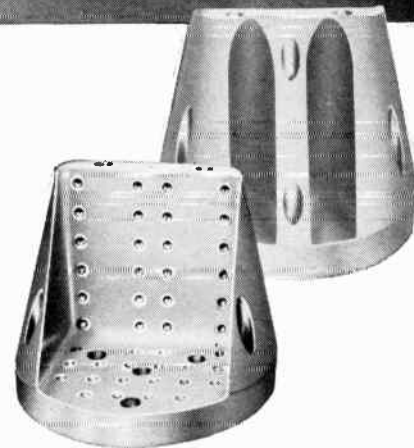
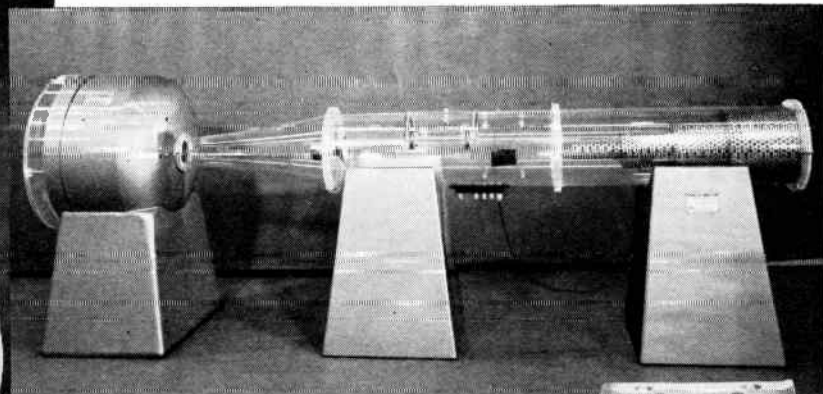
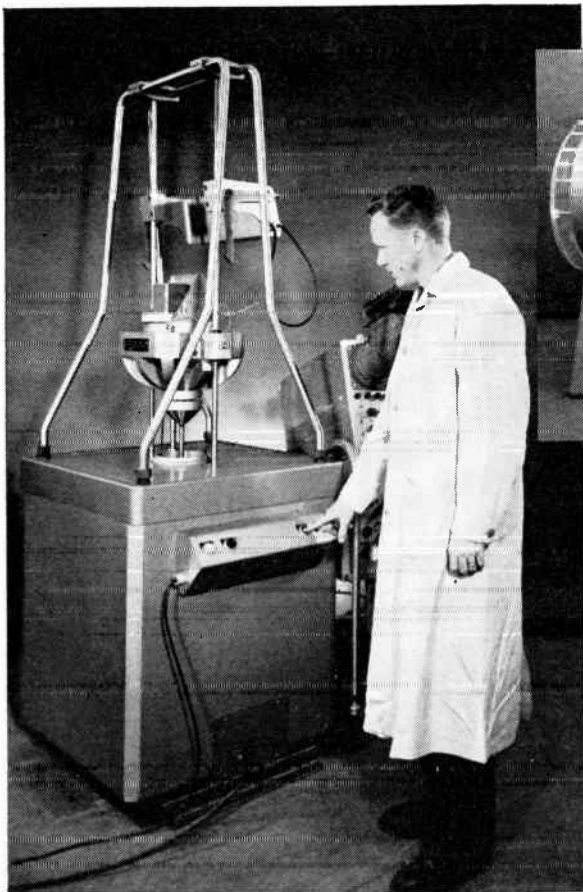

(left) **Shock Machine SM-010**, with shock pulses up to 1000 g's, meets rigid specifications of WS-107A-2 Environmental Test Requirements for ballistic missile components.

(above) **Acoustic Noise Generator AG-012**, producing up to 163 db of random noise, can be used singly or in systems with other speakers to meet specific testing requirements.

(right) **Environmental Test Fixture** (two views shown) is compact and versatile. Handles several specimens along three mutually perpendicular axes. Mounts on standard vibration exciters, centrifuges and shock machines.

NOW AVAILABLE...

USE-PROVEN ENVIRONMENTAL TEST EQUIPMENT

Avco test equipment meets severe environmental testing requirements of ballistic missile program

SHOCK TESTING. Shock Test Machine SM-010, first in a series of Avco-developed and use-proven shock test machines, answers broad categories of testing requirements.

- Produces shock pulses up to 1000 g's
- Handles specimen loads up to 100 pounds
- Provides sawtooth, quarter-sine, half-sine, square and triangular pulses
- Designed to permit easy duplication of particular shock pulse for repetitive testing
- Use-proven in qualification
- testing of electronic and electromechanical units for major missile program
- Occupies less than four square feet of floor space
- Incorporates operator safety features
- Shock pulses easily modified by changing lead pellet or rubber pad decelerators
- Provides capability of recycling for life testing

ENVIRONMENTAL TEST FIXTURE. This new unit was designed for general environmental lab use and has several advantages over the conventional unit.

- Mounts on vibration exciters, acceleration and shock test machines
- Permits simultaneous testing of several small components in three planes
- Both fixtures available in beryllium to meet more stringent requirements
- Virtually resonance-free up to 2000 cycles
- Two sizes available: TF-006-1 (specimen size—6 x 6 x 4½ inches) handles specimens up to 6 pounds; TF-025-1 (specimen size—12 x 12 x 9½ inches) handles specimens up to 25 pounds

ACOUSTIC NOISE TESTING SYSTEMS. Avco has pioneered in the development of these systems, featuring the Avco Acoustic Noise Generator AG-012.

- First noise generator to duplicate random noise of rocket engine firing
- Produces up to 160±3 db of random noise into a 4-inch progressive wave tube, thereby providing most powerful single electrodynamic loudspeaker available
- Peak single frequency of 170 db at 200 cycles per second
- Adaptors available for changing to 4-, 6-, 12-, 18-inch plane wave tubes in minutes
- Single electrodynamic loudspeaker offers maintenance advantages over multispeaker systems
- Designed for operation with existing vibration amplifiers—no additional capital equipment required
- Single Avco Noise Generator permits tests formerly requiring up to 50 speakers
- Single Avco AG-012 becomes heart of complete noise testing system
- Designed for progressive wave and reverberant chamber testing
- Frequency range from 20 to 2400 cps

Avco's line of Environmental Test Equipment is fully represented by local agents throughout the continental United States and the world. For further information write: *Products and Services Department, Research and Advanced Development Division, Avco Corporation, Wilmington, Mass.*

AVCO
Research & Advanced Development
division

How far can an engineer go at AC?

**SPECIAL EDUCATION PROGRAMS
DEVELOP CAREERS**

PROGRAM C



ENGINEERING SUPERVISORS

PROGRAM B



EXPERIENCED ENGINEERS

PROGRAM A



RECENT GRADUATE ENGINEERS

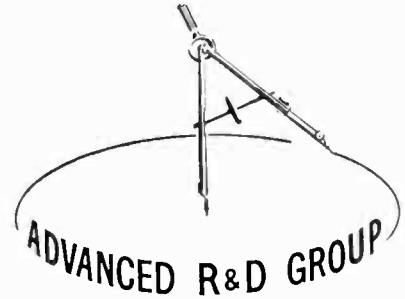

AC's instrumentation projects offer you a bright future of growth and job satisfaction, if you qualify. You can work on the AChiever inertial guidance system or many other electromechanical, optical and infra-red devices. The finest "in house" training programs are available to you. And AC's new R & D group assures a position of leadership in space age developments.

Three advanced education programs can help you enhance your professional status. AC offers them in addition to their educational assistance programs for men who wish to study for advanced degrees in nearby universities.

Program A—for recent graduate engineers—gives you a solid foundation in the theory and application of inertial guidance systems and servomechanisms.

Program B—for experienced engineers—consists of upgrading studies in inertial guidance, servomechanisms, environmental problems, engineering math and physics, plus advanced state-of-the-art courses.

Program C—for all engineering supervisors—involves management training developed by a team of AC executives and University of Chicago industrial relations experts.

AC's new R & D Group is devoted to the Research and Development of advanced systems and components. Current programs include many vital projects: interplanetary navigation and guidance; digital computer development; advanced inertial sensors; passive electromagnetic detection, surveillance and navigation systems; guidance systems for ballistic missiles, space vehicles and aircraft.

If you are a graduate engineer in the electronics, electrical or mechanical fields, or if you have an advanced degree in mathematics or physics, you should talk with the people at AC. Write the Director of Scientific and Professional Employment, Mr. Robert Allen, Oak Creek Plant, Box 746, South Milwaukee, Wisconsin.

INERTIAL GUIDANCE SYSTEMS • AFTERBURNER FUEL CONTROLS
BOMBING NAVIGATIONAL COMPUTERS • GUN-BOMB-ROCKET SIGHTS
GYRO-ACCELEROMETERS • GYROSCOPES • SPEED SENSITIVE SWITCHES
SPEED SENSORS • TORQUEMETERS • VIBACALL • SKYPHONE



SPARK PLUG ⚡ THE ELECTRONICS DIVISION OF GENERAL MOTORS



Peerless Electric Blowers perform an important and dependable cooling function in radio and radar equipment at hundreds of airports all over the world. Isolated transmitter equipment guiding aircraft in to safe landings *must* remain properly and continually ventilated to operate at peak efficiency. We are designing and building to customer and government specifications all the time. Whatever your air flow requirements or application, it will pay you to consult Peerless Electric.

Contact us today!

We're interested in your inquiry!

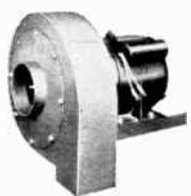

Electronic Cooling



No-Corrosion
Aluminum Construction

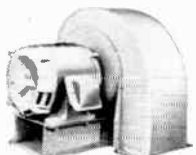

Heavy Machinery
Cooling



Insulated For
Temperatures

**Peerless
Electric**

FAN AND BLOWER DIVISION

THE Peerless Electric CO.

FANS · BLOWERS · MOTORS

W. MARKET ST. WARREN, OHIO

Magnetic Ink Sorts

New electronic data processing system designed for banks does not use magnetic tape



Punched Mylar tape stores instructions

PAOLI, PA.—This month Burroughs started accepting orders for its Visible Record Computer (VRC), an electronic data processing system that reads magnetic ink characters imprinted on bank checks, posts and totals customer ledgers without the intermediate step of putting the data on magnetic tape.

The company reports 10 systems on order. They sell for \$217,400, rent for \$3,975 monthly. Production is just starting at Burroughs' Plymouth, Mich., plant. First deliveries are slated for early 1961.

Applications

The system is designed to handle checking accounts, or as bankers say: demand deposits. In addition it is expected to find use in savings accounts, mortgage and installment loan work.

The manufacturer says the sys-

tem will pay for itself in a bank having 10,000 accounts. Reportedly life insurance companies and stores with heavy retail charge account business are also interested.

The VRC fills out the Burroughs line of automatic data processing equipment for banks: mechanical bookkeeping machines for very small operations, semiautomatic Sensitronic machines for larger operations, then the VRC and, finally, for large establishments, a magnetic-tape record computer (TRC).

How VRC Works

Magnetic ink characters in the so-called MICR (Magnetic Ink Character Recognition) format adopted last year by the American Bankers Association automation committee are imprinted on checks by Burroughs subsidiary Todd. Blank checks are imprinted by a manual off-line imprinter at the

Checks

bank. Magnetic heads (one for each digit) on a rotating drum sense the character. The signals are stored in delay lines and compared with character waveforms for recognition.

The computer portion of the system can perform 4,000 arithmetic operations a minute. The programming units are controlled by instructions punched into Mylar tape; 2,500 steps are available. The output printer has 160 character positions, prints 200 lines a minute. The printer is electronically controlled with a plugboard on console to select format.

The unit uses 5,500 transistors of the medium-speed switching and audio power types; 50,000 other electronic components; and 75,000 mechanical parts. Basic circuits are laid out on some 1,000 printed circuit cards. Wire-wrap joints are used throughout for interconnection.

Maintenance is facilitated by a panel showing the condition of all binary circuits. Dials permit manual set-up of the computer and step-by-step operation for maintenance or troubleshooting. The Mylar tape program units are pluggable to add flexibility to the computer. The system reportedly took 100 engineer-years, cost \$5 million to develop.

Tests Guidance



Test console and rate table, built by Amelco, Inc. for Douglas, makes all dynamic measurements necessary to evaluate the Inertial Guidance Flight Controller prior to its installation in the Thor IRBM

CerMac SPECIALTY SEALS High-temperature, Vacuum-tight

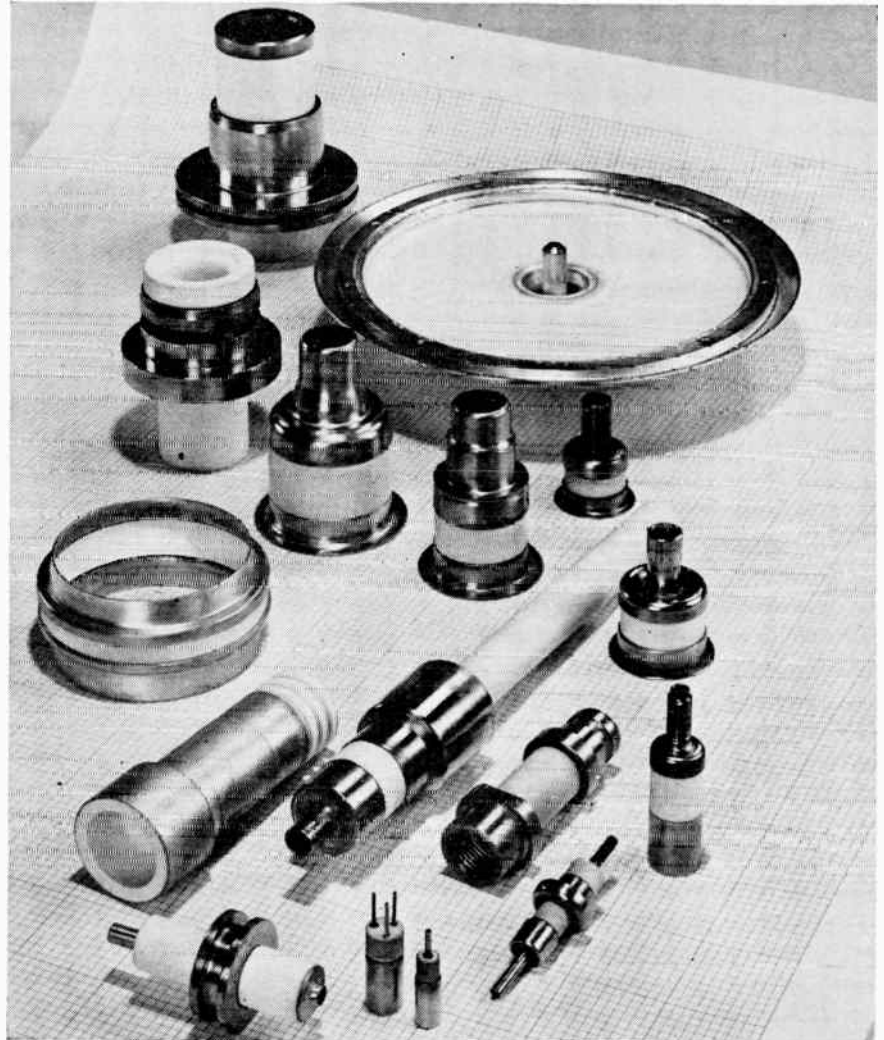

PRECISION-MADE ceramic-to-metal hermetic seals

For high temperatures, severe vibration and shock, CerMac Specialty Seals and Housings for semiconductor devices meet the most critical specifications, and are dimensionally accurate and uniform. They are produced in any quantity by an experienced organization employing modern equipment. Careful production control, inspection and testing assure highest quality. Send drawings for quotation.

Representatives in Principal Cities

CERAMIC-METAL ASSEMBLIES CORPORATION

P. O. Box E-328

Latrobe, Pennsylvania

Phone: Latrobe, Keystone 9-1757

"I wish I could have done something to help . . ."

You can do something

about traffic accidents! Drive safely yourself—obey the law. Sure. But you can do a lot *more!* Traffic accidents affect *everybody*. Reducing them is a community problem. Its solution calls for systematic, organized effort and cooperation with public officials—for teamwork and leadership. Here is where *you* can help. Join with others who are working actively to promote safe driving and secure strict enforcement of all traffic laws. Make your influence count. *Support your local Safety Council!*

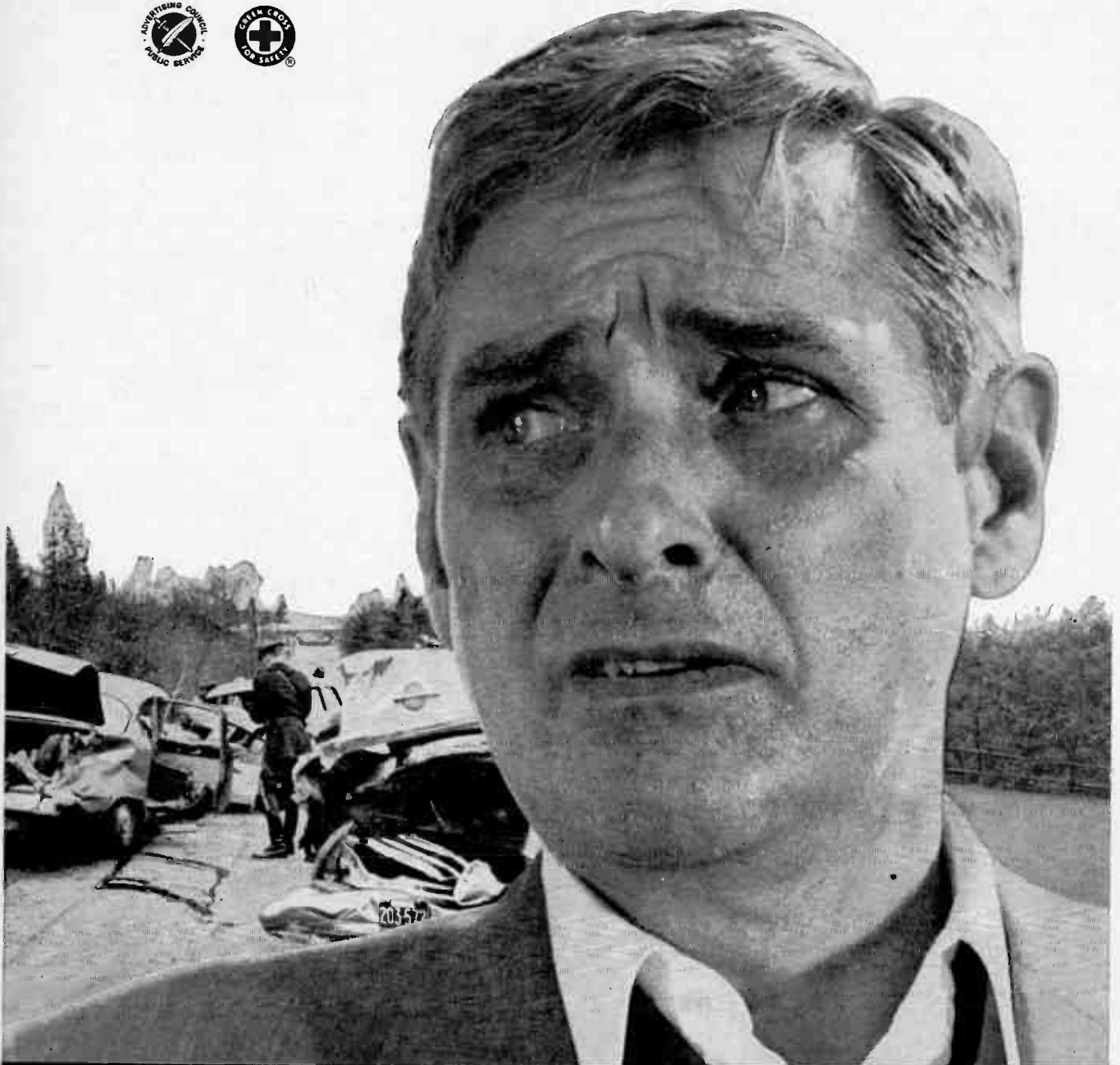

Where traffic laws are strictly enforced, deaths go 'DOWN!'

Published in an effort to save lives in cooperation with the National Safety Council and The Advertising Council.

Simplified, Accurate Broadband Measurements

Frequency Range 500 KC to 250 MC

The integral design of this RF bridge eliminates difficulties from leakage, hand effects or improper matching that can occur when several units must be interconnected to make measurements. Integrated within the 250-A are an accurate, continuously tuned RF oscillator, high frequency bridge, amplifier-detector and null indicating meter. Connections to the unknown impedance are arranged for practically zero lead length. Equivalent parallel resistance and capacitance are read directly from the calibrated dials over the entire range.

Typical Applications

The RX meter provides a quick accurate means of measuring the RF resistance and reactance of a wide variety of materials, components and circuits. Measurements can also be made of the dynamic parameters of transistors, vacuum tubes and diodes under selected conditions of D.C. bias and operating levels. Measurements of antennas and antenna systems are readily convertible to series equivalents or VSWR. Transmission line characteristic impedance, attenuation and velocity of propagation are easily determined.

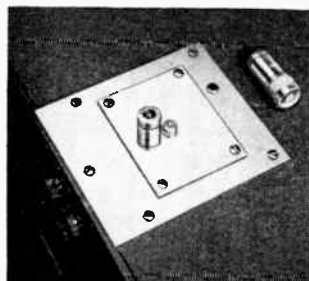

**CO-AX ADAPTER
KIT TYPE 515-A**
Permits connection to the RX Meter bridge circuit of any coaxial transmission line or fixture fitted with a type "N" male connector. PRICE: \$38.50 FOB Boonton, N. J.

**BRC Type 250-A RX Meter...
Complete, Integrated, Self-contained—
No External Units Required**

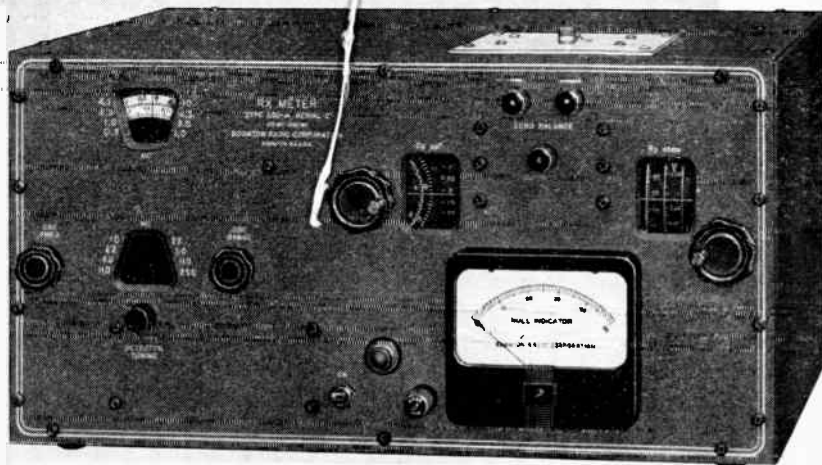

Specifications

Frequency Range: 500 KC to 250 MC

Frequency Accuracy: $\pm 1\%$

Resistance Range (Rp): 15 to 100,000 ohms (28" scale length)

Resistance Accuracy: $\pm \left[2 + \frac{F^*}{200} + \frac{R^*}{5000} + \frac{Q^*}{20} \right] \% + 0.2 \Omega$

*F = frequency (MC); R = RX Meter Rp reading (Ω);

$Q = \frac{R}{\omega C \times 10^{-12}}$, where C = RX Meter Cp reading ($\mu\mu\text{f}$)

Resistance Calibration: Increments of approx. 3% throughout most of range.

Capacitance Range (Cp): 0 to 20 $\mu\mu\text{f}$ (0.1 $\mu\mu\text{f}$ increments)

Capacitance Accuracy: $\pm (0.5 + 0.5F^2 \cdot C \times 10^{-5}) \pm 0.15 \mu\mu\text{f}$

*F = frequency (MC); C = RX Meter Cp reading ($\mu\mu\text{f}$)

Capacitance Calibration: 0.1 $\mu\mu\text{f}$ increments.

Inductance Range (Lp): .001 μh to 100 mh

Inductance Accuracy: Basic accuracy is capacitance accuracy given above.

Test Voltage: 0 volts D.C. (50 ma permissible thru unknown terminals)

0.1 to 0.5 volts RF (conveniently reducible to 20 mv)

Price: \$1525.00 F.O.B. Boonton, N. J.

25th
ANNIVERSARY

Precision Electronic
Instruments since 1934



BOONTON RADIO CORPORATION
BOONTON, NEW JERSEY, U.S.A.

World Radio History

Prices cut another 20% on

Mass production of SCR's is now a reality. The experience, skill and manufacturing knowhow of General Electric's SCR production line is your assurance of dependable quality-controlled SCR's—an assurance unmatched by any other manufacturer.



WHAT THE SCR DOES

The SCR is a miniature semiconductor device that blocks positive forward voltage in its "off" or non-conducting state. However, by applying a small signal to the gate terminal it switches rapidly to a conducting state and acts like a single junction silicon rectifier. It is completely static, arcless and fast. It is almost 100% efficient. It contains no mechanisms subject to wear. As a result, the SCR can switch and control power either faster, more safely, less expensively or more reliably than the many devices it replaces: circuit breaker, relay, thyatron, magnetic amplifier, rotating amplifier and many others. Among the many hundreds of circuit designs are these:

Superior d-c motor operation from an a-c source. Eliminates motor generator sets, tubes or magnetic amplifiers to provide controlled d-c. Replaces mechanical speed and direction changers.

Superior a-c generation from a variable d-c source. First really practical method of using static inverters with ratings of several kilowatts.

Simpler conversion to high frequency. SCR converters are small and efficient. Extends use of high frequency power where desirable, as in fluorescent lighting systems.

Pulse modulators. Compact, yet rugged replacement for hydrogen thyatrons in radar and beacon modulators.

D-c regulation. Control large blocks of voltage with small losses by pulse width modulation. Eliminate bulky rheostats and adjustable d-c generators.

Other applications: Battery charging regulator, transient voltage protection, dynamic braking, constant current supply, static switching, regulated power supply, d-c to d-c conversion, temperature control.

silicon controlled rectifier

*First test data revealed, new circuits developed,
customer designs move into manufacturing stage*

Prices again have been reduced an average of twenty percent on General Electric's Silicon Controlled Rectifier, providing greater values to users. These new prices have been made possible through expanding production and lower manufacturing costs.

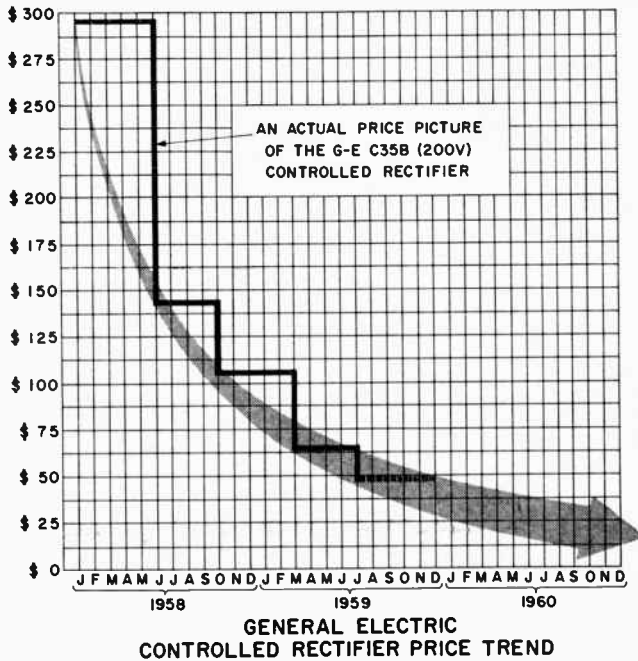

TESTS AND FIELD REPORTS PROVE RELIABILITY

Reliability of General Electric SCR's has been steadily improved over two years of manufacturing experience. Typical test results point to the reliability achieved to date.

MAXIMUM ALLOWABLE RATINGS (Resistive or Inductive Load)

	C35U	C35F	C35A	C35G	C35B	C35H	C35C	C35D
Continuous Peak Inverse Voltage (PIV)	25	50	100	150	200	250	300	400 volts
Transient Peak Inverse Voltage (Non-Recurrent < 5 millise.)	35	75	150	225	300	350	400	500 volts
RMS Voltage (V _{RMS}), Sinusoidal	17.5	35	70	105	140	175	210	280 volts
Average Forward Current (I _F)	Up to 16 amperes							
Peak One Cycle Surge Current (I _{surge})	150 amperes							
Peak Gate Power	5 watts							
Average Gate Power	0.5 watts							
Peak Gate Current (I _G)	2 amperes							
Peak Gate Voltage (V _G) (forward)	10 volts							
Storage Temperature	-65°C to +150°C							
Operating Temperature	-65°C to +125°C							
CHARACTERISTICS (At Maximum Ratings)	C35U	C35F	C35A	C35G	C35B	C35H	C35C	C35D
Minimum Forward Breakover Voltage (V _{BO})	25	50	100	150	200	250	300	400 volts
Maximum Reverse (I _R) or Forward (I _S) Leakage Current (Full Cycle Average)	6.5	6.5	6.5	6.5	6.0	5.5	5.0	4.0 ma
Maximum Forward Voltage (V _F avg)	0.86 volts (Full Cycle Average)							
Maximum Gate Current To Fire (I _{GF})	25 ma							
Maximum Gate Voltage To Fire (V _{GF})	3 volts							
Typical Gate Current To Fire (I _{GF})	10 ma at +1.5 volts (Gate to Cathode Voltage)							

C-35 Series—lower cost series with ratings similar to above, but for use up to 100°C maximum, with forward current ratings up to 10 amperes.
ZJ-50 Series—a high-current series now in development, and available on a prototype-sample basis.

98% survival after 1000 hours of storage at 125°.
97% survival after 1000 hours of operation at maximum ratings at 125°C.
No thermal fatigue failures after 30,000 cycles from 20°C to 135°C and return.
Less than one percent failures experienced by customers (many of which were traced to misapplication).

SCR NOW BEING USED BY MANY COMPANIES

The evaluation stage is passing rapidly into the application stage. Many products incorporating the SCR are being marketed, for the applications are proved, circuits refined and quantity production is a reality. These are just a few of the many cases where an SCR is now doing a job more efficiently, less expensively, faster or more reliably than previous designs:

- Power supplies incorporating transient voltage protection (for computers).
- Radar modulator.
- Static switch to replace mechanical relay for aircraft.
- Three phase inverter.
- Stage lighting lamp dimming.
- Regulated power supply.
- Battery charging regulator.
- Constant current supply for a magnetic yoke.

SEND FOR DESIGN INFORMATION

Detailed application notes and article reprints are available for the guidance of designers. Your General Electric Semiconductor Sales Representative will be pleased to provide you with complete details. Or write to Section S2599, Semiconductor Products Dept., General Electric Company, Electronics Park, Syracuse, New York. Many local G-E Semiconductor Distributors also stock General Electric SCR units for fast delivery at factory-low prices.

GENERAL ELECTRIC

Semiconductor Products Department

why should you consider going to work for Collins Radio?



You shouldn't if your present job is good enough. If it offers you enough individual expression, enough satisfaction, enough variety, enough incentive. And, yes, enough salary. But perhaps something is lacking. Perhaps you should consider Collins.

Collins has been the creative leader in electronics for over 25 years. The reason for this leadership is a continuous emphasis on advanced research and development. The results are impressive steps forward in communication and navigation. Collins was first to develop the radio sextant. Collins was first to bounce radio signals off the moon. Collins pioneered the development of single sideband communication, and is currently setting up the SAC global communication system.

Collins offers outstanding opportunities for professional advancement. Each engineer becomes a valuable specialist, or obtains the broad experience necessary for technical administration. And engineers are viewed as Collins' most important source of administrative leaders. In addition, Collins Radio offers you the advantages of your choice of location and project assignment.

If you are an engineer with a degree in EE, ME or Physics, Collins invites you to consider applying your talent and experience toward advancing your career in one of the following areas: With Collins in Dallas—circuit design, radar, microwave and carrier, telephone transmission, missile and satellite tracking and communication, airborne communication and navigation systems. With Collins in Cedar

Rapids—gyro controls, navigation and guidance systems, circuit design, vibrations. With Collins in Burbank—digital communication system transistorized circuit design, component engineering, test equipment design, reliability engineering, system design, and group project administration. U. S. citizenship is required.

Choose your climate and send your resume and home phone number in complete confidence to one of the following:

L. R. NUSS, Collins Radio Company,
855 35th St., N.E., Cedar Rapids, Iowa;

B. E. JEFFRIES, Collins Radio Company,
1930 Hi-Line Dr., Dallas 7, Texas; or

R. J. OLSEN, Collins Radio Company,
2700 W. Olive Ave., Burbank, California.



COLLINS RADIO COMPANY • CEDAR RAPIDS, IOWA • DALLAS, TEXAS • BURBANK, CALIFORNIA

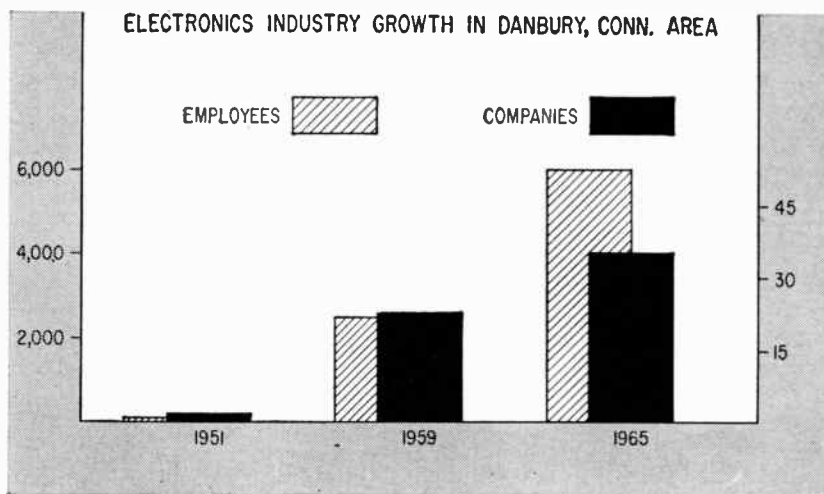

'Dead' Town Comes to Life

Electronics industry plays a major role as Danbury, Conn., starts booming once more

DANBURY, CONN.—This is the town that died twice.

This is the town the electronics industry, more than any other, is bringing back to life—for good.

The hat industry's departure decades ago killed the town. The town crept back slowly, only to be flattened again by the Connecticut floods of 1955. Today the area is booming. Here is the part electronics has played:

In 1951 two electronics firms here employed 100 persons. Today there are 23 plants and 2,500 workers. And the prediction for 1965 is this: 35 electronics companies hiring 6,000 men and women.

Land, Men Aplenty

Danbury has used no tax gimmicks, no stunts. It has attracted nearly 100 companies to its area in the last six years by pointing out its prime assets: available land and skilled manpower which works best under pressure.

Sixty miles from New York City, Danbury is the 13th largest city in the state, has an area population of 85,000.

"Danbury and the 14 smaller communities in its area cover 474 square miles," says Richard C. Gram, manager of the city's chamber of commerce. "And we have several thousand acres left for new companies to build on."

Of seven companies to pick the Danbury area in the past three months, five are in the electronics industry. By the end of next year, electronics firms expect to hire 1,000 more persons. Our industry now accounts for 25 percent of the area's 11,000-man labor force.

Company growth rates have been amazing. Data-Control Systems, Inc., went from four to 250 workers in six months. National Semiconductor Corp., just starting with 50 workers, expects to be hiring 500 shortly. Consolidated Controls Corp. expanded its facilities 75 percent in nine months.

Electronics companies in the greater Danbury area include:

Reeves Soundcraft Corp.; Sperry Products, Inc.; Electronic Fittings Corp.; Kanthal Corp.; National Semiconductor Corp.; Rapid Electric Corp.; Waltham Precision Instrument Co.; American Radionic Co., Inc.; Boesch Mfg. Co.; Brown Engine Products; Colin Campbell Co., Inc.; Danbury-Knudsen, Inc. div. of Amphenol-Borg Electronics Corp.; Data-Controls Systems; K-V Transformer Corp.; Republic Foil & Metal Mills; Viking Wire Co.; Pyno Moulding Corp.; Winchester Electronics, Inc.; Plastic Molding Corp.; Brandstrom Electric Co.; Berkshire Transformer Corp.; Consolidated Controls Corp.; Mosler Research Products, Inc.

Using Thermistors

Edited by
FENWAL ELECTRONICS, INC.

**STABLE THERMISTORS PERMIT
HIGH CONTROL ACCURACY
WITH SIMPLE CIRCUITRY**

Circuit shown for the Fenwal Electronics' Model 150 Temperature Controller is typical. It has a sensitivity of 0.001°C throughout its working range!

New, extremely stable, probes permit full exploitation of thermistors' inherently high sensitivity to temperature change.

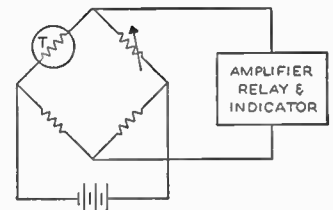
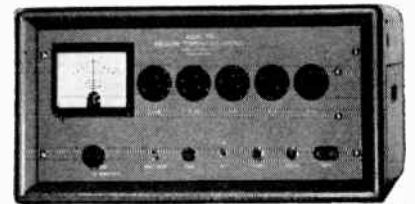

Fenwal Model 150 Thermistor Controller

Operating characteristics of the new probes are precisely predictable and repeatable over the entire control range. Furthermore, the large change in resistivity of a probe in response to a small temperature change greatly simplifies circuit design. (Resistance can change as much as 4000 ohms — or more — for a change of only 1° in temperature.) In most cases, a standard resistance bridge circuit is ample for measurement of signal output.

For full details on thermistors, send for Catalog EMC-2. Further details on Model 150 also available on request. Write FENWAL ELECTRONICS, Inc., 38 Mellen Street, Framingham, Mass. And simplify your circuit design problems with a G200 Experimental Kit of thermistors. Available from Fenwal Distributors or the Framingham plant.



Making Precision Thermistors
to Make Your Design Ideas Come True

A new dimension in

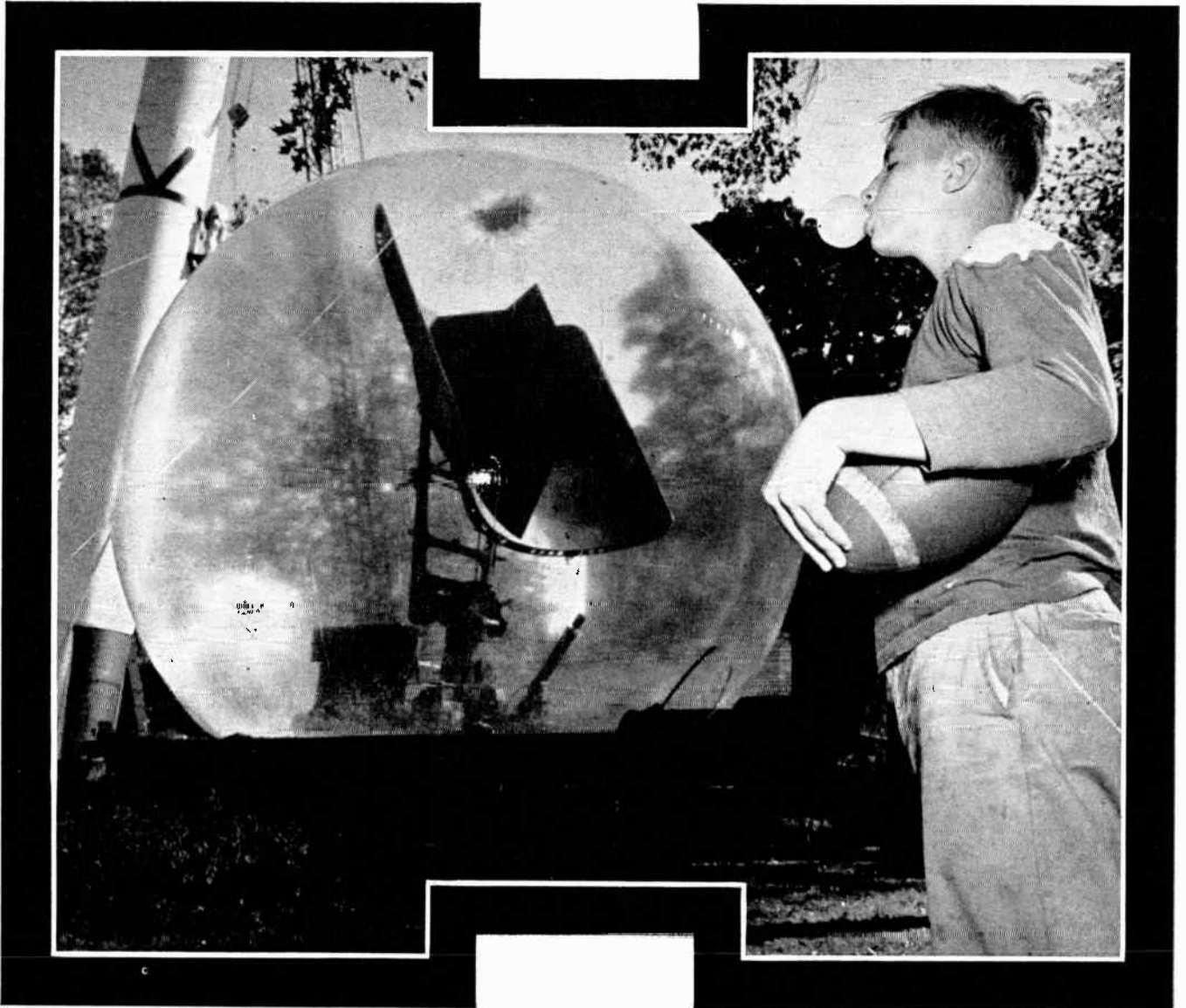

bubble blowing

This plastic bubble protects the antenna of a radically new aerial three-dimensional radar defense system.

Sensitive to the inadequacies of conventional radar systems, engineers at Hughes in Fullerton devised a radar antenna whose pointing direction is made sensitive to the frequency of the electromagnetic energy applied to the antenna. This advanced technique allows simultaneous detection of range, bearing and altitude...with a single antenna.

Hughes engineers combined this radar antenna with "vest-pocket sized" data processors to co-ordinate anti-aircraft missile firing. These unique data processing systems provide:

1. **Speed**—Complex electronic missile firing data was designed to travel through the system in milliseconds, assuring "up-to-date" pinpoint positioning of hostile aircraft.
2. **Mobility**—Hughes engineers "ruggedized" and miniaturized the system so that it could be mounted into standard army trucks which could be deployed to meet almost any combat problem—even in rugged terrain.
3. **Reliability**—By using digital data transmission techniques, Hughes engineers have greatly reduced any possibility of error.

Result: the most advanced electronics defense system in operation!

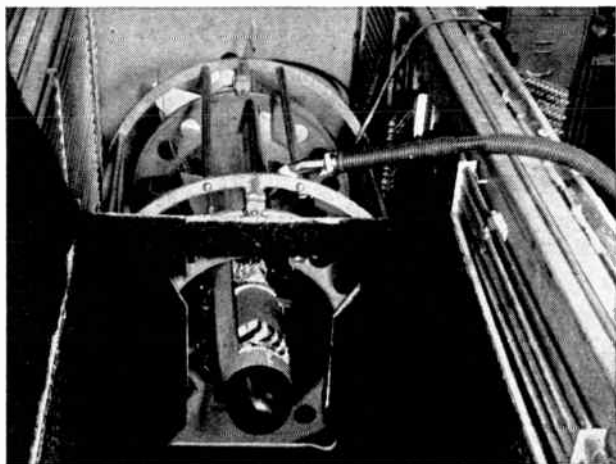

Falcon air-to-air guided missiles, shown in an environmental strato chamber are being developed and manufactured by Hughes engineers in Tucson, Arizona.

Reliability of the advanced Hughes systems can be insured only with the equally advanced test equipment designed by Hughes El Segundo engineers.

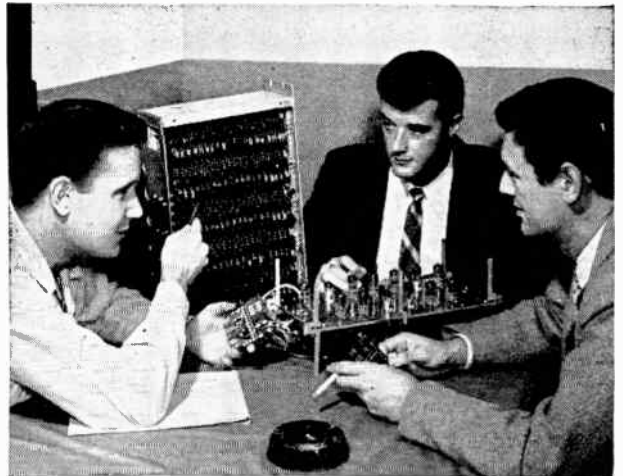

Other Hughes projects provide similarly stimulating outlets for creative talents. Current areas of Research and Development include advanced airborne electronics systems, advanced data processing systems, electronic display systems, molecular electronics, space vehicles, nuclear electronics, electroluminescence, ballistic missiles...and many more. Hughes Products, the commercial activity of Hughes, has assignments open for imaginative engineers to perform research in semiconductor materials and electron tubes.

Whatever your field of interest, you'll find Hughes diversity of advanced projects makes Hughes an ideal place for you to grow...both professionally and personally.

Newly instituted programs at Hughes have created immediate openings for engineers experienced in the following areas:

Infrared	Thin Films
Plasma Physics	Microwave Tubes
Digital Computers	Circuit Design & Evaluation
Field Engineering	Systems Design & Analysis
Quartz Crystal Filters	Logical Design
Communications	Semiconductor Circuit Des.

*Write in confidence to Mr. Mike Welds
Hughes General Offices, Bldg. 6-D9, Culver City, Calif.*

© 1959, H. A. C.

HUGHES

*The West's
leader in
advanced
ELECTRONICS*

HUGHES AIRCRAFT COMPANY

*Culver City, El Segundo, Fullerton, Newport Beach,
Malibu and Los Angeles, California
Tucson, Arizona*

LAPP COOLING

GIVES LONGER LIFE

TO HIGH-POWER TUBES



WATER-COOLED

Carrying cooling water which must undergo a change in potential is a job best handled by Lapp Porcelain Water Coils. These coils are completely vitrified, non-absorbent porcelain, white glazed inside and out, providing very low resistance to water flow and eliminating all possibility of contamination in the water. Assuring positive cooling and long tube life, a Lapp Porcelain Water Coil installation represents a permanent investment—a completely trouble-free cooling system.

AIR-COOLED

Use of Lapp standard-design

tube supports facilitates circuit design, improves production economy, provides interchangeability and easy replacement. They are compact, efficient and attractive in appearance, with polished nickel-plated brass hardware permanently attached to the body. Equipment manufacturers will realize a triple service from these supports, for they support the tubes and act as an insulator, and channel air over the fins for maximum cooling of tubes.

WRITE for Bulletin 301 containing complete description and specification data. Lapp Insulator Co., Inc., 158 Sumner Street, Le Roy, New York.



Lapp

MEETINGS AHEAD

Sept. 28-30: Telemetry, National Symposium, PGTRC of IRE, Civic Auditorium & Whitcomb Hotel, San Francisco.

Sept. 30-Oct. 1: Industrial Electronics Symposium, PGIE of IRE, AIEE, Mellon Inst., Pittsburgh, Pa.

Oct. 5-7: Communications Symposium, National Conf., PGCS of IRE, Hotel Utica, Utica, N. Y.

Oct. 5-9: Society of Motion Picture & Television Engineers, Annual Convention, Statler-Hilton Hotel, New York City.

Oct. 5-9: Audio Engineering Society, Convention and Exhibit, Hotel New Yorker, New York City.

Oct. 6-7: Value Engineering, EIA, Engineering Dept., Univ. of Penn. Museum Auditorium, Philadelphia.

Oct. 6-8: Radio-Interference Reduction, Annual, Armour Research Foundation of Illinois Institute of Tech., Chicago.

Oct. 6-9: High-Temperature Technology, International Symposium, Asilomar Conf. Grounds, Stanford Research Inst., Asilomar, Calif.

Oct. 7-9: Canadian IRE Convention, Automotive Building, Exhibition Park, Toronto, Canada.

Oct. 7-9: Vacuum Technology, National Symposium, Sheraton Hotel, Philadelphia.

Oct. 11-16: American Institute of Electrical Engineers, Fall General Meeting, Hotel Morrison, Chicago.

Oct. 12-14: National Electronics Conference, AIEE, EIA, IRE, SMPTE, Hotel Sherman, Chicago.

Oct. 12-16: Aeronautics and Space Administration Inspection, NASA, Langley Research Center, Norfolk, Va.

Oct. 19-21: National Academy of Sciences, Research Council, URSI-IRE Fall Meeting, El Cortez Hotel, San Diego, Calif.

Mar. 21-24, 1960: Institute of Radio Engineers, National Convention, Coliseum & Waldorf-Astoria Hotel, New York City.

There's more news in ON the MARKET, PLANTS and PEOPLE and other departments beginning on p. 104.

RELIABLE CONNECTIONS

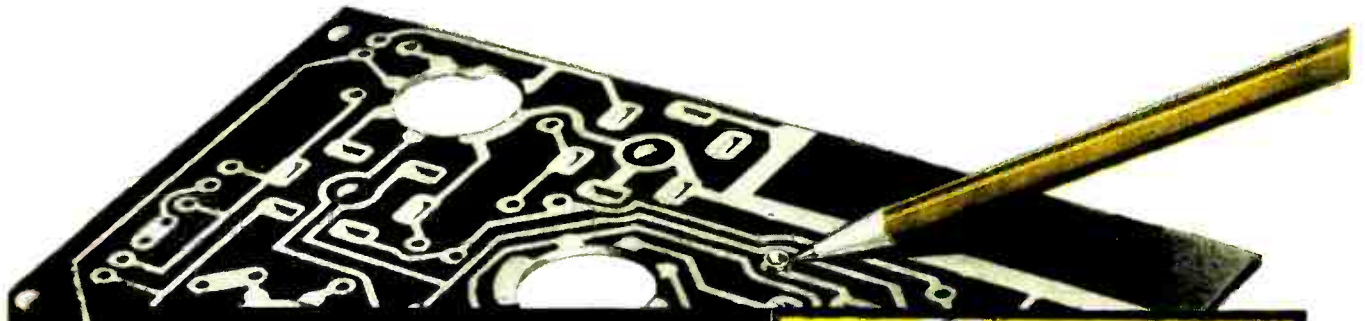

...with
LOW COST EYELETS



Eyelets give you unlimited opportunities for savings as connectors, fasteners, terminals, bushings, contacts for switches and hundreds of similar applications. Only with United Eyelets do you have such a wide choice of standardized sizes, special designs for cutting costs on unusual production problems, combined with a comprehensive line of the most versatile eyelet setting machines available.

In no other way can you get the flexibility obtainable with eyelets at comparable installed costs. Call or write us today for more information. Our national sales and service organization is ready to help with your most challenging problem.

NEW FUNNEL FLANGE eyelets designed especially as connectors for PW boards. Solves two-sided circuitry and solder problems. Speeds insertion. Are fed and set automatically on United Machines.

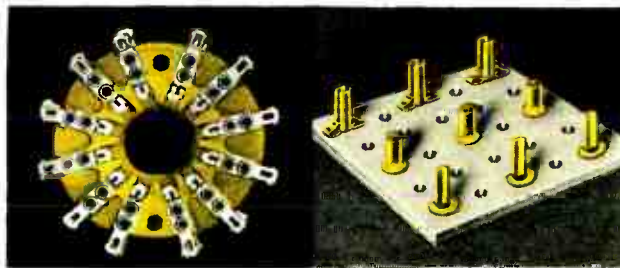

NEW MINIATURIZED EYELETS as connectors and fasteners for low cost, high speed insertion in components, PW boards, miniature equipment. Designed for high speed automatic feeding with United Machines. Copper or brass.

CUT COSTS WITH SHEARED EYELETS as stand-off terminals. Set as many as 3000 terminals per hour. Cuts soldering time too.



Simultaneous multiple eyeletting from either or both sides of machine. Typical six eyelet application illustrated. 50 years' experience is your assurance of complete dependability.



NEW EYELET SELECTOR — FREE

Simplify design, purchasing, inventory, and production. Decide the hole size and grip, and set the calculator to find the exact eyelet you need. Send for your free copy today!

United

UNITED SHOE MACHINERY CORPORATION
Boston 7, Massachusetts • Liberty 2-9100

Branches: Atlanta, Ga. • Chicago, Ill. • Cincinnati, Cleveland, Columbus, Ohio • Dallas, Texas • Harrisburg, Pa. • Johnson City, N. Y. • Las Angeles, Calif. • Lynchburg, Va. • Milwaukee, Wisc. • Nashville, Tenn. • New York, N. Y. • Philadelphia, Pa. • Rochester, N. Y. • St. Louis, Mo.

World Radio History

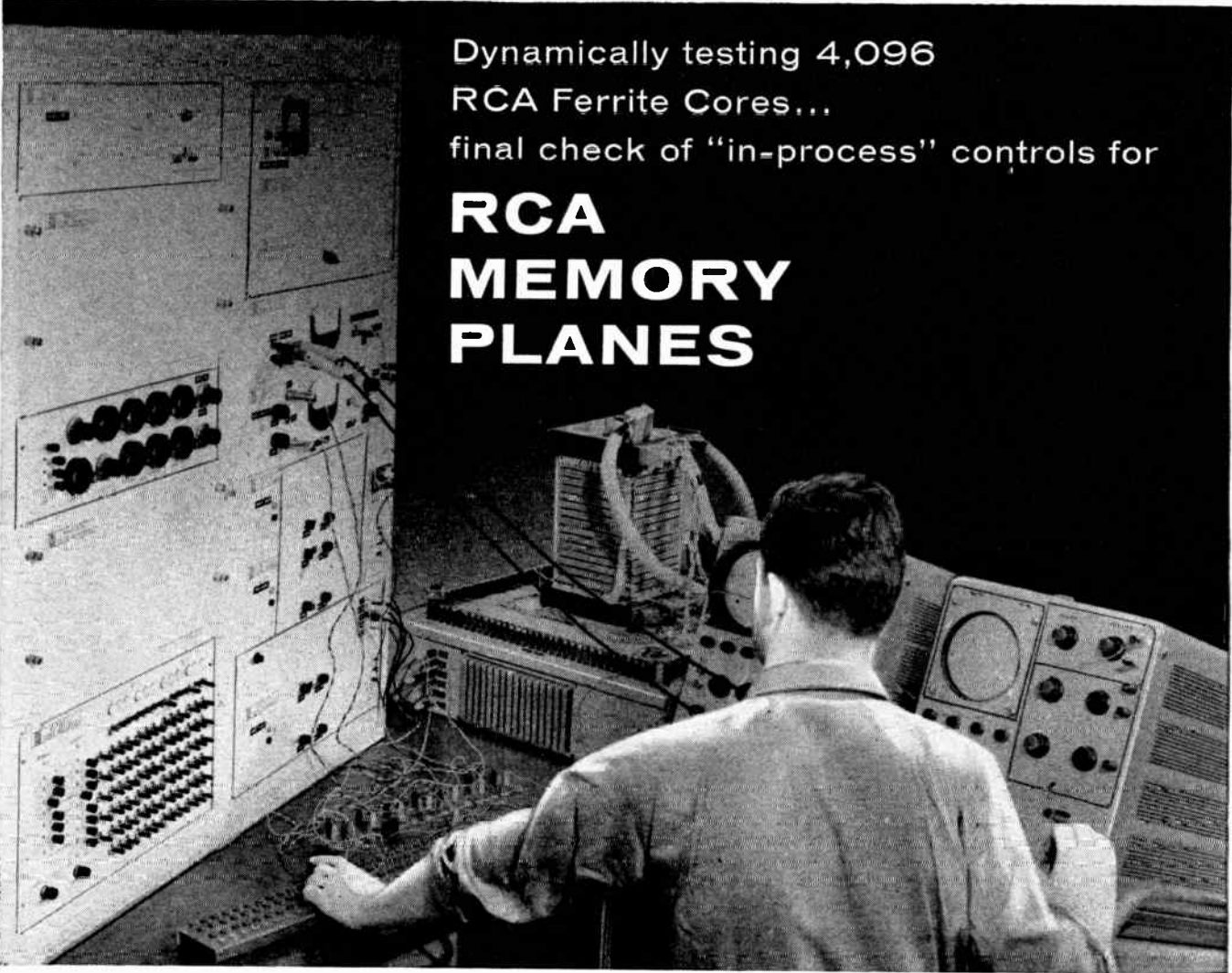

Dynamically testing 4,096
RCA Ferrite Cores...
final check of "in-process" controls for

RCA MEMORY PLANES

Unique memory plane and stack tester dynamically tests every RCA core in every RCA plane while the entire stack is being driven ... assures extremely high uniformity from core to core.

This dynamic Plane and Stack Tester at RCA's Ferrite Plant in Needham Heights, Massachusetts, is one of the most versatile and efficient test apparatus of its type in use today. It evaluates each RCA coincident current type of memory plane and stack *under actual use conditions* and provides 100% testing to your rigid specifications at typical computer frequencies. During tests, two programs are run alternately in the machine: first program 1 and then program 2. Each program is capable of writing all ones, all zeros, the double checkerboard pattern and its complement, or the double complemented checkerboard. Defective cores are immediately

detected and identified...cores with the highest ones or lowest zeros, or early or late peaking characteristics can also be eliminated to further assure uniformity from core to core.

This testing procedure is another example of "in-process" controls employed by RCA in every stage from the selection of raw materials to the inspection of finished product. For Ferrite Cores, Planes, and Stacks to meet your most rigid specifications, contact your local RCA Field Representative. For technical data, write RCA Commercial Engineering, Section I-19-NN-4, Somerville, New Jersey.



RADIO CORPORATION OF AMERICA
Semiconductor & Materials Division • Somerville, N. J.

East: 744 Broad Street, Newark, N. J.
HUmboldt 5-3900
Northeast: 64 "A" Street, Needham Heights 94, Mass.
Hillcrest 4-7200
East Central: 714 New Center Bldg., Detroit 2, Mich.
TRinity 5-5600
Central: Suite 1154, Merchandise Mart Plaza
Chicago, Ill., WHitehall 4-2900
West: 6355 E. Washington Blvd.
Los Angeles, Calif., RAymond 3-8361
Gov't: 224 N. Wilkinson St., Dayton, Ohio
BALdwin 6-2366
1625 "K" Street, N.W., Washington, D.C.
District 7-1260

Developing capacitors for unusual situations your job...and Centralab's

Centralab[®]

**CERAMIC
CAPACITORS**

for difficult applications

Ceramic capacitors have almost unlimited capabilities... but utilizing their full potential demands expert knowledge *not bound to conventional approaches*. Creative engineering, involving new concepts and new techniques, can broaden your design horizons.

That kind of creative engineering is a CENTRALAB specialty. As specialists in *ceramic* capacitors, CENTRALAB engineers have developed units to

meet an enormous variety of difficult size and rating requirements beyond the scope of oil, mica or vacuum capacitors. The unusual designs illustrated here are typical of CENTRALAB's answers to the problems no-one else could solve. A representative group of additional specialized units are described in Bulletin #42-719. Request your free copy of this bulletin today; it will stimulate your thinking towards making full use of the design potential of ceramic capacitors.

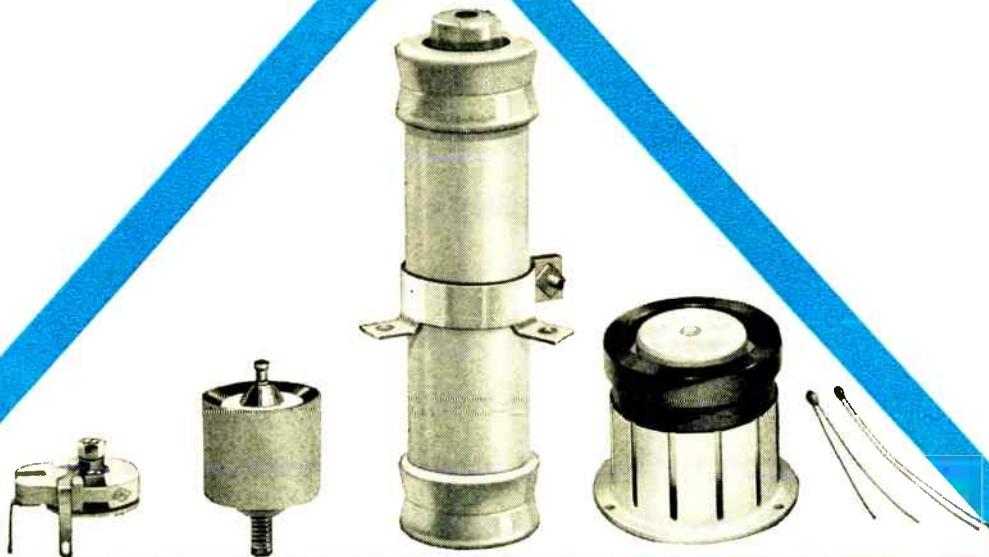

Variable Capacitors

600VDCW, capacity ranges to 250 mmf. Compact construction, 1 1/16" wide, 1 1/16" long, 1/16" deep overall. Temperature compensating units NPO, N650 are standard. Other temperature characteristics available on special order.

Precision Temperature Compensating Capacitors

Hermetically sealed, T.C. ± 10 PPM, capacity tolerance $\pm 1\%$. Outer shell grounded. Available in 50-3500 mmf range in NPO. Other T.C. ratings proportional.

High Voltage Capacitor

12KVDCW, 2000 mmf; 30 amps at 30 mc. Unit is 6" long, 2" O.D. Extremely flexible design—can be made to a wide range of dimensions and ratings. Units that operate at 125°C, without derating can be designed.

DC Blocking Capacitor

10KVDCW, 1700 mmf $\pm 10\%$; 12 amps at 4 mc, 80 amps at 30 mc. Measures only 4" high and 4" O.D. at base. Ideal for restricted space, high reliability applications. Can be used in parallel to handle large loads.

Ultra-Miniature Capacitor

3VDCW, .01 mmf G.M.V. Capacity change $+10^\circ$ to $+85^\circ\text{C}$, 25% maximum. Approximately 1/16" diameter. For transistor, coupling, by-pass, cathode and other low voltage, high capacity applications.

Centralab[®]
D-5947

A Division of Globe-Union Inc.
9141 E. KEEFE AVE. • MILWAUKEE 1, WIS.
In Canada: 669 Bayview Ave., Toronto 17, Ont.

VARIABLE RESISTORS • ELECTRONIC SWITCHES • PACKAGED ELECTRONIC CIRCUITS • CERAMIC CAPACITORS • ENGINEERED CERAMICS

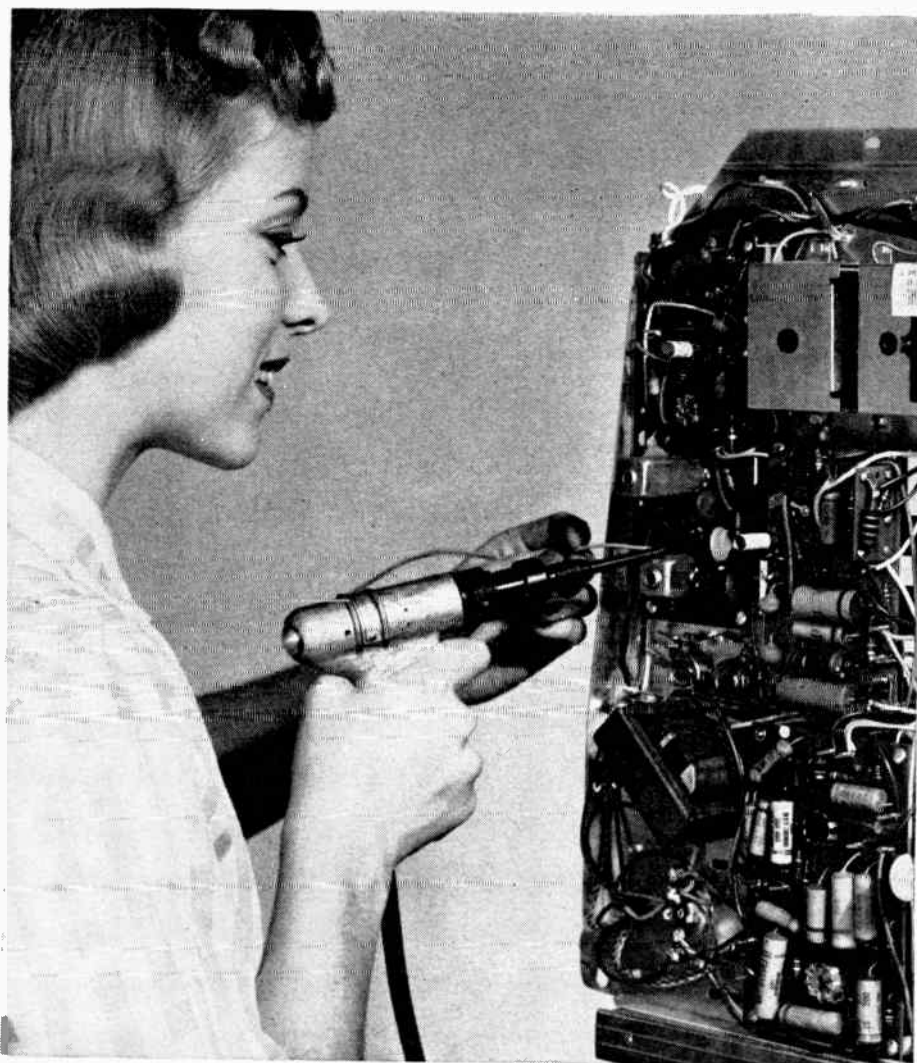

CONNECTIONS IN ONLY THREE SECONDS



Wire insertion and anchoring



Terminal insertion



Wrapping



Finished connection

Wrap up wiring jobs fast with Gardner-Denver "Wire-Wrap"® tools



Research takes the long view as Gardner-Denver engineers strive to improve existing products . . . to develop new ones to keep ahead of a fast-paced, rapidly growing industrial world.



EQUIPMENT TODAY FOR THE CHALLENGE OF TOMORROW

GARDNER - DENVER

Gardner-Denver Company, Quincy, Illinois

In Canada: Gardner-Denver Company (Canada), Ltd., 14 Curity Avenue, Toronto 16, Ontario

World Radio History

Fast, economical, solderless, metal-to-metal electrical connections which resist vibration failure and corrosion. That's the solderless wrapping method—proved superior by billions of connections without a reject.

With a lightweight, fast-acting Gardner-Denver "Wire-Wrap"® tool, you wrap up wiring jobs fast . . . and you get these profit-building benefits:

Greater production. Only three seconds total time per solderless connection. Actual connecting time, 1/10 second.

Lower production costs. You eliminate the expense of precise process control required by other methods.

Reduced labor costs. More connections per operator, with less fatigue. No faulty connections that require expensive hand repair work.

Higher quality. Mechanically strong connections electrically stable—proved most reliable in the industry.

Write for Bulletin 14-1

First of a series of
complementary power transistor lines

NEW CIRCUIT ECONOMIES THROUGH COMPLEMENTARY POWER TRANSISTOR PAIRS

Complementary pairs of CBS NPN and PNP power transistors eliminate input and output transformers in push-pull circuits. Resulting advantages are many: Economy. Miniaturization. Improved frequency response. Ease of applying negative feedback. Etc.

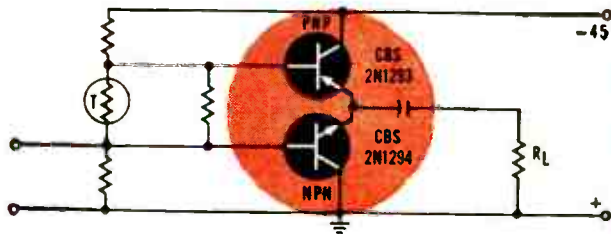

COMPLEMENTARY CLASS B AMPLIFIER

NOTE THE IDENTICAL DATA FOR THESE NPN-PNP PAIRS

NPN Type	Max. W. Diss.*	Max. V_{CBO} †	Max. V_{CES} ‡	Min. h_{FE} ($I_C = 0.5A$)	Max. Thermal Res. °C/W	PNP Type
2N326	7	35	35†	30	8	2N1291
2N1292	20	35	30‡	30	3	2N1291
2N1294	20	60	45‡	30	3	2N1293
2N1296	20	80	60‡	30	3	2N1295
2N1298	20	100	80‡	30	3	2N1297

All types have: Max. collector current, 3 amps; storage temperature, -65 to +85°C. *25°C base mounting temperature. †Polarity: NPN positive, PNP negative. ‡ $I_{CES} = 1$ ma max. † $I_{CES} = 10$ ma.



A SURVEY of customer applications resulted in this planned line of five CBS NPN-PNP pairs that make possible new design economies in complementary circuitry. Mounted in the popular TO-3 diamond package, they feature high voltages . . . up to 100 volts, and proven reliability (they exceed the MIL-T-19500A specification). They offer the first complete line of complementary power transistors . . . with more coming in flexible ranges of ratings and packages . . . for audio, control, voltage-regulation, servo and computer applications. Check the basic simplicity of the circuit and the abbreviated data for this first versatile and comprehensive CBS line. Write for complete technical Bulletin E-332A.

*More reliable products
through Advanced Engineering*



semiconductors

CBS ELECTRONICS, Semiconductor Operations
A Division of Columbia Broadcasting System, Inc.

Sales Offices: Lowell, Massachusetts, 900 Chelmsford St., Glenview 4-0446 • Newark, N. J., 32 Green St., Market 3-5832 • Melrose Park, Ill., 1990 No. Mannheim Rd.,
Estebrook 9-2100 • Los Angeles, Calif., 2120 S. Garfield Ave., Raymond 3-9081

a valuable first edition for circuit engineers

MOTOROLA'S new zener diode handbook

Here's the first manual of its kind—a 126-page guide to the basic theory, design characteristics and applications of zener diodes. These versatile, voltage-limiting components help solve circuit problems. Motorola's handbook tells how—and describes how the properties of these relatively new devices can be utilized in countless creative applications in industry.

This handbook is available from your nearest Motorola Semiconductor Distributor for only \$1. Call or write today for your copy!

THIS FIRST EDITION CONTAINS:
Nearly 150 illustrations, graphs and tables
...plus chapters devoted to:

- Characteristics of Silicon Zener Diodes
- Design Considerations
- Regulated Power Supplies
- Surge Protection
- AC and DC Amplifiers
- Temperature Compensation and Impedance Cancellation
- New Approaches in Zener Diode Applications
- The Motorola Zener Diode Slide Rule Calculator
- Specifications and Testing Methods

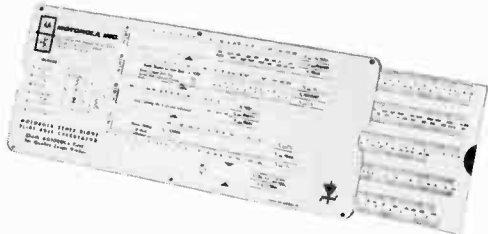
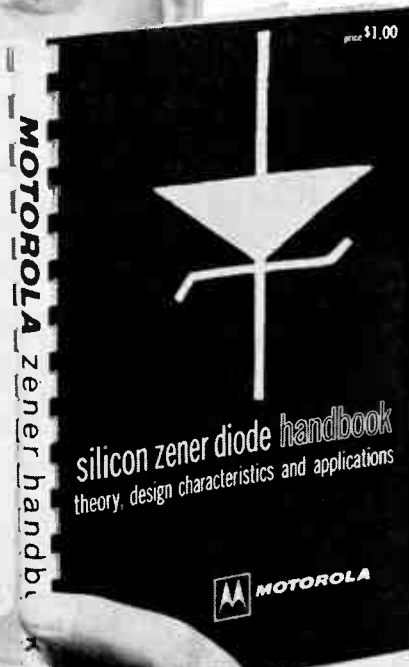

SPECIAL SLIDE RULE AVAILABLE

For rapid calculations involved in designing circuit configurations with Motorola Zener Diodes, use this special zener slide rule. It handles most design problems in zener applications. Available from your Motorola Semiconductor Distributor for just \$1.

MOTOROLA SEMICONDUCTOR DISTRIBUTORS

- ALAMOGORDO..... Radio Specialties, 209 Penn Ave.
 BIRMINGHAM..... Ack Radio Supply Co., 3101 Fourth Ave., So.
 BOSTON..... Cramer Electronics, Inc., 811 Boylston St.
 CAMDEN..... General Radio Supply Co., 600 Penn St.
 CEDAR RAPIDS..... Deeco Inc., 618 First St., N. W.
 CHICAGO..... Allied Radio Corp., 100 N. Western Ave.
 Newark Electric Co., 223 W. Madison St.
 CLEVELAND..... Main Line Cleveland Inc., 1260 E. 38th St.
 DENVER..... Denver Electronic Supply Co., 1254 Arapahoe St.
 DETROIT..... Radio Specialties Co., 456 Charlotte Ave.
 HOUSTON..... Lenert Co., 1420 Hutchins
 JAMAICA, N. Y..... Lafayette Radio, 165-08 Liberty Ave.
 LOS ANGELES..... Kierulff Electronics, 820 W. Olympic Blvd.
 MELBOURNE, FLA..... Electronic Supply, 909 Morningside Dr.
 MIAMI..... Electronic Supply, 61 N. E. 9th St.
 NEW YORK..... Milgray Electronics, 136 Liberty St.
 Lafayette Radio, 100 6th Ave.
 OAKLAND..... Elmar Electronics, 140 11th St.
 PHOENIX..... Radio Specialties, 917 N. 7th St.
 SAN DIEGO..... San Delco, 3821 Park Blvd.
 WASHINGTON, D. C. Electronic Industrial Sales, 2345 Sherman Ave., N.W.

FOR TECHNICAL INFORMATION on Motorola zener diodes and for details on recent price reductions, contact your nearest Motorola Semiconductor regional office:

- | | | |
|---|--|--|
| RIDGEFIELD, N. J.
540 Bergen Blvd.
Whitney 5-7500
(from New York, WI 7-2980) | CHICAGO 39, ILL.
5234 W. Diversey Ave.
Avenue 2-4300 | HOLLYWOOD 28, CALIF.
1741 Ivar Ave.
Hollywood 2-0821 |
|---|--|--|

Outside U. S. and Canada: MOTOROLA INTERNATIONAL, S. A.
4545 W. Augusta Blvd., Chicago, Ill.



"DEPENDABLE QUALITY—IN QUANTITY"

MOTOROLA SEMICONDUCTORS

MOTOROLA, INC., 5005 E. McDOWELL, PHOENIX, ARIZONA

RELIABLE ALWAYS ... ALWAYS AVAILABLE!

Specify

WBD

Precision Alloys

...unexcelled

engineering / production facilities

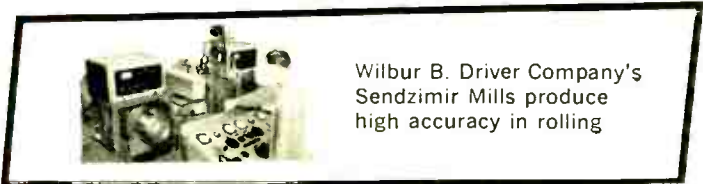

Wilbur B. Driver Company's Sendzimir Mills produce high accuracy in rolling



The WBD vacuum melting installation is the largest in the industry



This entire building is devoted to research and engineering at WBD

Specifying WBD precision alloys means quality alloys delivered quickly, in the quantities you require. Backing up the WILBUR B. DRIVER reputation for reliable performance are two complete manufacturing plants, a fully-equipped research and engineering facility, sales offices and warehouses strategically located across the nation, and in Canada. When you need alloys - in wire, rod, ribbon or strip - check with WBD for complete dependability!

...plus fast service nation-wide

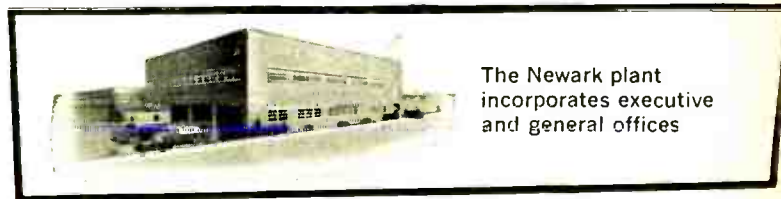

The Newark plant incorporates executive and general offices

WILBUR B. DRIVER CO.

NEWARK 4, NEW JERSEY
Telephone: HUmboldt 2-5550

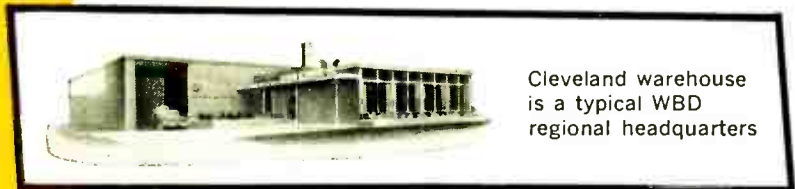

Cleveland warehouse is a typical WBD regional headquarters

Branch Offices and Warehouses in Principal Cities. Manufacturing Plants: 1875 McCarter Highway, Newark 4, N. J. 2734 Industrial Way, Santa Maria, California. Canadian Wilbur B. Driver Co., Ltd., Rexdale (Toronto), Canada.



West coast manufacturing plant located in Santa Maria, California



Precision Electrical, Electronic, Mechanical and Chemical Alloys for All Requirements

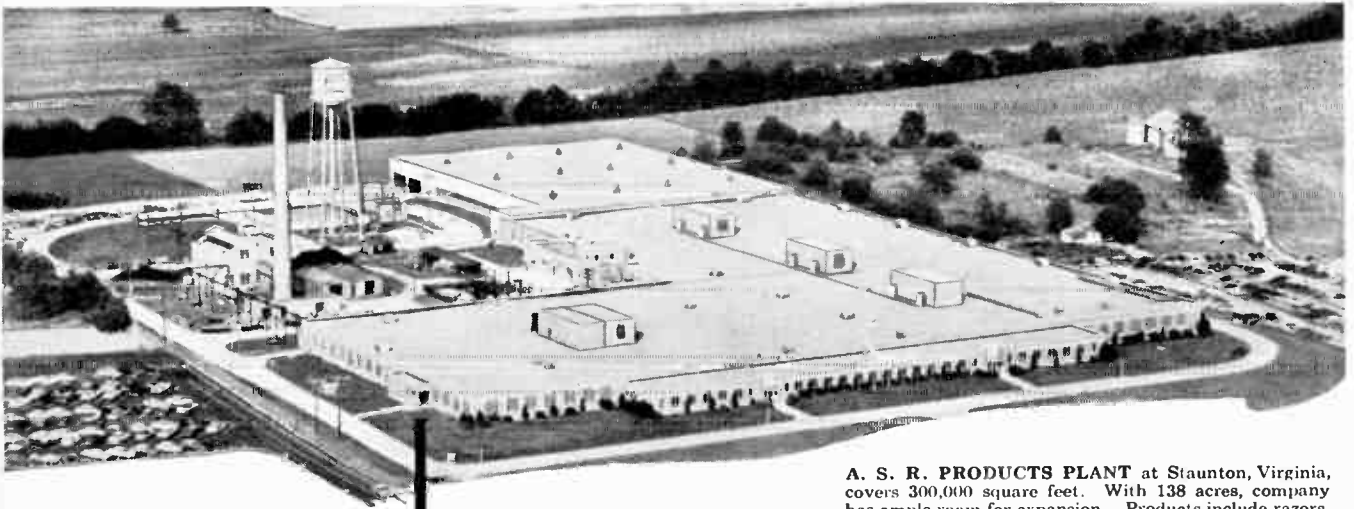

A. S. R. PRODUCTS PLANT at Staunton, Virginia, covers 300,000 square feet. With 138 acres, company has ample room for expansion. Products include razors, blades, plastics, sterile surgical blades, carpet industry blades.

"Productivity has never been so good. Absenteeism has never been so low."

says A.S.R. Products Corporation
after its move to Virginia



NATIONAL SAFETY AWARD has been won by the plant for the past two years. Virginians learn new skills quickly. For example, A. S. R. is now training its own tool and die makers at the plant.



TRANSFERRED EMPLOYEES love the good living and mild climate . . . enjoy the hunting, fishing and outdoor life. Executives are Virginia enthusiasts, too.

To make way for a proposed civic center, A. S. R. Products had to relocate their plant. After receiving bids from 50 to 60 localities, the company made a thorough study of 20 to 25 sites. Department heads visited the various sites and reported on taxes, transportation, power, water and many other factors. Employing almost 1000 people, special attention was given by A. S. R. to availability of man-

power, the number of schools and churches, housing . . . everything pertaining to people. After adding up the "score" on each site, Staunton, Virginia, won hands down. Among the deciding factors were Staunton's excellent location as a distribution center and Virginia's tax laws which, considered in their entirety, were found to be very reasonable.

Highest production ever

But it was *after* the move that the real wisdom of this choice became apparent. With almost 200 employees transferred and another 800 hired locally, productivity jumped so sharply that A. S. R. is hesitant to release the figure. They will admit that absenteeism is 1.8% compared to a national average of around 5%.

In the words of an A. S. R. executive, "It's been almost too good to be true."

Let us tell you more about the high productivity, the dependability of people in Virginia . . . and about the many other advantages of locating in this state. In confidence, phone, wire or write . . .

These Companies Benefit From PLANTS IN VIRGINIA

- General Electric Co.
- I. T. & T. Corp.
- Dow Chemical Co.
- Babcock & Wilcox Co.
- Sperry Piedmont Co.
- American Oil Co.
- Allied Chemical Corp.

Ask Them Why They Chose Virginia!

C. M. Nicholson, Jr., Commissioner
DIVISION OF INDUSTRIAL DEVELOPMENT

Virginia Dept. of Conservation and Economic Development
State Office Building, Richmond, Va., Telephone: Milton 4-4111 Ext. 2255

You, too, can find these... and many other great competitive advantages in

Whatever The Season, There's Always A Reason To Visit Virginia

World Radio History

VIRGINIA

E

ngineering SUPERIORITY

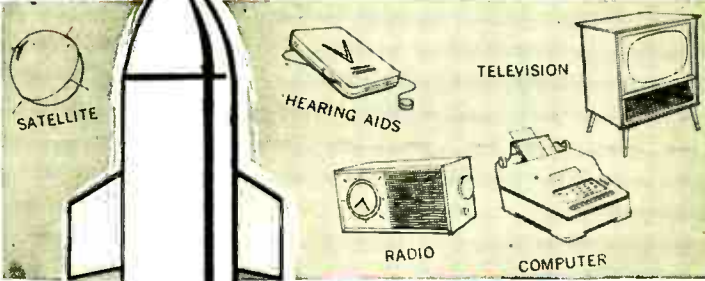

builds
SUPERIOR RELIABILITY

into . . .

El-Menco Dur-Mica CAPACITORS

**QUALITY MATERIALS • PRODUCTION INTEGRITY • "BUILT-IN" RELIABILITY A FACT!
UNSURPASSED PERFORMANCE PROVED IN EXHAUSTIVE LIFE TESTS!**

El Menco's advanced engineering vision . . . its rigid adherence to use of the finest grade materials . . . its complete and exhaustive "Debugging" Tests . . . make El Menco Dur Micas the unchallenged leaders in capacitor reliability.

Only the highest-quality materials, only the finest India Ruby Mica films, pretested to have the highest insulation resistance, greatest dielectric strength, lowest dissipation factor, are used.

El Menco's dominance in reliability has been proved beyond a doubt through "OPERATION DEBUGGING" — the removal of early failures by subjecting mica capacitors to a short life test at elevated voltage and temperature . . . DM30, 10,000 MMF, "Debugged" El Menco Dur-Mica Capacitors, subjected to 257,000 hours of life at 85°C with 100% of the rated DC voltage applied turned in a computed record reliability performance of APPROX. 0.6% CUMULATIVE FAILURES OR ONLY 1 FAILURE PER 43 MILLION UNIT-HOURS!

El Menco Dur-Mica Capacitors have proved their powerful performance under accelerated conditions of 1½ times rated voltage at ambient temperatures of 125°C and 150°C — proving longest life, greatest stability, finest performance.

DM15, DM16, DM19, DM20, DM30, DM40, DM42, DM43 — perfect for extreme miniaturization; ideal for new miniaturized designs and printed wiring circuits. New "hairpin" parallel leads insure easy applications. El Menco Dur-Micas meet and exceed all humidity, temperature and life requirements, including military specs.

Write for
FREE sample
and catalog
on your
firm's letterhead.

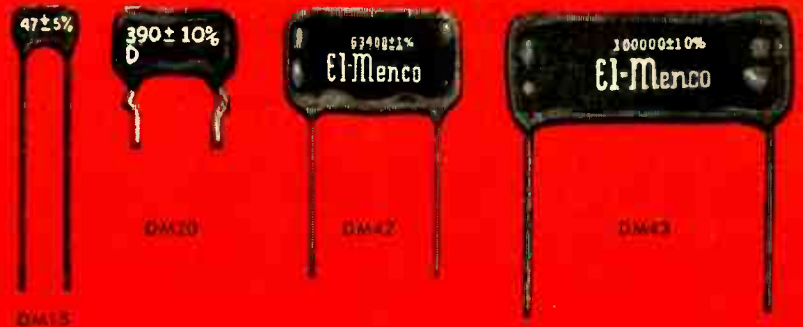

FROM GIANT COMPUTERS TO TINY TRANSISTOR RECEIVERS TO COMMUNICATION EQUIPMENT ON LAND, SEA AND IN THE AIR . . . EL MENCO DUR MICAS DO THE JOB BEST!

THE ELECTRO MOTIVE MFG. CO., INC.

Manufacturers of El-Menco Capacitors

WILLIMANTIC CONNECTICUT

- molded mica • dipped mica • mica trimmer • dipped paper
- tubular paper • ceramic • silvered mica films • ceramic discs

Arco Electronics, Inc., 64 White St., New York 13, N. Y.
Exclusive Supplier To Jobbers and Distributors in the U.S. and Canada

El-Menco
Capacitors

**Build extra value
into
Citizens Band radios
with Mallory vibrators**

Mobile, two-way Citizens Band radios bring new simplicity and convenience to communication for thousands, and open brand new markets for you.

If you're now building Citizens Band radios or planning to, Mallory vibrators deserve a place in your power supply design. Their exceptionally long life, quiet operation and constant output are the result of more than 25 years of Mallory pioneering in vibrator design. More Mallory vibrators have been used in mobile radios than all other makes combined. Mallory engineers have helped develop efficient, economical power supply circuits for many set manufacturers.

Make use of this experience. Let Mallory help you choose and apply the vibrator model that best fits your needs, as well as assist in the design of your power supply circuitry. Write today for a get-together with a Mallory vibrator specialist.

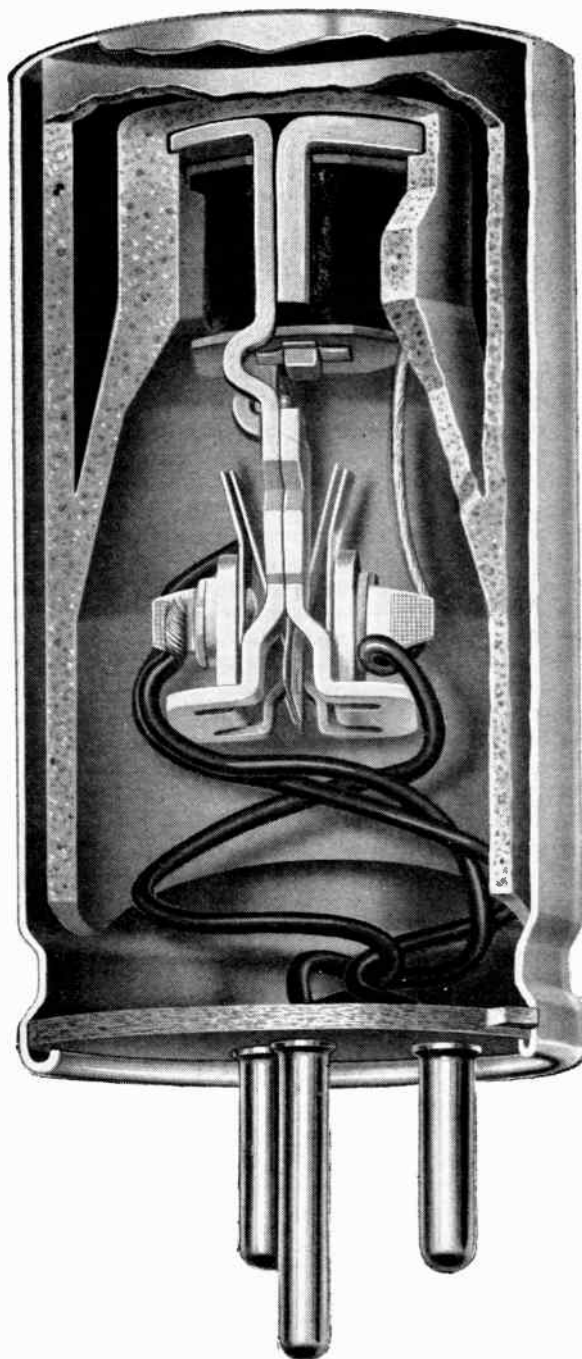

Series 1600 Vibrator

Contact buttons have been eliminated for far greater contact area . . . lower rate of erosion . . . steadier voltage . . . and an end to contact sticking. Light mechanical mass of vibrating reed assures quiet operation.

Elkon Division, Du Quoin, Ill.
Electromagnetic Department

P. R. MALLORY & CO. Inc.
MALLORY

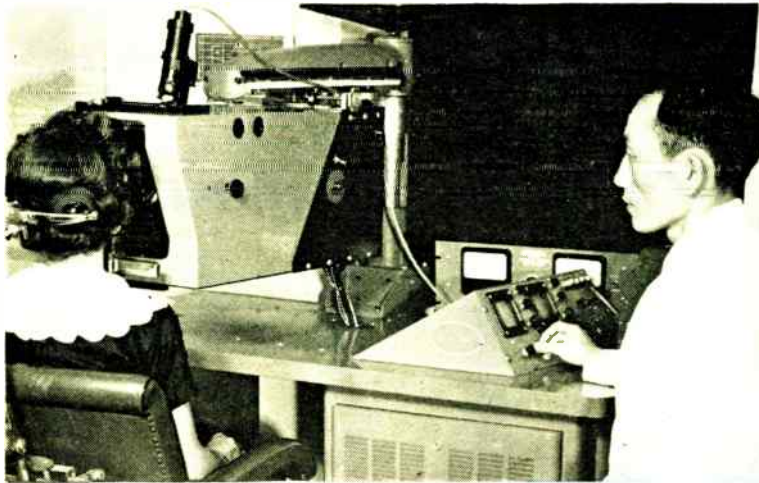

FRONT COVER — Shows pupillograph observing the pupillary action of a patient

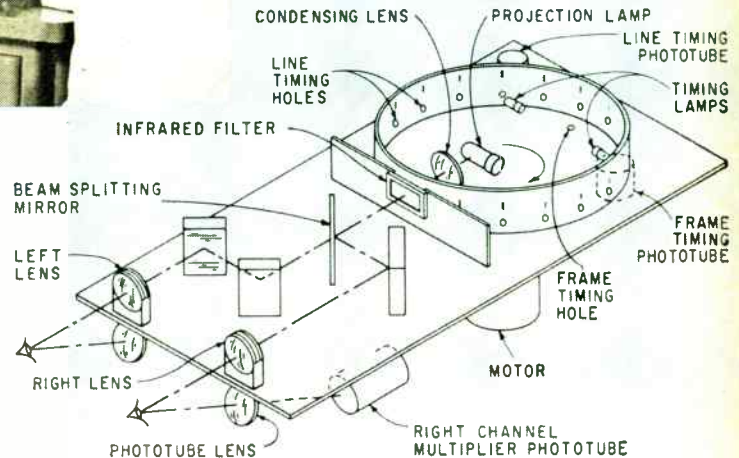

FIG. 1—Basic optical system without stimulation lamp uses a 500-w projection lamp operated at 90 percent of rated voltage to prolong its life

Recording Pupil Changes For Clinical Diagnosis

Movements of the pupil of the eye are accurately measured by electronic pupillograph. Device uses phototube to eliminate delays in obtaining data. Its direct writing feature makes it particularly valuable for clinical use

By **GEORGE W. KING**, General Precision Laboratory, Pleasantville, New York

AN ELECTRONIC PUPILLOGRAPH designed for clinical use in the recording and analysis of movements of the pupil of the eye has been developed. The measurement of these pupillary changes provides valuable information about the condition of the brain stem. Earlier pupillographs have involved complex, time-consuming operations making them unsuitable for clinical applications.

This instrument incorporates accuracy with its direct-writing capability. It can plot pupillary diameters with a maximum error of 1 percent of full

scale. The visible energy required at the patient's eye is so low that his dark adaption is not disturbed.

A scanning unit, amplifier-detector, and recorder are the pupillograph's three major components. The scanning unit is a flying-spot device in which a rotating drum with slits in its periphery is used for scanning the eyes and providing timing pulses for a cathode-ray tube monitor. In the amplifier-detector unit, the signals resulting from scanning the two eyes are amplified and converted to d-c analog voltages proportional to pupil diameter. These voltages are

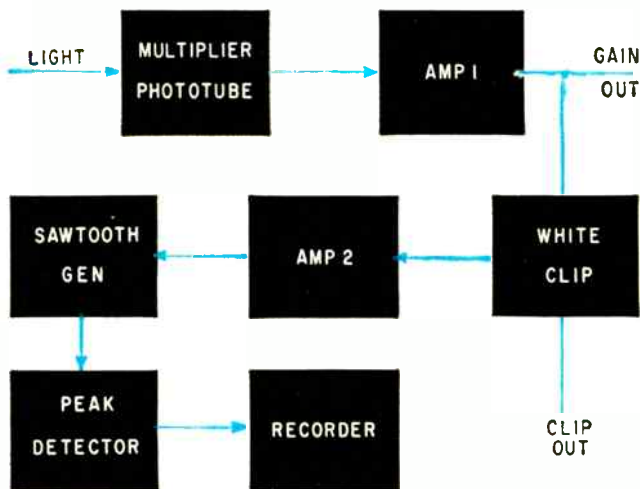

FIG. 2—Block diagram of single channel of two-channel measuring system shows provision for observing the waveform either before or after clipping

recorded as a function of time by two recorders. Power supplies and operating controls are in the desk which houses the amplifier-detector unit and supports the scanning unit.

SCANNING UNIT—Scanning of the 20-line, 30-frames-per-second raster is accomplished by slits in the periphery of a 10-in. diameter drum driven by a synchronous motor at 1,800 rpm. The scanned area is about 1½ in. wide by ¾ in. high at the drum, and each scanning slit is 0.060 in. high and 0.015 in. wide. The scanned area is evenly illuminated by a 500-watt projection lamp and f/2 condensing system mounted inside the scanning drum as shown in Fig. 1. The scanning slits are imaged by two high quality 3-in. focal length f/2.3 lenses onto the irises of the patient. Optical reduction makes the scanned area about 14 by 7 mm at the iris. The optical path is split by a half-silvered mirror so there can be no geometrical dissimilarity in the scanning of the two eyes.

A Wratten infrared transmitting filter is placed ahead of the beam-splitting mirror so the scanning energy is essentially invisible to a dark-adapted patient. The mirror and lens for the right eye are mounted to provide adjustment of interpupillary distance and to accommodate different elevations of right and left eye. The entire scanning unit is mounted on a crane which allows adjustment for the height of the seated patient and for optical focus.

Energy reflected from the scanned area of the patient's eyes is almost entirely diffused. A portion of this energy is picked up by an infrared-sensitive phototube through a simple lens. This lens roughly focuses the scanned area of the eye on the photocathode of the proper phototube and prevents interference from the opposite channel. The pickup lens is located below the optical axis of the scanning system to make sure mirror-like reflections from the surface of the cornea occur below the elevation of the scanning line which most nearly covers the horizontal diameter of the pupil.

The upper part of the scanner has dual reflective

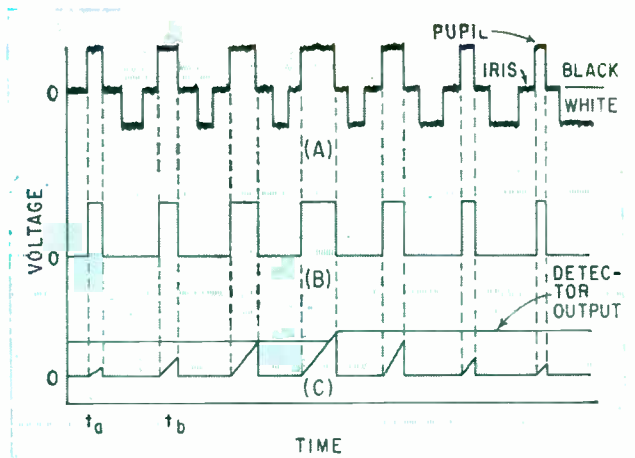

FIG. 3—Voltage waveforms show phototube output (A), phototube output clipped and amplified (B), and the sawtooth and detector output (C). Time lapse between t_a and t_b is 1.67 milliseconds

optical paths for each eye, which are used for insertion of the optical stimulation signals and for providing a red light for fixation of the gaze at a distance of 36 in.

CIRCUIT OPERATION—The system consists of two identical channels; a block diagram of one is shown in Fig. 2. The voltage waveforms are drawn in Fig. 3. The video signal is amplified by a direct coupled stage, V_1 in Fig. 4. The white portion of the phototube output (waveform A) is clipped by V_{2a} and amplified by a cathode follower for transmission to the amplifier and detector chassis.

Diode D_1 and its associated resistors reduce the gain of the signal channel for signals representing regions somewhat lighter than the iris. This nonlinear load and the reverse-connected diode V_{2b} prevent any large transient signals from the whites of the eyes from causing false back impulses by capacitance coupling across V_{2a} . Gain for the signal channel is controlled by changing the supply voltage for the dynodes of the multiplier phototube.

AMPLIFIER-DETECTOR UNIT—The amplifier-detector contains two identical measuring channels, each of which has wave shaping and detector circuits. Each channel produces an output voltage proportional to the diameter of the pupils by peak detection of sawtooth voltages whose amplitudes are proportional to the time required for the scanning spot to move across the pupil of the eye.

The signal from the pupil is amplified and clipped both top and bottom by V_3 which drives the switch or gate tube, V_{1a} . Tube V_3 sets the potentials in the sawtooth generator circuit during the time when the scanning spot is at any point other than the pupil. While the spot is traversing a pupil, V_{1a} is cutoff, and the grid potential of V_{1b} rises linearly. The charging current for C_1 is constant because the top of the charging resistor, is bootstrapped by capacitance coupling to the cathode of V_{1b} . Cathode follower V_5 also provides a low-impedance source to drive the

Designing Highly Stable Transistor Power Supplies

Summary of design techniques used in making extremely stable low-voltage power supplies for transistor circuits. Final circuit described has overall stability of plus or minus 250 microvolts and overall drift of less than 40 microvolts per hour

By E. BALDINGER and W. CZAJA, Institute of Applied Physics, University of Basle, Switzerland

CONVENTIONAL TRANSISTOR-STABILIZED power supplies use either shunt or series regulation. If the rectifiers and line transformer are suitably designed, the shunt-type circuit cannot be damaged by short circuits at the output terminals. The rectifier of the shunt-type circuit may be designed to have high efficiency and low cost since it operates at constant load. With no load, a high collector dissipation may occur within the shunt transistor. This may be prevented by

using a suitable collector resistor which in no way influences the properties of the device. The low overall efficiency (approximately 40-percent) is a disadvantage.

In the series regulator, additional circuits must be used to prevent overload or damage to the series transistor. The control range at high voltage is limited by the maximum ratings of the series transistor as the absolute values of voltage variations increase with increasing input voltages. For a

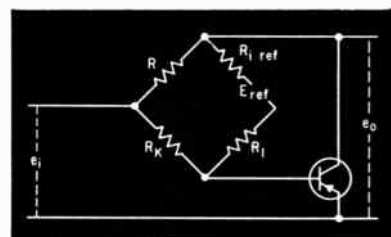

FIG. 3—Compensation of a shunt-type power supply

variable load, the rectifier internal resistance makes an important contribution to the input voltage variations that have to be controlled.

The circuits to be described show methods of improving circuit performance so that highly stable power supplies having an overall stability of $\pm 250 \mu\text{v}$ and overall drift of less than $40 \mu\text{v}/\text{hour}$ at outputs up to 17 volts can be designed.

Basic Circuits

Basic series and shunt regulating circuits are shown in Fig. 1. The stabilization factor η is defined as the relative change in input voltage e_i to the change in output voltage e_o produced.

The expressions for the stabilization factor η and the internal re-

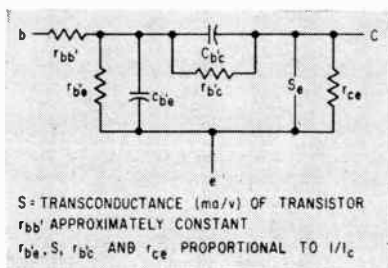
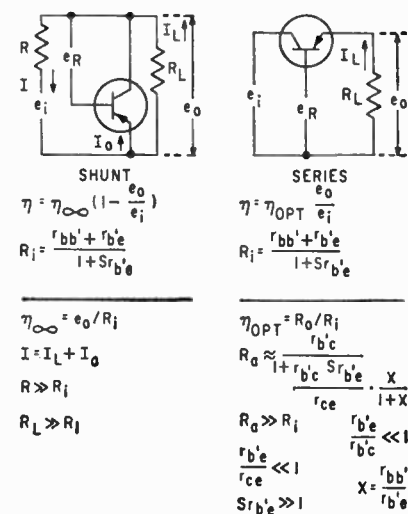

FIG. 2—Hybrid π transistor equivalent

FIG. 1—The two principal stabilizing circuits, shunt (left) and series (right)

ance input was provided for the first stage. Zener diode D_1 , together with compensation, prevents variation of the controlled chamber temperature due to variations of supply voltages. The internal temperature may be varied by changing the operating point of the temperature-sensing transistor. The temperature control device used in Fig. 9 has a controlled temperature of approximately 40 degrees C. A temperature stabilization ratio of $\Delta T_{\text{ambient}}/\Delta T_{\text{internal}} \approx 40$ to 50 has been achieved. The overall drift of the controlled temperature of 40 C over a period of one year is 0.4 C. Conventional carbon resistors were used and no selection was made of the transistor. The circuit shown in Fig. 9 has a variable output between 1 and 17 v, an internal resistance of 1.7×10^{-1} ohm at d-c and less than 0.05 ohm at 500 kc, a temperature coefficient of 0.1 mv/degree C and a ripple voltage of 0.1 mv peak to peak maximum.

After turning on, 4 to 5 hours are required until equilibrium temperature is reached. From that time, the overall drift over a 15 hour period was 36 $\mu\text{v}/\text{hour}$ at an output of 6 v.

The circuit shown in Fig. 9 is basically the same as that shown in Fig. 5 with a different reference source. A prestabilizer controls the temperature controller as well as a stabilizing circuit which serves as the voltage reference source.

Characteristics

Figure 10 shows the power supply output voltage plotted against input line voltage changes and loading. The major part of the short-term fluctuations is due to small temperature differences (0.05 C or less) within the thermostat.

Figure 11 shows the stabilized power supply compared with a lead-acid storage battery. Both the power supply and the battery were loaded. The long time period which the battery needs to establish equilibrium after load removal is typical.

The lead-acid storage battery has a time constant of about $\frac{1}{2}$ to $\frac{3}{4}$ hour resulting from the time required for diffusion of the chemical reaction products between the plates until equilibrium is reached.

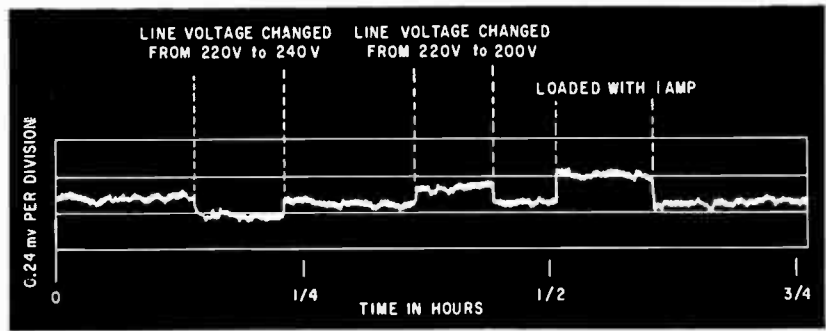

FIG. 10—Output characteristics of improved stabilized power supply

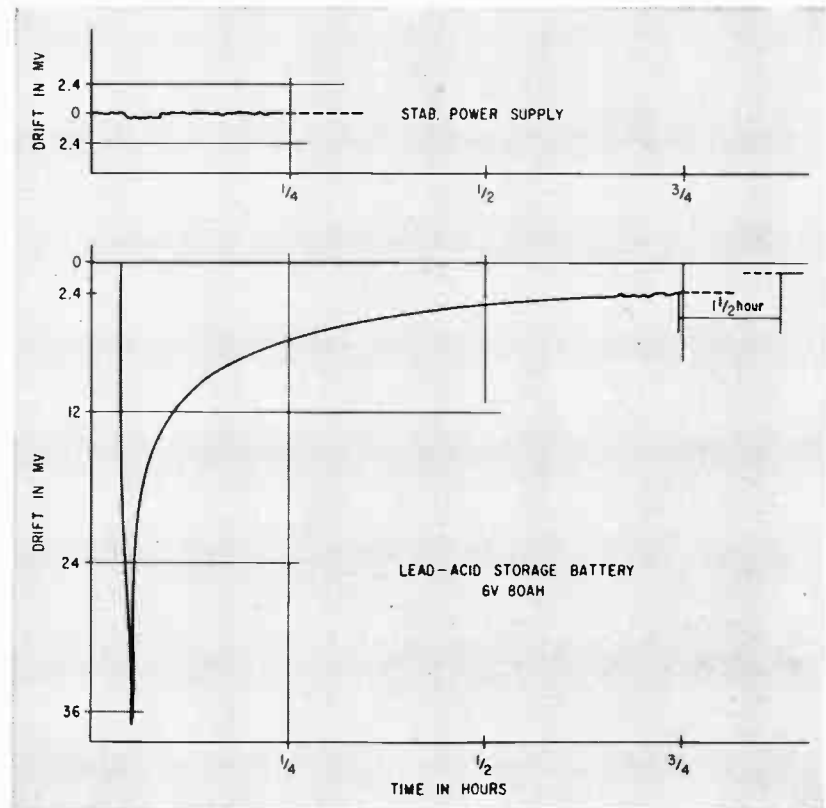

FIG. 11—Output characteristics of improved power supply compared with lead-acid battery (both 6 v)

During the preparation of this article, an American voltage reference (see last entry in Bibliography) was called to the authors' attention.

This device has excellent stability and temperature coefficient, the output voltage is practically constant but the output current is much smaller having a maximum of 100 milliamperes.

There are a number of applications for this highly-stable power supply where up to the present, only lead-acid batteries connected in parallel with a power supply of poor regulation have been used.

Further consideration of the

above described circuits show that this highly-stable power supply can be improved still further.

REFERENCES

- (1) E. J. Giacoletto, *RCA Rev.* 15, p 506, 1954; J. Zawels, *J. Appl. Phys.* 25, p 976, 1954; E. Baldinger, W. Czaja and M. A. Nicolet, *Zeitschrift für Angewandte Mathematik und Physik (ZAMP)*, 7, p 357, 1956.
- (2) E. Baldinger and W. Czaja, *ZAMP*, 9, p 1, 1958.
- (3) R. D. Middlebrook, *Proc IRE*, 45, p 1502, 1957.
- (4) E. Baldinger and A. Maier, *ZAMP*, 9, p 289, 1958.

BIBLIOGRAPHY

- M. E. Pemberton, *Marconi Rev.* 30, 125, p 39, 1957.
 W. W. Gartner, *Proc IRE*, 45, p 665, 1957.
 W. Cuggenbuhl and B. Schnieder, *Archiv für Elektrische Übertragung*, 10, p 361, 1956.
Rev. Scientific Inst., 30, p 211, 1959.

Here's a time delay relay that is adjustable. It can replace synchronous timers in industrial control circuits. Accurate relay has instant recycling

By LEON SZMAUZ and HAL BAKES, Engineering Dept., Heinemann Electric Company, Trenton, New Jersey

Transistor Time Delay

AN ADJUSTABLE time delay relay using transistors has been developed for use in various industrial or other processes. Advantages of the relay are timing repeatability and instant recycling.

These factors provide for maximum speed in automatic operations and cut production time.

One application of the relay is automatic cycling, where the relay can be used to endurance test other

relays and contactors. In other applications the relay can be used to replace synchronous timers, with a consequent saving in space, weight and cost. Delay periods between 1.5 sec and 30 sec are possible. The photograph shows a number of the relays used in an automation setup where a small brass tube goes through the operations of spinning, fluxing, placing solder and brazing. A considerable saving is effected since these operations previously required much handling and personal judgment.

Basic Operation

In a typical application, the user connects 12 volts d-c to the input with an external switch. The circuit is shown in Fig. 1. As soon as switch S closes, transistor Q_1 conducts, charging capacitor C_1 through the normally closed contacts of K_1 . Charging rate is controlled by variable resistor R_v . To simplify analysis, other charging resistances will not be considered. Transistor Q_2 is cut off by the action of Q_1 , and relay K_1 is held de-energized. When the current in the $R_v C_1$ network has dropped to approximately 37 percent of its maximum, Q_2 acts as a switch to connect K_1 across the supply. This actuates the relay which remains closed until the supply voltage is broken.

An extra set of contacts on the relay connects R_d across C_1 , thus discharging the capacitor preparation for the next cycle. When the 12-volt supply is broken, the circuit is instantly ready for another time

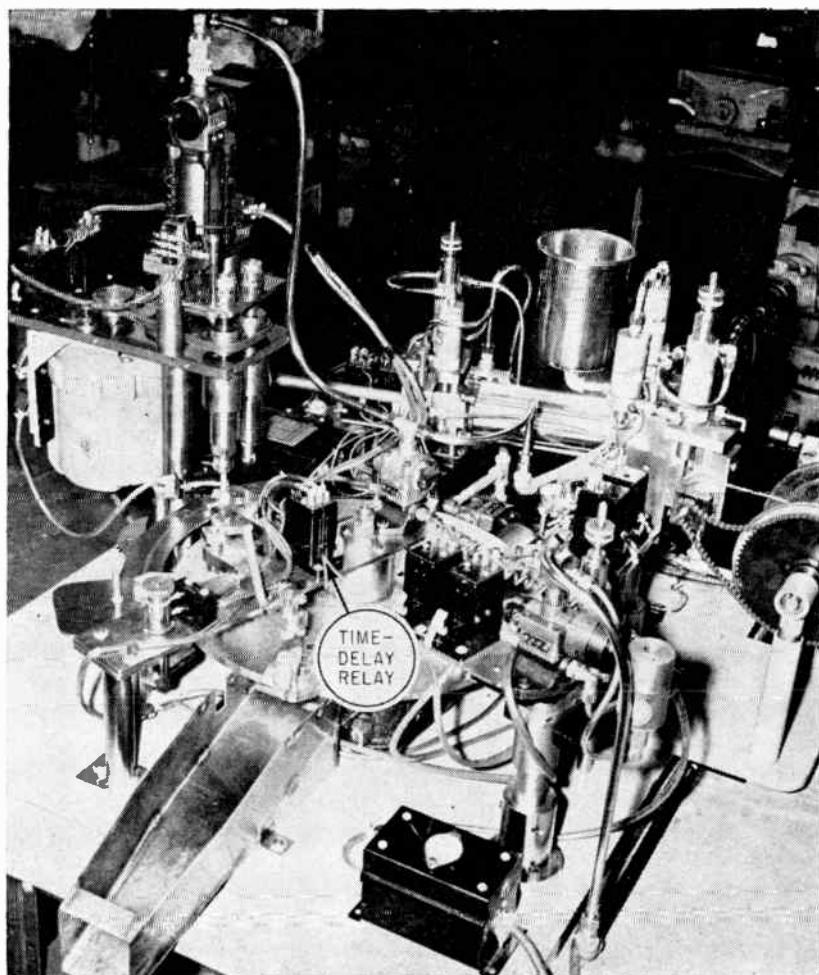

A number of the transistorized time delay relays are used to control a movable table for automatically processing a small brass tube

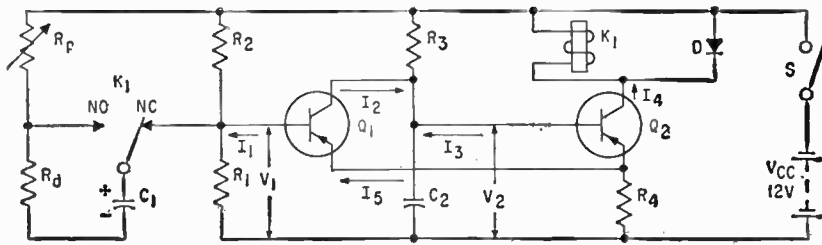
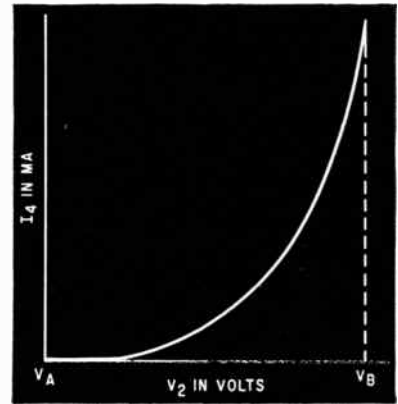

FIG. 1—Time delay begins when S is closed. Charging current of C_1 through R_p and Q_1 controls the circuit. Transistor Q_2 is held cut off until C_1 charges to the time-delay-setting voltage

FIG. 2—Relay current is a function of V_2 . Relay turn-on point occurs between V_A and V_B



for Industrial Control

delay cycle.

The circuit consists of two directly coupled alloy-junction, germanium transistors. Since Q_1 (Fig. 1) serves as a driver and Q_2 as a switch, the collector saturation voltage of Q_1 must be lower than its base to emitter drop. That is, when Q_1 is saturated, voltage V_2 must be sufficiently low that Q_2 is effectively cut off.

Because of direct coupling, the collector voltage of Q_1 is the same as the base voltage of Q_2 , as can be seen in Fig. 1. By varying the collector voltage of Q_1 , the bias voltage

saturation conditions. When Q_2 is saturated, maximum current is flowing through the relay. Under these conditions, Q_1 is not conducting since its base current has fallen to zero (except for a small bias current) because C_1 is not in the circuit. The maximum collector current of Q_2 is $I_4 = \beta I_3 = V_{cc}/R_L$. But the maximum value I_3 can have is V_{cc}/R_3 . From these equations it can easily be shown that R_3 must be less than βR_L if I_4 is to reach a specified value.

Timing Circuit

The simplified timing circuit consists of R_p in series with C_1 . The time delay period begins when external switch S is closed. A charging current begins to flow into C_1 , and into the base circuit of Q_1 . Transistor Q_1 conducts and holds the base to emitter voltage of Q_2 to a low value. As C_1 charges, the current through Q_1 decreases and the base voltage of Q_2 rises.

Base current of Q_1 , ignoring bias current, is given by $I_1 = (V_{cc}/R_p) e^{-t/R_p C_1}$. The initial base current is $I_{max} = V_{cc}/R_p$. This value of current is much greater than that needed to hold Q_2 at cutoff. Base current I_1 will decrease exponentially as shown in Fig. 3. For fast switching and good timing accuracy, it is desirable that Q_2 turn-on conditions be reached while I_1 is still changing rapidly. This condition is met when the time delay period is approximately equal to the time constant of the network, or $T \cong R_p C_1$.

Because of the variation of parameters of production lot transistors, some experimentation with component values may be required if the best performance of the circuit is to be obtained. The circuit of Fig. 1 is stabilized against minor temperature changes. Thus, for the condition $R_2 \gg R_1 \gg R_4$, the current through R_2 is essentially constant for a given supply voltage. When the emitter current of Q_1 increases because of an increase in temperature, the voltage across R_1 and R_2 increases. The current through R_1 is therefore larger since the voltage drop across it is larger. Since the current through R_2 is constant, base current I_1 must decrease. The decrease in I_1 will then act to decrease I_2 and I_3 .

If wide temperature swings are expected, compensation can be obtained with nonlinear elements and temperature sensitive resistors.

A diode is placed across the relay coil to prevent inductive transients which would otherwise appear when switch S is opened. Capacitor C_2 at the base of Q_2 acts as a low pass filter and keeps any sudden changes from being applied to Q_2 and thus accidentally triggering the relay.

Resistor R_d has a low value and is used to discharge C_1 as soon as the relay operates, thus readying the circuit for the next operation.

For appreciable time delays, electrolytic capacitors have to be used. Tantalum electrolytics should be used since they are more stable than the aluminum type.

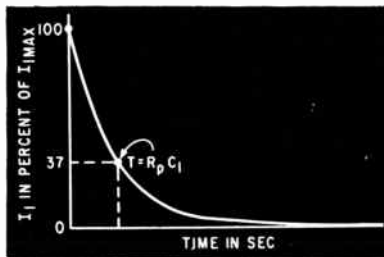

FIG. 3—Charging current of C_1 and thus base current of Q_1 follows typical exponential curve

of Q_2 will vary from V_A to V_B , as shown in Fig. 2. If V_A is the voltage just below or equal to the base cutoff bias, and V_B is the forward bias at saturation, Q_2 will switch the relay ON at some intermediate voltage.

The relay coil and the supply voltage are chosen to give rated relay current $I_4 = V_{cc}/R_L$, where R_L is the d-c resistance of the relay.

Resistor R_3 is determined from

Electronic Commutators in

Variety of sampling speeds and signal capacities are covered by production models of electronic commutators. Here is a listing of representative types

MULTIPLEX TELEMETERING systems of the time-division type require at least two commutators: one at the transmitter to sample the data to be transmitted and another at the receiver to decommutate the data so it can be displayed.

Most of the electronic commutators listed here can be used for pam/f-m, pdm/f-m or pdm/p-m time-sharing systems. An extremely large number of commutating systems is conceivable, but most practical telemetering needs can be met with a few simple methods.

Most commonly-used systems are included in the Inter-Range Instrumentation Group (IRIG) recommendation.^{1,2} A survey of telemetering methods, equipment and applications, which includes a glossary of terms, is also referenced.³

MODULATION METHODS—Pulse duration modulation systems (pdm) are suitable when all the measured parameters are changing slowly and time-sharing is feasible. Each time the output of the transducer is sampled, a pulse of duration proportional to the value of the sample is generated. These pulses then serve to modulate the radio-frequency transmitter.

Pulse amplitude modulation systems (pam) are also useful when the parameters are slowly changing. A pulse of amplitude proportional to the sample value is generated as a subcarrier and, again, modulates the r-f transmitter.

Table I—Typical Specifications for an Electronic Commutator

Characteristic	Specification
Duty Cycle	50 percent
Number of Channels	45
Sampling Speed	900 samples per second
Input Signal	0 to 5 volts
Output Signal	6 volts peak-to-peak
Output Load	1 megohm
Accuracy	1 percent
Linearity	0.25 percent of full-scale from best straight line
Crosstalk	0.1 percent of full-scale range
Noise	0.01 percent of full-scale range
Dimensions and Weight	5×3×4 inches, 2.5 pounds

Key to Manufacturers

- ARN Arnoux Corp.
- ASC Applied Science Corp. of Princeton
- BUR Burroughs Corp., Electronic Tube Division
- EMR Electro-Mechanical Research, Inc.
- GDI General Devices, Inc.
- PBI Packard Bell Co.
- TEL Telechrome Manufacturing Corp.

COMMUTATOR OPERATION—A typical electronic commutator has a master oscillator which drives a broken ring binary counter. The counter, in turn, sequentially drives diode gate matrixes. The diode gates are opened and closed each time a pulse is received from the master oscillator through the counter.

The level of the signals is raised 10:1 by d-e amplifiers. After gating, the common output signal is further amplified by a factor of 10. Frame synchronization is provided once for each complete ring sequence.

The commutator is housed in a small package and can be used for missile applications. External power and signal connections are made through a flush-mounted connector. Silicon diodes, transistors, or both, are used for all circuits. Modular construction may be employed.

Specifications for this typical unit might be as shown in Table I. Actual specifications for several of the commercially-available electronic commutators are given in Table II.

The list is not intended to be all-inclusive. In addition to solid-state types, beam-switching tube types are made.

Among the advantages of electronic commutators are, generally, high operating speed, low power consumption for a given application and long life due to the absence of moving parts.

REFERENCES

- (1) Inter-Range Telemetry Working Group, Inter-Range Instrumentation Group Recommendation No. 102-55, IRIG Secretariat, White Sands Proving Ground, 1955.
- (2) M. H. Nichols and L. H. Rauch, Appendix 14 (same as reference 1), "Radio Telemetry", John Wiley and Sons, New York, 1956.
- (3) A. A. McKenzie and H. Manoogian, Telemetering, ELECTRONICS, 29, p 153, April, 1956.

Multiplex Telemetry

By **ARTHUR S. KRAMER**, Senior Technical Specialist, Allen B. DuMont Laboratories, East Paterson, N. J.

Table II—Characteristics and Suggested Applications of Some Typical Electronic Commutators

Mfgr Model	Duty Cycle	Channels	Samples	Input (IN) and Output (OUT) Characteristics	Accuracy (A), Linearity (L), Crosstalk (C), or Noise (N)	Suggested Applications
DIODE-TRANSISTOR TYPES						
ARN Series pam 30	50 ±5%	30	900 per sec	IN: 0-5 v full scale, 0-25 K source impedance with filtering OUT: into any subcarrier osc with source impedance of 500 K ±50 K	L: within ±0.1% of full-scale range (fsr) C: 0.01 % of fsr; N: peak-to-peak, <0.01% fsr	pam telemetry
ARN Series pdm 90	45 ±5%	90	900 per sec	IN: same as PAM 30 OUT: 5-v input signal gives output pulse train of 6-6.5-v peak-to-peak amplitude	L, N: same as PAM 30 C: <0.1% of fsr	pdm/f-m or pdm/p-m telemetry
ASC EC-5800	50%	90	0-1,000 per sec	IN: -2.5 v to +2.5 v and 0-5 v signal amplitude OUT: recommended load impedance 10 Meg	A: 1% or better L: ±0.25% C: 1 mv N: 1 mv	pam and pdm telemetry
GDI Hi-Lo Level	10 to 90%	Lo 6 to Hi 10	to 10,000 per sec	IN: Lo, ±5 mv fs; Hi, ±5 v fs; input impedance >50 K OUT: Hi, >50 K impedance	A: Lo, 0.5%; Hi, 0.1% L: Lo, 0.2%; Hi, 0.1% C: Lo, 80-db down; Hi, <0.1% N: Lo, 30 μv; Hi, 1 mv	digital data logging
TEL 1480-A		45	900 per sec	IN: 2 sync chan; 43 chan, 0-5 v-dc; input impedance, 1/2 load impedance +10 K OUT: output impedance, source impedance +10 K	L: ±0.5% of 5-v fs C: <0.1% of full amplitude	pdm/f-m or pdm/p-m telemetry
TEL 1481-A		45	900 per sec	IN: 33 chan, 0-5 v-dc unbalanced; 10 chan, 0-50 mv bal or unbal input impedance, 1 Meg on high level, 20 K on low level channels OUT: output impedance, 20 K	L: ±2% C: <0.2% of full amplitude	pdm/f-m or pdm/p-m telemetry
OTHER ELECTRONIC TYPES						
EMR 99B	100%	up to 98	75-20,000 per sec	IN: 0-5 v signals, 285 K impedance OUT: output load 1 Meg or greater	A: better than 50 mv L: <0.03% of fs between end points C: <0.01% of fs	silicon diode switch; pdm and pam telemetry
GDI Elec-trocom	0 to 100%	4-100 per pole	to 10,000 per sec	IN: acts like constant current generator of 10-15 μ amp during sampling time OUT: emitter follower supplied	A: 0.25% L: better than 0.1% into 250 K load C: <0.1% fs N: <1 mv	silicon diode switch; light, low power telemetry
PBL Model EC		2 to 1,008	18,000-25,000 per sec	IN: voltage input ranges to ±8 v max; impedance 50 K OUT: ±10 v max at 5 ohm max impedance	A: ±0.02% L: 0.02% N: ±2 mv max	transistor type; pdm/f-m or pdm/p-m telemetry
BUR Beam-plexer		10	10 inputs to 100 kc	IN: signals to 200 v accepted, min pulse width +0.1 μsec OUT: signal pulses of 1.4 μsec, 20 v, + polarity	C: 0.5 v peak-to-peak max at 1 mc N: 0.4 v peak-to-peak max in channel	tube type; telemetry, neurology, vibration analysis

Realistic Simulation

Ultrasonic delay line and 30-mc Gaussian noise source are used to simulate actual clutter received during a number of consecutive sweeps

AUTHENTIC SIMULATION of radar echoes from wooded terrain and meteorological phenomena has been hampered by the difficulty of reproducing the particular statistical and spectral properties of reflections from this class of extended targets. The device to be described generates sweeps of Rayleigh-distributed clutter having video bandwidth in range, but only audio or subaudio bandwidth at constant range as a function of time. The audio fluctuation rate of the video at constant range duplicates the

by gain-programmed amplifiers. Ground clutter video originating from a piece of homogeneous terrain assumed to consist of random scatterers only which is being scanned by a ground-based search radar may be characterized as follows. The clutter video as a function of range has a Rayleigh amplitude distribution whose fluctuation spectrum is approximately determined by the i-f and video circuits of the radar. The clutter video at constant range and azimuth is also Rayleigh distributed as a function

shown in Fig. 1. The time delay is exactly equal to the interpulse period of the radar. The 30-mc Gaussian noise generator has a bandwidth comparable to that of the i-f bandwidth of the radar receiver whose clutter output is to be simulated. The gain a of the delay loop made up of delay line and i-f amplifier is less than unity.

The second detector is assumed to be linear. Its characteristics may be chosen to match those of the video detector in an actual radar. A long time-constant automatic gain control loop is provided to make the system amplitude stable and to keep the rms input to the ultrasonic delay line constant, thus fixing the value of a for each rms voltage level of the added 30-mc noise. The envelope of the 30-mc signal appearing at the input to the delay line constitutes the simulated clutter video.

Amplitude Correlations

The correlation in the clutter amplitudes received during a number of consecutive range sweeps is determined by the loop gain a . If no 30-mc noise is added to the signal circulating in the loop the loop gain will be unity and perfect correlation at fixed range will result. The fluctuation rate of the clutter signal in range is determined primarily by the frequency characteristic of the 30-mc Gaussian noise generator. Thus a signal with the statistical properties of ideal clutter is obtained.

The internal noise produced by a high-gain amplifier is used as the random signal source in the regulated 30 mc Gaussian noise generator. The noise voltage is regulated before it is transformer-coupled to the unit's output. There it is passed through a calibrated precision attenuator and then added to the signal circulating in the delay-line

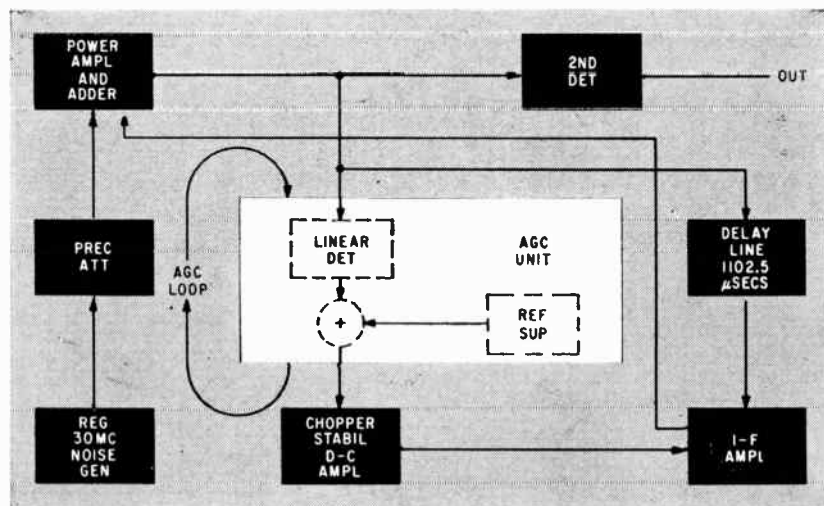

FIG. 1—Delay line exactly equal to interpulse period of radar used. Agc loop maintains output level constant

high correlation in real clutter amplitudes received during a number of consecutive sweeps differentiating such signals from ordinary noise. The key components in the clutter simulator are an ultrasonic delay line memory and a 30-mc Gaussian noise source.

Here it will be assumed that the statistical characteristics of clutter echoes are not affected by clutter range. Variations in the rms strength of reflections from extended targets as a function of azimuth and range can be simulated

of time. In the case of an S-band radar this ground clutter fluctuation spectrum typically has half-power frequencies between 1 and 6 cps. The shapes of the frequency spectra have been determined experimentally.^{1, 2}

The effect of the scanning radar antenna is to slightly widen the spectrum discussed above.

Clutter Simulator

A simplified block diagram of a clutter simulator capable of generating realistic clutter video is

of Radar Clutter

By **J. ATKIN**, Laboratory Supervisor, Columbia University, New York, N. Y.,

H. J. BIKEL, Senior Project Engineer **M. WEISS**, Project Engineer, Federal Scientific Corp., New York, N. Y.

storage loop. The physical addition takes place in the power amplifier used to drive the low impedance presented by the inputs of the delay line, the age unit, and the output unit. The signal present at the output of the power amplifier is then delayed by an ultrasonic delay line. The i-f amplifier is of high quality. The age unit contains a buffer amplifier, a linear detector of the average of the half-wave rectified signal and a circuit for comparison of the detector output with an internally-generated reference voltage. The chopper stabilized d-c amplifier raises the level of the error signal output.

Noise Generator

The noise generator uses a high gain i-f amplifier as the noise source. With the input terminal of this amplifier shorted, the output signal consists of internal noise enhanced by the gain of the amplifier. Noise generated in this manner has a Gaussian amplitude probability distribution with a frequency spectrum determined by the transfer function of the unit.

The i-f amplifier has the following characteristics: gain variable to

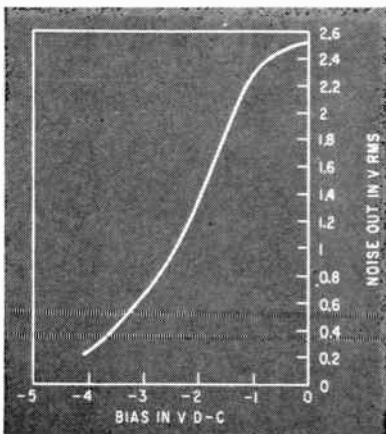

FIG. 2—Regulated 30-mc Gaussian noise generator output level plotted against gain control output bias

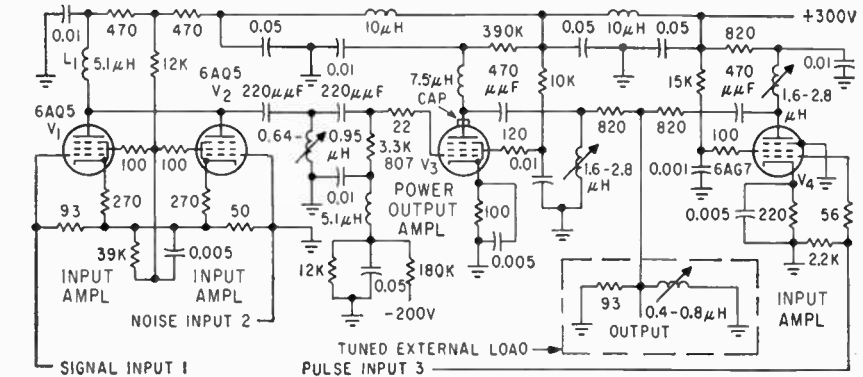

FIG. 3—Power amplifier and adder accepts delay line output and noise. Other input is for synchronizing pulse

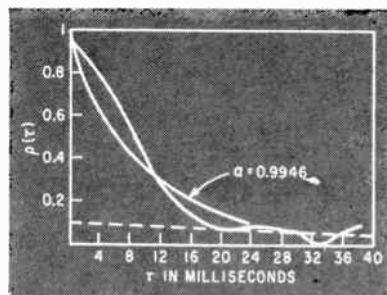

FIG. 4—Typical correlation function of real clutter compared with correlation function obtained by simulation

120 db, center frequency of 30 mc, half power bandwidth of 2 mc and an output impedance of 50 ohms. In its application in the clutter simulator, the i-f strip gain control is operated in the region which results in the greatest percentage variation in the output noise for a small change in the gain control voltage, the region being from -4.0 to -1.4 volts d-c. The noise available at the output terminal of the noise generator has a bandwidth of $1/2$ mc and may be varied from 0.3 to 2.0 volts, rms. A plot of the rms value of the generator's output noise as a function of the gain control bias is shown in Fig. 2.

The noise output is stabilized by a feedback circuit having a loop gain of approximately 34 db. The

3-db corner of the control loop is at 1 cps.

The capacitive load present at the output is driven by a buffer amplifier. This amplifier and output transformer have a gain of -2 db and a half-power bandwidth of 0.5 mc. The output is taken through a transformer designed to work into a 50-ohm load.

Power Amplifier

The power amplifier and adder whose schematic diagram appears in Fig. 3 is used to drive the delay line. Its inputs are the amplified version of the delay line output signal and narrow-band Gaussian noise. These signals are added in the common plate load of V_1 and V_2 and amplified by V_3 . The tuned circuits at the plate of tubes V_1 , V_2 and V_3 in addition to the tuned input to the delay line form a staggered Butterworth triple which is centered at 30 mc and has a half-power bandwidth of 2.75 mc. The overall gain of this unit is 0.92 for either input channel.

A third channel is included in this unit for addition of a pulse to the information entering the delay line. This pulse is used to provide a precise means for synchronizing to the repetition frequency of the clutter simulator. The pulse chan-

nel has a gain of 0.45, a center frequency of 35 mc and a half-power bandwidth of 6 mc.

The maximum undistorted voltage that the power amplifier can drive into the load represented by the input impedances of the delay line, the agc unit and the output unit is 8.4 volts peak-to-peak.

Ultrasonic Delay Line

The ultrasonic delay line uses a solid quartz delay medium. This line has a center frequency of 30 mc, an electrical half-power bandwidth of 10 mc and an acoustic half-power bandwidth 14.3 mc wide. Its delay time is about 1,000 microseconds. Its insertion loss (attenuation) with the 93-ohm terminations used is approximately 70 db. The spurious signal level is at least 50 db below that of the main signal.

I-F Amplifier

The clutter video at the output of the delay line must be amplified to restore its rms voltage to approximately the same value it had at the input to the delay line. A 2 mc commercial i-f amplifier centered at 30 mc provides the necessary voltage amplification. The gain of the amplifier can be varied to a maximum of 120 db.

AGC Unit

The function of the agc loop is to regulate the input voltage to the delay line.

The agc unit consists of a single stage of amplification followed by a linear envelope detector whose output is averaged. The frequency response of the post-detection filter is 3 db down at 1 cps. The signal at the output of the filter is compared with a reference voltage, and their difference is fed to a d-c amplifier.

The delay line input is fixed at a level determined by the value to which the reference voltage is set. Any drift in the rms level at the delay line input results in a change in the i-f amplifier gain in the direction which will return it to its initial value. However, any drift in the gain of the agc unit itself will cause the delay line input to drift from the desired level. For this reason, the agc amplifier is operated with an unbypassed cath-

Properties of Real Clutter

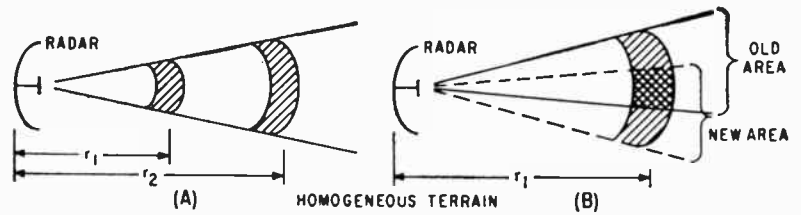

In general, a search radar echo is caused by reflections from all the targets illuminated by the radar antenna. The term target area is used to denote the radar coverage at a fixed range. For a ground-based installation, it is defined by the antenna beamwidth, one-half the radar pulse length and the vertical coverage of the beam. An echo from an extended target covering a region much larger than the target area is called clutter. Clutter from meteorological phenomena or ground vegetation exhibits fluctuations which are due to the motion of many reflectors within the target area. At S-band, for instance, the radar wavelength is 10 cm and a piece of terrain appears to the radar as an assembly of many individual targets. Due to wind, such reflectors as small branches and other forms of vegetation move slightly and change their distances from the radar antenna. Echoes from the various portions of the target area reinforce or cancel by wave interference. If the resultant echo is due to contributions from random scatterers only, its phase has a uniform probability distribution from zero to 2π radians while the amplitude of the fluctuating echo possesses a Rayleigh distribution. The power spectrum which characterizes the rate of fluctuation has been measured under a variety of conditions. To investigate the properties of clutter echoes, it is appropriate to consider two separate cases: pulse-to-pulse clutter fluctuations at constant range, and fluctuations which occur within a single sweep as a function of range.

Pulse-to-pulse clutter fluctuations at constant range can be studied most conveniently by stopping the search radar antenna and by recording range-gated clutter video. Under these conditions attention can be focused on radar echoes originating from a specific target area. Using this setup the amplitudes of precipitation echoes have been found to follow the Rayleigh distribution, and some indications of their power frequency spectra have appeared in the literature.^{2, 3}

So far, the radar antenna was held stationary and clutter echo amplitudes originating from a typical range element were observed from pulse-to-pulse. Figure A illustrates two range elements, one of which might be under observation. If the antenna rotates, the terrain illuminated by successive pulses will not be quite the same and this situation is depicted in Fig. B. The echo contribution from the incremental portion of new area which has come under surveillance because of antenna rotation between main bangs is statistically independent of the reflections from the old area. The overall effect is one of decorrelation of pulse-to-pulse clutter amplitudes at constant range. A one-degree radar antenna scanning a field of fixed, randomly-oriented scatterers at 6 rpm gives rise to clutter video having a fluctuation spectrum approximately 10 cps wide. The experimental frequency spectra of clutter echoes from random scatterers (chaff, rain, snow, some types of vegetation) have been found roughly similar in shape, resembling error curves centered at the origin.^{2, 3}

As mentioned previously, the second kind of clutter fluctuations to be considered are those which occur within a single sweep as a function of range. At any instant during a range sweep the signals received by the radar antenna originate from a patch of land of radial dimension $r = (\text{transmitter pulse length}) (\text{velocity of light}) / 2$

If the transmitter pulse length is designated by τ , it should be clear that echoes from a completely new target patch will be received every τ seconds. Based on the assumption that the terrain acts like an assembly of random scatterers, echoes received from distinctly different patches of land will be statistically independent. Taking into account transmitter pulse shape, radar i-f and video bandwidths, the exact clutter fluctuation spectrum can be calculated. For most practical radars, it will be determined substantially by the radar receiver low-pass video characteristic, provided that the product of radar i-f bandwidth times pulse length equals approximately unity and that the video bandwidth of the radar is matched to the i-f bandwidth.

ode resistor, thus introducing negative feedback to improve the stability of the unit.

The gain of the age unit is 17.5 volts d-c/v rms of Gaussian noise. The output is linear to 30 volts d-c, which is well above the operating level of the unit in the clutter simulator.

D-C Amplifier

This unit amplifies the error voltage produced at the output of the age unit. The amplified error signal is used to control the gain of the i-f amplifier. The d-c amplifier is chopper-stabilized and has a gain which is variable in discrete steps from 0 to 1,000. The 3-db passband is greater than 30 kc for all gain ranges. The maximum linear output is greater than ± 30 volts for 1,000-ohm output termination. The equivalent input noise of the amplifier is 10 μ v peak-to-peak. A line voltage variation of ± 10 percent caused an equivalent drift of 12.5 μ v.

Second Detector

The output consists of a stage of amplification with cathode feedback, followed by a positive peak detector and a 1 mc wide low-pass filter. The envelope output is taken from a cathode follower through a 30-mc rejection filter. In addition, an i-f output is available at the cathode of the amplifier. The gain from input to cathode follower output of the unit is 4.6 v video/volt rms of Gaussian noise. The half-power bandwidth is 4 mc centered around 30 mc. The output is linear to a voltage well above the maximum at which the unit will be operated.

Performance

A typical experimentally obtained normalized autocorrelation function of clutter power at constant range and azimuth appears in Fig. 4¹.

The slight rounding or decorrelation of the function for τ approaching zero is due to the presence of receiver noise in the radar output.¹ A possible reason for the departure from asymptotic behavior as τ approaches infinity has been explained as being due to a slow temporal change in the aver-

age power received by the radar.¹

The autocorrelation function of the simulated clutter video at a constant range as a function of time is

$$\overline{r(t)r(t+\tau)} \simeq \frac{\pi}{2} \sigma^2 \left[1 + \frac{2\tau}{\alpha T} \right] \quad (1)$$

where $\alpha^2 =$ the mean square voltage input to the detector; $\alpha =$ the storage loop gain; $\tau =$ time variable; and $T =$ radar interpulse period or delay of ultrasonic line.

The autocorrelation function of the clutter output power is

$$\overline{r^2(t)r^2(t+\tau)} \simeq 4\sigma^4 \left[1 + \frac{2\tau}{\alpha T} \right] \quad (2)$$

It is seen that the part of Eq. 2 which is a function of τ is exponential in nature and Fig. 4 shows how

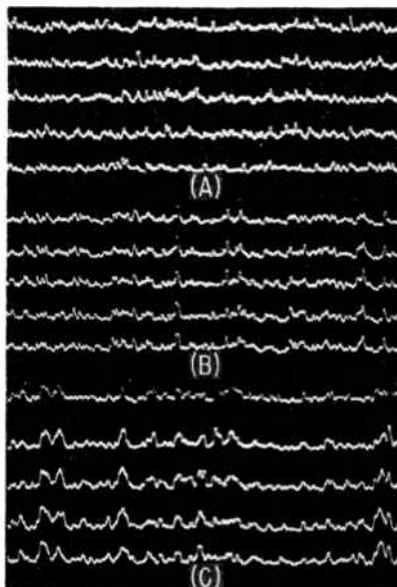

FIG. 5—Simulated clutter for a loop gain of 0.61 shown in (A), loop gain of 0.917 shown in (B) and loop gain of 0.98 shown in (C)

it (after proper normalization) approximates the experimental data. If a delay line of length 1,000 μ sec is used in the clutter simulator a loop gain α of 0.9946 is required for this approximation. Substitution of this α into Eq. 2 yields a bandwidth of 1.6 cps. The experimental data having this very low fluctuation rate at constant range was obtained by maintaining azimuth constant. Using the existing clutter simulation equipment α 's ≤ 0.98 ($f_{1/2} = 6$ cps) can be obtained reliably.

Various values of storage loop gain (α) permit simulation of clutter from meteorological phenomena such as rain or snow or chaff, as well as most ground clutter situations involving a scanning radar and antenna.

Figure 5 shows the video output waveform for various values of α . Each sweep shown is 500 μ secs long. The pulse repetition interval (T) is 1,000 μ secs. In order to display the correlation of the simulator output video at constant range as a function of time, a d-c voltage changing by a fixed increment every T (or $10 T$) seconds was added to the simulated clutter video. This permitted the observation and photographing of successive sweeps (or every tenth sweep) on a standard oscilloscope. By employing this display method to photograph the output, signals from the same range are directly below one another on the oscillograms. Therefore, each photo shows the variation of the clutter video as a function of range in the horizontal direction and as a function of time at constant range in the vertical direction.

The oscillogram in Fig. 5A was taken at $\alpha = 0.61$. The traces are consecutive sweeps of the simulator's video output, each trace containing approximately one-half of the sweep whose total length is 1,000 μ sec. A correlation at a constant range is just noticeable. In Fig. 5B, the loop gain of 0.917 results in a highly correlated signal. At a loop gain of 0.98 no decorrelation is noticeable from sweep to sweep. This is to be expected since the fluctuation rate at this α is 6 cps while the interval between successive sweeps is 1 millisecond.

Figure 5C shows every tenth sweep of the simulator's video output with $\alpha = 0.98$. Little decorrelation in the video at constant range as a function of time can be observed.

REFERENCES

- (1) J. L. Lawson and G. E. Uhlenbeck, "Threshold Signals", M.I.T. Rad. Lab. Series, 24, McGraw-Hill Book Co., 1950.
- (2) D. E. Kerr, "Propagation of Short Radio Waves", M.I.T. Rad. Lab. Series, 13, McGraw-Hill Book Co., 1951.
- (3) P. M. Austin, A Study of the Amplitude Distribution Function for Radar Echoes from Precipitation, Meteorological Department, M.I.T., May 1952.

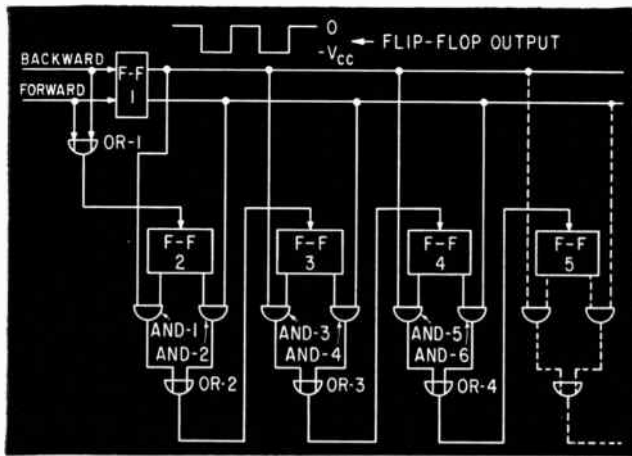
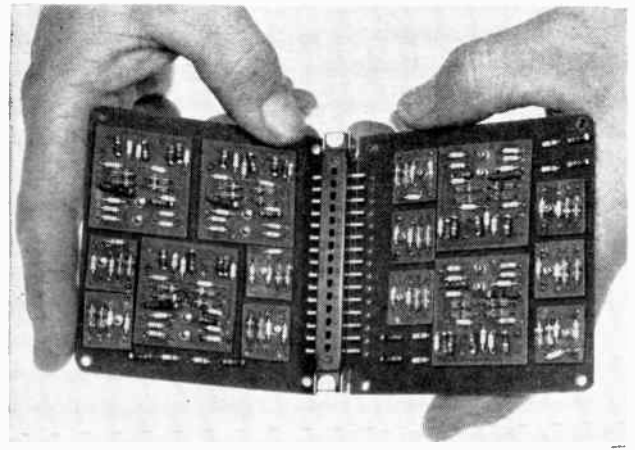

FIG. 1—Counter is broken down to basic building blocks. Dotted lines show how additional stages can be added



Use of submodules is shown in construction of counter. Larger printed boards are flip-flops, smaller boards are gates

Binary Circuits Count

BINARY COUNTERS generally consist of a number of stages of bistable storage elements whose purpose it is to count an incoming pulse train. This counting process is accomplished by cascading these devices so that two pulses applied to each stage result in a single output pulse which triggers the following stage. These bistable storage elements form a register; the number of pulses applied as an input appears as a binary representation in the states of the storage elements.

A counter of the type described above is capable of counting or adding a number of incoming pulses. This article describes the logic as well as the actual working circuits of a counter that is capable of adding and subtracting pulses at the control of the appropriate logic circuits.

This reversible binary counter¹ has been assembled using extremely small digital building blocks. The complete reversible counter fits on to a single plug-in unit 3.25 x 3.8 x 0.75 in. which includes the plug-in connector.

In explaining the theory of operation, the following definitions are used.

Input pulses applied to the forward and backward lines are of positive polarity. The ZERO state of a flip-flop is defined as 01; the ONE state as 10.

Transistors of the *pn*p type are used and the output from a flip-flop is as shown in Fig. 1.

ZERO state of a transistor is defined as the non-conducting state in which the collector is approximately $-V_{cc}$, the ONE state as the conducting state in which the collector is at approximately zero volts.

An output pulse of the proper polarity to trigger the following stage occurs only when the flip-flop changes from the ONE state to the ZERO state.

Finally, the flip-flops used in these circuits are operated in a saturation mode to provide maximum stability as well as independence from transistor parameters and selection.

Theory of Operation

The logic diagram for a four-stage reversible binary counter is shown in Fig. 1. It is understood that counters with any number of stages can be made; the method of assembly being simple repetitions of the four stages used here.

When this logic diagram is broken down to its submodule approach it becomes apparent that the reversible binary counter can be reduced to five flip-flops, six AND gates and four OR gates. Flip-flop 1 is the control or setting flip-flop which is operated in a set-reset manner. Flip-flops 2 to 5 comprise the storage register.

The reset switch shown in Fig. 2 is used to put the storage register in the ZERO state. Assume that flip-flops 2 through 5 are all in the ZERO state, 01. Then, if an input pulse is applied to the forward bus, flip-flop 1 is cut off and the forward bus line is at $-V_{cc}$. The same input pulse is also routed through OR-1 to trigger flip-flop 2 and change its state to 10.

Since the right-hand side of flip-flop 2 has changed state in the direction from 1 to 0, an output pulse would have been routed through AND-1 but for the fact that the second input to AND-1 is tied to the backward bus which is at ground potential. One input to AND-2 is tied to the forward bus which is at $-V_{cc}$, but since the left hand side of flip-flop 2 changed state from 0 to 1 no output is forthcoming from this gate. The counter has received one input pulse and this information is stored as 0001 in flip-flops 2 through 5.

Indicator

The least significant digit is stored in flip-flop 2 and since this stage is in the ONE state the indicator lamp associated with it lights up to show its condition.

When the flip-flop output is zero Q_c is nonconducting and the voltage at its collector is -45 . Therefore, the voltage across the neon lamp is 40 v, which is insufficient to break

Transistorized binary counter uses small digital building blocks to perform adding and subtracting functions. Technique of using digital building blocks can be applied to other applications

By H. J. WEBER, Section Head, Servomechanisms, Inc., Goleta, California

Backwards or Forwards

down the neon. When the flip-flop is at -12 v, Q_3 conducts heavily and the voltage at its collector is essentially zero. The voltage across the lamp is thereby increased to 85 v which is sufficient to break down the neon and light the bulb.

Now assume that another input

pulse is applied to the forward line. Although this pulse does not change the state of the control flip-flop, it serves to trigger flip-flop 2, which reverses its state to 01.

This change of state applies two negative voltages to D_1 and D_2 of AND-2, cutting off transistor Q_7 and

causing its emitter to drop to $-V_{cc}$. This negative voltage is transmitted through diode D_3 of OR-2, inverted and the resultant positive pulse used to trigger flip-flop 3. This changes the state of flip-flop 3 to 10. The count is now stored as 0010 in the storage register.

Assume now that a pulse is applied to the backward bus line. This pulse causes the control flip-flop (flip-flop 1) to change state, causing the backward line to assume $-V_{cc}$. The same input pulse triggers flip-flop 2 reversing it to the 10 state. This change of state permits a pulse output to get through the AND-1 gate thereby triggering flip-flop 3 back to the 01 state.

The register now displays the total count as 0001 and has, therefore, shown that it can cycle in a forward direction as well as in a backward direction.

Modular Design

The plug-in module described is a separately packaged function which may be subdivided into individual submodules or digital building blocks. These fully engineered and tested building blocks can then be used to assemble the particular counter in a minimum of time and at the lowest possible cost.

REFERENCE

- (1) R. L. Trent, A Transistor Reversible Binary Counter, *Proc of NEC*, 8, p 346.

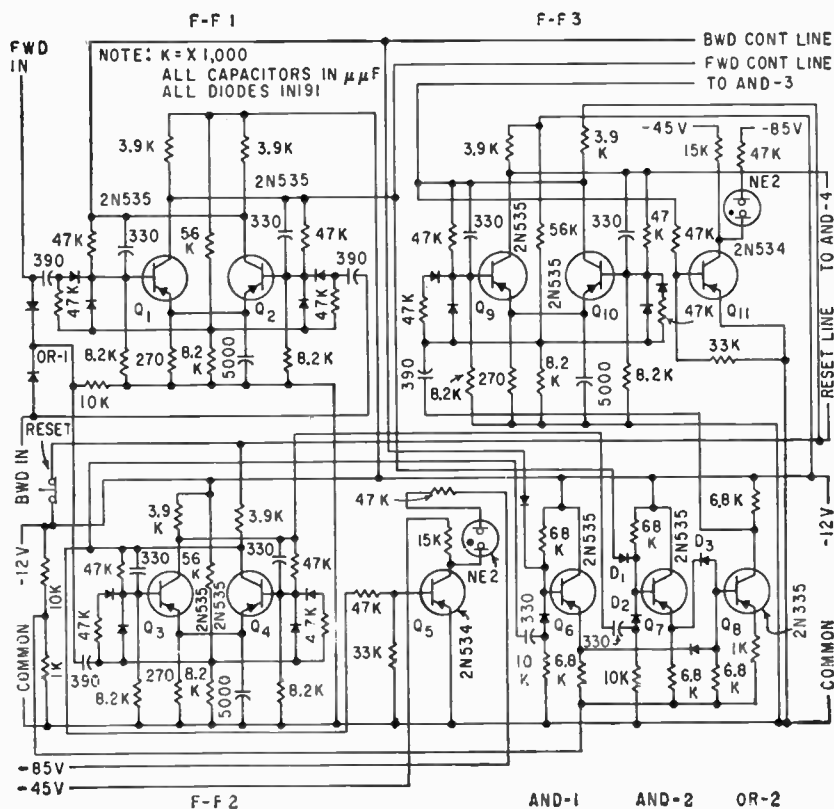

FIG. 2—Flip-flops used in counter are identical. Input voltages to flip-flops depend upon circuit function

Unusual Applications for Conventional Synchros

In addition to their regular use as an angular data link between remote points, standard synchros can be used for several other functions. Low frequency generators and linear induction potentiometers are just two examples

By **DAVID J. SALONIMER**, Missile Electronics Laboratory, Redstone Arsenal, Huntsville, Ala.

SEVERAL UNUSUAL USES for synchros have evolved in the development of test equipment in the Army missile program. Among these new ways to use synchros are as a difference frequency generator and as a direct reading frequency deviation meter.

Synchro control transformers, transmitters and repeaters are similar in construction but have significant differences. All three types have single winding rotors and three winding stators. The stators are wound as a three phase, Y-connected a-c machine but only single phase excitation is used. The main differences are in the rotors.

The rotor of a control transformer is cylindrical while the rotors of transmitters and repeaters have salient poles. Repeaters have a further difference in that they have damping or antihunt provisions. Synchro differentials are similar to control transformers in construction but the rotor is wound as a three phase, Y-connected machine.

Servo Loop

A typical control loop, as shown in Fig. 1A, might use a synchro transmitter as an error-sensing pickup. With a synchro control transformer linked electrically with the transmitter, the error signal is

introduced into the control loop. The servo motor positions the load and the control transmitter until the error signal is minimum. A servo of this type is analogous to a highly precise, flexible shaft. The accuracy and precision of such loops are determined largely by the characteristics of the synchros.

With a differential synchro placed in the loop as shown in Fig. 1B, the output position becomes a function of two angles, ϕ_i and ϕ_D . The

output is the sum or difference of the two inputs.

Because of their precise construction, low cost and special characteristics, synchros can be used in several applications unrelated to their principal uses.

Low Frequency Generator

A practical low frequency generator is shown in Fig. 2A. A low-speed motor is used to drive a synchro at the output frequency

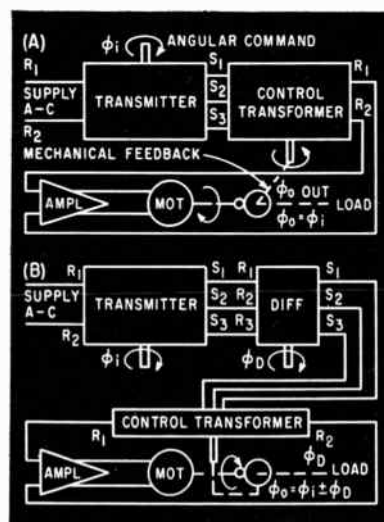

FIG. 1—Common type servo using two synchros to develop the error signal (A). Servo loop with differential performs a computer operation summing the two input angles θ_i and θ_D (B)

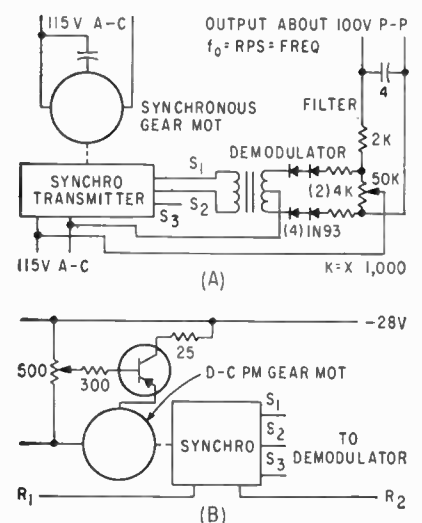

FIG. 2—Low-frequency sine-wave generator (A). Adjustable frequency generator using permanent magnet motor (B). A fixed speed motor and a variable transmission can also be used for drive

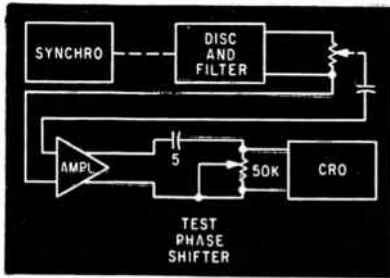

FIG. 3—Phase shift circuit and scope are used to measure distortion

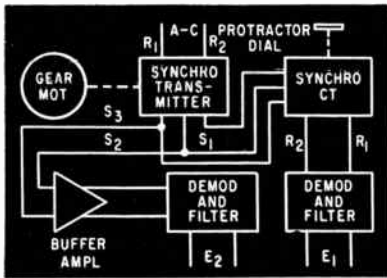

FIG. 4—Phase of voltage E_1 is adjustable with respect to E_2



Engineer tests the wave shape, frequency and distortion of an experimental low-frequency sine-wave generator

desired. The output of the synchro is a suppressed carrier signal which is amplitude modulated at the frequency of synchro rotation. When this signal is phase demodulated and filtered, the output becomes a sine wave at the same frequency as the synchro shaft rotation in rps.

Only one stator phase is needed to pick up the low frequency signal and it is not important whether the synchro is a transmitter, control transformer, repeater or resolu-

ver. A resolver, however, is built as a two phase a-c machine and it may be used as a low-frequency generator with two outputs shifted from each other by ninety degrees. A separate phase sensitive demodulator will be required for each output. If a transmitter, or other synchro with a three winding stator is used, three signals are available with 120 degrees phase shift between them.

There is no lower limit to the frequency generated and variable frequency generators are readily made as shown in Fig. 2B. The upper frequency limit depends on the allowable percentage of ripple and the high speed characteristics of the synchro brushes.

Low Frequency Distortion

Some applications require a low-frequency signal with a minimum amount of distortion. The most common causes of distortion are: misalignment of motor and synchro shafts; excessive phase shift of the carrier before demodulation; inadequate reference signal amplitude; circuits using nonpolarized tantalum capacitors with unequal forward and reverse capacitance; and an output amplifier used to increase the voltage or lower the output impedance.

A simple test to reveal distortion

in a low-frequency wave can be made with a capacitor, potentiometer and oscilloscope. The arrangement is shown in Fig. 3. If there is little distortion in the wave, the oscilloscope pattern will be a smooth sinusoid for any setting of the potentiometer. But even a little distortion, imperceptible in the full output, will show up as a lump or spike at some point on the wave as the time constant of the R-C high-pass filter is varied. Only a pure sine wave will remain smooth throughout the full filter range.

Using two synchros, such as a transmitter and control transformer as shown in Fig. 4, two signals of variable relative phase relation can be produced. The position of the rotor of the stationary synchro controls the phase shift.

A protractor dial on this synchro can be used to read the phase shift. The slowly rotating single phase field produced by the driven rotor will be established in the stator of the dial synchro and the position of its rotor, used here as a pickoff, will determine the phase relation of its output to that of one of the driven synchro field windings. This winding must not be loaded appreciably or distortion of the output waveform will result. A high input impedance buffer amplifier is desirable for isolation.

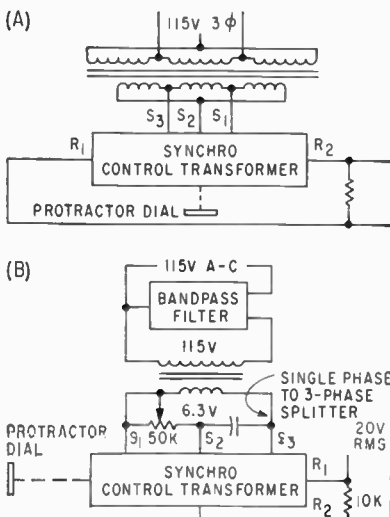

FIG. 5—A synchro control transformer is used to shift the phase of the carrier signal. Three-phase source should be balanced and have little distortion (A). Single phase to 3 phase splitting network (B)

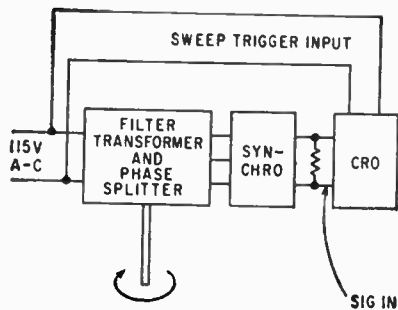

FIG. 6—Method of adjusting phase splitter for optimum phase shift linearity. See Fig. 5 also

Carrier Frequency

Because a control transformer has a well balanced three phase, Y-connected stator, it can be used as a carrier phase shifter. If a uniform rotating magnetic field is established in the synchro stator, a sinusoidal wave at the frequency of the rotating magnetic field is developed at the rotor terminals. Advancing the rotor in the same direction as the rotating field, with reference to a fixed position, provides a rotor signal whose phase position lags the reference. An opposite angular displacement produces lead. Fig. 5A shows an arrangement using a three-phase source.

If three-phase power is not available, or if because of unequal external loading the signal source would produce a distorted or non-uniform rotating magnetic field, a single-phase to three-phase splitting network can be incorporated. Fig. 5B shows such a network adapted to a synchro. Three points must be observed. First, the synchro must have a cylindrical rotor, not salient poles. Control transformers, resolvers or differentials are suitable but transmitters and repeaters are not. The salient poles distort the mag-

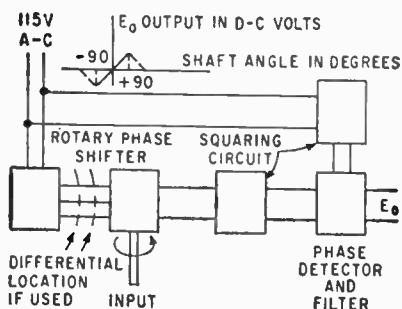

FIG. 7—Linear induction potentiometer has output linear to ± 80 degrees

netic field, resulting in a distorted output.

Second, the rotating magnetic field must be of uniform amplitude throughout the entire cycle. Hence the power source wave form must not be significantly distorted. A good band pass filter will aid greatly in achieving a precise unit.

Thirdly, only light loading of the rotor circuits can be permitted if an undistorted output waveform is to be attained.

Final adjustment of the phase splitter is a trial and error procedure, since no two synchros are exactly alike. Optimum values of resistance and capacitance are easily determined while testing the unit for linearity. Fig. 6 shows a method of testing using a triggered

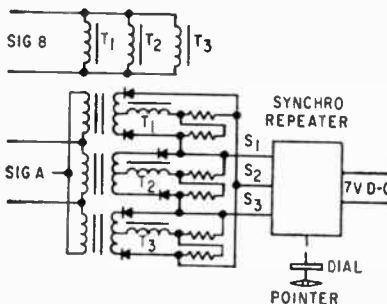

FIG. 8—Frequency deviation meter measures errors of ± 4 cps

oscilloscope. When the synchro shaft is spun with the fingers, the wave on the oscilloscope screen shifts right or left corresponding to the angle and direction of rotor movement. Resistance and capacitance are adjusted until the wave appears to shift smoothly and the amplitude of the wave remains constant as the shaft is rotated.

Difference Frequency Generator

Rotating the synchro of the phase shifter just described will produce a signal differing in frequency from the carrier by the speed of rotation in rps. A generator of this type, when driven from a precision variable speed source, is useful in testing the compensation circuits of a-c servos. A secondary frequency standard and amplifier may be used for the supply signal. With proper gearing, frequencies near the carrier may be generated with extremely high resolution.

The output of a synchro can be

made a linear function of shaft position if the output wave of the phase shifter described above is shaped into a square wave and applied to a phase detector in which the reference signal is a square wave. The linearity of the d-c output will depend largely on the flatness of the horizontal portion of the two square waves and the linearity of the phase shifter itself. Fig. 7 is a block diagram of this scheme. Good linearity can be achieved through a range of more than plus or minus 80 degrees.

Frequency Deviation Indicator

A high impedance synchro repeater and a three phase detector can be used to indicate a small difference in frequency or phase shift between two sources. Readout is by a pointer which rotates at the difference frequency of the two sources. See Fig. 8.

A three-phase signal from one source is phase demodulated by a single phase signal from the second source. The output of the three-phase demodulator is a three-phase signal at the difference frequency and is applied to the synchro stator. A small d-c current in the synchro rotor windings causes the rotor to align itself with the rotating stator field. The time in seconds for one revolution of the pointer is the reciprocal of the difference frequency. If no difference exists, the pointer measures the phase difference of the two signals.

Many Varieties

The repeater will turn a small torque potentiometer and the time integral of the deviation can be recorded. The technique is well suited to testing inverters for reaction to shock loads. Frequency deviations up to 3 or 4 cps and phase shift within plus or minus 1 or 2 degrees can be measured.

Many varieties of test and computation apparatus may be devised with these techniques. High quality precision synchros are in abundant supply and are relatively inexpensive. They have a high order of reliability, high sensitivity, low noise and light torque. The variety of secondary applications make synchros one of the designer's most versatile components.



More than thirty years experience in the design and manufacture of standard electronic components insure Cannon Connectors by CINCH to be of the highest quality materials, fabricated to specifications to maintain consistent quality of product; highest standards throughout all operations.

**DPX CONNECTORS
SPLIT SHELL. PIN AND
SOCKET INSERTS**

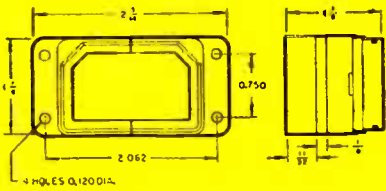

DPX 23-34P

**D SUB-MINIATURE and DPX SERIES
CONNECTORS**



DPX 23-33S

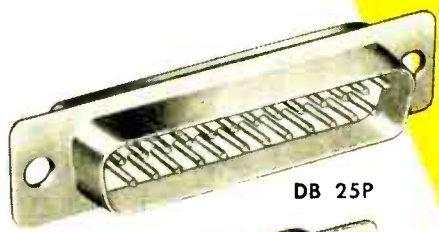

DB 25P



DB 25S

Send for illustrated catalog No. 100 with details of "D" Sub-Miniature and "DPX" Series.

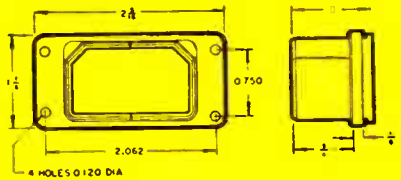

DPX SPECIFICATIONS:

Shell, die cast aluminum alloy. Finish, cadmium plate with clear Iridite. Contacts—Plugs, brass, Socket, phosphor bronze both with gold plate finish. Insulation material, Melamine type MME. Operating temperature -67° to $+280^{\circ}$ F. Available in 7 to 57 contacts in multiple variations of 5 and 10 amp terminals as well as coaxial terminations. Keystone cornered shell polarization.

**D SUB-MINIATURES:
STANDARD PIN AND SOCKET INSERTS.**

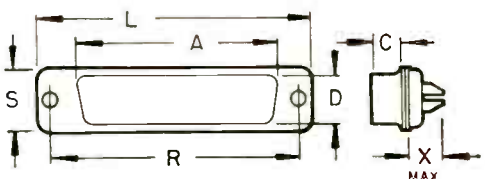

size	A	C	D	L	R	S	X	weight
DA-15P	1 1/4	1 3/4	2 3/4	1 1/2	1.312	3 1/4	3/16	.013
DA-15S	3/2	1 5/4	3/16	1 1/2	1.312	3 1/4	3/16	.014
DB-25P	1 1/16	1 5/4	2 3/4	2 3/4	1.852	3 1/4	3/16	.023
DB-25S	1 3/4	1 3/4	3/16	2 3/4	1.852	3 1/4	3/16	.031
DC-37P	2 1 3/4	1 5/4	2 3/4	2 2 3/2	2.500	3 1/4	3/16	.035
DC-37S	2 1 1/4	1 5/4	3/16	2 2 3/2	2.500	3 1/4	3/16	.035
DD-50P	2 7/4	1 5/4	1 1/2	2 3/8	2.406	3 3/4	3/16	.035
DD-50S	2 5/4	1 5/4	2 3/4	2 3/8	2.406	3 3/4	3/16	.040
DE-9P	4 5/4	1 5/4	2 3/4	1 1 3/4	.984	3 1/4	3/16	.011
DE-9S	4 1/4	1 5/4	3/16	1 1 3/4	.984	3 1/4	3/16	.012

FRACTIONS $\pm 1/64$ Tolerance DECIMALS ± 0.005 Tolerance

D SUB-MINIATURE SPECIFICATIONS:

Shell, including flange, steel or brass. Finish, Cadmium plate or Iridite. Contacts — No. 20, 5 ampere rating. Copper base alloy, gold plate finish. Insert arrangements — 5 plus coaxials in 9, 15, 25, 37, and 50 contacts.
Insulation material — Zytel 101, DIALL or Melamine.
Polarization — Keystone cornered shell.
Operating temperature -67° to $+310^{\circ}$ F.

Cinch Manufacturing Company

1026 South Homan Ave., Chicago 24, Illinois
Division of United-Carr Fastener Corporation, Boston, Mass.

**D SUB-MINIATURES:
HERMETIC SEAL PIN INSERTS**

size	A	B	O	D	G	L	S	X	max.	weight
DAH-15P-001	1 1/4	2 3/4	3/2	2 3/4	1/2	1 3 3/4	1/2	3/2		0.021
DAH-15P-002	1 1/4	2 3/4	3/2	2 3/4	1/2	1 3 3/4	1/2	1 3/4		0.021
DBH-25P-001	1 1/16	2 3/4	3/2	2 3/4	1/2	2 3/2	1/2	3/2		0.027
DBH-25P-002	1 1/16	2 3/4	3/2	2 3/4	1/2	2 3/2	1/2	1 5/4		0.027
DCH-37P-001	2 1 3/4	2 3/4	3/2	2 3/4	1/2	2 4 7/4	1/2	3/2		0.037
DCH-37P-002	2 1 3/4	2 3/4	3/2	2 3/4	1/2	2 4 7/4	1/2	1 5/4		0.037
DDH-50P-001	2 7/4	2 3/4	3/2	1 1/2	1/2	2 4 1/4	3 3/4	3/2		0.041
DDH-50P-002	2 7/4	2 3/4	3/2	1 1/2	1/2	2 4 1/4	3 3/4	1 3/4		0.041

Variation in final dash number indicates type of contact terminal. —001=eyelet type; —002=solder pot type.

FRACTIONS $\pm 1/64$ Tolerance DECIMALS ± 0.005 Tolerance

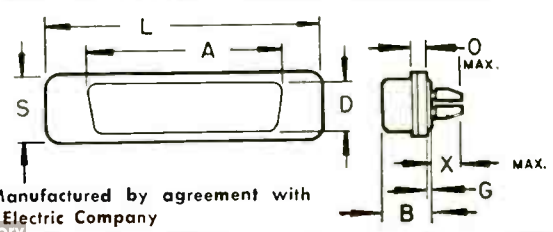

Manufactured by agreement with Cannon Electric Company



Antenna occupies entire left temple piece while radio occupies other temple piece

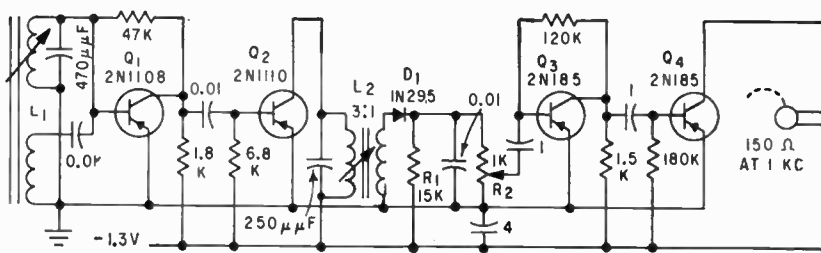

FIG. 1—Ferrite antenna has Q of 250. Base bias resistors in each stage are adjusted to give 0.5 ma collector current

Transistor Eyeglass Radio

Sensitive single-channel radio constructed in hearing aid eyeglass frame uses four transistors in tuned radio frequency circuit

By HARRY F. COOKE, Semiconductor Components Div., Texas Instruments Inc., Dallas, Texas

AUDIO MINIATURIZATION TECHNIQUES have been commercially used in the creation of hearing-aid eyeglasses. The eyeglass radio described in this article is a further extension of this idea.

Since a superheterodyne receiver is unnecessarily complex for single-channel operation and a regenerative detector is marginal on sensitivity and stability, a trf circuit, Fig. 1, was selected.

Circuit

The ferrite-core antenna has a high permeability which affords an effective area much greater than the actual size of the antenna. In the interests of sensitivity, the entire space within one temple piece is devoted to the antenna.

To obtain a reasonable r-f gain with a power supply consisting of a single 1.3 v mercury cell, grown-diffused transistors are used. These transistors have an h_{fe} (common emitter forward current gain) of 30 db at 455 kc. With fixed emitter current, the collector voltage may be dropped as low as 0.9 v without a serious loss in gain. The tran-

sistors were specially packaged in small diode cans.

For selectivity, a minimum of two tuned circuits are necessary with the antenna counting as one. A small ferrite E-transformer was selected for use as the second tuned circuit with the coils wound on the center leg. The transformer can be tuned by placement of the bar which closes the gap. The magnetic path is closed by the bar and there is minimum detuning once the bar has been cemented in place. The coil Q exceeds 100. The two tuned circuits are loaded to give a 10 kc at 6 db overall bandwidth.

Transistors Q_1 and Q_2 are resistance coupled to reduce complexity and give a degree of isolation between the two tuned circuits. The diode detector has a forward bias applied through R_1 to improve both detector sensitivity and linearity. The detected output is applied through volume control R_2 to audio stages Q_3 and Q_4 .

The output load (earphone) has a 1,000 cps impedance of 150 ohms and requires 50 mv for a medium loud output.

Single-resistor constant-base biasing has been used. This type of biasing does not provide the best interchangeability and stability but is used because it requires the minimum number of parts. Base bias resistors are individually selected to produce 0.5 ma collector current in each stage.

The overall sensitivity of the receiver is 1,000 μ V/meter for 50 mv across the earphone and the current drain is 2 ma giving a battery life of approximately 100 hours.

Antenna

The antenna primary is 79 turns of 10-44 Litz wire wound on a $\frac{1}{2} \times \frac{1}{2} \times 2\frac{1}{2}$ in. ferrite form. Adjust last ten turns for correct inductance. The secondary is 10 turns of the same wire wound at start of primary. Transformer L_2 primary is 65 turns 5-44 Litz wire and the secondary is 22 turns No. 40 enamel wire both wound on $\frac{1}{2} \times \frac{1}{2} \times \frac{3}{8}$ in. ferrite E-transformer core.

The eyeglass radio was constructed for use at a disk-jockey convention which was held at Miami, Florida.

covering the
IR spectrum
from the near to the far

Infrared at ITT includes complete detection systems as well as basic components

INFRARED is today, as it has been for a number of years, one of the "hottest" activities at ITT.

ITT Laboratories is equipped to design and develop new ideas in generation, transmission, detection, and utilization of infrared radiation.

ITT has made many important contributions in IR techniques —not only from one end of the spectrum to the other, but from simple devices for viewing objects in the dark to air-to-air search-track and tracking of satellites in orbit.

ITT's advanced position in the IR systems field is founded on its broad experience in basic IR components, such as lead telluride, doped germanium, and indium antimonide detectors; black-body radiation sources; image converter, photo-multiplier, and Iatron® direct-view storage tubes for display of IR information.

For increased detector efficiency, ITT has developed a full line of coolers, including cryostats for gaseous nitrogen, recirculating liquid nitrogen coolers, and liquid nitrogen dispensers that will cool cells for many hours—even after more than a day in storage. ITT also supplies component and system test equipment.

Whether infrared requirements are commercial or reach into the most sophisticated areas of military electronics, ITT's complete research and manufacturing facilities can meet the need.

For information on "active" or "passive" infrared systems, write ITT, 67 Broad Street, New York 4, N. Y.

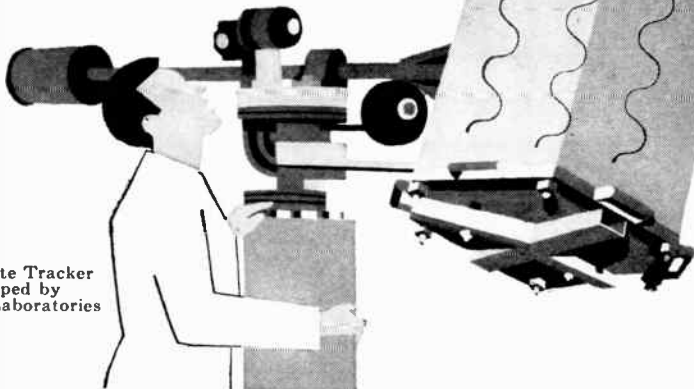

Satellite Tracker developed by ITT Laboratories

Among the infrared research activities at ITT Laboratories

- PRE-LAUNCH GUIDANCE
- SURVEILLANCE
- RECONNAISSANCE
- AIR-TO-AIR SEARCH
- AIR-TO-AIR SEARCH-TRACK
- JET AIRCRAFT DETECTION
- SATELLITE TRACKING
- AIRBORNE MAPPING
- FIRE CONTROL
- TEMPERATURE CONTROL
- MEDICAL ELECTRONICS
- COMMUNICATION SYSTEMS
- CRYOGENICS
- IR MASERS

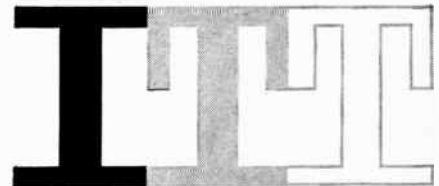

... the largest American-owned world-wide electronic and telecommunication enterprise, with 101 research and manufacturing units, 14 operating companies and 130,000 employees.

INTERNATIONAL TELEPHONE AND TELEGRAPH CORPORATION 67 Broad Street, New York 4, N.Y.

ITT COMPONENTS DIVISION • ITT FEDERAL DIVISION • ITT INDUSTRIAL PRODUCTS DIVISION • ITT LABORATORIES • INTELEX SYSTEMS INCORPORATED
 AIRMATIC SYSTEMS CORPORATION • KELLOGG SWITCHBOARD AND SUPPLY COMPANY • ROYAL ELECTRIC CORPORATION • AMERICAN CABLE & RADIO CORPORATION • FEDERAL ELECTRIC CORPORATION • ITT COMMUNICATION SYSTEMS, INC. • INTERNATIONAL ELECTRIC CORPORATION • INTERNATIONAL STANDARD ELECTRIC CORPORATION • LABORATORIES AND MANUFACTURING PLANTS IN 20 FREE-WORLD COUNTRIES

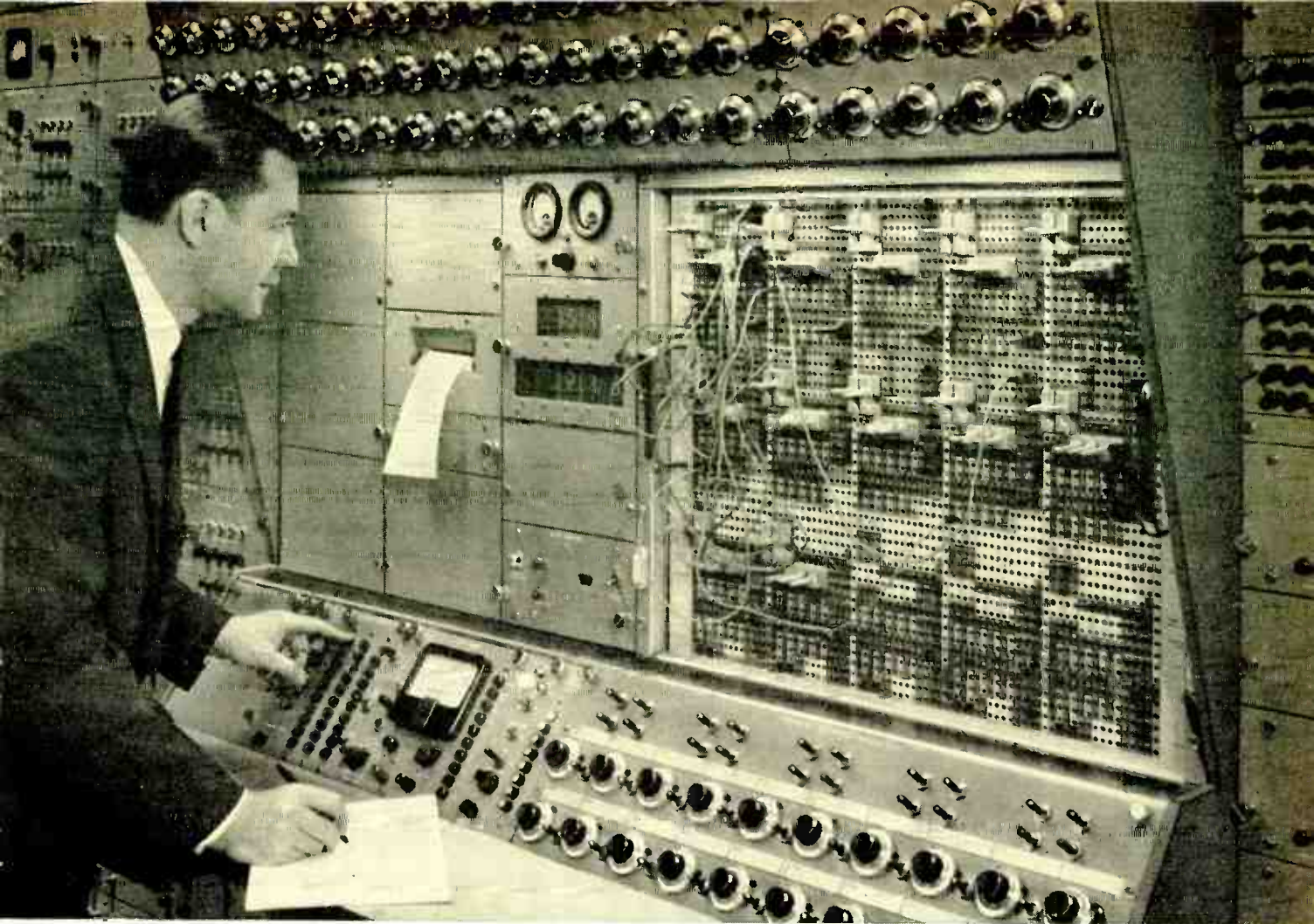

Engineer sets up a problem on patch panel control center of a PACE 231-R Analog Computer System made by Electronic Associates, Inc., Long Branch, New Jersey.

Tung-Sol electron tubes fill key sockets in computers!

Accurate and efficient computer operation permits no compromise on component quality. That's why Electronic Associates, Inc.—pioneer and leader in analog computer development and manufacture—specifies only materials of proved reliability for its Precision Analog Computing Equipment. In line with this policy, Tung-Sol tubes hold important posts in the 231-R and other EAI PACE systems.

EAI's experience matches that of the many other manufacturers who rely on Tung-Sol tubes. EAI requires tubes that consistently contribute high-grade dependability to operating efficiency. Special

'musts' for EAI computers are electrical stability and ability to handle initial current surges. Tung-Sol tubes have satisfactorily demonstrated these characteristics.

If your design calls for tubes or semiconductors, or combines both, specify Tung-Sol! Past performance in electronic equipment of all types—computers, communications, radar, industrial—lets you do so with full assurance of full-life dependability. For data on Tung-Sol tubes and semiconductors and how they can be applied most efficiently in your circuit, contact: Tung-Sol Electric Inc., Newark 4, New Jersey. TWX: NK 193



 **TUNG-SOL®**

small... but **mighty**

COMAR'S SUB-MINIATURE TYPE SM

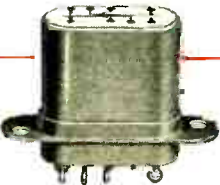

Less than an inch long  Weighs less than 1/2 oz.

big relay performance in crystal can size

A high precision, efficient sub-miniature relay.
Constructed to withstand severe vibration, heavy shock and temperature extremes. For control systems, missiles, computers, aircraft and similar applications requiring miniature size and dependable performance.



Nominal Coil Voltage: 26.5 Volts D.C.
Maximum Pull-In Voltage: 18 Volts D.C.
Maximum Drop-Out Voltage: 14 Volts D.C.
Coil Resistance: Approximately 570 Ohms.
Contact Arrangement: 2 P. D. T.
Contact Rating: 2 Amps. @ 28 V. D. C. Resistive (max.).
Maximum Operate Time (N.O. Contacts): 4 Milliseconds.
Maximum Release Time (N.C. Contacts): 3 Milliseconds.
Maximum Contact Bounce: 1 Millisecond.
Dielectric Strength: 1000 V. RMS, 60 Cycles (Sea Level).
Minimum Insulation Resistance: 100 Megohms.
Maximum Contact Resist: 0.05 Ohm; 0.10 Ohm (After Life).
Temperature Range: -65° to 125° C.
Operating Shock: 50 "G" for 11 Milliseconds.
Vibration: 20 "G"—5 to 2000 CPS.
Life: 100,000 Operations (Minimum).
Maximum Weight: .45 Oz.
Meets MIL-R-25018 and MIL-R-5757C specifications.

Send for Bulletin SM

COMAR

ELECTRIC COMPANY
3349 ADDISON ST., CHICAGO 18, ILL.

RELAYS • SOLENOIDS • COILS • SWITCHES • HERMETIC SEALING

World Radio History

capacitance is accomplished with a small unbypassed screen resistor without which quadrature feedback of oscillator to the control grid would upset the reference phase established by the color synchronizing signal. Oscillator output is derived from the output winding, inductively coupled to the oscillator tank circuit.

The filtered burst is clamped by the grid-cathode diode in the oscillator tube, developing a burst responsive bias voltage at the control grid. Detected bias voltage is filtered and delivered to terminal C for use with acc and color-killer circuits.

The oscillator tube may be used to provide additional d-c amplification for the detected burst-responsive bias voltage by a simple bootstrap arrangement. The cathode is returned to ground via a parallel RC network; R is effective d-c load and C holds the cathode at r-f ground potential. The control-grid tank circuit is returned to the cathode, rather than to ground, causing the clamping action to develop between grid and cathode. An amplified bias voltage appears between cathode and ground, which is filtered and delivered to terminal C for use with acc and color-killer circuits. This bootstrap arrangement preserves the proper phase relationship for the control-voltage source.

Simple Heart Pacer Is Highly Reliable

By L. D. TRUMP and R. L. SKINNER

EXPERIMENTAL heart-stimulating circuit may aid those suffering from heart block. In this condition, the heart may not beat or may beat very slowly unless stimulated.

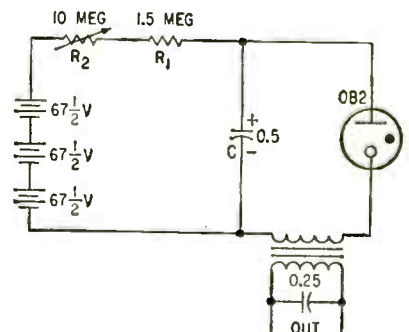

FIG. 1—Frequency of simple relaxation oscillator is controlled between 50 and 200 ppm by R₂.



Battery-operated heart pacer in small package can be mounted on harness of test animals

The portable pacer supplies electrical pulses that drive the heart at the desired rate. Output of the pacer is connected directly to the heart by small wires.

Simplicity of the circuit in Fig. 1 makes it very reliable. The entire assembly mounted in a small box can be carried about by a human or fastened to a dog harness as shown in the photograph. The circuit is simply a gas tube relaxation oscillator. Capacitor C_1 is charged through R_1 and R_2 until ionization voltage of the gas tube is reached. After the tube fires, C_1 is discharged through the primary of the transformer.

The transformer is a stepdown unit because impedance of the heart is only a few hundred ohms. Transformer output is a pulse of 3 to 4 millisecond duration and has an amplitude of about 10 volts. Charging rate of C_1 , and thus frequency of output pulses, is controlled by R_2 to give an output from 50 to 200 ppm. Total battery drain is only about 18 μ amp. One unit has been continuously running for about 8 months on the original battery.

An NE 51 neon bulb may be substituted for the OB 2 tube. This substitution results in lower output voltage.

This heart pacer has proved satisfactory on many research animals. In one case, it was used on an animal with an intentionally introduced heart block. The animal can be exercised on a treadmill while its heart is controlled at a fixed rate. This enables the researcher to obtain information on the mechanism that controls heart beat rate.

NEW IDEAS IN PACKAGED POWER

for lab, production test, test maintenance, or as a component or subsystem in your own products

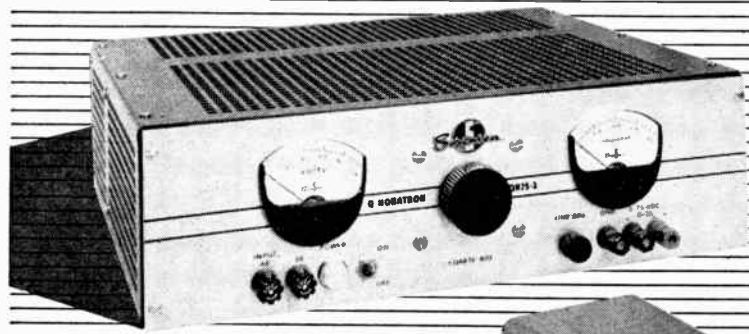

MODEL QR75-2

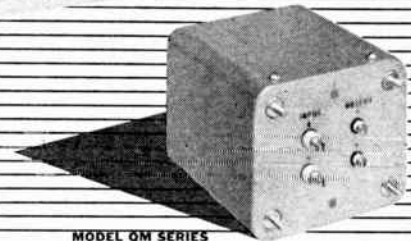

MODEL QM SERIES

3 new Sorensen transistorized d-c supplies can solve your lab, production and design problems

In the Sorensen "Q" Series, you can select from the most complete line of fully transistorized, highly regulated low-voltage d-c supplies on the market: **QR-Nobatrons**, (shown above, left) with output continuously adjustable down to zero volts, are ideal for labs or wherever maximum flexibility is required. Two models, QR36-4A and QR75-2, put out respectively 0-36V at up to 4 amps and 0-75V at 2 amps. Regulation of QR36-4A is $\pm 0.025\%$ or 4 MV for combined line and load variations. Input: 115vac 50-400 cps available for either bench or rack-panel ($5\frac{1}{2}$ " x 19") use.

Q-Nobatrons®, with 2:1 adjustable output, can render outstanding service in semi-permanent lab set-ups, in production test, or integrated into your own product. Available in 15 models up to

200 watts capacity with 6, 12 or 28 volts out. Specs and packaging are similar to QR models above. Models for $\pm 0.25\%$ or $\pm 0.05\%$ regulation are available. Lower wattages are available two to a single rack panel ($3\frac{1}{2}$ " or $5\frac{1}{4}$ " x 19").

QM-Series, solder-into-the-circuit supplies (shown above, right) mount like a potted transformer or choke and come in 36 variations: nine voltages from 3.0 to 36vdc, regulated $\pm 0.05\%$; and four wattages, 2, 4, 8 and 15. Input 50/60 and 400 cps at 115vac. (Incidentally, Sorensen also offers similarly packaged DC-to-DC and DC-to-AC converters.)

Ask us, or your nearest Sorensen representative, for the complete story on these precision transistorized regulated d-c supplies.

B.42



SORENSEN & COMPANY, INC.

Richards Avenue, South Norwalk, Connecticut

WIDEST LINE OF CONTROLLED-POWER EQUIPMENT FOR RESEARCH AND INDUSTRY

IN EUROPE, contact Sorensen-Ardag, Zurich, Switzerland. IN WESTERN CANADA, ARVA. IN EASTERN CANADA, Bayly Engineering, Ltd. IN MEXICO, Electro Labs, S. A., Mexico City.

World Radio History

Ceramic Wafer Tubes for Modular Units

By C. P. MARSDEN, Chief, Electron Devices Section, National Bureau of Standards, Washington, D. C.

Mechanized assembly and processing means have been designed and constructed to show that ceramic wafer tubes can be produced with a yield of better than 75 percent and with a high degree of reliability and ruggedness in military environments. This article discloses the design, methods of fabrication and the processing of these tubes.

CERAMIC WAFER tubes, conceived and developed at the National Bureau of Standards, demonstrate that tubes with a minimum 1,000-hr

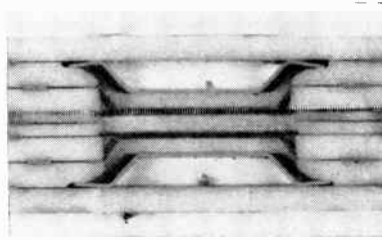

FIG. 2—Cross-section view of twin triode ceramic wafer tube. The three top shapes are repeated in the bottom half of the tube in reverse order. Simple wafer design makes stacking and assembly easy

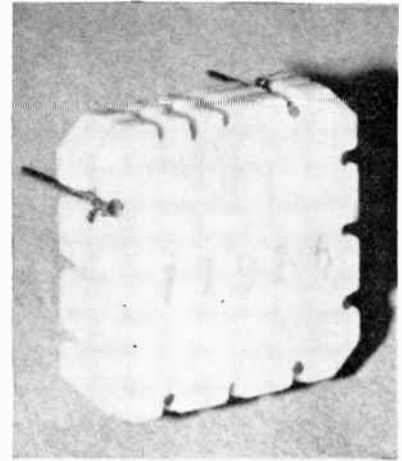

FIG. 3—Assembled ceramic wafer tube

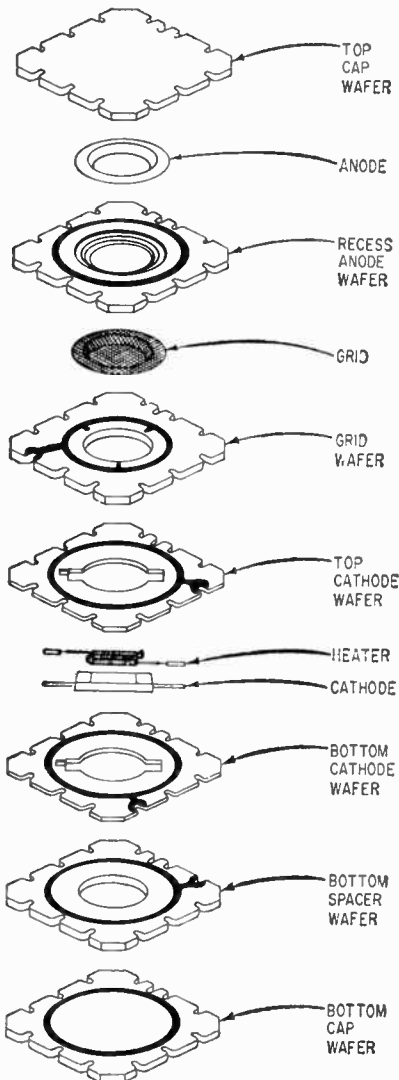

FIG. 1—Printed wafer tube developed at the National Bureau of Standards. This view is of an unassembled single-sided triode that uses printed conductors

life at 300 C can be produced with simple automatic equipment.

These tubes are designed to be compatible with the Tinkertoy¹ module, which contains only passive circuit elements. The main objective of the tube development program, supplemented by a contract with Sanders Associates, Inc., Nashua, N. H., has been to produce a rugged, reliable tube easily adaptable to high-speed, low-cost automatic assembling and processing.

Five tube types have been developed: a twin diode, a high- μ triode, a low- μ triode, a sharp cut-off pentode, and a remote cut-off pentode. Electrical characteristics of these tubes are similar to a number of military tubes now in widespread use.

Physical Description

The exploded view of a single-sided triode, Figure 1, shows the simplicity of the design. The tube consists of seven notched wafers, $\frac{7}{8}$ -in. square and 0.040-in. thick. The hole that forms the vacuum chamber is 0.340-in. in diameter. A silk-screen-printed metallic ring on each side of a wafer provides a vacuum-tight seal when brazed.

Anode and grid structures are pie-plate shaped. These elements drop into recesses around the edges of the holes in the wafers and make contact with printed conductors that extend out to the wafer

notches. The anode material is 0.005-in. nickel, and the grid is formed from a fine tungsten mesh, gold-plated and fused. The flat oxide-coated cathode structure contains a coiled heater.

The only close dimensional tolerances are the thickness of the wafers and the depth of the grid and anode "pie plates." No parts other than the wafers require orientation.

Design Characteristics

The tubes were designed to satisfy military requirements of ruggedness, reliability, low noise, and fast warm-up. Parts that are known to reduce tube reliability, such as micas, getters, tubulations, welds, and glass, have been eliminated.

Particular emphasis was placed on designing tubes with low interelectrode capacitance, low vibration noise, high interelectrode resistance, good shock resistance, and long life at high ambient temperatures. Measurements of some characteristics of production-line tubes show 20-sec average warm-up time, interelectrode resistance over 100 megohms throughout tube life, interelectrode capacitances ranging from $3\frac{1}{2}$ to $6 \mu\mu\text{f}$, and white-noise vibration output less than 100 mv.

Production

Tubes are assembled by stacking wafers and components in the

the significance of envelope delay in communication networks ...

The design of electronic wave filters is an exact science requiring painstaking attention to even the most minute detail. Of no less importance is the preparation of filter performance specifications. The transmission of pulsed sinusoids, steep-front modulation envelopes and other complex wave forms in modern telemetry, speech and facsimile systems has made the preparation of adequate component specifications an absolute necessity. The omission of a single required performance detail can lead to serious malfunctioning of the component in the completed system.

Envelope delay is one of the important characteristics in filter applications requiring minimum distortion of the transmitted signal. The systems engineer must give proper attention to this requirement. Mathematically, envelope delay may be defined as:

$$T_d = - \frac{d\beta}{d\omega}$$

Where: T_d = envelope delay in seconds
 β = phase shift in radians
 ω = angular frequency in radians per second

To hold distortion to a minimum, the envelope delay must be nearly constant over the entire frequency spectrum of the transmitted signal. It is the constancy of envelope delay rather than the actual magnitude of the delay which governs a network's ability to transmit a complex wave form without introducing objectionable distortion. The distortion arising from non-constant envelope delay is termed envelope delay distortion. From the above equation it is apparent that T_d is constant as long as phase shift varies linearly with frequency. Unfortunately, the realization of a filter network with perfectly linear phase shift over its entire pass band is not always practical or even possible. For this reason, the systems engineer should carefully evaluate the degree of constancy of T_d which his system requires as well as the range of frequencies over which T_d must be maintained nearly constant.

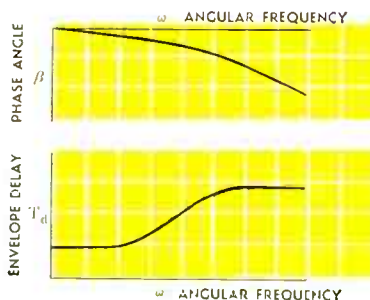

FIG. I Illustrates the relationship between phase shift and envelope delay.

The effect of envelope delay distortion on a transmitted signal is illustrated in figure 2. Figure 2 (a) shows the input signal. It is composed of a fundamental frequency plus the third and fifth harmonics. Figure 2 (b) shows the output signal. The network has shifted the fundamental frequency by 45° , the third harmonic by 90° and the fifth harmonic by 180° . The net result of such non-linear phase shift is a highly distorted output signal. If components of the wave had been shifted 45° , 135° and 225° respectively, the signal would have been transmitted without distortion.

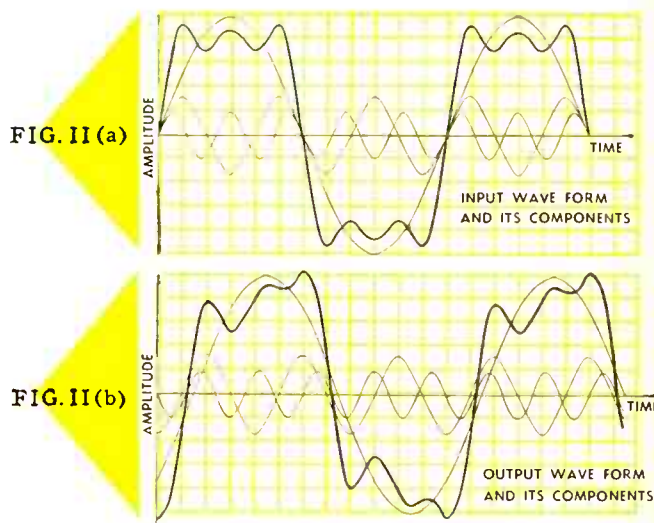

FIG. II (a)

FIG. II (b)

Since envelope delay is defined as the derivative of phase with respect to frequency, exact measurement of envelope delay is difficult. In practice, however, envelope delay may be approximated by the following definition:

$$T_{\Delta d} = - \left(\frac{\theta_2 - \theta_1}{f_2 - f_1} \right) \frac{1}{360}$$

Where: θ_2 = phase angle in degrees at f_2

θ_1 = phase angle in degrees at f_1

f_2 = frequency in cycles per second at which phase shift equals θ_2

f_1 = frequency in cycles per second at which phase shift equals θ_1

$T_{\Delta d}$ is the average envelope delay between f_2 and f_1 . By convention, $T_{\Delta d}$ is assumed to be the envelope delay at a frequency equal to $\frac{1}{2}(f_1 + f_2)$. When the approximate formula is used to calculate envelope delay from empirical phase shift versus frequency data, it should be remembered that the approximation holds only for small differences between f_1 and f_2 .



The IBM "650" computer services maintained at Sangamo materially aid our design engineers in solving complicated networks for envelope delay, phase shift and attenuation characteristics.

Write for Inductive Component Bulletin Series IC-260

SC-59-7

SANGAMO ELECTRIC COMPANY, Springfield, Illinois

--designing towards the promise of tomorrow

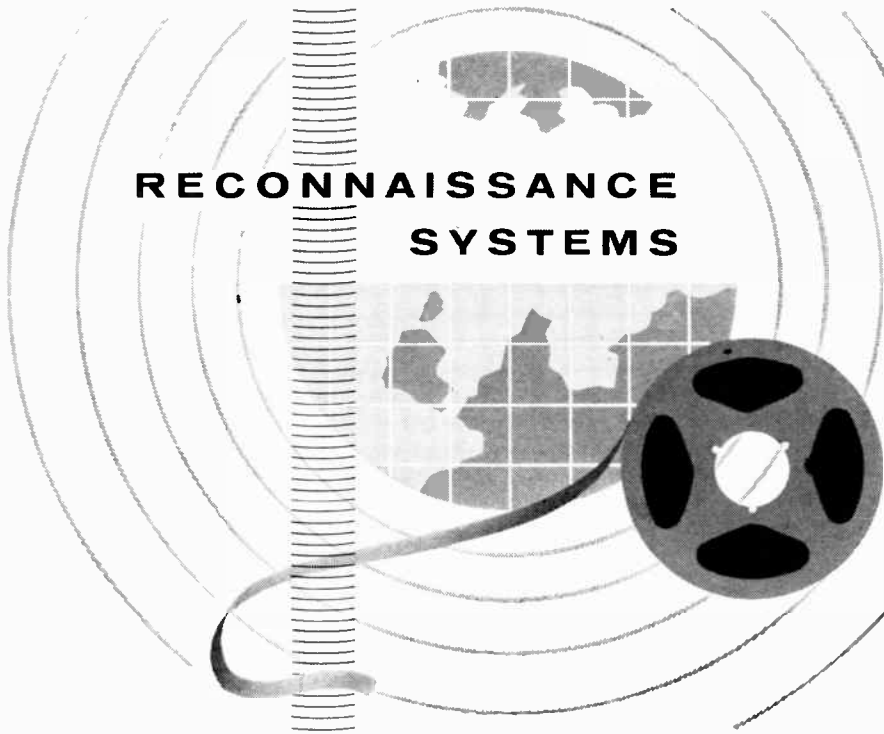

ADVANCED RECONNAISSANCE system developments at **Melpar** provide unusual opportunities for the technical advancement of participating professional personnel. Technological challenge in an area vital to our national defense assures our engineers and scientists that their contributions will have lasting significance. **Melpar's** reconnaissance systems engineering department has achieved national recognition for its outstanding accomplishments in the fields of acquisition, processing, and interpretation of intelligence. Techniques resulting from our deep probes into advanced aspects of electronics, optics, and physics are being quickly translated into operational equipment for the armed forces.

Positions in the following areas offer particular challenge at this time:

- | | |
|------------------------------------|------------------------------------|
| Reconnaissance Systems | Detection & Identification Systems |
| Airbourne Equipment | Antenna & Radiation Systems |
| Ground Data Handling Equipment | Chemistry Laboratory |
| Simulation & Training Systems | Applied Physics Laboratory |
| Communication & Navigation Systems | Production Engineering |
| Ground Support Equipment | Quality Control |

Melpar's remarkable growth continues to create attractive opportunities for the exceptional engineer and scientist. Your own intellectual dimensions govern remuneration and assignments.

INTERVIEWS ARRANGED IN YOUR LOCALE

*For Details
Wire Collect or Write to:
Professional
Employment Supervisor*



A SUBSIDIARY OF WESTINGHOUSE AIR BRAKE COMPANY
3306 Arlington Boulevard, Falls Church, Virginia
In Historic Fairfax County
10 miles from Washington, D. C.

proper order in a simple jig. This assembly is introduced into a vacuum and heated to a high temperature. The combination of heat and vacuum serves to degas the tube, activate the cathode, and braze together the metallized surfaces of the ceramic wafers to make a hermetically sealed unit in a single operation.

This processing is carried out in a continuous vacuum furnace. It is essentially a long vertical pipe of heat-resistant alloy steel, surrounded by a heating unit, and open to the atmosphere at both ends. Through the pipe passes a series of hollow carriers containing tube assemblies. Adjacent carriers are separated by short pistons fitting closely inside the pipe. These parts are introduced into the top of the pipe at atmospheric pressure; once inside, the air is evacuated through ports along the side of the pipe and through holes in the carriers. After processing, the parts are removed from the lower end of the pipe, at atmospheric pressure and at reduced temperature. The ceramic tubes are then ready for testing.

Evaluation

Tubes produced by this method were tested at normal electrical operating conditions for more than 1,000 hrs at room temperature and at 300 C. with less than 15 percent change in transconductance. They were also subjected to shock without loss of characteristics and vibrated at 15 g with noise output of less than 100 mv over the complete audio range.

Development Program

The wafer tube was conceived as part of an electronics development program formerly code-named Project Tinkertoy: The Modular Design and Mechanized Production of Electronics. The basic objective in establishing this project, sponsored at NBS by the Navy Bureau of Aeronautics, was the development of facilities or systems suitable for rapid mobilization in emergency periods. Circuitry and component activity was brought to a pre-scheduled conclusion in 1956, and private industry has carried it on since then. However, the tube development part of the program has been

continued by the National Bureau of Standards.

REFERENCE

(1) Project Tinkertoy, *NBS Tech News Bul.* 37, 11 Nov. 1953.

Advanced Image Tube Now Being Developed

IMAGE TUBES can make present optical telescopes equal, in observing power, to instruments 2½ times their actual size. Such tubes contain a sensitive surface of cesium with an antimony base. They do the work of coarse-grained photographic plates in telescopes, but much better.

Gerald E. Kron, astronomer at the University of California's Lick Laboratory, has been working full time for over half a year to develop an improved image tube, and now reports excellent progress.

The best image tube made so far has been designed by Andre Lallemand, a French astronomer. However, the key component of this instrument—the sensitive cesium surface—must be sacrificed after each experiment, and tedious procedures repeated to put the tube back into operation.

In an image tube, the cesium-antimony cell is the cathode in an electronic circuit. When photons, or packets of light energy from a star under observation, strike this cathode, electrons come off the other side of the surface. These electrons are accelerated towards the anode, a fine grain photographic film.

The electrons are focused sharply by a series of charged, annular rings through which they pass. The film makes a permanent record of the image. However, the cesium surface is easily contaminated. Kron is designing a very high vacuum unit, free of contamination, into which he can insert and remove films routinely without cell damage. He reports significant progress using the latest vacuum techniques and substituting fluorine plastics for rubber. A two-inch field, now used, would cover the whole field of the prime focus for the 120-inch telescope nearing completion at Lick Laboratory, and would make it equal to a 300-inch telescope.

BENDIX

TRANSISTOR

VERSATILITY

POWER SUPPLY • AUDIO AMPLIFIER (CLASS A OR B) • AUDIO OSCILLATOR • POWER SWITCH • TRANSISTOR DRIVER • SERVO CONTROL • RELAY DRIVER • MOTOR CONTROL



CHECKMATE HIGH COSTS AND DESIGN LIMITATIONS

The new Bendix™ "yeoman" driver transistor series is engineered to perform over a wide range of audio frequency applications. The new 2N1176 series will find broad use wherever reliability, versatility and low cost are primary design requirements.

Each of the three "yeoman" models, 2N1176, 2N1176A and 2N1176B, has a different voltage rating, but all are contained in a rugged, welded JEDEC TO-9 package. Dissipation ratings are 300 mW at 25°C and 50 mW at 75°C. Higher voltage rating and high current gain coupled with a more linear current gain curve yield low distortion and efficient switching. Saturation resistance

is very low—typical values are 1 ohm measured at 100 mAdc.

Write today for the new Bendix Semiconductor Catalog for more information on our complete line of power transistors, power rectifiers and driver transistors. SEMICONDUCTOR PRODUCTS, BENDIX AVIATION CORPORATION, LONG BRANCH, N. J.

	MAXIMUM RATINGS				TYPICAL OPERATION	
	Vce Vdc	Ic mAdc	Pc mW	Tj °C	Current Gain hFE at Ic	
2N1176	15	300	300	85	50	10 mAdc
2N1176A	40	300	300	85	50	10
2N1176B	60	300	300	85	50	10

West Coast Sales Office: 117 E. Providencia Avenue, Burbank, California
 Midwest Sales Office: 4104 N. Harlem Avenue, Chicago 34, Illinois
 New England Sales Office: 4 Lloyd Road, Tewksbury, Massachusetts
 Export Sales Office: Bendix International Division, 205 E. 42nd Street, New York 17, New York
 Canadian Affiliate: Computing Devices of Canada, Ltd., P.O. Box 508, Ottawa 4, Ontario, Canada

Red Bank Division



Ferrules Shield Multiconductor Cable

By FREDERICK C. MARCH, Omaton Div., Burndy Corp., Norwalk, Conn.

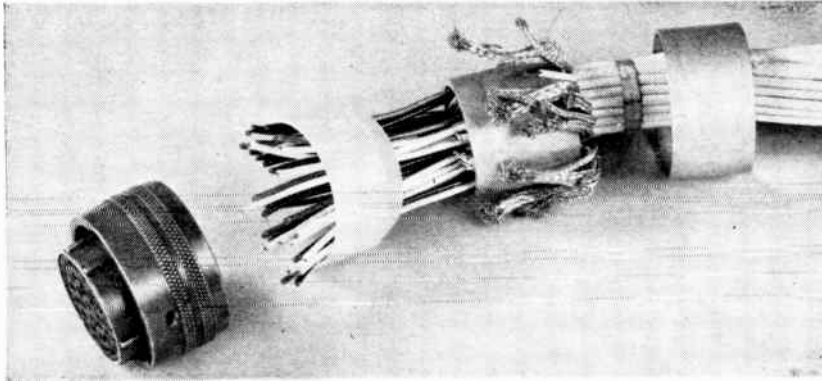

Exploded view of cable ends prepared for terminating. Left to right are miniature connector, potting shell, inner and outer ferrules. Individual conductors are pulled through braid shielding. All shields are folded back under inner ferrule and then brought back over the ferrule

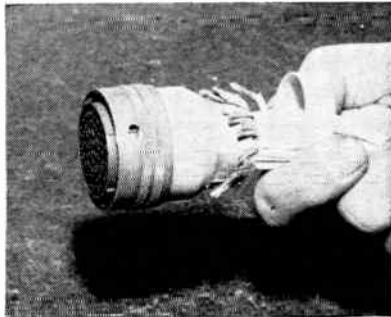

Assembled and potted connector ready for termination of shields. All conductor ends are stripped and attached to connector contacts. Potting shell and inner ferrule are in position

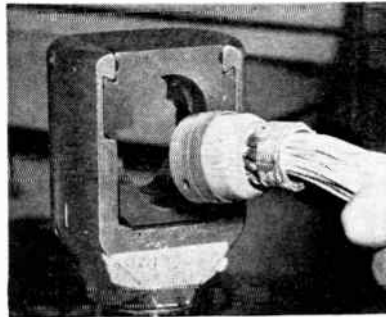

Completed cable assembly. Outer ferrule is slipped forward and positioned over conductor shields and ground wire. Assembly is crimped in Hypress compression tool with proper die set

TERMINATING SHIELDS on multiconductor cable used with round connectors can be troublesome. Space limitations prevent bridling the individual shields with standard compression type connectors for shielded cable.

For the Thor and Jupiter missile programs, a series of large Hyring compression sheath connectors were developed. These permitted grounding all shields by a single ground wire, terminated in a pin or socket of the AN type connector.

The problem was intensified in cable assemblies for the new solid-fueled Pershing missile, where there is even less space behind the connector for terminating the shields.

The solution was to shorten both the inner and outer ferrule of the connector and to develop a new ter-

mination technique (with Army Ballistic Missile Agency laboratory, Redstone Arsenal and the prime contractor, The Martin Company, Orlando, Fla.) Both ferrules have been designed dimensionally for each standard shell size from No. 8 through No. 24. The photographs



Old method (left) and new. Formerly all shields and the ground wire were soldered to common points. New technique grounds shield compactly, economically

show assembly steps and compare the new technique with the old method of soldering shields and ground wires to common points.

Martin has found that the new procedure speeds production and cuts costs appreciably. Sample installations by Burndy indicate that the time required to terminate the shields of a 50-conductor cable, for example, can be cut from about 5 hours to as many minutes.

Copper Braze Allows Steel Heat Treating

SILVER BRAZING is commonly used in electronic production. But copper brazing is an alternative method which permits high temperature processing after brazing.

The following method of copper brazing was devised by John Gombos Co., Clifton, N. J. to fix 52100 tool steel pivots on RH Monel gyro gimbals. The steel is hardened to a minimum of Rockwell 60 after brazing. A customer had specified silver braze, which was consistently damaged by the temperatures required for heat treating. Copper, 99.9 per cent pure, allowed a successful braze, without flux.

Gimbal brazing surfaces are finished to 32 microfinish or better and ultrasonically cleaned. Braze areas are liquid honed with a glass particle compound (Brite Blast 1,000) to clean any oxidation and slightly roughen the surface to facilitate brazing.

The castings are rinsed and stored in water. The honing is done just before brazing and underwater storage prevents oxidation in the interim. This method will also protect other high nickel alloys, Gombos reports.

Pivot braze areas are plated with 0.0005 inch of pure copper. The plating is the braze material. A copper braze ring is also used to provide a fillet. Gloved hands are used to assemble the gimbals, pivots

AT LAST!

Instrumentation Amplifiers with no moving parts

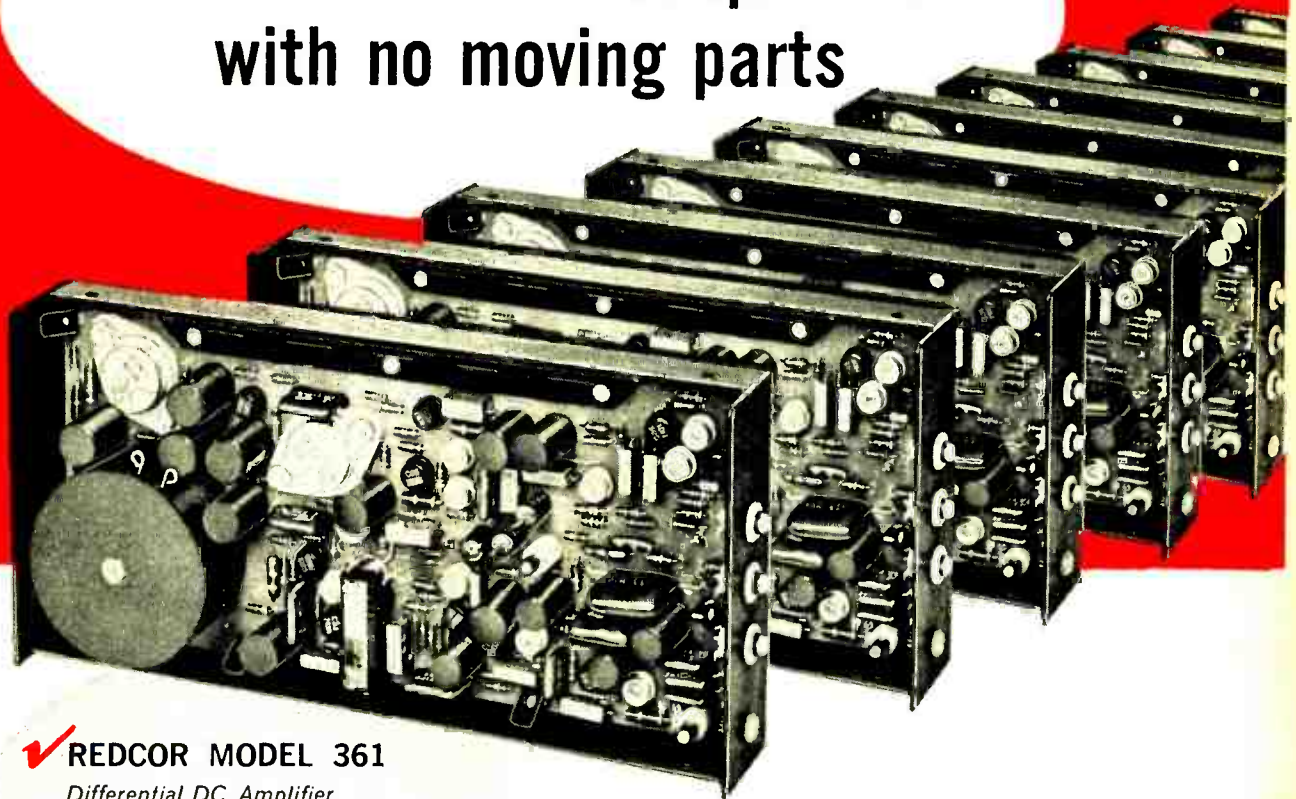

✓ REDCOR MODEL 361

Differential DC Amplifier

- 200 KC Bandwidth
- 100 megohm input impedance
- 120 db common mode rejection

REDCOR MODEL 259

Operational DC Amplifier

- 200 KC Bandwidth
- 0.001 ohm output impedance at dc
- .03% gain accuracy

REDCOR MODEL 260

Potentiometric DC Amplifier

- 200 KC Bandwidth
- 100 megohm input impedance
- 0.002% gain accuracy

New Transistorized Choppers mean Low Noise...High Reliability

Here is the first line of completely solid state amplifiers with solid state choppers for DC stabilization. These long life amplifiers have integral power supplies and operate over a wide temperature range. They meet the urgent need for wide-band, highly accurate amplification where noise reduction and reliability are of prime importance.

Redcor Development Corp.
Van Nuys, Calif.
Technically Represented By



PACKARD BELL COMPUTER CORP.

1905 Armacost Avenue, Los Angeles 25, California • GR 8-4247

HOW **SICKLES** SOLVED

the impossible!

DELAY LINE FOR A MISSILE

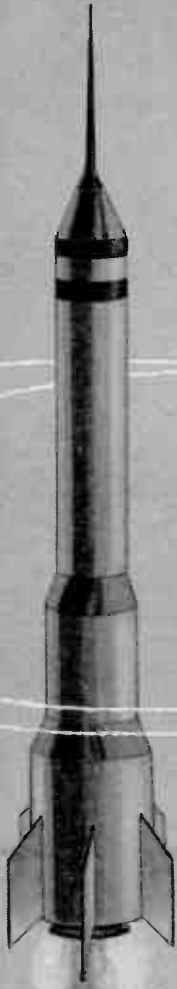

2½ times smaller than standard
...and a ratio of better than 60!

Everyone stubbed his toe on this project, until Sickles engineers used their skill. Needed for an important missile development, the delay line had to meet all the extreme environmental conditions inherent in space flight and occupy 30% less space than usual.

Because Sickles has no "standard" line, nor any pre-conceived notions, we developed some special tricks. With the customer's cooperation our engineers concentrated on the important requirements and attained a high degree of precision in all electrical parameters. The result is an unorthodox — but highly successful — multiple section lumped constant line with a delay to rise time ratio of better than 60 to 1. And it fits neatly into a space most engineers thought unfeasible.

Sickles' specialized skills and vast production capacity *plus* experience and creative imagination can help solve your delay line problem too. May we have a qualified representative discuss it with you? For information, write to Section 60.

F. W. SICKLES DIVISION

/General Instrument Corporation

Leaders in electronic coil winding
and assembly since 1921



165 Front Street (P. O. Box 330) Chicopee, Mass.

Other plants in Joliet, Ill. and Waterloo, Ont., Canada

GENERAL INSTRUMENT CORPORATION INCLUDES F. W. SICKLES DIVISION,
AUTOMATIC MANUFACTURING DIVISION, RADIO RECEPTOR COMPANY, INC.
AND MICAMOLD ELECTRONICS MANUFACTURING CORPORATION (SUBSIDIARIES)

and rings in the brazing fixtures.

Brazing is done in a pusher type furnace in dissociated ammonia, or in a bell type furnace in dry hydrogen.



Completed assembly. Pivots are brazed to Monel body



Liquid honing prepares braze areas by cleaning and roughening



Water protects cleaned nickel alloy during temporary storage

Temperature is held at 2,050 F for 25 to 35 minutes. The assembly is cooled in an atmosphere chamber for 35 to 45 minutes.

The steel is annealed in an atmosphere furnace for 2 hours at 1,250 F and then is cooled at 50 degrees an hour. After machining, it is hardened in a neutral atmosphere or neutral salt bath at 1,525 to 1,550 F and quenched in oil at 110 to 140 F. It is tempered in an air furnace at 250 F for 2 hours. Finish machining follows.

Only the pivot is hardened since the temperatures used are not high enough to disturb the Monel. The Monel is stress-relieved, however. Low sulfur oil is used for machining and quenching. Castings and pivots are periodically checked by Die

The **WHY** and **HOW** of your own copies of **electronics**

SPECIAL ISSUES TO COME

**Electronic Instruments for
Design and Production**

**Sophisticated Communications
Methods**

**Materials for Environmental
Extremes**

Electronics Statistics

**PRESENT
SUBSCRIBERS**

This subscription card is for NEW subscribers. It is not intended as a renewal notice. If you are already personally subscribing, we shall appreciate your passing the form to one of your associates. Thank you.

ELECTRONICS now brings you . . .

. . . latest technological and economic data and what it means to the Electronics Industry — and to you!

Every Friday, your personal subscription to *ELECTRONICS* delivers to you an ALL-IN-ONE fact-packed manual — the easy, practical way to make sure you're among the best informed electronic engineers and managers.

Specifically, each issue will cover Design, Research, Engineering, and Manufacturing . . . plus the Trends, Economic Developments, Markets, and Production Figures which interrelate with the Technical Breakthroughs and Economic Pressures.

YOUR PERSONAL SUBSCRIPTION TO "ELECTRONICS" TOTALLY INFORMS YOU

...and HERE'S HOW ↴

NEW subscription ORDER FORM

O.K. — put me down for a personal subscription to "electronics" . . . giving me benefit of your weekly editorial service . . .

Please One

- Send bill to home address
- Send bill to company address
- Payment Attached

Check here for 1 year \$6 for 2 years, \$9 for 3 years, \$12

Name _____ Position _____ Dept. _____

Company Name _____

Street _____ City _____ Zone _____ State _____

Products Mfrd. _____ Number of _____
Or Service _____ Employees _____

Check here if you want Publication sent to your home

Street _____ City _____ Zone _____ State _____

L.
M.

Please fill out card completely for best service

Foreign Rates (1 year) Canada \$10, Other Foreign: \$20

HOW
TO GET

YOUR PERSONAL COPY

of

electronics

ISSUED WEEKLY . . . EVERY FRIDAY
ENGINEERING
TECHNICAL DATA
EVERY ISSUE

This expanded service of **ELECTRONICS** provides the most comprehensive and fastest aid for the executive and engineer vitally *concerned with every phase of the electronics industry . . .*

New Ideas! . . . New Circuits! . . . New Engineering Techniques!

Improved Manufacturing Methods! . . . New Design! . . . Advances in Research!

Prompt word about New Electronic Equipment, Parts, and Components!

Latest Word on New Industrial, Scientific and Military Applications!

Sales and Production Figures! . . . Economic Trends to help you make sounder Investment Decisions!

... All the Vital News!

All subscribers get copies of the GIANT BUYER'S GUIDE

SUBSCRIBE PERSONALLY
electronics

for top-value in IDEAS and NEWS

Established 1930 — Pioneer Publication in the Field

FIRST CLASS
PERMIT No. 64
New York, N. Y.

BUSINESS REPLY MAIL

No postage stamp necessary if mailed in the United States

McGRAW-HILL PUBLISHING CO., Inc.

electronics

330 WEST 42nd STREET

NEW YORK 36, N. Y.

**Use this
handy
order card..**

**to profit by
ELECTRONICS
weekly
editorial service**

Check, Magnaflux or Zyglo methods to determine if any cracks or other defects have occurred.

Tapered Mandrel Puts Retainers onto Shaft

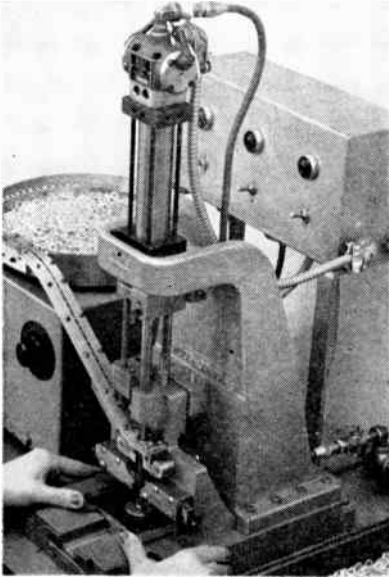

Hopper-fed station rapidly places retaining rings on control knob shaft

RETAINING RINGS may be automatically placed on assemblies by pushing them down over a free-floating tapered mandrel. The assembly station shown was developed by Waldes Kohinoor, Inc., Long Island City, N. Y., to place its external-type Series 5100 rings on a control knob stud and disc assembly.

Rings fed from a vibratory hopper are fed one at a time by an escapement. They drop onto the narrow upper portion of the mandrel and are pushed down by a sleeve. The rings are expanded by the bottom of the mandrel, slightly larger in diameter than the control knob shaft, and snap into a groove in the shaft.

Initially 2 mechanical fingers hold the mandrel upright. As the sleeve descends, the fingers are pushed aside and the mandrel is supported by the workpiece. As the sleeve retracts, the fingers return to support position and a bracket on the sleeve actuates the escapement.

Machines vary according to application. In most cases, Waldes Kohinoor supplies the ring user with basic components or construction plans.



NEW FROM SPECTROL

The Industry's First Complete Line of

METAL

Multi-Turn Precision Potentiometers



Spectrol's sturdy new metal multi-turns are as tough to push out of shape as Sir Spectrol, our man in armor. Available in eight models, featuring anodized aluminum cases with 3/16 inch thick walls that absorb no moisture—dissipate more heat faster and stay dimensionally stable. These armored pots, four 3-turn and four 10-turn, will operate from -55°C to $+125^{\circ}\text{C}$ and withstand relative humidity of 95%.

You can choose diameters of 7/8, 1, 1-5/16 and 1-13/16 inches in both three and 10-turn models. Standard linearity tolerance is $\pm 0.25\%$ with special linearity available to $\pm 0.020\%$. Like Sir Spectrol, the man in the iron suit, the new metal multi-turns will take a respectable jolt. They function to 20g vibration from 55 to 2,000 cps and withstand 30g shocks.

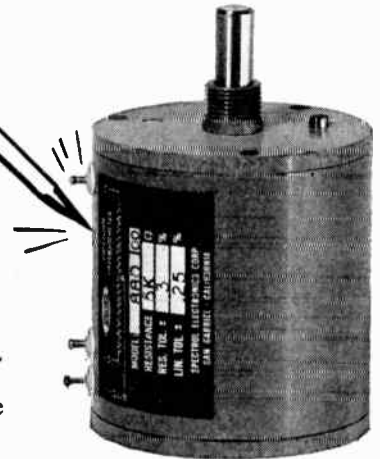

For more details, call your Spectrol engineering representative listed in the yellow pages or write us direct. Please address Dept. 18A.

MODEL	540	530	580	560	780	790	880	840
No. of coil turns	10	3	10	3	10	3	10	3
Diameter (inches max.)	7/8	7/8	1	1	1 1/8	1 1/8	1 1/8	1 1/8
Standard resistance range in ohms ($\pm 3\%$)	25-125K	10-36K	25-150K	10-40K	30-300K	10-90K	50-400K	20-120K
Special resistance to	250K	75K	250K	75K	750K	240K	1 meg	330K



ELECTRONICS CORPORATION

1704 South Del Mar Avenue
San Gabriel, California

Be sure your pot's in armor!

On The Market

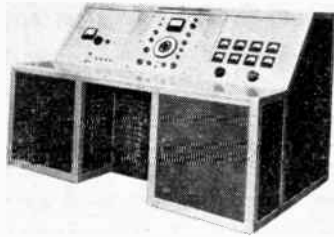

Power Amplifier 3-kw unit

MB ELECTRONICS, 20 Fitch St., New Haven 11, Conn. Model T-151 is a 3-kw power amplifier for vibration testing. The console unit's distortion is less than 5 percent at full

output. Noise and hum level is at least 40 db below signal level at full output. Unit features a new automatic power-factor corrector, and a new 5-5,000 cps wide band cycling oscillator with automatic acceleration and displacement control.

CIRCLE 200 ON READER SERVICE CARD

A-C Voltmeter transistorized

HEWLETT-PACKARD Co., 275 Page Mill Road, Palo Alto, Calif. Model 403A portable, battery-operated a-c voltmeter has a useful frequency range of 1 cps to 1 mc. It measures a-c voltages from 1 mv full scale to 300 v full scale with

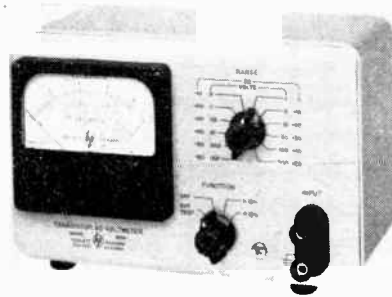

an accuracy of ± 5 percent from 5 cps to 500 kc, and ± 5 percent above and below this range. Unit has 12 voltage ranges and also reads db from -72 to +52 db. Battery life is 400 hr. Noise is less than 50 μ v, and the instrument is completely isolated from power line or ground interference. Price is \$250.

CIRCLE 201 ON READER SERVICE CARD

Thermistor Bridge precision unit

WEINSCHEL ENGINEERING, 10503 Metropolitan Ave., Kensington, Md. Model TB-2 d-c thermistor bridge is completely self-contained except

for the external thermistor mount and has an accuracy of $\frac{1}{10}$ of 1 percent of substituted power. This equipment is designed for use in the calibration of the output of signal generators at 1,000 mw.

CIRCLE 202 ON READER SERVICE CARD

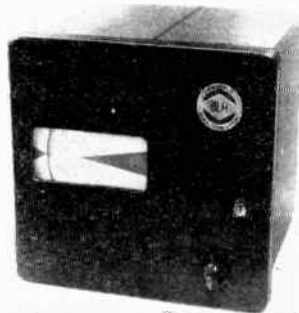

Disk Indicator medium-sized

BALDWIN-LIMA-HAMILTON CORP., 42 Fourth Ave., Waltham 54, Mass. The SR-4 type 12 disk indicator was developed specifically for use in measuring and control systems which employ resistance strain gage transducers. It provides the accuracy and ease-of-reading of larger

units, but requires less than a sq ft of panel area for mounting. It features a horizontal read-out window and up to 500 engraved dial graduations for fast, accurate reading. Unit is an automatic, null-balance type using a servo-driven slide wire to balance an internal bridge circuit. Specified accuracy is ± 0.15 percent of full scale.

CIRCLE 203 ON READER SERVICE CARD

Terminal Block side entry type

TWIN LOCK INC., 1024 W. Hillcrest Blvd., Inglewood, Calif. The T-1010 side entry terminal block is largely designed for use with ground support equipment such as missile launchers, trailers and test stand equipment. It is constructed of a

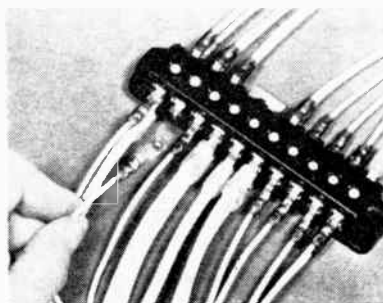

molded phenolic base with reinforced barriers between the numbered, easily-read terminal cavities; one cavity will accommodate four terminals. Up to 40 connections can be made with one block. Adjacent terminals can be bussed together with TwinLock jumpers. Block measures 5 in. long by 1 1/4 in. wide by 1 1/4 in. high. Terminal lugs

FAST DELIVERY

DC

AC



NEW

**PRECISION
DC - AC
DIFFERENTIAL
VOLTMETER**

MODEL 803
\$845.00

NOW . . . make precise measurements of either DC or AC voltages with this all new jf instrument. Use the 803 as an AC Differential Voltmeter, DC Potentiometer or DC/AC VTVM. Actually 3 INSTRUMENTS IN ONE.

- FEATURES**
1. Standard Cell Reference
 2. Direct in-line readout
 3. Mirror Scale Meter
 4. Eight Search and four Null ranges

DC

AC

Accuracy: .05% from .1 volt to 500 volts
 Input voltage ranges: 500-50-5-.5v
 Null ranges: 10-1-.1-.01v
 Input Resistance: Infinite at Null
 Resolution: .005v at 500v to .00005v at .1v

Accuracy: .2% from .5 volt to 500 volts from 30 CPS to 5 KC
 Input voltage ranges: 500-50-5v
 Null ranges: 10-1-.1-.01v
 Input Impedance: 1 Meg. shunted by approx. 25 mmf
 Resolution: .005v at 500v to .00005v at .1v

For complete details of the new jf Model 803 write direct or contact our engineering representative in your area
 Cabinet Size: 9 3/4 x 13 x 17—Price: \$845.00 F.O.B. Seattle factory

JOHN FLUKE MANUFACTURING CO., INC.
 1111 West Nickerson - Seattle 99, Washington



and block sockets are gold plated to meet environmental conditions of salt spray and humidity.

CIRCLE 204 ON READER SERVICE CARD



F-M Receiver

less than 200 w drain

ALTO SCIENTIFIC Co., INC., 855 Commercial St., Palo Alto, Calif. Model XN-305-A f-m receiver can be tuned ± 15 mc from its center frequency of 288 mc. With an input sensitivity (for limiting) of 10 mv, a video output of 2 v peak is obtained with a 20 mc swing. The instrument's output discriminator has a linearity of 5 percent over a 20 mc band, while the total i-f bandwidth is 24 mc. Video response ranges from 100 cps to $4\frac{1}{2}$ mc.

CIRCLE 205 ON READER SERVICE CARD

Power Transistors series of nine

BENDIX AVIATION CORP., Long Branch, N. J. Series of nine power transistors with high d-c current gain and flat beta curve for power switching and power control. Industrial applications include d-c/d-c converters, d-c/a-c inverters, static converters and regulators, relay replacements and drivers for relays, magnetic clutches, and solenoids.

CIRCLE 206 ON READER SERVICE CARD

microminiature toroidal inductors for printed circuit use are supplied with inductances up to 500 mh; recommended frequency is 30 kc max; Q is greater than 55 at 25 kc; size is 0.437 o-d by $\frac{1}{2}$ in.; spacing between leads 0.3 in., and weight, 0.06 oz. MT 35 inductance is up to 200 mh; frequency, 200 kc max; and Q, over 60 at 100 kc.

CIRCLE 207 ON READER SERVICE CARD

F-M Receiver

less than 200 w drain

ALTO SCIENTIFIC Co., INC., 855 Commercial St., Palo Alto, Calif. Model XN-305-A f-m receiver can be tuned ± 15 mc from its center frequency of 288 mc. With an input sensitivity (for limiting) of 10 mv, a video output of 2 v peak is obtained with a 20 mc swing. The instrument's output discriminator has a linearity of 5 percent over a 20 mc band, while the total i-f bandwidth is 24 mc. Video response ranges from 100 cps to $4\frac{1}{2}$ mc.

CIRCLE 205 ON READER SERVICE CARD

Toroidal Inductors to 500 mh

BURNELL & Co., 10 Pelham Parkway, Pelham, N. Y. MT 34 Kernel

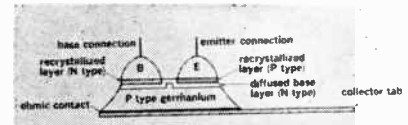

PNP Transistor 70 mc cut-off

AMPEREX ELECTRONIC CORP., 230 Duffy Ave., Hicksville, L. I., N. Y. Type OC170 germanium transistor, with its high cut-off frequency of 70 mc and high gain (average beta is 80), is designed for use in the vhf band as a mixer oscillator for mobile radio equipment, car radios and short wave receivers, and as an

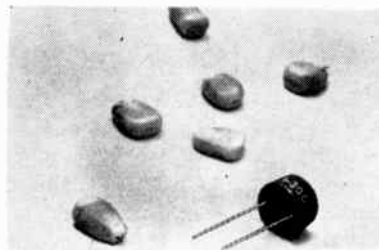

NOW!

Test Transistor Beta in the Circuit!

The new Sierra Model 219A Transistor Tester represents a genuine technical breakthrough—for the first time commercial equipment is available permitting in-circuit Beta testing of transistors. The instrument also readily measures Beta and collector current parameters with the transistor removed from its circuit.

The new Sierra 219A can save hours of troubleshooting and service time since testing is done without energizing equipment under test. Thus there are no spurious signals to confuse results. Low impedance design in both input and output circuits nullifies the effects of external circuitry.

Model 219A is compact, rugged, conservatively rated and built of high quality components throughout. Please request Bulletin from your Sierra representative or write direct.

sierra



SIERRA ELECTRONIC CORPORATION

A Subsidiary of Philco Corporation

5545A Bohannon Drive • Davenport 6-2060 • Menlo Park, Calif., U.S.A.

Sales representatives in all major cities

Canada: Atlas Instrument Corporation, Ltd., Toronto, Montreal, Vancouver, Winnipeg

Export: Frazar & Hansen, Ltd., San Francisco, New York, Los Angeles

r-f and i-f amplifier for f-m receivers. Units feature uniform characteristics and are priced at less than \$2. They are manufactured by the new alloy-diffusion process, a method said to combine the best features of the alloy and diffusion processes, without their drawbacks.

CIRCLE 208 ON READER SERVICE CARD

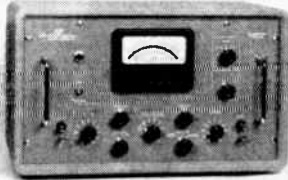

Phase Angle Meter highly accurate

AD-YU ELECTRONICS LAB., INC., 249 Terhune Ave., Passaic, N. J. Vectorlyzer can be used to measure very small phase angles (such as a fraction of 1 deg) with maximum error of 0.02 deg or 2 percent and a sensitivity of 1 deg full scale. Phase angle range is 0-1, 0-2, 0-4,



JERROLD'S

900A Sweep Generator Covers the Range of Three Regular Instruments!

The industry's most versatile Sweep Generator! Covers all your needs from 1/2 MC to 1200 MCS for IF's, radar, video, telemetering, communications.

Specifications: In two ranges—0.5 MC to 400 MC and 275 MC to 1200 MC—with center at any frequency from 500 KC to 100 MC and with sweep widths as broad as 400 MC and as narrow as 100 KC. The RF output is flat within ± 0.5 db at full sweep width up to 800 MCS and ± 1.5 db from 800 MCS to 1200 MCS. When using sweep widths as narrow as 20 MCS flatness is approximately ± 0.15 db. **\$1260.00**

Write today for on the spot demonstration of Jerrold 900A!

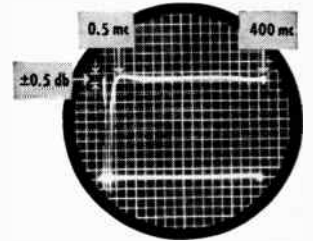

- **HIGH OUTPUT!**
 .25 volt RMS on VHF—.5 volt RMS on UHF
- **WIDE SWEEP WIDTHS!**
 VHF—100 KC to 400 MCS
 UHF—100 KC to 40% or more of C.F.
- **FLAT OUTPUT!**
 Flat to $\pm .5$ db on widest sweep width



JERROLD ELECTRONICS CORPORATION • Industrial Products Division

Dept. TED 47, The Jerrold Building, Philadelphia 32, Pa.

Jerrold Electronics (Canada) Limited

Export Representative: Roche International, New York 16, N.Y.

CIRCLE 138 ON READER SERVICE CARD

NEW MONITOR OSCILLOSCOPES

View up to 7 circuits simultaneously!

New Sierra Model 218 Monitor Oscilloscopes provide, in the smallest possible package, a convenient and practical means for viewing and evaluating complex voltages. Up to seven oscilloscopes can be mounted side by side in a standard relay rack—units measure only 10 1/2" high x 2 1/8" wide (front panel). Thus seven circuits can be monitored simultaneously.

Designed primarily for tape recording and data handling systems, the Monitor Oscilloscopes are particularly suited for measuring and analyzing mechanical quantities through a transducer. Such quantities include stress, strain

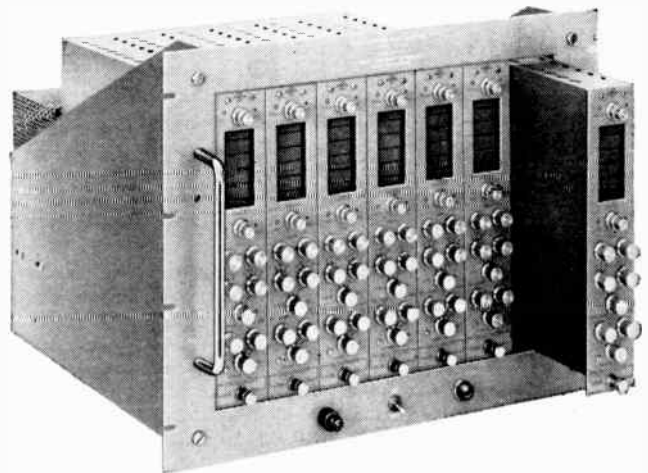

and vibration, pressure, displacement and acceleration.

The units are compact, rugged, and conservatively engineered from high quality components. Please request Bulletin and demonstration from your Sierra representative, or write direct.



SIERRA ELECTRONIC CORPORATION

A Subsidiary of Philco Corporation

5446A Bohannon Drive • DAVENPORT 6-2060 • Menlo Park, California, U.S.A.

Sales representatives in all major cities

Canada: Atlas Instrument Corporation, Ltd., Toronto, Montreal, Vancouver, Winnipeg

Export: Frazer & Hansen, Ltd., San Francisco, New York, Los Angeles

5446

CURTISS-WRIGHT CORPORATION

Offers Opportunities for Electronics Engineers

A continuing program of product expansion by Curtiss-Wright Corporation is creating the need for engineers and scientists. There are various career positions open to men with the right training, experience and talents . . . challenging projects, rewards and recognition.

ELECTRONICS DIVISION CARLSTADT, N. J.

Electronics Division has four plants, with headquarters at Carlstadt, N. J. Other plants and activities at Caldwell and E. Rutherford, N. J., and at Albuquerque, New Mexico. This division is engaged in the design, development and production of simulation systems for military aircraft, and for commercial jetliners. Additional major projects include simulated and operational radar equipment; anti-submarine sonar; photo reconnaissance trainers; electronic components; instruments; and real time digital computers. Current openings exist for digital computer engineers, radar engineers, sonar engineers, servo engineers, and instrument engineers.

RESEARCH DIVISION QUEHANNA, PA.

The Curtiss-Wright Research Division (40 miles northwest of State College, Pa.) is a major engineering center. Its work is closely coordinated with and supplements the projects at all other divisions. Engineers are needed at all levels for sonics and ultrasonics, circuit design, solid state applications, instrumentation, servos and controls, and communications.

Send resume, including salary requirements, to:

Mr. T. W. Cozine, Mgr.
Executive & Technical
Placement

Curtiss-Wright Corporation
Dept. G-44, Wood-Ridge, N. J.

All replies confidential

CURTISS-WRIGHT
CORPORATION • WOOD-RIDGE, N. J.

0-10, 0-20 and 0-180 deg full scale; frequency range, 20 cps to 150 kc with binding posts, 100 kc to 500 mc with probe; voltage range with binding post, 0.04, 0.1, 0.2, 0.4, 1, 2, 4, 10, 20, 40 and 100 v rms full scale; with probe, 0.4, 2 and 4 v rms full scale.

CIRCLE 209 ON READER SERVICE CARD

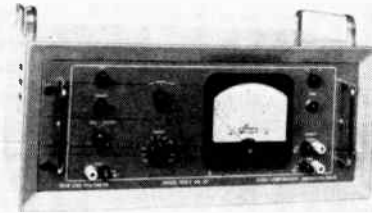

Random Signal Meter high peak factor

FLOW CORP., 85 Mystic St., Arlington 74, Mass. Model TEM-2 is a true rms voltmeter designed specifically for high-accuracy random signal power measurement, either frequency-filtered or broadband. Features include: high peak factor of 10 or more, even for full scale readings; two selectable time constants of 0.5 sec and 16 sec; wide frequency range between 1 cycle and 500 kc; 18 voltage ranges between 0.5 mv and 250 v, extra amplifier and meter outputs, and built-in line regulation.

CIRCLE 210 ON READER SERVICE CARD

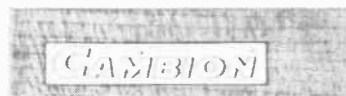

Plug and Jack five shaft lengths

CAMBRIDGE THERMIONIC CORP., 445 Concord Ave., Cambridge 38, Mass. The 2650 combination plug and jack is specifically designed to permit

World Radio History

Call these authorized

Simpson DISTRIBUTORS

for an immediate demonstration or delivery of Simpson Laboratory Test Equipment.

CALIFORNIA

R. V. WEATHERFORD COMPANY
6921 San Fernando Road
GLENDALE 1, Victoria 9-2471

NEWARK ELECTRIC COMPANY
4747 W. Century Blvd.
INGLEWOOD, ORegon 8-0441

ELECTRONIC SUPPLY CORPORATION
2085 East Foothill Blvd.
PASADENA, SYcamore 5-5901

COLORADO

WARD TERRY & COMPANY
70 Rio Grande Blvd.
DENVER, AMherst 6-3181

GEORGIA

ELECTRO TECH EQUIPMENT COMPANY
690 Murphy Avenue S.W.
ATLANTA 10, PLaza 3-4128

ILLINOIS

ALLIED RADIO CORPORATION
100 N. Western Avenue
CHICAGO 80, HAYmarket 1-6800

NEWARK ELECTRIC COMPANY
223 W. Madison Street
CHICAGO 6, SState 2-2944

MICHIGAN

RADIO SPECIALTIES COMPANY
456 Charlotte Avenue
DETROIT 1, TEmple 3-9800

MINNESOTA

NORTHWEST RADIO
123 East First Street
DULUTH 2, RAndolph 7-1565

NORTHWEST RADIO &
ELECTRONICS SUPPLY CO.
52 South Twelfth Street
MINNEAPOLIS 3, FEderal 9-6346

GOPHER ELECTRONICS COMPANY
370 Minnesota Street
SAINT PAUL 1, CApitol 4-9666

NEW YORK

STACK INDUSTRIAL ELECTRONICS, INC.
25 Susquehanna Street
BINGHAMTON, Phone: 3-6326

ELECTRONICS CENTER INCORPORATED
211 West 19th Street
NEW YORK 11, ALgonquin 5-4600

HARRISON RADIO CORPORATION
225 Greenwich Street
NEW YORK 7, BArcley 7-7777

NORTH CAROLINA

SOUTHEASTERN RADIO SUPPLY CO., INC.
414 Hillsboro Street
RALEIGH, TEmple 3-1936

DALTON-HEGE RADIO SUPPLY CO., INC.
912 West 4th Street (Rear)
WINSTON SALEM, Phone: 5-8711

OHIO

PIONEER ELECTRONICS SUPPLY CO.
2115 Prospect Avenue
CLEVELAND 15, SUperior 1-9410

PENNSYLVANIA

CONSOLIDATED RADIO COMPANY
612 Arch Street
PHILADELPHIA 6, WAlnut 5-7871

SOUTH CAROLINA

CAROLINA RADIO SUPPLY CO., INC.
221 W. Washington Street
GREENVILLE, CEdar 2-6740

TEXAS

ENGINEERING SUPPLY COMPANY
6000 Denton Drive
DALLAS 35, FLeewood 7-6121

MIDLAND SPECIALTY COMPANY
500 W. Paisano Drive
EL PASO, KEystone 3-9555

BUSACKER ELECTRONIC EQUIP. CO., INC.
1216 West Clay
HOUSTON 19, JACkson 9-4626

HARRISON EQUIPMENT COMPANY, INC.
1422 San Jacinto Street
HOUSTON 1, CApitol 4-9131

MIDLAND SPECIALTY COMPANY
2101 Andrews Highway
ODESSA, Phone: 7-7212

CIRCLE 139 ON READER SERVICE CARD
SEPTEMBER 25, 1959 • ELECTRONICS

DON'T INVEST IN TEST EQUIPMENT 'TIL YOU COMPARE FEATURES WITH THE

NEW *Simpson* LABORATORY LINE

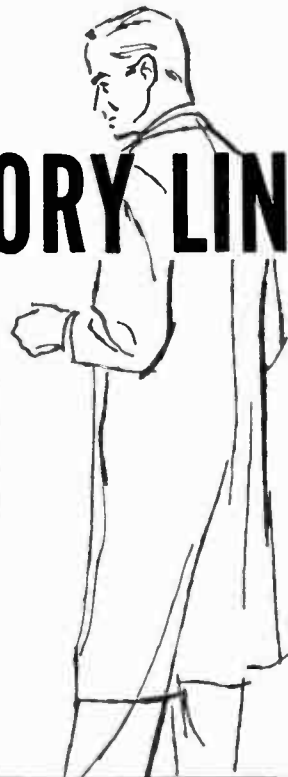

PULSE GENERATOR . . . model 2620

No Unit Offers Such Accuracy, Versatility, and Set-Up Speed Within This Price Range

Twin meters read pulse repetition frequency and pulse duration simultaneously. Rise time is 0.02 microseconds; decay time, 0.03 microseconds. Pulse duration, continuously variable from 0.1 to 1000 microseconds. Jitter, less than 0.005 microseconds. Pulse repetition rate, continuously variable from 10 to 100,000 pps in four ranges. Price **\$625**



WRITE FOR COMPLETE SPECIFICATIONS



WIDE-BAND OSCILLOSCOPE . . . model 2610

For the 1001 Jobs Where You Don't Need an Expensive Specialized Scope

Here's a high-gain scope that makes your test equipment appropriation go farther. Vertical sensitivity, 6 mv RMS. Vertical calibration accuracy, $\pm 3\%$. Response (linear position): DC to 5.0 mc/sec, ± 0.5 db; DC to 8.0 mc/sec, ± 1.5 db. Response (transient position): DC to 3.5 mc/sec, -3 db, and -6 db at 5.0 mc/sec. Triggered and recurrent sweeps. Precalibrated sweep positions of 5, 50, 500, 5000 microseconds. Price **\$575**

WRITE FOR COMPLETE SPECIFICATIONS



LABORATORY STANDARD

VOLT-OHM-MILLIAMMETER . . . model 2600

A Self-Powered Calibrator for Electrical Instrument Maintenance and High Accuracy Testing

Two terminal connections cover all 49 ranges for unusually fast operation. DC accuracy is $\pm 0.5\%$ F.S.; AC, $\pm 0.75\%$ F.S. (at 77°F, 25°C). Separate meters (self shielded movements) for DC and AC readings. Price **\$1620**

WRITE FOR COMPLETE SPECIFICATIONS

AVAILABLE FROM MANY INDUSTRIAL ELECTRONIC DISTRIBUTORS COAST-TO-COAST

Write to Factory for Details

**MANUFACTURERS OF
ELECTRONIC TEST
EQUIPMENT FOR OVER
50 YEARS**

Simpson ELECTRIC COMPANY

5203 West Kinzie St., Chicago 44, Illinois • Telephone: EStebrook 9-1121
In Canada: Bach-Simpson Ltd., London, Ontario

World Radio History

RONDO® "the pack with the built-in shock absorber"

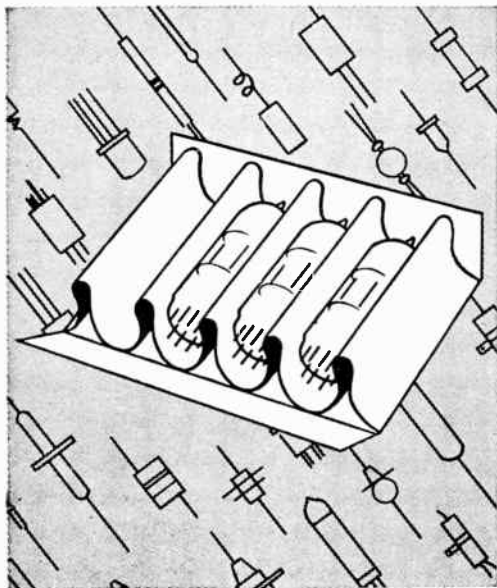

This Unique System

Holds Small Delicate Components by the spring-clip action of its fluted partitions and Offers:

PROTECTION in Handling and Shipping

FACILITY in Production, Storage, and Inventory

CONVENIENCE at Receivers End

ECONOMY in All Phases

RONDO IS A PAPER PRODUCT SOLD AT PAPER PRICES!

ANTI-TARNISH BOARD SUPPLIED

Holds objects from 5/16" to 1 1/4" in diameter.

Further information on request.

Rondo Process and Designs Patented in All Major Countries



RONDO of AMERICA, Inc. 100A SANFORD ST., HAMDEN 14, CONN.

Representatives: C. S. Shotwell, 527 S. Alexandria Ave., Los Angeles 5, Cal., Phone: DUnkirk 8-8879
Brown & Scratch, 664 N. Michigan Ave., Chicago 11, Ill., Phone: SUperior 7-2973

CIRCLE 140 ON READER SERVICE CARD

NOW POSSIBLE...

instant construction of Shielded cables with

NEW! SHIELDED AUTHENTIC Zippertubing

FEATURES:

- Pure metal foil now laminated to the inner surface of Zippertubing for immediate shielded cable.
- Shielded cable at a fraction of the cost of the conventional tin-copper shielding, plus outer jacket.
- Permits emergency and maintenance repair modifications in the field.
- Both high & low frequencies are shielded up to six gaussas with attenuation result up to 1200:1 at 250MC.
- Offered with overlap construction for 100% coverage protection.
- May be stored in flat form with sizes from 1/2" I.D. up.



A strong, durable, yet flexible shielded cover can be applied in minutes. With Shielded Zippertubing a manufacturer can create his own shielded cable at a fraction of the cost and approximately 1/10 of the delivery time. The normal time and labor spent in encasing cables and wire harnesses can be reduced by as much as 90%. No special equipment necessary.



Three ranges of shielding available; light-aluminum, medium-lead, heavy duty-magnetic foil.

SPECIFICATIONS:

Wall Thickness:
.020, .040, .060 AWG

Material:
Plastic saturated fiber glass backed material laminated to various metal foils.

Put-Up:
Available in 25 to 300 foot rolls. Longer lengths available upon specification.

Sizes:
3/8" I.D. up, in increments of 1/8", ± 1/64"

Colors:
Gray. Other colors available on special order.

Zippertubing MANUFACTURED BY
THE ZIPPERTUBING CO.

752 So. San Pedro Street, Los Angeles 14, Calif., Michigan 0831

piggy-backing of patch panels with additional plugs. It can be plugged into a Cambion 2378 jack on a board and another plug can be plugged into it. Equipped with a D slot or key and compression spring for permanent gripping power, the 2650 ensures solid electrical connections at all times. It is available in five shank lengths (0.062, 0.093, 0.125, 0.156 and 0.219 in.), has a 0.045 in. pin, and is processed from quality brass with a bright alloy plate.

CIRCLE 211 ON READER SERVICE CARD



Pulse Transformers kit of ten

CBC ELECTRONICS Co., INC., 2601 N. Howard St., Philadelphia 33, Pa. KA-1 kit consists of ten MIL-T-27 type transformers of the plug-in blocking oscillator and impedance matching types. Hermetically sealed units operate up to 95 C. Included in the standard line are seven different types for various mechanical and electrical applications.

CIRCLE 212 ON READER SERVICE CARD

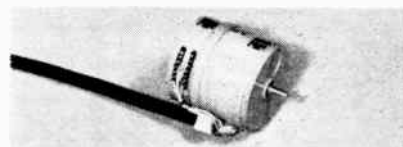

Encoder Assembly small, accurate

DATX CORP., 1307 So. Myrtle Ave., Monrovia, Calif. Resolving shaft positions to 1 part in 36,000 can be done with the CG-702 geared encoder assembly of minimum size and weight. Assembly uses two shaft position encoders and a gear box. Encoder on input shaft provides 1,000 positions of the least significant digit per 360 deg rotation. Because disk of this encoder

Our most potent weapon in the battle of time:

QRC*

In advanced military electronics research, the ability to do the job *isn't good enough*. The job must be done *reliably and on time*.

Hallicrafters' QRC program was originated to provide not only the finest of engineering facilities and people, but the flexibility required for immediate, crash effort on critical electronics problems.

Hallicrafters has provided our military forces for the past six years with a Quick Reaction Capability that has played a major role in helping to win the battle against time.

* Quick Reaction Capability: Refer to Air Force Reg. No. 80-32



hallicrafters
Chicago 24, Ill.

Qualified Engineers: new contracts have created openings. Contact William F. Frankart, Director of Engineering.

CIRCLE 141 ON READER SERVICE CARD



*The tough jobs
get off the ground
in a hurry at ...*

DID YOU KNOW THAT

PRODUCTS ADVERTISED in
electronics BUYERS' GUIDE
are UP-DATED WEEKLY?

Advertisers in the electronics BUYERS' GUIDE use the 52 regular issues of electronics magazine to promote new products and keep the industry informed about their latest technical developments. electronics advertisers are offered the opportunity to up-date their product advertising by keying it to the catalog-type advertising in the BUYERS' GUIDE.

electronics BUYERS' GUIDE
and Reference Issue



A McGraw-Hill Publication
330 West 42nd Street
New York 36, New York



POLARIZED RELAYS

**COMPACT
RUGGED
HIGH SPEED
LONG LIFE
TESTED and
PROVEN**

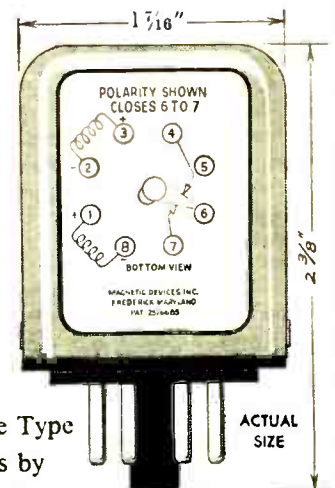

High speed, sensitive Type 300 Polarized Relays by MDI give long operating life—tested and proven by years of military use.

Coil Resistance
25 to 4,000 ohms

Operating Current
2 to 60 MA

Overall Dimensions
1-7/16" x 1-7/16" x 2-3/8"

For full details, write, wire or phone today

MAGNETIC DEVICES. MDI INC.

Dept. E, 712 East Street • Frederick, Md.



NEW MICROWAVE LIMITER

*protects receivers
against overload
and burnout*

Another unique "first" from Microwave Associates, Inc., is this family of all-new solid state devices, which require no external bias and are self-limiting devices. It is the simplest way yet to give radar and communication receivers needed protection.

The specifications chart and performance curve below tell you all you need to know to evaluate its capabilities. The two models are typical of units which can be designed for your applications at other frequencies. The package has female Type N coaxial connectors, for input and output.

Today for UHF . . . tomorrow for higher frequencies.

SPECIFICATIONS

	MA-3400	MA-3401
Frequency (center)	425 \pm 5%	600 \pm 5%
Low Level Insertion Loss	0.3 db	0.5 db
Peak Power	400 watts	200 watts
Duty Cycle	.002	.002
High Level Insertion Loss	20 db	20 db

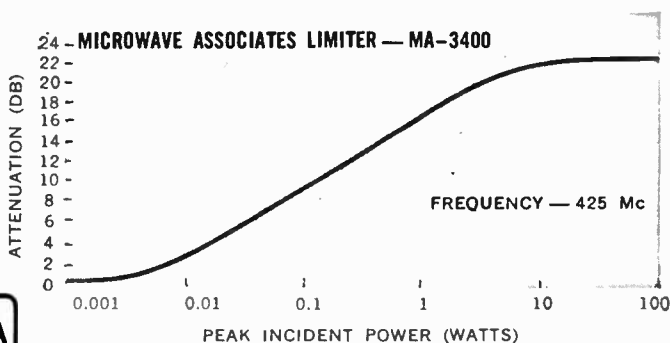

MICROWAVE ASSOCIATES, INC.

BURLINGTON, MASSACHUSETTS • Telephone: BRowning 2-3000

is coupled directly to the input shaft, accuracy is that of the encoder used (± 1 count). This input unit is then geared 36:1 to a 36-position encoder. The low speed encoder utilizes double-brush, lead-lag logic to eliminate ambiguities due to gear inaccuracy and backlash.

CIRCLE 213 ON READER SERVICE CARD

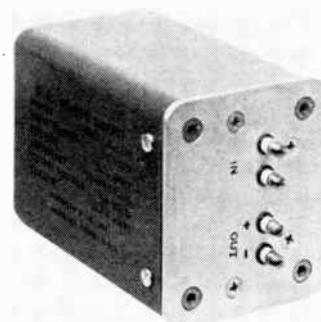

D-C Supplies regulated

SORENSEN & Co., South Norwalk, Conn. QM series miniature, transistorized supplies operate from 115 v a-c, 50-60 or 400 cps. For 50-60 cps input, 36 models cover 9 output voltages, from 3 to 36 v d-c in 14 percent increments, with output power capacities of 2, 4, 8 and 15 w; for 450 cps input, a like number of models is available. Voltage regulation is ± 0.05 percent against line and load variations and ripple is less than 0.01 percent.

CIRCLE 214 ON READER SERVICE CARD

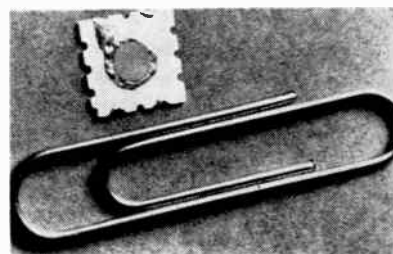

Germanium Diodes micromodule type

GENERAL INSTRUMENT CORP., 65 Gouverneur St., Newark, N. J. Contained in ceramic wafer only 0.01 in. sq and 0.016 in. thick, type F-1 gold-bonded germanium diode converts a-c to d-c, detects radio frequencies and acts as a switching device in computer circuits. Piv is 125; d-c output current, 75 ma; for-

ward current, 100 ma at 1 v max.; max. reverse current at room temperature, 10 μ a at 10 v and 50 μ a at 50 v; at 75 C, 75 μ a at 10 v and 250 μ a at 50 v.

CIRCLE 215 ON READER SERVICE CARD

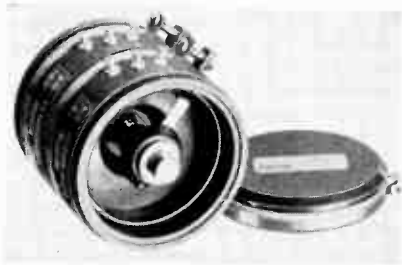

Single-Turn Pot high accuracy

GIANNINI CONTROLS CORP., 918 E. Green St., Pasadena 1, Calif. Model 1750 single-turn precision pot is 1 1/4 in. in diameter and is built to NAS-710 standard, style RR-18. It is highly accurate with linearity to ± 0.1 percent, resolution of 0.030 percent, and total resistances ranging from 10 to 300,000 ohms. Mounting surface is anodized aluminum with cups and rear cover of shock and humidity resistant molded plastic. Unit features versatility since it can be supplied singly, or in externally phaseable ganged units.

CIRCLE 216 ON READER SERVICE CARD

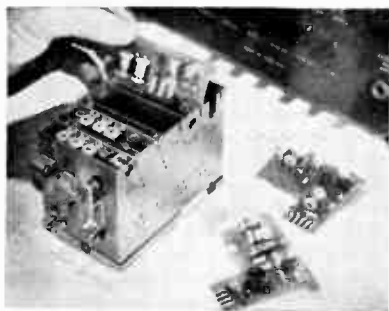

VHF Converter transistorized

P. R. MALLORY & Co., INC., 3029 E. Washington St., Indianapolis 6, Ind. A new transistorized vhf converter provides continuous tuning from 30-76 mc in two bands (30-53, 53-76) with 4.2 turns per band. Model HLH-103-1 utilizes printed circuitry for compactness and size reduction. The converter utilizes a new linearized Inductuner which

CIRCLE 113 ON READER SERVICE CARD →

AUGUST

27

*EEOCo meets crash schedule
...delivers electronic timing
equipment in record time!*

When electronic timing signal equipment was needed for the opening shoot on the Pacific Missile Range, Electronic Engineering Company of California was asked to deliver the goods... and they did. Within 27 days of order EEOCo delivered three distribution amplifiers and thirty neon driver amplifiers to Vandenberg Air Force Base.

EEOCo was able to meet this crash schedule because of the know-how gained in over nine years of supplying timing instrumentation equipment used on most major missile test ranges in the United States. This experience enables EEOCo design and production engineers to employ R & D production techniques with maximum effectiveness.

Typical of the instrumentation timing signal hardware sold by EEOCo are the airborne time code generators, distribution amplifiers and time code generators described below. For full data on these units, request Data File 101.

AIRBORNE TIME CODE GENERATOR provides a 10-digit time code recycling every 900 seconds. Output is pulse-width modulated for direct recording on oscillographs or as an AM carrier signal for recording on magnetic tape; also produces signals for timing lamps in cameras. Accuracy is one part in 10^5 with a stability of one part in 10^4 per day. Active elements are semi-conductors or magnetic cores.

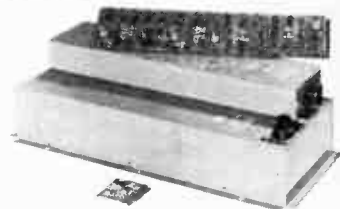

DISTRIBUTION AMPLIFIER (with neon driver in photo). Transistorized time code amplifier for handling up to 12 driver amplifiers for energizing neon timing lamps in instrumentation cameras. Accepts two timing signal inputs either of which can be supplied to any of 12 output circuits each capable of producing input for driver. Driver connects directly into timing signal cable near camera.

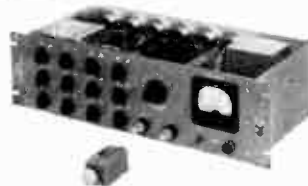

TIME CODE GENERATOR. Stable, crystal controlled unit generates 24-hour time-of-day code in modified binary-coded-decimal form. Each second is identified with 20-bit code. Code continuously displayed on hours, minutes, seconds and may be pre-set to clock time. Code automatically recycles at end of 24-hour interval. Drift is less than one second per week.

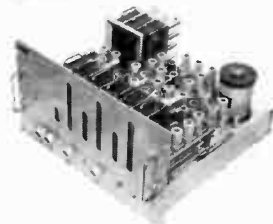

Electronic Engineering Company of California

1601 East Chestnut Avenue, Santa Ana, California

Several important career opportunities have just opened up in EEOCo's engineering department. For further information, call or write Merl Perkins.

World Radio History

MISSILE AND AIRCRAFT RANGE INSTRUMENTATION SYSTEMS • DIGITAL DATA PROCESSING SYSTEMS • COMPUTER

MIDWESTERN

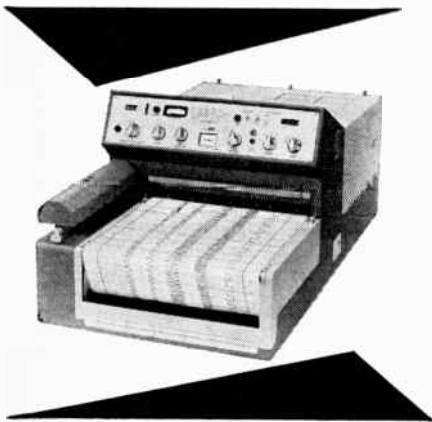

603/607

D/R OSCILLOGRAPHS

UNEQUALLED PERFORMANCE!

50 TRACES — 12" RECORD — 20 RECORD SPEEDS (.071 TO 173 IPS) — 6,000 CPS FLAT RESPONSE — REVERSING RECORD.

IF YOU NEED . . .

PRECISION ANALOG RECORDING SYSTEMS
MAGNETIC TAPE RECORDERS
COMPLETE FM GROUND STATION TELEMETERING SYSTEMS
SERVOVALVES—TORQUE MOTORS
CALL: RIVERSIDE 7-1331
TWX: TU 849
WIRE: FCB: FAX
WRITE: P. O. BOX 7186

 **MIDWESTERN INSTRUMENTS**
41ST & SHERIDAN RD./TULSA, OKLA.

ALSO MANUFACTURERS OF  **Magnecord**
FINE TAPE RECORDING INSTRUMENTS

provides essentially a straight line frequency - versus - rotation curve. Maximum deviation over the 30 to 76 mc range is 150 kc. Local oscillator stability of ± 130 kc maximum over the temperature range of -40 C to $+85$ C has been accomplished in the converter.

CIRCLE 217 ON READER SERVICE CARD

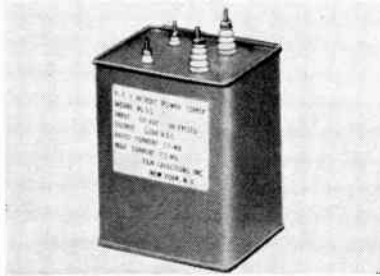

H-V Power Supply miniaturized

FILM CAPACITORS, INC., 3400 Park Ave., New York, N. Y. Hermetically sealed and oil filled power supply, variable from 0 to 5 kv at 5 ma, is housed in a CP70 container $3\frac{3}{8}$ by $3\frac{3}{8}$ by 5 in. Selenium rectifiers and safety rated capacitors ensure working dependability and long trouble-free life, at operating temperatures up to 65 C. Ripple is held to 1 percent and maximum output current is 7.5 ma.

CIRCLE 218 ON READER SERVICE CARD

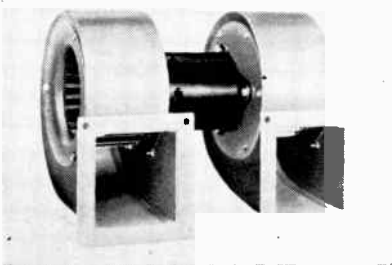

Dual Blowers two new models

MCLEAN ENGINEERING LABORATORIES, P. O. Box 228, Princeton, N. J. Dual blower units for electronic cooling: model 2NB300 will produce 160 cfm and model 2NB408 will produce 320 cfm. Both are equipped with a long life, quiet, isolated motor. Motors are shaded pole, semienclosed, fan cooled with Class A insulation (105C). Permanently sealed ball bearings are lubricated with a MIL-C-3278 lubri-

DO YOU KNOW?

You Can Locate Nearest SALES OFFICES in this year's BUYERS' GUIDE

A one-step method for locating the nearest sales office of every manufacturer listed in the **GUIDE**. The nearest sales offices to you (with addresses and phone numbers) are listed directly after manufacturers' names in the Manufacturers' Index.

One more reason why advertisers and users of the **BUYERS' GUIDE** receive extra benefits available in no other place.

electronics BUYERS' GUIDE and Reference Issue

A McGraw-Hill Publication
330 West 42nd St.
N. Y. 36, N. Y.



RAWSON ELECTROSTATIC VOLTMETERS



Type 518

Available ranges 100 volts to
35,000 volts

Measure true R.M.S. values on A.C., no waveform or frequency errors.

NO POWER CONSUMPTION

Leakage resistance greater than one million megohms. These meters may be used to measure STATIC ELECTRICITY! Ideal for measuring high voltage power supplies with zero current drain. Rugged, well-damped movement. All elements surrounded by metal shielding for accuracy and safety.

Write for Bulletin



111 Patter Street • Cambridge, Mass.

CIRCLE 143 ON READER SERVICE CARD

cant having a temperature range of - 68 C to + 93 C. Blowers have stainless steel shaft, are fungus protected, moisture and corrosion resistant.

CIRCLE 219 ON READER SERVICE CARD



Magnetic Circuit with Halltron

OHIO SEMICONDUCTORS, INC., 1035 W. Third Ave., Columbus 8, Ohio. Model MC-1 combines Halltron device and magnetic circuit. Special magnetic materials and indium arsenide Halltron result in extreme linearity, low hysteresis and accuracies of 0.1 percent. Circuit applications include choppers, analog multipliers, power meters, modulation, phase detectors and many other electronic functions.

CIRCLE 220 ON READER SERVICE CARD



Electronic Counter uniform readout

HEWLETT-PACKARD Co., 275 Page Mill Road, Palo Alto, Calif. Model 524D, featuring a uniform 8-decade numerical readout, has a crystal oscillator stability of 3 parts in 10⁷ short-term; 5 parts in 10⁷ per week. It provides for full frequency measurements from 10 cps to 10 mc and period measurements from 0 cps to 10 kc. These ranges may be extended by use of plug-in units. Another plug-in provides for time measurements from 1 μsec to 100

World Radio History

marion
advancement
in instrument
design



ACTUAL
SIZE

MM-1 MEDALIST* meter

Today's most readable, modern miniature meter. Shielded—no error from magnetic panels. Rugged Marion Coaxial mechanism. Max. weight 1.6 oz. In all standard ranges, various colors. Single hole mounting. Data on request. Marion Instrument Division, Minneapolis-Honeywell Regulator Co., Manchester, New Hampshire, U.S.A.

*T.M. Reg. U.S. Pat. Off. U.S. & Foreign Patents
Copyright © 1959, Marion

marion
"WHERE ELECTRONICS MEETS THE EYE"
meters



CIRCLE 145 ON READER SERVICE CARD

ripple at full load is only

0.005%

with new **EICO**

POWER & BIAS SUPPLY FOR TRANSISTORIZED EQUIPMENT #1020

- includes power transformer, full-wave silicon diode rectifier circuit, electrolytic capacitor input filter followed by a two-power transistor (2-2N256) cascaded filter circuit providing extraordinary ripple rejection • output voltage: 0-30 VDC continuously variable, monitored by dual-range voltmeter (0-6, 0-30 VDC) • continuous output current capacity: 150 ma @ 0-12V; 200 ma @ 12-24 V; 300 ma @ 24-30V • 0.5A fuse protects against short circuit • comparable in purity of output and in voltage and current capacity to transistorized supplies selling for several hundred dollars • ideal for laboratory, development and service work on transistors and transistorized equipment
- rugged grey wrinkle steel case (5" h, 4" w, 5 1/2" d)

KIT \$19.95
WIRED \$27.95

Add 5% in West.



Compare this versatile, dependable Model 1020 at your neighborhood EICO distributor. For free catalog on 65 models of EICO test instruments, hi-fi and amateur gear, write to Dept. E-9

ELECTRONIC INSTRUMENT CO., INC.
33-00 Northern Blvd., Long Island City 1, N.Y.

CIRCLE 115 ON READER SERVICE CARD 115



FOREMOST

in

UNDERWATER
DETECTION
SYSTEMS

EDO CORPORATION
College Point, L.I., N.Y.
Since 1923

CIRCLE 144 ON READER SERVICE CARD
ELECTRONICS • SEPTEMBER 25, 1959

AIRPAX

MAGMETER[®] Frequency Detector



The AIRPAX MAGMETER is a frequency detector which produces DC output pulses of constant volt-second area, the average value of the pulses being proportional to the input signal frequency.

MAGMETER output (0-1 ma DC) can be indicated on any readout device capable of responding to average values.

Linearity of better than 0.25% makes its use ideal for powerline frequency measurement, doppler radar and telemetry systems.

Hermetically sealed to operate under severe environmental conditions, MAGMETERS are available with octal-pin bases (illustrated) or rectangular bolt down cases.

Write for bulletin F-25 describing wide range and expanded scale types in the sub-sonic, audio and ultra-sonic ranges.

For your applications where failures are not tolerated.



SEMINOLE DIVISION • FORT LAUDERDALE, FLORIDA

SM32

days. Counter is priced at \$2,150 (cabinet) and \$2,125 (rack mount).

CIRCLE 221 ON READER SERVICE CARD



Tone Modulator for grid dip meters

JAMES MILLEN MFG. Co., INC., 150 Exchange St., Malden, Mass. Model 90751 transistor tone modulator is designed to modulate grid dip meters. A small package containing a transistor oscillator and its mercury battery plugs into the phone jack of a grid dip meter to modulate the signal at approximately 800 cycles. Modulator turns on when plugged into the meter.

CIRCLE 222 ON READER SERVICE CARD



Magnetic Amplifiers molded type

AIRPAX ELECTRONICS INC., Seminole Division, Ft. Lauderdale, Fla. A new line of 400-cps molded magnetic amplifiers feature: life at least 10 years, near indestructibility in shock and vibration, ability to operate efficiently with overloads of 1,000 percent and into dead shorts. The M-5501 is a general purpose unit with a wide variety of circuit applications. The M-5502 has one very sensitive 100 kilohm winding and a 5 kilohm feedback winding. The M-5503 is especially designed for use as a thermocouple amplifier. Type

M-5504 is a general purpose unit with smaller bandwidth and higher gain.

CIRCLE 223 ON READER SERVICE CARD

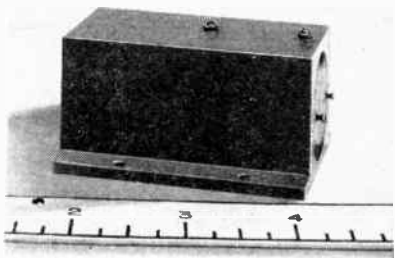

Inertia Switch for airborne use

INERTIA SWITCH, INC., 311 W. 43rd St., New York 36, N. Y. Model 60U-01 switch is sensitive to accelerations of 0.05 g to 1.0 g, for missile and airborne unidirectional control applications. Response time is less than 35 millisecond; accuracy, within 10 percent; service life, over 100,000 cycles; meets MIL-E-5272A or better. Unit is factory preset as specified by the user.

CIRCLE 224 ON READER SERVICE CARD

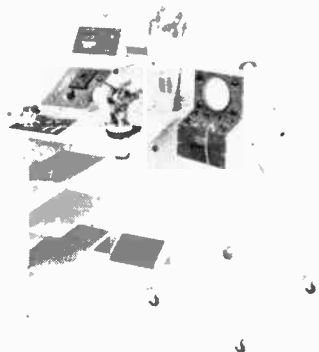

Coil Winder and comparator

UNIVERSAL MFG. CO., INC., 1168 Grove St., Irvington, N. J. S-series coil winding machines feature: shuttle speed of 1,200 rpm, minimum shuttle cross-section for winding coils with small inside diameters, and fast set-up. Inductance comparator for powdered molybdenum permalloy and ferrite cores is also available. Preset value of inductance shows operator when coil has reached required inductance, making core grading unnecessary.

CIRCLE 225 ON READER SERVICE CARD

MARCONI FOR FM TEST GEAR

For years Marconi's have been specialists in precision instrumentation for FM systems. Here are two models from our extensive range, designed to answer your FM measuring problems. Ask for leaflets B 149 for complete details.

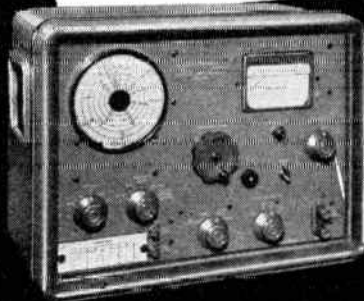

CARRIER DEVIATION METER Model 791D

Crystal locking facilities in this new deviation meter insure freedom from microphony, and allow measurement of FM hum and noise in VHF and UHF communication and broadcast transmitters.

MEASURES DEVIATION: 200 cps to 125 kc in four ranges; extended down to 10 cps using external readout. Indicates positive or negative deviation at the turn of a switch.

IN-BUILT DEVIATION STANDARD, crystal controlled, for sustained accuracy.

CARRIER FREQUENCY RANGE: 4 to 1,024 mc, directly calibrated.

MODULATION FREQUENCY RANGE: 50 cps to 35 kc.

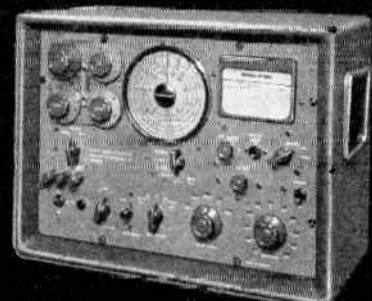

FM/AM SIGNAL GENERATOR Model 995A/4

Narrow-deviation FM, stepped and extra-fine incremental tuning, and a high-stability low-noise output make this versatile VHF generator particularly suitable for mobile radio testing.

FREQUENCY RANGE: 1.5 to 220 mc with crystal check points above 13.5 mc. Less than 0.002% short-term drift.

DIRECT-READING INCREMENTAL TUNING: Stepped control up to ± 40 kc, extra-fine continuous control up to ± 15 kc.

OUTPUT RANGE: 0.1 μ v to 100 mv at 52 and 75 ohms.

MODULATION: FM: deviation monitored and variable from 0 to 5 and 0 to 15 kc. AM: monitored and variable up to 50%. Modulation frequencies, 400 cps, 1 and 1.5 kc.

SPURIOUS FM ON CW: Less than 25 cps deviation.

MARCONI INSTRUMENTS

AM & FM SIGNAL GENERATORS
AUDIO & VIDEO OSCILLATORS
FREQUENCY METERS
VOLTMETERS • POWER METERS
DISTORTION METERS
FIELD STRENGTH METERS
TRANSMISSION MONITORS
DEVIATION METERS
OSCILLOSCOPES, SPECTRUM &
RESPONSE ANALYZERS
Q METERS & BRIDGES

111 CEDAR LANE • ENGLEWOOD • NEW JERSEY

Tel: Lowell 7-0607

CANADA: CANADIAN MARCONI CO • MARCONI BUILDING • 2442 TRENTON AVE • MONTREAL 16

MARCONI INSTRUMENTS LTD • ST. ALBANS • HERTS • ENGLAND

ANOTHER FIRST...

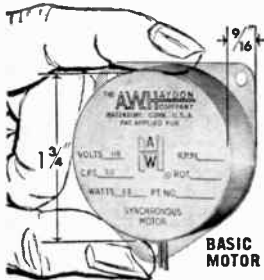

THE ONLY

Electro-Reliable A.C. TIMING MOTOR

Thinner... Quieter...
More Reliable... More Versatile



FINGER-THIN...

Only 9/16 Inches Short... Only 1 3/4 Inches in Diameter... very compact... reduces the size of your equipment.

WHISPER-QUIET...

Strictly an electrical motor... practically noiseless... no rattling of gears or ratchets.

HIGH TORQUE...

1/4 oz. inch at the rotor with an instantaneous start and stop... requires only 2 1/2 watts... can replace larger motors in recorders, controls and telemetering equipment.

HIGHEST RELIABILITY...

Longer life... no one-way gears or ratchets to fail... provides millions of operations without any trouble.

SPECIFICATIONS

Standard Voltage Ratings:
6, 12, 24, 115, 230 Volts
Frequency:
60 CPS Standard
25, 50 CPS Available
Power Input: 2.5 Watts
Maximum (60 CPS)

BASIC MOTOR

Weight: 4 ounces
Speed: 300 RPM
Torque: 1/4 oz.-in.
Length: 9/16 inch

WITH INTEGRAL GEAR TRAIN

Weight: 5 ounces
Speed: 300 RPM to 1/6 RPH
Torque: 30 oz.-in. @ 1 RPM
Length: 7/8 inch



WITH INTEGRAL GEAR TRAIN

Send for Special Illustrated
Bulletin AWH MO-806

© 1959



The **A.W. HAYDON Company**

235 NORTH ELM STREET
WATERBURY 20, CONNECTICUT

Custom Design & Manufacture Of Electronic
And Electro-Mechanical Timing Devices

CIRCLE 146 ON READER SERVICE CARD

Literature of the Week

MATERIALS

Copper-Cored Wire. Metals & Controls Division of Texas Instruments Inc., 34 Forest St., Attleboro, Mass. Copper-cored No. 446 alloy glass sealing wires are described in the second and third of a series of bulletins on cored and clad wires.

CIRCLE 250 ON READER SERVICE CARD

COMPONENTS

Delay Line Data. Delttime, Inc., 608 Fayette Ave., Mamaroneck, N. Y. Latest advances and refinements in delay-line techniques are dealt with in bulletins 201, 202 and 203.

CIRCLE 251 ON READER SERVICE CARD

Fixed Coaxial Attenuators. Weinschel Engineering, 10503 Metropolitan Ave., Kensington, Md., has released a 4-page, 2-color brochure containing detailed specifications on 1 to 12.4 kmc fixed coaxial attenuators.

CIRCLE 252 ON READER SERVICE CARD

Selenium Rectifier Selection. General Electric Co., Syracuse, N. Y. A 24-page brochure gives a step-by-step method for selecting specific selenium rectifiers for circuit applications.

CIRCLE 253 ON READER SERVICE CARD

EQUIPMENT

Shaft Position Encoders. Datex Corp., 1307 S. Myrtle Ave., Monrovia, Calif. Description, chief features and specifications on the C-100 and C-200 series shaft position encoders are contained in bulletin 319.

CIRCLE 254 ON READER SERVICE CARD

Computer. Ebex Sales Inc., Orem, Utah. A catalog lists the four models of the Microlog series 2 computer which is expressly designed to meet the requirements

GREEN PRINTED CIRCUIT DRILL

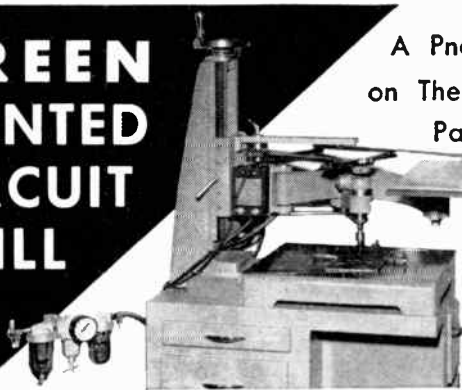

A Pneumatic Attachment
on The Green Model D2
Pantograph Engraver
rapidly drills
holes in printed
circuits by tracing
templates.

- Drill as many as 100 holes per minute, Foot switch actuates air powered operation.
- Drill speeds and feeds have independent adjustments. Feed regulated by air pressure.
- Spindle speeds up to 26,000 rpm. Permits use of carbide drills when required.
- D2-201 air attachment includes spindle air cylinder, regulating valve and pressure gauge, foot switch, filter and oiler, ready to operate when connected to compressor.

The Model D2 Heavy Duty Pantograph Engraver features ratios of 2 to 1 to infinity. Unobstructed on three sides to handle large work. Micrometer adjustment for depth of cut. Vertical range 10" adjusting copy table automatically with pantograph.

GREEN INSTRUMENT COMPANY, INC.

363 Putnam Ave. • Cambridge 39, Mass.

FOR
FULL
DETAILS,
WRITE, WIRE
OR CALL

Get out your pencil and help yourself to electronics READER SERVICE it's free—it's easy—it's for your convenience

Use these handy READER SERVICE CARDS for more information on:

ADVERTISEMENTS—NEW PRODUCTS—LITERATURE OF THE WEEK

- 1—Circle the number on the postpaid card below that corresponds to the number at the bottom of Advertisement, New Product item, or Literature of the Week selection.
- 2—Please print carefully, as it is impossible to process cards that are not readable.

A

FOR SPECIFIC ITEMS IN MULTI-PRODUCT ADVERTISEMENTS

For more information on specific items in multi-product advertisements, print carefully on the Reader Service Card below in Box "A" the circle number of the advertisement and the specific product(s) on which you desire more information.

HOW TO SUBSCRIBE—HOW TO RENEW YOUR SUBSCRIPTION TO electronics

If you are not a subscriber, or if your subscription is about to expire, to receive electronics regularly, fill in the section "FOR SUBSCRIPTIONS" on a card below. Send no money, electronics will bill you at the address indicated on the Reader Service Card.

Correct amount of POSTAGE must be affixed for all FOREIGN MAILINGS

SEPT 25 '59
CARD EXPIRES
NOV 25 '59

Correct amount of POSTAGE must be affixed for all FOREIGN MAILINGS

electronics • READER SERVICE CARD • Please Print Carefully

YOUR NAME _____ POSITION _____

COMPANY _____

ADDRESS _____

CIRCLE THESE NUMBERS WHEN INTERESTED IN ALL ITEMS SHOWN IN ANY ADVERTISEMENT

1	2	3	4	5	6	7	8	9	10	11	12	13	14	15	16	17	18	19	20	21	22	23	24	25	26	27	28	29	30
31	32	33	34	35	36	37	38	39	40	41	42	43	44	45	46	47	48	49	50	51	52	53	54	55	56	57	58	59	60
61	62	63	64	65	66	67	68	69	70	71	72	73	74	75	76	77	78	79	80	81	82	83	84	85	86	87	88	89	90
91	92	93	94	95	96	97	98	99	100	101	102	103	104	105	106	107	108	109	110	111	112	113	114	115	116	117	118	119	120
121	122	123	124	125	126	127	128	129	130	131	132	133	134	135	136	137	138	139	140	141	142	143	144	145	146	147	148	149	150
151	152	153	154	155	156	157	158	159	160	161	162	163	164	165	166	167	168	169	170	171	172	173	174	175	176	177	178	179	180
181	182	183	184	185	186	187	188	189	190	191	192	193	194	195	196	197	198	199	200	201	202	203	204	205	206	207	208	209	210
211	212	213	214	215	216	217	218	219	220	221	222	223	224	225	226	227	228	229	230	231	232	233	234	235	236	237	238	239	240
241	242	243	244	245	246	247	248	249	250	251	252	253	254	255	256	257	258	259	260	261	262	263	264	265	266	267	268	269	270
271	272	273	274	275	276	277	278	279	280	281	282	283	284	285	286	287	288	289	290	291	292	293	294	295	296	297	298	299	300

INSIDE FRONT COVER INSIDE BACK COVER

FOR SUBSCRIPTIONS:
(CHECK ONE BOX)

NEW RENEWAL

(CHECK ONE BOX BELOW)

DOMESTIC 1 yr. — \$ 6.00
 3 yrs. — \$12.00

CANADA 1 yr. — \$10.00

FOREIGN 1 yr. — \$20.00

Product(s) manufactured: _____

or Service(s) Performed: _____

A

Circle No.	Product
_____	_____
_____	_____
_____	_____
_____	_____

SEPT 25 '59
CARD EXPIRES
NOV 25 '59

Correct amount of POSTAGE must be affixed for all FOREIGN MAILINGS

electronics • READER SERVICE CARD • Please Print Carefully

YOUR NAME _____ POSITION _____

COMPANY _____

ADDRESS _____

CIRCLE THESE NUMBERS WHEN INTERESTED IN ALL ITEMS SHOWN IN ANY ADVERTISEMENT

1	2	3	4	5	6	7	8	9	10	11	12	13	14	15	16	17	18	19	20	21	22	23	24	25	26	27	28	29	30
31	32	33	34	35	36	37	38	39	40	41	42	43	44	45	46	47	48	49	50	51	52	53	54	55	56	57	58	59	60
61	62	63	64	65	66	67	68	69	70	71	72	73	74	75	76	77	78	79	80	81	82	83	84	85	86	87	88	89	90
91	92	93	94	95	96	97	98	99	100	101	102	103	104	105	106	107	108	109	110	111	112	113	114	115	116	117	118	119	120
121	122	123	124	125	126	127	128	129	130	131	132	133	134	135	136	137	138	139	140	141	142	143	144	145	146	147	148	149	150
151	152	153	154	155	156	157	158	159	160	161	162	163	164	165	166	167	168	169	170	171	172	173	174	175	176	177	178	179	180
181	182	183	184	185	186	187	188	189	190	191	192	193	194	195	196	197	198	199	200	201	202	203	204	205	206	207	208	209	210
211	212	213	214	215	216	217	218	219	220	221	222	223	224	225	226	227	228	229	230	231	232	233	234	235	236	237	238	239	240
241	242	243	244	245	246	247	248	249	250	251	252	253	254	255	256	257	258	259	260	261	262	263	264	265	266	267	268	269	270
271	272	273	274	275	276	277	278	279	280	281	282	283	284	285	286	287	288	289	290	291	292	293	294	295	296	297	298	299	300

INSIDE FRONT COVER INSIDE BACK COVER

FOR SUBSCRIPTIONS:
(CHECK ONE BOX)

NEW RENEWAL

(CHECK ONE BOX BELOW)

DOMESTIC 1 yr. — \$ 6.00
 3 yrs. — \$12.00

CANADA 1 yr. — \$10.00

FOREIGN 1 yr. — \$20.00

Product(s) manufactured: _____

or Service(s) Performed: _____

A

Circle No.	Product
_____	_____
_____	_____
_____	_____
_____	_____

ONE!

In every industry there's always ONE accepted Product and Data Buying Book...in electronics it's the BUYERS' GUIDE — fundamental in any sales program aimed at the electronics and allied industries. Its 52,000 paid subscribers are important Design-

Research/Production/Management Engineers, who, individually, or working in combination with one another, influence the purchase of products, materials and services... whatever is bought by the entire industry.



electronics 

A MCGRAW-HILL PUBLICATION

330 West 42nd Street • New York 36, N.Y.

BUSINESS REPLY MAIL

NO POSTAGE STAMP NECESSARY IF MAILED IN THE UNITED STATES

6¢ Postage Will Be Paid By
ELECTRONICS

Reader Service Dept.
330 West 42nd Street
New York 36, N. Y.

FIRST CLASS
PERMIT NO. 64
(SEC. 34.9 P.L.&R.)
NEW YORK, N. Y.



BUSINESS REPLY MAIL

NO POSTAGE STAMP NECESSARY IF MAILED IN THE UNITED STATES

6¢ Postage Will Be Paid By
ELECTRONICS

Reader Service Dept.
330 West 42nd Street
New York 36, N. Y.

World Radio History

FIRST CLASS
PERMIT NO. 64
(SEC. 34.9 P.L.&R.)
NEW YORK, N. Y.



of a successful training instrument for students of analog computer applications and techniques.

CIRCLE 255 ON READER SERVICE CARD

Microwave Meters and Filters. Frequency Standards, P. O. Box 504, Asbury Park, N. J., has available a 12-page catalog containing complete technical data on a line of microwave meters and filters.

CIRCLE 256 ON READER SERVICE CARD

Brazing Machines. Eisler Engineering Co., Inc., 750 So. 13th St., Newark 3, N. J., has released catalog No. 100-59 on automatic brazing and soldering machines.

CIRCLE 257 ON READER SERVICE CARD

D-C to A-C Inverters. Sorensen & Co. Inc., Richards Ave., South Norwalk, Conn., has available a bulletin containing a description, general information, specifications and prices for model QI series miniature transistorized inverters.

CIRCLE 258 ON READER SERVICE CARD

Plating Rectifiers. Djeco Division of Djordjevic Engineering Co., 1933 N. Damen, Chicago 47, Ill. Bulletin 100 is a 16-page description of rectifiers for electroplating and anodizing.

CIRCLE 259 ON READER SERVICE CARD

Recorder - Reproducer. The SoundScriber Corp., 6 Middletown Ave., North Haven, Conn., has available a brochure describing its 24-hr continuous tape recorder-reproducer.

CIRCLE 260 ON READER SERVICE CARD

Differential Amplifier. Epsco, Inc., 275 Massachusetts Ave., Cambridge, Mass. A recent folder illustrates and describes the DA-102 wide-band, low-level, differential d-c amplifier.

CIRCLE 261 ON READER SERVICE CARD

FACILITIES

Precision Metal Fabrication. Donnelly Mfg. Co., 580 Winter St., Waltham 54, Mass. A recent booklet illustrates samples and discusses the company's facilities for close-tolerance metal fabrication.

CIRCLE 262 ON READER SERVICE CARD

JUST THE PLIER FOR ELECTRONIC USE

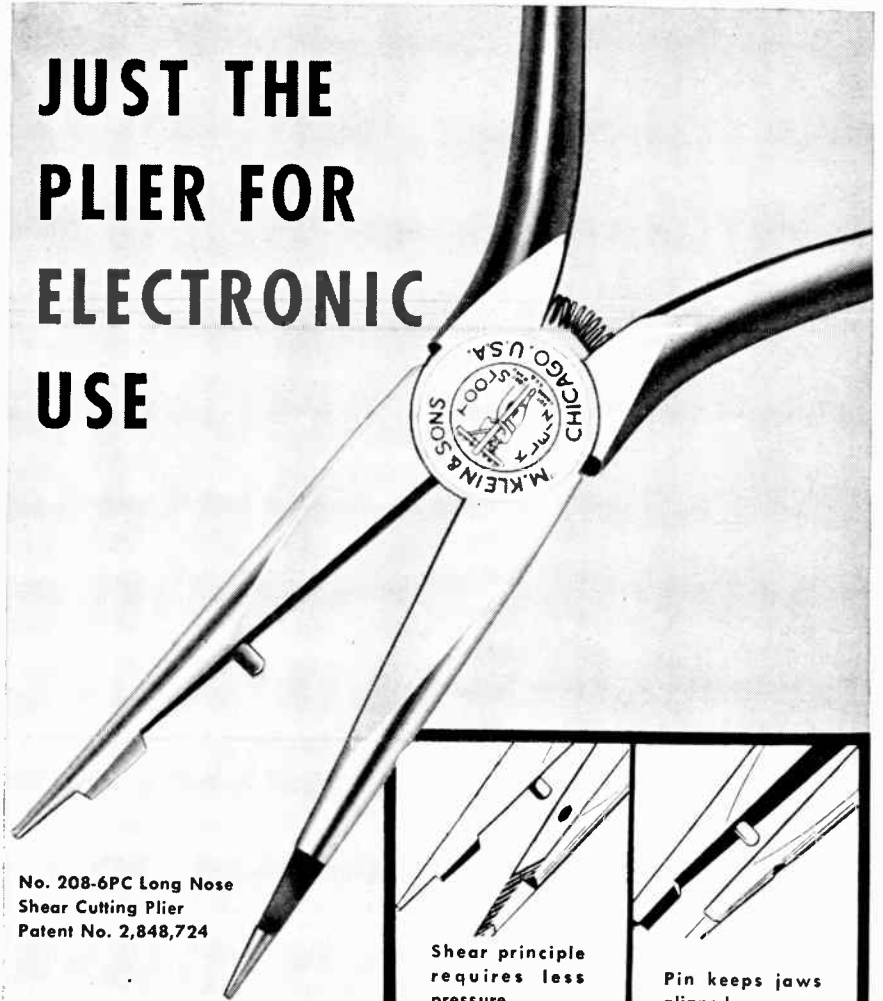

No. 208-6PC Long Nose
Shear Cutting Plier
Patent No. 2,848,724

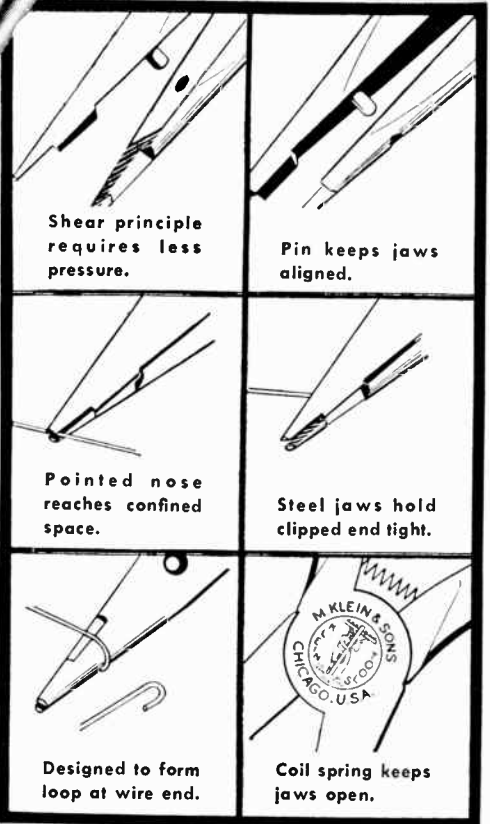

Here is a recently developed plier specially designed for electronic use. It will fit into confined space and the steel jaws hold clipped end of sheared wire firmly... nothing to wear out.

The shear blade is at an angle of 15 degrees (the standard angle of regular diagonal pliers). Shear principle assures smooth, continuous action without snap, preventing shock which might damage transistors and other delicate components. For use with bare wire up to 18 gauge.

See your electronic supply house or write for catalog.

WRITE FOR CATALOG 101-A

Klein Catalog 101-A, describing the 208-6PC and many other Klein Pliers, will be sent on request. Write for a copy.



Foreign Distributor: International Standard Electric Corp., New York



Mathias KLEIN & Sons
Established 1857 Chicago, Ill., U.S.A.
7200 McCORMICK ROAD • CHICAGO 45, ILLINOIS



BDSA Honors Spriggs

THE Business and Defense Services Administration of the U. S. Department of Commerce recently honored Commodore A. J. Spriggs (USN Ret.) with flag presentation ceremonies. The flag, which had flown over the Capitol, was presented to Spriggs, vice president of Packard-Bell Electronics Corp., on completion of his 10-month tour of duty as advisor to the director of the Electronics Division, BDSA. During this period he served the government without compensation, on loan from his company.

He also received a Certificate of Service and a personal letter of appreciation from the Secretary of Commerce.

Pictured in the foreground (l to r) are: Commodore Spriggs; H. Hubert Hughes, acting administrator, BDSA; Mrs. Spriggs; Capt. D. R. Hull (USN Ret.), president, Electronic Industries Association; and Donald S. Parris, director, Electronics Division, BDSA. In the background are other members of the Electronics Division.



Orbom Heads Epsco Division

ORVILLE E. ORBOM has been appointed to head Epsco-Worcester, new division of Epsco, Inc., of Cam-

bridge, Mass. Prior to joining Epsco in 1958, he was a research engineer with the Aluminum Co. of America and engineer in charge of automation at Allegheny Ludlum Steel Corp.

The Worcester division manufactures equipment for medical electronics and industrial instrumentation.

Daystrom Fills Four Positions

FOUR appointments were recently announced by Daystrom Systems, the San Diego division of Daystrom, Inc.

They are David Driscoll, former manufacturing division controller at Collins Radio, as controller; H. Lee Denning, former Marquardt

Aircraft controller, as contracts administrator; Cheng Ling, formerly with North American Aviation's Autonetics Division, as a systems analyst and project leader; and Gerald D. Hevron, formerly with Stromberg-Carlson, Rochester, N. Y., as production manager.

GE Establishes New Operation

MISSILES, Arming and Fuzing Program office, a new operation, has been established in General Electric's Missile and Space Vehicle Department, Philadelphia, Pa.

Named as manager of the new operation is Charles C. Botkin, formerly manager of the GE department's nuclear ordnance projects operation. He has been associated with GE's missile activities since 1947.

In his new position, Botkin will be responsible for the integration of the department's missile and arming and fuzing activities.



Elect Ginzton Board Chairman

EDWARD L. GINZTON is the newly elected chairman of the board of Varian Associates, Palo Alto, Calif., filling the vacancy left by the death of Russell H. Varian.

Like his predecessor, Ginzton was one of the original founders of Varian Associates and has served as a member of the board of directors and of key committees since

NOW, FROM FAIRCHILD

PNP SILICON MESA TRANSISTORS



A "MIRROR IMAGE" OF AVAILABLE NPN CHARACTERISTICS

Same high-speed switching capabilities with which Fairchild startled the industry are now available in PNP — 80 milli-micro-second rise time, 2 watts dissipation, 300° C. survival. Fairchild Silicon Transistors are multiple solid-state diffused. Their mesa construction affords excellent heat dissipation and extraordinary ruggedness.

Complementary symmetry within computer circuit designs now affords another technique for reducing number of components and increasing reliability. The advantages of complementary symmetry have been well known, but the high performance silicon transistors that could take advantage of the technique have not been available.

Direct replacement of germanium by silicon is feasible now that high performance silicon PNP mesa transistors are readily available. In silicon transistor circuits, you need no longer hesitate to make use of the particular advantages of PNP polarity. Availability is firmly assured.

COMPETITIVE ADVANTAGES FOR YOUR DESIGNS either in terms of price or functional efficiency are a likelihood that you should investigate. PNP silicon transistors with these speed-power characteristics have not been generally available, hence until now it has not been possible to design circuits using the complementary symmetry concept. Special attention will be given to inquiries received on company letterhead.

PNP — 2N1131, 2N1132

Symbol	Specification	Rating	Characteristics	Test Conditions
V_{CE}	Collector to Emitter voltage, 25° C.	30v		
P_C	Total dissipation at 25° C. Case temp	2 watts		
h_{FE}	D. C. current gain		2N1131 15 to 45 2N1132 30 to 90	I_C 150ma V_C 10v
R_{CS}	Collector saturation resistance		6 μ typical 10 μ max	I_C -150ma I_B 15ma
h_{fe}	Small signal current gain at f = 20Mc		2.5 typical	I_C 50ma V_C 10v

NPN — 2N696, 2N697

Symbol	Specification	Rating	Characteristics	Test Conditions
V_{CE}	Collector to Emitter voltage, 25° C.	40v		
P_C	Total dissipation at 25° C. Case temp	2 watts		
h_{FE}	D. C. current gain		2N696 -20 to 60 2N697 40 to 120	I_C =150ma V_C 10v
R_{CS}	Collector saturation resistance		3.5 μ typical 10 μ max.	I_C - 150ma I_B 15ma
h_{fe}	Small signal current gain at f = 20Mc		5 typical	I_C 50ma V_C 10v

545 WHISMAN ROAD • MOUNTAIN VIEW, CALIFORNIA
YORKSHIRE 8-8161



20
TO
200 D.P.

SEND YOUR
PRINTS FOR
QUOTATION

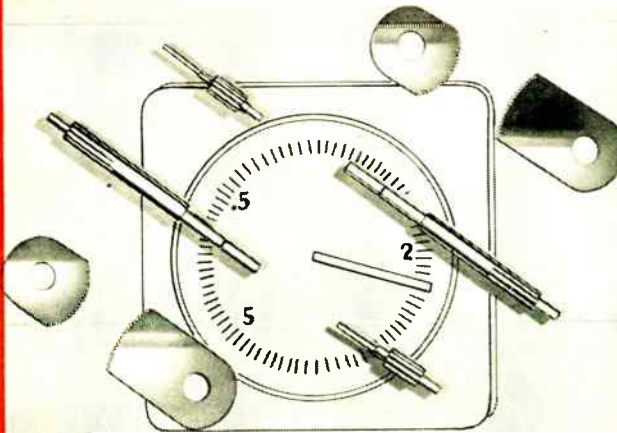

SPURS • HELICALS • WORM AND WORM GEARS • STRAIGHT BEVELS
LEAD SCREWS • RATCHETS • CLUSTER GEARS • RACKS • INTERNALS • ODD SHAPES

THE *Finest* IN GEARS



Beaver Gear Works Inc.

1021 PARMELE STREET, ROCKFORD, ILLINOIS

CIRCLE 147 ON READER SERVICE CARD

.. Electrical Coil Windings

For 40 years . . . specializing in all types of coils to customers' specifications. Design or engineering assistance available on request.

COTO-COIL CO., INC.

SINCE 1917

65 Pavilion Avenue Providence 5, Rhode Island

CIRCLE 148 ON READER SERVICE CARD

MEET ED DeJONGH

Associate Editor, electronics
MARKET RESEARCH EXPERT



A graduate of Oberlin, BA, and Harvard Business School, MBA, Ed DeJongh is the researcher and analyst who is responsible for "Market Research", "Figures of the Week", sales estimates, sales forecasts, marketing news, and developments in marketing. Ed is constantly preparing for a year-end statistical issue and forecast for the following year. If you're not a subscriber, if your subscription is expiring, if you need market data in your work, fill in box on Reader Service Card. Easy to use. Postage free.



electronics



A McGraw-Hill Publication

330 West 42nd Street, New York 36, N. Y.

the company's inception in 1948. For the past several years he also was assistant to the late chairman of the board.

Ginzton is director of the microwave laboratory at Stanford University as well as professor of applied physics and electrical engineering.

LEL Appoints Walter Hollis

AS PART of a planned program of expansion, LEL, Inc., Copiague, L. I., N. Y., has hired Walter Hollis, formerly director of engineering of Resdel Engineering Corp., Pasadena, Calif.

As engineering assistant to Charles Neubling, general manager, Hollis brings to LEL eighteen years of experience in the electronic field in radar, countermeasures, and communications equipment. Formerly he was associated with the Sperry-Rand Corp. and the W. L. Maxson Corp.

Krafve Moves Up In Raytheon Shift

SIX months after leaving Ford Motor Co. to join Raytheon, Richard E. Krafve takes over as executive vice president, a post vacated by Harold Geneen in June, when he became ITT president.

Krafve joins president Charles F. Adams and senior vice president Percy L. Spencer to make up the three-man Office of the President.

Homer R. Oldfield, vice president and manager of Raytheon's Government Equipment Division, takes over Oct. 1 the newly created post of group vice president—electronic components and devices. David D. Coffin is group vice president—government equipment and systems.

Reporting directly to the Office of the President will be the Equipment and Systems, Distributor Products, Industrial Apparatus, Research, and International divisions.

Underscoring the latest Raytheon organization chart are the firm's efforts to broaden its commercial base—now 15 percent of volume—and to decentralize operations, giv-

DO YOU KNOW?

You Can Locate Nearest SALES OFFICES in this year's BUYERS' GUIDE

A one-step method for locating the nearest sales office of every manufacturer listed in the GUIDE. The nearest sales offices to you (with addresses and phone numbers) are listed directly after manufacturers' names in the Manufacturers' Index.

One more reason why advertisers and users of the BUYERS' GUIDE receive extra benefits available in no other place.

electronics BUYERS' GUIDE and Reference Issue

A McGraw-Hill Publication
330 West 42nd St.
N. Y. 36, N. Y.



ing more authority to division managers.

While with Ford, Krafve helped decentralize manufacturing operations. He had been associated with the management consulting firm, of Cresap, McCormick and Paget before joining Ford in 1947.

Oldfield resigned as general manager of GE's computer department, Phoenix, in December '58 to join Raytheon. He was elected a vice president in July '59.

News of Reps

Associated Industries, Seattle, Wash., has been appointed to represent Rogers Corp., Rogers, Conn., in the states of Oregon and Washington and at the Boeing Co., Wichita, Kan. Rep firm will handle the Rogers line of electronic insulation, sealing and high temperature materials.

Manufacturer's reps for RCA mobile communications equipment have been named in five areas. They are: J. F. Ottmar Co. of Spokane, Wash., operating in north-east Oregon, northern Idaho and western Washington; Mobile Radio Service & Communications Corp. of Shreveport, La. (north-west Louisiana); Miami Mobile, Inc. of Miami, Fla. (southern Florida); Rocky Mountain Communication Co., Inc., Denver (Colorado, Utah, Wyoming, western Kansas and western Nebraska); and Modern Electronics Laboratory Corp., Syracuse, N. Y. (central New York State).

Chicago Telephone Supply Corp., Elkhart, Ind., appoints Koehler-Pasmore Co. of Detroit, Mich., and Hollingsworth & Still of Atlanta, Ga., to handle CTS variable resistors, switches, bobbinless precision fixed resistors and other products in those areas. This brings to 25 the firm's total number of U.S. sales offices and reps.

Freed Transformer Co., Inc., Brooklyn, N. Y., has appointed Nelson Co. of Denver, Col., as its rep covering eastern Montana, Wyoming, Utah, South Dakota and Colorado.

*Expanding the Frontiers
of Space Technology in*

RECONNAISSANCE

Lockheed Missiles and Space Division activities in reconnaissance are among the most advanced in industry. They include such areas as radar, optics, infrared and television. Work in the fields of radar and data link is concerned with research, design and development of systems and equipment for missile tracking, command guidance, detection and relay of information. Noise modulation techniques are under study as part of statistical communication theory and implementation of automatic space communication systems. Of special significance is the development of a radar firing error indicator that measures the intercept trajectory between target and attacking missile.

Solid state work in infrared embraces the development of new systems and subsystems for long range infrared communications, surveillance, range findings and target tracking. Considerable work is being conducted in optical devices and systems employing optics. Capability in this area also extends to scanners, encoders, detectors, read-out devices, and analytics of information processing.

ENGINEERS AND SCIENTISTS

Lockheed's programs reach far into the future and deal with unknown and stimulating environments. If you are experienced in work related to the above areas, you are invited to share in the future of a company that has an outstanding record of achievement and make an important individual contribution to your country's progress in the race for space. Write: Research and Development Staff, Dept. I-4-22, 962 W. El Camino Real, Sunnyvale, California. U.S. citizenship required.

Lockheed

MISSILES AND SPACE DIVISION

*Systems Manager for the
Navy POLARIS FBM;
DISCOVERER, SENTRY
and MIDAS; Army KINGFISHER;
Air Force Q-5 and X-7*

SUNNYVALE, PALO ALTO, VAN NUYS,
SANTA CRUZ, SANTA MARIA, CALIFORNIA
CAPE CANAVERAL, FLORIDA
ALAMOGORDO, NEW MEXICO • HAWAII

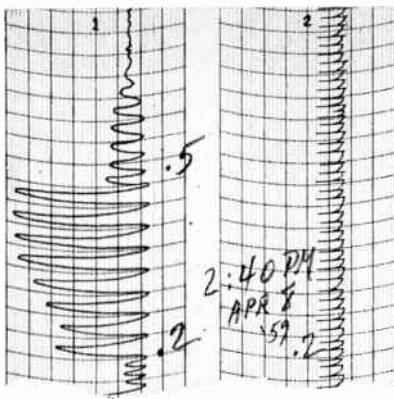

Recorded Events, only when referred to Time... have significance!

... and with today's accelerating technology, the need for the most accurate time reference available becomes more acute. It is available ... and free; the standard time and frequency transmissions of the National Bureau of Standards radio stations WWV and WWVH are accurate to better than 1 part in 50 million and are placed at the disposal of anyone having a receiver capable of tuning to one or more of the transmitting frequencies.

The new Model WWVT receiver, designed especially for remote operations under extreme environmental conditions, is a highly-sensitive crystal-controlled instrument capable of utilizing WWV and WWVH transmission.



Model
WWVT

A 6-position dial switches instantly to any Standard Frequency — 2.5, 5, 10, 15, 20 or 25 mc. It is small, light-weight and rugged — sealed metal case and potted components, all transistorized and battery operated, and has better than 2 mv sensitivity. Priced at \$545.00

Send for bulletin #159A which details many free services available from WWV & WWVH.

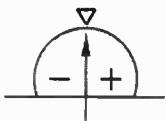

SPECIFIC PRODUCTS
Box 425, 21051 Costanso, Woodland Hills, Calif.

COMMENT

A Difference of Circuits

Re D. E. Thomas and J. M. Klein, "How to Construct a Miniature F-M Transmitter," p 80, July 31 ...

The article by Louis E. Garner, Jr., "Transistorized FM Wireless Microphone", in *Radio & TV News* for July, 1957, gives complete construction details and specifies standard components. While an experimental transistor was specified, it was available as a stock item with RETMA number by the time the article appeared.

Could it be that engineers and gadgeteers writing for more popular magazines frequently anticipate the work of ivory-tower professionals, but that their work is conveniently ignored unless it appears in a "professional journal?"

LUIS VICENS

OMNICO
WHEATON, Md.

Our article describes an f-m transmitter using a modern pnp alloyed-junction transistor; the *Radio & TV News* story described a transmitter using an experimental junction tetrode transistor. The single circuit described in *ELECTRONICS* performs the functions of audio amplification, r-f oscillation and frequency modulation; the signal from the microphone is effectively amplified by a common-emitter audio amplifier. In the *Radio & TV News* article, the signal from the microphone is used almost directly to frequency-modulate the r-f oscillator.

In July 1957, the ZJ7-2 (3N30) tetrode transistor was experimental and beyond the reach of most experimenters; it is now available at \$28.80. The 2N499 transistor in the *ELECTRONICS* article retails at \$8.25.

For many reasons we felt that authors Thomas and Klein described a substantial advance, not only over the circuit described by Garner, but also over a circuit described by Thomas in *ELECTRONICS* for Feb., 1954.

Transformerless Supplies

It would appear that the magnitude of the surge current at switch-on is not appreciated by your

DO YOU KNOW?

You Can Locate Nearest SALES OFFICES in this year's BUYERS' GUIDE

A one-step method for locating the nearest sales office of every manufacturer listed in the *GUIDE*. The nearest sales offices to you (with addresses and phone numbers) are listed directly after manufacturers' names in the *Manufacturers' Index*.

One more reason why advertisers and users of the *BUYERS' GUIDE* receive extra benefits available in no other place.

electronics BUYERS' GUIDE and Reference Issue

A McGraw-Hill Publication
330 West 42nd St.
N. Y. 36, N. Y.



contributor F. G. Kelly when he recommends the use of transformerless supplies in his article ("Transformerless A-C Filament Supplies," p 56, June 26).

If switch-on happens to occur at peak voltage, 165 v, and a tube heater (e.g. 12AU7) is cold, having, say, $\frac{1}{10}$ normal resistance, this is the only thing limiting surge current apart from supply impedance. Thus the surge current could be 20 amps; to use a series capacitor is to invite a high tube failure rate.

A. B. MORROW
BUSHEY HEATH, HERTS.
ENGLAND

Author Kelly replies:

I would like to point out that while it is theoretically possible to experience a surge approaching 20 amps, this situation does not invite a high tube failure rate. Consider the case of a series-string heater connection. Here surge currents of the order of 10 times normal are experienced for a significant fraction of a minute. Several decades of experience with so-called a-c/d-c radios point to an uncommonly high degree of reliability in such devices.

The surge current attendant with my proposed reactive voltage-divider lasts no more than a few milliseconds and induces no observable degradation of tube properties. It does cause physical stresses on the capacitor due to electrostatic attraction between electrodes, but I have been using this scheme with ordinary components for several years with abundant success.

F. G. KELLY
SPACE TECHNOLOGY LABORATORIES
LOS ANGELES

Credit Where Due

Re: our article "Data Storage and Display With Polarized Phosphors," p 39, Aug. 28.

In the section dealing with p.i.p. (persistent internal polarization) photography, Dr. Kallman and I wanted a footnote included giving credit to Miriam Sidran for this phase of the work. We would appreciate it if this were brought to the attention of your readers.

J. RENNERT
NEW YORK UNIVERSITY
NEW YORK CITY

BEST BY DESIGN

— Not by Chance

Constant attention to the wants and needs of users, has been worked into the finished recorder by trained designers, who devote their entire effort to producing the best in direct-writing recorders. *E-A Recorders* are designed to be the best. Performance has proved their superiority.



Ask for Catalog 657

PRODUCT REPRESENTATIVES IN MOST PRINCIPAL CITIES

The ESTERLINE-ANGUS Company, Inc.

Pioneers in the Manufacture of Graphic Instruments

Dept. E, P. O. Box 596, INDIANAPOLIS 6, INDIANA

CIRCLE 152 ON READER SERVICE CARD

NEW! ENGRAVED

Deep-Kut[®]

PIN & PEG STAMPS

are better than ordinary rubber
3 ways

★ ENGRAVED *Deep-Kut* is Acid-Proof

★ ENGRAVED *Deep-Kut* Stamping gives Razor-Sharp impressions every time

★ ENGRAVED *Deep-Kut* has cushion-like resilience

Engraved *Deep-Kut* stamp faces are adaptable to any marking device. They can be used to stamp on every surface, metal, wood, fabric, paper, plastic, etc.

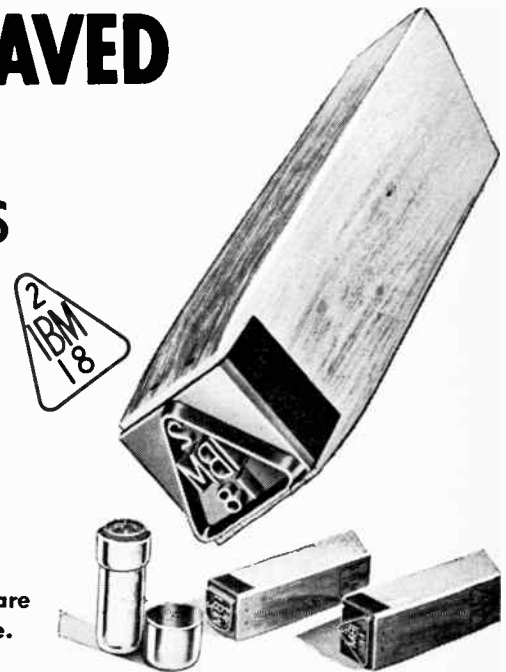

THE KRENGEL

INSPECTION POCKET STAMP

THE PIN & PEG

KRENGEL MANUFACTURING CO., INC. Tel. CO 7-5714
227 Fulton St., New York 7, N. Y.

Dept. EL

Please check the following
 FREE ENGRAVED *Deep-Kut* Sample & Price List
 Please have salesman call for appointment

NAME
 COMPANY
 STREET
 CITY ZONE..... STATE.....

High Level Openings at AVCO for

- **THEORETICAL PHYSICISTS**
- **EXPERIMENTAL PHYSICISTS**
- **PHYSICAL CHEMISTS**
- **ENGINEERS**

New and expanding programs concerned with the design, development, and flight evaluation of the Titan and Minuteman re-entry vehicles have opened up exceptional opportunities in the following areas:

Plasma Jets, Gaseous Discharge Phenomena, Plasma Physics

High-temperature Chemistry of Solids and Gases, High-temperature Properties of Materials, Vapor Pressure, Decomposition Species, Radiation Measurements

Microwaves, Telemetry, Propagation through Ionized Gases, Basic Space Communication Studies

Upper-Atmosphere Phenomena, Missile Detection and Discrimination, Advanced Missile Warfare Concepts

Hypervelocity Ballistics and Advanced Ballistic Techniques

Development of new sensors and recording devices for measuring high-temperatures, pressure, velocity, etc. under unusual conditions, microminiaturization

Advanced electronic circuits for missile-borne, missile detection, and monitoring instrumentation, including transistorized circuitry development. Ultra-high-speed optical and electronic instrumentation for laboratory and ballistics application. Radiometric measurements in the ultra-violet, visible and infrared.

Energy Conversion and Power Supply Studies

Broad solid-state program for theoretical and experimental research on high-temperature materials involving materials preparation, measurement of electrical and other properties, and device fabrication.

Challenging opportunity to apply unusual high temperature techniques developed in the Division to these areas.

The division's fully equipped laboratory and new suburban location provide an unusually attractive working, and recreational environment. Excellent opportunities exist for independent research.

Write to: Mr. Richard Rubino
Scientific & Technical Relations
Dept. E-9

Your reply will be accorded absolute confidence and you will receive a prompt answer.



201 Lowell St., Wilmington, Mass.

**• CONTACTS •
FOR THE FIELD OF
ELECTRONICS**

**"HOW TO MAKE MONEY
IN
Mobile Radio Maintenance"**

AUTHORITATIVE GUIDEBOOK
ABOUT THE BOOM IN TWO-WAY MOBILE-RADIO.
GIVES FACTS, FIGURES, PAY RATES.

WRITE TODAY!

FREE



LAMPKIN LABORATORIES, INC. Instruments Div. BRADENTON, FLA.

BEST PLACE TO STAY IN L.A.

New super-MOTEL. Luxury furnishings. Swimming pool, utter privacy, free TV, 24-hr. tel. service. Single rooms or suites. Heart of S.E. industrial area, 10 mins. from dntn. L.A. Handy all freeways. Clean. Commercial rates.

**DOWNEY-CAPRI MOTEL, 8220 Telegraph Rd.
between Lakewood & Paramount Blvds.**

**PROFESSIONAL
SERVICES**

YARDNEY ELECTRIC CORP.

"Pioneers in Compact Power" *

Electro-Chemical Generators of Energy

"from milliwatts to megawatts" *

40-50 Leonard Street
New York 13, N. Y.

Worth 6-3100
* T.M.

**SEARCHLIGHT
SECTION**

(Classified Advertising)

BUSINESS OPPORTUNITIES

EQUIPMENT - USED or RESALE

AVAILABLE

FROM INDUSTRIAL R & D
LABORATORY, JET AIRCRAFT
AND PILOT FOR HIGH ALTI-
TITUDE CONTRACT RESEARCH.

CWW-2607, Electronics

520 N. Michigan Ave., Chicago 11, Ill.

**Micro-wave Radio
TELECOMMUNICATIONS
ENGINEER**

Major eastern railroad now actively engaged in every area of communications is seeking experienced communications engineer who desires:

Practical application of his training and experience in an essential industry.
Good salary and benefits with definite growth potential leading to management position.

Candidate should have 3 to 5 years experience in communications field.
Send confidential resume to

MR. R. R. HICKS
Director of Personnel Services
N. Y. CENTRAL SYSTEM
New York 17, N. Y.

POSITIONS VACANT

B.S. and M.S. Electrical Engineers for research work on instrumentation and control problems related to the steel industry. Salary commensurate with training and experience. Large Research Laboratory, Pittsburgh Area. Forward complete resume and salary requirements to P-2283, Electronics, Class. Adv. Div., P. O. Box 12, N. Y. 36, N. Y.

Electrical Engineers. Evaluate instrument systems, establish calibration and operation procedures. Procurement, acceptance testing and shakedown of new instruments required in wind tunnel testing of models and propulsion systems of rockets and missiles. Establish preventive maintenance procedures. Monitor data quality and improve instrumentation. Send resume and salary requirements to Technical Employment, ARO, Inc., Tullahoma, Tenn.

**Antique
TELEPHONES**

As is complete, decorative purpose \$12.00. Working order, inter-comm. \$15.00. Ext. on dial \$17.50, talking circuit only. Write for complete list. All shipments FOB, Simpson, Pa.
TELEPHONE ENGINEERING CO.
Dept. E-109, Simpson, Pa.



**WANTED
ALLEN-BRADLEY
RESISTORS & POTENTIOMETERS**

LEGRI S COMPANY

391 Riverdale Ave. Yankers 5, N. Y.

WE'RE
LOOKING
FOR
A MAN
LIKE
Kepler



— WITH A MODERN TURN OF MIND



Johann Kepler proved that the planes of all the planetary orbits pass through the center of the sun.

Nearly four centuries later, his discoveries are helping us unlock the mysteries not just of our own solar system, but of myriads of others.

If you're a creative engineer of senior status and with advanced ideas, you can hang your hat at Goodyear Aircraft. We need you in astronautics, missile development and other programs too many to mention.*

And if you have some of the persevering spirit of Johann Kepler, we can use that, too. Write: Mr. Charles Jones, Director of Technical and Scientific Personnel, Goodyear Aircraft Corporation, Akron 15, Ohio.

**Rocket propulsion interplanetary guidance, advanced black boxes, crew escape capsules. Also in ground support systems for missiles, radar structures, radomes, radiation research — to name just a few.*

GOODYEAR AIRCRAFT

GENERAL ELECTRIC



MISSILE
SYSTEMS

INTELLIGENCE
SYSTEMS

INFORMATION
SYSTEMS

SUPPORT
SYSTEMS

RANGE
MANAGEMENT

SPECIAL CUSTOMER
SERVICES

ANNOUNCES

the establishment of the

Special Programs Section

of the

DEFENSE SYSTEMS DEPARTMENT

(A Department of the Defense
Electronics Division)

... to serve the needs of
THE UNITED STATES ARMY

in the areas of
SYSTEMS ENGINEERING and MANAGEMENT

A few senior positions exist for individuals with experience in missile and electronics systems engineering. We would welcome the opportunity to review your resume, sent to:

Dr. W. Raithel
Manager — Engineering
Special Programs Section; Dept. 309
General Electric Company
21 South 12th Street
Philadelphia, Pennsylvania*

*Temporary location while new facility is being constructed in suburban Radnor, Pennsylvania.

GENERAL ELECTRIC

IDEA

Quantizing Photographs—electronic surveillance pictures are a source of information, but the usefulness of such information when transmitted over long distances depends upon the faithfulness of the data link. Amplitude modulation, as the data-link approach, cannot be relied upon as signals are oftentimes attenuated to almost useless levels.

Quantizing photographs and then using a coded transmitting scheme such as pulse code modulation improves reproduction and surveillance usefulness at the receiving end of the digital transmission link.

RESULT: faithful transmission and reception over greater distances.



ORIGINAL PHOTO



TRANSMITTED: BY AMPLITUDE MODULATION



BY QUANTIZING AND CODING

design, manufacturing and quality control engineers — 3-10 years experience

careers and ideas at TI

Ideas come where they are encouraged, and at TI's Apparatus Division engineers work in a permissive atmosphere, one which produces creativity as a *natural* result. Both the modern air-conditioned work facilities and the pattern of life in the progressive city of Dallas encourage a man to his most efficient productivity and rewarding accomplishments.

Your experience in one of the following technologies may find immediate application in our Electronic Surveillance, Antisubmarine Warfare, Heavy Surface Radar, or Missile Systems programs.

radar • sonar • infrared • magnetic anomaly detection • passive detectors • servos • navigational systems • special-purpose computers • timers • programmers • microwave • telemetering • data link • optics • video mappers • visual displays • intercom

Our stable growth requires a steady influx of men qualified in these technologies. To learn more about us and how we can fit into your career plan, write for a copy of "We can tell you this much about Apparatus division" to: **J. R. Pinkston, Department 102 Apparatus Division**

current career openings

EE's & PHYSICISTS: missile guidance, control systems design and analysis, radar (ground and airborne), antenna and microwave components, servo-mechanisms, telemetry, digital circuits, sonar, infrared design, and flight test.

ME's: antenna, mechanisms, miniaturization, thermodynamics, refrigeration, insulation, packaging, and structures design.

INDUSTRIAL ENGINEERS: cost estimating, quality control, and quality assurance studies.

MANUFACTURING ENGINEERS: tooling design and production planning and supervision. (Degrees in EE or ME.)

PROFESSIONAL
PLACEMENT

APPARATUS
DIVISION

TEXAS  INSTRUMENTS
INCORPORATED

World Radio History

6000 LEMMON AVENUE

DALLAS 9, TEXAS

*Explore new areas
at IBM in*

MXATH+HEM

At IBM, creative mathematicians are discovering important, new applications of mathematics in the electronic computer field. Long before actual construction of IBM's unique Magnetic Character Sensing Machine, for example, mathematicians were at work on a mathematical model, testing both the over-all design and the logic circuitry needed for character recognition. In another project, mathematicians employed large-scale computers to simulate, in a matter of weeks, eight years of engineering work which have yet to begin. Currently under study are vehicular penetration problems involving thousands of variables. Projects of this sort demand keen, discerning minds. If you have a flair for creative mathematics, you're the man we want to talk to.

You will enjoy unusual professional freedom and the support of a wealth of systems know-how. Comprehensive education programs are available, plus the assistance of specialists of many disciplines. Working independently or as a member of a small team, your contributions are quickly recognized and rewarded. This is a unique opportunity for a career with a company that has an outstanding growth record.

CAREERS AVAILABLE IN THESE AREAS...

Analog & digital computers	Experimental techniques	Probability theory
Applied mathematics	Field theory	Reliability
Circuit design	Human factors engineering	Scientific programming
Communications theory	Logic	Solid state
Computer system design & analysis	Mathematical & numerical analysis	Statistics
Control system research	Operations research	Switching theory
		Theoretical physics

Qualifications: B.S., M.S., or Ph.D. in Mathematics, Physics, Statistics, Engineering Science, or Electrical Engineering – and proven ability to assume important technical responsibilities in your sphere of interest.

ASSIGNMENTS NOW OPEN INCLUDE . . .

MATHEMATICIAN: to handle mathematical analysis of advanced scientific computer programming for solution of systems problems, differential equations, probability-type problems, photogrammetry problems.

STATISTICIAN: to solve analysis-of-variance and multiple-regression type problems; to design experiments for various engineering applications and select form of statistical analysis of greatest value; to give statistical support to engineering departments in such areas as reliability analysis and human factors engineering by developing statistical programs for the IBM 704. Statistical experience in engineering problems and thorough knowledge of statistical distribution functions necessary.

RESEARCH MATHEMATICIAN: to investigate statistical problems in control system research on digital computer; to study control problems of analog to digital conversion, with particular reference to matrix problems; to apply experience with networks, statistics, or communications theory to problems in computer design; to solve problems involving switching theory, probability and information theory, and coding.

ATICS

APPLIED MATHEMATICIAN: to undertake assignments involving knowledge of feedback control theory, data systems theory, servomechanisms, information theory, statistical models, heat flow, circuitry, magnetics, probability.

MATHEMATICIAN-PROGRAMMER: to specify and program elements of a sophisticated automatic programming system. Must have considerable experience in automatic programming research.

OPERATIONAL PROGRAMMER: to develop computer program techniques for real-time military applications, using game theory and systems simulation.

OPERATIONS RESEARCH MATHEMATICIAN: to evaluate closed loop systems consisting of computers, radar displays, and inertial equipment; to simulate advanced weapons systems in order to evaluate alternate design concepts; to analyze and design electromechanical systems, studying targets, tactics, and operational effectiveness. Experience in applying advanced mathematical techniques to weapons systems analysis and evaluation. Knowledge of probability and linear programming techniques.

For details, write, outlining background and interests, to:
Mr. R. E. Rodgers, Dept. 55414
IBM Corporation
590 Madison Avenue
New York 22, N. Y.

IBM®

INTERNATIONAL BUSINESS MACHINES CORPORATION

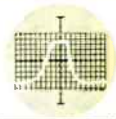
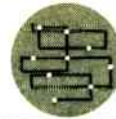

CIRCUIT DEVELOPMENT ENGINEER

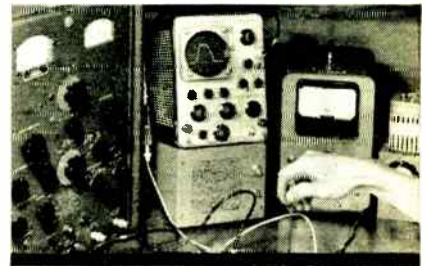
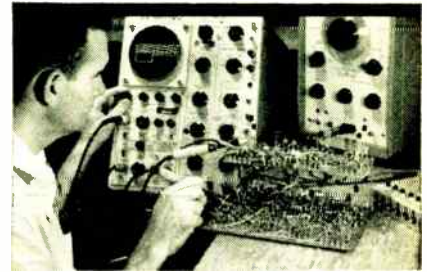

your future:
a challenging opportunity
with an industry leader

At Texas Instruments, your future is filled with specific, stimulating growth assignments in evaluating and characterizing transistors and special semiconductor devices. You'll participate in such transistorization projects as:

- AM, FM, and TV receivers
- audio and video, i-f and r-f amplifiers
- hi-fi and electronic organs
- nonlinear and switching circuits
- computer system logic
- servo and power amplifiers

With TI... receive liberal company-paid benefits, including profit sharing (last year 15% of base salary) ... enjoy premium living in a moderate climate with excellent neighborhoods, schools and shopping facilities.

Interviews will be held in your area soon. If you have an Electrical Engineering degree and/or knowledge of transistor circuitry, please send a resume to:

H. C. Laur, Dept. 200-E-EL
(for immediate Eastern appointment)
1141 E. Jersey Street, Elizabeth, New Jersey

or
C. A. Besio, Dept. 200-EL



TEXAS INSTRUMENTS
INCORPORATED
SEMICONDUCTOR - COMPONENTS DIVISION
POST OFFICE BOX 312 • DALLAS TEXAS

LENKURT

has openings for

- Communications Engineers
- Development Engineers
- Sales Engineers
- Asst. Electrical Engineers
- Engineering Writers

Live and work on the Beautiful San Francisco Peninsula!

Please call collect
LYtel 1-8461

or send resume to:

E. Jack Shannahan
Employment Manager

LENKURT
ELECTRIC CO., Inc.
1105 County Road
San Carlos, California

PRODUCT DESIGN ENGINEER

Permanent position. Commercial products only. Chicago area manufacturer of microphones and receivers has an opening for a supervisory engineer. This is a top level position. Candidate must be a graduate engineer with a B.S.E.E. or a graduate of a college level technical school and should have a minimum of 5 years experience as a product design engineer in the electronic component field. Experience should include test equipment maintenance and production line trouble shooting. Will be responsible for final designs of miniature electronic components after receipt of initial proto-types from the research and development group. Excellent salary. Send resume in confidence to: James G. McCracken, Director Industrial Relations.

KNOWLES ELECTRONICS, INC.
10545 Anderson Place
Franklin Park, Illinois
GLadstone 5-3600

CHALLENGING OPPORTUNITIES IN RESEARCH AND DEVELOPMENT

ELECTRONIC
ENGINEERS

SYSTEMS
ENGINEERS

Design of electronic instrumentation for underwater ordnance. Analytical and experimental treatment of scientific research problems in the fields of hydrodynamics, acoustics, electronics, network theory, servo-mechanisms, mechanics, information theory and noise analysis including analogue and digital computations.

THE
PENNSYLVANIA STATE UNIVERSITY
ORDNANCE RESEARCH LABORATORY

P. O. Box 30

University Park, Pennsylvania

- Opportunities for Graduate Study
- Faculty Appointments for Qualified Applicants
- Excellent Working and Living Conditions

Send Resume To:

ARNOLD ADDISON
Personnel Director

electronic instrument development engineers

Minimum of 5 years of applicable experience required. An advanced degree desirable but not essential.

Because Boonton pioneers in developing such fundamental precision measurement instruments as the "Q" meter and other pacesetter electronic devices, your opportunity to engage in creative research is unusually great. As a member of our development team, you'll be exchanging ideas with men who have made notable contributions to the state of the art. By joining our staff now, your opportunities to make contributions to our expanding product line will be great.

If your experience lies in:

- CIRCUIT ANALYSIS AND SYNTHESIS
- VHF OR UHF MEASUREMENT TECHNIQUE
- PRECISION MEASUREMENT OF FUNDAMENTAL PHYSICAL QUANTITIES

then we urge you to write or call
Mr. J. P. VAN DUYNÉ, Engineering Manager.

BOONTON
RADIO Corp.

BOONTON New Jersey

SENIOR ELECTRICAL ENGINEER

Development engineering in measurement and control of production machinery. Experience required: 5-8 years in electronics design with servo-mechanism background. Electro-mechanical design experience desirable. Engineering degree or equivalent required.

Please submit complete resume

TOBACCO PRODUCTION
DEVELOPMENT LABORATORY



**AMERICAN MACHINE
& FOUNDRY COMPANY**

Box 9127 Richmond 27, Virginia

MANUFACTURERS REPRESENTATIVES

Openings for experienced component sales engineering organizations interested in the following territories: New England States;—Minnesota, Iowa, Wisconsin;—South Carolina, Georgia, Alabama;—Kansas, Missouri, Arkansas;—Louisiana, Mississippi;—New Mexico, Arizona.

Firm is well established producer of wide range of electronic wiring devices with excellent product acceptance.
RW-2253, Electronics
520 N. Michigan Ave., Chicago 11, Ill.

ELECTRONICS-FRANCE

Aggressive well established—since 1932—sales-engineering organization. Best connections to govts & industry, well liked French-American management, will cooperate with U.S. mfrs wishing to enter EUROPEAN COMMON MARKET. Write

RA-2538, Electronics
Class. Adv. Div., P.O. Box 12, N.Y. 36, N.Y.

STAFF ENGINEER

Communications division of an alert expanding concern need B.S.E.E. or physics to supervise groups of technical tasks in phases of electronics systems. Potential \$14,000—\$15,000. No fee.

MONARCH PERSONNEL

28 East Jackson Blvd. Chgo, Illinois

*Your Inquiries to
Advertisers Will
Have Special Value . . .*

—for you—the advertiser—and the publisher, if you mention this publication. Advertisers value highly this evidence of the publication you read. Satisfied advertisers enable the publisher to secure more advertisers and—more advertisers mean more information on more products or better service—more value—to YOU.

INDEX TO ADVERTISERS

AC Electronic Division.....	45	Hewlett-Packard Company	42
A M P Incorporated.....	7	Hudson Tool & Die Co. Inc.....	19
Aeronautical Communications Equipment Co.....	10	Hughes Aircraft Company.....	29, 30, 31, 54, 55
Airpax Electronics Inc.....	116	Humphrey, Inc.	16
Allegheny Ludlum Steel Corp.....	9	International Rectifier Corp.....	23
Allied Control Company.....	13	International Resistance Co.....	3rd Cover
Aveco Corporation	44	IT&T Laboratories	89
Beaver Gear Works, Inc.....	124	Jerrold Electronics Corp.....	107
Bendix Aviation Corp. Red Bank Div.....	97	Klein & Sons, Mathias.....	121
Boonton Radio Corporation.....	49	Krengel Manufacturing Co., Inc.....	127
C B S Electronics.....	61	Lambda Electronics Corp.....	3
Cannon Electric Company.....	37	Lampkin Laboratories	128
United Carr Fastener Company.....	17	Lapp Insulator Co., Inc.....	56
Centralab, A Div. of Globe-Union Inc.....	59	Lockheed Aircraft Corp.....	125
Ceramic Metal Assemblies Corp.....	47	Magnetic Amplifiers, Inc.....	136
Cinch Manufacturing Company.....	87	Magnetics, Inc	24
Clevite Transistor Products A Div. of Clevite Corporation	15	Magnetic Devices, Inc.....	111
Collins Radio Company.....	52	Mallory & Co., Inc., P. R.....	66
Comar Electric Company.....	92	Marconi Instruments	117
Coto-Coil Inc.	124	Marion Instrument Div. Minneapolis- Honeywell Regulator Co.....	115
Curtiss-Wright Corp.	108	Melpar Inc.	96
Douglas Aircraft	20, 21	Metals & Controls, A Div. of Texas Instruments Incorporated	26, 34
Downey-Capri Motel	128	Microwave Associates Inc.....	112
Driver Co., Wilbur B.....	63	Midwestern Instruments	114
Edo Corporation	115	Moseley Co., F. L.....	39
Eitel-McCullough Inc.	10	Motorola, Inc	62
Electro Motive Mfg. Co., Inc., The.....	65	Narda Microwave Corp., The.....	12
Electronic Engineering Company of Calif.	113	Norton Company	6
Electronic Instrument Co., Inc. (EICO) ..	115	Oak Mfg. Co.....	2
Esterline Angus Co., Inc.....	127	Ohmite Mfg. Co.....	41
Fairchild Semiconductor Corp.....	123	Packard Bell Computer Corp.....	99
Fenwal Electronics	53	Peerless Electric Co., The.....	46
Fluke Manufacturing Co., John.....	105	Polytechnic Research & Development Co. ..	28
Gamewell Company	22	Radio Corporation of America 35, 58, 4th Cover	
Gardner-Denver Company	60	Rawson Electrical Instrument Co.....	115
General Ceramics Corp.....	36	Raytheon Company	2nd Cover
General Electric Co. Power Tube Div.....	32, 33	Rondo Of America, Inc.....	110
Semiconductor Dept.	50, 51	Sugamo Electric Company.....	95
General Instrument Corp.....	100	Sierra Electronic Corp.....	106, 107
General Transistor Corp.....	18		
Green Instrument Company, Inc.....	118		
Hallerafters	111		
Haydon Company, A. W., The.....	118		



COMPLETE LINE + FAST SERVICE

= HIPERSIL CORES

Westinghouse stocks all types and sizes of Hipersil cores in three locations to serve you better

COMPLETE LINE includes the new EIA, RS-217 standard sizes.

- Type C: 12,4,2 and 1 mil sizes, in single- and 3-phase, from a fraction of an ounce to 300 pounds.
- Ring Cores: with new polyclad treatment—assure best magnetic performance of any Epoxy resin-coated core ready to receive windings.
- Special Cores: to any specification and shape requirement—rectangular, triangular and others.

FAST SERVICE is assured by complete stocks at Greenville, Pa.; Boston, Mass.; and Los Angeles, Calif.

Performance of Hipersil® cores in "iron-core" components is guaranteed to meet or exceed specifications.

For more facts, write for Price List 44-520 and Descriptive Bulletin 44-550 to Westinghouse Electric Corporation, P.O. Box 868, Pittsburgh 30, Pa. J-70920

YOU CAN BE SURE... IF IT'S
Westinghouse

WATCH "WESTINGHOUSE LUCILLE BALLOES/ARNAZ SHOWS"
CBS TV FRIDAYS

New PRECISION
FREQUENCY

STATIC INVERTER SUPPLY

INPUT 28V D.C. \pm 10%
OUTPUT Nom. 115V \pm 2%
400 CPS \pm 0.01%
1 ϕ (2- or 3-phase output available)
RATINGS: 30VA 50VA 100VA
Higher ratings available.

APPLICATION:

For gyro wheel supplies and where precise 400 cycle voltages are required in aircraft, radar and missile computers.

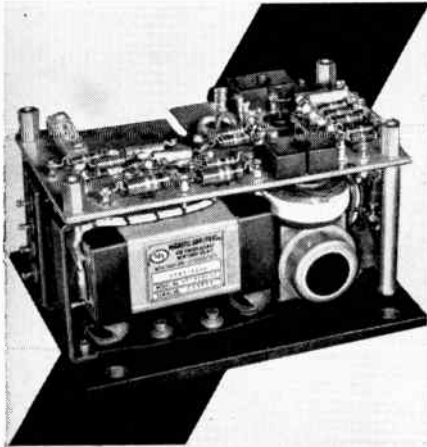

FEATURES:

- PRECISION OUTPUT FREQUENCY
 - RUGGED
 - EXCELLENT WAVEFORM
 - SIMPLICITY OF CIRCUITRY
 - FAST STARTING TIME
 - GOOD VOLTAGE REGULATION
 - throughout an adjustable range
 - ISOLATED CASE DESIGN
 - HIGH RELIABILITY
 - VIBRATION ISOLATED
 - COMPACT
 - LIGHTWEIGHT
 - MILITARY SPECIFICATIONS
- (Send for Bulletin S-864)



**MAGNETIC
AMPLIFIERS, INC.**

632 TINTON AVENUE • NEW YORK 55, N. Y. • CYPRESS 2-6610

West Coast Division

136 WASHINGTON ST. • EL SEGUNDO, CAL. • OREGON 8-2665

Silicon Transistor Corp.....	25
Simpson Electric Company.....	108, 109
Sorensen & Company, Inc.....	93
Specific Products	126
Spectrol Electronics Corp.....	103
Sprague Electric Company.....	5
Sylvania Electric Products, Inc.....	8
Tung-Sol Electric Inc.....	91
United Shoe Machinery Corp.....	57
Virginia Dept. of Conservation and Economic Development	61
Westinghouse Electric Corp.....	135
Weinschel Engineering	14
Weston Instruments	27
White, S. S.....	136
Zippertubing Co., The.....	110

CLASSIFIED ADVERTISING
F. J. Eberle, Business Mgr.

EMPLOYMENT OPPORTUNITIES	128-134
EQUIPMENT	
(Used or Surplus New)	
For Sale	128
WANTED	
Equipment	128

ADVERTISERS INDEX

American Machine & Foundry.....	134
Avco	128
Boonton Radio	134
General Electric Co.....	130
Goodyear Aircraft Corp., The.....	129
International Business Machines.....	132, 133
Knowles Electronics Inc.....	134
Legri S Co.....	128
Lenkurt Electric Co.....	134
Monarch Personnel	134
New York Central System.....	128
Pennsylvania State University.....	134
Telephone Engineering Co.....	128
Texas Instruments Incorporated.....	131, 133

This index is published as a service. Every care is taken to make it accurate, but ELECTRONICS assumes no responsibilities for errors or omissions.

Anywhere . . .
At sea, in the icy cold of the antarctic! S.S. WHITE Molded Resistors in values up to 50,000 megohms retain their characteristics.

in Any Weather
Airborne, in the steaming heat of the tropics! S.S. WHITE Molded Resistors are made of coated, non-hygroscopic material that resists moisture.

S.S. White
"ALL-WEATHER"
Molded Resistors
Withstand Temperature
and Humidity

FIXED RESISTANCE VALUES RANGE
FROM 1000 OHMS TO 10,000,000
MEGOHMS!

65X Molded Resistor — 1 watt
80X Molded Resistor — 3 watts

While bargain buys in resistors are wearing out and being replaced, durable S.S. White "All-Weather" Molded Resistors are still giving top performance in hundreds of commercial, industrial and scientific applications.

Our resistors are characterized by low noise level . . . precision . . . stability . . . have negative temperature and voltage coefficients. Compact . . . excellent stability and mechanical strength . . . values do not deteriorate due to age.

We'll be glad to cooperate with you in applying these high-quality resistors to your product. For our Bulletin 5409, just drop a line to Dept. R.

S.S. White
INDUSTRIAL DIVISION

10 East 40th Street
New York 16, New York

CIRCLE 151 ON READER SERVICE CARD
SEPTEMBER 25, 1959 • ELECTRONICS