

MARCH 6, 1959

electronics

A MCGRAW-HILL PUBLICATION

VOL. 32, No. 10

PRICE SEVENTY-FIVE CENTS

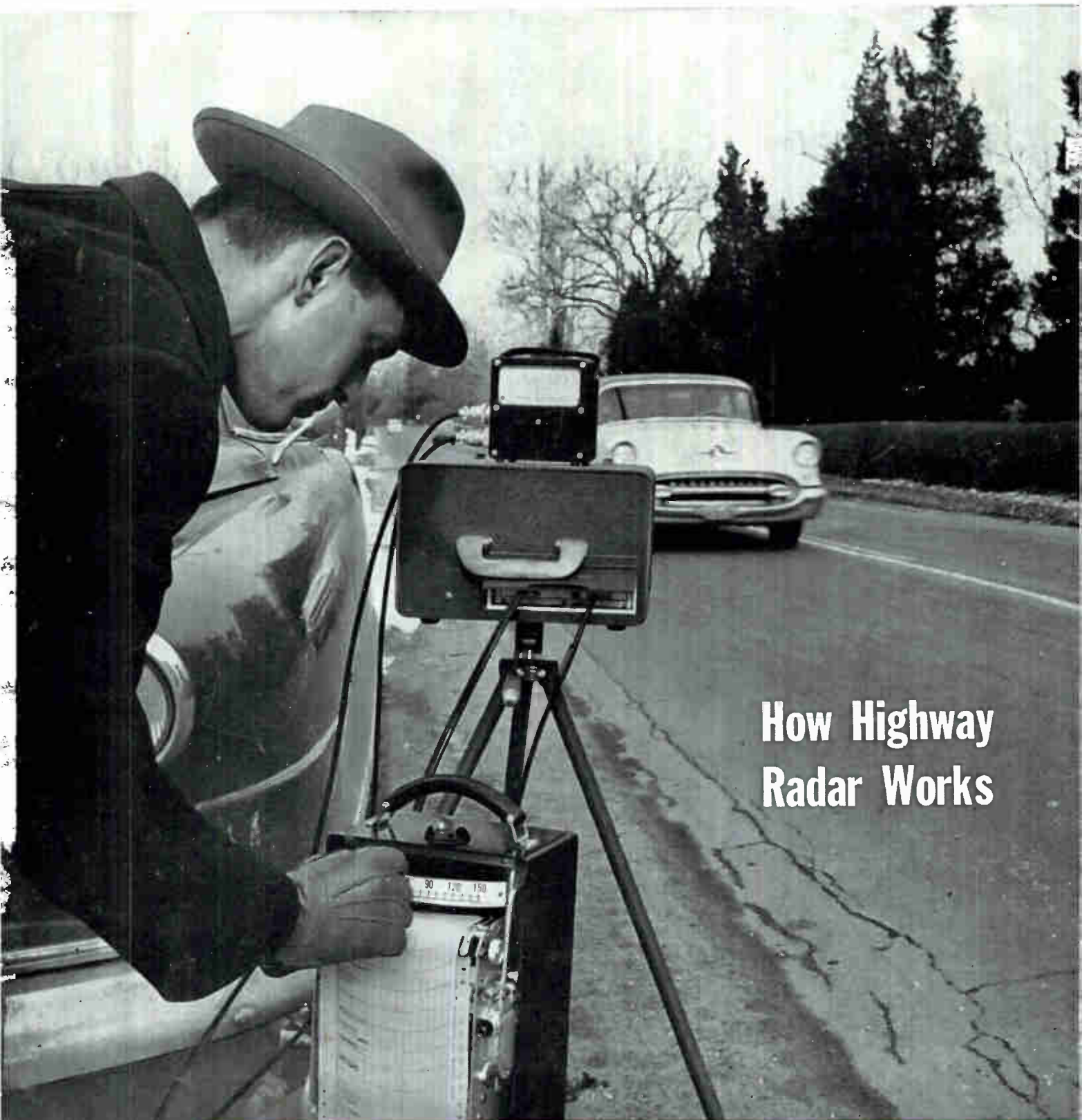

**How Highway
Radar Works**

New Computers Increase Transistor Sales

DIGITAL VOLTMETER, \$825

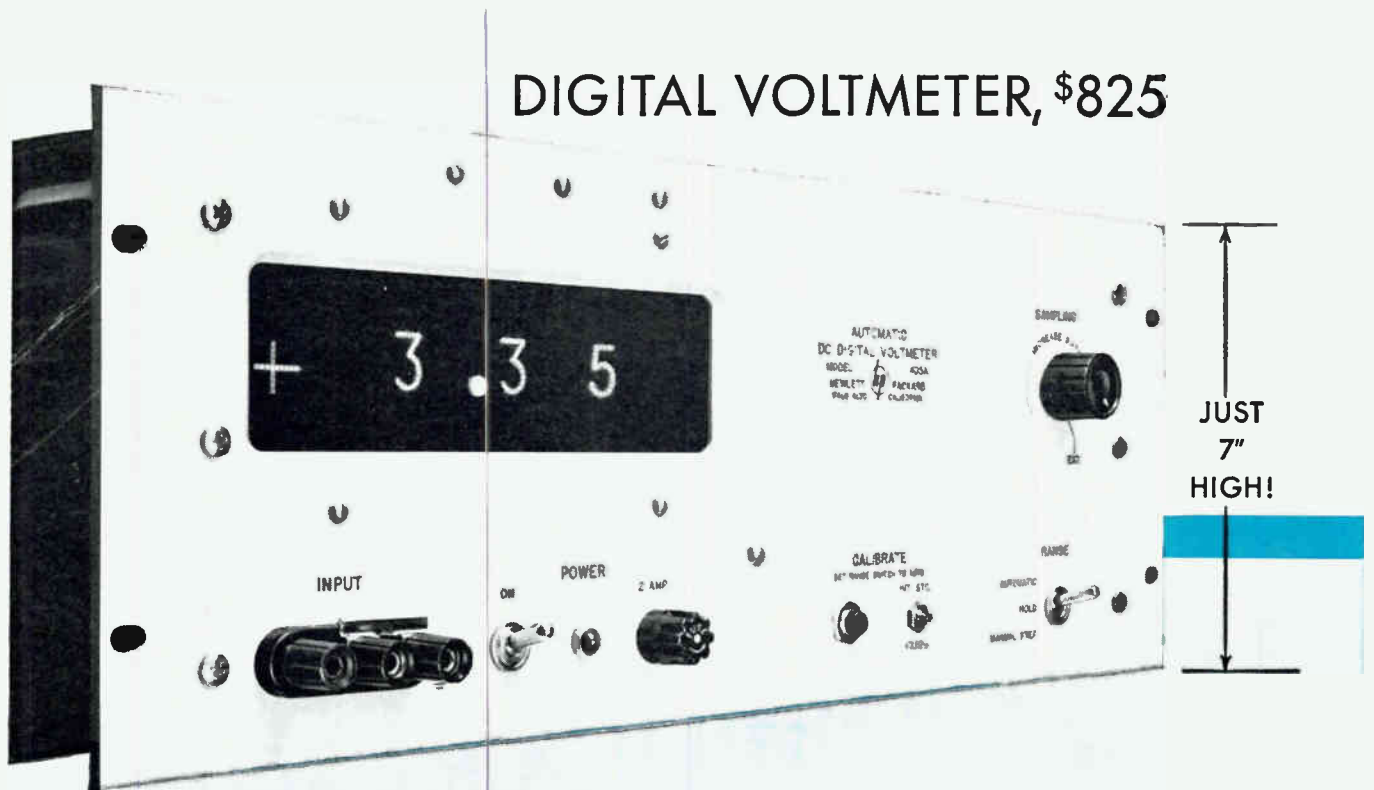

Automatic range and polarity selection. Just apply the probe and read voltage directly!

Ⓢ **405AR DC DIGITAL VOLTMETER** is a completely new instrument providing, literally, "touch-and-read" voltage measurements between 1 and 1,000 volts. *Range, even polarity, are automatically selected.* Readout is in-line, in bright, steady numerals. *New, novel circuitry provides a stability of readings virtually eliminating jitter in the last digit. This reduces operator fatigue and avoids uncertainty.*

Special features include a floating input, electronic analog-to-digital conversion, digital recorder output and front-panel "hold" control permitting manual positioning of decimal. Voltage sampling rate is variable from 1 reading every 5 seconds to 5 per second; or can be controlled externally by a 20 v positive pulse.

BRIEF SPECIFICATIONS

Range: 0.001 to 999 v dc; 4 ranges.
Presentation: 3 significant figures, polarity indicator
Accuracy: $\pm 0.2\%$ full scale ± 1 count
Ranging time: $\frac{1}{2}$ sec to 2 sec
Input impedance: 11 megohms to dc, all ranges
Response time: Less than 1 sec
AC rejection: 3 db at 0.7 cps; min. 50 db at 60 cps
Price: \$825.00

Data subject to change without notice. Price f.o.b. factory.



HEWLETT-PACKARD COMPANY

5100A PAGE MILL ROAD • PALO ALTO, CALIFORNIA, U.S.A.

CABLE "HEWPACK" • DAVENPORT 5-4451

FIELD REPRESENTATIVES IN ALL PRINCIPAL AREAS

Issue at a Glance

A McGRAW-HILL PUBLICATION
Vol. 32 No. 10

H. W. MATEER, *Publisher*

JAMES GIRDWOOD, *Associate
Publisher*

W. W. MacDONALD, *Editor*

JOHN M. CARROLL, *Managing
Editor*

*Feature Editor, John Markus.
Associate Editors: John M. Kinn,
Jr., Frank Leary, Michael F. To-
maino, Howard K. Janis, Sylvester
P. Carter, Haig A. Manoogian,
Roland J. Charest, William P.
O'Brien, George Sideris, John F.
Mason, William E. Bushor, Ronald
K. Jurgen, Thomas Emma, Samuel
Weber.*

*Pacific Coast Editor (Los Angeles)
Harold C. Hood; Midwestern Editor
(Chicago) Harold Harris; New Eng-
land Editor (Boston) Thomas Ma-
guire.*

*Art Director, Harry Phillips, Roy
Thompson.*

*Production Editor, John C.
Wright, Jr., Bernice Duffy, Jean L.
Matin.*

*Market Research, Edward De-
Jongh, Marilyn Koren.*

*Editorial Assistants, Gloria J.
Filippone, Arlene Schilp, Patricia
Landers, Catherine McDermott,
Eleanor Schaefer, Carol Weaver.*

*BRUCE A. WINNER, Advertising
Sales Manager. R. S. Quint, As-
sistant Advertising Sales Manager
and Buyers' Guide Manager. Fred
Stewart, Promotion Manager.
Frank H. Ward, Business Manager.
George E. Pomeroy, Classified
Manager. Hugh J. Quinn, Circula-
tion Manager.*

*New York: Donald H. Miller,
Henry M. Shaw, William J.
Boyle. Boston: Wm. S. Hodgkin-
son. Philadelphia: Warren H.
Gardner. Chicago: Harvey W.
Wernecke, Martin J. Gallay.
Cleveland: P. T. Fegley. San
Francisco: T. H. Carmody, R. C.
Alcorn. Los Angeles: Carl W.
Dysinger, D. A. McMillan. Denver:
J. Patten. Atlanta: M. Miller. Dal-
las: Gordon L. Jones, Robert T.
Wood. London: E. E. Schirmer.
Frankfurt: Michael R. Zeynel.*

BUSINESS

| | |
|---|----|
| Space Tracking Is Big Business. Today's U. S. net is only a start.... | 24 |
| Computers Lift Transistor Sales. Recent trends point to future..... | 29 |
| Six-Jet Drones on the Way. Much is happening in this field..... | 32 |
| New Tv Channels Pondered. FCC officials air views and plans..... | 35 |
| Shoptalk | 4 |
| Electronics Newsletter | 11 |
| Washington Outlook | 12 |
| Financial Roundup | 15 |
| Over The Counter..... | 15 |
| Market Research | 20 |
| Current Figures | 20 |
| Meetings Ahead | 38 |

ENGINEERING

| | |
|---|-------|
| How Radar Speedmeters Work. Details of Doppler transceiver used by many police organizations today. See p 48..... | COVER |
| Automatic Controls for Metal Working Machines. Determines and maintains correct tension at yield point.....By G. J. Crowdes | 41 |
| Vernier Chronotron Times Nuclear Particle Flight. Coincidence resolu- tion is one millimicrosecond... By H. W. Lefevre and J. T. Russell | 44 |
| Radar Meter Helps Enforce Traffic Laws. Battery-powered radar converts Doppler shift to speed reading in mph.... By J. Barker | 48 |
| Solid-State Thyratrons Available Today. Tabulation of character- istics of three-terminal switching transistors... By T. P. Sylvan | 50 |
| Time-Signal Generator With Flexible Output. Versatile bench unit can be used to form a variety of timed pulses... By D. E. Minow | 52 |
| Programmed Servo Speeds Short-Run Production. Unit selects com- ponents, directs component inserter.....By S. B. Korin | 54 |
| UHF Transistor Data. Tabulation of eight commercially available transistors operating above 300 mc.....By H. Tulchin | 57 |
| Magnetic Head Reads Tape at Zero Speed. Developed for timescale expansion of magnetic tape records.....By M. E. Anderson | 58 |
| Improved R-C Oscillator. Useful single-frequency oscillator for 4 cps to 350 kc.....By L. H. Dulberger | 62 |

DEPARTMENTS

| | |
|--|-----|
| Research and Development. Simulating Second-Order Equations.... | 64 |
| Components and Materials. Missile Shock and Vibration Protection.. | 68 |
| Production Techniques. Workpiece Controls Shaft Drill..... | 72 |
| On the Market..... | 76 |
| Literature of the Week..... | 86 |
| Plants and People..... | 88 |
| News of Reps..... | 90 |
| Comment | 92 |
| Index to Advertisers..... | 102 |



The King Company

buys a packaged plan for the future

... with the help of the Ætna Life's Business Planning Department

The King Electronics Company is a close corporation manufacturing television components. The stock of the company is held by President Herbert F. King and members of his family. They operate the business.

Recently a member of the local Ætna Life Business Planning Department explained how death of a principal stockholder can create major problems. His heirs may be forced to unload a substantial block of stock to pay death taxes, thus watering down their control of the corporation. With the help of their Ætna Life representative, attorney and accountant, a plan was developed to avoid this danger by taking advantage of certain favorable tax legislation designed for just such a situation. If you own or operate any kind of business, it will pay you to investigate the vital need for a business continuation plan — and no one is better equipped to serve your interests than the Business Planning Department of your local Ætna Life General Agency.

ÆTNA LIFE
INSURANCE COMPANY



Affiliates: Ætna Casualty & Surety Co. • Standard Fire Insurance Co. • Hartford, Conn.

INSPIRATION IN REFLECTOR ENGINEERING

We would like to paraphrase the 1959 IRE Show theme, Inspiration in Radio Electronics, by pointing out this example of Kennedy Inspiration in Reflector Engineering, a 40-foot reflector featuring quick in-the-field assembly and disassembly.

You can see this unique antenna at Booths 2532 and 2637 at the IRE Show.

CIRCLE 2 READERS SERVICE CARD



ANTENNA EQUIPMENT

D. S. KENNEDY & CO.

COHASSET, MASS. Evergreen 3-1200

*Down-To-Earth SOLUTIONS to
Out-Of-This-World PROBLEMS*

Tracking Antennas
Radio Telescopes
Radar Antennas
"Trans-Horizon" Antennas
Tropospheric Scatter
Ionospheric Scatter

SHOPTALK . . .

electronics

Mar. 6, 1959

Vol. 32 No. 10

Published weekly, with a BUYERS' GUIDE and REFERENCE issue in mid-June, by McGraw-Hill Publishing Company, Inc., James H. McGraw (1860-1948) Founder.

Executive, Editorial, Circulation and Advertising Offices: McGraw-Hill Building, 330 W. 42 St., New York 36, N. Y. Longacre 4-3000. Publication Office: 99-129 North Broadway, Albany 1, N. Y.

See panel below for directions regarding subscriptions or change of address. Donald C. McGraw, President; Joseph A. Gerardi, Executive Vice President; L. Keith Goodrich, Vice President and Treasurer; John J. Cooke, Secretary; Nelson L. Bond, President, Publications Division; Shelton Fisher, Senior Vice President; Ralph B. Smith, Vice President and Editorial Director; Joseph H. Allen, Vice President and Director of Advertising Sales; A. R. Venezian, Vice President and Circulation Coordinator.

Single copies 75¢ in the United States and possessions and Canada; \$1.50 for all other foreign countries. Buyers' Guide \$3.00. Subscription rates—United States and possessions, \$6.00 a year; \$9.00 for two years; \$12.00 for three years. Canada, \$10.00 a year; \$16.00 for two years; \$20.00 for three years. All other countries \$20.00 a year; \$30.00 for two years; \$40.00 for three years. Second class postage paid at Albany, N. Y. Printed in U.S.A. Copyright 1959 by McGraw-Hill Publishing Co., Inc.—All Rights Reserved. Title registered in U. S. Patent Office. BRANCH OFFICES: 520 North Michigan Avenue, Chicago 11; 68 Post Street, San Francisco 4; McGraw-Hill House, London E. C. 4; 85, Westendstrasse, Frankfurt/Main; National Press Bldg., Washington 4, D. C.; Six Penn Center Plaza, Philadelphia 3; 1111 Henry W. Oliver Bldg., Pittsburgh 22; 55 Public Square, Cleveland 13; 856 Penobscot Bldg., Detroit 26; 3615 Olive St., St. Louis 8; 350 Park Square Bldg., Boston 16; 1301 Rhodes-Haverty Bldg., Atlanta 3; 1125 West Sixth St., Los Angeles 17; 1740 Broadway, Denver 2; 901 Vaughn Bldg., Dallas 1. ELECTRONICS is indexed regularly in The Engineering Index.

Subscription: Address correspondence to: Fulfillment Manager, Electronics, 330 W. 42nd St., New York 36, N. Y. Allow one month for change of address, stating old as well as new address. Subscriptions are solicited only from persons engaged in theory, research, design, production, management, maintenance and use of electronics and industrial control components, parts and products. Position and company connection must be indicated on subscription orders.

Postmaster: please send form 3579 to Electronics, 330 W. 42nd St., New York 36, N. Y.



Member ABP and ABC

IRE SPECIAL. Later this month some 55,000 engineers will turn eastward on their annual pilgrimage to the Institute of Radio Engineers' National Convention and Radio Engineering Show.

Next week **ELECTRONICS** will publish its IRE Special. This issue will give you a chance to catch up with the fast-moving field of electronics and to preview the forthcoming IRE Show and Convention. This year's **ELECTRONICS** IRE Special will be truly the showgoer's vade mecum.

Our issue kicks off in the Engineering section with a special feature article, "Looking Ahead in Engineering" (see below). This article will help you put the products you see and the papers you hear into perspective with the overall trends of the field.

You will also read articles on topics such as: Technical highlights at the IRE; the status of technical manpower; what exhibitors are saying. There will be an intimate profile of Ernst Weber, new IRE president, and a list of exhibitors and booth numbers, as well as a preview of new products on exhibit at the show.

RESEARCH AND DEVELOPMENT. Our new R&D department has an illustrious family background. It descends directly from Tubes at Work, which became Electrons at Work after the transistor came along. Its present name, Research and Development, reflects the ever-shortening time lag between research and production in electronics.

In R&D you will find engineering articles shorter than those in the main feature section directly preceding it, but articles that are nevertheless highly significant and very timely.

Take, for example, Duane Chadwick's article in this issue. Mr. Chadwick, an Assistant Professor of Electrical Engineering at Utah State University, tells how a single operational amplifier can perform the functions necessary to solve second-order differential equations—instead of the three operational amplifiers used conventionally.

Research and Development is edited by Associate Editor Carter, with frequent contributions from other **ELECTRONICS** editors both in the New York office and in the field. Carter, a graduate of Hofstra College, also attended Columbia University. He was an Army radio technician for three years during World War II, served in New Guinea and the Philippines. Carter racked up 10 years in the electronics industry before joining **ELECTRONICS**. His experience includes work in radio, radar, autopilots and analog computers.

Coming in Our March 13 Issue . . .

LOOKING AHEAD. In the coming year, significant new developments will appear in solid-state technology, computers, microwave, and components and materials. In research and development centers throughout the world, emphasis on these areas of activity is paramount.

Next week, Managing Editor Carroll takes you editorially on a tour of these research centers and gives you a preview of what 1959 will mean to our industry in terms of technological progress. You'll learn of new transducers and energy converters, "thinking" computers, new point-to-point microwave techniques, and complete monolithic circuits, as well as many other significant developments.

DIGITAL MEMORY. A magnetic memory using a flat-surfaced aluminum disk with radially-spoked magnetic segments is described by Burroughs Corporation's T. C. Chen and O. B. Stram. This type of memory, used in low-cost computers, has a capacity of 50-100 words.

Circuits are kept simple by employing a new principle wherein the magnetic head is the transformer of a blocking oscillator circuit. No relays or diode networks are required.

NOW RELIABILITY +

in Button Base Subminiatures



CK6021WA

CK6111WA

CK6112WA

twin triodes



CK5639WA

video & power amplifier pentode

CK5902WA

beam power pentode

Only Raytheon makes these completely interchangeable Subminiature Tubes to meet the following tests above and beyond military specifications:

- **15g sweep frequency vibration controls**
- **10g sweep frequency fatigue controls**
- **75g, 10 millisecond shock controls**
(in addition to the usual test of only 1 millisecond duration)
- **2 hour and 20 hour stability life controls**
(guaranteeing stability control)
- **controlled end points for high temperature life test**
(now 1000 hrs. instead of 500 hrs.)
- **maximum rating life test control**
- **high sensitivity thyatron short test**
- **warm-up time controls**
- **heater cathode leakage control at elevated heater voltages**
- **pulse life test with triode connection on the CK6021WA and CK6111WA tubes**

and in addition these Raytheon Tubes are subject to

x-ray quality control
(an original Raytheon safeguard)

0.4% AQL final acceptance
(as compared with 0.65%)

Each of these popular, button base subminiature tubes has ratings equaling its original prototype



INDUSTRIAL TUBE DIVISION

RAYTHEON MANUFACTURING CO.

Reliable Miniature and Subminiature Tubes • Filamentary Tubes • VR Tubes • Rectifiers • Thyratrons • Cathode Ray Tubes
 New York, Plaza 9-3900 • Boston, Blgelow 4-7500 • Chicago, National 5-4000 • Los Angeles, NOrmandy 5-4221
 Baltimore, SOuthfield 1-1237 • Cleveland, Winton 1-7005 • Kansas City, Plaza 3-5330

VISIT RAYTHEON BOOTHS 2610-11-12-13-14 — I.R.E. SHOW N.Y.C.

NOTABLE ACHIEVEMENTS AT JPL . . .

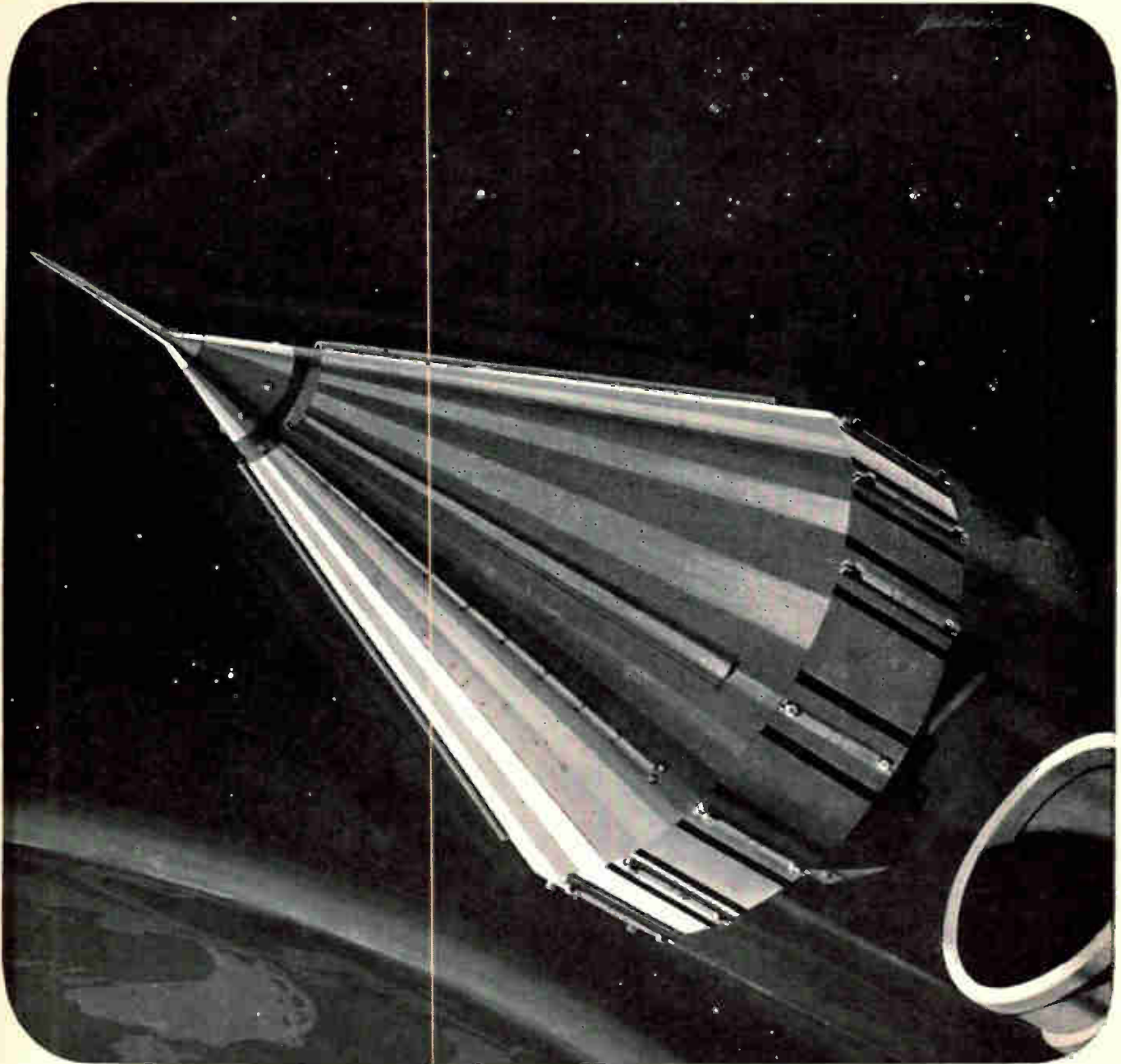

PIONEERING IN SPACE RESEARCH

Another important advance in man's knowledge of outer space was provided by Pioneer III. This, like many others of a continuing series of space probes, was designed and launched by Jet Propulsion Laboratory for the National Aeronautics and Space Administration. JPL is administered by the California Institute of Technology for NASA.

During its flight of 38 hours, Pioneer III

was tracked by JPL tracking stations for 25 hours, the maximum time it was above the horizon for these stations.

The primary scientific experiment was the measurement of the radiation environment at distances far from the Earth and telemetering data of fundamental scientific value was recorded for 22 hours. Analysis of this data revealed, at 10,000 miles from the Earth, the existence of a

belt of high radiation intensity greater than that observed by the Explorer satellites.

This discovery is of vital importance as it poses new problems affecting the dispatch of future vehicles into space. The study and solution of such problems compose a large part of the research and development programs now in extensive operation at the Laboratory.



CALIFORNIA INSTITUTE OF TECHNOLOGY
JET PROPULSION LABORATORY

A Research Facility operated for the National Aeronautics and Space Administration
PASADENA, CALIFORNIA

OPPORTUNITIES NOW OPEN
IN THESE CLASSIFICATIONS

APPLIED MATHEMATICIANS . ENGINEERING PHYSICISTS . COMPUTER ANALYSTS . IBM-704 PROGRAMMERS
AERONAUTICAL ENGINEERS . RESEARCH ANALYSTS . DESIGN ENGINEERS . STRUCTURES AND DEVELOPMENT ENGINEERS



WE
POINT
WITH
PRIDE

We point with massive and pardonable pride to our latest achievement—the new, reliable **Mincom Model C-100 Instrumentation Recorder/Reproducer**. Six speeds record frequencies from 50 cps to 100 kc. Only 500 watts input for 14 track system (all-transistorized electronics). No cooling necessary. No mechanical brakes. Only 0.1% flutter and wow. Instant push-button speed control, no belt changes. Interested? Write for specifications.

MINCOM
DIVISION

2049 SOUTH BARRINGTON AVENUE
LOS ANGELES 25, CALIFORNIA
TELETYPE: WEST LOS ANGELES 6742



MINNESOTA MINING AND MANUFACTURING COMPANY ... WHERE RESEARCH IS THE KEY TO TOMORROW

McGraw-Hill Mailing List Will Help You

- Merchandise your advertising
- Conduct Surveys
- Get leads for your salesmen
- Get inquiries about your product or service
- Pin-point geographical or functional groups
- Sell Direct
- Build up weak territories
- Aid Dealer Relations

Direct Mail is a necessary supplement to a well rounded Business Paper advertising program.

600,000 actual names of the top buying influences in all the fields covered by the McGraw-Hill publications make up our 150 mailing lists. These lists are built and maintained primarily for our own use, but they are available to you for Direct Mail purposes. Pick out a list of YOUR prospects from our Industrial Direct Mail Catalogue.

More and more, progressive companies are using Industrial Direct Mail regularly as an advertising medium. They effectively allocate a portion of their ad budgets to this second medium at the same time as they concentrate on the best business publications.

For complete, detailed information about our service, fill in the coupon or write for your copy of our free Business and Industrial Direct Mail catalogue.

for Results



Mc GRAW-HILL
DIRECT MAIL LIST SERVICE

Direct Mail Division

McGraw-Hill Publishing Co., Inc.
330 West 42nd St., N. Y. 36, N. Y.

Please forward my free copy of the
McGraw-Hill "Industrial Direct Mail Catalogue."

NAME _____

COMPANY _____

ADDRESS _____

CITY _____ STATE _____

Dr. Wright takes the



stand for **electronics**

What is your present work in electronics, Dr. Wright?

Vice President In-Charge-of-Operations-and-Engineering at Tung-Sol Electric Inc., a leading manufacturer of electron tubes, semiconductors, tv tubes, lamps, power supplies, flashers, selenium and silicon rectifiers.

How many people are at Tung-Sol?

Approximately 6,000.

Briefly, what is your background in electronics?

Twenty-two years with Tung-Sol.

How many years have you been reading electronics?

It goes back over twenty years..

Why have you continued to read it?

After all, this is a very technical and rapidly changing industry. I don't know which is more important, the editorial or advertising. They both help us to keep up with what's going on in the world of electronics.

It has been said that leading publications build a "personality" for themselves. This is a quality that cannot be measured with facts and statistics. How would you characterize the "personality" of electronics magazine?

It's not too highbrow, yet it's not a gossip sheet. It's an excellent middle-of-the-road job of reporting technical and business developments. electronics does a down-to-earth reporting job.

If it's about electronics, read it in electronics.

electronics

Published WEEKLY plus the mid-year electronics BUYERS' GUIDE
A McGraw-Hill Publication • 330 West 42nd Street, New York 36, N. Y.





MECHANIZATION



TI-designed fully automatic wafer sorter. Silicon wafers for TI diodes or rectifiers are vibration fed to pick-up stations where they are vacuum gripped by upper contacts of test arms. During transit to drop chutes, lower contacts are applied, polarity checked, test circuits adjusted, and tests performed . . . at a rate of more than 4000 per hour.

Greater reliability, faster delivery and lower unit costs for users of TI diodes and rectifiers result from mechanized production and testing facilities such as the silicon wafer evaluator shown here. Designed and built by the TI Semiconductor-Components division, this machine automatically tests and evaluates each wafer that later becomes the heart of a TI diode or rectifier.

Only advanced facilities can produce advanced components. The wafer evaluator automatically adjusts its own test conditions to correspond to each wafer being checked, measures the critical electrical parameters, and then guides it into an appropriate vial. These tests, performed before assembly at a rate of more than 4000 per hour, insure the performance of every TI diode and rectifier wafer.

Continuous improvements in production technology at TI provide engineers the world over with precise reliable devices of practical economy and make possible new areas of semiconductor application.



THE WORLD'S LARGEST SEMICONDUCTOR PLANT

ELECTRONICS NEWSLETTER

WESTERN JOINT COMPUTER CONFERENCE in San Francisco this week gave peripheral gear a big play, with tape transports and high-speed input and readout equipment strongly emphasized. Prominence of smaller packages featuring increased reliability pointed up recent effects of transistorization. Descriptions were given of a new magnetic matrix memory using an array of permanent magnets arranged on a plastic board, and a 314-million-bit memory with direct and fast access. Interest was shown in information retrieval and machine translation. Recruiters maintained a high level of activity, with attendance about 2,000, up one-third over last year. Latest wares of 36 firms were shown; 70 papers were presented.

Symposium on education in materials sponsored by the American Society for Testing Materials and the American Society for Engineering Education will be held at ASTM's meeting in Atlantic City, N. J., June 22-26. Report will be made on degrees in materials engineering now being considered by many schools.

RADAR LOCATING DEVICE is being tested by General Motors on its new Cadillac Cyclone experimental car. Proximity sensing units are housed in two large nose cones in front of the car. They are intended to alert the driver to other vehicles or objects he is approaching with both a warning light and an audible signal that rises in pitch as he nears the object.

DEW LINE contract from USAF totaling \$5,442,460 calls for "certain projects covering replacement, rehabilitation, modification and relocation of specific facilities at designated sites." Work will be done by Federal Electric, ITT service arm.

Radioisotope users in the electronic, electrical equipment and instrumentation manufacturing fields increased more than 17 percent in 1958, says Atomic Industrial Forum, association of the atomic industry.

COMPATIBLE STEREO transmitting system developed by Bell Telephone Laboratories aims to eliminate the need for broadcasters to dilute the stereo effect in order to preserve satisfactory reception for the single channel listener. Compatibility circuit uses the psychoacoustic phenomenon known as the "precedence effect." It op-

erates this way: When a single sound is reproduced through two loudspeakers, but is delayed 10 milliseconds in one, the listener hears the sound as if it came only from the speaker from which he heard it first. To produce the effect, circuits between microphone pickups and their corresponding radio or tv transmitters are cross-connected through two delay lines, each with its own buffer amplifier. Listener to two channels hears the sound as coming direct from each of his two speakers. Listener to one channel hears the total sound from both microphones, unaffected by slight built-in delay, Bell tests show.

AUDIO FEED DEVICE has been developed by Burden Associates, Mt. Kisco, N. Y., for use in the Halstead multiplex system supplied by Multiplex Services Corp., New York City. Device is said to enable a radio listener to get satisfactory monophonic reception of stereocasts by means of an electronically created "phantom channel." Signals of original right or left pickup are combined with "difference signals" on a single channel.

10,000 horsepower nuclear powered merchant ship will be developed in West Germany by INTER-ATOM, jointly owned by DEMAG AG and North American Aviation's Atomics International division. Ship will be propelled by an organic moderated reactor.

CZECHOSLOVAKIA'S Communist Party Secretary Hendrych has reportedly cancelled a sales and propaganda campaign to sell and praise Soviet television and radio sets. Reason: The Soviet tv sets are so sensitive to climate and shock that special shops had to be set up to handle the volume of repair work. Russian radios, supposedly able to receive a wide range of frequencies, are actually limited to reception of Czech and Moscow stations. Many faulty sets are reportedly not repaired for lack of parts.

MIDGET TAPE RECORDER five inches long and one inch wide is expected to be put on the market this month by Kofuku Industries of Nagoya, Japan. Instrument is said to record up to 30 minutes. Price is not yet disclosed. Meanwhile, a midget computer was announced by Nagoya University. The two-by-four-inch unit, designed for use with process control machines, is expected to be used in making regulators.

NEW

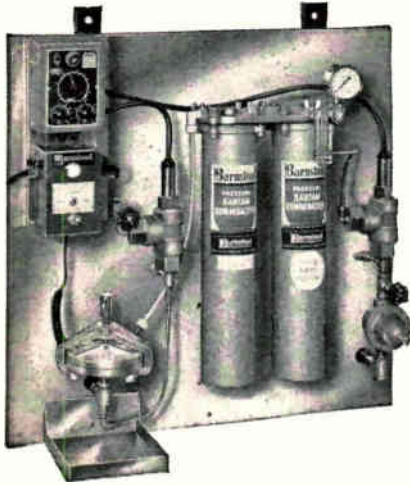

Barnstead Cooling Water Repurifying System...

*adds thousands of hours
to UHF transmitting
tube life.*

**PAYS FOR ITSELF OVER AND OVER IN
REPLACEMENT TUBE SAVINGS . . .
REQUIRED BY SOME MAKERS BEFORE
THEY GUARANTEE TRANSMITTING
TUBES.**

Research by a leading transmitting tube manufacturer shows that the life of UHF transmitting tubes is drastically shortened by impurities in cooling water. Dissolved impurities and suspended particles in the cooling water deposit on the tube anode forming an insulation. This causes overheating, and shortened tube life results. The most damaging of these impurities is copper oxide which is formed when carbon dioxide dissolves copper particles in the cooling water. The Barnstead Cooling Water Repurifying System substantially reduces and sometimes completely eliminates the copper oxide deposits by removing the dissolved copper, carbon dioxide and oxygen. Other dissolved scale-forming impurities are removed at the same time including submicroscopic particles. For the answer to your Pure Water Problems why not write to Barnstead today!

Barnstead
STILL & STERILIZER CO.

19 LANESVILLE TERRACE, BOSTON 31, MASS.

NEW YORK
Kingsbridge
8-1557

CLEVELAND
ACademy
6-6622

CHICAGO
Mulberry
5-8180

BOSTON
Jamaica
4-3100

PHILADELPHIA
LOcust
8-1796

LOS ANGELES
RYan
1-6663

SAN FRANCISCO
TEmplebar
2-5391

CIRCLE 9 READERS SERVICE CARD

WASHINGTON OUTLOOK

A LONG-RANGE PROGRAM of new space rockets that ultimately will be capable of carrying over 25 tons of payload to Mars has been unveiled by the National Aeronautics and Space Administration.

Here is what NASA plans in its step-up in rocket thrust: First, combination of an Atlas ICBM first stage and a single upper stage to put 3,000-lb satellites in orbit. Second, a family of new three-stage rockets dubbed Vega and Centaur. Vega rockets will use a first-stage Atlas, second stage from Vanguard, and the third stage will be a new rocket with a storable fuel capability.

Centaur rockets will be the same as Vega, except their second stage will be specially designed to burn hydrogen gas. Both new rockets will be used for Venus and Mars shoots. Additional details and exact timing of the program are classified.

Next in order is a four-stage rocket family that will use a cluster of Atlas booster rockets as a first stage, the Titan ICBM as a second stage, and two other stages not yet disclosed.

Supporting these and other NASA projects, R&D contracts totaling over \$100 million have been let by the agency since last Oct. 1. Another \$120 million, including \$12 million for new tracking facilities, will be chunked to industry by June 30. Some \$5.2 million of the tracking expenditure is for a new station in southern Texas to track the re-entry and landing of Project Mercury manned space flights. Balance of the money is for new Minitrack and Goldstone stations to be built around the world.

In 1960, NASA plans to spend another \$330 million for R&D. Its total budget next year will be some \$485.3 million. But, "this is the last time," Space Administrator Glennan told a Congressional committee, that the agency will be asking for budgets of only one-half billion dollars. In future years space programs will cost more and more, Glennan said.

Around 20 percent of NASA's money will go to space propulsion technology, including development of solid-fuel rockets, high energy fuel rockets, and the 1,500,000-lb thrust single-chamber nuclear rocket engine development. Some 50 percent of the money will go for procurement of vehicles and instruments. About 20 percent will be channeled toward manned space flight. Around 6 percent will be for specific investigations of satellite uses in meteorology and communications. Balance of the money will be used for tracking, data acquisition and new research.

Here are examples of R&D contracts let so far. Government agencies listed are the contracting agents between NASA and industry: \$8.2 million to Jet Propulsion Laboratory for general research; \$40,000 to Iowa State University for space probe instrumentation; \$23 million to Naval Research Laboratory for Vanguard support; \$470,000 to Smithsonian Institution for tracking and data reduction; \$120,000 to Smithsonian Astrophysics Laboratory for photo reduction equipment; \$140,000 to Minneapolis-Honeywell for automatic flight control systems for manned space flight; \$10 million to Rocketdyne division of North American for work on a 1,000,000-lb thrust engine.

- A House Commerce subcommittee on communications and power plans a searching technical study of the entire broadcast spectrum. Chairman Oren Harris of the parent committee asks \$150,000 for the study, which will be under chairmanship of Rep. John Bell Williams (D-Miss.).

Tentative plan is for the subcommittee to assemble an expert staff to go into problems of space division among present users. No timetable has been established, but Harris hopes to have the study completed sometime in 1960.

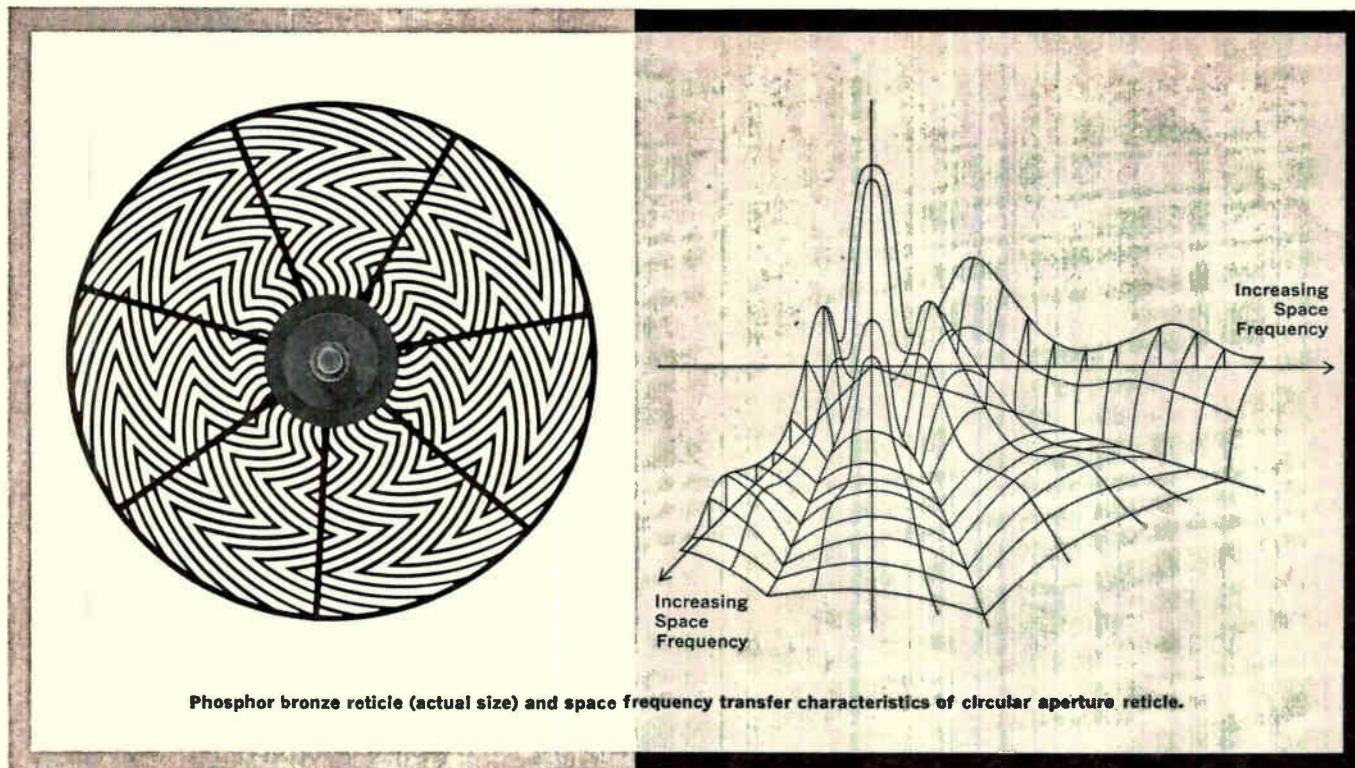

TARGET DISCRIMINATION IN INFRARED DETECTION SYSTEMS

The pioneering field of infrared detection offers many challenging opportunities to scientists and engineers at Ramo-Wooldridge for advanced studies in the solution of target discrimination problems. Research is continually under way at Ramo-Wooldridge in the integrating of infrared detection devices with the latest electronic systems techniques for enhanced target detection on the ground and in the air.

The phosphor bronze reticle, or image chopper, illustrated above was developed by Ramo-Wooldridge. It indicates a marked stride in space filtering discrimination concepts, and is used for target signal enhancement in guided missiles, anti-aircraft fire control and air collision warning applications.

The reticle is used in the focal plane of an infrared optical system and is rotated to chop the target image for the desired space filtering. It is also employed in time filtering, such as pulse length discrimination, or pulse bandwidth filtering.

Space filtering is critical to infrared systems, because of its ability to improve the detection of

objects located in the midst of background interference. In a manner similar to that used in the modification of electronic waveforms by electrical filtering, space filtering enhances the two-dimensional space characteristics of a target. The size and features of the target are highlighted and the undesired background eliminated.

Scientists and engineers with backgrounds in infrared systems—or any of the other important areas of research and development listed below—are invited to inquire about current opportunities at Ramo-Wooldridge.

- Electronic reconnaissance and countermeasures systems
- Analog and digital computers
- Air navigation and traffic control
- Antisubmarine warfare
- Basic research
- Electronic language translation
- Information processing systems
- Advanced radio and wireline communications
- Missile electronics systems

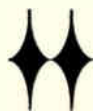

RAMO-WOOLDRIDGE

P. O. BOX 90534 AIRPORT STATION • LOS ANGELES 45, CALIFORNIA

a division of *Thompson Ramo Wooldridge Inc.*

HOW HIGH IS UP?



Some terms like "up," "long," "wide" or "high" are purely relative. "Reliability" is not a relative term—it is absolute!

The systems which regulate the flow of electricity, water, natural gas, petroleum and the other liquids and gasses which are so vital to our industrial and personal lives must be reliable—without compromise or qualification!

Since 1921 North Electric Company has designed, developed and manufactured thousands of such systems—systems which have established new standards of reliability.

North's unique capabilities in this field stem from 75 years of proven experience in the areas of communication and control, the two basic principles upon which a system complex is dependent.

For utilities, for industry, for defense—North engineered and built systems are functioning 24 hours a day, 365 days of the year—such reliability is inherent in every North Product.

North stands ready, *and able*, to give you specialized assistance in system design, development and manufacture.

Write, wire or phone

INDUSTRIAL DIVISION

NORTH ELECTRIC COMPANY

493 SOUTH MARKET STREET • GALION, OHIO



Sees Boom for Small Firms

REPORT FROM Washington on small business predicts this will be a banner year for small firms.

Of interest to small electronics firms is the forecast of W. B. Barnes, head of the Small Business Administration, that a good portion of the business increase will be in research, development and missile programs.

During 1958 small businesses received 22,965 government contracts valued at more than \$770 million, as compared with the 1957 figure of 13,874 contracts valued at about \$557 million.

Credit for the increase is in part attributed to the growing effect of SBA's "set-aside" policy. Under this policy, prime contracts are examined by SBA officials to determine which portions may be handled by small businesses. Once such determination has been made, the contract holder receives recommendations from SBA on which small firms may be able to perform sub-contract work.

SBA makes no attempt to force contract holders to follow recommendations, but concentrates on making it easy for prime contractors to find small firms.

An SBA official told ELECTRONICS that recommendations are "usually followed" since the policy of bringing small firms in contact with federal procurement officials is now backed by a Federal directive.

The interests of small firms are also protected under a recently-established policy covering direct bidding on main contracts as well as subs. In cases of contracts which are, by nature, capable of being executed by small firms, SBA also makes recommendations to the contracting agency that small firm bids be solicited.

In an effort to bring about greater participation on the part of small R&D firms in missile production and related fields, SBA has made two directories available. These list small companies interested in obtaining government business. One is "Missile Sub-Contracting," the other, "Research and Development."

Another innovation in SBA policy stresses the use of the Certificate of Competency. These certificates are, in effect, an appeal procedure for small firms whose low bid has been denied by a procuring official because he feels the small firm does not have the financial or production capacity to perform a specific contract. When SBA issues a Certificate of Competency, the procuring official must then award the contract to the low bidder.

OVER THE COUNTER

| 1958 BIDS | | COMMON STOCKS | WEEK ENDING | |
|-----------|---------|---------------------|-------------|-------------------|
| LOW | HIGH | | Feb. 13 BID | Feb. 20 BID ASKED |
| 33 1/2 | 20 1/2 | Acoustica Assoc | 21 1/2 | 23 25 1/2 |
| 15 1/2 | 3 | Advance Industries | 3 1/4 | 3 3/4 4 3/8 |
| 3 1/2 | 65 1/2 | Aerovox | 7 | 7 8 |
| 20 1/2 | 33 | Amer Res & Dev | 38 1/2 | 36 3/4 39 |
| 163 1/4 | 24 1/4 | AMP Inc | 24 | 24 1/2 27 1/4 |
| 5 1/2 | 15 | Appl'd Sci Princet | 9 1/2 | 11 12 1/4 |
| 1 1/2 | 87 1/2 | Avien, A | 7 3/4 | 9 1/2 11 |
| 63 1/4 | 24 | Baird-Atomic | 25 1/4 | 26 29 3/8 |
| 93 1/4 | 13 3/8 | Burndy | 14 1/2 | 14 5/8 17 1/4 |
| 63 1/4 | 9 | Cohu Electronics | 7 1/4 | 7 7 5/8 |
| 11 | 22 1/2 | Collins Radio, A | 22 1/2 | 23 3/4 28 |
| 10 1/4 | 22 1/4 | Collins Radio, B | 22 | 23 3/4 27 3/4 |
| 4 | 7 | Craig Systems | 6 7/8 | 6 3/4 7 7/8 |
| 30 | 50 1/2 | Dictaphone | 43 | 40 48 1/4 |
| 17 1/2 | 25 3/8 | Eastern Industries | 19 | 19 21 1/2 |
| 10 1/2 | 21 | Electro Instr | 22 1/2 | 23 27 |
| 34 | 49 | Electronic Assocs | 46 | 47 1/2 52 1/2 |
| 5 | 11 | Electronic Res'rch | 12 1/4 | 12 3/8 14 1/8 |
| 8 1/2 | 123 1/4 | Electronic Spec Co | 13 3/8 | 13 1/4 14 3/8 |
| 15 1/4 | 49 1/2 | Epsco, Inc | 35 | 36 40 3/8 |
| 5 1/2 | 93 1/2 | Erie Resistor | 9 1/2 | 10 11 1/2 |
| 10 | 17 1/2 | Fischer & Porter | 15 1/2 | 15 3/8 17 |
| 36 3/4 | 50 | Foxboro | 49 1/2 | 49 53 1/2 |
| 5 1/2 | 10 1/2 | G-L Electronics | 14 | 13 1/2 15 3/8 |
| 12 | 27 | Giannini | 26 | 28 30 3/8 |
| 30 | 39 1/2 | Hewlett-Packard | 37 1/2 | 38 1/2 43 1/4 |
| 23 1/4 | 48 | High Voltage Eng | 52 | 53 58 1/2 |
| 13 1/4 | 3 | Hycon Mfg | 3 | 3 3 3/8 |
| 1 1/2 | 5 1/2 | Industro Trans'tor | 2 3/4 | 2 3/4 3 3/8 |
| 1 1/2 | 4 3/4 | Jerrold | 4 3/4 | 4 4 3/8 5 1/8 |
| 21 | 30 | D. S. Kennedy | 33 1/2 | 32 3/4 36 3/4 |
| 3 1/4 | 29 | Lab For El'tronics | 26 | 26 1/2 29 3/8 |
| 19 1/4 | 28 | Leeds & Northrup | 28 1/2 | 27 3/4 30 3/8 |
| 2 | 3 1/8 | Leetronics | 2 1/4 | 2 1/4 3 1/4 |
| 5 | 18 1/4 | Ling Electronics | 16 3/8 | 17 1/4 19 1/8 |
| 16 | 20 1/2 | Machlett Labs | 24 1/2 | 24 1/2 27 3/4 |
| 3 1/4 | 8 1/4 | Magnetic Amplifiers | 7 1/4 | 7 3/8 8 1/2 |
| 2 7/8 | 4 1/2 | Magnetics, Inc | 3 3/8 | 3 3/8 4 1/4 |
| 4 1/2 | 12 | W. L. Maxson | 13 1/2 | 13 1/4 15 3/8 |
| 10 1/2 | 29 | Microwave Assocs | 32 | 31 35 3/8 |
| 5 1/4 | 11 3/4 | Midwestern Instr | 13 3/4 | 13 1/4 14 |
| 1 1/2 | 7 | Monogram Preci's'n | 8 3/8 | 8 3/8 9 3/4 |
| 3 1/2 | 7 1/4 | Narda Microwave | 7 3/4 | 7 3/8 8 3/8 |
| 93 1/4 | 16 | National Company | 18 3/4 | 19 1/4 22 3/4 |
| 14 1/4 | 56 | Nuclear Chicago | 29 1/2 | 32 1/2 36 1/2 |
| 14 1/2 | 29 3/4 | Orradio Industries | 28 1/2 | 30 1/2 34 1/2 |
| 4 1/2 | 7 3/8 | Pacific Mercury, A | 9 1/4 | 10 7/8 12 1/4 |
| 10 1/2 | 27 1/2 | Packard-Bell | 29 1/2 | 33 1/2 35 3/8 |
| 4 1/4 | 9 3/8 | Panellit, Inc | 6 3/4 | 6 3/4 7 3/8 |
| 21 | 53 3/4 | Perkin-Elmer | 45 1/4 | 47 53 1/2 |
| 11 3/8 | 19 1/2 | Radiation, A | 18 | 18 19 3/8 |
| 2 1/2 | 7 3/8 | Reeves Soundcraft | 6 3/8 | 6 3/8 7 3/8 |
| 13 | 32 1/2 | Sanders Associates | 29 | 28 1/2 32 1/2 |
| 7 | 12 | SoundScriber | 17 3/4 | 17 19 3/8 |
| 22 3/4 | 40 | Sprague Electric | 39 1/2 | 39 42 1/2 |
| 26 | 35 | Taylor Instruments | 32 1/2 | 32 1/4 37 |
| 5 1/2 | 15 | Technical Operat'ns | 16 1/4 | 17 1/4 21 1/2 |
| 5 1/2 | 15 3/4 | Telechrome Mfg | 16 1/2 | 17 19 1/8 |
| 3 1/4 | 7 3/4 | Telecomputing | 7 1/4 | 8 1/2 9 1/4 |
| 1 1/2 | 2 3/4 | Tel-Instrument | 2 3/4 | 2 3/4 3 1/4 |
| 8 3/4 | 16 1/4 | Topp Industries | 13 1/4 | 13 1/4 14 7/8 |
| 3 1/4 | 10 3/4 | Tracerlab | 10 | 10 10 3/4 12 |
| 1 1/2 | 3 3/8 | Universal Trans'tor | 1 | 7/8 1 1/4 |
| 14 1/4 | 40 | Varian Associates | 40 | 42 46 3/8 |
| 12 1/2 | 18 1/2 | Vitro Corp. Amer | 15 3/8 | 15 3/8 17 1/8 |

The above "bid" and "asked" prices prepared by the NATIONAL ASSOCIATION OF SECURITIES DEALERS, INC., do not represent actual transactions. They are a guide to the range within which these securities could have been sold (the "BID" price) or bought (the "ASKED" price) during preceding week.

CURTISS-WRIGHT STRIP CHART RECORDERS

come in **4** sizes

DOUBLE —



MINIATURES—SQUARE OR SLIM



STANDARD, OF COURSE



You'll learn more about strip chart recorders by talking to the man from Curtiss-Wright. For good reason, too. He has more models — and more features — to talk about.

He can show you *true multi-channel* recording — how you can record up to six variables simultaneously on a single chart.

He can demonstrate the advantages of inkless recording — and prove how the patented linkage that makes possible recitilinear recording saves time and eliminates errors.

Most important, you'll appreciate the precision and quality that have been built into these time-tested products.

Get in touch with us if you'd like to talk to the Curtiss-Wright man — or learn more through available data.



ELECTRONIC EQUIPMENT DEPARTMENT

ELECTRONICS DIVISION

CURTISS-WRIGHT
CORPORATION • CARLSTADT, N. J.

CIRCLE 12 READERS SERVICE CARD

Table-top operation . . . and full 42-inch width . . .



. . . combined in one
Whiteprinter

OZALID
Streamliner 200

Now all the advantages of whiteprinting are combined in a convenient TABLE MODEL—the new, low-cost Ozalid Streamliner 200.

Compact, easy to operate, the Streamliner 200 stands just 22" high, 38" deep (including feedboard). With it *anyone* can turn out sparkling whiteprints in seconds *up to 42 inches in width!*

Perfect for the small office, it's an ideal stand-by for the large printroom, too. For the full story call your local Ozalid representative or write Ozalid, Dept. L-3-6, Johnson City, N. Y.



A Division of General Aniline & Film Corporation. In Canada: Huesh Owens Company, Ltd., Montreal.

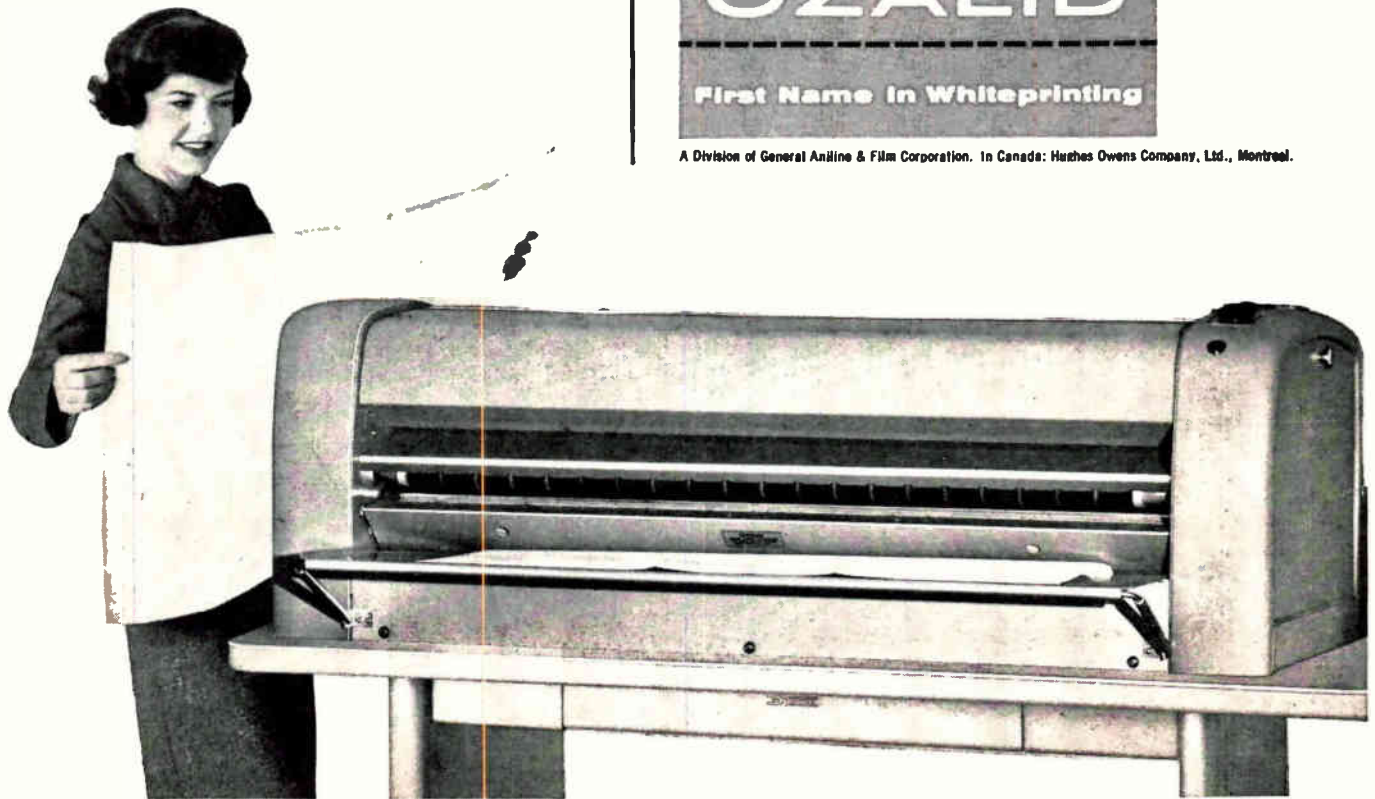

ENGINEERING KNOW-HOW..

Precision microwave and electronic measuring equipment, designed by the FXR staff of engineers to meet specific requirements, is used in the testing of the nation's leading missile and radar systems. Advanced engineering and reliability of performance keynoted the selection of FXR components for these important tasks.

Let FXR engineering know-how, expert craftsmanship and complete facilities supply the precision microwave and electronic measuring equipment that will surpass your most exacting requirements.

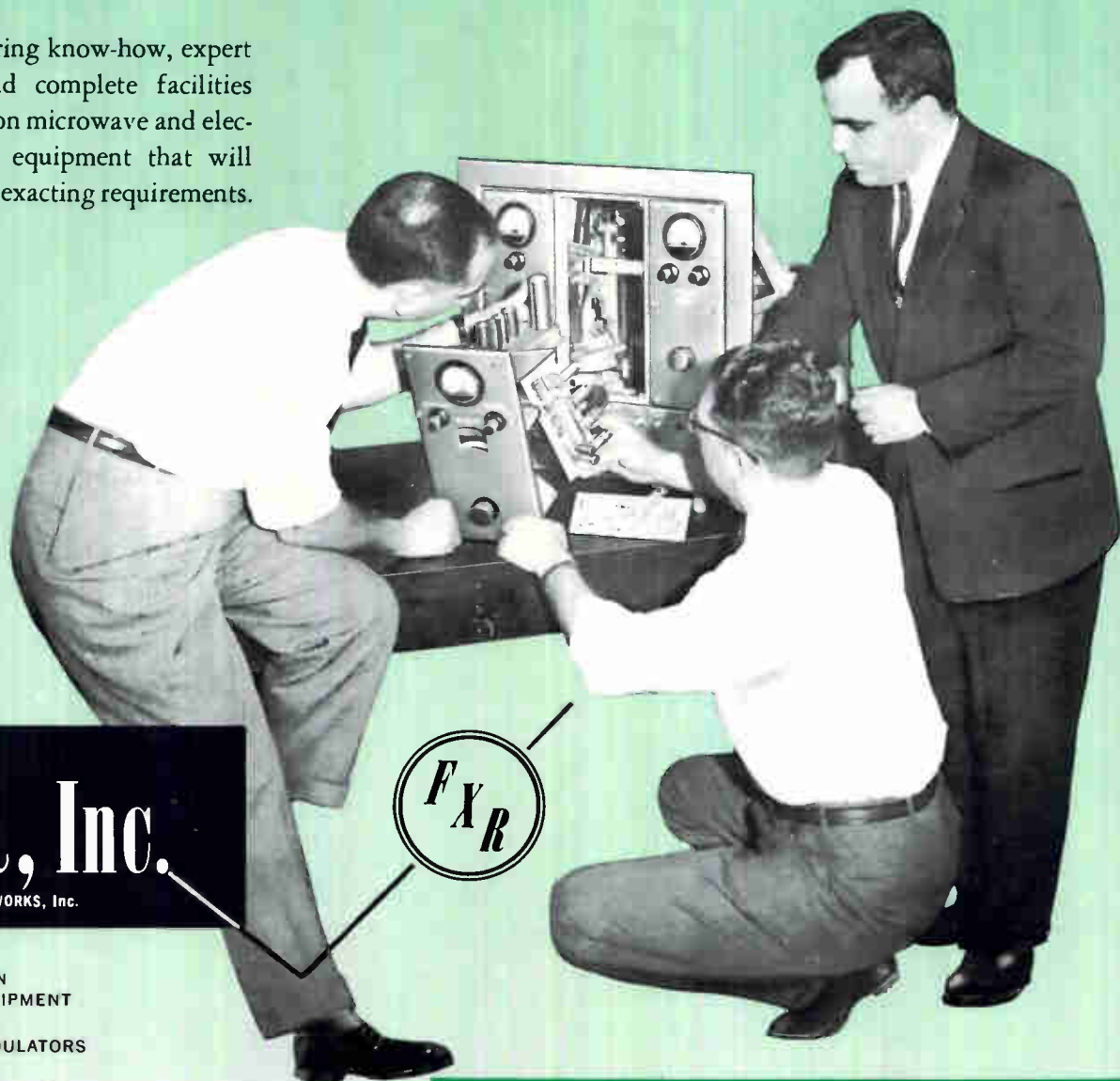

FXR, Inc.

formerly F-R MACHINE WORKS, Inc.



PRECISION
MICROWAVE EQUIPMENT
•
HIGH POWER MODULATORS
•
RADAR COMPONENTS
•
ELECTRONIC
TEST EQUIPMENT

DESIGN • DEVELOPMENT • MANUFACTURE
26-12 BOROUGH PLACE, WOODSIDE 77, NEW YORK

see the newcomer among FXR's extensive line of PRECISION MICROWAVE EQUIPMENT

IRE
BOOTHS
3713-3717



Model
B 812A

INNOVATIONS where they are most effective

- Oversized 5-inch mirror-backed meter, with 1% linearity, provides high resolution and accuracy. It can be tilted for even greater ease of reading than its oversize affords.
- The meter is also *REMOVABLE* for convenient placement and it is equipped with a vernier attenuator for remote adjustment over a 3 DB range.
- A filter, tunable between 950 and 1050 CPS, permits exact alignment of the instrument with the output frequency of the signal source.
- Range, 70 DB; expanded scale for VSWR and DB; panel switch shifts the meter reading -5 DB to move it to an area of the scale more easily read.
- Gain automatically maintained when readings are switched from normal to expanded scale.
- Low microphonic, subminiature tube in input circuit increases usable sensitivity.
- Full scale sensitivity, $0.1 \mu\text{V}$; signal to noise ratio, 3:1.

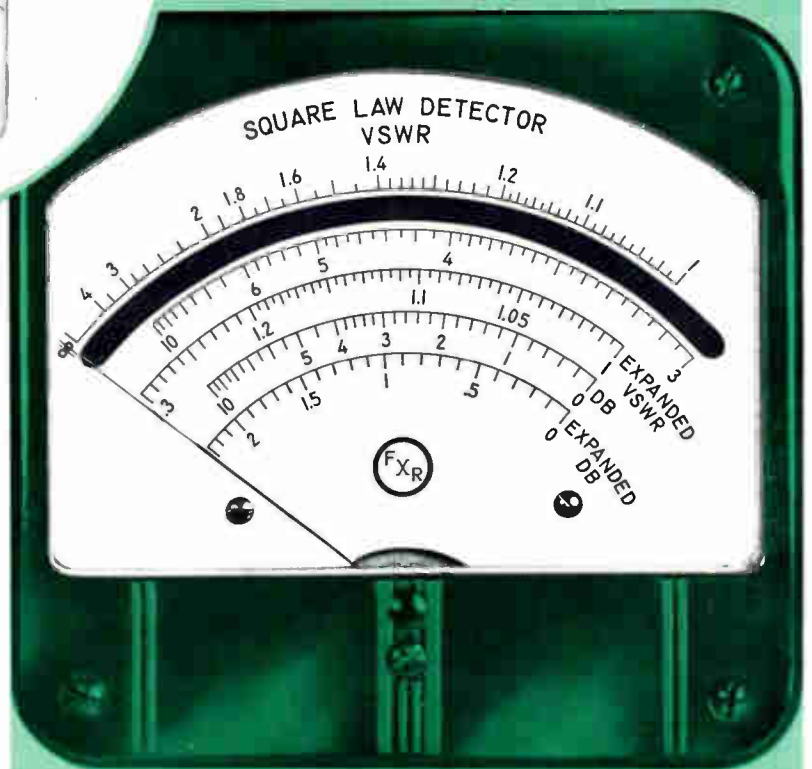

STANDING WAVE AMPLIFIER

FXR, Inc

formerly F-R MACHINE WORKS, Inc.



PRECISION
MICROWAVE
EQUIPMENT
•
HIGH POWER
MODULATORS
•
RADAR
COMPONENTS
•
ELECTRONIC
TEST
EQUIPMENT

DESIGN • DEVELOPMENT • MANUFACTURE
26-12 BOROUGH PLACE, WOODSIDE 77, NEW YORK

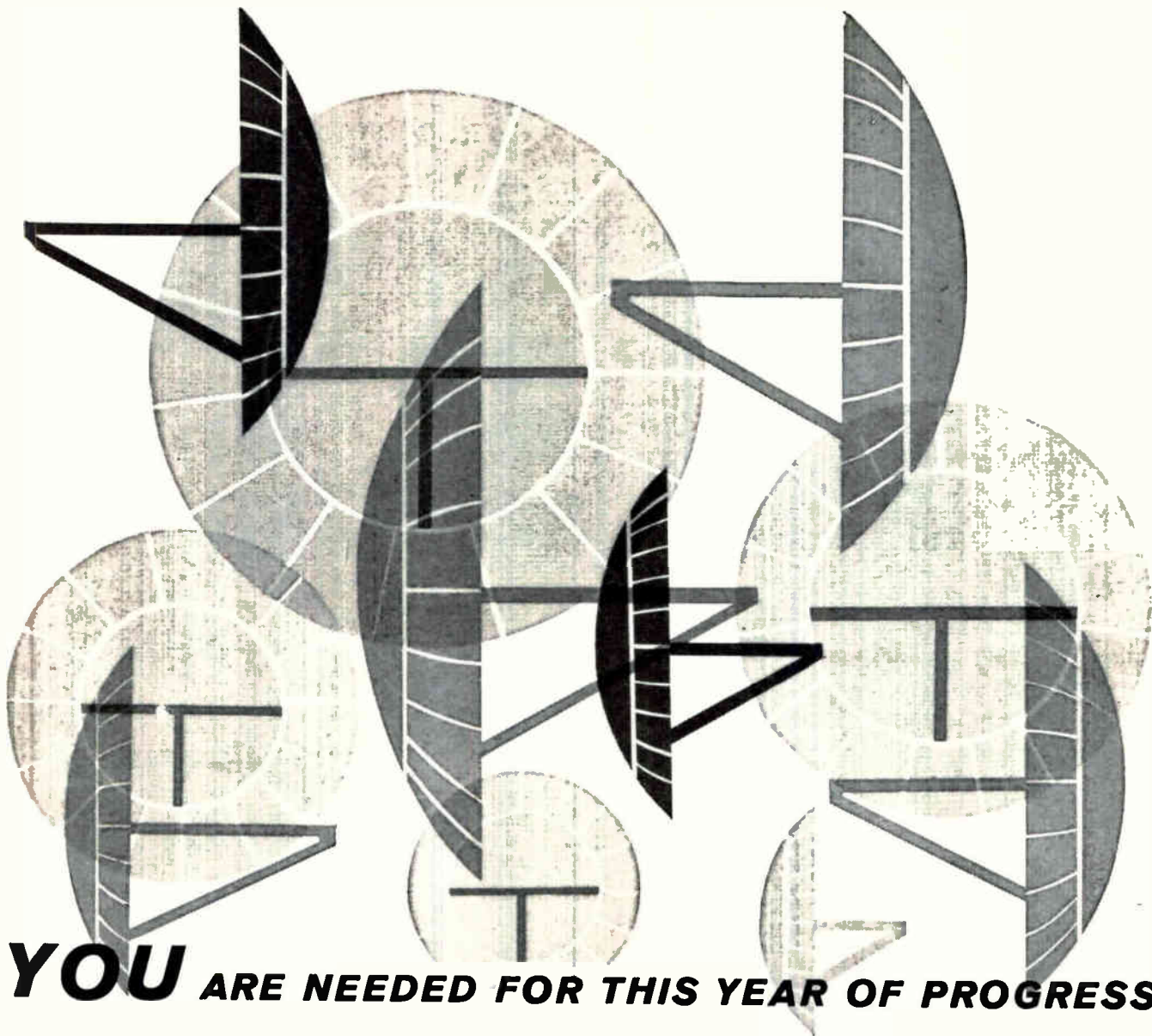

YOU ARE NEEDED FOR THIS YEAR OF PROGRESS

You are unique. You are a one-of-a-kind man needed to think for a new world of tomorrow. Your greatest gift to progress can be your ability to apply your inherent differences in thought and background to your field of specialty in radio electronics.

To help you think, to help you generate new

ideas, come see THE RADIO ENGINEERING SHOW that requires all 4 floors of New York City's Coliseum. Come hear your choice of more than 200 papers to be given during the CONVENTION. You are needed. Yes, it takes a coliseum to hold this great electronic show. Then, it takes you to have the great thought, the INSPIRATION IN RADIO ELECTRONICS.

THE IRE NATIONAL CONVENTION

Waldorf-Astoria Hotel

AND THE RADIO ENGINEERING SHOW

Coliseum, New York City

MARCH

23 • 24

25 • 26



THE INSTITUTE OF RADIO ENGINEERS

1 EAST 79th STREET, NEW YORK 21, N. Y.



LOOKING FOR THE IDEAL TERMINAL SETTER?

STOP. You've found it. A Black & Webster Electropunch or full automatic Electroset can solve your terminal setting problems **\$135⁰⁰** — for as little as



SHORT RUNS: Electropunch — sets hand fed terminals twice as fast as conventional methods. All electric. Foot switch operated.

LONG RUNS: Electroset — automatically feeds and sets terminals up to 3600 per hour. All electric. Customized to your needs.



WHAT'S YOUR PROBLEM? Black & Webster can help. Send sample terminal and requirements.

Write today for free 12-page catalog describing our complete line of production tools.

BLACK & WEBSTER, INC.

Dept. E, 445 Watertown Street
Newton, Massachusetts

CIRCLE 17 READERS SERVICE CARD

MARKET RESEARCH

RADIO-TV SET PRODUCTION

1956-1959

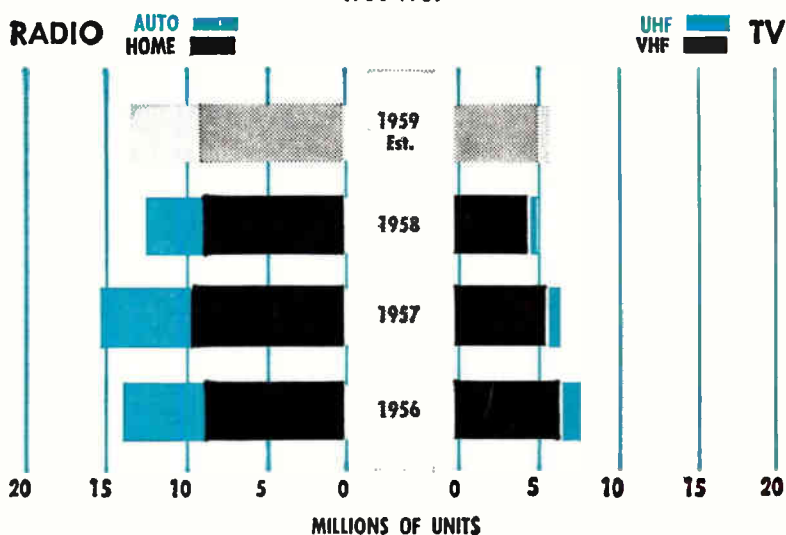

SOURCES: EIA, Actual-ELECTRONICS, Estimated

Radio, Tv Set Output Going Up

RADIO AND TV set production totals for 1959 should show significant gains over last year.

Preliminary estimates by ELECTRONICS anticipate production of 5.5 million tv sets and 13.5 million radio receivers, up 11.8 percent and 7.3 percent, respectively, over last year.

Radio estimates for 1959 include 4.5 million auto sets and 9 million home, clock and portable units. Of 5.5 million tv units, production of some 5,170,000 vhf receivers are expected. Remaining 330,000 units are uhf sets. Production volume of uhf sets continues to drop. Predicted number of units for 1959 comprises 6 percent of total tv set output. In 1956, uhf sets made up 13.5 percent of overall production.

Actual radio set production in 1958 amounted to 12.6 million units, comprising 3.7 million auto types and 8.9 million home, clock and portable sets. Tv in 1958 breaks down into 4.5 million vhf receivers and 418,000 uhf types.

One influence underlying the rise in radio output is expectation of stepped-up auto production. Tv production picture is brighter this year due to increasing number of second sets in homes and continuing re-

placement of obsolete receivers. Of course, improved business conditions exert positive influence on the entire consumer electronics market.

• **New product development** spending increases at Hewlett-Packard. Recent annual report shows firm spent \$2.1 million, or 6.9 percent of sales, in 1958 fiscal year ended Oct. 31, as against \$1.6 million, or 5.7 percent of sales, in 1957. H-P marketed 12 new products last year, the fruits of research and development expenses of three to five years ago.

FIGURES OF THE WEEK

LATEST WEEKLY PRODUCTION FIGURES

| (Source: EIA) | Feb. 13, 1959 | Jan. 16, 1959 | Change From One Year Ago |
|-----------------------|---------------|---------------|--------------------------|
| Television sets | 117,982 | 103,696 | +19.4% |
| Radio sets (ex. auto) | 278,318 | 279,954 | +31.6% |
| Auto sets | 107,936 | 109,765 | +56.7% |

STOCK PRICE AVERAGES

| (Standard & Poor's) | Feb. 18, 1959 | Jan. 21, 1959 | Change From One Year Ago |
|---------------------|---------------|---------------|--------------------------|
| Electronics mfrs. | 74.56 | 74.56 | +41.2% |
| Radio & tv mfrs. | 81.57 | 82.36 | +75.5% |
| Broadcasters | 83.68 | 79.77 | +45.8% |

LATEST MONTHLY SALES TOTALS

| (Add 000) | Dec. 1958 | Nov. 1958 | Change From One Year Ago |
|--------------------|-----------|-----------|--------------------------|
| Transistors, value | \$16,596 | \$12,442 | +150.7% |
| Transistors, units | 5,628 | 5,441 | +102.9% |
| Rec. tubes, value | \$25,123 | \$29,854 | +1.0% |
| Rec. tubes, units | 28,504 | 35,640 | +2.8% |
| Pic. tubes, value | \$12,644 | \$15,008 | -2.5% |
| Pic. tubes, units | 649 | 789 | +0.8% |

gnat on the nose of a missile

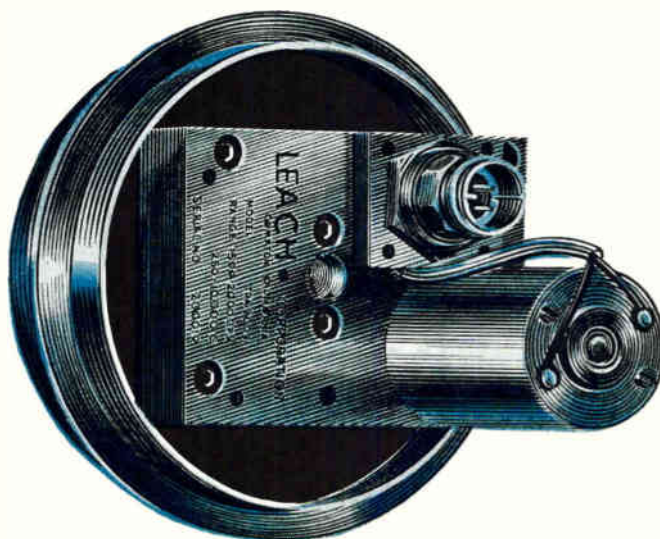

newest new product from Leach/Inet!

The compact, self-contained unit shown here actual size is Inet's new 6-ounce Triaxial Recording Accelerometer... attached to a 1½-inch-radius missile nose section.

This rugged unit has three sensing elements—reeds—that directly sense and record data on structures and components subjected to high-acceleration loads. It operates on 6 volts in a temperature range of -50° to $+160^{\circ}$ F., requires no connections to external devices except a power source. The unit records data on acceleration-time history

along each of three mutually perpendicular axes...in a transverse reed range of 1,500 cps, 250-7,500 G...and in a longitudinal reed range of 2,000 cps, 400-10,000 G.

Inet's Triaxial Recording Accelerometer is available for immediate delivery—for use in water-entry shock studies; ground impact, blast, and explosion studies; and for various other tests, including rocket motor, target impact, sled, and switch actuation tests.

Write today for further information.

FOR PRODUCT ADVANCEMENTS...



LOOK TO LEACH

INET DIVISION

LEACH CORPORATION

18435 SUSANA ROAD, COMPTON, CALIFORNIA

DISTRICT OFFICES AND FIELD REPRESENTATIVES IN PRINCIPAL CITIES OF U.S. AND CANADA • EXPORT: LEACH CORPORATION, INTERNATIONAL DIVISION

ELECTRONICS—March 6, 1959

CIRCLE 18 READERS SERVICE CARD

New noise microphone reports sonic damage to missiles in flight.

Expanding the Frontiers of Space Technology

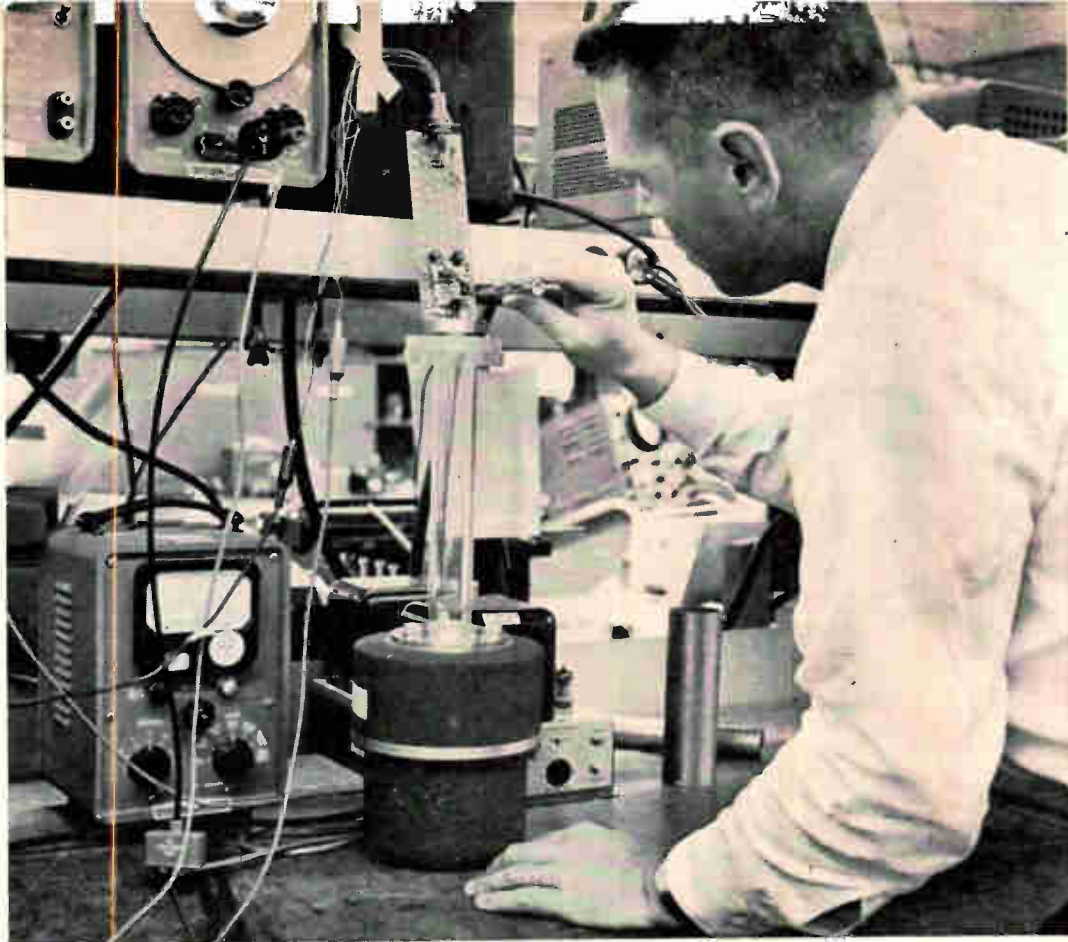

INSTRUMENTATION

Lockheed has an extensive research capability in the development of transducers and instrumentation for missile and spacecraft applications.

Under investigation are the properties of liquids and certain rubber-like solids as a function of amplitude and frequency of excitation; research and piezoresistive materials such as silicon, germanium, and indium antimonide in an effort to develop better transducers; research on capacitive methods of measuring extremely small displacements to 10^{-12} inch, and on a variety of other physical problems.

Scientists and engineers of outstanding talent and inquiring mind are invited to join us in the nation's most interesting and challenging basic research and development programs. Write: Research and Development Staff, Dept. C-22, 962 W. El Camino Real, Sunnyvale, California.

"The organization that contributed most in the past year to the advancement of the art of missiles and astronautics."

NATIONAL MISSILE INDUSTRY CONFERENCE AWARD

Lockheed

MISSILES AND SPACE DIVISION

SUNNYVALE, PALO ALTO, VAN NUYS,
SANTA CRUZ, SANTA MARIA, CALIFORNIA
CAPE CANAVERAL, FLORIDA
ALAMOGORDO, NEW MEXICO

(left) Research and Development facilities in the Stanford Industrial Park at Palo Alto, California, provide the latest in technical equipment.

(right) Ultrasonic temperature probe measures speed of sound in various gases—another Lockheed contribution.



NEW DISTRIBUTION NETWORK MAKES IMMEDIATELY AVAILABLE ALL THE IMPORTANT ADVANTAGES OF BENDIX CONNECTORS

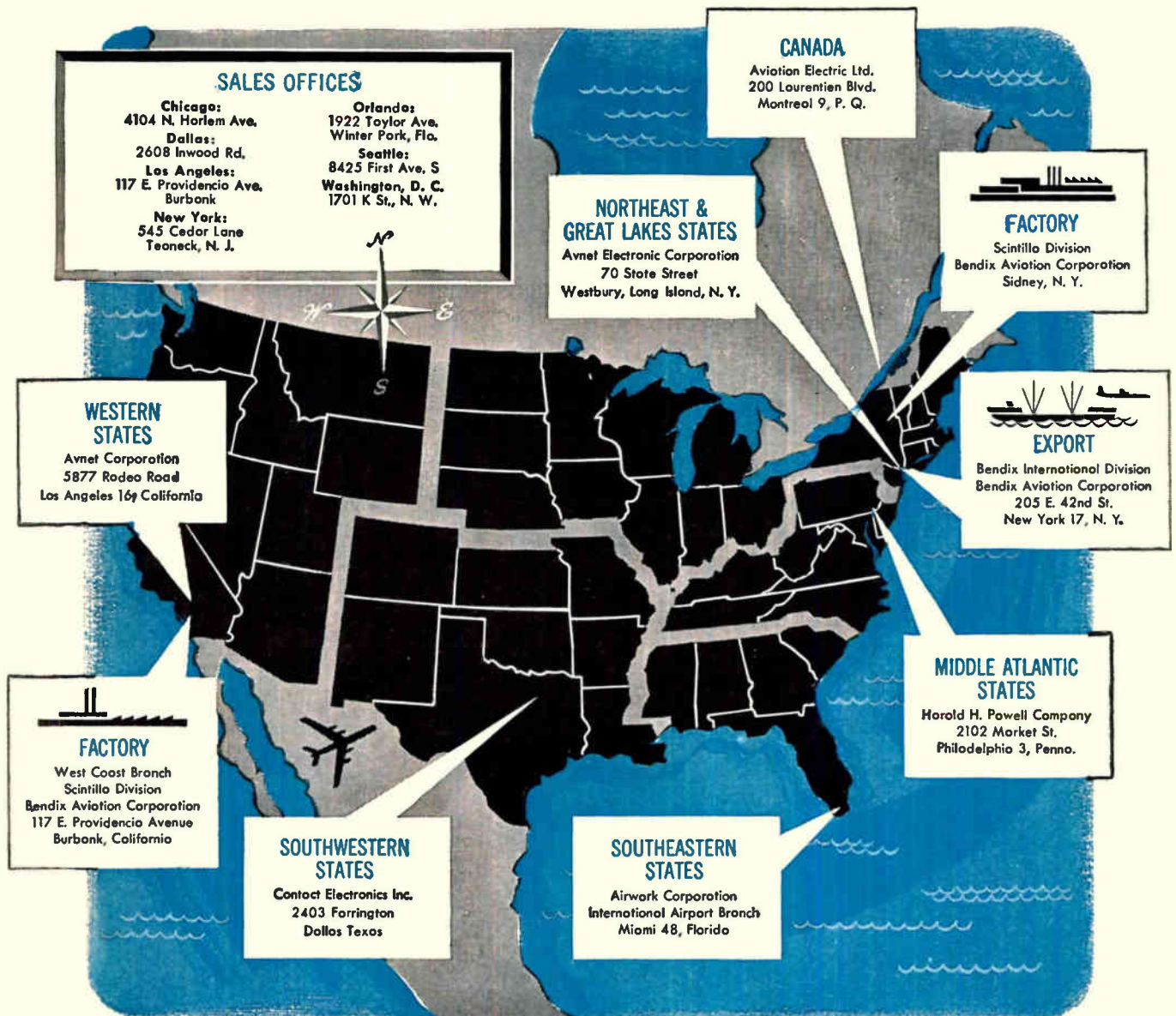

Large inventories of Bendix Electrical Connectors are now strategically located to assure you rapid delivery, regardless of your requirements or your location.

Each distribution center is factory-approved and inspected, and is stocked with connectors and components in an exceptionally wide range of types and sizes. Assembly and quality control facilities are maintained in complete accordance with factory standards and recommendations. Their staffs are

adequate to assure not only immediate service but also reliable, efficient shipment of your order.

This expanded distribution system, combined with our greatly enlarged factory production facilities, makes available to all users the important advancements in engineering and design for which Bendix Electrical Connectors are favorably known.

We suggest you check the map now for the source nearest you.

Scintilla Division
SIDNEY, N. Y.



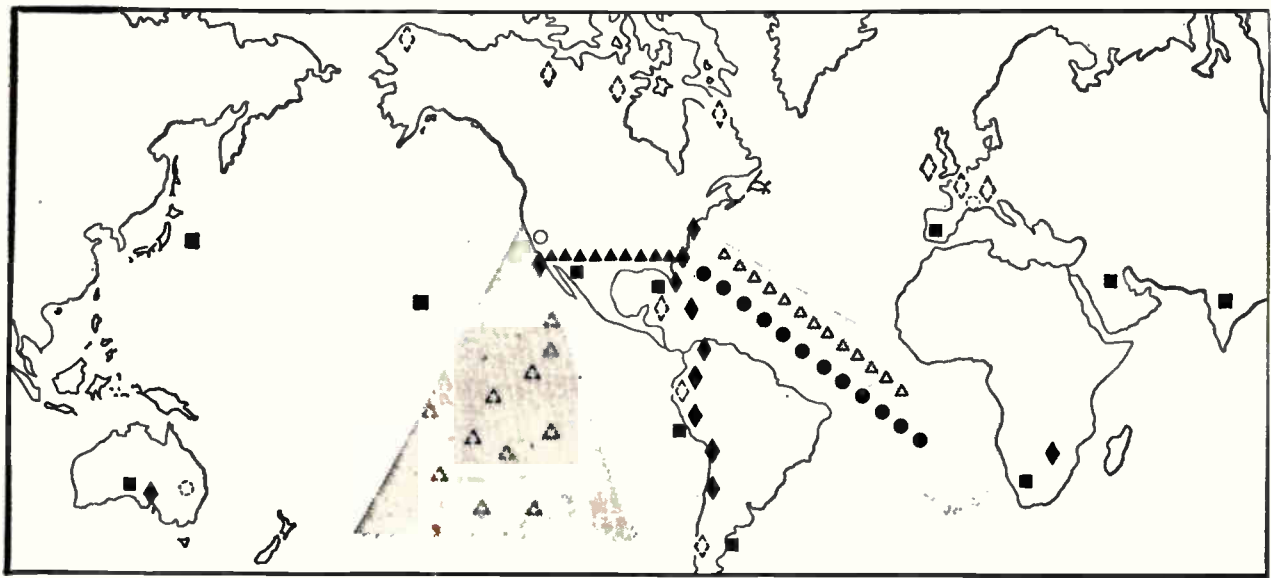

U.S. SATELLITE-MISSILE TRACKING NETWORK

- | | |
|--|--|
| ▲ SATELLITE DETECTION FENCE--9 STATIONS IN SERVICE | △ CANAVERAL MISSILE RANGE SHIPS--13 OPERATING |
| ○ GOLDSTONE STATIONS--1 OPERATING | △ PACIFIC MISSILE RANGE SHIPS--11, NONE NOW IN SERVICE |
| ○ GOLDSTONE STATIONS--2 TO BE BUILT | ◆ MINITRACK--12 STATIONS OPERATING |
| ■ MOONWATCH--11 STATIONS OPERATING | ◇ MINITRACK--10 STATIONS TO BE BUILT |
| ● MISSILE RANGE STATIONS--12 STATIONS OPERATING | |

Space Tracking Is Big Business

Today's U.S. missile and satellite tracking network—already in the multi-million dollar stage—is only a start. It'll get much bigger soon

WASHINGTON—As the U. S. steps up its space experiments, it is expanding its multi-million dollar missile and satellite tracking facilities. Already there is a far-flung net of Minitrack and Moonwatch stations spread around the world, with more to be added. All this is sure to mean millions of dollars to the electronics industry.

This month the new National Aeronautics and Space Administration officially takes over the net of stations set up under the International Geophysical Year program.

Already a net of some 45 stations and 13 ships are manned by more than 1,000 persons from the Bahama Islands to Woomera, Australia. Soon to be added are 12 more stations and 11 more tracking ships that will require upwards of 600 more persons. Though impressive, this activity is only the start of a worldwide tracking net that will take shape in the next few years, officials say.

Backbone of the satellite tracking system is a string of 12 Mini-

track stations spread from Blossom Point, Md., to Santiago, Chile, to Esselan Park, South Africa, and across to Woomera, Australia.

Contracts have already been let to build an additional station in Peru and one in Chile. A \$600,000 contract was let recently to Bendix Radio Corp. to shift a Minitrack station now at Havana to another location in Cuba.

Plans New Net

Within the next two years, NASA wants to set up a net of Minitrack stations across the north. One station will be built in Alaska, three in Canada and three in Europe.

Backing up the Minitrack net are some 11 Moonwatch telescope stations operated by the Smithsonian Astrophysical Observatory. They range from Florida to South America to Europe, the Middle East, India, Japan, Australia, and Hawaii.

No more are planned now.

A net of Goldstone tracking stations to follow deep space probes,

such as moon shoots and beyond, are planned. The first such facility was completed late last year at Camp Irwin, Calif. This year NASA plans to build another station in Australia and one in southwest Europe or northern Africa. Cost of one station runs around \$10 million. Ultimately, the agency would like to have as many as 40 to 50 such stations around the world.

Nub of Goldstone facilities is an 85-ft diameter parabolic antenna that will receive signals from deep space probes. The information is then relayed to a data-reduction center at the California Institute of Technology Jet Propulsion Laboratory in Pasadena, to be analyzed by an IBM 704 computer.

Augmenting the permanent satellite tracking stations are some 8 to 10 mobile Microlock stations mounted in trailers. These are shifted from location to location, depending on the space or missile experiment. The Microlock system was developed by JPL to operate under high noise levels on a nar-

row waveband. Mainly, the Micro-lock facilities are used for data acquisition from satellites. There are no plans at present to expand this net of auxiliary stations.

Complementing NASA's net of tracking stations for scientific satellite experiments is a net of military stations for both satellite and missile monitoring.

This January the military started operating a satellite detection fence across southern United States. The net is designed to detect enemy satellites that might be sent across the U.S. to ferret out secrets.

At present this fence has nine stations. Three operate on the Doppler principle and are dubbed Doploc. Six are of the Minitrack type. The stations range from Ft. Stewart, Ga., to San Diego, Calif. They are manned on a 24-hour basis.

The military has a tight secrecy lid clamped on this satellite detection fence. However, it is known the special Minitrack stations in the network are separate from those used by NASA. The Army developed the Doploc system being used at Fort Sill, Okla., Elephant Butte (near White Sands), N. M., and Memphis, Tenn.

Collecting Data

Control center will be set up by the Air Force at the Cambridge Research Center, where all information collected will be evaluated.

The network is now functioning in an R&D status. Efforts are being made to learn which of the two types of stations performs better, and whether more locations are needed. The Pentagon's Advanced Research Projects Agency now controls the program. Once it shifts from the R&D status, it will be turned over to one of the services.

In addition to the satellite detection fence, military has a net of tracking stations to monitor missile shoots. The Air Force operates 12 land-based stations downrange from Cape Canaveral, Fla., to Ascension Island, plus 13 tracking ships spread along the range.

The Navy will use 11 tracking ships when launches begin from the Pacific Missile Range on the west coast. Other stations may be added as the range develops.



**extended range
primary
pressure standard**

floats on air to minimize static friction



This flexible gage or absolute-type instrument is a true primary pressure standard that depends only on fundamental measurements of mass, length, and time for its accuracy. As a pneumatic dead-weight piston gage, it offers the advantages of air rather than oil as the pressure medium.

For extreme accuracy of 0.015% of full range, even at pressures of less than 1 psi... for cleanliness and portability... for extended range of measurements not available in any other similar equipment... specify CEC's 6-201 Primary Pressure Standard.

The 6-201 will calibrate any pressure-measuring device within the pressure limits of 0.3 to 500 psi. Six standard pressure ranges are provided starting with a range of 1.5 psi full scale.

For information, call your nearest CEC sales & service office, or write for Bulletin CEC 1581-X21.

Transducer Division

CEC

CONSOLIDATED ELECTRODYNAMICS / 300 N. Sierra Madre Villa, Pasadena, Calif.

FOR EMPLOYMENT OPPORTUNITIES WITH THIS PROGRESSIVE COMPANY, WRITE DIRECTOR OF PERSONNEL

You can explore new areas at IBM in

| | | | | | | |
|---|---|----|---|---|---|---|
| D | A | T | A | B | C | D |
| E | F | G | H | I | J | K |
| L | M | N | O | P | Q | R |
| S | T | U | V | W | X | Y |
| Z | & | \$ | ? | ! | : | ; |

COMMUNICA

Creative people at IBM are hard at work on a problem that has vexed man since the dawn of history—communication with his fellow beings. The rapid transmission of precise data is vital in this fast-moving age. One group of engineers and scientists at IBM is working on multiplexing techniques to channel data. This data has to be made available at maximum speed at desired times and places. Another group is developing computer systems that will control complete warehousing or industrial operations. For the military, IBM is designing a computer that will make available in real time, data concerning troop strength and dispositions. This important work needs imaginative people. If you want to be a part of this world of discovery and development, there are many opportunities at IBM.

A NEW WORLD OF OPPORTUNITY. Both technical and administrative engineering careers offer parallel advancement opportunities and rewards at IBM. You will enjoy unusual professional freedom, comprehensive education programs, the assistance of specialists of diverse disciplines, and IBM's wealth of systems know-how. Working independently or as a member of a small team, your individual contributions are quickly recognized and rewarded. This is a unique opportunity for a career with a company that has an outstanding growth record.

IBM

For details, write, outlining background and interests, to:
Mr. R. E. Rodgers, Dept. 554C1
IBM Corporation
590 Madison Avenue
New York 22, N. Y.

While in New York for the I.R.E. Show, you are cordially invited to visit the IBM booth and the IBM Product Display Center at IBM Headquarters, 590 Madison Avenue at East 57th Street.

INTERNATIONAL BUSINESS MACHINES CORPORATION

**CAREERS AVAILABLE
IN THESE AREAS...**

- CIRCUIT DESIGN & RESEARCH
- COMMUNICATIONS
- COMPONENT ENGINEERING
- COMPUTER ANALYSIS & DESIGN
- CRYOGENICS
- ENGINEERING PHYSICS
- INERTIAL GUIDANCE
- INDUSTRIAL CONTROL
- INFORMATION THEORY
- LOGICAL DESIGN
- MATHEMATICS
- OPTICS
- PROGRAMMING
- RADAR
- REAL TIME STUDIES
- SEMICONDUCTOR DESIGN
- SOLID STATE DEVELOPMENT
- SYSTEMS DEVELOPMENT

Qualifications: B.S., M.S., or Ph.D. in Electrical or Mechanical Engineering, Physics, or Mathematics — and proven ability to assume a high degree of technical responsibility in your sphere of interest.

| | | |
|---|---|---|
| T | 1 | 0 |
| | 2 | 9 |
| | 3 | 8 |
| | 4 | 7 |
| | 5 | 6 |

**GENERAL DESCRIPTIONS
OF SOME ASSIGNMENTS:**

SYSTEMS ENGINEERS to analyze and design computer systems. Backgrounds required include analog to digital conversion; analyses and preparation of diagnostic programs; development of complex devices in servo-mechanisms or radar for advanced systems.

LOGICAL DESIGNERS with two to four years' experience outlining logical blocks. Previous computer experience desirable. Some experience in transistorized equipment specification helpful. Must have strong interest in the theoretical and practical aspects of checking means and various codes, redundancy, error detection and correction, information flow, and other factors.

SOLID STATE ENGINEERS AND SCIENTISTS to do applied research on precision linear circuitry employing solid state devices using analog to digital conversion techniques and sample data. Experience in feed-back amplifier design desirable. Also opening for engineers with experience in precision, low-level linear circuits employing solid state, to work on analog to digital conversion techniques.

TENS:

INDUSTRIAL CONTROL ENGINEERS to perform precision AC and DC electric measurements. Assignments in amplifier design, relay circuit logic, test equipment development, analog to digital conversion, and noise reduction.

CIRCUIT DESIGNERS to design transistor amplifiers, relay lines, transistor tube conversion circuits. Develop systems circuit specifications, perform circuit evaluation experiments and reliability criteria. Other openings in circuit design for magnetic devices.

MATHEMATICIANS to do digital computer programming, handle analysis-of-variance and multiple-regression type problems. Design experiments for wide variation of engineering applications. Knowledge of application of probability or game theory desirable.

Here's how
you can
**MERCHANDISE
YOUR
ADVERTISING**

with
these
handy
9" by 12"
folders

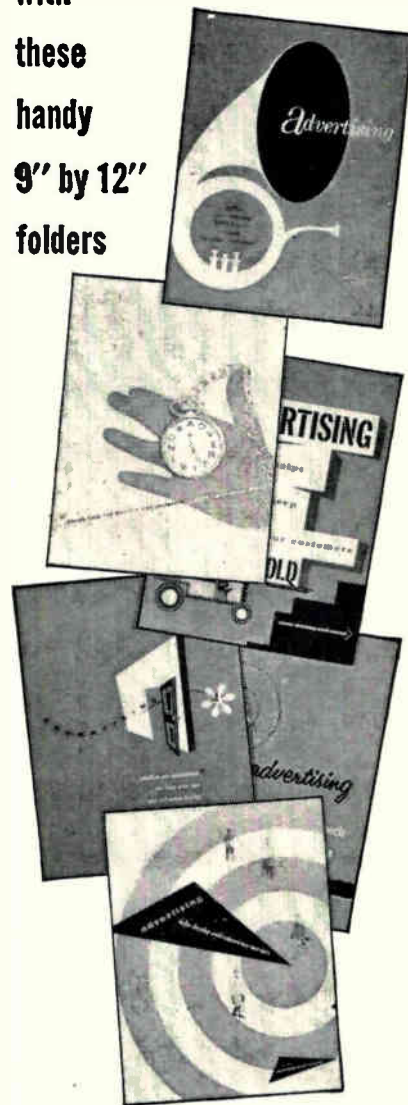

Keep your sales, management and distribution people informed on your advertising. Circulate preprints, reprints, schedules and other material in these folders, and make your advertising dollars work over and over for you.

Write for illustrated folder and price list
Promotion Dept. . . . Room 2700
McGraw-Hill Publishing Co., Inc.
330 West 42nd Street, New York 36, N. Y.

LIBRASCOPE

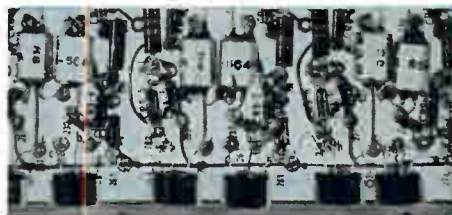
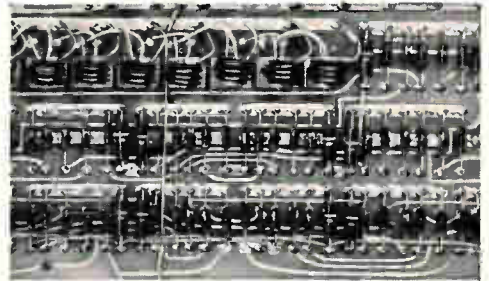
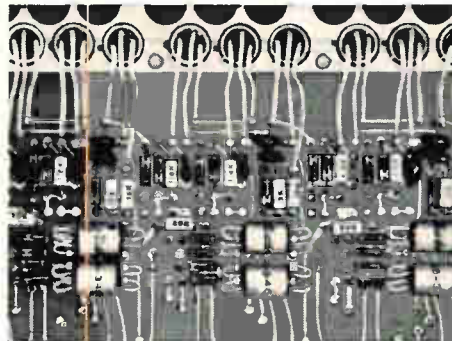
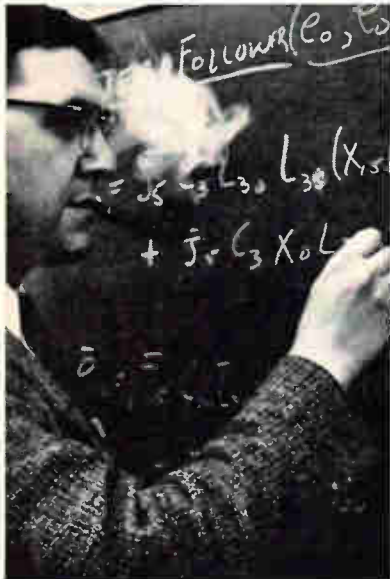

*what goes
into a
computer
system.....*

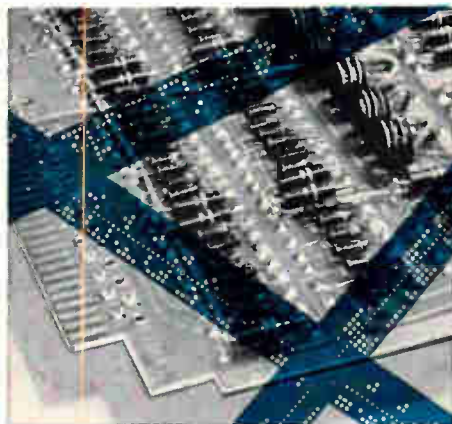

... more than experienced engineering, more than parts, plans and programs. At Librascope, it is the ability to integrate components and brain-power into workable computer systems for the accurate translation of data.

Librascope engineers attain optimum system accuracy by weighing problems in terms of inputs available and outputs required to provide reliable answers.

This process, from concept to reality, has unlimited room for expression at Librascope where facilities including field test and simulation laboratories cover hundreds of thousands of square feet... where research—development of electronic, electro-mechanical, magnetic and optical computing techniques is a continuing, progressive program.



What goes into a Librascope computer system represents the best experience of two decades. For full details on how Librascope can anticipate and solve your computer and control problems, write...

For information on career opportunities at Librascope, write Glen Seltzer, Employment Manager.

...



LIBRASCOPE, INC. • 808 WESTERN AVENUE • GLENDALE, CALIF. • A Subsidiary of General Precision Equipment Corporation

Computers Lift Transistor Sales

Solid-state data-processing systems introduced in last six months may account for 10 percent of year's transistor production

THEME of this year's Western Joint Computer Conference—"New Horizons with Computer Technology"—fits current developments in the computer field perfectly.

The conference, being held this week at San Francisco's Fairmont Hotel, actually stresses breakthroughs in information-handling which computers make possible. But it's timed to catch the first crest on a whole new wave of breakthroughs in computers themselves.

Yearend 1958 saw the introduction of several new computer systems, some built on radically different principles. The main characteristic common to them all was that they were solid-state computers.

Philco's S-1000 and S-2000 Transacs, first introduced early in 1958, pointed the trend. RCA's 501 and Minneapolis-Honeywell's 800 are among the new all-transistor systems. Remington Rand Univac's new data-processor is primarily made up of some 1,500 magnetic-circuit cards, has some transistors in these circuits, uses 20 electron tubes (in the clock circuit). The IBM 7070 and 7090 are all-transistorized; the latter is a solid-state version of the 709, and is claimed to be five times faster than the 709.

Market Impact

All this has a direct impact on the market for semiconductor products. Semiconductor market has been boosted by computers and industrial electronic products before. Starting in 1950, computers tremendously stimulated the production of semiconductor diodes. Each computer uses tens of thousands of these components: the Datamatic 1000, for example, requires over 135,000.

As computers become more completely transistorized, transistor growth will be similarly spurred.

RCA's industrial products di-



Compact circuit cards in Philco S-2000 characterize hardware in new transistorized computers

vision, which makes the 501 system, expects to use over a million transistors in original equipment this year. Not all will be used in computers, of course; but each basic 501 system requires about 20,000 transistors.

Production Data

Philco's S-2000 uses 41,610 transistors, with 19,297 used in the console (computing and control circuits) alone. Horseback estimate of IBM's, Rem Rand's and Honeywell's large-scale systems indicates that each system requires between 20,000 and 70,000 transistors.

Sales of transistors in 1959 will probably hit near 73 million units, some 40 percent greater than 1958's sales. Exactly how many of these will go into computers is difficult to determine: no major manufacturer of computers is releasing his production estimates in what has become one of the most hotly competitive areas in industrial electronics. But a firm, if erratic, upward trend in new computer orders has been recorded by all manufacturers since November of last year.

This trend points toward a reasonable estimate of 300 large- and

medium-sized systems to be produced this year. Roughly half of these will be transistorized; it is large- and medium-sized computers that are being redesigned as solid-state systems. As things stand now, computers should account for 10 percent of transistor sales in 1959.

Recession Spur

The sudden flood of solid-state systems in the last six months is the natural fruition of trials dating back five years. Around 1954, computer makers were almost universally complaining that reliable high-frequency transistors were too expensive. Some systems were partly transistorized anyway: the Datamatic 1000, for instance, uses 12,000 electron tubes and over 10,000 transistors. The clearly defined trend toward the solid-state computer began to take shape last year.

The business recession acted as a spur. Only about 200 large- and medium-scale computers were installed during 1958. New orders for such systems dropped during the year to less than half 1957's figure. During the lull, engineers were somewhat freer than usual from the constant pressure of field change orders, and marketing executives began casting about for product changes to stimulate sales.

The change within the easiest grasp of the technology was transistorization of existing systems.

The Honeywell 800, however, represents a major departure. The logical organization of this new system contains many characteristics of the second generation of computers. It is flexibly organized, can handle several computation processes simultaneously, corrects many of its own errors. Such facilities will characterize systems like Rem Rand's Larc (Livermore Atomic Research Computer), now under final checkout in Philadelphia, and IBM's Stretch.

GENERAL PLATE

Copper Cored Glass Sealing Wire Features a Sound Metallurgical Bond

... And Gives You These Advantages ...

GLASS SEALING ALLOY

COPPER CORE

- Leakproof Seal between Alloy and Core
- High Electrical Conductivity
- Increased Thermal Conductivity
- Coefficient of Expansion Matches Glass
- Facilitates Miniaturization
- Cuts Costs

General Plate Copper Cored Alloy Wire (33% copper clad core, 67% glass sealing alloy) gives you three times greater electrical conductivity than solid #52 alloy wire of equal diameter.

This means you can substantially increase the current carrying capacity of your solid sealed leads without going to larger diameters — or, if you have a miniaturization problem, you can reduce sealing wire diameters correspondingly. The sound metallurgical bond between the copper core and outer shell eliminates any air or gas leaks in the wire.

General Plate Copper Cored Glass Sealing Wires are used for better performance in glass-to-metal seals in hermetically sealed devices such as switches, relays, coils, controls, vacuum tubes and semiconductors.

They are available in #52 alloy, Type 446 stainless, low carbon steel, Kovar* and other glass sealing alloys. Write for Bulletin IND-15.

For details on the complete line of General Plate Clad Metals, ask for a free copy of GP-1 Catalog.

*T.M. Registered Carborundum Co.

*You Can Profit by using
General Plate Clad Metals*

METALS & CONTROLS CORPORATION
General Plate Division



1303 Forest Street, Attleboro, Mass.

FIELD OFFICES: NEW YORK • CHICAGO • DETROIT • INDIANAPOLIS • MILWAUKEE • PASADENA

NOW
from
AUTOMATIC

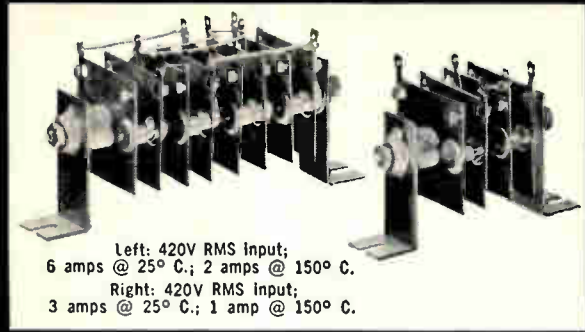

Left: 420V RMS input;
6 amps @ 25° C.; 2 amps @ 150° C.
Right: 420V RMS input;
3 amps @ 25° C.; 1 amp @ 150° C.

miniaturized Silicon Rectifier STACKS

No aging

Excellent regulation

**Wide range of operating and
storage temperatures**

**Designed to meet military
environmental requirements**

**Hundreds of cell combinations
available — Special circuit
configurations designed
to your order**

The same high efficiency, reliability and long lived Silicon Rectifiers that have made AUTOMATIC famous in the field are now available in stack assemblies. Arranged in stacks of up to twelve fins to produce hundreds of different circuit combinations, they are supplied in a range from 1 to 18 amperes, and from 15V D.C. output to 750V D.C. output.

As always, General Instrument's mass production experience and techniques make them available in production quantities at truly competitive prices. You can obtain them from authorized distributors throughout the country. Additional information is available upon request — Write today.

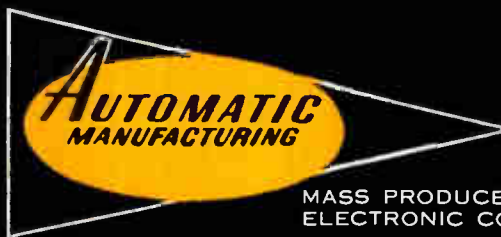

**MASS PRODUCERS OF
ELECTRONIC COMPONENTS**

**AUTOMATIC MANUFACTURING DIVISION OF GENERAL INSTRUMENT CORPORATION
65 GOVERNEUR STREET, NEWARK 4, N. J.**

GENERAL INSTRUMENT SEMICONDUCTORS

General Instrument Corporation
also includes
F. W. Sickles Division,
Radio Receptor Co., Inc., and
Micamold Electronics Manufacturing
Corporation (Subsidiaries)



See us in March at the IRE Show in New York—Booths 2211-2217

2

OUTSTANDING HIGH-TEMPERATURE MAGNET WIRES

Tetroc[®]

FOR CONTINUOUS OPERATION AT
HOTTEST SPOT TEMPERATURES
UP TO 200°C

Ceroc[®]

FOR CONTINUOUS OPERATION AT
HOTTEST SPOT TEMPERATURES
UP TO 250°C

For continuous operation at hottest spot temperatures up to 200°C (392°F) and up to 250°C (482°F) for short periods of time—depend upon TETROC—an all Teflon-insulated wire available in both single and heavy coatings.

CEROC is Sprague's recommendation for continuous operation at hottest spot temperatures up to 250°C (482°F) and up to 300°C (572°F) for short periods of time. Ceroc has a flexible ceramic base insulation with either single silicone or single or heavy Teflon overlays. The ceramic base stops "cut-through" sometimes found in windings of all-fluorocarbon wire. Both Tetroc and Ceroc magnet wires provide extremely high space factors.

Write for Engineering Bulletins 405 (Tetroc Wires) and 400A (Ceroc Wires).

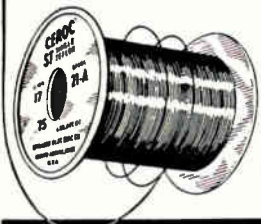

SPRAGUE
ELECTRIC
COMPANY

35 Marshall Street,
North Adams, Mass.

SPRAGUE[®]

THE MARK OF RELIABILITY

CIRCLE 27 READERS SERVICE CARD

Six-Jet Drones on

Two pilotless B-47's with uhf radio command guidance are being completed. Defense Dept. is committed to 32 for delivery by December

THE DEFENSE DEPARTMENT is moving fast to get into the air by year's end at least 32 QB-47 six-jet drones laden with electronic countermeasures equipment.

The pilotless bombers will be used in a variety of air defense tests by the Air Force, Army and Navy.

So far, conversion of two Boeing B-47's is being completed at Lockheed's Marietta, Ga., division under contract to the Oklahoma City Air Materiel Area. Lockheed is responsible for converting the Boeing airframe for drone operation. Sperry Gyroscope is providing the uhf radio command guidance and controls.

The first two drones are scheduled for delivery April 2 to USAF's Air Research and Development Command. Spring flight tests are expected. An ARDC spokesman says the two drones are intended primarily for testing Bomarc missiles and training missilemen.

The Defense Department is committed for 30 more QB-47 drones to be delivered between July and December. It's understood that all three services are planning to use QB-47's in a number of special programs.

Carries Jamming Gear

The fact that the B-47 has altitude characteristics similar to the Soviet Union's Bison, Beagle and Badger bombers makes the pilotless version a natural practice target in missile defense exercises.

The drone will carry chaff dispensers and gear to jam ground radar and firing systems on attacking weapons, such as surface-to-air missiles and manned interceptors equipped with air-to-air missiles.

The subsonic QB-47, flying at 30,000 to 40,000 ft, will have a command and guidance system that is compatible with existing electronic ground controls and monitoring

equipment at Eglin and Patrick AFB's in Florida and Holloman AFB, N. M.

The QB-47 will also be controllable from the air by a DT-33 jet director trainer, presently being used to guide and control smaller drones.

Besides its known future role in missile defense exercises, the QB-47 might be used to test the vulnerability of radar nets, such as the DEW Line, and the retaliatory effectiveness of continental air defense.

New Contract Given

In air defense tests, says Lockheed, the QB-47 could serve as scorekeeper for anti-aircraft missiles such as Nike-Hercules and Bomarc. Use in atomic weapons tests is another possibility.

Conversion of the Lockheed F-80 jet (already adapted as the DT 33 jet trainer) into a QF-80 drone may also be stepped up by the Air Force. QF-80's have been used as target drones for some time.

A new \$3,678,100 Air Force contract has just been awarded to Sperry Phoenix for production of a uhf radio command and guidance system for the QF-80. This system will also be compatible with existing ground environment equipment for drones.

Takeoff of the QF-80 is now controlled by a ground operator. Once airborne, a DT-33 takes over and controls the drone to the target area. The QF-80 can also be programmed to climb to a certain altitude, trim itself and orbit in a left turn at a constant altitude. On completion of the mission, the DT-33 returns the drone to the airfield for ground controls to take over.

In case the drone gets out of control, a dynamite charge is located in the left wing for destruction on a signal from the DT-33.

the Way

Meanwhile, the microwave command guidance system designed for Radioplane's Q-4 and Lockheed's Q-5 supersonic drones (ELECTRONICS, p 26, Apr. 18, 1958) is still under development by Sperry.

Uses One Frequency

This radar-controlled microwave command guidance system will be more sophisticated than the guidance for the QB-47 and the QF-80. Sperry hopes it will be adopted as a universal drone guidance system.

The supersonic Q-4 and Q-5, using a slingshot launcher system, are guided and controlled by ground or airborne stations. Operators track the drone, command its engine and flight control and receive flight data—all over a single radar frequency band.

In connection with missile testing, ARDC has announced development of a new electronic "proximity scorer" to indicate the miss distance after a missile has been fired at a target drone. But an ARDC spokesman says the new device is still in the experimental laboratory stage.

Airborne Controls

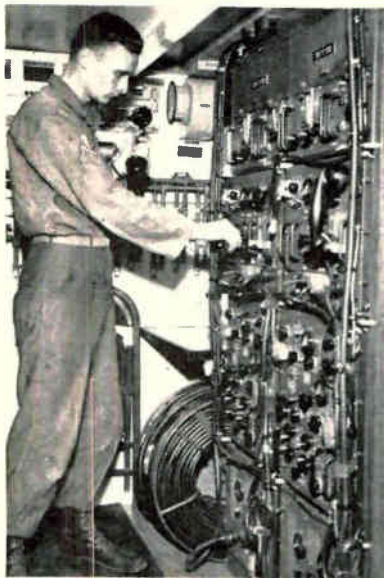

Radio equipment in Army's airborne communications center, designed by Army Signal R&D lab, could control widely-dispersed troops on atomic battlefield

Solid-Electrolyte Tantalex® Capacitors

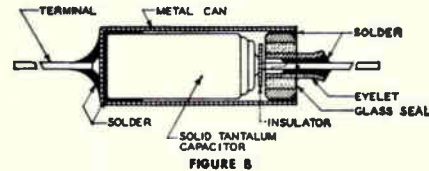
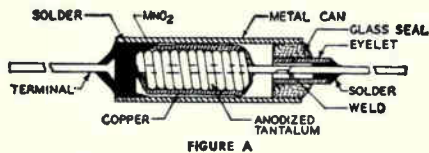

The ultimate in reliability, achieved through constant research, is evident in Sprague Type 150D Solid-Electrolyte Tantalex Capacitors. True miniaturization and excellent stability of electrical characteristics make them ideal for transistor circuits in military and industrial applications.

Figure A shows a typical construction used for low capacitance values. The anode is a coil of smooth-surfaced tantalum wire which has been anodized to obtain the dielectric surface film. This type of anode is used only for fractional capacitance values.

Figure B shows a typical porous-anode, hermetically-sealed capacitor. The anode is of the sintered tantalum pellet-type which exhibits a large gain in surface area per unit volume. Thus, the resulting capacitor has a large capacitance-to-volume ratio. It cannot leak or corrode even if the hermetic seal of the outer-metal case be broken or destroyed.

These capacitors may be used wherever stable capacitance and low dissipation factors are dictated over a wide temperature range. The capacitance varies by only a few per cent from room temperature down to -80°C or up to $+85^{\circ}\text{C}$ and the dissipation factor is nearly constant. These capacitors can be used at 125°C with proper voltage derating.

Write for Engineering Bulletin 3520C to Technical Literature Section, Sprague Electric Co., 35 Marshall St., North Adams, Mass.

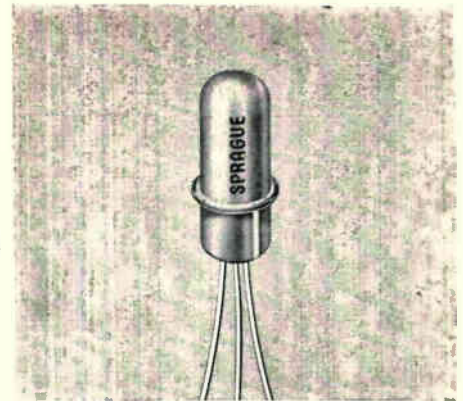

New Sprague TYPE 2N501

micro-alloy diffused-base transistors

FOR SUPER HIGH-SPEED SWITCHING

Here's the fastest switching transistor in commercial production today! Sprague Type 2N501 Germanium Micro-Alloy Diffused-Base Transistors not only exhibit excellent high gain and high frequency response, but also display unusual stability and high operating efficiency under severe environmental conditions and life tests. Type 2N501 Transistors are unexcelled for ultra-high speed computer applications.

Ultra-precise process control in manufacture results in superb and consistent high quality. Sprague mechanized electro-chemical process of fabrication takes the guesswork out of transistor manufacturing. The result is outstanding product uniformity at extremely reasonable prices.

Write for complete engineering data to the Technical Literature Section, Sprague Electric Company, 35 Marshall Street, North Adams, Massachusetts.



SEE US AT THE I.R.E. SHOW—BOOTHS 2416-2424
CIRCLE 28 READERS SERVICE CARD



SHRUNK BY EXPERTS

Burnell & Co. may not be experts in the art of head shrinking. But when it comes to toroids, filters and related networks, Burnell has the know-how to solve an infinite variety of small space problems. The new **MICROID**® filters by Burnell & Co. are a notable achievement in the shrinking of filters which can be designed for low pass or band pass applications.

For example, as a low pass filter, Type TCLJ starts at 400 cps. Physical size is 11/16" x 1-11/16" x 1/2" max. For higher frequencies from 7,500 cycles up to 100 kc, size is 3/4" x 1" x 1/2".

The band pass filter, Type TTJ pictured here, ranges from 7,350 cycles

up to 100 kc. Physical size is 1/2" x 19/32" x 15/16", weight .3 ounces, band width 15% at 3 db and + 60% - 40% at 40 db. Wherever space and performance are critical requirements, miniaturized **MICROID**® low pass and band pass filters provide utmost reliability as well as more unit surface economy on printed circuit boards. Completely encapsulated, they are ideally suited to withstand high acceleration, shock and vibration environments. Write for special filter bulletin to help solve your circuit problems.

See these and other subminiature components on display at Booth 2919-2921, IRE Exhibit.

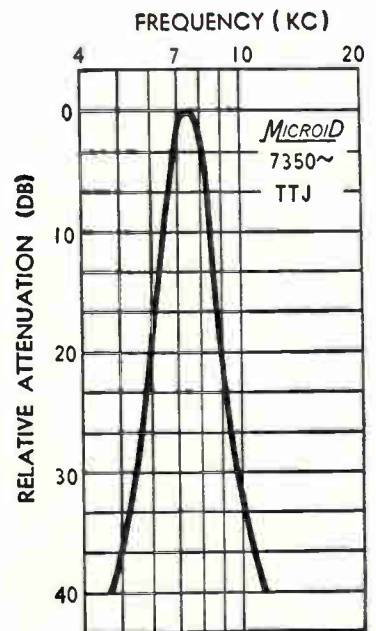

® REGISTERED TRADE MARK

Burnell & Co., Inc.

PIONEERS IN TOROIDS, FILTERS AND RELATED NETWORKS'

EASTERN DIVISION
DEPT. E-16
10 PELHAM PARKWAY
PELHAM, N. Y.
PELHAM 8-5000
TELETYPE PELHAM 3633



PACIFIC DIVISION
DEPT. E-16
720 MISSION ST.
SOUTH PASADENA, CALIF.
RYAN 1-2841
TELETYPE PASACAL 7528

New TV Channels Pondered

Spectrum studies widen as FCC officials and various companies offer usage plans

SPECTRUM ALLOCATION problems show no signs of lessening this month as the National Association of Broadcasters gets ready for its annual meeting (Mar. 15-18) in Chicago.

A count of uhf television stations during the past seven months shows 86 survivors out of 171.

Broadcasters and equipment manufacturers are wondering how plans now being studied will affect them. FCC officials offer three plans.

What's Proposed

Last July, Commissioner T. A. M. Craven advanced the idea of placing all tv allocations in a continuous band of 25 channels.

In mid-January of this year, a plan was mentioned by Commissioner R. E. Lee, that all television be made uhf, with frequent reminders to vhf viewers of the transition to come.

A third plan was advanced by FCC chairman J. C. Doerfer last month. Doerfer said "expansion in the vhf band is the logical solution (to the problem), and would create the least disruption."

Many industrial and commercial users are seeking additional spectrum space. Among them is American Telephone and Telegraph Corp., calling for use of a portion of the uhf spectrum for mobile telephone service.

Under the AT&T plan, the 765 to 840 mc band would be used for private telephones in vehicles. The 840 to 890 mc band at the upper end of the uhf band is currently being requested for common carrier fixed service.

An illustration of how closely users guard their frequencies is found in the contemplated proceedings of FCC to establish spectrum allocations for space communications under the International Telecommunication Union. FCC made mention of the 100 to 150 mc band as a possible area where such com-

munications could be conducted. The announcement drew a sharp retort from the National Association of Broadcasters, who reminded the FCC that f-m broadcasting is currently allocated the 88 to 108 mc band.

Equipment manufacturers are aware of problems and benefits that will arise if shifts are made. Several firms told ELECTRONICS that any appreciable changes would affect their equipment manufacture. One firm has mapped out formal standby plans to cope with design and service problems, should new rulings be made.

Many firms are acting through Electronic Industries Association to keep informed of changes that may affect them. EIA tracks legislation through committees concerned with particular areas of radio uses.

Additional thinking on spectrum usage may result when the Television Allocations Study Organization files its complete report. Washington sources say the TASO report is in final draft form and being readied for printing. Actual filing of the docket will not occur until later this year.

Checking Engine



Cylinder wall thickness in thousandths of an inch is shown by vertical step in bright horizontal line on oscilloscope screen, after operator places resonance frequency probe on inside wall of auto engine block. GM designed gage to improve quality control. If wall thickness is substandard, red light flashes above tv-like screen

Reduce rejects and operational failures caused by airborne dirt, dust, lint, abrasives with the

HONEYWELL ELECTRONIC AIR CLEANER

When microscopic airborne dirt, dust, lint and abrasives get into precision electric and electronic devices, the results are unusually high reject rates, poor product quality, operational failures. The Honeywell Electronic Air Cleaner will protect your precision components from the damaging action of these airborne spoilers by trapping particles 100 times as small as those stopped by mechanical filters.

Pays for itself! Send coupon today to learn how the Honeywell Electronic Air Cleaner soon pays for itself in:

- Electronic Manufacturing
- Controlled environment rooms for precision manufacturing, processing and assembly
- Switch & relay rooms
- Computer rooms
- Transmitter rooms
- Precision component manufacturing

MINNEAPOLIS-HONEYWELL
DEPT. EL-3-45, Minneapolis 8, Minn.
Please send free copy of Electronic Air Cleaner booklet, "A Close Look at Air-Borne Dirt." We have the following

problems: _____

Name _____

Company _____

Address _____

City _____ Zone _____ State _____

CIRCLE 30 READERS SERVICE CARD

*Meet Mr. Mu, the man from
Magnetic Metals*



**the superior
levels of**

Visit our booth
No. 3936
at the IRE Show
New York Coliseum
March 23-26, 1959





magnetic laminations with highest permeability ever attained

Performance of equipment can be no better than its components. Now you can design your product to tighter specifications . . . reduce its size . . . be positive of uniformity of its performance . . . with new **Supermu** laminations by Magnetic Metals. These laminations are carefully controlled and tested to meet your specific permeability ranges. They are produced from recently developed new alloys, mechanically and thermally processed to closer limits than ever before.

Magnetic Metals Company produces these superior grade laminations under a rigid 4-point control program:

- painstaking procurement and development in basic magnetic materials
- production and maintenance of the finest precision tools and dies
- superior annealing techniques that hold the process to an exact science
- extensive testing that rates **Supermu** laminations to uniform grades

When you specify **Supermu** laminations—a new development of Magnetic Metals . . . you're sure of uniform permeability ratings to *meet* your design requirements.

Write for complete details.

Magnetic
Metals

transformer laminations • motor laminations • tape-wound cores
powdered molybdenum permalloy cores • electromagnetic shields

MAGNETIC METALS COMPANY • Hayes Avenue at 21st Street, Camden 1, N. J.

**120 CFM
FAN WEIGHT
ONLY 6½ oz.!**

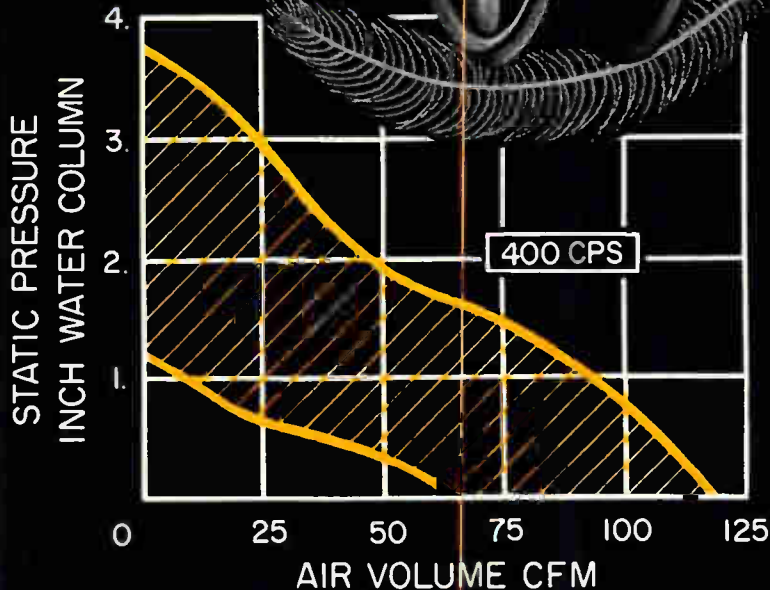

PROPIMAX 2®

Air delivery of 120 cfm is obtained from a fan only 3" in diameter by 1.4" in depth and weighing only 6½ ounces. The Propimax 2 is the perfect answer for 400-cps airborne or missile applications where maximum cooling with a minimum of space and weight loss is mandatory.

Variation in driving motors includes constant speed 21,000-rpm, 11,500-rpm and Altivar® versions. The latter automatically vary their speeds directly with altitude and thereby approach constant cooling with a minimum of power drain and noise.

Simplicity of mounting is achieved by provision of "servo" type rims at either end of venturi. Airflow is reversible by turning fan end-for-end. Electrical connections made to compact terminal block. Power requirement is 400 cps, 1 or 3 phase, sinusoidal or square wave.

Write for complete technical information . . .

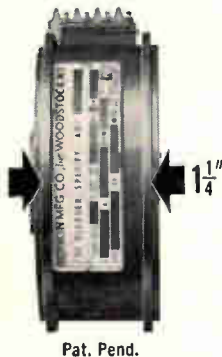

Pat. Pend.



ROTRON

mfg. co.,
inc.

WOODSTOCK • NEW YORK
In Canada: The Hoover Co., Ltd., Hamilton, Ont.

CIRCLE 33 READERS SERVICE CARD

MEETINGS AHEAD

Mar. 5-7: Western Space Age Conf. and Exhibit, L.A. Chamber of Commerce, Great Western Exhibit Center, Los Angeles.

Mar. 12-13: Canadian Aircraft Industry Instrumentation Symposium, I.S.A., Lord Simcoe Hotel, Toronto.

Mar. 15-18: National Assoc. of Broadcasters, Annual Convention, Conrad Hilton Hotel, Chicago.

Mar. 23-25: Flight Testing Conf., American Rocket Society, Daytona Plaza and Princess Issena Hotels, Daytona Beach, Fla.

Mar. 23-26: Institute of Radio Engineers, IRE National Convention, Coliseum & Waldorf-Astoria Hotel, New York City.

Mar. 31-Apr. 2: Millimeter Waves Symposium, Polytechnic Inst. of Brooklyn, USAF, ONR, IRE, USA Signal Research, Engineering Societies Bldg., N.Y.C.

Apr. 5-10: Nuclear Congress, sponsored by over 25 major engineering and scientific societies, Public Auditorium, Cleveland.

Apr. 6-7: Astronautics Symposium, Air Force Office of Scientific Research, Sheraton-Park Hotel, Washington, D. C.

Apr. 6-9: British Radio and Electronic Components Show, Great Hall, Grosvenor House, Park Lane, London W. 1.

Apr. 13-15: Protective Relay Conf., A & M College of Texas, College Station, Tex.

Apr. 14-15: Industrial Instrumentation & Control Conf., PGIE of IRE, Armour Research Foundation, Illinois Inst. of Tech., Chicago.

Apr. 16-18: Southwestern IRE Conf. and Electronics Show, SWIRECO, Dallas Memorial Aud. & Baker Hotel, Dallas.

Apr. 20-21: Analog & Digital Recording & Controlling Instrumentation, AIEE, PGIE & PGI of IRE, Bellevue-Stratford Hotel, Philadelphia.

Apr. 20-22: Instrument Society of America, Southeastern Conf. & Exhibit, Gatlinburg, Tenn.

Apr. 20-22: Man-in-Space Conf., American Rocket Society, Hotel Chamberlain, Hampton, Va.

There's more news in ON the MARKET, PLANTS and PEOPLE and other departments beginning on p 76.



EIMAC Klystrons are used in most tropo-scatter installations



EIMAC 4KM50,000LQ klystron

NOW, 400 TO 985 MEGACYCLES SPANNED WITH JUST TWO EIMAC 10KW KLYSTRONS

Exceptionally wide frequency coverage, 400 to 985 megacycles, is now available with just two interchangeable klystron amplifiers using the Eimac 4KM50,000LA and LQ 10 KW klystrons. This important tropo-scatter and UHF-TV range can now be covered with a single transmitter. In addition, both tube types offer exclusive design advantages that have made Eimac klystrons the most widely used power tubes in tropo-scatter networks.

Field-Proved External Cavity Design

Extra wide tuning range with single set of tuning cavities. Lower original cost. Tube replacement cost much lower since external tuning circuitry need not be replaced.

Uniform bandwidth through inductive tuning plus greater broadbanding by external cavity loading.

Wide Range Load Coupler

One coupler covers entire frequency range.

Modulating Anode

Provides simplified overload protection.

Protects cathode from internal arc damage.

EMA Cathode

Combines ruggedness and long life of a pure metal emitter with the high efficiency of an oxide cathode.

Extra large area cathode conservatively rated for exceptional reliability.

Eliminates need for high voltage bombarder power supply, reducing system cost and total power consumption.

Series Connected Body Magnet Coils

Permits use of single power supply and control for body magnets.

Performance Proved Reliability

In tropo-scatter service, individual Eimac klystrons have logged more than 25,000 hours air time.

EITEL-McCULLOUGH, INC.



San Carlos, California

These features of
new Brush
ultralinear
recording
systems . . .



. . . give you more application versatility!

Simplified Chart Re-loading.

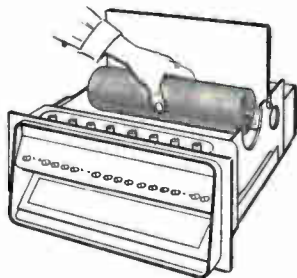

Interchangeable, plug-in signal conditioners.

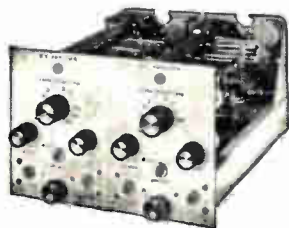

Positive Chart Take-up Drive.

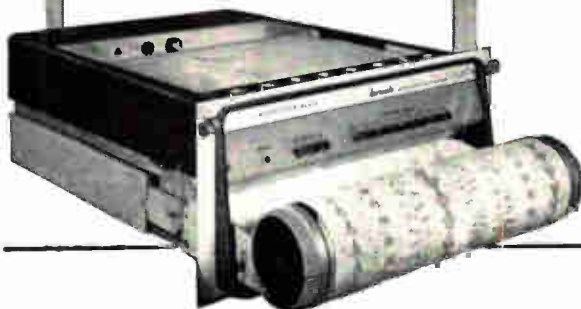

In the fields of telemetry, ground support systems, analog computing and laboratory testing, Brush recording systems have incorporated features which have consistently kept ahead of engineering requirements. Here are a few that show why—

INTERCHANGEABLE PLUG-IN SIGNAL CONDITIONERS. You get your choice of sensitivities—you get high input impedance—zero suppression.

SIMPLIFIED FAST CHART RE-LOADING. Loaded from the top—features automatic alignment and tracking.

ACCURATE, EASILY REPRODUCIBLE RECORDINGS. Your choice of rectilinear or curvilinear charts—rugged “throw-proof” pens.

Illustrated above is a Brush RD-1684 rectilinear, 8 channel recording system. Sensitivity of 10 millivolts per chart line—input impedance, 10 megs balanced or 5 megs grounded. Complete system includes mobile cabinet, oscillograph and 8 signal conditioners. No additional preamplifiers required. Available from stock.

brush INSTRUMENTS

DIVISION OF

37th & PERKINS

CLEVITE
CORPORATION

CLEVELAND 14, OHIO

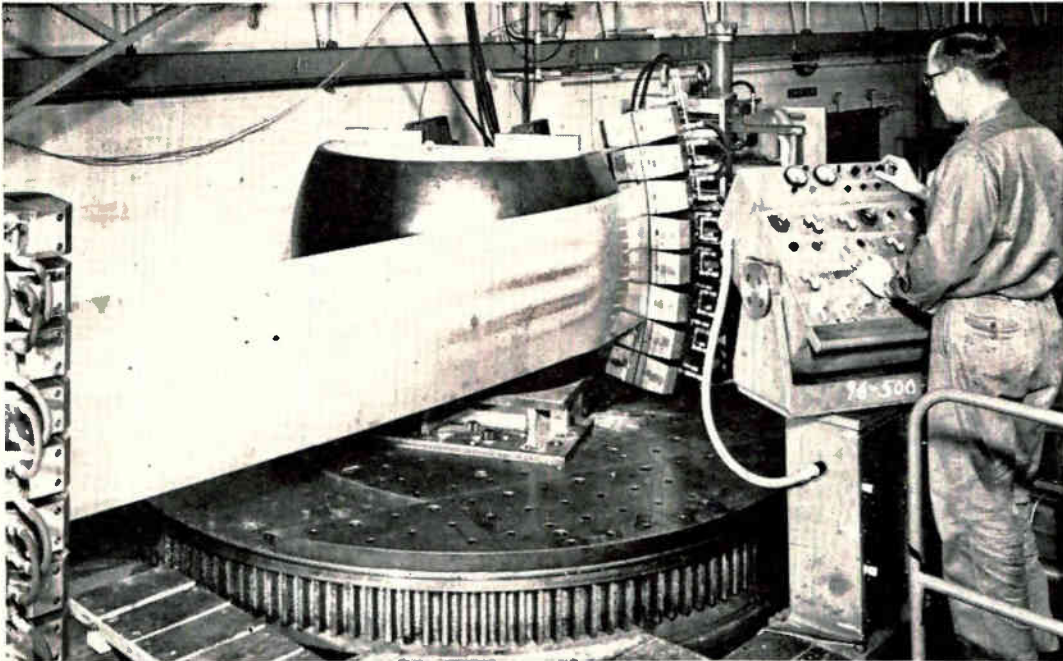

Hydraulically operated jaws grip and stretch a metal band while barrel-supported dies form the metal. The yield point detector and tension controller unit is contained in the upper section of the operator's control cabinet

Automatic Controls for Metal Working Machines

Control system guides machine that stretches and forms metals. System automatically applies tension to the metal to bring it to its yield point and then lowers the tension as dies are applied to the metal

By **GEORGE J. CROWDES**, Chief Engineer, Assembly Products, Inc., Chesterland, Ohio

ELECTRONIC CONTROL helps form metal with a high degree of precision. The machines guided by the control are being used increasingly for forming exotic alloys, which frequently can be worked only within narrow bands of tension and stress.

The control receives signals from a strain gage and an elongation detector and translates them to determine the yield point of the metal that is to be shaped (Fig. 1). Then the control momentarily drops the tension before the forming dies are brought against the metal; dropping the tension prevents

fracture of the metal. As the dies are brought against the metal, tension is increased to either the yield point or to a tension that is near the yield point. During the forming, the control maintains the selected tension.

The control features the use of locking contact meter relays as stable reference points for electronic components. Control signals from electronic units first pass to the meter relays for checking against values that must be maintained. Then the meter relays trigger other signals to controlling apparatus

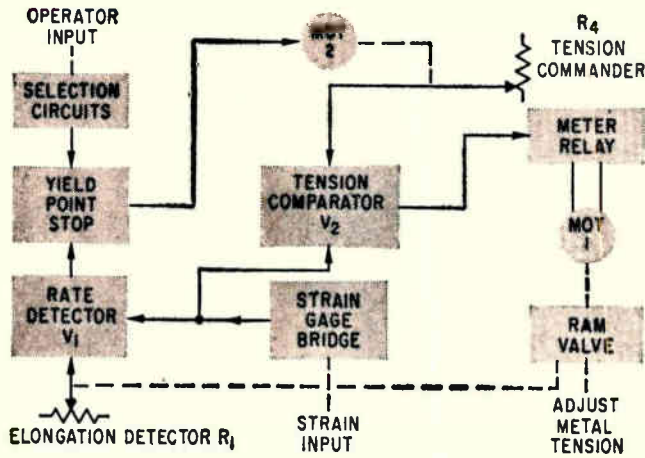

FIG. 1—Simplified representation of circuits that determine yield point

that might otherwise tend to hunt and drift. This procedure simplifies the circuits and saves the cost of complicated means of maintaining stability.

The meter relays also simplify the general problems of signal amplification in that they operate on relatively small signals and they effect an extremely high power gain by directly controlling relatively high power circuits.

DETERMINING YIELD POINT—The circuits that determine the yield point of metal follow logically from the definition of such a point: the stage at which tension and elongation begin increasing at a different rate. At the yield point considerable elongation takes place without appreciable increase

in tension that is applied to the material.

The elongation signal comes from a potentiometer, R_1 , Fig. 2, that is linked to the ram of a hydraulic relief valve. The valve, which is driven by a servo motor, No. 1, controls metal tension by varying hydraulic pressure. The potentiometer furnishes a d-c voltage that is proportional to the elongation, which is in the order of microinches per inch.

The tension signal comes from a strain-gage bridge which delivers from 0 to 10 mv, a-c, at 60 cps.

The elongation signal is fed to R_2 and the tension signal is fed to R_3 . These potentiometers are mounted on the same shaft and so connected that when the output setting of one is increased, the output setting of the other is decreased. This slope control allows the two analog voltages to be adjusted for identical rates of increase. Adjustment is made at the known linear part of the yield curve. The output from the two potentiometers is fed to separate grids of rate detector V_1 .

Tube V_1 acts as a rate-sensitive differential amplifier and powers the moving coil and pointer of meter relay K_1 . As long as the voltages increase equally on each grid of V_1 , the pointer of K_1 remains at center scale. When the elongation signal increases out of proportion, the pointer locks at the high limit and energizes K_2 . Circuit operations follow this action that fix the yield point by stopping the tension commander, R_4 . The final setting of this potentiometer corresponds to the yield point.

OPERATION—When S_1 and S_2 are switched to automatic operation and S_3 is deflected to INCREASE, relay

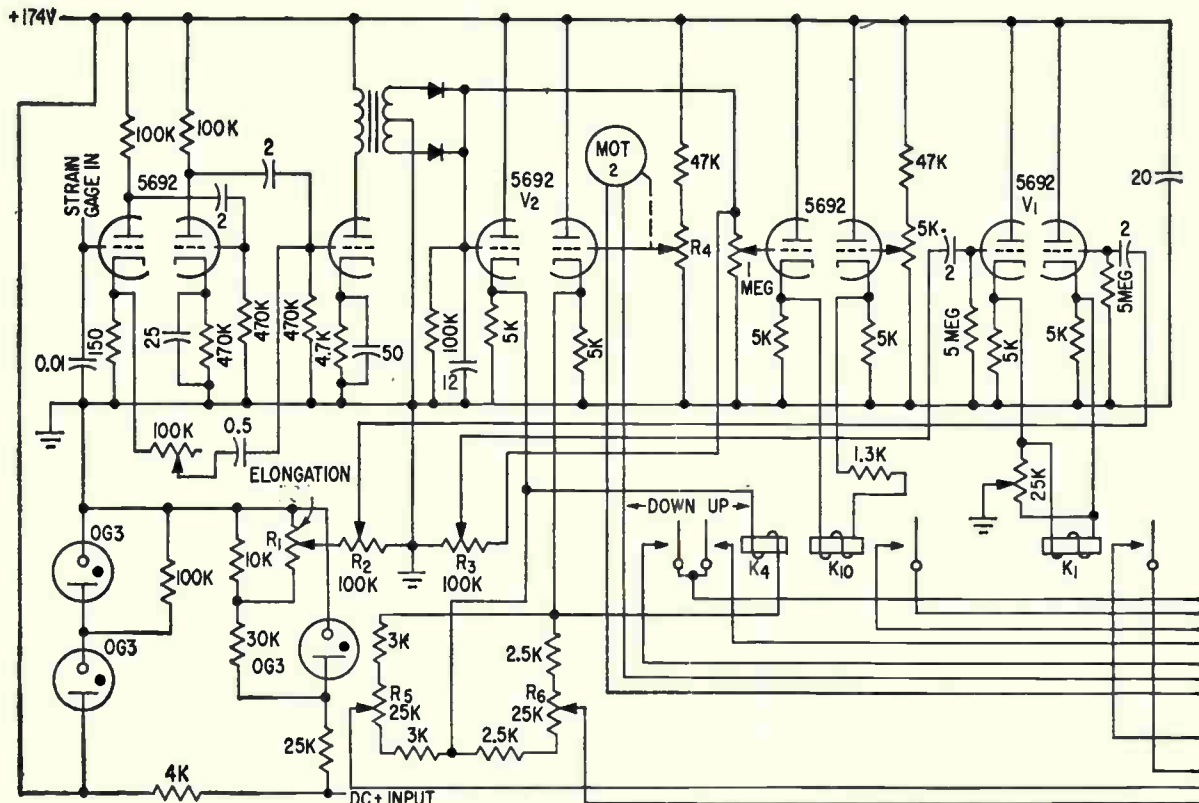

FIG. 2—Yield-point detector and tension controller. At the end of a cycle, the operator opens the stop switch, resetting the

K_5 locks in. Relay K_5 applies 24-v d-c to motor No. 2, which then drives potentiometer R_4 .

The signal from R_4 feeds one grid of differential amplifier V_2 , whose other grid is fed by a tension signal from the strain gage. Since the signal from R_4 leads the tension signal, the amplifier input is unbalanced in the raise direction. The pointers of meter-relay K_1 swing off center in the up direction and energize K_2 . Relay K_2 pulls in, and drops itself out by interrupting the current through its coil. Thus K_2 sends a series of pulses to servo motor No. 1.

The motor opens the hydraulic valve, increasing the metal tension. As the tension increases, the tension signal from the strain gage rises, thus following the increase of the signal from R_4 .

When the rate of elongation exceeds the rate of tension increase, V_1 energizes K_1 , which locks in and energizes K_2 . Relay K_2 energizes K_3 and deenergizes a clutch which stops the ram of the hydraulic valve. Relay K_3 locks in and deenergizes K_2 , energizes K_4 , and brings the tap of R_5 to ground.

When K_4 pulls in, it deenergizes K_3 , which stops motor No. 2. The tap of R_4 is now at the position that corresponds to the yield point.

When the tap of R_4 is brought to ground, V_2 is unbalanced in the direction that swings the pointers of K_1 to the down direction. Meter relay K_1 energizes K_5 , which pulses motor No. 1 in a direction that lowers metal tension.

A time delay, TD_1 , then energizes K_6 , which locks in and deenergizes K_5 . Relay K_6 grounds the tap of R_5 and relay K_6 ungrounds the tap of R_4 .

Relay K_6 also starts the die table. The setting of

R_6 determines whether the metal is formed at the yield point or a point that is slightly below or above the yield point.

MANUAL RETURN—At the end of the run, the control is still on automatic, holding tension even though the die table has been stopped. The operator then turns switch S_1 to manual and throws switch S_2 to DECREASE, thereby energizing K_{12} . Relay K_{12} drives valve motor No. 1 to zero tension. Since lowering the tension signal upsets the balance at V_2 , meter relay K_1 tries to restore balance by cranking down servo motor No. 2. When metal tension is zero and potentiometer R_4 is at the zero tension setting, the control is ready to begin the entire cycle with a new piece of metal.

Although operation is normally automatic, means are provided for adjusting the tension manually. To adjust the metal tension to a level below the yield point, the operator throws S_1 and S_2 to manual and holds S_2 until the desired tension is attained.

STRAIN INDICATION AND PROTECTION — Meter relay K_{10} indicates the pounds of tension applied to metal and shuts off the control if the metal breaks. The protective action is triggered when the tension falls to zero. A contact on the indicating pointer then locks with a contact on an adjustable pointer which is set at zero. The protective circuit cannot function at the start of operation as relay K_7 must be energized to allow K_{10} to energize the stop-operation relay, K_{11} .

The cooperation of the engineers of the Cyril Bath Company is acknowledged.

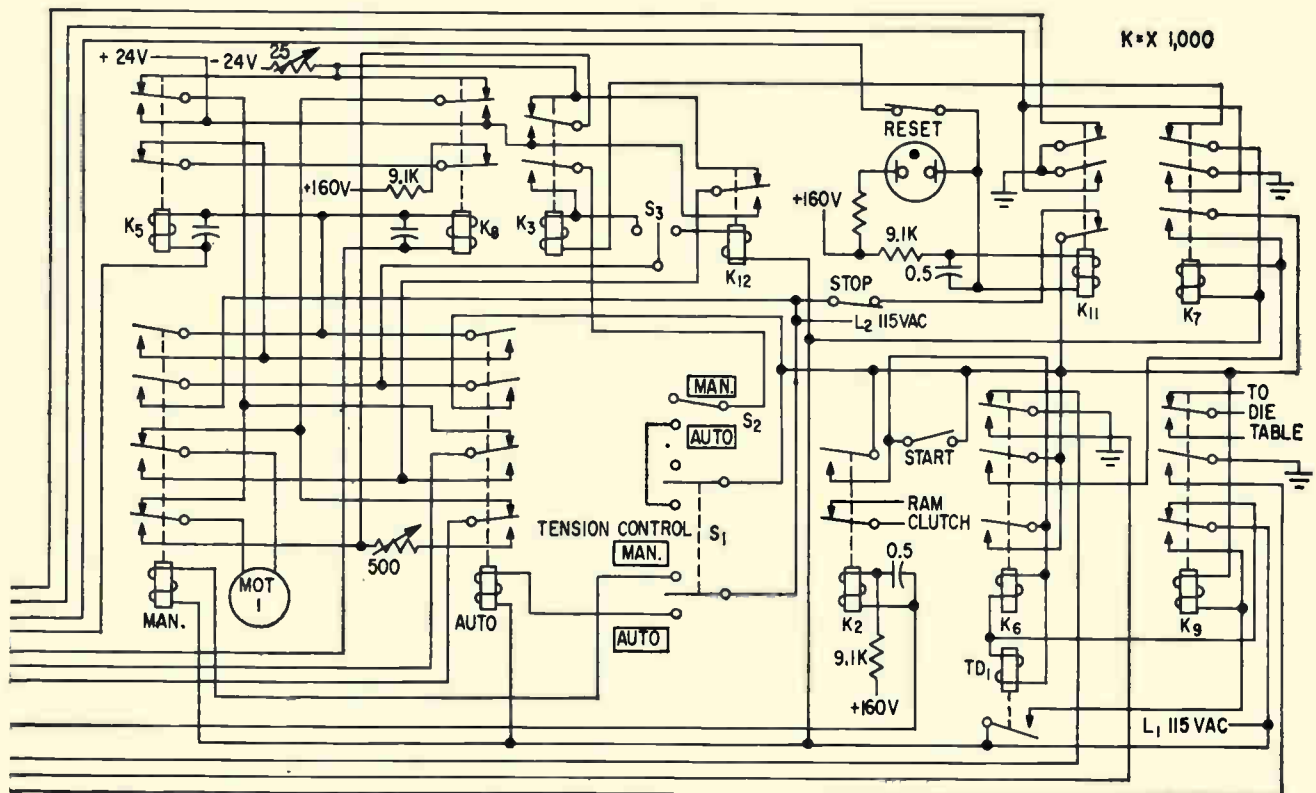

relays that are energized by power line L_2

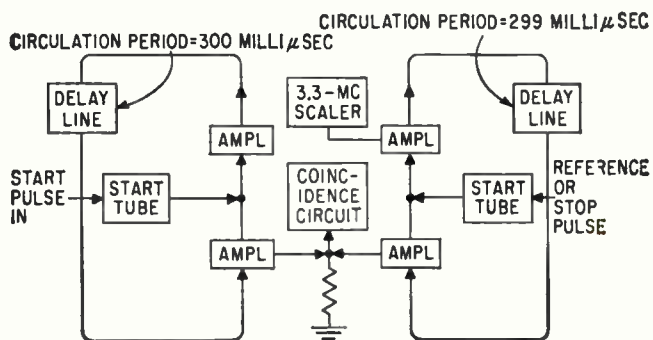

FIG. 1—Block diagram of the vernier chronotron

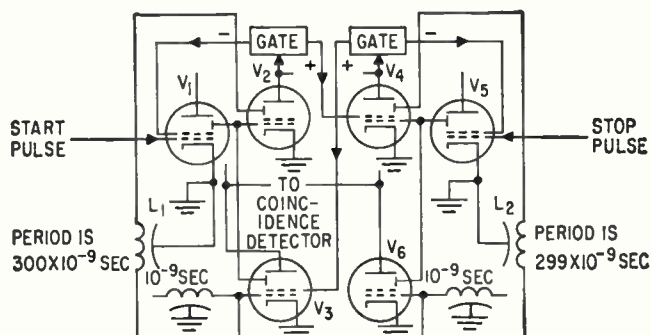

FIG. 2—Simplified schematic of the chronotron

In nuclear studies, knowledge of the energy levels of atomic particles such as neutrons is derived from velocity measurements. Such techniques require time measurements in the millimicrosecond region. A high-resolution time interval analyzer, such as described in this article, is invaluable

By H. W. LEFEVRE and J. T. RUSSELL, Hanford Laboratories Operation, General Electric Co., Richland, Wash.

Vernier Chronotron Times

TIME-OF-FLIGHT techniques have been used for many years to determine the velocity, hence the energy of neutrons. The fairly recent development of multiplier phototubes and organic scintillators which are capable of millimicrosecond timing accuracy now allows measurement of the velocity of much faster neutrons. Fast neutron studies are being made at many laboratories using millimicrosecond timing techniques. These studies are yielding valuable information on the interaction of

fast neutrons with atomic nuclei.

In any time-of-flight spectrometer, the resolution of velocity groups may be improved by using a longer flight path. The flight path may not be increased without limit, however, since with long flight paths counting rates become low, and background from stray particles and gamma rays becomes serious. The minimum flight path which may be used for a given energy or velocity resolution is determined by the time resolution of the clock and of the detectors.

The figure of merit of a time-of-flight spectrometer is thus closely related to the time resolution which may be achieved.

This article describes a high-resolution time interval analyzer for multichannel measurements in the millimicrosecond region. The resolution over a range of some hundreds of millimicroseconds is equivalent to that of fast coincidence circuits (better than one millimicrosecond). This instrument is quite different from those which have been used previously. The analyzer is best described as a vernier chronotron.^{1, 2, 3}

ABOUT NEUTRON STUDIES . . .

Intensive work in the field of nuclear research has increased requirements for precision electronic instrumentation. Of prime importance in this area is the spectroscope or spectrometer which separates particles according to their kinetic energies, masses and other dynamic parameters.

Most particle investigations involve interpreting data, derived from counters, which is dependent either on pulse amplitude or frequency. Hence nuclear studies require accurate counting of the number of pulses occurring and sorting them into discrete time intervals called channels. Data presentation is therefore in the form of a histogram. Channel width is the maximum variation a quantity can have and still be sorted into the same channel

Time Interval Measurement

A chronotron is an instrument which was originally suggested in 1947¹ and subsequently improved.^{5, 6} This type of instrument requires two pulses to define a time interval. An interval is measured by establishing the position of coincidence of oppositely directed pulses in one

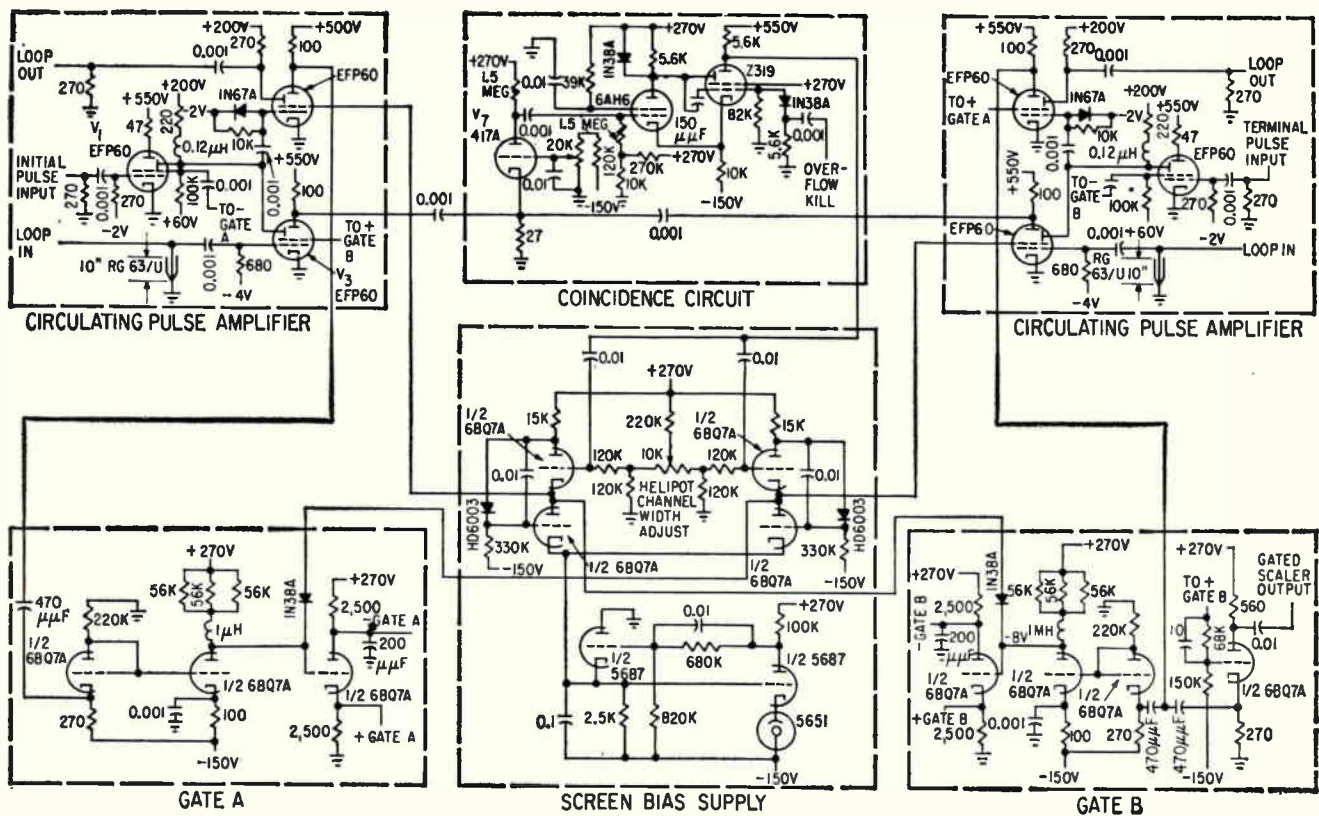

FIG. 3—Complete schematic diagram of the vernier chronotron. The circulating cable loops are not shown

Nuclear Particle Flight

or a pair of transmission lines.

Typically, a chronotron consists of two coaxial cables with several fast coincidence circuits spaced at intervals along the cables. When two pulses are fed into opposite ends of the two lines they travel toward each other at the same constant velocity. The coincidence circuit which indicates the largest superposition of the two pulses as they pass by each other gives the position of coincidence. The time interval between insertion of the pulses is then known in terms of distances of travel in the cables and the pulse propagation velocity of the cables.

The major disadvantages of this method are that a separate fast coincidence circuit is required for each channel, the number of channels is limited by pulse distortions caused by tapping the coincidence circuits into the cables, and to change channel widths, each coin-

cidence circuit must be physically moved along the cables.

Two basic modifications to the chronotron effectively remove these objections. The two pulses, separated by the interval to be measured are fed into the same (rather than opposite) ends of two transmission lines. By making the coincidence circuit spacing slightly smaller on the terminal (or later) pulse line than on the initial (or earlier) pulse line, the terminal pulse may be made to overtake the initial pulse. The second modification consists of making a loop with each line so that a single coincidence circuit may be used for every channel.

Method

Figure 1 shows how this is done. A pulse is fed into the loop through a start tube. It then circulates through the coaxial cable and two-stage noninverting saturating am-

plifier. With the circulation periods indicated in Fig. 1, a later pulse in the shorter line overtakes an earlier pulse in the longer line at the rate of one millimicrosec per transit. The pulses circulate until the coincidence circuit fires and stops them. Since the pulses approach coincidence at one millimicrosec per transit, a count of the number of transits before coincidence is numerically equal to the original time interval in millimicrosec. At the completion of a measurement, the number in the scaler indicates the channel in which one count is stored. This is precisely the form of channel address used in the magnetic storage system of commercial channel pulse height analyzers.⁷

Each time a pulse passes through the amplifier a time mark is delivered to the input of the coincidence circuit which adds the two signals if they overlap in time.

In measurements of interest in

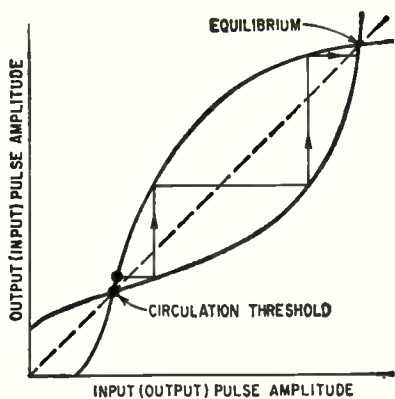

FIG. 4—Graphic method of predicting amplitude of successive circulating pulses

nuclear physics one or both of the timing signals arrive at a random rate from a scintillation detector. A system of fast gates is needed to prevent circulation in one line with no pulse in the other and to prevent subsequent pulses from starting before a previous measurement is completed. Figure 2 shows the method and sequence of gating.

In quiescent condition the amplifier output tube V_4 in the terminal pulse line is turned off by holding the screen grid at ground potential. A terminal pulse will not go through. The input tube V_3 in the initial pulse amplifier is also turned off. Gating sequence is as follows: an initial pulse comes in through start tube V_1 , gates on amplifier output tube V_4 in the terminal pulse line and proceeds through its coaxial cable L_1 . If no terminal pulse arrives, the initial pulse stops at normally off amplifier input tube V_3 . If a terminal pulse does arrive, it gates on V_3 and both pulses cir-

culate in their respective lines until coincidence. The gates also turn off start tubes V_1 and V_3 .

The gates are automatic in the sense that they both reset promptly unless they receive a repetitive signal following circulation. This method makes it impossible for a pulse to circulate in either line without a pulse in the other. The instrument accepts random pulses at each input but measures an interval only if the pulses satisfy the time and sequence requirements set by the gates. With the circulation periods shown in Fig. 2 the interval to be measured must be greater than 30 and less than 270 millimicrosec as 30 millimicrosec are required to open each gate.

Circuit

The complete circuit diagram of the vernier chronotron is shown in Fig. 3. The coincidence detector V_7 is a triode biased to pass only the coincidence-augmented part of the pulses above a preset level. The resulting current pulses are integrated to generate a staircase wave form. When the staircase reaches a selected voltage level, a discriminator is fired. The circulating pulse amplifiers are then disabled by the discriminator output before the pulses complete the next transit of the cables. Coincidence sensitivity of the circuit is 10 v/millimicrosec.

For time interval measurements the circulating pulses should be as short as possible since coincidence sensitivity is largely determined by pulse width. The coaxial cables used to carry the pulses should have

low loss to very high frequencies⁸. Type RG-63/U cable is used in the vernier chronotron. This cable has an impedance of 125 ohms and a propagation velocity of about ten in./millimicrosec.

Since the coaxial cables must be terminated in their characteristic impedance to prevent reflections, the input and output impedances of the circulating pulse amplifier are each about 62 ohms. High transconductance tubes are required to achieve unit gain. The amplifier gain must be greater than one in some amplitude region to allow a circulating pulse to grow to saturation. For a circulating pulse of several volts amplitude the required pulse currents are of the order of 100 ma.

The tube type chosen for the fast circulating pulse amplifier is the EFP60 secondary emission pentode. This tube has high transconductance; it is capable of high pulse currents and the dynode output is of the same polarity as the input signal. These tubes have a long electron transit time, however, so prompt regeneration cannot be used for pulse shaping. All regenerative effects are distributed over many circulations.

Behavior

For a loop system, stable circulation results for input pulses whose amplitude is above a certain threshold. In the absence of gating effects this threshold is determined by the amplifier transfer characteristic. Since the amplifier output signal is the amplifier input signal

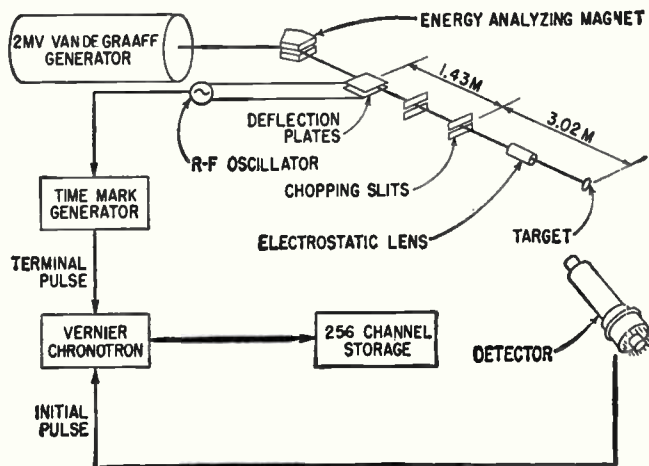

FIG. 5—Complete system for time-of-flight neutron studies used at Hanford

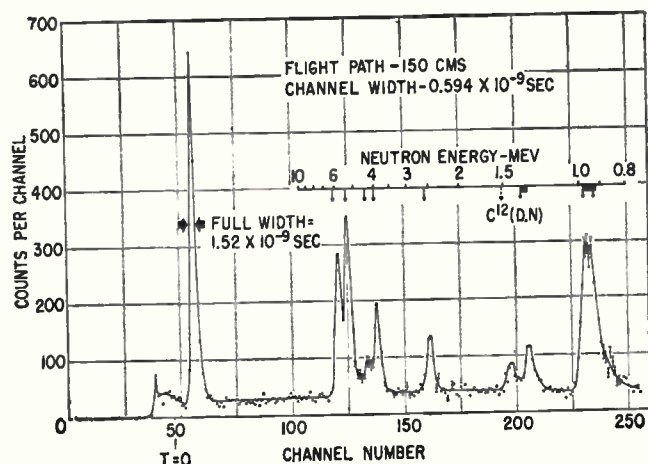

FIG. 6—Time-of-flight spectrum from reaction of beryllium-9 with 1.85 mev

(neglecting cable losses) the following graphical method may be used to predict the dynamic behavior of a circulating pulse.

If an image of the input-output transfer curve is reflected about a line at 45 deg representing unity gain, the original and reflected curves intersect at points where the amplifier gain is one. An input pulse whose amplitude falls in the region where the two curves overlap experiences a gain of more than one. The circulating pulse grows with successive circulations. If the input pulse amplitude falls below the first crossing of the curves, the gain is less than one and the pulse dies.

Figure 4 shows the input-output characteristic of a typical amplifier and an image of the curve reflected about a 45-deg line. Growth or decay of a pulse with successive trips through the amplifier is predicted by a staircase such as the one shown.

Channel Width Stability

Channel width in the vernier chronotron is equal to the difference in circulation period of the two lines. Anything which changes the period causes a change in channel width. Since in this analyzer the width of every channel is determined by the same variable, channel width stability is especially important. A small change in width of all the channels can cause a large shift in the position of the channels with respect to the spectrum of interest.

To monitor channel width an interval of fixed length is repetitively generated and the position of coincidence is observed. By using a narrow channel width with a long interval, and determining the position of coincidence to one tenth of a channel width, the average channel width can be monitored with a sensitivity of 10^{-1} millimicrosec. At this sensitivity a channel-width jitter of 3×10^{-4} millimicrosec is observed which is a function of the transconductance of the amplifier tubes.

Long-term drifts in channel width can be caused by changes in propagation velocity in the cables and changes of signal transit time in the amplifier tubes. The RG-63/

U cables are both located in the same environment so changes in period caused by changes in propagation velocity cancel out to first order and leave the period difference the same. Also, measured temperature coefficient of propagation velocity is only about +60 parts/million/deg C. Drifts in channel width from cable changes are thus quite small.

The effective signal transit time in the amplifier is determined primarily by electron transit time within the EFP60 pentodes and to a lesser extent by the transconductance of the tubes. The electron transit time is determined by the applied voltages and the spacing of the elements within the tubes.

To hold this transit time constant to 0.001 millimicrosec, the voltage should be stable to about one part in 1,800. However, as both loops derive their voltages from the same power supply, drifts in channel width from voltage drift cancel out automatically to first order, and by proper adjustment of voltage, drifts may be cancelled out to second order.

Figure 5 shows the Hanford time-of-flight system for fast neutron studies. A two-megavolt Van de Graaff generator is used to accelerate protons or deuterons. After magnetic analysis for energy control the beam is chopped at 3.3 mc by an r-f sweep and a slit system. The bursts of charged particles thus produced may be made as narrow as 1.1 millimicrosec full width at half maximum. The charged particle burst reacts with the target material to produce a burst of neutrons and gamma rays. These rays are separated by their time of flight to the detector. The inverse velocity of a neutron with an energy of one million electron volts is 72.3 millimicrosecs/m.

Figure 6 shows a time-of-flight spectrum from the reaction of deuterons with beryllium-9. Since the entire time spectrum may be shifted by delaying either signal, the zero time is arbitrary. For the spectrum of Fig. 6 the deuteron burst is shown reaching the target at channel 47. The large peak at channel 56 is produced by the arrival of the gamma ray burst at the detector. The highest energy neutrons move much more slowly



Adjusting channel width. Chronotron is device with two meters on front panel

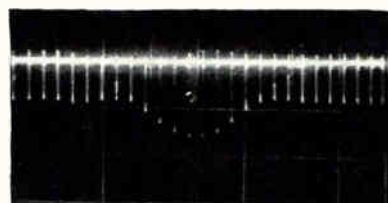

Oscillogram of input to coincidence circuit shows pulses at 170th trip around loops. Each marker is really double one from each loop. Superposition locus is typical as markers approach each other

than the gamma rays and do not arrive at the detector until channel 121—about 39 millimicrosec after the gamma rays. The remaining peaks are from neutron groups with lower energy which require longer flight times to reach the detector. The neutron group at channel 198 is from the reaction of deuterons with a carbon contaminant on the target. The arrows on the neutron energy scale are predicted positions of neutron groups based on energy level data.⁹

The authors wish to thank J. E. Faulkner for his support and encouragement throughout the course of this work, and J. DePangher, who originally suggested that this development would be worthwhile.

REFERENCES

- (1) H. W. Lefevre and J. T. Russell, *Bull Am Phys Soc II*, 2, p 175, 1957.
- (2) Hanford Reports HW-47012 and HW-49669.
- (3) R. G. Baron, *Proc IRE*, 45, p 21, 1957.
- (4) Neddermeyer, Althaus, Allison and Schatz, *Rev Sci Instr*, 18, p 488, 1947.
- (5) J. W. Keuffel, *Rev Sci Instr*, 20, p 197, 1949.
- (6) G. K. O'Neill, *Rev Sci Instr*, 26, p 285, 1955.
- (7) R. W. Schumann and J. P. McMahon, *Rev Sci Instr*, 27, p 675, 1956.
- (8) Q. A. Kerns, *Trans IRE on Nuclear Sci. NS-3*, No. 3, p 114, 1956.
- (9) F. Ajzenberg and T. Lauritsen, *Rev Mod Phys*, 27, p 102, 1955, and J. DePangher, Hanford Report HW-47284.

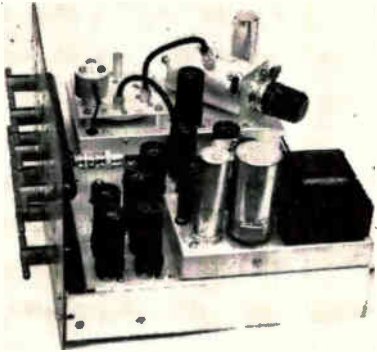

Complete transmitter and receiver assembly. Lighthouse oscillator tube is mounted horizontally at top-right

FRONT COVER. Radar speed meter mounted on tripod at roadside measures speed of passing car. Inside police car direct reading indication of speed in mph appears on meter while permanent record is made on strip-chart recorder



Enforce Traffic Laws

The received wave is combined with the oscillator frequency in the mixer and the difference frequency is fed into a broadband amplifier consisting of tubes V_2 , V_3 and V_4 . Tube V_{4B} serves as a frequency measuring circuit and operates between full conduction and full cut-off.

Output of V_{4B} charges capacitor C_1 which, in turn, discharges through diode V_5 and resistor R_1 . The voltage across R_1 is proportional to the frequency of the signal applied to V_{4B} .

Indicator Circuits

Tube V_6 in the transmitter-receiver assembly and meter M_1 in the remote indicator make up a conventional vtvm circuit. If a graphic recorder is connected to the vtvm circuit, the coil of relay K , is energized and the recorder is inserted in series with meter M_1 . The recorder used with the radar speed meter described has a 0- to 6-ma d-c movement and a 0- to 5-ma range calibrated to represent 0 to 100 mph.

This method of measuring differ-

ence frequency and converting it into a direct reading favors targets traveling at high velocities. Thus, if two cars are approaching on a single lane, the instrument will measure the speed of the first car. When two cars approach in separate lanes with one passing the other, the radar speed meter will record the speed of the faster, or passing, car.

Expander Circuit

To insure stable operation of the speed meter and to give a clean indication of a vehicle's speed, it was necessary to build in circuits of a precautionary nature. These provisions make certain that only signals of adequate strength are measured.

Tubes V_7 and V_8 comprise a two-level expander circuit. When V_7 conducts, it effectively puts resistor R_2 in parallel with the plate load of V_{3B} . When V_7 is not conducting, the clamping action is released permitting the amplifier to develop full gain.

Tube V_8 is used as a d-c amplifier. In the no-signal condition, V_{3B} is

nonconducting, therefore, its anode is highly positive. Since the coupling from V_{3B} to V_{4A} is direct, the high anode voltage is transferred to V_{4A} causing it to conduct and thereby lowering the plate potential of V_{4A} . This action supplies the necessary conditions to cause diode V_7 to conduct switching resistor R_2 into the circuit.

When a signal of sufficient magnitude to provide reliable indications is received, a positive shift of the average voltage on the plate of V_{4A} occurs.

The alternating-current component is filtered out by C_2 and the d-c is applied to the grid of V_{3B} . This situation causes V_{3B} to conduct and V_{4A} to become nonconducting. Diode V_7 then stops conducting and R_2 is switched out of the amplifier circuit.

Resistor R_3 is used to set the threshold for this switching action. Resistor R_4 is used to correct for unbalance in vtvm tube V_6 . The amplifier is protected against signals of excessive strength by the limiting action built into the circuit.

Solid-State Thyratrons

By T. P. SYLVAN, Application Engineer, Semiconductor Products Dept., General Electric Co., Syracuse, N. Y.

Tabulation of solid-state thyratrons, commercially available at time of writing, with a discussion of important features and what to look for in future

COMMERCIALY AVAILABLE three-terminal solid-state thyratrons include the Silicon Controlled Rectifier, Thyristor, Trinistor and Unijunction Transistor. These devices, as well as the switching diodes described in the previous issue (Feb. 27, 1959), have a wide variety of applications.

Lower-power units can be used in bistable circuits, memory circuits, ring counters and signal switching or gating circuits. High-power units can be used in practically all applications presently employing gas thyratrons. Many new applications in the high-power range are possible because of improved characteristics of solid-state units such as lower conducting voltage drop, faster switching speed, faster recovery time, higher peak-current capability and absence of filaments.

CHARACTERISTICS — All of the commercially available three-terminal devices are listed in Table I together with pertinent characteristics. Figure 1

shows the schematic symbol (A), equivalent circuit (B) and characteristic curve when base current is greater than firing current (C). In Fig. 1C, forward voltage and current, V_F and I_F , correspond to the quadrant in which switching occurs. Reverse voltage and current, V_R and I_R , correspond to the opposite quadrant.

As with a switching diode, the three-terminal device can be turned on by exceeding the breakover voltage V_{BO} and will remain on as long as a forward current flows greater than the holding current I_R . Unlike the diode, however, the three-terminal unit can be turned on also by forward biasing the base. As base current is increased, effective breakover voltage decreases. Firing base current is that current which will reduce the effective V_{BO} below some specified value—usually one to two volts.

Some types of *pnpn* units can be turned off by a reverse base current. But this can be done only for a limited range of forward current.

TABLE I—Trade Names, Symbols, Characteristics of Commercially Available

| Trade Name | Manufacturer | Type Number (Material) | Structure, Manufacturer's Symbol | AIEE Symbol | IRE Symbol | Range of V_{BO} I_{BO} |
|------------------------------|------------------|-------------------------------|----------------------------------|-------------|------------|----------------------------|
| Silicon Controlled Rectifier | General Electric | C35 ZJ39A ZJ39L (Si) | | | | 25-400 v 1-10 ma |
| Thyristor | RCA | (Ge) | | | | 100 v 2 ma |
| Trinistor | Westinghouse | (Si) | | | | 25-400 v 1-10 ma |
| Unijunction Transistor | General Electric | 2N489 to 2N494 (Si) | | | | 2-60 v 4 μ a |

Available Today

SPEED—Switching speed can be specified generally using delay time, rise time and fall time. In most circuits, the devices are turned off by applying a reverse bias between emitter terminals. Recovery time can then be defined as the minimum time for which the device must be reverse-biased before it can sustain a forward voltage. Recovery time corresponds roughly to deionization time of a gas thyatron.

Turn-on or rise time of some units can be extremely short—approaching one millimicrosec. Even in high-current units, turn-on time can be as low as 0.1 μsec for a 20-amp device.

Switching point is governed by variation of the alphas of the two transistors (one *npn* and one *pnp*) shown in the equivalent circuit of Fig. 1B. Silicon *pnpn* devices have alphas which increase with emitter current and will generally exhibit a switching characteristic. A germanium *pnpn* device will not exhibit a switching characteristic unless one of the bases is reverse biased. A germanium unit must be designed so that one or both of the alphas are low at low values of emitter current. With the Thyristor, this is done by using a metallic or M-type junction for one of the emitters. Another method of limiting and controlling the alphas includes use of a wide base region. Increased current flow across the base produces an IR drop which reduces the transport time and increases the alpha. Also, the alphas can be reduced by increasing the density of recombination centers in the base region by such means as electron bombardment.

FUTURE APPLICATIONS — New and improved solid-state switching diodes and thyratrons will be

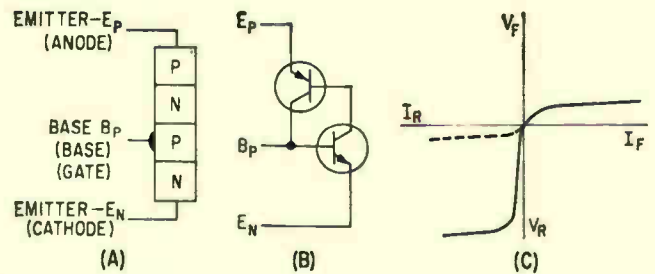

FIG 1—Schematic symbol (A), equivalent circuit (B) and characteristic curve when base current is greater than firing current (C)

developed to meet new application requirements. Possible future developments may include: symmetrical devices for use as a-c switches; voltage ratings exceeding 1,000 volts; current ratings exceeding 100 amp; operating temperature ranges approaching 200 C; improved stability of V_{bo} with temperature; devices with a short recovery time and devices having a high effective current gain with base turn-off.

REFERENCES

1. J. L. Moll, M. Tanenbaum, J. M. Goldy, N. Holonyak, "P-N-P-N Transistor Switches", *Proc. IRE*, 44, p 1174, Sept. 1956.
2. W. Shockley, "The Four-Layer Diode", *Elect Ind*, p 58, Aug. 1957.
3. C. W. Mueller, J. Hillbrand, "The Thyristor—A New High-Speed Switching Transistor", *IRE Trans on Electron Devices*, p 2, Jan. 1958.
4. J. Phillips, H. C. Chang, "Germanium Power Switching Devices", *IRE Trans on Electron Devices*, p 13, Jan. 1958.
5. S. R. Brown, T. P. Sylvan, "The Silicon Unijunction Transistor", *Elect Des*, Jan. 8, 1958 and Jan. 22, 1958.
6. R. P. Frenzel, F. W. Gutzwiller, "Solid-State Thyatron Switches Kilowatts", *ELECTRONICS*, p 52, Mar. 28, 1958.
7. R. W. Aldrich, N. Holonyak, "Multiterminal P-N-P-N Switches", *Proc. IRE*, 46, p 1236, June 1958.

Solid-State Thyratrons

| Base (Gate) Firing Current | Forward Voltage Drop at Rated Current | Turn-On Time Recovery Time | Reverse Characteristic | Essential Characteristics | References |
|----------------------------|---------------------------------------|---|------------------------|--|-------------|
| 10 ma | 1.2 v 16 amp | 1 μsec 10 μsec (10 amp) | Blocks | High-current, high-voltage operation | (1) (6) (7) |
| 0.05 | | 0.1 μsec 0.5 μsec (25 ma) | Conducts | Very low turn-on time, low base current for firing | (1) (3) |
| 25-50 ma | 1.0 v 20 amp | 0.1 μsec | Blocks | High-current, high-voltage operation | (1) |
| 0.7-7 ma (Base-two) | 3.5 v 70 ma | 1 μsec 5 μsec (20 ma) | Blocks | Very low breakover current, stable breakover voltage and negative resistance | (5) |

Timed-Signal Generator

It is relatively easy to arrange the circuits of this portable, multiple output unit to deliver a variety of timed pulse signals that can be controlled both in amplitude and width, and turned on or off at will

By DONALD E. MINOW,

Head, Electronic Branch, USA Air Defense Board, Instrumentation & Data Reduction, Fort Bliss, Texas

THIS TIMING-SIGNAL generator, Fig. 1, delivers pulses of controllable duration, amplitude and carrier content at rates of one per second in the A channel, and either one per five seconds or one per ten seconds in the B channel. Any decimal frequency multiple of 1, 2 or 5 from 100 to 0.1 cycles per second

may be obtained by simple connection. The output signals from each channel may be mixed with an audio carrier for transmission over radio or telephone links.

The two output channels are independent of each other. The A-channel output is from 1 to 100 cps; while the B channel operates at a

slower rate, usually from 0.1 to 1 cps. This provides a coarse and fine time scale which aids in data reduction.

The cathodes of the Dekatron tubes can be reconnected to provide many different rates. For example, a rate of ten per second could be made available in the A channel

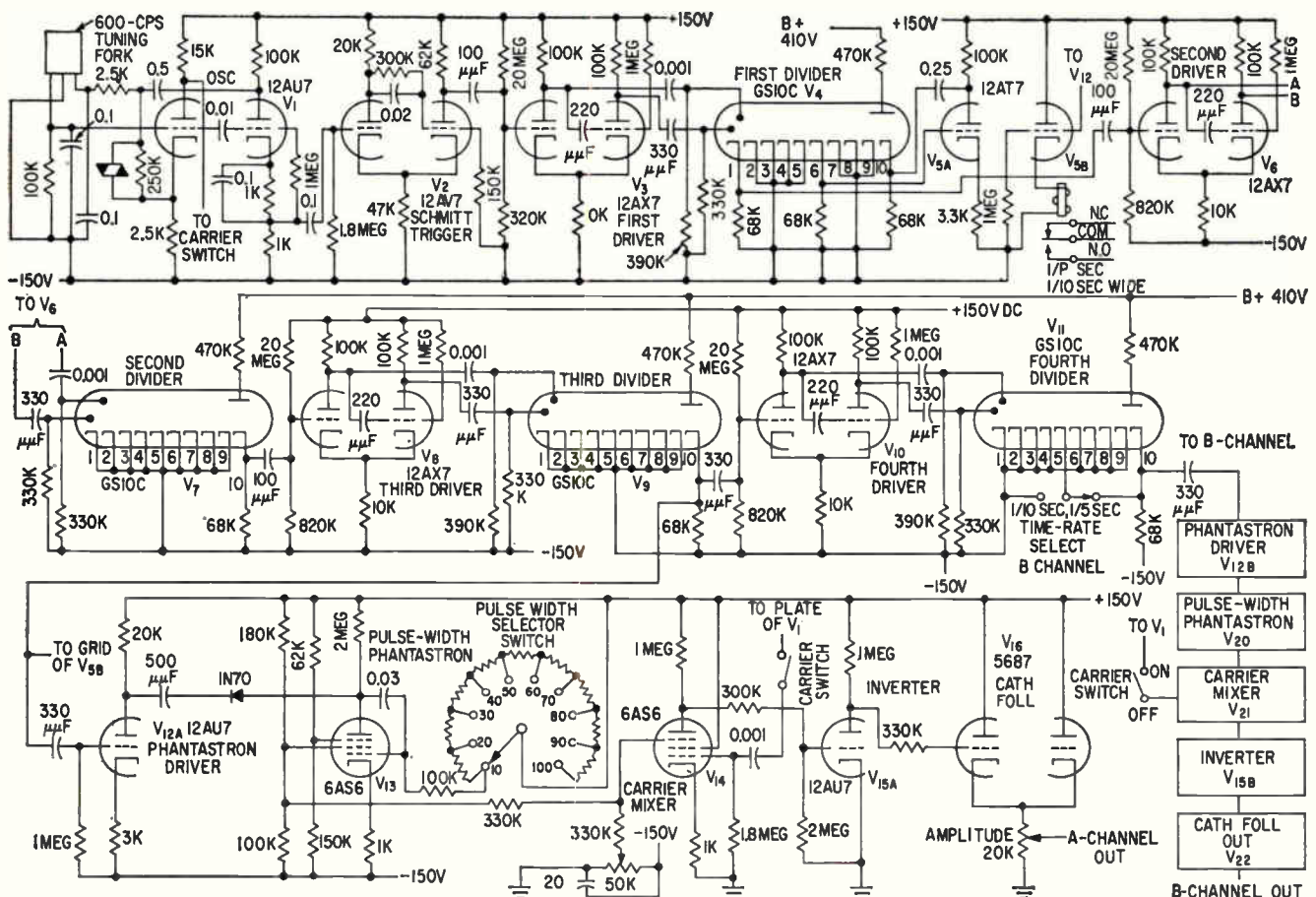

FIG. 1—Dual-channel timing-signal generator. Cold-cathode tube connections supply versatile outputs

With Flexible Output

by connecting the output of the tenth cathode of V_7 to V_{12A} .

In the same fashion, outputs at a two-per-second rate are obtained by connecting cathodes 5 and 10 in the third divider through a common cathode load resistor and applying this signal to the desired phantastron driver.

Also, five-per-second outputs are obtained by connecting the 1st, 3rd, 5th, 7th and 9th cathodes of the third divider together to ground through a common cathode resistor and supplying the resulting signal to the appropriate phantastron driver stage.

The cold cathode tubes, employed to scale down the relatively high rate of the 600 cycle oscillator, require minimum circuitry, low-power and supply versatile output connections. The decade-tube glow, appearing in the proper places, indicates that the generator is operating properly.

Circuit Details

The tuning fork oscillator, V_1 in Fig. 1, generates a 600-cps signal that drives a Schmitt trigger for the first driver stage. The shaped, amplified and delayed dual output is fed to the guide rods of divider V_2 , which is reset after the sixth input pulse. Consequently the first divider output is a 100-cps signal with a width of 1.67 millise.

Resetting is accomplished by inverting and amplifying the positive signal from the sixth cathode in V_2 , and applying it to the tenth cathode, driving it negative to transfer the glow, thus resetting the tube to the 10 position.

The first pulse received after this reset action causes the glow to advance to the one position, where the 100-cycle signal is obtained for the second driver, V_{10} .

In the fourth divider, a switch selects an output rate of either $\frac{1}{2}$ or $\frac{1}{10}$ of the input rate. In the $\frac{1}{2}$ -sec position, cathode 5 is connected to cathode 10, giving an output

pulse for every five input pulses.

Operation of the two output channels is identical. In the case of channel A, the selected rate is applied to V_{12A} , which supplies a negative-going trigger to the plate of V_{13} .

The desired output pulse width is selected in ten steps from 10 to 100 millise by varying the time constant of the phantastron grid, and a positive pulse is obtained from the phantastron screen.

This positive pulse is direct-coupled to the suppressor grid of V_{14} to preserve its shape. Adjustable bias is also applied to the suppressor to insure plate current cut-off in the absence of a pulse from V_{13} .

The output of the mixer may be a negative pulse, or, by placing the carrier switch in the on position, the 600-cps sine wave from the tuning-fork oscillator may be applied to the control grid of the mixer tube and the output of the mixer will be a burst of the pulse-width determining phantastron. The output of the mixer is direct-coupled to V_{10} , through an inverting amplifier to insure the transmission of the positive rectangular pulses.

Power Requirements

The power supply provides ± 150 -v d-c, voltage regulated in addition to the 410 v required for the Dekatrons.

The generator circuit is arranged between the two 150-v supplies so that the cathode of the output stage will be as near ground as possible in the absence of an output pulse, without sacrificing pulse amplitude from the inverter stage. The output pulse can be varied from zero to 100-v peak into a load consisting of 1,000 ohms.

The spdt relay is energized for 100 millise every second, to operate external equipment at this fixed rate when required. This relay signal rate is independent of



Timing signals for oscilloscopic photography in the field are provided by the generator

any other rate which may be selected.

Oscillographic type recorders, neon film timing lights, magnetic pen recorders and even T markers on strip chart recorders have accepted the time signals with no difficulty. No cross-coupling has been detected between the two output channels, and there has been no noticeable coupling of the various control functions.

The generator has operated for over a year without tube or circuit malfunction. It has operated from 60 to 400 cps primary power systems with no deleterious effects.

A greater variety of output rates may be obtained by 12-cathode tubes and additional resetting circuitry.

Higher rates may be obtained from the first and second dividers by connecting the cathodes as desired, if modification is made to phantastron pulse-width circuitry. If faster rates than 10 per sec are desired, it would be wise to incorporate an additional triode at the phantastron grid to speed up the recovery time of the phantastron circuit.

The initial request for this generator was received from Mr. Charles E. French, Head, Instrumentation Group of the Air Defense Board. The author wishes to thank Jose R. Dominguez for his valuable contribution in the design, fabrication and testing of this unit.

Programmed Servo Speeds

Computer printed-circuit boards are assembled by single-station inserter using programmed servos which position board in response to controller commands. Component selection and insertion are also directed by controller

By **S. B. Korin**, Corporate Manufacturing Engineer and **F. B. Spencer**, Staff Engineer, IBM Corp.

COMPUTER DESIGNS entail a large variety of board assemblies with a comparatively small production requirement for each assembly. Thus the benefits of in-line assembly machines have not always proved practical for the computer maker. In addition, engineering changes and circuit design improvements in the computer industry constantly add to the complexity and variety of the boards required for a particular system.

Existing assembly machines use in-line techniques in which a printed board is transported by conveyor past a series of insertion stations. The boards are fed into one end and as each board pauses at a station, an insertion head set in a prescribed position over the board inserts a component into it. Each component requires its own insertion head and the more components needed for the board, the more

heads needed for the assembly machine. Under this process, any changes in the component arrangement or assembly of the board involve corresponding changes in the prescribed locations of the heads. Changes consume much setup time.

System

The programmed automatic machine to be described copes with this problem by assembling standardized components and boards at a single station. The machine accommodates a maximum board size of 10 in. by 10 in. Components are mounted flush to the board and oriented parallel to each other. Axial-lead components 0.4 in. to 1.1 in. long are used. Grid spacing of the circuit board is 0.05 in. with mounting holes located on intersections.

The control unit (Fig. 1) reads its instructions from either business-machine cards or punched tape

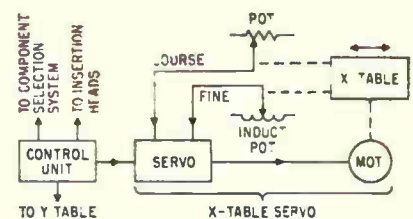
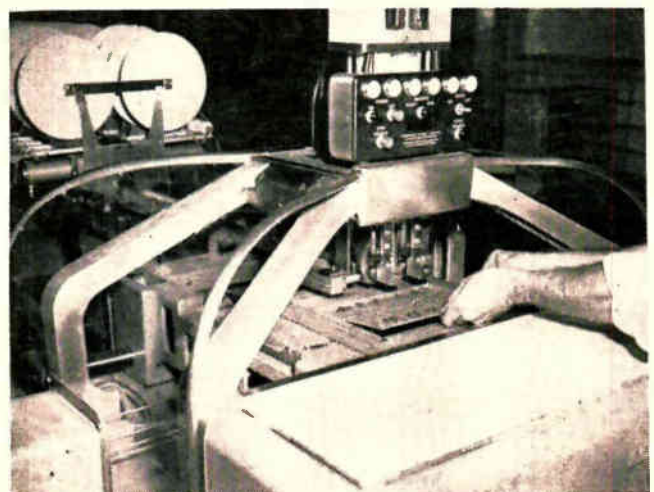
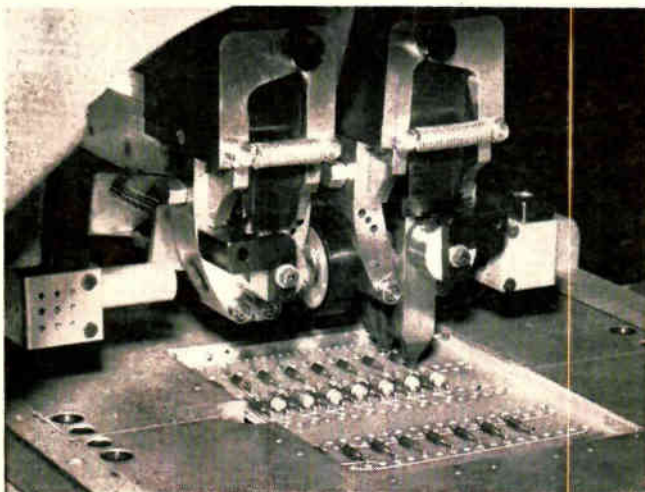

FIG. 1—Control unit selects component and insertion head and positions X and Y tables

and then selects one of 20 components and one of two insertion heads that are available. Each head inserts different sized components. After the component enters the head, the control unit commands the X and Y table servo positioning systems, which bring the desired coordinates of the printed-circuit board beneath the insertion head. The control unit then commands the insertion head to staple the component to the board.



Head inserts component into board and operator removes circuit board from pallet. Component arrives at head from raceway. Phototube checks component positioning in head

Short-Run Production

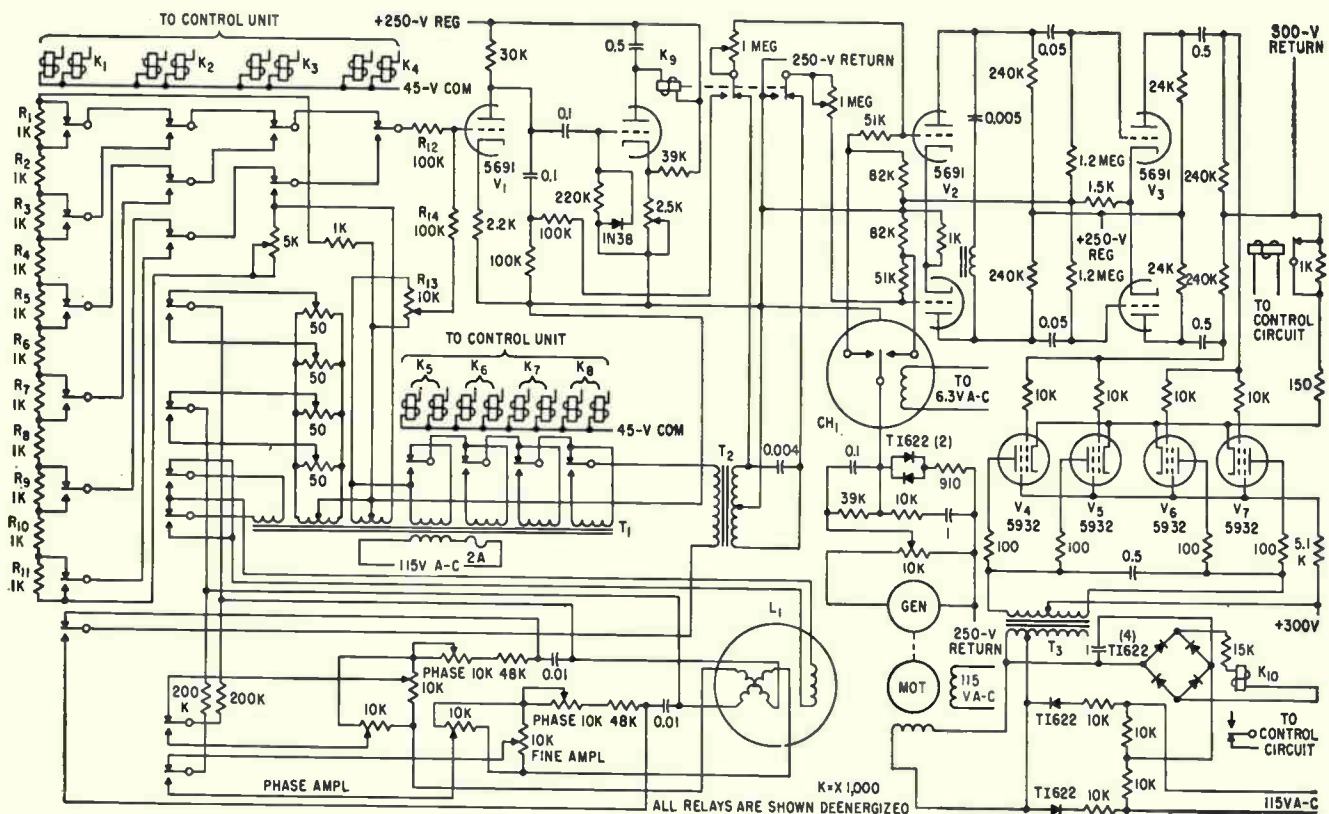

FIG. 2—Relays are directed by control unit to apply coarse and fine control voltages to servo positioner

If the card reader is used, then two columns are reserved for special coding. Since the control unit is capable of reading two punched cards, 156 columns are available for control instructions making possible the continuous assembly of 78 components.

Each component insertion requires a set of four separate instructions which are provided in binary-coded form and are punched into two columns of the card. The first instruction selects the desired component causing it to be delivered to the two-headed insertion system. The second instruction selects the insertion head that inserts the component. The third and fourth instructions position the printed-circuit board so that a selected pair of holes are aligned under the insertion mechanism.

When the four instructions have been fulfilled, the insertion-head mechanism automatically assembles the selected component into the

holes of the positioned board. The mechanism then notifies the card reader that it is ready for the succeeding operation. The cycle is repeated until all of the programmed instructions have been satisfied and the printed-circuit board is completely assembled. The system then shuts itself off.

Component Selection

The component selection system is composed of ten component cutoff units, an air delivery raceway, and a phototube sensing device. A cutoff unit consists of twin sections, each of which can carry its own reel of components and each of which can be independently selected to deliver one component at a time. Thus, the ten units provide 20 possible component selections. Every cutoff unit section contains an air cylinder which is energized by a control unit instruction.

Each reel can carry several thousand components, such as capaci-

tors, diodes, and $\frac{1}{2}$ - and 1-watt resistors. When a cutoff section is selected and its air cylinder energized, a pair of connected sprocket wheels index one position thereby pulling the taped components through a pair of cutting dies. The action of the air cylinder also causes the cutters to cut the component loose just inboard of the two strips of tape. The component free falls about an inch into the trough of an air delivery raceway.

The raceway is a 6-ft V-cut chute lying horizontally under the series of cutoff units and extending to the insertion heads. It is a pneumatic device which is designed to propel components to the selected insertion head by a series of air jets. These jets emanate from holes 0.020-in. square and spaced every tenth of an inch along the apex of the chute. These holes are cut in the chute at a 20-deg angle, permitting a series of air jets to escape from a manifold chamber in the base of

the chute.

The phototube sensing device, located at the insertion heads, has two functions: to detect the arrival of a component at the heads, and to assure its correct orientation. If the component arrives at the head in a skewed position, the phototube beam will not be broken and the insertion head will not operate.

Servo Positioning

The servo systems consist of a pallet for holding the circuit board, two tables for transporting the board in two directions and two servo amplifiers and motors which drive the tables.

The pallet is mounted on a small X table which, in turn, is mounted on a large Y table. Each table is independently driven by identical servo positioners. The tables move horizontally along separate guide shafts and ball-bearing systems. The central reference position of both tables is directly under the selected insertion head. Thus, the resultant motion of the tables positions any coordinates of the printed circuit board beneath the head.

Servo Positioner Operation

Figure 2 is the schematic of one of the servo positioners. Instructions punched into the business-machine card are read by the con-

trol reader and sent to the positioner relay tree, K_1 through K_n . The appropriate combination of relays determines the reference voltages obtained from voltage divider R_1 through R_{11} and transformer T_1 . These voltages, which represent the desired table position, are compared with voltages representing the actual table position. The difference, or error, is amplified, and drives the servo motor until the error is reduced to zero. In this condition, the table is in the correct position.

Relays K_1 through K_1 control the coarse reference voltage picked off the voltage divider. This voltage is fed to amplifier V_1 , through resistor R_{12} . At the same time, the voltage from potentiometer R_{13} , representing the actual table position, is fed to V_1 through R_{14} . The error signal is amplified and rectified. As long as this voltage is large enough to keep relay K_5 energized, the amplified coarse error signal is applied to the input of amplifier V_2 . When the error decreases below some minimum value, which corresponds to a table position that is near the correct position, K_5 is deenergized and the coarse error is replaced by a fine error signal.

Relays K_5 through K_n determine the fine reference voltage by selecting the secondary windings of transformer T_1 that drive one side

of the primary of transformer T_2 . At the same time, a voltage that corresponds to the actual table position is derived from L_1 , a Reeves induction potentiometer, and applied to the opposite side of the primary of transformer T_2 . The phasing of this voltage is determined by relays K_1 and K_2 . The error voltage at the output of T_2 is applied to the push-pull amplifier V_2 , driving the servo towards its final position.

Proper damping is achieved by applying a signal from a d-c tachometer generator to the grids of V_2 . Chopper CH_1 modulates this signal.

The error signal at transformer T_3 is also applied to a phase-sensitive demodulator circuit. The demodulator feeds a full-wave rectifier which operates relay K_{10} . When the error drops to zero, K_{10} is deenergized and its contacts indicate the arrival of the table at the correct position.

Component Insertion

The twin insertion heads are vertically mounted on a sliding shuttle, which, in turn, is supported by a spider-like aluminum casting. The shuttle, operated by an air cylinder and free to travel horizontally, precisely locates the selected head over the inserting position. One insertion head is designed for components of the size and proportions of $\frac{1}{2}$ -watt resistors; the other is designed for components of 1-watt resistor proportions. Each insertion head consists of two in-line air cylinders, one of which forms the axial leads into a U-shape, the other of which gently pushes these leads into the holes of the printed-circuit board.

The stapling device operates in conjunction with the twin head assembly which is actuated after the board positioning tables reach their correct positions. A limit switch detects the movement of the insertion head and causes the stapling device to rise and clamp the U-shaped axial leads against the bottom of the board.

Thanks are due designers from Reeves Instrument Corp. as well as C. O. Sage, F. Besha, M. English and J. Prop, all of IBM.

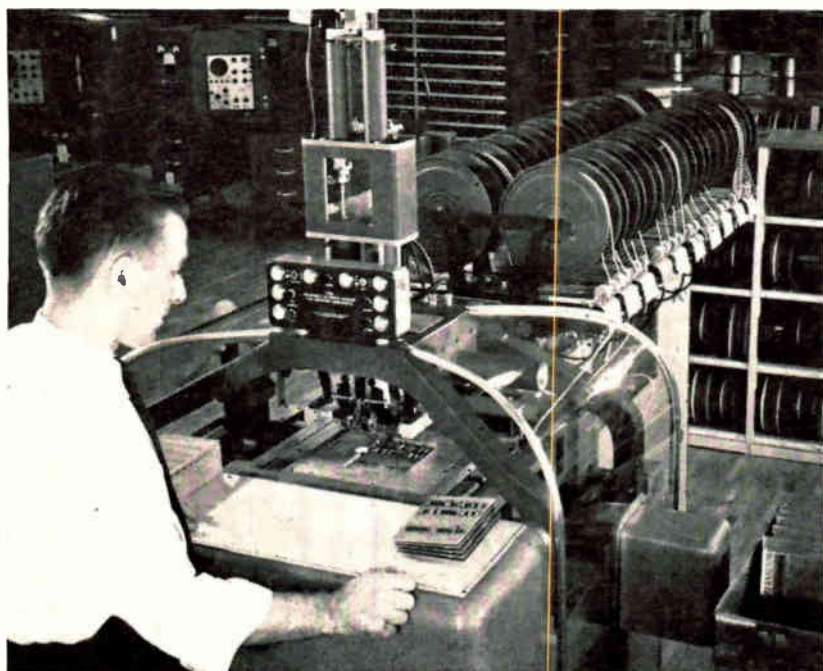

Control unit on the right selects components mounted on the reels in the background

UHF Transistor Data

As manufacturing techniques become more and more refined, frequency range of commercially available transistors goes up and up. At this stage of the art, the upper limit has not yet been reached

By HENRY TULCHIN, President, Derivation and Tabulation Associates, Inc., West Orange, N. J.

TEN YEARS after the discovery of the transistor, commercial units are becoming available which are capable of operating in the uhf region of 300 to 3,000 mc.

This tabulation of eight different transistors, Table 1, lists all commercial transistors at the time of this writing with a typical f_{os} greater than 300 mc. Two types have an f_{os} of 750 mc. At the present time,

only *pn*p germanium types produced by some diffusion technique operate in this range. All units in Table 1 are diffused germanium transistors. The first one listed is a microalloy diffused unit. Maximum BV_{cb} for all eight units ranges from 20 to 35 volts.

The tabulation presented here was extracted from a complete tabulation of more than 1,000 types published by Derivation and Tabulation Associates, Inc.

TABLE 1—Commercially Available Transistors Operating Above 300 Mc

| Type and Mfr. | f_{os} in mc | Max Coll. Diss. in free air in mw | Absolute Max Ratings at 25 C | | | | | Typical Parameters at 25 C | | | | | Max Temp |
|---|------------------|-----------------------------------|------------------------------|-------------|----------------|--------------------------------|--|----------------------------|------------------|-----------------------|----------------------|--------------------------------------|-----------------|
| | | | BV_{cb} in v | I_o in ma | BV_{cb} in v | Derate in Free Air in deg C/mw | Max I_{cbo} at max V_{cb} in μ a | Bias V_{cb} in v | Bias I_e in ma | h_{fe} β^{ab} | C_{ob} in μ mf | $r'_{bb} \times C_{ob}$ in μ sec | |
| 2N499 ^{j, k} Philco | 320 ^e | 30 | 30 | 50 | 0.50 | 0.80 | 15 | 10 | 3 | 8.5 | 1.3 | 40 | 85 |
| 2N1143 ^a Texas Instruments | 480 | 750 ^d | 25 | 100 | 0.50 | 0.10 | | 10 | 10 ^l | 32 | 1.5 | 113 | 100 |
| GA53233 ^{c, h} Western Electric | 500 | 200 | 20 | 10 | | | | 20 | 10 | 3 | | 5.0 | 90 ^m |
| 2N700 ⁱ Motorola | 600 ^e | 50 | 30 | | 0.50 | 1 | 10 | 6.0 ^e | 2.0 ^l | 10 | 0.80 | 40 | 100 |
| 2N1142 ^a Texas Instruments | 600 | 750 ^d | 30 | 100 | 0.70 | 0.10 | | 10 | 10 ^l | 32 | 1.5 | 113 | 100 |
| GA53194 ^c Western Electric | 600 | 100 | 30 | 30 | | 1.0 | 5 | 9.0 | 10 | 19 | 2.5 | 125 | 100 |
| 2N509 ^b Western Electric | 750 | 200 | 30 | 40 | 2 | 0.50 | 5 | 10 | 10 | 49 | 2.5 | 135 | 100 |
| 2N1141 ^a Texas Instruments | 750 | 750 ^d | 35 | 100 | 1 | 0.10 | | 10 | 10 ^l | 32 | 1.5 | 105 | 100 |

a. Tentative data b. Military use only c. Tentative data and military use only d. Infinite sink e. V_{ce} f. I_c g. Max frequency of oscillation in mc = $(\alpha f_{ab} / 8\pi r'_{bb} C_c)^{1/2}$ h. t_r in μ sec at 25 C = 0.03 j. Max noise factor in db at 25 C = 10 k. Gain in db at 25 C = 10 l. Gain in db at 25 C = 12 m. Storage temperature rather than junction temperature as in other units

Magnetic Head Reads

Magnetic modulator playback head, developed to collect original data recorded at high tape speeds, permits information playback at speeds including zero ips—with no deterioration in signal-to-noise ratio

By **MARVIN E. ANDERSON**, Armour Research Foundation, Illinois Institute of Technology, Chicago

HIGH-FREQUENCY signals, recorded on magnetic tape, can be played back at extremely slow speeds so that the highest frequency component is within the limited bandwidth of a pen recorder. A playback system that can do this, with no deterioration in signal-to-noise ratio, is an extremely

handy tool for signal analysis and data reduction problems. The most recent application is a drum-recorder modulator playback system, developed for automatically recording h-f transient-type data. The drum is driven by a 400-cps, three-phase motor at 4,000 or 8,000 rpm. Total recording time is re-

spectively about 15 millisecc or 7.5 millisecc. Frequencies ranging from about 25 kc to 1.5 mc can be recorded at 4,000 rpm and about 50 kc to 4 mc can be recorded at 8,000 rpm.

The record and playback heads are supported on air bearings thereby obtaining head to drum spacings as small as 80 millionths of an inch. The record head contains ten channels. The gaps are in line; pole pieces are made of a ferrite material. After a recording has been made, the data is read out at a reduced rate and plotted on graph paper by a pen recorder, thereby obtaining graphic data suitable for analysis.

The recorded data is read out at one 40,000th of the record speed. Since playback voltage is a function of the rate of change of flux, $d\phi/dt$, the output from ordinary velocity-type heads is low and cannot be extracted successfully from tube and resistor noise originating in the preamplifier. Therefore a ten-channel, flux sensitive, magnetic modulator playback system is employed.

Playback Head

The magnetic modulator playback head, developed for time-scale expansion of magnetic records in data processing, senses the recorded flux rather than the rate-of-change of flux. The output voltage is, therefore, independent of the tape speed. Figure 1 illustrates two modular head designs and shows the major flux paths.

Recorded tape passes over the playback gap in the same manner in which it passes over the record head gap.

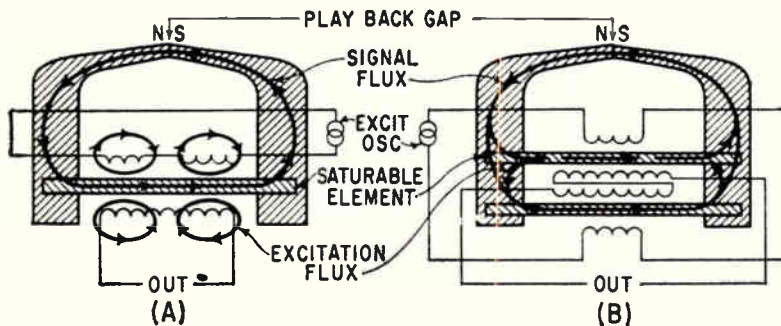

FIG. 1—Two modular head designs developed for time-scale expansion of magnetic records. Signal flux passes through the two saturable strips at the bottom of the head

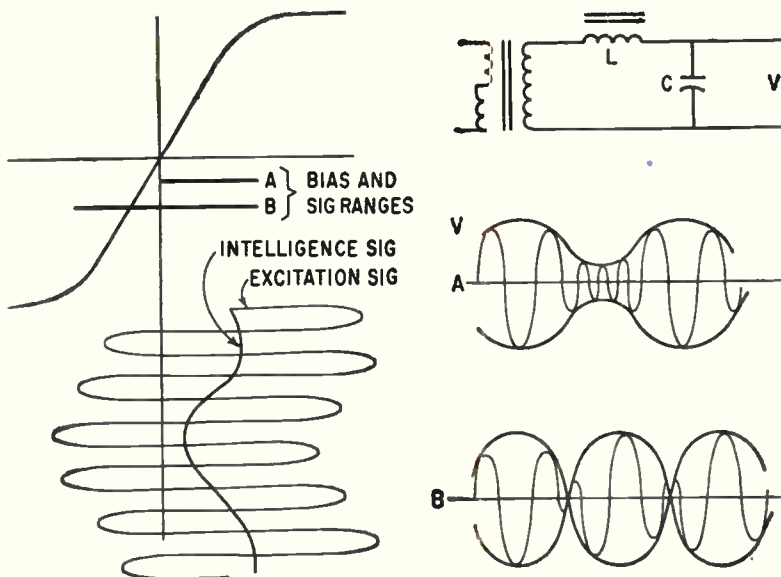
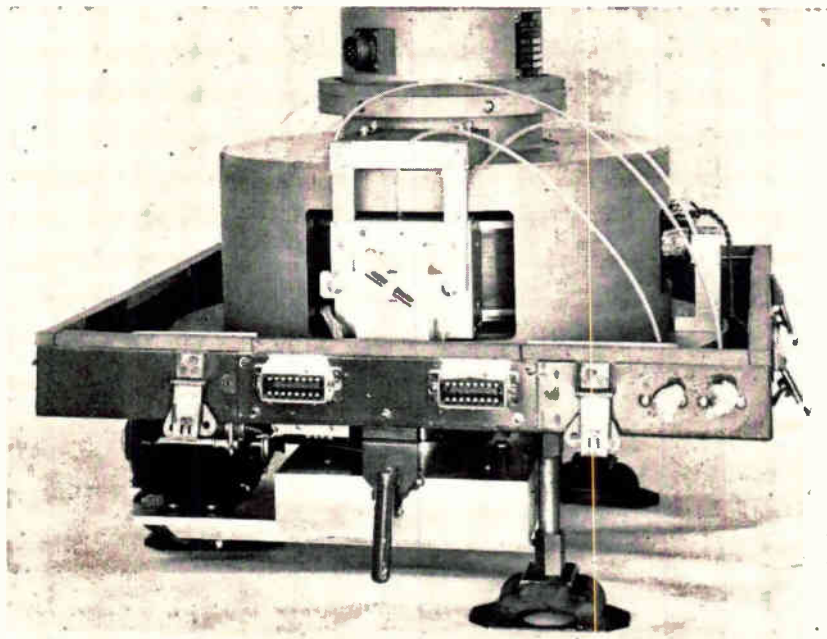

FIG. 2—Transfer characteristics of the modulator head. Undesired harmonics are eliminated by using circuit tuned to second harmonic of the excitation frequency



Drum recorder modulator playback system uses a record head consisting of ten channels. Recorded data can be read out at one 40,000th of the record speed

therefore simple diode detection can be employed.

The dynamic range can be doubled and distortion decreased if the bias and signal range, B , is used. Here a suppressed carrier type envelope is obtained which requires phase or synchronous detection.

The frequency of the excitation current and its level depends to a great extent on the application. Roughly, operation in the range of 10 to 400 kc is reasonable from the standpoint of tuned-circuit components and saturation problems or skin effects that result at the higher frequencies. Excitation currents of 50 to 500 ma are quite common. The modulated output signal, usually greater than 20 mv, can be as high as several volts depending on the playback gap size which in turn determines the intelligence flux level.

Signal Analysis

Figure 3 is a block diagram of the electronic auxiliaries of a magnetic modulator playback system which called for the analysis of transient recordings. Further the system was to be used for bandwidth reduction. In this application transients consisted of frequencies between 400 cps to 100 kc, recorded at 60 ips. Recorded wavelengths

ranged from 0.15 to 0.0006 of an inch. The system was required to playback recordings at tape speeds down to and including zero. Transient signals could therefore be pre-recorded for data interpretation. Test data, recorded in the field, would be transmitted over conventional telephone lines to the central laboratory for analysis, rather than employing wide band radio transmission equipment.

Test data was in the form of f-m subcarrier signals. Playback was accomplished on an Ampex machine with tape speed reduced from 60 ips on record to 3.75 ips on playback. The highest frequency signal used for timing, 100 kc, was therefore reduced to 6,250 cps. Distortion of overall playback had to be less than one percent; equalization was required so that the output of the 0.6-mil wavelength recording was within 15 db of the 3-mil wavelength when played back at 3 $\frac{1}{2}$ ips;



Dual channel magnetic modulator head. Right photograph shows the construction of one channel

a signal-to-noise ratio of 50 db was required; and crosstalk was to be at least 40 db below the normal playback signal.

The final head design was similar to the configuration shown in Fig. 1B. A laminated pole structure is used so that the higher frequencies will not be excessively attenuated due to eddy current losses in the head. Saturable elements of mo-permalloy are sandwiched between the two laminations which extend beyond the other laminations, so that the reluctance is minimum.

Figure 4 is the circuit of the oscillator and reference amplifier, and Fig. 5 shows the amplifier and output circuit.

The excitation oscillator operates at 100 kc and a current of 350 ma is supplied to the excitation coils of both channels of the head. Tuned amplifiers with a center frequency of 200 kc and a bandwidth of 20 kc separate the second harmonic signal containing the intelligence from the composite head output signal.

Signal to Noise

To obtain the maximum signal-to-noise ratio and minimum distortion, suppressed-carrier operation was employed. A second harmonic reference signal was extracted from the oscillator and applied to the deflector plates of the 6AR8 beam-deflection tube used for synchronous detection. The reference voltage applied to the deflectors is obtained at the cathode of the excitation source as shown in Fig. 4. The output of the 6AR8 synchronous detector is directly coupled to a pair of 6W6 cathode followers which are in push-pull to give a 600-ohm balanced output.

Experimentation with the modulator head lead to the use of laminated saturable elements which attained a signal-to-noise ratio of 50 db. Laminating was necessary because the excitation frequency was sufficiently high to cause pronounced skin effects.

This work was done under the sponsorship of Sandia Corp., the Department of Defense, C. H. Masland & Sons, and ARF. Thanks are due J. N. Van Scoyoc and R. W. Bull for their guidance and advice.

o-o-o-o-x

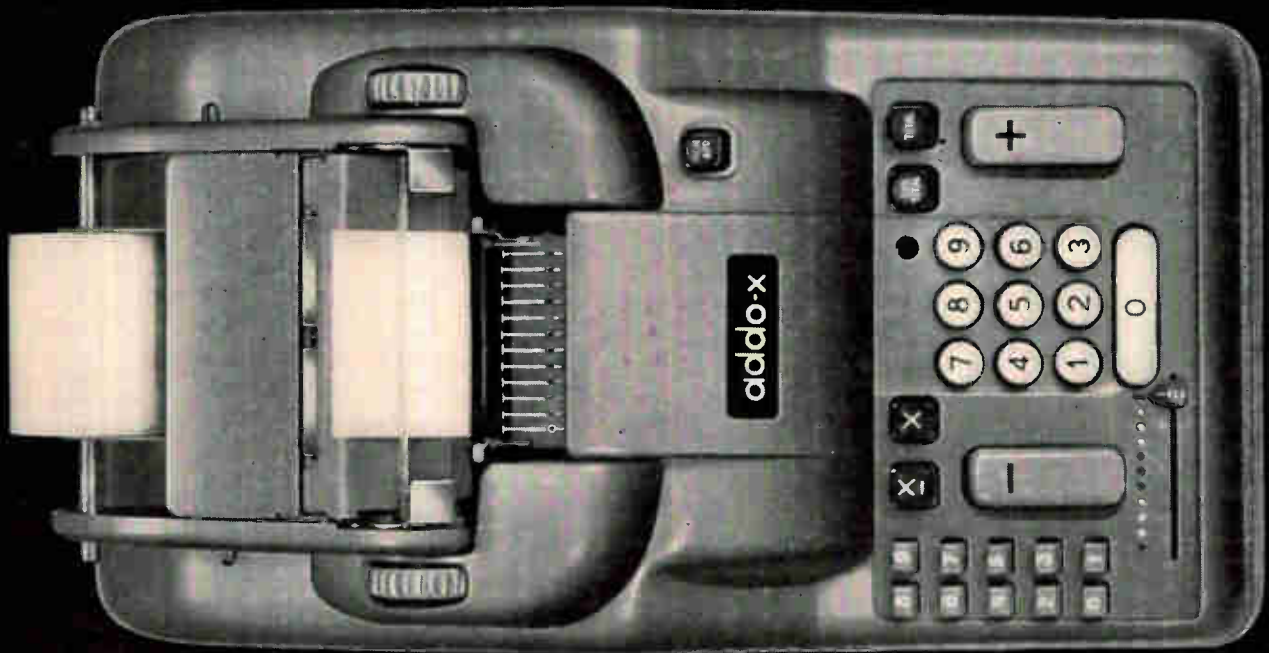

▶ **automatic multiplier 2341E at conventional adding machine cost**

a versatile, double keyboard machine—provides essentially calculator performance and speeds up all percentage, invoice, job cost and payroll computations——no stroke counting is required——has completely automatic multiplication feature——saves times and increases reliability

"addo-x" stands for a family of versatile, time-proven adding and calculating machines

——backed by nation-wide service facilities——lifetime guarantee repair parts availability

see your dealer for on-your-job proof or write: "addo-x" 300 Park Avenue, New York 22, NY

Improved R-C Oscillator

Direct-current coupled multiple-feedback oscillator gives excellent amplitude stability with low distortion in the output waveform

By LEON H. DULBERGER, Project Engineer, Research & Development Dept., Fischer & Porter Company, Hatboro, Pa.

THIS SINGLE FREQUENCY R-C oscillator, designed to operate in the 4-cps to 350-kc range, is a vibration and shock-proof version of the Sulzer bridged-T configuration¹. Also, direct-coupled signal paths avoid large capacitors as coupling components. Good amplitude and frequency stability are achieved, with little harmonic distortion in the output waveform.

Circuit

This new circuit, shown in Fig. 1, employs two negative feedback loops in addition to those required for oscillation. The tungsten lamp is eliminated as a feedback control element. Silicon diodes maintain a fixed forward voltage drop at a low a-c impedance. Frequency stability is maintained to above 100 kc.

The transistors are used to form a d-c amplifier and the types are given in Fig. 1, along with capacitance values of the bridged-T network. No circuit modifications are required for any of the three transistors. Coupling diode D_1 maintains a fixed 0.6-v d-c drop across its terminals. Thus Q_1 operates in a region of greater collector characteristic linearity than can be obtained normally with one supply voltage polarity.

The bridged-T network, directly coupled from the emitter of Q_2 to the base of Q_1 , produces negative feedback which reduces amplifier gain—having least effect at the notch frequency. Positive feedback is applied to the emitter of Q_1 . The amplitude of oscillation at the notch frequency is controlled by R_8 and R_9 , which are set for maximum output signal with low distortion into a given output load impedance. The

voltage drop of D_2 , 0.6 v, establishes the desired operating points of the transistors. An additional d-c negative feedback path, provided by R_7 , offsets d-c feedback in the positive loop, which would upset the operating point of Q_1 , with changes in ambient temperature.

Direct-current feedback to the emitter of Q_1 corrects I_{co} changes, and d-c feedback taken to the base of Q_1 from the collector of this same stage improves stabilization. Both paths also provide a-c feedback to improve amplitude and frequency

stability and reduce waveform distortion.

Tests on a 400-cps prototype, using 2N247 transistors, indicate a long-term frequency stability of ± 0.2 percent at ambient temperatures; and a ± 0.5 percent stability between 20 C to 55 C.

Components

Wirewound resistors in the bridged-T network exhibit a temperature coefficient of 20 ppm. Capacitors C_1 and C_2 are Mylar dielectric types. Silver mica capacitors are used to trim low-frequency operation, or as the basic components at high frequencies.

Power is provided by a ± 0.5 percent regulated power supply. An output blocking capacitor is included when the load can provide a d-c path of low enough resistance to alter circuit operating conditions, or when the load must be protected from the d-c present across R_{11} . Amplitude stability is ± 7 percent from 20 C to 55 C. Output impedance of the oscillator is 3,600 ohms into loads of 30,000 ohms or higher, when R_8 and R_9 are adjusted for maximum no load voltage with minimum distortion.

Voltage across the output terminals is 5.4 peak-to-peak under these conditions. Distortion with a 50,000-ohm load is 1.8 percent and includes all harmonics. Amplitude can be adjusted for a high output at low distortion for loads down to 3,000 ohms.

Transistor and component ageing have slight effect on operation.

REFERENCES

- (1) P. G. Sulzer, A Note On A Bridged-T Network, *Proc. IRE*, July, 1951.
- (2) P. G. Sulzer, Low-Distortion Transistor Oscillator, *ELECTRONICS*, p. 171, Sept., 1953.

| OSC FREQ | <10KC | TO 100KC | AT 350 KC |
|--------------------|--------|----------|-----------|
| Q_1 & Q_2 USED | 2N 270 | 2N 247 | 2N 384 |

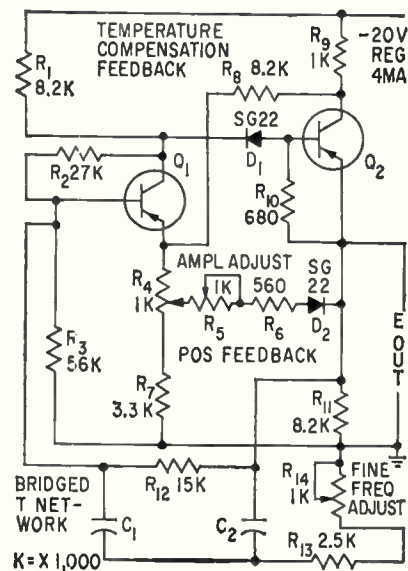

| FREQ IN CPS | $C_1 = C_2$ VALUES | FREQ IN KC | $C_1 = C_2$ VALUES |
|-------------|--------------------|------------|--------------------|
| 4 | 6.8 μ F | 1 | 0.025 μ F |
| 100 | 0.25 μ F | 10 | 2,300 μ F |
| 400 | 0.068 μ F | 100 | 200 μ F |

FIG. 1—Circuit diagram of R-C oscillator gives transistor types used at three frequency ranges along with capacitance values of the bridged-T network

now... capacitors
as dependable as
the time and tides



Cornell-Dubilier Certified High-Reliability Capacitors meet performance expectations for new environments and new complex military and industrial electronic equipment. These capacitors meet or surpass the exacting requirements of MIL-C-14157A and MIL-C-26244 (USAF). Each production lot is furnished with certified test data covering the stringent test program detailed in the specification.

When designing electronic equipment where *failure can't be tolerated* specify Cornell-Dubilier High-Reliability Capacitors. Write on your company letterhead for High-Reliability Bulletins 188A-1 and 188A-2 to Dept. 000, Cornell-Dubilier Electric Corporation, South Plainfield, New Jersey.

MILITARY "CPM" SERIES
in accordance with Spec.
MIL-C-14157A
300, 400, 600 volts DC Working



Uninsulated Body Type CPM08



Insulated Body Type CPM09

MILITARY & INDUSTRIAL
"TWK" SERIES
in accordance with
MIL-C-26244 (USAF)
200, 300, 400, 600 volts DC Working



Uninsulated Body Type TWKN
(equivalent to MIL-CPV08)

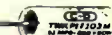

Insulated Body Type TWKP
(equivalent to MIL-CPV09)

CAPACITANCE:
001 mfd. to 1.0 mfd.
TEMPERATURE RANGE:
-55°C to +125°C.



Consistently Dependable
CORNELL-DUBILIER
CAPACITORS

Simulating Second-Order Equations

By DUANE G. CHADWICK, Assistant Professor, College of Engineering and Technology, Utah State University, Logan, Utah

ANALOG TECHNIQUE permits simulation of second-order differential equations using a single operational amplifier. No loss in flexibility is encountered over the conventional method requiring three operational amplifiers.

Electrical circuits having inductance, capacitance and resistance are frequently described by second-order differential equations. This is also true of mechanical hardware, such as rate gyros, accelerometers, hydraulic valves and mechanical linkages.

Simulating such elements on an analog computer requires that the computer solve a second-order differential equation.

Conventional simulation techniques, shown in Fig. 1, require three operational amplifiers to solve such an equation. Consequently, solution of complex problems may require one hundred or more amplifiers just for simulating the second-order equations representing the hardware of the system. Such a large number of amplifiers represents considerable set-up and check-out time for the engineer as well as cost to the company.

A method of simulating a second-order differential equation requiring only one operational amplifier is shown in Fig. 2. One or more inputs may be used, and gain of each channel is independently adjustable, as is natural resonant frequency (ω_0) and damping ratio (ζ).

A second-order differential equation is simulated through proper selection of input and feedback resistors and C_s and C_f in Fig. 2. Input and feedback resistors are determined by desired d-c gain. Output voltage (e_o) for various input voltages ($e_1, e_2 \dots e_n$) can be shown to be

$$e_o = -\left(e_1 \frac{R_f}{R_1} + e_2 \frac{R_f}{R_2} + \dots + e_n \frac{R_f}{R_n} \right)$$

After desired d-c gain of each input is established, the only unknown elements are C_s and C_f . (R_a is arbitrarily selected to be one

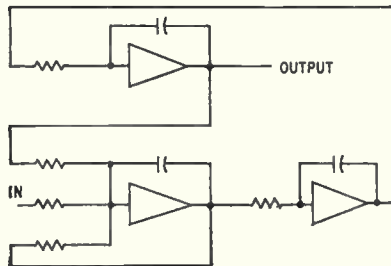

FIG. 1—Conventional method of solving second-order differential equations requires three operational amplifiers

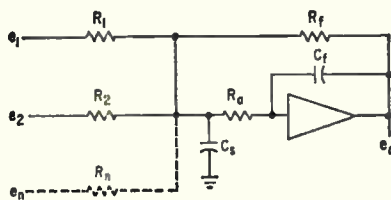

FIG. 2—One or more inputs can be used with method of simulating second-order differential equations

megohm for convenience and can be installed permanently.) With known resistive elements, natural frequency (in radians) and damping ratio (ζ), feedback capacitor C_f is

$$C_f = 2\zeta / \left[\omega_0 R_a \left(1 + \frac{R_f}{R_a} + \frac{R_f}{R_1} + \frac{R_f}{R_2} + \dots + \frac{R_f}{R_n} \right) \right]$$

Input capacitor is $C_s = 1/(\omega_0^2 R_a R_f C_f)$.

For example, assume that bandpass is 0 - 10 cps ($\omega_0 = 2\pi \times 10$), damping ratio (ζ) is 0.6 of critical, forward gain for input 1 is 2 and forward gain for input 2 is 0.1. With R_f equal to one megohm, R_a is 500,000 ohms, R_2 is 10 megohms, C_f is 0.00475 μ f and C_s is 0.0533 μ f.

Having installed the components, the bandpass and damping characteristics of the amplifier can be readily checked on an oscilloscope by two simple tests. At the cutoff frequency (ω_c), gain should equal d-c gain divided by 2ζ . Output should also lag input by 90 degrees. These conclusions can be made from a cursory inspection of the second-order equation shown in the standard form'

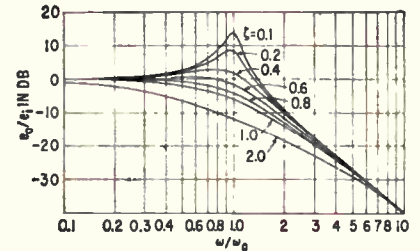

FIG. 3—Plot shows magnitude of e_o/e_1 versus frequency ratio ω/ω_0 for damping ratios from 0.1 to 2.0

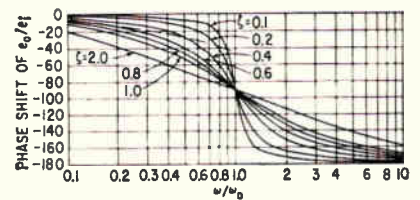

FIG. 4—Phase shift of e_o/e_1 versus frequency ratio ω/ω_0 is plotted for damping ratios from 0.1 to 2.0

Output/Input =

$$e_o/e_1 = -K \left(\frac{s^2}{\omega_0^2} + \frac{2\zeta s}{\omega_0} + 1 \right)$$

At cutoff frequency, $s = j\omega_c = \omega_c \angle +90$. Hence, the equation reduces to $e_o/e_1 = K/(-1 + j2\zeta + 1) = K/j2\zeta = K/2\zeta \angle -90$, where K is the d-c gain term.

Examples of performance of the circuit in Fig. 2 are illustrated in Fig. 3 and 4, which show gain and phase shift, respectively, versus frequency. The frequency axis in each figure is normalized in terms of frequency having a 90-degree phase shift or cutoff frequency.

REFERENCE

- (1) Chesnut and Mayer, Servomechanisms and Regulating Systems Design, John Wiley and Sons, Inc., 1951, p 312.

Evaluating Logarithmic Diodes

By ARTHUR GILL University of Calif. Berkeley, Calif.

LOW-LEVEL characteristics of semiconductor diodes closely obey, at a fixed temperature, the volt-ampere relationship $i = I_s (e^{v/V_T} - 1)$. Saturation current, I_s , and charac-



introduces
a
new
dimension
in
power
supplies

**3 1/2" PANEL
HEIGHT**

WITH VOLTAGE RANGE OF
125-325 VOLTS
200-400-600 MA. MODELS

the
new
HB
SERIES

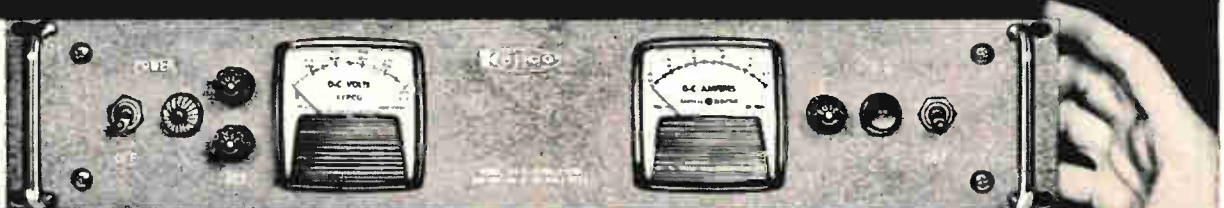

**0.1% REGULATION
and STABILITY**

| MODEL | VOLTAGE | MA. CURRENT | RIPPLE |
|-------|---------|-------------|--------|
| HB-2 | 125-325 | 200 | 0.003V |
| HB-4 | 125-325 | 400 | 0.003V |
| HB-6 | 125-325 | 600 | 0.003V |

0.01% MODELS AVAILABLE ON SPECIAL ORDER

*All this adds up
to MAXIMUM:*

- **SPACE ECONOMY**
- **OUTPUT CAPACITY**
- **QUALITY PERFORMANCE**

*Write for
complete specifications.*



131-38 SANFORD AVENUE • FLUSHING 55, N. Y. • INDEPENDENCE 1-7000

Visit our Booths 2636-38 • I.R.E. Show • N. Y. Coliseum • March 23-26

\$1,000,000 is looking for an electronics company that needs "working money"

You don't have to merge—give away equity, dilute profits, get new voices in management!

If your business is suffering from growing pains... caught in the trap of constantly increasing sales without a comparable increase in "working money" to carry them, we can help.

We have aided many sound and successful companies over this hump with our working money plan of financing. Today, they are among our best clients.

It is a familiar story to us. A business grows to the point where sales outstrip the financial ability to handle them. Money is tied up in materials, goods in process, new equipment. The payroll goes up and up. Swollen accounts receivable look fine on paper, but they are 30 to 60 days or more from helping today's pinch.

TBC's program offers you solid help in a very simple way. It will enable you to defrost your frozen assets. Put back into circulation the money... your own

money... now locked up in receivables and inventory. Turn your idle money into working money by using TBC's type of financing service.

Last year, we supplied more than \$500,000,000 of working money to successful, growing companies in various fields. Not only are they completely satisfied with our method of keeping them in a strong cash position... but also they value the helpful collateral services that are available to them if they wish.

If you sell on normal 30 to 60 day terms, we can supply you with working money to an amount generally limited only by your volume. And, in using our service, your management retains full operating control... does not suffer interference from us.

A normal requisite for our service is a minimum annual sales volume of a million dollars. But we *can* and *do* make exceptions for firms which have promising potentials for growth.

We will be glad to confer with you on your financing problems. Or, for further information, write for our free booklet "How to get cash to keep your business growing"... without any obligation, of course.



Textile Banking Company, Inc.
55 Madison Ave., Dep't. EM, New York 10, N. Y.

Subsidiaries:

T. B. C. Associates, Inc., New York, N. Y.
Southwest Texbank, Inc., St. Louis, Missouri

teristic voltage, V_0 , completely characterize the logarithmic behavior of a diode.¹

Saturating current, I_s , can be measured by applying a large negative voltage to the diode. However, no simple way has been proposed for measuring V_0 . The method described in this paper facilitates direct determination of V_0 by oscilloscopic means. It is especially useful in selecting matched diodes for low-level modulators and demodulators.² The tested units may be divided into batches according to their V_0 values, with units exhibiting the same characteristic voltage considered as matched.

The method is based on the fact that when voltage v applied to a logarithmic diode is linear with time, current i is linearly related to the current derivative di/dt . Thus, exciting the diode with a sawtooth voltage and plotting di/dt versus i on an oscilloscope yields a curve which, within the logarithmic range, is a straight line. Slope of this line is a function of V_0 , but not of I_s . Hence, it may be used to obtain the characteristic voltage directly. Specifically, the slope of the oscilloscopic trace is given by $s = K/V_0$, where K is a constant depending on parameters of the measuring circuit.

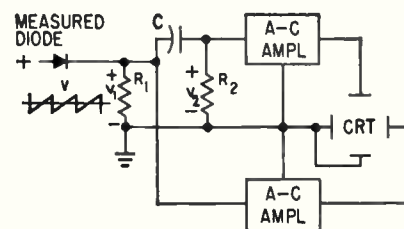

FIG. 1—Logarithmic behavior of 1N302 germanium diodes can be determined using a sawtooth input of 0.1 volt peak and a frequency of 30 kc

Given K , a vertical line (or a circle) may be calibrated on the face of the crt such that the intersection of the trace on the line (or circle) would correspond to the value V_0 .

The measuring setup shown in Fig. 1 was constructed for evaluating the logarithmic behavior of 1N302 germanium diodes. The sawtooth input, derived from the sweep generator of an oscilloscope, has a

peak value of 0.1 volt and a frequency of 30,000 cps. With $R_1 = 10$ ohms, v_1 was virtually proportional to i and was applied through a high-sensitivity a-c amplifier to the horizontal deflection plates of the displaying oscilloscope.

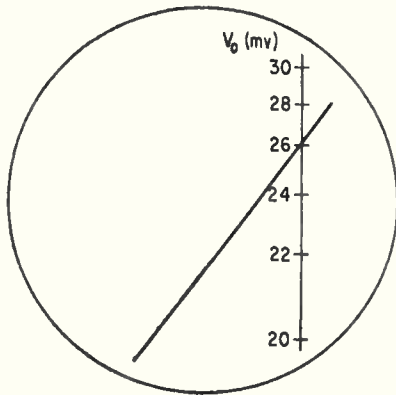

FIG. 2—Plot of di/dt vs i yields line whose slope is a function of V_o .

The series R-C circuit, with $R_2 = 50,000$ ohms and $C = 50 \mu f$, served as a differentiator to produce a voltage v_2 proportional to di/dt . Voltage v_2 was applied through another a-c amplifier to the vertical deflection plates of the displaying oscilloscope. The calibrated screen and a typical trace are shown in Fig. 2.

An important advantage of the proposed method is that the measured V_o values are practically independent of I_o . Since I_o is much more sensitive to temperature variation than V_o , the method is considerably more accurate than indirect methods currently in use (for example, measuring two points on the $v-i$ characteristics and simultaneously solving for I_o and V_o). The method may also be used for observing the effect of large temperature variations on V_o .

By using a sufficiently large sawtooth voltage, range of the logarithmic behavior can be readily determined by observing the range of linearity of the traced curve. This feature is especially useful in design of logarithmic transducers for nuclear instrumentation and analog computation.

REFERENCES

- (1) Y. Golahny, Silicon Diodes as Logarithmic Elements, *ELECTRONICS*, Aug. 1957, p 196.
- (2) A. Gill, Matching Transistor Diodes, *ELECTRONICS*, Jan. 17, 1958, p 75.

New
from
HYSOL...

Stable

EPOXY MOLDING POWDERS...

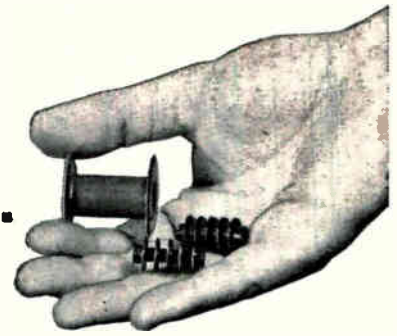

Made from HYSOL 8610

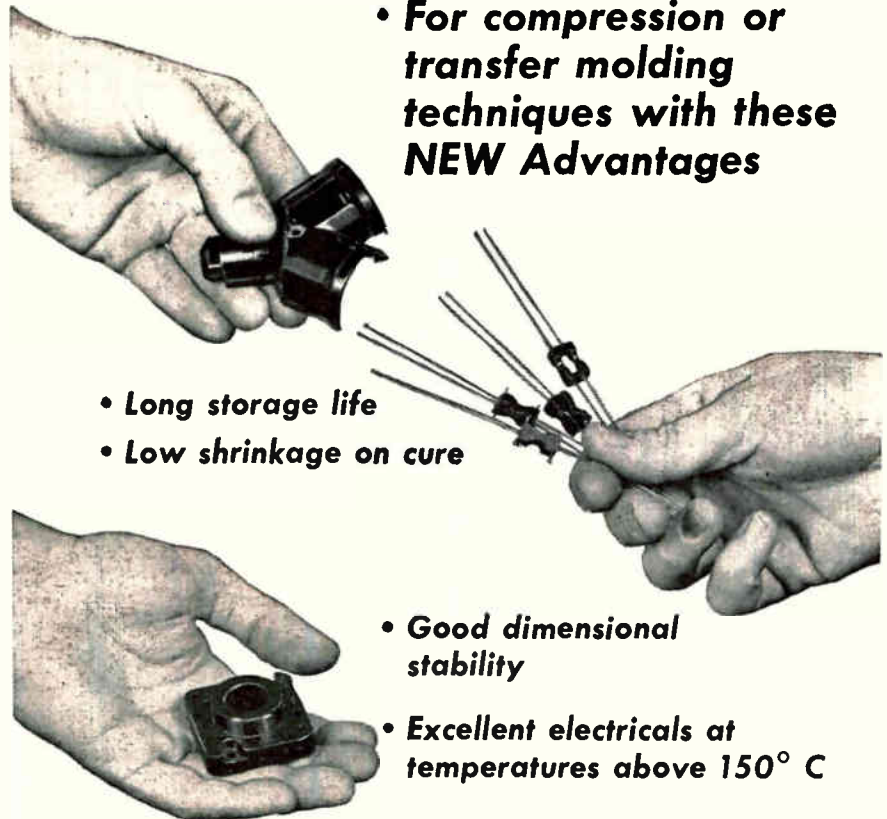

• For compression or transfer molding techniques with these **NEW Advantages**

- Long storage life
- Low shrinkage on cure

- Good dimensional stability
- Excellent electricals at temperatures above 150° C

To round out this important package, here are even more reasons why HYSOL 8610 can help you do those tough jobs BETTER. — And save money by slashing production costs.

**FAST CURE AT MODERATE TEMPERATURES
GOOD FLOW
A HEAT DISTORTION POINT ABOVE 150° C**

- Write today for free technical literature describing HYSOL 8610 or ask for a salesman to call.



HOUGHTON LABORATORIES INC.
OLEAN, NEW YORK

HYSOL of California
So. Elmonte

HYSOL (Canada) Ltd.
Toronto

Missile Shock and Vibration Protection

DEVELOPMENT of a new medium—any type of protective method, material or device—to protect electronic equipment against shock and vibration in missiles was undertaken recently at Armour Research Foundation sponsored by WADC.

Requirements

Some of the requirements for the new medium were: sufficient internal damping to limit maximum vibration transmissibility to 1.5; ability to withstand temperatures between -85 and $+482$ F and ability to function after five years of storage. Additional requirements pertained to omnidirectionality; stiffness; size; weight; static strength; shock strength; drift; steady-state acceleration; resistance to salt spray, humidity, fungus, hydrocarbon compounds and combustion; reduced pressure; material availability and cost.

According to R. H. Jacobsen of Armour, the most promising medium appeared to be an inexpensive slab that could be cut to size easily and placed between the equipment to be protected and the airframe. A wide variety of materials and combinations of materials were investigated from which a slab could be formed.

New Medium

After thorough investigation, a new medium was developed which was capable of producing a high degree of internal damping and was well suited to nearly all the physical and environmental requirements. This medium is a multilayer grid of $\frac{3}{8}$ -in. Teflon rods embedded in a

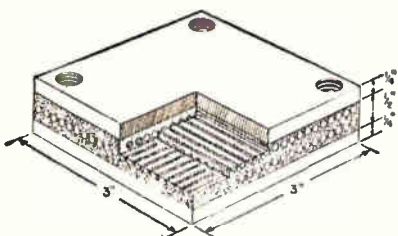

FIG. 1—Teflon rods supported in Silastic S-6508 make up the specimen shown

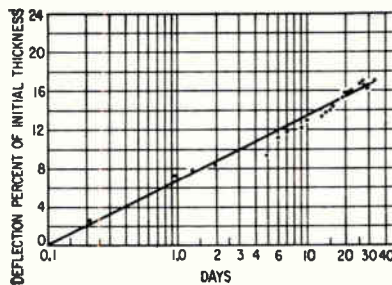

FIG. 2—Drift characteristics of sample with a 31-lb load in a 482 F chamber

matrix of Silastic S-6508 silicone rubber as shown in Fig. 1.

Samples prepared for test purposes were $\frac{1}{2}$ -in. thick, 3 by 3 in. in cross-section containing three rows of Teflon rods with 20 rods in each row. This configuration provides the greatest degree of internal damping.

Properties

Maximum transmissibility for the new medium is 2.1 obtained at a double input amplitude of 0.010 in. At 0.040 and 0.060 in. double amplitudes, maximum transmissibility was about 1.2. These ratings for commercial vibration isolators correspond to input double amplitudes of 0.060 or 0.080 in.

In compression, the new-medium sample withstood a load of 1,560 lb without failure but with excessive deformation. Stiffness is such that for a 33-lb load, a natural frequency of about 60 cps is obtained. No significant change of equivalent viscous damping ratio is observed when the load representing the isolated mass is changed from 33 to 85 lb.

Temperature Range

Temperature range for Silastic S-6508, as specified by the manufacturer is -100 to $+500$ F; for Teflon, -290 to $+500$ F. Therefore, both materials are capable of withstanding the specified temperature range of -55 to $+482$ F.

To determine drift characteristics, the specimen and a 31-lb load which it supported were placed in a

482 F chamber for a 30-day period. Deformations are shown in Fig. 2. The high temperature at which the test was conducted greatly accelerated the drift characteristics.

In testing for fatigue, specimens supporting 33-lb loads were vibrated at resonance for six-hour periods at input double amplitudes of 0.010, 0.020, 0.030, 0.040 and 0.060 in. No failures occurred.

Improvement Possibilities

It may be possible that some other combination of Teflon and Silastic S-6508 containing rods of different number, shape or orientation may produce even more internal damping. Improvements in the materials themselves may be possible to give greater high-temperature stiffness stability, greater resistance to hydrocarbon compounds and combustion and additional tensile strength. Fluorosilicone and nitrile silicone rubbers made available recently offer greater high-temperature stiffness stability than conventional silicone rubbers.

The high internal damping achieved in the sample is produced by slippage between the Teflon and rubber. Slippage occurs because the Teflon does not bond to the rubber during fabrication. Other materials such as fiber glass and rigid silicone resins may be available which will not bond to the rubber but will be less slippery than Teflon.

Tellurium Compounds for Semiconductors

RECENT WORK at Batelle Memorial Institute sponsored by the Tellurium Development Committee has shown some interesting characteristics for tellurium compounds.

Bismuth Telluride

Bismuth telluride exhibits a resistivity of 10^{-8} ohm-cm and a thermal conductivity about 1/200th that of copper. This combination gives

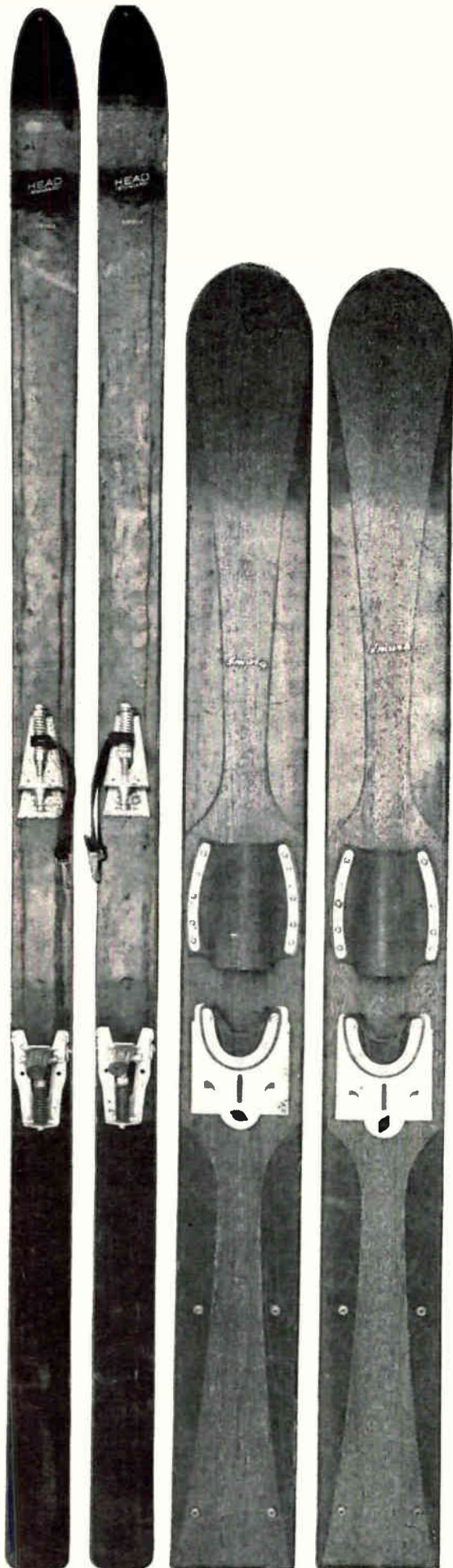

ENGINEERS MOVE FORWARD FAST AT LINK

Talented engineers who are *looking forward* to careers with genuine opportunity will find that they can keep *moving forward* at Link Aviation.

Located in Binghamton, in the heart of Upstate New York's all-season vacationland, Link's activities are steadily expanding. New positions exist for men with productive experience in several fields:

- *Staff scientists*, for advanced work on analog computers, airborne instrumentation, industrial controls and precision measurements
- *Mechanical engineers*, for electronic and electro-mechanical packaging
- *Design engineers*, for work on analog computers, systems, and components
- *Senior optics development engineers*
- *Applied mathematicians*

Link Aviation, Inc., is engaged in projects whose scope far exceeds its long-standing reputation for flight-simulation equipment. Engineers are stimulated by this diversity. And they like the recognition given them, in such forms as excellent salaries, exceptional insurance and retirement plans, and tuition-free advanced university courses.

If you want to progress in this direction contact us at once.

Write to: Mr. A. M. Wieland,
Link Aviation, Inc.,
Binghamton, New York



LINK AVIATION, INC.

A subsidiary of General Precision Equipment Corporation

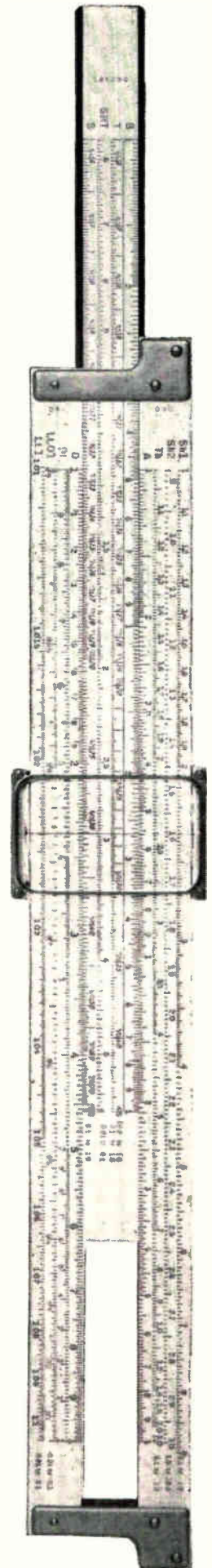



Stokes high vacuum oven installed in dry box at Raytheon's Semiconductor Division. Vacuum gages are on top of dry box.

AT RAYTHEON

Transistor reliability improved with Stokes High Vacuum Ovens

Stokes High Vacuum Ovens are featured in an entirely new method of baking and processing transistors at the Semiconductor Division, Raytheon Manufacturing Co. at Newton, Mass. Chosen because they met the rigid requirements set by Raytheon engineers, these ovens assure improved transistor quality and uniformity, more stable electrical parameters and increased production.

Operating continuously 24 hours a day, the twelve Stokes ovens consistently maintain the conditions demanded by Raytheon's closely controlled drying technique. Yet only one operator per shift is required to attend six ovens.

If high vacuum is an important aspect of your present or planned process, Stokes' long experience in vacuum techniques, and in designing and manufacturing high vacuum equipment, can be of valuable aid. Your inquiry is invited.

The Stokes Model 236 Vacuum Baking Oven includes fully automatic instrumentation. See it at the I.R.E. Show—Booth 4416.

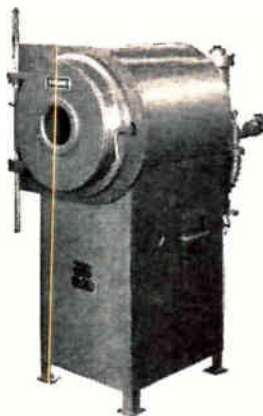

Vacuum Equipment Division
F. J. STOKES CORPORATION
5500 Tabor Road, Philadelphia 20, Pa.

STOKES

the material a high thermoelectric power of about $200 \mu\text{V}/\text{deg C}$. An experimental refrigerator using thermoelements of bismuth telluride studied at Batelle exhibited a maximum temperature difference between hot and cold junctions of 49 C when operated under no-load conditions. Refined means for preparing the bismuth telluride have made possible temperature differences of 68 C .

Antimony Telluride

Antimony and arsenic tellurides prepared in the same manner as the bismuth samples did not show superior properties for thermoelectric device application.

Cadmium Telluride

Cadmium telluride shows promise for high-temperature rectifiers, solar batteries and infrared optical system applications. An experimental rectifier was made by placing a cadmium dot on *p*-type material of about 300 ohm-cm resistivity, sealing the combination in an evacuated tube and heating to 500 C for 10 minutes. Copper was plated to the *p*-type region. Rectifier performance was poor but other adaptations of cadmium telluride may improve performance.

In investigation of solar-energy applications, a crude *pn* junction tested as a photovoltaic cell produced an open circuit voltage of 0.6 v and a short-circuit current of $30 \mu\text{a}$ when illuminated with a flash-light. High contact resistance and bulk resistivity resulted in high impedance and relatively low short-circuit current. The need for applications in this area is low-resistivity *n*- and *p*-type materials.

Infrared transmission in CdTe is about 70 percent in the region from 4 to 15 micron wavelengths which indicates usage in infrared windows and lenses.

Other Tellurides

Other telluride compounds investigated include copper telluride, silver telluride, magnesium telluride, tin telluride and indium telluride (InTe and In_2Te_3). Both copper telluride and silver telluride exhibit an abrupt change in conductivity at 270 C and 140 C , respectively.

This property would indicate that they may be useful in switching applications.

Muffin Fan Has Outside Rotor

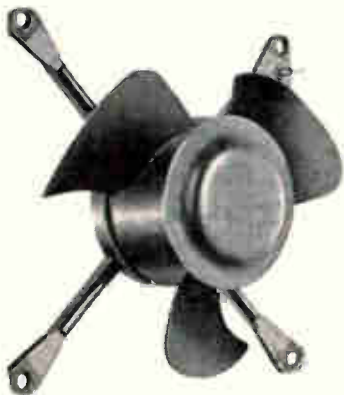

DEVELOPED by Rotron Mfg. Co., a new 60-cps fan makes use of a small, shaded-pole fractional-horsepower motor with the rotor on the outside and the stator on the inside. This is the first such unit made by the company for commercial use although similar 400-cps fans have been produced for the military previously.

Three Versions

The fan is available in three different versions—the basic fan itself; the fan and Venturi block and the fan, Venturi block and grille. It delivers 100 cu ft of air per minute at zero static pressure and 75 at 0.1 in. of water. The entire fan assembly is only 1½-in. thick, 4½-in. square and weighs but 1.2 lb.

Low-Cost Material Insulates UHF

DIELECTRIC STRENGTH of Enrad II, an improved irradiated polyolefin developed by Enflo Corp., Maple Shade, N. J., is about 1,000. This factor, together with a dissipation factor of 0.0005, makes the material well suited for uhf applications.

The new insulating material is available as a powder, or as bars, rods and sheets. It can be molded in both simple and complex shapes with complete uniformity of properties.

KELLOGG

TYPE "L" RELAY

miniaturized • versatile • reliable

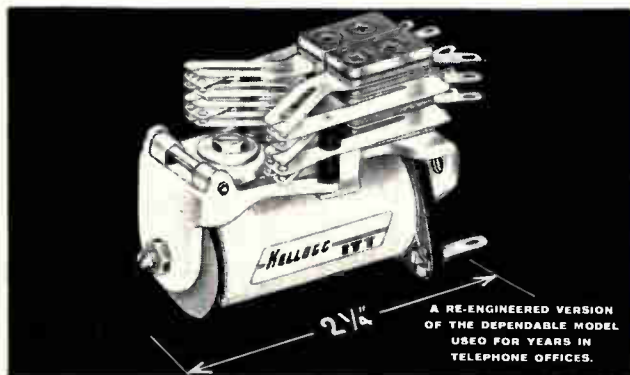

Kellogg's Type "L" Relay features—

High operating force: greater sensitivity, gram pressure, springs per pileup.

Rear mounting: for ease of wiring.

Wide coil variety: single or double wound, for any circuit needs.

Bifurcated stationary springs: for independent contact action and high reliability (single contacts also available).

Heavy duty bronze yoke and stainless steel bearing pins: for long life and stable adjustment.

Single or double arm type armatures available.

Hermetically sealed models, if desired.

Operating speed: minimum of 1-2 milliseconds.

Contact points: gold, silver, palladium, tungsten; others available.

Residual: adjustable and fixed.

Time delay: heel-end slugs and armature-end slugs for release time delay and operate time delay, respectively.

Terminals: slotted.

Weight: net, 2-1/4 oz.

Dimensions: 2-1/4" L x 1-1/8" W, height ranges from 17/32" to 1-1/16" (max.)

Operating voltages: up to 220 volts D.C.

Backed by Kellogg and International Telephone and Telegraph Corporation. Inquiries are invited. Send for a free catalog on Kellogg relays, components.



Kellogg Switchboard and Supply Company, 6650 South Cicero Avenue, Chicago 38, Ill. Communications division of International Telephone and Telegraph Corporation.

See the Kellogg-ITT Display at the IRE Show:
BOOTHS 2510-2625.

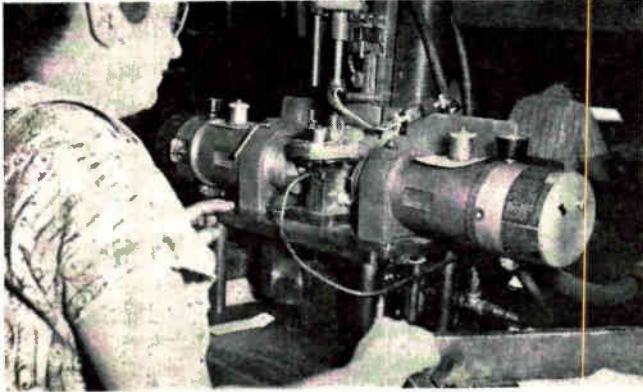

Automatic drill heads put lever shaft holes in switch when switch signals it is in drilling position

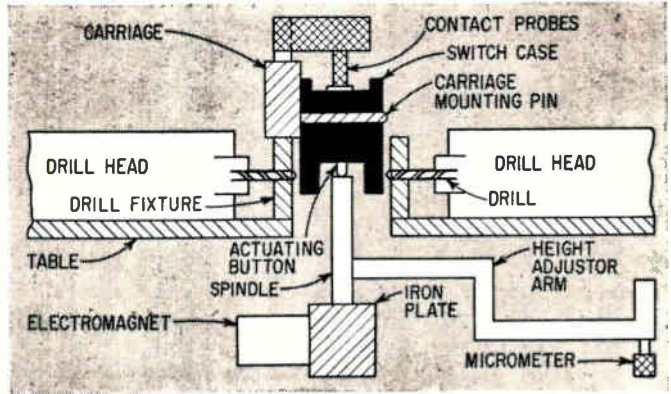

FIG. 1—Diagram of switch drilling machine. Dimensions have been exaggerated for clarity

Workpiece Controls Shaft Drill

ONE IDEAL form of production machinery control is the type which uses the workpiece as an integral part of the control circuit. This technique allows a built-in test of the workpiece during production while minimizing variables which might have been introduced during preceding production steps.

At the Unimax Switch Division, W. L. Maxson Corp., Wallingford, Conn., such a method guides one of the final steps in assembling precision snap-acting switches. The position of the drilled holes for the lever pivot shafts in each switch is determined by each switch. The firm has found that this mechanizes the operation and minimizes adjustments which might be needed on final calibration of the switches.

The lever pivot shafts must be positioned in the switch so that the switch will be actuated when the end of the lever is in its specified position, a point where a predetermined pressure on the actuating

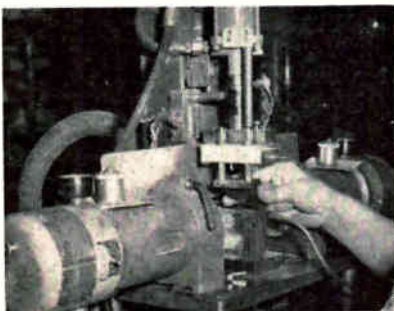

Operator places switch case on raised carriage

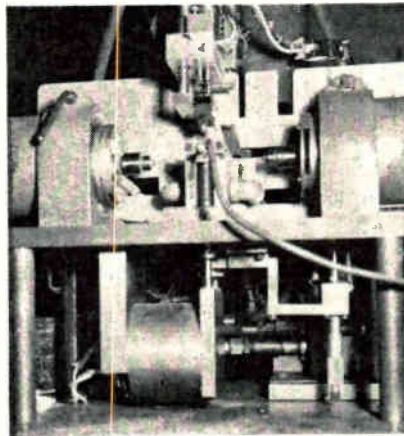

Closeup of mechanism. Drum of lower left is magnetic brake

button snaps the switch.

Two automatic drilling heads are set horizontally on a table so that the drills pass through the sides of the case, as shown in Fig. 1. A carriage mounted on a vertical air cylinder carries the cases down into a drilling fixture. The undrilled cases are put on the carriage, actuating button down, by means of carriage pins which fit into the mounting holes in the switch base.

As the carriage drops the switch case into the drilling fixture, the switch terminals press against spring-loaded contact fingers. The downward motion is slowed as the switch approaches the point at which it will be drilled. The switch actuating button comes into contact with a solidly-mounted spindle which actuates the switch. This stops the carriage and starts the

automatic drill heads.

Slowing the downward motion provides a more precise hole location and protects the switch from damage. As the switch is lowered, it passes a leaf spring connected to a cutoff switch. A properly positioned workpiece will just clear this spring.

When the button contacts the spindle, the switch closes an electrical circuit. The electromagnet is energized. An iron plate on the bottom of the spindle passes against the magnet. The magnet and plate brake the spindle and the switch case at the proper drilling point. The automatic drill heads drill the holes and then retract.

The plate is made of Swedish iron to avoid residual magnetism. Fine adjustments in the height of the spindle are made with a micrometer linked to the spindle by a balanced arm.

In operation, the operator puts a case on the carriage pins and starts the air cylinder down by pressing a button. The operation is then automatic until the switch is ready for unloading.

Pipe Ultrasonic Energy to Several Workpieces

ULTRASONIC MACHINE tool extensions which "pipe" ultrasonic energy from a single transducer to several working heads is offered by



"1PB600" Series pushbutton switch, one of many in the "One-Shot" line.

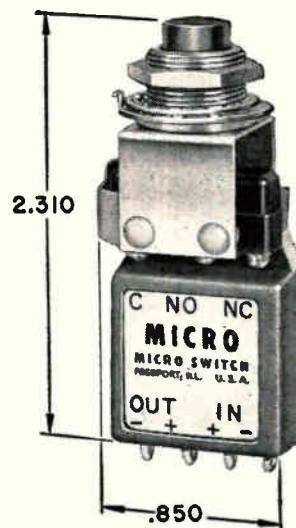

New "One-Shot" switches produce one square wave pulse per operation

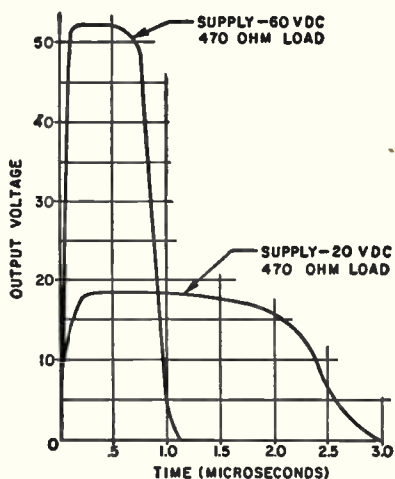

These are typical output curves for the "1PB600" Series "One-Shot" switch, illustrated above.

This new series of snap-action switches incorporates a special circuit which produces a single square wave pulse regardless of the speed of switch operation. Variations can be furnished with pulse widths from 0.1 to 10.0 microseconds. The basic "One-Shot" circuit can be provided with a variety of switch types. No standby power is required. The circuit is potted for physical and environmental protection.

These "One-Shot" assemblies provide a pre-engineered, compact package to accomplish a shaped wave output, thus eliminating costly, time-consuming custom development of circuits.

"One-Shot" switches are available for operation in temperatures from -65° to $+185^{\circ}$ F.

Applications include computer and radar consoles, keyboards, electronic test equipment, fusing, arming and firing circuits, checking ring counters, setting and re-setting flip-flops, and reflected pulse systems. Ask for data sheet 150.

Engineering assistance on switch application is available from the MICRO SWITCH branch office near you. Consult the Yellow Pages.

MICRO SWITCH . . . FREEPORT, ILL.

A division of Honeywell

In Canada: Honeywell Controls Limited, Toronto 17, Ontario

See working models of the "One-Shot" switch in Booth No. 2202 at the IRE Show



Honeywell

MICRO SWITCH PRECISION SWITCHES

expecting
a
check?

You'll get it quicker if you gave your postal delivery zone number with your address.

The Post Office has divided 106 cities into postal delivery zones to speed mail delivery.

Be sure to include zone number when writing to these cities; be sure to include your zone number in your return address—after the city, before the state.

The Sheffield Corp., Dayton, Ohio. The extensions allow one machine to be used for progressive machining of workpieces or reach otherwise inaccessible areas.

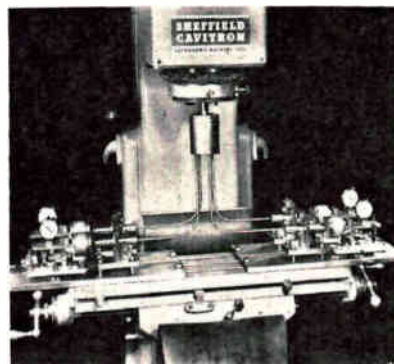

Setup with 4 cutting heads. Eight heads have been operated from a transducer

Units include modular-type tooling for machining and dicing germanium, silicon, ceramic and ferrite. Each unit accommodates a cutting tool up to 1.5 inches diameter and will machine workpieces up to 2 inches diameter to a depth of 0.050 inch. Each workpiece station has an independent feeding device and depth of cut is indicated in 0.0001 increments. Cutting position is horizontal.

Heated Hydrogen Bonds Leads to Transistors

HYDROGEN, HEATED to 190°C by passage through a modified heavy-duty soldering iron tip, is used to fix leads to the indium alloying dots of transistors made at the RCA Semiconductor and Materials Division plant, Somerville, N. J.

The heating equipment is housed in an asbestos composition box. The hydrogen is piped under pressure from a central supply into a nickel



Operator watches through microscope as bond is made

Don't get lost in a maze of wires!

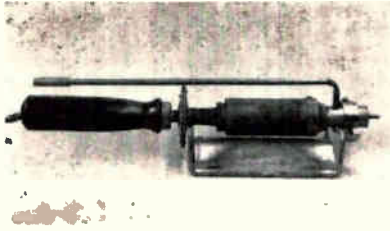

Uncased soldering iron. Tube is hydrogen inlet

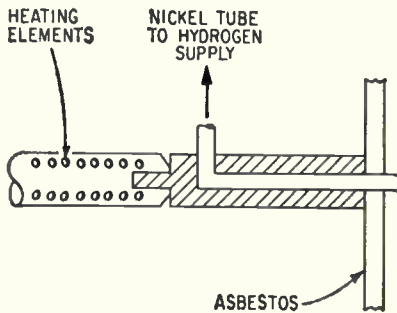
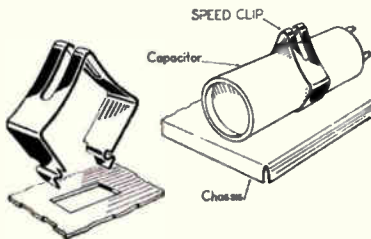

Fig. 1—Cutaway sketch of soldering iron tip in asbestos case

tube. The tube passes through the iron and extends about $\frac{1}{8}$ inch out the front of the housing.

Transistor subassemblies are supplied the operator with nickel leads in a pressure fit against the indium. The operator, using a microscope, dips the subassembly in flux and then holds it in front of the jet with a pair of tweezers. When she sees the indium flow over the nickel wire, indicating a solder bond has been made, the operator removes the assembly from the heat. A water rinse removes flux residue.

Spring-Leg Speed Cup



SPRING STEEL speed clip to hold capacitors, other round parts and cables in place on chassis is announced by Tinnerman Products, Inc., Cleveland, Ohio. The clip is placed over the component and the legs are snapped into a rectangular hole in the chassis, giving vibration-proof retention of the part. To remove the part, 1 leg is pressed to clear the panel and is lifted free. No special tools are required.

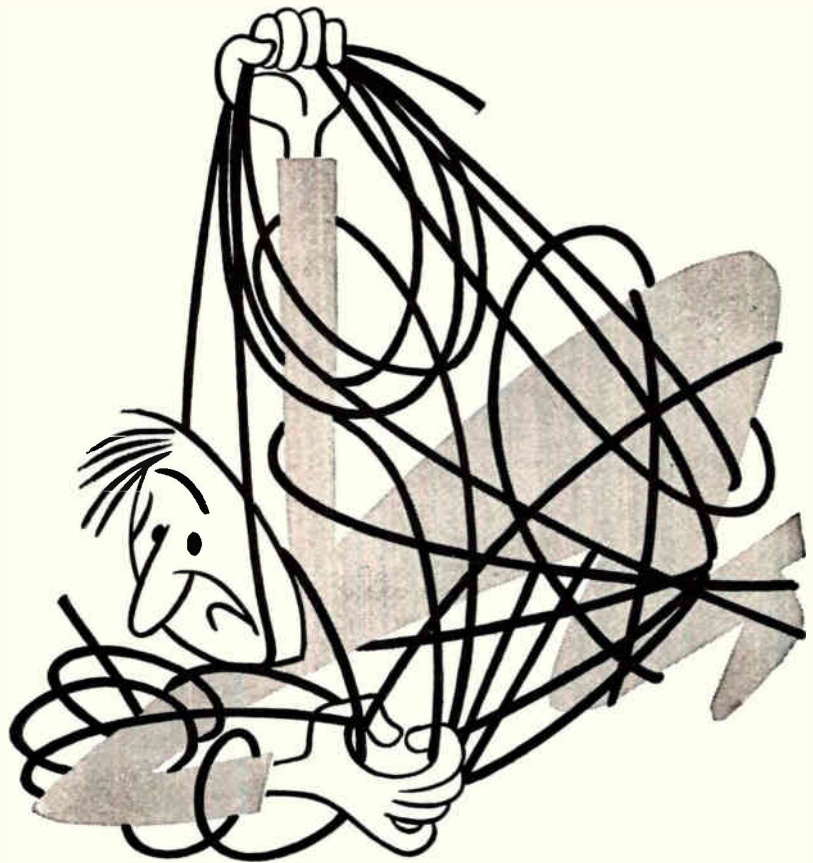

Cut cost of assembly by as much as 65%, with printed circuits on TAYLOR copper-clad laminates



Conventional circuitry is a maze of wire and spaghetti. It is costly to assemble and unpredictable in performance. A printed circuit on TAYLOR rolled copper-clad laminate is a strong prefabricated part of known reliability. This quality is largely due to the new finish on the copper. Both solder and ink go on uniformly. The handling of one part alone can cut assembly costs as much as 65%.

And there is an important passalong benefit: field repairs, when necessary, can be made easier and more economically. Write TAYLOR FIBRE Co., Norristown 40, Pa., for complete details.

Taylor

LAMINATED PLASTICS VULCANIZED FIBRE

ON THE MARKET



Digital Voltmeter 20 models available

COMPUTER EQUIPMENT CORP., 1931 Pontius Ave., Los Angeles 25, Calif. The series-A Digicorder measures millivolts accurately with both a digital visual indication and direct remote electrical readout. Full

scale ranges of zero to 10 mv, 100 mv, 1 v, 10 v, and 100 v are available without the use of external amplifiers. Also, units can be supplied with remote output printer connections for Clary printers, IBM summary punches, or serial drive devices. Circle 200 on Reader Service Card.

Potentiometer 25-turn unit

LITTON INDUSTRIES, INC., 215 S. Fulton Ave., Mt. Vernon, N. Y., has available model MD 20-25, a 25-turn, 2-in. diameter, ultra-precision pot. It has a linearity as close as 0.0075



percent and very high resolution. Unit is equipped with wire lead connections or can be supplied with terminals. Overall length is $2\frac{1}{8}$ in. with a bushing mount; standard servo mounts are also available when required. Circle 201 on Reader Service Card.

Ferrite Material for magnetic cores

KEARFOTT CO., INC., 1500 Main Ave., Clifton, N. J., has developed a new type of ferrite material, MN-31, having high initial and maximum permeabilities together with high saturation magnetization and low

losses in the 10 to 500 kc frequency range. Possessing properties which make the compound ideal for use in magnetic cores, this ferrite was especially developed for use at moderate frequencies and has high inherent resistivity which prevents eddy current losses. Circle 202 on Reader Service Card.

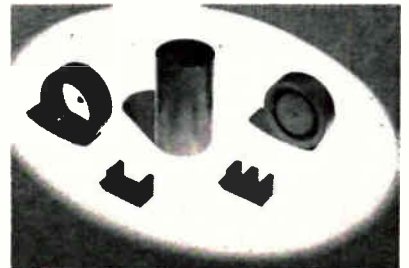

Servo Amplifier high gain

M. TEN BOSCH, INC., Pleasantville, N. Y. Model 1800-0300-2 is a high gain, miniaturized, hermetically-sealed, plug-in transistor servo amplifier. It is primarily intended

to receive signals from a low impedance bridge circuit and to operate a 400 cps servo motor at a maximum power level of approximately 8 w. Unit is designed to meet the environmental requirements of Specification MIL-E-5400A. Circle 203 on Reader Service Card.

Microwave Equipment for 2.6 to 140 kmc

DEMORNAY-BONARDI, 780 So. Arroyo Parkway, Pasadena, Calif.



Equipment for generating, detecting and measuring microwave frequencies up to 140 kmc is announced. Research previously considered impracticable at 140 kmc can

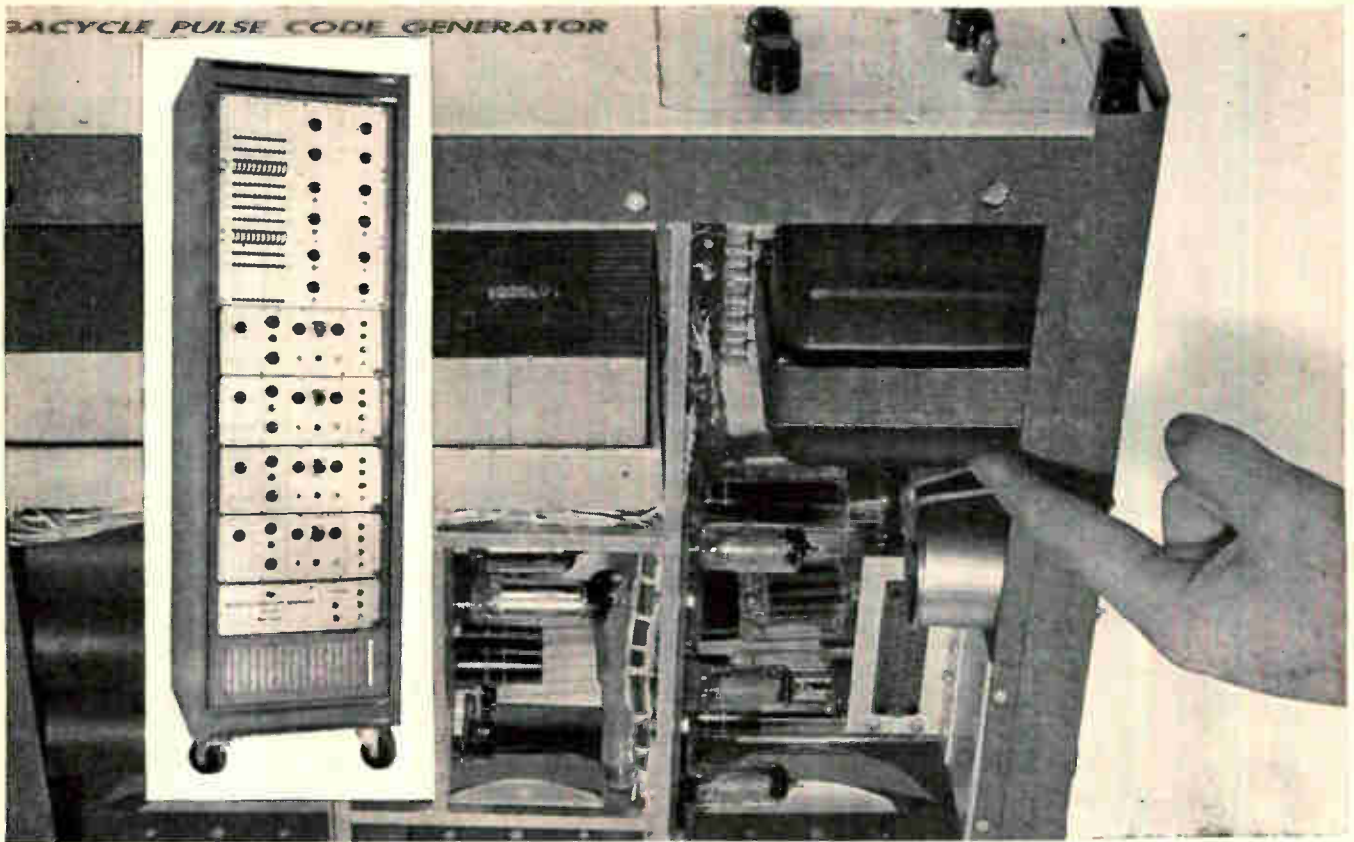

Sola Constant Voltage Filament Transformer is an integral part of this Electro-Pulse, Inc. Megacycle Pulse Code Generator. It provides regulated filament voltage for reliable operation of the equipment and for full life of its electron tubes.

Sola transformer regulates filament voltage within $\pm 1\%$ —protects tubes from inrush currents and line transients

Fluctuations in supply voltage for electron tube filaments can be costly . . . in shortened tube life . . . in substandard performance . . . in equipment downtime. Electro-Pulse, Inc. solved its filament voltage problems through this straightforward approach: the company's Megacycle Pulse Code Generator includes a Sola Constant Voltage Filament Transformer built-in as part of its power supply.

This versatile unit does the step-down job of a conventional transformer and it also regulates the filament supply — a task that ordinary filament transformers don't pretend to do. Filament voltages are stabilized to within $\pm 1\%$ even with line voltage variations as great as $\pm 15\%$. Its current-limiting characteristic protects tubes from cold inrush currents upon starting—as well as from line transients. It is a simple, reliable static-

magnetic regulator with automatic and virtually instantaneous action. Variations in input voltage are usually corrected within 1.5 cycles. There are no tubes or moving parts, and no manual adjustment or maintenance is necessary.

The filament voltage regulator illustrated is only one of a complete line of Sola Constant Voltage Transformers having wide application in electrical and electronic devices. They include such special types as harmonic-free, plate-filament, and adjustable output units—all provide the benefits of regulated input voltage. More than 40 ratings of these compact, economical regulators are available from stock, and Sola manufactures custom-designed units (in production quantities) to meet special needs.

For complete data write for Bulletin 7C-CVF-269

Sola Electric Co., 4633 W. 16th St., Chicago 50, Ill., Bishop 2-1414 • Offices in principal cities • In Canada, Sola Electric (Canada) Ltd., 24 Canmotor Ave., Toronto 18, Ont.

SOLA



CONSTANT VOLTAGE TRANSFORMERS



REGULATED DC POWER SUPPLIES



MERCURY LAMP TRANSFORMERS



FLUORESCENT LAMP BALLASTS

A DIVISION OF BASIC PRODUCTS CORPORATION

now be carried on successfully. Working models only 1/10th actual size are effective. Resolution is better by 10 to 1. The complete line in-

cludes crystal multipliers, crystal mounts, E-H tuners, cavity wave-meters, standing wave detectors, phase shifters, attenuators, elbows,

twists, terminations, standard gain horns, movable shorts, and magic T's. **Circle 204 on Reader Service Card.**

Miniature Pot metal-to-metal bond

BOURNS LABORATORIES, INC., P. O. Box 2112, Riverside, Calif. An improved version of the model 207 Hi-R Trimpot adjustment potentiometer features a fused element-to-



terminal bond which is virtually indestructible under thermal or mechanical stress. Unit has 100 K resistance, and power rating of 2 w at 50 C. Because of its small size seven units can be stacked in less than 2 sq in. of panel space. **Circle 205 on Reader Service Card.**

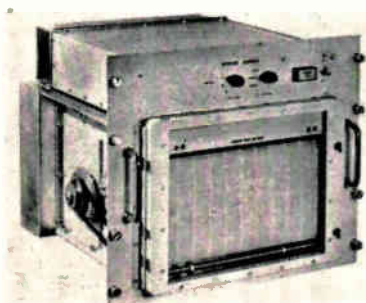

Operations Monitor electric writing

BRUSH INSTRUMENTS, Division of Clevite Corp., 37th and Perkins, Cleveland 14, Ohio, announces an operations monitor for military (MIL-E-4158B) and rigorous industrial applications. Instrument will record, simultaneously, up to

100 separate and distinct operations and events on a moving chart only 12 in. wide. It provides a permanent record of operations and events, indicating their duration and time relationship to each other. Electric writing provides a rapid response of up to 500 signal changes per sec. **Circle 206 on Reader Service Card.**

Converter transistorized

ELECTROSOLIDS CORP., 13745 Saticoy St., Panorama City, Calif., announces the model W-1328 transistorized converter. The transformer-rectifier unit is constructed of *pn*-junction type diodes to effect a

weight saving that results in a 200-ampere unit weighing only 17 lb. The 28-v unit accepts three phase input power at 400 cps, 115/200 v. The converter uses solid state components throughout, with operating life expectancy in excess of 50,000 hr. **Circle 207 on Reader Service Card.**

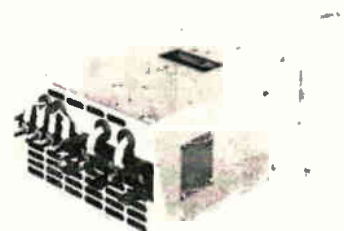

Connector for coax cable

EDLEN INC., 8105 Woodmont Ave., Bethesda 14, Md. The Crimpee CR-8-UF is a solderless, low cost uhf



connector for RG-8-U coaxial cable. Construction of the 50 ohm connector assures 360 deg contact with cable braid and high mechanical strength. The insulator is Teflon. **Circle 208 on Reader Service Card.**

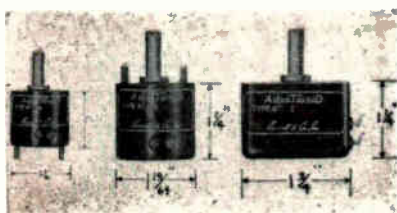

Adjustable Toroids pot and panel mount

BURNELL & CO., 10 Pelham Parkway, Pelham, N. Y., has developed a pot mounting Adjustoroid for panel mounting and knob adjust-

ment to insure easy access wherever slotted controls are difficult to reach. Another recent achievement is a stud mount encapsulated Adjustoroid. Designed for printed circuit use, it provides greater durability in high acceleration, shock and vi-



Our new plant draws workers from 900 square miles!

Each year, the march of mechanization on Shenandoah Valley farms frees a harvest of new industrial manpower. And the Valley's network of modern (fully paid for) highways brings that manpower to your plant parking lot from miles around.

Matching that growing manpower, is VEPCO's growing electric power . . . 1,700,000 kilowatts now, due to top 2,000,000 kilowatts by 1961.

It's proved a winning combination for giants of industry and smaller plants that have come to this land of many resources and pleasant living. For confidential site-finding help, write or telephone



VIRGINIA ELECTRIC and POWER COMPANY

Serving the Top-of-the-South . . . in Virginia, West Virginia and North Carolina

Clark P. Spellman, Mgr., Area Development, Electric Bldg., Richmond 9, Va., MI 9-1411

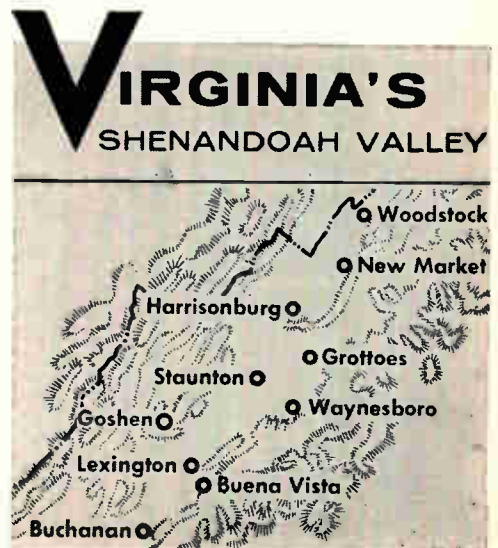

bration environments. Units are supplied hermetically sealed to meet government specifications MIL-E-15305A or encapsulated in many sizes and shapes to fit special applications. Circle 209 on Reader Service Card.

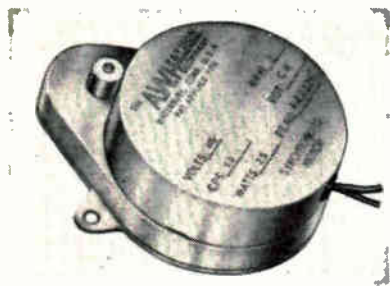

A-C Timing Motors 7/8 in. thick

THE A. W. HAYDON CO., Waterbury, Conn., has introduced the 22100 series extremely thin synchronous timing motors for 25, 50 or 60 cycle operation in five standard voltage ratings. They meet all significant requirements of specification MIL-E-5272A, and are designed for applications where high performance, reliability and immunity to rugged environments are required. Circle 210 on Reader Service Card.

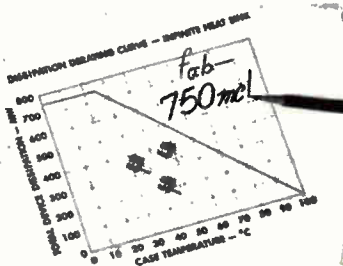

Germanium Transistors diffused-base

TEXAS INSTRUMENTS INC., P. O. Box 312, Dallas, Texas, has available a new series of germanium high frequency, diffused-base "mesa" transistors featuring alpha cutoff frequencies up to 750 mc and power dissipations of 750 mw. Highlighting minimum current gains of 12, 10 and 8 db at 100 mc, the new *mpn* devices operate at junction temperatures up to 100 C with 750 mw power dissipation at 25 C case temperature. Circle 211 on Reader Service Card.

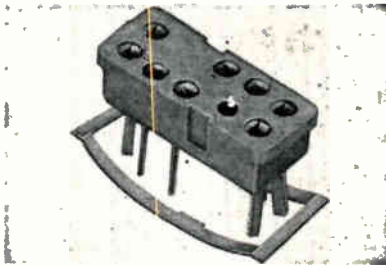

Relay Socket subminiature

ELCO CORP., M St. below Erie Ave., Philadelphia 24, Pa. A new subminiature relay socket mates with the following plug-in type relays: Elgin No. MV2C series, GE No. 352791 series, Ace No. 201 series, Brubaker No. K110 series and others. Current rating is 1 ampere. Withstanding voltage (sea level) is 1,200 v rms; withstanding voltage (3.4 in./Hg), 400 v rms. Contact resistance is 0.03 ohm maximum; insulation resistance, 1,000 megohms minimum. Circle 212 on Reader Service Card.

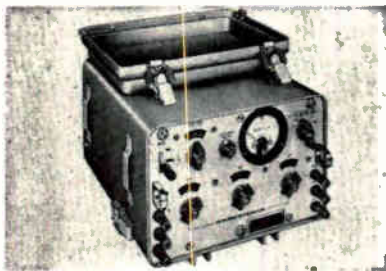

Test Set portable unit

THE DAVEN CO., Livingston, N. J. Model 87 (TS-913)/U is a portable electrical power test set. Unit is used for the adjustment of signal power for the accurate calibration of field transmission measuring instruments and for calibrating test circuits in wire transmission and related equipment. Frequency range is 10 cps to 1 mc. Input impedance is approximately 700 ohms; output impedance is 135, 150 and 600 ohms. Circle 213 on Reader Service Card.

Transformer isolation type

TRIAD TRANSFORMER CORP., 4055 Redwood Ave., Venice, Calif. A new isolation transformer, eliminating

FLIGHT DATA and CONTROL ENGINEERS

Cross new frontiers in system electronics at The Garrett Corporation.

High-level assignments in the design and development of system electronics are available for engineers in the following specialties:

1. ELECTRONIC AND FLIGHT DATA SYSTEMS AND CONTROLS A wide choice of opportunities exists for creative R & D engineers having specialized experience with control devices such as: transducers, flight data computers, Mach sensors, servo-mechanisms, circuit and analog computer designs utilizing transistors, magamps and vacuum tubes.

2. SERVO-MECHANISMS AND ELECTRO-MAGNETICS Requires engineers with experience or academic training in the advanced design, development and application of magamp inductors and transformers.

3. FLIGHT INSTRUMENTS AND TRANSDUCERS

1) DESIGN ANALYSIS Requires engineers capable of performance analysis throughout preliminary design with ability to prepare and coordinate related proposals.

2) DEVELOPMENT Requires engineers skilled with the analysis and synthesis of dynamic systems including design of miniature mechanisms in which low friction freedom from vibration effects and compensation of thermo expansion are important.

4. PROPOSAL AND QUALTEST ENGINEER For specification review, proposal and qualtest analysis and report writing assignments. Three years electronic, electrical or mechanical experience required.

Forward resume to:

Mr. G. D. Bradley

THE GARRETT CORPORATION

9851 S. Sepulveda Blvd.
Los Angeles 45, Calif.

DIVISIONS:

AIResearch Manufacturing—Los Angeles
AIResearch Manufacturing—Phoenix
AIResearch Industrial
Air Cruisers • Airsupply
Aero Engineering
AIResearch Aviation Service

CIRCLE 49 READERS SERVICE CARD

March 6, 1959 — ELECTRONICS

Advanced electro-mechanical systems

AiResearch Spoiler Servo Control System for Canadair's CL-28 and CL-44

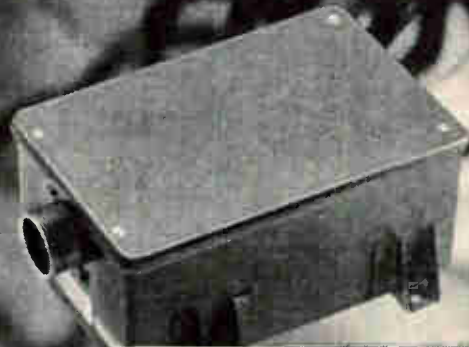
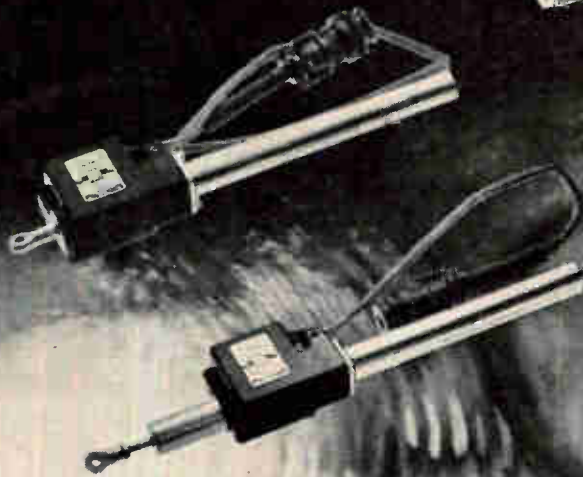
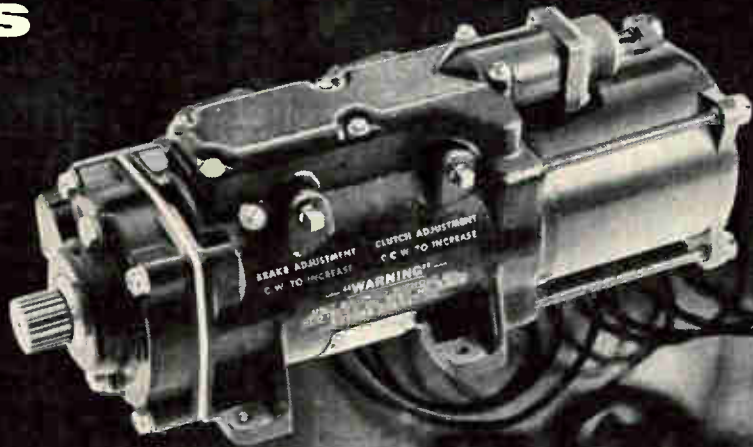

TO PILOT

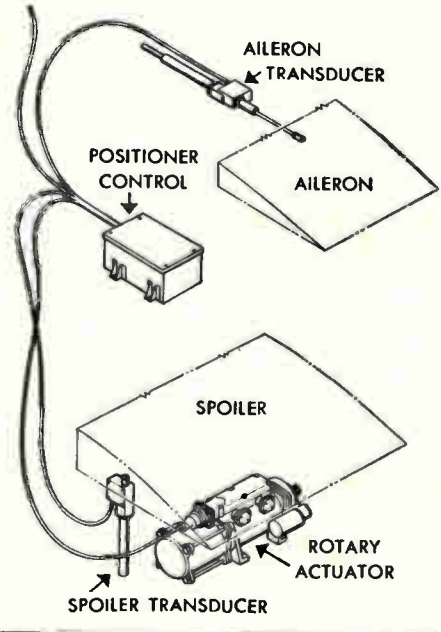

A substantial increase in aileron effectiveness is achieved by the AiResearch Spoiler Servo Control System which augments the function of the aileron by increasing the rate of roll of the aircraft. Full spoiler surface travel is achieved in 0.5 seconds by electromagnetic clutching of the 4 H.P. power servo.

The added control surface of the Spoiler Control Servo System operates on the inboard side of each aileron. This AiResearch electro-mechanical system automatically synchronizes the spoiler control surface to move simultaneously with the aileron by utilizing a magnetic amplifier and position transducers in the closed loop servo system.

This new Spoiler Control System is but one of the many types of electro-mechanical systems developed and manufactured by AiResearch. Other recent examples include radar antenna positioning equipment, magnetron and Klystron tuning devices, and safe-arm mechanisms for missile igniting.

The company's more than 20 years of experience in the development and manufacture of electro-mechanical equipment extends into aircraft, ground handling, ordnance and missile systems of all types. AiResearch capability and system responsibility can meet your specific electro-mechanical requirements. Your inquiries are invited.



ENGINEERING REPRESENTATIVES: AIRSUPPLY AND AERO ENGINEERING, OFFICES IN MAJOR CITIES

THE GARRETT CORPORATION

AiResearch Manufacturing Divisions

Los Angeles 45, California • Phoenix, Arizona

Systems, Packages and Components for: AIRCRAFT, MISSILE, ELECTRONIC, NUCLEAR AND INDUSTRIAL APPLICATIONS

ELECTRONICS — March 6, 1959

CIRCLE 50 READERS SERVICE CARD

PRESENT SUBSCRIBERS

— Please Note!

This subscription coupon is for NEW subscribers. It is not intended as a renewal notice. If you are already personally subscribing, we shall appreciate your passing the form to one of your associates. Thank you.

Mail Reply to: McGraw-Hill Pub. Co., Electronics, 330 W. 42nd St., N. Y. 36, N. Y.



NEW Subscription ORDER FORM

O.K. — put me down for a personal subscription to "electronics" . . . giving me benefit of your weekly editorial service . . .

Check here for 1 year, \$6 for 2 years, \$9 for three years, \$12

Please **One**

- Send bill to home address
- Send bill to Company address
- Payment Attached

Name _____ Position _____ Dept. _____

| |
|--|
| |
| |
| |
| |
| |

Please fill out card completely for best service

Company Name _____

Street _____ City _____ Zone _____ State _____

Products Mfrd. Or Service _____ Number of Employees _____

Check here if you want Publication sent to your home

Street _____ City _____ Zone _____ State _____

Foreign Rates (1 year) Canada \$10, Other Foreign \$20

ground loop feedback in stereophonic sound systems where either amplifiers or preamplifiers use a common ground, has been developed. Providing one to one impedance ratio at 0 dbm from 20 to 20,000 cps, the A-210P is furnished with a standard plug and socket ready for immediate installation at the input connection on either pre-amp. Circle 214 on Reader Service Card.

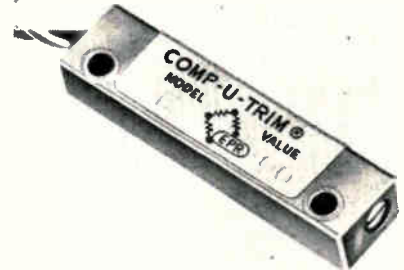

Linear Trimming Pot wire wound

EASTERN PRECISION RESISTOR CORP., 675 Barbey St., Brooklyn 7, N. Y. This wire wound linear trimming pot features an internally positioned wiper contact, a completely encapsulated unit, zero percent end resistance, one piece aluminum housing, positive end stops and 25 percent greater winding area than comparable units. Designed to operate at 1.0 w at temperatures up to 125 C, Comp-U-Trim model E can be mounted singularly or stacked. Measuring only 5/16 in. by 1/4 in. by 1 1/4 in., model E is available in standard resistance values from 10 ohms to 30,000 ohms with a temperature coefficient of 20 parts per million. Circle 215 on Reader Service Card.

Portable Test Set for aircraft

ITT FEDERAL DIVISION of ITT Corp., 100 Kingsland Road, Clifton, N. J. Type NUS3156, a portable test set, provides rapid ground testing of certain civil or military air navigation equipment while it remains undisturbed in an aircraft. The set checks the operation of both the distance- and the direction-measuring equipment of the military's TACAN (Tactical Air Navigation) system and the

distance-measuring equipment of the VORTAC civil air navigation system. Circle 216 on Reader Service Card.

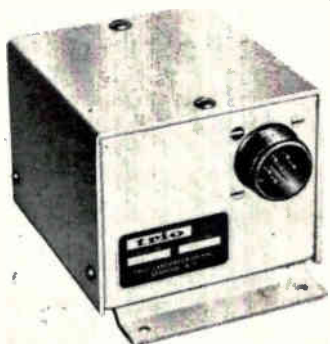

Relay Interlock protects equipment

TRIO LABORATORIES, INC., Plainview, L. I., N. Y. Light-weight and small, the model 113-386 relay interlock, is a relay device that fully protects delicate electronic equipment from failure of any or all phases of three phase 115 v a-c and/or 28 v d-c power. It meets appropriate MIL specs, and is ideal for airborne and missile applications. Circle 217 on Reader Service Card.

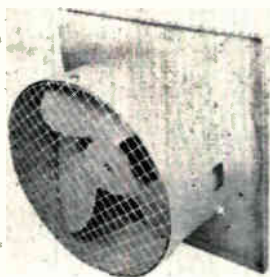

Axial Flow Fan versatile unit

AIR-MARINE MOTORS, INC., 369 Bayview Ave., Amityville, L. I., N. Y., announces a versatile, low cost tube-axial flow fan suitable for cooling electronic cubicles and flushing racks and cabinets. Model Y1241-3 can be readily supplied for commercial or military applications. The 1/150 h-p motor at 1,550 rpm delivers 430 cfm at 0 in. s-p. It operates from 115 v, single phase, 60 cycle source. Dimensions are 11½ in. by 5½ in. deep. Circle 218 on Reader Service Card.



makes computers

REMEMBER

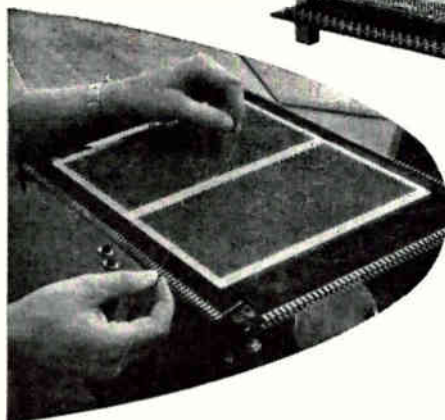
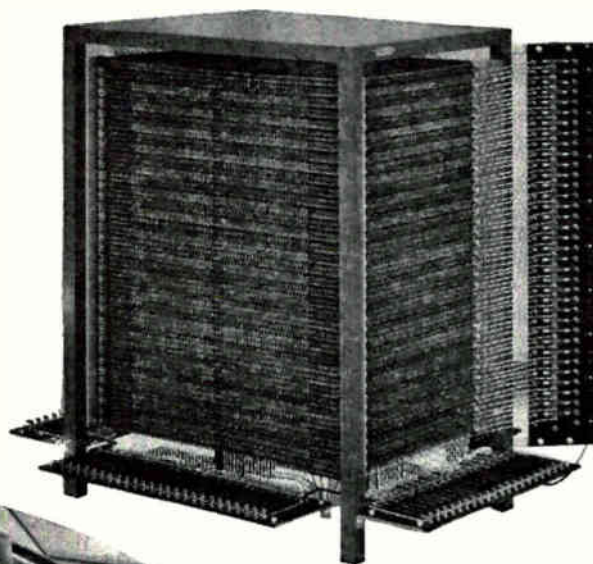

Pictured above is a typical FXC coincident current memory stack; appearing, at left, one of the memory planes used in its assembly.

Time was when the problem of "remembering" placed practical limitations on the speed and capacity of computers. Not so, today, because of a FXC-developed component called the *coincident current memory stack*. Main reason for the outstanding success of this important advancement in magnetic ceramics rests in FXC's ability to meet the computer industry's requirements for ferroxcube cores for recording heads . . . pulse transformers . . . coincident current planes, stacks and similar *precisely engineered* products. Call FXC's Computer Engineering Dept. whenever you need help on a ferroxcube application.



Say
ferroxcube
when you
need ferrite.

FERROXCUBE

CORPORATION OF AMERICA

50 East Bridge Street, Saugerties, New York

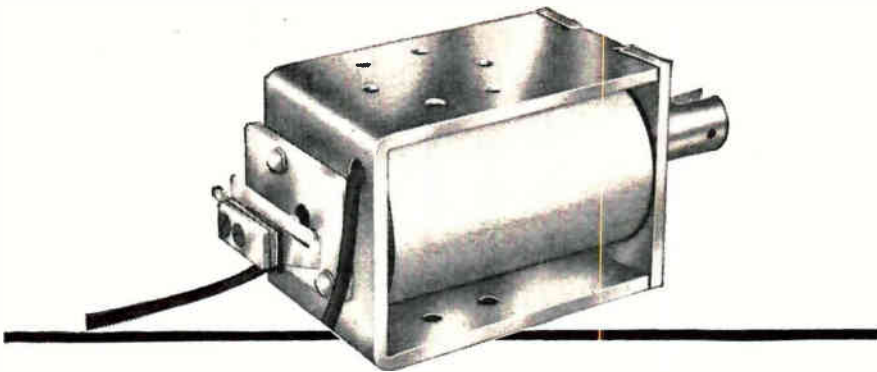

Write for Engineering Bulletins on

PHILLIPS SOLENOIDS



Designed for industrial control applications where long life and reliability are prime requirements. A wide range of types and sizes.

Manufacturers of Sub-Miniature, telephone, power, general purpose relays — solenoids.

Phillips Control Corporation, Joliet 2, Illinois—AN ALLIED PAPER CORPORATION
 SUBSIDIARY — SALES OFFICES: NEW YORK - PHILADELPHIA - BOSTON - SAN FRANCISCO - DENVER - SANTA MONICA - WASHINGTON - WINSTON SALEM - CLEVELAND - DALLAS - SEATTLE - KANSAS CITY - ST. LOUIS - DETROIT
 CIRCLE 53 READERS SERVICE CARD

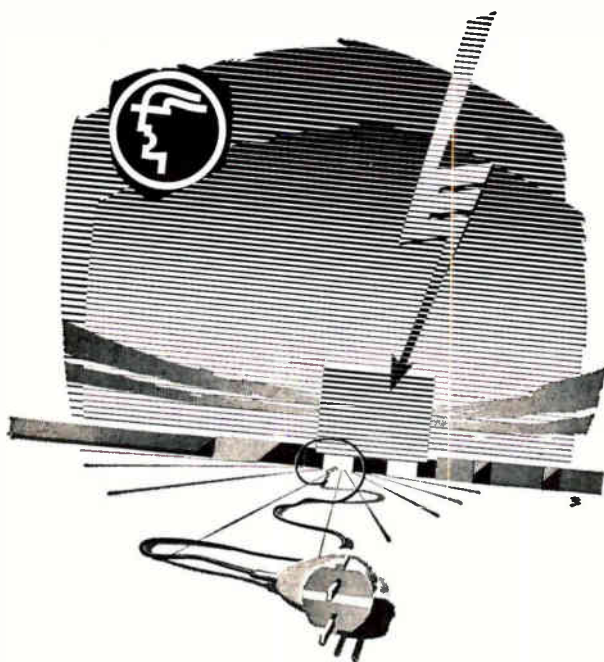

HANNOVER
 the most important Market of the
ELECTRICAL INDUSTRY
 for heavy equipment and consumer goods
GERMAN INDUSTRIES FAIR
 APRIL 26 — MAY 5, 1959

Information and catalogues from:
 German American Trade Promotion Office, Suite 6900 Empire State Bldg., 350 Fifth Ave., New York 1, N. Y.

Literature of

MATERIALS

High Temperature Wires. American Super-Temperature Wires, Inc., Winooski, Vt., has available the 64-page 1959 Super-Temp catalog on Teflon insulated wires and cables. Circle 250 on Reader Service Card.

Germanium. Sylvania Electric Products Inc., Towanda, Pa. A technical information bulletin describes the physical characteristics and purity standards of germanium and germanium dioxide used in the manufacture of semiconductor devices. Circle 251 on Reader Service Card.

Plastics for Electronics. Emerson & Cuming, Inc., 869 Washington St., Canton, Mass. A 20-page brochure entitled "Eccofoam" contains information on both plastic and ceramic foams used primarily in electrical and electronic applications. Circle 252 on Reader Service Card.

COMPONENTS

Fractional H-P Motors. Bodine Electric Co., 2500 W. Bradley Place, Chicago 18, Ill. A completely revised 12-page bulletin lists and describes 300 standard stock reducer and nonreducer motors of various types and sizes. Circle 253 on Reader Service Card.

Pushbutton Actuators. Micro Switch, Freeport, Ill. The new 12MA series of pushbutton actuators for basic switches is the subject of data sheet 155. Circle 254 on Reader Service Card.

Core Testing. Briggs Associates, Inc., 10 DeKalb St., Norristown, Pa. Bulletin 98-1 discusses Robert's constant-current, flux-reset method for testing magnetic amplifier cores. Circle 255 on Reader Service Card.

Potentiometers. Maurey Instrument Corp., 7924 S. Exchange Ave., Chicago 17, Ill., announces a com-

the Week

plete specifications catalog of single turn, wirewound precision potentiometers from 1/2 in. diameter to 3 in. diameter. Circle 256 on Reader Service Card.

EQUIPMENT

Magnetic Reader. McMurry Audio Electronics, Inc., 9740 Washington Blvd., Culver City, Calif. A new brochure describes the design and operation of the model 58 magnetic film and tape reader, a unit which simplifies movie sound editing. Circle 257 on Reader Service Card.

Tape Dispenser. W. H. Brady Co. 727 W. Glendale Ave., Milwaukee 9, Wisc. Bulletin 525 covers the Tapematic which will dispense pre-cut labels, masks or special die-cut shapes made of any pressure-sensitive tape: paper, cloth, foil, film, double-coated. Circle 258 on Reader Service Card.

Pulse Height Analyzers. Radiation Instrument Development Laboratory, Inc., 5737 S. Halsted St., Chicago 21, Ill. "Let's Analyze The Situation" is the title of a new bulletin comparing features of commercially available multichannel pulse height analyzers. Circle 259 on Reader Service Card.

FACILITIES

Transistor Digital Subsystems. Tempo Instrument Inc., 240 Old Country Road, Hicksville, N. Y. An 8-page brochure describes facilities for design, development and production of transistor digital subsystems. Circle 260 on Reader Service Card.

Environmental Testing. BJ Electronics, Borg-Warner Corp., 3300 Newport Blvd., Santa Ana, Calif. Facilities and function of an electronic and electromechanical environmental test laboratory are explained and illustrated in a 6-page folder. Circle 261 on Reader Service Card.

ALPHLEX® ZIPPER TUBING

NEWS

FROM ALPHA  WIRE

NEW CONSTRUCTIONS OF ALPHLEX® ZIPPER TUBING PROVIDE GREATER VERSATILITY



stock sizes: 1/2" to 4" I.D.
IMMEDIATE DELIVERY
WRITE FOR FREE CATALOG E-3

- Alphlex Zipper Tubing is the modern way to harness, cable and protect wire. Just zip to close—and just zip to re-open if you wish, permanent seal. Saves you time, labor, money. Strong, flexible, durable. Versatility unlimited.
- ZIP-31: polyvinyl sheet made from MIL-I-631C materials. All-purpose type, for general applications to 105°C.
- ZIP-44: polyvinyl sheet made from MIL-I-7444A materials. Extremely flexible; for aircraft and low-temperature uses to -67°C.
- ZIP-50: "sandwich" of aluminum foil laminated between 2 sheets of polyvinyl. For 100% RF shielding applications to 105°C.
- ZIP-90: polyvinyl bonded to woven fiberglass sheet per MIL-I-3190A. For rough usage, abrasion resistance, and high-temperature uses to 130°C.

ALPHLEX  **TUBING**

Division Alpha Wire Corporation
200 Varick Street
New York 14, N. Y.

IRE BOOTH 4103
CIRCLE 55 READERS SERVICE CARD

GREEN Pantograph Engravers

ELIMINATE DELAYS!

Keep the work
in your own plant.

PORTABLE
40-POUND
BENCH-
MODEL
106



Famous 2 or 3-dimensional engraver, successfully used by thousands, features 5 positive, accurate pantograph ratios. Versatile ball bearing spindle has three speeds up to 14,000 rpm; height of pantograph and position of cutter are continuously adjustable; one copy carrier (supplied) accepts all standard master type sizes.

The Model 106 has proven incomparable for speed and accuracy . . . yet reasonably priced.

Cutter grinders, rotary tables, master letters, compound slides, name plates and all required accessories. For complete information, write to



**GREEN
INSTRUMENT
COMPANY, INC.**

363 PUTNAM AVENUE, CAMBRIDGE 39, MASS.

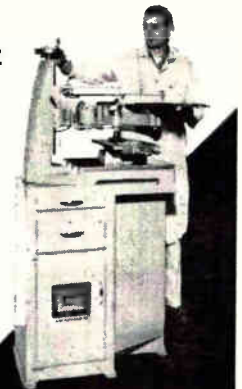

**MODEL D2 HEAVY-DUTY
2-DIMENSIONAL**

- 575 pounds — rigid, sturdy, precise
- Vertical adjustment of copy table automatic with Pantograph
- Unobstructed on three sides to take large work
- Micrometer adjustment for depth of cut
- Ball-bearing construction throughout — super-precision ball bearing spindle
- Spindle speeds up to 26,000 rpm for engraving or machining modern materials
- Ratios 2 to 1 to infinity — master copy area 26" x 10"
- Vertical range over 10"

CIRCLE 56 READERS SERVICE CARD

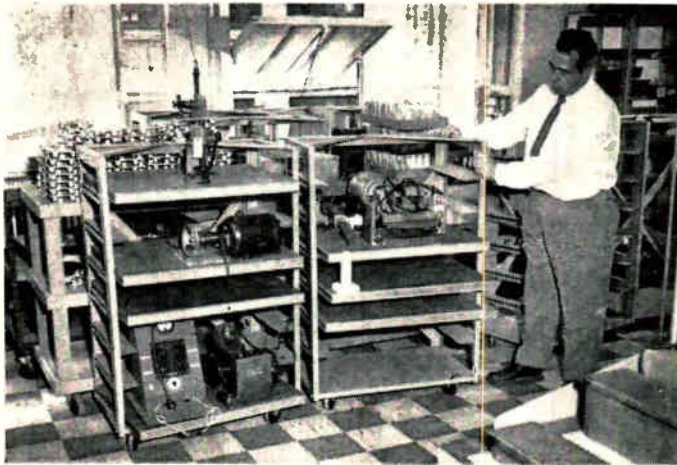

Solve Flexibility Problem

INTERCHANGEABLE tool-mounted bench tops (photo) constitute just one phase of the modernization program recently set up at the Instrument division of Thomas A. Edison Industries, West Orange, N. J.

Producing electronic components for aircraft, missiles, rockets, atomic submarines and industrial systems is not a mass-production operation. Each component is highly specialized, requiring hundreds of tests before the component can be considered "finished". Thus flexibility is of high importance.

In effect, the Instrument Division is a big "job shop", yet efficiency and volume require that operations be standardized to permit fast filling of orders.

More than \$370,000 to date has been spent by the Edison Company to provide new facilities which, officials say, will pay for themselves in one year. Also, centrally located power supplies are permanently installed and connected to busses going all over the labs. This permits a number of men or teams to use the same power supply simultaneously.

Additional economies were realized by reorganizing the Manufacturing and Engineering departments and combining the nearby Roseland plant with the West Orange facilities.

Principal reason for the expenditures in providing plant modernization, according to company officials, is to reduce lead time and fabricating time required to produce the many different products Edison manufactures, and to increase engineering lab and test facilities to permit the company to develop and produce missile guidance sub-systems and other more complicated type products.

In the assembly operation, new benches, specially designed, have been installed. These have removable, three-foot sectional tops. Tools, jigs, fixtures and even welders and presses can be permanently mounted on bench tops which in turn can be moved and shuffled around to create a production line in a matter of minutes. This new flexibility permits Edison to increase a production line to 10 times its size in minutes—or to reduce it to one-tenth its size in the same time.

Mallory Forms Subsidiary

ESTABLISHMENT of a new subsidiary, P. R. Mallory International Inc., to manage its foreign activities and interests, is announced by P. R. Mallory & Co. Inc.

Leon Robbin, a Mallory vice-president and director, has been elected president of the new company, and Hans G. Boehm, vice-president. Robbin will continue as an officer of the parent company.

Other officers are P. R. Mallory, chairman of the board; George Fotheringham, secretary; and Rich-

ard Lee, treasurer. Directors of the new subsidiary are P. R. Mallory, J. E. Cain, G. Barron Mallory, Hans G. Boehm and Leon Robbin. All of the officers and directors are associated with the parent company.

Thomas Joins Servo Corp.

NEWLY appointed development engineer at the railroad products division, Servo Corp. of America, New Hyde Park, N. Y., is Edward Utley Thomas.

Formerly with Union Switch & Signal Co., he has had extensive experience in the railroad and signalling field, and in the design of electronic instrumentation and systems.



Leach Upped to V-P and G-M

J. FRANK LEACH has been promoted to vice president and general manager of the Amphenol connector division of the newly merged Amphenol-Borg Electronics Corp., Chicago, Ill.

He formerly was vice president, manufacturing, of Amphenol Electronics Corp.

Hull Transfers Office to D.C.

DAVID R. HULL, vice president of Raytheon Mfg. Co. and president of the Electronic Industries Associa-

How CDF Di-Clad® can solve your printed-circuit problems

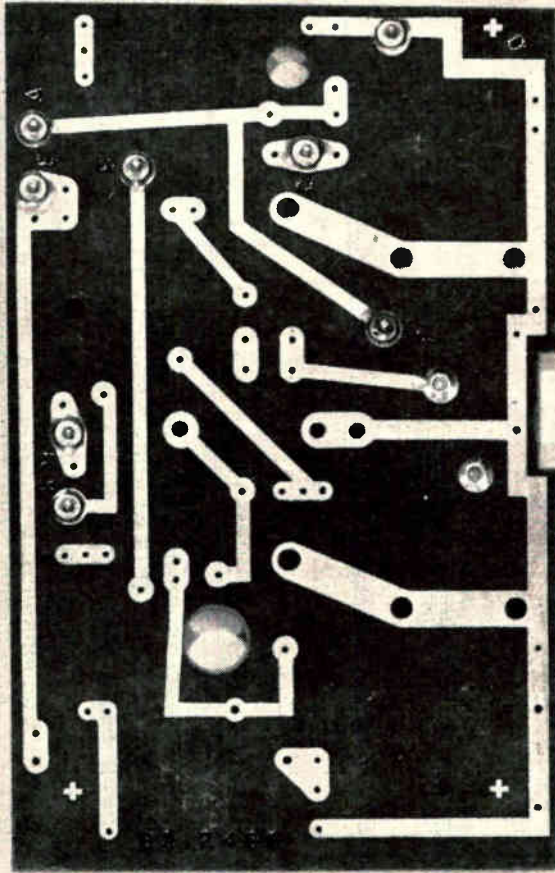

The CDF line of copper-clad laminates in all grades is now known by a new name—Di-Clad. Di-Clad grades meet the varying needs of design, production, and operation of electronic equipment. Grades other than those described are also available.

Di-Clad 28E. For high mechanical strength, low moisture-absorption, and good insulation resistance, CDF Di-Clad laminates of epoxy resin laminated with glass fabric offer the designer a strong, reliable combination.

Di-Clad 112T. A Teflon* glass-fabric laminate offering the best dielectric properties over a wide temperature and frequency range.

Send us your requirements and let our engineers help you select the right grade for your application.

*Du Pont trademark for its tetrafluoroethylene resin.

Di-Clad 2350. An economy paper-base phenolic grade having good tensile, flexural, compressive, and impact strength. Adequate for most non-critical printed-circuit applications. Can be cold punched and sheared up to 5/64 of an inch in thickness.



CONTINENTAL-DIAMOND FIBRE

A SUBSIDIARY OF THE *Bush* COMPANY • NEWARK 16, DEL.

TYPICAL Di-Clad PROPERTY VALUES

| | Di-Clad 2350 | Di-Clad 26 (NEMA XXXP) | Di-Clad 28 (NEMA XXXP) | Di-Clad 28E (NEMA G-10) | Di-Clad 112T Teflon* |
|--|--------------|---------------------------|---------------------------|---|---------------------------------------|
| BOND STRENGTH—0.0014" foil (lbs. reqd. to separate 1" width of foil from laminate) | 6 to 10 | 6 to 10 | 6 to 10 | 8 to 12 | 4 to 8 |
| MAXIMUM CONTINUOUS OPERATING TEMPERATURE (Deg. C.) | 120 | 120 | 120 | 150 | 200 |
| DIELECTRIC STRENGTH (Maximum voltage per mil for 1/16" thickness) | 800 | 900 | 850 | 650 | 700 |
| INSULATION RESISTANCE (Megohms) 96 hrs. at 35°C. & 90% RH (ASTM D257, Fig. 3) | 500 | 150,000 | 600,000 | 100,000 | 75,000 |
| DIELECTRIC CONSTANT 10 ⁶ Cycles | 4.5 | 4.0 | 3.6 | 4.9 | 2.6 |
| DISSIPATION FACTOR 10 ⁶ Cycles | 0.040 | 0.026 | 0.027 | 0.019 | 0.0015 |
| ARC-RESISTANCE (Seconds) | 5 | 10 | 10 | 130 | 180 |
| TENSILE STRENGTH (psi.) | 18,000 | 16,000 | 12,000 | 48,000 | 23,000 |
| FLEXURAL STRENGTH (psi.) | 27,000 | 21,000 | 18,000 | 70,000 | 13,000 |
| IZOD IMPACT STRENGTH edgewise (ft. lbs. per inch of notch) | 0.80 | 0.45 | 0.42 | 12.0 | 6.0 |
| COMPRESSIVE STRENGTH flatwise (psi.) | 32,000 | 28,000 | 25,000 | 62,000 | 20,000 |
| BASE MATERIAL OF LAMINATE | Paper | Paper | Paper | Medium-weave, medium-weight glass cloth | Fine-weave, medium-weight glass cloth |
| COLOR OF UNCLAD LAMINATE | Natural | Natural greenish | Natural | Natural | Natural |

All these standard grades are available with 0.0014" and 0.0028" or thicker electrolytic or rolled copper foil on one or both surfaces. Other metal foils and other resin-and-base combinations can be supplied on special order.

*Du Pont Trademark

PRECISION DEFLECTION WITH COSSOR YOKES

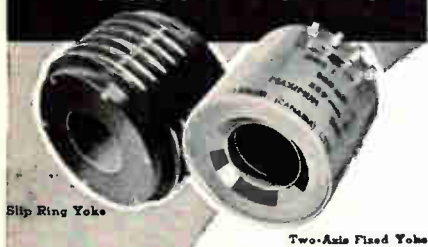

Component Development Engineering at its BEST!

- ADVANCED ELECTRICAL DESIGN
- PRECISION MECHANICAL DESIGN
- ACCURATE PRODUCTION METHODS

Custom Built to the most Exacting Specifications by Cossor Engineers

In Mumetal Cores for Optimum Geometry
In Ferrite Cores for Speed and Sensitivity
In Non-magnetic Cores for Perfection of Response

Any of Cossor's Three Core Types can be made in single or double axis with single or push-pull windings, and encapsulated for fixed or slip ring (rotating) use.

Normal characteristics of yokes for 1-1/2 in. neck tubes are:

Positional accuracy - the spot position will conform to the yoke current co-ordinates within 0.25% of tube diameter. For deflection angles less than $\pm 25^\circ$ better accuracy can easily be achieved.

Memory - 0.5% max. without overswing; 0.1% or less with controlled overswing.

Complete encapsulation in epoxy (stycast) or silicone resins is standard for all Cossor deflection yokes, and is done with special moulding tools ensuring accurate alignment of the yoke axis. When slip rings are added, solid silver rings are mounted in encapsulating resin. The finished slip ring yoke is precision turned to centre bore, and can include bearing mounting surfaces with dimensional tolerances approaching those associated with high quality metal parts.

Settling Time (Micro sec.) - $120 \sqrt{\text{Inductance in Henries}}$

Sensitivity degrees/milliamperes - $0.095 \sqrt{\frac{\text{Inductance - millihenries}}{\text{Accelerator Voltage - kV}}}$



COMPONENTS DIVISION

COSSOR

CANADA LIMITED

301 Windsor St., Halifax, N. S.
8230 Mayrand St., Montreal, Que.
648A Yonge St., Toronto, Ont.
Corporation House, 160 Laurier West, Ottawa, Ont.

CIRCLE 58 READERS SERVICE CARD

tion, has transferred his office from the firm's headquarters in Waltham, Mass., to the company's new offices in Washington, D. C.

Move was made to help develop a closer company relationship between Raytheon and various government agencies and industry, plus increase the effectiveness of the company's contributions to government programs.



Brafman Moves Up At Sprague

APPOINTMENT of Harold E. Brafman to the newly created post of field engineering specialist on mica capacitors at Sprague Electric Co., North Adams, Mass., is announced.

Brafman has been with Sprague since 1941 and was, for many years, superintendent of mica manufacturing operations and, more recently, was in charge of pilot plant operations for new product manufacture.

News of Reps

John Oster Mfg. Co., Racine, Wisc., names John Zaleski of St. Petersburg, Fla., to sell its line of servos, synchros, tachometers, electro-mechanical assemblies and other aircraft electronic components and systems in the entire state of Florida.

Richard C. Nearing, formerly purchasing agent for Gruen Electronic Products and Divco-Wayne

For HIGHEST ELECTRICAL & MECHANICAL EFFICIENCY! New JONES

SERIES 2400 PLUGS & SOCKETS

● Improved Socket Contacts - 4 individual flexing surfaces. Positive contact over practically their entire length.

● Cadmium plated Plug and Socket, Contacts mounted in recessed pockets, greatly increasing leakage distance, INCREASING VOLTAGE RATING.

● Interchangeable with 400 Series.



P-2406-CCT



S-2406-SB

Send for complete Catalog No. 22, Plugs, Sockets, Terminal Strips.

Visit Booth 2535 At The IRE SHOW

Jones HOWARD B. JONES DIVISION
CINCH MANUFACTURING COMPANY
CHICAGO 24 ILLINOIS
DIVISION OF UNITED-CARR FASTENER CORP.

CIRCLE 59 READERS SERVICE CARD

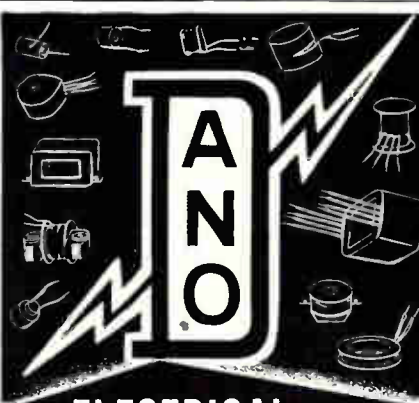

ELECTRICAL COIL WINDINGS

- Encapsulated
- Bobbin
- Paper Interleave
- Cotton Interweave
- Form Wound
- High Temperature

Send us your coil specifications for quotation.

TRANSFORMERS MADE TO ORDER

THE DANO ELECTRIC COMPANY

MAIN STREET • WINSTED, CONN.

CIRCLE 60 READERS SERVICE CARD

March 6, 1959 - ELECTRONICS

Electronics, has established a manufacturers' rep organization under the name of Nearing Associates, with offices in Cincinnati, to serve the territory of southern Ohio, northern Kentucky and eastern Indiana. New firm will represent Van Sell Engineering Corp., Indianapolis manufacturer of precision parts for the electronic and missile fields; Sloan Co., Burbank, Calif., manufacturer of subminiature indicator lights; and manufacturers of related products.

The Syncro Corp., Oxford, Mich., now producing electrolytic and dielectric capacitors at its electronics division plant in Hicksville, Ohio, appoints the following reps:

R. E. Breuer Co., Inc., of New York City, for the east; Clyde H. Schryver of Kansas City, Mo., for central midwest; Forcey Machine Tool Sales of St. Paul, Minn., for north midwest; and Dan Carmichael Sales Co., of Van Nuys, Calif., for the west coast.

National Union Electric Corp., Bloomington, Ill., appoints the following companies as reps for its line of special purpose tubes:

Birou Associates of Dayton, Ohio; O. F. Masin Co., of Pelham, N. Y.; Kenneth W. Meyers Co., of Chicago, Ill.; and Richard A. Strassner Co. of Los Angeles and Redwood City, Calif.

T. R. Jewell of Grand Rapids, Mich., is named to represent the electronics division of the Iron Fireman Mfg. Co., Portland Ore. Jewell will handle sales of Iron Fireman free and vertical gyroscopes, miniature and microminiature relays, and miniature precision slip ring and brush assemblies.

Technical Wire Products, Inc., Springfield, N. J., manufacturer of r-f shielding equipment, recently acquired new reps. J. C. Angel & Co. of Chicago, Ill., will cover Illinois, northern Indiana, Wisconsin and eastern Iowa. The George G. Scott Co. of Glenn Cove, N. Y., will cover western Connecticut, northern New Jersey, and New York State, including New York City and Long Island.

IF you are an experienced electronic engineer, you will find more challenging work ...more job stability...more chance for creative satisfaction...more diversified projects, at

SPERRY GYROSCOPE COMPANY
A Division of Sperry Rand Corp.

GREAT NECK, LONG ISLAND, N. Y.

For confidential interview, contact Mr. J. W. Dwyer, Employment Manager

Fieldstone 7-3665

Project Managers in Missiles, Radars and Countermeasures Engineering



Mc GRAW-HILL
DIRECT MAIL LIST SERVICE

McGraw-Hill Mailing Lists Will Help You

- Merchandise your advertising
- Conduct surveys
- Get inquiries and leads for your salesmen
- Pin-point geographical or functional groups
- Sell direct
- Build up weak territories
- Aid dealer relations

Direct Mail is a necessary supplement to a well rounded Business Paper advertising program.

Most progressive companies allocate a portion of their ad budgets to this second medium at the same time as they concentrate on the best business publications.

600,000 of the top buying influences in the fields covered by the McGraw-Hill publications make up our 150 mailing lists. Pick YOUR prospects out of our Industrial Direct Mail catalogue.

Write for your free copy. It contains complete information.

I Bought My Wife a Sports Car with the **EXTRA MONEY**



I learned in **Mobile-Radio Maintenance!**

Sure, an engineer's pay is good—but mine just wouldn't stretch far enough to give my family all the nice things they deserve. So in my spare time I'm servicing commercial mobile-radios in my home town. And I'm mighty proud to think of my wife driving that new Thunderbird!

This can be your story, too. Send coupon for your free copy of "HOW TO MAKE MONEY IN MOBILE-RADIO MAINTENANCE." Published by Lampkin Laboratories, Inc., manufacturers of the 105-B Micrometer Frequency Meter & 205-A FM Modulation meter.



105-B



205-A

LAMPKIN LABORATORIES, INC.
Instruments Div., Bradenton, Fla.

At no obligation to me please send "HOW TO MAKE MONEY IN MOBILE-RADIO MAINTENANCE."

Name _____
Address _____
City _____ State _____

CIRCLE 62 READERS SERVICE CARD

ATTRACT AND HOLD TECHNICAL PERSONNEL

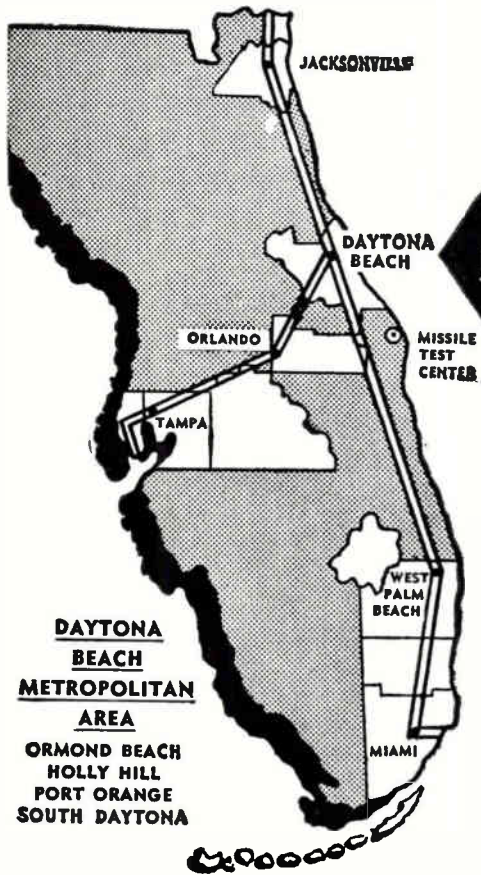

**STRATEGIC
LOCATION FOR
GROWTH INDUSTRIES**
DAYTONA BEACH
FLORIDA
Metropolitan Area
Industrial Sites

Daytona Beach, the east-to-west terminal on the north-to-south route of the projected Federal Limited Access Freeway System, gives industry a plus for the future.

Write for new 101 page
Industrial Brochure
R. H. MILES, MGR.
INDUSTRIAL DEPARTMENT
CHAMBER OF COMMERCE
DAYTONA BEACH, FLORIDA

CIRCLE 63 READERS SERVICE CARD

COMMENT

Bank Bookkeeping

On p 9 of your Jan. 23 issue, you ran an item (in Electronics Newsletter) concerning magnetic-ink character reading. . .

It would seem from the wording that IBM has "at last broken through this problem." Actually, our computer department has such a system already working. . .

PETER H. KINSEY

GENERAL ELECTRIC
PHOENIX, ARIZ.

We did not forget GE's 100-200-210 series of electronic bank bookkeeping equipment, but we must agree that the wording in the Newsletter item doesn't make this clear. The GE system, announced in mid-1958, will start working for Bank of America quite soon.

Magnets

The Jan. 9 issue of your magazine (p 63) contains your article "Hard Magnets for 500 C." I found your article very interesting. . .

A typographical error in Table I should be brought to your attention. Indalloy is listed there with a BH_{max} of 9,000,000 gauss-oersted. I suppose that 900,000 gauss-oersted was actually meant.

R. K. TENZER

INDIANA STEEL PRODUCTS
VALPARAISO, IND.

Reader Tenzer is right.

Insulation

We have read with interest the article entitled "Tape and Film Insulation for Electronic Equipment" in the Jan. 2 number of ELECTRONICS (p 42), but we are somewhat surprised to see that polyester film is classified as class A insulation, and that no reference is made to class E insulations.

In this country there is a rapidly growing interest in polyester film for use in electric motors as a class E material at 120 C, and we should be very interested to hear why you did not include this classification in your article.

For example, we are wondering
(Continued on p 95)

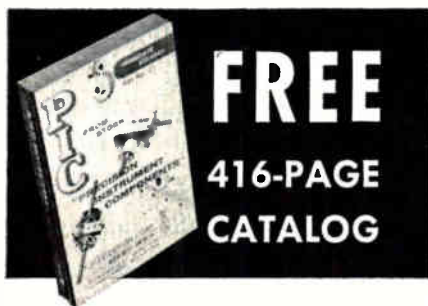

FREE
416-PAGE
CATALOG

Lists over 8,000 Precision Instruments, Parts and Components.

From stock! Complete with Drawings, Full Specifications and Prices.



FREE

14-Piece

"DESIGN-AID" TEMPLATE KIT

14 actual size templates, created to assist you in the design and development of specific mechanical systems.

Send for FREE Catalog
and "Design Aid" Today.

PIC DESIGN CORP.

Subsidiary of BENRUS WATCH COMPANY, Inc.

477 Atlantic Avenue
East Rockaway, L. I., N. Y.

CIRCLE 64 READERS SERVICE CARD

for Results



McGraw-Hill
DIRECT MAIL LIST SERVICE

McGraw-Hill Mailing Lists
Will Help You

- Merchandise your advertising
- Conduct surveys
- Get inquiries and leads for your salesmen
- Pin-point geographical or functional groups
- Sell direct
- Build up weak territories
- Aid dealer relations

Direct Mail is a necessary supplement to a well rounded Business Paper advertising program.

Most progressive companies allocate a portion of their ad budgets to this second medium at the same time as they concentrate on the best business publications.

600,000 of the top buying influences in the fields covered by the McGraw-Hill publications make up our 150 mailing lists. Pick YOUR prospects out of our Industrial Direct Mail catalogue.

Write for your free copy.
It contains complete information.

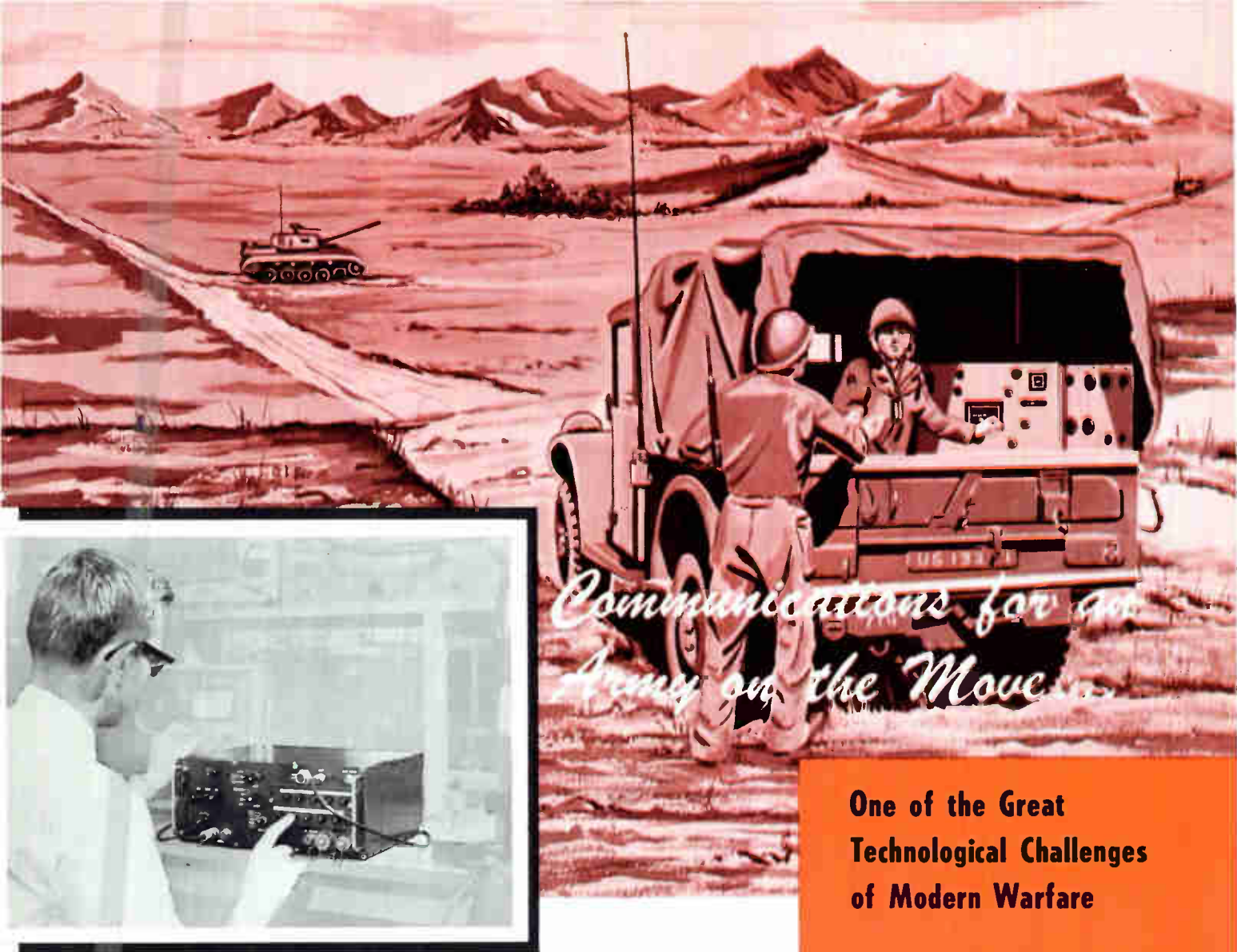

Communications for an Army on the Move

One of the Great Technological Challenges of Modern Warfare

Old vehicular communications systems suffered serious limitations . . . there weren't enough channels, nor was there sufficient range to keep up with fast-moving mobile warfare.

Then, Avco/Crosley engineering answered the challenge with the AN VRC-12, a transistorized system developed in collaboration with the U.S. Army Signal Corps. It provides 920 Crystal Control Channels . . . a range up to 30 miles . . . has extremely high sensitivity . . . operates on a standard vehicular battery . . . and weighs only 45 pounds, requiring merely 1500 cubic inches of space. A product of engineering ingenuity and teamwork, it will forge a strong, new chain of command to strengthen the striking power of U.S. Army mobile forces.

What challenge tomorrow? No one knows . . . but you can be sure that Avco/Crosley engineering will be there with an answer.

OPPORTUNITIES FOR ENGINEERS

In Communications and Navigation

A chance to own a share in America's future security.

Communication and Navigation Systems — Equipment design engineers at all levels required for research and development.

Telemetry and Guidance—Design experience on components and sub-systems in advanced military equipment for drone and weapon control.

Air Traffic Control — Experience with systems comprising radar search, computers, display and vehicle command. System syn-

thesis, analysis and equipment development experience needed.

Radar Surveillance — System and equipment design experience in high power heavy ground radar installations necessary. Acquaintance with associated data handling, computers and decision equipment required.

Technical Writing—Maintenance manuals, instruction books, progress reports, technical proposals and presentations.

Correspondence regarding these positions should be addressed to:
Director, Scientific and Technical Personnel

CROSLEY DIVISION — AVCO

1329-A ARLINGTON ST. • CINCINNATI 25, OHIO



Businesspaper advertising brings you information on new and better products, alerts you to new processes and production methods by which you can improve your own products. That's why it pays to read the advertising in your businesspaper. Helps you keep an ear to the ground for new and important developments you can put to work—profitably.

BETTER PRODUCTS
LOWER PRICES
MORE JOBS

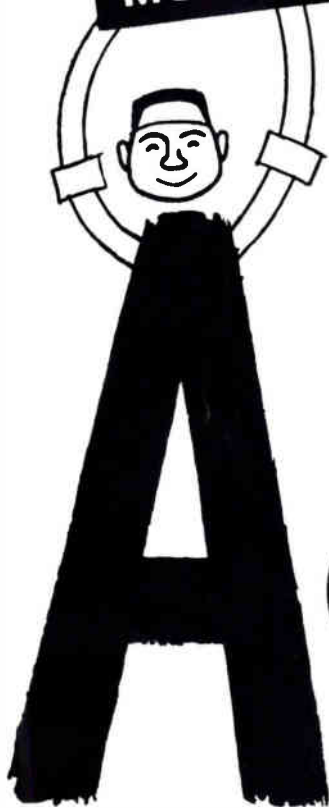

Businesspaper advertising helps to lower prices of the products you buy and sell by broadening markets, building sales volume, bringing you cost-saving opportunities. When you're looking for ways to lower costs and prices . . . give better value . . . and improve profits, it's the editorial pages of your businesspapers that tell you *how*—and the advertising pages that tell you *with what*.

Businesspaper advertising helps create demand, improve products, step-up production, distribution and sales. With new companies, new factories, new products, new services constantly being developed, you get a healthy, vigorous economy—a full-employment economy. Yes, sir! Advertising works. And it works for you.

Advertising works for you!

Advertising Federation of America



Advertising Association of the West





Award-winning 112-page

Minnesota SITE BOOK

Site-see from your desk! This factual brochure shows with photos latest industrial details of 123 Minnesota cities, and lists 424 current site areas with name of local contact. Write, on your firm's letterhead:

Dept. of Business Development
State Capitol, Dept. 437 St. Paul 1, Minn.
CIRCLE 66 READERS SERVICE CARD

sending a bill?

It'll get there quicker if you give your postal delivery zone number with your address.

The Post Office has divided 106 cities into postal delivery zones to speed mail delivery. Be sure to include zone number when writing to these cities, be sure to include your zone number in your return address—after the city, before the state.

whether class E is not recognized in the United States.

G. R. PETRIE

IMPERIAL CHEMICAL INDUSTRIES
LTD.

WELWYN GARDEN CITY, HERTS.
ENGLAND

We used definitions given by American Institute of Electrical Engineers, and cannot recall having seen class E used in this country. Classes A and B, which bracket class E, have been used here for a good many years.

Square Root

I am writing this letter to notify you of a minor error in the article "Dynamic Test of Choke Inductance" (Research & Development, p 54, Jan. 23). The equation

$$R = \frac{2 \sqrt{2} (23)}{I \pi}$$

incorrectly has the square-root sign over the (23).

Also, K was not defined in the article, although it is obviously

$$K = \frac{4 \sqrt{2} E_p}{\pi}$$

BENJAMIN AGUSTA
INTERNATIONAL BUSINESS
MACHINES
POUGHKEEPSIE, N. Y.

Author Agusta catches a printer's error which continued the vinculum over the (23).

I read in your Washington Outlook for Feb. 13 (p 14) that a "top Pentagon official (Roy Johnson, head of Advanced Research Projects Agency) . . . could use at least \$300 million more than the \$445 million the President's budget allows him."

Sure. Who couldn't? But it seems a big price to pay to perpetuate an agency that was supposed to be a temporary one, whose value is questionable, and which straddles the already existing overlap in responsibility of the Air Force and the National Aeronautics & Space Administration.

GENE C. GOODMAN
PHILADELPHIA

NEW! BEATTIE-COLEMAN PROGRAMER

...provides

4 to 2
HOUR
PROGRAM
on 13 channels

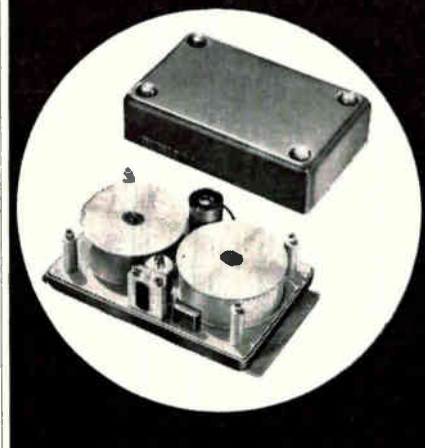

160 feet of punched Mylar tape is accommodated in the new Beattie-Coleman MLPR-13 Programer, providing a completely random program of 252 minutes duration on 13 channels. Extremely accurate time control with no cumulative error. Adjustable to five speeds: $\frac{3}{4}$ ", $\frac{3}{8}$ ", $\frac{3}{4}$ ", $1\frac{1}{2}$ ", and 3" per sec. Weighs less than 5 lbs., is easily removable for loading. Programs can be initiated or altered in a few minutes. Compatible with most missile guidance systems.

Write for complete data on the MLPR-13 and other multi-channel Beattie-Coleman Programers for either repeat cycling or random operation.

B BEATTIE-
C COLEMAN inc.

1000 N. Olive St., Anaheim, California
437 Fifth Avenue, New York, New York
CIRCLE 68 READERS SERVICE CARD

ENGINEERS...PHYSICISTS

NEW opportunities at Motorola in Chicago

give yourself and your family
all the big city advantages at a
relaxed midwest pace, while you
ADVANCE YOUR CAREER

Outstanding career opportunities are waiting at the many Motorola research and development laboratories in the Chicago area. This is your opportunity to advance your career with a swiftly expanding company, working in the most modern and well instrumented laboratories... with liberal employee benefits, including an attractive profit sharing plan and association with men of the highest technical competence.

You'll like living in one of the beautiful suburbs of the playground of the midwest, where there are endless social, cultural, and educational activities to choose from the year-round. Exciting life or quiet life—Chicago offers either.

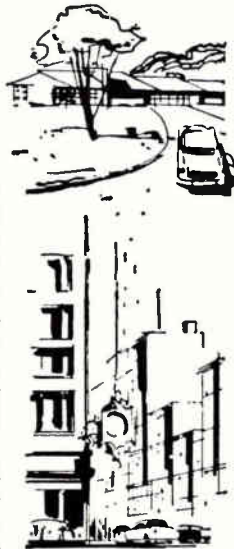

MILITARY POSITIONS OPEN

- Radar transmitters and receivers
- Radar circuit design
- Antenna design
- Electronic countermeasure systems
- Military communications equipment design
- Pulse circuit design
- IF strip design
- Device using klystron, traveling wave tube and backward wave oscillator
- Display and storage devices

CIVILIAN POSITIONS OPEN

2-WAY RADIO COMMUNICATIONS

- VHF & UHF Receiver • Transmitter design & development • Power supply
- Systems Engineering • Selective Signaling • Transistor Applications • Crystal Engineering • Sales Engineers

PORTABLE COMMUNICATIONS

- Design of VHF & UHF FM Communications in portable or subminiature development.

MICROWAVE FIELD ENGINEERS



Write to:
Mr. L. B. Wrenn Dept. D
MOTOROLA, INC.
4501 Augusta Blvd., Chicago 51, Ill.

ALSO . . . there are excellent opportunities in
PHOENIX, ARIZONA • RIVERSIDE, CALIFORNIA



MOTOROLA

AN INVITATION TO JOIN ORO

*Pioneer In
Operations Research*

Operations Research is a young science, earning recognition rapidly as a significant aid to decision-making. It employs the services of mathematicians, physicists, economists, engineers, political scientists, psychologists, and others working on teams to synthesize all phases of a problem.

At ORO, a civilian and non-governmental organization, you will become one of a team assigned to vital military problems in the area of tactics, strategy, logistics, weapons systems analysis and communications.

No other Operations Research organization has the broad experience of ORO. Founded in 1948 by Dr. Ellis A. Johnson, pioneer of U. S. Opsearch, ORO's research findings have influenced decision-making on the highest military levels.

ORO's professional atmosphere encourages those with initiative and imagination to broaden their scientific capabilities. For example, staff members are taught to "program" their own material for the Univac computer so that they can use its services at any time they so desire.

ORO starting salaries are competitive with those of industry and other private research organizations. Promotions are based solely on merit. The "fringe" benefits offered are ahead of those given by many companies.

The cultural and historical features which attract visitors to Washington, D. C. are but a short drive from the pleasant Bethesda suburb in which ORO is located. Attractive homes and apartments are within walking distance and readily available in all price ranges. Schools are excellent.

*For further information write:
Professional Appointments*

OPERATIONS RESEARCH OFFICE **ORO**

The Johns Hopkins University

6935 ARLINGTON ROAD
BETHESDA 14, MARYLAND

ENGINEERS

Why engineering staff turnover at General Electric's Heavy Military Electronics Dept. is less than 3½%

A Success Story of Particular Interest To The Engineer Capable of More Creative Productivity

There are many reasons for Heavy Military's remarkable turnover record. We believe that the preponderant factor is Heavy Military's policy of advancement based *solely* on individual contributions. Where a man goes—how fast he goes—is not determined by artificial standards: degrees, "salary norms," age, seniority. Recognition and remuneration, under our Salary Administration Plan, increase directly with accomplishment. And there are *two* parallel paths of advancement: as specialist consultant — or as manager-supervisor, with equal compensation and status.

The result? Professional achievements that have steadily enlarged Heavy Military's responsibilities. This has meant a 5-fold growth of the professional staff; a 4-fold increase in number of engineering management and supervisory positions in just 4 years.

Does this environment of vigorous accomplishment appeal to you?

If so, look into Heavy Military's openings on long-range projects in *all* the areas listed to the right:

There are many reasons for Heavy Military's remarkable turnover record. We believe that the preponderant factor is Heavy Military's policy of advancement based *solely* on individual contributions. Where a man goes—how fast he goes—is not determined by artificial standards: degrees, "salary norms," age, seniority. Recognition and remuneration, under our Salary Administration Plan, increase directly with accomplishment. And there are *two* parallel paths of advancement: as specialist consultant — or as manager-supervisor, with equal compensation and status.

Radiometry

3-D Radar Systems
Ultra-Range Radars

Data Processing

Sophisticated Display
Digital Detector Trackers
Integrated Air-Defense Environments
Air-Space Management Systems

Unconventional Communications Systems

Synchronous and Scatter Systems
Secure Communications
High-Speed Data Links
Space Communications

Advanced Sonar Systems

Long-Range Search Sonar
Doppler Sonar
Secure Underwater Communications
Mine Warfare Sonar

Your confidential resume will receive careful attention.

Write to: MR. GEORGE B. CALLENDER, DIV. 69-WI
HEAVY MILITARY ELECTRONICS DEPARTMENT

GENERAL  ELECTRIC

COURT STREET, SYRACUSE, N. Y.

A 4-year
average including
transfers to other
G-E components,
retirements, etc.

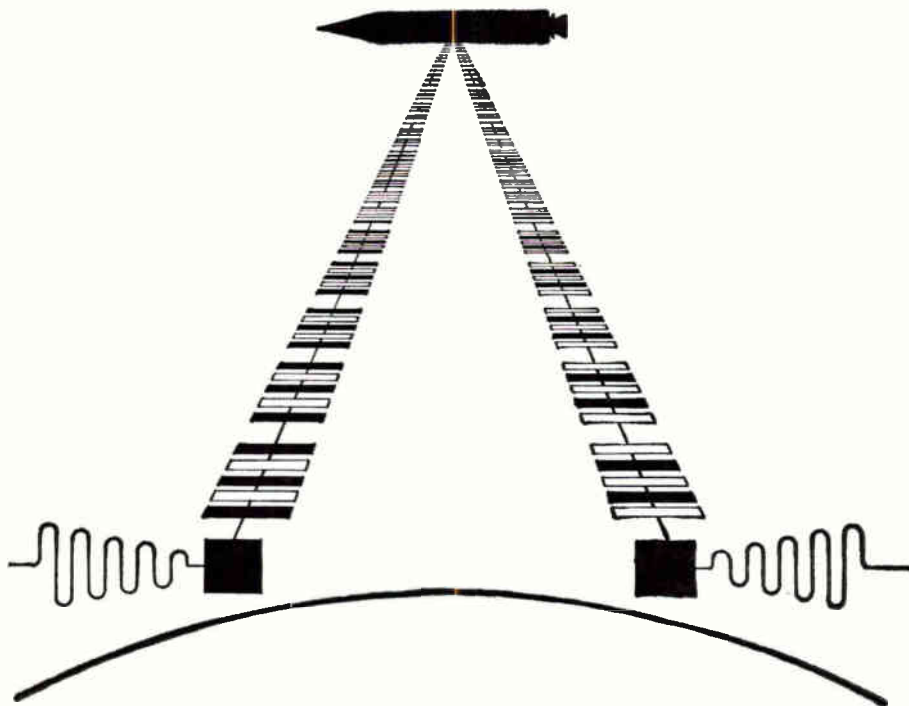

Probing Electronic Frontiers With MELPAR

Our mission is simply stated: advancing the state of the art in electronics to satisfy the demands of the space age and the increasingly complex problems of defense.

To the experienced engineer with an inquiring mind we extend an opportunity to blaze new technological trails and to constantly explore the parameters of his personal ability.

DURING THE I.R.E. SHOW, members of our technical staff will be available for interviews.

Opportunities are available in the following areas of Melpar's diversified activities:

Reconnaissance Systems Engineering Department

- Airborne Equipment
- Ground Data Handling Equipment
- Ground Support Equipment
- Simulation & Training Systems

Communication & Navigation Systems

- Detection & Identification Systems
- Chemistry Laboratory
- Antenna & Radiation Systems
- Applied Physics Laboratory
- Analysis & Computation Laboratory

For details about these openings and facts on a dynamically growing organization, write to:
Technical Personnel Representative



MELPAR Incorporated

A Subsidiary of Westinghouse Air Brake Company
3008 Arlington Boulevard, Falls Church, Virginia
10 miles from Washington, D. C.

A FINER CLIMATE



TO WORK IN...



...TO LIVE IN

*At Sylvania's
Mountain View Operations
in California
(SAN FRANCISCO BAY AREA)*

*you'll discover
more than just one
kind of climate.*

PROFESSIONAL CLIMATE—Advanced programs will challenge your technical creativity. You'll make major contributions in the fields of electronic defense, radar, communications and data processing systems. Because Sylvania is one of the nation's fastest growing electronics organizations, there are an unusual number of growth opportunities.

LIVING CLIMATE—You and your family will enjoy the healthful atmosphere and sunny climate of the San Francisco Peninsula. You'll find plentiful housing, excellent shops, fine schools and year round recreation.

Openings in:

System Studies / Circuit Design / Computers & Data Handling / Electronic Packaging / Development Engineering / Concept & Planning / Advanced ECM Circuitry / Equipment Development / Product Engineering / Tube Engineering / Tube Application Engineering / Mechanical Engineering / Tube Production Engineering / Theoretical Physics / Experimental Physics / Mathematics / Microwave Engineering.

You may communicate in confidence to Wayne L. Pearson

MOUNTAIN VIEW OPERATIONS



SYLVANIA ELECTRIC PRODUCTS INC.

P.O. Box 188
Mountain View, California



complete systems

- missile tracking**
- ground-space communications**
- airborne instrumentation**
- range design and operations**
- data processing**

these are the pursuits of

PHILCO

WESTERN DEVELOPMENT LABORATORIES

PALO ALTO

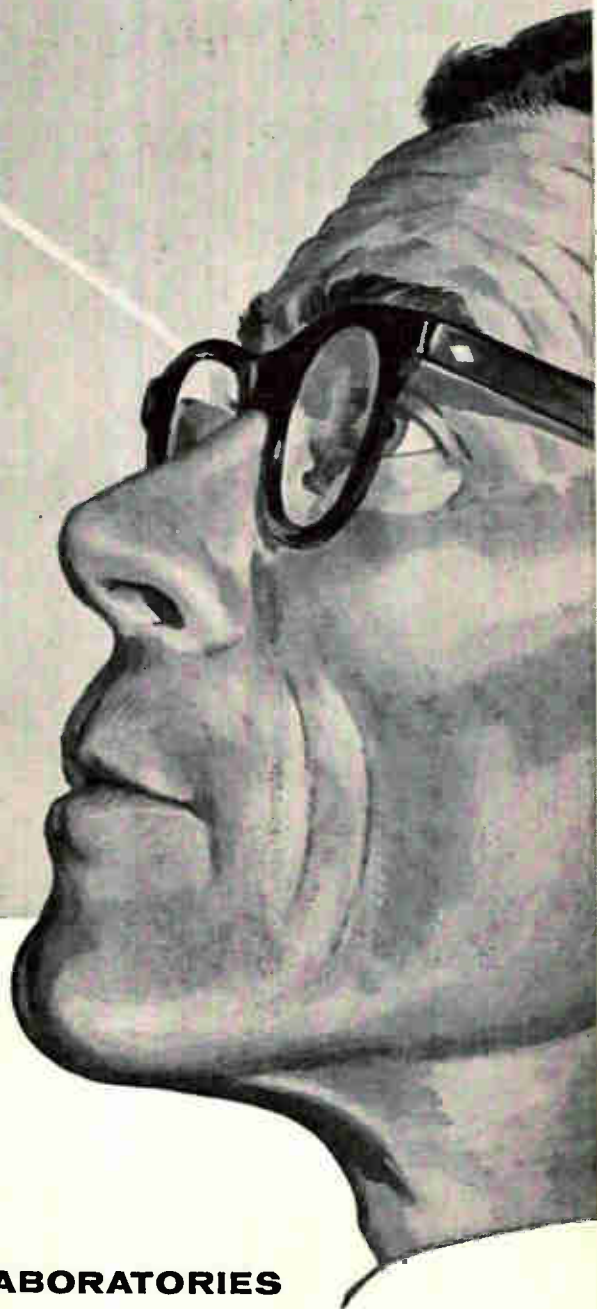

For industry, for the military . . . for ground, air or space . . . electronic and electromechanical systems designed and developed in superb new Palo Alto facilities . . . by the world's finest new team of senior specialists.

A rewarding share in this can be yours; your confidential inquiry is invited. Urgently needed:

Ph.D., MS, BS in

- ELECTRONIC ENGINEERING ENGINEERING PHYSICS
- MECHANICAL ENGINEERING MATHEMATICS

experienced in any of our basic pursuits in military electronic systems. Please write H. C. Horsley, Dept. E.

PHILCO WESTERN DEVELOPMENT LABORATORIES

3875 Fabian Way, Palo Alto, California

A part of the Government and Industrial Division of Philco Corporation

6184



Measuring phase stability vs. temperature during prototype equipment development



Developmental helical antenna, part of sophisticated new direction-finder system



Pattern measurements—vital to development of microwave dish antennas



60' parabolic receiving antenna for missile telemetry and tracking

Immediate Openings at ELECTRIC BOAT DIVISION OF GENERAL DYNAMICS CORPORATION



Birthplace of the Atomic Submarine

Now Building first 2 Ballistic Missile POLARIS Subs

RESEARCH & DEVELOPMENT DEPARTMENT

ELECTRICAL SYSTEMS EE, ME or Physics degree required. Responsible for conceptual engineering and system analysis of large complex devices employing a combination of electrical, electronic, electro-mechanical, hydraulic and pneumatic systems. Should be familiar with servomechanisms theory, experienced in use of analog or digital computers as a design tool, and have a good grasp of mathematics. Will work on proposal preparation, feasibility studies and execution of hardware contracts.

CIRCUITS—BSEE or Physics Responsible for conceptual and production engineering of electronic equipment. Familiar with servomechanisms and analog computer theory. Experienced in use of semiconductors, magnetic amplifiers, and vacuum tube circuit elements; good grasp of mathematics.

SERVOMECHANISMS For engineering design of servomechanisms in both the instrument and multiple horsepower class. Will interpret performance specifications and be responsible for design of a system including stability studies and the calculation of other performance criteria.

ENGINEERING SECTION-DESIGN DEPARTMENT

Circuit Development and Systems Installation assignments concerning application of missile fire control and shipboard navigation systems. Requires EE degree and minimum of 2 years missile or navigation system experience.

Development of Circuits and Equipment in conjunction with missile and navigation systems installations aboard submarines. Requires EE degree with advanced courses and experience in servomechanisms.

The professional development offered engineers at Electric Boat—largest and most highly trained engineering and design staff of any private shipyard in the United States—is outstanding in every way.

Electric Boat's location, in the New England community of Groton on the Connecticut shore near New London, provides excellent living and working conditions—just half way between New York and Boston. To arrange interview appointment, send resume to James P. O'Brien, Technical Employment Supervisor.

GENERAL DYNAMICS CORPORATION

ELECTRIC BOAT DIVISION

Groton, Connecticut



name your sport

Whatever your sport, you'll find it in abundance in Florida and you can enjoy an interesting career to boot with fast-growing Radiation, Inc. The climate here is ideal for outdoor sports the year around.

We have many openings for challenging and rewarding work in electronic design and development. Radiation is well known in DATA PROCESSING, TELEMETRY, ANTENNAS, INSTRUMENTATION, and other areas of MISSILE ELECTRONICS. Our stable growth indicates a secure future with professional advancement for qualified electronic engineers with ideas and energy.

Write today for complete details on opportunities available.

Technical Personnel Dept. 36



ELECTRICAL ENGINEERS

Challenging positions open for high calibre Electrical Engineers with 2 to 5 years experience to work in interesting research and development programs in instrumentation and circuitry. We offer you an opportunity to use your initiative and creative ability.

Excellent employee benefits including liberal vacation policy. Please send resume to:

E. P. Bloch

ARMOUR RESEARCH FOUNDATION

of
Illinois Institute of Technology
10 West 35th Street
Chicago 16, Illinois

ENGINEERS

Progressive research and development concern in the Chicago area is in need of several capable engineers to complete their expansion program. E. E. or Physicist with a good mathematical background will have an excellent opportunity for advancement. Will consider recent grads. Profit sharing plus usual fringe benefits. Reply in confidence.

P-9786 Electronics
520 N. Michigan Ave., Chicago 11, Ill.

TWO INSTRUCTORS

for instrumentation courses in training school

Conducted by long-established, major instrument-manufacturer. Previous teaching experience desirable, with degree in physics or electrical, mechanical, or chemical engineering. Duties include organizing and conducting one-week to three-month courses, repeated several times yearly, for field-engineering trainees of company and for customers' instrument-technicians. Subject matter covers operating principles, construction, installation, and maintenance of indicators, recorders, controllers, and telemetering equipment for pressure, temperature, flow, liquid-level, etc.; self-balancing potentiometers and bridges; pneumatic and electric valves; etc. These are new jobs created because of steadily increasing demand for company's products and services. Salary is open and will be made definitely attractive to the right men.

Write C. F. Johnson, Manager Education
THE BRISTOL COMPANY
Waterbury 20, Connecticut

POSITION VACANT

Instrument Engineer for expanding Middle Atlantic States paper mill. Electrical background desirable, minimum three years' industrial experience and college degree required. Excellent opportunity for top-flight engineer. Replies will be treated confidentially. P-9951, Electronics, Class. Adv. Div., P. O. Box 12, New York 36, N. Y.



MANUFACTURERS' REPRESENTATIVES
IN THE ELECTRONIC INDUSTRY
CONTRACT RATES GIVEN ON REQUEST. WRITE
ELECTRONICS

SAMUEL K. MACDONALD, INC.

manufacturers representatives over 25 years
1531 SPRUCE STREET, PHILA. 2, PA.

Territory:
Pennsylvania • New Jersey
Delaware • Maryland
Virginia • West Virginia
District of Columbia

Other Offices:
Pittsburgh
Baltimore
Washington, D.C.

PROFESSIONAL SERVICES

CROSBY LABORATORIES, INC.
Murray G. Crosby & Staff
 Radio - Electronics
 Research Development & Manufacturing
 Communications, FM & TV
 299 Robbins Lane, Syosset, New York
 WE 1-3191

ERCO RADIO LABORATORIES, INC.
Radio Communications Equipment
 Engineering - Design - Development - Production
 Our 30th Year in Air to Ground
 Communication and Radio Beacons
 Garden City • Long Island • New York

ALBERT PREISMAN
Consulting Engineer
 Television, Pulse Techniques, Video
 Amplifiers, Patent technical consultation.
 616 St. Andrews Lane, Silver Spring, Maryland

For Additional Information

About Classified Advertising,

Contact
The McGraw-Hill Office
 Nearest You

| | |
|---|---|
| ATLANTA, 3 1301 Rhodes-Haverty Bldg. JACKSON 3-6951 M. MILLER | DETROIT, 26 856 Penobscot Bldg. WOODWARD 2-1793 D. M. WATSON |
| BOSTON, 16 350 Park Square HUBBARD 2-7160 D. J. CASSIDY | LOS ANGELES, 17 1125 W. 6 St. HUNLEY 2-5450 T. H. HUNTER |
| CHICAGO, 11 520 No. Michigan Ave. MOHAWK 4-5800 W. HIGGENS D. C. JACKMAN | NEW YORK, 36 500 Fifth Ave. OXFORD 5-5959 H. T. BUCHANAN R. P. LAWLESS |
| CLEVELAND, 13 1164 Illuminating Bldg. SUPERIOR 1-7000 P. M. SULLIVAN W. B. BUTTS | PHILADELPHIA, 3 Six Penn Center Plaza LOCUST 8-4330 H. W. BOZARTH T. W. McCLURE |
| DALLAS, 2 1712 Commerce St. Vaughn Bldg. Riverside 7-5117 GORDON JONES F. E. HOLLAND | ST. LOUIS, 8 3615 Olive St. JEFFERSON 5-4867 |
| | SAN FRANCISCO, 4 68 Post St. DOUGLAS 2-4600 R. ALCORN |

SEARCHLIGHT SECTION

(Classified Advertising)

BUSINESS OPPORTUNITIES

EQUIPMENT - USED or RESALE

DISPLAYED

RATES

UNDISPLAYED

The advertising is \$24.75 per inch for all advertising other than on a contract basis. AN ADVERTISING INCH is measured 7/8" vert. on a column, 3 cols.—30 inches—to a page. EQUIPMENT WANTED or FOR SALE ADVERTISEMENTS acceptable only in Displayed Style.

\$2.40 a line, minimum 3 lines. To figure advance payment count 5 average words as a line. BOX NUMBERS count as one line additional.

DISCOUNT of 10% if full payment is made in advance for four consecutive insertions.

Send NEW ADVERTISEMENTS or Inquiries to Classified Adv. Div. of Electronics, P. O. Box 12, N. Y. 36, N. Y.
 The publisher cannot accept advertising in the Searchlight Section, which lists the names of the manufacturers of resistors, capacitors, rheostats, and potentiometers or other names designed to describe such products.

GLASS TUBING

PYREX - NONEX - URANIUM
 BULB & CYLINDERS
 WRITE FOR FREE MONTHLY LIST
 HOUE SUPPLY COMPANY
 PHONE COLFAX 4-1286
 P.O. Box 206 Keyport, N. J.

GENUINE OAK WOOD

Antique

TELEPHONES

As is \$9.00 complete. Tested working order \$12.00. Shipments FOB Simpson, Pa. Write for free list. TELEPHONE ENGINEERING CO. Dept. E-49 Simpson, Pa.



COLLINS 51J3 RECEIVERS

Like new, \$750.00.

GIZMOS & SUCH
 Still River, Mass.

SEARCHLIGHT Equipment Spotting Service

This service is aimed at helping you, the reader of "SEARCHLIGHT", to locate surplus new and used electronic equipment and components not currently advertised. (This service is for USER-BUYERS only) No charge or obligation.

How to use: Check the dealer ads to see if what you want is not currently advertised. If not, send us the specifications of the equipment wanted on the coupon below, or on your company letterhead to:

Searchlight Equipment Spotting Service

c/o ELECTRONICS

P. O. Box 12, N. Y. 36, N. Y.

Your requirements will be brought promptly to the attention of the equipment dealers advertising in this section. You will receive replies directly from them.

Searchlight Equipment Spotting Service

c/o ELECTRONICS
 P. O. Box 12, N. Y. 36, N. Y.

Please help up locate the following equipment components.

.....

 NAME
 TITLE
 COMPANY
 STREET
 CITY3/6/59

NEED METERS? STANDARD or SPECIALS

ANY QUANTITY—NEW—MILITARY

FOR ELECTRONIC—MILITARY
 AIRCRAFT—HAMS

ALL MAKES—MODELS
 RANGES—SIZES

METERS REPAIRED
 RESCALED
 RECALIBRATED

WRITE - PHONE - WIRE

A & M INSTRUMENT SERVICE INC.

76-14 Woodside Ave.
 Elmhurst 73, N. Y.

CAA No. 4264 Ltd. HA 9-2925

WE BUY . . .

ALLEN-BRADLEY

RESISTORS and
 POTENTIOMETERS

at highest prices.

Submit your offerings To:

LEGRI S. COMPANY

391 Riverdale Ave.
 YONKERS 5, NEW YORK

R A D A R

From Stock Delivery

Skysweep Antenna Pedestal. SCR 584 & 784
 Search-track Radars. MPN-1B GCA. APS-10,
 APS-31, APS-33 Airborne.

Navy Weather-Eye Radars

RADIO RESEARCH INSTRUMENT CO.

550 Fifth Avenue, N. Y. 36, N. Y. JUDSON 6-4691

All Brand RESISTORS

Type J Potentiometers Single-Duals-Triples
 Type G Miniature Potentiometers
 By Return Mail . . . From Stock

LEGRI S COMPANY

391 Riverdale Ave. Yonkers 5, N. Y.

Can You Use These **NEW** JUNCTION TERMINAL BUSHINGS?



1. On final production test lines, quick-disconnect feature has saved time and simplified removal of defective parts.
2. Color coded, the bushings speed assembly and insure correct harness connections.
3. They speed up and simplify the removal and testing of component assemblies.

THREE TERMINAL STYLES
mate with existing female terminations



SOLDER • CRIMP • QUICK-DISCONNECT

**Send for samples and
try them on your
products**

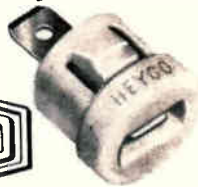

**HEYMAN
MANUFACTURING CO.**
KENILWORTH 2, NEW JERSEY
Manufacturers of the Industry Famous
HEYCO STRAIN RELIEF BUSHINGS

CIRCLE 69 READERS SERVICE CARD

INDEX TO ADVERTISERS

| | | | |
|---|-----------|---------------------------------------|-----------|
| Addo-X | 61 | *Phillips Control Corp. | 86 |
| Aetna Life Insurance Co. | 2 | PIC Design Corp. | 92 |
| *Alpha Wire Corporation. | 87 | | |
| | | *Radio Corporation of America. | 4th Cover |
| *Barnstead Still & Sterilizer Co. | 12 | Ramo-Woolldridge Div. of Thompson | |
| Beuttie-Coleman, Inc. | 95 | Ramo Woolldridge Inc. | 13 |
| *Bendix Aviation Corp. | | *Raytheon Mfg. Co. | 5 |
| Scintilla Division | 23 | Rotron Mfg. Co., Inc. | 88 |
| Black & Webster, Inc. | 20 | | |
| *Brush Instruments Div. of Clevite | | | |
| Corp. | 40 | *Sola Electric Co. | 77 |
| *Burnell & Co., Inc. | 84 | *Sperry Gyroscope Company. | 91 |
| | | Sprague Electric Co. | 32, 33 |
| Consolidated Electrodynamics | 25 | Stokes Corporation, F. J. | 70 |
| *Continental Diamond Fibre, a Sub. of | | | |
| the Budd Company | 89 | Taylor Fibre Co. | 75 |
| *Cosmor (Canada) Ltd. | 90 | *Texas Instruments Incorporated | 10 |
| *Curtiss-Wright Corp. | 15 | Textile Banking Co., Inc. | 68 |
| | | | |
| *Dano Electric Co. | 90 | Virginia Electric and Power Co. | 79 |
| Daytona Beach Chamber of Commerce. | 92 | | |
| | | Manufacturers' Representatives. | 100 |
| *Eitel-McCullough, Inc. | 39 | | |
| | | | |
| *FNR, Inc. | 17, 18 | | |
| *Ferroxcube Corp. of America. | 85 | | |
| | | | |
| Garrett Corporation | 80, 81 | Professional Services | 101 |
| *General Instrument Corp., | | | |
| Semiconductor Division | 81 | | |
| German Industries Fair | 86 | | |
| *Green Instrument Co., Inc. | 87 | | |
| | | | |
| *Hewlett-Packard Company. | 2nd Cover | | |
| *Heyman Mfg. Co. | 102 | | |
| Houghton Laboratories, Inc. | 67 | | |
| | | | |
| Institute of Radio Engineers. | 19 | | |
| International Business Machines. | 26, 27 | | |
| | | | |
| Jet Propulsion Laboratory. | 6 | | |
| *Jones, Howard B., Div. Clinch Mfg. Co. ... | 90 | | |
| | | | |
| Keillogg Switchboard & Supply Co. | 71 | | |
| *Kennedy & Co., D.S. | 3 | | |
| *Kepeo, Inc. | 65 | | |
| *Kintel, a Division of Cohu Electronics, | | | |
| Inc. | 3rd Cover | | |
| | | | |
| *Lampkin Laboratories, Inc. | 91 | | |
| *Leach Corporation | 21 | | |
| *Librascope, Inc. | 28 | | |
| Link Aviation, Inc. | 69 | | |
| Lockheed Aircraft Corp. | 22 | | |
| | | | |
| *Magnetic Metals Company. | 30, 87 | | |
| MacDonald, Samuel K. | 100 | | |
| Metals & Controls Corp. | 30 | | |
| Micro Switch, A Division of Honeywell. | | | |
| Minneapolis-Honeywell | 35 | | |
| Minnesota Dept. of Business | | | |
| Development | 95 | | |
| Minnesota Mining & Manufacturing Co. ... | 7 | | |
| | | | |
| *North Electric Co. | 14 | | |
| | | | |
| Ozald, Div. of General Aniline & Film | | | |
| Corp. | 16 | | |

CLASSIFIED ADVERTISING

F. J. Eberle, Business Mgr.

EMPLOYMENT OPPORTUNITIES..96-100

EQUIPMENT

(Used or Surplus New)

For Sale

WANTED

Equipment

ADVERTISERS INDEX

| | |
|--|-----|
| A & M Instrument Service Company. | 101 |
| Armour Research Foundation of Illinois | |
| Institute of Technology. | 100 |
| Bristol Company, The | 100 |
| General Dynamics-Electric Boat Div. | 100 |
| General Electric Co. | 97 |
| Gizmos & Such | 101 |
| Houde Supply Company. | 101 |
| Johns Hopkins University-Operations | |
| Research Office | 96 |
| Legri S. Company. | 101 |
| Melpar Incorporated | 98 |
| Motorola Incorporated | 96 |
| Philco Western Development | |
| Laboratories | 99 |
| Radiation Incorporated | 100 |
| Radio Research Instrument Co., Inc. | 101 |
| Sylvania Electric Company. | 98 |
| Telephone Engineering Company. | 101 |

* See advertisement in the June, 1958 Mid-Month
ELECTRONICS BUYERS' GUIDE for complete line
of products or services.

This index is published as a service. Every care is taken
to make it accurate, but ELECTRONICS assumes no
responsibilities for errors or omissions.

ONLY KIN TEL DIGITAL VOLTMETERS GIVE YOU ALL THESE ADVANTAGES

1. SINGLE-PLANE READOUT: KIN TEL digital voltmeters employ a simple projection system to present numbers on a readable single plane... no superimposed outlines of "off" digits... reduced possibility of error. Standard pilot lamps give extra long life.

2. ADVANCED CIRCUIT DESIGN: Transistors employed where they contribute to performance and reliability... relay drive coils energized with DC as in telephone type service to provide long, trouble-free operation... automatic, continuous standard cell calibration. No electronic circuitry in readout allows easy remote mounting. Sensitivity control permits stable reading of noisy signals.

3. MANUFACTURING EXPERIENCE: KIN TEL has manufactured over 10,000 "standard cell accuracy" DC instruments on a true production line basis. Only by this method, by years of repeated manufacturing experience, by an over-all awareness of the accuracies and tolerances involved, is it possible to guarantee consistent accuracy and reliability... to assure real value for every dollar you invest.

4. NATIONWIDE APPLICATION ENGINEERING FACILITIES: KIN TEL has engineering representatives in every major city. An experienced staff of over 200 field engineers is always immediately available to help solve your application problems, provide technical data, or prepare a detailed proposal. Factory level service is available in all areas.

5. DESIDERATE SPECIFICATIONS (MODEL 401B DC DIGITAL VOLTMETER): *Display*... 4 digit with automatic polarity indication and decimal placement. Total display area 2" high x 7½" long, internally illuminated. Each digit 1½" high. *Automatic Ranges*... .0001 to 999.9 volts covered in 4 automatic ranges. Sensitivity control provides gain ÷10 setting and least digit sensitivities of .1, 1, and 10 mv. *Accuracy*... 0.01% ±1 digit. *Counting Rate*... 20 counts per sec., providing average balance (reading) time of 1 sec. *Reference Voltage*... Chopper-stabilized supply, referenced to an unsaturated mercury-cadmium standard cell. *Input Impedance*... 10 megohms, on all ranges. *Output*... Visual display, plus print control. Automatic print impulse when the meter assumes balance. No accessories required to drive parallel input printers. *Input*... 115 volt, 60 cycle, single phase, approx. 75 VA. *Dimensions*... Control unit, 5½" high x 19" wide x 18" deep. Readout display, 3½" high x 19" wide x 9" deep. *Weight*... Approx. 40 lb. *Price*... \$2,450.

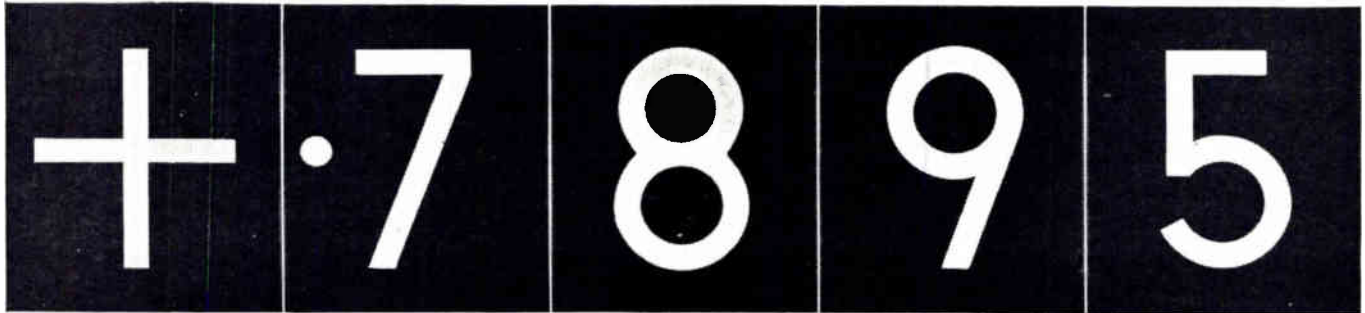

Model 402B AC/DC 4-digit



Model 401B DC 4-digit



Model 501 DC 5-digit

6. WIDE RANGE OF MODELS—ACCESSORIES—SPECIAL SYSTEMS: Versatile "digital building blocks" permit measurement of AC, ohms, ratios of AC and DC, automatic scanning of multiple inputs... 4- or 5-digit models. Preamplifiers increase digital voltmeter sensitivity to 1 microvolt DC, 10 microvolts AC. Buffers permit driving typewriters, tape punches and printers. KIN TEL's Special Products Department can design and manufacture digital instruments to meet special requirements... complete digital systems for data logging, missile checkout and automatic production line testing.



Write today for descriptive literature or demonstration. 5725 Kearny Villa Road, San Diego 11, California

*...from
watts
to
megawatts*

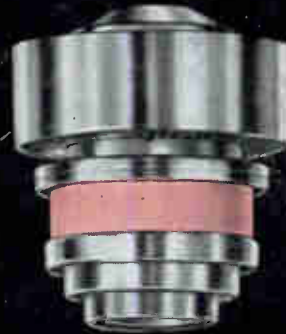
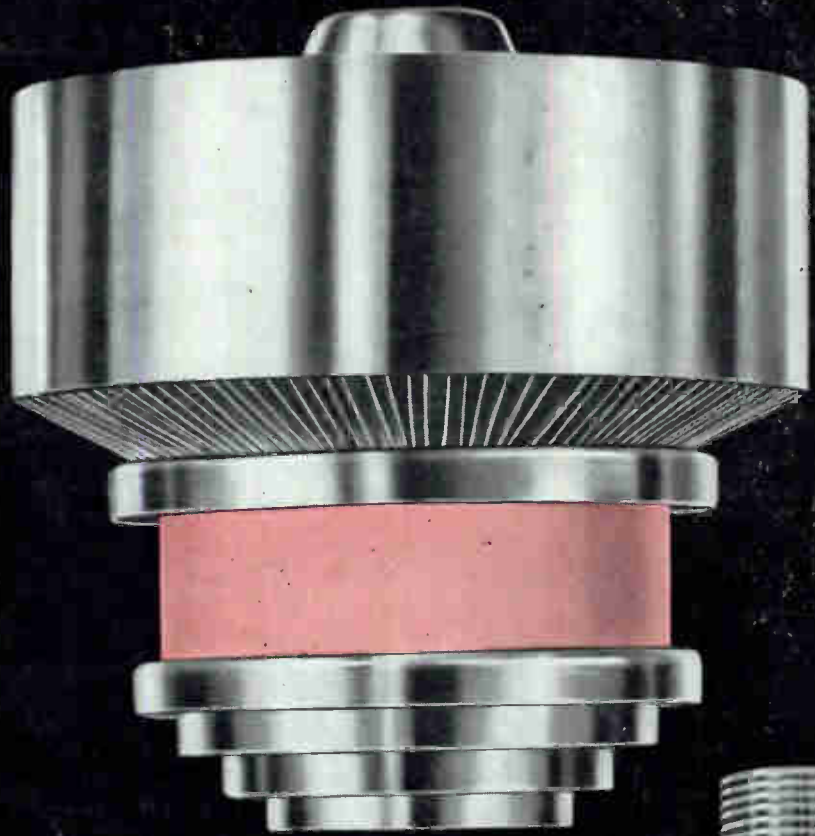
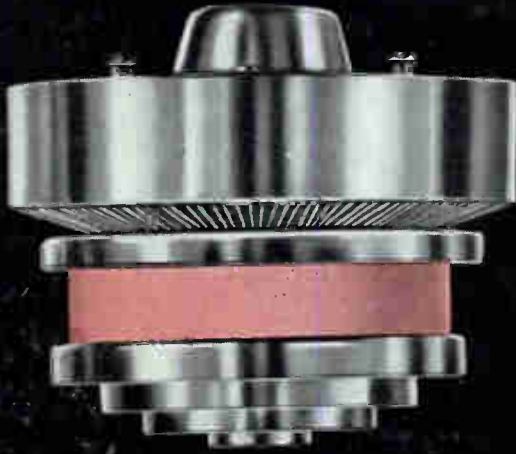

Typical RCA Ceramic-Metal Power Tubes utilize beam power design, and feature high-efficiency forced-air cooling.

RCA Ceramic-Metal Power Tubes

Known throughout industry and military services for high-efficiency operation and ability to withstand high voltages at ultra-high frequencies, RCA Ceramic-Metal Power Tubes are the answer for the designer who requires higher power in a smaller, compact tube design. No other power tubes in this class combine features such as: coaxial-electrode design; low-loss ceramic bushings between electrode contact surfaces; matrix-type cathode; extra-sturdy heater, low screen current, virtually no primary screen grid or control grid emission!

RCA Ceramic-Metal Power Tubes merit the attention of new equipment designers for a wide variety of applications. Your RCA Representative will be glad to discuss with you your requirements for RCA Ceramic-Metal Tubes and the availability of developmental types on a sampling basis.

Visit the RCA Exhibit at the New York IRE Show, Booths 1602-4-6, 1701-3-5-7



RADIO CORPORATION OF AMERICA
Electron Tube Division
Harrison, N. J.

| Typical RCA Ceramic-Metal Power Tubes | | | | |
|---------------------------------------|-------------------------------------|---|------------------------------------|--------------------------------|
| Type No. | CW Service max. Plate Input (Watts) | Pulse Service max. Peak Plate Input (Watts) | max. Frequency for full Input (MC) | max. Plate Dissipation (Watts) |
| A-2582* | 30 | — | 1215 | 25 |
| A-2587* | — | 3750 | 1215 | 25 |
| 6816 | 180 | — | 1215 | 115 |
| A-2543-A* | — | 9000 | 1215 | 115 |
| A-2572* | 1250 | — | 1215 | 600 |
| A-2585* | — | 64000 | 1215 | 600 |
| 7213 | 2500 | — | 1215 | 1500 |
| A-2576-A* | — | 180000 | 1215 | 1500 |
| A-2545* | 20000 | — | 400 | 10000 |
| A-2581* | — | 2000000 | 500 | 10000 |

*RCA Developmental Type—Available on Sampling Basis

GOVERNMENT SALES

HARRISON, N. J.
415 S. Fifth St., Humboldt 5-3900
DAYTON 2, OHIO
224 N. Wilkinson St., Baldwin 6-2366
WASHINGTON 6, D. C.
1625 "K" St., N.W., District 7-1260

INDUSTRIAL PRODUCTS SALES

NEWARK 2, N. J.
744 Broad St., Humboldt 5-3900
CHICAGO 54, ILLINOIS
Suite 1154, Merchandise Mart Plaza, Whitehall 4-2900
LOS ANGELES 22, CALIF.
6355 E. Washington Blvd., Raymond 3-8361
DETROIT 2, MICHIGAN
714 New Center Building, TRinity 5-5600