

A MCGRAW-HILL PUBLICATION

PRICE ONE DOLLAR

MARCH 28, 1958

electronics

engineering edition

**ENVIRONMENTAL
TESTING**page 59

**TESTING CAPACITORS IN
ENVIRONMENTAL CHAMBER**

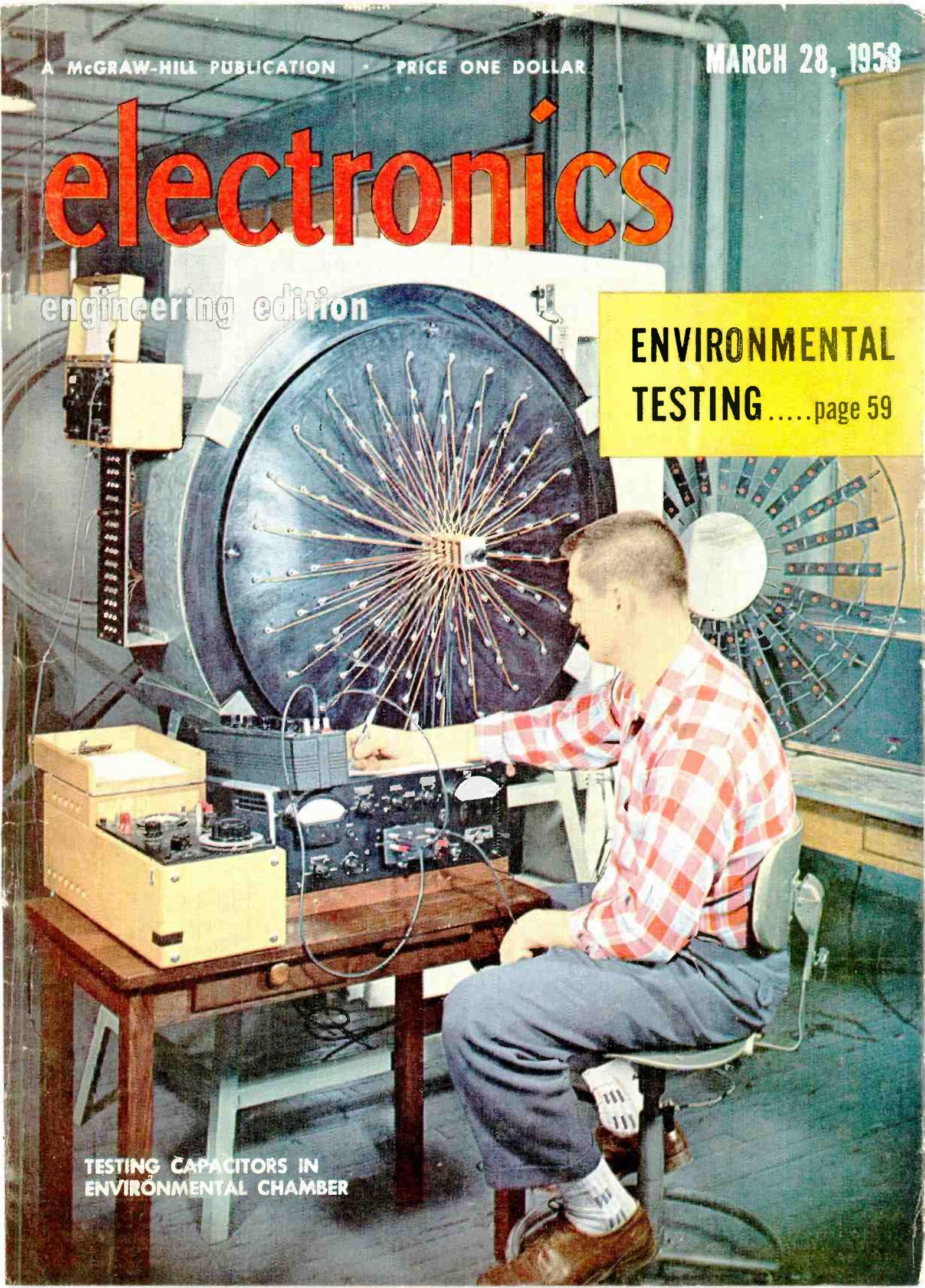

OUR MILLIONTH FILTER SHIPPED THIS YEAR...

FILTERS

FOR EVERY APPLICATION



TELEMETERING FILTERS

UTC manufactures a wide variety of band pass filters for multi-channel telemetering. Illustrated are a group of filters supplied for 400 cycle to 40 KC service. Miniaturized units have been made for many applications. For example a group of 4 cubic inch units which provide 50 channels between 4 KC and 100 KC.

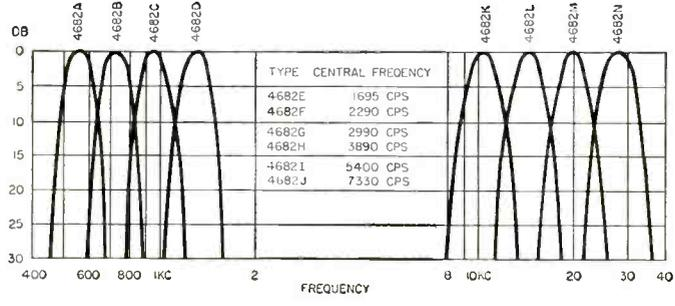

Dimensions:
(4682A) 1 1/2 x 2 x 4"

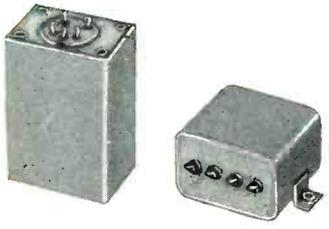

Dimensions:
(3834) 1 1/4 x 1 3/4 x 2-3/16"
(2000, 1) 1 1/4 x 1 3/4 x 1 5/8"

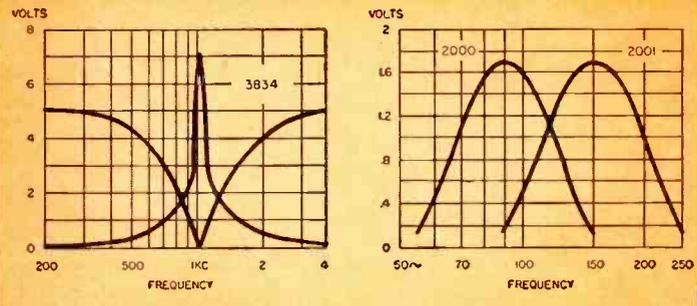

AIRCRAFT FILTERS

UTC has produced the bulk of filters used in aircraft equipment for over a decade. The curve at the left is that of a miniaturized (1020 cycles) range filter providing high attenuation between voice and range frequencies. Curves at the right are that of our miniaturized 90 and 150 cycle filters for glide path systems.

CARRIER FILTERS

A wide variety of carrier filters are available for specific applications. This type of tone channel filter can be supplied in a varied range of band widths and attenuations. The curves shown are typical units.

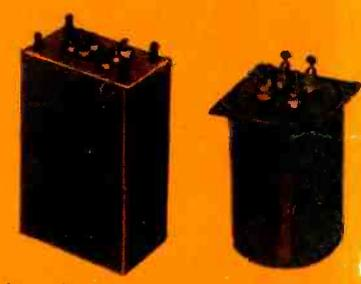
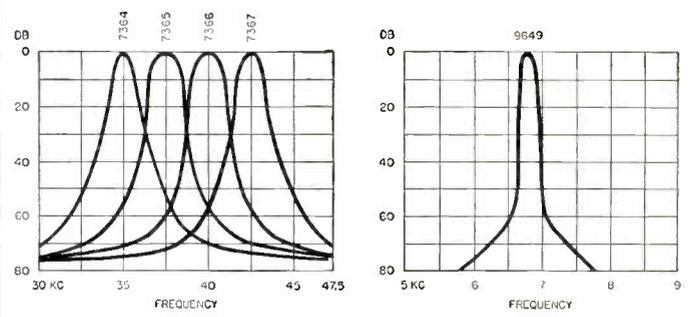

Dimensions:
(7364 series) 1 3/8 x 1 3/8 x 2 1/4"
(9649) 1 1/2 x 2 x 4"

DISCRIMINATORS

These high Q discriminators provide exceptional amplification and linearity. Typical characteristics available are illustrated by the low and higher frequency curves shown.

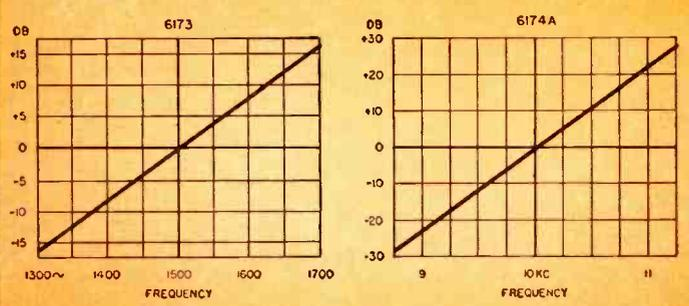

Dimensions:
(6173) 1-1/16 x 1 3/8 x 3"
(6174A) 1 x 1 3/4 x 2 1/4"

For full data on stock UTC transformers, reactors, filters, and high Q coils, write for Catalog A.

UNITED TRANSFORMER CORP.

150 Varick Street, New York 13, N. Y.
EXPORT DIVISION: 13 EAST 40th STREET, NEW YORK 16, N. Y. CABLES: "ARLAB"
PACIFIC MFG. DIVISION: 4008 W. JEFFERSON BLVD., LOS ANGELES 16, CALIF.

electronics engineering edition

A MCGRAW-HILL PUBLICATION • VOL. 31, NO. 13 • MAR. 28, 1958

ISSUE AT A GLANCE

H. W. MATEER, *Publisher*

W. W. MacDONALD, *Editor*

Managing Editor, John M. Carroll.

Feature Editor, John Markus.

Associate Editors: John M. Kinn, Jr., Frank Leary, Michael F. Tomaino, Howard K. Janis, Sylvester P. Carter, Haig A. Manoogian, Roland J. Charest, Donald C. Hoefler, William P. O'Brien, George Sideris, Edward DeJongh, John F. Mason, Barry Miller, E. A. Scutari, William E. Bushor, Ronald K. Jurgen, Thomas Emma, Patrick J. Lahey.

Pacific Coast Editor (Los Angeles) Harold C. Hood; *Midwestern Editor* (Chicago) Harold Harris; *New England Editor* (Boston) Thomas Maguire.

Art Director, Harry Phillips, Roy Thompson.

Production Editor, John C. Wright, Jr., Bernice Duffy, Jean L. Martin.

Editorial Assistants: Gloria J. Filippone, Arlene Schilp, Noreen Hennessy, Phylis A. Cronin, Barbara Habermann, Patricia Landers.

JAMES GIRDWOOD, *Advertising Sales Manager*. R. S. Quint, *Assistant Advertising Sales Manager and Buyer's Guide Manager*. Fred Stewart, *Promotion Manager*. Frank H. Ward, *Business Manager*. George E. Pomeroy, *Classified Manager*. Jean Heiges, *Research*.

New York: Donald H. Miller, Henry M. Shaw, Martin J. Gallay, *Boston*: Wm. S. Hodgkinson. *Philadelphia*: James T. Hauptli. *Chicago*: Bruce Winner, Walter M. Luce. *Cleveland*: Warren H. Gardner. *San Francisco*: T. H. Carmody, R. C. Alcorn. *Los Angeles*: Carl W. Dysinger, D. A. McMillan. *Denver*: J. Patten. *Atlanta*: M. Miller. *Dallas*: Gordon L. Jones. *London*: Herbert Lagler. *Frankfurt*: Michael R. Zeynel.

Testing Capacitors In Environmental Chamber. Cylindrical load-life oven, designed and constructed at Battelle reduces cold spots often found in rectangular chambers. See p 59.....COVER

Business Briefsp 7

Electronics Newsletter	7	Military Electronics	14
Figures of the Week	7	Electronics Gets Major Fusion Job	14
IRE Show Hears "Spectrum Stretches"	8	New Deflectors Help Research	16
Electronic Machine Line	8	Financial Roundup	16
I-G In Titan "Exceeds Hopes"	12	New Microwave Installations	16
Washington Outlook	12	New Sub Killer In Action	18
New Varistor Is Described	14	Meetings Ahead	18

Stair-Step Integrator Analyzes Rotation. Dynamic conditions such as pressure, velocity, torque and rate of angular motion are converted into electrical signals that are displayed on an oscilloscope.....p 41
By George E. Edens

Loaded-Lens Antenna Tracks Missiles. Foam plastic hemispheres covered with metal disks give conical scanning for efficient tracking during telemetry of long-range rockets.....p 44
By Lee S. Miller

Analog Comparator for Production Testing. Tester checks performance of potentiometer-type pressure sensing instruments over operating rangep 47
By C. N. Boode and C. E. Calohan

Acoustic Cavity Detects Breaks in Film. Interference by film passing through resonant chamber controls processing machine to reduce rethreading and film spoilage.....p 50
By E. L. Withey and R. G. Seed

Solid-State Thyatron Switches Kilowatts. Ability of the silicon controlled rectifier to switch kilowatts of power at speeds measured in microseconds opens wide fields of application.....p 52
By R. P. Frenzel and F. W. Gutzwiller

DIGEST CONTINUED ON NEXT PAGE

DIGEST continued

Selection of Modulation for Speech Communication. Modulation types are evaluated in terms of specific system requirements for voice communication p 56
 By George J. Kelley

Environmental Testing of Electronic Equipment. A 16-p special engineering report featuring the latest techniques, facilities and hardware for environmental testing of electronic equipment and components p 59
 By Michael F. Tomaino

Rapid Conversion of Hybrid Parameters. Chart and nomograph simplify conversion of grounded-base transistor parameters to grounded-emitter and grounded-collector forms p 75
 By Sol Sherr

Electrons At Work p 78

- | | |
|--|--|
| Diode Bridge Protects Meters... p 78 | Preamp Matches Input Impedance p 80 |
| By Ronald L. Ives | Transistor Temperature Controller p 80 |
| Ultrasonics Gives Preorbit Check. p 78 | By H. Sutcliffe |
| Low-Impedance Transistor Preamp p 78 | |
| By W. F. Jordan | |

Component Design p 86

- | | |
|---|-------------------------------------|
| Solid-State Light Digital Displays p 86 | Tube Tells Time p 86 |
| Breakdown Characteristics p 86 | Heaterless Ceramic Tubes p 88 |

Production Techniques p 90

- | | |
|--------------------------------------|-------------------------------------|
| Machine Winds Synchro Stator... p 90 | Holding Fixture Frees Hands... p 92 |
| Design Trends p 90 | Brazing Rings Made on Lathe... p 93 |

New Products p 94

Literature of the Week p 114

Plants and People p 116

News of Reps p 119

New Books p 120

Thumbnail Reviews p 121

Comment p 122

Index to Advertisers p 127

electronics

March 28, 1958 Vol. 31, No. 13

Published weekly, with alternating engineering and business editions, and with a BUYERS' GUIDE issue in mid-June, by McGraw-Hill Publishing Company, Inc., James H. McGraw (1860-1948) Founder.

Executive, Editorial, Circulation and Advertising Offices: McGraw-Hill Building, 330 W. 42 St., New York 36, N. Y.

Longacre 4-3000. Publication Office 99-129 North Broadway, Albany 1, N. Y. See panel below for directions regarding subscription or change of address. Donald C. McGraw, President; Joseph A. Gerardi, Executive Vice President; L. Keith Goodrich, Vice President and Treasurer; John J. Cooke, Secretary; Nelson Bond, Executive Vice President, Publications Division; Ralph B. Smith, Vice President and Editorial Director; Joseph H. Allen, Vice President and Director of Advertising Sales; A. R. Venezian, Vice President and Circulation Coordinator.

Single copies \$1.00 for Engineering Edition and 50¢ for Business Edition in United States and possessions, and Canada; \$2.00 and \$1.00 for all other foreign countries. Buyers' Guide \$3.00. Subscription rates—United States and possessions, \$6.00 a year; \$9.00 for two years; \$12.00 for three years. Canada, \$10.00 a year, \$16 for two years; \$20.00 for three years. All other countries \$20.00 a year, \$30.00 for two years; \$40.00 for three years. Second class mail privileges authorized at Albany, N. Y. Printed in U.S.A. Copyright 1958 by McGraw-Hill Publishing Co., Inc.—All Rights Reserved. Title registered in U. S. Patent Office. BRANCH OFFICES: 520 North Michigan Avenue, Chicago 11; 68 Post Street, San Francisco 4; McGraw-Hill House, London E. C. 4; A.M. Leonhards 12, Frankfurt Main; National Press Bldg., Washington 4, D. C.; Architects Bldg., 17th & Sansom Sts., Philadelphia 3; 1111 Henry W. Oliver Bldg., Pittsburgh 22; 1510 Hanna Bldg., Cleveland 15; 856 Penobscot Bldg., Detroit 26; 3615 Olive St., St. Louis 8; 350 Park Square Bldg., Boston 16; 1321 Rhodes Haverly Bldg., Atlanta 3; 1125 West Sixth St., Los Angeles 17; 1740 Broadway, Denver 2. ELECTRONICS is indexed regularly in The Engineering Index.

Subscriptions: Address correspondence to Subscription Manager, Electronics, 330 W. 42nd St., New York 36, N. Y. Allow one month for changes of address, stating old as well as new address. Subscriptions are solicited only from persons engaged in theory, research, design, production, management, maintenance and use of electronics and industrial control components, parts and products. Position and company connection must be indicated on subscription orders.

Postmaster: please send form 3579 to Electronics, 330 W. 42nd St., New York 36, N. Y.



Member ABP and ABC

SOLID-ELECTROLYTE
TANTALEX[®]
CAPACITORS

new dimensions in miniaturization and reliability

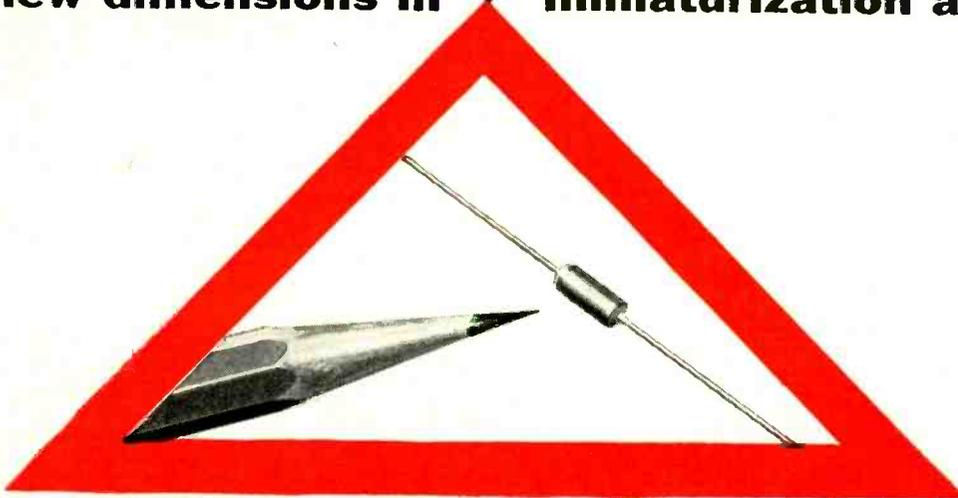

This solid-electrolyte Tantalex Capacitor (shown 1½ times actual size) is rated at 4.7 μ F, 10 volts d-c, and is only ¼" in diameter by ¼" long.

Now, circuit designers in computers and military electronics have an electrolytic capacitor that offers greater miniaturization than ever before . . . with no sacrifice in reliability. Sprague's recently announced solid-electrolyte Tantalex Capacitors find ideal application in the transistor circuits of these critical fields.

The tiny sintered tantalum anode of Type 150D Tantalex Capacitor is impregnated with a solid, non-corrosive, semi-conductor material which cannot leak under any circumstance. It combines true miniaturization with electrical stability previously unobtainable in an electrolytic capacitor of any type.

Thermal coefficient of these capacitors is sufficiently low and linear so that for the first time a circuit designer can think of an electrolytic in terms of parts per million capacitance change. Nominal value is +500 ppm/°C. The

capacitor may be used without derating over a range from +85°C to as low as -80°C, a temperature at which no other electrolytic has proved useful.

Solid construction permits the Type 150D to withstand the severe shock and vibration encountered in missile and ballistic applications. Hermetic sealing makes it completely immune to humid atmospheric conditions.

Complete performance data covering the wide range of sizes and ratings are in Engineering Bulletin 3520B, available on letter-head request to the Technical Literature Section, Sprague Electric Company, 35 Marshall Street, North Adams, Mass.

★ ★ ★

Sprague, on request, will provide you with complete application engineering service in the use of Tantalex Capacitors.

SPRAGUE[®]
the mark of reliability

SPRAGUE COMPONENTS:

CAPACITORS • RESISTORS • MAGNETIC COMPONENTS • TRANSISTORS • INTERFERENCE FILTERS • HIGH TEMPERATURE MAGNET WIRE • PULSE NETWORKS • PRINTED CIRCUITS

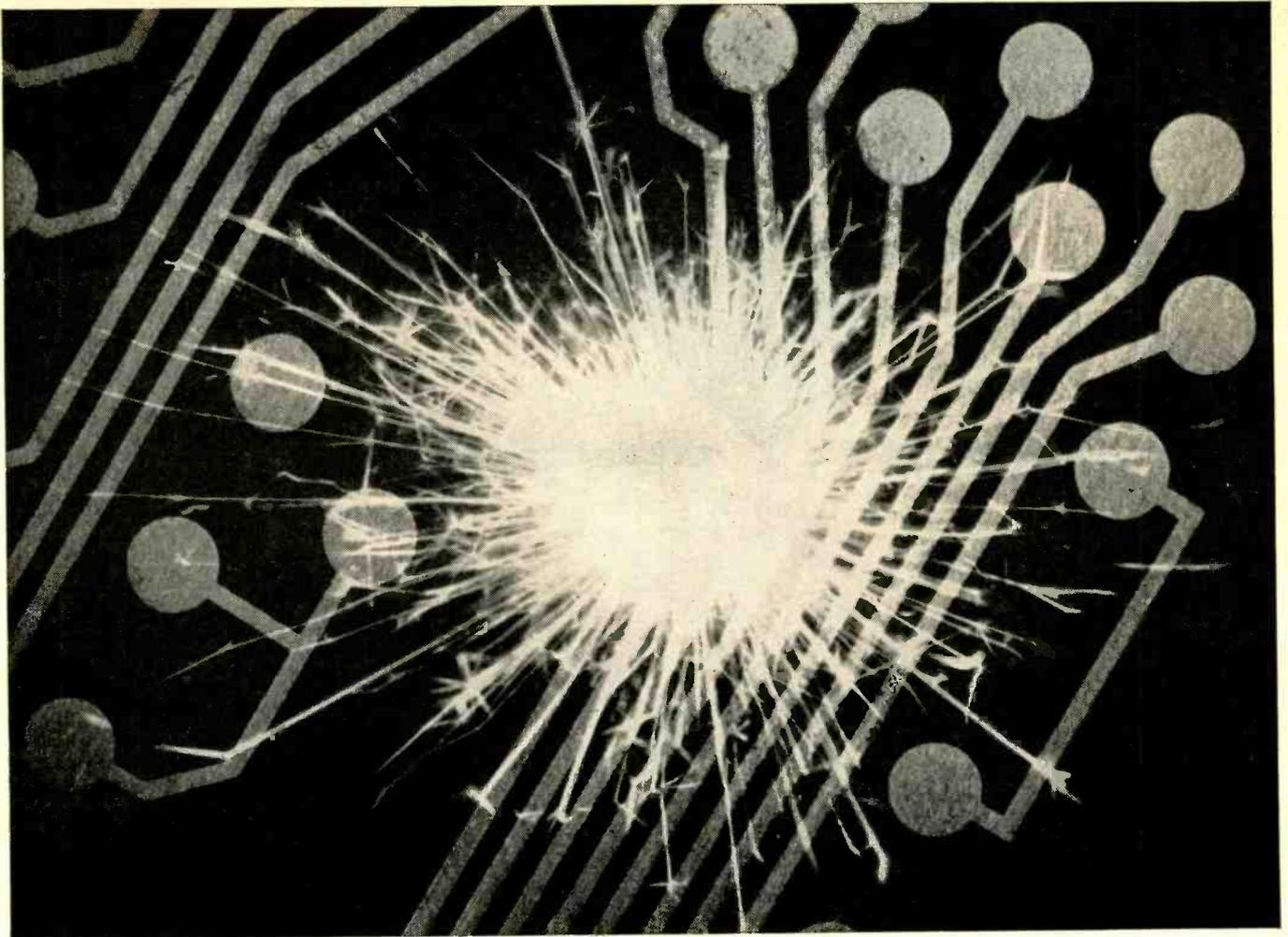

Uniformity of Taylor Rolled Copper-Clad Laminates helps prevent shorts in printed electronic circuits

Taylor Rolled Copper-Clad Laminates help prevent both shorts and open circuits: shorts because the copper is free of lead inclusions; open circuits because the metal is free of pits and pinholes. They have such high uniformity that even lines only 0.002 in. wide, and spaced only 0.004 in. apart, can be produced. These features also help prevent resistance buildup and other faults that cause failures in radios, television sets, and other electronic devices found in the home and industry.

Production control at Taylor Fibre Co. is responsible for this highly uniform printed circuit material. Taylor has

devised a unique method of bonding high-purity rolled copper to the base laminate—and keeping it securely bonded even under severe conditions of temperature, humidity and mechanical stresses. From this results the production of printed circuits of consistently high quality.

This is only one of the many Taylor Fibre Co. products that are meeting industry's demands for improved materials with superior performance characteristics. If your products require laminated plastics—in basic form or fabricated parts—contact the Taylor sales office nearest you. Save time and money by dealing with the right source of supply.

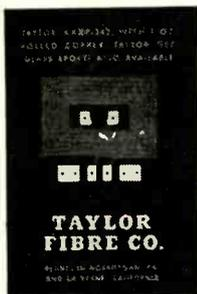

Actual size of printed circuit on Taylor Copper-Clad Laminate. The lines are only 0.002 in. wide and 0.004 in. apart.

TAYLOR
 Laminated Plastics
 Vulcanized Fibre

TAYLOR FIBRE CO. Plants in Norristown, Pa., and La Verne, Calif.

INTEGRATED MANUFACTURER AND FABRICATOR OF PHENOLIC, MELAMINE, SILICONE, EPOXY, COPPER-CLAD, AND COMBINATION LAMINATES • VULCANIZED FIBRE

First and largest volume producer of rolled copper-clad laminates for printed circuits

new High Current DC Supplies

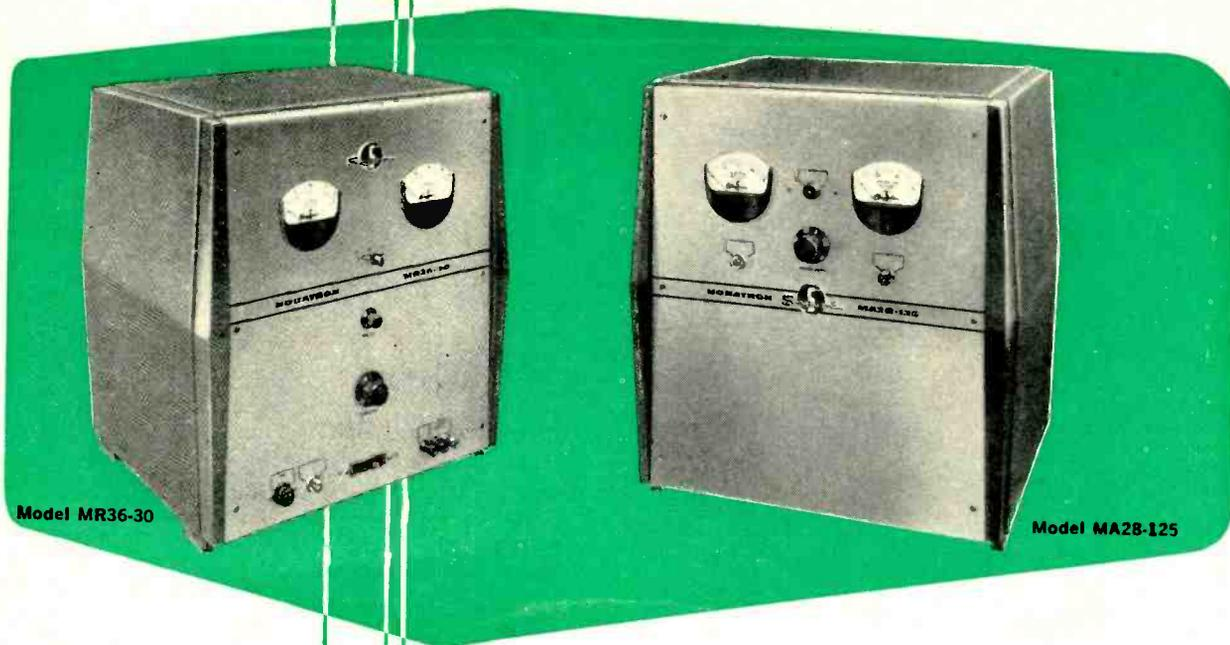

Fast Response...High Amps...External Sensing

Model MA28-125

Output: 28 VDC nominal at 125 amps.
Regulation accuracy of $\pm 0.2\%$.
Ripple: $< 1\%$ RMS.
Response time: < 0.1 second.
Choice of input voltage: 208, 230,
or 460 VAC, 3-phase.
Weight: 225 pounds.
\$1160 in cabinet.

Model MR36-30

Output current, 0-30 amps, output
voltage, 5 to 36 VDC continu-
ously adjustable with regulation
 $\pm 0.25\%$ against line or load
change.

Response time of 0.2 second.
Input voltage: 105 to 125 VAC,
single-phase.

Weight: 175 pounds.
\$890 in cabinet.

Also supplied, as Model MR36-15,
with output current 0-15 amps,
otherwise similar.
Weight: 100 pounds.
\$495 in cabinet.

Two new high output power-packs—with response time ranging from 0.2 second down, and with transistorized power reference and magnetic amplifier power control circuits for trouble-free performance—that's just part of the story on these Sorensen DC power supplies.

One model supplies an output of 18 to 36 VDC at 125 amperes; the other provides 5 to 36 VDC at 0 to 30 amps.

Zener diode reference circuit assures sharper regulation, and the external sensing provision puts this precise control at the load. Silicon power rectifiers and complete tubeless design increase durability with reduction in weight—and greater saving in size.

Get the full story from your Sorensen representative.
Or write for technical data.



CONTROLLED POWER FOR RESEARCH AND INDUSTRY

SORENSEN & COMPANY, INC.
Richards Avenue, South Norwalk, Connecticut

In Europe, contact Sorensen-Ardag, Eichstrasse 29, Zurich, Switzerland, for all products including 50 cycle, 220 volt equipment

NEW **RAYTHEON**

DIFFUSED JUNCTION
SILICON GLASS RECTIFIERS

400 MILLIAMPERES

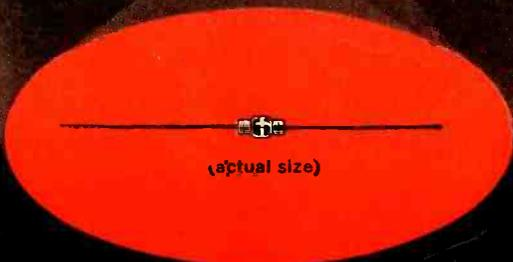

225 TO 500 PEAK
INVERSE VOLTS

-65°C TO +150°C TEMPERATURE RANGE

Type	Ave. Rectified Current		Peak Inverse Voltage		Reverse Current (μ Adc) max. at indicated volts		
	25°C mA	150°C mA	-65° to +150°C	25°C	volts	at 25°C	at 100°C
1N645	400	150	225	275	225	0.2	15
1N646	400	150	300	360	300	0.2	15
1N647	400	150	400	480	400	0.2	20
1N648	400	150	500	600	500	0.2	20

For all types

Voltage Drop (400mA, 25°C).....1.0 V max.
 Steady State Peak Forward Current (25°C).....1.25 A max.
 Surge Current (1 sec. 25°C to 150°C).....3.0 A max.
 Dissipation (25°C).....600 mW max.

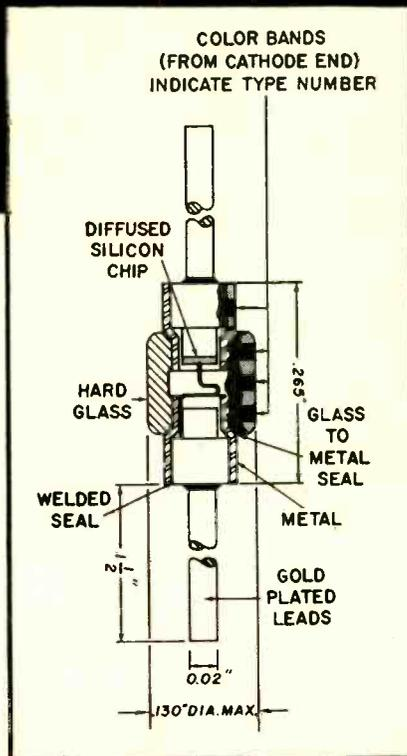

SEMICONDUCTOR DIVISION

Silicon and Germanium Diodes and Transistors • Silicon Rectifiers

Newton, Mass.....55 Chapel St., Bigelow 4-7500
 New York:.....589 Fifth Ave., Plaza 9-3900
 Chicago: 9501 Grand Ave., Franklin Park, NAional 5-6130
 Los Angeles: 5236 Santa Monica Blvd., NOrmandy 5-4221

BUSINESS BRIEFS

ELECTRONICS NEWSLETTER

VANGUARD SATELLITE which went into orbit on St. Patrick's Day is the first satellite to carry a solar battery-powered transmitter. It operates on 108.3 mc. Second transmitter powered by conventional batteries operates on 108 mc. Total weight is 3.4 lbs for the 6.4-in. diameter test sphere. Data from first trip around the earth indicated an apogee of 2,500 mi, a perigee of 400 mi. Life expectancy of the instruments is indefinite, says Naval Research Laboratory at press time. There's probability that more firings with bigger test spheres and more instrumentation will follow soon. However, it takes weeks between firings to assemble a satellite vehicle.

MINUTE MAN, the new solid propellant ICBM planned by the Air Force, will have a new pure inertial guidance system, it was disclosed by Maj. Gen. Bernard A. Schriever, chief of AF ballistic missiles division. He said invitations to bid on the new i-g system will be out between now and September. His statement, coming on the heels of the announcement of a \$140-million Titan i-g contract for American Bosch Arma, suggests that missile technology is now moving so fast that the services dare not mark time with any missile system no matter how excellent it is.

MISSILE TEST FACILITIES for evaluation of Atlas, Titan and Thor alone have cost more than one-half billion dollars. This is the estimate recently given by James C. Fletcher, director of electronic research at Ramo-Wooldridge's Space Technology Laboratories, to the Long Island section of the IRE. Fletcher cited five test categories: component, system simulation, sled and aircraft, captive and launch. Test results show, he said, that system reliability is more a function of environment than of operational life of the equipment. (See Special Report on environmental testing, p 59). Hardest single environmental condition to pin down, Fletcher believes, is vibration resulting from low frequency resonance of components. High g's from this source, he says, present greater design problems than do acceleration g's.

AIR SEARCH RADAR is the "Achilles' heel" of the Navy, retiring chief of the Bureau of Ordnance Rear Adm. Withington believes. Present rotating antennas, limited to 10-15 tons—the Navy's requirement for ship-based radar—are inadequate for long-range detection. Navy is now studying feasibility of a stationary antenna with four sides. Radar would completely scan north, south, east and west in turn, rotation to be accomplished electronically.

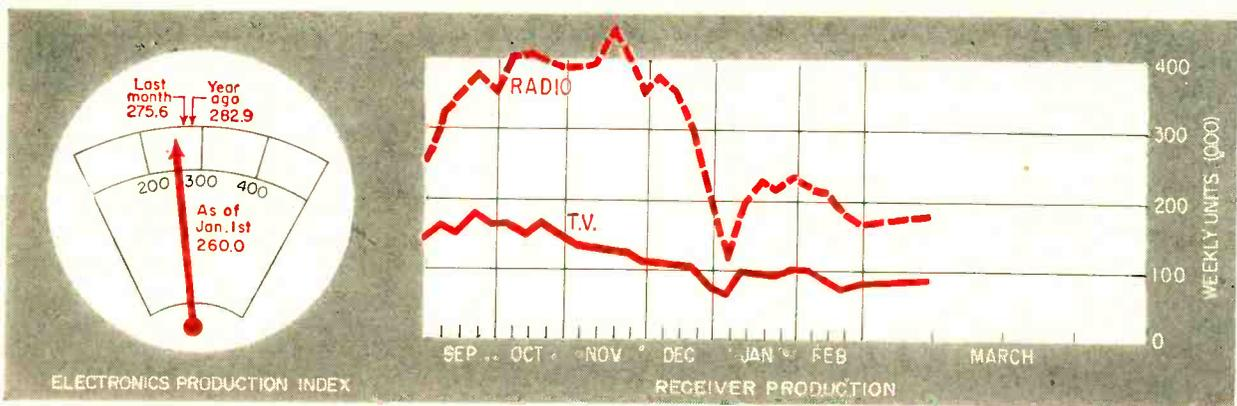

FIGURES OF THE WEEK

RECEIVER PRODUCTION

(Source: EIA)	Mar. 7, '58	Feb. 28, '58	Mar. 8, '57
Television sets, total	87,508	89,466	121,927
Radio sets, total	180,165	176,851	343,054
Auto sets	52,069	54,473	135,937

STOCK PRICE AVERAGES

(Source: Standard & Poor's)	Mar. 12, '58	Mar. 5, '58	Mar. 13, '57
Radio-tv & electronics	46.40	45.89	46.61
Radio broadcasters	56.79	55.04	63.28

FIGURES OF THE YEAR

	1958	1957	Percent Change
Receiving tube sales	26,805,000	37,571,000	- 28.6
Transistor production	2,955,247	1,436,000	+105.8
Cathode-ray tube sales	621,910	760,860	- 18.3
Television set production	433,983	450,190	- 3.6
Radio set production	1,026,527	1,085,529	- 5.4
TV set sales	581,486	623,359	- 6.7
Radio set sales (excl. auto)	534,640	563,363	- 5.1

MORE FIGURES NEXT PAGE

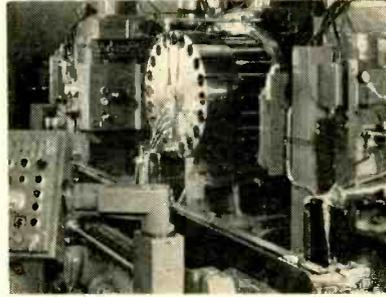

Master electronic control panel (left) directs milling, drilling and boring machines (right) at Hughes plant during unveiling of . . .

IRE Convention Hears "Spectrum Stretchers"

Engineers told inversion layers in air are among unexploited natural ducts

THERE IS ONLY one radio frequency spectrum. How to get more elbow room in it is a subject which pops up at every big electronics turkey shoot. The IRE Convention in New York this week is no exception.

One speaker took a bold look at some future alternatives to radio. J. L. Ryerson, of Rome Air Development Center listed among the unexploited natural ducts:

- Inversion layers in the air. There may be a uhf duct in trade winds.

- Temperature inversion ducts in the ocean could be used for global teletype.

- Interfaces of rock strata with sound-carrying abilities.

Ultraviolet waves are a good possibility at low altitudes. Gamma rays could turn out to be valuable in space.

More research is needed in improving bandwidth at 30 kc and below to take advantage of the low power requirements.

Two other Rome engineers, R. C. Benoit, Jr. and Francis Coughlin, Jr., outlined the Air Force effort to develop long-range directional communications at lower frequencies.

Conservation here is mainly an antenna problem.

Electronically steerable vertical antenna arrays permit direction shifting. Commercial radio, it's thought could use principles to get fuller use from the available

Electronic Machine Line

"Transfer line" techniques feature of numerically controlled machine tool group

A NUMERICALLY CONTROLLED machine tool group incorporating "transfer line" techniques was unveiled recently by Hughes Aircraft and Kearney and Trecker Corp.

Three production machines for milling, drilling and boring—together with automatic transfer equipment and electronic controls—constitute the punched-tape-controlled prototype group.

Complete prototype line demonstrated will cost approximately \$375,000 dollars. Tape cutter will be about \$7500 additional.

Each machine utilizes a transistorized digital computer. Easily replaceable plug-in circuit boards use miniaturized components and printed circuitry throughout. Electronic circuits compensate for tool wear during production run, feed back information of broken drills, and cutters to the control console for quick shut-down.

Prime advantages of electronic machine lines:

- Lead time is greatly reduced.

For a new run, just insert a new punched tape. For a dimensional modification, splice in a section of tape in the desired location. Complex jigs are eliminated. Only very simple work-holding fixtures are required. When repair or replacement parts are to be run, corresponding tapes are checked out of tape "library", inserted in control consoles and production is started.

- Production time is reduced. Optimum speeds and feeds are programmed into control tape and automatically selected. Tooling required for production run is approximately 50 percent less than with conventional machines.

- Scrap and rework held to minimum. Control tapes preclude dimensional variations. High repetitive accuracy is assured.

- Large inventories of parts no longer necessary. Parts can be produced one by one as they are required.

MILITARY ELECTRONIC BUYING, QUARTERLY

(Source: EIA)	4th quarter, '57	3rd quarter, '57	4th quarter, '56
Aircraft	\$346.0	\$340.0	\$270.0
Missiles	299.0	273.0	259.0
Electronics & com.	214.0	204.0	236.0
Research & development	74.0	73.0	76.0
Ships — harbor craft	25.0	23.0	19.0
Combat & support vehicles	.9	2.0	3.0
Miscellaneous	9.0	11.0	13.0
	5967.9	5926.0	5876.0

TRANSISTOR AND TUBE SALES, MONTHLY

(Source: EIA)	Jan. '58	Dec. '57	Jan. '57
Transistors, units	2,955,247	2,773,000	1,436,000
Transistors, value	\$6,704,383	6,619,000	\$4,119,000
Receiving tubes, units	26,805,000	27,736,000	37,571,000
Receiving tubes, value	\$23,264,000	\$24,881,000	\$31,170,000
Picture tubes, units	621,910	644,026	760,860
Picture tubes, value	\$12,341,927	\$12,971,489	\$13,594,525

ANOTHER

NEW SOLID STATE DEVICE

from TEXAS INSTRUMENTS

SENSISTOR SILICON RESISTOR RESISTANCE RELATIVE TO 25°C

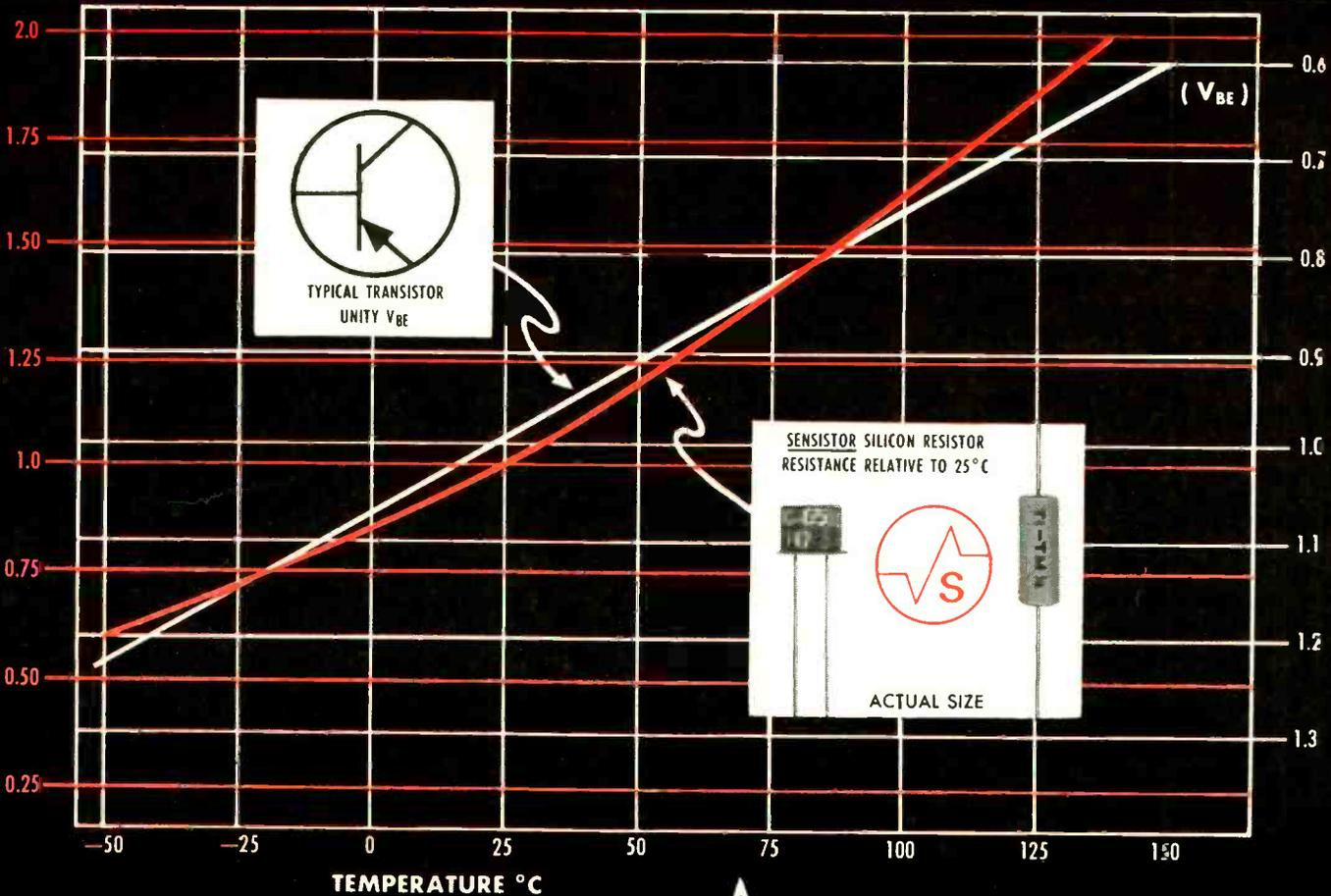

TRANSISTOR BASE-EMITTER VOLTAGE RELATIVE TO 25°C VALUE

sensistor

SILICON RESISTOR

Positive temperature coefficient of resistance (+0.7%/°C) plus a constant rate of change

Sensistor silicon resistors further stabilize temperature-induced variations in transistor characteristics... compensate for base-emitter bias voltage vs. temperature characteristics of transistors.

Sensistor silicon resistors are ideally suited for your temperature sensing and for temperature compensating type applications in amplifiers... computer switching circuits... servos... power supplies.

For your next temperature compensating or sensing requirement, specify a sensistor silicon resistor, the resistor with a positive temperature coefficient of resistance plus a constant rate of change.

STANDARD AVAILABLE RESISTANCES** AT 25°C: 100, 120, 150, 180, 220, 270, 330, 390, 470, 500, 560, 680, 820, and 1000 ohms.

electrical specifications	TM ¼	TC ¼	UNITS
wattage rating	¼	⅛	W
average temperature coefficient	+0.7	+0.7	%/°C
resistance tolerance	10	10	%

**Other resistance values and tolerances available on special order.

*Trademark of Texas Instruments Incorporated

Available now! Ask your nearest TI sales office for Bulletin DL-C 860

TEXAS INSTRUMENTS SALES OFFICES
 DALLAS • NEW YORK • CHICAGO • LOS ANGELES
 CAMDEN • DAYTON • DENVER
 DETROIT • OTTAWA • SYRACUSE • SAN DIEGO
 SAN FRANCISCO • WALTHAM • WASHINGTON D. C.



TEXAS INSTRUMENTS
 INCORPORATED
 SEMICONDUCTOR COMPONENTS DIVISION
 POST OFFICE BOX 312 • DALLAS, TEXAS

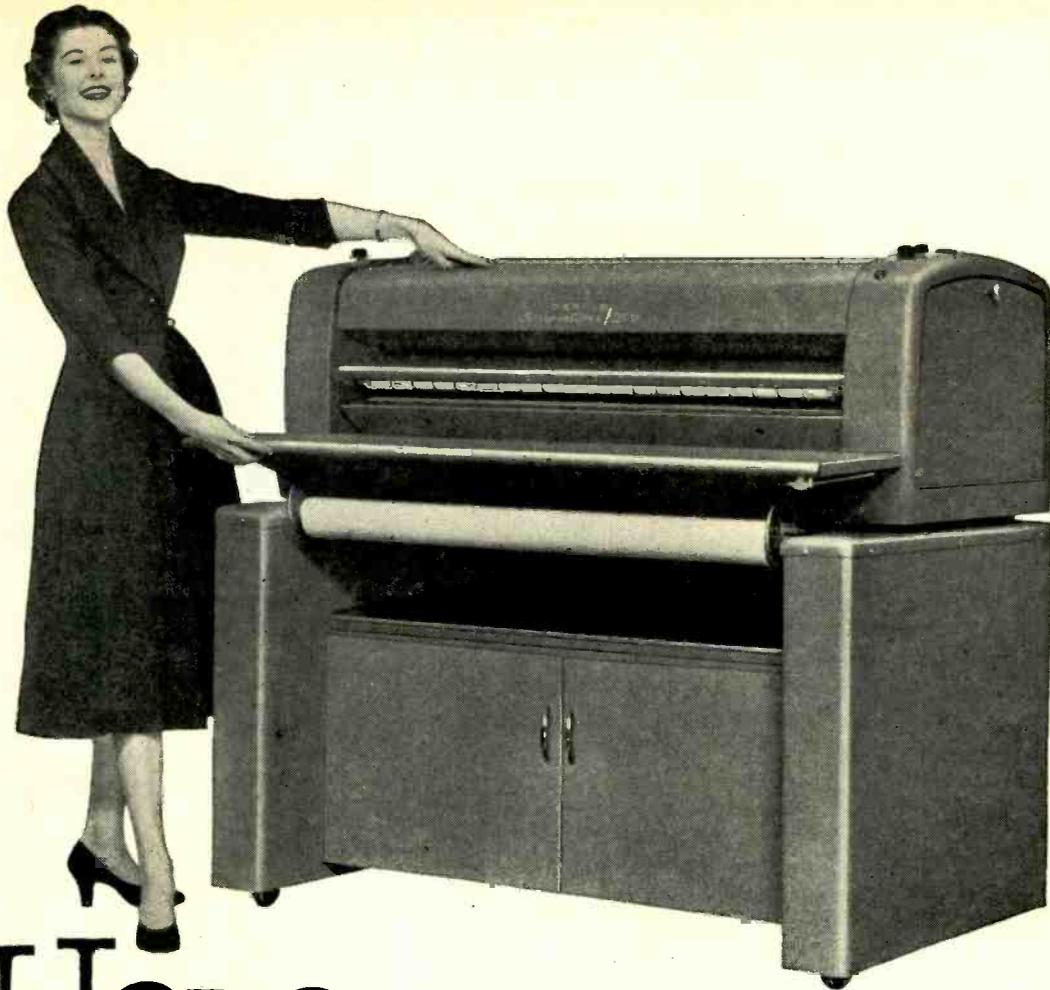

Here at last

FULL 42-INCH PRINTMAKING IN A CONVENIENT Table Model

Now, TABLE MODEL convenience, LOW COST and FULL WIDTH are combined in *one* whiteprinter—the new Ozalid Streamliner 200!

Now, anyone can turn out sparkling whiteprints in seconds—up to 42 inches in width! In the small office, the new Streamliner 200 gives you prints whenever you need them. For the large firm, it handles “rush work” . . . saves costly interruptions of volume printmaking . . . *stands by* when other

machines are “down” for service.

Compact in design, Streamliner 200 stands just 22” high . . . 38” deep, with feedboard. Prints stack automatically. Controls are simple, easy to operate. Stand, shown above, is optional.

Why not test-run your own tracings through the Streamliner 200? Call your local Ozalid representative or write: Ozalid, Department L-3-28, Johnson City, New York.

A Division of General Aniline & Film Corporation
In Canada: Hughes Owens Company, Ltd., Montreal

OZALID®

First name in whiteprinting

Foremost in the application of Electronics



IN AVIATION Over 30 Air Forces rely on Marconi radio, radar or navigational aids. For over three years Marconi's have been in quantity production with Doppler navigators for British and Commonwealth Governments.

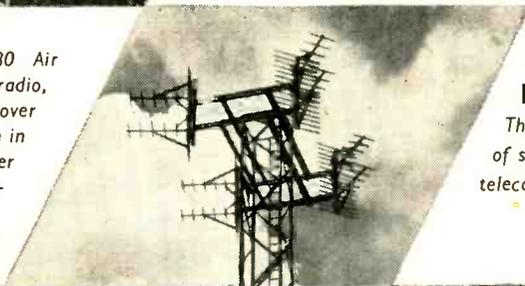

IN TELECOMMUNICATIONS The Post and Telegraph Authorities of some 80 countries use Marconi telecommunications equipment.

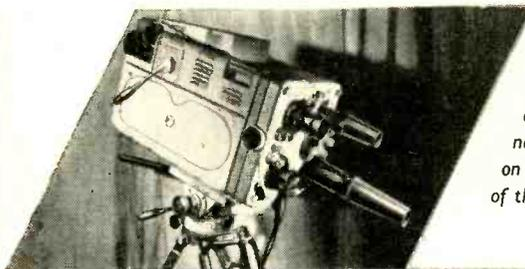

AT SEA Marine communication and radar equipment for navies and merchant fleets. Marconi navigation beacons are to be found on all the main shipping routes of the world.

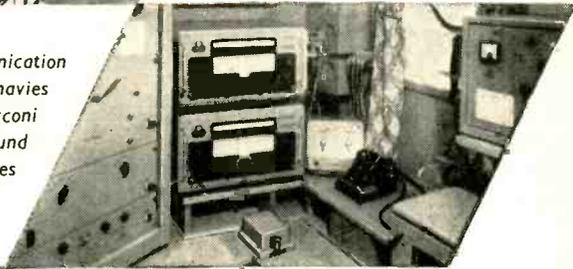

IN BROADCASTING AND TELEVISION The Broadcasting Authorities of 75% of the countries of the world are using Marconi sound broadcasting or television equipment.



IN TUBES AND CRYSTALS Valves of all powers and types, magnetrons, klystrons, stabilovolts, travelling wave tubes and television camera tubes. Crystals for all requirements up to the highest grade unit employed in frequency measuring.

IN RADAR The armed Services of Great Britain and many other countries rely on Marconi's radar for defence, surveillance, navigation and airport control.

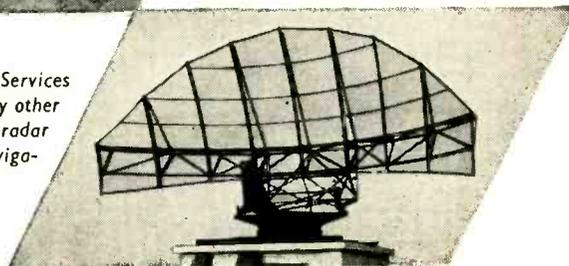

MARCONI

on land, at sea and in the air

The inquiries of radio and electronic engineers who wish to keep themselves posted about the latest Marconi equipment and activities are most welcome. Write to:

J. S. V. WALTON, MARCONI'S WIRELESS TELEGRAPH COMPANY LIMITED, 23-25 Beaver Street, New York City 4

MARCONI'S WIRELESS TELEGRAPH COMPANY, LIMITED, CHELMSFORD, ESSEX, ENGLAND

frequencies while increasing reliability and cutting power.

Leonard R. Kahn reported another aspect of his compatible single-sideband system. He figures it can cure much of the tv receiver interference with a-m radio reception in cities.

According to the speaker, horizontal amplifiers in tv sets may produce harmonics which interfere with radio reception.

To reduce interference, the sideband is placed on the side of the broadcast carrier frequency furthest from the strongest tv horizontal repetition rate harmonic. This permits the listener to tune away from the interference.

I-G in Titan 'Exceeds Hopes'

GLEN COVE, N. Y.—“Performance results of ground tests made this month on Titan’s pure inertial guidance system have been better than anticipated,” Gen. B. A. Schriever, Chief, USAF Ballistic Missile div., said recently at the official announcement meeting of American Bosch Arma’s \$140,357,000 R&D contract for the system.

First test flight of the system will take place this year in the Titan itself rather than in an aircraft or test missile.

Bell Telephone Labs radio-inertial system has not been scrapped, says Schriever. Both BTL’s and Arma’s systems will be used, thereby making two types of Titans, one with pure i-g and the other guided by radio-inertial. This procedure, however, will not be followed with the Thor. A. C. Spark Plug’s pure inertial will be used in production line Thors.

According to Schriever, Arma’s i-g system is one step ahead of Thor’s. Besides additional demands made on Arma’s system for longer range operation, the components in Titan’s system weigh less than Thor’s.

USAF’s other ballistic missile, Atlas, might also get an i-g system. Schriever says “engineering studies for putting an i-g system into Atlas are underway.”

Although Arma produces most equipment that goes into the i-g

WASHINGTON OUTLOOK

YOU’LL HEAR more talk from now on about continuing IGY-type space research into 1959, now that the Navy has shown its Vanguard rocket can put a satellite into space. The cooperative international program completes its scheduled 18 months at the end of December, and the Office of Naval Research plans to fire the remaining 12 or 13 Vanguard satellite-bearing rockets by then.

If plans are followed, there’s likely to be no additional Vanguard rockets produced. The military services each want their own scientific teams to make use of modified versions of their missiles. This could involve IRBM’s like Thor and Jupiter, and the two ICBM’s, Titan and Atlas.

Both Army and Air Force hope to put reconnaissance satellites up this year. The Air Force has its Pied Piper (probably with a Thor as the launcher); the Army will go ahead with beefed-up Jupiter-C’s.

- The business recession has supplanted the space-missile program as the leading political issue here. Antirecession proposals—centering on federal spending boosts, the tax cuts—are popping all over Washington.

The Administration points to a 50 percent hike in military hard goods procurement as an important economic prop. During January-June 1958, the military services will award \$4.7 billion worth of aircraft contracts, compared to \$3.5 billion in July-December 1957; \$2.2 billion in missiles, compared to \$1.2 billion in the preceding half-year; and \$802 million in communications and other electronics, compared to \$238 million.

- A tax-cut package of from \$5 billion to \$7 billion is being talked up both in Congress and the Administration. Among the specific proposals being considered: reductions in individual tax rates—as a means of bolstering consumer purchasing power; slashes in federal excise rates; and a cut in corporation taxes—most likely from the present 52-percent rate to 50 percent.

A reduction in the excise rate would help electronic consumer goods—radios, television sets, phonographs. Also, electronic components sold to parts jobbers and computers, which Internal Revenue threatens to tax as office equipment.

Electronic Industries Assn., which two months ago had written off the possibility of an excise-tax reduction is now optimistic about the chances. The most likely cut would be from the current 10-percent rate to 5 percent.

- Latest figures on capital expenditures, which show across-the-board reductions in business plans to spend from new plant and equipment, have heightened the recession fears. According to the latest government survey, business spending will drop below previous estimates.

In the Electrical Machinery category, which includes much of the electronics industry, the reduction is from \$599 million to \$563 million this year—one of the lighter industry cuts.

Plant expansion in Electrical Machinery, however, does point to an upturn by 1959. The industry expects to boost capital expenditures from \$273 million in January-June 1958 to \$290 million in the second half of the year.

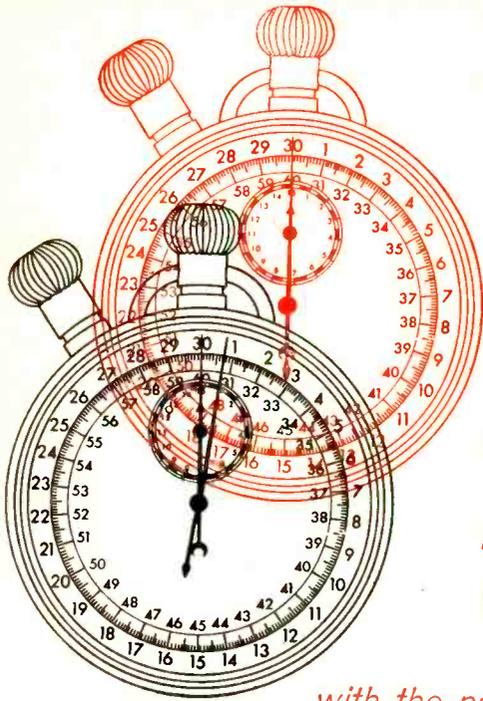

INSTANTLY...
measure and supply DC
voltages to 0.02%

with the new KIN TEL DC voltage standard and null voltmeter

LABORATORY ACCURACY. The Model 301 is an extremely compact and accurate variable DC power supply and calibrated null voltmeter. It employs KIN TEL's proved chopper circuit to constantly compare the output voltage against an internal standard cell. As a DC voltage standard, it combines the stability and accuracy of the standard cell with the current capabilities and excellent dynamic characteristics of the finest electronically regulated power supplies. The self-contained null voltmeter indicates the voltage difference between the supply in the 301 and the DC source being measured, affording simple and rapid measurement of DC voltages to an accuracy of 0.02%.

PRODUCTION LINE SPEED. DC voltage measurements can be made as fast as changing ranges on a VTVM. Merely set the direct reading calibrated dials on the 301 to exactly null out the unknown DC input voltage. The reading on the dials then indicates the value of the unknown input voltage to within 0.02%. As a variable DC standard or power supply, the calibrated dials provide instant voltage selection to an accuracy normally attained only with standard cells.

VERSATILITY. The KIN TEL Model 301 is ideal for rapid and accurate production calibration of precision measuring instruments and DC power supplies... design of DC amplifiers and complex electronic circuitry... computer reference... versatile precision reference for calibration and measurement laboratories.

0.01% stability
0.02% accuracy
1 to 501 volts at 20 ma
4 accurate null ranges
0.002% regulation
Less than 100 μ v ripple



IMPORTANT SPECIFICATIONS

Output Voltage & Current 1 to 501 volts at up to 20 ma
 Full Scale Meter Ranges (Zero Center)
 DC Output Range ± 500 , 50 volts
 DC Input Range ± 500 , 50 volts
 DC Null Meter Range .. ± 50 , 5, 0.5, 0.05 volts
 Long Time Stability ± 100 parts per million
 Output Voltage Calibration $\pm 0.02\%$ or 2 mv
 Output Hum and Noise Less than 100 μ v RMS
 Line and Load Regulation 0.002%
 DC Output Impedance Less than 0.01 ohm
 Response Time 0.2 millisecond
 Model 301 Price \$625.

Representatives in all major cities. Write today for demonstration or descriptive literature.
 5725 Kearny Villa Road, San Diego 11, Calif., BRowing 7-6700



system, Schriever says 35 to 40 percent of the work will be subcontracted.



Tests are made on new field effect varistor model, which appears just to left of oscilloscope

New Varistor Is Described

FIELD EFFECT VARISTOR—suitable as a current regulator in circuits where either the load or supply voltage vary widely—was described this week at the IRE convention.

The two-terminal, passive semiconductor component can also be used as a current limiter or pulse shaper and, says Bell Telephone Laboratories, the component's a-c impedance is very high, making it useful as a coupling choke or an a-c switch.

This new varistor, related to the field effect transistor, contains a single planar junction made by diffusion. Current passes parallel to the junction through a constricted region or "channel."

As voltage increases so does current, building up a depletion layer that eventually fills the channel. This is the "pinch-off" point, beyond which current is not increased. Between the pinch-off and the point at which increased voltage causes avalanche breakdown is the useful region of constant current.

Characteristics of the field effect varistor depend on parameters such as impurity gradient, channel depth, length and width, and the semiconductor used. Bell has fabricated silicon units with regulated

MILITARY ELECTRONICS

- **B-58** is dropping its photo reconnaissance pod for all time. Reason given by the Air Force is "a change in operational requirements." Photo system manager, Fairchild Camera and Instruments, had completed five years of development work and received \$18 million of the total \$20 million contract. The system can conceivably be used for future and higher-altitude aircraft.

- **Development schedule** for the electronic laden, exotic fueled B-70 will be moved up by 18 months, according to Gen. White. Cost of a B-70 wing will be eight to ten times as much as a B-52 wing, says Assistant Defense Secretary McNeil.

- **Air Force** will probably try North American's X-15B proposal for getting a man into orbit. X-15B will consist of a modified X-15 boosted to orbiting speed and al-

titude by the Navaho.

- **High Cost** of ground support equipment for missiles will have a serious impact on the defense effort unless altered, Gen. Irvine says. "Ten Atlas missiles at a launching site will represent less than 20 percent of the site's total costs. All kinds of spares will be valued at less than 10 percent. Almost 40 percent of the invested dollars will be in ground support equipment; the remaining 30 percent will represent the cost of technical facilities."

- **GE will design, develop, produce, test and place in operation** a large ground-based radar system as part of RCA's Air Force Ballistic Missile Early Warning System. The system will be operated in conjunction with the SAGE system. GE's subcontract with RCA for the equipment amounts to more than \$100 million.

current of 1 milliamper, pinch-off voltage of 10 v and breakdown of 150 v. Current can be held constant to within one percent over a 20-120 v range. Firm has made germanium units with a rating of 10 ma, pinch-off of 10 v and breakdown of 25 v.

"It appears feasible at present," says Bell, "to produce varistors which regulate current at any level between 10 microamperes and 10 milliamperes, and improvements in fabrication techniques should make higher current levels feasible."

In circuit applications consideration must be given a parasitic shunt capacitance of the order of a few mmfd. Ratio of a-c to d-c resistance in the constant current region is typically 100 and may run as high as 1,000, reports the firm, making it ideal as a coupling device. It differs from conventional choke in that its a-c impedance is constant over an appreciable frequency range.

The experimental device was developed by R. M. Warner, Jr., H. A. Stone and E. I. Doucette.

Electronics Gets Major Fusion Job

THERMONUCLEAR FUSION takes electronics in as a full partner, engineers were told this week at an IRE Convention session which outlined the progress and prospects of fusion power.

Unlike fission power, instrumentation and measurement will be only a small part of electronics' interest in fusion, according to E. W. Herold, of RCA Labs, session chairman.

Fusion power is featured by huge gas discharges, electric and magnetic control of electron and ion motion, induction heating of gas plasma.

Fundamentally, these are physics problems, but their practical applications are found in electronics, Herold says. Hoped-for features of fusion, production of power from free charge motion and power radiation, are hallmarks of electron tubes and radio.

Getting back to measurement,

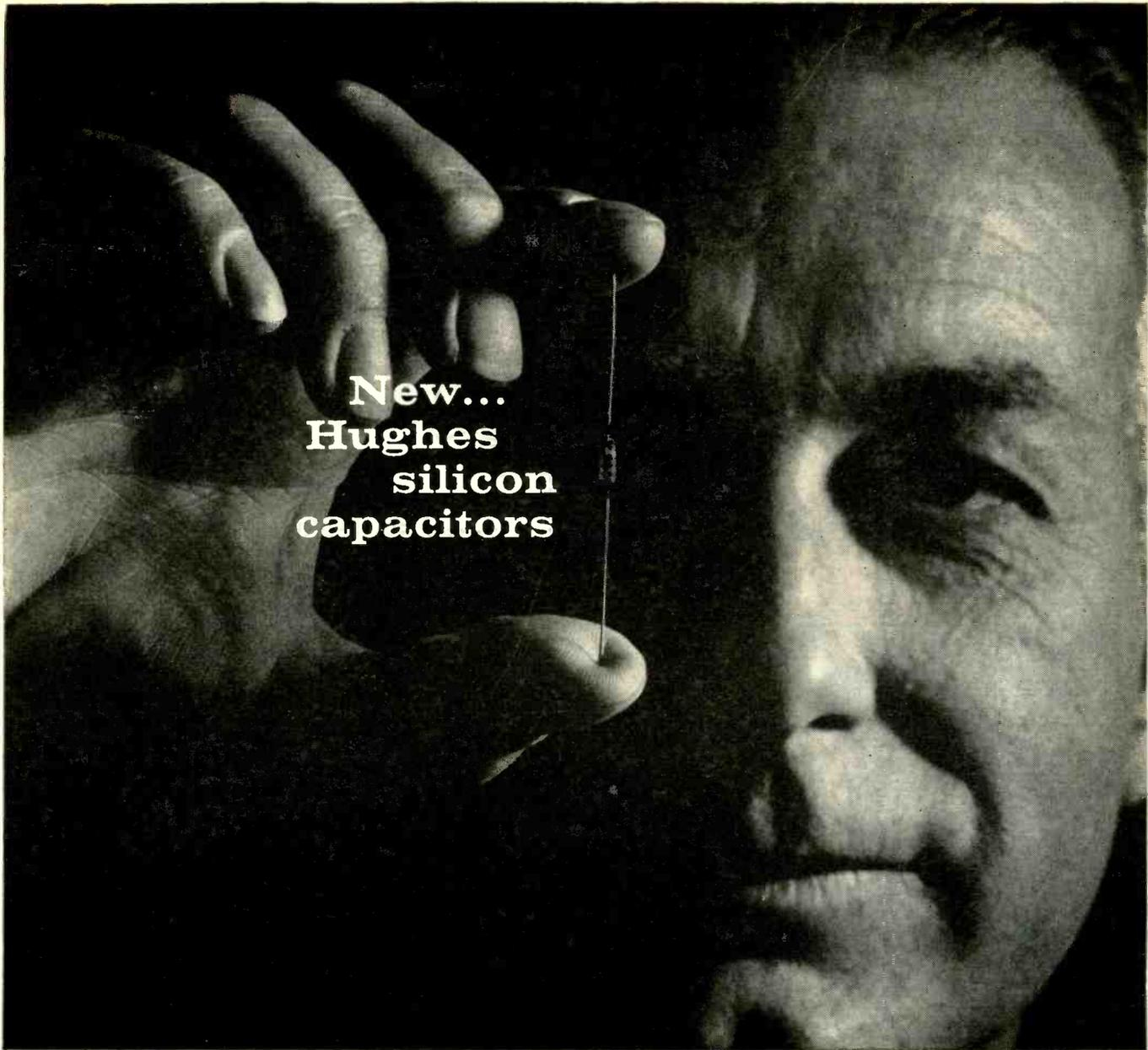

**New...
Hughes
silicon
capacitors**

high Q • wide capacitance range

This is a practical series of new components; capacitors whose capacitance is determined by the applied DC voltage. The Q is high and the capacity range, great. For the first time, circuits can be tuned by electrical rather than mechanical methods.

The concept opens up a whole domain of useful applications. And, in every instance, circuit simplification plus considerable reduction in space and weight result. When designed around Hughes silicon capacitors, remote tuning becomes practical. Automatic frequency controls, modulators, automatic gain controls, and band pass filters become smaller, lighter, and simpler. Additional possibilities are numerous.

SPECIFICATIONS				
Type	Capacity @ -4VDC ± 20% (μmf)	Typical Capacity Range (μmf)	Voltage Range Over Which Capacity Is Varied (VDC)	Typical Q @ 25Mc and Maximum Voltage
HC7111	35	6-90	0.1-130	75
HC7112	50	12-120	0.1-80	70
HC7113	70	20-170	0.1-60	58
HC7114	100	44-240	0.1-25	43

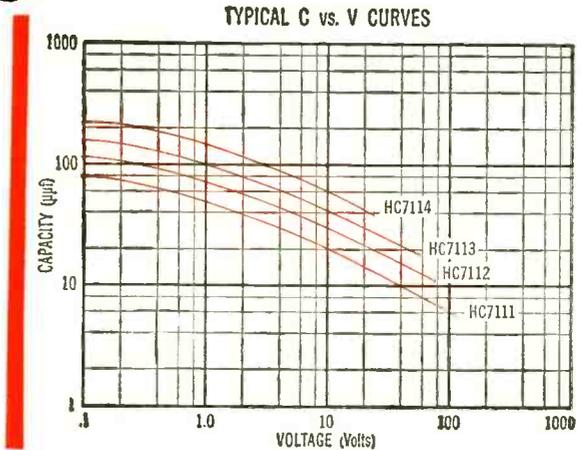

For additional data, please write: Semiconductor Division, HUGHES PRODUCTS, International Airport Station, Los Angeles 45, California

Creating a new world with ELECTRONICS



© 1958. HUGHES AIRCRAFT COMPANY

however, Mark Heald, of Princeton's Project Matterhorn, outlined how microwave is used to keep track of what goes on inside the magnetic bottles that hold the plasmas.

Using external oscillators, degree of plasma confinement is judged by measuring electron density through propagation constants. Thermal radiation, a temperature indication, is measured by microwave receivers.

The higher the frequency, the better the measurement. Fusion researchers have gone as far as radar and communications can carry them. Now, Heald says, they are looking for equipment ranging from 150 to 300 mc.

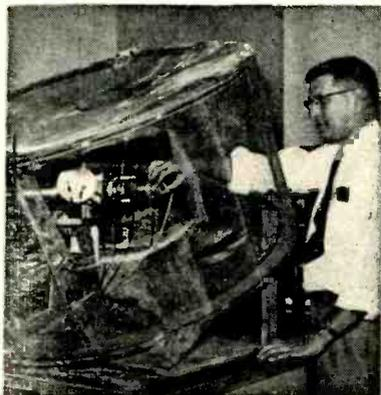

Stanford Research Institute's tiny linear accelerator has beam energy range from fraction of electron to several hundred electron volts

New Deflectors Help Research

UNIVERSITY OF CHICAGO is sporting two new electron particle deflectors. One is built into Enrico Fermi Institute's synchrocyclotron; the other is a cancer research tool for the Argonne Cancer Research Hospital.

A recently completed experiment room at the institute is the first in America with a proton beam not confined by an accelerator. A system of magnets extracts a beam ranging in energy from 444 to 150 million electron volts (mev) and directs it into the room.

Protons, 10 billion a second, travel 70 feet in an evacuated pipe. They are focused into a beam with

FINANCIAL ROUNDUP

- **Airborne Instruments of Mineola, Long Island, N. Y., and Cutler-Hammer of Milwaukee, Wis.,** announce merger plans. The Milwaukee manufacturer of electrical motor controls and switches will be the surviving company and the Long Island R&D firm will be operated as a division. The stock of the two firms will be exchanged on a share-per-share basis. Cutler-Hammer has 1,320,000 shares outstanding compared with 200,000 for Airborne. C-H has 6,170 employees and AIL has 1,500.

Just before press-time reports were that AIL was getting ready to announce a very large contract award from one of the big aircraft firms.

- **Tenney Engineering of Union, N. J.,** is getting ready for its first public stock issue. Firm manufactures environmental test equipment used in growing field of missiles, jet aircraft and outer-space projectiles. It has entered into an underwriting agreement with Milton D. Blauner of New York City and four other underwriters who would sell 99,333 shares of the firm's common stock at \$3.00 per share.

- **Columbus Electronics Corp., of Yonkers, N. Y.,** reports that it has successfully completed its first public stock sale. Offering in January of 110,000 shares of Class A common at \$2.50 per share was purchased within two weeks, the Yonkers firm states.

- **Marchant Calculators, Oak-**

land, Calif., privately places \$6.5 million of 5½ percent notes. Included are \$2.5 million of unsecured notes due March 1, 1974, and \$4 million of secured notes due June 1, 1975. Financing was arranged by Lehman Brothers, New York.

- **American Electronics of Los Angeles** registers \$3.5 million of convertible subordinated debentures and 80,000 shares of common stock with the Securities and Exchange Commission. At recent market prices, value of common stock issue would be about \$1.1 million. The LA firm plans to use the new money to repay \$2¼ million of bank loans and to retire debentures of **Taller & Cooper**, a subsidiary.

- **Industro Transistor, Long Island City, N. Y.,** registers 150,000 shares of common stock with the SEC. Selling price will be related to the over-the-counter-market price at time of offering, but will not be higher than \$6 per share. The transistor manufacturer will use proceeds to purchase additional raw materials and testing and manufacturing equipment; to enlarge its R&D department and for additional working capital.

S. D. Fuller & Co. of New York will underwrite the offering on an "all-or-none basis." This means underwriter is relieved of his purchase commitment unless entire issue is sold. Underwriter will receive commission of 15 percent and warrant purchase privileges.

a 7/8 sq in. cross section and directed to targets in the experiment room.

The external beam allows easy positioning of targets, detecting and recording equipment. Equipment in the control room includes closed circuit tv. Studies of proton bombardment had been confined to the vacuum chamber inside the synchrocyclotron.

The hospital's deflector, built by Varian Associates, will work with the hospital's linear accelerator.

New Microwave Installations

INSTALLATION OF TWO new microwave systems starts this month. One, costing \$1 million, is on the Illinois State Toll Highway. The other is a 175-mi network off the Louisiana coast.

Illinois highway officials anticipate completion of the system by year's end. It will cover the 187-mi roadway with microwave, mobile

**"DAD, WHAT'S
'OLD PRO'
MEAN?"**

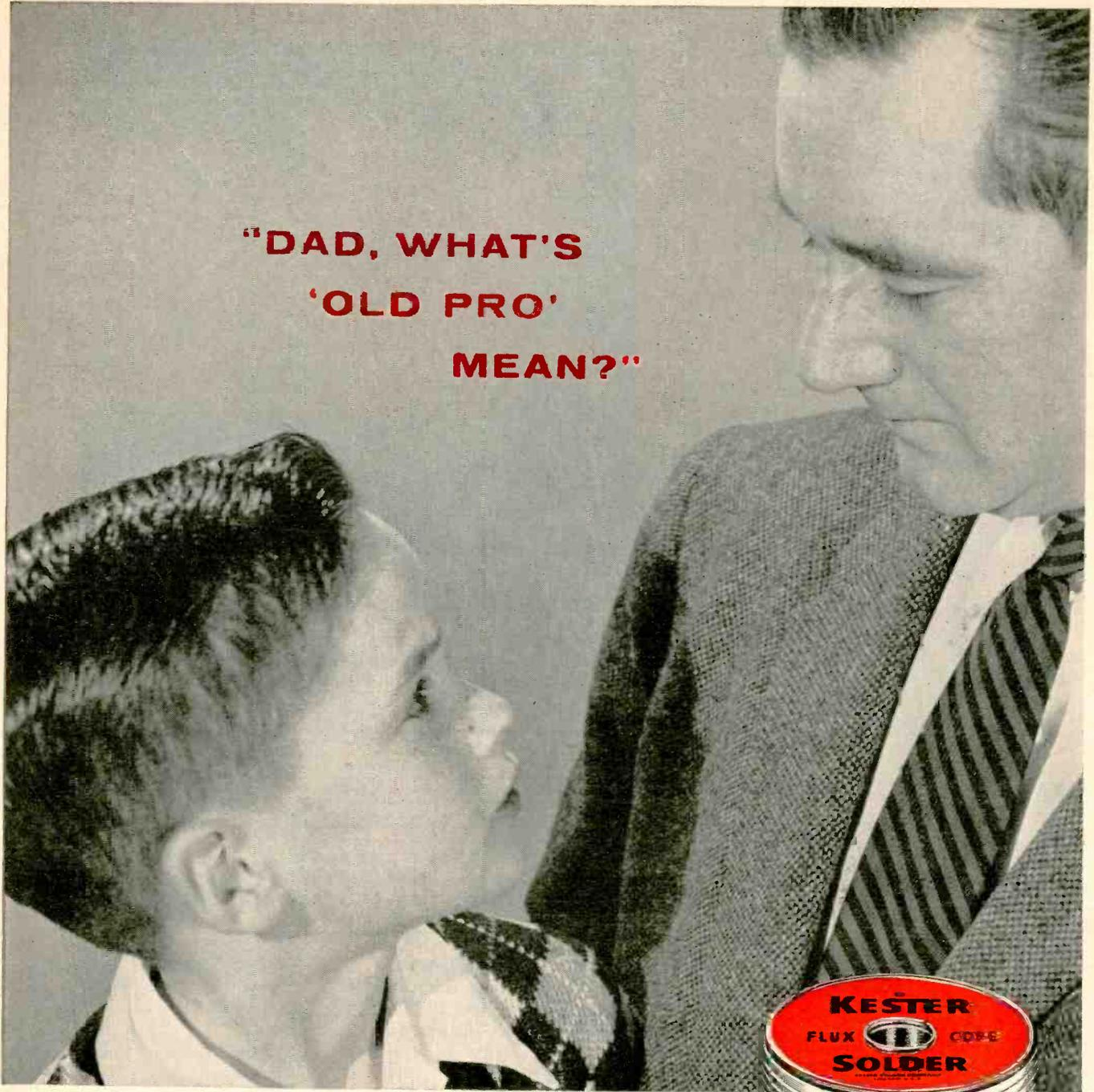

KESTER FLUX-CORE SOLDER

Leave it to a child to get to the heart of the matter quickly. No gobbledegook or double-talk is going to turn him aside from his single-minded objective.

It's like that with solder. No meager test dependent upon a "sample" or even a "one-line operational test" is going to prove conclusively the merits of a "Johnny-come-lately" solder from

that second source of supply. The wise buyer knows that the solder used on his production line must do the job he requires day-in and day-out without question.

And KESTER SOLDER has been time-tested and industry-proved for over 50 years.

That's what we mean by "old pro," Sonny!



SEND TODAY for your copy of the 78-page Kester textbook, "Solder ... Its Fundamentals and Usage." It's free!

KESTER SOLDER *Company*

4204 Wrightwood Avenue, Chicago 39, Illinois

Newark 5, New Jersey • Brantford, Canada

radio, and teleprinter facilities for police, maintenance, toll collection, and general administrative communications.

A novel feature of the system will be the use of two microwave tone channels that will automatically keep score on collected tolls.

In Louisiana, four oil companies are financing the system which will link a chain of off-shore installations with shoreline facilities in the Grand Isle area.

Target completion date is late this year.

Initially, the network will be used for voice communication. The equipment is designed for later use in automatic control of some of the off-shore operations.

Average hop distance between stations will be 25 miles. The seven installations to be serviced lie in a rough circle. The microwave signal will originate from the shoreline station nearest the water.

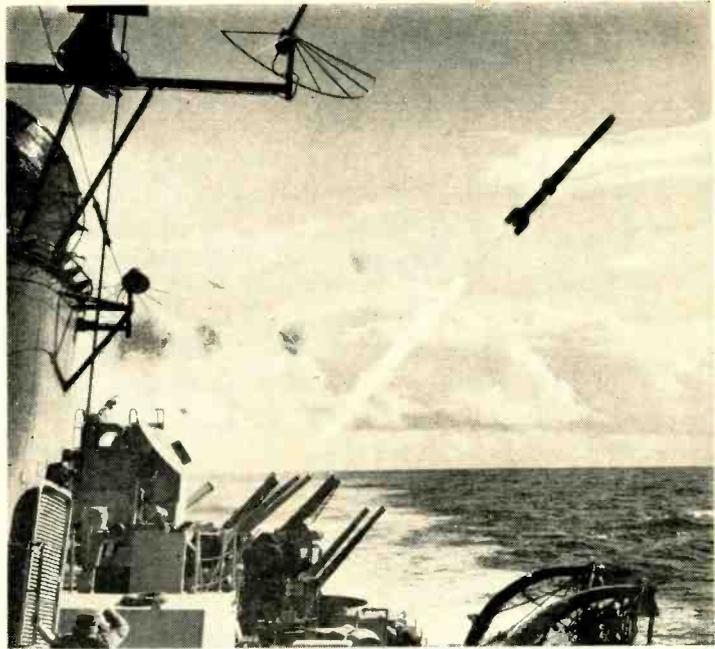

New Sub Killer In Action

In computer programmed flight, Navy's new rocket assisted torpedo takes off from destroyer in pursuit of enemy submarine. It's believed completely transistorized guidance system controls torpedo fin movement

MEETINGS AHEAD

Mar. 31-Apr. 2: Instrument & Regulators Conf., PGAC, ASME, AICHE, ISA, Univ. of Delaware, Newark, Del.

Mar. 31-Apr. 2: Southwest District Meeting of AIEE, Mayo Hotel, Tulsa, Oklahoma.

Apr. 2-4: Conf. on Automatic Optimization, PGAC, ASME, AICHE, ISA, Univ. of Delaware, Newark, Del.

Apr. 8-10: Sixth National Conference on Electromagnetic Relays, Oklahoma State University, Stillwater, Okla.

Apr. 8-10: Symposium on Electronic Waveguides, Microwave Research Institute of Brooklyn Polytechnic Inst., held at Engineering Societies Bldg., N. Y. C.

Apr. 10-12: Tenth Southwestern IRE Conference and Electronics Show, St. Anthony Hotel and Municipal Auditorium, San Antonio, Tex.

Apr. 14-16: Conf. on Automatic Techniques, IRE, ASME, Statler Hotel, Detroit, Mich.

Apr. 15: Closing date for registration, Intensive course in Automatic Control, scheduled for June 16-25 at Univ. of Mich., Coll. of Engineering.

Apr. 17-18: Second Annual Tech. Meeting, Institute of Environmental Engineers, Hotel New Yorker, N. Y. C.

Apr. 18-19: Twelfth Annual Spring Tech. Conf. on Television and Transistors, Engineering Society of Cincinnati Bldg., Cincinnati.

Apr. 20-24: Scientific Apparatus Makers, 40th Annual Meeting, El Mirador Hotel, Palm Springs, California.

Apr. 22-24: 1958 Electronic Components Conf., IRE, AIEE, Theme: "Reliable Application of Component Parts," Ambassador Hotel, Los Angeles.

Apr. 24-26: National Academy of Sciences, U. S. National Comm., Inter-

national Scientific Radio Union, Spring Meeting, Willard Hotel, Wash., D. C.

May 6-8: Western Joint Computer Conference, First National Symposium on Modern Computer Design, Ambassador Hotel, Los Angeles, Calif.

May 12-14: National Aero. & Nav. Elec. Conf., PGANE, Biltmore Hotel, Dayton, Ohio.

May 12-14: Eighth Annual Research Equip. Exhibit and Instrumentation Symposium, National Institutes of Health, Bethesda, Md.

May 19-21: Electronic Parts Distributors Show, Conrad Hilton Hotel, Chicago.

May 19-23: International Convention on Microwave Valves, Institute of Electrical Engineers, contact secretary, Savoy Place, London.

MARCH						
S	M	T	W	T	F	S
						1
2	3	4	5	6	7	8
9	10	11	12	13	14	15
16	17	18	19	20	21	22
23	24	25	26	27	28	29

APRIL						
S	M	T	W	T	F	S
			1	2	3	4
5	6	7	8	9	10	11
12	13	14	15	16	17	18
19	20	21	22	23	24	25
26	27	28	29	30		

MAY						
S	M	T	W	T	F	S
						1
2	3	4	5	6	7	8
9	10	11	12	13	14	15
16	17	18	19	20	21	22
23	24	25	26	27	28	29
30	31					



Abrasion Resistant

Sand Blast Nozzles. Spray Nozzles. Hard, homogeneous, long-lived. Suited to the most exacting uses.

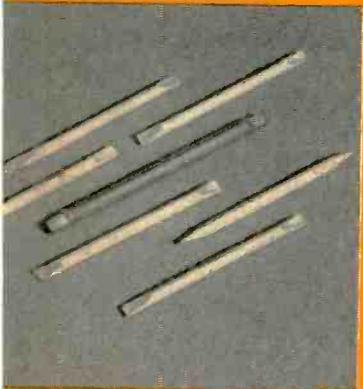

Non-Inductive

Alignment Tool Blades. Non-metallic, for sensitive machine and instrument settings—other demanding applications.



Thin . . . Strong

Electron Tube Spacers as thin as .009" have remarkable strength. Similar parts might solve other application problems where superior insulation is needed.

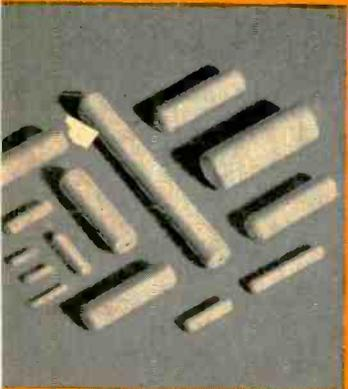

Precision Finishes

Smooth, easily coated AlSiMag Cores for Ink, Metal Film and Carbon Deposited Resistors.



ALSiMAG®

DATA FOR
DESIGNERS

NEW!

AlSiMag Alumina Ceramics open new fields for designers . . . permit designing to higher temperatures, higher frequencies, greater strengths.

Designers are generally familiar with the plus values of AlSiMag technical ceramics for standard industry applications. However, recent developments—particularly in new, high-strength, high-temperature AlSiMag Aluminas—have greatly enlarged their range of usefulness.

Do you need a material with such versatile characteristics as shown on this page? AlSiMag technical ceramics have helped many designers solve problems . . . may help solve yours. Send blueprint with complete operating details for our recommendations.

AMERICAN LAVA

CORPORATION
CHATTANOOGA 5, TENN.
56TH YEAR OF CERAMIC LEADERSHIP

A subsidiary of
Minnesota Mining and
Manufacturing Company

For service, contact Minnesota Mining & Manufacturing Co. Offices in these cities (see your local telephone directory): Atlanta, Ga. • Boston: Newton Center, Mass. • Buffalo, N. Y. • Chicago, Ill. • Cincinnati, O. • Cleveland, O. • Dallas, Texas • Detroit, Mich. • High Point, N. C. • Los Angeles, Calif. • New York: Ridgefield, N. J. • Philadelphia, Pa. • Pittsburgh, Pa. • St. Louis, Mo. • St. Paul, Minn. • So. San Francisco, Calif. • Seattle, Wash. • Canada: Minnesota Mining & Manufacturing of Canada, Ltd., P. O. Box 757, London, Ont. All other export: Minnesota Mining & Manufacturing Co., International Division, 99 Park Ave., New York, N. Y.



Precision Tolerances

Minute, yet strong tubing of AlSiMag Alumina. Parts in inset magnified three times (smaller one .013" OD); others approximate actual size.

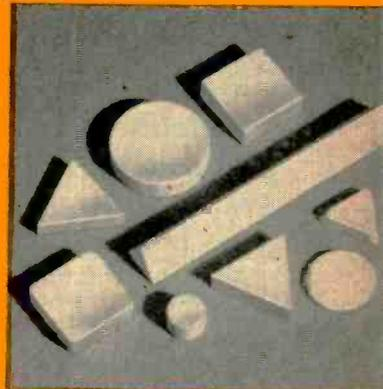

Hard

AlSiMag Tool Tips for cutting and machining strongest alloy steels.

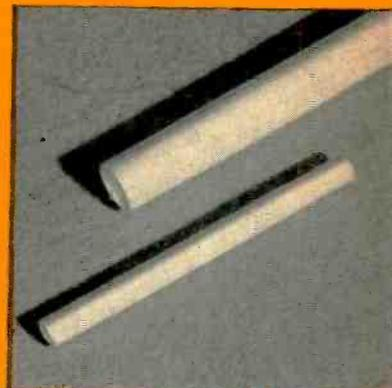

Durable

Rollers for flattening inductance wire—a new application for AlSiMag.



Heat Resistant

Support Rings for Heat Treating Fixtures. Welding Jigs. Hold-down Jigs for heat applications.

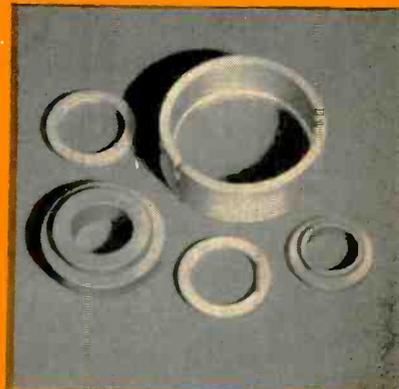

Acid Resistant

Rotary Seals and Plungers. Extraordinary wearing qualities. Surface finishes to most exacting specifications.

Nickelonic News

VOL. 1

DEVELOPMENTS IN NICKEL AND NICKEL ALLOYS AND THEIR APPLICATIONS

№ 3

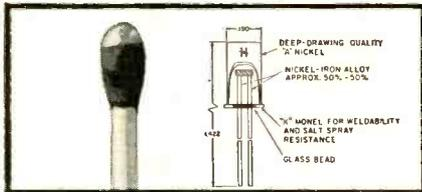

Four of six parts in miniature rectifier used in missile circuitry depend on Nickel (Hoffman Electronics Corp., Semiconductor Div.)

Matchhead-sized diode performs reliably at 400°F.

EVANSTON, ILLINOIS: Designers of circuit components for missile guidance find metals containing Nickel stand up under tremendous heat and vibration. Take above diode. Its easily-formed "A" Nickel cap resists oxidation at 400°F temperature. A corrosion-resistant "K" Monel* age-hardenable nickel-copper alloy header provides a high compression seal to glass bead. 50-50 Nickel-iron leads support diode in housing. Alloy works well with the glass, aids hermetic sealing. Tests show reliable operation for thousands of hours. **Pertinent Literature:** "Inco Technical Bulletin 'T-9'".

Nickel guards against shock in new high power ceramic tetrode



Assembling parts of Eimac, high-gain, amplifier tube. Nickel provides rugged structural support, helps assure electrical stability.

SAN BRUNO, CALIFORNIA: A high degree of immunity to damage by mechanical or thermal shock is claimed for a new, air-cooled, 1-kw ceramic tetrode produced by Eitel-McCullough, Inc. The tube (4CX1000A) is a low-voltage, high-current, class AB₁, RF, or AF linear amplifier designed for heavy-duty single side band operation with zero grid drive.

As the illustrations show, the designers have made liberal use of Nickel to give the tube maximum shock resistance. Most current-carrying supports are Inco Nickel "330". Non-current-carrying structurals are Nickel-clad steel. The inner cathode cylinder (oxide-coated) is Inco Electronic Nickel.

At the high temperatures met in processing and operating the tube, these Nickel parts retain exceptional strength, dimensional stability and oxidation resistance. Nickel is also easy to form and join and provides the good vacuum properties so essential in producing a clean, high-performance, long-life tube. **Pertinent Literature:** Write for "Inco Nickel Alloys For Electronic Uses".

New "Tom Thumb" cell miniaturizes photo circuits

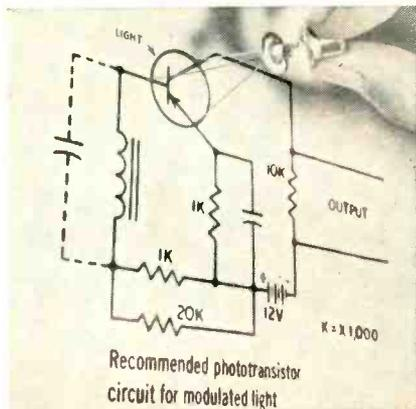

Germanium P-N-P photo transistor, Type 2N318.

"A" Nickel makes it rugged and reliable

JAMAICA, NEW YORK: General Transistor Corporation turns out this tiny transistor-type photocell. Its sensitivity (0.16 volts per foot-candle) is ample to assure positive relay operation by miniaturized circuits. It's tough enough, too, for portable instruments, industrial machines, other rugged service. Electronic Grade "A" Nickel base tab and leads provide high strength without contamination. Kovar®, a Nickel-containing alloy in base and header, insures a tight metal-to-glass seal. **Pertinent Literature:** Write for "Inco Technical Bulletin 'T-15'".

®Trademark Westinghouse Electric Corp.

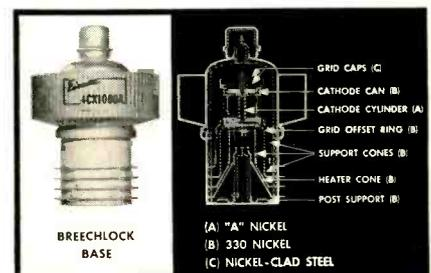

Where Inco Nickel is used in the Eimac stacked-ceramic tetrode.

"R" Monel provides advantages of Monel plus extra machinability of its own

"R" Monel* free-machining nickel-copper alloy is essentially Monel* nickel-copper alloy modified slightly to improve its machinability. As such, it provides all the desired properties of Monel alloy—corrosion resistance,

strength, ductility, weldability — with a plus. Table shows the machining advantage gained by using "R" Monel alloy. **Pertinent Literature:** Write for "Inco Technical Bulletin 'T-5'".

*Registered trademark

Machining speeds for "R" Monel on automatic screw machines with high speed steel tools¹

Operation	Surface speed (ft per min)	Feed (in per rev)
Turn	140-160	0.003 - 0.005
Form	140-160	0.0004-0.001
Drill	60-80	0.001 - 0.005
Ream	30-45	0.003 - 0.012
Tap	30-40	
Thread	30-40	
Cutoff	140-160	0.0005-0.001

¹For cemented-carbide tools, speeds may be increased 25-30%.



THE INTERNATIONAL NICKEL COMPANY, INC. • 67 Wall Street • New York 5, N. Y.



Mack

TRANSISTOR-MAGNETIC CORE SHIFT REGISTERS

**BETTER
THAN 15:1
signal to noise ratio**



CTR-250

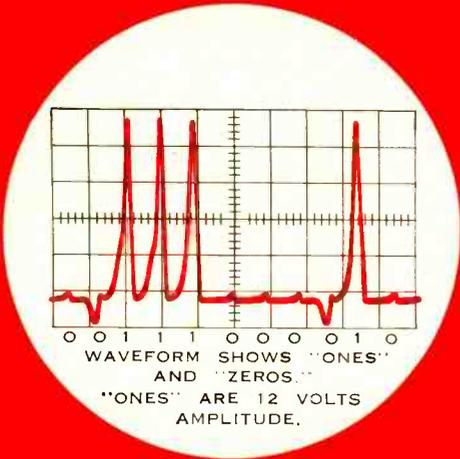

FEATURES:

- Reliability — life expectancy exceeds 50,000 hours
- Low Impedance
- Low Power Consumption
- Flexibility of Application
- Modular units reduce systems cost
- Wide operating margins

Mack offers the most diversified line of magnetic core components for computer and control applications. Hundreds of operating systems prove their reliability. Many years of design and application engineering are your assurance that Mack can fill all your needs — components — accessories — systems engineering. Mack's complete line of accessories including drivers, input amplifiers and mounting hardware, when used with the above components, permits the building of complete low cost systems. Write today for complete specifications.

Catalog Number	Applications	Repetition Rate (K C.)	OUTPUT SIGNAL			INPUT SIGNAL (Typical)		SHIFT PULSE (Typical)			Maximum Average Drive Power (Milliwatts)
			Amplitude (Volts)	Minimum Load (Ohms)	Min. Signal to Noise (1:0 ratio)	Current (ma)	Duration (μs)	Current (ma)	Range for Current (μs)	Drop for "1" Signal (volts)	
TRANSISTOR — MAGNETIC CORE UNITS											
CTL-50	Logic	50	12	2000	15:1	18	15	100	.5-4.0	.25	1.
CTL-100	Logic	100	12	2000	15:1	25	5	100	.5-3.0	.40	4.
CTR-250	Shift Register	250	12	2000	15:1	30	2	100	.3-1.5	.40	7.
DIODE — MAGNETIC CORE UNITS											
CDR-50	Shift Register	50	6	2000	10:1	6	15	220	.8-7.0	2.5	67.
CDR-100	Shift Register	100	6	2500	8:1	10	5	200	.5-4.0	5.0	160.
CDR-500	Shift Register	500	6	5000	8:1	30	1	250	.15-.65	10.0	200.
CDL-50	Logic	50	9	1000	7:1	9	15	250	1.0-6.0	3.5	120.
CD2W-50	Two Way Shift Register	50	4	1000	7:1	9	15	250	1.0-6.0	3.5	120.

* Maximum rate at which full operating margins are still obtained.

WEST COAST REPRESENTATIVE:
M. B. GILBERT CO.
1608 CENTINELA AVE.
INGLEWOOD 3, CALIFORNIA



ELECTRONICS DIVISION
OF MACK TRUCKS, INC.
1000 SO. SECOND STREET, PLAINFIELD, NEW JERSEY

Mack

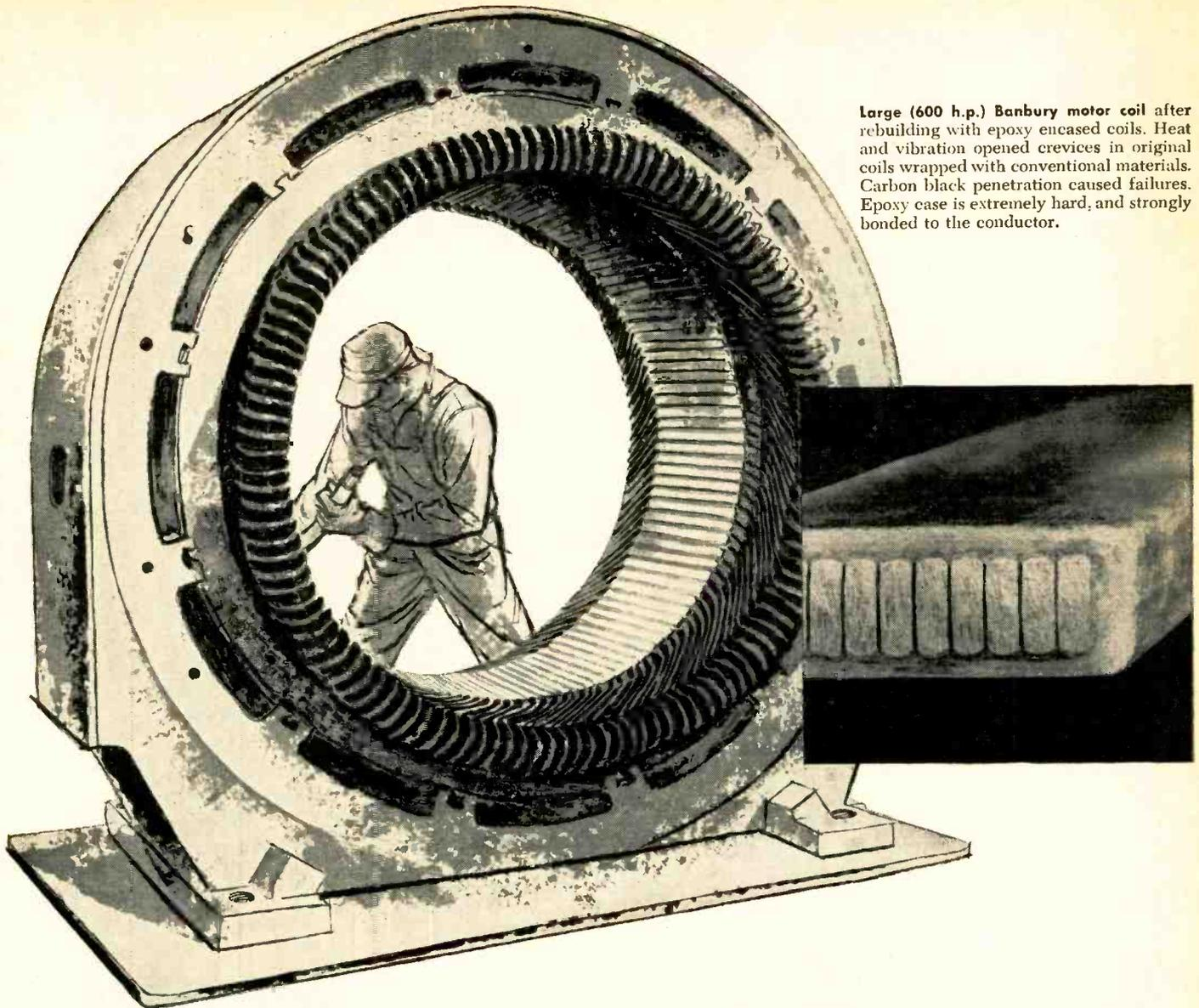

Large (600 h.p.) Banbury motor coil after rebuilding with epoxy encased coils. Heat and vibration opened crevices in original coils wrapped with conventional materials. Carbon black penetration caused failures. Epoxy case is extremely hard, and strongly bonded to the conductor.

TO PROTECT AGAINST FAILURE OF COMPONENTS...

embed them in BAKELITE

BRAND

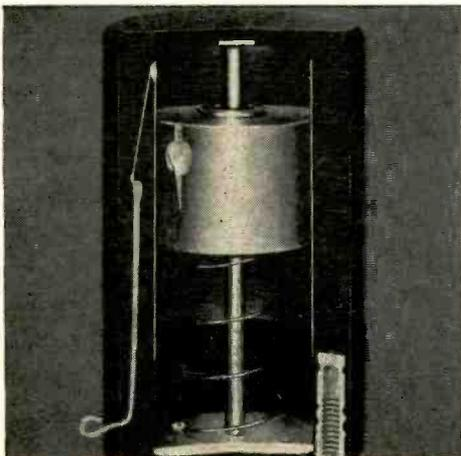

Shock in jet aircraft finds the RAM accelerometer prepared. It's a uniquely-designed, extremely low-friction type, hermetically sealed with compounds based on BAKELITE Brand Epoxy Resins, providing a constant self-damping factor over a wide altitude-temperature range. Vertical white lines in cross-section are fine wire windings embedded in the epoxy.

A 50% increase in mechanical life resulted when starter motors were equipped with this coil encapsulated in BAKELITE Epoxy Resins. It cut moisture-caused burnout almost to zero. Motors run eight per cent cooler. The tough resin prevents damage by vibration or impact. It virtually eliminated coil changing, and reduced stocking of coils and starters. Cured resin withstands temperatures from -90 to 250 deg. F.

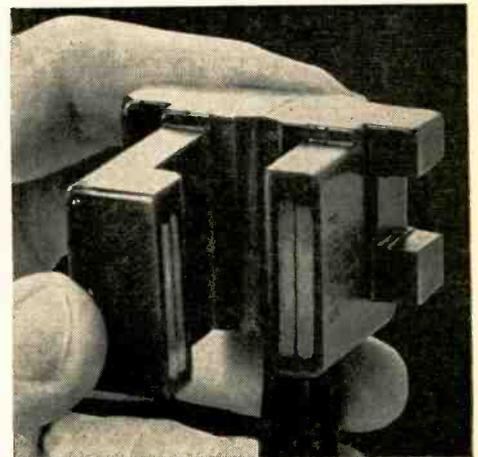



GIVE your delicate electrical components and subunits the protection to meet the most grueling performance demands... increase their reliability... avoid failures... cut down on costly maintenance...

Embed, encapsulate, or pot them in **BAKELITE Brand Epoxy Resins**—the “sturdy case” that hardens and keeps them safe. **BAKELITE Epoxy Resins** provide toughness, and mechanical strength... form a strong bond with metals, ceramics, and other surfaces... possess excellent corrosion resistance and dielectric properties.

A wide variety of formulations provides:

low viscosity—to permit penetration of fine crevices and the addition of fillers when economies demand it. Colors may be added for coding.

dispensing ease—for automatic machines.

sufficient pot life—long enough to permit proper handling.

safe exotherm—so that heat of reaction will not harm delicate components.

minimum shrinkage—to provide maximum dimensional stability.

From the advantages shown here, you can project many of the benefits your own products will enjoy. They are important to the engineer seeking miniaturization, handling safety, replacement speed, economy, and protection against moisture and vibration for sensitive electrical parts.

epoxy resins

Bakelite Company will help you with laboratory and research facilities, years of experience in plastics, and a variety of epoxy resins unsurpassed in quality. For information, write Dept. CE-50, Bakelite Company, Division of Union Carbide Corporation, 30 East 42nd Street, New York 17, N. Y.

Simple steps in casting with **BAKELITE Epoxy Resins**

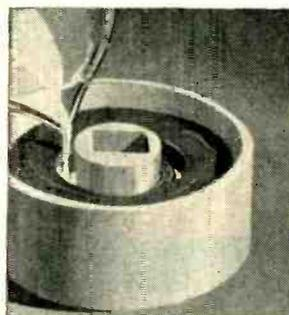

Poured as a liquid—resin mixed with hardener will cure without harm to fragile elements in the assembly.

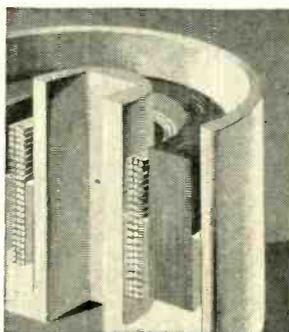

Fills every crevice—low viscosity permits complete penetration, minimizes air entrapment.

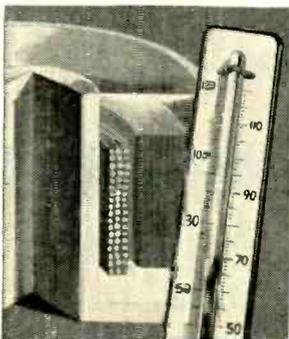

Hardens without heat—**BAKELITE Epoxy Resins** can be cured at room temperature or at elevated temperature.

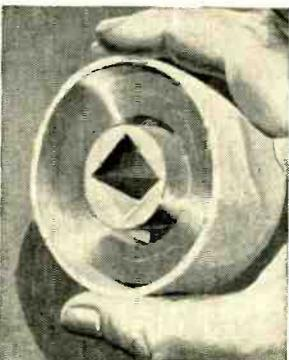

Keeps assembly safe—embedment resists shocks, chemicals, moisture, and holds components firmly.

It pays to protect with

BAKELITE
BRAND
PLASTICS



The terms **BAKELITE** and **UNION CARBIDE** are registered trade-marks of UCC.

Simple, direct hookup! Direct reading! Five 11-digit

Complete Printed Digital for Hewlett-Packard



-hp- 560A DIGITAL RECORDER

Analog output for strip-chart recorder. Expanded scale; full scale can represent $1/10^7$. Direct printout from counters; accuracy identical to counter used. Can record output of many electronic or mechanical devices.

SPECIFICATIONS

-hp- 560A/AR Digital Recorder

Accuracy:	Identical to counter used.
Printing Rate:	5 lines/sec maximum.
Digit Capacity:	11 per line.
Driving Source:	Parallel entry staircase voltages. Descending from 135 to 55 v, 0 to 9.
Analog Output:	Proportional to any 3 digits selected. Maximum amplitude 1 ma or 100 mv.
Print Command Signal:	1 μ sec minimum, pos. or neg. 15 v per pulse.
Paper:	3" roll or folded.
Line Spacing:	Single or double, adjustable.
Price: -hp- 560A/AR:	(11 digit, cabinet model) \$1,390.00 (11 digit, rack mount) 1,375.00 (6 digit, cabinet model) 1,265.00 (6 digit, rack mount) 1,250.00

Data subject to change without notice. Prices f.o.b. factory.

New -hp- 560A Digital Recorder works direct with all -hp- counters and most other precision electronic counters; no intermediate equipment is needed. It provides a complete record of all types of test data, plus, through an analog output, a convenient graphic record of very small data variations.

The analog output for driving a strip chart recorder is a voltage or current proportional to the number represented by any three consecutive digits of recorded data. The 560A permits expanded scale strip chart recording and the strip chart can never be driven off scale since range variation for the 3-digit scale is 0 to 999. Wider variation merely causes a repetition of the 0 to 999 sequence.

Model 560A is a complete, self-contained electronic instrument normally controlled by staircase voltages and a print command pulse from an electronic counter. It may, however, be controlled by other electronic or electro-mechanical devices. Printing speed is five, 11-digit lines per second; secondary or coding data may be entered simultaneously with primary data.

Maximum print capacity of the recorder is five, 11-digit lines per second but instruments can be supplied with any lesser number of digits desired.

464B



offers the most complete line



Newest News from

VEEDER-ROOT

Series 1527 Veeder-Root Miniaturized Electro-Magnetic Counters were originally developed for use in aerial cameras. These and similar counters are used to "post" the number of film-exposures, gallons or rounds of ammunition remaining after each use.

The new miniaturized counters present a

frontal area less than 1" x 1" . . . save an important amount of space over the older, larger counters. Yet they are designed to operate at speeds as high as 900 counts per minute. And this modern design includes a new push-in bi-directional reset knob, with speed-up gearing. Specifications meet most military requirements. Write for full details.

*Added Evidence
that Everyone
Can Count on*



VEEDER-ROOT

INCORPORATED
HARTFORD 2, CONNECTICUT

Hartford, Conn. • Greenville, S. C. • Altoona, Pa. • Chicago
New York • Los Angeles • San Francisco • Montreal
Offices and Agents in Principal Cities

New 5-megawatt ferrite isolator for high-power radars

FORCED AIR COOLED!

Another Sperry contribution to improved performance of radar systems is this new Model D44S1 ferrite isolator. It boosts efficiency of S-band radars by allowing optimum operation of high-power tubes.

In addition, this isolator protects high-power tubes from load mismatches, and eliminates frequency and power variations due to changing load impedances. It is rated at 5 megawatts peak, 5 kilowatts average, and features insertion loss of less than 0.3 db. Compact and small, the Model D44S1 measures only 6 inches in length and 8 inches in diameter. And its air-cooled design eliminates the extra expense and weight of liquid-cooling accessories.

Currently Sperry has under development or in production a wide variety of ferrite devices in addition to those shown here. These include megawatt duplexers, coaxial duplexers, octave-plus bandwidth isolators and attenuators, high-speed switches, modulators and choppers.

Sample quantities of the listed units are available immediately from our stock for test and evaluation in your system, with a view to production tailored to your specific requirements. Contact our nearest district office for further information.

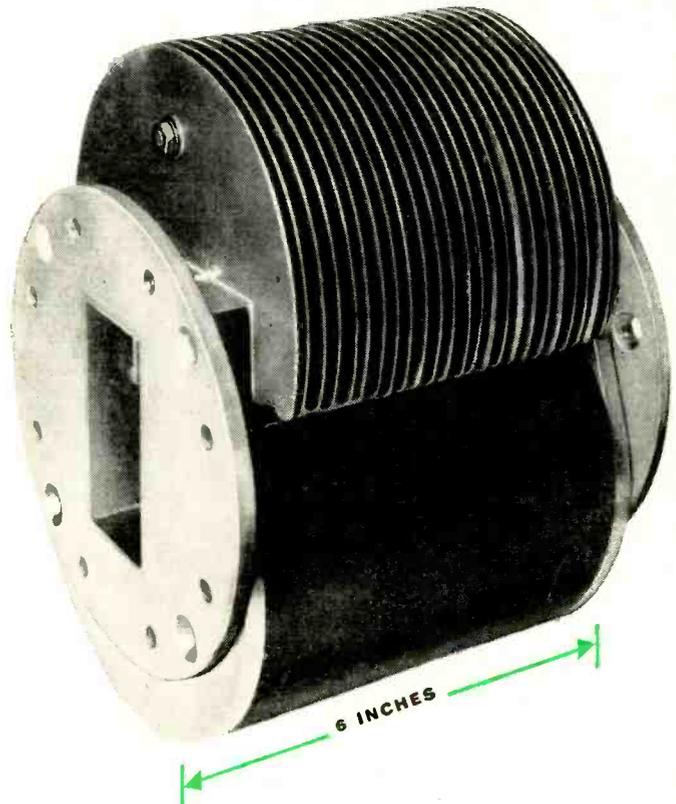

MODEL D44S1 SPECIFICATIONS

Power: 5 mw peak, 5 kw average
 Frequency: 2700-2900 mc
 Insertion loss: less than 0.3 db
 Isolation: 10 db min.
 Cooling: Forced air

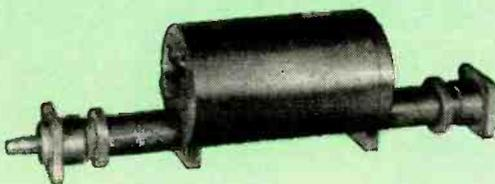

COAXIAL FERRITE ISOLATORS

MODEL	USE	FREQ. RANGE	MAX. AV. POWER	INSERTION/ISOLATION	DIMENSIONS
A44L1	Radar	1250-1365 mc	400 w	1 db 10 db	3" dia. x 13.25"
A44S1	Radar	2700-3100 mc	10 w	1 db 10 db	1.5" dia. x 5"
D44L1	Relay	1700-2400 mc	30 w	1.5 db 21 db	3" dia. x 13.25"
A44S4	ECM	2000-4000 mc	400 w	1 db 10 db	3" dia. x 13.25"



X-BAND FERRITE COMPONENTS

MODEL	USE	FREQ. RANGE	MAX. AV. POWER	INSERTION/ISOLATION	DIMENSIONS
A44X1	Isolator	8200-12400 mc	400 w	1 db 10 db	1.5" dia. x 5"
A43X1	Variable Attenuator	8500- 9600 mc	10 w	1 db 30 db var.	1.5" dia. x 2"

MICROWAVE ELECTRONICS DIVISION

SPERRY GYROSCOPE COMPANY
 Great Neck, New York

DIVISION OF SPERRY RAND CORPORATION

BROOKLYN • CLEVELAND • NEW ORLEANS • LOS ANGELES • SAN FRANCISCO • SEATTLE. IN CANADA: SPERRY GYROSCOPE COMPANY OF CANADA, LIMITED, MONTREAL, QUEBEC

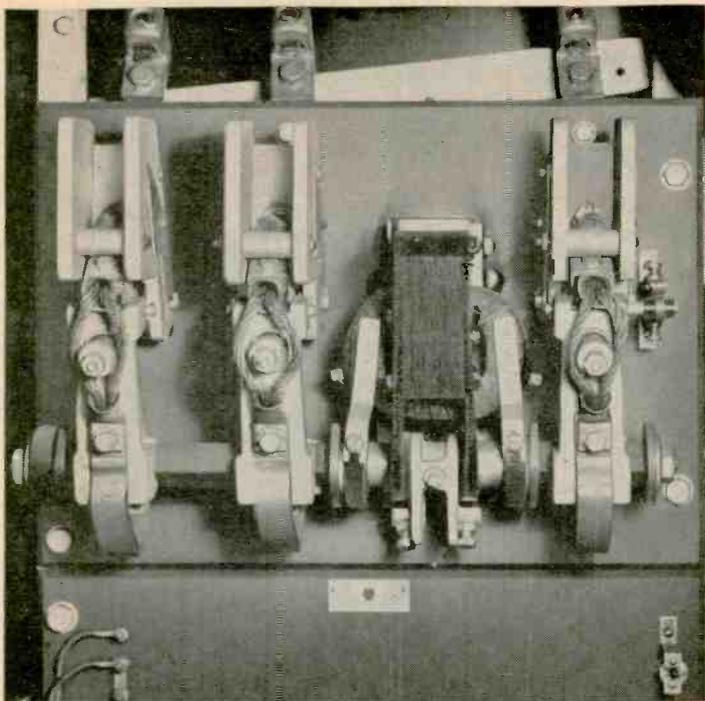

Leader in contact metallurgy, Mallory has created a complete range of contact materials applicable to instrument and control circuits . . . provides specialized engineering service to aid in selection of materials and in the design of complete contact systems.

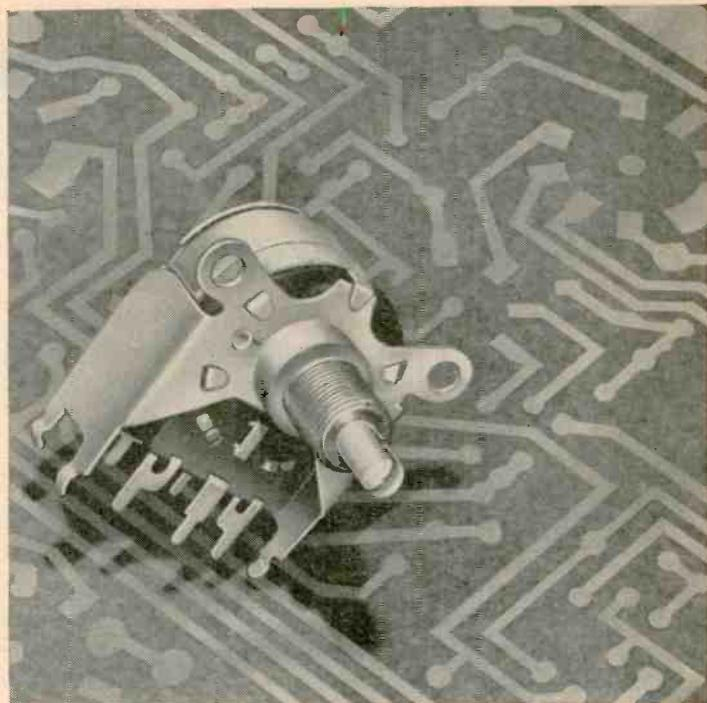

Especially designed for transistor circuits, new Mallory volume control has low hop-off resistance. Other Mallory resistors include printed circuit volume controls, wire wound controls, and a useful line of vitreous enamel, cement-coated and axial lead fixed resistors.

How Mallory Precision

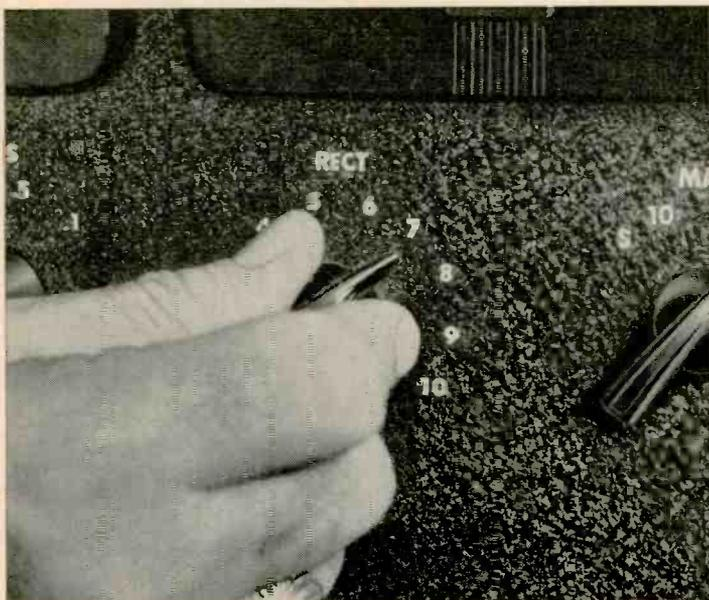

Selector switches by Mallory come in dozens of precision-made designs applicable to instrument circuits. In the line of special Mallory components are a wide selection of wafer and push-button switches, jacks and plugs . . . and the famous Mallory Inductuner, a high precision variable inductance tuning element, useful in many types of radio frequency measuring equipment.

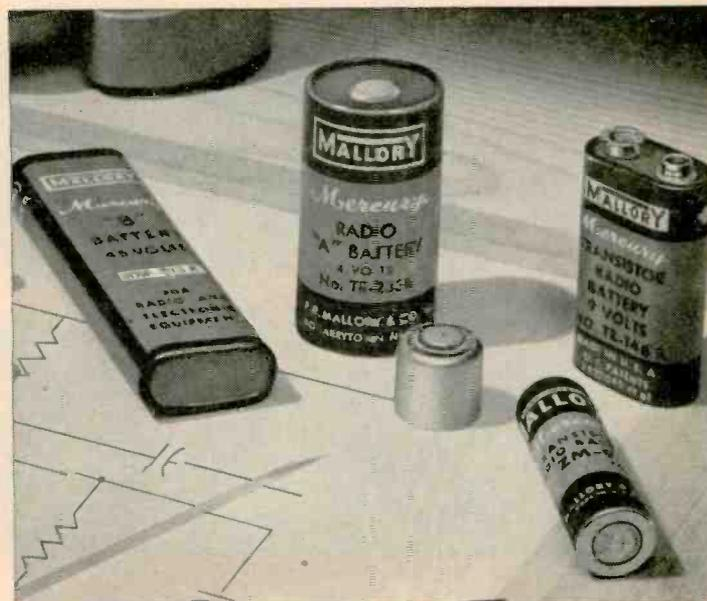

Unique dependability in portable power, Mercury Batteries, pioneered by Mallory, provide exceptionally long life, miniature size and constant-energy discharge. They are ideal for use with transistors . . . unequalled for performance and dependability in portable miniature instruments. Voltage output is extremely constant . . . useful in bias circuits and as a secondary reference standard.

Computer grade capacitors, designed for low leakage and high stability, are one of the many types Mallory makes for instrument use. Leader in electrolytics, Mallory originated the FP capacitor—pioneer in 85°C ratings, and manufactures a complete line of tantalum capacitors.

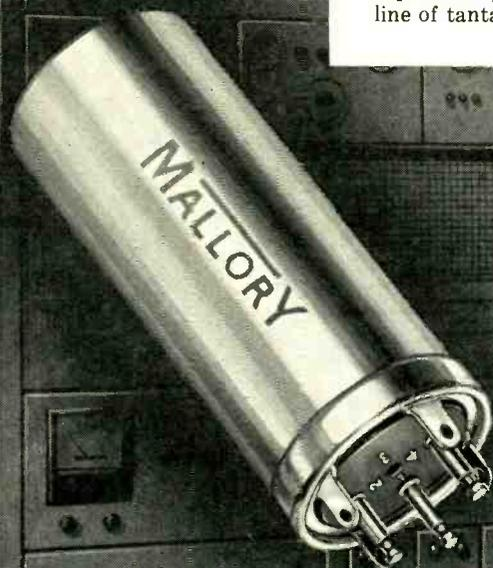

Products and Engineering

Serve The Instruments And Controls Industry

You'll find Mallory components in much of the instrumentation that controls today's chemical, petroleum and steel processes . . . harnesses electrical and nuclear power . . . gathers and correlates huge masses of data for science, industry and military projects.

Instrument and control manufacturers build precision into many of their products with Mallory components. Mallory capacitors, resistors, switches, controls, batteries and vibrators . . . long the standard of the electrical industry—are equally at home in today's electronic instruments.

Into Mallory components go more than thirty years of pioneering experience . . . and a tradition of

skilled design and craftsmanship. The ability of many instruments to operate unattended for long periods, is due in part to the precision and dependability of Mallory components that go into them.

In producing many of the components you work with, Mallory has become intimately familiar with many of your overall circuitry problems. This experience is at your command, to help you design the best possible performance into your products.

Our staff is ready to work with your designers in the application of Mallory components to the latest instrumentation and control techniques. Call or write, and we'll be glad to arrange a meeting at your convenience.

Serving Industry with These Products:

- Electromechanical**—Resistors • Switches • Tuning Devices • Vibrators
- Electrochemical**—Capacitors • Mercury and Zinc-Carbon Batteries
- Metallurgical**—Contacts • Special Metals • Welding Materials

Parts distributors in all major cities stock Mallory standard components for your convenience.



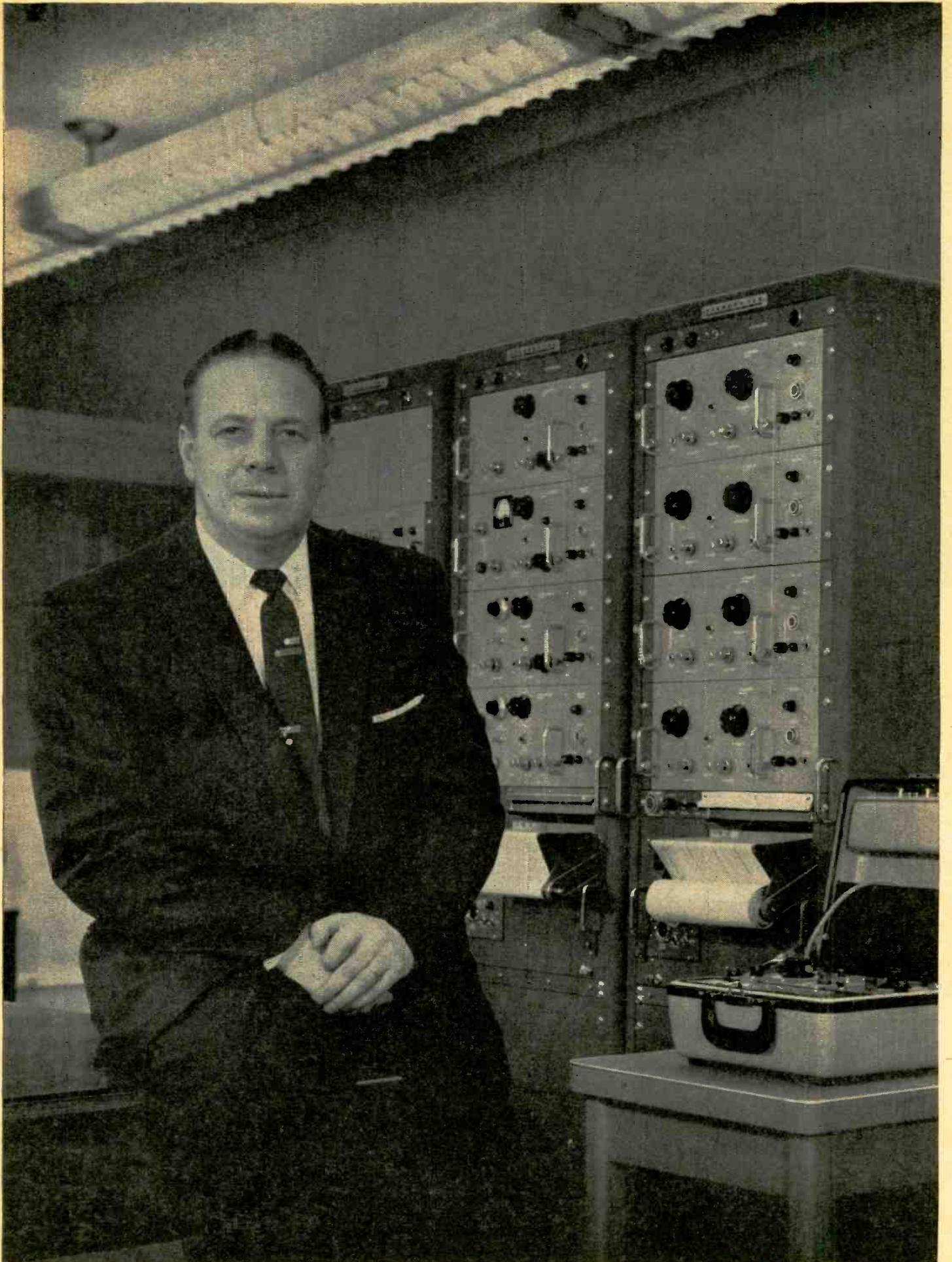

"ADVERTISING PRECEDES OUR SALES REPRESENTATIVES, INCREASES COMPANY RECOGNITION"

Alfred E. Lonnberg, Vice-President Sales of Sanborn Company, tells how business magazine advertising helps sell oscillographic recording systems and allied instruments:

"Business magazine advertising is the quickest and most efficient means we have of informing our market of the features of our products and indicating the character of our company. Recognition for Sanborn, built in this way, gives our sales representatives the advantage of being backed by a manufacturer known to be well established in its field.

"As an integral part of our complete advertising program, which in turn is an essential element of our total sales effort, business magazine advertising receives its share of credit from our management for the steady growth and success of Sanborn Company."

IF WHAT YOU MAKE OR SELL is bought by business or industry, you'll find that the consistent use of business magazine advertising will help "mechanize" your selling. Such advertising enhances your corporate image, creates preference for your brand . . . delivers your sales messages to the right men with minimum effort. By *concentrating* your advertising in one or more of the McGraw-Hill magazines serving your markets, you will create the recognition that gives your salesmen more time to make specific proposals and close sales.

McGRAW-HILL PUBLICATIONS



McGraw-Hill Publishing Company, Incorporated
330 West 42nd Street, New York 36, N. Y.

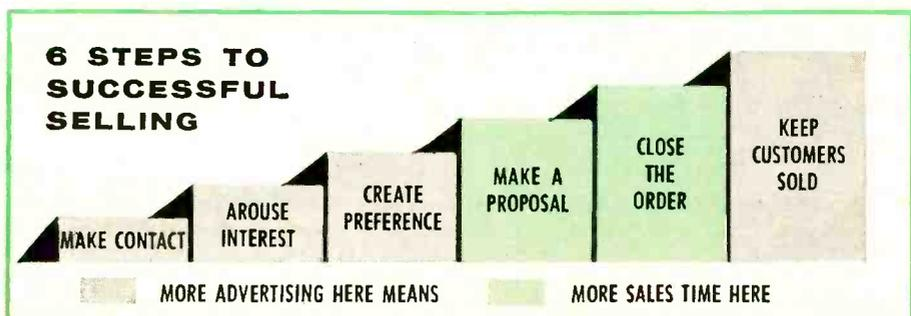

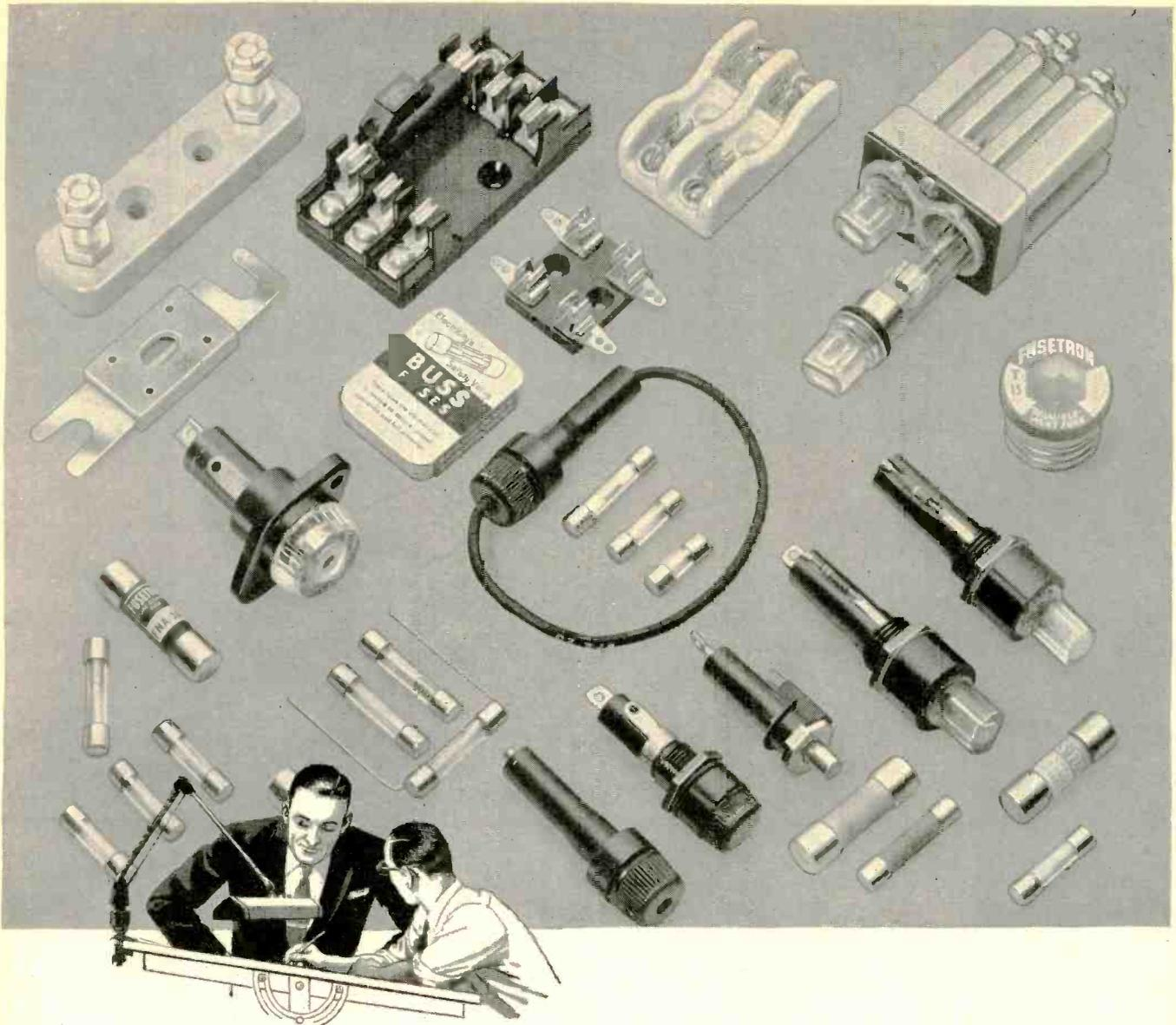

For Safe, Dependable Electrical Protection ... Standardize on BUSS Fuses!

To make sure of proper operation under all service conditions . . . every BUSS fuse is tested in a sensitive electronic device that automatically rejects any fuse not correctly calibrated, properly constructed and right in all physical dimensions.

This careful testing is your assurance BUSS fuses will provide equipment with maximum protection against damage due to electrical faults.

Just as important, BUSS fuses will not give a false alarm by blowing need-

lessly. Shutdowns due to faulty fuses blowing without cause are eliminated.

By specifying dependable BUSS fuses, you help safeguard the good name of your equipment for quality and reliability.

Complete Line—There is a complete line of BUSS fuses in sizes from 1/500 ampere up . . . plus a companion line of fuse clips, blocks and holders.

If your protection problem is unusual . . .

. . . let the BUSS fuse engineers work

with you and save you engineering time. If possible, they will suggest a fuse already available in local wholesalers' stock, so that your device can be easily serviced.

For more information on BUSS and FUSETRON Small Dimension fuses and fuseholders . . . Write for bulletin SFB. Bussmann Mfg. Division (McGraw-Edison Co.) University at Jefferson, St. Louis 7, Mo.

BUSS fuses are made to protect—not to blow, needlessly

358



Makers of a complete line of fuses for home, farm, commercial, electronic, automotive and industrial use.

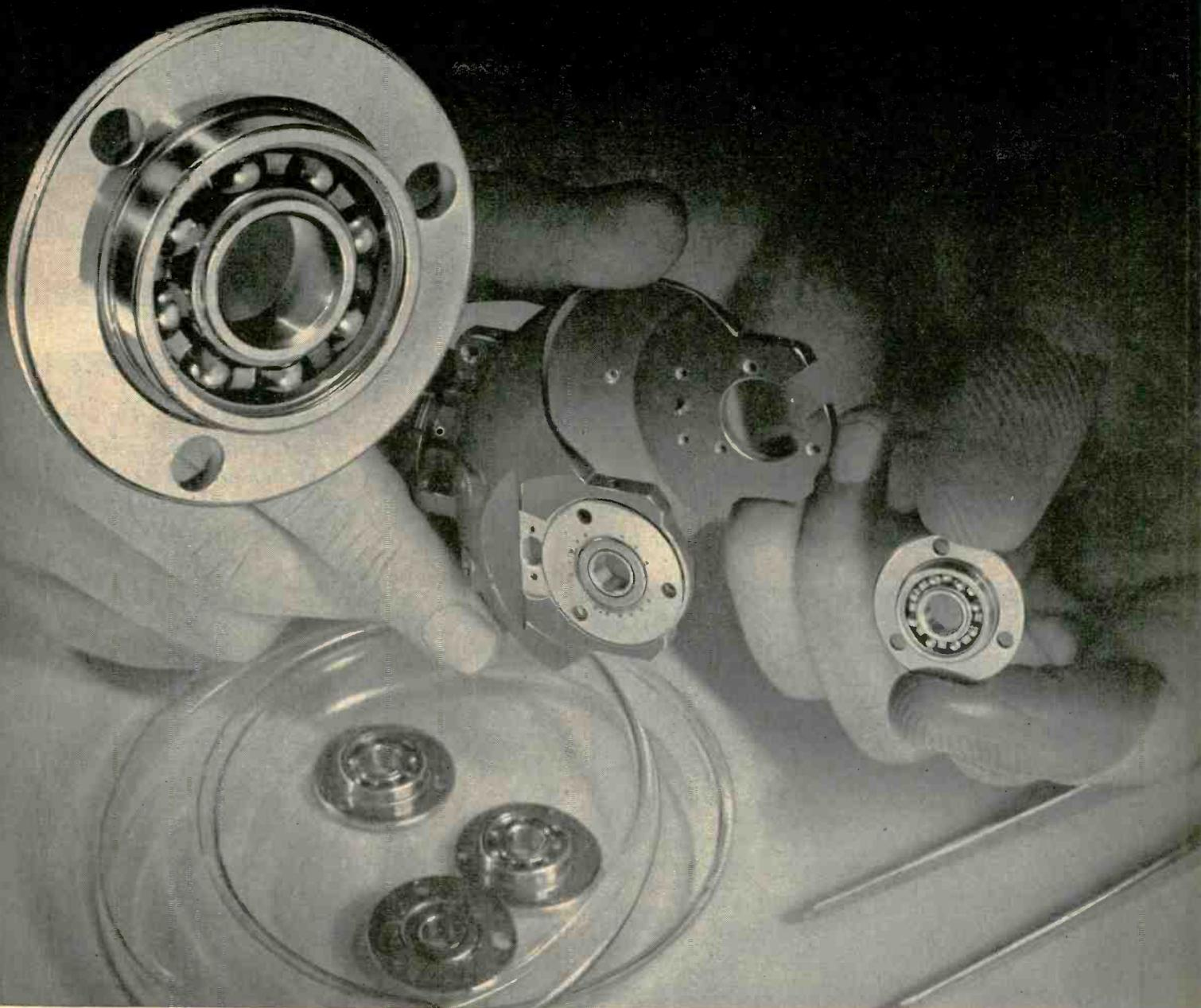

Barden Precision Z96SW bearings specially designed for a gyro gimbal

BARDEN Precision ball bearings set today's performance standards



The **Torkintegrator**, a high precision torque tester, was designed by Barden for extremely accurate response to torque variations. It is one of many Barden-developed test devices used for quality control or functional testing of Barden Precision ball bearings.

For accurate gyro indications, gimbals need bearings with uniformly low and predictable torque reactions. Other demands are extreme accuracy of rotation and exact positioning of the gimbal.

All standard *Barden Precision* bearings meet critical requirements for low torque and rotational accuracy. In addition, the special purpose Z96SW has these important design features:

Barden-developed "W" retainer—to minimize torque peaks . . . eliminate "windup"

Precision flange—for precise positioning and alignment . . . rigid mounting

Shield on exposed side—to prevent entrance of foreign matter

One of hundreds of Barden "specials," the Z96SW is an example of the results that stem from working creatively with Barden engineers from the earliest design stage.

Like all *Barden Precision* bearings, standard or special purpose, the Z96SW is planned for *performance* from research and design, through quality controlled production, functional testing and application engineering.

Your product needs *Barden Precision* if it has critical requirements for accuracy, low torque or low vibration . . . if it operates at extreme temperatures or high speed.

THE BARDEN CORPORATION

45 E. Franklin St., Danbury, Connecticut • Western office: 3850 Wilshire Blvd., Los Angeles 5, California

SPECIFY BARDEN PRECISION BALL BEARINGS FOR: INSTRUMENTS • COMPUTERS AND RECORDERS • AIRCRAFT ACCESSORIES • MACHINE TOOL AND TEXTILE SPINDLES • OTHER PRECISION APPLICATIONS

CIRCLE 22 READERS SERVICE CARD



MICRO SWITCH Precision

Highly Reliable MICRO for Electronic Computer

Here are six MICRO SWITCH Precision Switches, designed, produced and thoroughly tested for highly reliable performance in electronic computer consoles, aircraft instrument panels and other types of control panels. . . . The series "PB" illuminated pushbutton and the "AS" series of rotary selector switches typify the best in MICRO SWITCH design and the ultimate in MICRO SWITCH performance and reliability.

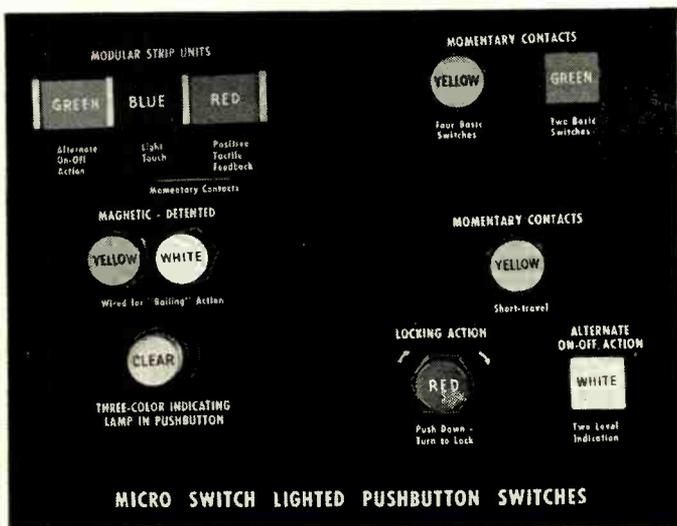

Eye Appeal and Positive "Feel" Within Minimum Panel Area

These are the Essentials in Console Design for Today and Tomorrow

Here are two of the many different designs available in Lighted Pushbutton Switches

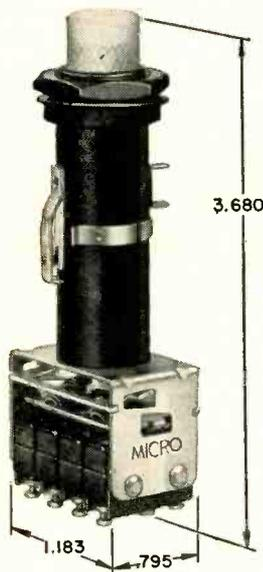

54PB67-T2 with 52PA5 Button

The "50" series switch, shown at left, is a two position, alternate-action switch. The two level visual indication allows extra flexibility in complex control panels. The position of the button—up or down—indicates the condition of the circuit. An independent indicator lamp is free to give additional information, or it can be wired to go "on" and "off" with the switch.

The "50" series switch, at right, is a unique magnetically held pushbutton. This extremely versatile switch combines multi-circuit switching, indicator light and d-c holding solenoid in one compact unit. When the button is pushed, the switch contacts are held actuated until electrically released. This permits one-by-one "bailing" operation with remote electrical release, allowing complete freedom of panel layout.

These switches are available with two, three or four SPDT contact structures. All lamp and button options may be used. They are rated at 5 amps., 125-250 vac. 3 amps., 30 vdc.

Request Data Sheet No. 133.

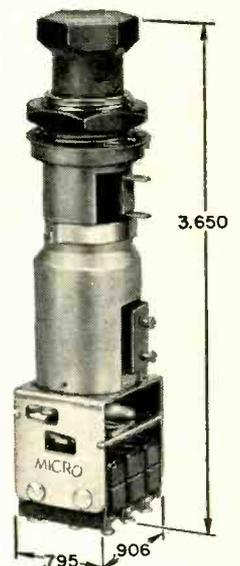

53PB8-T2 with 52PA8 Button

Switches have uses unlimited



SWITCH Precision Switches and Aircraft Instrument Panels

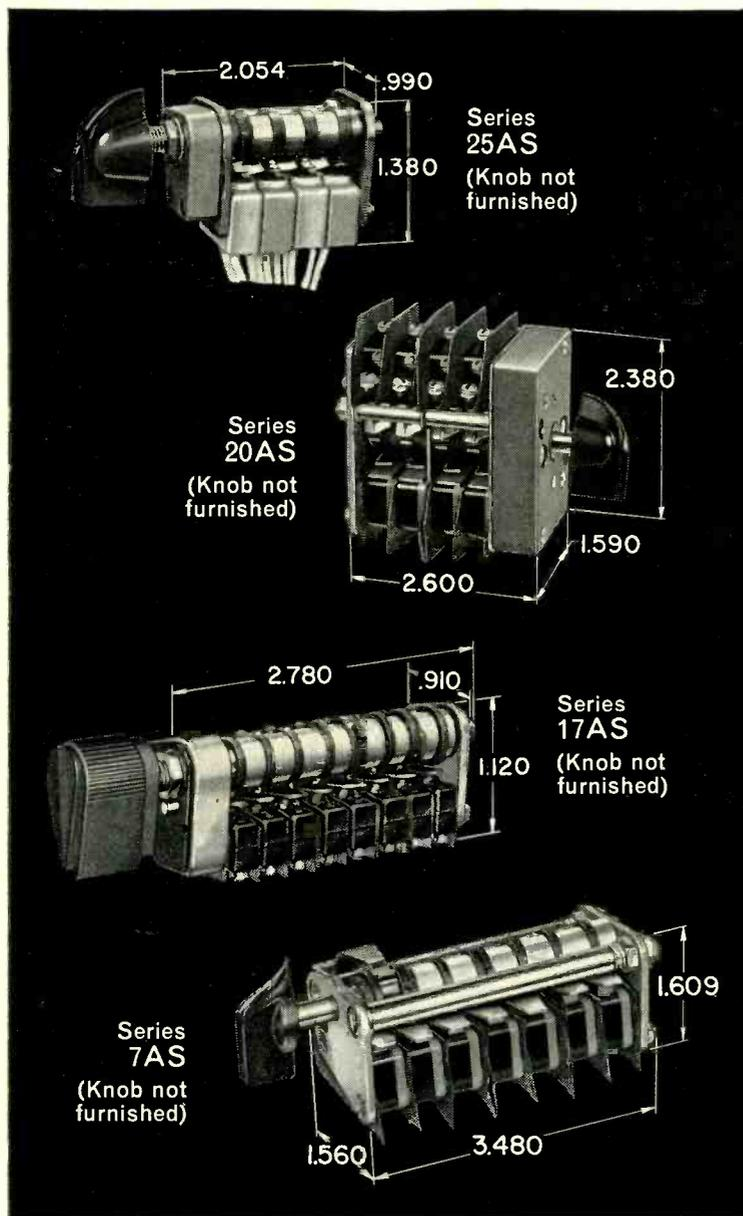

Smallest Rotary Selector Switch Assemblies Available . . . Provide up to 20 Switching Units.

"25As" series rotary selector switch assemblies are the smallest available with environment-proof sealed subminiature basic switching units. Assemblies are available with from two to eight SPDT sealed subminiature switches. Optional positive detent positions from 2 to 8. Rated 5 amps., 125-250 vac. 3 amps., 28 vdc.

"20As" series rotary selector switch assemblies are extremely versatile. Available with 4 to 20 "V3" type switching units. They are compact, sturdily constructed, and highly reliable. Panel sealing and detent positions are optional. Rated 10 amps., 125-250 vac. 10 amps., 30 vdc.

"17As" series rotary selector switches are small compact assemblies, available with up to ten SPDT subminiature basic switches. 45 degree angle detents are available in 2 to 8 positions. The use of these assemblies reduces instrument panel space. Rated 5 amps., 125-250 vac. 2½ amps., 30 vdc.

"7As" series rotary selector switches are compact and sturdy assemblies of two to eight SPDT "V3" type switches, ideal for applications requiring multi-circuit control of 10 amp. circuits. Available in 2 to 8 detent positions. Rated 10 amps., 125-250 vac. 10 amps., 30 vdc.

For complete details on these assemblies ask for Data Sheet 86a.

The two-word name "MICRO SWITCH" is NOT a generic term. It is the name of a division of Minneapolis-Honeywell Regulator Company.

MICRO SWITCH

A DIVISION OF MINNEAPOLIS-HONEYWELL REGULATOR COMPANY

In Canada, Leaside, Toronto 17, Ontario • FREEPORT, ILLINOIS



First in Precision Switching

SKY WARRIOR WITH HIS

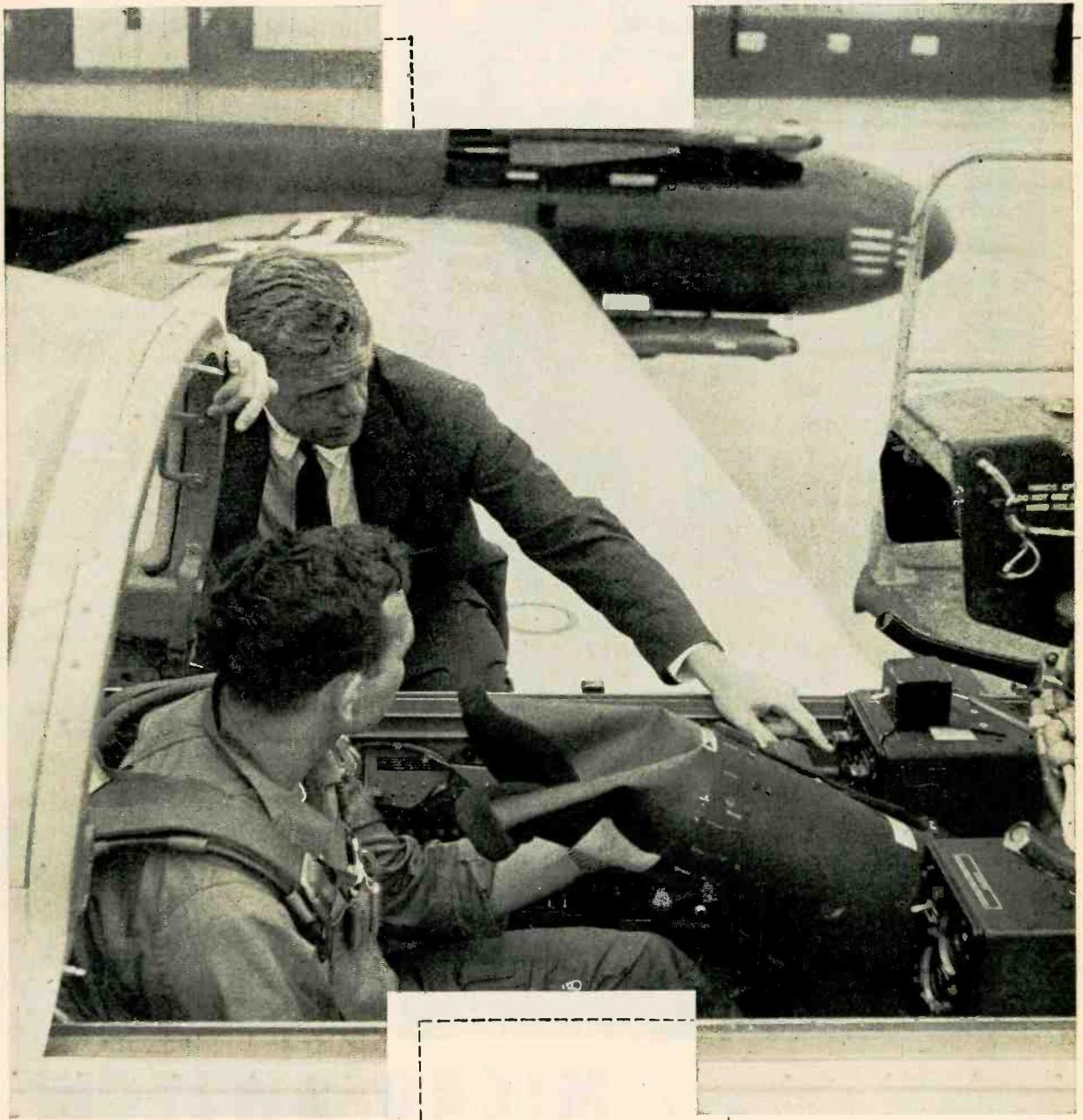

FEET ON THE GROUND

The advent of complex jet warfare has created a new, highly respected type of engineer—the Hughes Field Engineer. Responsible for the modification and maintenance of complex Electronics Armament Systems and guided missiles, he keeps in the forefront of the newest electronics developments.

The Hughes Field Engineer, working with complete integrated systems, learns how each component contributes toward the working, fighting total. He is given the opportunity to work with electronics systems right where they prove themselves—in actual use.

The Hughes Field Engineer is the final link in a strong chain. The Research and Development Laboratories form the first link by initiating the basic designs for the new system. The Hughes manufacturing facilities produce the

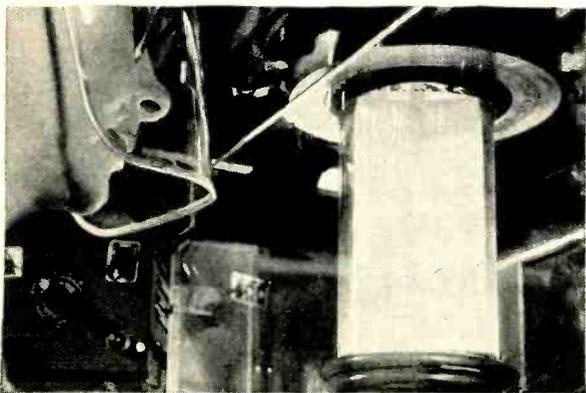

Molten Ladle of silicon is watched during first step in the precise manufacture of Hughes semiconductors. Constant innovations in Research, Development and Manufacture have positioned Hughes Products as a commercial electronics leader.

Electronic Scanning Radar systems, a radically new concept in radar beam positioning, is currently being developed and manufactured by the Hughes Ground Systems Division.

Creating a new world with *ELECTRONICS*

HUGHES

system, “building in reliability” with the most advanced techniques in testing. As the final link, the Field Engineer makes the system produce everything that was built into it.

The complete cycle of Research, Development, Manufacture, and Service is also evident in other Hughes activities. The commercial products activity performs all these phases in the areas of electron tubes, semiconductor devices, and industrial systems and controls. The Ground Systems Division performs all phases on protective radar systems. This diversity and wide scope of activity has made Hughes an ideal firm for present and prospective employees interested in career advancement.

Some of the highly rewarding positions now open include:

Computers	Solid State Physics
Microwaves	Semiconductor Sales
Reliability	Semiconductor Applications
Circuit Design	Systems Analysis

Write, briefly outlining your experience, to Mr. Phil N. Scheid, Hughes General Offices, Building 17M, Culver City, California.

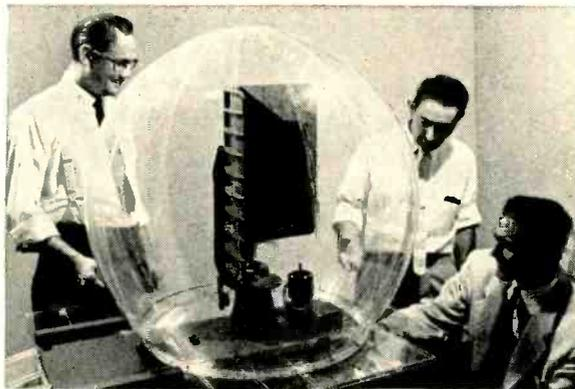

HUGHES AIRCRAFT COMPANY
Culver City, El Segundo,
Fullerton, Los Angeles, California
Tucson, Arizona

How CDF Di-Clad[†] can solve your printed-circuit problems

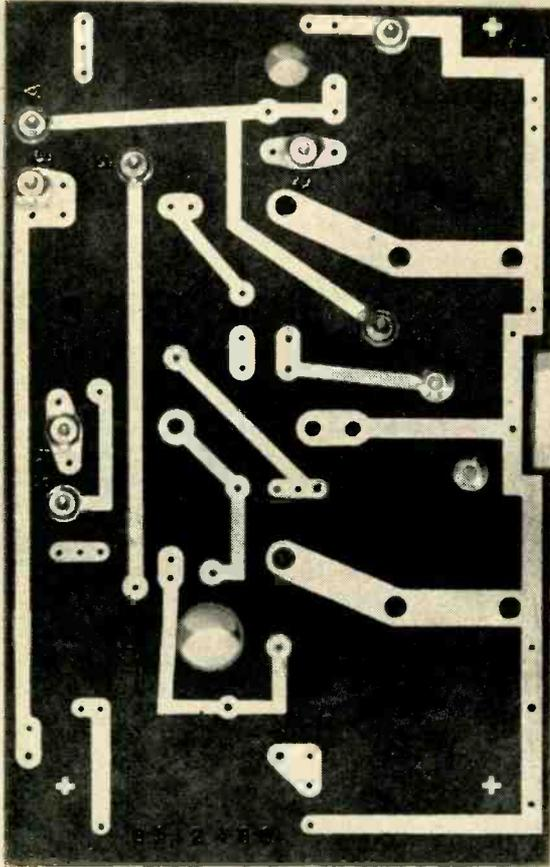

The CDF line of copper-clad laminates in all grades is now known by a new name—Di-Clad. Di-Clad grades meet the varying needs of design, production, and operation of electronic equipment. Grades other than those described are also available.

Di-Clad 28E. For high mechanical strength, low moisture-absorption, and good insulation resistance, CDF Di-Clad laminates of epoxy resin laminated with glass fabric offer the designer a strong, reliable combination.

Di-Clad 112T. A Teflon* glass-fabric laminate offering the best dielectric properties over a wide temperature and frequency range.

Send us your requirements and let our engineers help you select the right grade for your application.

[†]Trademark of Continental-Diamond Fibre Corporation
*Du Pont trademark for its tetrafluoroethylene resin.

Di-Clad 2350. An economy paper-base phenolic grade having good tensile, flexural, compressive, and impact strength. Adequate for most non-critical printed-circuit applications. Can be cold punched and sheared up to 5/64 of an inch in thickness.



CONTINENTAL-DIAMOND FIBRE

A SUBSIDIARY OF THE *Built* COMPANY • NEWARK 16, DEL.

TYPICAL Di-Clad PROPERTY VALUES

	Di-Clad 2350	Di-Clad 26 (NEMA XXXP)	Di-Clad 28 (NEMA XXXP)	Di-Clad 28E (NEMA G-10)	Di-Clad 112T Teflon*
BOND STRENGTH—0.0014" foil (lbs. reqd. to separate 1" width of foil from laminate)	6 to 10	6 to 10	6 to 10	8 to 12	4 to 8
MAXIMUM CONTINUOUS OPERATING TEMPERATURE (Deg. C.)	120	120	120	150	200
DIELECTRIC STRENGTH (Maximum voltage per mil for 1/16" thickness)	800	900	850	650	700
INSULATION RESISTANCE (Megohms) 96 hrs. at 35°C. & 90% RH (ASTM D257, Fig. 3)	500	150,000	600,000	100,000	75,000
DIELECTRIC CONSTANT 10 ⁶ Cycles	4.5	4.0	3.6	4.9	2.6
DISSIPATION FACTOR 10 ⁶ Cycles	0.040	0.026	0.027	0.019	0.0015
ARC-RESISTANCE (Seconds)	5	10	10	130	180
TENSILE STRENGTH (psi.)	18,000	16,000	12,000	48,000	23,000
FLEXURAL STRENGTH (psi.)	27,000	21,000	18,000	70,000	13,000
IZOD IMPACT STRENGTH edgewise (ft. lbs. per inch of notch)	0.80	0.45	0.42	12.0	6.0
COMPRESSIVE STRENGTH flatwise (psi.)	32,000	28,000	25,000	62,000	20,000
BASE MATERIAL OF LAMINATE	Paper	Paper	Paper	Medium-weave, medium-weight glass cloth	Fine-weave, medium-weight glass cloth
COLOR OF UNCLAD LAMINATE	Natural	Natural greenish	Natural	Natural	Natural

All these standard grades are available with 0.0014" and 0.0028" or thicker electrolytic or rolled copper foil on one or both surfaces. Other metal foils and other resin-and-base combinations can be supplied on special order.

*Du Pont Trademark

See how
the facts speak
for themselves

hcd ^{*}RADIO RECEPTOR Petti-Sel SELENIUM RECTIFIERS are revolutionizing the field!

* high current density

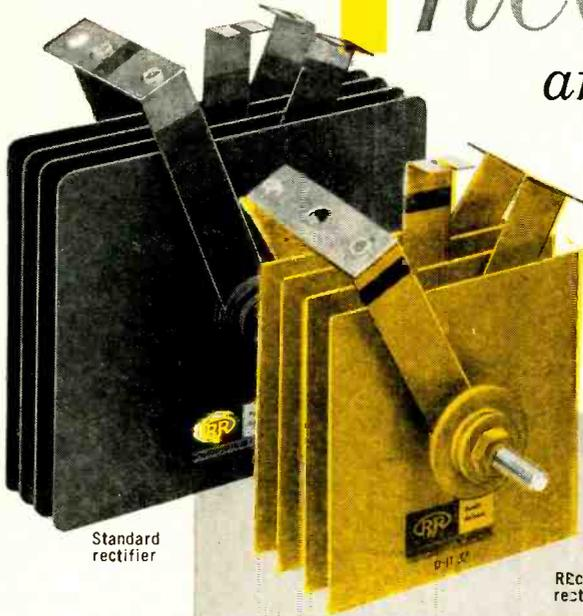

Standard
rectifier

RRco. Petti-Sel
rectifier

- ▶ 100,000 hours estimated life
- ▶ Lower voltage drop
- ▶ Higher current density
- ▶ Less reverse leakage
- ▶ Smaller size

Both rectifiers are rated at 26V, 8 amps,
but notice the significant space saving in the
compact Petti-Sel unit.

compare the size ...

compare the specs ...

STANDARD SELENIUM RECTIFIERS								
NOMINAL CELL SIZE (INCHES)		RRco. CELL CODE	Continuous DC Amperes at 35° C Ambient					
Vert.	Horiz.		SINGLE PHASE			THREE PHASE		
			Half Wave	Center Tap	Bridge	Half Wave	Center Tap	Bridge
1.0	1.0	M	.11	.22	.22	.29	.40	.33
1 1/16	1 1/16	P	.23	.45	.45	.60	.81	.67
1.5	1.5	Q	.45	.90	.90	1.2	1.6	1.3
2	2	S	.70	1.4	1.4	1.8	2.5	2.1
3	3	U	1.6	3.2	3.2	4.2	5.8	4.8
3 3/8	3 3/8	V	2.0	4.0	4.0	5.3	7.2	6.0
4	4	W	3.0	6.0	6.0	8.0	10.8	9.0
4.5	5	G	3.75	7.5	7.5	10.0	13.5	11.2
4 1/4	6	T	4.2	8.5	8.5	11.0	15.0	12.5
5	6	H	5.0	10.0	10.0	13.3	18.0	15.0
6	7 1/4	L	7.5	15.0	15.0	20.0	27.0	22.5

RRco. PETTI-SEL SELENIUM RECTIFIERS								
NOMINAL CELL SIZE (INCHES)		RRco. CELL CODE	Continuous DC Amperes at 35° C Ambient					
Vert.	Horiz.		SINGLE PHASE			THREE PHASE		
			Half Wave	Center Tap	Bridge	Half Wave	Center Tap	Bridge
1.0	1.0	6	0.2	0.4	0.4	0.6	1.0	0.6
1.3	1.3	11	0.5	1.0	1.0	1.5	2.5	1.5
1.6	1.6	16	0.75	1.5	1.5	2.25	3.75	2.25
2	2	25	1.25	2.5	2.5	3.75	6.25	3.75
2.6	2.6	44	2.25	4.5	4.5	6.75	11.25	6.75
4	4	100	4	8	8	12	20	12
4	8	200	8	16	16	24	40	24
4	12	300	12	24	24	36	60	36
8	8	402	16	32	32	48	80	48
8	12	600	22.5	45.0	45.0	67.5	112.5	67.5
8	16	800	30.0	60.0	60.0	90	150	90

In case you haven't noticed, the yellow and gray areas denote actual comparative sizes of the two rectifier types.

and compare the prices! HCD Petti-Sel rectifiers, developed in Western Germany by Siemens and now made in the U.S. by Radio Receptor, offer many important electrical advantages over standard types plus economic advantages.

See for yourself — We'll be glad to send you further information on this remarkable new rectifier line. Submit your requirements to Section E-3R.



Semiconductor Division
RADIO RECEPTOR COMPANY, INC.

Subsidiary of General Instrument Corporation
240 WYTHE AVENUE, BROOKLYN 11, N. Y. • EVergreen 8-6000

Radio Receptor products for Industry and Government:
Germanium and Silicon Diodes, Selenium Rectifiers, Thermatron Dielectric Heating Generators and Presses, Communications, Radar and Navigation Equipment

PHILCO

Silicon Transistors

2N495 - 2N496

For outstanding performance
at high junction temperatures

- Excellent performance at Temperatures from -65°C to $+140^{\circ}\text{C}$
- Collector Saturation Voltage of 0.1 Volt or Under
- Maximum Frequency of Oscillation in the 15 Megacycle Range

CHARACTERISTICS OF TYPES 2N495 and 2N496

CHARACTERISTIC	CONDITION	TYPICAL VALUE	
		2N495	2N496
Current Amplification Factor, h_{fe}	$V_{CE} = -6\text{ v}$ $I_E = 1\text{ ma}$	18	
Current Amplification Factor, h_{FE}	$V_{CE} = -0.5\text{ v}$ $I_C = -15\text{ ma}$		12
Output Capacitance, C_{ob}	$V_{CB} = -6\text{ v}$ $I_E = 1\text{ ma}$	$7\ \mu\text{f}$	$7\ \mu\text{f}$
Maximum Frequency of Oscillation, $f_{os\ max.}$	$V_{CE} = -6\text{ v}$ $I_E = 1\text{ ma}$	15 mc	
Frequency for Beta = 1, f_t^*	$V_{CE} = -6\text{ v}$ $I_E = 1\text{ ma}$ $f = 4\text{ mc}$		15 mc
Cutoff Current, I_{CBO} or I_{EBO}	V_{CB} or $V_{EB_s} = -10\text{ v}$.001 μA	.001 μA

Maximum Power Dissipation—150 mw Maximum Collector Voltage 2N495—25 V
2N496—10 V

* f_t (the frequency at which beta is unity) is typically 85% of the alpha cutoff frequency.

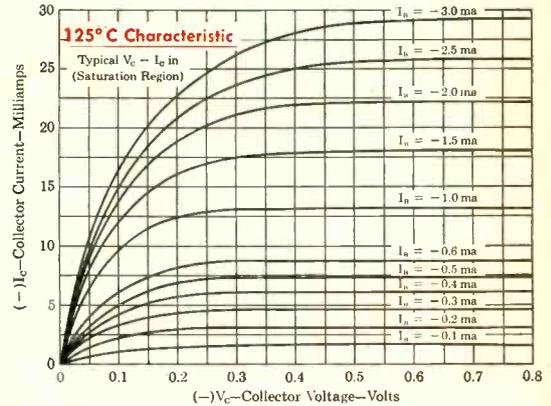

These new Philco PNP Surface Alloy Silicon Transistors permit transistorization of circuits where high ambient temperatures are encountered.

Type 2N495 is a general purpose silicon transistor, with excellent performance and reliability in amplifier and oscillator applications at frequencies through 15 mc. Units are rated at 150 mw total dissipation with a collector voltage rating of 25v.

Type 2N496 is specifically designed for high speed switching circuits . . . f_{ab} typically over 17 mc. This unit gives the designer the advantages of low saturation, low voltage operation and minimum load impedance even at junction temperatures as high as 140°C .

Make Philco your prime source for information and prices on silicon transistors.
Write Dept. E 358

PHILCO CORPORATION

LANSDALE TUBE COMPANY DIVISION

LANSDALE, PENNSYLVANIA

CIRCLE 27 READERS SERVICE CARD

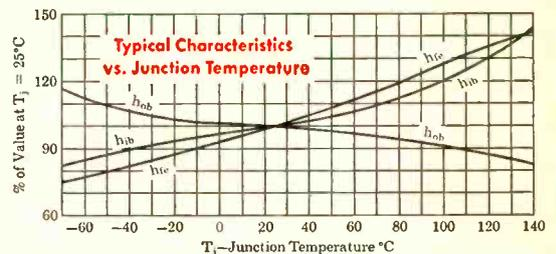

Stairstep Integrator Analyzes Rotation

Pressures, velocities, torque and rate of angular motion are indicated by angular displacement of a rotating disk and converted into electrical signals for oscilloscope display. Ferrite-coated fiber disk with one-degree magnetically recorded markers provides source for pulses amplified in transistor amplifier and coupled to a staircase integrating amplifier that feeds crt

By **GEORGE E. EDENS** Central Division Manager, Tektronix, Inc., Elmwood Park, Ill.

DYNAMIC CONDITIONS of interest to the mechanical engineer can be converted into electrical signals by transducers. Amplifiers and recording instruments, such as oscilloscopes, faithfully graph pressures, velocities and torque with respect to time, or occasionally with respect to each other.

Frequently, the quantities under observation are best observed as functions of the angular displacement of a rotating element, rather than as functions of time. If the data are to be shown in true perspective, the angular displacement, rather than time, must somehow be made the independent variable of the display.

Angular Displacement

Up to now, dynamic displays of rotation functions, such as engine cylinder pressure and ignition timing, have been extremely difficult to derive except at speeds low enough to allow use of linear potentiometers. With this system, dynamic data can be displayed during a single revolution, many revolutions, or fractions of revolutions. The display presents a convenient graph in rectangular coordinates, with angular position in one-degree increments as the independent variable. Speed changes between 30 rpm to over 5,000 rpm, are accommodated automatically.

A voltage waveform rises in proportion to the number of de-

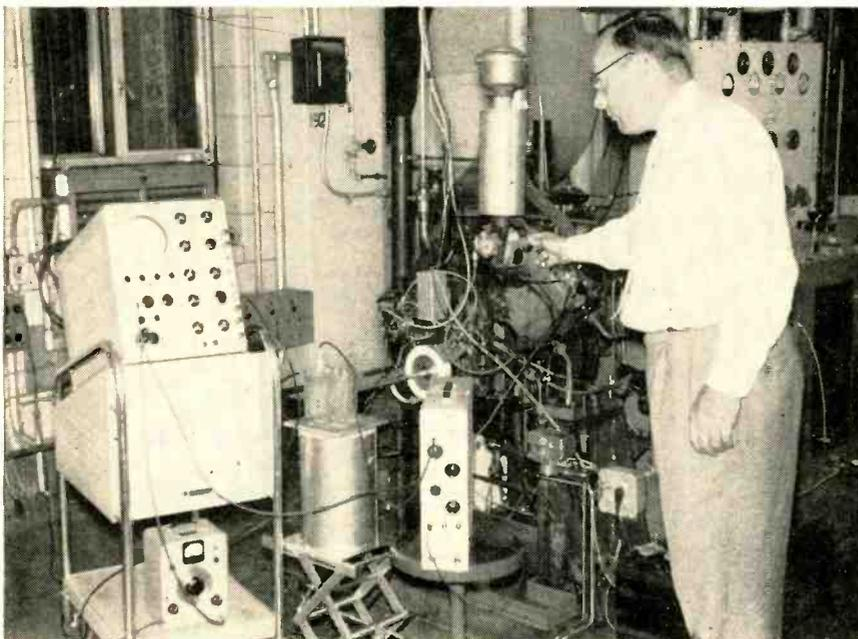

Rotation analyzer, coupled to crankshaft of gasoline engine, is set up to observe cylinder pressure and ignition timing versus crank angle. Here the effect of carburetor adjustment is being studied. Equipment includes pressure transducer preamplifier and pulse generator

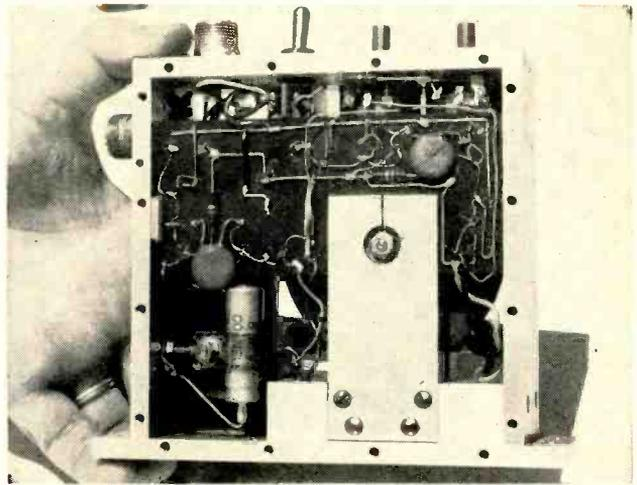
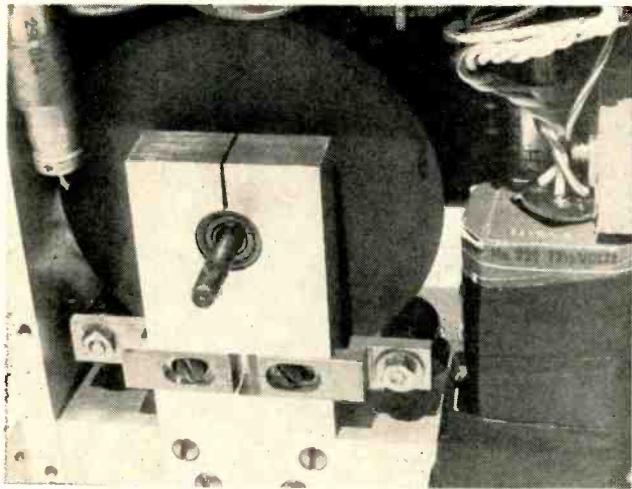

Front view of rotation analyzer, left, shows pickup heads mounted rigidly with one-mil clearance from peripheral surface of disk. Rear view, right, shows component parts layout in the transistor amplifier

degrees of revolution traversed by the rotating drum to which it is mechanically coupled. This waveform is used for horizontal deflection in a cathode-ray-tube display, so that the deflection is a function of angular displacement of the rotating drum.

In addition, the system is ideally suited to measure the time rate of angular motion.

Motion Sensing

One-degree markers are magnetically recorded in a ferrite coating on a three-inch fiber disk. The disk is mounted on a spindle,

coupled to the rotating shaft under test. As the disk rotates, the one-degree markers and a single revolution marker are read out by a magnetic-pickup head.

These two sets of marks are amplified and sent into the totalizing or integrating circuitry, Fig. 1, that translates them into a voltage waveform which rises according to the speed of the rotating disk.

At any instant, this voltage is proportional to total angular displacement from the single-revolution marker.

Accuracy of the electronic pulse integrator depends upon uniform-

ity of marker-pulse amplitude. The magnetic pickup head operates on a velocity principle and its output is a function of speed. An amplitude-standardizing amplifier must therefore be used between the pickup head and the integrator. Either a saturating amplifier or a bistable switching circuit is suitable. In either, a high sensitivity must be reached if the system is to work at low speeds.

At 30 rpm, the pickup output is only 20 mv. Optimum input to the integrator is 10 to 50 v. Further, the nearly sine-wave shape of the pickup output is not useful for op-

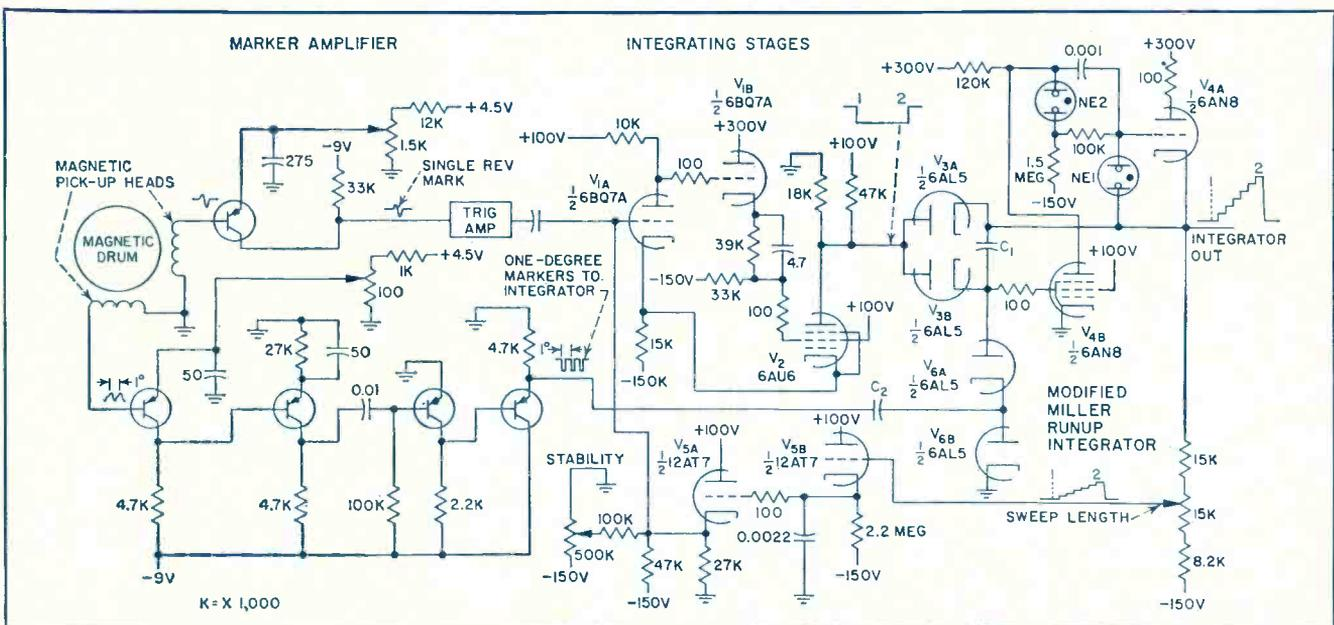

FIG. 1—Circuitry of rotation analyzer. The magnetic drum is mounted on a spindle, coupled to the rotating shaft under test. As the disk rotates, the markers are read out by the pickup heads, amplified and integrated.

erating the integrator circuits.

A saturating type of amplifier using transistors has proved particularly satisfactory. While barely saturating on the 20-mv pickup signal at 30 rpm, it continues to produce a 9-v square wave at 5,000 rpm where the pickup output is roughly 300 mv.

Marker Amplifier

As shown in Fig. 1, the one-degree marker amplifier consists of four cascaded stages, the first stage biased for maximum voltage gain. The second stage, directly coupled to the first for best low-frequency response, also contributes maximum gain. Combined gain of these two stages is sufficient to saturate the second stage, so a square-wave output results.

The third stage is biased to saturation. Marker pulses drive it to cutoff, causing its collector to swing rapidly back and forth between zero and negative voltage.

For low output impedance the output stage is connected as an emitter follower. Because it is directly coupled to the third stage, its emitter follows the preceding collector within a fraction of a volt and functions as a low-impedance source of negative pulses suitable for driving the integrator.

The single-revolution marker is a reference trigger for initiating integration, gain is not as great as the one-degree-marker channel. The main requirement for the single-revolution channel is a steep wave front, rising in a fraction of one degree. If extremely close reference is needed at low speeds, or if difficulty is encountered by false triggering from externally induced signals, more stages may be added.

The simple and rugged transistor amplifier is housed with the disk and pickup heads and shielded from interference which would induce false marker signals. Because vibration does not produce microphonic noise in transistors, the unit functions well when mounted on engines and other machines where high-intensity vibration is often unavoidable.

A voltage waveform representing total degrees of displacement, after passage of the single-revolution marker, is built up by the integrator. Each 9-v square-wave pulse places an increment of charge on capacitor C_1 , in the integrator. Each increment of charge is retained and added to all previous increments, so that the integrator output is a staircase waveform.

Stage V_{AB} operates in a modified Miller run-up integrator cir-

cuit. The time-base circuitry without the need for a special integrator. Only the simple change of removing the timing-resistor connection from the grid of the Miller integrator tube and replacing the resistor with the diodes V_0 is necessary.

Velocity and Acceleration

Both velocity and acceleration can be derived at each single degree of rotation by measuring the slope of the voltage waveform

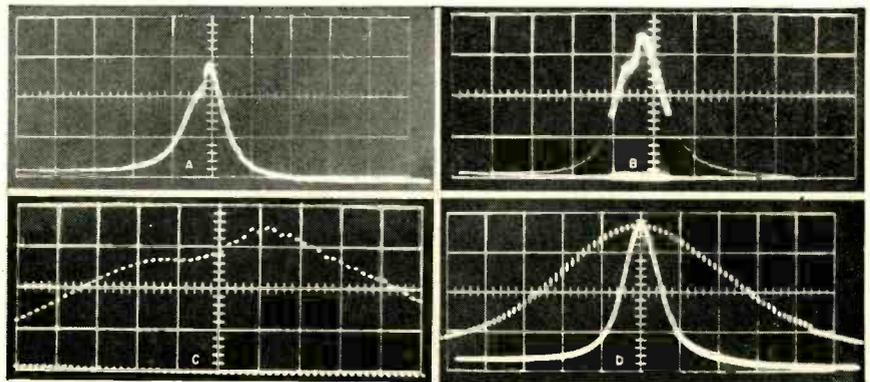

Oscillographs of cylinder pressure against crank angle of a diesel engine idling at 500 rpm (A) and under load at 1,800 rpm (B). In (C) the sweep is affected by main time-base generator set at 500 μ sec per division. Intensified dots are one-degree markers. Magnified display in (D) illustrates the staircase

cuit.^{1,2} When a single-revolution marker is received, V_1 and V_2 , operating as a modified Schmitt trigger,³ enable the Miller integrator to respond to the one-degree markers. The trigger amplifier is a conventional amplifier having a voltage gain of 100 or more.

Three factors determine the number of degrees n , represented by each excursion of the integrator. These are: the ratio C_2/C_1 , the input one-degree-marker pulse amplitude e , and the total voltage rise of the integrator output E . Their relationship is expressed as:

$$n = \frac{EC_1}{eC_2}$$

Vernier control of n is attained by making e , C_2 or both variable. The degrees n are changed in large steps by switching in other values of C_1 .

Minor modifications of the time-base generator system of some oscilloscopes permit integration to be carried out through the use of

against time. Passing the waveform through standard electronic analog operational amplifiers can yield the first derivative, velocity, and the second derivative, acceleration, on an instantaneous basis. These may be displayed against displacement if that relationship is of interest.

Possible applications of this system are abundant. In friction studies, many transient conditions arising in testing brakes and clutches can be measured accurately. Fluid coupling systems such as those used in automotive transmissions can be observed in action, without holding engine or load speed constant for point-by-point readings of torque, slip, speed of engine vacuum.

REFERENCES

- (1) O. S. Puckle, "Time Bases", 2d ed, p. 81 and 340, John Wiley & Sons, Inc, New York, 1951.
- (2) B. Chance, V. Hughes, E. F. Mac-Nichol, D. Sayre, F. C. Williams, "Waveforms", p. 37, 278, 323 and 664, McGraw-Hill Book Co., Inc., New York, 1949.
- (3) O. H. Schmitt, "A Thermionic Trigger," *Jour Sci Inst.*, 15 p. 24, 1938.

Loaded-Lens Antenna Tracks Missiles

Concentric hemispheres of foam plastic, each covered with metal disks, serve as artificial dielectric lens to provide nutation of circularly polarized feed source for illuminating 60-foot parabolic antenna in 216-245 mc telemetry band. Gain is 31 db. Resulting conical scanning gives efficient tracing of long-range rockets with minimum of moving joints in antenna system

By **LEE S. MILLER*** Radiation, Inc., Melbourne, Florida

TELEMETRY DATA is gathered automatically from long-range missiles and space satellites by an automatic tracking telemetry system designated the TLM-18. Tracking is accomplished in a conventional manner by a servo which nulls out the modulation resulting from conical scanning. Acquisition and data reception range is in excess of 1,000 miles with missile telemetry transmitter power of 10

* Now with Melbourne Engineering Corp. Melbourne, Florida

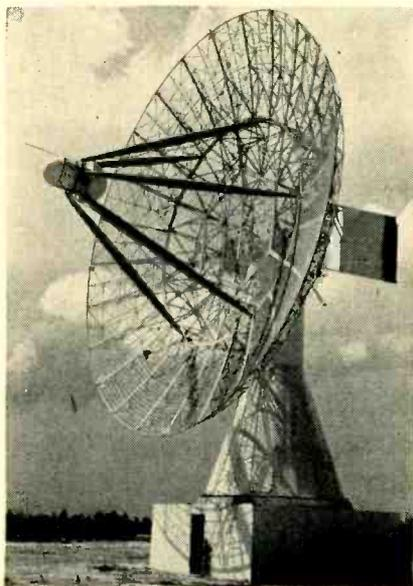

Final 60-foot-diameter paraboloid using new lens feed system

watts. Eight isolated data channels are provided in addition to the tracking channel.

Since the antenna is used in missile telemetry work, the plane and/or sense of polarization is subject to wide variations due to changes in aspect during flight, multipath effects and variations in radiators from missile to missile. For this reason a feed system with separate horizontal and vertical polarization outputs was adopted to provide maximum polarization versatility.

By suitably connecting the output terminals, reception to horizontal, vertical, 45 degree linear and right or left circular polarization is available. The system further implements later conversion to polarization diversity and other tracking modes. In tracking targets with strong cross-polarization components, polarization diversity would be particularly useful to negate sense-reversal fades.

Feed System

A number of feed systems were initially considered. Because of the offset distances required to produce the proper beam displacement angle and the excessive centrifugal forces encountered in nutating, a conventional feed such as crossed dipoles was not considered feasible. Motional joints were also a factor

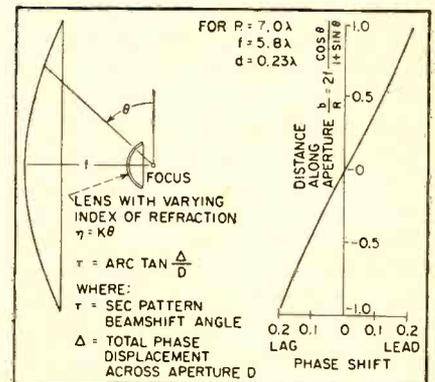

FIG. 1—Geometry of offset conical scanning and basic design equation

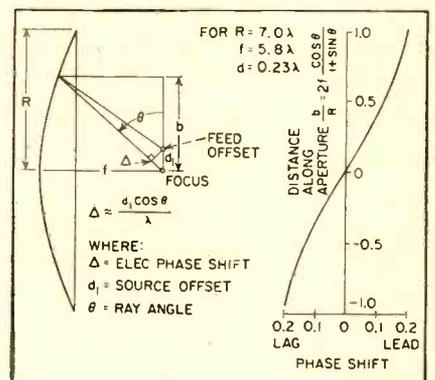
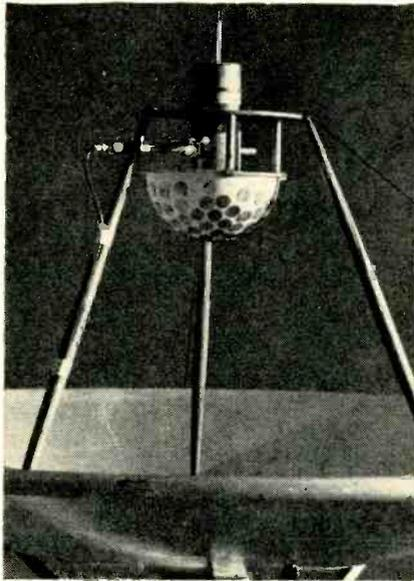
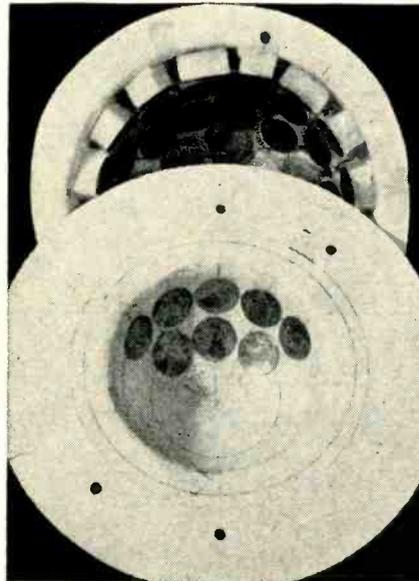

FIG. 2—Phase front produced by phase shift in primary radiator

because separate horizontal and vertical polarization terminals were used. The system further required noncontacting joints since the antenna is connected directly to a low-



Eight-inch model lens mounted on 5-ft parabola for tests at 2,700 mc



Internal layout of metal loading disks in foam plastic hemispheres for 5-in. model

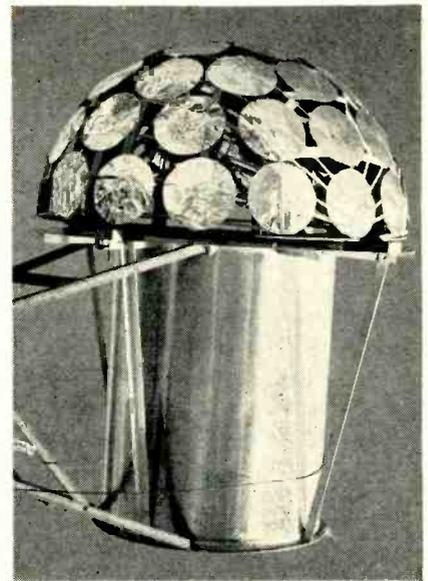

Full-scale mockup of lens, used in making phase-front measurements

noise (3.5 db) wide-band preamplifier mounted directly on the feed system.

Because of the simplicity of a rotating offset feed compared to a feed requiring nutational motion, a rotating circularly polarized source was initially considered. This produces a phase-modulation term only for ideal polarization circularity when receiving linearly polarized signals.

In practice, however, the departure from perfect circularity is comparable to the tracking error signal. This results in a second harmonic component of the tracking signal with attendant filtering problems. In addition the system is designed to track objects transmitting arbitrary polarizations such as spin-stabilized missiles transmitting linear polarization. Propagation conditions are also likely which could modify the character of the transmitted polarization. These conditions would result in spurious signal modulation for a rotating feed system.

With circular polarization, the use of an illuminating element possessing precise E and H-plane control is necessary. If appreciable phase or amplitude asymmetry exists in either the E or H-plane feed pattern, the crossover point will be somewhat different for horizontally and vertically polarized components.

As a result, crossover characteristics will vary with received polarization. A waveguide feed was utilized since it provided more independent control over the E- and H-plane patterns that other feeds evaluated.

Lens Principle

Operation of the evolved feed system can best be described by considering the operation of a conventional offset feed. Figure 1 shows a typical conical scanning situation with a rear feed and a paraboloid.

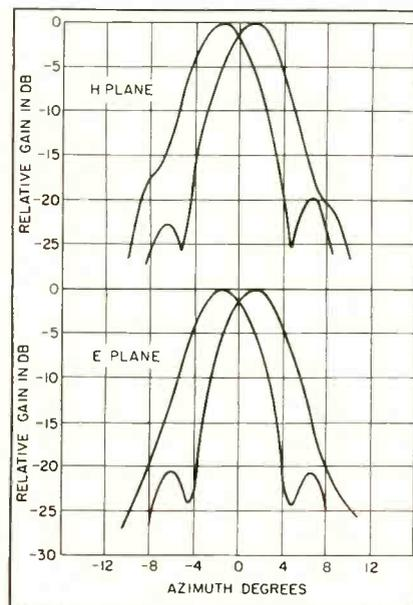

FIG. 3—Antenna patterns for scale model

The phase distribution across the parabolic surface is plotted versus vertical displacement along the aperture of the parabola, to illustrate the mechanism of offset scanning. The displaced feed produces a tilted phase front across the aperture of the parabola.

Since propagation is normal to the phase front, the secondary pattern is accordingly displaced from the parabola axis. This displacement indicates that phase shift of the uncollimated radiation at the focus would produce secondary beam shift since delay in the source radiation also results in a progressive phase distribution across the aperture. To produce this condition requires that a phase-shifting device be placed in the Fresnel region of the illumination source, as shown in Fig. 2. If a lens of linearly varying index of refraction is interposed between the focal plane and the parabola, the phase delay varies linearly with angle.

Model Measurements

An 8-in. diameter 12th-scale lens was constructed, consisting of hemispherical dielectric layers with metallic loading elements placed on each layer. Following successful tests, a smaller model was fabricated with a 5-in. outer-diameter lens approximately 1 in. thick centered about a 3-in. circular

waveguide aperture. The lens was fabricated using three $\frac{1}{8}$ -in.-thick dielectric hemispheres with diameters of 5, 4.5 and 4 inches. The metallic disks were placed on Styrofoam to locate the disks on the proper hemispherical surfaces. The waveguide aperture was surrounded by a flange used to equate E- and H-plane beamwidth and two orthogonal probes were used to excite TE_{11} circular modes.

The number of metallic elements in the lens was distributed such that the dielectric constant varied from unity to the maximum value in a square-law manner. A disk configuration was used in the artificial dielectric since polarization dependence was also to be investigated.

The equation for the effective dielectric constant ϵ is $\epsilon = 1 + 5.33 NA^2$ where N is the number of disks per unit volume and A is the radius of each disk. This equation is accurate for the usual range of dielectric constants, but above 3, some discrepancies arise from coupling between disks. The lens dielectric constant was experimentally verified by phase front measurements with the lens illuminated by a spherical phase front at the focus.

The number of disks was tailored to produce the desired phase shift across the parabola. A 0.4-wavelength phase shift was obtained over the 160-deg parabola sector, corresponding to a calculated beam shift of 1.65 deg at 2,800 mc for a parabola with an f/d of 0.415. Secondary patterns are shown in Fig. 3. The feed beamwidth was designed to provide an illumination taper of 10 db corresponding to optimum gain. The measurements show the side lobes to be approximately 20 db below the main lobes, indicating proper illumination.

Beamshift, beamwidth and gain are 1.45 deg, 4.6 deg and 30.9 db respectively, corresponding to computed values of 1.65, 4.5 and 31.3. The patterns show a change in side lobe level on opposite sides of the main lobe. This is due to the tilt in the phase front in the primary patterns and attendant amplitude shift corresponding to a somewhat different radiation level at opposite sides of the paraboloid. The vswr

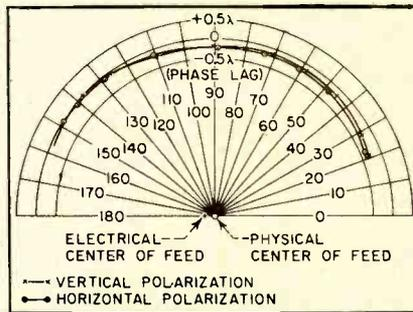

FIG. 4—Phase front measurements for full-scale dielectric lens

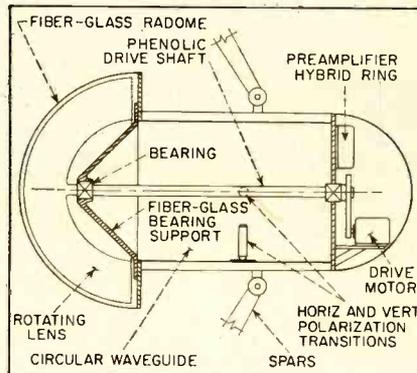

FIG. 5—Cross-section of complete feed system. Shaft is made of phenolic

measurements show the impedance match to be virtually independent of lens rotation.

The plot shown in Fig. 2 demonstrates that linear phase shift produces a slightly nonlinear aperture phase front. To produce a uniform aperture phase distribution across the parabola requires that the lens phase-shift function compensate for the vertical displacement versus angle term. Pattern measurements show the non-linearity to be a second-order effect for reasonable beam displacements and correction was not necessary in the present design.

Operational System

The full-scale feed system was designed from dimensions of the twelfth scale model. Since a full-scale paraboloid was not available until several months later, phase front measurements were made on a full-scale prototype lens to verify dimensions. The results, shown in Fig. 4, agreed with previous model data to within measurement accuracy.

The finished lens (manufactured by Emerson & Cumings) comprises four fiberglass hemispheres sup-

porting the aluminum loading disks, with honeycomb spacing material between hemispheres. The entire assembly is dynamically and statically balanced. A cross-section of the final feed assembly is shown in Fig. 5. The hemispherical lens is supported by a phenolic shaft attached to the center of the lens and extending concentrically through the waveguide to the rear dome. The drive motor, reference generator, preamplifier and coaxial hybrid are located in the rear dome and mounted on the rear wall of the waveguide. The lens is supported at two bearing points, one to the rear and the other at the center of gravity of the lens. A dielectric cone extends from the waveguide aperture to the front bearing location. The rotating assembly is enclosed in a protective radome. The feed assembly is supported at the focal point of the paraboloid by six fiber-glass spars.

Electrically the feed consists of a waveguide operating in the TE_{11} circular mode, with two radial probe transitions located 90 deg with respect to each other. The coax outputs thus provide reception for the orthogonal waveguide modes. During normal operation the two outputs are combined in a coaxial hybrid network through 90 deg of differential phase shift. The hybrid provides two output terminals, one for right circular polarization and the other for left circular polarization. The circular waveguide feed contains a symmetrical flange to equate the E- and H-plane apparent source points. By experimentally adjusting the flange dimensions, the phase centers can be made practically coincident.

The system has been subjected to operational evaluation using airborne targets, with satisfactory results. Tracking rates were 10 deg per sec for both azimuth and elevation. Angular acceleration was 10 deg per sec² maximum for both azimuth and elevation. Overall tracking accuracy at 6 deg per sec was 0.75 deg. Four of these systems are presently being installed over the 5,000-mile Air Force Missile Test Range.

The author thanks R. E. Wilt for his valuable assistance during the development of the antenna.

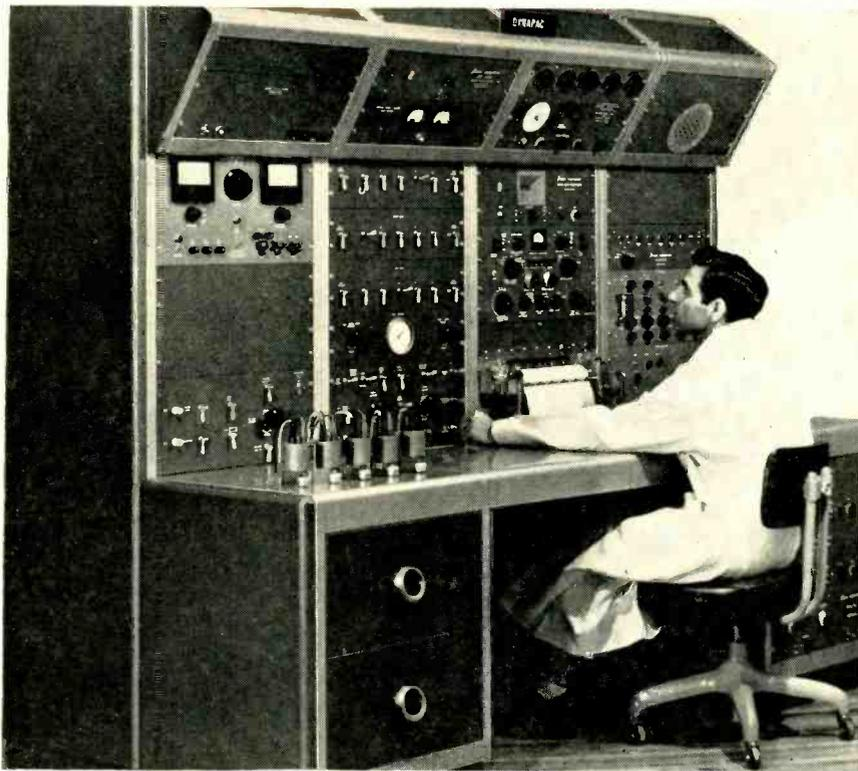

Operator can make calibration records of five pressure-sensing potentiometers in less than a minute. System also checks other characteristics at production-line speed

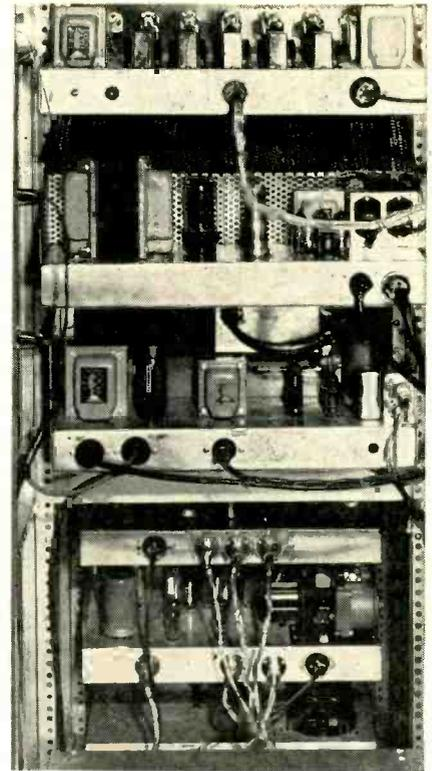

Back view of calibration system shows Y-axis and X-axis amplifiers

Analog Comparator for Production Testing

Records of continuous performance of potentiometer-type pressure-sensing instruments over their operating ranges show error from standard manometer, resolution, hysteresis and dynamic response at varying rates of pressure change. Records are made at production-line speed with indications of total resistance and insulation resistance

By **CARL N. BOODE** and **CARL E. CALOHAN** Bournes Laboratories, Riverside, California

P OINT-BY-POINT calibration of pressure-sensing instruments usually requires from ten to fifteen minutes for each instrument. Even then, discontinuities may exist that are not detected. Hysteresis and poor resolution are difficult to discover and dynamic response to varying rates of pressure change are not readily obtained.

The Dynapac, Dynamic Precision

Analog Comparator, provides a record of the continuous performance of five potentiometer-type pressure-sensing instruments in less than one minute. It also measures total resistance, provides a go-no go indication of insulation resistance, furnishes voltage ratio and equivalent noise resistance.

The system shown in the block diagram in Fig. 1 records simul-

taneously the outputs of five instruments throughout their operating ranges. The potentiometer instruments are excited from a constant-voltage source and the output of each instrument is compared with the output of a precision electromanometer. The resulting error voltages are fed to the inputs of a five-channel Y-axis amplifier. The output of the electromanometer is

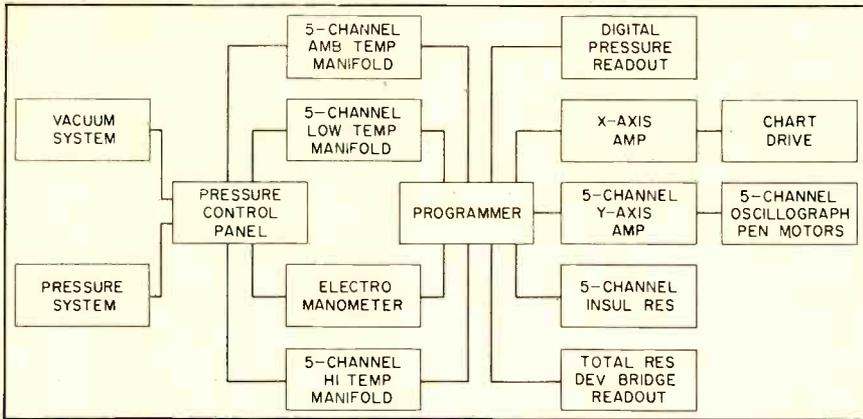

FIG. 1—Total resistance, insulation resistance and five channel recordings of deviation from standard electromanometer are provided by system

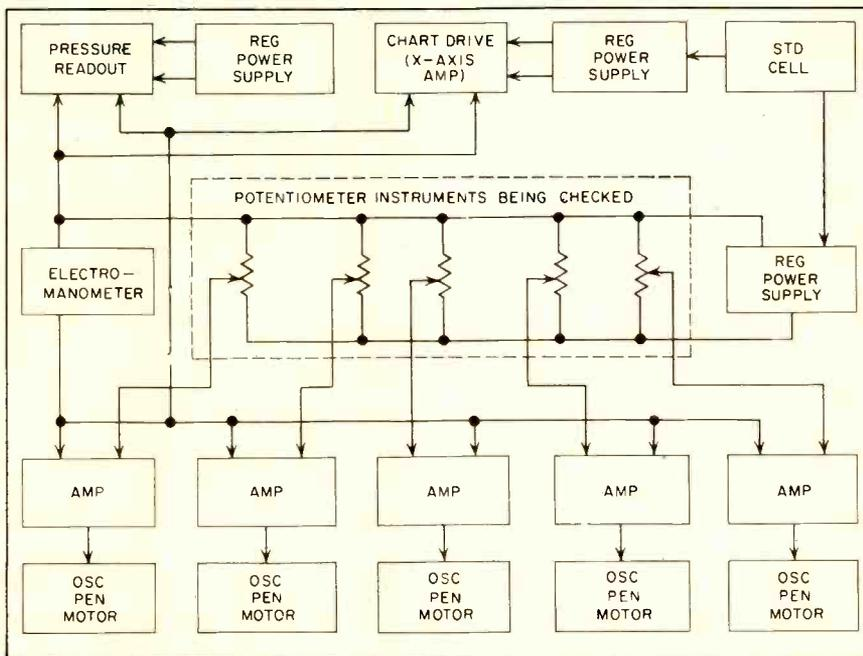

FIG. 2—Regulated power supply energizes potentiometers with voltage equal to output range of manometer over pressure range of instruments

also applied to the input of an X-axis amplifier, a servo amplifier that drives the chart paper as a function of pressure. The resulting record is a five-channel X-Y plot of instrument error against pressure, with an expanded scale on the error axis.

A digital readout of pressure is scaled to read either in psi or inches of mercury. Special circuits are incorporated for measuring total resistance, insulation leakage, noise and voltage ratio.

Continuous Calibration Recorder

The output of the electromanometer shown in Fig. 2 is the voltage developed across a precision resistor by the current that flows in the

restoring coil of a force-balance system. The potentiometer instruments that are to be calibrated are energized with a voltage that is equal to the range of output of the electromanometer over the entire pressure range of the particular instruments being tested. This is normally ± 10 v for a ± 15 -psi differential pressure range. The voltage can be adjusted up to a maximum of ± 100 v, the limitation being the power rating of the potentiometer instrument.

The power supply that furnishes the voltage for the instruments must have essentially zero regulation over the load ranges. It must also supply a wide variety of preset voltages at close tolerances.

As shown in Fig. 3, the voltage that appears across the potentiometer instruments is sampled and compared to the output of a mercury cell. The mercury cell is in turn checked periodically against a standard cell. The system provides a constant voltage to a load of low resistance.

With one terminal of the potentiometer instruments common with one side of the electromanometer output, the output of the wiper arms of the potentiometer instruments should be equal to the output of the electromanometer. The difference between these voltages is directly proportional to the error of the pressure instruments. The five error voltages are fed to the inputs of five Y axis amplifiers, which in turn drive their respective oscillograph pen motors.

To calibrate the system, a voltage divider is connected in parallel with the potentiometer instruments to provide a 5-percent calibration step to the Y-axis channels. The gain of each amplifier is adjusted to give a full-scale pen deflection on the chart paper.

On the record, the difference between an increasing pressure and a decreasing pressure trace is a direct measure of hysteresis. The resolution error can be interpreted from the width of the trace, and the linearity of the pressure instrument is determined by the deviation from a straight line connecting the end points.

Accuracy is governed by the accuracy of the reference electromanometer, the stability and accuracy of the reference power supply and the linearity of the Y-axis amplifiers. Accumulated system error is less than ± 0.1 percent, which corresponds favorably with that generally obtained using a high-quality mercury manometer and a precision voltage ratio device. Accuracy of the chart drive is limited by readability and is better than 1 percent. This accuracy is sufficient for all practical purposes.

The digital pressure readout consists of a self-balancing potentiometer circuit connected directly to a counter. The potentiometer voltage is compared to the electromanometer output. By switching the reference voltage to the potentiometer,

a counter can be changed to read directly in psia or in inches of mercury.

Insulation Resistance Tester

Checking the insulation resistance of five pressure instruments simultaneously with commercially available equipment would require using five independent systems. Keeping all instrument cases at ground potential required that measurement of leakage current be at some relatively high potential from ground. The circuit shown in Fig. 4 accomplishes this with a single high-voltage power supply and a minimum number of components.

The two amplifier stages serve a dual purpose. They amplify the voltage derived from the leakage current through a grid resistor and they provide the transition from -600 v to ground. When there is no leakage current, V_2 is conducting

approximately 1 ma, which establishes a potential at the grid of the thyratron of about -39 v. At this time V_1 is cut off by the voltage across its cathode resistor. As current through the insulation being checked increases, current starts to flow through V_1 . The 25,000-ohm potentiometer in the cathode circuit of V_2 is adjusted to a point where V_2 is cut off when the plate voltage of V_1 corresponds to a value determined by the preset insulation resistance level desired. Relatively large signal levels are involved, so cutoff of V_2 is abrupt.

The only limitation on the number of stages that can be effectively operated in parallel is the capacity of the high-voltage power supply. The circuit is inherently non-linear and as such is not suitable for direct indication of insulation resistance. But it can be made quite sensitive and lends itself to rapid and accurate calibration at predetermined

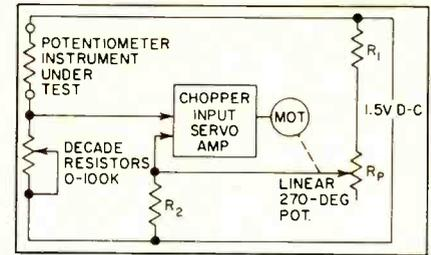

FIG. 5—Total potentiometer instrument resistance is shown on dial of servo-driven potentiometer

level as a go-no go type indicator.

Accuracy of the indication with this circuit is a function of the supply voltage and the drift in the 12AX7. With an unregulated -600-v supply from a voltage doubler circuit, accuracy has been found to be within ± 5 percent over a period of several months without requiring adjustment. This circuit was set for 100 megohms or 5 megohms—the 5-megohm value being used to test instruments under low-pressure conditions.

Total Resistance Bridge

To achieve an accuracy of ± 0.1 percent in total resistance measurements, while preserving the speed and easy readability of a deviation bridge, the system in Fig. 5 was developed. One arm of the bridge consists of a set of precision decades that are preset to the desired nominal resistance value. Resistance R_1 is selected so that its resistance is 4.5 times that of R_p , a linear 270-deg potentiometer. When R_p is at its mid-position, travel to either end changes the resistance of the sum of R_1 and R_p by ± 10 percent. The shaft of the potentiometer is connected to a dial hand and mounted to accommodate a 4-in. diameter dial face with graduations from -10 to +10 percent in tenths of a percent.

The resistance of R_2 is selected to equal R_1 plus one-half R_p . The error voltage from the bridge is fed to the chopper input of a servo amplifier, which in turn drives a servo motor that is coupled to the potentiometer. Balancing time of the bridge is approximately 0.2 sec.

The accuracy of this type system is limited by the accuracies of the precision standards, the linearity of the follow-up potentiometer and the sensitivity of the servo system.

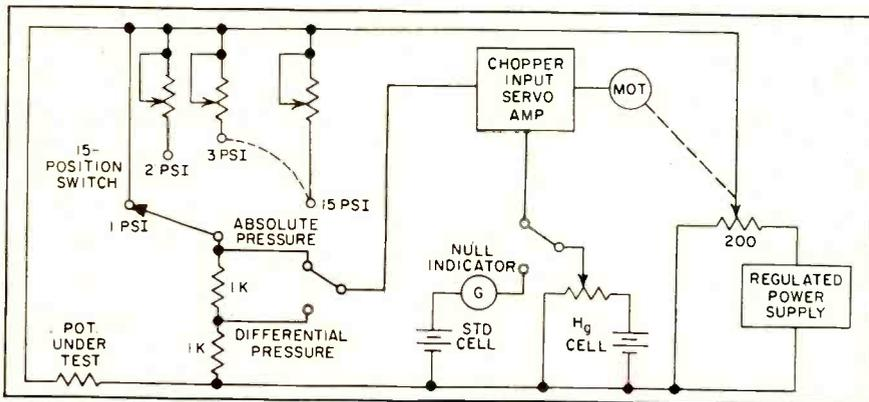

FIG. 3—Chopper is used to compare power supply output to that of reference mercury cell, which is checked periodically against standard

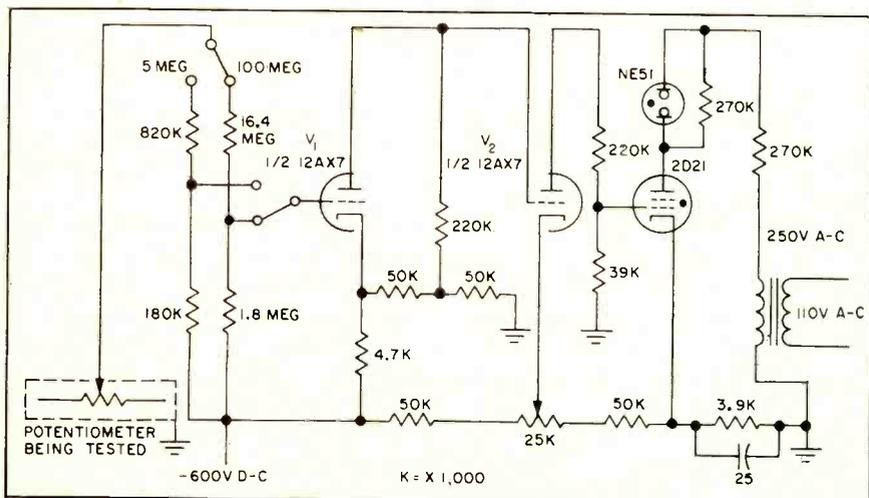
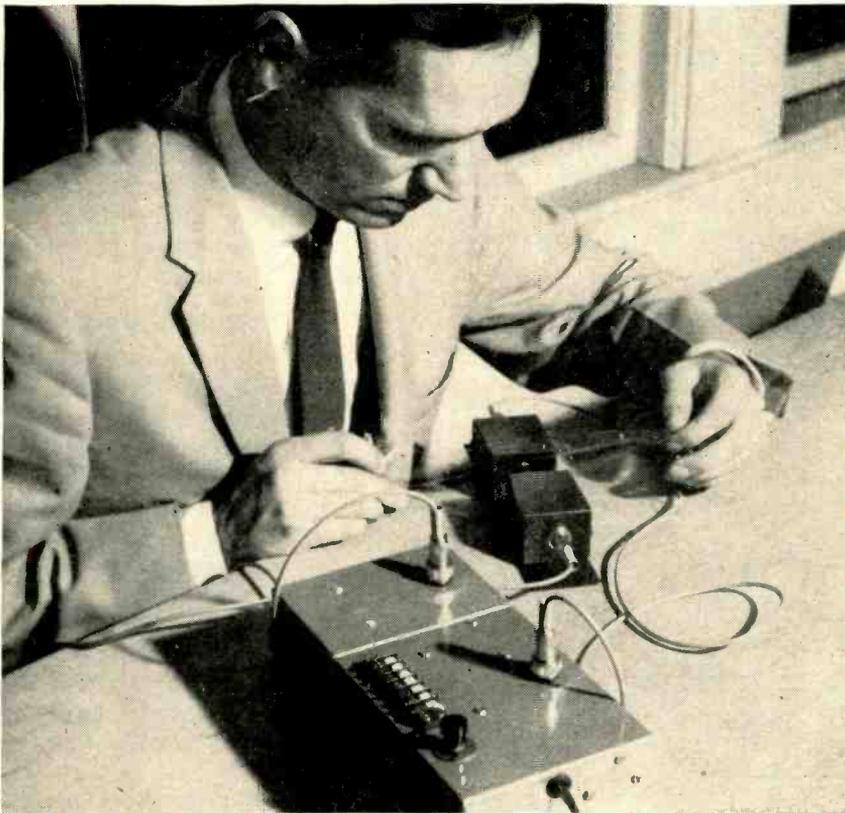

FIG. 4—Amplifiers and thyratron give go-no go indication of insulation resistance

Acoustic Cavity Detects

Interference by film passing through resonant chamber affects energy transfer between crystal transducers to control film processing equipment and reduce rethreading and film spoilage. Acoustic detector can also control transfusions and fluid-processing systems and indicate position of meter vanes



Acoustic detector is demonstrated using transparent plastic material

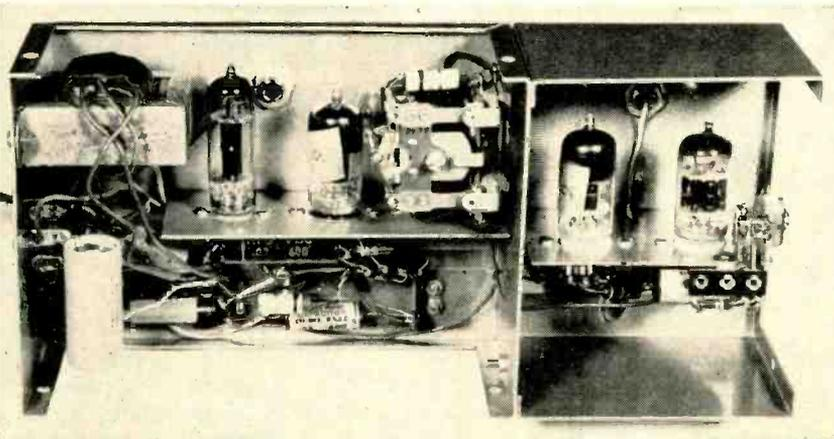

Two-compartment construction shields oscillator from detector section

DETECTION of the end of a film strip in the processing of black and white and color film can prevent a tedious job. If undetected, the machine unthreads, requiring rethreading sprockets in the dark through a series of wet processing tanks.

Film breakage presents an even worse problem. In addition to rethreading, film footage is often spoiled because of overprocessing.

The usual mechanical devices for detecting the end of a strip or a break in the film have shortcomings. Devices such as torque-controlled switches on the reels or sprockets or wiping contact arrangements wear film and respond slowly.

Transmitting and receiving transducers in a resonant sound chamber are used in a system that is simple, reliable and easy on the film. A change in the resonant chamber affects the transfer of energy between the two transducers.

The acoustic detector can also be applied as a control in a variety of other applications ranging from position detection to finding air bubbles during transfusions.

Acoustic Detector

The acoustic detector consists of two crystal transducers, a transmitter and a receiver-detector, facing each other at opposite ends of a resonant chamber. A gap is provided in the center of the chamber for introducing the element to be controlled—in this case film. The transmitting transducer is driven at the resonant frequency of the

Breaks in Film

By Edward L. Withey*
and
Richard G. Seed**

Sensiton Corp., Lexington, Mass.

crystal-chamber combination and the receiver output is used to control a relay.

Normally, the system is adjusted so that there is sufficient energy transfer between the transducers to hold the relay closed. Interposition of an absorber in the gap destroys the acoustic resonance and the relay opens.

Circuit Description

The circuit shown in Fig. 1 consists of a twin-T feedback oscillator and a detector. The twin-T network, which is designed for 1,700 cps, the resonant frequency of the system, provides a positive feedback path between V_1 and V_2 , permitting oscillation. Tube V_3 , the driver, functions as an amplifier.

Energy from the receiving transducer is fed through a simple high-pass filter, which attenuates 60-cycle pickup and low-frequency mechanical vibrations, to the grid of V_4 . Such a filter is adequate for the present application, however, a tuned amplifier may be used, with the pass band centered on the oscillator frequency. Stage V_4 amplifies the signal and feeds it to the half-wave voltage doubler, which drives the grid of relay control tube V_5 .

A sensitivity control is provided in the cathode circuit of V_5 to adjust the relay operating point. One contact of the double-pole double-throw plate relay is wired in a lock-up circuit so the relay will stay energized until released manually or by an external control circuit.

* Now with Advance Industries, Cambridge, Mass.
** Now with Sylvania Electric Products, Woburn, Mass.

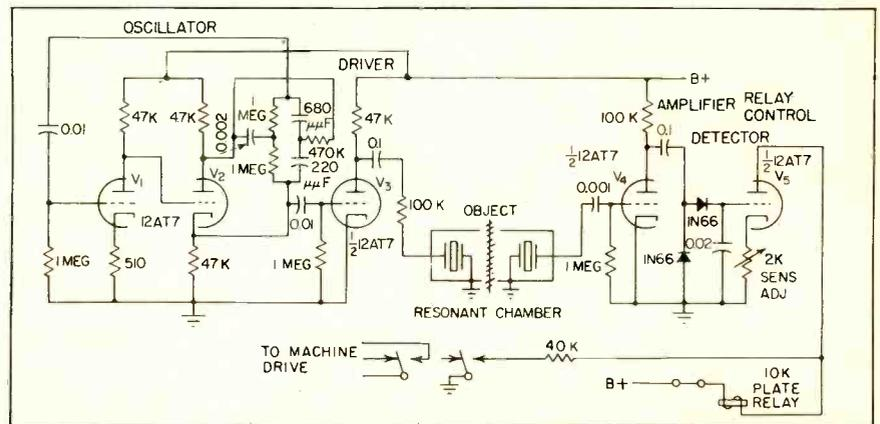

FIG. 1—Oscillator and amplifier drive one crystal transducer and other transducer receives energy that controls relay through amplifier and detector

The other contact controls the machine drive.

The control unit is constructed in two compartments to provide shielding between the oscillator and the detector sections. The detector head consists of a 2 by 10 in. plate on which the small aluminum transducer boxes are mounted. The receiving transducer is supported in its mounting box by foam rubber to isolate it from the mechanical vibrations of the oscillator and nearby machinery.

Applications

The acoustic detector can be used in other applications including the detection of cellophane, Mylar, glass, transparent and translucent plastics, water and other transparent liquids, and gases. The device is particularly useful where photosensitive compounds must be detected and a conventional photo-detector is not practicable. The detector can also be used with solid opaque objects such as boxes, cardboard and paper. The acoustic detector can also be used as a position indicator. When a vane of width approximately twice the diameter of the cavity orifices is positioned midway between them, the acoustic impedance is at a minimum, and output voltage is maximum. Moving the vane toward either orifice increases impedance and decreases output voltage.

This effect gives an output cor-

responding to the position of the absorber in the gap, as well as its presence or absence. The effect can be used to read a moving-vane indicator such as a meter. The output may also be coupled through a closed-loop servo system such that the vane is kept constantly centered.

For certain applications, the circuits can be considerably simplified by employing an air jet for sonic excitation. The jet is directed across or into the receiving transducer with the material to be detected arranged to interrupt the air stream. Such a combination has a broad frequency spectrum and the output level is sufficiently high so that operation of the receiver at resonance is not necessary. A small air stream results in a large signal.

Detection of bubbles and air spaces in liquid piping systems is another application. In this case the transmitter and receiver may be immersed directly in the liquid. A section of the pipe forms the resonant chamber. The appearance of a bubble of dimensions comparable to the diameter of the tube changes the resonance, reduces the signal and is detected. This effect can probably be used to detect gas bubbles in liquid oxygen fuel loading of missiles.

The detector can also be used for bubble detection in the rubber tubing used for intravenous infusions where air embolism can, in extreme cases, result in cardiac arrest.

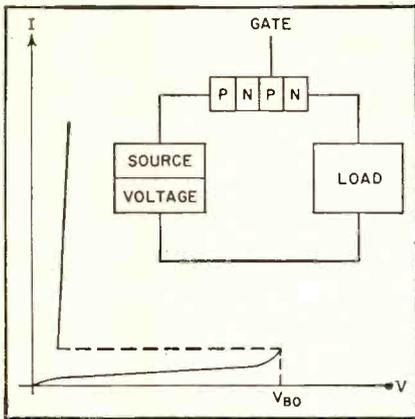
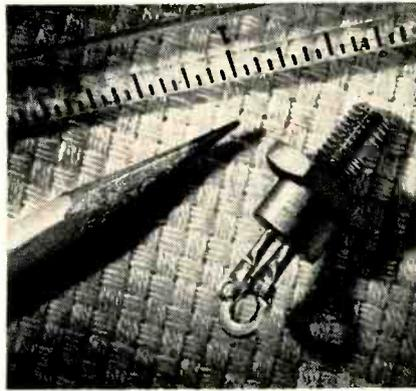
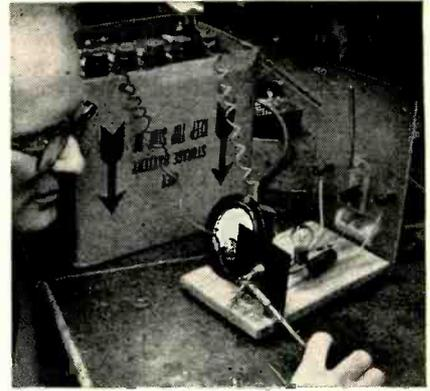

FIG. 1—Forward E-I characteristic of the ZJ-39A silicon controlled rectifier



Silicon controlled rectifier has third or gate lead analogous to grid of thyatron



Author soldering connection to gate in demonstration d-c static switching circuit

Solid-State Thyatron

DEVELOPMENT of a solid-state equivalent to the thyatron has been a goal of the semiconductor industry for many years. Such a device needs to switch electronically from an extremely high impedance to a low impedance. And it must do so easily.

The thyatron suffers from low power, slow switching speed, relatively high forward voltage drop, and the usual tube shortcomings. Mercury-arc rectifiers overcome the power disadvantage of thyatrons but retain the high forward voltage drop characteristic.

The silicon controlled rectifier is one answer to the problem. It is neither a transistor nor a rectifier but combines features of each. It opens up new fields of application for semiconductors, some of which are outlined in the latter part of this article.

Switching Mechanism

Design objectives in development of the silicon controlled rectifier were: current ratings comparable to thyatrons, blocking voltages useful in industrial circuits, complete control of current turn-on without complicated circuitry, switching speeds of the same order as small-signal transistors, efficiency equal to similarly rated silicon rectifiers and construction conducive to high-quality mass pro-

duction at reasonable costs. Result of the developmental program is the ZJ-39A silicon controlled rectifier. Its specifications are available from General Electric.

To understand the rectifier's operation as a two-terminal switch, Fig. 1 is helpful. The rectifier will block current flow in either direction until a critical forward break-

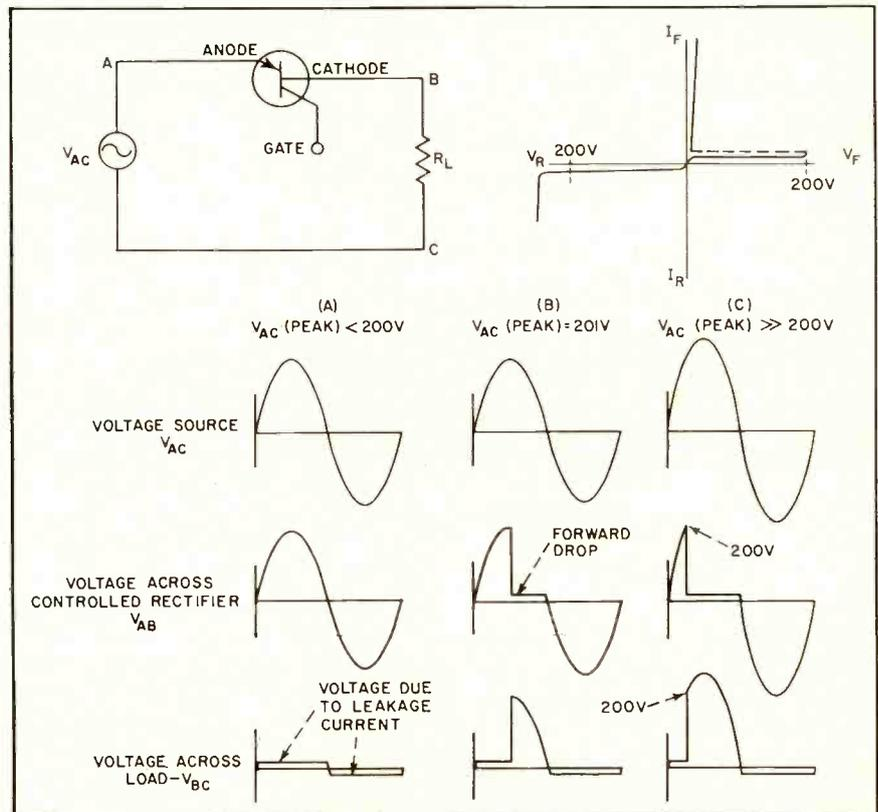

FIG. 2—Simple half-wave circuit showing operation of controlled rectifier without gate signal. Also shown are the voltage-current characteristic and pertinent waveforms. Losses due to forward voltage drop during conduction and forward and reverse leakage during blocking have been exaggerated for clarity

Applications for the silicon controlled rectifier, a recent addition to the growing list of semiconductor switches, include replacement of relays, thyratrons, magnetic amplifiers, power transistors, and conventional rectifiers of all types. Typical circuits presented and discussed are static switches, synchronized inverters, d-c to d-c converters, regulated d-c power supplies, dynamic braking, surge-voltage suppression and power flip-flop

By **R. P. FRENZEL**, Product Planner and **F. W. GUTZWILLER** Application Engineer,
Semiconductor Products Department, General Electric Co., Syracuse and Clyde, New York

Switches Kilowatts

over voltage, V_{no} , is exceeded. At this voltage, the center pn junction begins to avalanche. Current through the device increases rapidly until the current gain—the sum of the current gains of the overlapping pnp and nnp structures—exceeds unity. This current level is relatively low. When reached and exceeded, it effectively reverses the bias of the center pn junction. Voltage across the device then becomes low and the current is limited essentially only by the series load impedance.

A third electrode called a gate, which is an ohmic connection to the center p region of the controlled rectifier, switches it from the non-conducting state without the necessity of exceeding the critical break-over voltage.

The device can be fired by pulses of extremely short duration. With pulse switching, the average power control ratio in 60-cps circuits has been found to exceed twenty-five million to one.

Circuit Operation

Operation of the silicon controlled rectifier in a circuit is understood best by comparing it to that of thyatron—the third electrode of the rectifier is comparable to the grid of the thyatron. As with the thyatron, conduction can be achieved by exceeding some critical anode-to-cathode voltage or by applying power to the grid or gate in the presence of positive anode voltage. In a thyatron, this firing power is generally applied as positive grid-to-cathode voltage. In the rectifier, it is positive gate-to-cathode current since the firing mechanism of the rectifier is dependent on current rather than voltage.

Because the gate-to-cathode voltage-current characteristic of the rectifier is essentially that of a forward-biased semiconductor diode,

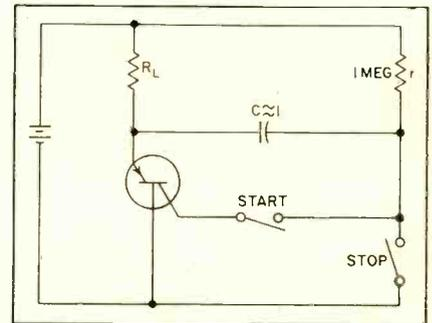

FIG. 5—D-c static switch circuit

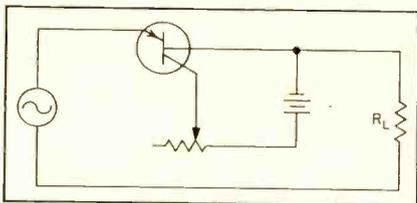

FIG. 3—Half-wave controlled rectifier circuit using simple d-c gate circuit

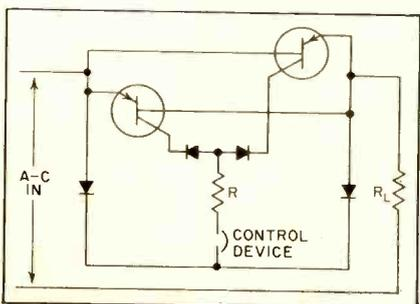

FIG. 4—A-c static switch provides high-speed switching of power loads

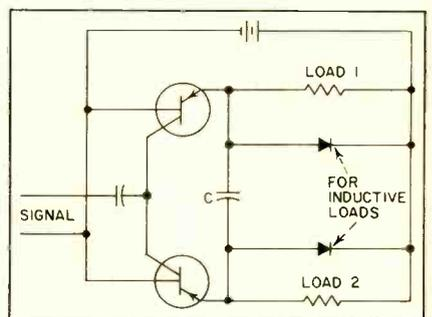

FIG. 6—Power flip-flop or static switching relay switches in one μ sec

gate-to-cathode voltage drop for the critical value of firing gate current is about one to two volts.

To illustrate how a controlled rectifier functions, consider it with no applied gate signal and a V_{no} of 200 v. Assume that the reverse breakdown occurs at a considerably higher voltage. If the peak supply voltage is limited to less than 200

A QUICK LOOK AT SEMICONDUCTOR SWITCHES

1. Point-contact transistor—regenerative action with current gains greater than unity.
2. Junction transistor—regenerative if current gains greater than unity are achieved through collector avalanche or charge storage.
3. Field-effect transistor—exhibits negative-resistance region which permits switching from one impedance state to another. (W. Shockley, A Unipolar Field Effect Transistor, *Proc. IRE*, 40, p 1365, Nov. 1952)
4. Nesistor—improved version of field-effect unit (R. G. Pohl, The Nesistor—A Semiconductor Negative Resistance Device, WESCON paper, Aug. 21 1957)
5. Filamentary transistor action—possible use in flip-flop and counter circuits (W. Shockley, "Electrons and Holes in Semiconductors", D. Van Nostrand Co., Inc., New York, N. Y., 1950, p 81)
6. Unijunction transistor or double-base diode—current multiplication resulting from conductivity modulation (R. F. Shea, "Principles of Transistor Circuits", John Wiley and Sons, Inc., New York, N. Y., 1953, p 467)
7. Semiconductor devices with thyatron-like characteristics (A. W. Berger and R. F. Rutz, A New Transistor with Thyatron-Like Characteristics, AIEE-IRE Electronic Components Conference paper, May 26 1955)
8. Hook collector transistors—three-terminal *pnpn* devices switched from low-conduction to high-conduction state (W. Shockley, "Electrons and Holes in Semiconductors", D. Van Nostrand Co., Inc., New York, N. Y., 1950, p 112)
9. Four-terminal *pnpn* hook transistors—feedback to a base electrode necessary to achieve regenerative switching; difficulty in achieving high current and voltage levels (J. J. Ebers, Four Terminal p-n-p-n transistors, *Proc. IRE*, 40, p 1361, Nov. 1952)
10. *Pnpn* transistor—regenerative switching achieved through avalanche breakdown of center *pn* junction (J. L. Moll, M. Tanenbaum, and N. Holonyak, P.N-P-N Transistor Switches, *Proc. IRE*, 44, p 1174, Sept. 1956; W. Shockley, Unique Properties of the Four-Layer Diode, *Electronic Industries*, p 53, Aug. 1957)
11. Dynistor—*pnp* structure with an additional modified junction (A. P. Kruper, The Dynistor Diode, A New Device for Power Control, Machine Tool Electrification Forum paper, Apr. 24, 1957)
12. Silicon controlled rectifier—efficient switching of kilowatts of power at speeds measured in μsec ; no feedback circuit necessary; turns on at extremely low power levels; ratios of load power to control power of 100,000 to 1 have been achieved; can be fired by pulses of extremely short duration; average power control ratio in 60-cps circuits exceeds 25,000,000 to 1 with pulse switching.

v , the voltage relationships of the rectifier in a simple a-c half-wave circuit are as shown in Fig. 2A. Here, full a-c forward and reverse half cycles of voltage are across the rectifier. Under these conditions, only the voltage due to leakage current (essentially zero in practical circuits) appears across the load.

Assume next that the peak a-c supply voltage is raised to 201 v. When the supply voltage reaches 200 v on its way toward 201 v, the rectifier will break over in the forward direction, essentially at 90 deg as shown in Fig. 2B. For the remainder of the forward half-cycle, the supply voltage appears across the load except for a one- to two-volt conduction drop across the controlled rectifier.

For supply-voltage peaks considerably higher than 200 v, the rectifier will fire earlier in the cycle, as shown in Fig. 2C. If reverse breakdown voltage is not exceeded, the rectifier will block reverse current flow as does a conventional rectifier. It will also

block current flow in the forward direction until the forward break-over voltage is exceeded. Then, it will fire and continue to conduct until the forward voltage is reduced essentially to zero. In reality, a small forward holding current is required to maintain forward conduction.

Consider the rectifier with a signal applied to its gate as shown in Fig. 3. Signal source is usually one of relatively high impedance and several volts strength. The

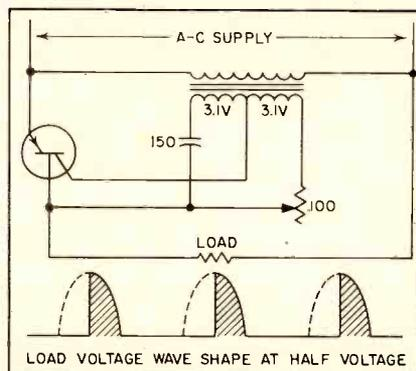

FIG. 7—Half-wave phase-controlled d-c power supply provides uniform output

source may be either a-c or d-c. For firing, the gate voltage should normally be positive with respect to the cathode. Gate input impedance of a typical medium-power controlled rectifier is in the 10- to 100-ohm range at the firing point depending upon the firing current required and the specific gate characteristic.

As the gate current is increased, a critical point, I_{OF} , is reached at which the rectifier will break over at any positive anode-to-cathode voltage greater than a few volts. After breakover, impedance of the rectifier is low and supply voltage appears across the load. The gate loses control after breakover and the rectifier can be cut off only by reducing the anode voltage and current to zero. This is analogous to loss of grid control in a thyatron.

The firing scheme shown in Fig. 3 is rudimentary. Firing may be accomplished by as many diverse methods as are used for firing thyratrons.

Circuit Applications

In designing circuits around the controlled rectifier, the engineer should have several factors in mind. (1) As in other semiconductor devices, rated peak inverse voltage and load current should not be exceeded. (2) The controlled-rectifier device should be cooled adequately since satisfactory operation depends largely on maintaining the junction at reasonable temperature levels. (3) To prevent possible damage to the device characteristics, reverse gate current should be limited to low values.

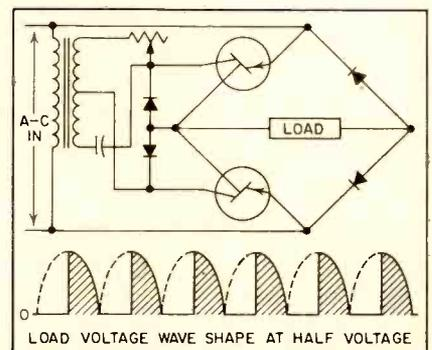

FIG. 8—Full-wave phase-controlled d-c power supply

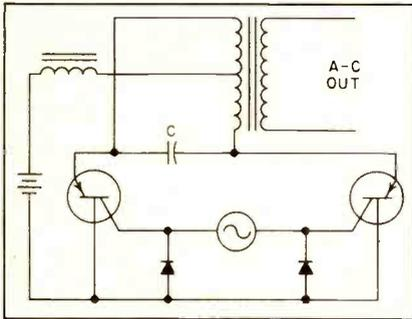

FIG. 9—Synchronized inverter. Feedback makes inverter free running

For this purpose, diodes are used in the gate circuit in several circuit applications. (4) Since the control characteristic varies with junction temperature and anode voltage among individual devices, it is usually desirable to fire the rectifier with a steep wavefront whenever precise timing or phase control is required. Saturable reactor and pulse types of control using such devices as the unijunction transistor are well suited for this purpose. For strictly on-off control, adjustment of gate-current magnitude is satisfactory provided ample excess current is furnished for positive firing.

Examples of well-established and new applications are given in Figs. 4 to 11. Circuit configurations and values are suggestions only and are not intended to imply optimized design. Other applications are limited only by the imagination of the circuit designer.

A-C Static Switch

Figure 4 shows a circuit for providing high-speed switching of power loads. It is ideal for applications with a high duty cycle. Contact bounce and mechanical wear as experienced on relays or contactors are eliminated. The control device can be contacts of a thermostat, pressure switch, current relay, or voltage-sensitive device. Signals from magnetic cores, transistors, or tubes can be used to control sizeable blocks of power in the controlled rectifier. Resistor R limits gate current. Its value depends on the magnitude of supply voltage and the current required for firing the rectifier.

Variations of this circuit can be used in connection with conventional d-c rectifier power sup-

plies to provide both switching and rectification with the same device. With contacts of a sensitive current relay in series with the gate current, such a circuit can interrupt fault currents in as little as one-half cycle.

D-C Static Switch

Figure 5 illustrates one way in which the rectifier can be used to switch d-c loads. To close the switch, the gate circuit is energized momentarily from the main d-c supply through some kind of signal device. This device is represented in Fig. 5 as a start push-button. As soon as the start button is released, capacitor C charges to essentially the d-c supply voltage through resistor r .

When the stop button is de-

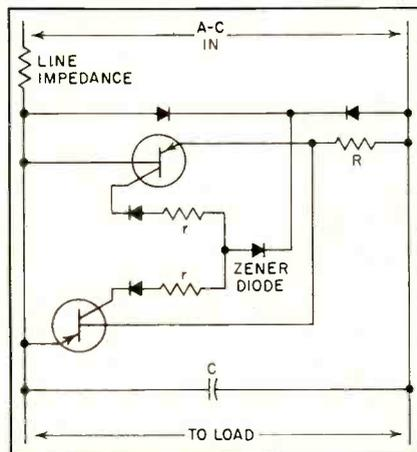

FIG. 10—Surge-voltage suppression circuit. Capacitor prevents overshoot

pressed momentarily, the positive terminal of C is connected to ground. This action impresses a negative voltage across the controlled rectifier for the few μsec necessary to return it to the blocking state.

In Fig. 6, voltage transfers from one lead to the other each time a pulse is fed into the gate circuit. Optimized circuits of this type yield switching times in the order of one μsec . Size of capacitor C depends on the load resistance and the energy stored in the rectifier loop. In circuits using the ZJ-39A, five μf are ample for 12-v circuits operating at one to five amperes.

The circuit shown in Fig. 7 uses a potentiometer control scheme that permits shifting the a-c gate-

current signal between 0 and 180 deg with respect to the anode supply voltage. This phase shift regulates the point at which the rectifier fires during each cycle. Average output voltage can be varied uniformly from zero to about 0.45 of the rms supply voltage.

Figure 8 shows a single-phase full-wave bridge using controlled rectifiers in two legs. The rectifiers control the average output voltage from zero to 0.9 of the rms supply voltage. In addition to the R-C circuit shown, excellent phase-shift circuits can be designed around transistors and saturable-core devices. These circuits control output automatically by signal or error currents and voltages. Through this type of gate control, the rectifier lends itself ideally to regulator circuits.

Synchronized Inverter

Figure 9 depicts two rectifiers in a circuit for generating an alternating voltage from a d-c source. The triggering gate signal for this inverter can be a sine wave, a series of pulses, or a square wave. A unijunction transistor in a relaxation-oscillator circuit makes a stable triggering source, assuring reliable starting and constant frequency. Insertion of suitable feedback makes the inverter free-running. By rectifying the output voltage, this circuit makes an efficient d-c to d-c converter.

The type of circuit shown in Fig. 10 is useful in protecting transistor and semiconductor-rectifier circuits from harmful line-voltage surges. When line voltage exceeds a predetermined value, one of the controlled rectifiers fires. It draws enough line current to drop the voltage across the line impedance.

Value of resistor R should be selected to limit anode current to the rating of the rectifier. For surge durations of less than one cycle, R should be selected to limit peak anode current to 150 amp when using this device. Voltage level at which suppression starts is determined by breakdown voltage of the Zener diode. Where temperature variations are not excessive, resistor r can be used instead of the diode to control firing level of the controlled rectifiers.

Selection of Modulation

Type of modulation used for a given communications application depends upon a number of variables. A logical method may be employed for evaluating the relative merits of a-m, f-m, ssb and dsb-sc for a specific requirement. Factors include effective range, bandwidth and interference rejection

By **GEORGE J. KELLEY** General Electric Company, Utica, New York

AN IMPORTANT DECISION in designing a new communications system is the modulation method to be used. In most cases several different types could be used, each having somewhat different performance characteristics. The type of modulation which is most suitable can be chosen on the basis of a logical evaluation.

The choice will involve simultaneous consideration of many factors for each available type of modulation in terms of the basic

requirements of the system. Because of the great variation in these factors with changing system parameters, no single type of modulation is best for all uses. But for the particular system being designed the relative merits of the various modulation methods can be established.

Modulation Methods

The four main methods considered here are standard amplitude (a-m), frequency (f-m),

single sideband (ssb) and double sideband suppressed carrier (dsb-sc) modulation. The factors by which they are compared include compatibility, effective range, signal-to-noise performance, interference rejection, distortion, stability, transmitter power and circuit complexity. Table I summarizes the comparative performance features.

Other factors may be important for a particular system. Many of the performance details can have

TABLE I—Comparative Performance of Four Types of Modulation for Voice Communication

Characteristic	Modulation Type				Comments
	a-m	dsb-sc	ssb	f-m	
Compatibility of receiver with other modulation types	Receives modified full-carrier ssb	Receives a-m and ssb	Receives a-m and dsb-sc	Receives f-m only	Each modulation integrates best with same type system
Effective range	Intermediate, determined by noise threshold	Longer, all r-f power is effective intelligence signal with lower noise threshold	Equal to dsb-sc for same average power	Shortest, since larger bandwidth increases noise threshold	Fig. 3 shows range-threshold of modulations having equal total r-f powers
Bandwidth	Twice the highest modulating frequency	Same as a-m	Equal to highest modulating frequency if one sideband is effectively suppressed	Twice the highest modulating frequency plus nominal deviation of f-m wave.	Assumes no over-modulation. See Fig. 1. Guard bands should be between channels
Signal-to-noise performance	Poorest, single carrier power doesn't contribute to output signal speech processed by preemphasis and peak clipping	All r-f power contributes to output signal. Allows speech processing by preemphasis and peak clipping	Like dsb-sc, but audio peak clipping produces higher r-f peaks, limiting its effectiveness	Improvement is possible by increasing nominal deviation. Pre-emphasis often used	A-m, ssb and dsb-sc give equal performance for equal average sideband powers. Also see Fig. 1.
Interference rejection	Selective filter will reject discrete interference	Selective filter will reject interference from either sideband	Selective filter will reject discrete interference	Rejects interference by capture effect	F-m capture requires signal stronger than interference
Distortion					
1. Circuit linearity	Intermediate	Intermediate	Greatest	Least	Refers to degree of circuit linearity required for satisfactory performance. Produces r-f components outside nominal bandwidth. Can be reduced by processing modulating signal
2. Over modulation	Peak sharply limited to four times carrier power	Peak limited by maximum transmitter capability	Peak limited by maximum transmitter capability	Peak limited by channel bandwidth	

For Speech Communication

complicated interactions that are beyond the scope of this article. The present analysis should therefore be considered a general survey, giving only the broad aspects of relative performance. It will indicate how comparison may be made in the early design stages. If the choice between alternative modulation methods is not clear-cut on the basis of these considerations, further investigation should be made, preferably including field tests of the possibilities.

Making the Choice

The decision may be expedited by constructing a system advantage profile chart, which depicts the relative performance of the modulation methods for the various factors under consideration. Evaluation is made in terms of the system parameters with appropriate weights assigned.

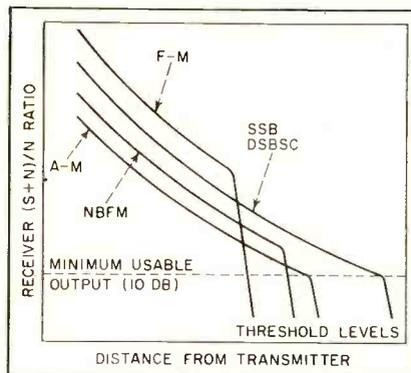

FIG. 1—Maximum transmitter range is primarily function of signal threshold, below which reception is unusable

If one type of modulation shows up best on this chart, it should be chosen. If the performance characteristics are mixed, as is often the case, the design engineer must use all his skill and judgment in making the selection. The SAP chart simply gathers together the

facts on which an intelligent decision can be made.

Suppose that a two-way voice communications system operating in the h-f region is required to be carried in a medium-sized airplane. Weight and antenna limitations will restrict the peak power to less than a kilowatt. Maximum possible range is highly important, see Fig. 1, while the bandwidth should be less than 8 kc. It is desirable but not necessary that the system work with an existing a-m system. Processing of the input speech will involve preemphasis and peak clipping as suitable for the particular modulation. Transmission will often be through a moderately disturbed path. Doppler frequency shifts resulting from the airplane's motion can be as much as 50 cps.

Beginning the Profile

Analysis for this system should

Characteristic	Modulation Type				Comments
	a-m	dsbc	ssb	f-m	
3. Distortion of pulsed data waveform	None	None	Perfect control of r-f frequency and phase required	None	If several data channels are multiplexed, combination may occasionally produce overmodulation.
4. Multipath distortion	Subject to fading	Less fading than a-m. Relative advantage 3 to 9 db for good to poor conditions	Like dsbc. See Fig. 4, where dsbc is between the two curves at a threshold 3 db above ssb	Subject to fading	Multipath conditions are variable; general statements may not always apply
Stability	Less frequency control and stability required	Intermediate stability required. Phase control loop locks receiver	High frequency control and stability required	Less frequency control and stability required	With Doppler shifts, a-m and f-m are least affected, ssb most distorted. Effect on dsbc is intermediate
Transmitter power	Average: carrier power plus average modulating power. Peak: four times carrier power. Circuit efficiency intermediate	All r-f power is in modulated signal. Relative average and peak values depend on modulating waveform. Circuit efficiency high	All r-f power is in modulated signal. Relative average and peak values depend on modulating waveform. Circuit efficiency low	Constant r-f power. Relative proportions of carrier and modulating signal calculated by a Bessel-function analysis. Efficiency is high	Typical ranking for total d-c power required to produce equivalent intelligence signal output, 1. dsbc, 2. ssb, 3. f-m and 4. a-m
Circuit complexity					
1. Receiver	Least complex	Somewhat less complex than ssb	Most complex	Somewhat more complex than a-m	Ssb two-way transceivers can use some circuits for both transmitting and receiving
2. Transmitter	Somewhat more complex than f-m	Least complex	Most complex	Intermediate	
3. Two-way system	Least complex	More complex than a-m or f-m	More complex than a-m or f-m	Slightly more complex than a-m	
4. Critical components	Least critical	Somewhat less critical than ssb	Most critical	Somewhat more critical than a-m	

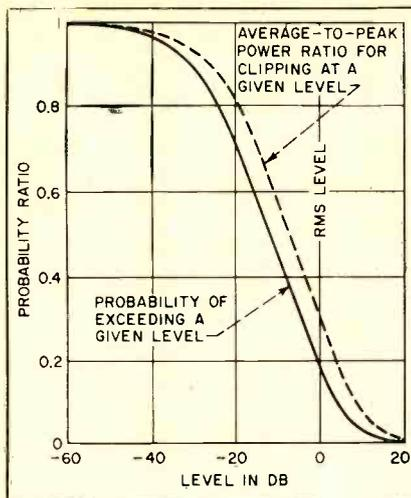

FIG. 2—Average power can be greatly increased by the clipping process

concentrate on factors influencing maximum available range. The most important of these is the average intelligence power that can be sent within the limits of peak power, and bandwidth. This power can be determined from the speech characteristic curves of Fig. 2.

First a value is set for the level at which peak clipping of the audio waveform is to occur. At this level, in db above the unclipped rms value, the solid curve of Fig. 2 gives the percentage of time that the speech wave is peak-clipped, and the broken curve gives the re-

FACTOR	ASSIGNED WEIGHT	RELATIVE ADVANTAGE									
		0	0.1	0.2	0.3	0.4	0.5	0.6	0.7	0.8	0.9
COMPATIBILITY	0.1	X	Δ	○							
EFFECTIVE RANGE	1			X	○				□	Δ	
BANDWIDTH	0	ASSIGNED EQUAL									
S/N PERFORMANCE	1			○	X				□	Δ	
INTERFERENCE REJECTION	0.4	○	Δ	X							
DISTORTION	0.8			○	X			□	Δ		
STABILITY	0.2	○	Δ	X							
POWER	0.8			X	○			□	Δ		
COMPLEXITY	0.3	○	X	○							
WEIGHTED TOTAL PERFORMANCE	4.6							○	X	□	Δ
CODE :		○	A-M	Δ	DSBSC	□	SSB	X	F-M		

FIG. 3—System advantage profile for h-f airborne transceiver

sulting average-to-peak power ratio.

Then dsb-sc modulation will produce the same power ratio for the r-f signal and a-m will have the same value for its average to-peak sideband power ratio. The peak a-m sideband power is equal to the unmodulated carrier power, which in turn is 0.25 the peak modulated power, so the average sideband-to-peak power ratio is 0.25 the value given in Fig. 2.

In computing the powers for ssb allow for the peak values produced by square-wave modulation. Speech has occasional high-power low-fre-

quency components which will become nearly square waves by clipping. When a square wave is sent through a typical low-pass filter which may pass up to the 11th harmonic, and then used to modulate an ssb transmitter, the peak r-f power is increased three times over what it would be in dsb-sc modulation. To avoid exceeding the peak power limitation the average signal level must be reduced to one-third. The modulation will not always be a square waveform, but an average-to-peak power ratio for ssb under these conditions is somewhat less than that in Fig. 2.

With f-m the bandwidth restriction of 8 kc is most important. The modulation characteristics of the transmitter should be set so that the speech amplitude corresponds to a peak modulation index of 0.8 and only the first order f-m sideband components have appreciable amplitude.

Then the average sideband signal power can be calculated from the input speech power ratio, using an analysis in terms of Bessel functions.

Speech Clipping

Similar calculations can be made for any desired degree of peak clipping. These values are summarized in Table II, along with the corresponding values for d-c power converted to r-f, as normalized for equal peak power or equal average intelligence power. The values for ssb in the more severely clipped cases are somewhat fictitious, since heavy clipping is not effective for ssb as distortion results and there is further loss of readability in the presence of noise. The bandwidths are identical by definition. F-m is therefore restricted to a low modulation index. Also the undesired sideband ssb cannot be completely suppressed. This leads to excessive interference if another transmitter uses that side for its primary ssb transmission.

Evaluations can be made for the other factors appropriate to this system. Then their relative importance is estimated and the advantages of the various modulations established on a scale. The possible results of such an analysis are presented in Fig. 3.

TABLE II—Performance for Degrees of Clipped Speech

Clipping level above rms	Modulation	Equal Peak Power (=1)			Equal Average Intelligence Power (=1)		
		Average intelligence power	Average carrier power	D-c power converted to r-f	Average carrier power	Peak power	D-c power converted to r-f
11 db	a-m	0.02	0.25	0.27	14	56	15
	dsb-sc	0.07	0	0.07	0	14	1
	ssb	0.07	0	0.07	0	14	1
	f-m	0.02	0.98	1	49	50	50
7 db	a-m	0.035	0.25	0.285	7	28	8
	dsb-sc	0.14	0	0.14	0	7	1
	ssb	0.09	0	0.09	0	11	1
	f-m	0.04	0.96	1	24	25	25
0 db	a-m	0.08	0.25	0.33	3.2	12.8	4.2
	dsb-sc	0.31	0	0.31	0	3.2	1
	ssb	0.10	0	0.1	0	10	1
	f-m	0.09	0.91	1	10	11	11
-10 db	A-m	0.15	0.25	0.4	1.7	6.8	2.7
	dsb-sc	0.59	0	0.59	0	1.7	1
	ssb	0.2	0	0.2	0	5	1
	f-m	0.17	0.83	1	4.9	5.9	5.9

ENVIRONMENTAL TESTING of Electronic Equipment

By **MICHAEL F. TOMAINO**
Associate Editor

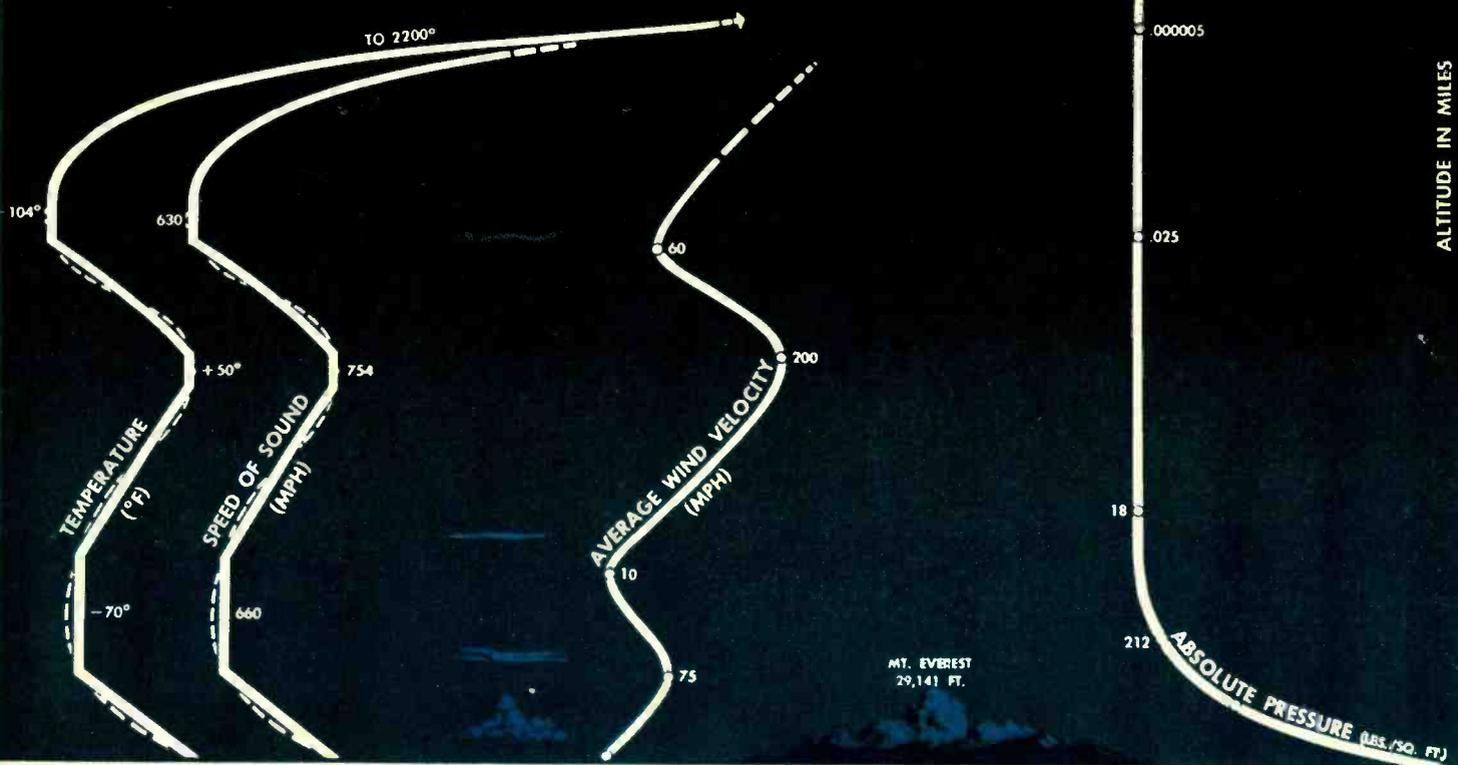
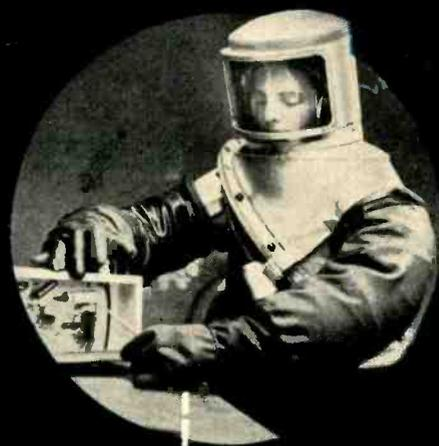
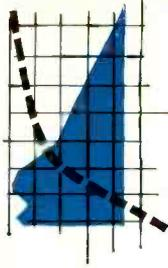

PHOTO COURTESY LITTON INDUSTRIES, BACKGROUND CHART DOUGLAS AIRCRAFT

An
electronics
Special Report
MARCH 28, 1958
© McGraw-Hill Publishing Co.

- 1 -Defining Stresses of Environment**
- 2-Designing for Environment**
- 3-Mechanical Testing Equipment**
- 4-Environmental Test Chambers**



Defining Stresses of Environment

Missile-borne gear must withstand extremely high temperatures and severe mechanical shock. Even equipment that never leaves the ground can encounter wide temperature swings, high humidity and destructive jostling in vehicles. And shipborne gear must hold up under reoccurring exposure to a number of unique stresses

Temperature, Pressure, Density and Sound Speed as Geometric Functions of Altitude

Altitude thsd of ft	Temperature		Pressure in millibars	Density in	Sound Speed in ft per sec
	C	F		lb force Sec ² ft ⁻⁴	
1,850	+1,263	+2,306	4.21-10 ⁰	1.02-10 ⁰	concept of speed of sound progressively loses its meaning at high altitudes except for frequencies approaching zero and for very short distances
1,700	+1,162	+2,123	6.92-10 ⁰	1.82-10 ⁰	
1,500	+1,025	+1,878	1.45-9	4.33-10 ⁰	
1,000	+ 677.2	+1,251	1.78-8	8.10-13	
900	+ 607.1	+1,125	3.51-8	1.79-14	
800	+ 537.3	+ 999.2	7.62-8	4.44-14	
700	+ 468.5	+ 875.4	1.88-7	1.28-13	
600	+ 402.0	+ 755.7	5.52-7	4.50-13	
500	+ 185.3	+ 365.6	2.33-6	2.86-12	
400	— 16.25	+ 02.8	2.92-5	6.56-11	
300	— 76.3	— 105.3	1.77-3	6.07-9	922.8
200	— 19.3	— 02.7	2.27-1	6.06-7	1,047.9
150	+ 4.7	+ 40.4	1.46	3.56-6	1,096.3
100	— 40.5	— 40.9	11.05	3.21-5	1,003.2
90	— 49.6	— 57.2	17.38	5.25-5	983.46
80	— 56.5	— 69.7	27.83	8.68-5	968.08
70	— 56.5	— 69.7	44.85	1.40-4	968.08
60	— 56.5	— 69.7	72.31	2.26-4	968.08
50	— 56.5	— 69.7	116.64	3.64-4	968.08
45	— 56.5	— 69.7	148.16	4.62-4	968.08
40	— 56.5	— 69.7	188.23	5.87-4	968.08
35	— 54.2	— 65.6	239.09	7.38-4	973.14
30	— 44.35	— 47.8	301.48	8.91-4	994.85
25	— 34.5	— 30.1	376.50	1.07-3	1,016.1
20	— 24.6	— 12.3	466.00	1.27-3	1,036.9
15	— 14.7	+ 5.5	572.07	1.50-2	1,057.4
10	— 4.8	+ 23.4	696.94	1.75-2	1,077.4
5	+ 5.1	+ 41.2	843.11	2.05-2	1,097.1
Sea Level	+ 15.0	+ 59.0	1,013.25	2.38-2	1,116.4
— 5	+ 24.9	+ 76.8	1,210.3	2.75-2	1,135.5
— 10	+ 34.8	+ 94.7	1,437.7	3.15-2	1,154.2
— 15	+ 44.7	+ 112.5	1,697.9	3.61-2	1,172.6

Figures taken from The ARDC Model Atmosphere, 1956, by R. A. Minzner and W. S. Ripley, an Air Force Survey in Geophysics, prepared by GRD, Air Force Cambridge

*Superscripts indicate the power of ten by which each tabulated value should be multiplied

DESIGNING EQUIPMENT to withstand anticipated environment goes back to Genesis. According to the biblical story of the flood, God gave Noah the specifications for building an Ark that would survive trial by water. And, following these detailed instructions exactly, Noah and his family alone of humanity survived the Deluge.

DEFINING THE ENVIRONMENT—Today man ranges from the poles to the tropics, from the ocean depths to the stratosphere. He sends missiles far into outer space, rings the earth with artificial satellites. In all his endeavors, electronic equipment is essential. Making sure it will work reliably is the function of environmental testing.

Nature provides part of the environmental framework in which electronic equipment must operate. On earth, man has recorded temperatures, between -100 and 136 F, he knows the temperature range at almost every spot on earth (greatest range in 24 hours at one spot: from 26 to 126 F), he knows the highest wind speed (231 mph) and the rainfall record for one day (46 in.).

Test methods for electronic equipment and component parts have been established.¹ They give general requirements and list methods for testing resistance to salt spray, temperature cycling, high humidity, immersion, in water or low barometric pressure, mechanical vibration and shock.

FIG. 1—Temperature, pressure, density and sound speed as geometric functions of altitude

TABLE 1 — Air Force Environmental Design Criteria

Stress of the Environment	Aircraft								Missiles				
	Present				Estimated				Present		Estimated		
	Test A	Test B	Test C	Test D	Test E	Test F	Test G	Test H	Test A	Test B	Test C	Test D	
Altitude	30,000 ft	50,000 ft	60,000 ft	70,000 ft	80,000 ft	90,000 ft	100,000 ft	150,000 ft	100,000 ft		3,000,000 ft		
Altitude Shock	0-30,000 ft 20 min	0-50,000 ft 15 min	0-60,000 ft 15 min	0-70,000 ft 15 min	0-80,000 ft 5 min	0-90,000 ft 5 min	0-100,000 ft 5 min	0-150,000 ft 5 min	0-50,000 ft 10 sec	0-3,000,000 ft 20 min	0-3,000,000 ft 20 min	0-3,000,000 ft 20 min	
Shock									50 g 11 = 1 ms	50 g 11 = 1 ms	50 g 11 = 1 ms	50 g 11 = 1 ms	
Temperature	M ₂	71 C 1 hr	95 C 10 min	125 C 10 min	150 C 10 min	260 C 10 min	375 C 10 min	400 C 10 min	500 C 10 min				
	Military Emergency	54 C 4 hrs	71 C 1 hr	95 C 1 hr	95 C 4 hrs	125 C 4 hrs	260 C 1 hr	375 C 1 hr	400 C 1 hr	- 54 C to 93 C	- 54 C 371 C	- 54 C to 538 C	- 54 C to 1093 C
	Cruise		54 C 4 hrs	71 C 4 hrs	95 C 4 hrs	125 C 4 hrs	150 C 4 hrs	260 C 4 hrs	375 C 4 hrs				
Temperature-Shock		-54 to 71 C 20 min	-54 to 95 C 15 min	-54 to 125 C 15 min	-54 to 150 C 10 min	-54 to 268 C 10 min	-54 to 375 C 5 min	-54 to 400 C 5 min	-54 to 500 C 5 min	-54 C to 93 C 5 min	-54 to 371 C 5 min	-54 to 538 C 5 min	-54 to 1093 C 5 min
Vibration, Acoust.		37.5 to 10,000 cps											
	External	130 db	150 db	145-165 db	148-168 db	152-172 db	155-175 db	160-180 db	160-180 db	150-175 db	150-175 db	153-178 db	138-183 db
	Internal	110-120 db	115-135 db	130-150 db	133-153 db	137-157 db	140-160 db	145-165 db	145-165 db	130-155 db	130-150 db	133-158 db	138-163 db
Vibration, Mechanical		10-55 cps 0.06 da in. double Amplitude	5-55 cps 0.06 in. da 55-500 cps 10 g		5-55 cps 0.06 in. da		55-1,000 to 2,000 cps 10 g to 20 g			5-55 cps 55-2,000 cps		possible complex wave simulation	?

NATURAL ENVIRONMENT—For military purposes, the Armed Services has tabulated natural environmental extremes.² Natural environmental stresses include heat and cold, humidity, precipitation, wind, dust penetration and abrasion, salt spray and atmospheric pressure. Probable extremes have been determined for each. Conditions have been established for design and evaluation of military equipment for use under world-wide, hot-desert, arctic-winter and moist-tropical climatic extremes.

For the Air Force, the Air Force Cambridge Research Center and the Air Weather Service are continually furnishing new information about the environment, and the AVS has reported all sorts of data from which climatic probabilities can be derived.

When electronic equipment must leave the earth and head into the upper atmosphere, the design engineer faces new environmental stresses. In a search for knowledge that will chart the upper atmosphere, the AFCRC has plotted probable atmospheric properties against altitude. This data is now compiled in a document.³ This document, used as a basis for environmental engineering and design work, presents tables and graphs on the environment at altitudes up to 1,850,000 feet: over 350 miles.

What happens to the temperature, atmospheric pressure, air density and sound speed, is shown in Fig. 1. Performance requirements for equipment to be made under new contract are based on these data.

MAN-MADE ENVIRONMENT—In addition to natural environment, man has superimposed certain arti-

TABLE 2 — USAF Environmental Test Procedures Used To Design Electronic Systems *

Category of the Environment	Ground Support Communications		Aircraft Communications	Guided Missile Communications
	Sheltered	Unsheltered		
Acceleration			Mil-E 5272	Mil-E 5272
Altitude	Mil-E 4970	Mil-E 4970		
Explosion Proof			Mil-E 5272	Mil-E 5272
Fungus	Mil-E 4970	Mil-E 4970	Mil-E 5272 Procedure I	Mil-E 5272 Procedure I
Humidity	Mil-E 4970	Mil-E 4970	Mil-E 5272 Procedure I	Mil-E 5272 Procedure I
Rain		Mil-E 4970		
Salt Spray		Mil-E 4970		
Sand & Dust		Mil-E 4970	Mil-E 5272	Mil-E 5272
Shock	Mil-E 4970	Mil-E 4970	Mil-E 5272	Mil-E 5272
Temperature, High	Mil-E 4970 Procedure II	Mil-E 4970 Procedure I	Mil-E 5272 Procedure I	Mil-E 5272 Procedure I
Temperature, Low	Mil-E 4970 Procedure III	Mil-E 4970 Procedure I	Mil-E 5272 Procedure II	Mil-E 5272 Procedure II
Temperature Shock				Mil-E 5272 Procedure I
Temperature — Altitude			Mil-E 5272 Procedure I	Mil-E 5272 Procedure I
Vibration, Acoustical			For appropriate test procedure contact WCLOD-4, Wright-Patterson AFB, Ohio	
Vibration, Mechanical	Mil-E 4970	Mil-E 4970	Mil-E 5272	Mil-E 5272

also see MIL-E 005272B, 5 June 1957

ficial environments. These man-made conditions include such stresses as mechanical and acoustical vibration, shock, explosion and artificially created temperatures, nuclear radiation, radio interference, high acceleration and other conditions.

Specific environmental requirements have been worked out for nearly all equipment manufactured under Government contracts. There are

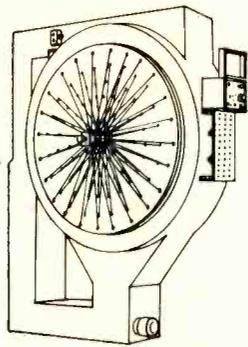

THE FRONT COVER

Cylindrical load-life environmental oven for testing capacitors, designed and constructed at Battelle Memorial Institute, reduces cold spots normally found in rectangular chambers. Components are mounted in concentric circles on two circular plates at each end of the two-compartment chamber. Each circular plate holds 96 capacitors.

Stray lead capacitance is reduced and corrected by short leads and symmetrical mounting. A circulating air system with diffusing plates maintains constant and uniform temperature. Close temperature control is maintained by switching 10 percent of the total heater power on and off.

Temperature is monitored at several points within the chamber to minimize the possibility of undetected uniformity of temperature.

Self-supporting leads are brought from the component binding posts through the door to connector pins. An insulated connector disk over the outside of the chamber door is fitted with jack leads that connect the pins on the chamber. Any desired component can be connected to the two output leads of a rotary switch

two basic military specifications that cover environmental testing.^{4, 6}

The Environmental Criteria Branch of the Wright Air Development Center publishes periodically a listing of reports and documents that deal with environmental testing, and these lists are obtainable upon request. WADC also offers an environmental criteria slide rule, which was developed by Southwest Research Institute.⁹

TEST PROCEDURES—A new trend in testing may be towards the combined-environment procedure, rather than checking various factors in the environment independently.⁷ The combined-environment approach provides for greater realism in the simulation of the actual conditions the equipment will meet.

Specifications are being modified continuously, and extended, as knowledge of the upper atmosphere increases. Table 1 presents present and predicted environmental design criteria for aircraft, airborne equipment and missiles. The table merely indicates certain procedures to be followed. It should not be taken as a test schedule in itself. Attention must also be given to the electronic system location within the weapons system. WADC supplies additional documents to be studied.^{8, 9}

Table 2 lists basic USAF environmental test procedures used to design electronic systems. In this table, no tests are specified for several environments in each category. This does not necessarily mean that equipment will not be exposed to these environments, but rather that the severity of the environment associated with this particular category is such that either equipment performance will not be affected or that environment has been included within another test procedure.

Model of giant hot cell used to determine effects of nuclear radiation at Cook Technological Center. Source consists of 6,200 curies of cobalt 60 stored under 22 ft of water

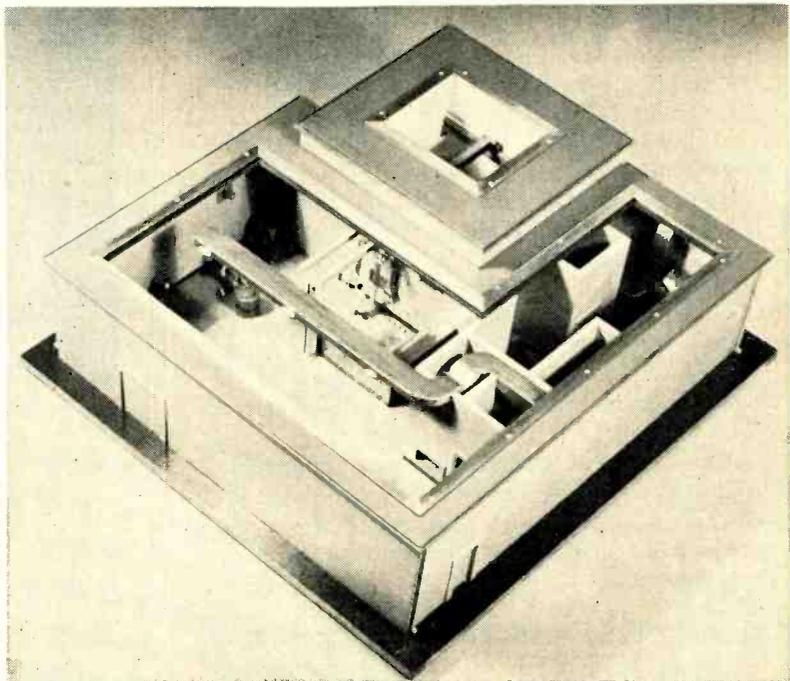

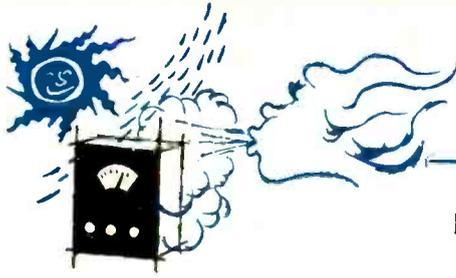

Designing for Environment

One way to make sure electronic equipment holds up in service is to check out every component. Several research groups are now doing just that. Studies of how, when and why certain components fail under a given stress are helping manufacturers make better components without incurring unrewarding production expense

ENVIRONMENTAL SCIENCE — Environmental evaluation of electronics equipment and components is big business today, involving millions of dollars of complex equipment. Much of the environmental test business is concentrated among five major groups: hardware producers, electronics manufacturer's environmental testing laboratories, privately owned independent testing laboratories, government test labs, and college and university research organizations.

The hardware producers specialize in making equipment to simulate actual environment. An organization known as the Environmental Equipment Institute, with headquarters at Princeton, N. J., serves many of them as a clearing house for shared information and establishment of standards. Members include such firms as Alpha Electric, American Research, Bemco, Cincinnati Sub-Zero Products, Harris Refrigeration, Hudson Bay Co. Division of Labline, Inc., International Radiant, Murphy & Miller, Standard Cabinet and Tenney Engineering. Also associated with EEI are diversified firms like Dean Products, Bristol Company and Minneapolis-Honeywell. Many of these firms have, of course, their own laboratories too.

Extensive environmental test laboratories have been set up within many electronics, aeronautical or industrial companies—corporations such as Convair, General Electric, Westinghouse, General Precision, Inland Test Labs of Cook Electric, IBM and practically all large firms that produce military electronics. Some of these companies also build specialized simulation equipment. Environmental test labs were set up to test the manufacturers' own products, and their military

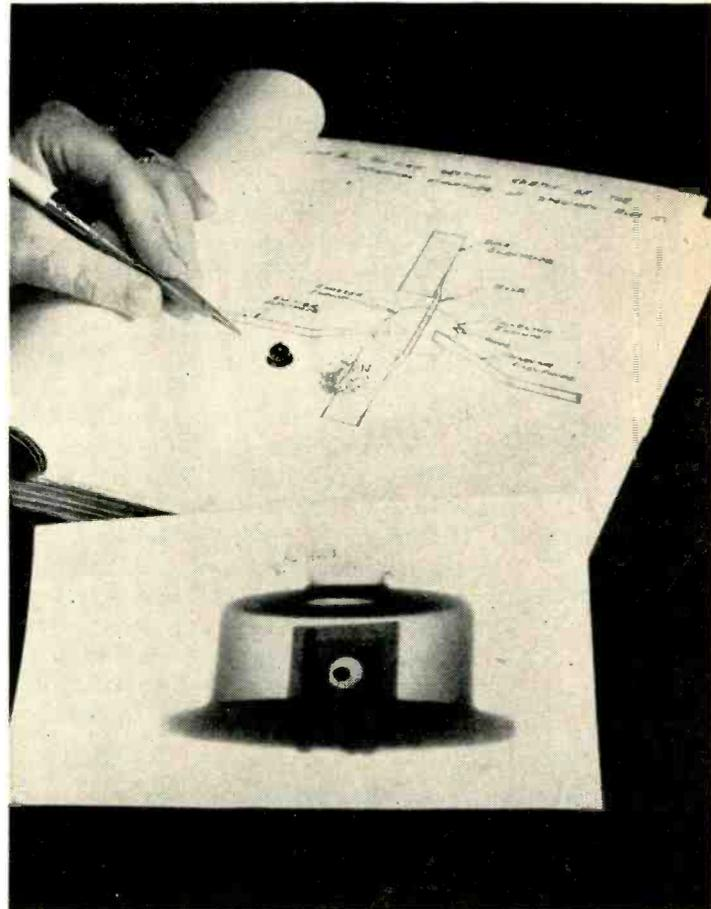

X-ray technique helps reliability engineer at Batelle examine interior of a transistor that failed under environment stress. Enlarged print helps engineer prepare sketch showing what happened

TABLE 3 — Order of Severity of Principal Types of Environments

Group 1	Group 2	Group 3	Group 4	Group 5	Group 6	Group 7
High Temperature	Low Temperature	Pressure	Acceleration	Sand & Dust	Temperature Shock	Insects
	Moisture	Shock	Explosive Atmosphere	Salt Spray	Wind	
	Vibration	Precipitation	Icing	Static Electricity	Solar Radiation	

Reference: John Grimm, WADC paper, 1956

output is often monitored by Government representatives. Sometimes these laboratories do testing for other manufacturers.

TESTING LABS—A third group concerned with environmental testing of electronics is the privately owned, independent commercial testing laboratory, and the nonprofit electronic research and certifying organization. Typical of this group is Electrical Testing Laboratory of New York. The U. S. Testing Co., the N. Y. Testing Labs, Avion, Associated Testing Laboratories, Shaevitz, Aero-test, United Electrodynamics, Horkey-Moore and Rototest are similar organizations. A directory of the American Council of Independent Laboratories (ACIL) lists member organizations and the kind of work in which they specialize.¹⁰

Government laboratories have extensive facilities for evaluating electronics. As one example, the Navy has an all-weather test facility at New York Naval Shipyard. Six environmental test chambers at the Wright Air Development Center, near Dayton, are designed to simulate conditions 50 miles above the earth or higher. The National Bureau of Standards and Diamond Ordnance Fuze Labs have extensive facilities, and so does the Naval Air Material Center at Philadelphia and the Signal Corps at Fort Monmouth.

Much research of World War II was performed by the research divisions of engineering colleges. And most of these colleges and universities still perform a large part of the government's research.

Rensselaer announces a four-year program leading to the degree of Environmental Engineering and graduate courses in the field will start next fall.

RELIABILITY REQUIREMENTS—Component-part reliability data is a must for the engineer who plans to design electronics that will function under specific conditions.

The objective of a components-reliability program is to supply the design engineer with data that will present failure rates and parameter drift characteristics of a component type under a variety

of environments and electrical loads.

Electronics Industries Association (formerly RETMA) estimates that the electronics industry spends between \$20 and \$25 million annually on components qualification tests, and some estimates double these figures.

Many companies have established their own incoming-components environmental test divisions. Government agencies and some private groups have assembled much component-reliability data.^{11, 12, 13}

The relative severity of various environmental conditions depends on the specific item, and where and how it is used. Table 3 lists the major environmental conditions and indicates one approximation of their order of severity.

Navy shipboard electronic equipment is subjected to a special set of reoccurring stresses.¹¹ Salt spray may cover the whole ship. So humidity and moisture environments may be quite severe. Development Engineering is one maker of room-sized salt-spray fog chambers. Also, the constant pitch and roll of a ship sets up frequent exposure to shock and vibration.

There are many other environments whose effects are being investigated, now that we can get artificial moons to orbit. These include ozone, dissociation of gases, meteorite dust, ultraviolet rays, soft X-rays, neutron and gamma rays, photoelectric effect, ionized gases, aurora, earth's magnetic field and high vacuum.

COMPONENT TESTING—Large-scale life testing programs such as the one currently being carried out at Inland Laboratories is one answer to the reliability program. Twelve environmental chambers, together with automated measuring equipment, are capable of 288,000 individual component measurements per day. This information is recorded on punch cards.

In England, Automation Consultants and Associates Ltd., of London, has designed and developed an automatic electronic-component testing laboratory which is indirectly connected with a guided-missile research project.



Mechanical Testing Equipment

Principle trends are toward higher vibration frequencies and more intense shock. Techniques include randomly applied shock, rapid acceleration and mechanical vibration that describes complex wave functions

VIBRATION—A severe type of environment is vibration, and to deal with this problem the Navy has built and staffed a facility at the \$45 million Naval Ordnance Laboratory in White Oak, Md. Here it can simulate practically any condition that ordnance may encounter in actual service.

At Lear's environmental test laboratory, shock and vibration phenomena are studied in the area of random or white noise. Random-noise equipment was designed and built by Ling Electronics and MB Manufacturing. In part, the equipment consists of a 30-kw amplifier, console for remote control and a vibrator. Systems weighing as much as 55 pounds may be tested up to 20 g's with this system. An Ampex magnetic tape recorder and other custom-designed equipment provide an analysis of random-noise.

A complex motion system is used to simulate a random vibration environment. Such a system consists of a vibration exciter used to shake the specimen, a large electronic amplifier to power the vibration exciter, and a complex-motion console which supplies a modified voltage to the amplifier. Sources of input voltage proportional to commonly desired accelerations are mounted in the console or externally connected.

Until recently, vibration requirements were limited to frequencies below 2,000 cps for use over a temperature range of -65 to plus 100 F. Concern with hypersonic environments today necessitate equipment for continuous measurements up to 20 kc at temperatures over 500 F. A large temperature chamber will house the entire vibration machine, or an external exciter may be

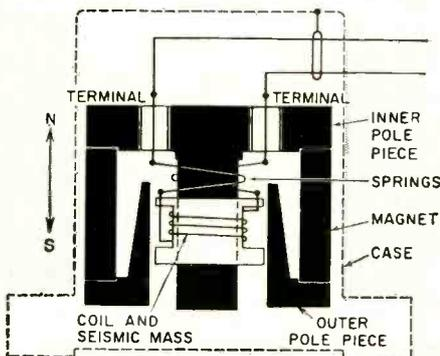

FIG. 2—Construction shows principle of Consolidated Electrodynamics' vibration pickup

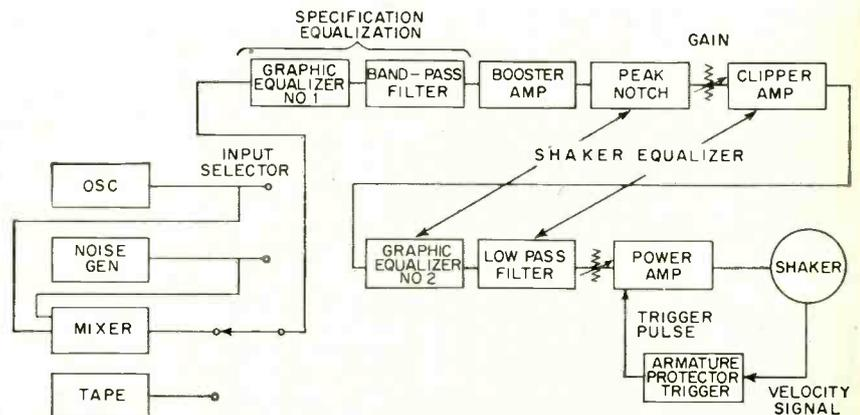
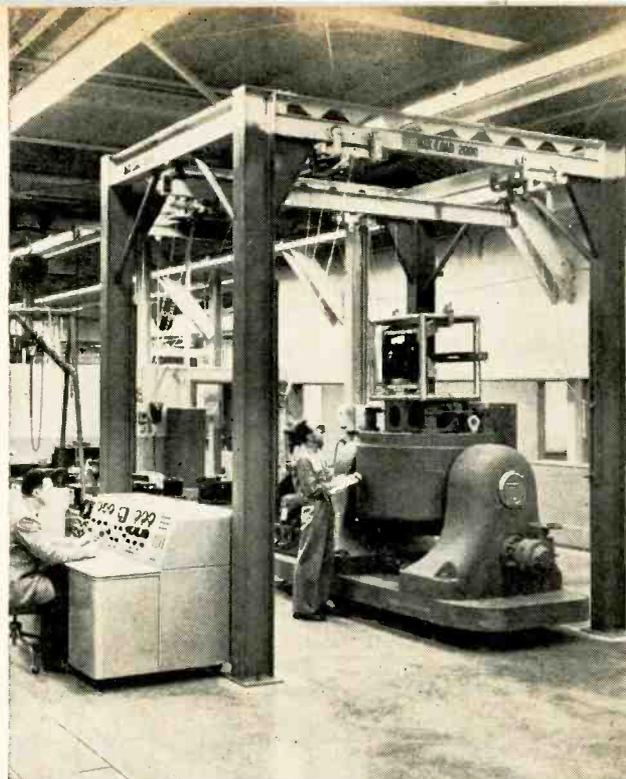
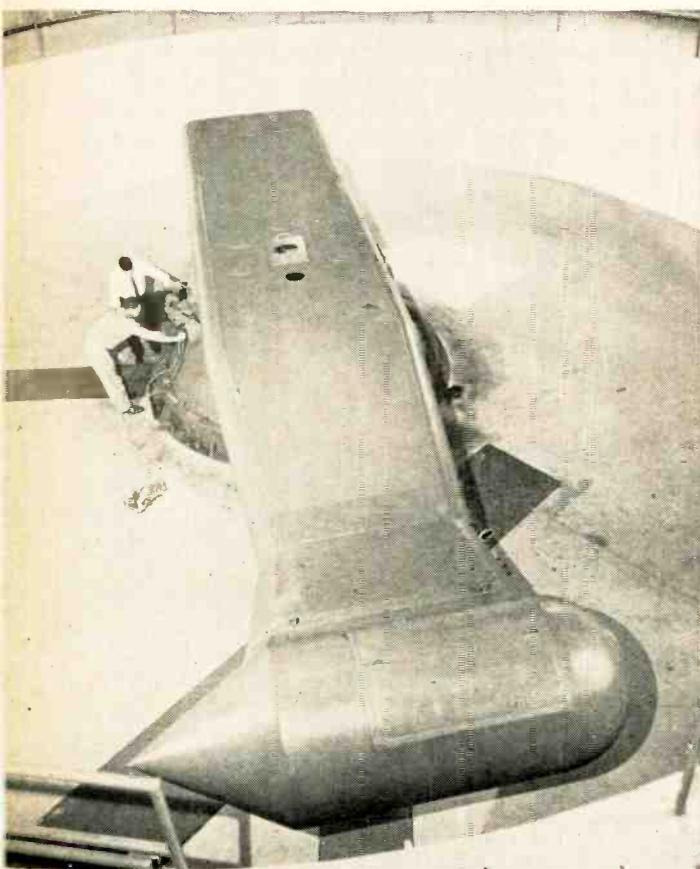

FIG. 3—Electronically controlled shaker system capable of applying complex vibration waveforms (Ling)



Powerful electrodynamic exciter used at North American has rated continuous output of 12,500 lbs, making it possible to simulate force of 45 g

Vibration exciter by MB, installed at Inland, has frequency range from 5 to 2,000 cps with maximum force output of 3,500 lbs.



Huge centrifuge by Ricker, installed at Convair plant, can exert force equal to 100 g for testing components for Atlas missile

used, connected to the vibration machine by a sealed connecting rod.

Other equipment includes a second vibrator with a frequency range to 2,000 cps and a vibratory force capability of 3,500 pounds. There are three additional vibration exciters at the laboratory.

A shock machine provides information on single-shock pulses with acceleration to 75 g without rebound. Equipment includes devices for measuring angular vibration amplitudes. The facility is acoustically controlled, with floated mounts for the vibrators to eliminate undesirable reactionary forces. One of these floated mounts is a six-foot cube of concrete weighing 15 tons supported by spring suspensions.

RANDOM VIBRATION—Vibration problems created in advanced components are involved.^{15, 16} Often the quality-control problem is complicated by the fact that the component itself is more precise than the available testing equipment.

Since random vibration is composed of many frequency components of randomly varied amplitude and phase, one cannot describe the vibration by stating the level of the sum of all these components, but must describe the contribution of each component in forming the total level.

Describing the random motion in terms of its components leads to a property of vibratory motion called "acceleration density," which gives a precise picture of random motion when plotted

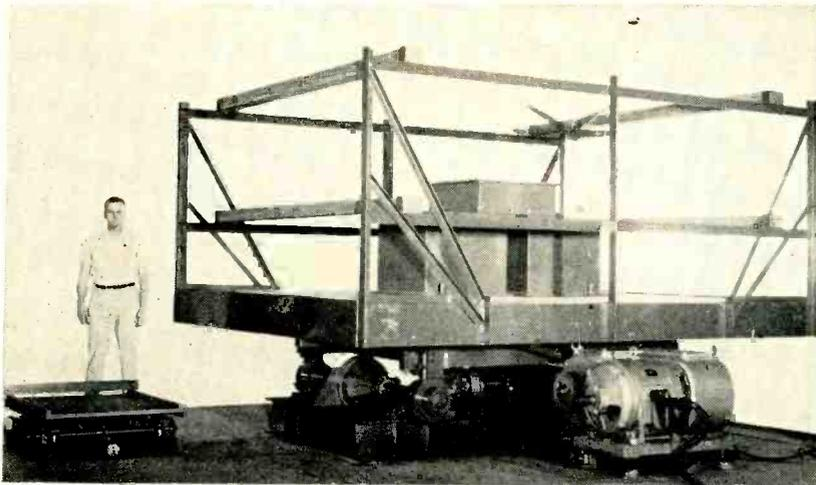

Large package tester (at right) by L.A.B. has 10,000-lb capacity, is used by missile manufacturer to test guidance components

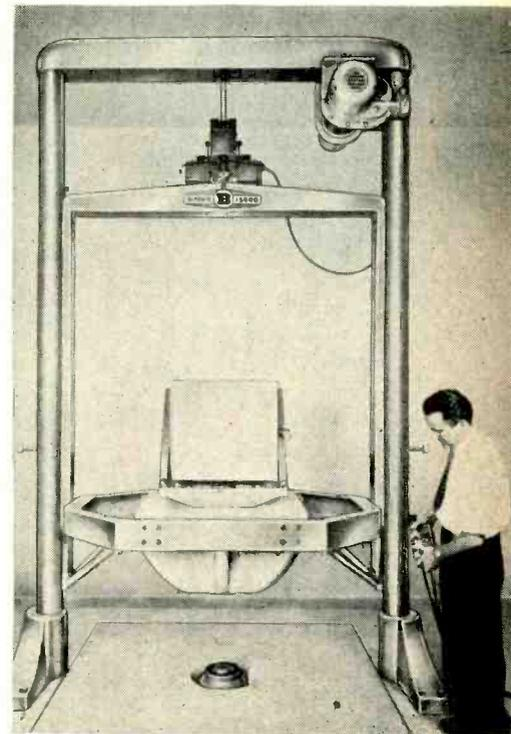

Shock tester by Barry generates repeatable shock pulses for testing missile and aircraft components

as a function of mechanical frequency.

A big shaker is the newest addition to North American Aviation's environmental laboratories. This shaker system weighs nine tons and can subject test equipment items for supersonic aircraft and guided missiles to 45 times the force of gravity.

Sylvania's white-noise vibration test equipment checks reliability of subminiature tubes used in guided missiles. The test presents a full range of frequencies over a broad spectrum at levels of 15 g peak.

SHOCK TESTING—A shock machine that provides increased accuracy and validity of simulating shocks in testing missile equipment has been developed by Barry. This shock tester provides control necessary to reproduce exactly the same waveform in repeated tests. It will generate with repeated uniformity the 100 g shock test defined by Ramo-Wooldridge missile specifications over a frequency range of 100 to 700 cps.

The HY 6000 shock tester, produced by Consolidated Electrodynamics, produces extremely high loads instantaneously at thrusts up to 40,000 pounds. Shock pulses are accurately controllable for both waveform and acceleration and deceleration levels. The machine consists essentially of a six-inch diameter cylinder containing a piston which is subjected to differential pressures on its two faces. Figure 2 shows the construction and principle of vibration pickup operation.

Typical shock testing machines for rapid and precise testing of small electronic components are manufactured by Jan Hardware and Massa Labs. Firms like Robinson Aviation make engineered mounting systems for missiles.

COMPLEX VIBRATIONS—Last September, an interesting principle of electronically controlled hydraulic power was presented. It took the form of a vibration excitation capable of providing unusual combinations of force, acceleration and frequency. The concept employed in the Hydrashaker originated with Northrop Aircraft and was developed by Wyle Manufacturing. With its moving assembly weighing only 16 pounds, it has a large force capacity.

Another manufacturer of vibration equipment and test instruments, Calidyne, makes shaker systems having up to 17,500 pounds force output.

PACKAGE TESTERS—A development in the use of vibration package testers for environmental testing of electronic equipment was brought about by U.S. Signal Corps during the early part of the Korean War. It was found that a man-carried vehicle-mounted equipment failed in the field, despite the fact that it had undergone thorough high-frequency sinusoidal vibration tests.

This led to the use of vibration package testers where the electronic equipment was placed on table and allowed to bounce freely when the machine was in operation, thus receiving a series of



Vibration testing at Sylvania approximates operational environment of subminiature electron tubes

shocks each time the test object struck the vibration table. By this method of testing, the shock impulses delivered to the test specimen excited various components to their natural resonant frequencies and field failures were reproduced in the laboratory.

L.A.B. Corp. manufactures vibration package testers that will simulate shocks produced by rough handling. These machines produce a basic sinusoidal waveform of displacement in both vertical and horizontal planes. Machines with load capacities up to 1,000 pounds can be supplied with frequency range of 35 to 60 cps, or 8 to 100 cps, capable of producing total peak-to-peak displacements of 0.125 in. for accelerations up to 20 g. Machines are also available with load capacities as great as 2,500 pounds, and with dead weight load capacities of 10,000 pounds. The larger machines will operate at frequencies up to 60 cps and are capable of developing a maximum acceleration of 10 g.

Ling Electronics manufactures a line of equipment for random noise and sine wave vibration testing. The master control console allows remote control of random noise and sine wave vibration testing. A block diagram of a typical electronic shaker is shown in Fig. 3.

VIBRATION CONTROL—Winkler Laboratories manufactures a stroboscopic synchronizer which makes possible the observation in slow motion of objects in vibration on high-frequency shake tables. The observed or visual frequency can be smoothly adjusted from zero to two cycles per second. Once adjusted, the visual frequency is independent of the vibration frequency. The vibration frequency may vary from 20 cps to 2,000 cps without requiring adjustment of the visual frequency.

A vibration test stand, developed and manufac-

tured by Vibration Specialty, is the result of study by the U. S. Navy and the Bureau of Standards. The stand is designed to produce a tridimensional vibratory motion of the testing rack or instrument support, the amplitude of vibration and the frequency of vibration being controlled.

Dynamic balances are becoming more important. Portable dynamic balancers for rotating parts in the speed range of 450 to 15,000 cpm are produced, for example, by International Research & Development Corp.

ACOUSTICAL VIBRATION—Vibration studies at Bell Aircraft have shown that high-intensity acoustic fields of approximately 140 to 160 db can cause electronic and structural failures that resemble those produced by vibration.

Acoustica Associates makes a whistle, used for simulation of jet engine noise, to test airborne structures and electromechanical assemblies. The acoustic power emitted is 1.2 kilowatts, which corresponds to sound levels well above 170 db in confined treatment chambers. Most of the energy is contained in a 2,430 cps audible fundamental frequency and in an inaudible harmonic whose frequency is 28,000 cps. The efficiency is 20 per cent.

The operating principle of this low-pressure air-operated stationary siren is based on the instability of a circular air jet impinging on a circular knife blade located between toroidal resonant cavities. The generated sound reaches into a treatment chamber through an annular exponential horn whose exit diameter is 47.5 inches.

Baldwin-Lima-Hamilton offers new multirange fatigue testers that provide both high-force and high-amplitude loading stations. These machines can test specimens under loads ranging from 50 lb to 120,000 lb. Through the use of multiplying fixtures, the capacities of each machine can be increased five times.

MEASUREMENT—Electro Products Labs manufactures two instruments of interest to the environmental testing field. A dynamic micrometer is used to measure displacements of either shake tables or parts under test on the shake tables. The firm's Sonometer is used to mechanically drive solid materials into resonance for determining Young's modulus of elasticity.

Genisco now manufactures a line of high powered amplifiers and shakers designed to meet the demands of vibration and fatigue testing. One accelerator is widely used for subjecting small missile and aircraft components to simulated operational accelerations in the medium-g range.

Epic manufacturers hand and universal vibrographs for recording vibrations. John Chatillon and Telectro Industries are active in the shock-testing field. And American Machine Tool and Manufacturing provides a line of fatigue testing machines. Product qualification testing firms, like Parameters, specialize in measurement.

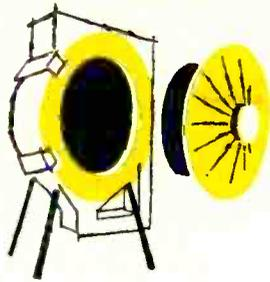

Environmental Test Chambers

Low-pressure chambers can simulate altitudes of several hundred miles. Ovens can achieve extreme temperatures caused by air friction of hypersonic aircraft and missiles. Other test chambers provide low temperatures, high humidity, corrosive, abrasive and even explosive atmospheres

THERMAL STRESS—Highly specialized environmental tests may require equipment that can simulate altitudes over 300 miles, and temperatures ranging from -350 to over $2,500$ F. Intense heating of aircraft and missiles at speeds above 5,000 miles per hour impose problems of structural design. To investigate and overcome these limitations, Westinghouse has developed a high-speed elevated-temperature structures-test facility.

The equipment consists of banks of tubular infrared lamps, electronically controlled to provide temperatures to $2,650$ F with ± 1 percent accuracy, strip-chart temperature recorders, regulator control and master-control desk. The equipment can create $2,500$ F in 12 sec. A block diagram of the elevated temperature structures test system is shown in Fig. 4.

At the research labs of National Carbon, an arc image furnace uses a carbon arc and mirrors to produce a small but extremely high-energy-level beam that can heat materials above $7,000$ F.

WALK-IN CHAMBERS—Dynamic accuracy-testing of bomber turret systems at a temperature of -50 C is now standard test procedure. One key to this accomplishment is a connecting chamber between a large environmental test chamber and a microwave free-space room.

At still another plant, environmental engineers can determine how well the complex radar and

computer equipment will work up to 90,000 feet, or over a 600-degree temperature range.

Martin has developed an airborne cooling system which will protect electronic equipment inside airplanes or missiles from the 800 F temperature of Mach 3 flight.

Figure 5 is a chart for estimating ram air temperature rise from Mach number, altitude and outside air temperature.

Information on future environmental temper-

Low-pressure chamber supplied by Tenney to Canadian Westinghouse can simulate altitude of 90,000 ft within 30 minutes



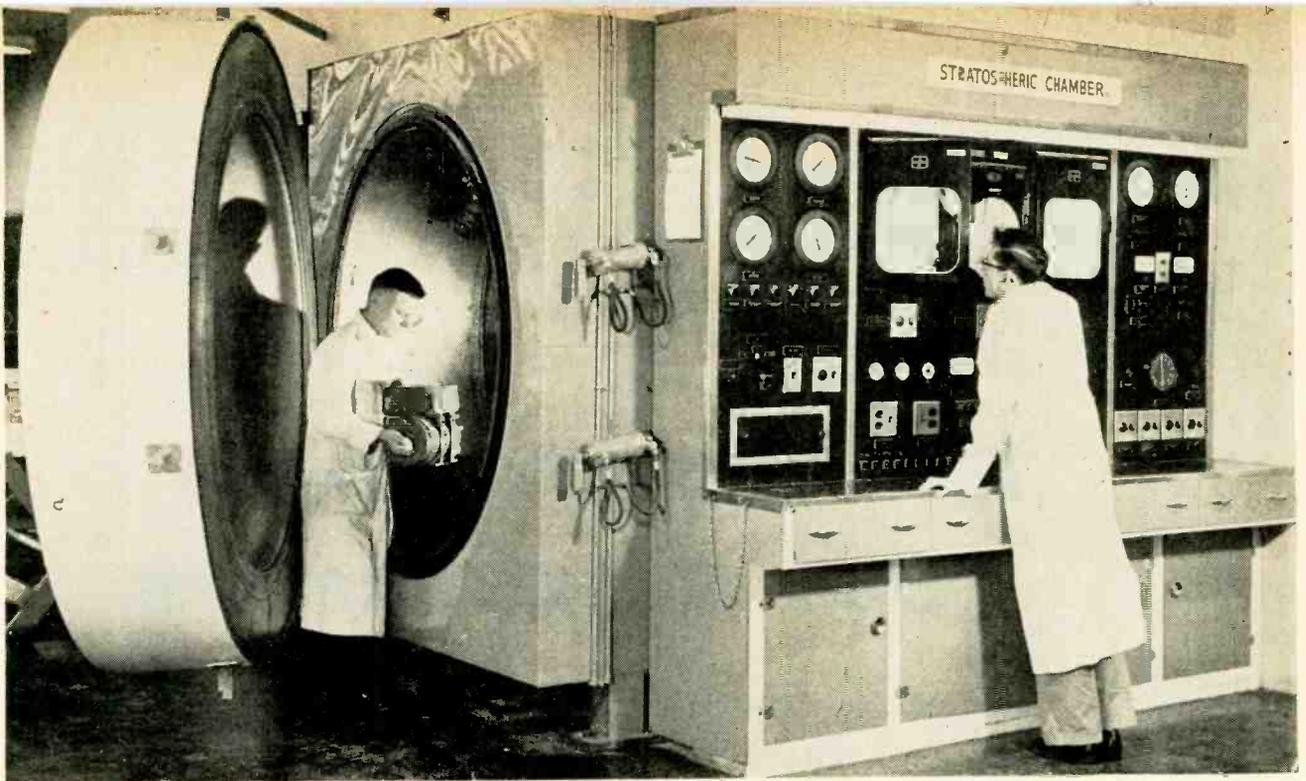

Chamber by Nuclodyne for Inland Labs simulates combined temperature, altitude and humidity

atures and weight penalties which can be tolerated for the next generation of aircraft has been analyzed in a general presentation.¹⁷ And Cornell Aeronautical Lab has completed studies on thermal evaluation of electronics.¹⁸

LOW-PRESSURE CHAMBERS—Altitude up to 100,000 ft and aerodynamic temperatures up to 830 F generated by Mach 3 speeds will be simulated in a new million-dollar electronics cooling test stand just completed for the F-106A Delta Dart at Convair.

The vacuum test chamber is a steel cylinder 12 ft in diameter and 70 ft long. The chamber will enclose a full scale fuselage to test how effectively the electronic and air-conditioning components in this all-weather jet interceptor perform under extremes of altitude and temperature.

A specialized cooling system for electronics, developed by AiResearch Mfg. Div. of Garrett, weighs 2 and a half lbs and measures 1 by 6 by 3 ins. Liquid or ram air may be used as cooling agent.

A large high-altitude climatic chamber for performing reliability tests of aircraft, missile systems and components was designed and constructed as part of the test facilities of the Tulsa Div. of Douglas Aircraft. The altitude chamber and its control console are located within the modification flight hangar. The chamber is over 22 ft in diameter (inside) and 17 ft high at its center point. It can be evacuated to the equivalent of 120,000 ft altitude rapidly enough to simulate high rates of climb. Temperatures within the chamber can be maintained anywhere in the range of -85 to 200 F. Chamber operation consists of simultaneous control of chamber, ram air and bleed air temperature and pressure.

COMBINED-ENVIRONMENT TESTING—Aireco has designed a chamber for GE that simulates dry bulb temperature between minus 100 degrees and plus 300 degrees F; relative humidity 20 to 95 percent; rain three inches per hour and altitude 0 to 100,000 feet. Each side of the chamber is provided with its individual refrigeration, heating facilities, humidification equipment and recording control system. Opening, closing and locking of all doors is accomplished by a 2,000-psi hydraulic system in conjunction with an electrical control system.

Guardite Division of American-Marietta, a producer of environmental test equipment, has built several hundred chambers for the military as well as industry. Recently a Guardite space cabin received attention when an airman spent a week in

Navy fighter-plane nose assembly with electronic gun-aiming system is rolled into 90,000-ft 600-deg F test chamber in Westinghouse plant

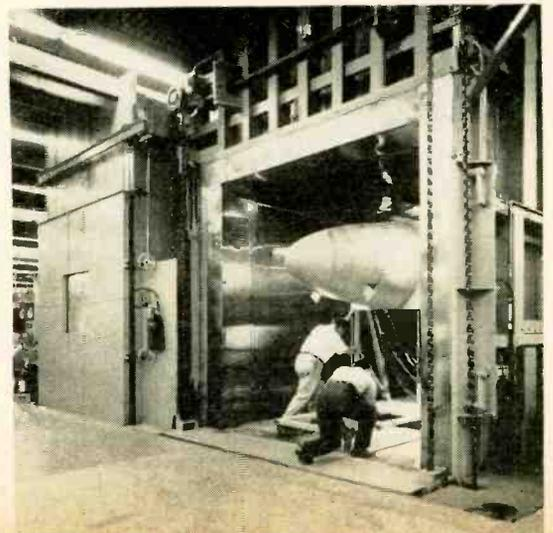

the chamber, simulating a trip around the moon.

Grieve-Hendry manufactures a line of high-temperature ovens pertinent to environmental testing where heat or elevated temperatures comprise the testing procedure.

Pacific Scientific's test furnaces are also used for production-line baking of resistors at Litton Industries. Missimiers produces ultra-low-temperature refrigeration equipment. Eastern Industries, John Wood, and Ellis & Watts Products manufacture cooling systems and heat exchange units.

LIFE-TEST OVENS—Dale Products load-life ovens provide constant temperature for 1,000 to 10,000-hour tests. The ovens are designed to test small components such as resistors, transistors, capacitors and diodes. The components are mounted on a removable drawer and electrical connections are brought through the front of the drawer. Temperature control of -1 C can be maintained for 1,000 hours after thermostats have stabilized. Temperature range is from 40 to 150 C.

Despatch Oven manufactures a useful line of forced convected ovens.

Trop-Arctic manufactures ultra-low-temperature equipment.

Environmental Equipment Corp. manufactures standard test chambers, test chambers engineered for special requirements and walk-in altitude-temperature-humidity rooms.

Modernlab manufactures constant temperature walk-in rooms controlled by dual safety thermostats. These rooms maintain constant temperature from 35 to 60 C. Sensitivity is 0.5 C at thermostat and 1 C or better between widely located points within the chamber.

Steiner-Ives high temperature test chambers are in the 1,000 to 1,200 F range. In addition to high-temperature test ovens, the company manufactures standard and special ovens.

The York installation of three cold rooms at the Signal Corps Lab at Fort Monmouth includes a three-stage system using two different refrigerants (Freon 13 on the first two stages

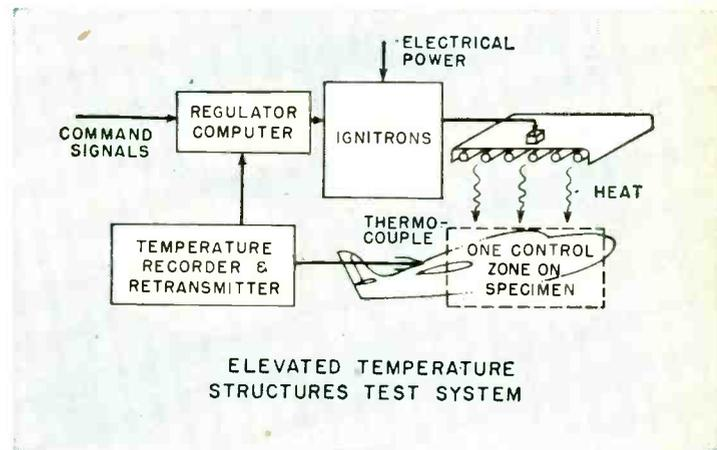

FIG. 4—Elevated temperature system for testing electronic systems actually installed in an airframe

and Freon 22 on the third) and employing six compressors to obtain a constant-operating temperature of from -100 to -120 F. Chilled brine is stored in an insulated tank 12 ft in diameter by 30 ft long.

Statham Development has an environmental test chamber with a control accuracy of $\frac{1}{2}$ percent over the range from -70 to 200 C.

Bluc M Electric manufactures humidity cabinets, ovens, furnaces and related controls.

Atlas Engineering designs and manufactures temperature, altitude and humidity chambers.

Mantec supplies environmental test equipment to many electronics and aircraft manufacturers.

INFRARED OVEN—Miskella and Fostoria manufactures infrared ovens, appliances, sectional units that have been purchased by electronic equipment manufacturers for setting up facilities for environmental testing. By using incandescent quartz-tube-unit lamps it is possible to secure temperatures approximating 1,800 F.

New England Oven & Furnace manufactures utility ovens for diversified sample testing.

NRC Equipment, supplier of high-vacuum

Small-component test oven by Dale Products provides still air and constant temperature for 10,000-hr tests



Temperature chamber by Conrad simulates temperatures from -120 to 500 F and altitudes to 300,000 ft

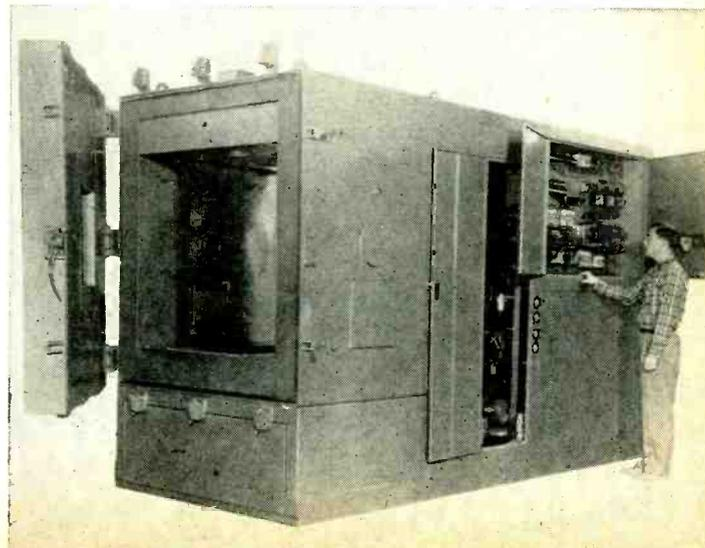

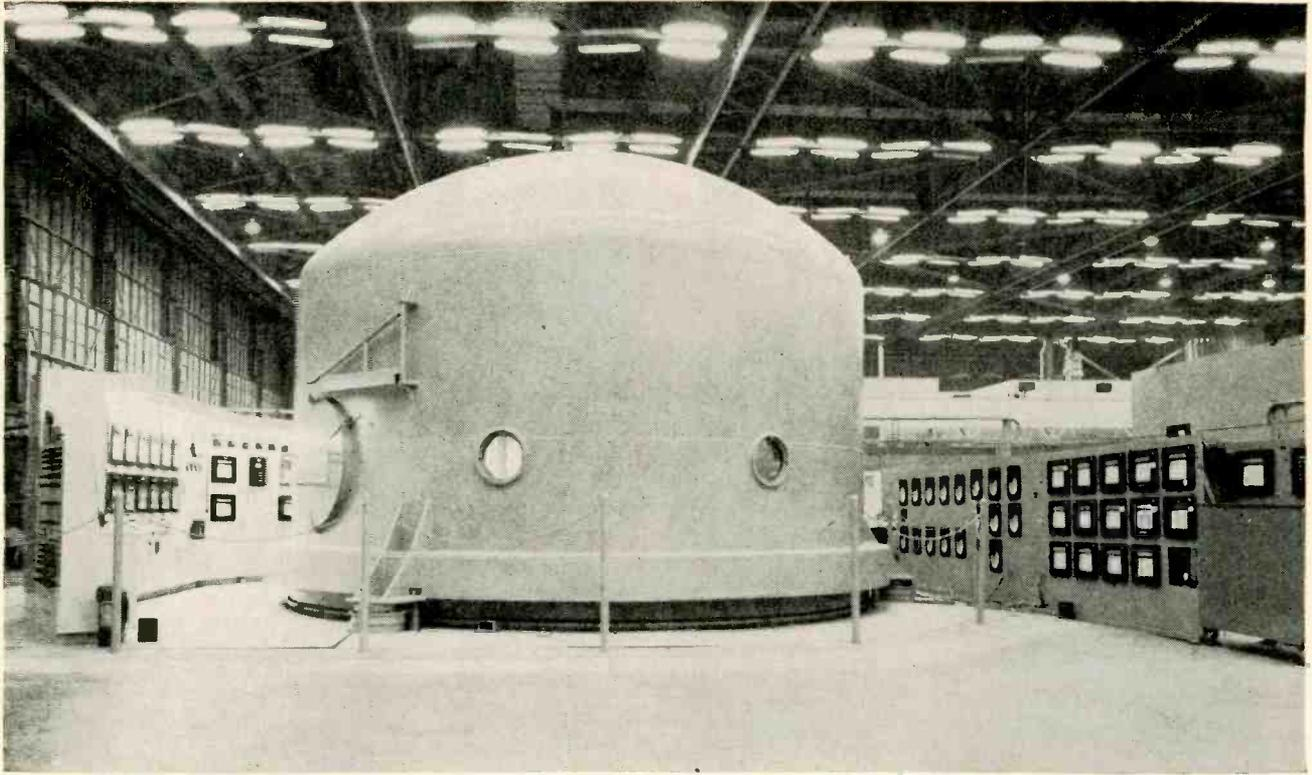

High-altitude chamber at Douglas Aircraft Tulsa Division can accommodate a typical full-scale aircraft component

components, equipment and systems, has been called on to furnish high-altitude chambers and pumping systems. Beach-Russ and International Pump and Machine Works are also active in the test field. The U.S. Air Force recently purchased nearly 200 special high vacuum pumps from

F. J. Stokes that will simulate high altitudes.

LOW-TEMPERATURE CHAMBERS—American Instrument manufactures a sub-zero test cabinet for temperatures from -120 to 200 F. Control of humidity and temperature is achieved by conditioning the air before it enters the test chamber.

American Gas Furnace has a furnace unit adaptable to high-temperature operation that employs a fuel mixture of air, oxygen and gas to achieve temperatures in excess of $3,000$ F.

One of Conrad's temperature altitude humidity chambers has a temperature range of -100 to 300 F, simulating altitudes from zero to $120,000$ feet, capable of 20 to 95 percent humidity.

OTHER TEST CHAMBERS—Atmosphere Controls and P.M. Lennard manufacture enclosures for humidity, dust and atmosphere control. Berneo Engineering, Century Engineers, Heatt, Summit Electronics and Whittington Pump and Engineering are also in the environmental test field.

Webber Corp., North American Instruments, Hicks and Hunter Bristol are manufacturers of temperature cabinets and atmospheric test equipment. And a recent trend shows that oven manufacturers who formerly specialized in pro-



Testing electronic components in forced-draft ovens by Fisher Scientific. Oven operates to 200 C with 1 C uniformity

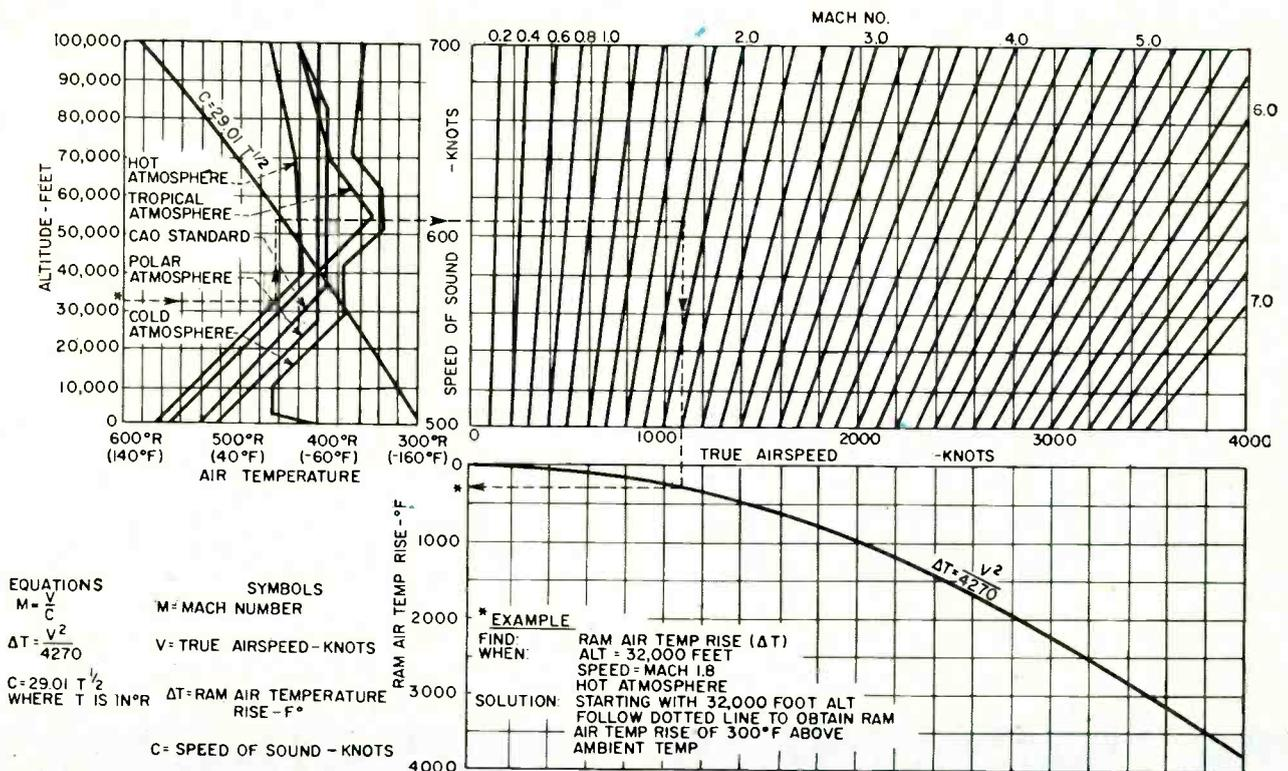

FIG. 5—Chart for estimating ram-air temperature rise from Mach number, altitude and outside air temperature

duction work are now becoming active in making cabinets for environmental testing.

CONCLUSION—In Greek mythology, there was the story of Daedalus who sought to escape imprisonment by King Minos.

"Minos may control the land and sea, but not the regions of the air", said Daedalus. And, being a skilled craftsman, he set to work to fashion wings for himself and his son Icarus.

When all was prepared for flight, Daedalus advised his son to keep at moderate height "for if you fly too low the damp will clog your wings, and if too high the heat will melt them".

The flight had a tragic ending—unreliability, 2,000 B. C.

REFERENCES

- (1) Test Methods for Electronic and Electrical Component Parts, MIL-STD-202, DOD, Wash., D.C., Jan., 1953
- (2) N. Sissenwine, A. Court, Climatic Extremes for Military Equipment, QOQMG, Wash., D.C., Nov., 1951
- (3) R. A. Minzner, W. S. Ripley, The ARDC Model Atmosphere, 1956, Geophysics Research Directorate, AF Cambridge Research Center, Bedford, Mass. Sept., 1956
- (4) Environmental Testing, Aeronautical and Associated Equipment, General Spec. for, MIL-E-5272, USAF, 5 June, 1957
- (5) Environmental Testing, Ground-Support Equipment,

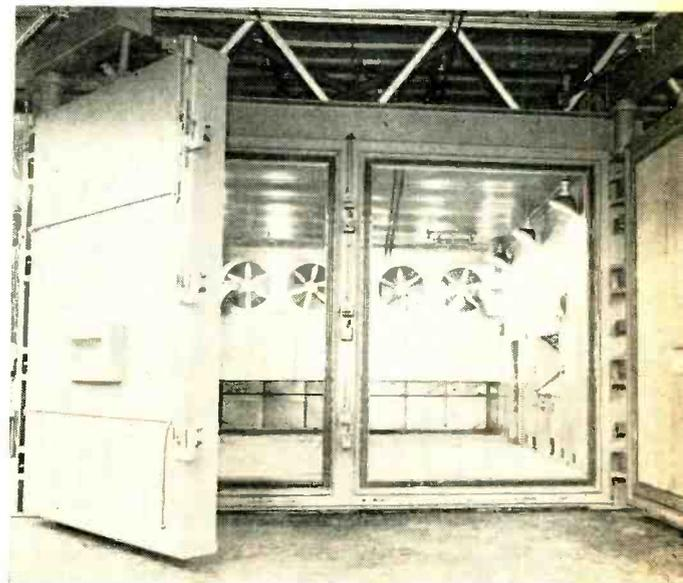

Removable-partition chamber designed by Aireco for GE has 2,000 psi hydraulic system to close and lock doors

- General Spec. for, MIL-E 4970, USAF, 1 June, 1955
- (6) Environmental Criteria Slide Rule, USAF Environmental Criteria Branch, Wright-Patterson AF Base, Ohio, June 1957
- (7) W. J. Carey, G. Kollin, Feasibility of Combined-Environment Testing, WADC Tech Report 56-546, Wright Patterson AF Base, Ohio, Sept. 1956

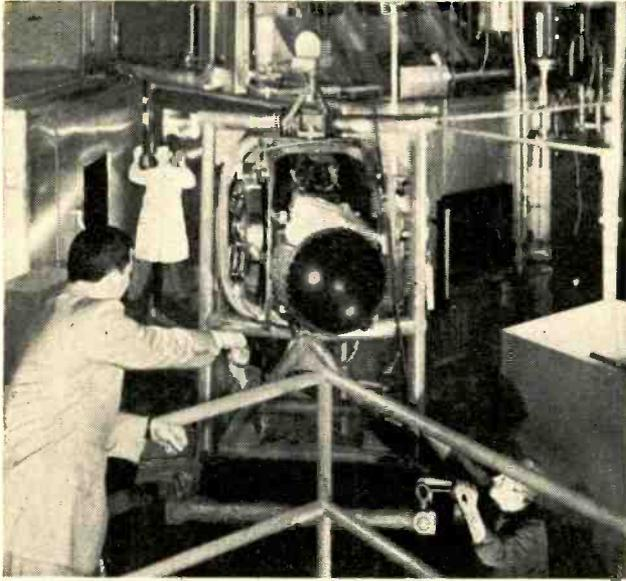

Television link fire control system for the B-52 is here lowered into environmental chamber designed at Arma, American Bosch

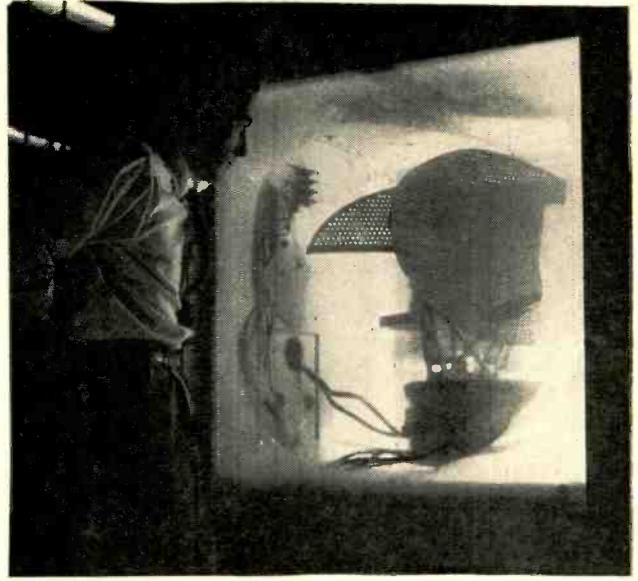

Sperry's APN 59 radar is subjected to exacting tests in an environmental chamber. These tests will qualify the system for reliable performance



Candy-striped bubble, radome of a Navy jet bomber's automatic armament system, is tested in a humidity chamber at Westinghouse



Explosion and altitude chamber at Rototest tests electronics to insure that the equipment will be safe when operating in an explosive atmosphere

- (8) Environmental Criteria for Guided Missiles Systems, USAF Spec. Bulletin No. 106, March 18, 1957
- (9) Environmental Criteria for Ground-Support Equipment, USAF Spec. Bulletin No. 115, July 6, 1955
- (10) Directory of American Council of Independent Labs., Inc., ACIL, Wash., D.C., 1956
- (11) Systematic and Scientific Development of a Handbook of Reliability Data for Electronic Parts, The HELPR Program, Inland Testing Laboratories, Morton Grove, Illinois, Sept., 1957
- (12) Environmental Test Data, General Papers presented at Science Section meeting of Environmental Equipment Institute, Princeton, N. J., Apr., 1956, and IEE 1957
- (13) Environmental Requirements Guide for Electronic Parts, Advisory Group on Electronic Parts, OASD, Wash.,

- D.C., PB 131423, Oct., 1957
- (14) Electronic Equipment, Naval Ship and Shore, General Spec for, MIL-E 16400A (Ships), March, 1955
- (15) C. E. Crede, M. Gertel, and R. D. Cavanaugh, Establishing Vibration and Shock Tests for Airborne Electronic Equipment, The Barry Corp., Report No. 230-B, Watertown, Mass., July, 1954
- (16) R. H. Jacobson, Vibration and Shock Evaluation of Airborne Electronic Component Parts and Equipment, WADC Tech Report 56-301, Dec., 1956
- (17) R. R. Janssen, How Badly are High Temperature Electronic Systems Really Needed? Society of Automotive Engineers, N.Y.C., Sept., 1957
- (18) Thermal Evaluation of Electronic Assemblies, HF-1053-D-7, Cornell Aero. Lab., Buffalo, N. Y.

Rapid Conversion of Hybrid Parameters

Chart and nomograph simplify conversion of grounded-base transistor parameters, which are usually used on manufacturers' specification sheets, to grounded-emitter form. In most cases, common-collector parameters are then either identical to common-emitter parameters or can be obtained from them by the simple process of subtraction

By **SOL SHERR** Section Head, General Precision Laboratory, Inc., Pleasantville, New York

CIRCUIT DESIGNERS frequently find transistor specifications contained in manufacturers' data sheets to be in only one set of parameter values, usually the common-base representation. To use the transistor in one of the other two representations, it is necessary to convert the parameters. This conversion is simplified by the accompanying chart and nomograph.

Relationships between common-base and common-emitter values are shown in the approximate expressions listed in Table I.¹ These equations assume $h_{12b} \ll 1$ and $h_{11b}, h_{22b} \ll 1$. These conditions exist in all acceptable transistors and the approximations do not generally result in errors greater than 1 percent.

The *e* subscript denotes common-emitter, the *b* subscript denotes common-base and the number subscripts denote four-terminal parameters.² Interchanging the *e* and *b* subscripts results in common-base parameters in terms of common-emitter parameters.

Another set of symbols employs only letter subscripts and is related to the number subscripts

(Continued on p 76)

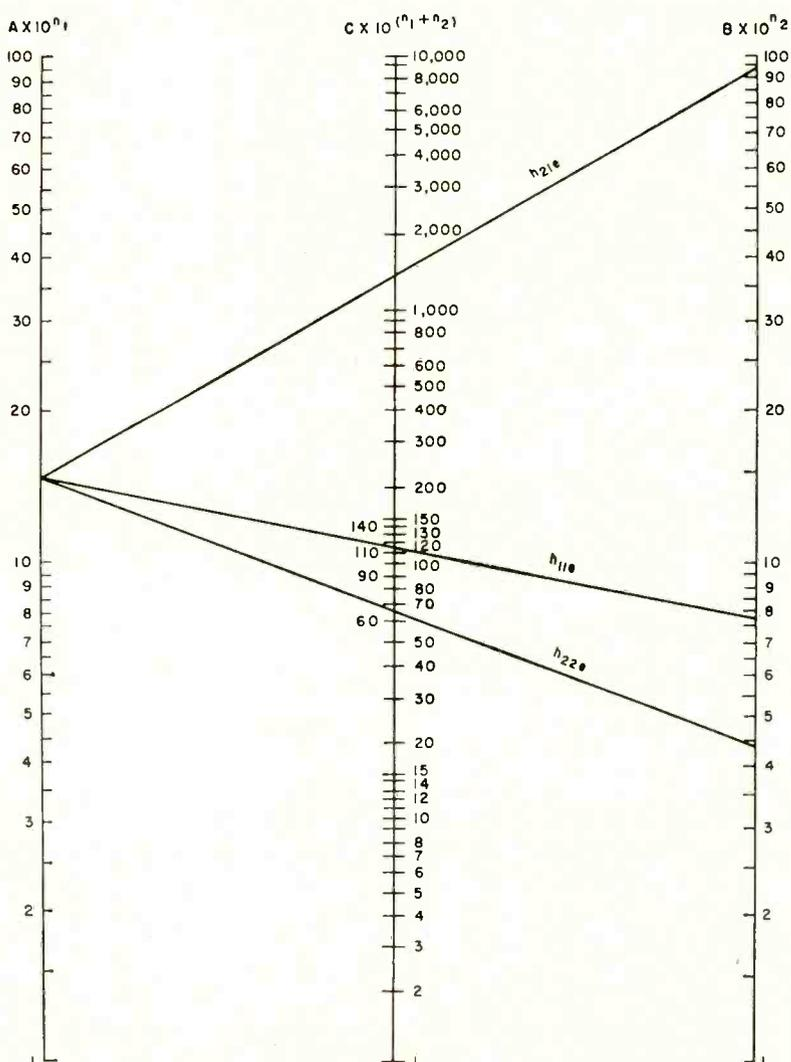

FIG. 1—Conversion nomograph constructed by reducing formulas to $Z=xy$

Diode Bridge Protects Meters

By RONALD L. IVES
Palo Alto, Calif.

COSTLY METER repairs can be eliminated in a wide variety of circuits with a small investment in components. The added circuitry has proved to be highly reliable and its cost is said to be less than that of one meter repair.

When low-voltage loads are supplied from high-voltage sources through a dropping resistor, a voltmeter across the load is likely to be damaged by an open load circuit. This situation is particularly annoying with photocell anemometers where the load is one amp.

In a few instances, the difficulty can be evaded by use of a series ammeter in place of the shunt voltmeter. The salient meter reading then becomes current through load instead of voltage across load. This expedient is also vulnerable, however. Meter damage can now occur when either line or load are short-circuited.

This recurrent difficulty can be eliminated inexpensively by use of a diode bridge circuit.

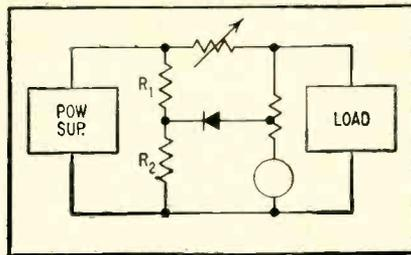

FIG. 1—Diode conducts to prevent excess voltage across voltmeter

In the circuit shown in Fig. 1, whenever the voltage at the tap on the meter multiplier resistance exceeds that at the junction of R_1 and R_2 , the diode conducts. The voltage at the tap, and hence that across the meter, never greatly exceeds that at the junction of R_1 and R_2 regardless of the voltage across the load.

To apply this method effectively, a voltmeter is selected whose full scale somewhat exceeds the voltage to be applied across the load. In many applications, the maximum voltage can be twice normal load voltage, so that the pointer is at center scale when everything is adjusted correctly.

Next, the meter multiplier resistance is tapped down a known distance, the exact value of which is not critical. The ratio of the untapped portion to the entire meter resistance can be anything from 0.25 to 0.75.

Bleeder resistors R_1 and R_2 are chosen so that the voltage at their junction is equal to that at the tap. However, the value of R_2 should be very much smaller than that of the tapped portion of the meter multiplier resistance. If the meter multiplier is evaluated in thousands of ohms per volt, the total bleeder value (R_1 and R_2) should be rated in hundreds of ohms per volt or less.

The anode of the diode is connected to the tap and the cathode to the bleeder junction. Whenever the voltage at the tap exceeds that at the junction, the diode conducts.

Low-Impedance Transistor Preamp

By W. F. JORDAN Teaneck, N. J.

AVERAGE low-signal general-purpose transistors in common-emitter circuits have input impedances of somewhere between 300 and 1,200 ohms. To get a voltage gain in between a microphone having 30 to 50 ohms impedance and a transistor amplifier, either matching transformers or cascading of two or more transistors is necessary. Bulk is the primary objection to these solutions.

Transistors are available, such as the CBS Hytron 2N256, that are designed for power output stages of automobile radios. The low impedance both in and out of this transistor makes it suitable for a low-impedance preamplifier.

The amplifier shown in Fig. 1 has a voltage gain of 26 db between a 50-ohm microphone and a 50-ohm input to an amplifier. It operates on very low current and with very little noise. Collector current is 5 ma with the bias, which is set by

Ultrasonics Gives Preorbit Check

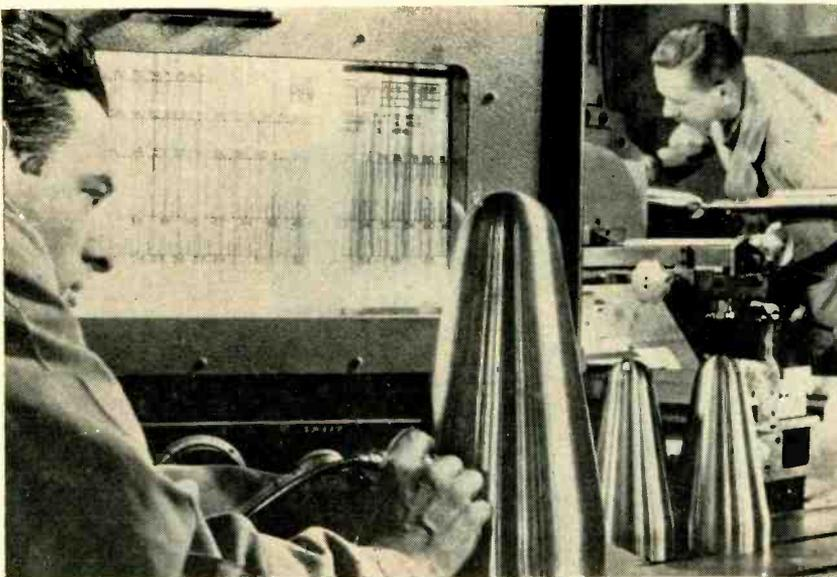

Explorer's stainless steel nose cones are checked with ultrasonic probe. Cone weighs 13 ounces and carries thermistors. Stripes of zirconium oxide average out temperature extremes as Explorer spins

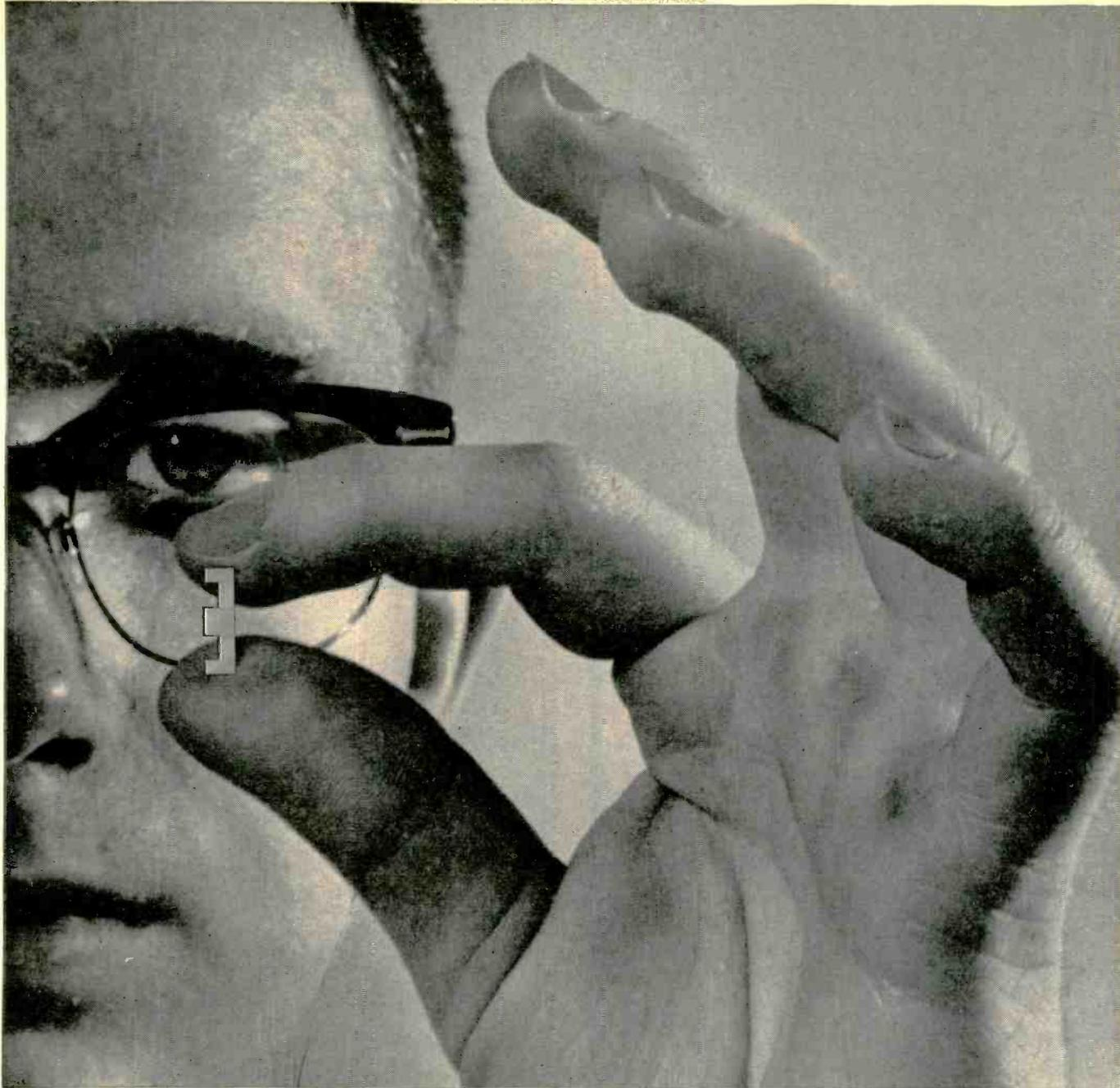

Here are laminations for miniaturization

If you are making transformers for transistorized or other miniaturized equipment, information about our ultra-small size "performance-guaranteed" laminations can be important news to you. These nickel-iron laminations are produced in standard gauges, and are available in Hy Mu 80, 48 Alloy and, if required, Orthonol.

Dry-hydrogen annealed by our exclusive process, these laminations provide all-important uniform quality. This annealing at a dewpoint of -60°C . brings our Performance-Guaranteed laminations to ultimate permeability from as little as 5% of that value in the unannealed state.

Like all laminations from Magnetics, Inc., the "miniatures" are packed in standard nine-inch boxes to facilitate handling in your plant, and are immediately available from stock. These features alone provide substantial savings.

Edges of these fine tolerance laminations are cut off squarely and cleanly to minimize air gap where mating parts are butted. Thus, high operating efficiency is insured.

There's no room here for the really detailed story, but for complete information on our "Performance-Guaranteed" magnetic laminations, send for our newest catalog—just published—ML-301. Write today. *Magnetics, Inc., Dept. E-41, Butler, Pennsylvania.*



DESIGNED TO MEET MIL-E-1

MILITARY TYPE

AUTOMATIC silicon rectifiers

JAN
TYPES

1N253

1N254

1N255

1N256



WRITE TODAY FOR
ENGINEERING
"SPEC" SHEETS
FOR ANY TYPE.

The reliability demanded by the rigid electrical, mechanical and environmental specifications of MIL-E-1 is now assured with Automatic's JAN TYPE silicon rectifiers . . . offered in production quantities at prices reflecting volume output.

Automatic offers, in addition to these JAN types, a complete line of Silicon Rectifiers for industry . . . including magnetic amplifiers, power supply, high voltage, germanium replacement and general purpose types.

TYPICAL VALUES FOR AUTOMATIC MILITARY TYPE SILICON RECTIFIERS

Type No.	Peak Reverse Voltage (VDC)	DC Output Current (MA) AV*	Maximum Reverse Current** (MA)	Mounting	MIL-E-1 Technical Spec. Sheet No.
1N253	100	1000	0.1	Stud-Mount	1024
1N254	200	400	0.1	Stud-Mount	989A
1N255	400	400	0.15	Stud-Mount	990A
1N256	600	200	0.25	Stud-Mount	991A

* CASE TEMPERATURE 135°C.

** AVERAGED OVER 1 CYCLE FOR INDUCTIVE OR RESISTIVE LOAD WITH RECTIFIER OPERATING AT FULL RATED CURRENT.

Available JAN TYPES: 1N253, 1N254, 1N255, 1N256

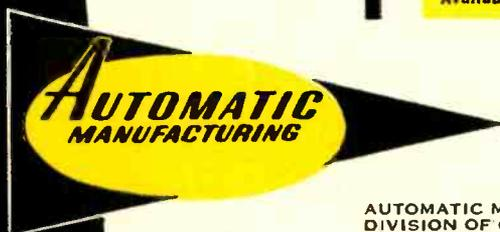

MASS PRODUCERS OF
ELECTRONIC COMPONENTS

AUTOMATIC MANUFACTURING
DIVISION OF GENERAL INSTRUMENT CORPORATION
65 GOUVERNEUR ST.
NEWARK 4, N. J.

R_1 . Hence a small mercury cell can be used.

Reducing the value of R_1 increases biasing voltage and gain but also increases collector current. The value was chosen mainly to keep current low, since maximum gain was not needed in the intended application.

The 2N256 transistor was designed to handle high currents. However, when operating at low current, temperature stability proved outstanding. Heating the casing to the point where it was too hot to touch resulted in no appreciable change in current gain. Neither was there any change in

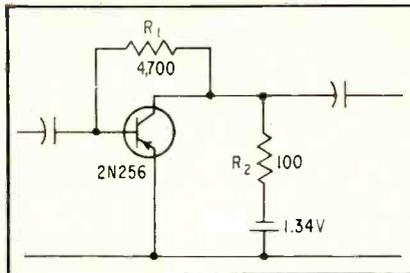

FIG. 1—Input and output impedances of 25-50 ohms make preamplifier suitable for use with low-impedance microphones

wave shape of the signal.

By direct comparison there was less noise than in a conventional vacuum-tube amplifier of the same gain.

Preamp Matches Input Impedance

AUTOMATIC impedance matching is accomplished in a transistorized preamplifier developed by I.D.E.A., Inc. The unusual features of the amplifier, which was designed for high-fidelity systems, may make it useful with other low-level sources.

The low-impedance input circuit shown in Fig. 1 is said to have practically constant voltage sensitivity over a range of impedances from less than 10 ohms to more than 10,000 ohms. One volt rms output is gotten from about 0.2

millivolts input.

The input is coupled directly to the base of Q_1 . Resistor R_1 is common to the input load and the negative feedback circuit comprised of R_2 and C_1 .

When input impedance is low, it has a shunting effect across R_1 . This decreases negative feedback and increases overall gain.

As input impedance increases, it has less shunting effect, permitting more negative feedback. Amplifier gain is therefore decreased.

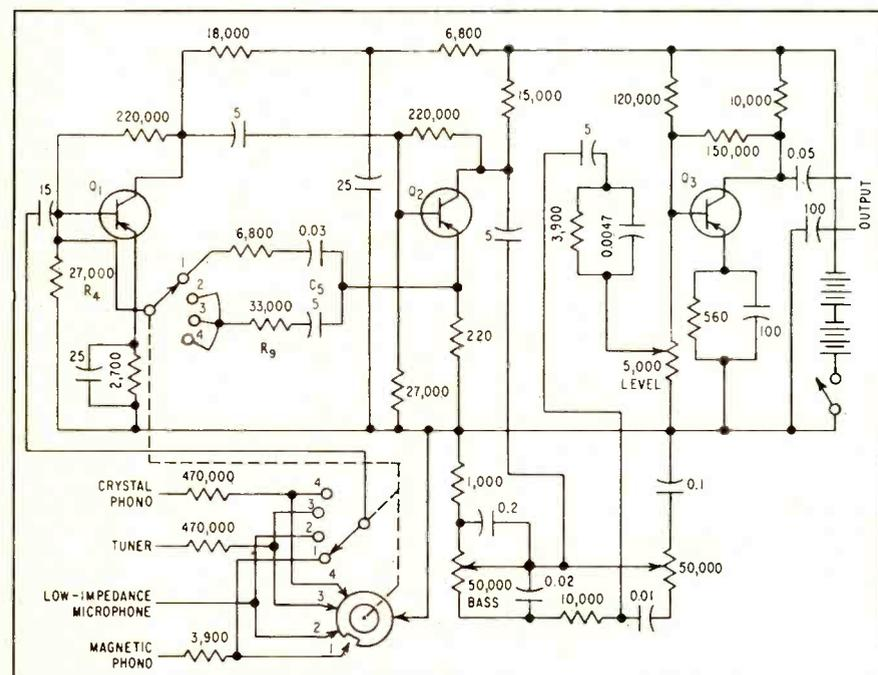

FIG. 1—Preamplifier uses controlled amounts of negative feedback to adapt to a range of low-level input impedances automatically

Transistor Temperature Controller

By H. SUTCLIFFE

Dept. of Electrical Engineering
University of Bristol
Bristol, England

A LOW-POWER transistorized thermostat takes advantage of reverse characteristics of *pn*p junctions to control temperature. Variation of junction conductance in reverse direction with change in temperature permits use of transistor as a temperature-sensing device. The thermostat described is more sensitive than a thermistor and provides continuous control. Additional features include quiet operation, remote resetting of temperature and small thermal time-constant. Principal disadvantage is high-impedance.

The change of reverse current in a germanium transistor junction is particularly spectacular. The type studied was an OC71 *pn*p fused-junction low-power audio transistor. The reverse characteristics of this transistor are similar to those of single junctions.

To promote rapid heat flow the emitter and collector leads should be common, as shown in Fig. 1A. The output voltage V is obtained by graphical construction on the I-V characteristic curve. In the equivalent dynamic circuit of Fig. 1B the parameters g and R_a are derived as follows:

$$\frac{dV}{d\theta} = -g \frac{R_a R_L}{R_a + R_L} \cong -5 \text{ volts per deg C}$$

Assuming V_n is 85 volts and R_L is 5 megohms the equivalent circuit shows that

where

$$g = \frac{\delta I}{\delta \theta} (\cong 1.5 \mu \text{ per deg C when } \theta = 40 \text{ C})$$

$$R_a = \frac{\delta V}{\delta I} (\cong 10 \text{ megohm when } \theta = 40 \text{ C})$$

The source impedance is several megohms, so before an amplifier is selected for use in conjunction with the device this loading requirement should be considered. One possible choice is a 2D21 tetrode thyratron whose control grid current before firing is a small fraction of a microamp. The thermostat described and shown in Fig. 2 uses a 6AM6

TOBE
CREATIVE
ENGINEERING

**THE NRG-200
SERIES OF
LOW-INDUCTANCE
THERMONUCLEAR
ENERGY-STORAGE
CAPACITORS**



NRG-200 SERIES SPECIFICATIONS				
Type No	Watt Secs	Rating		Self Inductance (Microhenries)
		Mfd.	DC Peak	
NRG-201	1000	5.0	20 KV	.04
NRG-202	1500	7.5	20 KV	.045
NRG-203	2000	10.0	20 KV	.055
NRG-204	3000	15.0	20 KV	.06

Tobe now announces the availability of a series of reliable, low-cost energy-storage capacitors for thermonuclear equipment and similar applications. The NRG-200 series capacitors have a minimum life expectancy of 1000 operations, and may be operated at ambient temperatures up to 40°C. Maximum permissible reversal voltage is 90%. They can be discharged into a very low-impedance load with complete safety.

For further technical information or engineering aid, write Tobe Deutschmann Corporation, Norwood, Mass.

Specify

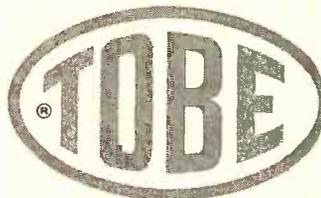

TOBE DEUTSCHMANN • CAPACITOR PIONEERS SINCE 1929

vacuum radio-frequency pentode as a d-c amplifier. Although this amplifier satisfied the loading requirement, care had to be taken in circuit design to avoid unwanted effects due to grid current.³

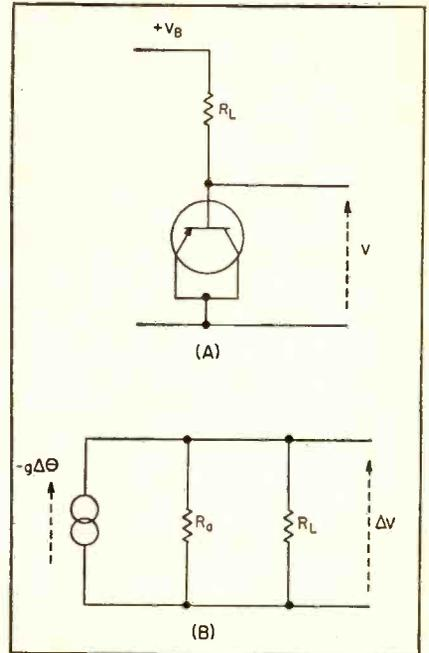

FIG. 1—Circuit for producing a temperature-dependent voltage. Basic circuit configuration to obtain voltage output (A) and equivalent circuit for small current changes (B)

The particular application considered was the continuous control of the cold-junction temperature of a thermocouple, using a 250-v d-c power supply. Ambient temperatures of the enclosure were expected to range from 5 to 30 C. Measurements on a d-c amplifier circuit using a small r-f pentode indicated that 100 to 600 mw of output power can be obtained for a grid-voltage swing of 1.5 volts, with negligible grid current. If the heat leakage from the enclosure is 15 mw per deg C (excess over ambient) and the temperature is to be stabilized at 40 C, then the heating power required can be expected to vary between 150 and 525 mw. If the control loop is stable the change of temperature of the enclosure, from the equation, should be less than 1.5/5 or 0.3 C for the full range of ambient temperature.

When the temperature is too low, which is the condition when the thermostat is placed in operation,

NEW MISSILE APPLICATIONS for HONEYCOMB STRUCTURES

TEST BENCHES

TRANSIT CASES

INERTIAL GUIDANCE

FIN CONTROL SYSTEMS

MICRO-WAVE DISCS

RADAR REFLECTORS

FIN COMPONENTS

GROUND EQUIPMENT

Catwalks Test Pallets
Portable Shelters

Honeycomb Structures* offer you the advantages of great economy in their weight-to-strength ratio, high rigidity and shock and fatigue resistance. Broad temperature range. We can furnish you with complete SUB-ASSEMBLIES ready for immediate installation.

Send prints for quotations, recommendations and samples.

RIGID APPROVED USAF QUALITY CONTROL STANDARDS MAINTAINED

SOURCE INSPECTION

*Available Combinations

Face

Magnesium
Stainless Steel
Aluminum
Fiberglas

Core

Aluminum
Fiberglas
Plastic Impregnated Papers



Write for this VALUABLE TECHNICAL DATA BOOK covering technical aspects of sandwich design construction.

THE ALBANO COMPANY, INC.

HONEYCOMB STRUCTURES DIVISION

549-555 West 54th Street, New York 19, N. Y.

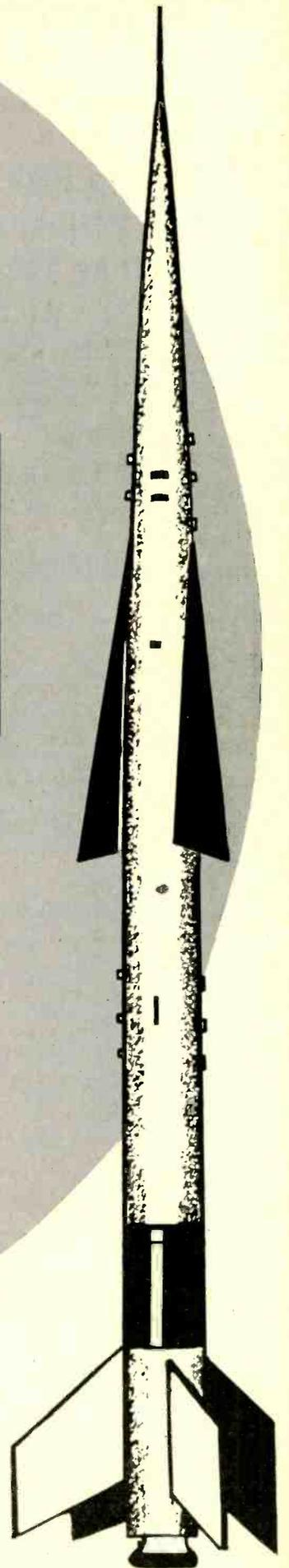



The Ultra High Frequency Performance of Receiving Tubes

JUST PUBLISHED! Here is a detailed and easy-to-understand theoretical account of the behavior of radio receiving tubes at ultra high frequencies. It supplies a thorough explanation of the interaction between tube and circuit and a practical appreciation of the advantages and limitations of space-charge control tubes. In line with the increasing use of vhf and uhf bands, the treatment is aimed solely toward the uhf properties of ordinary tubes (chiefly triodes) which show promise of outstanding performances as low noise amplifiers, oscillators, and mixers. By W. E. Benham, Consultant at Microwave Tubes, Standard Telephones, Ltd.; and I. A. Harris, Consultant in Electrical and Electronic Engineering. 173 pages, 5 1/2 x 8 1/2, illustrated, \$6.50

Process Instruments and Controls Handbook

JUST PUBLISHED! A thorough treatment of the operating and design fundamentals of measurement and automatic control systems used in the process fields. Serves as a ready review of the principles of many different types of measurement and control processes; a guide to the selection of instruments or automatic controls for specific jobs; and a compilation of formulas, constants, and critical and other engineering data for solving problems. Covers measurement systems, indicators and recorders, automatic controllers, electric and pneumatic telemetering, final control elements, process control, mathematical techniques, etc. Prepared by a Staff of Specialists; Edited by Douglas M. Considine, Staff Consultant, P. R. Mallory and Co. 1286 pages, 6 x 9, illustrated, \$19.50.

Control Engineering Manual

JUST PUBLISHED! Gives a logical, step-by-step approach to the practice of control systems engineering in modern industry. Covers specification of control systems, synthesis of control systems, evaluating control systems, generating control functions, design techniques, analog computers, nonlinearity in control systems—everything from the basic fundamentals to putting control systems into actual practice! Discusses a variety of typical processes and helps you analyze tentative control system configurations by means of mathematical, trial and error, computer, and graphical techniques. Gives you exact procedures, backed up by many practical examples, to evaluate your designed systems by actual tests. By the Staff of Control Engineering; Edited by Byron K. Ledgerwood, Managing Editor. 200 pages, 8 1/2 x 11, illustrated, \$7.50.

SEE THESE BOOKS 10 DAYS FREE

McGraw-Hill Book Co., Dept. EL-3
327 W. 41st St., New York 36, N. Y.

Send me book(s) checked below for 10 days' examination on approval. In 10 days I will remit for book(s) I keep, plus few cents for delivery costs, and return unwanted book(s) postpaid. (We pay delivery costs if you remit with this coupon—same return privilege.)

Benham—Ultra High Freq. Performance of Rec. Tubes, \$6.50

Considine—Process Instr. & Controls Hdbk., \$19.50

Ledgerwood—Control Engineering Manual, \$7.50

(PRINT)
Name

Address

City..... Zone..... State.....

Company

Position

For price and terms outside U. S. write McGraw-Hill Int'l., N. Y. EL-3

CIRCLE 73 READERS SERVICE CARD

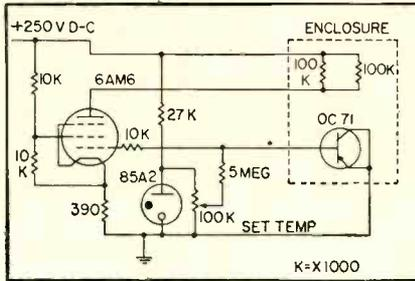

FIG. 2—Circuit of transistorized thermostat. Sensitive temperature controller provides stable and quiet operation

the control voltage V rises until it is limited by grid current. The amplifier bottoms and about one watt is applied to the two 100K heating resistors in the enclosures. When the temperature is too high, the amplifier is cut off. In the region of correct temperature, proportional control of heating power exists.

The stability of the control loop is dependent on a number of thermal time-constants which are not easily calculable. A safe principle to follow in feedback circuits is to incorporate a relatively large time-constant and to keep the remaining time lags as small as possible. This principle was applied by mounting the enclosure components in a solid aluminum cylindrical block 1 in. in diameter and 3/8 in. long. The two 100,000-ohm heating resistors, 1/2 watt carbon type with insulating sleeves, were wedged in holes drilled longitudinally in the cylinder. The transistor was mounted in a similar manner mid-way between the resistors. Its collector and emitter leads were kept as short as possible and soldered to a lug screwed to the cylinder. The cylinder was fixed at the center of a 3 x 3 in. cylindrical can, supported by cork and surrounded by loosely-packed cotton wool. The thermojunction was wedged in a small hole drilled in the block. The four leads to the resistors and transistor were 0.01 in.-diameter resistance wire, used to restrict the loss of heat by conduction.

REFERENCES

- (1) J. Tellerman, Measuring Transistor Temperature Rise, *ELECTRONICS*, p 185, April, 1954.
- (2) W. Shockley, Transistor Electronics . . . *Proc IRE*, p. 1289, Nov., 1952.
- (3) G. E. Valley, and H. Wallman, "Vacuum Tube Amplifiers", p. 418, McGraw-Hill Co., New York, N. Y.



he's working
for you

THIS FELLOW IS TRAINED IN YOUR BUSINESS. His main duty is to travel the country — and world — penetrating the plants, laboratories and management councils . . . reporting back to you every significant innovation in technology, selling tactics, management strategy. He functions as your all-seeing, all-hearing, all-reporting business communications system.

THE MAN WE MEAN IS A COMPOSITE of the editorial staff of this magazine. For, obviously, no one individual could ever accomplish such a vast business news job. It's the result of many qualified men of diversified and specialized talents.

AND, THERE'S ANOTHER SIDE TO THIS "COMPOSITE MAN," another complete news service which complements the editorial section of this magazine — the advertising pages. It's been said that in a business publication the editorial pages tell "how they do it" — "they" being all the industry's front line of innovators and improvers—and the advertising pages tell "with what." Each issue unfolds an industrial exposition before you — giving a ready panorama of up-to-date tools, materials, equipment.

SUCH A "MAN" IS ON YOUR PAYROLL. Be sure to "listen" regularly and carefully to the practical business information he gathers.



McGraw-Hill PUBLICATIONS

IT'S A MUST!

If you sell to the \$7 billion electronics industry, you'll want a *free* copy of *electronics* MARKET MEDIA FILE.

What are the prospects for:
 MILITARY ELECTRONICS?
 REPLACEMENT ELECTRONICS?
 HOME ELECTRONICS?
 INDUSTRIAL ELECTRONICS?

Who are the BUYING INFLUENCES?

Why are more than 9,000 men who make the buying decisions for 30 giant companies subscribers to *electronics*? . . . and what does that mean to your advertising dollar?

The 1958 *electronics* MARKET MEDIA FILE gives the answers in 12 fact-packed pages that you will refer to time and again throughout the year.

Send for your *free* copy today.

ABC electronics ABP
 A MCGRAW-HILL PUBLICATION
 330 W. 42nd St., New York 36, N. Y.

Now...

DIALCO Pilot Lights

with **Built-in Resistor** (18,000 ohms)
 (a patented DIALCO feature)

and the **NEW High Brightness Neon Glow Lamp NE-51H**



A New Advance in Pilot Light Design by DIALCO:

Three basic advantages are incorporated in this series of DIALCO assemblies: (1) *Built-in resistor* for direct use on 125 to 250 volt circuits . . . (2) *New plastic lens* designed to give attractive "halo" effect . . . (3) *New High Brightness Neon Glow Lamp NE-51H*. This lamp may be operated at about 3

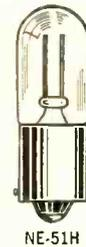

Catalog No. 132-408-991H

times the level of current that may be applied to the standard lamp, and it will produce 8 times as much light—with long life! Very low power is required, less than 1 watt on 250 volt circuit. Recommended for AC service only.

In the DIALCO assembly, the built-in current limiting (ballast) resistor (18,000 ohms) is *completely insulated in moulded bakelite* and sealed in metal (U. S. Patent No. 2,421,321) . . . Small space required—units are available for mounting in 9/16" or 11/16" clearance holes . . . A wide choice of optional features includes lens styles, shapes, and colors; terminal types; metal finishes, etc. . . . Meet applicable MIL Spec and UL and CSA requirements.

**All Assemblies Are Available Complete with Lamp
 SAMPLES ON REQUEST—AT ONCE—NO CHARGE**

DIALIGHT CORP., 58 Stewart Ave., Brooklyn 37, N. Y.

Send brochures on Pilot Lights for NE-51H Neon lamp Sub-Miniatures Oil-Tight

Name Position

Company

Address



58 STEWART AVE., BROOKLYN 37, N. Y. • HYacinth 7-7600

Solid-State Light Practical for Digital Display

ELECTROLUMINESCENCE — the solid state method of producing light—is being used by Westinghouse for a digital indicator. A series of phosphor-coated electroluminescent strips on a flat screen, which glow when electrically energized, form the digital display. Seven strips on a plate will make any number from zero through nine and 21 strips switched in and out of the circuit display any number from 0 to 999. With a different design, a screen of 14 strips can display any letter from A to Z plus the numerals from 0 through 9.

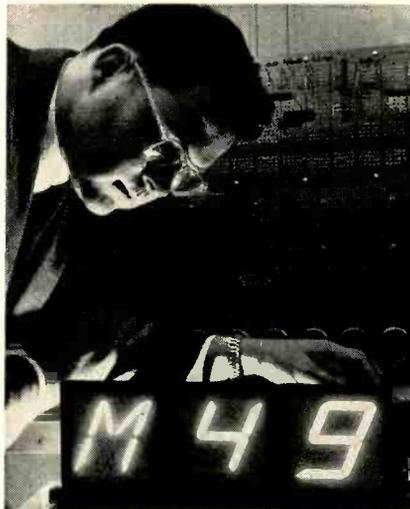

Light produced by exciting a phosphor with an electromagnetic field (electroluminescence) is bright enough in broad daylight to be used for digital display

Rugged, Low-Power Light

The numbers, which can be any desired size, are shown on thin panels no thicker than a sheet of ordinary glass. They are simple, rugged, low in power consumption and can be made in a wide variety of colors to identify different kinds of data.

Switching of electroluminescent strips to form the desired numbers can be done in several ways. Regardless of which method is used, information in the form of electrical signals is received by the switching mechanism, interpreted,

and fed to the correct strips to display the information as numbers on the screen.

Viewing From A Distance

A promising advantage of electroluminescent digital indicators is that manufacturing plates of enormous size does not develop extremely difficult problems. Since the numbers are displayed on a

single plane and can be viewed through a wide viewing angle without distortion, long distant display could easily become one of its most useful applications.

Low-power requirements of the display are easily met with miniature power supplies and the good screen detail permits display of numerals only a fraction of an inch high, if desired. The possibility of varying the color of the numbers gives an additional degree of freedom in interpreting the information displayed.

Tube Tells Time

A SIMPLE operating time indicator gives promise of replacing elaborate field tests and costly mechanical timers for obtaining reliability data. Lifetime of electronic components can be predicted with the indicator, and components or modules changed before failure.

"The tube that tells time," Raytheon calls its subminiature electrochemical device. It consists of a small glass cell containing an anode and cathode made of an electrochemically inert material. Platinum is used by Raytheon at the present time.

Passage of a constant direct current through the electrolytic cell plates out the metal ions onto the cathode. Concentration of metal ions remaining in solution is inversely proportional to the time current has been on.

Copper sulphate is the basic element in the electrolyte. Its color is directly proportional to the number of ions in solution and changes with the length of time a small constant d-c current is passed through the tube. Color change is measured with a colorimeter calibrated to read operating time directly.

The small glass cell is wired to the plate supply of the electronic equipment in series with a resistor which is specified for the voltage rating of the power supply.

To further simplify the measurement, Raytheon is investigating possible use of a color chart for direct comparison with the color

Breakdown Characteristics

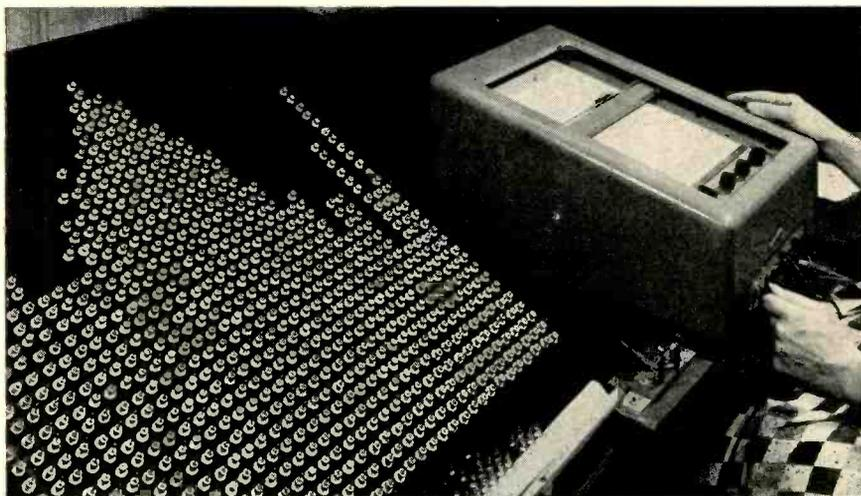

Reverse breakdown characteristics are automatically plotted for all zener diodes produced by International Rectifier Corp., El Segundo, Calif. and shipped with the diode. The graph eliminates in-plant expedient testing and supplies ready reference data on the exact breakdown point. Matching of diode characteristics is also simplified since graphs of the diodes available can be easily compared

DoALL MICROTOM-ATIC*

Slices your brittle materials

Where used?

In manufacture of electronic parts at:
 Bendix Aviation Corporation
 Convair
 Delco-Remy Division, General Motors Corp.
 Fairchild Semiconductor
 General Electric Company
 General Transistor Corp.
 Hughes Aircraft Company
 I.B.M. Corp.
 Linde Products
 Minneapolis-Honeywell Regulator Co.
 Pacific Semiconductor
 Philco Corporation
 R.C.A.
 Sylvania Electric Products, Inc.
 Westinghouse Electric Corp.

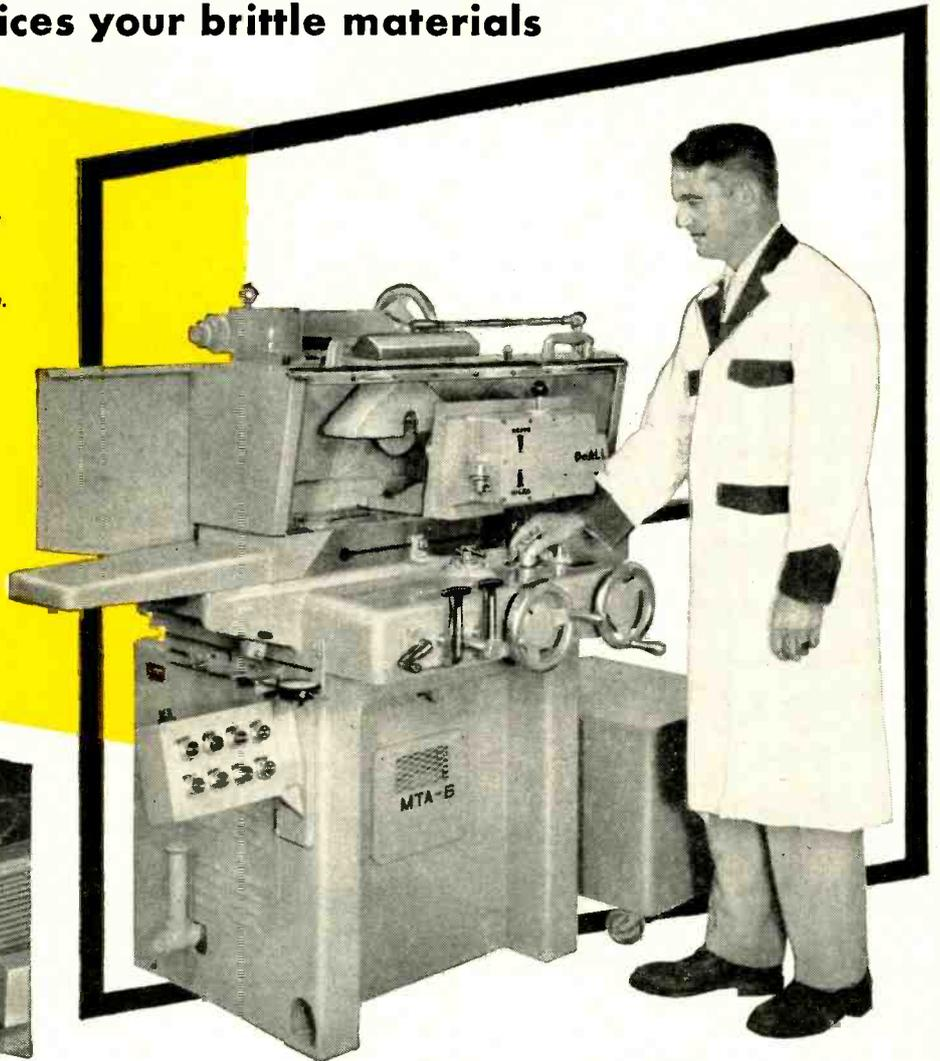

*Taken from the word *microtome*, defined by Webster as "An instrument for cutting very thin sections."

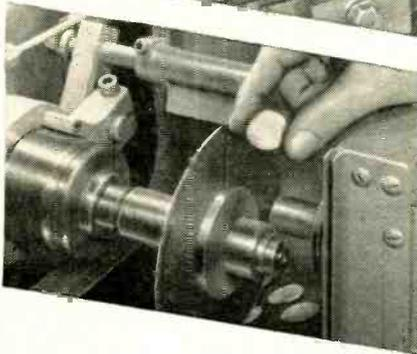
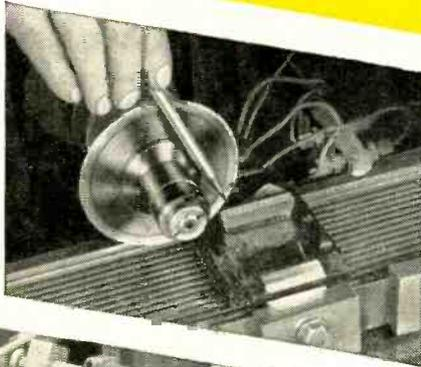

The quickest and most reliable answer to your precision slicing, dicing or parting operations is DoALL's Microtom-atic. It machines brittle, shock-sensitive materials to $\pm .0005$ " repeat index, providing uniform wafer thickness with excellent parallelism and micro-inch finish.

DoALL MICROTOM-ATICS are available with work areas ranging from $6\frac{1}{2}$ " x 19" to 10" x 30", table travel from 20" to 32", wheel sizes from 3" to 14". Various spindle speeds are available for different wheel sizes.

So whatever material you're working with—germanium, silicon, quartz or ferrites; ceramics, tungsten carbide or hardened steel—the DoALL Microtom-atic will part it automatically faster, more accurately and more economically than any other method known.

This versatile machine is also ideal for precision stock removal. See the new DoALL Microtom-atic demonstrated on your own samples at the DoALL Technical Institute, Des Plaines, Illinois—or send in samples and requirements for complete report. Call your local DoALL Store, or write today for information and new literature.

Ask About Our Lease Plan

DoALL originated the leasing of machine tools. Its successful operation for many years can mean immediate savings to you. All DoALL machine tools can be leased at low rental with purchase option.



This is a Typical DoALL Store

THE DoALL COMPANY, Des Plaines, Illinois

GR-23

of the electrolyte. A chart may be satisfactory in some commercial applications if extreme accuracy is not needed.

Accuracy of plus-minus 5 percent is claimed from 250 to well over 5000 hours.

For best accuracy, a well regulated d-c supply and precision resistors are needed. The better the control of the current drain, the better the accuracy. An Air Force official has said "If the tube lives up to the performance claims, it could become a required spec on all airborne equipment."

Commercial applications include all types of life-span tests especially when the equipment is guaranteed. In connection with warranties on high-cost components, such as color TV tubes, magnetrons and klystrons, the indicator could be used to certify hours of operating time.

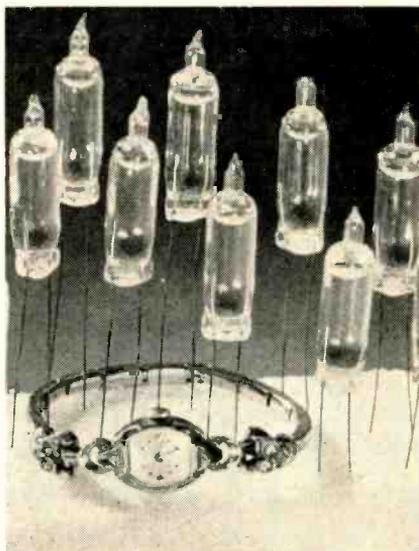

Current-flow through the Time-Tube forces metal ions out of a copper-sulphate electrolyte, changing its color. Equipment operating time from 250 to 5000 hours is determined from the color of the copper-sulphate electrolyte to an accuracy of ± 5 percent

Heaterless Tubes Become Smaller

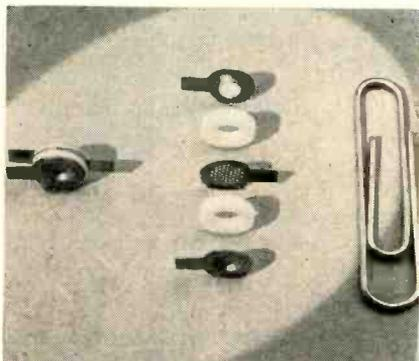

High temperature metal-ceramic triode uses titanium for the grid and plate separated by ceramic insulators which are free of contaminants harmful to cathode emission

IMPROVEMENTS in the ceramics for tubes have enabled General Electric to reduce the size of a metal-ceramic triode to not much larger than a shirt button. Frequency range of the tube is from d-c up to a tested value of 1200 mc at 700 C. It is believed that the upper frequency limit is far beyond this, but this is the extent to which they have been tested at this time.

The tube's most outstanding feature—the ability to operate at extremely high temperatures—is also one of the characteristics respon-

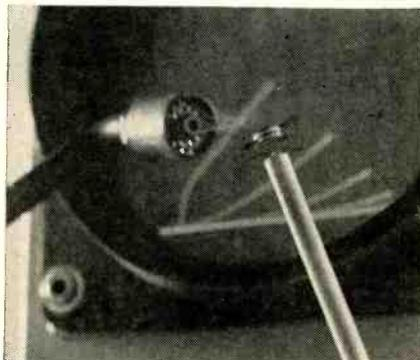

Red-Hot Tube: Miniature metal-ceramic tube operating under 600 C blowtorch flame. Oscilloscope pattern for tube plate current characteristics can be seen in background

sible for its very small size. At high temperatures ambient heat alone is sufficient to cause electron emission from the cathode. Heaters, therefore, are not required and an overall size of $\frac{1}{4}$ inch diameter and $\frac{1}{8}$ inch thickness was possible in the new model.

This new tube, like its larger forerunners which G.E. announced in September 1956, is not yet a production item. No definite information is available on production but it seems probable that the tubes will be available in about a year.



KEY ENGINEERING OPENINGS AT VOUGHT

ADVANCED WEAPONS ENGINEERING

This Vought division is planning, analyzing and proposing new concepts in missile and fighter weapon systems. Here, tactical requirements are established for new weapons, feasibility studies conducted, and proposals prepared.

Select openings exist in both the Advanced Missile Technical Group and the Advanced Aircraft Technical Group. These are responsible positions for engineering specialists and for design engineers up through lead level. Following are requirements for 4 openings which are typical of others in these groups:

Radar System Engineer or Specialist. Aeronautical or Electrical Engineer (M.S. preferred) with at least 7 years experience in systems and/or design for radar and fire control. To make high-level studies of advanced guidance and control systems.

Advanced Weapons Staff Engineer. Ph.D. preferred, with at least 10 years background in guidance or navigation and control systems. To develop completely new concepts in guidance, navigation, or control systems.

Electro-mechanical Systems Engineer or Specialist. Aeronautical, Electrical or Mechanical Engineer (advanced degree preferred) with at least 7 years experience in autopilot, flight control, stability systems and inertial guidance systems and design work. To make high-level technical studies of various control and stabilization systems for advanced weapons.

Advanced Weapons Engineer. Aeronautical, Electrical, or Mechanical Engineer (M.S. desirable) able to develop methods for dynamic stability and stabilization studies. To join in, or direct, studies in stabilization, dynamic stability, missile and airframe configurations, and to make flight path and trajectory analyses. All in supersonic and hypersonic range.

To arrange for a personal interview, or for a prompt report on these or other current openings, return coupon to:

C. A. Besio
Supervisor, Engineering Personnel
CHANCE VOUGHT AIRCRAFT, Dept. R-2
Dallas, Texas

I am a _____ Engineer,
interested in the opening for _____.
Name _____
Address _____
City _____ State _____

read'i.ness: *when a fighter as new as tomorrow is in service with the Fleet today*

There's a bright, new glint to our Fleet today.

Chance Vought's 1,000-plus-mph *Crusader* has arrived — in strength! This potent fighter was designed a champion — in speed, ceiling and firepower. It was engineered, too, for swift production and for smooth introduction to pilots.

This sped the *Crusader* to duty faster than any modern jet. It brought to the Fleet in an age of peril a *weapon that will hold its edge*.

With the *Crusader* comes a new realm of four-figure speeds. Already, Navy and Marine pilots have used its performance to smash major world's records. Their unprecedented supersonic and carrier-to-carrier cross-

ings of the U. S. signal a new chapter in manned aircraft speed and mobility.

Today, squadrons of *Crusaders* sweep the skies above the seas. Their trophy-winning performance adds unmatched combat strength to America's power for peace.

Scientists and engineers: pioneer with Vought in new missile, manned aircraft, and electronics programs. For details on select openings write to: C. A. Besio, Supervisor, Engineering Personnel, Dept. R-2.

CHANCE **VOUGHT AIRCRAFT**
INCORPORATED · DALLAS, TEXAS

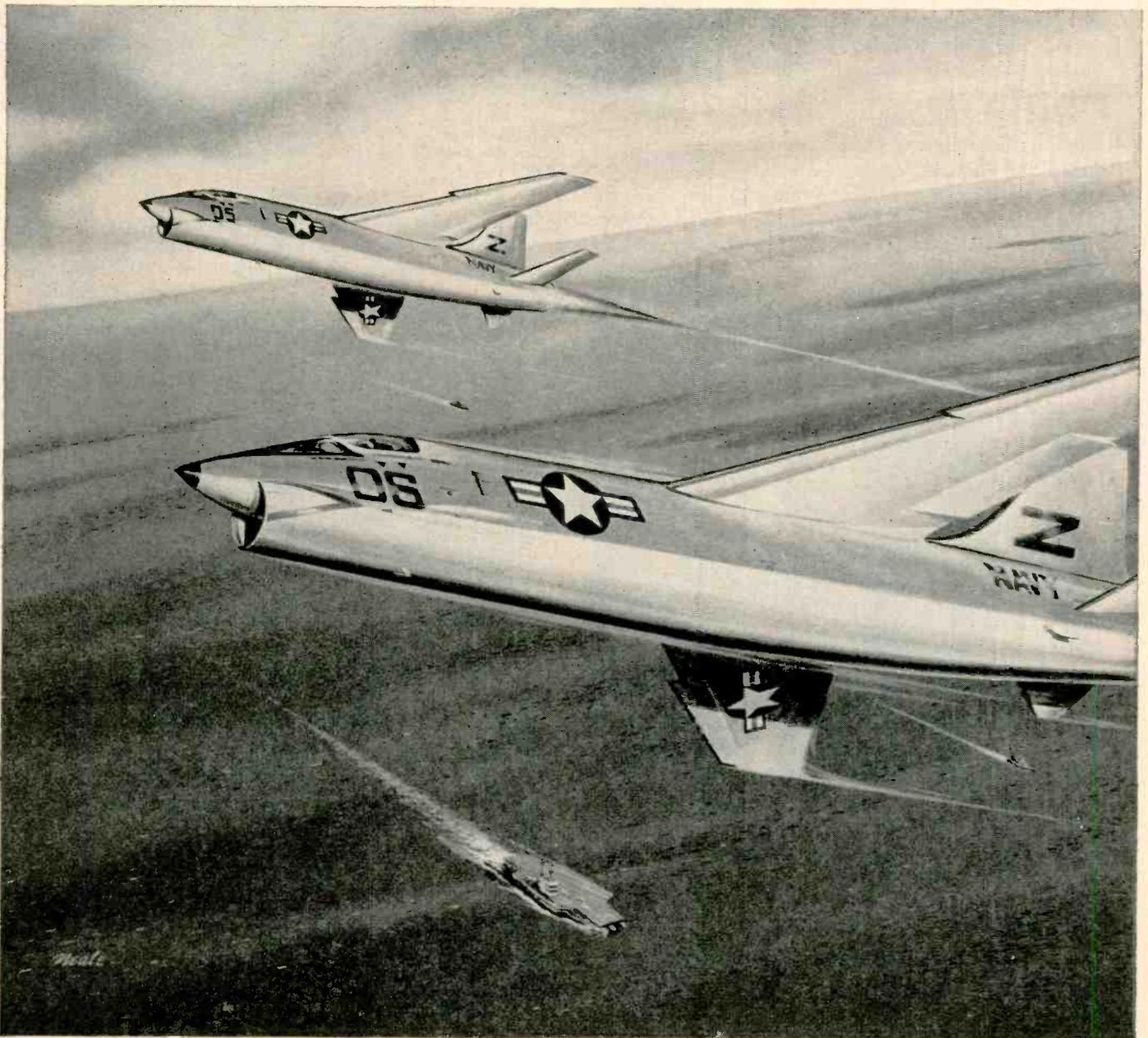

Machine Automatically Winds Synchro Stator

AUTOMATIC synchro stator winder has been developed by the General Engineering Laboratories, American Machine and Foundry Co., Greenwich, Conn., under a production engineering contract with Naval Bureau of Ordnance.

Following 1 minute operator setup time per unit, a complete stator, consisting for example of 15 coils of 90 turns each of number 33 wire, is wound in eight minutes. The machine will handle wire sizes from 31 to 44 (AWG).

Electrical interlocks and stepping switches synchronize motion of the machine's 2 basic mechanical systems, each driven by a d-c motor. A reciprocating arbor mechanism feeds the wire through a nylon nozzle, alternately through 2 stator slots, to form the turns.

After the completion of a coil, an indexing mechanism positions the stator for the next cycle. An electrical circuit monitors the number of turns and coils being wound, stops the winding motor, resets the counting circuit and starts the in-

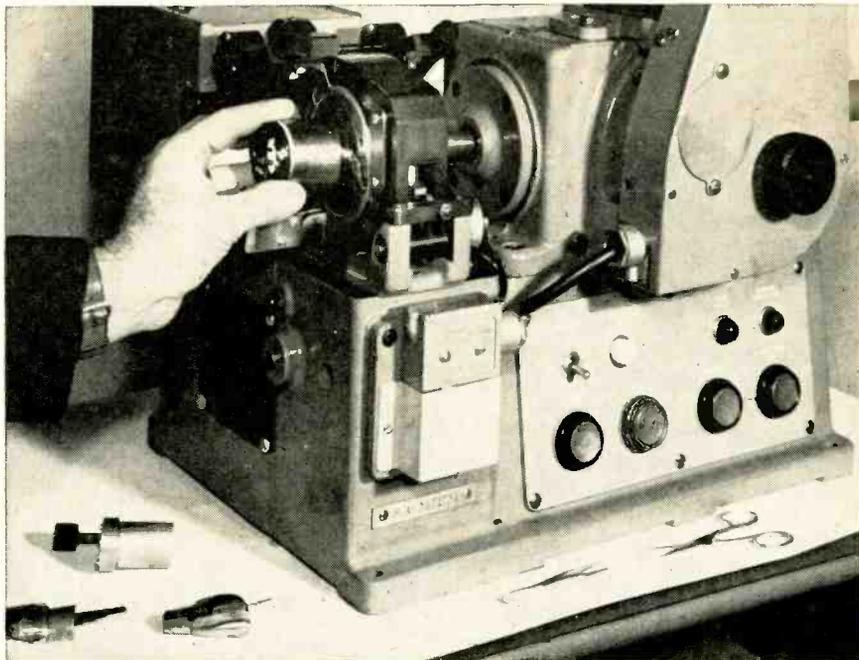

Stator is removed from chuck of new winding machine. Cylindrical stator aligning tool (lower left) positions the core in the chuck. Two-piece winding shoe shapes coil end turns

dexing motor. The last turn of a coil is wound at reduced speed to prevent overshooting the desired num-

ber. The motor is slowed by inserting a resistance into the armature circuit and removing a resistance

DESIGN TRENDS: Pinboard Programs Data Logger

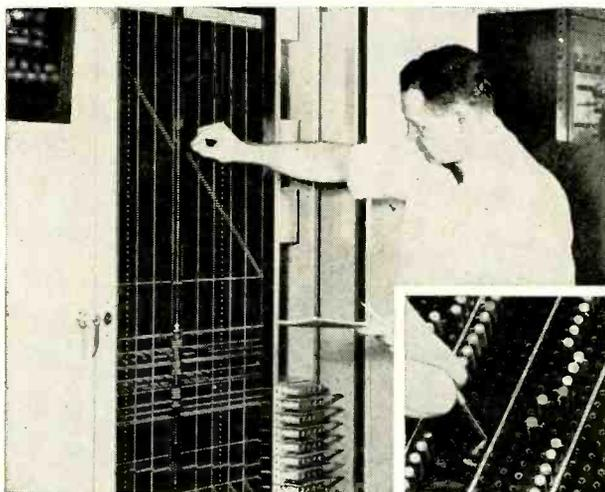

Neon lights isolate sections of a matrix built up with spring strips in this versatile pinboard programmer designed by Fischer & Porter Co., Hatboro, Pa. Programmer shown is 100-point version of data logger and alarm scanner made for industrial control applications which may require future expansion or modification. Modular construction permits addition of any number of points. Pin locations in top half of board determine sequence of data scanning and readout. Sections below program a variety of data conversions, presentations and alarms. Matrix is built of laminated phenolic in which the springs are arranged in graph-

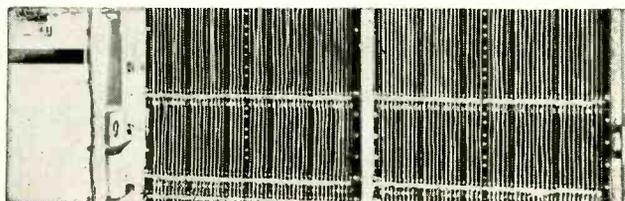
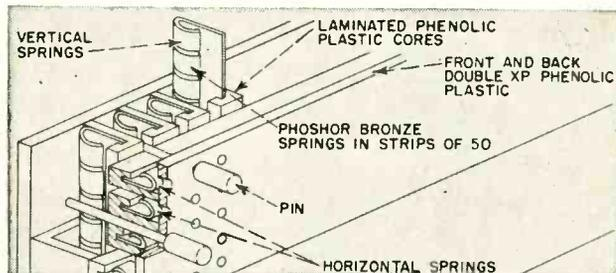

paper pattern (diagram). Pin placement establishes coordinate between data point and readout sequence or instruction. To prevent feedback through the matrix, neon lights, acting as diodes, pick off the voltage at 100 v and drop it to 60 v, which is sufficient to energize thyratrons and cause the circuits to perform. In wiring arrangements (bottom right), the lights isolate the matrix, since 90 v would be required to ionize the next light and pass a signal on to the neighboring circuit. The springs are fabricated in strips of 50 from single piece of phosphor bronze. Pins are made of stainless steel to combat corrosive industrial atmospheres.

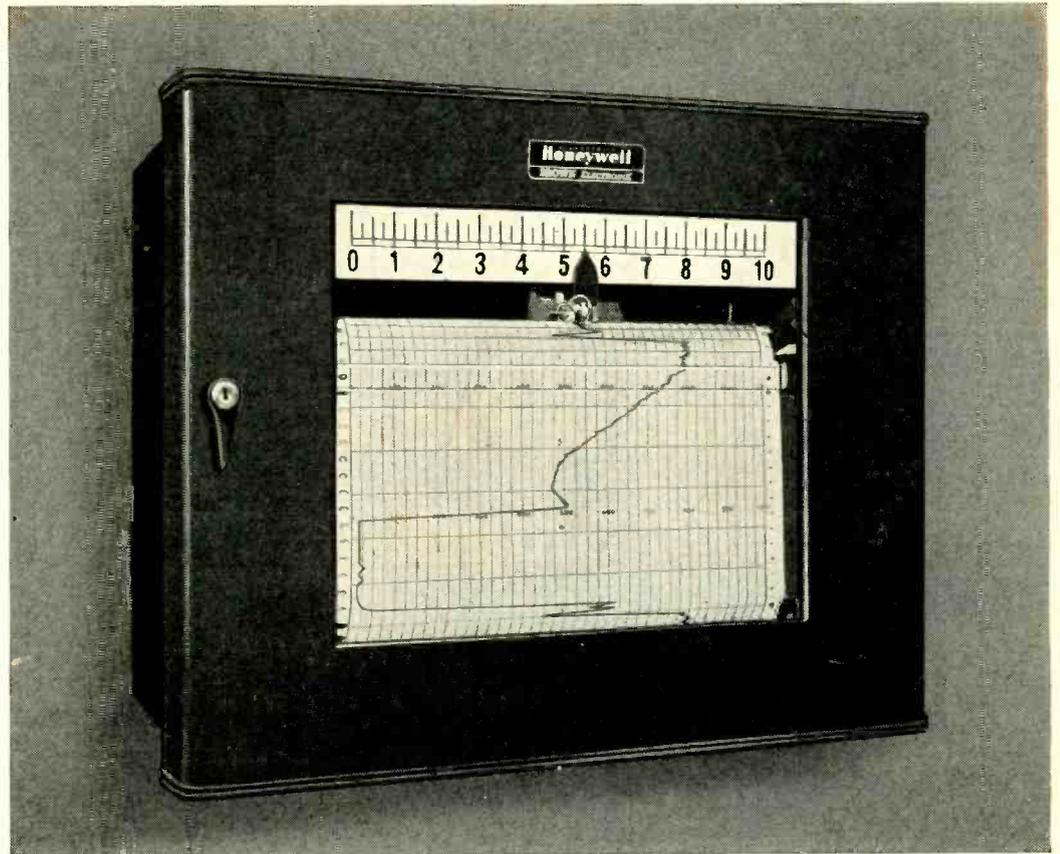

$\frac{1}{4}$, $\frac{1}{2}$ and 1-second recorders speed research and test projects by preserving accurate data.



Measure rapidly changing variables with *ElectroniK* fast speed recorders

Its high-speed recording makes the *ElectroniK* instrument ideal for accurately measuring split-second changes in many types of variables. Three models are available, with pens which traverse the full 11-inch width of the chart in $\frac{1}{4}$, $\frac{1}{2}$ or 1 second.

ElectroniK fast speed recorders combine the accuracy and dependability of standard *ElectroniK* instruments with special pens, specially geared motors and high powered amplifiers . . . to give precise, complete records.

You'll find these recorders particularly valuable in rocket or guided missile testing, spectography and other analyses, and jet engine development. Use them to measure thrust, torque, strain, temperature, pressure, fuel and air flows, and other rapidly changing variables requiring continuous, accurate recording.

Get complete details from your nearby Honeywell field engineer. He's as near as your phone.

MINNEAPOLIS-HONEYWELL REGULATOR Co., *Industrial Division*, Wayne and Windrim Avenues, Philadelphia 44, Pa.

Honeywell



First in Controls

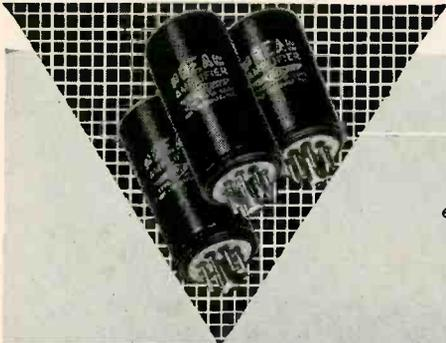

INSTRUMENT AMPLIFIERS

designed for amplification of low-level signals have exceptional sensitivity. Input of .0025 microwatts produces full output of 4 DC volts into 5000 ohms.

Low-Level Preac Magnetic Amplifiers

For sensitive thermocouples, strain gauges, and similar data sensing applications, Preac amplifiers provide low null drift. Power gain is so high (up to 60 db) that inverse feedback can readily be used to achieve special desired characteristics.

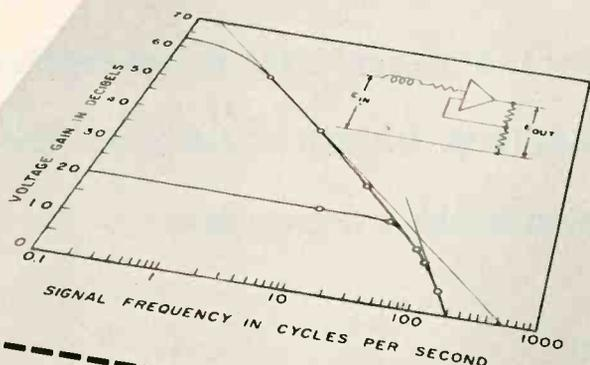

AMPLIFIER CHARACTERISTICS

Airpax Preac amplifiers are highly stable low-level magnetic amplifiers.

INPUT: DC polarity reversible. Below are input control powers in microwatts for full-scale outputs.

Type	Full-Scale Input
M-5249	0.0026 (both windings in series)
M-5250	0.011 (internal choke)
M-5251	0.025 (either winding)

OUTPUT: DC polarity reversible ± 4 DC volts into 5,000-ohm load, deviation from linearity less than 100 millivolts.

POWER SUPPLY: Less than 2 watts, about 2.5 VA, at 400 ± 40 CPS and 115 ± 11 RMS volts.



Airpax Products Company, Seminole Division, Fort Lauderdale, Florida

from the field current. The armature is shorted to stop the motor.

The turns and coil counting circuits consist of selector switches and corresponding stepping switches. They select any number of coils per stator between 1 and 15. Wire loop pickoffs made during winding later serve as interconnections to form a 3-phase stator. The locations on the stator winding at which the wire loop pickoffs are made are selected by means of jumpers on a terminal board. A stepping switch completes the circuit to a rotary solenoid, a pickoff arm on the solenoid armature then drawing a loop of wire away from the stator and holding it until the next coil is wound.

The machine is continuously monitored against wire breakage. One wire end is connected into the circuit while the other end feeds out through the arbor nozzle to a grounding post on the machine to complete a circuit through a sensitive relay. The relay contacts control the machine operation so that wire breakage will either cause the machine to stop or fail to start.

Holding Fixture Frees Hands In Assembly

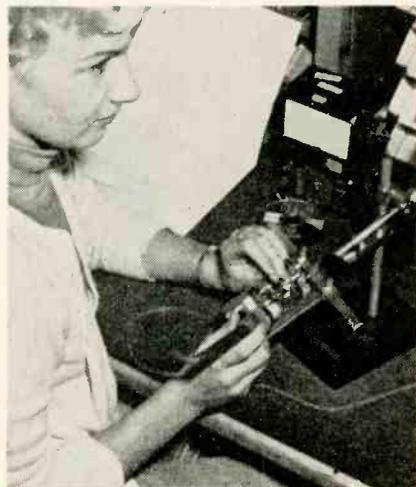

Adjustable fingers will hold printed circuit board in any desired position

ADJUSTABLE holding fixture for printed circuit boards, subassemblies and connectors gives assemblers equivalent of extra hand during assembly, wiring and soldering operations.

Fixture shown was developed by

Technical Devices Co., Los Angeles, Calif. Prototypes were tried out on a variety of jobs at Lockheed Aircraft Corp., Missile Systems Division.

The fixture holds boards ranging in size from $\frac{1}{4}$ inch square to 7 by 8 inches. The operator can work on both sides of the assembly in any position, inserting leads from one side and soldering from the other.

Thumb pressure on a spring-loaded cam lever releases the work. A second arm may be attached to the upright to accommodate sandwich-type assemblies. The fixture may be used on a moving belt assembly line or, with its cast iron base removed, bolted to a perpendicular conveyor.

Brazing Rings Made By Lathe Mandrel

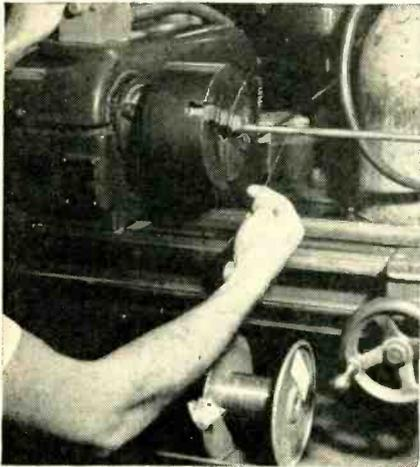

Placing wire spool in lathe tray leaves operator's hands free to adjust lathe speed and wire feed

BRAZING rings are quickly made at Fenwal, Inc., Ashland, Mass., by coiling wire on mandrel installed in shop lathe. Wire is inserted in hole in mandrel and secured by a bend around mandrel. Lathe chuck is rotated for a few turns by hand to obtain proper lay of the wire before starting the lathe. Wire feed and lathe speed should be balanced so that coil is just loose enough to slip off mandrel. Coil is then clipped up the side by wire cutters, producing several hundred rings. Wire used is silver alloy made by Handy and Harman, New York City.

INFINITE RESOLUTION SPIRALPOT®

IMMEDIATE DELIVERY

$\pm 0.1\%$ Linearity

10 TURNS

1,000 OHMS

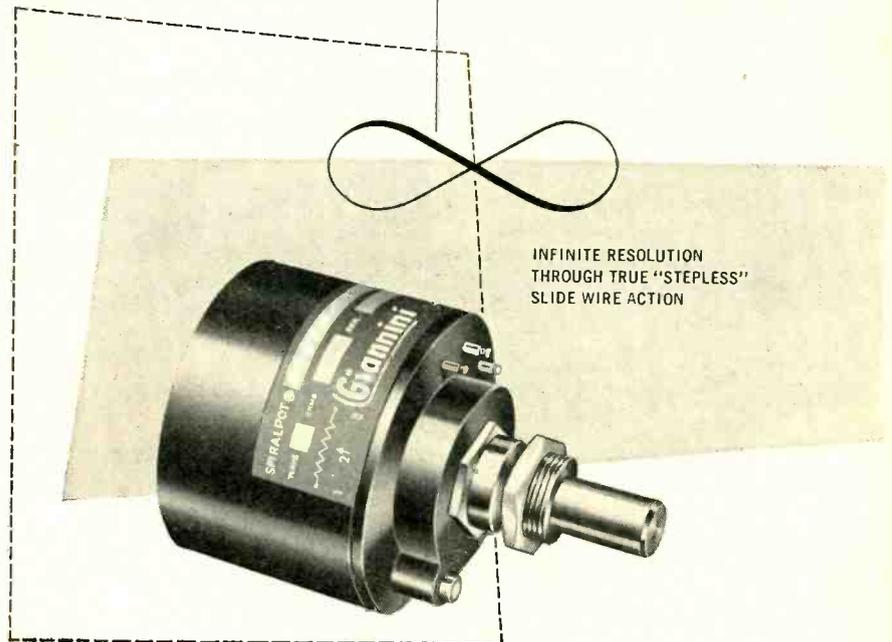

INFINITE RESOLUTION THROUGH TRUE "STEPLSS" SLIDE WIRE ACTION

Quantity production now makes the popular 10 turn 1000 ohm Model 85175 Spiralpot available for immediate delivery.

Designed to eliminate hunting in sensitive servo systems, the Spiralpot finds many applications where infinite resolution and precise linearity are required. Only 1.5 inches in length and 1.5 inches in diameter, this rugged instrument mounts identical to wire-wound types and can be used as a direct replacement in many cases. Low inductance and capacitance effects make it ideal for AC as well as DC applications.

Standard 85175 Spiralpots are available in three or ten turn models with resistance ranges from 50 to 250 ohms per turn. For special applications, the unit can be supplied with resistance ranges as low as two ohms per turn and linearity to $\pm 0.05\%$. Other Spiralpot models are available with synchro mounting, in resistance ranges to 625 ohms per turn, and for use at elevated temperatures.

For complete information on these versatile infinite resolution potentiometers, write for Spiralpot Bulletins.

Gianni

NEW JERSEY DIVISION

G. M. GIANNINI & CO., INC. • PASADENA, CALIFORNIA

Introduce More New Tubes

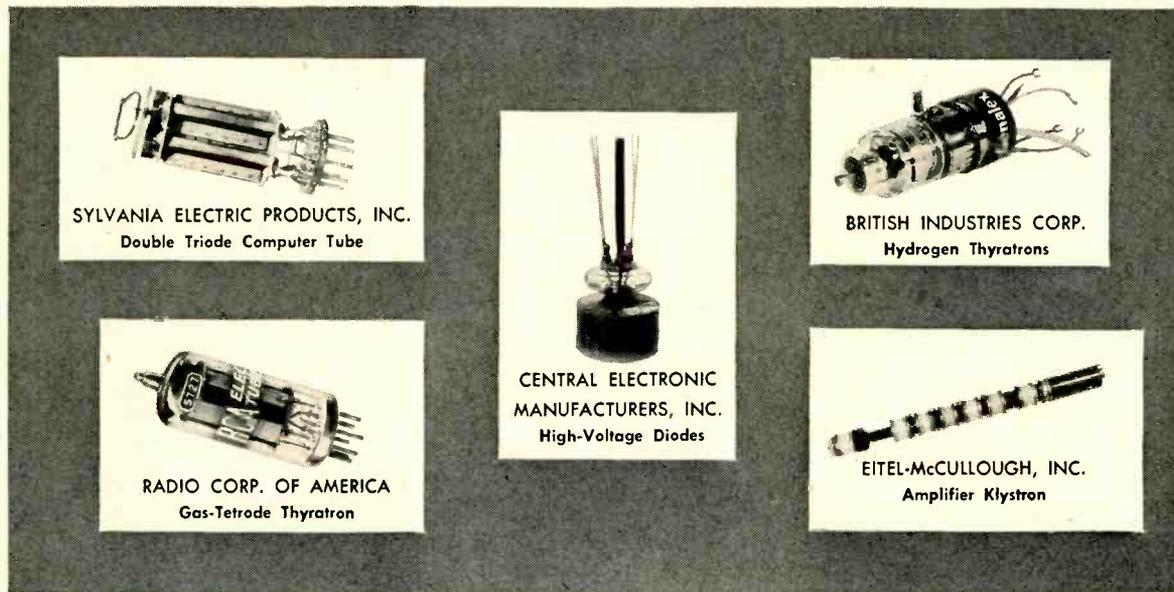

Special Types Offered

IN COUNTLESS fields of business activity the electron tube plays an increasingly vital role. Performing new functions and doing old ones better constitute the purpose of tubes now being produced.

Sylvania Electric Products, Inc., 1740 Broadway, New York 19, N. Y., (300) produces a long-life, high perveance T-6½ medium mu double triode computer tube. Type 7044 features high zero bias plate current, separate cathode connections, freedom from cathode interface and interelement leakage.

The XD series of h-v diodes are announced by **Central Electronic Manufacturers, Inc.**, 2 Richwood Place, Denville, N. J. (301). The tube's conservative ratings permit operations in the piv range of 40-80 kv at average plate currents of 3 amperes in rectifier service and 5 amperes rms in clipper diode service (per tube). The 600-w cathode permits operation peak emissions of 150 amperes.

British Industries Corp., 80 Shore Rd., Port Washington, N. Y., (302), has available the Genalex hydrogen thyratrons which feature high reliability and long life. Designed for radar and other high-power pulse modulators, they have a specially designed baffle which prevents deposition of barium from the cathode onto the grid.

Offered by **Eitel-McCullough, Inc.**, San Bruno, Calif., (303) is a six-cavity water-cooled amplifier klystron. Designed for use in the 720 to 980 mc range it delivers 10 kw c-w power output at 10 mc bandwidth with a 5-w driving power and 40% efficiency.

Radio Corp. of America, Harrison, N. J., (304), has a miniature 7-pin gas-tetrode thyatron. It is designed for use in relay, grid-controlled rectifier, and pulse-modulator circuits of military and industrial electronic equipment where dependable performance under shock and vibration is a prime consideration.

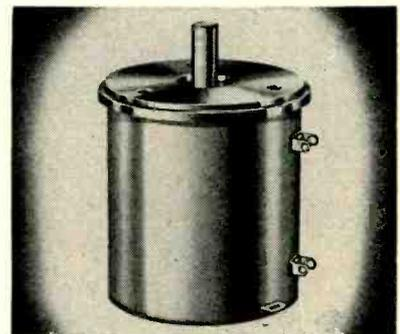

Ten-Turn Pot has wide resistance range

BECKMAN-HELIPOT CORP., Newport Beach, Calif. Model 7603 is a 10-turn precision potentiometer for servo mounting, 1½ in. in diameter, with a wide range of total resistance—from 350 to 450,000 ohms. Company engineers have used new design principles and new materials to come up with a potentiometer of exceptional stability, standard independent linearity of ±0.15 percent, and minimum noise characteristics.

Ambient temperature range is from -55 to +80 C, with a power rating of 5 w at 40 C. Full use of pot resistance range is possible since 90 deg overtravel is available at each end of the coil. The one-piece

For more information use READER SERVICE CARD



our leadership protects yours...

It takes a lot of doing to produce the exact same thing over and over again hundreds of thousands of times—without slipping up on a thousandth of an inch, watt, or milligram. This insistence on *uniformity* has helped build our reputation as the world's most Consistently Dependable producer of CAPACITORS. Continuously uniform production is a science—one that we've painstakingly pursued since 1910.

Typical of the "countless" C-D electrolytics used by major equipment manufacturers the world over are:

"EC" MINIATURIZED CERAMIC CASED TUBULARS For cramped-space applications in hearing aids, transistorized devices, and remote control assemblies. Less than $\frac{1}{4}$ " D., only $\frac{1}{4}$ " L.

"NL" ULTRA-SMALL Hermetically sealed aluminum cased electrolytics, built for compactness, ruggedness, low leakage, long shelf and in-use life.

TANTALUM 3 tubular types, all with low power-factor, moisture-impervious hermetic seal, long service and especially long shelf life. "TX" with sintered anode; "TAN" miniature foil type; sub-miniature, low-voltage wire anode type "NT".

TYPE "UP" Made in the smallest tubular aluminum cans possible for any given capacity and voltage combination. In single, dual, triple and quadruple capacity combinations.

Write for catalog to Cornell-Dubilier Electric Corporation, South Plainfield, New Jersey.



CONSISTENT HI-DEPENDABILITY
CORNELL-DUBILIER CAPACITORS



SOUTH PLAINFIELD, N. J.; NEW BEDFORD, WORCESTER & CAMBRIDGE, MASS.; PROVIDENCE & HOPE VALLEY, R. I.; INDIANAPOLIS, IND.; SANFORD, FUQUAY SPRINGS & VARINA, N. C.; VENICE, CALIF.; & SUB.: THE RADPAPT CORP., CLEVELAND, OHIO; CORNELL-DUBILIER ELECTRIC INTERNATIONAL, N. Y.

Resinox molded housing is highly resistant to moisture as well as being a good insulator.

Application of a V-groove lathe-bed technique in design of the

rotor and slider results in maximum precision, essentially zero backlash and low torque.

For dependable performance and precise mechanical conformity,

stainless steel ball bearings are used, and critical machined surfaces in the housing are turned in one set-up. **Circle 305 on Reader Service Card.**

Input Unit for use with typewriter

COLEMAN ENGINEERING CO., INC., 6040 West Jefferson Blvd., Los Angeles 16, Calif. A newly developed typewriter input unit is designed to operate with an IBM output writer or other solenoid-operated electric typewriter directly.

The unit includes a patching program plug the arrangement of which is easily variable and which

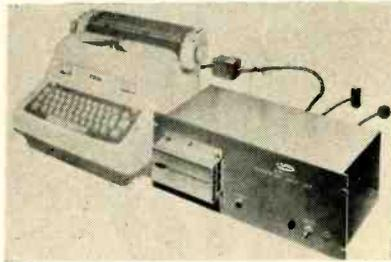

determines the format of the typewritten copy. The combination of

input unit and typewriter form a "usable as is" package that needs only the digital input to form a working system.

Two models, each suitable for rack panel mounting and complete with 90 v d-c power supply, are available: (1) model AV98 with capacity of up to 98 bits of information (digits, tabs, carriage return, etc.); and (2) model AV49 with capacity of up to 48 bits of information. **Circle 306 on Reader Service Card.**

Parabolic Antenna for communications



TECHNICAL APPLIANCE CORP., Sherburne, N. Y., announces a series of 19-ft parabolic antennas available in various combinations of mounts and feed systems.

The 19-ft parabolic reflector is made up of four pie-shaped sections to facilitate easy transportation. Individual sections are readily assembled and result in a very rugged structure. The structural base of the antenna is a circular ring truss 8 ft in diameter. Pre-formed radial members fan out from the ring truss to the tips of

the reflector. Circumferential tubing is Heliarc welded to the radial members. A rigid ring circumvents the entire structure. Reflecting surface is $\frac{1}{2}$ in. expanded aluminum mesh, the entire antenna being iridited and painted for long-lasting finish.

A choice of ground mount or tower mount is available. Both permit azimuth and elevation adjustments through 10 deg of travel. Standard feeds are either dipole or horn type. Special feeds for specific requirements are available on order. In addition, the reflector is available without feed system, with or without mount. **Circle 307 on Reader Service Card.**

Analyzer Computer versatile, compact

NUCLEAR-CHICAGO CORP., 229 West Erie St., Chicago 10, Ill. Model 132 analyzer computer is designed for use with all gamma-sensitive scintillation counters. The instrument represents a unique gain in versatility and compact design. This was accomplished by combining a well-regulated h-v supply, sin-

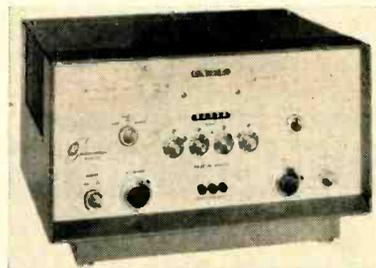

gle channel pulse-height analyzer, binary scaler, and an automatic push-button computing circuit, all in one chassis.

The instrument's single channel analyzer section materially reduces background and scatter radiation through the rejection of gamma or other radiation which have energies above or below the desired level.

Regulated high voltage to the external scintillation counter is var-

A McGraw-Hill Publication  
330 West 42nd St., N. Y. 36, N. Y.

*Call now
for space reservations
in the 1958-1959
electronics
BUYERS' GUIDE*

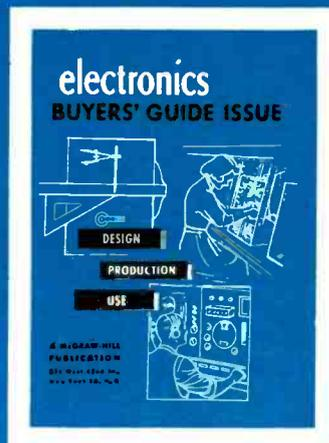

The
**PROVEN
REFERENCE
SOURCE**
in the
electronic
field for
the past
18 years



In **NEW YORK**



In **SAN FRANCISCO**

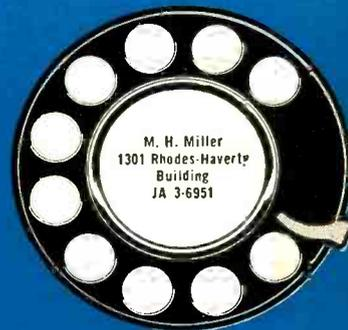

In **ATLANTA**



In **LOS ANGELES**



In **DENVER**

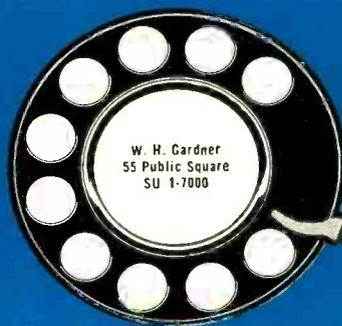

In **CLEVELAND**



In **DALLAS**



In **CHICAGO**



In **LONDON**



In **PHILADELPHIA**



In **BOSTON**

In every industry there is only one product & data source
In electronics it is the **electronics BUYERS' GUIDE**

able from 500 to 1,500 v with a 10-turn h-v adjust panel control.

A 2- μ sec binary scale of 512 is provided, with a choice of 8 scale

selections from 4 to 512, plus a line-frequency test position. Automatic percentage reading, an additional feature of the unit, is particu-

larly useful whenever a number of radioactive samples are to be measured in terms of a standard. **Circle 308 on Reader Service Card.**

Resistors encapsulated type

JULIE RESEARCH LABORATORIES INC., 556 W. 168th St., New York 32, N. Y. Heretofore available in a sealed oil-bath construction, the company now announces the production of encapsulated resistors in accuracies to 0.001 percent.

Encapsulated units are available in a variety of styles with resistance tolerances to 0.0025 percent relative or 0.005 percent absolute, with

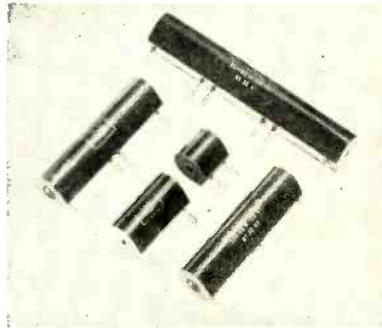

temperature coefficients of resistance of 2.5 ppm per deg C absolute or 0.7 ppm relative. Units can be furnished trimmed under specified ambient temperature and dissipation level and to track over MIL specification temperature ranges, for example to 0.01 percent from -45 to +85 C.

Of particular interest in tracking applications are group encapsulated units which simplify mounting and eliminate the possibility of production errors in mixing up resistors. **Circle 309 on Reader Service Card.**

Transformer with 90 db shielding

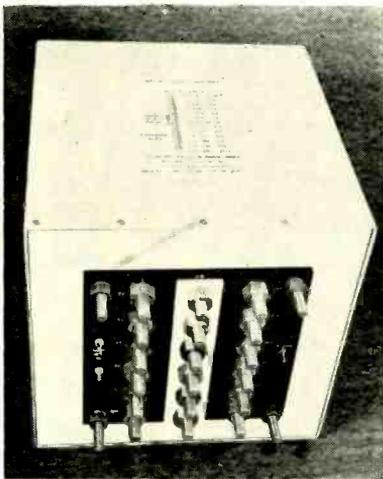

OSBORNE ELECTRONIC CORP., 712 S. E. Hawthorne Blvd., Portland, Ore., has produced a transformer originally required by a client for the operating base of a complex measuring and computing device.

Unusual in the fact that it features 90 db shielding, the transformer is also unique in other respects. It has a ratio accuracy of 0.01 percent with a phase angle error not exceeding 2 minutes. Output voltages range from 7.2 to 230 v, and performance is maintained for any condition of loading, from open circuit to 100-w total of loads

on all windings. In some combinations of loading, currents of over 2 amperes may be drawn.

Approximately 500 separate conductors in series and parallel combinations are assembled in a Litzendraht type cable in order to achieve the proper degree of each winding among all the others. These interconnections take up nearly twice the volume occupied by the core and coil constituents.

This transformer has been subjected to a 1,500-v dielectric strength test among all 500 conductors without breakdown. Actual breakdown in samples tested to destruction occurred at 3,500 to 5,000 v rms. **Circle 310 on Reader Service Card.**

Digital Voltmeter all electronic instrument

SERVONICS, INC., 822 N. Henry St., Alexandria, Va., announces an electronic digital voltmeter, or high speed encoder, that works on a time modulation principle. A very linear sawtooth or sweep voltage is generated. This voltage increases linearly as a function of time. The input voltage to be measured is compared to the sawtooth in a



comparator circuit. When coincidence occurs between the sawtooth and input d-c voltage, a time delayed pulse is generated. This time delay is proportional to the magnitude of the input d-c voltage.

Time demodulation is accomplished by counting pulse outputs of a crystal oscillator which have been gated from the time the sawtooth starts until the time delayed pulse has occurred.

The EDR, with accuracy of 0.01 percent, has 4 digit visual readout

How the man  from Tensolite can widen your safety margins on 250° C. hook-up wire

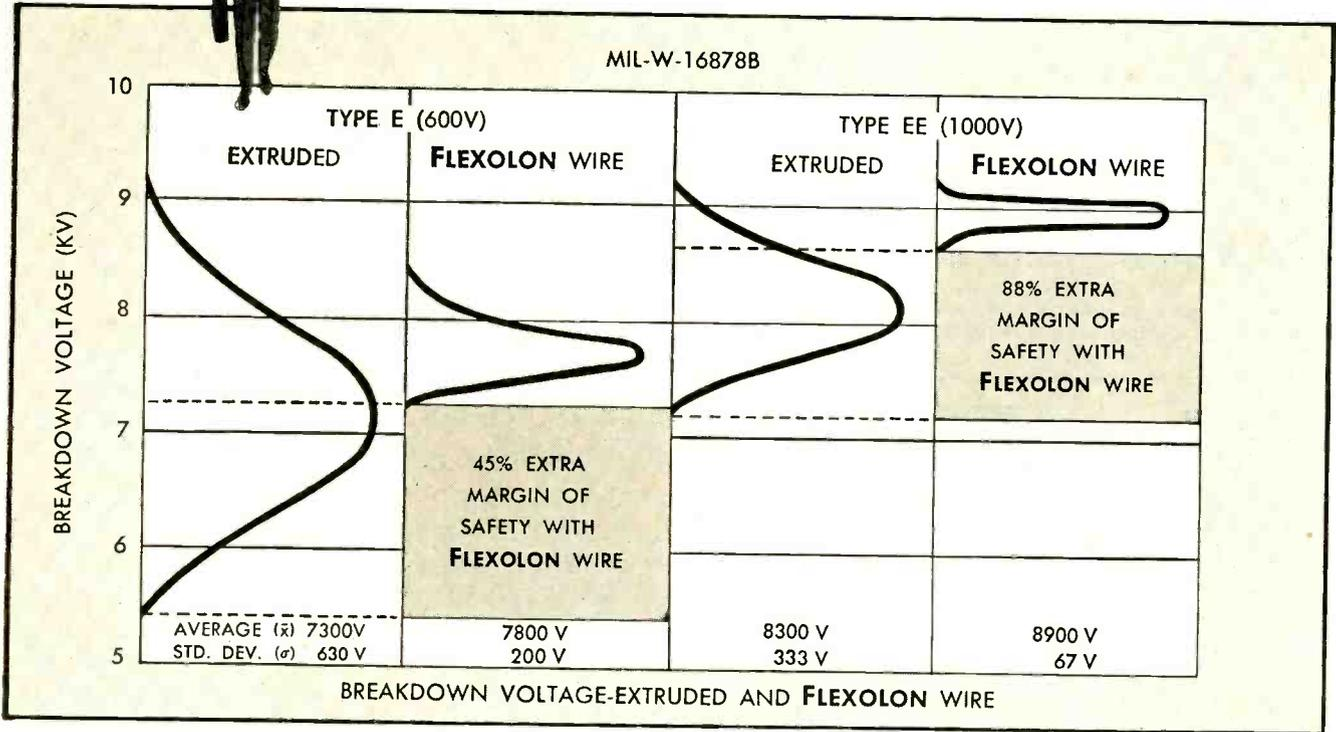

Test proves new FLEXOLON high temperature wire highest in dielectric strength

Superiority of Tensolite's new FLEXOLON wire, manufactured to exceed the requirements of MIL-W-16878B, Types E and EE, gives designers greater safety factor than ever before

If you want to widen the safety margins in your product or merely maintain the present margins with smaller wire, Tensolite's new FLEXOLON high temperature hook-up wire can solve your problem.

Rugged tests — In a series of extensive tests, FLEXOLON wire's dielectric strength was charted against the strength of extruded wire. Ten-foot samples, selected at random, were immersed in a water bath containing a suitable wetting agent for 4 hours. Each piece was then subjected to a high-potential test with voltage increasing from 0 at the rate of 3 kv per 10-second interval until breakdown was observed.

Results conclusive — In the type E category, extruded wire fell 45 per cent below FLEXOLON wire's minimum dielectric strength. In the type EE category, the extruded samples were 88 per cent lower than the minimum dielectric strength of FLEXOLON wire.

Extra advantages — Tensolite's unique process which permits application of 2½ times more layers of tape to FLEXOLON wire assures full insulation protection and far superior performance. The new manufacturing technique also gives FLEXOLON wire perfect concentricity which provides easier stripping, faster and cleaner cuts, and added protection against strand damage.

Complete information — Ask the man from Tensolite for full details on the many advantages of FLEXOLON high temperature hook-up wire. Or write to Tensolite for informative FLEXOLON wire bulletin.

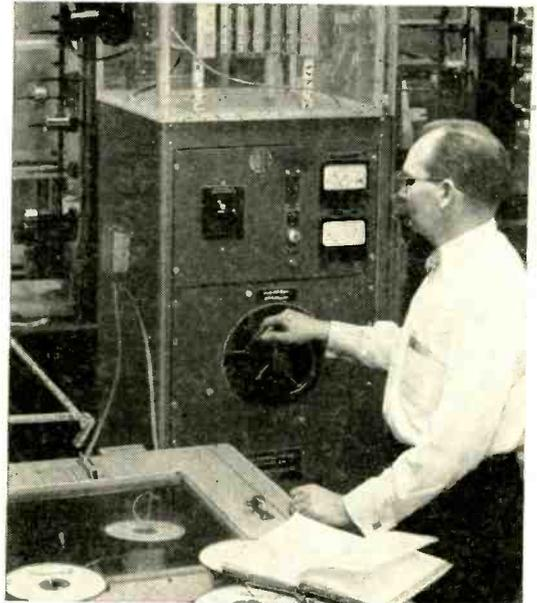

88 per cent extra margin of safety — This high potential test proved that Type EE extruded wire fell 88 per cent below FLEXOLON wire's minimum dielectric strength.

Tensolite INSULATED WIRE CO., INC.

West Main Street, Tarrytown, N. Y. • Pacific Division: 1516 N. Gardner St., Los Angeles, Calif.

"FLEXOLON" is a trademark of Tensolite Insulated Wire Co., Inc.

CIRCLE 36 READERS SERVICE CARD



They can be your design assistants on other Essex Engineered Products.

WIRE AND CABLE

These "power full" lead, appliance, electronic, Sil-X 200°C and the Mil-W-76-A and Mil-W-16878 govt. spec. wires are standard—save industry special engineering, source and delivery problems.

Wire and Cable Div., Ft. Wayne, Ind. 

COILED CORDS-CORD SETS

Prime source for plastic and rubber power supply cords. Terminations of all types (molded plastic and rubber) with infinite design possibilities. Complete line of Coiled Cords including HPN.

Cords Limited Division, DeKalb, Ill. 

TYPE MS RELAY

A low cost, space saving single pole or common multiple contact D.C. unit. Highly reliable. Can be built to withstand extreme environmental conditions.

R-B-M Control Div., Logansport, Ind. 

 **ESSEX**
WIRE CORPORATION

CIRCLE 44 READERS SERVICE CARD

and an encoding rate of 98 per sec. In the EDV models, with 3 digit visual readout and accuracy of 0.05 percent, encoding rates are 98 readings per sec and 980 per sec in two models. Encoding rates are controllable from one per hr to maximum speed.

Encoding time is from 1μsec to 1 millisecc full scale. Drift is less than ± ½ count over long periods of time.

The instrument has application with analog computers, data logging, laboratory measurements and quality control operations. Circle 311 on Reader Service Card.

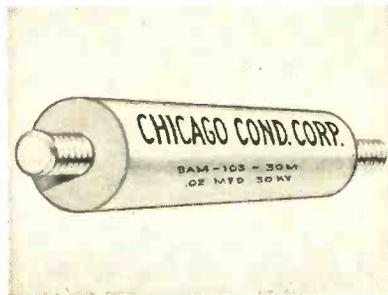

H-V Capacitors film dielectric

CHICAGO CONDENSER CORP., 3255 West Armitage Ave., Chicago 47, Ill. New BAM type capacitors are highly adaptable for h-v use up to 150,000 v d-c, through use of the insulated type bakelite case. The capacitor employs film dielectric which has a high capacity yield per volume and a high volts per mil rating which results in a small h-v unit as compared to a Kraft paper dielectric h-v capacitor. Circle 312 on Reader Service Card.

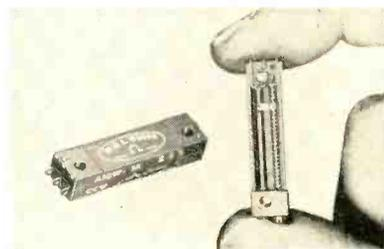

Trimmer Pot wire wound

DALE PRODUCTS INC., Box 136, Columbus, Nebraska. Model A10-W Mil-E-Trized trimmer ex-

ceeds requirements of JAN-R-19, MIL-Std.-202, MIL-E-5272A and MIL-R-12934 concerning trimmer potentiometers. New radical internal design changes make possible such performance as 100 ppm temperature coefficient, dependable continuity, reduced end resistance and zero end shake.

The resistance element is precision wire wound and immediately available in 40 standard values, ranging from 10 ohms to 100,000 ohms. Standard tolerance is ±5 percent but 1 percent tolerance can be ordered. The unit is rated at 1 w up to 70 C; derating to 0 at 175 C.

Trimmer adjustment is smoothly achieved with a 25 turn screw. The wiper blade of this trimming unit has a safety clutch to prevent internal damage from over-exursion.

Ruggedized housing is air evacuated and filled with a special silastic compound to eliminate breathing, moisture, dirt, oxidation and undesirable vibration characteristics. Circle 313 on Reader Service Card.

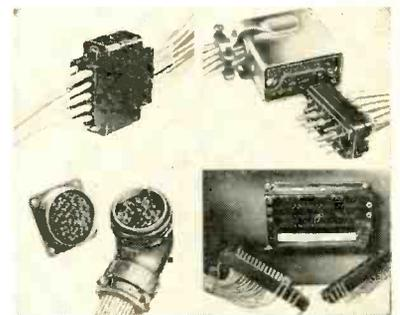

Connectors use crimped pins

BURNDY CORP., Norwalk, Conn. A new line of Hyfen connectors is designed to speed the wiring of electronic and missile harnesses and add greater dependability by utilizing crimped pins and sockets that snaplock into a plug or receptacle. Elimination of solder provides greater reliability and speeds production time, with the application of the Hyfen principle allowing the design of lighter and more compact equipment.

Hyfen types available include a 15 contact, multipurpose plug and receptacle connector; a feed-through, modular design, multiple insert connector with inserts re-

NEW RBM

BHSM and BHSM HT TYPES

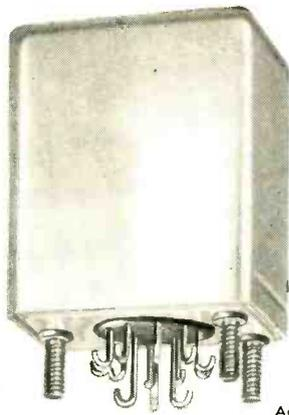

Actual Size

Miniature Hermetically Sealed Relays

The reliability of this relay under severe conditions of vibration and shock has been field-proven in many applications. It is another example of how R-B-M's production maturity and complete facilities can eliminate many of your engineering problems.



WITHSTANDS 10⁹-
500 CYCLE VIBRATION

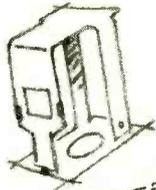

"RUGGEDIZED"
WELDED RELAY AND
BRACKET ASSEMBLY

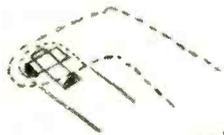

DEPENDABLE
X-BAR
CONTACTS

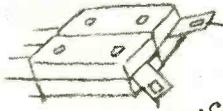

SILICONE-GLASS
PILE UP
INSULATORS
(HT VERSION)

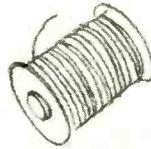

KEL-F COIL
BOBBIN AND
TEFLON MAGNET
WIRE (HT VERSION)

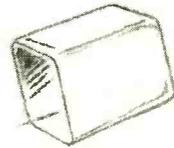

HERMETICALLY
SEALED OR DUST
COVER AVAILABLE

OPERATING BENEFITS

- 125°C OPERATING AMBIENT
- TEMP. RANGE } 22700 BHSM TYPE, -55° TO +85°C
22800 BHSM HT TYPE, -65° TO +125°C
- COIL UP TO 130V.D.C. } SENSITIVITY 0.2W. MIN. PER POLE
MAX. COIL DISSIPATION 3.75 W.
- CONTACTS-MAX. 4PDT 3AMP. AT 32 V.D.C.
OR 115 V.A.C. (NON-INDUCTIVE)
- SPECIAL CONTACTS AVAILABLE FOR
LOW LEVEL OR DRY CIRCUIT
APPLICATIONS
- APPROX. WEIGHT - 3.25 OZ.
- 30g OPERATING SHOCK, 70g NON-DESTRUCTIVE

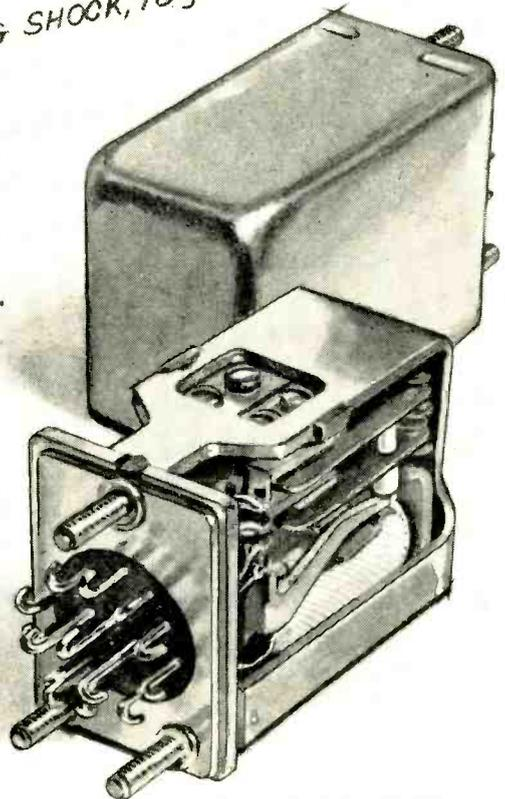

Consult your local RBM Product Application Engineer

or write for Bulletin BHSM-1.

RBM Division

ESSEX WIRE CORPORATION, LOGANSPORT, INDIANA

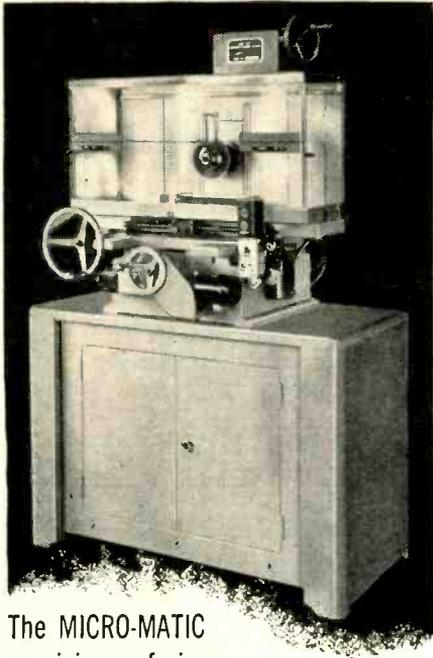

The MICRO-MATIC precision wafering machine—fully automatic model-WMA

SLICES

to extremely close tolerances

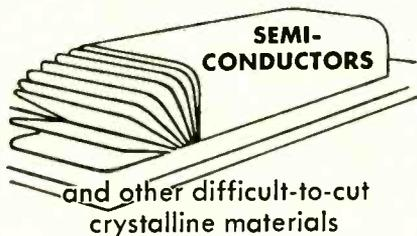

AUTOMATIC INDEXING ON FULLY AUTOMATIC PRODUCTION MODELS

Write for descriptive literature

**MICROMECH
MANUFACTURING CO.**
1020 Commerce Ave. • Union, N. J.

CIRCLE 45 READERS SERVICE CARD

movable from frame for easy contact insertion or removing; an An type; and an MS miniature type. As the Hyfen principle is not limited to either size or number of contacts, variations can be engineered to meet specific requirements. Circle 314 on Reader Service Card.

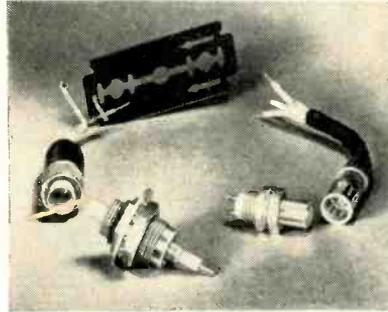

Cables/Connectors microminiature

MICRODOT, INC., 220 Pasadena Ave., South Pasadena, Calif., has developed two new microminiature cables and connectors to fill the need for multiple carrier cables and connectors. The Twimax component consists of 160 ohm, low capacitance and two conductors which are shielded and jacketed. This connector is a slide-on type keyed for polarity. The Triax component is 50 ohm, double shielded coax with insulation between the shields and is jacketed. The connector is a screw-type. Circle 315 on Reader Service Card.

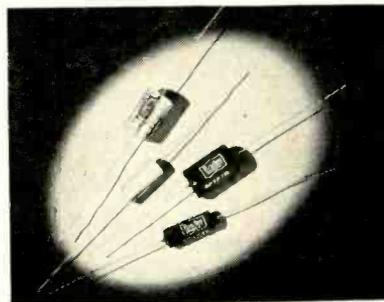

Selenium Rectifiers arc suppressors

BRADLEY LABORATORIES, INC., 170 G Columbus Ave., New Haven, Conn., has in production an extensive line of selenium rectifiers designed specifically for use as arc suppressors. Units are available for

a-c or d-c arc suppression housed either in hermetically sealed metal containers or in moisture sealed phenolic tubes. Designation for hermetically sealed units is SP3 series; for phenolic housed units, SP7 series.

Units are suitable for a-c circuits which draw up to 600 ma operating current at 150 v and for d-c circuits drawing up to 750 ma operating current at 147 v. Higher currents and voltages are available.

Advantages of selenium rectifiers for arc suppression, according to the manufacturer, are: arcing is eliminated during opening and closing of contacts; rectifiers have negligible effect on circuit operation; low cost, small size and easily mounted. Circle 316 on Reader Service Card.

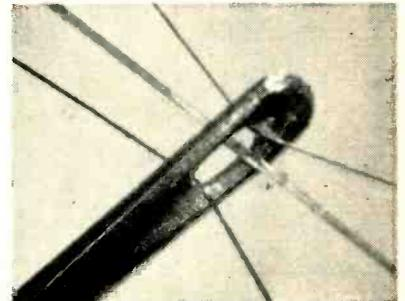

Magnet Wire microminiature

HITEMP WIRES, INC., Westbury, N. Y. Thermester-L insulated magnet wire is available in a broad range of sizes including fine wire gages down to 50 Awg. (Illustrated is a magnification of two pieces of the wire compared with a human hair in the center. All are threaded through the fine eye of a No. 10 sewing needle.) Thermester-L magnet wire has a maximum operating temperature of 155 C, and has excellent electrical and mechanical properties.

Also available in gages as fine as 50 Awg is Temprite (Teflon) magnet wire. Temprite has a temperature range as high as 250 C. Along with excellent dielectric strength and chemical resistance, this magnet wire exhibits extremely low dielectric constant and power factor.

The space factor for both of these film insulated magnet wires makes

them ideal for delicate and sensitive instruments, which have to meet commercial and military standards. Circle 317 on Reader Service Card.

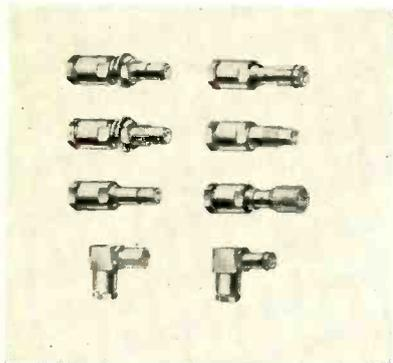

R-F Connectors subminiature type

AMPHENOL ELECTRONICS CORP., 1830 S. 54th Ave., Chicago 50, Ill. Field serviceable subminiature r-f connectors have been added to the company's line of Subminax components. Besides miniature size, features include easy assembly (requiring no special tools), anchored center contact (to prevent possible contact recession under temperature extremes) and an improved cable clamp mechanism. Plugs, jacks, bulkhead jacks and right angle plugs are available in screw-on and push-on coupling designs which mate with other Subminax r-f connectors previously released. Connectors have a nominal impedance of 50 ohms, and are for use with miniature RG-198/U Teflon coaxial cable.

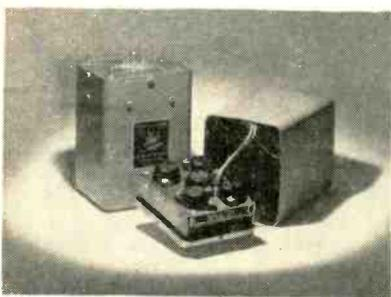

H-V Power Packs transistorized

ELECTRONICS RESEARCH ASSOCIATES, INC., 67 Factory Place, Cedar Grove, N. J. New miniaturized h-v transistorized power packs permit



ERIE...
**A Quality Source
for
Custom Built**

MINIATURE PULSE TRANSFORMERS



ERIE has the engineering skill to design, and the trained production personnel and integrated facilities to build Miniature Pulse Transformers to meet your most exacting specifications.

In complex circuitry requiring low power combined with high reliability, ERIE Miniature Pulse Transformers are outstanding in their performance. They can be made with pluggable bases, terminals, or leads to meet your needs, and to meet MIL-T-27A specifications.

ERIE Miniature Pulse Transformers can be used in switching circuits to develop pulses of desired characteristics, to store information, or to provide close coupling.

Contact ERIE Electro-Mechanical Division regarding your particular requirements.

Typical Applications of ERIE Miniature Pulse Transformers

Computers • Counting Circuits • Blocking Oscillators • Pulse Generators • Telemetry Systems • Pulse Forming Network • Control Equipment—Industrial and Military • Interstage Coupling Transformers for Pulse Amplifiers • Magnetic Core Memory Systems • Wave Shapers



MARCONI

DIRECT DISPLAY OF RESPONSE UP TO 20 Mc

The Marconi 20-Mc Sweep Generator can be used in conjunction with any oscilloscope for direct display of video response characteristics up to 20 Mc. The instrument is designed for precise measurement. Frequency is indicated by crystal-controlled marker pips; and a special circuit provides for differential amplitude measurements, enabling relative response to be determined with a discrimination better than 0.01 dB.

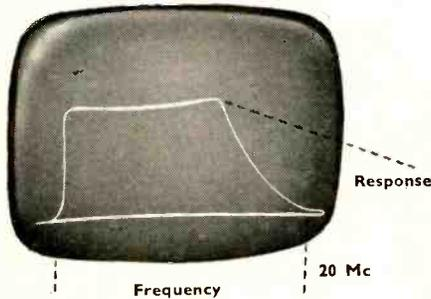

MARCONI 20-Mc SWEEP GENERATOR TYPE 1099



Abridged Specification

Frequency Swept Output: Frequency Range: Lower limit 100 kc, Upper limit 20 Mc. Output level: Continuously variable from 0.3 to 3 volts. Output Impedance: 75Ω. *Time Base:* Repetition Rate: 50 to 60 cps. Output for c.r.o. X deflection: 250 volts. *Frequency Markers:* At 1 Mc intervals; every fifth pip distinctive and crystal controlled. Tubes: 6AK5, 6BH6, 5763, 6BJ6, 6CD6G, 6BE6, 12AT7, 12AU7, 6C4, 5V4G, OA2, 5651.

Send for leaflet B124/A.

**MARCONI
INSTRUMENTS**

111 CEDAR LANE
ENGLEWOOD
NEW JERSEY
Tel: LOwell 7-0607

CANADA: CANADIAN MARCONI CO. • 6035 COTE DE LIESSE • MONTREAL 9
MARCONI INSTRUMENTS LTD. • ST. ALBANS • HERTS • ENGLAND

full input voltage to be repeatedly applied and abruptly disconnected without deterioration of performance. High surge currents such as produced by suddenly connecting or disconnecting high capacitances to the output load will not cause transient burn-out. These units may also be completely short-circuited without damage to the semi-conductors or other components.

The new power packs are available in 150 v d-c and 300 v d-c ratings, 0-100 ma. Input is 105-125 v a-c, 60 or 400 cps. Regulation is better than 0.1 percent; ripple, less than 0.02 percent. Size of the 150 v model is 3 $\frac{1}{8}$ by 3 $\frac{1}{8}$ by 4 $\frac{7}{8}$ in.; weight, approximately 4 lb.

Ideally suited for computers, missiles, aircraft and all miniaturized applications, these power packs are available in moderate priced commercial versions or high temperature types intended for military applications. Circle 318 on Reader Service Card.

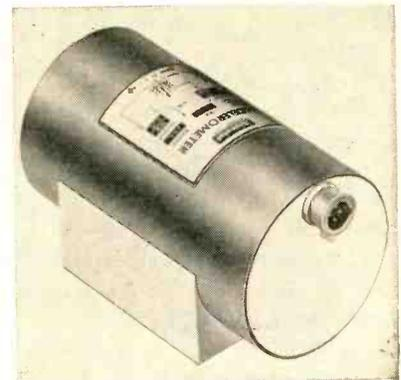

A-C Accelerometer wide dynamic range

G. M. GIANNINI & Co., INC., 918 E. Green St., Pasadena 1, Calif. Accelerations on the order of 0.0017 g will produce a 10 mv output change in the new model 24614 a-c accelerometer. Available in a variety of low natural frequencies, and in ranges from ± 1 g to ± 20 g, this instrument provides accurate, consistently reliable a-c output proportional to linear acceleration parallel to its mounting base.

Wide dynamic range is provided by a full scale output of 6 v and a maximum null of 0.015 v (of which

TC124

at least 90 percent is harmonic). Output can be fed directly into a relatively low impedance, with little or no phase shift.

Bearings are eliminated by suspending the magnetically damped mass between two disk springs. The output of a differential transformer is varied in proportion to movement of the mass. Crosstalk effect is minimum (0.003 g/g at 10 g cross acceleration on a 1 g instrument), repeatability and hysteresis are below thresholds of measuring equipment, and there is no coulomb friction. Circle 319 on Reader Service Card.

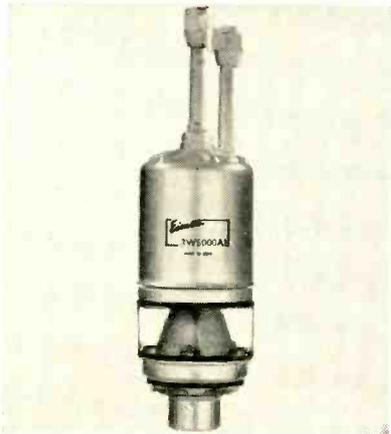

Power Vacuum Tubes new 5,000-w triodes

EITEL-McCULLOUGH, INC., San Bruno, Calif. Two new audio amplifier or modulator low- μ triodes with 5,000-w plate dissipation are available. The 3W5000A1 (illustrated) and the 3W5000F1 are water-cooled versions of the 3X3000A1 and 3X3000F1, and except for higher plate dissipation, have the same ratings as the air-cooled versions.

The 3W5000A1 has rugged concentric contact surfaces for efficient socketing, while the 3W5000F1 is supplied with flexible filament and grid leads for applications where this is preferable. Both tubes are recommended for use when water cooling is preferred or when reserve anode dissipation is required. They are well suited for industrial applications where the load encountered may be reactive, as in vibration table drivers and ultrasonic transducers. They also may be used as

Economy and Quality with

NEW 22 Circuit Centralab[®]

MINIATURE SWITCHES

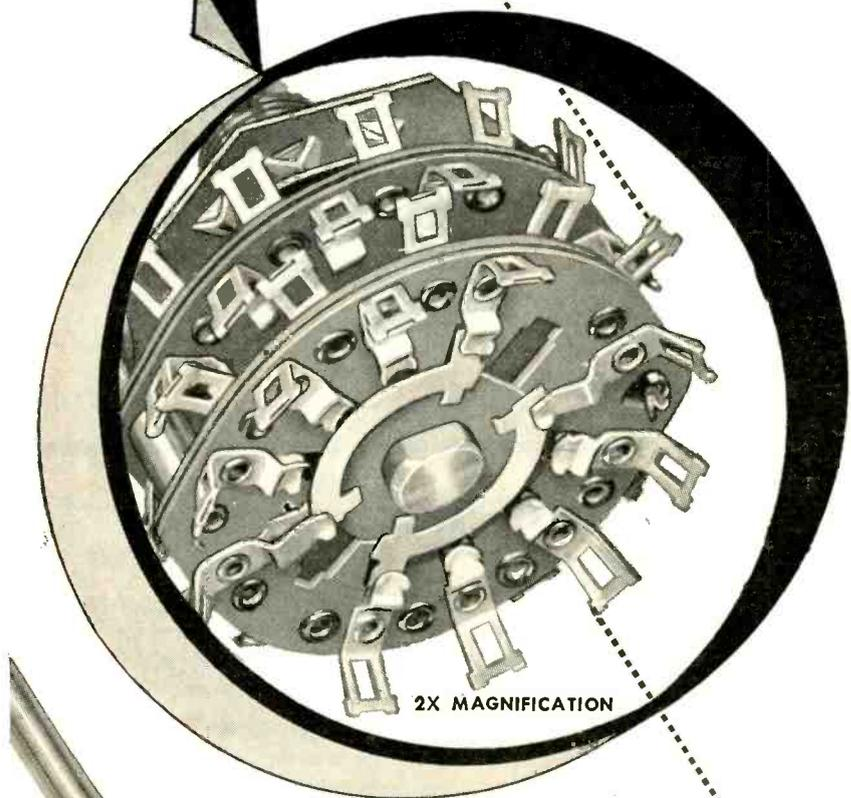

2X MAGNIFICATION

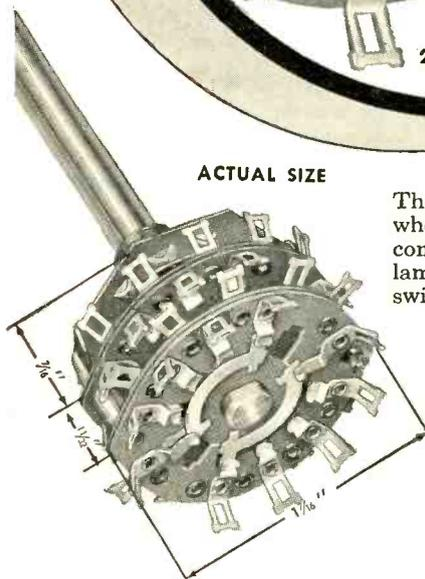

ACTUAL SIZE

For detailed specifications, write for Bulletin EP-90 or contact your Centralab representative.

These new switches are designed for application where costs must be kept to a minimum without compromising rigid electrical specifications. New laminated construction allows up to 22 separate switch points on a $1\frac{1}{16}$ " diameter.

- Voltage breakdown, 1000 volts R.M.S. Back to back insulated clips, 500 volts R.M.S. Laminated phenolic sections type PBE per specifications MIL-P-3115.
- Current rating 2 amp. at 15 volts DC; 150 milliamps at 110 volts AC (resistive load).
- Minimum life, 10,000 cycles.
- Supplied as single section, double section, or single section with line switch. 2-12 positions per switch.
- AC line switches for single section units in SPST, DPST and SPDT switching arrangements.

Centralab[®]

P-5808

A DIVISION OF GLOBE-UNION, INC.
914C E. KEEFE AVE. • MILWAUKEE 1, WIS.
In Canada: 804 Mt. Pleasant Rd. • Toronto, Ontario

VARIABLE RESISTORS • PACKAGED ELECTRONIC CIRCUITS • ELECTRONIC SWITCHES
CERAMIC CAPACITORS • ENGINEERED CERAMICS • SEMI-CONDUCTOR PRODUCTS

stoddart coaxial attenuators and terminators

*made with exclusive
Stoddart Filmistors
for highly accurate
and stable resistive values*

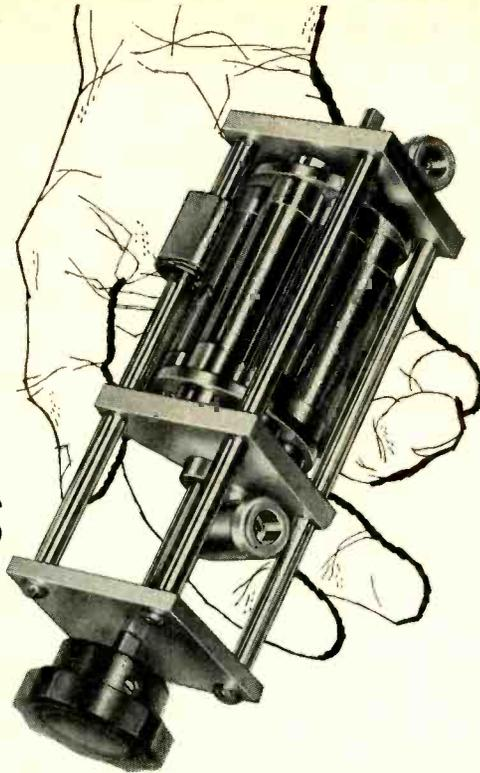

6 position TURRET ATTENUATORS

with simple "pull-turn-push" operation

Extremely precise resistance values from dc to 3000 mc are maintained by Stoddart-developed Filmistors—thin metallic films in ceramic forms which are assembled in properly designed coaxial sections. Turret units are small, and built for long service.

VSWR: Better than 1.2 to 3000 mc.
Characteristic Impedance: 50 ohms
Attenuation Value: Any value from 0 db to 60 db
Accuracy: ± 0.5 db
Power Rating: 1.0 watt sine wave
Connectors: Type N, female

ATTENUATOR PADS

Uniform size, many combinations



You can specify these small "in-the-line" pads in any conceivable combination of male and female Type C and Type N connectors. Single pads with female connectors can be provided with flange for panel mounting. Convenient to use... pads have maximum length of only 3" for any attenuation value. Electrically, pads are the same as those in turret model above.

COAXIAL TERMINATIONS

small, stable—50 or 70 ohm



1/2-watt terminations—50 ohms impedance, TNC or BNC connectors, to 3000 mc. Low cost. VSWR less than 1.20.

1-watt terminations—50 ohms, DC to 3000 mc or DC to 7000 mc. VSWR less than 1.20. Type N or Type C connectors, male or female. 70-ohm, Type N, male or female terminations available.

Platinum film resistors, gold-plated electrical contacts, durable satin chrome exterior finish. Wattages are continuous sine wave ratings.

All items immediately available from stock

Send for Attenuator Catalog A-2

stoddart

aircraft radio co., inc.

6644 Santa Monica Blvd., Hollywood 38, Calif. • HOLLYWOOD 4-9294

a series regulator tube in electronically regulated power supplies. Circle 320 on Reader Service Card.

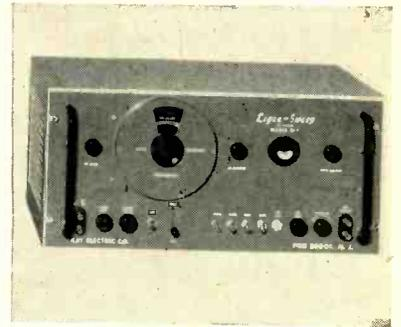

Sweeping Oscillator covers 100 kc-150 mc

KAY ELECTRIC CO., 14 Maple Ave., Pine Brook, N. J., has added the Ligna-Sweep model CP to its precision sweeping oscillators. It provides continuously variable center frequencies calibrated on a direct reading dial from 100 kc to 150 mc with continuously variable sweep widths. It employs up to 15 sharp, crystal-positioned pulse markers set to customer specifications within this range.

The instrument's high output is automatically held constant over each band and the entire frequency range. The crystal markers are available in five groups of three and are controlled by a separate rotary switch. By decreasing its sweep width to a minimum, the model CP may be used as a c-w signal generator. Circle 321 on Reader Service Card.

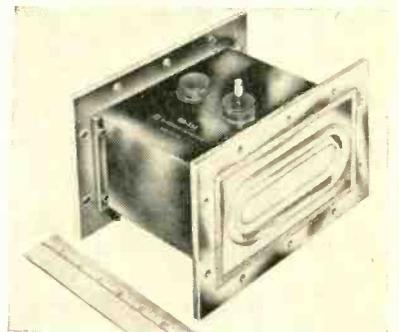

Duplexer Tube for L-band radars

MICROWAVE ASSOCIATES, INC., Burlington, Mass., has developed the MA-336/7166, first in a new series

of L-band high power duplexer tubes for use in L-band radars. The tube is conservatively rated at 2 megawatts peak power and 4 kw average power for continuous operation over a minimum life span of 500 hours.

Features include a ruggedized window construction which eliminates tube failure due to thermal shock or mechanical strain during high power operation. A new design incorporated into the keep-alive structure of the tube has resulted in controlled TR leakage energy over 500 hour operation as evidenced by a negligible change in the overall noise figure of crystals mounted behind the tube. Overall length of the tube is 7.25 in. Circle 322 on Reader-Service Card.



Magnetic Amplifier plug-in type

ACROMAG, INC., 22519 Telegraph Road, Detroit 41, Mich., offers the model 410 magnetic amplifier for signal mixing and summing. The unit is a completely self-contained, plug-in magnetic amplifier and power supply weighing less than 9 oz. It is designed for missile guidance, analog controls, telemetering, and null-balance detectors. It operates directly from standard 115 v 400 cycle power.

Regulated power supplies, bias supplies, and external gain and balance controls are not required; the amplifier is inherently stable. Transimpedance is 25,000 ohms; 100 μ a/d-c control current give 2.5 v/d-c output; less than 10 μ w of signal energy are required for full control; frequency response is d-c to 50 cps depending on circuits used.

Model 410 is hermetically sealed.

look what **\$24⁵⁰** buys
in test equipment!



**HEATHKITS
GIVE YOU
TWICE AS MUCH
equipment for
every dollar
invested**

The famous model V-7A Vacuum-Tube-Voltmeter is a perfect example of the high-quality Instruments available from Heath at $\frac{1}{2}$ the price you would expect to pay! Complete, only **\$24⁵⁰**



Get the most out of your test equipment budget by utilizing HEATHKIT instruments in your laboratory or on your production line. Get high quality equipment, without paying the usual premium price, by dealing directly with the manufacturer, and by letting engineers or technicians assemble Heathkits between rush periods. Comprehensive instructions insure minimum construction time. You'll get more equipment for the same investment, and be able to fill your needs by choosing from the more than 100 different electronic kits by Heath. These are the most popular "do-it-yourself" kits in the world, so why not investigate their possibilities in your particular area of activity! Write for the free Heathkit catalog now!



Contains detailed descriptions of Heathkit models available, including VTVM's, scopes, generators, testers, bridges, power supplies, etc.

FREE catalog

Mall coupon below for
your copy—Now!

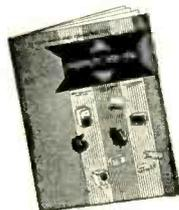

Also describes Heathkit ham gear and hi-fi equipment in kit form. 100 interesting and profitable "do-it-yourself" projects!

HEATH COMPANY
A SUBSIDIARY OF DAYSTROM, INC.,
BENTON HARBOR 14, MICHIGAN

Name _____

Address _____

City & Zone _____

State _____



**NEW
TWIN CONTACT
MINIATURES**

**DC-AC
CHOPPERS**

Eleven types,
both single and
double pole.

Long life.

Low noise level.

Extreme reliability.

Write for Catalog.

**STEVENSON
INCORPORATED
ARNOLD**

7 ELKINS STREET
SOUTH BOSTON 27, MASS.

S/A-11

CIRCLE 51 READERS SERVICE CARD

ruggedized, and has a standard 11-pin plug with octal type key. Circle 323 on Reader Service Card.

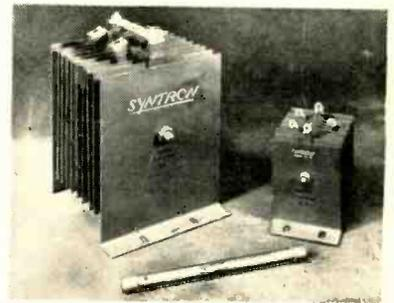

**Selenium Rectifiers
variety of cell sizes**

SYNTRON Co., Lexington Ave., Homer City, Pa. The new selenium rectifiers, with cell sizes from 0.280-in. diameter to 12 in. by 16 in., provide versatility for stack assembly. The larger cells reduce the number of parallel paths needed for higher current applications.

Cell voltages of 15, 18, 22, 26, 33, 40 and 45 v rms ratings are available. The higher cell voltages permit fewer cells in series for h-v applications. The lower voltage cells may be operated at current densities of twice the 26-v cell ratings, thus reducing the stack size and cost. Circle 324 on Reader Service Card.

ATTRACT AND HOLD TECHNICAL PERSONNEL

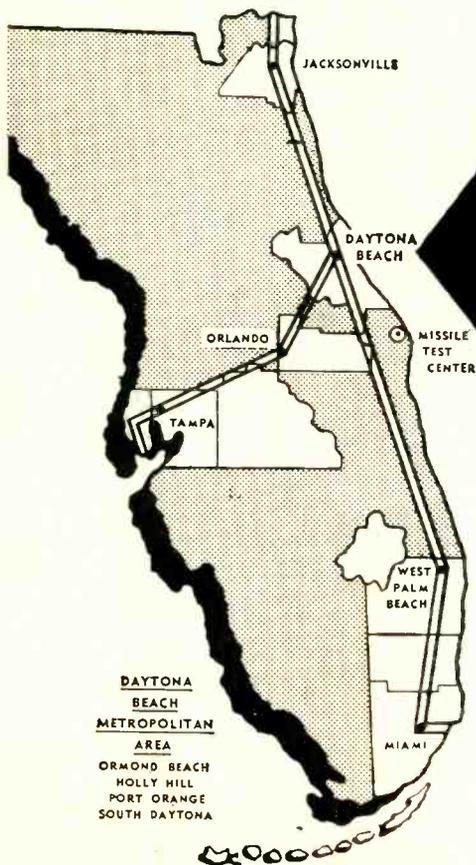

**SERVE
FLORIDA'S
METROPOLITAN AREAS
FROM A
DAYTONA BEACH
INDUSTRIAL SITE**

Daytona Beach, the east-to-west terminal on the north-to-south route of the projected Federal Limited Access Freeway System, gives industry a plus for the future.

Write for new 90 page Industrial Brochure

**INDUSTRIAL DEPARTMENT
CHAMBER OF COMMERCE
DAYTONA BEACH, FLORIDA**

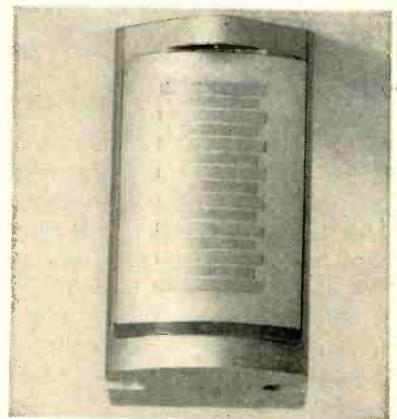

**Magnetic Head Stack
All-metal**

CONSOLIDATED ELECTRODYNAMICS CORP., 300 N. Sierra Madre Villa, Pasadena, Calif., announces a line of high-performance, all-metal magnetic head stacks for tape recording applications. Offered in a number

of standard and special sizes, the new heads present an all-metal surface to the magnetic tape, thus eliminating oxide and dirt deposits.

Exceptional stability of all dimensions and track alignment has been achieved, and simultaneity of the recorded data preserved, by eliminating plastics and resins as binding agents for aligning individual heads within the stack.

Head gaps are aligned to ± 50 microinches, and the line of gaps in each stack is perpendicular to the stack base plane within 0.02 deg. Circle 325 on Reader Service Card.

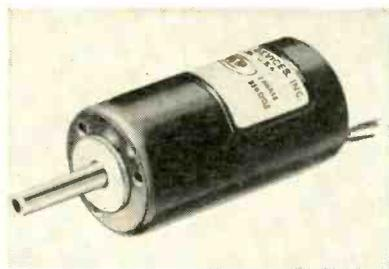

P-M Alternator
Features compactness

EASTERN AIR DEVICES, INC., 385 Central Ave., Dover, N. H. A new miniature permanent magnet alternator measures only 0.990 in. o-d and 1 3/4 in. in length, and weighs only 4 oz. It is available in one, two, or three phase output with various frequency ranges. The 6-pole model develops 350 cycles, 14 v, and 80 ma at 7,000 rpm with less than 5-percent distortion. A 2-pole version of this unit develops less than 3-percent distortion. Circle 326 on Reader Service Card.

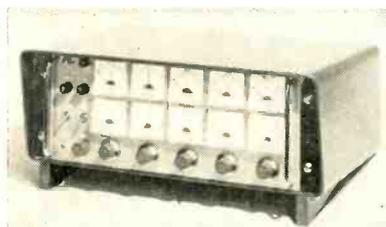

TWT Power Supply
general purpose unit

WAVE/PARTICLE CORP., Box 252, Menlo Park, Calif. Model 499B general purpose traveling wave tube power supply is a compact



Since 1942 the Bird Electronic Corporation has met the challenge of a constantly growing electronic industry. Today, enlarged engineering facilities demonstrate our intention to maintain leadership in our field. A wide range of coaxial line instruments and accessories are being designed to meet a variety of specifications; and new applications are continuously being sought.

In addition to experience and established leadership, Bird has the physical facilities to produce and dependably deliver coaxial line instruments and accessories meeting your highly exacting requirements.



BIRD

ELECTRONIC CORP.
EXpress 1-3535
1800 E. 38 St., Cleveland 14, Ohio
Western Representative:
VAN GROSS COMPANY • Woodland Hills, California

IMMEDIATE DELIVERY!



ON $\frac{3}{8}$ " AND $\frac{1}{2}$ " O.D.
Non-Magnetic

18-8 TYPE 303 STAINLESS

UNIVERSAL JOINTS

Manufacturers of electronic equipment have come to depend on Curtis for precision-made non-magnetic universal joints of 18-8 Type 303 stainless steel, in the sizes most frequently used in the industry. Other sizes are also readily available; also bronze joints.

Curtis joints benefit by a rigid insistence on uncompromising inspection and quality control at every stage of manufacture, insuring minimum backlash.

Curtis torque and load ratings are entirely dependable, since they are based on continuous testing under actual operating conditions.

Not sold through distributors. It will be to your advantage to write or phone (REpublic 7-0281) for free engineering data and price list.

CURTIS TRADE MARK

UNIVERSAL JOINT CO., INC.
19 Birnie Avenue, Springfield, Mass.

As near to you as your telephone

**A MANUFACTURER OF
UNIVERSAL JOINTS SINCE 1919**

CIRCLE 54 READERS SERVICE CARD

unit for operation of most low level and intermediate level p-m twt's. It is mounted behind a 7 in. by 19 in. standard rack mount panel. The unit is completely metered for easy and quick determination of all important voltages and currents. The 499B rack mount is priced at \$1,450, and a matching solenoid supply is also available. Circle 327 on Reader Service Card.

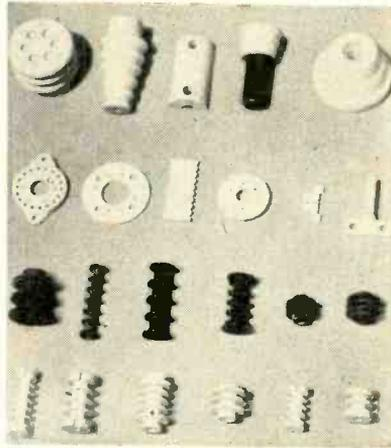

Bobbins varied, shapes, sizes

THOR CERAMICS, INC., 225 Belleville Ave., Bloomfield, N. J., offers a complete line of custom-fabricated winding forms, coil forms and bobbins. These bobbins, in addition to an unlimited variety of other shapes and sizes, can be made of epoxy, ceramics, nylon, polyesters, fluorocarbons, teflon, polystyrenes and other materials. A large variety of standard or custom sizes and shapes of steatite, either pressed or machined, are also available to meet both Jan-1-10 and commercial applications. Circle 328 on Reader Service Card.



Scaler/Ratemeter plug-in design

NUCLEAR ELECTRONICS CORP., 2632 W. Cumberland St., Philadelphia 32, Pa. Complete plug-in

Using Thermistors

Edited by
FENWAL ELECTRONICS

MATCHED THERMISTORS FOR GAS ANALYSIS

Now Fenwal Electronics offers resistance and voltage-current matched thermistor assemblies which are particularly useful for gas chromatography and other gas analyses.

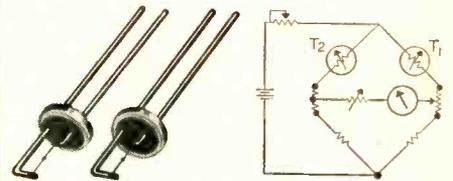

The matched thermistor assemblies above are used in a balanced bridge circuit. One assembly is in each arm of the bridge and equal current is applied to each. The thermistors, self-heated by the passage of current, will dissipate heat at equal rates if the medium surrounding each thermistor is identical. The meter will show an equilibrium reading.

If the thermal conductivity of the gas surrounding either one of the thermistors should change, the rate of heat dissipation will also change, altering the resistance of the thermistor and unbalancing the bridge, thus causing a reading on the meter. The meter can, therefore, be calibrated to give an accurate indication of the percentage of a foreign element in the gas being analyzed, as related to a known reference gas.

It's all based on the unique characteristic of thermistors — when temperature rises, resistance falls. This relationship occurs whether the thermistor is self-heated, as in the example above, or externally heated through a liquid, gas or solid.

Write FENWAL ELECTRONICS, INC., 22 Mellen Street, Framingham, Mass., for complete information on matched thermistors (Bulletin EM-14), and for many other thermistor applications (Catalog EMC-1).



Design — Engineering — Production

of Precision Thermistors
CIRCLE 55 READERS SERVICE CARD

design of this new Super Series instrument model PFA-100 reduces initial investment, saves space and avoids obsolescence by combining several instruments into one. Pulse amplifier or linear amplifier and single channel analyzer are available for input section. The counting unit can be either a high-speed decade scaler (choice of 100 kc or 1 mc) or wide-range ratemeter with aural monitor. Chassis can be changed from front of cabinet by simply loosening thumb screws. Instrument includes built-in timer, continuously variable voltage for probe with $\frac{1}{2}$ percent regulation 500 to 2,500 v, self-contained calibrator, hermetically sealed transformers, connection for 1 ma pen recorder and many other features. Circle 329 on Reader Service Card.

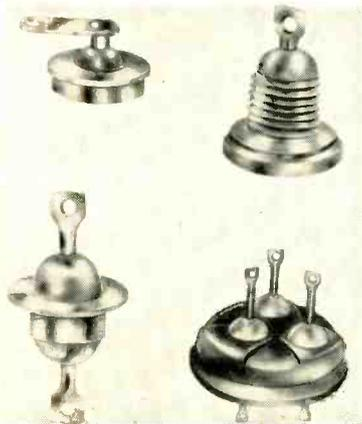

Compression Seals more glass mass

HERMETIC SEAL CORP., 29 South Sixth St., Newark 7, N. J. Hi-Dome compression seals now permit the fused glass to extend beyond the metallic configuration without cracking or shearing. They combine the superior mechanical strength of compression seals with the highly desirable electrical and physical operating characteristics of glass-to-metal kovar seals. The dielectric properties of the increased glass mass in Hi-Dome seals provide higher electrical surface resistance and higher arc-over values eliminating potential moisture traps and faulty glass fusion.

The newest progression in glass-to-metal compression seals will permit further miniaturization of

Sola Electric Co. uses

Phaotron CUSTOM Panel Meters

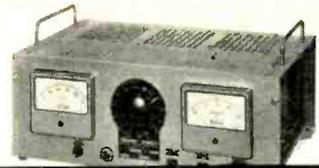

PHAOSTRON CUSTOM PANEL METERS

METAL CASED FOR
LASTING ACCURACY
SHOCK MOUNT JEWELS

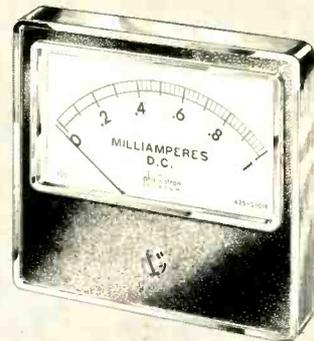

PHAOSTRON CUSTOM PANEL METERS are being selected by many famous manufacturers because of their superior precision construction, accuracy and price. Pivots are ground and polished with shock mounted jewels. Accuracy is permanent within 2% (3% on rectified types). Phaotron's metal case protects the D'Arsonval movement against stray magnetic fields... can be mounted on any panel material without recalibration. Scales are large, easy to read Die Cast Bezels. Expanded Scales are available. Zero adjustment is fully insulated. Available in a wide variety of colors and chrome.

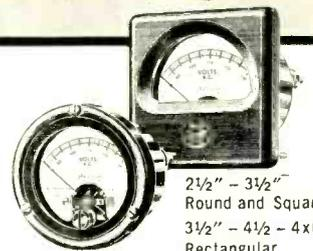

2 1/2" - 3 1/2"
Round and Square
3 1/2" - 4 1/2" - 4x6"
Rectangular

PHAOSTRON Instrument & Electronic Co.

151 Pasadena Avenue, South Pasadena, California

CIRCLE 56 READERS SERVICE CARD

PHAOSTRON

A new name and a new standard in intercontinental communications



RA.17C

RACAL



Already this revolutionary new receiver is accepted as a standard equipment by British forces; and is in service with many other government, armed forces, postal, broadcasting and news organisations throughout the world. The RA.17C is equipped with American tubes and connectors throughout. Ancillary equipments include an LF convertor, SSB adaptor and FSK facilities. Write for full specification and performance data to

- ★ A sensational advance in H.F. communications receivers
- ★ 0.5—30 Mc/s without bandswitching
- ★ Exceptional sensitivity and stability
- ★ Setting accuracy within approx. 200c/s.

RACAL ENGINEERING LTD · BRACKNELL · BERKS · ENGLAND



CONVERTS ANALOGS TO DIGITS DIGITS TO ANALOGS

*without complex
electronic equipment*



DECIMAL
DIGITIZER

Also available for analog-digital conversion:



BINARY OR
BINARY CODED
DECIMAL DIGITIZER

Write for free Data File. Mention your application.

Your name _____
Company _____
Address _____



ENGINEERING COMPANY, INC.
6040 West Jefferson Boulevard
Los Angeles 16, California

CIRCLE 58 READERS SERVICE CARD

components, closer terminal connections, and other improved operational characteristics. Applications include filters, transformers, capacitors, relays and refrigeration seals. Circle 330 on Reader Service Card.

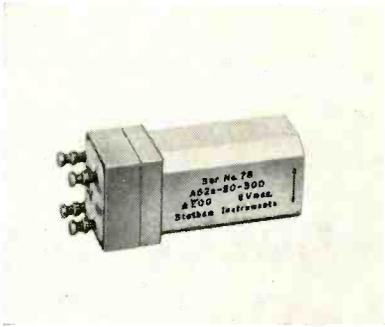

Accelerometer linear unit

STATHAM INSTRUMENTS, INC., 12401 W. Olympic Blvd., Los Angeles 64, Calif. The A52 linear accelerometer is about $\frac{1}{4}$ the size of comparable instruments. Utilizing the unbonded strain gage principle, it has the extremely small dimensions of 0.32 in. by 0.35 in. by 0.97 in. and weighs 7.2 grams. Exact laboratory calibration makes it especially well suited for use in missile guidance systems, within control surfaces for vibration studies on aircraft or missiles, within wind tunnel models, or in a wide variety of applications containing critical space limitations yet requiring a high degree of accuracy.

With an output of approximately 32 mv full scale open circuit per 8 v excitation, it has a maximum allowable static acceleration of two times its rated range. The circuit of this miniature instrument forms a complete balanced bridge which has a nominal resistance of 300 ohms.

By employing the principle of the unbonded strain gage, this tiny accelerometer can be used with dynamic measuring equipment without the need of acquiring additional accessory equipment for amplification. Its other advantages include rugged construction and a minimum of moving parts which provide wearing qualities that stand up under years of constant and heavy use. Circle 331 on Reader Service Card.



S.S. White FLEXIBLE SHAFTS simplify product design

Whether your product is in the design stage . . . or in full production. S. S. WHITE Flexible Shafts may be the simple, economical road to improvement. Power sources, driven members, controlled parts and their controls can be positioned to better advantage. Alignment problems, costly methods of connection and adapting can be eliminated.

Our engineers will be glad to assist you in working out application details.

Write for Bulletin 5601 for useful data on how to select and apply flexible shafts.



S. S. WHITE INDUSTRIAL DIVISION
Dept. E, 10 East 40th Street, New York 16, N. Y.
Western Office:
1839 West Pico Blvd., Los Angeles 6, Calif.
CIRCLE 57 READERS SERVICE CARD

YOU WILL RECEIVE 53 ISSUES IN 1958

alternate
engineering
and business
editions
plus . . .
the
buyers' guide

electronics  

A MCGRAW-HILL PUBLICATION
130 WEST 42nd STREET, NEW YORK 36, N.Y.

CHART OF PUBLISHING CYCLES

electronics engineering edition	electronics business edition	electronics engineering edition	electronics business edition
CYCLE A	CYCLE B	CYCLE C	CYCLE D
JAN. 3	JAN. 10	JAN. 17	JAN. 24
JAN. 31	FEB. 7	FEB. 14	FEB. 21
FEB. 28	MAR. 7	MAR. 14	MAR. 21
MAR. 28	APR. 4	APR. 11	APR. 18
APR. 25	MAY 2	MAY 9	MAY 16
MAY 23	MAY 30	JUNE 6	JUNE 13
JUNE 20	JUNE 27	JULY 4	JULY 11
JULY 18	JULY 25	AUG. 1	AUG. 8
AUG. 15	AUG. 22	AUG. 29	SEPT. 5
SEPT. 12	SEPT. 19	SEPT. 26	OCT. 3
OCT. 10	OCT. 17	OCT. 24	OCT. 31
NOV. 7	NOV. 14	NOV. 21	NOV. 28
DEC. 5	DEC. 12	DEC. 19	DEC. 26

BUYERS' GUIDE ISSUE—JUNE 15

FIRST CLASS
PERMIT NO. 64
(Sec. 34.9 P.L.6R.)
NEW YORK, N. Y.

BUSINESS REPLY CARD

NO POSTAGE STAMP NECESSARY IF MAILED IN THE UNITED STATES

4¢ Postage Will Be Paid By

ELECTRONICS

Reader Service Dept.

330 West 42nd Street

New York 36, N. Y.

PUSHBACK WITHOUT BREAKDOWN



BH VINYL-SIL

Permanent flexibility for coil transformer leads was pioneered by Bentley, Harris in 1949 with the introduction of the first truly workable vinyl-glass sleeveings for the rough handling encountered in this application.

Today, BH Vinyl-Sil has ten times the heat resistance and flex-life of the original product. Class B operation — for minutes or years — is now possible with this vinyl-glass sleeveing. Careful formulation insures a balance of essential properties to meet almost any insulating requirement.

BH Vinyl-Sil is just one of many customized BH Sleeveings designed for specific applications and constantly improved through research and development. We'd like to help you determine the *right* BH product for you. A few facts about conditions to be met will bring you samples and data sheets.

BENTLEY, HARRIS MANUFACTURING CO.

300 Barclay Street

CONSHOHOCKEN 4, PA. TELEPHONE: TAYLOR 8-0634

BENTLEY, HARRIS

Flexible

SLEEVINGS

BH Non-Fraying glass fiber sleeveings are made by exclusive Bentley, Harris process (U.S. Pat. Nos.: 2393530; 2647296 and 2647299).

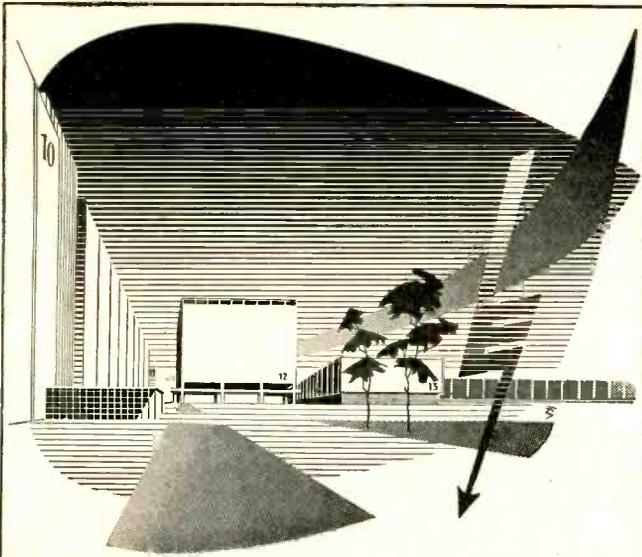

HANNOVER
 the most important Market of the
ELECTRICAL INDUSTRY
 for heavy equipment and consumer goods
GERMAN INDUSTRIES FAIR
APRIL 27 - MAY 6, 1958

Information and catalogues from:
 German American Trade Promotion Office, Suite 6900
 Empire State Bldg., 350 Fifth Ave., New York 1, N. Y.



CIRCLE 60 READERS SERVICE CARD

YOUR BEST BUY!

RIBWOUND HI WATTAGE
RESISTORS

Your inquiry or drawing will bring quotations
 samples on request

MILWAUKEE RESISTOR CO.

702 W. Virginia Street

Milwaukee 4, Wisconsin

CIRCLE 61 READERS SERVICE CARD

For Those Who Demand Service!

COSMIC

**ELECTROLYTIC
 & PAPER
 TUBULAR**

"35 YEARS OF PROVEN
 DEPENDABILITY"

Condensers

COSMIC CONDENSER CO.
 853 Whittier St., Bronx, N. Y.
 PHONE
 LUdlow 9-3360

Literature of

MATERIALS

Purifier Color Pigments. Liquid Nitrogen Processing Corp., 451 Booth St., Chester, Pa., announces literature on its purified color pigments for color coding of high temperature electrical grade plastic materials such as Teflon. The purity of the color pigments listed has also resulted in their use in other plastic lines where the impurities caused electrical breakdown or had abrasive characteristics. Circle 332 on Reader Service Card.

COMPONENTS

Teflon Insulated Wire and Cable. American Super-Temperature Wires, Inc., Winooski, Vt. Inspection and testing samples of high temperature insulations are being offered. Of special interest are the company's newer products, including teflon insulated bondable wire, as well as multiconductor and coaxial cables. Circle 333 on Reader Service Card.

Waveguide Pressure Windows. Microwave Associates, Inc., Burlington, Mass. A brochure describing waveguide pressure windows and their uses has been prepared. Performance curves, outline dimensions and drawings, and complete electrical and mechanical data are given for each window type. Helpful installation instructions are also included. Circle 334 on Reader Service Card.

EQUIPMENT

Control System. Leeds & Northrup Co., 4934 Stenton Ave., Philadelphia 44, Pa. Complete information about a new current-adjusting type control system for use with magnetic amplifiers and saturable core reactors is now available in a series of data sheets. The illustrated sheets fully describe how the control system will continuously regulate power input to a variety of electric furnaces—

the Week

either continuous or batch. Circle 335 on Reader Service Card.

Pressure Standards. Wiancko Engineering Co., 255 N. Halstead St., Pasadena, Calif. Engineering data sheet 857-419 contains an illustrated description and specifications for the type Q3401, a new standard for the calibration of pressure instruments, and for direct pressure measurements. Circle 336 on Reader Service Card.

Radar Calculator. Avco Mfg. Corp., Research and Advanced Development Div., 750 Commonwealth Ave., Boston, Mass., has designed a radar self-screening range calculator which provides a jamming figure of merit for radar system engineers. The hand calculator with its simplified scale settings eliminates slide rule calculations formerly required to determine the distance at which signal energy received at the radar is large enough to show through the jamming noise. Copies of the calculator may be obtained by radar engineers through request on company letterhead.

Servomotor. Beckman/Helipot Corp., Newport Beach, Calif. Data sheet 1258 introduces a new 115-v 400-cycle size 15 servomotor. The unit described offers acceleration at stall of 100,000 rad/sec², weighs 8 oz, and is cut out for operation at 200 C. Circle 337 on Reader Service Card.

FACILITIES

Facilities and Products. Western design & Mfg. Corp., Santa Barbara Airport, Goleta, Calif. A new 46-page brochure sets forth the design, engineering, and manufacturing facilities, and shows typical electromechanical and electronic products and systems in the fields of power supplies, actuators, blowers, timing devices, and inverters as used in the manufacture of aircraft and missiles. Circle 338 on Reader Service Card.

NEW

KLEIN shear cutting plier



Patent applied for

207-5C shear cutting oblique plier 5½ inches long. Coil spring keeps jaws apart ready for use.

Here is the greatest advance in oblique cutters. This new Klein tool with shear blades is ideal for cutting hard wire such as tungsten filament or dead soft wire. Also recommended for cutting small bundles of wire. The shearing action assures easy, positive cutting at all times.

Regular cutters at the nose give added usefulness and convenience. The shear blade is easily replaceable. Plier never needs sharpening.

This plier is supplied with a coil spring to keep the handles in open position. Can also be had with Plastisol dipped handles if desired.

Write for full information

LONG NOSE SHEAR CUTTING PLIERS

Patent applied for



208-6C long nose shear cutting plier. A 6½-inch long nose plier with shear blades. Point of nose ¼-inch diameter. Coil spring keeps jaws open ready for use.

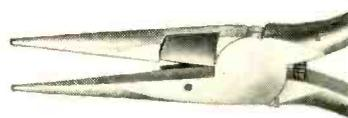

208-6NC. Similar in design to 208-6C but reverse side designed to put a positive ⅜-inch hook on the end of a resistor wire. Smooth one-motion operation saves production time on every television or radio set.

FREE POCKET TOOL GUIDE



100 years of service to linemen, electricians and industry is back of this new Pocket Tool Guide No. 100. A copy will be sent you on request without obligation.

ASK YOUR SUPPLIER

Foreign Distributor:
International Standard Electric Corp.
New York



Mathias KLEIN & Sons
Established 1857
Chicago, Ill., U.S.A.
7200 McCORMICK ROAD • CHICAGO 45, ILLINOIS

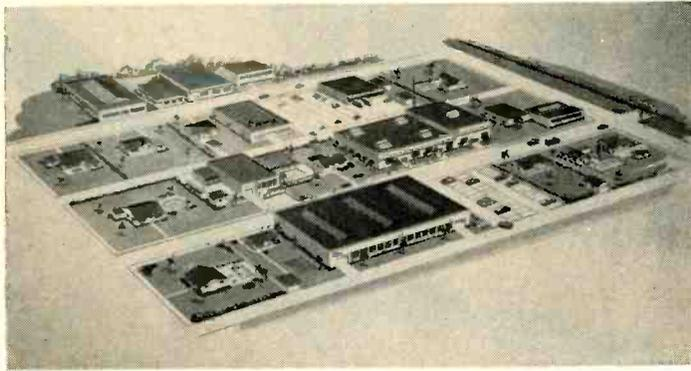

Merit Coil Consolidates

IN HOLLYWOOD, Florida, Merit Plaza (above) an ultra-modern plant area, recently went into full production of Merit Coil and Transformer Corporation's complete line of transformers, coils and associated components. Four company plants are now in operation.

Consolidation in Hollywood of the firm's production facilities was completed over the weekend of March 15th, when an airlift using chartered planes brought the last of the company's production files, records and equipment from the Chicago plant to Merit Plaza. Key personnel were on hand for business as usual on Monday, the 17th.

All heavy production machinery used in the Chicago plant has been duplicated or replaced with modern and specially designed equipment already installed in the first four completed buildings.

Merit Plaza plans call for a dozen or more separate buildings. The fifth unit is under construction alongside a main line railroad and express highways. The area has easy access to airports. Some executive and research offices eventually will be housed in detached bungalow-type buildings in the area.

First step in the development was taken five years ago when Charles C. Koch, company president, established Florida-Merit, Inc., in Hollywood as an R&D project—the theory being that coil and transformer products built in Florida to withstand extremes of humidity and salt content in the air would prove to be operational wherever used. After five years of rigorous tests, Koch began setting

up production lines for coils and transformers, designing new machinery to produce products heretofore manufactured in Merit's Chicago plants. New buildings were added to Florida-Merit and associated plants, culminating in Merit Plaza.

RCA Elects Three V-P's

AT A RECENT meeting of the board of directors, three new vice presidents of the Radio Corp. of America were elected.

James Hillier becomes vice president, RCA Laboratories, the research organization of RCA, of which he has been general manager since January 1957.

Raymond W. Saxon, formerly director, regional operations, was elected vice president and general manager, RCA Victor Radio and Victrola Division.

Joseph M. Herzberg steps up to vice president, defense marketing, Defense Electronic Products, of which he has been manager since July 1957.

Bendix Names Top Engineers

THREE major appointments on the staff of the missile section of the products division of Bendix Aviation Corp., Mishawaka, Ind., are announced.

D. M. Heller and R. E. Whiffen are named assistant general man-

agers, and W. P. Bollinger, director of engineering. Previously Heller served as director of engineering, and Whiffen as plant manager. Bollinger was assistant director of engineering.

Heller joined the research staff of the radio division in Baltimore, Md., in 1947. In 1950 he was named chief engineer of the commercial products engineering department. He joined the staff of the missile section in 1954.

Whiffen became associated with the Bendix radio division staff after the war, working on the design and development of uhf airborne communications, microwave components and radar systems. In 1953 he was transferred to the missile section as technical staff assistant to the general manager.

Bollinger joined the staff of the missile section in 1953. Previously he served as project manager of fire control design and development for the Radio Corp. of America.



Elect Haller V-P at GE

GENERAL manager of GE's defense electronics division since 1956, George L. Haller (picture) is elected a vice-president of General Electric Co.

During the period 1946 to 1954, Haller helped found and served on the board of directors of the consulting firm of Haller, Raymond and Brown, Inc. In 1954, after serving as a part-time consultant to

Where does progress begin?

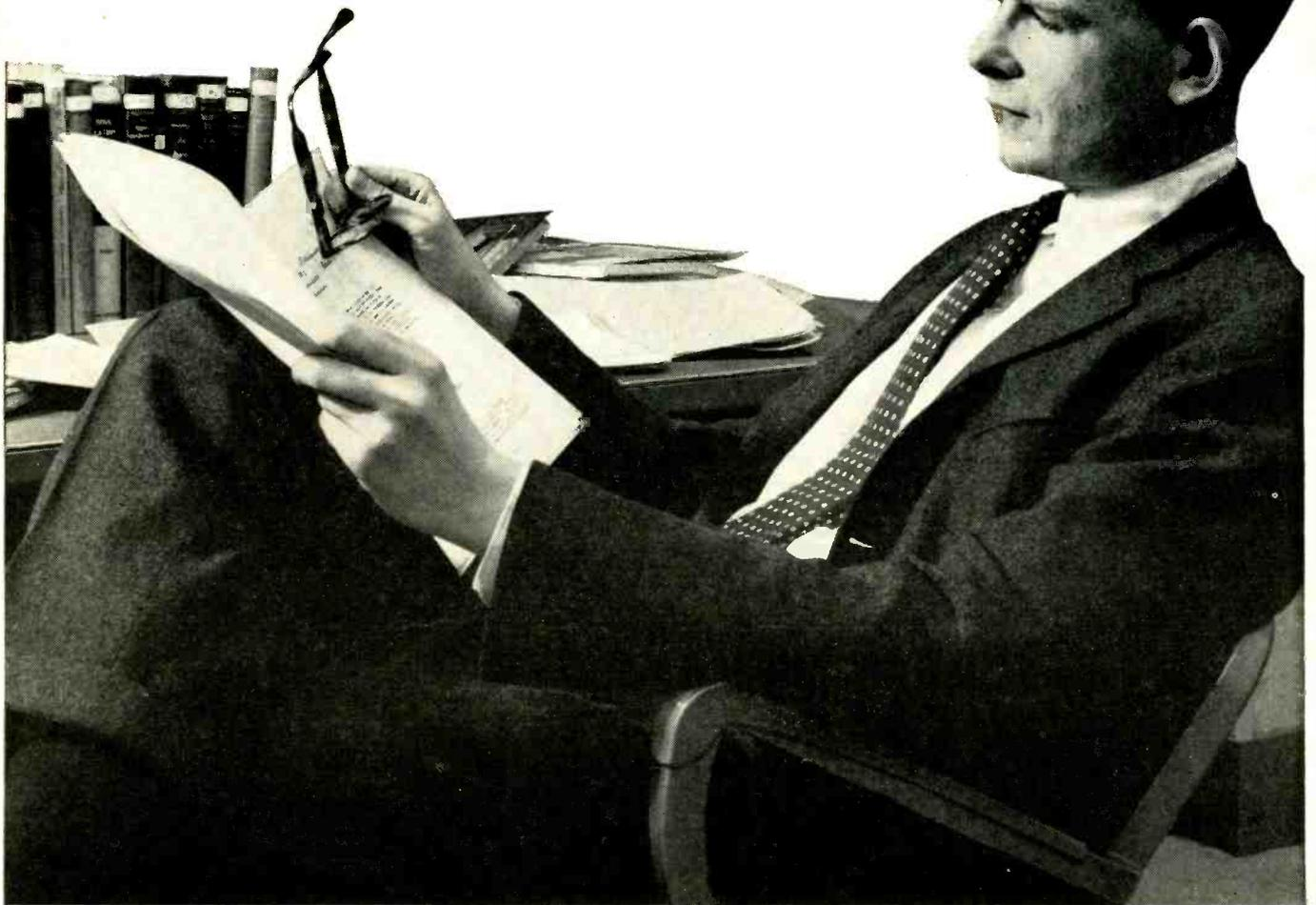

Kendall Preston Jr., S.M. in engineering from Harvard University . . . graduate of the Laboratories' Communications Development Training Program.

Progress begins in the mind—in the perception and appreciation of new ideas. In the past the ideas that sparked progress too often had to wait on the random interest of genius. Today more and more new ideas come from men trained to an awareness of that which is yet to be accomplished.

At Bell Laboratories, communications science is entering upon its most challenging era in history. As never before, progress will depend upon men who have acquired the special training needed to think creatively in this exciting field.

Bell Laboratories provides the young college graduate with unique opportunities to develop his creative

abilities. During his first two years, he spends two or three days a week as part of his job, taking postgraduate courses in basic mathematics, physics and electronics. This he does at a graduate study center which has been established at the Laboratories by New York University. As he gathers a broad fundamental knowledge which will enable him to tackle every type of communications problem, he also gathers credits toward advanced degrees. To round out his education, he spends a third year on special phases of communications technology.

By helping scientists and engineers to reach their top development, Bell Laboratories has helped to make your telephone system the world's best—and will keep it so.

BELL TELEPHONE LABORATORIES
WORLD CENTER OF COMMUNICATIONS RESEARCH AND DEVELOPMENT



For industrial applications



Stromberg-Carlson "Push-to-talk" HANDSETS

You'll find many valuable uses for Stromberg-Carlson's "Push-to-talk" telephone handsets in your day-to-day operations. These instruments feature switch assemblies with various spring combinations mounted in the handles, actuated by a rocker-bar lever. A few typical applications:

- **Push-to-talk and Push-to-receive:** for two-way radio communication.
- **Push-to-open and Push-to-close external circuit:** for use with dictating machines and in remote control operations.

You have a choice of two types of handset: No. 28, which is the standard model; and No. 29, a special high-gain, high-efficiency handset with Western Electric type receiver and transmitter. Available with either coiled or straight cord.

For complete technical details on these handsets and other Stromberg-Carlson telephones and components for industrial use, send for Bulletin T-5005. Write to:



STROMBERG-CARLSON

A DIVISION OF GENERAL DYNAMICS CORPORATION
TELECOMMUNICATION INDUSTRIAL SALES
114 CARLSON ROAD, ROCHESTER 3, N. Y.
ELECTRONIC AND COMMUNICATION PRODUCTS
FOR HOME, INDUSTRY AND DEFENSE

CIRCLE 41 READERS SERVICE CARD

GE for several years, he joined the company as manager of its electronic laboratories, with headquarters at Syracuse, N. Y. He was later appointed general manager of the defense electronics division.



Goodhue Elected R&D V-P

THE BOARD of directors of Universal Winding Co., Providence, R. I., recently elected William V. Goodhue (picture) to the position of vice president in charge of research and development.

Goodhue joined Universal in 1946 as associate director of research and became director of research in 1956. He has been instrumental in the development of many of Universal's new machines and processes for the textile and electronic industries.

IRE Sets Up New Group

A NEW IRE professional group on radio frequency interference has been organized and is now in operation. The group's activities will include investigations of the origin effect control and measurement of r-f interference.

Officers include H. R. Schwenk, chairman, Leonard Milton, vice chairman, A. R. Kall, secretary and J. P. McNaull, treasurer. They have announced plans for a symposium on radio frequency interfer-

ELECTRONIC ENGINEERS

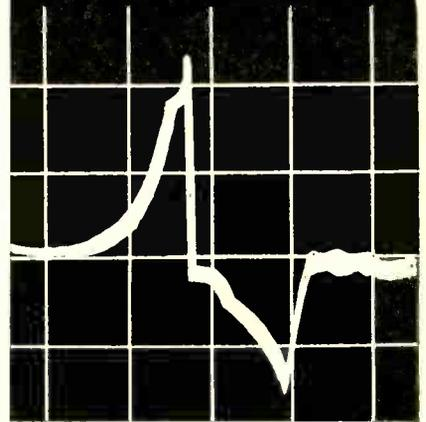

SEVERAL UNUSUAL OPENINGS

Unfaltering progress, even during the past six months, in the Electronics and Avionics Division of Emerson Electric is directly attributable to the sound planning of our long-range expansion program. As a result, we must broaden our organizational structure and immediately staff several excellent, challenging career positions.

We emphasize research, design and development and maintain a sound ratio of production. Current projects include the B-58 fire control system, mortar locators, radar components and assemblies, servomechanisms, missiles and rockets, ground support equipment, microwave antennas, F-101 Voodoo subsystems, plus many other classified electronic devices for the supersonic era.

You must have an E.E. degree plus 4-6 years' experience in electronics. Your electronic design experience must be in either servomechanisms, radar systems, analog or digital computers, fire control systems or ground support equipment. Missile guidance and/or infra-red experience is helpful but not essential.

Emerson Electric is one of the leading missiles and military electronics firms—well established, medium size, aggressive. Salaries are top level, benefits are fully comprehensive. Location is perfectly suburban. All moving expenses completely paid.

Your Future Is Our Business!

Please send your complete resume
NOW, with business experience,
education and salary requirements,
to A. L. Depke.

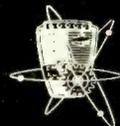

EMERSON ELECTRIC

Electronics and Avionics Division
8100 W. Florissant • St. Louis 21, Mo.

ence to be held in the near future. Transactions in the field of r-f interference, its problems and solutions will be published by the group as a service to the electronics industry as a whole.

The officers of the new group extend an invitation to all engineers presently engaged in this field who might wish to join. Contact the IRE, 1 East 79 St., New York 21, N. Y.

News of Reps

SLIP-RING assemblies and other precision components of ElectroTec Corp., South Hackensack, N. J., will be handled by R. B. Barnhill Co. in the following territory: District of Columbia (excluding Government prime contract agencies), Delaware, Maryland, Virginia, Florida, New Jersey (all counties south of and including Mercer and Monmouth), North Carolina, Pennsylvania (limited to counties of Potter, Clinton, Centre, Blair, and Bedford and all counties east of those).

Plastic Capacitors, Inc., Chicago, Ill., appoints the following new manufacturer's reps:

The Braum Co. for territories of Texas, Oklahoma, Arkansas and Louisiana; Mark Electronics Sales Co., for Florida, southern Georgia, southern Alabama; Arthur N. Elliott Co., for Kansas, Nebraska, Missouri, southern Illinois; and Howell Sales, Inc., for Washington, Oregon, northern Idaho, western Montana, British Columbia and Alaska.

Mid-Century Instrumatic Corp., New York, N. Y., names Gay Sales Co. Associates, Houston, Texas, as sales rep for its line of analog computers, simulators, recorders and accessories and components. Rep firm will cover Texas and Louisiana.

Hamner Electronics Co., Inc., Princeton, N. J., appoints McCarthy Associates, of Pasadena and Palo Alto, Calif., to handle its line of nuclear and electronic instruments. Rep firm will cover the California, Arizona and Nevada areas.

See us at **BOOTH 850**
Design Engineering Show
April 14-17th—Chicago



if you use small gears & pinions

IT WILL PAY YOU TO CHECK

GRC'S STOCK SHEET

Before you order gears or pinions, see GRC's new Stock Sheet. All items listed are cast from stock dies, individually or in various combinations of gears, pinions, hubs, shafts, etc. Holes, shafts, spacers, shoulders, etc., are made to your exact specifications at no extra tool charge, quantity permitting. Maximum O.D. about 1 1/2", with 1/16" face width; wider faces for smaller diameters. • Unusual shapes, extra precise requirements, available on special order.

Write today for new stock sheet. SEND SPECIFICATIONS FOR PROMPT QUOTATION — 100,000 TO MILLIONS.

GRIES REPRODUCER CORP.

World's Foremost Producer of Small Die Castings

151 Beechwood Ave., New Rochelle, N. Y. • Phone NEW Rochelle 3-8600
CIRCLE 42 READERS SERVICE CARD



ENVIRONMENTAL TEST EQUIPMENT

TEST RANGES

- TEMPERATURE — 150°F to 500°F
- HUMIDITY (RH) 20% to 95%
- ALTITUDE up to 150,000 feet
- TEST SPACE 1 cu. ft. to Walk-In Rooms

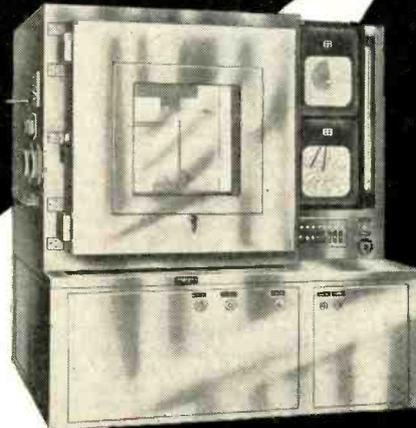

Also Test Equipment for

- Sand & Dust • Fungus
- Rain • Sunshine
- Explosion
- Temperature Test Baths
- Sub-Zero Metal Aging
- Special Test Equipment

Write For FREE Engineering Catalog

Built to meet
MILITARY—GOVERNMENT—INDUSTRY—Specifications

ENVIRONMENTAL EQUIPMENT CORP.
371 LINDEN STREET, BROOKLYN 27, N. Y. • HEGeman 3-9872

Make a **GM**

PORTABLE D'ARSONVAL

GALVANOMETER

*the Heart
of Your
Instrument*

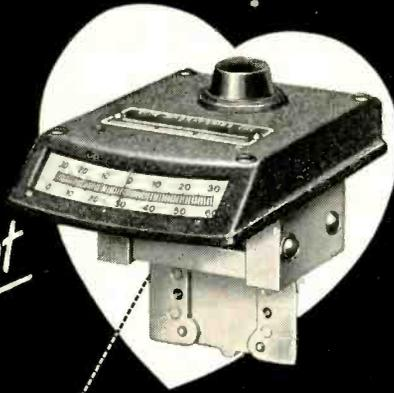

FOR MEASURING LIGHT reflectance and color, the Photovolt Corporation of New York uses a Model 600 G-M Galvanometer for its popular Reflection Meter (left). Whatever your own particular instrument field, you can achieve this same self-contained portability, ruggedness and high sensitivity with G-M Galvanometers. Complete catalog on request.



GM LABORATORIES, INC.

4336 NORTH KNOX AVE., CHICAGO 41
CIRCLE 64 READERS SERVICE CARD

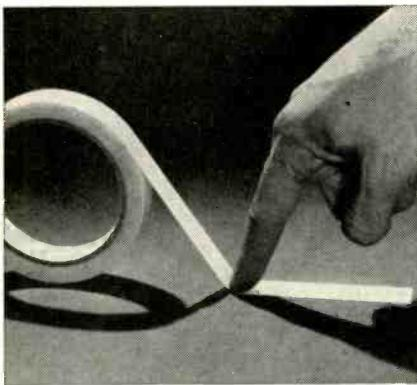

New—.002", 2750 v/m pressure-sensitive tape for 500°F operation

New TEMP-R-TAPE C, Teflon* film with pressure-sensitive, thermal curing silicone adhesive is only .002" thick overall, has 2750 v/m dielectric strength, -100°F to 500°F (-70°C to 260°C) temperature range. Easy-to-apply, it presses in place on any surface and can be cured to form permanent bond. Send for data on TEMP-R-TAPE C and CHR's other extreme temperature tapes.

*duPont TM.

THE CONNECTICUT HARD RUBBER CO.
407 East St., New Haven 9, Conn., Spruce 7-3631

TEMP-R-TAPE®

CIRCLE 65 READERS SERVICE CARD

SAVE 1/2 — PAY PART-BY-PART — HAVE FUN

Assembling the **SCHOBER ELECTRONIC ORGAN** in KIT form



**NO SPECIAL
SKILLS
NEEDED**

Now you can afford a real, full concert organ, just like those made by the foremost organ manufacturers. Because over 1/2 the cost is saved when you assemble it yourself. And it's REALLY EASY: only 24 separate units, all with printed circuits, and detailed-to-the-smallest-step instructions. In addition, you purchase each of the 24 kits when you are ready for it — and can afford it.

You'll get a real kick out of putting the Schober Electronic Organ* together — and then sitting down and pulling the stops for Strings, Trumpets, Clarinets, Diapasons, Flutes, etc. Electronic Percussion optional; chimes available.

Compact CONSOLE

One of the many exclusive features of this exceptional organ is the handsome console, in a wide variety of finishes. It is equally at home in a traditional or modern setting, and takes little more space than a spinet piano.

Free Literature

Complete descriptive booklet and price list are available on request. And, if you wish to hear the glorious pipe organ tone of the Schober Electronic Organ, a 10" long-playing demonstration recording is available for \$2. This is refundable when you order. Write today and see what a fine instrument you can get at such a great saving.

The SCHOBER ORGAN CORP.

2248M Broadway, New York 24, N. Y.

*Designed by Richard H. Dorf

CIRCLE 66 READERS SERVICE CARD

NEW BOOKS

Digital Computer Components and Circuits

BY R. K. RICHARDS

D. Van Nostrand Company, Inc.,
1957, 511 p., \$10.75.

DR. RICHARDS has written a companion volume to his "Arithmetic Operations in Digital Computers," which was published in 1955. The intention of the present volume is to cover the design considerations involved in the various available methods for implementing circuit logic and storage functions. For the most part, the book consists of a collection of ideas related to digital circuit techniques and storage systems which have been published in technical journals in the last ten years. This is not to be interpreted as a derogatory comment, for the inclusion of such a vast amount of information between two covers is a definite contribution, especially in reference to its utility to the neophyte computer engineer. The up-to-date, excellent bibliography adds greatly to the value of the work.

Approach—The book is of a qualitative rather than a quantitative nature, but quantitative details are generally at hand via the bibliography. A quantitative treatment of the many examples of circuit design would, of course, fill many volumes of this size.

The first chapter introduces the relatively new statistical approach to circuit design, with circuit reliability considerations given their rightful, often neglected emphasis.

Diode Switching—Some of the basic practical considerations which the designer of diode switching circuits faces are discussed in the second chapter. The approach here is not design in the sense of minimization of Boolean expressions for diode circuit synthesis, but is an introduction to the engineering aspects of the design of diode logical circuits.

The requirements of power supply voltages and AND and OR circuit resistors for particular switching circuit arrangements with diodes of particular resistances and capacitances, are described. Diode recovery time is mentioned only in

general terms, but the details are available through reference to the bibliography. The reference book quality of the work should make it handy as a starting point in the solution to many digital technique problems.

Next follows an analysis of many approaches to vacuum tube, transistor, and magnetic core systems of logic circuit design. It appears that every significant approach that has appeared in the technical literature is presented and discussed. Although this section represents about 40 percent of the book, in some places the attempt at brevity leaves the reader with rather a vague idea of the circuit function and its significance relative to other similar circuits.

Storage Systems—Following the three chapters on circuit logic the reader is introduced to large capacity storage systems. The coverage is once again very complete including discussion of methods of storage which have never gone beyond the experimental stage, such as spin-echo storage. The emphasis is placed very sensibly, however, on magnetic storage methods; an entire chapter is devoted to magnetic core memories.

Chapter nine treats circuits and tubes used for decimal counting and some miscellaneous components, which very well might be the basic elements of future computers, have been introduced here with the description of the cryotron and some logical circuits employing cryotrons. Analog-to-digital and digital-to-analog conversion is the subject matter of the last chapter of the volume.

In summary, the author has accomplished his intention, stated in the preface, of providing a ready source of reference material for the practicing engineer and of providing a means for the newcomer to the computer field to "get on board." D. E. ROSENHEIM, IBM Watson Laboratory at Columbia University, New York, N. Y.

THUMBNAIL REVIEW

Auto Radio Removal—1957. Howard W. Sams & Co., Inc., Indianapolis, Ind., 1957, 104 p, \$2.95 (paper). Step-by-step instructions for removal of radios, power supplies and speakers from 1957 cars.

NEW AUTOMATIC CIRCUIT TESTING BRIDGE



ROTOBRIDGE

• 99 test positions • one test per second • tolerances of 5, 10 and 20% • wide component range • stabilized circuitry and simple, tamper proof operation.

AUTOMATIC, SEQUENTIAL, CIRCUIT TESTING BRIDGE FOR CIRCUITRY AND COMPONENTS WITH EASILY PROGRAMMED INTERNAL STANDARDS

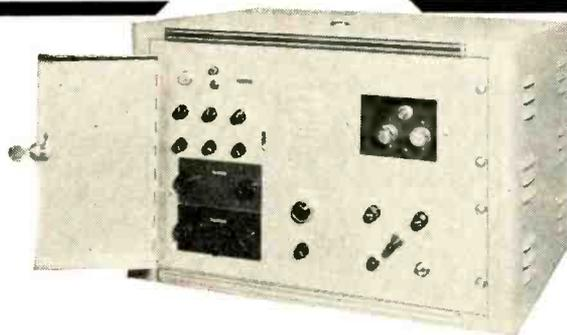

Improve your quality control and save time and money by automatically testing circuit assemblies in seconds with the all new Model 1020.

FEATURING:

1. A quality switch with more than a decade of telephone industry development.
2. Easily programmed standards and tolerance drawers.
3. Stabilized circuits to insure accuracy of measurements.
4. Audible and visual alarms for rejects or end of testing cycle.
5. Easily read "Nixie" tubes indicate digitally the circuit under test.



COMMUNICATION MEASUREMENTS LABORATORY, INC.

350 LELAND AVENUE, PLAINFIELD, NEW JERSEY

CIRCLE 67 READERS SERVICE CARD

Electrical Coil Windings

For 40 years . . . specializing in all types of coils to customers' specifications. Design or engineering assistance available on request.

COTO-COIL CO., INC.

SINCE 1917

65 Pavilion Avenue Providence 5, Rhode Island

CIRCLE 68 READERS SERVICE CARD



Mc GRAW-HILL
DIRECT MAIL LIST SERVICE

If You Are Having Difficulty Maintaining Your Mailing Lists...

Probably no other organization is as well equipped as McGraw-Hill to solve the complicated problem of list maintenance during this period of unparalleled change in industrial personnel.

McGraw-Hill Mailing Lists cover most major industries. They are compiled from exclusive sources, and are based on hundreds of thousands of mail questionnaires and the reports of a nation-wide field staff. All names are guaranteed accurate within 2%.

When planning your direct mail advertising and sales promotion, consider this unique and economical service in relation to your product. Details on request.

McGraw-Hill Publishing Co., Inc.

DIRECT MAIL DIVISION

330 West 42nd Street

New York, 36, New York

Military reliability in
**SEMI-CONDUCTOR
 POWER
 CONVERTERS**



PS-1018 supply for AN. DPN-19 Beacon



PS-3002 28 Volt DC input: 400 cps sine wave output

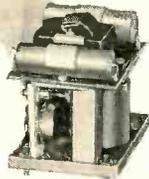

PS-1004B standard 325 Volt, 200 ma dc-dc converter



PS-4000 115 volt AC input; 300 volt 1.5 ampere regulated DC output supply

Power Sources units are now in production missiles

Complete range of sizes, types and capacities for military and commercial requirements:

★ DC to AC available in any power up to 1500 watts . . . square or sine wave output.

★ AC to DC available with voltages up to 500V, and currents to 3 amps . . . DC Regulation to 0.1% . . . Impedances to .05 ohms . . . Over-all efficiencies 70-75%.

★ DC to DC available in combinations of the DC to AC and AC to DC ratings shown above.

★ Military Reliability is assured by extremely conservative designs and the use of the best, pretested military grade components and advanced semiconductor techniques. Meet MIL-E-5400 and MIL-E-8189.



SEND FOR TECHNICAL DATA

POWER SOURCES, INC.
 Burlington, Massachusetts
 BRowning 2-3005

CIRCLE 70 READERS SERVICE CARD

COMMENT

Classroom Tv

"Classroom Tv Makes Grade" (Jan. 24, p 19) was quite interesting. I note that we were not mentioned among the companies "already active in the field."

We have made a large number of educational tv installations for both closed circuit and broadcast applications. Included among our educational customers are two which are probably among the biggest single installations in the country: the recently installed campus closed circuit instructional system at San Jose State College and the instructional system at the University of Texas Dental School.

In all fairness I must also add that you will find several other companies that have been very active in this field besides those you mentioned.

R. T. SILBERMAN

KIN TEL DIVISION,
 COHU ELECTRONICS
 SAN DIEGO, CALIF.

In ("Classroom Tv Makes Grade") I found reference to the State University College for Teachers at Albany. The article indicates that the system uses a camera located twenty miles away to pick up the activities of a classroom to be viewed by college students. In principle the statement is true, but in fact it is in error.

I am sending along with this letter several documents which will give you a better perspective of the work we are doing at the college. . .

FRANCIS E. ALMSTEAD

STATE EDUCATION DEPARTMENT
 ALBANY, N. Y.

Reader Almstead's interesting documents convey the impression that the students are closer to the classroom than 20 miles.

And a Dropped Byline

I was pleased to see my article "Cathode Follower Gain Approaches Unity" in ELECTRONICS Jan. 3 (p 94). However there was no byline giving my name and address as author.

DON D. DAVIS

GENERAL ELECTRIC, HIGH VOLTAGE RESEARCH
 PITTSFIELD, MASS.

DELL

Precision Quality

**FUSED
 QUARTZ**

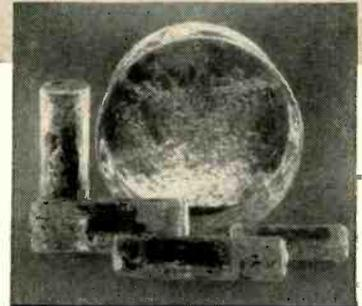

**Clear Fused Quartz
 Custom Fabricated
 in Commercial
 or Optical Grades**

Fused Quartz provides high transparency, high transmission of ultra-violet and thermal properties particularly adaptable for special light sources in therapeutic and photochemical equipment. Resists scratching and weathering; has excellent mechanical strength.

*Let Dell supply
 Fused Quartz for —*

- Absorption Cell Plates
- Windows ● Electrical Insulators
- Plungers ● Microscope Slides
- Cover Slips ● Cell Spacers
- Phase Shifters ● Delay Lines

*Complete Optical Service
 on Precision Glass
 Fabrication including —*

- IR Domes ● Filters ● Prisms
- Lenses ● Optical Flats
- Mirrors ● Commercial Flats
- Windows ● Attenuator Blanks

Precision drilling a specialty—tolerances held to specifications. Technical assistance is available to help solve your problems. Send for brochure.

**DELL OPTICS
 CO. LIMITED**
 327 55th ST., WEST NEW YORK
 NEW JERSEY—Tel. UNION 7-1599

CIRCLE 71 READERS SERVICE CARD

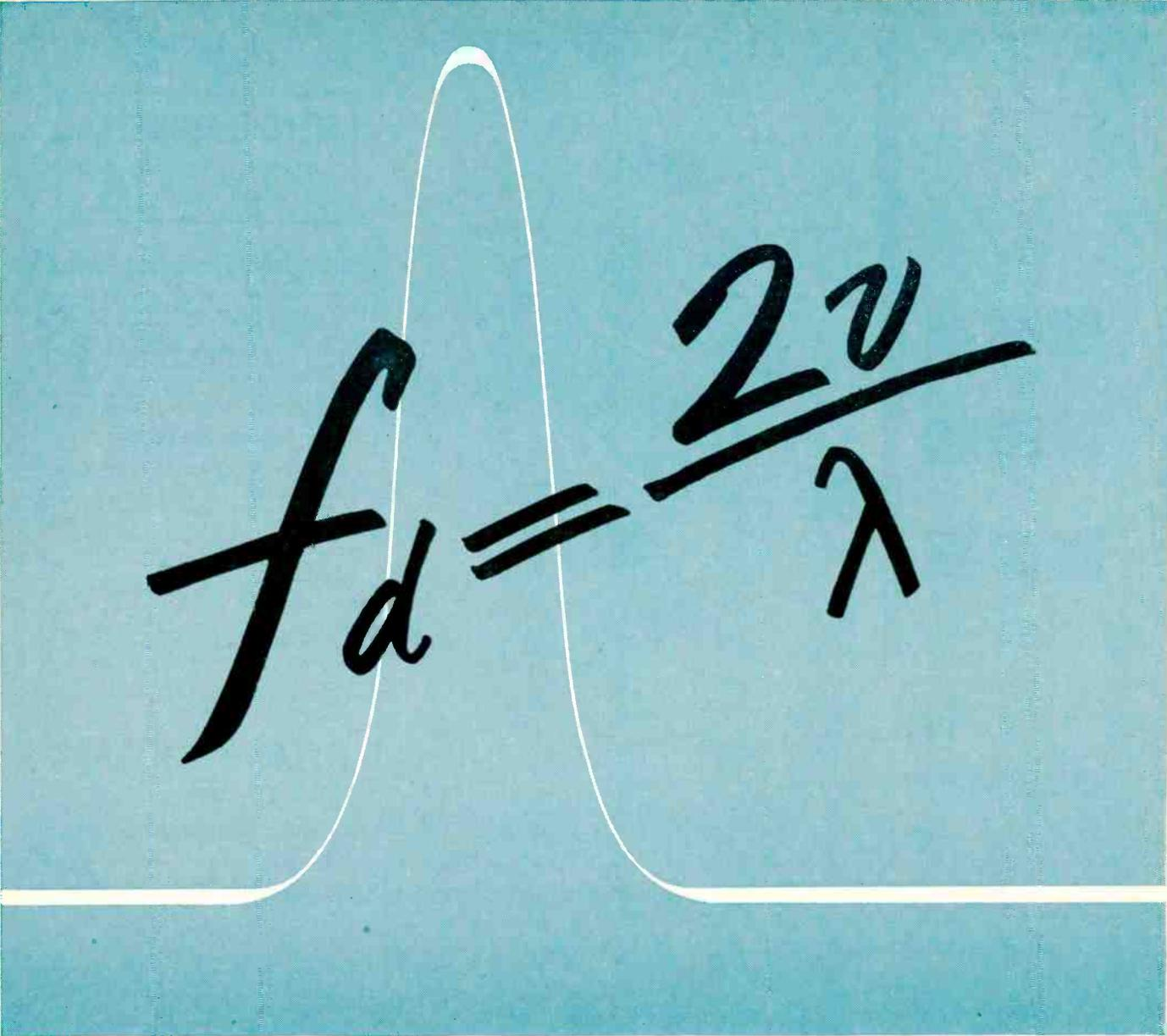
$$f_d = \frac{2v}{\lambda}$$

DOPPLER NAVIGATION SPECIALISTS

Work on advanced doppler radar navigation and guidance projects at Raytheon.

Some of the most interesting and vital projects of the day are now in the works at Raytheon's Maynard Laboratory.

Challenging assignments are given to engineers with specialized radar experience in doppler navigation and guidance systems... and to others with backgrounds in radar interested in working with these new systems.

Are you a circuit design engineer, microwave design engineer, product design engineer, or systems engineer with radar experience?

PLEASE CALL COLLECT. Ask for John J. Oliver at TWin Oaks 7-2945, Ext. 246, or write him for details. He'll be glad to arrange an appointment at your convenience.

RAYTHEON MANUFACTURING COMPANY
Maynard Laboratory
P. O. Box 87E, Maynard, Massachusetts



*Excellence
in Electronics*

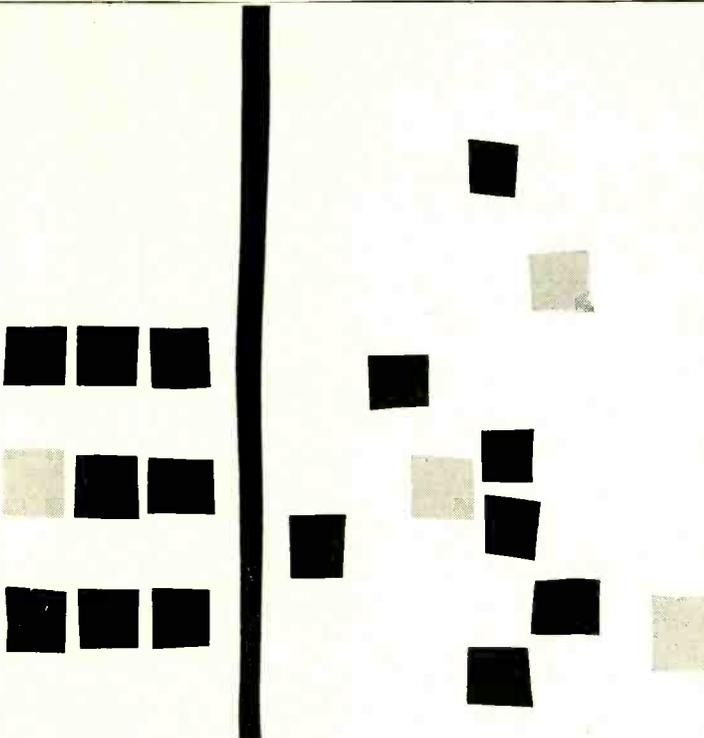

**THE
ELEMENT
OF
FREEDOM**

and the Circuit Design Engineer

Freedom is doing what you like. Some Circuit Design Engineers like best to match their wits and skills against difficult technical problems. This characteristic (or idiosyncrasy) of liking complicated technical problems is one of the chief qualifications of the engineer we need.

To qualify, at least three years' experience in general circuitry design in both tubes and transistors is required. Experience should encompass areas such as video and pulse circuits, cathode ray tube displays and analog and/or digital computer techniques.

You are invited to write for more information or phone collect. Address R. W. Frost, System Development Corporation, 2410 Colorado Avenue, Santa Monica, Calif.; phone EXbrook 3-9411.

SYSTEM DEVELOPMENT CORPORATION
An independent nonprofit organization, formerly a division of the Rand Corporation

**FIELD ENGINEERS
FOR LIBYA**

Senior Telecommunications Engineer

Full responsibility for all work necessary to the completion of the installation and commissioning of a modern tele-communications system. Graduate E. E. or equivalent with minimum 10 years experience in similar type work. Thoroughly familiar with field construction and installation techniques and American, British and/or European communications systems design consideration required.

Senior Troposcatter Engineer

Responsible for the installation, commissioning and performance testing of 1 KW and 10 KW tropospheric scatter radiolink. Graduate E. E. or equivalent with minimum of 5 years experience with radio-links systems is required. Must have sound theoretical background in radio-relay and tropospheric scatter technology or should have had installation and operational experience with high power water-cooled transmitters. Supervisory and training ability desirable.

Interesting foreign assignments with the opportunity to display and utilize your abilities in engineering work of a non-routine nature.

*Send complete resume and salary requirements to
D. E. Doule*

HYCON-PAGE LARC

238 Main Street, Cambridge, Massachusetts

TELECOMMUNICATIONS ENGINEERS

Senior Engineers

Required with some years experience and recent responsibility, preferably in the field of multi-channel line communication systems, for work on submerged repeaters, components and other equipment aspects of submarine telephone cable systems.

Positions vacant in research, design, development and production of the above and in project engineering.

The product has to meet the highest possible standard of performance and reliability and all work will be in new and up to date premises equipped with modern instrumentation.

Senior applicants must have H.N.C. or Degree in Engineering, Maths, Physics or Chemistry and be capable of justifying salary in the range £1000-£2000.

Posts also available, for those with lesser experience in the range £600-£1000.

Applications from women will receive equal consideration.

Graduate apprenticeship courses, generally with National Service deferment, can be arranged. Encouragement will be given to suitable applicants to proceed to a higher degree. Opportunities will occur for original work.

Applications to be made to:— Personnel Manager, Submarine Cables Ltd., Telcon Works, Christchurch Way, Greenwich, London S.E. 10, England.

WANTED

**MANUFACTURER'S
REPRESENTATIVES**

For the following territories

- Philadelphia
- Washington
- Baltimore
- Pittsburgh

TRONIC

Coil Winding Company
58 Wesley St., Waterbury, Conn.
Phone PLaza 6-4668-9

CHIEF ENGINEER

Closed Circuit Television Equipment

An extraordinary opportunity for an engineer with broad technical background to assume complete technical responsibility for a line of closed circuit television equipment and accessories. The right man has both electronic and mechanical design experience with at least 3 years of his career at a project, administrative, or supervisory level.

Must be able to plan development projects, supervise product design and administer a small engineering group in a separate division backed by a 50-year-old aggressive corporation.

Diamond's Electronics Division was a pioneer in its field and today stands on the threshold of substantial expansion. For a chance to become a key member of this group and open an entirely new phase in your career, write at once to:

General Manager
Electronics Division
DIAMOND POWER SPECIALTY CORPORATION
 Lancaster, Ohio

MID-AMERICA Co., Inc

Test-Equipment Sale!

The following test equipment originates from the research labs engineering & production departments of one of the largest TV-Radio Electronic manufacturers. All top name brands available at far below original cost. Contact us immediately for further information. Write, Wire or Phone Rogers Park 4-3745, Attention I. Merens.

Daven Co OP-182 Power Output Meters	\$45.00 ea.
Dumont 208B—5" oscilloscopes	\$49.95 ea.
Ferris Inst 18C Microvolters	\$54.50 ea.
Federal 804CSI UHF Signal Generator 8 to 330 mc.	\$99.50 ea.
Jackson CRO-1 5" oscilloscopes wide band	\$44.50 ea.
Kay Electric Megaliner 19 to 30 Mc and 30 to 49 Mc.	\$55.00 ea.
Kay Electric RF-P Marka Sweep 12 channel	\$149.50 ea.
Kay Electric RF-P Marka Sweep 12 channel with IF positioner	\$169.50 ea.
Kay Electric Co Mega Marker 19-29 Mc and 20-39 Mc.	\$17.50 ea.
Kay Electric Mega-Sweeps.	\$99.50 ea.
Leeds Northrup Speedomax — 30 to +350 deg. F. and — 30 to +250 deg. F.	\$135.00 ea.
Measurement Corp 78FM signal generator 86 to 108 Mc.	\$45.00 ea.
Polytechnic 907 sweep frequency oscillators 40 to 900 Mc.	\$194.50 ea.
RCA 689 High Frequency sweep generator with rectifier power unit	\$99.50 ea.
RCA—WO-60C—5" oscilloscopes	\$49.95 ea.
Simpson Genescope No. 480	\$195.00 ea.
Tel Instrument Co (TIC) Model 1212, 13 channel RF Wobblers.	\$174.95 ea.
Tel Instrument type 2113 12 channel TV signal generator.	\$199.50 ea.
Tel Instrument Co Type 1000 teleprinters	\$39.50 ea.
Tel Instrument type 2120 RF picture signal generator	\$199.50 ea.
Tel Instrument type 2111—12 channel television transmitters.	\$199.50 ea.

ATTENTION PURCHASING AGENTS & PLANT MANAGERS. Write on company stationery to our 2412 S. Michigan office for catalog which lists production quantities of brand new electronic components at far below original equipment cost prices. Thousands of items. Cut production cost. Get our Catalog now.

Mid-America Co, Inc

6101 N. Broadway Chicago 40, Ill.

Phone ROgers Pk 4-3745 Attention: I. Merens

JUST PUBLISHED

ELECTRONIC DESIGNERS' HANDBOOK

A handbook of fundamentals and data to aid in the design of all types of electronic equipment. A large number of circuits used by engineers is covered, with theoretical and technical discussions, design examples, etc. Covers the entire electronic field from vacuum tube fundamentals to waveform and network analysis. By Robert W. Landee, Potter Pacific Corp, Donovan C. Davis and Albert P. Albrecht, Gilfillan Brothers, Inc., 1152 pp., 984 illus., \$16.50

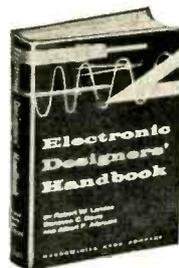

PROCESS INSTRUMENTS and CONTROLS HANDBOOK

Here are the instrumentation techniques to help you detect, measure, record and control industrial processes. From simple measuring instruments to complex mathematical techniques, you will find here the kind of help that is valuable, time-saving, and based on the best experience in the field. Edited by Douglas M. Considine, Hughes Aircraft Co. with the aid of 71 experts in all fields of instrumentation. 1383 pp., 1137 illus., \$19.50

CONTROL ENGINEERING MANUAL

Covering control systems engineering in both industry and the military, this book brings you the latest facts, methods, and engineering know-how from the nation's leading specialists in the field. Helps you analyze tentative control system configurations by means of mathematical, trial and error, computer and graphical techniques. Edited by Byron K. Ledgerwood, Man. Ed., Control Engineering. 185 pp., 200 illus., \$7.50

FREE EXAMINATION COUPON

McGraw-Hill Book Co., Dept. FL-3, 327 W. 41st St., N.Y.C. 36

Send me book(s) checked below for 10 days' examination on approval. In 10 days I will remit for book(s) I keep plus few cents for delivery costs, and return unwanted book(s) postpaid. (We pay delivery costs if you remit with this coupon—same return privilege.)

- Landee et al.—Elect. Designers' Hdbk., \$16.50
 Considine—Process Instr. & Cont. Hdbk., \$19.50
 Ledgerwood—Contr. Engrg. Manual, \$7.50

For price and terms outside U. S., write McGraw-Hill Int'l., N.Y.C.

(PRINT)
 Name

Address

City Zone..... State.....

Company

Position

FL-3

SEARCHLIGHT SECTION

RDO

V.H.F. U.H.F.

38-4,000 MC precision receivers covering complete range using 5 tuning units. The RDO is a high quality Navy search receiver and has input and output signal strength DB meters, audio output metering, noise limiter, greater stability for noise measuring etc. Priced at a fraction of what a similar set would cost if manufactured today. Power input 110V60CYC. Panadaptor, pulse analyzer, chart strip signal recorder avail. P.O.R.

MAGNETOMETER AN/ASQ-1

The ASQ-1 is a very sensitive gimbal type magnetometer. This instrument will measure the earth's magnetic field and record it on a chart recorder such as the Esterline Angus. The sensitivity of the set is 2 gamma. The equip. may be operated airborne or on the ground. Complete sets avail. P.O.R.

DBM-1

90-5,000 MC DIRECTION FINDER

The DBM-1 used with the APR-4, APR-5, APR-6, APR-9, etc. will provide an automatic bearing pattern on a cathode ray screen. The set will indicate whether the signal is horizontally or vert. polarized. THIS EQUIP. MAY BE USED TO TAKE A BEARING ON THE 108 MC SATELLITE TRANSMITTER AND TRACK IT. Complete sets avail. P.O.R.

SEARCH RADAR AN/TPS-1B

The AN/TPS-1B is a late portable airsearch radar operating in L-band with a range of 200 miles. This set has "P.P.I." and "A" scope indicators. The TPS-1B is currently used by the armed services. Complete sets avail.

P.P.I. REPEATERS

We have avail. many types of remote P.P.I. repeaters such as the VD, VE, VF, VG, VJ, VK, VL, screen sizes from 5" to 24". Video, Synch. signals from the radar and a Synchro. signal from the radar provides angular data for the sweep. Power inputs 110V 60CYC. State requirements as to screen size. P.O.R.

RC-120-FX-1

PAGE PRINTING FACSIMILE TRANSCIEVERS
The RC-120 will trans. & rec. 7" x 7" copy. The FX-1 will take 12" x 17" copy. The material can be copied on either electrosensitive paper or photographic paper. Both sets may be used on a wire or radio circuit either AM or FM RC-120 will send-rec. a page in 7 min. the FX-1 in 20 minutes, power input 110 Volts 60 Cyc. Mfg. by Times Facsimile. P.O.R.

AN/ARC-27-GRC-32B

200-400 MC TRANSCIEVERS
The ARC-27 is a 1,700 channel transceiver for aircraft operation. This set is a current service equipment. Power input is 28V DC. The GRC-32B is an adaptation of the ARC-27 to operate as a ground station from 110V 60CYC. Complete sets avail.

TECHNICAL SYSTEMS CORP.

12-01 43rd Av., L. I. C. 1, N. Y.
RAvenswood 9-0652-3

We solicit inquiries from overseas governments and electronic firms, universities, institutions having research contracts. If you need anything in military, industrial & experimental electronics, call on us for prompt and efficient service. We maintain a complete testing, and overhauling lab. If you require additional technical or other information, do not hesitate to call. We guarantee all equipment will be delivered in condition quoted.
Ed Charol, President

SCR-399/499 AN/GRC-26

The SCR-399/499 are high power stationary or mobile voice and c.w. radio sets covering 2-18 mc. The trans. is the famous BC-610E. The receivers are the BC-312 and BC-342. The AN/GRC-26 is a current version of this equip. Write us on this set. We can supply the above with or without the PE-95 power plant. We can supply SCR-399/499 with a teletype system installed. P.O.R.

BC-1269 145-600 MC RECEIVER

The BC-1269 is a communication receiver covering the above range in 2 bands. The dial is calibrated in MC. AM & FM signals may be received. Power input 110V 60CYC. P.O.R.

RECEIVERS BC-312-342

We can supply large quantities of these 1.5-18mc precision receivers. These sets are one of the most popular receivers in use throughout the world. The BC-312 operates from 12 v.d.c. The BC-342 from 110V 60 cyc. We will quote on supplying these sets from other power sources such as 220V and cycle ranges 40-60 eye. Write.

ALSO AVAIL.

AN/UPN-1 X-Band Portable Radar Beacon
AN/APS-10 X-Band Airborne Navigation Radar weight is 110 lbs.
Installed
SCR-Sets of all types
AN/GRC-3-32 Late Equip. Mfg. 1954 and up.

AN/CPN-6, B, 17
AN/TRC-1-12
AN/sets of all types
Navy Communications & Radar Equip.
Teletype sets
Test equipment
AN, TS, IE commercial

WRITE FOR OUR CATALOG

ANTENNA ROTATING PEDESTAL
SATELLITE TRACKING
RADIO RADAR OPTICAL



Size 32" High
48" Bottom
Diam.

Rotating
Capacity to
2,000 lbs.

A Rotating weight up to 2,000 lbs. may be mounted on this pedestal, enabling very large antennas to be used. The only ped. of this capacity avail. 360° rotation. 3 selsyns are included in the data takeoff system. Rotating motor is 250 v.d.c. reversible. Rotating speed is 4 RPM. This may be changed easily. 44 power and 4 R.F. co-ax cables are transmitted through the slip ring. This allows a very large quantity of equip. to be mounted on the rotor. A pulse cable is also provided. A tilt system may be easily mounted. Brand new in cases wt. approx. 2,000 lbs. Price \$2,500 ea. F.O.B.

THESE WILL GO FAST!
VERY FEW AVAIL.

MICROWAVE COMPONENTS

Waveguide test fixtures, C-Thru V-Band mixers, tees, attenuators, transitions, W-meters, etc. Test sets. Let us know your exact wants and get our quote.

R.F. POWER SOURCES ALSO AVAILABLE
Motorola - General Electric - Link Etc - Mobile 30-40 M.C. & 162-172 MC sets avail. Complete.

LARGEST STOCK OF

RELAYS

IN THE WORLD

SOLENOIDS • STEPPERS
SENSITROLS

PRODUCTION QUANTITIES
MOST MAKES IN STOCK

Send for Latest Catalog E

Universal RELAY CORP.
Formerly Universal General Corp.

42 WHITE ST., NEW YORK 13, N. Y. • WAlker 5-9257

CASH PAID! Sell your surplus electronic tubes. Want unused, clean transmitting, special purpose receiving TV types, magnetrons, Klystrons, Broadcast, etc. Also want military & commercial lab test and communications gear. We swap too, for tubes or choice equipment. Send specific details in first letter. For a fair deal write, wire or telephone: WAlker 5-7000
Barry, 512 Broadway, New York 12, N. Y.

New Advertisements

received by April 4th will appear in the April 25th issue subject to space limitations.
Classified Advertising Division

ELECTRONICS

P. O. Box 12 New York 36, N. Y.

PROFESSIONAL
SERVICES

TELECHROME MFG. CORP.

Electronic Design Specialists
COLOR TELEVISION EQUIPMENT
Flying Spot Scanners, Color Synthesizers, Keyers, Monitors, Oscilloscopes and Related Apparatus Telemetering for Guided Missiles.
J. R. Popkin-Curman, Pres. & Dir. of Eng.
28 Itanek Dr. Amityville, L. I., N. Y.

Your Inquiries to
Advertisers Will
Have Special Value . . .

—for you—the advertiser—and the publisher, if you mention this publication. Advertisers value highly this evidence of the publication you read. Satisfied advertisers enable the publisher to secure more advertisers and —more advertisers mean more information on more products or better service—more value—to YOU.

FOR RATES OR
INFORMATION

About Classified Advertising

Contact The McGraw-Hill Office
Nearest You

- ATLANTA, 3
1301 Rhodes-Haverty Bldg. Jackson 3-6951
M. MILLER
- BOSTON, 16
350 Park Square Hubbard 2-7160
J. WARTH
- CHICAGO, 11
520 No. Michigan Ave. MOhawk 4-5800
W. HIGGINS
- CINCINNATI, 37
2005 Seymour Ave. Elmhurst 1-4150
F. ROBERTS
- CLEVELAND, 13
1164 Illuminating Bldg. Superior 1-7000
W. SULLIVAN
- DALLAS, 1
1712 Commerce St., Vaughn Bldg. Riverside 7-5117
G. MILLER
- DETROIT, 26
856 Penobscot Bldg. WOODward 2-1793
J. GRANT
- LOS ANGELES, 17
1125 W. 6th St. MADison 6-9351
R. YOCUM
- NEW YORK, 36
500 Fifth Ave. OXFord 5-5959
R. LAWLESS R. OBENOUR D. COSTER
- PHILADELPHIA, 3
17th & Sansom St. RIttenhouse 6-0670
H. BOZARTH R. EDSALL
- PITTSBURGH, 22
1111 Oliver Bldg. ATLantic 1-4707
W. SULLIVAN
- ST LOUIS, 8
3615 Olive St. JEFFerson 5-4867
F. HOLLAND
- SAN FRANCISCO, 4
68 Post St. DOuglas 2-4600
R. ALCORN

INDEX TO ADVERTISERS

Airpax Products Co.	92	Fenwal Electronics, Inc.	110
Albano Company, Inc., The	83	GM Laboratories, Inc.	120
American Lava Corporation	19	Giannini & Co., Inc., G. M.	93
Automatic Mfg., Division of General Instrument Corp.	80	Gries Reproducer Corp.	119
Bakelite Plastics-Div. of Union Carbide	22, 23	Heath Company	107
Barden Corporation, The	33	Hewlett-Packard Company	24, 25
Bell Telephone Laboratories	117	Horlick Co., Inc., William L.	128
Bentley Harris Mfg. Co.	113	Hughes Products, a Div. of Hughes Aircraft Co.	15, 36, 37
Bird Electronic Corp.	109	International Nickel Co., Inc.	20
Bussmann Mfg. Co.	32	International Radiant Corp.	127
Centralab, A Division of Globe-Union, Inc.	105	Kester Solder Co.	17
Chance Vought Aircraft, Inc.	88, 89	Kintel (Kay Lab)	13
Cinch Mfg. Corp.	77	Klein & Sons, Mathias.	115
Coleman Engineering Co., Inc.	112	Mack Electronics Division Inc., of Mack Trucks, Inc.	21
Communication Measurements Laboratory Inc.	121	Magnetics, Inc.	79
Connecticut Hard Rubber Co.	120	Mallory and Co., Inc., P. R.	28, 29
Continental-Diamond Fibre Div. of the Budd Company, Inc.	38	Marconi Instruments, Ltd.	104
Cornell-Dubilier Electric Corp.	95	Marconi Wireless Telegraph Co., Ltd.	11
Cosmic Condenser Co.	114	McGraw-Hill Book Co.	81
Coto-Coil Co., Inc.	121	Micromech Manufacturing Co.	102
Curtiss Universal Joint Co., Inc.	110	Micro Switch a Div. of Minneapolis- Honeywell Regulator Co.	34, 35
Daven Company	3rd Cover	Milwaukee Resistor Co.	114
Daytona Beach Chamber of Commerce	108	Minneapolis-Honeywell	91
Dell Optics Co., Limited	122		
Dialight Corporation	85		
DoAll Company	87		
Electronics	85		
Emerson Electric	118		
Environmental Equipment Corp.	119		
Eric Electronics Div., Eric Resistor Corp.	103		

CHAMBERS FOR ENVIRONMENTAL TESTING

VACUUM OVENS
ALTITUDE AND VACUUM
ALTITUDE CHAMBERS
HUMIDITY CHAMBERS
DIAPHRAGM EXERCISERS
LOW TEMPERATURES
HIGH TEMPERATURES
AIR CONDITIONING (TEST)
SAND and DUST
LIQUID HOT & COLD BATHS
EXPLOSION CHAMBERS
SUNSHINE CHAMBERS
RAIN CHAMBERS
FUNGUS CHAMBERS
PLASTIC BELL JAR
SYSTEMS
SALT SPRAY
SUBLIMATORS
MOBILE REFRIGERATION
IMMERSION TESTS
WALK-IN ROOMS for all
environmental tests



**TEMPERATURE
ALTITUDE CHAMBER**
-100° F to +400° F
up to 100,000 ft.



RAIN & SHINE
Makes rain up to 4" per
hr. Sunshine to govt.
specs.

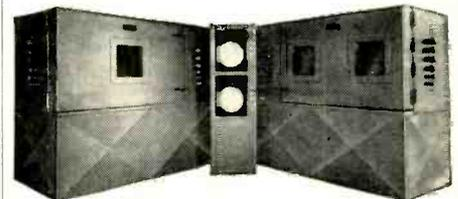

HOT & COLD

Separate units with cen-
tral control. -100° to
+200° F. in one am-
bient to +600° F. in
other.



JET FUEL TEST

Six tank portable explo-
sion proof unit for testing
fuel controls of jet engines.

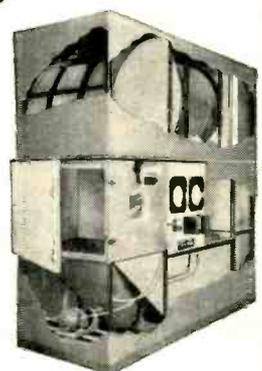

SAND and DUST

A complete self-con-
tained unit to meet
all govt. specs.

For further infor-
mation on these and the
many other environ-
mental test units
send for catalog.



Members: **E.E.I.**
Environmental Equipment Institute
INTERNATIONAL RADIANT
CORPORATION
141 New York Avenue, Westbury, L.I., N.Y.

CIRCLE 72 READERS SERVICE CARD

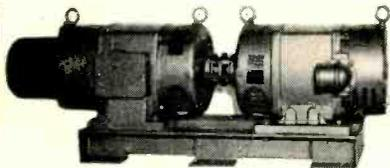

**QUALITY HIGH PERFORMANCE
400-MOTOR-GENERATOR
TYPE B**

MOTOR: 5 HP, 220/440 Volts, 3 Ø,
60 Cycles, 3450 RPM

GENERATOR: 3 KVA, .8 PF, 120/
208Y Volts or 115Δ Volts,
3 Ø, 6 Wire, 400~, with
end-mounted DC exciter
generator.

Complete with electro-mechanical
voltage regulator and field
rheostat.

Distortion 5%
Voltage Regulation 2%

\$465.00/ fob Boston

William I. Horlick Co., Inc.

266 Summer Street
Boston 10, Massachusetts

CIRCLE 69 READERS SERVICE CARD



Men on the Move

Now available
in a new edition...
with new figures.

This popular booklet points up the important sales problem of personnel turnover in industry. Out of every 1,000 key men (over a 12-month period) 343 new faces appear... 65 change titles... 157 shift... and 435 stay put. These figures are based on average mailing address changes on a list of over a million paid subscribers to McGraw-Hill magazines.

Write us for a free copy

Company Promotion Department
McGraw-Hill Publishing Co., Inc.
330 West 42nd Street,
New York 36, New York

Ozafid-10... General Aniline... 10 Veeder-Root, Inc. 26

Phaostrotron Instrument & Electronic Co... 111
Philco Corporation 40
Power Sources Inc. 123

White S. S., Industrial Division..... 112

RBM Division, Essex Wire Corp....100, 101
Racal Engineering Ltd. 111
Radio Corporation of America... 4th Cover
Radio Receptor Co., Inc..... 39
Raytheon Mfg. Company6, 123

Professional Services 126

CLASSIFIED ADVERTISING

F. J. Eberle, Business Mgr.

**EMPLOYMENT
OPPORTUNITIES**124, 125

**EQUIPMENT
(Used or Surplus New)
For Sale**125, 126

**WANTED
Equipment** 126

Schober Organ Co. 120
Sorensen & Co. 5
Sperry Gyroscope Company, Division of
Sperry Rand Corp. 27
Sprague Electric Co. 3
Stevens Arnold, Inc. 108
Stoddart Aircraft Radio Co., Inc..... 106
Stromberg-Carlson Company 118

ADVERTISERS INDEX

Taylor Fibre Co. 4
Tensolite Specialties 99
Texas Instruments Incorporated 9
Tishbein, O. F. 114
Tobe Deutschmann Corp. 82

Barry Electronics Co..... 126
Diamond Power Specialty Corp..... 125
Hycon-Page Larc 124
Mid-America Co., Inc..... 125
Submarine Cables Ltd.....124
System Development Corp..... 124
Technical Systems Corp..... 126
Tronic Coil Winding Co., Inc..... 124
Universal Relay Corp.
(Formerly Universal General Corp).... 126

United Transformer Co.2nd Cover

This index is published as a service. Every care is taken to make it accurate, but ELECTRONICS assumes no responsibilities for errors or omissions.

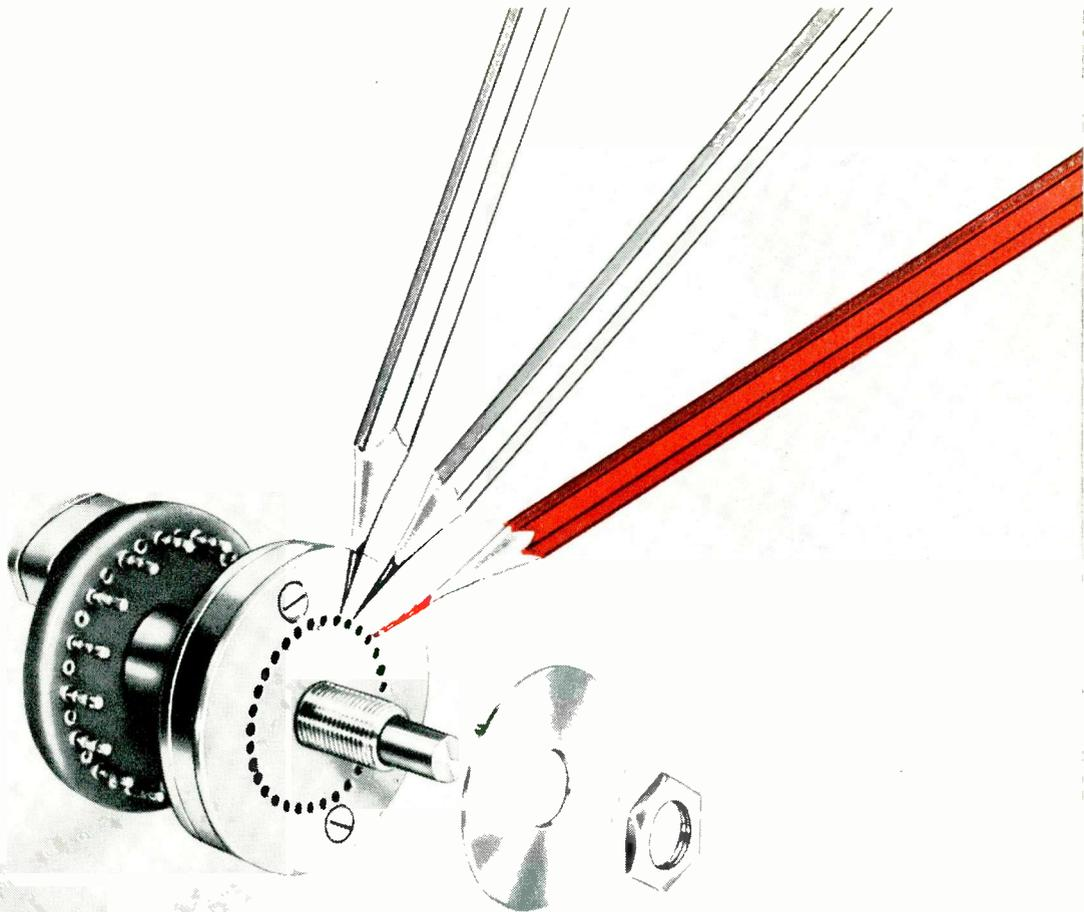

Stop it

... where you want it!

Daven's New Rotary Switch with Adjustable Stop

For flexibility in all types of circuit experimentation, laboratory work, breadboard setups, and in circuitry where the exact number of switch positions might be changed at a later date, the new DAVEN Rotary Switch with an Adjustable Stop is ideal. This unit, as a single pole switch, can have a maximum of either 24 shorting positions with 15° spacing or 32 shorting positions with $11\frac{1}{4}^\circ$ spacing. One, two, three, and four pole units are available in this design.

In common with all other DAVEN Rotary Switches, the Adjustable Stop Switch features sturdy, dependable construction; silver alloy contacts and slip rings; tamper-proof,

KNEE ACTION* silver alloy rotor blades; high grade, accurately machined dielectric; and gold flashed turret-type terminals for ease of soldering.

*Patented

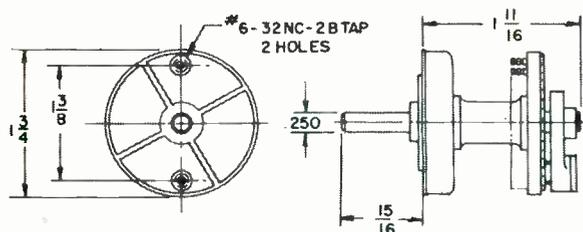

Write for complete information.

THE **DAVEN** CO.

LIVINGSTON, NEW JERSEY

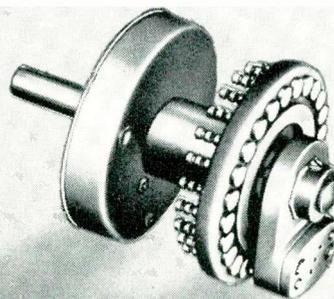

AVAILABLE THROUGH SELECTED DISTRIBUTORS

TODAY, MORE THAN EVER, THE DAVEN © STANDS FOR DEPENDABILITY!

*Two new RCA tubes
offer outstanding performance
for your most critical
high-fidelity audio designs*



...important contributions
to designers of
high-quality audio amplifiers

The organ hurls its thunderous tones! The piano strikes an answering chord! A triangle sparkles its crisp note and an orchestra expands to full forte! These are the exciting, timbre-rich sounds which require full realism in reproduction and make extraordinary demands on the performance capabilities of your audio amplifier designs. The RCA-7025 and -7027 have been developed specifically for such performance requirements in high-quality high-fidelity audio amplifiers.

The RCA-7027 is a glass-octal type beam power tube. Two 7027's in class AB, push-pull service *with only 450 volts on the plate* can handle up to *50 watts of audio power with only 1.5 percent distortion*. Structural features contributing to the exceptionally high plate dissipation (25 watts) of this compact tube are: metal base collar, heavy stem leads having high heat conductivity, heavy plate material, radiating fins on control grid, and double base-pin connections for both control grid and screen grid.

The RCA-7025 is a miniature 9-pin high mu twin-triode. This tube has been developed specifically for applications in audio preamplifier stages where extremely low noise and low hum are critical performance requirements.

For further information on these two new outstanding tubes, call your field representative at the RCA District Office nearest you. Or, write RCA, Commercial Engineering, Section C-19-Q-1, Harrison, N. J.



RADIO CORPORATION OF AMERICA
Electron Tube Division
Harrison, N. J.

