

# electronics

DECEMBER · 1955

**HOW ACCURATE  
ARE RADAR  
SPEED METERS?**

page 132

**New Module  
Technique** .....218

**Plants of  
the Future** .....348



**CANCER DIAGNOSIS  
SPEEDED BY  
COLOR TV  
MICROSCOPE**

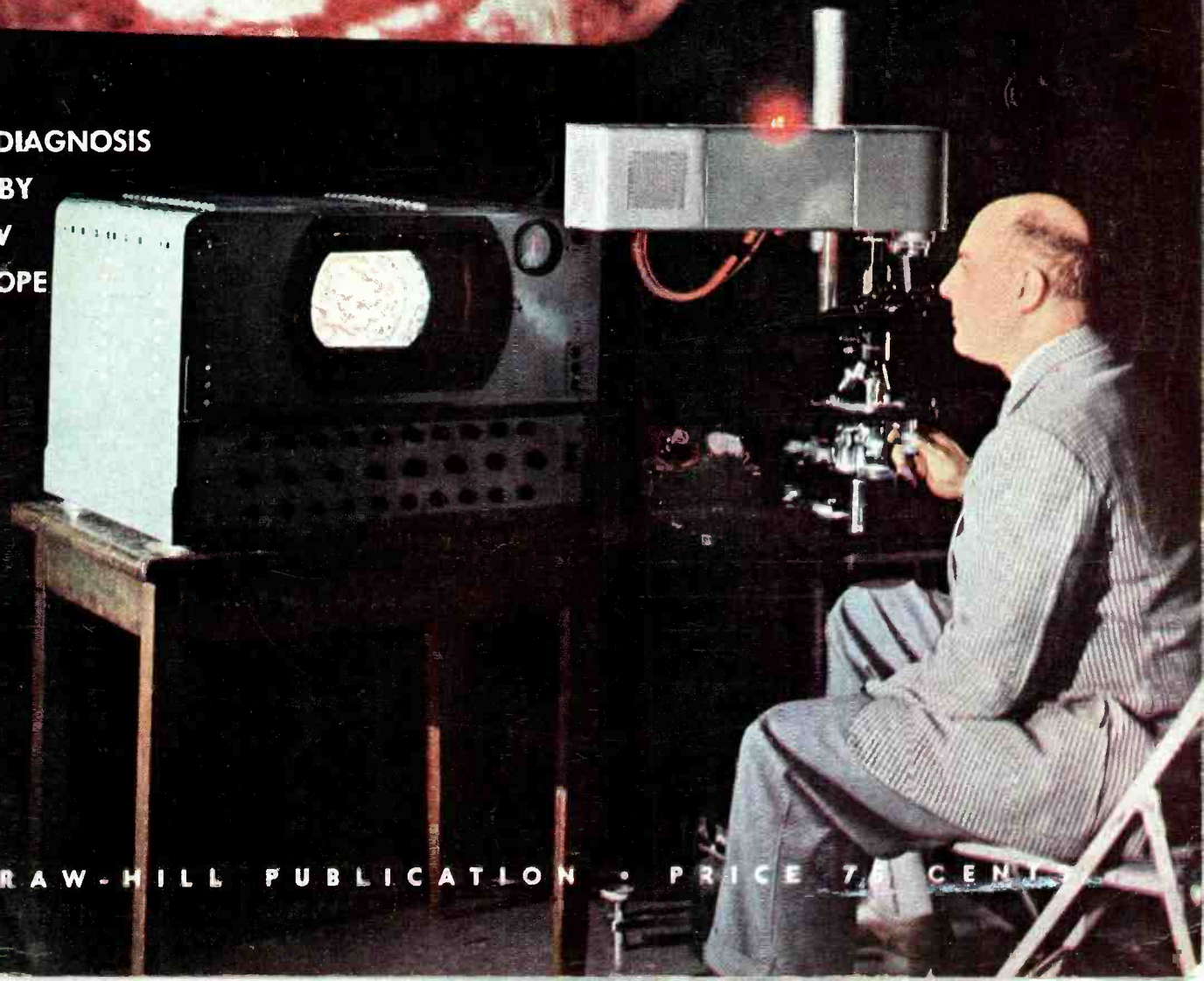

A MCGRAW-HILL PUBLICATION • PRICE 75 CENTS



LEADERS IN  
MINIATURIZATION  
FOR OVER  
TWENTY YEARS...



# MINIATURIZED TRANSFORMER COMPONENTS FROM STOCK

Items below and 650 others in our catalog A.

## HERMETIC SUB-MINIATURE AUDIO UNITS

These are the smallest hermetic audios made.

Dimensions . . . 1/2 x 11/16 x 29/32 . . . Weight .8 oz.



### TYPICAL ITEMS

Type No.	Application	MIL Type	Pri. Imp. Ohms	Sec. Imp. Ohms	DC in Pri. MA	Response $\pm 2$ db (Cyc.)	Max. level dbm
H-30	Input to grid	TF1A10YY	50*	62,500	0	150-10,000	+13
H-31	Single plate to single grid, 3:1	TF1A15YY	10,000	90,000	0	300-10,000	+13
H-32	Single plate to line	TF1A13YY	10,000*	200	3	300-10,000	+13
H-33	Single plate to low impedance	TF1A13YY	30,000	50	1	300-10,000	+15
H-34	Single plate to low impedance	TF1A13YY	100,000	60	.5	300-10,000	+6
H-35	Reactor	TF1A20YY	100, Henries-0 DC, 50 Henries-1 Ma. DC,	4,400 ohms.			
H-36	Transistor Interstage	TF1A15YY	25,000	1,000	.5	300-10,000	+10

\*Can be used with higher source impedances, with corresponding reduction in frequency range and current

## COMPACT HERMETIC AUDIO FILTERS

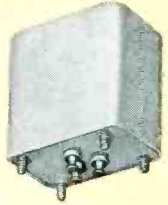

UTC standardized filters are for low pass, high pass, and band pass application in both inter-stage and line impedance designs. Thirty four stock values, others to order. Case 1-3/16 x 1-11/16 x 1-5/8 — 2-1/2 high . . . Weight 6-9 oz.

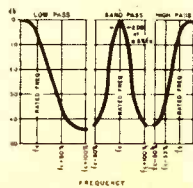

## HERMETIC MINIATURE HI-Q TOROIDS

MQE units provide high Q, excellent stability and minimum hum pickup in a case only. 1/2 x 1-1/16 x 17/32 . . . weight 1.5 oz.

### TYPICAL ITEMS

Type No.	Inductance	DC Max.
MQE-1	7 mhy.	135
MQE-3	20 mhy.	80
MQE-5	50 mhy.	50
MQE-7	100 mhy.	35
MQE-10	.4 hy.	17
MQE-12	.9 hy.	12
MQE-15	2.8 hy.	7.2

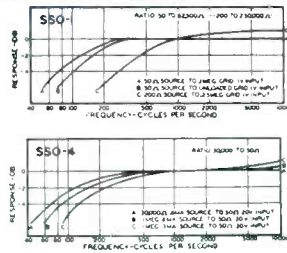
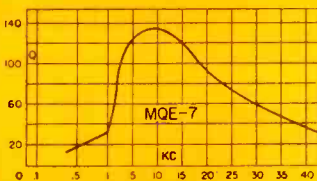

## SUB-SUBOUNCER AUDIO UNITS



UTC Subouncer and sub-subouncer units provide exceptional efficiency and frequency range in miniature size. Constructional details assure maximum reliability. SSO units are 7/16 x 3/4 x 43/64 . . . Weight 1/50 lb.

Type	Application	Level	Pri. Imp.	MA D.C. in Pri.	Sec. Imp.	Pri. Res.	Sec. Res.
*SSO-1	Input	+ 4 V.U.	200 50	0	250,000 62,500	13.5	3700
SSO-2	Interstage /3:1	+ 4 V.U.	10,000	0-.25	90,000	750	3250
*SSO-3	Plate to Line	+20 V.U.	10,000 25,000	3 1.5	200 500	2600	3500
SSO-4	Output	+20 V.U.	30,000	1.0	50	2875	4.6
SSO-5	Reactor 50 HY at 1 mil. D.C. 4400 ohms D.C. Res.						
SSO-6	Output	+20 V.U.	100,000	.5	60	4700	3.3
*SSO-7	Transistor Interstage	+10 V.U.	20,000 30,000	.5 .5	800 1,200	850	1250

\* Impedance ratio is fixed, 1250:1 for SSO-1, 1:50 for SSO-3. Any impedance between the values shown may be employed.



## SUB-SUBOUNCER (WIDE RANGE) AUDIO UNITS

Standard for the industry for 15 yrs., these units provide 30-20,000 cycle response in a case 7/8 dia. x 1-3/16 high. Weight 1 oz.

### TYPICAL ITEMS

Type No.	Application	Pri. Imp	Sec. Imp
0-1	Mike, pickup or line to 1 grid	50, 200/250, 500/600	50,000
0-4	Single plate to 1 grid	15,000	60,000
0-7	Single plate to 2 grids, D.C. in Pri.	15,000	95,000
0-9	Single plate to line, D.C. in Pri.	15,000	50, 200/250, 500/600
0-10	Push pull plates to line	30,000 ohms plate to plate	50, 200/250, 500/600
0-12	Mixing and matching	50, 200/250	50, 200/250, 500/600
0-13	Reactor, 300 Hys.—no D.C.; 50 Hys.—3 MA. D.C., 6000 ohms		



## HERMETIC VARIABLE INDUCTORS

These inductors provide high Q from 50 - 10,000 cycles with exceptional stability. Wide inductance range (10-1) in an extremely compact case 25/32 x 1-1/8 x 1-3/16 . . . Weight 2 oz.

### TYPICAL ITEMS

TYPE No.	Min. Hys.	Mean Hys.	Max. Hys.	DC Ma
HVC-1	.002	.006	.02	100
HVC-3	.011	.040	.11	40
HVC-5	.07	.25	.7	20
HVC-6	.2	.6	2	15
HVC-10	7.0	25	70	3.5
HVC-12	50	150	500	1.5

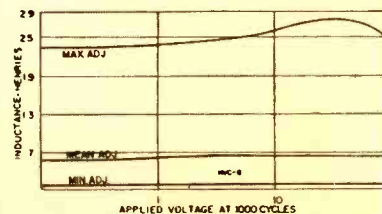
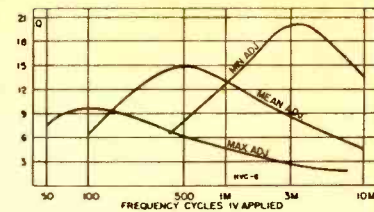

**UNITED TRANSFORMER CO.**

150 Varick Street, New York 13, N. Y. • EXPORT DIVISION: 13 E. 40th St., New York 16, N. Y.

CABLES: "ARLAB"

LET US MINIATURIZE YOUR GEAR.

SEND DETAILS OF YOUR NEEDS for SIZES and PRICES



# electronics

DECEMBER • 1955

A MCGRAW-HILL PUBLICATION

**H. W. MATEER**, *Publisher*

**W. W. MacDONALD**, *Editor*

**VIN ZELUFF**, *Managing Editor*

JOHN MARKUS, *Associate Editor*

ALEXANDER A. MCKENZIE, *Associate Editor*

JOHN M. CARROLL, *Associate Editor*

WILLIAM P. O'BRIEN, *Assistant Editor*

WILLIAM G. ARNOLD, *Assistant Editor*

DAVID A. FINDLAY, *Assistant Editor*

HAIG A. MANOOGIAN, *Assistant Editor*

GLORIA J. FILIPPONE, *Editorial Assistant*

ARLENE SCHILP, *Editorial Assistant*

FRANCES SULLIVAN, *Editorial Assistant*

GLADYS T. MONTGOMERY, *Washington Editor*

HARRY PHILLIPS, *Art Director*

**WALLACE B. BLOOD**, *Manager*

R. S. QUINT, *Buyers' Guide Manager*

FRANK H. WARD, *Business Manager*

GEORGE E. POMEROY, *Classified Manager*

DONALD H. MILLER, *New York*

JAMES GIRDWOOD, *New York*

WM. S. HODGKINSON, *New England*

JAMES T. HAUPTLI, *Philadelphia*

CHARLES WARDNER, *Chicago*

BRUCE WINNER, *Chicago*

HENRY M. SHAW, *Cleveland*

T. H. CARMODY, *San Francisco*

R. C. ALCORN, *San Francisco*

CARL W. DYSINGER, *Los Angeles*

WM. D. LANIER, *Atlanta*

JAMES H. CASH, *Dallas*

KEITH HENNEY, *Consultant*

CANCER DIAGNOSIS SPEEDED BY COLOR TV MICROSCOPE—Cancerous tissue is shown magnified 7,500 times on screen by electronic color microscope developed by CBS Laboratories to aid in medical and industrial research (see p 176) . . . . . COVER

SHOPTALK . . . . . 2

FIGURES OF THE MONTH . . . . . 6

INDUSTRY REPORT . . . . . 7

Aerial Inspection Goes Robot . . . . .	7	Why Television Sets Are Failing . . . . .	20
Color TV Warns Up For Takeoff . . . . .	7	Tube Machinery Sales Stack Up . . . . .	22
More Small Computers Appear . . . . .	8	Research Heads For Billion Mark . . . . .	22
Electronics Gains In Atomics . . . . .	8	Subminiature Relay Business . . . . .	24
Industry Plans More Spending . . . . .	10	Electronics Crows In Business . . . . .	24
Wrist Radio Uses Transistors . . . . .	10	Television Girds For New Markets . . . . .	24
Home Cooking Goes Microwave . . . . .	12	Civil Defense Fosters Sales . . . . .	26
Small Business Gains More Work . . . . .	12	Set Prices Go Up . . . . .	26
FCC Looks At TV Competition . . . . .	14	Glass Makes Headway In Resistors . . . . .	26
Gear Withstands Blast . . . . .	14	Financial Roundup . . . . .	28
Operations Research Gains . . . . .	14	Future Meetings . . . . .	28
Personal Paging Business Advances . . . . .	16	Industry Shorts . . . . .	28
High-Fidelity Hits the Road . . . . .	16	Annual Index . . . . .	30
Transistors Gain In The Military . . . . .	20		

CROSSTALK . . . . . 121

## FEATURES

Basic Control Circuits Are Packaged . . . . . 122  
By L. S. Klivans

Designing Over-Horizon Communications Links . . . . . 126  
By David Davidson and Alfred J. Pote

How Accurate Are Radar Speed Meters? . . . . . 132  
By James Q. Brantley, Jr.

Multichannel Switch for Biological Observations . . . . . 135  
By Robert W. Woods

Automatic Colorimeter Checks TV Color Tubes . . . . . 138  
By Emil Sanford

Ice Detector for Lighter-Than-Air Craft . . . . . 142  
By E. G. Thurston

Transmission Gain Set . . . . . 145  
By Gerald R. Chinski

Dielectric Transformers for X-Band Waveguide . . . . . 146  
By Irwin D. Olin

Precision Digital Delay Generator . . . . . 148  
By William Perzley

CONTINUED ON NEXT PAGE



# contents

continued

High-Quality Receiver for TV Rebroadcasting.....	152
By Raymond S. Rosenberg	
Sawtooth Pulser Gives Voltage-Current Curves.....	156
By N. Sclar and R. L. McFolin	
Wide-Band Amplifier for UHF Receivers.....	158
By Richard B. McWhirt	
Audio-Standard Generator.....	161
By Peter Koustas	
Expanded-Scale Voltmeter for A-C Measurements.....	164
By Herbert Galman	
Staggered Triple Crystal Filter.....	166
By D. E. Hildreth	
VHF Transmission Line Calculator.....	168
By A. E. Sanderson	
Annual Index, Volume 28.....	434

## ELECTRONS AT WORK..... 172

Over-Horizon Radio Links.....	172	Radar Movie.....	198
Sensitive Thyatron Relay.....	172	Testing UHF DX.....	200
Japanese Transistor Receiver.....	174	Zero Hysteresis Relays.....	202
Flat-Top Communications.....	174	Light Beam Control.....	204
The Front Cover.....	176	Volscan Evaluation.....	206
Digital Voltage Divider.....	176	Triode-Connected Pentodes.....	208
Air-Conditioned Shielded Room.....	180	Faster Radiosonde.....	208
Zener-Voltage Breakdown Uses.....	182	Radio Opens Garage Door.....	212
Reflection-Type Waveguide.....	192	One-Man TV Camera Aligner.....	214

## PRODUCTION TECHNIQUES..... 218

New Plug-In Module Assemblies.....	218	Automatic Tester for Ferrite Cores.....	244
Toothpick Screwdrivers for Cores.....	222	Mounting Color TV Picture Tube.....	246
Router Cuts Wiring Boards.....	224	Eyelets in Etched Wiring.....	250
One-Way Pallet-Return Conveyor.....	224	Grounding Wiring Boards.....	256
Double-Dip Soldering.....	226	Tools Added to Wire Cutter.....	258
Modular Etched-Wiring Bundles.....	230	Producing Curved Etched Wiring.....	262
Dip-Soldering Clamp.....	242	Locating Heater Shorts.....	264

## NEW PRODUCTS..... 266

## LITERATURE..... 331

## PLANTS AND PEOPLE..... 348

## NEW BOOKS..... 376

## THUMBNAIL REVIEWS..... 379

## BACKTALK..... 380

## INDEX TO ADVERTISERS..... 428

# SHOP

► **CAREER** . . . One of the things that helps **ELECTRONICS** maintain its unique position in the field is the magazine's receptivity to ideas suggested by readers. A surprising number of presumably busy men volunteer topic and treatment suggestions and, in so doing, exhibit considerable publishing flair.

There is an opportunity for one such man to turn pro; we're looking for an editorial staffer. As you would expect, the job requires an engineer with industry experience. Reporting, writing or editing knowhow would represent plus value.

Take a look at the names on our page 1 masthead back over the years and it will be obvious that many of us like our work, our paper and our company very much indeed. There is nothing like an editing career for the right man, nothing tougher for the wrong.

If you think you are the right man write the editor.

► **ATOMIC READERS** . . . At the Hanford atomic plant, more than 75,000 copies of 800 different magazines are circulated annually among General Electric personnel.

An estimated 1,500 of the 9,200 people on the payroll receive one or more weekly or monthly publications.

Of the 10 magazines most in demand by Hanford people on regular circulation lists, 4 are published by McGraw-Hill; *Nucleonics*, *Busi-*

# electronics

DECEMBER, 1955 Vol. 28, No. 12



Member ABC and ABP



# TALK

ness Week, Today's Secretary and ELECTRONICS. The latter is the only one in its field in the top 10.

► **DX AID . . .** The problem we had of obtaining a certain 1951 issue (Shoptalk, May '55) brought in a number of suggestions from readers. One of these is from L. van Zeyl of Pretoria, South Africa. He did some research into photocopying equipment and found that there is at least one machine that reproduces book or magazine pages, even though curved, without harming the binding.

► **MOVING TORQUE . . .** We met recently a friend of a friend of ours, Harold Varley, an electronics engineer with one of the large firms in the business. He told us of a problem he had several years ago when he was transferred to a West Coast branch.

At that time he had ten years, 120 copies, of ELECTRONICS which provided him with reference material. The bulk and weight of these brought up two problems, convincing his wife that the issues were really going with them, and the problem of packing them for a cross-country trip.

The trucker refused to take the first packing because of excess weight per package. This meant a complete repacking of all the boxes and barrels and redistributing the 120 copies with a few issues in each box and barrel. Each was then filled with lighter items from the household.

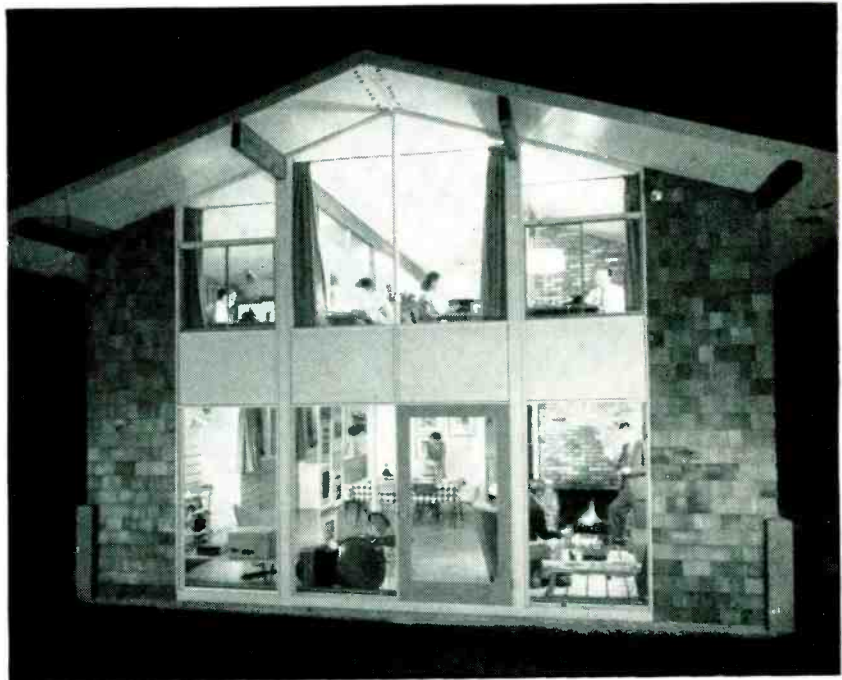

**EDITORS** and engineers often dream of a vocational environment like this one but few achieve it. The staff shares this shop pin-up with readers; it's the headquarters of Technical Marketing Associates, Inc., Concord, Massachusetts

Everything reached the West Coast in good order, fortunately. We didn't mention it to Harold, but suppose he now wanted to move east; his number of copies is now nearly doubled.

► **DESK PROBLEM . . .** Engaged in a research project, a visiting engineer commented that our Industry Report each month provides him with much useful data.

His boss, however, is quite a stickler for maintaining clear desk tops. Our friend goes along with this completely for most of the material he handles. But his present assignment requires keeping a dozen or more open copies of ELECTRONICS on his desk top for

ready reference at all times. What to do?

► **ANNUAL INDEX . . .** Industry Report articles are indexed cumulatively for the first time on p 30 of this issue. This step has been prompted by the number of telephone calls we get like this:

Voice on phone: "I read something on rising design costs in your magazine. What issue was it in?"

Editor (after a mad scramble through back issues: "That article was in Industry Report, for April."

Voice: "In Industry Report! No wonder I couldn't locate it in the general index."

Published monthly with an additional issue in June by McGraw-Hill Publishing Company, Inc., James H. McGraw (1860-1948), Founder, Executive, Editorial and Advertising Offices: McGraw-Hill Building, 330 W. 42 St., New York 36, N. Y. Longacre 4-3000. Publication Office, 89-129 North Broadway, Albany 1, N. Y. Donald C. McGraw, President; Paul Montgomery, Executive Vice-President; Joseph A. Gerardi, Vice-President and Treasurer; John J. Cooke, Secretary; Nelson Bond, Executive Vice-President, Publications Division; Ralph B. Smith, Vice-President and Editorial Director; Joseph H. Allen, Vice-President and Director of Advertising; J. E. Blackburn, Jr., Vice-President and Circulation Director.

Subscriptions: Address correspondence to Electronics—Subscription Service, 330 W. 42nd St., New York 36, N. Y. Allow one month for change of address. Subscriptions are solicited only from persons engaged in theory, research, design, production, maintenance and use of electronic and industrial control components, parts and end products. Position and company connection must be indicated on subscription orders.

Single copies 75¢ for United States and possessions, and Canada; \$1.50 for Latin America; \$2.00 for all other foreign countries. Buyers' Guide \$3.00. Subscription rates—United States and possessions, \$6.00 a year; \$9.00 for two years. Canada, \$10.00 a year; \$16.00 for two years. Other western hemisphere countries and the Philippines, \$15.00 a year; \$25 for two years. All other countries \$20.00 a year; \$30.00 for two years. Three-year rates, accepted on renewals only, are double the one-year rate. Entered as second-class matter August 29, 1936, at the Post Office at Albany, N. Y., under act of Mar. 3, 1879. Printed in U.S.A. Copyright 1955 by McGraw-Hill Publishing Co., Inc.—All Rights Reserved.

BRANCH OFFICES: 520 North Michigan Avenue, Chicago 11, Ill.; 68 Post Street, San Francisco 4; McGraw-Hill House, London, E. C. 4; Washington, D. C. 4; Philadelphia 3; Cleveland 15; Detroit 26; St. Louis 8; Boston 16; 1321 Rhoads-Haverty Bldg.; Atlanta 3, Ga.; 1111 Wilshire Blvd., Los Angeles 17; 819 Oliver Building, Pittsburgh 23. ELECTRONICS is indexed regularly in The Engineering Index.



# THE NEW SIGN OF SERVICE

FOR USERS OF REGULATED POWER



This new trademark highlights Sorensen's dynamic new program of product development and service.

Back of the new trademark is the established reputation of "the world's authority on regulated power." Yet to be unveiled is a whole new concept of design, even better product performance and service convenience for every user of Sorensen's wide variety of equipment.

Selected sales and service representatives — functioning as an integral part of the Sorensen team — can place at your disposal the complete design and production facilities of Sorensen . . . yet they are local specialists in your particular area. Sorensen's Los Angeles warehouse facilities mean improved deliveries for West Coast customers.

Be sure you get *all* of the information available on any regulated power application. Make it a rule to check *first* with your local representative of Sorensen . . . "the world's authority on regulated power."

## COAST-TO-COAST

ARIZONA — Tucson  
Gerald B. Miller Co. (L. A. Wilson, Jr.)  
P.O. Box 11246  
Phone Tucson 4-6293

CALIFORNIA — Hollywood 28  
Gerald B. Miller Co.  
1550 N. Highland Ave.  
Phone Hollywood 2-1195

CALIFORNIA — San Francisco  
Gerald B. Miller Co.  
1334 Old County Rd., Belmont  
Phone Lytell 3-3438

COLORADO — Denver 3  
Hytronic Measurement Associates  
446 Broadway  
Phone Sherman 2501

CONNECTICUT — Bridgeport  
Yewell Associates (Peter Lahana)  
1101 East Main Street  
Phone Forest 6-3456

D.C. — Washington 9  
Horman Associates, Inc. (F. L. Horman)\*  
2017 S. Street, N.W.  
Phone Decatur 2-8000

FLORIDA — Fort Myers  
Arthur H. Lynch & Associates  
P.O. Box 466  
Phone 5-6762

GEORGIA — Atlanta  
Floyd Fausett & Son  
777 Pinehurst Terrace, S.W.  
Phone Raymond 3104

ILLINOIS — Chicago 39  
Loren F. Green & Associates  
4949 W. Diversey Avenue  
Phone National 2-2370

MARYLAND — Baltimore  
Horman Associates, Inc.  
635 St. Johns Road  
Phone Hopkins 7-2290

MASSACHUSETTS — Boston  
Yewell Associates (Paul G. Yewell)\*  
751 Main Street, Waltham  
Phone Waltham 5-7420

MICHIGAN — Detroit  
S. Sterling Company\*  
15510 W. McNichols Road  
Phone Broadway 3-2900

MISSOURI — Kansas City 30  
Harris-Hanson Co. (R. C. Bacon)  
7916 Paseo Ave.  
Phone Hilland 6744

MISSOURI — St. Louis 9  
Harris-Hanson Co.  
(Harold H. Harris)  
5506 South Kingshighway  
Phone Flanders 1-5384

NEW JERSEY (Northern)  
RMC Associates (Chas. Sargeant)  
114 East Main Street, Bogota  
Phone Diamond 2-5343

NEW JERSEY (Southern)  
I. E. Robinson Co. (Leon Levy)  
702 Mattison Ave., Asbury Park  
Phone Ailenhurst 3-2402

NEW MEXICO — Albuquerque  
Gerald B. Miller Co.  
327 Wyoming, S.E.  
Phone 5-6466

NEW YORK — New York  
RMC Associates (Robert Asen,  
Milton Lichtenstein)\*  
170 East 80th Street  
Phone Trafalgar 9-2023

NEW YORK — Syracuse 2  
J. D. Ryerson Associates, Inc.\*  
412 E. Genesee Street  
Phone Syracuse 76-8344

NORTH CAROLINA — Charlotte  
James L. Highsmith  
P.O. Box 1011  
Phone 5-6436

OHIO — Cleveland 21  
S. Sterling Co.  
4311 Mayfield Rd.  
Phone Evergreen 2-4114

OHIO — Dayton 2  
S. Sterling Co.  
379 West 1st Street  
Phone Fulton 8794

OREGON — Portland 16  
James L. Kearns Company  
P.O. Box 5108  
Phone Empire 2444

PENNSYLVANIA — Harrisburg  
I. E. Robinson Co.  
304 Thomas St.  
Phone Harrisburg 8-9054

PENNSYLVANIA — Philadelphia  
I. E. Robinson (Ivan E. Robinson)\*  
7404 W. Chester Pike,  
Upper Darby, Pa.  
Phone Flanders 2-7017

PENNSYLVANIA — Stroudsburg  
I. E. Robinson Co.  
P.O. Box 68  
Phone 1519

PENNSYLVANIA — Pittsburgh  
H. E. Ransford Co. (Sam Coombs)  
Grant Building  
Phone Grant 1-1880

TENNESSEE — Knoxville  
A. R. Hough Co.  
P.O. Box 1452  
Phone Knoxville 7-6660

TEXAS — Dallas 5  
Earl W. Lipscomb Associates\*  
P.O. Box 7084  
Phone Elmhurst 5345

TEXAS — Houston 5  
Earl W. Lipscomb Co.  
2422-A Rice Blvd.  
Phone Jackson 4-9303

HAWAII — Honolulu 17  
Gene Piety  
2030 Home Rule St.

CANADA — Vancouver 5, B.C.  
Frederick Goertz, Ltd.  
1170 Hobson St.  
Phone Tatlow 5377

CANADA — Toronto 10, Ontario  
Charles W. Pointon, Ltd.  
6 Alicia Ave.  
Phone Oliver 7984

\*Complete service facilities maintained for rapid local servicing of all Sorensen equipment.



SORENSEN & COMPANY, INC. • 375 FAIRFIELD AVENUE • STAMFORD, CONN.



# VIBRATION

...the enemy  
of industry



Mechanical vibration waveforms can now be measured and analyzed with the greatest accuracy, using the revolutionary MUIRHEAD-PAMETRADA Model D-489 Wave Analyzer. Complex vibration waveforms can now be isolated and measured

within a wide frequency range, overcoming amplitude and frequency fluctuation and the proximity of component frequencies.

The MUIRHEAD Wave Analyzer operates as a negative feedback, tuned band-pass filter insuring constant selectivity at all frequencies, and simplifying frequency selection. Output voltage is available at tuned frequency for viewing or recording.

This highly versatile instrument has a wide diversity of applications in many industries: aviation, automotive and manufacturing, shipbuilding and electric power generation, to name only a few.

## FEATURES

- No internal oscillator—eliminates drift
- R/C-tuned circuits—reduces hum and noise pickup
- Choice of 4 bandwidth characteristics: In-tune High, In-tune Medium, Narrow Band and  $\frac{1}{3}$  Octave.
- High selectivity characteristic (1% bandwidth for greatest discrimination)
- Auxiliary pre-amp permits use of high-impedance pickups or transducers.

## SPECIFICATIONS

- Frequency range—19 c/s to 21 kc (extendable down to 2 c/s)
- Frequency Stability— $\pm 1$  db over several days
- Measurement Accuracy— $\pm 0.3\%$  over most of range
- Output Voltage—10 v
- Input Voltage—1 mv to 300 v rms (FSD)
- Input Impedance—0.1 megohms
- Hum and Noise Level—Equivalent to .05 mv input at maximum gain
- Power Supply (external)—100/120 v, 60 or 400 cycles, 130 w
- Dimensions—12 $\frac{3}{4}$ " x 13 $\frac{1}{2}$ " x 17 $\frac{1}{2}$ "
- Weight—55 pounds

Write TODAY for your **FREE** brochure on Vibration Measurement and Waveform Analysis.

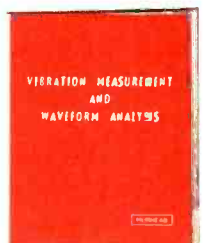

**MUIRHEAD**

**MUIRHEAD INSTRUMENTS, Inc. 677 Fifth Ave., New York 22, N.Y.**

United States Sales and Service for **MUIRHEAD & CO., LTD.** • Beckenham • Kent • England

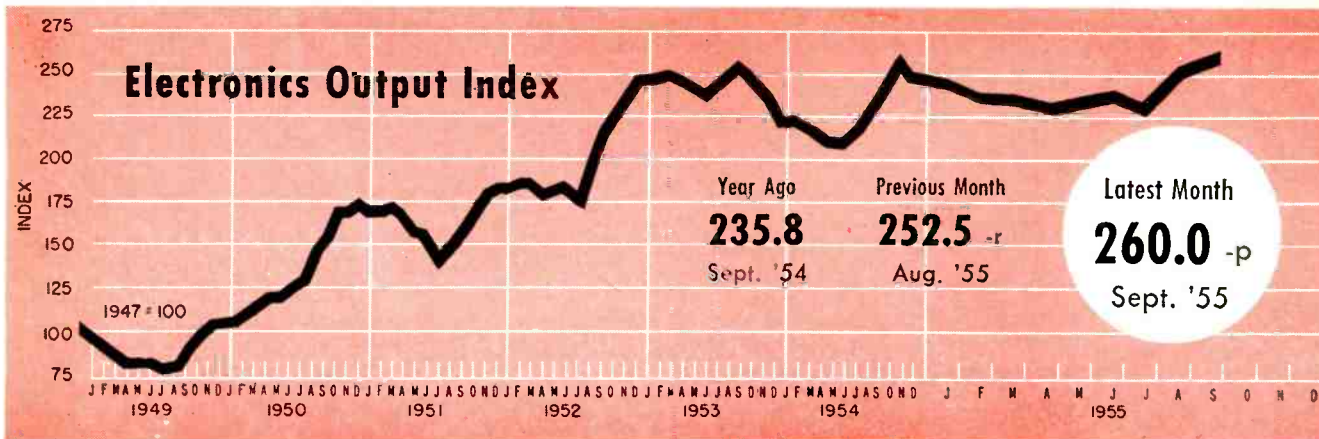

## FIGURES OF THE MONTH

	Latest Month	Previous Month	Year Ago		Latest Month	Previous Month	Year Ago
<b>RECEIVER PRODUCTION</b>				<b>TV SETS INSTALLED*</b>			
(Source: RETMA)	Sept. '55	Aug. '55	Sept. '54	(Source: NBC Research Dept.)	July '55	June '55	July '54
Television sets, total	939,515	647,903	947,796	Total sets	36,477,000	36,100,000	30,717,000
With UHF	140,022	105,673	136,613				
Color sets	nr	nr	nr	<b>BROADCAST STATIONS</b>			
Radio sets, total	1,302,350	947,634	932,323	(Source: FCC)	Oct. '55	Sept. '55	Oct. '54
With F-M	27,313	13,172	17,644	TV stations on air	473	473	431
Home sets	417,802	300,513	352,499	TV stations CPs—not on air	110	108	147
Clock radios	234,106	137,604	207,226	TV stations—new requests	35	28	167
Portable sets	139,164	106,197	76,271	A-M stations on air	2,788	2,771	2,627
Auto sets	511,278	403,320	296,327	A-M stations CPs—not on air	110	113	126
				A-M stations—new requests	235	219	137
				F-M stations on air	539	538	558
				F-M stations CPs—not on air	14	17	10
				F-M stations—new requests	9	7	2

	Sept. '55	Aug. '55	Sept. '54
<b>RECEIVER SALES</b>			
(Source: RETMA)	Sept. '55	Aug. '55	Sept. '54
Television sets, units	978,838	586,577	986,136
Radio sets (except auto)	753,068	456,625	763,589

	Sept. '55	Aug. '55	Sept. '54
<b>RECEIVING TUBE SALES</b>			
(Source: RETMA)	Sept. '55	Aug. '55	Sept. '54
Receiv. tubes, total units	47,588,000	45,238,000	40,966,063
Receiv. tubes, value	\$34,596,000	\$33,099,000	\$28,953,592
Picture tubes, total units	1,202,430	1,048,534	1,149,791
Picture tubes, value	\$22,867,851	\$19,812,567	\$23,892,469

	Aug. '55	July '55	Aug. '54
<b>SEMICONDUCTOR SALES</b>			
Germanium diodes, units	1,700,000	911,000	1,150,000
Silicon diodes, units			

	Quarterly Figures		
	Latest Quarter	Previous Quarter	Year Ago
<b>INDUSTRIAL TUBE SALES</b>			
(Source: NEMA)	2nd '55	1st '55	2nd '54
Vacuum (non-receiving)	\$8,933,453	\$8,784,478	\$9,851,020
Gas or vapor	\$3,365,008	\$3,747,490	\$3,987,036
Phototubes	nr	nr	nr
Magnetrons and velocity modulation tubes	\$13,193,395	\$14,229,442	\$16,429,553
Gaps and T/R boxes	\$1,677,574	\$1,434,683	\$1,914,313

	Sept. '55	Aug. '55	Sept. '54
<b>COMMUNICATION AUTHORIZATIONS</b>			
(Source: FCC)	Sept. '55	Aug. '55	Sept. '54
Aeronautical	44,183	45,203	40,695
Marine	52,908	52,440	47,360
Police, fire, etc.	19,153	18,877	16,109
Industrial	26,357	25,189	22,132
Land transportation	8,078	7,804	6,982
Amateur	139,628	138,852	121,762
Citizens radio	13,530	13,189	8,143
Disaster	319	319	305
Experimental	661	652	600
Common carrier	2,001	1,988	1,699

	Sept. '55	Aug. '55	Sept. '54
<b>EMPLOYMENT AND PAYROLLS</b>			
(Source: Bur. Labor Statistics)	Sept. '55	Aug. '55	Sept. '54
Prod. workers, comm. equip.	389,700-p	371,300-r	365,200
Average weekly earnings, comm.	\$74.34 -p	\$72.32 -r	\$69.95
Average weekly earnings, radio	\$70.30 -p	\$69.43 -r	\$68.57
Average weekly hours, comm.	41.3 -p	40.4 -r	40.2
Average weekly hours, radio	40.4 -p	39.9 -r	40.1

	Oct. '55	Sept. '55	Oct. '54
<b>STOCK PRICE AVERAGES</b>			
(Source: Standard and Poor's)	Oct. '55	Sept. '55	Oct. '54
Radio-tv & electronics	428.9	467.7	360.4
Radio broadcasters	486.9	537.7	400.7

p—provisional; r—revised  
 nr—not reported  
 \*being revised in light of Census data

## FIGURES OF THE YEAR

	TOTALS FOR FIRST NINE MONTHS			1954 Total
	1955	1954	Percent Change	
Television set production	5,760,506	4,733,315	+ 21.8	7,346,715
Radio set production	10,027,362	7,042,442	+ 42.4	10,400,530
Television set sales	5,149,997	4,645,063	+ 10.9	7,317,034
Radio set sales (except auto)	3,942,676	4,032,704	- 2.2	6,430,743
Receiving tube sales	347,668,000	266,050,907	+ 30.7	385,089,458
Cathode-ray tube sales	7,680,781	6,476,566	+ 18.6	9,913,504



# INDUSTRY REPORT

electronics—December • 1955

## U. S. Air Force Aerial Inspection Goes Robot

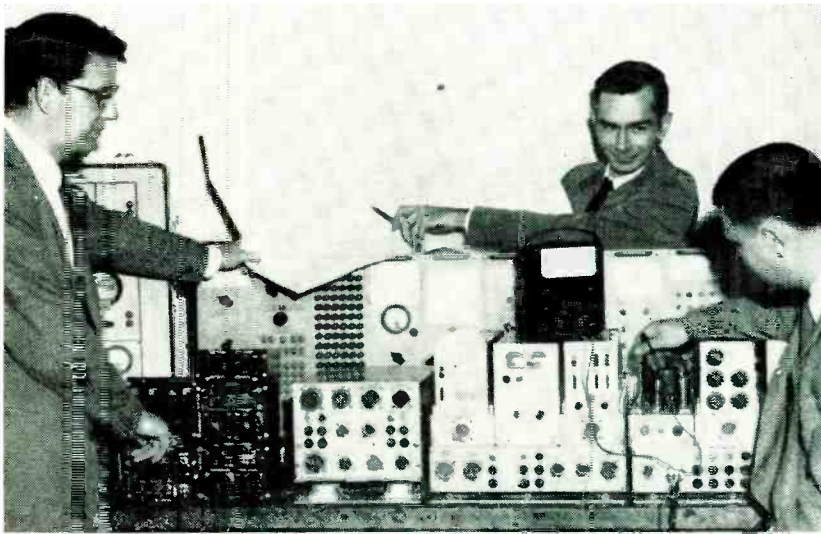

**ELECTRONICS** automatically controls photo settings and operation as . . .

### Air Force uses computers to automatically adjust airborne cameras for best pictures

NEW automatic, electronic remote control system to operate aerial cameras in high-speed photo reconnaissance, developed by the Air Research and Development Command, is now used by the Air Force. The equipment, known as the Universal Camera Control System, (UCCS) can operate in flight without human attention. It eliminates the need for many camera controls and can be adapted to operate as many as 11 cameras.

► **How**—The heart of UCCS is a series of analog computers into which focal length, camera angles, film sensitivity, shutter, type of lens, ground speed and altitude information is set manually. After

that, all operation is automatic and the system constantly adjusts the cameras for best pictures.

For night work, the system records when flash bombs have been released then calculates when each is to explode and works camera shutters accordingly. The equipment is built on a building block plan so that faulty electronic assemblies can be changed easily.

► **Who**—The Aerial Reconnaissance Lab at Wright ADC laid out the performance requirements and general electronic design of the system. The firms that developed and constructed the system are the Bill Jack Scientific Instrument Co., which did much of the development work, A. B. DuMont Labs, Chicago Aerial Industries and Fairchild Camera and Instrument Corporation.

► **Ike's Plan**—Practicality of aerial photographic inspection of military installations in both Russia and the U. S., as proposed by President Eisenhower, has been questioned by the U.S.S.R. But the value of the method has been upheld by both the U.S. government and private aerial survey firms.

Photographic Survey Corp. of Canada has pointed out that even during World War II, aerial photos taken at 30,000 feet showed objects as small as 18 inches. Today, with the aid of electronics, a jet fighter ten miles above West Germany can photograph Czechoslovakia, Poland as far east as Warsaw, all of Hungary, as well as a large part of the western areas of Romania and the Ukraine.

### Color TV Warms Up For Takeoff

**Industry moves ahead in color planning and sales, but has a long way to climb**

IN November, NBC, RCA and Westinghouse stepped-up their tv activities. The network announced a \$12-million program to expand its color facilities in New York, Chicago and Hollywood, doubling its present live-color schedule of 40 hours monthly by the fall of 1956. It also announced that its station in Chicago, WNBQ, will be made an all-color tv station by April 15, 1956.

► **Tube**—Westinghouse announced

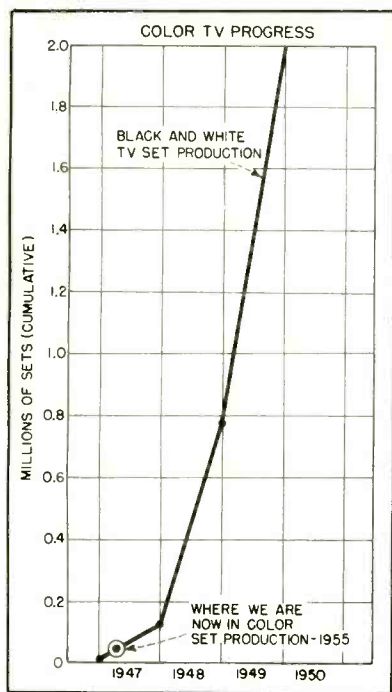

a \$1-million program to buy equipment for the production of its new all-glass color tv picture tube which it feels will be ready for the market next spring.

► **Sets**—RCA reports a current sales rate of 1,000 color sets a week. A recent survey by the firm showed its distributors' color-set sales in individual markets. Its Cincinnati distributor reported that 68 color sets were sold during the World Series. Its Washington, D. C. outlet reported sales of 28 sets to consumers and 7 to public places during the first three weeks of October.

The RCA Philadelphia distributor, during the three-week period before, during and after the Series, sold 333 sets to authorized dealers who moved 109 to consumers and public places. In the Los Angeles area, 181 color sets were sold in a 10-day period before and during the Series.

► **Time**—Despite sizable gains being made in color-set production and sales, the industry has a long way to go to equal present black-and-white business. This is shown in the chart of present total color set output on black-and-white tv's time scale. On that basis, color tv now is about where monochrome was in mid-1947.

## More Small Computers Appear

**Prototype machine employs magnetic amplifiers. General purpose unit is desk size**

MAGNETIC amplifiers have made their appearance in the electronic digital computer field. A business-type machine announced by Sperry Rand uses magnetic-amplifier units known as micro-ferractors instead of electron tubes or transistors.

A prototype unit was built last June and models will be available early in 1957. It will sell for about \$12,500.

Other computer designers, engaged largely in government work, are working on machines combining transistors and magnetic amplifiers. The transistors will provide the high-speed switching while the magnetic amplifiers will build up the necessary amplification for driving the ferrite-core memories.

**General Purpose**—A desk-sized computer designed for engineering and scientific computation has been unveiled by Librascope of Glendale, Calif.

The machine has 16 basic orders. A library of subroutines is available. The magnetic-drum memory stores 4,096 30-bit words. The machine operates serially using single-address internal binary operation with fixed point.

Access time varies from 2 to 17 milliseconds. Clock frequency is 120 kc. Addition requires 0.26 milliseconds excluding access time; multiplication and division require 17 milliseconds. The machine consumes 1.5 kw; sells for \$29,800.

► **New Company**—Boston's Laboratory For Electronics, makers of character recognition devices and other electronic equipment, is working on a general-purpose digital computer.

Through arrangement with British Tabulating Machine, LFE intends to have available a comprehensive line of data-processing equipment, it is reported.

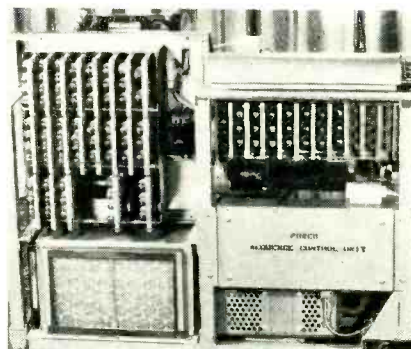

Librascope general-purpose computer

► **Tandem**—In some government applications, any failure of data processing equipment could be disastrous. A new wrinkle is connecting two IBM model 704 computers in tandem with connecting equipment to enable one machine to act as a spare in the event of failure.

The model 704 is a large-scale digital computer especially designed for engineering and scientific computation.

## Electronics Gains In Atomic Energy

**Many companies move into the field as peacetime use of nucleonics gains ground**

TWENTY percent of the exhibitors at the U. S. Nuclear Congress Exposition in Cleveland are in electronics. At the recent atomic exposition in Geneva in August and in New York in October nearly 40 percent of the exhibitors were electronics producers.

► **Equipment**—For many electronics firms now in the atomic field, instrumentation is the big business. It includes prospecting equipment, radiation monitoring instruments, instrument components, low-level anticoincidence counters, radiation spectrometers, pulse-height analyzers, and medical instruments.

But electronics manufacturers (Continued on page 10)



## Typical current

### Amplification characteristics

Checked against similar types  
Sylvania's Power Transistor consistently provides higher current gains.

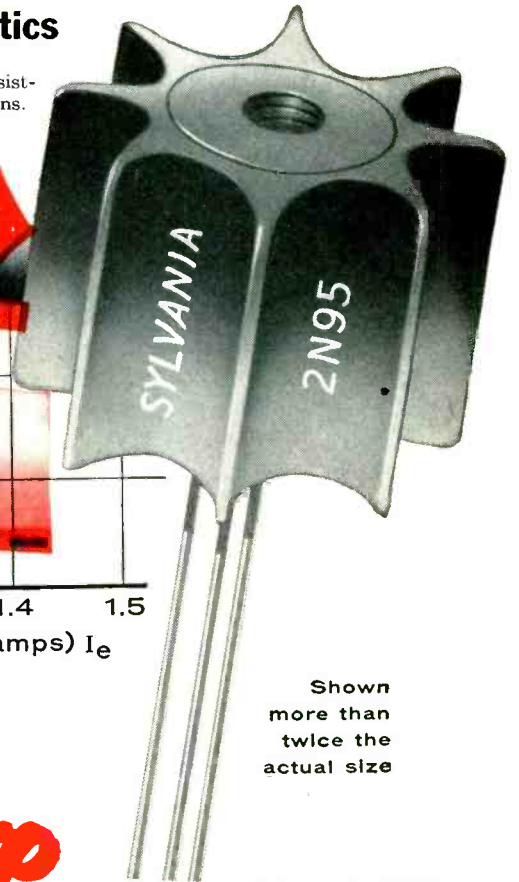
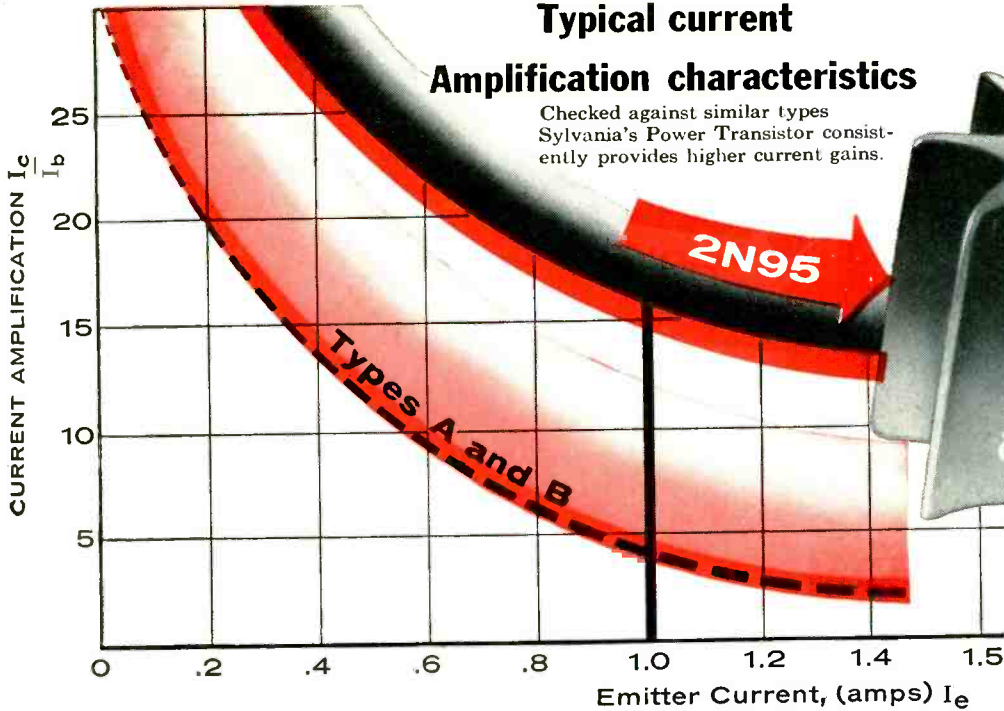

Shown  
more than  
twice the  
actual size

## Sylvania NPN Power Transistor 2N95 Exhibits

# 3 1/2 times more gain

Operated at 1.0 amp emitter-current, the Sylvania 2N95 Transistor typically provides a current gain of 17... 3 1/2 times that of comparable types A and B. Even at 1.5 amp emitter current the 2N95 typically exhibits a high gain of 13... in fact, as the curve shows, the Sylvania 2N95 provides the highest gain over the widest range of operating current conditions.

In addition, Sylvania's 2N95 com-

bines all the important features you want in a power transistor, whatever your application. If, for example, yours is a switching application, the 2N95 offers high gain at high currents.

Designed for low thermal resistance, the Sylvania 2N95 Transistor provides dissipation up to 2 1/2 watts without an external heat sink and up to 4 or more watts with a suitable heat sink. This insures stable operation in high ambient temperatures.

### You compare

Check the Sylvania 2N95 against similar Transistor types yourself—for current gain as well as all of these important power Transistor features.

#### Does the Sylvania 2N95 offer—

Does the Sylvania 2N95 offer—	Answer
1. lower cost	yes ✓
2. low input impedance	yes ✓
3. low thermal resistance	yes ✓
4. high current switching	yes ✓
5. high current gain	yes ✓
6. mounting for air cool or heat sink	yes ✓
7. hermetic seal	yes ✓

A smaller version for heat sink mounting, the Sylvania 2N102 is also available with the above features.

*"another reason why it pays to specify Sylvania"*

# SYLVANIA®

SYLVANIA ELECTRIC PRODUCTS INC.  
1740 Broadway, New York 19, N.Y.

In Canada: Sylvania Electric (Canada) Ltd.  
University Tower Building, Montreal

Check your application for complete data on other

Sylvania Transistors

High gain, low frequency  
Types 2N34 and 2N35

High power, low frequency  
Types 2N95 and 2N68  
Types 2N101 and 2N102

High frequency  
Types 2N94 and 2N94A

Dept. M20R

Sylvania Electric, 1740 Broadway, New York 19, N.Y.

Name \_\_\_\_\_

Company \_\_\_\_\_

Address \_\_\_\_\_

LIGHTING • RADIO • ELECTRONICS • TELEVISION • ATOMIC ENERGY

are not only in instrumentation for the atomic field. Sylvania, for example, is producing reactor fuel elements. Others produce special electronic components for reactors. As much as \$85,000 worth may be used in the typical small unit.

► **Potential**—It is estimated that a total annual volume of over \$200 million in electronic equipment will result within the next ten years from the expansion of the peaceful use of atomic energy. In addition, there will continue to be considerable government and military business for the industry.

This volume will not be gained

without increased expenditures for control and instrumentation research. According to the Atomic Industrial Forum, such spending will rise from the \$106,000 of 1953 to \$4.2 million by 1958.

It was pointed out that the industry does not know which type of reactor will prove superior in the near future. Consequently the development of control and sensing components will have to be approached on a piece by piece basis. For instrumentation components, however, design and development can proceed nearly unhampered because the general outline of the system is known.

## Wrist Radio Uses Three Transistors

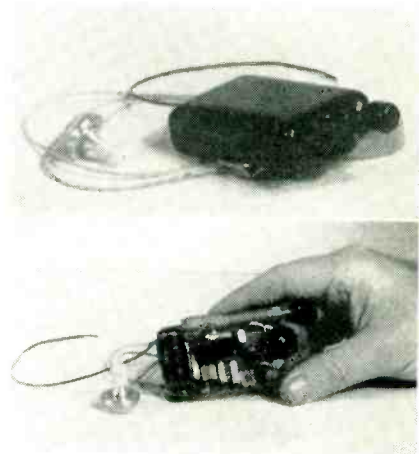

Wrist radio, complete with earphone and a few inches of antenna

FULL advantage is taken of the inherent small size of the transistor in a wrist radio receiver just announced.

The receiver contains three transistors. One is employed as a regenerative detector and the other two comprise the audio stages. One control allows slug tuning from 550 to 1,600 kc and the other is a regeneration control.

► **Operation**—Sensitivity of the receiver, designed by Linear Equipment Labs, Copiague, N. Y., is high. In the environs of New York City no antenna is needed for most stations. Six inches of wire is sufficient to pick up the weaker locals. At 30 miles from the city, one to three feet of antenna provides reception.

Mercury cells provide 6 volts to power the receiver. Total power input is 3 milliwatts.

Operation of the detector at the point of oscillation is different from that of vacuum tubes. No beat note is heard with the transistor detector of this receiver. Instead, circuit constants have been chosen so that oscillation takes place at a low pulse rate, similar to that of motorboating in an audio amplifier. The effect on the listener who misadjusts the regeneration control while tuning is much less disconcerting.

(Continued on page 12)

## Industry Plans Spending for '56

Companies schedule increased plant and equipment outlays, see increased sales

SPENDING for new plants and equipment next year by electronic and electrical machinery firms will be 13 percent higher than this year, according to a preliminary survey of business' plans for capital spending in 1956 by the McGraw-Hill Department of Economics.

Over \$507 million will be spent by companies in the field in 1956 compared to \$449 million this year and \$439 million in 1954. Most of the firms surveyed believe that they will equal or exceed their 1956 spending in 1957. Some 62 percent of companies surveyed are planning about the same investment and 10 percent expect to increase plant and equipment investment in 1957.

► **Sales Higher**—The survey also shows that electronic and electrical machinery firms expect sales in 1956 to be 7 percent higher than in 1955, explaining to some extent the reason for increased expansion. The sales increase equals that expected by industry as a whole. For individual industries the expected increases range from 2 to 12 percent.

► **Status**—Although spending in the electronics and electrical ma-

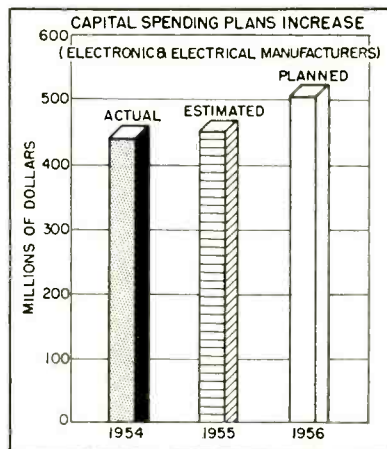

chinery industry will be up in 1956, plans are not yet equal to the peak expenditures made in 1953. Also, compared to all manufacturing the increase for the electronics industry is relatively small. Manufacturers as a whole plan to increase capital spending 30 percent in 1956. The largest increases are in primary metals, the chemical industry and the automobile industry.

► **Future**—Indications that plant expansion in the electronics and electrical machinery field will continue in 1957 show that the industry may not lose its expansion momentum. Although such plans are tentative now, in the past companies have usually added to their advance plans, as the target date drew near.



**ceramic capacitors  
designed for  
mechanized assembly**

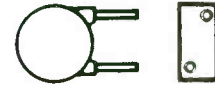

**Pin Terminal Disc Ceramic Capacitors**

The short, stiff terminals, 3/16" long, are accurately held to predetermined lead spacings. Closely controlled coating "pants" on the leads prevent resin from extending beyond the tangent line of the disc, yet no bare disc is exposed between leads. Available in bulk or in Tube-Paks.

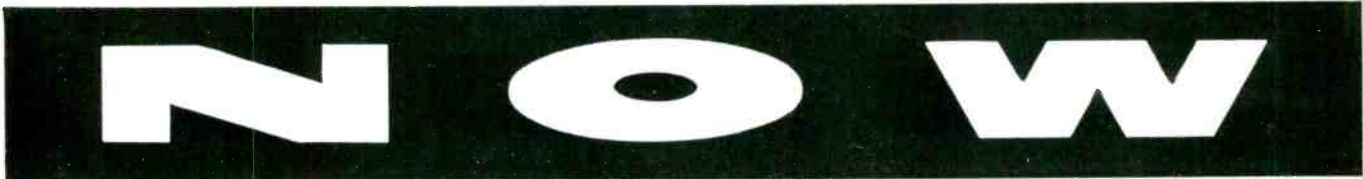

Just as Sprague pioneered in the automatic *manufacture* of capacitors, it now takes the lead in supplying these capacitors for automatic *insertion*. New ceramic capacitor configuration—with double-tinned leads and terminals spaced precisely to a tolerance of  $\pm .005"$ —assures foolproof automatic insertion in printed wiring boards. New packaging means top efficiency in handling, testing, and feeding the capacitors. And whichever styles you choose, you benefit from the advanced manufacturing techniques . . . exhaustive quality control procedures . . . and priceless on-the-spot engineering counsel which have built Sprague's reputation.

Brief descriptions of the designs and packages are shown at right. Complete information is available on letterhead request to the Technical Literature section, Sprague Electric Company, 35 Marshall St., North Adams, Massachusetts.

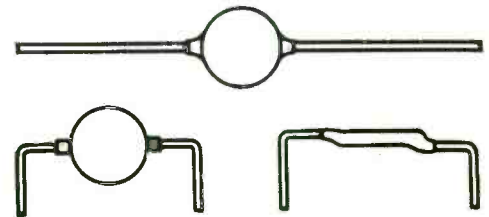

**Diametral Lead Disc Ceramic Capacitors**

After tape loading in magazines by the manufacturer, these capacitors need only have their leads precut before automatic insertion.



**Taper-Tab Terminal Disc Ceramic Capacitors**

Flat terminals are designed to jam easily into chassis slots, holding capacitors firmly during subsequent assembly steps prior to dip soldering. Available in bulk or in Tube-Paks.



**Tube-Pak<sup>★</sup> Packaging**

Up to 200 disc capacitors, pin terminal or taper-tab terminal, can be packed in each two foot long Tube-Pak. These slotted cylindrical magazines are a perfect fit for automatic insertion equipment now in use by several leading television manufacturers. Both types are plugged at each end before shipment.

★Trademark



WORLD'S LARGEST CAPACITOR MANUFACTURER



Export for the Americas: Sprague Electric International Ltd., North Adams, Mass. CABLE: SPREXINT



FIRST electronic range comes off the Tappan Stove production line as . . .

## Home Cooking Goes Microwave

Units priced at \$1,200 go on the consumer market. Plant expansion to boost output

MAGNETRONS started moving into home kitchens last month when the Tappan Stove Co. put a microwave range designed for home use on the market. The electronic unit was developed in conjunction with Raytheon which has had a commercial electronic range available for some time.

► **Features**—The range is offered by the firm as a built-in or stack-on type. It weighs 150 pounds and is about the same size as conventional built-in ovens. It incorporates an electric unit for browning, since microwave cooking cooks uniformly throughout and doesn't produce a hardened surface.

Temperature controls have been eliminated on the new range. The four controls are high and low speed selectors and individual timers for the microwave and browning units. The microwave timer is calibrated in seconds for the first three minutes of its settings because of the fast cooking speed. A potato can be baked in 5 minutes, a five-pound rolled rib

roast in 30 minutes and a two-layer cake in six minutes.

The range operates on 220-volts with the same type of cable as an electric range. It requires no special installation or plumbing. The magnetron operates at 2,400 mc, a frequency assigned by FCC for microwave cooking. Power is supplied by a four-tube rectifier unit.

► **Market**—Although Tappan does not plan immediate nationwide distribution of the electronic range, it will be offered in Detroit and several other major markets this year. The introduction is being limited to enable factory service personnel and home economists adequately to train distributor personnel.

Although the price of the range is higher than conventional units, the cost of operation is lower, according to Tappan.

Tappan is allocating some of the space provided by a \$300,000 plant expansion for increased electronic range production. GE plans to put its version of the electronic range on the market in 1956. Other major range makers including Westinghouse and Frigidaire are also expected to move into the field.

## Small Business Gets More Air Force Work

Total of \$20 million more in prime contracts went to firms with under 500 workers

AIR FORCE spending for electronic equipment totaled \$350 million in fiscal '55. The Air Force spends more for electronics than any other armed service.

Small business firms, those having less than 500 employees, are getting more of this business. In fiscal 1955, small business was awarded \$20 million more in prime contracts than in 1954. See chart.

Total awards were less than in 1953 and 1952 but an apparent downward trend has been reversed. The figures represent all Air Force awards to small business. A significant portion goes for electronics.

► **Orders**—During fiscal 1954, a total of 5,614 awards of over \$10,000 were placed with small business for a total value of \$425.2 million. In addition, \$131.4 million was placed in orders under \$10,000 to bring the grand total to \$556.7 million. In fiscal 1955, 801,555 contracts and purchase orders were awarded worth a total of \$576.8 million.

► **Reasons**—Air Force expenditures rose from \$5.6 billion in 1954 to \$6.1 billion for fiscal 1955. More of the equipment needed by Air Force in '55 could be produced by small business.

In 1954, it was estimated that

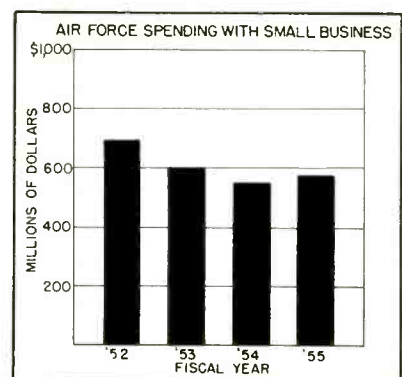

(Continued on page 14)



# For all your Tape Wound Core Requirements, specify **"CORES by ARNOLD"**

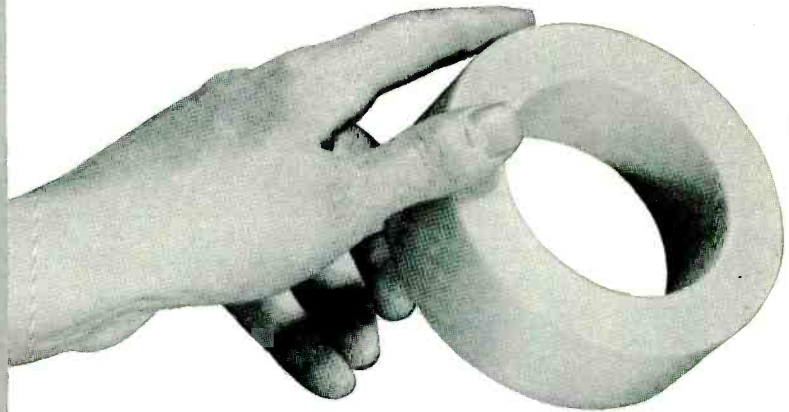

You'll be *assured* of the performance and uniformity you want, when you use Arnold Cores as magnetic components in your amplifier, transformer and reactor assemblies.

Our facilities for production and testing are highly modern and complete. Arnold is a fully integrated company, controlling every manufacturing step from the raw material to the finished core, and therefore best able to maintain high quality control. You'll have at your command the most complete line in the industry . . . containing every type, shape or size core you may require to meet design needs or electrical characteristics.

Many sizes of Arnold Tape-Wound Cores are carried in stock for immediate delivery. • *Write for additional information*, and let us quote on your requirements and help solve your problems.

## HERE'S DATA YOU NEED . . . Write for these Booklets

**1 BULLETIN TC-101A** . . . "Properties of Deltamax, 4-79 Mo-Permalloy and Super-malloy"—28 pages of technical data on Arnold Tape-Wound Cores of high-permeability alloys.

**2 BULLETIN SC-107** . . . "Arnold Silectron Cores"—round, square, rectangular, or C and E cores; 52 pages of data on shapes, sizes, properties, etc.

ADDRESS DEPT. E-512.

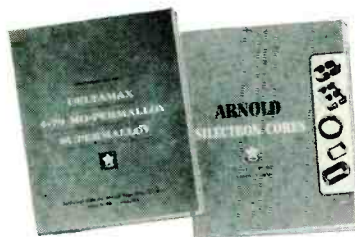

WAD 5648

## THE ARNOLD ENGINEERING COMPANY

SUBSIDIARY OF ALLEGHENY LUDLUM STEEL CORPORATION

General Office & Plant: Marengo, Illinois

DISTRICT SALES OFFICES . . . New York: 350 Fifth Ave.

Los Angeles: 3450 Wilshire Blvd.

Boston: 200 Berkeley St.



contracts worth \$733 million could be handled by small business. For 1955 the figure was \$755 million. When actual awards were made, 76 percent of the amounts in both years went to small business.

This was due to prices that were out of line, physical facilities that were inadequate, inability to meet delivery dates or no bids being received from small business.

► **More**—Along with the increased volume of Air Force prime con-

tracts, small electronic businesses are receiving greater help in securing subcontracts. Large prime contractors have been active in supporting small businesses.

GE, for example, has a manufacturing services division to funnel orders to defense subcontractors and suppliers that have available production capacity. The government has asked large prime contractors to report periodically on the number of subcontracts awarded to small business.

## Electronic Gear Withstands Atom Blast

### Communication equipment stands up under impact of 30-35 kiloton blast

DETAILED information released on the effects of atomic-blast exposure on commercial communication equipment indicates that it is generally much more resistant to nuclear effects than some typical residential structures.

A brick building located at a test point 4,700 feet from ground zero collapsed but a tv receiver, located in the same building, was still in operation without any servicing required.

► **Damage**—Mobile-radio antennas members were bent but still usable as a result of direct blast damage at the building location. Minor damage to coaxial cable coverings was caused by thermal radiation.

The plastic cases and knobs on tv sets and radios were cracked and chipped when struck by falling objects. However, performance was in no case seriously impaired.

Under blast conditions, whip antennas on mobile rigs showed a tendency to bend or break off where attached to the vehicle. Television receiving antennas were damaged beyond repair.

Outage of one a-m broadcast transmitter was due to the failure of the 60-cycle power supply.

## Operations Research Gains In Industry

### Some firms establish new departments; others retain consultants

APPLICATION of operations research is gaining ground in the electronics industry according to a survey reported at the operations research conference held in New York City by the Society for Advancement of Management.

(Continued on page 16)

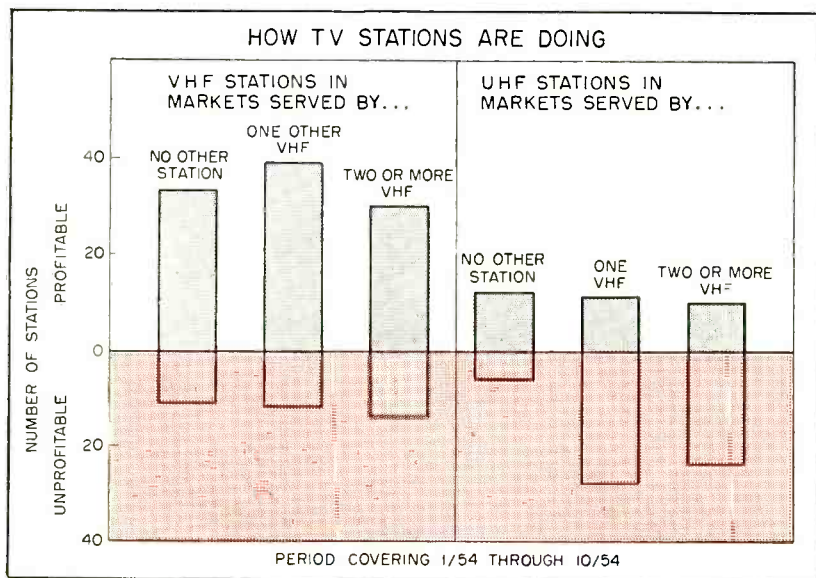

## FCC Looks At TV Competition

### Survey of uhf and vhf stations shows effect of competition, population and programs

THIRD survey of post-freeze tv stations by FCC compared the profits of uhf and vhf stations. As shown in the chart, the number of unprofitable vhf stations increased with the number of vhf competitors. For uhf stations with vhf competition, the same thing happened only more so.

► **Losses**—In areas served by two or more vhf stations, 70 percent of surveyed uhf stations and 32 percent of the vhf stations covered had continuing monthly losses during the ten-month period of the

survey. In areas served by one vhf, 71 percent of the uhf's and 29 percent of the vhf's were unprofitable every month. In single-station markets, 33 percent of the uhf's and 25 percent of the vhf's were in the red.

► **Other Factors**—In addition to competition, the size of the market and programs offered were important to the profit-loss picture. Over half of the vhf stations with continuing monthly losses were in communities with less than 75,000 population. As for the effect of network programs, the study showed that only 18 percent of the vhf stations that carried network programs in excess of 7.5 hours a week and 38 percent of uhf lost.



# KÄHLE

## automatic machines

WILL PRODUCE YOUR

**GLASS DIODES**

TRANSISTORS, TUBES  
AND OTHER  
ELECTRONIC COMPONENTS  
faster,  
more economically

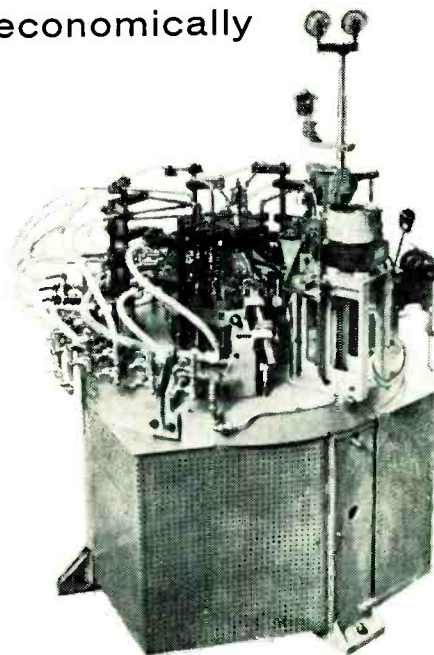

Automatic Diode Beading Machine #2549



Send for Kahle's valuable file on automatic equipment — today!

**Kähle** ENGINEERING COMPANY

1310 SEVENTH STREET NORTH BERGEN, N. J.

Designers and builders of special automatic and semi-  
automatic equipment for all industrial operations.

► **Survey**—Of 33 electrical and electronic firms queried, 22 replied. Twelve of the 22 companies now use operations research and have a total of 59 people assigned to the work. Six of the companies use consultants for operations research studies.

► **Use**—Operations research was developed during World War II by the military. According to SAM, it helps executives predict the results of an operation under different sets of variable conditions. This provides a sound basis for decision-making and forecasting.

Operations research has been applied to marketing, determining radar reliability, blending raw materials, scheduling of personnel, industrial communications, budgeting, financial incentives, transportation, traffic, allocation of sales effort and production and inventory control. Operations research has boosted use of electronic computers in business and industry.

## Personal Paging Business Advances

### Potential market seen for thousands of tiny vhf receivers and 200 transmitters

PHYSICIANS, delivery services and repair crews are finding radio paging essential in their work.

The paging transmitter continuously broadcasts numbers assigned to the individuals paged until the person calls into the office by telephone.

Signals are received on a pocket-size vhf receiver. Transmitters operate on 35.58 or 43.58 mc and cost about \$2,000. The paging service usually operates on a subscription service with each subscriber paying \$12 to \$15 a month.

► **Operators**—A paging service is in general an outgrowth of telephone answering services. There are currently 50 to 100 services with an estimated total of 4,000 receivers.

Potential market at present is about 200 transmitters.

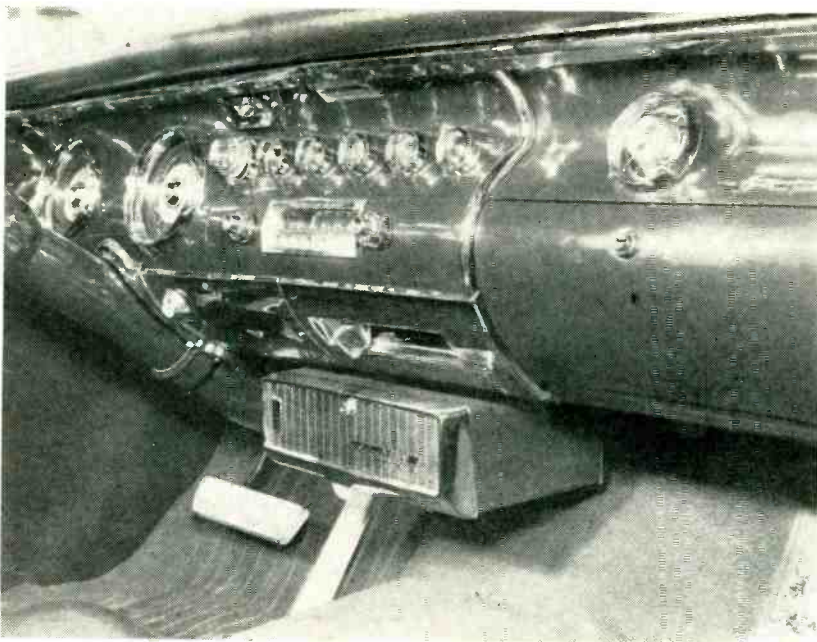

RECORDS can now be heard while traveling as

## High-Fidelity Hits the Road

### Automobile record players introduce new style and disk standards and open new market

FOR \$80, any owner of a 1956 Chrysler Corp. automobile may have his car equipped with a newly developed record player that mounts under the car's dashboard. The player's pickup arm will track the record under all road-operating conditions . . . short of a collision.

Each player is supplied with six records. Additional records can be purchased for \$2.50 to \$4.95.

► **Technical Details**—The record player was developed by CBS-Columbia Laboratories. It operates at 16 $\frac{2}{3}$  rpm from 18 v 60 cps, which is converted from 12 v d-c cps by a vibrator power supply.

The pickup cartridge is of ceramic and is mounted in a counter-balanced arm that concentrates the mass at the pivot point. The cartridge is fed into the car's radio.

Records are 7 inches in diameter and are cut with 550 to 700 grooves per inch depending on whether music or speech is recorded. (LP records have an average groove pitch of 235 lines

per inch.) Playing time of the records varies from 20 to 40 minutes per side depending on the groove pitch.

The fine grooves of the 7-in. record require a stylus with a 0.3-mil tip radius, ten times smaller than that used with conventional 78-rpm records.

► **Other developments**—A German portable, distributed by Chemtron Industries, Inc., N. Y. features a-m/f-m reception and a built-in 45-rpm record player. The unit operates from 110/220 v a-c or from self-enclosed batteries. The rec-



A-M/F-M radio has built-in 45-rpm record player

(Continued on page 20)



# ANNOUNCING

# NEW W5

# VARIAC<sup>®</sup>

Essential Dimensions  
Types W5 and WSM VARIACS

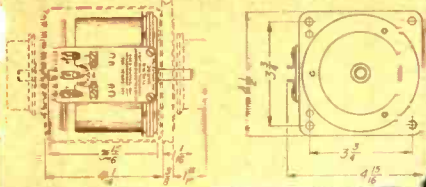

- ★ Higher Rating
- ★ More Rugged Construction
- ★ U-L Approved
- ★ Industrial-Type Cased Models  
Completely Enclosed
- ★ Portable Model  
with Overload Protection

Basic Type W5 VARIAC  
... 6 amperes rated and  
7.8 amperes maximum current (0.90 kva)

The new W5 Series VARIACS are another step in General Radio's continuing research and development program to assure users that the VARIAC will always be the best continuously-adjustable auto-transformer available anywhere in the world.

The new W5's have many improvements over the popular Type V-5, electrically and mechanically and in operating convenience.

Type W5MT3 VARIAC  
... 6 amperes maximum  
... 5 amperes rated current ... light weight,  
provided with carrying handle, overload protection,  
line switch, convenience outlet, 3-wire grounding  
cord and plug (WSMT is identical except 2-wire line cord is used)

**Some Features Are:**

Basic W5 model has 20% Increased Power Rating Drawn Wrought-Aluminum Square Base, Designed for Excellent Heat Transfer ... much more rugged ... will withstand MIL-T-945A Shock and Vibration Tests

Improved Brush Radiator ... setting of radiator and brush independent of position of shaft ... disc-type radiator completely covers and protects Duratrak brush track

Enclosed single and ganged models in industrial-type rectangular cases ... can be panel, behind panel, wall or table mounted ... conduit knock-outs conveniently located ... all mounting hardware included

Same mounting holes as all V-5's plus additional mounting holes in each corner of square base for convenience and extra rigidity. In most cases can be substituted directly for V-5's.



Type W5M VARIAC, panel mounted  
... four screws in corners of square base



Flip-on-type manually reset thermal  
overload breaker provides protection from prolonged overloads



Type W5M VARIAC ... 6.5 amps maximum ... 5.0 amperes rated current ... completely enclosed ... for wall, bench, panel or behind-panel mounting ... aluminum gray Hammer-tone finished cases with four conduit knockouts

Type W-5 VARIAC Assemblies		
Type	Description	Price
W5G2	2-Gang W5	\$41.00
W5G2M	2-Gang W5 completely enclosed with conduit knockouts	49.00
W5G3	3-Gang W5	61.00
W5G3M	3-Gang W5 completely enclosed with conduit knockouts	69.00
W5HG2	2-Gang W5H	45.00
W5HG2M	2-Gang W5H completely enclosed with conduit knockouts	53.00
W5HG3	3-Gang W5H	67.00
W5HG3M	3-Gang W5H completely enclosed with conduit knockouts	75.00

INPUT Volts	KVA	OUTPUT			Type	Price	Description
		Volts	Rated	Amperes Max.			
115	0.90	0-115	6.0	7.8	W5	\$17.00	Uncased
		0-135	6.0	6.0			
115	0.75	0-115	5.0	6.5	W5M	21.50	see footnote A
		0-135	5.0	5.0			
115	0.69	0-115	5.0	6.0	W5MT	26.50	see footnote B
		0-135	5.0	5.0			
115	0.69	0-115	5.0	6.0	W5MT3	28.50	see footnote C
		0-135	5.0	5.0			
230*	0.60	0-230	2.0	2.6	W5H	19.00	Uncased
		0-270	2.0	2.0			
230*	0.60	0-230	2.0	2.6	W5HM	23.50	see footnote A
		0-270	2.0	2.0			
230*	0.55	0-230	2.0	2.4	W5HMT	28.50	see footnote B
		0-270	2.0	2.0			

\*The 230-volt models can be used on 115-volt lines. When so used, the 0-270 volt output range is limited to a rated and a maximum current of 1 ampere.

A Completely enclosed with conduit knockouts  
B Bench model with 2-wire line cord, line switch, outlet, overload breaker and carrying handle  
C same as (B) except 3-wire grounding line cord and 3-terminal plug

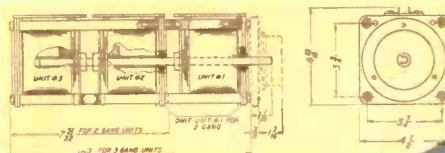

Essential Dimensions  
Types W5G2, W5G3,  
W5G2M and W5G3M  
VARIACS

Three-gang cased models showing extra-heavy internal construction ... can be panel mounted ... 4 mounting brackets provided for table mounting or vertical wall use ... 8 conveniently-located conduit knockouts

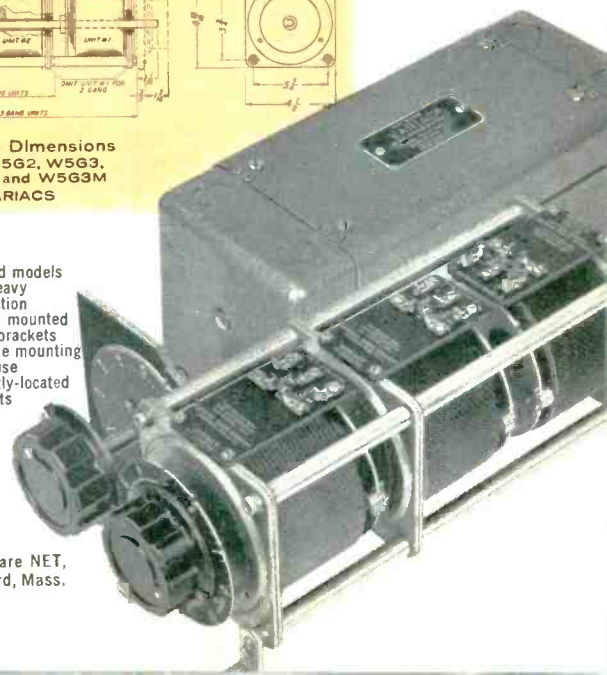

## GENERAL RADIO Company

275 Massachusetts Avenue, Cambridge 39, Massachusetts

90 West Street NEW YORK 6  
8055 13th St., Silver Spring, Md. WASHINGTON, D. C.  
1150 York Road, Abington, Pa. PHILADELPHIA  
920 S. Michigan Ave. CHICAGO 5  
1000 N. Seward St. LOS ANGELES 38



We sell direct. Prices shown are NET,  
f.o.b. Cambridge or W. Concord, Mass.

# for TRANSISTORS... RAYTHEON



Raytheon's new  
Semiconductor Division  
Plant at Newton, Mass.

With this \$3,000,000 plant Raytheon now utilizes approximately 180,000 square feet of space for semiconductor research, engineering and manufacturing activities.

Not only in better supply, but of the highest quality, uniformity and reliability. All are PNP Germanium Transistors hermetically sealed.

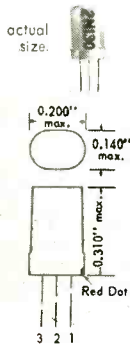

## SUBMINIATURE LOW FREQUENCY TRANSISTORS

Type	Collector			Emitter Current mA	Base Resistance ohms	Base Current Ampl. Factor	Max. Noise Factor db	Alpha Freq. Cutoff mc.
	Volts	Meg. ohms	Cutoff $\mu$ A					
2N130	-6	2.0	6	-1.0	350	22	25	0.6
2N131	-6	2.0	6	-1.0	700	45	22	0.8
2N132	-6	2.0	6	-1.0	1500	90	20	1.2
2N133	-1.5	1.0	6	-0.5	700	45	10	0.8
new 2N138	-6	2.0	6	-1.0	1800	140	25	1.2

## RAYTHEON TRANSISTOR FIRSTS

**FIRST** company to make point contact transistors commercially available — in late 1948.

**FIRST** to mass produce germanium junction transistors — in late 1952.

**FIRST** to mass produce fusion-alloy RF transistors — in late 1954.

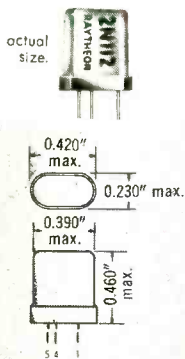

## HIGH FREQUENCY TRANSISTORS

Type	Collector		Emitter Current mA	Extrin. Base Resis. ohms	Base Current Ampl. Factor	Alpha Freq. Cutoff mc.	Coll. Capac. $\mu$ f	Gain		Rise time* $\mu$ secs	Decay time* $\mu$ secs
	Volts	Cutoff $\mu$ A						at 455kc db	at 2 mc db		
new 2N111/CK759	-6	1	-1.0	50	25	3	12	33	18	—	—
2N112/CK760	-6	1	-1.0	55	40	5	12	35	20	0.05	0.06
2N113/CK761	-6	1	-1.0	60	65	10	12	36	22	0.04	0.05
2N114/CK762	-6	1	-1.0	75	100	20	12	36	25	0.02	0.03

\*measured in circuit which will be supplied on request

Note: above characteristics are average except where noted

# RAYTHEON TRANSISTORS

more in use than all other makes combined





Presents...

# A COMPLETE LINE OF Bonded Silicon Diodes

TYPICAL REVERSE VOLTAGE CHARACTERISTICS AT 25°C.

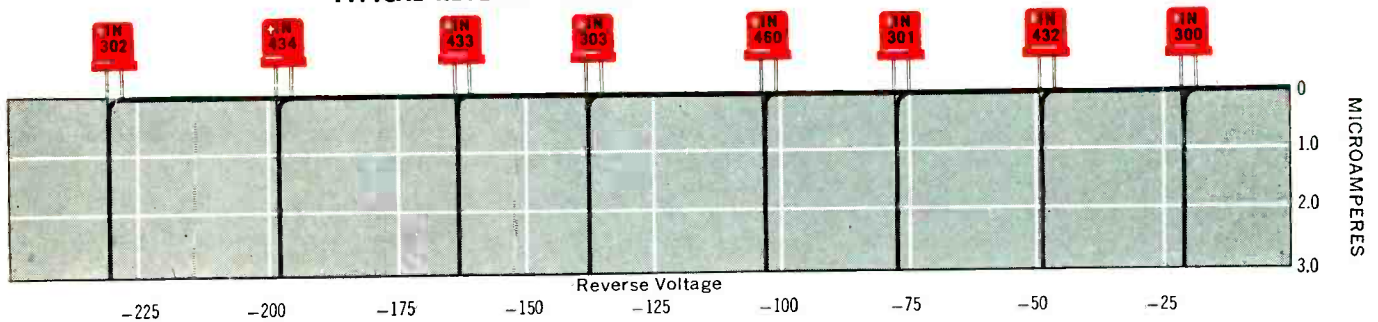

TYPICAL REFERENCE DIODE CHARACTERISTICS

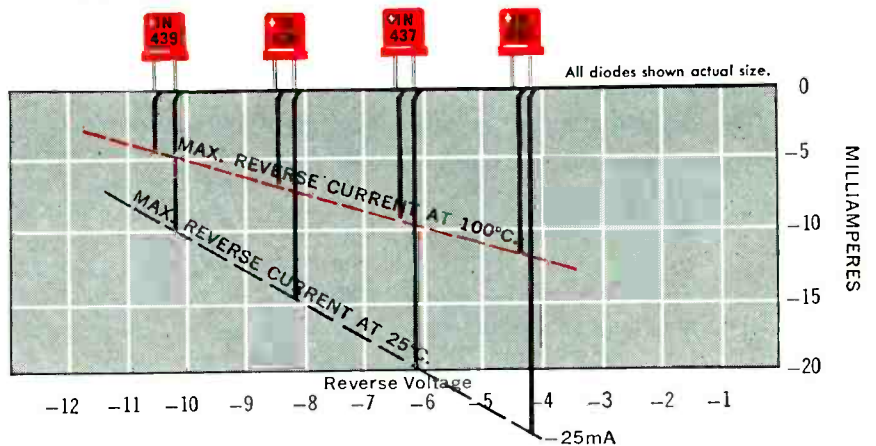

Raytheon Bonded Silicon Diodes provide low reverse current and good stability at high temperature. Every diode receives four temperature cycles of one hour at  $-55^{\circ}\text{C}$  and one hour at  $+150^{\circ}\text{C}$ , followed by thirty-six hours at 95% relative humidity and  $70^{\circ}\text{C}$ . Exact characteristics are maintained after temperature cycling and stability remains excellent over long periods.

Type	Peak Inv. Volts	Min. Forward mA at +1.0V	Max. Reverse $\mu\text{A}$ at Volts
1N300	15	8	0.001 -10
1N432	40	10	0.005 -10
1N301	70	5	0.05 -50
1N460	90	5	0.1 -75
1N303	125	3	0.1 -100
1N433	145	3	0.1 -125
1N434	180	2	0.1 -150
1N302	225	1	0.2 -200

Above ratings at 25°C



**RAYTHEON MANUFACTURING COMPANY**

Semiconductor Division

Home Office: 55 Chapel St., Newton 58, Mass., Bigelow 4-7500

For application information write or call the Home Office or:  
 9501 Grand Ave., Franklin Park (Chicago), Ill., TUxedo 9-5400  
 589 Fifth Avenue, New York 17, New York, PLaza 9-3900  
 622 South La Brea Ave., Los Angeles 36, Calif., WEbster 8-2851

**RAYTHEON MAKES ALL THESE:**

RELIABLE SUBMINIATURE AND MINIATURE TUBES • SEMICONDUCTOR DIODES, POWER RECTIFIERS AND TRANSISTORS • NUCLEONIC TUBES • MICROWAVE TUBES • RECEIVING AND PICTURE TUBES

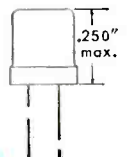
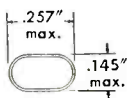

ord player operates from the batteries too. European-type tubes are used.

Battery or a-c line operation is

also a feature of a new RCA Victor portable radio and 45-rpm record-player combination now on the market.

## Why Television Sets Are Failing Today

**Tubes and capacitors lead as troublemakers; average is down to 1½ service calls**

WITH the average number of service calls per tv set settling down to around 1½ per year, as compared to 6 or more in the early postwar days, the causes of trouble change also.

Percentage figures compiled five years ago (*Why Television Receivers Fail in Service*, *ELECTRONICS*, p 66, July 1950) are summarized in the accompanying tabulation for comparison with the 1955 year-end picture for representative service organizations.

Reason for Service Call	1955	1950
Replace regular tube	60	28
Replace picture tube	2	6
Repair antenna system	2	14
False call	1	13
Replace paper capacitor	9	4
Replace electrolytic	3	1
Replace selenium rectifier	2	—
Replace resistor	6	6
Repair or replace tuner	3	8
Replace other component	6	6
Repair regular connection	3	4
Repair etched wiring	1	—
Realignment and adjustment	2	12
Total	100%	100%

► **Trends**—Although tube performance in tv sets is much better today, the tube percentage figure is up for two reasons: the tube failure rate is still highest for the first few months, hence tube troubles run high in factory service organizations where many repair jobs are within the 90-day warranty period; and independent servicemen tend to replace weak tubes hoping the resulting higher gain will offset the circuit defect and avoid pulling the entire chassis. Where organizations train servicemen to repair only the primary cause of trouble, the tube percentage drops to approximately 35 percent.

With the almost complete demise of the service contract, false calls have just about vanished. However, with around 60 percent of its calls still made under service contracts, RCA Service Co. reports 4 percent false calls.

Although millions of antennas are now well over five years old,

(Continued on page 22)

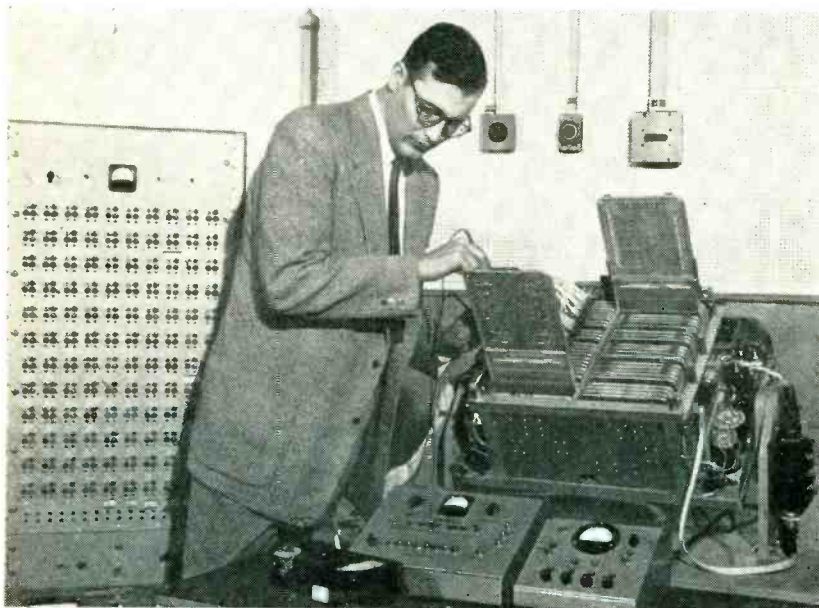

SMALLER lighter equipment, like this airborne digital computer, is developed as . . .

## Transistors Gain In The Military

**Airborne digital computer and underwater torpedo control operate without tubes**

ELECTRON tubes have been replaced by transistors in an Air Force airborne digital computer and in a Navy ultrasonic torpedo control system.

► **Airborne**—The computer, developed and flight tested by North American Aviation for the Air Force, uses some 1,000 transistors and etched circuits. It takes up only three cubic feet of space and weighs 125 pounds.

An electron-tube computer with half the capacity would be four times heavier and would take the space of an average closet. The computer uses less than 100 watts compared to about 3,000 watts for an electron-tube counterpart with only half the capacity.

The etched and transistorized circuits in the unit are designed in

the form of 51 standardized panels for reliability and quick servicing. The panels can be pulled out like file cards for testing and replacement. The computer can continuously integrate 93 quantities simultaneously and generate continuous solutions of differential and trigonometric problems.

► **Underwater** — Developed by Westinghouse research laboratories for the Navy's Bureau of Ordnance, the new ultrasonic torpedo control is fully transistorized. The transistors can operate directly on the low voltage of the torpedo battery. This eliminates the need for a separate source of power and makes the system more simple and compact. The total power required for the control using transistors is only about one-tenth that of an equivalent electron-tube control. With transistors the warmup time of 30 seconds or more needed for electron tubes is eliminated. The transistorized torpedo is ready for instant operation.



**AT MACH 1+**



PHOTOS COURTESY OF  
CONVAIR AND JACK & HEINTZ.

## **ALL-ANGL Barry Mounts give sure protection**

Jack & Heintz proved this in testing mounts to protect their Hi-Phase voltage regulators and control panels for Convair's supersonic F-102A interceptor.

No other miniature isolator tested could meet Procedure I of MIL-E-5272A. ALL-ANGL Barry mounts exceeded life-test requirements.

And the ALL-ANGL works in any position—to give sure protection for vital controls through every twist, turn, and dive in the aircraft's most violent maneuvers.

Write for Data Sheet J-11. And for your airborne requirements to meet standard MIL specifications, ask about All-Metl, Air-damped, and special Barry mounts.



JACK & HEINTZ  
MODEL 50127-000  
CONTROL PANEL

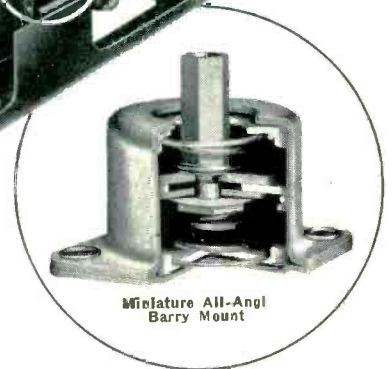

Miniature All-Angl  
Barry Mount

Here's the mount that meets the new needs of today's jet aircraft and missiles—where equipment must have greater protection against shock and high-frequency vibrations—and where MIL-standard mounts prove inadequate.

**BARRY CONTROLS** incorporated 707 Pleasant St. Watertown 72, Mass.

*New engineering opportunities are open in Barry's expansion program, at all levels in all departments. Send resumé.*

increased sensitivity of new sets may be one factor covering up gradual deterioration in antenna and transmission-line insulation.

One independent serviceman summarized his experience this year in one sentence: "Half the troubles are tubes and the other half are in the horizontal sync system."

## Tube Machine Makers Stack Up Big Year

**New plant expansions for increased tube output has upped machinery sales**

GROWING production of all types of tubes has increased the business of the industry's tube machinery makers. One firm estimates that sales in the field this year will top \$20 million.

► **Why**—A look at the plant expansions of the industry's tube makers so far this year indicates the reason for increased business. In the first 10 months of the year a dozen tube firms have announced new plant construction.

In the past month, two tube makers announced extensive expansions. Sylvania will construct a 110,000 sq ft receiving tube plant and Westinghouse has placed orders for \$500,000 worth of new equipment, primarily exhaust machines, for color picture tubes.

► **Types**—Most of the production equipment sold so far this year has been for picture tubes and special-purpose tubes. The machinery market for standard receiving tubes has dropped in importance and consists mainly of replacement business.

► **Firms**—There are some 15 manufacturers of tube machinery. Among the largest producers are several tube manufacturers themselves. They build machinery for their tube licensees and for themselves. But most of the companies are independent machinery firms, some specializing solely in equipment for the electronics industry.

# Research Heads For Billion Mark

**Investment in research and development will rise as the industry's volume climbs**

SPENDING for electronics research and development will reach a billion dollars a year in the next decade if present spending and sales rates continue.

Currently, the industry spends approximately 6 percent of its total sales on research and development. This figure is indicated by an analysis of the expenditures of 13 firms in the field and by a government survey of research in electronics and electrical machinery firms.

► **Companies**—Present importance of research in the industry has been indicated by recent statements of firms in the field. It was also pointed up at the American Management Association's special conference on managing product research and development.

RCA recently estimated that 80 percent of its business in 1955 will be in products and services introduced on the market during the last ten years.

IBM has indicated that it now spends about 4 percent of its gross on research and development. In its accounting and data processing division there are about 2,100 people working on development.

GE indicates that its Electronics Division's laboratory has a budget of \$3.6 million. The laboratory has the following subdivisions: engineering analysis, semiconductors and solid state, thermionics, dielectrics and magnetics, advanced circuits, communication and computers, video circuits and display, microwave and radar, application engineering.

Remington Rand had a total of 75 people working on Univac five years ago. It now has approximately 500 in the division's engineering research and development group alone.

► **Budget**—Consolidated Engineering increased research and devel-

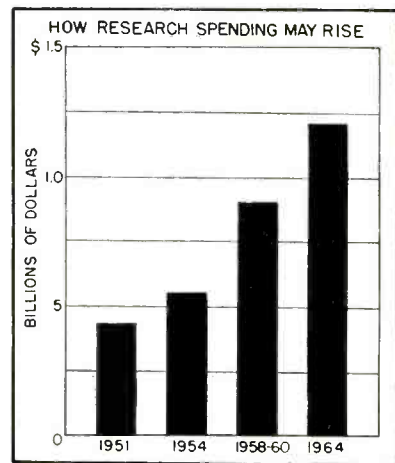

opment expense from \$165,502 in 1946 to \$1.7 million in 1954, according to AMA. In the same period, sales increased from \$925,787 to \$15.7 million. The firm allocated research and development expense as follows: 21.5 percent for improvement of released products; 24.7 for product design; 35.9 for product development; 13.2 for applied research and 4.7 for studies and service. Its research and development expenditures are normally set at 10 to 12 percent of predicted sales for the next year.

Varian Associates has announced that it plans to up its research expenditures and plans to spend \$500,000 on new product research this year.

► **Shortages**—Growth of research in electronics is also indicated by the shortage of research personnel. A survey by the Department of Labor showed that in the electronics and electrical equipment industry, three-fifths of the surveyed companies reported shortages of scientists and engineers.

All the firms with shortages said that this was impeding their research and development programs. Several manufacturers of electronic equipment stressed that their shortage of research engineers and scientists was extremely acute. One of the companies had been able to fill only half the budgeted research positions.

(Continued on page 24)



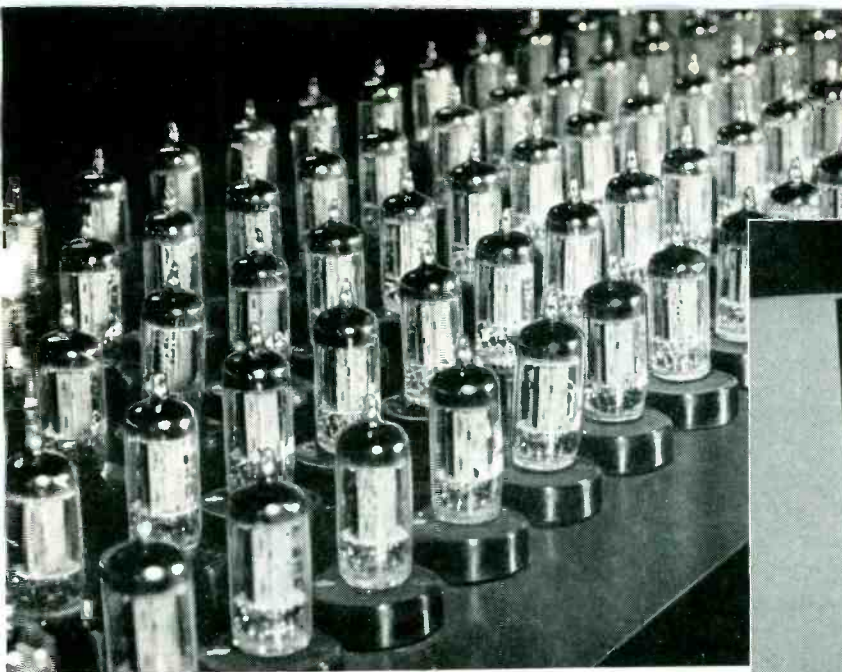

◀ LEFT: G-E computer tubes undergo a cut-off life test. The tubes are operated for long intervals with their grids biased to cut-off. Periodically the tubes are given a cathode interface check, to make sure no "sleeping sickness", or failure to respond to changed grid voltage, has developed during inactivity.

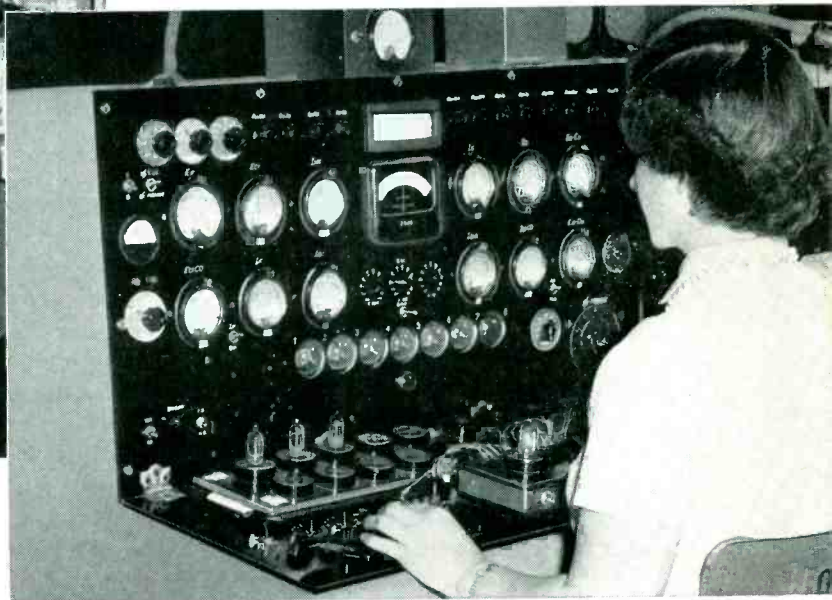

RIGHT: extensive instrumentation is used to test tube electrical qualities that closely affect operation in computer circuits. Zero-bias plate current; cut-off performance; any difference in cut-off between twin-triode sections—these are three of many characteristics checked. ▶

## G-E Computer Tubes are specially tested for qualities that safeguard computer reliability!

General Electric pioneered special tubes for computers . . . also developed tests such as those above, which assure that G-E tubes in your computer circuit can be relied on to meet designers' aims in all respects.

The tests are specific in purpose. Each covers one or more tube characteristics important in computer use, and which closely influence the accuracy and reliability of the equipment.

*There is no substitute for G-E computer-tube quality, which starts with special tube design—extends through precision manufacture—concludes with exhaustive tube tests that relate directly to computer service.*

Also . . . there is no counterpart to G.E.'s range of special computer tubes *now in production*. You have a choice of proved G-E types

available for your present circuit needs, with new tubes constantly being added.

Ask for "G-E Computer Tubes And Their Applications" (ETD-1140). 54 pages—just off the press. A book every designer and builder will find useful! *Tube Department, General Electric Company, Schenectady 5, New York.*

\* \* \*

● G-E computer-tube development is a continuing process, with new types being added regularly for faster, more advanced equipment, or to meet special customer requirements where volume warrants. Five types—proved popular—already are in full production:

GL-5844	GL-6211
	GL-5965
GL-5915A	GL-6463

*Progress Is Our Most Important Product*

**GENERAL**  **ELECTRIC**

## Subminiature Relay Makers Grow

**More relay makers widen lines to include the small units for military use**

IN the past two years, the number of relay manufacturers in the subminiature field has more than doubled. Today there are about 35 relay manufacturers who produce subminiature relays while in 1953 about 15 firms were in the field.

Main reason for the trend to miniaturization in relays, as with many other components, is that weight and size considerations are becoming increasingly more important in military equipment, particularly airborne gear, the principal market for the units.

► **Market Survey**—One of the latest entrants into the subminiature and miniature relay field is Elgin National Watch Co. which has acquired two relay firms. In making its move into the field, it surveyed the market.

Elgin estimates 85 percent of the miniature and subminiature-relay business is accounted for by the military and aviation markets; 10 percent by the industrial market and 5 percent by the commercial equipment market.

Because of the trend toward greater use of business machinery and toward automatic production in industry, use of small relays in industrial and commercial lines is expected to increase considerably in the next 5 to 10 years. It estimates the military and aviation market will account for 50 percent of small relay output; the industrial field, 35 percent and the commercial field, 15 percent.

► **Size Defined**—In differentiating between miniature and subminiature relays, Elgin defines the miniatures as those that have a volume of approximately 1 to 3 cubic inches and subminiatures as those with a volume of less than 1 cubic inch.

## Electronics Grows In Business

**Intercoms and dictating machines take the spotlight at Business Show**

GROWING use of electronic equipment in the nation's business offices was mirrored at the National Business Show in New York City. Over 25 companies displayed electronic gear ranging from dictating machines to facsimile equipment. Electronic computers were not shown this year.

► **Dictation**—Trend toward greater use of multiple dictating systems was evident. Up to 20 phones can be connected to a single recording unit. One manufacturer estimates that it is adding more than 1,000 new users a month. The price of the equipment is roughly  $\frac{1}{3}$  the price of individual dictating instruments.

Indications are that the systems can cut dictation costs by nearly

50 percent. A net saving of almost \$15,000 was made by one user with 20 stations and 4 recorders. Annual savings of over \$24,900 are expected when the system is expanded.

► **Intercoms**—Estimates based on Department of Commerce figures place the annual value of intercommunication equipment shipments in the range of \$20 to \$30 million, more than double 1947 shipments of \$9.9 million. A substantial part of this volume is accounted for by the office equipment field.

► **Future**—Intercom and dictating machine firms see expanding sales ahead for the equipment. They feel that the vast market of over 4.1 million business establishments in the U. S., not counting individual offices, has hardly been scratched.

As for future equipment design

changes, indications are that more dictation and intercom equipment may be combined in a single unit. A few companies already have such dual phone-dictation and intercommunications systems available.

## Television Girds For New Markets

**Vidicon tube prices are lowered. Low-priced tv station is demonstrated**

SALES help for expanding television applications was indicated recently when RCA announced lower prices on two vidicon tubes and Dage demonstrated a complete tv broadcasting station costing less than \$50,000.

► **Tubes Drop**—Suggested resale prices were reduced from \$315 to \$230 on vidicon type 6198 which is used for industrial television applications. Type 6326, used in black-and-white and in color tv broadcast film cameras, was reduced from \$565 to \$515. According to RCA, the reductions were made possible by substantial savings in manufacturing costs.

► **Low Power**—The Dage station is designed for communities of less than 50,000 population. It is adapted from one developed by the firm for military installations overseas where stations now in operation include those in the Azores; DeFlavik, Iceland; Thule, Greenland; and Bermuda.

The equipment meets the requirements of the recent FCC change in tv rules reducing the minimum required power of tv stations in small communities to 100 watts and eliminating any requirements as to antenna height.

► **School Circuit**—Dage also demonstrated a plan to transmit audio-visual programs to schools via closed-circuit tv based on the use of a central point to originate all audio-visual activities. A three-

(Continued on page 26)



# For VARIABLE CAPACITORS...



**"BFC"** butterfly-type capacitor with isolated rotor, very low minimum capacity and low inductance. For VHF applications as series capacitor with no rotor connection.

**"MAC"** Low minimum capacity and very low inductance. Ideal for VHF-UHF applications. Designed for use in miniaturization. Also available as butterfly type "MACBF".

**"APC"** A compact, high quality air dielectric trimmer. Extremely high resistance to temperature changes, moisture and vibration.

**"MAPC"** A scaled down version of the "APC". Designed to fill the needs of miniaturization. Suitable for VHF use.

**"HF"** A high frequency design featuring extra long sleeve bearing and positive contact nickel-plated phosphor bronze wiper. Also available as a dual unit.

*naturally,*



**"HFA"** Similar to "HF" model, but with larger air gaps for higher breakdown ratings. Used for high-frequency, low-power transmitting. Also available as dual unit.

**"MC"** Designed for maximum versatility in mountings, connections and capacity characteristics. Rotor stop permits 180° clockwise rotation with increasing capacity. Also available as dual unit.

**"RMC"** Similar to "MC-5" but featuring extra rigid design. Heavy frame of aluminum tie rods and end plates.

**"NZ"** Compact transmitting neutralizing capacitor designed for easy and accurate adjustment. Long leakage paths to ground from both rotor and stator.

**"VU"** Permits use of "lumped constant" circuits up to 500 MC. Two sections in series eliminate rotor wiper. Pyrex glass ball bearings eliminate noise from usual metal-to-metal bearings.

*it's*  
**HAMMARLUND**



For commercial, military and industrial applications, you just can't beat Hammarlund Variable Capacitors for uniformly high quality design, materials and workmanship. The capacitors illustrated here are just a small representative portion of the complete Hammarlund line. In addition to stock designs, Hammarlund offers you unparalleled variable capacitor know-how in development, design and production. Whatever your needs, when it comes to special or standard variable capacitors, naturally, come to Hammarlund.

**HAMMARLUND MANUFACTURING COMPANY, INC.**  
460 West 34th Street, New York 1, N. Y.

● Send for your copy of Bulletin 55E

vidicon color tv film camera which uses a folded optical system was also demonstrated by the firm along with a tv-microscope system and a servo pan and tilt mechanism for remote control of industrial tv.

## Civil Defense Fosters Electronics Sales

### Federal, state and local governments spend increasing amounts on equipment

IN fiscal 1955, approximately \$2.4 million was available from the federal government for civil-defense communications equipment. When matched by state and local groups, this brings the total available near the \$5 million mark.

To qualify for federal aid electronic equipment to be purchased by local units must meet engineering specifications of the Federal Civil Defense Administration.

► **Markets**—A number of electronics manufacturers have garnered a sizable share of the business. Probably the largest amount has been spent with two-way mobile radio manufacturers. But other equipment is taking a share.

For example, the Cincinnati division of Bendix Aviation, received an order for 30,000 self-indicating ionization-chamber dosimeters. The units, which sell for approximately \$10 apiece, will be stockpiled throughout the country for emergency purposes.

Bell Telephone has available its bell-and-lights air-raid warning system. It consists of a special telephone dial, located at a central control point, connected by private one-way telephone circuits to any number of bell-and-lights signal boxes, at warning points. One turn of the control dial flashes warning signals and sounds to all warning points. Bell also supplies two-way radio equipment which it leases and maintains.

Alden Electronics & Impulse Recording Equipment Co. has facsimile equipment available for civil defense use.

## Set Prices Go On The Upgrade

### Set makers revise prices upwards in face of rising labor and materials costs

NEARLY every major tv-set manufacturer has increased receiver prices in the past few months causing an average rise of \$10 in the retail price of many models. According to set makers, the rise is due to increasing costs of material and labor.

► **Chart**—Trend of radio and tv factory prices over the past year is indicated by the government's wholesale price indexes for the products which cover factory prices. Latest figures are beginning to show recent tv price increases. They may also indicate that more higher price sets are being sold.

The radio index shows recovery from the sharp drop that took place in August.

► **TV Price Drops**—Every year since 1947 the average retail price of tv receivers has fallen. Last year it took one of its biggest drops, a \$50 decline from \$280 to \$230. The decline is expected to continue this year despite recent price increases, but it may not be as severe.

Manufacturers have emphasized

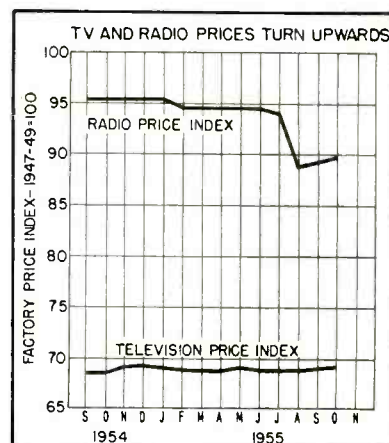

lower priced sets for the second set market. Large-screen sets priced below \$100 are reported to be selling well. Indications are that a greater proportion of total set sales this year will be in table models than last year. In June the ratio stood at 60 percent table models and 40 percent consoles.

► **Radio Down Too**—Radio receiver prices have also followed a downward path over the years. In 1954, average retail prices declined by about \$3 from 1953. The drop in the U. S. wholesale price index for the product in August indicates that the decline will be much more severe this year, despite the upward trend of the last few months.

## Glass Makes Headway In Resistors

JUST about a year has passed since low-power glass resistors first became available for use in radio and television receivers. In that time a dozen tv manufacturers have adopted the component for use in current sets and another has the units on order.

► **Why**—Glass resistors have been used in specialized military electronic equipment, but cost was prohibitive for civilian consumer goods. It was not until low-cost low-power types with 3, 4 and 5-watt ratings were introduced that

volume use began. Now prices of the units, depending on size, range from 30 cents to \$1. In quantities the price is lower. In some cases these lower prices have forced price adjustments in the conventional resistor field.

► **Construction** — The low-power resistors are made of a film of metallic oxides bonded to a Pyrex glass rod under heat. By means of electronically controlled machines, the film is automatically cut to the proper value and as-

(Continued on page 28)



# KAY

## Wide Band Sweeps for Aligning Radar IF Amplifiers



A combined sweeping oscillator and crystal marker generator, the Rada-Sweep is designed especially for rapid alignment of radar IF amplifiers. Used with an oscilloscope, it will display response curves of IF amplifiers and mark up to nine frequencies to allow precise adjustment of response.



The Radaligner is a two-band sweeping oscillator designed to be used with a standard oscilloscope to determine frequency response of circuits from 10 to 170 mc. For frequency identification, the Radaligner includes eight narrow, customer-specified, crystal-controlled markers and a single variable marker covering both sweeping oscillator ranges. Center frequencies of sweep ranges also set to customer's requirements.

For complete information write:

### KAY ELECTRIC COMPANY

DEPT. E-12 14 MAPLE AVENUE PINE BROOK, N. J.

## KAY Rada-Sweep

### SPECIFICATIONS

- Center Frequencies:** 30 and 60 megacycles. Others may be added to special order.
- Sweep Width:** Wide—20 mcs or Narrow—3 mcs selected by a panel switch.
- Sweep:** All electronic, linear sawtooth. Sweep signal is brought out to terminals for connection to oscilloscope horizontal amplifier. Sweep repetition rate is adjustable around and may be synchronized to the cps line.
- Markers:** Up to 9 crystal positioned pulse type marks fed directly to scope vertical amplifier. Four supplied standard at 25, 35, 55 and 65 mcs. Others located as specified by purchaser. The standard marks may be replaced with others as specified. Individual on-off control of each mark.
- Amplitude Modulation While Sweeping:** Less than .05 db/mc.
- RF Output Voltage:** 250 millivolts across 70 ohms.
- RF Output Control:** Switched Attenuator: 20 db, 20 db, 10 db. Continuous Attenuator: covers approximately 5:1 ratio.
- Marker Output Voltage:** Positive pulse, approx. 10 V peak.
- Marker Output Control:** Continuously variable, 0 to maximum.
- Power Supply:** 105 to 125 volts, 50 to 60 cps. Power input approximately 100 watts. Circuit electronically regulated.
- Price:** \$395.00 f.o.b. plant with standard marks. Any standard mark may be replaced with a special frequency—\$10.00 each. Additional marks at \$20.00 each.

## KAY Radaligner

### SPECIFICATIONS

- Sweep:** Regular sawtooth, adjustable around or synchronized with 60 cps power line.
- Frequency Range:** Center frequencies may be selected at any two points in the 10 to 170 mc band.
- Sweep Width:** Center Frequency below 30 mcs:  $\pm 5$  mcs Wide Band,  $\pm 0.5$  mc Narrow Band; Center Frequency above 30 mcs:  $\pm 10$  mcs Wide Band,  $\pm 1.5$  mcs Narrow Band.
- Amplitude Modulation While Sweeping:** Less than 0.05 db/mc.
- RF Output Voltage:** 250 millivolts into 70 ohms.
- RF Output Control:** Switched attenuators: 20 db, 10 db and 3 db. Continuous attenuator: approximately 6 db.
- Markers: Fixed:** Eight, narrow pulse-type, crystal-controlled markers, positioned at customer's option. Available singly or in any combination through individual switches. Variable: Frequency continuously variable throughout selected sweep ranges. Frequency calibration accurate to within 0.5%.
- Marker Output Voltage:** Positive pulse, approximately 10 volts peak.
- Marker Output Control:** Continuously variable, zero to maximum.
- Power Requirements:** 105 to 125 volts, 50-60 cps, approx. 110 watts.
- Price:** \$795.00 (rack-mounted), f.o.b. plant. Cabinet \$35.00 extra.

sembled with caps and leads.

Corning Glass, makers of the low-power units, has formed a components department to handle increased business from the electronics industry.

## Financial Roundup

### Many companies rack up record net profits for 1955's first nine months

THIRD quarter profits for many companies in the electronics field helped to boost nine month's earnings to new highs. Following are the net profit reports of 23 companies for the fiscal periods indicated:

Company	1955	Net Profit	1954
Avco 9m		\$63,801	\$3,336,721
Borg-Warner 9m	26,076,149		14,052,304
Burrhoughs 9m	8,255,002		6,922,436
Clevite 9m	3,219,431		1,980,501
T. A. Edison 9m	900,162		500,873
Elgin Watch 6m	268,446		269,648
Garrett 3m	1,093,000		840,000
General Controls 9m	1,156,664		717,237
General Electric 9m	141,359,000		136,191,000
Hoffman 9m	934,292		1,139,421
Magnavox 3m	564,807		331,729
Minn. Mining 9m	24,685,380		17,308,226
Motorola 9m	4,855,848		4,590,067
Philco 9m	4,854,000		2,275,000
Radio Instru-mer's 9m	496,658		122,835
RCA 9m	30,995,000		27,557,000
Standard Coil 9m	304,753*		1,912,279
Stewart-Warner 9m	4,345,959		1,831,719
Sylvania 9m	9,556,210		6,166,226
Texas Instruments 9m	1,099,748		811,842
Tung-Sol 9m	2,286,511		1,478,493
Varian Assoc 12m	433,000		225,000
Webster-Chicago 9m	691,476		236,894
			*(loss)

► **Securities** — Pyramid Electric filed with SEC covering 35,000 shares, par \$1, to be issued against warrants, at \$3.25 per share. Net proceeds are to be used for general corporate purposes.

RCA registered with SEC covering \$100 million of 25-year convertible subordinated debentures to be offered to its common stockholders. They will be offered in the ratio of \$100 principal amount for each 14 shares of common stock held of record. The offering will represent the first public financing by the company. Proceeds will be used for working capital, property additions and improvements and for further expansion of facilities.

## FUTURE MEETINGS

DEC. 12-16: Nuclear Engineering and Science Congress, coordinated by Engineers Joint Council, Cleveland, Ohio.

DEC. 14: IRE Operations Research Symposium, University Museum, University of Pennsylvania, Philadelphia, Pa.

DEC. 15-17: URSI Fall Meeting, University of Florida, Gainesville, Fla.

JAN. 9-10, 1956: Second National Symposium on Reliability and Quality Control In Electronics, ASQC and RETMA, Hotel Statler, Washington, D. C.

JAN. 18-20: 12th Annual Technical Conference, Society of Plastics Engineers, Hotel Statler, Cleveland, Ohio.

JAN. 19-21: IRE National Simulation Conference, AIEE, ACM, Baker Hotel, Dallas.

JAN. 25-26: Third Annual Industrial Show, Penn Sherwood Hotel, Philadelphia, Pa.

FEB. 2-3, 1956: IRE National Symposium on Microwave Techniques, University of Pennsylvania, Philadelphia.

FEB. 9-11: IRE Southwestern Regional Conference and Show University of Pa. Philadelphia, Pa.

FEB. 15-17: 1956 Conference On High-Speed Computers, Louisiana State University, Baton Rouge, La.

FEB. 16-17: IRE, AIEE, Univ. of Pa. Conference on Transistor Circuits, University of Pennsylvania, Philadelphia, Pa.

FEB. 28-29: Scintillation Counter Symposium, IRE, AIEE, Shoreham Hotel, Washington, D. C.

MAR. 19-22: IRE National Convention, Waldorf-Astoria Hotel, Kingsbridge Armory, New York, N. Y.

APRIL 5-6: IRE, AIEE, ISA, Magnetic Amplifier Conference, Hotel Syracuse, Syracuse, N. Y.

APRIL 10-12: Twelfth Annual Meeting and Metal Powder Show, Hotel Cleveland, Cleveland, Ohio.

APRIL 11-13: 1956 IRE 7th Region Technical Conference, Hotel Utah, Salt Lake City.

APRIL 13-14: Tenth Annual Spring Television Conference, IRE, Engineering Society Building, Cincinnati, Ohio.

APRIL 23-24: New England Radio Engineering Meeting, IRE, Sheraton Plaza, Boston, Mass.

## Industry Shorts

► **Total** of eleven f-m subsidiary communications authorizations have been approved by the FCC.

► **Market** in batteries for transistorized radios will reach \$100 million in three years, according to Olin Mathieson Chemical Corp.

► **Small** airborne Pye tv camera has been used to observe deicing tests on Britannia airliner engines.

► **Selenium** shortage continues and the government is again urging tv and radio repairmen to salvage discarded selenium rectifiers.

► **New** techniques of broadcast transmission which use the scatter principle make possible the im-

mediate establishment of tv relay stations linking America and Europe, according to Allen B. Du Mont.

► **Latest** Admiral tv sets have three automated printed circuits equivalent to 80 percent of all the wiring in the set.

► **Color** film-scanner shipments total 63 units to 59 stations.

► **Two** contracts to apply the principle of acoustic interference (electronic sound absorption) to military problems have been undertaken by RCA.

► **General** Electric now employs some 16,000 people in the electronics field in central New York state alone, with an annual payroll of

(Continued on page 30)

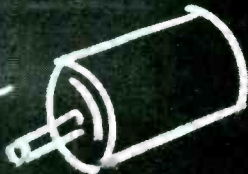

G-M Servo Motors 

GUARANTEED

TO MEET ALL MIL.  
ENVIRONMENTAL  
SPECIFICATIONS

By specializing in servo motors only—not systems—G-M gives you these advantages...

- A broader line of servo motors in sizes and types to meet a wide range of applications.
- Servo motors available in all the standard sizes.
- Standard sizes specially modified to meet specific circuit requirements—available on a quick-service basis.
- Creative engineering in designing special motors with special characteristics.
- Faster production—better service.

When reliability under extreme conditions is essential—specify G-M Servo Motors! G-M has long specialized in supplying precision servo motors to the Military Avionic Industry, especially designed to meet

military specifications for humidity, salt spray, temperature, vibration and altitude. Whatever your needs, let G-M build a servo motor with the *right* characteristics to perform to your specifications.

Write today for G-M charts, specifications, or consultation.



Servo Motors



Motor Generators



Synchronous-Hysteresis Motors



**G-M Servo Motors**

manufactured by the Components Division of  
**G-M LABORATORIES INC.**

4336 N. Knox Avenue • Chicago 41

between \$76 to \$80 million, according to R. J. Cordiner, president.

► **Single-sideband** for all mobile, Alaskan and maritime fixed service radiotelephone below 25 mc is under consideration by FCC to help

provide more communications channels.

► **Production of tv sets in Germany** is expected to reach 350,000 this year and may rise to 1.2 million sets by 1958, according to Telefunken.

# Industry Report Index

**Aircraft**

- Air force long-distance circuits use vhf.....7 Nov
- Automatic pilot sales.....16 Feb
- Civil air patrol radio.....20 Jul
- Private-plane market.....20 May
- Radar folds into floor.....24 Jun
- Radar network link.....16 Oct
- TACAN.....7 Oct
- Trainer business.....14 Apr

**Audio**

- Diamond-needle market.....20 Jan
- Juke box business.....14 Jul
- Magnetic recording markets.....12 Jul
- Mobile high fidelity.....16 Dec
- Taped music future.....22 Sept

**Broadcast**

- A-M and tv broadcasters make progress.....12 Jun
- Armed forces tv.....16 Jun
- Broadcasters add up 1954 tv business.....8 Aug
- Broadcasters focus on color.....10 Jul
- Commercial tv for Britain.....24 Sept
- Educational tv.....22 Sept
- F-M subsidiaries may subsidize f-m.....22 Jun
- Networks plan more color.....16 Sept
- Soundcasting continues profitable.....12 Jan
- Soundcasting stations cover nation.....24 Feb
- TV shows in every state.....24 Apr
- TV transmitter market.....14 Apr

**Business and Finance**

- Arizona state tax.....14 Aug
  - Arizona wants electronics plants.....16 Jun
  - Auto and parts firms feature electronics.....22 Sept
  - Bankers pronounce industry healthy.....7 Jun
  - Big business' stake in electronics.....22 Aug
  - Community tv growth.....12 Jul
  - Electronics assets climb.....20 Apr
  - Electronics booms in west.....22 May
  - Electronics firms in nuclear power.....8 Apr
  - Electronics in business.....24 Dec
  - Electronics industry spreads out.....14 Aug
  - Electronics in Massachusetts.....20 Nov
  - Electronics profits gain.....8 May
  - Factory inventories high.....20 Oct
  - Pewer firms failed in 1954.....24 Aug
  - Flooded industries bounce back.....16 Oct
  - Industry future holds \$20 billion.....12 May
  - Industry grows.....16 Nov
  - Industry shows mixed record.....20 Sept
  - Infrared scopes go commercial.....24 Sept
  - Los Angeles updates progress.....20 Apr
  - Maintenance is \$10-billion business.....24 Apr
  - Manufacturers display 1955 models.....24 Feb
  - Microwave ovens in home kitchens.....22 May
  - Operations research gains.....14 Dec
  - Parts distributors grow.....14 Jan
  - Plant expansions.....20 Aug
  - Productivity gains in industry.....12 Sept
  - Reactors expand electronics.....12 Sept
  - Transistor wrist radio.....10 Dec
  - Transistor's future.....14 Nov
  - Transistors in consumer products.....12 Jul
  - Transistors progress.....8 Jul
  - Tube machine makers big year.....22 Dec
  - Tubes process checks.....24 Jul
  - Tubes show tubes on tv.....12 May
  - TV and radio get set for summer.....10 Jul
  - Ultrasonic processing in three markets.....12 Feb
  - Ultrasonics gains.....14 Mar
  - U. S. budget jets electronics spending.....20 Mar
  - What's ahead for the remainder of 1955.....14 Sept
  - What it takes to be an executive.....24 May
- Foreign**
- Electronics in France.....22 Jul
  - Japanese transistor portable.....12 Oct

- Offshore purchases bolster Europe's plants.....22 Feb
  - Puerto Rican boom.....7 Jul
  - TV output in Canada.....16 Mar
  - U. S. electronics at German fair.....24 May
  - West German industry.....22 Feb
- Sales**
- Dry-cell business.....10 Feb
  - Gas-tube shift.....22 Oct
  - Industry volume for 1954.....20 Feb
  - Industry looks at 1955.....24 Jan
  - Klystron business.....16 Sept
  - Magnetic amplifier sales.....14 May
  - Magnetron sales.....14 Feb
  - Manufacturers eye selling costs.....10 Jun
  - New transistor radio.....7 Jun
  - Orthicon output.....10 Sept
  - Phototube sales.....10 Apr
  - Renewal market gains.....16 May
  - Transistor portables.....10 Feb
  - Traveling-wave tubes.....22 Jun
  - TV manufacturers appraise 1955.....8 Feb

**Communications**

- Businessmen adopt citizens' radio.....16 Aug
- Facsimile sales.....16 Apr
- Microwave relay business.....24 Sept
- More two-way radio.....22 Jan
- Radar helmet.....10 Oct
- Radio aids flood-stricken east.....12 Oct
- Radio replaces cable.....14 Nov
- Robot op takes code at 600 wpm.....24 May
- Sun powers telephone line.....20 Nov
- Taxi radio market.....20 Jun
- Transistors aid long distance calls.....26 Apr
- Yachtsmen boost electronics.....22 Mar

**Computers**

- Analog computers help design brakes, missiles.....16 Sept
- Build-it-yourself computer.....14 Nov
- Computers cut machining costs.....24 Oct
- Computer controls inventory.....20 Aug
- Computer firms report gains.....20 Oct
- Computer manufacturer presses 1,000 mark.....8 Sept
- Computer men scan low-price field.....20 Jan
- Computers seek new fields.....10 Nov
- Computers improve operations.....10 Feb
- Engineers humanize computer.....8 Jan
- Magnetic memory goes juke box.....10 Jun
- More small computers appear.....8 Dec
- New computer models.....12 Apr
- Personal paging business.....16 Dec
- Specialized computers.....14 Mar
- Transistor computer.....7 May

**Government**

- Government probes mergers.....14 Jul
  - U. S. contract awards emphasize radar.....22 Oct
  - U. S. urged to increase surplus disposal.....12 May
- Federal Communications Commission**
- FCC asks military for vhf channels.....10 Nov
  - FCC estimates its budget.....12 Feb
  - FCC looks at tv competition.....14 Dec
  - FCC moves in on ultrasonics.....25 Apr
  - FCC okays low-power television.....22 Aug
  - FCC reveals mobile radio use.....16 Apr
  - Mack named to FCC.....24 Aug
  - NAM wants in mobile radio.....12 Mar
  - Toll television.....16 Jul

**Industry**

- Auto industry eyes electronics.....12 Aug
- Electronic headlight dimmers.....22 Nov
- Electronics in atomic energy.....8 Dec
- Electronics in chemical plants.....10 Oct
- Electronics gains in movies.....22 Apr
- Fire alarms go radioactive.....22 Jun
- Industry plans spending for '56.....10 Dec
- Industry stresses reliability.....8 Jun
- Machine makers go electronic.....14 Nov
- More locomotives use rectifiers.....24 Oct
- Oil firms team with electronics.....14 Jun
- Oil industry goes automatic.....22 Aug

- Punch cards batch concrete mixer.....20 Jun
- Subminiature relays in industry.....24 Dec
- Tones control plant services.....20 Apr
- Tubes in metal trades.....20 May
- Tubes moving underground.....24 Jun
- Tubes in tool industry.....10 Aug

**Materials**

- Copper prices soar.....14 Oct
- Dwindling selenium conserved.....10 Oct
- Glass in resistors.....26 Dec
- Glass makers push parts-fields invasion.....14 May
- Synthetic mica output.....24 Jan
- Wiring board hypo plastic sales.....10 May

**Military**

- Air force backs industry.....8 Jul
- Air force plans parts handbook.....22 Mar
- Army buys transistor transceiver.....12 Sept
- Civil defense fosters electronics sales.....26 Dec
- Civil-defense helmet.....22 Jan
- Defense department wants more reliability.....24 Nov
- Defense in Canada.....20 Nov
- DEW line radar.....10 Apr
- Early warning radar goes airborne.....10 Jan
- Electronics military contracts.....8 Aug
- Flat-top sounds off with tubes.....24 Nov
- Hurricanes speed radar islands.....8 Sept
- Industry holds share of defense buying.....8 Nov
- Military to give navoids business.....26 May
- Military probes spurious radiations.....7 Apr
- Missiles business shoots up.....14 Sept
- Navy sees \$7.0 billion for 1955.....7 Aug
- Radar platform.....16 Jul
- Robot aerial camera inspection.....7 Dec
- Small business gains military work.....12 Dec
- Transistors in military equipment.....20 Dec
- Twenty-MM transmitter.....14 Jan

**Personnel**

- Engineers guide missile design.....7 Apr
- Mock reactor trains engineers.....16 Oct
- Supply of technicians.....24 Mar

**Production**

- Automatic machine wires chassis.....8 Oct
- Electrolytic capacitor output.....14 Jun
- Mechanized assembler builds computers.....8 Mar
- Mechanized production takes hold.....20 Feb
- New tv sets utilize automatic production.....7 Jul
- Parts makers try new packaging.....20 Mar
- Robot assemblers coming soon.....14 May
- Tape controls panel hole pattern.....16 Mar

**Research and Development**

- Complex scope patterns form art studies.....24 Jul
- Electronic cooler.....10 Mar
- Electronics and atomic blast.....14 Dec
- Electronics aids space station.....7 Sept
- Electronics revives Aladdin's lamp.....20 Jul
- Electronics withstands nuclear explosion.....20 Sept
- Finder accelerates tetrode transistor production.....12 Mar
- Hollow tubes carry conversations.....22 Mar
- Magnistors promise to supplement transistor.....10 May
- Microwave cooking.....12 Dec
- Moving engine x-rayed with itv and betatron.....20 Mar
- Music synthesizer.....24 Mar
- Phosphor sandwich brightens pix.....12 Feb
- Research buys testing gear.....12 Nov
- Research heads for billion mark.....22 Dec
- Research radio stations.....8 Oct
- Testing laboratories use electronics.....24 Apr
- Transistor quality improves.....16 Mar
- Transistor radio details.....26 Feb
- Transistor transmitter.....24 Nov
- Transistor uhf tetrode.....7 Sept

**Television**

- Aluminized tubes.....16 Jan
  - Bundling cuts cost.....12 Nov
  - Medical television.....24 Oct
  - More industries use itv.....14 Oct
  - New markets for television.....24 Dec
  - New tube materials.....16 Nov
  - Set prices increase.....26 Dec
  - Submarine tv checks fish nets.....26 Mar
  - Wall-mounted tv picture tubes.....7 Feb
  - Why television sets fail.....20 Dec
- Color**
- Color bulbs go conventional.....22 Nov
  - Color set makers get set for '55.....14 Jan
  - Color-tube design.....8 Nov
  - Color tube output.....16 Aug
  - Color tv warms up.....7 Dec
  - Economy forecast for color camera.....16 May
  - Europeans to study U. S. standards.....7 Nov
  - More setmakers move into color.....7 Oct
  - Projection receiver enters color field.....7 Jan
  - Push for color tube output.....7 May
  - Tape used for color tv.....8 Jun
  - Taped color moves toward market.....12 Apr





**IMMEDIATE DELIVERY  
on a NEW TUBELESS!**

**MAGNETIC AMPLIFIER**

# AC LINE VOLTAGE REGULATOR

**MODEL MLR - 1000**

## 1 KVA

- ☆ NO TUBES TO REPLACE
- ☆ NO MOVING PARTS
- ☆ NO VIBRATING CONTACTS
- ☆ REGULATES RMS VALUE
- ☆ IDEAL FOR UNATTENDED INSTALLATIONS

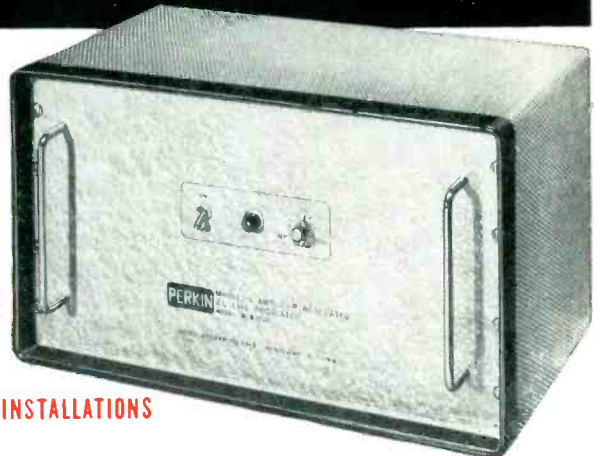

### Specifications...

- Input Voltage Range: 95 to 135 volts
- Output Voltage: Nominal 115 volts, can be adjusted from 110 to 120 volts.
- Output Current: 8.5 amperes
- Regulation Accuracy:  $\pm 0.25\%$  for any combination of line or load
- Frequency Range: 60 cycles  $\pm 10\%$
- Wave Form Distortion: 3% maximum
- Power Factor Range: 0.5 lagging to 0.9 leading
- Response Time: 0.2 sec.
- Maximum Load: 1.0 KVA
- Ambient Temperature Range: Up to 45° C.
- Dimensions: 19½" wide x 11" high x 11½" deep (cabinet)  
19" wide x 10½" high x 11½" deep (rack panel)
- Mounting: Cabinet or 19" Rack Panel
- Finish: Gray Hammetone
- Weight: 85 lbs.

Write for Bulletin MLR 1000



**PERKIN ENGINEERING CORP.**  
345 KANSAS ST. EL SEGUNDO, CALIF. PHONE: OREGON 8-7215

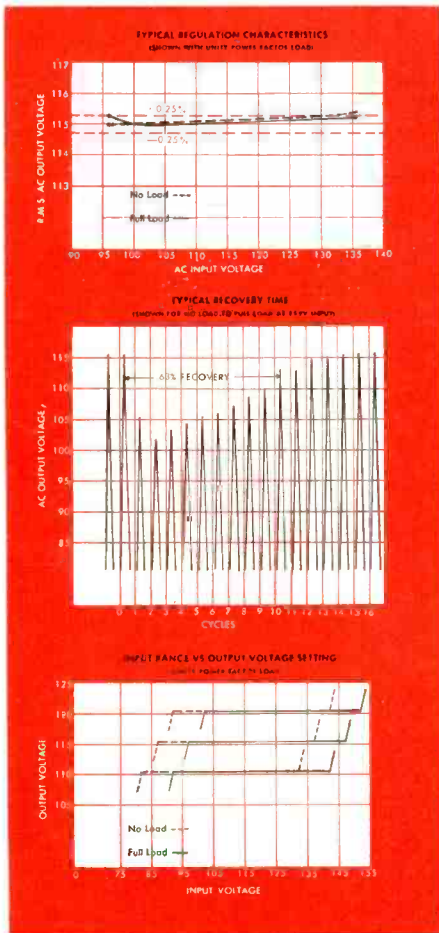

For PROMPT REPLY, wire the factory collect or phone our nearest sales office.

New York City: HUinter 2-7784  
Philadelphia: NOrristown 5-2600  
Chicago: DIversey 8-6885  
St. Louis: DElmar 7701  
Kansas City, Mo.: JEFFerson 7221  
Dallas: FOrrest 8-8306  
Denver: MAIn 3-0343  
San Francisco: ULmar 1-7129  
Syracuse: 2-1167  
Pittsburgh: WALnut 1-2959  
Minneapolis: MIldway 4-7884  
Seattle: MOhawk 4895  
Albuquerque: 5-9632  
Los Angeles: SYcamore 8-5790

try this one for ... **HEAT**



What happens when you put a soldering iron to your present insulation? Ten to one it cracks or melts right off the wire. But replace or protect it with BH"1151" Sleeving and your troubles are over.

BH"1151" is an inspired combination of two inorganic materials—Fiberglas and silicone rubber. The Fiberglas is braided and heat-treated under BH patented methods, then the silicone is fused on to become an integral part of the sleeving. It can be twisted and bent, but it will not craze or crack. It is completely unaffected by hot spot temperatures up to 700°F.—can even be potted in molten solder without injury. To be sure, it costs a little more than ordinary sleeveings, but the money saved by using a less effective sleeving will be lost on your first reject.

If you are interested in effective insulation for continuous operation through a temperature range of —90°F. to 400°F.—then try BH"1151". If you are interested in a sleeving with permanent flexibility—then try BH"1151". If you are interested in fungus resistance—then try BH"1151". If you are interested in a sleeving that conforms to the stringent requirements of MIL-I-18057—then try BH"1151".

You'll probably prefer spool or coil put-up, but 36" lengths and short pieces are available on special order. You can get BH"1151" the way you want it. Write today for data sheets and free Production Testing Samples—you'll welcome the extra protection your products gain with BH"1151".

BENTLEY, HARRIS MANUFACTURING CO.  
1312 Barclay St.  
CONSHOHOCKEN, PENNSYLVANIA  
Telephone: Conshohocken 6-0634

**BENTLEY, HARRIS**

*Fiberglas\**  
**SLEEVINGS**

\*BH Non-Fraying Fiberglas Sleeveings are made by an exclusive Bentley, Harris process (U.S. Pat. Nos. 2393530; 2647296 and 2647288). "Fiberglas" is Reg. TM of Owens-Corning Fiberglas Corp.



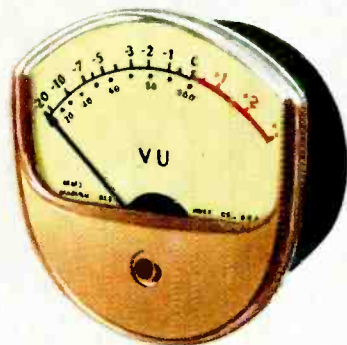
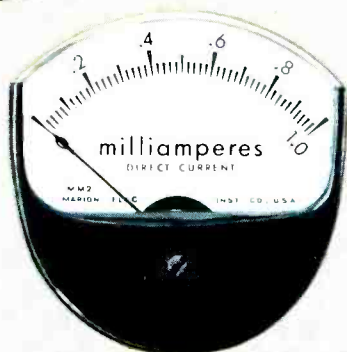
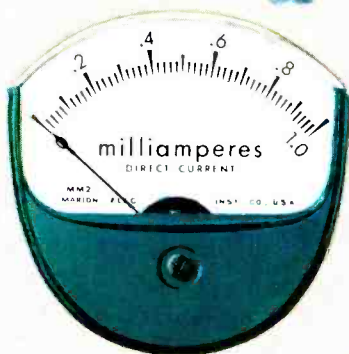
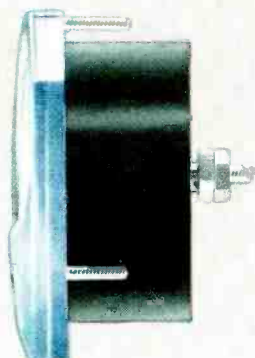
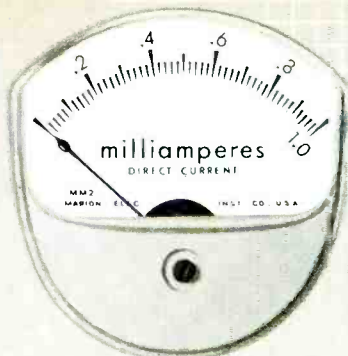

NOW

BRINGS  
*color harmony*

**AND FUNCTIONAL BEAUTY  
TO PANEL DESIGN**

Marion Medalist meters combine handsome, modern design in a choice of colors to enhance the styling of your equipment, with the greater readability of scales up to 50% longer than ordinary type panel instruments of the same size. They are interchangeable with ASA/JAN 2½ and 3½ inch sizes. Delivery now in all standard ranges.

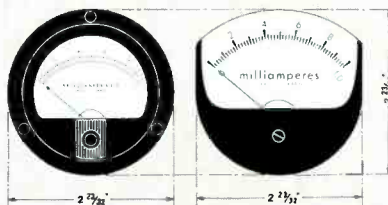

*Comparison of Medalist and Standard Style*

**marion**  
**meters**

marion electrical instrument company



**GRENIER FIELD, New Hampshire's NEW Air-Industry Area**  
Manchester, N. H., U. S. A.



*Marion Medalist\* Meters,  
described on the reverse side . . . as well as  
Ruggedized, Hermetically Sealed and other types of  
Marion instruments for the electronics  
and aviation industries — are now produced in this  
modern plant. Providing an appropriate setting for  
its outstanding products, Marion's new home combines advanced  
architectural design with the most modern materials . . .  
creating a unique and efficiently integrated manufacturing facility.  
We invite your inspection.*



M A R I O N   E L E C T R I C A L   I N S T R U M E N T   C O M P A N Y



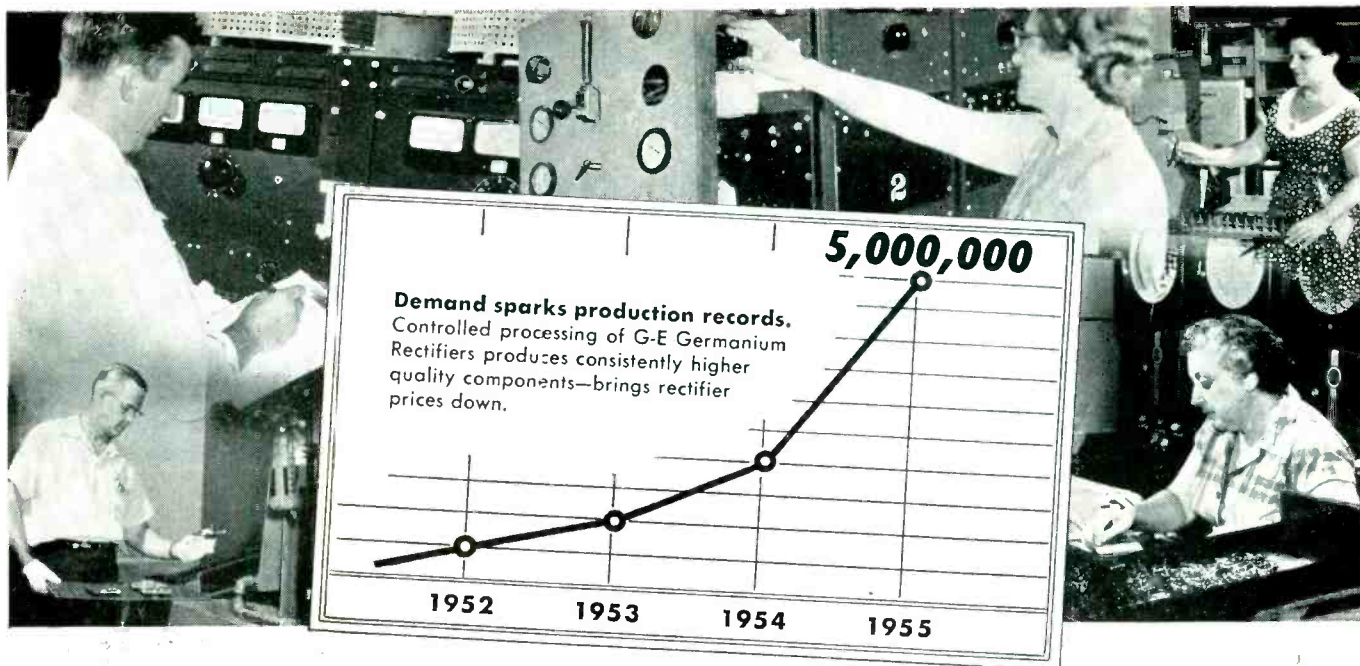

## G-E Germanium Rectifier Production Breaks the 5 Million Mark

**Customer requirements accelerate the production of a full line of highly reliable, long-life germanium rectifiers**

**T**HE NEW germanium rectifiers were introduced by General Electric in 1952 and since then more than 5 million units have been produced for industrial and military needs. In effect, this achievement represents more than *ten billion hours* of rectifier life—in hundreds of diversified commercial and military applications.

**PROVED QUALITY!** Of the 5,000,000 rectifiers produced, only a fraction of 1% have required adjustment under the terms of General Electric's full year warranty!

**Wide Range of Designs.** G-E rectifiers are available in a broad range of designs for many applications—for electronic computers, control equipment, power supply units, magnetic amplifiers; for military and industrial needs requiring custom designs; and for almost any application where DC power is required. G-E Germanium Rectifiers are more compact, and weigh less—as much as 75% less than comparable rectifiers of other types—and meet the rigid requirements for performance established by the U. S. Navy, Air Force, and Signal Corps. What's more, G-E Germanium Rectifiers are *warranted for one full year.*

**Immediate Delivery.** Mass production assures fast delivery on all G-E Germanium Rectifiers regardless of quantity. For complete information concerning your rectifier needs, contact your G-E Semiconductor Representative. Or, write: *General Electric Company, Semiconductor Products, Section X4125, Electronics Park, Syracuse, New York.*

*Progress Is Our Most Important Product*

**GENERAL  ELECTRIC**

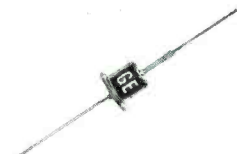

**Diffused Junction Germanium Rectifiers** combine very high forward conductance with very high back resistance. The high temperature and magnetic amplifier rectifiers feature very low reverse current ratings at ambient temperatures of 85°C.

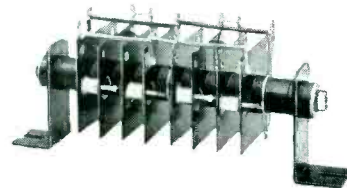

**Power of the basic rectifier unit** is boosted 5 times by adding a copper fin. Stacked one to twelve fins in series or parallel, the rectifier may be operated as half wave, full wave, or bridge circuits, and many other types of single or polyphase circuits. Typical power ratings are as high as 3 amps @ 190 volts; 1.3 amps @ 575 volts; 3.6 amps @ 140 volts, etc.



**The Medium Power Rectifier** has a 5 amp rating at 200 volts (55°C). At 85°C it is rated 2.5 amps at 100 volts. These rectifiers, stacked in series or parallel, have ratings in thousands of watts depending on the design of the circuit.

# International Rectifier

## Selenium and Germanium Rectifiers

### International Selenium Products

*Pressed powder or vacuum process used as determined by our Applications Engineering Dept. The most widely used Industrial Power Rectifiers in Industry today!*

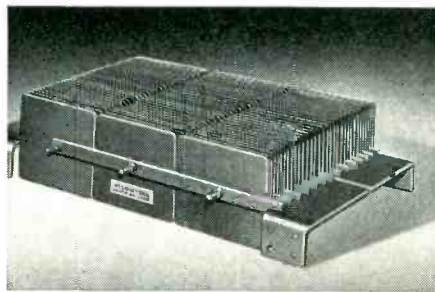

**INDUSTRIAL POWER RECTIFIERS**

For all DC power needs from microwatts to kilowatts. Features: long life; compact, light weight and low initial cost. Ratings: to 250 KW, 50 ma to 2,300 amperes and up. 6 volts to 30,000 volts and up. Efficiency to 87%. Power factor to 95%. **Bulletin C-349**

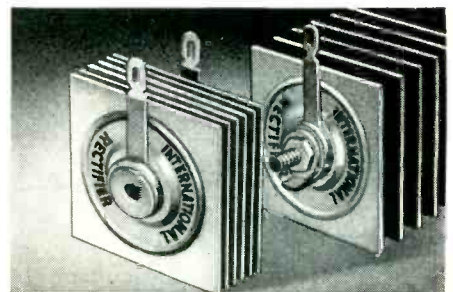

**TV AND RADIO RECTIFIERS**

The widest range in the industry! Designed for Radio, Television, TV booster, UHF converter and experimental applications. Input ratings from 25 to 195 volts AC and up. DC output current 10 to 1,200 MA. Write for application information. **Bulletin ER-178-A**

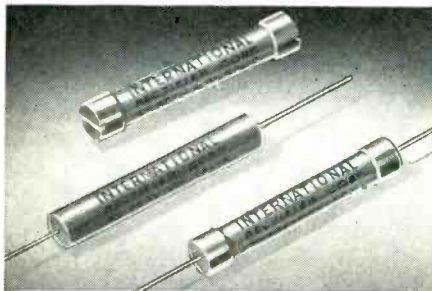

**HIGH VOLTAGE CARTRIDGE RECTIFIERS**

Designed for long life and reliability in Half-Wave, Voltage Doubler, Bridge, Center-Tap Circuits, and 3-Phase Circuit Types. Phenolic Cartridge and Hermetically Sealed types available. Operating temperature range:  $-65^{\circ}\text{C}$  to  $+100^{\circ}\text{C}$ . Specify **Bulletin H-2**

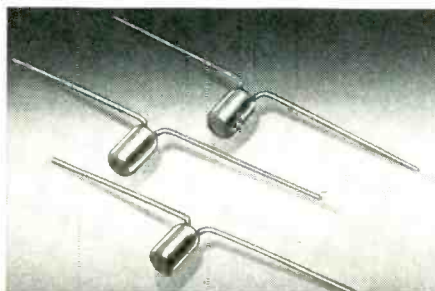

**SUB-MINIATURE SELENIUM DIODES**

Developed for use in limited space at ambient temperatures ranging from  $-50^{\circ}\text{C}$  to  $+100^{\circ}\text{C}$ . Encapsulated to resist adverse environmental conditions. Output voltages from 20 to 160 volts; output currents of 100 microamperes to 11 MA. **Bulletin 5D-1B**



**PHOTOELECTRIC CELLS**

Self-generating photocells available in standard or custom sizes, mounted or unmounted. Optimum load resistance range: 10 to 10,000 ohms. Output from .2 MA to 60 MA in ave. sunlight. Ambient temperature range:  $-65^{\circ}\text{C}$  to  $+100^{\circ}\text{C}$ . **Bulletin PC 649**

### International Germanium Products

*High quality units of improved design are the results of years of experience in the production of exceptionally fine germanium crystals plus extensive research, development and field performance testing!*



**GERMANIUM POWER RECTIFIERS**

This new line features: High efficiency—up to 97%, Lowest forward drop, High reverse to forward current ratio, unlimited life expectancy. No reforming required after storage. Ratings: 26 to 66 AC input v. per junction: 150 to 100,000 amps DC output. Operating temperature range:  $-55^{\circ}\text{C}$  to  $+75^{\circ}\text{C}$ . In three styles. **Bulletin GPR-1**

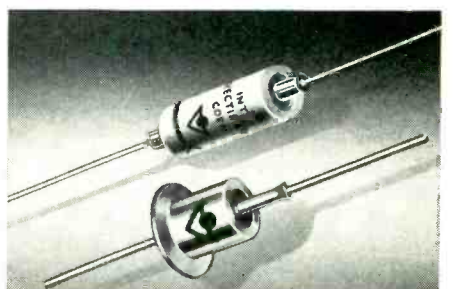

**GERMANIUM DIODES**

**POINT CONTACT.** High quality crystals—long reliable life—superior resistance to humidity, shock, temp.-cycling. **Bulletin GD-2**  
**JUNCTION POWER.** Hermetically sealed—welded construction. Available in Standard JETEC 1N91, 1N92, 1N93 types. For diodes to meet your specific requirements, consult our Semiconductor Division.

a world of difference through research!



For bulletins on products described WRITE ON YOUR LETTERHEAD  
to our PRODUCT INFORMATION DEPARTMENT

# International Rectifier

C O R P O R A T I O N

EXECUTIVE OFFICES: 1521 E. GRAND AVE., EL SEGUNDO, CALIFORNIA • PHONE OREGON 8-6281

WORLD'S LARGEST SUPPLIER OF INDUSTRIAL METALLIC RECTIFIERS



Announcing **A-MP**®

**MINIATURE TAPER PINS**

**FOR MINIATURIZED COMPONENTS!**

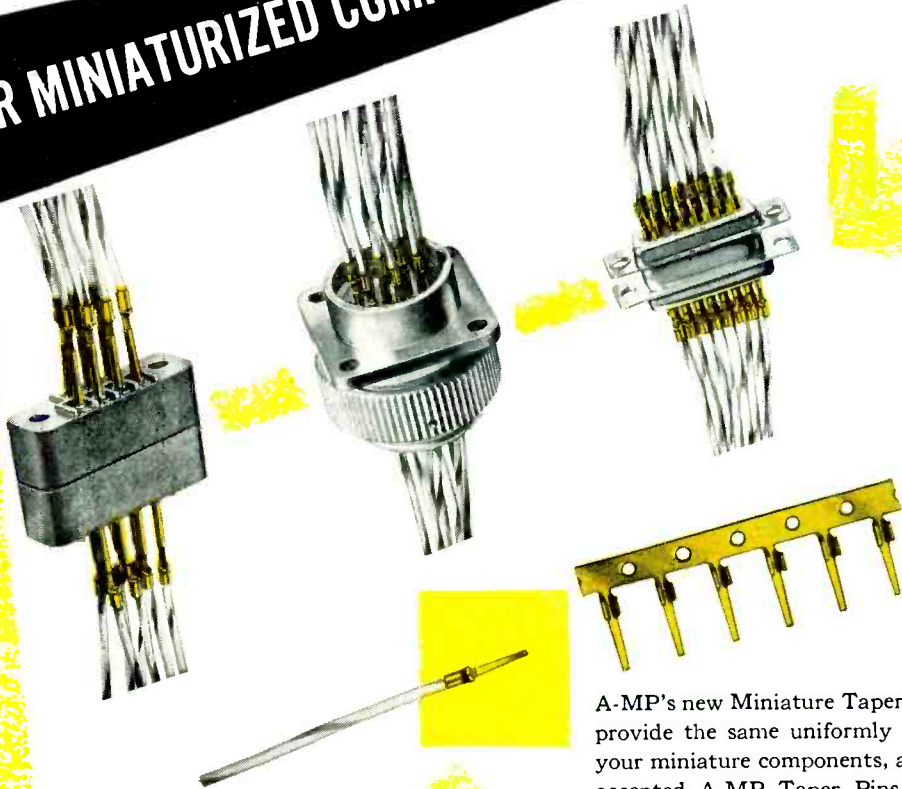

A-MP's new Miniature Taper Pins, shown here actual size, provide the same uniformly reliable wire connections for your miniature components, as the larger, widely used and accepted A-MP Taper Pins. Miniature Taper Pins are applied to wire with A-MP Automatic Machines at speeds up to 4000 per hour. They are then inserted into components quickly and easily with A-MP CERTI-LOK Insertion Tools. Miniature Taper Pins are available for wire sizes #26 to #20.

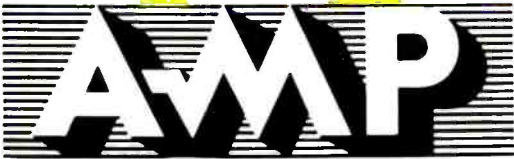

©A-MP



Send today for your copy of "A-MP's Creative Approach to Better Wiring"

**AIRCRAFT-MARINE PRODUCTS, INC., 2100 Paxton Street, Harrisburg, Pa.**  
In Canada: AIRCRAFT-MARINE PRODUCTS OF CANADA, LTD., 1764 Avenue Road, Toronto 12, Ontario, Canada

# TWENTIETH CENTURY

# Relay

## The Potter &

One of the reasons that keeps Potter & Brumfield Relays out in front.

The best Engineering design is not enough. Prototypes must pass all torture qualification tests. More important the manufactured product must meet engineering expectations. Not just now and then, but for as long as the relay is made.

That is why Potter & Brumfield relays are tortured regularly throughout production runs.

### POTTER & BRUMFIELD

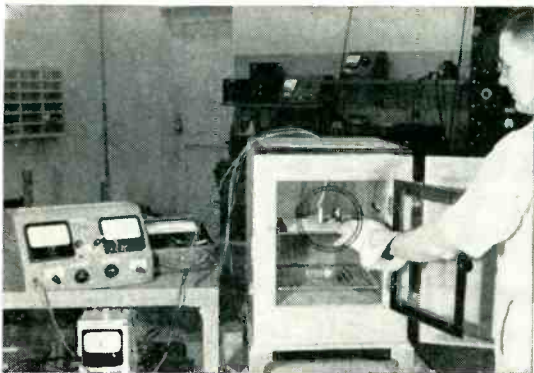

Relays operating in special constructed ovens are subject to temperatures exceeding 400° Fahrenheit. Recording instruments indicate any malfunction.

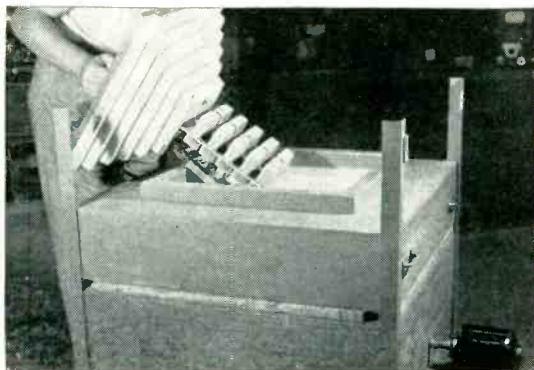

Frost covered sealed relays are taken from especially designed sub-zero chamber which has subjected them to continuous operation at -100° Fahrenheit.



Shaker and power supply located in soundproof room has frequency range of 0 to 2000 C.P.S. Complete with automatic servo control of acceleration and frequency cyler.

**ALL TYPES—ALL SIZES—FOR ALL APPLICATIONS**



# Torture



## Brumfield Way

Different relay designs are subjected to torture tests in varying degrees.

Potter & Brumfield builds relays to all quality levels and at the best possible price to you.

Samples available for immediate delivery. Send your specification for recommendation and quotations.

*For quick delivery over 350 different standard relays stocked by 500 Franchised Electronic Parts Distributors throughout the United States and Canada.*

### PRINCETON, INDIANA

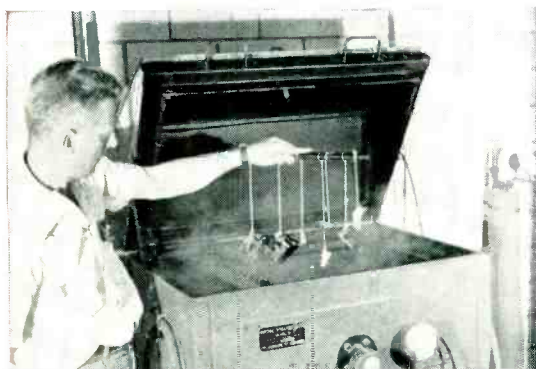

Control of metal finishes are a must for accurate relay operation. Parts are periodically subjected to a minimum 20% salt spray to check their resistance to corrosion.



Tester built to JAN specifications provides shock of over 100 G's. Contact reactions are indicated on oscilloscopes—thyratrons or other special equipment depending on speed.

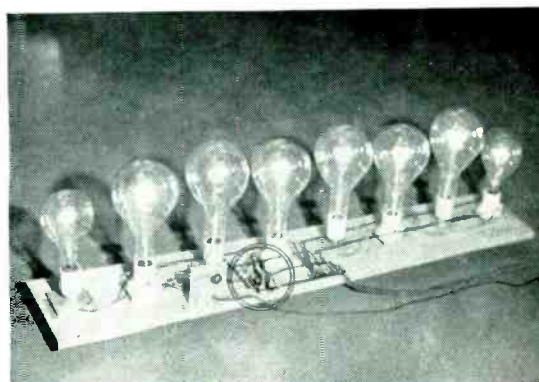

Typical rugged life test using a series of 1000 watt lamps causing the relay to operate under a load 10 times more severe than normal.

**ALL TYPES—ALL SIZES—FOR ALL APPLICATIONS**



# Is contract fulfillment YOUR responsibility?

This valuable book is *must* reading if your contract specifies precision image formation . . . exact control of light and color. It's *rewarding* reading . . . you'll learn how revolutionary new achievements in optical engineering can help simplify your product design; how laboratory precision in volume production assures performance to contract specifications, yet keeps costs down. Find out how Bausch & Lomb coordinated contract execution protects your contract commitments, from design to delivery. Get better acquainted now with America's major source of optical products.

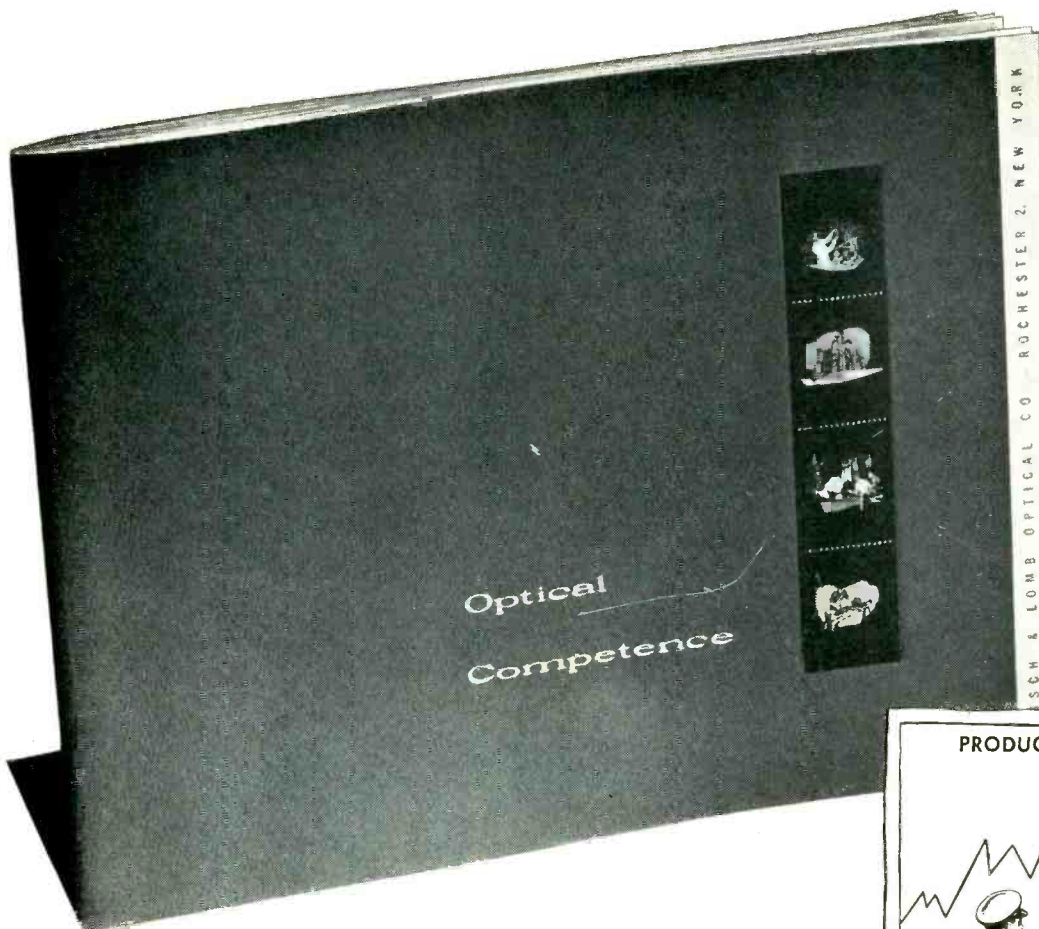

**WRITE** for your complimentary copy  
(on company letterhead, please, indicating  
your title). Bausch & Lomb Optical Co.,  
81248 St. Paul St., Rochester 2, New York.



America's only complete optical source... from glass to finished product.

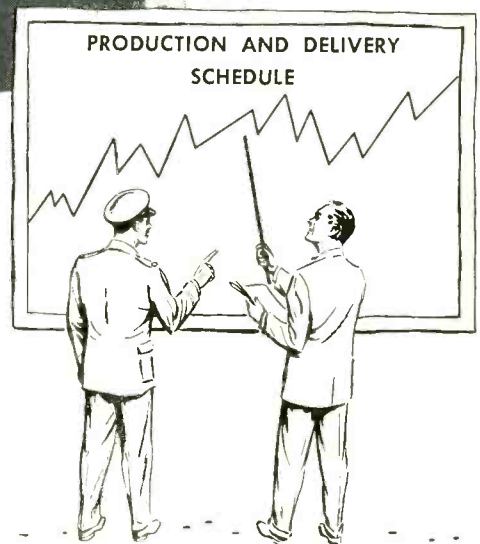



TRADE MARK

# ERIE

## PAC

### Facts

• **Cost Savings**

Fewer insertions  
Simplified insertion equipment  
Fewer items purchased  
Fewer chassis holes  
Smaller chassis  
Reduced inspection  
Simplified chassis wiring

• **Simplified Circuit Design**

Design engineers can determine optimum parameters by quick, easy component "snap-in" kit, simulating actual final layout.

• **Easy Circuit Changes**

Component value changes facilitated by simple assembly program variation. Modest circuit modification costs.

• **Flexibility**

All resistance values between 5 ohms and 50 megohms. All capacitance values between 1 mmf and 5100 mmf. Parallel and series arrangements readily obtained. Excellent Circuit Flexibility thru use of printed wiring type base.

• **Isolated Components**

Low shunt capacitance due to low K base.

• **Close Tolerances**

Resistors as close as  $\pm 5\%$ .  
T.C. capacitors as close as  $\pm 1\%$  or  $\pm 1$  mmf.

• **Ruggedness**

Reduced breakage. No pulled-off terminals.

• **Reduced Chassis Area**

15 components per square inch — achieved by mounting "PAC" in vertical plane.

• **Low, Uniform Strays**

# PAC\*

## ERIE'S New Simplified Automation \* PIN ASSEMBLY CIRCUIT Lowers TV Costs

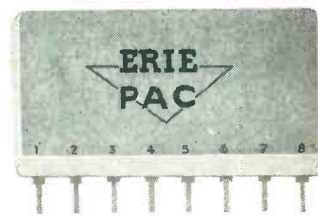
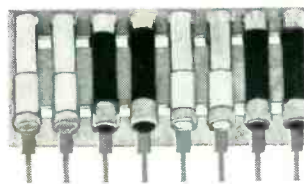
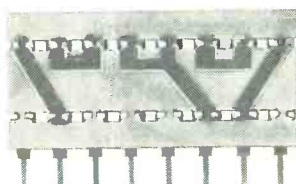

TYPICAL CIRCUIT — ACTUAL SIZE

The Pin Assembly Circuit "PAC" simplifies automation for the electronic industry by the grouping of components such as resistors and capacitors into a unitized modular package for quick, accurate installation. Packaging a group of components greatly reduces assembly labor costs. This is the real key to lower cost television sets, radios, computers, controls and other electronic items, both commercial and military.

Based on uniform "building block" components, having a  $\frac{1}{8}$ " diameter and a  $\frac{5}{8}$ " length, the Pin Assembly Circuit combines up to 92 individual components in one package. Thus, in a conventional 21" television receiver, all resistive and capacitive elements can be included in just a few "PAC" modules. This means a considerable reduction in cost of assembly labor and equipment, whether modules are assembled to the chassis by hand or by automatic equipment.

Write for Erie Engineering Bulletin #450.

TRADE MARK

# ERIE

electronics

ERIE ELECTRONICS DIVISION

ERIE RESISTOR CORPORATION

Main Offices and Factories: ERIE, PA.

Manufacturing Subsidiaries

HOLLY SPRINGS, MISSISSIPPI • LONDON, ENGLAND • TRENTON, ONTARIO

# need quick service on **TIMERS** for automatic control?

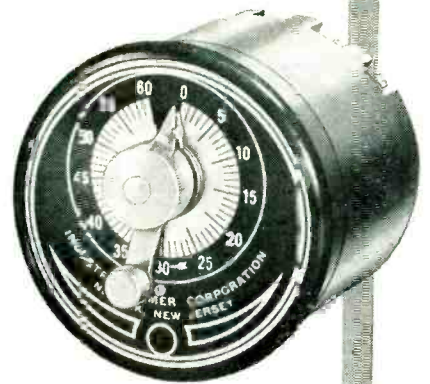

Time Delay Timers

The more automatic control problems we get, the better we like it. For while it's true each automatic control job is a bit different from the rest, the record shows that our 19 years of timer experience has given us the special knowledge it takes to give you the right answers, and in near-record time.

If one of our standard timers won't do your job — or one of the 721 combinations we have thus far developed from our 17 basic units — our engineers will go right to work to develop a new combination that's the one for you. That's the way we grow — and we like it.

We manufacture a complete line of timers in these 4 broad classifications:

**TIME DELAY TIMERS • INTERVAL TIMERS**  
**RE-CYCLING TIMERS • RUNNING TIME METERS**

And since we maintain large stocks of our 17 basic units, we can assure you of rapid deliveries — of excellent deliveries even on special orders. So whatever your automatic control problem, you have everything to gain by submitting it to our timer specialists. They'll give you a profitable answer — almost with the speed of automatic control itself.

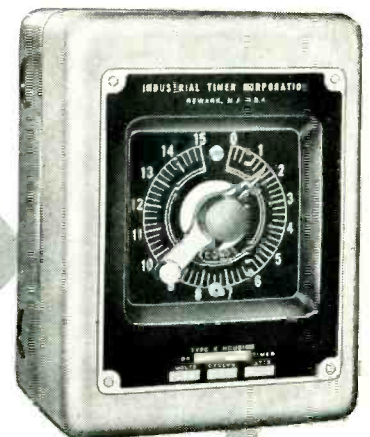

Interval Timers

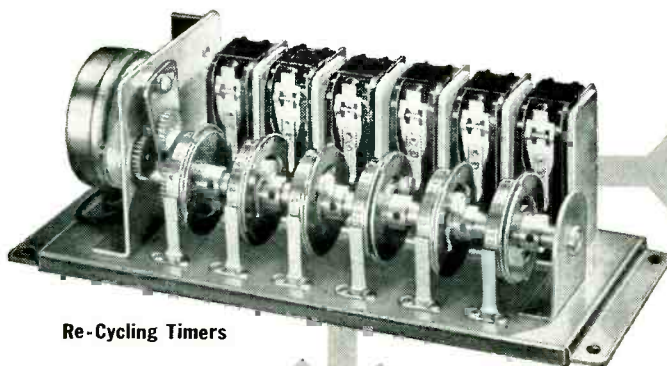

Re-Cycling Timers

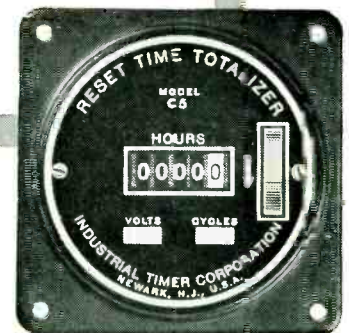

Running Time Meters

*Timers that Control  
the Pulse Beat of Industry*



**INDUSTRIAL TIMER CORPORATION**  
131 OGDEN STREET, NEWARK 4, N. J.



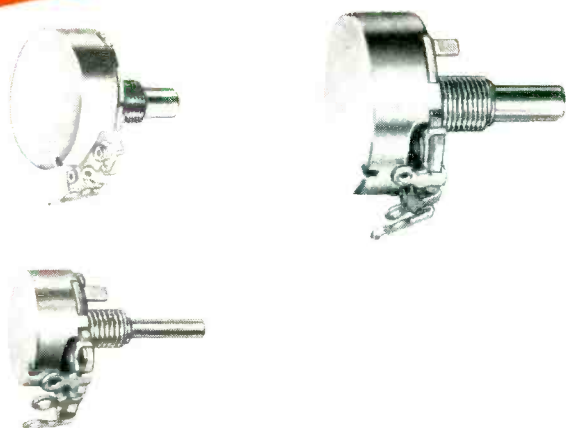

# VARIABLE RESISTORS

**EAST COAST OFFICE**  
Henry E. Sanders  
130 N. Broadway  
Camden 2, New Jersey  
Phone: Woodlawn 6-1668  
TWX No. Camden NJ 380  
Phila. Phone: Market 7-3129

**WEST COAST OFFICE**  
Robert A. Stackhouse  
928 S. Robertson Blvd.,  
Los Angeles 35, Calif.  
Phone: Crestview 4-5931  
TWX No. BEV H 7666

**SOUTHWESTERN U.S.A.**  
John A. Green Company  
6815 Oriole Drive  
P.O. Box 7224  
Dallas 9, Texas  
Phone: Dixon 9918

**CANADIAN DIVISION**  
C. C. Meredith & Co., Ltd.  
Streetsville, Ontario  
Phone: 310

**SOUTH AMERICA**  
Jose Luis Pontet  
Buenos Aires, Argentina  
Montevideo, Uruguay  
Rio de Janeiro, Brazil  
Sao Paulo, Brazil

**OTHER EXPORT**  
Sylvan Ginsbury  
8 West 40th Street  
New York 18, New York  
Phone: Pennsylvania 6-8239



275,000 sq. ft. plant area . . . 1500 employees . . .  
making ALL TYPES of variable resistors by the million . . . for  
ALL TYPES of military and commercial applications.

Dependable delivery. Exceptionally good delivery  
cycle due to enormous mass production facilities.

A CTS control can be tailored to your specific requirement.  
Refer your control problems to CTS specialists today.



**CHICAGO TELEPHONE SUPPLY**  
*Corporation*

ELKHART \* INDIANA  
FOUNDED 1896

*The Exclusive Specialists in Precision Mass Production of Variable Resistors*



# ENGINEER'S EXPERIMENTAL KIT!

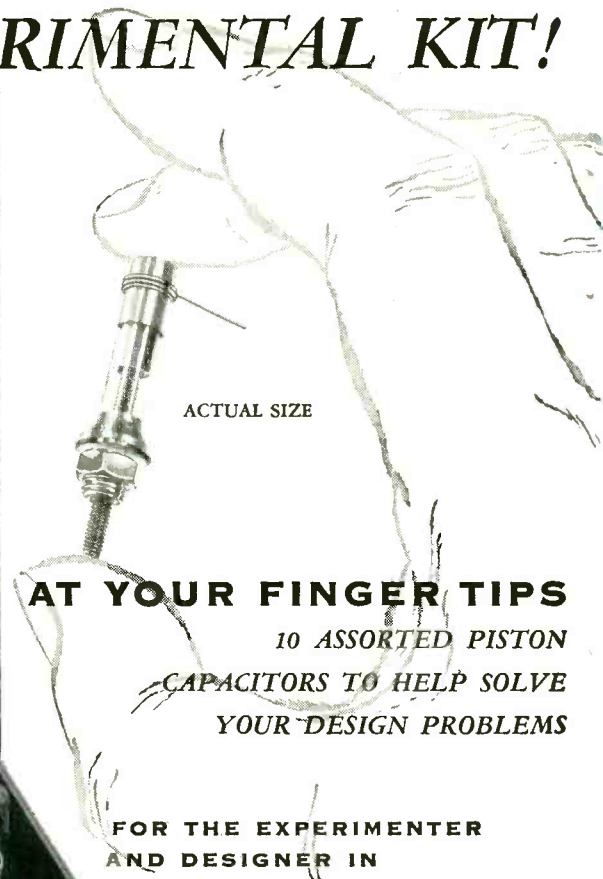

## AT YOUR FINGER TIPS

10 ASSORTED PISTON CAPACITORS TO HELP SOLVE YOUR DESIGN PROBLEMS

FOR THE EXPERIMENTER AND DESIGNER IN

- RADAR
- RADIO
- TELEVISION
- COMMUNICATIONS
- MICROWAVE
- TRANSMISSION
- AUTOMATION
- GUIDED MISSILES
- NUCLEAR PHYSICS

## IT'S THE ELECTRONIC ENGINEER'S BEST FRIEND!

Here are 10 different, precision quartz and glass dielectric JFD Variable Trimmer Piston Capacitors to speed your research and experimentation—complete with electrical characteristics charted in easy-to-follow tables—characteristics which offer you:

Matched temperature coefficients to meet a wide number of requirements . . . incremental adjustment of capacity for highly critical tuning . . . plus a new differential type ideal for oscillator and discriminator network applications. All housed in a handsome, felt-lined, dust-proof styrene container. Better order yours today.

THIS KIT CONTAINS THE FOLLOWING 10 JFD PISTON CAPACITORS WITH THE CHARACTERISTICS INDICATED BELOW.

ORDER NO. **PK10**

MODEL	CAPACITY RANGE MMF	OPERATING TEMPERATURE RANGE °C	TEMPERATURE COEFFICIENT 1KC P.P.M./°C	Q at 1MC	DIEL.	MOUNTING THREAD SIZE
VC5	.5 to 5	-55° to +200°	Approx. 0	1800	Fused Quartz	¼ - 28
VC11	1 to 10	-55° to +200°	Approx. 0	1800	Fused Quartz	¼ - 28
VC12	10 to 20	-55° to +200°	Approx. 0	1200	Fused Quartz	¼ - 28
VC1G	.5 to 8	-55° to +125°	+50 ± 50	600	GLASS	¼ - 28
VC3G	.7 to 8	-55° to +125°	+500 ± 100	600	GLASS	¼ - 28
VC4G	1 to 18	-55° to +125°	+500 ± 100	700	GLASS	¼ - 32
VC8G	1 to 8*	-55° to +125°	+50 ± 50	700	GLASS	¼ - 28
VC11G	.7 to 12	-55° to +125°	+50 ± 50	700	GLASS	¼ - 28
VC13G	1 to 10	-55° to +125°	+400 ± 100	625	GLASS	¼ - 28
VC30G	1 to 30	-55° to +125°	+100 ± 50	600	GLASS	¼ - 28

\*For complete physical and electrical data see Engineering Bulletins.



**ELECTRONICS CORP.**  
1462 - 62 STREET  
BROOKLYN, N. Y.

"Go Forward with JFD Engineering"



"We use

**NOPCO® LOCKFOAM** for the radome

because it is uniform, offers better electrical properties, and permits closer dimensional tolerances"

says **THE BRUNSWICK-BALKE-COLLENDER CO.**

**U. S. NAVY'S F3H-2N  
ALL-WEATHER "DEMON"**

single-jet, carrier-based fighter plane made by McDonnell Aircraft Corp., St. Louis, Mo. The "Demon" is an all-weather, high performance fighter combining interceptor speed and fighter maneuverability with the payload of an attack bomber. It utilizes the latest in electronic aiming devices. The high precision radome—one of the largest in commercial production—is made for McDonnell by The Brunswick-Balke-Collender Co., Plastics Division, Marion, Va.

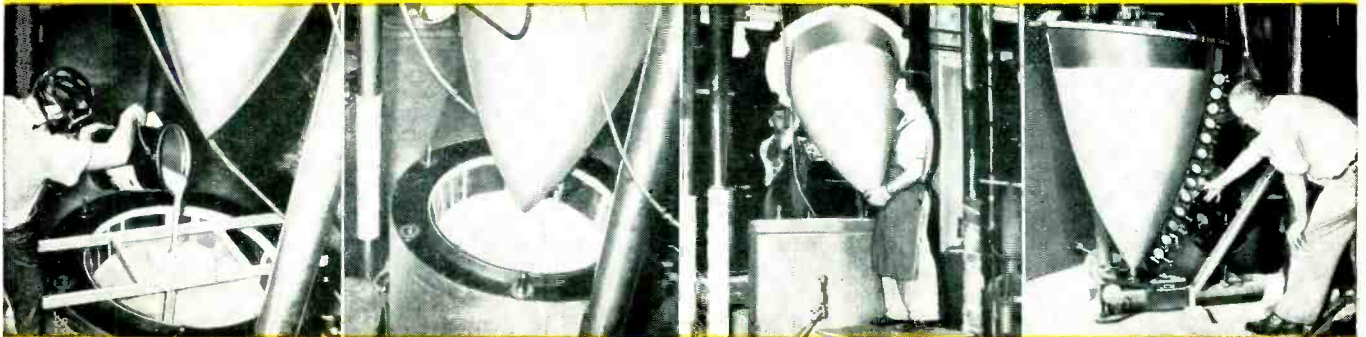

Sequence of photographs showing Nopco Lockfoam being poured into the mold—where it solidifies in a matter of minutes—removed as the finished radome, and inspected. These show some of the reasons for Brunswick's statement that with Lockfoam they have been able to reduce the man-hours needed.



**PLASTICS DIVISION**  
HARRISON, NEW JERSEY  
Los Angeles, Calif.

Where you find the most modern in construction, you are very apt to find Nopco Lockfoam being used. And that goes not only for aviation and electronics manufacture, but in many other industries as well. Airplane radomes are but one of the first conspicuous applications which are using to good purpose Lockfoam's excellent electrical properties, its strength-weight ratios, plus Lockfoam's ability to fill exactly the configurations of any cavity into which it is poured.

Nopco's technical staff will cooperate with you to the fullest. Write today for the Nopco Lockfoam booklet. Nopco Chemical Company, 200 Stier St., Harrison, N. J.

# Here's Mid-Century's Analogue Computer Installation

AT **REPUBLIC**  **AVIATION**

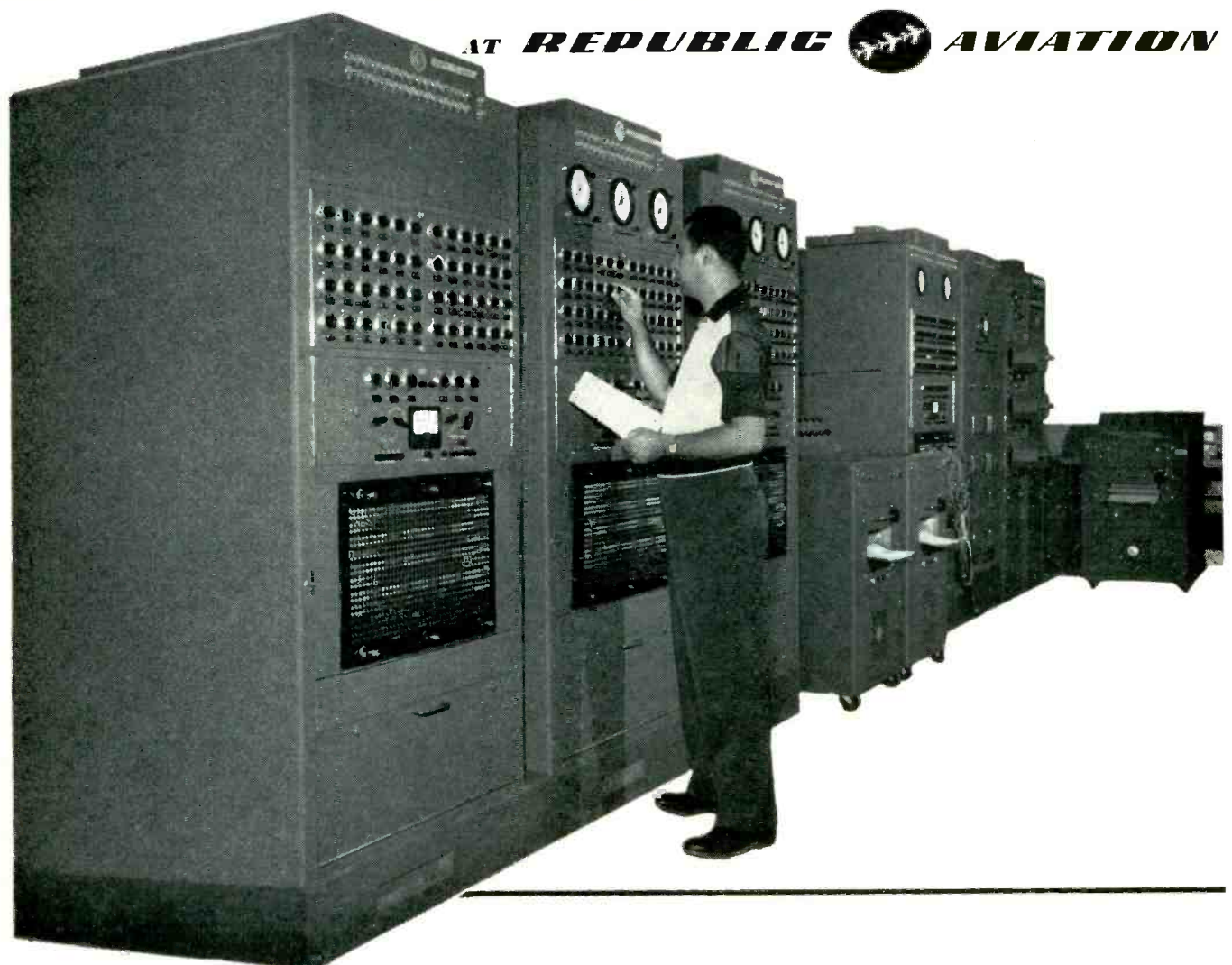

**Where huge savings in time and costs will be realized!**

Because Republic can "fly" an aircraft or guided missile, including take-off, cruise, landing, maneuvers and emergency conditions right in this computer center. Here, the actual performance is actually and accurately simulated, in a safe and in a relatively inexpensive manner. Here the optimum in design characteristics is determined without endangering human lives or incurring losses of millions of dollars with test flight models.

Every industry that now utilizes test models can save millions of dollars in time and model costs with a

Mid-Century analogue computer center. Every industry that needs production or automation controls can do likewise by substituting Mid-Century analogue computers to more easily and cheaply adjust their manufacturing processes to a higher optimum of production with greater uniform quality.

For a Free Survey on how Mid-Century computer equipment can help solve your specific problems, you need only mail the coupon today — and add to your earnings tomorrow!

**MID-CENTURY INSTRUMATIC CORP.**

611 Broadway, New York 12, N. Y.

Please have a representative call to discuss a specific problem on which we would like to cut costs.

Firm Name.....

Street.....

City..... Zone..... State.....

By.....

EI-55



"precision is our business"

**MID-CENTURY INSTRUMATIC CORP.**

611 BROADWAY

NEW YORK 12, N. Y.



# Toroids, Subminiature

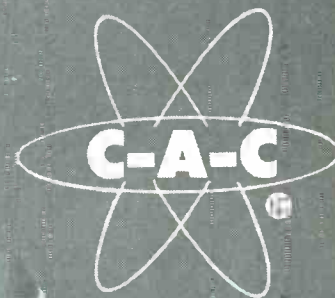

HS—HERMETIC SEALED  
MP—MOLDED PLASTIC

Subminiature Package Types — Others Available

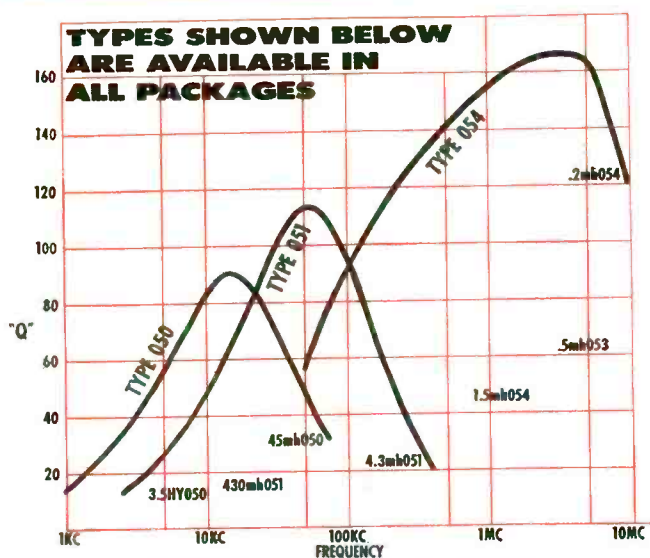
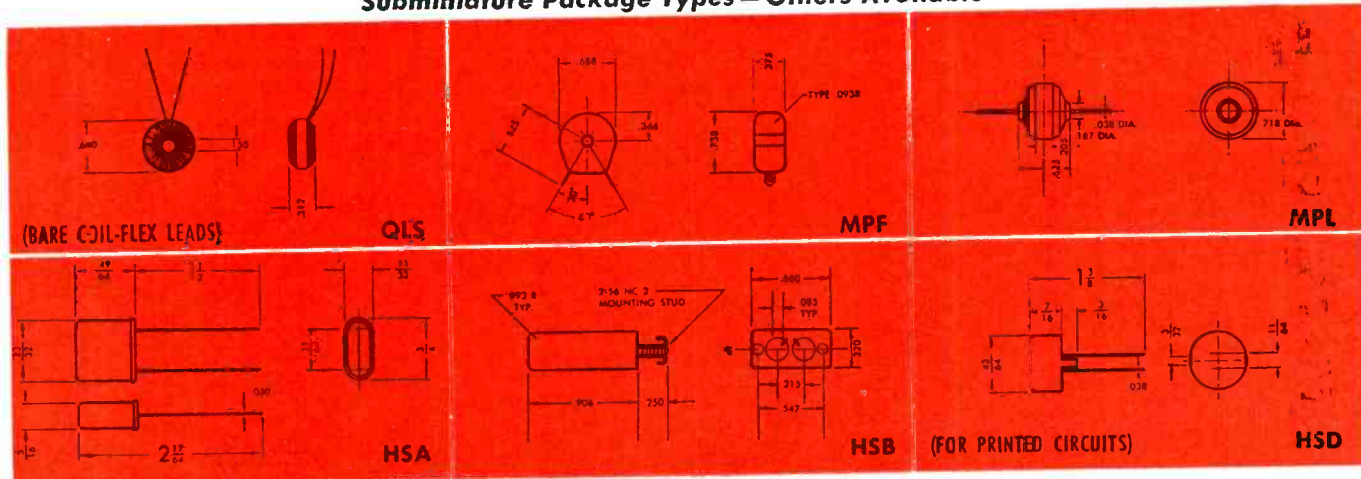

● Our Network Designers can solve your space problems in filters, discriminators and delay lines with the subminiature toroids.

*Inquiries are invited.*

C-101

**COMMUNICATION ACCESSORIES COMPANY**  
HICKMAN MILLS, MISSOURI • PHONE KANSAS CITY, SOUTH 5528

# reduce costs

with

**SOUTHCO**

## CAPTIVE PANEL SCREWS from stock

Here's a low-cost retractable screw fastener to save you assembly time and to eliminate the frequent need for costly special design fasteners. Unmatched for fast, economical use by assemblers of electronic units and other paneled cabinets.

"Floating" screw insures easy alignment no matter how many screws are engaged in a single panel. No special skills or tools needed; installation fast and simple.

3 head sizes and 3 standard thread sizes available. On special order, slotted heads, stainless steel screws, and extra long screws.

Write for complete information. Southco Division, South Chester Corporation, 233 Industrial Highway, Lester, Pa.

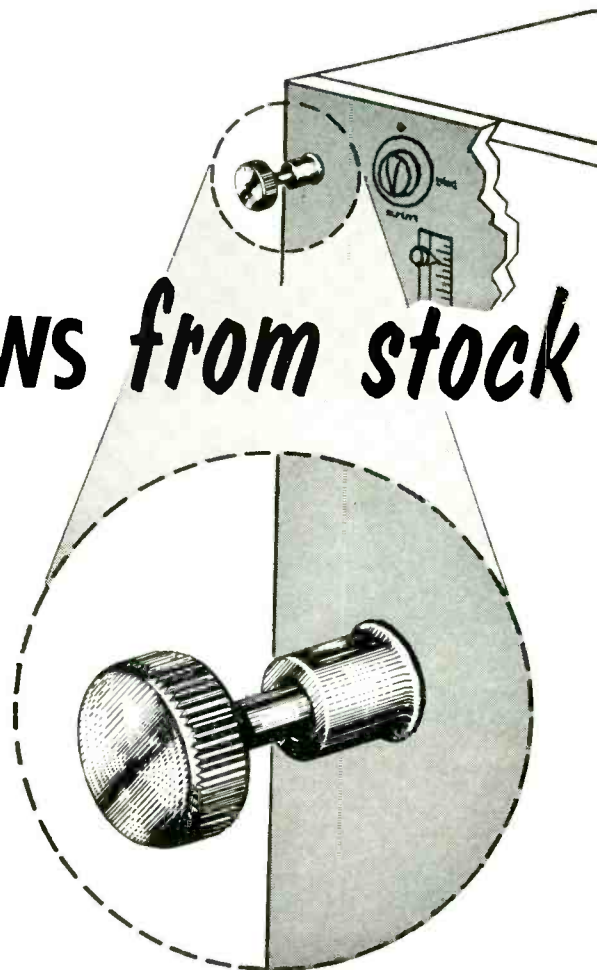

### 3 SIMPLE COMPONENTS

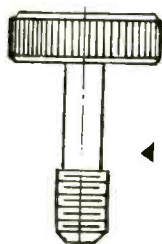

← SCREW



← STAND-OFF



← RETAINING RING

#### EASILY INSTALLED

Stand-off is flanged into panel. Screw is inserted into oversize hole in stand-off and locked in place by retaining ring, which is passed over threads to seat behind last thread.

### A SIZE FOR EVERY NEED

#### LARGE HEAD ( $\frac{3}{4}$ " diameter)

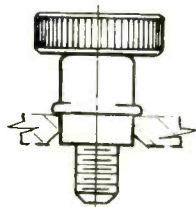

$\frac{1}{4}$ "-20 thread

#### MEDIUM HEAD ( $\frac{1}{2}$ " diameter)

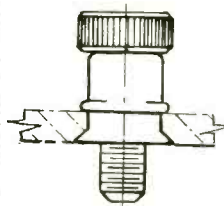

$\frac{1}{4}$ "-20 and  
12-24 thread

#### SMALL HEAD ( $\frac{1}{8}$ " diameter)

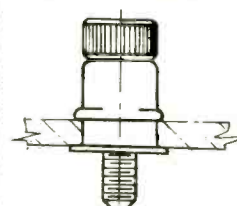

10-24 thread

Screw and stand-off are brass, nickel plated. Retaining ring is durable vinyl plastic.

Choice of stand-offs for each screw size to accommodate panel thicknesses from  $\frac{1}{16}$ " to  $\frac{1}{64}$ ".

**SOUTHCO**

**FASTENERS**

**PAWL • SCREW AND SPRING •  
DRIVE RIVETS • ANCHOR NUTS •  
ENGINEERED SPECIALTIES**

OFFICES IN PRINCIPAL CITIES

WHEREVER TWO OR MORE PARTS ARE FASTENED TOGETHER, STANDARD AND SPECIAL DESIGNS FOR IMPROVED PERFORMANCE AND LOWER PRODUCTION COSTS



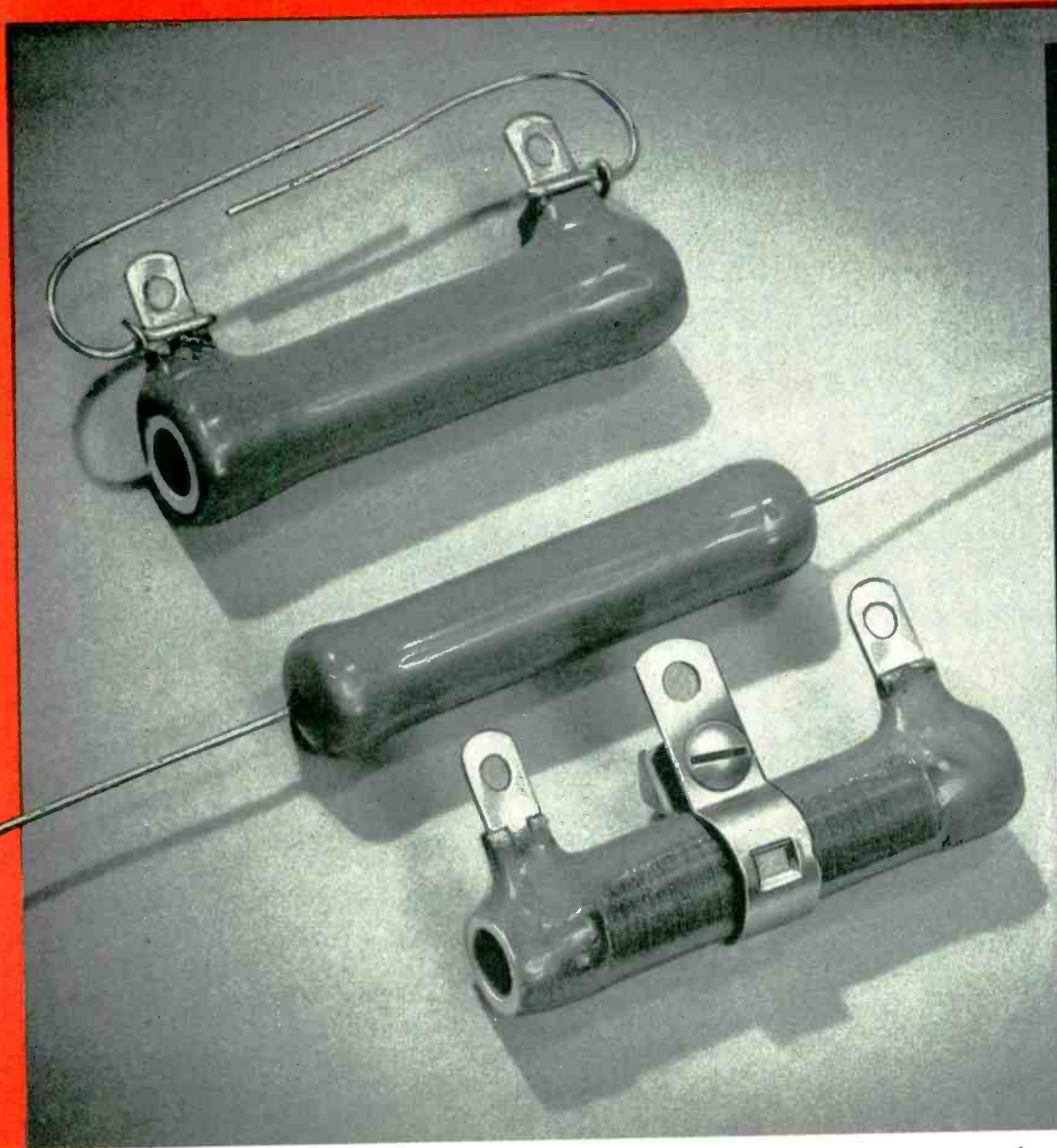

**NOTE** all diameters and lengths are identical. Photo twice actual size.

## How do you want your **10-watt resistors?**

Here are a few of the variations you can get in basic design, terminals and mountings on a standard 10-watt Vitrohm resistor.

It's this tremendous variety (we make a wider range of resistors than anybody else) that enables Vitrohm resistors to do so many jobs so well — and save you installation costs at the same time.

Add to this Ward Leonard's performance standards — insured by the 19 separate

inspection tests we run on every single resistor we make — and you see why you get more resistor for your money in a Vitrohm.

Prompt delivery, too, by the way.

Our engineers will be glad to show you which Vitrohm design best meets your specific needs. A line or call to Ward Leonard Electric Company, 450 South Street, Mount Vernon, N.Y. is all it takes.

5.4

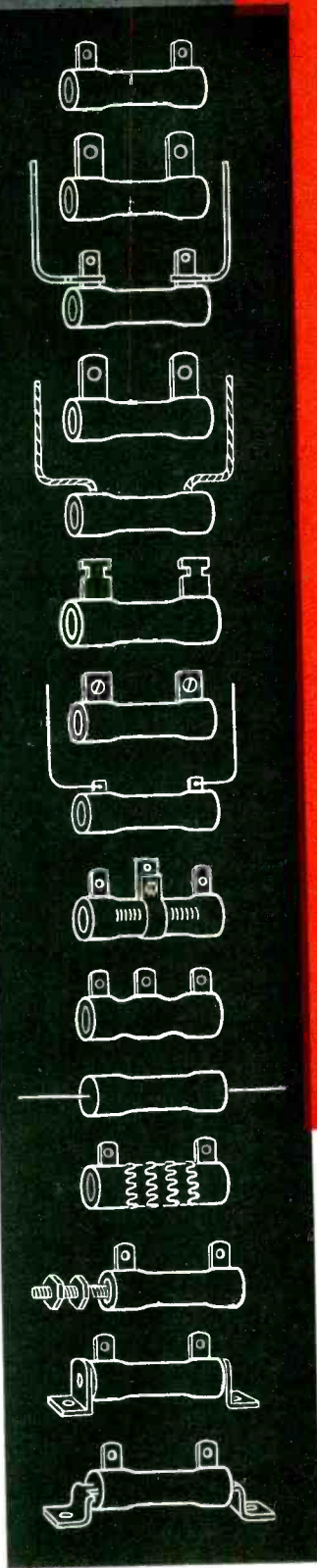

**WARD LEONARD  
ELECTRIC COMPANY**  
MOUNT VERNON, NEW YORK



STATES



RESISTORS



RELAYS



MOTOR CONTROLS



DIMMERS



CHASSIS

**R**esult - **E**ngineered Controls Since 1892



## Ucinite Test Jacks

In addition to Test Jacks with a brass, nickel-plated shell and nut with nylon insulator, Ucinite now offers a less expensive version with all-nylon threaded insulator for low capacity to panel and high voltage breakdown.

These Ucinite Test Jacks—designed for standard .080 phone tips—are available in a variety of colors... ideally suited to coded application. Silver-plated, heat treated beryllium copper contact is made in one piece with large

terminal ends for easy soldering. The feed through type is provided with a one-piece brass terminal stud, tin-plated.

The specialized abilities and experience of Ucinite's own staff of design engineers are available for work on new and unusual problems. Volume production facilities ensure fulfillment of the largest requirements. For full information, call your nearest Ucinite or United-Carr representative or write directly to us.



**The**  
**UCINITE CO.**  
*Newtonville 60, Mass.*  
Division of United-Carr Fastener Corp.

*Specialists in*  
**ELECTRICAL ASSEMBLIES,**  
**RADIO AND AUTOMOTIVE**



How many ways can you use

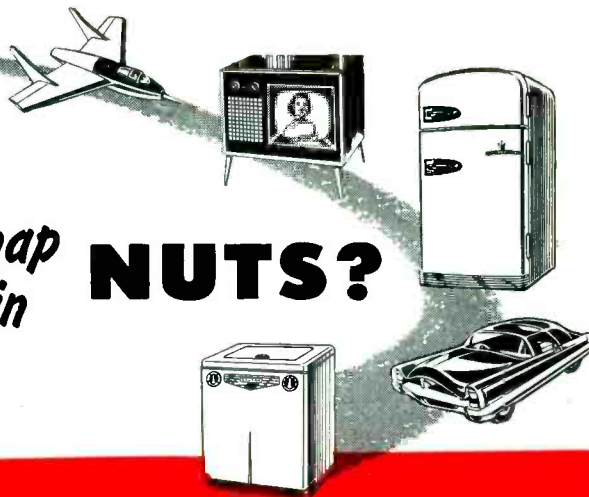

# PLASTIC *snap in* NUTS?

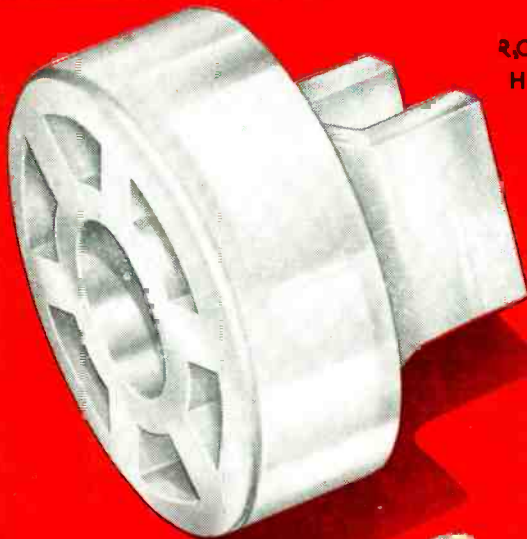

ROUND HEAD



SQUARE HEAD

## QUICK, EASY ASSEMBLY

Nut is pressed into square hole punched in sheet metal

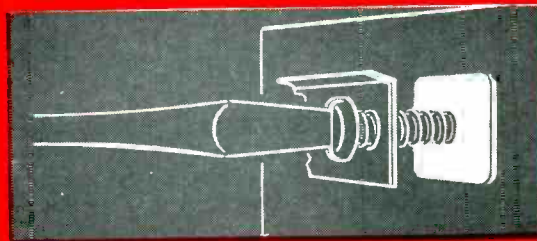
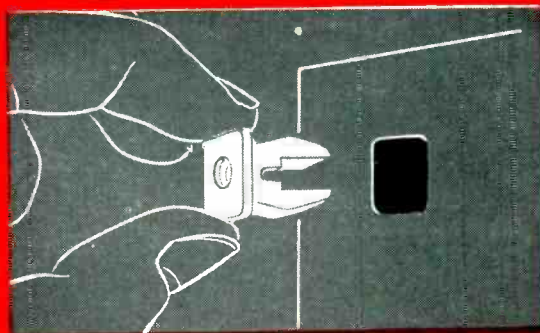

Ordinary sheet metal screw cuts its own threads as it is driven into the nut, expands fingers, locks nut and screw securely.

United-Carr's new self-locking, plastic nut is designed for blind application and can be used with all types of metal finishes without scratching or chipping the surface. Its plastic fingers provide rigid anchorage yet will not mar paint, polished metals or even porcelain.

Inexpensive sheet metal screws cut their own threads and expand the nut's fingers as they are driven, locking both nut and screw tightly in

place. Screws can be removed and replaced several times without damage to the nut.

DOT plastic snap-in nuts are electrically non-conductive and provide a high degree of insulation against heat transfer. For all practical purposes, they also provide an effective vapor seal.

Available in several styles and sizes. Write for full information and samples or contact your nearest United-Carr representative.

## UNITED-CARR FASTENER CORP.

CAMBRIDGE 42, MASSACHUSETTS

MAKERS OF



FASTENERS

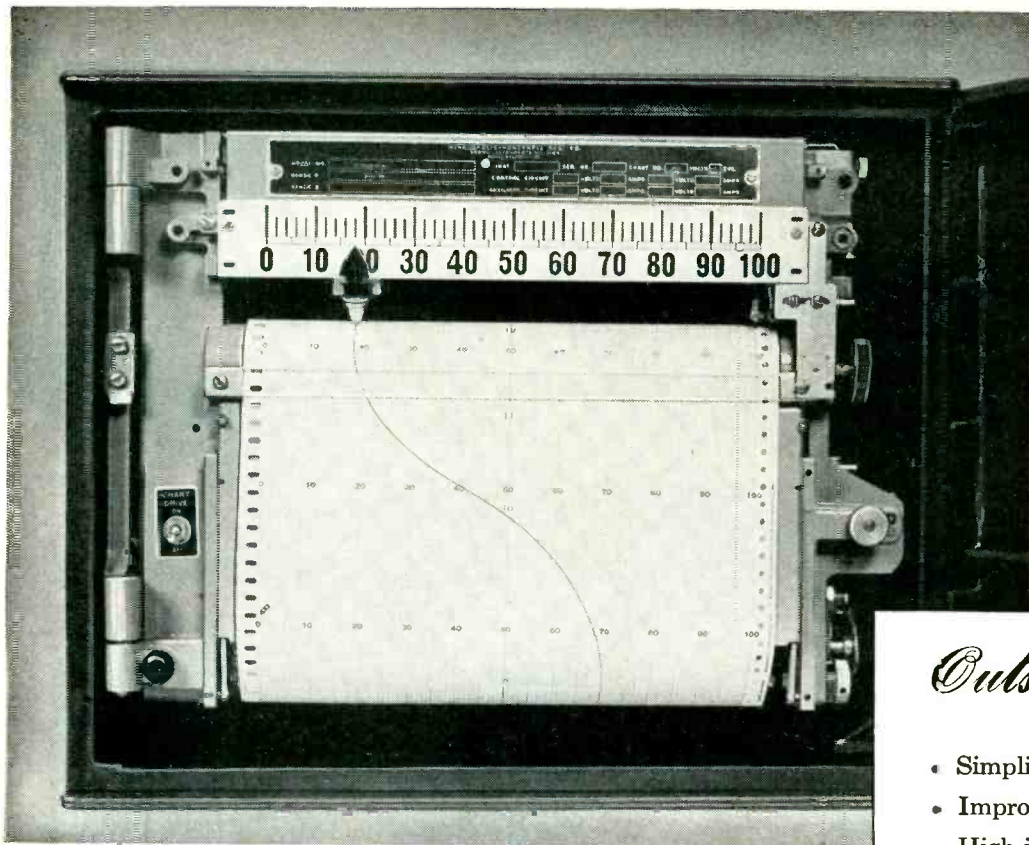

## Outstanding

### NEW FEATURES

- Simplified design
- Improved damping
- High input impedance
- Continuous standardization

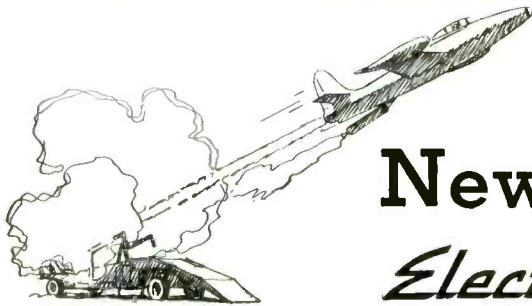

# New $\frac{1}{4}$ -second *ElectroniK* recorder

*follows fast-changing variables with split-second response*

Designed to meet the special data-recording requirements of experimental stations, laboratories, and research centers, the new  $\frac{1}{4}$ -Second Pen Speed *ElectroniK* Recorder fills an important gap between conventional large-chart recorders and oscillographic instruments.

This new *ElectroniK* Recorder is the *fastest* large-chart instrument available today . . . the perfect solution for high-speed plotting of any function that can be reduced to a d-c millivolt signal. It offers the investigator extreme sensitivity, complete flexibility, laboratory precision . . . plus many *new* features the research man will appreciate:

**Easy range change**—All components of the potentiometer bridge are located on an interchangeable bakelite card.

**New design plug-in amplifier**—has many times the power output of standard units . . . features high input impedance, easy accessibility, flexible gain control, and rugged construction.

**New pen and carriage designs**—prevent pen clogging and paper tearing. Ball point pen easily removed. Transparent cartridge shows ink supply.

**New slidewire and contacts**—Designed for long life under high speed operation.

Your nearby Honeywell sales engineer will be glad to discuss applications in your research work . . . and he's as near as your phone.

MINNEAPOLIS-HONEYWELL REGULATOR CO.,  
*Industrial Division*, Wayne and Windrim Avenues,  
Philadelphia 44, Pa.—in Canada, Toronto 17,  
Ontario.

● REFERENCE DATA:

Write for Instrument Data Sheet No. 10.0-21  
" $\frac{1}{4}$ -Second Pen Speed *ElectroniK* Recorder."



MINNEAPOLIS  
**Honeywell**  
BROWN INSTRUMENTS

*First in Controls*



# Stability and Reliability make CLARE Relays and Stepping Switches ideal components for DASAC

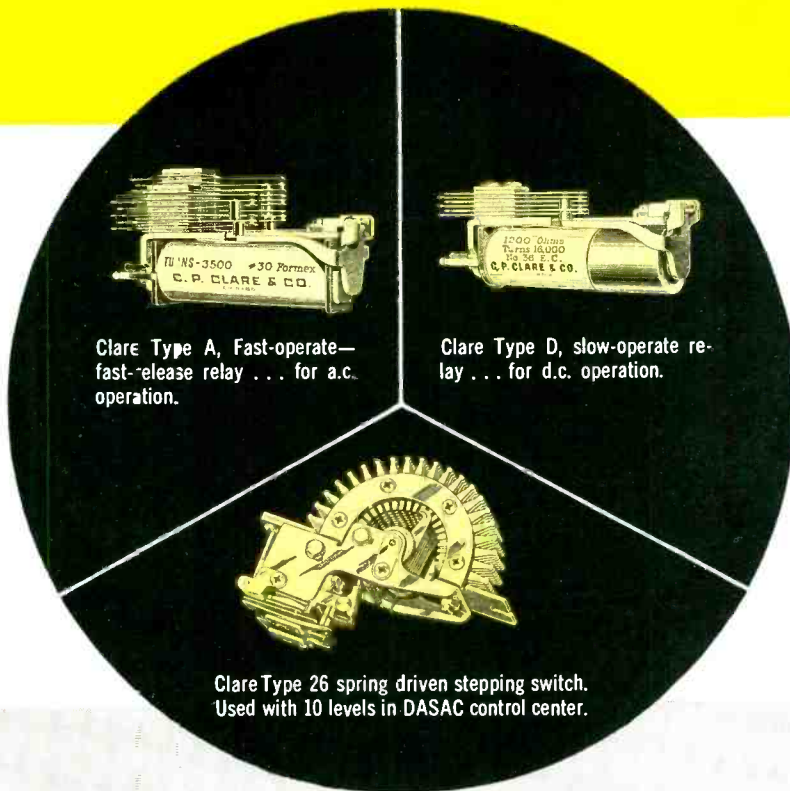

Clare Type A, Fast-operate—fast-release relay . . . for a.c. operation.

Clare Type D, slow-operate relay . . . for d.c. operation.

Clare Type 26 spring driven stepping switch. Used with 10 levels in DASAC control center.

● Pushbutton control center of the DASAC warehousing and assorting system makes use of over a hundred CLARE Type A and D relays and CLARE 10 level, 26 point stepping switches.

This device, which speeds and simplifies order picking operations, was developed by New York's Dasol Corporation, consulting engineers, to facilitate the warehouse operations of their client, Judy Bond, Inc., large blouse manufacturer.

The DASAC Control Center performs three basic functions. These include selection of container destination, "memorizing" the selections in consecutive order and coordinating the information to stop the container at its proper discharge point. "Relay requirements," said Sol Tanne, Dasol Chief Engineer, "above all, demanded stability and reliability. They had to be fast-acting, quiet, stable telephone-type relays which could easily be replaced if necessary."

Ability of CLARE Relays to perform millions—in some cases billions—of trouble-free operations has made them increasingly in demand as reliable components for today's high speed devices. If your design calls for long-life, high-quality relays or stepping switches, it will pay you to bring your problem to CLARE. Experienced field engineers are located near you. Contact them or call C. P. Clare & Co., 3101 Pratt Blvd., Chicago 45, Illinois. In Canada: Canadian Line Materials, Ltd., Toronto 13. Cable Address: CLARELAY.

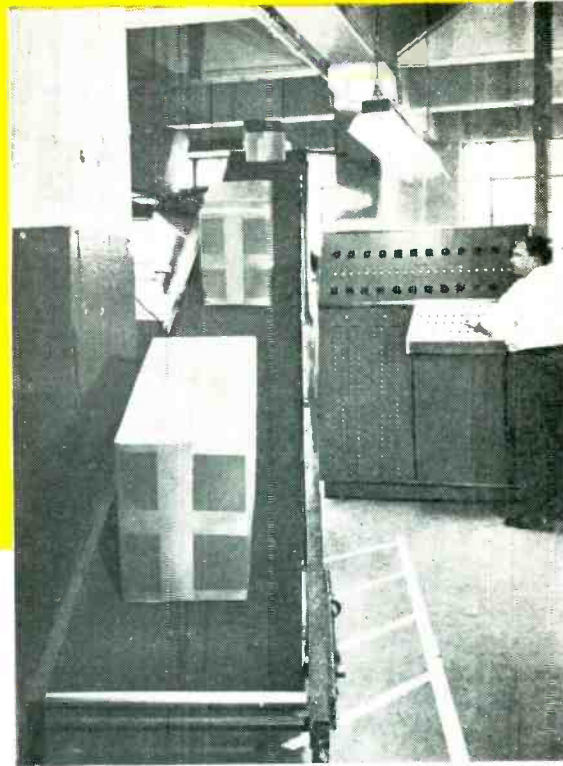

DASAC Push Button Control Center which uses Clare relays and stepping switches in automatic control of warehouse assorting system.

Rear view of panel shows Clare relays, provided with dust tight covers, accessible for quick inspection and maintenance.

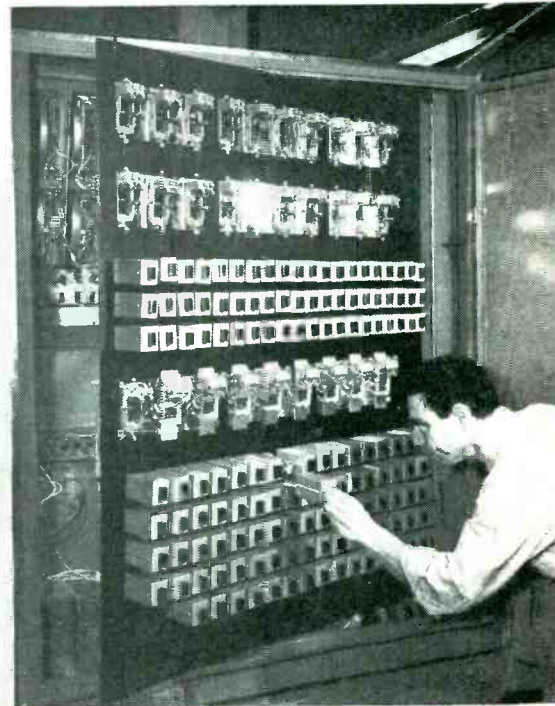

## CLARE RELAYS

FIRST in the industrial field



# dependable controls

... backed by dependable service  
in matching your specifications  
and delivery requirements.

## STACKPOLE

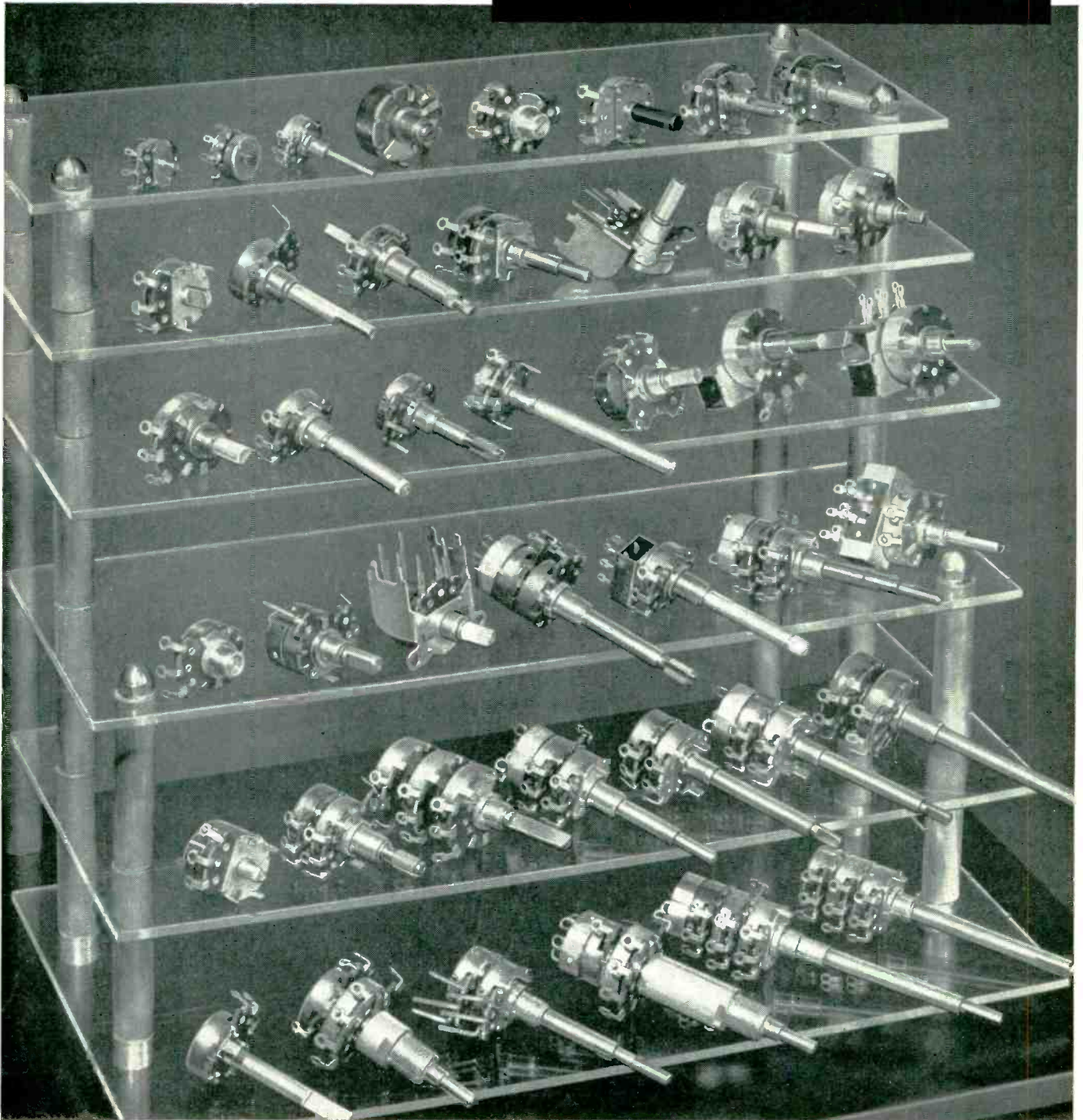

*Electronic Components Division*

**STACKPOLE CARBON COMPANY**

**St. Marys, Pa.**



Why the leaders choose **RESINOX\* 3700**  
for molding profit-making electrical parts

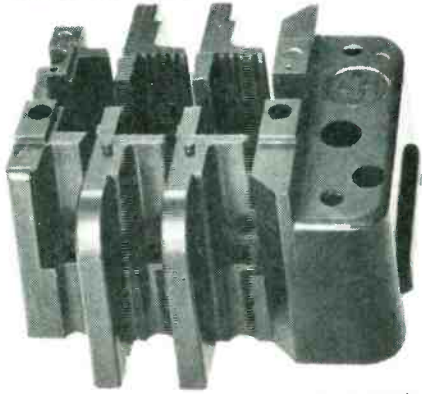

**Arrow-Hart & Hegeman** are making profitable use of critical electrical parts molded of Resinox 3700 in their combination starter where high arc-resistance is a must.



**Wells Manufacturing** ignition coil top molded of Resinox 3700 outperformed all others in racing car tests on Utah salt flats. Because of Resinox 3700 no spark power was lost at speeds up to 140 m.p.h.

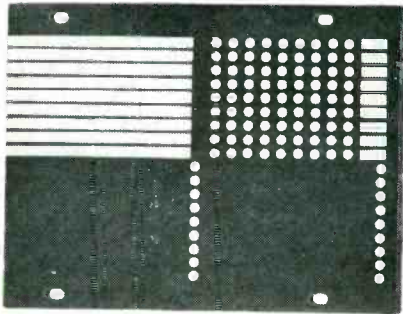

**IBM** specifies Resinox 3700 for cross bar emitter—and cuts production costs of this vital "Check Prover" part in half because Resinox 3700 has outstanding dimensional stability.



**American Bosch** uses this distributor plate molded of Resinox 3700 where its superior arc-resistance is giving top performance in the field. (Part made for them by Specialty Insulation Mfg. Co.)

**THE PREFERENCE FOR RESINOX 3700** grows every day. This thermosetting mineral-filled molding powder was developed by Monsanto for superior performance in magneto ignitions, motor control and transmission circuits, and countless other electrical applications. • It combines high arc-resistance with outstanding dimensional stability. • It eliminates undesirable after-shrinkage. • Its moldability is excellent and its impact resistance is good. • It has good transfer molding properties. • It offers superior heat resistance. For full information on Monsanto's Resinox 3700, write today to Monsanto Chemical Company, Plastics Division, Dept. E12, Springfield 2, Massachusetts.



*Serving Industry...  
which serves mankind*



For current limiting and for  
obtaining lagging power fac-  
tors without distortion —

### NWL Air Core Reactors

Capacity of  $\frac{1}{4}$  to 2000 Amperes and  
25 to 400 cycles

For lowest possible capacitance  
and non-resonating  
peaks —

### NWL Radio Frequency (R.F.) Chokes

Available in sizes 1 ampere and larger.  
In illustration below terminal is not  
shown.

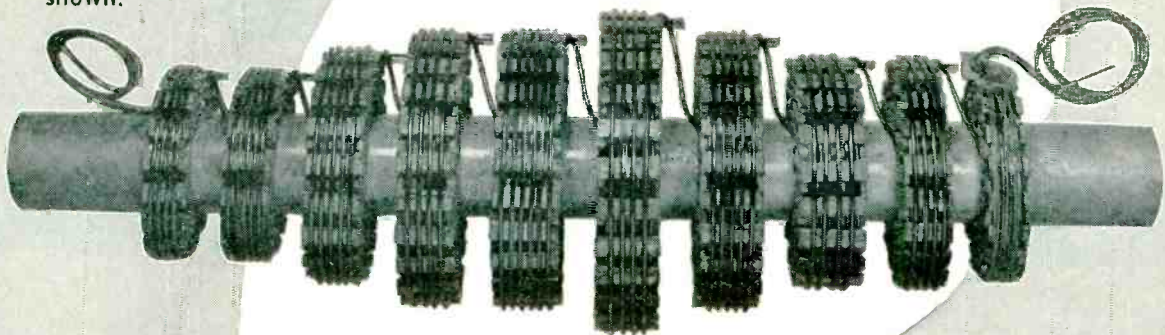

ESTABLISHED 1920



*Notteboffer*

Write for complete information

**WINDING LABORATORIES, INC.**

P. O. Box 455, Dept. 107 TRENTON, N. J.



ANOTHER FIRST BY

**Greenleaf**

# Dynamic Integrating Gyro Servo Table

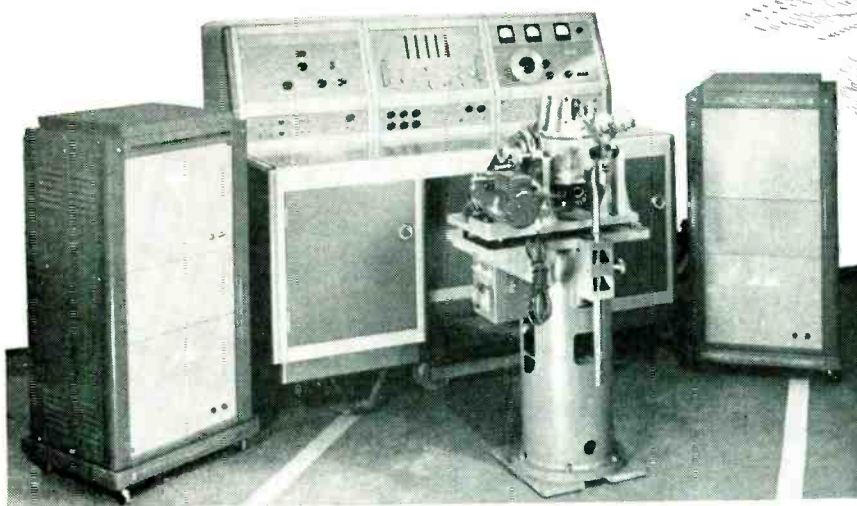

Greenleaf Manufacturing Company, as a producer of Integrating Gyros, realized the need for a Dynamic Integrating Gyro Servo Test Table. This Test Table was designed and developed to facilitate the evaluation of Integrating Gyros, and Greenleaf now makes this valuable test unit available to industry.

**The Gyro Servo Test Table can measure the following characteristics:**

1. The drift rate of the gyro unit.
2. The current product angular velocity sensitivity ratio.
3. The characteristic time.
4. The angular velocity input voltage rate output sensitivity.
5. Minimum rate detectable.
6. High limit angular velocity deviation of performance.
7. Low limit angular velocity deviation.
8. Signal generator linearity.
9. Torque generator linearity.

**Since a time interval meter is incorporated in the system, the following data can also be obtained:**

10. Spin motor excitation frequency.
11. Spin motor excitation voltage.
12. Spin motor excitation current.
13. Signal generator excitation current.
14. Signal generator null output voltage.

**In addition the following tests can be made:**

15. Gyro damping gap temperature.
16. Accurate determination of the input axis.

THE



ENGINEERING • DEVELOPMENT • PRODUCTION  
**MANUFACTURING COMPANY**

7814 Maplewood Industrial Court • St. Louis 17, Missouri

Producers of the HIG-3 and HIG-4 Gyros, Rate and Free Gyros, Differential Pressure Mach Meters, Air Speed Indicators, Computers, Switches and many other precision-built components.

**YEARS AHEAD of the industry...**



**Type 105 Model 6**

**New!**

**Northern Radio  
FREQUENCY  
SHIFT  
KEYER**

**New!** Highest Stability achieved  
by any Frequency Shift Keyer

**New!** Increased Frequency Range  
1.0 to 7.0 mc

**New!** Pre-selection of Proper  
Frequency Shift for any  
particular transmitter fre-  
quency multiplication

**New!** Permits use with  
external oscillator  
without need of adapters

**New!** Improved  
Accessibility —  
for even easier  
maintenance

Sets a new standard for  
the Industry. It supersedes and  
directly replaces its  
**LEADER PREDECESSOR,**  
the Type 105  
Model 4.

The new Northern Radio Frequency Shift Keyer Type 105 Model 6, is a very high stability RF oscillator which provides a means for shifting an RF carrier in accordance with the intelligence. This exciter replaces the crystal oscillator in a transmitter and produces "Mark" and "Space" carrier shift for transmission of teleprinter or telegraph signals, or a linear carrier shift for transmission of FM telephone, facsimile or telephoto. In addition to the technical advancements mentioned above, this new Keyer continues to embody the following performance-proven features:

- Direct-reading frequency calibration of shift from 0 to 1000 cps.
- Frequency shift dial adjusts "Mark" and "Space" frequencies equally above and below the carrier position, which remains fixed.
- Simplified frequency setting makes only the upper sideband tuning indication visible on the meter over substantially all of the tuning range.
- Direct-reading frequency calibration of mixer and output tuning dials from 1.0 to 7.0 mc.
- Direct-reading calibration of output frequency vernier  $\pm 600$  cps.
- Pulse-shaping circuit to permit operation within assigned bandwidth with no adjacent channel radiation.
- Highly stable temperature-controlled oven with control of  $\pm 0.1^\circ\text{C}$ . at  $60^\circ$
- Linear carrier shift up to 1400 cps for Fax operations.
- Component ratings according to JAN specs for greater assurance of trouble-free operation.



Pace-Setters in Quality Communication Equipment  
**NORTHERN RADIO COMPANY, inc.**

147 WEST 22nd ST., NEW YORK 11, NEW YORK

In Canada: Northern Radio Mfg. Co., Ltd., 1950 Bank St., Billings Bridge, Ottawa, Ontario.

Write for Free Catalog E-12.



# 4 Waldes Truarc Rings Cut Costs Drastically, Increase Versatility of Precision Automatic Drill

## Dumore's New Automatic Drill

Dumore Precision Tools, Racine, Wisconsin, uses 4 Waldes Truarc Retaining Rings in their versatile new automatic drill unit. Machining operations have been eliminated, assembly simplified. Great labor savings have resulted from use of Truarc rings.

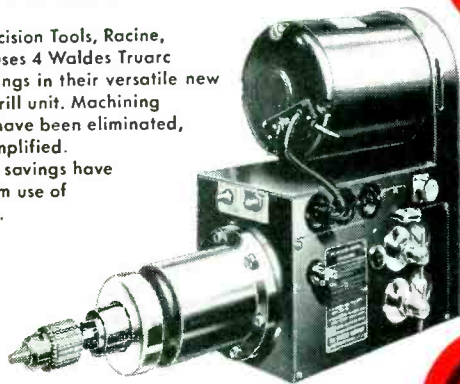

## Drive Spindle Assembly

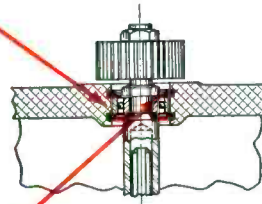

Bearing is held in position by two Waldes Truarc Rings—Standard (Series 5000) and Bowed (Series 5001). Two grooves are turned and housing rough bored in one operation. Alternate method would require at least two additional machining operations. Bowed Truarc ring takes up accumulated tolerances resiliently.

## Actuator Lever Shaft Assembly

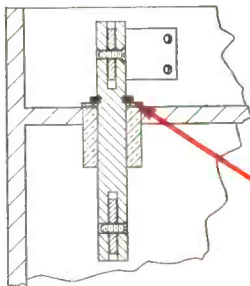

A Single Waldes Truarc External Retaining Ring (Series 5100) acts as shoulder, holds the lever in position. Labor savings are tremendous—a simple groove cutting operation replaces turning a shoulder, grinding and polishing.

## Piston Assembly

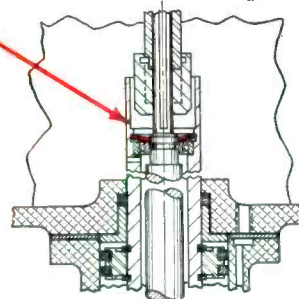

Easy assembly is assured by use of one Waldes Truarc Bowed Ring (Series 5001) to lock the bearing to the piston assembly. When unit is to be used in tapping applications, entire spindle assembly can be removed without disassembly.

Whatever you make, there's a Waldes Truarc Retaining Ring designed to improve your product... to save you material, machining and labor costs. They're quick and easy to assemble and disassemble, and they do a better job of holding parts together. Truarc rings are precision engineered and precision made, quality controlled from raw material to finished ring. **36 functionally different types... as many as 97**

different sizes within a type... 5 metal specifications and 14 different finishes. Truarc rings are available from 90 stocking points throughout the U.S.A. and Canada. **More than 30** engineering-minded factory representatives and 700 field men are available to you on call. Send us your blueprints today... let our Truarc engineers help you solve design, assembly and production problems... without obligation.

For precision Internal grooving and undercutting... Waldes Truarc Grooving Tool!

Send for new catalog supplement

**WALDES**  
**TRUARC**®  
**RETAINING RINGS**

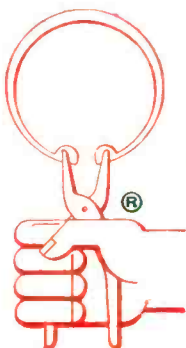

Waldes Kohinoor, Inc., 47-16 Austel Place, L. I. C. 1, N. Y.  
Please send the new supplement No. 1 which brings Truarc Catalog RR 9-52 up to date.  
(Please print)

Name.....  
Title.....  
Company.....  
Business Address.....  
City..... Zone..... State.....

E 127

WALDES TRUARC Retaining Rings, Grooving Tools, Pliers, Applicators and Dispensers are protected by one or more of the following U. S. Patents: 2,382,948; 2,411,426; 2,411,761; 2,416,852; 2,420,921; 2,428,341; 2,439,785; 2,441,846; 2,455,165; 2,483,379; 2,483,380; 2,483,383; 2,487,802; 2,487,803; 2,491,306; 2,491,310; 2,509,081; 2,544,631; 2,546,616; 2,547,263; 2,558,704; 2,574,034; 2,577,319; 2,595,787, and other U. S. Patents pending. Equal patent protection established in foreign countries.



# LIQUID COOLING

of  
Electronic  
Tubes

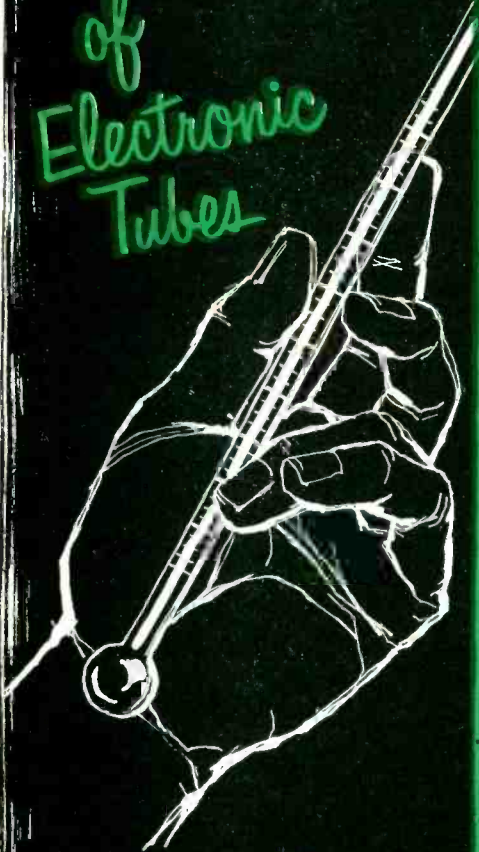

## WITH **Eastern** COOLING UNITS

By a sustained program of research, Eastern continuously extends the uses of the latest units in electronic tube cooling, pressurizing electronic equipment, and pumping fuels and hydraulic fluids. Research and testing laboratories, a model shop, and three manufacturing plants provide the specialized equipment and manpower to turn out fully qualified units to meet appropriate government specifications.

From our extensive line of existing units, adaptations of these units, or completely new designs, Eastern can provide equipment to handle your project well. Your inquiry is welcomed.



**EASTERN INDUSTRIES, INC.**  
100 SKIFF STREET  
HAMDEN 14, CONNECTICUT

Eastern Cooling Units provide coolant liquid for maintaining within safe operating temperature limits liquid cooled electronic tubes or similar devices. The units are completely self-contained and usually comprise such components as heat exchangers, fans or blowers, liquid pumps, reservoirs, flow switch, thermostat, etc. Cooling units can be modified as required for varying conditions encountered in land or sea as well as aircraft service. Almost all units are designed to meet such specification as MIL-E-5400 and MIL-E-5272.

The units shown below are intended only to illustrate the varying requirements which can be satisfied. By utilizing fairly standard components and designs based on broad experience in this field, Eastern is able to provide at minimum cost equipment exactly suiting a specific requirement.

Eastern welcomes your consultation on liquid cooling problems ranging from 200 to 20,000 watts dissipation.

Write for Aviation Products Bulletin 330.



**MODEL MB-175, TYPE 200 DISSIPATION:** 2,000 watts. **ALTITUDE RANGE:** sea level to 50,000 feet. **POWER REQUIRED:** 28 volts D.C. **WEIGHT:** 25 pounds. **SIZE:** 10" x 15-15/16" x 10 3/4" high.

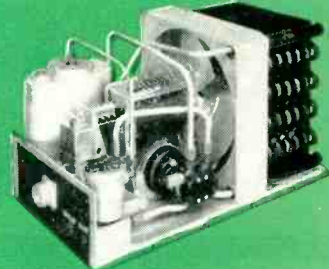

**MODEL E/HT-205, TYPE 200A DISSIPATION:** 1600 watts. **ALTITUDE RANGE:** sea level to 5,000 feet. **POWER REQUIRED:** 28 volts D.C. **WEIGHT:** 25 pounds. **SIZE:** 10" x 21" x 10" high.



**MODEL MB-177, TYPE 202 DISSIPATION:** 1700 watts. **ALTITUDE RANGE:** sea level to 50,000 feet. **POWER REQUIRED:** 110 volt, 400 cycle, 3 phase. **WEIGHT:** 27 pounds. **SIZE:** 10" x 19 15/32" x 7 3/4" high, per JAN-C-1720A, size B1-D1.



**MODEL E/HT-210, TYPE 200 DISSIPATION:** 1500 watts. **ALTITUDE RANGE:** sea level to 10,000 feet. **POWER REQUIRED:** 208 volts, 400 cycle, 3 phase. **WEIGHT:** 35 pounds. **SIZE:** 11 1/4" x 19 1/2" x 12 1/2" high.

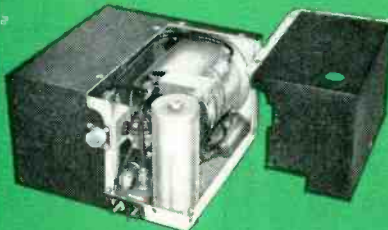

**MODEL E/HT-200, TYPE 201 DISSIPATION:** 1,000 watts. **ALTITUDE RANGE:** sea level to 50,000 feet. **POWER REQUIRED:** 28 volts D.C. **WEIGHT:** 14 1/2 pounds. **SIZE:** 10" x 10" x 6" high.

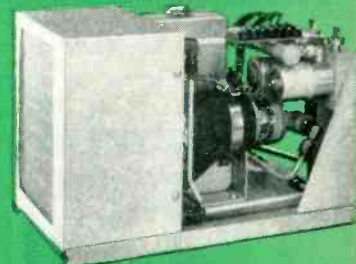

**MODEL NO. 5-A DISSIPATION:** 1,000 watts. **ALTITUDE RANGE:** sea level to 5,000 feet. **POWER REQUIRED:** 100 to 110 volts D.C. **WEIGHT:** 10 pounds. **SIZE:** 7 1/4" x 13 1/2" x 9-1/16" high.



# SOLVING TOMORROW'S PROBLEMS

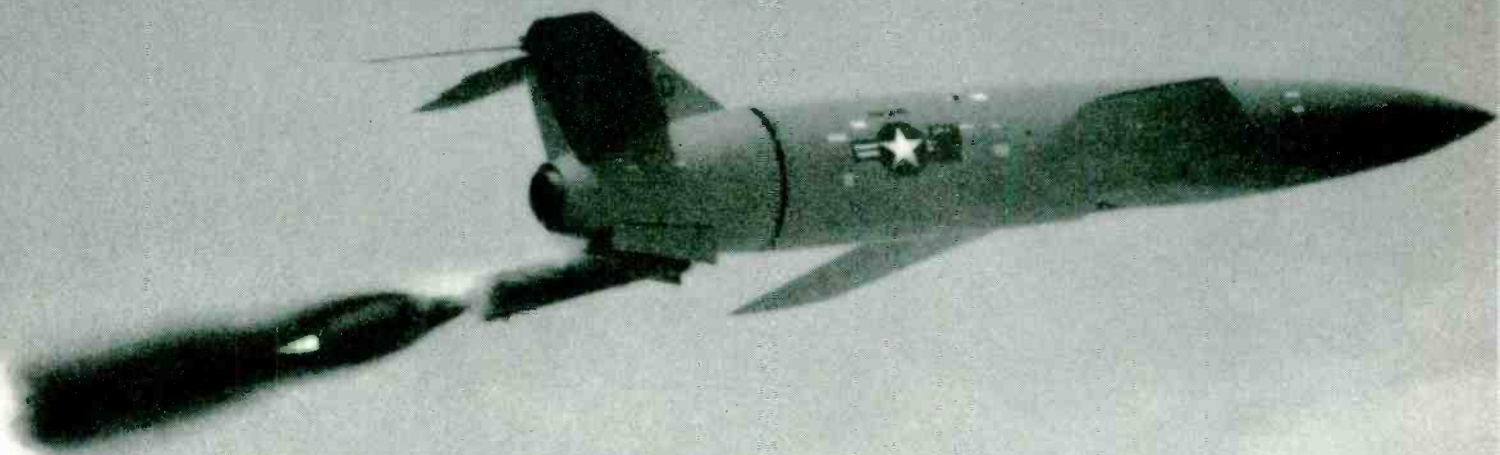

## Try hiding from this one!

Ground Forces are more mobile these days. Better dispersed. Harder to hit. But the modern guided missile can find them.

Launched from either ground or air, it seeks and finds and strikes—remotely controlled through electronic assemblies manufactured by Webster-Chicago.

This is another example of how Webster-Chicago's Government Division serves the Services. For research, development and production that solve tomorrow's problems today, our engineers and facilities are at your call.

... from an idea to a prototype  
... from a prototype to production

**WEBSTER**  
**CHICAGO**

Maker of Webcor Products since 1914  
Government Division • 816 N. Kedzie, Chicago 51

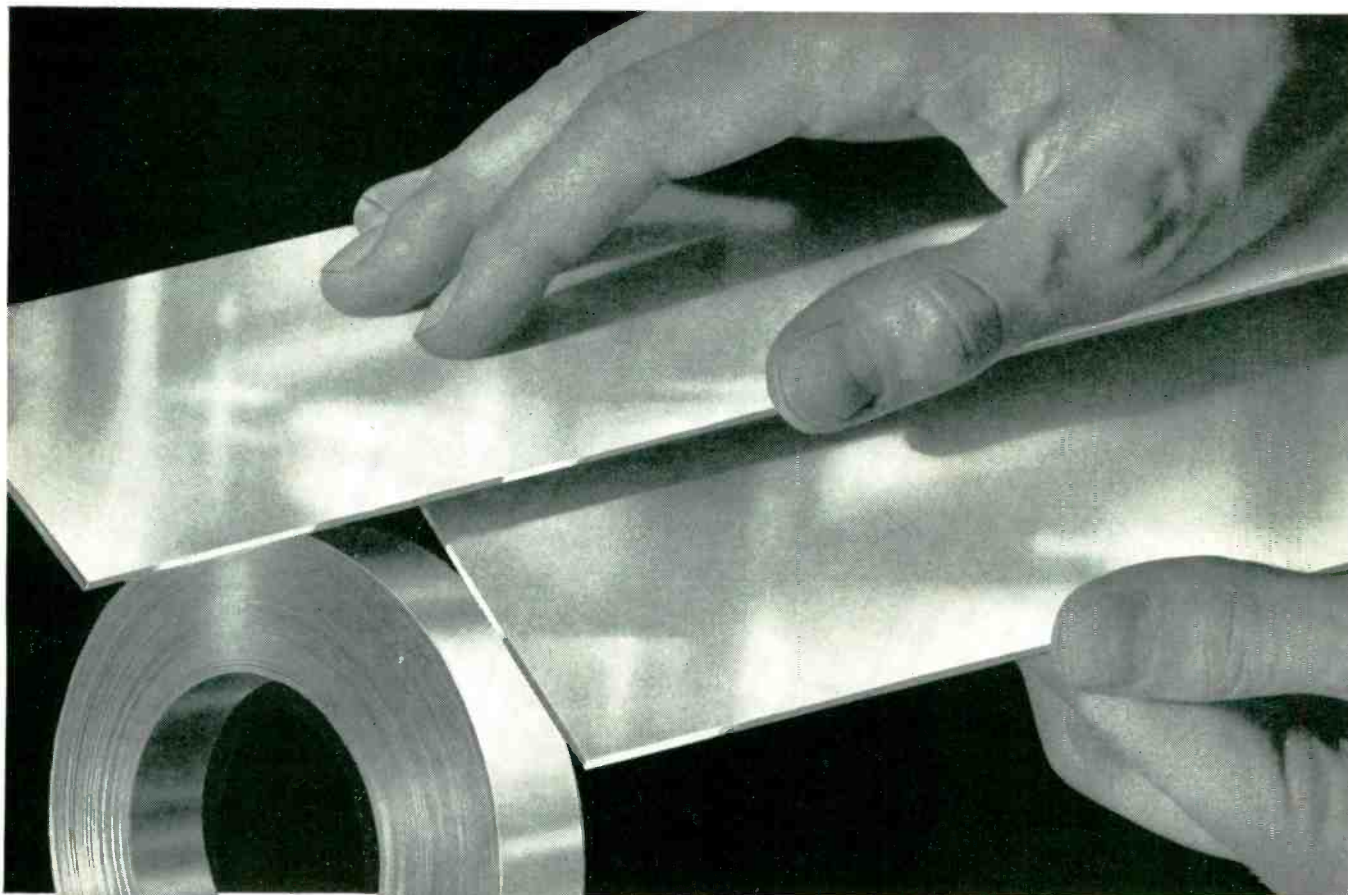

## Two Metals are Better Than One

...and **GENERAL PLATE Composite Metals Provide Performance plus Economy**

Virgin metals and alloys have their limitations, and to overcome them . . . to get the *exact* performance you want . . . General Plate Composite Metals are the answer. They give you broadened physical and metallurgical characteristics . . . meet your specific requirements closer and do the job better, at lower costs.

For instance — permanently bonded copper to steel gives both high conductivity and extra rigidity. Silver or gold bonded to copper or bronze combines workability with high corrosion resistance. Bronze on copper makes ideal current carrying spring material with higher conductivity. Ferrous and non-ferrous combinations give you composite metals with magnetic and non-magnetic surfaces.

General Plate Composite metals in dozens of combinations eliminate many headaches . . . are

the answer to corrosion, conductivity, heat dissipation, cost and many other problems.

General Plate products include . . . precious metals clad to base metals, base metals clad to base metals, thin-gauge rolling, composite contacts, buttons and rivets, *Truflex*<sup>®</sup> Thermostat Metals, *Alcuplate*<sup>®</sup>, platinum fabrication and refining, #720 Manganese Age-hardenable Alloy. Write for complete information and Catalog PR-700 today.

**You can profit by using  
General Plate Composite Metals!**

**METALS & CONTROLS CORPORATION  
GENERAL PLATE DIVISION  
312 FOREST STREET, ATTLEBORO, MASS.**



# CODE MODULATED MULTIPLE-PULSE MICROWAVE SIGNAL GENERATOR

**Model B 950-10,750 mc**

*Generates multi-pulse modulated carrier for beacons, missiles, radar... provides 5 independently adjustable pulse channels, 4 interchangeable r-f oscillator heads, precision oscilloscope, self-contained power supplies ... all in one integrated mobile instrument.*

The Polarad Model B is an essential instrument for testing beacons, missiles, radar, navigational systems such as DME, Tacan, H. F. Loran, etc., where multi-pulse modulated, microwave frequency energy with accurately controlled pulse width, delay, and repetition rate is required for coding.

**A fully integrated self-contained equipment with these features:**

**Four Interchangeable Microwave Oscillator Units**—all stored in the instrument... each with UNI-DIAL control... precision power monitor circuit to maintain 1 mw power output reference level... keying circuit to assure rapid rise time of modulated r-f output... non-contacting chokes.

**Five Independently Adjustable Pulse Channels**—each channel features variable pulse width and delay; has provisions for external pulse-time modulation.

**Precision Oscilloscope with Built-In Wide Band RF Detector** for viewing the modulation en-

velope and accurately calibrating the r-f pulse width, delay, and group repetition rate. Equipped with built-in calibration markers.

**Self-Contained Power Supplies**—Model B operates directly from an AC line through an internal voltage regulator. The coded multi-pulse generator is equipped with an electronically regulated low voltage DC supply. Klystron power unit adjusts to proper voltage automatically for each interchangeable band.

Contact your Polarad representative or write to the factory for detailed information.

Variable width—width of each of 5 pulses can be adjusted independently.



Variable delay—delay between each of 5 pulses can be adjusted independently.

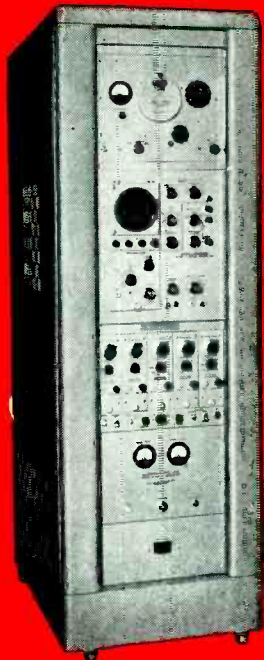

**CODE MODULATED MULTIPLE-PULSE  
MICROWAVE SIGNAL GENERATOR  
Model B**

Pulse-time modulation—input provided in each of 5 pulse channels for external pulse-time modulation.



Variable repetition rate—repetition rate of each group of pulses can be varied.

## SPECIFICATIONS:

### Frequency Range:

- Band 1 ... 950 to 2400 mc
- Band 2 ... 2150 to 4600 mc
- Band 3 ... 4450 to 8000 mc
- Band 4 ... 7850 to 10,750 mc

Frequency Accuracy ...  $\pm 1\%$

RF Power Output ... 1 milliwatt maximum (0 DBM)

### Attenuator:

- Output Range ... 0 to  $-127$  DBM
- Output Accuracy ...  $\pm 2$  db
- Output Impedance ... 50 ohms nominal

### RF Pulse Characteristics:

- a. Rise Time ... Better than 0.1 microsecond as measured between 10 and 90% of maximum amplitude of the initial rise.
- b. Decay Time ... Less than 0.1 microsecond as measured between 10 and 90% of maximum amplitude of the final decay.
- c. Overshoot ... Less than 10% of maximum amplitude of the initial rise.

### Internal Pulse Modulation:

- No. of Channels ... 1 to 5 independently on or off
- Repetition Rate ... 40 to 4000 pps
- Pulse Width ... 0.2 to 2.0 microseconds
- Pulse Delay ... 0 to 30 microseconds
- Accuracy of Pulse Setting ... 0.1 microsecond
- Minimum Pulse Separation ... 0.3 microsecond
- Initial Channel Delay ... 2 microseconds from sync. pulse
- Internal Square Wave ... 40-4000 pps (separate output)

### Pulse Time Modulation:

- Frequency ... 40-400 cps any or all channels
- Required Ext. Mod. ... 1 volt rms min.
- Maximum deviation ...  $\pm 0.5$  microsecond
- Power Input (built-in power supply) 105/125 v, 60 cps 1200 watts.

**AVAILABLE ON EQUIPMENT LEASE PLAN**

**FIELD MAINTENANCE SERVICE AVAILABLE THROUGHOUT THE COUNTRY**



**ELECTRONICS CORPORATION** 43-20 34th STREET, LONG ISLAND CITY 1, N. Y.

REPRESENTATIVES • Albuquerque • Atlanta • Baltimore • Boston • Buffalo • Chicago • Dayton • Englewood • Fort Worth • Los Angeles • New York • Philadelphia • San Francisco • Syracuse • Washington, D. C. • Westbury • Winston-Salem • Canada, Arnprior, Toronto—Export: Rocke International Corporation

# RCA ALUMINIZES TV TUBES ON



Overall view of Stokes continuous vacuum metallizing dolly system for aluminizing TV tubes at RCA's Marion, Indiana plant. Operator is required only to load and unload tubes from the 22 carts.

## THE COMPLETE LINE OF STOKES

Stokes manufactures a complete line of vacuum pumping equipment. This includes mechanical vacuum pumps, diffusion and booster pumps, vacuum valves and gages, and complete vacuum instrumentation. In engineered high vacuum equipment, Stokes builds vacuum metallizers, vacuum furnaces and other vacuum processing equipment.

Stokes has for many years been active in vacuum research. Vacuum experience among our engineers covers the range from laboratory equipment to some of the largest vacuum equipment in service. This experience is available to help solve your vacuum problems.

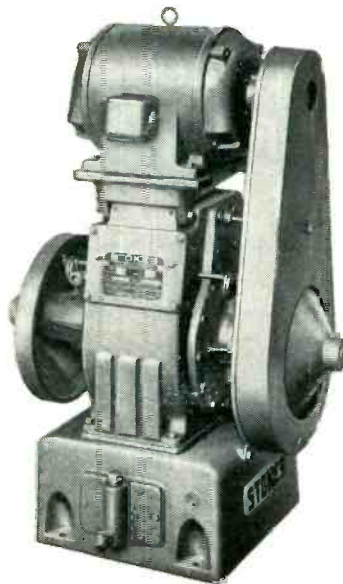

### STOKES MECHANICAL VACUUM PUMPS

For vacuum processing systems and for maintaining low forepressures in high-vacuum systems, the Stokes Microvac pump provides efficient, economical operation. Designed with fully automatic lubrication and a long-lasting exhaust valve assembly, every Microvac pump is assured of smooth, trouble-free operation. Six sizes give capacities from 15 to 500 cfm. Gas-ballast available on all sizes. Send for catalog listed.





# STOKES METALLIZING DOLLIES

The new Stokes installation at RCA's Marion, Indiana, plant is a valveless, rugged system capable of aluminizing up to 120 TV picture tubes per hour. Low in operating cost, it is by far the least complex continuous aluminizing system available. It is designed without timers, gadgets or intricate accessories, any of which could fail and stall production. The system is so free of vibration that a five-cent piece can be balanced on the dollies while they are in motion.

Operation is simplicity itself: the operator loads one tube to a cart; pressure is automatically reduced to the required vacuum, the filament is automatically flashed and the completed metallized tube delivered to the operator's station.

For metallizing COLOR or BLACK AND WHITE TV tubes, Stokes designs and installs automatic or semi-automatic in-line systems or stationary units, in standard designs or to customer's requirements.

F. J. STOKES MACHINE COMPANY  
PHILADELPHIA 20, PA.

## SEND FOR TECHNICAL LITERATURE:

Microvac Pumps—Catalog 750  
Diffusion and Booster Pump Specification sheets and performance curves  
The Story of the Ring-Jet Pump Complete Vacuum Processing Systems—Catalog 730  
How to Care for Your Vacuum Pump—Booklet 755  
Vacuum Impregnation—Catalog 760  
Vacuum Drying—Catalog 720  
Vacuum Furnaces—Catalog 790  
Vacuum Metallizing—Catalog 780  
Vacuum Calculator Slide Rule

## VACUUM EQUIPMENT



### STOKES RING-JET DIFFUSION AND BOOSTER PUMPS

The new Stokes Ring-Jet Pumps embody a new concept of the diffusion principle. Size for size, they have pumping speeds of 10% to more than 100% above any other diffusion pump for a given heat input. Ring-Jet Diffusion Pumps are available in sizes of 4, 6, 10, 14 and 16 inches; Booster Pumps in sizes of 4, 6, 10 and 16 inches. Send for information listed.



### STOKES VACUUM VALVES

To control vacuum safely and surely, Stokes vacuum valves are available in 4, 6, 10 and 16-inch standard flange sizes.

### STOKES-McLEOD VACUUM GAGES

For measuring vacuums from fractions of a micron up to 50 mm, Stokes-McLeod gages are the standard of reference. Four sizes available.



# STOKES

**ENGINEERS:** Stokes is continually adding to its engineering and technical sales staffs in the high vacuum, industrial tableting, powder metal and plastics molding fields. If you can qualify, there may be a position for you.

OFFICES IN PRINCIPAL CITIES,  
REPRESENTATIVES THROUGHOUT THE WORLD

To withstand high heat, shock, and continuous off-on cycling . . .

## Centralab ceramic insulator

used as igniter in new,  
instant car heater

A newly designed, gasoline-burning, instant heater for passenger automobiles uses the principle of reliable aircraft heaters.

The new heater is an injection-type system which is complete in itself. Ignition is accomplished by a spark plug of Centralab Electrical Porcelain, energized by a separate ignition system.

The spark is cycled off and on with the fuel — usually several times per minute, as the off-on cycling modulates heater output. Ignition is instantaneous.

This calls for complete reliability and perfect timing — accomplished with Centralab Electrical Porcelain made for specific heat-range and heat-shock requirements. Like all Centralab ceramics, it has high heat resistance, high dielectric strength, and dimensional stability.

Get the whole story on *all* the Centralab ceramics — including Steatite, Cordierite, Zirconite, and Titanate. Write for Centralab Ceramic Buyer's Guide, Bulletin 42-221. Or refer to it in Sweet's Product Design File.

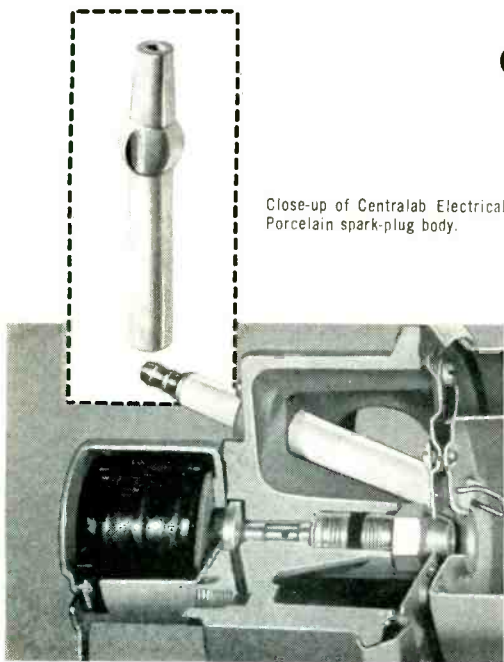

Close-up of Centralab Electrical Porcelain spark-plug body.

Cutaway view of the heat exchanger and burner assembly. Centralab Electrical Porcelain spark plug is in upper left-hand corner. Fuel is ejected through metal nozzle just below spark plug.

**More proof that  
if it's a job  
for electronic components,  
it's a job for Centralab**

Centralab's  
advanced engineering  
continues to create  
the prototypes  
of the components  
industry



CERAMIC  
CAPACITORS



SWITCHES

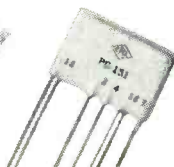

PACKAGED  
ELECTRONIC  
CIRCUITS

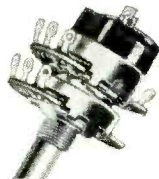

CONTROLS



CERAMICS

X-5513



**A DIVISION OF GLOBE-UNION INC.**

914L E. Kefauver Avenue • Milwaukee 1, Wisconsin  
In Canada: 804 Mt. Pleasant Road, Toronto, Ontario

SINCE 1922, INDUSTRY'S GREATEST SOURCE OF STANDARD AND SPECIAL ELECTRONIC COMPONENTS

SPECIAL  
this month only!

## Centralab Sweepstakes

**28**  
Big Prizes!

*Nothing to buy!  
Nothing to answer!*

**1st PRIZE** — \$100.00 Gift Certificate for a Hart-Schaffner & Marx Suit.

**2nd PRIZE** — Four (4) Arrow Shirts.

**3rd PRIZE** — Two (2) Arrow Shirts.

**Twenty-five (25) 4th PRIZES** — One (1) Arrow Tie each.

To be eligible for the grand drawing, simply send us your name and address on your letterhead. Or ask your Centralab rep for an entry blank. Entries must be postmarked no later than midnight, December 31, 1955. Contest not open in states where prohibited.



# RUGGEDIZED-SEALED METER-RELAYS

These ruggedized versions have the same electrical specifications and use the circuitry shown in Bulletin G-6.

Meter-relays are indicating meters with built-in relay contacts. One contact is carried on the moving pointer. The other is carried on a semi-fixed pointer. When the two pointers meet, the contacts close and lock. Locking coil is wound directly over moving coil. Reset can be manual or automatic. It consists of opening the locking circuit. Spring action in contacts kicks them apart forcefully. There are no pushers nor solenoids inside meter case. These instruments meet the mounting dimension requirements of MIL M-6A. The degree of resistance to shock and vibration depends upon sensitivity and type of action wanted. In general, the relays will not be permanently damaged by shocks of 100 G's and vibrations up to 2,000 cps at 3-4 G's. The most sensitive relays may close their contacts under these conditions.

Usual meter ranges can be supplied from 0-20 Ua. to 0-50 A., or, 0-5 Mv. to 0-500 V. All ranges can be supplied either AC or DC except low millivolts (under 0-250 Mv.). These come only in DC because of limitations of instrument rectifiers. Higher voltage or current ranges are made with external multipliers. Contact setting is adjustable from front to any point on scale arc. Or, it may be pre-set at any fixed point. Contact arrangements are (1) single high (2) single low (3) double, high and low. When used only as relays they can be made to operate on as little as 0.2 microamperes (3000 ohms) or 0.05 millivolts (20 ohms).

All models can be supplied as contact meters, illustrated in the upper photos, or as a panel meter, shown below.



**Black Face**  
**MODEL 355-C 3 1/2 INCH**  
**White Face**

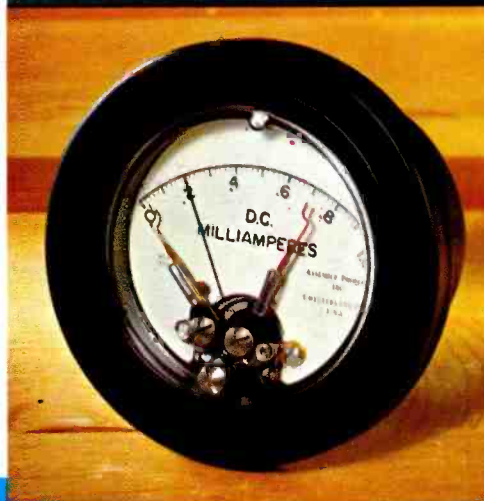

**MODEL 255-C** Narrow bezel provides same dial area as usual 3 1/2 inch meter.  
**2 1/2 Inch** MIL M-6A Mounting Dimensions

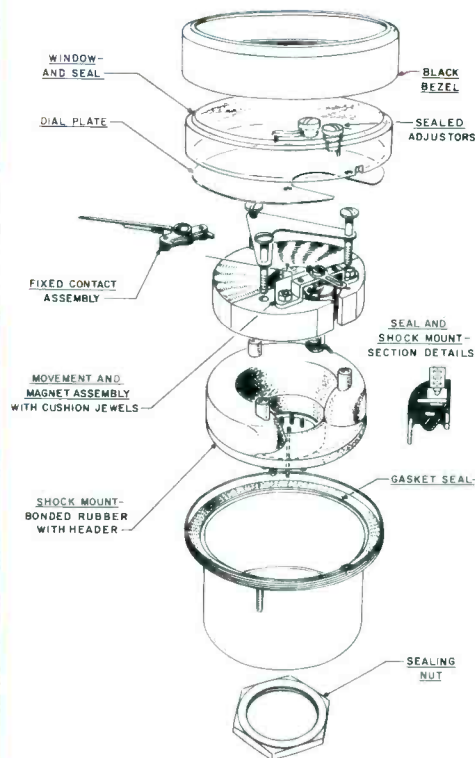

**MODEL 455, 4 1/2 INCH**



## The DEW Line:

The Model 255-C meter-relays perform a vital function in DEW Line (Distant Early Warning Radar Screen) equipment manufactured by Raytheon Manufacturing Company, Waltham, Mass., where they meet these specifications:

- ELECTRICAL:** 0/100 microamperes with specified speed and damping.
- SHOCK:** 1 and 3-foot drops, 400 lb. hammer, 3 planes.
- VIBRATION:** MIL-M-10304 (Sig C)
- SALT SPRAY:** QQ-M-151 A
- TEMPERATURE:** -30° C to +70° C
- SEALING:** MIL-M-6A

## CHESTERFIELD CIGARETTES:

Cigarette quality is controlled by the AccuRay Cigarette Gauge-Controller made by Industrial Nucleonics Corporation, Columbus, Ohio. It has appeared in Chesterfield ads in newspapers and magazines, and on the Dagnet, Gunsmoke, and Warner Brothers Presents television shows. The Model 355-C double contact meter-relay is a basic component of this automatic process control.

## ASSEMBLY PRODUCTS, INC.

Wilson Mills Road  
Chesterland 4, Ohio  
Telephone (Cleveland, Ohio)  
Hamilton 3-4436

Or

69-873 Dillon Road  
P. O. Box 308  
Desert Hot Springs 1, California  
Telephone 4-2468

# RUGGEDIZED-SEALED METER-RELAYS

## DATA SHEET

### Ordering Specifications

CONTACTS: The same size contacts (platinum-iridium) are used for all contact ratings. Locking coil turns vary for different ratings. Standard rating 5 - 25 DC milliamperes, 75 - 125 volts. Other ratings to 100 Ma.

- HIGH LIMIT CONTACTS: Standard.
  - LOW LIMIT: Same price, specify "Low Limit".
  - DOUBLE CONTACT: Add \$10.00.
  - FIXED CONTACT: Single  deduct \$2.00.  
Double  deduct \$3.00.
  - ISOLATED COILS: (Maximum insulation 50 volts) add \$5.00.
  - DOUBLE LOCKING COIL: (for same contact polarity on both high and low limits) add \$5.00.
  - SUPPRESSED ZERO: (scale 40-80 etc.) add 10%. (Specify range).
  - AC METER-RELAYS: (rectifier type) add \$5.00 and specify AC (minimum volts range 0/250 AC millivolts).
  - SPECIAL CONTACT RATING: \_\_\_\_\_ DC volts,  
\_\_\_\_\_ DC milliamperes.
  - MOUNTING: Will be mounted in steel   
or non-magnetic material
- RANGE: \_\_\_\_\_

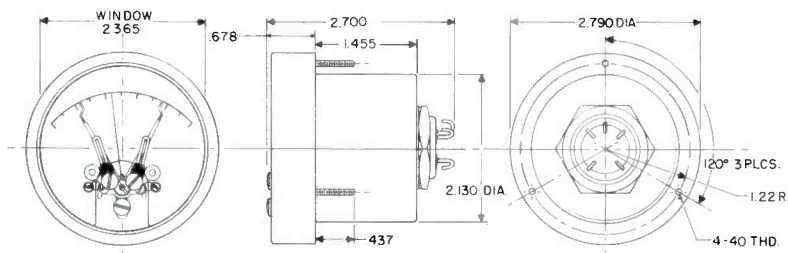

MODELS 255 and 255-C

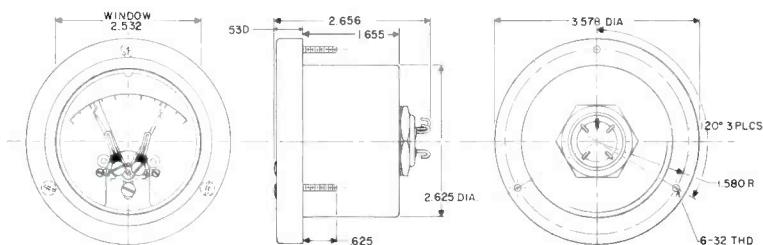

MODELS 355 and 355-C

### POLARITY

Note common connection between coils. (Other polarities can be supplied)

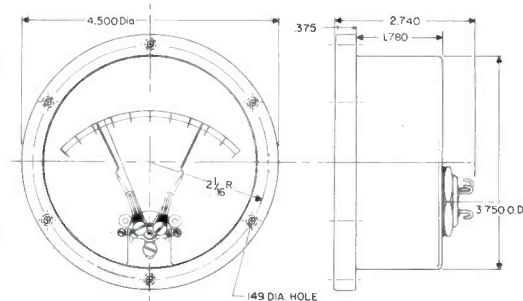
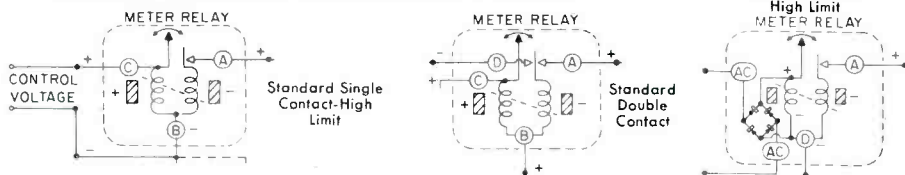

MODELS 455 and 455-C

### RUGGEDIZED-SEALED METER-RELAY PRICES

Model 255-C 2 1/2 Inch    Model 355-C 3 1/2 Inch    Model 455-C 4 1/2 Inch

DC Microamperes	Ohms	Model 255-C 2 1/2 Inch	Model 355-C 3 1/2 Inch	Model 455-C 4 1/2 Inch
0-20	3,000	\$63.25	\$68.25	\$73.25
0-50	3,000	51.00	56.00	61.00
0-100	950	46.00	51.00	56.00
0-250	650	43.00	46.00	51.00
0-500	100	41.00	45.50	49.00
(Intermediate and higher ranges priced same as nearest listed)				
DC Milliamperes				
0-1 to 0-50 (Approx. 100 Mv.)		\$40.00	\$44.50	\$48.00
0-55 to 0-1000 (Approx. 50 Mv.)		45.00	49.00	53.00
DC Amperes				
0-1 to 0-50 (Approx. 50 Mv.)		45.00	49.00	53.00
(External shunt required for ranges over 50 Amperes)				
DC Millivolts	Ohms			
0-5	20	\$63.25	\$69.00	\$75.00
0-10	40	51.00	56.00	61.00
0-25	100	45.00	50.00	55.00
0-50	50*	41.00	46.00	51.00
*(Supplied as standard. 5 ohms, 200 ohms, and other resistances available.)				
(Intermediate and higher ranges priced same as nearest listed)				
DC Volts				
0-1 to 0-500 (Approx. 1000 ohms per Volt. Other sensitivities available.)		\$42.50	\$47.00	\$50.50
(External resistor required for ranges over 500 volts)				

### CONTACT PYROMETER PRICES (4 ohms/millivolt with bimetal compensation)

Int. Res.	Ext. Res.	Thermo-couple	Model 255-C 2 1/2 Inch	Model 355-C 3 1/2 Inch	Model 455-C 4 1/2 Inch
0-3000°F	0-1650°C	70 10 Pt 13% Rh	\$46.00	\$51.00	\$56.00
0-2500	0-1370	212 10 C/A	41.00	46.00	51.00
0-2000	0-1100	172 10 C/A	41.00	46.00	51.00
0-1500	0-800	179 10 I/C	41.00	46.00	51.00
0-1000	0-500	112 10 I/C	44.00	49.00	54.00
0-750	0-400	81 10 I/C	46.00	51.00	56.00
0-500	0-260	52 10 I/C	49.00	54.00	59.00
0-300	0-150	22 10 I/C	54.00	59.00	64.00
-75 to +225	-60 to +110	22 10 I/C	54.00	59.00	64.00
-200 to +100	-130 to +40	22 10 C/C	59.00	64.00	69.00

Thermocouples shown are standard. Pyrometers can be calibrated for use with most other types at extra charge. Ranges listed are standard. Special ranges made to order.

Litho in U. S. A.

### QUANTITY DISCOUNTS

Meter-Relays and Contact Pyrometers

Quantity	Discount
1-4	Net
5-24	15%
25-49	20%
50-99	22 1/2%
100-199	25%

200 up request quotation.

For one range of one model only.

### ASSEMBLY PRODUCTS, INC.

Wilson Mills Road  
Chesterland 4, Ohio  
Telephone (Cleveland, Ohio)  
HAmilton 3-4436

Or

69-873 Dillon Road  
P. O. Box 308  
Desert Hot Springs 1, California  
Telephone 4-2468



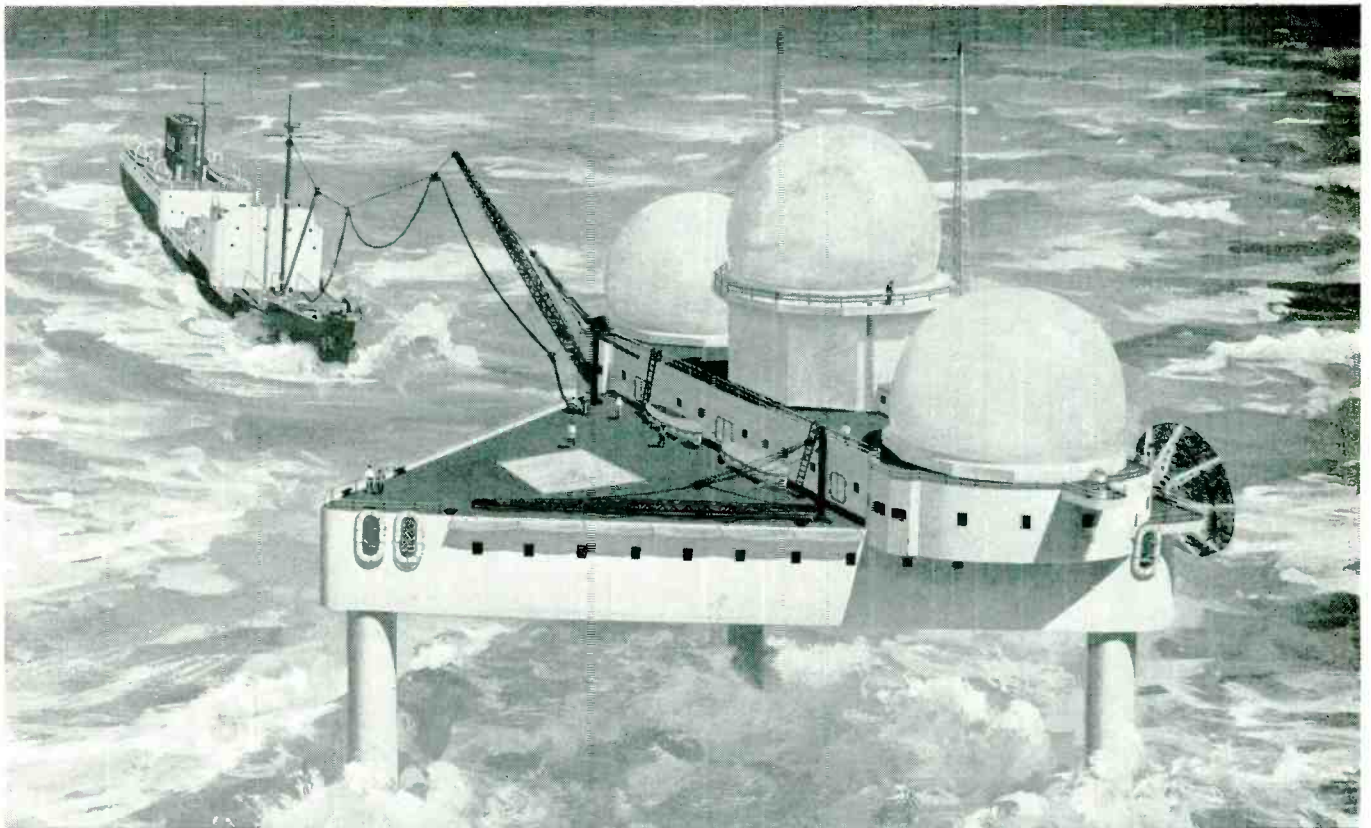

## EIMAC KLYSTRONS are used in Texas Towers forward-scatter communications system

High power UHF/microwave forward-scatter transmitters by National Company are an example of reliable National equipment designed to meet the most exacting requirements. From the first National Company forward-scatter development link to the advanced Texas Tower communication net, Eimac klystrons have been used exclusively as high power final amplifier tubes. Eimac amplifier klystrons provide the power necessary to make long distance communication through forward-scatter techniques practical at microwave frequencies.

- *Second in a series of advertisements emphasizing the extensive application of Eimac amplifier klystrons and circuit components by the leading manufacturers of forward-scatter UHF/microwave transmitters.*



National Company two, ten and fifty kilowatt transmitters employing Eimac klystrons and circuit components are among the pace-setters in the revolutionary art of forward-scatter propagation.



**EITEL-McCULLOUGH, INC.**  
 SAN BRUNO • CALIFORNIA  
 The World's Largest Manufacturer of Transmitting Tubes

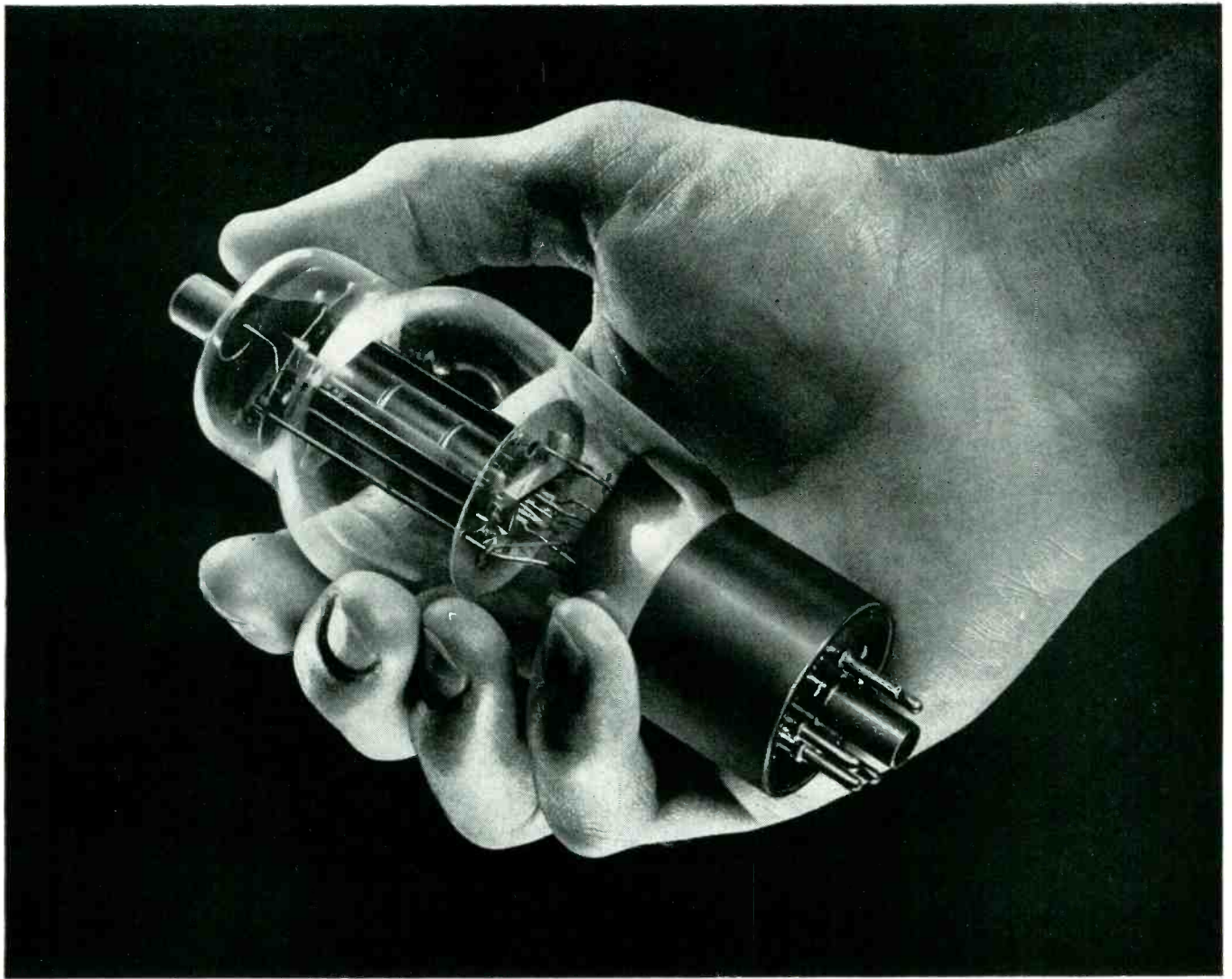

## vacuum-melted components give long, reliable performance . . .

Vacuum-melted metals are the answer to the engineer's search for more *reliable* materials. In vacuum tube components, for example, these superior metals mean longer tube life . . . *stable* electrical characteristics even after repeated heatings. For vacuum-melting *removes* undesirable gases *before* they are put in the tube.

*Vacuum-melting literally sucks gaseous impurities and inclusions from the molten metal.* You get high-purity, gas-free metals that far outperform conventional air-melted metals. Cathode nickel alloys, iron, and alloys for metal-glass seals

are held to *uniformly* close standards of composition. Purity and soundness of *any* metal is improved.

Vacuum Metals Corporation, pioneer in development and leading producer of vacuum-melted and cast metals, has available a wide range of these unique metals designed for electrical and electronic uses. If you believe they might improve your product, please write, giving full details. Our engineers will give them careful attention. *Vacuum Metals Corporation, P. O. Box 977, Syracuse 1, N. Y.*



# VACUUM METALS CORPORATION

Jointly owned by Crucible Steel Company of America and National Research Corporation



# TELEMETERING

## • BAND PASS • LOW PASS FILTERS

in Standard  
Miniature  
Subminiature  
sizes

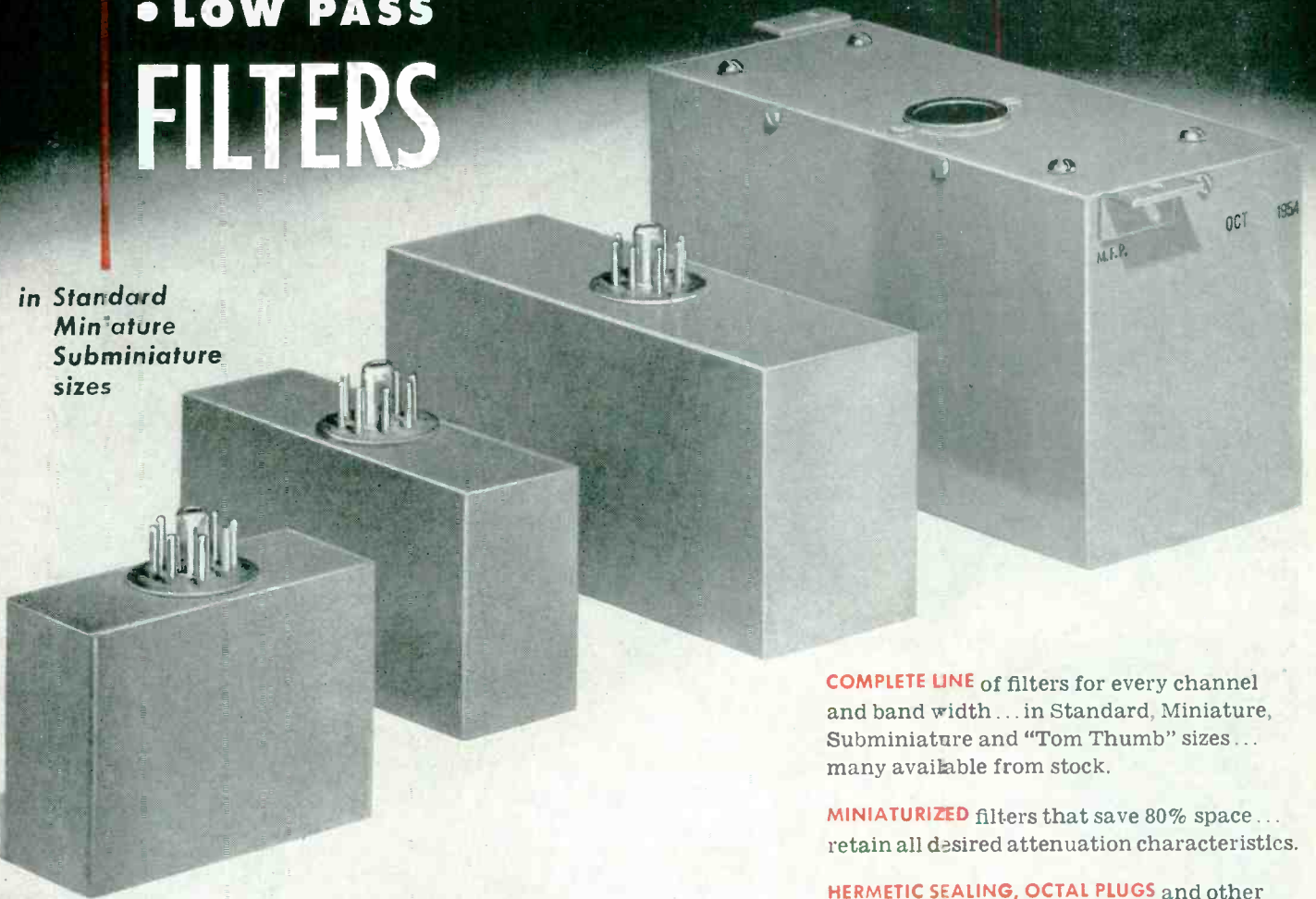

**COMPLETE LINE** of filters for every channel and band width... in Standard, Miniature, Subminiature and "Tom Thumb" sizes... many available from stock.

**MINIATURIZED** filters that save 80% space... retain all desired attenuation characteristics.

**HERMETIC SEALING, OCTAL PLUGS** and other new features.

**only Burnell offers you . . .**

**SPECIAL PHASE LINEARITY** characteristics to conform to new concepts of high accuracy telemetering practice.

**SPECIFICALLY DESIGNED** for telemetering, these filters have found great utility in a wide variety of communications and control applications.

**APPLICATION ENGINEERING** service plus complete technical literature. Write Dept. C-12 for Catalog 102A.

PARTIAL LISTING OF MINIATURE TELEMETERING BAND PASS FILTERS										
Channel Freq.	15% Band Width	30% Band Width	Case Size			Approx. Weight	Attenuation			
			Type No.	Type No.	Type No.		W.	L.	H.	15% B. W.
400 CPS.	S-15456									
560 "	S-15457	S-15477	2 x 6 x 2 3/4	3 lbs.		4DB - 15%	4DB - 30%			
730 "	S-15458	S-15478				20DB - 23%	20DB - 46%			
960 "	S-15459					40DB - 27%	40DB - 54%			
1300 "	S-15460		1 3/8 x 4 1/2 x 2 1/4	1 lb. 7 oz.		3.5DB - 15%	3.5DB - 30%			
1700 "	S-15461					20DB - 23%	20DB - 46%			
2300 "	S-15462					40DB - 27%	40DB - 54%			
2570 "	S-15463		1 3/8 x 3 x 2 1/4	9 3/4 oz.		3DB - 15%	3DB - 30%			
3000 "	S-15464	S-15479								
3900 "	S-15465									
4500 "	S-15466									
5400 "	S-15467									S-15480
7350 "	S-15468									S-15481
10500 "	S-15469									S-15482
12300 "	S-15470									S-
14500 "	S-15471									S-15483
22000 "	S-15472									S-15484
27000 "										S-15485
30000 "	S-15473									S-15486
40000 "	S-15474									S-15487
52500 "	S-15475									
70000 "	S-15476									S-15488
OPTIMUM OPERATING IMPEDANCES      SOCKET TERMINAL CONNECTIONS										
INPUT					OUTPUT					
Terminals 1 & 2    500 ohms					Terminals 1 & 6    500 ohms					
Terminals 1 & 3    10000 ohms					Terminals 1 & 7    50000 ohms					



Teletype: Yonkers, N. Y. 3633

**BURNELL & CO., INC.**  
YONKERS 2, NEW YORK

Pacific Division: 720 Mission St., S. Pasadena, Calif.

**FIRST IN  
TOROIDS,  
FILTERS AND  
RELATED  
NETWORKS**



# WIRE AND CABLE FOR EVERY ELECTRONIC PRODUCT

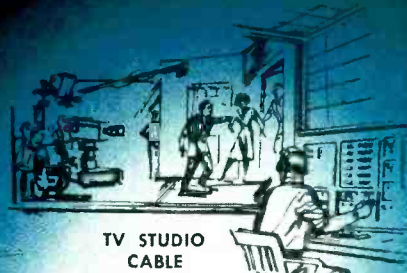

TV STUDIO  
CABLE



MICROPHONE CABLE

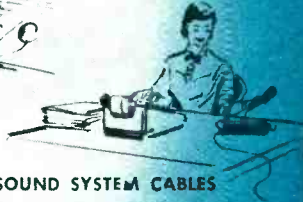

SOUND SYSTEM CABLES

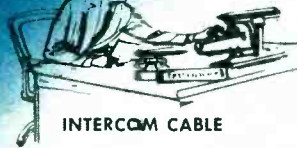

INTERCOM CABLE



MAGNET WIRE—HOOK-UP WIRE



BROADCAST AUDIO CABLES

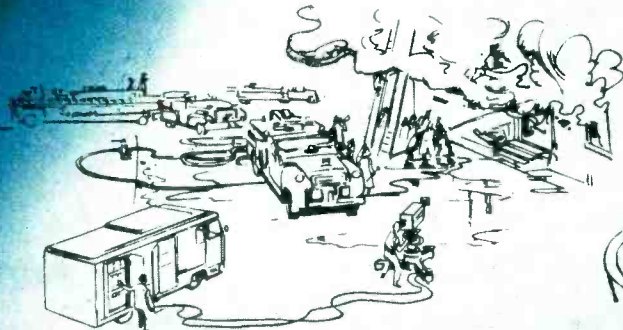

TV CAMERA CABLE

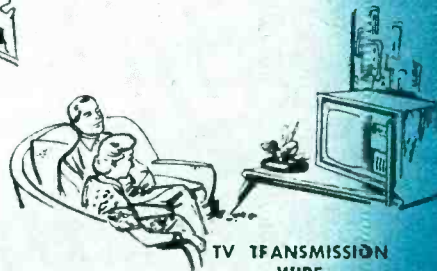

TV TRANSMISSION  
WIRE

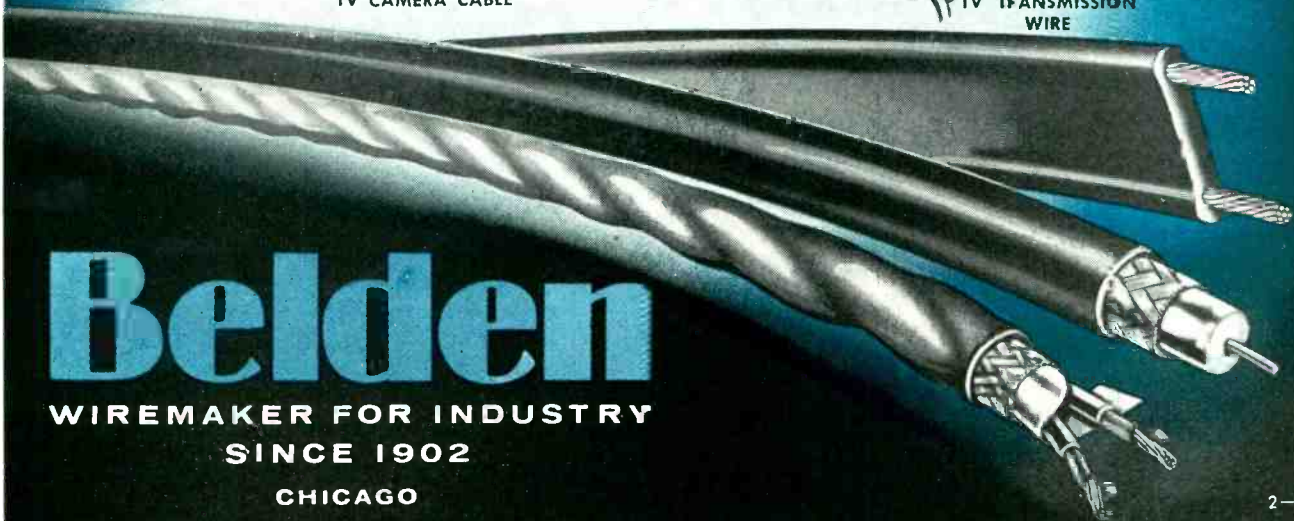

# Belden

WIREFAKER FOR INDUSTRY  
SINCE 1902  
CHICAGO

2-8



*The National Merit Scholarship Corporation*

# Business is Offered Big Dividends on Investment in Higher Education

**B**usiness firms searching for a satisfactory avenue to provide financial aid for our colleges and universities now have a new opportunity of major importance. It is provided by the National Merit Scholarship Corporation, which has offered to devote \$8 million to matching, dollar for dollar, gifts by business firms for college scholarships and supplemental gifts to the institutions where the scholarships are used.

The National Merit Scholarship Corporation, an independent agency financed initially by gifts of \$20 million from the Ford Foundation and \$500,000 from the Carnegie Corporation, has three major purposes which are closely related. They are:

1. To locate those of the nation's young men and young women who are best equipped to go to college.
2. When necessary, to help these young people go to college by giving them financial aid.
3. To help colleges and universities meet the full cost of the instruction of those to whom National Merit scholarships are granted.

At present about half of the nation's top high

The McGraw-Hill Publishing Company is availing itself of the opportunity to establish ten National Merit Scholarships. They will be known as the McGraw-Hill Merit Scholarships. The scholarships are to be awarded to qualified candidates for a four-year college course in the fields of science, engineering and the other professions and the liberal arts. There will be no limitation, beyond the appropriate professional accrediting, on the college or university selected by a successful candidate. As part of a continuing program to aid higher education and educational institutions, McGraw-Hill is happy to be able to share in what it believes to be the constructive educational endeavor of the National Merit Scholarship Corporation.

school graduates do not go to college. The principal reason is that they do not have the money required.

## To Save Unused Brain Power

The National Merit Scholarship Corporation will strive to eliminate this dangerous neglect of top-flight ability. To this end it is inviting the nation's high schools, numbering more than 24,000, to participate in its program by designating as available candidates for National

Merit scholarships the top 5 percent of their senior classes. Those so designated are then invited to take a series of tests and to submit reports designed to assure selection of the very best talent in each state. The number of scholarships to be allotted to each state will be proportionate to the number of high school graduates in the state.

The winners, the total number of whom will be determined by the amount of money the Scholarship Corporation has available, will be eligible for awards. For those who need no financial help to go to college there will be honorary awards of \$100. For those who must have help the Corporation will grant scholarships covering as much as necessary

of the cost of instruction and living expenses for a four-year college course.

## Colleges Get Financial Help

The provision of funds to cover the students' expenses does not, however, solve the financial problems faced by many colleges. That is because the tuition charges paid by the students do not cover the cost of the instruction. The deficit must be met by drawing upon endowment funds, gifts, grants, and other available sources.

Consequently, to prevent holders of National Merit scholarships from imposing any additional financial burden on the colleges and universities they elect to attend, the Corporation will make a supplementary grant to these institutions. The supplementary grant will be the equivalent of regular tuition charges made by the school, with a top limit of \$1,500 a year for both the tuition and the supplement.

As the scholarship grants to the winning students will vary, depending upon how much financial help they need, so will the supplementary grants vary from one college to another, depending on their regular tuition charges. However, it is anticipated that on the average the full cost of a National Merit scholarship—including aid to the student and the supplement to the college—will be about \$1,500 a year.

Many business firms will find a compelling appeal in a program which is designed at once to mobilize the nation's intellectual resources more effectively and, in the process, give very badly needed financial help to our colleges and universities.

## Two For One Return Offered

However, there are numerous other inducements to business firms to finance National Merit scholarships. These scholarships may:

1. Carry the name of the firm or be named in honor of someone designated by the firm.
2. Be limited to use in types of colleges of particular interest to the sponsoring firm.
3. Be limited to a college course, such as science, engineering or liberal arts, of special concern to the sponsor.
4. Be restricted to candidates or institutions in geographic areas specified by the sponsor.

In addition to these advantages there is a special financial inducement to help the Merit Scholarship program. It is that for every Merit scholarship a firm or individual finances, the Corporation will, up to the limit of \$8 million, match the funds and make another National Merit scholarship available.

There are many good ways of helping our financially beleaguered colleges and universities, and many corporations are already using one or more of them.\* For those companies that can do so without embarrassing complications one of the best ways is to make unrestricted gifts directly to the institutions. But this new way provided by the creation of the National Merit Scholarship Corporation (Address: 1580 Sherman Avenue, Evanston, Illinois) has the broad appeal of serving two purposes of transcendent importance simultaneously. The purposes are to see that our best brains are fully trained and utilized and that our colleges and universities, crucial contributors to this process, are helped at the same time. Business will serve the nation and its own community well by giving the National Merit Scholarship Corporation generous help.

\* These, as well as the plight of our colleges and universities, are discussed in a pamphlet, "Business Aid to Our Colleges and Universities," which embodies a series of five editorials which appeared in all McGraw-Hill publications. Copies of the pamphlet can be obtained without charge by addressing the Department of Economics, McGraw-Hill Publishing Company, Inc., 330 West 42nd Street, New York 36, New York.

Methods of helping our colleges and universities financially are also outlined and discussed in a pamphlet, "Aids to Corporate Support of Higher Education," which may be obtained without cost by addressing the Council for Financial Aid to Education, 6 East 45th Street, New York 17, New York.

*This message is one of a series prepared by the McGraw-Hill Department of Economics to help increase public knowledge and understanding of important nationwide developments that are of particular concern to the business and professional community served by our industrial and technical publications.*

*Permission is freely extended to newspapers, groups or individuals to quote or reprint all or parts of the text.*

*Donald C. McGraw*  
PRESIDENT

McGRAW-HILL PUBLISHING COMPANY, INC.



# Farnsworth

**IS EXPERIENCE!**

**FOR OVER 10 YEARS . . . .**

Since the beginning of our country's missile activity . . . Farnsworth has participated in the design, development and production of electronic equipment for such missiles as Terrier, Talos, Sparrow and others. This tremendous background of technical skills and know-how qualifies Farnsworth — uniquely — to cope with all phases of a missile program.

**FOR OVER 30 YEARS . . . .**

Farnsworth has carried on an unbroken tradition of achievement in defense and industrial electronics. The genius that created electronic television, pulse techniques, electron optics and photomultipliers, continues to lead advances in radar, special purpose tubes and electronic research.

This is Farnsworth . . . pioneer in electronics . . . dedicated to the extension of man's **VISION beyond the range of sight.**

**MISSILES**

**INDUSTRIAL ELECTRONICS**

**RADAR**

**ELECTRON TUBES**

**RESEARCH**

*Farnsworth*



A DIVISION OF

**ITT & T**

**FARNSWORTH ELECTRONICS COMPANY**

*a division of International Telephone and Telegraph Corporation*

**FORT WAYNE, INDIANA**



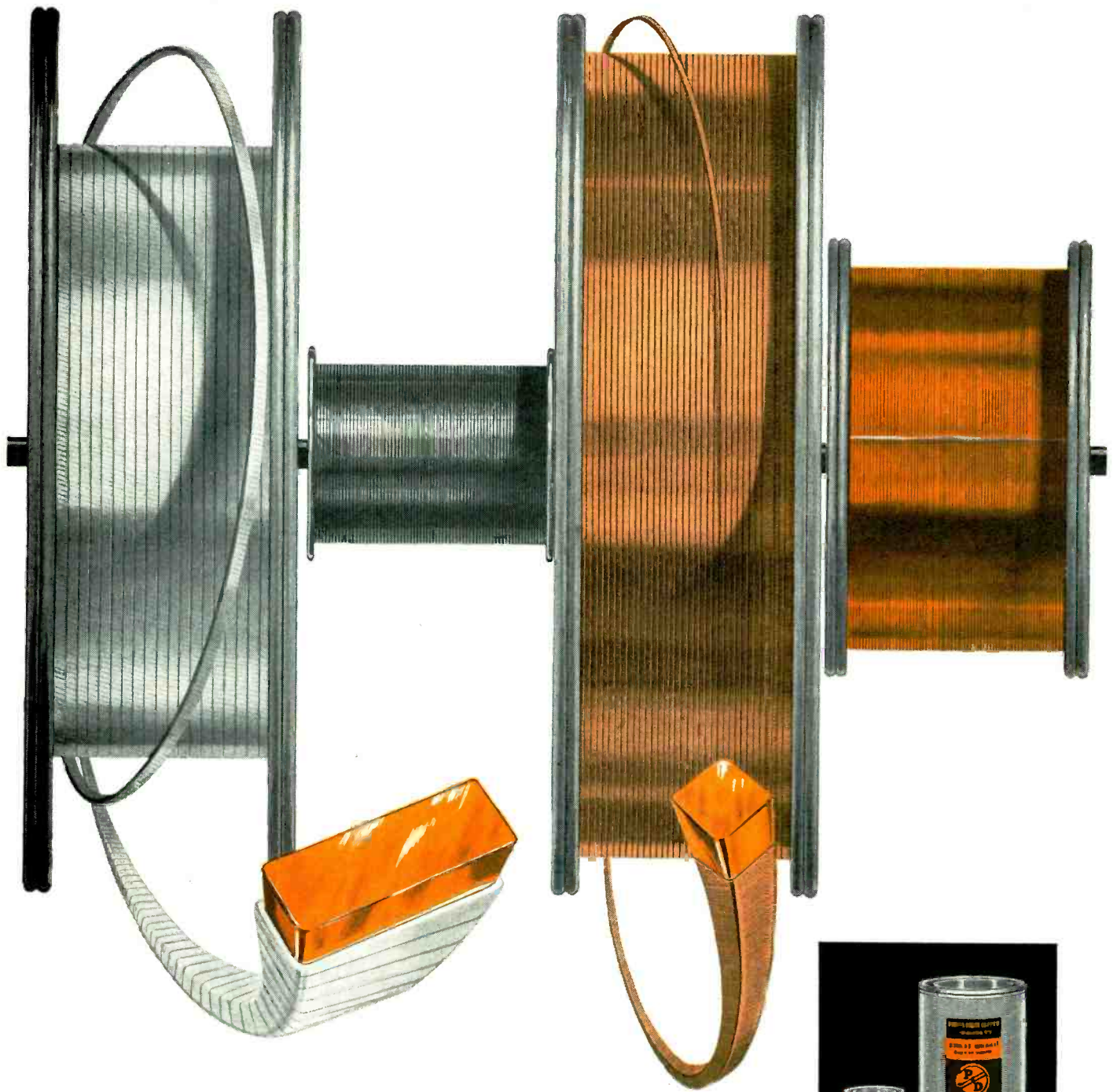

Wire packaged in Phelps Dodge special "Pakeze" containers if required.

*First for Lasting Quality—from Mine to Market!*



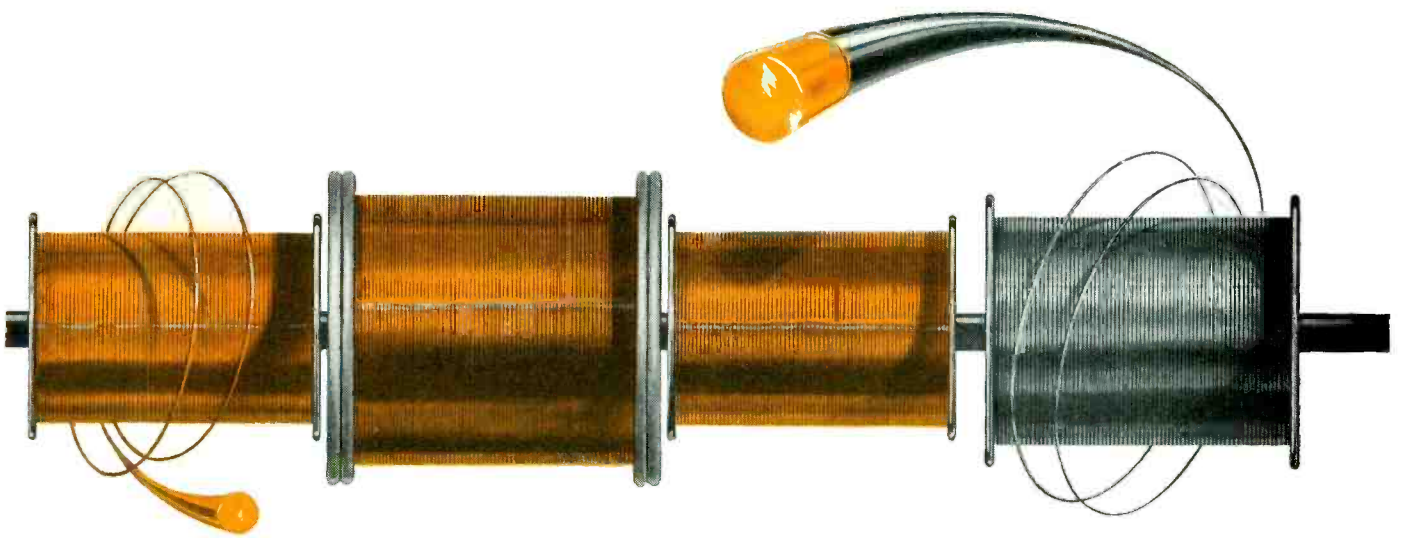

*If it Calls for* **MAGNET WIRE**—*Call on* **PHELPS DODGE** *for*  
**INDUSTRY'S MOST COMPLETE,  
 MOST UP-TO-DATE LINE!**



Every type of insulation to meet design requirements.  
 Enamel • Formvar • Sodereze® • Bondeze® • Daglas® • Thermaleze®  
 Silicone • Paper • Cotton • Multiple Combinations.



Available in all sizes and shapes—round, square, rectangular.  
 Over 400 different types!



Special emphasis on research and development—your assurance  
 of the latest advances in magnet wire.



Vast background of application engineering experience to help  
 solve your problems.

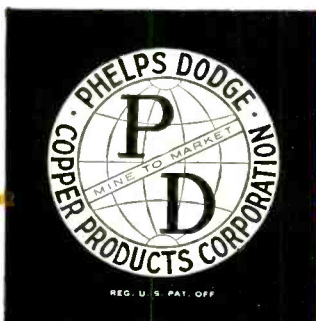

***PHELPS DODGE COPPER PRODUCTS***  
**CORPORATION**

**INCA MANUFACTURING DIVISION**  
 FORT WAYNE, INDIANA

**MICRO SWITCH Precision Switches**  
A PRINCIPLE OF GOOD DESIGN

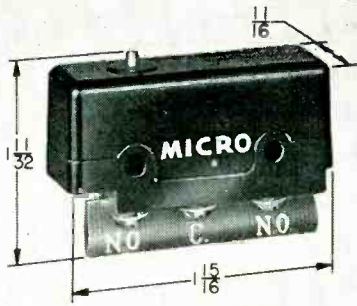

Double-pole,  
double-throw  
basic switch

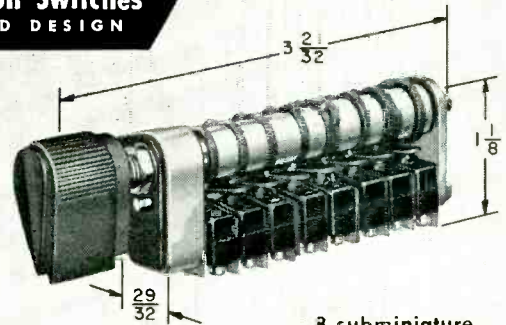

3 subminiature  
SPDT switches with rotary selector actuator

**Here are 6 reliable  
precision switches  
for multiple circuit control**

Whether your requirement is a single switch to control one circuit or an assembly of switches to control many circuits you will find that MICRO SWITCH engineering keeps pace with your needs.

Pictured here are just a few of the many small, sensitive, precision switches MICRO SWITCH has developed to meet specific applications. Push button, toggle and rotary actuators permit extreme versatility of design without any compromise with reliability.

Should your design call for special small switches for use with high temperatures, difficult environments, high inrush currents or unusual circuitry, for instance, MICRO SWITCH engineering can quickly put the proper switch in your hands.

Call MICRO SWITCH engineering today. You'll be glad you did. There are 20 branch offices to bring you quick, intelligent cooperation on every switch problem. There is no obligation.

16 subminiature  
SPDT switches  
with toggle  
actuator

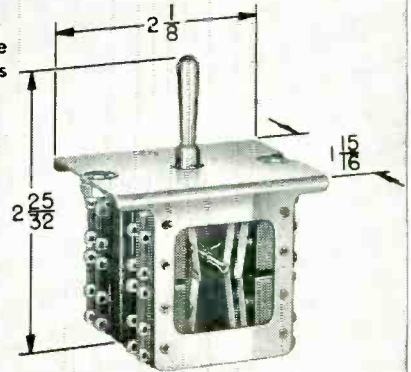

Two-circuit  
double-break switch

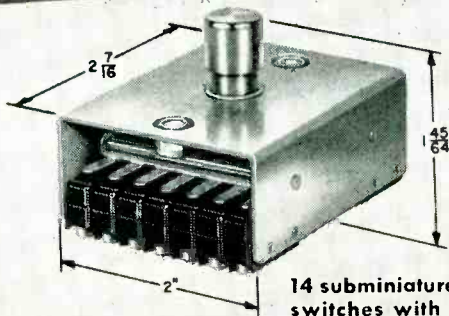
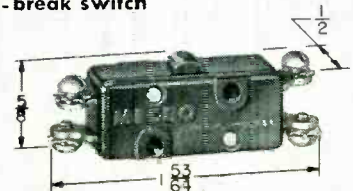

14 subminiature SPDT  
switches with single  
push button actuator

High capacity "V3" switches  
(may be gang-mounted)



A complete line of snap-action and mercury switches

MICRO SWITCH provides a complete line of extremely reliable, small-size, high-capacity, snap-action precision switches and mercury switches. Available in a wide variety of sizes, shapes, weights, actuators and electrical characteristics. For all types of electrical controls.

**MICRO SWITCH**

A DIVISION OF MINNEAPOLIS-HONEYWELL REGULATOR COMPANY

In Canada, Leaside, Toronto 17, Ontario • FREEPORT, ILLINOIS





# Federal SMASHES THE Heat Barrier

...and cuts the size and weight of cable

**Federal's miniature coaxial cables—about 1/4 the size of comparable RG types—save critical space and weight in aircraft and instrument uses.**

Challenged by the high temperature and minimum weight requirements of jet aircraft and guided missiles, Federal has designed RG cables that perform perfectly at a blistering 500° F.! New Federal miniature coaxials have a top temperature rating of 150° C. . . . up to 200° C. with an impregnated fiber glass jacket!

The key to these new cable developments lies in advanced designs.

Based on utilization of "Teflon," this superior dielectric maintains its excellent low loss and high voltage characteristics through a temperature range of 500° F. to -100° F. "Teflon" has no measurable water absorption; it is chemically inert . . . unaffected by alkalis, acids, aromatic fuels, aromatic organic solvents, and highly corrosive aviation hydraulic fluids.

**If your cable problems involve heat, space or weight, it will pay you to consider Federal's new "Teflon" insulated cables. For information, write Dept. D913.**

#### "TEFLON" HIGH TEMPERATURE CABLES

**RG-87 A/U** 50 ohms; 69.5% V.P.; 29.5 mmfd/ft. Cap; 4,000 operating volts.

**RG-140/U** 75 ohms; 69.5% V.P.; 29.5 mmfd/ft. Cap; 1,700 operating volts.

**RG-141/U** 50 ohms; 69.5% V.P.; 29.0 mmfd/ft. Cap; 1,500 operating volts.

#### "TEFLON" MINIATURE COAXIAL CABLES

**K-256** 50 ohms; 29 mmf/ft. Cap; 72% V.P.; 850 V rms Corona; 13 db/100 ft. Atten. at 400 mc; 0.095 O.D. dielectric; 7/30 silver-plated Copperweld conductor; 0.135 O.D. jacket.

**K-257** 70 ohms; 21 mmf/ft. Cap; 72% V.P.; 850 V rms Corona; 14 db/100 ft. Atten. at 400 mc; 0.095 O.D. dielectric; 7/34 silver-plated Copperweld conductor; 0.135 O.D. jacket.

**K-258** 93 ohms; 16 mmf/ft. Cap; 72% V.P.; 850 V rms Corona; 15 db/100 ft. Atten. at 400 mc; 7/38 silver-plated Copperweld conductor; 0.135 O.D. jacket.

**"TEFLON" HOOK-UP WIRE**—Type E, EE and FF Hook-Up Wires meet MIL-W-16878A. Available in all standard colors.

# Federal



A DIVISION OF

# ITT &

**Federal Telephone and Radio Company**

A Division of INTERNATIONAL TELEPHONE AND TELEGRAPH CORPORATION

COMPONENTS DIVISION • 100 KINGSLAND ROAD • CLIFTON, N. J.

In Canada: Standard Telephones and Cables Mfg. Co. (Canada) Ltd., Montreal, P. Q.  
Export Distributors: International Standard Electric Corp., 67 Broad St., New York



# DESIGNER'S

## New G-E *Vac-u-Sel*\* component rectifiers top 80,000-hour-life expectancy

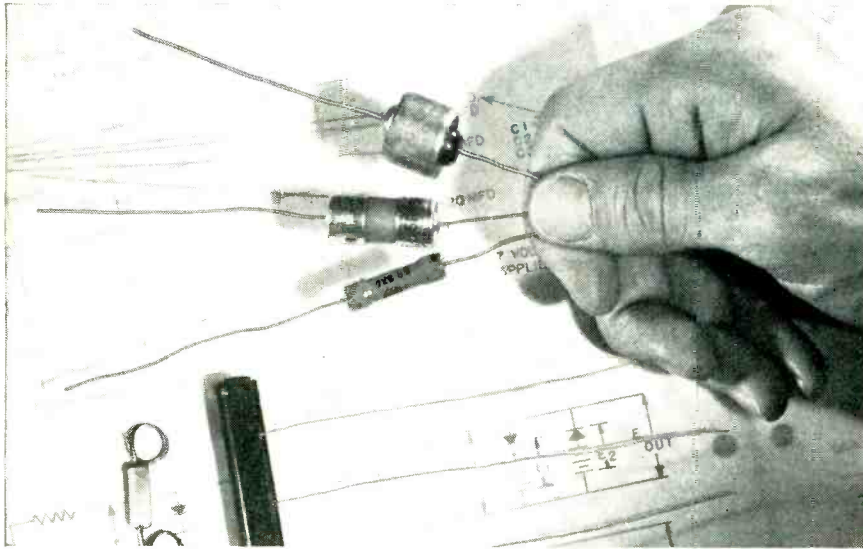

Life expectancy has now been raised from 60,000 to over 80,000 hours for General Electric's new miniature *Vac-u-Sel* rectifier stacks. Achieved by constantly improving processing techniques, this 20,000 hour increase in life is backed up by laboratory tests. Developed for electronic, industrial-control, and power applications, these units offer compactness and stability of electrical characteristics. Ambient temperature range is broad— $-65^{\circ}\text{C}$  to  $130^{\circ}\text{C}$ —and a wide variety of sizes, housings and finishes are available.

The "Selecto-Chart" shown below is part of a new application approach developed by G.E. It gives you greater freedom of design in selecting from the many rectifier sizes and types. Send for GEA-5935A, GEA-6273.

\*Registered trade-mark of General Electric Co.

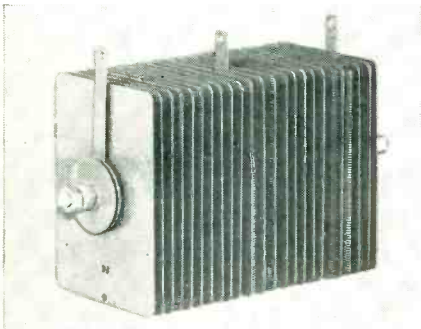

**COMPACT RECTIFIER STACKS** offer designers stable electrical characteristics.

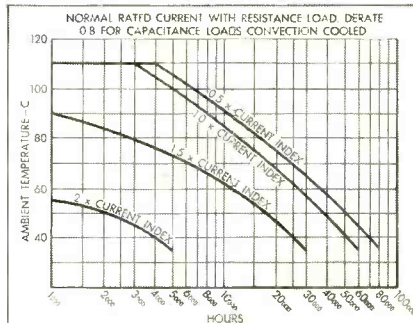

**INCREASE IN LIFE EXPECTANCY** is shown in typical curves for 45-volt cells.



**SELECTION IS EASY** with new G-E *Vac-u-Sel* rectifier "Selecto-Chart."

## G-E molded-case circuit breakers provide safe fuseless circuit protection

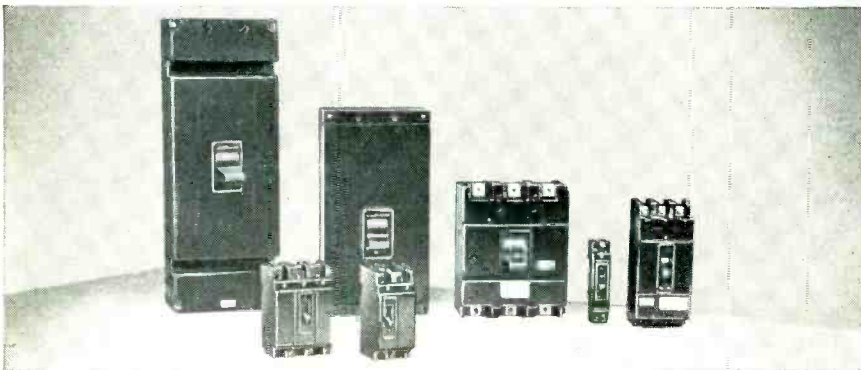

Thermal-magnetic trip elements in G-E molded-case circuit breakers help guard conductors against short circuits and sustained overloads. Operation is cool, life is lengthened through de-ionizing arc quenchers that quickly dissipate arcs.

Extra safety results from trip-free operating mechanism that opens contacts against overcurrents even if handle is held closed. Solderless lugs, straight-in wiring make installation simple.

Ratings from 10 through 600 amperes for circuits of 120, 240, 480, 600 volts a-c, and for 125, 250 volts d-c. GEC-1032.

# — GENERAL ELECTRIC —



# DIGEST

## TIMELY HIGHLIGHTS ON G-E COMPONENTS

### G.E. cuts radar transformer weights up to 35%



Small or large, narrow or wide, light weight, long life—whatever your requirements, General Electric will build high-voltage, oil-filled transformers and inductors to your specifications. The picture at left, for example, shows how G.E. cut 61 pounds from a typical radar power supply by redesigning with smaller embedded-layer coil. These corona-free components are suitable for many electronic applications other than radar.

Among the advantages of these smaller and more reliable G-E components are: (1) more efficient cores permit weight savings to 11%, (2) alumina terminals add reliability, and (3) the use of Formex\* wire and new embedded-layer winding techniques re-

duce coil sizes as much as 53%.

All G-E radar components are designed for compact installation. All can be manufactured to MIL-T-27 specifications. All have characteristics and features to meet a wide range of requirements. G.E.'s fully equipped model shop pools engineering and manufacturing skill to fulfill your needs. The shop can deliver prototype units for your experimental or system development projects—in a hurry—because work on your jobs begins immediately. Testing is strict. Vibration, thermal-cycling and moisture resistance tests are extra steps that can be taken by G.E. to assure components of the highest quality. Ask for Bulletin GEA-5963.

\*Registered trade-mark of G.E. Co.

### Two oz. switchette operates up to 50,000 ft. alt., from -70° F to 200° F

Versatile, corrosion-resistant and compact, General Electric Size 2 switchettes perform perfectly under extremes of altitude and temperature, combine low-inertia moving parts with high contact-tip force. Totally enclosed contact structure protects it from tampering and dirt. Screw-type terminals simplify wiring. For aircraft use where vibration is severe and space limited, its snap action and double-break-contact construction are especially valuable. Spring-return button on the housing can be actuated by lever, bellows, or other means. Bulletin GEC-207A.

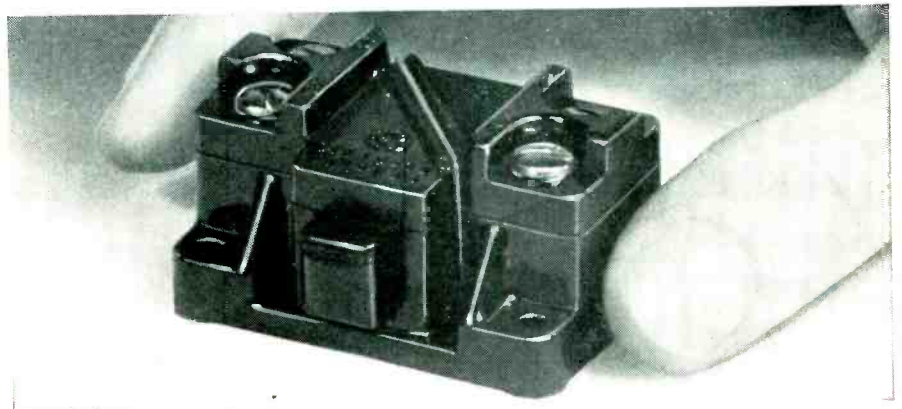

#### EQUIPMENT FOR ELECTRONIC MANUFACTURERS

##### Components

Meters, instruments  
Dynamotors  
Capacitors  
Transformers  
Pulse-forming networks  
Delay lines  
Reactors  
Motor-generator sets  
Inductors  
Resistors  
Voltage stabilizers

Fractional-hp motors  
Rectifiers  
Timers  
Indicating lights  
Control switches  
Generators  
Selsyns  
Relays  
Amplidynes  
Amplistats  
Terminal boards  
Push buttons  
Photovoltaic cells  
Glass bushings

##### Development and Production

**Equipment**  
Soldering irons  
Resistance-welding control  
Current-limited high-potential tester  
Insulation testers  
Vacuum-tube voltmeter  
Photoelectric recorders  
Demagnetizers

General Electric Company, Apparatus Sales Division  
Section B667-32  
Schenectady 5, N. Y.

Please send me the following bulletins:

for reference only     for planning an immediate project

- GEA-5963 Radar Transformers
- GEC-207A Switchettes
- GEC-1032 Molded-case Circuit Breakers
- GEA-5935A Miniature Vac-u-Sel Rectifiers
- GEA-6273 New Vac-u-Sel Component Rectifiers

Name .....

Company .....

City..... State.....

**TURN PAGE FOR MORE G-E COMPONENT HIGHLIGHTS**

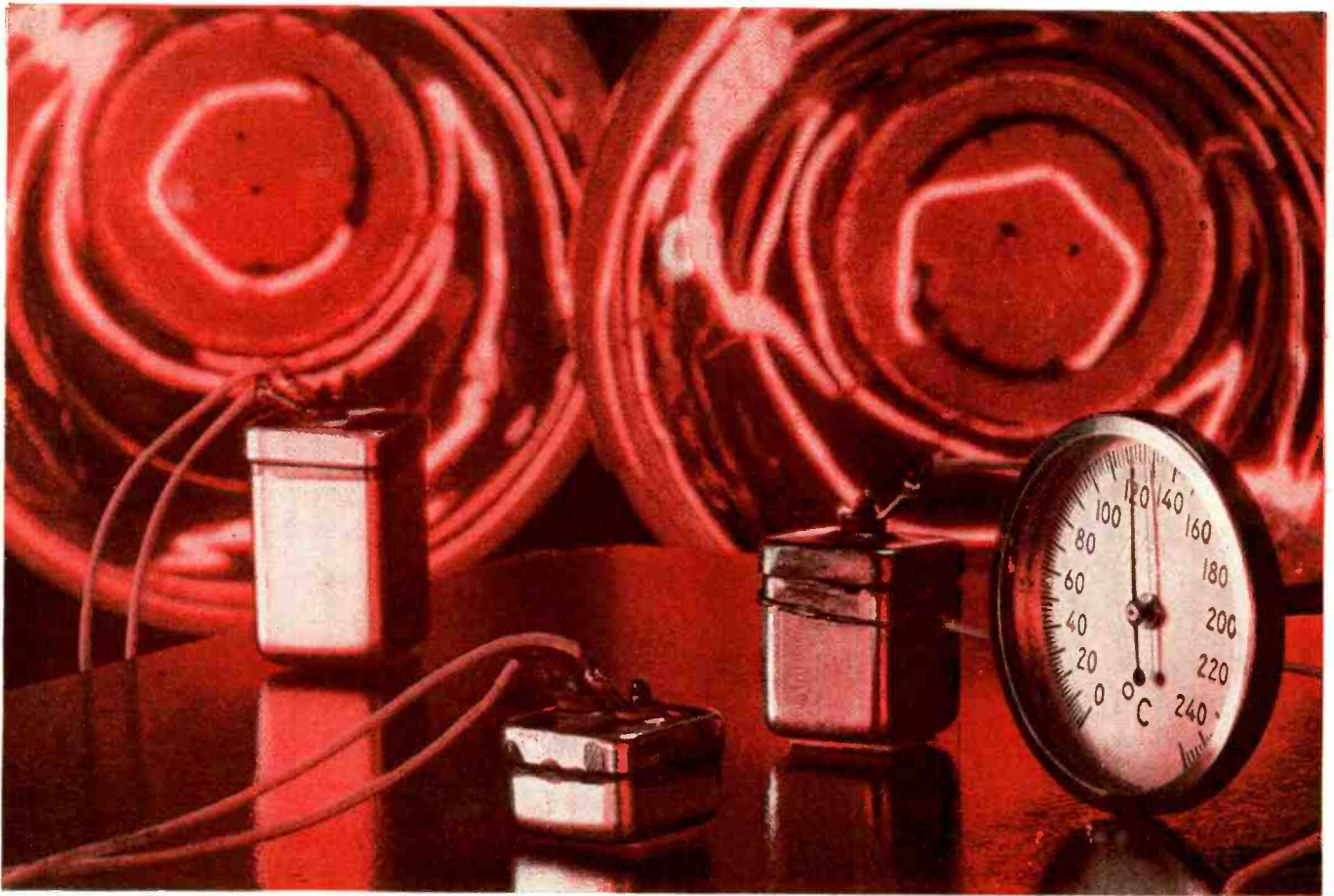

INFRA-RED LAMPS subject new G-E capacitor to 125° C ambient temperature.

# New G-E high-temperature Tantalytic\* capacitors operate in +125° C ambient at full voltage

Where quality, long life and small size are required in high-temperature, miniaturized, high-reliability equipment, specify General Electric's new 125° C Tantalytic capacitors. Designed to operate at full voltage in high temperature, they

meet the tough requirements of miniaturized military equipment: energy storage, filtering, or by-pass applications in electronic ordnance, guided missile, navigation, communication, and control equipment.

Three rectangular case sizes permit ratings from 36 uf at 100 volts d-c to 180 uf at 30 volts d-c. All three sizes have same square base, varying only in height to maintain high volumetric efficiency at lower ratings.

Features: low leakage currents, long shelf and operating life, availability in polar and nonpolar construction for use in both a-c and d-c circuits. When operated at ambient of 125° C at rated voltage, units meet qualification requirements of 1000 hours with not more than 20 per cent loss in initial 25° C capacitance.

Unlike other types of Tantalytic capacitors, the foil construction offers chemically neutral electrolyte to minimize corrosion danger, plus excellent mechanical stability and freedom from electrical noise under shock or vibration. Ask for Bulletins GEA-6258 and GED-2620.

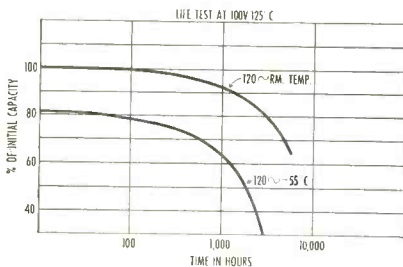

LONG LIFE of G-E 125° C Tantalytic capacitors is shown by graph of life vs. loss of capacitance for typical 100-v d-c unit.

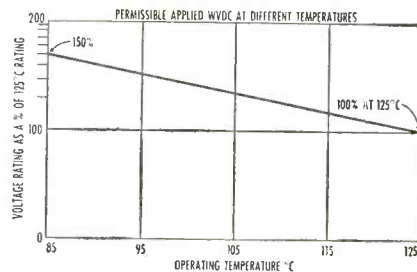

HIGHER VOLTAGES than 100 VDC can be applied with no life loss at ambients below rated +125° C as shown above.

GENERAL  ELECTRIC



### G.E. protects equipment with instantaneous voltage stabilization within $\pm 1\%$

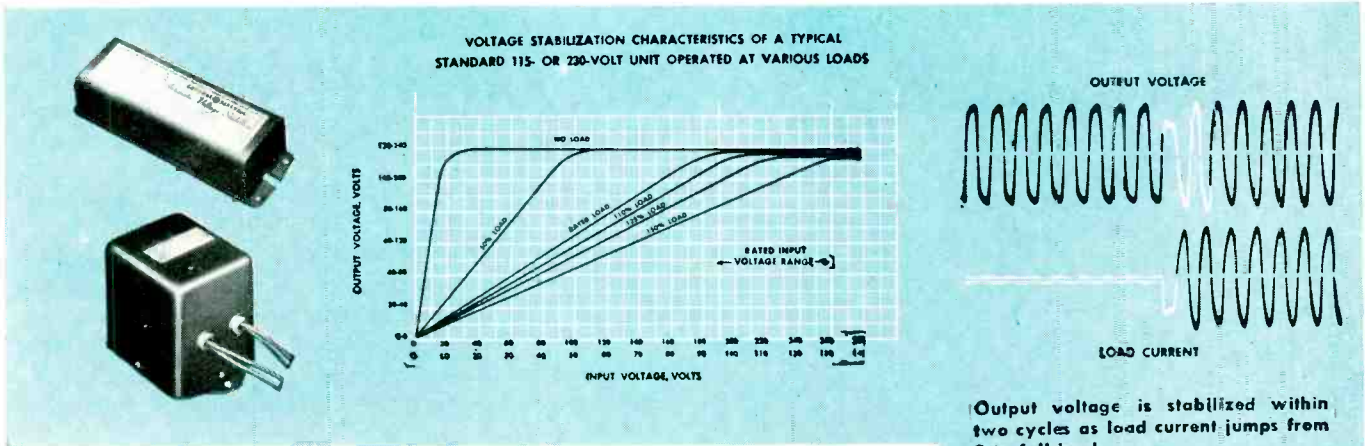

General Electric voltage-stabilizing transformers are completely automatic. The compact units offer low losses, high input factor, fast response. They are easily installed, have no moving parts, and need virtually no maintenance. Often designers find standard units most satisfactory, either incorporated in new equipment or adapted to existing circuits. If special units are required, G-E engineers will co-operate in finding solu-

tions for you. You can use them in literally hundreds of types of equipment. New applications and new methods of applying these voltage-stabilizing transformers are continually being discovered. The rapid responses of control with these units are shown graphically in the three curves at right, and typical characteristics above. Bulletin GEA-5754A.

### G-E saturable reactors control individual power loads at low cost

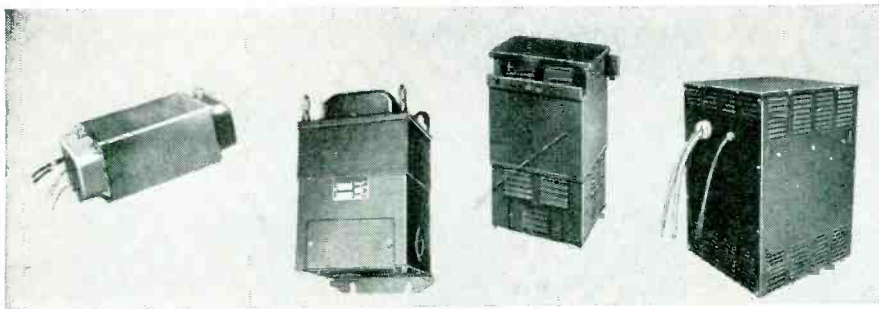

Faced with fixed power sources, application and design engineers can draw on General Electric's "design pool" of more than 1000 different saturable reactor designs. This will simplify solving the problems they often face of controlling individual power loads manually or automatically at low cost. Very efficient even at light loads, a G-E saturable reactor provides control in an a-c circuit by direct current. Adjustment is smooth all the way. They can be satisfactorily utilized in a wide range of applications, including electrically heated furnaces and boilers, or milk pasteurizers and X-ray equipment. Apply them, too, in reduced-voltage starting, or continuously adjustable re-

active load banks. G.E. can design them in a wide variety of a-c and d-c ratings to meet your special application needs. Bulletin GEA-6354.

Output voltage is stabilized within two cycles as load current jumps from 0 to full load.

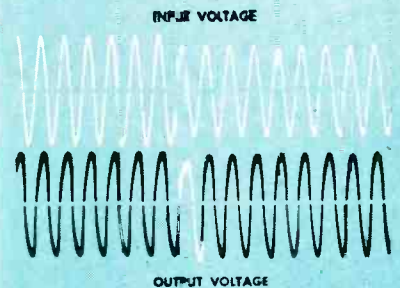

Output voltage is stabilized in less than  $1\frac{1}{2}$  cycles as input drops from 130 to 100 volts.

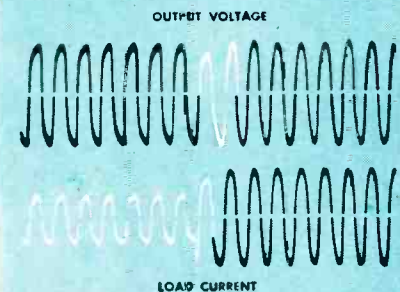

Output voltage is stabilized within two cycles as load current jumps from half load to full load.

General Electric Company, Apparatus Sales Division  
Section B667-32  
Schenectady 5, N. Y.

Please send me the following bulletins:

- for reference only
- GEA-6258 125C Tantalum Capacitors
- GED-2620 Capacitors for Electronics

- for planning immediate project
- GEA-6354 Saturable Reactors
- GEA-5754A Voltage Stabilizers

For information on other products, contact your nearest G-E Apparatus Sales Office.

Name.....  
Company.....  
City..... State.....



*this is not something new!*

Leading members of the aviation industry have long known about this means of measuring aircraft and missile antenna radiation patterns. In the course of various engineering projects, they have come repeatedly to Airborne Instruments Laboratory with antenna test problems. As always, Airborne's scientists sought to create equipment, singularly perfect in performance yet flexible enough to meet many specific needs. Their efforts resulted in the Type 105 Model Range System, which automatically records polar plots of the relative field strength of aircraft radiation patterns.

The Type 105 System, however, is not only important within itself. Out of its totality have merged several significant devices, designed for many recording purposes. Among these are the 116R Polar Pattern Recorder, the Type 20 SWR Indicator, and the Type 373 Rectangular Coordinate Recorder.

Here again is an example of creative initiative, by ALL engineers, providing a continuous succession of advanced instruments for America's industrial progress.

*Send for information about the 105 Model Range System and literature on other recording devices.*



Type 116R Polar Pattern Recorder



Type 373 Rectangular Coordinate Recorder



Type 20 SWR Indicator



**AIRBORNE  
INSTRUMENTS  
LABORATORY**  
I N C.

160 OLD COUNTRY ROAD • MINEOLA, NEW YORK



# why fiddle and fuss?

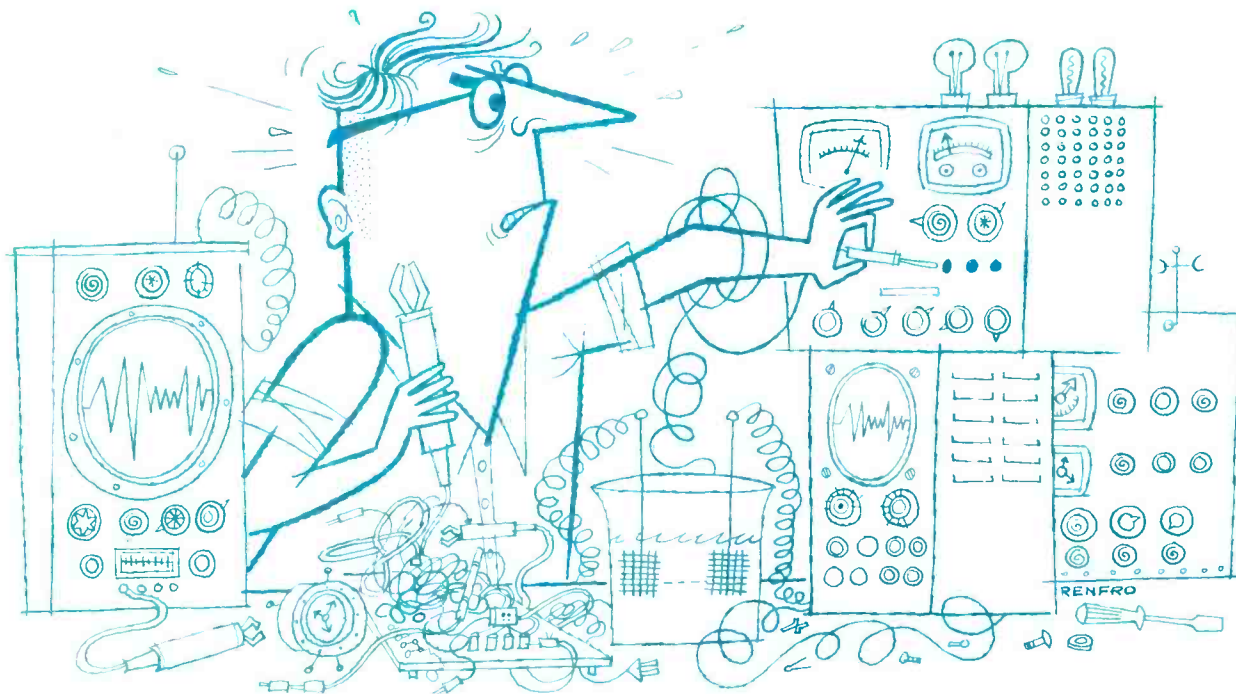

**New -hp- 711A Power Supply makes it easy to power experimental and bench setups**

**0-500 volts dc, 6.3 v ac**  
**High regulation**  
**Current, voltage meters**  
**Overload protection**  
**All-purpose utility**

The new -hp- 711A was developed to do just one thing—simplify your job of powering all kinds of electronic circuitry in laboratory, field and factory.

This compact (18 lbs.) instrument is ideal for driving low level amplifiers, constant frequency oscillators and similar jobs where highly stable voltage is essential. Voltage range is very broad—0 to 500 volts. No-load to full-load regulation is better than  $\pm 0.25\%$  or 0.5 volts. Ripple is less than 1 millivolt.

For added convenience, there are separate current and voltage meters with new push-button range switching for accurate measurement of small voltages and currents. Other features include overload protection and grounding on either positive or negative dc terminals. The price is \$225.

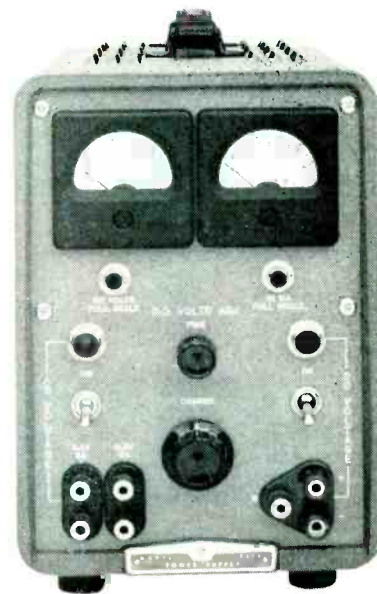

*Electronic instruments for complete coverage, quality, convenience*

## **HEWLETT-PACKARD COMPANY**

3332A PAGE MILL ROAD • PALO ALTO, CALIFORNIA, U.S.A.,

DAvenport 5-4451 • Cable "HEWPACK"

Field Representatives in all principal areas



AT HOME ANYWHERE . . .

# HUBBELL *Interlock*

TRADE MARK

automatic locking . . . quick disconnect plugs make Voltage Tap Panel more flexible on

## KLEINSCHMIDT TELEPRINTERS

Anywhere in the world Kleinschmidt Teleprinters are set up, they're completely at home! Designed to operate on alternating current, these modern teleprinter machines are quickly and easily adapted to use from 95 to 250 volts, simply by plugging the specially designed Interlock Angle Plugs into the proper receptacle on its voltage tap panel — an ideal arrangement when machines are moved from place to place.

While connected, Interlock plugs provide a constant, low resistance contact that cannot disconnect accidentally. A vibration and impact proof contact is made on two surfaces under constant coil spring pressure, which adjusts automatically with changes in pressure or temperature.



Rubber Insulated Type "A" Angle Plugs and Set-In Interlock Panel Jacks

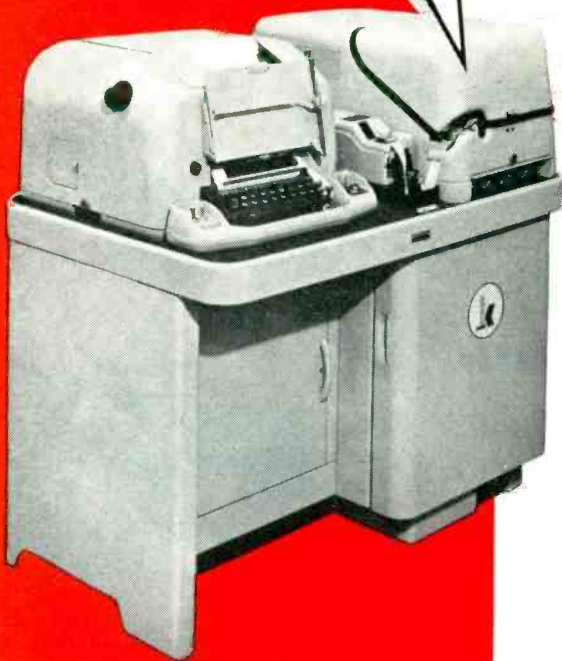

There is . . . or can be designed an  
**INTERLOCK CONNECTOR**  
For Every Wiring Problem



**Type "A" Plugs and Jacks** Insulated and Non-Insulated. Current Cap. — 10 amps., Wire Sizes #14 to #18

**Type "B" Plugs and Jacks** (Miniature) Insulated and Non-Insulated. Current Cap. — 5 amps. Wire Sizes #18 to #22



**Type "C" Plugs and Jacks** (Sub-miniature) Current Cap. — 1 ampere, Wire Sizes #20 to #22 or smaller



**Type "S" Plugs and Jacks**  
Current Cap. — 15 amps.  
Wire Sizes #14 to #18



**Type "S" 4 in 1 Test Prod Kit**  
(8 interchangeable test tips)



For Further Information, Write Dept. A:

**HARVEY HUBBELL, INC.**  
Interlock Electronic Connector Dept., Bridgeport 2, Conn.



Pats. & Pdg. Pats.



# new versatile data tape recorder

## THE MOBILE AMPEX 800

records the broadest combination of data ever obtained concurrently on one magnetic tape—performs with laboratory precision under severe field, airborne, shipboard and vehicular conditions—and furnishes data compatible with the most widely used playback equipment.

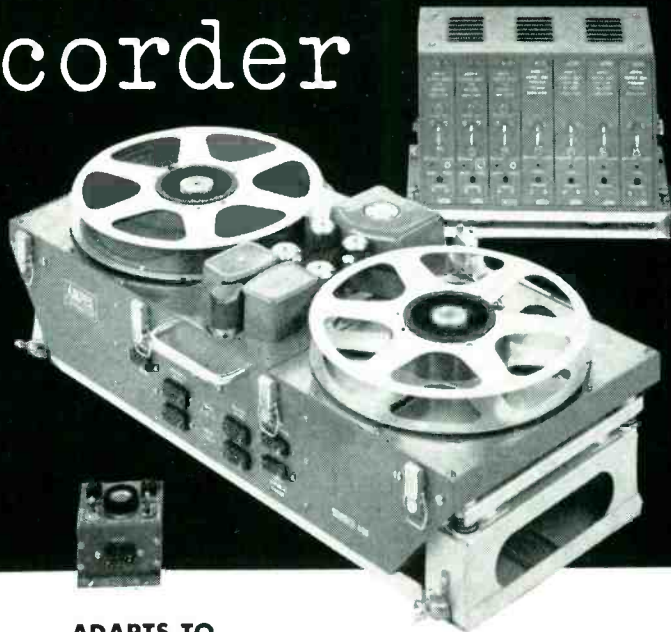

The Ampex 800 can provide from 1 to 28 data channels. By interchangeable amplifier units, each one can be adapted to any one of three basic magnetic recording techniques:



▨ **Direct recording** — 300 to 35,000-cycle response for wide-band data or multiple recording of RDB subcarriers.

▨ **FM-carrier type recording** — D.C. to 5000 cycles and high instantaneous accuracy suitable for shock and vibration data.

▨ **Pulse-width modulation recording** — Up to 90 instrument readings commutated on to each tape track with frequency response 0 to 2 cycles/sec. With fewer instrument readings, frequency response is greater.

## ADAPTS TO

**ANY DATA REQUIREMENT** The Ampex 800's three available recording techniques can satisfy practically any test requirement by simple insertion of the proper plug-in amplifiers. Separate channels can be assigned to measurements requiring wide-band response or high transient accuracy. And by using pulse-width techniques, many relatively steady instrument readings can be commutated on to a single channel. All will have a common time base.

## WITHSTANDS THE RIGORS OF AIRBORNE, SHIPBOARD, VEHICULAR AND GENERAL MOBILE USE

The Ampex 800 will perform within specifications under vibrational forces as high as 10G—operates over a temperature range from  $-65^{\circ}\text{F}$ . to  $130^{\circ}\text{F}$ .—is unaffected by altitudes to 50,000 feet—and withstands a relative humidity of 100% up to  $122^{\circ}\text{F}$ . The Ampex 800 is light in weight. It operates on 27.5 volts D.C. and 115 volts, 400 cycle, A.C. All operating functions can be remotely controlled.

## RETAINS WIDELY ESTABLISHED

**RECORDER STANDARDS** The majority of all magnetic recorders now in instrumentation use are Ampex machines. Their recording characteristics, tape speeds, track widths and other parameters have become standards. The Ampex 800 retains these while greatly extending the environmental and mechanical conditions under which accurate test data can be gathered.

Performance specifications, descriptions and explanations have necessarily been limited by the space on this page. A full description and detailed specifications on the Ampex 800 are available by writing Dept. E2338

**AMPEX**  
CORPORATION

## FIRST IN MAGNETIC TAPE INSTRUMENTATION

934 CHARTER STREET • REDWOOD CITY, CALIFORNIA

Branch Offices: New York; Chicago; Atlanta; San Francisco; Dayton; College Park, Maryland (Washington D.C. area)

Distributors: Radio Shack, Boston; Bing Crosby Enterprises, Los Angeles; Southwestern Engineering & Equipment, Dallas and Houston; Canadian General Electric Company, Canada

# FACTS YOU SHOULD KNOW ABOUT CELLULAR

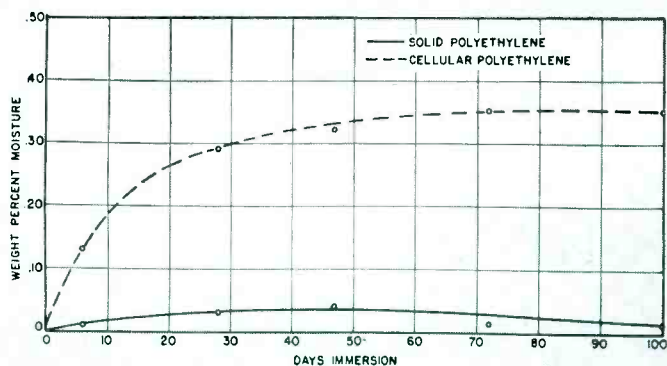

**1.** Moisture absorbed vs. days of immersion in tap water at 23 deg. C. Since BAKELITE Cellular Polyethylene is made up of hollow cells completely separated by walls of BAKELITE Polyethylene, its moisture absorption is low.

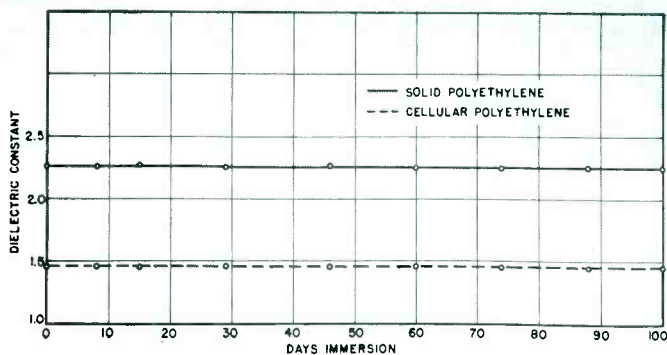

BAKELITE Brand Cellular Polyethylene for wire and cable insulation is a superior low-loss plastic that consists structurally of unconnected hollow cells. It is produced by the formulation of solid polyethylene with a foaming agent which, at the time of extrusion causes expansion to a cellular form. Properly extruded, the material will expand 100 per cent, giving a density about half that of solid polyethylene.

These are the principal advantages of BAKELITE Cellular Polyethylene for high-frequency electronic service:

- Low order of moisture absorption (Fig. 1).
- Lower dielectric constant than that of solid polyethylene (Fig. 2).
- Low power factor, comparable to that for solid polyethylene (Fig. 3).
- Dielectric constant directly related to density formulation, while power factor remains uniform (Fig. 4).
- Uniformly low power losses over a broad frequency range (Fig. 5).
- Minimal power losses over wide temperature range (Fig. 6).

For more information on the properties, fabrication, and use of BAKELITE Cellular Polyethylene, write Dept. ME-50.

**2.** Dielectric constant at 1 megacycle vs. days of immersion in tap water at 23 deg. C. Note that BAKELITE Cellular Polyethylene retains its dielectric constant—considerably lower than that of solid polyethylene—throughout long immersion periods. The lower dielectric constant results in insulated conductors with a lower capacitance per foot than when the solid material is used.

**3.** Power factor at 1 megacycle vs. days of immersion in tap water at 23 deg. C. Even after extended periods of water immersion, BAKELITE Cellular Polyethylene demonstrates a low power factor.

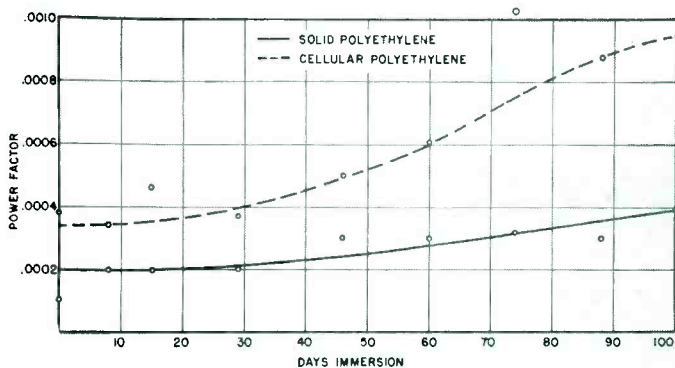



# POLYETHYLENE

## FOR WIRE AND CABLE INSULATION

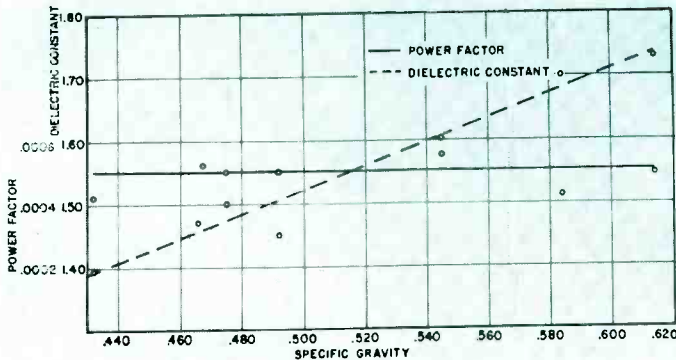

4. Power factor and dielectric constant at 1 megacycle vs. specific gravity. BAKELITE Polyethylene has a dielectric constant about midway between that of solid polyethylene (2.3) and that of the inert gas yielded by the blowing agent (1.0). Its value depends on the degree of expansion of the foam. The low power factor remains uniform.

5. Power factor and dielectric constant vs. frequency. Both the power factor and dielectric constant of BAKELITE Cellular Polyethylene are relatively unchanged over a broad frequency range, indicating that power losses will be uniformly low.

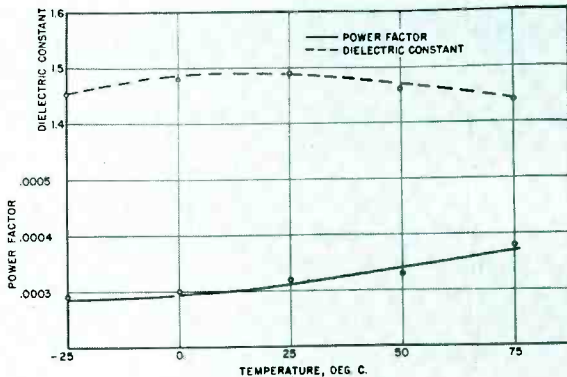
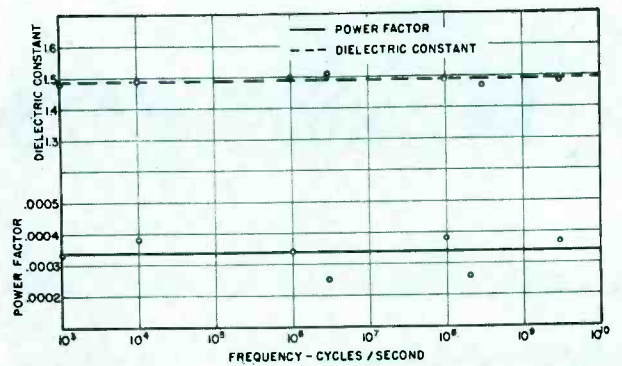

6. Power factor and dielectric constant at 1 megacycle vs. temperature. These properties of BAKELITE Cellular Polyethylene are consistent over a considerable operating temperature range, indicating minimal power losses due to seasonal variations.



**BAKELITE COMPANY**, A Division of Union Carbide and Carbon Corporation **UCC** 30 East 42nd Street, New York 17, N. Y.  
 In Canada: Bakelite Company, Division of Union Carbide Canada Limited, Belleville, Ontario  
 The term BAKELITE and the Trefoil Symbol are registered trade-marks of UCC

# The unfailing Dependability of BUSS FUSES . . .

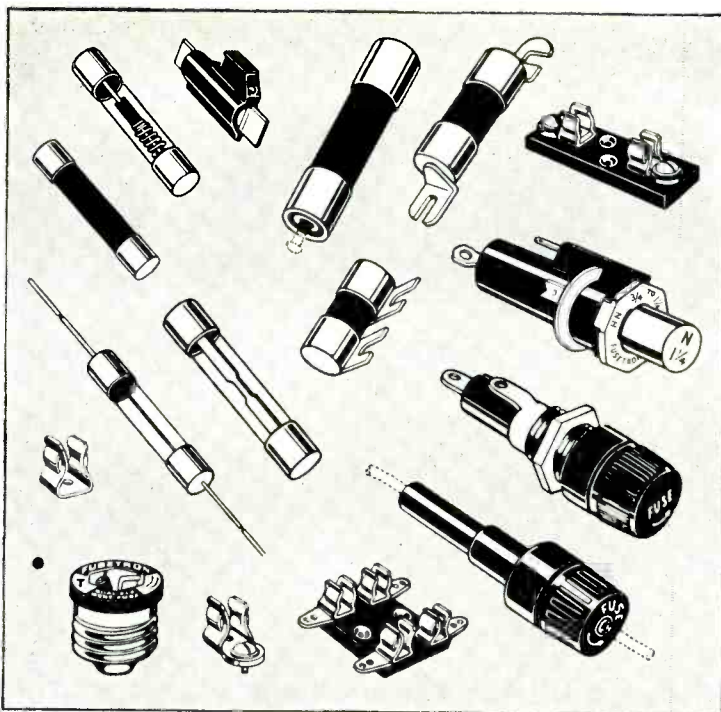

## helps you keep customers satisfied!

By operating properly under all service conditions — BUSS fuses can help safeguard the reputation of your product or service against loss of customer good will.

When there is an electrical fault — BUSS fuses open and prevent further damage to equipment, saving users the expense of replacing needlessly burned out parts.

And just as important, BUSS fuses won't give a false alarm by blowing when trouble doesn't exist. Useless shutdowns caused by poor quality fuses blowing needlessly are not only irritating to customers — but customers' confidence in your product or service could be jolted.

**Every BUSS fuse is electronically tested to assure "trouble-free" operation.**

Every BUSS fuse normally used by the Electronic Industries is electronically tested. A

sensitive device automatically rejects any fuse not correctly calibrated, properly constructed and right in all physical dimensions.

With a complete line of fuses, fuseholders and fuse blocks available — it is just good business to standardize on BUSS.

For more information on FUSETRON and BUSS small dimension fuses and fuseholders . . . Write for bulletin SFB.

*Makers of a complete line of fuses for home, farm, commercial, electronic, automotive and industrial use.*



**BUSSMANN MFG. CO.**  
(Division of McGraw Electric Co.)  
UNIVERSITY AT JEFFERSON  
ST. LOUIS 7, MO.

ELRC  
1255

**BUSS FUSES ARE MADE TO PROTECT  
— NOT TO BLOW**



which way\*  
to measure  
jet engine  
performance?

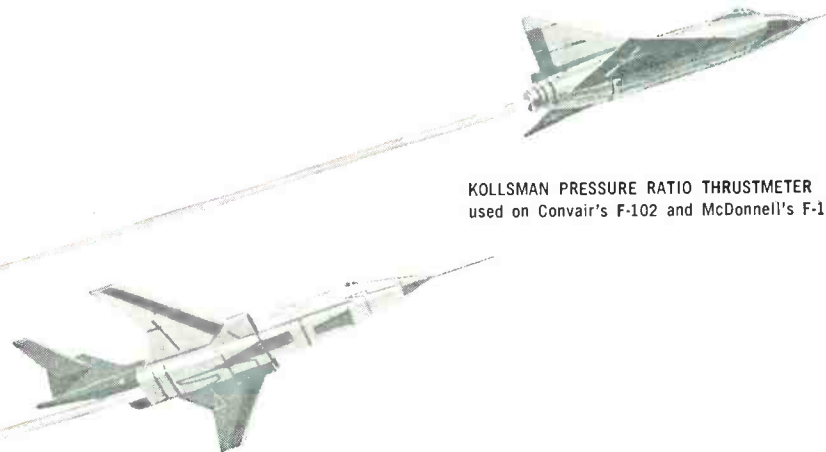

KOLLSMAN PRESSURE RATIO THRUSTMETER  
used on Convair's F-102 and McDonnell's F-101

# thrustmeters

to indicate PRESSURE RATIO...to indicate DIFFERENTIAL PRESSURE

**KOLLSMAN is in production...**  
on components for BOTH TYPES—for Remote or Direct reading

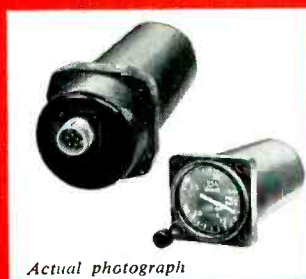

Actual photograph

#### TYPICAL SYSTEM OPERATIONAL DATA

1. Accuracy: .015 in 100% of readings at room temperature.  
.025 in 85% of readings at  $-55^{\circ}\text{C}$  and  $+70^{\circ}\text{C}$ .  
.035 in 15% of readings at  $-55^{\circ}\text{C}$  and  $+70^{\circ}\text{C}$ .
2. Altitude: No specific limitation.
3. Power: 115V, 400CPS, single phase, 18VA
4. Pressure Ratio Range: 1.2 to 3.4
5. Pressure Ranges (operating):  
 $P_{t_2}=2$  to 50" Hg. Abs.  
 $P_{t_7}=2.4$  to 100" Hg. Abs.  
 $P_{t_7}-P_{t_2}=0.4$  to 70" Hg.
6. Temperature Range:  $-55^{\circ}\text{C}$  to  $+120^{\circ}\text{C}$
7. Weights:  
Transmitter: 2.2 lbs.  
Indicator (including integral amplifier): 1.8 lb.
8. Response: Full Range in 7 seconds.

For over a quarter century, Kollsman has been making precision pressure sensitive mechanisms using displacement type diaphragms. This diaphragm can be called the heart of a thrustmeter pressure indicating system.

Our long experience making displacement type diaphragms guarantees reliable thrustmeters.

Proven Kollsman displacement type diaphragms, when fitted with Kollsman Synchrotels, comprise the transmitters for remote indicating types. Thousands of Synchrotels are now in use in other applications equally demanding of accuracy and durability.

Tailor-made Thrustmeters can be supplied for any engine-airplane combination. Write for complete technical information.

*\*The Pressure Ratio System has advantages for indicating optimum climb and cruise throttle setting, whereas the Pressure Differential System has a definite advantage at take-off.*

Kollsman activities cover these seven fields:

AIRCRAFT INSTRUMENTS • PRECISION CONTROLS  
PRECISION COMPUTERS AND COMPONENTS • OPTICAL COMPONENTS AND SYSTEMS  
RADIO COMMUNICATIONS AND NAVIGATION EQUIPMENT • MOTORS AND SYNCHROS  
INSTRUMENTS FOR SIMULATED FLIGHT TRAINERS



**kollsman** INSTRUMENT CORPORATION

80-10A 45th AVE., ELMHURST, NEW YORK • GLENDALE, CALIFORNIA • SUBSIDIARY OF *Standard* COIL PRODUCTS CO. INC.

# "Nothing can go wrong with Roto-Lock performance"

Says Elgin Metal Casket Company

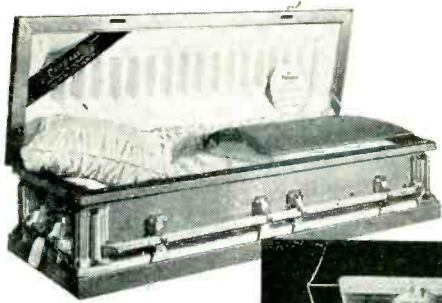

**Roto-Lock operation is simple:** Serrated, tapered cam engages latch — draws panels tightly together when turned by crank or other hand tool.

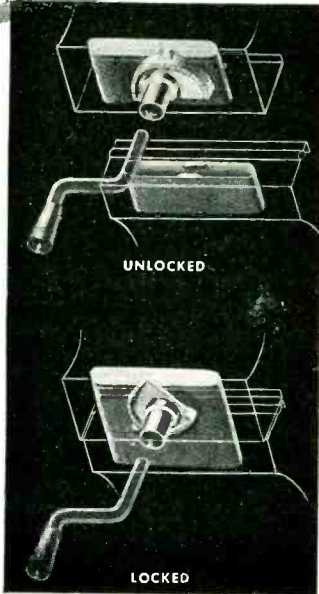

Simmons Roto-Lock Fasteners are used by Elgin Metal Casket Co., of Elgin, Illinois, to give its Permaseal Caskets a perfect hermetic seal against air and water. Drawn down with a pressure of up to 1500 lbs., Roto-Lock guarantees an absolutely tight seal and strength far beyond requirements.

President E. B. Stewart of Elgin says: "Roto-Lock worked out particularly well because of the simplicity of its construction, and the fact that it was a lock already in a housing which could readily be sealed. Functionally the lock is very good since it pulls the lid down with ease and is a quick-operating mechanism. In other words, *the locking and sealing operation can be accomplished quickly and easily in a matter of seconds.* Since the whole locking and sealing mechanism contains only one moving part, *there is nothing that can go wrong with the performance of the lock.* Of course, this is important since mal-function at a funeral service would be a serious matter."

## and there's a Roto-Lock application to improve your product

Roto-Lock, which makes butt or right-angle joints quickly, is finding wide application in portable shelters, air freight and cold storage shipping containers, walk-in coolers, demountable furniture and scaffolding. It fastens in any misaligned position and recesses completely into panels. *Wherever demountability is important, there's a Roto-Lock application.*

Write today for our 36-page catalog. It's filled with applications of Roto-Lock and Simmons' four other special fasteners engineered to improve products and reduce assembly costs.

**SIMMONS FASTENER CORPORATION**  
1750 N. Broadway, Albany 1, New York

# Simmons

QUICK-LOCK • SPRING-LOCK • ROTO-LOCK • LINK-LOCK • DUAL-LOCK

**FASTENERS WITH USES UNLIMITED**

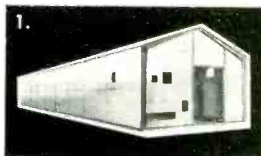

Some applications of Roto-Lock:



1. Portable Shelter
2. Partition
3. Demountable Refrigerator Unit
4. Demountable Desk

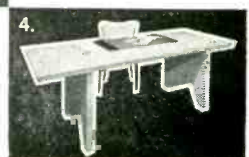
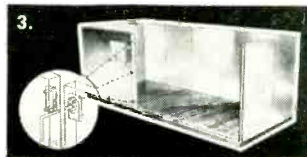



# MINIATURE CIRCUIT BREAKER

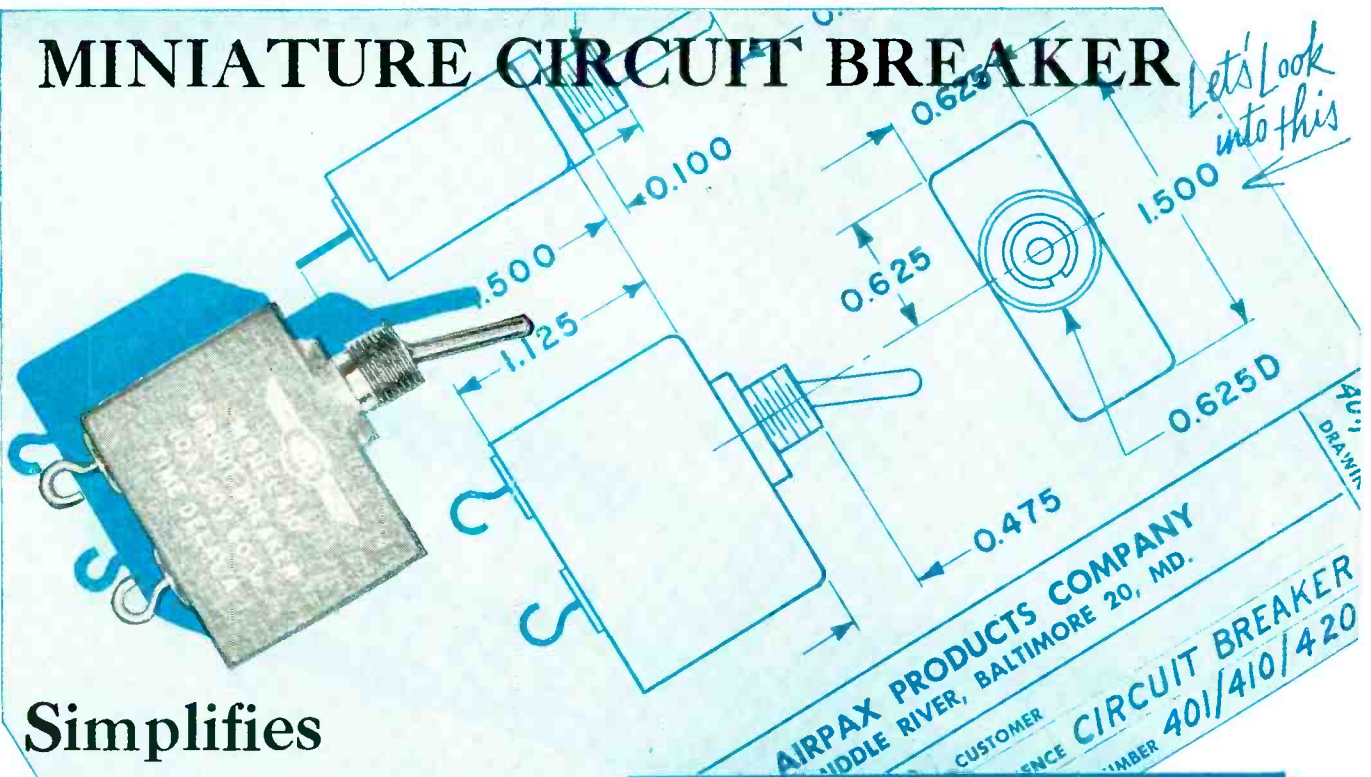

## Simplifies Circuit Design

You can now perform the *two* functions of power ON-OFF control and circuit protection with *one* miniature fully magnetic time-delay trip-free circuit breaker. Save space (see diagram above); save weight (weighs less than 2 oz). The characteristics (tabulated at right) of this new Airpax component show it to be a significant advance in power control; just what you need.

Handle has ON and OFF positions; it moves to OFF position when breaker trips, yet breaker cannot be prevented from tripping by holding handle in ON position. Stable tripping mechanism assures reliable operation even under adverse temperature and vibration. Give your equipment the protection it deserves.

To restore service after fault has been removed, simply reset the breaker. A breaker having a 30-sec time delay recovers full delay in about 20 sec.

To receive complete engineering data, simply write to

### CHARACTERISTICS

**RATINGS:** 0.05 amp to 10 amp at 50 V DC or 1.0 to 10 amp at 120 V AC

**MINIMUM TRIP:** 125% of rated load

**INSTANTANEOUS TRIP:** 1,000% of rated load

**INTERRUPTING CAPACITY:** a typical value is 500 amp at 30 V DC

**POWER CONSUMPTION:** 0.6 watt in lower current ratings, rising to about 2 watts at 10 amp rating

**SHOCK:** resists 50 g in all directions

**VIBRATION:** 10 to 55 CPS at 0.06 in. total excursion in all directions

**TEMPERATURE:** -40 C to +100 C

**LIFE:** 10,000 operations at rated current into resistive load

**ENCLOSURE:** hermetically sealed



ENGINEERS

DESIGNERS

MIDDLE RIVER

BALTIMORE 20, MD.

The greatest Names in British Electronics use

# Mullard TUBES



## Mullard

Electronic Tubes — used throughout the world

MULLARD OVERSEAS LTD., CENTURY HOUSE, SHAFTESBURY AVENUE, LONDON, ENGLAND.



*Mullard is the Trade Mark of Mullard Ltd. and is registered in most of the principal countries of the world*

British equipment manufacturers are making a vital contribution to the development of electronics in all fields of application.

Their products are being exported to every corner of the world, earning a universal reputation for advanced techniques and excellent performance.

The majority of these electronic equipment manufacturers consistently use Mullard tubes. This choice is decided upon because they prefer the greater assurance of efficiency and dependability, and because the vast manufacturing resources of the Mullard organisation guarantee ready availability of Mullard tubes wherever they are needed.

Supplies of Mullard tubes for replacement in British equipments are available from the companies mentioned below:—

**In the U.S.A.** International Electronics Corporation, Department E12, 81, Spring Street, N.Y. 12. New York, U.S.A.

**In Canada** Rogers Majestic Electronics Limited, Department ID, 11-9 Brentcliffe Road, Toronto 17, Ontario, Canada

MEV32





**ELECTRONIC DESIGN**  
PROPERTY AND APPLICATION DATA ON THESE  
VERSATILE ENGINEERING MATERIALS: "ZYTEL,"  
"ALATHON," "TEFLON," "LUCITE."

# NEWS

Better Things for Better Living  
... through Chemistry

## Interlock plugs insulated with ZYTEL® easily crimped for solderless connections

Interlock Type B plugs are now available with jackets of Du Pont "Zytel" nylon resin to prevent shocks and shorts. This insulation of "Zytel" protects the complete plug except contact points — allows plugging in or disconnecting with greater safety.

"Zytel" has excellent crimping properties — the terminal can be crimped tight enough for a good connection without any danger of the insulation cracking and exposing the live portion of the plug.

Use the coupon below for complete property information on this tough, durable insulating material — Du Pont "Zytel" nylon resin.

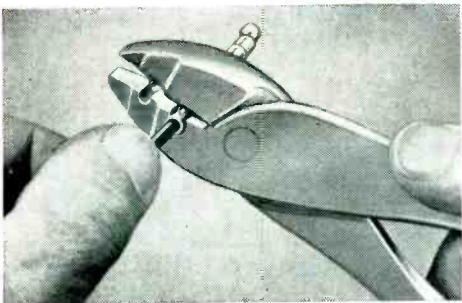

This interlock Type B plug insulated with Du Pont "Zytel" nylon resin can be easily crimped and has excellent dielectric properties. Plug manufactured by Harvey Hubbel, Inc., Bridgeport, Connecticut.

## Laminations of TEFLON® for printed circuit bases

Typical uses of glass-cloth laminations of "Teflon" tetrafluoroethylene resin include:

1. Conductor insulation, slot and phase insulation and slot wedges (motors and generators).
2. Conductors and ground insulation, coil separators and layer insulation (transformers).
3. Hookup wire, power cables, ignition wire.
4. Printed circuit bases.
5. Structural parts.

The laminations combine the dielectric properties, chemical inertness and heat resistance of "Teflon" with the tensile strength, resistance to cut-through, and resistance to creep of woven glass fiber.

An informative free bulletin describing the preparation and uses of laminations and impregnations of glass cloth employing "Teflon" is now available. Write for a copy of Bulletin X-64.

## Picture-tube shield of ALATHON® used in new RCA color-TV receiver

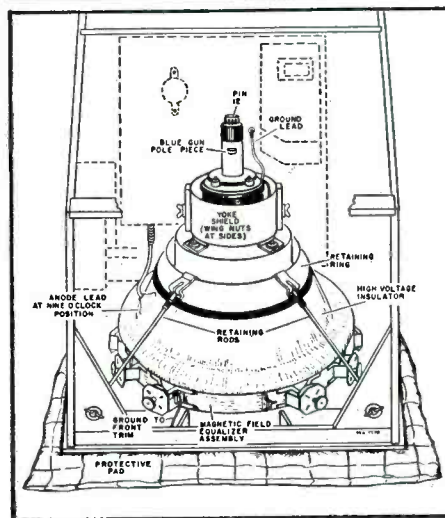

Shield of Du Pont "Alathon" serves as insulator for both the deflection yoke and kinescope retaining assembly on RCA Victor's new 21-inch color-TV set. (Kine shield molded of Du Pont "Alathon" polyethylene resin for RCA Victor by Sinko Manufacturing & Tool Co., Chicago, Ill.)

## ALATHON® has high dielectric strength, is strong and lightweight

The picture tube in the new RCA Victor color-television receiver operates at 25,000 volts. To provide insulation for this tube, RCA Victor engineers needed a material that could be readily and inexpensively molded into the complex shape of a kinescope shield . . . yet had high dielectric strength. Du Pont "Alathon" polyethylene resin proved to be an ideal material for the shield on all counts. In addition to providing the needed insulation, the shield of "Alathon" gives mechanical protection to the tube when it is shipped or handled.

"Alathon" not only has excellent insulating properties but is strong, lightweight and flexible. It is chemical-resistant, as well as odorless, tasteless and non-toxic. Because of these properties, and the ease with which parts can be molded, extruded or fabricated, "Alathon" has helped engineers solve many design and operating problems.

Get complete property and application data on "Alathon," and on the other Du Pont engineering materials. Each has unique properties suited to a wide range of cost-saving applications. Clip and mail the coupon below.

### NEED MORE INFORMATION?

CLIP THE COUPON for additional data on the properties and applications of these Du Pont engineering materials.

\*"Teflon," "Alathon," "Zytel" and "Lucite" are registered trade-marks of E. I. du Pont de Nemours & Co. (Inc.).

E. I. du Pont de Nemours & Co. (Inc.), Polychemicals Department  
Room 2212, Du Pont Building, Wilmington 98, Delaware  
In Canada: Du Pont Company of Canada Limited,  
P.O. Box 660, Montreal, Quebec.

Please send me more information on the Du Pont engineering materials checked:  "Zytel"\* nylon resin;  "Teflon"\* tetrafluoroethylene resin;  "Alathon"\* polyethylene resin;  "Lucite"\* acrylic resin. I am interested in evaluating these materials for \_\_\_\_\_

NAME \_\_\_\_\_  
COMPANY \_\_\_\_\_ POSITION \_\_\_\_\_  
STREET \_\_\_\_\_  
CITY \_\_\_\_\_ STATE \_\_\_\_\_  
TYPE OF BUSINESS \_\_\_\_\_

Radar

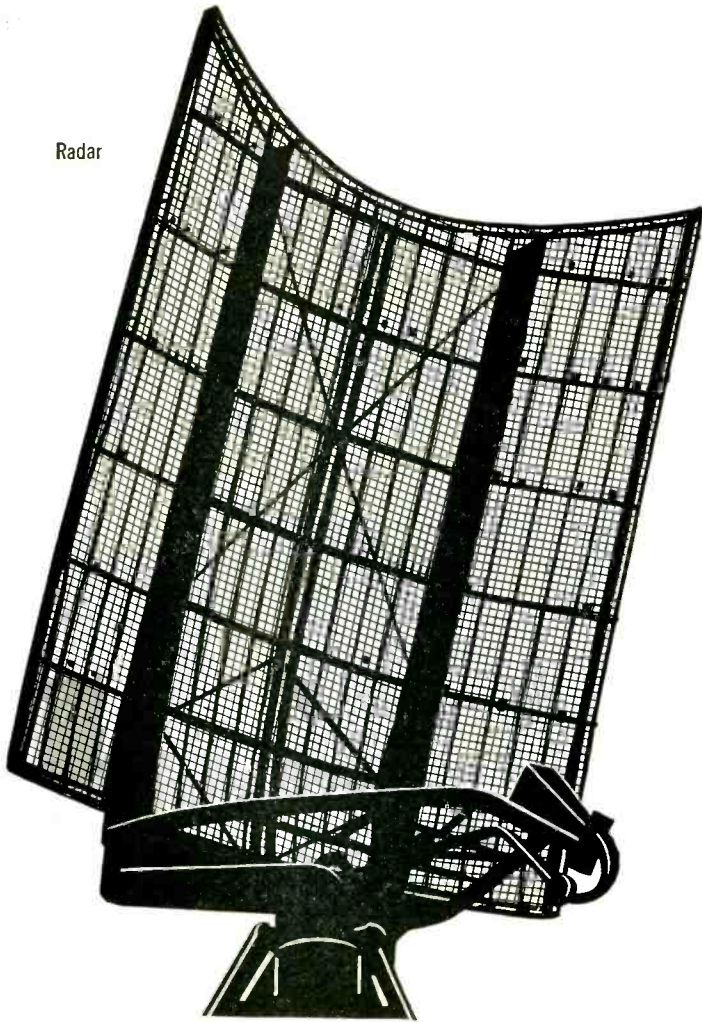

Navigation

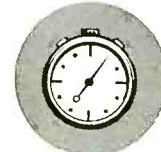

Timing



Nucleonics



Geophysics

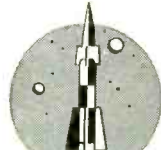

Ordnance

## PRECISION DIGITAL DELAY GENERATOR

FOR GENERAL-PURPOSE LABORATORY USE

Generates pulses accurately spaced in time with respect to an internally generated reference pulse—range 0 to 100,000 microseconds

Complete generality permits numerous and varied uses such as radar range calibration, target simulation, generation of secondary frequency standards, elapsed time measurements, phase measurements, etc. Fields of application include Radar, Navigation, Telemetry, Nuclear Studies, Computer Research, Geophysics, Ordnance, and any other fields in which timing is significant.

The ability to generate a specific delay at accurate variable repetition rates sets this instrument apart from any other pulse or delay generator in the field today. Write for full details.

Pulses can be supplied under either one-shot conditions or at variable repetition rates. Both pulse delay and repetition period can be established in increments as small as 1 microsecond.

The repetition period can also be externally triggered, in which case two inde-

pendently variable delayed pulses are available. Accuracy of both repetition period and pulse delay are held to one part in  $10^6$  by the thermostatically controlled crystal oscillator. The digital circuitry and the built-in self-checking features make continuous calibration unnecessary.

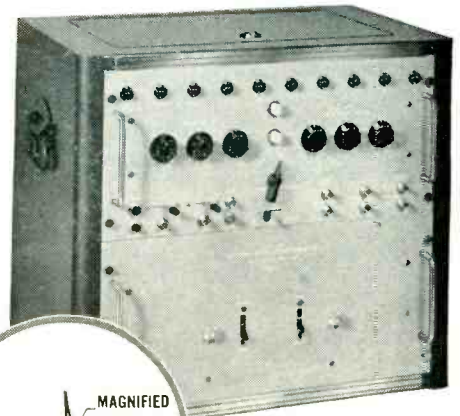

MODEL 743

Observed pulse as viewed on a suitable synchroscope

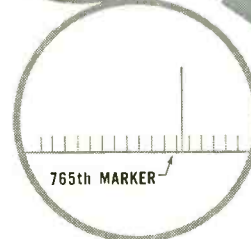
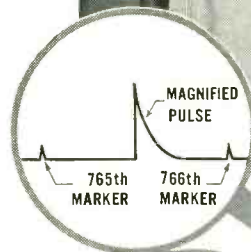

**KAISER METAL PRODUCTS, INC.**  
BRISTOL, PA.



# 8 Dependable Solutions TO HERMETIC SEALING PROBLEMS...

## E-I HERMETICALLY-SEALED TERMINALS AND MINIATURE CLOSURES



**MULTIPLE HEADERS**—Vacuum tight, cushioned glass construction. Strain-free, tin dipped for easy soldering and silicone treated for maximum dielectric strength.



**SEALED TERMINALS**—Featuring cushioned glass construction, high thermal shock resistance. Available in economical preferred types and special designs.



**END SEALS**—For condensers, resistors and other tubular components. Completely strain-free and provide a permanent hermetic seal. Standardized, economical types.



**COMPRESSION TYPE HEADERS**—Super rugged, absolutely rigid, practically indestructible multiple headers. Exclusive E-I development offers greatly increased resistance to shock and vibration.



**OCTAL HEADERS**—Plug-in and multiple types. Feature new principle of hermetic sealing. Solid metal blanks assure maximum mechanical strength and rigidity.



**TRANSISTOR CLOSURES**—For transistors and other components requiring hermetic sealing. Available in standard types or custom design to specifications. Cases supplied round, rectangular or square.



**LUG-TYPE, LEAD-THRU INSULATORS**—For "bath tub" condensers, transformers, other applications requiring voltage ratings from 2000 to 4000 (rms.). Compression sealed, super rugged. Inside or outside mounting.



**COLOR-CODED TERMINALS**—Feature glass inserts in standard, easily identified RMA color codes. Coloring is in the glass.

**New Catalogs on Request**—Illustrated literature on any of the above is available without obligation. Call or write for new bulletins, today!

**E-I... HEAD-QUARTERS FOR HERMETICALLY-SEALED MULTIPLE HEADERS, OCTAL PLUG-INS, TERMINALS, COLOR CODED TERMINALS, END SEALS**

\*PATENT PENDING  
ALL RIGHTS RESERVED



DIVISION OF AMPEREX  
ELECTRONICS CORPORATION

## ELECTRICAL INDUSTRIES

44 SUMMER AVENUE, NEWARK 4, NEW JERSEY

# ADVANCED DESIGN OF NEW FEATURES METAL-

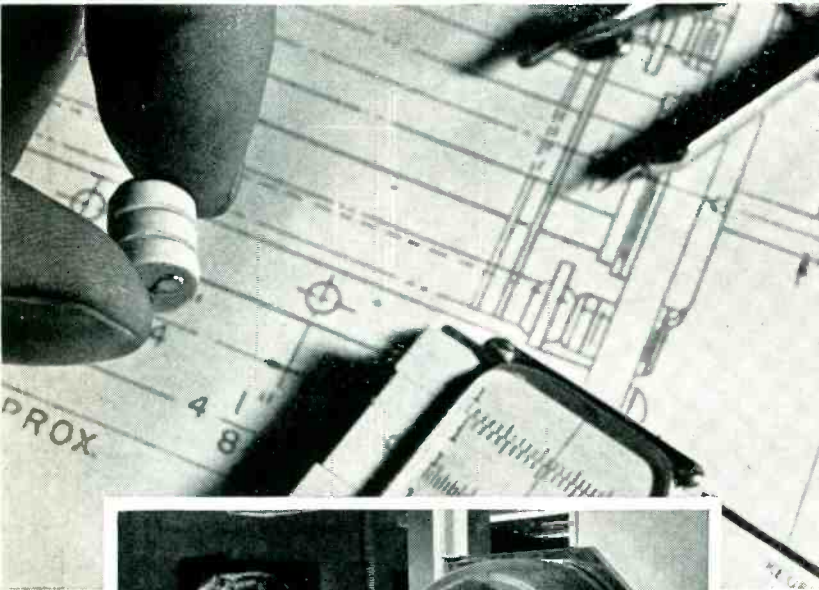

**Above:** metal parts for G-E micro-miniatures are fired in a high-vacuum furnace. Titanium is employed—this substance has the unique advantage of freeing virtually all its own gases when fired to 700 C. Result of using pre-fired titanium parts: there is no subsequent vacuum contamination from metal-liberated gases when tubes operate at high temperatures. Instead, titanium serves as a gas absorber!

**Right:** in an operation calling for utmost delicacy, the tube's cathode disc is fitted into the support cylinder. Note rubber finger cots on the fingers holding the tiny cylinder! Changed hourly, these finger cots help ward off dirt and moisture—are worn when handling all micro-miniature tube parts, to keep the parts scrupulously clean. Other G-E aids to cleanliness are air-pressuring, air-conditioning, and lint-free Nylon and Daeron uniforms.

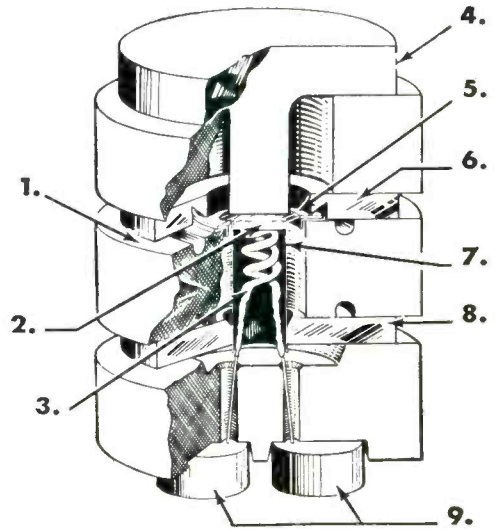

**ONLY 3/8" HIGH! THE 6BY4 IS G.E.'S ULTRA-COMPACT NEW METAL-CERAMIC R-F AMPLIFIER TRIODE FOR UHF-VHF TV TUNERS.**

Installs in a fraction of the space required by other tuner tubes—yet out-performs them! At 900 mc operation with 10 mc bandwidth, new tube has the low noise factor of approx 8 db, and a power gain of approx 15 db. Filament and plate voltages, 6.3 v and 200 v . . . amplification factor, 100. The metal-ceramic, parallel-plane design as illustrated in the cutaway, gives the new 6BY4 short electron transit time and an extremely low r-f loss; also high structural rigidity. In type 6BY4 this rigidity is employed to attain minimum microphonics rather than maximum tube resistance to shocks and vibration, since TV circuits do not undergo the same physical hazards as military and commercial airborne and mobile equipment.

- |                         |              |                     |
|-------------------------|--------------|---------------------|
| 1. Reference plane      | 4. Anode     | 7. Support cylinder |
| 2. Oxide-coated cathode | 5. Grid      | 8. Cathode ring     |
| 3. Heater               | 6. Grid ring | 9. Heater buttons   |

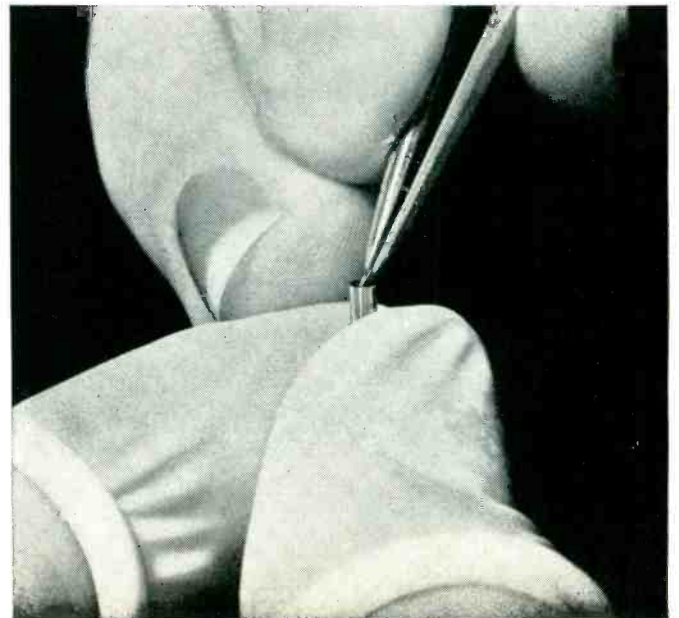



# G-E MICRO-MINIATURE TUBES CERAMIC CONSTRUCTION

Heat-resistant! Micro-miniatures will operate up to 500 C!

The new G-E tubes withstand shocks and vibration; have high gain, minimum noise.

Breaking sharply with traditional concepts of tube design, G-E micro-miniatures are as new as the era of advanced electronic performance that lies directly ahead.

In structure, these extremely small, rugged tubes show a straightforward engineering approach to high electrical efficiency. The materials of tomorrow are used to achieve full-rating operation at high temperatures, with no sacrifice of service life or tube dependability.

Type 6BY4—tuner triode designed expressly for TV, no bigger than a pencil-eraser, amazingly

low in microphonics—is the first of an outstanding new series of metal-ceramic micro-miniatures by General Electric. Designers of electronic equipment can meet new, exacting, commercial and military requirements by means of micro-miniature tubes—space-saving, virtually heat-proof.

Ask for full information! If your design problem is one calling for tube analysis . . . if your new circuit needs a special high-performance tube type—G-E tube engineers will be glad to consult with you. *Tube Department, General Electric Company, Schenectady 5, New York.*

Tube grids are carefully micro-inspected. High-power lenses give the necessary magnification to check G-E micro-miniature grids—for the 6BY4, wire only  $3/10,000$  inch in diameter, wound 1,000 times per inch! Special equipment, new techniques are used at every stage of micro-miniature assembly and inspection. These mark the highest precision standards attained in receiving-tube manufacture. ▼

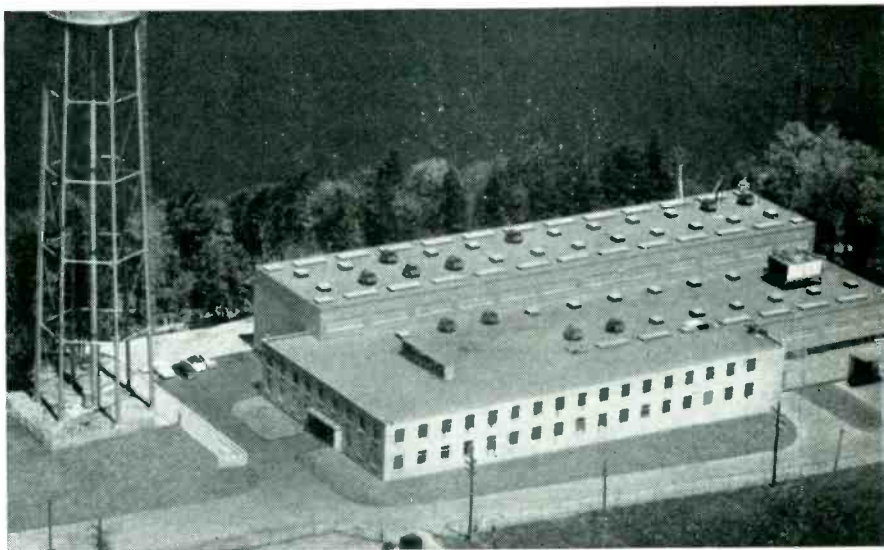
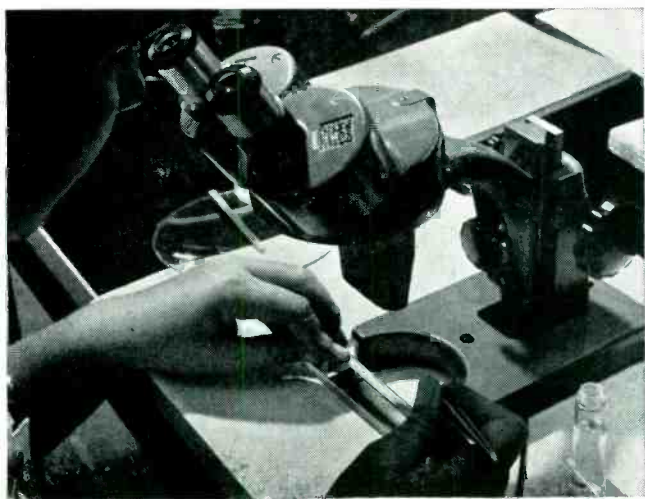

Importance of metal-ceramic research in the development of electronic tubes and other products, is accented by this new, separate Metals and Ceramics Building at the General Electric Research Laboratory, Schenectady, N. Y. Here G-E scientists, research engineers, and skilled workers investigate and measure metal and ceramic properties and performance under every possible condition that will be encountered. ▲

*Progress Is Our Most Important Product*

GENERAL  ELECTRIC

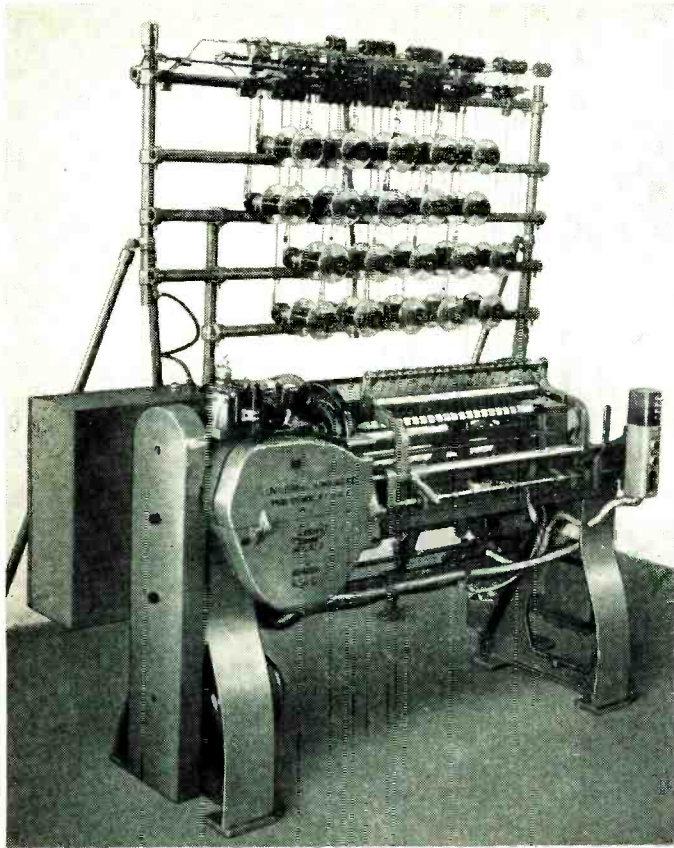

**Fully Automatic.** The Leesona No. 107 Automatic-Feed Coil Winder provides the quickest, easiest way to wind paper-insulated coils accurately. Winds four to thirty coils in stick form simultaneously. Safely handles wire sizes from No. 19 to No. 42 (B&S). Electronic drive assures a slow, smooth start that minimizes breakage when winding fine wires.

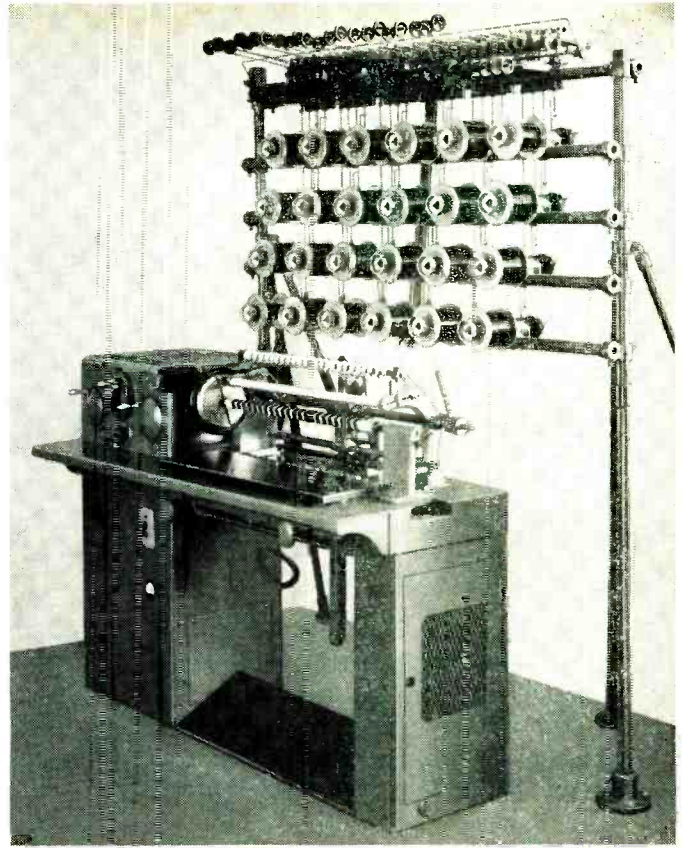

**Meets Many Needs.** The Leesona No. 108 Coil Winder is the most efficient and economical hand-feed coil winder ever designed. Winds four to thirty paper-insulated coils in stick form simultaneously. Reduces set-up time and cuts winding time and costs on long or short runs, for a wide variety of coils.

*Now...Get the modern, cost-cutting coil winders  
you need...with one of the two*

## Leesona Pay-As-You-Profit Plans

Here's how many forward-looking plants are now meeting competition on even terms — or better.

They're eliminating the financial waste caused by obsolete or insufficient coil winding machinery. They're cutting operating and maintenance costs, and boosting production rates, with up-to-the-minute Leesona Coil Winders — secured through one of Universal's two famous Pay-As-You-Profit Plans.

These Plans provide the economies of modern coil winding production, while safeguarding your cash,

capital position and borrowing power. Take your choice of:

- I. *Leesona Long-Term Purchase Plan*
- II. *Leesona Long-Term Lease Plan*

One of these Plans may be your long-sought answer to a major production problem — may enable you to make immediate operating cost cuts, while improving your competitive position. Investigate this fast, simplified, practical financing. For information about the Pay-As-You-Profit Plan that best meets your needs, contact your Universal Representative or write direct.

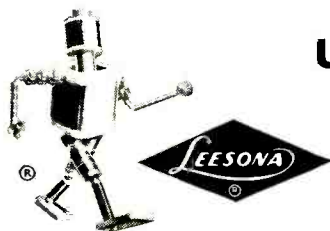

### UNIVERSAL WINDING COMPANY

P. O. BOX 1605, PROVIDENCE 1, RHODE ISLAND, Dept. 212

E. G. PAULES & COMPANY, 1762 West Vernon Avenue, Los Angeles, California  
Western Representatives

W. J. WESTAWAY & COMPANY, LIMITED, Montreal & Hamilton, Canada  
Canadian Representatives

UNIVERSAL WINDING COMPANY, 9 South Clinton Street, Chicago, Illinois

UNIVERSAL WINDING COMPANY, 1500 Walnut Street, Philadelphia, Pennsylvania



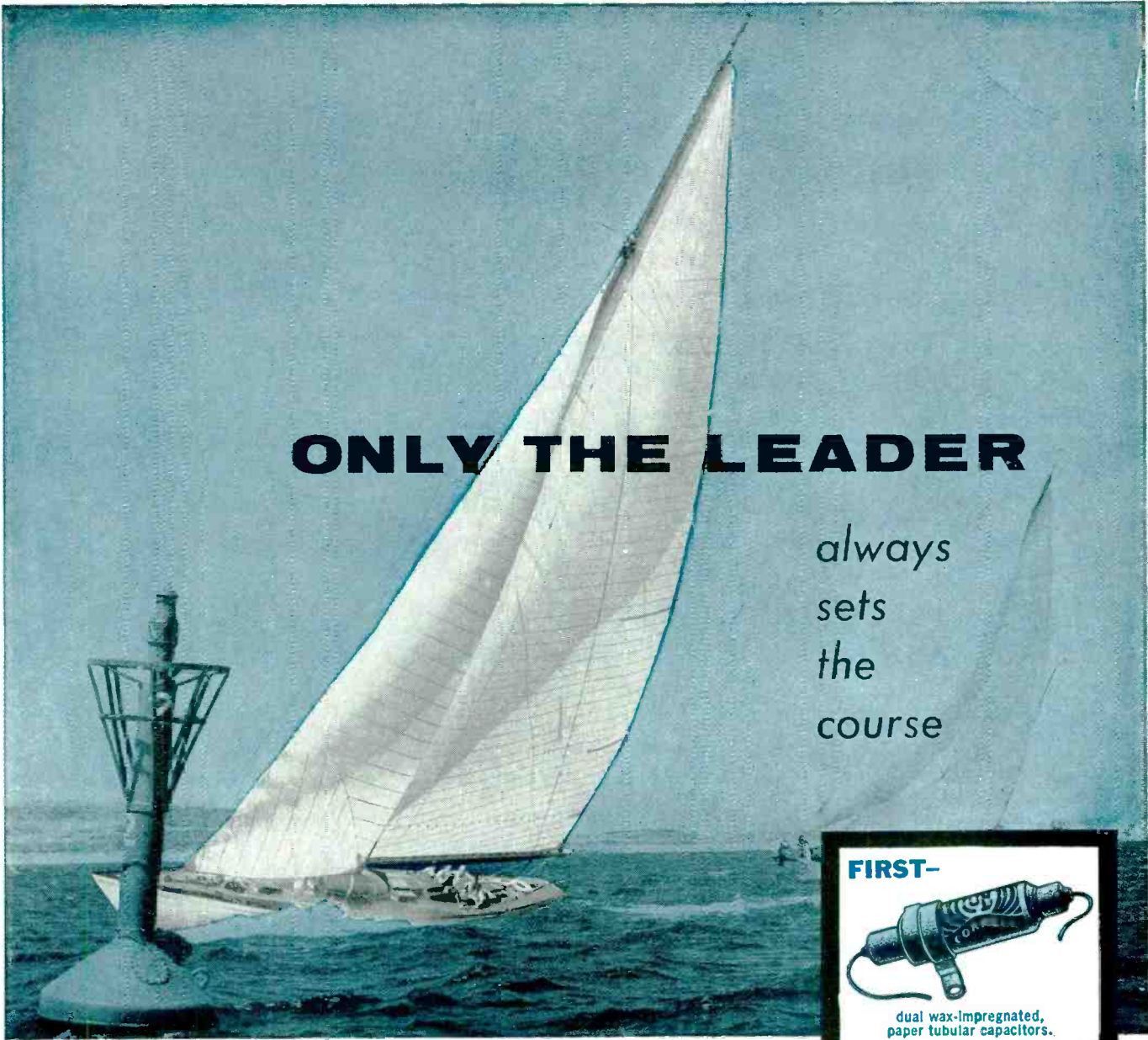

# ONLY THE LEADER

always  
sets  
the  
course

**FIRST-**



dual wax-impregnated,  
paper tubular capacitors.

**FIRST-**



low voltage dry  
electrolytic capacitors.

## C·D...45 YEARS OF FAMOUS FIRSTS

Typical of these "famous firsts" are the three examples shown here . . . proof that whatever your capacitor requirements may be, your needs can be filled by C-D. Write to Cornell-Dubilier Electric Corp., Dept. K-125, South Plainfields, N. J.

**FIRST-**



capacitor used in proximity fuse.

# CONSISTENTLY DEPENDABLE CORNELL-DUBILIER CAPACITORS



PLANTS IN SO. PLAINFIELD, N. J.; NEW BEDFORD, WORCESTER AND CAMBRIDGE, MASS.; PROVIDENCE AND HOPE VALLEY, R. I.; INDIANAPOLIS, IND.; SANFORD AND FUGUAY SPRINGS, N. C.; SUBSIDIARY, RADIART CORP., CLEVELAND, OHIO.

THERE ARE MORE C·D CAPACITORS IN USE TODAY THAN ANY OTHER MAKE

**ELIMINATE  
UNNECESSARY  
OWNERSHIP**

**PRESERVE  
PROFITS**

**MAINTAIN  
WORKING  
CAPITAL**

**YOU CAN HAVE THE MICROWAVE  
EQUIPMENT YOU NEED...RIGHT NOW!**

**LEASE IT!**

Now, Polarad with a unique Lease Plan in electronics industry gives you the use of the microwave test equipment you need right now—without the burdens of ownership.

Management officials charged with financial responsibilities will appreciate the many advantages of leasing at a time when profits are small and corporate taxes are high. And, in the Polarad Lease Plan they will find many opportunities to preserve working capital hitherto impossible

under normal fixed asset purchasing . . . Companies dealing in contract work can bid more competitively by reducing test facilities costs, because of the Polarad Lease Plan.

Profits may be preserved by the tax advantages inherent in a rental expense as opposed to a long term depreciation write-off. Write today for complete details of this plan. Polarad will be happy to review your individual requirements, and if necessary modify the plan to your needs.

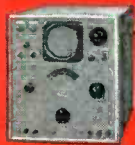

**TSA SPECTRUM  
ANALYZERS**  
10 to 44,000 MC



**MODEL R MICROWAVE  
RECEIVERS**  
950 to 11,260 MC



**MODEL B MULTIPLE  
PULSE SIGNAL  
GENERATOR**  
950 to 10,750 MC

**Partial Listing of POLARAD MICROWAVE Test Equipment  
Available on Lease Plan:**

- Signal Generators 950 MC to 39.7 KMC
- Signal Sources 650 MC to 50 KMC
- Spectrum Analyzers 10 MC to 44 KMC
- Multiple Pulse Signal Generators 950 MC to 10.75 KMC
- Microwave Receiver 1000 MC to 10.75 KMC
- Micro Power Meters DC to 11,000 MC
- Klystron Tube Testers
- Klystron Power Supplies
- Stark Modulators
- The complete line of color and B & W TV equipment.

**FIELD MAINTENANCE SERVICE THROUGHOUT THE COUNTRY**

**POLARAD Equipment Saves  
Engineering Manhours**



**ELECTRONICS CORPORATION**

43-20 34th STREET, LONG ISLAND 1, N. Y.

**REPRESENTATIVES** • Albuquerque • Atlanta • Baltimore • Boston • Buffalo • Chicago • Dayton • Englewood • Fort Worth • Los Angeles • New York  
Philadelphia • San Francisco • Syracuse • Washington, D.C. • Westbury • Winston-Salem • Canada, Arnprior, Toronto—Export: Rocke International Corporation



# FREE TO ELECTRONIC ENGINEERS & DESIGNERS

**A new Superior Tube catalog gives complete facts on cathodes, anodes, grid cups—their characteristics, uses, variety**

For the first time, Superior Tube Company puts all the basic data on its broad line of cathodes and other vacuum tube components into a single catalog. The new CATHALOYS are fully described. Easy-to-read tables give dimensions and tolerances on all standard cathode types, plus detailed chemical and physical properties on 23 different alloys. If you design vacuum tubes or electronic equipment using fabricated tubular parts, don't fail to send for this complete new catalog from Superior Tube Company—world's leading independent supplier of cathodes to the electronics industry.

\*Manufactured under U.S. Patents. †TM Reg. U.S. Pat. Off., Superior Tube Co.  
NOTE. Cathaloy is a trademark of Superior Tube Co., Reg. U.S. Pat. Off.

# Superior Tube

**The big name in small tubing**

All analyses .010" to 3/4" O.D.  
Certain analyses in light walls up to 2 1/2" O.D.



## HOW YOU CAN USE THIS CATALOG



**WHICH ALLOY.** Complete descriptions of Superior Tube alloys make it easier for you to make the right selection.

**WHICH TYPE.** Tabulated dimensional information given on seamless, Lockseam\*, and WELDRAWT cathodes.



**ANY KIND OF TUBE.** Section covers receiving tubes, cathode ray tubes, transmitter tubes, other tubing applications.



**SALES POLICY.** Detailed explanation simplifies ordering procedure for you, and shortens your procurement cycle.

## SEND FOR YOUR COPY

Use this handy coupon or write

Superior Tube Company  
2500 Germantown Ave., Norristown, Pa.  
Yes, I want a copy of your new Electronics Catalog #50

Name \_\_\_\_\_ Title \_\_\_\_\_

Department \_\_\_\_\_

Company \_\_\_\_\_

Street \_\_\_\_\_

City \_\_\_\_\_ Zone \_\_\_\_\_ State \_\_\_\_\_



OFFERS MORE TYPES OF 1%

## Deposited Carbon

Here's 1% accuracy in an extremely stable non-wire wound resistor at a price low enough to permit its use wherever the characteristics of composition carbon resistors are not fully suited. IRC's unmatched experience in producing film type resistors has led directly to the superior reliability and stability of IRC Deposited Carbons. Outstanding characteristics include load, environmental and age stability and ability to operate at higher temperatures than MIL specification requirements, low wattage coefficient, and low capacitive and inductive reactance in high frequency applications.

3 SMALL SIZES—DCC 1/2 WATT  
DCF 1 WATT and DCH 2 WATTS

MEET ALL REQUIREMENTS OF  
MIL-R-10509A SPECIFICATION

Wherever the Circuit Says

### Subsidiaries :

Circuit Instruments Inc., St. Petersburg, Fla. • Hycor Company, Los Angeles, Calif. and Vega Baja, Puerto Rico • IRCAL Industries, Los Angeles, Calif.

## Molded Deposited Carbon

Molded Deposited Carbon resistors are now available from IRC in 3 sizes: Types MDA—1/8 watt, MDB—1/4 watt and MDC—1/2 watt. The molded plastic housing provides complete mechanical protection, minimizes the effect of moisture and improves load life characteristics. These 1% precision film type units exceed MIL-R-10509A specifications.

COMPARISON SURFACE TEMPERATURE RISE VS. LOAD  
Molded vs. Unmolded Deposited Carbon Resistors

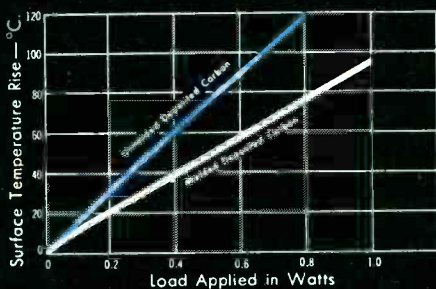

## Boron Carbon

Where a high degree of accuracy under widely varying temperatures is required, IRC Boron Carbons offer an ideal combination of characteristics. Their superior temperature stability is provided in 3 sizes: Types BOC—1/2 watt, BOF—1 watt and BOH—2 watts—all 1% accuracy. Considering weight, size and cost factors, plus lower capacitive and inductive reactance, these film type precision resistors can satisfactorily replace wire wounds.

IRC TYPE	BOC	BOF	BOH
Equivalent MIL Style	RN 20R	RN 25R	RN 30R
Wattage (40°C. Ambient)	1/2	1	2
Max. Continuous Voltage	350 V.	500 V.	750 V.
Minimum Ohms	10	20	30
Maximum Ohms (IRC)	0.5 meg	2.0 meg	5.0 meg

makes them all... can recommend without bias...



# TOLERANCE RESISTORS than any supplier in the industry



## Molded Boron Carbon

Only from IRC can you obtain Boron Carbon resistors with the protection of a *molded* plastic housing. Any risk of mechanical damage to the coating or of insulation breakdown is overcome. Any need for special handling is eliminated, and moisture and load life characteristics are improved. 3 sizes—Types MBA 1/8 watt, MBB 1/4 watt and MBC 1/2 watt—all exceed MIL-R-10509A specifications.

### TYPICAL TEMPERATURE COEFFICIENT

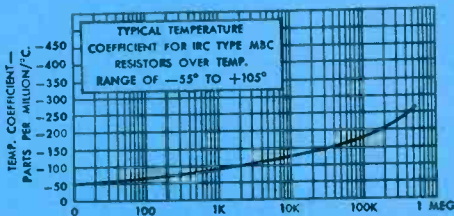

**MANY COMBINATIONS OF CHARACTERISTICS AND OPPORTUNITIES FOR COST REDUCTION ARE INVOLVED WHEN SPECIFYING CLOSE TOLERANCE RESISTORS. NO OTHER SINGLE SOURCE CAN OFFER YOU THE SCOPE OF TECHNICAL GUIDANCE AVAILABLE FROM IRC.**

*use coupon for complete data!*

**In Canada:**

International Resistance Co., Ltd., Toronto, Licensee



## Wire Wound

IRC's winding skills and automatic assembly equipment provide precision windings to exacting standards. Continuous inspections at every stage of manufacture assure maximum reliability in each finished resistor. IRC Mil Type precision wire wounds meet all requirements of MIL-R-93A specification. In addition to 6 Mil sizes, IRC supplies tiny Type WW10J—1 1/2 x 3/32". Standard tolerance  $\pm 1\%$ ; minimum tolerances are shown below.

Minimum Tolerances

Resistance	IRC MIL TYPES	TYPE WW10J
10 ohms & up	0.1%	
5 ohms & up	1.25%	
1 ohm & up	0.5%	
1500 ohms & up		0.1%
200 ohms & up		0.25%
65 ohms & up		0.5%



## Encapsulated Wire Wound

Tru-Mite encapsulated wire wound precision resistors are produced to IRC's high standards by its West Coast subsidiary, IRCAL INDUSTRIES. Available in 11 sizes and axial lead or lug types. Standard tolerance  $\pm 1\%$ ; also  $\pm 1/2$ ,  $1/4$ ,  $1/10$  and  $1/20\%$  tolerances can be supplied. Tru-Mite core material is the same epoxy resin as is used for the embedment. This eliminates the normal effects of temperature and moisture. Tru-Mite resistors exceed MIL-R-93A specifications.

## INTERNATIONAL RESISTANCE COMPANY

Dept. 373, 401 N. Broad St., Philadelphia 8, Pa.

SEND ME TECHNICAL BULLETINS ON—

- Deposited Carbons  
 Molded Deposited Carbons  
 Boron Carbons  Molded Boron Carbons  
 Wire Wound Precisions  IRCAL Tru-Mites

Name \_\_\_\_\_

Company \_\_\_\_\_

Address \_\_\_\_\_

City \_\_\_\_\_ State \_\_\_\_\_



## INCOMPARABLE Frequency Stability...

### for Airborne X-Band Radar Receivers

**Now — at a New Low Cost** — Varian announces the rugged VA-203 . . . most advanced reflex klystron ever developed for airborne radar and beacon local oscillator service. The exclusive brazed-on external tuning cavity provides frequency stability obtainable in no other klystron. This construction provides outstanding stability during shock, vibration and temperature cycling . . . takes punishing 50 to 100 G shocks and provides absolutely reliable operation at high altitude WITHOUT pressurization.

**For Super-Rugged Service** (Shocks to 250G) . . . Varian offers the VA-201 klystron. This tube is equipped with integral molded silastic leads, is similar to the VA-203 and performs with the same absolute reliability.

#### All these exclusive Varian features . . .

- ★ Unique brazed-on external tuning cavity assures exceptional frequency stability.
- ★ Reliable operation at low voltage and from poorly regulated power supplies.
- ★ Negligible microphonics.
- ★ Slow tuning rate . . . long tuning life . . . single shaft tuner adapts easily to motor tuning.
- ★ Withstands 50 to 100 G shocks (up to 250 G's for the VA-201)
- ★ VA-203 weighs less than 4 ounces. Both tubes mate directly to standard waveguide flanges.

GUARANTEED SPECIFICATIONS		
8500 to 9600 mc	VA-203	VA-201
Resonator Voltage	300 V	250 V
Heater Voltage	6.3 V	6.3 V
Heater Current	0.45 Amp	1.2 Amp
Power Output	20mW, Min	15mW, Min
Electronic Tuning Range	30 Mc, Min	30 Mc, Min
Vibration FM at 10 G	1 Mc, p-p, Max	0.2 Mc, p-p, Max

GET COMPLETE TECHNICAL DATA and specifications on the outstanding new VA-203 and its companion VA-201 . . . finest klystrons made for airborne radar. Write to our Applications Engineering Department today.

THE  
MARK OF  
LEADERSHIP

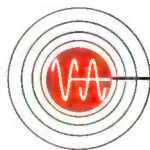

**VARIAN associates**

PALO ALTO 1, CALIFORNIA

Representatives in all principal cities

KLYSTRONS, TRAVELING WAVE TUBES, BACKWARD WAVE OSCILLATORS, R.F. SPECTROMETERS, MAGNETS, STALOS, U.H.F. WATERLOADS, MICROWAVE SYSTEM COMPONENTS, RESEARCH AND DEVELOPMENT SERVICES



by PYRAMID  
for ANY  
climatic condition

### Pyramid Type CT Ceramic Case Tubular Paper Capacitors

The Pyramid version of the CT capacitor has been particularly engineered to be adaptable to any customer's requirements. Particular emphasis has been placed on resistance of Pyramid's CT's to high humidity; withstand 20 cycles of the RETMA humidity test. Non-inductive extended foil section assembly in the highest grade ceramic (steatite) tube. Tinned leads are firmly imbedded and the unit is permanently sealed against moisture or humidity. End seals cannot soften or melt even at more than 85°C operating temperature.

Burton Browne/  
New York

For full information on available ratings and sizes request catalog J-8 or send details on your particular applications to



Sales Engineering Department, Capacitor Division

**PYRAMID ELECTRIC COMPANY**

1445 Hudson Blvd., North Bergen, N. J.



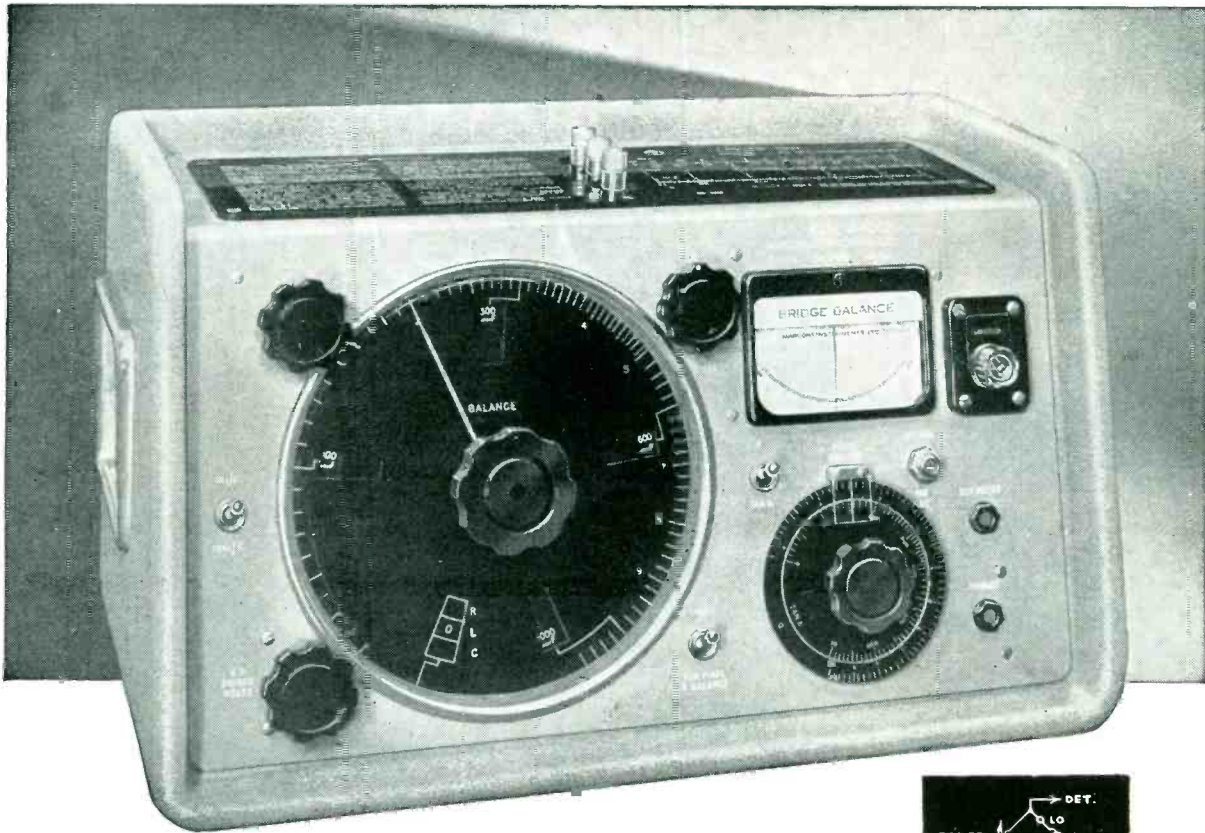

**ACCURATELY MEASURED**

- L** - AT 1 OR 10 kc
- C** - AT 1 OR 10 kc
- R** - AT D.C.

INDUCTANCE, CAPACITANCE, RESISTANCE and power factor measured quickly and accurately on this self-contained and robust instrument. Its industrial-designed appearance fits well in modern surroundings and partners its outstanding electrical performance.

**UNIVERSAL BRIDGE TYPE TF 868/I**

Inductance from  $1\mu\text{H}$  to  $100\text{H}$ , Capacitance from  $1\mu\text{F}$  to  $100\mu\text{F}$ , and Resistance from  $0.1\Omega$  to  $10\text{M}\Omega$ .

Single direct reading L.C.R. dial — no multiplying factors involved.

Continuously variable a.c. bridge voltage and automatic detector sensitivity control.

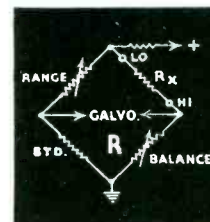
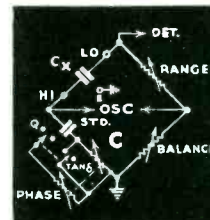
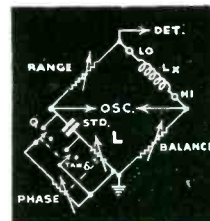

**MARCONI INSTRUMENTS**

44 NEW STREET · NEW YORK 4

CANADA: CANADIAN MARCONI CO., MARCONI BUILDING, 2442 TRENTON AVENUE, MONTREAL  
 ENGLAND: Head Office: MARCONI INSTRUMENTS LIMITED, ST. ALBANS, HERTFORDSHIRE

Managing Agents in Export: MARCONI'S WIRELESS TELEGRAPH COMPANY LIMITED, MARCONI HOUSE, STRAND, LONDON, W.C.2



CLIFTON PRECISION'S

**NEW 8**

SIZE

**SYNCHROS**

ACTUAL SIZE



*Available in all Types!*

**ACCURACY 7 MINUTES · WEIGHT 32 GMS.**

Function	Type Number	Primary Element	Excitation Voltage 400 cy.	Input Current (ma.)	Input Power (Watts)	Primary Impedance Secondary Open (Phase)	Primary Resistance (line)	Secondary Element	Output Voltage	Secondary Impedance Primary Open (Phase)	Secondary Impedance Primary Shorted	Secondary Resistance (line)	Phase Shift Degrees	Sensitivity mv./deg.	Accuracy Minutes Max.
Transmitter	CGC-8-A-7	Rotor 3 Phase	26	100	50	54+ j260	37.0	Stator 3 Phase	11.8	12+ j45	15+ j3.5	11.8	8	200	7
Control Transformer	CTC-8-A-1	Stator 3 Phase	11.8	90	.230	28+ j110	24.7	Rotor 1 Phase	23.6	220+ j740	246+ j60	143	8.5	400	7
Control Transformer	CTC-8-A-4	Stator 3 Phase	11.8	37	.091	67+ j270	59.5	Rotor 1 Phase	24	508+ j1680	640+ j190	381	9.2	400	7
Resolver	CSC-8-A-1	Stator 2 Phase	11.8	84	.268	38+ j136	27.0	Rotor 2 Phase	23.2	280+ j600	344+ j75	230	11	400	7
		Rotor 2 Phase	26	39	.430	280+ j600	230	Stator 2 Phase	10.6	38+ j136	70+ j29	27.0	20	180	7
Repeater	CRC-8-A-1	Rotor 1 Phase	26	100	50	54+ j260	37.0	Stator 3 Phase	11.8	12+ j45	15+ j3.5	11.8	8	200	30**
Differential	CDC-8-A-1	Stator 3 Phase	11.8	85	.21	27+ j120	25.0	Rotor 3 Phase	11.8	38+ j122	47+ j14	36	9	200	7 Rotor 7 Stator

Total Null max. 20mv for each unit

Also available in 115v 400 cy. primary, 90v secondary Transmitters, C.T.'s, Receivers

\*Torque 2600 mg.-mm./degree from CGC-8-A-7

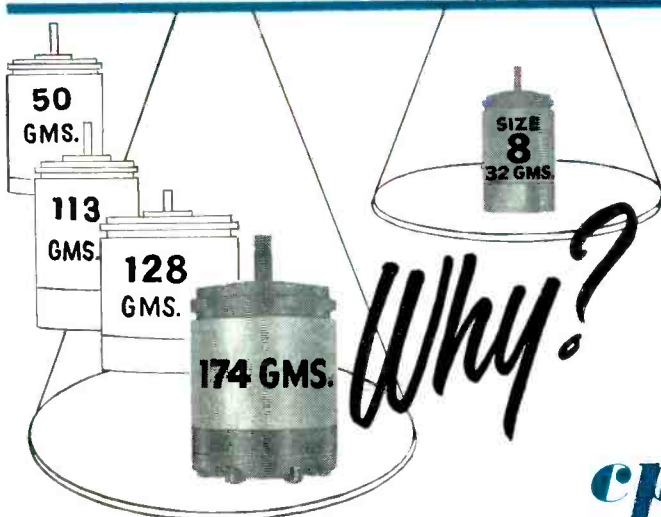

**WHY USE 1945 SYNCHROS IN 1956 DESIGNS ?**

Clifton's new Size 8's can take the place of larger units at very significant saving in bulk and *weight*.

These new Size 8's are now in use in some of the latest and *lightest* avionic equipment. In equipment which must be flown, why load on extra weight ?

Samples are available from stock, quantities from the production line.

LOOK TO CPCC FOR SYNCHRO PROGRESS



**CLIFTON PRECISION PRODUCTS COMPANY INC.**

**CLIFTON HEIGHTS**

**PENNSYLVANIA**

*Get in touch  
with Budd-Stanley*

## **FOR WAVEGUIDE AND MICROWAVE TRANSMISSION EQUIPMENT**

- • production skill and experience.
- • unique manufacturing methods to meet unusual specifications.
- • unexcelled facilities from model shop to assembly line.
- • transmission lines and associated elements manufactured and tested to your specifications.

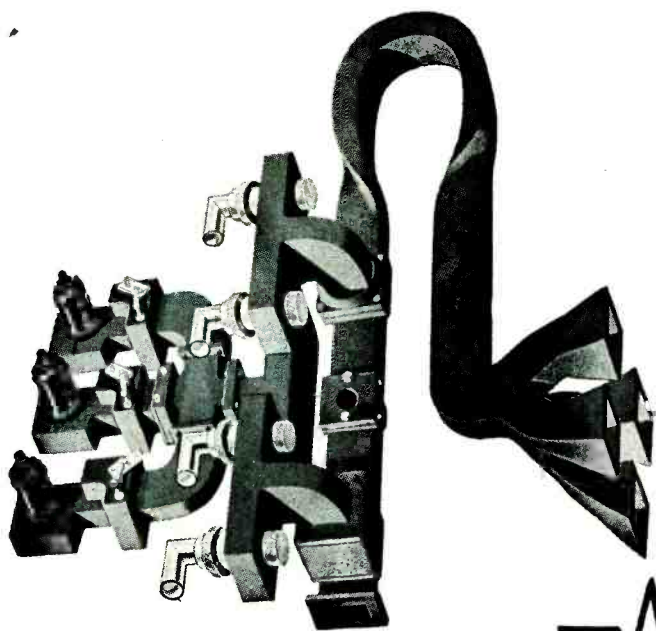

*Quality  
Economy  
Dependability*



*Write, wire or phone*

**BUDD-STANLEY CO. INC.**

43-01 22nd St., LONG ISLAND CITY 1, N. Y.

• Phone STillwell 6-1706

• Cable Address "BUDDSTAN"



*this photograph*

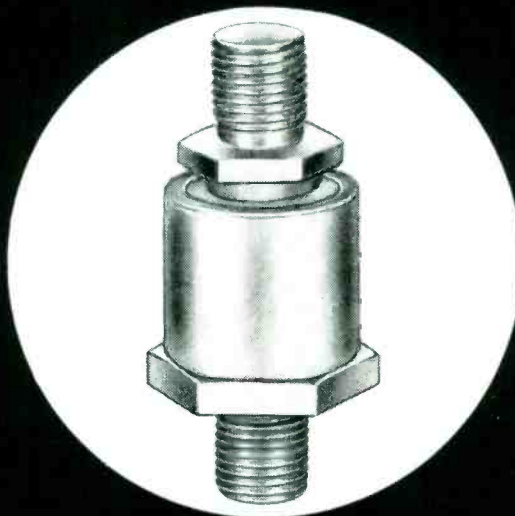

*is actual size*

**a silicon  
power rectifier  
with an overall dimension  
of only two inches that will  
operate at currents in excess of  
50 amperes  
and in ambient temperatures up to 200°C  
with suitable derating**

National Semiconductor's new silicon power rectifier is designed to provide high power output and reliability in the extremely high temperature ranges.

The rectifier is housed in a rugged, shock and vibration resistant case measuring only 1 1/8" diameter and 1 1/4" high. Including threaded mounting studs, the unit measures approximately two inches. Total weight is 4 ounces. The light weight, compact design and stable peak inverse voltage characteristics at high temperatures makes this unit especially adaptable for use in supersonic aircraft and guided missiles.

Write for your copy of detailed operating characteristics

**→ NATIONAL SEMICONDUCTOR PRODUCTS**

930 Pitner Avenue, Evanston, Illinois Phone: Davis 8-0800

A Division of **Hoffman**  
ELECTRONICS CORPORATION





CAPACITORS

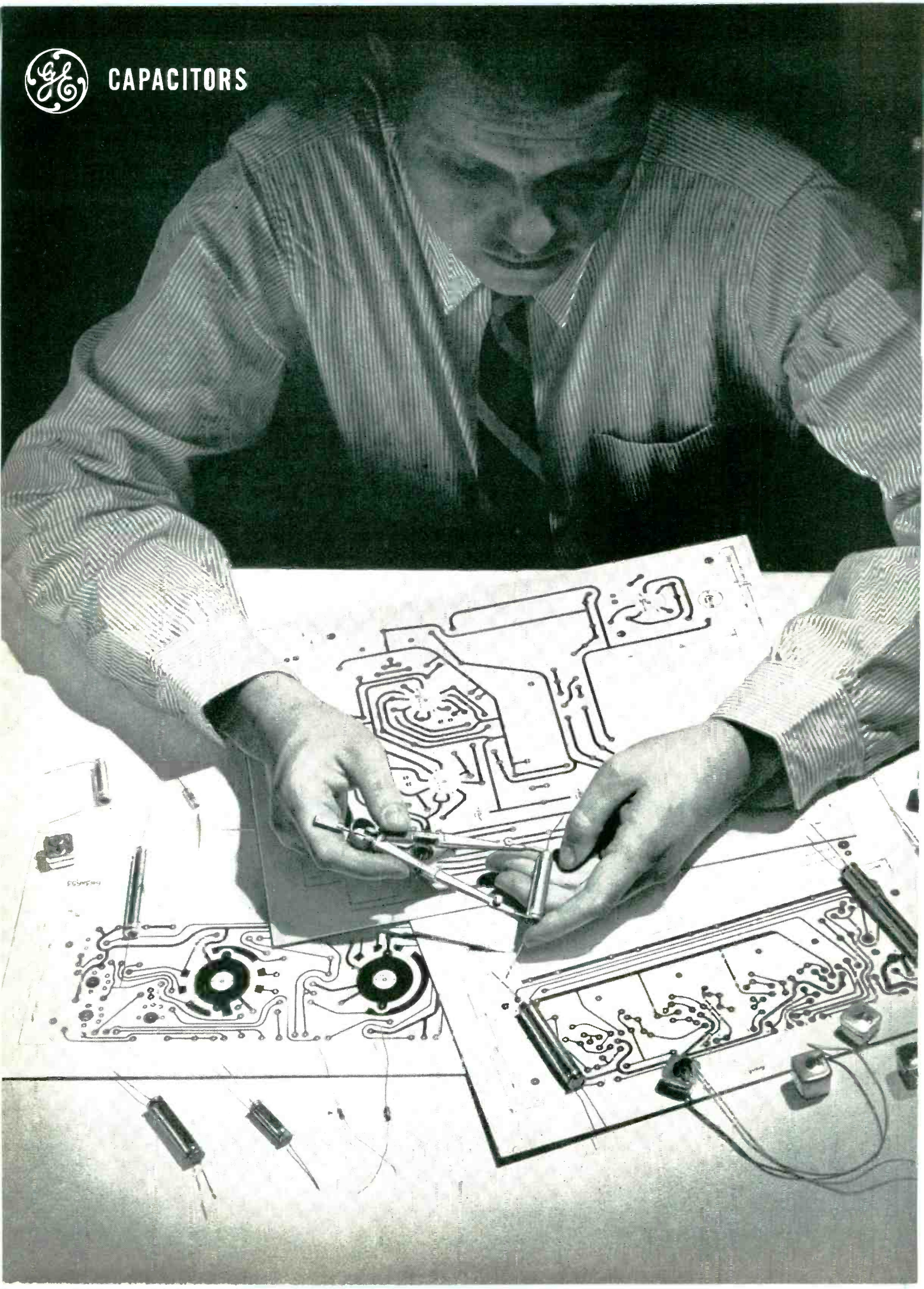



# How G-E Tantalytic\* Capacitors help solve your critical design problems

Three separate lines of G-E tantalum electrolytic capacitors to meet your size and temperature needs

No matter what capacitor problems you face in your most critical electronic applications, you're almost sure to find an answer in the three proven lines of Tantalytic capacitors now offered by General Electric.

**Is size your problem?** G-E Tantalytic capacitors carry extremely high uf ratings per cubic centimeter, especially in the 0-150 VDC range. In some ratings, Tantalytic capacitors are actually less than 1% the size of comparably rated paper capacitors.

**Is high reliability your problem?** Where small size and high reliability are "musts," as they are in communications equipment for example, G-E Tantalytic capacitors meet the challenge. Their high quality assures long, more reliable operation—at a real saving in circuit space.

**Is high temperature your problem?** For extremely high ambient temperatures, as found in

high-speed aircraft and guided missile applications, you can count on G-E high-temperature Tantalytic capacitors. They operate at full rated voltage from -55C to +125C. Rectangular and tubular designs are available to meet the varying requirements of modern electronic design.

**General Electric engineers** have accumulated a wealth of life test and other data through a long period of testing tantalum capacitors under every conceivable condition of operation. As a result, G-E Tantalytic capacitors may be relied upon for mechanical and electrical stability and maximum efficiency in operation.

Let your G-E Apparatus Sales Representative show you how these capacitors can answer your particular problems. Or, if you would like further information (ratings and specifications) on G-E Tantalytic capacitors write directly to the General Electric Company, Section 442-30, Schenectady 5, N. Y.

\*Reg. trade-mark of General Electric Co.

*Progress Is Our Most Important Product*

GENERAL  ELECTRIC

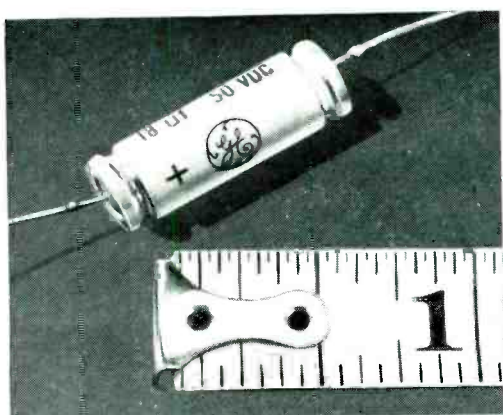

**85 C TANTALYTIC CAPACITORS** for circuits requiring low leakage current, long shelf life. Available in polar or non-polar types for a-c and d-c. Ratings 0.25-580 uf, 3.75-150 v. Tol.  $\pm 20\%$  (plain foil), -15 to +75% (etched). Temp. range -55 to +85 C. Write for Bulletins GEC-808 and GET-2333.

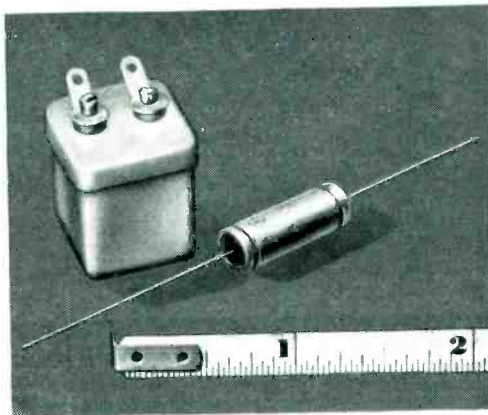

**125 C TANTALYTIC CAPACITORS** for high-speed aircraft and guided missile electronic systems where quality, long life, small size are main requirements. Available in plain or etched foil, in rectangular or tubular designs. Ratings 0.25-180 uf, 10-100 v. Tol.  $\pm 20\%$  (plain foil), -15 to +75% (etched). Temp. range -55 to +125 C. Write for Bulletins GEA-6258, GET-2502, and GET-2513.

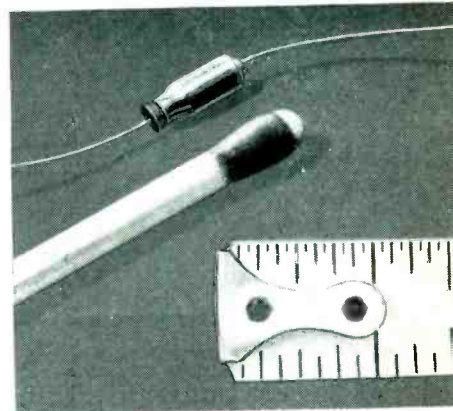

**MICRO-MINIATURE TANTALYTIC** capacitors for low-voltage d-c, transistorized electronic equipment such as hearing aids, pocket radios. Ratings 1-8 uf at 4 VDC, 1 uf at 8 VDC, 0.5 uf at 16 VDC. Tolerance -0 to +200%. Temperature range -20 to +50 C. Bulletins GEA-6065 and GET-2405.

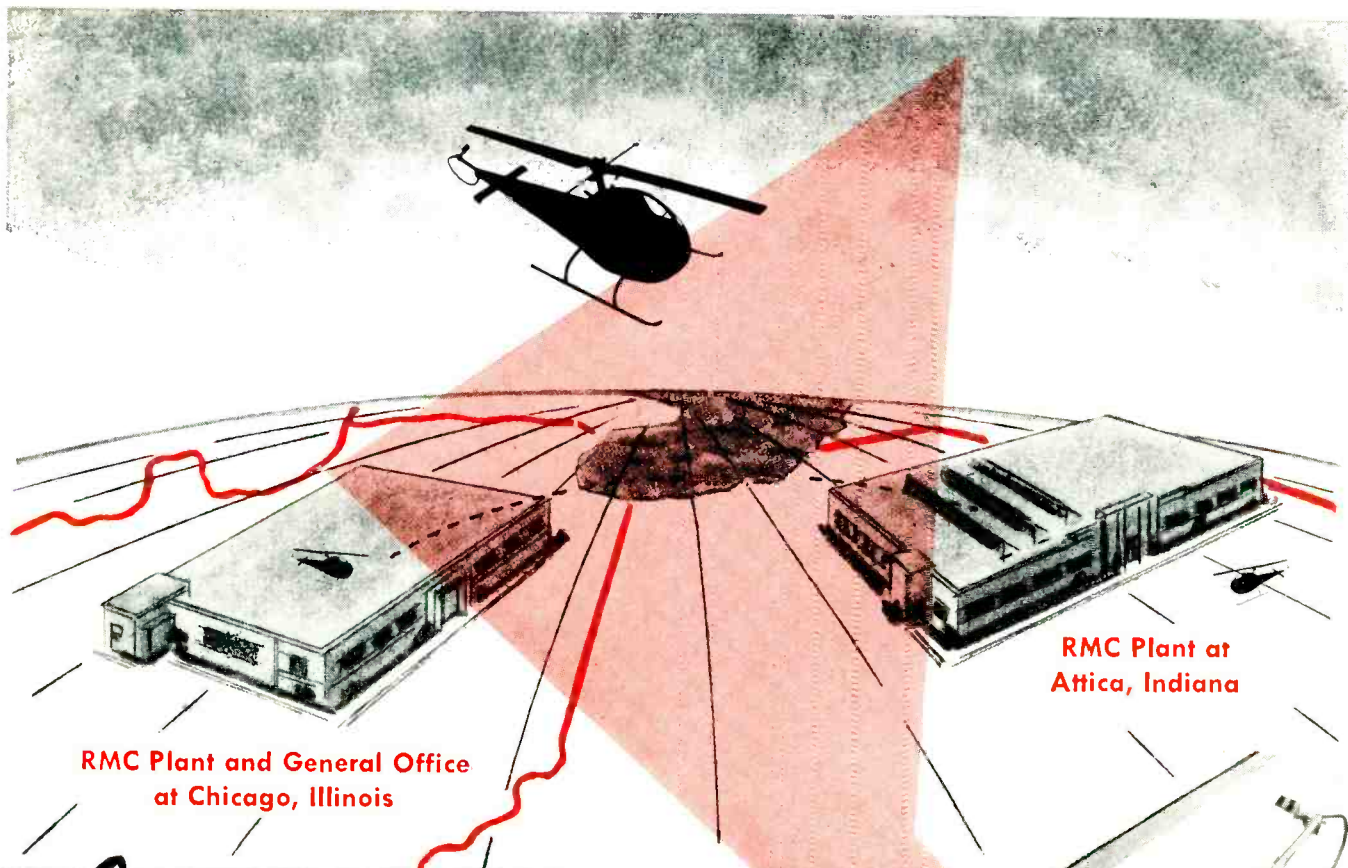

# Another RMC First!

## Plant to Plant Helicopter Service

The tempo of RMC service has always been geared to the needs of important customer production schedules. Now RMC's modern manufacturing facilities at Chicago, Illinois and Attica, Indiana are provided with fast, dependable helicopter flights, enabling executive and engineering personnel to travel door to door in slightly more than one hour as compared to a previous four hours.

The new Bell 47H helicopter makes regular flights unhampered by weather and traffic. RMC is the first in the electronics industry to use this new mode of travel.

Now you, as an RMC customer, are assured of even faster service on your production and engineering requirements.

If you are now using any type of ceramic capacitor in the manufacture of your products, it will pay you to investigate DISCAPS...and the many other advantages offered by RMC.

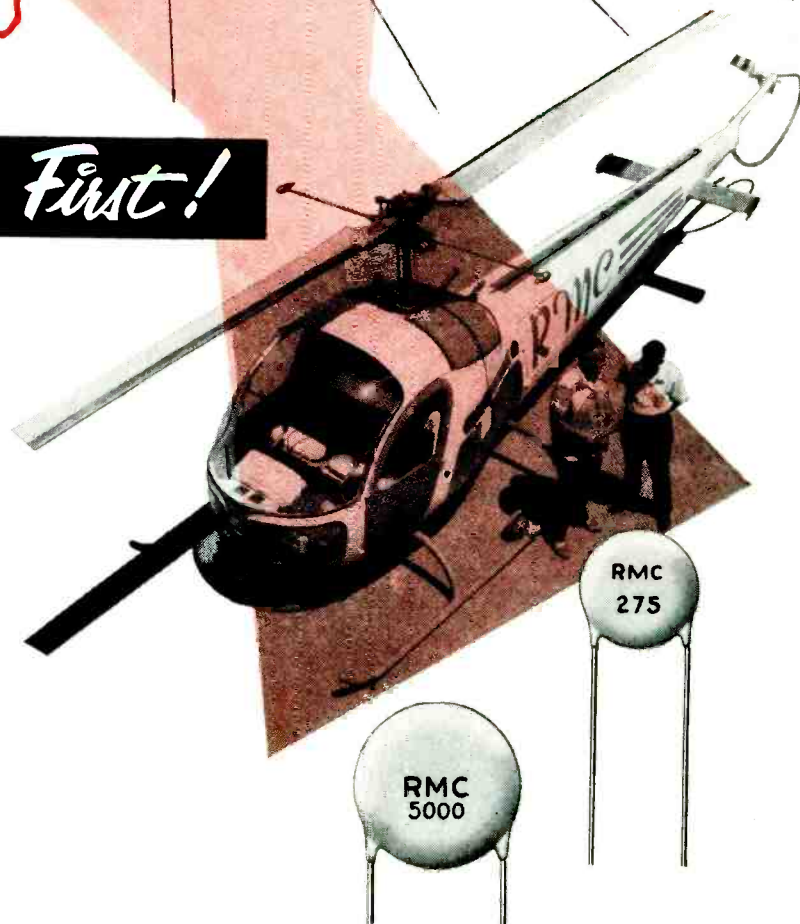

DISCAP  
CERAMIC  
CAPACITORS



**RADIO MATERIALS CORPORATION**  
 GENERAL OFFICE: 3325 N. California Ave., Chicago 18, Ill.  
 Two RMC Plants Devoted Exclusively to Ceramic Capacitors  
 FACTORIES AT CHICAGO, ILL. AND ATTICA, IND.



# you can't match **TRIPLET** model 630 VOM

for **SPEED  
ACCURACY  
DURABILITY  
CONVENIENCE!**

*heavy molded case*

— $\frac{1}{4}$ " thick for high impact.  
Fully insulated.

*sure grip battery contacts*

Balanced double-spring tension grip assures permanent contact.

*"this wide-range mode!*

tests AC-DC Volts (DC at 20,000 O/V); DC Microamperes, Milliamperes, and Amperes; Ohms (to 100 Megohms); Decibel and Output. Its easy-to-read scales are the longest in this type tester."

*streamlined design*

No protruding knobs on switch or ohms control—both are flush with the panel.

*king size recessed knob*

—Only one switch; (fully enclosed) selects both circuit and range. Just turn the switch and make your reading.



*for quick positive connections*

—Banana jacks and plugs on test leads are best. Alligator clips are provided to slip on test prods for extra convenience.

*for convenience in reading*

—Available as an extra (only 50c), this special stand tilts meter at best angle for easy reading

*for most efficient meter use*

—With every Model 630 you receive complete, simplified instructions on how to use and maintain most efficiently.

*no slip feature*

Four rubber feet furnished as standard equipment fit in back of the case to prevent slipping on smooth surfaces.

*advanced engineering*

—Molded mounting for resistors and shunts allow direct connections without cabling. No chance for shorts. Longer life and easy-to-replace resistors in their marked positions.

**TRIPLET ELECTRICAL INSTRUMENT CO.**  
Bluffton, Ohio

## MODEL 630 | \$39.50

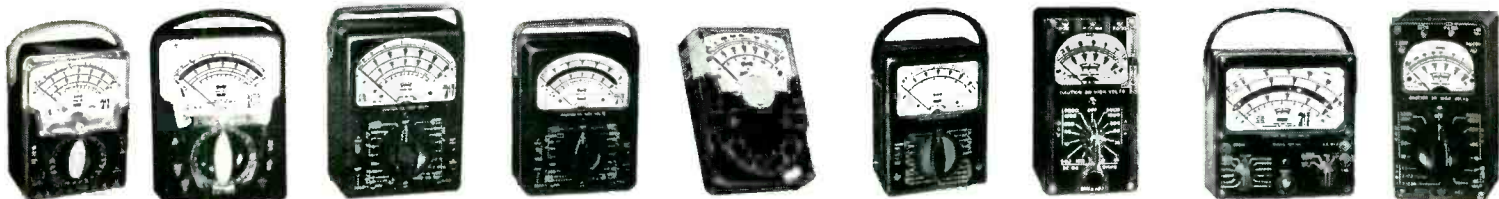

### THE MIGHTY NINE VOM LINE

**631**  
Combination  
V-O-M—VTVM

**630-NA**  
For Best Testing  
Around The Lab,  
Production Line  
or Bench

**630**  
The Popular  
All-Purpose  
V-O-M

**630-A**  
A Good Lab and  
Production Line  
V-O-M

**310**  
The Smallest  
Complete V-O-M  
With Switch

**630-T**  
For Telephone  
Service

**666-HH**  
Medium Size  
For  
Field Testing

**625-NA**  
The First V-O-M  
With 10,000  
Ohms/Volt AC

**666-R**  
Medium Size  
With  
630 Features

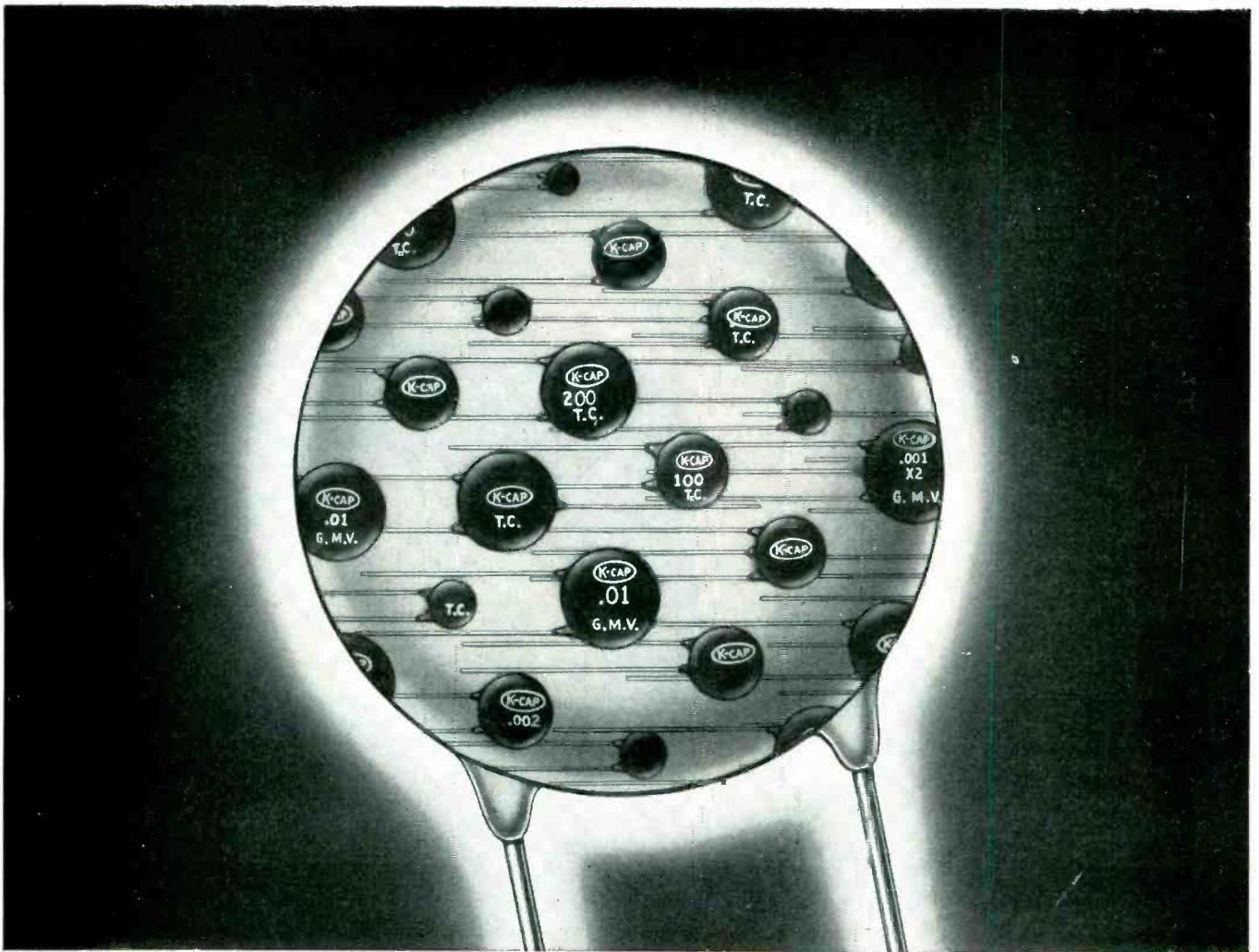

# Did you know that only **AUTOMATIC** makes K-CAP Ceramic Disc Capacitors?

K-CAP\* Ceramic Disc Capacitors are another mass produced electronic product made by Automatic Manufacturing Corporation, originators of the famous K-Tran\* and J-Tran\* I.F. Transformers...the first standardized I.F.'s in the industry.

K-Cap capacitors, like K-Tran and J-Tran, are manufactured completely within our own plant from the basic powders to the completed capacitor. The high K ceramic bodies are developed in our own modern laboratory and produced under the exacting supervision of our quality control engineers. The silvering process is done by men with more than 20 years experience in silvering trimmers and condensers.

K-Cap Ceramic Capacitors are distinguished by their black, wax impregnated, phenolic coating, stamped with red markings. All bear the registered trade mark K-Cap.

They are made in 4 standard types:

**GUARANTEED MINIMUM VALUE**  
*for bypassing, etc.*

**GENERAL PURPOSE**  
*for coupling, etc.*

**TEMPERATURE COMPENSATED**  
*in a range of T.C. from N.P.O. through N2200*

**HIGH STABILITY**  
*for elimination of drift*

Available in either single capacitor, dual capacitor unshielded, and dual capacitor shielded, in a range from 2. uuf to .02 uf.

☆ ☆ ☆

For more information about K-Cap, K-Tran and J-Tran, write for a copy of the K-Tran-K-Cap Manual—56 pages of engineering information, most valuable to you in Electronic designing.



*Every part Automatic uses  
... Automatic makes.*



**MASS PRODUCERS OF  
ELECTRONIC COMPONENTS**

65 GOUVERNEUR ST.,  
NEWARK 4, N. J.

\*T.M. Reg. U.S. Pat. Off.



Raytheon — World's Largest Manufacturer of Magnetrons and Klystrons

VOLTAGE TUNABLE  
1,000 mc. ← → 16,000 mc.



### QK518 specifications

Frequency: 2,000-4,000 mcs.  
Rapid electronic tuning by varying delay line voltage from 150-1,500 Volts.  
Power output: 0.1 to 1 watt  
Complete with compact permanent magnet  
Approximate maximum dimensions: 10" long, 4 $\frac{3}{8}$ " high, 4 $\frac{7}{8}$ " wide.

# NEW

## Raytheon Backward Wave Oscillator Series

**for wide, rapid electronic tuning — 1,000 mc. to 16,000 mc.**

The tubes in this revolutionary new line of Raytheon Backward Wave Oscillators give you four outstanding performance advantages:

1. Electronically tunable over an *extremely* wide range of frequencies
2. Frequency insensitive to load variations
3. High signal-to-noise ratio
4. Can be operated under conditions of amplitude or pulse modulation

These new tubes are finding fast-growing applications in microwave equipment, including radar and signal generators.

Write today for free Data Booklet on the QK518 (above) which is available for delivery. We'll also be happy to answer any questions you may have on this new line.

**RAYTHEON MANUFACTURING COMPANY**



Microwave and Power Tube Operations, Section PT-28, Waltham 54, Mass.

*Excellence in Electronics*

Raytheon Makes: Magnetrons and Klystrons, Backward Wave Oscillators, Traveling Wave Tubes, Storage Tubes, Power Tubes, Receiving Tubes, Transistors

Want more information? Use post card on last page.

**KOCH**...World's largest fabricator of moulded Fiberglas products

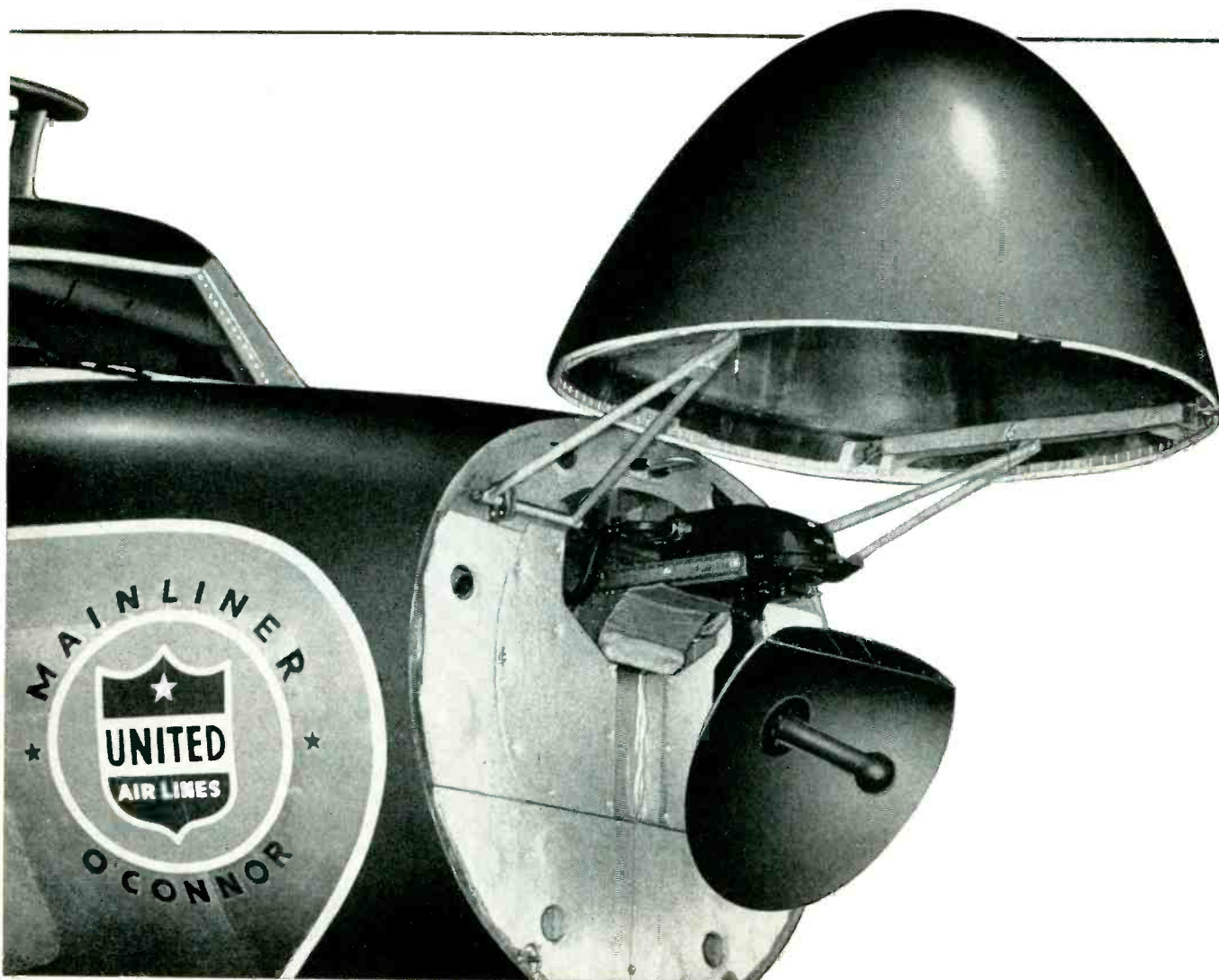

## How Convair 340's Solve a Housing Problem for United Air Lines' All-Weather Radar



**The nose knows** when and where bad flight weather threatens! Radar weather-spotting equipment in the nose of United's Convair 340 now sees through a Koch Fiberglas Radome.

When Convair received United's order for radar-equipped 340's, they naturally turned to Koch, world's largest fabricator of moulded Fiberglas, for domes to house the radar.

The life expectancy of the Koch Radome is many, many times that of any other Radome. This Radome is made possible only by Koch's own exclusive method of moulding.

W. J. Flanagan, Convair Purchasing Agent, wrote Koch upon completion, "You have made

substantial contributions to this industry by proposing and successfully applying new departures and moulding technique."

If you are a plane manufacturer, or if you install airborne radar, investigate Koch's Moulded Fiberglas Radome. If you manufacture any equipment that needs special protection, ask the people who know the most about Fiberglas fabrication. We will be glad to confer with you about your project. Address Dept. EKE.

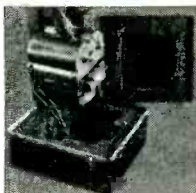

**KOCH** *Fiberglas*  
PRONOUNCED "KOKÉ"

Pioneer in industrial products of moulded Fiberglas  
CORTE MADERA, CALIFORNIA



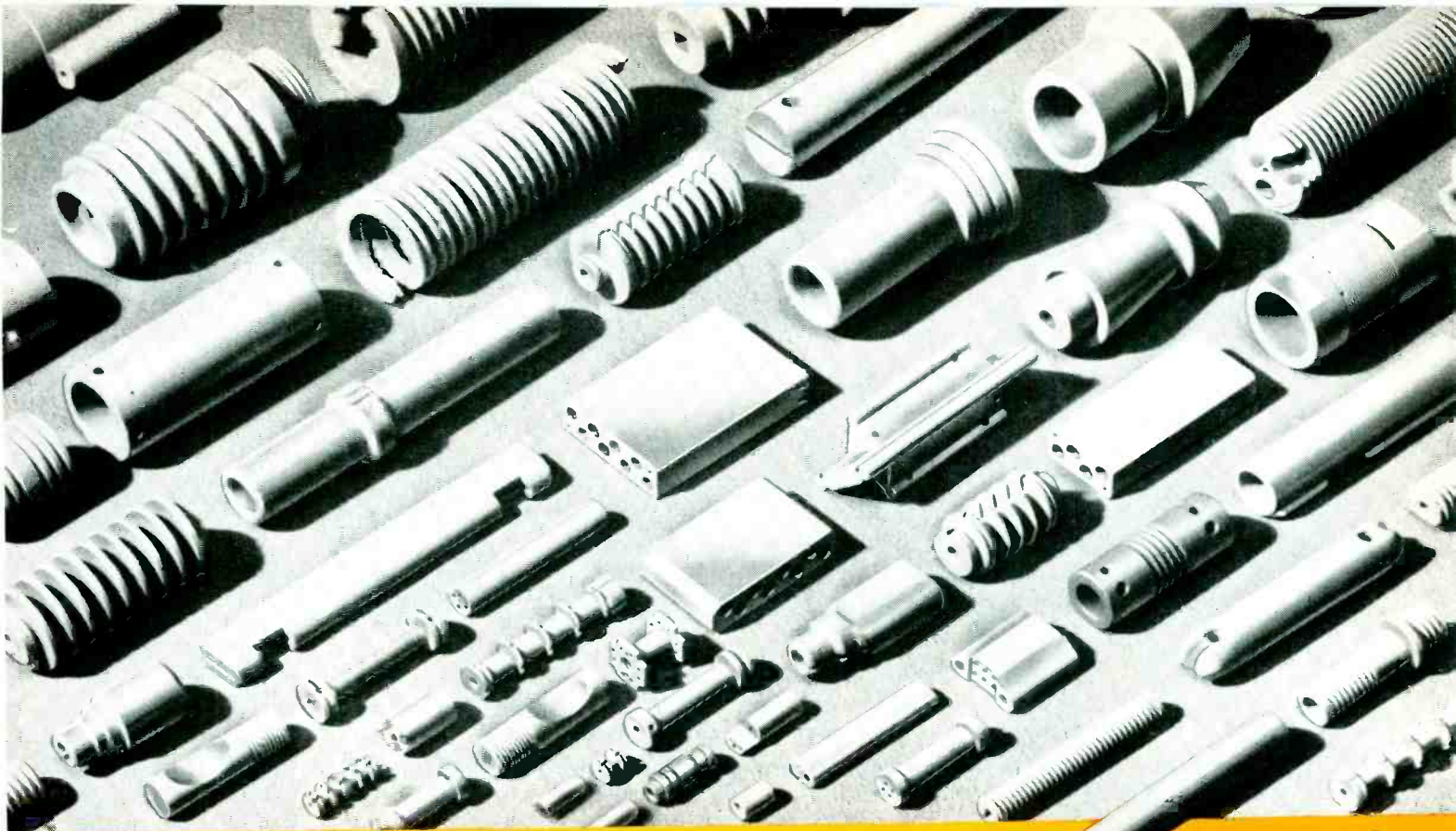

# ALSiMAG<sup>®</sup> EXTRUSIONS

*speed production.....*

**FASTER DELIVERY.** Four things are vital to quick ceramic deliveries: Plenty of Materials, Machinery, Firing Facilities and "Know How." You'll find all four in greater abundance where ALSiMag is made.

**SIMPLIFIED ASSEMBLY.** Versatile ALSiMag extrusions can often be chosen or designed to combine several functions, thus eliminating costly production steps. Wider range of shapes, sizes and cross sections.

**HIGHER QUALITY.** Uniformity and precision tolerances make ALSiMag extrusions easy to assemble. Other "plus" factors: Strength. Permanent rigidity. Resistance to chipping. Corrosion resistance. Favorable heat shock characteristics. Superior performance at higher temperatures and higher frequencies. Widest choice of materials in the industry.

**LOWER COSTS.** Ceramic production by the extrusion method is economical. Since basic extruded shapes can be machined before firing, extremely intricate as well as simple designs can be produced rapidly at prices favorable to production budgets.

ALSiMag Extrusions May Solve Your Problems!  
Send us a blueprint or sketch for full details.

54TH YEAR  
OF CERAMIC  
LEADERSHIP

**AMERICAN LAVA  
CORPORATION**

CHATTANOOGA 5, TENNESSEE  
A Subsidiary of  
Minnesota Mining and Manufacturing Company

Branch offices in these cities (see your local telephone directory): Cambridge, Mass. • Chicago, Ill. • Cleveland, Ohio • Dallas-Houston, Texas • Indianapolis, Ind. • Los Angeles, Calif. • Newark, N. J. • Philadelphia, Pa. • St. Louis, Mo. • South San Francisco, Calif. • Syracuse, N. Y. • Tulsa, Okla. Canada: Irvington Varnish & Insulator Div., Minnesota Mining & Mfg. of Canada, Ltd., P. O. Box 757, London, Ontario. All other export: Minnesota Mining & Mfg. Co. International Division, 99 Park Ave., New York, N. Y.





# DATA FOR

## SOLID-STATE ELECTRONICS . . . AT RCA



For many years the Radio Corporation of America has been actively engaged in a broad program of research, development, and production of solid-state materials and devices.

Many of the electronically active solids under study and development at RCA have opened or are opening the way for new products and circuits. For example, photo-emissive and secondary-emissive materials have made possible the Image Orthicon and the multiplier phototubes. Photoconductive materials are used as light-sensitive elements in the compact Vidicon camera tube; and in new developments, they are making possible sensitive photoconductive cells for a host of potential applications.

RCA work on cathodoluminescent materials so widely used for the screens of cathode-ray tubes is being extended to find new applications for these materials; in addition, the newer electroluminescent materials are also being investigated to determine potential fields of application. By combining photoconductive and electroluminescent materials, RCA Laboratories are developing the light amplifier for intensifying images.

RCA advances in the understanding of semiconductors have resulted in important improvements in transistors. In addition to its commercial line of precision-made transistors and germanium point-contact crystal diodes, RCA has under development other types which will open new avenues of circuit design.

New ferromagnetic and ferroelectric materials under study are expected to facilitate the construction of miniature components for transistorized equipment . . . for electronic computers and business machines . . . and for many other applications symbolic of electronic progress.

Both in research and production, RCA is geared to contribute to the needs of industry for new and better products for expanding markets.

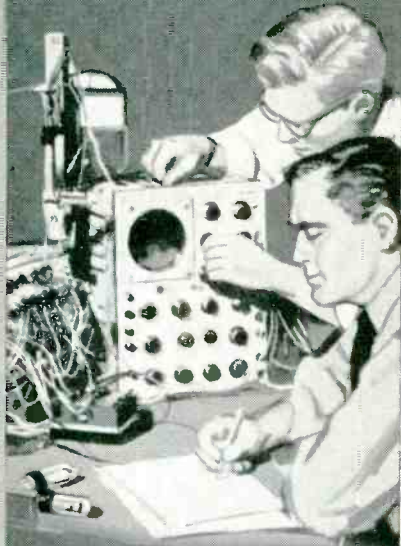
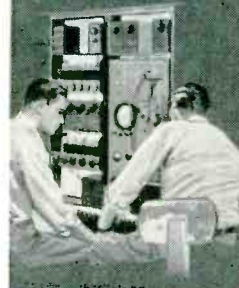

### RCA DISTRICT OFFICES

**East:** HUmboldt 5-3900  
744 Broad Street,  
Newark 1, N. J.

**Midwest:** WHitehall 4-2900  
Suite 1181,  
Merchandise Mart Plaza,  
Chicago 54, Ill.

**West:** RAymond 3-8361  
6355 East Washington Blvd.,  
Los Angeles 22, Calif.



# DESIGNERS

**ELECTRON TUBES**  
**SEMICONDUCTOR DEVICES**  
**BATTERIES**  
**TEST EQUIPMENT**  
**ELECTRONIC COMPONENTS**

## RCA TRANSISTORS FOR AF APPLICATIONS

**RCA-2N77**—  
for low-power  
af applications.

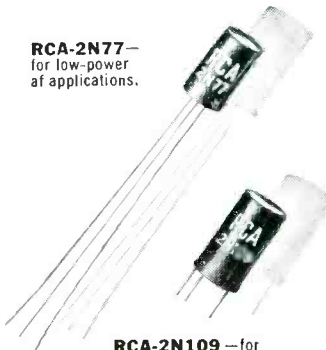

**RCA-2N104**—  
for low-power  
af service in  
communications  
and general  
electronic  
equipment.

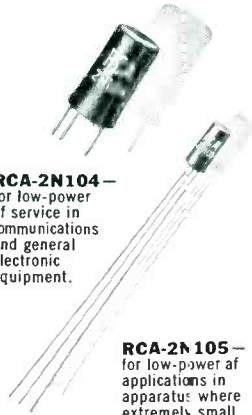

**RCA-2N109**—for  
large-signal audio  
applications, such as in  
class B p-p power out-  
put stages of battery-  
operated portable  
radios operating at  
power levels of  
approx. 160 milliwatts.

**RCA-2N105**—  
for low-power af  
applications in  
apparatus where  
extremely small  
size is required.

RCA Transistors listed below are germanium, p-n-p, alloy-junction, hermetically sealed types, in insulated metal jackets. These high-quality transistors are designed specifically for applications where extreme stability and exceptional uniformity of characteristics are paramount—initially and throughout life—and for circuits where very low collector cutoff current is essential. In addition to the units described here, RCA is developing new transistor types which will broaden transistorization of electronic equipment.

	RCA-2N77	RCA-2N104	RCA-2N105	RCA-2N109
<b>MAX. RATINGS</b> (Absolute Values):				
Collector Volts	-25	-30	-25	-25
Collector $I_c$	-15	-50	-15	-70
Collector Dissip. (mw)	35	up to 150*	35	50
Operating Temperature ( $^{\circ}$ C)	50	70	50	50
<b>TYPICAL OPERATION:†</b>				
Collector Volts	-4	-6	-4	-9
Collector $I_c$	-0.7	-1	-0.7	-13
Alpha (Collector- to-base connection)	-55	-44	-55	70††
Power Gain (db)	44	41	42	33**
Power Output (mw) Approx.	—	—	—	160**
Source Imped. (ohms)	1980	1400	2300	375 per base connection
Load Imped. (ohms)	100,000	20,000	20,000	200 per collector
Noise Factor (db)	6.5 av.	12 max.	4.5 av.	—
Cutoff Freq. (Kc)	700	700	750	—
Figure of Merit for High Frequency Performance (Mc)	1.7	1.6	2.6	—

\* Depends on temperature and circuit parameters †† Large-Signal  
 † In common-emitter circuit at ambient temperature of 25 $^{\circ}$  C.  
 \*\* For 2 transistors in class B of circuit; distortion of less than 10 percent

## NEW SOLID-STATE DEVICES UNDER DEVELOPMENT

### Ferrites

RCA has an extensive background of more than 5 years in the design, development, and manufacture of ferrites. Under development for a great diversity of electronic applications are the following four categories of ferrites:

1. **Hard**—displaying a large hysteresis loop, as in permanent magnets;
2. **Soft**—having small hysteresis losses, as required in deflection-component cores and high-frequency transformers;
3. **Square Loop**—with "square" hysteresis loops, as used in computer memory devices and high-speed switching circuits;
4. **Magnetostrictive**—exhibiting change in physical dimensions when placed in a magnetic field, as in transducers.

### Semiconductor Photocells

RCA's many years of experience in solid-state electronics serves as excellent background for its developmental programs in semiconductor photocells. When such cells become commercially available, it is expected that they will find application in street-lighting control, headlight-dimming control, animated-sign control, computer and business-machine reading devices, and other light-actuated devices.



**RADIO CORPORATION of AMERICA**  
 TUBE DIVISION  
 HARRISON, N. J.

Radio  
Receptor's  
**NEW**  
money saving  
rectifier  
mounting!

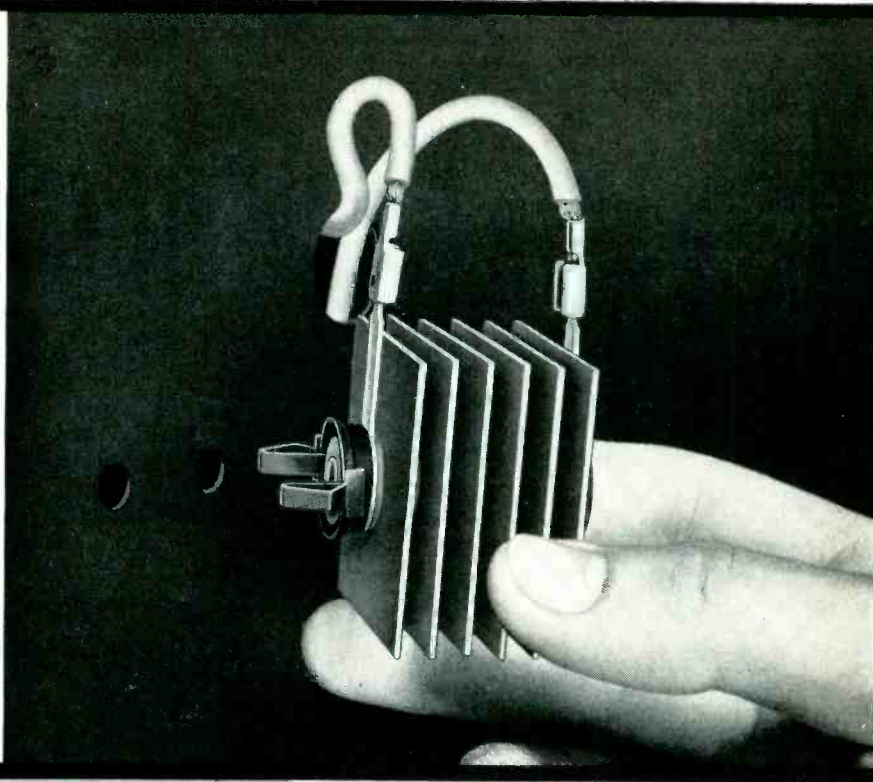

**"QUI-KLIP"** *snap-in type*  
**SELENIUM RECTIFIERS**

**QUICK MOUNTING! QUICK REMOVAL!**

Spring steel clips with safe edges snap into two round, large tolerance holes in chassis (approx  $\frac{3}{16}$ " dia.,  $\frac{3}{4}$ " c. to c.). Solderless connectors as shown, when used, simplify servicing

Radio Receptor's unique QUI-KLIP rectifiers will soon make their debut in TV sets produced by one of the country's leading manufacturers, saving them countless dollars in production costs.

QUI-KLIP requires no tools or sockets for mounting. There are no studs to break or threads to strip and the locating tab is now unnecessary. QUI-KLIP provides a positive seat for the rectifier — no rocking. Yet any serviceman can remove the stack quickly by squeezing the QUI-KLIP prongs with his fingers and removing the solderless connectors.

Let us show you how to put the cost saving QUI-KLIP selenium rectifiers to work in *your* production . . . Available in most popular sizes with cells from 1" square to 2" square, for radio, TV and other electronic circuits. For detailed information, write Dept. E-13.

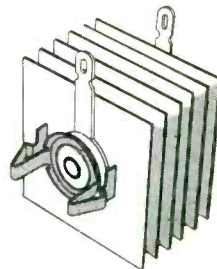

- Speeds assembly time.
- Slashes production costs.
- Simplifies assembly.
- Eliminates stud rejects (No studs or nuts needed.)
- Permits easier replacement in the field.

Really



Reliable

Semiconductor Division

**RADIO RECEPTOR COMPANY, INC.**

*In Radio and Electronics Since 1922*

SALES OFFICES: 251 WEST 19TH ST., NEW YORK 11, N. Y., WAtkins 4-3633 • Factories in Brooklyn, N. Y.

SELENIUM RECTIFIERS, THERMATRON DIELECTRIC HEATING GENERATORS AND PRESSES, COMMUNICATION, RADAR AND NAVIGATION EQUIPMENT





# M E M O

**FROM:** The Custom Engineering Staff at NJE  
**TO:** Engineers and Purchasing Agents  
 who buy power supplies

**SUBJECT:** The \$64 ANSWER

Our weekly mail never contains fewer than 35 requests for quotation on non-standard power supplies.

Some of these requests can be handled by modification of standard supplies, but most of them require a custom unit.

When we say "custom" we mean it in the fullest sense of the word -- custom design, custom construction, custom test...but first (and most important) of all -- custom specification.

A complete regulated power supply specification contains at least fifty\* facts about the equipment it describes.

We don't ask our customers to be that complete, because we've become very good at long-distance mind-reading. Just give us a good start, describing the application if possible. We'll give your request the "full treatment".

If you need expert advice in formulating your specification, call in one of our local engineering representatives. He can show you copies of hundreds of different custom quotes we have made recently, from \$65 to \$180,000. If you wish, he will write up the specification for you, and transmit it to us for quick action.

### INCIDENTALLY—

The average quote takes 7½ man-hours of design, pricing, soul-searching, and just plain crystal-gazing. It takes secretarial time, paper, postage, and something called overhead. It costs us, according to our accountant (who never crystal-gazes), exactly \$67... but who ever heard of a \$67 answer? So we called this memo the \$64 answer. Need one? Write, wire, phone.



Hard to believe? Not when you start adding them up. For example, here are some of the most important!

- Input voltage range
- Input current
- Input power
- Input power factor
- MIL Spec conformance
- Output voltage range
- Output current range
- Regulation—static
- Regulation—dynamic
- Response time
- Output impedance—DC
- Output impedance—dynamic
- Ripple and Noise
- Stability
- Circuit Protection (fusing, etc.)
- Personnel Protection (interlocks, etc.)
- Meters (accuracy, size, etc.)
- Housing
- Size
- Weight
- Price
- Delivery

For our complete line of electronic power supplies See electronics Pp. 113-120 **BUYERS' GUIDE**

# NJE

Write for Catalog Z-5

corporation

Electronic Development & Manufacturing

345 CARNEGIE AVENUE, KENILWORTH, NEW JERSEY

Competent Engineering Representation Everywhere

Rapid, complete, competitive custom quotes from 1000 Amperes (low voltage) to 250 KV (low current.)

P O W E R S U P P L I E S U N L I M I T E D

New Phone No.  
Chestnut 1-1500

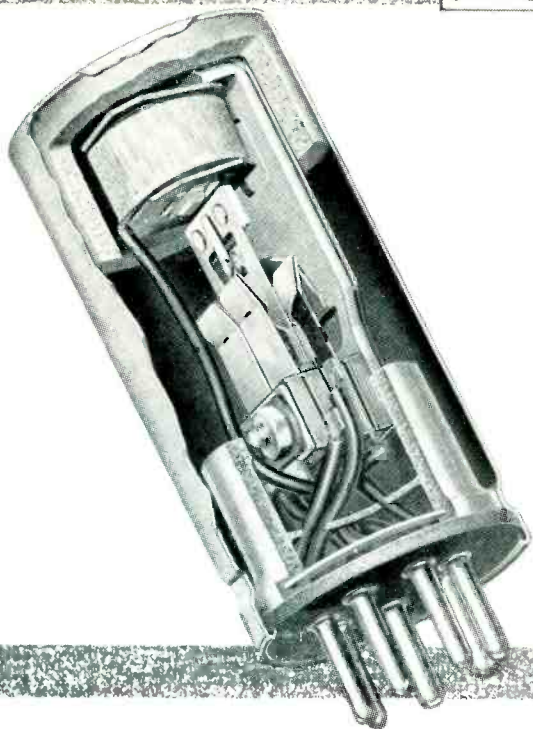

*New 1700 series Mallory split-reed vibrator\* uses special alloy leaves which serve both as contacts and as springs . . . eliminating usual button contacts. Life is greatly increased, constancy of output improved, and driving power reduced.*

*\*Patent Applied For*

## New Heavy Duty Mallory Vibrator

*gives far longer life, constant output*

For the peak in dependability and performance, plan to use this newest Mallory vibrator in your communications equipment. A completely new idea in vibrator design eliminates conventional contact buttons. The spring leaves themselves . . . made of special contact alloy . . . act as contacting members. This design provides greatly increased contact area, with these important advantages:

**Consistently Longer Life.** Tests made on heavy duty cycles prove up to 100% greater service can be expected . . . with a high degree of consistency.

**Steadier Output.** The decreased rate of erosion means less change in contact spacing, less variation in voltage.

**Flare-Proof Starting.** The new low-mass design permits wider contact spacing to prevent start-up flare . . . without need for greater driving power.

**Exceptional Uniformity** of characteristics is made possible by the simplified design.

**Minimum Size** for heavy duty ratings.

The new design is available in the split-reed type shown here, for 6/12 volt service, and in the Duplex heavy duty model without the split reed construction. For full technical data, and for a consultation on your specific power supply requirements, write or call Mallory.

### COMPLETE POWER SUPPLIES

It may be that you can save time and reduce over-all costs by employing a complete Mallory Vibrapack® power supply. Vibrapacks can be engineered around the new heavy-duty 1700 series vibrator to give long, reliable service. Design includes precise balancing of critical components. Normal ratings are conservative. Compact-sized Vibrapacks fit readily into crowded layouts. For further information, advise Mallory of your specific requirements.

#### Serving Industry with These Products:

**Electromechanical**—Resistors • Switches • Television Tuners • Vibrators  
**Electrochemical**—Capacitors • Rectifiers • Mercury Batteries  
**Metallurgical**—Contacts • Special Metals and Ceramics • Welding Materials

Parts distributors in all major cities stock Mallory standard components for your convenience.

**Expect more . . . get more from**

P. R. MALLORY & CO. Inc.  
**MALLORY**

P. R. MALLORY & CO., Inc., INDIANAPOLIS 6, INDIANA



CROSS  
TALK

► CONVERSATIONAL SERVICE

... Following up last month's editorial entitled D.O.A., we call attention to a particular kind of repair work that often goes hand in hand with skimmed products.

The essential tool is the tongue rather than the test set. From the tip of this instrument, firmly embedded in cheek, rolls such phrases as "They all work that way in this neighborhood," or "That's the way it's supposed to work," or "I don't see nuthin' wrong with it," or "There, that's a little better."

Much of this goes back to the fact that a man can't fix what isn't there. And so we repeat: There should be more design margin . . . and men with a conscience. More rugged assembly . . . and men with a conscience. More careful adjustment . . . and men with a conscience. More critical testing . . . and men with a conscience.

People are getting tired of being talked out of it.

► SEGREGATION . . . Because the electronics industry continues to grow and diversify, it is inevitable that from time to time someone will suggest further grouping of like exhibits at trade shows. Component parts would all be together in one area, instruments in another, transmitters in another, industrial controls in another and so on. This would permit highly specialized technicians to concentrate upon areas containing products of obvious immediate interest,

therefore the suggestion has some merit.

Similar segregation of printed pages has several times been suggested to ELECTRONICS magazine. We have weighed the pros and cons, and continue to resist because ideas generated in one branch of this business have a habit of solving problems in other branches. Anything tending to reduce the exposure of the audience to overall technical advances would reduce the idea carryover.

We think, too, that while segregation might be neat it also could be deadily dull.

► PORTICO . . . Speaking of shows, we were intrigued enroute to the huge WESCON meeting in San

Francisco by a program note that said exhibits would be in the Civic Auditorium and an adjacent *portico*.

Were it not for the fact that our dictionary says a portico is "a structure consisting of a roof supported by columns or piers," and the absence of tanbark on the ground, we would have sworn it was a tent.

► BOUNCE . . . You can knock a New Englander down but it is hard to knock him out. A manufacturer in the flooded northeast fished some equipment out of the drink the other day and noted that several panel meters were filled with water. "That," he remarked, "is what I call optimum damping."

LOOKING AHEAD . . .

Transistor production techniques quite different from those currently in use are well along in an advanced laboratory stage, may late next year radically reduce waste, cut costs, expand applications

*Earth's magnetic field can displace a tv picture a fraction of an inch when a set is moved. Not noticeable with monochrome, but suggests need for easily accessible adjustment when dealing with color*

Watch for announcement of less complex color tube shadow mask, expected momentarily.

*Machines that type words instead of letters of the alphabet are already in experimental use. Next step will be broadening of vocabulary by means of magnetic storage. Ultimate may be typewriter you just talk to*

Industrial process control is simplified when . . .

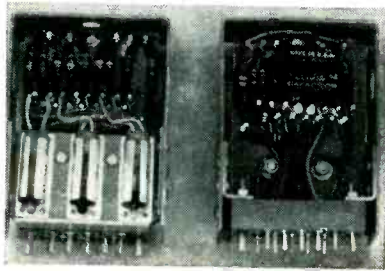

Operational d-c amplifier

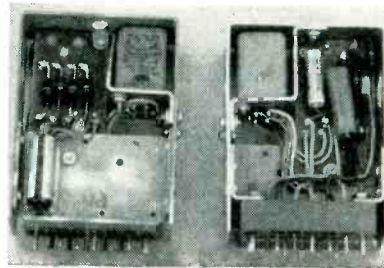

Modulator

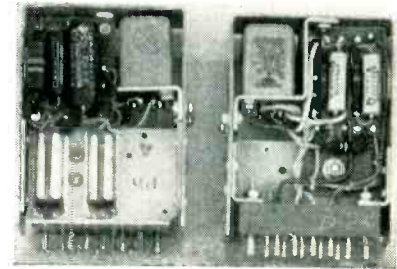

Demodulator

# Basic Control Circuits

**SUMMARY** — These basic circuits will solve more than 75 percent of an industrial control engineer's electronic problems. When the circuits are built up in plug-in form and stocked, relatively complex systems can be assembled off-the-shelf

**A**UTOMATIC CONTROL in industry requires many mechanical, electromechanical and electronic subassemblies. To develop a new control system, it would be desirable to have an on-the-shelf stockpile of building blocks to perform the various functions required.

Development time could be reduced considerably. All that would be required would be to connect these building blocks to satisfy the specified requirements. There will always be a few specialized items in each system that must be developed to satisfy a particular need. However, these cases represent only 10 to 15 percent of the total system.

## Circuits Required

Amplifiers, power supplies, modulators and demodulators represent over 75 percent of the units required for an automatic control system.

The specifications for an amplifier, modulator or demodulator should include: gain, frequency

response, phase shift, drift stability, linearity, input, output and load impedance, maximum linear voltage output swing, output voltage with zero input voltage and power.

The specifications for a power supply should include: nominal output voltage, output current range,

load-change and line-change regulation, output impedance and power.

## D-C Amplifier

There are as many types of amplifiers as there are electronic engineers. However, the most versatile type of amplifier may be used for adding, subtracting, integrating or differentiating. This amplifier is usually direct coupled as found in analog computers. But it may be an a-c amplifier if only addition or subtraction is required and extreme simplicity as well as long-time high-gain drift stability are desirable.

The theory of operational amplifiers is available in many textbooks.<sup>1</sup>

Figure 1 illustrates the basic operations that may be performed by operational amplifiers. Figure 2 is the schematic for a d-c operational amplifier with the specifications listed in the accompanying table.

Closed-loop gain may be adjusted by varying the ratio  $R_{fb}/R_{in}$ . The values of the cathode resistor and

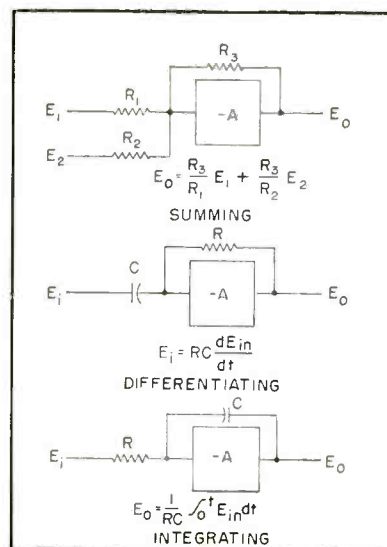

FIG. 1—Operational amplifiers sum, differentiate and integrate



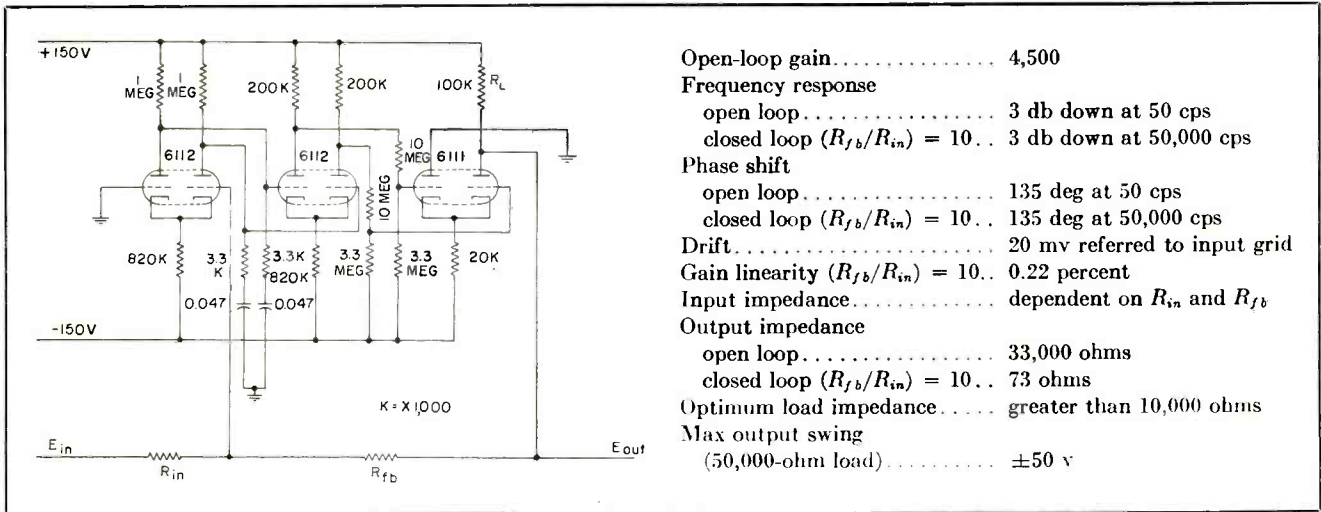

FIG. 2—Circuit and specifications for a d-c operational amplifier such as used in analog computers

# Are Packaged

By L. S. KLIVANS\*

Northrop Aircraft, Inc.  
Inglewood, California

$R_L$  at the output are a function of the load impedance and the maximum desired output voltage swing. A plug-in version of this amplifier is shown in a photograph.

## A-C Amplifier

Figure 3 is a schematic of an a-c operational amplifier with the specifications listed in the table.

Closed-loop gain may be adjusted by varying the ratio  $R_{fb}/R_{in}$ . The values of  $R_i$  and  $R_L$  at the output are a function of the load im-

pedance and the maximum desired linear output voltage swing.

## Servo Amplifier

Figure 4 is a schematic of a 60 or 400-cps servo amplifier. Although both of the operational amplifiers can be used also as servo amplifiers if a large number of inputs and low gain as well as power output is required, in general this is not the case. For simplicity, as well as increased performance, it is desirable to have a servo amplifier

building block.

Servo amplifier gain may be adjusted by varying the ratio  $R_{fb}/R_{in}$ .

The output transformer is chosen to match load impedance characteristics. It was selected to drive a Transicoil 11MG 400-cycle induction motor-generator.

## Power Supplies

A series-regulated power supply package is excellent for the 0.5 to 1-

\* Now with Radioplane Co., Van Nuys, California.

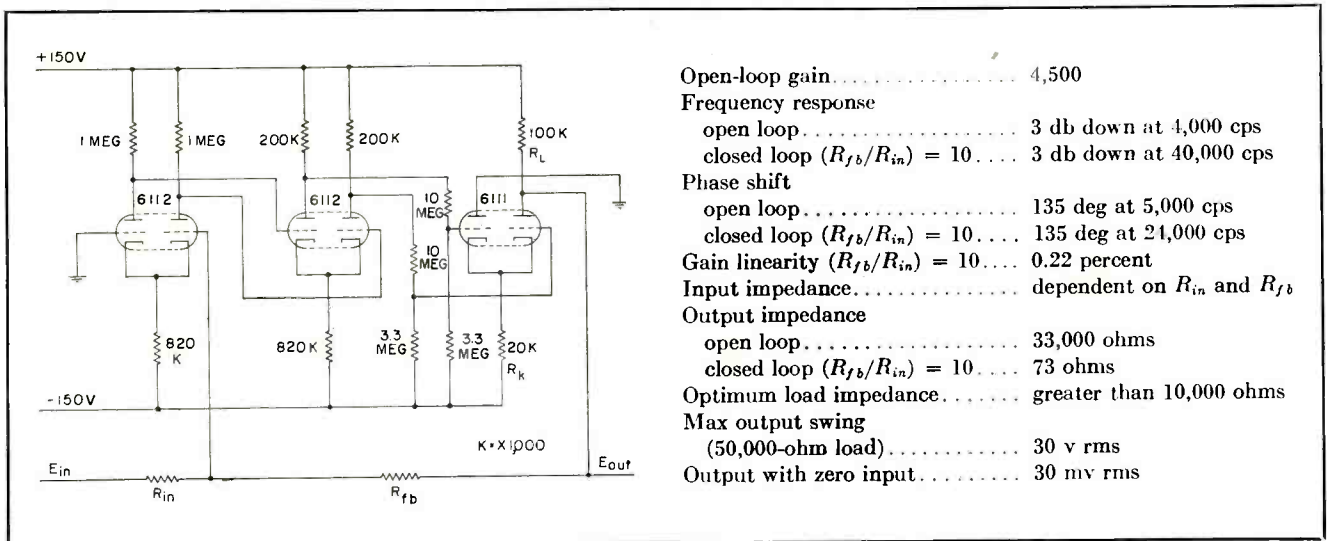
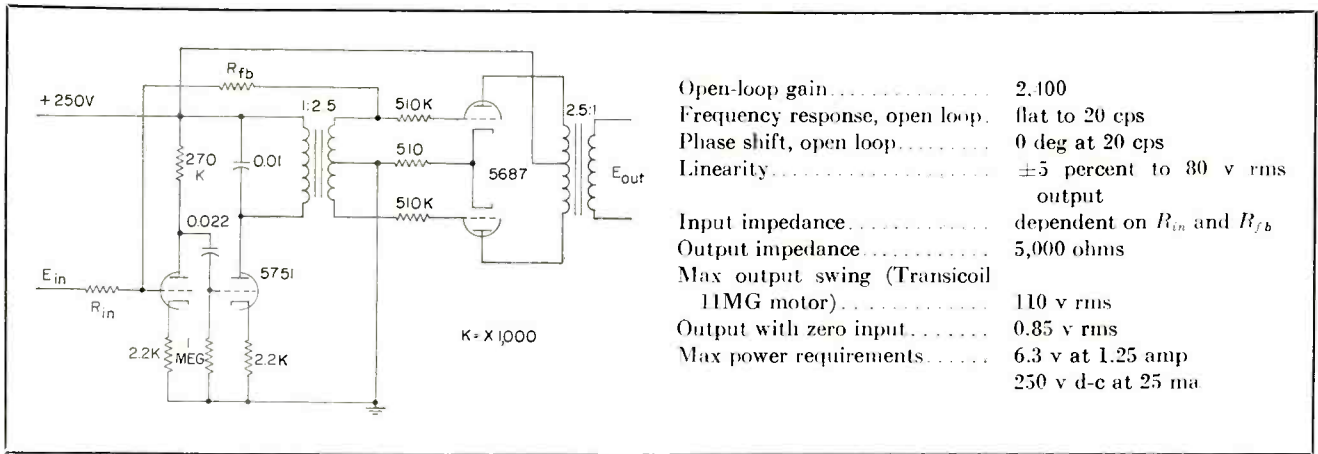

FIG. 3—Long-time high-gain drift stability characterizes this a-c operational amplifier



Open-loop gain	2,100
Frequency response, open loop	flat to 20 cps
Phase shift, open loop	0 deg at 20 cps
Linearity	±5 percent to 30 v rms output
Input impedance	dependent on $R_{in}$ and $R_{fb}$
Output impedance	5,000 ohms
Max output swing (Transicoil 11MG motor)	110 v rms
Output with zero input	0.85 v rms
Max power requirements	6.3 v at 1.25 amp 250 v d-c at 25 ma

FIG. 4—Servo amplifier for 60 or 400 cps features simplicity and increased performance over operational types

percent regulation range. Where 2 to 5-percent regulation is satisfactory, simplicity may be gained by utilizing voltage-regulator tubes. The latter category is suitable for servo amplifiers. The former is recommended for operational amplifiers to insure long-time drift stability.

Figure 5A is a schematic of a subminiature plug-in series-regulated power supply utilized with the operational amplifiers shown in Fig. 2 and 3.

Figure 5B shows a regulated power supply utilizing voltage-regulator tubes. This power supply will suffice for servo amplifiers or applications where 2 to 5-percent supply changes are not detrimental.

The specifications for the two supplies are listed in the table.

### Modulators

Modulators and demodulators are necessary in an automatic control system to convert from d-c to a-c or a-c to d-c.<sup>2</sup> In a modulator, the a-c output will be proportional to the d-c input and the phase will depend on the polarity of the input signal. For the demodulator the d-c output will be proportional to the a-c input and the polarity will depend on the phase of the input signal.

The decision as to which type of signal will be used arises from characteristics of the control sensor (pressure transducer, acceler-

ometer, strain gage, phototube, etc) and the power actuation system. Where one is d-c and one is a-c, it is necessary to convert the signals.

Where it is desired to convert an a-c signal to phase sensitive d-c, a demodulator is used. Figure 6 is the schematic of a 400-cps demodulator with the specifications listed in the table.

Figure 7 is the schematic of a 400-cps modulator with specifications as given.

This modulator is designed to be utilized in the error portion of the control system. Therefore linearity and maximum output swing requirements are not excessive. An electromechanical chopper is recom-

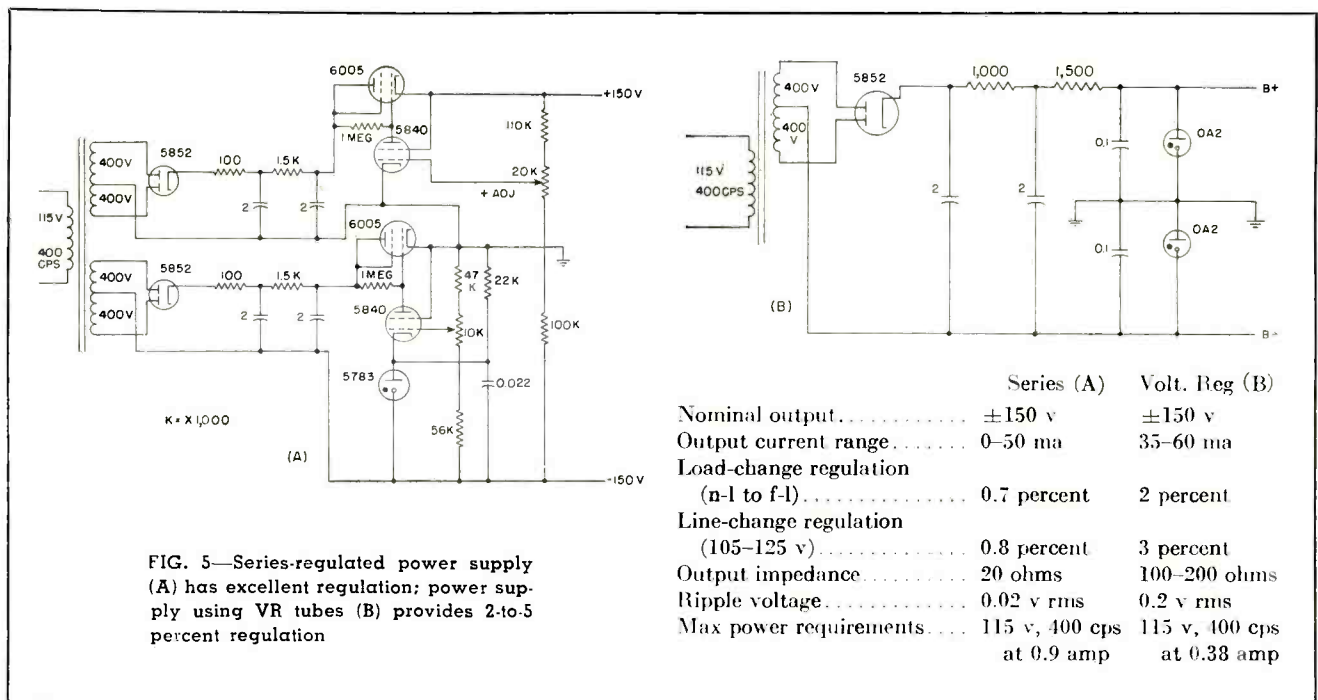

FIG. 5—Series-regulated power supply (A) has excellent regulation; power supply using VR tubes (B) provides 2-to-5 percent regulation

	Series (A)	Volt. Reg (B)
Nominal output	±150 v	±150 v
Output current range	0-50 ma	35-60 ma
Load-change regulation (n-1 to f-1)	0.7 percent	2 percent
Line-change regulation (105-125 v)	0.8 percent	3 percent
Output impedance	20 ohms	100-200 ohms
Ripple voltage	0.02 v rms	0.2 v rms
Max power requirements	115 v, 400 cps at 0.9 amp	115 v, 400 cps at 0.38 amp



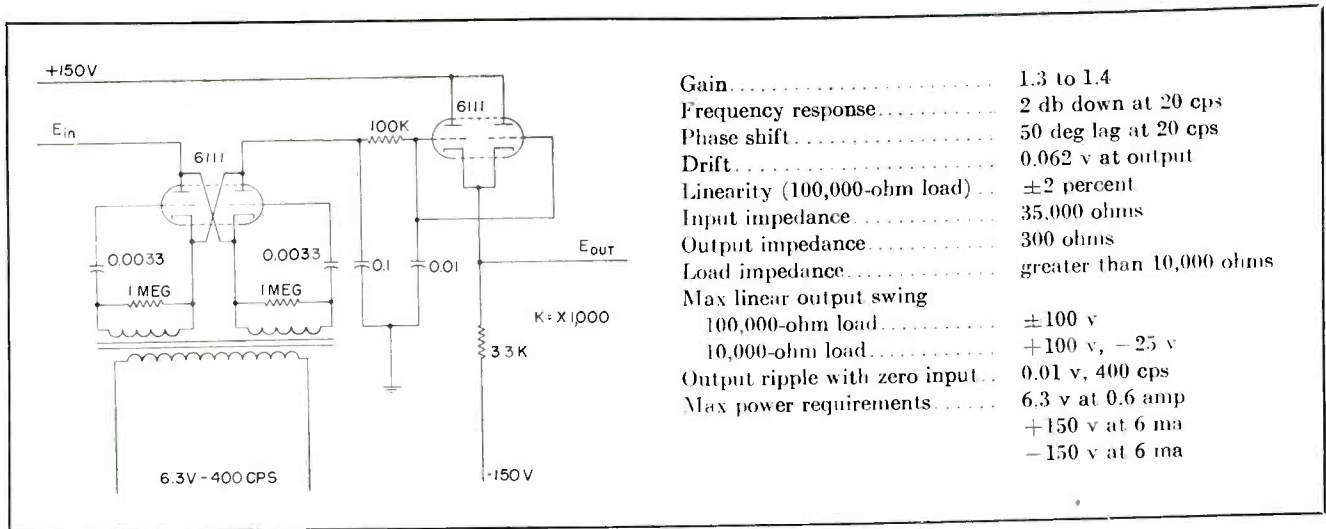

FIG. 6—Demodulator is used to convert a-c signal to phase-sensitive d-c

mended where low drift rates, large voltage swings and high signal-to-noise ratios are required.<sup>3</sup> A sub-miniature plug-in modulator is shown in a photograph.

The modulator and demodulator may be utilized with different carrier frequencies with minor circuit changes. A subminiature plug-in phase-sensitive demodulator is shown in a photograph.

### Pressure Control

Figure 8 illustrates an automatic system to control pressure accurately with reference to a pressure at a remote location. The reference pressure transducer transmits a low-level a-c voltage proportional to pressure. It is necessary to amplify this signal to drive a hydraulic control valve

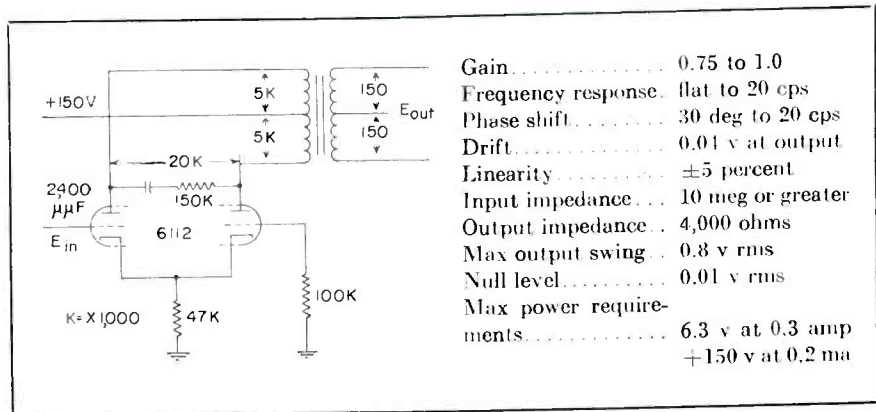

FIG. 7—Modulator for error portion of control system converts from d-c signal to a-c

and actuator to displace a bellows that produces a pressure equal to the reference pressure.

A pressure transducer equal in characteristics to the reference transducer generates the feedback

signal. Three of the building blocks are utilized. An a-c operational amplifier amplifies the error signal from the two transducers. A demodulator converts this error signal to d-c. A d-c operational amplifier provides error-network equalization to improve system stability and response and drives the electrohydraulic control valve of the hydraulic actuator.

The overall system could be put together and checked out in a matter of days utilizing the building-block techniques rather than in the weeks or even months that normally would be required if the electronic circuitry had to be developed to satisfy the requirements.

### REFERENCES

- (1) G. A. and T. M. Korn, "Electronic Analog Computers", McGraw-Hill Book Company, Inc., New York, 1952.
- (2) I. A. Greenwood, Jr., J. V. Holdam, Jr. and D. Macrae, Jr., "Electronic Instruments", p 375, McGraw-Hill Book Company, Inc., New York, 1948.
- (3) B. Chance, V. Hughes, E. F. Mac-Nichol, D. Sayre and F. C. Williams, "Waveforms", p 389, McGraw-Hill Book Company, Inc., New York, 1949.

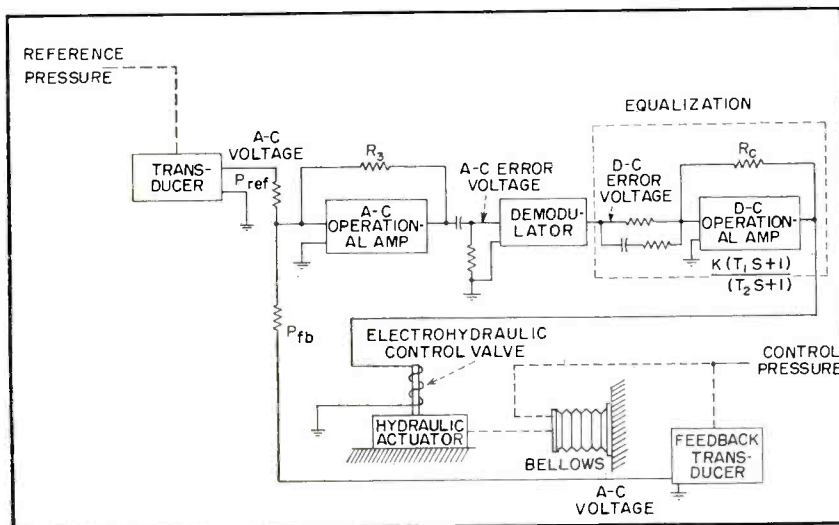

FIG. 8—Pressure regulating system uses three plug-in units: a-c amplifier, modulator and d-c amplifier

# Designing Over-Horizon

**SUMMARY** — Long-distance, wide-band circuits are possible using the phenomenon of tropospheric propagation provided high transmitter power and diversity receiving equipment are used. Design considerations, including antenna gain and order of diversity, show how to set up a working system with a given percentage of reliability

**P** OINT-TO-POINT communication with ultrahigh and super-high frequency transmissions has always appeared attractive because of three important considerations: high reliability as a result of freedom from ionospheric, atmospheric and geomagnetic disturbances; large information bandwidths; and privacy.

For many years these transmissions were believed to be of service only within or slightly beyond the radio horizon, although Marconi refused to recognize this limitation. However, with advances in transmission and reception techniques and in the technology of materials, it was demonstrated that useful signals could indeed be propagated well beyond the horizon, for distances of several hundred miles, possibly by a forward-scattering mechanism or by progressive partial reflections within the troposphere.

The discussion presented here outlines briefly the design of typical point-to-point over-the-horizon cir-

cuits, with emphasis on the operating margins that must be incorporated for accommodation of various types and grades of service.

## Frequency Range

The frequency range from 100 to 5,000 mc is best suited for point-to-point over-the-horizon (o-h) transmissions. The propagation mechanism still operates at frequencies as low as 30 mc, but difficulties in achieving narrow-beam antennas and intrusion of ionospheric effects raise the lower limit to about 100 mc.

The upper frequency limit is established by the heavy absorption of very short microwave radiation by water vapor in the atmosphere. Accordingly, the relationships that will be employed in discussing various system parameters as a function of frequency will be treated as valid only in the range 100 to 5,000 mc.

The path loss between two points connected by an o-h link consists of two major contributions, a free-

space loss and an over-the-horizon loss. This breakdown of the total loss is purely a bookkeeping convenience, since experimentally only the total loss can be measured. The free-space loss contains the frequency dependence, while the o-h loss (in the 100-5,000 mc range under discussion) is substantially independent of frequency.

Both losses, however, are dependent upon distance, with the o-h loss exacting the greater toll at long distances. The free-space loss represents the reduction in power density with increasing distance in free-space from the source of radiation. The frequency dependence of the free-space loss stems from the variation in collecting area (expressed in square wavelengths) of any receiving aperture of given gain as the frequency is altered.

The o-h loss is the loss remaining when the free-space loss expressed in decibels is subtracted from a median total loss (also in db) determined by a number of experiments<sup>1,2,3</sup> over the frequencies and distances of interest. Various theoretical foundations for the form of the o-h loss<sup>4-7</sup> have been given. It is the experimentally determined path loss that must be principally considered in the design of point-to-point o-h links.

## Free-Space Loss

The free-space loss,  $L_{fs}$ , when expressed in decibels, takes the form

$$L_{fs} = 10 \log_{10} \frac{G_r G_t}{P_r / P_t} = \quad (1)$$

$$20 \log_{10} \left( \frac{4\pi d}{\lambda} \right) = 22 + 20 \log_{10} (d/\lambda)$$

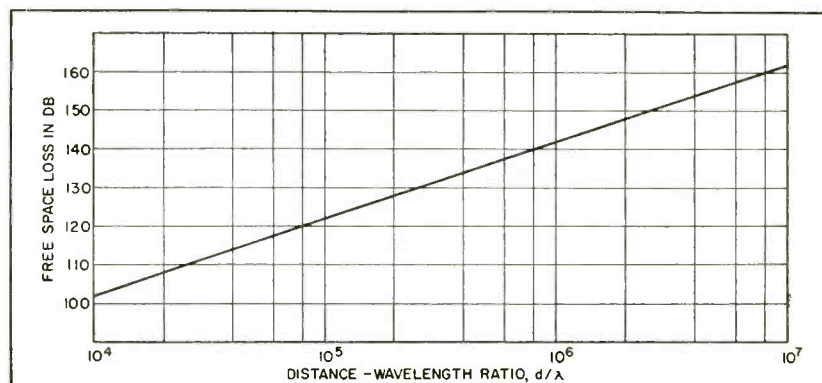

FIG. 1—Free-space loss is dependent upon distance and wavelength



# Communications Links

By DAVID DAVIDSON and ALFRED J. POTÉ

*Hycon Eastern, Inc.  
Cambridge, Mass.*

where  $P_r$  is the received power at a receiving antenna of gain  $G_r$  in the direction of the link,  $P_t$  is the transmitted power delivered to an antenna of gain  $G_t$  in the direction of the link,  $d$  is the distance between terminals and  $\lambda$  the wavelength. Note that it is the ratio  $d/\lambda$ , the distance in wavelengths, that determines the character of the free-space loss as shown in Fig. 1.

## Over-Horizon Loss

Path loss  $L_p$  is the sum of  $L_{fs}$ , the free-space loss and  $L_{oh}$ , the o-h loss, all quantities being expressed in decibels. The empirical formulation of  $L_{oh}$  is

$$L_{oh} = A + B(d - d_o) \quad (2)$$

where  $A$  is the o-h loss associated with the distance  $d_o$  and  $B$  is the rate at which the o-h loss accrues with distance (attenuation rate). For present purposes,  $d_o$  will be taken as 100 miles; the expression then becomes

$$L_{oh} = 57 + 0.13(d_{mi} - 100) \quad (3)$$

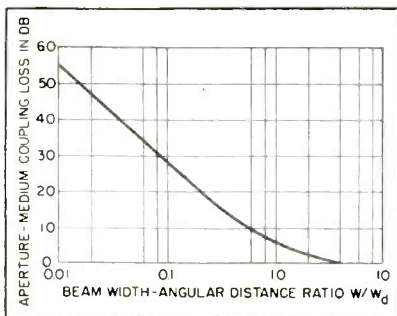

FIG. 3—Aperture-to-medium coupling loss results from failure to realize plane-wave antenna gain

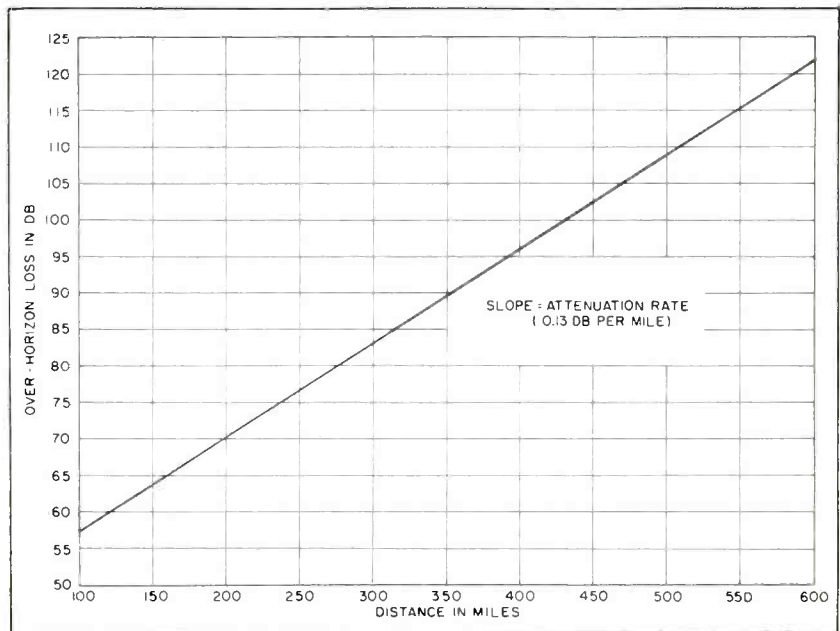

FIG. 2—Over-horizon loss for typical northern U.S. overland transmission

where  $d_{mi}$  indicates that distance should be entered in miles. The attenuation rate  $B$  is dependent on the average refractive properties of the atmosphere for the path under discussion. The value 0.13 db per mile is taken as typical for overland transmission in northern U. S. A. and southern Canada. It may be as low as 0.11 db per mile for semitropical, over-water paths and as high as 0.15 db per mile for dry, arctic conditions.

Parameter  $L_{oh}$  is plotted in Fig. 2 for the case of  $B = 0.13$  db per mile. For other values of  $B$ , some adjustment might be necessary for the value of  $A$ .

Total path loss  $L_p$  in decibels, can then be written as

$$L_p = L_{fs} + L_{oh} + 79 + 20 \log_{10}(d/\lambda) + 0.13(d_{mi} - 100) \quad (4)$$

## Antennas

The ratio of antenna gains to the ratio of received and transmitted powers, as shown in Eq. 1, implies that transmitted power may, up to a point, be exchanged for antenna power gain. Since increasing the antenna gain results in a narrowing of the antenna beam, an exchange of transmitted power for antenna gain is accompanied by increased privacy. This is not directly evident from Eq. 1.

Assuming that paraboloidal reflector antennas of diameter  $D$  are used, with illumination efficiencies of 64 percent, numerical power

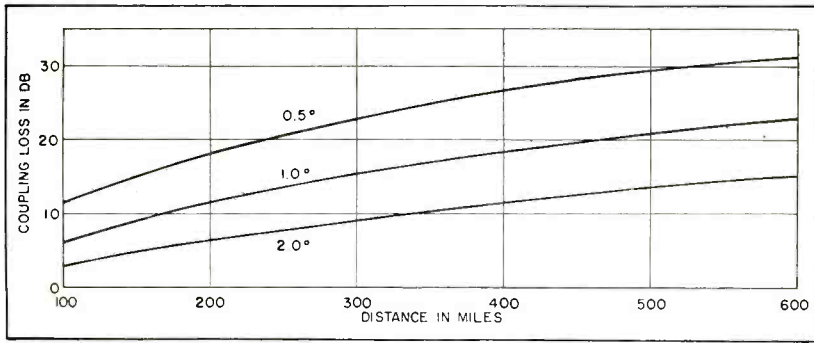

FIG. 4—Coupling loss for three different beam widths

gain is given by

$$G = 2\pi (D/\lambda)^2 \quad (5)$$

The half-power beam width in degrees,  $w^\circ$ , is given<sup>7</sup> by

$$w^\circ = 70\lambda/D \quad (6)$$

The net path loss  $L_{net}$  can then be expressed in decibels as

$$L_{net} = L_{fs} - G_s + L_{oh} \quad (7)$$

where  $G_s$  is the system gain and is the sum of the terminal antenna gains expressed in decibels. That is, for similar antennas

$$G_s = 20 \log_{10} 2\pi (D/\lambda)^2 \quad (8)$$

The relation of system gain to beam width can be expressed in decibels as

$$G_s = 89 - 40 \log_{10} w^\circ \quad (9)$$

For example, with a beam width of  $1^\circ$ ,  $G_s$  equals 89 db; with a beam width of  $2^\circ$ ,  $G_s$  falls to 77 db.

Thus far, the effect of increased antenna gain has been related to increased privacy and a reduction in the net path loss. When the antenna beams become extremely narrow (large apertures), the volume of the atmosphere intercepted by the beams does not contribute as much to the scattering process<sup>8</sup> as it would with wider beams. The result can be regarded as an increase in o-h loss or as a failure to realize the full plane-wave antenna gain; the latter view is presently more prevalent.

This aperture-to-medium coupling loss  $L_c$  has been defined theoretically<sup>2</sup> under the assumption of identical terminal antennas. The magnitude of  $L_c$  depends on antenna beam width and distance between stations. As shown in Fig. 3,  $L_c$  is a function of  $w/w_d$ , where  $w$  is the beam width and  $w_d$  the angular distance between stations for an

assumed radius of the earth of 5,000 miles. Loss  $L_c$  is a function of distance only for a given antenna beam width.

An example of this dependence on distance is given in Fig. 4 for beam widths of 0.5, 1.0 and 2.0 degrees. It is difficult to determine  $L_c$  experimentally, but this has been done<sup>9</sup> by Lincoln Laboratory, M.I.T. The results indicate that  $L_c$  is generally several decibels lower than predicted in Fig. 3 and 4. Temporal variations noted in  $L_c$  are indicated in Fig. 8 of Reference 9.

Besides increasing privacy, the narrowing of an antenna beam provides increased protection from the strong, interfering reflections caused by aircraft flying in or near the path. These reflections produce violent, rapid fading and furthermore, introduce multipath distortion that may be extremely deleterious to certain pulse transmissions and which may also restrict the effective information bandwidth.

A radio receiver amplifies and demodulates not only the input

signal but also the noise voltages generated in the antenna and in its own resistances and tubes. Since all antennas generate noise, all received signals are inherently contaminated by noise. To this minimum noise the receiver adds its own noise. As a practical matter, only the first two stages of a receiver contribute significantly to the noise output.

A measure of this additional noise output is the so-called noise factor that may be defined as the quotient of the s-n ratio at the receiver input terminals and the s-n ratio at the receiver output. When expressed in decibels it is called the noise figure  $F_n$ . The minimum attainable noise figure in a receiver depends largely on the state of the art. In general, the figure increases with frequency.

For receivers of current design, at frequencies above 100 mc, a conservative estimate of the noise figure in decibels is

$$F_n = 5.3 + 3.6 \log_{10} (f_{mc}/100) \quad (10) \\ = 3.6 \log_{10} f_{mc} - 1.9 \quad (f_{mc} \geq 100)$$

where  $f_{mc}$  is the frequency in mc.

For a frequency of 2,000 mc Eq. 10 yields  $F_n = 10$  db, a figure that agrees well with recent developments<sup>10</sup> in r-f amplifier design.

Noise appearing in a receiver when an antenna is connected may be considered as arising in a resistance equal to the radiation resistance of the antenna, assuming the antenna is not trained on a cosmic noise source. This thermal noise power as it affects the receiver output is

$$P_n = k T B \quad (11A)$$

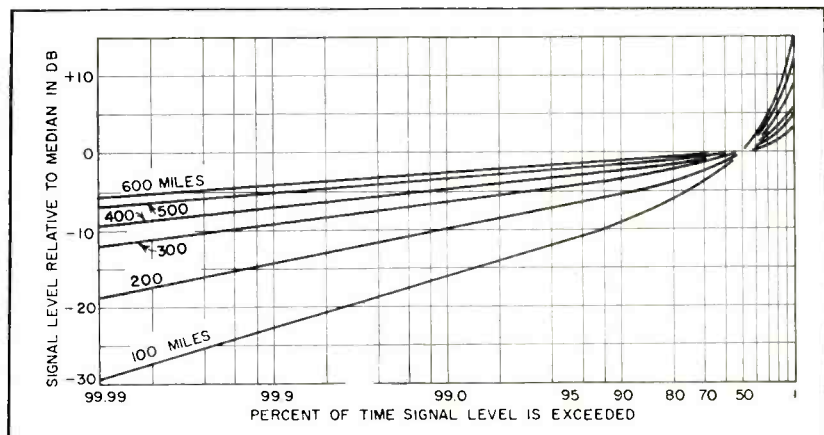

FIG. 5—Long-term fading characteristic based on 100-mc data



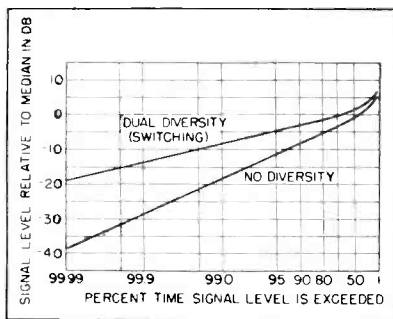

FIG. 6—Short-term fading characteristic taking place within an hour

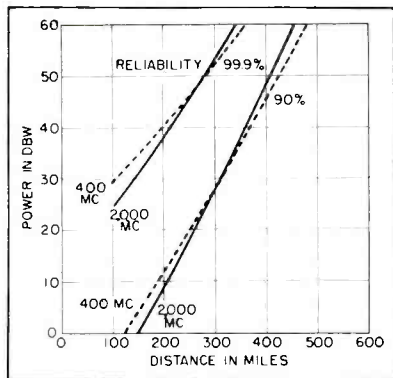

FIG. 7—Required power depends upon reliability desired

where  $P_n$  is the noise power in watts,  $k$  is Boltzmann's constant,  $T$  is the absolute temperature and  $B$  is the receiver i-f bandwidth in cps.

The minimum noise output of a receiver is proportional to the i-f bandwidth. Hence, for low noise output, the receiver must be designed for the minimum bandwidth commensurate with the rate of information involved.

As an example, assume that a proposed link is to handle a single teleprinter channel at 60 words per minute.

While in an ideal wire circuit a 60 wpm transmission would require a bandwidth of only 22.5 cps, the characteristics of practical wire transmission circuits are such that 100 cps is necessary. In a radio link more bandwidth may be used to give the required reliability in the presence of fading. For conventional frequency-shift (fsk) systems a bandwidth of about 1,000 cps is needed for a 60-wpm circuit. This value of 1,000 cps will be used as reference bandwidth  $B_0$ .

In Eq. 11A the noise introduced by the antenna in the range of frequencies discussed is described by a temperature  $T$  which is custom-

arily taken as 60 F (289 degrees absolute). Since then  $kT = 4 \times 10^{-21}$  watt-seconds, Eq. 11A becomes, if all figures are expressed in decibels

$$P_n (60F) = 10 \log_{10} B - 204 \quad (11B)$$

For the reference bandwidth  $B_0$ , Eq. 11B becomes (relative to 1 watt)

$$P_n (60F) = -174 \text{ dbw} \quad (11C)$$

For any other bandwidth simply add  $10 \log_{10} (B/B_0)$  to the right hand side of Eq. 11C. Some typical services with corresponding bandwidth figures are listed in Table I.

### Signal-to-Noise Ratio

In a communications link, the transmitter not only must deliver enough signal power to overcome noise in the receivers; it must also provide enough additional signal power for acceptable readability. Readability depends upon the signal-to-noise ratio at the detector input and upon the possible improvements achieved by the method of detection for some systems<sup>18</sup> of modulation.

With frequency modulation, for example, the improvement is proportional to the square of the modulation index. For a given information rate the latter can be increased only at the expense of greater bandwidth, which in turn involves more thermal noise and hence raises the level to which a signal must rise before the improvement can be realized.

In the examples in this discussion it is assumed that an input signal-to-noise ratio of 10 db is just acceptable for reception of 60-wpm teleprinter. With other

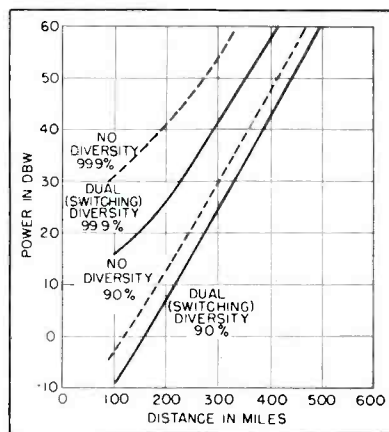

FIG. 8—Advantage of dual diversity for teleprinter channel

Table I—Teleprinter and Voice Requirements

Teleprinter, 60 wpm, fsk 425 cps	i-f band- width <sup>11</sup>	db added to -174 dbw (Eq 11C)
1 channel	1,000 cps	0
4 channels	1,700	2.3
12 channels	3,400	5.3

Voice, 4 kc per channel	Subcarrier modulat- ing fre- quency	i-f band width <sup>12</sup> (mod index = 1.5)	db added to -174 dbw (Eq 11C)
12 channels	12-60 kc	468 kc	26.7
24 channels	12-108 kc	842 kc	29.3
36 channels	12-156 kc	1,220 kc	30.9

systems an adjustment of this figure will be necessary; for example, in commercial (a-m) television a signal-to-noise ratio of at least 40 db is required for high-grade service.

### Fading Safety Margins

The o-h loss  $L_o$ , shown in Fig. 2 represents a median value obtained from experimental data. There is a long-term, seasonal fading that is not yet completely known for the entire frequency range 100-5,000 mc. However, some very complete data<sup>1</sup> have been obtained through transmissions in the commercial f-m band centered at 100 mc. It is this long-term fading characteristic that is displayed in Fig. 5.

Other experimental evidence indicates that the 100-mc information may be applied to much of the uhf range. As Fig. 5 shows, the long-term fading becomes less and less pronounced as the length of the link is increased. For 99-percent reliability on a long-term basis it is necessary to supply a margin of about 11 db to the median o-h loss for a path 200 miles long, while at 400 miles only 5.0 db need be supplied.

Short term, within-the-hour, fading follows a Rayleigh law; this is shown in Fig. 6 for a nondiversity system, and for a dual-diversity system that merely utilizes the better of two signals received in widely separated antennas. This technique is known as switching diversity and is less effective than combining diversity.<sup>14</sup>

In computing the total safety margin for fading, it is well to

note that long-term and short-term fading are essentially independent. Long-term fading establishes the immediate median level upon which within-the-hour fading is superimposed. It is thus reasonable to strive for a system that will possess a given signal-to-noise ratio for at least a certain percentage of time on a long-term basis and in addition will provide perhaps equal protection on a short-term basis.

Whatever combinations of fading margins are used, there will be periods of the year characterized by low path loss during which most of the fading margin incorporated results in the realization of an unusually high within-the-hour reliability. Weighting of the two types of fading margins will be influenced by the kind of information to be transmitted and whether errors will accumulate often enough to be objectionable.

A complete consideration involves not only the fading statistics shown in Fig. 5 and 6 but also the effect of the rate of fading upon the transmitted information. The fading rate increases with frequency.<sup>1</sup>

In an illustrative example reliability will be assumed for  $q$  percent of the time on a long-term basis along with reliability  $p$  percent of the time on a short-term basis. The two fading margins are simply added.

### Terminal Loss and Site Noise

Certain other losses are always considered when designing o-h links. These are losses in transmission lines and connectors at each terminal and losses in effective operating margins owing to site noise.

Transmission line and connector losses arise from the attenuation characteristics of the lines connecting transmitter to antenna, antenna to receiver, from the power wasted in impedance mismatches at each terminal and from power lost to connector junctions. These losses generally increase with frequency. The losses at transmitter and receiver may be conveniently grouped together and denoted by  $L_j$ . A typical behavior of this loss in decibels is

$$L_j = 5 \log_{10} (f_{mc}/100) = 5 \log_{10} f_{mc} - 10 \quad (12)$$

The losses  $L_j$  should be evaluated

**Table II—System Parameters At 400 Mc**

Item	100 mi	200 mi	300 mi	400 mi	500 mi	600 mi	Remarks
$L_{fs} + L_{oh}$	185	20	221	239	257	275	Eq 2 and 3
$L_j$	3.0	3.0	3.0	3.0	3.0	3.0	Eq 10
$G_s$	-52	-52	-52	-52	-52	-52	20-ft dish
$L_c$	0	0.9	1.8	2.7	3.6	4.5	from Fig. 3
$s/n$	10	10	10	10	10	10	acceptable teleprinter
$F_n$	7.5	7.5	7.5	7.5	7.5	7.5	Eq 8
$10 \log_{10} B$	30	30	30	30	30	30	$B = 1,000$ cps
$10 \log_{10} kT$	-204	-204	-204	-204	-204	-204	$T = 60$ F dbw
$P_m$	-20.5	-1.6	17.4	36.2	55.1	75.0	median
$ML_{90}$	9.0	5.5	3.5	2.5	2.0	1.8	based on 100-mc data (Fig. 5)
$MS_{90}$	8.0	8.0	8.0	8.0	8.0	8.0	no diversity Fig. 6
$P_{90}$	-3.5	11.9	28.9	46.7	65.1	83.8	plotted in Fig. 7
$ML_{99.9}$	22.5	14	8.5	7.0	5.0	4.0	based on 100-mc data (Fig. 5)
$MS_{99.9}$	28	28	28	28	28	28	no diversity Fig. 6
$P_{99.9}$	30.0	40.4	53.9	71.2	88.1	106	plotted in Fig. 7
$P^{(2)}_{90}$	-8.8	6.6	23.6	41.4	59.8	78.5	dual diversity switching Fig. 6
$P^{(2)}_{99.9}$	15.2	25.6	39.1	56.4	73.3	91.2	dual diversity switching Fig. 6

**Table III—System Parameters At 2,000 Mc**

Item	100 mi	200 mi	300 mi	400 mi	500 mi	600 mi	Remarks
$L_{fs} + L_{oh}$	199	216	235	253	271	289	Eq 2 and 3
$L_j$	6.5	6.5	6.5	6.5	6.5	6.5	Eq 10
$G_s$	-80	-80	-80	-80	-80	-80	20-ft dish
$L_c$	3	7	10	13	15	16	from Fig. 3
$s/n$	10	10	10	10	10	10	acceptable teleprinter
$F_n$	10	10	10	10	10	10	Eq 10
$10 \log_{10} B$	30	30	30	30	30	30	$B = 1,000$ cps
$10 \log_{10} kT$	-204	-204	-204	-204	-204	-204	$T = 60$ F; dbw
$P_m$	-25.5	-4.5	17.5	38.5	58.5	77.5	median
$ML_{90}$	9.0	5.5	3.5	2.5	2.0	1.8	based on 100-mc data Fig. 5
$MS_{90}$	8.0	8.0	8.0	8.0	8.0	8.0	no diversity Fig. 6
$P_{90}$	-8.5	9.0	29.0	49.0	68.5	87.3	plotted in Fig. 7
$ML_{99.9}$	22.5	14.0	8.5	7.0	5.0	4.0	based on 100-mc data Fig. 5
$MS_{99.9}$	28	28	28	28	28	28	no diversity Fig. 6
$P_{99.9}$	25.0	37.5	54.0	73.5	91.5	99.5	plotted in Fig. 7
$P^{(2)}_{90}$	-13.8	3.7	23.7	43.7	63.2	82.0	dual switching diversity Fig. 6
$P^{(2)}_{99.9}$	10.2	22.7	39.2	58.7	76.7	94.7	dual switching diversity Fig. 6



carefully for a given equipment, transmission line and operating condition. In practice, these losses may be found to be greater than that indicated by Eq. 12 and frequently losses that are charged mistakenly against the propagation path will be found to occur at the terminals.

At any appreciable distance from a terminal the cross section of even a narrow antenna beam is large, so that the system may become vulnerable to impulse noise generated near the path by a city, a town, a manufacturing activity or a radar transmitter. In that event, an additional amount of power may be required for the link to overcome this site noise. No simple rule exists for the margin to be allowed for this kind of noise, since

The symbols have the same meanings as before and  $s/n$  is the signal-to-noise ratio expressed in decibels. For service at least  $q$  percent of the time on a short-term and a long-term basis

$$P_q = P_m + ML_q + MS_q \quad (14)$$

where  $P_q$  is the power required for  $q$  percent reliability,  $ML_q$  is the long-term fading margin for  $q$  percent reliability and is a function of distance,  $MS_q$  is the short-term fading margin for  $q$  percent reliability.

Tabulations of the various losses and system parameters are given for 400 mc in Table II and for 2,000 mc in Table III. The results are plotted in Fig. 7 for the 90 and 99.9-percent reliabilities desired. While the tables show powers in excess of 60 dbw (1 megawatt) for

presence of obstacles in the path. It is assumed that along the path to the horizon the clearance between the path and any obstacle exceeds the radius of a first Fresnel zone. If obstacles are present, the computation must be altered as recommended<sup>1, 10</sup> in the literature.

The advantage to be gained by employing dual diversity of the switching type at one terminal is illustrated in Fig. 8 for 400-mc transmission. While diversity can be regarded as a means of saving transmitted power, if it is done by spacing the receiving antennas, or as an increase in reliability, it is instructive to evaluate its advantage in extending the working distance possible with a given transmitted power.

Table IV presents the additional distances obtainable by including the diversity fading margins as scaled from Fig. 8. With higher orders of diversity and with systems that combine<sup>17</sup> the outputs of spaced antennas, greater gains in distance or savings in power are possible.

#### REFERENCES

- (1) J. W. Herbstreit, P. L. Rice, E. B. Sprecker, Survey of CRPL Research in Tropospheric Propagation, National Bureau of Standards Report No. 3,520.
- (2) I. H. Gerks, Factors Affecting Spacing of Radio Terminals in a UHF Link, Collins Radio Co., Report No. CTR-126, Feb. 18, 1955.
- (3) K. Bullington, Radio Propagation Beyond the Horizon in the 40-4000 mc Band, *Proc IRE*, 41, p 132, 1953.
- (4) W. E. Gordon, Radio Scattering in the Troposphere, *Proc IRE*, 43, p 23, 1955.
- (5) J. Feinstein, The Role of Partial Reflections Beyond the Horizon, *Trans IRE PGAP-2*, p 2, Mar. 1952.
- (6) F. H. Northover, Long Distance VHF Fields, *Canad Jour Phys* 33, p 241 and p 316, 1955.
- (7) J. Ortusi, The Various Theories on Propagation of Ultra-Short Waves Beyond the Horizon, *Trans IRE PGAP-3*, p 86, Apr. 1955.
- (8) H. G. Booker and J. T. deBettencourt, The Theory of Radio Transmission by Tropospheric Scattering Using Very Narrow Beams, *Proc IRE*, 43, p 281, 1955.
- (9) G. L. Mellen, W. E. Morrow, A. J. Poté, W. H. Radford and J. B. Wiesner, UHF Long Range Communication Systems, *Proc IRE*, p 1,269, Oct. 1955.
- (10) J. E. Beggs, N. T. Lavoo, A Triode Useful to 10,000 mc, *Proc IRE* 43, p 15, 1955.
- (11) Federal Telephone and Radio Co., "Reference Data for Radio Engineers", 3rd Edition; bandwidths, p 18; noise, p 451; signaling speeds, p 507; antennas, p 437.
- (12) D. G. Fink, "Television Engineering", 2nd Edition, p 412, McGraw-Hill, New York, 1952.
- (13) H. S. Black, "Modulation Theory", Chap. 14; D. Van Nostrand, New York, 1953.
- (14) C. L. Mack, Jr., Diversity Reception in UHF Long-Range Communications, *Proc IRE*, p 1,281, Oct. 1955.
- (15) National Bureau of Standards, Washington, D. C., Circular No. 462, p 151.
- (16) K. Bullington, Propagation of UHF and SHF Waves Beyond the Horizon, *Proc IRE*, 38, p 1,221, 1950.
- (17) J. R. Day, Beyond-Horizon Signals Extend Communications, *ELECTRONICS*, p 122, Oct. 1955.

Table IV—Additional Distance With Diversity at 400 Mc

Reliability	Order of Diversity	1 kw	10 kw	100 kw	1,000 kw
90%	1	308 mi	366 mi	420 mi	472 mi
90%	2	336	384	448	500
	Additional Distance:	28	28	28	28
99.9%	1	98	200	275	340
99.9%	2	217	300	360	420
	Additional Distance:	119	100	85	80

this will depend on the character of the noise and the way in which the improvement normally afforded by the modulating method<sup>13, 15</sup> is degraded in its presence.

#### Illustrative Example

An organization wishes to provide over-the-horizon communication for a number of links of various lengths and has two frequency allocations at its disposal, 400 mc and 2,000 mc. Equipment can be obtained for these frequencies. The paraboloidal antenna aperture must not exceed 20 feet in diameter because of cost and mounting difficulties. It is desired to determine the power required for both 90 and 99.9-percent reliability, for 60-wpm teletype, single channel, fsk, with a frequency shift of 425 cps.

The power required, in decibels above 1 watt, for median service, 50-percent the time, is given by

$$P_m = L_{fs} + L_{oh} - G_s + L_c + L_i + F_n + (s/n) + 10 \log_{10} B_o - 204 \quad (13)$$

completeness, the curves in Fig. 7 are carried only up to this level.

#### Interpretation

Added gain provided by the 20-foot paraboloid at the higher frequency is hardly sufficient at the longer distances to overcome the additional free-space loss. This is the result of the increasing effect of  $L_c$ , the aperture-to-medium coupling loss for the narrowed beam.

Curves in Fig. 7 are plotted for distances from 100 to 600 miles. Some reservations should be attached to extension of the curves for distances of less than 100 miles. In that range, depending upon the height of the terminal antennas, there may be an appreciable diffracted surface wave present that would serve to widen the fading range and in any case, would provide substantially different short-term fading characteristics<sup>1</sup> than are indicated by Fig. 6.

The curves do not include any gains or losses incurred by the



Meter on police-car dashboard records speed of passing car. Radar transmitter and receiver are mounted in trunk

# How Accurate Are

**SUMMARY** — Erroneous readings of radar units used by police departments to enforce speed laws arise from carrier frequency shift of transmitter, parallax when radar car is parked off highway, and multiple reflections from other passing cars or nearby objects. However, these errors usually give the speeder a break

**M**OST SPEED radars commercially available have the basic form shown in Fig. 1 and depend upon precise measurement of the Doppler shift in signal frequency. Energy radiated by the transmitter at a frequency  $f_0$  is reflected by the moving target and gives rise to a

detected signal having a frequency  $f_0 + f_d$ .

The relative speed  $V$  of the automobile is related to the Doppler frequency  $f_d$  and to  $f_0$  by

$$V = C f_d / 2 f_0$$

where  $C$  is velocity of propagation

of the radar waves. Therefore, if  $f_0$  is known,  $f_d$  provides a direct and precise measure of  $V$ .

In the system shown the received signal is mixed with feedthrough power from the transmitter and the difference frequency  $f_d$  is filtered out and amplified. The signal is then limited and a frequency counter and meter or pen recorder provide a direct speed reading. Photographs show a typical radar installation in a police car.

The principal sources of error in the radar used resulted from shifts in carrier frequency, counter and/or meter inaccuracies and errors in reading due either to parallax or human error. Other errors resulted from the fact that the quantity measured is the relative speed and not the linear speed of the vehicle

Table I—Speed-Counter Errors

Input Frequency in cps	Calculated Speed in mph	Indicated Speed in mph	Radar Error in mph	Percent Error
60	8.2	7.0	-1.2	14.6
120	16.4	15.0	-1.4	8.5
180	24.6	23.5	-1.1	4.5
240	32.9	33.0	+0.1	0.3
300	41.1	41.0	-0.1	0.2
360	49.3	49.0	-0.3	0.6
420	57.6	57.5	-0.1	0.2
480	65.8	65.5	-0.3	0.5
540	73.9	73.5	-0.4	0.5



## ENGINEERS AS EXPERT WITNESSES

Nationwide, law-enforcement agencies are readying a crackdown on careless driving. The coming year may see vastly expanded use of radar for speed control.

However, in several instances the validity of radar speed readings have been challenged in court. Such cases may become more numerous.

The arresting agency must then call upon a qualified expert to testify to the accuracy of the radar. Thus, it behooves the electronics engineer, who may be called upon, to know something of the accuracies attainable with a typical unit.

The author describes results of independent accuracy tests made by him for the City of Buffalo traffic department. The results were observed on a single unit and cannot be applied in general. However, they indicate the precision that can be achieved and point out certain situations in which operation is unreliable

By **J. Q. BRANTLEY, JR.**

Consultant, Traffic Department  
City of Buffalo  
Buffalo, New York

# Radar Speed Meters?

relative to the ground. Reference to Fig. 2A shows that the speed of the car relative to point  $P$  is equal to  $V_0 \cos \theta$ . The error in the radar observation comes from the cosine factor and is negligible for small values of  $\theta$ . It always yields a reading which underestimates the actual speed of the target vehicle.

The first method used to measure radar performance involved measurements of  $f_0$  followed by meter calibrations taken with known frequency inputs to the counter. The second method employed a precision odometer attached to a test vehicle. Radar readings were compared with readings obtained on the odometer and related to time. The first set yields information about the inherent accuracy of the radar and the odometer readings shed light on the overall performance under actual operating conditions.

### Precision Measurements

Precise error measurements were made by injecting signals of known frequency into the speed counter. Integral multiples of power-line frequency were used. The corresponding speed represented by each

of these frequencies was computed from the Doppler equation using the measured carrier frequency of 2,447 mc. Line frequencies were accurate to within 0.08 cycle. The results are shown in Table I.

In actual operation, the carrier frequency will drift varying amounts depending upon external factors such as temperature and line voltage. It was not possible to make long-term frequency checks on the unit tested but it was assumed frequent adjustments would

keep  $f_0$  within  $\pm 10$  mc. Based upon this assumption the maximum variation in speed readings will be approximately  $\pm 1.4$  mph at 35 mph.

It was noted during these tests that the readings were sensitive to voltage variations in the radar-car power supply. Subsequent tests showed that the errors in Table I which were taken with car generator off, were increased by from 5 to 6 percent with the engine idling.

Numerous tests were made in the

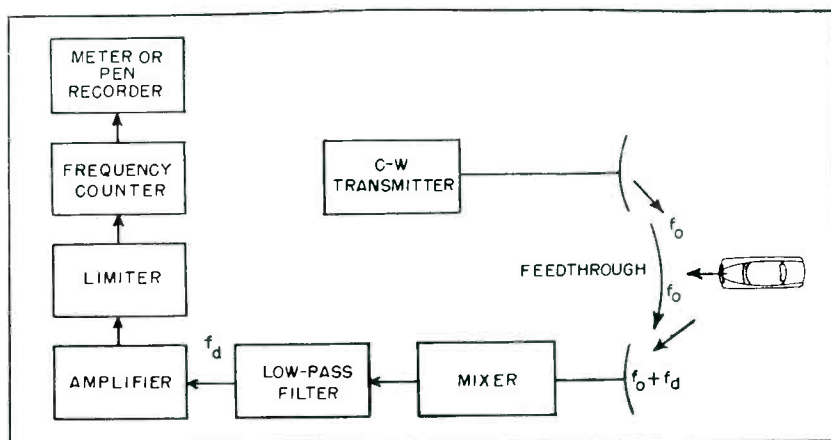

FIG. 1—Speed radar depends for its operation on Doppler frequency shift

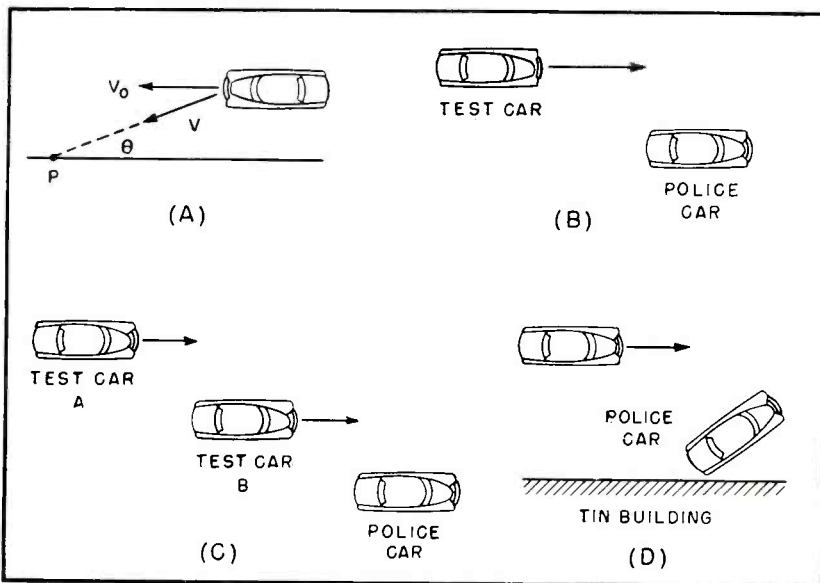

FIG. 2—The parallax problem (A), typical installation (B), condition where echoes from two passing cars may cause inaccuracy (C) and test setup for studying effect of reflection from nearby object (D)

manner illustrated in Fig. 2B. Radar readings made by police officers were compared with those made by an observer riding in the test vehicle and reading the odometer. The test car was driven close to the radar car to minimize cosine errors. Table II shows the results of these runs.

The total errors include contributions from the radar itself, external factors such as reflections and reading errors, the cosine term and the odometer. Because of the high degree of inherent radar accuracy it may be assumed that it is more accurate than the odometer. However, comparison of the radar readings with those of the odometer makes it possible to estimate the influence of factors not associated with the internal operations of the radar, such as the effect of the cosine factor and secondary radar reflections.

While the spreads were relatively large the average errors were small in all speed ranges. Readings which overestimated the target's speed

were rare and on the average the errors favored the driver.

To confirm expected cosine errors, some runs were made which were similar to those of Fig. 2B, but with a wider passing margin. Passes were made at distances from 6 to 15 feet with increasing errors. Readings generally took place at ranges between 50 and 65 feet from the radar. When cosine errors were estimated for the individual cases and compensated for, the residual errors were comparable to those of Table II.

To assess the radar's performance in situations where two cars pass it simultaneously several runs of the type shown in Fig. 2C were made. Several speed differentials between A and B were tried and runs were made at various values of individual speeds. The readings varied over such a wide range that they were considered unusable for determining the speed of either A or B. In one case A's speed was 35.5 mph, B's was 21 mph and the radar gave a single reading of 24 mph.

Tests were also run in the manner illustrated in Fig. 2D. These were intended to determine the effects of nearby reflecting objects. The readings obtained gave speeds which were consistently lower than would normally be the case. The indications were similar to those observed with two cars because the radar sees not only the car itself but its image in the reflector as well.

Maximum parallax errors were measured by setting the meter precisely at given speeds and then reading values observed from either side. The results are tabulated in Table III. By observing the manner in which police officers made this reading, it was estimated that errors due to this effect were practically always less than 0.2 mph.

### Conclusion

Speed errors made by the radar were almost always in a direction which favored the passing vehicle. The one exception occurred when observations were made with the engine in the radar car idling. The radar then consistently overestimated actual speeds.

Principal errors arose from differences between actual and relative speeds, speed-counter inaccuracies especially those due to shifts in line voltage, meter inaccuracies and parallax. Additional errors can be expected as a result of carrier-frequency shifts. While these were not measured over a long period it is assumed that they are periodically checked and kept within  $\pm 10$  mc. Periodic calibration of the counter and speed meter are necessary but the reported measurements were made without prior calibration.

The author acknowledges the assistance of Walter A. Flood and John J. Earshen in conducting these tests.

Table II—Speed Meter vs Odometer

Speed Ranges (mph)	20-30	30-40	40-50
Spread in errors (mph)	6.3	4.0	1.5
Maximum error (mph)	-5.3	-3.0	-2.0
Minimum error (mph)	+1.0	+1.0	+0.5
Average total error (mph)	-1.7	-0.9	-1.1
Average radar error (mph)	-0.9	-0.03	-0.2
(See Table I)			

Table III—Parallax Errors

Speed	Maximum Error
60	$\pm 2.0$
40	$\pm 1.5$
30	$\pm 1.0$
20	$\pm 1.0$



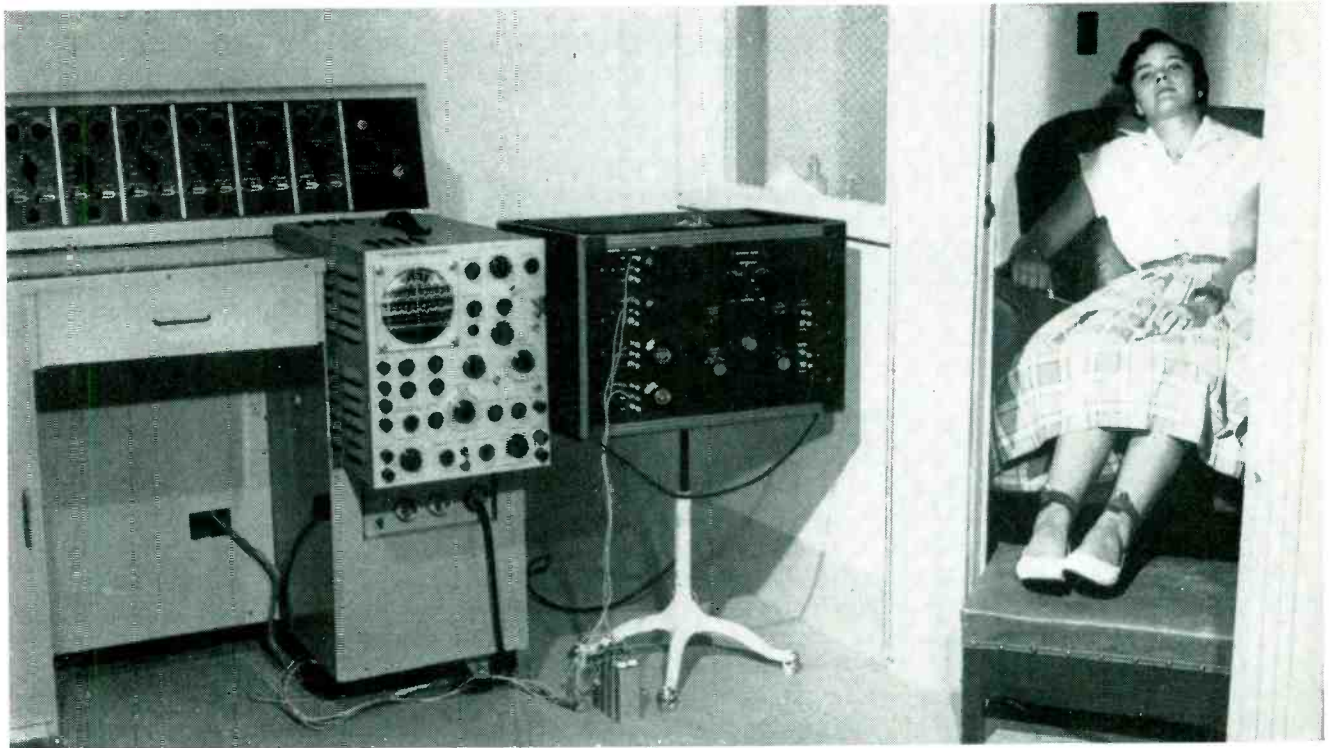

Electronic switch at center measures heart-muscle potentials of patient at right. High-gain preamplifiers of electroencephalograph at left bring signal levels up to that required by switch. Switch effectively converts oscilloscope into four-beam instrument

# Multichannel Switch For Biological Observations

**SUMMARY** — Simultaneous observation of four signals is provided by oscilloscope accessory. Each channel is a d-c amplifier with a gain of five. Frequency of switching between channels is variable between 1 and 30,000 cps. Unlimited number of channels can be added if necessary

**D**ESIGNED as an oscilloscope accessory, the electron switch to be described permits simultaneous observation of related biological phenomena such as electrical potentials occurring across membranes in the body of an animal or man.

The instrument as constructed provides a maximum of four channels; the principle of operation, however, makes it possible to have any number of channels desired by the addition of five triodes for

**By ROBERT W. WOODS**

*College of Medical Evangelists  
Loma Linda, California*

each additional channel. A channel switch sets the number of channels in use and a channel-stop switch confines the operation to continuous observation of any single channel desired. Switching transients are of extremely short duration, essentially limited by stray capacitance. Frequency of switching is continuously variable

from 1 to 30,000 cps, the repetition rate being 1 to 30,000 divided by the number of channels in use.

In addition to the signal output, a pulse output with either positive or negative polarity is available. If the internal multivibrator is made inoperative, the same terminals may be used as an external-pulse input to actuate the switching circuits. This external pulse may be regularly produced at low frequencies or irregularly, as desired.

In the diagram of Fig. 1, the

output of multivibrator  $V_1$  is made asymmetrical so the fine frequency control may be affected by  $R_1$  in the left-hand grid circuit, which lengthens the time constant of discharge for that grid. The right-hand grid circuit, from which the output pulse is taken, has a relatively short time constant of charge and discharge and since the transient time of switchover in this grid is independent of the setting of the fine frequency control, there is a more consistent pulse shape. Switch  $S_1$  inactivates the multivibrator. This permits pulsing from an external source through  $C_1$  and  $S_2$ .

In the pulse-forming circuit, triode  $V_{2A}$  is biased positively so an additional positive pulse is ineffective, but it is responsive to a negative pulse. From the plate of  $V_{2A}$  the resultant positive pulse is fed through differentiator  $C_2R_2$  to the grid of  $V_{2B}$  which is biased to cutoff. The negative pulse output of  $V_{2B}$  is available for control of the switching circuit.

Dual-triodes  $V_3, V_4, V_5$  and  $V_6$  are

flip-flop or trigger-circuit stages. The negative pulse formed in  $V_2$  is fed to the left-hand grid of each of these flip-flops in parallel. This negative pulse would be without effect if the left-hand triodes of the flip-flops are nonconducting; but if one of them, say flip-flop  $V_3$ , is conducting the negative impulse would cut it off and the corresponding right-hand triode would begin conduction producing a negative pulse on its plate. This pulse, fed to the right-hand grid of flip-flop  $V_4$ , would cut off its right-hand triode, cause its left-hand triode to conduct and thus prepare it for reception of the next pulse from  $V_2$ . Successive pulses from  $V_2$  would step the left-hand conduction from flip-flop  $V_3$  to  $V_4$  to  $V_5$  to  $V_6$ .

### Ring Operation

If the last in line is connected back to the first making a ring, a cyclic rotation of this left-hand conduction is obtained which can be used to switch the channels. The number of flip-flops in this ring determines the number of channels in

use. Switch  $S_3$  makes it possible to feed flip-flop  $V_3$  from the output of  $V_4$  or  $V_5$ , etc., thus controlling the number of flip-flops in the ring and the number of channels in use.

When the number of channels is three or more, it is necessary to establish the condition that only one flip-flop shall have left-hand conduction. When the instrument is first turned on, for example, more than one flip-flop may show left-hand conduction and a form of multiple wave will travel around the ring. The single condition may be established, however, by returning one of the right-hand grids, for a time as long as one cycle of operation, directly to the common cathode return at  $-255$  volts.

The various conducting cycles travel around the ring and stop at the flip-flop with the shorted grid, leaving that flip-flop the only one with left-hand conduction. Switch  $S_4$  performs this function, but since shorting the grid stops the switching  $S_4$  has been designed to stop the switching on any desired channel at the will of the operator and

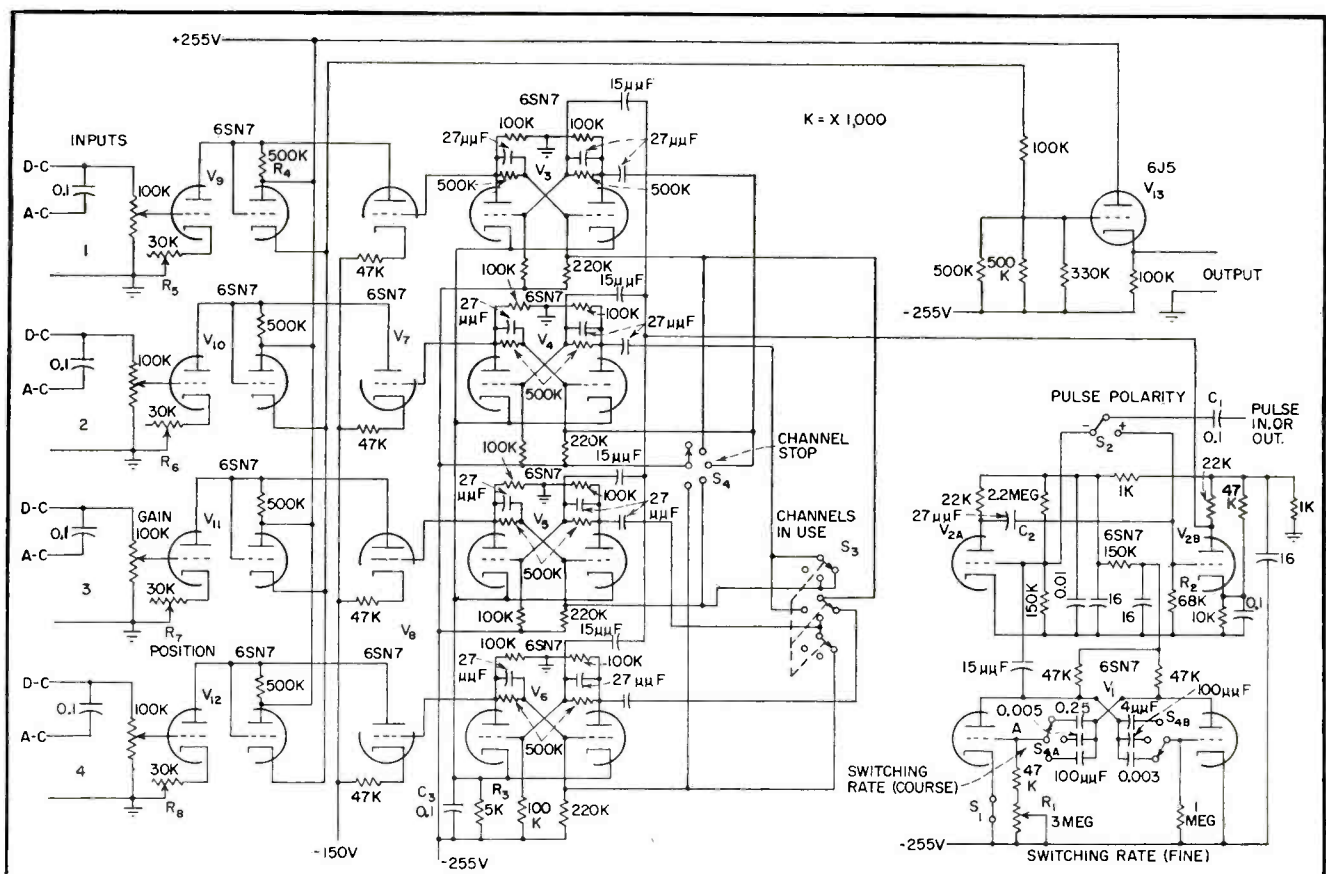

FIG. 1—Electronic switch requires five triode stages for each input channel. Voltages indicated are from regulated supplies



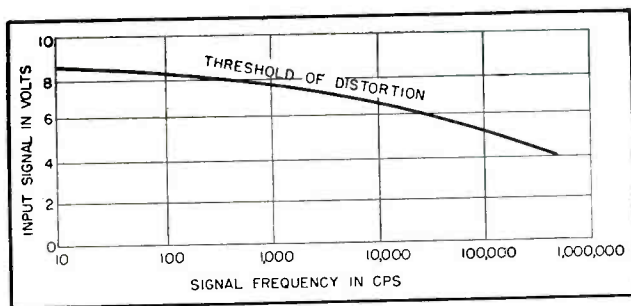

FIG. 2—Threshold of distortion vs input signal and frequency

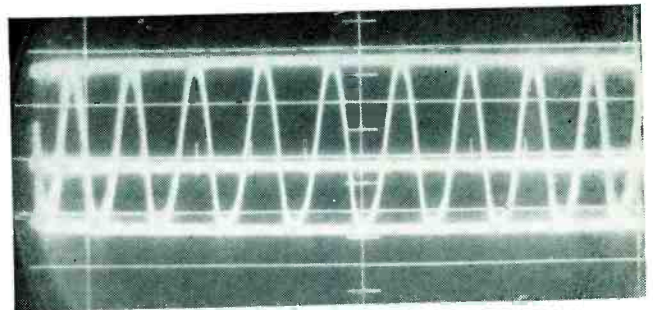

FIG. 3—Using spare channels as markers

serves as a channel stop switch as well as to establish the one-channel-at-a-time condition.

The  $C_3$ - $R_3$  bias combination for the flip-flops maintains a constant bias voltage since the number of conducting triodes is invariable. Capacitor  $C_3$  is necessary to smooth switching transients.

Sections of  $V_7$  and  $V_8$  are direct coupled to the plates of corresponding left-hand triodes of the flip-flops. If the flip-flop is not conducting the plate voltage is high and the corresponding  $V_7$  or  $V_8$  triode is conducting, but if the flip-flop is conducting, the  $V_7$  or  $V_8$  triode is cut off and is not conducting. All of the  $V_7$  or  $V_8$  triodes except one are conducting at any one instant.

### Signal Inputs

Dual-triodes  $V_9$ ,  $V_{10}$ ,  $V_{11}$  and  $V_{12}$  are the input stages. The first triode sections are essentially triode amplifiers with gain controls in the grid circuits and variable bias or positioning controls in the cathode circuits. These amplifiers are direct coupled to the second triode sections, which operate as cathode followers. Gating is accomplished, in the first channel for example, by drawing the plate current of the first triode section of  $V_9$  and the associated triode of  $V_7$  through the same plate-load resistor,  $R_1$ . If the  $V_7$  triode is conducting, the drop through  $R_1$  reduces the grid voltage of the cathode follower to a point beyond cutoff and the plate voltage of the first triode of  $V_9$  to a point near ground potential. Thus only one channel at a time is operative.

The output of the several cathode followers is connected in parallel and fed to the grid of  $V_{13}$ , the output cathode follower. The voltage divider in the grid circuit of  $V_{13}$  is

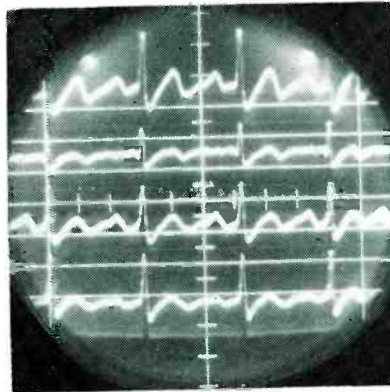

FIG. 4—Simultaneous four-lead electrocardiograph traces

adjusted so with positioning controls  $R_5$ ,  $R_6$ ,  $R_7$  and  $R_8$  set at the midpoint of their range, the voltage at the cathode of  $V_{13}$  is zero with respect to ground. The values given accomplished this result with the tubes used; other tubes may require a different ratio.

### Modifications

To keep the frequency of the multivibrator independent of external capacitance effects at the synchronizing input connections, an isolating triode amplifier capacitance coupling a positive pulse to one of the grids of  $V_1$  at point A would be a valuable addition to the circuit.

As it stands, the unit is a high-level switching device because of a 60-cycle hum pickup of approximately 0.001 volt. By using d-c on the filament of  $V_{13}$  this hum is greatly reduced, but not entirely eliminated. Direct-current filament power for all amplifier filaments would probably increase the utility of the instrument for low-level switching. Better shielding and placement of parts for shorter leads would also decrease the hum-pickup problem.

The amplifier section of the switch, consisting of  $V_9$  to  $V_{12}$  and  $V_{13}$ , was tested for fidelity by applying a sine wave to one of the inputs, with gain wide open, and varying the amplitude until the output wave showed visible evidence of distortion on the oscilloscope. This was repeated at spot frequencies from 10 to 100,000 cps and the threshold of distortion, the amplitude of the input signal at which distortion just becomes evident, was plotted against frequency as shown in Fig. 2.

The channels may be used for measurement. For example, if channel 1 is to carry the signal, channel 2 can be superimposed on the zero-signal trace of channel 1 to mark the zero line. With the signal applied to channel 1, channels 3 and 4 can be moved to mark the positive and negative peaks as shown in Fig. 3. Subsequently a calibrated voltage applied to channel 1 could be adjusted to make channel 1 coincide with the peak marker. A time comb could also be applied to channel 2.

To date, the instrument has been used for measurement of peak potentials and for simultaneous observation of the four standard leads in electrocardiography as shown in the photograph and Fig. 4.

In Fig. 4, channels 1 to 4 are positioned top to bottom. Channel 1 carried the standard first lead (right arm against left arm), channel 2 the second lead (left arm against left ankle), channel 3 the third lead (right arm against left ankle) and channel 4 the fourth lead (chest against left ankle). This setup is shown in the photograph.

A word of appreciation is in order to Gordon Simkin, technical assistant, for his work on this project.

# Automatic Colorimeter

**SUMMARY** — Three-phototube measuring head with associated electronic equipment give readings of percent saturation on three meters marked red, blue and green. Can be used for quality control of color television picture tube production

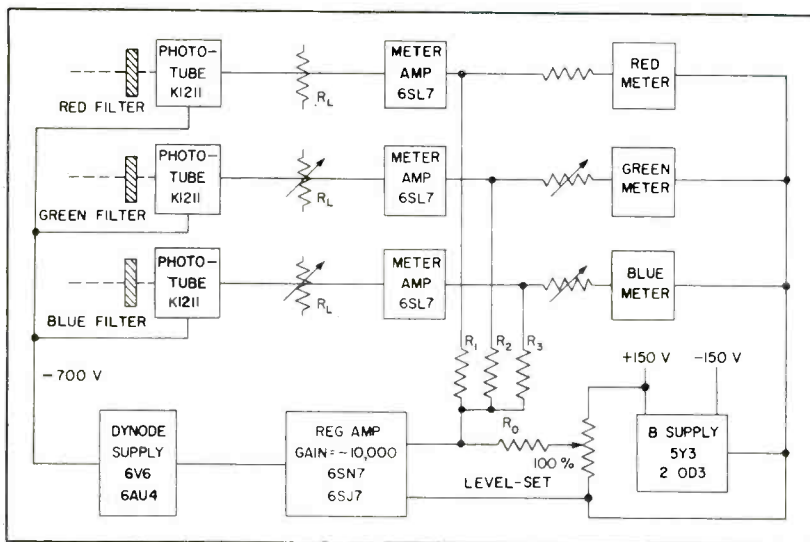

FIG. 1—Negative feedback is used to stabilize colorimeter against source brightness variations. Meters indicate primary color proportions

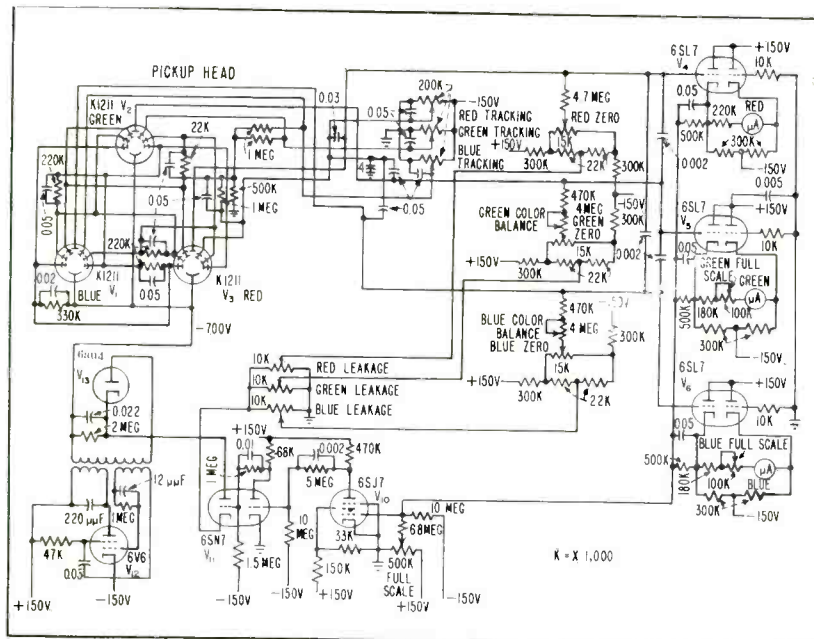

FIG. 2—Complete schematic diagram illustrates controls used to calibrate instrument with white light source

**D**EVELOPED primarily for checking tricolor television tubes by production personnel the colorimeter to be described imitates the color vision properties of the human eye. When the color pickup head is aimed at a luminous surface, its color content is analyzed and three meter indications are obtained within a second or so provided the surface brightness is sufficient.

Selectively energized through red, green and blue filters, the meter indications are a direct measure of the primary color proportions and numerically define the hue and saturation of the luminous source. Color comparison accuracy is good as time lapse between successive measurements can be only a few seconds. Source brightness within limits has a negligible effect on the indicated color proportions.

The pickup head is housed in an aluminum shell 6 inches long and 2 1/4 inches in diameter. The circular red, green and blue color transmitting filters are arranged in an equilateral triangle. The filters are of gelatin film cemented between 22-mm glass disks. They are fitted into blackened, undercut rims cut on end-capped aluminum shells enclosing three multiplier phototubes.

The K1211 miniature phototubes are six-stage dynode multiplier types having end-on cathodes of 1/2-inch diameter and S-11 photometric response. Cathode sensitivity is rated at 50  $\mu$ A per lumen average response to a 2,870 K incandescent lamp. The amplified anode current



# Checks TV Color Tubes

By **EMIL SANFORD**

Tube Engineering Department  
Allen B. Du Mont Laboratories, Inc.  
Clifton, New Jersey

is an exponential function of the applied dynode voltages.

Since multiplier phototubes, with their built-in electrostatically focusing dynodes, are operationally disturbed by magnetic fields, the pickup head has a layer of Mumetal wrapped around the aluminum enclosures of the phototubes.

## Operation

The operation of the instrument is explained by the block diagram, Fig. 1. Light striking the cathodes of the multiplier phototubes, through the respective color filters, causes current flow in each anode load resistor. The resultant voltages are a measure of the color composition of the light source and its brightness.

However a high-gain regulating amplifier and a fixed-voltage dynode power supply control the operating voltage applied to the parallel-connected phototube dynodes. The phototubes are gain controlled by a common signal. This signal is developed from the light-source in-



Color measurements are made by placing pickup head of colorimeter on face of operating tricolor tube and noting three meter readings

tensity and automatically suppresses the brightness variations. The instrument thus responds only to the color composition of the light source.

The phototube anode voltages are transferred to the indicating meters through cathode-follower meter amplifiers. From each point a sampling current is developed in  $R_1$ ,  $R_2$ ,  $R_3$  whose sum is balanced against the adjustable current through  $R_0$  of opposite polarity. The voltage at the junction of these four resistors is the input signal to the regulating amplifier. The amplifier has a reversed-polarity output to the dynode voltage divider and forms a negative feedback loop.

The meter voltage sum is thus constrained to a fixed value which is adjusted to exactly the full-scale value of one meter by the level-set control. Since the meters and phototubes are linear, each meter deflects to the relative excitation of its respective photocathode regardless of the common light intensity. The light level must be greater than a minimum threshold value or the full-scale sum cannot be maintained.

Whenever the input light level

to the pickup head is insufficient to develop the total meter voltages to a level needed to equalize through  $R_1$ ,  $R_2$ ,  $R_3$ , the reference current in  $R_0$ , the amplifier stays saturated. The applied dynode voltages are maximum and the phototubes operate at maximum gain. An increase of the source brightness that would develop too much signal output is counteracted by the amplified difference voltage. The stabilizing ability when one or all phototubes are variably illuminated above the threshold value is:  $\Delta E_m = \Delta E_d / A_e \approx 300/3,000 = 1/10$  v, where  $\Delta E_m$  = indicating meter voltage variation for brightness changes,  $\Delta E_d$  = dynode voltage swing with regulation against brightness changes  $\approx 300$  volts and  $A_e$  = effective loop gain  $> 3,000$ .

The meters contain 50- $\mu$ a movements and with 220,000-ohm series resistors have a full-scale reading of 11 volts. Therefore,  $\Delta E_m / E_m < 1/110$  unit of full-scale error.

This is distributed among the three meter readings according to the chromaticity of the luminous source. Raising  $E_m$  would decrease the error and raise the threshold but caution is to be observed in



Internal construction of pickup head showing filters, phototubes and circuitry

operating too closely to the knee of the phototube anode characteristic.

### Circuit Details

The schematic diagram is shown in Fig. 2. The grid-cathode elements at the input of regulating d-c amplifier  $V_{10}$ - $V_{11}$  develop a contact potential that cannot be distinguished from the control signal. A variation of 0.1 volt will cause a full-scale meter error of 3 percent. The 100-percent level-set control (labeled FULL-SCALE in Fig. 2) compensates for this effect.

The phototube anode load resistors are adjustable in the green and blue channels for setting gain relative to the red channel. Each anode load resistor returns through the meter zero-set controls. The three leakage compensating controls effectively complete the zeroing circuits. The leakage controls permit application of a canceling potential that maintains zero meter readings in the absence of light input to the photocathode despite dynode voltage variations.

### Feedback Loop

The indicating meters are cathode-coupled to balance dual triodes  $V_4$ ,  $V_5$  and  $V_6$ . The green and blue meter series resistors are full scale adjusted to equal the full-scale red meter reading. The three 500,000-ohm summing resistors are tapped from each meter drive point to include the indicators in the feedback loop.

Even though the three K1211's,  $V_1$ ,  $V_2$  and  $V_3$  are paralleled, a dif-

ferential gain control condition is encountered. In practice, this would be interpreted as a color variation when only the incident brightness changed. At least two-point compensation is possible by the adjustment of the three tracking controls. These fix the voltage on the last dynode in each phototube.

Therefore, as the parallel connected forward dynodes approach the voltage levels of the last dynodes, the phototube with the highest fixed dynode voltage has the most gain reduction. The tracking adjustments are usually made to bracket the normal range of operating brightness levels. A white cathode-ray tube (P4 screen) with variable grid drive for changing brightness permits a simple checking procedure.

The dynode power supply  $V_{12}$  and  $V_{13}$  uses a relaxation oscillator to generate, in a stepup isolation transformer, a voltage which is then rectified and filtered. The 6AU4 is used for its heater to cathode insulation. Since the oscillator plate voltage is obtained from the stabilized  $\pm 150$ -volt supplies in the chassis, it is free from line-voltage fluctuation. It is limited to 700 volts to keep leakages in the multiplier phototubes at low levels.

### Calibration

The zero-settings of the color indicating meters are made when the pickup head is placed face down on any nonluminous surface. The effective dynode voltages are at a maximum and the regulating feed-

back loop is broken during this interval. An unstable dynode supply can be the cause of zero shifts at this time which result in color reading errors.

The initial adjustments of this colorimeter were made with a white television picture tube. The final white color calibration can be made and maintained with a reference white working standard such as an incandescent lamp combined with a daylight glass filter. A crt was selected having a close match to illuminant C as measured on a Barnes XYZ colorimeter. For brightness data the Weston 931 foot-lambert meter was used. This meter has a circular opening only slightly smaller than the pickup head. The adjustments require the use of a calibrating plug. This is a shallow piston-and-rod unit that closely fits the open end of the pickup head and inserts to the bottom. A circular cutout permits, by rotation, the exposure of any one of the three filter-photocathode areas.

The picture tube is operated with a square raster and 100 foot-lamberts of luminous intensity. The pickup head is centered on the raster and the calibrating plug is sequentially positioned to expose the red, green and blue filters. For each position the 100-percent level-set, green full scale and blue full scale adjustments are made. In addition, the respective leakage adjustments are completed with an opaque sheet placed on the opening of the pickup head. The results should be full-scale on one and zero readings on two meters in turn.

### Color Balance

The color balance controls are set to fix the relative meter readings to the white color standard. For illuminant C,  $R = 29$ ,  $G = 33$  and  $B = 38$  as the comparative offset to equal energy excitation, which is defined by  $R = G = B = 33\frac{1}{3}$ .

The three tracking controls are successively adjusted to maintain steady meter readings as the reference picture tube brightness is varied between 10 and 100 foot-lamberts. By reducing the brightness level to the point where the meter reading sum suddenly slumps, a check is made for the

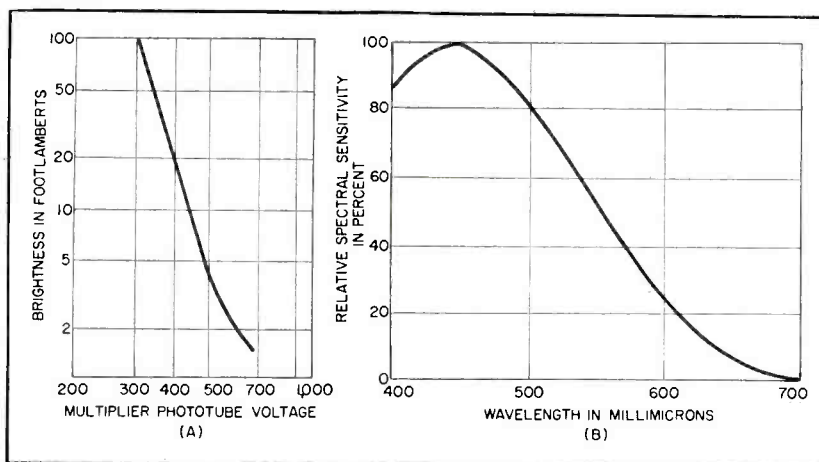

FIG. 3—Regulation of colorimeter shown by straight line above 5 foot-lamberts (A) and spectral response of K1211 phototube (B)



threshold value of response.

The colorimeter's amplitude-regulating circuit attempts to maintain a constant value of meter readings. This is illustrated by the straight line to 5 foot-lamberts on the log-log plot of dynode feedback voltage versus source brightness, Fig. 3A. The color threshold is 1.5 foot-lamberts, which is low enough for ambient lighting to contaminate color indications. Below this level the meter indications are about proportional to the brightness and do not contain usable color information.

Theoretically the instrument could read color for all increasing brightness levels. But a limit is imposed by the K1211 photocathode at 10 microamperes peak emission. This is about the point where the current ceases to be a linear function of the incident light.

From the spectral sensitivity of the cathode, in Fig. 3B, the blue filtered phototube has the largest probability of limiting. A light source emitting energy equally throughout the spectrum would reach this limit with a brightness of about 1,000 foot-lamberts.

### Filters

The photometric filters used are red = one red cellophane sample and one Wratten No. 86, green = two Wratten No. 102 and blue = one Wratten No. 48.

A Wratten No. 25 is also usable for the red filter even though its sharp cutoff for orange and yellow is not precisely suitable.

These filters provide high transmittance coincident with the desired spectral response when combined with the spectral sensitivity of the K1211 phototube. The resultant spectral discrimination of this colorimeter is shown by Fig. 4. The curves are established largely by the spectral characteristics of the phototubes, the availability of filter material, and the desire for high optical efficiency. The area under the red response curve represents about 5 percent of the K1211 unfiltered sensitivity to equal radiant energy.

The curves are based upon ICI mixture data for real spectral primaries and the condition for equal radiant energy response. They pro-

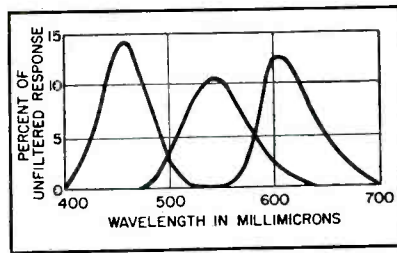

FIG. 4—Response of red, blue and green phototubes when balanced for equal meter readings and with an equal-energy spectral source

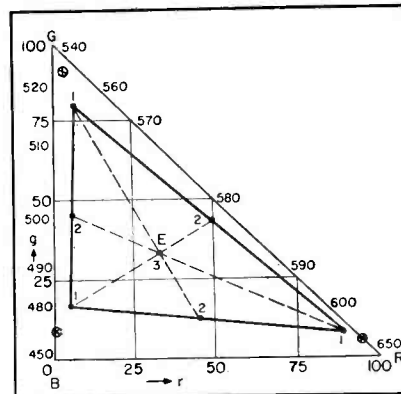

FIG. 5—Colorimeter indications recorded in R-B-G diagram for single-screen primary color phosphors (crosses) and same phosphors on a tricolor shadow-mask tube (line-connected dots)

vide meter indications that read the percentage of red, green and blue colors in the luminous sample. These are directly transferable to an R-G-B diagram as shown in Fig. 5. Equal curve areas result in equal indications for an equal energy spectrum. The approximate spectral wavelengths are indicated around the edge of the triangle.

The colorimeter responds to luminous excitation so that  $R + G + B = 100$  percent where R, G and B each may be between 0 and 100 percent. White color is indicated by similar percentages on each meter. Equal energy white, the center of the triangle, is defined as color of zero saturation. The edges of the triangle define colors of maximum saturation with the corners identifying the pure primary colors. These are indicated, respectively, by two meters summing to 100 percent, one meter at zero, and by one meter totaling 100 percent, two meters at zero. The blue indicating meter is operationally unnecessary. It is retained for its convenience in operation and the monitoring of the 100-percent level.

The spectral acceptance of a similar instrument may be modified to the ICI distribution coefficients that permit color interpretation in the familiar XYZ form. This compresses the color information into a fraction of the R-G-B scale lengths. The reading accuracy is reduced for only real colors are available in any case. However, the double peaked  $x$  tristimulus function can be simulated by tying a resistor from the Z blue meter drive point to the X red phototube anode load resistor. This is effectively a unilateral signal so that no red peak is introduced into the  $z$  function.

The primary target of this colorimeter is a cathode-ray tube. The usual display is a tv raster of large area and medium brightness generated by a small moving spot of high intrinsic brightness. To the pickup head, this is an intermittent light with a low duty cycle. The resultant peak phototube currents greatly exceed the average currents to which the indicating meters respond. The short persistence of most phosphors does little to modify the peak to average brightness.

### CRT Indicator

It is possible to use a cathode-ray tube as the color indicator. The deflection plates are cross-connected to develop 120-degree radial scan separation for primary color excitation. The display is in polar coordinate form on a circular grid with the radial and angular spot displacement identifying the quantities saturation and chromaticity, respectively.

In Fig. 5 the crosses record the hue and saturation of color tube phosphors as measured on single screen experimental cathode-ray tubes. The same phosphors, applied to a typical 19TP22 tricolor tube, have the measured hue and saturation as shown by the line-connected dots. Some tolerable desaturation of the display colors must be established. To fix these limits realistically, a measuring instrument of this kind is needed if every manufactured tube is to be checked.

The author acknowledges the work of Frank Kliminski in the construction of this instrument.



Indicating unit has provision for calibrating meter for three separate sensing units. Relay built into meter sets off alarm at preset ice-load level

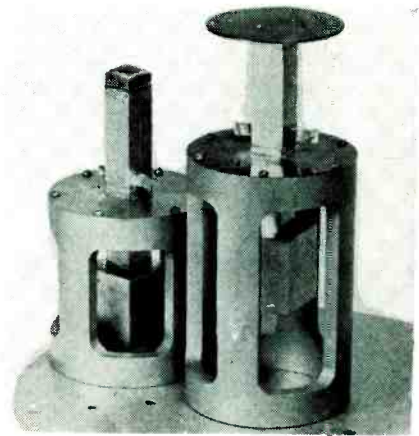

Piezoelectric sensing unit shown in cross-section in Fig. 1

By **E. G. THURSTON\***

*Supervisor, Acoustics Section,  
Physics Dept.  
Armour Research Foundation  
Chicago, Ill.*

# Ice Detector for

**A**CCURATE determination of ice accretion on lighter-than-air craft is especially acute as the ice cannot be removed by any practical, self-contained means. The quantity of heat required to melt even a thin ice coating by heating and circulating the helium would be astronomical.

The system described here is designed to measure quantitatively the actual deposited mass per unit area as a primary variable. This is done by causing the accumulated ice mass to change the equivalent mass of a vibrating system and thus to alter its frequency of vibration. The change in the system resonant frequency is measured and a quantitative measure of the amount of deposited mass per unit area is thus obtained.

The system consists of three basic parts: the piezoelectric vibrating elements, the oscillator circuits whose frequencies are controlled by the piezoelectric elements and a frequency detector and indicating circuit.

This piezoelectric unit consists of two elements. One is cemented to

the inside surface of the fabric which covers the top of the container of the unit so that the formation of ice actually adds to its equivalent mass. The other element is not in contact with the surface and is not affected by the formation of ice. This latter element acts as a frequency control unit against which the frequency of the sensing element can be compared.

## Crystal Stacks

Figure 1 shows the construction used in the final model. The sensing element consists of four parts. The first is a tapered beryllium disk driven by an adp crystal stack. This driving stack is separated from the beryllium plate by a small quartz plate. Another quartz plate is affixed to the opposite end of the stack and to this is cemented a terminating equivalent quarter-wave aluminum bar.

The adp stack is made of four crystal slabs each  $1\frac{1}{2}$  in. by  $\frac{1}{2}$  in. by  $\frac{1}{2}$  in. giving a total stack  $1\frac{1}{2}$  in. by  $\frac{1}{2}$  in. by  $\frac{1}{2}$  in. The adp was chosen because it combines a good coupling factor with frequency stability.

The use of the two quartz elements on each end of the stack provides two desirable effects. First, they dielectrically insulate the adp from the beryllium disk and terminating aluminum bar. Second, by splitting the quartz plate, the compliance in a plane perpendicular to the direction of motion of the crystal stack is increased. This reduces the tendency to clamp the end of the bar which would reduce the effective coupling coefficient and thus reduce the system sensitivity.

The vibrating element which is used as a reference is identical to the sensing element except for the beryllium plate which is replaced by a small piece of lead with a roughly equivalent mass. This element is then mounted in a similar fashion to that used for the sensing element but no portion of it is in contact with the cover on which the ice forms. The frequency difference between the sensing element and the reference element is therefore a measure of the deposition of ice on

\*Work done while with Clevite-Brush Development Co.



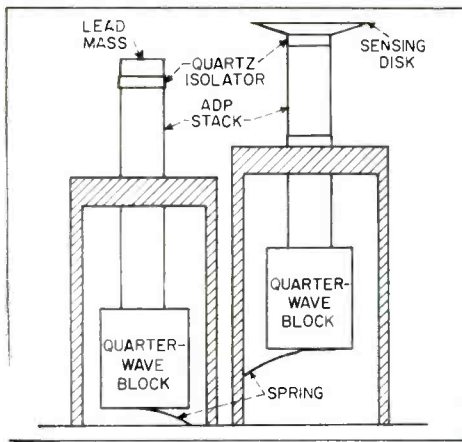
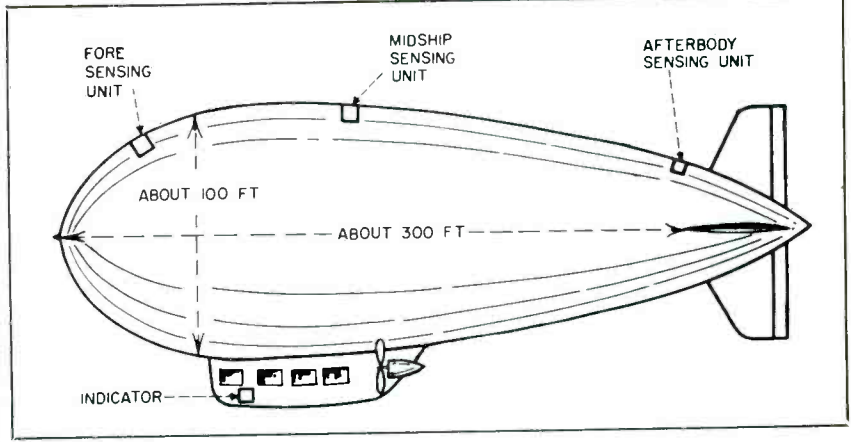

FIG. 1—Cross-section of piezoelectric stacks. Lead on top of reference stack approximates mass of sensing disk



Locations of indicator and sensing units on blimp. On preliminary test flights remote-control tv and motion-picture cameras were mounted on top of gas bag to monitor ice formation as a check on detector accuracy

# Lighter-Than-Air Craft

**SUMMARY** — Piezoelectric Meacham-bridge oscillator system determines ice accretion on surface of blimps. System also has applications in remote monitoring of ice formation on radomes and in automatic measurement of deposited coatings such as oil, grease or water

the former. Cold chamber measurements have shown that such a system effectively eliminates second order variables such as temperature and pressure.

A photograph shows the sensing and comparator elements as constructed in the first model.

### Oscillator Circuits

The schematic diagram of the oscillator circuits is shown in Fig. 2. This circuit consists essentially of a Meacham-bridge oscillator wherein the nonlinear bridge element which is usually an electric light bulb has been replaced by a vacuum-tube agc circuit. The most severe problem that was encountered in the development of this circuit was that of obtaining satisfactory operation under conditions of low  $Q$  in the vibrating crystal system and over a large range of

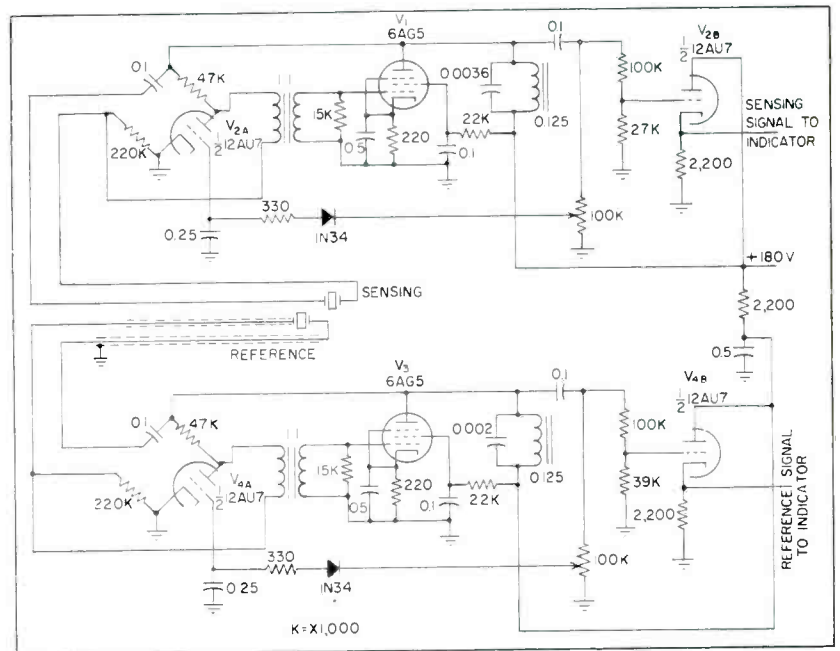

FIG. 2—Duplicate Meacham bridge circuits are used for sensing and reference. Triode in one leg of bridge functions as automatic gain control

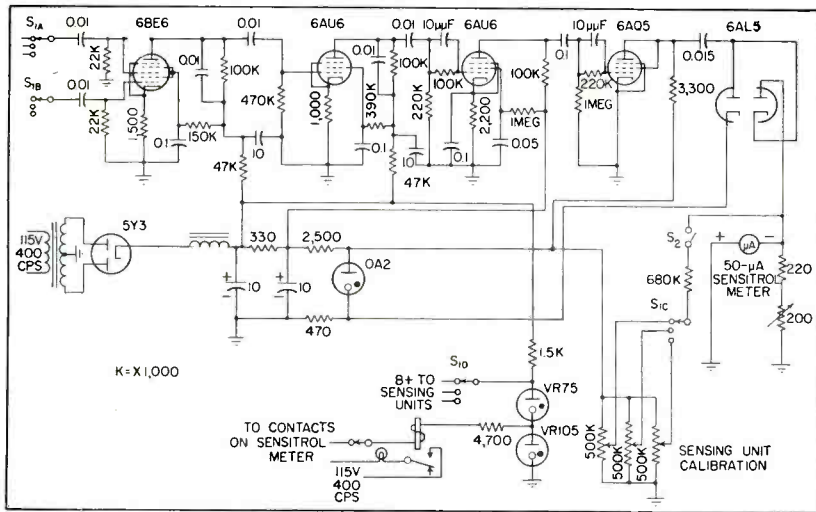

FIG. 3—Indicating unit is connected to either of three sensing units by switch  $S_1$ . Separate meter calibration is provided for each sensing unit

equivalent resistances. These two effects are, of course, intimately related and require the same circuit modifications for their accommodation.

In the normal Meacham-bridge circuit, the equivalent resistive impedance of the crystal element, when operating at its resonant frequency, is low, and therefore low-impedance elements can be used in the other arms of the bridge. In this application, however, the equivalent resistive impedance of the crystal was high and varied over a considerable range between unloaded and fully ice-loaded conditions.

The equivalent resistive impedance of the crystal without any ice load is approximately 20,000 ohms, and this value increases to between 80,000 to 90,000 ohms with full ice loading of 0.050 in.

Operation at spurious resonant frequencies of the vibratory system was avoided by the use of tuned circuits having a bandwidth wide enough to accommodate the range of frequencies occurring between unloaded and fully loaded conditions and yet narrow enough to exclude operation at any other system resonance.

The oscillator circuit consists of a 6AG5 vacuum tube with tuned grid and plate and grid excitation fed back through the frequency-controlling bridge circuit which embodies the vibrating crystal as one arm.

A portion of the output of the

6AG5 is rectified through a 1N34 diode and then applied to the control grid of one half of a 12AU7 which is inserted as a level control in the Meacham bridge.

The output is also fed to the grid of the other half of the 12AU7 which acts as a cathode follower providing a low output impedance to the long length of cable running over the surface of the airship from the sensing units on top to the indicating unit in the gondola. An identical oscillator circuit is provided for the reference crystal.

Although this circuit is basically simple and straightforward in design, extreme care had to be taken in the determination of the proper circuit values so that successful operation could be achieved with the low  $Q$  in the crystal vibrator. These modifications to the usual Meacham circuit should have other applications where similar problems are encountered.

### Detection and Indicator Circuit

The sensing system produces two outputs, one from each cathode follower. It is necessary, therefore, to provide a circuit which will detect the frequency differences and display the resulting output in a manner which can be correlated with the amount of deposited ice.

The operation of this part of the system can be seen by reference to Fig. 3. The signals from the two cathode followers are fed into a 6BE6 multiple-grid mixer. The output of the mixer tube is passed

through one stage of amplification provided by a 6AU6. The associated circuits of this tube are designed to pass only the difference frequency, as are subsequent stages. The signal is passed to another 6AU6 which provides additional amplification and effects a partial transition from sine-wave operation to square-wave operation. The 6AQ5 stage completes the transition to square-wave operation.

The final stage uses a 6AL5 as a counter-type discriminator. The output of this stage is fed to a microammeter having a sensitive relay which can be adjusted to flash a warning signal for any predetermined accumulation of ice up to 0.25 lb per sq ft.

### Performance Characteristics

Operation from no ice loading to an ice loading of 0.25 lbs per sq ft has been achieved. The indicating meter has been calibrated to read directly in lbs per sq ft of deposited ice and experiments to date have shown that this calibration holds equally well for water films.

To date it has been possible to achieve reproducible indications of deposited ice within the basic accuracy originally desired (minimum measurable and reproducible increments of 0.010 in. of ice). The system is now undergoing flight tests at the Naval Air Development Station, South Weymouth, Massachusetts.

Further development will permit considerable extension of the dynamic range of the instrument and provide a safety device applicable to heavier-than-air as well as lighter-than-air craft.

Applications other than those involving use with aircraft include the remote detection and control of ice formation on radomes or other structures, recording of ice or frost for meteorological purposes and the automatic measurement and recording of any deposited coating, such as oil, grease, soft mud or water, which has reasonable adherence and which does not introduce damping beyond the present operating range of the instrument.

The work described in this article was sponsored by the Office of Naval Research under contract No. Nonr-1494 (00).



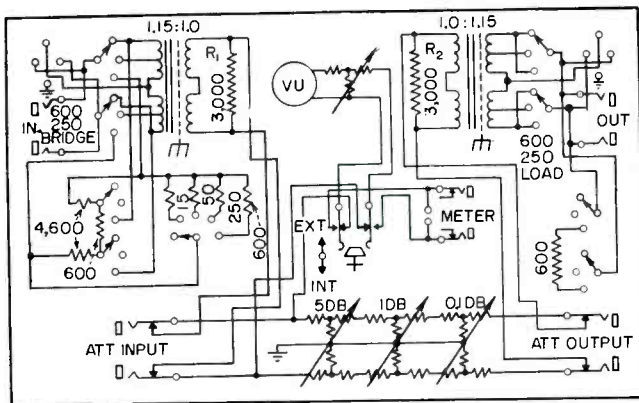
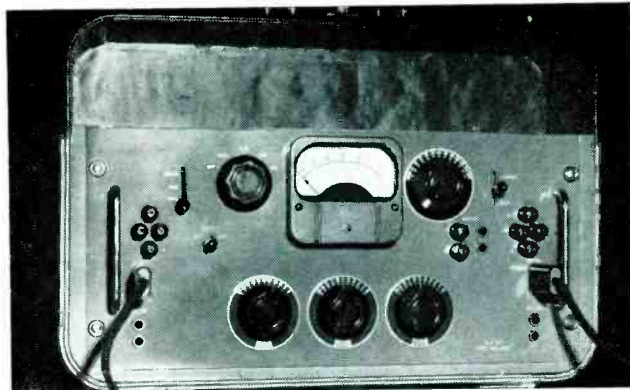

FIG. 1—Complete gain set has frequency response of 20 to 20,000 cps,  $\pm 0.7$  db when loading and  $\pm 1.5$  db when bridging



Gain set is housed in luggage case with breakdown hinges for removing cover. Case provides room for leads and accessories

# Transmission Gain Set

**SUMMARY** — Precision attenuator aids testing of a-m and f-m broadcast stations' audio facilities. Unit has total maximum attenuation of 63.5 db in steps of 5, 1 and 0.1 db. Minimum insertion loss is 2.5 db over frequency range of 20 to 20,000 cycles per second

**A**S AN AID to meeting increased need for better and faster measurement and servicing techniques for a-m and f-m broadcast stations, an audio-transmission gain set has been constructed.

The equipment is shown in the photograph and in the schematic diagram, Fig. 1. It is housed in a heavy-duty luggage case that has extra space for packing accessory cables and patch cords.

## Circuit

The heart of the instrument is a precision variable balanced H-type attenuator having zero insertion loss and a maximum selective loss of 61 decibels. The individual elements, cascaded to form the attenuator, are three 600-ohm, 0.5-percent accuracy controls. These controls have, from left to right in Fig. 1, ten steps of 5 db per step, ten steps of 1 db per step and ten steps of 0.1 db per step.

The attenuator is capable of

**By GERALD R. CHINSKI**

*Technical Director  
Radio Station KXYZ  
Houston, Texas*

handling a maximum power level of about +55 dbm and the overall power level is +30 dbm. There is no frequency discrimination in the attenuator, even at maximum loss, out to 80 kc. The balanced attenuator is made directly available through break-in jacks.

Overall input and output is provided by both jacks and instrument binding posts. Switching provision is made for input and output impedance matching at 600 and 250 ohms. A third position on the input selector key makes the input bridging at 9,500 ohms. This produces a fixed 30-db loss when fed from a loaded 600-ohm source.

In the bridging position power-loading resistors of values shown can be switched across the input terminals. This provides a handy

arrangement for measuring amplifiers while being driven at high output. The output impedance selector key also terminates the gain set unit in 600 ohms when in the up position.

The end matching coils are excellent at low level and have no tendency to saturate at higher levels of the order of +30 dbm. They are well balanced and have 90-db magnetic shielding. Windings are arranged to cancel out externally induced electromagnetic fields and are provided with electrostatic shields between primary and secondary.

Resistors  $R_1$  and  $R_2$  build out the attenuator loading, so that the transformed impedance, at the input and output terminals, is close to the value selected and almost purely resistive.

The gain set is equipped with a standard vu meter, having a 1 mw in 600 ohms reference and a multiplier range of 24 db.

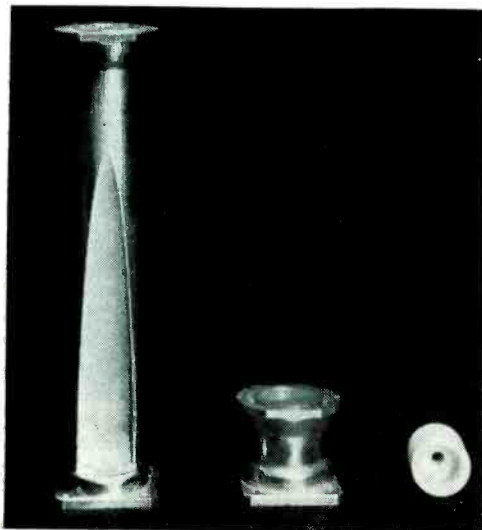

By **IRWIN D. OLIN**

*Naval Research Laboratory  
Washington, D. C.*

The conventional tapered transducer at left and the new stepped transducer, center, showing reduced size. Transformer dielectric insert is at right

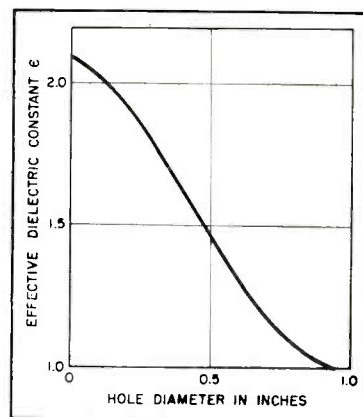

FIG. 1—Dielectric constant vs bore for a Teflon tube, 15/16 in. i/d, in a circular waveguide

# Dielectric Transformers

**SUMMARY** — Dielectric sections provide reflectionless match between differing waveguide impedance levels and maintain match over a broad frequency range. Dielectric version of conventional rectangular-to-circular waveguide transducer is 80 percent shorter and has improved performance

**M**ANY PROBLEMS encountered in microwave transmission require impedance transformers to optimize system performance. This paper describes the application of dielectrics to dominant-mode circular-waveguide transformers. Two designs are presented both operating within the X-band from 8,500-9,600 mc and using 15/16 in. i-d circular waveguide.

The first design is a rectangular-to-circular waveguide transducer, a dielectric transformer which, when inserted in a circular waveguide, permits the rectangular guide to join it directly.

The second design is a pressure seal for circular waveguide. Seals of this type may be used to provide weather-proof protection of a waveguiding system or enable a section of guide to operate under pressure.

These designs use a transformer composed of dielectric sections to provide a reflectionless match be-

tween differing impedance levels and maintain this match over a broad frequency band.

The configuration of the matching transformer is arbitrary. It could be a section of smoothly tapered dielectric or it could be composed of dielectric steps. The problem of converting from one impedance level to another is approached through the use of intermediate dielectric sections of varying impedance levels.

The change in the amount of reflection introduced as a wave travels from one section to another describes this variation. This may be termed the reflection taper. The number of these sections is arbitrary, being finite for a stepped section (each section made one-quarter guide wavelength long at the design frequency) and tending toward infinity in the case of the smooth taper.

The solution which results in the

most compact design is the stepped matching transformer. The number of steps employed and the reflection taper govern the bandwidth over which the match between the two impedance levels is maintained.

## Binomial Taper

Assume  $n$  steps will be used ( $n-1$  quarter-wavelength sections) in going from one impedance level to another. The reflection taper depends upon the reflection coefficient of each step in relation to an adjacent step. The reflection taper is given by  $1, k_2, k_3, \dots, k_n$ .

One of the most satisfactory tapers which provides a broadband design is the binomial taper. The reflection taper corresponds with the coefficients in the binomial expansion. Thus for a three-step design ( $n=3$ ) the reflection taper would be given by  $1, k_2, k_3 = 1, 2, 1$ .

Several 15/16-inch o-d Teflon tubes about 5 inches long were



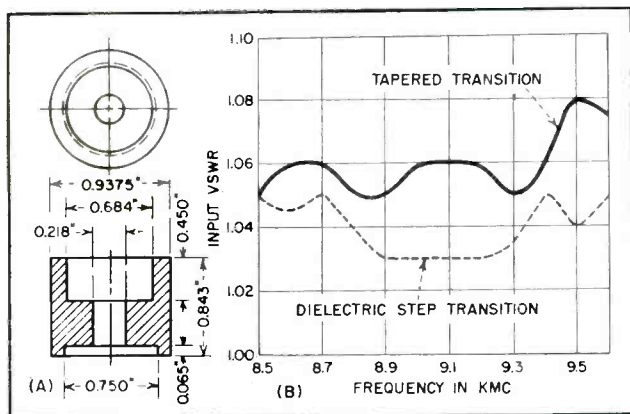

FIG. 2—Stepped transformer for the rectangular-to-circular waveguide transducer (A) and performance characteristics of new stepped transducer and conventional tapered transducer (B)

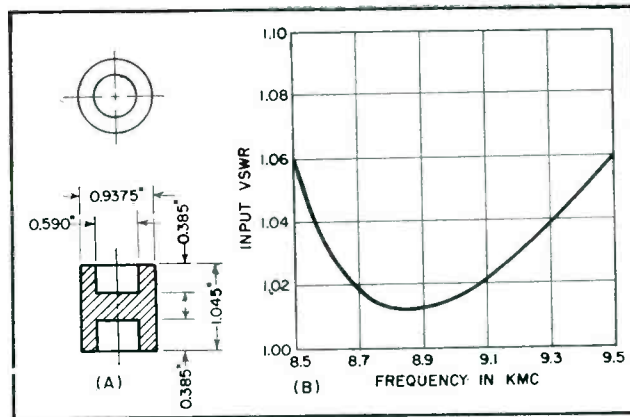

FIG. 3—Teflon pressure seal design for circular waveguide (A) and performance characteristic of the pressure seal (B) which provides weather-proof protection

## for X-Band Waveguide

bored with varying inside diameters and a small longitudinal slot milled into the surface. The tubes were successively placed in a precision circular slotted line and the guide wavelength measured.

Using these figures and assuming only dominant mode transmission, a value of effective dielectric constant was computed for each tube. This value represents the dielectric constant of a material completely filling the guide and resulting in the same guide wavelength.

For a given tube several values were determined, one for each frequency at which measurements were taken. These values showed no appreciable variance, within the limit of experimental error. A curve of the effective dielectric constant versus the bore diameter of the tube was thus obtained, shown in Fig. 1. This curve gives all the information necessary to design Teflon dielectric matching sections in this size circular guide.

The transformer is circularly symmetrical, being composed of dielectric tubes. Hence it satisfies conditions for exciting the  $TE_{11}$  mode at any angle in the circular waveguide from the  $TE_{10}$  mode in the rectangular waveguide.

The problem reduces to provid-

ing an impedance match between the two waveguide sections. Since two different cross-sectional geometries are involved, the definition of waveguide characteristic impedance becomes ambiguous. However, by constructing transformers designed according to the different definitions, it was found that the definition based on power-voltage considerations gave the best results.

### Stepped Design

A binomial stepped design was employed using three impedance steps between the impedance level of the two guides. All the calculations were referred to 9,100 mc. Due to the step-like nature of the design, a discontinuity susceptance is effectively placed at each abrupt change in dimension. If this change is small, compared to the waveguide dimensions, the overall performance will not be greatly different from that predicted.

In this design the following adjustments were made: the transformer was positioned 0.065 inch away from the circular-rectangular junction; the low-impedance section was lengthened; and its impedance slightly increased.

Note that since the junction is the place at which the change in

cross section takes place, the coupling flanges used here contributed to the performance of the overall transducer. The rectangular waveguide was equipped with a UG 40A/U choke flange and the circular waveguide with a flat flange.

The completed design is shown in Fig. 2A and its performance illustrated in Fig. 2B. The same figure shows the performance of a typical tapered transducer designed to perform the same function.

The pressure-seal design is composed of a section of waveguide completely filled with a dielectric and some means for providing a broadband match to the adjacent unfilled waveguide. In this type of design, or in any design where only one waveguide cross section is involved, any choice of characteristic impedance definition will result in the same dimensions for the matching section. The design chosen for the matching section was a single binomial step. After slight modification the performance shown in Fig. 3B resulted. The dimensions for the design are shown in Fig. 3A.

The author wishes to acknowledge the contributions of P. J. Allen and R. D. Tompkins in the work described.

# Precision

By **WILLIAM PERZLEY**  
Kaiser Metal Products, Inc.  
Bristol, Pennsylvania

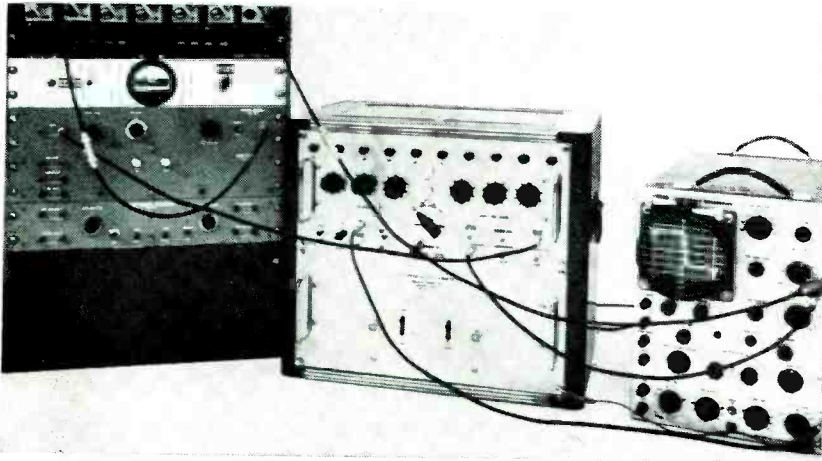

To make delay measurement, delay trigger 2 is fed to external sync input of crt. Initiating trigger goes through target simulator (left) to crt vertical input. One-microsecond markers are fed directly to crt vertical input

chain depending upon the number of controllable delay periods desired.

The unit has two selection gates. The first gate output provides a pulse, delay trigger 1, delayed with respect to the start of the cycle, while the second selection gate determines the period for cyclic operation. This arrangement allows maximum flexibility for a count chain of fixed length. The settings of both the first and second encoder-gating systems can be varied throughout the full count range if the second selection gate is set equal

**A** PPLICATION of digital-computer techniques to time-interval generation and measurement can provide a highly accurate generated delay and exact time discrimination.

The precision digital delay generator to be described gives as its output a reference pulse followed by pulses precisely delayed in time with respect to the reference pulse. It can supply these pulses under one-shot or variable frequency steady-state conditions. Its accuracy is determined by the frequency stability of a 1-mc crystal-controlled master oscillator, which is thermostatically controlled and accurate to one part in one million. Performance characteristics are given in Table I.

Figure 1 illustrates the output pulses available under steady-state conditions. In this mode, both  $t_1$  and  $t_2$  are independently controlled by their respective input dial settings. Figure 1B gives the output pulses available under one-shot conditions.

The ability to supply pulses accurately positioned, as shown in Fig. 1, makes the digital delay generator useful in radar and sonar range calibration and target simulation. In this application, the initiating trigger is used as the system trigger and delay trigger 1 at preset delay settings is injected as the simulated target. The process of calibration involves adjusting the range-measuring circuitry of the system to agree with the known target delay.

The technique used in delay

measurement is to compare the delayed signal with signals of known delay generated by the delay generator, making a vernier measurement or interpolation with a synchroscope. The equipment setup is shown in the photograph.

## Logic of System

The block diagram (Fig. 2), shows the 1-mc crystal-controlled oscillator followed by two cascaded divide-by-ten counters to provide three separate ranges of operation. Range 1 utilizes the 1-mc crystal output directly, range 2 uses the 100-kc output from the first divider circuit. Range 3 uses the 10-kc output of the divider. The unit provides an external input jack which will accept other standard frequency inputs.

The crystal-controlled master pulses of ranges 1, 2 or 3 are fed to a 10-stage binary counter. The stored count provides the time-measurement information which is used in the selection of a specific input pulse. This is accomplished by diode gating circuits which are connected to the outputs of the binary counters through a manually controllable decimal-to-binary encoder. The arrangement makes it possible to set manually any count up to the maximum capacity of the binary counter  $2^n$  where  $n$  represents the number of counter stages—and extract an output pulse, delay trigger 1, at that particular count for each cycle of the count chain. Any number of encoder-gate combinations can be used with a single count

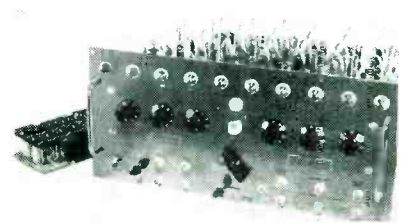

Chassis of precision digital delay generator illustrating modular design

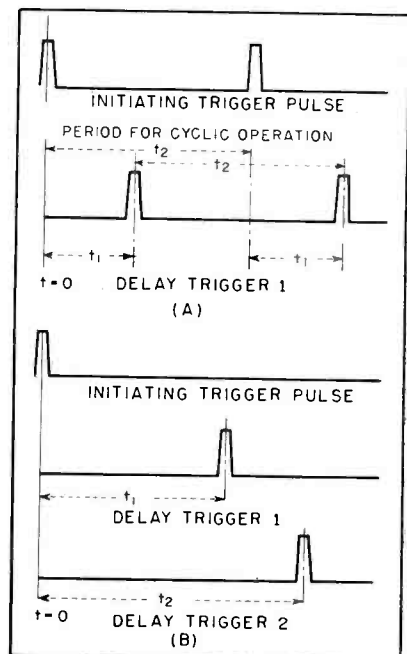

FIG. 1—Pulse outputs for cyclic operation (A) and one-shot operation (B)



# Digital Delay Generator

**SUMMARY** — Pulses for calibrating radar equipment and for target simulation are made available by instrument using 1-mc crystal oscillator and flip-flop frequency dividers. Precision of pulse timing is independent of flip-flop transition time

to or greater than the first.

The accuracy of the generated delay is not dependent on flip-flop transition time or length of flip-flop counter chain and consequently represents an improvement over conventional digital and analog methods of generating precise time intervals. The pulses from the crystal continuously sample the selection gates as well as pulse the count chain. There is sufficient inertia in the count chain so that the  $M$ th pulse which sets the counter to  $M$  will not pass through the selection gate assuming that the

output of the decimal to binary encoder is  $M$ . However, the  $(M + 1)$ th pulse will pass directly through the selection gate and be available without accumulative delay. This arrangement is one count off and is readily corrected by a one-unit compensation in the decimal to binary encoder. Its advantage is zero phase lag regardless of time delay setting.

## Operation

Under steady-state conditions, the start button triggers the one-shot generator which in turn sets

control flip flop 1. Control flip flop 1 gates the succeeding master clock pulse through gate 3. This gated pulse marks the start of the time cycle and is called the initiating trigger pulse. The initiating trigger pulse resets control flip flop 1 and sets control flip flop 2. Control flip flop 2 opens gate 4 which allows the succeeding clock pulses to flow into the count chain and sample the selection gates.

A recycling scheme enables the pulse selected by the second selection gate to reset the binary counters and cut off the input flow of

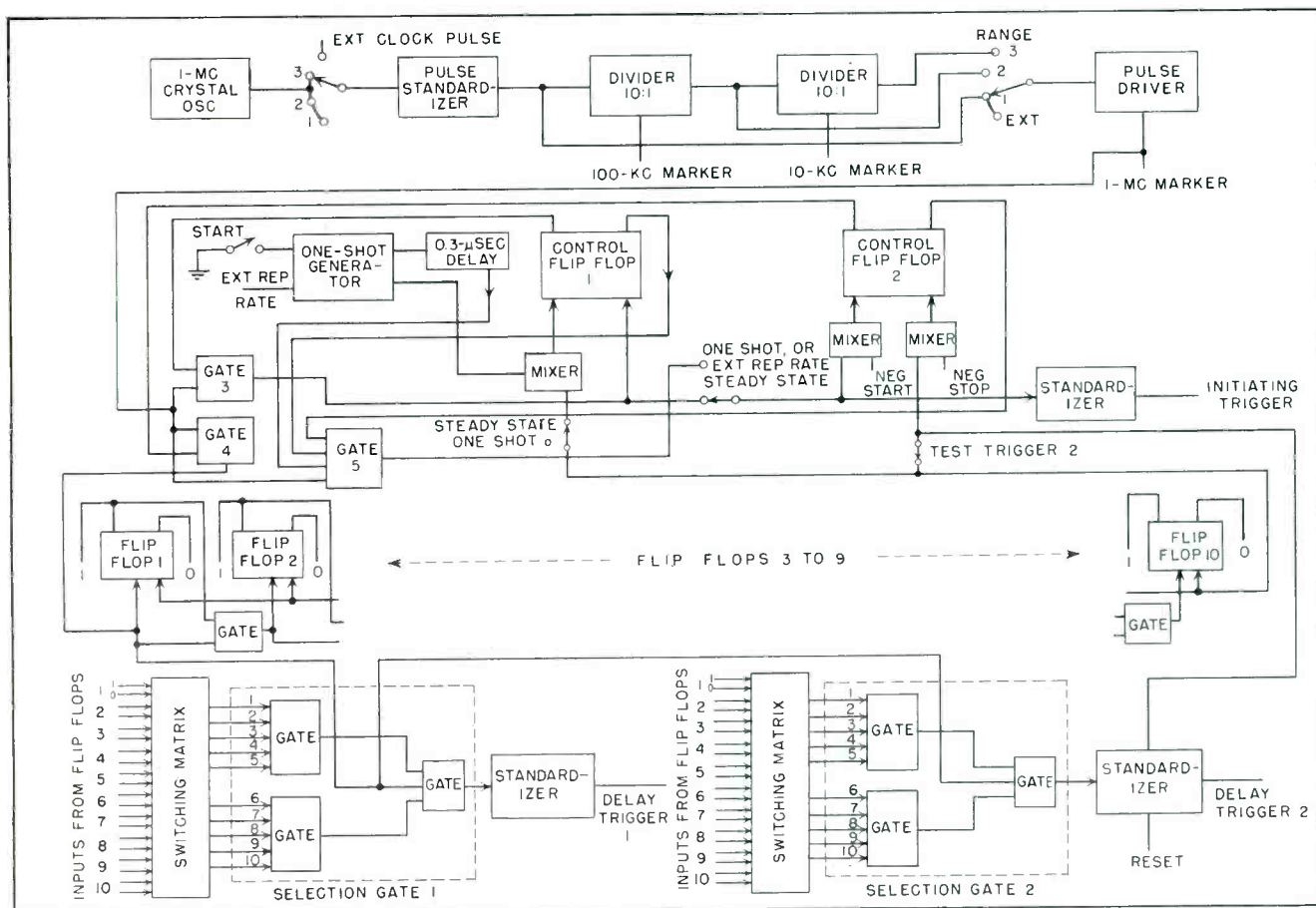

FIG. 2—Logical design of the precision delay generator and its detailed operation may be traced from this functional block diagram. Crystal oscillator and counter chain provide three operating ranges

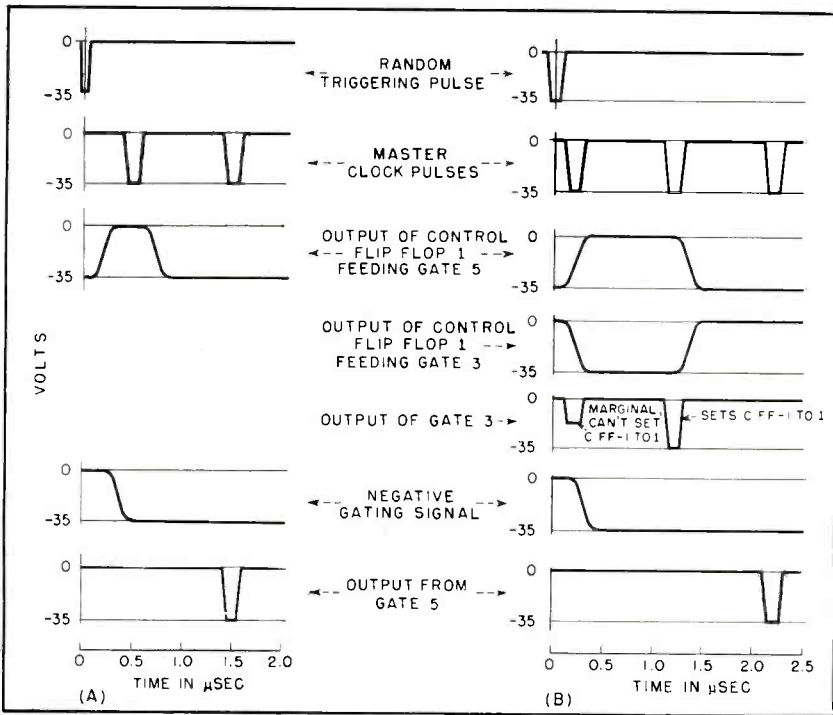

FIG. 3—Waveforms in buffer circuit when clock pulse occurs more than 0.3  $\mu$ sec after trigger (A) and when clock pulse occurs less than 0.3  $\mu$ sec after trigger (B)

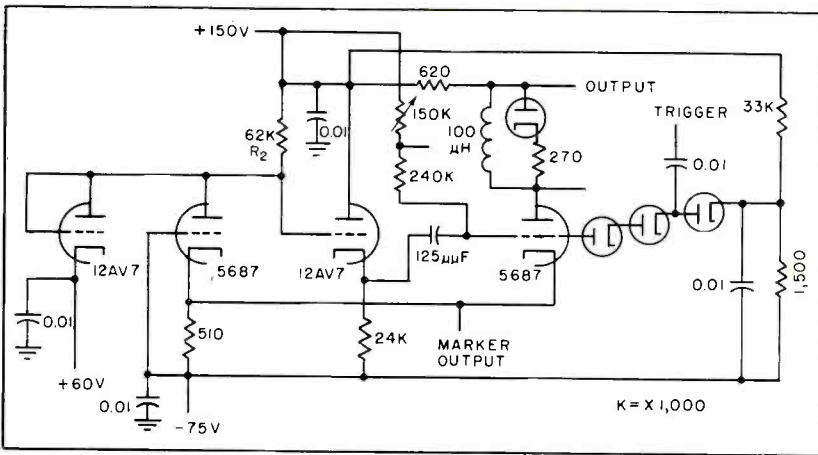

FIG. 4—One-megacycle to 100-kc count-down circuit is monostable multivibrator with common-cathode coupling

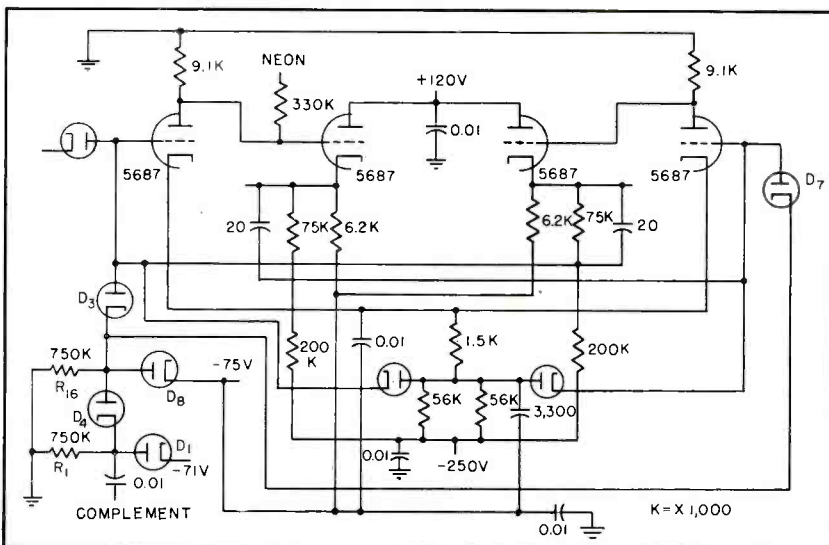

FIG. 5—One-megacycle binary counter is modified Eccles-Jordan flip-flop circuit

pulses by resetting control flip flop 2. This shuts gate 4. The pulse selected by the second selection gate sets control flip flop 1 to allow the succeeding pulse from the master clock to pass through gate 3 and set control flip flop 2. Control flip flop 2 then opens gate 4 and the cycle repeats.

Marker pulses are supplied for each of the three ranges. They are in time synchronization with the selected pulses from selection gates 1 and 2. The marker pulses are useful when making delay measurements with an oscilloscope.

Should the total count available in the chain be insufficient to yield a low enough repetition rate for a specific test, an external repetition rate source can be used to provide increased delay time.

### One-Shot Operation

When operating asynchronously, one-shot or with external repetition rate control, the two selection gates are so set that selection gate 2 is higher than selection gate 1. The external trigger pulse hits the one-shot generator, resulting in a trigger pulse applied to control flip flop 1. This pulse sets control flip flop 1.

Control flip flop 1 gates the succeeding master clock pulse through gate 3 to reset itself. The one-shot generator also generates a negative gating signal which is first delayed by 0.3 microsecond, time for the flip flop to change state, and then applied to gate 5. The negative gating signal is delayed to insure that control flip flop 1 has had sufficient time to reach the 1 state to insure keeping gate 5 closed to the first clock pulse succeeding the initiating external repetition trigger pulse. This could occur within 0.3 microsecond after application of the random external trigger. The gate is unprimed during this 0.3-microsecond interval, this, plus the fact that control flip flop 1 will hold it closed until the next master clock pulse arrives, insure that the master clock pulse gated by gate 5, whether it be the second or third pulse succeeding the random external trigger, will be full amplitude. This technique eliminates marginal operation. The first master clock pulse after  $t = 0$  may or may not



pass through gate 3 and reset control flip flop 1 but the second master clock pulse will most certainly do so. Should the first clock pulse reset control flip flop 1 the second clock pulse will pass through gate 5, setting control flip flop 2 and mark the start of a new count cycle. The arrangement described functions as a buffer between the two random control frequencies insuring error-free operation. The instantaneous repetition interval resulting can vary as much as one cycle of the master clock rate per count cycle. This represents a repetition frequency variation of less than 1 part in 1,000. Figure 3 indicates two possible timing diagrams for the buffer.

### Self-Checking Feature

The unit is capable of checking essentially all its own circuits.

The unit is placed into operation in the one-shot mode. The output from delay trigger 1 is fed back into the negative stop terminal of control flip flop 2. The start button sets the unit into operation and master clock pulses flow into the count chain as well as sample the selection gates. When the count reaches a value equal to one less than that set on the delay trigger 1 input dials, selection gate 1 is primed and the succeeding master clock pulse is gated out of delay trigger 1. Feeding this pulse back into control flip flop 2 immediately resets control flip flop 2, which in turn shuts gate 4. The count chain now stores the number which had previously been set on the input dial. The stored count can be read at front panel from neon indicators. Any disagreement indicates that there has been a system malfunction.

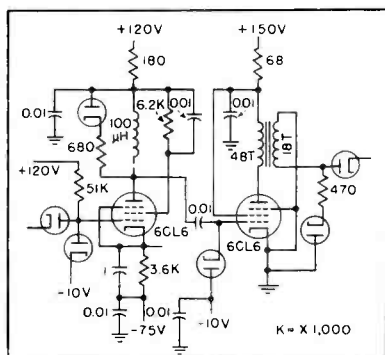

FIG. 6—Pulse standardizer

The same procedure can be used to check the delay of delay trigger 2. For this test, the system functions as it normally would in the one-shot mode, except that the front-panel switch test trigger 2 is thrown, which opens the reset line to the count chain thereby retaining the accumulated count. Testing the system under one-shot conditions is generally more severe than under similar steady-state conditions.

### Circuits

The internal circuitry operates in straight binary using negative pulses throughout. The signal amplitude required for triggering all regenerative circuits is -10 volts. A combination of d-c and capacitive coupling incorporating d-c restoration is used throughout.

The 10-to-1 divider circuit given in Fig. 4 is a modified monostable multivibrator incorporating common-cathode coupling. Clamping of the plate swing of the normally cut-off tube and the grid swing of the normally conducting tube provides for stability of operation. The circuit utilizes a cathode follower within the plate-to-grid feedback loop which isolates plate load  $R_2$  from the interstage capacitive loading. This provides rapid recovery as well as large output swing result-

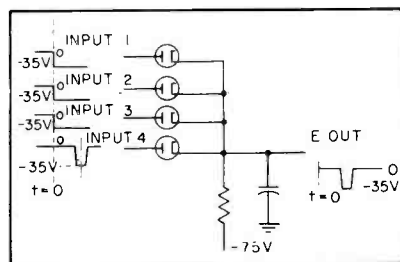

FIG. 7—Diode coincidence circuit

ing in a stable count down from 1-mc to 100-kc. A similar circuit is used for the 100-kc to 10-kc count.

The 1-mc binary counter given in Fig. 5 is a modified Eccles-Jordan flip flop so designed as to provide a high degree of reliability. The circuit employs cathode followers within the plate-to-grid feedback paths providing a high output voltage swing at high switching speeds since the capacitive load is driven by the cathode followers. The flip flop employs cathode stabilization insuring satisfactory operation

Table I—Performance of Delay Generator

Accuracy of Generated Time Intervals	
Range	Accuracy
0-1,000 $\mu$ sec	better than $\pm 0.002 \mu$ sec
0-10,000 $\mu$ sec	better than $\pm 0.01 \mu$ sec
0-100,000 $\mu$ sec	better than $\pm 0.1 \mu$ sec
Accuracy of Delay Measurement*	
Range	Accuracy
0-1,000 $\mu$ sec	$\pm 0.03 \mu$ sec
0-10,000 $\mu$ sec	$\pm 0.3 \mu$ sec
0-100,000 $\mu$ sec	$\pm 3.0 \mu$ sec
Secondary Standard Pulse Rates	
Range	Formula for Freq in cps
0-1,000 $\mu$ sec	$\sum_{n=1}^{1,000} 1/n \times 10^{-4}$
	$\sum_{n=1}^{1,000} 1/10n \times 10^{-4}$
0-10,000 $\mu$ sec	$\sum_{n=1}^{1,000} 1/100n \times 10^{-6}$
	$\sum_{n=1}^{1,000} 1/100n \times 10^{-6}$

\* Using Tektronix 514AD or equivalent cr.

with half-emission tubes. The grid swing is clamped at both ends, removing all grid recovery problems. Complementing is accomplished by driving both flip-flop grids negative simultaneously through isolation diodes  $D_3$  and  $D_4$ . The negative in-the complement pulse passes through the d-c restoration clipping circuit composed of  $R_1$ ,  $D_1$ ,  $D_4$ ,  $R_2$ , and  $D_3$  where the most positive 4 volts of signal is clipped. This provides immunity to spurious signals under 4 volts in amplitude.

The pulse-standardizer circuit given in Fig. 6 is composed of two cascaded 6CL6's. The first stage consists of a conventional cathode-stabilized amplifier with plate ringing circuit wherein a positive standardized output pulse is generated for each negative input trigger. The output pulse is further amplified and shaped by the normally cut-off output tube. The output circuit is transformer coupled to the load and operates in the bottom portion of its plate characteristic thereby effectively clamping the output pulse amplitude.

Gating is accomplished with diode coincidence circuits of the type shown in Fig. 7. Proper design can insure zero delay in gate output when coincidence is detected.

# High-Quality Receiver

**SUMMARY** — Off-the-air pickup of television signals for commercial rebroadcast requires features often lacking in modified home receivers. Article describes how a set especially designed for rebroadcasting attains operational reliability, immunity to interference and proper video i-f response

By **RAYMOND S. ROSENBERG**

*Nems-Clarke, Inc.  
Silver Spring, Maryland*

**S**EVERAL STATIONS engaged in direct pickup and rebroadcast of television signals have modified home tv receivers to meet their needs.

Some requirements of a tv receiver for commercial rebroadcast operation have been found lacking in modified home-type receivers. These requirements include: reliability in terms of uninterrupted service, accessibility of all components, interference immunity to high-level signals at the antenna and to strong radiated signals at the intermediate frequency, correct video i-f response, stabilized local oscillator and low audio harmonic distortion with proper receiver frequency response.

Front and rear views of a television receiver designed for commercial rebroadcast service are shown in the photographs. Figure 1 is a block diagram.

## Front End

Each front end (Fig. 2) is a complete subassembly which plugs into the main chassis. This construction eliminates moving contacts and optimizes circuit constants for each channel.

One-half of a 6BQ7A serves as a modified Colpitts oscillator, the other half as the control tube for afc. The reactance tube utilizes the internal capacitances of the tube and resistor,  $R_2$ , as the grid phase-shifting network. The value of

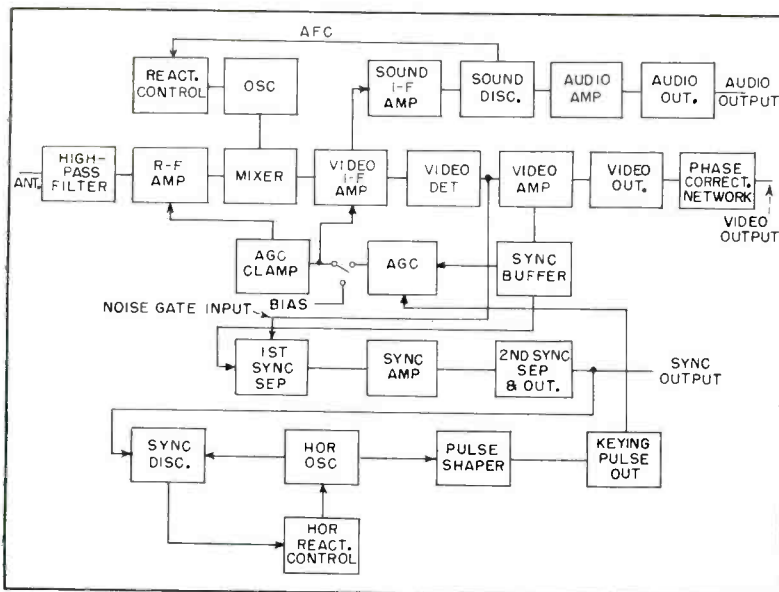

FIG. 1—Receiver incorporates automatic frequency control of local oscillator for greater frequency stability

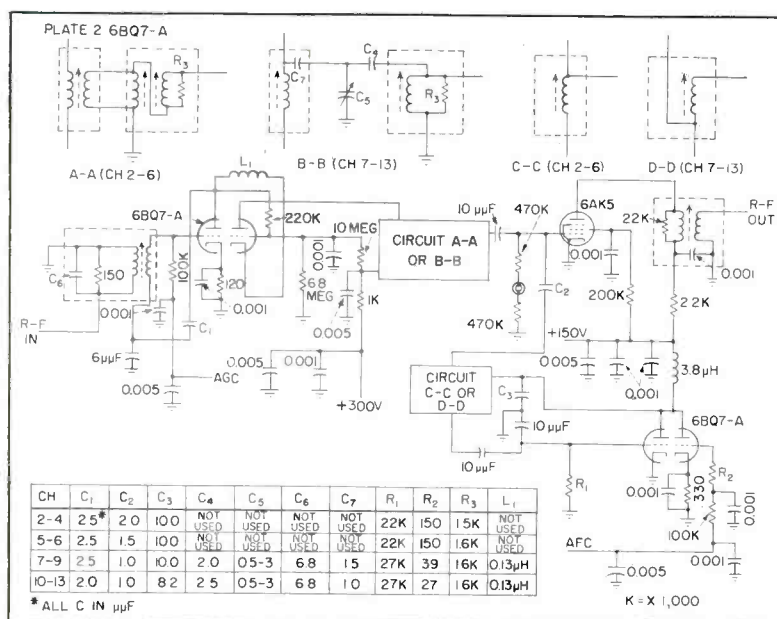
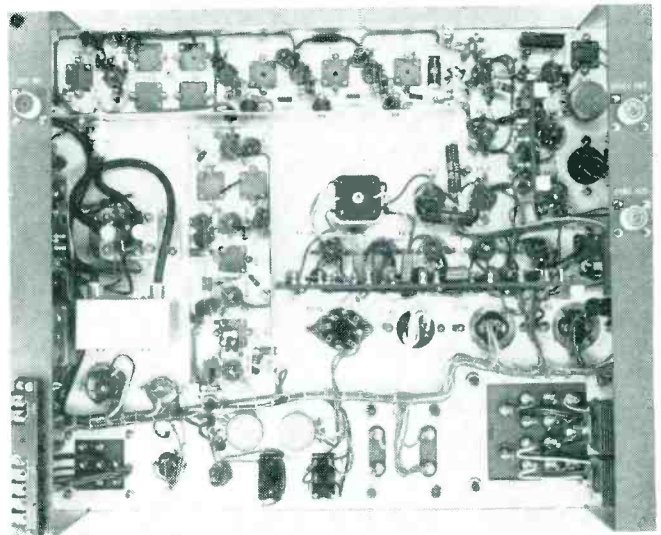
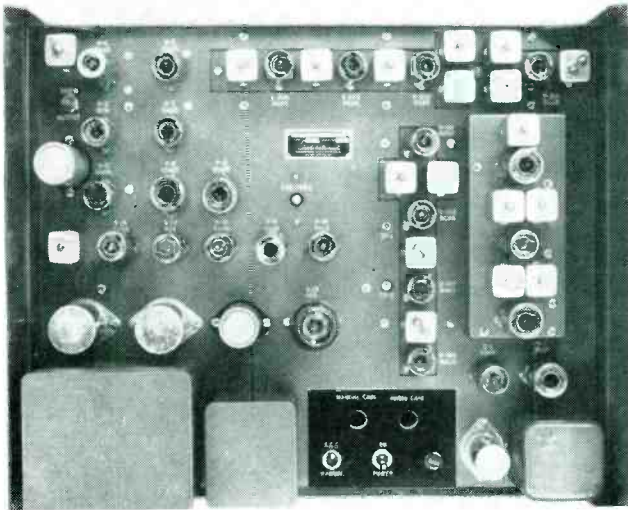

FIG. 2—Plug-in front ends are designed for optimum performance at frequency of desired channel



# for TV Rebroadcasting



Front and rear views of television receiver for off-the-air pickup. Set is designed for rack mounting

$R_2$  used is a function of the operating frequency and is selected for maximum frequency control. Resistor  $R_3$  loads the oscillator tuned circuit and its maximum value is limited by the plate dissipation of the local oscillator.

Included as an integral part of the receiver is a high-pass filter. The filter has greater than 50-db rejection at 21 mc and eliminates interference due to strong signals received at the intermediate frequency and prevents overload of the first r-f stage by high-power a-m broadcast and other low-frequency emissions. The response of the filter is shown in Fig. 3A.

## Accessory Filters

To eliminate cross-modulation interference in high-signal areas, accessory high- and low-pass filters were developed. Both have appreciable attenuation in the f-m band. The response curves are shown in Fig. 3B.

Figure 4 is a schematic of the rest of the receiver.

Particular attention was devoted to producing an overall response that did not appreciably change with agc level and to producing the proper low-frequency slope with a minimum number of tuned circuits.

The mixer plate circuit on the tuner chassis is link coupled to a

tuned circuit in the grid of the first i-f amplifier forming a double-tuned transformer. The secondary of this transformer is inductively coupled to the first sound trap (21.25 mc), which also provides the signal source for the 21.25-mc sound i-f amplifier.

An M-derived filter network is used between the plate of the first and the grid of the second i-f amplifier. This network contains two traps, one tuned to 21.25 mc for additional sound rejection, the other tuned to 27.25 mc, the adjacent picture carrier frequency.

The first and second i-f stages

are gain controlled. Cathode compensation of input capacitance variations with bias is used.

The last three i-f stages form a flat staggered triple with a flat-top bandwidth of 3.75 mc.

The first stage, due to the M-derived filter structure in its plate, will not respond to screen neutralization, and for this stage a 6AU6 with its low grid-plate capacitance was selected.

The desired video i-f response, in particular the critical low-frequency slope, has been produced in only two stages of the receiver. The wide bandwidth of the r-f circuits

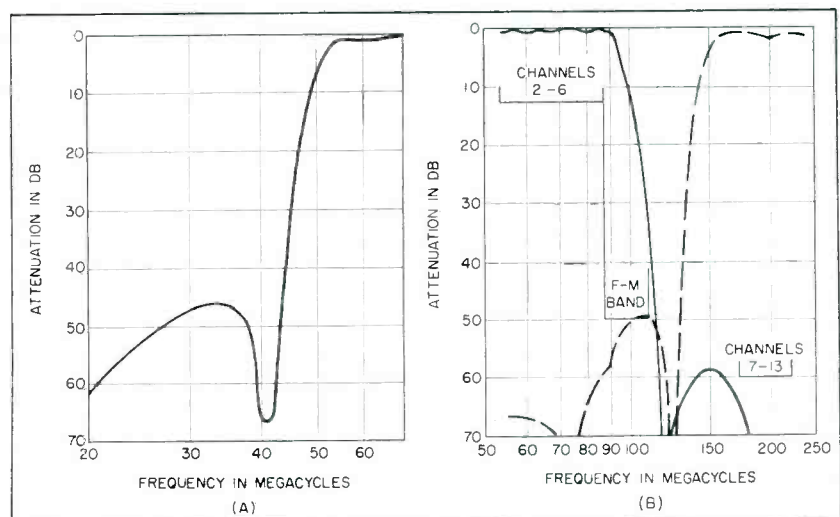

FIG. 3—Response of antenna filter (A) and high-band and low band filters (B)





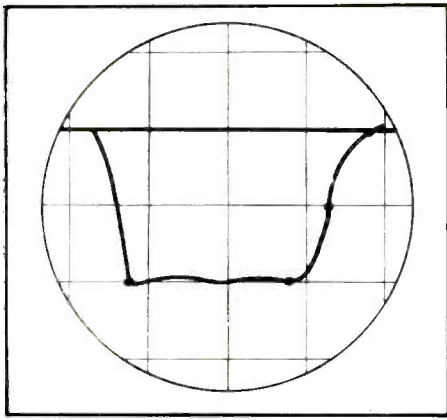

FIG. 5—Overall video i-f response

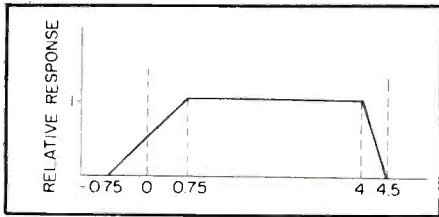

FIG. 6—Ideal receiver response

addition of the all-pass phase-correcting network in the receiver. Compared with Fig. 7B it shows that almost perfect compensation has been achieved.

Figure 7E is the response of the receiver without phase compensation to a single sideband transmission. Comparison of Fig. 7E with Fig. 7C shows no increase in transient distortion due to uncompensated delay caused by the transmitter vestigial sideband filter. It appears that the most serious source of transient distortion in the television system is uncompensated delay introduced by the low-frequency cutoff characteristic of the video i-f amplifier.

Figure 7F is the response of the receiver with normal phase compensation to a single-sideband transmission. Compared with Fig. 7D, the same receiver with double-sideband input, the effect of the transmitter sideband filter is negligible.

### Sync Amplifier

Tube  $V_7$  is a 6AS6 dual-grid sync separator with the composite input signal applied to the suppressor grid. The control grid is connected to the video detector output. On large amplitude noise bursts there

is sufficient voltage of negative polarity at the detector to cut off  $V_7$  and prevent the suppressor grid from drawing current and setting up a bias. Under normal operating conditions, however, there is insufficient voltage available at the detector to overcome the clamping action produced by the current through  $R_1$  and the control grid to cathode. Voltage amplifier  $V_8$  operates at fixed bias derived from the -41-volt supply. Tube  $V_8$  consists of both halves of a 12AU7 connected in parallel and plate coupled to the sync output connector. Sync positive pulses are obtained at the cathode to drive the horizontal sync discriminator.

To obtain a high-voltage pulse to operate an agc system, it is necessary to build a horizontal oscillator with synchronizing circuits, a waveform shaper and a pulse power amplifier. Tubes  $V_{10}$ ,  $V_{11}$  and  $V_{12}$  form a horizontal sync circuit. Tube  $V_{11}$  is an electron-coupled oscillator operating at 15,750 cps. crimator,  $V_{10}$ . The output of the tube connected across the oscillator tuned circuit and controlling its frequency in response to a control voltage obtained from the sync discriminator,  $V_{10}$ . The output of the oscillator is differentiated and am-

plified in  $V_{13}$ . The signal voltage on the grid of  $V_{13}$  drives it beyond cutoff and produces a sharpened pulse. Power amplification takes place in  $V_{14}$ . An output pulse of greater than 700 volts is obtained in synchronism with the horizontal sync pulse in the video amplifier.

### Keyed AGC

Tube  $V_9$  provides a keyed agc voltage. Composite video is applied to the control grid and a high-voltage pulse is applied to the plate. These two voltages appear simultaneously and an output is produced proportional to the grid voltage.

The agc voltage is connected through a divider circuit to the first and second video i-f grids. A delay circuit is connected in the agc line to the front end to prevent application of agc voltage to the r-f stage until the signal has built up to such an extent that noise is negligible. The keyed agc circuit minimizes picture degradation due to impulse noise and is effective in reducing flutter and rapid fading produced by reflections from aircraft. The highest flutter frequency the receiver will handle is 90 cps.

The author acknowledges the contributions of Ralph E. Grimm, chief engineer of Nems-Clarke, Inc.

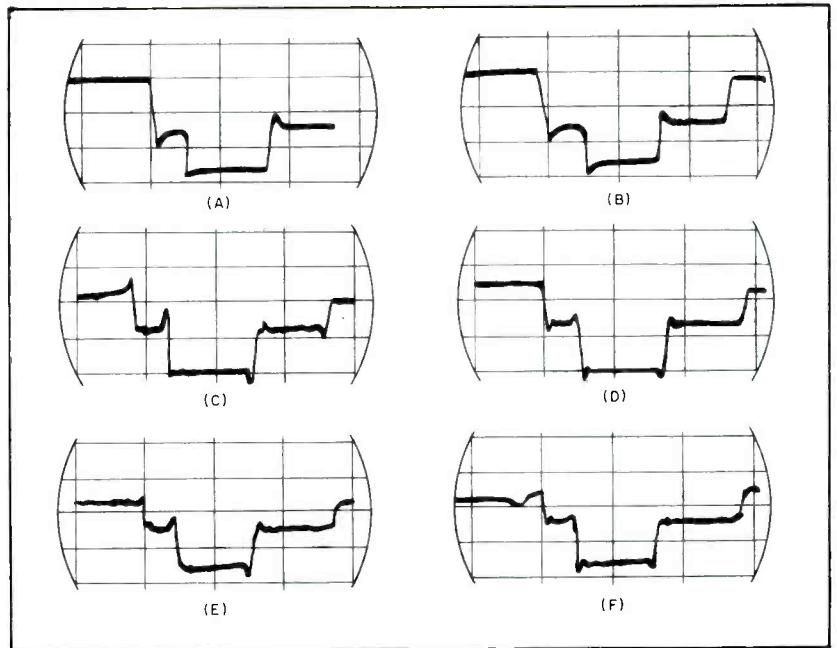

FIG. 7—Horizontal sync pulse into transmitter (A) and same pulse at double sideband detector (B). Pulse at output of receiver with phase-correcting network removed and double sideband input (C)—same pulse with network in place (D). Single sideband pulse without (E) and with (F) phase-correcting network

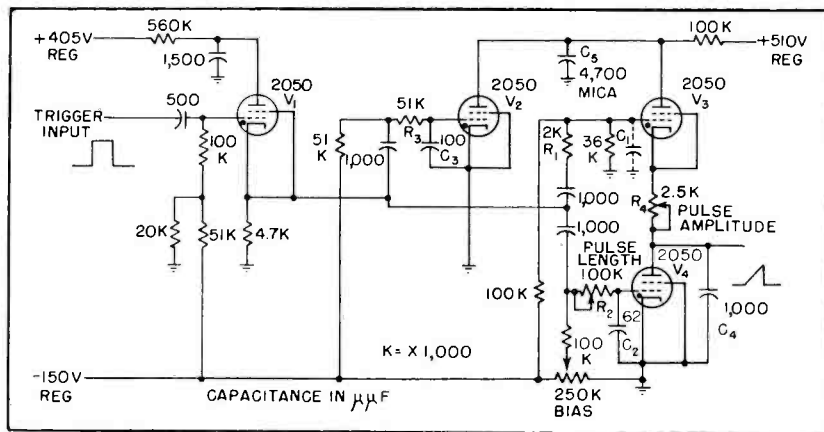

FIG. 1—Sawtooth pulser circuit may be triggered at rates from 50 to 5,000 cps

By N. SCLAR  
and  
R. L. McFOLIN

United States Naval Research Laboratory  
Washington, D. C.

# Sawtooth Pulser Gives

**V**OLTAGE-CURRENT characteristics of circuit elements may often be obtained by d-c methods involving the measurement of the voltages across the element and across a standard resistance in series with it. Drawbacks of this, however, are polarization effects, heating effects and the need to make point-by-point plots.

The polarization effects can be avoided by using pulses or a-c with periods shorter than the polarization time. By using a-c and employing the well-known technique whereby the V and I outputs are used to deflect the beam of an oscilloscope along perpendicular directions, the characteristic curve may be obtained as an oscilloscope trace.

Unfortunately, however, in many cases the characteristic obtained is sensitive to the local temperature of the element and this may depend on the Joule heat dissipated in the specimen. In these cases it is imperative to use pulse techniques, the Joule heating being reduced in proportion to the smaller time that the voltage is impressed on the specimen.

## Circuit Requirements

To retain the convenience of obtaining the characteristic as a trace on a scope, it seemed desirable to carry over to pulse measurements the techniques customarily used

with a-c. This can be achieved by using a pulse whose amplitude is a well-defined function of time over the desired voltage range. The exact waveform of the voltage variation supplied to the specimen is unimportant as long as the pulse voltage and current outputs from the test circuit are synchronized.

To obtain traces of uniform brightness and to cover the voltage range in a monotonically increasing fashion, a sawtooth pulse voltage is used. To minimize Joule heating it is desirable to use both as short a pulse and as low a repetition rate as possible. As a check on the possibility of thermal effect, it is useful to be able to change the repetition rate easily, since thermal effects can be identified by their dependence on the repetition rate.

These conditions are satisfied in the equipment to be described. It provides a sawtooth-shaped pulse output whose repetition rate is determined by the frequency of the external trigger generator. The trigger frequency may be varied from 50 to about 5,000 cycles per second. This is conveniently accomplished with a Hewlett-Packard model 212A pulse generator.

The length of the output pulse is variable from about 0.2 to 5 microseconds while the pulse amplitude extends over a range of voltage from 0 to about 300 v. Additional

d-c bias may also be applied in series with the pulses to extend the voltage range.

## Circuit Operation

The circuit is made up of four tetrode thyratron tubes whose operation may be understood by referring to Fig. 1. Tube  $V_1$ , triggered externally, produces a standard pulse with a fast rise time and several hundred volts amplitude.

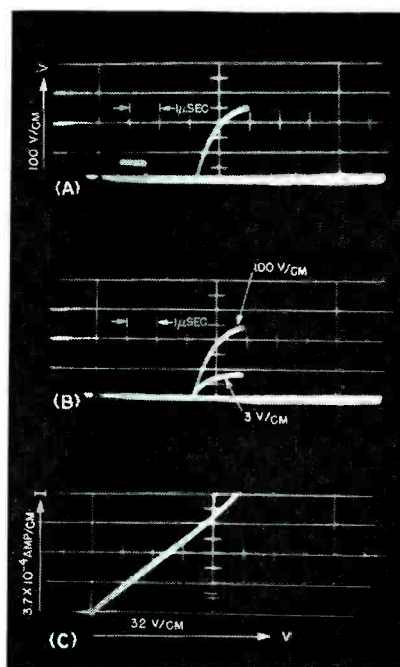

FIG. 2—Example of curves obtained for 100,000-ohm component, with 1,000-ohm resistor in series to give measure of current for vertical plates of scope



**SUMMARY** — Four-thyratron circuit triggered by external variable-rate pulse generator makes it possible to display complete voltage-current characteristics of a wide range of circuit elements on an oscilloscope screen. Reverse characteristics of germanium diffused junction rectifier are shown as one example of use

# Voltage-Current Curves

This standard pulse is fed by parallel paths to the control grids of  $V_3$ ,  $V_4$  and  $V_5$ .

The arrival of the pulse at the control grid of each tube is determined by the delay introduced by an integrating network consisting of a resistance and capacitance in the grid circuit of each tube. The standard pulse, after being delayed by  $R_1 - C_1$  where  $C_1$  is the stray circuit capacitance to ground, causes tube  $V_3$  to fire. The cathode of  $V_3$  is thus raised to approximately the plate potential of 510 volts as stored on  $C_5$ . This action produces a constant-amplitude pulse on the cathode of  $V_3$  which is fed through the integrating network  $R_4 - C_4$  to produce on  $C_4$  a single sawtooth wave which is the output pulse.

The zero time of the output signal is determined by  $R_1 - C_1$ . After a delay determined by  $R_2 - C_2$ ,  $V_4$  fires, lowering its plate potential, and discharges  $C_4$  to approximately ground potential, thus terminating the output pulse. Variation of  $R_2$  adjusts the lengths of the output pulse.

The standard pulse, also having been fed through integrating network  $R_3 - C_3$ , then fires  $V_5$  to completely discharge  $C_5$ , and resets the thyratron tubes by lowering their plate potentials below the extinction point.

The time delay introduced by  $R_3 - C_3$  is approximately 5 micro-

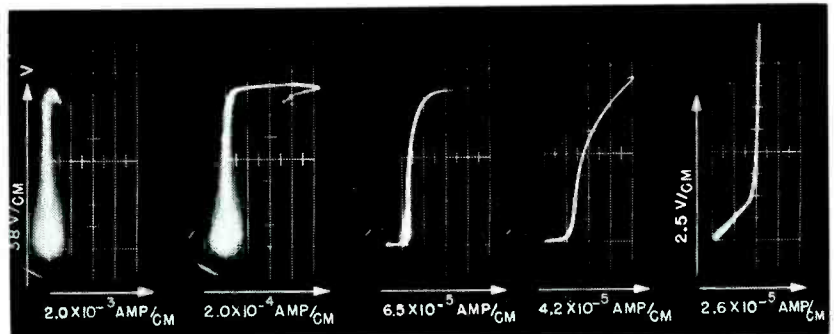

FIG. 3—Example of curves obtained for type 1N92 germanium rectifier when tested with five different values of resistance in series

seconds, which limits the maximum length of the output pulse. The amplitude of the output pulse is determined by the value of  $R_4$  which adjusts the time constant of  $R_4 - C_4$  and thus controls the voltage rise on  $C_4$ .

In the load circuit, if the series resistance is made small compared to the element resistance, then the total voltage across the combination is approximately the voltage on the specimen while the voltage across the series resistance is the measure of the current.

## Resistor Curves

When using the sawtooth pulser on a 100,000-ohm test element in series with a resistance of 1,000 ohms, the triggering rectangular input pulse and the resultant approximate sawtooth output are as shown in Fig. 2A. The voltage outputs obtained from the total

combination and from the series resistance are shown in Fig. 2B. Figure 2C shows the resultant traces when the voltage and current outputs are applied to the horizontal and vertical axes of the oscilloscope.

## Crystal Diode Curves

In Fig. 3 the apparatus was used to obtain the reverse characteristic of a GE 1N92 germanium diffused junction rectifier. By changing the value of the series resistance, it was possible to look at different regions of the curve in detail.

The equipment described here dissipates less power in the test specimen than that previously described by Pankove; series resistance and repetition rate are readily varied, and time or hysteresis effects are essentially eliminated.

## BIBLIOGRAPHY

J. I. Pankove, Pulsed Curve Tracer for Semiconductor Testing, *ELECTRONICS*, p 172, Sept. 1954.

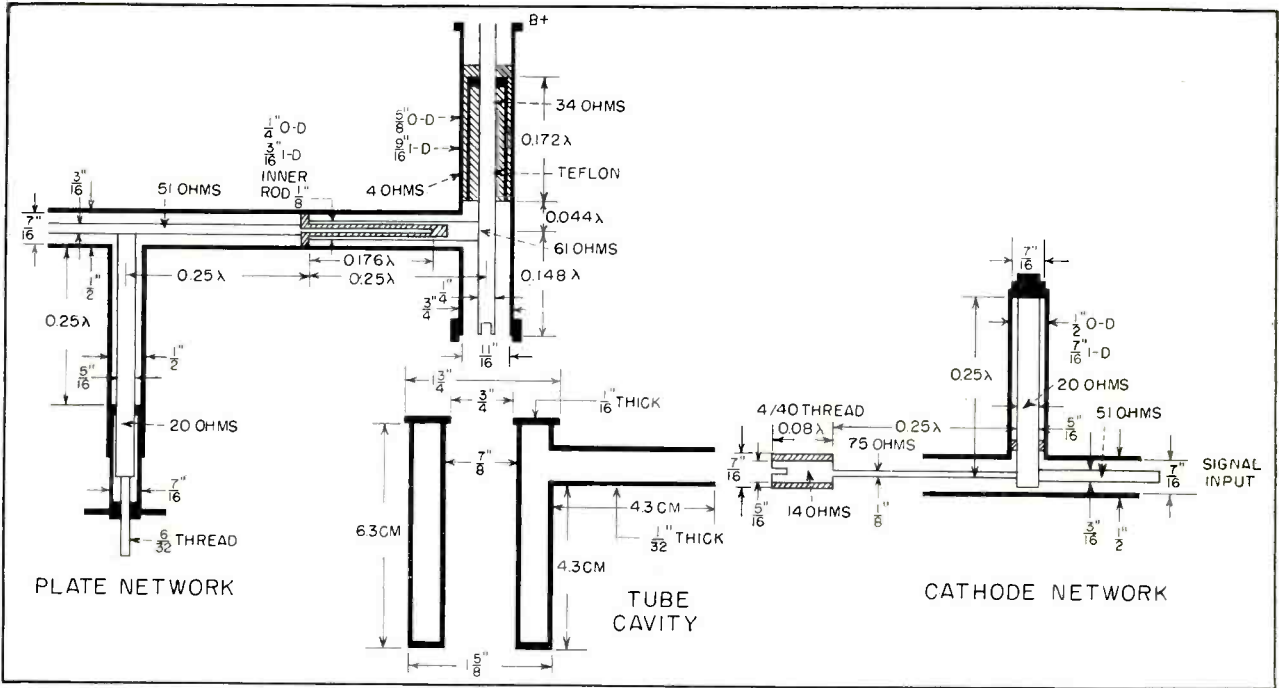

FIG. 1—Details of wide-band amplifier showing plate network, left, tube cavity, center, and cathode network, right

# Wide-Band Amplifier

**SUMMARY** — Low-noise r-f amplifier for uhf receiving equipment provides a 5 to 10-db gain in the 1,000-mc region, a bandwidth better than 200 mc and 51-ohm input and output impedances. Amplifier uses a 416B planar triode. Detailed design procedure is given

By **RICHARD B. McWHIRT**

*Naval Research Laboratory  
Washington, D. C.*

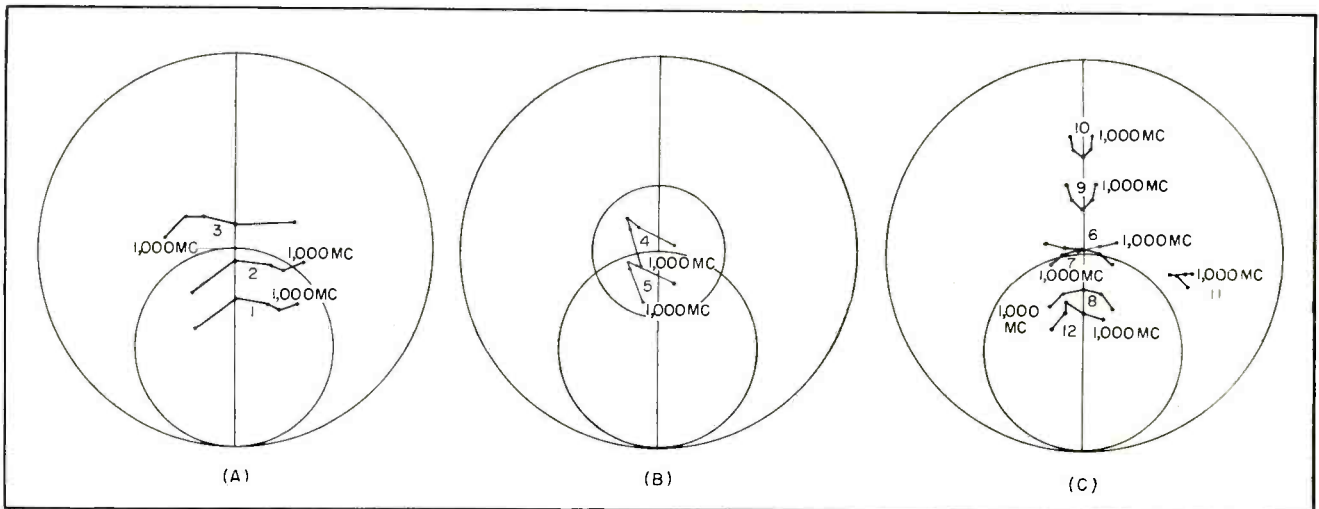
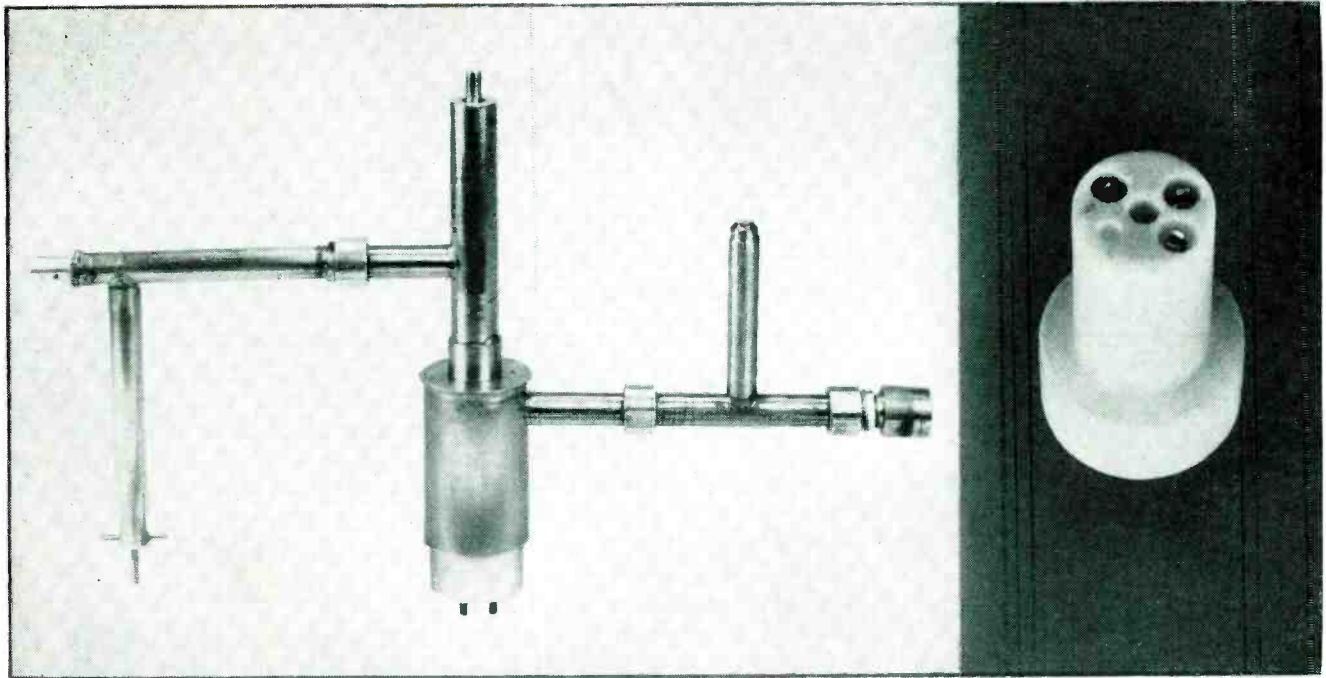

FIG. 2—Smith chart curves showing values of impedance at various points in cathode network (A and B) and in the plate network (C). Plotting points on curves designate 50-mc steps from 1,000 to 1,200 mc





Wide-band uhf amplifier. Special Teflon tube socket for 416B planar triode is shown at right

## for UHF Receivers

**I**N UHF receiving equipment it is often desirable to have a low-noise, wide-band r-f amplifier.

For one particular application it was necessary to have such an amplifier operate in the 1,100-mc region with a bandwidth of 200 mc, a gain of 5 to 10 db and an input and output impedance of 51 ohms.

Several types of tubes were investigated and it was decided that the 416B planar triode would be most suitable.

Perhaps the most outstanding feature of the 416B is its transconductance, 50,000  $\mu$ mhos for a plate current of 30 milliamperes. This high value of  $g_m$  is obtained by using close grid and interelectrode spacing and tight tolerances.

Other characteristics of the 416B are: amplification factor 200, plate resistance 4,000 ohms and plate current 30 ma at 200 volts. One objectionable feature is the heat generated by the tube: about 7 watts from the filament and 6 watts from the plate.

Since it was desired to match the input of the 416B to a 51-ohm sig-

nal source, the cathode impedance of the tube under grounded-grid conditions had to be determined. The tube cavity, which provided for measuring the cathode impedance, is shown in Fig. 1, center.

From previous measurements it was known that the cathode had an inductive reactance component. A shunt capacitor with a 14-ohm impedance was inserted in the input line immediately at the cathode shell of the tube. This capacitor served not only to add a capacitive reactance component but also offered a point from which the input network could be designed.

### Measurements

Values of cathode impedance were measured with a slotted line between 1,000 and 1,200 mc and are shown by curve 1 of the Smith chart, Fig. 2A. This plot is at 51 ohms since that is the characteristic impedance of the slotted line.

A satisfactory match between the cathode of the 416B and a 51-ohm signal source was obtained using a quarter-wave transformer and a

quarter-wave shorted stub in the input network, also shown in Fig. 1 (right).

The quarter-wave transformer was made by transforming the impedance at the input side of the shunt capacitor from 51 ohms to 75 ohms (curve 2, Fig. 2A) and moving one quarter wavelength toward the generator, curve 3. At this point, a quarter-wave shorted stub was shunted across the line causing the arms of the curve to fold inward, curve 4. This result is then transformed back to 51 ohms, curve 5. Moving away from this point along a 51-ohm line revolves the points on the curve about the center of the chart.

From curve 5 it can be seen that the effective load resistance presented by this network varies from 56 ohms to 89 ohms. However there is actually only about an 8-percent change in the power developed across the load resistance.

The circle shown in Fig. 2B represents a voltage standing wave ratio of two. Curve 5 lies within this circle showing that the voltage

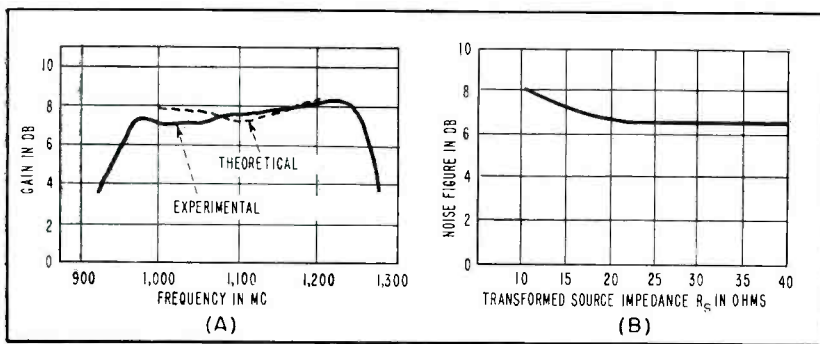

FIG. 3—Gain in db versus frequency (A) and noise figure versus transformed source impedance ( $R_s=1/G_s$ )

standing wave ratio of the input network is less than two over the band from 1,000 to 1,200 mc which is adequate.

### Output Network

Before the design of the plate network could be started, it was necessary to determine the impedance of the plate of the 416B under operating conditions by using the slotted line for frequencies from 1,000 to 1,200 mc. These values of impedance were found to range from  $7.3 - j 104$  ohms for 1,000 mc to  $0.9 - j 79$  ohms for 1,200 mc.

After the values of plate impedance had been determined, a network was designed which would match the tube to a 51-ohm load and keep the value of equivalent series resistance presented to the plate of the 416B reasonably constant. This network consisted of a quarter-wave shunt stub, a quarter-wave series capacitor, and a quarter-wave choke as shown at the left in Fig. 1.

The graphical representation of the operation of the network can be seen on the Smith chart, Fig. 2C. Starting from the 51-ohm load and moving any distance along a 51-ohm line has no effect on the impedance at any frequency. Therefore, the impedance at the shunt stub is a pure resistance of 51 ohms. This can be represented by a point at the center of the chart  $1 + j0$ .

At the point where the shorted stub joins the line, a shunt reactance is injected which spreads the points out from the center of the chart, curve 6. Moving from this point toward the generator along the 51-ohm line a distance equal to one quarter wavelength at 1,100 mc rotates the curve half way around

the chart and tends to fold the arms of the curve in slightly, curve 7. Also at this point there is a series capacitor. The impedance of this capacitor has little effect upon the overall impedance and can therefore be neglected.

The values of impedance are next transformed from 51 ohms to 33.5 ohms, curve 8, which is the impedance of the outside shell of the series capacitor. Moving along the 33.5-ohm line one quarter wavelength rotates the curve another 180 deg around the chart causing the arms to fold in somewhat more, curve 9.

### Connection to Tube

At this point the 33.5-ohm line joins the 61-ohm section of line which attaches to the tube. There is also a quarter-wave choke on this line which is placed such that it reflects an open circuit at the point where the 33.5-ohm and the 61-ohm lines join. This makes it possible to apply B+ to the 416B plate without allowing any signal to travel into the power supply.

Moving from the junction of the 33.5-ohm and 61-ohm line, curve 10, down to the tube a distance of 4.04 cm, moves the points on the chart about  $0.150 \lambda$  toward the generator, curve 11. These values of impedance are then added in parallel with the impedances presented by the plate of the 416B to obtain the total impedance, curve 12.

In curve 12 (Fig. 2) the values of equivalent series resistance presented to the plate vary between 104 and 131 ohms. The average value for the five frequencies is about 120 ohms. The variation from 120 ohms is about  $\pm 10$  percent and

satisfactory.

To supply filament voltage and cathode bias to the 416B, it was necessary to construct the special tube socket shown in the photograph. Since there is a considerable amount of heat dissipated by the filament, Teflon was chosen as the socket material.

To block any r-f on the filament or cathode leads, quarter-wave chokes were constructed using polystyrene and pressed into holes drilled in the Teflon plug. These chokes have spring clips attached to one end which will engage the pins on the base of the tube when the Teflon plug is inserted into the base of the tube cavity.

### Experimental Results

The response of the amplifier was determined experimentally using an input signal between 925 and 1,275 mc from a 51-ohm signal generator and a 51-ohm bolometer load on the output.

For an input of 1 mw, the output averaged about 5.7 mw over the band between 1,000 and 1,200 mc. This average is in close agreement with the calculated average of 6 mw.

The overall response was flat within  $\pm 0.6$  db as compared with the theoretical value of  $\pm 0.5$  db. It can be seen from the graphical representation shown in Fig. 3A that the 3-db bandwidth is over 300 mc.

The noise figure of the first model wide-band amplifier, constructed from brass rod and tubing, was measured using a fluorescent tube noise source which had an output of 16.4 db above *KTB*. The resulting value of noise figure was 11.9 db.

A second model was constructed which was a duplicate of the first except that all of the brass parts were plated with 0.001 inch of silver. The noise figure of this unit was 10.0 db, or an improvement of about 2 db over the brass model.

Although the noise figure of the silver-plated model is 2 to 3 db above theoretical, it is still satisfactory since the theoretical noise figure is difficult to realize at this frequency.

A view of the completed amplifier is shown in the photograph.



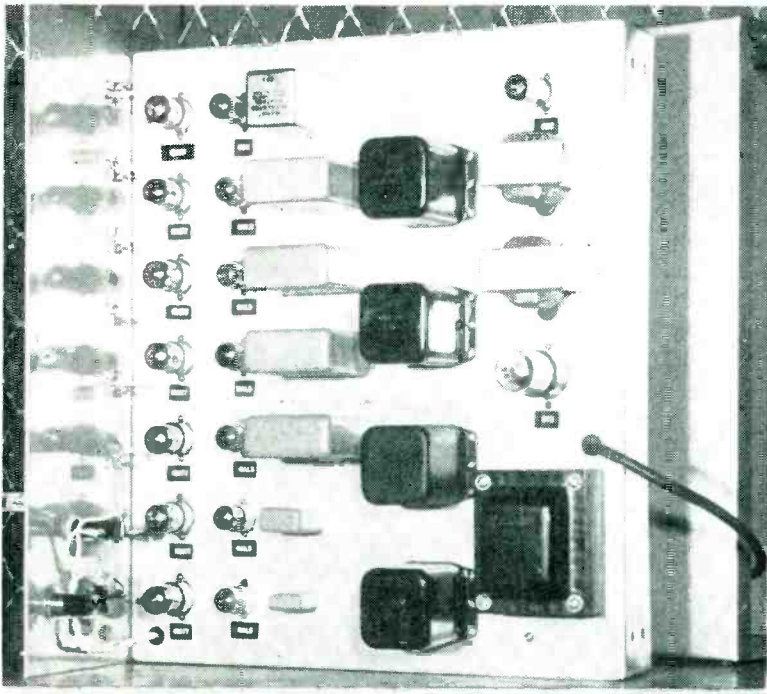

Top view of chassis showing physical layout of components

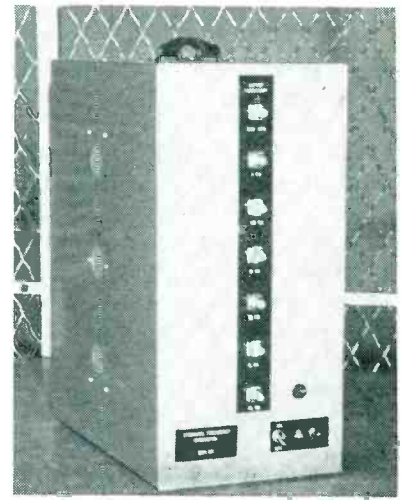

Complete generator showing outputs

By **PETER KOUSTAS**

*Tube Division  
Radio Corporation of America  
Harrison, New Jersey*

# Audio-Standard Generator

**SUMMARY** — Simultaneous output voltages are available at frequencies of 500 cps, 1, 1.5, 2, 3, 5 and 10 kc from unit employing tuning-fork standard. Technique involves full-wave rectifiers as doublers to achieve desired frequencies

**C**ALIBRATION of sensitive test equipment often requires an accurate source of audio frequencies.

For example, the pulse-repetition frequency of pulsed-magnetron test sets must frequently be calibrated by means of a high-quality audio generator.

When a wide range of harmonically related frequencies is desired, a crystal-controlled oscillator utilizing multivibrator-type dividers is often used to furnish an output at submultiples of the crystal frequency.

This article describes a less complex and less expensive experimental unit which features tuning-fork frequency control, relatively simple circuitry, reliability and elimination of the need for adjustments. Seven triode sections are used as cathode-follower output stages and all frequency multiplication is accomplished by diode doublers.

### Frequency Control

The tuning fork is a frequency standard comparable in stability and accuracy to the quartz crys-

tal.<sup>1,2</sup> Mechanically resonant reeds may also be used for frequency control with a slight sacrifice in accuracy. These mechanically vibrating elements are useful as the frequency-determining portion of an electron-tube oscillator such as that used in the standard audio-frequency generator described in this paper.

Oscillator-frequency control elements of the resonant-reed and tuning-fork types are readily available for any frequency in the lower audio range. The accuracy of commercial units ranges from 0.1 to

0.001 percent; higher values of accuracy are available on special units, depending on the characteristics desired.

The tuning-fork or resonant-reed controlled oscillators are electrically equivalent to the Meissner r-f oscillator.<sup>8</sup> This is shown in Fig. 1. The frequency of the r-f oscillator is determined primarily by the circuit within the dotted lines, which is composed of  $L_1$ ,  $L_2$ ,  $L_3$  and  $C_1$ .

This circuit may be considered as a transformer whose primary and secondary,  $L_1$  and  $L_2$ , are coupled through a high-Q resonant circuit composed of  $C_1$  and  $L_3$ . If there is little coupling from  $L_3$  to  $L_1$  and  $L_2$ , the frequency of oscillation is approximately equal to  $1/2\pi\sqrt{L_3C_1}$  and is substantially independent of external circuit parameters. Examples of these are tube capacitance or plate voltage.

### Operation

In the tuning-fork oscillator, however, the transformer is physically quite different, although electrically equivalent. The primary and secondary are separated and not mutually coupled. One leg of a tuning fork made of magnetic material forms the core material of each coil.

Plate-current disturbances of any kind, such as those which occur

when voltage is applied, have two simultaneous effects: the tuning fork is set in motion; and a magnetic flux is induced in it by the coil whose core it forms. Because a well-made tuning fork is mechanically equivalent to a high-Q resonant circuit, it vibrates only at its resonant frequency when shock excited. The loaded Q of a tuning fork can easily be made greater than 10,000.

When the tuning fork is excited, both legs exhibit some movement. The motion of the leg used as the core of the grid winding induces a voltage in the coil  $L_2$ . The circuit will then oscillate, provided the polarity of the grid voltage is such that it reinforces the plate signal and the tube supplies enough gain to offset circuit and mechanical losses.

Because feedback can occur only when the tuning fork is vibrating, the accuracy and stability of the oscillator depend directly upon the mechanical properties of the vibrating element.

### Circuit

A complete schematic of the standard-frequency generator is shown in Fig. 2. Triode  $V_1$  is the tuning-fork-controlled master oscillator from which all output frequencies are derived. A small amount of negative feedback, provided by resistor  $R_1$ , limits the gain of the oscillator tube. Thereby the tuning fork is prevented from being overdriven and the purity of the waveform is improved to an appreciable extent.

The oscillator operates at a frequency of 500 cycles per second. This frequency was arbitrarily chosen because lower frequencies can be calibrated against the power-line frequency by Lissajous figures<sup>4</sup> observed on an oscilloscope. This technique may also be used to extend the usefulness of the standard-frequency generator down to 100 cycles or up to a frequency of 100 kilocycles.

Multiples of the base frequency are obtained by principles which are commonly known but not often applied to this particular application. The first four terms of the Fourier expansion of the full-wave rectification of a sine wave will

result in the following expression

$$e = \frac{2E_m}{\pi} - \frac{4E_m}{3\pi} \cos 2\omega t - \frac{4E_m}{15\pi} \cos 4\omega t - \frac{4E_m}{35\pi} \cos 6\omega t$$

This expansion includes a second harmonic equal to  $4/3\pi$  times the peak voltage applied. The presence of this second harmonic may be used to provide multiples of the oscillator frequency.

One half of twin triode  $V_2$  is a cathode follower providing a low-impedance output at the fundamental frequency; the other half is an amplifier. The plate load of the amplifier consists of a transformer in which a center-tapped secondary provides a phase difference of 180 degrees between the voltages at the two ends with respect to ground.

### Rectification

Diode  $V_3$  is a full-wave rectifier. The original sine wave is thus converted to the familiar output waveform of a full-wave rectifier having a resistive load which is rich in harmonic content. The high-Q parallel-tuned circuit included in the diode load eliminates all harmonics except the second. The unloaded Q of the inductors used in this circuit ranges from 120 to 200.

An isolating resistor in series with the tuned circuit maintains a high loaded Q by minimizing d-c through the inductor and equalizes the amplitude of all frequency generator outputs.

The filtered second-harmonic voltage is then fed into a second twin triode,  $V_4$ . One triode amplifies the second harmonic in preparation for the next diode frequency doubler; the other triode provides another low-impedance cathode-follower output stage.

Frequency doubling provides only frequencies which are  $(2)^n$  times the oscillator frequency, where  $n$  is an integer. Often, however, frequencies such as 3, 6 or 10 times the fundamental frequency are required. Two methods of achieving such frequencies were considered. The sine wave could be shaped to a form, such as a square wave, containing odd harmonics and then filtered.

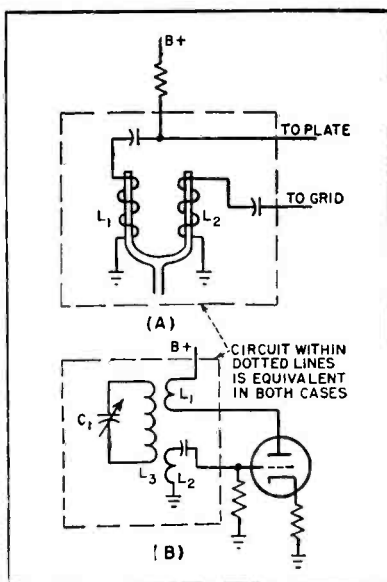

FIG. 1—Schematic diagram of tuning-fork-controlled oscillator (A) and Meissner r-f oscillator (B)



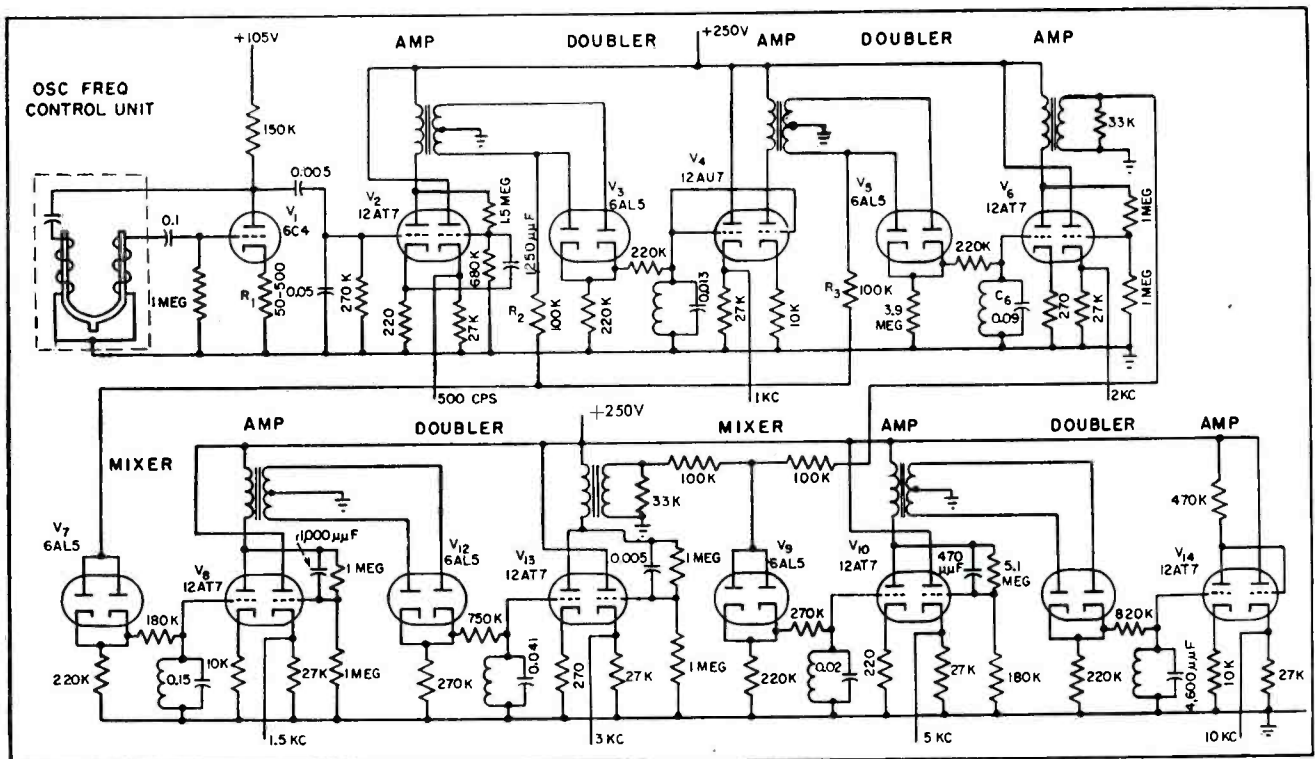

FIG. 2—Schematic of audio-frequency generator employing tuning-fork-controlled master oscillator. Diode frequency multipliers are used to obtain frequency doubling

Alternately, two of the available frequencies could be added and then rectified to provide either their difference or sum and associated harmonics.

### Diode Doubler

The second method was used because it required only a single tube, a diode. Two mixing stages are incorporated which furnish output at 1,500 and 5,000 cycles. Each of these stages combines two frequencies whose sum or difference is desired and the resultant voltage is then rectified. If the two voltages are represented by  $E_1 \sin \omega_1 t$  and  $E_2 \sin \omega_2 t$ , the Fourier expansion of the rectified output contains the two terms  $k E_1 E_2 \sin (\omega_1 + \omega_2) t$  and  $k E_1 E_2 \sin (\omega_1 - \omega_2) t$  where  $k$  is a mathematical constant of proportionality.

The rectifier output will contain voltage components whose frequencies are equal to the sum and the difference of the two original frequencies. The particular component desired may then be selected by a suitable tuned circuit similar to that previously described in this article.

The 500-cycle and 1,000-cycle

voltages, obtained from  $V_2$  and  $V_4$ , respectively, are combined through resistors  $R_2$  and  $R_3$  and applied to the diode mixer  $V_7$ . The 1,500-cycle component is selected from the mixer output by a tuned circuit and amplified by  $V_8$ , fed through diode doubler,  $V_{12}$  to furnish a 3,000-cycle output.

A second diode mixer,  $V_9$ , provides a 5,000-cycle output by combining the 3,000-cycle and 2,000-cycle voltages. The 5,000-cycle voltage is then amplified by one half of  $V_{10}$  and rectified by the final diode frequency multiplier to provide an output frequency of 10 kilocycles. The number and choice of output frequencies is determined by the particular requirements of the application and not limited to those shown here.

### Advantages

Reliability is inherent in this experimental standard-frequency generator because all tubes are operated conservatively and use of capacitors has been held to a minimum. Because there are no multivibrators nor oscillating circuits other than the master oscillator, output is limited to the frequencies

designed into this piece of equipment.

Power-supply requirements are simplified because variations in supply voltage affect only the oscillator circuit. An OB2 voltage-regulator tube of the glow-discharge type provides adequate regulation of oscillator plate voltage for practically all purposes. Total power-supply drain is approximately 60 milliamperes.

All output voltages are available simultaneously at 500 cycles, 1, 1.5, 2, 3, 5 and 10 kilocycles. Peak-to-peak amplitude of all outputs is 20 volts. No perceptible drift has been observed at any time during long periods of continuous operation of this equipment.

The author expresses his appreciation to D. Mawhinney who constructed the unit and simplified many of the difficulties prior to the completed design.

### REFERENCES

- (1) F. E. Terman, "Radio Engineer's Handbook", p 950, McGraw-Hill Book Co., Inc., New York, 1943.
- (2) E. Norrman, A Precision Tuning-Fork Frequency Standard, *Proc IRE*, 20, p 1,715, Nov. 1952.
- (3) F. E. Terman, "Radio Engineer's Handbook", p 480, McGraw-Hill Book Co., Inc., New York, 1943.
- (4) Seeley, "Electron Tube Circuits", p 486, McGraw-Hill Book Co., Inc., New York, 1950.

# Expanded-Scale Voltmeter

**SUMMARY** — Instrument shows rms voltage with 0.25-percent accuracy over range of 100 to 500 volts. Hot-wire thermal bridge provides highly stable voltage standard, which is relatively independent of frequency from 50 to 2,000 cycles per second

**M**ANY applications in electronic engineering require an indicating instrument that will accurately measure high voltages.

To meet this need, an expanded-scale voltmeter has been developed which permits the indication of a narrow voltage range over the complete indicating-meter scale.

In the laboratory-model instrument, a tapped input transformer permits this voltage range to be placed conveniently, so that in actual use the applied voltage is equal to the sum of the readings of two knobs plus the reading of the meter. In the panel-mounted voltmeters, this adjustable feature is eliminated and the scale is expanded about the nominal voltage.

Accuracies of 0.25 percent over a frequency range of 50 to 2,000 cycles are achieved in the laboratory-model voltmeter and accuracies of 0.5 percent over the same frequency range are achieved in the panel meter. Sensitivities as high as 0.3 inch per volt are obtainable.

## Principle of Operation

A thermal bridge is used as the voltage standard in both models of the expanded-scale voltmeters. By exploiting the nonlinear properties of a hot wire, a highly stable voltage standard has been developed. This element is used in a bridge circuit with wire-wound resistors to give a system whose output is shown in Fig. 1. The output voltage goes through a null at an input of  $E_s$ . For small deviations from  $E_s$ , the output voltage is proportional to  $(E_m - E_s)$ . Since the nonlinearity is produced by heating of the wire, the indication is rms and relatively

independent of the frequency.

High-frequency limitations imposed are those of wire-wound resistors and low-frequency limitations result from distortions caused by nonlinearity during a cycle of the input frequency. These impose limits of about 20 to 100,000 cps on the voltage standard. Accuracy of 0.1 percent can be obtained.

The temperature coefficient of the bridge is very small because of the high operating temperature of

the wire in the nonlinear element, since a change in ambient produces only a small percentage in the wire's temperature rise. This small coefficient is compensated for by using a temperature-sensitive resistor in one branch of the bridge. The high operating temperature of the nonlinear element also produces rapid response to voltage changes.

## Laboratory Model

The circuit of the laboratory model of the expanded-scale voltmeter is shown in Fig. 2. The nonlinear voltage standard is driven from a precision tapped transformer which permits measuring a wide range of input voltages. The taps are arranged in decades with 10-volt steps from 100 to 390 volts on the input, providing exact input ratios to the voltage standard. An accurately center-tapped secondary

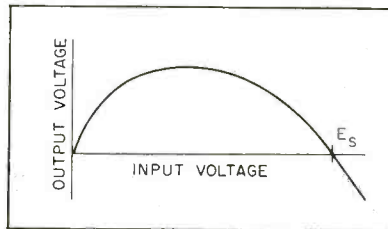

FIG. 1—Characteristic of hot-wire thermal bridge used as voltage standard

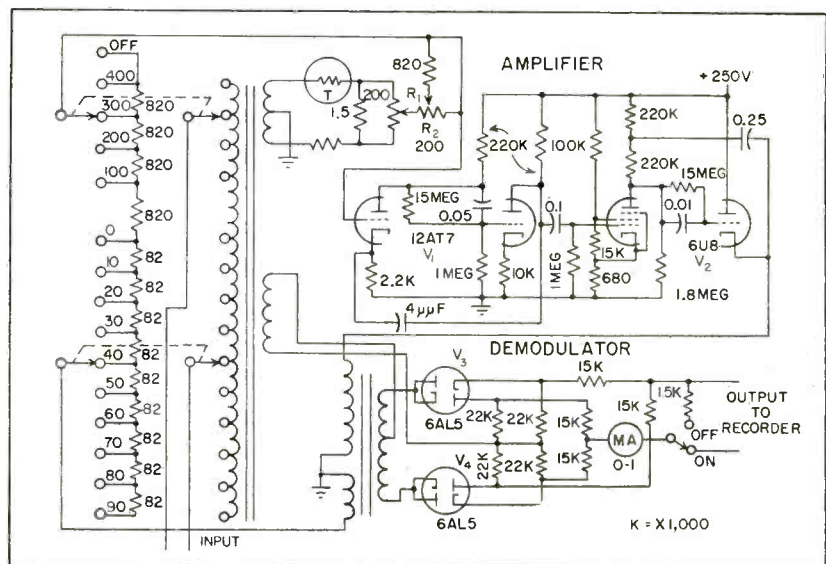

FIG. 2—Laboratory-model expanded-scale voltmeter has provision for operating 1-milliamper external recorder



# for A-C Measurements

By **HERBERT GALMAN**

Chief Development Engineer  
Arga Division, Beckman Instruments, Inc.  
South Pasadena, California

on the transformer permits eliminating two resistors in the bridge to give a half-bridge voltage standard. The transformer has 0.1-percent accuracy from 50 to 5,000 cps.

The transformer-voltage standard combination produces an output proportional to  $(N_s/N_p)(E_m - E_s)$  where  $N_s/N_p$  is the ratio of the transformer's secondary voltage to its primary. By multiplying this output by  $N_p/N_s$ , a voltage proportional to  $[E_m - (N_p/N_s)E_s]$  is obtained. Since  $N_p/N_s$  was chosen to be decade voltages from 100 to 490 volts in 10-volt steps, a method of accurately subtracting these voltages from the input voltage is obtained. This subtraction is rms.

The amplifier, consisting of  $V_1$  and  $V_2$ , multiplies the voltage standard's output by  $N_s/N_p$  through changing the feedback resistors with changes in the transformer taps. Negative feedback makes the gain very accurately proportional

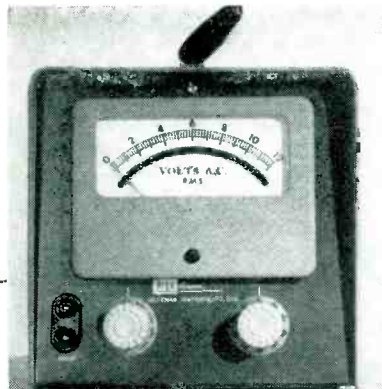

Expanded-scale voltmeter is read by adding dial settings to meter reading

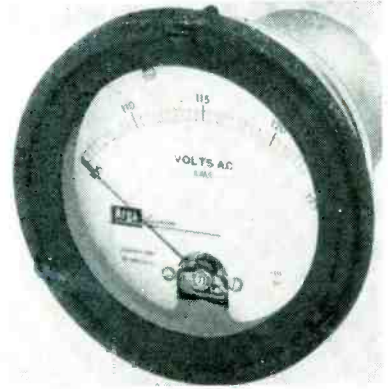

Panel-model meter has circuitry in can attached to meter housing

to the feedback resistors. The feedback reduces the gain by more than 100, giving almost complete freedom from change of gain due to variations in tubes and associated components.

The amplifier's output transformer drives  $V_3$  and  $V_4$ —a balanced, full-wave, phase-sensitive demodulator. This demodulator produces an output of one milliampere to drive a panel meter. In addition, terminals permit operation of a 1-milliampere recorder. The high output resistance of 30,000 ohms produces optimum response from the recorder.

Because of the balanced operation and the high output voltage of the demodulator, negligible zero drift is encountered in this stage making a zero adjustment unnecessary.

Potentiometer  $R_1$  adjusts  $E_s$  and is set by applying an input of 100 volts to the instrument from an accurate standard and setting the decade knobs to 100. The potentiometer is then adjusted to bring the panel meter to zero. Potentiometer  $R_2$  sets the full-scale reading of the panel meter and is adjusted by applying 110 volts and making the panel meter read 10.

### Waveform Correction

The demodulator reads the average value of the voltage applied to it. This results in a waveform error. Since this error is only in the difference output of the voltage

standard, the resulting error is usually negligible.

Typical errors are given in Table I, which gives the error in volts. This table shows that no waveform error exists at the 0-volt end of the panel-meter scale. Maximum error occurs at the 10-volt end of the scale. For a given harmonic content, the maximum error in volts is independent of the voltage range used. For normally encountered waveforms, with less than 10-percent distortion, only small errors will result.

To operate the voltmeter the hundreds and tens knobs are turned to bring the meter needle on scale and the setting of the knobs are added to the meter reading. For example,  $200 + 30 + 3.7 = 233.7$  volts. The meter has a full scale reading of 12 volts, giving a 2-volt overlap and eliminating the necessity of switching back and forth when the voltage is close to the end of the scale.

### Panel-Mounting Meter

The panel-model of the expanded-scale voltmeter, Fig. 3, has one range. The network containing the voltage standard and demodulator are packaged in a hermetically sealed can attached directly to the meter itself.

In this version of the voltmeter the thermal bridge is operated at a voltage of 6 or 12 volts. A transformer is used to step down the input voltage to the proper voltage for bridge operation.

Table I—Typical Voltage Errors

Harmonic Content	RMS Voltmeter Reading					
	100	104	108	400	404	408
10% 2nd	0	0	0	0	0	0
10% 3rd	0	0.15	0.30	0	0.15	0.30
10% 4th	0	0	0	0	0	0
10% 5th	0	0.10	0.20	0	0.10	0.20
10% 7th	0	0.06	0.12	0	0.06	0.12

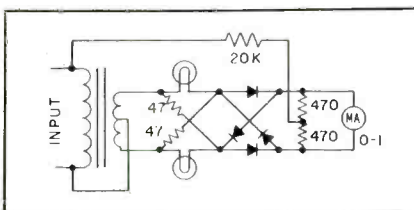

FIG. 3—Panel-type expanded-scale voltmeter for specific voltage ranges

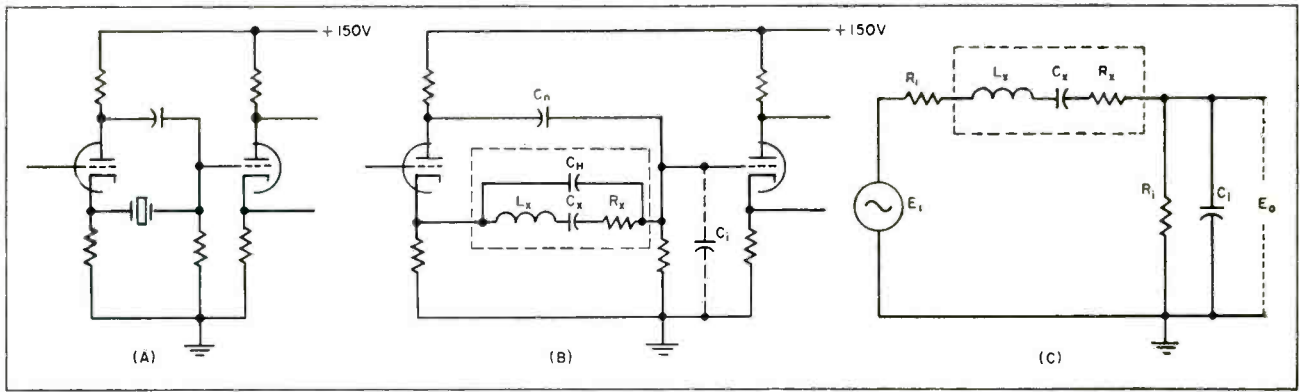

FIG. 1—Crystal filter circuits showing basic staggered element (A), with its equivalent circuit (B) and a further simplification (C)

# Staggered Triple

**SUMMARY** — Narrow-band filter with extremely sharp skirts is provided by piezoelectric crystals in stagger-tuned system. Circuit functions from 400 kc to 5 mc by suitable choice of crystals

By **D. E. HILDRETH**

*Electronic Products Corporation  
Santa Barbara, California*

**R**ECENT DEVELOPMENTS found in mechanical filters and the more familiar lattice systems seem to cover sharp filter applications quite well. However, the need occasionally arises for a filter outside of the frequency range of the mechanical filters or more simple in terms of component requirements and adjustments than lattice systems. Results with the staggered crystal filter shown here have been promising.

## Unit Function

Basically, a staggered element in this system contains a phase inverter, to facilitate neutralization of crystal holder capacitance, a crystal and an isolation stage which may be a cathode follower or an amplifier. Maximum energy is transferred to the isolation stage at the series-resonant mode of the crystal. Circuit Q can be altered by the addition

of resistance in series with the crystal-neutralizing circuit and the input of the isolation stage of this system.

Design criteria for the use of staggered elements is well covered in the literature.<sup>1</sup> Design criteria usually given is to enable the design of a system with maximal flatness. Higher Q's than those dictated by design criteria can be used where peak-to-valley ratios on the order of 3 to 6 db can be tolerated. The allowance of a peak-to-valley ratio is usually more than compensated for in terms of a superior skirt-shape factor.

A basic element is shown in Fig. 1A and its equivalent circuit is shown in Fig. 1B. It is further simplified in Fig. 1C.

If Fig. 1C is used to evaluate an indication of stage gain at resonance and  $R_i$  is made much larger than  $X_{ci}$ , the approximate equation

for stage gain is the following

$$\text{Gain} = \frac{E_o}{E_i} = \frac{IX_{ci}}{E_i} = \frac{X_{ci}}{R_i + R_x}$$

A typical apparent voltage gain for a crystal circuit at 400 kc assuming  $C_i$  to be  $5 \mu\text{mf}$  and total  $R$  to be 5,000 ohms would be  $80,000/5,000 = 16$ .

## System Results

The circuit shown in Fig. 2 is the prototype which was built to be used with 400-kc crystals. The curve shown in Fig. 3 indicates frequency response which was present with a voltage gain of 20.

Figure 4 indicates results when crystals at 1.599, 1.600 and 1.601 mc were used. Inherently, this system is most practical where overall system Q's are on the order of 2,000 to 20,000. Where lower system Q's are required, staggered systems employing Q multipliers or normal



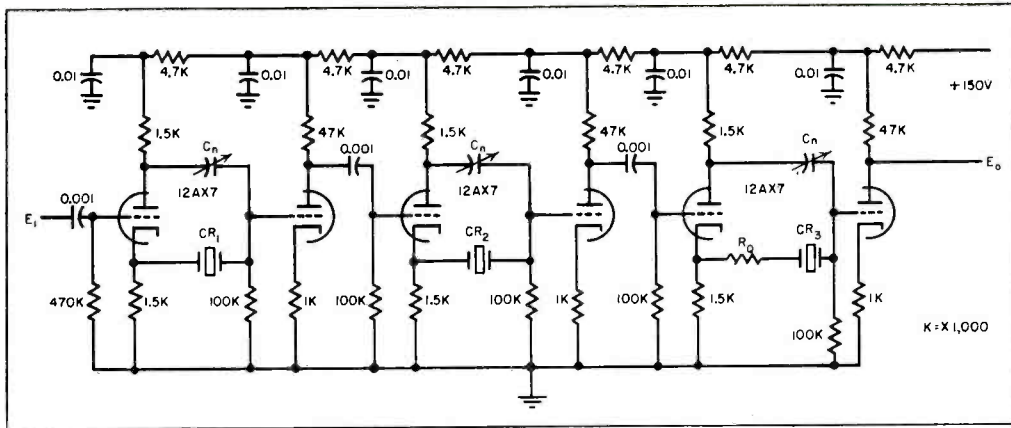

FIG. 2—Circuit diagram of prototype model of staggered triple crystal filter using 400-kc crystals

# Crystal Filter

resonant circuits may be used to advantage.

Since resistance ( $R_0$  in Fig. 2) must be added in series with a series resonant circuit to reduce  $Q$ , the circuits shown would result in signal attenuation rather than gain if crystals were to be used for low- $Q$  elements. This may easily be determined by referring to the gain equation where the  $Q$ -reducing resistance would appear in the de-

nominator of this expression.

Where skirt-rejection requirements are not too severe, a single staggered pair may be used or a single crystal circuit where a sharp peak is desired.

Applications of this type of filter system seem to be large. It may readily be adaptable in the elimination of the double-heterodyne process in some high-frequency receiver applications where a high degree

of both image rejection and selectivity are required. The size of such equipment could immediately be reduced and less shielding would be required to reduce the multiple beats present when more than one local oscillator is used in a receiver system.

## REFERENCE

(1) H. Wallman, Stagger-Tuned Amplifier Design, p 682, "Electronics Manual for Radio Engineers," Zeluff and Markus, McGraw-Hill Book Co., New York, 1949.

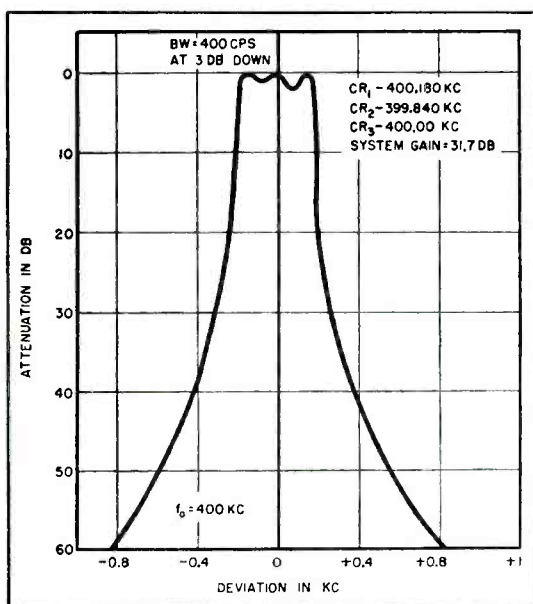

FIG. 3—Frequency response of filter circuit using 400-kc crystals with a voltage gain of 20

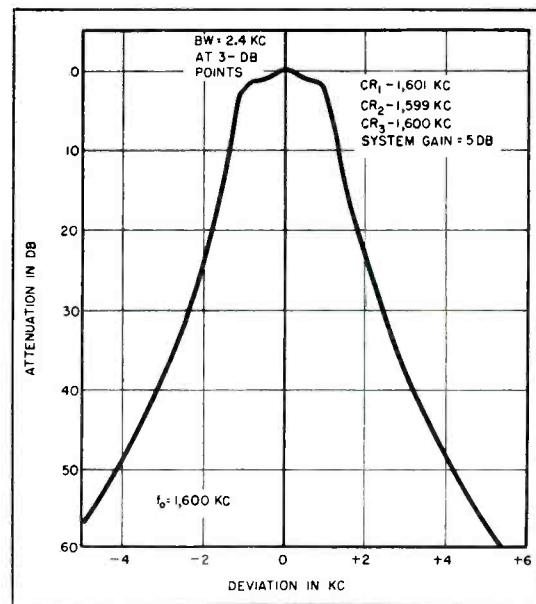

FIG. 4—Curve shows frequency response with a center frequency of 1,600 kc

# VHF Transmission Line Calculator

By A. E. SANDERSON

Aircraft Radio Corporation  
Boonton, New Jersey

**SUMMARY** — Phase shift and attenuation introduced by transmission line connecting unknown impedance and measuring equipment can be quickly corrected by use of simplified calculator dial together with Smith or Z-<sup>⊙</sup> chart. Dial is also useful in design of filters, antennas and matching networks

**C**ORRECTION of vhf impedance measurements for phase shift and attenuation introduced by the transmission line connecting an unknown impedance with measuring apparatus can be made with the calculator shown here.

It is used in conjunction with

either a Smith chart or Z- $\theta$  chart. With this device corrected measurements may be plotted directly on the Smith chart without the necessity of reading values from a separate calculator and transcribing them. Scales not necessary for transmission line corrections are omitted for sim-

plicity on the chart below.

An impedance curve plotted on these charts is valuable in the design of vhf filters, matching networks and antennas. Such a curve will tell not only how good the network may be in terms of vswr, but with proper interpretation, will tell exactly what steps should be taken to perfect the design of the network.

## Calculator Design

The transmission line calculator consists of a clear plastic disk about 8 inches in diameter with printed scales. Two D-shaped sections and a radial slot are cut out of the disk to allow marks to be made directly on the graph paper as the measurements are taken. A small hole is located at the center for a thumbtack pivot.

A scale around the outer perimeter of the calculator is marked off in units of 1/1,000 wavelength. The scale goes from 0 to 500, since 1 revolution of the calculator corresponds to the phase-shift correction for a section of line  $\frac{1}{2} \lambda$  in length. A scale along the upper edge of the radial slot from the center to the outer edge of the calculator is marked off in vswr from 1 at the center to  $\infty$  at the outer edge. This scale is nonlinear, but may easily be calculated from the re-

(Continued on page 170)

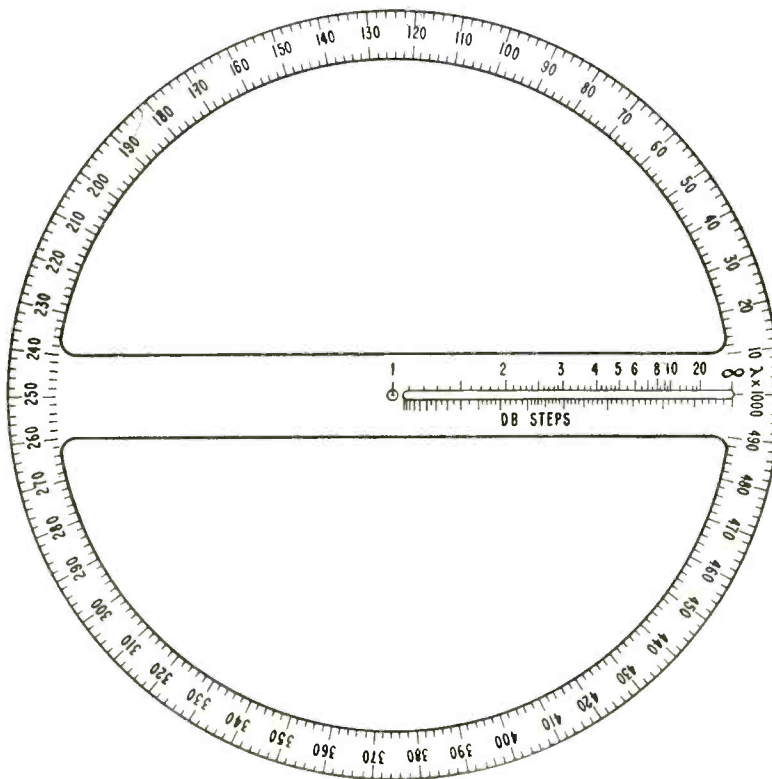



# ETCHED CIRCUITRY

## AND RELATED ASSEMBLIES

**Graphic Circuits Reduce Wiring Costs •  
Cut Down Assembly Time • Eliminate  
Errors • Miniaturize • Guarantee  
Uniformity**

### RIGHT ANGLE BOARD (Right)

Developed and produced for right angle application. The right angle board accommodates all of the CINCH socket sizes, and can be bonded with epoxy resin or snapped in and retained by newly developed CINCH hardware. All units meet or exceed Military Specifications.

Sockets, terminals and other hardware installed to customer specifications using the latest equipment in automatic assembly.

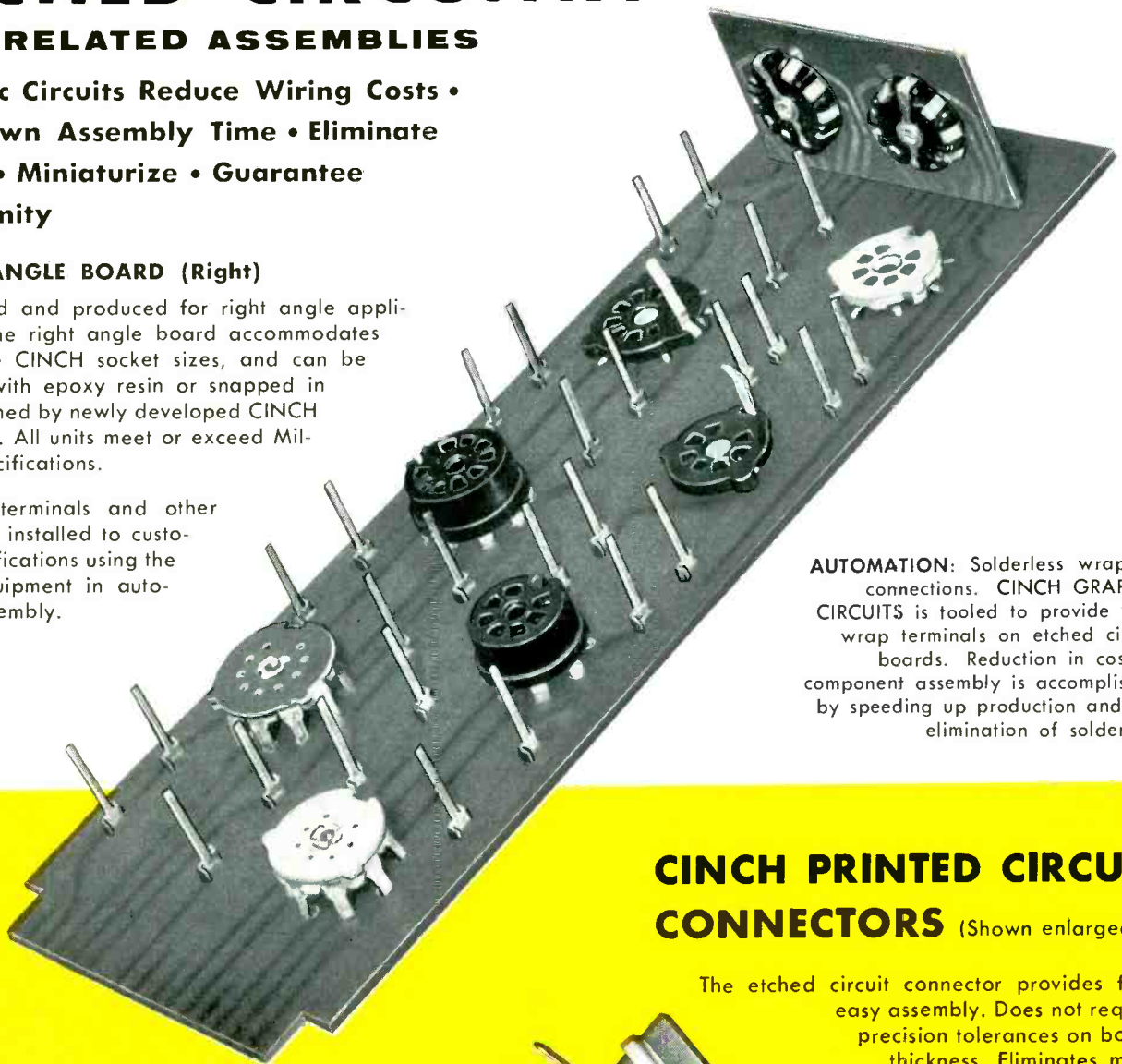

**AUTOMATION:** Solderless wrapped connections. CINCH GRAPHIK CIRCUITS is tooled to provide wire wrap terminals on etched circuit boards. Reduction in cost of component assembly is accomplished by speeding up production and the elimination of soldering.

Complete facilities for engineering production design, drafting, artwork, development, prototyping and manufacturing photo-printing, silk screen, etching, machining and punching, fabricating, mechanical assembly, electrical assembly, encapsulating, quality control, and fluoroscopic inspection.

Centrally located plants at Chicago, Shelbyville, Pasadena and St. Louis.

## CINCH PRINTED CIRCUIT CONNECTORS (Shown enlarged)

The etched circuit connector provides fast, easy assembly. Does not require precision tolerances on board thickness. Eliminates moisture trap. Allows greater flexibility of configuration. Lower cost.

CINCH will design new, or re-design parts within the category of their manufacture to fit your particular plans, and will also assist in the introduction in the assembly of CINCH's specially designed component in your radio and TV equipment.



### CONSULT CINCH

CINCH components are available at leading electronic jobbers—everywhere.

## GRAPHIK CIRCUITS

Division of Cinch Manufacturing Corporation

221 South Arroyo Parkway, Pasadena 1, California

## CINCH MANUFACTURING CORPORATION

1026 South Homan Ave., Chicago 24, Illinois

Subsidiary of United-Carr Fastener Corporation, Cambridge, Mass.



**Cinch**  
ELECTRONIC  
COMPONENTS

# VHF Transmission Line Calculator

(Continued from page 168)

lation  $vswr = (1 + \Gamma)/(1 - \Gamma)$  where  $\Gamma$  is a linear function, being 0 at the center and 1 at the outer edge. This scale allows impedance points to be interpreted directly in terms of vswr.

A third scale extends along the lower side of the radial slot from the center to the outer edge of the calculator. This scale is marked off in db steps, starting from the outer edge as reference. Each db step represents the radial movement of a point by a given percentage of its distance from the center. Since this motion can be either toward or away from the center, no numbers appear on the scale. Lines marking 1-db steps are longer than the intermediate lines. This scale allows corrections to be made for the effect of line attenuation.

To determine proper line corrections as a function of frequency for the length of line used between the measuring equipment and an unknown impedance, the line is first terminated in a known or calibrating impedance. This may conveniently be a short circuit. The input impedance of the line is then measured at one frequency and the point is plotted on the Smith chart. The calculator is placed over the Smith chart and rotated until the slot is aligned with the point. Assuming a short-circuit termination, the phase correction for the line is read on the outer scale of the calculator at zero ohms on the Smith chart. The attenuation correction is the number of db steps between the measured input impedance point and the outer end of the scale.

This process is repeated for each frequency at which measurements are to be made and the phase and attenuation corrections recorded. The line input impedance can then be transformed to corresponding terminating impedances and plotted directly on the Smith chart.

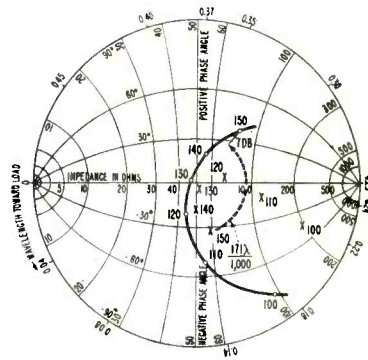

FIG. 1—Solution of transmission line problem. Input impedance of transmission line is indicated by crosses and impedance of antenna by circles

To do this, the short-circuit is replaced by the unknown impedance and the input impedance of the line is measured at one of the chosen frequencies. The slot of the calculator is then positioned over the point representing this measured impedance. Moving outward along the slot from this point by the tabulated db step correction gives the vswr of the unknown terminating impedance. The calculator is then rotated counterclockwise by the tabulated phase correction and the chart is marked through the slot opposite the vswr previously established. The impedance represented by this point is the terminating impedance.

With lines that are several wavelengths long, some precautions should be observed. Frequencies of measurement must be accurately determined, preferably with a crystal calibrator, be-

cause a small frequency error will result in a large error in the phase-shift correction.

Attenuation correction may become large and should therefore be determined quite accurately. For best accuracy, the calibrating impedance should have a vswr fairly close to that of the unknown impedance since the attenuation of the line is a function of vswr and will be greater for large vswr. If such a calibrating impedance is used, the line corrections must be determined by a method analogous to that described above for a short-circuit termination.

## Example

As an example, consider the determination of the input impedance and resonant frequency as seen at the terminals of an experimental antenna unit mounted on a finite ground plane. The desired resonant frequency is 133 mc. The line used to feed this antenna has a characteristic impedance of 50 ohms.

Figure 1 illustrates measured data on such an antenna, plotted with the calculator. The antenna was replaced by a short-circuit and input impedance of the shorted line was measured at 100, 110, 120, 130, 140 and 150 mc. A table of line corrections was then made up (see Table I). The antenna was put back on the line, the new input impedances were measured, corrections applied and a corresponding series of five points were obtained. A smooth curve connecting these points intersects the axis of pure resistance at 46 ohms. The frequency at which this occurs is 129 mc. When the antenna was shortened to become a pure resistance at 133 mc, the vswr was 1.08.

Table I—Line Corrections for 133-mc Antenna

Frequency in Mc	Phase Correction $\lambda$	Attenuation Correction in Db Steps
	1,000	
100	455	0.7
110	398	0.7
120	341	0.7
130	285	0.7
140	228	0.7
150	171	0.7

## BIBLIOGRAPHY

- P. H. Smith, A Transmission Line Calculator, *ELECTRONICS*, p 29, Jan. 1939.  
 P. H. Smith, An Improved Transmission Line Calculator, *ELECTRONICS*, p 130, Jan. 1944.



**MALLORY**

*This capacitor changed designers' ideas  
about how well...and how long...  
an electrolytic capacitor could  
be relied upon to operate*

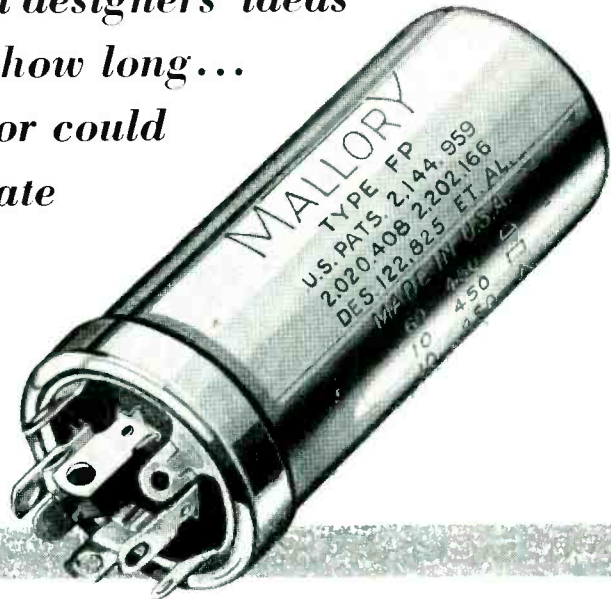

## *On Electrolytic Capacitors...*

# Mallory FP is the Sign of Dependability

### **AUTOMATIC CONTROLS**

*An example of a field  
served by Mallory*

The long life and uniform high quality of Mallory electrolytic capacitors are particularly valuable, in modern electronic instrumentation, which must deliver consistent and uninterrupted service as the "brainpower" guiding complex production processes.

Also serving the manufacturers of measurement and control equipment are other Mallory precision components . . . contacts, resistors, controls, switches, rectifiers, vibrators and mercury batteries. Because of this wide range of components, Mallory engineers have a unique fund of experience—available to assist you in meeting special requirements and in balancing related circuit elements.

Serving Industry with These Products:

**Electromechanical**—Resistors • Switches • Television Tuners • Vibrators  
**Electrochemical**—Capacitors • Rectifiers • Mercury Batteries  
**Metallurgical**—Contacts • Special Metals and Ceramics • Welding Materials

Parts distributors in all major cities stock Mallory standard components for your convenience.

"FP" is the mark of a unique capacitor construction, pioneered and perfected by Mallory, which sets the industry's standards for performance and service life. It signifies these features:

- Ability to operate at ambients of 85° C without derating.
- High ripple current rating; suitable for use with metallic rectifiers and in doubler circuits.
- Exceptional life, in service and on the shelf.
- Compact, standardized case size.
- Quick, economical twist-prong mounting and variety of printed circuit mountings.

For premium performance and reliability . . . without premium price . . . be sure to specify Mallory FP Capacitors. Our capacitor engineers will be glad to consult on your circuit requirements, to assist in effective application and often to aid in simplification of circuitry. For technical data, or for a discussion of your particular requirements, write or call Mallory today.

*Expect more . . . Get more from*

**P. R. MALLORY & CO. Inc.**  
**MALLORY**

P. R. MALLORY & CO., Inc., INDIANAPOLIS 6, INDIANA

## Over-Horizon Radio To Link Islands

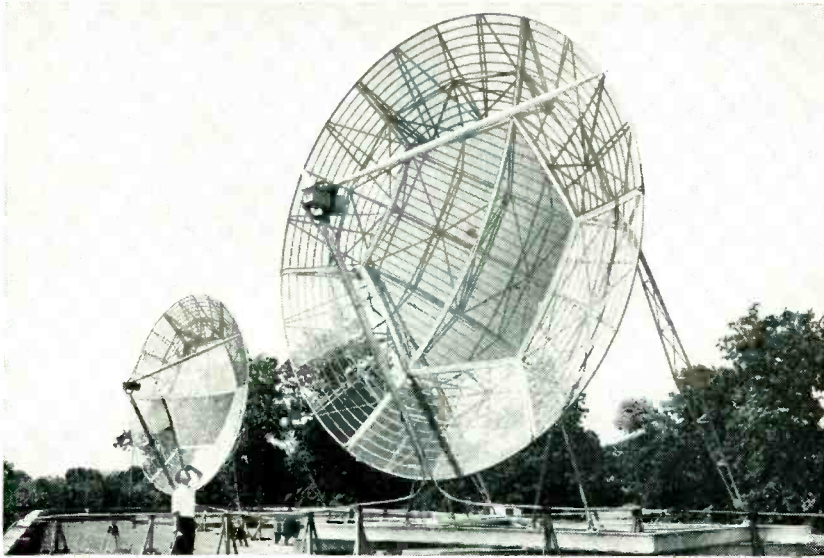

Pair of 28-foot paraboloidal diversity antennas at Nutley, N. J.

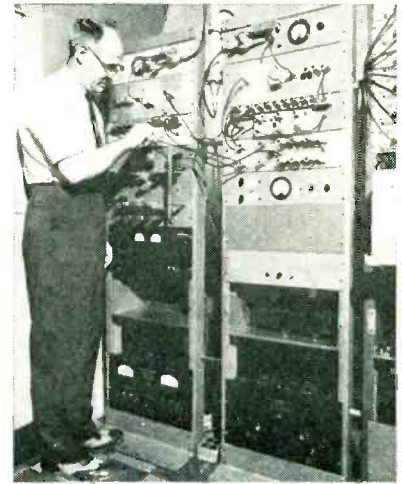

Technician adjusts frequency division multiplex f-m receiver at Nutley terminal of tropospheric 91-mile 900-mc circuit to Southampton, N. Y.

PROPAGATION over distances in the order of 200 miles using uhf has recently proved feasible when appreciable transmitting power and diversity reception are suitably employed.

Tropospheric beyond-horizon circuits are to be installed between Florida and Cuba in a joint endeavor of American Telephone and Telegraph Co. and International Telephone and Telegraph Corp.

In addition, Radio Corp. of Porto

Rico, IT&T subsidiary has recently filed application with FCC for the development of a radio link between San Juan, Puerto Rico and Ciudad Trujillo, Dominican Republic. The new link will be necessary to meet increasing traffic demands. Propagation tests will probably start in late 1955.

Experimental work in progress at Federal Telecommunication Labs (IT&T subsidiary) includes a 91-mile, 900-mc multiplex circuit be-

tween Nutley, N. J. and Southampton, L. I., N. Y. Loss over the path exceeds by some 30 db that predicted or encountered elsewhere. Some of the loss may be seasonal in character and some may result from the proximity of a ridge formed by the Palisades along the Hudson River. There appears to remain an additional loss factor that is suspected to arise from the overland nature of the path, perhaps from the over-city portion.

## Sensitive Thyatron Relay Operates On Microampere

By JOHN N. HARRIS

*Staff Member  
Lincoln Laboratory  
Massachusetts Institute of Technology  
Lexington, Mass.*

OFTEN there is need for a very sensitive relay that will operate from currents as low as a microampere. The circuit shown here has been successfully used in conjunction with a mercury thermostat for controlling temperature. It is suitable for many other applications.

When the input is open, the grid is returned through  $R_1$  and  $R_2$  to the cathode and the tube is ignited

during the positive portion of the cycle. When the input circuit is closed, the filament voltage is in

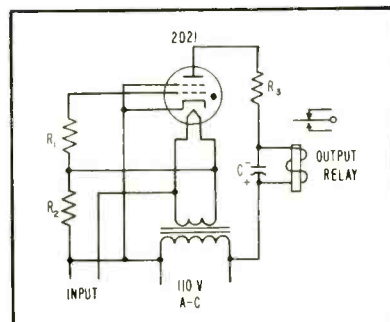

Circuit of the sensitive thyatron relay

series with the grid return (since  $R_2 \gg$  resistance of the filament winding) and of such a phase as to prevent the tube from igniting.

Resistance  $R_3$  is chosen so that the rated current (usually 1 to 10 ma) passes through the relay. A resistance of 10,000 to 30,000 ohms has been satisfactory in most cases. The capacitance  $C$  is across the coil to prevent chattering and may be about 12  $\mu$ f. Resistors  $R_1$  and  $R_2$  are chosen to satisfy the input impedance and current limitations. When it is desired to have very low current in the input circuit, values



# KEPCO

## KR SERIES

### VOLTAGE REGULATED POWER SUPPLIES

for powering electronic equipment



MODEL KR4-MC



MODEL KR7

save time  
...and money...

**Build these compact Power Supplies into your equipment!**

Kepeco Voltage Regulated Power Supplies are conservatively rated and are designed for continuous duty at 50°C ambient.

**REGULATION:** Specified for each unit is available throughout its output voltage range and is less than 0.2 volts for line fluctuation from 105-125 volts and less than 0.2 volts for load variation from 0 to maximum current.

**RIPPLE:** Less than 3 mv. rms.

**FEATURES:**

- Superior Regulation.
- Ultra-Stable 85A2/0G3 Reference Tube.
- Low Ripple.
- Low Output Impedance.
- Fast Recovery Time, Suitable for Square Wave Pulsed Loading.
- Voltage Range continuously variable without Switching.
- Either Positive or Negative may be Grounded.
- Oil Filled Condensers.
- Wire Harness and Resistor Board Construction.
- Power Requirements 105-125 volts, 50-60 cycles.
- Terminations and locking type voltage control on rear of unit.
- AC, DC Switches, Fuses, and Pilot Lights on Front Panel.
- Color Grey Hammertone.
- Guarantee One Year.

To include 3" Current and Voltage Meters, Add M to Model number (e.g. KR 1-M) and Add \$30.00 to the Price.

To include Dust Cover and Handles for Table Mounting, Add C to Model number (e.g. KR1-C) and Add \$10.00 to the Price.

To include Meters, Dust Cover and Handles, Add MC to Model number (e.g. KR-1MC) and Add \$40.00 to the Price.

PRICES F.O.B. Flushing

### 600 ma. KR SERIES

Model	Volts	6.3V AC	Rack Mount			Price
			W	H	D	
KR 8	0-150	Each supply	19"	10½"	13"	\$330
KR 5	100-200	has two	19"	10½"	13"	\$240
KR 6	195-325	10 Amp.	19"	10½"	13"	\$240
KR 7	295-450	outputs	19"	10½"	13"	\$250

### 300 ma. KR SERIES

Model	Volts	6.3V AC	Rack Mount			Price
			W	H	D	
KR 12	0-150	Each supply	19"	7"	11"	\$270
KR 3	100-200	has two	19"	7"	11"	\$180
KR 4	195-325	5 Amp.	19"	7"	11"	\$180
KR 10	295-450	outputs	19"	7"	11"	\$190

### 125 ma. KR SERIES

Model	Volts	6.3V AC	Rack Mount			Price
			W	H	D	
KR 11	0-150	Each supply	19"	7"	11"	\$180
KR 1	100-200	has one	19"	7"	7½"	\$ 90
KR 2	195-325	3 Amp	19"	7"	7½"	\$ 90
KR 9	295-450	output	19"	7"	7½"	\$ 97

### A LINE OF 45 MODELS

Available from Stock - Catalog on Request



# KEPCO LABORATORIES

131-38 SANFORD AVENUE • FLUSHING 55, N.Y. • INDEPENDENCE 1-7000





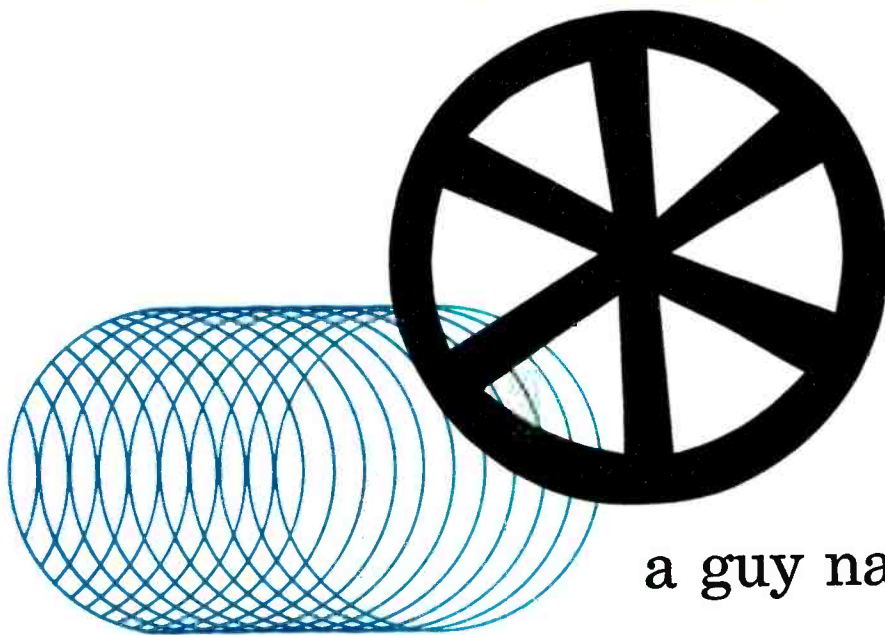

## a guy named Og

Once your name was Og. You tired of shouldering  
mastodon steaks...of dragging your mate by her hair.  
You invented the wheel.

Later, your name was Watt. Steam made your kettle-lid  
dance...and the Industrial Revolution was on.

Yesterday, you were a bicycle mechanic named Henry...today,  
your brainchild's descendants are counted in millions.

Your name is legion. You created every linkage...  
every device...every system.

You're an engineer.

You make things work better...faster...more accurately  
...more economically.

Next week...next month...next year...some system will need  
a better, faster, more accurate or more economical  
means of recording...or indicating...or computing...or  
controlling a process.

You'll want precision potentiometers.

You'll discover that Helipot makes the most complete line...  
linear and non-linear versions...in the widest choice  
of sizes, mounting styles and resistances.

*many models of HELIPOT\*  
precision potentiometers are  
stocked for immediate shipment  
...our engineers will gladly  
adapt standard HELIPOTS to your  
requirements...or build  
entirely new HELIPOTS for you.*

*for information and specifications  
...write for data file 1103*



# Helipot

*first in precision potentiometers*

*Helipot Corporation/South Pasadena, California  
Engineering representatives in principal cities  
a division of BECKMAN INSTRUMENTS, INC.*



You're an engineer.  
Your career is in  
the making.  
Helipot would like  
to hear from you.

## THE FRONT COVER

**A**N ELECTRONIC microscope designed by CBS Laboratories allows researchers in medicine and industry to view microscopic objects in color. Components of the system include a standard laboratory microscope, color camera, camera control console, color monitors and projectors.

Resultant images from the system are brighter than images using conventional optical methods. In addition, much less light is required at the specimen. Large bright color images using strictly optical microprojectors require such large amounts of light that many live specimens and some fixed slides are destroyed. Consequently, many specimens which up to this time have escaped practical enlarge-

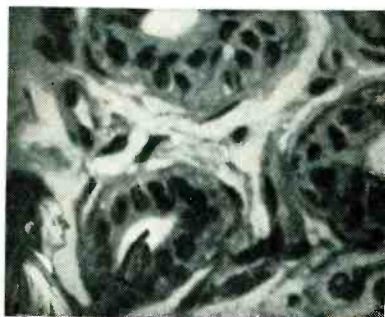

ment can now be observed.

In this system, a color camera is mounted on a laboratory microscope. The optics are adjusted to focus the real field through the color drum segments onto the face of the single image-orthicon pickup tube.

The field-sequential system uses a 24 cps color-frame repetition rate. Horizontal scanning

frequency is 29,160 cps and the vertical frequency is 144 cps interlaced 2 to 1. Aperture correction and crispening circuits are used.

The image from the compound microscope normally viewed by the eye is, in the color microscope, formed at the photocathode of the image orthicon. This image, with a diagonal of 1.6 in., is amplified electronically in brightness and then magnified in size to a diagonal of approximately 11.5 in. on a small monitor, 18.5 in. on a larger monitor and 83 in. on a large-screen projector. This results in image size magnification of 7, 12 and 52 respectively. Using a 2-mm objective and a 10× ocular, the overall magnification can be 46,800.

provides greater communications range than equipment used in World War II.

Characteristics of the antenna

system were tested in advance by Federal Telecommunication Labs using a scale model of the carrier equipped with a scaled receiving an-

tenna. The rotating model was illuminated by a microwave horn and recordings made of signal strength versus orientation.

## Digital Voltage Divider Using Four Resistors

DIGITAL voltage dividers are potentiometers consisting of a set of fixed resistors that are switched by a keyboard or other means to effect a voltage division. The simplest is the series type shown in Fig. 1A. When two or more decimal digits are used to set up a voltage division the number of resistors becomes large and since precision resistors must be used, the total cost is high. A parallel type of divider has been developed in which only four resistors are required per decimal digit regardless of the number of digits. Fig. 1B shows the basic circuit.

The output voltage is

$$v = \frac{G_2}{G_1 + G_2} V$$

where the resistors are expressed as conductances.

The value of  $v$  can be varied by

By L. J. KAMM

Chief Electrical Engineer  
Schatzki Engineering Co.  
Springfield Gardens  
Long Island, N. Y.

transferring resistors from group  $G_1$  to group  $G_2$ . Proper choice of values for  $g_1, g_2$ , make possible a

large number of different values of  $v$  by different groupings of a small number of resistors. For example for a one digit divider, let  $g_1 = 1$  mho,  $g_2 = 2$  mho,  $g_3 = 3$  mho and  $g_4 = 4$  mho.

Then  $G_1 + G_2 = 10$  mhos and the combinations that can be made are

Table I—Digital Combinations of  $G_1$  and  $G_2$  Using Four Resistors

$v/V = G_2/(G_1 + G_2)$	$G_1$	Value in mhos	$G_2$	Value in mhos
0	$g_1 + g_2 + g_3 + g_4$	10	0	0
0.1	$g_2 + g_3 + g_4$	9	$g_1$	1
0.2	$g_1 + g_3 + g_4$	8	$g_2$	2
0.3	$g_1 + g_2 + g_4$	7	$g_3$	3
0.4	$g_1 + g_2 + g_3$	6	$g_4$	4
0.5	$g_2 + g_3$	5	$g_1 + g_4$	5
0.6	$g_1 + g_3$	4	$g_2 + g_4$	6
0.7	$g_1 + g_2$	3	$g_3 + g_4$	7
0.8	$g_2$	2	$g_1 + g_3 + g_4$	8
0.9	$g_1$	1	$g_2 + g_3 + g_4$	9
1.0	0	0	$g_1 + g_2 + g_3 + g_4$	10



## A COMPLETE LINE OF DEPENDABLE ENCAPSULATED RESISTORS



# PERMASEAL<sup>®</sup>

## PRECISION WIREWOUND RESISTORS FOR 85C AND 125C AMBIENTS

When you have applications requiring accurate resistance values at 85C and 125C operating temperatures, in units of truly small physical size—you'll find the resistor you want is one of the 46 standard PermaSeal designs in tab and axial lead styles.

They meet or exceed requirements for all types of military and industrial electronic apparatus and instruments. They are "extra-protected" by a special Sprague-developed plastic embedding material that performs beyond the se-

vere humidity resistance specifications of MIL-R-93A and Proposed MIL-R-9444 (USAF).

PermaSeal winding forms, resistance wire and embedding material are matched and integrated to assure long term stability at rated wattage over the operating temperature range.

These high-accuracy units are available in close resistance tolerances down to  $\pm 0.1\%$ . They are carefully and properly aged for high stability by a special Sprague process.

# SPRAGUE

FOR COMPLETE DATA  
WRITE FOR COPY  
OF SPRAGUE  
ENGINEERING  
BULLETIN NO. 122A



SPRAGUE ELECTRIC COMPANY • 35 MARSHALL ST. • NORTH ADAMS, MASS.

# greater electrical reliability

NEW  
**AMPHENOL**  
 COMPONENTS

## "AN" CONNECTORS for POTTING

Potting is the *modern* moisture-proofing method for AN connectors. AMPHENOL offers AN connectors in our (438) construction for potting at your factory or complete potted AN connector assemblies. The AMPHENOL (438) construction is covered in Bureau of Aeronautics Specification 54A-3A-225. REQUEST BULLETIN 2555

## Blue RIBBON CONNECTORS

These unique connectors provide quick connect, quick disconnect of electronic sub-assemblies by utilization of improved *ribbon*-type contacts. Blue RIBBON connectors are available with pin and socket or barrier polarization—keyed shells and latch-lock can types may be ordered in the latter type. REQUEST CATALOG R1

## SUBMinax RF CONNECTORS

A new line of subminiature RF connectors available in push-on or screw-on coupling and in 50 or 75 ohms. Subminax connectors are the smallest ever offered for RF applications. Full-size efficiency has been compressed into space-saving, weight-saving design in new Subminax connectors. REQUEST BULLETIN 2500

AMERICAN PHENOLIC CORPORATION

**AMPHENOL**

chicago 50, illinois

In Canada: AMPHENOL CANADA LIMITED, Toronto

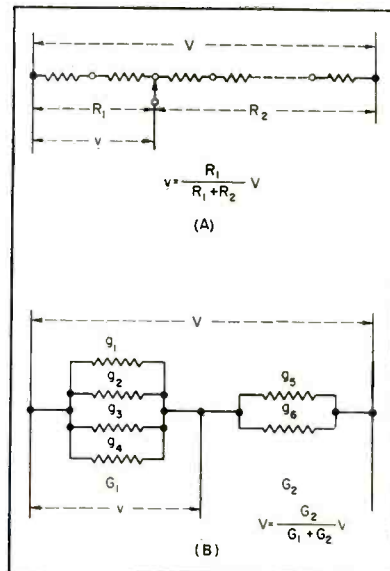

FIG. 1—Simple series voltage divider (A) requires a large number of precision resistors. Parallel type (B) can form a large number of digital values by varying combinations in  $G_1$  and  $G_2$

given in Table I.

Similarly for a two-digit divider, 8 resistors are used with values as follows

$g_1 = 10$	$g_8 = 1$
$g_2 = 20$	$g_6 = 2$
$g_3 = 30$	$g_7 = 3$
$g_4 = 30$	$g_5 = 4$

Resistors  $g_1$  to  $g_4$  are controlled by the hundredths digit switching while resistors  $g_5$  to  $g_8$  are controlled by the tenths digit switching.

For example, to obtain a value  $v_1/V = 0.68$  let  $G_1 = g_1 + g_2 + g_6$  or  $10 + 20 + 2 = 32$  and let  $G_2 = g_3 + g_4 + g_5 + g_7 + g_8$  or  $30 + 30 + 1 + 3 + 4 = 68$ . Then  $G_1 + G_2 = 32 + 68 = 100$  and  $G_2/(G_1 + G_2) = 68/100$ .

With the proper choice of  $g$  values,

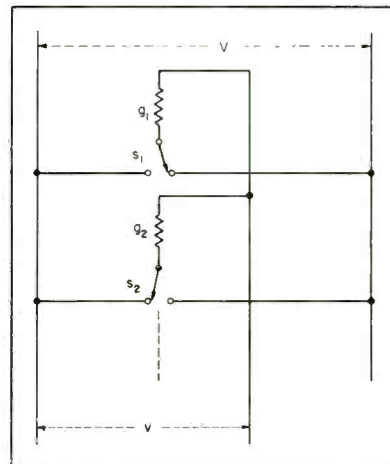
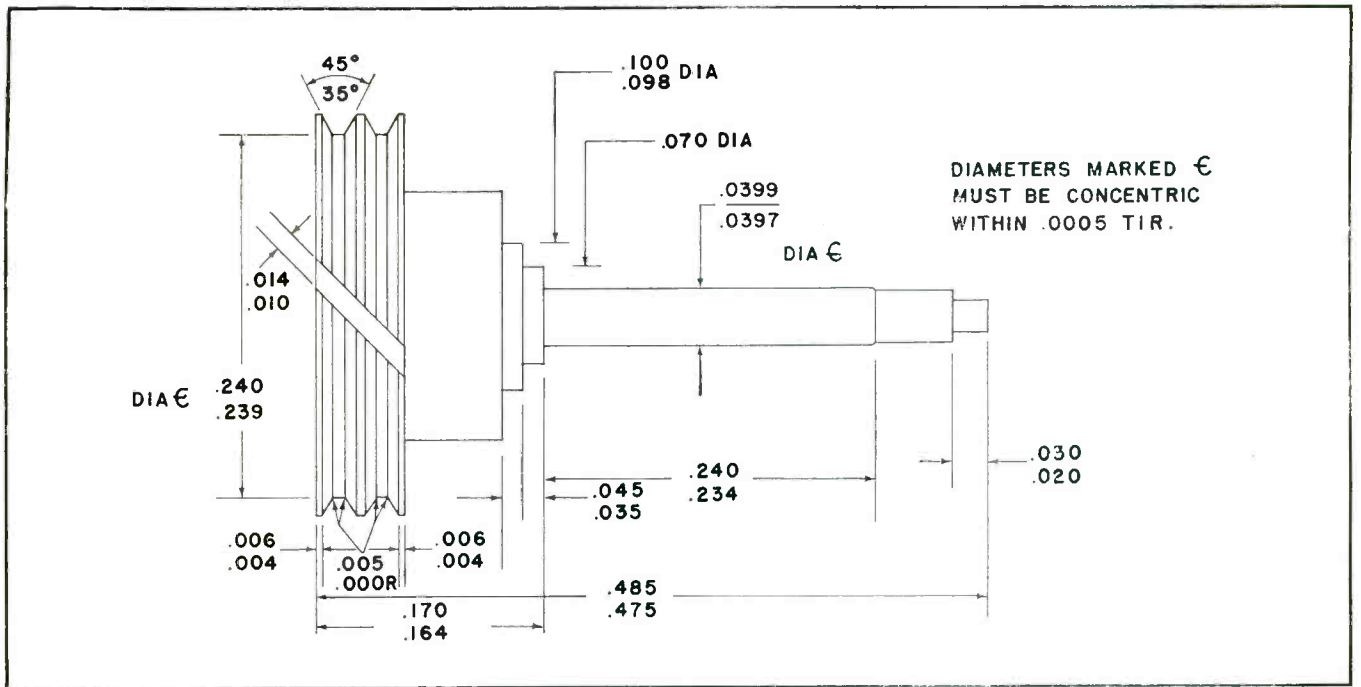
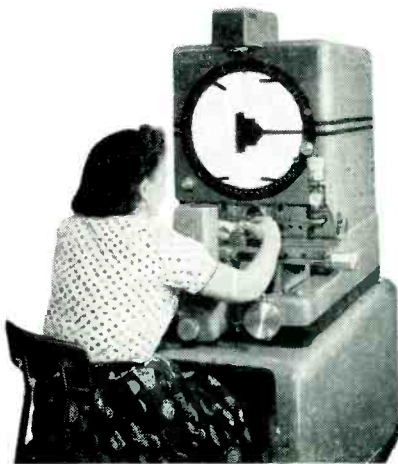

FIG. 2—Single-pole double-throw switching system for transferring resistors between groups  $G_1$  and  $G_2$





## Five times as many parts checked per day... with a Kodak Contour Projector



Here's one company's approach to the problem of receiving inspection that may help you save time, improve accuracy.

TECHNOLOGY INSTRUMENT CORPORATION'S receiving inspection used to require 10 to 15 minutes each to check incoming precision shafts by mechanical gaging. Inspection involved concentricity, diameters, shoulder locations, and other hard-to-measure dimensions. Tolerances on these shafts—components of precision potentiometers—ranged from .002" to .0002".

Then they turned to optical gaging with a Kodak Contour Projector; inspection time was cut to 2 to 3 minutes per shaft.

Here, again, is proof of how a Kodak Contour Projector often speeds inspection of precision parts. Dimensions difficult or impossible to measure by mechanical methods frequently are easily checked using optical methods. And you can shift from one part to another simply by changing a fixture and chart-gage.

There's a Kodak Contour Projector for every inspection or measurement job, whether in the toolroom, in receiving, production, or final inspection. And there's a representative in your area who can evaluate your needs for you. To get in touch with him, or for a copy of the booklet "Kodak Contour Projectors," mail the coupon below.

## the KODAK CONTOUR PROJECTOR

### EASTMAN KODAK COMPANY

Special Products Sales Division, Rochester 4, N. Y.

- Please send me a copy of your booklet "The Kodak Contour Projectors."  
 Put me in touch with your representative.

NAME \_\_\_\_\_ TITLE \_\_\_\_\_  
 COMPANY \_\_\_\_\_  
 STREET \_\_\_\_\_  
 CITY \_\_\_\_\_ STATE \_\_\_\_\_  
 (Zone)

**Kodak**  
TRADE-MARK

**CIRCUIT DESIGN  
ENGINEERS**



for the

**FALCON  
GUIDED MISSILE**

So accurate and deadly is the Hughes Falcon guided missile produced in Tucson, Arizona, for the U.S. Air Force, that it has knocked maneuvering drone bombers out of the air even without an explosive warhead. Although its electronic brain can outwit any enemy bomber, it is the smallest guided missile in production.

Because of this small size and consequent extreme miniaturized packaging, new production techniques have had to be conceived. This leads to production testing of individual parts, small integrated units, self-contained components, complete integrated systems, and simulated environmental performance.

The development of equipment for producing and testing of such a missile provides a continuous challenge to engineers experienced in electronic circuit design including the following:

Pulse—Power Supply—Transistor—IF and RF—Clamping—Wave Shaping—Switching—Phase Shift—Input-Output—Modulator—Discriminator—Feedback—Video Circuits.

Write to  
ENGINEERING  
STAFF RELATIONS  
**HUGHES**  
Aircraft Company  
Tucson, Arizona

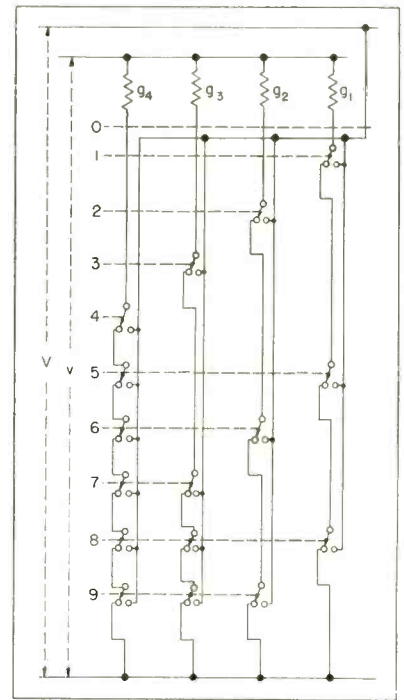

FIG. 3—Ten-position switch circuit for setting up digital voltage values with four resistors

switching for each digit is independent of the switching for the other.

For a three digit divider, 12 resistors are used with values as follows

$g_1 = 100$	$g_5 = 10$	$g_9 = 1$
$g_2 = 200$	$g_6 = 20$	$g_{10} = 2$
$g_3 = 300$	$g_7 = 30$	$g_{11} = 3$
$g_4 = 300$	$g_8 = 30$	$g_{12} = 4$

The simplest way to transfer re-

**Air-Conditioned  
Shielded Room**



Double-walled screen room comprising aluminum sheeting separated by insulating cores of paper honeycomb filled with plastic resin provides 100-db shielding from 14 kc to 1 mc. Internal temperature can be maintained anywhere between -65 F and 140 F. It was designed by NYU for the Air Force and is air-transportable



NOW  
 ...GERMANIUM  
 FUSED  
 JUNCTION

- MEDIUM POWER
- LOW NOISE FIGURE
- HIGH GAIN
- AXIAL LEADS
- MINIMUM ALPHA-CROWDING EFFECT AT HIGH CURRENTS
- CLIP-IN STYLE PACKAGE
- HERMETIC SEAL

# NPN TRANSISTORS BY HUGHES

*These devices offer excellent performance characteristics, even up to higher power ratings, together with high gain and low noise figures.*

*The new package is designed to dissipate more heat. This makes it possible to maintain the high performance characteristics.*

The low alpha-crowding effect makes the new Hughes transistors particularly adaptable to high current medium power amplifiers, in addition to: Computers... Switching... Audio Amplifiers... I-F Amplifiers... Oscillators. For all types, maximum collector current is 100 milliamperes, and collector dissipation is 500 milliwatts. Under certain conditions, or when used with clips or with suitable heat sinks, these ratings can be increased substantially.

Detailed specifications for each type are available in pertinent data sheets.

ACTUAL SIZE (photo, transistors in hand).

New Hughes Fused Junction NPN Germanium Transistor, available in (A) Three leads, to fit conventional transistor socket mountings; (B) Clip-in style package.

RATINGS AT 25°C

Type	Alpha		Maximum Collector-to-Base Voltage (V <sub>C</sub> )
	Min.	Max.	
HA5001	0.975	1.0	30V
HA5002	0.950	0.965	15V
HA5003	0.975	0.99	20V

Collector Cut-Off Current (I <sub>CO</sub> )	Alpha Cut-Off Freq. (∞ cogb)	Rise Time	Noise Figure
5μA	2.5	2.5 μsecs	....
12μA	1.0	....	15.0 db
10μA	1.5	....	15.0 db

**HUGHES**

SEMICONDUCTOR DIVISION

Aircraft Company, Culver City, California



New York Chicago  
 Los Angeles

**Relay Sales**

Telephone Relays

Midget Relays

Keying Relays

Rotary Relays

Sealed Relays

Sensitive Relays

Latching Relays

Stepping Relays

Delay Relays

Timers

Contactors

Motor Starting Relays

Differential Relays

Polarized Relays

# RELAYS

# NOW!

Your immediate needs for one or more relays of any kind are shipped from our greatly enlarged stock which includes hundreds of types in all popular contact arrangements and coil ratings.

Complete stocks of current standard types of leading manufacturers are maintained for your convenience.

All relays are new, inspected and unconditionally guaranteed to be as represented. 24 hour delivery is routine. Phone us.



Distributors For  
**ADVANCE ELECTRIC & RELAY CO.**

All standard distributor types of Advance Relays are on hand in quantity. Save precious time — order from Relay Sales!

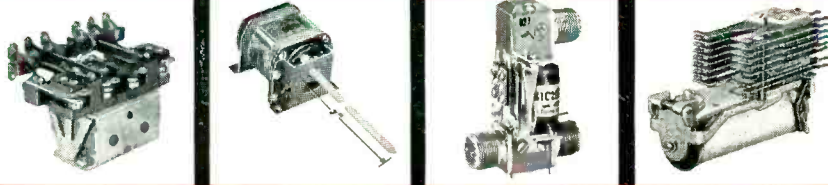

Write for

**Relay Sales**

Catalog

C-6

## RELAY SALES HAS MOVED TO THE COUNTRY!

Bigger, more efficient office, warehousing and shipping facilities are providing even faster service for our customers. Lots of parking space. Route 64 at E.J. & E. R.R.

Please change your records

Phone: West Chicago 1100

**RELAY SALES**

P.O. Box 186-A

West Chicago, Ill.

sistors from group  $G_1$  to group  $G_2$  is to connect one side of each resistor permanently to the output wire and connect the other side to one or the other of the end wires by a single-pole double-throw switch as in Fig. 2.

For manual setting by rotary switch, each resistor is switched by a 10-position switch with certain positions connected to one side of the line and the other positions connected to the other side. For manual setting by keyboard, each key must have 1, 2, 3 or 4 transfer contacts and each resistor wired as shown in Fig. 3 for the single digit case.

Other values of  $g$  may be chosen that are equally useful. Also, analogous circuits may be developed for binary and other number systems. This circuit has been used in digital servomechanisms using both 2 digits and 3 digits and has worked satisfactorily.

## Zener-Voltage Breakdown Uses In Silicon Diodes

By CARL N. WULFSBERG

*Air Force Cambridge Research Center  
Cambridge, Mass.*

GENERAL CHARACTERISTICS of the silicon junction diode shown in Fig. 1 indicate that it differs markedly from the point-contact germanium type in two ways.

Back resistances may exceed 10,000 megohms at moderate back voltages, and a sharp breakdown in back resistance occurs at a particular back voltage, the so-called Zener voltage. A third important difference is the ability of the silicon diode to operate at high temperatures without serious degradation

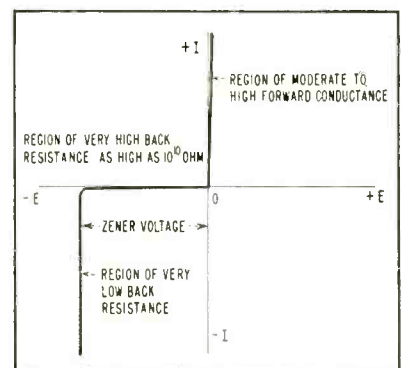

FIG. 1—Characteristics of silicon junction diodes



*PERFORMANCE - GUARANTEED*

# Magnetic Shields

*COST NO MORE -*

*WHY TAKE LESS?*

You're time and money ahead with Performance-Guaranteed Magnetic Shields, for our shields are *guaranteed* to meet the requirements of your circuit to mutually agreed upon shielding specifications. Dry hydrogen annealed, as required . . . of MuMetal, A.E.M. 4750, or whatever commercially available material is most suitable . . . fabricated or drawn . . . painted or lacquered to match any shade, or unfinished. Write for the industry's most complete catalog, MS-104, today.

**MAGNETICS inc.**

DEPT. E-26, BUTLER, PA.



# What is YOUR RELAY PROBLEM?

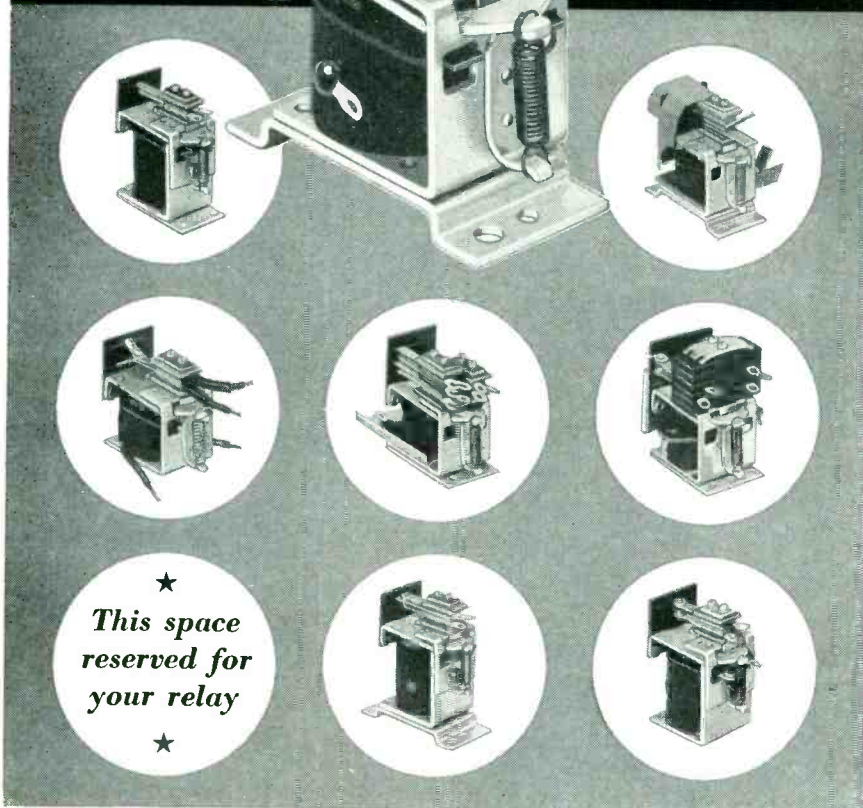

## R·B·M General Purpose Relays..

have solved many specific relay problems with no development or tooling cost to the customer. RBM has produced hundreds of thousands of magnetic relays from standard parts—designed and initially produced over seven years ago—to fulfill the need for dependable relays at low cost.

The many variations of contact form and ratings, as well as ter-

minal arrangements and mounting brackets, may well provide just the right relay for you. WRITE FOR BULLETIN 570—or better yet, tell us your requirements. Bulletin 570 shows only a few of the many variations.

Whether a single relay or a relay panel complete with wire assemblies and cord sets, RBM may help you lower your costs.

**R-B-M DIVISION**  
**ESSEX WIRE CORPORATION**  
 Logansport, Indiana

Controls for Electronic,  
 Refrigeration, Industrial, Appliance,  
 Communication and  
 Automotive Industries

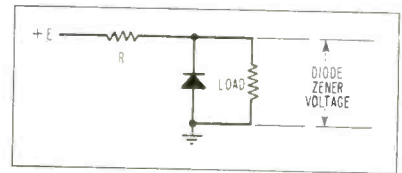

FIG. 2—Direct-current voltage regulator

of its characteristics.

Although back resistance decreases rapidly with increasing temperature, values in excess of a megohm may be expected at 150 C. Forward resistance also decreases, but more slowly, while the Zener voltage normally increases slowly with temperature. Being junction devices, the diodes may have rather

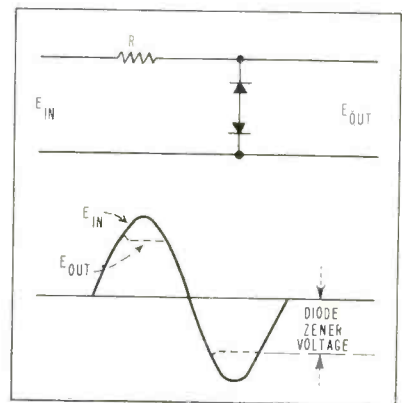

FIG. 3—Alternating-current peak voltage regulator

high shunt capacitances. From one manufacturer's data, very low Zener voltage diodes have capacitances in the order of 50  $\mu\text{f}$ ; the capacitance decreases with increasing Zener voltage and drops to 2 or 3  $\mu\text{f}$  for diodes with high Zener voltages.

Numerous applications of silicon diodes in switching circuits suggest themselves, especially where high back resistances are desirable, such as diode gates and matrix switches. Matched pairs and quads are available, which should provide more stable operation than the comparable germanium types in discriminator and modulator circuits, especially under the condition of widely varying temperature. Silicon diodes are efficient rectifiers, with rectification ratios at one volt of  $10^9$  or higher. High-power types recently made available will undoubtedly find wide application as power rectifiers and in magnetic amplifiers.

Silicon diodes are suited for use in diode-capacitor memory devices;



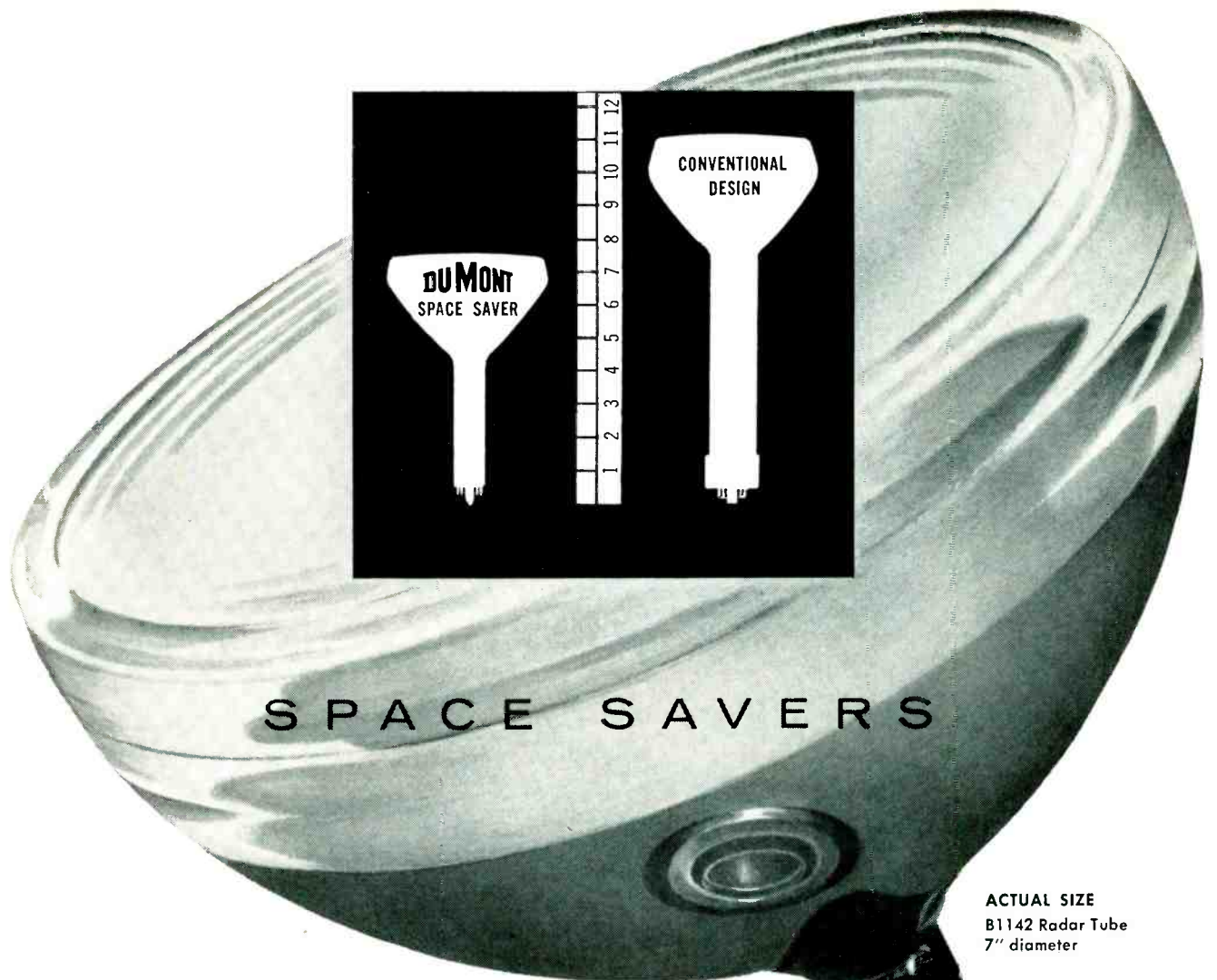

SPACE SAVERS

ACTUAL SIZE  
B1142 Radar Tube  
7" diameter

## DUMONT Radar Tubes aid Miniaturization

The new Du Mont compact, high-resolution radar tubes will save space and weight permitting full use of miniaturization techniques in airborne and other portable radar receivers.

With resolution or light output comparable to standard tubes, these tubes offer substantial savings in both space and weight over more conventional designs. Tubes are designed to be supported at the faceplate only. Together with the small neck ending in a nine-pin miniature base, this simplifies connections to the tube and saves weight in supports and tube socket.

The low-current heaters in the 5" and 7" tubes draw only 0.3A. Therefore cooling problems and power requirements are much less in equipment using one of these tubes.

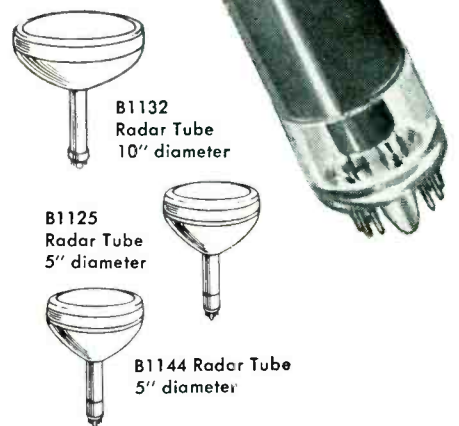
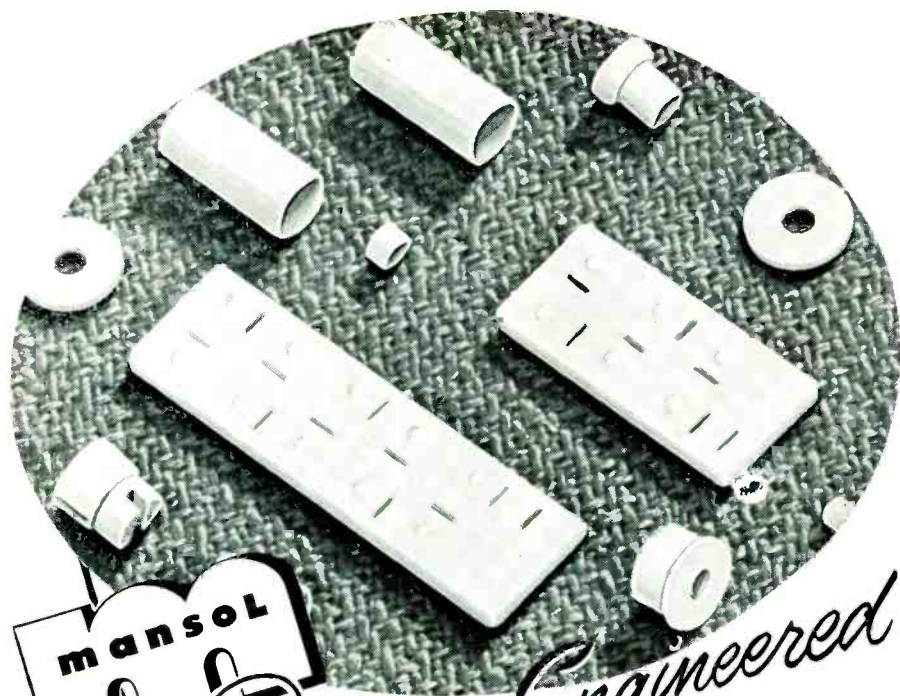

TABLE OF IMPORTANT SPECIFICATIONS							
TYPE	DIAMETER	LENGTH	FOCUS	DEFLECTION	NECK DIAM.	VOLTAGE	DEFLECTION ANGLE
B1125	5"	7"	mag.	mag.	7/8"	8 kv	70°
B1144	5"	7"	mag.	mag.	7/8"	16 kv	70°
B1142	7"	8½"	mag.	mag.	7/8"	8 kv	70°
B1132	10"	12½"	elect.	mag.	1-7/16"	10 kv	90°

● FOR COMPLETE DETAILS, WRITE: TECHNICAL PRODUCTS DIVISION

ALLEN B. DU MONT LABORATORIES, INC., 760 Bloomfield Avenue, Clifton, N. J.

# DU MONT



**mansol**

*Quality Engineered*

# STEATITE MULTIFORMS

to your exact specifications  
FOR FAST SHIPMENT ANYWHERE

We EXCEL in small die-pressed parts held to the closest tolerances. Try us and be convinced of our exacting workmanship and QUICK DELIVERY.

# GLASS MULTIFORMS

to meet your most exacting needs

Ideal Multiforms for Iron and Kovar Sealing. They resist mercury attack, have ample mechanical strength and seal readily.

OUR LABORATORY IS PREPARED TO ASSIST YOU IN THE SELECTION OF THE PROPER MULTIFORM FOR YOUR SPECIFIC PURPOSES. NO OBLIGATION FOR THIS SERVICE.

• If you are still making your own multiforms — let Mansol help you with your particular problems.

• Write to Dept. E for complete information about Steatite, Glass Multiforms and our production facilities.

CABLE ADDRESS: Mansol - Belleville, New Jersey



since the back current may be in the order of  $10^{-10}$  ampere, relatively long storage times should be possible. Low back resistance of the diode at the Zener voltage may be utilized in a number of applications, such as limiting or clipping circuits in which no bias voltage is required and in devices protecting against voltage surges.

Since Zener voltage for a particular diode is constant over wide variations in reverse current, the diode is suited for use in d-c voltage-

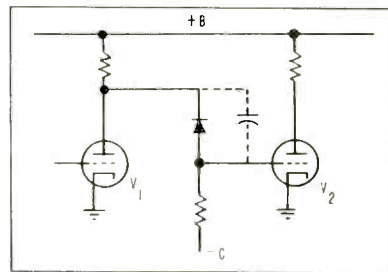

FIG. 4—Diode used as d-c coupling device

regulating or reference circuits, such as that shown in Fig. 2. Resistor  $R$  should be so chosen that the reverse current in the diode does not exceed a value given by the ratio of the maximum power dissipation of the diode to the Zener voltage.

Silicon diodes have several advantages over gas tubes as voltage regulators. Since any Zener voltage in the range of three volts to several hundred volts may be specified, the diode is a highly flexible device in this application.

No special provision need be made to insure a minimum starting potential, since this and the working potential are virtually the same in the silicon diode. A further advantage is that the diode may be shunted with a large filter capacitor without danger of oscillation.

A simple a-c peak voltage regulator may be constructed by connecting two silicon diodes back to back, as shown in Fig. 3. The peak output voltage is limited to the Zener voltage of the diodes, which may lie anywhere in the range from three to several hundred volts. This circuit could also be used as an effective speech clipper.

Figure 4 shows a diode used as a coupling device between the plate of one stage of an amplifier and the



TUNING FORK  
RESONATORS •  
THE ULTIMATE  
IN PRECISION  
AUDIO  
FREQUENCY  
CONTROL



**PHONE OR WRITE** for complete information regarding  
component type Tuning Fork Resonators, or  
variously packaged Tuning Fork Frequency Standards.



**PHILAMON LABORATORIES INC.**

*90 Hopper Street, Westbury, Long Island, N. Y. EDgewood 3-1700*

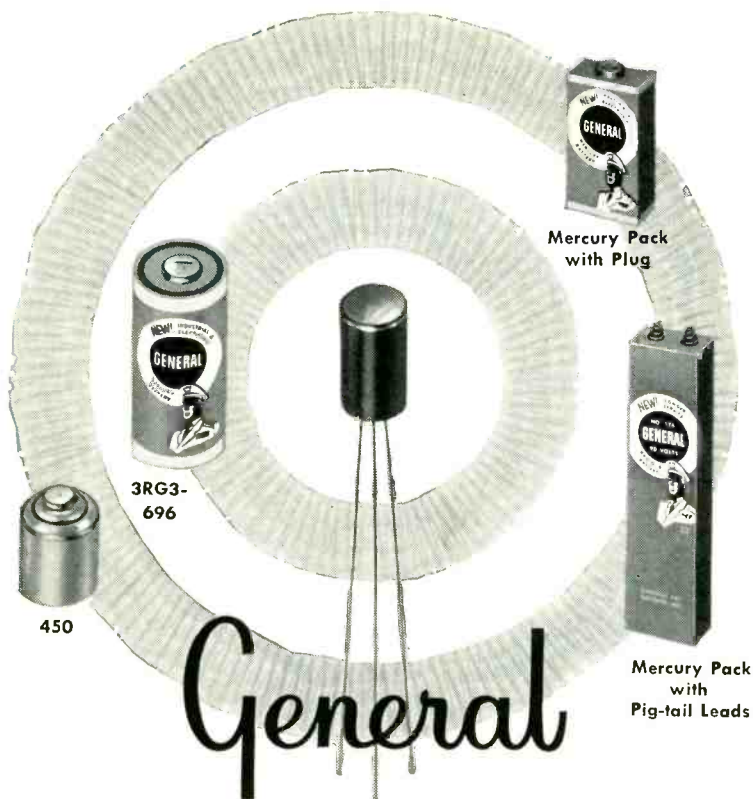

## General Mercury Batteries Provide Dependable Power in Small Space

General Mercury Batteries are helping many manufacturers take even greater advantage of transistors. The outstanding quality, and the high ratio of energy to size of these batteries is helping to build more compact, easier-to-handle portable miniaturized products without loss of efficiency.

Already the use of these tiny but powerful mercury batteries has spread throughout the hearing aid industry. The results are smaller, lighter instruments with greatly improved performance.

We invite you to investigate the possibilities General Mercury Batteries have for your product. They can be made in "power packs" in an unlimited number of series, parallel or series-parallel combinations. General "power packs" are made up of individual cells joined together by General's special surge-weld process. We will be glad to send you complete technical data. If you have specific questions we will be most happy to answer them.



**General**  
**DRY BATTERIES, INC.**

13000 ATHENS AVE., CLEVELAND 7, OHIO  
BOulevard 2-0030

grid of a following stage. While a resistor may be used in place of the diode to achieve the necessary change in level, there is a signal loss owing to the voltage-divider action of the resistors. By using a diode, the full signal amplitude is retained, the d-c level being reduced by a factor equal to the Zener voltage of the diode.

Good transient response is possible with a proper shunt capacitor. A 1-mc square wave with 0.1- $\mu$ sec

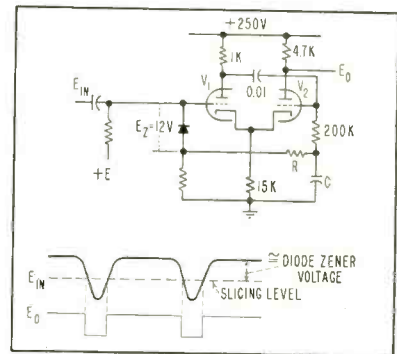

FIG. 5—Silicon diode slicing circuit

rise and fall times was generated at the plate of  $V_1$  of Fig. 4 and, with the diode properly shunted, virtually no change in amplitude or waveform was observed at the grid of  $V_2$ . The d-c level, however, was reduced by 60 volts, the Zener voltage of the particular diode used.

Figure 5 shows a fast slicing circuit;  $V_1$  conducts until its grid potential falls below the slicing level, when the current is suddenly transferred to  $V_2$ , as indicated by the waveforms. Normally, the grid of  $V_2$  is returned to a fixed direct voltage, which makes the slicing level dependent on the d-c level of the incoming signal.

By including a silicon diode as shown, with a suitable R-C smoothing network, the difference in the d-c levels of the two grids is fixed by the Zener voltage of the diode. With output amplitude dependent on the d-c level of the input signal, there is virtually no change in the slicing operation of the circuit with input levels ranging from 75 to 175 volts.

Silicon diodes facilitate design of a simple and accurate method of converting a binary number stored in a shift register into an analog direct voltage. The accuracy required of such a device is 1 part in





**TRU-OHM NEWS**



TRU-OHM PRODUCTS, division of Model Engineering & Mfg. Co., Inc., General Sales Office: 2800 N. Milwaukee Ave., Chicago 18, Ill.

Vol. 80,000,000

1955-56

No. 80,000,000

# 80 MILLION SOLD!

*TRU-OHM is Now the World's Largest Producer of Wire-Wound Resistors!*

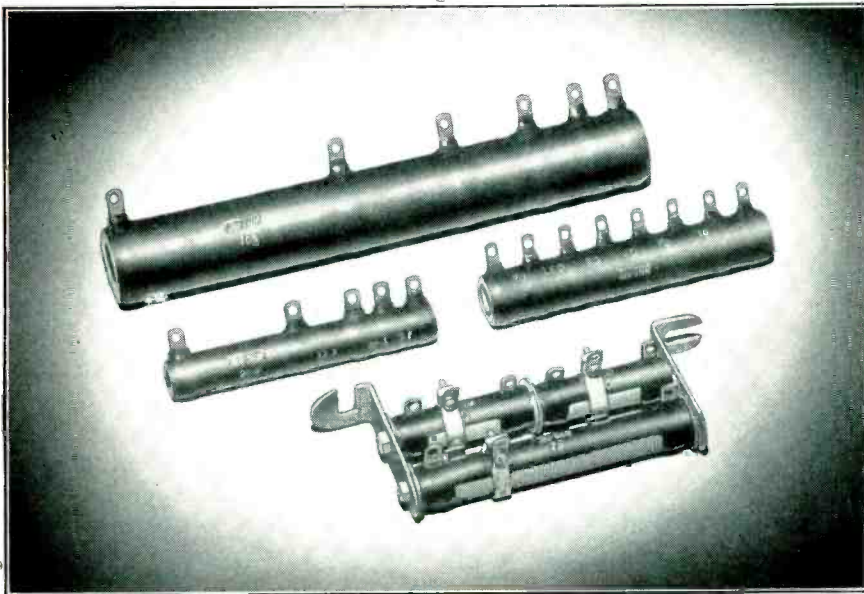

*Special size resistors: Tru-Ohm's highly skilled factory trained technicians turn out large varieties of special resistors. Complete data of these special size resistors is available.*

Chicago . . . From Tru-Ohm's general sales office. Since starting just a few short years ago, TRU-OHM PRODUCTS has grown phenomenally to ten times its original capacity. Having just produced its 80,000,000th wire-wound resistor, Tru-Ohm is now the world's largest growing and largest producers of wire-wound resistors.

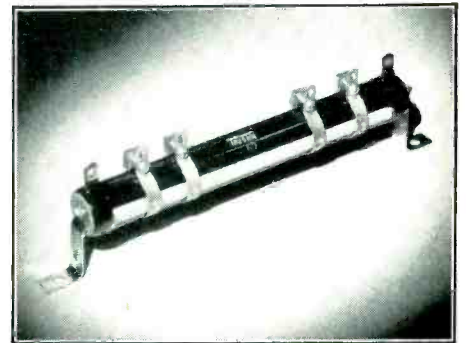

*Resistor No. 80,000,000. One of many wire-wound resistors which are turned out by the thousands daily.*

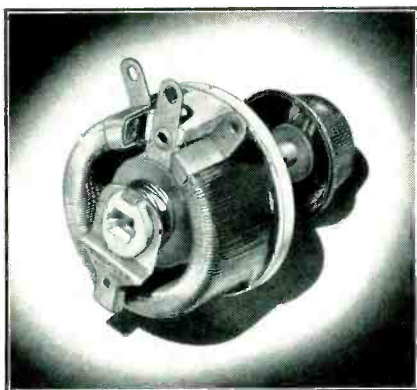

*Complete line of power rheostats . . . of finest quality with UL approval; variety from 25 watts up.*

## High Quality, Speedy Delivery Sets Record

Over 50,000 square feet of the most modern manufacturing facilities, including a brand new furnace, enable volume production . . . assure faster delivery, finer quality, better prices. And TRU-OHM EXPEDITES FOR YOU . . . ships on time.

**Inquiries Invited.** You can get the complete story of Tru-Ohm's tremendous growth and why, by writing to 2800 N. Milwaukee Ave., Chicago 18. Let Tru-Ohm's experts solve your resistor and rheostat needs.

## For Original Equipment or Replacement Needs

A complete line of resistors as well as a complete line of power rheostats are now produced for the finest industrial manufacturers in the world . . . for replacement applications . . . sold through parts jobbers.

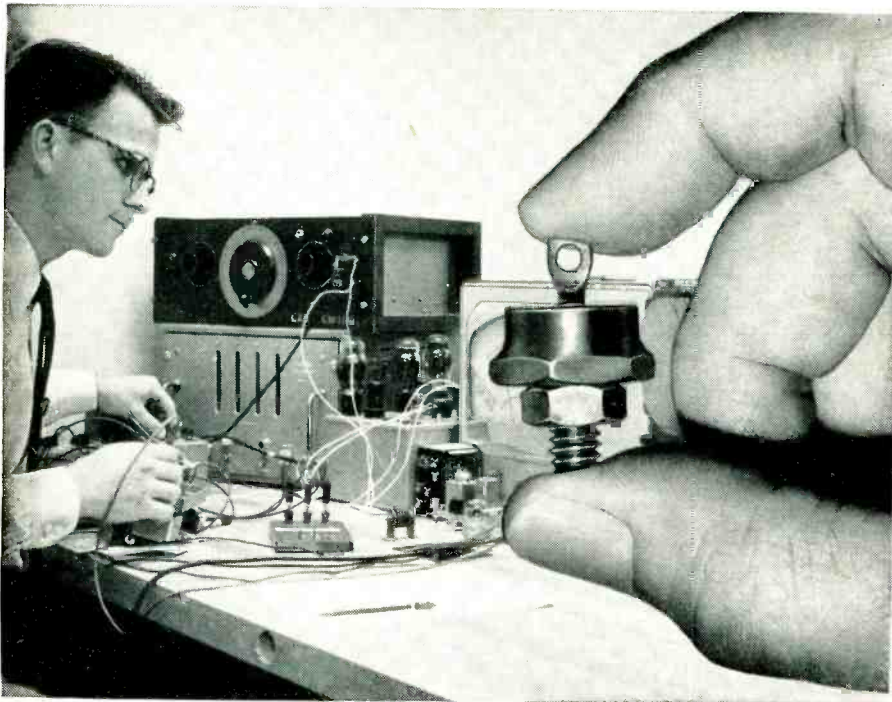

$2^n$ , where  $n$  is the number of binary digits. If  $n$  is greater than 4 or 5, it is usually necessary to provide the flip-flops in the register with buffer stages, which may work into a ladder-adding network or drive relays that control suitably weighted resistors.

The method shown in Fig. 6 requires no additional stages, and is relatively independent of tube characteristics and supply voltages. The shift register flip-flops are comprised of pentode pairs, with the

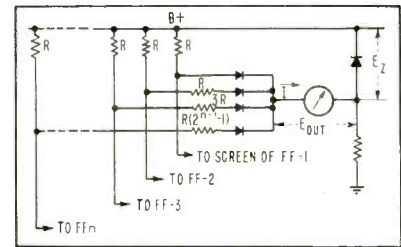

FIG. 6—Digital-to-analog voltage converter

screen of each pentode that is cut off when storing a one connected as shown. With ones stored in the flip-flops (screens cut off), the first flip-flop, which contains the most significant digit, contributes a current  $E_z/R$ , the second a current  $E_z/2R$ , and so on.

This binary weighting of the currents supplied by the various stages then results in a current (or voltage) proportional to the binary number stored. The only requirements placed on the tubes are that no screen current flow when a one is stored and that sufficient current be drawn when a zero is stored to cut off the associated collector diode, with resultant zero current contribution.

Use of silicon diodes as collectors reduces the back current of a cut-off diode to a negligible value, while offering a very small resistance in the forward direction. The accuracy of the circuit is chiefly dependent on the tolerances of the resistors and the ability of the regulating diode to maintain a constant voltage  $E_z$ . The most critical resistor is the one associated with the first flip-flop, which should have an accuracy of at least 1 part in  $2^n$ .

Since highly precise resistors are available, the limiting factor will normally be the regulating diode, which must compensate for varia-

# WESTINGHOUSE NEW SILICON POWER RECTIFIER puts you ahead...

**High-temperature operation.** Exhaustive tests have shown that these units are capable of operation up to 200°C with *no* detectable aging in their characteristics.

**In rectifier efficiency.** Forward voltage drop reaches only 0.85 volts at 40 amperes, 190°C junction temperature. Efficiency is over 99%. Ratings up to 200 volts maximum peak inverse are available in four classifications: 50, 100, 150 and 200 volts.

**In compact design.** Westinghouse silicon power rectifier (shown actual size above) takes only 1/50th the volume of the comparable selenium rectifier.

Write today for your free application *Facts Folder* describing the full range of silicon power rectifier characteristics. These rectifiers are available for immediate delivery. Call your local Westinghouse sales office, or write: Westinghouse Electric Corporation, 3 Gateway Center, P. O. Box 868, Pittsburgh 30, Pa. J-80002

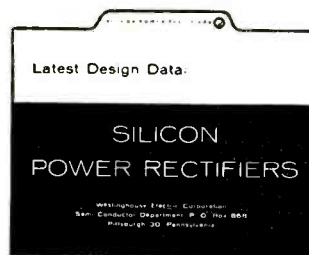

YOU CAN BE SURE...IF IT'S  
**Westinghouse** 



# Something New Under The Sun!

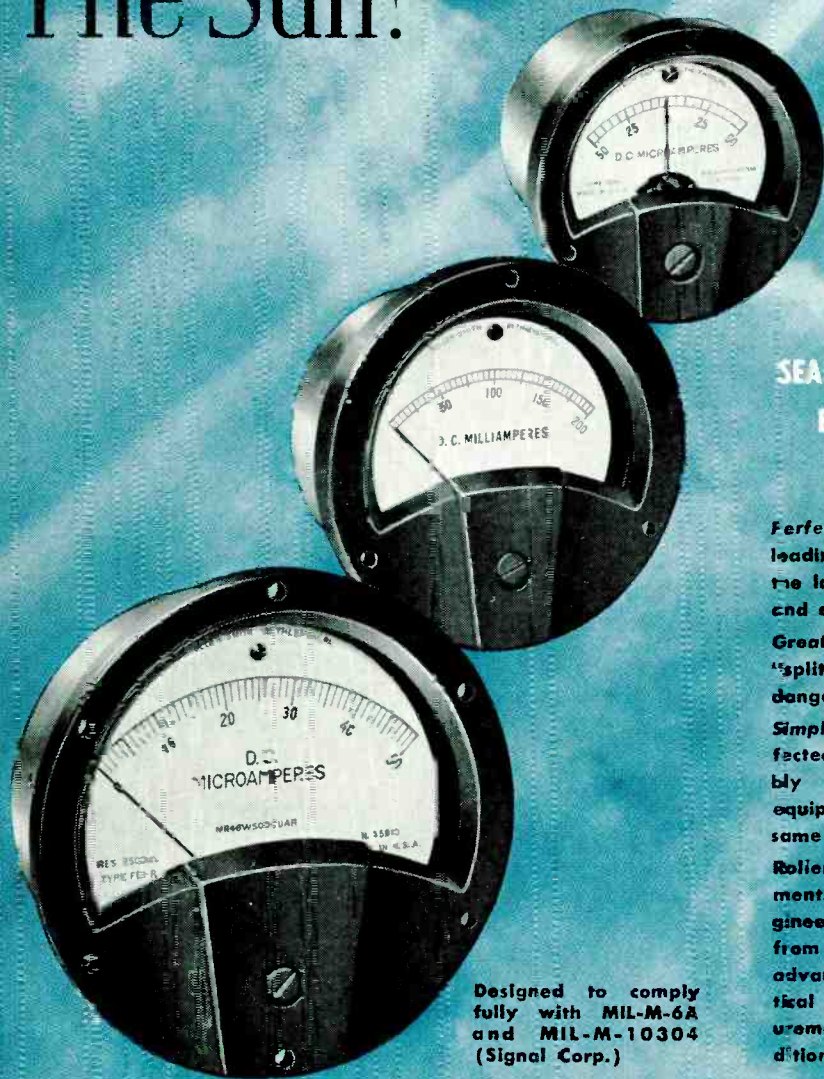

Designed to comply fully with MIL-M-6A and MIL-M-10304 (Signal Corp.)

An extra feature—new “wrap around” shroud with gasket seal makes these meters as modern in appearance as they are in performance. Precisely built, their neat functional form expresses the forward-thinking of our engineers.

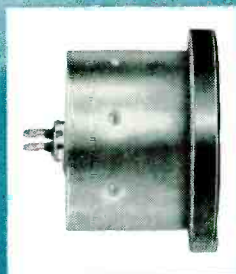

## SEALED—RUGGEDIZED INSTRUMENTS BY ROLLER-SMITH HAVE THAT “NEW LOOK” FOR

**Perfect Readability:** New shrouds designed by leading industrial designers focus attention to the large dial, assuring “one look” readability and enhanced appearance.

**Greater Accuracy:** New zero adjuster permits “split-second” adjustment from the front. No danger of leaks.

**Simplified Maintenance:** New gasket seal perfected by Roller-Smith permits easy disassembly for service—NO expensive soldering equipment—NO wasted glass—you use the same glass over and over. Costs are reduced.

Roller-Smith sealed and ruggedized instruments feature these three outstanding engineering and design improvements in all sizes from 1½ to 4½ inches to make them the most advanced on the market. Available in all practical ranges of AC and DC for accurate measurements under extreme environmental conditions.

Consult our engineering staff with over 50 years experience to solve your specific research and development problems.

**ROLLER-SMITH**  
Instrument Division  
CORPORATION

1025 WEST MARKET STREET  BETHLEHEM, PENNSYLVANIA

Precision Products Since 1908



tions in the supply voltage as well as a total variation  $2E_s/R$  in the output current. By choosing the proper diode and operating it at a suitably high current, variations in  $E_s$  can be held sufficiently low that the circuit can be made good to 8 digits, which implies an accuracy of 1 part in 256.

### Reflection-Type Asymmetrical Waveguide

By KORYU ISHII  
 Microwave Laboratory  
 Nihon University  
 Surugadai, Tokyo, Japan

ONE-WAY TRANSMISSION waveguides using ferrite and resistive film attenuators depend on Faraday rotation of the electromagnetic wave. Waves in the forward direction may pass through the waveguide without high attenuation but waves in the opposite direction are absorbed by the resistive film and cannot pass.

A reflection-type asymmetrical waveguide described here uses a combination of  $H$ -plane tapered iris and matching screws. Figure 1 shows a diagram of the reflection-type asymmetrical waveguide.

The  $H$ -plane tapered iris made of thin metallic film is located in the rectangular waveguide. This iris determines direction of power transmission. The discontinuity of

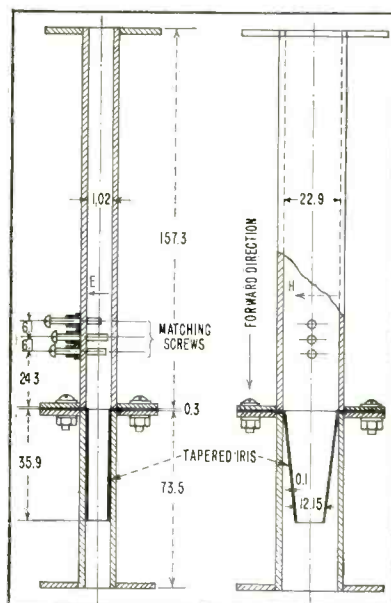
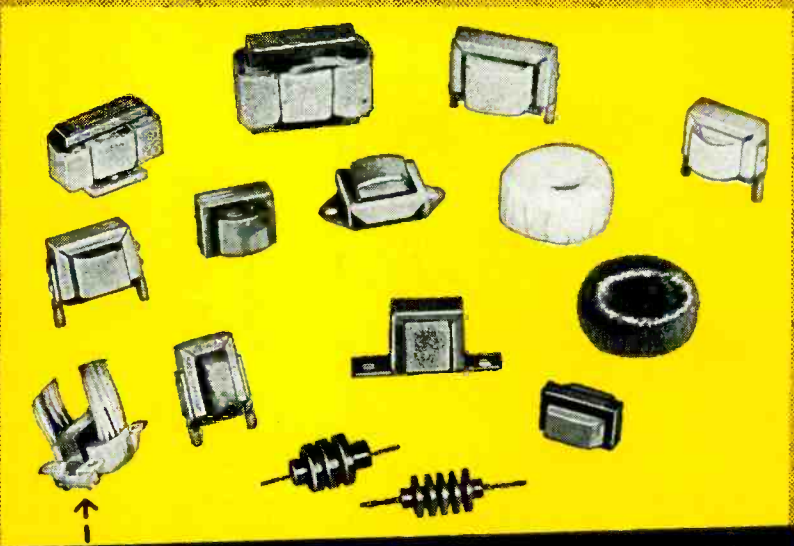

FIG. 1—Cross-section of asymmetrical waveguide in the E and H planes



## ADVANCED TRANSFORMERS AND MAGNETIC AMPLIFIERS

### AT Celco

"Advanced" means the smallest, most modern and most efficient miniature components it is possible to make today . . . built to the most precise, demanding specifications of the electronics industry.

#### BETTER PERFORMANCE WITH LESS WEIGHT AND SPACE

1. Thin-gauged, grain-oriented nickel alloys yield improved magnetic properties.
2. Glass, asbestos, silicone, and polyester film insulations allow higher operating temperatures.
3. Skilled craftsmen using miniaturization techniques highly developed and applied at Celco.

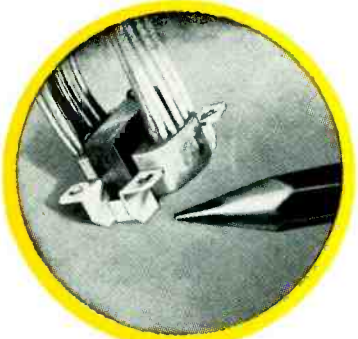

One of Celco's "advanced" miniatures compared to an ordinary lead pencil.

#### MISSILE AND AIRCRAFT Miniaturized Components

##### Transformers

- Chokes
- Matching
- Low Level Input
- Output
- Transistor Circuits

##### Magnetic Amplifiers

- Demodulators
- Limiters
- Saturable Reactors
- Signal
- Pulse



Take advantage of the Celco design and production experience in this specialized field. Get a Celco estimate—improve your quality—reduce your cost.

Constantine Engineering Laboratories Co.

Island Avenue

Mahwah, N. J.



# BRC RX Meter combines all necessary RF Bridge Test functions

Completely self contained . . . quick, easy broad band measurements, on components or coaxially connected elements

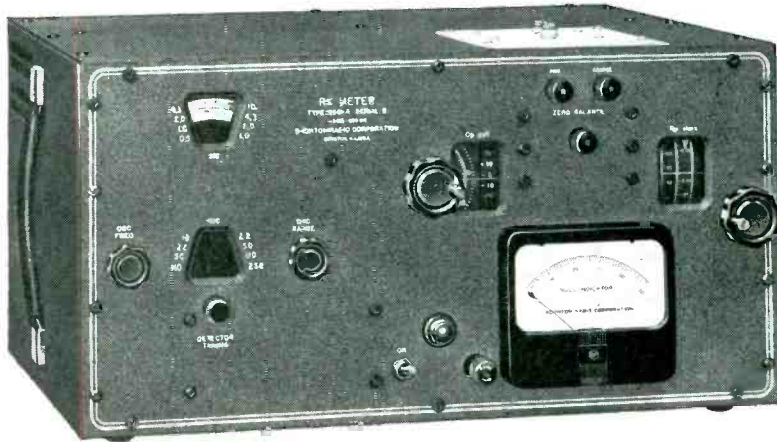

## TYPE 250-A FREQUENCY RANGE 500 kc to 250 mc

The RX Meter Type 250-A is a completely engineered measuring instrument including a broad band RF oscillator, RF bridge and null detector. The parallel resistance and parallel capacitance or inductance of the unknown is indicated on precise, easily-read dials. Components such as resistors, capacitors or coils, are connected across two unbalanced binding post connections on top of the instrument. The Co-ax Adapter Type 515-A, shown above, replaces the binding posts in a few seconds with a Type N Connector for measurement of coaxially connected devices. No corrections are necessary over the entire frequency range for most measurements.

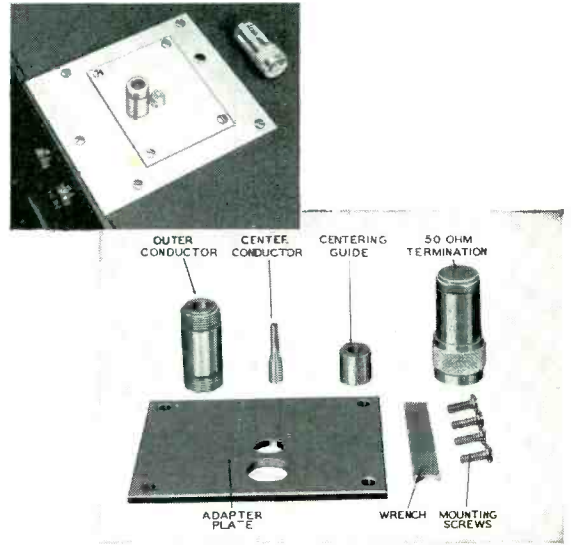

Co-ax Adapter Kit Type 515-A adapts RX Meter for coaxial connections.

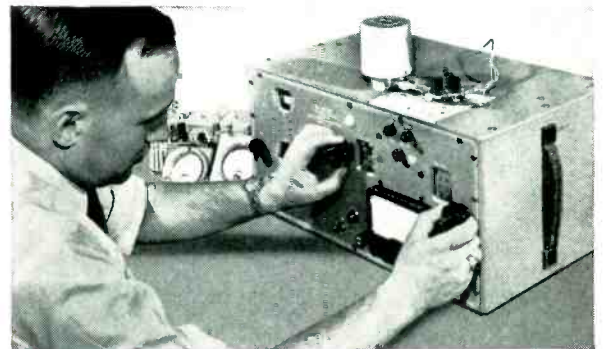

Dynamic measurement of a junction transistor under conditions of variable bias and applied RF. Similar procedures can be used with vacuum tubes.

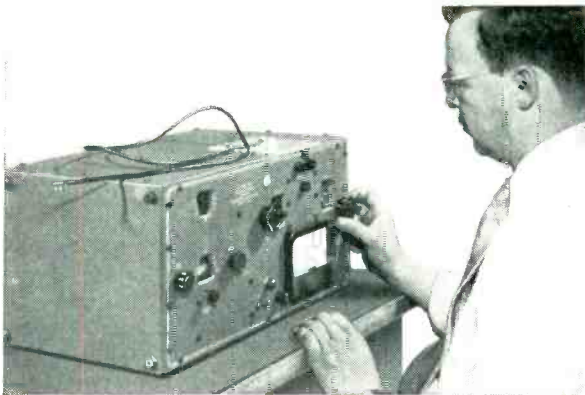

The RX Meter measures the characteristic impedance, attenuation and propagation velocity of RG-58/U Cable.

### SPECIFICATIONS

FREQUENCY RANGE: 500 KC to 250 MC in eight ranges.

FREQUENCY ACCURACY:  $\pm 1\%$ .

RESISTANCE RANGE ( $R_p$ ): 15 to 100,000 ohms.

CAPACITANCE RANGE ( $C_p$ ): -100 mmf to +20 mmf (may be extended).

INDUCTANCE RANGE ( $L_p$ ): 0.001 uh to 100 mh.

TEST VOLTAGE: 0 volts D.C. (Up to 50 ma may be passed through unknown terminals). 0.1-0.5 volts R.F. (may be conveniently reduced to 20 mv).

POWER REQUIREMENTS: 105-125 volts, 50/60 cps, 60 watts (internally regulated).

The RX Meter provides a simple, accurate means of measuring, independently, the RF resistance and reactance of a wide variety of materials, components and circuits. It is also useful in making other types of measurement.

Dynamic measurements of the parameters of transistors and vacuum tubes can be made. D.C. current up to 50 ma can flow through the bridge terminals permitting simple direct biasing of the unknown element. By a simple procedure, the RF voltage across the unknown can also be varied, permitting measurement of input and output impedance under a wide variety of conditions.

Cable characteristics can be measured on the RX Meter using a very short cable sample. A simple measurement will yield the characteristic impedance, attenuation and propagation constant. By the use of a balun the same characteristics can be measured for balanced cables.

Type 250-A Price: \$1250.00 F.O.B. Boonton, N. J.

Type 515-A Price: \$32.50 F.O.B. Boonton, N. J.



**BOONTON RADIO**  
Boonton · N. J. · U. S. A. Corporation

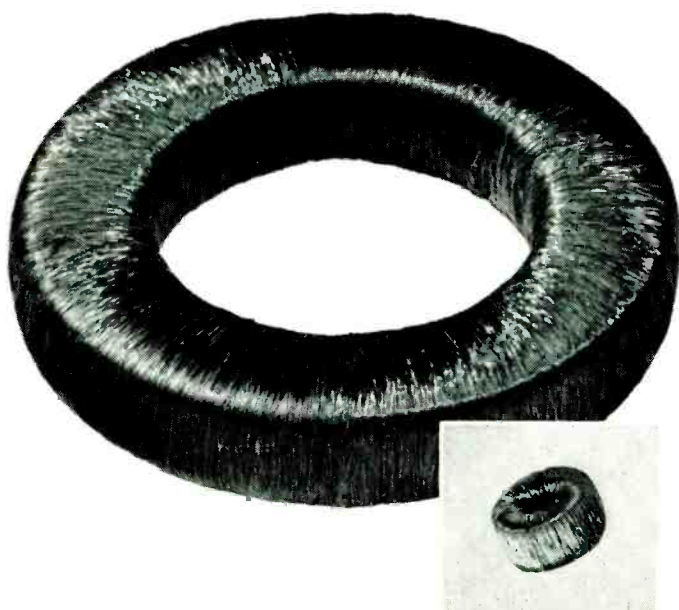

## How Big is a Toroid?

As large or as small  
as your needs require . . .

if your source is B&W.

Barker & Williamson can  
provide precision toroidal  
coils wound on a production  
line basis from doughnut  
size to aspirin size.

A sure cure for production  
and miniaturization  
headaches.



**B&W**

**Barker & Williamson, Inc.**  
237 Fairfield Ave., Upper Darby, Pa.

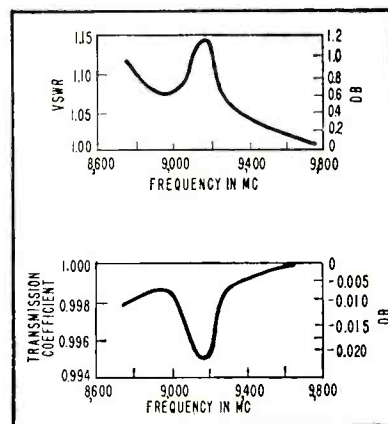

FIG. 2—Frequency characteristic of reflectionless termination

the iris for forward transmission is compensated by matching screws.

Operation in the forward direction is as follows. Transverse  $H$ -plane width of the narrow mouth of the iris is shorter than the half of the cutoff wavelength. Therefore, even if the iris is made of tapered waveguide and the impedance is gradually transformed, this section acts as a discontinuity. This discontinuity is, however, compensated with matching screws.

If the wave comes from the opposite direction, power cannot pass the narrow mouth of the iris. Because this size is below cutoff and since there is no matching device the discontinuity of the narrow mouth is not compensated. Matching screws at the right side do not act in the field free region this time.

Wave power transmission coeffi-

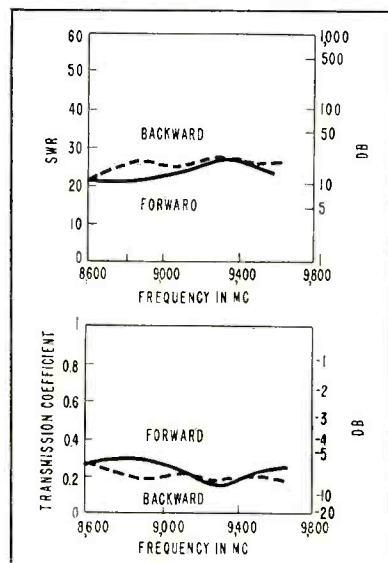

FIG. 3—Transmission characteristic of tapered iris in both directions



# "TO PEACE

**because the awful  
alternative is the  
end of all life" \***



\* **Seawolf Launching Invocation, July 21, 1955, by Lt. Comdr. Paul F. Bradley, (ChC), USN. "Therefore, reverently we ask Thee, O God, of both the atom's law and man's reason, to bless and guide them to life more abundant . . . to peace . . . because the awful alternative is the end of all life."**

**Our expansion program requires: Scientists • Engineers • Precision Instrument Makers—write to S. W. Wilson**

**T**hese are the last twelve words of the invocation given at the launching of "Seawolf." As the *second* nuclear-powered submarine to be completed within the past 20 months . . . it dramatically re-affirms our entrance into a brand new era!

In a smaller way . . . yet significantly . . . it also re-affirms Norden-Ketay's leadership in the field of electronics and instrumentation. For based upon their experience, research facilities, and performance in volume production . . . The Precision Components Division of Norden-Ketay was chosen by General Dynamics Corporation, builder of "Seawolf," to supply the *SYNCHROS* which translate electrical impulses into positioning data . . . another example of how Norden-Ketay serves most of the leaders in automatic controls . . . where reliability counts most!

#### *Look to Norden-Ketay for*

**SYNCHROS • SERVO MOTORS • DIGITAL CONVERTERS • RATE GENERATORS • RESOLVERS • MAGNETIC AMPLIFIERS • GEAR TRAINS • VARI-OHM POTENTIOMETERS • NAVIGATIONAL SYSTEMS • FIRE CONTROL SYSTEMS • SERVO MECHANISMS • AIRBORNE INSTRUMENTS • BOMB DIRECTOR SYSTEMS • COMMUNICATION EQUIPMENT • COMPUTERS • ACRAGAGE PRESSURE GAGES**

## **NORDEN-KETAY CORPORATION**

**99 Park Avenue, New York 16, N. Y.**

#### **DIVISIONS:**

*The Norden Laboratories, White Plains, N. Y.  
Precision Components Division, New York, N. Y.  
Commack, Long Island, N. Y.  
Western Division, Hawthorne, California  
Instrument and Systems Division, Milford, Connecticut*

#### **SUBSIDIARIES:**

*The Frohman Manufacturing Company, Inc., Miami, Fla.  
Nuclear Science and Engineering Corporation, Pittsburgh, Pa.  
Vari-Ohm Corp., Amityville, Long Island, N. Y.  
Scientific Specialties Corporation, Boston, Mass.*



# Over 455

## PRECISION PUSH-BUTTON SWITCH TYPES

Looking for precision-built push-button or snap-action switches in the 15 to 50 ampere range with operating pressures of approximately 4 pounds?

Chances are, Hetherington has just what you want—in standard types—backed by a record of proved performance in critical aviation or military applications. Just about any circuit, activating arrangement or mounting style is available and each standard type is readily adaptable to numerous and inexpensive variations.

Write for catalog—or send details of your requirement for recommendation by Hetherington switch specialists.

**HETHERINGTON, INC., SHARON HILL, PA.**

West Coast Division: El Segundo, California

**PROMPT  
DELIVERIES . . .  
LARGE QUANTITIES  
OR SMALL**

### **HETHERINGTON**

SWITCHES WITH BUILT-IN INDICATOR LAMPS  
MINIATURE SWITCHES  
TOGGLE SWITCHES • ROTARY SWITCHES  
SWITCHES TO MILITARY SPECIFICATIONS

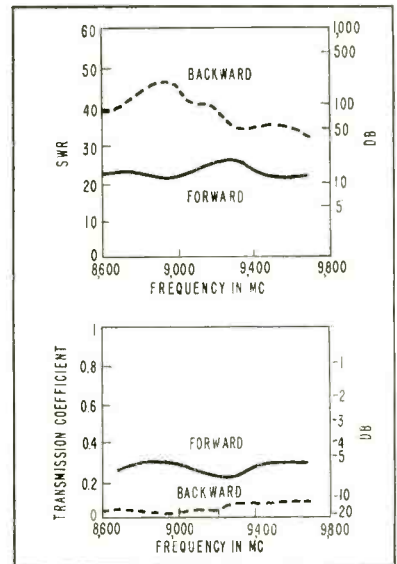

FIG. 4—Characteristics of matching transformer section of asymmetrical waveguide

coefficients of this asymmetrical waveguide were measured by conventional method using a standing wave detector and reflectionless termination.

Figure 2 shows the frequency characteristics of the reflectionless termination. The  $v_{swr}$  is less than 1.15 and the power transmission coefficient is more than 99.5 percent over the range of 8,700 to 9,700 mc.

Transmission characteristics of a section of the tapered iris alone is shown in Fig. 3. The wave transmission is asymmetrical but the forward transmission coefficient is too small.

Figure 4 shows the transmission

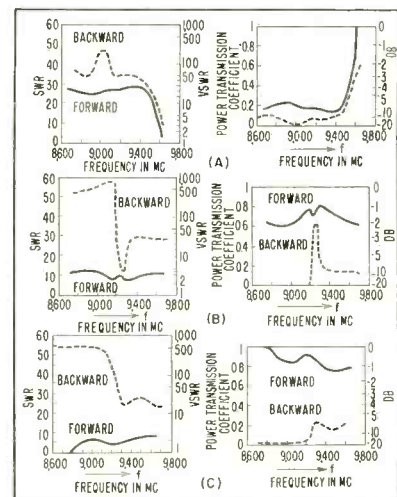
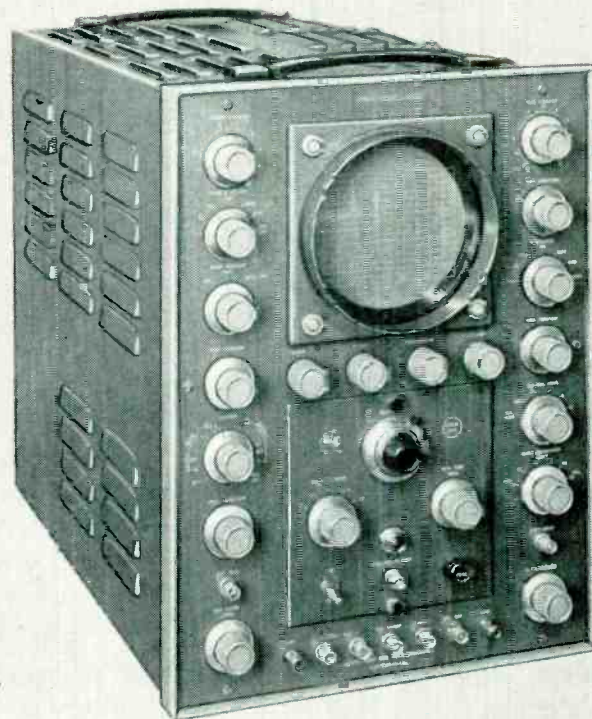

FIG. 5—Characteristics of complete waveguide adjusted for maximum forward transmission (A) and optimum transmission coefficients at 9,180 mc (B) and 8,785 mc (C)



One  
easy  
answer  
to all  
your  
test  
problems...



## LFE's 411 **"EASY-SIX"** oscilloscope

Gone are the days when a scope with 100 kc bandwidth would satisfy most of your research requirements. Today you need a precision instrument of unparalleled accuracy, capable of tackling dozens of different assignments.

That's where the "Easy-Six" comes in. Precision engineered to handle the most advanced electronic research, this LFE Model 411 is nonetheless so easy to use even unskilled operators can quickly grasp the essentials. Six X-axis plug-in units provide the flexibility needed to meet a wide range of requirements.

If you're looking for an accurate, precision, general-purpose scope that's easy to operate, write for our free bulletin about the LFE 411 "Easy-Six", or contact your local LFE Engineering Representative.



**LABORATORY FOR ELECTRONICS, INC.**

*75 Pitts Street, Boston 14, Massachusetts*

FOR EXPORT SALES CONTACT ANDREW SZUCS, INC., 50 BROAD ST., NEW YORK 4, NEW YORK

# Semiconductor Engineers and Scientists

GENERAL MOTORS offers exceptional opportunities in this field as a result of newly expanded programs of research and development—and now, also, pilot plant production.

These are permanent programs of great and increasing importance to General Motors in its electronic, automotive, aircraft engine, locomotive, household appliance and military activities—not just temporary study or short-term development programs.

Physicists, physical chemists and electronic engineers with baccalaureate or advanced degrees and those with transistor, diode, photo-cell, other semiconductor and related experiences in research, development or process and production will find:

- Important, interesting and challenging problems
- Modern facilities
- Congenial association with others skilled in these sciences

Resulting in maximum personal satisfaction, development and recognition.

Upper-level positions for those shown to qualify.

The unusual employe benefits of General Motors are provided by this 20-year-old GM electronics division. Relocation expenses are paid. Pleasant Indiana community with excellent living conditions, schools and many other advantages. Letters held in complete confidence. Give information on education, experience, military duty and personal data.

Address: Personnel Director, Department MM



*Delco Radio*

DIVISION OF

**GENERAL MOTORS**

KOKOMO, INDIANA

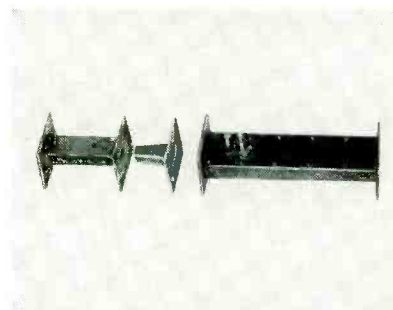

Three sections of asymmetrical waveguide before assembly. Tapered iris is at center

characteristics of the matching-screw section. This section is almost symmetrical.

With the iris section and the matching-screw section combined the power transmission characteristics is as shown in Fig. 5. In Fig. 5A, the matching screws were adjusted to obtain maximum forward power transmission coefficient at 9,615 mc. Fig. 5B and Fig. 5C show optimum transmission coefficient at frequencies of 9,180 mc and 8,785 mc, respectively.

For Fig. 5A, the backward transmission coefficients were also improved by the matching screws but the asymmetrical nature of the waveguide is not so good.

In the case of Fig. 5B, the asymmetrical nature of the waveguide is very good over the range of 8,790 to 9,270 mc. Resonance due to both the tapered iris and the screw tuners are observed at 9,250 mc and forward attenuation is a bit

## Radar Movie



A twenty-minute motion picture film called "Safe Passage" produced by Raytheon Mfg. Co., Waltham, Mass., shows some of the faulty techniques that have resulted in collisions between ships equipped with radar. Made with the assistance of the Coast Guard and others, the sound film is available on loan for education



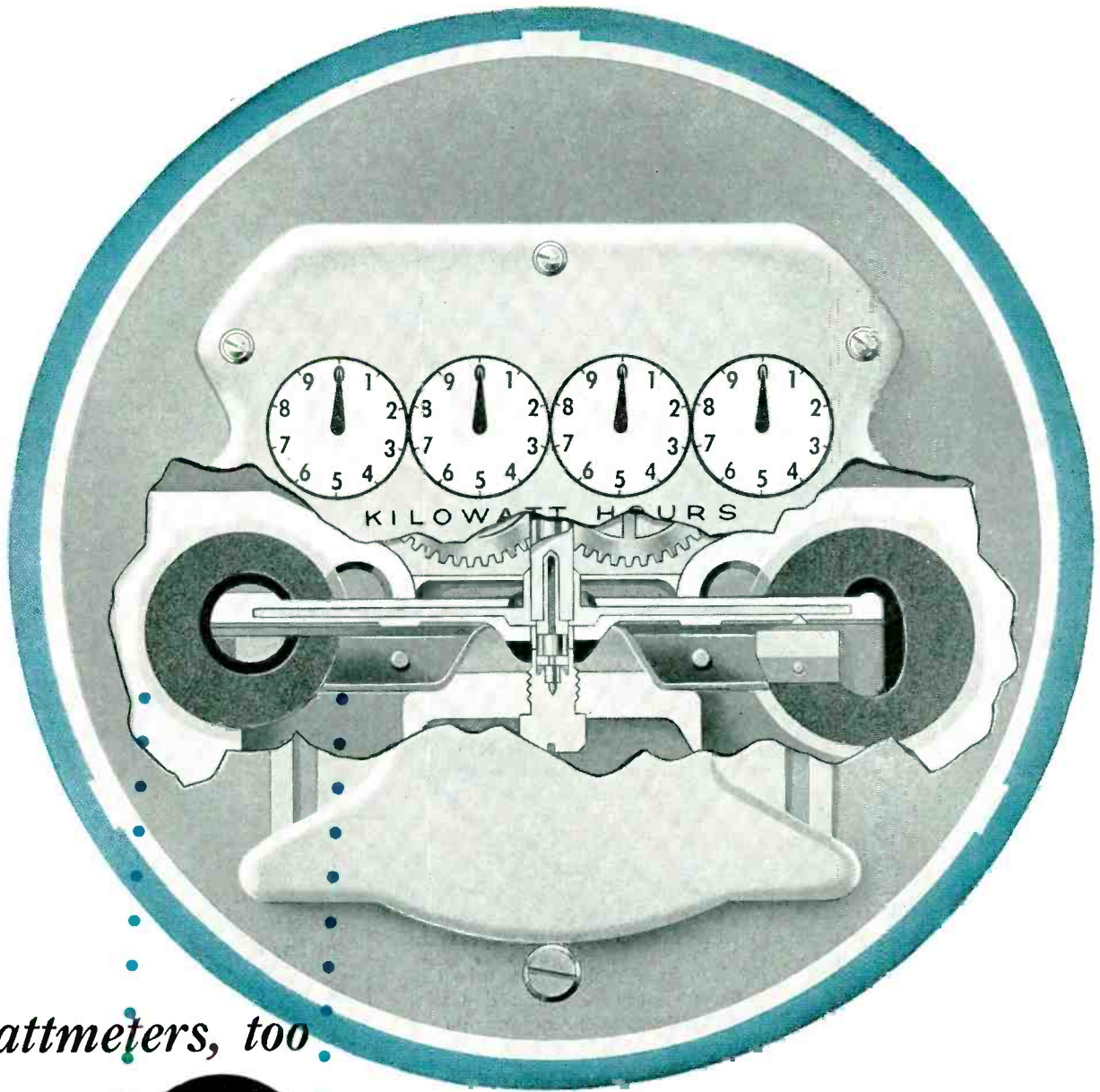

*wattmeters, too*

**USE  CRUCIBLE PERMANENT MAGNETS**

*for maximum energy . . . minimum size*

With Crucible alnico magnets you get *consistently higher energy product . . . which means more energy from a smaller magnet.*

That's why they provide maximum design freedom for manufacturers of watt-hour meters, voltmeters, and devices of all kinds requiring magnets from 0.2 ounces to several hundred pounds.

Crucible has been a leading producer of these powerful magnets ever since alnico alloys were first developed. And its magnet experience is backed by over a half-century of *special purpose* steelmaking.

For technical assistance in solving magnet applications, call Crucible. *Crucible Steel Company of America, Henry W. Oliver Building, Pittsburgh 22, Pa.*

**CRUCIBLE**

first name in special purpose steels

**Crucible Steel Company of America**

# RAYONIC CATHODE RAY TUBES

by

# Waterman

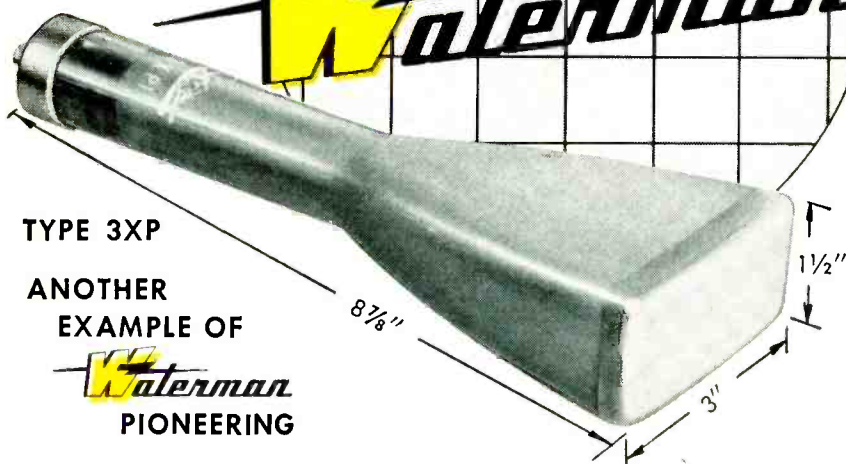

TYPE 3XP

ANOTHER  
EXAMPLE OF

  
PIONEERING

3XP RAYONIC CATHODE RAY TUBE provides a brilliant and sharply-defined trace and high deflection sensitivity at medium anode potentials. When comparing 3RP operating at 1000 volts second anode against 3XP operating at 2000 volts, the results are astonishing. For the same spot size, 3XP light output is improved by a factor greater than 4, vertical deflection sensitivity improved by a factor of 2, while the horizontal sensitivity remains unchanged. Because 3XP is enclosed in a short envelope and has half the inter-electrode capacities of the 3RP, the tube lends itself admirably to high frequency video work as well as for low repetitive operation.

**TECHNICAL DATA** The basic properties of the cathode ray tube that concern the designer or the user are: deflection sensitivity, unit line brightness, line width, static voltage requirements and physical size. A comparison between cathode ray tubes manufactured by Waterman Products Company is shown in the table below. These tubes are available in P1, P2, P7 and P11 phosphors. 3JP1, 3JP7, 3SP1 and 3XP1 are available as JAN tubes.

TUBE	PHYSICAL DATA			STATIC VOLTAGE			DEFLECTION*		LIGHT OUTPUT**
	Face	Length	Base	A3	A2	A2 Max.	Vert	Hor	
3JP1	3"	10"	Med Diheptal	3000	1500	2000	111	150	352
3MP1	3"	8"	Sm Duodecal		750	2500	99	104	33
3RP1	3"	9 1/8"	Sm Duodecal		1000	2750	61	86	44
3SP1	1.5x3"	9 1/8"	Sm Duodecal		1000	2750	61	86	44
3XP1	1.5x3"	8 7/8"	Loctal		2000	2750	33	80	218

\*Deflection in volts per inch.

\*\*Light output of an element of a raster line (one mm long and not exceeding .65mm in width) in microlumens.

All heaters 6.3 V AC, .6 AMP.

**WATERMAN PRODUCTS CO., INC.**  
PHILADELPHIA 25, PA. CABLE ADDRESS: POKETSCOPE

MEMO...  
Write for  
details  
today!

  
WATERMAN PRODUCTS

WATERMAN PRODUCTS INCLUDE

3JP1, 3JP7, 3SP1, 3XP1 JAN RAYONIC®  
Cathode Ray Tubes  
3JP—3MP—3RP—3SP—3XP RAYONIC  
CATHODE RAY TUBES  
Available in P1, P2, P7, and  
P11 Phosphors  
POCKETSCOPES® PULSESCOPES®  
RAKSCOPES®

And Other Associated Equipment

high for some purposes.

In Fig. 5C, the asymmetrical nature is best over the frequency band from 8,700 to 9,200 mc. In this range, the forward attenuation is less than 0.8 db.

At frequencies higher than 9,250 mc the cutoff effect of the tapered iris is not as effective for backward transmission and asymmetrical nature is weakened. In the useful range of the frequencies, high standing-wave ratio for backward transmission shows part of the incident wave power is reflected.

The author wishes to thank K. Owaki, S. Sonoda, I. Yokochi, Kenichi Fujinawa, Takeshi Hara and Nobuyoshi Watanabe.

## Testing UHF DX

AN EXPERIMENTAL beyond-horizon circuit has been set up by Radio Corporation of America in co-operation with RCA Victor Ltd. of Canada, linking Covey Hill, Huntingdon County, Quebec, with Riverhead, L. I., N. Y.

Put into operation last August, the circuit spans 288 miles. Frequency of operation is 468 mc, so that propagation is necessarily by means of tropospheric scatter. The parabolic antenna used is a 40-foot dish mounted on a 50-foot tower. Covey Hill, most northerly peak of the Adirondacks, has an elevation of 1,100 feet.

Effectuated radiated power of the transmitting installation is 428 kw,

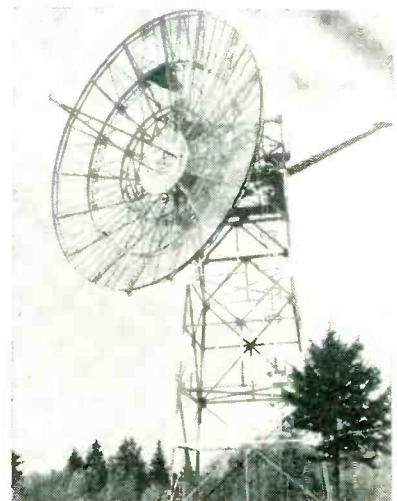

Forty-foot parabolic antenna beams RCA signals from Canada to Long Island in test of long distance uhf propagation



# What is "solid state electronics"?

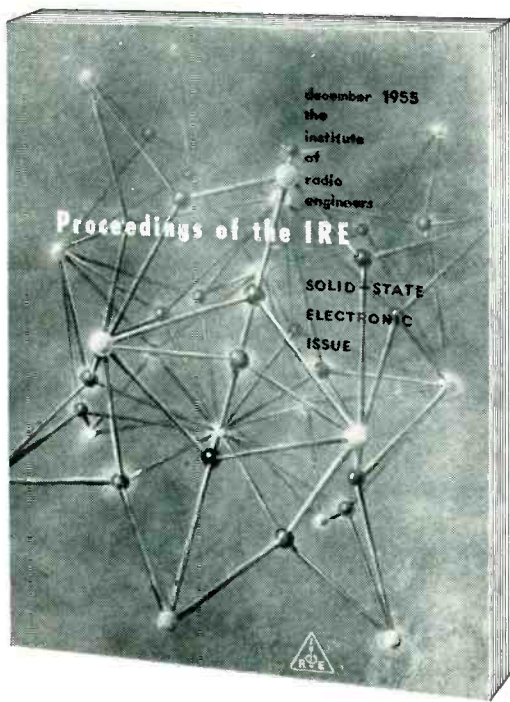

**You** have already received great services from "Solid State Electronics"... but much more is coming your way!

This side of radio science is both old and new. It started with the galena detector which gave you signals you could hear. In phosphors that glow in response to electronic bombardment, it gave you, first, a picture tube—and now, full color television.

Ferrites that store and repeat electronic signals—the memory elements of the computer—are the next stage in this radio engineering. Tomorrow, "stearetronics" (as Cornelius Ryan calls it in Collier's) will provide silicones and other solid state materials which will store heat and power from the sun to serve you.

A working summary of this science is offered to you in the December issue of "Proceedings of the IRE"—from background data to the newest research. This one issue, some 300 pages, is the word count equivalent of a 600-page text book... useful, up-to-the minute. It is a history-making issue you will treasure for years.

Price to non-members... **\$3.00**

(All IRE members will receive this December issue as usual. Extra copies to members, \$1.50 each.)

## Every Article Is a "Treasure" in this History-Making Issue

"Lead Article," by Dr. Frank Herman, RCA Laboratories, Inc.

"Field of Ferrites," a paper covering the history of the development of ferrites, by Dr. E. W. Gorter, The Philips Co.

"Ferrite Developments," by Dr. Paul N. Russell

"Historical background and current state of the art in dielectric materials," by Dr. E. T. Jaynas, Stanford University

"Future trends and unsolved problems in dielectric materials," by Dr. Gen Shirane, Pennsylvania State University

"History of Semiconductor Research," by G. L. Pearson and W. H. Brattain, Bell Telephone Laboratories, Inc.

"Germanium and Silicon," by G. A. Morton and M. L. Schultz, RCA Laboratories, Inc.

"Conductivity, Hall effect and optical absorption of intermetallic compounds," by Dr. H. P. R. Prederikse, National Bureau of Standards

"Photoconductivity in some of the sulfides and selenides," by Dr. Richard H. Bube, RCA Laboratories, Inc.

"Performance of Photoconductors," by Dr. Albert Rose, RCA Laboratories, Inc.

"Lead Salts or Infra-red Photoconductors," by T. S. Moss

"Design & Performance in a Storage Light Amplifier," by Rosenthal Jennie, Allen B. Dumont Labs.

"An Electroluminescent Light, Amphytyme Picture Panel," by B. Kazan and F. H. Nicoll, RCA Laboratories, Inc.

"Cathodoluminescence," by Dr. G. F. J. Garlick, University of Birmingham

"Electroluminescence," by Prof. Georges Destriau and Dr. Henry F. Ivey, Faculte des Sciences de Paris

"Physical Chemistry of Phosphors," by Dr. F. A. Kroger, The Philips Co.



## The Institute of Radio Engineers

1 East 79th Street

New York 22, N. Y.

### PROCEEDINGS OF THE IRE

1 East 79th Street, New York 22, N. Y.

Enclosed is \$3.00

Enclosed is company purchase order for the December, 1955 issue on "Solid State Electronics"

Send to:

Name \_\_\_\_\_

Company \_\_\_\_\_

Address \_\_\_\_\_

City & State \_\_\_\_\_



# LAPP

## GAS-FILLED CONDENSERS



for duty at

**High Voltage**

**High Current**

**High Frequency**

Lapp's experience of 18 years of design and manufacture of gas-filled condensers is back of this precision-made unit and its promise of years of trouble-free duty. It is small in size and low in loss,

offers high voltage and current ratings, high frequency limits, safety, puncture-proof operation and constant capacitance under temperature variation.

The entire electrical and mechanical assembly of the Lapp gas-filled condenser is supported by a top aluminum ring, the steel tank serving only as a support for this ring and as a leak-proof gas container. High-potential plates are carried on a rigid center stud which is supported by a top ceramic bowl. Grounded rotor plates are carried on ball bearings nearly the full tank diameter. This construction provides a grounded tuning shaft on variable models and makes possible efficient and complete water cooling for high current operation.

Models in four tank diameters, 7" to 18", are available, in variable or fixed capacitances, for duty up to 30,000mmf; in current ratings to 400 amps at 1mc; operating voltages to 80Kv peak. Write for Bulletin 302, with complete description and characteristics data. Lapp Insulator Co., Inc., Radio Specialties Division, 244 Sumner Street, Le Roy, N. Y.

# Lapp

ELECTRONS AT WORK

(continued)

much of which results from a high antenna gain. RCA engineers stress the fact that this circuit is experimental, for data gathering and is not currently in use for communications.

The over-horizon technique is particularly applicable in remote regions where the cost of maintaining conventional microwave repeaters every 25 or 30 miles would be either prohibitive or physically impossible.

### Zero Hysteresis Relays

By IRVING BARDITCH  
Baltimore, Md.

USE OF A RELAY that has identical values of pull-in and drop-out current is sometimes mandatory. Almost any relay can be made to do this in combination with the proper

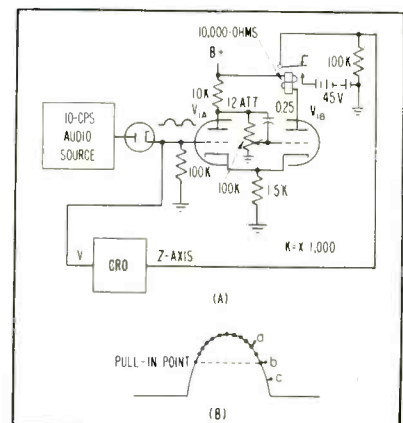

Circuit for comparing pull-in and drop-out voltage of relays (A). Oscilloscope waveform (B) shows position of closure point for early drop-out (a) equal pull-in and drop-out (b) and late drop-out (c)

vacuum-tube drive circuit. A zero or even negative hysteresis can be obtained.

The circuit diagram shows the trigger circuit with the relay in the plate of  $V_{1B}$ . Adjustment of the bias on  $V_{1B}$  allows the relay drop-out current to be made equal to, less than or greater than the pull-in current. A 100,000-ohm potentiometer permits this adjustment to be made without difficulty.

The set-up shown allows the relay action to be shown on the scope. The half-wave sinusoid pulses at a 10 to 20-cps rate drive the relay and present the pattern on the scope



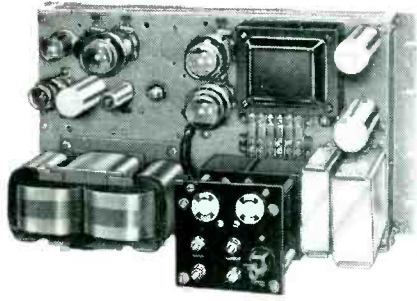

**INSTANTANEOUS ELECTRONIC (type IE)**  
For instantaneous correction and extremely close control. Completely electronic. No moving parts.

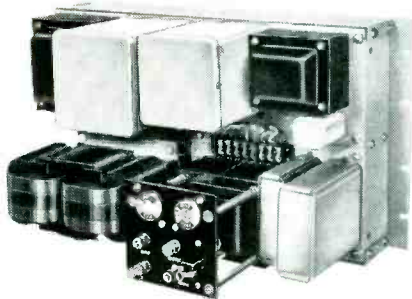

**TUBELESS MAGNETIC (type TM)**  
For unattended locations and critical uses where tube failure cannot be tolerated.

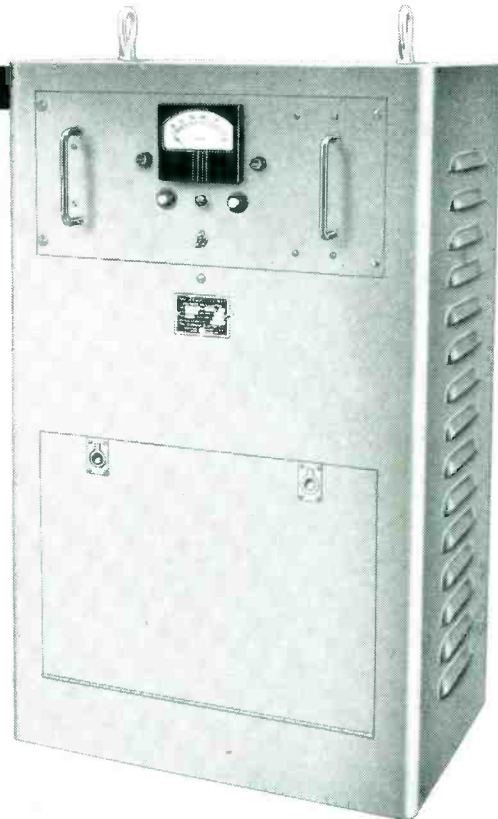

**ELECTRO MECHANICAL (type EM)**  
For large industrial loads or for applications requiring zero waveform distortion and high efficiency.

# STABILINE **AUTOMATIC VOLTAGE REGULATORS**

*Designed to  
Maintain  
Root Mean Square  
Voltage*

Here is a complete line of automatic voltage regulators designed with the application in mind . . . with *operating* characteristics that *always* equal or better the nameplate rating.

Of special importance is the fact that STABILINE maintains the root mean square voltage — the voltage rating for which all electrical equipment is designed. Before you purchase automatic voltage regulation equipment, make sure it is R.M.S. responsive.

We have detailed information about STABILINE automatic voltage regulators. Send the coupon for your copy of our Bulletin S351.

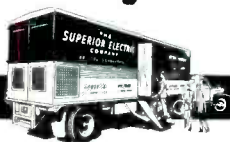

Be sure to see Superior Electric's Mobile Display when it is in your area.

FOR OUR COMPLETE  
PRODUCT LINE... SEE  
electronics Pg. 302-303  
'55 BUYERS' GUIDE

**THE SUPERIOR ELECTRIC COMPANY**

**SALES OFFICES: The Superior Electric Company**  
1436 N. Serrano Avenue  
Hollywood 27, California  
P. O. Box 946, 2881 El Camino Real  
Redwood City, Cal.  
453-A Eglinton Ave., West, Rm. 202  
Toronto 12, Ontario, Canada  
P. O. Box 48, 721 So. Boulevard  
Oak Park, Illinois  
6716 Laurel Drive, Baltimore 7, Md.  
250 Park Ave., Rooms 502, 503, 504  
New York 17, New York  
P. O. Box 132  
101 Public Square  
Medina, Ohio  
4515 Prentice St., Rm. 201  
Dallas 6, Texas

**REPRESENTATIVES**  
Beryl R. Hill Co.  
19481 James Couzens Hwy  
Detroit 35, Mich.  
Fred H. Haight Co.  
3212 Eastlake  
Seattle 2, Wash.

**THE SUPERIOR ELECTRIC COMPANY**  
212 Reynolds Avenue, Bristol, Conn.

Please send my copy of the STABILINE Bulletin

Name .....

Position .....

Company Name .....

Company Address .....

City ..... Zone ..... State .....

# Cramer

## TIME TOTALIZER

a highly  
accurate  
electrical stop  
clock . . .



Type 690 . . .

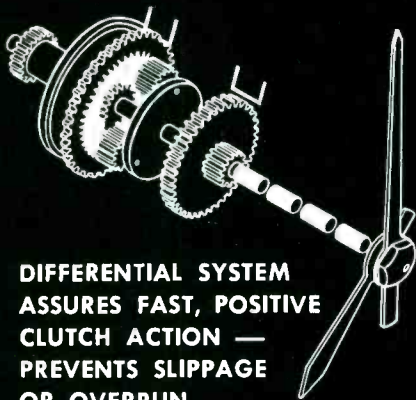

**DIFFERENTIAL SYSTEM  
ASSURES FAST, POSITIVE  
CLUTCH ACTION —  
PREVENTS SLIPPAGE  
OR OVERRUN.**

Positive engagement of pawl with gear combined with fine gear teeth provides the instant response necessary for a timing accuracy of  $\pm .01$  seconds on the 60-second timer, and  $\pm .005$  minutes on the 60-minute unit.

On the dial face, a large sweep hand makes possible fast, exact readings from the outer scale, while an accumulator pointer records larger time units on a separate scale in the center of the dial.

This compact unit is available for AC or DC operation in commercial and military applications. It is used in laboratory experimentation, for testing communications equipment and systems, and in the field of nuclear research, as well as for timing critical industrial processes.

For complete information on the Type 690, write for bulletin PB-610.



SPECIALISTS IN TIME CONTROL

*The R. W. CRAMER CO., Inc.*

BOX 3, CENTERBROOK, CONNECTICUT

11CR55

Want more information? Use post card on last page.

that is blanked during relay closure. This shows the exact timing for opening and closing of contacts.

## Light Beam Controls TV Receiver

CONTROL of a modern television receiver by a flashlight depends upon selection of an appropriate photo-sensitive target. Photocells located near the four corners of the television screen determine clockwise and

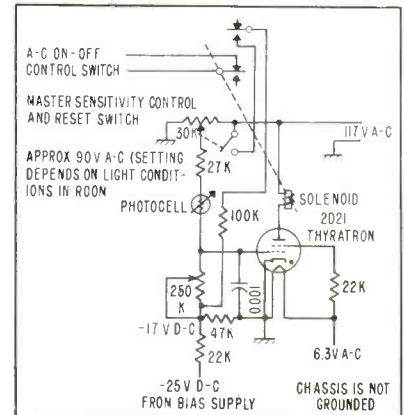

FIG. 1—Thyratron control circuit used for power switch and muting

counterclockwise channel selection, operation of the power switch and sound muting. Sensitivity, volume control and other adjustments must be manually preset.

Photoelectric devices used are cadmium-sulfide photocells. They change resistance with change in light. Resistance is an inverse function of light intensity, being extremely high in the absence of light. The range may be as great as 100 megohms to 25,000 ohms.

Two different types of controls are used. The motor drive unit is actuated through a pair of thermionic motor-control tubes (both in the same envelope) and relays. Loudspeaker muting and power switching is handled using a pair of thyratrons.

When the control grid of the 2D21 thyatron in Fig. 1 is near zero, conduction occurs. Since the plate voltage is alternating, the tube stops conducting every time the a-c swings negative. Alternating voltage applied to tube plate and control grid are in phase and tube conduction occurs during the positive



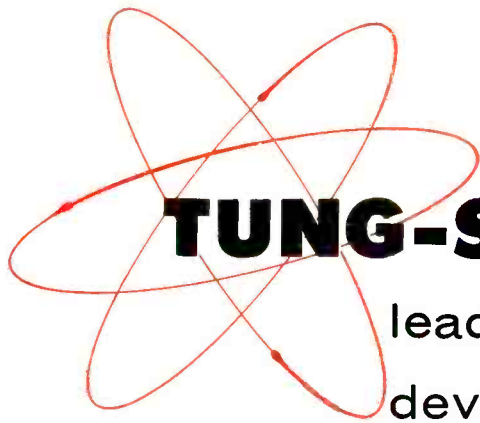

# TUNG-SOL

Acknowledged quality leadership . . . in research, design, development and manufacture . . . of all the basic components on which the science of electronics is founded.

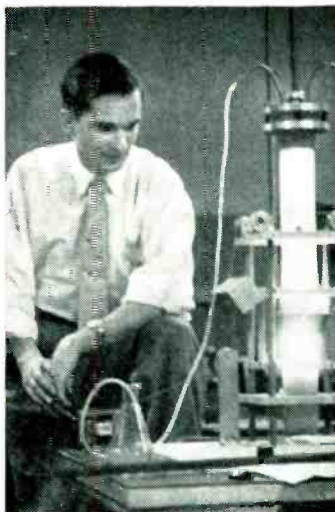

Research



Design

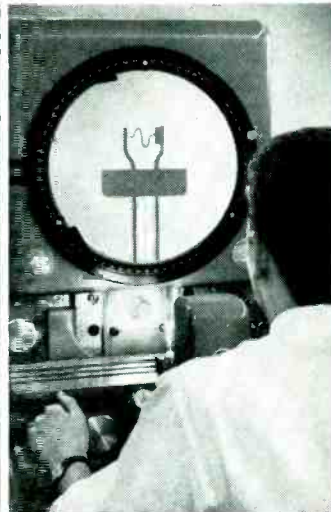

Development

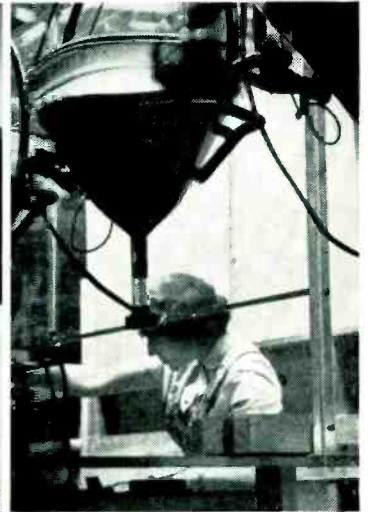

Manufacturing



Aluminized Picture Tubes

Color Picture Tubes

Special Purpose Tubes

Radio and TV Tubes

Semiconductors



**TUNG-SOL ELECTRIC INC.,** Newark 4, New Jersey

**SALES OFFICES:** ATLANTA, CHICAGO, COLUMBUS, CULVER CITY, DALLAS, DENVER, DETROIT, NEWARK, SEATTLE.

# BALLANTINE Sensitive, Wide Band Electronic Voltmeter

measures 1 millivolt to 1000 volts  
from 15 cycles to 6 megacycles

Accuracy 3% to 3 mc; 5% above

Input impedance 7.5 mmfds shunted by 11 megs

When used without probe, sensitivity is increased to 100 MICROVOLTS but impedance is reduced to 25 mmfds and 1 megohm

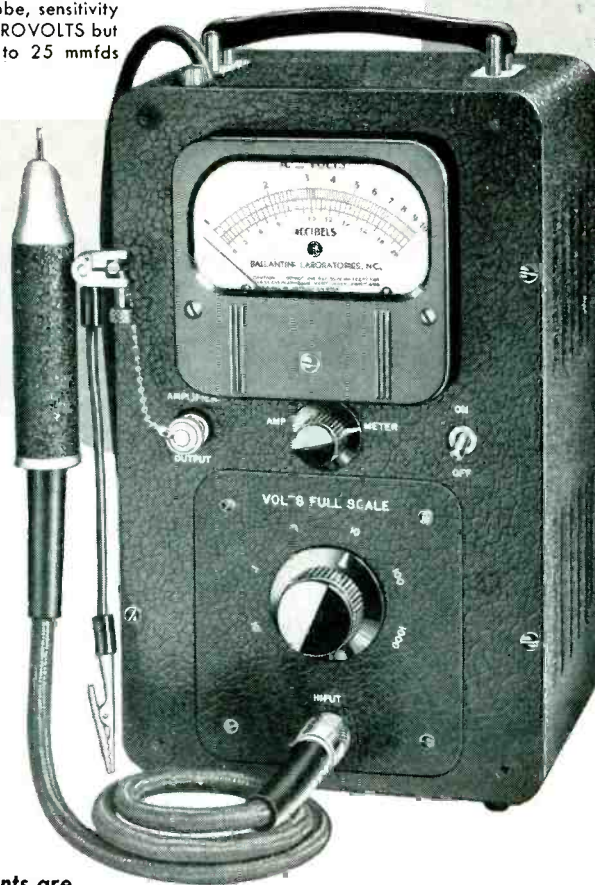

MODEL 314  
Price \$285

All Ballantine instruments are

## SENSITIVE - ACCURATE - DEPENDABLE

- Same accuracy at ALL points on a logarithmic voltage scale and a uniform DB scale.
- Only ONE voltage scale to read with decade range switching.
- No "turnover" discrepancy on unsymmetrical waves.
- Easy-to-use probe with self-holding connector tip and unique supporting clamp.
- Low impedance ground return provided by supporting clamp.
- Stabilized by generous use of negative feedback.
- Can be used as 60 DB high fidelity video pre-amplifier.

Write for catalog for more information about this and other BALLANTINE voltmeters, amplifiers, and accessories.

# BALLANTINE LABORATORIES, INC.

100 FANNY ROAD, BOONTON, NEW JERSEY

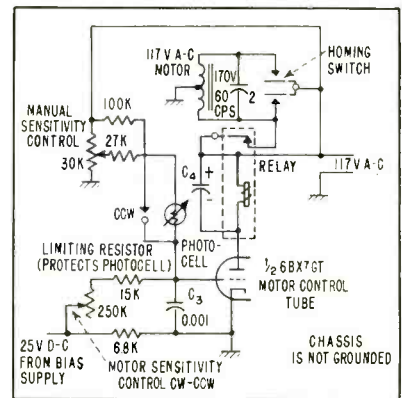

FIG. 2—Motor control circuit selects channels

swing. The plate-circuit solenoids are energized by pulsating direct current.

Since the photocell decreases resistance when illuminated, the thyatron will fire owing to rising potential on the control grid, energizing the solenoid that performs the appropriate switching function.

Action of the tuning motor control circuit is similar to the thyatron action. Because only momentary contact and release are required, plate-current relays are operated by conduction of either half of a dual-triode 6BX7 tube, as shown in Fig. 2.

When the amplitude of a-c control voltage swings the grid of the tube sufficiently positive for an average 9-ma rectified direct-current flow through the coil the relay will operate. With no excitation voltage at the grid, no d-c plate current will flow since the tube is normally biased to cutoff.

Filter capacitors  $C_1$  and  $C_2$  smooth out the pulsating voltage and avoid relay chatter that would otherwise result during negative swing of the alternating current.

Information on the Zenith Flashmatic remote control has been abstracted from an operating guide furnished through the courtesy of Zenith Radio Corp.

## Volscan Evaluation

AIR TRAFFIC control tests will be conducted for Air Research and Development Command by engineers of Air Force Cambridge Research Center. Evaluation of the Volscan (AN/GSN-3) system will be conducted at Clinton County Air



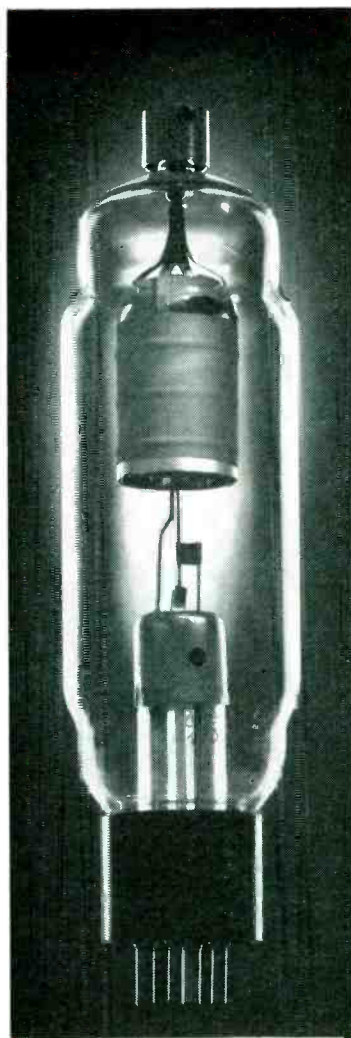

**Like all Los Gatos Tubes**

# LONG ON SERVICE

Designed from the pins up to take a beating in modern power, communications, and radar surge-limiting and rectifier applications, Los Gatos 8020's routinely give the long life users have come to expect from all Los Gatos Tubes.

Send for your data sheet—

**LEWIS and KAUFMAN, Ltd.**

**LOS GATOS 1**

**CALIFORNIA**



Export Representatives:  
**MINTHORNE INTERNATIONAL CO., INC.**  
15 Moore St., N.Y. 4, N.Y., Cable: Minthorne

In Canada:  
**RADIO VALVE COMPANY, LIMITED**  
189 Dufferin Street, Toronto 1, Ontario, Canada

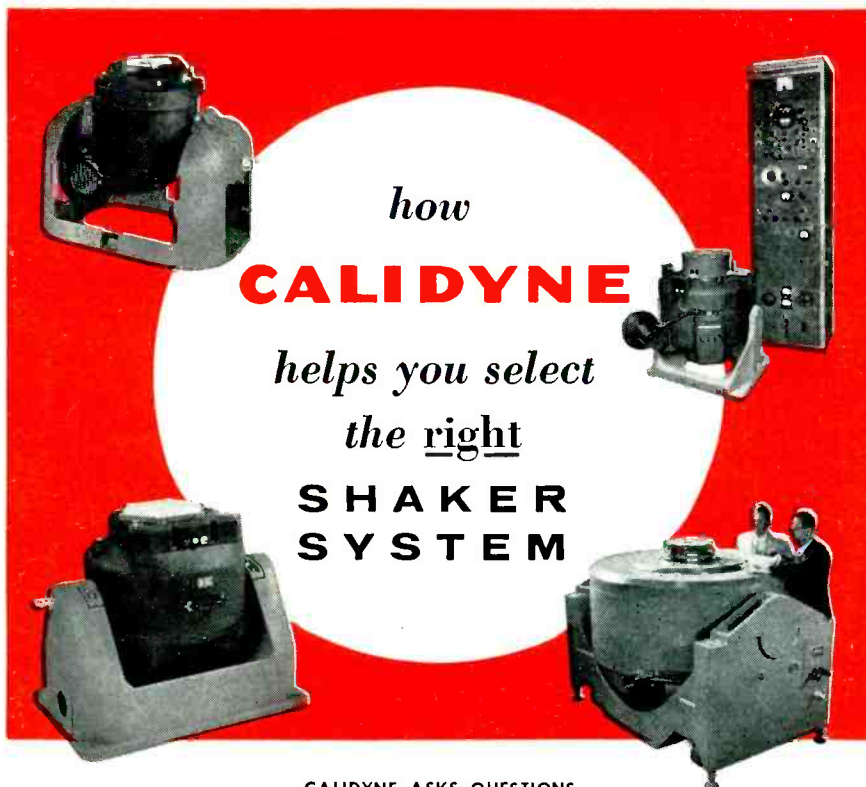

*how*  
**CALIDYNE**  
*helps you select*  
*the right*  
**SHAKER  
SYSTEM**

**CALIDYNE ASKS QUESTIONS**

When you inquire about Calidyne Shaker Systems, you're asked "What *type* of vibration testing is required — conventional environmental testing? Fatigue testing? Structural response determination? Mechanical noise reduction?" Further, "What are your present, and anticipated, requirements for force, frequency, and stroke?" In this way, Calidyne can recommend the equipment which will provide *maximum* usefulness for your investment, with as much flexibility as possible for future needs.

**CALIDYNE DELIVERS**

To meet your requirements, Calidyne offers complete Shaker Systems ranging in force output from 25 to 12,500 pounds. Systems consist of one or more electrodynamic Shakers, a rotary or electronic power supply, a control console and various optional accessories for monitoring, measuring or automatically cycling tests. Calidyne Shakers feature greater useful force output through lighter armatures, true linear armature motion, rugged construction. Certain Calidyne power supply units, also, will operate Shakers of widely different force outputs. Any accessory may be added to a basic system at any time, without costly revamping or modification.

**CALL CALIDYNE**

For competent help in solving your vibration testing problems, or technical data on any Calidyne Shaker System, call Calidyne now.



THE  
**CALIDYNE**  
COMPANY

120 CROSS STREET, WINCHESTER, MASSACHUSETTS

**SALES REPRESENTATIVES:**

**WALTHAM, MASS.**  
Robert A. Waters, Inc.  
Waltham 5-6900

**NEW HAVEN, CONN.**  
Robert A. Waters, Inc.  
Fulton 7-6760

**NEW YORK CITY AREA**  
G. C. Engel & Associates  
Rector 2-0091

**RIDGEWOOD, NEW JERSEY**  
G. C. Engel & Associates  
Gilbert 4-0878

**PHILADELPHIA, PA.**  
G. C. Engel  
Chestnut Hill 8-0892

**NORTHERN NEW YORK**  
Technical Instruments, Inc.  
Waltham, Mass.  
Waltham 5-8445

**CLEVELAND, OHIO**  
M. P. Odell Co.  
Prospect 1-6171

**DAYTON, OHIO**  
M. P. Odell Co.  
Oregon 4441

**DETROIT, MICHIGAN**  
M. P. Odell Co.  
Superior 8-5114

**WASHINGTON, D. C.**  
F. R. Jodon, Inc.  
Hobart 2-4300

**SOUTHEAST**  
W. A. Brown & Assoc.  
Alexandria, Va.  
Overlook 3-6100

**CHICAGO, ILLINOIS**  
Hugh Marstrand & Co.  
Ambassador 2-1555

**INDIANAPOLIS, INDIANA**  
Hugh Marstrand & Co.  
Glendale 3803

**MINNEAPOLIS, MINN.**  
Hugh Marstrand & Co.  
Calfax 7949

**DALLAS, TEXAS**  
John A. Green Co.  
Fleetwood 7-7385

**HOLLYWOOD, CALIFORNIA**  
G. B. Miller Co.  
Hollywood 2-1195

**SAN FRANCISCO, CALIF.**  
G. B. Miller Co.  
Lytell 3-3438

**ALBUQUERQUE, NEW MEXICO**  
G. B. Miller Co.  
Albuquerque 5-8606

**SEATTLE, WASH.**  
G. B. Miller Co.  
Lander 3320

**CANADA**  
Measurement Engineering Ltd.  
Arnprior, Ont., Phone 400  
Toronto, Ont., Mayfair 8860

**EXPORT**  
Rocke International Corp.  
13 East 40th St., N. Y. 16, N. Y.  
Murray Hill 9-0200

Force Base, Ohio.

Present equipment provides automatic control instruction for 14 aircraft simultaneously. The equipment selects for each aircraft the earliest possible time of arrival consistent with speed of the aircraft and which does not conflict with other planes already scheduled.

An automatic device continually computes control orders for each aircraft so that it will arrive on schedule within a precise interval. The computer accomplishes this spacing by heading control, which comprises automatic issuance of minor offset headings for the aircraft to fly when it is necessary that it be delayed.—G.T.M.

## Dynamic Characteristics of Triode-Connected Pentodes

By ALEXANDER J. DESSLER and  
H. G. ROBINSON  
*Duke University  
Durham, North Carolina*

APPROXIMATION formulas accurate to within 20 percent are given in this article for the  $\mu$ ,  $g_m$  and  $r_p$  of triode-connected pentodes utilizing

## Faster Radiosonde

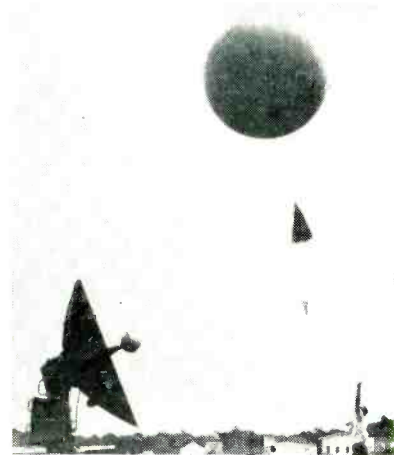

Weather information can be collected quickly using radio sounding apparatus carried by a new type of balloon. Made of neoprene, the new balloons can be inflated with 300 cu ft of hydrogen and will rise at 1,800 ft a min until they burst at about 15 miles. Conventional types rise at 1,000 ft a min. Advantage of the newer technique is that pressure, temperature and humidity data can be received before the balloon, which also indicates wind direction and velocity at various levels, is blown beyond the range of reception.



Pye Telecommunications announce a

# NEW TWO-WAY RADIO EQUIPMENT

Demonstrations of a new equipment, designed in Cambridge, have been given in London recently to representatives of Police and Fire Services, Local Authorities and Industrial Organisations. This equipment has been designed to defeat the chronic shortage of two-way radio channels.

**Known as the Pye "Ranger" it is the solution to the frequency shortage which is hamstringing mobile radio users in Great Britain!**

The new equipment operates on a channel spacing of only 25Kc/s—a quarter of the customary spacing—thus potentially quadrupling the number of mobile radio channels. Robust construction, excellent performance and carefully selected components make it capable of operating under arduous conditions and in any weather.

This mobile radio is designed for fitting in the dashboard of ordinary cars and vehicles. The price of the equipment, notwithstanding its many-times improved specification, is approximately the same as that of earlier equipments which it now replaces.

*Please write for full details*



## Telecommunications

Pye (New Zealand) Ltd.  
Auckland C.I., New Zealand  
Pye Radio & Television (Pty.) Ltd.  
Johannesburg  
South Africa

Pye Canada Ltd.  
Ajax, Canada  
Pye Limited  
Mexico City

Pye Pty., Ltd.  
Melbourne, Australia  
Pye Limited  
Tucuman 829  
Buenos Aires

Pye (Ireland), Ltd  
Dublin, Eire  
Pye Corporation of America  
270 Park Avenue  
New York

**PYE LIMITED**

**CAMBRIDGE**

**ENGLAND**

Phone: Teversham 311



**Best way to get authoritative answers on your flexible shaft problems**



Call in an S.S.White engineer when working out any problem involving flexible shafts. He has at his fingertips the accumulated knowledge of over a half a century of specialization in the design, manufacture and application of flexible shafting to all types of remote control and power drive set ups.



For instance, if you're working on a new design, he'll be able to save you valuable time in selecting the proper shaft, and can often make recommendations which will help cut costs and improve performance.

Even when it's a case of replacing shafts in an existing application, his help will prove invaluable in suggesting the correct shaft for the job, especially if you've been having difficulty with the old one.



Best of all, this advisory service costs nothing and entails no obligation. Its one purpose is to insure your getting the best in flexible shafting.

**Flexible shaft information for you...**



Bulletin 5306 has basic information and data on selection and application. Send for a copy. Address Dept. E.

**S.S.WHITE INDUSTRIAL DIVISION**  
10 East 40th Street, New York 16, N. Y.



**S.S. White**

**FIRST NAME IN FLEXIBLE SHAFTS**

F-12A.

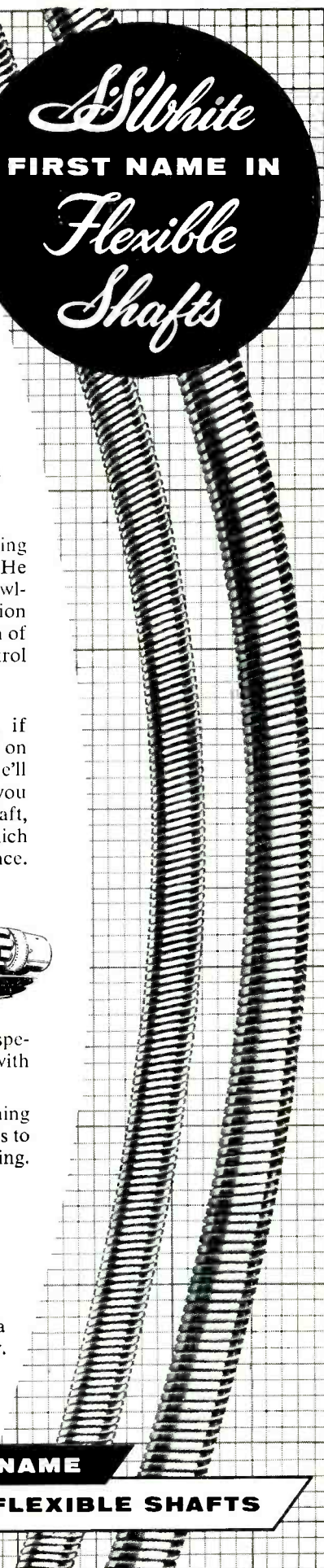

only readily obtainable pentode-connected data. A formula is also given for the dynamic screen-grid resistance of a pentode.

The formulas, based on the approximations that the characteristic curves are linear in the vicinity of the quiescent operating point and that the shielding of the screen grid essentially prevents changes in the plate voltage from affecting the cathode current, give the dynamic characteristic values for triode-connected pentodes:

$$g_{m,T} \approx \left(1 + \frac{I_s}{I_b}\right) g_m$$

$$r_{p,T} \approx \frac{E_s}{(I_b - g_m E_c) \left(1 + \frac{I_s}{I_b}\right)}$$

$$\mu_T \equiv \frac{g_m E_s}{I_b - g_m E_c}$$

$$\mu_T \approx (g_{m,T})(r_{p,T})$$

where

- $g_{m,T}$  = triode-connected transconductance
- $\mu_T$  = triode-connected amplification factor
- $r_{p,T}$  = triode-connected dynamic plate resistance
- $g_m$  = pentode-connected transconductance
- $I_s$  = d-c pentode screen grid current
- $I_b$  = d-c pentode plate current
- $E_s$  = d-c pentode screen grid voltage
- $E_c$  = d-c control grid bias (negative) or  $-R_k(I_b + I_s)$  when the cathode bias resistor,  $R_k$  is given.

The following is an example using the 6AK5 sharp-cutoff pentode. The pentode connected data for typical operation is obtained from the tube manual.

$$\begin{aligned} g_m &= 5,000 \text{ } \mu\text{mhos} \\ I_s &= 2.5 \text{ ma} \\ I_b &= 7.5 \text{ ma} \\ E_s &= 120 \text{ v} \\ E_c &= -R_k(I_s + I_b) \\ &= -180(10 \times 10^{-3}) = -1.8 \text{ v} \end{aligned}$$

$$g_{m,T} \approx \left(1 + \frac{2.5}{7.5}\right) 5,000 = 6,700 \text{ } \mu\text{mhos}$$

$$\mu_T \approx \frac{5,000 \times 10^{-6} \times 120}{7.5 \times 10^{-3} + 5,000 \times 10^{-6} \times 1.8} = 36$$

$$\begin{aligned} r_{p,T} &\approx \frac{120}{(7.5 \times 10^{-3} + 5,000)} \\ &\quad \times 10^{-6} \times 1.8 \left(1 + \frac{2.5}{7.5}\right) \\ &= 5,400 \end{aligned}$$

The plate voltage for triode operation should equal the pentode operated screen voltage; also the triode-connected control-grid bias should remain the same as that on the pentode.

Higher order correction terms added by more exact analysis were not included since for design pur-



# When Specifications Contain

## These

# Musts

### KEL-F PLASTIC

Hard, dense, molding thermoplastic with high impact, tensile and compressive strength. Resistant to chemical attack, heat and cold. Impervious to moisture, non-wettable, outstanding electrical characteristics. Applications include: terminals, tube sockets and bases, wire and cable insulation, connectors, transistor encapsulation.

### KEL-F DISPERSIONS

Finely divided plastic solid in volatile medium. Applied by spray, spread or dip coating. KEL-F Dispersions give metallic and other surfaces the corrosion resistance and non-adhesive, non-wettable characteristics of KEL-F plastic. Coating formed is dense, tough, chemically resistant. Applications include: component coatings, dielectric shields, insulation on instruments and apparatus.

### KEL-F OILS, WAXES AND GREASES

KEL-F Oils, Waxes and Greases are low molecular weight polymers. Resistant to chemicals, heat, cold, and are non-flammable. Oils are fluid at room temperature. Waxes are solid at room temperature. Greases are compounded from oils and filler. Lubricity of oils is equivalent to extreme pressure additive. Applications include: lubrication, hydraulic fluids, heat transfer, damping, potting.

### KEL-F ELASTOMERS

Highly resistant fluorocarbon elastomer for critical applications subject to corrosive conditions. Possess excellent elastomeric properties, flexibility at low temperature, stability at high temperatures up to 400°F., low moisture absorption. Processed on standard equipment, and can be molded and calendered.

Applications include: seals, valve diaphragms, industrial clothings, wire insulation, micro-switch coverings, gaskets, etc.

### KEL-F PRINTING INKS

Fluorocarbon base printing inks, are resistant to moisture, corrosive chemicals and gases, and abrasion. Produced in range of 10 colors. KEL-F Printing Inks are recommended for striping polyethylene, nylon and KEL-F wire insulation. Combining effectively with the substrate, they offer high performance under difficult conditions.

**ZERO MOISTURE ABSORPTION**

**CHEMICAL RESISTANCE** (acids, alkalis, gases, oxidants)

**THERMAL RESISTANCE** (—320° F. to 390° F.)

**NON-WETTABILITY**

**ANTI-ADHESIVE SURFACE...**

*With Superior Electrical Properties*

## INVESTIGATE THE **KEL-F**<sup>®</sup> FAMILY OF FLUOROCARBON PRODUCTS

KEL-F fluorocarbon products include thermoplastic molding compounds, Dispersions, Oils, Waxes, Greases, Elastomers and Printing Inks. Unique among commercial synthetics they provide the solution to difficult design and production problems when no other materials prove satisfactory.

Based on the extremely stable fluorocarbon molecule, KEL-F products are outstanding for their resistance to chemical corrosion, heat, cold and moisture. Because of their unique combination of properties they can help you make a better product . . . protect equipment against wear or deterioration . . . make possible improved product design . . . meet more rigid performance specifications.

Write for special literature covering your particular interests.



**THE M. W. KELLOGG COMPANY**  
Chemical Manufacturing Division, P. O. Box 469, Jersey City, N.J.  
SUBSIDIARY OF PULLMAN INCORPORATED

® Registered trademark of The M. W. Kellogg Company for its fluorocarbon polymers





Hand-split mica from selected grades is scarce—almost all imported.

Treated and untreated continuous machine-made sheet mica now freely available in capacitor grades

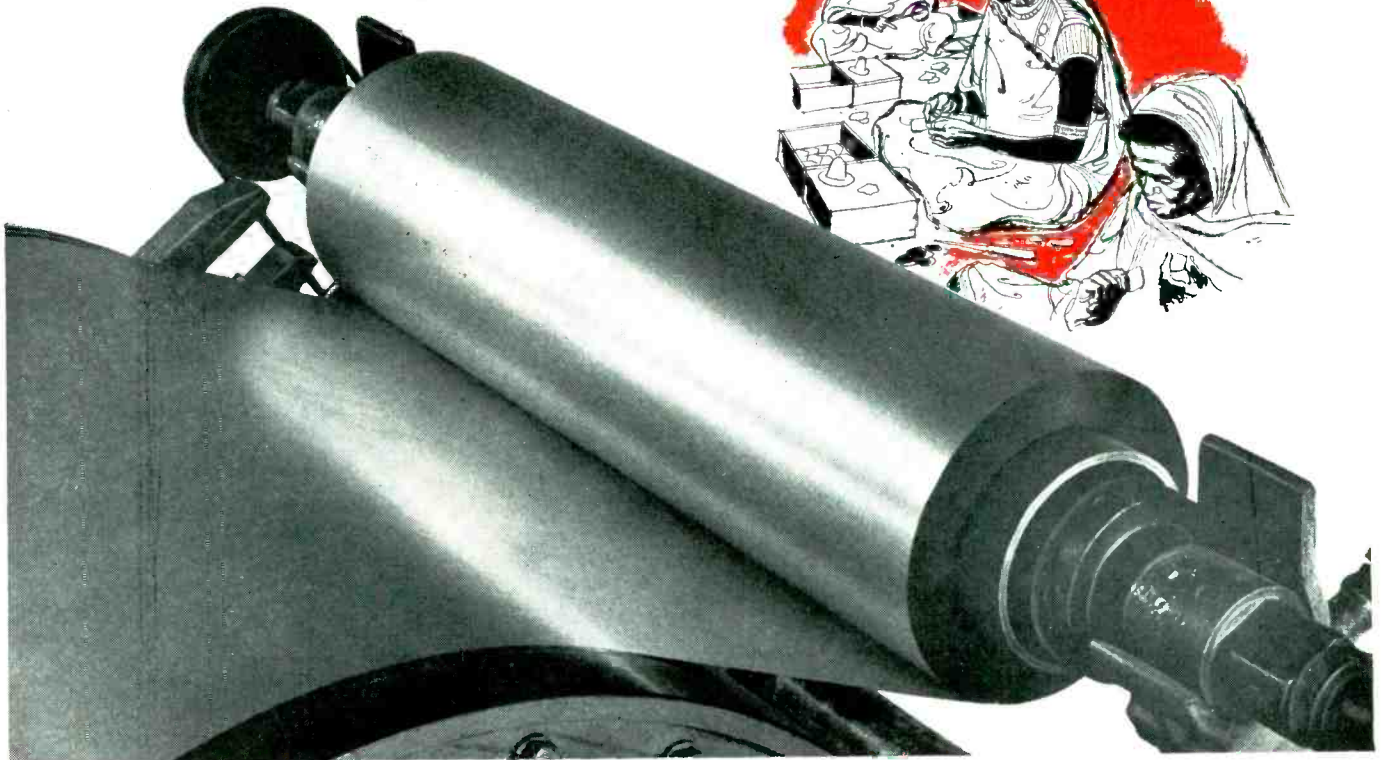

## Revolutionary new capacitor material offers cost savings up to 90%

... with improved performance in both stacked and rolled capacitors.

Two new products developed by Mica Insulator Company offer many important advantages, savings and new design opportunities in stacked and rolled capacitors.

These new materials are Capacitor Grade ISOMICA® and SAMICA® machine-made continuous, 100% pure mica. Capacitor Grade ISOMICA is treated and impregnated with special high-temperature resins. Capacitor Grade SAMICA is a manufactured continuous, pure mica product and may be impregnated by the user.

**Better stacked capacitors at lower cost.** Previously only high grades of costly natural mica could be used in stacked capacitors. Supply was, and

continues to be extremely limited. Capacitor Grade ISOMICA and SAMICA, available in unlimited quantities, may now be used in many stacked capacitor applications in jet aircraft ignition and electronic systems, as well as high-powered ground radar, etc. Use of these new materials makes possible stacked capacitors which are much less costly, easy to manufacture by automatic techniques.

**Better performance in rolled capacitors.** In rolled capacitors, organic paper and other materials used were subject to failure at high temperatures. Capacitor Grade ISOMICA and SAMICA make possible rolled capacitors that perform well over a wide temperature range . . . in many cases mean a reduction in size and weight for the same electrical rating.

**Important savings, opportunities.** Capacitor Grade SAMICA is freely available in sheets 36" wide, tapes or punched pieces. Capacitor Grade ISOMICA is available in sheets 36" x 36" or fabricated pieces. They offer you manufacturing economies and lower material costs, inventory savings, new design possibilities in both miniature and large sizes, better physical and electrical properties, and alleviate dependence on foreign sources of supply.

Mail This Coupon  
for Complete Technical Data

- Mica Insulator Company
- Schenectady 1, New York
- I am interested in your new Capacitor Grade ISOMICA and SAMICA.
- Please send technical data
- Please have Technical Service Representative call.

• Name \_\_\_\_\_

• Title \_\_\_\_\_

• Company \_\_\_\_\_

• Address \_\_\_\_\_



### MICA INSULATOR COMPANY

Schenectady 1, New York

Offices in Principal Cities

In Canada—Micanite Canada Ltd., Granby, Quebec

LAMICOID® Laminated Plastic • MICANITE® Built-up Mica • EMPIRE® Coated Fabrics and Papers • ISOMICA®

# PRECISION COIL BOBBINS ARE THE MOST WIDELY USED in the ELECTRONIC INDUSTRY . . . .

## Here's why:

- 1** PRECISION patents covering bobbin constructions give guaranteed protection against infringements.
- 2** Many tools are available to fit standard laminations, solenoids and relay brackets.
- 3** Low initial tooling and tool revision charges.
- 4** Less rejects—no parting line flash to break wire during winding. No cold flow.
- 5** Will not shatter under thermal expansion or physical shock.
- 6** PRECISION combines materials to solve your mechanical, dielectric, temperature or moisture problems.

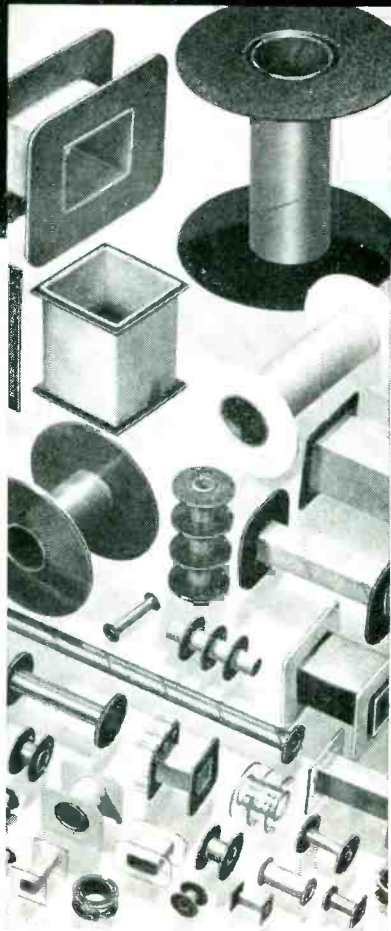

PRECISION Bobbins are available in any size, round, square or rectangular. Cores fabricated from dielectric kraft, fish paper, acetate, Resinite, quinterra or combinations, including Mylar\*. All orders to customer specifications.

\*DuPont trademark

## Plus the Most Complete Coil Form Service Available!

### Square and Rectangular Tubes

Any length, shape, size, I.D. or O.D.

### Round Tubes

Any decimal size up to 8" I.D.

### Resinite Coil Forms

Highest resistivity of any resinated product.

### Bobbins

Round, square or rectangular.

### Mandril Service

Accurately ground mandrils at low cost.

### Fabricating Service

Complete facilities to meet any customer requirement.

### Sales Representatives in:

New England: Framingham, Massachusetts, Trinity 3-7091  
Metropolitan New York, New Jersey:  
Jersey City, New Jersey, Journal Square 4-3574  
Upstate New York: Syracuse, New York, Syracuse 4-2141  
Northern Ohio, Western Penn.: Cleveland, Ohio, Atlantic 1-1060  
Indiana, Southern Ohio: Logansport, Indiana, Logansport 2555  
California: Pasadena, California, Sycamore 8-3919  
Canada: Montreal, Quebec, Canada, Walnut 0337

SEND FOR BULLETIN  
AND ARBOR LIST

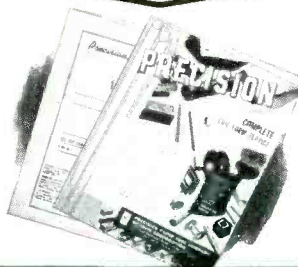

**PRECISION PAPER TUBE COMPANY**  
2041 West Charleston Street, Chicago 47, Illinois  
Plant No. 2: 79 Chapel Street, Hartford, Conn.

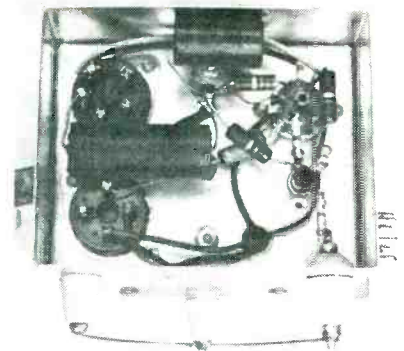

Loop is shown mounted on side of transmitter box (bottom of photograph)

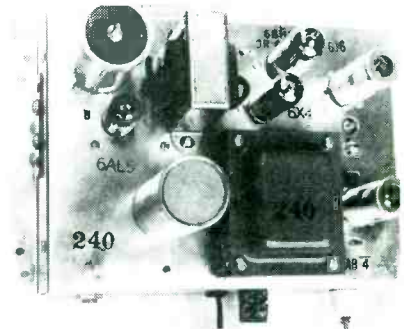

Receiver that is actuated by 7-ke modulation. Equipment is mounted near door-operating motor under a dust cover

ent available radio signals. Frequencies in the same neighborhood can be staggered to avoid false operation of adjacent systems.

Besides a radio-frequency tuning control (not shown in detail) in Fig. 1, there is a plug-in audio oscillator circuit to match the discriminator in the receiver. Power is obtained from a vibrator power supply connected to the car battery.

The receiver, Fig. 2, depends both upon reception of a radio-frequency signal to which the receiver is tuned and output from an audio discriminator to operate a relay that actuates the door motor. The power supply (not shown) is conventional.

## One-Man TV Camera Aligner

By W. L. SHEPARD  
General Electric Co.  
Electronics Park  
Syracuse, N. Y.

ADJUSTMENT of either a black and white or color camera requires setting the alignment controls. This requires that the beam-focus voltage be rocked through focus setting. Normally this involves a manual adjustment at a point remote



# BENDIX-PACIFIC SPECIALIZES IN AIRBORNE RADAR

## WHICH IS YOUR RADAR REQUIREMENT?



**TERRAIN  
CLEARANCE  
RADAR**



**NAVIGATIONAL  
RADAR**



**TAIL-WARNING  
RADAR**



**MISSILE  
GUIDANCE**



**MAPPING  
RADAR**



**RADAR  
BEACONS**

**Bendix-Pacific** specializes in airborne radar, having design experience and manufacturing ability to develop and produce radar systems to meet your requirements.

*Let us send a qualified radar systems engineer to visit you at your convenience.*



**EAST COAST OFFICE:** 475 5th AVE., N.Y. 17 • **DAYTON, OHIO**—1207 AMERICAN BLDG., DAYTON 2, OHIO • **WASHINGTON, D.C.**—SUITE 803, 1701 "K" ST., N.W.  
**CANADIAN DISTRIBUTORS:** AVIATION ELECTRIC, LTD., MONTREAL 9 • **EXPORT DIVISION:** BENDIX INTERNATIONAL, 205 E. 42nd ST., NEW YORK 17

# News in Analog Computing . . .

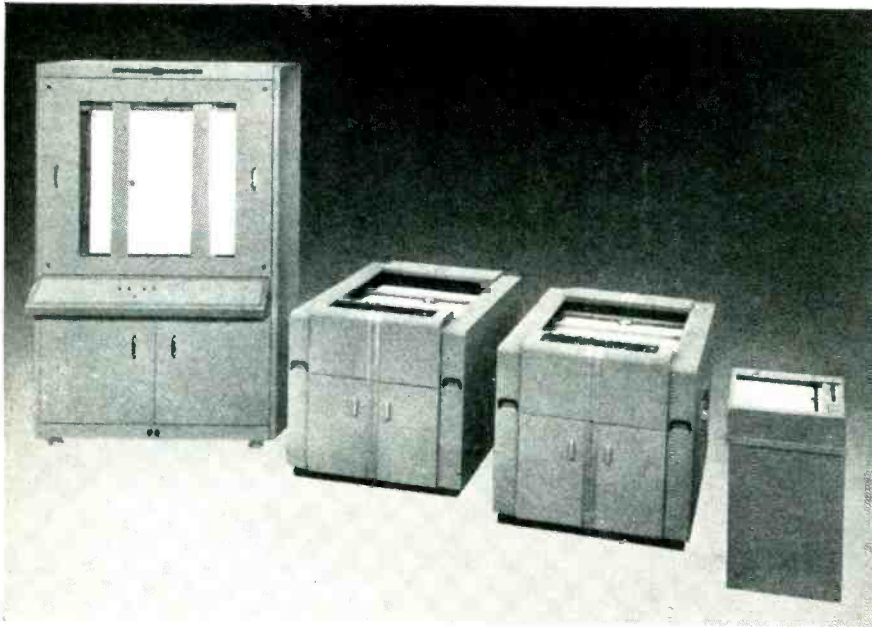

## A choice of Plotting Boards . . .

A Chicago business analyst reports engineers and industries must have versatility in equipment selection, if they are to carry out the expanded research programs planned for 1956.

Foreseeing this, Electronic Associates is making available the only complete line of plotting boards. Four different models of the famous Variplotter Plotting Board, designed to give a rapid, accurate, graphic recording of any information that can be reduced to electrical form.

Reading from left to right in the picture above, there is the vertical Variplotter, Model 205J, with two arms and four pens . . . the horizontal Variplotter Model 205 K, with one arm and one pen . . . the horizontal Variplotter Model 205L, with two arms and two pens . . . and the latest Variplotter, the Model 1100 A, with one arm and one pen, and featuring small, convenient size, outstanding performance, and low cost.

For detailed information on Variplotter plotting boards, Precision Analog Computing Equipment, or rental of time at the EAI Computation Center in Princeton, New Jersey, contact Dept. EL-14. Electronic Associates, Inc., Long Branch, New Jersey.

from the camera, requiring a second man at this remote point.

A simple circuit used in some equipment automatically eliminates the necessity for manual rocking of the beam focus. Thus the need for two men to perform the adjustment procedure is eliminated.

The circuit requires few parts. When switch  $S_{1A}$  is turned to the on position, voltage is applied to the circuit and the short across  $R_1$  is removed. Capacitor  $C_1$  charges through  $R_1$  until a voltage high enough to fire the neon bulb is reached. Then  $C_1$  is discharged through the bulb. The time constant of  $R_1$  and  $C_1$  determines the number of times per second that the beam focus is rocked through the focus position.

The resultant sawtooth is then applied to  $C_2$  through  $R_2$ . This results in a partial integration of the sawtooth to produce a triangular waveform. This waveform is then applied through  $R_3$  and  $C_3$  to  $R_4$ . Resistor  $R_3$  serves to isolate the circuit and divide the voltage to obtain the correct swing of the beam focus. The triangular waveform superimposed on the correct direct voltage causes the beam focus to go in and out of focus.

The values given will cause the beam focus to rock completely through focus approximately twice a second. This rate can be adjusted easily by changing the values of either  $C_1$  or  $R_1$ .

It is necessary, when installing this device, to use shielded wire for any long leads going to the image orthicon tube. This prevents any tendency for feedback.

To use this device it is only necessary to adjust the beam focus voltage for best focus. Then switch  $S_1$  is turned on. After the alignment procedure is completed, the switch is turned off and the camera then functions normally.

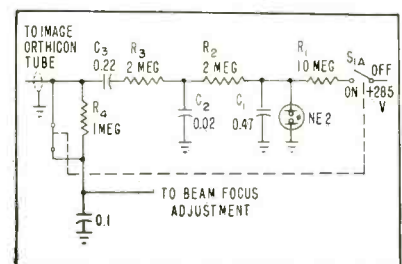

Circuit of the focus adjustment unit that can be mounted in the television camera



E A I S E T S T H E P A C E

PRECISION ANALOG COMPUTING EQUIPMENT

LONG BRANCH, NEW JERSEY



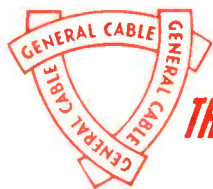

**THE GREATEST NAME IN ELECTRICAL WIRE AND CABLE**

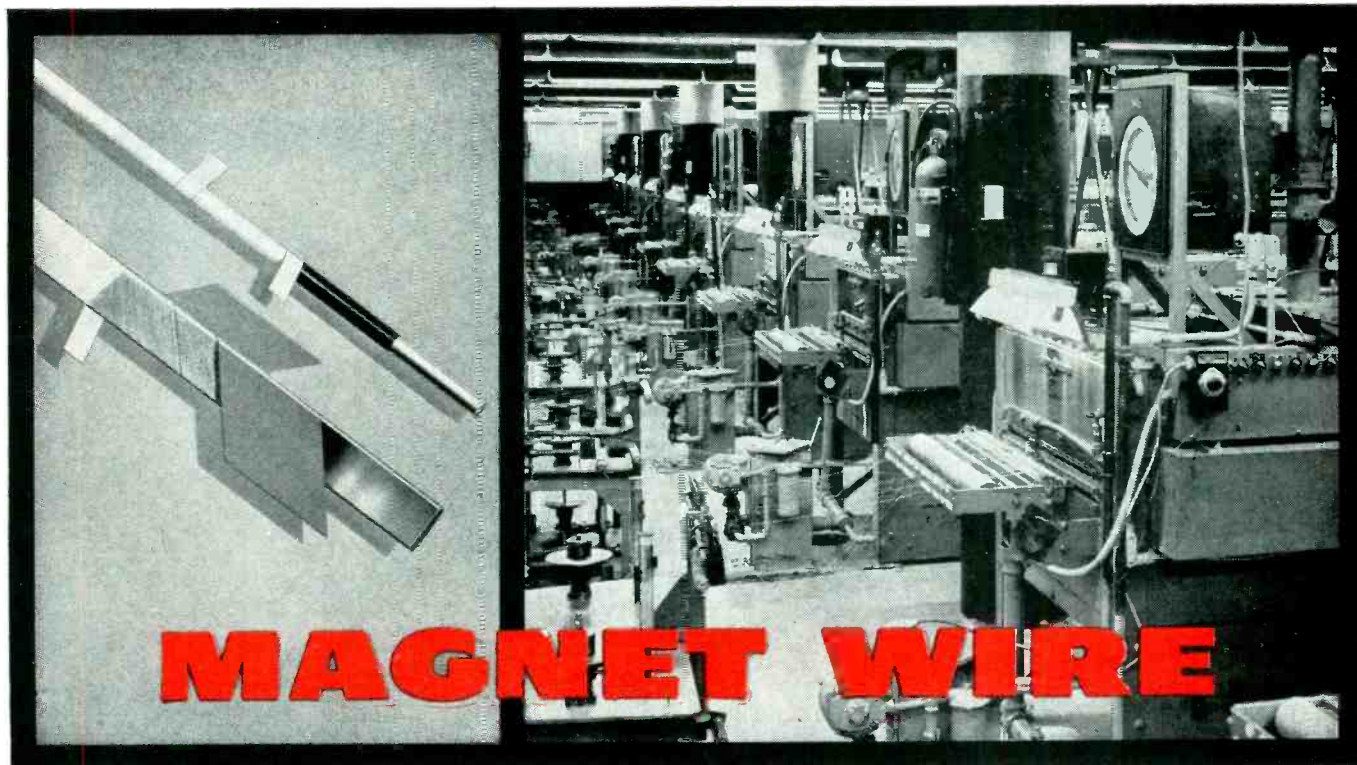

Modern methods assure product uniformity.

It takes a unique combination of modern production facilities, rigid quality control techniques and skilled workers to make *consistently* top quality magnet wire...and General Cable has it! That's why General Cable magnet wire is noted throughout industry for its extraordinary uniformity...providing the ultimate in high level performance.

Important, too, General Cable can always supply you with *exactly* the magnet wire you want...when you want it! They make every type, shape and size:

Formvar, Plain Enamel, Nylon Enamel, Silicone, and other synthetic enamels, with light, intermediate or heavy coatings.

Cotton, Paper, Silk, Nylon, Glass and Special High Temperature Covering with single and double wrappings, similar and dissimilar materials.

*Plus* bonded paper and glass, or other specialized types. You name it and General Cable makes it... and makes it *right!* So look to General Cable for *all* your electrical wire and cable needs!

## **GENERAL CABLE** CORPORATION

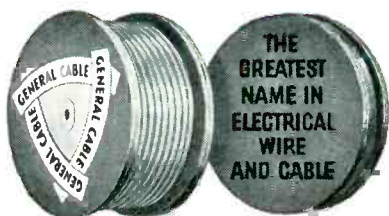

**BARE, WEATHERPROOF, INSULATED WIRES and CABLES FOR EVERY ELECTRICAL PURPOSE**

**GENERAL CABLE CORPORATION**  
*Executive Offices: 420 Lexington Ave., New York 17, N. Y.*

**SALES OFFICES:** Atlanta • Baltimore • Boston • Buffalo  
Chicago • Cincinnati • Cleveland • Dallas • Dayton • Denver  
Detroit • Erie (Pa.) • Greensboro (N. C.) • Houston  
Indianapolis • Kansas City • Lincoln (Neb.) • Los Angeles  
Memphis • Milwaukee • Minneapolis • New Haven • New  
Orleans • Newark (N. J.) • New York • Philadelphia  
Pittsburgh • Portland (Ore.) • Richmond (Va.) • Rochester  
(N. Y.) • Rome (N. Y.) • St. Louis • San Francisco  
Seattle • Springfield (Ill.) • Syracuse • Tampa • Tulsa  
Washington (D. C.)

## Plug-In Assemblies Use Standard Component Bodies

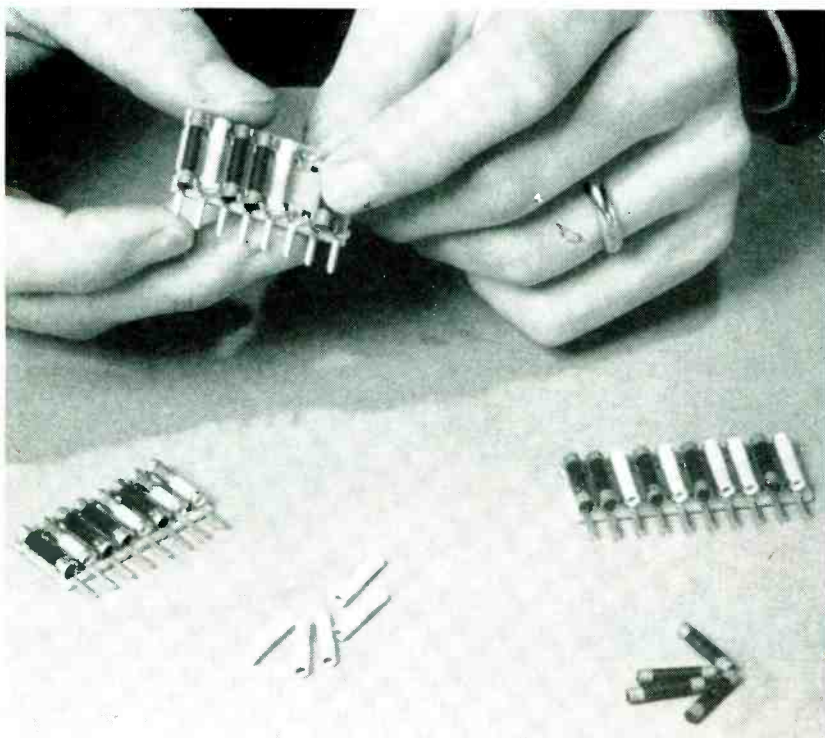

During development of a new design, engineer can make up own module by snapping components into clips, then soldering clips conventionally



Finished modules are easily inserted in punched holes of etched wiring board

PACKAGED SUBASSEMBLIES of standard composition resistors and tubular ceramic capacitors, mass-produced at an overall cost approximating that of individual components, have been announced by Erie Resistor Corp. Called PAC, for Pin Assembly Circuit, the new modules can be plugged into holes of etched-wiring boards either manually or by machine, for lower-cost tv and radio sets as well as computers, industrial controls and other military and commercial electronic equipment.

► **General Details**—The mounting base used for each module is XXXP copper-clad paper-base phenolic. Sprocket-like terminal holes are punched along both sides of long strips of the material. The strips can later be chopped into shorter lengths holding up to 92 components. After applying embossed wiring to one side of the base for

interconnections, terminals are installed on the other side by automatic machinery, to make contact through the board with the embossed wiring.

The terminals are like miniature fuse clips, for holding cylindrical leadless standard component bodies. One row of terminals has integral terminal pins. The components are pushed into these clips and the edges of the board are dipped in solder, after which the assembly is given a dipped or molded plastic jacket.

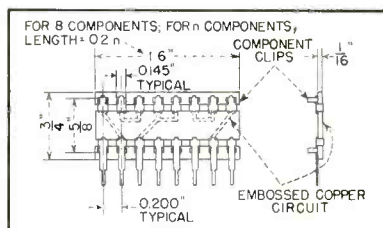

FIG. 1—Base and terminal dimensions

► **Dimensions**—The new modular assembly is based on use of uniform components  $\frac{1}{8}$  inch in diameter and  $\frac{3}{8}$  inch long. These outline dimensions have been standard for ceramic tubular capacitors and composition resistors for many years. Other components having these dimensions can be used equally well.

A standard center-to-center spacing between components of 0.200 inch has been selected, as shown in Fig. 1. This spacing provides maximum utilization of space, with corresponding economy of production cost both for the modules and the finished electronic equipment.

Resistors available for these dimensional requirements are rated at  $\frac{1}{2}$  watt and 500 volts with tolerances of 5 percent or wider in values from 5 ohms to 50 megohms. Back-of-board wiring readily permits connecting components in series or parallel for higher wattage ratings. Capacitors are available





going...

going...

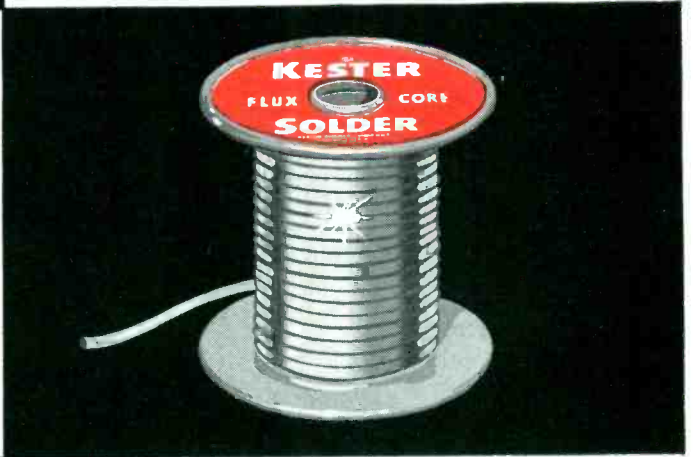

gone!



**KESTER "44" RESIN, PLASTIC ROSIN AND "RESIN-FIVE" FLUX-CORE SOLDERS** owe their production line popularity to the simple fact that they provide the exactly right solder for every soldering application. It's not difficult to realize why Kester is consumed so rapidly . . . because of its great adaptability to so many different soldering operations.

**SEND TODAY** for Kester's new 78-page informative textbook "SOLDER . . . Its Fundamentals and Usage."

# KESTER SOLDER

**COMPANY** 4204 Wrightwood Avenue, Chicago 39, Illinois; Newark 5, N. J.; Brantford, Canada

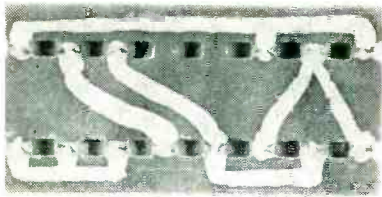

Embossed wiring on back of base

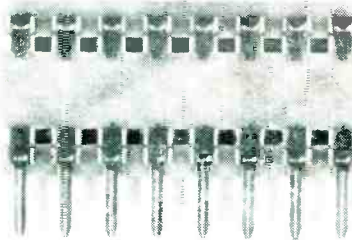

Front view of base after staking pins

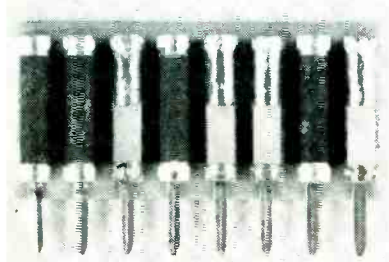

Appearance after installation of component bodies and dip-soldering

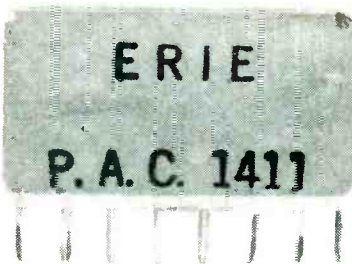

Finished module in plastic jacket

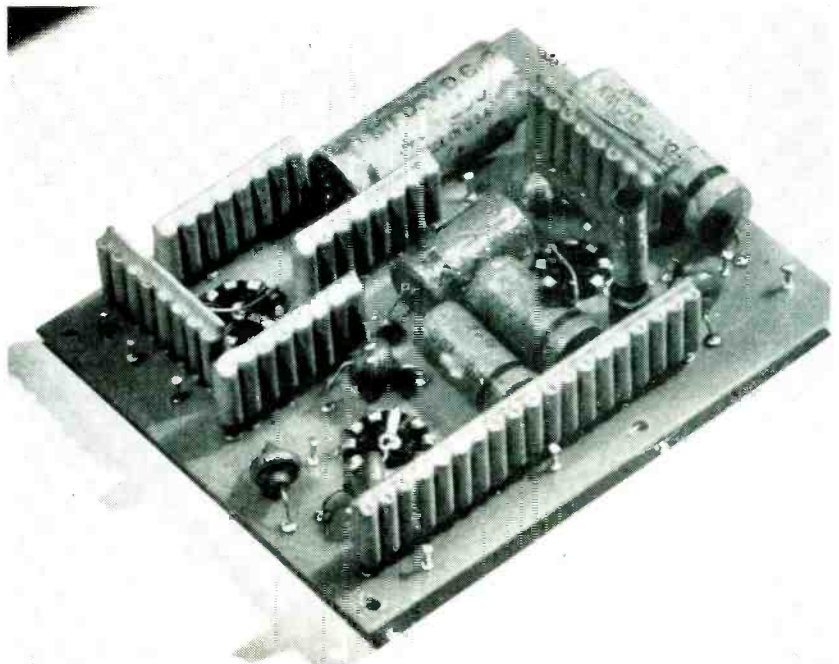

Six of the new modules replace 53 individual components on this etched wiring board, reducing the original 69 insertion operations to only 16

in the range of 1 to 5,100  $\mu\text{f}$ .

► **Advantages**—Since each circuit element is individually made and tested prior to assembly, no compromises in characteristics and tolerances are needed. Tolerances can be as close as those available for individual components.

Individual capacitors mean complete diversity in selecting values and temperature characteristics. The same module can include low-capacitance temperature-compensating units and high-capacitance bypass units.

Since the components are mounted vertically with respect to the etched-wiring chassis, area requirements on the wiring board are greatly reduced. A pin-assembly circuit containing 15 components

occupies only 1 sq in. of chassis area.

Design engineers can be supplied with mounting-base samples with clips attached. These, together with kits of resistor and capacitor bodies in a wide range of values, facilitate experimental breadboard layouts.

After a circuit is tooled and being produced, component value changes merely involve substituting new parts at the assembly station.

The laminated phenolic base strip insures against breakage in shipping and handling. Terminals are firmly staked to the base.

► **Wiring**—Connections between components are facilitated by embossing the copper wiring on the back of the base. This process is



Long strip has components in position before cutoff. At lower left is section cut from strip and at right is finished module



# The Only COMPLETE Line...

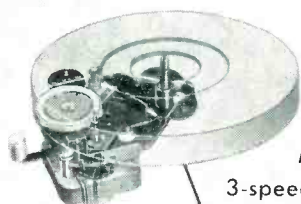

Model SS  
3-speed, 2-pole motor

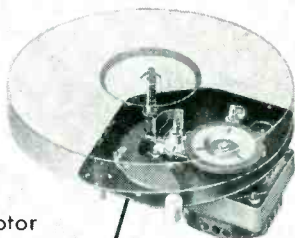

Model DSS  
3-speed, 4-pole motor

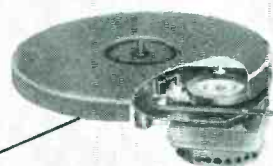

Model DR  
2-speed,  
4-pole motor



Model AX  
Single speed,  
2-pole motor



Model RM 4  
Single speed,  
4-pole motor

Model D-10  
4 pole, shaded pole AC  
Induction type for  
tape, wire or disc  
recorders

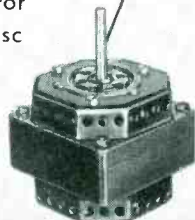

**GI**  
*Smooth Power*  
**PHONOMOTORS**

- FOR PORTABLE PHONOS
- FOR HI-FI UNITS
- FOR COMBINATIONS
- FOR RECORD CHANGERS
- FOR TAPE RECORDERS
- FOR REPLACEMENT USE
- FOR EVERY PHONO APPLICATION

Follow the lead of America's foremost manufacturers — Specify GI for all your phonomotor needs. A complete range of speeds and types to meet every requirement — backed by over half a century of design leadership!



**THE GENERAL INDUSTRIES CO.**

DEPARTMENT GA • ELYRIA, OHIO

Designed for



Application

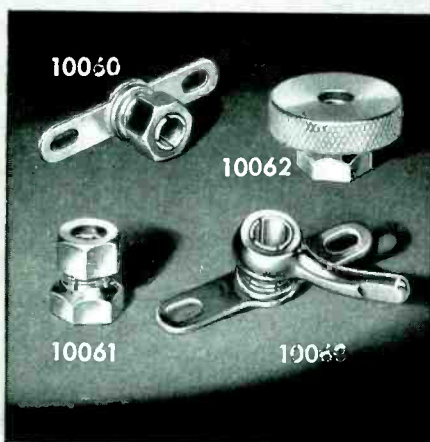

### SHAFT LOCKS

In addition to the original No. 10060 and No. 10061 "DESIGNED FOR APPLICATION" shaft locks, we can also furnish such variations as the No. 10062 and No. 10063 for easy thumb operation as illustrated above. All types are available in bright nickel finish to meet Signal Corps requirements or black oxide to meet Navy specifications.

**JAMES MILLEN  
MFG. CO., INC.**

MAIN OFFICE AND FACTORY  
MALDEN  
MASSACHUSETTS

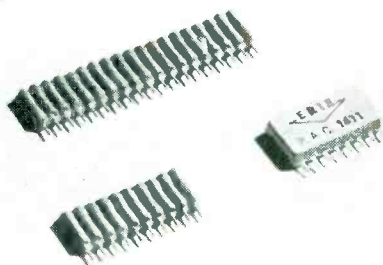

Comparison of dip-coated and molded packaging for modules

unique in that no chemicals are used in preparation of the circuit. The desired pattern of wiring is punched below the surface of the copper-clad laminate. Unwanted surface copper is then ground off to leave the wiring. Either 1-oz (0.00135-inch) or 2-oz (0.0028-inch) electrolytic copper foil is used.

Terminals are tinned flat stock having an enlarged portion near the unit to serve as an automatic stop for mounting. Dip-soldering gives intimate noise-free contact between terminals, contact clips, wiring and components.

The adhesive bond used with the laminate will withstand solder-dip temperatures up to 570 F for 2 seconds immersion or 500F for 10 seconds without causing blistering or weakening of the bond. When

tested before soldering in accordance with NEMA standards, a peel strength of 6 to 8 lb is obtained.

Minimum line width and spacing is  $\frac{3}{32}$  inch. Large conductor areas such as shields and grounds can be embossed if broken by picket-fence barriers.

After soldering, the unit is dipped or molded into a jacket of plastic for environmental protection and ease of manual or automatic handling. Finished dimensions are shown in Fig. 2.

PAC units are designed primarily for use with etched wiring boards. Components for one or several stages can be inserted in one plugging-in operation. If done manually, labor costs are drastically reduced as compared to individual insertion of components. If automatic insertion equipment is used, the number of insertion heads is correspondingly reduced.

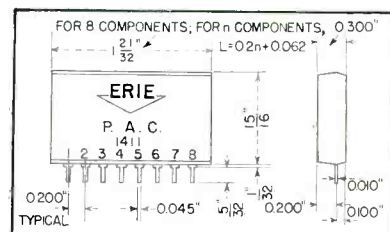

FIG. 2—Dimensions of finished unit and method of marking

## Toothpicks Screwdrivers for Fragile Cores

WHEN SCREWDRIVERS snapped slot shoulders of sintered-iron cores during factory test adjustments in small coils for airborne radar, Fred Olney suggested using common toothpicks which would twist be-



Using toothpick to adjust sintered iron core while measuring inductance at production test setups



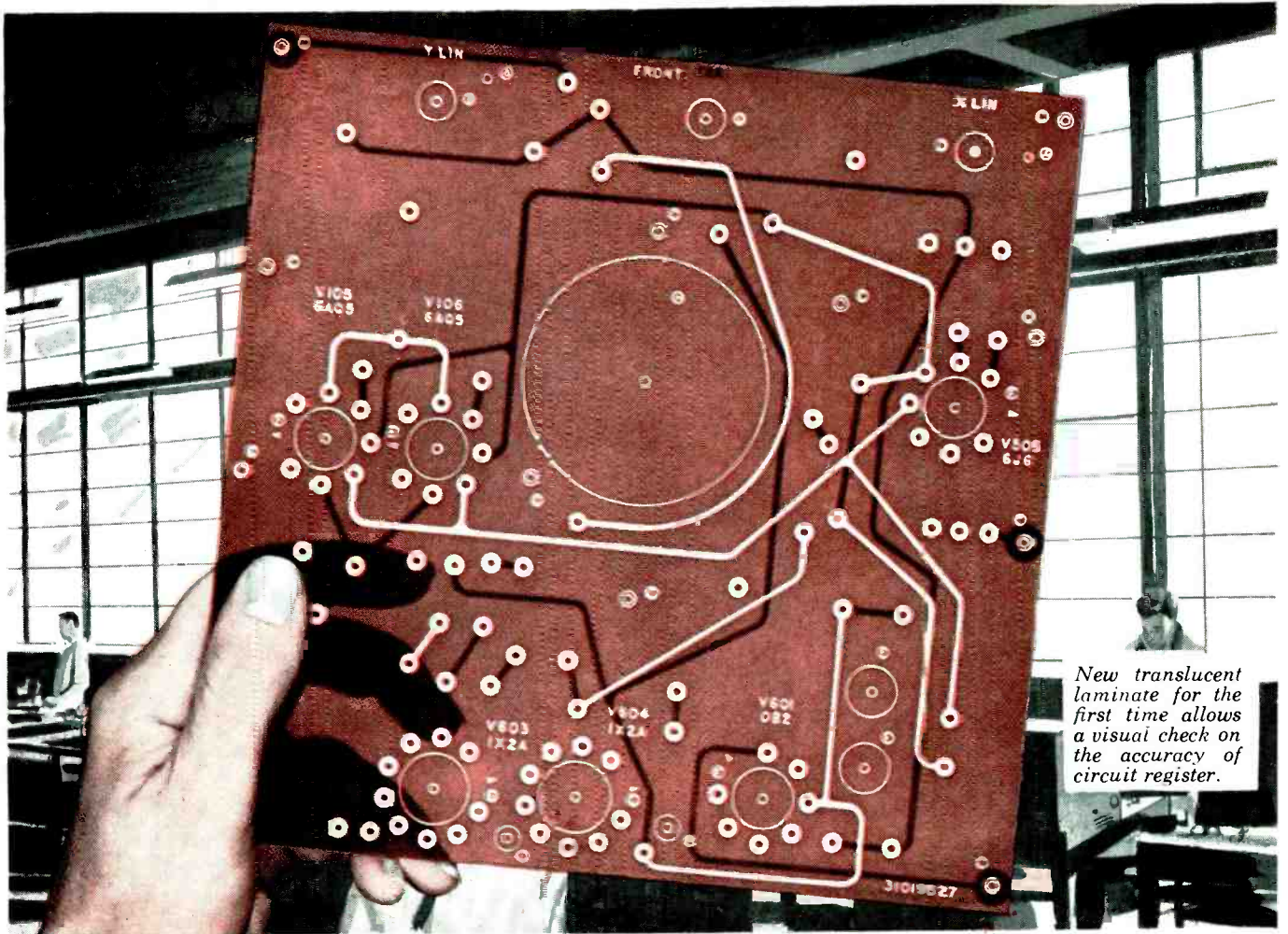

## Formica Research perfects sensational new cold punching laminate

*Brings 1,000,000 megohms resistance value, precision and translucency to printed circuitry . . . .*

Research, an important part of the exclusive new Formica 4-point service, has just perfected a new cold punching paper base laminate offering 1,000,000 megohms insulation resistance and valuable new translucent properties.

Known as XXXP-36, the new grade brings greater accuracy to printed circuitry. Because of its cold punching qualities, XXXP-36 requires no heat cycle. Therefore, the base laminate is not subject to dimensional

change as in grades which must be heated before punching. This means that with Formica XXXP-36, you can now produce printed circuits with new and higher standards of accuracy.

XXXP-36 translucency can be doubly useful. Make this simple test: hold it to the light. You can see (1) the smooth, homogenous structure, the total absence of resin pockets, voids and imperfections that dissipate the insulating properties of ordinary paper base

laminates . . . and (2) how perfectly the circuit on one side registers with that on the other. New XXXP-36 is ideal for terminal boards and tv insulators requiring high I. R. Formica's engineering skill can help you find new materials for new products and processes. For complete information on the new XXXP-36, or on the new "Formica-4" service, use coupon below. The Formica Co., 4640 Spring Grove Ave., Cincinnati 32, Ohio.



FORMICA®—the most famous name in laminated plastics—Engineered for industry, Beauty Bonded for the home.

Make the Formica Translucency Test. Send for a sample XXXP-36 printed circuit. Fill out and mail coupon today.

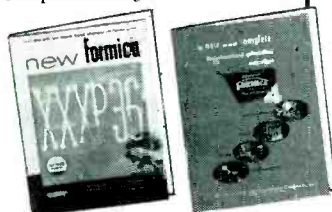

Gentlemen:

- I'd like a sample XXXP-36 printed circuit and complete information on this new grade.
- Send bulletin showing how I can take advantage of the new "Formica-4" laminated plastics service.

Name \_\_\_\_\_

Company \_\_\_\_\_ Title \_\_\_\_\_

Address \_\_\_\_\_

City \_\_\_\_\_ Zone \_\_\_\_\_ State \_\_\_\_\_



fore they snapped the shoulders and ruined the coils. The idea brought him a \$225 suggestion award at General Electric's Light Military Electronic Equipment Dept. in Utica, N. Y.

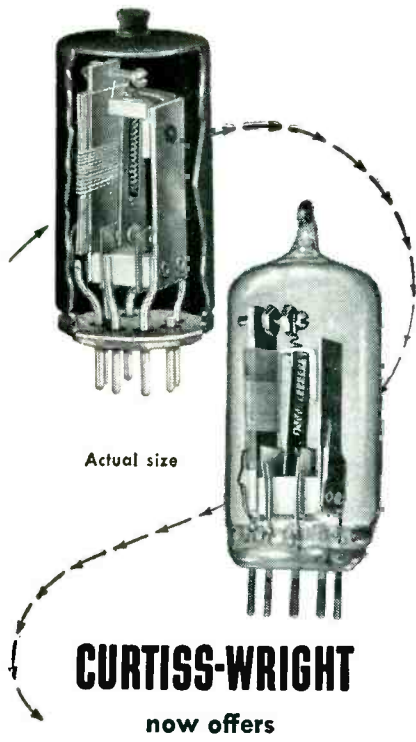

**CURTISS-WRIGHT**

now offers

## THE "SNAPPER" THERMAL TIME DELAY RELAY

Relied on for positive action and long life in scores of applications involving time delay in electrical circuits, the "SNAPPER," formerly produced by Elly Electronics Corp., is now a Curtiss-Wright product.

Single pole, double throw contact action eliminates chatter. These unique relays feature snap action, double throw, reliability, small size. They are adaptable to military and commercial applications. Time delay periods: preset from 3 seconds up. Envelope: metal, miniature (7 and 9 pin) or octal (8 pin). Glass, 9 pin only.

### High-Low Differential Thermostat

The "SNAPPER" Thermostat is a single pole, double throw snap action temperature sensitive switch. Its snap action principle has been extended to provide a low differential thermostat with precision characteristics, at low cost.



Write for detailed data



## Router Cuts Curves In Wiring Boards

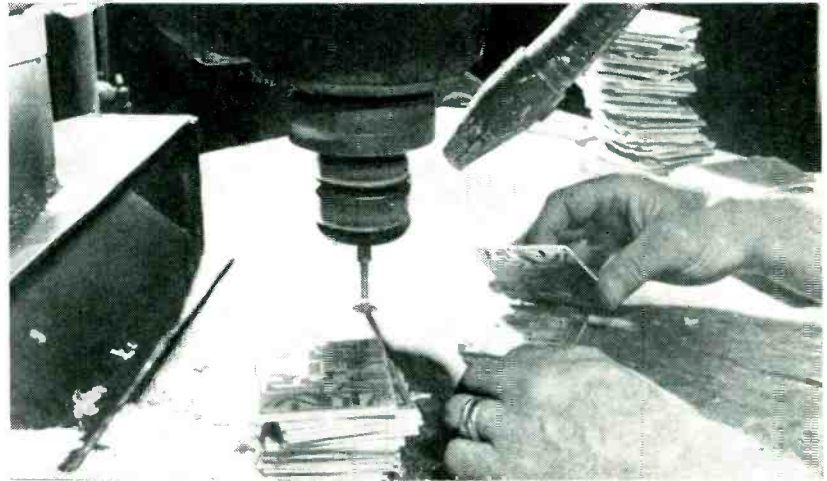

Placing board on template. Dust-collecting duct is at left of router

FINISHED etched wiring boards are cut to irregular shapes with the aid of a unique production setup involving a steel template and a router, in the Glen Cove, N. Y. plant of Photocircuits Corp. Each board in turn is placed over two positioning pegs on the template and the combination is then run

directly under the router on the table of the machine serves as a stop for the template to give the required shape of cut without dulling the cutter through contact with the template.

A stream of compressed air is directed at the router to blow cut particles into a vacuum collecting duct just behind.

## One-Way Pallet-Return Conveyor

WHEN a new radio assembly line was first set up in Westinghouse's Metuchen, N. J. plant, delays were caused by the return of empty pal-

lets to the start of assembly lines. With benches and equipment already installed, overhead and aisle space was at a minimum for me-

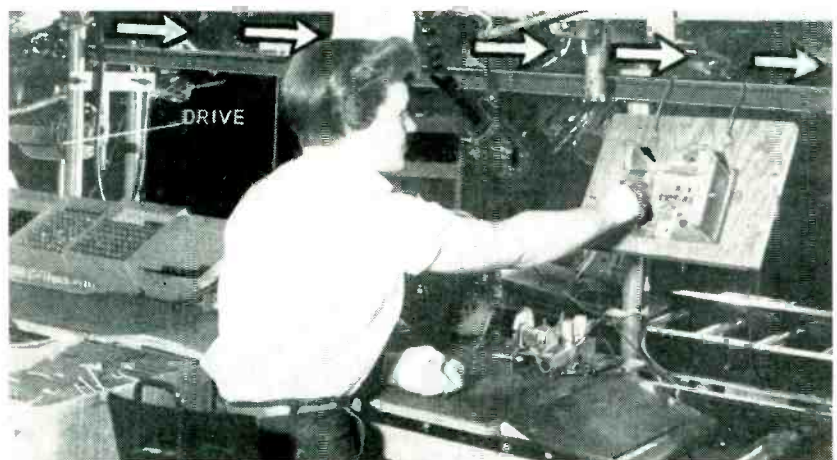

Hooks of empty pallet ride on rotating screw of monoflow conveyor



*Speed up  
production with*

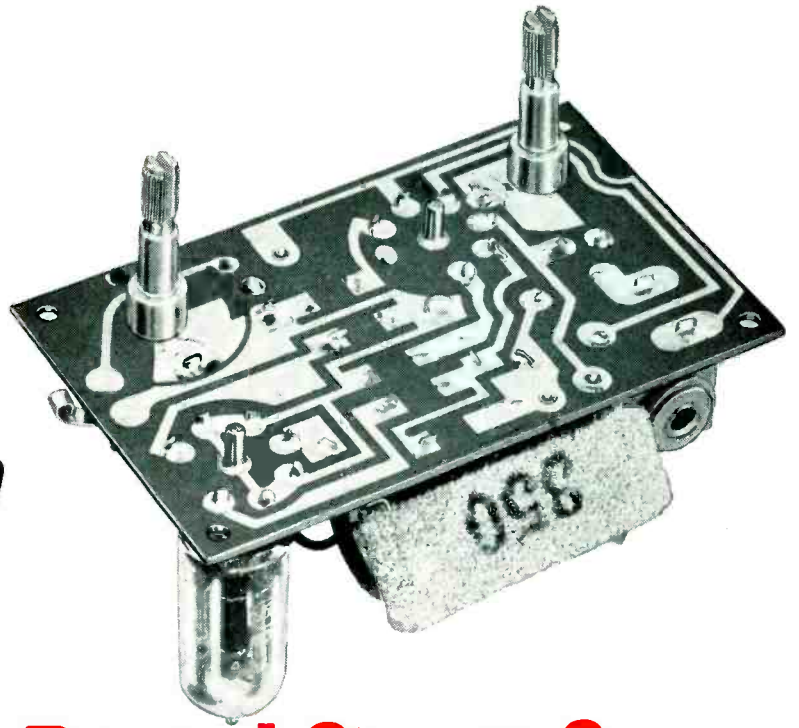

## REVERE ROLLED Printed Circuit Copper

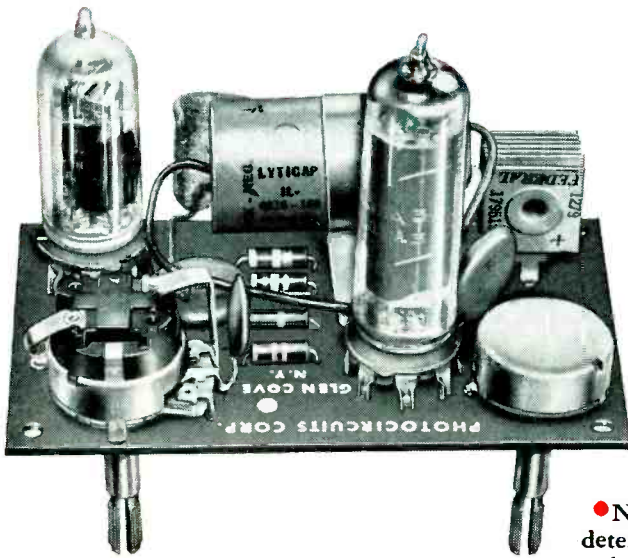

Audio amplifier unit by Photocircuits Corp., Glen Cove, N. Y., using Revere Rolled Printed Circuit Copper.

*Available  
NOW!*

• Now that Revere *Rolled* Printed Circuit is available, nothing need deter you from switching to printed circuitry. This copper is supplied to laminators in standard coils of 350 lbs., in widths up to 38", and in .0015" and .0027" gauges, weighing approximately 1 oz. and 2 oz. per square foot.

High in conductivity, uniformly dense through and through and side to side, Revere *Rolled* Printed Circuit Copper is easily etched and soldered.

When ordering blanks from your laminator, specify Revere *Rolled* Printed Circuit Copper.

# REVERE

**COPPER AND BRASS INCORPORATED**

Founded by Paul Revere in 1801  
230 Park Avenue, New York 17, N. Y.

Mills: Baltimore, Md.; Brooklyn, N. Y.; Chicago, Clinton and Joliet, Ill.; Detroit, Mich.; Los Angeles and Riverside, Calif.; New Bedford, Mass.; Newport, Ark.; Rome, N. Y.  
Sales Offices in Principal Cities, Distributors Everywhere.

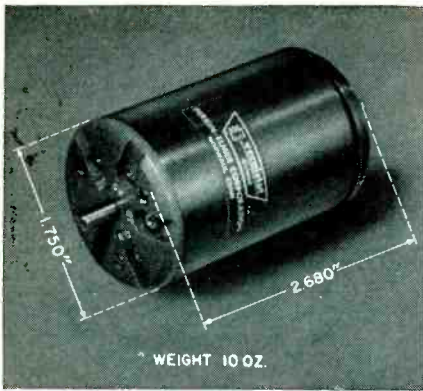

**NEW...the 400 cycle  
vernistat\*  
a.c. Potentiometer  
you asked for!**

The 400 cycle Vernistat is an a.c. potentiometer-type voltage divider that combines *high* linearity and *low* output impedance. It is essentially a non-dissipative element adaptable to high temperature operation. Size and mounting dimensions are designed to the BuOrd specification for a size 18 synchro.

Here are the details:

- **high linearity**, inherent in the design principle, is *maintained* over the life of the unit.
- **low output impedance** eliminates need for isolation amplifiers in many applications.
- **high output current capability**.
- **low phase shift** — less than 90 seconds, depending on model.
- **can be coupled with synchros**, resolvers and other components — as well as ganged.
- **nonlinear functions can also be generated**.

Class 5 ball bearings, centerless ground shaft, and an aluminum housing machined to close tolerances combine to make the Vernistat a precision instrument. Shaft seals will be supplied where they are required by environmental conditions.

*check these  
specifications:*

Linearity Tolerance .....  $\pm 0.05\%$   
 Minimum Output  
 Voltage Increment .....  $0.01\%$   
 Output Impedance... less than 130 ohms  
 Input Voltage..... 130 v max.  
 Input Impedance... up to 75,000 ohms

\*Trademark

**vernistat**  
division

PERKIN-ELMER CORPORATION  
Norwalk, Connecticut

Want more information? Use post card on last page.

chanical handling of the pallet-return operation.

The problem was solved by ordering a rotating-cable conveyor 60 ft long, equipped with  $\frac{1}{2}$ -hp motor drive. The conveyor extends the full length of the workers' bench lines at a convenient height of about 2 $\frac{1}{2}$  ft above bench level. The conveyor consists of a flexible carbon-steel screw  $\frac{1}{4}$  inch in diameter that turns in a metal retaining rail. The top of the rail is open to expose this screw. The wire hooks of

empty pallets are hooked over the screw and are moved at approximately 12 feet per minute to a point at the start of production. These pallets can be placed on the conveyor at any time, at any point, in one motion.

This type of rotating conveyor eliminates the need for a return strand or loop, thus permitting installation in minimum space. The conveyor was designed and installed by M-H Standard Co., Jersey City, N. J.

**Double-Dip Soldering Uses Chassis Vibrator**

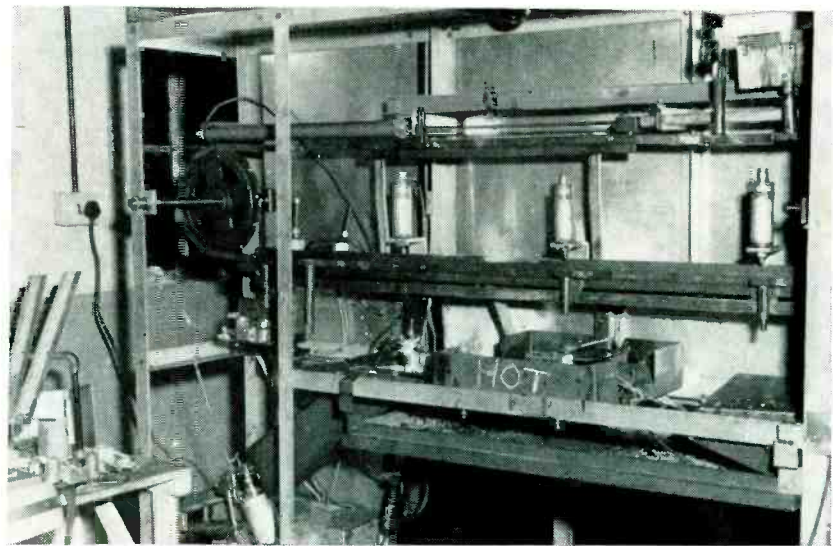

Conveyorized dip soldering machine is operated by long air cylinder mounted horizontally at upper left. Assembled wiring board is taken from end of assembly line at left and hooked over bracket on lower chain. The three vertical air cylinders push the board down at the spray fluxing station (left), the soldering station (center) and the unloading or cleaning station (right)

By W. R. CASS  
Pye Ltd., Radio Works  
Cambridge, England

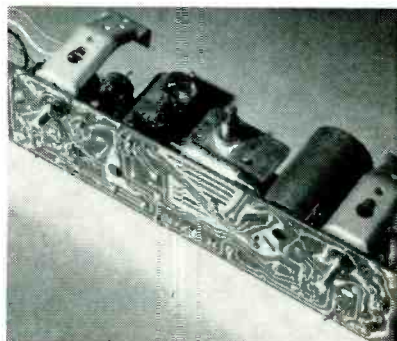

Appearance of board after soldering. Rubber caps protecting control shafts have been removed. Keyhole slots on brackets are used to attach chassis to carrier of soldering machine

A DIP soldering machine developed for use on radio etched wiring boards uses an overhead-chain conveyor driven intermittently by a long air cylinder. At the feed position, the operator hooks each assembled wiring-board pallet in turn onto brackets on the chain. The chassis is first moved to a flux spray position, then is given two dips in molten solder. During each dip and for a short period thereafter, the chassis is vibrated by air hammers to help break down oxide film on joints and to remove any excess solder.

Instead of having the chain conveyor dip down at each station, an air cylinder is mounted above each station. When the chain has come



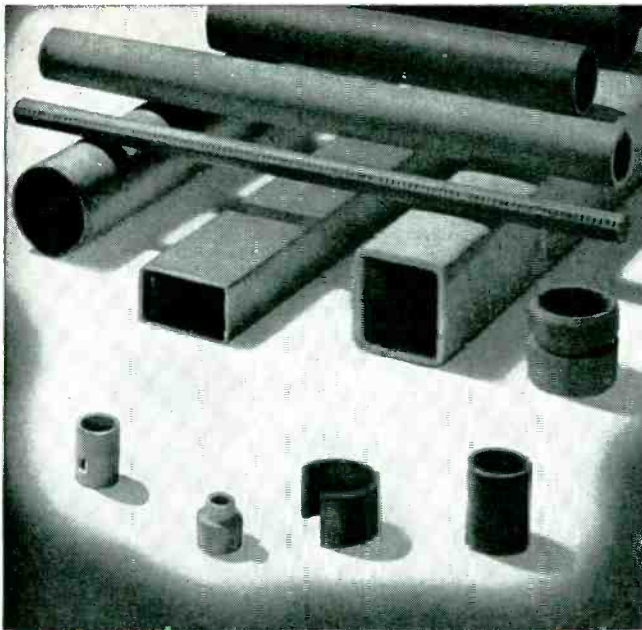

**C-D-F SPIRAL TUBING** offers many advantages to the cost-conscious design engineer and purchasing agent. It is low-cost, moisture-resistant, high-strength, and easy to fabricate. It has sufficiently low dielectric loss properties and good dielectric strength for many applications.



## New **C-D-F** Plastic Spiral Tubing reduces unit costs, improves products

Using C-D-F's new Spiral Tubing is a way of saving money in buying electronic insulation . . . without lowering the electrical and mechanical characteristics of the part required. This special tubing is a high-strength plastic made from paper or vulcanized fibre that is spirally wound. It is available in two basic forms in various grades: (1) as plain untreated tubing. (2) as impregnated tubing containing various types of thermosetting insulating varnishes.

**BUY ONLY THE PROPERTIES YOU NEED**

Spiral Tubing can be used to replace rolled or molded laminated phenolic tubing in many cases. As the degree of moisture resistance and mechanical strength is established during the manufacturing process, you specify . . . and buy . . . only those properties required for the application. C-D-F also offers complete designing, machining and assembly. You can get finished components, or random length tubing, with fast deliveries. Write for Technical Folder ST-53 and samples, after checking our catalog in Sweet's Design File. Call the C-D-F sales engineer listed there—he can save you time and money immediately with C-D-F Spiral Tubing!

*Continental-Diamond Fibre*

CONTINENTAL-DIAMOND FIBRE DIVISION OF THE BUDD COMPANY, INC.  
NEWARK 16, DELAWARE

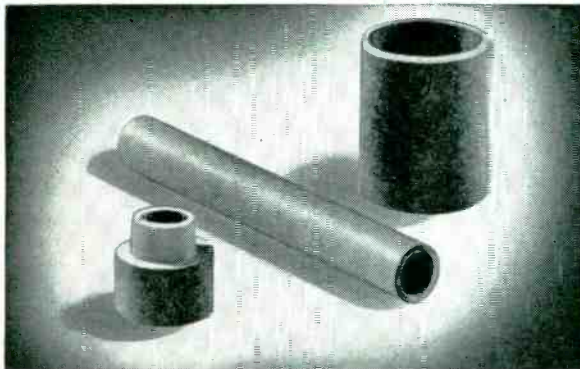

**A VERY HARD TUBE** is supplied in C-D-F Grade 6A. The parts shown have maximum mechanical strength, lowest water absorption rate under immersion conditions and most stable dielectric loss properties. Fine for bushings and cores.

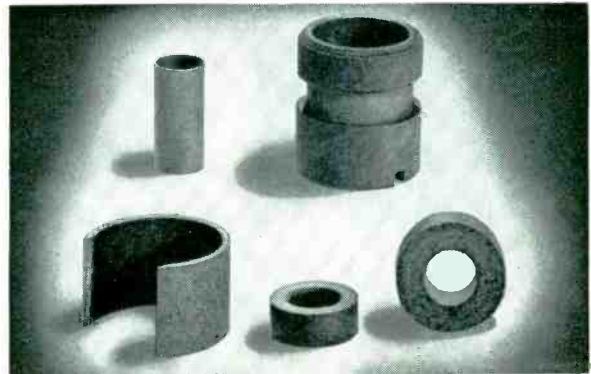

**THIN-WALL SPIRAL TUBING** has good concentricity and is tough. Note thin wall construction, cleanness of machining, variety of shapes. C-D-F Spiral Tubing is easily machined, formed, punched. Made in many grades for special applications.

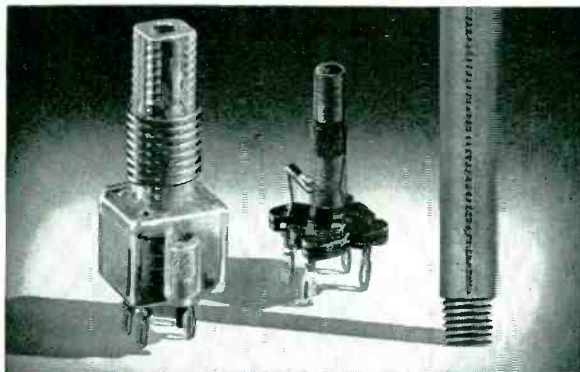

**NEW CONSTANT TORQUE TUBING**, for permeability tuning with iron cores, features exact internal threading with three point suspension of the core to prevent binding . . . no external embossing to lower dielectric strength. Write for samples.

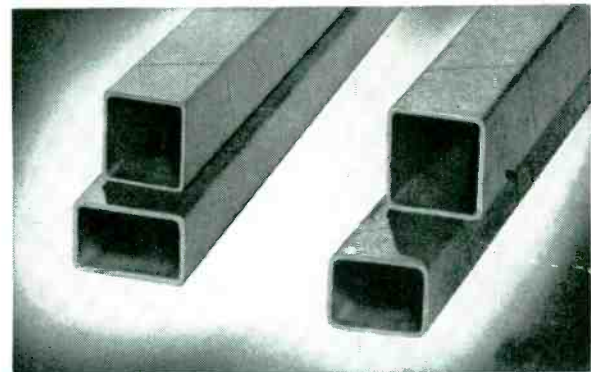

**HARD OR SOFT**, square or rectangular coil-form tubing is made for solenoid and transformer applications. Sides are straight with minimum gap in paper winding. Supplied in soft, varnished kraft, or hard, rigid tubing.



# HF

... HIGH FREQUENCIES

*radio  
interference  
and  
field  
intensity\**

MEASURING EQUIPMENT



**Stoddart RI-FI\*** meters cover the frequency range 14kc to 1000 mc

### VLF

NM-10A, 14kc to 250kc  
Commercial Equivalent of AN/URM-6B.  
Very low frequencies.

### VHF

NM-30A, 20mc to 400mc  
Commercial Equivalent of AN/URM-47.  
Frequency range includes FM and TV bands

### UHF

NM-50A, 375mc to 1000mc  
Commercial Equivalent of AN/URM-17  
Frequency range includes Citizens band and UHF color TV band.

## Stoddart NM-20B

150kc to 25mc

Commercial Equivalent of AN/PRM-1A

### WIDE FREQUENCY RANGE . . .

Covering the most widely used portion of the radio-frequency spectrum, the NM-20B is a precision instrument designed for field or laboratory measurement, analysis and interpretation of all types of radiated and conducted radio-frequency signals and interference.

Sturdy dependability, broad frequency range and a full complement of accessories fit this instrument's outstanding characteristics to an impressive variety of applications. Includes standard broadcast band, radio range, WWV, ship-to-shore, amateur and other communication frequencies.

### SELF-CONTAINED BATTERIES . . .

Battery power allows portable operation of the NM-20B. The ac power supply permits operation from 105 to 125 volts or 210 to 250 volts ac at any frequency between 50 cps and 1600 cps. Its versatile power requirements and special weather-proof construction provide unlimited field operation.

### PICKUP DEVICES . . .

Pickup devices available for use with the NM-20B include the loop and loop probe, rod antennas and matching impedances for conductive inputs. These permit unlimited usefulness in measuring both conducted and radiated interference.

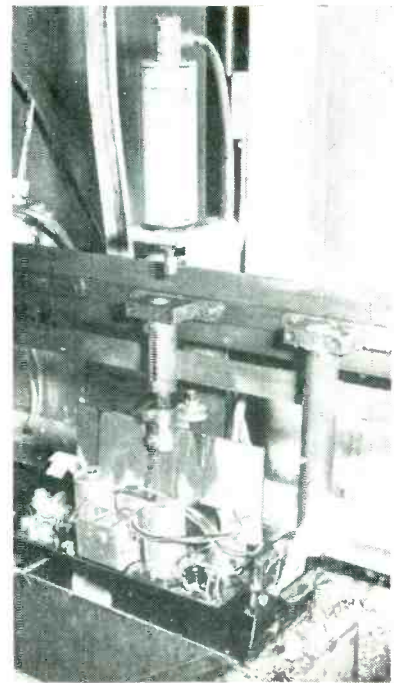

Spray fluxing station. Board is pushed down into baffles by air cylinder to minimize escape of spray during fluxing. Teflon wiper blade, mounted on conveyor chain ahead of wiring board bracket, wipes dross off solder pot at next station

to rest after an advance, the air cylinders are actuated to push the pallets down at their respective stations. The rod on the air cylinder comes down through a hole in the bracket on the chain to push down a spring-loaded inner shaft on which the pallet bracket is hung. The spring brings the chassis up again after the air cylinder has retracted entirely out of the bracket.

A hinged wiper blade is attached to a long rod bolted to the chain

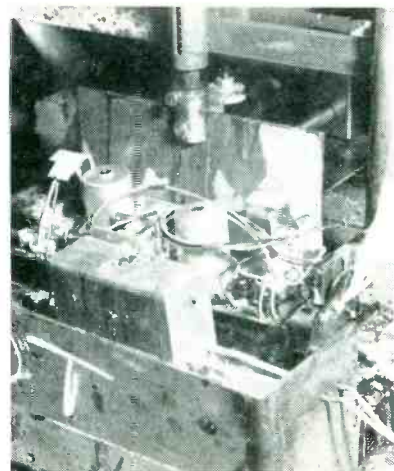

Radio wiring board, hooked over conveyor bracket, is here in position over solder pot

**STODDART** aircraft radio co., inc.  
6644-A SANTA MONICA BLVD., HOLLYWOOD 38, CALIFORNIA · HOLLYWOOD 4-9294



# MICROWAVE SIGNAL GENERATORS

950 to 11,500 mc

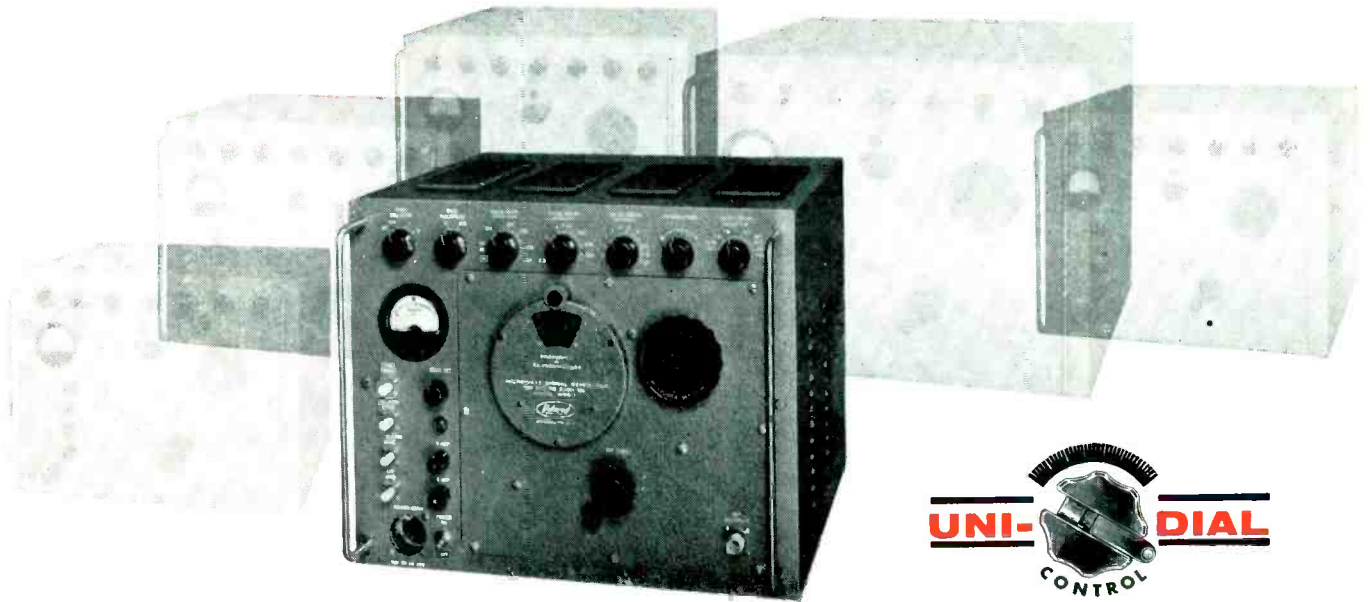

## JUST ONE POLARAD MICROWAVE SIGNAL GENERATOR CAN MAKE ALL THESE MEASUREMENTS

Each Polarad Microwave Signal Generator (4 models cover 950-11,500 mc) is equipped with the unusually simple UNI-DIAL control that tracks reflector voltages automatically while tuning continuously. Frequency, accurate to  $\pm 1\%$ , is read directly on the single frequency dial. There are no mode charts, no slide rule interpolations necessary.

But, most significant are the built-in features that enable use of these rugged instruments for so many applications: internal modulation, pulse and FM, internal square wave modulation; synchronization outputs, delayed and undelayed; provision for multi-pulse modulation input; provision for external modulation and synchronization; variable attenuator calibrated directly in -dbm; engineered ventilation to insure specification performance over long operating periods.

Contact your local Polarad representative or write directly to the factory for the latest detailed specifications.

### SPECIFICATIONS (all models unless indicated)

<b>Model #</b>	<b>Frequency Range</b>	<b>Internal pulse modulation:</b>	<b>External pulse modulation:</b>
MSG-1	950 - 2400 mc	<b>Pulse width:</b> 0.5 to 10 micro-seconds	<b>Polarity:</b> Positive or negative
MSG-2	2150 - 4600 mc	<b>Delay:</b> 3 to 300 microseconds	<b>Rate:</b> 40 to 4000 pps
MSG-3	4450 - 8000 mc	<b>Rate:</b> 40 to 4000 pps	<b>Pulse width:</b> 0.5 to 2500 microseconds
MSG-4	6950 - 10,800 mc	<b>Synchronization:</b> internal or external, sine wave or pulse	<b>Pulse separation (for multiple pulses):</b> 1 to 2500 microseconds
MSG-4A	6950 - 11,500 mc	<b>Internal FM:</b>	<b>Output synchronizing pulses:</b>
<b>Frequency accuracy:</b> $\pm 1\%$		<b>Type:</b> Linear sawtooth	<b>Polarity:</b> Positive, delayed & undelayed
<b>Power output:</b>		<b>Rate:</b> 40 to 4000 cps	<b>Rate:</b> 40 to 4000 pps
MSG-1 & 2: 1 mw		<b>Synchronization:</b> Internal or external, sine wave or pulse	<b>Voltage:</b> Greater than 25 volts
MSG-3, 4 & 4A: 0.2 mw		<b>Frequency deviation:</b>	<b>Rise time:</b> Less than 1 micro-second
<b>Attenuator range:</b> 120 db		MSG-1 & 2: $\pm 2.5$ mcs	<b>Price:</b>
<b>Attenuator accuracy:</b> $\pm 2$ db		MSG-3, 4 & 4A: $\pm 6$ mcs	MSG-1, 2 ..... \$1,720.00
<b>Output impedance:</b> 50 ohms nominal		<b>Internal square wave modulation:</b>	MSG-3, 4 ..... \$2,190.00
		40 to 4000 pps	MSG-4A ..... \$2,450.00

- Receiver sensitivity
- Noise figure
- Signal to noise ratio
- Image rejection
- Beacon sensitivity
- Bandwidth
- Standing wave ratio
- Antenna gain and pattern
- Conversion gain or loss
- Attenuation
- Filter characteristics
- Multi-pulsed systems, such as Beacons, DME, Tacan, etc.

**AVAILABLE ON EQUIPMENT LEASE PLAN**  
**FIELD MAINTENANCE SERVICE AVAILABLE THROUGHOUT THE COUNTRY**

Prices subject to change without notice.



**ELECTRONICS CORPORATION**

43-20 34th STREET, LONG ISLAND CITY, N. Y.

REPRESENTATIVES • Albuquerque • Atlanta • Baltimore • Boston • Buffalo • Chicago • Dayton • Englewood • Fort Worth • Los Angeles • New York • Philadelphia • San Francisco • Syracuse • Washington, D. C. • Westbury • Winston-Salem • Canada, Arnprior, Toronto Export: Rocke International Corporation

# New 7/8" Precision Potentiometer by GAMEWELL

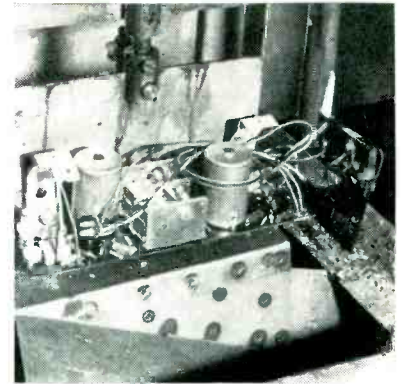
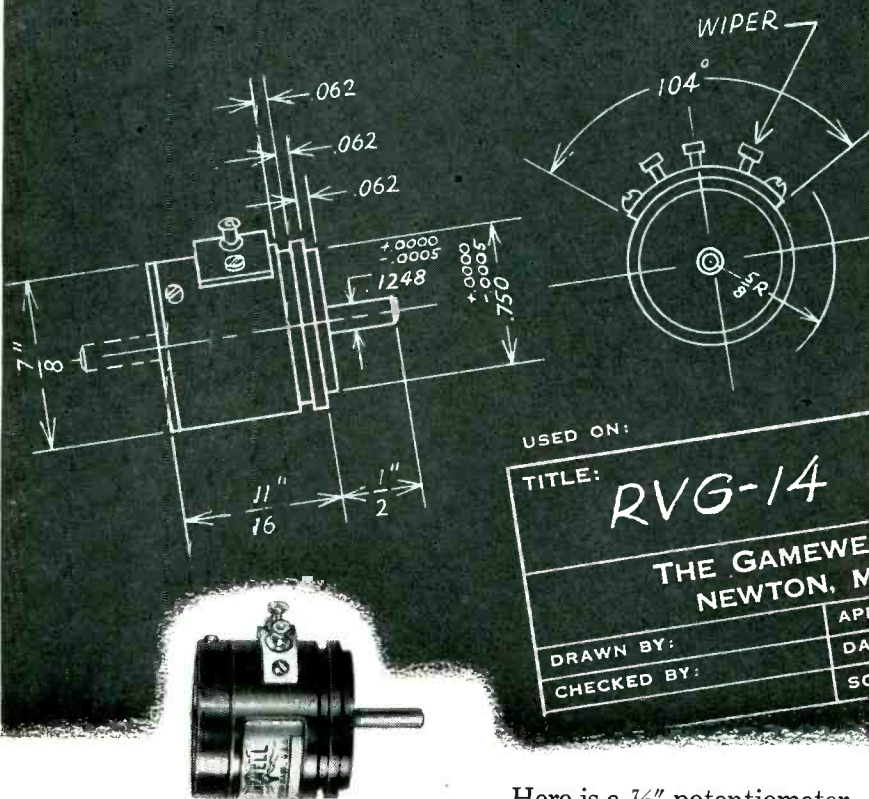

Unloading station. Air cylinder is provided here for use if cleaning is needed after soldering

just ahead of each bracket, to sweep the dross off the solder pot just before dipping.

Silicone rubber caps are pushed over the shafts of the volume control and band-changing switch before dip soldering, to give automatic masking. The caps are gripped by the threads of the controls, and are easily removed afterward.

## Modular Bundles Use Etched-Wiring Boards

By ROBERT J. ROMAN  
Eastman Kodak Co.  
Rochester, N. Y.

LOW-VOLUME users of printed circuits look to mechanization for versatility and low tool cost, to permit frequent changes in the product without excessive change-over costs. This is very difficult to accomplish with machines alone. Great simplification of the problem has been achieved by stand-

Here is a 7/8" potentiometer that offers you the extreme precision found in larger sizes of Gamewell Potentiometers.

Body is of anodized aluminum and the shaft is made of stainless steel. Kohlrausch type winding provides excellent linearity and the unit meets MIL-E 5400 specifications as they apply.

The unit can be modified for special mounting. Write for additional information about the new 7/8" type RVG-14 precision potentiometer.

**THE GAMEWELL COMPANY**  
NEWTON UPPER FALLS 64, MASS.



**PRECISION POTENTIOMETERS**

Manufacturers of Precision Electrical Equipment Since 1855

### CONDENSED SPECIFICATIONS

Potentiometer Type No.	RVG-14
Diameter (inches)	7/8"
Rating (watts)	1
Torque, max. (ounce-inches)	0.25
Weight (ounces)	3/4"
Max. Resistance (ohms) ±5%	45,000
Min. Resistance (ohms) ±5%	25
Useful Angle (deg.)	354°
Min. Resolution (%)	0.06
Linearity (%)	±0.5

Multiple sections can be ganged; add 1/2" to overall length for each additional section. Better linearities can be obtained on special order.

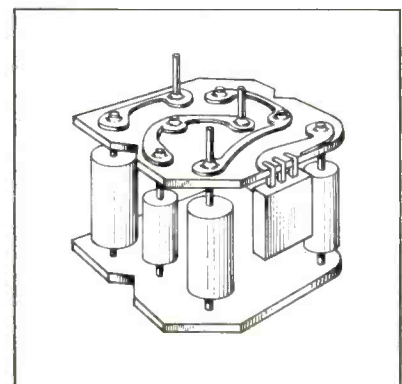

Example of Paraplate bundle, showing how some leads can be left long after soldering, for use as interconnecting terminals. Multiple-lead couplates can be soldered into notches on edge of one plate, as on upper plate here





**POURED  
AS A LIQUID**

BAKELITE Epoxy Resin, mixed with hardener, is poured into place, without harm to fragile elements in the assembly. The mixture will cure with excellent adhesion to metal, ceramics or glass, bonding them firmly in position.

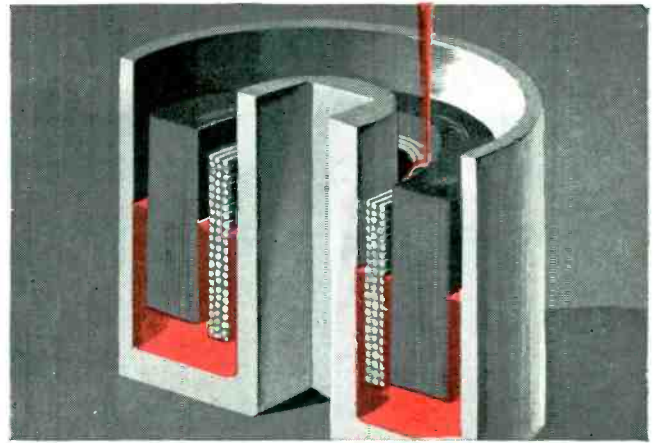

**FILLS EVERY  
CREVICE**

Low viscosity permits BAKELITE Epoxy Resin—hardener combination to penetrate extremely minute cavities. Air entrapment is minimized. Vibration or centrifugal casting reduces it further, aids in filling, and eliminates bubbles.

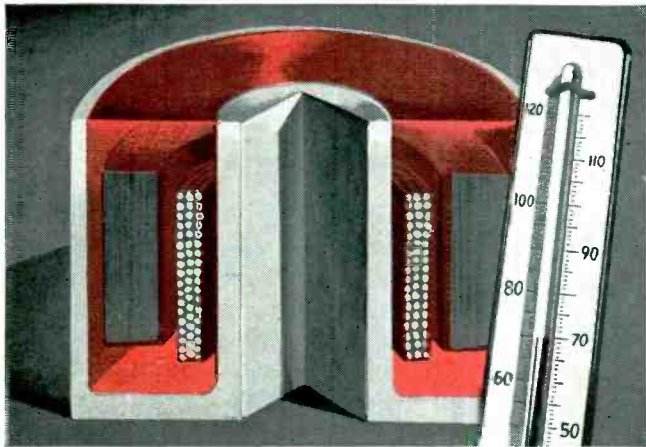

**HARDENS  
WITHOUT  
HEAT**

BAKELITE Epoxy Resins can cure at room temperature—another advantage where parts would be damaged by high temperatures needed to set other potting materials. Oven curing at low temperatures may be used for more complete reaction.

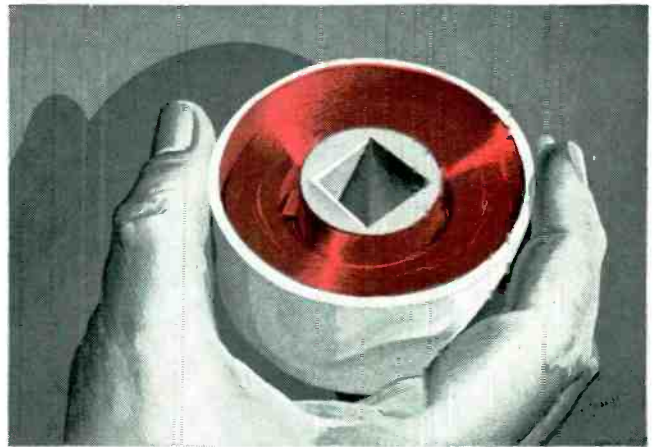

**KEEPS  
ASSEMBLY  
SAFE**

Cured BAKELITE Epoxy Resin resists shocks, chemicals, moisture. It keeps the assembly solidly embedded, safe from external hazards. Resin shrinkage is so slight as to be unimportant for most applications, but can be further reduced by use of fillers.

## Potting and encapsulating with BAKELITE Epoxy Resins make delicate electrical assemblies stronger, easier to handle

Many electrical assemblies seem to grow more fragile as they become more efficient. But BAKELITE Brand Epoxy Resins are making them more serviceable than ever. Three different types of these resins are available for potting and encapsulating techniques. They can be cured by any of four specially formulated BAKELITE Epoxy hardeners designed to give a variety of viscosities and curing speeds, or by several conventional catalysts. We can help you pick the combination with the best set of properties for your product. In addition, there are BAKELITE Phenolic and Polyester Resins ideally suited to give you the widest selection of materials available. Find out what all these resins can do. Write Dept. BL-50.



**BAKELITE COMPANY**, A Division of Union Carbide and Carbon Corporation 30 East 42nd Street, New York 17, N. Y.  
The term BAKELITE and the Trefoil Symbol are registered trade-marks of UCC

# MISSILE SYSTEMS ELECTRONICS

A number of significant developments have created new positions for engineers possessing unusual ability and advanced academic training in the following fields:

**Antenna Design** . . . to develop advanced flush type antennas in connection with Missile guidance and other data transmission systems. Specialized training is desirable.

**Guidance Systems** . . . to develop guidance systems and electronic circuitry for missiles. The position requires experience in micro-wave circuitry, pulse techniques and systems analysis.

**Data Transmission** . . . to develop advanced automatic equipment for the transmission of data for missiles. The position requires at least three years' development experience in instrumentation and telemetering and knowledge of communication theory.

*Lockheed* **MISSILE SYSTEMS DIVISION**

*research and engineering staff*

LOCKHEED AIRCRAFT CORPORATION • VAN NUYS, CALIF.



Method of soldering leads of subminiature tube to edge notches of board

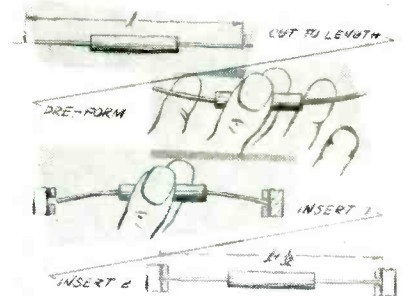

Steps in inserting resistor manually

ardizing on a basic module for axial-lead components, called a Paraplate bundle. Here the components are installed between two parallel etched-wiring boards and the connections are dip-soldered in two operations.

Nonaxial-lead components, such as tubes, transistors and switches, can be added at any time by using slot-soldering terminations around the edges of the boards. A slotted termination is ideal for this application as it will not close up or bridge when dip-soldered without a wire inserted.

► **Advantages**—When properly supported, modules of this type satisfy varied environmental requirements at least as well as the average components they support. For most component groupings, the bundle requires less total etched-wiring-board area than most flat mounts.

Space characteristics are exceptionally good for most component groupings. The two-plate construction allows for crossovers without expensive, troublesome double-sided prints. Exclusive of any mounting structures which may be required, the bundles are self-supporting.

An improved new assembly method for the modular system



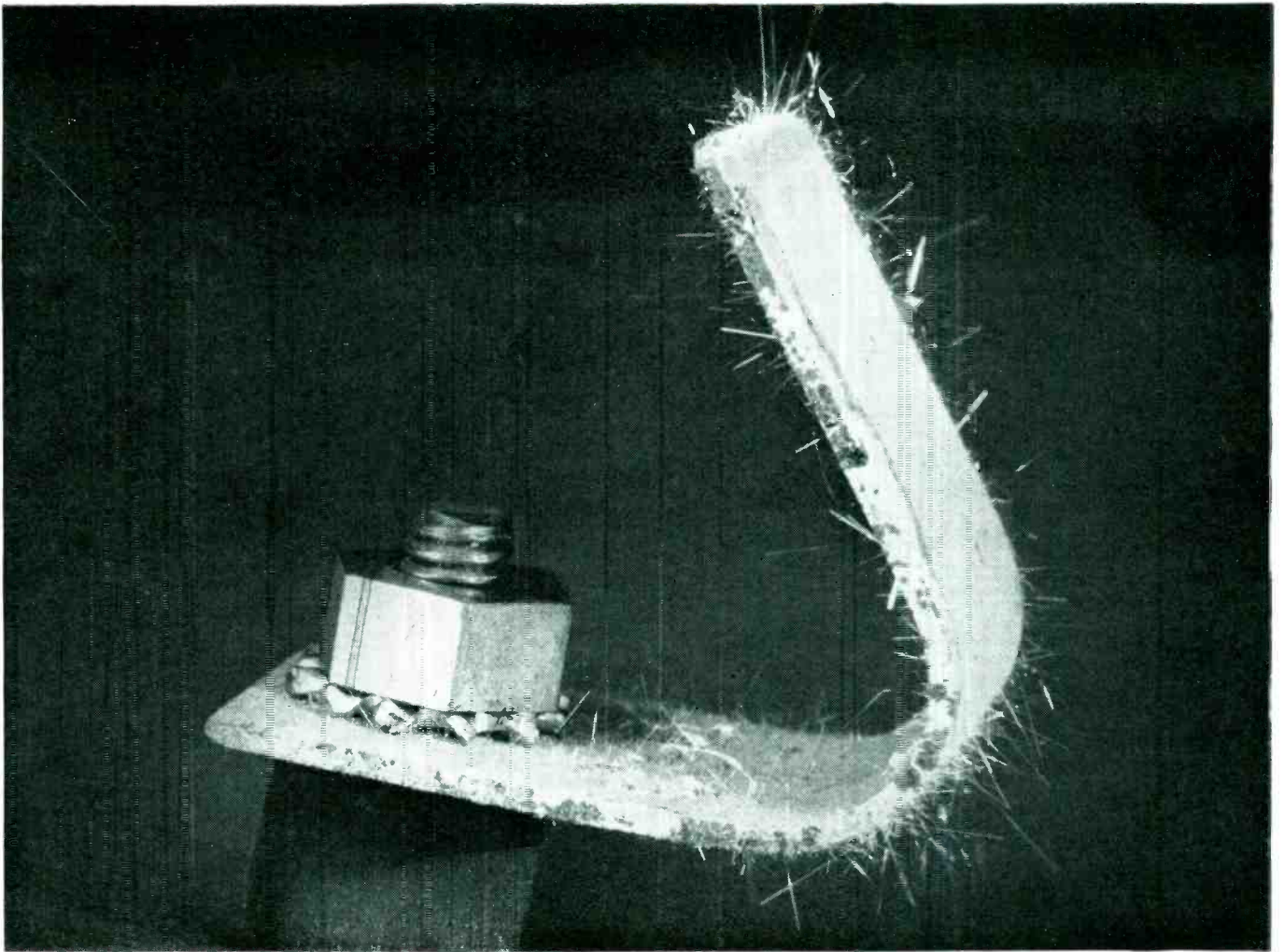

*Whiskers on tin-plated steel, enlarged 6 times. Immense yield strength of metals in whisker form was discovered by Bell scientists.*

## The clue of the metal whiskers

The habit of close observation at Bell Laboratories often turns "tremendous trifles" into important scientific progress. Such a case occurred when unexplained short circuits in wave filters seemed to be associated with a zinc-plated mounting bracket.

Close scrutiny disclosed a whiskery growth on the zinc plating. Similar whiskers of tin were found growing on tin-plated equipment. Studies showed the whiskers to be tiny single crystals of metal.

Suspecting that these unusual crystals might be of essentially perfect structure, alert Laboratories scientists saw an opportunity at last to test

an important metallurgical theory.

The scientists studied the whiskers, grew larger ones, and showed that the crystals had enormously high yield strength as predicted by the theory for perfect crystals—a strength far greater than for the same metal in any other known form. This clue has opened new frontiers in the study of what makes metals strong or weak, and has excited metallurgists all over the world.

Thus, another new advance has come out of the Bell Telephone Laboratories practice of scrutinizing everything that can play a part in better telephone service.

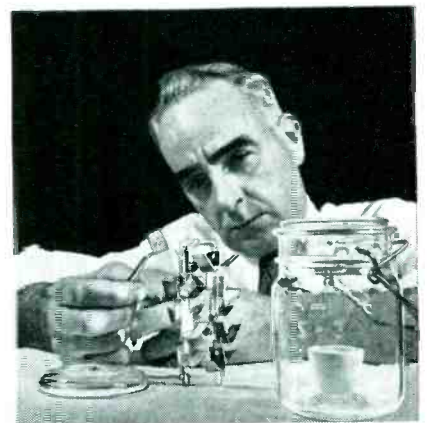

*Through the study of thousands of specially cultivated whiskers, Bell scientists seek to prevent treacherous growths in telephone equipment.*

**BELL TELEPHONE LABORATORIES**



IMPROVING TELEPHONE SERVICE FOR AMERICA PROVIDES CAREERS FOR CREATIVE MEN IN SCIENTIFIC AND TECHNICAL FIELDS

Want more information? Use post card on last page.

**NOW**

*adjustable*

**POLYSTYRENE CAPACITORS**

*with Accuracy*

*in the order*



*of 0.1% or better*

*and Long Time*

*Stability in*

*the order*

*of 0.03%*



Check these outstanding features:

- I. R. - @ 25° C -  $10^{12}$  OHMS
- Dielectric Absorption - .015%
- Dissipation Factor - .0002
- Temp. Coeff. (-20° to 140° F.)  
100 P.P.M. per °C

Excellent for Computer Integration, Test Equipment or Secondary Standards.

Join these other leading firms in specifying Southern Electronics' precision polystyrene capacitors for your most exacting requirements: Reeves Instrument Corp., Electronic Associates, Inc., Convair, Berkeley Scientific, M.I.T., Calif. Inst. of Tech., and many others.

Write for complete catalog -

Available from 0.1 M.F.D. to 8 M.F.D.

**SOUTHERN ELECTRONICS**



*Corporation*

239 West Orange Grove Ave., Burbank, Calif.

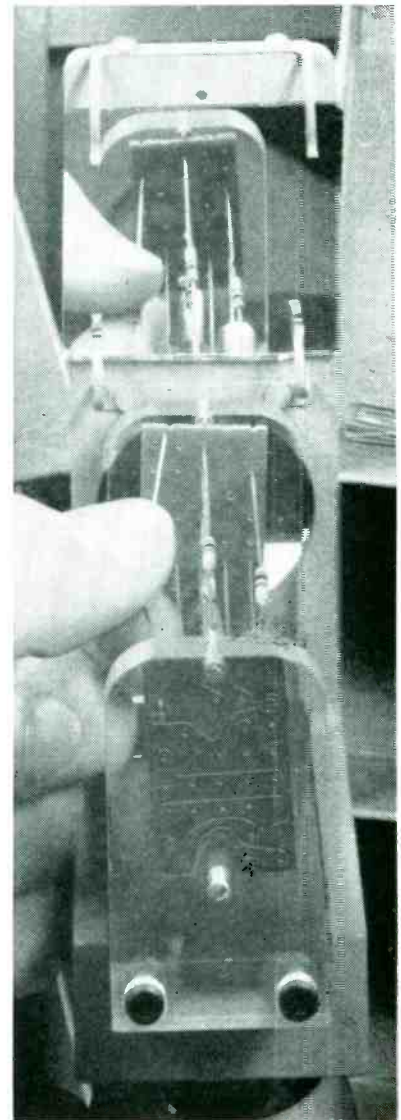

Method of inserting component by hand. Mirror at rear aids operator in putting lead into board closest to her

features ready adaptability to high or low production with negligible tool and equipment cost.

With the two 1/8-inch-thick etched wiring boards held against back-up plates at some distance  $L - 1/8$  inch, where  $L$  is the cut length of all components, the component is inserted in four steps: (1) precut to length  $L$ ; (2) preform slightly to decrease overall length approximately 1/8 inch; (3) insert first component lead; (4) insert second component lead; (5) straighten leads.

► **Manual Assembly Fixture**—The U-shaped assembly cradle has a steel base with clear plastic back-up plates affixed to each end. As the printed circuit plates do not have to be accurately located, they are



# NOW... THE NEW FAST WAY TO TEACH MICROWAVE TECHNIQUES

## FXR'S MICROWAVE TRAINING KIT Demonstrates with the Newest Equipment Actually Used in the Field

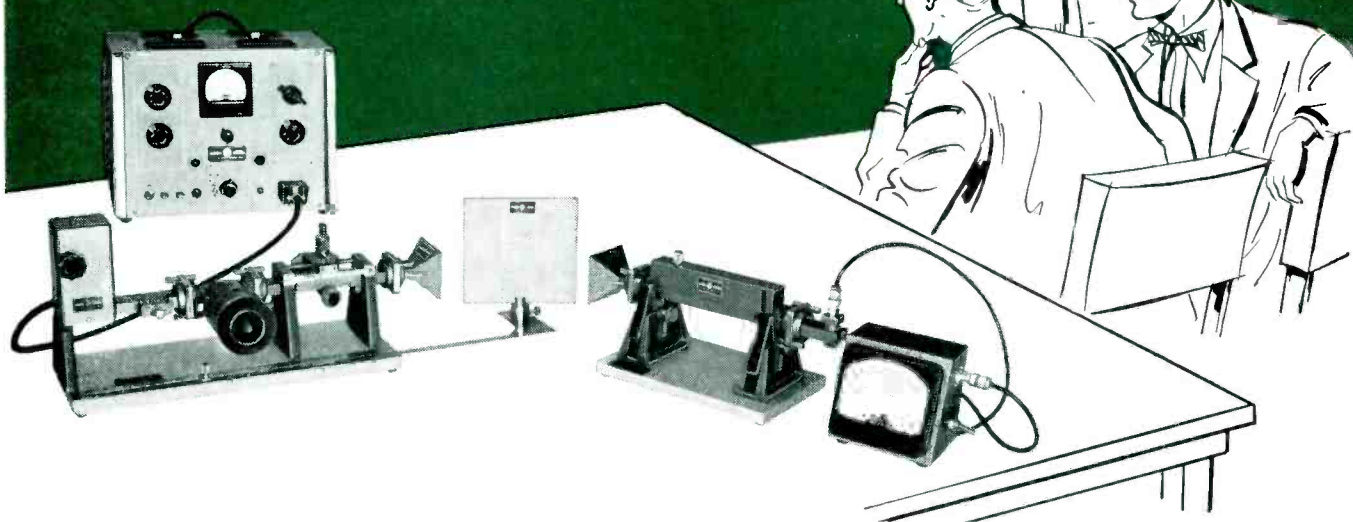

FXR presents a complete packaged training program, the first in the industry specifically designed to teach the fundamentals of microwave techniques. This field-tested FXR Microwave Training Kit consists of a complete receiver, transmitter, and accessory group in a convenient carrying-case. Text material, including instructor's demonstration notes with extensive student laboratory exercises, are also furnished. By interchanging the accessories, the students learn fundamentals of propagation and the method and effects of such phenomena as shielding, polarization, reflection, focusing and bending of microwaves.

The Microwave Training Kit, an FXR exclusive, trains students to take numerical data and learn the methods and techniques of microwave measurements. This simple, efficient training program provides the student with a foundation of practical knowledge and experience necessary to his work in the microwave field.

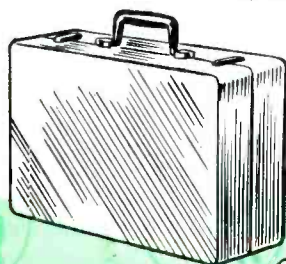

WRITE TODAY FOR  
FULL INFORMATION ON THE  
FXR TYPE X845A MICROWAVE TRAINING KIT.

FOR OUR COMPLETE  
PRODUCT LINE... SEE  
electronics Pg. 263-266  
'55 BUYERS' GUIDE

A complete catalog of FXR  
PRECISION MICROWAVE  
TEST EQUIPMENT is avail-  
able on request.



FIRST BY FAR

*Electronics & X-Ray Division*

**F-R MACHINE WORKS, Inc.**

26-12 BOROUGH PLACE, WOODSIDE 77, N. Y. • ASTORIA 8-2800



# REQUEST ALL FOUR

for up-to-date  
data on MICRO  
instrument bearings

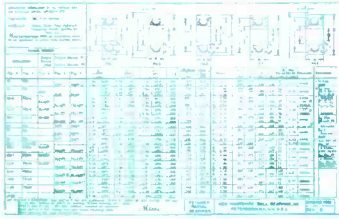

(1) For your drafting board or desk, PRINT 1031 HANDY WORK SHEET with complete line of Retainer Radial Bearings.

ENGINEERING BULLETIN			
Q. No.	Q. Text	A. Text	Q. No.
1	What is the best material for a bearing?	Steel is the best material for a bearing.	1
2	What is the best material for a bearing?	Steel is the best material for a bearing.	2
3	What is the best material for a bearing?	Steel is the best material for a bearing.	3
4	What is the best material for a bearing?	Steel is the best material for a bearing.	4
5	What is the best material for a bearing?	Steel is the best material for a bearing.	5
6	What is the best material for a bearing?	Steel is the best material for a bearing.	6
7	What is the best material for a bearing?	Steel is the best material for a bearing.	7
8	What is the best material for a bearing?	Steel is the best material for a bearing.	8
9	What is the best material for a bearing?	Steel is the best material for a bearing.	9
10	What is the best material for a bearing?	Steel is the best material for a bearing.	10

(2) Answers to specific Questions are provided by more than 20 current N. H. B. B. ENGINEERING BULLETINS.



(3) Concise yet complete, the N. H. B. B. CATALOG 53 is the Handbook of the Instrument Bearing field.



(4) Monthly, the NEW HAMPSHIRE SCENE (friendly house organ) provides humor plus CURRENT ENGINEERING TIPS from N. H. B. B.

## CALL FOR OUR BEARING ENGINEERS

- **PACIFIC COAST**  
KERMIT T. SIMONS  
Tel. RYan 1-9051  
434 North Lake Ave.  
**PASADENA 4, CALIFORNIA**
- **MIDWEST**  
JOSEPH W. DANIELS  
Tel. SUperior 7-0984  
CHARLES S. WARD  
Tel. Trnity 1-4601  
49 E. Cedar St.  
**CHICAGO, ILLINOIS**  
646 Hazelwood  
**DETROIT, MICHIGAN**
- **SOUTHWEST**  
J. ROBERT NATOLI  
Tel. Sterling 2826  
P. O. Box 10203  
**DALLAS, TEXAS**
- **EAST**  
SIDNEY J. GOODRICH  
Tel. HUNter 2-8633  
CARL F. GRAESSER, JR.  
61 Cutter Mill Rd.  
**GREAT NECK, NEW YORK**  
Tel. 424 or 425  
**PETERBOROUGH, N. H.**

**NEW HAMPSHIRE  
BALL BEARINGS, INC.**



**Peterborough, N. H.**

Phone 424 - 425

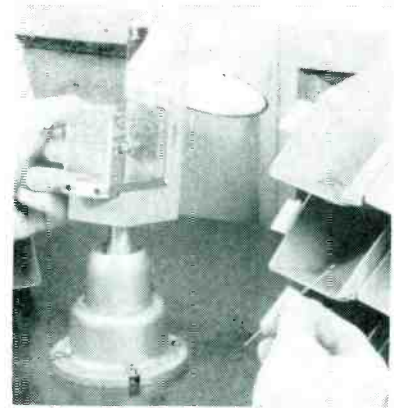

Work setup of manual assembly, using bench fixture to hold wiring boards

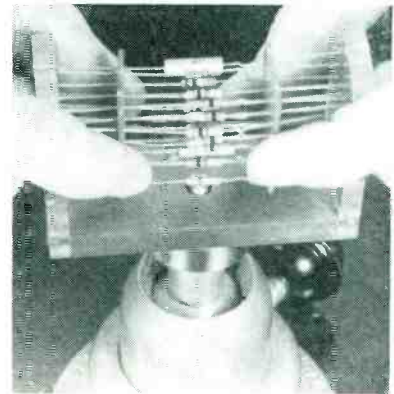

Pushing wiring boards together after inserting all components

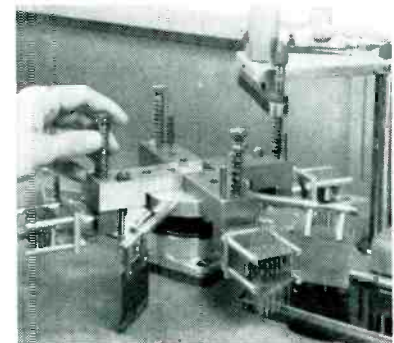

Setup used for fluxing and dip soldering after loading boards manually

affixed to the back-up plates with simple spring clips. Each station has a universal holding fixture with an inset Alnico magnet for firmly gripping the cradle. An adjustable mirror on the holding fixture allows the operator to see both plates at once. Depending on the volume and complication of the bundle being run, two or more work stations can be lined up, with bundle cradles passing from one to the other.

When all components have been assembled, an operator removes the bundle from its cradle after first pushing the wiring boards together



# THE NEW LOOK

...in vhf-TV tuners

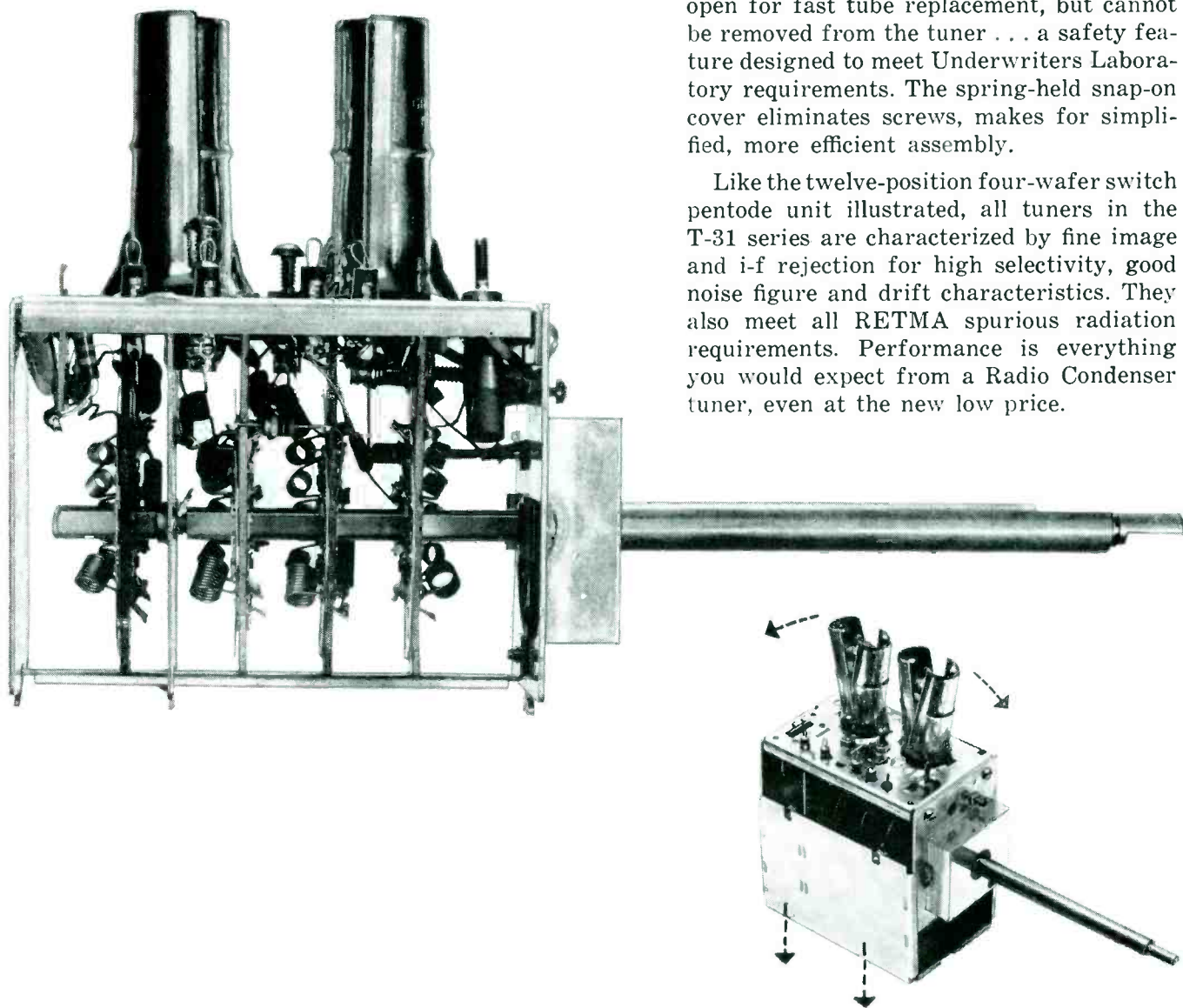

NOW . . . all the desirable performance characteristics of Radio Condenser's well known T-31 series vhf-TV tuners in a completely new package. Designed for greater safety and easier installation, the new T-31 carries an even *lower price*, because of mechanized production methods now in effect.

Here are just a few of the design improvements that make the new T-31 far superior to the original. As you can see in the illustrations, tubes are mounted at the extreme right, for easier installation beside large cathode ray tubes. Captive tube shields snap open for fast tube replacement, but cannot be removed from the tuner . . . a safety feature designed to meet Underwriters Laboratory requirements. The spring-held snap-on cover eliminates screws, makes for simplified, more efficient assembly.

Like the twelve-position four-wafer switch pentode unit illustrated, all tuners in the T-31 series are characterized by fine image and i-f rejection for high selectivity, good noise figure and drift characteristics. They also meet all RETMA spurious radiation requirements. Performance is everything you would expect from a Radio Condenser tuner, even at the new low price.

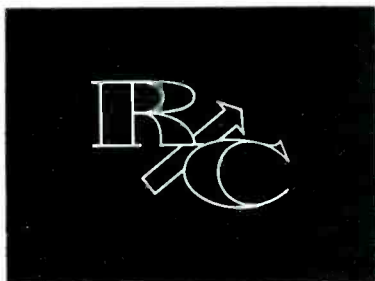

*Get Complete Engineering and Performance Data*

Write Radio Condenser for your free copy of Bulletin T-31.

## RADIO CONDENSER Co.

Davis & Copewood Streets • Camden 3, New Jersey

EXPORT: Radio Condenser Co., International Div., 15 Moore St., N.Y. 4, N.Y. CABLE: MINTHORNE

CANADA: Radio Condenser Co. Ltd., 6 Bermondsey Rd., Toronto, Ontario



A GREAT NAME CONTINUES GREAT NEW ACHIEVEMENTS

Thomas A. Edison

# How Edison achieves extraordinary timing accuracy in a thermal relay

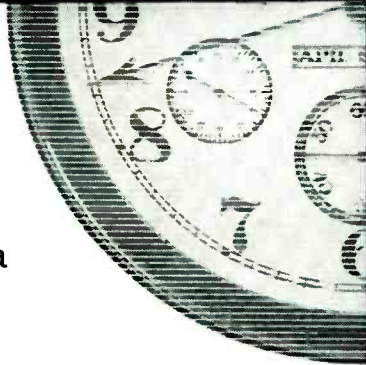

By calibrating each 501 Thermal Relay *after* hermetic sealing, EDISON provides unequalled timing accuracy — assures absolute production uniformity. Circuit designers can realize *all* of the benefits of a thermal relay without concern for changes in atmospheric pressure — or the problems of relay maintenance.

This exclusive method of calibrating, developed in the world-famous EDISON Laboratory, is just one of the features that have earned the EDISON 501 Relay an outstanding in-use record. A high degree of vibration and shock resistance, extreme light weight and typical EDISON construction ruggedness are but a few of the other features of the EDISON 501 Relay that lend it to such applications as these:

- ▶ Sustained over-current or over-voltage protection
- ▶ Integration of pulses or intermittent current
- ▶ Improving sensitive contact operation
- ▶ General control use
- ▶ Cathode protection
- ▶ "Holdover" circuits
- ▶ Motor starting



Send for complete information on the dependable EDISON 501 Thermal Relay — now.

# Thomas A. Edison

INCORPORATED

INSTRUMENT DIVISION • 54 LAKESIDE AVENUE • WEST ORANGE, NEW JERSEY

to the final bundle distance. The bundles are then inserted in the holders of a dipping machine, where all joints are dip-soldered automatically.

▶ **Automatic Insertion Head**—The basic principle of the retraction insertion head developed for mechanized assembly is not altogether different from the manual method. The component is first picked up by a four-jaw head. The two inner jaws lock against the wire when closed, but the two outer or metering jaws permit the wire to slip when closed. When the inner jaws retract in the second step, about 1/8 inch of wire is pulled through each metering jaw and stored in the loop. After the excess wire is cut off in the third step the head has both wires in excellent length and coordinate control. The head is then placed in position between two etched-wiring boards and the inner jaws are returned to their original position to complete the insertion.

▶ **Automatic Assembly Machine**—A proposed in-line transfer machine has etched-wiring boards carried from station to station on platens or cradles in a manner similar to the hand method. Insertion head assemblies are mounted in pairs at each station. The head will pick up a component, retract and cut, then move between the circuit plates for an insertion. Horizontal and vertical

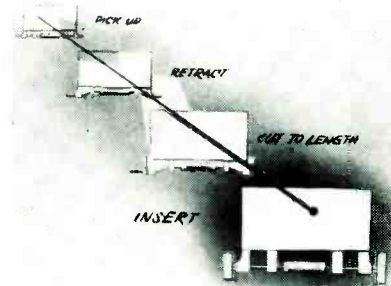

Steps in achieving automatic insertion

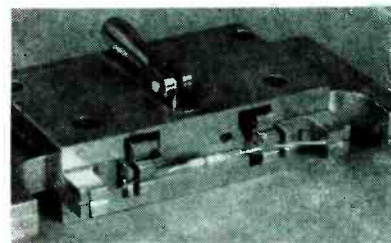

Basic tool used for automatic insertion



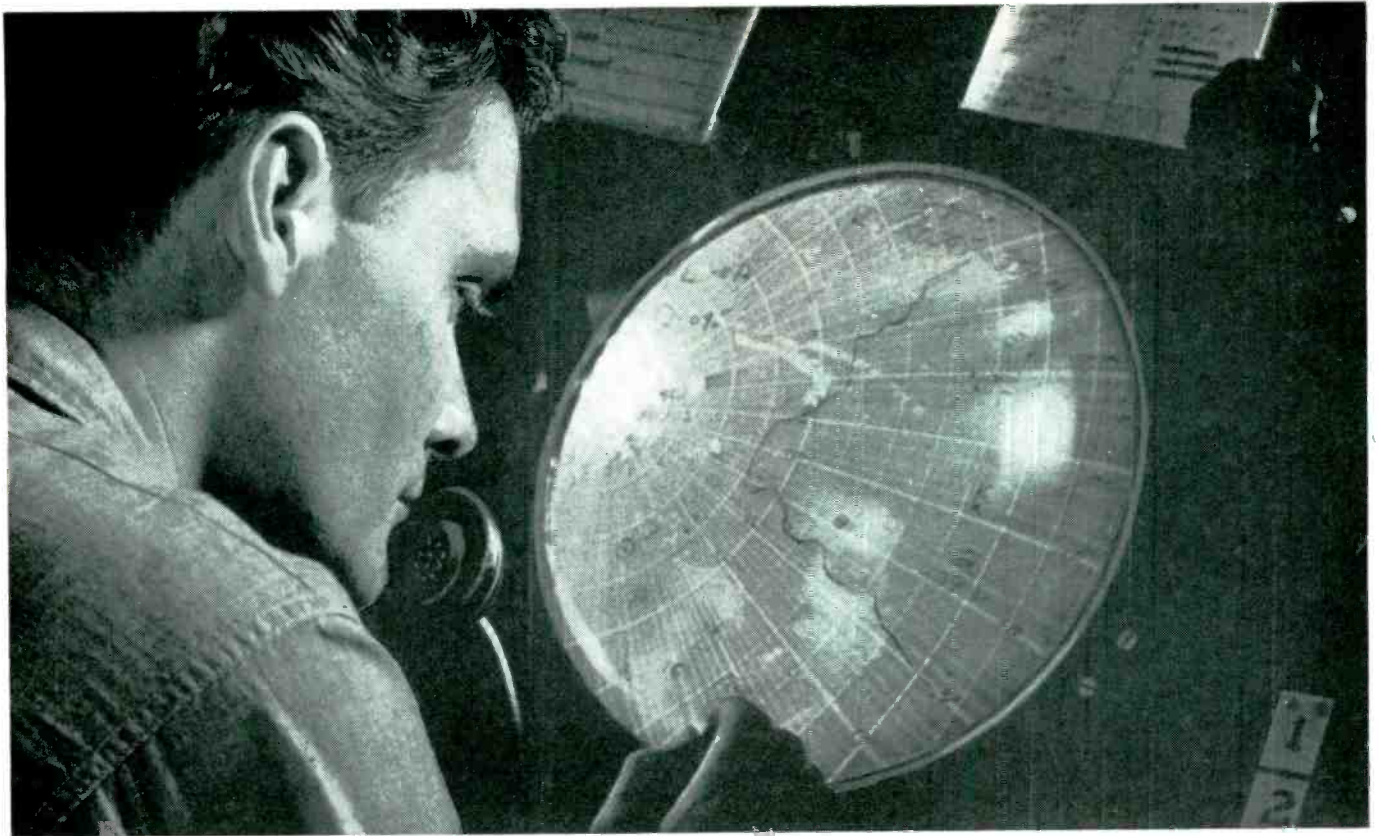

## Will Vacuum Melted Metals do for YOUR Product What They do for Radar?

### A Vacuum Furnace will help you get the Answer

Vacuum melting produces metals and alloys having unique properties of reproducibility, homogeneity, cleanliness, and ductility with impact and fatigue strength. Alert engineers are upgrading their products and cutting costs by taking advantage of these properties.

For instance, Radar benefits from tubes made of vacuum melted component parts. Improved machinability and reproducibility assure precise electrode dimensions and composition, which give more consistent tube characteristics. Greater thermal and electrical conductivity and elimination of "outgassing" increase tube life.

Would such metals make *your* product better? A vacuum furnace will enable you to develop materials especially suited to your needs. We have made and operated more high vacuum furnaces than any other manufacturer in the world. Can we help you, too? Send coupon below today.

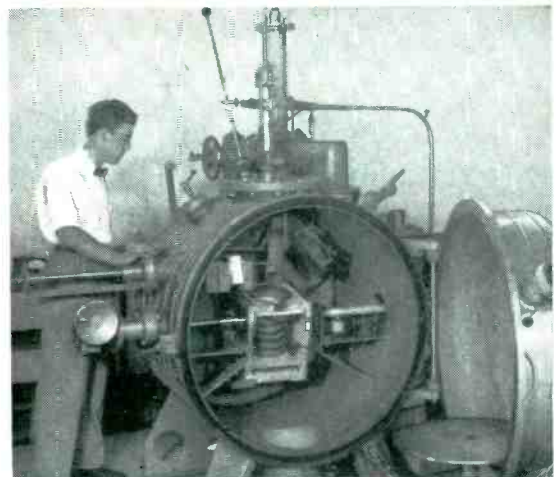

NRC Model 2555 Vacuum Furnaces are now being used by aircraft companies, engine manufacturers, investment casters, specialty steel producers to speed up development of new materials that will meet ever more severe operating requirements.

**SALES OFFICES:**  
 Boston, Chicago, Cleveland,  
 Houston, Los Angeles, New York,  
 Palo Alto, Philadelphia;  
 in Canada: Toronto, Ampror



#### NARESCO EQUIPMENT CORPORATION

Subsidiary of NATIONAL RESEARCH CORPORATION  
 Dept. 412, Charlemont St., Newton Highlands 61, Mass.

Please send me Model 2555 Data Sheet  NRC Vacuum Furnace Bulletin   
 Have your representative call

Name.....Title.....

Company.....

Address.....

City.....Zone.....State.....

# HYCON EASTERN

a complete facility for  
DESIGN • ENGINEERING • PRODUCTION

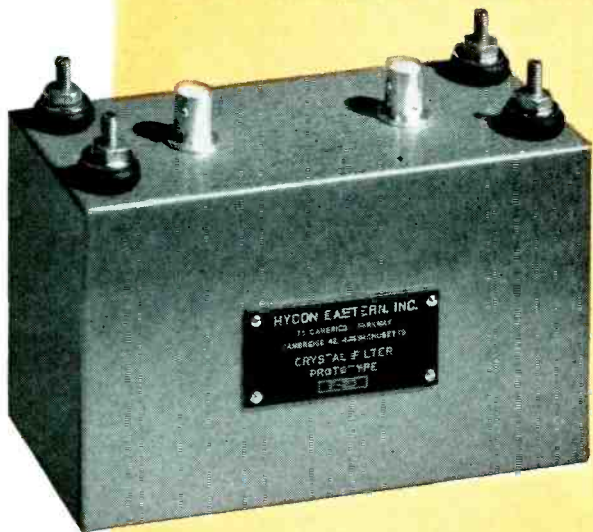

## CRYSTAL FILTERS

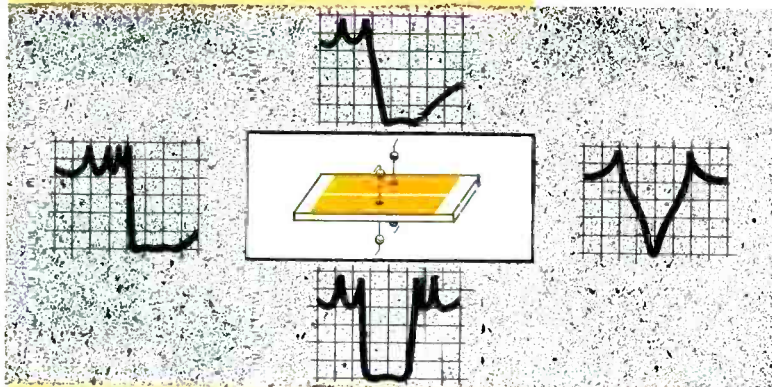

**FREQUENCY RANGE:** 10 kilocycles to 10 megacycles for all types of filters.

**BANDWIDTH RANGE:** 0.01% to 14% of center frequency.

**APPLICATIONS:** Carrier Communication Systems: Telephone Channel Filters, Pilot Selection Filters, Telemetering Channel Filters, Teletype Channel Filters, Other Frequency Multiplexing Systems. Single Side Band Filters. High Selectivity Amplifiers. Noise and Sound Analysers. Carrier Current Systems. Harmonic Selection.

ANNOUNCEMENT is made of a new technique for the synthesis of crystal filters which resolves many of the problems heretofore associated with their design and production. High initial cost and long lead time have been eliminated. System design no longer need be compromised because of the limited number of existing filters. Filters can be produced on short notice in large or small quantities to meet *exact* performance requirements. Curves shown above suggest the wide variety of characteristics. *Your inquiry is invited.*



**HYCON EASTERN, INC.**

75 Cambridge Parkway, Dept. A, Cambridge 42, Massachusetts

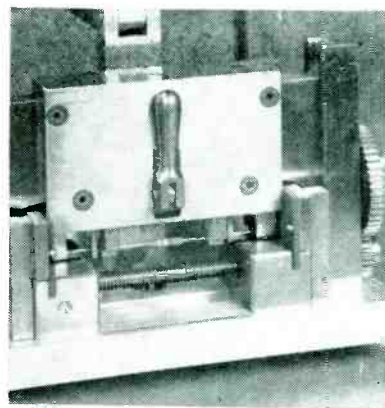

Inserting head, shown just as it is putting resistor into holes of etched wiring boards held on positioning pegs in fixture

position adjustments are made independent of head motion. Since the head will accommodate a wide range of components, accurate direct-reading adjustment devices can be employed to minimize changeover time.

Etched wiring boards are fed in at one end of the machine and completely assembled bundles removed from the other. Although the machine is planned for magazine-type board feed and an automatic-bundle-transfer head, the feed and removal can be accomplished in any way consistent with the size of the run.

Here, as with the hand method, bundles are transferred to another machine for dip soldering.

### ► Automatic Soldering Machine—

The transfer head at the output of the assembly machine would be equipped with cutter plates which cut excess wires during the transfer cycle. The bundle is transferred to a relatively simple holder on the dipping machine.

The soldering machine is basically an indexing-turret type with

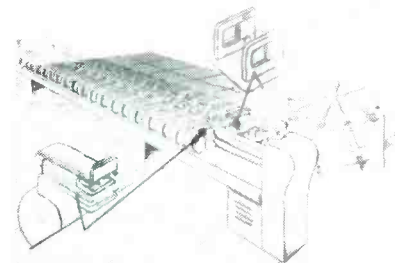

Sketch of automatic assembly and soldering setup planned for use with Paraplate bundles



TYPE 50C, LEFT  
TYPE 50, RIGHT  
240 TO 800 CY.

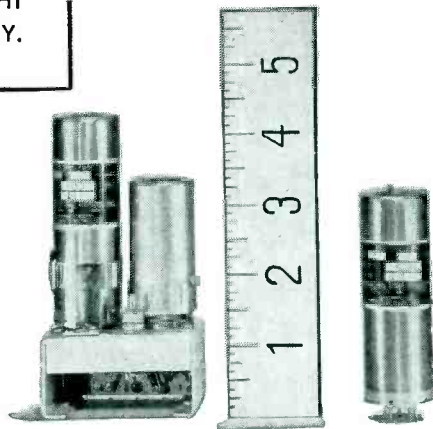

Another  
"New"

**SUBMINIATURIZED**

Introduced here are miniature versions of our popular Type 2003. They have equivalent accuracy but are much smaller, lighter and have fewer component parts. In the Type 50, all critical components are housed within the fork container.

Both the Types 50 and 50C offer superior shock resistance, up to 60 G. Hermetically sealed and shielded. When requesting information, please state type number.

*Precision*

## FREQUENCY STANDARDS ■ AND PRECISION FORKS

PICTURED AT LEFT, ABOVE

### TYPE 50C SPECIFICATIONS

SIZE...2 1/4" x 2" x 4 3/8" high. WEIGHT...8 ozs.  
ACCURACY.....±.02% from -65° to 85°C  
OUTPUT......5V into 250,000 ohms  
TYPE R50C..... Same as Type 50C with  
accuracy of ±.002% from 15° to 35°C

PICTURED AT RIGHT, ABOVE

### TYPE 50 SPECIFICATIONS

SIZE...1" dia. x 3 3/4" high. WEIGHT...3.5 ozs.  
ACCURACY.....±.02% from -65° to 85°C  
OUTPUT......5V into 250,000 ohms  
TYPE R50..... Same as Type 50 with  
accuracy of ±.002% from 15° to 35°C

For 17 years this company has produced precision frequency standards for integration in highly accurate instruments and timing devices of our own and other manufacture. We make frequency standards within a range of 30 to 30,000 cycles, a field in

which we offer maximum accuracy, simplicity and durability. Our products are now serving in many and varied applications—in industry, government (including the armed services, particularly in the field of aviation) and for laboratory uses.

IF YOU HAVE A FREQUENCY PROBLEM AND WILL DESCRIBE IT, WE SHALL BE PLEASED TO SUBMIT OUR RECOMMENDATION TOGETHER WITH PRICE QUOTATION

**American Time Products, Inc.**  
580 Fifth Avenue  
New York 36, N. Y.

OPERATING UNDER PATENTS OF WESTERN ELECTRIC COMPANY



SINCE 1915 LEADERS IN AUTOMATIC CONTROL

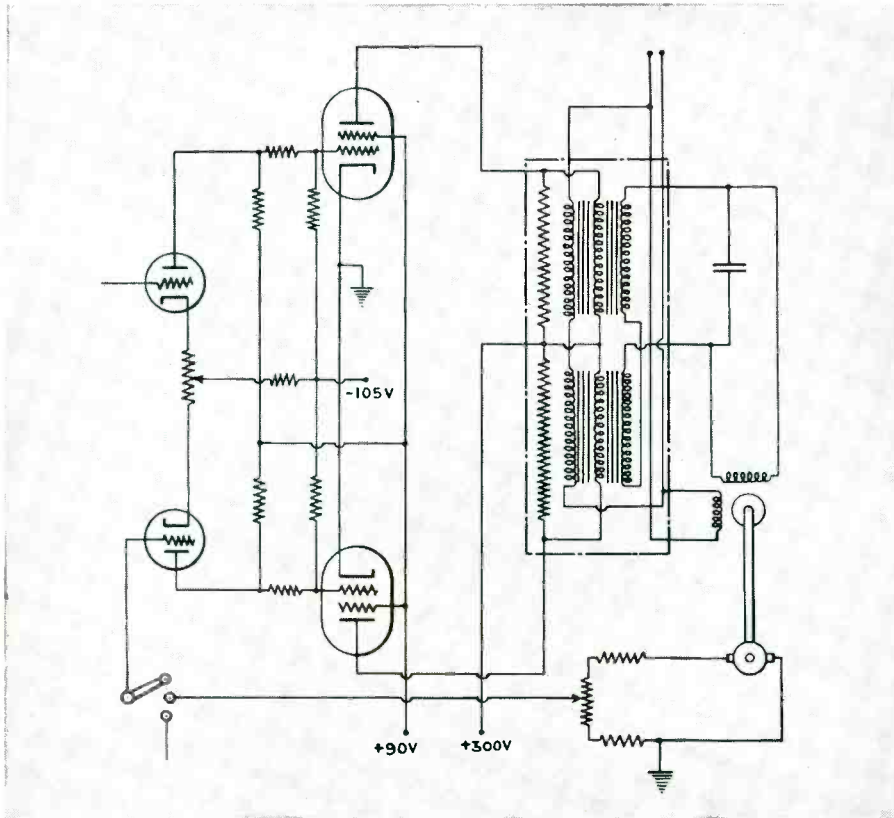

## Servo Motor Control System

Most engineering ingenuity concentrates not on basic principles, which are relatively simple, but on the fine details that make the difference between good and poor design, between high and low cost, or between efficient and inefficient component arrangement. For instance, the motor control system patented by the Ford Instrument Company. The purpose of the system is to provide a sensitive control system to make an induction motor respond accurately to a relatively small reversible input signal. This system employs saturable-core transformers to combine the sensitivity of vacuum tube amplifiers with the high power-carrying capacity of saturated-core devices. This also facilitates the problem of matching the motor impedance with that of the amplifier.

In the circuit shown the first pair of tubes act as a phase inverter, with the control signal applied to the grid of one inverter tube. The feedback signal, produced by a d-c generator coupled to the controlled motor, is applied to the inverter tube. The output of the inverter is the signal of the servo loop. The second pair of tubes acts as a driver-stage for the saturated transformers that supply one winding of the controlled two-phase induction motor; the other motor winding is connected to the power line.

This is typical of the things Ford engineers do . . . every day. If you have a control problem it will pay you to talk to the Ford Instrument engineers.



**FORD INSTRUMENT COMPANY**

DIVISION OF SPERRY RAND CORPORATION  
31-10 Thomson Avenue, Long Island City 1, N. Y.

83

### ENGINEERS

of unusual abilities can find a future at FORD INSTRUMENT COMPANY. Write for information.

vertical-acting dipping arms, similar to the prototype operating on the hand line. The dipping machine features simplicity of action and peninsular location of solutions.

Making full use of advantages gained by modular restrictions and the reliable simplicity of retraction insertion, the inherently high-capacity multihead machine is easily adapted to economical low-volume operation. It is estimated that a 40-head machine equipped with suitable short-run component programming could be completely changed over in less than 15 minutes.

### Dip-Soldering Clamp Masks Tube Socket



Immersing board in first soldering pot. Cake of beeswax in left hand will be wiped over next pot before transferring board to it

A SPRING-LOADED clamp assembly welded to the jaws of long-nosed pliers serves as a convenient tool for holding a small wiring board during dip soldering in RCA's Indianapolis plant. Squeezing the plier handles together opens the disk-shaped jaws of the clamp enough to permit placement over the tube socket. When the jaws are released, the entire tool serves as a handle for immersing the board in the pool of molten solder. The metal disks of the clamp prevent solder from getting into the tube socket contacts.

Two solder pots are used side by side. After immersing the board in the first one, the operator wipes a cake of beeswax over the surface of the second pot and immerses the board in this, to complete the



# A uniquely NEW Oscillograph from Midwestern Instruments

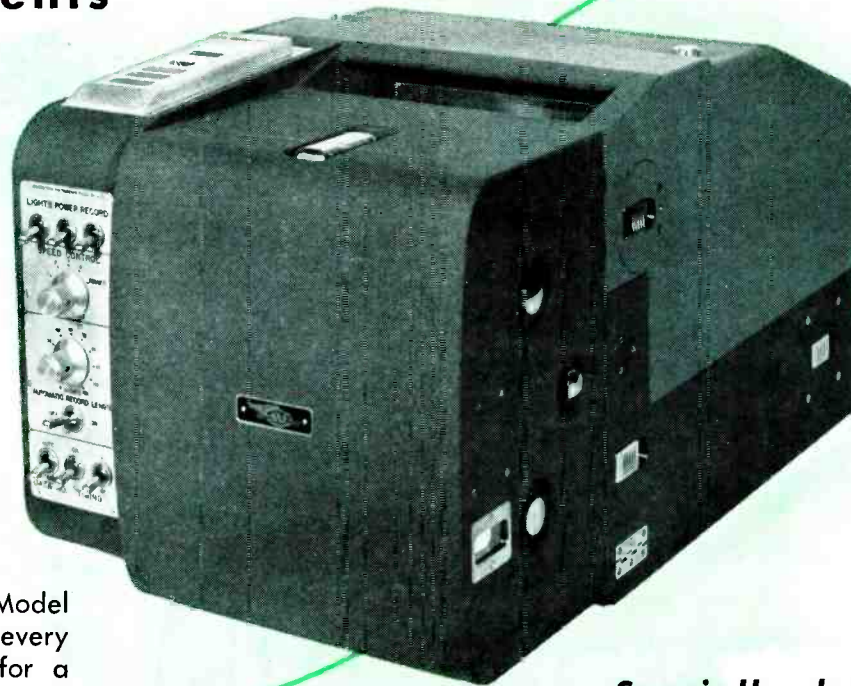

Midwestern's New Model 590 incorporates every feature necessary for a successful flight-test instrument.

**Specially designed  
for remote control\***

*\*If desired the instrument can be supplied with no controls on it. All control then originates at a remote location.*

Here's another great development in Midwestern's series of famous flight-test instruments. It is based on extensive experience applying other Midwestern oscillographs to many combinations of environmental conditions. One of the many features is a remotely-controlled jump-speed system. Speed may be changed at any time by simply positioning a rotary switch to the required setting. 20 recording speeds are possible with this electrically-actuated system and change gears within the oscillograph. Lamp intensities are automatically adjusted to a previously-set value for recording at the new speed. The single aluminum alloy casting is ribbed for the strength and rigidity needed under high acceleration conditions.

*Write for Complete Details and Specifications*

## products

- OSCILLOGRAPHS  
(LABORATORY AND FLIGHT TEST)
- MAGNETIC STRUCTURES
- GALVANOMETERS
- AMPLIFIERS
- HYDRAULIC SERVOVALVES
- TORQUE MOTORS
- SERVOAMPLIFIERS
- DATA REPEATERS
- WATERPROOF CONNECTORS
- GEOPHYSICAL EQUIPMENT



## MIDWESTERN INSTRUMENTS

41st and Sheridan Road

Tulsa, Oklahoma

# Do you have source spots?

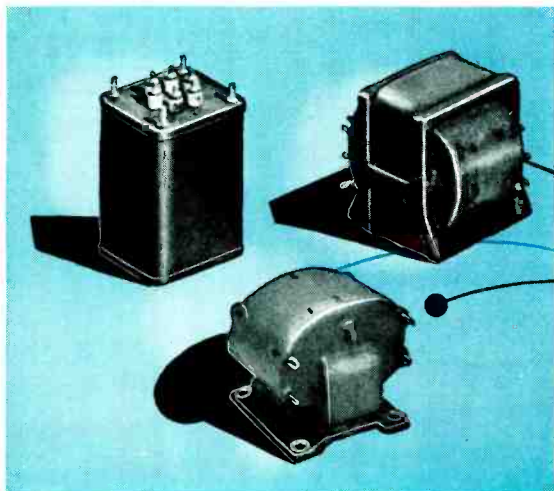

Every design engineer or production man we ever met makes mental notes of good places to get quick aid on needs out of the ordinary.

You might like to know, therefore, that a great deal of the work we do here at Wheeler on transformers, coils, harnesses, custom-built electronic assemblies, and communications components is just that kind of assignment.

We publish no catalog of the everyday standard items . . . they present no problem to anyone. We do serve an increasing group of engineering and production departments that require competent help . . . backed by ample manufacturing facilities . . . in producing components that are "a little (or a lot) different." Call or write us for an interesting story.

TRANSFORMERS • COILS • AMPLIFIERS  
CUSTOM ELECTRONIC AND WIRING ASSEMBLIES  
COMMUNICATIONS EQUIPMENT

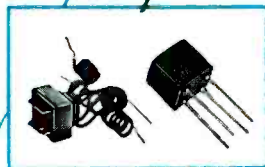

Wheeler is constantly adding to its staff of engineers. If you are available and quality in this field, call us now.

**THE WHEELER**  
INSULATED WIRE COMPANY, INC.

Division of Sperry Rand Corp.  
1101 EAST AURORA STREET  
WATERBURY 20, CONNECTICUT

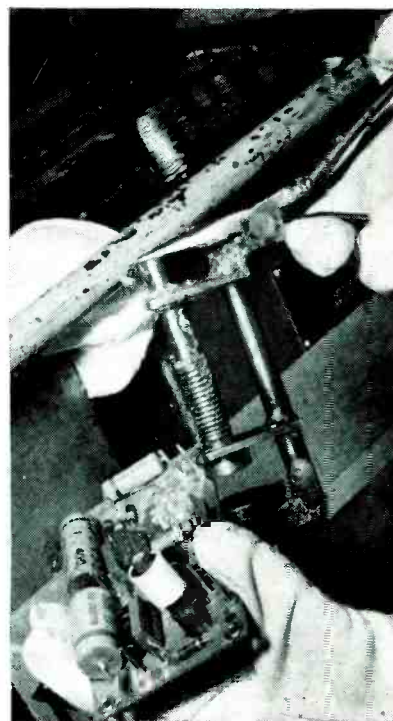

Method of placing clamp over socket of wiring board

buildup of solder over each of the clinched leads. The double-pot technique has greatly improved the reliability and uniformity of dip-soldered joints on etched wiring boards used in the firm's radio and television receivers.

## Automatic Tester for Ferrite Memory Cores

FERRITE storage cores are automatically tested and graded by International Telemeter Corp. of Los Angeles with a new machine incorporating a Syntron model EB-01-B vibrating parts feeder. The cores are placed in the feeder, which lines them up and delivers them down a chute to a mechanism that sorts into sixteen uniform

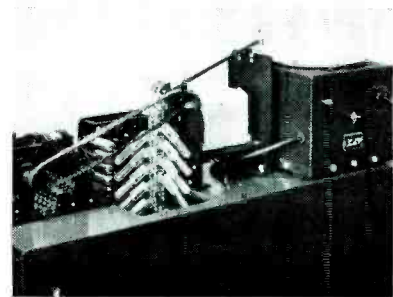

Core tester, with feeder at right, sorting mechanism at center and motor drive at left





# 1100-cm/ $\mu$ sec writing rate!



**Price \$3500**

f.o.b. Portland (Beaverton), Oregon

Includes indicator unit, power-supply unit, scope-mobile, cathode-follower probe, 7-step attenuator unit, viewing hood, bezel, 170-ohm cable.

Complete specifications and information on demonstration schedules are available from your local Tektronix Field Office or Representative, or from...

## **Tektronix, Inc.**

P. O. BOX 831, PORTLAND 7, OREGON  
Cypress 2-2611 • Cable: TEKTRONIX

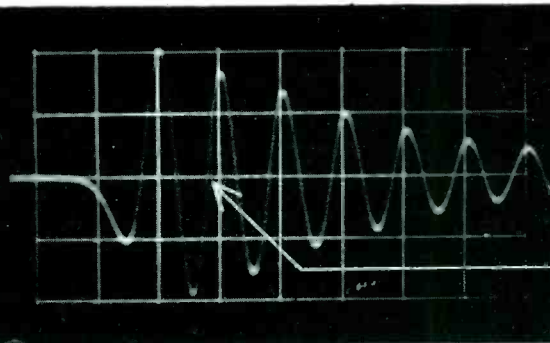

Arrow indicates 1100-cm/ $\mu$ sec writing-rate point on 100-mc damped oscillation, displayed on single 0.01  $\mu$ sec/cm sweep of Type 517A Oscilloscope with T54P11H crt. Recorded on 35-mm TRI-X film at  $f$  1.9 with 4.2 to 1 reduction, developed 26 minutes in D-19 at 68° F.

The Tektronix Type 517A Cathode-Ray Oscilloscope has the high writing rate, faithful transient response, fast sweeps, and dependable stability necessary for accurate analysis of single high-speed occurrences. Improvements in several performance areas, made possible by the development of a new Tektronix high-voltage cathode-ray tube, make the Type 517A even more useful than its famous predecessor, the Type 517. Sensitivity of the Type 517A is double that of the Type 517, both sweep and vertical linearity are improved, and the viewing area is increased to a full 4 cm by 8 cm. An automatic duty-cycle limiter prevents accidental damage to sweep-circuit components. The exceptional performance characteristics and accurate display of the Type 517A can speed up progress in work involving high-speed transients.

**Transient Response — Risetime seven millimicroseconds.**

No overshoot or ringing.

**Maximum Sensitivity — 0.05 v/cm.**

**Sweep Range — Eleven calibrated sweeps** from 0.01  $\mu$ sec/cm to 20  $\mu$ sec/cm. Each can be adjusted to the accuracy of an external standard.

**Regulated Accelerating Potential —** 24 kv on T54P11H Tektronix metallized precision cathode-ray tube.

**Low Displacement Error —** Less than 1% of 8 cm horizontal, less than 2% of 2 cm vertical.

**Rate Generator —** 15 to 15,000 cycles, accurate within 5% of full scale.

**Amplitude Calibrator —** Pulse-type, accurate within 4% of full scale.

**Regulation —** All dc supplies electronically regulated. Indicator-unit heater voltages regulated.

**Calibrated Horizontal-Position Vernier**

*In the newest  
computers...*



## BRUSH MAGNETIC HEADS

*help provide system  
flexibility—accuracy—high  
storage density*

### IN DRUM MEMORY SYSTEMS...

Several basic Brush multichannel and single channel heads (and their modifications) permit flexibility in Magnetic Drum design. Low loss materials provide greater magnetic head efficiency.

### IN TAPE MEMORY SYSTEMS...

Precision construction of Brush multichannel heads with close tolerances on gap and track alignment permits greater pulse packing and closer track spacing. Equipment can be designed with increased storage capacity and faster access with Brush heads.

For specifications on standard products or designs to your requirements, write Brush Electronics Company, Dept. K-12A, 3405 Perkins Avenue, Cleveland 14, Ohio.

## BRUSH ELECTRONICS COMPANY

*Division of  
Clevite Corporation*



BK-1300 series—up to 25 interlaced channels per inch.



BK-1500 series—ultimate in precision-made multichannel heads.

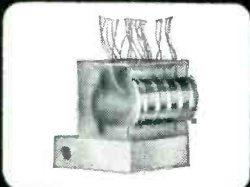

BK-1605 series—simple mounting and adjustment, ideal for drum computers.



BK-1501 series—compact, wafer-thin, permit individual adjustment.



BK-900, BK-1000, BK-1200 series—variety of types for single channel applications.

grades on the basis of magnetic properties. The tester is able to handle one core per second; in this time, as the core passes through the test contacts, 5,000 separate trials of each of two tests are made.

## Mounting Picture Tube in Color TV Cabinet

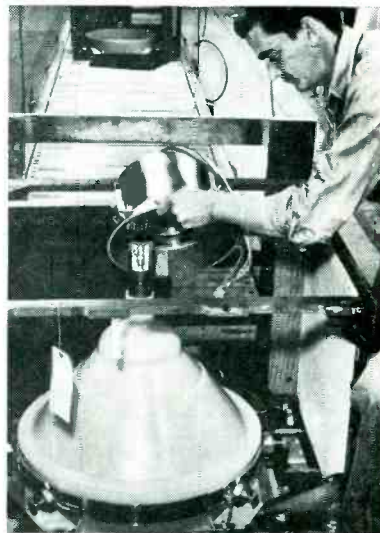

Placing yoke assembly over neck of color picture tube. Tube rests on molded plastic ring which can be seen in cabinet at rear on conveyor

ON THE final cabinet assembly line for 26-tube color-tv consoles in RCA's Bloomington, Ind. plant, the cabinet is placed face down on a wood slat conveyor. This position simplifies the installation of the molded plastic support ring for the picture tube, which is fastened with wood screws driven by an air gun. The picture tube, with molded plastic jacket over its metal wall and

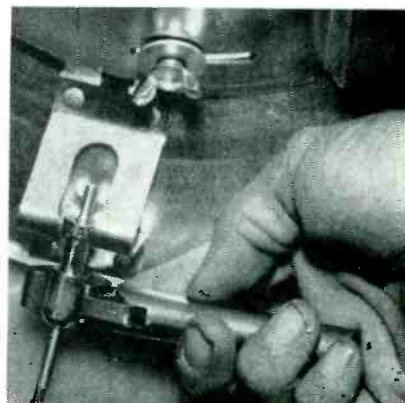

Using special cam-action ratchet wrench to tighten knurled nut on one of three tie rods that hold picture tube assembly against front of cabinet



**TOPS for  
All Electrical Uses**



# CLEVELITE\*

## LAMINATED PAPER BASE PHENOLIC TUBING

Outstanding for many years as the Top Performer, Clevelite is unmatched in its ability to meet unusual specifications.

Built-in Dimensional Stability, High Dielectric Strength, Low Moisture Absorption, Great Mechanical Strength, Excellent Machining Qualities and Low Power Factor make Clevelite Tubing outstanding.

Available in diameters, wall thicknesses and lengths as desired, for Collars, Bushings, Spacers, Cores and Coil Forms.



Our improved Torkrite internally threaded and embossed tubing affords better control of adjustments in coil forms using threaded cores.

Write for your copy of the latest Clevelite brochure.

WHY PAY MORE? For Good Quality . . . call CLEVELAND!

\*Reg. U. S. Pat Off.

### THE CLEVELAND CONTAINER COMPANY

6201 BARBERTON AVE. CLEVELAND 2, OHIO

PLANTS AND SALES OFFICES:

CHICAGO • DETROIT • MEMPHIS • PLYMOUTH, WIS. • OGDENSBURG, N.Y. • JAMESBURG, N.J. • LOS ANGELES

ABRASIVE DIVISION at CLEVELAND, OHIO

Cleveland Container Canada, Ltd., Prescott and Toronto, Ont.

**Representatives:**

NEW YORK AREA: R. T. MURRAY, 604 CENTRAL AVE., EAST ORANGE, N. J.  
 NEW ENGLAND: R. S. PETTIGREW & CO., 62 LA SALLE RD., WEST HARTFORD, CONN.  
 CHICAGO AREA: PLASTIC TUBING SALES, 5215 N. RAVENSWOOD AVE., CHICAGO  
 WEST COAST: IRV. M. COCHRANE CO., 408 S. ALVARADO ST., LOS ANGELES

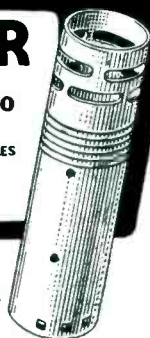

Take advantage of our  
Fast Dependable Delivery.

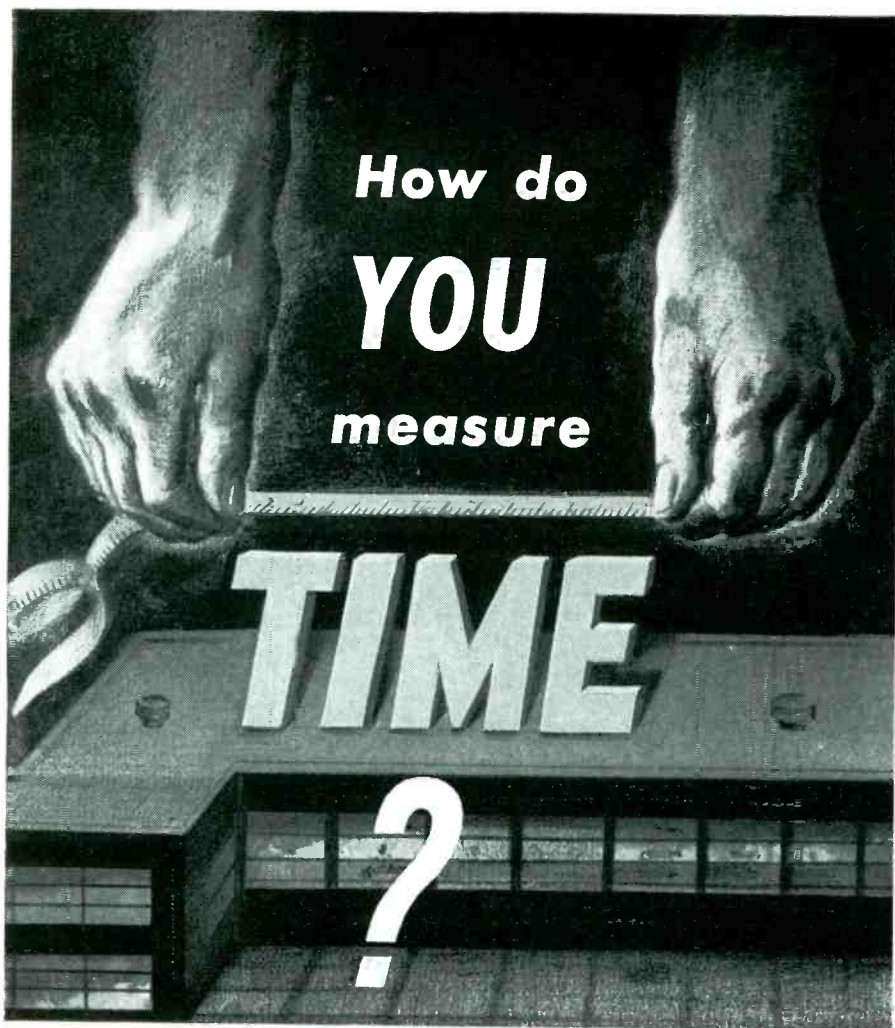

*If your business involves measuring time in hours, minutes or seconds, you know that there are other, equally important standards of measure for Time and Timing. Check your present Timing sources; how do they measure up in terms of —*

**QUALITY?** — Remember that HAYDON\* has the complete, up-to-the-minute research and manufacturing facilities, the long experience and the skilled personnel essential to producing Timing Motors and Devices of the highest uniform quality and the most advanced design.

**COMPLETE SERVICE?** — Ready to serve you for all your timing needs, HAYDON has the complete, fully integrated engineering and manufacturing facilities to take your timing projects from design and development through to finished product . . . economically manufactured in small or large lots to meet your requirements.

**TRAINED REPRESENTATIVES?** — Making all of these facilities and services conveniently available to you are HAYDON's Field Engineers. Each of these men is a Timing Specialist . . . fully qualified by training and experience to help fill your timing needs. There is one of these Specialists in your area. Why not phone him today and make an appointment to discuss your requirements!

\*Trademark Reg. U.S. Patent Office

**HAYDON**  
AT TORRINGTON

---

HEADQUARTERS FOR  
**TIMING**

A SUBSIDIARY OF GENERAL TIME CORP

**HAYDON Manufacturing Company, Inc.**  
2436 ELM STREET, TORRINGTON, CONNECTICUT



Method of degaussing yoke assembly. Earth's-field compensating magnets can be seen on band surrounding rim of picture tube. Yoke tie-rods go to metal inserts in wood corner brackets

with the earth's-field compensating magnets mounted around its rim, is then lowered into position on the plastic ring.

The yoke assembly is brought down over the neck of the picture tube, and three steel tie rods are run from the cabinet to the frame of the yoke to hold the entire picture tube assembly in position. A special ratchet wrench is used to tighten the knurled nut that goes



New 26-tube color-tv consoles on wood shipping pallets ride down slat conveyor at lower level and are pushed up over rollers on incline to start of next slat conveyor at higher level, for passage through screened and partially darkened final test rooms



Speed-Up Your Work with the *All-New*  
**RCA SENIOR VOLT OHMYST®**

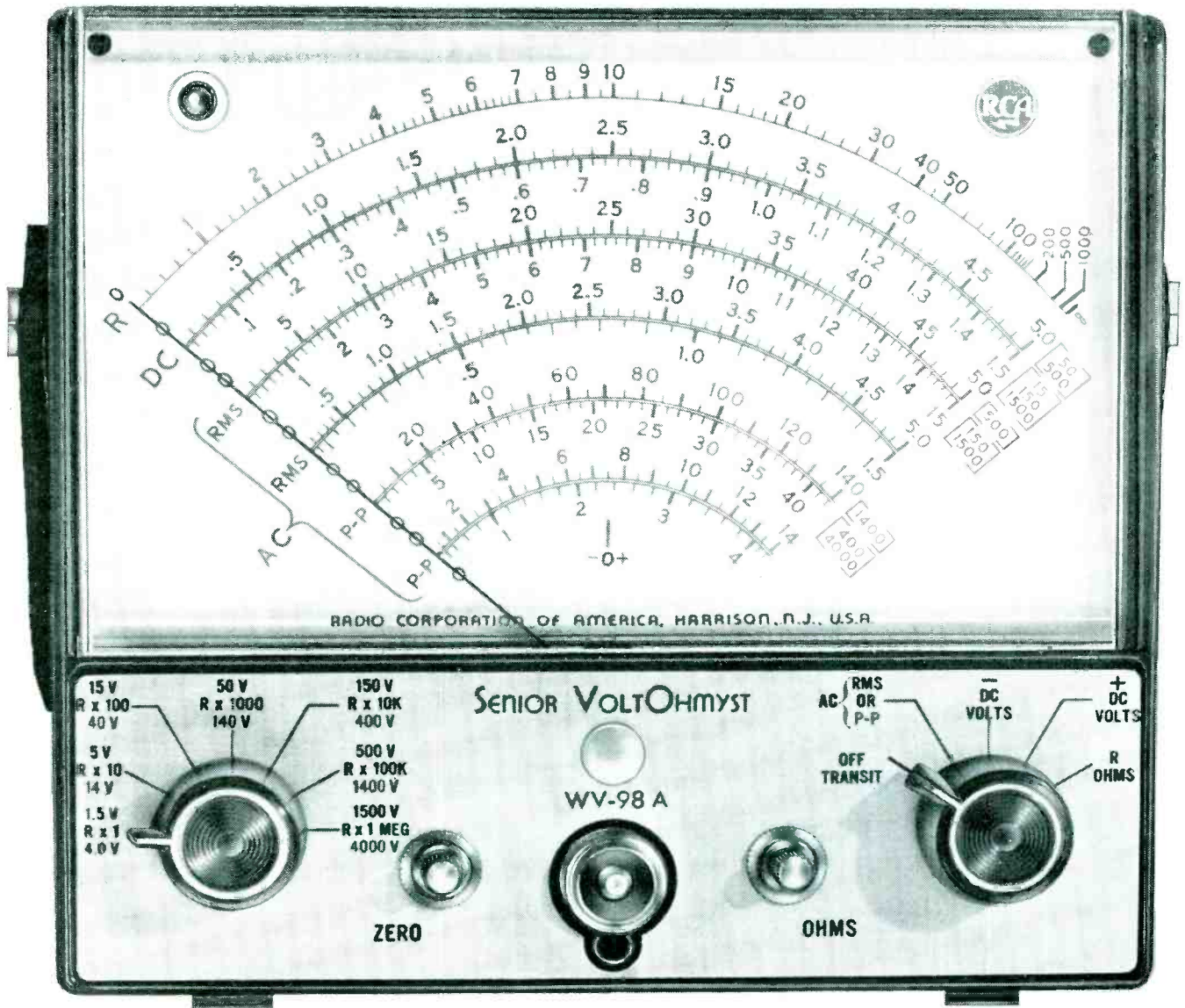

Senior VoltOhmyst, RCA WV-98A, only \$75.00 User Price\* including probe and cable, instruction booklet, complete and ready-to-use . . . Shown slightly smaller than actual size.

\* Optional

*new!*

You can work faster, more accurately—when you own and use the new RCA WV-98A SENIOR VOLT OHMYST with the extra-large full-vision meter-face. “Speed-up” in your service work—without the slightest sacrifice in quality—means a “build-up” in your profits. Look at the easy-to-read expanded scales. Then look at some of the other advanced features you also get.

- Large, easy-to-read, wide-vision meter (6½" w).
- Expanded meter scales . . . separate peak-to-peak voltage scales.
- Accuracy of 3% full-scale on BOTH ac and dc voltage measurements.
- Sturdy, single-unit streamlined probe with built-in ac-ohms/dc switch.
- Rugged die-cast aluminum case.
- Compact design: 7" wide, 3¾" deep, 6½" high, 6 lbs.

The all-new WV-98A has all the important, time-proved performance features of earlier VoltOhmysts including direct reading of peak-to-peak voltages of complex waveforms. See this highly accurate, versatile, service instrument at your RCA Distributor! Order now.

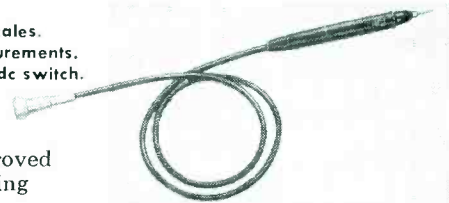

NEW! WG-299A slim, single unit DC/AC-Ohms Probe and Shielded cable is provided with the RCA WV-98A. Probe has handy built-in switch permitting instant selection of dc or ac/ohm operation.



**RADIO CORPORATION of AMERICA**  
 TEST EQUIPMENT HARRISON, N. J.

® Trade Mark "VoltOhmyst" Reg. U.S. Pat. Off.

# "PRINTED CIRCUIT OUTPUT UPPED *when we* switched to HUNT R.C.E." (RAPID CIRCUIT ETCH)

## —the FASTEST ETCHING SOLUTION for PRINTED CIRCUITS

Here indeed is good news for all makers of etched printed circuits. Philip A. Hunt Company, world-famous makers of photographic and photo-engraving chemicals, now offers Hunt R.C.E. Solution, a special etching solution with these BIG advantages, *guaranteed*:

1. Controlled rapid etching speed, permitting standardization of a high production etching schedule
2. Instant and uniform etching over entire circuit
3. Maximum etching capacity
4. Full protection of tops

Contact your nearest Hunt branch, or write us at Palisades Park, N. J., today for full information on Hunt R.C.E. Solution.

*Hunt R.C.E.  
Solution is  
supplied in  
145 lb. rubber  
drums*



## PHILIP A. HUNT COMPANY

PALISADES PARK, N. J.

Chicago • Cleveland • Cambridge • Brooklyn • Atlanta • Dallas • Los Angeles • San Francisco

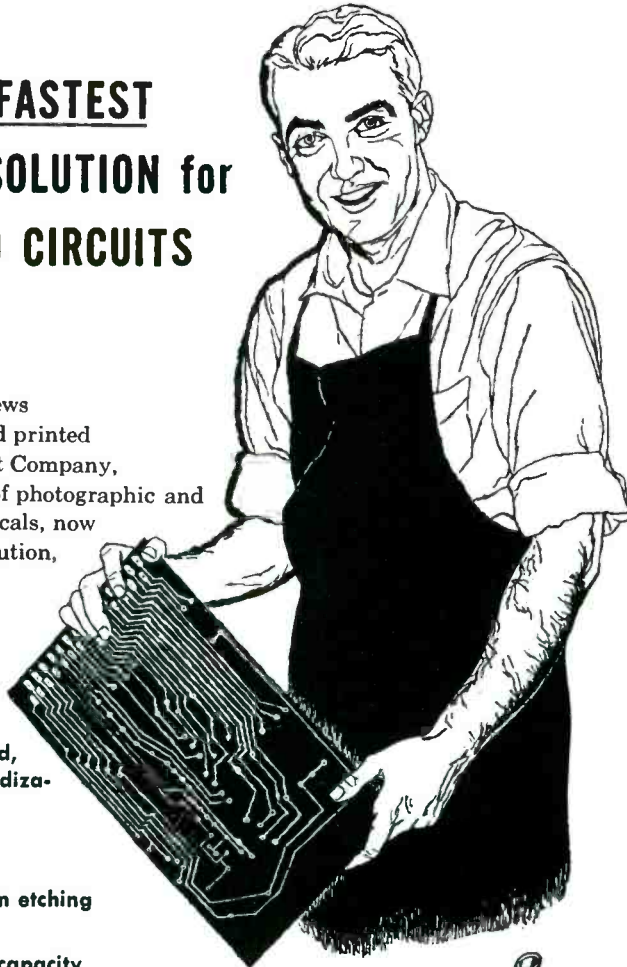

over the threaded end of each tie rod.

The final step is degaussing the yoke structure. This is done by lowering over the neck of the picture tube a large coil connected to the 115-volt a-c line, leaving it there about 10 seconds, then slowly lifting up the coil.

After mounting the picture tube, the cabinet is turned upright and assembly is completed at subsequent positions on the conveyor. The back cover and the removable top of the cabinet are put on last. The top is made removable so that servicemen can reach in from above to adjust the earth's-field compensating magnets around the rim of the picture tube.

## Substitutes for Eyelets in Etched Wiring

By L. J. MARTIN and M. J. VAVRA  
*Weapon Systems Development  
Laboratories  
Hughes Aircraft Co.  
Culver City, Calif.*

OPEN circuits and poor joints are a major threat to etched circuit reliability. Open circuits are most apt to occur in the vicinity of connections to component leads, either through failure of soldered connections or through breakage of the etched conductors. Bond strength between the conductor and laminate is limited and may be impaired if a connection is overheated by hand-soldering, as in replacing components. These conductors are unable to withstand heavy stresses applied by component leads if these stresses tend to pull the conductor away from the laminate or even to rotate or shear the bond. They are, however, amply immune to stresses directed toward the laminate. This is illustrated in Fig. 1.

Connections should be protected

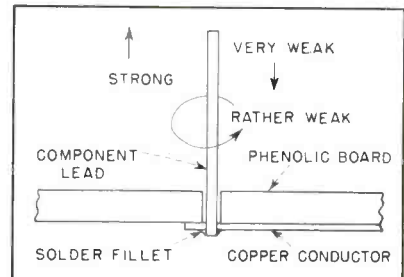
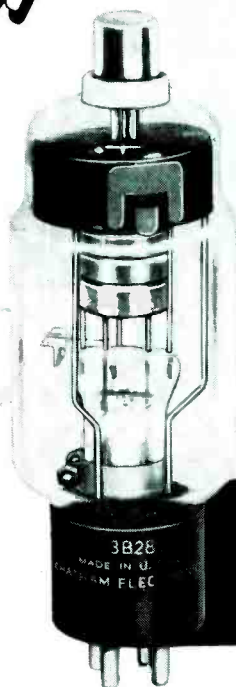
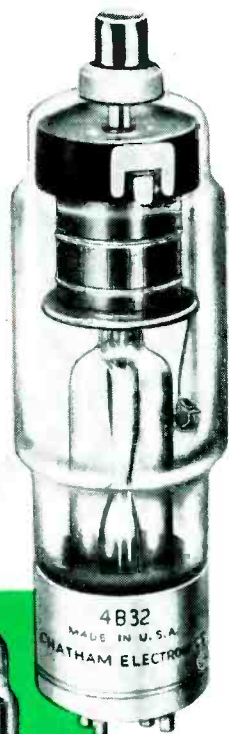

FIG. 1—Ability of conventional lead to withstand stresses in various directions when soldered to etched wiring board



**CHATHAM** advance-designed yesterday

— in  
industry-wide  
use today!



AMPLIFIERS • REGULATORS • INERT GAS  
AND MERCURY RECTIFIERS • MERCURY,  
INERT GAS AND HYDROGEN THYRATRONS

# CHATHAM SPECIAL-PURPOSE TUBES



● **3B28 RECTIFIER**

Rugged half-wave Xenon filled rectifier. Operates in any position. Ambient temperature range  $-75^{\circ}$  to  $+90^{\circ}\text{C}$ . Inverse peak anode voltage 10,000, average current .25 amps. Filament 2.5v., 5 amp.

● **4B32 RECTIFIER**

Ruggedly built, half-wave Xenon filled rectifier. Ambient temperature range  $-75^{\circ}$  to  $+90^{\circ}\text{C}$ . Inverse peak anode voltage 10,000, average current 1.25 amp. Filament 5v., 7.5 amp.

● **VC-1258 MINIATURE HYDROGEN THYRATRON**

for pulse generation. Handles 10 kw peak pulse power.

● **6336 TWIN TRIODE**

for voltage regulation. Features high plate dissipation, hard glass envelope.

● **5R4WGB RECTIFIER**

Full wave rectifier manufactured to MIL-E-1B reliable tube specifications.

● **5651-WA VOLTAGE REFERENCE TUBE**

Stable, rugged. Available in both commercial or reliable tube MIL types.



5R4WGB



VC-1258



5651-WA

STANDARD TYPES DIRECT FROM STOCK

PLUS SPECIAL DESIGNS BUILT TO REQUIREMENTS

Chatham specializes in the development of general and special purpose tubes for both electronic and industrial applications. Many of the tubes originally developed by Chatham to fill a specialized need, now number among the most widely used tubes in the industry. For complete information on Chatham tubes — either stock items or types built to your requirements — call or write today.

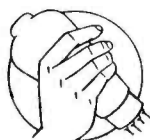

**CHATHAM ELECTRONICS**

Division of Gera Corporation — LIVINGSTON, NEW JERSEY

# INSTRUMENTS INDUSTRY NEEDS

Hycon engineering skill and design keep pace with ever-changing industry, producing instruments that anticipate need—designed to simplify and speed production. Depend on Hycon for electronic testing equipment.

## MODEL 625 DIGITAL RATIO METER

Measures ratio of two DC voltages where one is derived from the other. Ratio is displayed on a three digit servo-positioned counter. Provides a discreet indication of one part in a thousand. Slewing time is less than  $4\frac{1}{2}$  seconds full scale. The response is critically damped. **\$550<sup>00</sup>**



## MODEL 615 DIGITAL VTVM

Ideal for production-line testing and the laboratory, this new VTVM gives direct readings, without interpolation. Features illuminated digital scale with decimal point and polarity sign... 12 ranges (AC, DC, ohms)... response with auxiliary probe to 250 mc... accuracy: 1% on DC and ohms; 2% on AC. **FIELD RUGGEDNESS... LAB PRECISION \$374<sup>50</sup>**

## MODEL 617 3" OSCILLOSCOPE

Designed both for color TV servicing and laboratory requirements. Features high deflection sensitivity (.01 v/in rms); 4.5 mc vertical bandpass, flat within  $\pm 1$  db; internal 5% calibrating voltage. Small, lightweight... but accurate enough for the most exacting work. **SPECIAL FLAT FACE 3" CRT PROVIDES UNDISTORTED TRACE EDGE TO EDGE \$269<sup>50</sup>**



Write for catalog sheets and detailed specifications of any of the instruments shown above — or for complete list of Hycon field testing equipment.

**Hycon**  
**ELECTRONICS, INC.**

321 SOUTH ARROYO PARKWAY  
PASADENA, CALIFORNIA

A SUBSIDIARY OF HYCON MFG. COMPANY

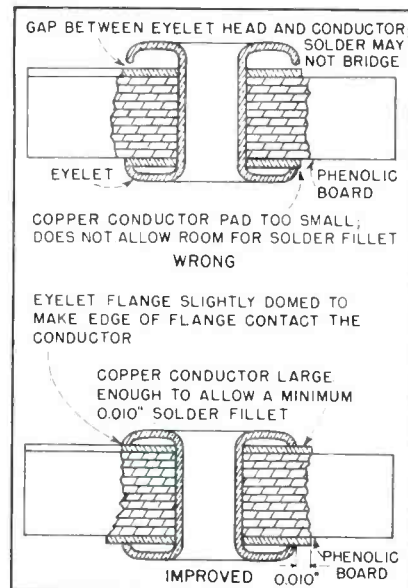

FIG. 2—Forming of eyelets on etched wiring

from those stresses to which they are weak, either by forming the leads and placing the components to prevent these stresses or by reinforcing the connections with eyelets.

► Drawbacks of Eyelets—Eyelets frequently are used to provide interconnection between etched wiring on opposite sides of the board, as well as to provide mechanical bonding of the conductors to the board. This use of eyelets allows repeated change of components without danger of lifting the conductors from the base material. These eyelets, however, form additional links in the wiring and unless properly used may be a source of unreliability. Gold-plated or solder-plated eyelets wet readily when solder-dipped, this being essential for obtaining reliable joints. After plating, the eyelets should be cleaned, dipped in stearic acid flux and baked dry.

Installation of eyelets is accomplished by applying controlled pressure to a pair of eyelet-heading dies. The shape of the forming cavity of the die is important. Improper forming of the eyelet heads may cause poor solder joints, as illustrated in Fig. 2. Improper eyeletting can, and has, caused unreliability of the most troublesome kind because, when corrosive flux residues become trapped under their heads, failures may develop



# TAYLOR

Laminated Plastics  
Vulcanized Fibre

# Shop Talk

TAYLOR FIBRE CO.

Plants in Norristown, Pa. and La Verne, Calif.

PHENOL—MELAMINE—SILICONE—EPOXY LAMINATES • COMBINATION LAMINATES • VULCANIZED FIBRE • POLYESTER GLASS ROD

## Tips for designers

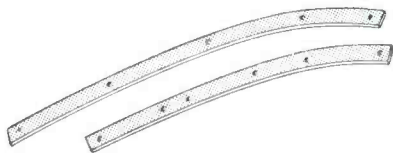

**Sealing strips** for crew doors of 4-engine commercial transport plane are made from Taylor canvas base phenol laminate . . . chosen for its flexibility and long-wearing qualities.

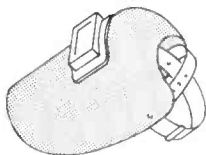

**Welders' helmets** are fabricated from tough, durable Taylor Vulcanized Fibre . . . readily formed to many desired contours.

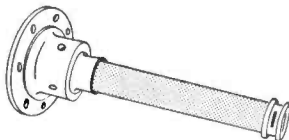

**Aircraft fuel gage tank unit** uses a tube of Taylor Epoxy Glass Base Laminate . . . an unusual material noted for excellent corrosion resistance and electrical insulation over a wide humidity range.

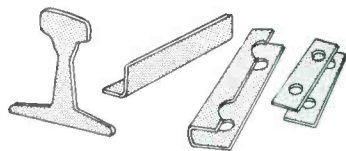

**Railroad track-joint insulation**, a specially developed grade of Taylor Vulcanized Fibre, withstands heavy impacts and mechanical stress of high-speed trains.

### TAYLOR FABRICATING FACILITIES

Your production can be simplified . . . schedules safeguarded . . . inventory headaches cured . . . and overall costs reduced by having Taylor fabricate finished parts to your specifications. Efficient, modern facilities are ready to serve you. Get in touch with Taylor about your requirements.

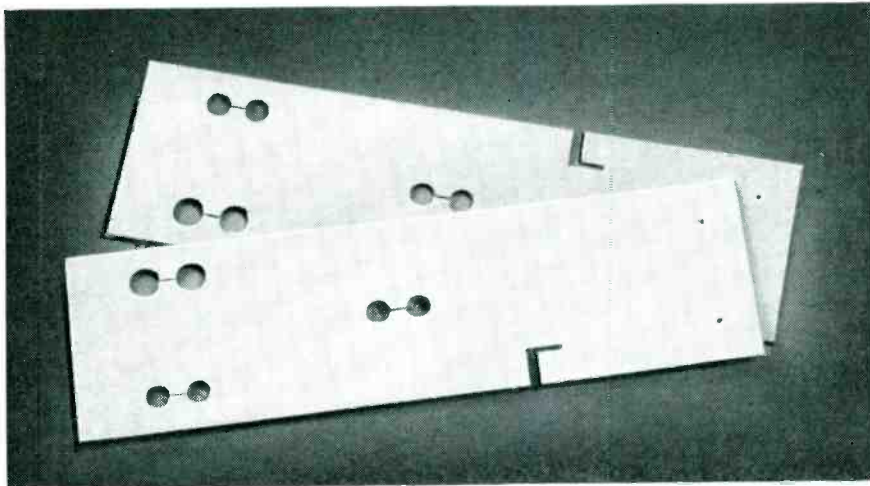

Support for antenna lead in is punched from Taylor Insulation . . . a light-weight, flexible material ideal for mechanical applications and rough usage.

## New Products, too, Use Tough, Flexible Taylor Insulation

When you're designing new products or modernizing old ones, take advantage of the unique characteristics . . . both in performance and economy . . . of Taylor Insulation. Also called "fish paper," this versatile material has long been a favorite of designers. It offers properties that have not been duplicated by more recently developed materials . . . many of which Taylor also makes.

Most outstanding properties of Taylor Insulation are its extreme toughness, excellent bending qualities, high dielectric strength and arc resistance. Its durable surface withstands abrasion. It is an ideal insulating material for slot wedges in electric motors, for field coils, for transformers, and for arc shields.

Taylor Insulation is not limited to insulation work. Its strength, tough-

ness and resistance to many chemicals qualify it for gaskets, washers, metal box liners and a wide variety of mechanical products.

To insure uniformity of its useful characteristics, Taylor Insulation's base is a high grade rag paper manufactured in Taylor's own paper mill. Taylor Insulation comes in sheets, strips, rolls and coils for high speed production equipment . . . sheets approximately 56" x 90", and rolls up to 56" wide.

Write to Taylor for a copy of its general catalog with complete technical data on this and other grades of Taylor vulcanized fibre and laminated plastics. And have a Taylor engineer consult with you for specific recommendations on your particular materials application.

**the future resides  
IN MEN WITH  
IMAGINATION!**

# los alamos scientific laboratory

*... the nation's most important institution for the development of nuclear and thermonuclear weapons is seeking professional engineers and scientists, particularly those vitally interested in the development of the atomic age.*

*In addition to its continuing and ever-expanding achievement in weapons research, the Laboratory is now pioneering in the fascinating fields of nuclear and thermonuclear power and nuclear propulsion.*

*At the Laboratory, staff members have the opportunity of associating with leaders in research and experimentation... of working with some of the Western World's finest equipment and facilities... of winning recognition... of achieving advancement commensurate with ability.*

*If you would like more information about the Laboratory's career opportunities which are not civil service... about the delightful climate and area in which Los Alamos is located,*

send your inquiry to

DEPARTMENT OF  
SCIENTIFIC PERSONNEL  
Division 303

**los alamos**  
scientific laboratory  
OF THE UNIVERSITY OF CALIFORNIA  
LOS ALAMOS, NEW MEXICO

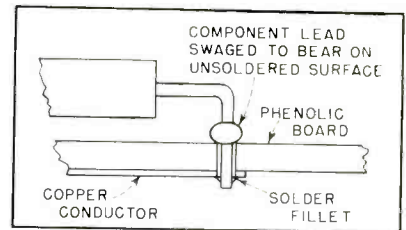

FIG. 3—Method of swaging component lead to obtain greater mechanical strength in etched wiring assembly

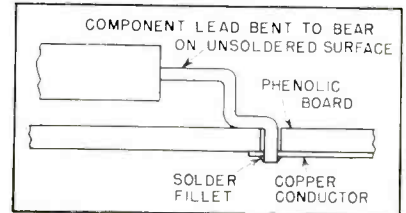

FIG. 4—Method of forming component lead to obtain greater strength

later. Not only are proper forming and soldering difficult, but the labor required is costly and this destroys much of the economic attractiveness of dip-soldered etched circuitry. Consequently, there is a trend toward eyelet elimination.

►Eyelet-Eliminating Techniques—

If wiring boards are to be produced without eyelets, provision must be made to insure that the stresses applied to the leads of components cannot be transmitted to the conductor on the board in such a manner as to tear it away from the base material or fracture it. This can be done by swaging the component lead on the unsoldered side, as shown in Fig. 3. Another method is to form the lead in such a manner that it bears against the unsoldered surface for a short distance before it enters the hole (Fig. 4). Still another way is to arrange the components for edge-dipping as in Fig. 5. This provides

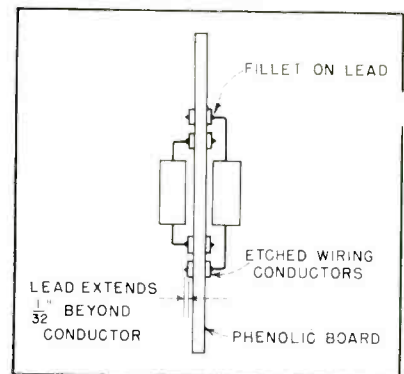

FIG. 5—Arrangement of components for edge dip soldering, to obtain strong fillets on both sides of board





# DIANA RADAR

In this age of man-made satellites, knowledge of space is being expanded by the moon radar system now in operation by the U.S. Army Signal Corps at Belmar, N. J.

Both the transmitter and receiver, which were designed and manufactured by REL, are held stable by a single crystal to better than one part in  $10^6$ . Output power is 50 kw, and frequency is 151.11 mc. The receiver noise factor is better than 3 db, with gain of 170 db.

REL's world-famed experience and facilities are available for the solution of your specialized radio problem.

*Seventh in a series describing REL versatility*

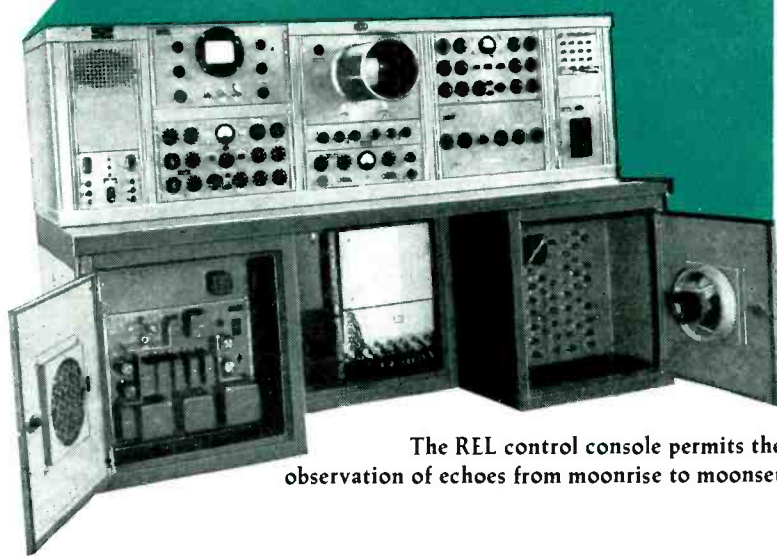

The REL control console permits the observation of echoes from moonrise to moonset

## RADIO ENGINEERING LABORATORIES · INC.

36-40 37th St · Long Island City 1, N. Y.

STillwell 6-2100 · Teletype: NY 4-2816

Canadian representative:

Ahearn & Soper Co., P. O. Box 715, Ottawa

MOON PHOTOGRAPH: G. P. SERVISS



# Phalo Cables are Customer-Made...

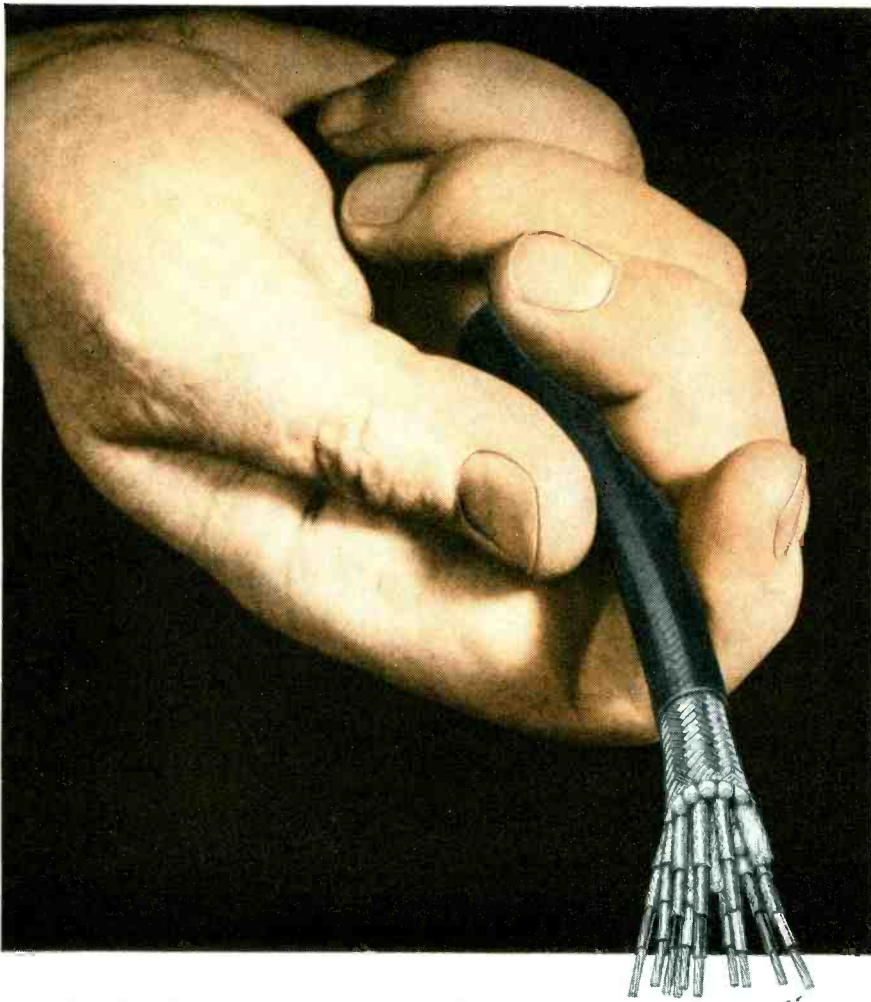

## ...Ask Any of Our "Custom" Customers!

Because this statement could be made by many Phalo customers who saw us turn "specs" into a custom cable built for their express purpose, we have not shown the personality behind this statement.

We can, however, show you some very interesting examples of the scope of

Phalo's custom cable operation . . . and we can translate your "specs" however complex and exacting they are.

If you're holding cable specs that are holding up progress and you wish you were holding the finished custom cable, get hold of your Phalo man.

*Ask For The Complete Phalo Catalog*

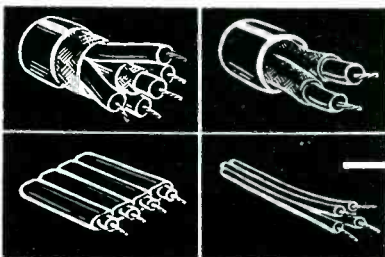

# PHALO

PLASTICS CORPORATION

*The Custom Cable House*

CORNER OF COMMERCIAL STREET  
WORCESTER, MASS.

Insulated Wires, Cables - Cord Set Assemblies

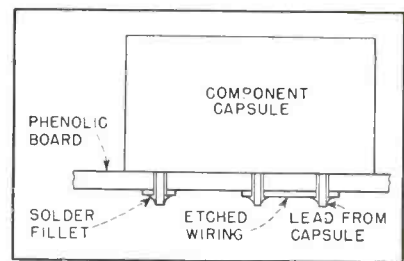

FIG. 6—Mounting component flat on board gives greater strength

a fillet of solder around the lead on both sides of the board, preventing the stripping of conductors from the board by a force exerted on the lead from the component side of the board. Eyelets also can be eliminated when leads emerge from the bottom of a component capsule, as in Fig. 6.

### ► Coatings for Wiring Boards—

After the etched circuit assembly has been completed, it often is desirable to coat the board to control subsequent surface contamination. The requirements of a good protective coating are: high humidity resistance consistent with good recovery properties; adequate electrical properties; cure at 75C or less so that the coatings can be cured in the presence of temperature-sensitive components; good physical properties such as adhesion to the board; transparency so color coding can be recognized; easy application in the required thickness.

Although the ideal coating which will meet all of the above requirements has not been found, coatings can be selected which will most closely meet the desired application.

A 5-mil coating, although difficult to apply, gives a reasonable compromise between good humidity protection and rapid recovery. Thicker coatings show greater resistance to humidity exposure but show slower recovery after long exposure and also make component replacement very difficult.

### Grounding Wiring Boards

AFTER installation of the assembled etched-wiring boards on the metal chassis with self-tapping screws, an operator on Admiral's assembly line solders certain of the screws to the chassis to insure good per-



AEROCOM'S 1046 H. F. TRANSMITTER

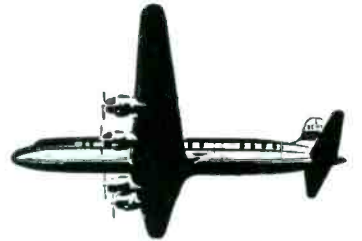

# POWER + STABILITY

1000 WATTS

WITH

.003% STABILITY

Rugged, versatile general purpose H. F. transmitter—Aerocom's 1046 packs 1000 watts of power and high .003% stability under normal operating conditions (0° to +50°C.). Excellent for point-to-point or ground-to-air communications.

Multi-channel operation on telegraph A1, or telephone A3 with GM-8A modulator... new Aerocom 1046 can be *remotely controlled* with TMC-R at control position and uses only one pair of telephone lines. In A3 operation, the local dial control panel is located in modulator cabinet.

Transmitter cabinet has 8¾ inch panel space available for either local dial control panel or frequency shift keyer.

Model 1046 operates on 4 crystal-controlled frequencies (plus 2 closely spaced frequencies) in the band 2.0—24 Mcs. Operates on one frequency at a time; channeling time 2 seconds. Operates into either balanced or unbalanced loads. Operates in ambient -35° to +50° C. Power supply: nominal 220 volts, 50-60 cycles, single phase.

*Complete technical data on request*

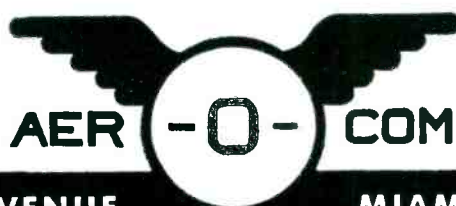

3090 S.W. 37th AVENUE

MIAMI 33, FLORIDA

# MORE WAYS TO SQUEEZE PENNIES OUT OF UPSET SPECIALS COSTS

Specially designed upset products are solving thousands of problems. Dozens of design pointers on them are yours for the asking. Send us your sketches, prints, finished products for suggestions.

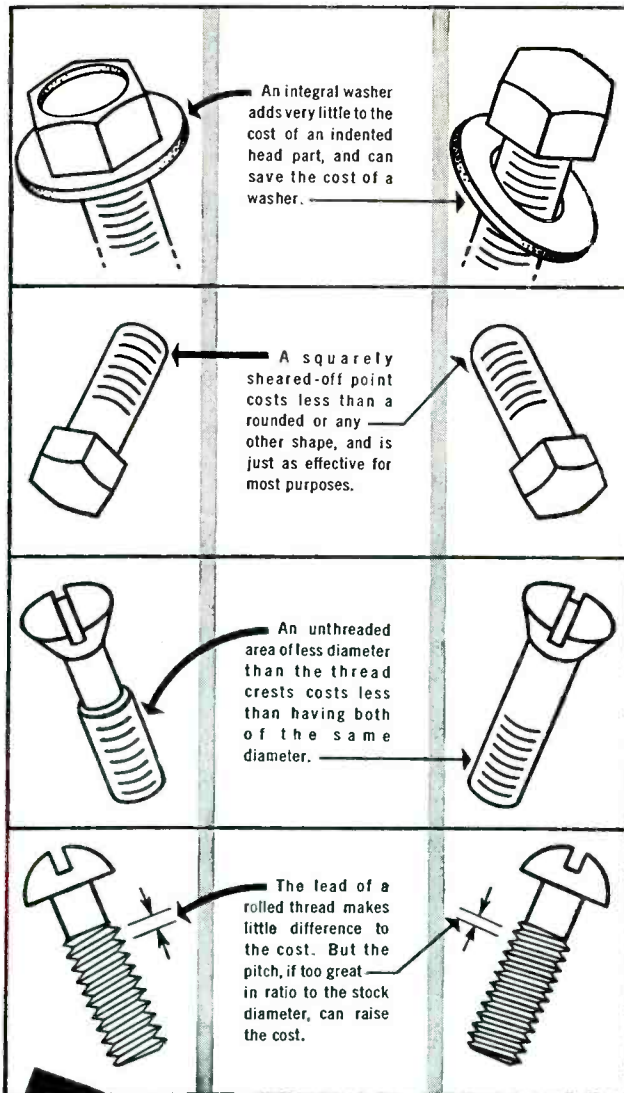

An integral washer adds very little to the cost of an indented head part, and can save the cost of a washer.

A squarely sheared-off point costs less than a rounded or any other shape, and is just as effective for most purposes.

An unthreaded area of less diameter than the thread crests costs less than having both of the same diameter.

The lead of a rolled thread makes little difference to the cost. But the pitch, if too great in ratio to the stock diameter, can raise the cost.

**REPRINTS**

of this chart are available on request for use in drafting and purchasing departments.



**A HALF-CENTURY OF MACHINE SCREWS AND SPECIAL FASTENERS**

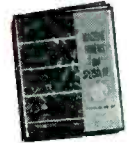

WRITE FOR OUR CATALOG

**THE PROGRESSIVE  
MANUFACTURING COMPANY**  
50 NORWOOD ST., TORRINGTON, CONN.



Soldering insures good ground to etched wiring by anchoring mounting screw permanently in position. The solder here doesn't reach the etched wiring itself

manent r-f grounds for the etched wiring in critical circuits. Solder from an overhead spool is fed freely to each of these grounds after heating with the iron. Two irons are used alternately, since the metal chassis cools an iron faster than it can heat up again on a moving conveyor line operating at about a 30-second cycle.

## Terminal and Marking Tools Added to Wire Cutter

THE ADDITION of terminal-attaching and wire-printing mechanisms to an Artos automatic wire-measuring, cutting and stripping machine brings further speed and production economy in preparing large quantities of wire leads for use in electronic equipment. The new TA-20-S machine made by Artos Engineering Co., Milwaukee, can be op-



Wire-cutting machine with terminal-attacher at right end. Reel of prefabricated terminals can be seen at upper right, with wire supply reel just below. Terminals are attached at only one end of each lead. Wire printer, not shown here, mounts on bar projecting at left of machine



another outstanding  
feature... REEVES

# REAC 400

ANALOG COMPUTER

new

# HIGH SPEED

# SERVOS

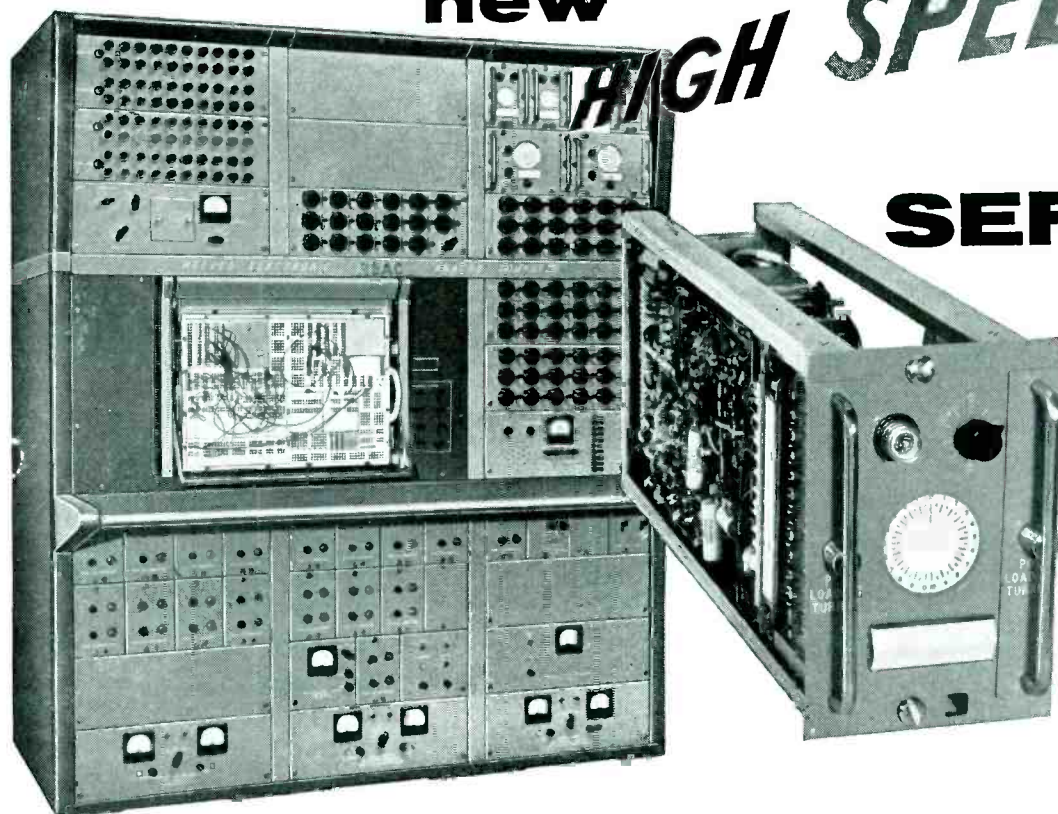

- Bandwidth over 50 cps.
- Velocity 1500 v/sec.
- Plug-in turrets for function generation

**New BUILDING-BLOCK CONSTRUCTION**

Permits assembly of computer elements in any desired combination to do particular job or expand existing installation

**New CONVENIENT PATCHBAY**

Available in units of 1632, 3264 or 4896 holes for maximum flexibility. Patchboard changes possible during operation.

**New POWERFUL AMPLIFIERS**

Noise less than 3 mv rms in cabinet. Phase shift 0.075° @ 100 cps. in cabinet. Bandwidth over 10 KC in cabinet.

**New HIGH SPEED RESOLVERS**

Vastly improved dynamic performance... 35-cycle bandwidth.

- ★ **Six gang multiplying potentiometers.** Accuracy equivalent to 0.1% linearity potentiometers (over-all multiplying accuracy 0.2% including mechanical non-linearities). Two gangs tapped for function generation.
- ★ **Two front panel plug-in turrets** for padding or feeding voltages into the tapped pots for function generation. Turrets may be stored for future use.
- ★ **High Speed** — Velocity 1500 v/sec.
- ★ **Long Life** — Carbon film potentiometer gives exceptionally long life even at high velocities.
- ★ **Superior Frequency Response:**  
Maximum amplitude rise 1.4 @ 40 cps.  
Bandwidth over 50 cps.  
Dynamic error less than 0.5% of input @ 2 cps.  
Phase shift less than 0.3° @ 3 cps.!
- ★ **Exceptional low speed performance too** — Typical tracking error less than 0.05 volts maximum for ramp input as low as 0.01 v/sec.



## REEVES INSTRUMENT CORPORATION

A Subsidiary of Dynamics Corporation of America  
201 East 91st St., New York 28, N. Y.

REAC  
Analog  
Computers



Precision  
Floated  
GYROS



Precision  
RESOLVERS and  
PHASE SHIFTERS



SERVO  
MECHANICAL  
PARTS



5RV5



Always Right...  
**ALL  
WAYS**

"PRESS-FIT"\*

**TEFLON† TERMINALS**

"Mike" is the hardest worker at Sealectro. For in every operation—from tooling up to setting up the automatic machines, and again from outpouring production to final inspection—the micrometer is everywhere in evidence. Sealectro has set those close-tolerance standards which others try to follow.

Sealectro's "Press-Fit" terminals are the precision terminals press-fitted into chassis or component, eliminating usual hardware and soldering, and minimizing labor. Piece after piece after piece of absolute uniformity. And they "stay put." Yes, always right, all ways, thanks to "Mike", the hardest worker at Sealectro, the original and still the leading exclusive Teflon terminal producers.

\* Trade-mark † Trade-mark of E. I. Du Pont de Nemours & Co.

**GET YOUR COPY...**

This "Press-Fit" Manual provides that practical "know-how" you want on superlative insulated terminals. Write for it on your business stationery. Also let us collaborate on your insulated terminal problems and requirements.



ACTUAL SIZE



Manufacturers of "PRESS-FIT" TERMINALS

186 UNION AVE., NEW ROCHELLE, N.Y. • NEW ROCHELLE 2-6015

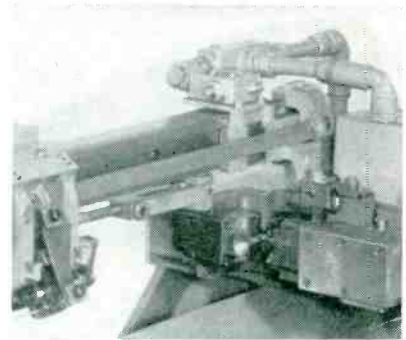

Terminal attacher, showing cone-shaped die into which the traveling overhead wire gripper pushes the stripped end of a lead

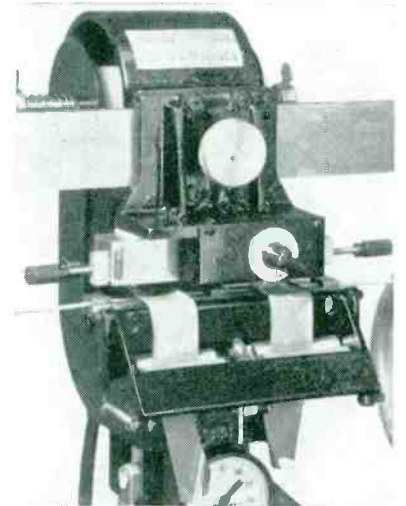

Lead-marking attachment mounted on steel bar at input end of machine

erated by unskilled labor once it is set up. Die units are simply and quickly changed.

► **Terminals**—The motorized terminal attacher is mounted at the right-hand end of the machine and synchronized with the operation of the wire cutter. The traveling overhead wire-gripper pulls out the wire the desired distance for cutting, then moves further to the right to bring the stripped end into the terminal die unit. Simultaneously, a switch is actuated by the overhead mechanism to operate the terminal-attaching unit. Various types and sizes of terminals can be handled if available in strip form on reels.

► **Printer** — The attachment for printing identifying nomenclature on the wire is clamped to a steel bar projecting out from the input of the machine, so that printing is done before cutting and stripping. This bar also supports the



ITEMS LIKE THESE AVAILABLE AT

**Chase**<sup>®</sup>  
**WAREHOUSES!**

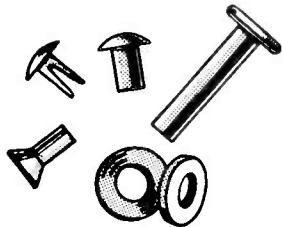

BRASS or COPPER  
RIVETS and WASHERS



BRASS, COPPER, BRONZE  
COTTER PINS

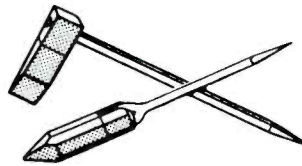

SOLDERING COPPERS

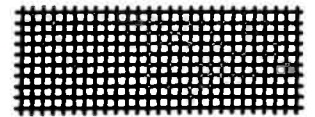

INDUSTRIAL WIRE CLOTH

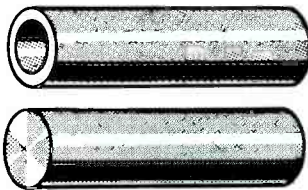

SOLID or CORED BEARING BRONZE



BRASS or BRONZE WOOD  
and MACHINE SCREWS

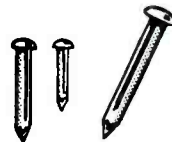

BRASS ESCUTCHEON PINS

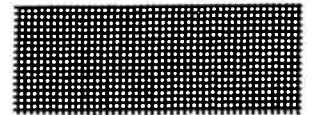

BRASS STRAINER CLOTH

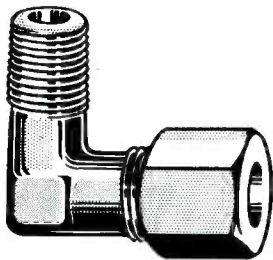

INDUSTRIAL and  
AUTOMOTIVE FITTINGS

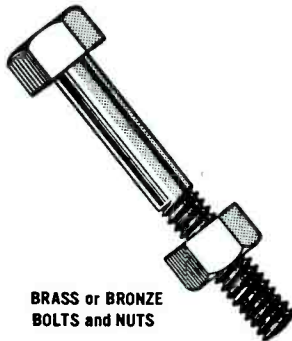

BRASS or BRONZE  
BOLTS and NUTS

CALL US FOR ANYTHING from Bearing Bronze Bars to Brass or Bronze Bolts...or other fastenings like those shown here for maintenance, repair, operating or production. Twenty-five Chase warehouses are located in major industrial centers from coast to coast. Phone the one nearest you. We can usually fill your orders from stock.

NEW! Chase's informative rod and wire movie: "IN THE CHIPS." Arrange for a free loan of this film by contacting the Chase warehouse or sales office near you. Write on your company letterhead, today!

**Chase**<sup>®</sup>  
**BRASS & COPPER CO.**

WATERBURY 20, CONNECTICUT • SUBSIDIARY OF KENNECOTT COPPER CORPORATION

The Nation's Headquarters for Brass & Copper

Atlanta Baltimore Boston Charlotte† Chicago Cincinnati Cleveland Dallas Denver Detroit Grand Rapids† Houston Indianapolis Kansas City, Mo. Los Angeles Milwaukee Minneapolis Newark New Orleans New York Philadelphia Pittsburgh Providence Rochester† St. Louis San Francisco Seattle Waterbury (†sales office only)

# Langevin AMPLIFIERS

No matter which way  
you look at it, the  
LCM 5000 SERIES  
is the smallest size,  
high quality amplifier

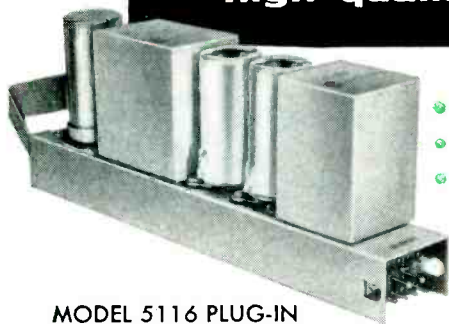

MODEL 5116 PLUG-IN  
BROADCAST PRE-AMPLIFIER

- LENGTH - 9"
- WIDTH - 1 3/8"
- HEIGHT - 3"



(ACTUAL  
SIZE)

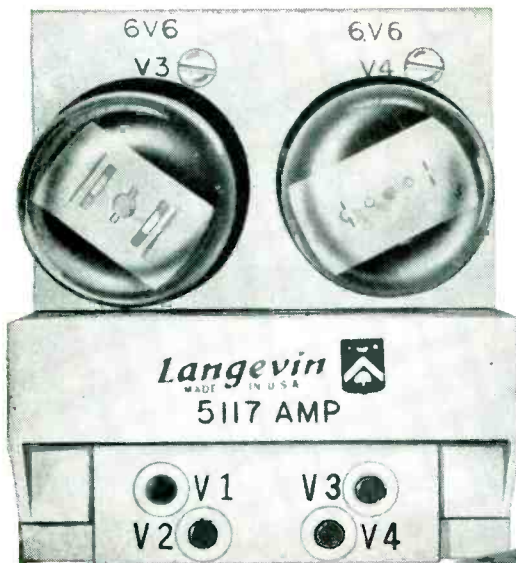

MODEL 5117 PLUG-IN  
BROADCAST PROGRAM AMPLIFIER

- LENGTH - 10 1/4"
- HEIGHT - 3"
- WIDTH - 2 5/8"

Complete specifications for the 5000 Series, including amplifiers and power supplies, available on request. Phone, write or wire today.

Quality deserving  
the serious  
consideration  
of responsible  
engineers

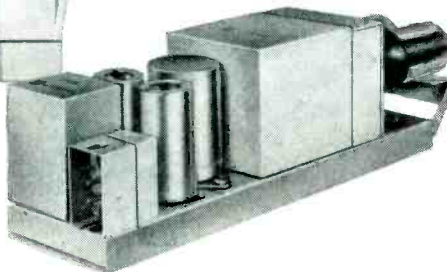

**LANGEVIN MANUFACTURING CORPORATION**  
47-37 AUSTELL PLACE, LONG ISLAND CITY I, N. Y.  
Telephone: RAvenswood 9-1860

A Subsidiary of the W. L. Maxson Corporation

compensating mechanism for the wire prefeeder. The printer is a dual unit, with the printing units about 3 inches apart. The printer is positioned in such a way that it is centered on the point at which the wire will later be cut. It operates each time the wire puller stops, so as to give a printed identification near each end of each lead.

## Production of Curved Etched-Wiring Boards

POST-FORMING of etched-wiring boards has been placed on a production basis in the Minneapolis plant of Bureau of Engraving, Inc. Thermocontact presses provide pre-heating and special rollers do the actual forming.

Partially cured laminates, rigidly tested for forming ability, shrinkage, delamination and ability to hold the radius after forming are used for the base material. Nylon-base phenolics and glass-base epoxy resins are examples of materials that have proved satisfactory.

► **Forming Procedure**—After the board is etched on one or both sides, it is placed in a timer-controlled hot-plate press for 30 to 120 seconds at 250 F to 350 F, depending on the material. High-temperature rubber plates in the press provide good overall thermal contact. The timer automatically opens the press at the end of the selected heating cycle. The board is then immediately transferred to a specially designed roller-type press for the actual forming.

The board is sandwich-rolled



Placing board in heating press to soften base material



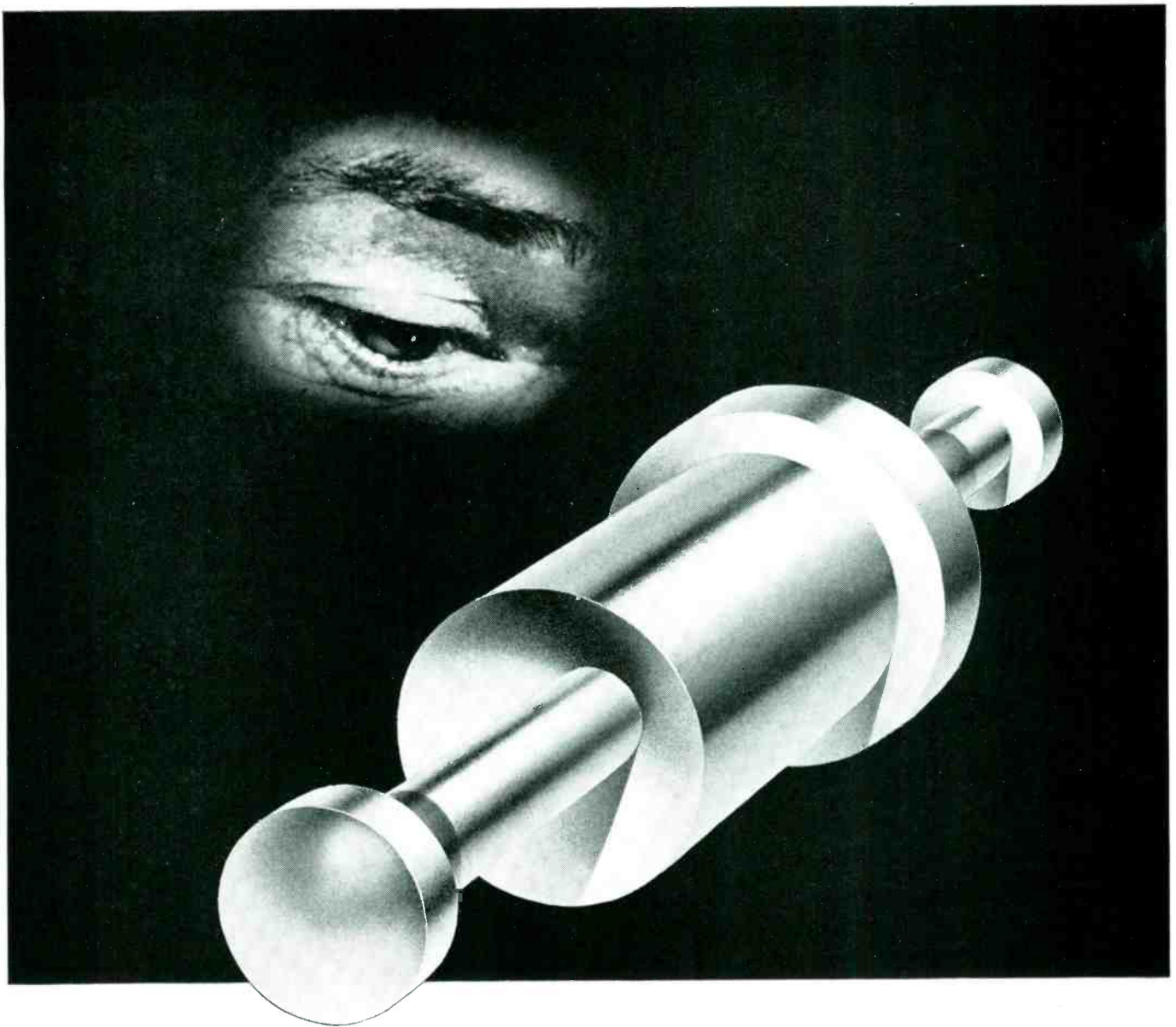

## The "skin" we love to watch

The "skin," or plated coating, on CTC terminals gets extremely close scrutiny from our quality control engineers. And we take pleasure in this careful watching because —

We know, as a result, that you can depend on CTC terminals for electroplated coatings of guaranteed minimum thickness — whether to government specifications or your own.

Our "watching" of these coatings includes periodic bend tests for adhesion, and periodic microscopic inspection of cross sections for coating thickness. These are but two of many examples of quality control that enable us to offer customers *guaranteed* electronic components . . . custom or standard.

Besides terminals, we pay close attention to the production of CTC terminal boards, capacitors, swagers, hardware, insulated terminals, coil forms and coils. For all specifications and prices, write to Cambridge Thermionic Corporation, 437 Concord Avenue, Cambridge 38,

Mass. West Coast Manufacturers contact: E. V. Roberts, 5068 West Washington Blvd., Los Angeles 16 and 988 Market St., San Francisco, California.

*Terminal Data:* Our standard terminal line includes 30 types, each in varied shank lengths. Made of silver plated brass, coated with water dip lacquer to keep them chemically clean for soldering. Also available: combination screw and solder terminals in 3 sizes, and a complete line of phenolic and ceramic insulated terminals. All materials, processes and finishes meet applicable government specifications. Special order finishes include hot tin, electrotin, cadmium plate or gold plate.

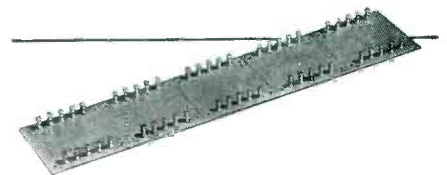

*Standard CTC Terminal Boards* as well as those made to your own specifications by CTC are available. Standard in cotton fabric phenolic, nylon phenolic or grade L-5 silicone impregnated ceramic. Custom made in cloth, paper phenolic, melamine, or silicone fibreglas laminates, imprinted as required and lacquered or varnished to specifications MIL-V-173 and JAN-T-152.

# CTC

**CAMBRIDGE THERMIONIC CORPORATION**

*makers of guaranteed electronic components,  
custom or standard*



## Direct, accurate measurements of signal components—15 to 500 kc



### Model 121 Wave Analyzer

This new Sierra Wave Analyzer is designed to give you maximum operating ease, high accuracy and broad applicability in analyzing complex wave forms between 15 and 500 kc. The instrument is particularly useful for carrier system frequency analysis and induction studies, for determining filter transmission characteristics, or for measuring distortion and intermodulation components of rf signal sources and transmitters.

The Model 121 makes possible direct measurement of signal components throughout its range, and eliminates complex expensive setups with conventional receivers and signal generators. Input level range is +42 to -70 dbm at 600 ohms impedance. Measuring accuracy is  $\pm 2$  db; selectivity is such that response is 45 db down at 1 kc off resonance. Input bridging impedance is 10,000 ohms in the pass band.

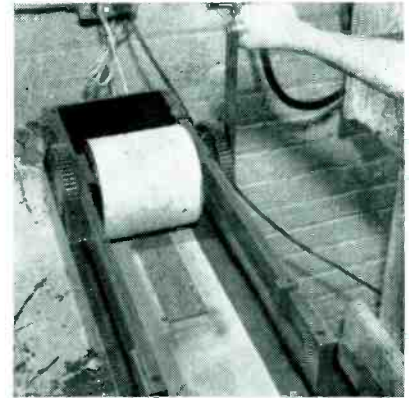

Board in loading position on bed of forming press

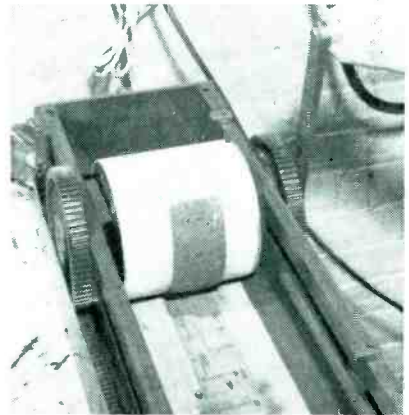

Curved board emerging from roller after slow cooling

within a felt layer that extends the cooling time to prevent thermal shock. Even pressure of the roller prevents damage to the delicate wiring on both sides of the board, permitting forming to an inside radius as small as three times the thickness of the material. Studs and components are now added after forming, but experiments are under way involving forming after insertion of components.

### Locating Heater Shorts

WHEN a cathode-heater short develops during aging of tubes in batches of 100, a heavy-duty relay or switch is closed to burn out the heater and thereby eliminate the short. This technique saved \$375.00 per year when first introduced in Sylvania's Emporium plant as a result of a suggestion by Donald Crawford.

The previous technique involved pulling tubes out of the aging rack one at a time until the shorted tube was located. This meant pulling up to 100 tubes.



### Model 122 LINE-BRIDGING TRANSFORMER

The Sierra 122 Line-Bridging Transformer instantly converts Model 121 Wave Analyzer from single-ended to balanced input. The transformer is a broad band ferrite core unit operating flat within 0.5 db. from 15 to 500 kc. It is compensated so that Analyzer readings are corrected for the transformer's small insertion loss. Offered in three impedances: Model 122A, 135 ohms; 122B, 500 ohms; 122C, 600 ohms.

For complete information see your local Sierra sales representative or request Bulletin 103A

# sierra

### Sierra Electronic Corporation

San Carlos 2, California, U. S. A.

Sales representatives in major cities

Manufacturers of Carrier Frequency Voltmeters, Wave Analyzers, Line Fault Analyzers, Directional Couplers, Wide-Band RF Transformers, Custom Radio Transmitters.







John O. Gantner, Jr., President of Gantner of California, reveals why

## “She always has the last word!”

“They say a woman will always have the last word. It’s certainly true when she shops for a swimming suit!

“She waits till the last possible minute, and insists she get the ‘last word’ in style. Pressure on stores is terrific. If ‘hot’ styles run out of stock, those sales are gone forever.

“But our retail accounts know they can depend on Gantner.

“Gantner styles can be restocked to any store in the country in a few hours, *while the ads are running*. Not a moment is lost — not a sale is lost — thanks to Air Express!

“And one last word — about costs. Specifying Air Express can save you money, too. 15 lbs. from San Francisco to Chicago, for example, costs \$10.91. That’s \$1.09 less than any other complete air service!”



# Air Express



GETS THERE FIRST via U.S. Scheduled Airlines

CALL AIR EXPRESS . . . division of RAILWAY EXPRESS AGENCY

# New Products

Edited by WILLIAM P. O'BRIEN

71 New Products and 63 Manufacturers' Bulletins Are Reviewed  
... Control, Testing and Measuring Equipment Described and  
Illustrated ... Recent Tubes and Components Are Covered

## TRANSISTORS

### of the medium-power type

TRANSITRON ELECTRONIC CORP., Melrose 76, Mass. The new medium-power type transistors are designed for high power dissipation with linear operation over a wide collector current range. They are hermetically sealed under vacuum to insure reliability under the most severe operating conditions.

Efficient thermal connections provide greater power dissipation at elevated temperatures (up to 750 mw dissipation at 25 C). Maximum

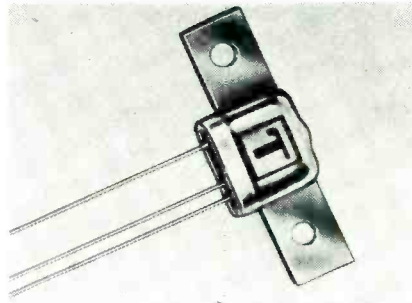

dissipation ability of 2N85, 2N86 and 2N87 medium power transis-

tors is obtained by chassis mounting

► **Output**—These transistors are intended for Class A or B output or driving stages, and will provide high output with a minimum of distortion. Approximately 1.5-w output can be obtained from a pair of 2N86 medium-power transistors operated in push-pull class B, even at temperatures up to 70 C when mounted on an aluminum chassis for heat-sink purposes.

Prices range from about \$3.00 each to approximately \$4.50.

## PLUG-IN MODULES

### use standard component bodies

ERIE RESISTOR CORP., Erie, Pa., announces a new packaged subassembly that can be mass-produced at an overall cost approximating that of individual components, while greatly reducing the cost of assembly labor and equipment. Called PAC, for Pin Assembly Circuit, the new module permits installation of resistors and capacitors as a unitized plug-in package in etched wiring boards either manually or by machine, for lower-cost tv and radio sets, computers, industrial controls and other military or commercial electronic equipment.

The modules employ standard composition resistor and ceramic tubular capacitor bodies without leads, fitting into miniature fuse clips anchored in holes along the sides of the XXXP phenolic base plate. Interconnecting wiring is applied to the other side of the plate by an embossing process giving the equivalent of etched wir-

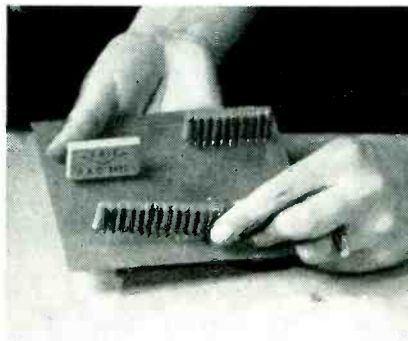

ing without immersion in chemical solutions.

► **Components**—Development engineers can readily make their own experimental modules. Up to 92 individual components may be combined by using an appropriate length of base plate, for insertion in a single operation. Basic component size is  $\frac{1}{8}$  inch diameter and  $\frac{3}{8}$  inch long, for which resistors are rated as  $\frac{1}{2}$  watt and 500 volts, with tolerances of 5 percent or wider, in values from 5

ohms to 50 megohms. Multiple pins are connected in series or parallel for higher wattage ratings. Capacitors range from 1 to 5,100  $\mu\text{f}$ . The adhesive bond of the conductive pattern on the back will withstand solder dip temperatures up to 570 F for 2 sec immersion or 10 sec at 500 F.

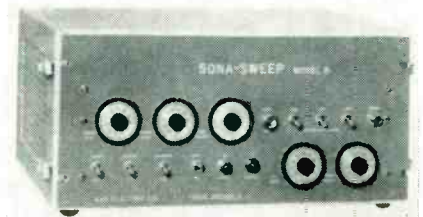

## SWEEP GENERATOR with sync pulse added

KAY ELECTRIC CO., 14 Maple Ave., Pine Brook, N. J., has announced the Sona-Sweep model TV, which permits overall visual examination of the low end of the video spectrum. Features include separate



*Now available*

the revolutionary  
**ELECTRO TEC**  
 process\* for your  
**LARGE**  
**SLIP RING ASSEMBLIES**

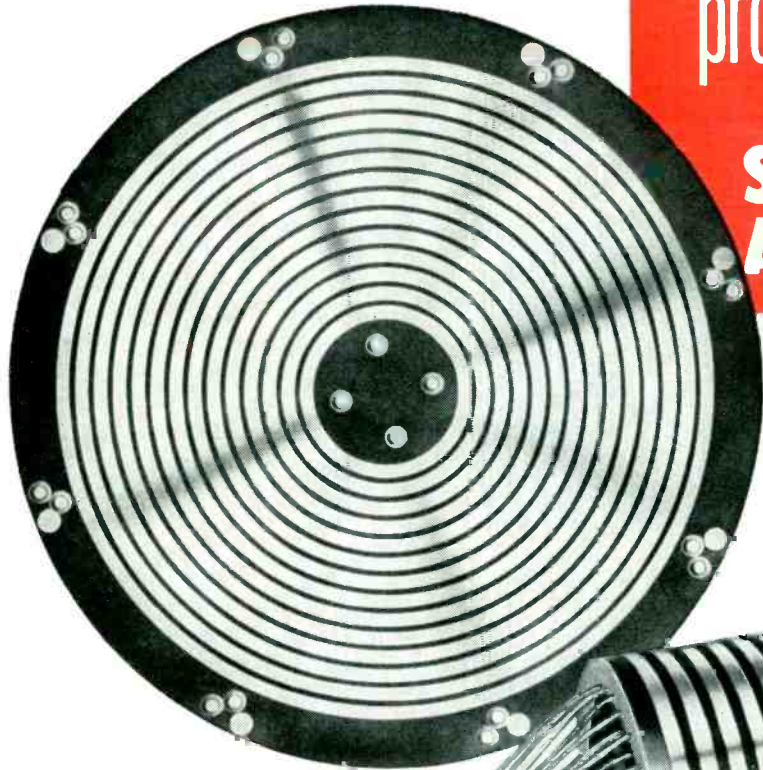

↑ An assembly with 14 concentric, hard silver rings electro deposited into machined plastic blank. Dovetail locks rings in place. Machined blank insures accuracy. Diameter approx. 11", thickness approx. 5/16".

→ Cylindrical assembly with 25 rings. Three wide rings accommodate large contact area brushes for high current capacity. Length 14", O.D. approx. 5 3/8".

→ An assembly with 30 rings of various widths to accommodate various current requirements. Unit is approx. 4-5/16" long, designed for flange mounting.

→ Cylinder type assembly approx. 3 3/4" long with 24 hard silver rings. 1 5/8" O.D. with wall thickness less than 1/4".

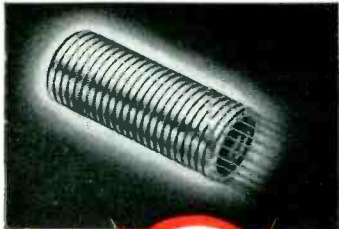
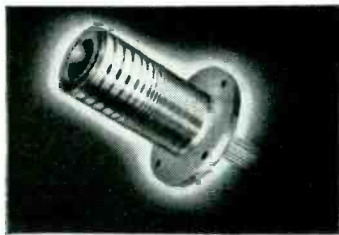

\*PAT. NO.  
2,696,570

Our Engineering Department is available for consultation on any of your slip ring problems without obligation.



**ELECTRO TEC CORPORATION**  
 SOUTH HACKENSACK • NEW JERSEY

*featuring*

- LOWER COST • CLOSER TOLERANCES
- ONE-PIECE CONSTRUCTION • JEWEL-LIKE FINISH • UNIFORM RING HARDNESS
- REDUCED WEIGHT

**Now a Complete Service  
 in all sizes of Slip Ring Assemblies**

ELECTRO TEC is now tooled up, with new expanded facilities for production of large Slip Ring Assemblies to exact customer specification. Sizes range up to 36" in diameter, either cylindrical or disc type.

The exclusive ELECTRO TEC PROCESS\*—the electro-deposition of hard silver rings into an accurately machined plastic blank—consistently yields a high degree of dimensional accuracy, excellent concentricity, and a jewel-like ring finish. This process also eliminates expensive tooling and mold charges, frequently lowers costs to 30% of other methods of manufacture. The silver rings are uniformly hard for long life—70-95 Brinell.

ELECTRO TEC one-piece construction precludes dimensional variation due to accumulated errors. The plastic base is fully cured before rings are plated into it, thus preventing separation of base material from the rings.

ELECTRO TEC LARGE SLIP RING Assemblies are widely used in Radar Equipment, Fire Control Systems, Test Tables and many other critical applications. Light weight combined with rugged durability recommends their use in airborne applications.

Every user knows the ELECTRO TEC reputation for quality and superiority in miniature and sub-miniature slip ring assemblies.

controls on sync pulse and sweep generator, r-f output and adjustable equalizer for better than 0.5-percent accuracy in any one region in the band.

Blanking is added to provide zero level base line; permits locking of scope at test receiver end. Output is attenuated in steps for all of the

sync and sweep pulse signal. A frequency vernier control permits observation of specific portions of the spectrum when sweep is turned down to narrow range.

► **Specifications**—Range is 0 to 350 kc; r-f output, 0 to 1 v peak-to-peak into 75 ohms; flatness of sweep

over entire range, 0.5 percent; output attenuator, 2, 4 and 6 db for whole signal; variable sweep rate, 2 to 0.5 cps; variable sweep width, 0 to 350 kc; sync pulse output, 0.3 to 1 v into 75 ohms; sync pulse duration, 5-milliseconds; sync pulse frequency, adjustable 15,750 cps  $\pm 750$  cps (accuracy:  $\pm 10$  cps).

## PROTOMAKA

makes etched circuit in 1/2 hr

PRINTED ELECTRONICS CORP., 15 Willow St., Natick, Mass. The Protomaka, a unit for making production prototypes of printed electronic circuits, measures only 60 in. long by 50 in. wide by 45 1/2 in. high, but can produce an average printed circuit in only 30 to 40 min. Circuits up to 10 in. by 16 in. in size can be manufactured.

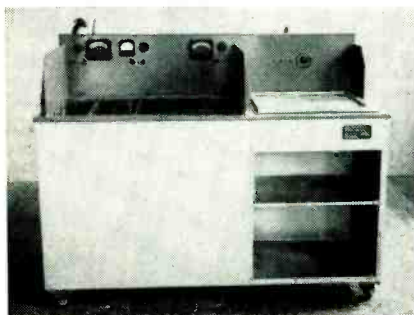

► **How It Works**—The Protomaka is simply plugged into a standard 110-v line, one hose is connected to a cold water faucet and another to a waste drain. With these simple

connections the unit is ready to operate. It produces etched wiring by the photographic process. Copper clad material is coated with photosensitive resist on a whirler.

The board is held by a pair of quick-acting clamps while the solution is poured on the surface. Centrifugal force spreads the resist evenly, any excess flowing into the aluminum bowl in which the whirler spins. An infrared lamp dries the resist as the piece rotates. The circuit board is then exposed on the light table where the negative is placed under the resisted panel, and pressed firmly to it by the vacuum frame table top. Exposure time is only 30 sec. A developing tank with an overflow water rinse is conveniently located to complete the printing cycle.

The compact unit will sell between \$3,000 and \$3,500.

## MALE CONNECTOR

ups printed circuit progress

CIRCON COMPONENT Co., 17544 Raymer St., Northridge, Calif., announces the new male connector for

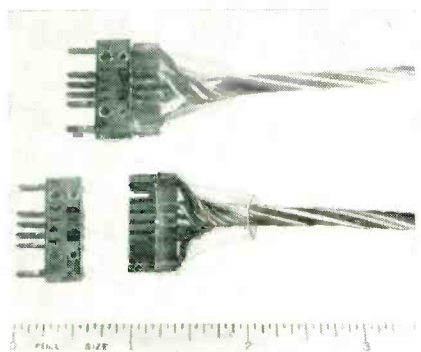

electronic, instrument and printed circuit uses. Available in both miniature and subminiature series, the connectors show five improvements over previous models.

They provide higher insulation resistance and humidity performance due to new phenolic base material which exceeds all requirements of MIL-P-15035, type PRE-P. A sustained near-perfect contact is maintained with the new shot-burnished gold deposition process employed in the production of the contact surfaces.

Interface bond between the contact and the body of the connector is such as to eliminate virtually any damage to the contact bond due to careless application of wires to contacts. Increase in width of extremity contacts provides sound cabling and relief of strain at these critical points. Vinyl insulating hood provides built-in mold for potting of connectors should user desire.

► **Prices**—A schedule is available listing prices of 16 models (sub-miniature and miniature series), which range from 73 cents to \$4.72. Quantity discounts are also shown.

## GALVANIC INSULATORS

of Zytel polyamide resin



CRAWFORD FITTING Co., 884 E. 140th St., Cleveland 10, Ohio, has announced the latest addition to the line of Swagelok tube fittings—Swagelok galvanic insulators of Zytel polyamide resin. The in-

sulators offer a new method of eliminating galvanic action which results from joining dissimilar metals.

► **Uses**—With their use, brass, aluminum, copper and steel may now be joined. Moreover, they will find many applications at junction



Sylvania

# PHOSPHORS

For Color Television  
For Black and White Television  
For Radar and Oscilloscopes



## BRAND NEW

### and waiting for you . . .

INTERESTED in high-purity phosphors . . . for color, black and white television tubes . . . for radar or oscilloscope tubes? Here is your opportunity to get the latest information directly from Sylvania—your prime source of phosphors and screen settling chemicals.

This new 24-page publication contains specifications and more than forty performance charts to guide in the selection of phosphors for every application. You will find helpful hints on almost every page, based on Sylvania's own experience in manu-

facturing the world's finest television and cathode ray tubes.

Something worth keeping in mind, too: Sylvania phosphors and chemicals are manufactured under a rigid control system that assures high performance from every batch. Prove this to your satisfaction by placing your next order with Sylvania!

### WRITE FOR YOUR COPY

Sylvania Electric Products Inc.  
1740 Broadway, New York 19, N. Y.

Name \_\_\_\_\_ Title \_\_\_\_\_

Company \_\_\_\_\_

Address \_\_\_\_\_



# SYLVANIA<sup>®</sup>

SYLVANIA ELECTRIC PRODUCTS INC.  
1740 Broadway, New York 19, N. Y.  
In Canada: Sylvania Electric (Canada) Ltd.  
University Tower Bldg., Montreal

Lighting • Radio • Electronics • Television  
Atomic Energy

# TENSOLON WIRE & CABLE

... for  $-90^{\circ}\text{C}$  to  
 $+250^{\circ}\text{C}$  operation

A *Tensolite*  
PRODUCT

For an extra margin of dependability at maximum operating temperatures, specify Tensolite's rugged Teflon<sup>®</sup> insulated wire and cable products. Resistant to all chemicals and solvents, Teflon combines minimum wall thickness with highest dielectric strength.

® Du Pont

## TEFLON INSULATED HOOK-UP WIRE

Extruded Teflon insulation to meet the requirements of MIL-W-16878A Types E and EE, sizes 10-30 AWG in 14 solid colors and spirally striped. Parallel wrapped Teflon—exclusive patented construction featuring super-flexibility, sizes 20-34 AWG in 14 solid colors to MIL-W-16878A Types E and EE.

Spiral wrapped Teflon—special cross-lapped construction with spiral striping conforming to commercial (GEN-104) and military (MIL-W-76A) specifications having the standard stripe width, lay and spacing. Sizes 8-30 AWG to MIL-W-16878A Types E and EE Specification.

NEW 5 mil wall subminiature Teflon hook-up wire for applications where space factor is extremely critical. Sizes 26, 28, 30 and 32 AWG in 4 solid colors.

## TEFLON LEAD WIRE

Teflon impregnated fibreglas braid over Teflon insulated wire for high temperature motor and transformer leads. Sizes 8-32 AWG, solid and tracer colors.

Silicone lacquered fibreglas braid over Teflon insulated wire for class H applications. Sizes 8-32 AWG, solid and tracer colors.

## SHIELDED TEFLON WIRE

All of the above described hook-up and lead wires are available with closely woven wire braid shields to all military and customer specifications.

100% shielding provided with a close-fitting drawn copper or aluminum tubing available on request.

## TEFLON TUBING

Ultra-flexible slip-on insulation for 20-30 AWG sizes available in 14 solid colors.

## TEFLON AIRCRAFT WIRE

New improved Teflon-glass-Teflon sandwich construction providing superior resistance to abrasion and vibration, as well as increased margin of safety for overload protection and emergency operation. Conforms fully to MIL-W-7139A, available in sizes 6 to 22 AWG.

## JACKETED SHIELDED TEFLON INSULATED CABLE

Teflon outer jacket cross-lapped and fused to provide an impervious and flexible covering completely resistant to all corrosive chemicals. Available in 10 solid colors, or spiral striped, sizes 10-30 AWG.

Teflon impregnated or silicone lacquered fibreglas braid outer covering over shielded Teflon insulation. These class H cables are available in solid and tracer colors, sizes 10-30 AWG.

Extruded vinyl or nylon jackets over shielded Teflon wire for high frequency, moderate temperature applications. All standard sizes and colors.

Nylon lacquered nylon braid outer covering over shielded Teflon wire for extra rugged applications at temperatures not exceeding  $120^{\circ}\text{C}$ . Solid colors and tracers, sizes 10-30 AWG.

## MINIATURE TEFLON COAXIAL CABLE

50, 70 and 93 ohm extruded Teflon insulated miniature coaxial cables with extruded vinyl, nylon or Teflon outer jackets. Also available with lacquered over-braids.

Finished coaxial cable assemblies are now being supplied with miniature connectors and fittings.

Copper or aluminum clad miniature Teflon insulated coaxial cables for rugged applications with extreme size and weight limitation. The semi-rigid nature of this construction minimizes self-generated noises.

Flexible low-noise miniature Teflon insulated coaxial cables are also available on request.

## MULTI- CONDUCTOR TEFLON CABLE

Teflon insulated conductors cabled together to exact customer specifications.

Shielded multi-conductor Teflon insulated cables.

Teflon outer jacket, silicone or Teflon impregnated fibreglas braid and nylon lacquered nylon braid over shielded multi-conductor Teflon insulated cables are available for numerous specialized applications in tele-metering and instrumentation.

## CUSTOM TEFLON CABLE

Tensolite's development facilities are ready to assist you in the design and selection of special Teflon wire, cable and thermocouple constructions as well as custom wire assemblies and harnesses.

WRITE FOR  
CATALOG

Telephone:  
Medford 1-2300

*Tensolite*

INSULATED WIRE CO • INC

198 MAIN STREET, TARRYTOWN, NEW YORK

boxes, panel boards and bulkheads. The insulators are made in a complete line of shapes and in  $\frac{1}{8}$  in. to 1-in. tube and pipe sizes.

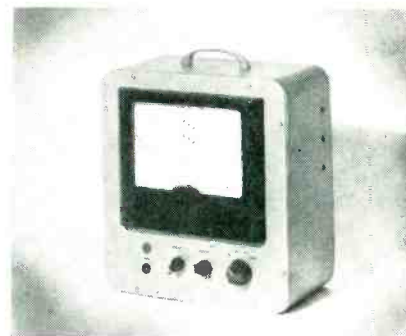

## VTVOM gives automatic reading

LEITCH ENGINEERING CORP., Manchester, N. H., has announced a new vtvom, the Meter-Matic, with completely automatic range switching. Application of the probes to points being checked gives an immediate reading on a large  $8\frac{1}{2}$ -in. meter. Each set of calibrations is complete without the need of adding zero multipliers. Measurement of a-c and d-c voltages is from 0.1 v to 1,500 v. The unit is particularly valuable when dealing in unknown voltages.

Similarly, in measuring resistance, automatic reading is possible from 0.5 ohm to one billion ohms in 6 ranges.

► **Protection**—The entire instrument is protected from burn-out or damage up to 2,000 v. On ohms the unit is similarly protected against accidental application of voltages up to 300 v, a-c or d-c. This protection applies equally to the equipment under test.

The entire unit sells for \$149.50.



## SUBMINIATURE RELAY 1 sec to 5 min delay

FALCON ELECTRONICS CORP., 308 William St., Harrison, N. J., has



"Agreed! Airfreight's the best way to ship them. But, which do we use?"

"American! Traffic says they're the most experienced. Able to provide fast, dependable service."



To be certain of rapid and reliable deliveries, specify shipment by American Airlines Airfreight. In addition to being the most experienced, American also leads all other airfreight carriers in:

**CAPACITY** - with the largest cargo capacity of any airline, American has space where it's needed, when it's needed.

**COVERAGE** - with routes to more key industrial areas, American is able to provide the most direct one-carrier service.

**SCHEDULES** - with the most frequent schedules, American keeps terminal time to a minimum, assures you of prompt forwarding.

For complete information about the advantages of shipping American, wire collect to American Airlines, Inc., Cargo Sales Division, 100 Park Avenue, New York 17, New York.



# AMERICAN AIRLINES AIRFREIGHT

- carries more airfreight than any other airline in the world

# SUPERSEDES 100-1000 MC SLOTTED SECTIONS!

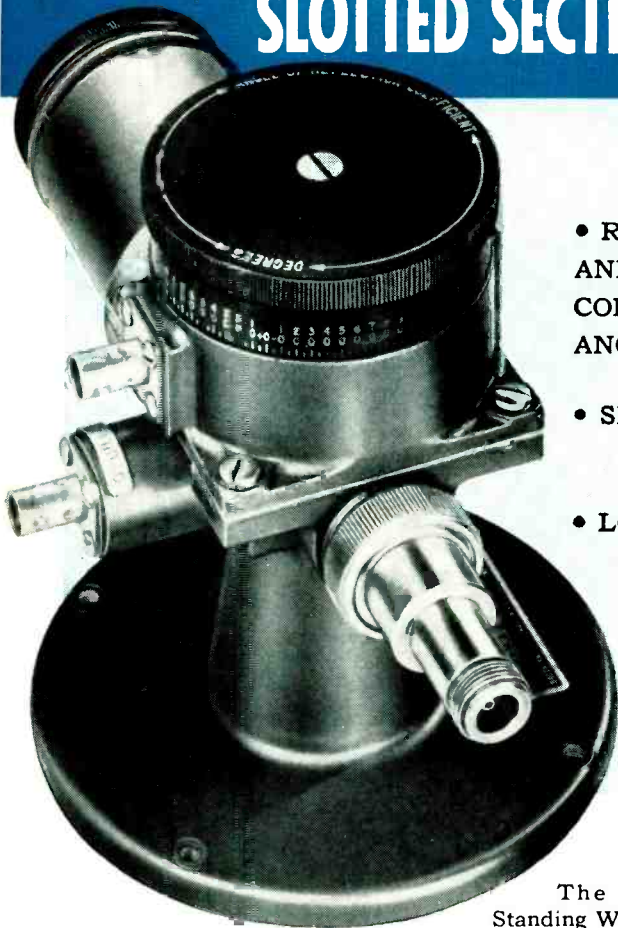

- READS VSWR AND REFLECTION COEFFICIENT ANGLE DIRECTLY
- SMALL AND COMPACT
- LOW IN COST

## SPECIFICATIONS

Frequency Range:  
100 to 1000 mc/s

Residual VSWR:  
Less than 1.05

Accuracy of Reflection  
Coefficient Angle:  
Better than  $\pm 5^\circ$

Characteristic Impedance:  
50 ohms

Output Terminals:  
Type N jack.  
Other interchangeable  
connectors

Min. Input Signal:  
Approx. 1 volt  
at 100 mc/s,  
0.1 volt at 1000 mc/s

Dimensions:  
8" l. x 5" w. x 5 3/4" h.

Weight:  
4 1/2 lbs.

The PRD Type 219 Standing Wave Detector is the *small package, low cost* solution for making measurements easily and accurately in the 100 to 1000 mc/s region. By connecting the output to a VSWR indicator, such as the PRD Type 277, VSWR may be read directly on the indicator meter. No special detection equipment is required. The reflection coefficient angle is easily determined merely by rotating the top drum dial to a minimum indication on the meter and reading the angle on the dial *directly in electrical degrees*. No calculations are required. The probe and crystal detector are self-contained.

Usually it is more convenient to work with VSWR and reflection coefficient angle directly instead of with other components of the measured impedance. When other quantities are also of interest, they can easily be read from a conventional impedance chart. Only \$475 f.o.b. N.Y. Write for PRD Reports, Vol. 3, No. 2, and for 1955 catalog.

## Polytechnic RESEARCH & DEVELOPMENT CO. INC

202 TILLARY STREET  
BROOKLYN 1, N. Y.

Telephone:  
ULster 2-6800



Midwest Sales Office:  
1 SO. NORTHWEST HWY., PARK RIDGE, ILL. — TAicot 3-3174  
Western Sales Office:  
741 1/2 NO. SEWARD ST., HOLLYWOOD 38, CAL. — HO 5-5287

announced the new subminiature Shorty relay ideal for guided missiles and printed circuits. Height when seated is less than 1 in.

► **Specifications**—Delay range is from 1 sec to 5 min; power drain, approximately 4 w; heater voltages, up to 125 v (230 v available if required); interchangeable on d-c or a-c of any frequency; insulated for test voltages of 1,000 v a-c (1,250 v a-c on special order). Contacts are rated at 6 amperes 115 v a-c, noninductive load, 3 amperes d-c spst only. The relay is hermetically sealed, fully compensated for ambient temperature ranges of  $-60^\circ\text{C}$  to  $+85^\circ\text{C}$ ; up to  $125^\circ\text{C}$  if required. It will withstand vibration of from 5 to 500 cps at accelerations of 10 g; shock up to 50 g.

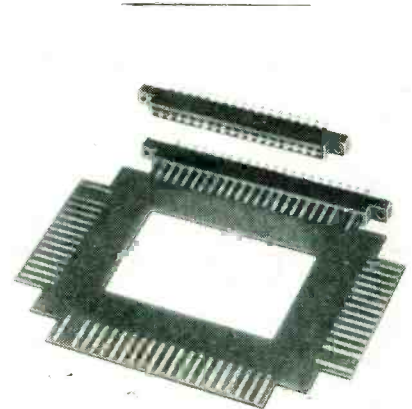

## CONNECTORS with Bellows type contacts

DEJUR-AMSCO CORP., 45-01 Northern Blvd., Long Island City 1, N. Y. The newly developed Bellows type contacts are now supplied with the company's printed-circuit receptacles. They are available in single and double-row construction of 6, 10, 15, 18 or 22 contacts.

► **Features**—The new design provides longer contact life and smoother engagement. The connector accepts 0.054 in. to 0.071 in. variation of standard 1/8 in. copper clad printed circuit laminated card (receptacle to accommodate 3/8 in. board also available on special order).

Wiring styles include solderless wire wrap, solder lugs or taper pins for AMP 53. A choice of mold-



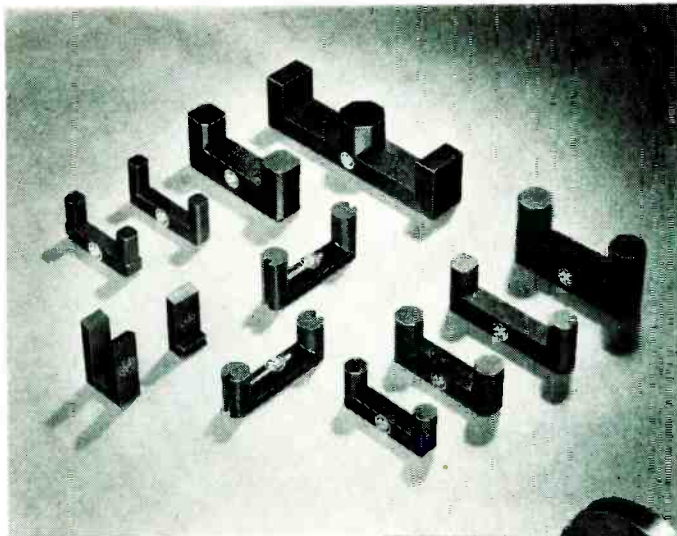

E-cores, L-cores & U-cores

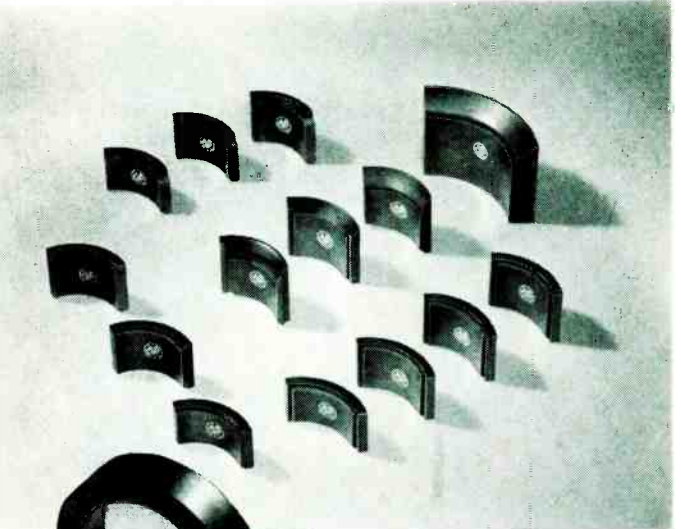

Deflection yoke cores— $\frac{1}{4}$  section

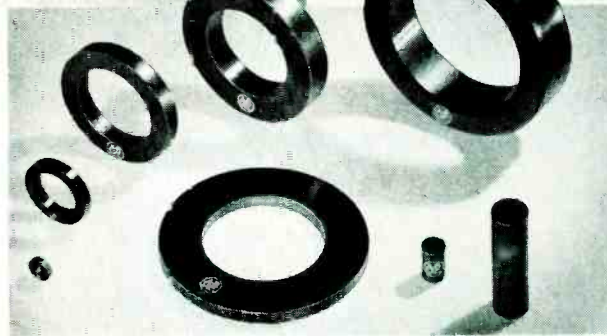

Toroid, cylinder, & ring cores



## HIGH EFFICIENCY FERRITE COMPONENTS

### For TV and Electronic Circuits

Three performance standards—WO-1, WO-2, and WO-3—have been established for the performance characteristics of Allen-Bradley ferrite parts:—

WO-1 and WO-3 are somewhat more efficient but are interchangeable with other makes of ferrite components.

Allen-Bradley WO-2 ferrite parts have much lower losses and higher permeability with greater flux

density at maximum operating temperature. Their higher magnetic efficiency permits reduction in size of the ferrite parts and the use of less copper. Lower over-all cost is often the result.

In some color TV circuits, Allen-Bradley WO-2 ferrites have eliminated two tubes and related parts. It will pay you to investigate the use of Allen-Bradley ferrites in your electronic circuits.

Allen-Bradley Co., 110 W. Greenfield Ave., Milwaukee 4, Wis. • In Canada—Allen-Bradley Canada Limited, Galt, Ont.

### OTHER QUALITY COMPONENTS FOR RADIO, TV & ELECTRONIC APPLICATIONS

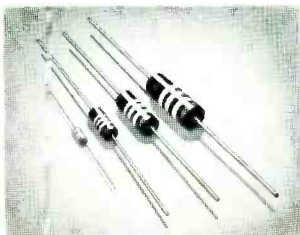

Fixed Molded Resistors  
1/10, 1/2, 1 & 2 watt

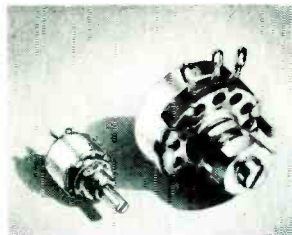

Variable Molded Resistors  
1/2 & 2 watt

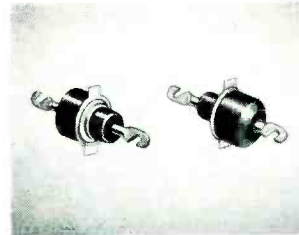

Ferri-Cap Feed-thru Filters  
with ferrite material

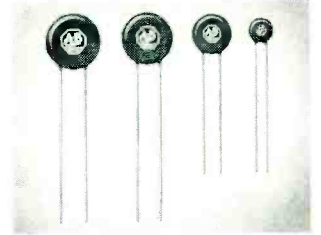

Ceramic Dielectric Capacitors  
for by-pass and filtering

# ALLEN-BRADLEY

## RADIO, ELECTRONIC AND TELEVISION COMPONENTS

# A New Approach To Precise 400 Cycle Frequency Control

with  
American  
Electric's  
Unique  
"MIC"  
DRIVE!

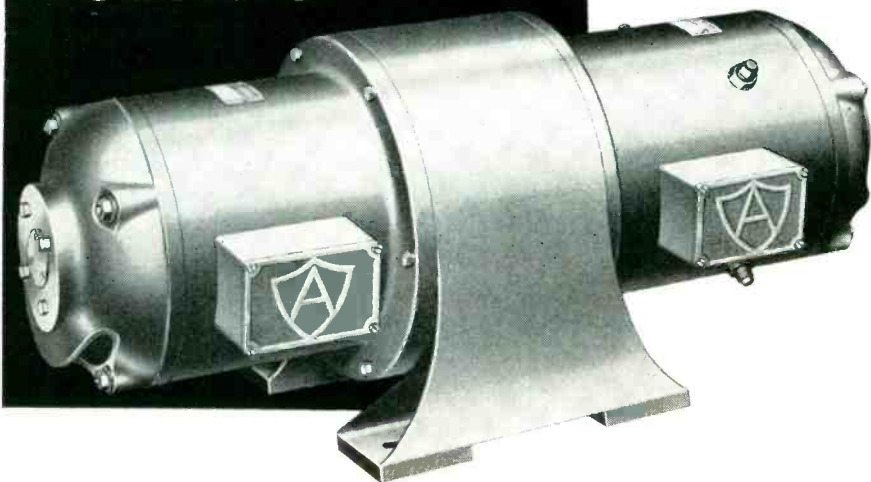

Here's the answer to *exceptional 400 cycle frequency control regardless of input frequency variations or changes in load!* It's the result of American Electric's "MIC" drive... a MOTOR-INDUCTION COUPLING which produces a new standard of *automatic speed control!* No belts, no gears... speed changes are instantly sensed and automatically corrected electronically.

400 cycle output is held to  $\pm 1/4\%$  despite input frequency changes or load variations which ordinarily affect alternator rpm. *Even closer control is available for special applications!*

All other advantages of American Electric's proven alternator designs are retained... low overshoot, fast transient voltage recoveries, low harmonic content, minimum maintenance.

**Capacities:** Single phase, 1/2 KVA to 40 KVA  
Three phase, 1/2 KVA to 100 KVA

*Write for quotations on your specific requirements*

Application  
Engineering  
offices  
in principal  
industrial  
areas

**American Electric Motors, Inc.**  
Electric Machinery & Equipment Division of



2112 Chico Avenue, El Monte, Calif.

ing compounds is available: mineral filled Melamine, Plaskon reinforced (glass) Alkyd 440A, and Orlon filled diallyl phthalate.

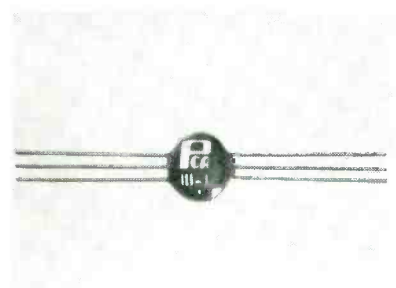

## PULSE TRANSFORMER is highly miniaturized

PCA ELECTRONICS INC., 2180 Colorado Ave., Santa Monica, Calif. The MPT miniaturized pulse transformer is available in 2, 3 and 4 windings, and a pulse-width range of 0.01 to 25  $\mu$ sec.

As an encapsulated unit, it is commonly mounted by soldering into a circuit. Because of its small size, there are no shock or vibration problems. The transformer meets MIL-T-27A, wherever applicable.

► **Applications**—It is ideally suited for: blocking oscillators, impedance matching and phase inversion; as wide-band input and output transformers; l-v interstage coupling; triggering and counting circuits; d-c isolation; pulse shaping and many other applications.

Prices range from \$4.45 each to \$8.05 each, depending on design and quantity.



## POWER SUPPLY is focusing-magnet type

LEVINTHAL ELECTRONIC PRODUCTS, INC., 2760 Fair Oaks Ave., Redwood City, Calif. Designed for use with



FEATURING TEMPERATURE COEFFICIENTS AS LOW AS  
10 PARTS PER MILLION PER DEGREE C. BETWEEN  $-55^{\circ}$  AND  $+85^{\circ}$

# NEW FREED HIGH FREQUENCY - HIGH "Q" TOROIDAL INDUCTORS

PRODUCTS OF  
QUALITY - DEPENDABILITY  
RESULTS OF  
EXTENSIVE ENGINEERING

**HIGH FREQUENCY  
TOROIDAL INDUCTORS**  
featuring very high Q,  
temperature stabiliza-  
tion and low pickup  
utilizing the latest ma-  
terials and techniques.

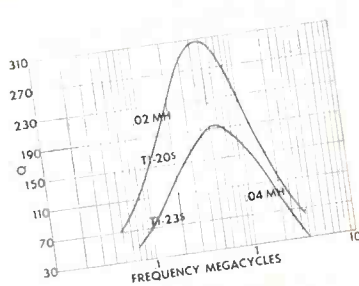

**TI-20S**

14 stock values  
from 0.05 Mhy. to  
4.5 Mhy.

**TI-23S**

15 stock values  
from 10 Mhy. to  
700 Mhy.

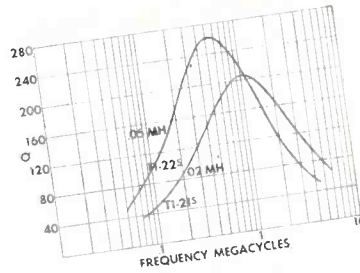

**TI-21S**

15 stock values  
from .01 Mhy. to  
1 Mhy.

**TI-22S**

10 stock values  
from 10 Mhy. to  
150 Mhy.

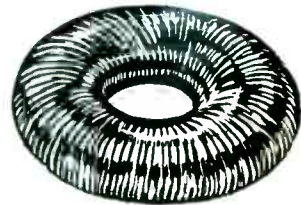

	OD	H
TI-20	1"	9/16
TI-21	5/8	9/16
TI-22	7/8	3/8
TI-23	7/8	3/8

Can be supplied hermeti-  
cally-sealed, encapsulated  
or in a metal can.

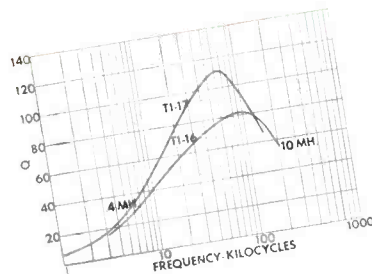

**TI-16**

20 stock values  
from .1 Mhy. to  
100 Mhy.

**TI-17**

18 stock values  
from .1 Mhy. to  
100 Mhy.

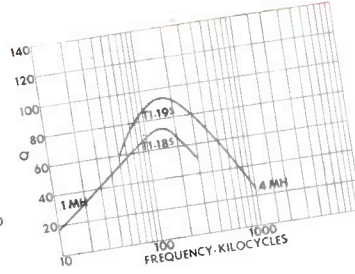

**TI-18**

18 stock values  
from .1 Mhy. to  
100 Mhy.

**TI-19**

13 stock values  
from .1 Mhy. to  
5 Mhy.

THESE TOROIDS ARE  
FEATURING HIGH Q  
AND SUBMINIATURE  
SIZE. Our unique wind-  
ing and impregnation  
process insures very  
low distributed capac-  
ity and consequently  
self-resonant frequen-  
cies far removed from  
the operating range.

**NOW AVAILABLE FROM STOCK FOR IMMEDIATE DELIVERY**

**FREED TRANSFORMER CO., INC.**

1722 WEIRFIELD ST., BROOKLYN (Ridgewood) 27, NEW YORK

Phone: EVergreen 6-1300

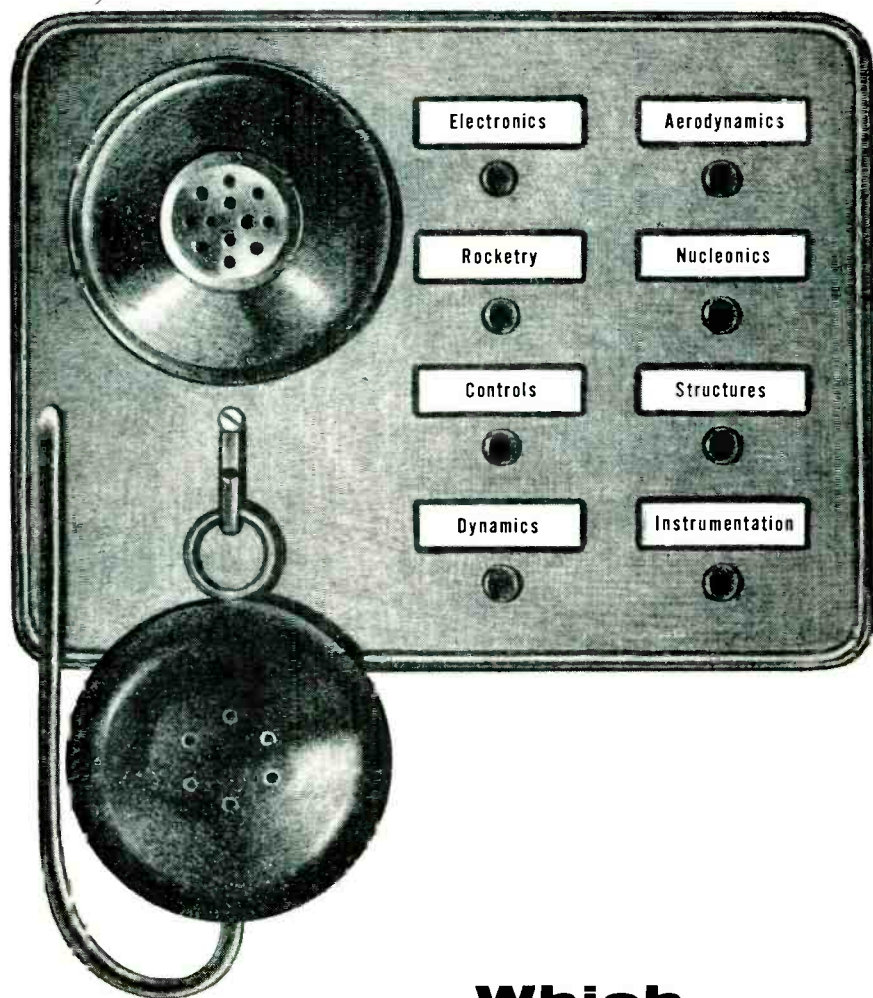

## Which button ?

Today at Martin, one of the finest engineering teams in the whole new world of flight systems development is at work on tomorrow's design and development problems.

Most of the people on that team are young—and moving ahead fast with a dynamic and fast-moving management.

Push any button and you can get the story of some of the exciting things that are happening there.

Contact J. M. Hollyday, Dept. E-12, The Martin Company, Baltimore 3, Maryland.

**MARTIN**  
BALTIMORE

high-power klystrons and traveling-wave-tube focusing magnets, a continuously-variable 150-v 4-ampere power supply with less than 0.1-percent current ripple is now available.

It is designed to operate from 115-v 60-cps single-phase power.

► **Components**—Units include an undercurrent relay to interlock with tube beam supply and indicator light, main power switches, pilot light, and appropriate fusing.

The power supply is designed to fit standard 19-in. relay-rack mounting. Price is \$275.

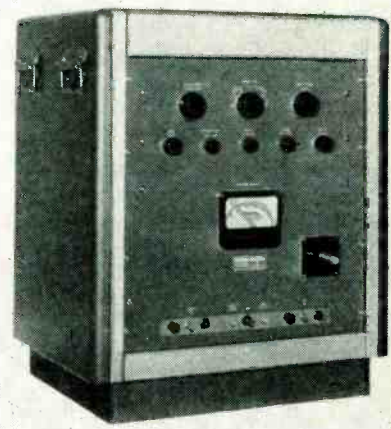

## SWEEP GENERATOR covers the entire X-band

ROGER WHITE ELECTRON DEVICES, INC., 12 West Island Road, Ramsey, N. J. The SWM-5 sweep generator is designed to permit rapid evaluation, measurement and adjustment of microwave circuits and systems.

Incorporating the BC-X10m backward-wave oscillator, the generator supplies a microwave signal swept in frequency across a waveguide range or any portion of it from 66 mc to 60 kmc. The unit can also operate as a manually controlled c-w source if desired.

► **Sweep Width**—The range of frequencies covered in each sweep can be adjusted to cover the entire range or any portion as small as 10 percent of the band. This makes the unit equally useful for examining the performance of components over narrow bandwidths or across the full waveguide range.

Power output may vary as much



# Now Puerto Rico Offers 100% Tax Exemption to New Industry

by BEARDSLEY RUMI

"We don't want runaway industries" says Governor Muñoz. "But we do seek new and expanding industries." Federal taxes do not apply in Puerto Rico, and the Commonwealth also offers full exemption from local taxes. That is why 325 new plants have been located in Puerto Rico, protected by all the guarantees of the U.S. Constitution.



Beardsley Rumi

**I**N A dramatic bid to raise the standard of living in Puerto Rico, the Commonwealth Government is now offering U. S. manufacturers such overwhelming incentives that more than three hundred new factories have already been established in this sunny island 961 miles off the Florida coast.

First and most compelling incentive is the 100% tax exemption for most manufacturers who set up new plants in Puerto Rico.

**For example, if your company is now making a net profit after taxes of \$53,500, your net profit in Puerto Rico would be \$100,000—a gain of 87 per cent, simply because Federal corporate income taxes do not apply in Puerto Rico and all local taxes are waived as well.**

Your dividends in Puerto Rico from a corporation there could be \$50,000 against \$25,000 net in the U. S.—because Federal personal income taxes do not apply either.

### What About Labor?

Puerto Rico's labor reservoir of 637,000 men and women has developed remarkable levels of productivity and efficiency—thanks, in part, to the Commonwealth's vocational training schools. These schools also offer special courses for managers and supervisors.

**The progress made in technical skills may be gauged from the fact that there are now twenty-eight factories producing delicate electronic equipment.**

Among the U.S. companies that have already set up manufacturing operations in Puerto Rico are Sylvania Electric, Carborundum Company, St. Regis Paper, Remington Rand, Univis Lens, Shoe Cor-

CORPORATE TAX EXEMPTION	
If your net profit after U. S. Corporate Income Tax is:	Your net profit in Puerto Rico would be:
\$ 17,500	\$ 25,000
29,500	50,000
53,500	100,000
245,500	500,000
485,500	1,000,000

DIVIDEND TAX EXEMPTION	
If your income* after U. S. Individual Income Tax is:	Your net income in Puerto Rico would be:
\$ 3,900	\$ 5,000
7,360	10,000
10,270	15,000
14,850	25,000
23,180	50,000
32,680	100,000
43,180	200,000
70,180	500,000

\*These examples are figured for dividends paid in Puerto Rico to a single resident. Based on Federal rates effective Jan. 1, 1954.

poration of America, and Weston Electric.

### "Close to Paradise"

Listen to what L. H. Christensen, Vice President of St. Regis Paper, says:

*"The climate is probably as close to paradise as man will ever see. I find Puerto Ricans in general extremely friendly, courteous and cooperative.*

*"This plant in Puerto Rico is one of our most efficient operations, in both quality and output. Our labor has responded well to all situations."*

Mr. Christensen might have added that the temperature usually stays in the balmy 70's twelve months a year.

The swimming, sailing and fishing are out of this world. Your wife will rejoice to hear that domestic help is abundant.

The Commonwealth will leave no stone unturned to help you get started. It will build a factory for you. It will help you secure long-term financing. It will even

screen job applicants for you—and then train them to operate your machines.

### Transportation

Six steamship companies and five airlines operate regular services between Puerto Rico and the mainland. San Juan is just 5½ hours by air from New York.

Light-weight articles such as radar components come off the line in Puerto Rico one day and are delivered by air freight next day in Los Angeles, Chicago and other mainland cities. And, of course, there is no duty of any kind on trade with the mainland.

### Are You Eligible?

Says Governor Muñoz: *Our drive is for new capital. Our slogan is not "more something old to Puerto Rico," but "start something new in Puerto Rico" or "expand in Puerto Rico."*

**To get all the facts, and to find out whether you and your company would be eligible for complete tax exemption, telephone our nearest office.**

New York ..... MU 8-2960 ..... 579 5th Ave.  
Chicago ..... AN 3-4887 ..... 79 W. Monroe  
Los Angeles ..... WE 1-1225 ..... 5325 Wilshire

### OR MAIL COUPON

Commonwealth of Puerto Rico  
Economic Development Administration  
579 Fifth Ave., New York 17, N. Y.  
Dept. V4

Mail me "Facts for Businessmen." I am interested in the advantages of Puerto Rico for the industry I have checked.

Electronics     Plastics     Apparel  
 Leather         Optical      Metals

Other \_\_\_\_\_

Name \_\_\_\_\_

Company \_\_\_\_\_

Address \_\_\_\_\_

\_\_\_\_\_

# Memo to transmitter designers

Specify MicroMatch Directional Coupler as built-in R.F. and VSWR monitoring equipment. Transmitter customers stay "sold" by the coupler's continuous RF power output indication. Its VSWR monitor is your customer's transmission line and antenna "watch-dog".

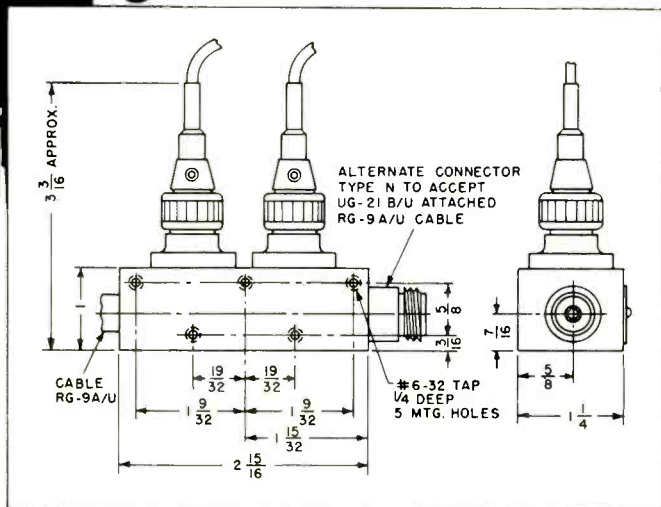

Outline Drawing Model 575N Double Coupler.

Performance proven, you will find these small, extremely low-cost MicroMatch couplers now incorporated in the most modern Government and commercial transmitters. MicroMatch Directional Couplers produce an output essentially independent of frequency over the range of 20 to 2000 megacycles. Couplers are adjusted to produce full scale meter deflection at power levels of 1.2 watts to 120 KW. Accuracy of power measurement is plus or minus 5% of full scale.

For complete details on the MicroMatch line of monitoring equipment, please consult Page 495 of Electronics Buyer's Guide, or, better still, write for our 46-page catalog.

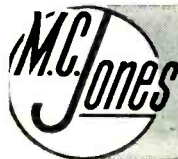

**M. C. JONES ELECTRONICS CO., Inc.**  
BRISTOL, CONNECTICUT

as 10 db from minimum to maximum in the band but the variation over any 100-mc band is usually small.

Price of the unit is \$2,800. A data sheet is available giving additional information.

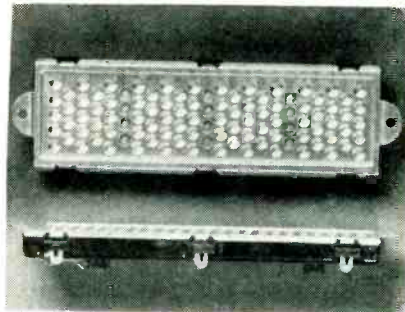

## LOUDSPEAKERS

### Isophon electrostatic types

ARNHOLD CERAMICS, INC., 1 E. 57th St., New York 22, N. Y., announces the new Isophon line of electrostatic loudspeakers, manufactured in West Germany. Two types are available—the rectangular type St H 8 (illustrated) and round type St H B7.

► **Frequency**—The loudspeakers are suggested for use over a 7,000 to 20,000-cycle frequency range. Special construction of the membrane results in far reaching and evenly distributed volume and sound even in the higher frequencies, where cone speakers often develop trouble.

The small size, in particular the thickness of less than 1 in., and the low cost make the speakers desirable for manufacturers of radio, tv, high-fidelity and other applicable sound equipment.

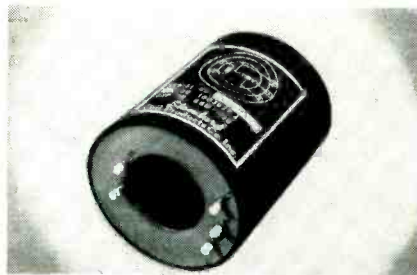

## DEFLECTION YOKE

has high linearity accuracy

STANDARD COIL PRODUCTS CO., INC.,  
2085 N. Hawthorne Ave., Melrose



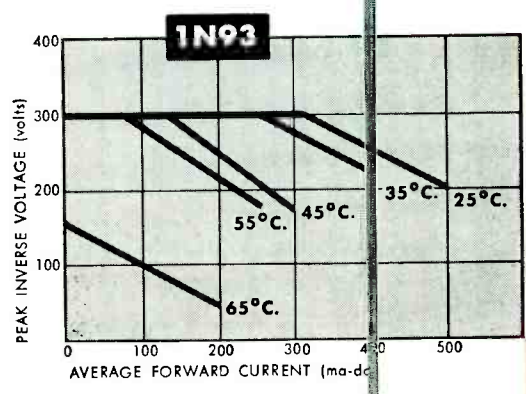
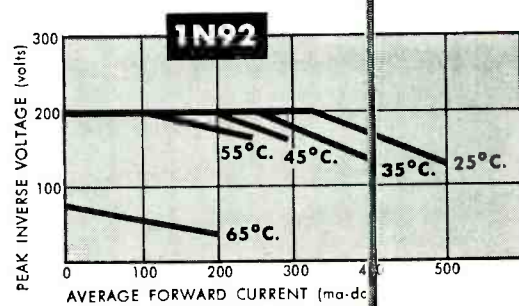
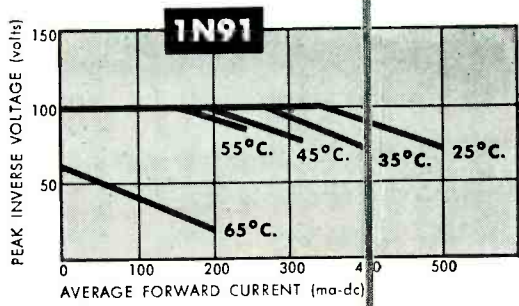

ARMED SERVICES and A.E.C.  
Source Inspection Available

Write for Power Diode Bulletin PD2

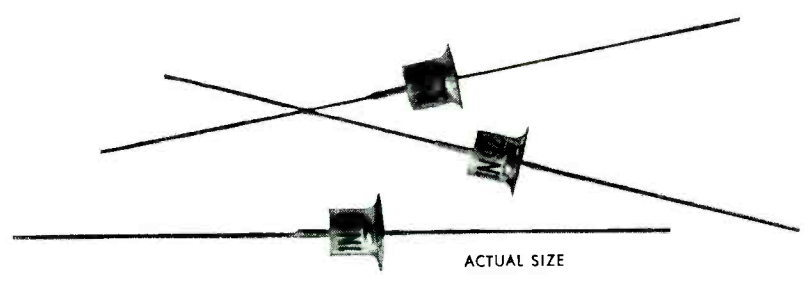

# CLEVITE TRANSISTOR PRODUCTS IMMEDIATE DELIVERY PRODUCTION QUANTITIES\* POWER DIODES

## AN ADVANCE IN ELECTRONICS

Germanium Junction Power Diodes Types 1N91, 1N92, and 1N93 achieve characteristics never before possible in either thermionic or other types of solid state rectifiers. For example:

- **SMALL SIZE-HIGH POWER**—approximately four times the rectified power in the same space as other devices.
- **HIGH EFFICIENCY** — combines very low forward resistance with high back resistance . . . 100% rectification efficiency is approached.
- **LONG LIFE** — unlike other semi-conductor metals, Germanium does not age . . . in addition, hermetically sealed construction.

## 100% RIGID CONFORMANCE TO SPECIFICATIONS

Quality control of Clevite Transistor Products Power Diodes is based on a 100% sampling. Each and every unit is individually tested for rigid conformance to specifications.

- **ELECTRICALLY TESTED** — each unit must meet or surpass performance requirements.
- **HIGH PRESSURE HUMIDITY TESTED** — each unit is checked to assure perfect hermetic sealing.

# CLEVITE TRANSISTOR PRODUCTS

241-257 CRESCENT STREET  
WALTHAM 54, MASSACHUSETTS



A DIVISION OF THE  
CLEVITE CORPORATION

TRANSISTORS • DIODES • SEMI-CONDUCTOR DEVICES

### ABSOLUTE MAXIMUM RATINGS (for 60 cycle, 55°C. resistive load)

	1N91	1N92	1N93
Peak Inverse Voltage (volts)	100 v. at 2.7 ma	200 v. at 1.9 ma	300 v. at 1.2 ma
Peak Forward Current (amps)	0.47	0.31	0.24
DC Output Current (ma)	150	100	75
DC Surge Current (amps)	25	25	25
Full Load Voltage Drop (volts)	0.5	0.5	0.5
Continuous Reverse Working Voltage (volts)	30	65	100
Operating Frequency (Kc.)	50	50	50
Storage Temperature (°C.)	85	85	85



A midwestern electronics manufacturer has cut soldering time a full 60% by changing from cadmium plated to tin-zinc plated parts. As a result they increased assembly production by 250%.

Corrosion-resisting tin-zinc offers many assembly and plating advantages to manufacturers of electronic parts —

**PRODUCTION** — The soldering operation is made easier and considerable assembly time can be saved—parts can be soldered at lower temperatures . . . Embrittlement of fine wire is greatly reduced — solderability is retained longer (*even after 3 years on the shelf tin-zinc plated parts have been soldered without difficulty*) . . . Flux is not necessary.

**PLATING** — M&T tin-zinc plating is economical, easy, and assures a corrosion-resisting finish with good coverage even on difficult metals such as malleable iron.

M&T tin-zinc plating may solve your production problems, too. For detailed information on the process or technical assistance, write us without obligation.



## METAL & THERMIT CORPORATION

*Chemical & Metals Department*

100 EAST 42nd STREET • NEW YORK 17, N. Y.

Park, Ill. Designed for accurate control of the spot position in a crt intended for radar application, the new precision deflection yoke has a linearity accuracy in the azimuth direction of better than  $\frac{1}{2}$  percent. Linearity in the range direction is better than  $\frac{1}{2}$  percent.

► **Orthogonality**—Angle between azimuth and range directions is held to an accuracy of 1/10 deg. This performance is brought about as a result of a special winding technique and the use of molded coil forms combined with equipment for measuring deflection accuracy to within 0.03 percent.

A cylindrical iron core surrounds the windings for shielding purposes. The entire assembly is pressed into a phenolic cylinder, then completely impregnated and sealed to prevent entrance of moisture.

Dimensions are as follows: inside diameter,  $1\frac{1}{2}$  in.; outside diameter,  $3\frac{1}{2}$  in.; length,  $3\frac{3}{4}$  in. Windings can be made to suit practically any specified requirement. Size can also be varied where required.



### AMPLIFIER-VOLTMETER is highly sensitive

ALLEN B. DUMONT LABORATORIES, INC., 750 Bloomfield Ave., Clifton, N. J. Type 346 sensitive amplifier-voltmeter can make precise measurements of a-c signals from 100  $\mu$ v to 300 v at frequencies from 10 cps to 2 mc.

The  $4\frac{1}{4}$ -in. meter scale is illuminated to facilitate use under low ambient light conditions. Readings are provided from -72 to +52 db. Calibration is in two linear voltage scales (0 to 1 and 0 to 3) and



**NOW** **2** different methods  
**FOR** **2** different requirements

## AEROVOX PRINTED WIRING

You are now offered the choice of TWO different printed-wiring methods: (1) The Aerovox exclusive **Pressed Silver** or (2) The Aerovox **Etched Copper**. Each has its particular field of applications.

Furthermore, Aerovox also offers a choice of different base materials, such as: Phenolic-paper Base, Phenolic Fabric, Epoxy Glass, Melamine Glass, Teflon Glass, Polystyrene and Methacrylite, each with certain characteristics for given usages.

### **PRESSED SILVER**

Produced by a hot die-stamp process in which the conducting pattern is mechanically embossed in one or both sides of the selected base material. Does not rely on any adhesive agent for the bond between conductive and base materials. Pure silver conductors are partially imbedded in base support. Compared with copper, the silver is more resistant to oxidation, solders more readily, and provides superior electrical contact surface with greater resistance to wear, particularly for switching applications.

### **ETCHED COPPER**

Produced by applying an etch-resistant pattern on to a metal foil, usually copper clad. Unprotected metal areas of printed pattern are then etched away leaving desired wiring pattern. The resistant enamels may be applied by (a) Direct photographic means, or (b) Screen printing. The former achieves maximum definition of lines held to close tolerances at relatively modest costs; the latter effects cost savings where extremely fine detail is of secondary importance.

### **PRINTED WIRING PRIMER . . .**

Write on your business stationery for this practical guide on printed wiring. And let our printed wiring specialists collaborate on your particular applications.



**AEROVOX CORPORATION**

**SPECIAL PRODUCTS DIVISION  
NEW BEDFORD, MASSACHUSETTS**

In Canada: **AEROVOX CANADA LTD., Hamilton, Ont.**



True sine and square waves for servo, geophysical, and computer work. 0.01 to 1000 cps in 5 decades. High stability, low distortion. Accurate frequency calibration and precisely metered output.

**DONNER MODEL 15  
LOW FREQUENCY  
GENERATOR**

\$365, F. O. B. Berkeley

# ADVANCED INSTRUMENTATION

Versatile engineering tool solves both differential equations and transfer functions. Detachable problem boards, plug-in components. Function generator, multiplier, other accessories available. High accuracy with operating simplicity.

**DONNER MODEL 30  
ANALOG  
COMPUTER**

\$995, F. O. B. Berkeley

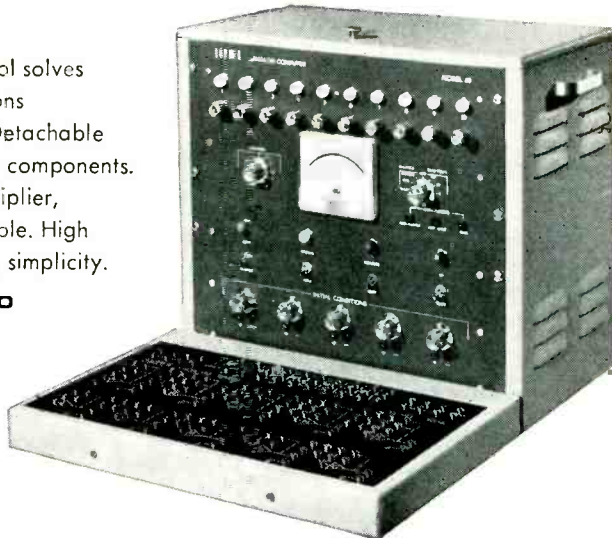

2802 Seventh St.  
Berkeley 10, Calif.

Complete Data  
on Request

**DONNER** SCIENTIFIC  
COMPANY

a db scale (-12 to +2 dbm). The rectifier is of the full-wave average type to offer greatest accuracy when dealing in complex waveforms.

► **Specifications** — Meter ranges are 0.001, 0.003, 0.01, 0.03, 0.1, 0.3, 1.0, 3.0, 10, 30, 100 and 300 v full scale. Accuracy is  $\pm 3$  percent, 20 cps to 1 mc;  $\pm 5$  percent, 10 cps to 2 mc. Stability is  $\pm 1$  percent at any line voltage between 105 and 130 v. Input impedance is 10 megohms shunted by 24  $\mu$ f.

► **Physical Characteristics** — It measures 6½ in. high, 4½ in. wide and 7½ in. deep overall. Weight is 6½ lb.

Price of the unit is \$200.

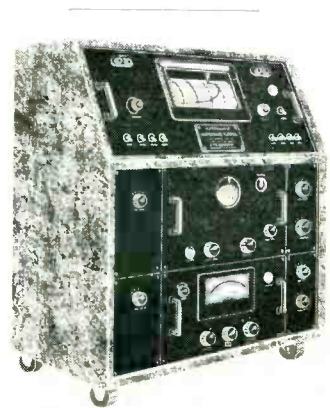

**IMPEDANCE PLOTTER**  
for instantaneous recording

CHESAPEAKE INSTRUMENT CORP., Shadyside, Md., announces an automatic impedance plotter for instantaneous recording of real and imaginary components of impedance as a function of frequency, temperature or other variables. It eliminates point by point plotting procedure, thereby serving as a practical production control tool as well as a valuable research instrument.

► **Ranges** — Frequency range is 10 cps to 100 kc with a rated accuracy of  $\pm 2$  percent. Resistance range is 0 to 10,000 ohms; reactance range,  $\pm 10,000$  ohms.

The apparatus uses Mosely Autograf recorder which plots on standard 8½ in. by 11 in. graph paper.

► **Applications** — The AIP has demonstrated its usefulness in the de-



# Picture Quality Is Our Business Too!



Set designers assure their customers steady, clear pictures by careful component selection. Good-All backs that selection with reliable capacitors at economical cost. The enthusiastic acceptance of **GOOD-ALL MARBELITE** and **SERAMELITE** tubulars is a measure of the confidence designers have in these capacitors. Tens of millions are in use today in TV and Radio Sets of leading manufacturers.

**Good-ALL**  
capacitors

## MARBELITE



Marbelite capacitors are best known for their physical and electrical ruggedness. The Good-All type 503-M capacitors provide solid plastic construction at a surprisingly low cost. A miniature series of Marbelites is also available for applications in which the space is limited.

## SERAMELITE



The seramelite family of capacitors is housed in ceramic tubes with end-seals of a tough, dense plastic. Their performance under conditions of high temperature and humidity is outstanding. Seramelite types with "MYLAR" dielectric are becoming increasingly popular.

*Get full information by writing Good-All direct or by contacting our nearest sales representative.*

**GOOD-ALL ELECTRIC MFG. CO. • GOODALL BLDG. • OGALLALA, NEBRASKA**

## HOKUM ON PREAMPLIFICATION

Way out in our back room we have a section devoted to Engineering.<sup>1</sup> One purpose of this group is to see to it that our relays work in the job for which our customers purchased them. Our man Waldo Hokum, one of the members of this group, has for years been untangling circuit problems<sup>2</sup> that have had an unflattering effect on our relays and during this time he has been able to segregate many problems and assemble them in definite categories.<sup>3</sup>

One category soon became so large that we had to take more floor space to make room for it — that was, and is, how to get conventional relay response to low impedance D.C. signals of the order of 0.1 to 100 microwatts. Many relay uses call for amplifying these signals so that they will be strong enough to activate even our most sensitive relays.<sup>4</sup> This is especially important to people who work with photocells, thermocouples and the like.

Waldo stuck with this one through various stages of vacuum tubes, transistors, toroidal coil magnetic amplifiers and such, but never was really happy about his progress.<sup>5</sup> There was always something like high cost, fragility or instability to cast a dark shadow on his otherwise blissful existence.<sup>6</sup> It wasn't until he designed and made his own magnetic amplifier that he began to see the sunshine again.<sup>8</sup>

What he came up with was a magnetic amplifier which, among other things, included conventional bobbin wound coils rather than toroids. This made our directors happy,<sup>9</sup> because even they know that the manufacturing costs are much less with bobbins, and, what is more important, it made Waldo happy.<sup>10</sup> He discovered that his new gismo,<sup>11</sup> together with the circuitry that he developed to go with it, had some rather interesting specs,<sup>12</sup> generally as follows:

### MAGNETIC AMPLIFIER RELAY SERIES 8000\*

Sensitivity:	0.1 to 100 microwatts	
Nature of signal:	D. C. from 0.1 to 30,000 ohms	
Relay response:	Polarity sensitive — snap action	
Contact form:	(1) 3-position, center neutral (2) SPDT	
Contact rating:	1.5 amperes at 28VDC or 115VAC	
Speed of response:	30 to 300 milliseconds depending on overdrive and L/R of input circuit	
Environment:	Standard	Available
Vibration:	5 g.	10 g.
	to 30 cps.	to 500 cps.
Temperature:	0° to 50°C	-55° to 125°C
Shock:	10 g	100 g
Power Supply:	115V @ 60 cps.	115V @ 400 cps.

This thing is now at the point where it would be worth your time to play around with — that is if the above specs bracket your problem generally and especially if you need to monitor the conditions of bridge balance<sup>14</sup> or compare the outputs of low impedance D.C. signal sources.

If such is the case, Waldo has some sample "packages" that not only include his magnetic amplifier, and a Sigma Relay (natch), but also the circuitry that makes the thing work.<sup>15</sup> If you think you'd like one of these to fool with, or wish more information on this subject, we suggest you write to us, attention of our man Waldo. His name really is spelled Holcombe.



# SIGMA

SIGMA INSTRUMENTS, INC.  
62 Pearl St., So. Braintree, Boston 85, Mass.

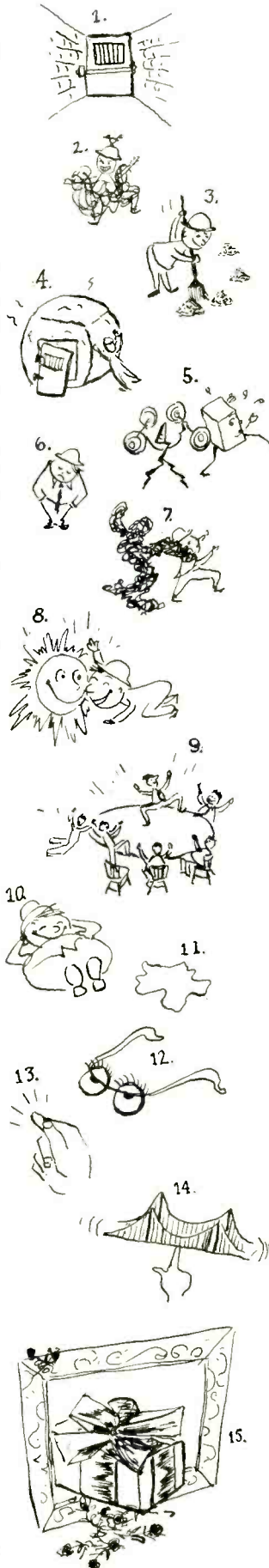

sign and control of electroacoustic transducers, loudspeakers, electrical filters, electromechanical filters, microphones, accelerometers, transformers and similar devices.

Literature is available.

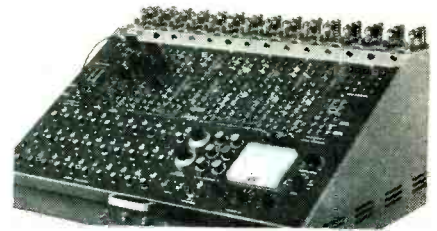

## ANALOG COMPUTER available in kit form

HEATH Co., a subsidiary of Daystrom, Inc., Benton Harbor, Mich., has available an inexpensive electronic analog computer in kit form. It incorporates such features as: 30 coefficient potentiometers, each of which is capable of being set to an accuracy of better than 0.1 percent; one standard reference supply for all d-c voltages; a nulling meter for accurate setting of computer voltages; and a unique patch-board layout which enables the operator to see his computer block layout.

► **Makeup**—The computer is comprised of the model ES-400 computer cabinet, model ES-200 amplifier, model ES-100 power supply, model ES-100 initial conditions and model ES-600 function generator.

Selling price is under \$700.

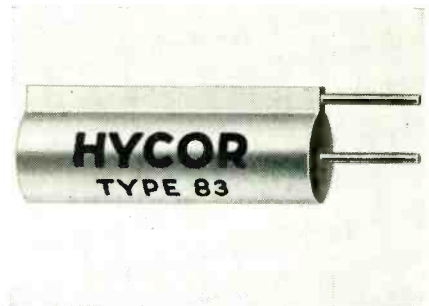

## WIRE-WOUND RESISTORS for mechanized production

HYCOR Co., INC., 11423 Vanowen St., North Hollywood, Calif., has announced the series A precision wire-wound resistors for use in



*New*

# COMPONENTS PRODUCE MICRO-SECOND

## Vari-Count

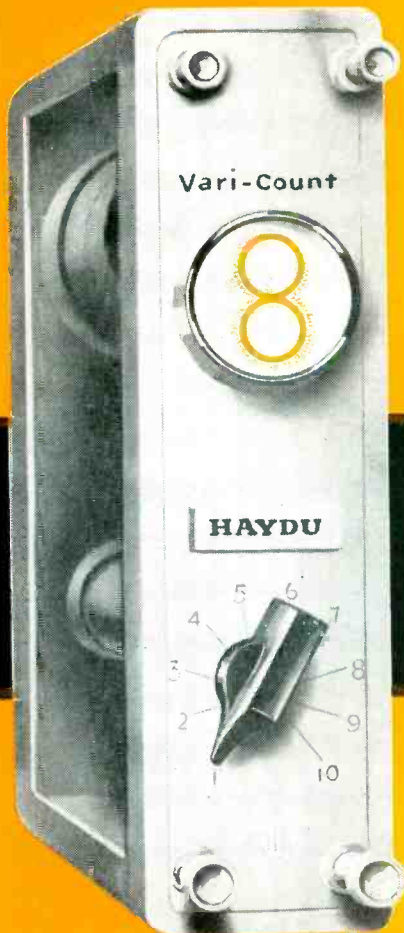

=



H-B101

Haydu Beam Switching Tube MBS

+



Haydu Numerical Indicator Tube "Nixie"

Two outstanding basic electron components . . . Haydu's "Beam Switching Tube" and "Nixie" the numerical indicator tube . . . are combined to make possible this *versatile* new instrument.

### • VARI-COUNT

Static to megacycle counter distributor  
Microsecond electronic preset  
Microsecond variable scale output

Microsecond recycling  
Microsecond clearing  
Preset gating

### • BEAM SWITCHING TUBE (6700)

Replaces 20 Tubes  
Megacycle counting 0-9  
Megacycle preset

Low power consumption  
Electronics most reliable distributor  
Pentode "working" output

### • NIXIE (HB106)

1" x 1"  
10 digit 0-9 gas indicator tube  
"Two-dimensional"

In-line readout  
Common anode prebiasing  
Low power

Write for complete technical data to:

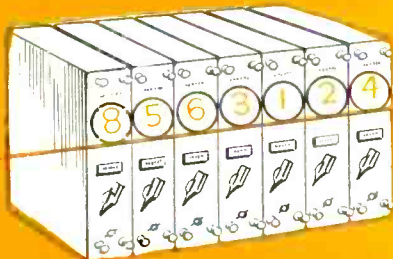

Large, in-line numbers  
assure quick, accurate readings

# HAYDU



BROTHERS OF NEW JERSEY  
PLAINFIELD, NEW JERSEY

SUBSIDIARY OF BURROUGHS CORPORATION 

printed wiring circuits. They are designed to conform to specifications proposed by RETMA for components to be used in automatic assembly equipment.

► **Encapsulation**—The resistors are encapsulated in a tough epoxy compound for protection against extreme humidity, mechanical and thermal shock. The plastic is filled with heat-conducting mineral which dissipates the heat and equalizes hot spots in winding. Sealed-in terminal connections are welded. They satisfy military requirements of MIL-R-93A and JAN-R-93.

► **Specifications**—Temperature coefficient is  $\pm 0.0022$  percent per deg C; operating temperature,  $-65$  C to  $+125$  C; wattage range, from 0.25 w to 1 w with tolerances to 0.1 percent.



**FIVE-MC OSCILLOSCOPE for lab and production line**

EICO, 84 Withers St., Brooklyn 11, N. Y. The No. 460 5-mc oscilloscope is designed for laboratory, production line, and monochrome and color tv servicing. Kit price is \$79.95; factory-wired price, \$129.50.

► **Features**—Some of its outstanding features include: reproduction of the 3.58 mc sync burst and 3.58 mc oscillator signals in color tv sets; flat from d-c to 4.5 mc, usable to above 5 mc; built-in voltage calibrator; vertical amplifier push-

**THERMOSTATIC DELAY RELAYS**

Provide delays ranging from **2 to 150 SECONDS**

**A  
M  
P  
E  
R  
I  
T  
E**

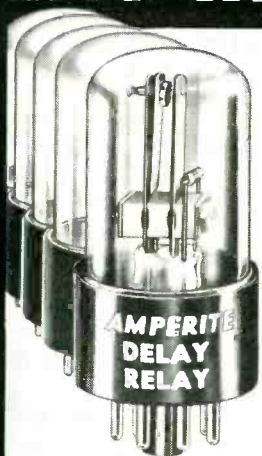

STANDARD

The units are most compact, rugged, explosion-proof, long-lived, and — inexpensive! TYPES: Standard Radio Octal, and 9-Pin Miniature.

**MOST COMPACT  
MOST ECONOMICAL  
HERMETICALLY SEALED**

- Actuated by a heater, they operate on A.C., D.C., or Pulsating Current.
- Hermetically sealed. Not affected by altitude, moisture, or other climate changes.
- Circuits: SPST only—normally open or normally closed.

Amperite Thermostatic Delay Relays are compensated for ambient temperature changes from  $-55^{\circ}$  to  $+70^{\circ}$  C. Heaters consume approximately 2 W. and may be operated continuously.



MINIATURE

**PROBLEM? Send for Bulletin No. TR-81**

Also—a new line of Amperite Differential Relays — may be used for automatic overload, over-voltage, under-voltage or under-current protection.



T9 BULB

**BALLAST REGULATORS**

- Amperite Regulators are designed to keep the current in a circuit **automatically regulated** at a definite value (for example, 0.5 amp).
- For currents of 60 ma. to 5 amps. Operates on A.C., D.C., or Pulsating Current.
- Hermetically sealed, light, compact, and most inexpensive.

Amperite Regulators are the simplest, most effective method for obtaining automatic regulation of current or voltage. Hermetically sealed, they are not affected by changes in altitude, ambient temperature ( $-55^{\circ}$  to  $+90^{\circ}$  C), or humidity. Rugged; no moving parts; changed as easily as a radio tube.

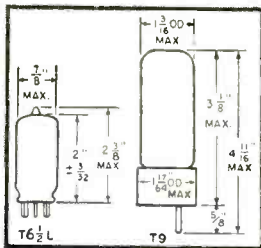
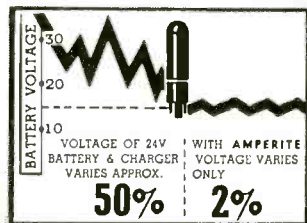

**AMPERITE CO., Inc.**

561 Broadway, New York 12, N. Y.

In Canada: Atlas Radio Corp., Ltd., 560 King St., W., Toronto 2B

Write for 4-page Technical Bulletin No. AB-51



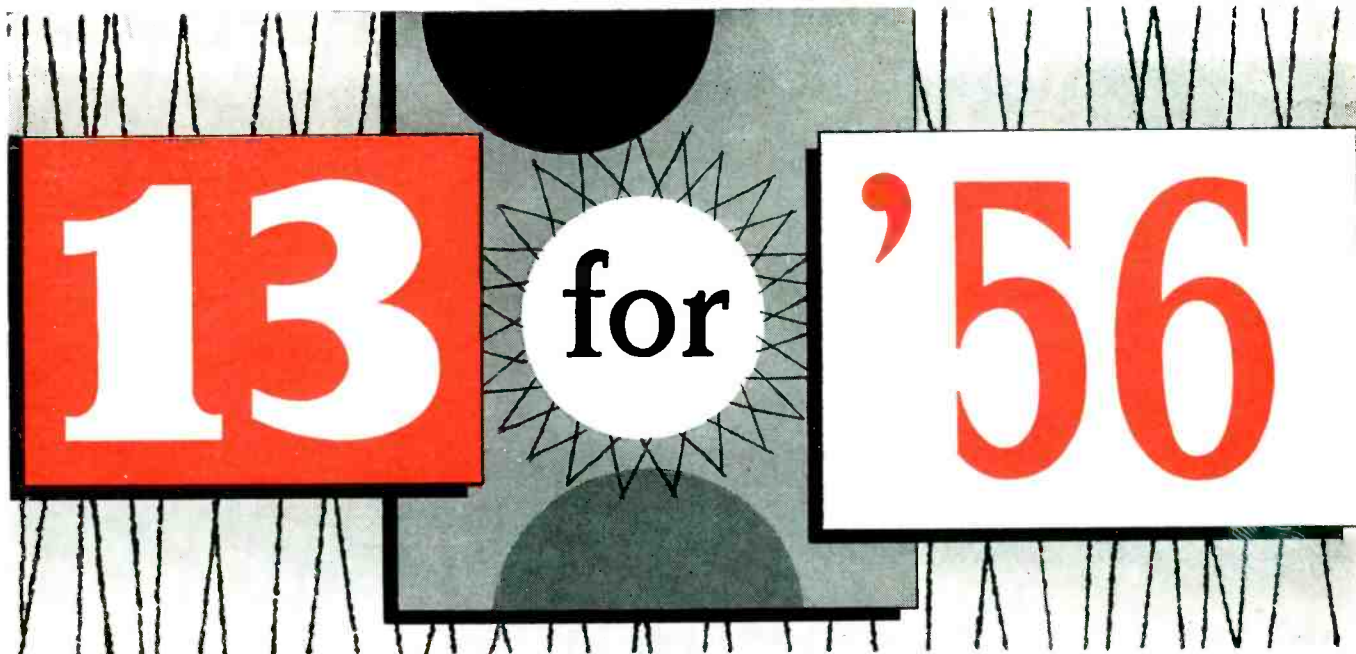

... what we mean is a promotion package of  
**12** REGULAR ISSUES OF **ELECTRONICS** plus the **BUYERS' GUIDE**

Whatever other dilemma the advertising budget planner may be in, he is in agreement on one salient point: *advertising, to develop maximum effectiveness, must be continuous.* Nothing, absolutely nothing, pays off on the long run more than getting potential buyers familiar with your product and trade name by way of consistent, all-the-year-'round advertising. Once ascertaining what your market is, the logical approach is to keep your product in view of this market through continuous, consistent advertising.

For instance, the value of continuity in advertising was demonstrated by a series of surveys conducted by McGraw-Hill's Research Department. It was found through the results of these surveys that continuity in advertising increased the recognition of an electronic firm's products 26% in nineteen months.

For the budget planner with an electronic account, there is a ready-made promotion

package for the consistent, continuous year 'round advertising program. That program is 12 regular issues of **ELECTRONICS** plus the 1 issue of the **ELECTRONICS BUYERS' GUIDE** . . . 13 insertions for 1956! Here you will reach more than 40,000 subscribers who pay to get **ELECTRONICS** — owners, partners, corporate officers, managers, department heads, chief engineers and especially: electronic, electrical, design and research engineers; in brief, the people of the industry who are responsible for buying the products you promote in the sales pages of **ELECTRONICS** and the buying reference pages of the "Guide." With a consistent, continuous advertising program in 13 issues of **ELECTRONICS** (12 regular issues plus the "Guide") manufacturers have discovered that they get the greatest return from their advertising dollar investment because **ELECTRONICS** reaches the men who influence purchasing.

**BUDGET NOW FOR 13 INSERTIONS IN '56!**



**electronics**

A McGraw-Hill Publication



**BUYERS' GUIDE**

330 West 42nd Street, New York 36



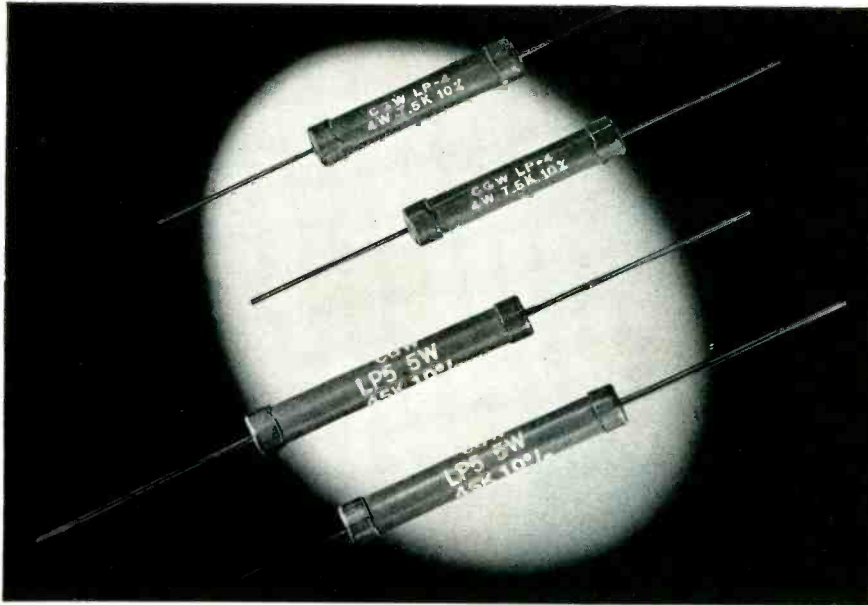

Types LP4-4W. and LP5-5W. shown. Also LP3-3W., LP7-7W. and LP10-10W.

## Corning Low-Power Resistors for Radio and TV

You'll find that Corning Low-Power Resistors perform admirably under the most adverse radio and TV operating conditions. Their resistance range is the highest of any low-power resistor.

Small and compact, they save space. They are non-inductive and exceptionally stable.

The fired-in film of metallic oxides on glass forms is tough, abrasion-resistant, difficult to scratch. No need for special handling to prevent damage during installation.

The automatic resistance spiralling of these LP-type resistors is electronically controlled. Press-fitted caps with axial tinned leads ready to solder complete the assembly. This guarantees reliable uniformity of the following characteristics.

### CHARACTERISTICS

**Range**—LP3 resistors are available from 200 to 20,000 $\Omega$ ; LP4 from 200 to 40,000 $\Omega$ ; LP5 from 200 to 45,000 $\Omega$ ; LP7 from 200 to 36,000 $\Omega$ ; LP10 from 200 to 50,000 $\Omega$ ; with a  $\pm 10\%$  tolerance.

**Power Rating** is based on 40 $^{\circ}$ C. ambient temperature for the LP3, LP4 and LP5 resistors and 25 $^{\circ}$ C. ambient

for the LP7 and LP10 with an average hot spot of 275 $^{\circ}$ C.

**Derating**—With suitable derating, resistors can be operated at ambient temperatures over 120 $^{\circ}$ C.

**Overload**—Operated at 10 times the rated wattage for 5 seconds, resistance change is less than 2%.

**Soldering**—Permanent change in resistance due to normal soldering technique is less than 1/2%.

**Moisture**—Resistance change is less than 1% after 100 hours at an ambient temperature of 40 $^{\circ}$ C. and 95% relative humidity.

**At Radio Frequencies**—The LP resistors are essentially non-inductive.

**Mechanical Protection**—A high temperature lacquer coating provides added protection during handling.

**Availability**—Immediately . . . through Corning Glass Works or authorized distributors of Erie Resistor Corp. For new low prices and other information send the coupon, or write to Corning Glass Works, Corning, New York.

pull throughout for reduced distortion, and choice of direct or capacitive coupling; 25 mv per in. vertical sensitivity; and full d-c horizontal and vertical positioning.

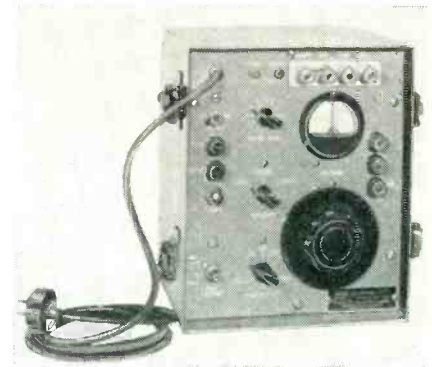

### MEGOHM BRIDGE uses encapsulated networks

TELECTRO INDUSTRIES CORP., 35-18 37th St., Long Island City 1, N. Y. Model 750 megohm bridge is a portable self-contained instrument for measuring resistance values to 1 million megohms. It contains a specially designed highly sensitive electronic detector and galvanometer for null indications. Overall accuracy is better than 2 percent of scale reading.

► **Uses**—Model 750 is designed to measure resistances, voltage coefficient of resistors, insulation resistances of transformers, and resistances of three terminal networks.

A special feature of the construction is the use of encapsulated networks to assure maximum stability of components.

Price is \$550.

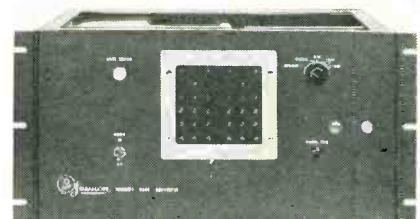

### CONVERTER card data into analog form

LIBRASCOPE, INC., 808 Western Ave., Glendale, Calif. Model 250 punched card converter is an automatic data processing accessory that



*Corning means research in Glass*

**CORNING GLASS WORKS**  
36-12 CRYSTAL STREET, CORNING, NEW YORK  
New Products Division

Please send me descriptive catalog sheet on Corning Low-Power Resistors.

Name..... Title.....

Company.....

Address.....

City..... Zone..... State.....



# THE ONLY COMPLETE LINE OF VIDEO TRANSMISSION TEST EQUIPMENT

**TELECHROME**  
INCORPORATED

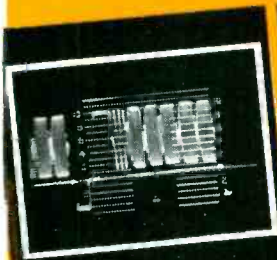

**AMPLITUDE vs FREQUENCY.** Check wide band coaxial cables, micro-wave links, individual units and complete TV systems for frequency response characteristics without point checking or sweep generator—Model 1070-BR.



**LOW & HIGH FREQUENCY CHARACTERISTICS.** Determine ringing, smears, steps, low frequency tilt, phase shift, mismatched terminations, etc. in TV signals or systems.—1071-AR thru 1070-BR or 1072-AR alone.

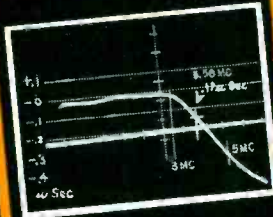

**ENVELOPE DELAY vs FREQUENCY.** Shown: envelope delay characteristics of Model 620 BR NTSC receiver equalizer as indicated by Model 1603-AR.

Measures "funny paper" effect.

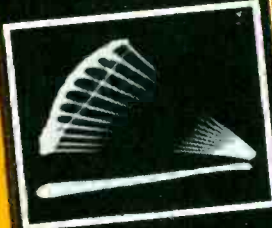

**DIFFERENTIAL PHASE vs. AMPLITUDE.** Check for ability of system to transmit color with fidelity at varying amplitudes. Shown is 6AC7 video amplifier with 4° differential phase. Model 1044-AR or 1041-BR plus 1070-BR with 1601-AR.

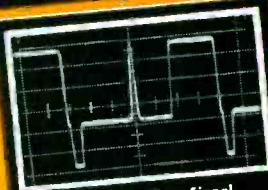

Sin<sup>2</sup> Square Wave Signal.

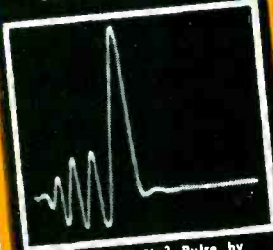

Effect on Sin<sup>2</sup> Pulse by NTSC phase equalizer.  
Check for transient response of a unit or system—Model 1073-A.



STAIRCASE SIGNAL—MODEL 1044-AR OR MODULATED—1041-BR THRU 1070-BRM



(ABOVE)—STAIRCASE SIGNAL—THROUGH HIGH PASS FILTER



(ABOVE)—STAIRCASE SIGNAL—THROUGH LOW PASS FILTER  
Hi-Lo Cross Filter for Signal analysis—608-A.



**1041-BR STAIR STEP GENERATOR**—Checks amplitude linearity, differential amplitude linearity and differential phase of unit or system. Variable 4-15 steps. 1044-AR—above with built in sync and blanking adder and 3.58 mc adder for modulating steps & burst on back porch.

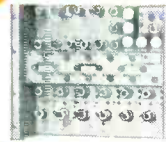

**1070-BR MULTI-BURST GENERATOR**—Provides white bar and 6 bursts of pre-set freq. 0.5-6.0 mc. Own sync and blanking adder. Checks freq. response or complete system incl. those using keyed clamps. Used to add sync and blanking to output of other units (window and step generators). 1070-BRM has own 3.58 mc adder.



**1071-AR WINDOW GENERATOR**—Checks low frequency response of system. Fast rise time leading edge checks high frequency response. Output may be displayed on kinescope or oscilloscope. 1072-AR includes sync blanking adder.



**608-A HI-LO CROSS FILTER** with 3 pos. switch for viewing signal directly, or thru low or high pass filter. Allows individual observation of either high or low freq. component of signal or signal directly. Sensitive check of diff. amplitude distortion using modulated step signal from (1044-AR) through high pass section.



**1603-AR PHASE SLOPE (ENVELOPE DELAY) CURVE TRACER**—Instantaneous scope or meter reading of the envelope delay and amplitude characteristics vs. frequency of any network, video amplifier, or system up to 8 mc. Precise, time saving. Has separate transmitter and receiver units which allow one way or loop measurements.



**1601-AR CHROMASCOPE**—For accurate checking of color signals, or simultaneous amplitude and phase characteristics of a signal also used for measurement of phase and differential phase.

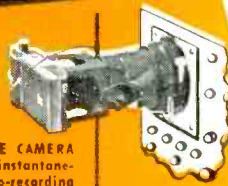

**1521-A OSCILLOSCOPE CAMERA**—Polaroid type for instantaneous 1 to 1 ratio photo-recording from any 5" oscilloscope.



**1073-A SIN<sup>2</sup>-SQUARE WAVE GENERATOR**—Closely equivalent to actual camera signal. Used for rapid checking of frequency and phase characteristics of a TV or pulse unit or system. Simultaneously shows amplitude, phase, and envelope delay. (Described by R. C. Kennedy, N.B.C., in "Electronics.")

**DELIVERY 30 DAYS**

Literature on these and more than 150 additional instruments for color TV by TELECHROME are available on request.

**TELECHROME**  
INCORPORATED

The Nation's Leading Supplier of Color TV Equipment  
88 Merrick Road Amityville, N. Y.  
AMityville 4-4446





A complete range of MIL-T-27 units is available for quick delivery from your Chicago Standard distributor.

- POWER
- FILAMENT
- BIAS
- CHOKES
- AUDIO INPUT  
3 frequency ranges
- AUDIO OUTPUT  
3 frequency ranges
- PULSE
- 400 CYCLE  
Power  
Filament  
Chokes
- MS (Military Standard)  
Power,  
Filament

Ask for the free CHICAGO catalog, listing detailed electrical and physical specifications on all these transformers. Available from your electronic parts distributor or from Chicago Standard Transformer Corporation.



## CHICAGO STANDARD TRANSFORMER CORPORATION

ADDISON AND ELSTON • CHICAGO 18, ILLINOIS

Export Sales: Roburn Agencies, Inc., 431 Greenwich Street, New York 13, N.Y.

translates the decimal code punched into cards into an analog signal for automatic point plotting by X-Y plotter and recorder model 200-A.

► **Accuracy**—The punched card converter has an accuracy of 0.1 percent when used alone and an accuracy of 0.25 when used in conjunction with a plotter.

When used with the Librascope X-Y plotter the instrument will plot approximately 60 cards per minute. Used with the IBM 523 punch machine, cards are simply loaded into the hopper, no special panel connections being necessary.

Individual punched cards may be read separately on a visual display located on the front panel of the instrument. The chart scale of the converter can be expanded independently by a factor of 10 to 1 for special data process applications.

Current price of the instrument is \$2,450.

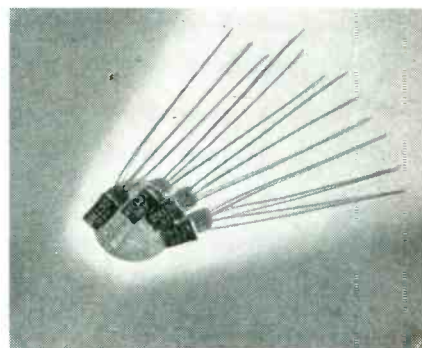

### GERMANIUM TRANSISTOR in much smaller size

RAYTHEON MFG. Co., 55 Chapel St., Newton 58, Mass., announces four new transistors which are  $\frac{1}{4}$  to  $\frac{1}{3}$  the size of former units. These *pn-p* fused junction germanium transistors have a volume of only 0.0087 cu in. and are designated types 2N130, 2N131, 2N132 and 2N133. The first three are intended for use in audio or low r-f applications; the fourth is a low-noise transistor for use in low-level audio circuits.

► **Noise Factor**—Average noise factor of the 2N133 is 6.5 db and will not exceed a maximum limit of 10 db. This is an improvement over the older type 2N106/CK727,



# TO SOLVE A PROBLEM...

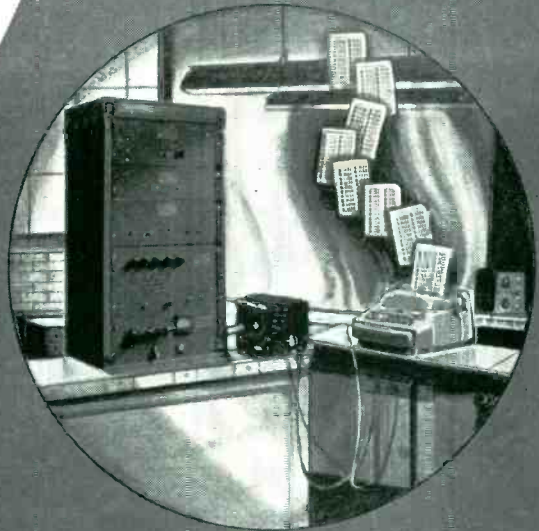

To eliminate manual null detection, visual dial reading and hand-typing of each calibration point, with costly man-hour waste, plus the possibility of human error...

## ...THE AUTO-CAL WAS BORN!

● **AUTOMATIC FREQUENCY CALIBRATOR**

CONCEIVED and DEVELOPED BY



*Imprint of Integrity*

*Only* the AUTO-CAL can:

**AUTOMATICALLY** Calibrate over 1000 Frequencies  
in ONE HOUR! and SIMULTANEOUSLY

**AUTOMATICALLY** Type these Frequencies on CALIBRATION DATA CARDS

The **LORAL** AUTO-CAL has slashed  
CALIBRATION and RECORDING TIME by  
**533%** within an accuracy of .005%

*Only* **LORAL** HAS THE **AUTO-CAL!**

Your inquiry for CALIBRATION or RECALIBRATION of FREQUENCY METERS — Military, Industrial or Commercial — is solicited!

# LORAL ELECTRONICS CORPORATION

794 EAST 140th STREET

NEW YORK 54, N. Y.

Serving in AVIONICS • AIRBORNE NAVIGATIONAL EQUIPMENT • COMMUNICATION SYSTEMS • RADAR EQUIPMENT • TEST EQUIPMENT

now discontinued, which had a maximum noise factor of 12 db.

Maximum ambient temperature is 85 C. These transistors are electrically similar to and are designed to replace the CK731 series. Technical catalog sheets are available.

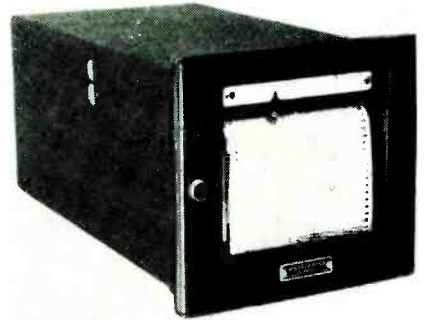

### RECORDING POT with thermocouple calibrations

WESTRONICS, INC., 3605 McCart St., Fort Worth, Texas, has announced a miniature strip-chart recording potentiometer weighing less than 25 lb. It is available with standard charts and ranges for copper-Constantan, iron-Constantan and Chromel-Alumel thermocouples, and has internal cold-junction compensation.

This recorder, of the null-balance potentiometer type, records on a 5-in. strip chart, with a pen speed of 1 sec full scale and an accuracy of better than 0.5 percent.

► **Prices**—The standard recorder with single speed chart drive is \$425. Manual change gears to provide three speeds are optional with single-speed instruments for \$15. The three speed, quick change, gear shift chart drive feature is \$50.

► **Special Features**—Backset Micro Switches for alarm or auxiliary control, additional chart speeds, other than standard ranges and transmitting slidewires are some of the special features which can be incorporated in the recorder.

### POTENTIOMETER for 50 to 70,000-ohm range

FAIRCHILD CONTROLS CORP., Hicksville, L. I., N. Y. Type 747-E potentiometer provides a resistance range of 50 to 70,000 ohms with a standard linearity of  $\pm 0.15$

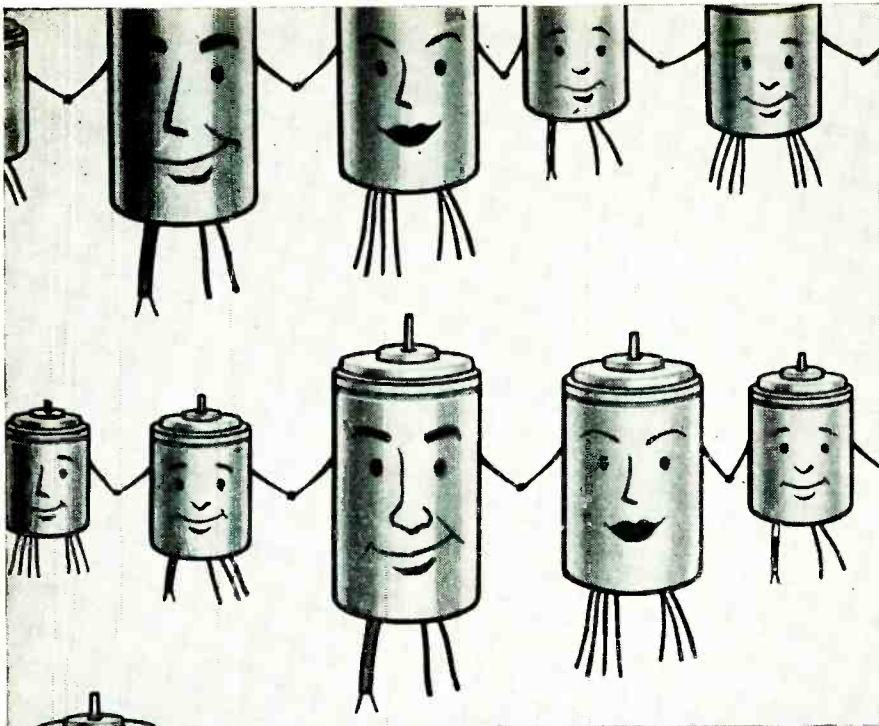

(See you at the Wescon Show, Booth 1417-18)

## WE MAKE ALL TYPES OF SYNCHROS

*and more than anyone else!*

What's your pleasure in synchros? High temperature? High frequency? Linear? Corrosion-resistant? *Whatever* your needs, we either already have a type to fit them . . . or can build a special type for you.

Fine precision synchros have been one of our specialties for over twenty years . . . with more E-P synchros in use today than any other make.

Write, wire or call us for information on standard and special types . . . prices . . . and deliveries. ECLIPSE-PIONEER DIVISION, BENDIX AVIATION CORPORATION, TETERBORO, N. J.

*Eclipse-  
Pioneer*  
DIVISION



West Coast Office: 117 E. Providencia, Burbank, Calif. • Export Sales:  
Bendix International Division, 205 E. 42nd St., New York 17, N. Y.

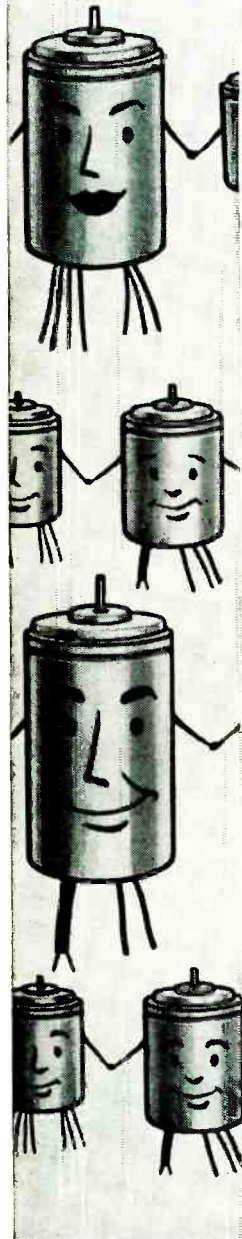



# McGraw-Hill Mailing List Will Help You

- Merchandise your advertising
- Conduct Surveys
- Get leads for your salesmen
- Get inquiries about your product or service
- Pin-point geographical or functional groups
- Sell Direct
- Build up weak territories
- Aid Dealer Relations

Direct Mail is a necessary supplement to a well rounded Business Paper advertising program.

600,000 actual names of the top buying influences in all the fields covered by the McGraw-Hill publications make up our 150 mailing lists. These lists are built and maintained primarily for our own use, but they are available to you for Direct Mail purposes. Pick out a list of YOUR prospects from our Industrial Direct Mail Catalogue.

More and more, progressive companies are using Industrial Direct Mail regularly as an advertising medium. They effectively allocate a portion of their ad budgets to this second medium at the same time as they concentrate on the best business publications.

For complete, detailed information about our service, fill in the coupon or write for your copy of our free Business and Industrial Direct Mail catalogue.



## Direct Mail Division

McGraw-Hill Publishing Co., Inc.

330 West 42nd St., N. Y. 36, N. Y.

Please forward my free copy of the McGraw-Hill "Industrial Direct Mail Catalogue."

NAME \_\_\_\_\_

COMPANY \_\_\_\_\_

ADDRESS \_\_\_\_\_

CITY \_\_\_\_\_ STATE \_\_\_\_\_

# marion

advancement  
in instrument  
design

## NO DOUBT ABOUT IT

... with the versatile  
**MULTI-RANGE  
METER TESTER,**  
Power Supply,  
and  
Limit Bridge

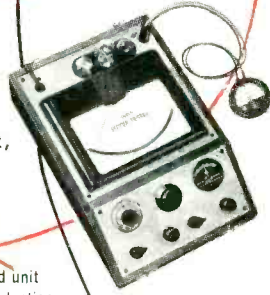

Precise, self-contained unit for laboratory and production use. For DC instrument calibration from 25  $\mu$ a full scale to 10 ma full scale, and 0-100 V DC; sensitivity and resistance measurement; DC current-voltage source; limit or Wheatstone bridge measurements from 0-5000 ohms. Regulated Power supply. Stepless vacuum tube voltage control. Accuracy exceeds 1/4% (current), 1/2 ohm or 1/2% (resistance). For 115 V, 60 cycle AC. Complete — needs no accessories.



## marion meters

marion electrical  
instrument company

GRENIER FIELD, *New Hampshire's NEW Air-Industry Area*  
MANCHESTER, N. H., U. S. A.



copyright 1965 M. E. I. Co.

## NO SHORT CIRCUITS when you use . . .

ALL SIZES  
1/2" dia. to  
1 1/4" dia.



### EthoLoc\* CABLE CLIPS

Made of ETHYL CELLULOSE . . .  
A TOUGH, DURABLE PLASTIC

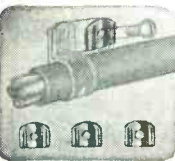

NOW . . .  
For Extra Strength  
"D" WASHERS  
TO FIT OUR  
CABLE CLIPS

Write for Sample and  
Full Information

### WECKER CO.

5267 N. AVONDALE AVE. • CHICAGO 30, ILL.

West Coast Representative:  
5777 West Pico Blvd. • Los Angeles 19, Calif.



NEW PRODUCTS

(continued)

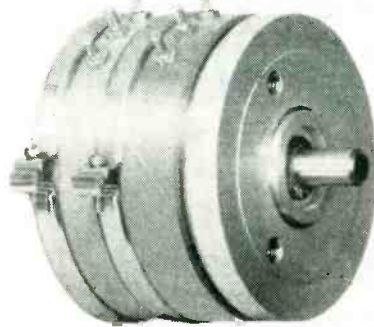

percent. A special clamp provides an unrestricted tapping area allowing up to 19 taps and presents a simplified means of phasing units in a ganged assembly without disassembling the units.

► Uses—The low noise level and high resolution of these units make them particularly desirable for computer assemblies, calibration controls, servomechanisms and other similar applications.

Type 747-E has a diameter of 2.100 in. and a cup width of 0.984 in. and up to 6 units can be ganged on a single shaft. The units are furnished with welded taps and end leads. Low starting torque is only 1.0 oz-in. per cup section.

Prices range from \$30 to \$40 a cup in sample quantities; \$15 to \$25 a cup in production quantities.

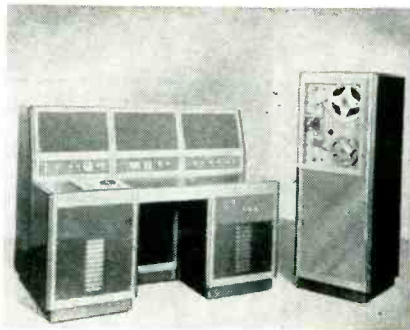

### CONVERTER analog-to-digital type

J. B. REA Co., INC., 1723 Cloverfield Blvd., Santa Monica, Calif., has available a high-speed, accurate analog-to-digital converter with capacity of up to 100,000 conversions per sec, 30 mv resolution and 0.1 percent guaranteed accuracy. It will accept signals from transducers, f-m discriminators, f-m or pwm magnetic tapes, film

## for that short grid lead

### use the Sangamo



## tote-m-pole

First used in Navy electronic gear, Tote-m-poles are invaluable for "bug-resistant" wiring of models and production units. Advantages: Short leads; high component density; improved ventilation.

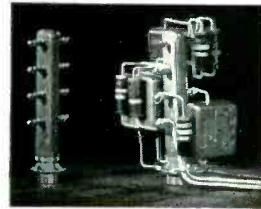

Tote-m-pole supporting  
"T" network of 5 resis-  
tors and 4 capacitors.



CUSTOM COMPONENTS SALES\*  
SANGAMO ELECTRIC COMPANY  
SPRINGFIELD, ILLINOIS

\*H. V. Power Supplies • Inductive Components  
Servo Instruments • Low-X Resistors

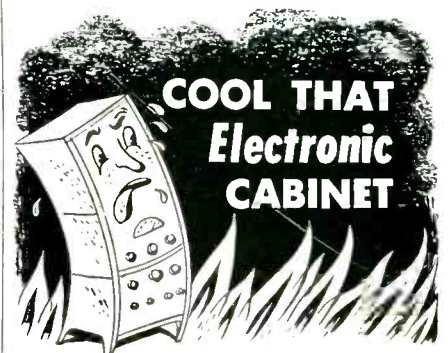

## COOL THAT Electronic CABINET

### Use McLEAN Electronic Cabinet COOLING FANS

Now for the first time, a rack-mounted, self-contained unit is offered for cooling electronic cabinets. Twin blowers mounted side by side, provide maximum filtered air with minimum panel height. Specially designed to fit standard 19" racks, this unit pressurizes cabinet with filtered air, keeping dust out. Complete in one unit and ready for use. No cutting or fitting necessary. Smart, stainless steel grille adds beauty and eliminates matching of cabinet finish. Made in two sizes:

Small Size (7" high x 19" wide with 4 1/4" blower wheels). Delivers 300 CFM.  
Large Size (10 3/4" high x 19" wide with 6" blower wheels). Delivers 600 CFM.  
Send for literature.

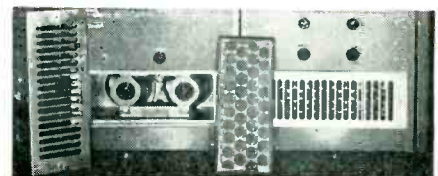

McLEAN ENGINEERING  
PRINCETON, N. J.



*The Standard  
of Accuracy for*

# FREQUENCY MEASUREMENT and CONTROL



## FREQUENCY STANDARDS

*Offers a Comprehensive Line of—*  
**MICROWAVE FILTERS  
AND PRESELECTORS**

- SINGLE SHAFT TUNING AVAILABLE
- TSCHEBYCHEFF RESPONSE



- COMPACT DESIGN
- USABLE OVER WIDE  
TEMPERATURE  
RANGES
- HERMETIC SEALING  
AVAILABLE

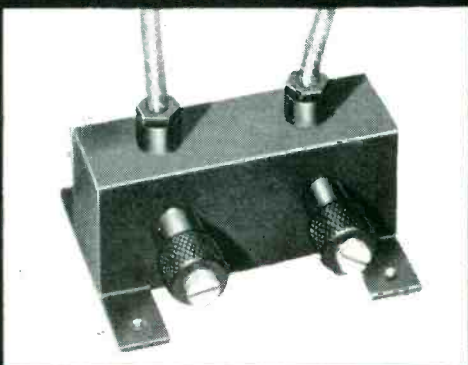
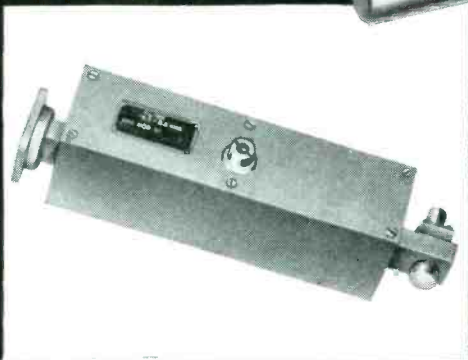

In order to utilize the crowded microwave spectrum to the greatest possible advantage, Frequency Standards now offers a comprehensive line of filters and preselectors. These units are engineered and constructed with the same exacting care and precision which has made Frequency Standards' wavemeters a standard in the industry.

Frequency Standards is proud of its reputation to undertake development and production work in the fields of preselection, frequency measurement and control, which approaches the "state of the art." Our engineering services are available at all times to assist you with your problems.

### RESONANT FREQUENCIES AVAILABLE

	L	S	C	X
Bandwidth (Maximum available)	5%	3%	2%	1%
Number of Sections*	2, 3, 4	2, 3, 4	2, 3, 4	2, 3, 4
Insertion Loss (For 1% bandwidth)	≤ 1.5 db	≤ 1. db	≤ 1. db	≤ 1. db
Rejection ( $F_0 \pm 2x BW$ ) (db)	24 36 48	24 36 48	24 36 48	24 36 48
Input VSWR (Matched Load)	≤ 1.5	≤ 1.5	≤ 1.5	≤ 1.5

\*More Sections Available without Gang Tuning.

NEW CATALOG ON REQUEST—Call or write for new Brochure with complete data on precision-built Microwave Filters, Preselectors, Frequency Meters and Field Test Instruments.

**Frequency Standards**  
ASBURY PARK, NEW JERSEY

Please address  
inquiries to BOX 504A

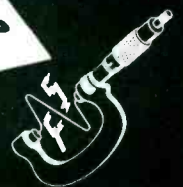

# PRECISION Continental Connectors

## mechanical connect and disconnect

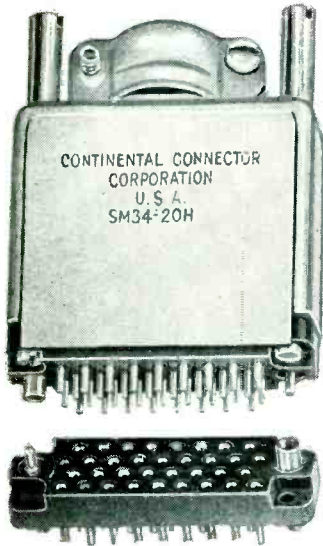

SM-34 with hood  
34 Contacts  
ACTUAL SIZE

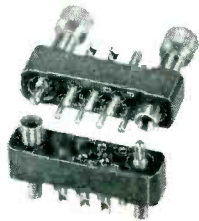

SM-7  
7 Contacts  
ACTUAL SIZE

## now available in Continental subminiature screwlock connectors

Now, for the first time, you can have the dependability of a polarizing screwlock connector in subminiature size.

Polarizing screwlocks eliminate the need for prying, "rocking" or forcing the connector when disconnecting the plug from the receptacle. They provide absolute protection against accidental separation of the plug and receptacle.

**These screwlocks were developed to provide vibration-proof connectors for critical armed services equipment.**

*Technical data on these connectors, and special designs requiring the use of subminiature, printed circuit, hermetic seal, pressurized, high voltage, or power connectors, are available on request. Write today for complete catalog.*

From the tiny 7-contact (illustrated above, right) to connectors accommodating as many as 50 leads of #20 AWG wire, Continental can provide you with precision-made subminiatures for any project. The screwlock feature is also available in a variety of larger connectors, including miniature, hermetic seal, and high voltage.

readers or other analog sources, and convert them to any desired digital code.

► **Sampling**—Used with appropriate commutating, it will sample, in sequence, data from any number of analog sources. Digital output may be printed out, or used as input to a digital computer. Interim storage of the digital data can be accomplished, if desired, by a programmed magnetic tape unit.

► **Price**—The basic converter price is \$12,000, with the price adjustable depending on the speed required by the application. The price of a complete conversion system varies of course with the extent of the requirements of each individual application.

A Rea high-speed input commutation switch, digital output magnetic recorders and programming circuits are among the new features offered in complete converter systems. An 8-page illustrated brochure is offered.

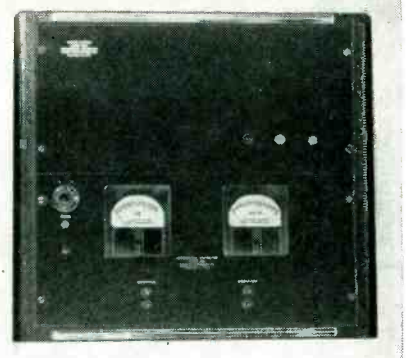

### VOLTMETER measures differentials

FREED TRANSFORMER CO., INC., 1715 Weirfield St., Brooklyn 27, N. Y. Type 1560 differential voltmeter is extremely useful when checking response and attenuation of filters, transformers, amplifiers and other applications where a small difference in two voltages is to be measured, as it measures differences in voltage levels as low as 0.01 percent regardless of their relations.

Because of its stability and sensitivity, it may also be used to observe drift in amplifiers, meters and filters. The a-c input signals

Electronic Sales Division  
DeJUR—Amsco Corporation,  
45-01 Northern Boulevard, Long Island City 1, N. Y.

# DeJUR



a  
**WESTINGHOUSE**  
BALTIMORE DIVISIONS  
opportunity

for experienced electronic engineers seeking long-range positions of responsibility and opportunity.

Current opportunity at the Westinghouse Baltimore Divisions combines most of the ordinary advantages—such as good income and employe benefits—with a foremost program of professional recognition, advanced education at company expense, and long-range development work that is creative and interesting. Work in modern facilities that are ideally located. Apply today!

**OPENINGS**  
EXIST IN THE FIELDS OF:

- \*CIRCUITRY
- \*MICROWAVES
- \*SERVOMECHANISMS
- \*MAGNETIC AMPLIFIERS
- \*PACKAGING
- \*DIGITAL COMPUTER PROGRAMMING
- \*FIRE CONTROL SYSTEMS
- \*ANALOG COMPUTER DESIGN
- \*TRANSFORMERS
- \*VIBRATION
- \*RADAR DESIGN
- \*FIELD SERVICE

**TO APPLY**

Send letter outlining your experience to—

Technical Director, Dept. 278  
Westinghouse Electric Corp.  
2519 Wilkens Avenue  
Baltimore 3, Maryland

YOU CAN BE **SURE**...IF IT'S  
**Westinghouse**

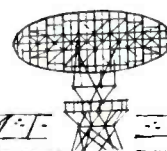

# NEW—Air-transportable Shelter

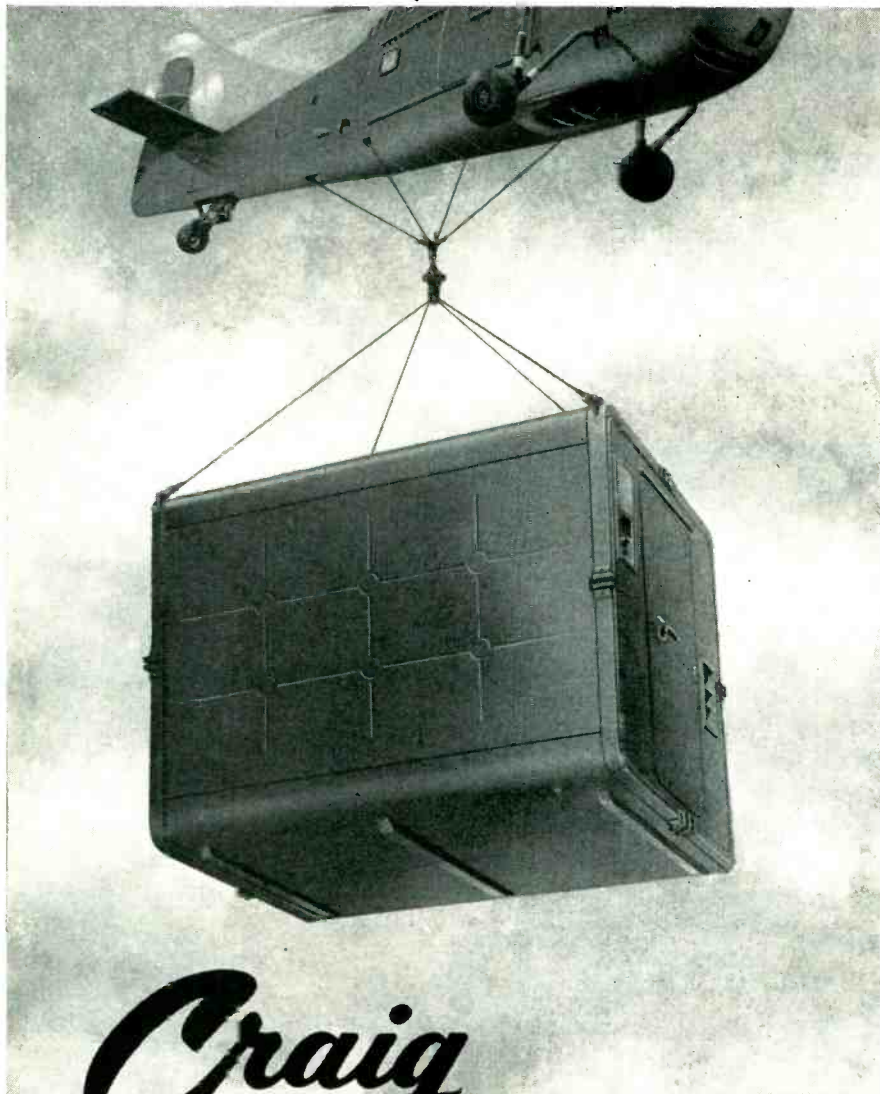

## Craig

### HELICOP-HUT\*

One of the many types of special enclosures designed by Craig for electronic installations and other uses.

A streamlined, lightweight shelter with "big shelter" strength and proportions — aluminum or Fiberglas skins bonded by a special process to a foam core — model shown 76" x 76" x 96" inside dimensions — weighs under 1000 lbs. completely equipped with lighting and ventilation systems.

\*TRADE MARK

**Craig** SYSTEMS, INC.  
DANVERS, MASSACHUSETTS  
TEL: DANVERS 1870

NEW PRODUCTS

(continued)

are amplified, then rectified and compared, so that an accurate comparison may be obtained regardless of the phase of the input signals.

► **Specifications**—Difference voltage range is -10 percent to +5 percent in 0.01 percent increments. Input voltage levels are from 0.1 v to 100 v. Frequency range is 30 cps to 20 kc. Input impedance is 500,000 ohms. The instrument is entirely self-contained and operates from a 115-v, 60-cycle line.



### GAMMA GUN is fully transistorized

UNIVERSAL ATOMICS CORP., 19 E. 48th St., New York 17, N. Y., has available the fully transistorized gamma gun, a self-contained, hand-portable scintillation counter giving 500,000 counts per minute—300 times as sensitive as a single Geiger tube. It has a 2½ in. sodium iodide crystal, a built-in preamplifier and a full-view ore evaluation meter.

► **Uses**—The gamma gun is designed for use both on the ground and in the air. Its light weight and small area permit it to be used comfortably in the smallest plane.

It has six operating ranges to give maximum sensitivity and four time constants ranging from 1 to 60 seconds. The use of transistors in combination with mercury cells completely eliminates drift.

The gamma gun will operate for over 1,000 hours of continuous field use with no battery charges. It sells for \$995.

### POTENTIOMETER for 80 to 150,000 ohms

FAIRCHILD CONTROLS CORP., Hicksville, N. Y. Type 748-E potentiometer





**is this link**



When headers, connectors,  
single terminals  
or transistors  
delay YOUR production  
— consult L. L. Constantin & Co.

Constantin's  
progressive design  
and engineering,  
plus 2 plant production  
facilities assure you  
prompt delivery  
on a complete line  
of high quality  
glass-to-metal  
vacuum seals.

**missing  
in your  
production  
chain?**

*L. L. Constantin & Co.*

GLASS-TO-METAL VACUUM SEALS



Route 46, Lodi, New Jersey  
187 Sargeant Avenue, Clifton, New Jersey

- Transistor Mounts
- Single Terminals
- Compression Headers
- End Seals
- Crystal Bases
- An Connectors
- Miniaturization

here's how to get  
the fast, precise  
answers you need

- for:
- AUDIO FREQUENCY WAVEFORM ANALYSIS
  - ULTRASONIC WAVEFORM ANALYSIS
  - RF, VHF and UHF SPECTRUM ANALYSIS
  - MICROWAVE SPECTRUM ANALYSIS
  - SONIC AND ULTRASONIC FREQUENCY RESPONSE TRACING

...and many other analysis and measurement problems...

the pioneer  
is the leader

consult... **PANORAMIC**  
RADIO PRODUCTS, INC.

the pioneer—  
for instruments  
designed to your needs.

Shown here are just a few of the many instruments Panoramic has designed to meet your needs for rapid, yet accurate analysis and measurement. Send for Panoramic's Catalog and find out how Panoramic can give you the right answer to your research, development and production problems. Our specialists are available for consultation, without obligation.

**LP-1—AP-1 PANORAMIC SONIC ANALYZER** for Audio Frequency Waveform Analysis—20 cps—20 kc.

**SB-7a—PANORAMIC ULTRASONIC ANALYZER** for Ultrasonic Waveform Analysis—1 kc—300 kc.

**SB-8b—SA-8b, SC-8b—PANALYZOR, PANADAPTOR and PANORAMIC INDICATOR** for RF, VHF and UHF Spectrum Analysis.

**SPA-1—PANORAMIC SPECTRUM ANALYZER** for Microwave Spectrum Analysis—50 mc—4000 mc.

**SC-1—PANORAMIC SWEEP GENERATOR** for Sonic and Ultrasonic frequency response tracing—20 cps—200,000 cps with one instrument.

Write today for complete Catalog and prices. Inquiries invited for development of special Panoramic analyzers.

**PANORAMIC RADIO PRODUCTS, INC.**  
10 S. Second Ave., Mount Vernon, N. Y., Mount Vernon 4-3970



eter offers a high degree of accuracy in a resistance range of 80 to 150,000 ohms.

► **Linearity**—Standard linearity tolerance for the potentiometer is  $\pm 0.10$  percent. On special order linearity up to  $\pm 0.05$  percent can be obtained on higher resolution windings.

Low starting torque is only 1.0 oz-in. per cup.

► **Tapping Area**—A special clamp-band feature provides an unrestricted tapping area allowing up to 33 taps and presents a simplified means of phasing units in a ganged assembly without disassembling the units. The unit is furnished with welded taps and leads.

The potentiometer is gangable in assemblies of up to 6 cup units on a single shaft. It has a diameter of  $3\frac{1}{4}$  in. maximum and a cup width of 0.984 in.

Prices range from \$30 to \$40 a cup in sample quantities; \$15 to \$25 a cup in production quantities.

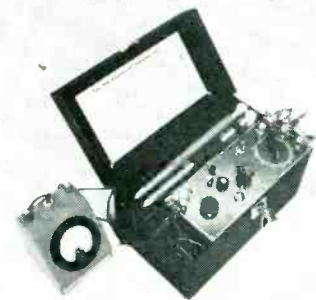

**GROUNDMETER**  
is completely portable

BORDEN ENGINEERING Co., Division of M. J. Johnson Aircraft Engineering Co., 39 E. Hanover Ave., Morris Plains, N. J. The new type W4 Groundmeter is a null-reading Wheatstone bridge for measuring the resistance to ground of driven





# SANBORN

OSCILLOGRAPHIC RECORDING SYSTEMS

**"ON THE JOB"**

PROVIDE VALUABLE  
DYNAMIC ANALYSIS DATA

## PRODUCTION TESTING

of components is accomplished by a Servo Component manufacturer by means of a Sanborn Single-Channel Recording System with a Sanborn Servo Monitor Preamplifier.

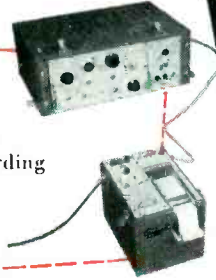

*Sanborn  
Single-Channel  
System*

## DYNAMIC PERFORMANCE

of valves when equipped with a certain pneumatic Valve Positioner is determined by the manufacturer with a Sanborn Two-Channel System and Sanborn Carrier Amplifiers.

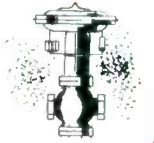

*Sanborn  
Two-Channel  
System*



## ACCELERATION and TORQUE

are recorded simultaneously by an oil company in their study of fuels and lubricants as they relate to engine performance.



*Sanborn  
Four-Channel  
System*



## DRONE MISSILE

manufacturer can simulate the flight of the missile and derive information concerning its behavior under certain conditions by means of an analog computer and a Sanborn Four-Channel System with four Sanborn AC-DC Preamplifiers.



*Sanborn  
Eight-Channel  
System*



## ATOMIC REACTOR

to be used for power generation in prototype plant is studied with the help of a Sanborn Eight-Channel System which records the output of thermocouples, strain gage pressure pickups, and resistance devices.

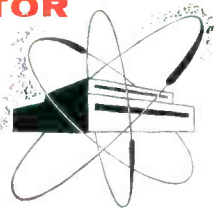

## ANALOG COMPUTING

center uses Sanborn Eight-Channel Systems to record the solutions of problems having six or eight variables. Sanborn systems specially designed for this type of work utilize Dual-Channel DC Amplifiers.

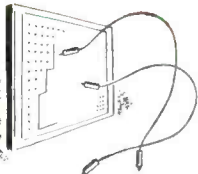

A new 16-page Catalog fully describes Sanborn "150" Series Systems, Components and Accessories. Copies on request.

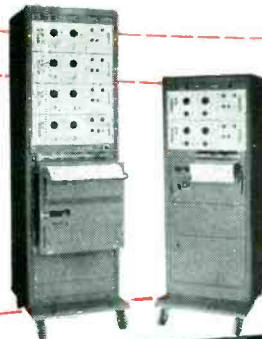

### SANBORN 150 FEATURES INCLUDE:

- Inkless Recording in True Rectangular Coordinates
- Preamplifier Interchangeability
- Eleven Types of Preamplifiers
- Improved Over-all Linearity
- Accessibility of Chart During Recording

INDUSTRIAL DIVISION  
**SANBORN  
COMPANY**  
CAMBRIDGE 39, MASSACHUSETTS

**NEW!**

**MINIATURE**

**SERVO**

**Magnetic Amplifiers**

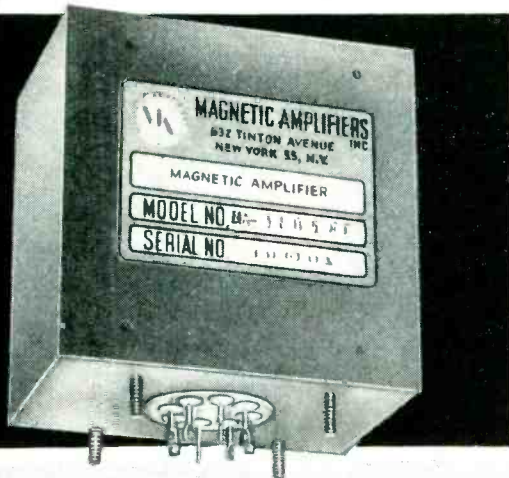
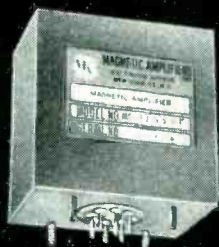

**Three New AC Servo Types Available..**

**STANDARDIZED SERVO SYSTEMS AND OTHER STANDARD TYPES FOR AUTOMATIC CONTROL —**

In addition to new lines illustrated, many standard and higher power magnetic amplifiers are available for applications involving automatic control.

**CUSTOM DESIGNS FOR SPECIAL REQUIREMENTS**

— we design and engineer complete servo or automatic control systems

AFFILIATE OF THE GENERAL CERAMICS CORPORATION

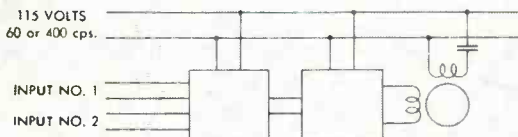

● **MAGNETIC PRE-AMP + SATURABLE TRANSFORMERS**  
 Supply: 115 volt 400 cps.  
 Power output: 3.5, 6, 10, 18 watts  
 Sensitivity: 1 volt AC  
 Response Time: .03 sec.  
 Lowest Cost — Smallest Size  
 For further information request Form S493

● **MAGNETIC PRE-AMP + HIGH GAIN MAGNETIC AMPLIFIER**  
 Supply: 115 volt 400 cps.  
 Power output: 5, 10, 15, 20 watts  
 Sensitivity: .1 volt AC  
 Response Time: .008 to .1 sec.  
 Highest performance — All magnetic  
 For further information request Form S496

● **TRANSI-MAG\*: TRANSISTOR + HIGH GAIN MAGNETIC AMPLIFIER**  
 Supply: 115 volt 400 or 60 cps.  
 Power output: 2, 5, 10, 15, 20 watts  
 Sensitivity: .08 volt AC into 10,000 ohms  
 Response Time: .01 sec.  
 Fast response at high gain  
 For further information request Form S499  
 (400 cps.); Form S497 (60 cps.)

\*TRADE NAME

**MAGNETIC AMPLIFIERS • INC**

Telephone: CYPRESS 2-6610  
 632 TINTON AVE., NEW YORK 55, N. Y.

ground rods, transmission line towers, radio and tv antenna grounds and industrial plant grounds. It has full scale ranges of 1-5-10-50-100-500-1,000-5,000 and 10,000 ohms.

The instrument has, in its portable carrying case, a compartment for all the necessary reference rods and test leads, which are of the proper lengths to serve as measuring lines for the correct reference electrode spacing. Due to its patented circuit, only the 10-in. reference rods need be used and the Y-reference electrode may be as high as 400 times the resistance of the ground being measured.

► **Other Use**—The W4 can also be used as a d-c Wheatstone bridge from 0.01 ohm to 100,000 ohms at 0.1 percent accuracy by connecting an exterior d-c galvanometer.

The complete instrument is 7½ in. by 7½ in. by 12 in. and weighs only 16 lb. Price is \$160 plus \$25 for the galvanometer if it is desired.

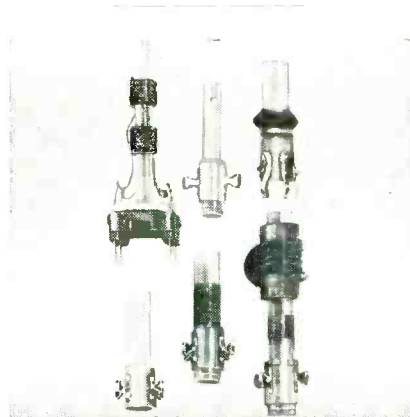

**COIL FORMS**  
 less production time, costs

RADIO INDUSTRIES, INC., 5225 Ravenswood Ave., Chicago 40, Ill. New, one-piece coil forms reduce coil production time and costs by eliminating the need for mounting clips and minimize the number of assembly operations.

RI-1 on precision molded forms of high temperature plastic are being used in the manufacture of RI-tran transformers and coils for countless r-f applications.

The RI-1 form construction is used in both conventional and printed-circuit type applications and is available in a variety of colors for easy identification. RI-tran



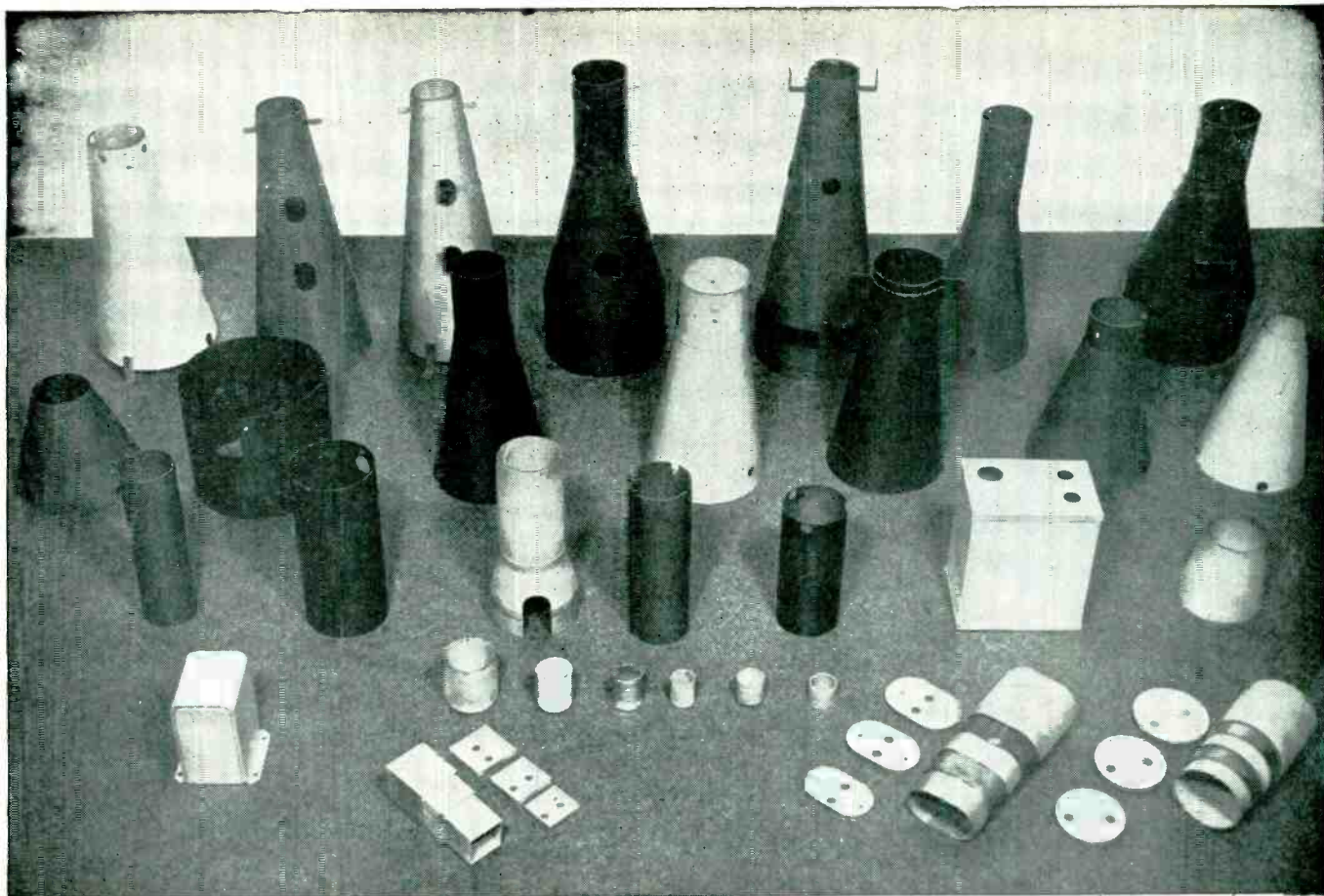

## Get out of the Magnetic Doghouse with **MUMETAL** Shields

**Write for  
your copy**

**"MAGNETIC MATERIALS"**

This 32-page book contains valuable data on all Allegheny Ludlum magnetic materials, silicon steels and special electrical alloys. Illustrated in full color, includes essential information on properties, characteristics, applications, etc. Your copy gladly sent free on request.

**ADDRESS DEPT. E-72**

Mumetal shields will give instant relief to interference caused by extraneous magnetic fields. This material can cure many troubles—solve many a problem for you.

Use it where high permeability is required at low flux densities, such as in input and microphone transformers, hearing aid diaphragms, instruments, wire and tape recorders, etc. For properly heat treating Mumetal, we can also offer commercial hydrogen annealing facilities.

A fund of technical data on

shields and other applications for Allegheny Mumetal is available—let us help with your problems.

In addition to Mumetal and other high-permeability alloys, we offer a range of magnetic and electrical alloys and steels that is unmatched in its completeness. Our services also include the most modern facilities for lamination fabrication and heat treatment. ● Let us supply your requirements. *Allegheny Ludlum Steel Corporation, Oliver Building, Pittsburgh 22, Pa.*

**STEELMAKERS** to the Electrical Industry  
**Allegheny Ludlum**

W&O 5379



# marion

## new MEDALIST meters

advancement  
in instrument  
design



Greater readability and modern styling in minimum space. Interchangeable with ASA/JAN 2½ and 3½ inch sizes. Up to 50% longer scale in same space as ordinary type. Available in various colors. Complete data on request.



### marion meters

marion electrical  
instrument company

GRENIER FIELD New Hampshire's NEW Air-Industry Area  
MANCHESTER, N. H., U. S. A.

copyright 1955 M. E. I. Co.

# Beattie

## ELECTRIC CAMERAS

For Practically  
Every Industrial Use!



Beattie VARITRON  
Electric Camera—Model E

Data Recording Cameras that save you time... give you a permanent, accurate record. Built to withstand environmental conditions, on land, in the air or at sea. Completely automatic at any time interval. Choice of fifteen models... specially engineered variations can be supplied.

Write for complete detailed literature today

# Photographic Products Inc.

1000 NORTH OLIVE STREET  
ANAHEIM, CALIFORNIA

NEW PRODUCTS

(continued)

transformers are available in 8-32 or ¼-28 RI-lon tube construction.

► Design—A new snap-in keyed design eliminates the need for mounting clips, but is interchangeable with clip-mounting chassis cut out. RI-lon one-piece forms resist electrolysis indefinitely, have uniform characteristics and simplify components for automatic insertion in printed-circuit type applications.

## RESISTORS are deposited carbon type

DALE PRODUCTS, INC., Columbus, Neb. The Dalohm deposited carbon resistors are now being supplied with an improved coating material. The material incorporates such features as extreme toughness for rough handling; low temperature cycling (to -85 C); resistance to humidity, and high-temperature characteristics, making these resistors suitable for printed circuit solder dipping without the added space required for sleeving.

Identified as types DC (per Spec MIL-R-10509A) and CC (commercial grade), Dalohm deposited carbon resistors are available in 8 standard sizes from ¼ w to 5 w, and resistance range to 500 megohms. Standard tolerance is 1 percent.

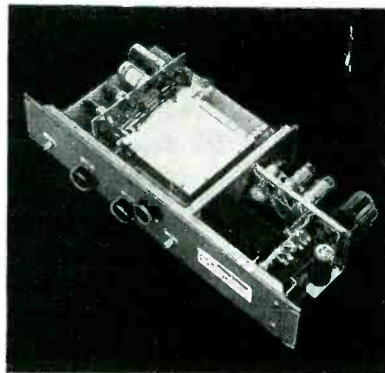

## DELAY CHANNEL available as complete unit

STURRUP, INC., Middletown, Conn., has announced the model 500 ultrasonic delay system available as a complete unit. The unit includes a compact solid ultrasonic delay line with pre-delay and post-delay circuits, and a self-contained, regulated power supply, particularly suiting it for radar, computer and

For consistently high purity...

# "LINDE" M.S.C. RARE GASES

Trade-Mark  
(Mass Spectrometer Controlled)

- Helium
- Argon
- Neon
- Krypton
- Xenon

In radar electronic equipment, nuclear radiation counters, cosmic ray cloud chambers, and thyratrons, where the purest rare gases are demanded, LINDE M.S.C. Grade gases meet the specifications. They are produced under continuous mass spectrometer control to assure you of gases of known purity and consistently high quality. LINDE, the world's largest producer of gases from the atmosphere, can meet your individual needs of volume, mixture, and container.

For information on the physical, chemical, and electrical properties of these gases, send for the booklet, "LINDE Rare Gases."



## LINDE AIR PRODUCTS COMPANY

A Division of  
Union Carbide and Carbon Corporation  
30 E. 42nd Street UCC New York 17, N.Y.

In Canada:  
LINDE AIR PRODUCTS COMPANY, Division  
of Union Carbide Canada Limited, Toronto  
The term "Linde" is a registered trade-mark of Union Carbide and Carbon Corporation.

# HERE'S BIG HELP IN TERMINAL WIRING!

The New

## JONES FANNING STRIP

Connections are made through Fanning Strip, on bench or anywhere apart from barrier strip, and quickly slipped into assembly.



9-141  
Barrier  
Strip

9-161  
Fanning  
Strip—  
Pat.  
applied  
for.

Use with Jones Barrier Terminal Strips, Nos. 141 and 142, for 1 to 20 terminals.

Simplifies soldering. Insures correct connections. Saves time. Ideal for harness or cable assembly. Brass terminals, cadmium plated. Bakelite mounting. Send for complete data.



HOWARD B. JONES DIVISION  
CINCH MANUFACTURING CORPORATION  
CHICAGO 24, ILLINOIS  
SUBSIDIARY OF UNITED-CARR FASTENER CORP.



now . . . . .

**VEEDER-ROOT**  
gives you

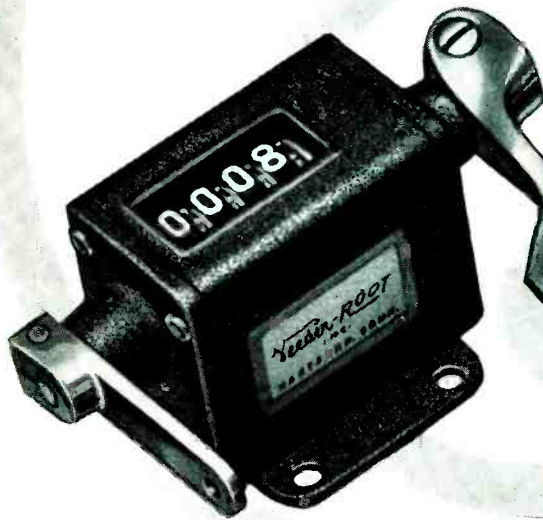

instant "push-button"  
resetting

Just press the easy-acting lever on this Quick-Reset Ratchet Counter . . .  
and all 4 figures reset to zero as instantly as though you used a push-button.  
This saves time and speeds work on short machine runs, inspection and many  
other jobs. Counter is compact . . . 2.69" long, 1.44" high, 1.29" wide.  
The 4 white-on-black figures are .166" high. You can order it (Series 1126)  
from stock right now . . . just like scores of other Veeder-Root Counters  
for manual, mechanical and electrical operation in every field from  
electronics to atomics.

**VEEDER-ROOT INCORPORATED**  
HARTFORD 2, CONNECTICUT  
Greenville, S. C. • Chicago 6, Ill.  
New York 19, N. Y. • Montreal 2, Canada  
Offices and Agents in Principal Cities



EVERYONE CAN COUNT ON  
**VEEDER-ROOT**  
"THE NAME THAT COUNTS"

# Parabolic MICROWAVE ANTENNAS

for all bands 2000 mc - 4000 mc

7000 mc  
X and K

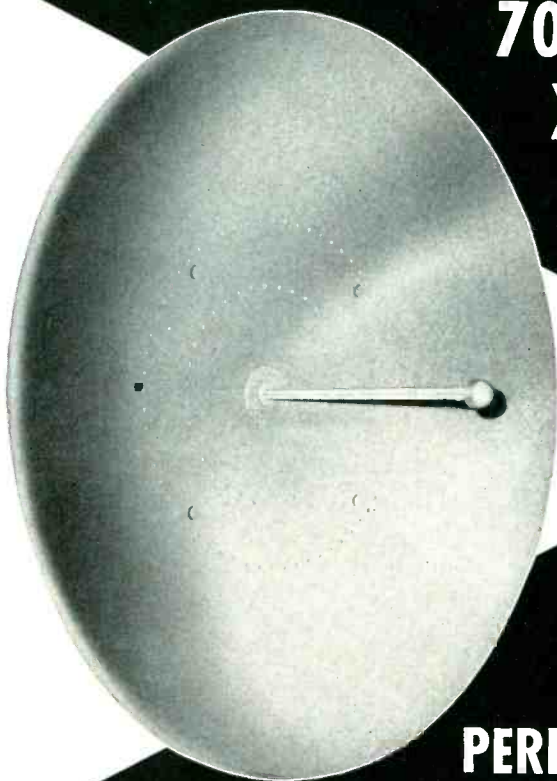

4000 mc antenna  
with Gabriel  
waveguide feed.

with these  
**PERFORMANCE  
ADVANTAGES**

- Low VSWR
- High gain
- Low side and back lobes
- Pressurized feeds
- All-weather dependability
- Ready adaptability to special service requirements



2000 mc antenna with dipole feed.

For every microwave application, Gabriel can furnish antenna equipment of proved efficiency and reliability. The experience and facilities of Gabriel Laboratories offer prompt, dependable solution of your antenna problems. And the manufacturing plant of Gabriel Electronics Division assures volume production to the Laboratories' performance specifications.

For analysis of your antenna or microwave problems,  
write us or telephone NEedham 3-0005 (through Boston).



**GABRIEL ELECTRONICS DIVISION**

THE GABRIEL COMPANY, Needham Heights 94, Massachusetts

autocorrelation systems as well as general laboratory use.

► **Specifications**—The unit illustrated has a delay of 500  $\mu$ sec  $\pm$ 5 percent. Characteristics include a video response of -3 db between 10 cps and 4.5 mc and a signal-to-noise ratio of 40 db. Several units may be cascaded for longer delays.

## VARNISH for printed circuits

THE INSL-X SALES Co., 26 Rittenhouse Place, Ardmore, Pa. A new varnish designed especially as a protective insulating coating for modular assemblies, printed circuits and printed circuit components has been developed by the Schenectady Varnish Co.

► **Complete Sealing**—Far more flexible than conventional coatings, the Schenectady No. 642 printed-circuit varnish can be baked or air-dried to a tough resilient coating that completely seals the laminate and component leads against arc-producing moisture. A 2½ mil coating of this water-white varnish withstands 1,250-v—even after 72 hours exposure at 100 percent relative humidity.

► **Other Features**—The highly arc-resistant varnish will not support tracking, nor will it char. It is completely free from aging characteristics or discoloring and may be readily thinned with Xylol or its equivalent.

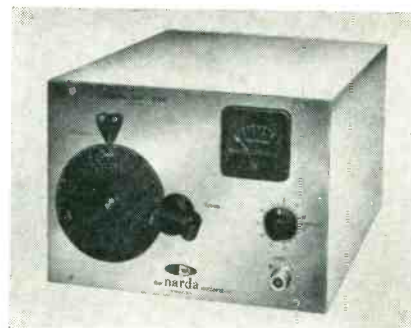

## ECHO BOX tests airborne radar

THE NARDA CORP., 66 Main St., Mineola, N. Y. Model 833 echo box is a high Q resonant cavity, specifically designed for rapid test-



# VULCAN

## ELECTRIC HEATING UNITS

### FINNED STRIP



For use in blower type electric unit heaters, as oven or space heaters in dryers, pump rooms, switch towers, etc.

From 10½" to 42½" overall  
500 watts to 3250 watts.  
for 115 and 230 volts

Steel sheath and fins (rust resisting)



For use where sheath temperature will not exceed 750° F.

# VULCAN

## ELECTRIC COMPANY

DANVERS 10, MASS

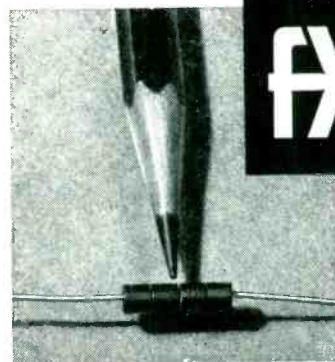
# FERROXCUBE SHIELDING BEADS

EFFECTIVELY PREVENT PARASITIC RESONANCES

Ferroxcube shielding beads on input leads provide simple, efficient decoupling so that h-f, i-f and pulse signals from output stages will not be picked up by input wiring. High-permeability Ferroxcube material increases inductance so that lead acts as h-f choke while i-f, h-f and pulse oscillations are damped by high losses that occur in Ferroxcube 3B at frequencies over 0.5 mc.

Ferroxcube shielding beads also increase the h-f effectiveness of button-type ceramic feed-thru capacitors.

SEND FOR BULLETIN FC 5112

## FERROXCUBE CORP. OF AMERICA

A Joint Affiliate of Sprague Electric Co., and Philips Industries,  
Managed by Sprague

35 East Bridge Street • Saugerties, New York



Hunting COILS For High Temp. Application?

## DANO makes them!

For specifications calling for coils to be used for high temperature applications, Dano will supply the exact coils needed.

Dano, makers of a wide variety of coils, is fully equipped to meet the increasing demand for these special coils. Keeping pace with modern design, Dano offers encapsulated coils with tough, molded covers that spell extra electrical insulation with freedom from moisture.

Every Dano Coil is custom-made to your specific requirements. Call or write today, and Dano's quote will be on the way!

- Incapsulated Coils • Form Wound
- Bakelite Bobbin • Cotton Interweave
- Paper Section • Acetate Bobbin
- Coils for High Temperature Applications
- Also, Transformers Made To Order



## DANO Electric Co.

MAIN ST., WINSTED, CONN.

# MOLYBDENUM

## PURE and THORIATED TUNGSTEN

For ELECTRONIC APPLICATION

## RIBBONS

## STRIPS

## FORMED PIECES

Your special metals rolled to thin sizes - close tolerances

# H. CROSS CO.

15 BEEKMAN ST., N. Y. 38, N. Y.  
Worth 2-2044 and COrtlandt 7-0470

# SAVE MONEY!

Measure frequency and FM deviation on a multitude of channels with just two small LAMPKIN METERS



LAMPKIN 105-B MICROMETER FREQUENCY METER—Heterodyne-type, universal coverage, 0.1 to 500 MC. Accuracy 0.005%. Weight 13 lbs. Width 13". Price \$220.00.



LAMPKIN 205-A FM MODULATION METER—Indicates FM voice deviation, ± 25 KC., all channels, 25 to 500MC.; meets FCC mobile specs. Weight 13 lbs. Width 12¼". Price \$240.00.

NEW booklet: "HOW TO MAKE MONEY IN MOBILE-RADIO MAINTENANCE" free on request. Write today!

## LAMPKIN LABORATORIES, INC.

Instruments Division  
BRADENTON, FLORIDA

**BIG IN CAPACITY . . . . SMALL IN SIZE**

# Fansteel



## Tantalum CAPACITORS

**30.0 mfd in less than 0.03 cu. in.**

The tantalum oxide film employed in Fansteel Capacitors is the most stable dielectric, chemically and electrically, yet discovered. Fansteel Tantalum Capacitors have a practically unlimited life, either in use or on the shelf; have a maximum d-c leakage of only 0.000008 ampere; and stable characteristics are unchanged over a wide temperature range.

Fansteel offers Tantalum Capacitors in 58 sizes and ratings. A partial listing is shown here. All sizes are available from stock.

Send for  
bulletin 6.100



**FANSTEEL METALLURGICAL CORPORATION**  
North Chicago, Illinois, U.S.A.

**TANTALUM CAPACITORS . . . DEPENDABLE SINCE 1930**

CATALOG NUMBER	CAPACITY MFD*	WORKING VOLTAGE D-C	MAXIMUM D-C LEAKAGE †
PP30B6A1	30	6	1.0
PP25B8A1	25	8	1.0
PP20B10A1	20	10	1.0
PP15B15A1	15	15	1.5
PP10B25A1	10	25	2.0
PP8B30A1	8	30	2.0
PP5B50A1	5	50	3.0
PP4B60A1	4	60	3.0
PP3.5B75A1	3.5	75	3.0
PP2B100A1	2	100	3.0
PP1.75B125A1	1.75	125	3.0
PP140B6A1	140	6	2.0
PP100B10A1	100	10	2.0
PP70B15A1	70	15	3.0
PP40B30A1	40	30	4.0
PP25B50A1	25	50	5.0
PP20B60A1	20	60	5.0
PP15B75A1	15	75	6.0
PP11B100C1	11	100	7.0
PP9B125C1	9	125	7.0
PP325B6A1	325	6	3.0
PP250B10A1	250	10	3.0
PP175B15A1	175	15	4.0

\* -15% +20% at 120 cps, 25°C  
† Microamperes, at 25°C

ing of the overall performance of C-band (5,350 to 5,450 mc) airborne weather radars. The cavity is coupled to the radar transmission line through a directional coupler or with a pickup antenna placed near the radar antenna.

► **How It Works**—During the radar transmitted pulse, microwave energy is stored in the echo box. Immediately following the pulse, the energy is returned to the radar over the same path producing a signal or target on the radar indicator. At the end of the pulse the returned energy decays exponentially, finally disappearing into the background noise clutter at a point determined by the receiver sensitivity and transmitter power output.

Therefore, the time interval between the beginning of the transmitted pulse and the point where the signal on the radar indicator disappears into the noise (called the ring time) measures the overall performance of the radar. Price is \$970.

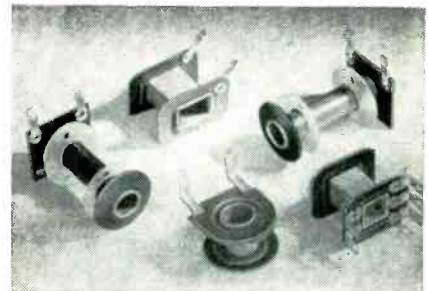

### COIL BOBBIN lug terminals attached

PRECISION PAPER TUBE Co., 2035 W. Charleston St., Chicago 47, Ill., can supply coil bobbins with any desired number of lug terminals attached. The attached lug feature perfectly adapts the bobbins for use with printed circuits.

► **Another Advantage**—These coil bobbins can be insulated from the coil winding by washers as an integral part of the assembly. This not only improves insulation, but it greatly facilitates easier and faster production of the finished coil.

Bobbins are available in any size with round, square or rectangular core, and flanges of all shapes. Cores are wound from dielectric



kraft, fish paper, acetate or combinations, including DuPont Mylar. They can also be supplied Resinite impregnated.

Since the bobbins are made to order, cost will be affected by such factors as specifications, the number of lugs attached and the time element involved in making them.

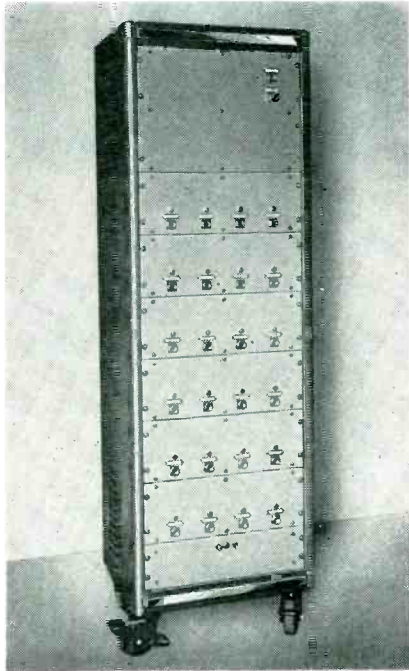

### DATA REDUCER shows vibration frequencies

HYCOR Co., INC., 11423 Vanowen St., N. Hollywood, Calif., announces a data reduction filter set for analyzing vibration frequencies in aircraft and missiles. In use, a tape recorder containing the complex wave form is fed into the unit which separates the component frequencies into 24 components.

► **Cathode-Follower Amplifiers**—The unit consists of 24 cathode-follower amplifiers which feed 23 band-pass filters ranging progressively from 30 cps to 2,000 cps, and one 20-cycle low-pass filter.

Output of each filter appears on jacks on the front panel. A channel-level control is provided for each filter. A set of jacks is also included on the front panel for oscilloscopic viewing of the complex waveform at the input.

The individual frequencies may be analyzed separately to determine the exact nature of the mechanical

SMALL IN SIZE . . . **BIG IN CAPACITY**

# Fansteel



150°C

## Selenium RECTIFIERS

about 1/3 the size and 1/4 the weight of a comparably rated standard rectifier

CATALOG NUMBER	CIRCUIT	INPUT A-C VOLTS	CONT. D.C. OUTPUT AT 100°C	
			VOLTS	AMPS.
TADL35L	1-35-1-H	455	402	0.004 <sup>(1)</sup>
TEUH315 <sup>(2)</sup>	2-8-1-D	132	254	0.020 <sup>(1)</sup>
TBU100L	1-100-1-H	2600	1090	0.020
TEB328L <sup>(3)</sup>	2-11-1-D	363	297	0.150
TEW066L	4-4-1-B	132	108	0.180
TEC070L	4-5-1-B	165	135	0.300
TEX034L	4-1-3-B	33	27.8	1.59
TED200LN	2-13-1-C-N	214	-175	0.600
TBY060L	4-3-1-B	78	62.7	1.0
TBY060L	4-3-1-B	41	62.7	1.0 <sup>(1)</sup>
TEEW334L <sup>(4)</sup>	2-7-1-D	231	295	2.3 <sup>(2)</sup>
TEFW332L <sup>(4)</sup>	2-13-1-D	429	548	4.6 <sup>(2)</sup>
TBG084L	2-1-1-C	13	10.4	5.2
TET050L	4-2-1-B	66	53.9	4.6
TEP314L <sup>(2)</sup>	2-7-2-D	231	189	14.0
TER020L	6-3-1-B	66	79.5	12.9 <sup>(2)</sup>
TER034L	4-1-3-B	33	27.8	25.8
TBR008L	6-1-4-B	26	32.5	51.6 <sup>(2)</sup>

<sup>(1)</sup> Capacitive Load. Ratings unmarked are for resistive or inductive loads.

<sup>(2)</sup> Hermetically Sealed.

<sup>(3)</sup> Two stacks required.

<sup>(4)</sup> Three stacks required.

<sup>(5)</sup> Resistive, inductive or capacitive load.

Operating at 100°C (212°F) Fansteel High Temperature Rectifiers deliver full rated power output, continuously, with no derating whatever. At temperatures up to 150°C (302°F), only moderate derating is necessary.

Fansteel High Temperature Rectifiers are available in all standard cell sizes and all standard circuit arrangements and with all standard protective finishes—moisture resistant, fungus resistant and a salt-spray resistant finish that really works! The table indicates a partial list of over 100,000 available types.

Send for  
bulletin 6.401

FANSTEEL METALLURGICAL CORPORATION

North Chicago, Illinois, U.S.A.



E556A

DEPENDABLE RECTIFIERS SINCE 1924

# Stupakoff

## ALUMINA CERAMICS

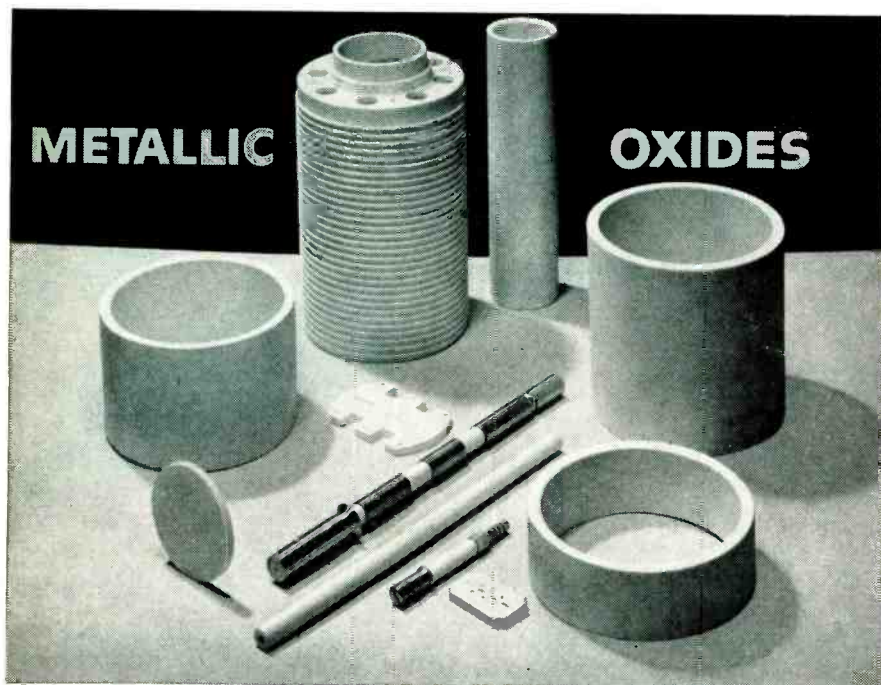

These man-made "sapphires" provide  
**EXTRA strength . . .**  
**EXTRA hardness . . .**  
**EXTRA precision . . .**

For mechanical, electrical and electronic applications, Stupakoff Alumina Ceramics provide highly valuable characteristics. Because they are exceptionally hard, parts made of this material serve well under conditions of abrasion and wear. Because of the material's high strength, it finds many applications where its resistance to pressure, shock and impact adds to the life and service of an assembly. Because Stupakoff has the equipment and skill to mass-produce alumina parts with dimensions held to close tolerances, Stupakoff precision ceramics assemble readily and function correctly.

Parts may be simple or complex, ground or machined, plain, metallized or assembled. Our research and engineering facilities are available to assist in the design of your parts.

# Stupakoff

Division of The **CARBORUNDUM Company**

**LATROBE, PENNSYLVANIA**

*Write Dept. E.*

NEW PRODUCTS

(continued)

vibration. The entire unit, including power supply, is contained in a standard enclosed 5-ft cabinet rack.



### AXIAL BLOWER is smaller and lighter

JOHN OSTER MFG. Co., Avionic Division, 1 Main St., Racine, Wisconsin, has developed a smaller, lighter 2-in. axial blower with exceptionally high air delivery in relation to volume and weight.

► **Performance** — Type AXB2249 puts out 25 to 30 cu ft of air per minute at zero static pressure yet weighs only 8 oz and measures only 3.375 in. long by 2.87 in. o-d. Operating temperature range is from -55 C to +71 C. Other military aircraft environmental requirements are also met.

The device consists of an aluminum blower housing black anodized, a 2-in. aluminum fan and a 115-v 400-cycle motor.

Type AXB2249 is used for cooling a wide variety of electronic equipment in aircraft and industrial applications.

### LAMINATED PLASTIC for printed circuitry

THE FORMICA Co., Cincinnati 32, Ohio. The XXXP-36 Formica cold-punching laminate brings translucency, greater accuracy and super-insulation to printed circuitry. Since it punches cold in thicknesses up to and including  $\frac{1}{8}$  in., no heat cycle is required. Thus the base laminate is not subject to dimensional change as in grades which must be heated before punching. Circuits made from the new grade will be more accurate.

Formica XXXP-36 also offers



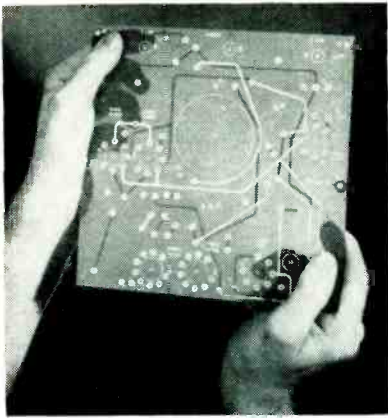

high dielectric strength, greater heat resistance and superior bonding strength. Simply by holding the Formica sheet to the light it is possible to see the smooth, homogenous structure, and to note how well the circuit printed on one side registers with that on the other.

For a free sample, write the company.



**INDICATOR**  
checks coils for shorts

KARTRON, Drawer 472, Huntington Beach, Calif. Model 101-D electronic shorted turn indicator is sensitive, rugged and nonshocking when checking unmounted electrical coils for shorts. Mandrel size is small enough for all but the smallest coils; large enough for coils up to about a 2-in. cube outside, or equivalent volume in most other shapes.

The unit is designed to detect

# Stupakoff

## CERAMIC MATERIALS

*At your fingertips...*

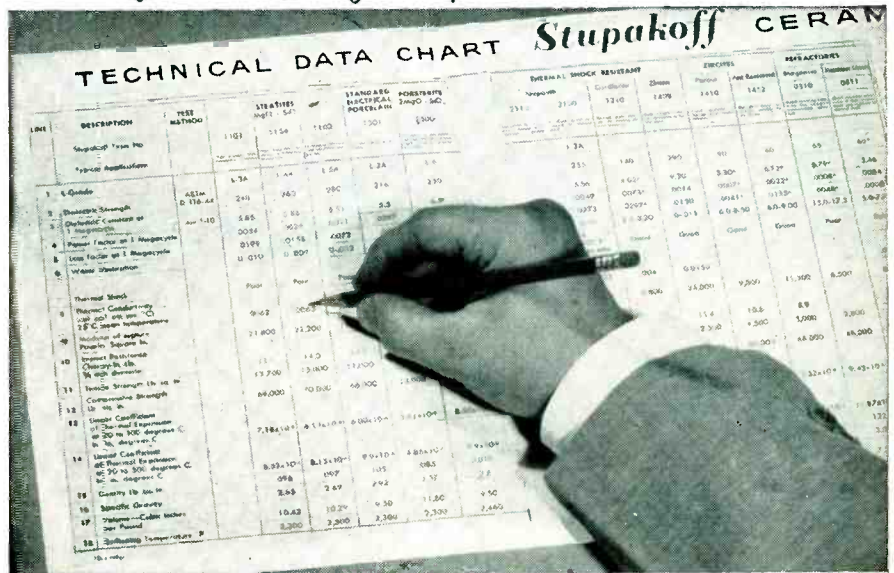

# NEW TECHNICAL DATA on Stupakoff CERAMIC MATERIALS

The very latest technical information on a wide range of ceramic materials is given in the new Stupakoff Technical Data Chart. Electrical and physical characteristics and the chemical composition of various grades of the following ceramic materials are included:

- ALUMINA
- PORCELAIN
- ZIRCON
- ALUMINUM SILICATE
- STUPALITH
- ZIRCITE
- STEATITE
- CORDIERITE
- FORSTERITE
- MAGNESIA

Valuable design and application suggestions included in the Stupakoff Data Chart help you engineer your ceramic parts for lowest cost and greatest satisfaction.

*Send* today for your free copy of the new Stupakoff Data Chart. Arranged for ready reference.



Write Dept. E

**Division of The CARBORUNDUM Company**

**LATROBE, PENNSYLVANIA**

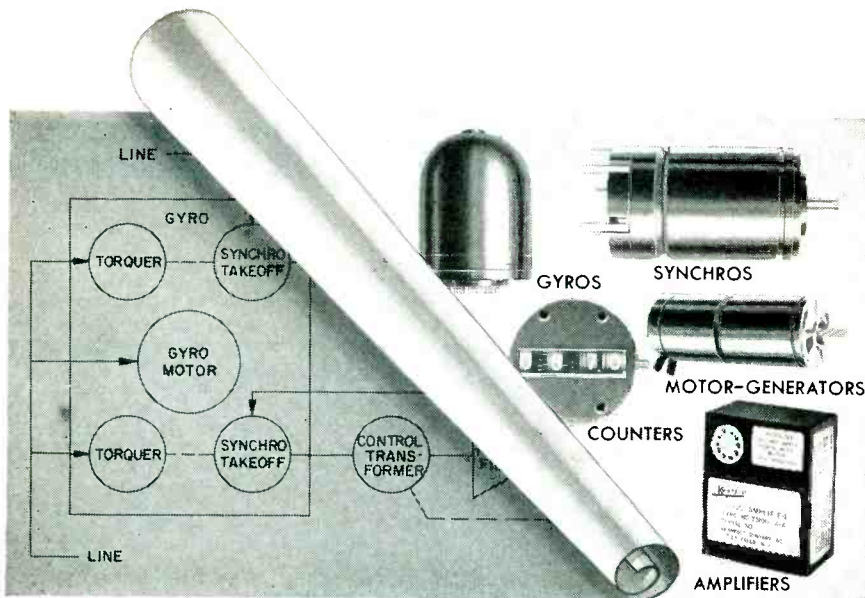

# KEARFOTT

... from  
problem  
through  
production

Engineering ability and production facilities are as important to you as the characteristics of the components you select. After components are approved, you are dependent upon your supplier . . . dependent upon him for engineering assistance . . . dependent upon his ability to produce quality products in the required quantities.

Many of the servo motors, synchros, gyros and systems in use today had their inception on the drafting boards of Kearfott's engineers. This is proof of Kearfott's engineering ability. Kearfott offers complete engineering service before, during and after the purchase of a component.

Modern buildings, over 430,000 square feet of floor space, equipped with the latest in precision machinery, manned by 3,400 highly skilled specialists, are your assurance of Kearfott's ability to produce.

Yes, Kearfott is a dependable source of supply. If you have a design problem or require a special or standard component, contact Kearfott.

#### KEARFOTT COMPONENTS INCLUDE:

Gyros, Servo Motors, Synchros, Servo and Magnetic Amplifiers, Tachometer Generators, Hermetic Rotary Seals, Aircraft Navigational Systems, and other high accuracy mechanical, electrical and electronic components.

Send for bulletin giving data of components of interest to you.



A SUBSIDIARY OF GENERAL PRECISION EQUIPMENT CORPORATION

### KEARFOTT COMPANY, INC., LITTLE FALLS, N. J.

Sales and Engineering Offices: 1378 Main Avenue, Clifton, N. J.  
Midwest Office: 188 W. Randolph Street, Chicago, Ill. South Central Office: 6115 Denton Drive, Dallas, Texas  
West Coast Office: 253 N. Vinado Avenue, Pasadena, Calif.

one shorted turn of No. 44 wire and built for years of production line high speed testing. Shorts are indicated on the 1-ma meter by a downward deflection  $\frac{1}{2}$  to  $\frac{1}{2}$  full scale.



#### SMALL OSCILLOSCOPE weighs 8½ lb

PROBESCOPE Co., 44-05 30th Ave., Long Island City 3, N. Y., has designed a portable miniature oscilloscope weighing 8½ lb and taking up less than  $\frac{1}{4}$  sq ft on the bench. It measures 9 in. high, 6 in. wide and 5 in. deep.

Model MO-1 has the following features: an input impedance of 2 megohms shunted by 15  $\mu$ f; a 10-to-1 attenuator; vertical sensitivity of 100 mv full scale; sweep rate of 20 cycles to 30 kc in 5 steps. It is ideal for waveform analyzing and quick troubleshooting.

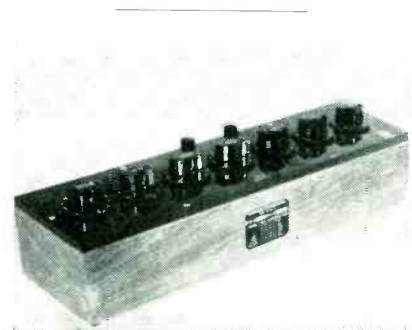

#### RESISTANCE DECADE has seven dials

INDUSTRIAL INSTRUMENTS, INC., Cedar Grove, N. J. A new resistance decade featuring accuracy of better than  $\pm 0.1$  percent of each resistance increment is announced. The



instrument has 7 dials having decade steps of 0.1, 1, 10, 100, 1,000, 10,000 and 100,000 ohms. Decades are available with each dial having 9 or 10 steps.

Resistance coils are of manganin wire, bifilar wound, with the exception of 10,000 ohms and over which are low temperature coefficient nickel-chromium-iron alloy wound. All resistance coils are wound on ceramic cores, oven-aged and varnish impregnated.

Switches are the self-cleaning type with 4 phosphor-bronze spring wipers and detent mechanism for positive location of switch points. Switches and resistors are mounted below the panel for maximum protection from dust.

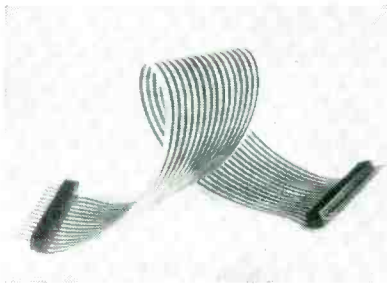

## FLEXIBLE CABLES for printed circuits

SANDERS ASSOCIATES, INC., Nashua, N. H. Flexible printed circuit cables—made by a process of laminating the versatile plastic Kel-F with copper in thin sheets—are now being introduced. The new cables have excellent electrical and mechanical properties for operation over a wide range of environmental conditions.

Complete encapsulation of the conductors in Kel-F ensures maximum protection against moisture. Glass cloth can also be included in the laminations for increased strength and high temperature stability. The new lighter and thinner cables are adaptable to many types of connectors or terminations and are easily secured by clamps, rivets or cement. The manufacturing technique eliminates wiring errors.

Additional conducting and insulating layers can be added to the basic cable to provide a greater number of separate conductors. Stacked circuits have been built up

**EPSCO** INCORPORATED  
Bulletin DL-55  
July 11, 1955

### Precision Delay Lines

Current developments in microprocessor systems, guided navigation controls, computers and instrumenting equipment have placed increasingly rigid requirements on Delay Lines. EPSCO has met the delay line will by promptly evolving new requirements and providing industry with products requested for tomorrow's applications. The considerable technological advances made by EPSCO in the design of special production and new equipment, plus the utilization of new materials and techniques, allow us to produce delay lines of unusual characteristics at a minimum cost.

EPSCO Precision Delay Lines are Application Engineered for:

Navigation Systems	Logic and Switch
Digital Computers	Navigation Systems
Pulse Timing Length	Wide Area Reference Unit
Analog Computing Function	Word to Parallel Data Converter
	Special Applications

**EPSCO** Incorporated  
BOSTON - WASHINGTON - LOS ANGELES - NEW YORK

**now**... new technical data  
bulletin on delay lines from

# EPSCO

## New Technical Advances, New Materials and Techniques Have Resulted in Delay Lines of Unusual Characteristics . . . And At Low Cost:

If you use delay lines in: Telemetry — Digital or Analog Computers — Pulse Circuits — Coders and Decoders — Navigation Systems — Stable Time Reference Units — or in special applications — you'll find this brand new technical bulletin of great interest and use in your work.

### CHARACTERISTICS OF NEW STANDARD\* UNITS

All Standard units are guaranteed to have the following characteristics:

Temperature coefficient of delay less than 50 parts per million per °C.

Operating temperature range: —55C to 125C.

Delay tolerance 3%.

Spurious signals less than 5%.

Characteristic impedance tolerance 5%.

Attenuation in DB approximately 0.1 to 0.2 times delay-to-rise-time ratio.

\*Custom units are built to even more stringent specifications.

## CONTENTS

New Standard Series  
Precision Audio Delay Lines  
Custom Designed Units  
Special Applications

Design Formulas  
Typical Circuits

Characteristic Impedance  
Attenuation  
Delay Time  
Rise Time  
Delay-To-Rise-Time Ratio  
Bandwidth  
Phase Linearity  
Spurious Signals  
Operating Temperature Range



**SEND FOR BULLETIN DL-55 TODAY!**

588 Commonwealth Ave., Boston, Mass.

# UNION

## Selenium Power Rectifiers with "Solid Stack" assembly

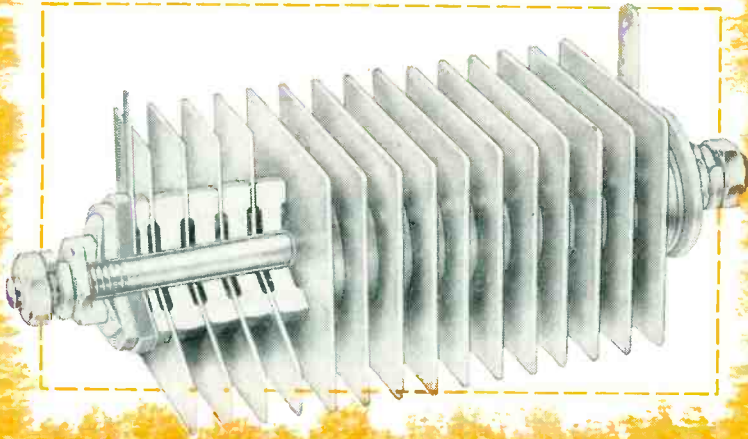

The "solid stack" assembly of the new line of UNION Selenium Rectifiers provides utmost rigidity and far more resistance to vibration. It eliminates radial movement and prevents breaks in the paint seal.

This extra rigidity is obtained by using larger, non-resilient spacer washers finished flat to close tolerances and all parts are under constant pressure exerted by Belleville springs at the ends of the stack.

The selenium cells are produced by a special and carefully controlled process which assures uniform high quality and better performance. Corners are rounded instead of sharp for safety, and to assure an un-

broken coating. Connectors are made of brass or bronze for better service under adverse conditions.

Ratings: The standard line of UNION selenium rectifier cells range in size from 1" x 1" to 5" x 6" and with convection cooling, are rated from .180 to 10.0 amperes per cell on a single phase fullwave bridge basis. Cells can be "stacked" in series, parallel or series-parallel combinations to fit practically any current and voltage conversion requirement. The stack assemblies conform to NEMA specifications.

Write for our Bulletin 1009, or contact any of our distributors listed below for complete information.

NEW PRODUCTS

(continued)

to 5 layers and may go higher depending on the application.

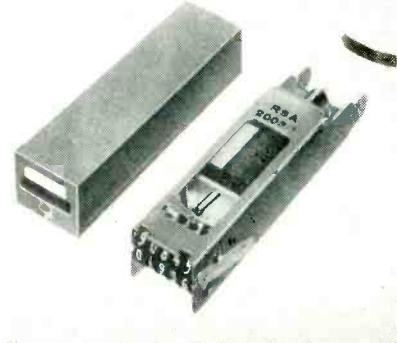

### ELECTRICAL COUNTER wheels cannot jam

NORTH ELECTRIC Co., Galion, Ohio, has announced a 5-digit electrical counter designed for reliable high-speed impulse recording. Type E-RSA-200 is compact and light in weight, and is suitable for installation in small spaces, measuring  $\frac{3}{4}$  in. by  $1\frac{1}{8}$  in. by  $4\frac{1}{8}$  in. overall. Each counter is enclosed in a sturdy metal cover, available either as an individual unit or in strips of ten, with a common cover.

A flexible spring clip holds each unit firmly in place on the mounting plate. The mechanism of the counter is built so that the wheels cannot jam or get out of mesh. Each counter wheel is made of nylon for extra long wear. The coil of the unit is terminated with soldering lugs in rear.

Final inspection tests are made at a rate of 20 impulses per second.

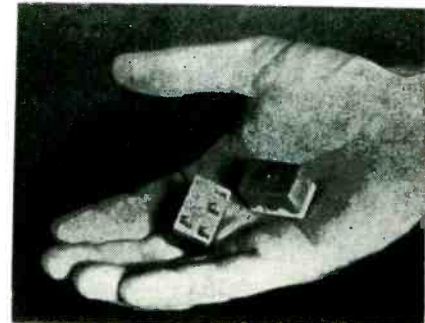

### SINE SWITCH has high shock resistance

METALS & CONTROLS CORP., Spencer Thermostat Division, Attleboro, Mass., has announced the Klixon K

GENERAL APPARATUS SALES

## UNION SWITCH & SIGNAL

DIVISION OF WESTINGHOUSE AIR BRAKE COMPANY

PITTSBURGH 18



PENNSYLVANIA

NEW YORK, IVanhoe 3-2424 (Hempstead)  
BALTIMORE, Valley 5-3431

BOSTON (Ashland) TRinity 2-4485  
ST. LOUIS, Jefferson 5-7300

CHICAGO, LONgbeach 1-3042 · LONDON, OHIO, LONdon 1555 · LOS ANGELES, CLinton 6-2255



series sine switches, for aircraft and industrial controls, actuators, relays and instruments. A highly precise sensitive snap switch is available for applications requiring small movement differential with high resistance to shock and vibration. The sine-curve switching element withstands from 0 to 500 cps at 10 g while continuously loaded the within 0.0002 in. of the actuation point.

Movement differential as well as operating and release forces can be adjusted and set to meet a wide variety of application requirements.

Once calibrated, the Klixon sine switch precisely maintains its operating characteristics throughout its life. Movement differential is 0.0005 in. minimum; shock, 200 g; temperature,  $-65^{\circ}\text{F}$  to  $+350^{\circ}\text{F}$ ; life, 100,000 cycles minimum; and size,  $1\frac{1}{8}$  in. by  $\frac{5}{8}$  in. by  $\frac{1}{16}$  in.



### CAVITY WAVEMETERS cover 2.6 kmc to 90 kmc

DEMORNAY-BONARDI, 780 South Arroyo Parkway, Pasadena, Calif., is in production on a line of precision cavity wavemeters designed to give unusually broad coverage of microwave bandwidths. Only 11 sizes are needed to serve the entire range from 2.6 kmc to 90 kmc. Hence fewer sizes are required to cover wide segments of the total range. Each instrument measures all frequencies within the range.

Accuracy of these units is so high that they may be used as secondary standards, suitable for calibrating all other laboratory cavities. Units are nitrogen filled, and hence unaffected by changes in humidity or atmospheric pressure.

High resolution is accomplished with a precision micrometer-type turning screw which resolves

# UNION

## Now a complete line of "Selenium Slim" Rectifiers in the ratings you need



Now you can get UNION "Selenium Slims" in five ratings ranging from 1.25 to 20.0 milliamperes and maximum peak inverse voltages from 36 to 9360 with condenser input filter. They are available in diameters from  $\frac{1}{8}$ " to  $\frac{1}{2}$ ".

These high-voltage, low-current rectifiers are made by a new process which assures *superior quality and trouble-free performance*. They are designed to outlast and outperform vacuum tube circuits at a comparable price.

"Selenium Slims" are made in as-

semblies of 1 to 260 miniature cells spring-loaded in either tough phenolic tubes or hermetically-sealed glass tubes. You can snap them into your circuits with standard fuse clips or solder in with pig-tail leads. Special assemblies are available to meet customer requirements.

A few applications are television receivers, electronic equipment, electro-static precipitators, business machines and Geiger counters.

Send for our new Bulletin 1007 for complete information, or contact one of our distributors listed below.

GENERAL APPARATUS SALES

## UNION SWITCH & SIGNAL

DIVISION OF WESTINGHOUSE AIR BRAKE COMPANY

PITTSBURGH 18



PENNSYLVANIA

NEW YORK, IVanhoe 3-2424 (Hempstead)

BOSTON (Ashland) TRinity 2-4485

BALTIMORE, Valley 5-3431

ST. LOUIS, JEFFerson 5-7300

CHICAGO, LONgbeach 1-3042 · LONDON, OHIO, LONdon 1555 · LOS ANGELES, CLinton 6-2255



## CVC thermocouple vacuum gauge offers high sensitivity, rapid response

This single-stage thermocouple vacuum gauge gives rapid readings in the 1 to 1,000 micron range. It is the CVC type TG-029, designed around a printed circuit.

The gauge is compact, portable, and priced considerably lower than the previous single-station model.

### Its outstanding features include:

- No compensating adjustments—just plug it into a 115-volt outlet and turn on the power switch.
- Measures the total pressure of condensable vapors and permanent gases.
- Is not harmed by exposure to atmospheric pressure.
- One direct reading meter scale

covers the range from 1 to 1,000 microns Hg.

### New, more rugged gauge tube

This gauge uses the new TG-77 gauge tube which eliminates the fragile junction weld of previous tubes.

The tube is less subject to organic vapor contamination and its electrical characteristics do not vary appreciably from one tube to another.

The TG-029 is the latest addition to a complete line of CVC thermocouple gauges including the *battery-operated*, panel-mounted, single-station unit type TG-025; the *one-to-six* station unit type TG-09; and the *automatic control* unit type TG-010 which actuates a double-pole, double-throw relay at any predetermined pressure.

### Specifications

Range.....	1 to 1,000 microns
Case Dimensions.....	5 $\frac{5}{16}$ " x 6 $\frac{5}{16}$ " x 6 $\frac{1}{8}$ "
Weight.....	5 lb. 14 oz.
Power.....	115 V. 60 cycle, AC
Type TG-77 Tube.....	2 $\frac{7}{16}$ " with $\frac{1}{8}$ " NPT nipple
Cord.....	10 ft.

For further information write for copies of CVC Data Sheets 9-35 and 9-37.



**Consolidated Vacuum Corporation Rochester 3, N. Y.**  
a subsidiary of CONSOLIDATED ENGINEERING CORPORATION, Pasadena, California

CVC sales now handled through Consolidated Engineering Corporation with offices located in: Albuquerque • Atlanta • Boston • Buffalo • Chicago • Dallas • Detroit • New York • Palo Alto • Pasadena • Philadelphia • Seattle • Washington, D. C.

plunger travel into 0.001-in. increments, and also with a multipage calibration chart furnished with the instrument.

The units are designed for operation in a temperature range of -30 C to +70 C. The line comprises reaction types, absorption and transmission types, all priced low. Literature is available.

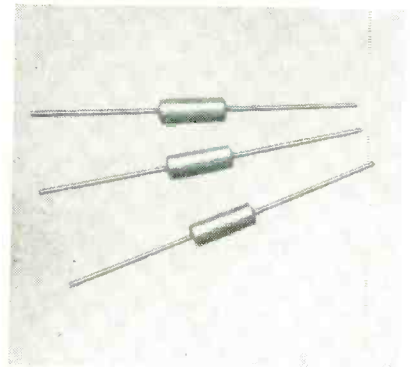

### MOLDED RESISTOR with double insulation

ELECTRA MFG. Co., 4051 Broadway, Kansas City, Mo., has announced a new  $\frac{1}{2}$  w molded deposited carbon resistor. Its double insulation results in these advantages: complete mechanical protection, longer load life, better electrical insulation, greater moisture resistance and performance that exceeds all electrical requirements of MIL-R-10509A.

Complete information may be had by writing for bulletin No. 70.

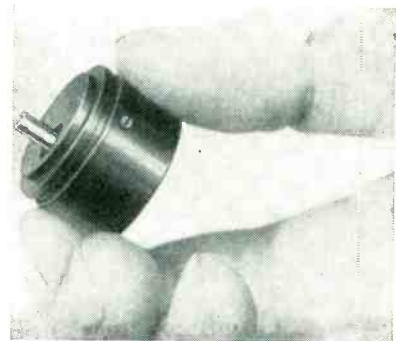

### GEAR HEAD for subminiature motors

BOWMAR INSTRUMENT CORP., 2415 Pennsylvania St., Fort Wayne, Ind., has introduced a new subminiature motor gear head. The device measures 0.937 in. in diameter and adds



just  $\frac{5}{8}$  in. length to size 10 motors in its 26.4-to-1 reduction ratio.

Model 937 speed reducer contains internally, in addition to its gear clusters, a unique adjustable slip clutch. Backlash is less than 30 minutes, and its weight is 1 $\frac{1}{4}$  oz.

Applications include computers, servo controls and general instrumentation where weight and size limitations are critical.

## MAGNETIC TAPES for electronic computers

ORRADIO INDUSTRIES, INC., 120 Marvyn Road, Opelika, Ala., has announced 50 different types of magnetic tapes for electronic computers. Reading and writing are performed at the rate of 15,000 alphabetical or numerical characters per second on Irish instrumentation tape No. 311.

The 50 types of tape will include tapes on acetate and Mylar films in 1,200 ft, 2,400 ft, and 4,800-ft lengths, and in  $\frac{1}{4}$ ,  $\frac{1}{2}$ ,  $\frac{5}{8}$ ,  $\frac{3}{4}$  and 1-in. widths. The manufacturing technique produces a mirror-finish, and a tape virtually drop-out free, which is so important in electronic computer applications.

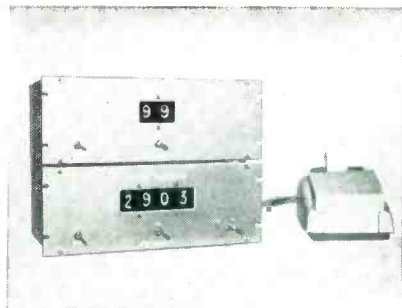

## INPUT SCANNER selects 100 data channels

ELECTRO INSTRUMENTS, INC., 3794 Rosecrans St., San Diego 10, Calif. The IS100 input scanner sequentially selects 100 channels of data. When used in conjunction with the company's digital voltmeters and ohmmeters (and printer), one has a complete automation system for component and system testing. The IS100 consists of a series of stepping switches with all neces-

# Designing A New Satellite?

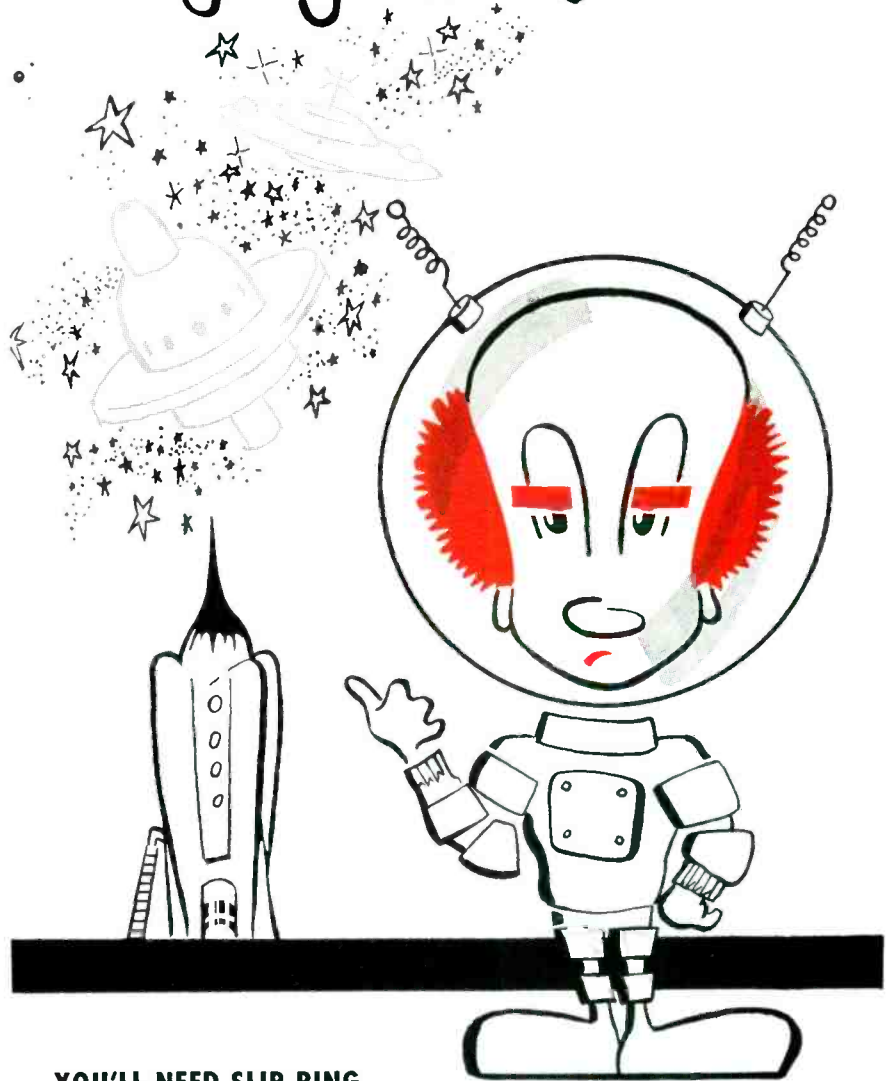

## YOU'LL NEED SLIP RING ASSEMBLIES . . . AND NO ONE CAN MAKE THEM BETTER THAN PMI

Before your new design leaves the drawing board, whether it be for a synchro or a satellite, if the plans call for a slip ring (collector ring) assembly, let us give you the benefit of our 13 years experience. From one circuit miniatures to 500-circuit giant installations, we can design, develop and produce the assembly to do the job.



PMI Engineers work out all production and design details. Give us a call for free estimate.

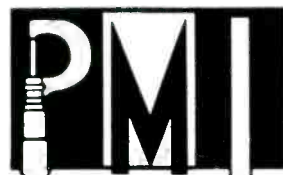

## P M INDUSTRIES, INC.

270 FAIRFIELD AVENUE  
STAMFORD, CONNECTICUT

# Eccosorb CH

## Microwave Absorber for Darkrooms

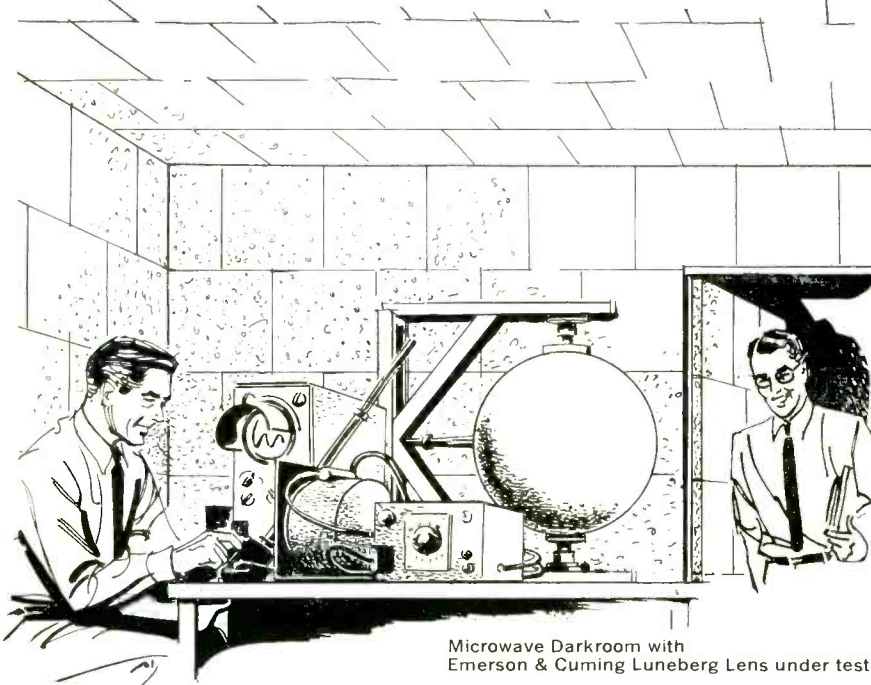

Microwave Darkroom with  
Emerson & Cuming Luneberg Lens under test

Eccosorb CH is a series of broadband absorbers reflecting less than 2% of the energy incident upon its surface. It is composed of enmeshed, rubberized fibers and made in sheets 2 feet by 2 feet in various thicknesses. Eccosorb CH is light weight and flexible. It is easily mounted and its natural, white surface color gives good light reflection.

**Free Space Rooms** are easily and economically built for indoor antenna measurements. Reflections are eliminated for all practical purposes. You can build your own microwave dark room or we offer you a complete **Free Space Room** ready to use. Emerson & Cuming engineers design and build special types for unusual conditions. Send us your specifications.

Another absorber, ECCOSORB HF comes in rods, sheets or molded shapes in several volume resistivities for waveguide terminations and similar uses. If you have a problem write for information on . . .

## Plastics for Electronics

# Emerson & Cuming, Inc.

869 WASHINGTON STREET, CANTON, MASS.

Sales Representatives

**DAYTON**  
ROBERT G. SIFF & ASSOCIATES  
11 W. Monument Bldg., Dayton 2, Ohio  
Hemlock 1254

**KANSAS CITY**  
ENGINEERING SERVICES COMPANY  
4550 Main Street, Kansas City 11, Mo.  
Jefferson 7765

**NEW YORK**  
M. RAYMOND KALLMAN  
P. O. Box 104, Roslyn, L. I., New York  
Roslyn 3-6511

**ST. LOUIS**  
ENGINEERING SERVICES COMPANY  
6635 Delmar Blvd., St. Louis 5, Mo.  
VO 3-3661

**WASHINGTON, D. C.**  
TED BRITT  
1500 Mass. Ave., Washington 5, D. C.  
Columbia 5-2694

**WEST COAST**  
McCarthy Associates  
P. O. Box 36, Altadena, Calif  
Sycamore 8-5790

PLASTIC FOAMS  
LAMINATING AND  
IMPREGNATING RESINS  
PLASTIC-FIBER GLASS  
LAMINATES  
HIGH DIELECTRIC  
CONSTANT PLASTICS  
METALIZED PLASTICS  
ELECTRONIC  
EMBEDMENTS  
CASTING RESINS  
LOW LOSS ROD  
AND SHEET STOCK  
MICROWAVE ABSORBERS

NEW PRODUCTS

(continued)

sary controls and power supplies.

It is rack mounted (7 in. by 17 in. by 16 in.) and operates on 115-v power. When used with digital voltmeter and printer, 100 channels can be printed out in approximately 5 minutes.



### GENERATOR for signal and sweep

DECADE INSTRUMENT CO., 14 Maple Ave., Pine Brook, N. J. The Sweepalator serves as a combined signal generator and sweep generator. It features decade switching, crystal c-w or center frequencies and wide range calibrated output. Specifications include the following: range, 10 kc to 1.5 mc; steps, 1 kc in 3 decades; interpolation, calibrated 0-1 kc; accuracy, 100 cps; short term stability,  $\pm 25$  cps; harmonic content, 3 percent maximum; output, 3 v rms; attenuator, 3 v, 1 v, 0.3 v, 0.1 v, 0.03 v, 0.01 v full scale; meter, calibrated 0-1 and 0-3 v.

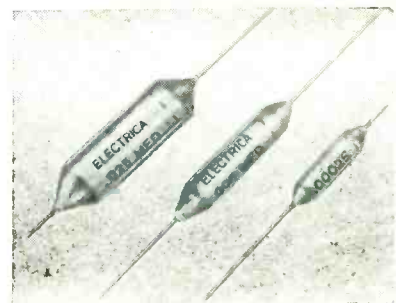

### CAPACITORS with immersion-proof shell

ARNHOLD CERAMICS, INC., One East 57th St., New York 22, N. Y. The new Electrifica capacitors function at temperatures from  $-20$  C to  $+110$  C and meets the demands of broadcast, tv and measurements fields for light weight and minimum size. Thermoplastic protective covering makes the capacitors air-tight, moisture and fungus



proof. Coating remains stable at all normal operating temperatures and insures high mechanical strength. The capacitors are economically priced. For complete data write for bulletin E.

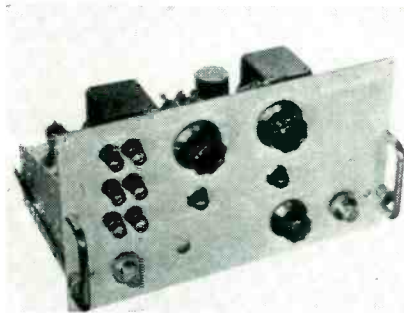

**PREAMPLIFIER**  
for oscillographic recording

SANBORN Co., 195 Massachusetts Ave., Cambridge, Mass., has developed a preamplifier which converts an average value of a-c watts into a proportional d-c voltage suitable for recording. Model 150-2300 a-c wattmeter preamplifier is designed as a front-end for plug-in installation in a model 150-200 driver amplifier unit, used in Sanborn one-to-eight-channel recording systems. Complete performance data and specifications are available from the company.

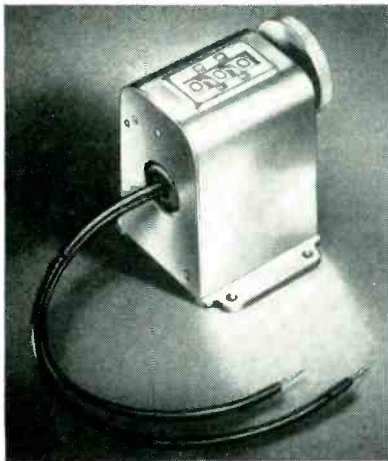

**MAGNETIC COUNTER**  
is miniature type

VEEDER-ROOT INC., Hartford 2, Conn., has developed a small reset magnetic counter for moderate counting duty on the many applications where extreme long life is not required. Compact and easily

*now in full production*

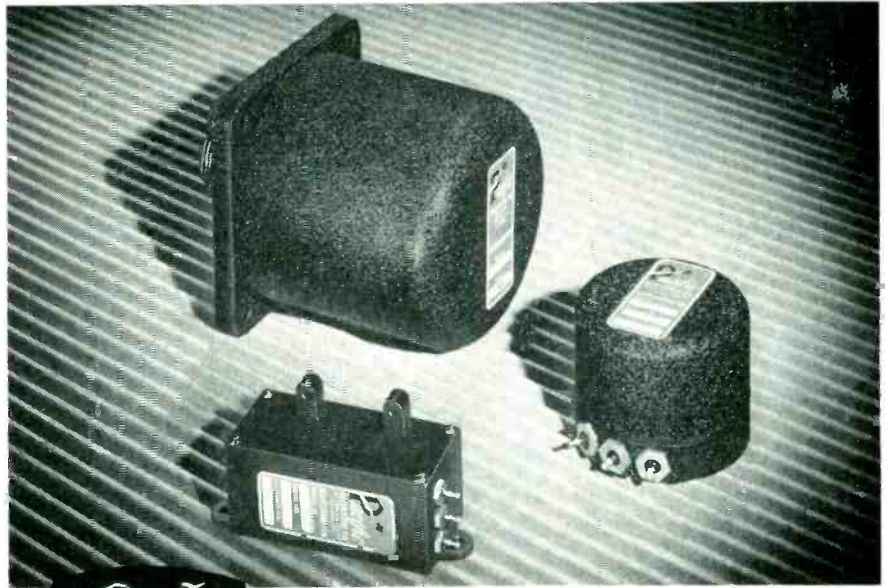

\* precision potentiometer-output

*accelerometers*

for fire control systems • power controls  
computers • telemetering • stabilization

Pacific Scientific now offers you three new production model accelerometers — fully tooled, tested and approved. You can save both time and money with these full production units — especially if they're incorporated into your designs at an early stage. Listed below are some of the general specifications, and your nearest Pacific representative will be glad to discuss your specific requirements. Write or phone today!

	A15-1000 SERIES	A15-2000 SERIES	LA06-0100 SERIES
Range:	up to +15 G	up to +10 G	up to +15 G
Output:	Dual Potentiometers or switches —or one pot & one switch	Potentiometer	Potentiometer
Accuracy:	to 1%	to 1%	to 1%
Natural Frequency:	10 CPS at 0 to 4 G	Radically low for any given G range	Radically low for any given G range
Caging:	Electrical	Manual for Shipping only	Manual for Shipping only
Damping:	Viscous (Temperature-controlled)	Air	Air

\*TRADE MARK

**PACIFIC SCIENTIFIC CO**  
LOS ANGELES • SAN FRANCISCO • SAN DIEGO • SEATTLE • ARLINGTON, TEXAS

REPRESENTATIVES:  
AERO ENGINEERING CO.  
Atlanta, Ga. • Baltimore, Md.  
Indianapolis, Ind. • Mineola, L.I., N.Y.  
Columbus, Ohio • St. Louis, Mo.  
GARRETT MFG. CORP., Toronto, Canada  
In England: BLUELEX PROD., LTD.  
In France: SERRA — St. Vallier

PACIFIC SCIENTIFIC—pioneers in the field of aircraft instrumentation since 1919

**PACIFIC SCIENTIFIC COMPANY**  
1422 Grande Vista Avenue  
Los Angeles 23, California

Please send me detailed information on Pacific Accelerometers

name \_\_\_\_\_  
company \_\_\_\_\_  
street \_\_\_\_\_  
city \_\_\_\_\_ state \_\_\_\_\_

# FOR *the scientist or engineer who has more to offer...*

## A limited number of positions of unusual responsibility

IBM, long a leader in the growing field of digital computers for business, science, and government, offers a limited number of long-range creative assignments to outstanding men with Master's or Doctor's Degrees in Electrical Engineering, Physics, Mathematics, Chemistry or Physical Chemistry.

- **Research in solid state materials**
  - Investigation of electronic phenomena in solids
  - Study of ferrite and semi-conductor characteristics
  - Study of the role of surface effects in semi-conductor device characteristics
  - Evaluation of sample semi-conductor or ferrite components
- **Development of new concepts, new approaches to internal handling of information in computer systems**
  - Information Theory
  - Research in Machine Organization
  - Theory of Control of Digital Devices
  - Switching Circuit Theory
  - Digital Data Transmission
- **Circuit Design, Systems Design and Analysis**
  - Electronic pulse circuits for accounting and data processing machines—arithmetic switching and logical circuitry—pulse amplifiers, shapers, gates, etc.—magnetic storage—transistor circuitry—input-output device controls.

## If you have more to offer, IBM offers you

### ● Stimulation . . . Satisfaction

At IBM men find the kind of facilities, associates and climate which stimulate achievement.

### ● Professional Growth

In Company growth lies personal opportunity, and IBM has an enviable record of steady and consistent growth. Over the past quarter century, IBM's business has doubled

every five years on the average.

Out of respect for the unusual man's talent and promise, IBM encourages qualified candidates to visit its Poughkeepsie, N. Y. laboratory—at their convenience, and IBM's expense. Write, outlining your qualifications, to: William M. Hoyt, International Business Machines, Room 412, 590 Madison Avenue, New York, N. Y.

**IBM**  
®

*Producer of electronic  
data processing machines,  
electric typewriters,  
and electronic time equipment.*

connected in series with any device having a contact arrangement, the series 1507 counter may be actuated by any type of switch, relay or photoelectric unit. Maximum recommended speed is 700 counts per min. Watt consumption is 4.5 at rated voltage (24 and 110 v a-c/d-c types are standard). Voltage variation is permissible up to 10 percent but not more than 10 v. The counter measures approximately 2¼ in. wide by 2½ in. high. Figures are 0.188 in. high.



## BREAKDOWN TESTERS with range to 100 kv

INDUSTRIAL INSTRUMENTS, INC., 89 Commerce Road, Cedar Grove, N. J. Type PA-50 h-v a-c breakdown tester permits tests from 0 to a maximum of 100,000 v, continuously variable. It is rated at 5 kva available at breakdown. The PA-50 is entirely self-contained eliminating the dangers in multiple unit setups. The entire instrument is housed in a 30-in. relay rack, 6½ ft high. It is designed for either laboratory or production testing of such items as insulating tapes, transformers or any application requiring a variable, safe, dependable source of high a-c voltage.

## DUAL SWITCH is single-actuated

MINNEAPOLIS-HONEYWELL REGULATOR Co., 4428 Wayne Ave., Philadelphia 44, Pa., has developed a new single-actuated dual switch designed for a wide range of in-



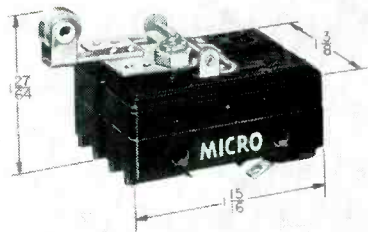

dustrial control and electronic applications. The 6AS13 is a low-force, double-pole switch consisting of two basic switching units operated by a single roller-lever actuator. It is available with a variety of lever lengths, either straight or formed levers, with or without roller. Basic switching units of the 6AS13 are listed by UL at 15 amperes—125, 250 or 460 v a-c, 1/2 ampere—125 v d-c and 1/4 ampere—250 v d-c. Various other basic switching units can be used to provide higher electrical capacity for d-c circuitry, or for special circuit applications. Operating characteristics may be had for the asking.

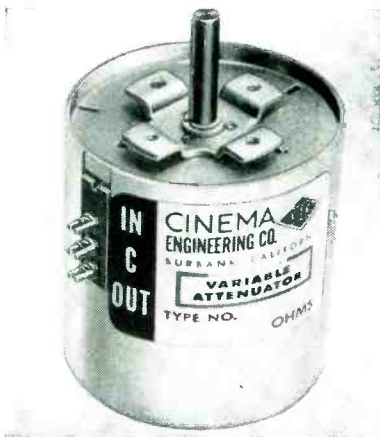

**AUDIO ATTENUATOR**  
manufacturers' type

CINEMA ENGINEERING CO., AEROVOX CORP., Burbank, Calif., is producing a new manufacturers' type audio attenuator for sound attenuation, sound mixing, special measuring and calibration units. The item, featuring self-wiping contacts of nickel silver, carbon composition and wire-wound resistors, is available in 150, 250 and 600 ohms. Resistance element values are standard 5-percent accuracy. Audio ladder controls have a 6-db inherent



*Oregon Electronics*  
Model PR 300

**PRECISION REGULATED**

- ✓ **STABILITY**  
(Long term  $\pm 100$  ppm—  
Short term  $\pm 50$  ppm per hour)
- ✓ **LOW RIPPLE**
- ✓ **LOW IMPEDANCE**

Here's a voltage reference that can be depended upon for many laboratory functions, but specifically suited for calibrating meters, powering multi-stage amplifiers and computers.

**OUTPUT TOLERANCE** for 10% line voltage variation:  $\pm .002\%$  or less.  
**VOLTAGE RELIABILITY** read on decade dials: .02% or 5 millivolts, whichever is greater.  
**OUTPUT VOLTAGES:** (1) 10 to 310 volts in 1 volt steps @ 150 ma. max. (2) 0-150 volts continuously variable @ 5 ma. max. (3) 6.3 volts unregulated @ 3 amperes CT.



*Oregon Electronics*  
Model 32V15A

**CLOSELY REGULATED**

- ✓ **Low Voltage—High Current**
- ✓ **DC POWER SUPPLY**

A Magnetic Amplifier Power Supply with output at 15 amperes continuously variable from 5 to 32 volts without switching.

**REGULATION:**  $\pm 1\%$  from no load to full load,  $\pm 1\%$  from 105 to 125 volts input.  
**RIPPLE VOLTAGE:** 1% RMS @ 32 volts and full load, increasing to 2% @ 5 volts and full load.

Complete specifications and details upon request—write or wire today.

*Oregon Electronics*

2232 EAST BURNSIDE STREET  
PORTLAND 15, OREGON  
BEImont 6-9292

**MANUFACTURERS OF SPECIAL ELECTRONIC EQUIPMENT**



*you can rely on ARC Test Equipment!*

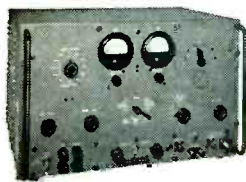

Type H-14 Signal Generator



Type H-16 Standard Course Checker

Unerring precision is yours in the ARC Type H-14 Signal Generator! For either pre-flight or bench checks, this instrument tests *all* ARC Omni and Localizer Receivers with vital accuracy and speed. The H-14 clears one unit or a complete squadron . . . in under sixty seconds!

Checking up to 24 omni courses, to-from and flag-alarm operation, omni course sensitivity, calibration accuracy and left-center-right on localizer, the versatile H-14 also may be used to transmit voice instructions to pilots along with test signals.

ARC supplies the watchdog H-16 Standard Course Checker for *exact* course accuracy and phase measurement checks on the H-14, or any other omni signal generator. Both instruments available from factory only. Write for literature.

Dependable Airborne Electronic Equipment Since 1928

## Aircraft Radio Corporation

BOONTON, NEW JERSEY

Omni Receivers • 900-2100 Mc Signal Generators • UHF and VHF Receivers and Transmitters • 8-Watt Audio Amplifiers • 10-Channel Isolation Amplifiers • LF Receivers and Loop Direction Finders



insertion loss. All other network types of mixer controls have zero loss. The attenuator comes without knob and dial, but they are available as accessory items. Shipping weight is 8 to 12 oz per section.

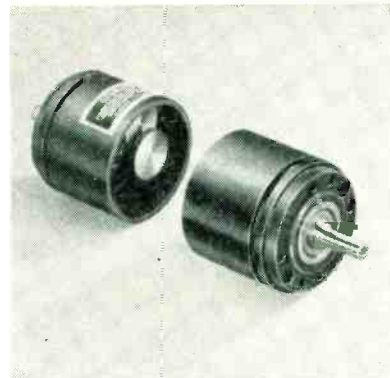

### GEAR HEAD used with servo motors

STERLING PRECISION INSTRUMENT CORP., 34-17 Lawrence St., Flushing 54, N. Y. Designed for use with most Bureau of Ordnance servo motors, the model 600 series standard gear heads will fit units from  $1\frac{1}{8}$  in. diameter to  $1\frac{1}{4}$  in. diameter. Special heads can be designed for servo motors outside this group. The company's standard gear heads have the output shaft concentric with the servo mounting diameters. Attaching these gear heads to a servo motor creates a clean, fully enclosed self-contained unit.

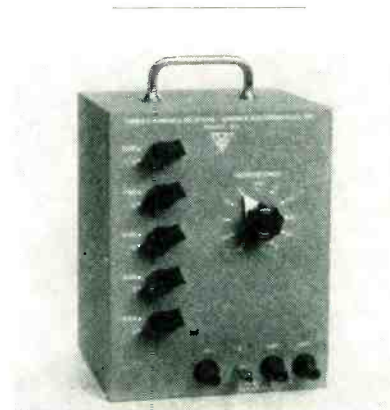

### DELAY LINES are continuously variable

ADVANCE ELECTRONICS CO., INC., 451 Highland Ave., Passaic, N. J. Type 611 variable delay lines are continuously variable from 0 to



beyond 10  $\mu$ sec. The continuously variable delay line in type 611a is essentially a condensed r-f cable with one conductor changed into a long thin coil and the other spaced closely to the first, thus producing a large amount of time delay, yet maintaining low attenuation at high frequencies. The tapped delay line in type 611b has 10 or more sections of m-derived LC networks with similar electrical performance to that of the step variable delay line.



**DATA TRANSLATOR includes visual readout**

EPSCO INC., 588 Commonwealth Ave., Boston 15, Mass., announces the new Datrac data translator for ultraprecision voltage-to-digital and digital-to-voltage conversion. Model E Datrac converter provides 2 voltage-to-digital conversions per sec or 30 digital-to-voltage conversions per sec to an accuracy of  $\pm 0.01$  percent  $\pm 1$  least significant digit. The converter includes a visual readout and output conversion for direct control of printers, typewriters, or card punching equipment. Five decimal digits are provided. Three floating decimal ranges provide full-scale readings of  $\pm 99.999$ ,  $\pm 9.9999$ , and  $\pm 0.99999$  v, thus providing 10- $\mu$ v sensitivity. A number of optional features may be provided.

**WAFERING MACHINE is fully automatic**

MICROMECH MFG. CORP., 1020 Commerce Ave., Union, N. J. The Micro-Matic precision wafering machine is made specifically for use

**WIDE-BAND POWER OSCILLATOR**

**200 to 2500 mc/sec**

**40 watts at 200-400 mc  
25 watts at 400-1000 mc  
10 watts at 1000-2500 mc**

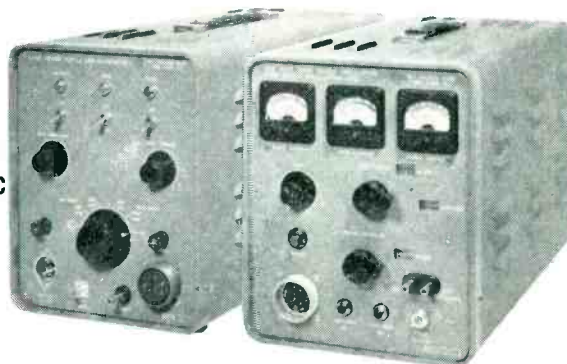

Provides exceptionally broad frequency coverage and substantial power output in a single source. Offers smooth tuning and precise resettability, with overlapping coverage of the full range in two bands.

Price, including oscillator and power supply-modulator, \$2250.00 net F.O.B. Long Island City, N.Y. Write for free bulletin.

Frequency ranges....200 to 1050 mc, 950 to 2500 mc  
Calibration accuracy..... $\pm 1\%$  or  $\pm 5$  megacycles whichever is greater  
Resettability.....better than 0.1%  
Modulation.....internal square-wave and sine-wave, 400 and 1000 cps; also external  
Output impedance.....50 ohms (nominal)

**Subminiature I-F AMPLIFIERS**

- High gain and sensitivity
- Wide-band response
- Rapid recovery
- 40 db manual gain adjustment
- Low noise

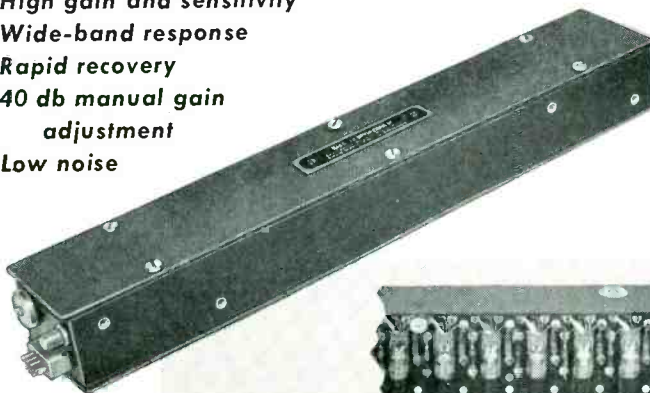

Designed for aircraft and electronic instrumentation, these amplifiers can be furnished to meet specific performance requirements. Typical specifications are given at right.

Model No.	Center frequency mc/sec	Band width mc/sec	Noise figure db	Gain db
M1154	30	12	1.7	100
M1155	60	12	3.7	100
M1156	90	12	5.0	100

Maxson Instruments products include: power oscillators, I-F amplifiers, mag-amp voltage regulators, frequency regulators for aircraft inverters, ultrasonic flowmeters, acceleration-sensitive switches, and statistical accelerometers. For detailed information, contact our main office, or Maxson District Office at:

**Dayton, Ohio:**  
3229 Wonderview Drive  
Michigan 2232

**Washington, D. C.:**  
202 World Center Building  
Sterling 3-7393

**Beverly Hills, California:**  
8840 Olympic Boulevard  
Bradshaw 2-0316



47-37 Austell Place  
Long Island City 1  
New York  
Tel: RAvenswood 9-1850



"CLIP-TYPE" closed entry socket  
contact now standard in

**Bendix**

# SCINFLEX ELECTRICAL CONNECTORS

**CANNOT** be overstressed—eliminates intermittent circuit  
problems resulting from socket contact malfunction.

Bendix-Scinflex\* socket contacts have always been machined from bar stock. Stampings, with their required thin sections, can be easily overstressed.

Industry has also been plagued with overstressed spring leaves due principally to the misuse of test probes and lax tolerances on pin contacts. Bendix engineers now provide the only socket contact which completely eliminates all these problems.

The "Clip-Type" socket will not accept any oversize probe or pin, nor can one be forced into it. Also, no amount of wrenching or twisting of an acceptable pin or probe can possibly distort the spring clip. This new socket is now standard in all Scinflex connectors including those using solderless, high-temperature and thermocouple contacts.

Complete detailed information is available on request.

\*TRADE-MARK

**Bendix**

SCINTILLA DIVISION of  
SIDNEY, NEW YORK

**Bendix**  
AVIATION CORPORATION

Export Sales and Service: Bendix International Division, 205 East 42nd St., New York 17, N. Y.

FACTORY BRANCH OFFICES: 117 E. Providencia Ave., Burbank, Calif. • 512 West Ave., Jenkintown, Pa. • Stephenson Building, 6560 Cass Ave., Detroit 2, Mich. • 5906 North Port Washington Road, Milwaukee 17, Wisc. • American Building, 4 S. Main St., Dayton 2, O. • 8401 Cedar Springs Road, Dallas 19, Tex. • Boeing Field, Seattle 8, Wash. • 1701 "K" St., N. W., Washington 6, D. C.

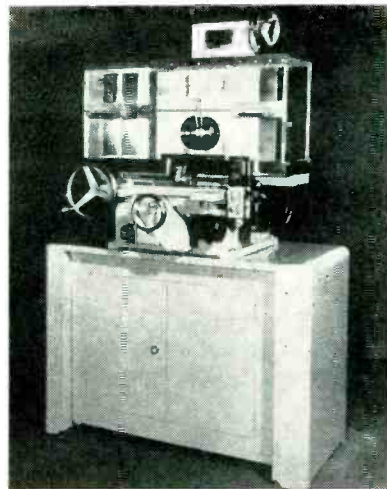

by the electronic industry for slicing and dicing germanium, silicon and quartz used in transistor and diode manufacture. It is equipped with control mechanisms and other automatic devices together with in-built accuracy. The wafers produced are consistent in thickness, and parallelism is controlled to within several ten thousandths variation. Any predetermined thickness may be obtained, ranging from 0.010 to 0.225. A 4, 5, or 6-in. diamond impregnated metal saw may be used for slicing and dicing. The working capacity of the machine is 6 in. transverse, 12 in. longitudinal and up to 12 in vertical.

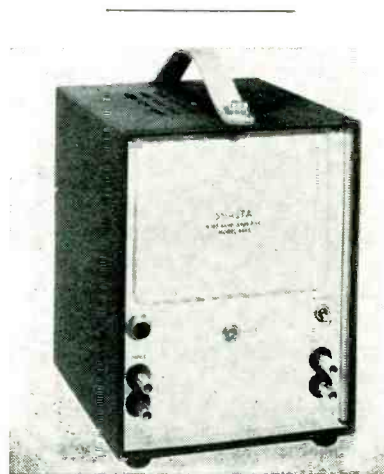

## AMPLIFIER for 10 cps to 1 mc

SHASTA DIVISION, Beckman Instruments, Inc., P.O. Box 296, Station A, Richmond, Calif. Model 854A amplifier provides a choice of two fixed voltage gains of 10 and 100 times, over the frequency range of 10 cps to 1 mc. The instrument is



usable to higher frequencies with some slight sacrifice in uniformity of response, namely,  $\pm 1$  db, 5 cps to 2 mc at a gain of 100 times. The circuit used introduces distortion of less than 1 percent when operating into recommended loads. Equivalent input noise is  $20 \mu v$  on 100 times gain setting, and  $80 \mu v$  with a gain of 10. Output voltage is a maximum of 10 v into a minimum load of 3,000 ohms. The input impedance is one megohm shunted by approximately  $15 \mu f$ .

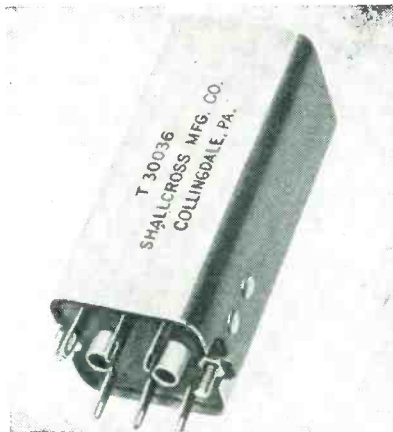

**DELAY LINE for color television**

SHALLCROSS MFG. Co., Collingdale, Pa., has announced an inexpensive, distributed-constant delay line designed for use as a compensating delay in the luminance channel of color tv receivers. The type T30036 delay line has an impedance of 4,300 ohms and uniform response to 4 mc. Phase characteristics also are linear within 5 percent to 4 mc. Total delay is  $0.8 \mu sec$ . Rise time is only  $0.1 \mu sec$ . The unit is enclosed in an aluminum can only  $1\frac{1}{8}$  in. square by  $3\frac{1}{8}$  in. high, exclusive of terminals. Modifications of the basic electrical and physical characteristics can be made for quantity users.

**FREQUENCY CHANGER uses synchronous motor drive**

GEORATOR CORP., Manassas, Va. Answering the need for a compact supply to furnish constant 420 cycles, with output frequency as invariable as the input, the unit pictured has been developed. Motor

# PANELOC announces a new rotary latch

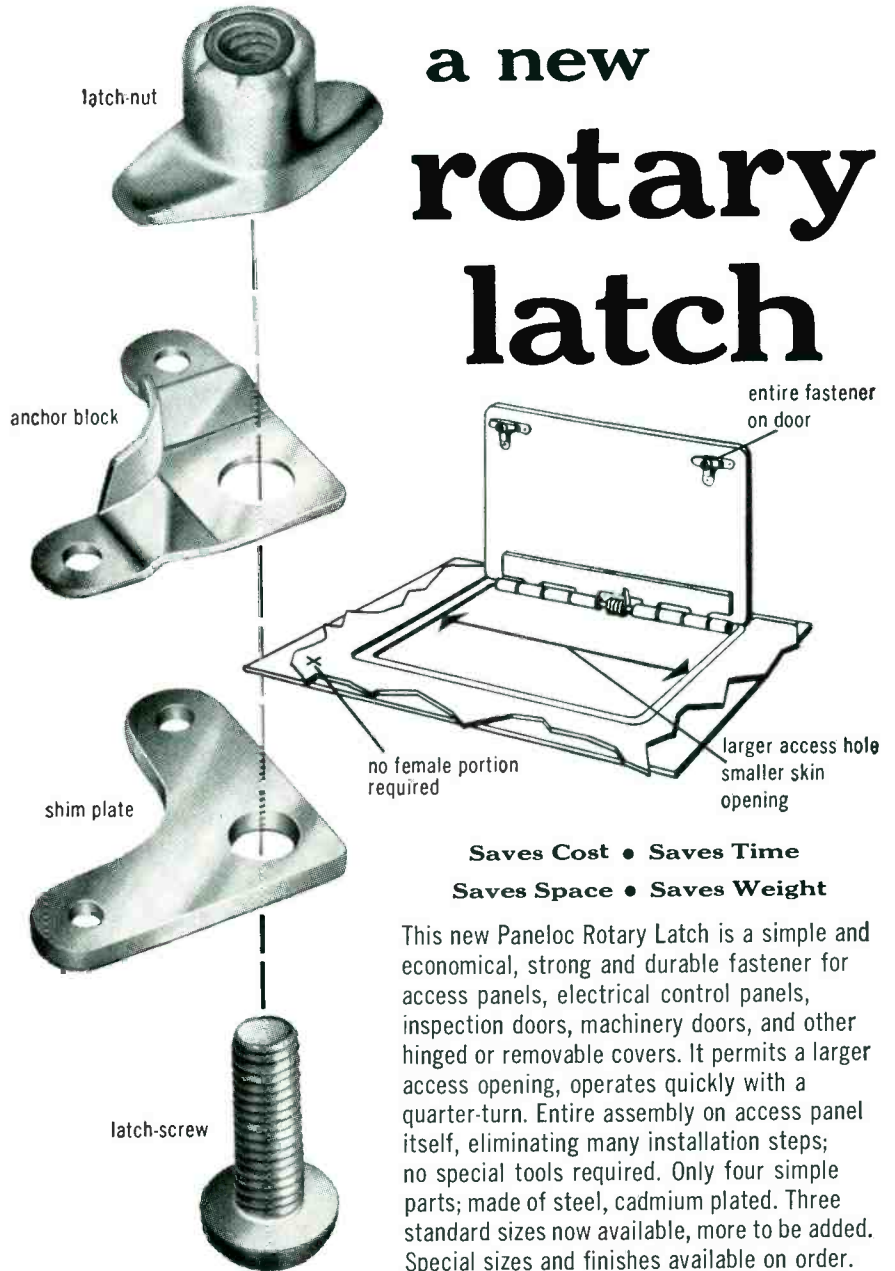

**Saves Cost • Saves Time  
Saves Space • Saves Weight**

This new PaneLOC Rotary Latch is a simple and economical, strong and durable fastener for access panels, electrical control panels, inspection doors, machinery doors, and other hinged or removable covers. It permits a larger access opening, operates quickly with a quarter-turn. Entire assembly on access panel itself, eliminating many installation steps; no special tools required. Only four simple parts; made of steel, cadmium plated. Three standard sizes now available, more to be added. Special sizes and finishes available on order. Cost very low, performance unsurpassed. Write for a catalog and price list for your file.

**PANELOC**...America's most versatile line of aircraft fasteners... Rotary Latches, Styles 1, 2, and 3 Panel Fasteners, High Performance Fasteners, Snap Fasteners.



**PANELOC—A product of Scovill**

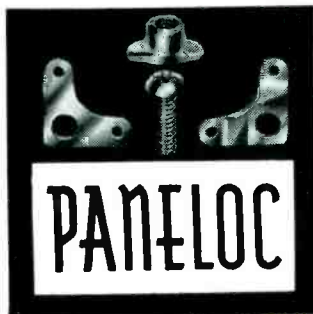

Scovill Manufacturing Company, Aircraft Fastener Div.

46 Mill Street, Waterbury 20, Connecticut

Please send me fastener catalogs checked:

- Rotary Latch
- Style 3 (MIL-F-5591A)
- Styles 1 & 2 (MIL-F-5591A)
- High Performance (NAS-547)
- Snap Fasteners (AN 227)

Send to:

Name \_\_\_\_\_ Title \_\_\_\_\_

Company \_\_\_\_\_

Address \_\_\_\_\_

## precision plumbing for microwave transmission

With unequalled experience in all of the accepted waveguide metals, Technicraft's thorough, stage-by-stage inspection and measurement policy assures delivery of only the most precise plumbing, both electrically and mechanically.

Technicraft employs the most advanced attaching techniques, including dip brazing. Manufacturing standards under constant supervision of experienced microwave engineers. Extensive lab facilities available for development and production tests.

*For complete details and characteristics ask for our specification sheets.*

# TECHNICRAFT LABORATORIES

INCORPORATED

1550 THOMASTON RD. • THOMASTON, CONNECTICUT

Designers and Manufacturers of Rigid and Flexible Waveguide Assemblies, Microwave Test Plumbing and Components, Waveguide Systems.

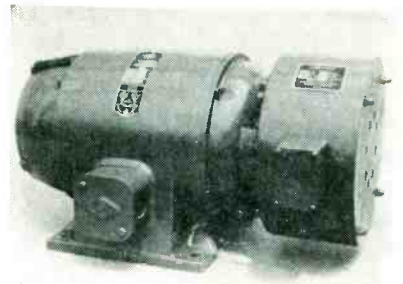

is synchronous type, direct coupled in a compact unitary combination with a Nobrush 420-cycle generator. The resulting combination is free of brushes, exciter and slip rings, yet delivers as constant a 420-cycle frequency as the input 60 cycle. Without any regulator or delicate auxiliary, the unit will maintain output voltage to better than 2 percent for a given load. The generator creates no radio interference, is immune to damage from short circuits, will withstand moisture, dust and grit. Converters are available in this design (150 va to 5 kva), with any desired combination of single or three-phase input and output.

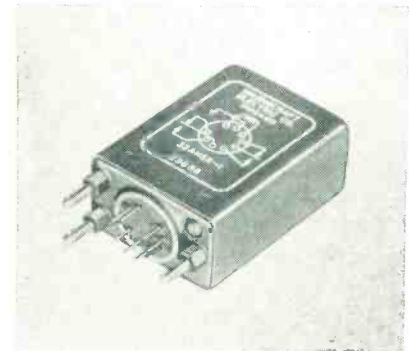

### RECTIFIER RELAYS for better a-c reliability

MAGNECRAFT ELECTRIC Co., 3350 W. Grand Ave., Chicago 51, Ill. Increased operating reliability throughout the wide range from 25 to 400 cycles a-c is provided in recently announced rectifier relays. Full wave rectifiers incorporated in these relays convert a-c to rectified d-c; thus providing d-c operation from a-c power supply. Advantages obtained in comparison with conventional a-c operation include: increased operating sensitivity, higher contact pressures, greater resistance to vibration, reliable operation through much wider variation in voltage or cur-



rent, freedom from a-c hum and, in many cases, reduced size. The rectifier relays are available with a wide range of contact combinations in hermetically sealed or dust-proof enclosures as well as open. Literature is available on request.

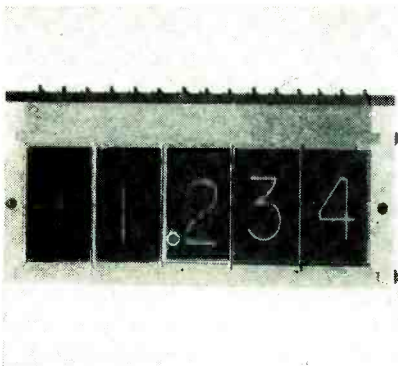

### DIGITAL READOUTS with advanced design

NON-LINEAR SYSTEMS, INC., Del Mar Airport, Del Mar, Calif. The NLS 3W series is the most recent and advanced design of the company's in-line, luminous digital readouts. Standard readouts are available with from one to six windows arranged horizontally. The edge-lighted Lucite plates are engraved with numbers from 0 through 9, decimal points and polarity signs. The numbers are  $\frac{1}{2}$  in. wide and 1 in. high, spaced  $1\frac{1}{2}$  in. on centers to provide maximum legibility. A new quick change terminal strip to which connecting wires can be soldered retains the lamps, maintains spring-loaded contact with each lamp, and eliminates resoldering connections when replacing lamps. Improved design of the interlocking frame members provides maximum precision and sturdiness. Volume production tooling and assembly methods provide high quality and variety at low cost.

### NOISE GENERATOR used with analog computers

AUTOMATION LABORATORIES INC., 517 W. 207th St., New York 34, N. Y. The low-frequency Gaussian noise generator provides a random voltage whose amplitude probability distribution is Gaussian to within 1

## JET PROPULSION LABORATORY OF THE CALIFORNIA INSTITUTE OF TECHNOLOGY Pasadena, California

# jpl

has positions now open in several fields of

### MISSILE GUIDANCE SYSTEM DEVELOPMENT

This is an opportunity to associate yourself with the nation's foremost guided missile research and development facility.

#### 1) System Analysis

Engineers, Physicists or Mathematicians are wanted for rocket guidance system planning and analysis. The work requires a combination of imagination and a high level of analytical ability. Experience in the engineering type problems of guidance or related equipment is very desirable. This overall system work provides the opportunity to become familiar with a broad variety of interesting and challenging fields. Excellent digital and analogue computers are available for use in the studies.

#### 2) Inertial Guidance

Engineers and Physicists are wanted for missile inertial guidance component development. Work involves design, development and evaluation of gyros, accelerometers, integrators, stable platform systems and associated apparatus. Particular emphasis is placed on the problem of achieving component performance under severe environmental conditions, and on development of advanced testing techniques.

#### 3) Layout and Packaging

Engineers are wanted for layout design and proof testing of electronic and electro-mechanical packages with emphasis on meeting vibration, temperature, and system operation requirements.

#### 4) Switching Circuits

Engineers are wanted to design low power switching, control, and power circuits, with emphasis on reliability and ease of operation.

The Jet Propulsion Laboratory is located in a suburban area of Pasadena, California. It offers these advantages:

- Desirable academic associations
- Emphasis placed on research and development
- Excellent laboratory and model shop facilities
- Attractive salaries
- A stable yet progressive organization

Interviews are conducted by members of our engineering staff.

Airmail your summary of qualifications to:

CALTECH | JET PROPULSION LABORATORY  
4800 Oak Grove Drive Pasadena, California

**PRINT  
ELECTRONIC  
CIRCUITS  
AUTOMATICALLY**

**BY SILK SCREEN →**

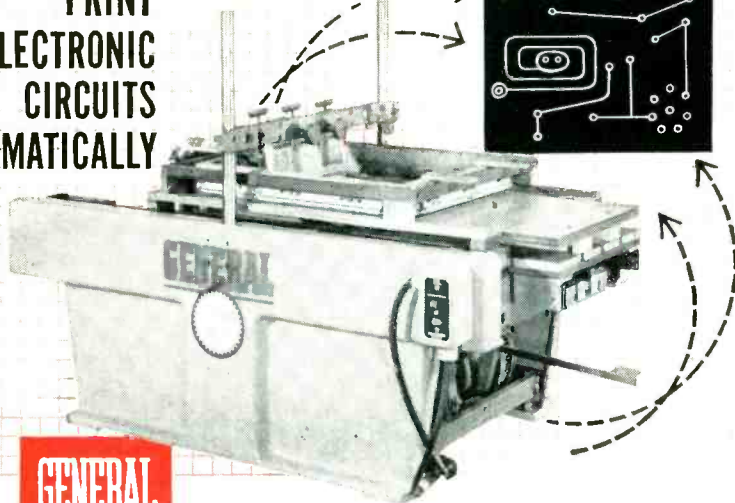

**GENERAL**

**DECORATOR PRESSES-SERIES B**

■ The Silk Screen method is being widely accepted for preparing copper laminated plastic panels prior to etching printed circuits. General Decorator Presses put printed circuits on an automatic, high production basis. Bowed panels are held flat by vacuum. Line contact impression and accurate register give clean, sharp reproduction of fine lines. Controlled inking lays down a thick, uniform layer of resist.

Model No.	B1224	B1824	B1836
Sheet Size	13x25"	19x25"	19x37"
Speeds Up To	1000 per hr.	800 per hr.	800 per hr.

**ThermoJet  
DRYER**

Utilizes a new system for high speed drying of inks, resists and coatings by greatly accelerated evaporation of solvents.



**GENERAL**

Write for complete information

**RESEARCH AND SUPPLY COMPANY**

572 S. Division Avenue  
Grand Rapids 3, Michigan



percent. The output frequency spectrum is flat to within 1 db from d-c to 27 cps in the standard model, but the frequency spectrum can be modified upon special request. Output voltage is 5 v rms, regulated to within 0.1 db, and available from a low source impedance. A continuously adjustable calibrated attenuator permits the output to be decreased from this value. A front panel meter continuously monitors the rms value of the output voltage. The instrument can be removed from the cabinet and mounted in a standard rack. It is intended for use with analog computers, simulators, servo testing and many other applications.

**GOLD INLAY KNOBS  
IN ANY QUANTITY!**

... and Never a Tool Charge

**NEW GEE-LAR  
GOLD INLAY KNOBS**

You can get beautiful gold inlay knobs, pointers, instrument controls . . . thousands of styles and varieties . . . in any quantity from GEE-LAR—The House of Knobs. They're available in both knurled and spring types, in either walnut or ivory backgrounds. For faster service and lower cost . . . plus the widest selection . . . get your Gold Inlay Knobs from GEE-LAR!

WRITE TODAY  
for Gee-Lar Catalog  
IT'S FREE!



THE HOUSE OF KNOBS

**GEE-LAR MANUFACTURING COMPANY**

821 ELM ST. • Rockford, Illinois



**RELAY  
operates at 10 milliseconds**

HEDIN TELE-TECHNICAL CORP., 87 Dorsa Ave., Livingston, N. J. Relay 100-MS operates at 10 milliseconds and incorporates a thorough wiping effect. Available either hermetically sealed or with dust cover, it is designed for d-c applications in contact combination from spst to dpdt. Capacity is up to 1.5 amperes inductive and 5 amperes resistive with coil resistance to a maximum of 30,000 ohms. Bounce and chatter are eliminated by the built-in wiping action in the con-



tact movement. Drop-out if desired can be adjusted to about 65 percent of pickup. Wattage requirement is 250 mw per pole. The relay's applications include controls, recording, signal systems and electronic instrumentation, particularly in plate circuits and in circuits employing transistors.

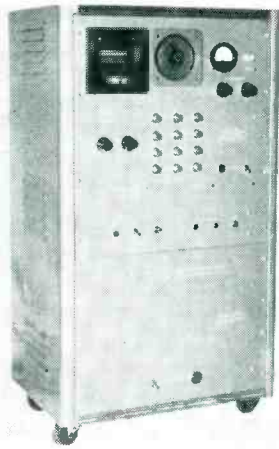

**TEN-MC SCALERS**  
for high-speed counting

ELECTRICAL AND PHYSICAL INSTRUMENT CORP., 42-19 27th St., Long Island City 1, N. Y. Model 4104 and 4124 10-mc scalers have a binary or decade scale of 4.096 or 1,000 respectively, or larger if desired. A five digit electrical reset register with any count predeterminable, a predetermined timer, a regulated h-v supply (0 to 2,500 v) for photomultipliers and the availability of a general purpose 10-mc preamplifier and pulse height discriminator make these units ideal for high-speed scintillation counting in nuclear and medical applications.

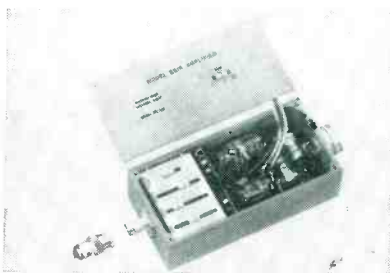

**PREAMPLIFIER**  
for use with pickups

ENDEVCO CORP., 180 E. California St., Pasadena, Calif., announces a

**NEW**

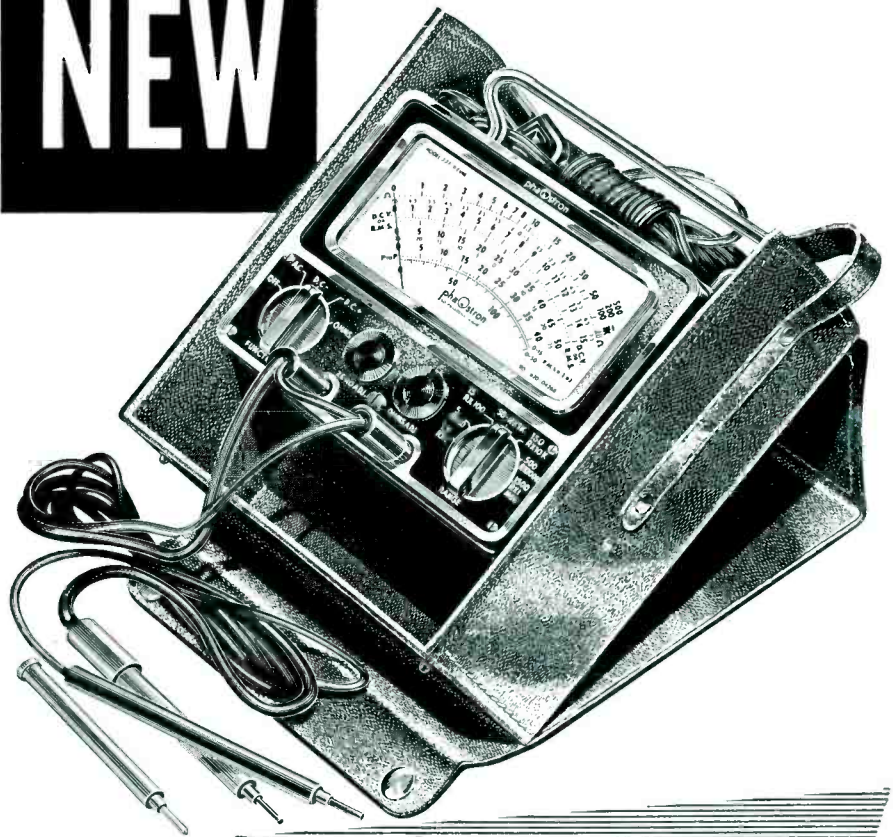

**PHAOSTRON**  
NONE FINER

**"777"**  
**V. T. V. M.**  
(VACUUM TUBE VOLTMETER)

The MODEL "777" V.T.V.M. is a completely self-contained, ready-to-use test instrument. Its accessories and the HF co-ax cable, DC Probe, AC line cord and instruction book all fit in the genuine California Saddle Leather carrying case that is furnished with the instrument.

- 42 Unduplicated Ranges**
- Illuminated Dial (5000 hour self-contained lamps)**
- Die Cast Chrome Finished Bezel**
- Metal Case, unbreakable, ultra compact**
- Doubly Shielded, time proven 200 microamp movement**
- Permanent Accuracy . . . 3% DC, 5% AC**
- Large, Easy to Read Scales 4 7/8" Long**
- Color Coded Scales: green—ohms; black—AC, DC; Red—P. to P.**
- 2 Zero Center Scales for FM Discriminator Alignment**
- Separate Range and Function Switches**
- Only 2 Jacks for All Measurements**
- New, High Style, Easy-to-Use Chrome Bar Knobs**
- Dual Purpose Handle also serves as AC line cord reel**

YOUR KEY TO EXCELLENCE



"777" V.T.V.M. complete with Coaxial Cable, DC Probes and Leather Case at your PARTS DISTRIBUTOR **\$69<sup>95</sup>**

**PHAOSTRON INSTRUMENT AND ELECTRONIC COMPANY**  
151 PASADENA AVE., SOUTH PASADENA, CALIF.

# PRECISION ATTENUATION TO 3000 mc!

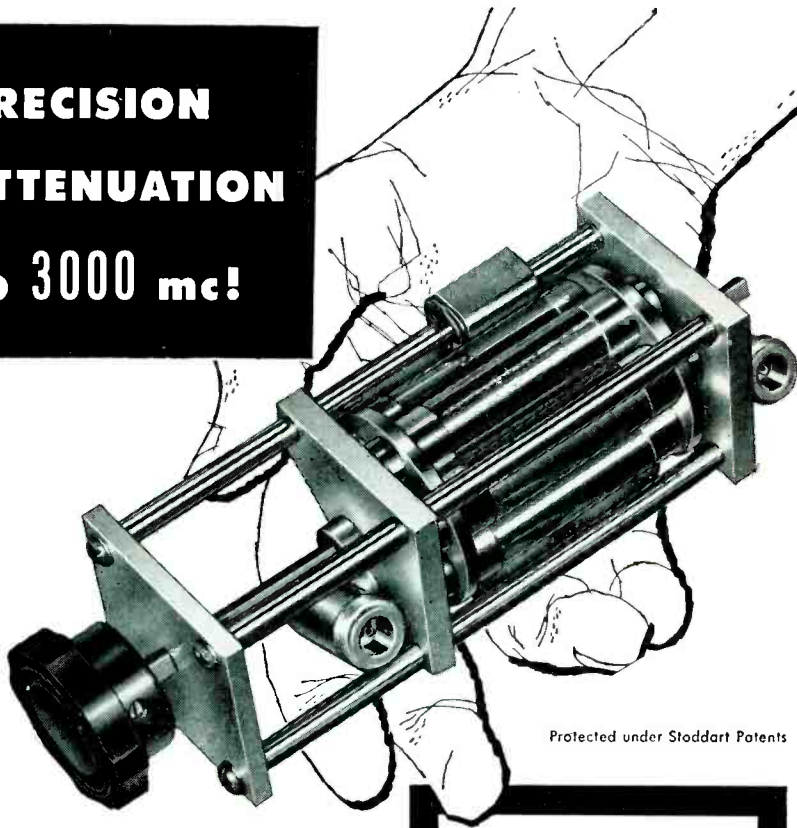

Protected under Stoddart Patents

six-position

**TURRET ATTENUATOR**featuring **PULL-TURN-PUSH** action

FREQUENCY RANGE: dc to 3000 mc.

CHARACTERISTIC IMPEDANCE: 50 ohms.

CONNECTORS: Type "N" Coaxial female fittings each end.

AVAILABLE ATTENUATION: Any value from 1 db to 60 db.

VSWR: 1.2 max., dc to 3000 mc/s, values from 10 to 60 db. As value decreases below 10 db, VSWR increases to not over 1.5.

ACCURACY:  $\pm 0.5$  db.

POWER RATING: One watt sine wave power dissipation.

**SINGLE "IN-THE-LINE" ATTENUATOR PADS  
and 50 ohm COAXIAL TERMINATIONS**

This new group of pads and terminations features the popular Type C and Type N connectors, and permits any conceivable combination of the two styles. For example, the two connector types, either male or female, can be mounted on the same attenuator pad, with or without flanges, so that it may serve as an adapter as well as an attenuator. Frequency range, impedance, attenuation, VSWR, accuracy and power rating are as designated above. Send for free bulletin entitled "Measurement of RF Attenuation."

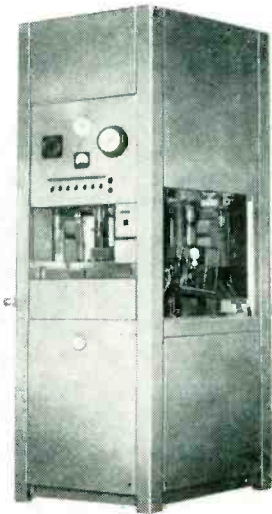

new probe type of preamplifier for use with piezoelectric pickups permitting the user to trim the self-generating pickup output sensitivity to an even or standard value so that direct reading of physical parameters such as acceleration, force and pressure is possible with standard v-t voltmeters. Model 2614 features an input selector switch for the choice of 3 input conditions: 1,000 megohms for use with vibration pickups, extending the 1-f range of piezoelectric pickups to 2 cps; 1,000 megohms with d-c isolation for general uses; and 22 megohms for shock pickups, and fast recovery from overloads. In addition, a sub-miniature 3 decade shunt capacity switch is provided with a total capacitance from 10  $\mu\mu\text{f}$  to 9,990  $\mu\mu\text{f}$  in 10  $\mu\mu\text{f}$  steps. The unit features amplifiers gains of 1, 3 and 10, with stability of 1 percent or better, a frequency response from 2 cps to 15,000 cps, and an output of 5 v into 2,500 ohms.

**WET BLAST UNIT  
cleans tube leads**

THE CRO-PLATE Co., INC., 747 Windsor St., Hartford 1, Conn. Designed for the high production rate cleaning of electronic receiving tube leads to insure good welding bond, a new rotary automatic is capable of blast cleaning, rinsing, drying and unloading at the rate of approximately 1,200 parts per hour. All chemical cleaning is eliminated through the use of the wet blast

**STODDART AIRCRAFT RADIO Co., Inc.**  
6644-A Santa Monica Blvd., Hollywood 38, California • Hollywood 4-9294



method. Mounted vertically within the cabinet is a 6-station, air-operated rotary indexing table to which 6 vertically positioned work holding spindles are attached. Each spindle supports a chuck which, in turn, carries the tubes through each of the separate, baffled operating stations. The use of different work holding fixtures makes the unit highly adaptable to the finishing of a wide variety of other parts.



### SILICON POWER RECTIFIER for miniaturization purposes

AUTOMATIC MFG. CORP., subsidiary of General Instrument Corp., 65 Gouverneur St., Newark 4, N. J. The tiny silicon power rectifier illustrated, designed for use in equipment where miniaturization and high temperature reliability are vital, takes up only 3/100 cu in. of space and weighs only 7/100 oz. It should play an important role in electronic gear for guided missiles, supersonic aircraft and other military equipment. In the commercial and industrial field, the new rectifiers are designed for manufacturers of power supplies, magnetic amplifiers, communications equipment, and many types of computers, whose bulk can be greatly reduced by use of the tiny semiconductors instead of vacuum tubes or selenium rectifiers. They are available in 6 voltage ranges, capable of handling voltages as high as 1,000 v, with d-c output currents on the order of 300 to 400 ma. They operate at temperatures as high as 200 C.

## Literature

Electronic Test Instruments. Shasta Division, Beckman Instruments, Inc., P. O. Box 296, Station A, Richmond, Calif., has available

# Taping the data of Aviation-Electronics

Davies magnetic tape equipment  
and systems for recording, reproducing,  
and analyzing data

#### STANDARD RECORDING & PLAYBACK HEADS

Precision multi-track heads, shielded for negligible cross talk. Precision gap alignment for uniform time and phase reproduction among the various tracks. Encapsulated in thermosetting resin. Complete range available from 2 tracks on 1/4" tape, to 42 tracks on 2" tape—for use in data processing equipment, analog and digital work, telemetering, and automatic control.

WRITE FOR BULLETIN 55-B

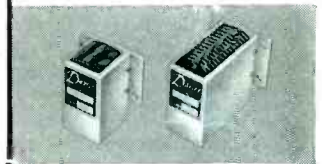

#### RECORDERS—PORTABLE & LABORATORY

Portable recorders, flight-proved to withstand extreme conditions, furnished as self-contained units or subdivided for space/weight distribution. Laboratory recorders are available with complete reproducing systems as an integral unit. Both have a full range of speeds for direct recording or recording by FM, PWM, or digital pulse—with full wow and flutter compensation.

WRITE FOR BULLETINS 54-D AND 54-E



#### REPRODUCERS

These unitized assemblies reproduce data from all Davies recorders with unparalleled accuracy. They include a tape transport mechanism, a speed control servo, and playback amplifiers with power supply, for direct recorded, PWM, or digital signals; and a high stability discriminator, in addition, for FM carrier systems. Units are available individually or as a complete system.

WRITE FOR BULLETIN 54-D

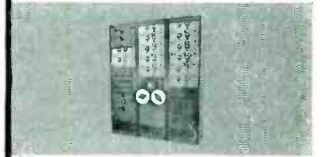

#### AUTOMATIC WAVE ANALYZER

This heterodyne type analyzer provides a complete fourier analysis (amplitude vs. frequency) of up to 14 inputs—all automatically. It is adaptable to any source supplying a repetitive signal in the range of 3 to 2000 cps to analyze signals from vibration, transients, noise, shock, power lines, etc.

WRITE FOR BULLETIN 54-C

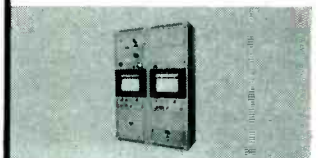

THE *Davies* LABORATORIES, INC.

4705 Queensbury Road • Riverdale, Maryland



## How many patents per Ph. D.?

*Some of the young fellows on our staff have been analyzing our files of personal data regarding scientists and engineers here at Hughes. What group characteristics would be found?*

*With additional facts cheerfully contributed by their colleagues they have come up with a score of relationships—some amusing, some quite surprising. We shall chart the most interesting results for you in this series.*

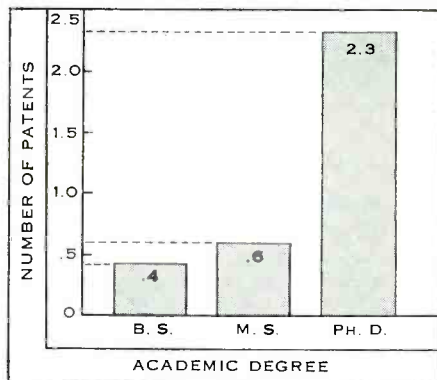

Data obtained from a 20% random sample of the 2,200 professional engineers and scientists of Hughes Research and Development Laboratories.

In our laboratories here at Hughes, more than half of the engineers and scientists have had one or more years of graduate work, one in four has his Master's, one in 15 his Doctor's. The Hughes research program is of wide variety and scope, affording exceptional freedom as well as exceptional facilities for these people. Indeed, it would be hard to find a more exciting and rewarding human climate for a career in science. Too, the professional level is being stepped up continually to insure our future success in commercial as well as military work.

Hughes is pre-eminent as a developer and manufacturer of airborne electronic systems. Our program includes military projects in ground and airborne electronics, guided missiles, automatic control, synthetic intelligence. Projects of broader commercial and scientific interest include research in semiconductors, electron tubes, digital and analog computation, data handling, navigation, production automation.

*RIGHT NOW the Laboratories in Culver City, California, and the Missile Production facility in Tucson, Arizona, have positions open for engineers who are experienced in any or all phases of Test Equipment Design.*

### SCIENTIFIC STAFF RELATIONS

## Hughes

RESEARCH AND DEVELOPMENT LABORATORIES

Culver City, Los Angeles County, California

a new 8-page catalog describing its line of electronic test instrumentation including expanded scale voltmeters and frequency meters, vtvm's, oscillators, resistance bridges, power supplies, wide-band amplifiers, WWV receiver, decade inductor and various accessories.

**Fluorocarbon Plastics.** United States Gasket Co., P. O. Box 93, Camden, N. J. Those interested in Fluorocarbon plastics in their products will find a 20-page brochure helpful. "Inside U.S.G." is a concise, word and picture story of the company—fabricators of Teflon, Kel-F, Bakelite Fluorothene, and similar engineered plastics—and how it functions as a supplier of these plastics for electronic purposes. It highlights the specialized engineering and production facilities available to customer manufacturers to assure sound application and the most economical production of their requirements.

Ask for bulleting No. IN-554.

**Electronic Design and Manufacture.** Electronic Products Corp., 322 State St., Santa Barbara, Calif., has released a bulletin describing facilities for the design and manufacture of electronic equipment for military and industrial applications. The bulletin describes the company's facilities for the fabrication of cables and electrical wiring harness assemblies including facilities for braiding and molding.

The bulletin also tells of the company's activities in the assembly of electronic devices, design and manufacture of specialized electronic test equipment, power supplies, subminiature electronic assemblies and etched-circuit wiring.

**Vibration Measurement.** General Radio Co., 275 Massachusetts Ave., Cambridge 39, Mass. A 64-page booklet covers the meaning of vibration terms, description of vibration-measuring instruments, procedures, typical examples, and interpretation of results. Unwanted vibration, like noise, plagues nearly every industry and plant at one time or another.

There are also many types of



desirable vibrations. The first step toward understanding what is happening in all these cases is the measurement of the vibration, and a useful guide for this work is the "Measurement of Vibration."

**Calibrator.** Allegany Instrument Co., 1000 Oldtown Road, Cumberland, Md. A single-sheet bulletin illustrates and describes the type C calibrator, a universal tool for the standardization of wire strain gages, transducers and thermocouples. Features, operation information and specifications are given. Price of the unit discussed is \$650.

**Electronically Regulated Power Supplies.** Tarc Electronics Inc., 48 Urban Ave., Westbury, N. Y. A new data sheet describes a line of four power supplies, electronically regulated and designed to meet the extremely close tolerances encountered in color and monochrome television. Specifications for units with output currents ranging from 50 ma to 600 ma are given.

**High-Frequency Resistors.** International Resistance Co., 401 North Broad St., Philadelphia 8, Pa., has announced catalog data bulletin F-3 containing comprehensive data on characteristics, applications, resistance values, tolerances, terminations, insulation and voltage rating for type HFR high-frequency resistors. Included are charts and graphs.

**Electronic Frequency Meter.** Hewlett-Packard Co., 275 Page Mill Road, Palo Alto, Calif. Volume 7, No. 1 of the *Journal* illustrates and describes the model 500 B electronic frequency meter, a 3-cps to 100-kc unit with discriminator output and expandable scale. Complete technical specifications are listed. Also included are specifications for the electronic tachometer indicator.

**Master TV Manual.** Blonder-Tongue Laboratories, Inc., 526 North Ave., Westfield, N. J. A 12-page master tv installation manual discusses all types of multiple tv systems, industrial tv systems and the proper use of Masterline equipment. Illustrated sections cover antenna and line installation, signal

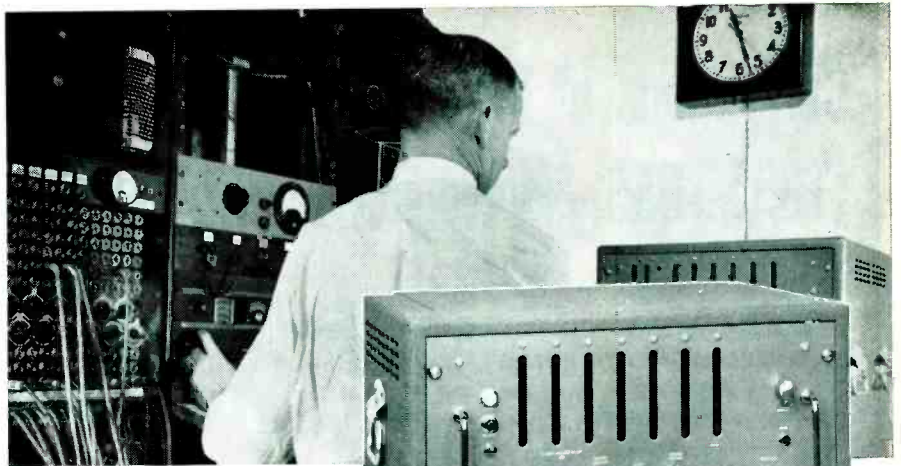

**3 reasons  
why your  
best buy is the**

## Berkeley MODEL 5571 FREQUENCY METER...

### 1. Wider Frequency Coverage...

0-42 mc without plug-ins, extendable to 515 mc with Model 5580 VHF-UHF converter.

### 2. Universal-Instrument Versatility...

a frequency ratio meter, 0-1 mc period meter, 1  $\mu$  sec to 10,000,000 sec time interval meter, 0-2 mc EPUT\* meter, or 1 mc counter.

### 3. Reasonably Priced...

unmatched in range, precision and utility at anywhere near the price.

#### FEATURES

- Direct-coupled input amplifiers
- Direct connections to digital printer, digital-to-analog converter, or data converters for IBM card punches, electric typewriters or telemetering systems
- Provision for external frequency standard input
- Coupling to WWV receiver
- Relay rack mounting if desired

#### BRIEF SPECIFICATIONS

Frequency Meas. Range: 0 cycles to 42 mc  
 Time Interval Meas. Range: 1  $\mu$  sec. to 10<sup>7</sup> seconds  
 Period Meas. Range: 0 to 1 mc (Period x 10, 0 to 100 kc)  
 Input Requirements: 0.1 v. peak to peak  
 Time Bases: Frequency: 0.000002 to 20 seconds, decade steps. Time Interval and Period Meas: 1 mc to 1 cps, decade steps  
 Accuracy:  $\pm 1$  count of unknown (or time base) = crystal stability  
 Crystal Stability: Temperature stabilized to 1 part in 10<sup>7</sup> (short term)  
 Display Time: 0.2 to 5 seconds  
 Power Requirements: 117 v.  $\pm 10\%$ , 50-60 cycles, 260 watts  
 Dimensions: 20 $\frac{3}{4}$ " W x 19" H x 16" D. Weight, 100 lbs.  
 Price: \$1,745.00 (f.o.b. factory)

No other frequency meter offers all the advantages of the Model 5571 — why settle for less? Write now for complete technical and applications data; please address Dept G-12

78

# Berkeley

division

INDUSTRIAL CONTROL SYSTEMS

ANALOG COMPUTERS • COUNTERS • TEST & NUCLEAR INSTRUMENTS

BECKMAN INSTRUMENTS INC.  
 2200 Wright Avenue, Richmond 3, California

# Corrections of Product Listings for the 1955-1956 Electronics Buyers' Guide

**BOLD FACING AND ADVERTISING PAGE NUMBER ARE  
OMITTED IN THE FOLLOWING:**

## **AUTOMATIC ELECTRIC MFG. CO.,**

62 State St.,  
Mankato, Minn.

ADVERTISING PAGE 560

### **RELAYS**

Impulse  
Latching  
Power  
Sensitive  
Sub-Miniature  
Telephone  
Time Delay

**TIMERS**—Automatic Cycle  
**TIMERS**—Automatic Interval  
**TIMERS**—Automatic Reset  
**TIMERS**—Cycle  
**TIMERS**—Motor Operated  
**TIMERS**—Multicontact  
**TIMERS**—Sequence

**SWITCHES**—Time

\* \* \* \* \*

## **DIMCO-GRAY CO.,**

207 E. 6th St.,  
Dayton, Ohio

ADVERTISING PAGE 678

### **FASTENERS & FASTENING DEVICES**

### **INSULATION PARTS**

Plastic Insulation Parts—  
Molded

### **KNOBS**

### **RELAYS**

Time Delay

**SWITCHES**—Time  
**TIMERS**—Automatic Interval  
**TIMERS**—Motor Operated

\* \* \* \* \*

## **EMELOID CO., INC.,**

1239 Central Ave.,  
Hillside 5, N. J.

ADVERTISING PAGE 539

### **KNOBS**

ABP **electronics BUYERS' GUIDE** ABC

A McGraw-Hill Publication 330 West 42nd St., New York 36

distribution, closed-circuit tv, system maintenance and trouble-shooting procedures.

Simplified charts and tables, with specific examples, show how to calculate signal levels at any point. All the company's amplifiers, converters, tapoffs and accessories are fully described. Also offered is free engineering assistance.

### **Infrared Radiation Pyrometers.**

Servo Corp. of America, 20-20 Jericho Turnpike, New Hyde Park, L. I., N. Y. A new 4-page brochure describes 2 infrared radiation pyrometers. The IR-2 is an industrial instrument designed for temperature measurement of moving objects in process as well as the location of hot spots in inaccessible equipment.

The IR-1 discussed covers a nominal temperature range of ambient to 1,000 C. As a control instrument, the unit described is highly suitable for fine measurements. As a control instrument it is outstanding for processes requiring high sensitivity near ambient.

**Bobbin Winder.** Geo. Stevens Mfg. Co., Inc., Pulaski Road at Peterson, Chicago 30, Ill., has available a data sheet on the new compact front-loading multiple-head adjustable-length bobbin winder. Model 314-AM3 is pictured and completely described.

Technical data include dimensions, weights, types of windings, coil o-d and length, maximum distance between winding centers, wire sizes, tension equipment, built-in adjustable cam, gears, slow-start and winding speed, new one-way clutch, set up time, motor equipment, brake, counter, instant reset and start, automatic one-shot lubrication and new instant automatic brake release.

**Dielectric Capacitors.** Corson Electric Mfg. Corp., 540 39th St., Union City N. J. A 2-page, 2-color catalog sheet describes and lists a new line of ultrahigh-stability polystyrene dielectric capacitors. The capacitors discussed are designed for use where low leakage and low dielectric absorption are important. The sheet shows standard units which come in bathtub



and rectangular can types in 200, 400 and 600-v ratings, from 0.05 to 25  $\mu$ f. Also described are special units which may be ordered with a variety of housings and terminals, still lower temperature coefficients, higher insulation resistance, silicone impregnation, lower power factors, lower retrace, and other special specifications.

**Resistors.** International Resistance Co., 401 North Broad St., Philadelphia 8, Pa. Catalog data bulletin P-2a covers types PW-7 and PW-10 resistors. Comprehensive data on applications, design and construction, characteristics, ranges, power ratings, tolerance, stamping and derating are given. Charts and graphs are included.

**Electromanometer.** Consolidated Engineering Corp., 300 N. Sierra Madre Villa, Pasadena 15, Calif. Bulletin 1547 illustrates and describes the type 37-103 Electromanometer, a precision, pressure-measuring instrument. A functional diagram is included, along with pressure balance information, specifications, applications and readout methods. A price list for the type 37-103 Electromanometer system is also included.

**Captured Spot Displacement Follower.** The Optronic Co., 136 Caputo Lane, San Jose, Calif. A 12-page folder illustrates and describes the Optron, a device for measuring displacement, runout or vibration of oscillating or rotating parts from 1  $\mu$ in. to 5 in. with frequency response from 0 to 100,000 cps.

The captured spot displacement follower discussed may be used to measure amplitude and frequency of any displacement or vibration within the specified ranges. Principle of operation, component description, overall assembly and specifications are included.

**Cable Harness Tester.** Industrial Instruments Inc., 89 Commerce Road, Cedar Grove, N. J. A single-sheet bulletin illustrates and describes the type A-1 electric cable harness tester, a compact, rugged instrument. The tester discussed makes continuity measurements,

# MICROWAVE POWER MEASUREMENT FROM DEGREES...

SPECIFICATIONS	
Average Power	0-600 watts
Peak	600 KW
VSWR	1.1 max.
Freq. range	
Basic unit	2.6 to 3.95 kmc
With Adapters	2.6 to 18.0 kmc

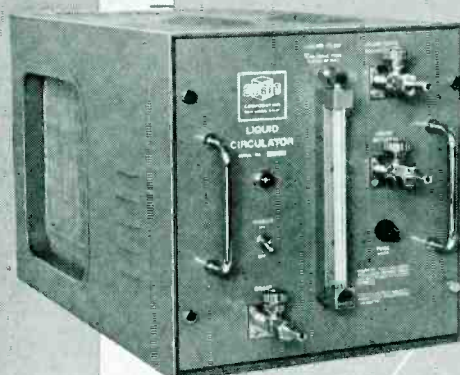

CIRCULATOR

...TO **WATTS**  
*directly!*

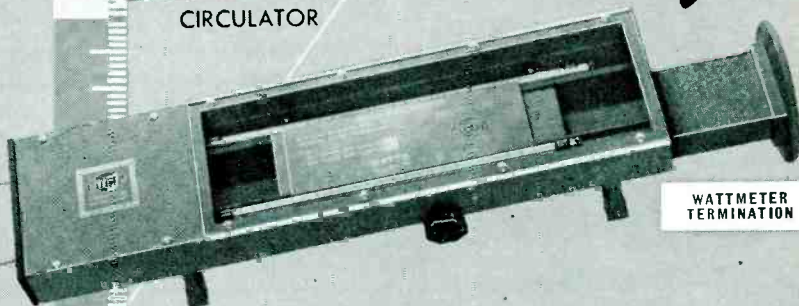
WATTMETER  
TERMINATION

## CUBIC'S 2-UNIT CALORIMETRIC WATTMETERS

... for obtaining direct power readings in testing electronic equipment—without guessing!

Three of the world's largest producers of electronic equipment have recently made CUBIC Calorimetric Wattmeters standard test equipment in their laboratories and plants.

For very good reason. No other instrument designed for power measurement gives you direct power readings... with such precision, and yet so simple in its application.

The model shown is the MC-1B for power measurement from 2600 to 26,500 MC. Also available are the models MCX-1A (coaxial type) for power measurement from 100 to 3000 MC, and MCL-1A (L-Band waveguide type) for power measurement from 1120 to 2600 MC.

Whether checking field equipment, developing or making acceptance tests on new equipment or magnetrons in the lab, or in production, one of CUBIC'S Calorimetric Wattmeters will be an invaluable addition to your test equipment. Standard laboratories calibrate secondary power devices, especially bridge type bolometer instruments. Exact calibration is provided month to month.

Write for more information, and ask for our catalog of other test equipment and waveguide components. Or if you have a problem in development or engineering, CUBIC offers the services of its engineering staff and facilities in its solution.



**CUBIC**  
CORPORATION

ELECTRONIC EQUIPMENT  
RESEARCH...DEVELOPMENT  
2481 CANON STREET  
SAN DIEGO, 6, CALIFORNIA

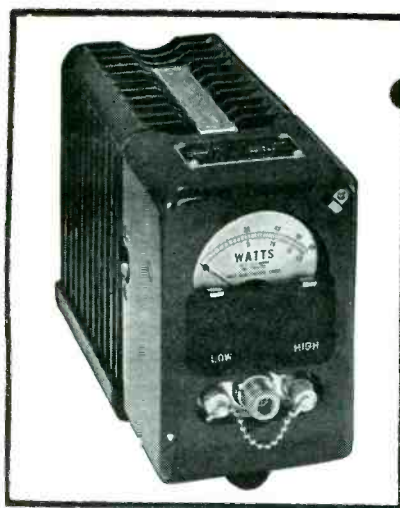

## TERMALINE DIRECT READING R. F. WATTMETERS

(DUAL RANGE)

MODEL 611—0-15 and 0-60 Watts

MODEL 612—0-20 and 0-80 Watts

IMPEDANCE—51½ Ohms

Models 611 and 612 are popular instruments in research and design laboratories, vacuum tube plants, transmitter manufacturing plants, and in fixed and mobile communication services.

They are ruggedly built for portable use, and are as simple to use as a D.C. voltmeter. The power absorbing load resistor is non-radiating, thus preventing transmission of unwanted signals which interfere with message traffic in communication services.

*Frequency range:* 30 to 500 MC (30 to 1,000 MC by special calibration)

*Impedance:* 51.5 OHMS—VSWR less than 1.1

*Accuracy:* Within 5% of full scale

*Input connector:* Female "N" which mates with UG-21 or UG-21B. Adapter UG-146/U is supplied to mate with VHF plug, PL259.

Special Scale Model "61s" are available as low as ½ watt full scale, and other models as high as 5 KW full scale.

*Catalog Furnished on Request*

insulation resistance tests, dielectric strength tests, and provides terminations for the use of external instruments. It is designed for use in production or maintenance work. Price is included.

**Precision Instruments.** Allen B. DuMont Laboratories, Inc., 760 Bloomfield Ave., Clifton, N. J. A recent pocket-sized folder covers 13 new precision instruments. Included are 5 cro's including 21-in. indicator, portable field unit, and others to cover the range of d-c to 20 mc; 4 new oscillograph-record cameras; new high-quality vvm and 2 low-distortion oscillators. Illustrations, brief details and prices are given.

**Precision Cleaning.** Cobehn, Inc., Caldwell, N. J. An 8-page folder deals with a solvent and equipment that safely spray cleans electronic components, contact points and precision instruments; and removes oil and grease, rosin flux, abrasives, lapping compounds and dust, dirt and lint.

The Cobehn solvent and equipment are described with an illustration of a typical installation of a bench unit. The booklet discusses the company's engineering service which is available without cost or obligation. Also available is a single page list of satisfied user companies of this technique of precision cleaning.

**Boron-Carbon Precistors.** International Resistance Co., 401 North Broad St., Philadelphia 8, Pa. An illustrated description of ½-watt molded Boron-Carbon precistors is contained in catalog data bulletin B-8a. It includes comprehensive data on characteristics, applications, wattage rating, tolerance, dimensions and insulation. Charts and graphs are also shown.

**Lubricants.** The Alpha Molykote Corp., 65 Harvard Ave., Stamford, Conn. Bulletin 103-A is a 4-page 2-color catalog of the variety of Molykote lubricants now available to industry. It lists 17 types of this molybdenum disulfide lubricant line and features a complete explanation, with diagrams, of the importance of this compound in extreme bearing pressure, and high,



# BIRD ELECTRONIC CORP.

1800 EAST 38<sup>TH</sup> ST., CLEVELAND 14, OHIO  
TERMALINE Coaxial Line Instruments

VAN GROOS  
COMPANY  
Sherman Oaks, Cal.

RON MERRITT  
COMPANY  
Seattle

# ILSCO CONNECTORS

MAKE  
YOUR  
PRODUCT  
PERFORM  
BETTER

All these ... and more ... for  
**YOUR BEST CONNECTIONS**

U/L AND CSA TESTED	HI-RUGGED STRENGTH
PURE COPPER	RE-USABLE
100% CONDUCTIVITY	ALL WIRE SIZES
COOLER OPERATION	ECONOMICAL

WRITE FOR  
80-PAGE CATALOG

**ILSCO CORPORATION**  
5753 Mariemont Ave.  
Cincinnati 27, Ohio

SLU 11 SIZES



#1000 MCM - #14

XT 6 SIZES



#500 MCM - #14

LO 7 SIZES



#1000 MCM - #14

VT 6 SIZES



#600 MCM - #14



TERMINAL BLOCKS

CAN NEUTRAL



60, 100 & 200 AMPS

FUSE CLIPS



MANY SIZES AND TYPES

MU 3 SIZES



#600 MCM - #6



low and normal temperature lubrication applications. Five new Molykote lubricants are discussed.

Also included is a selector chart which describes each Molykote type, the kind of carrier used in it, the temperature range in which it operates best, and the proper method of application.

**Subminiature Relays.** Elgin-Neomatic, Inc., 2435 N. Naomi St., Burbank, Calif., has issued a new brochure illustrating rugged subminiature relays designed for a wide variety of high-precision applications. The brochure includes the Neomite, a tiny precision relay, built in a standard transistor case for transistorized circuitry.

Also featured are the Neomatic VK and VR series, lightweight, compact units with excellent vibration resistance due to counterbalanced armature design. The brochure lists a variety of enclosures available in the VR and VK series and a complete rundown on specifications.

**Wire-Wound Resistors.** International Resistance Co., 401 North Broad St., Philadelphia 8, Pa. Type MW wire-wound resistors are covered in the 4-page bulletin B-2a. Comprehensive data on construction, tolerance, power rating, marking, humidity, adaptability and frequency characteristics are given. Detailed charts and graphs are included.

**Precision Indicators.** Minneapolis-Honeywell Regulator Co., Wayne and Windrim Aves., Philadelphia 44, Pa. Data sheet No. 10.02a gives specifications, dimensions and operating characteristics of the Brown-Rubicon precision indicator. Now available in two overall ranges, the instruments described greatly speed laboratory-type electrical measurements.

**Infrared Detectors.** Barnes Engineering Co., 30 Commerce Road, Stamford, Conn. The latest type of infrared detectors used as sensing elements in radiometers, pyrometers, infrared spectrometers and other infrared instruments are described in a new bulletin called "OptiTherm Infrared Detectors." It covers the characteristics, con-

# TIC's New 800A



## VACUUM TUBE VOLTMETER\*

### A MEASUREMENT LABORATORY IN ONE COMPACT INSTRUMENT

#### featuring

- Wider ranges of current, voltage and resistance
- High accuracy
- Portability
- Very high stability
- Wide frequency range
- Rugged construction

#### UNMATCHED IN RANGE

DC and AC Volts a full decade lower (0.1V to 1000V, full scales)

Resistance values a full decade lower and higher  
(0.02 ohms to 5000 megohms)

Current values from 1 millimicroampere to 100 MA (full scales)

Sale of the Instrument Division of Technology Instrument Corporation to Acton Laboratories, Inc. becomes effective January 1, 1956. With the transfer, Acton Labs. adds to its own high precision instruments the full, industry-endorsed TIC line. Acton Laboratories' expanded staff means stepped up deliveries . . . its experience in the manufacture of both select lines assures continuing emphasis on quality.

\*Patents applied for

## TECHNOLOGY INSTRUMENT CORP.

533 Main Street, Acton, Mass. COlonial 3-7711  
West Coast Plant — Box 3941, No. Hollywood, Calif. POplar 5-8620

# electronic power to spare...

LM Electronics, Inc.  
40,000 watt model PP-40/40-A  
Electronic Power Supply



Pioneered by LM Electronics, the advanced design of these new electronic power supplies provides up to 125,000 watts of audio frequency power, permits vibration test programming unattainable by other means. Systems using LM power supply units can produce single sweep-range sine wave, complex wave, noise, and flight simulation vibrations with unmatched ease and accuracy. Designed for laboratory, production and field use, LM electronic power supplies also have wide applications as variable frequency power sources and ultrasonic generators.

WRITE TODAY for detailed specifications and technical data on our complete line of electronic power supplies and vibration test equipment.



NEW PRODUCTS

(continued)

struction, circuitry and uses of these high-speed thermistor-type sensing elements.

**Four-Watt Resistors.** International Resistance Co., 401 North Broad St., Philadelphia 8, Pa. Catalog data bulletin P-1a illustrates and describes the type PW-4 4-watt resistors. It contains comprehensive data on tests, applications, ranges, tolerance, stamping, rating and derating. Two graphs are included.

**Power Supply.** Technical Advisory Associates Corp., 30 Broad St., New York 4, N. Y. A single-page bulletin covers the AC700 power supply, a unit designed for use in critical resistance heating applications, for example the heat sealing of glass diodes.

The automatically recycling timer discussed allows precise timing of the heating cycle over a wide range. Output current is continuously variable up to 25 amperes. Full specifications are listed in the bulletin. Price of the power supply described is \$350.

**VTVM's.** Technology Instrument Corp., 531 Main St., Acton, Mass., has prepared an 8-page brochure describing the outstanding features of its new extended range type 800A and 800B vtvm's. The 800A is priced at \$275; the 800B, \$325. Die-cut into the shape of the instruments, the brochure explains their operation and use in simple terms.

Also available is Laboratory Report No. 16, entitled "Basic Theory of the Type 800A Vacuum Tube Voltmeter," which discusses in detail the design consideration, giving basic circuits and development logic. Die-cut brochure No. I-105 and Laboratory Report No. 16 are available upon written request.

**Delay Lines.** Helipot Corp., 916 Meridian Ave., South Pasadena, Calif., has available the second technical paper on Helidel delay lines, entitled "Criteria and Test Procedures for Electromagnetic Delay Lines." Technical paper No. 491 discusses general types of fixed and variable electromagnetic delay lines and defines conventional ter-

Telonic

SWEEP GENERATORS

EXCELLENT FLATNESS

within 5% over max. sweepwidth



MODELS COVERING. 0-1400 mc;  
WIDE SWEEP WIDTHS. up to 85% of  
center freq.; HIGH OUTPUT VOLT-  
AGE. 1 volt into 50 ohms at fundamental  
frequency; LOW LEAKAGE, sufficiently  
low to permit measurements at maximum  
receiver gain; LOW MAINTENANCE,  
standard receiving-type tubes (6AF4A for  
UHF), laced cable harness and terminal  
board component mounting.

Complete Line of Sweep Generators

write
right
now

PLEASE SEND NEW COMPLETE LINE CATALOG

PLEASE HAVE REPRESENTATIVE CALL

NAME \_\_\_\_\_

COMPANY \_\_\_\_\_

ADDRESS \_\_\_\_\_ City \_\_\_\_\_ State \_\_\_\_\_

Telonic

INDUSTRIES  
73 N. 2nd Ave.  
Beech Grove, Indiana



Genisco's New GOH Accelerometer  
**WITHSTANDS VIBRATIONAL  
 ACCELERATIONS**  
*of 15 G's up to 2000 cps*



PHYSICAL DIMENSIONS	
OVERALL HEIGHT	3 1/16"
OVERALL WIDTH	3 1/4"
OVERALL DEPTH	3 3/4"
WEIGHT	38 OUNCES
Hermetically sealed	

This newest Genisco Accelerometer is a rugged, oil-damped, potentiometer-type instrument designed to operate in the most severe missile and aircraft vibrational environment. For example, in a recent production test the GOH performed satisfactorily after vibrational environment of 15 G's up to 2000 cps. As further proof of its ruggedness, the GOH will withstand 40-G shocks of 5 millisecond duration on the sensitive axis, and steady-state accelerations of 30 G's on the non-sensitive axes and 10 G's on the sensitive axis without damage.

**HEATING ELEMENT AVAILABLE**—A thermostat-controlled, internal heater may be installed in the GOH to keep operating characteristics constant between -50° F. and +160° F. However, thermostat operation is limited to 60,000 feet or less, 95% relative humidity at 160° F., and a vibrational environment of 10 G's up to 500 cps.

**SPECIFICATIONS**

- Ranges:** ± 1 G to ± 3 G's inclusive.
- Natural Frequencies:** 7 cps. to 12 cps.
- Nominal Damping:** 0.65 of critical at 75° F. Values between 0.4 to 1 set if desired.
- Resistance:** 14000 ohms (± 5%); center tap at 0 G-point. Other resistances also supplied.
- Potentiometer Voltage:** Up to 60 volts.
- Resolution:** One part in 300 for standard potentiometer.
- Noise Levels:** Less than 10 mv at 0.1 ma brush current.
- Linearity:** Within 1% of full scale from best straight line through calibration points.

Complete technical data on the GOH and other Genisco Accelerometers and Pressure Transducers is available from Genisco, Incorporated, 2233 Federal Avenue, Los Angeles 64, California. Write for your copy today.

**RELIABILITY FIRST**



minology. Common delay-line distortions are illustrated, methods for correction are analyzed, test procedures (both pulse and sinusoidal) and methods for measuring linearity and phase shift are described.

**Deposited Carbon Resistors.** International Resistance Co., 401 North Broad St., Philadelphia 8, Pa. Comprehensive data on tests, applications, specifications, tolerance, ranges, performance and dimensions of deposited carbon resistors are available. Detailed charts and graphs are given in the 4-page catalog data bulletin B-4a.

**Vitreous-Enamelled Resistors.** Ohmite Mfg. Co., 3680 Howard St., Skokie, Ill. A 2-page bulletin, No. 147, gives specifications and features of the company's new line of small wire-wound, vitreous-enamelled resistors with axial leads. It shows the two sizes, rated at 5 and 10 w, that are carried in stock in a wide range of resistance values. Also shown is a price schedule.

**Connector Bulletin.** DeJUR-Amsco Corp., 45-01 Northern Blvd., Long Island City 1, N. Y. A 2-page illustrated color bulletin describes features of the new 37-contact Continental connector suitable for airborne electronics. It includes electrical and mechanical ratings, mounting and clearance dimensions and diagrams. Write for bulletin CCC20.

**Building Blocks.** Servo Corp. of America, 20-20 Jericho Turnpike, New Hyde Park, L. I., N. Y. A 12-page brochure describes a versatile array of electromechanical general purpose analog computer components. Called the Servomation building blocks, various component combinations provide the means for industrial control, design and mathematical problem solving, classroom demonstration and data processing. The units discussed are coordinated modular assemblies which match each other in all the important mechanical and electronic specifications. Featured are the Servoscope for analysis of phase and gain shifts, the Servoboard for breadboarding electromechanical

**America's most  
 complete line**



**ROTARY POWER  
 IS BEST**

The "clap-clop" of "Old Bess" gave Grndma's buggy ride more vibration than the smooth Rotary Power of today's modern automobiles. **ROTARY POWER** is best for mobile radio, too . . . and for all DC to AC conversion . . . smoother . . . more dependable.



**DC TO AC CONVERTERS**

For operating tape recorders, dictating machines, amplifiers and other 110-volt radio-audio devices from DC or storage batteries. Used by broadcast studios, program producers, executives, salesmen and other "field workers".

**DUO-VOLT GENEMOTORS**

The preferred power supply for 2-way mobile radio installations. Operates from either 6 or 12-volt batteries. Carter Generators are standard equipment in leading makes of auto, aircraft, railroad, utility and marine communications.



**CHANGE-A-VOLT DYNAMOTORS**



Operates 6-volt mobile radio sets from 12-volt automobile batteries . . . also from 24, 32 and 64-volt battery power. One of many Carter Dynamotor models. Made by the world's largest, exclusive manufacturer of rotary power supplies.

**BE SAFE . . . BE SURE . . . BE SATISFIED**

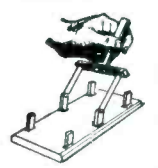

AC can be produced by reversing the flow of DC, like throwing a switch 120 times a second. But **ROTARY** converters actually generate AC voltage from an alternator, same as utility stations. That is why **ROTARY** power is such clean AC, so dependable . . . essential for hash-free operation of recorders from DC power.

**MAIL COUPON** for illustrated bulletin with complete mechanical and electrical specifications and performance charts. Carter Motor Co., Chicago 47.

**CARTER MOTOR CO.**  
 2646 N. Maplewood Ave.  
 Chicago 47, Illinois

**Carter**

Please send illustrated literature containing complete information on  Carter "Custom" Converters and  Dynamotor Power Supplies

NAME .....

Address .....

City ..... State .....

Specify **DKE** for -  
**PRECISION QUALITY Components**  
 OF TUNGSTEN, MOLY, NICKEL CLAD WIRE, ALLOYS, KOVAR

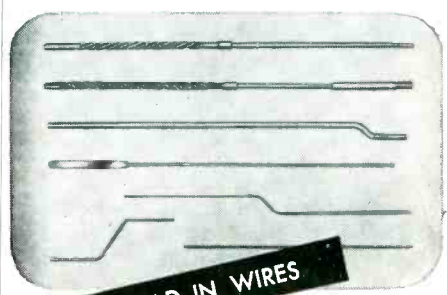

• DKE LEAD IN WIRES

Quality controlled throughout production with Tungsten hard glass leads produced under General Electric Timing Control. Each tungsten lead is microscopically inspected for flaws. DKE offers highest quality and LOW PRICES. Send drawings for quotations and let us prove the economy of our prices.



• DKE TUBE BASES

The Engineering Company can give you immediate delivery on following bases: 50 Watt, 3303B, 412 Industrial Base, Giant 7 Pin Bayonet, 4310 Four Pin Jumbo, Tetrode, Hydrogen Thyatron Bases in both Aluminum and Copper up to 6.50 dia, etc. All bases to JAN-1A/MIL-E-1B and subjected to weights and strength tests.

**DKE HYDROGEN THYATRON TUBE BASES**



CALL OR WRITE FOR QUOTATIONS ON YOUR SPECIFIC REQUIREMENTS

**THE engineering co.**  
 27 WRIGHT ST., NEWARK 5, N.J.

assemblies, amplifiers, modulators, demodulators, corrective network, power supplies, jack panels and cabinetry.

**Nuclear Reactor Brochure.** Minneapolis-Honeywell Regulator Co., Wayne and Windrim Aves., Philadelphia 44, Pa., has available a brochure reviewing the amplifiers, power supplies, detectors and recorders applicable to nuclear reactor control. An illustration of typical reactor-control instrumentation is also shown along with panels in operation. Readers are invited to request the brochure on their own letterheads.

**Magnetic Cores.** General Ceramics Corp., Keasbey, N. J. A 4-page folder illustrates and describes Ferramic magnetic cores. Specifications and data on standard grades of Ferramic H are given. A table of magnetic properties of other Ferramic bodies is included.

**Precision Oscilloscope.** Laboratory For Electronics, Inc., 75 Pitts St., Boston 14, Mass. The model 411 Easy-Six, a wide-band, adaptable, precision oscilloscope, is described in a new 4-page brochure. The leaflet describes the way ease of operation has been brought to a complex, precision piece of test equipment. It also describes six plug-in packages which make it possible to use the oscilloscope as a delayed or undelayed model, a gated marker generator, a tv test instrument, a video switch and a long sweeps generator.

**Plug-In Units.** EECO Production Co., 506 E. First St., Santa Ana, Calif. The new 40-page illustrated catalog 827 presents circuit drawings and specifications on 36 of the company's different plug-in units for the design, development and production of electronic equipment. A number of typical applications are also presented to show the use of the units.

**Magnetic Components.** Milwaukee Transformer Co., 5231 North Hopkins St., Milwaukee 9, Wisc. A 16-page catalog lists various transformers and other magnetic components manufactured by the com-

**CODE MARK Anything!**  
 WITH

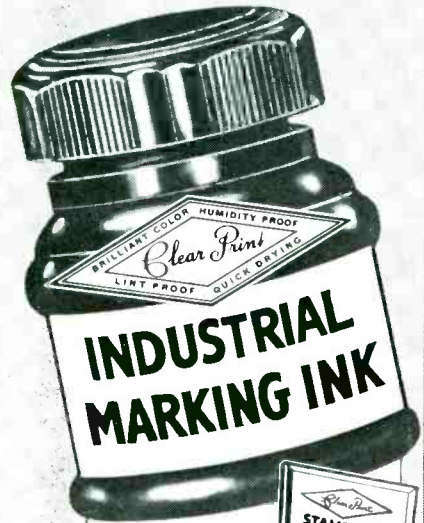

**★ CODE MARKING INKS**  
 For Resistors and Capacitors. For Machine or Hand Application.

Whatever the substance, Phillips has an ink to mark it permanently and legibly—or can make one. Marking experts insist on "Clear Print" Wood Block Stamp Pads and Opaque Inks. They get clear, sharp, fast-drying impressions. Also inks for brush, pen, stencil or machine application available in a variety of colors and quantity containers.

**★ Quick Laboratory Service On Your Problem Markings.**  
**★ To Permanently Mark . . .** Metals, Plastics, Glass, Wood, Paper, Leather, Ceramics—glazed, varnished or lacquered surfaces and virtually every other known material.

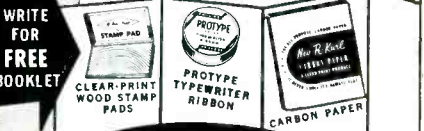

**L. A. PHILLIPS, President**  
**PHILLIPS PROCESS CO. INC.**  
 192 MILL STREET  
 ROCHESTER 14, N. Y.

- CANC
- INSP
- RECD
- 42
- 35
- 721
- PART NO
- 10
- RU

WRITE FOR FREE BOOKLET



pany. Case dimensions and ratings of many of the company's stock types are given and illustrated. The components described are engineered for commercial, industrial, laboratory and government applications.

**Elapsed Time Indicators.** Haydon Mfg. Co., Inc., Subsidiary of General Time Corp., Torrington, Conn., announces availability of product engineering bulletin No. 5 describing the new 60 and 400-cycle hermetically sealed total hour indicators now being manufactured for military applications. Complete specifications are listed. The rugged running time meters described indicate and repeat hours-of-operation up to 10,000 on a dial-type face.

**Potentiometer Checker.** Analogue Controls Inc., 37 W. 20th St., New York 10, N. Y. A 2-page flyer describes the model PC-15 potentiometer checker. The calibration standard instrument discussed finds wide application in receiving inspection of potentiometers and in calibration use where system performance may be improved by trimming potentiometers in accordance with individual error distribution as determined by comparison with an accurate standard. Complete operation information and technical specifications are included.

**Electronic Instruments.** Krohn-Hite Instrument Co., 580 Massachusetts Ave., Cambridge 39, Mass. Catalog D is a 36-page booklet giving illustrated descriptions, chief features and specifications for a line of versatile electronic instruments. It covers 8 models of oscillators, 6 filters, 6 power supplies and an amplifier. Included are 4 pages of reference material and suggestions for ordering.

**Electronic Thermostat.** Minneapolis-Honeywell Regulator Co., 4428 Wayne Ave., Philadelphia 44, Pa. A 16-page illustrated booklet tells how electronic flexibility lets you sequence from your thermostats when you want to, locate your thermostats where you want to, and compensate your thermostats as



★ **ULTRA LOW**

capacitance & attenuation

WE ARE SPECIALLY ORGANIZED TO HANDLE DIRECT ORDERS OR ENQUIRIES FROM OVERSEAS  
**SPOT DELIVERIES FOR U.S.**  
 BILLED IN DOLLARS—  
 SETTLEMENT BY YOUR CHECK  
**CABLE OR AIRMAIL TODAY**

TYPE	μF/ft	IMPED.Ω	O.D.
C1	7.3	150	.36'
C11	6.3	173	.36'
C2	6.3	171	.44'
C22	5.5	184	.44'
C3	5.4	197	.64'
C33	4.8	220	.64'
C4	4.6	229	1.03'
C44	4.1	252	1.03'



**NEW** 'MX and SM' SUBMINIATURE CONNECTORS  
 Constant 50Ω-63Ω-70Ω impedances

TRANSRADIO LTD. 138A Cromwell Rd. London SW7 ENGLAND CABLES: TRANSRAD, LONDON

**SOLID** *ULTRA-SONIC* **DELAY LINES**  
 RUGGED . . . RELIABLE  
 DELAY TIME: to 4500 microsec.  
 TEMPERATURE: -65° to +85°C

**AT andersen** *Laboratories*  
 INCORPORATED  
*Research Design* solves the toughest delay line problems. produces rugged, efficient, reliable delay lines able to withstand wide temperature variation. meets delivery schedules.  
*Production*

**Characteristics of typical radar delay line:**

- ▶ 2780 microsec. ± 0.1% at 20°C
- ▶ 20 Mc. carrier frequency
- ▶ 6 Mc. bandwidth
- ▶ Less than 56 db insertion loss into 200 ohm load
- ▶ -46 db spurious response ratio

Do you have a delay line problem? Write for Technical Bulletin 55 or call us today. Your inquiry will receive prompt attention.



39 Talcott Road  
 West Hartford 10, Conn.

ADams 3-4491

## WAVE FILTERS AND OSCILLATOR NETWORKS FOR FREQUENCY-DIVISION MULTIPLEX SYSTEMS

Radio Engineering Products are leading designers and manufacturers of advanced-technique wave filters and bridge-stabilized oscillator networks for the voice-frequency and carrier-frequency ranges. These filters are mostly miniaturized in hermetically-sealed cases, and meet applicable military specifications. Standard units currently produced include those listed below. Delivery is from stock.

Service	Type	Function	Spacing	Range	No. of chans.
A-M Carrier-Telegraph	F2124	Send filter	170 cycles	255-4835 cycles	28
"	F2125	Receive filter	170 "	255-4835 "	28
"	F9610	Oscillator network	170 "	255-4835 "	28
"	F6131	Send filter	120 "	300-4980 "	40
"	F8261	Receive filter	120 "	300-4980 "	40
"	F9631	Oscillator network	120 "	300-4980 "	40
F-S Carrier-Telegraph, S+Dx	F11294	Send filter and oscillator network	120 "	3120, 3240, 3360 "	3
"	F11291	Receive filter and discriminator network	120 "	3120, 3240, 3360 "	3
"	F11209	Low-pass filter	—	0 to 2950 "	—
Carrier-Telephone (Type C System)	F15002	Channel filter	approx. 3 kc.	3-32 kc.	8
Carrier-Telephone (Type C System)	F15340	Oscillator network	approx. 3 kc.	3-32 kc.	8
Carrier-Telephone	F9511	Channel filter	4 kc.	4-36 kc.	8
"	F9520	Oscillator network	4 kc.	4-36 kc.	8
Carrier-Telephone (Type C System)	F2121	Line filter and balancing network	—	5-kc. crossover	—
Carrier-Telephone (Type C System)	F8910	Line filter and balancing network	—	3-kc. crossover	—
Carrier-Telephone (Type H System)	F1922	Line filter and balancing network	—	3-kc. crossover	—

We will promptly supply full information on these and other types on request.

### RADIO ENGINEERING PRODUCTS

1080 UNIVERSITY STREET, MONTREAL 3, CANADA

Telephone: UNIVERSITY 6-6887

Cable Address: Radenpro, Montreal

MANUFACTURERS OF CARRIER-TELEGRAPH, CARRIER-TELEPHONE AND BROAD-BAND RADIO SYSTEMS

# CONRAD, Inc.

HOLLAND,

MICH.

## ENVIRONMENTAL TEST CHAMBERS

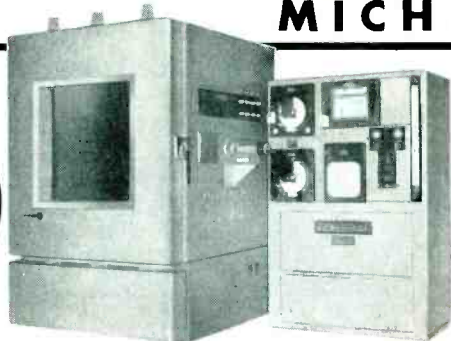

### TEMPERATURE CABINETS

Two Types  
"F" Series — Front Opening  
"C" Series — Top Opening  
Range:  
-150° F. to +500° F.  
Size:  
4 cu. ft. to 72 cu. ft.

### HUMIDITY AND TEMPERATURE CABINETS

"F" Series — Front Opening  
Range:  
-150° F. — +500° F.  
Humidity:  
10% to 97%  
Controlable above a 35° F. D.P.  
Size:  
4 cu. ft. to 64 cu. ft.

### ALTITUDE AND TEMPERATURE CABINETS

"F" Series — Front Opening  
Range:  
Temperature:  
-150° F. — +500° F.  
Altitude:  
Up to 125,000 ft.  
Size:  
4 cu. ft. to 64 cu. ft.

**CONRAD**  
*Inc.*

SUBSIDIARY OF CRAMPTON MFG. CO.

*Write for File Folder*

141 JEFFERSON ST., HOLLAND, MICH.

MEMBER OF ENVIRONMENTAL EQUIPMENT INSTITUTE

NEW PRODUCTS

(continued)

much as you want to. The booklet explains how electronic control of heating and air conditioning is as flexible as a strand of wire.

**Selenium Rectifier Design.** Federal Telephone and Radio Co., 100 Kingsland Road, Clifton, N. J., has issued a 12-page booklet entitled "Federal Selenium Rectifier Design Data Guide." It gives engineers the factors that should be considered in the design of industrial and military rectifiers and tells why these factors are important. The explanations are given simply and briefly, and cover a wide range of rectifier applications.

Included in the data guide is a questionnaire which may be filled in and returned to the company for full evaluation of any specific design. The company's complete line of industrial rectifier products is also briefly described and illustrated.

**Electronic Controls.** Eaton Manufacturing Co., Kenosha, Wis. Complete with illustrations and circuit diagrams, the 16-page bulletin EC-1 contains nontechnical, simplified information on the installation, performance and maintenance of the basic Dynamatic electronic control. The principles utilized to accomplish stepless speed control of Dynamatic eddy-current rotating equipment, using an a-c line as the power source, are described in detail. Precise speed control in addition to many other features which provide individual control requirements are presented.

**Photoelectric Systems.** Worner Electronic Devices, Box 118, Rankin, Ill. A new 20-page booklet on photoelectric systems covers the uses of electronic equipment in industry. It is written in nonengineering terms for easy understanding. Copies are available by request made on business stationery.

**R-F Connectors.** American Phenolic Corp., 1830 South 54th Ave., Chicago 50, Ill., has released a new 64-page D3 catalog covering the following r-f connector series: N, BN, C, LC, UHF, BNC, HN, between series adapters, coaxial cable fittings, push-on and Sub-



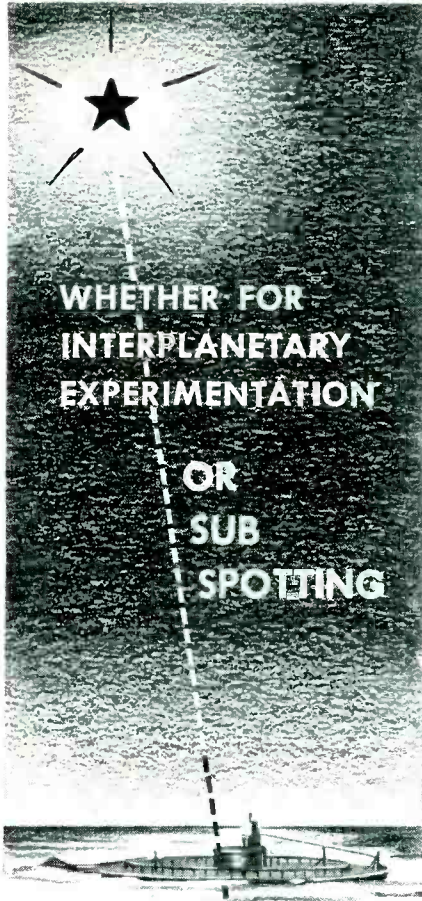

**AINSLIE REFLECTORS  
GIVE ACCURATE PERFORMANCE**

Complete coordination of design, manufacture and performance gives permanent reliability to AINSLIE Reflectors. We deliver, from stock, mesh reflectors from 4' diameter to 18'; spun reflectors from 4' to 10'; larger sizes and radar reflectors made on special order to your specifications.

Designed and Manufactured for:

- RADIO-ASTRONOMY
- MICRO-WAVE RELAY
- AIRCRAFT
- MISSILES
- RADAR

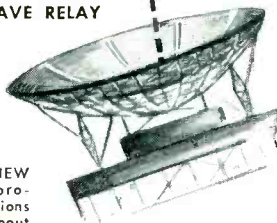

Send for our NEW illustrated brochure. Quotations on request without obligation.

We will gladly work with you in the development of any unusual antenna requirements.

**Ainslie**  
CORPORATION

312 QUINCY AVENUE, QUINCY, MASS.

minax. Dimensions, mounting holes, weights, impedance, materials and matching cable types are given for each connector. The DC3 also contains illustrated connector cable assembly methods for each series. Requests for the catalog on company or government letterhead will be promptly filled.

**Horn Antennas.** Waveline Inc., Caldwell, N. J. Microwave optimum standard gain horns are illustrated and described in a single-page loose-leaf perforated leaflet. The leaflet describes a set of 8 horn antennas covering the frequency range from 2.6 to 40.0 kmc. Gain of each horn discussed is 15.0 db ± 0.2 at the specified frequencies.

**Sine and Pip Generator.** Dalmotor Co., 1329 Clay St., Santa Clara, Calif. A new leaflet, form GPM-3, describes a small generator suited for continuous-indicating duty in radar instrumentation and similar applications. It produces simultaneously a two-phase sine-wave and two indicating pips per revolution.

Included in the leaflet are an illustration of the unit, a dimensioned outline drawing, a list of mechanical and electrical specifications and performance curves relating output voltage in volts to load resistance in ohms for both 20-cps (1,200 rpm) and 35-cps (2,100 rpm) operation.

**Resistor Engineering Guide.** International Resistance Co., 401 North Broad St., Philadelphia 8, Pa. Comprehensive data on the company's complete line of resistors and special products are listed in the revised 1955-1956 official resistor engineering guide. Data given include JAN or MIL equivalent, rated wattage, standard tolerances, temperature rise, temperature coefficient, maximum operating temperature, ohmic values available, dimensions and approximate prices.

**Precision Potentiometer.** Helipot Corp., 916 Meridian Ave., South Pasadena, Calif. A recent technical paper, No. 573, tells what happens to the operating characteristics of a precision potentiometer during its working life. Entitled "Precision Potentiometer Life and



**YOU BUILD  
EICO  
KITS  
IN ONE  
EVENING-  
but they  
last a lifetime...  
and you  
save 50%**

**38 Kits and 42 Instruments —  
the industry's most complete  
line of MATCHED  
TEST INSTRUMENTS**

1/2 - million EICO Instruments are now in use the world over! That's the proof of EICO's leadership in Value.

For latest precision engineering, finest components, smart professional appearance, lifetime performance and rock-bottom economy — see and compare the EICO line at your Jobber before you buy any higher-priced equipment! You'll agree with over 100,000 others that only EICO Kits and Instruments give you the industry's greatest values at lowest cost



Write NOW for FREE latest Catalog E12

**EICO**  
Laboratory Precision at lowest cost

ELECTRONIC INSTRUMENT CO., Inc.  
84 Withers Street, Brooklyn 11, N. Y.

# New!

## Andrew CATALOG

ANTENNAS • ANTENNA SYSTEMS  
TRANSMISSION LINES



100 pages of the most complete and comprehensive data of antenna equipment and radio frequency transmission line ever published! There are 80 pages of product description and 20 pages of technical data... complete information for the engineer planning antenna systems. Send in the coupon below for your copy.

Get your Copy • Fill out Coupon Now!

**ANDREW Corporation**  
Dept. E-12, 363 East 75th Street  
Chicago 19, Illinois

Name.....

Title.....

Company Name.....

Address.....

City..... Zone..... State.....

Our interests are in:      In this field we are:

<input type="checkbox"/> Radio communications <input type="checkbox"/> Broadcast equipment <input type="checkbox"/> Military equipment <input type="checkbox"/> Other, please specify	<input type="checkbox"/> Manufacturers <input type="checkbox"/> Dealer or distributor <input type="checkbox"/> Users <input type="checkbox"/> Other, please specify
--	--

### NEW PRODUCTS

(continued)

Reliability," the paper discusses the effects of wear on operating characteristics (linearity, total resistance, noise, torque and shaft play) and the operating characteristics of potentiometers which are affected during use. Suggestions for increasing useful life are also given.

**Punched-Tape Control System.** Barnes Engineering Co., 30 Commerce Road, Stamford, Conn. A brochure describing the application of Binotrol, a punched-tape control system, to a turret lathe to make it completely automatic, has recently been published.

The 8-page booklet describes the operating principles of Binotrol and relates in detail how all of the motions of the lathe are completely controlled by the system.

Preparation of the punched tape, application of binary number coding to the lathe's functions, and advantages of the new lathe are also discussed. The Binotrol system described has an operating principle that is digital-to-analog, and contains few vacuum tubes.

**Four-Channel Carrier System.** Lenkurt Electric Co., San Carlos, Calif. Volume 4, No. 10 of the *Demodulator* illustrates and describes the type 45CB carrier system, which operates in the 40 to 76-kc frequency range, and transmits up to 4 high-quality voice and signaling channels over an open-wire pair.

New design features incorporated in the system include transistors. Design features, block diagrams, frequency allocation and modulation plan, as well as possible applications, are given.

**Photoelectric Pyrometer.** Photo-switch Division, Electronics Corp. of America, 77 Broadway, Cambridge 42, Mass. The 4-page illustrated bulletin PT556 contains descriptive data, specifications and dimensions on pyrometer type P2T, which provides new and greater flexibility in the fast and accurate measurement and automatic control of high temperatures.

The photoelectric pyrometer described operates over a range of from 1,000 to 5,000 F and will

## pulse transformer kit simplifies circuit design

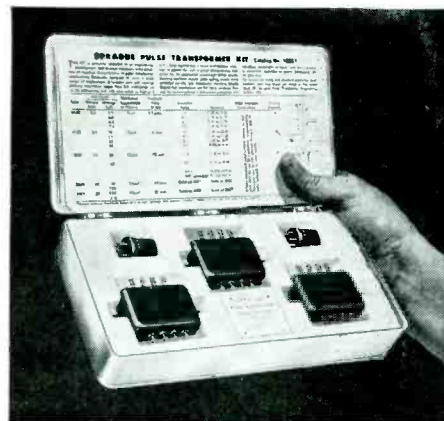

Sprague's new Type 100Z1 Pulse Transformer Kit contains five multiple winding transformers, each chosen for its wide range of practical application. Complete technical data on each of the transformers is included in the instruction card in each kit so that the circuit designer may readily select the required windings to give transformer characteristics best suited for his applications, whether it be push-pull driver, blocking oscillator, pulse gating, pulse amplifier, or impedance matching. Electrical characteristics of the transformers in the kit have been designed so they may be matched by standard Sprague subminiature hermetically-sealed pulse transformers shown in engineering bulletin 502B.

For complete information on this kit, as well as the extensive line of Sprague pulse transformers, write to the Technical Literature Section, Sprague Electric Company, 35 Marshall Street, North Adams, Massachusetts.

### CHARACTERISTICS OF KIT TRANSFORMERS

Type	Induct. Pri. ( $\mu$ H)	Leakage ( $\mu$ H)	Dist. Cap. of Pri. ( $\mu$ F)	Max. Nom. P.W. Range ( $\mu$ sec)	Avail. Ratios
4122	0.5	2.5 4.0 4.5 7.0	5	0.5	1:1 2:1 3:1 5:1
4123	5.0	13 15 25 30	15	6	1:1 2:1 3:1 5:1
2027	10	20 40	12	12	1:1 8:1 1:1:1 8:8:1
2028	20	50 150	15	25	same as 2027
2029	50	150 210	20	50	same as 2027

**SPRAGUE**  
the mark of reliability



respond to temperature changes of 5 F, indicating this change on a meter and providing relay action to give a signal or to control heating devices. Accuracy of the unit is practically unaffected by oxides or scale formation on the work, or by smoke or vapors between the pyrometer scanner and the hot object. Plug-in chassis design of the pyrometer simplifies maintenance, and the use of rugged industrial-quality components assures on-the-job dependability.

**Instrument Catalog.** Norden-Ketay Corp., 555 Broadway, New York 12, N. Y. Bulletin No. 364 is a 4-page folder dealing with solid front Acragages. Specifications are given on pressure, vacuum, compound, pneumatic and electric transmitters, receiver, test, chemical protectors and gages. Dimensional diagrams are included.

**Potentiometers.** Leeds & Northrup Co., 4934 Stenton Ave., Philadelphia 44, Pa. Complete information about the type K-2 potentiometer is available in a 4-page data sheet. The publication points out the widespread use of this potentiometer in industrial and research labs for potential difference measurements, for instrument checking, and for precise temperature measurements.

This concise sheet describes the circuitry and construction of the type K-2 in detail, and lists the accessories required for typical measurements. Ask for data sheet E-51(3).

**Variable Inductance Coils.** North Hills Electric Co., Inc., 203-18 35th Ave., Bayside 61, N. Y. A single-sheet bulletin deals with a new series of miniature variable inductance coils covering the 1 to 1,000- $\mu$ h range completely.

Designed for such applications as video peaking, r-f and i-f amplifiers and filter networks, the coils described feature ceramic forms, split bushings and locknuts, and single D-hole type mounting.

**Recording Oscillograph.** Consolidated Engineering Corp., 300 N. Sierra Madre Villa, Pasadena 15,

## CONTINUOUS, DIRECT-READING X-BAND VSWR MEASUREMENT

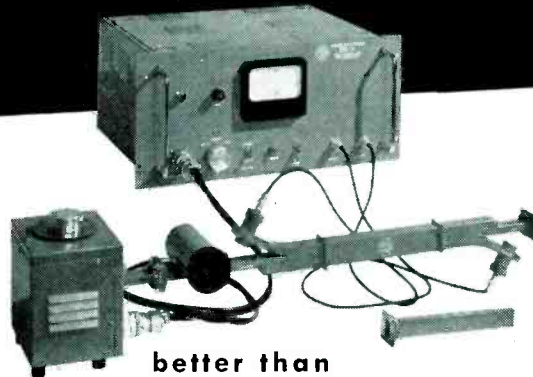

better than  
**2% overall accuracy!**

For speedy and accurate VSWR measurements in laboratory or production use, the CTI Model 1108 Measuring System reads directly, is continuously tunable from 8,500 to 9,600 mc.

### SPECIFICATIONS

Two VSWR Ranges:	1.02 to 1.2; 1.2 to 2.5
Attenuation Scale:	0 to $\infty$ ; 1.5 db midscale
Waveguide Fitting	UG-39/U
Directional Couplers, directivity	over 40 db

COLOR TELEVISION INCORPORATED

SAN CARLOS 1, CALIFORNIA



## WATLOW'S NEW

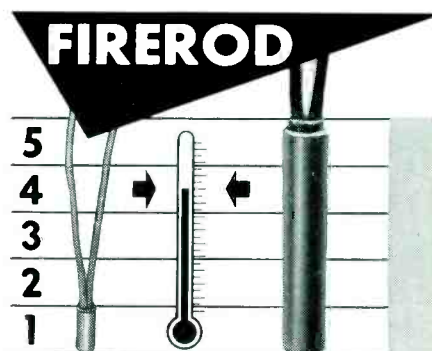

WATLOW  
FIREROD

STANDARD  
CARTRIDGE UNIT

CARTRIDGE  
HEATING  
UNIT

**...HOT  
NEWS**

in cartridge  
heating units

**SAME HEAT in 1/5 the size!**

- A NEW HIGH of 375 watts per sq. in. (500°F operating temp. with .005" fit in hole.)
- L-O-N-G-E-R cartridge life.
- LIGHTER WEIGHT and smaller size—for greater flexibility in installation and design application.

WRITE for Bulletin 355.

# WATLOW

SINCE 1922—DESIGNERS AND MANUFACTURERS OF ELECTRIC HEATING UNITS

**ELECTRIC MFG. CO.**  
1390 FERGUSON AVE.  
SAINT LOUIS 14, MO.

# A COMPLETE SPINNING SERVICE

FOR THE

## ELECTRONIC INDUSTRY

*Metal Spinning*

FROM 10' PARABOLA TO THIMBLE-SIZE CASE

*Metal Fabrication*

COMBINES SPINNING WITH FABRICATION,  
WELDING and ANNEALING TO PRODUCE A  
FINISHED PART. (Gov't. certified welders)

*Mu Metal Shields*

ANNEALED IN OUR OWN HYDROGEN ATMOSPHERE OVEN



COMMITMENTS SOLICITED. SEND FOR OUR BROCHURE  
WE ARE A JOB SHOP — WE HAVE NO PRODUCT OF OUR OWN



# TEINER *engineering corporation*

115-E Madison Street, Malden 48, Mass.

## Borg 900 Series Micropots offer everything you want in a potentiometer



- 1 Versatility — 1 to 5 gang models, single or double shaft, servo or bushing mount.
- 2 Permanent Accuracy — Resistance element integrally molded within housing. Leads, taps and terminals firmly encapsulated.
- 3 Long Life — Scanning action distributes wear across face of bar contact. Rigid, fixed lead screw.
- 4 Dependability — Mechanically and electrically stable. Effectively sealed against dust and moisture.
- 5 Absolute Linearity — Uniform resistance distribution. No external trimming required.
- 6 Specifications — Meets extreme commercial and military requirements for all applications.
- 7 Availability — Quick deliveries on production quantities.

### Borg 1100 Series Micropots

Accurate, dependable, long-lived. Has 9 inch coded leads for easy installation. Offers your products a competitive price advantage.



WRITE FOR CATALOG BED-A13B  
BORG EQUIPMENT DIVISION  
GEORGE W. BORG CORPORATION  
JANESVILLE, WISCONSIN



*Built by Borg*

NEW PRODUCTS

(continued)

Calif. Bulletin 1521B illustrates and describes the type 5-116 recording oscillograph. The unit discussed was developed to provide the dynamic test-measurement field with a high-precision, compact, reliable and extremely rugged multi-channel recording oscillograph.

Features, specifications, prices and data on associated equipment and other Consolidated products are included.

**Flexible Electrical Insulations.** Irvington Varnish & Insulator, Division of Minnesota Mining & Mfg. Co., Irvington, N. J., has available a general catalog of flexible electrical insulation materials. It is a compilation of technical data sheets of the company's products which are grouped into three categories: coated products, varnishes and plastic products.

Included also are many useful charts and conversion tables. The catalog is supplied in a loose-leaf binder which makes it possible to change or add additional sheets as required.

**Measurement and Control Systems.** Daytronic Corp., 216 S. Main St., Dayton 2, Ohio. A 6 page folder covers linear variable differential transformer measurement and control systems for laboratory and industry. Illustrations, specifications and operating principles are included.

**Plastic Dielectric Capacitors.** The Gudeman Co., 340 W. Huron St., Chicago 10, Ill. A 6-page engineering bulletin (No. XC-201-4) illustrates and gives complete technical information on high temperature 165 C XC plastic film dielectric hermetically sealed tubular capacitors with exceptionally high insulation resistance, low power factor, and low dielectric absorption.

Included are capacitance listings, dimensions and voltages, dimensional drawings, and engineering data on test voltage, life test, power factor, insulation resistance, capacitance change, moisture resistance, vibration and typical curves.

**Control Relay.** Clark Controller Co., 1146 E. 152nd St., Cleveland 10, Ohio. A new line of sectional-



pole heavy-duty 10-ampere control relays, to occupy minimum panel space, is described in an 8-page bulletin. Bulletin PL 7305-PM completely describes the new relays, available in models with from 2 to 12 poles. (Up to 8 poles are available without double-decking).

The bulletin pictures each of the 10 models in the line; gives dimensions, enclosures, features and data on maintenance and pole conversion from normally-open to normally-closed; and lists the other literature and layout template kits which are available.

**Magnetic Shields.** Magnetics, Inc., Butler, Pa. Catalog MS-104, "Performance-Guaranteed Magnetic Shields," describes the shield alloys which are used, the dry hydrogen annealing process used for controlling shielding properties, fabrication and finishes.

Some discussion is devoted to mounting brackets and availability of single or multiple nested shields made from Mumetal alone or with alternate layers of Mumetal and copper. Thirty-three pages of working drawings are included showing the diversity of shields which the company manufactures, and describing materials used.

**Battery-Operated pH Meter.** Photovolt Corp., 95 Madison Ave., New York 16, N. Y. Bulletin No. 118 covers the battery-operated pH meter model 125. It illustrates and describes the unit which is powered by three ordinary radio batteries that last 2,000 hr. Price of the unit described is \$145 including batteries and electrodes. The bulletin discusses a number of useful accessories which have recently been developed.

**Portable Potentiometers.** Allegany Instrument Co., 1000 Oldtown Road, Cumberland, Md. A 4-page folder contains descriptive information and illustrations of a line of portable potentiometers and millivolt sources used to calibrate amplifier gain and linearity, recording potentiometers, millivoltmeters and thermocouples. Prices of the units described are as follows: models P-55 and P-55M, \$215; model P-55MB, \$240; and model P-102, \$345.



# Sub-Miniature PILOT LIGHTS



**A. PLASTIC PLATE LIGHT ASSEMBLIES**



**C. LIGHT SHIELD ASSEMBLY**

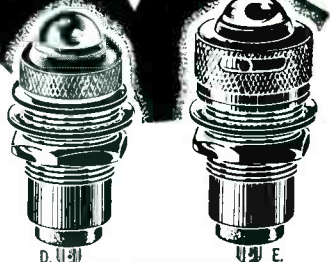

**D. SUB-MINIATURE INDICATOR LIGHTS**

**A great aid to miniaturization**  
Require a single 15/32" hole

All lens colors  
All units applicable to Mil Specifications

*when you're CRAMPED for SPACE*

(All illustrations are approx. actual size.)

Foremost Manufacturer of Pilot Lights

## DIALIGHT CORPORATION

60 STEWART AVE. • BROOKLYN 37, N. Y.  
HYACINTH 7-7600

A) No. TT-51; No. TT-51A with No. 327 amp. For edge lighting. Red or other color filters, black top.  
 B) No. 8-3730-111; for Mil-7788 panels.  
 C) No. 4-1930; light shield.  
 D) No. 8-1930-111; non-dimming.  
 E) No. 11-1930-111; mechanical dimmer. No. 3-1930-111; polaroid dimmer.

All assemblies accommodate midget flanged base lamps like this one (actual size); easily replaced. Available for voltages of 1.3, 2.7, 6, 14, and 28.

Any assembly available complete with lamp.

**SAMPLES ON REQUEST — NO CHARGE**  
Write for latest Catalogues and Design Brochure.



superior for unsurpassed control of frequency oscillation

# REEVES

## CRYSTAL UNITS

exceptional as High-Q elements in wave filters

Write today for further information. Get your copy of Reeves fact-filled Crystal Unit Brochure.

RH-3



**REEVES — HOFFMAN CORPORATION**  
a subsidiary of the Dynamics Corporation of America

**CHERRY AND NORTH STREETS      CARLISLE, PENNSYLVANIA**

# Plants and People

Edited by WILLIAM G. ARNOLD

Manufacturers continue to expand plants and facilities for future growth. Technical societies elect new officers, honor engineers for technical accomplishments. Engineers are promoted and move to new positions in the industry

## Mycalex Opens Synthetic Mica Plant In New Jersey

PLANT designed solely for the production of synthetic mica was formally opened in Caldwell Township, N. J. by Synthetic Mica Corp., wholly owned subsidiary of the Mycalex Corp. of America.

Production of the highly strategic material, under the trade-name Synthamica, has been under way for several months. At first the bulk of the synthetic mica produced will be pulverized and bonded with electrical glass to produce an electrical insulation material called Supramica. The material is currently being used in supersonic aircraft, guided missiles and nuclear development.

The formal opening of the new plant marked a 10-year effort to produce mica synthetically to reduce U. S. dependence on foreign sources for the material.

In the first batch of synthetic mica, produced at the new plant, the crystals, although not large, were larger than any produced in earlier pilot plant operations, and the chem-

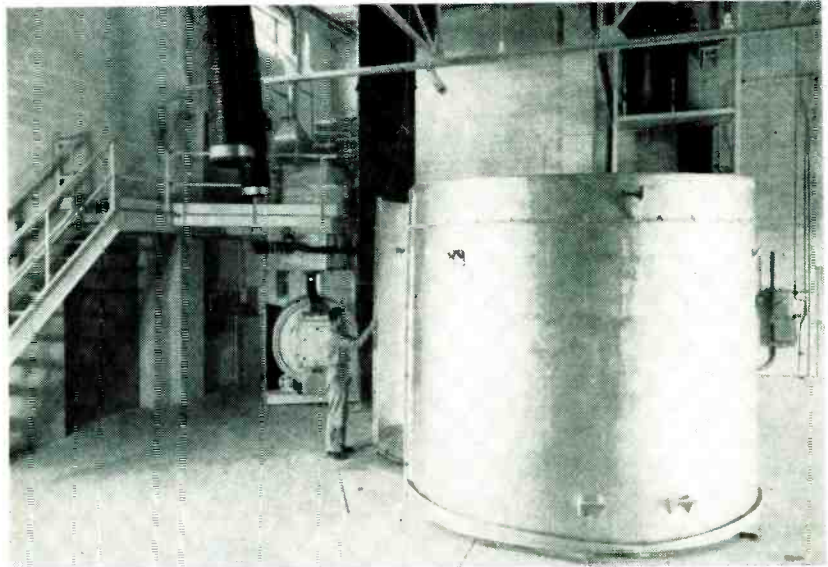

Production furnace and auxiliary processing equipment in new mica plant

ical purity of the new batch was "above expectations." The company has also announced an expanded research and development program whose twin goal is to produce synthetic mica in forms that will

eventually service all the critical markets where natural mica is used today, and to evolve modern mechanized methods to supersede the present laborious hand processing associated with natural mica.

## New Transistor Firm Expands Into Aviation Field

ACQUISITION of National Aircraft Corp., Metropolitan Airparts Co. and Florida Aviation's western division, was announced by Reagan C. Stunkel, who recently acquired the transistor facilities of Hydro-Aire. Stunkel was formerly vice-president of Hydro-Aire.

Metropolitan Airparts, Florida Aviation and the former Hydro-Aire facilities, now called Mar Vista Electronics, will operate as separate divisions of National Aircraft under the presidency of Stunkel.

Total employment of the combined operation is more than 300 employees, all of whom will be retained under the new organization.



R. C. Stunkel, president of National Aircraft, right, and H. H. Roads, president of Hydro-Aire

Headquarters of National Air-

craft will be located in Burbank, Calif. adjacent to Lockheed Air Terminal. Some 30,000 sq ft of office and manufacturing facilities have been leased there from Pacific Air-motive Corp.

The Mar Vista Electronics division also will be located there. The manufacture of diodes, transistors, and other semi-conductor devices under the trade name, Marvelco, will be conducted under the direction of Robert Vaughn, vice-president of the firm.

Twenty-two acres of manufacturing buildings and hangars are occupied in Van Nuys, Calif. and will house the aircraft and manufactur-



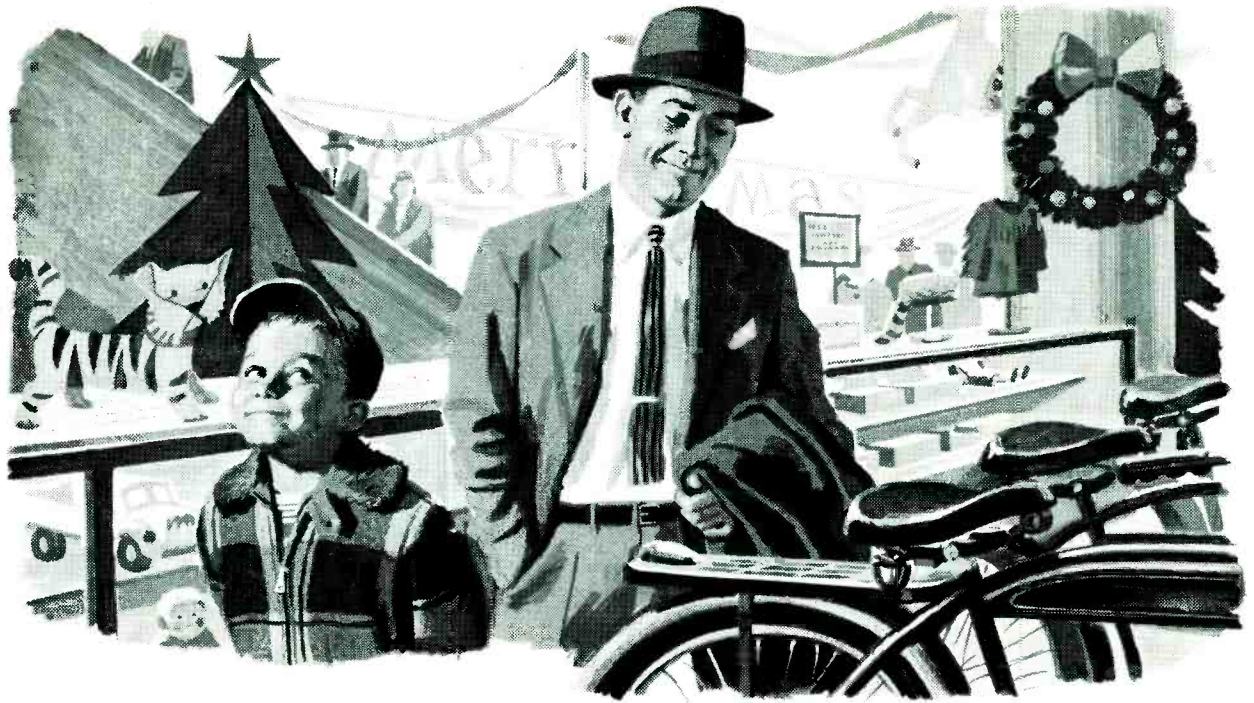

Best for meeting customer demand... all year round

## ***United Air Lines Air Freight***

Many businesses first learned the advantages of United Air Lines Air Freight by using it to "fill in" inventories during peak buying seasons.

Now they use it profitably and enthusiastically throughout the entire year for many other good reasons—to maintain a better control of inventories . . . to improve customer service . . . to obtain higher prices through better service . . . to reduce the number of cancelled orders through faster delivery . . . to protect the condition and appearance of goods at destination by reducing in-transit

damage . . . and to bring down the cost of packing, crating and warehousing.

Why not plan to use United Air Lines Air Freight regularly during the coming year? The cost is lower than you might think. For example, a leading dress manufacturer ships children's dresses coast to coast for only about 14¢ each!

Remember, too, only United offers Reserved Air Freight space on all equipment—not only over its own routes, but world-wide through connecting airline agreements.

For speed, dependability and economy, learn the advantages of United Air Lines Air Freight Service. Call the nearest United Air Lines Representative or write for free booklet, "Industry's Flying Partner." Cargo Sales Div., Dept. V-12, United Air Lines, 5959 S. Cicero Avenue, Chicago.

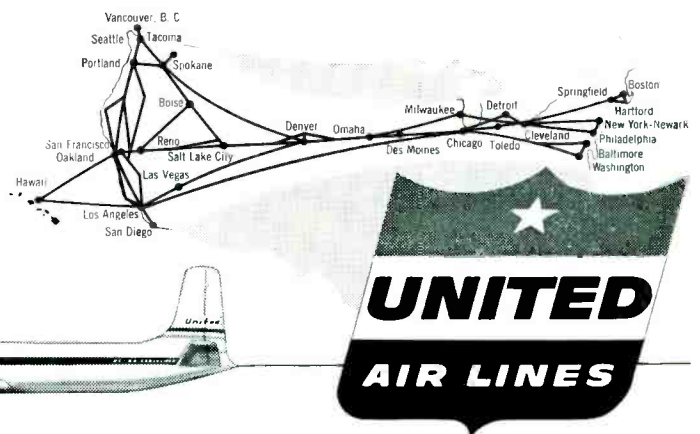

ing divisions of the firm.

Combined operation under the name of National Aircraft Corp. began in October. New officers in addition to Stunkel include: Jack Ferris, vice-president; L. D. Harrison, vice-president and treasurer; J. Guenette, secretary; Ruth Fitzgibbons, assistant secretary, and Charles Thompson, chief counsel.

### Stromberg Begins \$5 Million Expansion

A FIVE-MILLION-DOLLAR expansion program has been started at the main plant and offices of Stromberg-Carlson, a division of General Dynamics.

More than a quarter of a million sq ft of floor space will be added to the firm's facilities.

The new building will adjoin the north side of the company's main plant in Rochester. It will be completed in 1957.

The building will be divided into three main sections: an administration and research building, providing more than 100,000 sq ft of space; a kitchen and cafeteria section; and a factory building providing approximately 110,000 sq ft.

## Sylvania Dedicates Plant, Starts Another

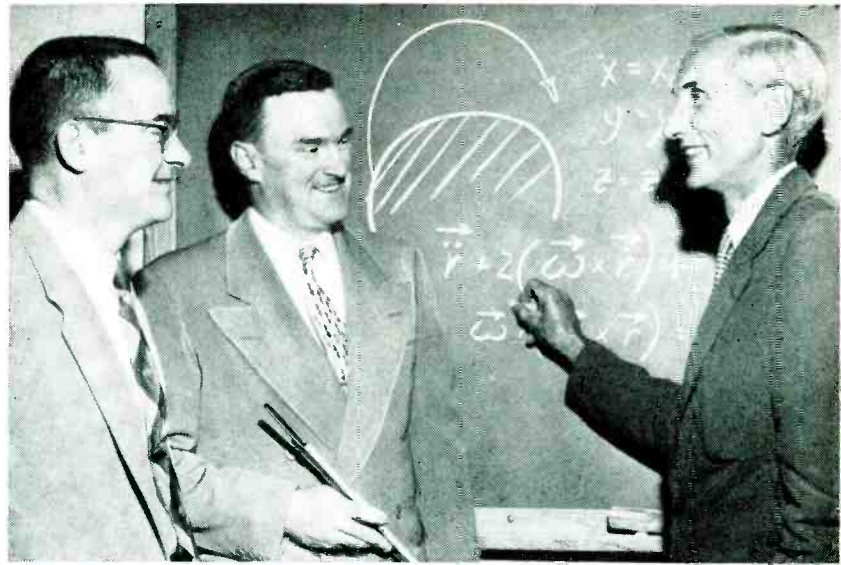

NEW WALTHAM Laboratories of Sylvania, where guided missiles and the development of electronics means to detect and destroy them are a primary concern, were recently dedicated. Discussing the problems presented by an enemy missile and equations of its path are, left to right Dr. Oliver G. Hayward, manager of the Waltham laboratories; Paul Black, manager of the avionics laboratory and Dr.

Edwin G. Schneider, manager of the missile systems laboratory.

Some 700 mathematicians, physicists, electronic engineers, and other members of the firm's avionics and missile systems laboratories work in the 120,000 sq ft building.

Sylvania also began construction of its new data processing center in Camillus, N. Y.

The 50,000 sq ft center, scheduled to begin operations February 1,

## RETMA Board of Directors And Officers For 1955-56

 Frank W. Gadias Jr.	 B. W. Cooper	 Herbert W. Clegg	 H. J. Hoffman Vice President	 R. E. Carlson Vice President	 F. R. Lack Vice President	 Robert S. Bell Vice President	 R. G. Zander Vice President	 Paul V. Gordin	 Allen S. DuMont	 Robert C. Tait	
 Parker H. Emmons	 Harry A. Ehrig	 C. C. Truesdell	 Max F. Kalcun	 Leslie F. Muter Treasurer	 W. R. G. Baker Director Engineering Dept.	 Robert C. Sprague	 A. D. Plamondon Jr.	 Lewis F. Hardy	 Benjamin Abrams		
 Charles F. Stromberg	 W. J. Haffigan	 Rex S. Sparrow	 R. S. Gaffes	 Glenn M. Daniel Interim Treasurer	 H. Leslie Hopkins President	 James D. Secrest Executive Vice Pres. and Director	 Frank F. Johnson	 W. Austin Dixon	 A. Blumentrans	 R. J. Carter, Jr.	
 L. S. Racine	 E. N. Foster	 C. Russell Cox	 David T. Schultz	 Earl C. Saterlin	 J. M. Douglas	 John W. 420 Albee General Counsel Emeritus	 R. J. Shank	 Edward C. Tudor	 Lester Roggen	 W. S. Fairbanks	 Lam Nestis



1956, will house a Sperry-Rand Univac and will be the focal point of a 12,000-mile private electronic communication system linking the firms facilities in 51 cities.

By the leased Western Union network, these various installations will feed financial and production information to the center.

### RCA Expands Research In Canada



James R. Whitehead

DR. JAMES RENNIE Whitehead of McGill University has been appointed to head the new RCA Victor Research Laboratories in Canada. Dr. Whitehead's work will be in the field of pure physics and electronics research not necessarily connected with company projects or developments.

Associated with him will be Dr. Sydney Wagner, also of McGill University, and a staff of Canadian physicists. The new laboratories will be opened before the end of the year.

From 1939 to 1951 when he joined McGill, Dr. Whitehead was associated with the British Government Telecommunications Research Establishment engaged on important war and defense projects. Beginning with work on the Mark I prototype aircraft system for radar identification, he put in 1,500 hours of actual flight testing of radar systems. He then designed the Mark III airborne equipment which was fitted to all Allied ships

# HERE'S HELP IN TESTING

**INSTRUMENTS**  
**EQUIPMENT**  
**PARTS**  
**COMPONENTS**  
**MATERIALS**

A single test to check your own findings  
— or a complete qualification series to  
satisfy your customer or the Government.\*

## 13 Laboratories within 1 Organization

To do your testing, E.T.L. maintains thirteen separate well equipped, fully staffed laboratories in these fields:

Electronic\*  
Environmental  
Electrical  
Chemical

Mechanical  
Physical  
Photometric  
Radiometric  
Photomicrographic

Radioactive  
Spectrophotometric  
Ultrasonic  
X-ray

\*In the Electronic field, for instance, measurements and determinations can be made over extreme high and low range of parameters for the usual characteristics such as Capacitance, Resistance, Frequency (including the microwave region), Power, Power Factor, Interference, etc. Qualification Tests can be made to Military Specifications such as:

ASESA List No. 100  
MIL-E-5272  
MIL-E-5400  
MIL-E-8189  
MIL-I-6181  
MIL-STD-108  
MIL-STD-202  
MIL-L-770  
MIL-L-25412

Electronic Parts and Materials  
Electronic Equipment, Aeronautical  
Electronic Equipment, Airborne  
Electronic Equipment, Pilotless  
Electronic Equipment, Interference

Radioactive Material  
Luminescent Material—Fluorescent

E.T.L. Services are independent, impartial, and as confidential as your own. Using E.T.L. Services is like finding extra trained talent and extra test equipment without adding to your payroll or capital investment.

A bulletin outlining services will be supplied on request

Testing for Industry  for 60 Years

**ELECTRICAL TESTING LABORATORIES, INC.**  
2 EAST END AVENUE • BUTTERFIELD 8-2600 • NEW YORK 21, N. Y.

## An Invitation TO MANUFACTURERS OF ELECTRONIC EQUIPMENT

1. Friendly labor supply.
2. Unusual city, county, and state tax advantages.
3. Industrial sites plentiful.
4. Good banking facilities.
5. Full cooperation guaranteed.
6. Strategic location.

for  
SMALL  
or  
MEDIUM  
INDUSTRIES

Businessmen of Lakeland, Florida will cooperate fully and furnish complete information to manufacturers who will consider relocating or establishing a branch unit in this fast-growing central Florida city . . . . .

INDUSTRIAL DEVELOPMENT COMMITTEE OF 100  
LAKELAND TERRACE HOTEL

# LAKELAND, FLORIDA

and aircraft and was named head of the research group responsible for ground and airborne systems.

Dr. Wagner joined the physics department at McGill in 1946, and was appointed associate professor in 1954. From 1950 until this year, he also held a research appointment in the Eaton Electronics Research Laboratory, where he did research on electronic beams and traveling wave tubes.

### Marion Instrument Moves To New Plant

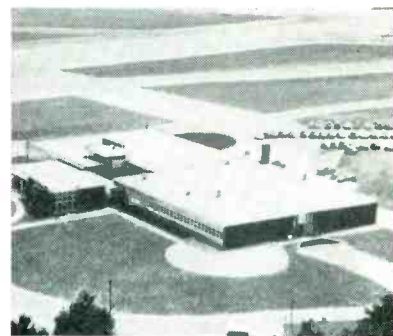

MARION Electrical Instrument Co. transferred all its operations to a new, half-million-dollar plant erected at Grenier Field, Manchester, N. H. The facilities produce more than 85% of the components used in Marion panel instruments, meters, aircraft instruments and mechanisms.

The new plant has 40,000 sq ft of space.

### Hoover Buys Control Of Electronics Firm

THE HOOVER Company has purchased controlling interest in PhebcO, a Baltimore electronics firm.

The purchase will involve no changes in the personnel of PhebcO, or changes in its current research and production programs. PhebcO specializes in designing and making electronic equipment for industrial use, radar and guided missiles.

Hoover plans to expand and develop PhebcO's current activities, and later to coordinate some of its work with that in the international Hoover organization.

Plans are to secure larger quarters for PhebcO so it can expand its

### Metallurgists & Specialists in Small Wire

Serving  
Industry—  
FOR OVER  
54 YEARS

#### COATED WIRES

Comprising an extensive range of electroplated grid wires . . . Enamel insulated wires for precision resistors and potentiometers.

#### BASE METAL WIRES

Very small diameter — for filaments, thermocouples, resistance units.

#### PRECIOUS METAL WIRES

Produced in Platinum, Gold, alloys and pure metals — small diameter . . . Platinum alloy resistance wires . . . Pure Iridium and Rhodium-Iridium alloy Thermocouple Wire.

Write for Latest List of Products



SINCE 1901

SIGMUND COHN CORP. 121 So. Columbus Avenue • Mount Vernon, N.Y.





research work on electronic equipment for industrial uses. Phebeco is currently devoting most of its efforts toward developing and making guided missile electronic equipment.

### Centralab Names Three Engineers



Robert L. Wolff

ROBERT L. WOLFF has been elected vice-president in charge of engineering of the Centralab division of Globe-Union.

Wolff, an employe of the company since 1937, has been director of products engineering since 1951.

Other appointments are W. S. Clark as division manager of the Badger Centralab plant and R. C. Anderson as division manager of Keefe plant. Anderson has been with the company since 1950 and Clark since 1948.

### Columbia Acquires Armstrong's Station

COLUMBIA University's school of engineering has acquired the steel radio tower and laboratory building in Alpine, N. J. from the estate of the late Major Edwin H. Armstrong, inventor of f-m radio and long a professor of electrical engineering at Columbia. The installation will be known as the Edwin H. Armstrong Field Laboratory and will be used by the department of electrical engineering for research in radiation and propagation of various types of radio waves, particularly with respect to their behavior in the atmosphere, ionosphere and upper atmosphere. It will also be available for military

# HEAVY DUTY

*Multiple Arm*

## RELAYS by SIGNAL

Versatile — Rugged  
Cast Aluminum Base  
High Shock and Vibration  
Resistant  
Available AC — DC  
Contact Capacities Available  
10; 35; 50 amp.  
Contact Combinations on  
Same Base  
Designed to Meet Many  
MIL Spec's

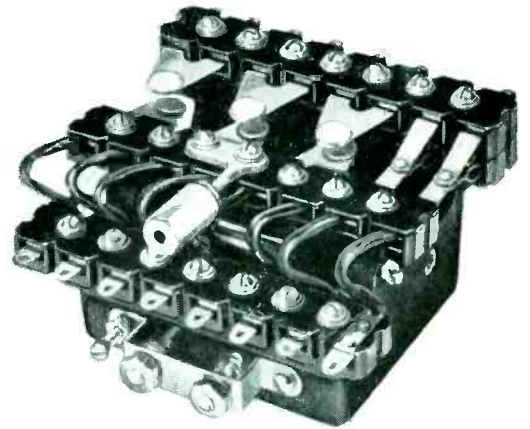

A superior relay that has endured the test of time . . . Specified for many years by America's largest manufacturer of electrical controls and communications equipment.

For complete data, write for Bulletin No. 30-6

Engineering  
representatives  
in principal cities

*Wheelock*

RELAYS  
**SIGNAL**  
ENGINEERING & MFG. CO.  
LONG BRANCH, NEW JERSEY

## THE BEST TEST FOR TV

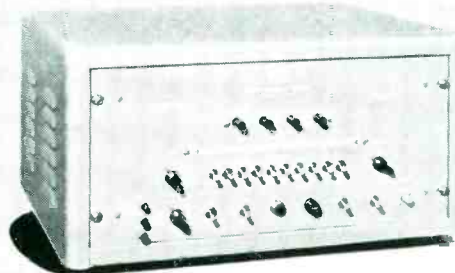

### TIC's TYPE 1105 VIDEO SWEEP GENERATOR

Price: \$600. F.O.B. Carlstadt, N. J.

- High Output
- Flat Frequency Response
- Keyed Carrier Markers to Zero Amplitude
- 75-ohm Internal Impedance
- Sawtooth Sweep Signal

Expressly designed for testing Video equipment requiring a high level signal, the Tel-Instrument Type 1105 provides a 2.0 V. Max. p-p signal from a 75-ohm source into a 75-ohm load, with a sweep range from 50 KC to 10 MC. Features include: Ten selectable crystal controlled pulse-type markers supplied at either integral megacycle point, or as desired; flat output within  $\pm 0.2$  db over entire range, attenuated over 60 db; and external markers.

TIC has a complete line of monochrome and color TV studio and production test equipment. Complete information sent at your request.

**TIC** Tel-Instrument  
ELECTRONICS CORP.

728 GARDEN STREET • CARLSTADT, NEW JERSEY

Make a **GM** PORTABLE D'ARSONVAL

# GALVANOMETER

*the Heart  
of Your  
Instrument*



FOR MEASURING LIGHT reflectance and color, the Photovolt Corporation of New York uses a Model 600 G-M Galvanometer for its popular Reflection Meter (left). Whatever your own particular instrument field, you can achieve this same self-contained portability, ruggedness and high sensitivity with G-M Galvanometers. Complete catalog on request.

**GM LABORATORIES · INC.**

4336 NORTH KNOX AVE., CHICAGO 41



## SHOCK PROOF

### VACUUM TUBE RETAINERS

These retainers are used to secure Vacuum Tubes and to resist side motion of Vacuum Tubes used in radio equipment which is subject to shock and vibrations. These retainers meet the requirement of all JAN specifications. The insulated portion is made of a melamine base Fibre Glass Phenol which provides 300 volts insulation to ground and withstands a temperature of 350 F. The insulated plate can readily be fastened or released by hand.

Available for envelope types T7, T8, MT8, T9, T12, ST12, T12ZDL, ST14, S14, ST16, T5½, T6½, MT-IC, ST19, T14, ST128CT-9.

*Manufacturers of  
Electronic Components*

# JAMES IPPOLITO & CO., INC.

1624 Stillwell Ave., Bronx 61, N. Y.

and industry projects.

In addition to the Alpine site, Columbia also acquired from the Armstrong estate, 57 acres of land in the towns of Catskill and Hunter, New York. This area includes one of the taller peaks of the Catskill Mountains. These two sites plus Columbia's engineering camp near Litchfield, Connecticut, will form a triangular range for extensive field studies in radar and radio.

The tower and laboratory were built in 1938 by Major Armstrong to perfect frequency modulated radio transmission. During World War II the station was also used in radar developments.

## Beckman Instruments Plans Expansion

BERKELEY Division of Beckman Instruments plans to build an addition to its plant in Richmond, Calif. The \$350,000 expansion program will add 44,000 sq ft of working area to the plant. It is to be completed by mid-January. The addition will permit doubling of the work force and a 100 percent space increase for all departments.

## General Ceramics Appoints Bouwmeester



JOHN H. BOUWMEESTER has been appointed vice-president of manufacturing and a director of General Ceramics Corp.

He was associated, until recently, with the Indiana Steel Products



**NEW PRODUCT PREVENTS TARNISH!**

**NOX-TARNISH**

**PROVEN** first truly effective product for prevention of Tarnish! NOX-TARNISH is a high grade packaging paper impregnated with a stable, non-volatile, non-toxic chemical composition capable of removing hydrogen sulfide from the atmosphere.

NOX-TARNISH eliminates production rejects because it insures bonding on soldering operations by keeping silver tarnish-free. It also keeps gold, cadmium or copper bright and free of sulfide stains.

In every case where tests have been made by industrial concerns with NOX-TARNISH, the product has proven far superior to any product on the market today. NOX-TARNISH is used by many of the largest manufacturers of electronic components, silverware and hollow ware.

Available in rolls, sheets or shredded. It can be fabricated into bags, envelopes, caseliners to meet individual packaging requirements. Write today for samples and technical bulletin N.T.

\*Patent Applied for.



Protective Packaging Division  
**DAUBERT CHEMICAL CO.**  
formerly NOX-RUST CHEMICAL CORP.  
333 No. Michigan Ave.  
Chicago 1, Illinois

Manufacturers of  
RUST PREVENTIVES • V.C.I. PAPERS  
ADHESIVES • AUTOMOBILE UNDERCOATINGS  
Want more information? Use post card on last page.  
ELECTRONICS — December, 1955

Company in a similar position.

Appointment of James W. Schallerer to the position of project engineer developing magnetic memory devices and allied equipment was also announced.

He was formerly with Lincoln Laboratory of M. I. T. as a staff member in charge of a magnetic material testing laboratory.

### Texas Instruments Builds New Plant

CONSTRUCTION has begun on the new main plant for Houston Technical Laboratories, the geophysical instrumentation subsidiary of Texas Instruments. The 40,000 sq ft plant is being built on a five-acre tract in Houston, Texas.

When the modern new building is completed next spring, the lab's research, design, and manufacturing operations now being carried on in several rented buildings in Houston will be consolidated.

The new building will provide facilities for more than a hundred occupants.

### Union Switch & Signal Realigns Engineers



G. W. Baughman, F. E. Lowance and E. F. Brinker, right to left, discuss a new inert train-carried coil for an electronic train identification system

UNION Switch & Signal, division of Westinghouse Air Brake Co., has made the following personnel and organization changes:

George W. Baughman, vice-president, formerly in charge of the railway signal engineering department, has been appointed to the staff of the vice-president and general manager.

A newly established position,

**NOW!**  
more for your  
connector dollar...

with these rugged nylon tip and banana plugs!

Illustrated above—Johnson's new nylon insulated banana plug. Below—a cut-away view of the new nylon insulated tip plug... two of the toughest, most durable connectors available today!

#### Look at these features:

- Shock-proof nylon insulating handles—won't chip or crack with the hardest usage.
- provides high voltage insulation.
- Highly resistant to extremes of heat, cold and moisture.
- Special design for simplified solderless connection of up to 16 gauge stranded wire.
- Economical—simple, functional engineering design gives you top quality at low cost.

#### SPECIFICATIONS

**BANANA PLUG**—nickel-plated brass construction with nickel-silver springs. Spring plug is .175" diameter, fits all standard banana jacks.  
**TIP PLUG**—recessed metal head is fully insulated, preventing exposure of metal surfaces when tip plug is engaged in any standard tip jack. Metal parts are brass, nickel-plated. Pin is .081" diameter—fits all standard tip jacks. Available in 11 bright colors to match Johnson nylon tip jacks.

#### Also New

##### NYLON TIP JACK AND INSULATING SLEEVE



Complete assembly includes a standard nylon tip jack with a threaded nylon insulating sleeve. Ideal for patch cards, this assembly is also excellent for panel mounting, where an insulated rear connection is desired.

Investigate today! Write for prices, further information.



**E. F. JOHNSON COMPANY**

2331 SECOND AVE. S.W. • WASECA, MINN.

Want more information? Use post card on last page.

450-470 MCS

152-174 MCS

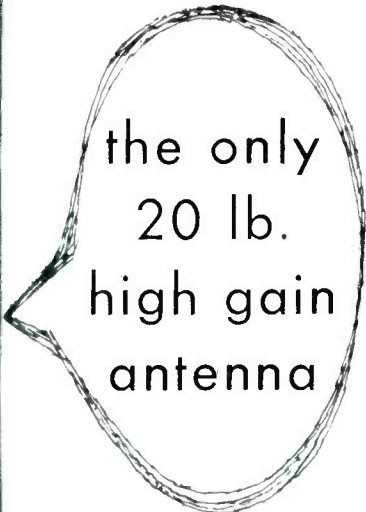

the only  
20 lb.  
high gain  
antenna

- highest gain antenna available—7.2 db gain 450-470 Mcs 4.3 db gain 152-174 Mcs).
- 20 lb. weight permits "one man" installation—no crane or crew needed.
- Fibreglas\* construction permanently seals against weather. Closed cellular core eliminates internal moisture problem.
- guaranteed 100 MPH with 1/2" radial ice load.
- grounded structure minimizes lightning hazard.
- power capacity 250 watts continuous.
- termination—coaxial 50 ohms nominal.
- overall length approximately 15'.
- write for engineering data and patterns—Mark Products Co., 6412 W. Lincoln Ave., Morton Grove, Illinois. Phone ORchard 5-4999.

MARK  
PRODUCTS  
company

OWENS-CORNING  
FIBERGLAS

(Reg. U. S. Pat. Off.)

director of research and engineering, will be filled by Dr. F. E. Lowance, formerly on the staff at Air Brake executive headquarters.

The present research department and the present development group in railway signal engineering will be merged to form a new research and development department, with E. F. Brinker as manager and D. P. Fitzsimmons as assistant manager.

In addition to his other duties Dr. Lowance will be acting manager of the railway signal engineering department with H. L. Ludwig assigned as assistant manager.

### L. M. Engineering Constructs New Plant

THE L. M. ENGINEERING Co. of Los Angeles, Calif. plans to build a 36,000 sq ft building in Hawthorne, Calif. It will consolidate activities now housed in separate buildings.

The new \$600,000 project, to be completed early in 1956, will include electronic, engineering and fabrication operations and office facilities. It is expected to increase production four-fold.

L. M. Engineering designs and manufactures special machinery, tooling, handling equipment, and electronic shakers. The electronics division makes testing equipment.

### Rea Appoints Three Executives

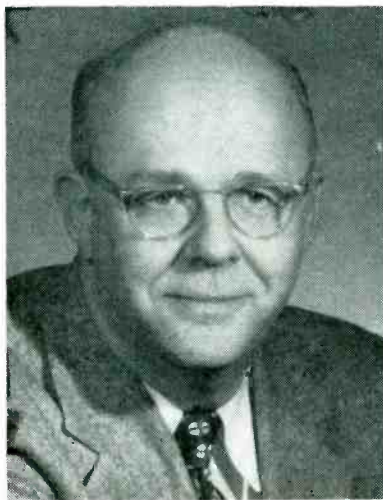

D. T. Gundersen

D. T. GUNDERSEN, who joined J. B. Rea as chief engineer in 1954, has been appointed vice-president in charge of engineering and produc-

# ACME MAGNET WIRE

made by  
SPECIALISTS  
for  
Over 50 Years

The Acme Wire Company's balanced pioneering experience of more than a half-century has made this company the leader in the field for the *best* in magnet wire. Highly trained personnel inspect Acme magnet wire at *all* stages of manufacture to make *sure* that this important product is of top quality.



An Acme Wire  
inspection station

The Acme Wire Company have been specialists for over fifty years in the field of *dependable* electrical insulations.

### Do You Know These Other Acme Products?

Varnished Electrical Insulations  
Coil Windings  
Electrical Insulating Varnishes  
and Compounds

FOR OUR COMPLETE  
PRODUCT LINE... SEE  
electronics Pg. 701  
'55 BUYERS' GUIDE

## ACME WIRE CO.

NEW HAVEN, CONN.

MAGNET WIRE • COILS  
VARNISHED INSULATIONS  
INSULATING VARNISHES AND  
COMPOUNDS



tion. He was with Cook Research Laboratories as chief administrative engineer. Prior to that he was chief engineer for the Askania Regulator Co.

L. E. Schumacher, who has been sales manager of the Rea Company since 1953, has been appointed vice-president in charge of sales and customer relations. He was formerly sales manager for Logistics Research.

Francis A. Oliver has been appointed as manager of the newly created data storage devices unit of the company.

The new unit will be responsible for the development and manufacture of magnetic storage components.

Oliver, designer of the new magnetic components, was formerly head of research and development of magnetic storage devices at National Cash Register's electronic division. Prior to that he headed a similar division at the computer division of Bendix Aviation Corp.

## Kester Enlarges Plant

KESTER SOLDER CO. of Chicago has expanded its plant facilities at Newark, N. J., by more than 50 percent. All phases of its Newark factory, manufacturing operations, warehouse and shipping areas, have been enlarged.

## William Barkley Joins Rust Co.



WILLIAM J. BARKLEY has been appointed as vice-president of Rust Industrial Co.

He founded the Wireless Specialty Co. of Boston, Mass., in 1907,

designed  
for the  
user



### Other Shasta Quality Instruments

Expanded Scale Frequency Meters and Voltmeters • Log Scale Voltmeters • Audio Oscillators Square Wave Generators • Power Supplies • Wide Band Amplifiers Bridges • WWV Receivers • Decade Inductors.

S 10

by **Shasta** division



## MODEL 702A REGULATED POWER SUPPLY

### features:

- ★ Regulation ¼% or better
- ★ Ripple less than 10 mv peak to peak
- ★ 0 to 400 v output @ 200 ma; continuously variable
- ★ 0 to - 150 v bias output @ 3 ma
- ★ Insulated + and - terminals permits use of high voltage with reference to ground
- ★ Exclusive SHASTA chassis construction

### brief specifications:

Output voltages: 0 to + 400 at 200 ma  
0 to - 150 @ 3 ma  
6.3 ac @ 8 amp.

Ripple, peak to peak: 10 mv or less

Regulation: Better than ¼%, 0 to full load

Input: 105/130 v, 50-60 cycles

Dimensions: 8" x 12" x 10"

Price (f.o.b. factory): \$205.00

Write today for Technical Bulletin 702A; please address Dept. 5G-12.

**Shasta**

division

BECKMAN INSTRUMENTS INC.

P.O. BOX 296, STATION A • RICHMOND, CALIFORNIA  
TELEPHONE LANDSCAPE 6-7730

# free... AGF BURNER CATALOG

## AVAILABLE NOW!

The first complete catalog containing technical data on air-gas and oxygen-gas burner equipment is yours for the asking.

Wherever gas burners are used, AGF has been supplying them for 77 years. New Catalog C6A covers:

- Sharp Flame Ribbon Burners
- Fishtail Burners
- Needle Point Glass Fires
- Blowpipes
- Hand Torches
- Mixing Equipment
- Flow Meters
- Fire Checks
- Ball Joints
- Blast Burners
- Oxygen-Hydrogen Burners

Write for your copy today  
on your company  
letterhead.

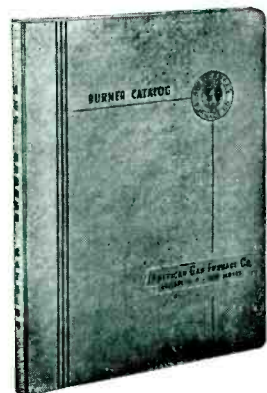

**AMERICAN GAS FURNACE Co.**  
130 SPRING STREET - ELIZABETH 4, N. J.

## Can you make your transformers smaller, lighter... with Class C encapsulation?

Where a higher hot spot is permissible, you can reduce the ounces and the inches of your transformers by  $\frac{1}{4}$  to  $\frac{1}{2}$ .

How? With *silicone rubber encapsulation*. This allows operation in the 160°C. to 200°C. range at a reduced size.

Silicone rubber encapsulation is one of the many services available to the communications industry at Caledonia. (We provide Class C transformers open and in cases, too.) All encapsulation is done *in our plant*.

For help with this problem, and others involving transformers and related electronic assemblies, contact Caledonia.

*When you have a transformer problem, call on*

### CALEDONIA

ELECTRONICS AND TRANSFORMER CORPORATION

Dept. E-12 Caledonia, N. Y.

WHAT CLAMP TO USE WHERE TOLERANCES ARE LARGE

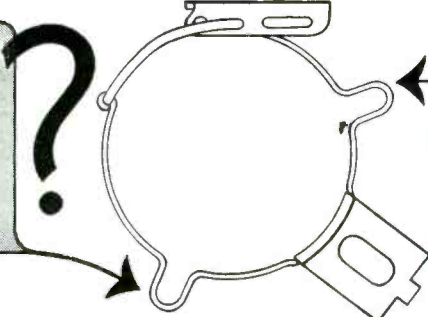

AUGAT'S NEW TWO TENSION LOOP CLAMPS

Augat two-tension loop clamps are the long-sought answer for uses where tube base tolerances vary up to .040. The bands of these sturdy clamps are made of Beryllium copper, heat treated to retain original tension and nickel plated to withstand a 96 hour salt spray test with no adverse effect.

The remaining parts of Augat's two-tension loop clamps are made of 18% nickel silver.

*Write today for catalog and samples.*

**AUGAT BROS. INC.**  
31 PERRY AVENUE • ATTLEBORO, MASS.

manufacturing crystals, receiving sets and spark transmitters.

Barkley later was associated with Dr. Lee DeForest as vice-president of the DeForest Radio Co.

His later associations included the position of general manager of the power and transmitting tube division of Sylvania. Following that, he joined the staff of Collins Radio Co. of Cedar Rapids, Iowa, where he acted in the capacity of general sales manager and executive vice-president from 1934 until April 1, 1955.

Barkley will head up an expansion program at Rust Industrial in the manufacture of remote control equipment and other electronic devices in the communication and navigation fields.

## IBM Plans Swiss Research Lab

IBM PLANS to establish a research and development laboratory in Zurich, Switzerland. It is expected to be in operation the first of next year.

The new laboratory is intended to establish closer contact between the domestic IBM organization and development activities being conducted by European scientists and engineers in the accounting and data processing equipment field. The firm expects to be able to incorporate in its machines the technical advances of both European and American scientists.

Dr. Ambros P. Speiser, associate professor at the Swiss Federal



Ambros P. Speiser



Institute of Technology, has been appointed as director of the laboratory and will assume his new position after completing present work as head of the computer group at the Institute.

IBM also has leased a 20,000 sq ft building in San Jose, Calif., for development and pilot production of a new machine. Work at the new facility will start in December. The newly-acquired space boosts total working area of the IBM research and development laboratory in San Jose to 52,000 sq ft.

### Bourns Adds Plant In Iowa

BourNS Laboratories of Riverside, Calif., manufacturer of precision potentiometer instruments, has added a subsidiary plant in Ames, Iowa, devoted to the manufacture of miniature instruments.

Managed by Arthur J. Miller, the plant will have 25 employees and occupy an area of 12,000 sq ft.

### IRC Appoints Iowa Plant Head



Guy B. Entrekkin

GUY B. ENTREKIN has been appointed plant manager of International Resistance's fifth and newest manufacturing branch plant located in Burlington, Iowa.

He was formerly IRC chief product engineer, and led a special research and development project on carbon composition resistors. Prior to joining the company seven years ago, he was product engineer

## STORED-ENERGY WELDING SPEEDS VACUUM TUBE ASSEMBLY

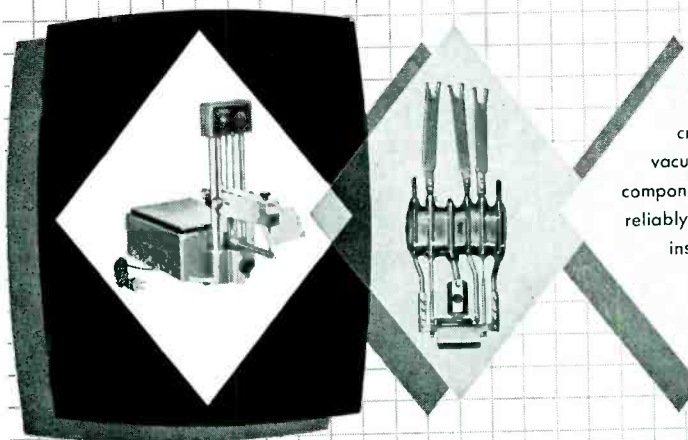

critical vacuum tube components welded reliably, uniformly, instantly\*

WELDMATIC MODEL 1015 precision welder firmly joins wires, sheets and blocks of tungsten, nickel, nichrome, steel, silver and copper in tube element assembly for mass spectrograph guns. Molybdenum and tantalum also welded in plate assemblies.

Made by Consolidated Engineering



**UNITEK CORPORATION**  
258 Halstead Avenue • Pasadena 8, California  
Write for complete Technical Information on Stored-Energy Welding

for service and lab. work

### Heathkit PRINTED CIRCUIT OSCILLOSCOPE KIT FOR COLOR TV!

① Check the outstanding engineering design of this modern printed circuit Scope. Designed for color TV work, ideal for critical Laboratory applications. Frequency response essentially flat from 5 cycles to 5 Mc down only 1 1/2 db at 3.58 Mc (TV color burst sync frequency). Down only 5 db at 5 Mc. New sweep generator 20-500,000 cycles, 5 times the range usually offered. Will sync wave form display up to 5 Mc and better. Printed circuit boards stabilize performance specifications and cut assembly time in half. Formerly available only in costly Lab type Scope. Features horizontal trace expansion for observation of pulse detail — retrace blanking amplifier — voltage regulated power supply — 3 step frequency compensated vertical input — low capacity nylon bushings on panel terminals — plus a host of other fine features. Combines peak performance and fine engineering features with low kit cost!



MODEL 0-10  
\$69.50  
Shpg. Wt. 27 lbs.



MODEL TS-4  
\$49.50  
Shpg. Wt. 16 lbs.

### Heathkit TV SWEEP GENERATOR KIT ELECTRONIC SWEEP SYSTEM

② A new Heathkit sweep generator covering all frequencies encountered in TV service work (color or monochrome). FM frequencies too! 4 Mc — 220 Mc on fundamentals, harmonics up to 880 Mc. Smoothly controllable all-electronic sweep system. Nothing mechanical to vibrate or wear out. Crystal controlled 4.5 Mc fixed marker and separate variable marker 19-60 Mc on fundamentals and 57-180 Mc on calibrated harmonics. Plug-in crystal included. Blanking and phasing controls — automatic constant amplitude output circuit — efficient attenuation — maximum RF output well over .1 volt — vastly improved linearity. Easily your best buy in sweep generators.

**Heath COMPANY**  
A SUBSIDIARY OF DAYSTROM, INC.  
BENTON HARBOR 14, MICH.  
WRITE FOR FREE CATALOG ... COMPLETE INFORMATION

If your problem involves accurate division of AC voltage, you need a

## STANDARD RATIO TRANSFORMER

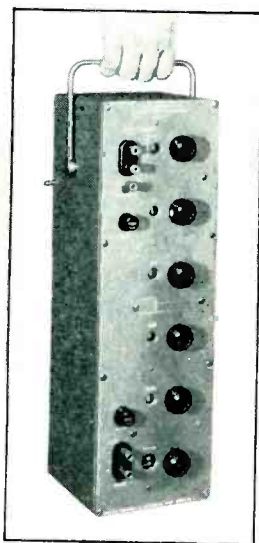

AC voltages can be divided with accuracies as good as .005% and resolution as good as .00001%

The PT Series (7 models) precision AC voltage dividers have been specifically designed to divide AC voltage with unusual accuracy. Push button and rotary switch models available, in both carrying case and rack mounting styles. Models available to cover frequencies from 30 to 3,000 cps (to 10,000 cps at reduced accuracy). PT-5, illustrated, covers 50-3,000 cps, with continuous resolution.

### For design and production use

Applications include: Bridge Ratio Arm, AC potentiometer; checking resolvers, servos, transformers, computers; for meter calibration, and as a ratio standard.

For complete information contact your Gertsch representative or

**= GERTSCH =**

GERTSCH PRODUCTS, INC.  
11846 Mississippi Avenue  
Los Angeles 25, California

## MARKEM<sup>®</sup> MACHINES

### Solve "IN-PLANT" PRINTING PROBLEMS

- FASTER - NEATER - AT LOWER COST

The Markem Model 45AF Machine prints trade name, trade mark, specifications, etc., on resistors, condensers, capacitors, diodes, triodes, transistors, etc., at production rates. Feeds, prints, and ejects automatically. Quickly insertable type provides easy change in data being printed.

Write for further information. Submit sample of item you wish to mark.

### WIRE LEAD COMPONENT PRINTING

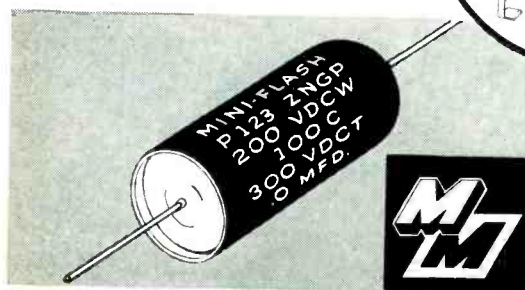
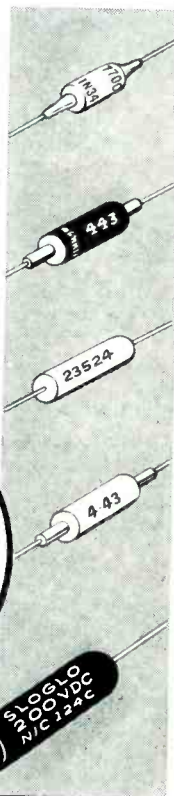
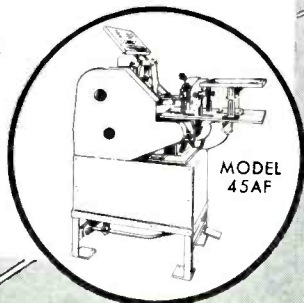

MARKEM MACHINE CO.  
KEENE 5, NEW HAMPSHIRE

for Western Electric.

The Burlington plant is expected to start production of deposited and boron carbon type resistors on or about December 1, 1955.

### Bristol Engineering Expands Plant

BRISTOL Engineering Corp. has doubled its working area by leasing a 33,000 sq ft factory in Bristol, Penna. The newly acquired building will house the firm's electronic division and also its experimental and fabricating shops.

### Harrington Joins Arthur D. Little



JOSEPH HARRINGTON, formerly of United Shoe Machinery, has joined the staff of the mechanical division of Arthur D. Little, consulting industrial research firm of Cambridge, Mass. Dr. Harrington will be concerned with the design, development and fabrication of automatic machinery for the assembly of intricate equipment, particularly in the electronics field. He will also assist in the technical audit services offered by the company. Dr. Harrington joined the research division of the United Shoe Machinery Corp. in 1932, where he became assistant director of research in 1947.

### Precision Radiation Acquires Radio Craftsmen

PRECISION Radiation Instruments of Los Angeles, producers of radiation detection units, has acquired



# Aerohm Precision wire-wound Potentiometers

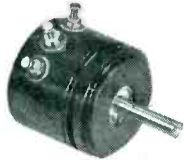

"Lo-TORK" POT LT 7/8

For minimum-torque uses in computer, servo, and selsyn service. Stainless-steel precision ball bearings. Maximum torque is 0.01 inch-ounce. Dissipates one watt at 80°C. Resistances—100 to 100,000 ohms. Weight is only 1/2 ounce. Ganging to six decks; internal clamps hold 7/8" diameter. Standard linearity 0.5%; on special order 0.25%; toroidal winding allows winding angles to 360°; standard 354°.

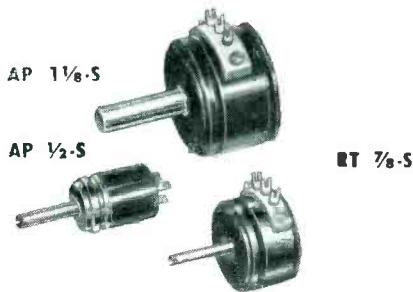

## MICRO-MINIATURE and MINIATURE

**Series AP 1/2-S**—2 watts continuous at 80°C; resistances 10 to 20,000 ohms, 5% tolerance standard; diameter 1/2", depth 3/8", weight 1/4 ounce; sealed well enough for potting.

**Series RT 7/8-S**—3 watts continuous at 80°C; resistances 10 to 100,000 ohms; diameter 7/8", depth 3/2", wt. 1/2 oz.; standard linearity 2%.

**Series AP 1 1/8-S**—4 watts continuous at 80°C; resistances 10 to 150,000 ohms; diameter 1 1/8", depth 1/2", wt. less than 3/4 oz.; standard linearity 1%.

All precision-machined, with anodized aluminum bodies, line-reamed phosphor bronze bearings, centerless-ground stainless steel shafts, and gold-plated fork terminals. Fully sealed and fungus-proofed. Can be processed, on special order for use at 125°C. Aerohm potentiometers are individually checked for quality and performance.



Write for copy  
of our new  
catalog.

**WATERS MANUFACTURING, Inc.**  
Waltham 54, Massachusetts  
APPLICATION ENGINEERING OFFICES IN PRINCIPAL CITIES

Want more information? Use post card on last page.  
ELECTRONICS — December, 1955

PLANTS AND PEOPLE

(continued)

Radio Craftsmen of Chicago, manufacturers of high fidelity components and equipment.

The new, wholly-owned subsidiary will be operated as a division of PRI, with the executives of Precision Radiation operating as the governing body of the new subsidiary.

Radio Craftsman, which has been selling directly to the consumer, will now market its products through dealers in a one-step distribution plan.

## Sanborn Selects Engineering Head



Maurice S. Hartley

MAURICE S. HARTLEY has assumed the post of director of engineering for Sanborn Co. of Cambridge, Mass., manufacturers of medical and industrial instruments.

He was with Raytheon as product manager. He has also been connected with Imperial Oil of Canada, as senior research physicist, and previously was engaged as manager of the technical-commercial division of Philips Industries, also of Canada.

## Raytheon Shuffles Equipment Operations

RAYTHEON has established two new integrated organizations in its equipment operations. One is responsible for commercial equipment and the other for government equipment. Each will have its own

**WE'VE  
GOT 'EM**

any amount  
any kind  
any time

plugs



**CANNON  
PLUGS**



**U.S.  
RELAYS**

**GREMAR R.F.  
CONNECTORS**

**WOODS  
Aircraft Supply**

309 West Elmwood Avenue  
Burbank, California  
Telephones: Victoria 9-3211  
THornwall 2-8182



**The right connection  
for the right connectors**

Want more information? Use post card on last page.



## POWER MEASUREMENT IN LIQUID LOADS

**MODEL 3901 THERMOPILE**

\$75.00 f.o.b. Grass Valley, Calif.

- 30 pair junction moulded in polyethylene
- All Plastic Case
- 1/4" copper tube fittings
- Rapid take-up for cleaning
- From 10 watts to several kilowatts per unit

**SPECIFICATIONS**

Internal resistance	5 ohms
Voltage	1 millivolt per °C
Maximum pressure	75 PSI
Dimensions	6-3/16 x 2 1/8 x 2 3/4
Weight	15 oz.

**MODEL 5800 CALORIMETER**

\$360.00 f.o.b. Grass Valley, Calif.

- A complete comparator to measured 60 cycle power, utilizing above thermopile.
- Built-in calibration circuit and heater.
- Sensitive, non-clogging flow valve.

**SPECIFICATIONS**

Weight	Approx. 21 pounds
Dimensions	8 1/4" x 9" x 17"
Maximum pressure	50 PSI
Range full scale	300, 600, 1500, 3000 watts
Meter sensitivity	1.5 mv
Thermopile sensitivity	1 mv/°C
Controls	Range switch, Calibrating valve, Calibrating potentiometers
Fittings	For 1/4" x 3/8" plastic tubing

Other equipment for use in power measurements and specific equipment for microwave power measurement set-up.

- Model 5801 Calorimeter—Range 60, 150, 300, 600 watts.
- Model 3701 Water load calibrator heater.
- Model 4105 X Band Water load • 1000 watts CW 300 Kw. peak • Less than 1.2 VSWR over 7000/10000 mc.
- Model 5500/5501 Variable phase standing wave introducer at X band.

Let us send you full specifications on these tools for power measurement, or send for our complete catalogue.

- Glass Working Lathes, equipment.
- High Vacuum Pump and Gauge.
- Hydrogen Bell Jars.
- Vacuum Tube Laboratory Equipment.
- Spot Welder and Timers.

3237



**Litton Engineering Laboratories**  
Grass Valley, California • P. O. Box 949

Want more information? Use post card on last page.

engineering and development facilities.

Two new positions created by the change have been filled by John H. Beedle as manager of commercial equipment, and Gordon S. Humphrey as manager of government equipment. Each man has had more than a dozen years' service with the company.

Raytheon also announced that it has built a room with solid lead walls, for use in the x-ray study and inspection of electronic vacuum tubes.

The structure, weighing several tons, was designed by Raytheon engineers to house a powerful x-ray machine which is capable of maximum operation at 300,000 volts. Initial facilities make it possible to photo-inspect 20 tubes at a time.

## Kuthe Labs Elects President

WILLIAM P. MAGINNIS has been elected president of Kuthe Laboratories of Newark, N. J., subsidiary of IT&T. He succeeds Dr. Herman Kuthe, founder and first president, who has been elevated to chairman of the board.

Prior to his present appointment, Maginnis was vice-president and works manager of the components division of Federal Telephone and Radio. For 21 years before his affiliation with Federal, which he joined in 1951, he was with RCA. His last position with that company was as head of component engineering at the Camden plant. Before that he was chief engineer at Bloomington, Indiana.

## GE Expands Control And Radio Plants

PILOT operations will start this fall at GE's new multi-million dollar plant near Roanoke, Va. The plant of more than 600,000 sq ft will house manufacturing and office facilities for the company's industry control department, currently headquartered in Schenectady, N. Y.

The new plant is expected to be completed about January, 1956, and the transfer should be completed early in 1957.

The plant will employ some 1,800

# SANDERS MINICUBE BLOWER

*ruggedly  
constructed  
for use on aircraft  
and guided  
missiles*



The Sanders Minicube Blower contains both miniature blower and motor in a rugged, 1" cube. A single package, it is designed for use on aircraft and guided missiles operating under severe environmental conditions. It is operable over wide ranges of vibration, acceleration and temperature, and is suitable for many exacting applications.

The Sanders Minicube Blower can be used to:

- Eliminate hot spots in subminiature equipment
- Prevent fogging of lens or viewing glasses
- Cool Klystrons and other electronic tubes and devices
- Maintain uniform flow of air in restricted space

**SPECIFICATIONS**

Output: 3 cubic feet of air/minute	Speed: 22,000 RPM
Input: 400 cps, 4 watts	Size: 1" x 1" x 1"
Voltage: Model 1: 6 volts Model 2: 26 volts	Weight: 1 oz.

For detailed specifications,  
write Dept. E



Want more information? Use post card on last page.

December, 1955 — ELECTRONICS



persons upon completion of the move from Schenectady.

The company also has expanded its communication equipment manufacturing, warehouse, and office facilities in Utica, N. Y.

The company has signed a lease for 60,000 sq ft, or roughly half of the former Oneida Bleachery building in Utica.

The new space is to be used to augment two-way radio manufacturing operations and to consolidate various office and warehousing activities now at several locations throughout the Utica area.

The electronics division also announced that Lawrence R. Cohen has been appointed to the newly-created position of manager of application engineering in the laboratories department. He was previously sales manager for Army equipment. He joined GE in 1946 as a design engineer.

The new position will include liaison with outside customers, including the military services, to determine their technical trends and requirements and to advise them of General Electric's facilities for applied electronic research and advance electronic development.

### Shannon Receives Ballantine Medal

DR. CLAUDE E. SHANNON, member of the technical staff of the Bell Telephone Laboratories, received the Stuart Ballantine Medal of The Franklin Institute for outstanding achievement in the field of communication.

Among Dr. Shannon's early contributions to the field of communication was the development of a mathematical theory of switching circuits which led to switching algebra.

His other contributions have dealt with the fundamental theory of transmission. Using statistical concepts in communication theory, he devised a quantitative means of measuring the size and complexity of the communication facilities needed to handle messages. He recognized that the fundamental factor limiting the ability to transmit information is noise. Using

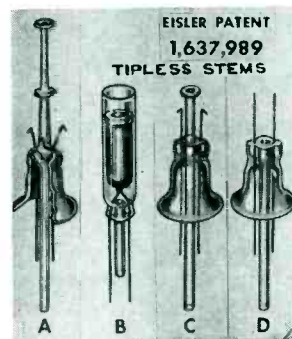
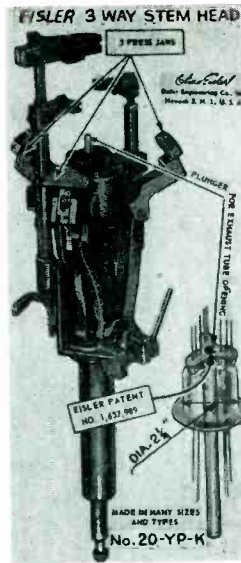

## You Name It EISLER Makes it...

Eisler tipless stem patents have been extensively used by incandescent lamp and radio tube manufacturers. Eisler patents are free and have been a source of protection to the radio tube and lamp industry. Why not consider your next machine an Eisler? Serving the Industry over 35 years.

Send for Catalog

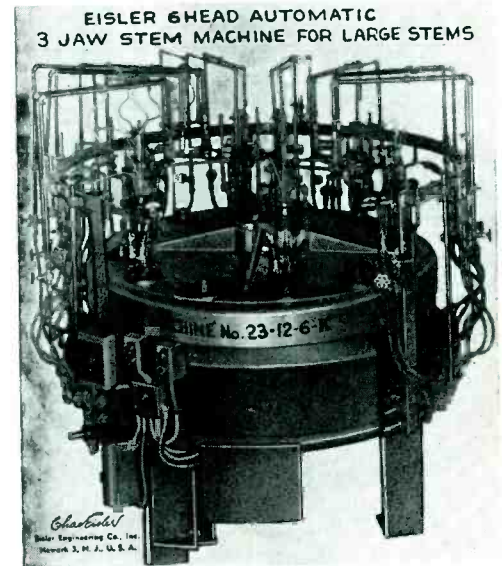

CHAS. EISLER JR., PRES.

**EISLER ENGINEERING CO., INC.**

751 So. 13th St. NEWARK 3, N. J.

**Simplicity of Design**

Requires less than one-half the space usually needed for a lever switch.



**SWITCHCRAFT INC.**

**"LEV-R-SWITCHES"**

**Plus Serviceability**

Made in two and three position types; momentary and locking actions. Single hole mounting. Attractive hardware. Long springs without any "forms" at point of flexing insure long spring life. Springs insulated from each other by phenolic spacers with hard rubber tubing press fit through the stack—insures correct alignment of the contacts and provides high insulation resistance. "Soft" easy action actuator; real detent action on locking types.

Fine silver contacts, rated at 3 amperes, 120 volts, A.C. non-inductive load — standard. Also available on special order with larger silver contacts for higher currents and Palladium contacts for low current — low voltage circuits.

**TELEVER SWITCH**

For more rugged applications. Features unusual "T-Beam" frame construction—light design with ruggedness of a structural "T-Beam".



Full details in Catalog S-52—fourth printing—send for your copy.

**SWITCHCRAFT INC.**

1336 N. Halsted Street, Chicago 22, Ill.

Canadian Representative: Atlas Radio Corp. Ltd., 50 Wingold Avenue, Toronto, Canada

**AVAILABLE AT ALL LEADING RADIO PARTS JOBBERS •**

# YOKE SPECIALISTS



- Military or special yokes and focus coils designed to your specifications.
- Production yokes for TV sets.

For your answer to yoke problems write Dr. Henry Marcy today.

*syntronic*

**INSTRUMENTS, INC.**

100 Industrial Road • Addison, Ill. • Phone: Terrace 4-6103

To supplement their line of ANALOG units

Rutherford adds a new

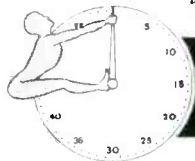

**DIGITAL TIME DELAY GENERATOR**  
... Model A-6

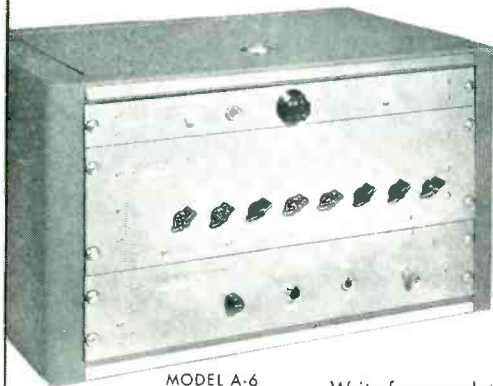

MODEL A-6

Provides accurate and variable delays from 1  $\mu$ s to 100 seconds in steps of 1  $\mu$ s.

Available also are units with maximum delay ranges of 1,000  $\mu$ s, 10,000  $\mu$ s, 100,000  $\mu$ s, 1 sec. or 10 secs.

Trigger type input circuit permits operation on slowly changing input signals.

Write for complete data on our DIGITAL Time Delay Generators: Bulletin E-A-6

For our ANALOG Time Delay Generator data, ask for:

Model A-2 (1  $\mu$ s to 100,000  $\mu$ s): Bulletin E-A-2

Model A-4 (.00001 to 10 secs): Bulletin E-A-4

Model A-5 (1  $\mu$ s to 1,000  $\mu$ s): Bulletin E-A-5

**Rutherford** ELECTRONICS CO. Telephone: TEXAS 0-4362  
3707 S. ROBERTSON BLVD. CULVER CITY, CALIFORNIA

statistical notions, he devised a quantitative measure for the information handling capacity of communication means. The theory of these researches is contained in his paper "The Mathematical Theory of Communication." The contents of this paper have become known as information theory, and by virtue of their generality form a new and basic philosophy for the communications industry.

The AIEE presented him with the Alfred Noble Prize in 1940. During 1940-41, he was a National Research Fellow. He joined Bell Telephone Laboratories in 1941.

In 1949 the Morris Liebman Memorial prize of the IRE was awarded him for his "original and important contributions to the theory of the transmission of information in the presence of noise."

## Sensitive Research Expands Facilities

SENSITIVE Research Instrument Corp. moved to new and larger production and engineering laboratories in New Rochelle, N. Y.

The building has complete facilities for manufacturing electrical indicating instruments. It gives Sensitive about three times the production and engineering facilities heretofore available.

## Servo Promotes Three Executives

A. ERIC THEIS has been promoted to vice-president in charge of manufacturing at Servo Corpora-



A. Eric Theis



tion of America. Charles F. Healey was named vice-president in charge of administration; and H. Gordon Hawthorne, treasurer. Dudley L. Miller continues as secretary of the company.

This was production manager of Servo before his recent promotion. He is an engineer with over twenty years experience in the manufacture and production of radio communication, navigation, and electronic control systems and instruments.

### Lenkurt Electric Enlarges Facilities

LENKURT Electric signed a two-year lease for use of a new building being constructed in San Carlos, Calif.

The building will have 14,400 sq ft of space.

When completed in December, some of the company's business divisions and some manufacturing operations will be transferred there.

The company now has 155,000 sq ft of floor space and owns or leases approximately 45 acres in the San Carlos industrial area.

Most of the equipment produced by Lenkurt goes to telephone companies in the United States and Canada for use in increasing long-distance circuits.

The company has more than 1,000 employees and a monthly business volume exceeding \$1,000,000.

### Clevite Units Select Executives

J. KNEELAND NUNAN has been named to the new position of vice-president and general manager of Clevite Research Center in Cleveland, Ohio.

Nunan has been president of Consolidated Vacuum Corp.

Transistor Products, an operating unit of Clevite, announced the appointment of E. F. Giguere as vice-president for sales.

He joined Transistor Products in 1953 and served as director of sales prior to his promotion to vice-president.

He was associated with Federal Telephone & Radio Co. for 14 years, rising to the position of broadcast sales manager. During 1952 and

lower costs . . .  
improve design  
save time . . .  
with

## GRC die cast GEARS & PINIONS

Cast in one piece, at one time—and one low unit cost! Produced precisely to your specifications, permitting a wide flexibility of design heretofore impractical. One-piece assemblies can be cast with shafts or center holes, or in combination with cams, hubs, spacers, flanges and other mechanical elements. Maximum size: 1-5/16" outside diameter x 1/16" face width; wider faces for smaller diameters.

MANY COMBINATIONS AVAILABLE FOR LESS PRECISE APPLICATIONS FROM STOCK DIES AT NO TOOLING CHARGE.

Write Today For Full Information and Samples

Send specifications for prompt quotation—100,000 to millions

**GRIES REPRODUCER CORP.**

World's Foremost Producer of Small Die Castings

151 Beechwood Avenue, New Rochelle, N. Y. • Phone: NEw Rochelle 3-8600



## JET PROPULSION LABORATORY OF THE CALIFORNIA INSTITUTE OF TECHNOLOGY Pasadena, California

# jpl

has positions now open in the fields of

### GUIDED MISSILE INSTRUMENTATION AND TELEMETERING

The Laboratory has the responsibility for the design and development of complete guided-missile systems such as the Corporal. Much of its success is credited to its small but outstanding telemetering and instrumentation group, which was one of the first in the nation to design and employ transistor telemetering systems.

This is an opportunity to associate yourself with the nation's foremost guided-missile research and development facility. Applicants must have at least a B.S. in a related field from an accredited university with good academic standing and meet one of the following experience requirements:

- 1) Experience or training in transistor circuit design.
- 2) Experience in the development of missile telemetering systems.
- 3) Experience in instrumentation system design and data processing.

Airmail your summary of qualifications and references to:

CALTECH | **JET PROPULSION LABORATORY**  
4800 Oak Grove Drive Pasadena, California

1953 he served as a consultant to the FCC and the CAA.

Transistor Products also announced that Allen J. Dusalt, formerly semiconductor sales manager for CBS-Hytron, has been appointed general sales manager for Transistor Products.

Samuel Rubinovitz, formerly assistant to the director of sales, has been named government sales manager.

In Clevite's Brush Electronics Co., John H. Harris, formerly vice-president and general works manager, has been made vice-president in charge of planning, and Wallace T. Gray has been appointed general works manager.

Perry C. Smith has been appointed manager of the equipment department of Brush Electronics.

He joined Brush earlier this year. He was formerly general manager of the electronics instruments division of Burroughs Corp. Prior to that he was manager of scientific instruments engineering for RCA.

### CBS-Hytron Builds Tenth Warehouse

CBS-HYTRON plans to build a 55,000 sq ft warehouse in Chicago for tubes. Completion is scheduled for early spring.

The new warehouse will have an engineering application laboratory, sales, service, and engineering offices, branding and packaging facilities.

The new structure will bring to ten the number of the firm's warehouses in operation.

### General Mills Adds Five Engineers

L. K. LEE, former head of the advanced techniques laboratory at Stanford Research Institute, and George H. Geick of Emerson Radio, have joined the mechanical division of General Mills.

Lee, a specialist in miniaturization and automatic production techniques for electronics, will be technical advisor to the engineering research and development department. He will concentrate on design for automatic production.

Geick will be assistant manager



**No. 99  
Junior  
Kit**



## IT'S THE MOST!

—MOST for your money

—MOST compact 11-tool pocket kit

—MOST useful service kit

—MOST popular since the '99"

Yes, since the 99 JUNIOR was introduced in May, technicians have kept us busy making enough! If you don't already have one of these pocket kits with the 7 quality XCELITE nut drivers and 4 screwdrivers, ask your supplier—they're in stock!

**XCELITE, INCORPORATED**  
Dept. C  
Orchard Park, N. Y.

For Originality  
LOOK TO XCELITE

## Use "Unusable" Spaces with this SUBMINIATURE RECEIVER and POWER SUPPLY



Our Model 128 subminiature power supply (left) is designed to provide B + and filament voltages to various equipments. Being extremely compact (1" x 3" x 9") it may be mounted in inaccessible or normally unusable spaces. Lightweight (only 36 oz.), it has been ideal for critically balanced airborne devices. Consider it for your applications. The model 127 VHF receiver, as shown at right, incorporates modular design for flexibility of installation as one unit or separated for better space utilization. Wideband characteristics and module size (1" x 3" x 9") permit application in all fields of instrumentation and communication—airborne or otherwise. This receiver features crystal frequency control plus excellent sensitivity, quieting and noise rejection. Send the coupon below today for our Data Sheets 100 and 101 which give detailed specifications on this versatile equipment.





Instrument and Electronic Division  
Oakland Int'l. Airport      Oakland 14, Calif.

Subsidiary of California — Eastern Aviation, Inc.

---

**Send me Data on your Subminiature Equipment:**

Name .....

Address .....

City ..... State .....



of systems analysis. He was assistant to the executive vice-president of Emerson, concerned with the administration of commercial and military design and production in radio, television and related fields.

Three German scientists have also joined the division.

Dr. Otmar M. Stuetzer has been named to head the electron physics lab. He was radar section chief of the German Research Council and coordinator of the German radar and countermeasures program during World War II. He comes to General Mills from the U. S. Air Force Wright Air Development Center at Dayton, Ohio, where he was chief of the advanced development branch in the electric components lab.

His staff will include Dr. Gottfried K. Wehner and Ludwig J. Mayer, who worked with him at WADC. Dr. Wehner, a specialist in gas discharge and surface physics, was a branch chief at Flugfunkforschung, the German Air Radio and Radar Research Institute, during World War II. Mayer was chief of the microwave tube laboratory at the same establishment.

## Telerad Elects New President

CHARLES GEORGE has been elected president and chairman of the board of Tetrad Manufacturing. George, who has served as vice-president and general manager for



Charles George

# HOMELITE

will meet your specs for  
**LIGHTWEIGHT GENERATORS**

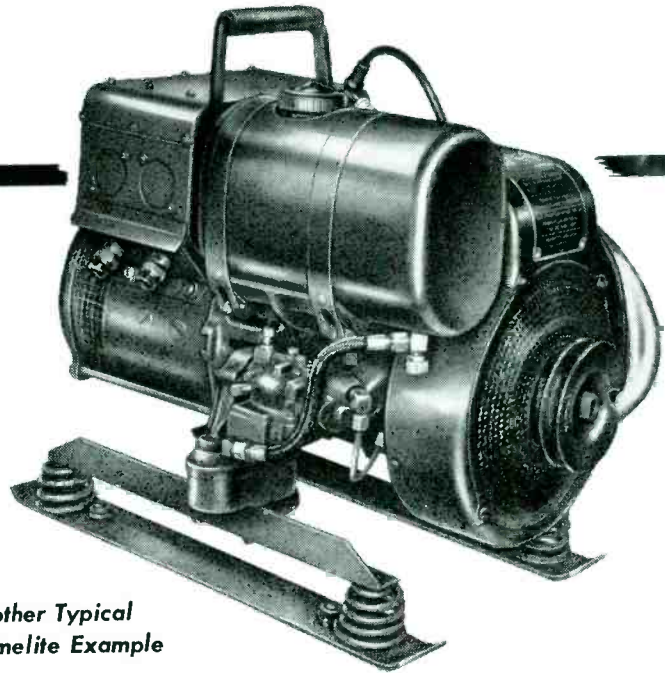

### Another Typical Homelite Example

To meet the requirements for lighter, smaller and more powerful auxiliary gasoline-engine-driven generators for both rotary and fixed wing aircraft, Homelite has designed and built several special units.

Typical of these new Homelite generators is the Model 34D28 shown above.

Weighing only 67 pounds . . . almost half the weight of previous auxiliaries with comparable power . . . this Homelite develops 70 amperes at 28.5 volts DC and is capable of starting 700 h.p. aircraft engines either directly or with a small battery floated on the line.

Requiring less than 3 cubic feet of storage space, this unit is equipped for push button or manual starting and starts without preheating in temperatures as low as minus 40 degrees Fahrenheit.

Meeting specifications for lightweight, powerful generators . . . for both military and commercial applications . . . is the specialty of the house with Homelite. We've been doing it for close to half a century.

No matter how new, how different or how tough your requirements . . .

turn them over to Homelite. The chances are you'll get the most satisfactory answer . . . faster.

Write and our engineers will get in touch with you.

Homelite builds generators in sizes from .15KW up to 5KW in all voltages and frequencies . . . with either gasoline engine or electric motor drive.

Manufacturers of Homelite  
Carryable Pumps  
Generators • Blowers  
Chain Saws

PERFORMANCE • DEPENDABILITY  
SERVICE

## HOMELITE

A DIVISION OF TEXTRON AMERICAN, INC.

6812 RIVERDALE AVENUE  
PORT CHESTER, N. Y.

Canadian Distributors: Terry Machinery Co., Ltd., Toronto, Montreal, Vancouver, Ottawa

IF IT'S NEW . . . IF IT'S NEWS . . . IT'S FROM **ELCO**

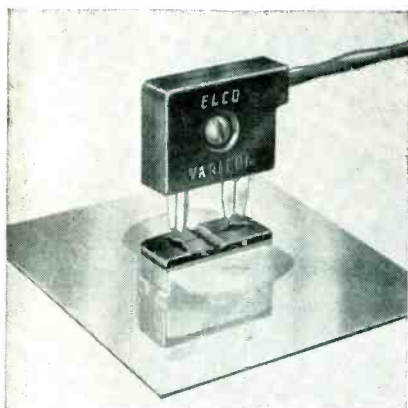

Figure A.

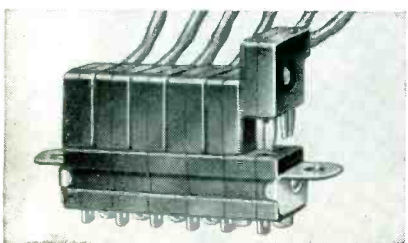

Figure B.

### NEW RIGHT-ANGLE VARICON INTRODUCED

ELCO announces a new Right-Angle Varicon as the latest noteworthy addition to its world-famous line of miniature connectors. The new Right-Angle Varicon (Fig. A.) available in 2-contact male plugs, makes it possible to run wires or cable parallel to panel, thus conserving space. Units may be plugged into mating portion of connector, side by side. (Fig. B.).

Insulator acts as strain relief for cable, permitting exertion of heavy forces without breaking connections. Plugs are polarized the same as other standard Varicons; with the same high current and voltage rating, low resistance, low capacitance.

For further information, or a copy of the new Varicon Catalog V-2, please write us on your company letterhead.

ELCO CORPORATION, M STREET BELOW ERIE, PHILA. 24, PA., CU 9-5500

eight years, purchased controlling interest in the company.

Telerad has expanded its operations into the guided missile field and will manufacture beacons and guidance equipment in its new Flemington, N. J. plant.

### Kinevox Purchased By Electromation

KINEVOX, of Burbank, Calif., manufacturer of synchronous magnetic recording equipment, has been purchased by the Electromation Co., an enterprise of F. Kirk Johnson of Fort Worth.

Kinevox will be a division of Electromation. A second division specializes in automation systems and components and a third division is responsible for the development and sale of Radad, a radiation exposure safety device which warns of dangerous radiation exposure.

C. A. Hisserich, as chief engineer, will direct research, development and engineering for Kinevox as well as the other two divisions. He will be aided by William C. B. Evans who will continue in his capacity of electronic engineer for Kinevox, and assume the duties of production engineer for Electromation.

### Burroughs Research Appoints Two

ROBERT V. D. CAMPBELL has been named to fill the newly created office of deputy director at the Burroughs Corporation's research center. In this new position he will have responsibility for the line management of the research activity.

Prior to joining Burroughs, Campbell was a member of the staff of the equipment engineering division of Raytheon Manufacturing.

He joined the research activity of Burroughs in 1949 as supervisor in the planning department. In 1953 he became technical consultant on the technical planning staff and in 1954 he was named associate director.

Howell K. Fesq has been appointed manager of the administrative engineering department of

**ALLIED  
CONTROL**

starts with  
the finest . . . . .

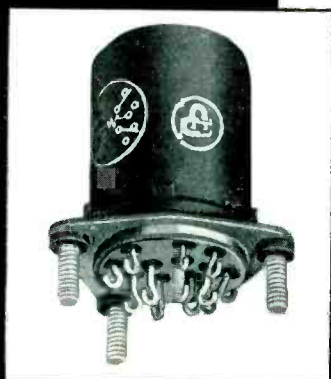

**GARFIELD  
WIRE**

*Garfield  
Wire*

When you specify Allied Control, you're asking for the best. For example, take the relay shown here. It's the finest there is — in split-second response, unflinching accuracy, rugged dependability.

Design — construction — materials — all have to be the best for Allied . . . and the heart of this relay is wound with Garfield Enameled Magnet Wire.

You'll start with the finest in wire, too, when you specify Garfield. Our modern drawing and enameling equipment, our rigid production control and our stringent inspection system are geared to produce only top-quality wire with tolerances closer than NEMA specifications.

Write for price lists and specification chart on Garfield bare wire, plain and heavy enamel additions today.



142 Monroe Street, Garfield, N. J., GRegory 2-3661-2



the special products division at the center. He has been staff engineer with Sperry Gyroscope, senior project engineer with Curtiss-Wright and administrative engineer of Simmonds Aerocessories. Prior to his present appointment he was contract engineer for Fairchild Aircraft Corp.

### Eitel-McCullough Expands For Super Klystrons

A NEW 17,000 sq ft building with facilities for the production of super klystron amplifier tubes up to twenty feet long will be added to the main San Bruno, Calif., plant of Eitel-McCullough. Present plans call for completion of the building in early Spring.

According to the company, the need for additional klystron facilities arises from an increasing number of electronic applications, including forward-scatter.

One section of the building will include a two-ton crane to handle the giant klystrons.

The new extension will bring the total area at the main Eimac plant in San Bruno to approximately 170,000 sq ft.

### Norden-Ketay Sets Western Division

NORDEN-KETAY Corp. has established a Western Division in Gardena, Calif.

The division consists of two plants, one in Gardena, the other in nearby Hawthorne, Calif. Together the plants comprise a unit of 30,000 sq ft, equipped for research, design, development and quantity production of synchros and resolvers and other components.

General manager is Arnold Raines, who was previously assistant general manager of the Arga division of Beckman Instruments.

Manager of the engineering department is Herbert Galman, who was previously chief development engineer of Beckman's Arga division.

The division will have a research and development department under the direction of Harold H. Sarkisian. He was previously vice-presi-

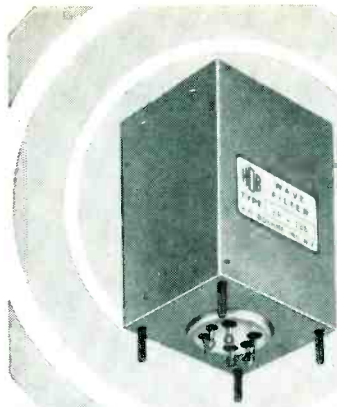

## Clarify all types of Keyed Audio Signals

### Boehme Communication Filters Especially designed...

- for minimum "ringing" or "tailing" (transient response)
- for optimum results under dynamic conditions

Available in a wide variety of types, frequency characteristics and impedance matches.

Write for data sheets, today!

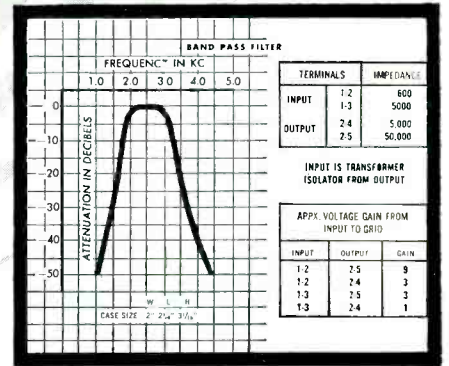

## H.O. Boehme, Inc.

Designers and Manufacturers Communication Equipment

Precision Electro-Mechanical Apparatus

915 Broadway • New York 10, N. Y.

### HEYCO NYLON STRAIN RELIEF BUSHINGS CUT PRODUCTION COSTS AND IMPROVE PRODUCT QUALITY

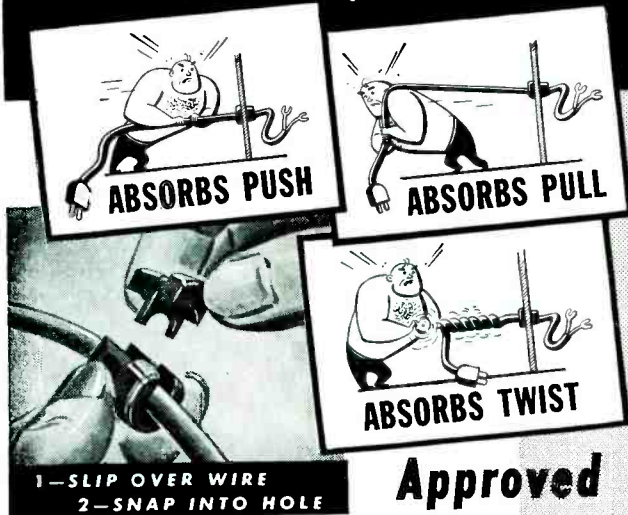

With Heycos it's no longer necessary to tie wire knots or use insulating grommets. Product life is increased and product appearance is greatly enhanced.

HEYMAN MANUFACTURING COMPANY  
Kenilworth 15 New Jersey



Send wire sizes for free samples and specifications.

THE HEYMAN ORGANIZATION WITH 25 YEARS STAMPING EXPERIENCE HAS MODERN PRESS CAPACITY FOR OVER 2,000,000 FINISHED STAMPINGS PER DAY. ASK FOR BULLETIN 33



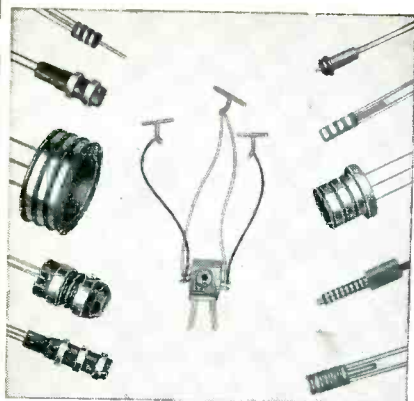

Miniature and Sub-Miniature  
**SLIP RING ASSEMBLIES**  
**BRUSH BLOCK ASSEMBLIES**  
**COMMUTATORS**  
 and other  
 Electro-Mechanical Components  
**PRECISION MADE**  
**TO YOUR OWN SPECIFICATIONS**

Precision molded products with exacting tolerances in precious and non-precious solid metals of all alloys. All types of Thermo-Plastic and Thermo-Setting materials.

Slip Ring Assemblies fabricated or one-piece precision molded to your specifications in Nylon, Kel-F, Mineral filled Mellamine, Phenolic, and other materials. Rings and leads spot welded or brazed together for positive electrical circuit.

**Our Swiss methods and techniques are geared to meet exacting requirements. We invite your inquiries.**

## COLLECTRON CORPORATION

Murray Hill 2-8473 • 216 East 45th Street • New York 17, N. Y.



Arnold Raines

dent and a member of the board of Computer Research Corp. and chief engineer of National Cash Register Co.

Norden-Ketay's present manufacturing operation in California, under Harry Loveman as operations manager, has been integrated into the new divisional organization.

Norden-Ketay also announced that George D. Butler has been appointed director of sales.

Before joining the firm, he was vice-president in charge of sales of Warren Electronics. Prior to that, he was district sales manager of Beckman Instruments.

During the war he was a project engineer at Bendix Aviation Corp., and also senior engineer at Carl L. Norden in New York.

### Tracerlab Builds New Plant

CONSTRUCTION has been started by Tracerlab on a new 164,000 sq ft plant in Waltham, Mass.

The new plant will be ready in the Summer of 1956. Tracerlab's operations have grown from \$30,000 in 1946 to over \$12,000,000 in 1954.

The new plant will also house certain operations of Keleket X-Ray Corp., a Tracerlab subsidiary.

### Erie Resistor Promotes Foster

JAMES H. FOSTER has been appointed general manager of Erie Resistor's electro-mechanical division. Since joining the firm five

**REL RADIO ENGINEERING LABORATORIES, INC.**

*prove MAGNATRAN dependability*

(Type L3-01) Askarel immersed Filter Reactor.

(Type J3-01) Askarel immersed high impedance Filament Transformer.

(Type N3-01) Unitized Rectifier askarel immersed for Klystron Bombarding.

(Type N3-02) Unitized Rectifier askarel immersed Beam Supply.

"Magnatran components have contributed considerably to the fact that REL now makes more beyond-the-horizon FM multiplex relay equipment than all other manufacturers combined. They have been proven in use to be very dependable, both in performance and maintenance."  
 Join the ranks and enjoy reliable Magnatran magnetic components for the electronics industry.

*Write for Catalog*

**MAGNATRAN**  
 incorporated  
 KEARNY, NEW JERSEY, U.S.A.



## McGraw-Hill MAILING LISTS WILL HELP YOU

- Merchandise your advertising
- Conduct Surveys
- Get leads for your salesmen
- Get inquiries about your product or service
- Pin-point geographical or functional groups
- Sell Direct
- Build up weak territories
- Aid Dealer Relations

Direct Mail is a necessary supplement to a well rounded Business Paper Advertising program.

600,00 actual names of the top buying influences in all the fields covered by the McGraw-Hill publications make up our 150 mailing lists. These lists are built and maintained primarily for our own use, but they are available to you for Direct Mail purposes. Pick out a list of YOUR prospect from our Industrial Direct Mail Catalogue.

More and more, progressive companies are using Industrial Direct Mail regularly as an advertising medium. They effectively allocate a portion of their concentrate on the best business publication.

For complete, detailed information about our service, fill in the coupon or write for your copy of our free Business and Industrial Direct Mail catalogue.

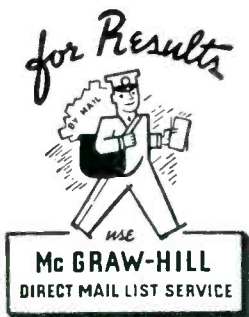

Direct Mail Division,  
McGraw-Hill Publishing Co., Inc.  
330 West 42nd St., N. Y. 36, N. Y.

Please forward my free copy of the McGraw-Hill "Industrial Direct Mail Catalogue."

Name \_\_\_\_\_  
Company \_\_\_\_\_  
Address \_\_\_\_\_  
City \_\_\_\_\_ State \_\_\_\_\_

Want more information? Use post card on last page.

ELECTRONICS — December, 1955

years ago he has served as chief of electronic research and assistant general manager of the division he now heads.

### New Firm Formed By RC Controls

COMPUTER-MEASUREMENTS division of Detectron Corp. has been acquired by RC Controls Corp. of North Hollywood and formed into a new company to be known as Computer-Measurements Corp. The firm has a new plant in North Hollywood, Calif. Development, design, manufacturing and sales will take place there under John K. Rondou, president and J. L. Cassingham, vice-president.

### Baldwin-Lima Elects Three V-Ps

ROBERT B. MURRAY, JR., former Undersecretary of Commerce, has been promoted to vice-president and has been elected a member of the board of directors of Baldwin-Lima-Hamilton Corp. He has been assistant to the B-L-H president since leaving his government post.

James M. White has been elected vice-president in charge of manufacturing for B-L-H, resigning a similar post at ACF Industries to accept the new position. He formerly also was manufacturing vice-president for Allis-Chalmers.

Colonel John R. Martin, who recently retired from the U. S. Air Force as director of procurement for the Air Research and Development Command at Baltimore, Maryland, has been appointed vice-president in charge of electronics and instrumentation operations.

### U. S. Officials Honor Canada's Browne

IN CANADA, the Department of Transport's retired controller of telecommunications, G. C. W. Browne was presented with a scroll and a wrist watch from his friends and acquaintances in Washington, D. C. The presentation was made on behalf of U. S. officials in the communications field of the State Department, Military Services, Coast Guard, CAA, FCC, the



## HYCOR TELEMETERING FILTERS



Hycor band-pass and low-pass telemetering filters are produced in exact accordance with accepted military standards. In addition to designs which conform to Applied Physics Laboratory specifications, miniature units are available.

Hycor Telemetering filters are potted for complete protection against vibration and humidity. The finest components are used to minimize aging effects on characteristics.

Send for Bulletin TF which describes standard types available.

Hycor engineers will be pleased to quote on your most exacting specifications.

Representatives in  
Principal Cities

**HYCOR**  
Company, Inc.

Subsidiary of International Resistance Company

11423 Vanowen Street  
North Hollywood 1, Calif.

Want more information? Use post card on last page.

# Reliance Mica Co., Inc.

## MICA SPECIALTIES



### RADIO and TV TUBE SPACERS



### CAPACITOR FILMS



### HEAT RESISTANCE WASHERS

Reliance are specialists in the fabrication of Mica parts. For 27 years, they have met industry's specifications for critical tolerance and quality control. Our years of experience meeting close tolerance work can help you whenever you are faced with tight specifications and our quality control will meet the increasing rigid specifications of today's design

#### QUALITY MICAS MAKE QUALITY TUBES

Is your application of Mica correct?

Consult us for help in obtaining the proper use of Mica in your products.

## RELIANCE MICA CO., INC.

341-351 39th St.

Brooklyn 32, N. Y.

# Cosmic

CONDENSER SPECIALISTS SINCE 1923  
ELECTROLYTIC & PAPER TUBULAR  
**CONDENSERS**  
For A.C., D.C. Sets - Phonographs etc.

**COSMIC CONDENSER CO.**  
853 WHITTIER ST., BRONX  
N. Y.

for

performance  
quality  
price

Phone — LU 9-3360

## Cunningham

ESTABLISHED 1929



## CROSSBAR

A truly superior switch  
for  
MASTER CONTROL AND  
MONITOR SWITCHING OF  
AUDIO & VIDEO CIRCUITS

Also

COMPUTERS • TELEMETERING  
TELEPHONY • DELAY LINES  
ETC.

### Advantages

Extreme flexibility  
Fast quiet switching  
Crosstalk down 60 Db at 19 MC  
Any group of setups may be held  
intact while setting up others  
Provision for spot or remote control  
Strapwiring eliminated  
Excellent HF characteristics  
Palladium contacts  
Reduced cost  
Compact design, small size  
Low operating power—2.5 watts  
Simple "package" installation

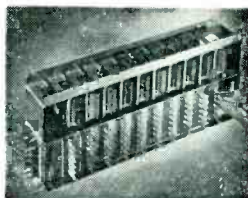

- Individual magnets at each cross-over.
- Maximum, six conductors per circuit
- Life-tested to 100 million operations.

### JAMES CUNNINGHAM, SON & CO., INC.

33 Litchfield St., Rochester, N. Y.

Tel: Baker 7240

Department of Agriculture and the Department of the Interior.

Previously RETMA of Canada and the Department of Transport had honored him.

## Moloney Electric Promotes Two

C. M. LOVELL, formerly vice-president and chief engineer of Moloney Electric, transformer manufacturer, has now been named vice-president in charge of engineering and research.

He joined the firm in 1920 as an engineer. He was made chief engineer in 1928. In 1942, he was appointed as vice-president and he was also elected to the board of directors.

Lovell has been instrumental in the development of concentric-layer winding and its application to transformer manufacture at Moloney.

The company also announced that David F. Winter has been appointed vice-president, chief engineer and director of research. He will continue in his recently-appointed post as director of the newly-formed engineering research and development laboratory of Moloney Electric.

He has served as a staff member at the radiation laboratory of MIT.

In 1948 he joined the staff of Washington University as an assistant professor of electrical engi-



C. M. Lovell





D. F. Winter

neering.

On leave of absence, Winter joined the DuMont Laboratories as a senior engineer and then as an engineering consultant to the instrument division in 1949. From 1950 to 1952 he served first as a senior engineer under special contract with the Naval Ordnance Plant at Indianapolis, Indiana, and then as project head.

In 1951, Winter was made an associate professor at Washington University in St. Louis. He came with Moloney Electric in 1952 as a consultant.

In 1954, Winter joined Moloney on a full time basis with a leave of absence from Washington University.

Winter received a full professorship at Washington University in 1955 and is now an affiliate professor with that institution.

### Tharpe Leaves Du Mont, Petersen Named

JAMES B. THARPE has joined Visual Electronics Corp., of New York as president.

He resigns as manager of the Du Mont television transmitter sales department to associate himself with the independent selling agents representing Du Mont in the sale of TV broadcast equipment. He will directly handle all New York City and network accounts, and, in conjunction with Herbert Bloomberg, will handle key

## THE NEW WAY TO MARK EQUIPMENT....

with

**GRAVO**  
*flex*

the first chip-proof, flexible engraving stock

on the versatile

**Engravo**  
*graph*

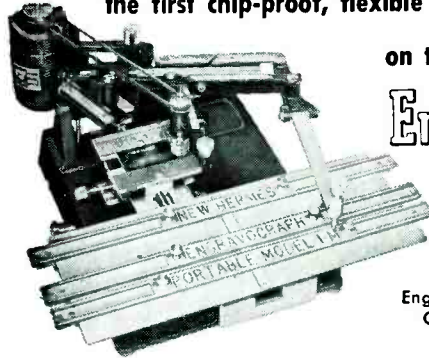

Send for booklets:  
Engravo-graph Booklet 1M-29  
Gravoflex Booklet G-29

So simple to engrave Gravoflex. Lettering stands out permanently on contrasting background. No paint needed. 10,000 Engravo-graphs used for engraving on metals and plastics. Only Engravo-graph has these patented features:

- Adjustable for 15 ratios.
- Self-centering holding vise.
- Automatic depth regulator.
- Adjustable copy holders.

**NEW HERMES ENGRAVING MACHINE CORP.**

13-19 UNIVERSITY PLACE, NEW YORK 3, N. Y.

shear it



bend it

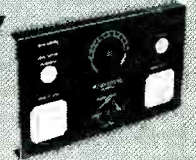

form it



punch it

## TUNABLE DETECTOR AMPLIFIER TYPE FT-UBM

### Applications—

- Bridge Detector
- Selective Amplifier
- Wave Analyzer
- Carrier Frequency Test Set
- Variable Frequency Filter

### Specifications—

- Range:** 45 cps to 400 kc.
- Selectivity:** Adjustable from 1% to 10% or flat response over entire band.
- Sensitivity:** 10 $\mu$ v (with band width of 2% and deflection of 10% full scale).
- Amplification:** 5 steps from 1:10 to 1:10<sup>5</sup>.
- Power:** 110/220v., 40 to 60 cps.



S-913

Federal Telephone and Radio Company, A Division of International Telephone and Telegraph Corporation, Instrument Division, 100 Kingsland Road, Clifton, N. J.

- Please send further information on Tunable Detector Amplifier, Type FT-UBM.
- Please send latest instrument catalog.

NAME \_\_\_\_\_

TITLE \_\_\_\_\_

COMPANY \_\_\_\_\_

ADDRESS \_\_\_\_\_

CITY \_\_\_\_\_ ZONE \_\_\_\_\_ STATE \_\_\_\_\_



# 3 Relay Types by FILTERS, INC.

Now a Leader in the  
Sub-miniature Relay Field

## NEW—DPDT

SUB-MINIATURE  
Actual Size

Engineered for critical  
Airborne and Guided  
Missile Applications

TYPE: M26F6

CONTACT RATING:  
2 A Res. at 26.5 vdc  
or 115 vac

Dia.: .635  
Mtg. Ctrs.: .0875  
Shock: 50 G  
Vibration: 10 G  
at 5 to 2000 cps  
Amb. Temp.: -65°C to +125°  
Weight: 1.3 oz.

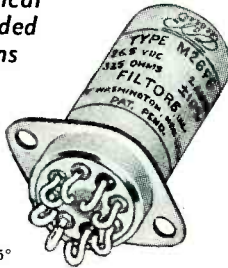

## NEW-LATCHING

SUB-MINIATURE  
6PDT

Magnetically Held—  
Electrically Reset

UNBELIEVABLY SMALL

FOR A  
LATCHING  
RELAY

TYPE: L26F18

CONTACT RATING:  
3 A Res. at 26.5  
vdc or 115 vac

Mtg. Ctrs.: 1.406  
Shock: 50 G  
Vib.: 10 G at 5 to  
500 cps  
Amb. Temp.: -65°C  
to +125°C

(Also available in  
2PDT and 4PDT)

Weight: 3.3 oz.

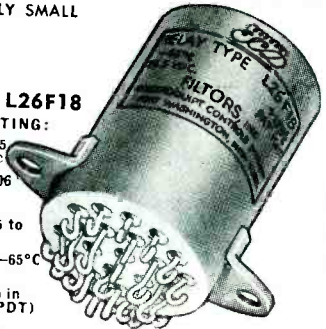

## SUB-MINIATURE 4PDT

Actual Size

The Smallest,  
Hermetically-Sealed  
4PDT Relay  
Available Today

TYPE: 26SR12

Mtg. Ctrs.:  
1.406

Shock: 50 G

Vib.: 10 G at 5  
to 500 cps

Amb. Temp.: -65°C  
to +125°C

Weight: 2.6 oz.

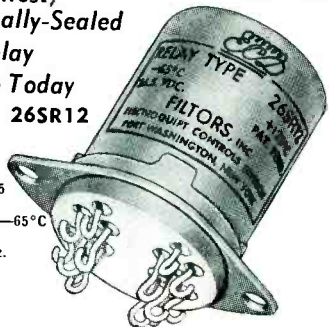

MIL SPECIFICATIONS

All Made to MIL-R-5757B and MIL-R-25018  
(USAF)

DRY CIRCUIT RELAYS AVAILABLE  
IN PRODUCTION QUANTITIES

Write Today For New Catalog Listing  
Sales & Engineering Office Nearest You

## FILTERS, INC.

30 Sagamore Hill Drive  
Port Washington, L. I., N. Y.

Canadian Office:  
MJS ELECTRONIC SALES, LTD.  
P.O. Box 240, Ajax, Ontario  
Tel.: EMpire 8-3806

Export Office:  
MAURICE I. PARISIERS & CO.  
1860 Broadway, New York 23, N. Y.

Cable Address:  
MIPARISIERS NEW YORK

Want more information? Use post card on last page.

PLANTS AND PEOPLE

(continued)

television broadcast equipment accounts in the area between New York and Chicago.

Kenneth F. Petersen succeeds Tharpe at Du Mont. He was formerly marketing manager for Du Mont tv transmitter sales and before that director of engineering facilities for WPIX in New York.

## Alto Scientific Adds Engineers

PRINCIPALS of the Alto Scientific Co. now include president Lester L. Libby, vice-president Thomas F. Turner and secretary-treasurer Dr. David D. Cherry. Together, the background of the trio includes experience in development, manufacturing or sales with Tung Sol, Federal Telegraph Co., Federal Telephone and Radio Corp., Kay Electric, Omega Laboratories, Civil Aeronautics Administration, Northrop Aircraft Co., Sierra Electronic Corp. and Bell Telephone Laboratories.

New engineers joining Alto recently include James F. Melton, formerly with the Stanford Research Institute and Hewlett-Packard Co., Lawrence R. Teeple of California Research & Development and Consolidated Aircraft, and Kenneth A. McQueeney who came to Alto from Sierra Electronic Corp.

## New Glass Seal Company Established

W. P. SPEER, formerly manager of the glass seal division of Cannon Electric, has organized Seals, Ltd. in South Pasadena, Calif.

The company specializes in the design, manufacture and sale of glass-seal type connectors.

## Summers Gyro Appoints Romig

HARRY G. ROMIG has been appointed staff engineer at Summers Gyroscope Co.

He comes to the Santa Monica concern with 30 years of varied experience in industry. Twenty-

# USERS of EPOXIES and POLYESTERS

for embedded circuits and parts

Can Now

- Replace or Repair Defective Parts
- Salvage Valuable Parts

in embedded circuits by fully or partly removing the encapsulating resin with the

NEW STRIPPER-SOLVENT  
"MONASTRIP" EP

SAVE COSTLY LABOR AND PARTS. No special equipment needed. MONASTRIP E.P. is non-inflammable and can be reused. Write for details to Chem. Division, Section E.S.

# M O N A INDUSTRIES, INC.

PATERSON 4,

NEW JERSEY

## WIDE-RANGE FREQUENCY METER 85-1000 MEGACYCLES

TS-175A/U

Government  
Approved  
Calibration  
Accuracy:  
.005%  
Stability:  
.0025%  
Resettability:  
.0025%



IMMEDIATE  
DELIVERY

A VERSATILE PRECISION MEASURING  
INSTRUMENT Recommended Applications:

- Precise Measurements of Frequencies
- Production Testing
- Alignment of Transmitters and Receivers
- Laboratory Testing
- Portable Field Testing
- A Secondary Frequency Standard
- Signal Generator Calibration
- U.H.F. and V.H.F. Television Alignment

## COLORTONE ELECTRONICS, Incorporated

200 Frank Road, Hicksville, L. I., N. Y. HI 4-2124

Export Rep: Andrew S. Szucs, Inc.  
50 Broad St., N. Y. C.

Want more information? Use post card on last page.

December, 1955 — ELECTRONICS



# AUTOMATIC ELECTRONIC DECADE SCALER AND TIMER

for optimum speed  
and accuracy

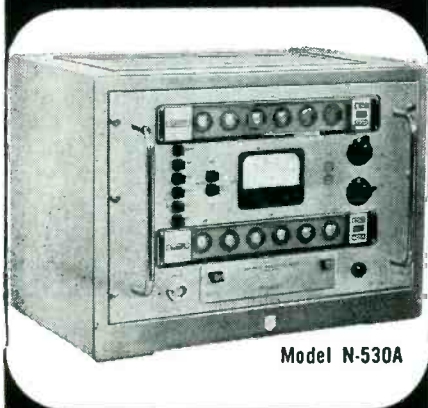

Model N-530A

The simplicity and accuracy of Dekatron counting and timing circuits make the Ekco Model N-530A Automatic Scaler the most outstanding and most versatile instrument of its kind. This scaler will time a pre-determined count, count for a pre-determined time, or can be manually operated.

#### FEATURES:

- Preset elapsed time interval—100-100,000 seconds in 10ths
- Preset elapsed count interval—100-1,000,000 counts
- Maximum counting rate—60,000 counts/second
- Maximum stopping time—2 milliseconds
- Six electronic decades
- Dekatron direct-reading counting and timing tubes
- Pulse height discriminator permits use with G-M, scintillation, flow or proportional counters—variable 5-50 volt preset acceptance level

#### SPECIFICATIONS:

- Input sensitivity—negative 0.1 volt and positive 5 volts
- Input resolution time—5 microseconds, low coincidence loss
- Power Requirements—110-250v, 50/60 cycles, 130 watts
- Dual-range Power Supply—250-1000 and 500-2000 volts

Stability— $\pm 0.5\%$  for variations up to  $\pm 10\%$ .  
Ripple—less than 5 mv. rms peak

Write TODAY to our American representative for technical data on the complete line of EKCO equipment.

## EKCO

ELECTRONICS, LTD.  
Southend-on-Sea,  
Essex, England

U. S. Sales and Service  
AMERICAN TRADAIR CORP.  
Long Island City 6, New York

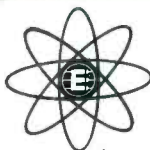

Want more information? Use post card on last page.

ELECTRONICS — December, 1955

five of these years he was with Bell Telephone Laboratories, New York, N. Y., as a member of the technical staff specializing in quality control. He was with Hughes Aircraft Co., Culver City, Calif., for almost three years, serving ultimately as technical director of quality control after being quality manager of central quality control. Recently, in addition to consultant work, he was employed by International Telemetering Corp., Los Angeles, as quality director.

### Midwestern Elects New President

G. R. MORROW, vice-president and manager of Midwestern Instruments, has been elected president.

M. E. Morrow, founder and president, became chairman of the board.

E. J. Handly was elected vice-president of finance. Other re-elected officers were D. G. O'Brien, vice-president in charge of engineering and production; A. E. McCoy, vice-president in charge of sales; John F. Y. Stambaugh, secretary-treasurer and Truman R. Howell, assistant secretary-treasurer and comptroller.

The company now occupies its new million dollar plant in Tulsa, Okla.

### NBS Appoints Parts Chief

ROBERT D. ELBOURN has been appointed chief of the components and techniques section of the National Bureau of Standards. This section investigates new components and devices for electronic computers and explores techniques for applying them.

Elbourn is a member of the original team that developed in 1950 the Bureau's electronic computer, SEAC.

He has been with the Bureau since 1947.

Prior to joining the Bureau's staff, he was an electronic engineer with the Naval Ordnance Laboratory and with C. G. Conn of Elkhart, Ind.

## NOW... a DC Reference Voltage

That's Constant  
from  $-55^{\circ}$  to  $+100^{\circ}$ C



### K-Volt Standard\*

Tubeless Constant Voltage Source  
For Measurement & Control Circuits

Designed to replace the chemical cell and VR tube in airborne, laboratory and other critical instrumentation, the K-Volt Standard provides constant voltage through extremes of operating conditions... including ambient temperatures as low as  $-55^{\circ}$  and up to  $100^{\circ}$ C. Operating from AC or DC supply, it employs no tubes or moving parts, is unaffected by position, vibration or mechanical shock. Negligible temperature coefficient, dependable regulation characteristics and rugged design make it applicable as an absolute reference, a constant output working supply, or a precision voltage regulator wherever specifications demand highest stability. Other important features are:

- Small size:  $1\frac{1}{2}$ " by  $1\frac{1}{4}$ " dia.
- Power drain less than 1.8 watts
- Life: more than 10,000 hrs.
- Vibration: conforms to MIL-E-5272A
- Miniature 7-pin base
- Weight: less than 3 oz.
- Hermetically sealed
- Random drift less than 0.1% over 1000 hrs.

Models to Meet Wide Range of Application Requirements: The K-Volt Standard is available for operation from 26.5 volts DC, or 117 volts AC, 60 or 400 cycles; DC output 6 volts or 1 volt, at 1 ma or 10 ma.

For complete specifications  
and performance data  
send for bulletin No. A128

\*TRADE MARK

## AVIEN

Precision Instruments and Control Systems  
58-15 Northern Blvd., Woodside 77, N. Y.

Want more information? Use post card on last page.

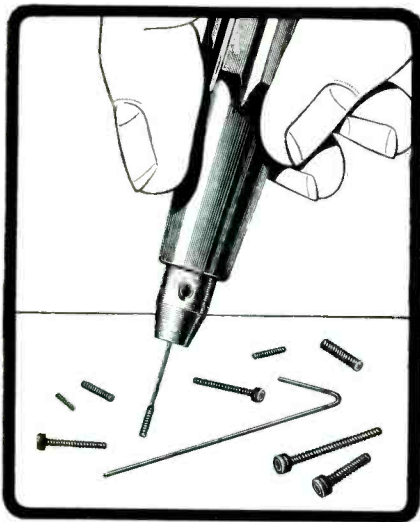

You can "miniaturize"  
a lot smaller with these

ALLEN  
**MINICAP**  
AND  
**MINISET**  
SOCKET SCREWS!  
#0 THRU #3 DIAMETERS

Whatever you're "miniaturizing," Allen Minicap and Miniset Socket Screws are ready to hold the parts securely. Say the word — and Allen engineers will gladly work with you to show you how Minicaps and Minisets make it possible to scale down sizes even farther in your miniaturization designs.

Allen Minicaps and Minisets are tiny, but tough — true Allens in their accurate and uniform sockets, threads, heads and sizes. They're so strong, you can safely specify fewer screws or smaller sizes.

With precision-fit Allen sockets, the key fits tight — makes starting easier, saves time in assembly. Allen Minicaps are knurled, and *trimmed* on top and under the heads — fit better and look better.

Your Industrial Distributor has Allen Minicaps and Minisets now. He will show you why Allens hold better and last longer.

Sold Only Through Leading  
Industrial Distributors.



**ALLEN**  
MANUFACTURING COMPANY  
Hartford 2, Connecticut, U.S.A.

Want more information? Use post card on last page.

## New Books

### Elements of Electronics

BY HENRY V. HICKEY AND WILLIAM M. VILLINES. McGraw Hill Book Co., New York, 1955, 487 p, \$5.00.

IN THIS volume the authors get right down to business; they introduce the vacuum tube soon after describing the basic behavior of the electron. This may seem an unconventional approach, but it steers the beginner immediately to the most important electronic device with which he is to become intimately acquainted. To make the story particularly pertinent in the first chapter, the explanation of direct currents and static electricity are immediately entered together with a brief introduction to mathematics involving the power of ten.

#### A-C and D-C Circuits

The principles and operation of simple d-c circuits, natural and electromagnetism plus a working knowledge of meters, follow in simple logical sequence.

Alternating-current theory is treated with sufficient detail and is accompanied by two chapters, one on trigonometry and one on phase relationships; these three chapters adequately fill out the picture on a-c fundamentals with a minimum of confusion.

The action of capacitive and inductive circuits as described in the following two chapters are relatively simple since the reader has first been given a background in alternating-current theory.

#### Electron Devices

The remainder of the volume deals with vacuum tubes and their application to electronic equipment. The primary vacuum-tube functions of amplification and oscillation, are covered in six chapters, five of which are devoted to types of amplifiers. The relationship of the basic electronic functions to concrete operating equipment is covered in ten chapters—five on transmitter theory and operation—five on receivers.

A short chapter on transistors follows, to end the book rather abruptly.

Granted that receivers and trans-

## RAWSON ELECTROSTATIC VOLTMETERS

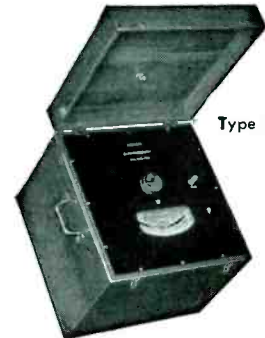

Type 518

Available ranges 100 volts to  
35,000 volts

Measure true R.M.S. values on A.C., no waveform or frequency errors.

#### NO POWER CONSUMPTION

Leakage resistance greater than one million megohms. These meters may be used to measure **STATIC ELECTRICITY!**

Ideal for measuring high voltage power supplies with zero current drain. Rugged, well-damped movement. All elements surrounded by metal shielding for accuracy and safety.

Write for bulletin

**RAWSON ELECTRICAL  
INSTRUMENT CO.**

111 POTTER ST.

CAMBRIDGE, MASS.

## WANTED!

We're looking for engineers whose prime responsibility is to seek ways and means to make products or parts better, more efficient and at lower cost. To you, we recommend Frenchtown *Engineered Ceramics*.

Very possibly you can profit from the many valuable properties of Frenchtown *Engineered Ceramics* to give you resistance to *high temperatures* and low thermal expansion; excellent mechanical strength and wear resistance; superior dielectric strength at both high and low frequencies.

This helpful 4-page bulletin contains complete data on electrical and mechanical characteristics of Frenchtown high-performance bodies. Send for a free copy today.



**frenchtown**

PORCELAIN COMPANY

86 Muirhead Ave. • Trenton 9, N. J.

Want more information? Use post card on last page.

December, 1955 — ELECTRONICS



mitters form the major portion of electronic gear, it would have been pertinent to round out the volume with a few pages more on electronic circuitry as applied to control, measurement, photoelectricity and television.

On the whole, the book gives a well planned and clear explanation of electronic principles. Circuit functioning and practical commercial applications are covered with excellent technique.

Enough restraint has been exercised in the descriptive matter to give a clear picture without letting the text become confused with redundant material.

HARRY E. THOMAS, *Senior Project Engineer, Federal Telecommunication Laboratories, Nutley, N. J.*

### Electronic Measuring Instruments

By E. H. BANNER. *The Macmillan Co., New York, 1955, 395 p., \$8.50.*

INTENDED primarily for the information of instrumentation engineers, this book is neither a text nor a handbook. It covers basic theory of electronic devices useful in instrumentation and their application. The instruments described include industrial, scientific and medical instruments. Electronic test equipment is not covered in this book.

#### Arrangement

The book is presented in three parts. The first discusses electronic devices such as vacuum and gas-filled tubes, cathode-ray tubes,

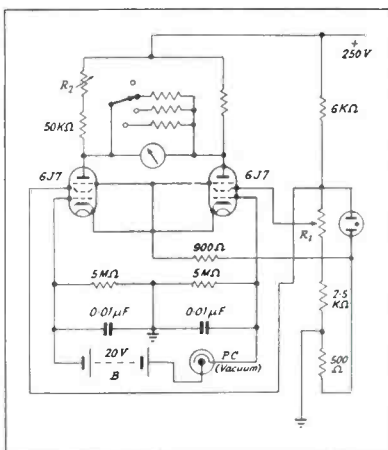

Bridge circuit for measuring low light intensity



- HIGH ACCURACY
- MEASURES FROM 0 TO 360 DEGREES
- READINGS NOT AFFECTED BY NOISE AND HARMONICS
- PHASE SHIFTS OF THE ORDER OF .01° CAN BE MEASURED EMPLOYING SPECIAL CIRCUIT TECHNIQUES
- MEASURES IN-PHASE AND QUADRATURE COMPONENTS SEPARATELY

For further information contact your nearest representative or write for brochure

**INDUSTRIAL TEST EQUIPMENT CO.**  
55 E. 11th ST. · NEW YORK 3 · GR. 3-4684

Manufacturers of:

- PHASE METERS
- NULL DETECTORS
- IMPEDANCE COMPARATORS
- POWER OSCILLATORS
- VACUUM TUBE VOLTMETERS
- FREQUENCY STANDARDS
- AUTOMATIC HI-POT

Other Electronic Test Equipment

# COILS

## YOKES

Industrial Camera Yokes  
Alignment Yokes  
Image Orthicon Yokes  
Focus Coils  
Image Orthicon  
Terminal Board Assemblies

Variable R.F.  
Variable I.F.  
Plate Coils  
Oscillator Coils  
Crystal Heater Units

## COIL ASSEMBLIES

Impedance Coils  
Peaking Coils  
R.F. Chokes  
Video Peaking Coils  
Transmitter Coils

## TELE COIL CO., Inc.

SAMUEL FELDMAN, Pres.

2733 Saunders St.
Camden 5, N. J.
Phone EMerson 5-7528

DE MORNAY-BONARDI

## first in ultramicrowave equipment

A complete line of research instruments covering frequencies up to 90,000 mc... proved in laboratories the country over.

DE MORNAY-BONARDI · 780 SOUTH ARROYO PARKWAY · PASADENA, CALIFORNIA

# PRESET COUNTERS



Automatically count and control to 1,000,000 events.

Dual and multi-sequence models available to provide output signals and relay contact closure at any two or more preset totals

## FEATURES

- Absolute Accuracy
- High Speed
- Reliable
- Automatic
- Rugged
- Economical
- Small Size



D-115

### Model DS-8600 Series (5 Models)

Designed to control any operation after a preselected total count has been reached. Used to count pills, bottles, cans, machine parts, etc. for automatic packaging. If an event can be converted to an electrical impulse, it can be counted and controlled with a Detron Preset Counter.

Count Capacity: 100 to 1,000,000 (depending on model); Counts per second: 0-100,000 (as a straight counter); Recycling rate: 35,000 per sec. (as a preset counter); Input Sensitivity: 0.1 V RMS; Output Signal: 50 volt positive pulse; Relay Contacts: 5 amps., 115 v. 60 cycle, non-inductive load.

WRITE FOR COMPLETE DETAILS

Representatives in all major areas.

## COMPUTER-MEASUREMENTS CORP.

Formerly Detron Corporation  
5457 Cleon Avenue Dept. 78-P  
North Hollywood, California

# PLASTICON

## THE PLASTIC FILM CAPACITOR OF MYLAR MEETS MIL - C25A

Characteristics	Type MACM	Type MSCM
Temperature Range	-55°C to 85°C*	-55°C to 125°C
Insulation Resistance @ 25°C	100,000 Meg./mfd.	100,000 Meg./mfd.
Except that need not exceed	125,000 Megohms	125,000 Megohms
Insulation Resistance at High Ambient Temp	5,000 Meg./mfd.	400 Meg./mfd.
Except that need not exceed	10,000 Megohms	1,000 Megohms
Capitance Change 25°C to -55°C	6%	10%
Life Test - Percentage of Rated Voltage at High Ambient Temperatures	140	140
Power Factor - 1000 c.p.s.	0.5%	0.5%

All Case Sizes, Leads, Mounting Brackets and Tolerances to Meet MIL - C25A SPECIAL UNITS DESIGNED UPON REQUEST

\* Rated to 125°C with Derating



## CONDENSER PRODUCTS

Division of the New Haven Clock and Watch Co.  
140 Hamilton Street, New Haven 4, Connecticut

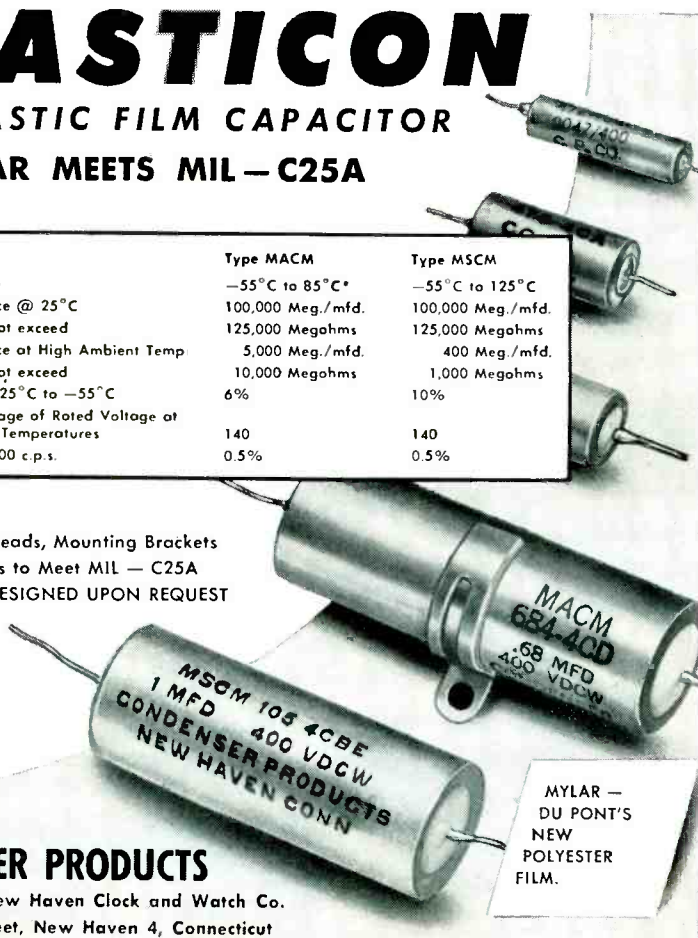

MYLAR - DU PONT'S NEW POLYESTER FILM.

phototubes, solid-state devices and particle detectors.

Part two discusses electronic measuring instruments making use of these devices. Part three covers other measuring instruments including electronic and other counters, electromechanical transducers, electrical instruments and instruments for measuring physical quantities.

Usefulness of the book to American engineers is somewhat limited in that many of the electron tubes and commercially available instruments described are, understandably, of British origin.

Striking a humorous note in the preface, the author suggests that thermopiles might have been used at Thermopylae or that diodes and triodes are extensions of the Odes of Horace.—J.M.C.

## Electronic Musical Instruments

By RICHARD H. DORF, *Radio Magazines, Inc., Mineola, New York, 1955, 326 p, \$7.50.*

THAT THERE is a need for a book covering the field of Electronic Musical Instruments is obvious since there have been so many new and interesting applications of electronic (and electric) devices to the music world. The book "Electronic Musical Instruments" does describe most of the innovations currently on the market.

It is apparently written for three groups: the musician, the engineer-technician, and the build-it-yourself enthusiast. As a result—interested musicians find it lacking since

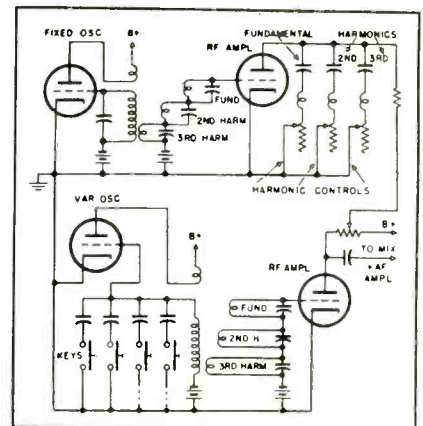

Heterodyne instrument with harmonic synthesis



it does not delve into the musical aspects of the subject in sufficient detail. The engineer-technician finds many instances where subjects are excessively simplified, and the build-it-yourself enthusiast finds not enough detail to permit finished construction.

Further, a speaking-to-class presentation is used rather than a less verbose and more professional writing technique. The book is well illustrated with pictures showing the various instruments, and schematic drawings are used profusely and advantageously for greater clarity. The book is well printed with exceptionally few typographical errors. The appendix of electronic music patents is quite extensive.

G. EDWARD HAMILTON, *American Broadcasting Company, New York, N. Y.*

## Thumbnail Reviews

**The Mobile Manual for Radio Amateurs.** American Radio Relay League, West Hartford, Conn., 1955, 352 p, \$2.50 (paper). Selected articles from *QST* dealing with design of station equipment for mobile operation. Articles described receivers, transmitters, antennas and power supplies.

**Basic Synchros and Servomechanisms.** Van Valkenburg, Nooger & Neville, Inc. John F. Rider Publisher, Inc., New York, 1955, two volumes: 272 p, \$5.50 (paper), \$6.95 (cloth, one volume). Material from Navy course on Basic Synchros and Servomechanisms. Pictorial presentation, quite elementary. Covers servo components, servo fundamentals and design, error detectors, amplifiers and control circuits.

**Handbook of Engineering Materials.** D. F. Miner and J. B. Seastone. John Wiley & Sons, Inc., New York, 1955, 1,391 p, \$17.50. Includes sections on general information about materials, metals, nonmetals and construction materials. Covers common chassis metals, papers, fibers, plastics and rubbers, organic finishes, carbon products and ceramics.

**Proceedings of the First Conference on Training Personnel for the Computing Machine Field.** A. W. Jacobson. Wayne University Press, Detroit, Mich., 1955, 104 p. Proceedings of a conference held at Wayne University June 22-23, 1954. Includes 17 papers, reports on 3 panel discussions and roster of persons attending conference. Subject headings include: manpower requirements, educational programs, influence of computers on technical and general education and cooperative efforts for training and research.

# FOR MARKING...



**PLASTIC • METAL  
GLASS • PAPER  
RUBBER • CERAMIC  
CARDBOARD**

*in such products as  
Resistors, capacitors,  
valves, tubes, labels,  
sleeves, spark plugs, car-  
tons, etc., etc.*

**THESE PRODUCTS  
AND MANY OTHERS  
OF ALMOST ANY  
MATERIAL AND SHAPE  
CAN BE IMPRINTED**

ON THE

## REJAFIX MARKING MACHINE

**Why not send us samples of your products? They will be test-printed and returned to you for your examination!**

- REJAFIX HAND-OPERATED MODELS FOR SMALL RUNS. FULLY AUTOMATIC MODELS FOR MASS PRODUCTION.

EST. 1922

**POPPER & SONS INC.** 300 FOURTH AVENUE  
NEW YORK 10, N. Y.

**M-DC-3A super-regulated voltage standard**

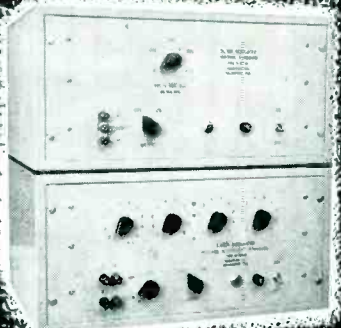

**M-DC-2A super-regulated voltage and current standard**

### Calibration Partners

The two units combined, provide voltages up to 509.99 volts dc in 0.01 volt steps, however, either unit can function independently. The M-DC-2A provides current outputs of from 0 to 109.99 ma dc in 0.01 ma steps and voltages from 0 to 109.99 volts dc in 0.01 volts steps. Overall accuracy of both units is within 0.05 pct. of selected voltage or current.

**RADIATION Inc.** Melbourne, Fla.  
Orlando, Fla.  
Electronics • Avionics • Instrumentation

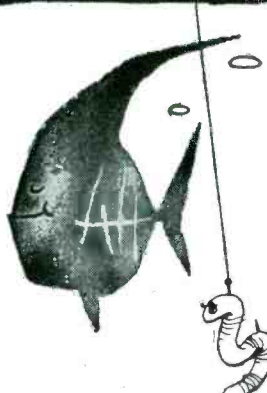

**experience pays**

let TWS\* prepare  
your industrial literature

**\*TECHNICAL WRITING SERVICE**  
McGraw-Hill Book Co.  
330 W. 42nd St., N.Y.C.

send for information

AMERICAN TELEVISION &  
RADIO CO. ST. PAUL, MINN.

introduces the  
**new**

**ATR TV**

*Full Door Console  
Receiving Sets*

UNSURPASSED  
IN BEAUTY

UNEQUALLED  
IN PERFORMANCE

UNMATCHED IN  
QUALITY  
CONSTRUCTION

exclusive  
profitable  
dealer  
franchises  
now available

*designed  
with the  
Serviceman  
in mind  
... easy to  
get at*



WRITE TODAY FOR COLORFUL  
BROCHURE SHOWING THE  
NEW LINE OF ATR TV SETS

ALSO MANUFACTURERS OF DC-AC INVERTERS,  
"A" BATTERY ELIMINATORS, AUTO RADIO VIBRATORS

**ATR** AMERICAN TELEVISION & RADIO CO.  
Quality Products Since 1931  
SAINT PAUL 1, MINNESOTA-U. S. A.

Want more information? Use post card on last page.

## Backtalk

### Resistance Analyzer

DEAR SIRS:

WE BELIEVE you will be interested in knowing that your printer must have dropped one or two lines of type when making the break in that story between pages 290 and 292, September 1955.

The last sentence on page 290 should have read: "It was designed to check such characteristics as d-c resistance, temperature coefficient, and voltage coefficient of resistors according to JAN specifications. Voltage coefficient of any resistor up to a capacity of 2 w can be determined down to as low as 0.0002 percent per volt."

RICHARD G. MORRIS  
Manager  
Advertising, Public Relations  
The Kuljian Corporation  
Philadelphia, Pennsylvania

### Patent Examiners Needed

DEAR SIRS:

THERE is a serious delay in the processing of patent applications in the U. S. Patent Office because the size of the examining staff has not kept pace with the increased number of patent applications filed. This creates uncertainty as to the patent status of new products and processes and tends to slow down or defer their adoption by industry and their introduction to the public.

This is a matter that can handicap the larger corporation and can be critical for the individual inventor and the small business whose operations revolve around patented products and processes.

Congress has appropriated additional funds for new patent examiners, but with the existing demand for engineers and scientists in industry it has been difficult to obtain enough candidates having the necessary technical qualifications . . .

There are vacancies in the examining staff which should be filled promptly this fall and we appeal to you . . . since ELECTRONICS is read by the technically and scientifically trained people whom the Patent Office is trying to reach. Steps have already been taken

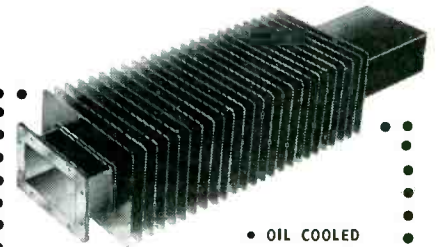

- OIL COOLED
- WATER COOLED
- AIR COOLED

**NEW!**

## High Power DUMMY LOADS

Waveguide and Coaxial

Coaxial Loads:

up to 10 KV Average Power.

Waveguide Loads:

X-Band Loads up to 1000

Watts Average Power.

S-Band Loads up to 4000

Watts Average Power.

L-Band Loads up to 6000

Watts Average Power.

WRITE FOR NEW CATALOG

**Electro Impulse Laboratory**

208 River St.

Red Bank, N. J.

Red Bank 6-0404



**SPADE  
BOLTS**



specialists in designing and manufacturing of all-purpose fasteners and wire forms. Tooled to produce over 1000 styles in any screw size, material, finish, quantity, to your specifications.

Serving Industry for Thirty-five Years

— OTHER PRODUCTS —

**Simplex**  
WIRE STRIPPERS & CUTTERS

• TOOLS • DIES • STAMPINGS  
Bulletins on complete line upon request

**WENCO MANUFACTURING CO.**  
1133 W. Hubbard St., Chicago 22, Ill., U. S. A.

Want more information? Use post card on last page.

December, 1955 — ELECTRONICS



# PROFESSIONAL SERVICES

Consulting—Patents—Design—Development—Measurement

in

Radio, Audio, Industrial Electronic Appliances

## AIRPAX PRODUCTS CO.

Development Division  
Specialists in the  
Design and Manufacture of  
UNUSUAL TRANSFORMERS AND RELAYS  
Middle River Baltimore 20, Ind.

## ELECTRONIC RESEARCH ASSOCIATES, INC.

"TRANSISTORIZE" YOUR PRODUCT!  
Complete Service in consulting, research, develop-  
ment, and production on Transistor circuitry, prod-  
ucts and instrumentation.  
67 East Centre Street Nutley, N. J.  
NUTley 2-5410

## PICKARD & BURNS, INC.

*Consulting Electronic Engineers*  
Analysis and Evaluation  
of Radio Systems  
Research, Development and Production  
of Special Electronic Equipment  
240 Highland Ave. Needham 94, Mass.

## ANALYSIS INSTRUMENT CO.

*Consultants on Magnetic Problems*  
Magnetic Materials Tested  
Special Magnetic Devices Designed  
Magnetizing & Testing Equipment Supplied  
P. O. Box 7 Pequanock, New Jersey

## ERCO RADIO LABORATORIES, INC.

*Radio Communications Equipment*  
Engineering - Design - Development - Production  
Our 27th Year in Air to Ground  
Communications and Radio Beacons  
Garden City • Long Island • New York

## ALBERT PREISMAN

*Consulting Engineer*  
Television, Pulse Techniques, Video  
Amplifiers, Phasing Networks,  
Industrial Appliances  
Affiliated with  
MANAGEMENT-TRAINING ASSOCIATES  
3224 - 16th St., N. Y. Washington 10, D. C.

## H. O. BIXBY ASSOCIATES

*Consultants to the Electronic Industry*  
SURVEYS — PROMOTIONS — LIAISON  
PERSONNEL PLACEMENT — TECHNOLOGY  
238 Main St. Cambridge 42, Mass.  
ELiot 4-9404

## HANSON-GORRILL-BRIAN INC.

*Product & Mfg. Development*  
ELECTRICAL - ELECTRONIC  
HYDRAULIC - MECHANICAL  
One Continental Hill Glen Cove, N. Y.  
Glen Cove 4-7300

## SUNSTEIN ENGINEERING CO.

*David E. Sunstein and Associates*  
Consulting Services for Research, Engineering  
and Production of Industrial, Consumer, and  
Government Products.  
464 Conshohocken State Road  
Bala-Cynwyd, (Phila.) Pa.  
MOhawK 4-0459

## THOMAS H. BRIGGS & ASSOCIATES

*Electronics Consultants*  
Electron Tubes - Automation - Project Surveys  
Tube Materials & Reliability - Servo-mechanisms  
Engineering and production facilities.  
Box 135 RD#2 Norristown, Penn. Tel. No. 8-7671

## THE KULJIAN CORPORATION

*ELECTRONICS DIVISION*  
*Consulting Electronic Engineers*  
Research, Development, Production of  
Automatic Controls — Special Instrumentation  
1200 No. Broad St., Philadelphia 21, Pa.  
Stevenson 2-9000

## THE TECHNICAL MATERIAL CORPORATION

*Communications Consultants*  
Systems Engineering  
General Offices and Laboratory  
700 Fenimore Rd., Mamaroneck, N. Y.

## CROSBY LABORATORIES, INC.

*Murray G. Crosby & Staff*  
Radio - Electronics  
Research Development & Manufacturing  
Communication, FM & TV  
Robbins Lane, Hicksville, N. Y.  
WElls 1-3191

## Measurements Corporation

*Research & Manufacturing Engineers*  
HARRY W. HOUCK MARTIAL A. HONNELL  
JOHN M. VAN BEUREN  
Specialists in the Design and  
Development of Electronic Test Instruments  
Boonton, New Jersey

## TELECHROME, INC.

*Electronic Design Specialists*  
COLOR TELEVISION EQUIPMENT  
Flying Spot Scanners, Color Synthesizers, Keyers,  
Monitors, Oscilloscopes and Related Apparatus  
J. R. Popkin-Curman, Pres. & Ch. Engr.  
88 Merrick Rd. Amityville, L. I., N. Y.

## DELAWARE PRODUCTS CO

Analog Voltage to Digital Conversion  
Digital Voltage Recording Systems  
Design-Development-Manufacturing  
300 Broadway Camden 3, N. J.

## MINOT INFORMATIC DEVICES

AUTOMATIC RECOGNITION OF  
SHAPES, PATTERNS & INFORMATION  
RESEARCH - INVENTION - CONSULTING  
or detection and interpretation of  
complicated forms, characteristics of  
materials, printed characters, etc.  
Otis N. Minot, 22 Eliot Rd., Lexington 73, Mass.  
Tel. VOLunteer 2-9465 or -3974

## WALSH ENGINEERING CO.

Design and Prototypes  
of Electronic Apparatus  
in which Transformers and Magnetic Components  
are especially important factors in Performance,  
Size, Weight and/or Cost  
34 DeHart Place Elizabeth, N. J.  
ELizabeth 2-7600

## EDGERTON, GERMESHAUSEN & GRIER, INC.

*Consulting Engineers*  
Stroboscopy — Transient Oscillography  
Photoelectricity — Pulse Techniques — Timing  
High-Speed and Electronic Flash Photography  
Telemetering - Industrial Television Applications  
160 Brookline Avenue Boston 15, Mass.

## NEW ROCHELLE TOOL CORP.

FOR CERTIFICATION OF INDUCTION  
AND DIELECTRIC HEATING EQUIPMENT  
IN ACCORDANCE WITH F.C.C. RULINGS  
Mobile Test Unit Available Entire U. S.  
320 Main St. New Rochelle, New York  
Phone NE 2-5555

## WHEELER LABORATORIES, INC.

Radio and Electronics  
Consulting — Research — Development  
R-F Circuits — Lines — Antennas  
Microwave Components — Test Equipment  
Harold A. Wheeler and Engineering Staff  
Great Neck, N. Y. HUNter 2-7876

## Eldico of New York, Inc.

Pioneers of Television Interference Elimination from  
Transmitters, Induction Heaters, Diathermy and etc.  
Donald J. S. Merten & Engineering Staff  
72 E. Second St. Mineola, L. I., N. Y.  
Pioneer 6-5212

## NIAGARA ELECTRON LABORATORIES

CONSULTATION - DESIGN - CONSTRUCTION  
MFG. THE THERMOCAP RELAY  
Specializing in solution of problems of electronic  
and electro-physical instrumentation for the research  
or analytical laboratory. Industrial plant problems  
also invited.  
Andover, New York Cable Address: NIATRONLAB

## YARDNEY LABORATORIES

*Research-Design-Development*  
Electro-Chemical Generators of Energy  
40-46 Leonard Street Worth 6-3100  
New York 13, N. Y.

# DC-AC CHOPPERS

0-500 cycles  
DEPENDABLE



All military specifications met. Liberal factors of safety to meet emergency conditions.

1. Production sampled daily and life tested to check 1,000 hour rating.
2. Every Chopper given not only one but two tests over the full range of military temperatures before shipment.
3. Only gold contacts used for superior operation in the vital 0-1½ volt d-c range.
4. Liberal safety factors to meet emergency conditions.
  - a. 0-500 cps.
  - b. Input voltage  $\pm 30\%$ .

WRITE FOR THESE CATALOGS:  
No. 371, 0-500 CPS.  
No. 370, 60 CPS.

## STEVENS ARNOLD INCORPORATED

22 ELKINS STREET  
SOUTH BOSTON 27, MASS.

S/A-11

Want more information? Use post card on last page.

BACKTALK

(continued)

in this direction and over 100 new patent examiners have been added to the examining staff since June of this year, and it is understood that the Patent Office plans to build this number up to a total of 350 new examiners by the end of 1956 . . .

Salaries for examiners start at \$4,345 a year, and it is possible to reach a salary of \$7,570 in 5½ years. The Patent Office also offers liberal vacations and sick leave and pension benefits.

Engineers and scientists holding a college degree in engineering or applied science, or a degree with a major in chemistry or physics, or with certain combined credits in these fields, are eligible for appointment as patent examiners, without examination, upon application to the Commissioner of Patents in Washington.

HENRY E. SHARPE  
*The New York Patent Law Assoc.  
New York, N. Y.*

## Face-Plate Seal

DEAR SIRs:

THE STATEMENT in the news story on p 22 (Nov. 1955) that "a low temperature solder glass seal is used to seal the face plate to the funnel . . ." is incorrect. The face plate and cone of the all-glass color television tube are sealed by the same method used regularly to seal the face plate and cone of black and white television tubes.

H. C. MCDANIEL  
*Westinghouse Electric Corp.  
Pittsburgh, Pa.*

## Transistor Symbol

DEAR SIRs:

I HAVE found it quite convenient and, I believe, also appropriate to use the symbol *XR* to indicate or label a transistor in schematic diagrams and as an abbreviation in written material.

I understand the name transistor was originally a combination of *trans* (across) and *resistor*. Since *X* is often used in place of *trans* and *R* is, of course, the symbol for a resistor, *XR* could very well be the symbol for a transistor.

WILLIAM G. SHEPARD  
*Seattle, Washington*

## CONTACTS

EST. SINCE 1927

**FLUXES**  
SODERING  
BRAZING & WELDING

**ALLEN**

L. B. ALLEN CO. INC. Chicago 31, Ill.  
6751 BRYN MAWR AVE.

ETCHED CIRCUITS  
**24 HOUR SERVICE**  
On  
SAMPLES, MODELS & PROTOTYPES  
SILK SCREENS MADE TO ORDER

**ROWE ENGRAVERS**  
492 E. 39 St. Paterson 4, N. J.

## MANUFACTURER'S REPRESENTATIVES

As a service to readers, ELECTRONICS presents the advertisements for some of the leading manufacturer's representatives in the electronics industry. These firms are qualified to help the Manufacturer with his distribution problems; the Buyer with his product needs.

### S. BOSWORTH & CO.

*Engineering Sales Representatives*  
PRECISION ELECTRONIC INSTRUMENTATION  
COMPUTERS—CONTROLS  
Industrials—Aircraft—Government—Universities  
In Metropolitan New York and Adjoining Areas  
244 Old Country Road, Hicksville, L. I., New York  
Hicksville 4-2232

### ART CERF & CO. *Manufacturers' Representatives*

LEADING ELECTRONIC LINES  
Regular Coverage • 10 Men  
16 States and District of Columbia

Phone: Mitchell 2-6734  
744 Broad St.  
NEWARK 2, N. J.

### PAUL HAYDEN *Associates*

ENGINEERING

Calling on {  
JOBBERs  
INDUSTRIALS  
AUDIO SPECIALISTS

P. O. Box 331, EAST POINT, GA.  
Telephone (Atlanta): FAirfax 9646  
BRANCH OFFICES AT

Burlington, N. C. • Birmingham, Ala. • Mt. Dora, Fla.

### SAMUEL K. MACDONALD, INC.

*manufacturers representatives over 25 years*  
1531 SPRUCE STREET, PHILA. 2, PA.

Territory:  
Pennsylvania • New Jersey  
Delaware • Maryland  
Virginia • West Virginia  
District of Columbia

Other Offices:  
Pittsburgh  
Baltimore  
Washington, D. C.

### "OUR FOURTH YEAR" The NEWHOPE CORPORATION

Lee Rocks, Associate  
A Sales Organization for the  
RADIO, TV and ELECTRONIC INDUSTRIES  
Four salesmen concentrating in Metropolitan New York City and New Jersey—in a 50-mile radius

Telephone: LEExington 2-7372  
6 East 39th Street New York 16, New York



*An Invitation*  
 TO DISCUSS YOUR FUTURE  
 WITH THE WORLD'S LEADING  
 PRODUCER OF SEMICONDUCTORS

### LOOK AT THIS RECORD OF GROWTH

A few short years ago, a handful of people pioneered advanced semi-conductor development at Transitron.

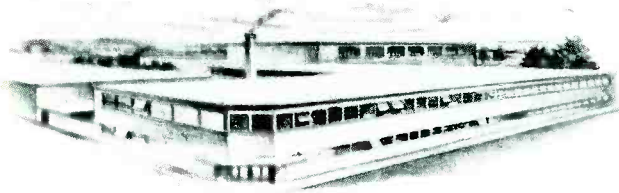

Today Transitron employs over 500 people in a modern plant of 65,000 square feet at Melrose, Massachusetts.

### AND NOW... FURTHER EXPANSION

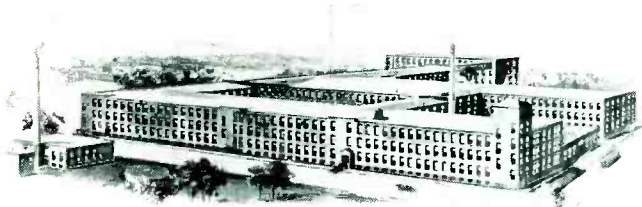

A newly modernized second plant of 250,000 square feet is being equipped at Wakefield, Massachusetts.

If you're in search of real opportunity, you'll find your professional horizons unlimited at Transitron. In a few short years this young company has carved out a leading position in the field of semiconductors. It is now undergoing further expansion into a second plant of 250,000 square feet.

Here is your chance to work with stimulating, congenial associates in an atmosphere of progress — informal and *free of red tape*. You'll be located in pleasant, suburban Boston, in the heart of one of America's technical centers — where cultural and educational advantages are found for you and your family. And you're only an hour's drive from New England's vacationland!

So, if your experience is any of these fields:

SOLID STATE PHYSICS      ELECTRICAL ENGINEERING  
 METALLURGY                  SALES ENGINEERING  
 MECHANICAL ENGINEERING      PRODUCTION ENGINEERING

... there is an unparalleled opportunity for you *right now* with Transitron. Salaries are attractive; vacation, insurance and retirement benefits are liberal and your opportunities for professional growth are unlimited.

A letter to Transitron with your resume will receive our prompt attention, and will be held in strictest confidence. Transitron Electronic Corporation, Telephone: MELrose 4-9600.

**Transitron** electronic corporation  
 melrose 76, massachusetts

"The MARK of Quality in Electronics"



**Bendix**

**needs  
ELECTRONIC  
and  
MECHANICAL  
ENGINEERS  
in  
SOUTHERN  
CALIFORNIA**

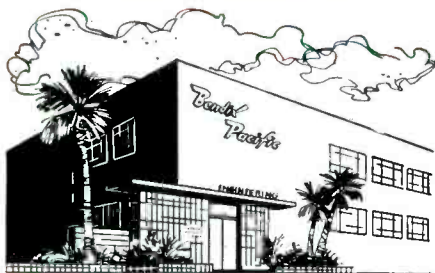

Unusual engineering positions in electrical and mechanical design of radar, sonar and telemetering are available. These positions, which are directly associated with our long-range projects for industry and for defense, are available at all levels.

Now nearing completion at Bendix-Pacific is the new Engineering Center. With more than 100,000 square feet of area it represents the latest and one of the most complete engineering facilities in the nation.

You are invited to consider becoming a member of this vital engineering group — with a forward looking company in Southern California.

Please fill in the coupon or write us for complete information.

W. C. Walker, Engineering Employment Manager  
Pacific Division, Bendix Aviation Corp.  
11608 Sherman Way, North Hollywood, Calif.

Please send information.

I am a graduate engineer with \_\_\_\_\_ degree.  
I am not a graduate engineer but have \_\_\_\_\_ years experience.

Name \_\_\_\_\_

Address \_\_\_\_\_

City \_\_\_\_\_ Zone \_\_\_\_\_ State \_\_\_\_\_



**SYLVANIA'S  
CALIFORNIA RESEARCH LABORATORY**

(San Francisco Bay Area—Near Palo Alto)

*Needs experienced creative engineers for a long range research and development program in microwave electronic systems and components. Also needs experts in design and custom packaging of specialized electronic communications equipment.*

**We have specific openings for  
ENGINEERING SPECIALISTS and SENIOR ENGINEERS in:**

**SYSTEMS ANALYSIS** For weapons systems planning, operational analysis and data handling problems.

**MICROWAVE ANTENNAS** For investigation of new concepts in polarization and pattern control, direction finding and multi-function radiators.

**MICROWAVE CIRCUITS** For advancements in synthesis of filters, broadband mixers, power dividers, etc., involving modern techniques of stripline, ridge guide and periodic structures.

**TRANSMITTER DEVELOPMENT** For research and development involving microwaves and pulse techniques.

**FIELD ENGINEERING** For advanced engineering field tests of prototype equipment.

**COMMUNICATIONS SYSTEMS** For design and development of complex communications systems.

*Sylvania offers the finest facilities and equipment available. We also provide financial support for advanced education, as well as a liberal insurance, pension and medical program.*

*Our Laboratory is located 5 miles from Palo Alto in the San Francisco Bay area, close to excellent schools and universities, unexcelled living conditions, ideal climate and ample housing.*

**RELOCATION EXPENSES PAID**

Please send complete resume to  
**JOHN C. RICHARDS**  
Electronic  
Defense  
Laboratory  
Box 205  
Mountain View,  
California

**ELECTRONIC**

**DEFENSE LABORATORY**

*All inquiries  
will be answered  
within two weeks.*



**SYLVANIA**  
SYLVANIA ELECTRIC PRODUCTS INC.



If you qualify, here is the  
**KEY TO YOUR FUTURE**

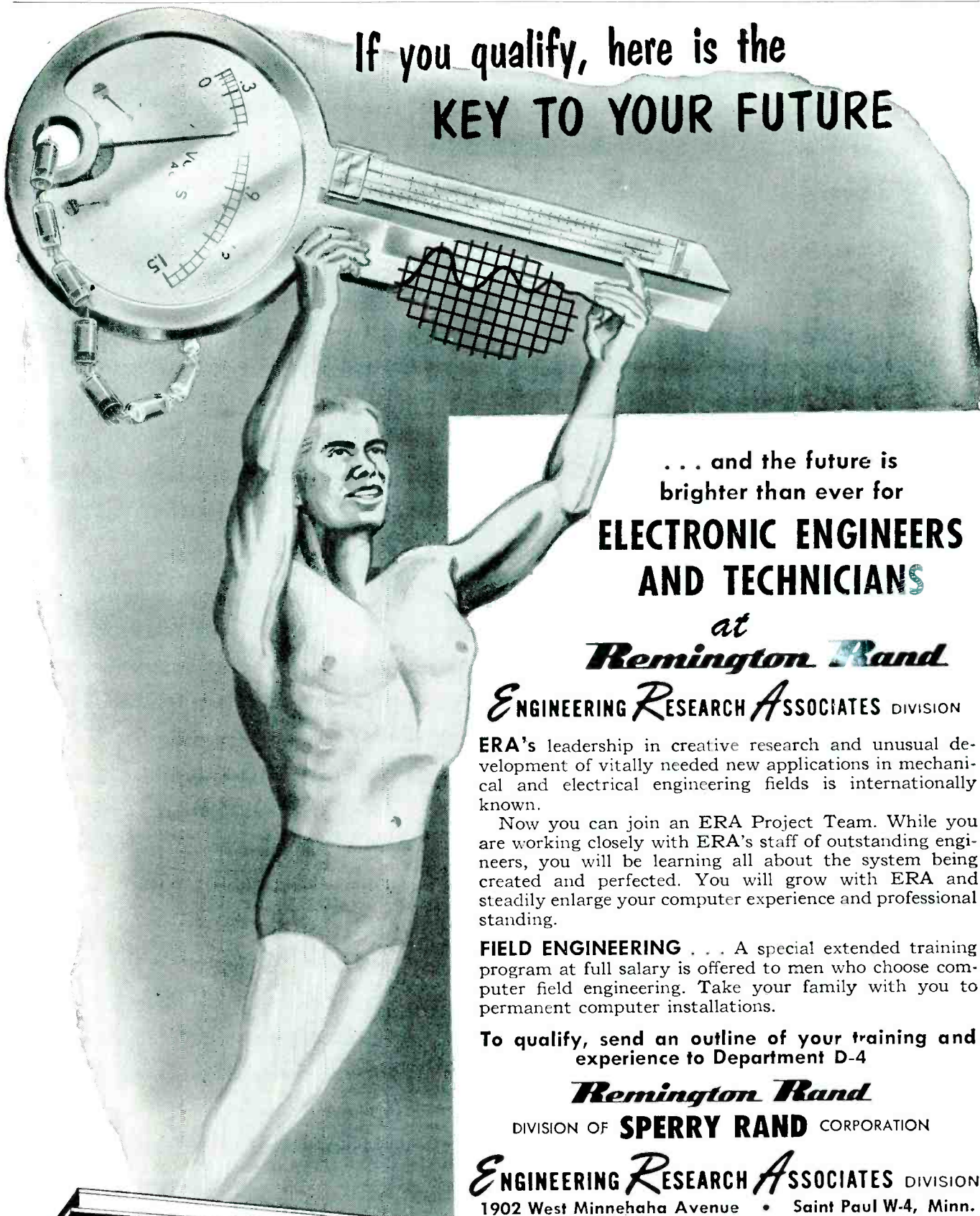

... and the future is  
 brighter than ever for  
**ELECTRONIC ENGINEERS  
 AND TECHNICIANS**

at  
*Remington Rand*

*ENGINEERING RESEARCH ASSOCIATES* DIVISION

ERA's leadership in creative research and unusual development of vitally needed new applications in mechanical and electrical engineering fields is internationally known.

Now you can join an ERA Project Team. While you are working closely with ERA's staff of outstanding engineers, you will be learning all about the system being created and perfected. You will grow with ERA and steadily enlarge your computer experience and professional standing.

**FIELD ENGINEERING** . . . A special extended training program at full salary is offered to men who choose computer field engineering. Take your family with you to permanent computer installations.

To qualify, send an outline of your training and experience to Department D-4

*Remington Rand*

DIVISION OF **SPERRY RAND** CORPORATION

*ENGINEERING RESEARCH ASSOCIATES* DIVISION

1902 West Minnehaha Avenue • Saint Paul W-4, Minn.



Behind RCA's 1955 record...

Behind RCA's 1956 opportunities...

Stand these RCA advantages for you!

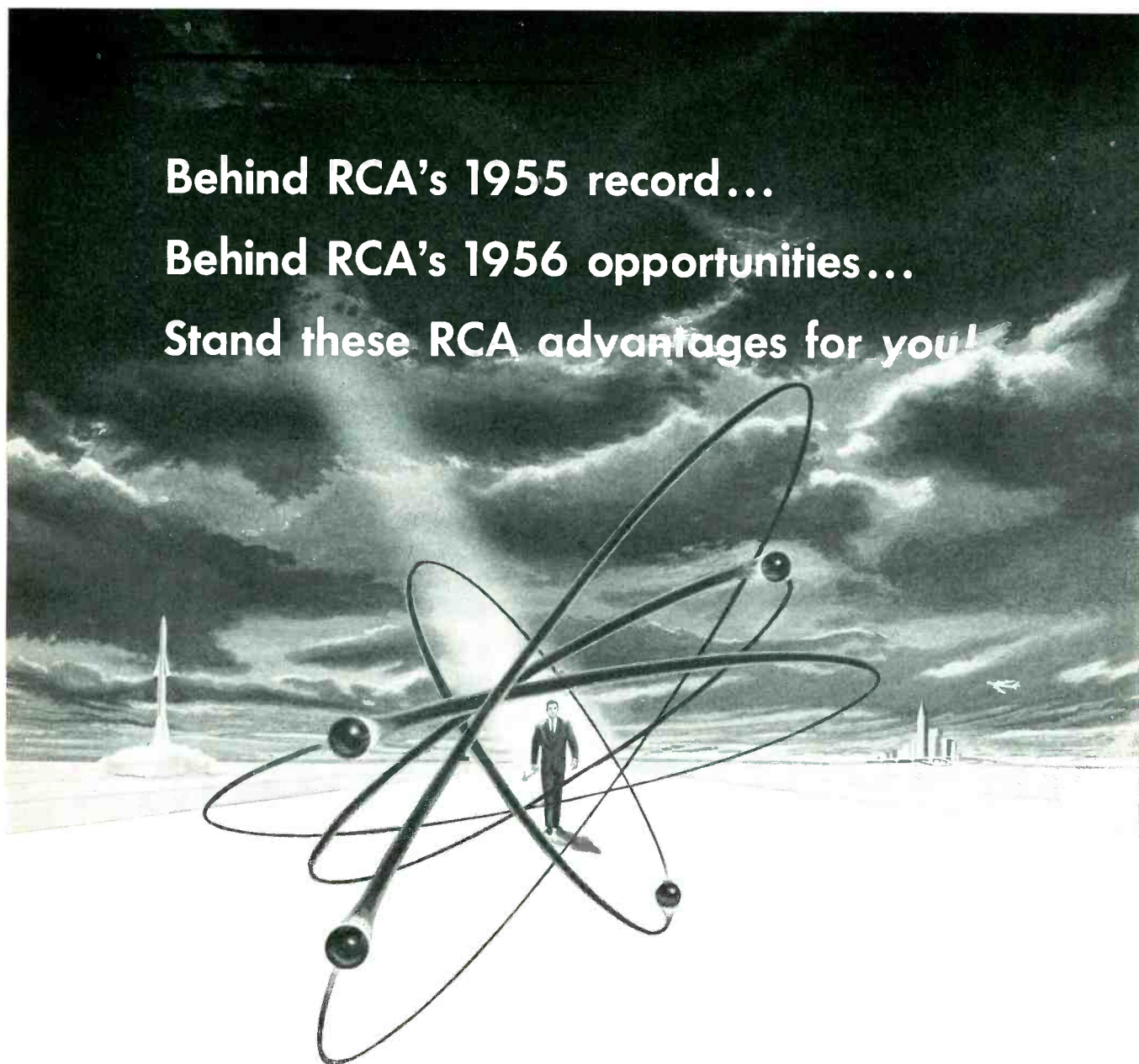

**SALARIES**—At RCA, engineering salaries average measurably higher than those of other companies in the field. Intermediate engineers range from \$5000 to \$8500, senior engineers from \$8500 to \$15,000. Staff and supervisory salaries open

**INDIVIDUAL RECOGNITION**—RCA organizes engineering activities into groups small enough to allow broadest scope for your individual accomplishment. The average group has just 11 engineers. Yet, in all activities, you are backed by the entire facilities and engineering resources of RCA.

**LOCALITIES**—At Camden or Moorestown, you enjoy the educational advantages of Greater Philadelphia, with moderate-cost living in pleasant suburban communities. Waltham offers at-home opportunity for New England engineers. Los Angeles, ideal West Coast location.

Harrison lies next to Greater New York. Lancaster and Findlay have small-city advantages.

**ADVANCEMENT**—Regular, objective appraisal of your work speeds your promotion. Professional and financial progress is just as sure as your achievements make it.

**PROFESSIONAL STATUS**—RCA world leadership in electronics is based on the abilities of exceptional men on every organizational level. Many have widely known engineering and scientific reputations. You work in day-by-day association with these leaders.

**BENEFITS**—There's a complete program at RCA. A very liberal Tuition Refund Plan. Company-paid life, sickness and accident, hospital-surgical insurance for you and your family. Modern retirement plan. Relocation assistance, suggestion and patent awards.



1955

OVER 600 EXPERIENCED ENGINEERS AND SCIENTISTS\* CHOSE RCA SYSTEMS, DESIGN OR DEVELOPMENT CAREERS

1956

NEW SYSTEMS, DESIGN AND DEVELOPMENT POSITIONS AT RCA OPEN HIGH-LEVEL OPPORTUNITY FOR YOU!

\*Plus hundreds of field service, recent graduates and other engineers.

FIELDS OF ENGINEERING ACTIVITY	M A N A G E R S	TYPE OF DEGREE AND YEARS OF EXPERIENCE PREFERRED															
		Electrical Engineers			Mechanical Engineers			Physical Science			Chemistry Ceramics Glass Technology Metallurgy						
		1-2	2-3	4-15	1-2	2-3	4-15	1-2	2-3	4-15	1-2	2-3	4-15				
<b>SYSTEMS</b> <i>(Integration of theory, equipments and environment to create and optimize major electronic concepts.)</i>																	
<b>AIRBORNE FIRE CONTROL</b>				W			M					W					
<b>DIGITAL DATA HANDLING DEVICES</b>	M			C			C					C					
<b>MISSILE ELECTRONICS • RADAR</b>	M			M	X		M					M					
<b>INERTIAL NAVIGATION</b>	M			M			M					M					
<b>COMMUNICATIONS</b>				C								C					
<b>DESIGN • DEVELOPMENT</b>																	
<b>KINESCOPES (B &amp; W and COLOR), OSCILLOSCOPES</b> —Electron Optics—Instrumental Analysis—Solid States (Phosphors, High Temperature Phenomena, Photosensitive Materials and Glass to Metal Sealing)			L	L	L	L	L	L	L	L	L	L	L	L	L	L	L
<b>RECEIVING TUBES</b> —Tube Design—Test and Application Engineering—Chemical and Physical Development—Methods and Process Engineering—Advanced Development			H	H	H		H	H				H	H			H	H
<b>SEMI-CONDUCTORS</b> —Transistors—Semi-Conductor Devices—Materials			H	H	H	H	H	H	H	H	H	H	H	H	H	H	H
<b>MICROWAVE TUBES</b> —Tube Development and Manufacture (Traveling Wave—Backward Wave)	H		H	H			H	H				H	H			H	H
<b>GAS, POWER AND PHOTO TUBES</b> —Photosensitive Devices—Glass to Metal Sealing			L	L	L	L	L	L	L	L	L	L	L	L	L	L	L
<b>AVIATION ELECTRONICS</b> —Radar—Computers—Servo Mechanisms—Shock and Vibration—Circuitry—Remote Control—Heat Transfer—Sub-Miniaturization—Automatic Flight—Design for Automation—Transistorization	M	C	M	C	M	C	M	C	M	C	M	C	M	C	M	C	
<b>COMPUTERS</b> —Systems—Advanced Development—Circuitry—Assembly Design—Mechanisms—Programming			C	C	M	C	C	C	M	C	C	C	C	C	M	C	
<b>RADAR</b> —Circuitry—Antenna Design—Servo Systems—Gear Trains—Intricate Mechanisms—Fire Control	M	C	M	C	M	C	M	C	M	C	M	C	M	C	M	C	
<b>COMMUNICATIONS</b> —Microwave—Aviation—Specialized Military Systems			C	C	C		C	C				C	C				
<b>RADIO SYSTEMS</b> —HF-VHF—Microwave—Propagation Analysis—Telephone, Telegraph Terminal Equipment			I	I	I		I	I				I	I				
<b>MISSILE ELECTRONICS</b> —Systems Planning and Design—Radar—Fire Control—Shock Problems—Servo Mechanisms	M		M	M	M	M	M	M	M	M	M	M	M	M	M		
<b>COMPONENTS</b> —Transformers—Coils—TV Deflection Yokes (Color or Monochrome)—Resistors			C	C	Z	C	C	Z	C	Z	C	C	C	C	C		Z
<b>MACHINE DESIGN</b> Mechanical and Electrical—Automatic or Semi-Automatic Machines				L	L			L		C	L		L	L			

Locations: C—Camden, N.J. H—Harrison, N.J. I—International Div L—Lancaster, Pa. M—Moorestown, N.J. W—Waltham, Mass. X—Los Angeles, Calif. Z—Findlay, Ohio

Modern benefits program . . . Liberal relocation assistance.

Please send resume of education and experience, with location preferred, to:

Mr. John R. Weld, Employment Manager  
Dept. A-15M, Radio Corporation of America  
30 Rockefeller Plaza, New York 20, N. Y.



**RADIO CORPORATION of AMERICA**

Copyright 1955 Radio Corporation of America

TO THE FINE ENGINEERING MIND  
SEEKING THE CHALLENGING PROJECTS IN

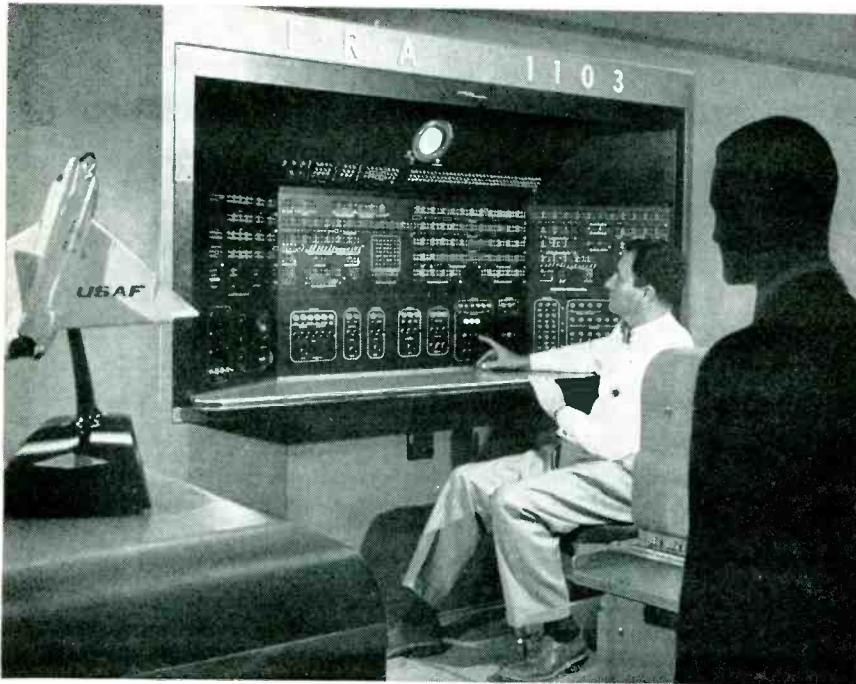

**ELECTRONICS**

**ELECTRONICS ENGINEERS** are urgently needed to fill top career openings at Convair in beautiful San Diego, California. Qualifications include experience in missile guidance systems, microwave techniques, digital computers, servomechanisms, test equipment design, circuit analysis, transistor and magnetic amplifier circuit design, and electronic reliability. Antenna engineers also needed for airborne antenna research and development projects.

**CONVAIR** offers you an imaginative, explorative, energetic engineering department...truly the "engineer's" engineering department to challenge your mind, your skills, your abilities in solving the complex problems of vital, new, long-range programs. You will find salaries, facilities, engineering policies, educational opportunities and personal advantages excellent.

Generous travel allowances to engineers who are accepted. Write at once enclosing full resume to:

H. T. BROOKS, ENGINEERING PERSONNEL, DEPT. 912

**CONVAIR**

A Division of General Dynamics Corporation  
3302 PACIFIC HIGHWAY  SAN DIEGO, CALIFORNIA

**SMOG-FREE SAN DIEGO**, lovely, sunny city on the coast of Southern California, offers you and your family a wonderful, new way of life...a way of life judged by most as the Nation's finest for climate, natural beauty and easy (indoor-outdoor) living. Housing is plentiful and reasonable.

REPLIES (Box No.): Address to office nearest you  
NEW YORK: 330 W. 42nd St. (36)  
CHICAGO: 520 N. Michigan Ave. (11)  
SAN FRANCISCO: 68 Post St. (4)

**POSITION VACANT**

**Instrument Maker—Electronics—Technical** school training in electronics with 3 to 4 years experience in repair, maintenance and development work on electronic instruments. Knowledge of physics and radiation-detection instruments desirable. Appointment before January 1956. Starting salary \$80-\$90 per week depending on qualifications; \$90-\$105 for higher qualifications. Vacation, sick leave, hospitalization, Social Security. Reply Box 117, Oak Ridge, Tennessee.

**POSITION WANTED**

**Component Parts Engineer** specialized in small electronics parts with a practical reliability philosophy for missile environments. Fifteen years experience in aircraft and missile electronics. Desires a responsible position where evaluation and test methods can be of value. PW-7311, Electronics.

**SELLING OPPORTUNITY WANTED**

**Detroit Manufacturer's Agents, Established** twenty years. Clientele with Automotive, Chemical and Metal Industries in Laboratory, Engineering and Operating office. Complete Chemical, Metallurgical and Electronics education and broad experience. Have new fully equipped electronics service shop. RA-8334, Electronics.

**PART-TIME WORK WANTED**

**Seattle sales engineer** seeks part-time work for supplier. Aircraft only. PTWW-8261, Electronics.

**MANUFACTURERS REPRESENTATIVE**

Engineer desires repeat and expandable electronic and electro-mechanical products for sale to Guided Missile and Aircraft Companies located in Southern California. Reply to:

**LEE GRANT SNYDER COMPANY**  
Technical Sales & Contract Administrators  
1418 N. Highland Ave. Hollywood 28, Calif.  
Phone Hollywood 9-6278

**DRAKE PERSONNEL**

National Placement Center for  
**EXECUTIVE AND  
TECHNICAL PERSONNEL**

General and Plant Managers  
Plant Superintendents—Foremen  
Accounting—Staff Personnel  
Engineers: Design—Production  
Sales Managers—Engineers

Please outline briefly your  
experience or personnel needs to:

John Cope  
220 S. State St., Chicago 4, Ill.  
Harrison 7-8600

**ENGINEERS — SCIENTISTS**

**\$6,000 - \$20,000**

World Wide Coverage

**NO FEE**

Thousands of engineers have used National as a clearing house—let us assist you.

Send detailed resumes

Specify positions preferred and choice of geographic locations

1108 - 16th St., N.W. Wash. 6, D. C.

**NATIONAL EMPLOYMENT SERVICE**

**Assistant to President, Chief Engineer** Moderate size, extremely progressive manufacturer electro-mechanical and electronic devices starting 2nd plant. President, general manager, desires man familiar with engineering, tooling and manufacture to assume some of the increased managerial work load. Starting salary 10,000 to 13,500. Company pays fees, relocation expense.

**MONARCH PERSONNEL**  
28 E. Jackson Blvd. Chicago 4, Ill.



# A new Bendix Radio Engineering Building

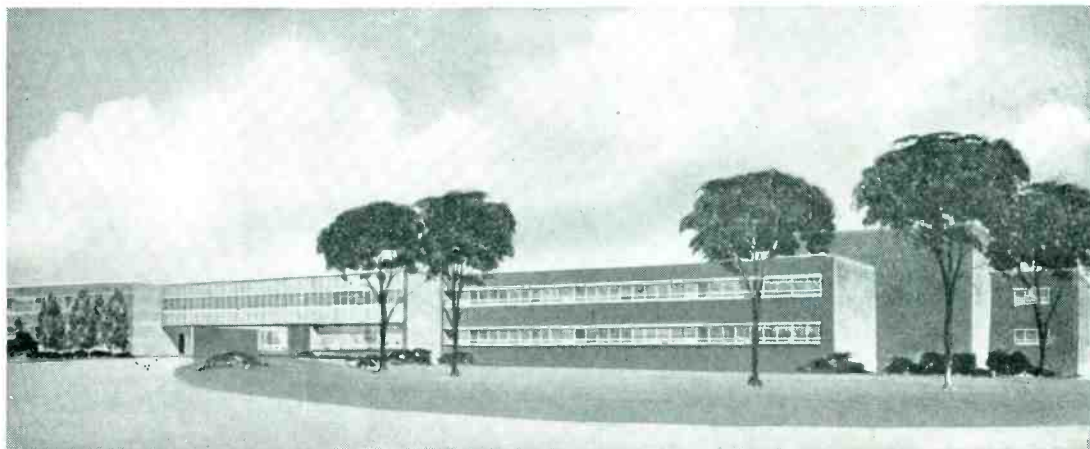

## AND WHAT IT CAN MEAN TO YOUR FUTURE!

### ELECTRONIC ENG. PHYSICISTS MECHANICAL ENG.

Our new Engineering Building is one manifestation of our continuing rapid growth. Yes, we are expanding both our government and commercial business. This means you can step up your engineering career fast with us! You'll benefit from top salaries . . . a secure future . . . placement at highest level of your capabilities . . . pleasant living in beautiful residential area. Simply drop us a postal card, briefly stating your education and experience. We'll act fast . . . and confidentially!

*More AHEAD with Bendix!*

*Do research, development & design in these fields:*

- COMPUTERS
- RADAR (Fixed, Airborne, Mobile)
- AIRBORNE COMMUNICATIONS & NAVIGATION EQUIP.
- MISSILE GUIDANCE SYSTEMS
- MOBILE COMMUNICATIONS
- AUTO RADIO
- MICROWAVE DEVELOPMENT
- TRANSISTOR APPLICATIONS
- TECHNICAL WRITING
- RADAR FIELD ENG.

Address: Personnel Manager, Dept. J

# Bendix Radio

DIVISION OF  
BENDIX AVIATION  
CORPORATION

Baltimore 4, Maryland

**RAYTHEON** Excellence in Electronics



*Excellent for Engineers*

**SPECIFICATIONS ENGINEER**

Three or more years of experience in electronic design or applications engineering. Familiarity with military specifications and technical writing experience desirable.

**SYSTEMS ENGINEERS**

Responsible experienced engineers required for design and development of airborne electronic systems including navigational and fire control systems. Systems engineers also required for integration of missile system with aircraft fire control systems.

**CIRCUIT DESIGN ENGINEERS**

Positions available at all levels from recent graduates to engineers with relevant supervisory experience. Electronic circuit design experience required. Should be capable of independent design and analysis for work in development of circuits for complex radar and missile systems.

**SYSTEMS ANALYSIS ENGINEERS**

For synthesis and analysis of complex missile guidance and radar systems. Degree in electrical engineering or physics and three or more years experience in servo, feedback control systems, and dynamics required. Familiarity with noise theory desirable.

**ELECTRONIC PACKAGING ENGINEERS**

For packaging of electronic units of radar and missile systems. EE or ME degree required and three or more years experience in design or packaging.

• **MISSILE AND RADAR DIVISION** •

Continued expansion of Raytheon's Missile and Radar Division has created long range opportunities for experienced engineers. This Division is engaged in all phases of missile development from study programs through design, development, and flight testing to production. Prime contracts for missile systems involve overall responsibility for system design including airframe, guidance, motor and auxiliary equipment. This Division is located 20 miles from Boston, offering a choice of urban or country living, excellent recreational facilities and proximity to Boston's educational and entertainment advantages.

**GENERAL INFORMATION**

Salary and advancement commensurate with ability. Liberal vacation, sick leave, group life and health insurance and a worthwhile pension system. Tuition support plan for engineering courses. Relocation expenses paid. Write giving details on experience to G. P. O'Neil. A mutually convenient time for interview will be arranged.

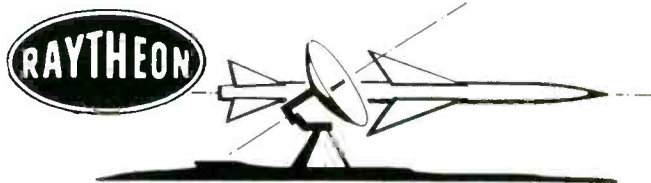

MISSILE AND RADAR DIVISION - BEDFORD, MASS.

**ENGINEERS**  
**Honeywell**

"First in Controls"  
**OFFERS EXCELLENT OPPORTUNITIES IN RESEARCH**

... including analysis of electronic controls and control systems, using control theory and analog tests. Variety of other applied research activities.

**DEVELOPMENT**

... of electronic and electromechanical devices for detection and control of all types of industrial process variables.

... development and design of complex industrial instrumentation systems, data reduction and data handling systems.

... development of pneumatic and mechanical devices for flow measurement and control and other small electromechanical controls and recording instruments.

**APPLICATION**

... personal contact with customers, determining exact needs for custom-built devices or systems, determine feasibility of manufacturing special products by estimating engineering time necessary, etc.

**Excellent Opportunities FOR MEN WITH**

- 1.—A degree in E.E., M.E. or Physics
- 2.—From 1 to 7 yrs' experience in instrumentation or similar fields
- 3.—Group or Project Leader Potential

Send a confidential resume of your qualifications for consideration in the area of your interest.

**HONEYWELL**  
**BROWN INSTRUMENTS**

Wayne & Windrim Avenues  
Philadelphia 44, Pa.

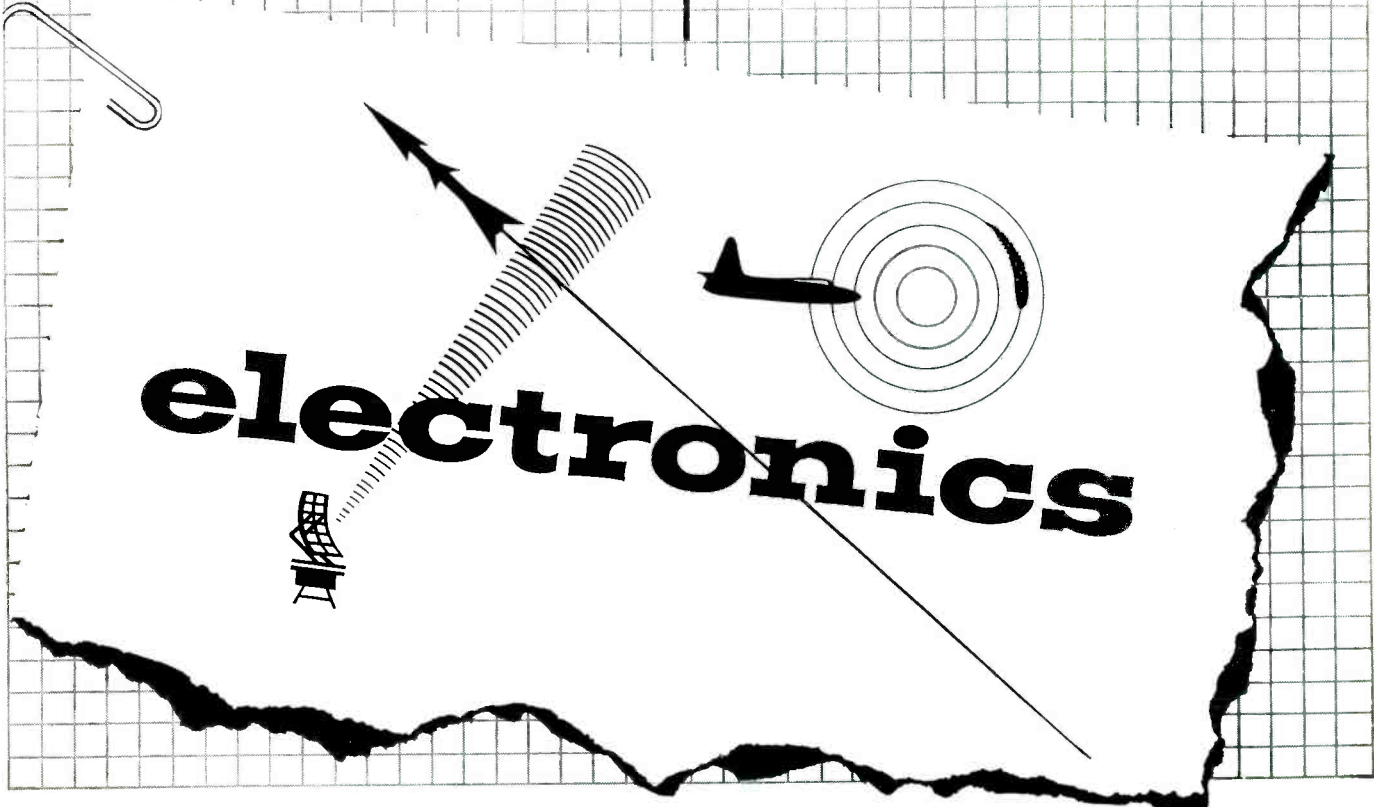

**E**ngineering**D**esign**R**esearch**D**evelopment

**electronics**

Among the challenging assignments which foretell bright futures for engineers at Goodyear Aircraft Corporation — consider what goes on at Goodyear in the field of electronics:

Consider "ATRAN," the all-weather electronic equivalent of a contact pilot—pioneered, patented and produced at Goodyear Aircraft. Still "under wraps" for the military — it is a device with a brilliant commercial future, *the most brilliant performer in its field!*

Consider "GEDA" — the Goodyear-built analog computer, stalwart of one of the world's largest computer laboratories—facilities readily available to creative engineers who come to Goodyear

Aircraft where you're invited to explore new avenues of approach to problems.

Consider radomes, ground and air-borne radar, test equipment for cross-talk and deflection. And beyond the locked doors: interesting and complete challenges in the fields of missiles, weapons systems and new concepts involving electronic nerve centers.

Consider—by all means—what the future can mean for you at Goodyear Aircraft! Send resumé, request application: C. G. Jones, Personnel Department, Goodyear Aircraft Corporation, Akron 15, Ohio. Plants in Akron and Litchfield Park, Arizona.

ATRAN, GEDA — T.M.'s Goodyear Aircraft Corporation, Akron 15, Ohio

**T**hey're doing big things at

**GOOD YEAR AIRCRAFT**

THE TEAM TO TEAM WITH in AERONAUTICS

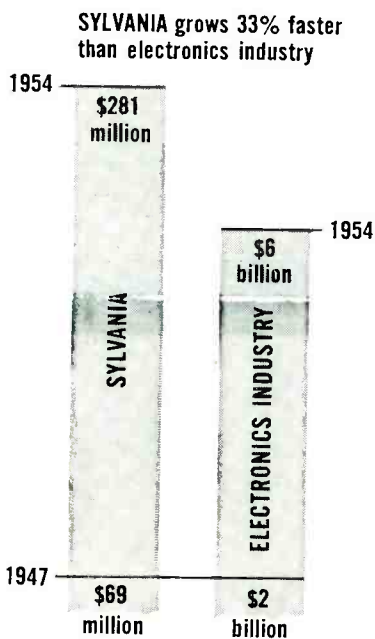

## ENGINEERS

Your Future  
Lies with a  
**GROWTH**  
Firm in a  
**GROWTH**  
Industry

You can move up fastest and most securely with a firm that grows ... in an industry that grows.

Projected growth of the electronics industry is more than double for the next ten years. Past indications prove that your best chance for a career is with Sylvania... in the past eight years Sylvania has grown 33% faster than the electronics industry of which it is a part.

*Join Sylvania now and grow with it.*

### WALTHAM Engineering

Majors in E.E., M.E., Math, Physics. Research & Development experience in—

Countermeasures  
Systems Analysis  
Transistor Applications  
Noise Studies  
Antenna Res. & Dev.  
Systems Development  
Mechanical Design  
Miniaturization  
Digital Computer  
Circuits & Systems  
Circuit Designs  
Shock & Vibration  
Technical Writing  
Missile Analysis

### Missile Systems Laboratory

Radar Research & Development  
Missile Guidance & Ground  
Equipment Analysis  
Systems Evaluation Operations  
Research

### BUFFALO Engineering

Majors in E.E., Math or Physics. Experience in Advanced Development and Product Design

Information Theory  
Advanced Circuit Design  
VHF-UHF Systems Design  
& Evaluation  
Logical Circuit Design  
Mathematical Analysis for  
Numerical Computation  
Pulse Techniques  
Data Processing Devices  
Components & their Applications  
Magnetic Amplifier Techniques  
Servo Techniques & Applications  
Digital Computer Design  
Control Circuits & Devices

### INTERVIEW & RELOCATION EXPENSES WILL BE PAID BY SYLVANIA

Sylvania provides financial support for advanced education as well as liberal insurance, pension and medical programs.

Please forward resume to: Professional Placement Supervisor

Thomas A. Tierney | Randall A. Kenyon  
100 First Ave. | 175 Great Arrow Ave.  
Waltham, Mass. | Buffalo 7, N. Y.

Your inquiries will be answered within 2 weeks

 **SYLVANIA**   
SYLVANIA ELECTRIC PRODUCTS INC.

## DEVELOPMENT ENGINEERS

PROJECT  
SENIOR  
INTERMEDIATE

- Antenna & Microwave Systems & Components
- Pulse & Radar Circuitry
- Telemetering Systems
- Communications
- Navigational Systems

TAKE A STEP TOWARD THE  
FUTURE WITH . . . . .

the progressive and well established Maryland Electronic Manufacturing Corporation.

We've grown to now number more than 300 employees . . . steady growth, too, with never a layoff. Because MEMCO is an engineering-managed organization we feel that we offer an exceptional atmosphere for personal growth, with real opportunity for your recognition and advancement.

Here's what you **MEMCO**  
will find at

- Modern, complete and self-sufficient engineering and production facilities in suburban College Park, Md. 6 miles from Washington, D. C.
- Attractive salaries and profit sharing plan.
- Aid and encouragement in the presentation of technical papers plus the educational opportunities at 4 nearby universities.
- Suburban living with fine schools and housing plus the cultural advantages of the nation's capitol.
- A real challenge for imaginative and energetic engineering talent.

For interview please write  
Mr. J. E. Richardson

**MARYLAND  
ELECTRONIC**  
Manufacturing Corporation

5009 Calvert Road  
College Park, Maryland



Here's Proof that

# Burroughs Means Business!



- Engineers
- Physicists
- Mathematicians
- Administrators

## Yes, There Is Something New Under The Sun . . .

### New 86,000 Sq. Ft. LABORATORY ADDITION

New work under contract at the Burroughs Research Center has saturated our present facilities, making necessary the erection of the new 86,000 Sq. Ft. addition pictured above to assure an uninterrupted continuity in the planned expansion of our activities for industry and government.

. . . and we here at Burroughs, believing that there are entirely new, undiscovered concepts and approaches in the Field of Computers, Solid State Techniques, Data Processing and Transmission, Automation and Process Control are expanding the scope of our research functions in order to find the ideas needed to meet the anticipated needs of industry and government. To accomplish this end we are offering unlimited opportunity for a parallel personal growth to qualified people in all levels of engineering, physics and administration.

**If you can let yourself go . . . think and create new ideas in the above fields . . .**

### ACT NOW!

*For a Personal Interview at YOUR Convenience . . .*

PLEASE WRITE OR CALL

**M. E. JENKINS**, Professional Placement Manager  
 PHONE: PAOLI 3500 Paoli, Pa.

Our Company benefits will meet the most exacting standard . . . our pay is commensurate with your ability and if you seek advancement and responsibility, THIS IS IT!

PERSONNEL GAINS SINCE DEC. 31, 1954

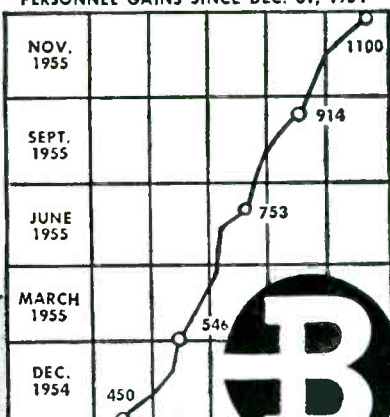

# Burroughs

## RESEARCH CENTER

Paoli, Pa. • On Philadelphia's Beautiful Main Line

WORK AND LIVE WHERE THE BEST IN EVERYTHING IS AVAILABLE TO YOU AND YOUR FAMILY

99.07\*

ENGINEERS  
and DESIGNERS

Stay with



THE ELECTRONICS DIVISION  
OF  
GENERAL MOTORS

\* Our current monthly turn-over figures are phenomenally good. Have been, we are proud to say, for years. It speaks well for the job opportunities, working conditions and the wages we pay our Engineers and Designers. Investigate for your future. Write us today.

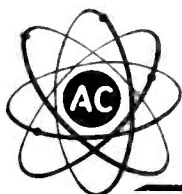

Write today for Employment Application:  
Mr. Louis R. Berks, Supervisor of Employment

AC SPARK PLUG • THE ELECTRONICS DIVISION  
GENERAL MOTORS CORPORATION  
MILWAUKEE 2, WISCONSIN

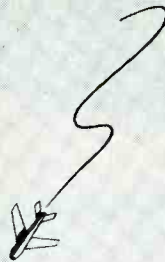

PIONEERING  
OPPORTUNITIES  
in the following fields!

- MISSILE GUIDANCE SYSTEMS
- JET and TURBO PROP ENGINE CONTROLS
- BOMBING NAVIGATIONAL COMPUTER SYSTEMS
- AIRBORNE FIRE CONTROL
- U.H.F. COMMUNICATIONS
- MICRO-WAVE EQUIPMENT



## ELECTRONIC ENGINEERS

Young men interested in design development of UHF, VHF and other TV equipment will find excellent opportunity for valuable training and advancement in lab of engineer-owned manufacturer of specialized TV products.

No government work. Degree not essential if otherwise qualified. Congenial surroundings. Liberal employee benefits.

Phone or write to:

### BLONDER-TONGUE LABS, INC.

526 North Avenue, East  
Westfield, New Jersey  
Westfield 2-7032

### ENGINEERS, TECHNICIANS AND OPERATIONAL ANALYSTS • FIELD SERVICE •

Experience in one or more of the following categories: Digital Computers, Ground Radar, Communications and Microwave.

DYNAMIC ELECTRONICS N. Y. Inc.  
73-39 Woodhaven Blvd., Glendale, L. I.  
Illinois 9-700—x-3 Mr. Schwartz

## ELECTRONIC ENGINEERS

Technical Operations, Inc., is looking for an electronic engineer with three to five years of experience, capable of supplying original ideas in the fields of transistor circuitry and operations research instrumentation. Join an expanding research and development organization located in suburban Boston. Please send complete resume and requirements to:

R. R. SMYTH  
**Technical Operations,  
Inc.**

6 Schouler Court Arlington 74, Mass.



# **Bendix** OFFERS

## **3 SENIOR ENGINEERING JOBS**

### **WELL WORTH LOOKING INTO...**

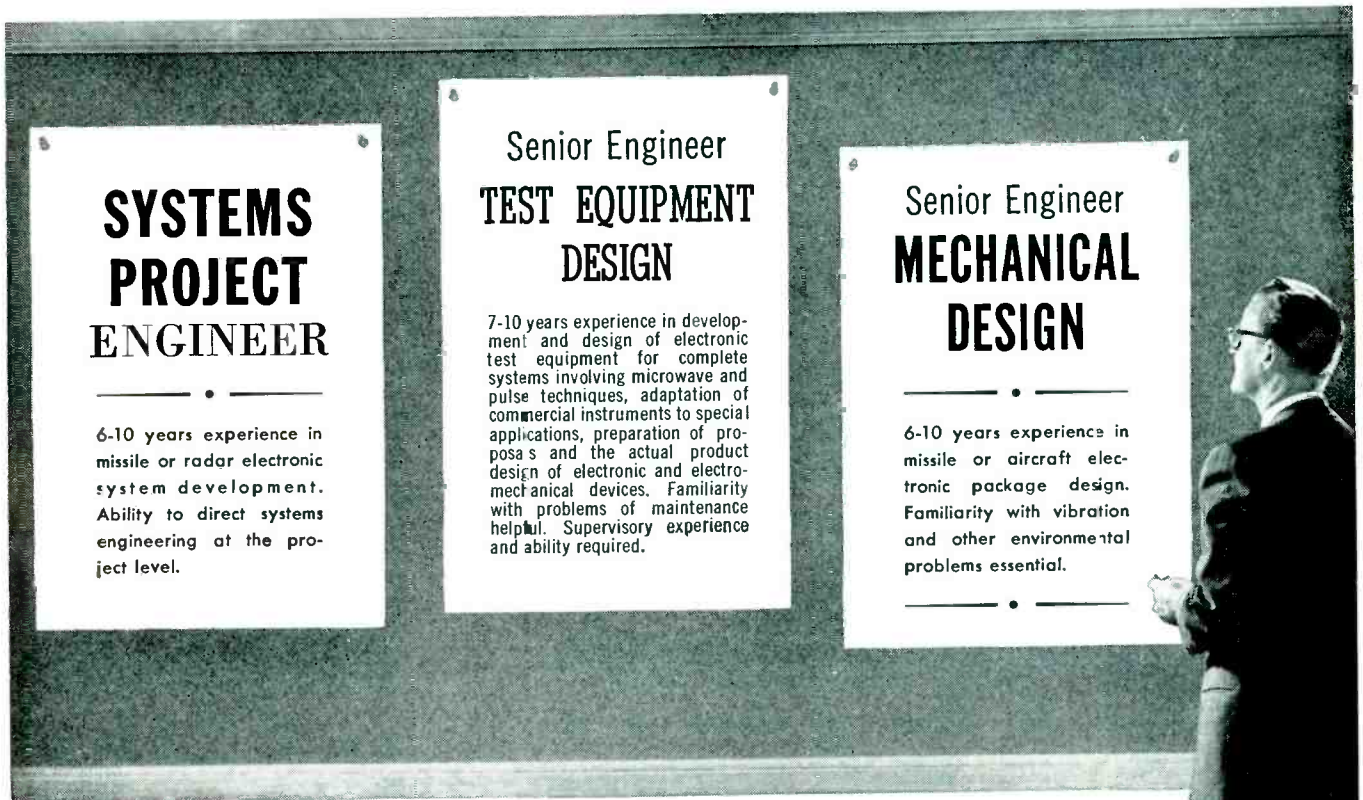

### **SYSTEMS PROJECT ENGINEER**

6-10 years experience in missile or radar electronic system development. Ability to direct systems engineering at the project level.

### **Senior Engineer TEST EQUIPMENT DESIGN**

7-10 years experience in development and design of electronic test equipment for complete systems involving microwave and pulse techniques, adaptation of commercial instruments to special applications, preparation of proposals and the actual product design of electronic and electromechanical devices. Familiarity with problems of maintenance helpful. Supervisory experience and ability required.

### **Senior Engineer MECHANICAL DESIGN**

6-10 years experience in missile or aircraft electronic package design. Familiarity with vibration and other environmental problems essential.

Here are three especially attractive job opportunities for engineers who want to get on the ground floor in the important, interesting, and challenging phase of a new industry—guided missiles.

Qualified men are given real job responsibilities with Bendix and grow with the development of what is not only the nation's most important weapon system, but a project that will undoubtedly lead to new and im-

portant long-range commercial application.

At Bendix you will be associated with top missile authorities and have at your command unexcelled engineering and manufacturing facilities. Salaries for these top jobs and other opportunities are open for discussion. Write today to: Mr. W. L. Webb, General Manager, Missile Section, Bendix Products Division, Bendix Aviation Corporation, 401 North Bendix Drive, South Bend, Ind.

## **23 OTHER ENGINEERING POSITIONS!**

Bendix also offers unusual job opportunities for assistant engineers, junior engineers, and technicians, as well as a score of other assignments. A 30-page book describing in

detail every phase of our guided missile operation will be sent to you on request. If you are interested in guided missiles, this book is bound to interest you. Write for it today.



CHALLENGING CAREERS AT RAYTHEON

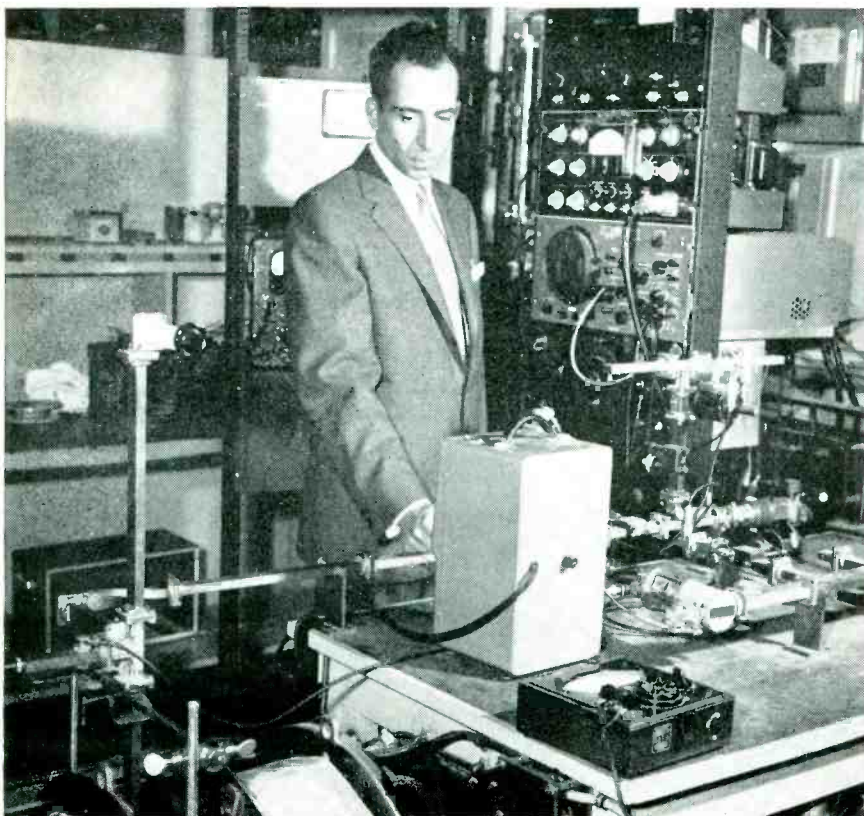

Studying ferromagnetic resonance. A cavity perturbation method is used, in which a ferrite specimen placed in a high Q microwave cavity changes cavity properties in accordance with electrical and magnetic properties of the material.

## Looking for a good place to grow?

When you join Raytheon you work in an atmosphere of progress. Advanced work on ferrites for microwave applications is proceeding in Raytheon's modern ceramic research facilities. Various types of gyrators, isolators and other ferrite microwave devices have resulted from development work in the equipment systems and component development laboratories.

University graduate study is encouraged through a tuition refund plan. Openings now for engineers, scientists in many areas including:

microwave tubes • special purpose tubes • guided missiles  
transistors • diodes • receiving tubes • TV receivers • radar  
metallurgy • ceramics • communications • cathode ray tubes  
sonar • servomechanisms • solid state physics • field engineering

Join a team where performance pays off. Please address inquiries to L. B. Landall, Professional Personnel Section.



**RAYTHEON MANUFACTURING COMPANY**

190 Willow St., Waltham 54, Mass.

Plants also located in California and Illinois

## ENGINEER

### MISSILE & WEAPONS CONTROL SYSTEMS STUDIES

Enjoy full use of your skill and imagination, and friendly, professional give and take with top men in the field of electromechanical precision equipment.

You will perform studies related to airborne weapons control and guidance systems with the object of determining requirements, feasibility, performance and specifications of computers and over-all systems.

A degree in physics, ME or EE—or the equivalent in experience—is required. Must be able to handle problems in such diversified fields as: digital computers, digital data transmission systems, logic counting and conversion circuits, high precision gyro and gimbal structures, dynamic behavior of missiles; alignment of inertial platforms for guidance systems, and flight evaluation of guidance systems and instrumentation. Send resume in confidence to:

Technical Personnel Dept. 2-580

### ARMA

Division American Bosch Arma Corp.  
Roosevelt Field, Garden City  
Long Island, N. Y.

## COMMUNICATIONS ENGINEERS and TECHNICIANS

EXCELLENT SALARIES  
MINIMUM PREREQUISITES

ENGINEER EE Graduates with 3 years experience  
TECHNICIAN 2 years technical school in communications and 3 years experience.

Require installation adjustment and maintenance experience with communication receivers and associated terminal equipment. Also, men with similar experience with high-powered transmitters, antennas, transmission lines.  
*Must be willing to travel in United States and Overseas.*

Page Communications Engineers, Inc.  
710 Fourteenth St., N.W., Washington 3, D.C.

## Systems Synthesis Engineer GUIDED MISSILES FIELD

A creative and responsible position with General Electric, a company noted for maintaining a stimulating environment for engineers.

Progress in the development of guided missiles has created an opportunity for an experienced engineer capable of applying a broad viewpoint to the problems of weapons systems and of using a creative approach to synthesize systems meeting military requirements.

At least ten to fifteen years experience is desirable, and should include a background in servo systems, radar systems, guidance systems, etc. An engineer with three to seven years experience will also be considered for work in carrying out the more detailed portions of the systems synthesis function.

THIS IS AN UNUSUAL OPPORTUNITY TO JOIN AN OUTSTANDING SCIENTIFIC STAFF IN WORK OF MAJOR IMPORTANCE FOR THE FUTURE.

Send complete resume to  
MR. JAMES HEVELIN  
SPECIAL DEFENSE PROJECTS DEPT.,  
Rm. 206E

**GENERAL ELECTRIC**

2900 CAMPBELL AVENUE  
SCHENECTADY, N. Y.



The Producer of  
**UNIVAC**

Is Expanding Its  
**Field Of Operations!**

Yes . . . these are all-important facts to men who are not content to follow established patterns created by others . . . but seek, by their own creative and pioneering instinct, to lead the field through the development of even **NEWER** and **MORE ADVANCED** methods to be incorporated into UNIVAC III.

Here at Remington Rand, the *first* name in electronic computing, we encourage creative thinking. Where others stop, we carry on with new applications and developments. That's why only Univac, with no "extra" equipment, can check its own work, read, write and compute *simultaneously*. To these already proved superior accomplishments add the speed of Univac II's magnetic-core storage — and you have the first electronic business data-processing system to use magnetic core storage successfully.

**To Qualified Men**  
**THE REMINGTON RAND**  
**UNIVAC DIVISION**  
**Offers**  
**Permanent, Well Paying**  
**ENGINEERING**  
**POSITIONS**

WRITE OR PHONE  
**D. A. BOWDOIN**  
Placement Manager

BALDWIN 3-7300

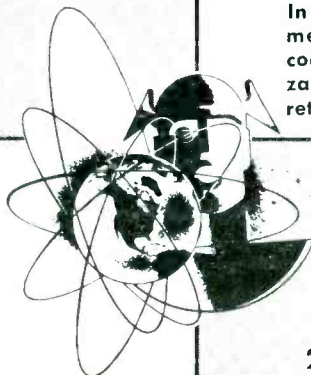

The  
**FIRST NAME**

★ **In Complete Electronic Computing**  
**Presents**

**OPPORTUNITIES UNLIMITED**

**To Experienced Men . . or Those**  
**Recent Graduates**  
**Who Can Qualify As**

- ▶ **Electrical Engineers** . . . Circuit Designers to develop and apply new circuit techniques. Degree in E.E. or equivalent experience required.
  - ▶ **Mechanical Engineers** . . . to design and develop electro mechanical devices; electronic packaging design and development.
  - ▶ **Physicists** . . . for Solid State computer components development. Also design of various optical systems; phosphors and ferromagnetism; electric contacts research.
  - ▶ **Logical Designers** . . . for system design in effecting logical functions of electronic data processing equipment.
- The above openings lie in the field of electronic or electro-mechanical data processing equipment, research and development and specifically in such areas as Magnetic Tape Mechanisms . . . Paper Handling Devices . . . Magnetic Drum or Tape Applications . . . High Speed Mechanisms . . . Transistors . . . Electronic Packaging Design . . . Servo-Mechanisms and many other areas of interest.

- ▶ **Mathematicians and Programmers** . . . with experience in electronic digital computer programming or extensive math background.
- ▶ **Chemists and Metallurgists** . . . electro-chemical; physical or inorganic chemistry; magnetic materials; magnetic film deposition.
- ▶ **Product Analysts** . . . experienced in customer application of business machines or related equipment; applications analysis.

In addition to the challenge of being associated with the leading men in this field, our qualified employees benefit by a liberal cooperative educational aid program . . . health and hospitalization benefits for BOTH you and your family . . . progressive retirement plan . . . moving and travel expenses.

**Remington Rand**

**UNIVAC DIVISION**  
SPERRY RAND CORPORATION

2300 W. Allegheny Ave.

Philadelphia, Pa.

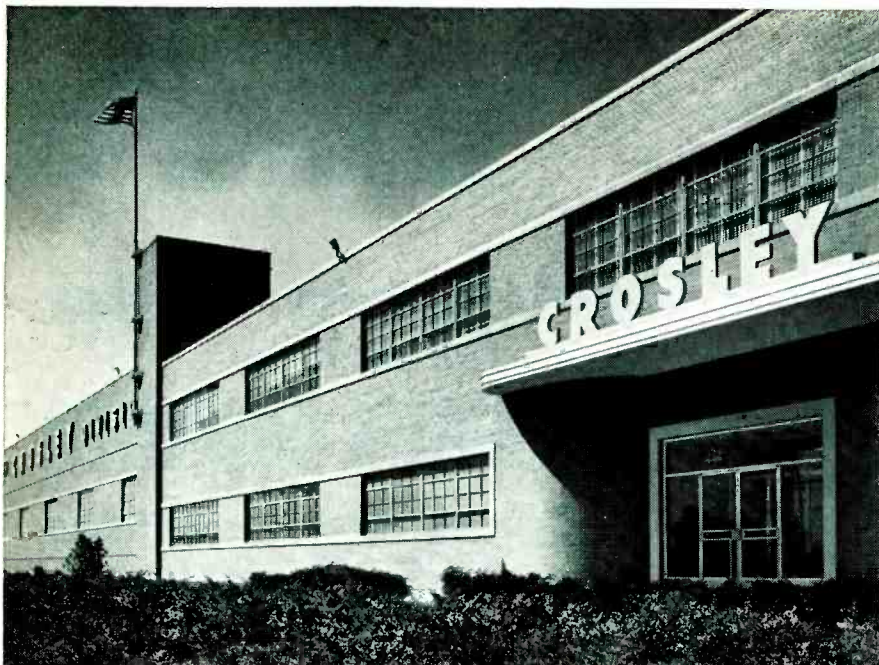

*This is the Evendale Plant, "headquarters" of the Crosley Government Products Division, AVCO Manufacturing Corporation. Located in Evendale, a Northern suburb of Cincinnati, this plant has every facility for long range research and development programs.*

**ENGINEER REQUIREMENTS**  
(IN PERCENT)

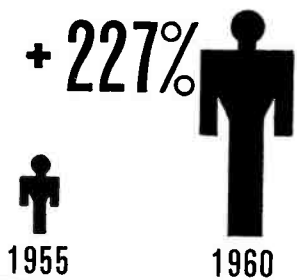

*Engineers...*

Our continuing expansion program means that highly creative opportunities are now available to Electronic, Electrical, Aeronautical and Mechanical Engineers, Physicists and Mathematicians. Crosley offers you a chance to achieve individual recognition in a successful growing organization.

Crosley's Engineering Staff is engaged in the design and development of a selected diversity of defense equipments. There are openings at all levels of Research, Advanced Development and Product Engineering for individuals experienced with any of the following: Guided Missiles, Air Navigation, Radar Systems, Communications, Gyros, Magnetic Amplifiers, Servos, Computers, UHF, VHF, Printed Circuitry, Transistors, Circuit Design, Fire Control Systems, Infra-Red Radiation, Detection Nucleonics and Human Engineering.

Address your resume to:

Director of Engineering  
Government Products, Dept.



2630 Glendale-Milford Road  
EVENDALE, CINCINNATI 15, OHIO

**ENGINEER,  
ME or EE**

**GYROSCOPICS**

Research facilities that enable you to test out your most revolutionary ideas and encouragement to publish original work available to the engineer experienced in precision gyroscopic equipment.

Assignments in the field of missile guidance systems will include both mechanical and electrical problems involving lubrication, temperature control, bearings, vibration and shock mounts, development work in components such as pickups, accelerometers, amplifiers and computers, plus project work on complete gyroscopic systems.

ME, EE or equivalent experience required. Send resume in confidence to:

Technical Personnel Dept. 2-500

**ARMA**

Div. American Bosch Arma Corp.  
Roosevelt Field, Garden City  
Long Island, N. Y.

**ELECTRONIC and ELECTRICAL  
ENGINEERS and PHYSICISTS**

Armour Research Foundation has openings in Chicago, Illinois and Fort Huachuca, Arizona, for graduate engineers or physicists with experiences in one or more of the following areas:

- Radio and radar
- Electronic Instrumentation
- Communication systems evaluation
- Electric machine components, measurements.

These are permanent positions offering attractive salaries, liberal benefits, and excellent opportunities for personal and professional growth. Send resume to:

Mr. T. E. DePinto  
Armour Research Foundation  
of Illinois Institute of Technology  
10 West 35th St.  
Chicago 16, Illinois

**ELECTRICAL  
ENGINEERS**

To work on engineering problems in development of new Regulated AC and DC supplies, transistors, semi-conductor circuitry and magnetic amplifiers. BEE, or BS with physics or math major, plus some allied experience.

**SORENSEN & COMPANY, INC.**  
375 Fairfield Avenue Stamford, Conn.



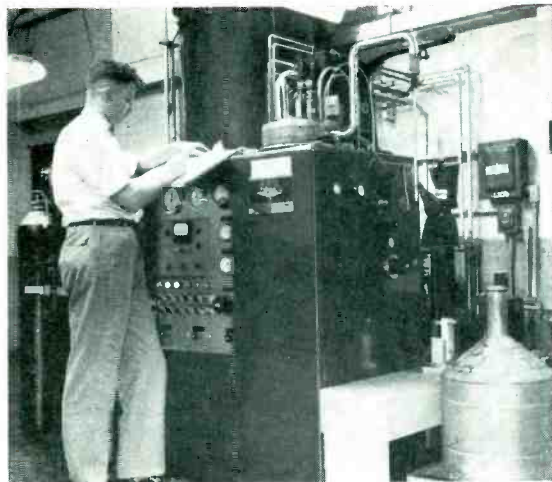

LOW TEMPERATURE

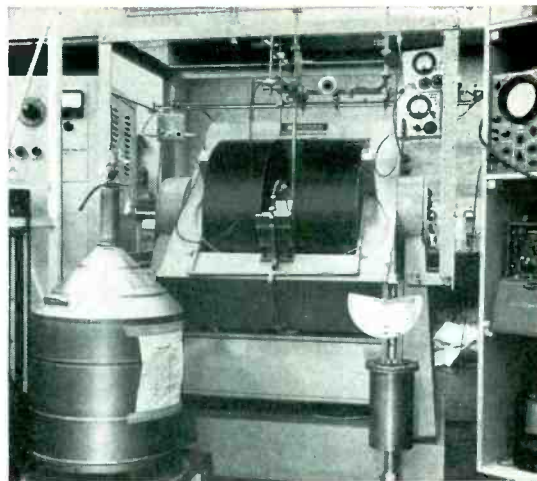

SPIN RESONANCE

# ENGINEERS, PHYSICISTS, CHEMISTS

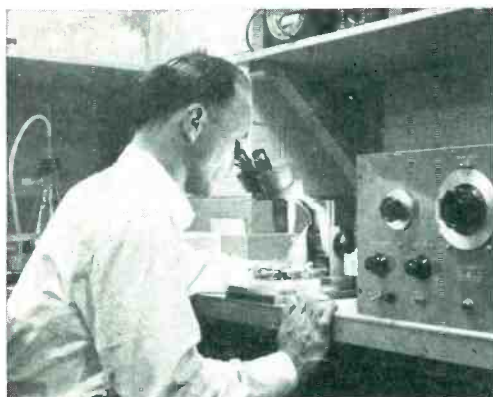

TRANSISTORS

## Zenith wants to talk to you about:

- Solid State Physics
- Transistors
- Circuits for Color & Monochrome Television and Radio
- New Types of Vacuum Tubes
- Radio & TV Receiver Design
- Subscription TV (Phonevision)
- Ceramic Engineering (High Dielectric, Piezoelectric)
- Patents
- Industrial Engineering (Automation)

Modern Air-Conditioned Laboratories  
 Attractive Profit Sharing and Insurance Plans  
 Outer Chicago Location with Opportunity for Suburban Living  
 and Graduate Study  
 Non-Classified Work—Publication Encouraged

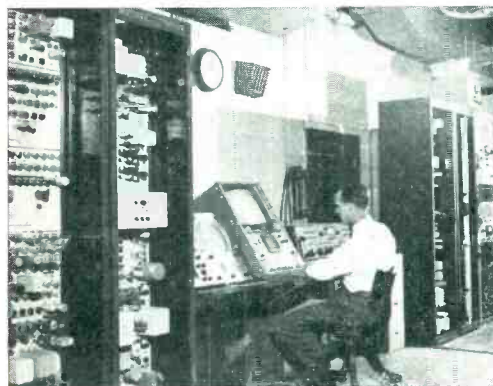

SYSTEMS ENGINEERING

Since 1919 Zenith has manufactured radios for home use and is one of the country's oldest companies continuously in this field. It is today a leading manufacturer of quality television sets and hearing aids. Continuity of management, a record of pioneer technical developments and a reputation for quality products are important factors for you to consider. Zenith's consistent, steady growth and unusually low engineering turnover rate indicate a desirable combination of opportunity and stability.

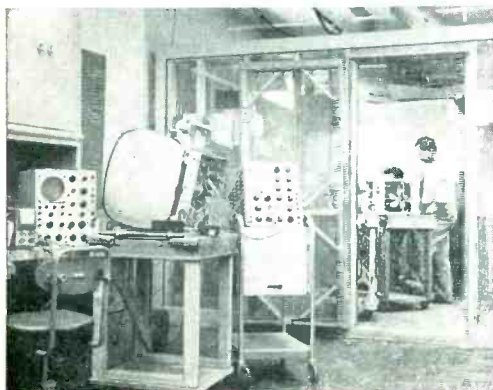

TELEVISION RECEIVER DESIGN

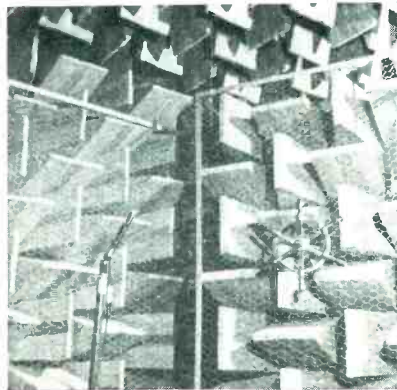

ACOUSTICS

For an appointment, write to  
 G. E. GUSTAFSON  
 Vice President, Engineering  
 Zenith Radio Corporation  
 6001 Dickens Avenue, Chicago 39, Illinois

**ZENITH**  
 RADIO CORPORATION



Dear wife and kids:

Got here o.k. today. Couldn't wait to tell you what I think of Farnsworth and Fort Wayne. It's more than a place to work.. it's a way of life! Most of the folks here own their own homes. There are no row houses and that cottage in the country is real and only 10 minutes from everywhere.

Schools? There are 50 of them (full time .. no half day shifts!) 5 beautiful High Schools and I can take grad work at Purdue here at Farnsworth's expense!

This is also a town of churches ... 132 in a town of 135,000 that boasts one of the lowest juvenile delinquency rates in the country.

There's also a full size, full season symphony orchestra ... World championship basketball and hockey in a new 3 million dollar coliseum that's out of this world. (Are you listening, Jackie?)

Tell Joe and his wife to start packing because there's plenty of room here for more engineers like him in R and D and systems engineering in missiles, radar, antennas, microwaves, test equipment, countermeasures, transistor applications and other phases. Tell him to write the Technical Employment Manager, Farnsworth Electronics Co. (a division of IT & T) at Fort Wayne, Ind. He'll be glad he did.

I can't wait until you and the kids get here ... I know you'll love it. And, like they say at Farnsworth, "Very, very few ever leave it."  
Love Jack

## PROJECT ENGINEER

Design and development of mechanical or electro-mechanical mechanisms in the field of ammunition. Projectiles, fuses, training devices, weapons systems. M.E. or Physicist, 5-10 years experience. Advanced degree preferred. Enjoy advantages of Connecticut living.

Reply

Employment Manager

WINCHESTER - WESTERN DIVISION

**OLIN MATHIESON CHEMICAL CORPORATION**

P.O. Box 906

NEW HAVEN 4, CONN.

## CAC NEEDS AN S.E.

The Communication Accessories Company of Hickman Mills, Missouri, one of the country's leading producers of toroidal components, needs a sales engineer—preferably between 25-35 with a BS degree in electronics.

You will specialize in filter networks and transformers . . . give customers technical assistance . . . have some field duties. Attractive compensation.

Hickman Mills, a suburb of Kansas City, Missouri, offers rural comfort near metropolitan Kansas City. Phone Kansas City, SOuth 5528, or write George E. Guidi, Hickman Mills, Missouri.

## RESEARCH and DEVELOPMENT Ph.D.

### Management Level Openings

A major industrial company is forming a laboratory operation to carry out basic long range research and development in the field of guided missiles. This work will be divorced from immediate production problems and will be undertaken in an appropriate laboratory environment.

The nucleus of a staff is now being selected. Candidates having Ph.D. or equivalent degrees with some years post doctoral experience are being sought. Positions are open in the fields of guidance, electronics and physics.

Liberal benefit program:  
Northeast location.

Replies will be considered confidential.

P-8376 Electronics  
330 W. 42 St., New York 36, N. Y.



# PRODUCT PLANNING ENGINEERS

to study customer requirements and engineering techniques in order to formulate the characteristics of new products. Should have broad background in engineering and business.

# TECHNICAL LIAISON ENGINEERS

to perform liaison between development design, manufacturing and sales groups to insure successful production and marketing of company products. Should have background in administration and coordination of technical activities.

**TRAINING**  
at our expense at full salary.

**HOUSEHOLD GOODS**  
moved at our expense.

**INSURANCE, PENSION**  
and other liberal employee benefits.

**INTERVIEWS**  
arranged at our expense.

Send written resume to  
Department D-8

# univac

DIVISION OF

## Remington Rand

Division of SPERRY RAND Corporation

1902 W. Minnehaha Ave.  
St. Paul W4, Minn.

# ENGINEERING OPPORTUNITIES

*for you!*

CONVAIR-Pomona is engaged in development, engineering and production of electronic equipment and complex weapons systems. The Convair-Pomona engineering facility is one of the newest and best equipped laboratories in the country. The work in progress, backed by Convair's outstanding record of achievement, offers excellent opportunities for recent graduates and experienced engineers in the following fields:

- ELECTRONICS**
- DYNAMICS**
- AERODYNAMICS**
- THERMODYNAMICS**
- OPERATIONS RESEARCH**
- HYDRAULICS**
- MECHANICAL DESIGN**
- LABORATORY TEST ENGINEERING**

Generous travel allowance to engineers who are accepted.

\*For further information on Convair and its fields of interest, write at once, enclosing a complete resume to:  
Employment Department 3-G

\*ENGINEERING  
BROCHURE  
TO QUALIFIED  
APPLICANTS

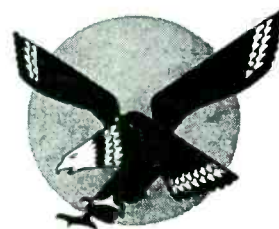

# C O N V A I R

A DIVISION OF GENERAL DYNAMICS CORPORATION  
POMONA, CALIFORNIA

# LAND-AIR, INC.

OFFERS EMPLOYMENT  
IN  
NEW MEXICO

Interesting positions open on U. S. Army-Air Force integrated missile-test range working for private contractor.

Work located near cities of Alamogordo and Socorro, New Mexico. Dry climate, pleasant communities, good schools, outdoor and indoor duties. Congenial working groups:

## ENGINEERS—

We have several opportunities for Electronic and Mechanical Engineers, with and without experience, to work with various instrumentation systems used in guided missile testing. Graduate engineers desiring *field experience* will find this work both challenging and interesting. Also some lab positions open in development of instrumentation systems. Pertinent experience as an engineer may be acceptable in lieu of degree.

## TECHNICIANS—

Electronic and Mechanical Technicians needed for operation, maintenance, and improvement of electronic, electro-optical-mechanical instrumentation devices used in obtaining data from guided missile tests. Very interesting, mainly outdoor work—some lab work, requires good physical condition, good vision, driving ability, plus technical background.

### NOTE OUR EMPLOYEE BENEFITS:

1. Excellent pay
2. Paid vacation (2 weeks per year)
3. Paid accident & health (income) insurance
4. Paid hospital, surgical, polio & life insurance
5. Excellent contributory insurance plan for dependents
6. Merit system of pay raises
7. Travel and moving expense

### YOUR CONTACT IS:

W. J. McClarin, Personnel Director, Land-Air, Inc.,  
P. O. Box 394, Holloman, New Mexico.

### LEGAL NOTICE

STATEMENT REQUIRED BY THE ACT OF AUGUST 24, 1912, AS AMENDED BY THE ACTS OF MARCH 3, 1933, AND JULY 2, 1946. (Title 39, United States Code, Section 233) SHOWING THE OWNERSHIP, MANAGEMENT, AND CIRCULATION

Of Electronics published monthly at Albany, New York for October 1, 1955.

1. The name and address of the publisher, editor, managing editor, and manager is Publisher McGraw-Hill Publishing Company, Inc., 330 West 42nd Street, New York 36, N. Y.; Editor, W. W. MacDonald, 330 West 42nd Street, New York 36, N. Y.; Managing editor, Vin Zeluff, 330 West 42nd Street, New York 36, N. Y.; Manager, Wallace B. Blood, 330 West 42nd Street, New York 36, N. Y.

2. The owner is: McGraw-Hill Publishing Company, Inc., 330 West 42nd Street, New York 36, N. Y.; Stockholders holding 1% or more of stock: Donald C. McGraw and Willard T. Chevalier, Trustees for Harold W. McGraw, Donald C. McGraw and Elizabeth M. Stoltzfus, all of 330 West 42nd Street, New York 36, N. Y.; Donald C. McGraw and Harold W. McGraw, Trustees for Catherine

### LEGAL NOTICE

M. Rock, 330 West 42nd Street, New York 36, N. Y.; Donald C. McGraw, 330 West 42nd Street, New York 36, N. Y.; Mildred W. McGraw, Madison, New Jersey; Grace W. Mehren, 536 Arenas Street, LaJolla, California; Touchstone & Company, c/o Wellington Fund, Inc., Claymont, Del.

3. The known bondholders, mortgagees, and other security holders owning or holding 1 percent or more of total amount of bonds, mortgages, or other securities are: None.

4. Paragraphs 2 and 3 include, in cases where the stockholder or security holder appears upon the books of the company as trustee or in any other fiduciary relation, the name of the person or corporation for whom such trustee is acting; also the statements in the two paragraphs show the affiant's full knowledge and belief as to the circumstances and conditions under which stockholders and security holders who do not appear upon the books of the company as trustees, hold stock and securities in a capacity other than that of a bona fide owner.

McGraw-Hill Publishing Company, Inc.  
By J. A. GERARDI, Vice Pres. & Treas.  
Sworn to and subscribed before me this 15th day of September, 1955.  
[SEAL] ELVA G. MASLIN.  
(My Commission expires March 30, 1956)

## SALES ENGINEERS WANTED

Excellent opportunities for several engineers with well established East Coast instrument manufacturer now expanding its line of aviation products which includes electronic and electro-mechanical components for jet engines and guided missiles. Electrical engineering background essential. Must have established contacts with the aircraft industry. Openings in Los Angeles, Dallas, and East Coast areas. Generous company paid benefits include hospitalization, pension, insurance, and vacation plans.

P-7913, Electronics  
330 W. 42nd St., New York 36, N. Y.

## REPRESENTATION WANTED

Electronic Instrument Representative Wanted by established manufacturer of digital instruments. Require sales engineering organization now calling on industrial manufacturers, research laboratories and military in Metropolitan New York City area, Long Island, New Jersey and Eastern Pennsylvania. Write full details including lines carried.

Computer-Measurements Corporation  
(formerly Detectron)  
5457 CLEON AVENUE  
North Hollywood, California

## REPRESENTATIVES WANTED

Manufacturer of electronic test equipment for military and commercial applications needs technically qualified representatives. Write giving qualifications, lines handled, territory covered.

RW-2178, Electronics  
1111 Wilshire Blvd., Los Angeles 17, Calif.

## PROGRESSIVE L. I. FIRM needs ELECTRONIC ENGINEERS

Opportunity for self-expression and growth. Must have 2-6 yrs. exp. in the design of LF, VHF and/or UHF broad band systems. Many personal benefits. Phone or write Mr. G. W. Feilendorf, Vice Pres.

Instruments for Industry, Inc.  
Mineola, N. Y. Pioneer 2-5300

## NUCLEAR INSTRUMENTATION

Physicist or electrical engineer with minimum of 5 years' experience in nuclear instrumentation. Position open for a qualified man interested in the administrative and operational aspects of the electronic development division of a large midwest laboratory. Age range 30 to 40 years. Salary open.

P-8326, Electronics  
520 N. Michigan Ave., Chicago 11, Ill.

An employment advertisement in this EMPLOYMENT OPPORTUNITIES section will help you find the engineers you need. It's an inexpensive, time saving method of selecting competent personnel for every engineering job in the electronic field.



ELECTRONIC ENG.  
MECHANICAL ENG.

**LARGE Company...**  
Stability &  
Security

**SMALL Division...**  
Recognition &  
Responsibility

**Bendix York offers both!**

As a young, expanding Division of Bendix Aviation Corporation, Bendix York is adding key personnel RIGHT NOW! . . . It's your chance to get specific assignments at the peak of the art in electronics and microwave development and design. Good salaries, all employee benefits, ideal suburban living conditions. Openings for Principal, Senior and Junior Electronic Engineers, Mechanical Engineers, designers and draftsmen.

Address: Dept. H

**Bendix**  
AVIATION CORPORATION  
**York**  
DIVISION

York, Penna. York 5521

**New Products**



**Engineer**

Exceptional opportunity for creative engineering work in the New Products Engineering Laboratory of a leader in the consumer, products field. The work includes application of present products to new devices and the development of new products of wide consumer appeal.

The man we are looking for should have a degree in electrical engineering and be familiar with electrical and electronic instrumentation. He should be strong in circuit analysis of electro-mechanical and electronic equipment, including transistor devices, with a record of achievement to substantiate his abilities and interests.

Age 25-32. Salary will depend upon educational background and experience. Summary of education and job history should be addressed to:

Mr. N. M. Potter, Head, New Products Engineering Lab., National Carbon Co., A division of Union Carbide and Carbon Corporation, P. O. Box 6056, Cleveland 1, Ohio.

**HERE'S A CHANCE FOR  
A REAL CHANGE - - - -**

*Right Now* there are some fine career positions open in the ever expanding electronics industry. Why not write us and weigh the advantages of working with a leader in the field —

**Admiral  
Corporation**

*Your Opportunity* may be listed below if you have background or interest in these fields:

**RADAR — MILITARY AND COMMERCIAL**

Gun laying, IFF and beacons, navigational aids, air traffic control, video processing and distribution systems.

**TELEVISION — MILITARY AND COMMERCIAL**

Mobile TV systems, cameras, complete systems including RF front ends, IF amplifiers and RF cavities in the UHF region. Household TV section requires engineers at all levels who are capable of offering original ideas of value in highly competitive field, monochrome and color.

**RADIO — MILITARY AND COMMERCIAL**

Airborne and ground communication systems at HF, VHF and UHF level. Domestic and export receivers, HI FI and phonographs.

**TRANSISTORS**

Development group being augmented to explore all phases of transistor application.

**PHYSICISTS**

Research in, and analysis of, high level nuclear radiation effects on electronic components. This concerns original investigations at reactor levels.

**TECHNICAL WRITERS**

To organize, write and edit instruction books, operating and maintenance manuals for electronic equipment. Experience preferred, but will consider qualified trainees.

*Admiral engineers know the satisfaction of creative work that gives them the opportunity to explore and expand new techniques in their field.*

• *Let's discuss our mutual interests.*

Send complete resume to: Mr. Walter A. Wecker, Personnel Division

**Admiral Corporation**

3800 W. Cortland St.  
Chicago 47, Illinois

# ELECTRONIC ENGINEERS

*What Should  
an  
EE Know  
About  
Atomics?*

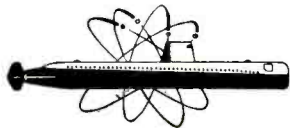

Quite a bit these days, with so many companies getting into the field. While many new firms are now starting to explore the field, Electric Boat Division of General Dynamics Corporation led the way with the building of the first nuclear powered submarines, Nautilus and Sea Wolf.

In addition to increasing its engineering force for work on new and greatly advanced nuclear submarines, Electric Boat is expanding Research and Development operations to include the development of additional practical uses for nuclear energy.

Right now Electric Boat has interesting positions for EE's versed in

servo-mechanisms, circuitry, motors and generators, radar & sonar, or electro-mechanical systems.

Study for bachelor's or advanced degrees is encouraged at Electric Boat, with courses in mathematics, naval architecture, nuclear engineering and nuclear submarine systems offered within the plant, and tuition paid by the company for study in these or other fields at leading colleges and universities.

Men interested in these openings should write complete details of background and experience including initial salary requirements. Interviews will be arranged promptly for qualified applicants. Address Mr. Peter Carpenter.

**Electric Boat Division**

**GENERAL DYNAMICS CORPORATION**  
GROTON CONNECTICUT

*near New London on the Connecticut shore*

**For a BETTER JOB in ENGINEERING  
The Swing's to**



**CHIEF RF ENGINEER**

To design or supervise the design of Radio Frequency components for radar, radio equipment, antennas, horns, mixers, directional couplers, rotating joints and radomes. Must know cost estimating of this equipment and be able to advise shops on the best fabrication methods. Should be capable of setting up RF section. Approximately 10 years experience in design of RF components and systems.

**SYSTEMS SPECIALIST**

For the analysis of electronic system performance and establishment of design parameters for electronic systems. Must be able to prepare or supervise the preparation of technical proposals and act in the capacity of technical advisor on engineering program. Approximately 10 years experience in general electronic design work.

**MECHANICAL ENGINEERS**

Product Design, Production liaison on electronic packaging and mechanisms. Involves gear trains, printed circuits and electronic layout work. Knowledge of military specifications. Minimum 6 years experience in electronic equipment design and manufacture.

**ELECTRONIC ENGINEERS**

Experienced in Product Design and Production. Production liaison requires wide knowledge of electronic circuits and packaging. System and Component Testing. Some experience in cost estimating and project administration. Familiarity with all types of military specifications.

**And remember that AMF is well-known  
for its liberal benefits program.**

*Please send complete resume to:*  
**Personnel Manager, Electronics Division**

**American Machine & Foundry Co.**

1085 Commonwealth Ave — Boston, Mass.

**ENGINEER**  
M. E. or E. E.  
**DIGITAL  
COMPUTER DEVELOPMENT**

Excellent opportunity to join an expanding, stable company, with an outstanding position in the precision electronic control industry.

Opening now available for an engineer able to assume responsibility for the development of complete systems for fire control and guidance, or major portions of such systems. Work will include research and development in the field of complex analog or digital computers.

A degree in electrical or mechanical engineering is required or the equivalent in experience. Send resume in confidence to:

Technical Personnel Dept. 2-500

**ARMA**

Division American Bosch Arma Corp.  
Roosevelt Field, Garden City  
Long Island, N. Y.

**ELECTRONICS ENGINEER  
RADIO ENGINEER**

Outstanding long-range opportunity for creative individual with a leading mfr in Hi-Fi and electronics field. Substantial salary. Min 5 yrs exp AM-FM receivers, EE or equiv. Please write fully, in confidence.

**Address: President, Fisher Radio Corp.  
21-21 44th Drive, Long Island City 1, N. Y.**



## What Opportunities in Electronics are on the Horizon at GENERAL ELECTRIC?



Huge antenna used with new radar height-finder needs a room all its own above the control center in the radome building erected in Arctic climates. Air pressure supports the rubberized glass fabric radome "balloon." Entrance to the radome is through an air lock chamber.

Advances in electronics are so rapid at General Electric that today's predictions appear tomorrow as equipment bearing the GE symbol.

The opportunities created by the scope and pace of the field are increased at General Electric by the facilities and range of professional advantages which GE engineers enjoy.

This means that GE electronics engineers have incentives, satisfactions and rewards that lead to accelerated personal development and advancement in the company.

### ENGINEERS • PHYSICISTS

*Positions available in the following fields:*

Advanced Development, Design, Field Service and Technical Writing in connection with:

MILITARY RADIO & RADAR • MULTIFLEX MICROWAVE  
MOBILE COMMUNICATION • SEMICONDUCTORS • ELECTRONIC COMPONENTS • TELEVISION, TUBES & ANTENNAS

*Bachelor's or advanced degree in Electrical or Mechanical Engineering, physics, and experience in electronics industry necessary.*

Please send resume to:  
Dept. 12-5-E — Technical Personnel

**GENERAL  ELECTRIC**

ELECTRONICS PARK, SYRACUSE, N. Y.

## ELECTRONIC ENGINEERS

Research & Development  
Physicists - Engineers  
(SENIORS)

Experienced in research and development of various radar systems including: beacons, missile guidance and counter measures. Advanced training in applied mathematics, noise theory and probability analysis desirable. EE degree or equivalent required.

## FIELD ENGINEERS (SENIORS)

Local & Field Assignments

Must have EE degree, with 3-5 years experience in one of the following:

- Flight Simulators
- Radar & Sonar Trainers
- Fire Control Radar
- Electronic installation and maintenance.

### • EQUIPMENT ENGINEERS

3-5 years experience with at least 3 years in circuit packaging. EE degree with mechanical background.

### • APPLICATION ENGINEERS

5-10 years experience on coil and transformer development.

Salary and advancement commensurate with ability; liberal vacation, sick leave, 9 paid holidays, group life, sickness and accident insurance plans, and a worthwhile pension system.

**STAVID  
Engineering, Inc.**

U. S. Highway 22, Watchung, P. O.  
Plainfield, N. J.—PLainfield 7-1600

## FIELD ENGINEERING WITH A FUTURE

Practical experience acquired in the field has enabled many of our former Field Engineers to qualify for responsible positions. These men are now Assistant Vice-Presidents, Division Managers, Department Managers, Assistant Managers, Department Supervisors, District Supervisors, Consultant Staff Engineers, Product and Development Engineers.

RAYTHEON FIELD ENGINEERING is diversified. Radar, Sonar, Guided Missiles, Computers, Microwave, and other specialized equipments offer outstanding opportunity to earn excellent salaries while working among authorities in these fields. This is an opportunity to associate and grow with Raytheon, renowned worldwide for EXCELLENCE IN ELECTRONICS.

Special training will be provided by our Training Facility to prepare you for your field assignments. Your performance regulates your progress. Liberal insurance and retirement plans. Generous travel allowances and other benefits.

Excellence



in Electronics

**RAYTHEON MANUFACTURING COMPANY**

Government Service Department

100 River St.,

Waltham 54, Massachusetts

permanent assignments in the field of  
**MILITARY WEAPONS SYSTEMS**

Missiles                      Reliability Studies                      Fire Control  
Radar                              Sonar                              Underwater Ordnance

**REAL CAREER OPPORTUNITIES**

You'll enjoy the advantages of a small company atmosphere in the Silver Spring Laboratory . . . along with the stability of being part of the rapidly growing Vitro Corporation of America with 5 diversified operations throughout the United States

- Suburban Location in residential community adjacent to Washington, D. C.
- Plentiful housing — modern apartments, houses to rent or buy
- Advanced courses available at 4 major universities
- Cultural advantages of the nation's capitol

Vitro has similar opportunities also available at West Orange, N. J. laboratory and Eglin Air Force Base, Florida.

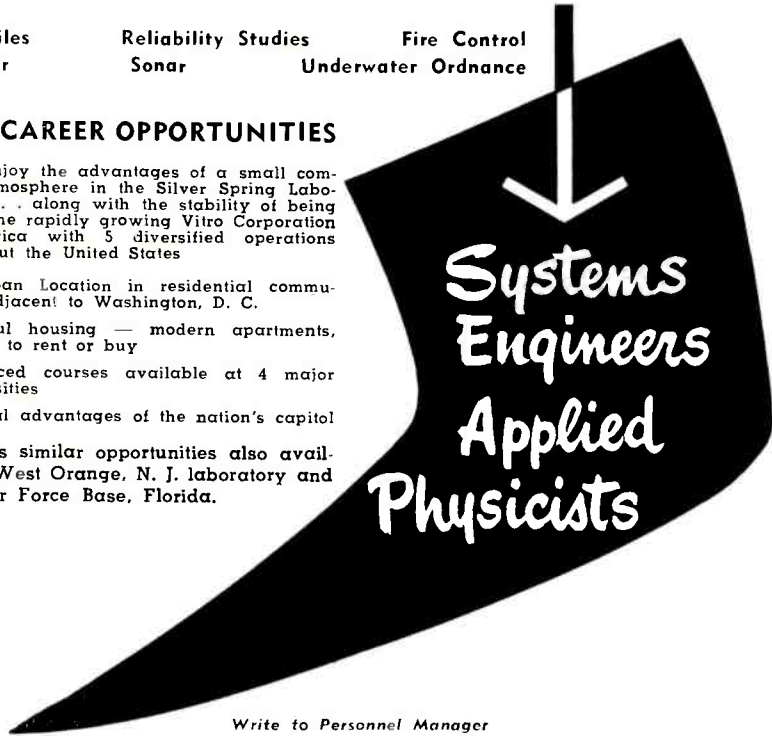

Write to Personnel Manager



**VITRO LABORATORIES**  
962 WAYNE AVE., SILVER SPRING, MD.

**EXCELLENT OPPORTUNITIES**

FOR ENGINEERS & SCIENTISTS

In Research and Development of Instruments & Equipment

**QUALIFICATIONS:**

BS, MS or PhD degrees in mechanical, electrical, electronics and chemical engineering, physics and chemistry.



**A CAREER WITH A FUTURE:**

Permanent, responsible positions for qualified, creative men to develop, design and apply special instruments and equipment to our pilot plant and process operations.

**EMPLOYEE BENEFITS:**

Excellent working conditions, modern facilities, Retirement and Insurance Programs, Company Contributed Savings Plan.

**GOOD LOCATION:**

Modern, medium sized Southwestern community. Pleasant surroundings with excellent family recreation, religious and educational facilities.

Reply by letter giving age, experience and other qualifications. All applications carefully considered and kept strictly confidential. Write:

Industrial Relations Manager  
Research and Development Department  
**PHILLIPS PETROLEUM COMPANY**  
Bartlesville, Oklahoma

**RATES . . . . .**

**"Employment Opportunities"**

*Displayed*—The advertising inch is \$21.50 per inch for all advertising appearing on other than a contract basis. Contract rates quoted on request.

An advertising inch is measured 7/8" vertically on a column—3 columns—30 inches to a page.

Subject to Agency Commission.

*Undisplayed*—\$1.80 per line, minimum 3 lines. To figure advance payment count 5 average words as a line.

Discount of 10% if full payment is made in advance for 4 consecutive insertions.

Not subject to Agency Commission.

Send NEW ADS to ELECTRONICS

330 W. 42nd Street  
New York 36, N. Y.

**CORNELL AERONAUTICAL LABORATORY, INC.**  
of Cornell University

is seeking

**ELECTRONIC ENGINEERS**

for positions in all levels of experience above Junior Engineer

- Communications
- Dynamic Control Systems
- Aircraft Instrumentation
- Radar
- Computers
- Electrical Measurements
- Varied Electronic Circuits
- Servo-Mechanisms
- Missile Guidance
- Microwave

If you have a B.S. degree and experience, imagination and potential, we invite you to communicate with our Employment Manager

**Cornell Aeronautical Laboratory**

BOX 235                      BUFFALO 21, N. Y.

**WHEN**

*Answering Advertisements*

**P**LEASE do not send original letters, certificates or photographs. We cannot be responsible for their return. Please send photostat or carbon copies.



# ENGINEERS

The APPLIED PHYSICS LABORATORY of THE JOHNS HOPKINS UNIVERSITY offers an exceptional opportunity for professional advancement in a well-established Laboratory with a reputation for the encouragement of individual responsibility and self-direction.

Our program of

## GUIDED MISSILE RESEARCH and DEVELOPMENT

provides such an opportunity for men qualified in

Design and Analysis of Pulse Circuits  
Research and Development in Radar and Microwaves

Electronic Packaging

Development of Telemetry, Data Processing, and Special Switching Equipment

Magnetic Amplifier Design & Analysis

Development and Application of Printed Circuits

Servomechanisms and Control-System Analysis

Please send your resume to  
Professional Staff Appointments

APPLIED PHYSICS LABORATORY  
THE JOHNS HOPKINS UNIVERSITY

8609 Georgia Avenue  
Silver Spring, Maryland



## Executives and Engineers deserving higher salary

now can *completely, confidentially* make arrangements for better positions through our unique Job Improvement Service.

As publishers of Engineers' Job Directory we have close contact with leading manufacturing and research firms in all sections of the country.

Here's what you do. Send us your name, title, company and home address. We will forward to your home brief forms which you fill out and return. We compare your experience and desires with our file of specific job openings. You make the decision. No obligation to you, no cost whatsoever. Our clients pay us to find you. Find out what you're really worth—today. Write, phone or wire.



### DECISION INC.

Management and  
Recruitment Consultants  
Oliver P. Bardes, President  
440-A First National Bank  
Building  
Cincinnati 2, Ohio

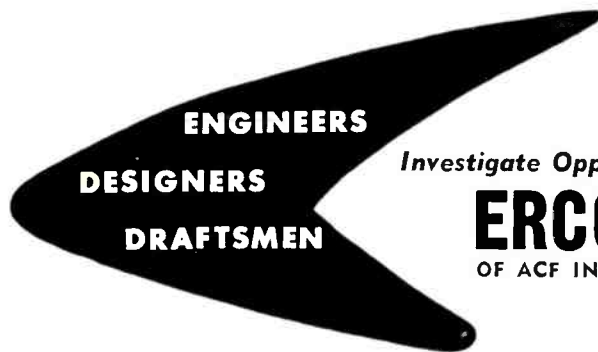

Investigate Opportunities at

**ERCO** DIVISION  
OF ACF INDUSTRIES INC.

**ERCO** Engineers have built a record of continuous progress and growth for themselves and for the Company for a quarter of a century . . . growth in physical plant, personnel, number and diversity of products and services.

**Today** this growth continues and we are constantly on the alert for new men to add fresh impetus to that progress . . . paying top salaries to capable people.

**Your** work will be interesting and stimulating . . . it might include electronic flight simulators, machine tools, guided missiles, or a variety of specialized electronic devices.

**You** can choose a home from a number of fine nearby residential areas convenient to both shopping centers and plant . . . and you can further your education at the many nearby Universities . . . you can enjoy suburban living and be within easy reach of the cultural advantages of the Nation's Capital.

**ERCO** now needs Electronic Engineers (all levels with some overseas positions available). Aerodynamicists, Analog Computer Engineers, Mechanical Design Engineers, and supporting personnel. Send resume or request for additional information to:

**ERCO** DIVISION  
OF ACF INDUSTRIES  
RIVERDALE • MARYLAND

## SENIOR ELECTRONICS ENGINEER

needed for new contracts section of rapidly expanding military engineering department

### NATURE OF WORK

System Analysis and Study  
Preparation of Technical Proposals  
Long Range Planning  
Evaluation of Engineering Problems at Early Stages

### REQUIREMENTS

High Degree of Technical Skill and Imagination  
Ability to Organize and Compose Complex Technical Documents  
Friendly and Personable — Must Deal Extensively with Stromberg-Carlson and Military Engineering Personnel

Stromberg-Carlson has recently become a Division of the General Dynamics Corporation and is located in the Finger Lakes region of upstate New York. Excellent educational, living, and recreational facilities are available in this area. Please send resume to

Charles W. Finnigan, Chief Electronics Engineer

## STROMBERG-CARLSON COMPANY

A DIVISION OF GENERAL DYNAMICS CORPORATION

Rochester 3, New York

## Immediate Openings at **KOLLSMAN**

**SYSTEMS ENGINEERS** . . . For development, testing and field service of airborne navigational systems. Some experience with servos utilizing electronic and electro-mechanical components desirable.

**ELECTRICAL ENGINEER** . . . Experience in small electro-mechanical devices, motors, synchros and induction pick-offs.

### DESIGNERS

#### Electronic, Electro-Mechanical, Mechanical

1. Electronic and electrical packaging. Knowledge of sub-miniaturized techniques. Work is associated with servos, amplifiers and components.
2. Mechanical or electro-mechanical packaging of precision flight instruments.

*These are permanent positions with Kollsman, designers of America's finest aircraft instruments . . . a progressive, growing organization in which the atmosphere is friendly, the facilities of the best, and the employee benefit program liberal.*

*Please submit complete resumes, preliminary to confidential interview to Thomas A. DeLuca.*



**kollsman** INSTRUMENT CORPORATION

80-08 45th AVENUE, ELMHURST, NEW YORK • SUBSIDIARY OF *Standard* COIL PRODUCTS CO. INC.

## Employment Opportunities ADVERTISERS INDEX

Armour Research Foundation of Ill. Inst. of Tech.	398
Admiral Corp.	403
Arma Division	
American Bosch Arma Corp.	396, 398, 404
American Machine & Foundry Co.	404
AVCO Mfg Corp.	
Crosley Division	398
Avion Division of ACF Industries Inc.	411
Bendix Aviation Corp.	
Pacific Division	384
Products Division, Missile Section	395
Radio Division	389
Research Laboratories	412
York Division	403
Bonder-Tongue Labs.	394
Brown Instruments Div., Honeywell	390
Burroughs Research Center	393
Calidyne Co., The	410
Cardwell Electronics Prod. Corp., Allen D.	411
Communication Accessories Co.	400
Computer-Measurements Corp.	402
Convair, A Div. of General Dynamics Corp.	
San Diego, Calif.	388
Pomona, Calif.	401
Decision Inc.	407
Drake Personnel Inc.	388
Dynamic Electronics NY, Inc.	394
Electric Boat Div.	
General Dynamics Corp.	404
Electronic Engineering Co. of Calif.	408
ERCO Div., of ACF Industries	407
Farnsworth Electronics Co.	400
Fisher Radio Corp.	404
General Electric Co.	396, 405
General Motors Corp.	
AC Spark Plug Electronics Div.	394
General Precision Lab. Inc.	411
Goodyear Aircraft Corp.	391
Instruments for Industry Inc.	402
Jet Propulsion Lab., Calif Institute of Tech.	411
Johns Hopkins University, Applied Physics Inc.	407
Kollsman Instrument Corp.	408
Land-Air Inc.	402
Maryland Electronic Mfg Corp.	392
Melpar Inc.	409
Monarch Personnel	388
National Carbon Co.	403
National Employment Service	388
Olin Mathieson Chemical Corp.	400
Page Communications Engineers	396
Phillips Petroleum Co.	406
Radio Corp. of America	386, 387
Radio Receptor	409
Raytheon Mfg Co.	
Missile and Radar Div.	390
Waltham, Mass.	396, 405
Newton, Mass.	410
Remington Rand, Div. of Sperry Rand Corp., Engineering Research Assoc., Div.	385
Remington Rand Univac Div. of Sperry Rand Corp.	397, 401
Sanders Assoc., Inc.	409
Sikorsky Aircraft	412
Sorensen & Co., Inc.	398
Snyder Co., Lee Grant	388
Stavid Engineering Inc.	405
Stromberg-Carlson Co., Div. of General Dynamics	407
Sylvania Electric Products Inc., Buffalo, N. Y.	392
Waltham, Mass.	392
Mountain View, Calif.	384
Technical Operations	394
Tracerlab., Inc.	409
Transitron Electronic Sales Corp.	383
Vitro Corp.	406
Zenith Radio Corp.	399

This index is published as a convenience to the readers. Care is taken to make it accurate but CLASSIFIED assumes no responsibility for errors or omissions.

• • • for those who qualify

**Security**

**Understanding**

**Know how**

Send resume to:



offers

## ELECTRONIC ENGINE

- HEAVY BACKLOGS
- SOUND FINANCING
- TOP BENEFITS
- MANAGEMENT BY ENGINEERS
- EDUCATIONAL AID
- MINIMIZED RED-TAPE
- VARIED SPECIALIZATION
- FLEXIBLE ORGANIZATION
- VERSATILE PERSONNEL

R. F. LANDER

**Electronic Engineering Company**  
of California



180 SOUTH ALVARADO STREET  
LOS ANGELES 57 • CALIFORNIA



# ENGINEERS SCIENTISTS

Junior to Senior Levels  
with some experience in:

SEMICONDUCTOR DEVICES  
CIRCUIT DESIGN  
RADAR

you are needed, well-appreciated, and well-rewarded . . .

In **GOOD PAY**  
In **INTERESTING WORK**  
In **LONG-TERM PROGRAMS**

that will increase your  
career potential at . . .

## RADIO RECEPTOR CO.,

240 Wythe Ave., Bklyn, N. Y.

• Send resume to: S. Winston •

# ENGINEERS

Electronic • Mechanical  
DESIGNERS • DRAFTSMEN

## How do you Measure success?

Some measure success only by money; others by the enjoyment they get out of their work. But the true measure of success is a combination of both *plus* the knowledge that your efforts are recognized and appreciated.

Melpar engineers find diversity and opportunity for professional growth; they enjoy being part of a highly creative staff without losing their individuality; and they benefit from Melpar's completely integrated facilities for system responsibility from design concept through production.

To learn how Melpar measures up to your own standards send complete resume to

Technical Personnel Representative



## melpar, inc.

Subsidiary of Westinghouse Air Brake Co.

3000 Arlington Blvd., Dept. E-24 Falls Church, Va.

11 Galen Street, Watertown, Mass. • 99 First St., Cambridge, Mass.

- Network Theory
- Systems Evaluation
- Automation
- Microwave Technique
- UHF, VHF or SHF Receivers
- Analog Computers
- Digital Computers
- Magnetic Tape Handling Equipment
- Radar and Countermeasures
- Packaging Electronic Equipment
- Pulse Circuitry
- Microwave Filters
- Flight Simulators
- Servomechanisms
- Subminiaturization
- Electro-Mechanical Design
- Quality Control & Test Engineers

## ELECTRONIC ENGINEERS

### GROW WITH ATOMIC ENERGY!

Here is an outstanding opportunity even in this era of plentiful jobs! Openings exist at all levels.

EXPERIENCE in pulse circuitry, DC amplifiers or automatic control will be most helpful.

CONSIDER these advantages . . .

- First and foremost company in the atomic field!
- Commercial work!
- Modern suburban plant under construction!
- Diversity of products and job security!
- Professional development in new field!
- And, of course, excellent fringe benefits and competitive salaries!

IF you are alert to new ideas and aggressive enough to pursue them . . . if you are capable of shouldering responsibility . . . if you would like to develop electronic equipment and systems for the new and exciting nucleonic industry . . . if you are looking for a real challenge . . . write in confidence to . . .

# Tracertab

130 HIGH STREET, BOSTON 10, MASS.

## ENGINEERS

### Puzzled...about PANAR?

- ... it's a startling new conception of radar, developed by Sander Associates, Inc.
- ... it's only one of many "firsts" achieved by this company since its founding 4 short years ago.
- ... it's typical of the way this organization—run BY engineers, FOR engineers—is shaping the future of electronics.

Problems off the beaten track are not new to Sanders Associates, Inc. Unregimented thinking is characteristic of the organization, and the ability to assess a new conception with an open mind. This has led to such important developments as tri-scan antenna, "tri-plate" microwave plumbing, and—of course—PANAR.

Inevitably, Sanders Associates, Inc. is expanding . . . looking for a number of engineers with inventive minds—men with at least 3 years experience in guidance systems, weapons systems, countermeasures, system concepts, basic circuitry, component development, microwave antenna or electro-mechanical transducers.

We would value the opportunity to discuss your future at Sanders with you. Drop a note to D. H. Johnson, outlining your experience. Interviews can be arranged either in Nashua or in your own area.



137 Canal St., Nashua, New Hampshire

(A pleasant community set in the beautiful New Hampshire hills, only an hour from Boston.)

## JOIN THE ELECTRON TUBE BANDWAGON!

CONTINUING INCREASE IN THE DEMAND FOR RAYTHEON'S LINE OF RELIABLE TUBES HAS CREATED SEVERAL OUTSTANDING OPPORTUNITIES FOR FUTURE-MINDED ENGINEERS.

- PROJECT ENGINEERS to supervise important and interesting projects. 3-5 years experience in vacuum tube design, development, or production engineering required.
- DEVELOPMENT ENGINEERS to work on short and long range electron tube developmental projects. 1-2 years experience desired.
- PRODUCTION ENGINEERS to work on electron tube production problems. Minimum experience of 1 year.
- EXCELLENT BENEFITS
- FULL TUITION REFUND PLAN FOR IMPROVEMENT OF FORMAL EDUCATION
- RECOGNITION OF ABILITY



Please Send Complete Resume to  
**TECHNICAL PLACEMENT OFFICE**  
**RAYTHEON MANUFACTURING CO.**  
 SPECIAL TUBE DIVISION  
 55 Chapel St. Newton 58, Massachusetts

### ELECTRONIC ENGINEERS

Degree in Electrical Engineering or Physics with experience in servo-mechanism, electronic control devices, computer theory highly desirable.

### SALES ENGINEERS

Engineering background essential. Experience in instrumentation desirable.

### DESIGN ENGINEERS

Capable of responsible design in development projects in complex equipment. Background in Aeroelasticity, structural dynamics, machine design and electronics helpful.

### THE CALIDYNE COMPANY

*Manufacturers of Vibration Test Equipment*

120 Cross Street

Winchester, Massachusetts

## ELECTRICAL ENGINEER

Opening for recent Electrical Engineer graduate in electrical-instrument department of a rapidly growing New England chemical-plastics company. To an energetic young man with creative ability who is interested in the rapidly growing instrumentation field in chemistry, we offer singular opportunity to acquire breadth and scope of electronics-electrical instrumentation experience. Our plant is located in pleasant New England community. Send resume and salary requirements to

P-8165, Electronics  
 330 W. 42 St., New York 36, N. Y.

## INDEX TO THE SEARCHLIGHT SECTION ADVERTISERS

Allied Electronics Sales.....	418
Alltronics .....	422
Amber Industrial Corp.....	413
American College of Engineering .....	413
Arch Electronics Co.....	418
Arrow Sales Inc.....	424
Barry Electronics Corp.....	425
B & C Distributors Co.....	413
Belevision Inc.....	422
Blan .....	416
Cagan Sales, R. C.....	422
Chase Electronic Supply Co.....	426
C & H Sales.....	423
Communication Devices Co.....	416
Communications Equipment Co.....	421
Compass Electronics Supply Div., of Compass Communications Corp.....	426
Cramer Electronics Inc.....	424
Electronicraft Inc.....	427
Empire Electronics Co.....	424
Engineering Associates .....	418
Delaware Equipment Co.....	412
Fair Radio Sales.....	414
Fay-Bill Distributing Co.....	420
Finnegan, H.....	413
Gould Green .....	414
Greene, G.....	413
Harjo Sales Co.....	416
Hodgson Co., R. W.....	413
Houde Supply Co.....	424
Instrument Service Corp.....	422
JSH Sales Co.....	417
Lapirow Bros.....	422
Lectionic Research Labs.....	412
Legri S. Co., Inc.....	416
Liberty Electronics Inc.....	427
L & M Associates.....	422
Magnetran Salvage Co.....	413
McNeal Electronic & Eqpt. Co.....	416
Mogull Co., A.....	426
M. R. Co., The.....	424
Radalab .....	414
Radio & Electronic Surplus.....	424
Robinette Co., W. C.....	413
Red Arrow Electronic Sales Co.....	413
Relay Sales.....	420
Rex Radio Supply Co.....	414
Ruxur Electronics Corp.....	425
Sanett, Bob.....	413
Semler Industries Inc.....	422
Societe Industrielle Alfa, S. A.....	412
S. & R. Electronics Inc.....	426
"TAB".....	415
Telemarine Communications Co.....	418
Universal General Corp.....	424
V & H Radio & Electronics Supply.....	422
Western Engineers .....	419
Wilgreen Industries .....	420

This index is published as a convenience to the reader. Care is taken to make it accurate but Classified assumes no responsibility for errors or omissions.



**DESIGN ENGINEERS**

**GUIDED MISSILES FIELD**

Transducer, Modulator, Transmitter Designers

Progress in guided missile development at this major company, located in upper New York State, has resulted in an opening for a transducer designer able to design circuits or components to transform vibration, temperature, electrical currents, and other data into voltage form compatible to telemetry or recovery instrumentation. This includes application of existing designs, and testing all designs.

There is also an opening for an engineer able to design and test airborne modulator and transmitter equipment, and evaluate and test commercial equipment of this type.

These jobs require minimum of five years experience. Working conditions and salary at this company are excellent and living conditions equally attractive. Many opportunities for additional education.

Send complete resume in confidence to

P-8207, Electronics  
330 W. 42 St., New York 36, N. Y.

**ENGINEERS**

Say  
"YES"  
to a Life  
With  
Roots

If you are ready to put down roots . . . to embark on a permanent career with deep professional and personal satisfaction . . . General Precision Laboratory may have an opening for you.

There is a variety of long-range projects underway at GPL, a subsidiary of the large and diversified General Precision Equipment Corporation. We look for engineers who can contribute advanced ideas, sometimes pursuing an independent line, sometimes collaborating with experts in several fields. GPL men can count on recognition following quickly upon accomplishment.

Not the least of the advantages of working at GPL is the location in New York's well-known Westchester County. It's a particularly fine place to put down roots, with its beautiful countryside, modern homes and fine schools.

If your experience qualifies you for the work being done at GPL and you are looking for a stable future, send details of your background to Mr. Hollis F. Ware. Expenses will be paid for qualified applicants who come for interview. We regret we can consider only U. S. citizens.

**GENERAL PRECISION LABORATORY INCORPORATED**

*A Subsidiary of General Precision Equipment Corporation*

63 Bedford Road

Pleasantville, N. Y.

GPL DOES RESEARCH & DEVELOPMENT WORK IN:

. . . Electronics . . . Television, Motion Pictures . . . Aircraft & Missile Control, Guidance . . . Radar, Microwave . . . Systems Engineering: (aeronautical, industrial) . . . Precision Mechanics, Optical Devices . . . Instruments, Servos, Controls: (electro-mechanical, magnetic, electronic)

**RECEIVER ENGINEERS  
TRANSISTOR CIRCUIT ENGINEERS  
SUBMINIATURE EQUIPMENT ENGINEERS**

Career Opportunities  
With Well Established  
Central Connecticut Firm

Challenging Projects  
Top Salaries  
Suburban Living

Replies Held in Strict Confidence  
Wire or Phone Collect  
Personnel Mgr. SHERWOOD 7-2741

**THE ALLEN D. CARDWELL ELECTRONICS  
PRODUCTIONS CORPORATION**  
Plainville, Connecticut

**ELECTRONIC  
DEVELOPMENT  
ENGINEERS**

**Challenging DESIGN & DEVELOPMENT  
POSITIONS for CREATIVE ENGINEERS**

These positions are tailor-made for highly imaginative engineers who enjoy problems of more than ordinary difficulty; problems that require a maximum of individual electronic creativity. Men selected will be entrusted with the complete electronic or electro-mechanical design and development tasks (initial circuits, systems, components, or product design) entailed in carrying a prototype project from original conception to its completion.

**REQUIREMENTS:** Senior and intermediate engineers with degrees and 4 to 8 years' experience; Junior engineers with degrees and 1 to 3 years' experience, capable of growing with our long-range, electronic design and development program in the following fields:

- |                          |                     |
|--------------------------|---------------------|
| (1) ANALOG COMPUTER      | (4) ELECTRO-OPTICS  |
| (2) RADAR BEACONS        | (5) MISSILE SYSTEMS |
| (3) MAGNETIC AMPLIFIERS  | (6) SERVOS          |
| (7) FIRE CONTROL SYSTEMS |                     |

**PROOF OF U. S. CITIZENSHIP REQUIRED**

WE ARE LOCATED in a suburban area, at the Paramus exit of Garden State Pkwy., convenient to the N. J. Turnpike and only 15 minutes from Manhattan. If you choose, you can live nearby, avoiding the discomforts, costs and time wasted in commuting. Enjoy living in a clean, friendly community, minutes from work!

Interviews will be arranged at convenient locations. Send resume to:

**AVION DIVISION  
OF ACF INDUSTRIES INCORPORATED**

Route 17, Paramus, N. J. COLfax 1-4100

Only 15 minutes from  
George Washington Bridge

**JET PROPULSION LABORATORY**  
of the  
**CALIFORNIA INSTITUTE OF  
TECHNOLOGY**  
Pasadena, California

Excellent opportunities exist for professional growth in research atmosphere for Engineers and Physicists of all grades. Facilities and equipment are superior.

Airmail your summary of qualifications to:

CALTECH  
**JET PROPULSION LABORATORY**  
4800 Oak Grove Drive  
Pasadena, California

# Electronics Engineers

expanding helicopter field offers you excellent opportunities

Both Junior and Senior electronics engineers are needed to work with those who design, test, and build rotary wing aircraft.

Challenging positions are open to men with experience or a good educational background in:

- Radar
- Flight Test Instrumentation
- Strain Gage Circuitry
- Oscillographic Data Recording Systems
- Vibration and Temperature Measuring Systems
- Work on Automatic Control Systems—  
both test and development
- Automatic Pilot and Blind Flying Instrumentation

Not only will your professional achievements be recognized, but you and your family will enjoy many personal benefits.

Apply in person or send complete resume to  
R. L. Auten, Personnel Department

**SIKORSKY AIRCRAFT**  
Bridgeport 1, Connecticut

## SEARCHLIGHT SECTION

(Continued on pages 413-427)

## TEST EQUIPMENT

- HEWLETT PACKARD 200B Audio Oscillator (Rack Mounting type) 20 to 20,000 cycles. Like new...\$75.00
- HEWLETT PACKARD 400-A Vacuum Tube Voltmeter—Like new...\$95.00
- HEWLETT PACKARD 325 Distortion Analyzer—30 to 15,000 cycles. Excellent .....\$220.00
- GENERAL RADIO 713-B Beat Frequency Oscillator—0.40 KC. Excellent .....\$225.00
- GENERAL RADIO 723-C Vacuum Tube Fork—New .....\$89.50
- GENERAL RADIO 572B Microphone Hummer, new .....\$7.50
- WATERMAN S-12-B Rakscope, new .....\$325.00
- DUMONT 208 Cathode Ray Oscilloscope—Excellent .....\$95.00
- NAVY LAE-1 Signal Generator—510 to 1300 MC, CW or internal pulse modulation. New .....\$225.00
- MEASUREMENTS CORP. 79-B Pulse Generator—New .....\$165.00

All prices net FOB Phila., Pa.  
SEND FOR LATEST CATALOG

**ELECTRONIC RESEARCH LABS.**  
715-19 ARCH STREET  
Phila. 6, Pa. Phone MA 7-6771

## UNUSUAL CREATIVE FREEDOM at *Bendix* AVIATION RESEARCH LABORATORIES DIV.

• The center of advanced development activities for the Bendix Aviation Corporation offering excellent opportunities in design, research and development.

### SYSTEMS ENGINEERS

To coordinate and supervise a group of engineers and mathematicians in systems analysis and design.

### MATHEMATICIANS

Evaluation of servo control and guidance systems and components of a system Analysis of systems and applications.

### MACHINE DESIGNERS

Design of automatic machine tools, machine tool hydraulic servos, and digitally controlled tools.

### CONTROLS ENGINEERS

Analyse and synthesize control system and design, develop and package such systems.

### COMPUTER ENGINEERS

Development of special purpose digital and analog computers for process and business applications.

### MICROWAVE SPECIALISTS

Research and development in advanced microwave techniques.

### MECHANICAL ENGINEERS

Develop mechanical and hydraulic components for servo controls. Systems engineering and dynamic analysis of numerically controlled machine tools.

- Staff will participate in the initial exploration of new fields and the development of new commercial products.

All replies confidential—  
send brief resume to:

**DIRECTOR OF PERSONNEL**  
BENDIX AVIATION CORPORATION  
RESEARCH LABORATORIES DIVISION  
4855 Fourth Avenue • Detroit 1, Mich.

## RELAYS

3600—6 PDT—Struthers Dunn, type 220XFX100, 26.5 VDC, hermetically sealed.  
\$2.95 ea.—10 for \$25.00—100 for \$200.00

## SELENIUM RECTIFIERS

Sarkes Tarzian miniature rectifier, 1/2 wave, bridge embedded selenium, 52VAC input, 21 VDC output at 5 milliamps, axial wire leads.  
\$1.00 ea.—10 for \$8.50—100 for \$70.00

**DELAWARE EQUIPMENT COMPANY**  
124 N. 3rd St. Phila. 6, Penna.  
Lo-3-4930

## Exceptional offer

**40,000 BALL BEARINGS**  
brand new

SKF Rigid Type EL4—4 mm. int.—13 mm. ext.—5 mm. thick one range of balls—net price: Belg. francs 10.- or \$ 0.20.

Type 126—6 mm. int.—19 mm. ext.—6 mm. thick two ranges of balls—rotule rolling net price: Belg. francs 7.50 or \$ 0.15

F.O.B. Antwerp, export packing included.

**SOCIETE INDUSTRIELLE ALFA Soc. Anon.**  
80, rue de la Senne, Brussels (Belgium)



## UNDISPLAYED RATE:

\$2.10 a line, minimum 3 lines. To figure advance payment count 5 average words as a line.

PROPOSALS, \$2.10 a line an insertion.

BOX NUMBERS count as one line additional in undisplayed ads.

DISCOUNT of 10% if full payment is made in advance for four consecutive insertions of undisplayed ads (not including proposals).

Send NEW ADVERTISEMENTS to N. Y. Office, 330 W. 42nd St., N. Y. 36, N. Y. for January issue closing December 2nd.

The publisher cannot accept advertising in the Searchlight Section, which lists the names of the manufacturers of resistors, capacitors, rheostats, and potentiometers or other names designed to describe such products.

## DISPLAYED RATE:

The advertising rate is \$18.50 per inch for all advertising appearing on other than a contract basis. Contract rates quoted on request.

AN ADVERTISING INCH is measured 7/8 inch vertically on one column, 3 columns—30 inches—to a page.

EQUIPMENT WANTED or FOR SALE ADVERTISEMENTS acceptable only in Displayed Style.

## BUSINESS OPPORTUNITY

Do you have a circuit, gadget or little black box that can be sold for some industrial application? We'll make it and sell it for you. write—Research Electronics, Roslyn, Pa.

## ENGINEERING DEGREES

(Under and Postgraduate)

E.E. Major in Electronics,  
Earned Through Home Study.

AMERICAN COLLEGE OF ENGINEERING

Affiliated with University of the West

Box 27724(G), HOLLYWOOD 27, CALIF.

## For Quick Delivery

Large Quantities—EE-8 Field Telephone—New  
Ma-manufacture

3—Complete BC-694. Large Stock  
Replacement Parts.

Large Quantities BC-312, BC-342  
100 BC-224. Checked Out

## WANTED

BC-312, 224, 342, 348 Complete Units and all  
Component Parts.

EE-8 Complete Units and Components

ART-13 Complete Units and Component Parts

RED ARROW ELECTRONIC SALES CO.

1217 Summit Ave Union City, N. J.

N.Y. Tel. Oxford 5-0934

N.J. Tel. Union 3-7916

TRANSFORMERS  
RECTIFIERS  
IRON CORE COMPONENTS

BOUGHT & SOLD

SEND US YOUR REQUIREMENTS

MAGNETRAN SURPLUS CO.

96 Newport St. Brooklyn 12, N. Y.

## WANTED

## WILL BUY ALL

ART-13 T47A Transmitters	BC-348 Rec'r Modified	\$25.00
ART-13 T47 Transmitters	BC-348 Rec'r Unmodified	\$50.00
BC-788C Altimeters	ARC-1 Radio Complete	\$250.00
ARC-3 Complete	BC-312 Receiver	\$40.00
RS/ARN-7 Radio Compass	BC-342 Receiver	\$50.00
Ship via Express C.O.D.	Subject to inspection to	
H. FINNEGAN		
49 Washington Ave. Little Ferry, N. J.		

## WANTED

ELECTRONIC TUBES, all types. Also want all types airborne electronic equipment: ART-13; BC-788; I-152; ARC-1; ARN-7, etc. Top dollar paid!

BOB SANETT, W6REX

1524 S. Edris Dr.

Los Angeles 35, California

## FOR SALE

Wholesale to Institutions  
Industrials & Dealers Only

RELAYS ● METERS  
MOTORS ● BLOWERS  
SWITCHES ● MAGNETS  
SYNCHROS ● RECEIVERS  
I.F. STRIPS ● NETWORKS  
ANTENNAS ● RESISTORS  
DUPLEXERS ● CAPACITORS  
CONNECTORS ● CONTACTORS  
INSTRUMENTS ● WAVE GUIDES  
MODULATORS ● DYNAMOTORS  
TRANSMITTERS ● TRANSFORMERS  
TORQUE UNITS ● SYNCHRONIZERS  
TEST EQUIPMENT ● CONTROL BOXES  
POTENTIOMETERS ● KLYSTRON MOUNTS  
JUNCTION BOXES ● MICROWAVE PARTS

ALL TYPES OF TUBES

WRITE TO

AMBER INDUSTRIAL CORP.  
METALS AND SALVAGE DIVISION

732 E. Monument Ave. Dayton, Ohio

HIGH QUALITY  
TUBES!

GUARANTEED  
LOW PRICES!

Full Line Of Radio and TV  
Receiving Tubes

OA2	74¢	6A56	\$1.50
OA3	\$1.00	5981/5650	
2C39A	\$7.50		\$40.00
2C40	\$7.00	HF200	\$6.00
2C43	\$7.00	807W	\$3.50
2C46	\$6.00	832A	\$5.00
2D21	75¢	872A	\$1.25
2K25	\$7.00		

THIS IS JUST A PARTIAL LIST OF AVAILABLE TYPES. Send for our complete tube list! Phone and mail orders accepted.

B & C DISTRIBUTORS COMPANY

180 Spring Street Paterson, N. J.

MUlberry 4-4010

★ **Manufacturers**

Let us handle  
TECHNICAL SALES  
representation of  
your products

★ **Inventors**

We will  
SHARE THE COST  
of protecting  
your invention  
if accepted for  
commercialization

★ **WE SPECIALIZE IN**

Electronics, Nucleonics, Instrumentation, Servomechanisms & Cybernetics.

**R. W. HODGSON CO.**

Technical Sales Representation &  
Research & Development Engineering

3406 W. Washington Blvd., Los Angeles 18, Calif.  
REpublic 2-2651

## HELIPOTS

TEN TURNS; 50,000 OHMS

Linearity tolerance 0.05%

Resistance tolerance 1%

3/8" standard bushing mounting

New, clean, original bulk pack. Regular factory cost cut drastically because of contract termination.

**\$12.95 each**, postpaid in U.S.A.

Also available: 0.1 and 0.5% linearity at lower prices; write for quote.

QUANTITY USERS WRITE FOR QUOTATION ON these and other quality components

G. GREENE

166-04 67th Avenue Flushing 65, N. Y.

1500-2000 POWER TRANSFORMERS,  
115V60, 550vct075, 6.3v2a, (lbs.) 2 3/4#,  
Thermador V case, 2 3/4 x 3 x 3 3/4 h,  
about 1/2 OEM price, make offer.

W. C. ROBINETTE CO.

802 Fair Oaks Ave. S. Pasadena, Calif.

## SEARCHLIGHT SECTION

### WANTED

BC-788,T-47A/ART-13,  
BC-348R, R-5/ARN-7,  
RT-18/ARC-1

### AN/ASQ-1 and 1A MAGNETOMETERS

This is an airborne magnetometer used to measure the magnetic flux of the earth and to locate submarines and other metallic objects by their distortion of the magnetic field. Sensitivity 2-3 gamma or better. POR.

### AN/GSQ-1 A SPEECH SCRAMBLERS

Speech scrambler for use on any comm. channel to insure privacy. We can supply complete installations of this equipment 28v DC input. Also 110v 60 cyc.

### SCR-281A DIRECTION FINDER

Automatic ground direction finder covering 1.5mc-30mc. Provides instant bearings on a C.R. indicator of any signal in its range. This equipment is transportable and can be set up quickly. 110v 60 cyc. POR.

### P.P.I. REMOTE RADAR REPEATERS

We can supply the following types of remote Radar P.P.I. Repeaters. The main radar provides the Synchronizing, Syncro. and Video. Pulses to operate the Repeaters. These repeaters may be used with any marine ground or airborne.

VC 7" P.P.I. Upright deck mount Repeater. 4 Ranges are provided from 4-200 miles. Input 110 Volt 60 Cyc.

VD 7" P.P.I. Deck mount Repeater. This unit is very similar to the VC but is completely Waterproof and may be used on deck. The ranges are the same as the VC. Input 110 Volt 60 Cyc.

VE 7" P.P.I. Table mount Repeater. This is a very compact set. 4 ranges are provided from 4-200 miles. Input 110 Volt 60 Cyc.

VF 9" P.P.I. Deck mount Repeater. This is a very late model Repeater enabling 20 radars to be fed into it. 4 Ranges from 4-200 miles are provided. Input 110 Volt 60 Cyc.

VG 12" P.P.I. Plotting Table Projection Repeater. This is a very elaborate Remote Indicator. For use in a plotting center. Up to 20 Radars may be fed into it. This set utilizes a Skiatron tube to provide data that can be retained on the screen and can be erased at will. Input 110 volt 60 Cyc.

Accessories are available such as repeater adaptors enabling the set to be used at a greater distance than normal. Input switches to select the radar to be viewed etc.

# RADALAB

87-17 124th STREET  
Richmond Hill 18, New York  
Phone Virginia 9-8181-2-3

### SCR-682-A RADAR

10CM high power long range harbor surveillance and early warning RADAR. This equipment is a 3000 mc mobile search radar that can be transported in a truck. The equipment incorporates a 7" PPI for operation up to 240,000 yards. Azimuth accuracy is  $\pm 1\%$ . Range accuracy is 100 yards at 10,000 yard range and 5000 yards at 240,000 yard range. Trans. output is approx. 225 KW, pulse width is one microsecond. Antenna beam width is 6". Input is 110v 60 cyc. Can be supplied with or without operating shelter or antenna tower. POR.

**We can supply many types of radars, test sets, communications equipments, manufactured after 1947. Write us if you cannot find it.**

### AN/APR-4 38-4000 MC RECEIVER

This is a precision receiver covering 38-4000 mc. The set utilizes 5 tuning units with direct reading dials in megacycles. The receiver has a wide and narrow band-width 30mc. I.F. strip which may be selected at will. An output meter is provided to measure signal strength. Each tuning unit has an automatic sweeping mechanism which enables any portion of the tuning range to be scanned automatically. Input 110v 60 cyc. POR.

### 500-1300 MC SIGNAL GENERATOR

This is a high precision signal generator covering 500-1300 mc. A precision attenuator is built in providing accurate determination of output from 0-100,000 microvolts. Either CW or pulsed carrier output with the following characteristics are provided. Pulse rate 60-2,500 CPS. Pulse length 2-30 microseconds. Output line 30 Ohm impedance. Accuracy better than one percent. Input 110 v 60 cyc. With calibration charts. Price \$249.50

### 90-600 MC SIGNAL GENERATOR

This set covers 90-600 mc. with an accuracy of one percent or better. C. W. or pulse output with the following characteristics are provided. Output from 0-100,000 microvolts 2-30 microseconds long. Pulse rate 60-2500 cps. Pulse delay 3-300 microseconds. Output 50 ohm line. Input 110v 60 cyc. Price \$249.50

Prices FOB NYC. Rated firms open account. Prices subject to change without notice.

CABLE: Radalab, NY  
TELETYPE: NY-4-4361

### CF-3A CARRIER REPEATER

This is a transportable 4 wire carrier telephone repeater. This set amplifies all signals when used in an intermediate position on a carrier system to extend the range. DC signaling and telegraph communications can be performed to the terminal equipments or to other repeaters. Monitoring and transmission circuits are built in. Power input 110 or 220v or 12v DC. This set can be used with all CF terminals and commercial equipments. Brand New in original cases. POR.

### AN/APA-17 DIRECTION FINDER

This is an automatic direction finder covering 300-1,000 mc to be used with the APR-1 and APR-4 radar search receivers. The bearing is presented on a cathode ray screen in a cardoid pattern. The set can be used in aircraft or on the ground. Input 110v 400 cyc and 28v DC. POR.

### RADAR BEACONS

X and S Band High and Low Power Racons

We can supply the following Beacons in Portable and Stationary Models. The X-BAND models will operate with the new Weather Radars.

AN/CNP-6 X-Band high power Radar Beacon. This is a 40 KW set for use at an Airport. This set will interrogate X-BAND Radars up to 200 miles. Variable Coding is provided as well as monitoring facilities. Input is 110 V 60 CYC.

AN/CPN-8 S-BAND HIGH POWER Airport Beacon. This is a very compact set. This set will interrogate S-BAND Radars up to 200 Miles. Variable Coding and monitoring facilities are provided. Input 110 Volt 60 Cyc.

AN/CPN-17 S-BAND High power version of the CPN-6 with all the latest improvements. Input 110 Volt 60 Cyc.

AN/UPN-4 X-BAND Very lightweight Portable Beacon. This set will interrogate X-BAND Radars up to 60 miles. Variable Coding is provided. Input 12 Volts D.C. Weight approx. 40 Lbs.

AN/UPN-1 and 2 S-BAND Portable Beacons. This set will interrogate a S-BAND Radar up to 60 Miles. Variable Coding is provided. Input is 12 Volts D.C. and 110 Volts 60 Cyc. Weight Approx. 50 Lbs.

## TOWERS and ANTENNA EQUIPMENT

### TRIANGLE TOWER

(Illustrated) Galvanized Steel Tower, 12 1/2" Base, 30 Ft. High in 10 Ft. Sections. Knocked down. Complete with Hardware, two 50 Ft., one 80 Ft. Guys; three 5 Ft. Anchors, and Base Plate. Each section weighs 45 lbs. Complete with Erection Manual. Shipping Weight: Approx. 350 lbs. F.O.B. **\$31.95**

### MAST BASES—INSULATED

MP-22 BASE—Ins. spring action, direction of bracket can be raised or lowered easily. \$2.95  
MP-33 BASE—Ins. type with heavy coil spring and 5" dia. Ins. Requires 2" hole for mounting. Weight: 9 lbs. \$5.95  
MP-37 BASE—Ins. type with heavy coil spring, 7" dia. Ins. Requires 1 1/2" hole for mounting. Weight: Approx. 10 lbs. \$8.95

### MAST SECTIONS FOR ABOVE BASES:

Tubular steel, copper coated, painted—in 3 ft. sections, screw-in type. MS-53 can be used to make any length with MS-52-51-50-49 for taper. Any section... @ 50¢ Each. Larger Dia. Section MS-54 75¢ Ea.

### DYNAMOTORS:

INPUT VOLTS:	OUTPUT VOLTS:	MA.	STOCK NO.	PRICES USED:	NEW:
12 VDC	625	225	DM-35	\$8.95	\$12.95
12 or 24	230	100	DA-12		8.95
12 or 24	540	450	DA-14		14.95
12 or 24	500	50	USA/0515		4.95
24	250	60	PE-86		8.95
14 VDC	330	150	BD-87	3.95	5.95
14	250	50	DM-25	6.95	8.95
14	1000	350	BD-77	14.95	29.95
28	1000	350	PE-73	8.95	
12 or 24	275	110	USA/0516		4.95
12	230	90	PE-133	4.95	6.95
14 VDC	375	150	BD-83	3.95	4.95
12 VDC	220	80	DM-4	2.95	4.95

## BLOWERS:



12/21 VDC—AC CAST ALUMINUM BLOWER (Pictured at left) 100 CFM; 3" intake; 2" outlet. Stator Motor 2 1/2" 3000 RPM @ 24 VDC. \$5.95  
6 VDC SINGLE—100 CFM—No. 6100.....\$4.95  
6 VDC FLANGE—150 CFM—No. 6150.....\$6.95

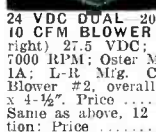

24 VDC DUAL 20 CFM—Min—No. 2420.....\$7.95  
10 CFM BLOWER (Pictured at right) 27.5 VDC; 1/100 HP; 7000 RPM; Oster Motor C2BP-1A; L-R Mig. Co. Bakelite Blower #2, overall size: 3" x 4 1/2". Price.....\$5.95  
Same as above, 12 VDC operation. Price.....\$5.95



115 V. 400 CYCLE—10 CFM—Eastern Air Devices Motor #31A—7200 RPM; 1 1/2" H. L. #2 Blower Assy. Overall Size: 4 1/2" x 3 1/2". No. 3110.....\$5.95  
10 CFM BLOWER (Pictured at left) 28 VDC—6 A; 5000 RPM; Pioneer Motor SS-2345; Aluminum Blower Housing; Overall Size: 4 1/2" x 3 1/2". Price.....\$5.95

### 115 V. 60 CYCLE BLOWERS:

115-VAC 60 cycle SINGLE TYPE—100 CFM; 2 3/4" intake; 2" outlet. Complete size: 5" x 6" **\$8.95**  
—No. 1C839  
115 VAC 60 cycle DUAL TYPE—100 CFM; 4" intake; 2" Dis. Each side. Complete size: 8" x 6" **\$13.95**  
—No. 1C880  
115 VAC 60 cycle COMPACT TYPE—108 CFM; Motor built insidequirrel cage; 4 1/2" intake; 3 3/4" x 3" Dis. Complete size: 4 1/2" W x 8 3/4" H x 8 1/2" D—No. 2C067 **\$14.95**  
115 VAC 60 cycle FLANGE TYPE—140 CFM; 3 1/2" intake; 2 1/2" Dis. Complete size: 7 1/2" x 7 1/2" **\$13.95**  
W x 3 1/2" H x 6 3/4" D—No. 1C807  
115 VAC 60 cycle FLANGE TWIN—275 CFM; 4 3/4" intake; 3 3/4" x 3" Dis. Complete size: 11 3/4" W x 3 3/4" H x 8-1/16" D—No. 2C069 **\$21.95**  
115 VAC 60 Cycle BLOWER—200 CFM; 4" intake; 3" x 3" outlet. Overall size: 8" x 7" x 6". Bodine Motor NSI-33. Removed from New Equipment. #BOD-200 **\$14.95**  
115-VAC 60 Cycle BLOWER—100 CFM; 3 3/4" intake; 2" outlet; Rd. Flange with Flap Director. Overall size with bracket: 8" L x 6 1/2" W x 7" H. Removed from New Equipment. Diehl Motor PB-2106-6 No. FDH-2108. **\$6.95**  
Same as above, but with 12 Curved Director. No. CDH-2106 **\$7.95**  
Previously Adv. Items Still Available. Please Write!

## Surplus ELECTRONICS Components Industrial Equipment

RAYMARK TRANSMITTER—TB-144. Mfg. by Raytheon self cont. 115V-60 cycle pow. source. Output 30 watts av. emission-wise modulated. 3256 mc. with tubes excell. cond. Abt 75 lb.—\$50.00

TEST SET—TS 173/UP—Power Source 115-v 60c. Complete with calibration book, spare tubes, and crystal. This is the high frequency version of the LM and BC221 frequency meter. Excellent condition. Freq.—90—450MC. **\$150.00**

RADAR TEST EQUIPMENT—MODEL LW—Mfgd by West. Elect. Self-Cont. Pow. Source—115V. 60 cycle. Consists of 1 CW-AAL Wavemeter; 1 CW-66A BL Antenna Assy; 680-720 MC. Micrometer Leads; Cables Test Cord. Carry Case, Calib. Curve Furnished. Near New Cond. **\$100.00**

STEP-DOWN XFORMER—Available in production quantities—115-v-60 to 28-v 1.5 amps. Open frame constr. Lots of 100—\$1.00 ea. Lesser quant. \$1.50 ea. Write for large quant. price.

WESTERN ELECTRIC STEPPER SWITCH—Production quantities—Coil voltage from 4.5-v to 12 VDC—44 steps. 4 decks. D162768—ea. \$7.95—\$0 @ \$5.00—Quantities—write.

VIBRAPACK—PE-104—P.O. Scr. 284—Exc. cond. **\$9.95 ea.**

VIBRAPACK PE-204—New—Orig. pack..... **\$2.50**

TS-33/AP FREQUENCY METER—Mfg. by West. Elect. Used for measuring CW, Pulsed Signals, Radar Install., Etc. Freq.—8700—9500 MC—New. Complete **\$175.00**

SPERRY KLYSTRON SIGNAL SOURCE—Model 444 (Standard Gtalon) Like New Cond. **\$250.00**

WESTERN ELECTRIC POWER SUPPLY—Input 115 VAC 60c—output 115 VDC 600 MA. Regulated Filtered. Beautiful construction, all UP components. With diagram (Bell Labs) Brand new #68 800156. **\$29.95**

KLYSTRON 2K39—Guaranteed. Tested..... **\$100.00**

1625 TUBES—Large lot—Individual boxed. Lots of 100—22¢; Lots of 600—17¢; Lots of 1200—15¢.

AIRCRAFT TRANSMITTER CAT. 52173A—Unit of model GP-7—With all tubes, 1 tuning unit—Exc. cond. **\$50.00**

MAST BASE—MP-22A—New..... **\$2.00 ea.**

## REX RADIO SUPPLY CO.

88 CORTLANDT ST. N.Y. 7, N.Y.  
Phone CO-7-1617 — Prices F.O.B. N. Y.

### CAPACITORS

gov't termination purchase  
Oil filled-impreg., micas.  
Write for current listings

### RESISTORS

insl. quality 1/2-1 & 2 watts  
Wirewound—3-5-10-20-50 watts

GOULD GREEN, 252 Greenwich St., NYC 7

# FAIR RADIO SALES • 122 SOUTH MAIN ST. LIMA, OHIO







# AN/GRC-13 FIELD SET

2 to 12 MC. Transmitter—Receiver. C.W. and Radiotelephone. Complete. OUTPUT: 20 watts CW—6 watts voice.

Consists of: RT-136/GRC-13 Receiver-Transmitter  
PP-272/U Power Supply (12-24 V. DC & 110Vac).  
G-28A/U Hand Generator with mount and cranks.  
MX-1012/U Installation Kit.  
Accessories: Microphone, headset, cables, antennas, guys, hardware and transit trunks, for all the above.

This unit—new and unused—is of latest design and can be operated in the field with hand-driven generator or a generator and self-contained battery system. Also operable from A. C. mains. Provision for 1 mile pair of telephone wires included. All packed in waterproof cases for field transportation. Both whip and long wire antennae included. Ten preset crystal-controlled frequencies. Engine generator kit MX-1010/U available if desired. Manufactured by R.C.A. These units are complete and operable. They are available—new and unused—in quantities.

# AN/PRC-14 WALKIE-TALKIE

Transmitter — Receiver (30 Mile Range)  
FREQUENCY: 225 to 400 M.C.—4 channels

EMISSION:—A3 only. OUTPUT—1 watt.

Large quantity of brand-new—never used — components and partially completed sets to make up approximately 400 complete units. All are absolutely new including such items as cases, straps, antennas, etc. for the assembly of this recently manufactured set. Here is a great opportunity to make an unusually fine buy—the result of a recently terminated contract. Technical data available to qualified inquirers.

# RADIO TRANSMITTERS

in all power ranges.  
R.C.A. - COLLINS - BENDIX and others.

We have and offer for sale the largest quantity of Medium powered transmitters available in the market, today. Your inquiries will be answered promptly.

# SPARE PARTS SCR-300

The largest supply under one roof —anywhere. Ask us for any item used in this famous walkie-talkie from the headset to the antenna

# COMMUNICATION DEVICES CO

TWX—NY1—223  
Cable—Communidev, N. Y.  
Tel. ADironclack 4-6174

2331 TWELFTH AVENUE

NEW YORK 27, N. Y.

**3 Cond. KOILED KORDS**  
22 inches long stretches to 9 feet  
List price \$3.00 Net \$1.26

### REVERSIBLE GEARED-MOTOR

Delco-PM-Permanent Magnet Amico Field Motor



#5071895 1/4 SHAFT or 11/16 GEAR... \$17.50  
#5089600... \$18.50  
Gromms to hold motor: \$1.50 ea.

MERCURY Switches 59¢ to \$6.00  
Send sketch or old switch.

Hg. We Buy MERCURY Hg.

FILAMENT TRANSFORMER 97¢

G.E. SWITCHETTES • ALL TYPES  
75¢ ea • 10 for \$6.00 • 100 for \$50.00

115v A.C. Relay... \$2.90

### TELECHRON Motors

4 RPM on 50 cy	3.6 RPM. 3.15
or 1/4 RPM	1 RPM. 3.95
on 60 cy. \$2.85	3 R.P. Hr 2.95
2 RPM .. \$2.90	1 R.P. 2 Hr 2.80
3 RPM .. 3.90	1 R.P. 12 Hr 3.25
4 RPM .. 2.90	60 RPM. 4.85

Laboratory Special 1 of Each Motor \$25.

please include postage **BLAN**

### BLOWERS 115 Volts A.C. 60 cy.

REDMOND 5" 18 watts... \$9.95  
DELCO 60 cfm. 40 watts... \$14.99  
#5062369 used in 584 RADAR

### HAND WOUND 10 Sec. to 24 Min. TIMER SWITCH... \$1.20

6 Watt Most POWERFUL TELECHRON 1 RPM  
110 v. 60 cy. .... \$6.50  
10 for ..... \$50.00

3" Round Elapsed Time Meter Square Case \$14.50

### MARKTIME 5 HOUR SWITCH

A 10 amp. timing device. Pointer moves back to zero after time elapses. Ideal for shutting off radios and TV sets when you go to bed. Limited supply at this SPECIAL PRICE... \$4.90  
Also available in 15 min. or 30 min. or 1 hr. at... \$6.50

**HAYDON TIMING MOTORS**  
110v 60 cycle 30 RPM \$2.60  
110v 60 cycle 1 RPM... 2.60  
230v { 1 RPM... 1.00  
60cy { 2 RPM... 1.00

EST. 1923 64P Dey Street New York 7, N. Y.

### RCA TV CAMERA

NEW Surplus for Labs! Export! Industrials! Medicine! Closed Circuit TV!

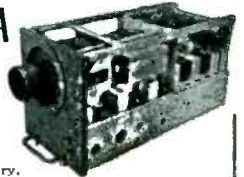

Ideal for labs, industry, prisons, TV technicians, medical—mechanical eye\*\* for closed circuit TV, 1846 Iconoscope, 6-stage video amplifier and clipper. THE REAL THING! Send for new, free, complete technical data. SOLD AT FRACTION OF REAL VALUE!

Write today! Note our new address!

## Harjo Sales Co.

Office-Warehouse: Dept. E-12, 503 N. Victory Blvd., BURBANK, CALIFORNIA

### LOW-VOLTAGE TRANSFORMERS

New Release of Government Surplus Material Model #S-9527. KENYON TRANSFORMER CO. — 2.2 KVA. Input 110/220 volts 50/60 Cy. Output 11 Volts C.T. (5.5-0-5.5) AT 200 Amperes! Continuous Duty. Case Size 8 1/2 x 10 1/2 x 13 1/2.

Price BRAND NEW ONLY... \$23.95 Ea. #S-9527-WE. — WESTINGHOUSE — Same Specs. But Single 115 V Input & Higher P.F. NEW \$23.95 DOZENS OF USES FOR INDUSTRIALS, TESTING LABS, EXPERIMENTAL UNITS & SCHOOLS  
★ Heavy-Duty Soldering ★ Dip-Soldering ★ Plating  
★ Battery-Chargers ★ Spot Welding ★ Welding  
★ Magnetizers ★ Heat-Treating ★ Electromagnets  
★ Testing — Tubes, Coils, Breakers, & Relays.  
Terms: Prices FOB St. Louis. Cash With Orders. Well Rated Concerns (D&B) Net 10 Day's Cash.

McNEAL ELECTRIC & EQUIPMENT CO. 4736 Olive St., Dept. E-12, St. Louis 8, Mo.

We Buy

We Sell

# All Buyers: RESISTORS

Phone: Yonkers 9-6000

Legri S Company

391 Riverdale Ave. Yonkers 5, N. Y.



SAVE ON TUBES BRAND NEW TUBES GUARANTEED TUBES

OA2 . . . . . 75	2J55 . . . . . 35.00	4X150A . . . . . 22.50	VT158 . . . . . 9.75	464A . . . . . 2.25	836 . . . . . 1.50	5656 . . . . . 7.00
OA3 . . . . . 1.00	2J56 . . . . . 50.00	4X500A . . . . . 55.00	FG166 . . . . . 15.00	RH507 . . . . . 25.00	837 . . . . . 1.00	5657 . . . . . 125.00
OB2 . . . . . 75	2J61 . . . . . 15.00	5BP2A . . . . . 5.00	FG172 . . . . . 15.00	CK512AX . . . . . 1.10	838 . . . . . 75	5663 . . . . . 1.50
OB2WA . . . . . 3.00	2J62 . . . . . 5.00	5BP4 . . . . . 2.00	WL200 . . . . . 75.00	527 . . . . . 22.50	838W . . . . . 3.00	5667 . . . . . 125.00
OC3/VR105 . . . . . 75	2J62A . . . . . 50.00	5CP1 . . . . . 1.75	CE-203 . . . . . 3.75	ML531 . . . . . 4.00	842 . . . . . 2.00	5670 . . . . . 1.50
OD3 VR105 . . . . . 75	2JB51 . . . . . 35	5CP1A . . . . . 9.50	203A . . . . . 5.00	559 . . . . . 50	845 . . . . . 5.00	5672 . . . . . 1.25
ELC1B . . . . . 1.50	2K22 . . . . . 14.50	5C22 . . . . . 29.50	204A . . . . . 35.00	KU610 . . . . . 3.50	849 . . . . . 22.50	CK5678 . . . . . 1.00
1AD4 . . . . . 85	2K25 . . . . . 12.00	5C30/C5B . . . . . 1.50	207 . . . . . 50.00	HY615 . . . . . 50	851 . . . . . 10.00	5686 . . . . . 2.00
1B23 . . . . . 2.75	2K26 . . . . . 45.00	5CP7A . . . . . 10.00	211/VT4C . . . . . 50	WL616 . . . . . 50.00	852 . . . . . 5.00	5687 . . . . . 3.00
1B24 . . . . . 5.50	2K28 . . . . . 35.00	5D23 . . . . . 7.50	212E . . . . . 17.50	KU627 . . . . . 10.00	860 . . . . . 3.00	5691 . . . . . 4.75
1B24A . . . . . 15.00	2K33A . . . . . 60.00	5FP7 . . . . . 1.50	217A . . . . . 1.50	KU628 . . . . . 10.00	861 . . . . . 15.00	5692 . . . . . 5.00
1B26 . . . . . 2.00	2K34 . . . . . 99.50	5JP2 . . . . . 7.00	217C . . . . . 2.00	648P1 . . . . . 7.50	865 . . . . . 50	5693 . . . . . 4.75
1B27 . . . . . 10.00	2K39 . . . . . 100.00	5JP4 . . . . . 7.00	WL218 . . . . . 19.00	WL652 . . . . . 20.00	872A . . . . . 1.35	5696 . . . . . 1.00
1B35 . . . . . 4.50	2K41 . . . . . 100.00	5JP5 . . . . . 7.00	QK221 . . . . . 125.00	HK654 . . . . . 25.00	874 . . . . . 60	5702 . . . . . 1.40
1B36 . . . . . 4.00	2K43 . . . . . 125.00	5JP11A . . . . . 19.50	RX233A . . . . . 75	WE701A . . . . . 1.85	878 . . . . . 50	5702WA . . . . . 6.00
1B40 . . . . . 2.00	2K44 . . . . . 125.00	5J23 . . . . . 20.00	FG235A . . . . . 25.00	702A . . . . . 50	884 . . . . . 1.00	5703 . . . . . 1.10
1B51 . . . . . 6.75	2K45 . . . . . 45.00	5J26 . . . . . 125.00	QK249 . . . . . 150.00	WE703A . . . . . 1.25	GL889 . . . . . 50.00	5718 . . . . . 3.00
1B63A . . . . . 22.00	2K47 . . . . . 125.00	5J29 . . . . . 5.00	WE249B . . . . . 2.50	WE704A . . . . . 75	GL889A . . . . . 65.00	5719 . . . . . 2.50
1N21 . . . . . 75	2K48 . . . . . 80.0	5J30 . . . . . 5.00	WE249C . . . . . 3.00	WE705A . . . . . 75	889A . . . . . 125.00	RK5721 . . . . . 175.00
1N21B . . . . . 1.50	2K54 . . . . . 15.00	5J33 . . . . . 5.00	250TL . . . . . 15.00	706AY-GY . . . . . 15.00	902A . . . . . 3.00	5725 . . . . . 1.85
1N22 . . . . . 75	2K56 . . . . . 50.00	5MP1 . . . . . 3.95	WF-251A . . . . . 47.50	707A . . . . . 3.50	902P1 . . . . . 3.00	5726 . . . . . 75
1N23 . . . . . 75	2V3G . . . . . 2.00	5NP1 . . . . . 5.00	WE252A . . . . . 10.00	707B . . . . . 4.50	917 . . . . . 2.75	5727 . . . . . 2.25
1N23B . . . . . 1.50	2X2A . . . . . 1.00	5R4GY . . . . . 1.90	QK253 . . . . . 149.50	WE708A . . . . . 75	919 . . . . . 2.25	5744 . . . . . 1.90
1N23BM . . . . . 3.50	3AP1 . . . . . 2.95	5R4WGY . . . . . 2.25	WE254A . . . . . 5.00	713A . . . . . 50	922 . . . . . 1.25	5750 . . . . . 3.10
1N25 . . . . . 4.00	3BP1 . . . . . 2.00	C6J . . . . . 6.50	FG258A . . . . . 90.00	714A . . . . . 12.50	927 . . . . . 1.00	5751 . . . . . 2.20
1N26 . . . . . 4.50	3B22 . . . . . 1.50	6AJ5-JAN . . . . . 1.25	271A . . . . . 10.00	715A . . . . . 2.00	SN930 . . . . . 4.50	5780 . . . . . 199.50
1N28 . . . . . 5.00	3B24 . . . . . 1.00	6AK5W . . . . . 1.50	WE274B . . . . . 1.00	715B . . . . . 4.00	931A . . . . . 2.50	CK5787 . . . . . 4.95
1N34A . . . . . 50	3B24W . . . . . 5.00	6AL5W . . . . . 65	WE282B . . . . . 5.00	715C . . . . . 12.00	935 . . . . . 4.00	5814 . . . . . 1.00
1N35 . . . . . 1.50	3B26 . . . . . 3.00	6AR6 . . . . . 1.25	QK283A . . . . . 100.00	717A . . . . . 50	954 . . . . . 35	5814A . . . . . 2.25
1N42 . . . . . 8.00	3B28 . . . . . 6.00	6AS7G . . . . . 2.50	QK284A . . . . . 100.00	719A . . . . . 9.50	955 . . . . . 35	5819 . . . . . 35.00
1N47 . . . . . 3.00	3B29 . . . . . 5.50	6D21 . . . . . 150.00	WE287A . . . . . 3.50	720AY-EY . . . . . 50.00	956 . . . . . 35	5825 . . . . . 7.95
1N63/K63 . . . . . 1.75	3C22 . . . . . 60.00	6F4 . . . . . 3.25	WE300B . . . . . 5.00	721A . . . . . 75	957 . . . . . 35	5829 . . . . . 1.80
1N69 . . . . . 40	3C23 . . . . . 5.00	6J4 . . . . . 1.95	GB302 . . . . . 5.00	721B . . . . . 7.25	958A . . . . . 35	5837 . . . . . 70.00
1P21 . . . . . 22.50	3C24 . . . . . 1.50	6K4 . . . . . 2.25	304TH . . . . . 8.95	722A . . . . . 3.50	959 . . . . . 1.50	5840 . . . . . 5.00
1P22 . . . . . 6.50	3C27 . . . . . 1.00	6SK7W . . . . . 2.00	304TL . . . . . 12.50	723A/B . . . . . 8.50	991 . . . . . 35	5842 . . . . . 13.50
1P28 . . . . . 9.00	3C31 . . . . . 1.50	6SL7WGT . . . . . 2.00	WE305A . . . . . 3.00	WE724A . . . . . 85	CK1005 . . . . . 35	5844 . . . . . 3.00
1P29 . . . . . 2.00	3C33 . . . . . 9.95	6SU7GTY . . . . . 2.25	307A/RK75 . . . . . 1.00	WE724B . . . . . 85	CK1006 . . . . . 2.75	5851 . . . . . 4.00
1P36 . . . . . 2.50	3C45 . . . . . 6.00	6X4W . . . . . 1.00	WE308B . . . . . 10.00	725A . . . . . 3.25	CK1007 . . . . . 75	5896 . . . . . 6.50
1P39 . . . . . 1.20	EL3CJA . . . . . 9.00	6X5WGT . . . . . 1.30	WE312A . . . . . 2.95	726A . . . . . 7.00	1603 . . . . . 3.00	5899 . . . . . 7.00
1W5 . . . . . 1.25	3DP11A . . . . . 7.50	7C22 . . . . . 50.00	WE313C . . . . . 2.75	726B . . . . . 30.00	1620 . . . . . 3.25	5901 . . . . . 6.50
2AP1 . . . . . 5.00	3D21A . . . . . 4.00	7C23 . . . . . 69.50	WE316A . . . . . 50	726C . . . . . 20.00	1623 . . . . . 2.25	5905 . . . . . 8.95
2C26A . . . . . 50	3DP1S2 . . . . . 5.00	7C24 . . . . . 95.00	327A . . . . . 2.50	730A . . . . . 7.50	1624 . . . . . 1.00	5907 . . . . . 7.90
2C33 . . . . . 75	3E29 . . . . . 8.50	NE16 . . . . . 35	WE336A . . . . . 5.00	750TL . . . . . 42.50	1625 . . . . . 30	5908 . . . . . 7.95
2C34 . . . . . 35	3FP7A . . . . . 3.50	FG17 . . . . . 2.95	WE338A . . . . . 5.00	800 . . . . . 1.50	1626 . . . . . 35	5910 . . . . . 45
2C35 . . . . . 2.50	3GP1 . . . . . 1.95	RK21 . . . . . 1.00	WE349A . . . . . 6.00	801A . . . . . 50	1630 . . . . . 50	5932 . . . . . 4.00
2C39 . . . . . 7.50	3J30 . . . . . 35.00	RX21 . . . . . 5.50	WE350A . . . . . 2.75	802 . . . . . 2.75	1636 . . . . . 1.90	5933/807W . . . . . 4.00
2C39A . . . . . 8.00	3J31 . . . . . 45.00	HK24 . . . . . 3.00	350B . . . . . 2.75	803 . . . . . 1.40	1641 . . . . . 1.35	5965 . . . . . 1.50
2C40 . . . . . 12.50	3K30 . . . . . 125.00	D42 . . . . . 40.00	354C . . . . . 5.00	804 . . . . . 9.75	1642 . . . . . 50	5998 . . . . . 15.00
2C42 . . . . . 10.00	4B23 . . . . . 6.00	HK54 . . . . . 2.00	356B . . . . . Q	805 . . . . . 4.00	1945 . . . . . 60.00	6005 . . . . . 1.75
2C43 . . . . . 7.00	4B24 . . . . . 6.00	QK59 . . . . . 30.00	357B . . . . . 50.00	806 . . . . . 7.50	2050 . . . . . 1.00	6021 . . . . . 5.00
2C44 . . . . . 50	4B26 . . . . . 6.00	QK60 . . . . . 25.00	WE359A . . . . . 2.00	807 . . . . . 1.20	2051 . . . . . 65	CK6050 . . . . . 2.00
2C46 . . . . . 6.00	4B27 . . . . . 2.50	RK60/1641 . . . . . 1.35	368AS . . . . . 2.00	807W . . . . . 4.00	ZB3200 . . . . . 75.00	6147 . . . . . 3.00
2C51 . . . . . 3.00	4C27 . . . . . 3.50	RK61 . . . . . 2.95	371B . . . . . 50	808 . . . . . 1.25	5517A . . . . . 1.75	6177 . . . . . 49.50
2C52 . . . . . 3.50	4C28 . . . . . 25.00	QK61 . . . . . 25.00	WE388A . . . . . 1.20	809 . . . . . 2.25	5551 . . . . . 25.00	8005 . . . . . 4.95
2C53 . . . . . 10.00	4C35 . . . . . 13.50	QK62 . . . . . 25.00	WE393A . . . . . 4.50	811 . . . . . 2.90	5553/655 . . . . . 190.00	8012 . . . . . 1.00
2D21 . . . . . 60	4E27 . . . . . 8.75	HY65 . . . . . 1.50	WE394A . . . . . 3.00	812 . . . . . 2.50	5557/FG17 . . . . . 2.95	8013 . . . . . 4.95
2D21W . . . . . 1.35	4J22 . . . . . 35.00	RK65/5D23 . . . . . 10.00	WE396A . . . . . 3.00	813 . . . . . 11.00	5559/FG57 . . . . . 10.00	8025A . . . . . 2.00
2E27 . . . . . 75	4J28 . . . . . 35.00	FG67/5728 . . . . . 19.00	403B/5591 . . . . . 2.75	814 . . . . . 1.75	5561 . . . . . 29.50	9001 . . . . . 85
2E32 . . . . . 1.00	4J29 . . . . . 35.00	RKR72 . . . . . 50	GL414 . . . . . 99.50	815 . . . . . 1.50	5586 . . . . . 125.00	9002 . . . . . 65
2J31 . . . . . 14.50	4J31 . . . . . 65.00	RKR73 . . . . . 50	417A . . . . . 3.50	826 . . . . . 75	5591/403B . . . . . 2.75	9004 . . . . . 85
2J32 . . . . . 14.50	4J34 . . . . . 50.00	100TH . . . . . 6.50	RT434 . . . . . 25.00	829 . . . . . 6.00	5611 . . . . . 99.50	9005 . . . . . 1.50
2J33 . . . . . 14.50	4J42 . . . . . 25.00	FG104 . . . . . 29.50	434A . . . . . 3.00	829B . . . . . 8.50	5634 . . . . . 7.50	9006 . . . . . 25
2J34 . . . . . 14.50	4J50 . . . . . 99.50	FG105 . . . . . 11.00	446A . . . . . 50	830B . . . . . 75	5636 . . . . . 4.00	
2J36 . . . . . 20.00	4J52 . . . . . 50.00	F123A . . . . . 2.95	446B . . . . . 2.00	832 . . . . . 3.75	5637 . . . . . 5.50	
2J39 . . . . . 10.00	4J57 . . . . . 100.00	F128A . . . . . 15.00	450TL . . . . . 35.00	833A . . . . . 27.50	5651 . . . . . 1.40	
2J40 . . . . . 14.50	4J58 . . . . . 100.00	FG154 . . . . . 15.00	WL456 . . . . . 59.50	834 . . . . . 5.00	5654 . . . . . 1.50	
2J42 . . . . . 60.00						
2J48 . . . . . 35.00						
2J49 . . . . . 40.00						
2J50 . . . . . 35.00						
2J51 . . . . . 150.00						

THIS IS ONLY A PARTIAL INVENTORY. CHECK WITH US FOR YOUR REQUIREMENTS

Thousands of other types in stock. Send us your requirements. RECEIVING TUBES! We Carry a complete line in stock. Standard brands only.



**ELECTRONICS**  
Dept. EW  
1100 Venice Blvd  
Los Angeles 15  
California

All Prices F.O.B. Los Angeles, subject to change without notice. Minimum order \$5.00. Check with us for items not listed.

**POWER RHEOSTATS**

Over 25,000 Rheostats for immediate shipment

25 WATT			25 WATT			50 WATT		
Ohm	Shaft Length	Price	Ohm	Shaft Length	Price	Ohm	Shaft Length	Price
1.3	5/16"	69c	3000	1 1/16"	89c	1000	5/16"	5.99
2	7/16"	79c	3500	5/8"	79c	1800	7/16"	1.09
4	7/16"	79c	5000	7/16"	89c	10000	7/16"	1.49
10	7/16"	79c	5000	5/8"	79c			
12	7/16"	79c						
20	7/16"	79c						
25	7/16"	79c						
50	7/16"	79c						
60	7/16"	79c						
70	3/8"	79c						
75	1 1/8"	79c						
75	7/16"	79c						
100	7/16"	79c						
100	7/16"	79c						
125	7/16"	79c						
160	3/8"	79c						
185	7/16"	79c						
200	7/16"	79c						
250	3/8"	79c						
350	7/16"	79c						
370	7/16"	79c						
500	7/16"	79c						
500	5/8"	69c						
750	7/16"	69c						
1000	7/16"	69c						
2500	5/8"	79c						

**ALL BEST CARBON RESISTORS**

Brand New—Fresh Stock  
All Standard R.M.A. values available  
EB 1/2 GB 1 HB 2

**Price Schedule**

	Tol.	1 to 99	100 of a value
1/2 WATT	10%	\$0.05 ea.	\$2.95
	5%	.10 ea.	6.00
1 WATT	10%	.08 ea.	5.00
	5%	.16 ea.	11.00
2 WATT	10%	.10 ea.	9.00
	5%	.20 ea.	18.00

WE SHIP AT THESE PRICES

**ALL BEST TYPE "J" POTS**

• JLU Locking Bushing • Shaft for Knob  
Your Choice—95¢ ea.

OHMS	OHMS	OHMS	OHMS	OHMS
50	100	100	100K	500K
100	1K	1K	100K	1 MEG
250	2K	10K	100K	2 MEG
500	2500	15K	150K	2.5 MEG
		25K	250K	5 MEG

**SELSYN C78248 ea. . . . . \$6.95**

**Differential C78249 ea. . . \$2.95**

Mounting Brackets for Above 35¢ Pair

**Diehl Midget PM Motor \$3.95**

KS—15098—LO1 27 VDC

**Utah Pulse Transformers**

9262 . . . \$6.95 9280 . . . \$7.95

**BC-221 FREQUENCY METER \$115.00**

**COAX CONNECTORS**

**BARGAIN: SO 239 } 35¢ ea. Brand New**

	U.C.		U.C.
83-1AC	5.42	83-22R	5.68
-1AP	1.30	-22S	.80
-1BC	.35	-22T	1.95
-1F	1.10	-18	1.12
-1H	1.12	-18S	1.12
-1HP	.22	M-358	1.30
-1J	.70	M-359	.30
-1K	.35	M-359A	.65
-1RTY	.65	PL-258	.75
-1SP	.35	PL-259	.35
-1SPN	.35	PL-259A	.35
-1T	1.30	PL-274	1.10
-22AP	1.40	SO-239	.35
-22F	2.10	U.C.	2.10
-22J	1.40	218/U	1.00
		278/U	2.35

**PRECISION WIREWOUND RESISTORS**

**1/4 WATT - 30¢**

OHMS	OHMS	OHMS	OHMS	OHMS	OHMS
10	10.84	13.52	105.8	301.8	2,193
12	12.77	16.20	127.8	386.6	2,731
2	11.74	14.98	125	434.3	3,500
5	12.32	16.37	147.5	705	36,000
6	13.02	17.54	220.4	723.1	59,348
10.48	13.15	79.81			

**1/2 WATT - 35¢**

OHMS	OHMS	OHMS	OHMS	OHMS	OHMS
25	25	260	4,300	14,823	36,000
334	46	270	6,451	15,000	37,000
444	52	293.3	5,000	15,750	43,000
802	55.1	400	5,900	16,700	45,000
817	66.6	600	6,500	17,000	50,000
76	75	855	6,650	25,000	59,000
1	90	1,500	7,000	30,000	68,000
1.01	97.8	2,250	7,300	32,700	100,000
2	125	2,500	7,500	32,888	120,000
2.54	150	3,000	8,000	33,000	180,000
11	180	3,27	8,500	33,500	200,000
11.1	210	4,000	10,000	35,888	500,000
13.3	235				

**1 WATT - 45¢**

OHMS	OHMS	OHMS	OHMS	OHMS	OHMS
2	5.21	425	4,000	15,000	55,000
225	15	1,200	5,000	20,000	56,000
861	38	2,000	8,000	30,000	60,000
1	91	2,200	8,250	40,000	68,000
2.58	250	2,400	9,000	50,000	84,000
2.65	270	3,000	10,000		
3.39	420	3,300	12,000		

**1 WATT - 60¢**

OHMS	OHMS	OHMS	OHMS	OHMS	OHMS
100,000	130,000	220,000	270,000	320,000	590,000
105,000	132,000	240,000	296,000	348,000	645,000
120,000	150,000	250,000	297,000	350,000	680,000
128,000	175,000	260,000	300,000	522,000	700,000

**1 MEGOHM 1 WATT 1%—90¢; 5%—60¢**  
EXPORT ORDERS SHIPPED PROMPTLY

Orders f.o.b. Philadelphia Minimum order \$3.00  
WRITE TO BE PLACED ON OUR MAILING LIST WALNUT 2-3553  
**ARCH ELECTRONICS CO.** 634 ARCH STREET PHILADELPHIA 6, PA.

**TELEMARINE**

PARTIAL LISTING OF OUTSTANDING SURPLUS COMMUNICATIONS EQPT.

WE 248-A RADIOTELEPHONE EQPT. 250/350 Watts, 2-20 MC, 30 Channels Transmit and Receive all crystal-controlled, monitors 3 separate channels simultaneously, uses standard modern type tubes. COMPLETE, NEW (Not Gov't Surplus). Operates from 110 Volts, 50/60 Cycles AC. IDEAL FOR SHIP RADIOTELEPHONE, OR FIXED-RADIO INSTALLATION. WRITE FOR DESCRIPTIVE LITERATURE AND PRICE.

GE 10 KW RF POWER AMPLIFIERS, 88-108 MC, Class "C", with separate Rectifier Power Supply. Operation from 220 V, 3-phase, 50/60 Cycles AC. Easily modified for other frequencies. NEW. Not Gov't Surplus. WRITE FOR DESCRIPTIVE LITERATURE AND PRICE.

MODEL LSR 420F: RADIO BEACON OR SHIP RADIO TRANSMITTER. Freq. Range: 275-510 KC. Power Output 100 Watt CW, 150 Watts MCW. Operates from 115 V. AC. 60 C. New Expt. LSR-520-C RADIO BEACON POWER AMPLIFIER, Class B Linear Amplifier used with above LSR-420 to increase power output to 600 Watts CW or 800 Watts MCW. Operates from 115 Volts 60 C. AC.

BC-797 VHF 10-126 MC. 50W. AM Output for 110 V. 50/60 C. AC. BC-460 Collins Autotune Transmitter, 250 W. Al. 200 W. A3 or A2, 10-Channels 2-16 mc. BC-447, 300 W. Al. 4-13.4 mc. 2-channels. SCR-510/610. FM Trans-Receiver, 20 to 28 and 28 to 37 mc respectively. With PE-17 or 120 Vibrator Power Supply and other accessories. SCR-619. FM Trans-Receiver 27 to 38.9 mc. complete with all accessories. NEW units. SCR-522. VHF, 4-Channel, 100-156 MC Trans-Recv. Eqt. for Plane or Ground Communications.

SCR-511. Walkie-Talkie, 3-6 MC. Crystal Controlled Trans-Recv. with Plug-In Units for Freq. Changing. BC-611 SCR-536. HANDY and WALKIE-TALKIES. SCR-300 (BC-1000) WALKIE-TALKIES, 40-48 MC 2 channel FM Trans-Recievers.

TCS X-mtr-Receiver for Ship or Shore. TCS Accessories available; Remote Controls, Antenna, Loading Coils, Etc. TBK HF 500W 2-20 Mc Transmitter with MG. Starter and Spares. TAJ 500 W. Output, 175-550 Kc. with M.G. for AC or DC operation. TAQ. Same as TAJ above but 1,000/1,500 W. output with MG. TBL 350 W. Output, A1, A3, IF, & H.F. for AC or DC operation.

PE-75U Gas Engine Generators NEW w/Spares. T-21GR-3-C Sound Hanging Microphones for locating Artillery Fire. RC-263 TRANSMITTING EQPT. 1.5-10.0 mc. 4-channel crystal or VFO control. Operates from 100 to 260 V. AC. 25-60 cycles built-in power supply 75 Watts CW, 50 W. phone conservative output rating. NEW. Complete with Remote Control and case of spares. LARGE QUANTITY IN STOCK!

SCR-543 RADIOTELEPHONE EQPT. 45 W. Radiotelephone (Trans Receiver Ept.), 6-channel 1.5 to 4.3 mc. crystal controlled. NEW and excellent units. LARGE QUANTITY IN STOCK. LINK-1498. VHF Trans-Recv Ept., 70-100 MC. 50 Watts output FM. Available in 14 VDC & 110 V AC operation.

150-AY Mackay IF Ship X'mttrs. 870 OMGA Ship Radio Compass. LRN-1A Loren Equipment. TE-54 & 55 Cable Vulcanizing Equipment. SB-14GY Console Switchboard. SB-23/GTA Power Supply for above. BC-224 Receivers.

HEADQUARTERS FOR TCS EQUIPMENT AND SPARE PARTS: WALKIE-TALKIES (SCR-300 OR BC-1000) AND SPARE PARTS, HANDY TALKIES (SCR-536 OR BC-611) AND SPARE PARTS, SCR-543 (BC-669 AND ACCESSORIES) IN NEW OR LIKE NEW CONDITION. WE HAVE LARGE QUANTITIES OF THESE EQUIPMENTS. ALSO DM-35 DYNAMOTORS AND PE-104 (FOR SCR-284) VIBRATOR POWER SUPPLIES, GM-59 HAND GENERATORS, AND PE-237 POWER SUPPLIES FO RSCR-694 AND GR-9 EQUIPMENTS. WRITE FOR PRICES & DESCRIPTIVE LITERATURE.

SELECTIVE RINGER for MOBILE or SHIP-TO-SHORE RADIOTELEPHONES Permits Phone Operator to call your Radiotelephone exclusively, when operator has a call for you, by ringing a bell or lighting a light. Designed & Mfd. by Western Electric. MODEL 107A. modern, compact and efficient. Can be attached to any receiver, complete Instruction Book supplied. Dim.: 1 3/4" long, 8 1/2" high, 5 1/2" wide. Shpg. Wt. 25 lbs. NEW UNITS. Reg. value \$245.00 each. OUR LOW PRICE—EACH \$85.00.

EXPORTERS, GOVERNMENT AGENCIES, INDUSTRIALS!  
We have a large stock of Transmitters, Receivers, Walkie-Talkies, VHF Equipment, Ship & Shore Communications, FM Broadcast Stations, Radar, Accessories, etc. Write and tell us of your requirements. Descriptive literature and prices available upon request.

**TELEMARINE COMMUNICATIONS CO.**

3040 W. 21st Street, Brooklyn 24, N.Y.  
Phones: ES 2-4300  
CABLE ADDRESS: TELEMARINE, N. Y.

**AN/APR-4 LABORATORY RECEIVERS**

Complete with all five Tuning Units, covering the range 38 to 4,000 Mc; wideband discords and other antennas, wavetraps, mobile accessories, 100 page technical manual, etc. Versatile, accurate, compact—the aristocrat of lab receivers in this range. Write for data sheet and quotations.

We have a large variety of other hard-to-get equipment, including microwave, aircraft, communications, radar, and laboratory electronics of all kinds. Quality standards maintained.

NEW TS-13/AP X-BAND SIGNAL GENERATORS with manual \$575.00; T-47A/ART-13 Transmitters, \$450.00; H-P, Boonton, G-R, Measurements, many others in stock.

**ENGINEERING ASSOCIATES**

434 PATTERSON ROAD DAYTON 9, OHIO



# SPECIAL PURPOSE TUBES

OA2	\$ .75	2K54	7.50	EL-C6A	6.00	RK-65	7.00	EL-302.5	5.00	800	1.50	1616	.50
OA3	.90	2K55	5.00	EL-C6J	6.50	FG-67	9.00	CE-303	2.25	801A	.50	1619	.30
OA5	4.00	2P21 (image-orthicon)	50.00	EL-C6L	3.75	RK-69	2.00	WE-304B	7.50	802	2.25	1620	3.25
OB2	.65	2V3G	1.35	EL-6C	8.00	RK-72	.50	304TH	8.50	GL-803	2.00	1622	1.50
OB3	.75	2V3G	1.35	6AC7W	.75	RK-75	.50	304TL	15.00	803	1.40	1623	2.35
OC3	.70	2X2	.35	6AJ5	1.15	RY-75	3.00	WE-305A	3.00	804	9.00	1624	.95
OD3	.70	2X2A	.90	6AJ6	2.00	RK-75	.85	CE-306	7.50	805	4.50	1625	.30
EL-C1B	2.00	3A4	.50	WE-6AK5	1.35	VR-75	.95	307A	.85	806	5.00	1630	.40
EL-1C	1.50	3A5	.50	6AK5W	1.35	75TL	5.50	CE-309	2.75	807	1.20	1631	1.40
XFG1	2.00	3AP1	3.00	6AL5W	.65	VR-78	.50	WE-310A	3.50	807W	3.85	1635	1.50
1AF4	2.50	3B21	5.00	6AN5	2.75	FG-81A	5.00	WE-311A	5.00	808	1.00	1636	1.00
1AG5	2.00	3B22	1.50	6AR6	1.25	VR-90	.75	WE-313C	2.85	809	2.50	1641	1.35
1B22	1.35	3B23	3.50	6AS6	1.25	CV-92	3.50	316A	.50	810	10.00	1642	.50
1B23	3.00	3B24	1.00	6AS6W	1.50	FG-95	17.50	WE-323A	7.50	811	2.75	1649	1.00
1B24	5.00	3B24W	5.00	6AS7G	2.35	VF-98BR	12.50	323B	4.50	811A	3.50	1654	3.50
1B27	10.00	3B25	3.00	6B6	20.00	HF-100	7.50	WE-328A	3.50	812	2.25	1656	6.50
1B32	1.00	3B26	2.85	6C21	17.50	100R	5.00	WE-331A	7.50	RCA-813	12.50	1661	6.00
1B35	4.50	3B27	3.00	6G4	2.00	100TH	6.50	WE-337A	10.00	814	1.75	1846	50.00
1B36	3.75	3B28	2.50	6J4	3.00	WE-102D	2.50	WE-339A	10.00	815	1.50	1851	1.75
1B38	25.00	3BP1	5.50	6J6W	1.25	FG-105	12.00	WE-347A	3.00	816	1.25	1904	9.00
1B40	2.35	EL-3C	5.00	6L6WGB	3.35	VR-105	.70	WE-349A	7.50	822	10.00	1960	.50
1B42	4.50	EL-3CJ	8.50	6SC7GT	2.00	VU-1115	1.00	WE-350A	3.00	826	.75	1984	10.00
1B47	7.50	3C23	3.50	6SN7WGT	1.50	HY-114B	.75	350B	2.50	828	7.50	9000T	175.00
1B59	10.00	3C24	2.50	6SU7GT	2.00	WE-121A	3.50	WE-352A	15.00	829	6.00	8050	.95
1C21	2.00	3C31	2.00	7BP7	5.00	WE-122A	1.50	F-353A	2.00	829B	8.50	2051	.65
1P23	2.00	3C33	9.50	7CP1	12.50	F-123A	3.50	WE-353A	3.50	830B	.75	2172	10.00
1P24	.50	3C37	10.00	7EP4	10.00	WE-123A	5.00	WE-354A	14.00	832	3.75	2183	5.00
1P28	8.75	3C45	6.00	9GP7	5.00	WE-124A	3.75	WE-355A	15.00	832A	30.00	ZB-3900	75.00
1P29	1.50	3D21A	5.00	9LP7	3.50	VT-127A	2.50	WE-356B	7.50	833A	30.00	R-4100	5.75
1P30	1.50	3D22	9.75	9MP7	7.50	F-128A	15.00	WE-368A	2.00	834	5.75	R-4330	8.50
1P32	1.00	3DP1	3.75	10Y	.25	HF-130	.90	WE-368AS	2.50	835	5.00	5528	3.75
1P34	1.75	3DP1A	7.50	CE-11V	2.25	VR-150	.70	371A	1.00	836	1.50	5550	25.00
1P36	2.50	3E29	8.50	12A6	.50	FG-154	15.00	371B	1.50	837	.90	5551	35.00
1Z2	2.00	3EP1	2.00	12DP7A	25.00	HF-154	5.00	WF-388A	1.50	GL-838	2.00	5553	100.00
CE-2C	1.50	3FP7	2.00	12GP7	17.50	FG-166	15.00	WE-393A	5.00	838	.75	5556	9.75
VG-2C	7.50	3FP7A	3.50	12J5WGT	1.50	FG-172	15.00	394A	1.85	842	2.25	5557	17.50
2A4G	1.15	3GP1	2.00	12K8Y	.50	OK-181	20.00	WE-394A	3.00	843	.35	5560	17.50
2AP1A	4.00	3HP7	3.00	12L8GT	.75	FG-190	7.50	WE-396A	3.00	845	5.00	5610	8.50
2AS15	5.00	3J21	50.00	LM-15	50.00	HF-200	10.00	WE-404A	10.00	845W	8.50	5632	5.00
2B21	.90	3J31	35.00	NE-16	.30	CE-201	2.75	410R	100.00	849	18.50	5637	5.00
2B26	1.25	3K27	150.00	FG-17	2.75	CE-203	5.00	WE-417A	10.00	851	10.00	5644	7.50
2C21	.50	3KP1	6.00	RK-19	.85	203A	2.50	WL-417A	2.85	852	5.00	5645	6.50
2C22	.35	3RP1	7.25	RK-20A	7.50	203Z	5.00	WE-418A	12.50	860	3.00	5650	85.00
2C24	.75	3X2500A3	125.00	TZ-20	1.75	204A	25.00	WE-421A	7.50	861	15.00	5651	1.35
2C25	.35	4A4P10	3.75	CE-21C	2.00	WE-205B	.75	GL-434A	10.00	865	.35	5654	1.35
2C26A	.50	4B22	6.50	RK-21	.85	207	50.00	446A	.50	866A	1.10	5656	6.50
2C33	.75	4B23	6.50	RK-22	3.50	211	.50	446B	1.85	866-JR	1.25	5670	1.50
2C34	.35	4B24	5.00	CE-23C	1.40	WE-211C	10.00	451	5.00	868	2.00	5687	2.50
2C38	10.00	4B25	8.00	PJ-23	2.00	WE-211D	8.00	WL-460	8.50	869B	30.00	5691	4.50
2C39	5.00	4B26	3.00	RK-23	2.50	WE-212E	25.00	464A	2.25	GL-872A	2.50	5696	1.00
2C39A	10.00	4B27	2.75	HK-24	2.85	217A	1.50	WL-468	12.50	CE-872A	1.50	5703	1.00
2C40	7.50	4B28	3.00	HK-24G	2.00	217C	3.00	RH-507	20.00	872A	1.35	5720	15.00
2C42	10.00	4B30	3.00	CE-25A/B	2.00	WL-218	20.00	CK-510AX	.50	874	.50	5725	1.50
2C43	7.50	4B32	10.00	RK-25	2.25	CE-220	5.00	527	15.00	876	.75	5726	.65
2C44	.35	4C22	7.50	25E6WG	4.00	CE-221	8.00	WL-530	25.00	878	.50	5727	1.40
2C46	6.00	4C25	3.00	25T	2.85	221A	2.00	WL-531	7.50	879	.35	5728	9.00
WE-2C51	3.00	4C27	3.50	25TG	2.50	CE-222	1.50	WL-532A	1.00	884	1.00	5740	44.00
2C53	10.00	4C35	15.00	CE-28D	2.50	CE-224	5.00	GL-546	2.00	885	1.00	5763	1.00
2D21	.65	4E27	8.00	RK-28	2.50	CE-225	3.00	559	.50	902P1	3.00	5801	2.50
2D21W	1.40	4J34	35.00	28D7	.75	CE-226	3.00	GL-575A	10.00	905	2.00	5819	25.00
2E22	2.00	4J52	35.00	23D7W	1.50	WE-231D	2.00	WL-579B	10.00	913	20.00	5820	400.00
2E24	1.95	4X100A	18.50	CE-29	1.25	RX-233A	.75	631-P1	5.75	917	2.25	5827	2.50
2E25	1.85	EL-C5B	1.00	CE-30C	1.25	CE-235A	5.00	WL-632A	17.50	918	1.85	5829	1.50
2E26	3.25	EL-5BHD	6.50	Twin 30	7.50	WE-242A	5.00	WL-655/658	100.00	919	2.00	5842	10.00
2E29	1.00	EL-5B2.5	6.50	HY-30Z	2.65	WE-242C	8.00	WL-670A	8.00	920	2.00	5847	10.00
2E36	1.25	5AP1	3.00	CE-31V	2.00	WE-249B	2.50	WL-681/686	25.00	921	1.00	5932	4.00
2E41	2.00	5B21	2.00	FG-32	6.00	WE-249C	2.50	WE-701A	2.00	922	1.20	5933	4.00
2J21A	2.75	5B21	2.50	FG-33	15.00	250R	4.75	702A	.50	923	1.40	5948	250.00
2J26	4.75	5BP1A	7.50	RK-33	.50	250TH	18.50	702B	1.00	924	1.35	5963	1.25
2J27	4.75	5BP2A	5.00	VX-33A	2.50	250TL	15.00	703A	1.50	925	2.00	5981/5650	85.00
2J29	15.00	5BP4	2.00	RK-34	.35	WE-251A	47.50	WE-704A	.85	926	2.50	5998	7.50
2J30	15.00	5C21	7.50	35T	4.50	WE-252A	9.50	705A	.75	927	1.00	6031	4.75
2J31	14.00	5C22	25.00	35TG	3.00	WE-253A	3.50	707A	3.00	928	2.50	6097	.65
2J32	14.00	5C30	1.00	RK-38	6.50	WE-254A	4.75	707B	4.50	929	1.25	6187	1.50
2J33	14.00	5CP1	2.00	RK-39	1.50	HK-257B	8.50	WE-708A	.75	930	1.25	6188	2.00
2J34	14.00	5CP1A	8.50	T-40	2.35	WE-257A	3.50	WE-709A	1.00	931A	3.00	R-6210	15.00
2J36	15.00	5CP7	8.50	TZ-40	3.50	FG-258A	100.00	713A	.35	SN-948	7.50	UX-6653	.75
2J37	5.00	5D21	5.50	VX-41	2.50	WE-261A	10.00	715A	2.00	954	.35	8001	8.50
2J38	10.00	5D23	7.00	CE-42C	1.50	WE-262B	7.00	715B	4.00	955	.35	8002R	15.00
2J39	10.00	5FP7	1.35	RK-44	1.00	WE-264C	3.00	715C	12.00	956	.35	8005	4.75
2J40	14.00	5FP14	5.00	OK-47	50.00	WE-267B	10.00	WE717A	1.00	957	.35	8008	6.00
2J50	35.00	5GP1	5.00	RK-47	1.75	WE-268A	7.50	717A	.35	958A	.35	8011	.75
2J51	100.00	5J29	7.50	CE-48	1.75	FG-271	25.00	WE-719A	9.50	959	1.50	8012	1.00
2J52	50.00	5J30	5.00	RK-49	2.85	WE-272A	5.00	721A	.75	972A	3.50	8012A	2.50
2J53	25.00	5J32	15.00	FP-54	.75	WE-274A	3.00	721B	7.25	991	.30	8013	2.50
2J54	50.00	5J1P	12.50	HY-51B	44.00	WE-274B	1.00	722A	3.50	1000T	100.00	8013A	3.50
2J55	50.00	5J2P	7.00	HK-54	2.00	274B	.50	723A/B	9.00	CK-1005	.25	8016	2.50
2J56	75.00	5J4A	7.00	T-55	3.50	WE-275A	5.00	WE-724A	.85	CK-1006	2.00	8020	1.50
2J61	15.00	5J5A	7.00	RK-57	4.50	WE-276A	7.50	WE-724B	.85	CK-1007	.65	8021	.75
2J62	4.75	5J11	10.00	RK-58	.90	276A	2.50	WE-725A	3.00	CK-1009	3.50	8022	.75
2J62A	50.00	5LP1	7.50	OK-59	25.00	WE-282A	7.50	WE-726A	5.00				

# FAY-BILL DISTRIBUTING CO.

Partial Listing Only

LARGEST SURPLUS DEALER IN THE COUNTRY—STANDARD BRANDS—TRANSMITTING AND RECEIVING

Type	Price	Type	Price	Type	Price	Type	Price	Type	Price	Type	Price	Type	Price	Type	Price
AB-150	52.99	2N27	1.29	2K55	29.95	5BP4	2.99	259A	6.99	725A	6.95	1500T	84.50	6A55	7.74
CEP-220	.94	1N27	1.89	2-2/279	3.29	5BP4	2.99	259A	6.99	725A	6.95	1500T	84.50	6A55	7.74
CK-508A X	.99	1P28	9.00	2V3	1.29	5BP4	2.99	259A	6.99	725A	6.95	1500T	84.50	6A55	7.74
CK-521A X	.99	1P30	2.48	2V3	1.29	5BP4	2.99	259A	6.99	725A	6.95	1500T	84.50	6A55	7.74
CRK-72	.79	2AP1	5.99	3A5	5.99	5BP4	2.99	259A	6.99	725A	6.95	1500T	84.50	6A55	7.74
CG-1290	3.99	7B22	1.49	3AP1	5.99	5BP4	2.99	259A	6.99	725A	6.95	1500T	84.50	6A55	7.74
EF-50	.39	2B11	7.99	3BP1	3.29	5BP4	2.99	259A	6.99	725A	6.95	1500T	84.50	6A55	7.74
E-1148	.39	7C22	1.49	3BP1	3.29	5BP4	2.99	259A	6.99	725A	6.95	1500T	84.50	6A55	7.74
EC1	.39	7C23	3.99	3BP1	3.29	5BP4	2.99	259A	6.99	725A	6.95	1500T	84.50	6A55	7.74
EM3GA	39.99	2C26	.92	3BP1	3.29	5BP4	2.99	259A	6.99	725A	6.95	1500T	84.50	6A55	7.74
FI13A	4.99	2C24A	1.49	3BP1	3.29	5BP4	2.99	259A	6.99	725A	6.95	1500T	84.50	6A55	7.74
FI27A	4.99	2C20	4.95	3BP1	3.29	5BP4	2.99	259A	6.99	725A	6.95	1500T	84.50	6A55	7.74
F128A	19.50	2C33 RX233	.99	3BP1	3.29	5BP4	2.99	259A	6.99	725A	6.95	1500T	84.50	6A55	7.74
FG-105	1.44	2C39A	8.40	3BP1	3.29	5BP4	2.99	259A	6.99	725A	6.95	1500T	84.50	6A55	7.74
FG-154	16.99	2C39A boxed	12.40	3BP1	3.29	5BP4	2.99	259A	6.99	725A	6.95	1500T	84.50	6A55	7.74
HF-100	6.99	2C40	8.99	3BP1	3.29	5BP4	2.99	259A	6.99	725A	6.95	1500T	84.50	6A55	7.74
HF-150	15.99	2C43	10.40	3BP1	3.29	5BP4	2.99	259A	6.99	725A	6.95	1500T	84.50	6A55	7.74
HF-200	19.99	2C43 boxed	14.40	3BP1	3.29	5BP4	2.99	259A	6.99	725A	6.95	1500T	84.50	6A55	7.74
HF-300	19.99	2C44	.85	3BP1	3.29	5BP4	2.99	259A	6.99	725A	6.95	1500T	84.50	6A55	7.74
HK-24	3.99	2C45	1.42	3BP1	3.29	5BP4	2.99	259A	6.99	725A	6.95	1500T	84.50	6A55	7.74
HK-54	3.49	2C51	3.29	3BP1	3.29	5BP4	2.99	259A	6.99	725A	6.95	1500T	84.50	6A55	7.74
HY-114B	.69	2C53	11.75	3BP1	3.29	5BP4	2.99	259A	6.99	725A	6.95	1500T	84.50	6A55	7.74
HY-615	.29	2D21	1.79	3BP1	3.29	5BP4	2.99	259A	6.99	725A	6.95	1500T	84.50	6A55	7.74
KU-610	4.99	2D21W	1.79	3BP1	3.29	5BP4	2.99	259A	6.99	725A	6.95	1500T	84.50	6A55	7.74
OK-59	39.50	2E22	2.49	3BP1	3.29	5BP4	2.99	259A	6.99	725A	6.95	1500T	84.50	6A55	7.74
OK-61	63.00	2E24	3.29	3BP1	3.29	5BP4	2.99	259A	6.99	725A	6.95	1500T	84.50	6A55	7.74
OK-62	69.00	2E26	1.19	3BP1	3.29	5BP4	2.99	259A	6.99	725A	6.95	1500T	84.50	6A55	7.74
OK-185 110.00		2G-22	1.19	3BP1	3.29	5BP4	2.99	259A	6.99	725A	6.95	1500T	84.50	6A55	7.74
OK-185 110.00		2J-21	3.79	3BP1	3.29	5BP4	2.99	259A	6.99	725A	6.95	1500T	84.50	6A55	7.74
OK-185 110.00		2J-22	3.59	3BP1	3.29	5BP4	2.99	259A	6.99	725A	6.95	1500T	84.50	6A55	7.74
OK-185 110.00		2J-26	4.99	3BP1	3.29	5BP4	2.99	259A	6.99	725A	6.95	1500T	84.50	6A55	7.74
OK-185 110.00		2J-27	6.99	3BP1	3.29	5BP4	2.99	259A	6.99	725A	6.95	1500T	84.50	6A55	7.74
OK-185 110.00		2J-31	14.99	3BP1	3.29	5BP4	2.99	259A	6.99	725A	6.95	1500T	84.50	6A55	7.74
OK-185 110.00		2J-32	15.99	3BP1	3.29	5BP4	2.99	259A	6.99	725A	6.95	1500T	84.50	6A55	7.74
OK-185 110.00		2J-33	16.99	3BP1	3.29	5BP4	2.99	259A	6.99	725A	6.95	1500T	84.50	6A55	7.74
OK-185 110.00		2J-34	16.99	3BP1	3.29	5BP4	2.99	259A	6.99	725A	6.95	1500T	84.50	6A55	7.74
OK-185 110.00		2J-35	16.99	3BP1	3.29	5BP4	2.99	259A	6.99	725A	6.95	1500T	84.50	6A55	7.74
OK-185 110.00		2J-36	16.99	3BP1	3.29	5BP4	2.99	259A	6.99	725A	6.95	1500T	84.50	6A55	7.74
OK-185 110.00		2K-22	18.99	3BP1	3.29	5BP4	2.99	259A	6.99	725A	6.95	1500T	84.50	6A55	7.74
OK-185 110.00		2K-23	19.95	3BP1	3.29	5BP4	2.99	259A	6.99	725A	6.95	1500T	84.50	6A55	7.74
OK-185 110.00		2K-25	14.99	3BP1	3.29	5BP4	2.99	259A	6.99	725A	6.95	1500T	84.50	6A55	7.74
OK-185 110.00		2K-28	28.99	3BP1	3.29	5BP4	2.99	259A	6.99	725A	6.95	1500T	84.50	6A55	7.74
OK-185 110.00		2K-33A	79.50	3BP1	3.29	5BP4	2.99	259A	6.99	725A	6.95	1500T	84.50	6A55	7.74
OK-185 110.00		2K-35	144.00	3BP1	3.29	5BP4	2.99	259A	6.99	725A	6.95	1500T	84.50	6A55	7.74
OK-185 110.00		2K-41	94.00	3BP1	3.29	5BP4	2.99	259A	6.99	725A	6.95	1500T	84.50	6A55	7.74
OK-185 110.00		2K-45	49.50	3BP1	3.29	5BP4	2.99	259A	6.99	725A	6.95	1500T	84.50	6A55	7.74
OK-185 110.00		2K-49	53.50	3BP1	3.29	5BP4	2.99	259A	6.99	725A	6.95	1500T	84.50	6A55	7.74
OK-185 110.00		2M-42	19.50	3BP1	3.29	5BP4	2.99	259A	6.99	725A	6.95	1500T	84.50	6A55	7.74
OK-185 110.00		2K54	19.50	3BP1	3.29	5BP4	2.99	259A	6.99	725A	6.95	1500T	84.50	6A55	7.74

Buy Your Surplus Tubes.  
Send Us Your List For Highest Quotation  
LARGEST BUYERS IN THE COUNTRY

5RAWGY	2.22	434A	3.99	828B	10.49	
6-4	1.49	446A	2.45	830B	1.99	
6C21	19.99	446B	8.49	832A	8.49	
6JAWA	6.79	462A	3.99	833A	37.49	
7C22	49.50	462B	4.77	833B	7.99	
7C25	89.50	462C	2.35	834	1.99	
78P1	6.99	462D	5.27	835	1.99	
78P7	6.99	462E	23.50	838	1.99	
78P7	6.99	462F	19.95	841	.26	
78P7	6.99	462G	1.43	843	.49	
78P7	6.99	462H	.99	845	.74	
78P7	6.99	462I	9.99	849	32.50	
78P7	6.99	462J	3.99	851	32.40	
78P7	6.99	462K	1.99	860	3.99	
78P7	6.99	462L	1.59	864	14.99	
78P7	6.99	462M	4.44	864	.49	
78P7	6.99	462N	2.29	865	1.19	
78P7	6.99	462O	1.99	866A	1.19	
78P7	6.99	462P	1.07A	866B	15.99	
78P7	6.99	462Q	707B	4.59	872A	1.26
78P7	6.99	462R	707C	2.45	874	.74
78P7	6.99	462S	707D	1.19	876	.74
78P7	6.99	462T	707E	1.19	878	.96
78P7	6.99	462U	707F	27.99	881	1.29
78P7	6.99	462V	707G	1.19	885	.99
78P7	6.99	462W	707H	6.99	9-3	.69
78P7	6.99	462X	707I	14.99	902A	3.99
78P7	6.99	462Y	707J	1.89	918	2.10
78P7	6.99	462Z	707K	21.99	927	1.65
78P7	6.99	462AA	707L	11.75	931A	1.19
78P7	6.99	462AB	707M	29.75	931B	1.19
78P7	6.99	462AC	707N	1.91	954	.26
78P7	6.99	462AD	707O	1.91	955	.49
78P7	6.99	462AE	707P	1.91	956	.59
78P7	6.99	462AF	707Q	1.91	957	.59
78P7	6.99	462AG	707R	1.91	958	.59
78P7	6.99	462AH	707S	1.91	959	.59
78P7	6.99	462AI	707T	1.91	960	.59
78P7	6.99	462AJ	707U	1.91	961	.59
78P7	6.99	462AK	707V	1.91	962	.59
78P7	6.99	462AL	707W	1.91	963	.59
78P7	6.99	462AM	707X	1.91	964	.59
78P7	6.99	462AN	707Y	1.91	965	.59
78P7	6.99	462AO	707Z	1.91	966	.59
78P7	6.99	462AP	707AA	1.91	967	.59
78P7	6.99	462AQ	707AB	1.91	968	.59
78P7	6.99	462AR	707AC	1.91	969	.59
78P7	6.99	462AS	707AD	1.91	970	.59
78P7	6.99	462AT	707AE	1.91	971	.59
78P7	6.99	462AU	707AF	1.91	972	.59
78P7	6.99	462AV	707AG			



# COMMUNICATIONS EQUIPMENT CO.

## MICROWAVE MAGNETRONS

*2J21A.....	\$2.25	3J31.....	\$32.50	700B.....	\$8.75
2J22.....	2.50	4J34.....	22.50	700D.....	8.75
2J26.....	2.50	4J42.....	47.50	706A.....	9.75
2J27.....	3.00	5J23.....	34.50	706D.....	14.75
2J29.....	18.50	5J30.....	14.50	706CQ.....	9.75
2J31.....	13.95	5J33.....	4.75	708EY.....	9.75
2J32.....	14.50	QK 59.....	35.50	725A*	
2J33.....	8.25	QK 60.....	35.00	730A.....	8.75
2J39.....	8.25	QK 61.....	50.00		
2J62.....	6.75	QK 62.....	54.00		

## X BAND - 1" x 1/2" WAVEGUIDE



AT-68/UP 3 Cm Horn with type N feed for receiver measurements, etc. New (as shown) \$7.45  
 ROTARY JOINT (APS-6) Sperry PT #058275, 180 deg. rotation, choke-to-choke. Has "Built-in" Di-Coupler, 20 DB, with "N" Takeoff 22.50  
 PARABOLOID DISH, 18" diam. Spun Aluminum. \$4.95  
 Focus. For AN/APS-6  
 3 CM. DIPOLE and Feed Assembly. (May be used with above dish.) 8 inches long. \$5.00  
 FLEXIBLE SECTION 9 in. long Cover to Cover. \$5.50  
 3CM. DIPOLE FEED, 15" L. for APS-15 10 1/2" Focus \$14.50  
 MITRED ELBOW. Cast aluminum. 1 1/4" x 3/4" W.G. W.E. Flanges. "E" Plane. \$3.50  
 3 CM. ANTENNA ASSEMBLY: Uses 17" paraboloid dish, operating from 24 vdc motor. Beam pattern: 6 deg. in both Azimuth and elevation. Sector Scan: over 160 deg. at 35 scans per minute. Elevation Scan: over 2 deg. Tilt: Over 24 deg. \$35.00  
 Cross-Guide Directional Coupler. UG-40 output flange. Main Guide is 6" Long, with 90 Deg. "E" Plane bend at one end, and is fitted with Std. UG 39/UG 40 flanges. Coupling figure: 20 db Nominal. \$22.50  
 RG52/U Waveguide in 8' lengths, fitted with UG 39 flanges to UG40. Silver plated. per length \$5.00  
 Rotating-Joints supplied either with or without deck mountings. With UG40 flanges. each \$17.50  
 Bulkhead Feed-thru Assembly. \$15.00  
 Pressure Gauge Section with 1/2 in. gauge. \$10.00  
 Directional Coupler, UG-40/T Take off 20db. \$17.50  
 MAGNET AND STABILIZER CAVITY FOR 2J41 Magnetron \$24.50  
 90 degree elbows. "E" plane 2 1/2" radius. \$8.50  
 ADAPTER, waveguide to type "N", UG 81-U, p/o TS 12, TS-13, Etc. \$7.50  
 ADAPTER, UG-163/U round cover to special PWT. Flange for TS-45, etc. \$2.50 ea.

## I. F. AMPLIFIER STRIPS

Model 15: 30 Mc Center frequency. Bandwidth 2.5 Mc gain figure: 65 db. Uses 5 stages of 6AC7's. Has D. C. Restorer and Video Detector A.F.C. Strip included. Input impedance: 50 Ohms. Tubes \$14.50  
 60 MC. Miniature IF strip, using 6AK5's 60 Mc center Freq. Gain: 95 db at Bandwidth of 2.7 Mc. New Complete with tubes. \$15.00

## JAN WAVEGUIDE FLANGES

UG 39/U.....	\$1.10	UG 51/U.....	\$1.65
UG 40/U.....	\$1.25	UG 52/U.....	\$3.40
UG 40A/U.....	\$1.85	UG 52A/U.....	\$3.40

## COAXIAL R.F. FILTERS

F-29/SPR-2. Hi-Pass, with 1000 mc Cut-off. Type "N" input and output. 50 Ohms Z. \$9.50  
 F-41/SPR-1. Hi-Pass, with 300 mc cut-off. Type "N" input and output. 50 Ohms Z (As shown) \$10.50



## PULSE TRANSFORMERS

4P37 Primary. 50 Ohms 750V. .001 Duty. Sec. 15KV. 1000 Ohms Inductance. Bill. 12.6V. 2.5A. \$32.50  
 RAYTHEON WX 4298E: Primary 4KV. 1.0 USEC. SEC. 16KV-16 AMP DUTY RATIO: 001 400 CYCLES. FIL TRANS. "BUILT-IN" \$42.50  
 WECO: D-163247 For Modulator of SCR 720. \$22.50  
 GE #K-2449A. Primary: 9.33 KV. 50 ohms Imp. Secondary: 28 KV. 4.05 usec. Pulse length: .05 usec @ 635/120 PPS. Pk Power Out: 1.740 KW. Bifilar: 1.5 amps (as shown) \$62.50  
 GE #K 2748-A. 0.5 usec @ 2000 Pps. Pk. Pwr. out is 32 KW impedance 40:100 ohm output. Pri. volts 2.3 KV Pk. Sec. volts 11.5 KV Pk. Billar rated at 1.3 Amp. Fitted with magnetron well. \$24.50  
 K-2745. Primary: 3.128 KV. 50 ohm Z. Secondary: 14/12.6 KV 1025 ohms Z. Pulse Length: 0.25/1.0 usec @ 600/600 PPS. Pk. Power 200/150 KW. Bifilar: 1.3 Amp. Has "built-in" magnetron well. \$32.50  
 K-2461-A. Primary: 3.1/2.6 KV—50 ohms (line). Secondary 14/11.5 KV—1000 ohms Z. Pulse Length: 1 usec @ 600 PPS. Pk. Power Out: 200/150 KW. Bifilar 1.3 Amp. Fitted with magnetron well. \$29.50  
 K35145—Pulse Inversion: PRI: 5 KV PK. Pulse Negative. Sec: Pos. Pulse, 4 KV; 1 usec. and .001 DUTY RATIO \$6.50  
 541318-1—3 wdg's. Ratio: 1:1:1. 1.10 uh./wdg. 2.5 ohms DCR \$3.50

## PULSE MODULATORS

MIT. MOD. 3 HARD TUBE PULSER: Output Pulse Power 144 KW (12 KV at 12 Amp.) Duty Ratio: .001 max. Pulse duration: 0.5, 1.0, 2.0 microsec. Input voltage: 115 v. 400 to 2400 cps. Uses 175B-1 8291B 3-72's, 17F3. New. \$1535  
 ASD Modulator. Harits, 1000 Hz. Special Harits tubes pulser delivers Pk. pulse of 144 kw. Similar to Mod 3 unit. Brand new, less tubes. \$385.00

Alrborne RF head, model ASD. delivers 50 Kw peak output at 9000 mc. at .001 duty. 1 usec./1000 PPS. Complete with pulser unit and all tubes. \$210

## 3 CM. TEST SETS

TS 12/AP. For standing wave measurement of plumbing. TR/ATR boxes, crystal mixers, antennas, etc. The TS 12 consists of two basic units: Unit 1 is a high gain stable amplifier followed by a 3-inch meter which reads SWR directly. UNIT 2 consists of waveguide accessories, including a slotted line, probes, dummy load, adapters, etc. Either bolometer or crystal input may be used. Both units are portable, self contained. Operates from 115 v. 60-800 cps. New\*  
 TS 13/AP. Signal source 9305-9445 mc. 50 microwatts. Comes with a wavemeter, thermistor-bridge power meter, and calibrated attenuator. Oscillator is a klystron type 723/a-b which may be internally (self-synch) or externally tuned. Controls are provided for FM operation, variable pulse delay, pulse width and phasing. Operates from 115 v. 60-800 cps. New\*  
 \* Price on Request

## - IN STOCK -

AIA	ASH	SO-8
APA-9	BG	SG-1
APA-10	DAS†	SJ-1
APN-3	DBS†	TAJ
APN-7	APT-2	TBK
APN-9*	APT-4	TBL
APS-2	MKIV	SCR520*
APS-3	MKX	SCR521
APS-4	RC145	SCR518
APS-6	RC148	SCR545
ASD	SO-1	SCR584

\* COMPONENTS. † LORAN EQUIPMENT

## - TEST SETS -

TS-10	TS-12	TS-159
TS-36	TS-56	TS-90
TS-47	TS-34	TS-98

## BARGAIN SPECIALS

Barry shock mounts: nos. 2045, C-2060, C-2070, C-2080. \$45 ea.  
 Trihedral radar reflector, MK-1, aluminum. \$3.50  
 SPLICER, for 11/16 perforator tape. WECO # X-61859 list 20 SCS #4TW 61859-20. Complete set, with number tape dispenser. \$8.50

## SPARES FOR PRC-10

3C1084H-67	3C1084H-71	2Z5822-488
3C1084H-68	3C1084Z-74-3	2Z5822-503
3C1084H-69	2Z9632.611	3DA1-304
3C1084H-70	2Z9631.407	3DA10-543

MN 28Y Control box, unit of MN 26 compass. New. \$3.75  
 Noise filters. Mallory NF1-1, 100 amp/35 vdc. \$1.00  
 Power supply unit, navy type—JL-2. Input: 115 vac. 60 cy. Output: 135 vdc/10 ma. 90 vdc/5ma; 3 vdc/360 ma. New, complete with spare parts box. To be used with model TBX radio gear. \$9.50  
 Coaxial switch, 12-position, with type "N" fittings. Type SA-14/SPR-1. \$17.50  
 Amplifier, Altec A-127. 18 Watts output with response from 20-20,000 cps. Operates from 115 v. 60 cps. Std. rack panel mte. Used, excellent. \$103  
 Pulse analyzer, type APA-6. With 3 in. scope. \$235  
 BC 602 Control box for SCR 522 (pushbutton). \$3.75  
 24-volt Transformer, Input 115 v/60 cy. Output 24 v/3A \$1.79  
 Phase-shifter, Helmholtz type: 0-360 deg. \$2.50  
 Capacitor, oil filled, 0.25 mfd./25,000 volts dc. \$15  
 Hydrophone, MODEL M1-2. A lattice of 3 crystals in a disk-like structure: 17-37 Kc. \$27.50  
 AN/CRW-2A Remote control receiver, for operating target planes, etc. New, with soundproof mounting box. \$34.50  
 TEL. REPEATER, EE 89, complete with tubes and tech. manual. \$17.50  
 TEL. REPEATER, EE 99, with 12 vdc. vibrator power supply (PE 204) \$49.50  
 F. T. & R. 101-A. Two-wire applique, contains equalizing devices, and balancing circuits. Used for adapting 2-wire military circuits to 4-wire systems. \$47.50  
 RADAR TRAINER, Model 15-C. Brand new, complete with pulser generator, power supply, main unit, all cables and instruction book. \$125  
 UNDERWATER MICROPHONES, Model JR—Consists of a mosaic of 7 crystals. May be used at 17-73 Kc. omnidirectional, 50 ohm output. \$27.50  
 SA4A/APA-1 Motor Driven Coaxial Ant. Switch DPDT Continuous Operation from 24VDC. Completely Enclosed. 352-7096 \$34.60  
 MP-22 MAST Base Mobile Antenna Mount. \$4.59  
 SA-A/APN-1 Altitude Limit Switch for APN-1 Altimeter \$7.95  
 ALTITUDE INDICATOR for APN-1 \$12.50  
 C-37D Final P.A. Coil for BC610 2-3.5 MC. Variable Link \$4.89  
 RA-74 Power Supply for Super Pro. \$69.50

## ELECTRIC MEGAPHONE SYSTEM

For Rural Areas, Hotels, Commercial Steamers, Ball Parks, Etc.

U. S. NAVY type PAE-1 Electric Megaphone equipment is designed for voice reinforcement in much the same manner as, but to a greater degree than, the familiar acoustic megaphone. Consists of Megaphone Unit (which combines a microphone and reproducer in a single assembly). Portable Amplifier which electrically amplifies the output signal of the microphone section of the megaphone and feeds this amplified signal to the reproducer section. Charging rack for recharging the self-contained storage battery of the portable amplifier. BRAND NEW \$129.50



## DYNAMOTORS

TYPE	INPUT VOLTS	INPUT AMPS	OUTPUT VOLTS	OUTPUT AMPS	Price
BDAR83	14	375	375	150	\$6.50
35X-059	19	3.8	405	095	4.35
PDSX-15	14	2.8	220	08	8.95
DF35A	28	7	540	250	3.95
23350	27	1.75	285	075	3.95
B-19	12	9.4	275	110	6.95
			500	050	
DA-3A*	28	10	300	260	3.95
			150	010	
			14.5	5	
PE 73CM	28	19	1000	350	10.50
BD 691	14	2.8	220	08	8.95
DAG-33A	18	3.2	450	06	2.50
DM25†	12	2.3	250	05	6.95
BDA93	28	3.25	375	150	6.95

† Load filter  
 \* Used, Excellent.  
 PE 94—, Brand New. 5.95  
 \*Replacement for PE 94.

## INVERTERS

800-1B Input 24 vdc, 62 A. Output: 115 V, 800 cy. 7A. 1 phase. Used, excellent. \$18.75  
 PE-218H: Input: 25/38 vdc. 92 amp. Output: 115V 300/500 cy 1500 Volt-ampere. NEW \$32.50  
 PE206: Input: 28 vdc, 36 amps. Output: 80 V 800 cy. 500 volt-amp. Dim. 13 x 5 1/2 x 10 1/2. New. \$22.50  
 AN187-1. Input: 13.75 V; 18.4 A. Output: 115 V/400—3φ. 0.95 PF. New. \$59  
 PU 7/AP. Input: 28 vdc/160 A. Output: 115 VAC. 400—, 1φ. 500 VA., 21.6 Amp. Volt. and Freq. Reg. Used, Exec. \$76

## TS-56A/AP TEST EQUIPMENT

Slotted line test equipment designed for operation over a frequency of 500-675 MC. Has impedance of 51 ohms. Ideal test set for matching antennas, measurement of characteristics of transmission line. With instructions manual. New. Shipping \$1200 wt.: 41 lbs.

TEST OSCILLATOR TS-47/APR. 40-2000 + Mc. Fundamental coverage 40-500 Mc in two ranges. Harmonics above 2000 Mc. Provides a calibrated (dial) accuracy ± 0.7 per cent) H.F. source for testing receiving equipment. Output 3MW or more up to 400 Mc. less on harmonics. C.W., mod. pulse or sine wave output. Operates on 115/230/60 Cy. or batteries wt.: 41 lbs. \$1650

## VHF ANTENNA



Sig. Corps. AN164. 150-200 mc. Consists of 3 vertical dipoles working in phase against a mesh reflector, 90 in. x 40 in. Spacing between elements is 1/2 wavelength. Unit comes complete with portable carrying chest and 1/12 antenna folds up to 46 in. sq. x 18 in. height. \$22.50 Hhpg. wt. approx. 200# (as shown)

## 400 CYCLE TRANSFORMERS

Model	Primary	Secondary	Price
KS13101	(All Primaries 115V. 400 Cycles) 6.3V/15A, 7.6V/0.9A, 6.3V/0.4A,		
KS13104	1450VCT/0.283A, 1050VCT/0.217A,	\$3.85	
KS9615	6.3V/4A, 3V/1A	7.50	
KS9608	1233/35MA, 1140VCT/0.7A	1.57	
302433A	6.3V/9.1A, 6.3VCT/6.5A, 2.5V/3.5A,	5.79	
	2.5/3.5A		
KS 9445	592VCT/118MA, 6.3V/8.1A, 5V/2A,	4.85	
KS 9685	6.4/7.5A, 6.4V/3.8A, 6.4/2.5A	5.39	
	ALL CT	4.79	
70G30G1	600VCT/36MA	2.65	
M-7474318	2100V/0.27A	4.95	
352-7069	2-2.5V Wdg's at 2.5A, Each Lo-Cap., 22Kv Test		
	2.5V/1.79A, 5V/3A, 6.5V/6A, 6.5V/1.2A, 0V BC800	5.95	
352-7096	360VCT/20MA, 1500V/1MA, 2.5V/1.75A, 6.3V/2.5A, 6.3V/6A, P/O BC-929	4.95	
352-7099	5200V/0.02A, 2.5V/5A	6.45	
D163253	5200V/0.02A, 2.5V/5A	5.35	
M-7471957	2.5V/20A, 12KV Test	4.85	
52-1717 9	5200V/100MA, 6.5V/12ACT, 5V/2A	3.45	

MAIL ORDERS PROMPTLY FILLED. ALL PRICES F.O.B. NEW YORK CITY. M.O. OR CHECK. ONLY SHIPPING SENT C.O.D. RATED CONCERNS SEND P. O. PARCELS IN EXCESS OF 20 POUNDS WILL BE SHIPPED VIA CHEAPEST TRUCK OR RAILCAR.

131 Liberty St., New York 7, N. Y. Dept. E-12 Chas. Rosen • Phone: DIghy 9-4124

# ELECTRONIC TUBES — All types — one dependable source!

- ALL V. H. TUBES are new, first quality and unconditionally guaranteed.
- ALL V. & H. TUBES advertised are in stock.
- ALL V. & H. TUBES are standard brands—R.C.A., Sylvania, G.E., Raytheon, Federal, W.E., etc.
- ALL TUBES—NATO, JAN, commercial, special purpose, transmitting and receiving from one source—V. & H. RADIO AND ELECTRONICS!

6A2	1N73	2J55	4J42	6SJ7Y	252A	574A X	878	5644	5915
6A3	1N76	2J56	4J50	6SK7W	253A	592	879	5645	5931
6AR5	1N78	2J61A	4J51	6SL7W	258A	615	880	5646	5932
6B2	1N81	2J62A	4J52	GT	259A	KU627	884	5647	5933
6B4	1N83	2K21	4J58	6SM6W	266B	631-P	885	5648	5948
6B5	1N92	2K23	4PR60A	GT	274B	648-P1	889RA	5651	5949
6B6	1N93	2K25	4X-150A	65117	QK284	HM654	891	5654	5962
6B7	1N126	2K26	4X-150B	290A	200A	703A	892	5657	5963
6B8	1N127	2K28	4X250B	6X4W	HF300	704A	893F	5659	5965
6B9	1N128	2K29	4X-500A	7AK7	300B	705A	893A	5660	5977
6C3	1N158	2K30		78P7, A	304B, B	706A	898	5663	5980
6C4	1N198	2K33A	CSB	7CP1	304B, L	TH, TL	708	5665	5987
6C5	1P23	2K39	EL5B	7UP7	GG305	SERIES	920	5667	5993
6C6	1P24	2K40	5BP1	7X2	CE306	707A, B	923	5670	5995
6D3W	1P30	2K42	5BP1	8D21	307A	708A	929	5672	5998
6E1	1P31	2K43	5BP4	9LP1	310A	710A	930	5677	6002
6E2	1P32	2K44	5CP1	9C7	311CT	713A	931A	5684	6095
6E3	1P36	2K45	5CP1	10E/13	312A	714A, AY	931A	5685	6012
6E4	1P37	2K46	5CP2A	10E/222	316A	715A, B, C	954	5686	6021
6E5	1P39	2K47	5CP2A	10K/171	ML-322	717A	955	5687	6028
6E6	1P40	2K48	5D21	10KP17	719A	719A	956	5688	6044
6E7	1P42	2K50	5FPTA	A-11	C-33S	720	957	5691	6045
6E8	1P44	2K51	5FPTA	12T7	337A	SERIES	958A	5692	6050
6E9	1P45	2K52	5G1A	12T7	337A	721A	959	5693	6052
6E10	1P46	2K53	5G1A	12T7	337A	721A	959	5693	6052
6E11	1P47	2K54	5G1A	12T7	337A	721A	959	5693	6052
6E12	1P48	2K55	5G1A	12T7	337A	721A	959	5693	6052
6E13	1P49	2K56	5G1A	12T7	337A	721A	959	5693	6052
6E14	1P50	2K57	5G1A	12T7	337A	721A	959	5693	6052
6E15	1P51	2K58	5G1A	12T7	337A	721A	959	5693	6052
6E16	1P52	2K59	5G1A	12T7	337A	721A	959	5693	6052
6E17	1P53	2K60	5G1A	12T7	337A	721A	959	5693	6052
6E18	1P54	2K61	5G1A	12T7	337A	721A	959	5693	6052
6E19	1P55	2K62	5G1A	12T7	337A	721A	959	5693	6052
6E20	1P56	2K63	5G1A	12T7	337A	721A	959	5693	6052
6E21	1P57	2K64	5G1A	12T7	337A	721A	959	5693	6052
6E22	1P58	2K65	5G1A	12T7	337A	721A	959	5693	6052
6E23	1P59	2K66	5G1A	12T7	337A	721A	959	5693	6052
6E24	1P60	2K67	5G1A	12T7	337A	721A	959	5693	6052
6E25	1P61	2K68	5G1A	12T7	337A	721A	959	5693	6052
6E26	1P62	2K69	5G1A	12T7	337A	721A	959	5693	6052
6E27	1P63	2K70	5G1A	12T7	337A	721A	959	5693	6052
6E28	1P64	2K71	5G1A	12T7	337A	721A	959	5693	6052
6E29	1P65	2K72	5G1A	12T7	337A	721A	959	5693	6052
6E30	1P66	2K73	5G1A	12T7	337A	721A	959	5693	6052
6E31	1P67	2K74	5G1A	12T7	337A	721A	959	5693	6052
6E32	1P68	2K75	5G1A	12T7	337A	721A	959	5693	6052
6E33	1P69	2K76	5G1A	12T7	337A	721A	959	5693	6052
6E34	1P70	2K77	5G1A	12T7	337A	721A	959	5693	6052
6E35	1P71	2K78	5G1A	12T7	337A	721A	959	5693	6052
6E36	1P72	2K79	5G1A	12T7	337A	721A	959	5693	6052
6E37	1P73	2K80	5G1A	12T7	337A	721A	959	5693	6052
6E38	1P74	2K81	5G1A	12T7	337A	721A	959	5693	6052
6E39	1P75	2K82	5G1A	12T7	337A	721A	959	5693	6052
6E40	1P76	2K83	5G1A	12T7	337A	721A	959	5693	6052
6E41	1P77	2K84	5G1A	12T7	337A	721A	959	5693	6052
6E42	1P78	2K85	5G1A	12T7	337A	721A	959	5693	6052
6E43	1P79	2K86	5G1A	12T7	337A	721A	959	5693	6052
6E44	1P80	2K87	5G1A	12T7	337A	721A	959	5693	6052
6E45	1P81	2K88	5G1A	12T7	337A	721A	959	5693	6052
6E46	1P82	2K89	5G1A	12T7	337A	721A	959	5693	6052
6E47	1P83	2K90	5G1A	12T7	337A	721A	959	5693	6052
6E48	1P84	2K91	5G1A	12T7	337A	721A	959	5693	6052
6E49	1P85	2K92	5G1A	12T7	337A	721A	959	5693	6052
6E50	1P86	2K93	5G1A	12T7	337A	721A	959	5693	6052
6E51	1P87	2K94	5G1A	12T7	337A	721A	959	5693	6052
6E52	1P88	2K95	5G1A	12T7	337A	721A	959	5693	6052
6E53	1P89	2K96	5G1A	12T7	337A	721A	959	5693	6052
6E54	1P90	2K97	5G1A	12T7	337A	721A	959	5693	6052
6E55	1P91	2K98	5G1A	12T7	337A	721A	959	5693	6052
6E56	1P92	2K99	5G1A	12T7	337A	721A	959	5693	6052
6E57	1P93	2K100	5G1A	12T7	337A	721A	959	5693	6052
6E58	1P94	2K101	5G1A	12T7	337A	721A	959	5693	6052
6E59	1P95	2K102	5G1A	12T7	337A	721A	959	5693	6052
6E60	1P96	2K103	5G1A	12T7	337A	721A	959	5693	6052
6E61	1P97	2K104	5G1A	12T7	337A	721A	959	5693	6052
6E62	1P98	2K105	5G1A	12T7	337A	721A	959	5693	6052
6E63	1P99	2K106	5G1A	12T7	337A	721A	959	5693	6052
6E64	1P100	2K107	5G1A	12T7	337A	721A	959	5693	6052
6E65	1P101	2K108	5G1A	12T7	337A	721A	959	5693	6052
6E66	1P102	2K109	5G1A	12T7	337A	721A	959	5693	6052
6E67	1P103	2K110	5G1A	12T7	337A	721A	959	5693	6052
6E68	1P104	2K111	5G1A	12T7	337A	721A	959	5693	6052
6E69	1P105	2K112	5G1A	12T7	337A	721A	959	5693	6052
6E70	1P106	2K113	5G1A	12T7	337A	721A	959	5693	6052
6E71	1P107	2K114	5G1A	12T7	337A	721A	959	5693	6052
6E72	1P108	2K115	5G1A	12T7	337A	721A	959	5693	6052
6E73	1P109	2K116	5G1A	12T7	337A	721A	959	5693	6052
6E74	1P110	2K117	5G1A	12T7	337A	721A	959	5693	6052
6E75	1P111	2K118	5G1A	12T7	337A	721A	959	5693	6052
6E76	1P112	2K119	5G1A	12T7	337A	721A	959	5693	6052
6E77	1P113	2K120	5G1A	12T7	337A	721A	959	5693	6052
6E78	1P114	2K121	5G1A	12T7	337A	721A	959	5693	6052
6E79	1P115	2K122	5G1A	12T7	337A	721A	959	5693	6052
6E80	1P116	2K123	5G1A	12T7	337A	721A	959	5693	6052
6E81	1P117	2K124	5G1A	12T7	337A	721A	959	5693	6052
6E82	1P118	2K125	5G1A	12T7	337A	721A	959	5693	6052
6E83	1P119	2K126	5G1A	12T7	337A	721A	959	5693	6052
6E84	1P120	2K127	5G1A	12T7	337A	721A	959	5693	6052
6E85	1P121	2K128	5G1A	12T7	337A	721A	959	5693	6052
6E86	1P122	2K129	5G1A	12T7	337A	721A	959	5693	6052
6E87	1P123	2K130	5G1A	12T7	337A	721A	959	5693	6052
6E88	1P124	2K131	5G1A	12T7	337A	721A	959	5693	6052
6E89	1P125	2K132	5G1A	12T7	337A	721A	959	5693	6052
6E90	1P126	2K133	5G1A	12T7	337A	721A	959	5693	6052
6E91	1P127	2K134	5G1A	12T7	337A	721A	959	5693	6052
6E92	1P128	2K135	5G1A	12T7	337A	721A	959	5693	6052
6E93	1P129	2K136	5G1A	12T7	337A	721A	959	5693	6052
6E94	1P130	2K137	5G1A	12T7	337A	721A	959	5693	6052
6E95	1P131	2K138	5G1A	12T7	337A	721A	959	5693	6052
6E96	1P132	2K139	5G1A	12T7	337A	721A	959	5693	6052
6E97	1P133	2K140	5G1A	12T7	337A	721A	959	5693	6052
6E98	1P134	2K141	5G1A	12T7	337A	721A	959	5693	6052
6E99	1P135	2K142	5G1A	12T7	337A	721A	959	5693	6052
6E100	1P136	2K143	5G1A	12T7	337A	721A	959	5693	6052
6E101	1P137	2K144	5G1A	12T7	337A	721A	959	5693	6052
6E102	1P138	2K145	5G1A	12T7	337A	721A	959	5693	6052
6E103	1P139	2K146	5G1A	12T7	337A	721A	959	5693	6052
6E104	1P140	2K147	5G1A	12T7	337A	721A	959	5693	6052
6E105	1P141	2K148	5G1A	12T7	337A	721A	959	5693	6052
6E106	1P142	2K149	5G1A	12T7	337A	721A	959	5693	6052
6E107	1P143	2K150	5G1A	12T7	337A	721A	959	5693	6052
6E108	1P144	2K151	5G1A	12T7	337A	721A	959	5693	6052
6E109	1P145	2K152	5G1A	12T7	33				



**ELECTRONIC**

WAR TERMINATION INVENTORIES

WRITE OR WIRE FOR INFORMATION ON OUR COMPLETE LINE OF SURPLUS ELECTRONIC COMPONENTS. ALL PRICES NET F.O.B. PASADENA, CALIFORNIA

**C&H SALES CO.**

2176-E East Colorado St.  
Pasadena 8, California  
RYan 1-7393

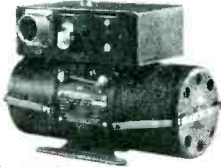
**INVERTERS**

10042-1-A Bendix  
DC Input 14 volts; output: 115 volts; 400 cycles. 1-phase; 50 watt **\$35.00**

12116-2-A Bendix  
Output: 115 VAC; 400 cyc; single phase; 45 amp. Input: 24 VDC, 5 amps. **\$35.00**

12117 Bendix  
Output: 26 volts; 400 cycles, 6 volt amperes. 1 phase. Input: 24 VDC; 1 amp. **\$15.00**

12121 Bendix  
Input: 24 volt D.C. 18 amp. 12000 r.p.m. Output: 115 volts, 400 cycle, 3-phase, 250 volt amp, 7 pf. **\$49.50**

12123 Bendix  
Output: 115 V; 3-phase; 400 cycle; amps .5 Input: 24 VDC; 12 amp. **\$49.50**

12126-2-A Bendix  
Output: 26 volts; 3 phase; 400 cycle; 10 VA; .6 PF. Input: 27.5 volts DC: 1.25 amps. **\$24.50**

12130-3-B Bendix  
Output: 125.5 VAC; 1.5 amps. 400 cycles single phase, 141 VA. Input: 20-30 VDC. 18-12 amps. Voltage and frequency regulated. **\$49.50**

12133 Bendix  
Input: 26/29 volt D.C., 28 amps Output: 115 volt, 3 phase, 400 cycle, 250 volt amp., .8 pf. **\$59.00**

12143-2-A Bendix  
Output: 115 volts: 400 cycles; 250 VA; single phase pf. 9-1. DC Input: 26-29 VDC; 25-22 amp; voltage & frequency regulated **\$49.50**

778 Bendix  
Output: 115 volt, 400 cycle; 190 VA; single phase and 26 volt, 400 cycle, 60 VA, single phase. Input: 24 VDC. **\$37.50**

10285 Leland  
Output: 115 volts AC; 750 VA, 3 phase, 400 cycle, .90 pf and 26 volts, 50 VA, single phase, 400 cycle, .40 pf. Input: 27.5 VDC, 60 amps. cont. duty, 6000 rpm. Voltage and frequency regulated. **\$59.50**

10339 Leland  
Output: 115 volts; 190 VA; single phase; 400 cycle; .90 pf. and 26 volts; 60 VA; 400 cycle, .40 pf, input: 27.5 volts DC, 18 amps cont. duty, voltage and freq. regulated. **\$49.50**

10486 Leland  
Output: 115 VAC; 400 cycles; 3-phase; 175 VA; .80 pf. Input: 27.5 DC; 12.5 amps; cont. duty. **\$70.00**

10563 Leland  
Output: 115 VAC; 400 cycle; 3-phase; 115 VA; 75 pf. Input: 28.5 VDC; 12 amps. **\$35.00**

PE109 Leland  
Output: 115 VAC, 400 cyc; single phase; 1.53 amp; 8000 rpm. Input: 13.5 VDC; 29 amp. **\$50.00**

PE218 Leland  
Output: 115 VAC; single phase pf 90; 380/500 cycle; 1500 VA. Input: 25-28 VDC; 92 amps; 8000 rpm; Exc. Volts 27.5 BRAND NEW. **\$30.00**

MG149F Holtzer-Cabot  
Output: 26 VAC @ 250 VA; 115 V. @ 500 VA; single phase; 400 cycle; input: 24 VDC @ 36 amps. **\$40.00**

MG153 Holtzer-Cabot  
Input: 24 VDC; 52 amps. Output: 115 volts - 400 cycles, 3-phase, 750 VA. Voltage and frequency regulated. **\$95.00**

DMF2506M Continental Electric  
24-30 volts input; 5.5-45 amps; cont. duty. Output: 115 volts; .44 amps; 400 cyc; 1 phase; pf 1.0; 50 watts. **\$39.50**

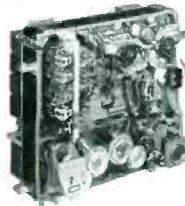

**PARALLAX COMPUTER** used with B29 sighting station; approximate dimensions 18" x 19" x 10"; approximate weight 100 lbs.

Contains:  
Servo amplifier  
7-24VDC Gearhead Motors  
6-400 cy. Selsyns  
Position Analyzer  
Many mechanical differentials  
Hundreds of precision gears  
Relays  
Government cost approximately **\$8000.00**  
Our price **\$100.00**

**SELSYNS-SYNCHROS**

1SF Syn. Mtr. 115/90V 400cy.	<b>\$12.50</b>
2J1F1 Gen. 115/57.5V 400 cy.	<b>7.50</b>
2J1F3 Gen. 115/57.5V 400 cy.	<b>10.00</b>
2J1FA1 Gen. 115/57.5V 400 cy.	<b>7.50</b>
2J1C1 Cont. Trans.	
57.5/57.5V 400 cy.	<b>5.00</b>
2J1I-1 Diff. Gen. 57.5V 400 cy.	<b>7.50</b>
2J5C1 Cont. Trans. 105/55V 60 cy.	<b>17.50</b>
2J5F1 Cont. Trans. 105/55V 60 cy.	<b>17.50</b>
2J5I-1 Gen. 115/105V 60 cy.	<b>17.50</b>
2J1EM1 Gen. 115/57.5V 400 cy.	<b>17.50</b>
5CT Cont. Trans. 90/55V 60 cy.	<b>34.50</b>
5D Diff. Mtr. 90/90V 60 cy.	<b>34.50</b>
5DG Diff. Gen. 90/90V 60 cy.	<b>34.50</b>
5F Syn. Mtr. 115/90VAC 60 cy.	<b>34.50</b>
5G Syn. Gen. 115/90VAC 60 cy.	<b>34.50</b>
5HCT Cont. Trans. 90/55V 60 cy.	<b>42.50</b>
5SDG Diff. Gen. 90/90V 400 cy.	<b>12.50</b>
6DG Diff. Gen. 90/90V 60 cy.	<b>25.00</b>
6G Syn. Gen. 115/90VAC 60 cy.	<b>34.50</b>
7G Syn. Gen. 115/90VAC 60 cy.	<b>42.50</b>
R110-2A Kearfott Cont. Mtr. 115V 400 cy.	<b>17.50</b>
R200-1A Kearfott Cont. Trans. 2E/11.8V 400 cy.	<b>15.00</b>
R210-1A Kearfott Trans. 2E/11.8V 400 cy.	<b>15.00</b>
R235-1A Kearfott Resolver 2E/11.8V 400 cy.	<b>22.50</b>
C567-01 Type 11-4 Rep. 115V 60 cy.	<b>20.00</b>
C694-05-2 Type 1-1 Transm. 115V 60 cy.	<b>20.00</b>
C694-06 Syn. Transm. 115V 60 cy.	<b>20.00</b>
C694-06-1 Type II-2 Rep. 115V 60 cy.	<b>20.00</b>
C76166 Volt. Rec. 115V 60 cy.	<b>10.00</b>
C782-48 Syn. Transm. 115V 60 cy.	<b>12.50</b>
C782-49 Syn. Diff. 115V 60 cy.	<b>5.00</b>
C78E63 Repeater 115V 60 cy.	<b>7.50</b>
C793-31 Transm. Type 1-4 115V 60 cy.	<b>20.00</b>
851 Bendix Autosyn Mtr. 32V 60 cy.	<b>7.50</b>
403 Kollsman Autosyn Mtr. 32V 60 cy.	<b>7.50</b>
CK5 Bendix Mtr. 2 phase 26V 400 cy.	<b>17.50</b>
FPE-43-1 Resolver 400 cy.	<b>25.00</b>
FJE-43-9 Resolver 115V 400 cy.	<b>25.00</b>
999-0411 Kollsman 26V 400 cy.	<b>15.00</b>
1377-0410 Kollsman 26V 400 cy.	<b>10.00</b>
1515B-0410 Kollsman 26V 400 cy.	<b>20.00</b>
10047-2-A Bendix 26V 400 cy.	<b>12.50</b>
2900 Transicoil 115V 400 cy.	<b>15.00</b>

**ESTERLINE-ANGUS RECORDER****Model AW 0-1 MA**

DC Milliammeter permanent magnet moving coil type. Spring clock dual speed drive (hour and minute). Instructions including connection diagrams and instrument data sheet with each instrument.  
Portable case **\$200.00**

**TELECON OSCILLATOR**

Input: 115 volts, 60 cycle; Output: 26.5 volts, 400 cycle 3-watts @ 250 ohm load. Ideal for laboratory use... approx. 10" x 7" x 8", wt. 16 lbs. **\$29.95**

**PIONEER TORQUE UNITS**

Type 12602-1-A. Includes CK 5 Servo motor coupled to output shaft thru 125:1 gear reduction train. Output shaft coupled to autosyn follow-up (AY-43). Ratio of output shaft to follow-up autosyn is 30:1 Includes base mounting type cover for motor and gear train. **\$34.95**

**SMALL DC MOTORS**

(approx. size overall 3/4" x 1 1/4" dia.:-)  
5069600 Delco PM 27.5 VDC 250 rpm **\$12.50**  
5069230 Delco PM 27.5 VDC 145 rpm **15.00**  
5068750 Delco 27.5 VDC 160 rpm w/brake **6.50**  
5068571 Delco PM 27.5 VDC 10,000 rpm (1x1x2") **5.00**  
5069625 Delco 27.5 VDC 120 rpm w/governor **15.00**  
MM A-11 Globe PM 24 VDC **7.50**  
5BA10AJ18 GE 24 VDC 110 rpm **10.00**  
5BA10AJ37 GE 27 VDC 250 rpm reversible **10.00**  
5BA10AJ52 27 VDC 145 rpm reversible **12.50**  
806069 Oster series reversible 1/50 h.p. 10,000 rpm 27.5 VDC 1 5/8" x 3 1/2" **5.00**  
C-28P-1A 27 VDC 1/100 h.p. 7,000 rpm **3.00**  
7100-B PM Hansen 24 VDC 160 rpm **7.50**  
SSFD-6-1 Diehl PM 27.5 VDC 10,000 rpm **4.00**  
6-volt PM Mtr. mfgd. by Hansen 5,000 rpm 1 1/4" in dia. 2" long overall **4.00**

# SELLING

Receivers  
Transmitters  
Radar  
Special Purpose Tubes  
Relays  
Meters  
Switches  
Connectors  
Rectifiers  
Transformers  
Motors & Generators  
Wiring Cable  
Instruments  
and  
All Electronic Components

# WILL BUY ALL

New or Used

Leach Relay	#5059-R
	#5058
	#5055
	#5053-SM
	#5053
Price Bros. Relay	#10
Relay	#5586
	#5587
Antenna Switching Relay	
Box	# CBY 23049
	# BG-AN-198
	# BC -408
Tubes	#53A
	VT-127A
	35T
	WL-530

Highest prices paid for most all types of aircraft sparkplugs any condition

## RADIO & ELECTRONIC SERVICE

Wholesale Only

13933-9 BRUSH STREET  
Detroit 3, Mich. TO 9-3403

Wholesale Only

# A DEPARTMENT STORE FOR YOUR ELECTRONIC SUPPLIES

WE'RE SELLING YOU RELAYS —  
WHAT ARE YOUR OTHER NEEDS?  
Our normal Inventory Includes Over  
80,000 Different Items in the Electronic,  
Radar and Radio Fields

## RELAYS



ALLIED • LEACH • TELEPHONE TYPE  
MINIATURE AIRCRAFT • GUARDIAN  
SIGMA • HERMETICALLY SEALED  
and many others



## SENSITROLS

## STEPPING SWITCHES



SEND FOR OUR LATEST BULLETINS  
AND ADD YOUR NAME  
TO OUR MAILING LIST  
cable address: UNIGENCOR, N. Y.

324 CANAL ST. (Near B'way) N. Y. — WA 5-9642  
**Universal general corp.**

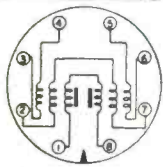

## PULSE TRANSFORMER PT-3 TUBE BASE PLUG-IN TYPE

Similar characteristics to UX 7350. Precision-made. Two 100-turn and two 50-turn coils wound on high quality hypersil cores. Built into octal bakelite tube bases. Completely impregnated and sealed—humidity-resistant. Diagram on end disc of each unit provides versatility of application.



THESE PT-3 TRANSFORMERS  
may be used

- In Blocking Oscillator, Multivibrator and Scope Circuits.
- For Interstage coupling, impedance matching and isolation.
- Wherever accurate timing and triggering are essential.
- In circuit applications requiring the generation of low power and low voltage pulses.
- In circuits utilizing repetition rates from 0 to well over 1 MC and pulse widths from .03 microsecond.

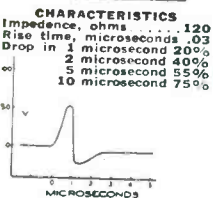
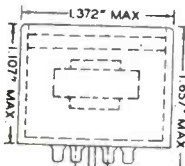

LOW INTRODUCTORY PRICE { Only \$5.95 ea.  
2 for \$11.00

**Cramer Electronics, Inc.**  
811 Boylston St., Boston 16, Mass. CO 7-4700  
Write for Bulletin of late items.

### TIME DELAY RELAY

Haydon 115v 60 cy. adj. in 5 sec. steps to 40 sec. spot mu sw. \$5.95. With 2 arms & 2 sw. \$9.95  
PULSE xfmr Utah 1059-AA, 3-50T Windings \$3.95

Hundreds of other items, see ad in Buyers Guide Issue, write for listings.

**EMPIRE ELECTRONICS COMPANY**  
409Q Ave. L Brooklyn 30, N. Y. Cloverdale 2-4000

### GLASS TUBING

PYREX - NONEX - URANIUM  
BULB & CYLINDERS  
WRITE FOR FREE MONTHLY LIST  
HOUE SUPPLY COMPANY  
PHONE KEYPORT 7-1286

M. R. #1 Box 86X Keyport, N. J.

## A BARGAIN FOR YOU in a . . .

# SOLA Constant Voltage TRANSFORMER

End  
Fluctuating  
Line  
Voltage

OVER 60% OFF . . .

the factory price of a 1-input 2,000 VA unit! And here's another bonus! This Air Forces 2,000 VA overstock, Sola Cat. No. 30768, has 4 inputs! 90-125 V., 190-250 V., 60 cy. or 50 cy. Isolated secondary is constant 115.0 V. ± 1% from no-load to full-load of 17.4 amp. So, if you choose, use it as a 220:115 V. step-down. And slash \$147.50 off the factory 1-input price!



Brand new in original wood box. 4 cu. ft. Ship. wt. 254 lbs. F.O.B. Pasco, Wash. Only **\$97.50**

(EXPORTERS: Note choice of 50 cycles.)

**THE M. R. COMPANY**

P. O. Box 1220-B Beverly Hills, Calif.

For:

- ★ Test Sets
- ★ Airborne Electronics
- ★ Radar
- ★ Navigation Aids
- ★ Parts—Meters—Tubes

Ask for:

**NEW CATALOG NO. 114**  
Lists latest inventory of aircraft, industrial and military electronics equipment.



### "VARIAC"

(Mfg. by American Transformer Co.)

100 amp, 110 V. or 220 VAC. 60 cycle input. Output variable from 0 to 130 V. or 0 to 240 V.

Brand new. Special . . . **\$99.50**

## ARROW SALES, INC.

P. O. Box 3878-E, North Hollywood, Cal.

Phones: STAnley 7-0406 POplar 5-1810

Telegraph Address: WUX, No. Hollywood

Cable Address: ARROWSALES, North Hollywood



**Bargains in Brand New Surplus**

Write for special quantity prices on starred\* items

**OIL FILLED CAPACITORS**

VOLTS	MFD	Price	VOLTS	MFD	Price
25KV	1.0	★49.95	2KV	.25	.89
25KV	0.5	★39.95	1000	28.0	6.50
25KV	0.1	14.95	1000	2.0	.69
7.5KV	0.5	4.25	600	10.	1.29
8KV	0.25	1.09	600	8	1.19
3KV	0.5	1.59	600	4	★.69
3KV	0.1	★1.19	600	2	★.39
2.5KV	2.0	★2.95	600	1	★.19
2KV	5.0	2.95	660AC	5	2.95
			330AC	5	1.29

**SPECIAL SWITCHES**

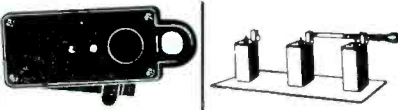

SW 141 ( ) DPST normally open with or without lock-in position on push button, part of CD-318 cord set  
★.34¢

SW 244 SPDT Antenna change switch Square D Cat. No. 9320-962 SC #3ZK-9503 - 20 Bakelite Base 2x8x1/4  
★.49¢

Sensitive MU-Switch 15A. 125 V. AC 15/32-32 threaded bushing. SPST N.C.—44¢; SPST N.O.—49¢; SPDT—69¢

**MULTIPLE SECTION OIL CAPACITORS**

10 Mfd 400 volts	9 1/2 Mfd 600 volts
★59¢	★59¢
Dual 5 mfd 3 term.	8 Section 2-2-1-1-1-.5-.5-.5 Rated by Western Electric at -50 to +85°C will pass 1000 V. 600 V operation at 40°C. 3 3/4 x 3 3/8 x 2
	4 3/4 x 1 1/2

**Molded, Upright and Ceramic-Cased Mica Capacitors**

.01 4LS	600WV	CM45B103J	.32
.02 4LST	600WV	CM50B203G	★.45
.001 A2L	2500WV	Thickness 1/16"	.49
.02 6S	2000WV		1.65
.0068 F2	3000WV		★1.35
.00015 Type 59	10,000WV	3amp @ 1MC	★9.95

**PULSE NETWORK SPECIAL ★\$2.95**

Sprague 15-1-400-50 15 Kv 1.0 usec 400 P.P.S. 50m Z

Variable Transmitting Capacitor: 19 to 116mmid 27 plates, .085" air gap. O/a dim. 4 3/4 x 3 1/2 x 2 1/4 SC# 3D 9019V-1 P/O Tuning Units TU-7A a TU-79.....★98¢

**OCTAL SOCKETS ★\$5.00 C**

Johnson 122-128 steatite sockets; Amphenol 49-558, steatite ring mounting; Amphenol ceramic and mica filled 1 1/2 and 1 1/2 mounting centers.

**R  
E  
L  
A  
Y  
S**

Allied BJ6D36 DPDT, 24VDC coil contacts rated 5 Amp @ 24VDC, or 115V AC.....★.59¢  
Allied BO 13D35 SPST Double break normally open 24V DC. Coil Silver contacts each rated 15 Amp @ 24V DC or 115V AC.....★.98¢  
Autelco Jr Type 16 115V AC coil DPDT Snap Action contacts rated 15 Amp 115V, 5 Amp 230V.....2.95  
Cook #773 Standard Telephone Relay 900 ohm DC coil double arm 14 contacts 11A-1B-1C-1D 4 1/2 x 1 1/2 W x 2 1/2 H.....★1.09

**COAXIAL CABLE**

RG 9 B/U	★15.00 C. FT
PL 259 Plug	★29¢
M 359 Angle Adapter	★23¢

Power Rheostat famous make Model I 3000 Ohm 50 Watts.....★.79¢  
Potentiometer JLU 2000 Ohm 2w with lock nut.....★.44¢

These are only a few of our specials; write us your requirements

ALL PRICES F.O.B. OUR WAREHOUSE  
TERMS: Net 10 days to firms rated well in D.B. Others deposit or cash with order balance C.O.D. Please include postage.

**RUXUR ELECTRONICS CORP**  
623 HUDSON ST., NEW YORK 14  
Watkins 4-7260

**TUBE CARTONS • STACKERS**

Super glass red & black, or plain glossy white. Both types with new safety partition that meet U. S. government specifications! Specify white or colored when ordering.

SIZE	FOR TUBE TYPE	PRICES	
		Quantity per case	Per 100
Mixture red & black 1" x 1" x 3"	6AU6, 6AL5, etc.	3000	\$27.00
Miniature glossy white		3000	27.00
GT red & black 1 1/4" x 1 1/4" x 3 3/8"	6SN7GT, 6W4GT, etc.	2000	22.50
GT glossy white		2000	22.50
Large GT red & black 1 1/2" x 1 1/2" x 4 1/2"	1B3, 6BQ6GT, etc.	1500	20.25
Large GT white		1500	20.25
G red & black 2" x 2" x 6"	5U4G, 6DG6G, etc.	1000	18.00
G white		1000	18.00
Small Jumbo, white 3" x 3" x 7 1/2"	809, 866A, etc.	550	41.25
Large Jumbo, white 4" x 4" x 10"	813, 872A, etc.	300	27.00
Ministackers, white (holds 10 mintubes)		1000	13.50
GT stackers, white (holds 10 GT tubes)		1000	18.00
		Carton Per	Each
		Lot	10
		144	12.90



Lead sheaths for crystal diodes

**DIRECTRON SELENIUM RECTIFIERS**

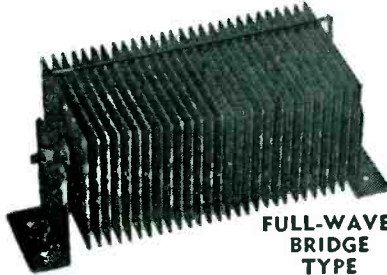

**FULL-WAVE BRIDGE TYPE**

Max. Amps.	18VAC 14VDC	36VAC 28VDC	54VAC 42VDC	72VAC 56VDC	130VAC 100VDC
1	\$1.35	\$2.35	\$3.75	\$4.50	\$7.45
2	2.00	2.75	5.35	5.90	9.15
2 1/2	2.95	4.15	5.85	7.85	12.75
3	3.50	6.45	11.35	14.35	21.75
4	4.00	7.75	12.85	17.30	29.75
6	5.90	11.45	19.50	24.80	41.35
10	7.25	14.35	22.10	29.75	44.25
12	13.05	25.05	37.25	48.75	78.50
20	14.25	28.75	44.50	57.65	81.00
30	17.95	34.35	56.50	71.00	109.00
36	22.45	42.35	65.00	86.95	134.00
50	29.50	54.35	105.45	115.75	174.00
100	59.50	119.00			

We build our Selenium Rectifiers, Transformers, and Chokes to your specifications. Buy from the Direct Source for Quick Delivery.

**NEW RECTIFIER TRANSFORMERS**

Continuous Ratings 1 Amp \$5.75  
2 Amps. 6.75  
Pri: 115V, 60 cycles input 4 Amps. 8.75  
SEC: 9, 12, 18, 24, and 36 12 Amps. 16.65  
volts. 24 Amps. 35.65  
50 Amps. 59.00  
100 Amps. 108.00

**NEW RECTIFIER CHOKES**

Continuous Ratings  
1 Amp. .1 Hy. 1.5 ohm. \$4.95  
2 Amps. .04 Hy. .9 ohm. 5.95  
4 Amps. .07 Hy. .6 ohm. 7.95  
12 Amps. .01 Hy. 1 ohm. 14.95  
24 Amps. .004 Hy. .025 ohm. 29.95  
50 Amps. .005 Hy. .01 ohm. 54.00

**FILTER CAPACITORS**

Capacity	W. Voltage	Each
500 MFD	150 V.	\$1.95
500 MFD	50 V.	.85
1300 MFD	15 V.	.35

**U. S. NAVY INFRA-RED SNOOPERSCOPE/TELESCOPE**

An ingenious infra-red device that lets you see in the dark. Powered by two ordinary type "D" flashlight cells, the unit is completely portable and independent of all other sources of power. Each scope is complete with lens, IP25 viewing tube, focusing adjustment, hand and shoulder straps, special mount for fixed use, and waterproof rubber-oid shoulder type carrying case. Very light and compact. Easy to use. Requires only standard light source with infra-red filter. Absolutely BRAND NEW! (Original cost to government over \$1,500.00)  
RCA Model US/C-3 SNOOPER-SCOPE NET EACH.....\$160.00

**SELSYN CLOSEOUT!**

Only 150 Left!

115 volt, 60 cycle repeater selsyns. Track perfectly in pairs. Originally used as part of Sig. Corps remote indicator I-227-A. Made by Bendix, Type XV, CAL-11900A, NO. 78386. Removed from equipment, all are clean and in guaranteed perfect appearance and operating condition. Will sell all or part. \$4.95  
SPECIAL NET EACH.....\$4.95

**CONSISTENTLY HIGH QUALITY ELECTRONIC TUBES**

Guaranteed • Unused & Boxed

• Critical Types Lab Tested for Your Protection

0A4G	\$1.00	6J4W	2.50	833A	34.00
0B3/VR90	.85	6K4	2.25	838	1.00
0C3/VR105	.85	6SN7W	1.50	845	5.00
0D3/VR150	.85	821	85.00	851	9.50
1B24	4.95	8K28A	7.70	860	3.50
1B24A	15.00	V45		866A	1.25
1B26	1.50	Klystron	525.00	872A	1.50
1B32	2.00	8M60	1.00	872A(G.E.)	2.75
1B35	3.50	8M61	2.75	874(RCA)	.60
1B45	37.00	OK6	25.00	876(RCA)	.85
1B63A	22.50	OK61	25.00	891	125.00
1B85	8.95	FG67	12.00	902/902P1	6.00
1B86	7.75	RKR-72	.50	931A	3.00
1N21B	1.50	RKR-73	.50	932	1.25
1N34	4.44	90-NB		938A	.50
1N34A	.65	Amperex	7.00	CK-1007	.90
1N48	.65	FG98A	20.00	1000T	137.50
1N48	1.00	100R Surplus	5.00	1500T Surp.	120.00
1N54	.55	100TH Surp	6.75	1603	3.00
1N56	.85	100TL Surp	8.50	1619	.30
1N64	.70	FG127	15.00	874(RCA)	2.15
1N65	.75	VT127A	2.50	GL5551	
1N69	.60	VXR130	1.75	FG721	47.50
1N70	1.20	FG172	45.90	5553/655	95.00
1N81	.90	HF201A	27.50	5633	8.00
1P23	1.90	QK181	35.00	5634/SD828	7.00
1P30	2.00	203A		5637	5.00
WL1P41	1.25	204A	0.00	5638	8.50
2C39A	11.00	207	45.00	5641	6.00
2C40	9.50	211/VT4C	.50	5642	1.00
2C43	7.75	212E	15.00	5643	6.00
2C51	3.00	227A	2.00	5644	8.50
2C53	10.75	245A	15.00	5645	2.25
2D21W	2.40	246A	15.00	5654	1.55
2E30	1.60	249A	3.50	5656	6.50
2E35	1.95	251A(WE)	45.00	5670	1.50
2J36	35.00	HK253	5.00	5672	1.25
2J32	15.00	266B	45.00	5676	39.50
2J37	10.00	272A	9.25	5678	2.00
2J54	35.00	274B	5.00	5686	2.00
2K25	19.95	275A	3.50	5687	3.00
2K28	28.50	276G	8.50	5691	5.50
2K45	50.00	287A	3.00	5692	6.25
2K55	18.00	GL299	3.50	5693	4.75
3B23/RK22	4.00	304TH Surp	8.75	5696	
3B24	1.50	304TL Surp	10.75	5698	2.00
3B24 W	5.00	311A	5.50	5704	1.90
3B25	5.00	311C	2.50	5718	4.24
3B27	3.50	313CA	2.95	5819RCA	33.00
3B28	6.00	313CC	1.75	5820 Icon	185.00
3B29	6.00	337A	6.50	5726/6AL5W	1.10
3C23	7.50	WE339A	14.00	5727	3.00
3C24	4.25	417A	3.25	5744	.90
3C45	7.50	350A(WE)	3.00	5749	2.00
3D21A	4.50	350R	2.75	5751	2.50
3J30	45.00	WE355A	17.50	5763	1.10
3J31	45.00	359A	2.00	5780	25.00
3BP1	2.95	726C	35.00	6113	4.75
3BP1	7.00	417A	3.50	5794	7.75
3DP1	3.00	Klystron	3.50	5795	250.00
4B24	5.00	429A	8.75	5814	1.20
4B28 6 Amp Rectifion	3.00	464A	2.55	5814A	2.00
4E27	9.50	CK503AX	1.50	5820	37.50
4J30	39.50	GL562	50.00	5829	2.00
4J36	75.00	WL651/5552.50	50.00	5840	5.00
4J37	75.00	WL-653B	110.00	5844	4.00
4J63	7.00	GL673	13.00	5879	1.25
4K25A Surp	19.00	703A	1.75	5882	2.75
4X150A Surp	707A	707A	4.00	5915	1.00
4X150G Surp	24.00	707B	5.00	5932	6.50
4X250B Surp	35.00	708A	2.00	5965	1.45
4X500F Surp	42.50	709A	1.75	5993	10.00
4-750A Surp	65.00	715B	3.95	6021	1.65
4-1000A Surp	50.00	721A	.75	6095	1.25
4-1000A Surp	75.00	723A/B	9.50	6097	1.50
5BP1	3.75	726B	4.50	6098	1.90
5BP4	3.95	726C	25.00	6100	4.75
5C22	2.95	750TL	35.00	6113	1.85
5D21	7.95	800	2.00	Jan.	70.00
5FP7	1.30	803	2.00	6183	275.00
6D21	7.75	807	1.20	6186	4.00
5JPS					





## TEST EQUIPMENT

**FLUX-METER.** Measures flux of magnetron magnets from 500 to 4000 gauss. New... \$14.95  
**FREQ.-METER.** TS-127/U. Range 375-725 Mcs. New with spare tubes and manual... \$34.50  
**PANADAPTER.** AN/APA-10. For 115v. 60 cy. New with 80 page tech manual... \$97.50  
**40-500 Mc TEST OSC.** TS-47/APR. New... \$149.50  
**FREQ-STANDARD.** Telrad 18A. New... \$23.95  
**RECEIVER.** 158-210 Mc. BC-1068A. 60 cy. \$29.50  
**RECEIVER.** MX-24/APR-1... \$97.50  
**PULSE TIMER.** CUZ-50AGD. For 115/60/1. \$65.00  
**OSCILLATOR.** 300-1600 Mc. AN/APT-5. New... \$139.50  
**OSCILLATOR.** 450-710 Mc. AN-APT-2. New... \$29.75  
**MODULATOR.** BC-1203. For 115v. 60 cy. \$125.00  
**MODULATOR.** BC-423B. Radiates 205Mc. pulsed sig. at 4.098 cps. New 60 cy. \$19.50  
**PULSE ANALYZER.** Airborne counter-measures model ID-59/APA-11. New... \$149.50  
**FREQ.-METERS.** LINK 250-D2. For testing mobile equip. One each 152-270-157-530, 152-300-157-650, 152-510-157-770, 152-630-157-890, 35-420-43-420 Mc. Price per set... \$49.50  
**SIG. GEN.** I-222A, 115-230 Mc. 8-15 Mc. \$89.50  
**20-250 Mc. FREQ-METER.** TS-174... P.O.R.  
**SIG. GEN.** SQ-13/AIN. AM-PM 105-138 Mc. For aircraft loc. and glide slope tests... P.O.R.

## HI-VOLT OIL CAPACITORS

Mfd.	KV	Price
.001	50	22.95
.01	5	2.50
.02	8	4.50
.05	20	6.75
.025/.025	50	17.95
.1	3	1.75
.1	4.5	3.50
.135	7.5	6.95
.2	15	29.50
.25	15	9.95
.25	20	15.95
.5	50	44.50
1.	25	39.50
1.	7.5	6.95
1.	15	29.50
1.	20	42.50
2.	5.5	9.50

## SPECIAL!

PYRA-NOL FILLED CAPACITOR



Cat. No. 26F681

ONLY \$6.95



.02 mfd. 20,000 volts. 1 1/2 x 2 1/2 dia. in. A real value at only... \$6.75

## AMPLIDYNES

5 AM21J7. Input 27 VDC @ 15 A. Output 60 VDC @ 5.5A. 400 RPM. New... \$34.50  
 5AM31J9A. Input 27 VDC @ 45 A. Output 80 VDC @ 8.8 A. 7500 RPM. New... \$23.50  
 5AM31J18A. Input 27 VDC @ 44 A. Output 60 VDC @ 8.8 A. 8300 RPM. New... \$12.50

## INVERTERS

Leland Elec. C. PE206A. Input: 28DC at 38 Amp. Output: 80V, 800 Cy., 1 Ph., 485V. New... \$16.50  
 PE213H. Input: 28DC. Output: 115. 400 cy., 1 Ph. 1.5 KVA. New... \$32.50  
 G.E. SAS131J11A. Input: 28DC. Output: 115, 400 cy., 1 Ph., 1.5 KVA. Regulated. New... \$89.50

## DYNAMOTORS

Navy type CAJ0-211444. Input: 105 to 130 VDC. Output: either 26 VDC at 20 amps, or 13 VDC at 40 amps. Radio filtered and complete with line switch. New... \$89.50

## SMALL DC MOTORS

G.E. 5BA50L2A. Armature 60 VDC at 8.3 Amps. Field 27.5 VDC at 2.3A RPM 4000. I.P. 0.5. New... \$27.50  
 Oster E-7.5. 27.5DC. 1/20 HP, 3600 RPM. Shunt Wound. New... \$9.50

## 9 CONDUCTOR CABLE

Army spec. CO-215 Weatherproof 9 Cond. No. 20 AWG stranded tinned copper, plastic ins., colored coded, double vinyl jackets with tinned copper braid between Dia. 5/16" made by G.E. Available 1000, 1500, 2000 ft. reels. Price 10¢ per foot. Sample 100 ft. Coil \$10.00

## NEW SCR-522A EQUIPMENT

Complete BC-824C receivers and BC-925AM Transmitters including mounting racks, plugs, connectors, dynamotor. Brand new equipment with instruction manuals. Write for details

## NEW REPAIR PARTS FOR BC-348

(Models H, K, L, R only)  
 4 gang tuning capacitor... \$ 3.95  
 Aluminum front panel... \$ 3.75  
 1st, 2nd, 3rd, and 4th I.F. transformer assy. Each \$ 2.00  
 Crystal filter assy inc. 915 Kc. Crystal... \$ 5.50  
 C.W. Oscillator assembly... \$ 2.00  
 R.F. Unit Assembly in can... \$12.50  
 Dual Volume Control... \$ 2.75  
 Spring tuning knob... \$ .50  
 Ant., RF, Det. and Osc. coils for bands 1 to 6. Per Band... \$ 2.00  
 Complete Dial assembly... \$16.50

## 10 CM. RADAR ANTENNAS

SO-1 (1CM) assembly with reflector, wave-guide nozzle and drive motor... \$279.50  
 SO-3 (3CM) Surface Search type with reflector and drive motor, but less plumbing... \$99.50  
 SO-13 (10CM) Complete assembly with 24" dish, dipole, drive motor and gearing... \$49.50

## RA38 RECTIFIER

Stepless, adjustable output from zero to 15,000 volts V DC @ 300 MA. Input 115V 60 cy. 1 Ph. Size 63 x 53 x 56 in. Write for detailed information.

## HIGH POT TRANSFORMER

Westinghouse. Pri: 115. 60 cy. Sec: 15,000V C.T. @ .060A. C.T. undergrounded. Excellent for high potting tests. Size 6A 12H x 8 1/2W x 9 1/2D. Weight 67 lbs. Fully enclosed steel case. Price... \$29.50

## 6 KVA. STEPDOWN TRANSFORMER

G. E. Step-Down. 6KVA. Pri: 230/460. Sec: 115/125, 60 Cy. Size: 20" x 11" x 9 1/2". Weight: 225 lbs. Navy grey finish. Integral junction box and mounting brackets... \$49.50

Phone: DEerfield 7-0044

## ELECTRONICRAFT

27 MILBURN ST. BRONXVILLE 8, N. Y.

## NEW YORK'S RADIO TUBE EXCHANGE

## NEW TUBES











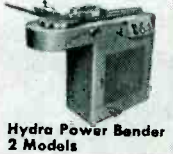

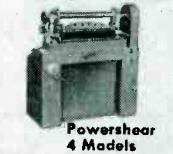
Standard brands. First grade only. No pull outs. No rejects. No rebrands. At lowest prices.

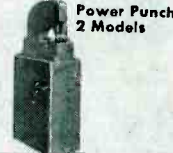
Type	Price	Type	Price	Type	Price	Type	Price	Type	Price	Type	Price	Type	Price
OA2	\$1.00	2T34	\$6.00	3E29	\$5.50	12AP4	\$50.00	357A	\$15.00	726C	\$45.00	958A	\$60.00
OA3	\$1.10	2J36	\$90.00	3GP1	\$5.00	12AD7A	\$9.00	368AS	\$4.95	730A	\$22.50	959	\$22.50
OB2	\$9.99	2J38	\$8.95	3JF1	\$75.00	1M18	\$200.00	371B	\$1.50	750TL	\$5.00	E1148	\$25.00
OB3	\$1.10	2J39	\$8.99	4B26	\$4.50	15E	\$1.75	385A	\$4.50	801A	\$9.00	1280	\$95.00
OC2	\$6.24	2J40	\$29.00	4C27	\$10.00	18R	\$7.50	388A	\$1.80	802	\$3.95	1500T	\$135.00
OD2	\$9.99	2J42	\$13.00	4C28	\$10.00	18R	\$7.50	388A	\$1.80	805	\$5.95	1612	\$25.00
OB2	\$1.10	2J39	\$8.99	4E27	\$15.00	20A	\$2.04	394A	\$3.95	806	\$4.95	1603	\$50.00
OC2	\$6.24	2J40	\$29.00	4J28	\$50.00	KH24G	\$1.50	448A	\$1.95	810	\$10.50	1616	\$1.50
OB2	\$1.10	2J39	\$8.99	4J28	\$50.00	25T	\$2.95	448A	\$1.95	811A	\$3.75	1622	\$1.75
OB2	\$1.10	2J39	\$8.99	4J28	\$50.00	35T	\$4.95	450TII	\$5.00	812A	\$3.95	1624	\$1.75
OB2	\$1.10	2J39	\$8.99	4J28	\$50.00	35T	\$4.95	450TII	\$5.00	813	\$13.75	1625	\$3.50
OB2	\$1.10	2J39	\$8.99	4J28	\$50.00	35T	\$4.95	450TII	\$5.00	814	\$4.95	1626	\$3.50
OB2	\$1.10	2J39	\$8.99	4J28	\$50.00	35T	\$4.95	450TII	\$5.00	815	\$3.25	1851	\$1.80
OB2	\$1.10	2J39	\$8.99	4J28	\$50.00	35T	\$4.95	450TII	\$5.00	816	\$1.45	2000T	\$150.00
OB2	\$1.10	2J39	\$8.99	4J28	\$50.00	35T	\$4.95	450TII	\$5.00	817	\$1.95	2050	\$1.80
OB2	\$1.10	2J39	\$8.99	4J28	\$50.00	35T	\$4.95	450TII	\$5.00	818	\$1.95	2051	\$1.00
OB2	\$1.10	2J39	\$8.99	4J28	\$50.00	35T	\$4.95	450TII	\$5.00	819	\$11.00	VARIOUS 5000 AND 6000 SERIES OF NEW PRODUCTION	
OB2	\$1.10	2J39	\$8.99	4J28	\$50.00	35T	\$4.95	450TII	\$5.00	820	\$12.00	5820	\$475.00
OB2	\$1.10	2J39	\$8.99	4J28	\$50.00	35T	\$4.95	450TII	\$5.00	821	\$12.00	5824	\$450.00
OB2	\$1.10	2J39	\$8.99	4J28	\$50.00	35T	\$4.95	450TII	\$5.00	822	\$12.00	8012	\$2.00
OB2	\$1.10	2J39	\$8.99	4J28	\$50.00	35T	\$4.95	450TII	\$5.00	823	\$12.00	8013A	\$2.50
OB2	\$1.10	2J39	\$8.99	4J28	\$50.00	35T	\$4.95	450TII	\$5.00	824	\$12.00	8013	\$3.00
OB2	\$1.10	2J39	\$8.99	4J28	\$50.00	35T	\$4.95	450TII	\$5.00	825	\$12.00	8013A	\$3.50
OB2	\$1.10	2J39	\$8.99	4J28	\$50.00	35T	\$4.95	450TII	\$5.00	826	\$12.00	8019	\$1.75
OB2	\$1.10	2J39	\$8.99	4J28	\$50.00	35T	\$4.95	450TII	\$5.00	827	\$12.00	8020	\$1.80
OB2	\$1.10	2J39	\$8.99	4J28	\$50.00	35T	\$4.95	450TII	\$5.00	828	\$12.00	8025	\$3.75
OB2	\$1.10	2J39	\$8.99	4J28	\$50.00	35T	\$4.95	450TII	\$5.00	829	\$12.00	PD8865	\$96.00
OB2	\$1.10	2J39	\$8.99	4J28	\$50.00	35T	\$4.95	450TII	\$5.00	830	\$12.00	9001	\$1.52
OB2	\$1.10	2J39	\$8.99	4J28	\$50.00	35T	\$4.95	450TII	\$5.00	831	\$12.00	9002	\$2.90
OB2	\$1.10	2J39	\$8.99	4J28	\$50.00	35T	\$4.95	450TII	\$5.00	832	\$12.00	9003	\$1.25
OB2	\$1.10	2J39	\$8.99	4J28	\$50.00	35T	\$4.95	450TII	\$5.00	833	\$12.00	9004	\$3.35
OB2	\$1.10	2J39	\$8.99	4J28	\$50.00	35T	\$4.95	450TII	\$5.00	834	\$12.00	9005	\$2.75
OB2	\$1.10	2J39	\$8.99	4J28	\$50.00	35T	\$4.95	450TII	\$5.00	835	\$12.00	9006	\$1.25
OB2	\$1.10	2J39	\$8.99	4J28	\$50.00	35T	\$4.95	450TII	\$5.00	836	\$12.00	9007	\$3.75
OB2	\$1.10	2J39	\$8.99	4J28	\$50.00	35T	\$4.95	450TII	\$5.00	837	\$12.00	9008	\$1.25
OB2	\$1.10	2J39	\$8.99	4J28	\$50.00	35T	\$4.95	450TII	\$5.00	838	\$12.00	9009	\$3.75
OB2	\$1.10	2J39	\$8.99	4J28	\$50.00	35T	\$4.95	450TII	\$5.00	839	\$12.00	9010	\$1.25
OB2	\$1.10	2J39	\$8.99	4J28	\$50.00	35T	\$4.95	450TII	\$5.00	840	\$12.00	9011	\$3.75
OB2	\$1.10	2J39	\$8.99	4J28	\$50.00	35T	\$4.95	450TII	\$5.00	841	\$12.00	9012	\$1.25
OB2	\$1.10	2J39	\$8.99	4J28	\$50.00	35T	\$4.95	450TII	\$5.00	842	\$12.00	9013	\$3.75
OB2	\$1.10	2J39	\$8.99	4J28	\$50.00	35T	\$4.95	450TII	\$5.00	843	\$12.00	9014	\$1.25
OB2	\$1.10	2J39	\$8.99	4J28	\$50.00	35T	\$4.95	450TII	\$5.00	844	\$12.00	9015	\$3.75
OB2	\$1.10	2J39	\$8.99	4J28	\$50.00	35T	\$4.95	450TII	\$5.00	845	\$12.00	9016	\$1.25
OB2	\$1.10	2J39	\$8.99	4J28	\$50.00	35T	\$4.95	450TII	\$5.00	846	\$12.00	9017	\$3.75
OB2	\$1.10	2J39	\$8.99	4J28	\$50.00	35T	\$4.95	450TII	\$5.00	847	\$12.00	9018	\$1.25
OB2	\$1.10	2J39	\$8.99	4J28	\$50.00	35T	\$4.95	450TII	\$5.00	848	\$12.00	9019	\$3.75
OB2	\$1.10	2J39	\$8.99	4J28	\$50.00	35T	\$4.95	450TII	\$5.00	849	\$12.00	9020	\$1.25
OB2	\$1.10	2J39	\$8.99	4J28	\$50.00	35T	\$4.95	450TII	\$5.00	850	\$12.00	9021	\$3.75
OB2	\$1.10	2J39	\$8.99	4J28	\$50.00	35T	\$4.95	450TII	\$5.00	851	\$12.00	9022	\$1.25
OB2	\$1.10	2J39	\$8.99	4J28	\$50.00	35T	\$4.95	450TII	\$5.00	852	\$12.00	9023	\$3.75
OB2	\$1.10	2J39	\$8.99	4J28	\$50.00	35T	\$4.95	450TII	\$5.00	853	\$12.00	9024	\$1.25
OB2	\$1.10	2J39	\$8.99	4J28	\$50.00	35T	\$4.95	450TII	\$5.00	854	\$12.00	9025	\$3.75
OB2	\$1.10	2J39	\$8.99	4J28	\$50.00	35T	\$4.95	450TII	\$5.00	855	\$12.00	9026	\$1.25
OB2	\$1.10	2J39	\$8.99	4J28	\$50.00	35T	\$4.95	450TII	\$5.00	856	\$12.00	9027	\$3.75
OB2	\$1.10	2J39	\$8.99	4J28									

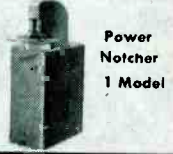
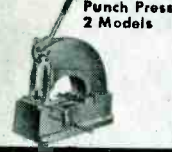
# SPEED FORMING and FABRICATING JOBS

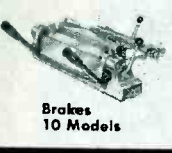

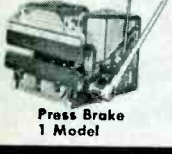
for die-less  
duplicating

 Benders 5 Models	 Hydra Power Bender 2 Models
 Shears 4 Models	 Powershear 4 Models
 Rod Parter 2 Models	 Power Punch 2 Models
 Notcher 1 Model	 Power Notcher 1 Model
 Punch Press 2 Models	 Power Parter 1 Model
 Brakes 10 Models	 Rollers 8 Models
 Press Brake 1 Model	 Spring Winder 1 Model
 Power Press Brake 1 Model	Di-Acro Engineering Service is available without cost or obligation.

New 36 page catalog... packed with time saving "Die-Less Duplicating" techniques



Bending Manual gives exact methods for bending a variety of materials.



**O'NEIL-IRWIN MFG. CO.**  
321 8th Ave. • Lake City, Minn.

Want more information? Use post card on last page.  
428

# INDEX TO ADVERTISERS

Acme Wire Co.....	356	Caledonia Electronics Transformer Corp.	358
Aeronautical Communications Equip- ment, Inc.....	257	Calidyne Company, The.....	208
Aerovox Corp.....	281	Cambridge Thermionic Corp.....	263
Ainslie Corp.....	343	Carter Motor Co.....	339
Airborne Instruments Laboratory.....	80	Centralab, Div. of Globe-Union, Inc.....	64
Aircraft Radio Corp.....	322	Cerf & Co., Art.....	382
Aircraft-Marine Products, Inc.....	35	Chase Brass & Copper Co.....	261
Airpax Products Co.....	89	Chatham Electronics, Div. of Gero Corp.....	251
Allen-Bradley Co.....	273	Chicago Standard Transformer Corp.....	290
Allen Co., Inc., L. B.....	382	Chicago Telephone Supply Corp.....	41
Allen Manufacturing Co.....	376	Cinch Mfg. Corp.....	169
Allegheny Ludlum Steel Corp.....	303	Clare & Co., C. P.....	51
American Airlines, Inc.....	271	Clevite Transistor Products.....	279
American Electric Motors, Inc. Electric Machinery & Equlpt. Div. of American Electronics, Inc.....	274	Cleveland Container Co.....	247
American Gas Furnace Co.....	357	Clifton Precision Products Co., Inc.....	105
American Lava Corporation.....	115	Cohn Corp., Sigmund.....	352
American Phenolic Corp.....	178	Collectron Corporation.....	370
American Television & Radio Co.....	380	Color Television Inc.....	345
American Time Products, Inc.....	241	Colortone Electronics Inc.....	374
Amperite Co., Inc.....	286	Commonwealth of Puerto Rico.....	277
Ampex Corporation.....	83	Communication Accesories Co.....	45
Andersen Laboratories, Inc.....	341	Communication Measurements Laboratory, Inc.....	430
Andrew Corporation.....	344	Computer Measurements Corp.....	378
Arnold Engineering Co.....	13	Condenser Products Div. of New Haven Watch & Clock Co.....	378
Assembly Products, Inc.....	64A-64B	Conrad Inc.....	342
Augat Bros., Inc.....	358	Consolidated Vacuum Corp.....	316
Automatic Manufacturing Corp.....	112	Constantin & Co., L. L.....	299
Avion, Inc.....	375	Constantine Engineering Laboratories Co.....	192
Bakelite Co., a Div. of Union Carbide and Carbon Corp.....	84, 85, 231	Continental-Diamond Fibre, Div. of the Budd Company, Inc.....	227
Ballantine Laboratories, Inc.....	206	Cornell-Dubiller Electric Corp.....	97
Barker & Williamson, Inc.....	194	Corning Glass Works.....	288
Barry Controls, Inc.....	21	Cosmic Condenser Co.....	372
Bausch & Lomb Optical Co.....	38	Craig Systems, Inc.....	298
Belden Manufacturing Co.....	68	Cramer Co., Inc., R. W.....	204
Bell Telephone Laboratories.....	233	Cross Co., H.....	307
Bendix Aviation Corporation Eclipse-Pioneer Div.....	292	Crucible Steel Co. of America.....	199
Pacific Div.....	215	Cubic Corporation.....	335
Scintilla Div.....	324	Cunningham Son & Co., Inc., James.....	372
Bentley, Harris Mfg. Co.....	32	Curtiss-Wright Corp.....	224
Berkeley Division, Beckman Instruments, Inc.....	333	Dano Products Co.....	307
Bird Electronics Corp.....	336	Daubert Chemical Co.....	355
Boehme, Inc., H. O.....	369	Daven Company.....	3rd Cover
Boonton Radio Corp.....	193	Davies Laboratories, Inc.....	331
Borg Corporation, George W.....	346	DeJur-Amsco Corporation.....	296
Bosworth & Co.....	382	Delco Radio Div. of General Motors.....	198
Brush Electronics Company.....	246	DeMorney-Bonardi.....	377
Budd-Stanley Co., Inc.....	106	Dialight Corporation.....	347
Burnell & Co., Inc.....	67	Donner Scientific Co.....	282
Busmann Mfg. Co.....	86		



Dumont Airplane & Marine Instruments, Inc. ....	429
Du Mont Laboratories Inc., Allen B. ....	185
DuPont de Nemours & Co., (Inc.) Polychemicals Dept. ....	91

Eastern Industries, Inc. ....	58
Eastman Kodak Company ....	179
Edison Inc., Thomas A. ....	238
Eisler Engineering Co., Inc. ....	363
Eitel McCullough, Inc. ....	65
Ekco Electronics Ltd. ....	375
Elco Corp. ....	368
Electrical Industries, Div. of Ampere Electronic Corp. ....	93
Electrical Testing Laboratory, Inc. ....	351
Electro Impulse Laboratory ....	380
Electro Tec Corp. ....	267
Electronic Associates, Inc. ....	216
Electron Instrument Co., Inc., (EICO) ....	343
Emerson & Cuming Inc. ....	318
Engineering Co., The ....	340
Epsco, Inc. ....	313
Erle Resistor Corp. ....	39
Essex Wire Corp., R-B-M Div. ....	184

Falcon Electronics Corp. ....	432
Fansteel Metallurgical Corp. ....	308, 309
Farnsworth Electronics Co. ....	71
Federal Telephone & Radio Co. ....	75, 373
Ferroxcube Corp. of America. ....	307
Filters, Inc. ....	374
Ford Instrument Co., Div. Sperry Rand Corp. ....	242
Formica Company ....	223
Freed Transformer Co., Inc. ....	275
Frenchtown Porcelain Company. ....	376
Frequency Standards ....	295
F-R Machine Works Inc. ....	235
Furst Electronics, Inc. ....	432

G M Laboratories, Inc. ....	29, 354
Gabriel Electronics Div. of Gabriel Co. ....	306
Gamewell Co. ....	230
Garfield Wire Div. of the Overlakes Corp. ....	368
Gee-Lar Manufacturing Company. ....	328
General Cable Corp. ....	217
General Dry Batteries Inc. ....	188
General Electric Company Apparatus Dept. .... 76, 77, 78, 79, 108, 109 Electronics Dept. .... 33 Tube Dept. .... 23, 94, 95	
General Industries Co. ....	221
General Radio Co. ....	17
General Research & Supply Co. ....	328
Genisco Incorporated ....	339
Gertsch Products Inc. ....	360

# DUMONT TINYCAPS

TYPE RT 3

## NOW

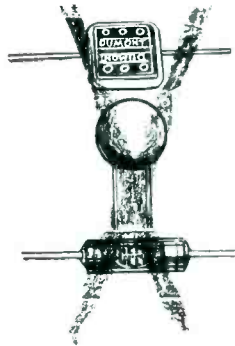

NO  
MICAS  
•  
NO  
CERAMICS  
•  
NO  
PAPERS

### ONE TYPE REPLACES ALL THREE

EASY  
TO  
STOCK



EASY  
TO  
HANDLE

600V - 1000V - 1500V  
OPERATING MIN.

- ★ 125°-150°C OPERATING TEMP.
- ★ HIGHLY MOISTURE PROOF
- ★ IDEAL FOR PRINTED CIRCUITS
- ★ NON-INDUCTIVE • CEMENTED COATED PLASTIC FILM

*The Greatest Advance yet made  
in Small Capacitors*

ANOTHER DUMONT *First* DESIGNED  
BY DUMONT ENGINEERS . . .

Send for Descriptive Bulletin #60 Now.

**DUMONT-AIRPLANE & MARINE INSTRUMENTS, Inc.**  
OFFICE  
15 William Street  
New York 5, N. Y.  
FACTORY  
Clearfield  
Pennsylvania

#### SALES REPRESENTATIVES

George Brant P.O. Box 911 Pittsburgh 30, Pa.	Engineering Service Co. 6635 Delmar Blvd. St. Louis, Missouri R. B. Dillon	J. Duncan How, Inc. R.M. 445 Statler Office Bldg. Park Square, Boston 15, Mass.	R. J. Miller 45 W. Golf View Rd. Haverstown, Pa.
J. G. Bucher & Associates 205 E. First St Rm. 6, Dayton 2, Ohio	Haggerty-Ludwig 23525 Woodward Ave. Ferndale 20, Mich.	Knoblock & Malone 4000 W. North Av. Rm. 322, Chicago 39, Ill.	Jlm & Dave Packard P.O. Box 15234 Houston, Texas
Frank A. Emmit Co. 2837 W. Pico Blvd. Los Angeles 6, Cal.	Roland R. Hitchens 323 Homestead Av. Haddonfield, N. J.	John J. Kopple Assts. 9 W. Prospect Av. Mt. Vernon, N. Y.	Reed-Tollefson Corp. Brighton Station Box 7, Rochester 10, N. Y.

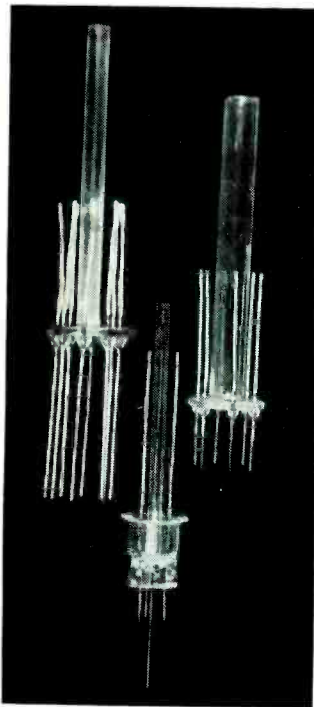

(A)

## TUBE COMPONENTS AND HERMETIC SEALS

- (A) Molded Button Stems
- (B) Silicon Diode Closure — 100 amperes
- (C) Silicon Diode Closure — 50 amperes
- (D) Silicon Diode Closure — 10 amperes
- (E) Silicon Diode Closure — 5 amperes

We are also equipped for custom glass operations, both hand & machine. Complete facilities available for sealing & evacuation. Write now for immediate quotations on any quantity.

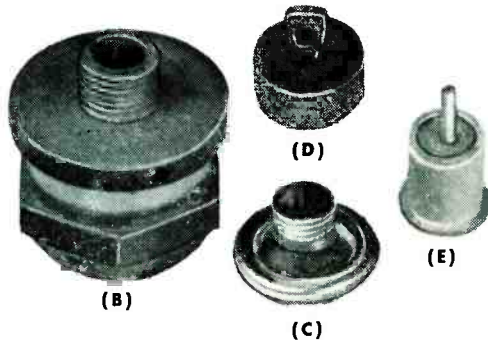

(B)

(D)

(E)

(C)

Over a Quarter Century of Sealing Experience

## SCIENTIFIC ELECTRONIC LABS

866 Bergen St.

Bigelow 3-8676

Newark 8, N. J.



## POWER AT PRECISELY THE FREQUENCY YOU REQUIRE

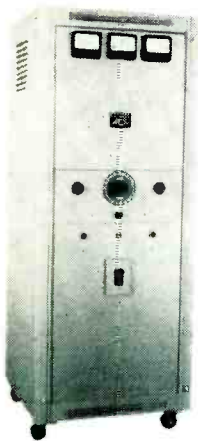

Model 1435  
2 KVA Unit

Any CML Electronic Generator is available with a total of up to four *precision* American Time Products tuning fork oscillators in the 50-6000 cps range.

The use of these precision oscillators gives a frequency accuracy and stability of 1 part in 50,000 *entirely independent* of line voltage or frequency.

CML Electronic Generators are available in single and three phase units in power output ratings from 50 VA to 80 KVA. Write for Catalogue "N".

## COMMUNICATION MEASUREMENTS LABORATORY, INC.

350 LELAND AVE., PLAINFIELD, N. J.

Good-all Electric Mfg. Co.	283
Greenleaf Manufacturing Co.	55
Gries Reproducer Corp.	365
Hammarlund Mfg. Co., Inc.	25
Harvey Hubbel, Inc.	82
Hayden Associates, Paul	382
Haydon Manufacturing Co., Inc.	248
Haydu Brothers of New Jersey	285
Heath Co.	359
Helipot Corp., Div. of Beckman Instruments, Inc.	175
Hetherington, Inc.	196
Hewlett-Packard Co.	81
Heyman Manufacturing Co.	369
Hornelite a div. of Tectron American, Inc.	367
Hughes Aircraft Co.	180, 181
Hughes Research & Development Laboratories	332
Hunt Company Philip A.	250
Hycor Company, Inc.	371
Hycor Eastern, Inc.	240
Hycor Electronics, Inc.	252

Ilseco Corporation	336
Industrial Development Committee of 100, Lakeland, Florida	352
Industrial Test Equipment Co.	377
Industrial Timer Corp.	40
Institute of Radio Engineers	201
International Business Machines	320
International Rectifier Corp.	34
International Resistance Co.	100, 101
Ippolito & Co., Inc., James	354

Jet Propulsion Laboratory	327, 365
J F D Electronics Corp.	42
Johnson Company E. F.	355
Jones Div., Howard B., Cinch Mfg. Co.	304
Jones Electronics Co., Inc. M. C.	278

Kahle Engineering Co.	15
Kaiser Metal Products Inc.	92
Kay Electric Co.	27
Kearfott Company, Inc.	312
Kellogg Company, M. W.	211
Kepec Laboratories	173
Kester Solder Co.	219
Koch Fiberglass	114
Kollsman Instrument Corp.	87



L M Electronics, Inc.	338
Laboratory for Electronics, Inc.	197
Lampkin Laboratories, Inc.	307
Land-Air, Inc.	366
Langevin Manufacturing Corp.	262
Lapp Insulator Co., Inc.	202
Lewis & Kaufman Ltd.	207
Linde Air Products Company, Div. of Union Carbide & Carbon Corp.	304
Litton Engineering Laboratories	362
Lockheed Missile Systems Div.	232
Loral Electronics Corp.	291
Los Alamos Scientific Laboratory of the University of California	254

MacDonald Inc., Samuel K.	382
Magnatran, Inc.	370
Magnetic Amplifiers, Inc.	302
Magnetics, Inc.	183
Mallory and Co., Inc., P. R.	120, 171
Mansol Ceramics Co.	186
Marconi Instruments, Ltd.	104
Marion Electrical Instrument Co. 32A, 32B, 294, 304	
Markem Machine Co.	360
Mark Products	356
Martin Company, Glenn L.	276
Maxson Instruments	323
McLean Engineering	294
Metal & Thermit Corporation	280
Metals & Controls Corp., General Plate Div.	60
Mfgs. Representatives	382
Mica Insulator Co.	213
Micro Switch, a Div. of Minneapolis- Honeywell Regulator Co.	74
Mid-Century Instrument Co.	44
Midwestern Instruments	243
Millen Mfg. Co., Inc., James	222
Minneapolis-Honeywell Regulator Co., Industrial Div.	50
Mona Industries, Inc.	374
Monsanto Chemical Co.	53
Muirhead & Co., Ltd.	5
Mullard Overseas Ltd.	90

N J E Corporation	119
Naresco Equipment Corp., Sub. of National Research Corp.	239
National Semiconductor Products	107
New Hampshire Ball Bearings, Inc.	236
New Hermes Engraving Machine Corp.	373
Newhope Corporation	382
Nopco Chemical Co.	43
Norden-Ketay Corp.	195
Northern Radio Co., Inc.	56
Nothelfer Winding Labs, Inc.	54



## everything in Fluorocarbons... the most complete service in parts and stock

■ United States Gasket Company offers precision parts fabricated from duPont TEFLON, Kellogg KEL-F, BAKELITE Fluorothene and other plastics. U.S.G. facilities provide cold molding and sintering techniques, compression molding, extruding and injection molding—quality controlled “from powder to part,” to assure uniform electrical, chemical and physical characteristics of the highest quality.

U.S.G. also maintains a machine shop specially equipped for the precision machining of parts from fluorocarbon stock.

Come to U.S.G. for all your requirements—sheets, rods, tubing, tape, cylinders, bars, beading, electrical spaghetti—as well as custom-molded and machined parts.

Write for Catalog No. 300.

**United States Gasket Company**  
CAMDEN 1, NEW JERSEY

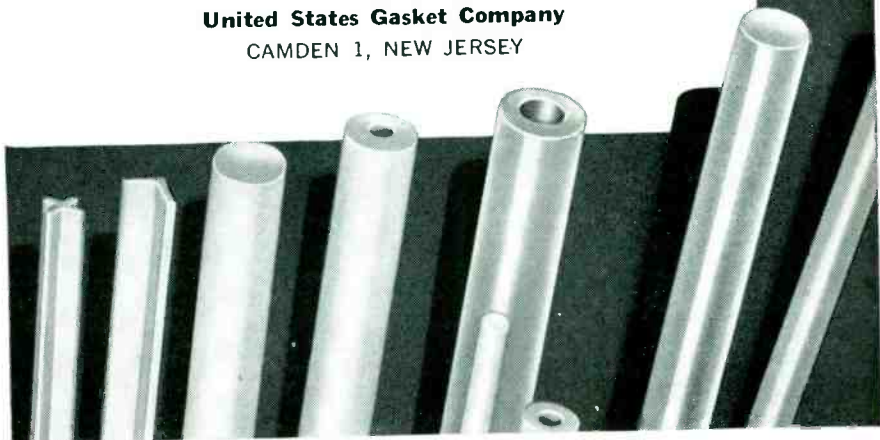

**FABRICATORS OF FLUOROCARBONS  
AND OTHER PLASTICS**

Representatives in principal cities throughout the world

# AT LAST! A SUBMINIATURE THERMAL TIME DELAY RELAY\*

## for GUIDED MISSILES and PRINTED CIRCUITS

The only Relay under 1" in height that offers the following:

- Time delays from 1 second to 5 minutes.
- Heater Voltages to 230 volts. Interchangeable on A.C. or D.C. of any frequency.
- Contact rating up to 6 amps.
- Hermetically sealed.
- Fully compensated for ambient temperatures of from  $-65^{\circ}\text{C}$  to  $+100^{\circ}\text{C}$ .
- Will withstand vibration of from 5 to 500 CPS at acceleration of 10 G.
- Shock up to 50 G.
- Rapid reoperating time.
- Available in 7 and 9 pin.
- Price of sample \$9.25 net each.

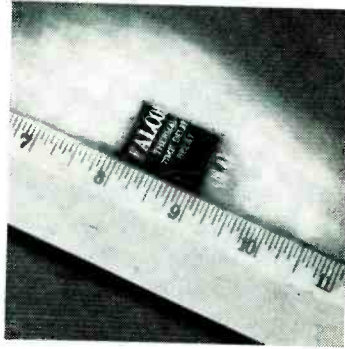

\*PATENT PENDING

## FALCON ELECTRONICS CORP.

308 WILLIAM STREET, HARRISON, N. J.

O'Neil-Irwin Mfg. Co. .... 428  
Oregon Electronics ..... 321

PM Industries, Inc. .... 317  
Pacific Scientific Co. .... 319  
Panoramic Radio Products, Inc. .... 300  
Perkin-Elmer Corporation ..... 226  
Perkin Engineering Corp. .... 31  
Phalo Plastics Corp. .... 256  
Phaotron Instrument & Electronic Company ..... 329  
Phelps-Dodge Copper Products Corp., Inca Mfg. Div. .... 72, 73  
Philamon Laboratories, Inc. .... 187  
Phillips Process Co., Inc. .... 340  
Photographic Products, Inc. .... 304  
Polarad Electronics Corporation ... 61, 98, 229  
Polytechnic Research & Development Co., Inc. .... 272  
Popper & Sons, Inc. .... 379  
Potter & Brumfield Mfg. Co. .... 36, 37  
Precision Apparatus Co., Inc. .... 433  
Precision Paper Tube Co. .... 214  
Progressive Mfg. Co. .... 258  
Pye Limited ..... 209  
Pyramld Electric Company ..... 103

## Model 220

# WIDE BAND D.C. AMPLIFIER

INPUT IMPEDANCE: 1 Megohm shunted approx. 20 mmF for each single-ended or differential input; 2 Megohms shunted approx. 10 mmF for push-pull signals.

FREQUENCY RESPONSE: d.c. to 100,000 cycles within 1 db, 6 db down at 200,000 cycles

MAXIMUM GAIN:  $100 \pm 10\%$  for balanced or unbalanced inputs or outputs

INPUT ATTENUATORS: 100 10 or 1 and "off" positions, independently in each channel

DC INPUT CONNECTIONS: Two posts for push-pull or differential, one post connected to ground; for single-ended signals, other input is disabled by setting attenuator to "off" position

AC INPUT CONNECTIONS: Arranged like DC connections; signal terminals connected to DC terminals through coupling condensers

OUTPUT IMPEDANCE: Approx. 250 Ohms single-ended, approx. 120 Ohms push-pull. Minimum load resistance; 250 Ohms

UNDISTORTED OUTPUT: 20 volts or 5 Milliampere (peak) max.

NOISE AND HUM: Below 40 microvolts referred to input

MOUNTING: Meta cabinet, 8" wide by 8" high by 13" deep

POWER CONSUMPTION: 120 watts from 115 volt 50-60 cycle, single-phase a.c. power line



A precision instrument designed for use as a preamplifier in conjunction with cathode-ray oscilloscopes, vacuum tube voltmeters and other instruments.

R. B. M. Division, Essex Wire Corp. .... 184  
Radiation, Inc. .... 379  
Radio Condenser Co. .... 237  
Radio Corporation of America ..... 116, 117, 249, 4th Cover  
Radio Engineering Laboratories, Inc. .... 255  
Radio Engineering Products ..... 342  
Radio Materials Corp. .... 110  
Radio Receptor Company, Inc. .... 118  
Railway Express Agency, Air Express Div. .... 265  
Rawson Electrical Instrument Co. .... 376  
Raytheon Mfg. Co. .... 18, 19, 113  
Reeves-Hoffman Corp. .... 347  
Reeves Instruments Corp. .... 259  
Relay Sales ..... 182  
Reliance Mica Co., Inc. .... 372  
Revere Copper & Brass, Inc. .... 225  
Roller-Smith Corp. .... 191  
Rowe Engravers ..... 382  
Rutherford Electronics Co. .... 364



Write today for descriptive literature on the Furst Model 220 D.C. Amplifier and other precision laboratory instruments.

## FURST ELECTRONICS, INC.

3324 W. Lawrence Ave., Chicago 25, Illinois

Sanborn Company ..... 301  
Sanders Associates, Inc. .... 362  
Saugamo Electric Co. .... 294



Scovill Manufacturing Company	325	Vacuum Metals Corp.	66
Scientific Electronic Labs.	430	Varian Associates	102
Scintilla Div., Bendix Aviation Corp.	324	Veeder-Root, Inc.	305
Sealectro Corp.	260	Vulcan Electric Co.	307
Shasta, Division Beekman Instruments, Inc.	357		
Sierra Electronic Corp.	264	Waldes Kohnoor, Inc.	57
Sigma Instruments, Inc.	284	Ward Leonard Electric Co.	47
Signal Engineering & Mfg. Co.	353	Waterman Products Co., Inc.	200
Simmons Fastener Corp.	88	Waters Manufacturing, Inc.	361
Sorensen & Co., Inc.	4	Watlow Electric Mfg. Co.	345
South Chester Corp.	46	Webster Chicago	59
Southern Electronics Co.	234	Weckesser Co.	294
Sprague Electric Co.	11, 177, 212, 344	Wenco Manufacturing Co.	380
Stackpole Carbon Co.	52	Westinghouse Electric Corp.	190, 297
Stevens Arnold, Inc.	382	Wheeler Insulated Wire Co., Inc., Div. of Sperry Rand Corp.	244
Stoddard Aircraft Radio Co., Inc.	228, 330	White Dental Mfg. Co., S. S.	210
Stokes Machine Co., F. J.	62, 63	Woods Aircraft Supply	361
Stupakoff Ceramic & Manufacturing Co. Div. of the Carborundum Co.	310, 311		
Superior Electric Company	203	Xcelite, Inc.	366
Superior Tube Co.	99		
Switchcraft, Inc.	363		
Sylvania Electric Products, Inc.	9, 269		
Syntronic Instruments, Inc.	364		

MANUFACTURER'S REPRESENTATIVES ..... 382

Taylor Fibre Co.	253
Technicraft Laboratories, Inc.	320
Technology Instrument Corp.	337
Teiner Engineering Corp.	346
Tektronix, Inc.	245
Telechrome, Inc.	289
Tele Coll Co., Inc.	377
Tel-Instrument Electronics Corp.	353
Telonic Industries	338
Tensolite Insulated Wire Co., Inc.	270
Transradio, Ltd.	341
Triplett Electrical Instrument Co.	111
Tru-Ohm Products, Div. of Model Engineering & Mfg. Co.	189
Tung-Sol Electric, Inc.	205

PROFESSIONAL SERVICES ..... 381

CLASSIFIED ADVERTISING  
F. J. Eberle, Asst Mgr.

SEARCHLIGHT ADVERTISING.....	412-427
ADVERTISERS INDEX .....	410
EMPLOYMENT OPPORTUNITIES.....	383-412
ADVERTISERS INDEX .....	408

Ucinite Co., The	48
Union Carbide and Carbon Corp.	
Bakelite Co.	84, 85, 231
Union Switch & Signal, Div. of Westinghouse Air Brake Co.	314, 315
United Air Lines	349
United-Carr Corporation	49
United States Gasket Co.	431
United Transformer Co.	2nd Cover
Unitek Corp.	359
Universal Winding Company	96

This index is published as a convenience to the readers. Every care is taken to make it accurate, but ELECTRONICS assumes no responsibility for errors or omissions.



**THE NEW  
PRECISION  
MODEL 88**

**HIGH SENSITIVITY VTVM  
and ELECTRONIC OHMMETER**  
Complete with 3-way Universal Test Probe  
**PEAK TO PEAK VOLTAGE  
RANGES TO 3200 VOLTS**

A compact wide range VTVM-Ohmmeter for modern electronic circuit checking in the laboratory, on the production line and for general service-maintenance. Features include Peak-to-Peak voltage ranges which afford a new high in P-P reading accuracy of pulsed wave-forms in color or monochrome TV and similar applications.

**7 DISTINCTLY SEPARATE FUNCTIONS  
40 SELECTED, WIDE-SPREAD RANGES**

- ▶ 6 TRUE-ZERO-CENTER DC VOLT RANGES: Constant 26 $\frac{2}{3}$  Megs input resistance. 0  $\pm$ 1.2  $\pm$ 6  $\pm$ 12  $\pm$ 60  $\pm$ 300  $\pm$ 1200 volts.
- ▶ 5 ELECTRONIC OHMMETER RANGES: 0-1000-10,000 ohms. 0-1-100-1000 Megs.
- ▶ 6 PLUS and 6 MINUS DC VOLT RANGES: (Left-Hand-Zero) constant 13 $\frac{1}{2}$  Megohms input. 0-1.2-6-12-60-300-1200V.
- ▶ 6 HIGH IMPEDANCE RMS AC VOLT RANGES: 0-1.2-6-12-60-300-1200 volts  
Input Characteristics: Up to 60V Range - 3 Megs., 90 mmfd; 300 V Range - 1 Meg., 70 mmfd; 1200V Range - 4 Megs., 67 mmfd.
- ▶ 6 HIGH IMPEDANCE P-P AC VOLT RANGES: 0-3.2-16-32-160-800-3200 volts  
Input Characteristics: Up to 160V Range - 6 Megs., 90 mmfd; 300V Range - 1 Meg., 70 mmfd; 3200V Range - 4 Megs., 67 mmfd.
- ▶ 5 SPECIAL HIGH FREQUENCY PROBE RANGES: 0-1.2-6-12-60-300 volts RMS. (Requires optional PRECISION RF-10AHF Probe). Probe input capacity: -approximately 5 mmfd.
- ONE UNIVERSAL COAX. AC-DC VTVM PROBE serves all functions other than HF ranges.
- PEAK-TO-PEAK "RE-SET" PUSH-BUTTON for rapid "zero" return of special electronically damped test circuit.
- EXTRA-LARGE 5 $\frac{1}{4}$ " RUGGED PACE METER. 200  $\mu$ A sensitivity  $\pm$ 2% accuracy.
- 1% MULTIPLIERS and SHUNTS.

MODEL 88: complete with detachable AC line cord, internal ohmmeter battery, coaxial VTVM Probe and operating manual. Size: 5 $\frac{3}{8}$  x 7 x 3 $\frac{1}{8}$ ".....\$69.75 net

ACCESSORIES FOR THE MODEL 88  
RF-10A HF vacuum tube probe.....\$14.40 net  
TV-8 60 Kilovolt safety probe..... 14.75 net  
ST-1 Snap-on foldaway tilt-stand..... 1.00 net

**PRECISION** Apparatus Company, Inc.  
70-31 84th Street, Glendale 27, L. I., N. Y.  
Export: 458 Broadway, New York 13, U. S. A.  
Canada: Atlas Radio Corp., Ltd., 50 Wingold Ave., Toronto 10

Want more information? Use post card on last page.

# electronics

VOLUME XXVIII

January to December Issue Inclusive 1955

McGraw-Hill Publishing Company, 330 West 42nd St. New York 36

**A**

A-C bridge sorts ceramic capacitors 106 Jul  
 Accelerator, current regulator for van de Graaff 151 Oct  
 Acoustic effects on components 181 Mar  
 Acoustics, electronic sound absorption 188D Jun  
 Acoustics, microphone nomograph 172 Oct  
 Acoustical research, electronic switch for 163 Oct  
 Adder, binary, tube 161 Sept  
 ADF for small airport 184D Jun  
 Adjustable power supply 164 Nov  
 Aeronautical communications recommendation 202D Sept  
 AEW planes keep continuous watch 178D Nov  
 AFC for f-m tuning 180D Jun  
 Airborne interrogator spots location, Applegarth 170 May  
 Airborne wave propagation laboratory with mast 164D Aug  
 Air-conditioned shielded room 180D Dec  
 Aircraft antenna, a-m system tunes 152 Aug  
 Aircraft, autopilot magnetic servo amplifier 208D May  
 Aircraft carrier, antennas, for 174D Dec  
 Aircraft communications recommendations 202D Sept  
 Aircraft, etched antenna for super-sonic 130 Jul  
 Aircraft, ice detector for 142 Dec  
 Aircraft, magnetic audio amplifier 122 Sept  
 Aircraft models for avoiding radar 122 Jan  
 Aircraft, portable precision approach radar 154 Oct  
 Aircraft, propagation laboratory 164D Aug  
 Aircraft, robot guidance system 162D Jul  
 Aircraft, TACAN navigation system 174D Oct  
 Aircraft, temperature indicator for engine 129 Nov  
 Aircraft, testing electronic components 181 Mar  
 Aircraft, transistor modulator for trainer 126 Sept  
 Aircraft, weather mapping radar 178D Sept  
 Air Force scientists plot static direction in D-layer study 178D Feb  
 Airplane models reveal how to avoid radar, Cole 122 Jan  
 Air-powered tilt-table speeds chassis-mounting 268D Apr  
 Air shield on air gun stops flying chips 246D Apr  
 Alarm, fog, microwave controlled 122 Jul  
 Alarm system, design of ultrasonic 106 Aug  
 Alfenol recording heads 137 Jun  
 Alfenol sources 208D Jun  
 Aligning tv receivers by pulse-cross display, Thomas 184D Apr  
 Alignment, tv camera, one man 214D Dec  
 All-magnetic audio amplifier, Suozzi & Hooper 122 Sept  
 Alloy improves magnetic recording, Lucy & Heath 137 Jun  
 All-pass amplifier, Woll 155 Jul

Items for which the page reference is marked "D" are editorial material published monthly in *Electrons at Work and Production Techniques*.

**Amplifier, see also type, audio, pulse, video, etc.**  
 Amplifier, all-pass 155 Jul  
 Amplifier, anode-dynode beam deflection 132 Aug  
 Amplifier, audio, circuit design factors 166 Apr  
 Amplifier, audio, magnetic 122 Sept  
 Amplifier, booster, for uhf-tv 112 Jul  
 Amplifier, d-c, criss-cross 198D Aug  
 Amplifier, d-c, electronic chopper 192D Nov  
 Amplifier, d-c, for computer 119 Jul  
 Amplifier, d-c, transistor chopper for 135 Apr  
 Amplifier-detector, infinite impedance 168D Aug  
 Amplifier, differential, for null detector 148 Aug  
 Amplifier for fast rise-fall pulses, Deming 170 Sept  
 Amplifier, high power uhf-tv 130 Apr  
 Amplifier, i-f, chassis design for 182D Aug  
 Amplifier, light, employs electro-luminescence 178D Feb  
 Amplifier, linear power, for ssb 124 Aug  
 Amplifier, logarithmic, for target discriminator 118 Aug  
 Amplifier, low-noise input stage 147 Feb  
 Amplifier, magnetic, autopilot servo 208D May  
 Amplifier, pulse, cathode compensation 156 Nov  
 Amplifier, stagger-tuned, design 158 Jul  
 Amplifier, studio, for color television 154 Mar  
 Amplifier, transistor audio 119 Jul  
 Amplifier, transistor, feedback-stabilized 174 May  
 Amplifier, transistor, for analog computer 119 Jul  
 Amplifier, transistor, performance 196D Feb  
 Amplifier, transistor power 174D Sept  
 Amplifier, two-way repeater 164 Jan  
 Amplifier, wideband uhf 158 Dec  
 Amplifier, X-band receiving 202D Apr  
 A-M system tunes aircraft antennas, Geisler 152 Aug  
**Analog computer, see also computer**  
 Analog computers simulate engines 214D May  
 Analog function multiplier, wide-band 160 Feb  
 Analyzer, servo testing 172 Apr  
 Analyzer, spectrum, for crystals 160 Oct  
 Analyzer, spectrum, for mobile radio 180D Feb  
 Anesthesia, physiological monitor for 130 Oct  
 Anode-dynode beam deflection amplifier, Wolkstein & Kaiser 132 Aug  
 Antenna, a-m system tunes aircraft 152 Aug  
 Antenna arrays insure flat-top communications 174D Dec  
 Antenna, automobile reflection in vhf-tv 166D Jul

Antenna, broadband horn 188D Aug  
 Antenna, Empire State WOR-TV 214D Apr  
 Antenna, etched, for supersonic aircraft 130 July  
 Antenna, f-m, inside a-m tower 130 Aug  
 Antenna, fan-pencil radar 142 May  
 Antenna, for vhf direction finder 172 Feb  
 Antenna, helmet, pack-set using 150 Mar  
 Antenna, moon-tracking 166D Aug  
 Antenna pattern measured by helicopter 134 Nov  
 Antenna, sailboat, design of 140 Jun  
 Antenna, spider, six direction 180D Jun  
 Antenna system for missile telemetering, Bower & Wynn 164 Jun  
 Approach radar, portable 154 Oct  
**Array, see also antenna**  
 Aseptic machine shop 204D Oct  
 Astronomy, radio, as navigation aid 182D Jan  
 Astronomy, radio, spider antenna 180D Jun  
 Astronomy, spectrum analyzer for sun 176D Oct  
 Atmospheric research, balloons gather lightning information 218D Oct  
 Atomic clock, cesium frequency standard 180D Apr  
**Attenuation, see also attenuators**  
 Attenuator, transmission test set 145 Dec  
 Audience survey techniques 126 Jan  
 Audio amplifier circuit design factors 166 Apr  
 Audio amplifier, magnetic 122 Sept  
 Audio amplifier, telephone repeater 164 Jan  
 Audio amplifier, transistor 196D Feb  
 Audio amplifier, transistor power 174D Sept  
 Audio, improving mobile 190D Oct  
 Audio, low-noise input stage for pre-amplifier 147 Feb  
 Audio oscillator, L-C 216D Mar  
 Audio oscillator has low distortion, Sulzer 158 May  
 Audio-standard generator, Koustas 161 Dec  
 Audio tones control refinery operations, Van Wambeek 130 Jan  
 Audio transmission gain test set 145 Dec  
 Automatic a-c bridges sort ceramic capacitors, Upham 106 Jul  
 Automatic belting of machine-fed components 248D Nov  
 Automatic blood pressure recorder will sound alarm 178D Jun  
 Automatic colorimeter for tv color tubes, Stanford 138 Dec  
 Automatic control, capacitor sorting 106 Jul  
 Automatic control, electronic weighing 152 Jun  
 Automatic control, extrusion of wire insulation 144 Apr  
 Automatic control in refinery operation 130 Jan  
 Automatic control, label counter 128 Oct  
 Automatic control, micrometer sorter 156 May  
 Automatic control, packaging basic circuits 122 Dec  
 Automatic control, phase shifter for industrial 138 Mar  
 Automatic control, variable-speed for motors 162 Apr  
 Automatic damping improves tv monitor, Thomas, Demars & Jones 230D Mar



Automatic inspection for green-rot in eggs .....140 Jul  
 Automatic micrometer sorts insulating wafers, Fearon .....156 May  
 Automatic music-speech discriminator silences speaker, Roth .....162D Aug  
 Automatic production, punch cards control job-lot assembly .....122 Nov  
 Automatic programming cuts broad-casting costs, Smaller .....135 Oct  
 Automatic recorder for complex im-pedances, Sharaf .....167 Sept  
 Automatic testing—mechanized pro-duction of electronic equipment .....159 Sept  
 Automatic tuning of aircraft antenna .....152 Aug  
**Automation, see automatic control**  
 Automobile, headlight dimmer for .....170 Mar  
 Automobile, power supply for 6 and 12 volts .....216D May  
 Automobile, radar speed meter .....132 Dec  
 Automobile reflection in vhf-tv, Geist .....166D Jul  
 Autopilot magnetic servo amplifier, Zucchini .....208D May

**B**

Balloons gather lightning information .....218D Oct  
 Band-pass filters using strip-line tech-niques, Bradley and White .....152 May  
 Baseline determined by geodimeter .....194D Jul  
 Basic chassis for experimental work, Emslie .....166 Nov  
 Basic control circuits are packaged, Killvans .....122 Dec  
 Batching counter .....182D Jun  
 Battery, solar, efficiency doubled .....182D Jun  
 Battery, solar, powers telephone .....178D Nov  
 Beacon, radar, calibrator checks .....150 Apr  
 Beam deflection amplifier tube .....132 Aug  
 Bevatron, generating r-f energy for .....164 Feb  
 Beyond-horizon signals extend commu-nications, Day .....122 Oct  
 Bias source, reactance voltage .....218D Feb  
 Bias supply design for bolometers, Braun .....208D Oct  
 Binary-adder tube for high-speed com-puters, Maynard .....161 Sept  
 Binary counter, four decade frequency divider using .....154 Apr  
 Biology, electronic switch for .....135 Dec  
**Biophysics, see medical electronics**  
 Blackboard substitute .....248D Feb  
 Blimp, ice detector for .....112 Dec  
 Blind, radar, guides .....208D Jun  
 Blood, pressure recorder .....178D Jun  
 Boat antennas, design of .....140 Jun  
 Bolometer, bias supply design .....208D Oct  
 Booster amplifier for uhf-tv .....112 Jul  
 Bounce in relay contacts, measuring .....137 Aug  
 Bovine gyrations measured electronic-ally .....198D Jun  
 Brain surgery, ultrasonic substitute for lobotomy .....164D Jul  
 Breadboard, chassis for experimental work .....166 Nov  
 Bridged-T network, design of notch .....172 Sept  
 British color tv tests .....206D Sept  
 British tv tower .....188D Nov  
 Broadband horn antennas .....188D Aug  
**Broadcast, see also f-m television**  
 Broadcast, antenna for WOR-TV .....214D Apr  
 Broadcast, automatic programming .....135 Oct  
 Broadcast, Canadian time signals .....182D, 196D Jun  
 Broadcast, color-burst deviation meter .....149 May  
 Broadcast, color-video envelope-delay measurement .....144 Jun  
 Broadcast, f-m antenna inside a-m tower .....130 Aug  
 Broadcast, feedback clamp circuit for tv .....182D Jul  
 Broadcast, high quality receiver for tv re .....152 Dec  
 Broadcast, matrixing and encoding color .....140 Nov  
 Broadcast, multiplexing f-m .....146 Oct  
 Broadcast, pulsed tones control a-m and f-m .....132 Sept  
 Broadcast receiver, Japanese transistor .....174D Dec  
 Broadcast, tabulating radio-tv audi-ence .....126 Jan  
 Broadcast, transmission test set .....145 Dec  
 Broadcast, uhf re .....131 May  
 Broadcast, video patch panel .....210D Apr  
 Broadcast, WOR master control .....204D Sept  
 Broadcast receiver, transistorized port-able .....159 Mar  
 Broadcast transmitter, fifty kw .....168 Mar  
 Building potted amplifiers .....250D Sept  
 Burglar alarm, design of ultrasonic .....106 Aug  
 Business machine, computer as .....122 Jun  
 Business machine, photoelectric reader .....134 May

**C**

Cable plug wrench .....264D May  
**Calculator, see computer**  
 Calibrator checks radar beacons .....150 Apr  
 Calibrator, industrial microwave .....168 Jun  
 Camera alignment, one man tv .....214D Dec  
 Camera, underwater television .....174D Sept  
 Canadian observatory broadcasts talk-ing clock .....182D, 196D Jun  
 Cancer diagnosis, ultrasonic .....174 Mar  
 Cancer research, cytoanalyzer .....182D Apr  
 Cane, radar, for blind .....208D Jun  
**Capacitance, see also capacitor**  
 Capacitance transducer, single-tube .....182D Oct  
 Capacitive transducer has low imped-ance, Kalmus .....161 Jun  
 Capacitor, a-c bridge sorts ceramic .....106 Jul  
 Capacitor energy storage .....216D Oct  
**Capacitor Production Techniques**  
 Adhesive tape capacitors .....238D Feb  
 Automatic sorting .....230D Sept  
 Installing electrolytics .....240D Sept  
 Limit bridge tests ten-at-a-time .....24D Jun  
 Placing plastic tubing on metal-cased capacitors .....280D Apr  
 Card-controlled machines are thrice as productive .....178D Oct  
 Cathode compensation linearizes video stages, Millman & Taub .....156 Nov  
 Cathode-follower detector .....168D Aug  
 Cathode-follower, improving frequency response .....190D Aug  
 Cathode-ray display of seismic record-ings, Groenendyke and Loper .....160 May  
 Cathode-ray tube changes signal to letters .....182D May  
 Cathode-ray tube deflection circuit .....146 Jul  
 Cathode-ray tube, flat .....214D Mar  
 Cathode-ray tube, flat .....186D Nov  
 Cavity, tunable X-band .....136 Jun  
 Ceramic capacitors sorted by a-c bridge .....106 Jul  
 Ceramic relay, electrostrictive .....226D Mar  
 Cesium frequency standard controls accurate atomic clock .....180D Apr  
 Characteristic, dynamic, triode-con-nected pentode .....208D Dec  
 Chart, dielectric mixture .....176 Apr  
 Chart, linear reactor design .....208 Mar  
 Chassis, basic for experimental work .....166 Nov  
 Chassis design for i-f amplifiers, Linden .....182D Aug  
 Chemical analysis, tape-controlled .....136 Feb  
 Chopper, electronic .....192D Nov  
 Chopper, transistor, for d-c amplifier .....135 Apr  
 Choppers, design trends in .....150 Feb  
 Circuit design factors for audio ampli-fiers, Kiebert .....166 Apr  
 Circuit standards, preferred .....182D Nov  
 Circuit, transistor switching .....168 Jan  
 Clamp circuit, feedback, for tv .....182D Jul  
 Closed-circuit television adds eyes in sawmill .....214D Mar  
 Coaxial coupler for uhf multiplexer .....152 Nov  
 Coaxial filter, band-pass using a strip line .....152 May  
**Coil Production Techniques**  
 Applying varnish to coil with pres-urized hypo .....228D Nov  
 Die-casting dies cost .....222D Jun  
 One-way pallet-return conveyor .....224D Dec  
 Toothpick screwdrivers for fragile cores .....222D Dec  
 Winding coils on lathe .....274D Feb  
 Color-burst, meter for deviation of .....149 May  
 Color computer .....166 Oct  
 Colorimeter for color television tube .....138 Dec  
**Color television, see also television**  
 Color television, colorimeter for .....138 Dec  
 Color television, computer for color curves .....166 Oct  
 Color television, differential gain test .....114 Aug  
 Color television, flying spot pickup .....176D Jul  
 Color television, matrixing and en-coding .....140 Nov  
 Color television, phase measurement .....142 Feb  
 Color television, studio amplifier for .....154 Mar  
 Color transparencies aid assembly .....234D Jul  
 Color tv, British .....206D Sept  
 Color tv pallet design .....318D Mar  
 Color-video envelope-delay measure-ment, Kennedy & French .....144 Jun  
 Colpitts oscillator, producing oscilla-tions with .....184D May  
 Communications, designing links .....126 Dec  
 Communication, electronics markets .....138 Apr  
 Communication, mobile radio squeal circuit .....143 Jul  
 Communication, power amplifier for ssb .....124 Aug  
 Communications, aircraft recommenda-tions .....202D Sept  
 Communications, beyond horizon sig-nals extend .....122 Oct  
 Communications, design of boat an-tennas .....140 Jun  
 Communications, designing compo-nents for 2,000 mc .....186D May  
 Communications, improving mobile radio .....156 Jun  
 Communications, parts speeded by radio .....176D Nov  
 Communications, series-tube modulator .....158 Nov  
 Communications, single-tone calling for mobile .....144 May

Comparator for small phase angles Niisen & Tufte .....188D Jan  
 Compensated squeal for mobile radio receivers, Hargreaves .....143 Jul  
 Compensation, cathode, for video stages .....156 Nov  
 Complex impedance recorder .....167 Sept  
 Component design trends—Metallic rectifiers approach infinite life .....162 Mar  
 Component design trends—New relay materials improve performance .....144 Jan  
 Component design trends—special-pur-pose relays gain new uses .....150 Feb  
 Component preparation—mechanized production of electronic equipment .....141 Sept  
 Components, design for uhf .....186D May  
 Components, testing airborne .....181 Mar  
 Computer, analog, color .....166 Oct  
 Computer, analog, transistor amplifiers for .....119 Jul  
 Computer, binary adder tube for .....161 Sept  
 Computer-controlled stabilizing fin .....212D Nov  
 Computer, d-c transistor circuits .....132 Jun  
 Computer, data reduction for missiles .....126 May  
 Computer, ferrite-core memory .....194 Mar  
 Computer, flying-spot function gene-rator .....149 Jun  
 Computer, for ram jet engine tests .....180D Jun  
 Computer, modulator for flight trainer .....126 Sept  
 Computer, photoelectric reader .....134 May  
 Computer, square-law circuit .....192D Sept  
 Computer storage systems .....122 Jun  
 Computer, synchronizing drum storage speed .....140 Aug  
 Computer tracks mortar shells .....180D Feb  
 Computer, wide-band analog function multiplier .....160 Feb  
 Computers for business .....122 Jun  
 Computers, see Capacitor  
 Constant-current power supply, regu-lator for .....170D Aug  
 Contact bounce in relays, measuring .....137 Aug  
 Continuous weather map recorder .....196D Jul  
**Control, see also automatic control**  
 Control circuits, packaging .....122 Dec  
 Control, launching, for guided missiles .....122 Feb  
 Control, machine tool .....178D Oct  
 Control of magnetic drum speed by tones .....140 Aug  
 Control of a-m and f-m stations by tones .....132 Sept  
 Control system for motors .....126 Aug  
 Controlling extrusion of foam plastic on wire, Cambrill .....144 Apr  
**Conveyor Belt Production Techniques**  
 Air cylinder pushes pallets .....238D Feb  
 Cart simplifies handling of power transformers .....246D Jan  
 Installing mounting clips for i-f transformers .....262D Sept  
 Midge: train delivers cabinets to tv assembly line .....224D Nov  
 Oil damper controls wire tension .....268D Apr  
 Pallet turnaround .....268D Apr  
 Paper templates speed start of wiring line .....276D Feb  
 Quick-release clamps pull chassis dollies .....230D Nov  
 Shadowless lighting for tv assembly .....234D Oct  
 Silicon-steel slitter cuts transformer costs .....232D Jul  
 Three-operator assembly-turntable .....222D Nov  
 Tote rack for i-f strips loads from both sides .....226D Nov  
 TV assembly line uses red trouble lamps .....260D Apr  
 Cork tape cutter .....244D Sept  
 Counter, extended range flip-flop .....149 Jan  
 Counter, short-interval timer .....168 May  
 Counter, silicon transistor decade .....112 Aug  
 Counter tube batching .....157 Feb  
 Countermeasure, target discriminator .....118 Aug  
 Counting circuit batches components, Tooke .....157 Feb  
 Counting labels with ferresonant rings, Swarthe & Isborn .....128 Oct  
 Coupler, selective, for uhf multiplexer .....152 Nov  
 Criss-cross d-c amplifier, Morrison .....198D Aug  
 Crystal, changing properties of lead sulfide .....178D Oct  
 Crystal filter, staggered .....166 Dec  
 Crystal, spectrum analyzer for quartz .....160 Oct  
 Current regulator for van de Graaff magnet, Rogers .....151 Oct  
 Curve plotter, voltage-current .....156 Dec  
 Cytoanalyzer compares cancer cells .....182D Apr

**D**

Damping, automatic for tv monitor .....230D Mar  
 Dark-trace tube has infrared erasure .....170 Feb  
 Data processor prepares computer in-put on ram jets .....180D Jun  
 Data reduction system for missile tele-meters, McCormick .....126 May  
 Dawn chorus, ionospheric disturbances .....198D May

D-C amplifier, criss-cross ..... 198D Aug  
 Decade counter employs silicon transistors, Krenitsky ..... 112 Aug  
 Decade counter for labels ..... 128 Oct  
 Defense-emergency radio van ..... 214D Oct  
 Deflection circuit, transistor c-r tube ..... 146 Jul  
 Delay generator, digital ..... 148 Dec  
 Delay-line design (reference sheet), Sodaro ..... 176 Jun  
 Delay line subcarrier discriminator, Morgan & Blake ..... 203 Mar  
 Demodulator, dynamic diode limiter for f-m ..... 146 Aug  
 DEW line radar network in the north spots planes ..... 184D May  
 D-layer, plotting static direction ..... 178D Feb  
 DME, airborne interrogator for ..... 170 May  
 Deposited magnetic materials ..... 210D Jun  
 Design, cathode compensation for video stages ..... 156 Nov  
 Design chart for linear reactor ..... 208 Mar  
 Design chart, noise factor nomograph ..... 174 Nov  
 Design chart, power rating of parasitic suppressors ..... 170 Oct  
 Design chart, r-f filter ..... 176 Feb  
 Design, chassis for experimental work ..... 166 Nov  
 Design of audio amplifiers ..... 166 Apr  
 Design of bias supply for bolometer ..... 208D Oct  
 Design of chassis for i-f amplifier ..... 182D Aug  
 Design of delay lines ..... 176 Jun  
 Design of i-f transistor transformers ..... 156 Aug  
 Design of microwave gain-standard horns, Slayton ..... 150 Jul  
 Design of notch networks ..... 172 Sept  
 Design of overstaggered doublet amplifiers ..... 158 Jul  
 Design of transistorized high-gain portable, Sheehan and Ivers ..... 159 Mar  
 Design trends in metallic rectifiers ..... 162 Mar  
 Designing over-horizon communications links, Davidson & Pote ..... 126 Dec  
 Designing stable triode microwave oscillators, Stephenson ..... 184 Mar  
 Designing 2,000-mc components for communications, Colby ..... 186D May  
 Designing ultrasonic alarm systems, Bagno ..... 106 Aug  
 Detector-amplifier, infinite impedance ..... 182D Aug  
 Detector, fire, ionization chamber ..... 200D Jun  
 Detector, ice, for aircraft ..... 142 Dec  
 Detector, limit ..... 202D Oct  
 Detector, null, differential amplifier for ..... 148 Aug  
 Detector, photoelectric rot, for eggs ..... 140 Jul  
 Detector, square-law for rms voltages ..... 170 Nov  
 Detector, ultrasonic burglar and fire ..... 106 Aug  
 Developments in radioastronomy produce navigation aid ..... 182D Jan  
 Diana antenna tracks planets ..... 166D Aug  
 Dielectric heating generator, dummy load for ..... 162D Jul  
 Dielectric lens for microwaves, Keleher & Goatley ..... 142 Aug  
 Dielectric mixture chart (reference sheet), Sion ..... 176 Apr  
 Dielectric transformers for X-band waveguide, Olin ..... 146 Dec  
 Differential amplifier for null detection, Barnette & Giacetto ..... 148 Aug  
 Differential gain tests tv color, Schroeder ..... 114 Aug  
**Digital computer, see computer**  
 Digital delay generator ..... 148 Dec  
 Digital voltage divider using four resistors, Kamm ..... 176D Dec  
 Diode, double-based ..... 198 Mar  
 Diode limiter, dynamic, for f-m demodulator ..... 146 Aug  
 Diode, silicon, using Zener effect in ..... 182D Dec  
 Diode, used in time-delay generator ..... 194D Nov  
 Dip soldering—mechanized production of electronic equipment ..... 157 Sept  
 Direct-reading noise-figure indicator, Chase ..... 161 Nov  
 Direction finder for small airports ..... 184D Jun  
 Direction finder, vhf ..... 168D Jul  
 Direction finding, vhf, resonant-loop antenna for ..... 172 Feb  
**Directional antenna, see antenna**  
 Directly coupled transistor circuits, Beter, Bradley, Brown & Rubinoff ..... 132 Jun  
 Discriminator, delay line subcarrier ..... 203 Mar  
 Discriminator, music-speech ..... 162D Aug  
 Discriminator, target, for countermeasures ..... 118 Aug  
 Distance measurement, airborne interrogator ..... 170 May  
 Distribution amplifier for color television ..... 154 Mar  
 Diversity reception, ultrasonic switch for ..... 169 Nov  
 Divider, digital voltage ..... 176D Dec  
 Divider, frequency, four-decade ..... 154 Apr  
 Dominion time signals ..... 182D, 196D Jun  
 Door opener, radio ..... 212D Dec  
 Double base expands diode applications, Suran ..... 198 Mar  
 Dual diversity reception, ultrasonic switch for ..... 169 Nov  
 Dummy load, paralleled beacon lamps ..... 162D Jul  
 Dynamic characteristics of triode-connected pentodes, Dessler & Robinson ..... 208D Dec  
 Dynamic-diode limiter for f-m demodulators, Mural ..... 146 Aug  
 Dynamic receiver selectivity, McLaughlin ..... 128 Feb  
 Dynamic spectrum analyzer to study sun ..... 176D Oct

**E**

Eddy current plating thickness gage ..... 146 Nov  
 Egg inspection, photoelectric ..... 140 Jul  
 Electric punch speeds insertion of plug-nuts ..... 234D Jun  
**Electrocardiograph, see medical electronics**  
 Electrodynamic scales ..... 152 Jun  
 Electroluminescence, light amplifier using ..... 178D Feb  
 Electromagnet removes nonferrous metals, Lovell ..... 164 Sept  
 Electromechanical networks for a-c servo systems, Savant & Savant ..... 190D Feb  
 Electron microscope exposure timer ..... 206 Mar  
 Electron paths, tracing ..... 174 Jun  
**Electron Tube, see Tube**  
 Electronic chopper for d-c amplifiers ..... 192D Nov  
 Electronic computers for the business-man, Carroll ..... 122 Jun  
 Electronic equipment, mechanized production of ..... 137 Sept  
 Electronic filter for high-voltage power supply ..... 154 Aug  
 Electronic load ..... 216D Nov  
 Electronic organ uses rotating loudspeakers, Markowitz ..... 116 Jul  
 Electronic switch eliminates transients, Ludwig & Hind ..... 163 Oct  
 Electronic switch for biological observations, Woods ..... 135 Dec  
 Electronic switch, music-speech discriminator ..... 162D Aug  
 Electronic weighing on the production line, Bell & Perstle ..... 152 Jun  
 Electronics markets for equipment ..... 138 Apr  
 Electronics, survey of 25 years ..... 124 Apr  
 Electrostrictive ceramic relay ..... 226D Mar  
 Embedding technique for three-tube plug-in unit, Fox ..... 250D May  
 Empire State antenna for WOR-TV, Adams, Alford, Leach, Rubin & Abel ..... 214D Apr  
 Encapsulation, dielectric mixture chart ..... 176 Apr  
 Encoding and matrixing color television ..... 140 Nov  
 Engine temperature indicator ..... 129 Nov  
 Engine, x-ray television shows inside ..... 182D Apr  
 Envelope-delay measurement, color-video ..... 144 Jun  
 Equipment data sheets ..... 228D Mar  
 Equipment, markets for electronic ..... 138 Apr  
 Equipment reliability ..... 180D Jul  
 Erasing, infrared, for dark-trace tubes ..... 170 Feb  
 Etched antenna for supersonic aircraft ..... 130 Jul  
 Etched wiring band-pass filter ..... 152 May  
 Etched wiring—mechanized production of electronic equipment ..... 138 Sept  
 Evaporated magnetic materials, Blois ..... 210D Dec  
 Expanded-scale voltmeter for a-c measurements, Galman ..... 164 Dec  
 Experimental light amplifier employs electroluminescence ..... 178D Feb  
 Exposure timer for the electron microscope, Bishop ..... 206 Mar  
 Extending uhf-tv with booster amplifiers, Epstein, Morrison & Woodward ..... 112 Jul  
 Extrusion of plastic insulation, control ..... 144 Apr  
 Eye, electromagnet removes nonferrous metal from ..... 164 Sept

**F**

Facsimile speeds plant messages ..... 222D Jun  
 Facsimile speedup enhances usefulness, Hogan ..... 134 Jul  
 Fan-pencil antenna for search radars, Trinter ..... 142 May  
 Farm machinery parts speeded by radio ..... 176D Nov  
 Faster radiosonde ..... 208D Dec  
 Feedback clamp circuit for tv, Wendt & Squires ..... 182D Jul  
 Feedback-stabilized transistor amplifier, Slaughter ..... 174 May  
 Ferrite core memory used in juke box ..... 133 Oct  
 Ferrite-core memory uses pulse transformers ..... 194 Mar  
 Ferrite microwave modulator ..... 139 May  
 Ferroresonant rings used in label counter ..... 128 Oct  
 Ferrule wrench aids mounting of panel lamps, Ives ..... 213D Jul

**Field strength, see propagation**

Filter, band-pass, using strip-line ..... 152 May  
 Filter design, r-f ..... 176 Feb  
 Filter, electronic, for high-voltage power supply ..... 154 Aug  
 Filter, staggered triple crystal ..... 166 Dec  
 Flinsert touch actuates circuit ..... 200D Oct  
 Fire call box ..... 198D Oct  
 Fire detection, ionization chamber ..... 200D Jun  
 Fire detector, ultrasonic alarm system ..... 106 Aug  
 Fire watching by remote tv ..... 178D Oct  
 Fixed L-C oscillator without taps, Fleming ..... 216D Mar  
 Flat cathode-ray tube simplifies cockpit instrumentation ..... 214D Mar  
 Flat cathode-ray tubes ..... 186D Nov  
 Flight trainer, transistor modulator for ..... 126 Sept  
 Flip-flop counter has extended range, Beckwith ..... 149 Jan  
 Fluorescent lighting, magnetic frequency multiplier for ..... 224D May  
 Flush-panel doors serve as tops for engineering desks ..... 266D Mar  
 Flying-spot function generator ..... 149 Jun  
 F-M antenna inside the a-m tower, Scheldorf & Klink ..... 130 Aug  
 F-M demodulator, dynamic diode limiter for ..... 146 Aug  
 F-M discriminator, delay line subcarrier ..... 203 Mar  
 F-M, multiplexing transmitters ..... 146 Oct  
 F-M, phase measurement ..... 142 Feb  
 F-M signal generator, transistorized ..... 133 Feb  
 Fog alarm, microwave controlled ..... 180D Jun  
 Formica bench-tops reduce rejects ..... 240D May  
 Forward scatter, designing communication links ..... 126 Dec  
 Forward scatter, extend uhf communications ..... 122 Oct  
 Four-decade frequency divider, Jensen & McGeogh ..... 154 Apr  
 Frequency divider, four-decade ..... 154 Apr  
**Frequency Modulation, see broadcast, communication, f-m, etc**  
 Frequency multiplier, magnetic, for fluorescent lighting ..... 224D May  
 Frequency response, improving cathode-follower ..... 190D Aug  
 Frequency selective coupler for uhf multiplexer ..... 152 Nov  
 Frequency standard, cesium, for atomic clock ..... 180D Apr  
 Frequency standard, microwave ..... 168 Jun  
 Frequency synthesizer for Navy transmitter ..... 138 Jan  
 Frequency tripler in magnetic amplifier ..... 122 Sept  
 Function generator, flying-spot ..... 149 Jun

**G**

Gage, pressure, for ship models ..... 196D Jan  
 Gage, pulsed eddy current plating thickness ..... 146 Nov  
 Gain-standard horns for microwave ..... 150 Jul  
 Garage door opener, radio ..... 212D Dec  
**Gas discharge tube, see tubes**  
 GCA, portable ..... 154 Oct  
 Generating r-f energy for 6-bev bevatron, Winnigstad ..... 164 Feb  
 Generator, signal, see also oscillator  
 Generator, audio standard ..... 161 Dec  
 Generator, millimeter wave produces light ..... 180D Feb  
 Generator, nonlinear time delay ..... 194D Nov  
 Generator, precision digital delay ..... 148 Dec  
 Generator, pulse-series ..... 224D Mar  
 Generator, pulse, transistor ..... 132 Nov  
 Generator, repetition rate ..... 148 Nov  
 Generator, transistor waveform ..... 138 Jul  
 Generator, transistorized f-m signal ..... 133 Feb  
 Generator, waveform, using pulse technique ..... 149 Jun  
 Generator, waveshape, high voltage ..... 222D Apr  
 Geodimeter determines precise baselines ..... 194D Jul  
 Geological survey, cro display for seismic recordings ..... 160 May  
 Geophysical exploration speeded by improved magnetometer ..... 162D Aug  
 Geophysics, tape recorder for ..... 152 Jan  
**Germanium, see transistors**  
 Getting the most from mobile radio, McKenzie ..... 156 Jun  
 Goniometer for D-layer study ..... 178D Feb  
 Green-rot detector, photoelectric ..... 140 Jul  
 Grid-control tube, uhf-tv ..... 130 Apr



Ground controlled approach radar...154 Oct  
 Guardian picket ship...164D Jul  
 Guided missile, antenna for tele-  
 metering...164 Jun  
 Guided missile, data reduction sys-  
 tem for...126 May  
 Guided missile launching control...122 Feb  
 Guided missile, simulator tests radar  
 127 Jul  
 Gyrator, ferrite microwave modulator  
 139 May

Interior Dept. uses underwater tv...218D Oct  
 Interrogator, airborne...170 May  
 Interval timer, short...168 May  
 Ion-gage supply protects tubes, Raible  
 and Testerman...210D Feb  
**Ionosphere, see also propagation**  
 Ionosphere research, airglow aids...212D Mar  
 Ionospheric disturbances...198D May  
 Ionospheric research, theory of thun-  
 derstorm electricity...134D Apr  
 Ionization chamber detects fires  
 quickly...200D Jun  
 Irradiation, insect control by electron  
 202D May

Limiters, dynamic, for f-m demodulator  
 146 Aug  
 Linear accelerator, r-f power supply  
 164 Feb  
 Linear accelerator, spectrometer requi-  
 sitor for r-f...137 Nov  
 Linear power amplifier for ssb trans-  
 mitters, Bruene...124 Aug  
 Linear reactor chart (reference sheet),  
 Lee...203 Mar  
 Linearity and phase nomograph...178 Apr  
 Linearity, measurement, sawtooth  
 204D Nov  
 Linearity, video, by cathode compen-  
 sation...156 Nov  
 Loading, potentiometer design for,  
 minimal...184D Feb  
 Lobotomy, ultrasonics as a substitute  
 for...164D Jul  
 Local oscillator for c-w radars, Gold-  
 berg...166 May  
 Logarithmic amplifier, target dis-  
 criminator...118 Aug  
 Long-distance waveguide may rival  
 coaxial cables...212D Mar  
 Long-wave transmitter, Navy...138 Jan  
 Loop antenna for vhf direction find-  
 ing...172 Feb  
 Loudspeakers, electronic organs using  
 rotating...116 Jul  
 Low-distortion audio oscillator...158 May  
 Low-frequency oscillator...144 Oct  
 Low-frequency sound reducer...188D Jun  
 Low-impedance capacitive transducer  
 161 Jun  
 Low-noise input stage for audio pre-  
 amplifier, Noble & Hilliard...147 Feb  
 Low-ripple adjustable regulated power  
 supply, Hetland & Buss...164 Nov

**H**

Head, alloys improve magnetic record-  
 ing...137 Jun  
 Headlight dimmer for automobiles...170 Mar  
 Helicopter measures antenna pattern  
 Brueckmann...134 Nov  
 Heliography, spectrum analyzer for sun  
 176D Oct  
**High fidelity, see also audio**  
 High fidelity transistor power amplifier  
 Riddle...174D Sept  
 High-power uhf-tv uses grid-control  
 tube, Koros...130 Apr  
 High-quality receiver for tv rebroad-  
 casting, Rosenbert...152 Dec  
 High-speed photography, shutter for  
 171 Jun  
 High-voltage supply uses electronic  
 filter, Wouk...154 Aug  
 High-voltage waveshape generator,  
 Reed...222D Apr  
 Higher velocity of propagation...180D Sept  
 Highly regulated r-f voltage supply,  
 Sloan, Raible & Testerman...192D Apr  
 Horn antenna, broadband...188D Aug  
 Horn, microwave gain-standard...150 Jul  
 House analog...206D Aug  
 How accurate are radar speed meters?  
 Brantley...132 Dec  
 How to design i-f transistor trans-  
 formers (reference sheet), Webster  
 156 Aug  
 How to design overstaggered doublets  
 (reference sheet), Webb...158 Jul  
 How to design sailboat antennas,  
 Roberson...140 Jun  
 Hysteresis, testing in relays...202D Dec

**J**

Japanese transistor broadcast receiver  
 174 Dec  
**Jig Techniques**  
 Chassis centering guides...236D Jan  
 Chassis-holding fixture...251D Jan  
 Chassis-holding fixture...264D Jun  
 Handball in clamp holds subas-  
 semblies...222D Jan  
 Jack-wiring jig...290D Apr  
 Magnetic holding tool makes parts  
 serve as drilling gage...222D Nov  
 Metal jig aids assembly of coaxial  
 tuning units...238D Jul  
 Prop on pallet supports chassis at  
 angle...288D Apr  
 Wood jigs speed mounting of large  
 parts...252D Apr  
 Terminal plug holder...236D Nov  
 Juke box uses ferrite-core memory,  
 Schultz & Boesen...138 Oct  
**Junction transistor, see also transistor**  
 Junction transistor switching circuits,  
 Prugh...168 Jan

**K**

Kerr-cell shutter has submicrosecond  
 speeds, Nicholson and Ross...171 Jun  
**Klystron, see also tube**  
 Klystron, modulated...186D Jan  
 Klystron, tunable X-band...135 Jan

**L**

Ice detector for lighter-than-air craft,  
 Thurston...142 Dec  
 I-F amplifier, chassis design for...182D Aug  
 I-F transformer, design for transistor  
 156 Aug  
 Impedance recorder, complex...167 Sept  
 Improving audio quality of mobile  
 radio, Buesing...190D Oct  
 Improving cathode-follower frequency  
 response, Woods...190D Aug  
 Impulse magnetizer for permanent  
 magnets, Moore...121 Aug  
 Indicator, noise figure...161 Nov  
 Indicator, temperature, for engine...129 Nov  
 Induction heating for high purity  
 silicon...182D Feb  
 Induction soldering of coaxial tuned  
 stubs...278D May  
 Industrial control, phase shifter for  
 188 Mar  
 Industrial electronics markets...138 Apr  
 Industrial microwave calibrator, Vog-  
 ler and Steinhelfer...168 Jun  
 Industrial oscillators, reducing shock  
 hazard...180D Jan  
 Infinite impedance detector-amplifier,  
 Armstrong...168D Aug  
 Infrared spectrophotometer, tape-con-  
 trolled...136 Feb  
 Infrared speeds erasure of dark-trace  
 tubes, Holborn & Hodowanec...170 Feb  
 Input, low noise, for preamplifier...147 Feb  
 Insect control by electron irradiation,  
 Baker, Taboada & Wiant...202D May  
**Instrument, see measuring equipment**  
 Instrument, noise figure indicator...161 Nov  
 Insulation, automatic control of ex-  
 trusion...144 Apr  
 Intense sound bad for tubes...196D Feb  
 Intercity consultation uses color tele-  
 vision...216D Mar

**Labeling Techniques**  
 Numbered clips simplify replace-  
 ment of parts...228D Aug  
 Overhead conveyor for tv uses  
 color-coded carriers...212D Aug  
 Press-driven turntable aids printing  
 of selenium rectifiers...232D Jul  
 Punching chassis stencils on Ad-  
 dressograph...242D Feb  
 Red flag on clip serves as parts-  
 needed signal...248D Feb  
 Shop-made rubber stamps identify  
 chassis parts...254D Apr  
 Tape printer aids identification of  
 antenna parts...236D Apr  
 Yellow alligator clips identify ter-  
 minals...292D Apr  
 Launching control for guided missiles,  
 Schrock...122 Feb  
 Lens for microwave, dielectric...142 Aug  
 Letters printed by c-r tube...182D May  
 Light amplifier uses electrolumines-  
 cence...178D Feb  
 Light beam controls tv receiver...204D Dec  
 Light control for automobiles...170 Mar  
 Light hydraulic presses cut phono  
 pickup costs, Holmes...250D Jan  
 Light produced by millimeter wave  
 generator...180D Feb  
 Light traffic, controlled by radio...194 Jun  
 Lighting, magnetic frequency multi-  
 plier for fluorescent...224D May  
 Limit detector, sensitive...202D Oct  
 **Limiter, see also f-m**

Machine assembly—mechanized pro-  
 duction of electronic equipment...147 Sept  
 Magnet, impulse magnetizer for per-  
 manent...121 Aug  
**Magnetron Production Techniques**  
 Controlling dust in microwave tube  
 assembly plant, Leng...238D Apr  
 Magnetic amplifier, audio...122 Sept  
 Magnetic amplifier, autopilot servo  
 208D May  
 Magnetic drum, synchronizing...140 Aug  
 Magnetic frequency multiplier for  
 fluorescent lighting, Downie...224D May  
 Magnetic materials, evaporated...210D Jun  
 Magnetic recording, alloys improve...137 Jun  
**Magnetic tape, see also record, tape**  
 recording  
 Magnetic tape controlled chemical  
 analysis...136 Feb  
 Magnetic tape improves geophysical  
 recordings, Begun...152 Jan  
 Magnetizer, impulse for permanent  
 magnets...121 Aug  
 Magnetometer for geophysical explora-  
 tion...162D Aug  
**Magnetron, see tube**  
 Marine communications, design of boat  
 antennas...140 Jun  
 Market for electronic equipment...138 Apr  
 Milek for control WOR...204D Sept  
 Master control, evaporated magnetic...210D Jun  
 Materials for relays...144 Jan  
 Matrix, ferrite-core memory...194 Mar  
 Matrix, ferrite core memory used in  
 juke box...138 Oct  
 Matrixing and encoding color for tele-  
 casting, Taub, Rabinowitz, Schacher  
 & Star...140 Nov  
 Measurement, micrometer sorter...156 May  
 Measurement, phase meter for water  
 velocity...128 Sept  
 Measurement, sawtooth linearity...204D Nov  
 Measuring equipment, antenna for vhf  
 direction finding...172 Feb  
 Measuring equipment, audio standard  
 generator...161 Dec  
 Measuring equipment, color-burst devi-  
 ation meter...149 May  
 Measuring equipment, color-video  
 envelope delay...144 Jun  
 Measuring equipment, differential  
 amplifier for null detector...148 Aug  
 Measuring equipment, differential gain  
 test for color tv...114 Aug  
 Measuring equipment, expanded-scale  
 voltmeter...164 Dec  
 Measuring equipment, goniometer for  
 D-layer study...178D Feb  
 Measuring equipment, phase angle  
 comparator...188D Jan  
 Measuring equipment, phase meter for  
 color tv...156 Jan  
 Measuring equipment, phase meter for  
 color tv and f-m...142 Feb

**M**

Machine assembly—mechanized pro-  
 duction of electronic equipment...147 Sept  
 Magnet, impulse magnetizer for per-  
 manent...121 Aug  
**Magnetron Production Techniques**  
 Controlling dust in microwave tube  
 assembly plant, Leng...238D Apr  
 Magnetic amplifier, audio...122 Sept  
 Magnetic amplifier, autopilot servo  
 208D May  
 Magnetic drum, synchronizing...140 Aug  
 Magnetic frequency multiplier for  
 fluorescent lighting, Downie...224D May  
 Magnetic materials, evaporated...210D Jun  
 Magnetic recording, alloys improve...137 Jun  
**Magnetic tape, see also record, tape**  
 recording  
 Magnetic tape controlled chemical  
 analysis...136 Feb  
 Magnetic tape improves geophysical  
 recordings, Begun...152 Jan  
 Magnetizer, impulse for permanent  
 magnets...121 Aug  
 Magnetometer for geophysical explora-  
 tion...162D Aug  
**Magnetron, see tube**  
 Marine communications, design of boat  
 antennas...140 Jun  
 Market for electronic equipment...138 Apr  
 Milek for control WOR...204D Sept  
 Master control, evaporated magnetic...210D Jun  
 Materials for relays...144 Jan  
 Matrix, ferrite-core memory...194 Mar  
 Matrix, ferrite core memory used in  
 juke box...138 Oct  
 Matrixing and encoding color for tele-  
 casting, Taub, Rabinowitz, Schacher  
 & Star...140 Nov  
 Measurement, micrometer sorter...156 May  
 Measurement, phase meter for water  
 velocity...128 Sept  
 Measurement, sawtooth linearity...204D Nov  
 Measuring equipment, antenna for vhf  
 direction finding...172 Feb  
 Measuring equipment, audio standard  
 generator...161 Dec  
 Measuring equipment, color-burst devi-  
 ation meter...149 May  
 Measuring equipment, color-video  
 envelope delay...144 Jun  
 Measuring equipment, differential  
 amplifier for null detector...148 Aug  
 Measuring equipment, differential gain  
 test for color tv...114 Aug  
 Measuring equipment, expanded-scale  
 voltmeter...164 Dec  
 Measuring equipment, goniometer for  
 D-layer study...178D Feb  
 Measuring equipment, phase angle  
 comparator...188D Jan  
 Measuring equipment, phase meter for  
 color tv...156 Jan  
 Measuring equipment, phase meter for  
 color tv and f-m...142 Feb

Measuring equipment, photometer for reflecting road signs... 204D Feb  
 Measuring equipment, relay contact bounce... 137 Aug  
 Measuring equipment, sawtooth pulser gives voltage current curves... 156 Dec  
 Measuring equipment, servo analyzer... 172 Apr  
 Measuring equipment, spectrum analyzer for mobile radio... 180D Feb  
 Measuring equipment, transistorized f-m signal generator... 133 Feb  
 Measuring equipment, transmission test set... 145 Dec  
 Mechanized production of electronic equipment, Markus... 137 Sept  
 Mechanized production, punch-card control... 122 Nov  
 Medical electronics, blood pressure recorder... 178D Jun  
 Medical electronics, cytoanalyzer for cancer cells... 182D Apr  
 Medical electronics, electromagnet moves nonferrous metals from eye... 164 Sept  
 Medical electronics, electronic switch for... 163 Oct  
 Medical electronics, electronic switch for biological observation... 135 Dec  
 Medical electronics, exposure timer for electron microscope... 206 Mar  
 Medical electronics, physiological monitor for anesthesia... 130 Oct  
 Medical electronics, ultrasonic cancer diagnosis... 174 Mar  
 Medical electronics, ultrasonics as substitute for lobotomy... 164D Jul  
 Memory, ferrite-core... 194 Mar  
 Memory, ferrite-core used in juke box... 138 Oct  
 Memotron storage tube... 161 Jan  
 Metal, nonferrous, removed from eye... 164 Sept  
 Metallic rectifiers approach infinite life, Rockett... 162 Mar  
 Meteorology, radar aids... 182D Sept  
 Meteorology, rain gage sends radio report... 186D Sept  
 Meteorology, weather mapping radar... 178D Sept  
 Meter, phase, for color tv... 156 Jan  
 Meter shows color-burst deviation, Joffe... 149 May  
 Micrometer, automatic, sorts insulating wafers... 156 May  
 Microphone nomograph (reference sheet), Conover... 172 Oct  
 Microphonics in transistors... 206D Sept  
 Microscope, exposure timer for electron strip-line... 206 Mar  
 Microwave, band-pass filter using strip-line... 152 May  
 Microwave, broadband horn antenna... 188D Aug  
 Microwave calibrator, industrial... 168 Jun  
 Microwave, dielectric transformer for X-band... 146 Dec  
 Microwave, extended range transmission... 182D May  
 Microwave gain-standard horns... 150 Jul  
 Microwave lens, dielectric... 142 Aug  
 Microwave, long distance waveguide... 212D Mar  
 Microwave, millimeter wave generator produces light... 180D Feb  
 Microwave, modulated klystron... 186D Jan  
 Microwave modulator uses ferrite gyrator, Barry and Clarke... 139 May  
 Microwave, noise figure indicator... 161 Nov  
 Microwave, nomograph for rectangular waveguides... 172 Jan  
 Microwave oscillator, designing stable triode... 184 Mar  
 Microwave, reflection-type asymmetrical... 192D Dec  
 Microwave, rural telephone... 208D Jan  
 Microwave system controls fog alarm, Park... 122 Jul  
 Microwave, tunable X-band cavity... 135 Jan  
 Microwave, X-band amplifier... 202D Apr  
 Military electronics, antenna for aircraft carrier... 174D Dec  
 Military electronics, antenna for missile telemetering... 164 Jun  
 Military electronics, data reduction for missile telemetering... 126 May  
 Military electronics, equipment reliability... 180D Jul  
 Military electronics, fan-pencil radar antenna... 142 May  
 Military electronics, launching control for guided missiles... 122 Feb  
 Military electronics markets... 138 Apr  
 Military electronics, models reveal how to avoid Radar... 122 Jan  
 Military electronics, multicolor radar for navy... 254D Mar  
 Military electronics, navy transmitter uses frequency synthesizer... 138 Jan  
 Military electronics, pack set using helmet antenna... 150 Mar  
 Military electronics, radar and computer track mortar shells... 180D Feb  
 Military electronics, simulator tests missile radar... 127 Jul  
 Military electronics, sonar target simulator... 167 Mar  
 Military electronics, target discriminator for countermeasures... 118 Aug  
 Military electronics, telephone channels increased... 180D Apr  
 Military electronics, testing airborne components... 181 Mar  
 Millimeter wave generator produces visible light... 180D Feb  
 Mobile direction finder, antenna for... 172 Feb

Mobile power supply for 6 and 12 volts, Backman... 216D May  
 Mobile radio, compensated squelch for... 143 Jul  
 Mobile radio, improving... 156 Jun  
 Mobile radio, improving audio... 190D Oct  
 Mobile radio, single tone calling... 144 May  
 Mobile radio, spectrum analyzer measures... 180D Feb  
 Models for avoiding radar... 122 Jan  
 Modern fifty-kilowatt broadcast transmitter, Witty... 168 Mar  
 Modular simulator tests missile radar, Krakauer and Bibbero... 127 Jul  
 Modulated klystron... 186D Jan  
 Modulator, ferrite microwave... 139 May  
 Modulator, series-tube... 158 Nov  
 Modulator, transistor, for flight trainer... 126 Sept  
 Monitor for anesthesia... 130 Oct  
 Monitor, tv receiver used as... 131 May  
 Moon tracking antenna... 166D Aug  
 Mortar shells tracked by radar and computer... 180D Feb  
 Motor control, variable speed... 162 Apr  
 Motor speed control... 126 Aug  
 Multichannel oscillator, phase controlled... 164 Apr  
 Multiple waveform generator, transistor... 138 Jul  
 Multiplexer, uhf, uses selective couplers... 152 Nov  
 Multiplexing f-m broadcast transmitters, Bose... 146 Oct  
 Multiplier, wide-band analog... 160 Feb  
 Multivibrator, junction transistor... 168 Jan  
 Music, electronic organ with rotating loudspeaker... 116 Jul  
 Music, electronic synthesizer... 200D Aug  
 Music-speech discriminator... 162D Aug  
 Muting circuit for mobile radio... 143 Jul

Navigation, adf for small airport... 184D Jun  
 Navigation, airborne interrogator for DME... 170 May  
 Navigation, computer-controlled fin... 212D Nov  
 Navigation, microwave controlled fog alarm... 122 Jul  
 Navigation, TACAN system... 174D Oct  
 Navy transmitter uses frequency synthesizer, Romander & Watson... 138 Jan  
 Negative resistance diode, double based... 198 Mar  
 Network, design of notch... 172 Sept  
 Network, electromechanical for a-c systems... 190D Feb  
 New ferrite-core memory uses pulse transformers, Paplan... 194 Mar  
 New government patents... 190D Feb  
 New relay materials improve performance, Rockett... 144 Jan  
 New transmission techniques extend range sevenfold... 182D May  
 Night airglow aids ionosphere research... 212D Mar  
 Nipkow disk, use in headlight dimmer... 170 Mar  
 Noise factor nomograph (reference sheet), McCarrell... 174 Nov  
 Noise figure, indicator, direct reading... 161 Nov  
 Noise testing for electronic components... 181 Mar  
 Nomograph, microphone... 172 Oct  
 Nomograph, noise factor... 174 Nov  
 Nomograph, phase-linearity... 178 Apr  
 Nomographs for rectangular waveguides (reference sheet), Chen... 172 Jan  
 Nonferrous metal removed from eye... 164 Sept  
 Nonlinear time-delay generator uses diodes... 194D Nov  
 Notch network design (reference sheet), Savant & Savant... 172 Sept  
 Nuclear magnetic resonance magnetometer... 182D Aug  
 Nuclear research, current regulator for van de Graaff generator... 151 Oct  
 Nuclear research, r-f power supply for bevatron... 164 Feb  
 Nuclear research, spectrometer regulator stabilizes r-f... 137 Nov  
 Null detector, differential amplifier for... 148 Aug  
 Nut starters, Ives... 236D Jul

Observing whistlers... 198D May  
 Oil prospecting, cro display for seismic recordings... 160 May  
 One-hand vacuum lift moves tv tubes safely... 320D Mar  
 One-man tv camera aligner, Shepard... 214D Dec  
 Optical images superimposed on radar oscilloscope... 214D Mar  
 Optics of dielectric microwave lens... 142 Aug  
 Organ, electronic, using rotating loudspeakers... 116 Jul  
 Oscillator, audio, low-distortion... 158 May  
 Oscillator, blocking, transistor... 168 Jan  
 Oscillator, Colpitts, failure to oscillate... 184D May  
 Oscillator, L-C, without taps... 216D Mar  
 Oscillator, local, for c-w radar... 166 May  
 Oscillator, phase controlled multi-channel... 164 Apr  
 Oscillator, reducing shock hazard of industrial... 180D Jan  
 Oscillator, stable triode microwave... 134 Mar  
 Oscillator, subaudio... 144 Oct  
 Oscillator, subharmonic crystal... 206D Jan  
 Oscillator, transistor multiwaveform... 138 Jul  
 Oscillator, tunable cavity X-band... 135 Jan  
 Oscillator, two-terminal push-pull... 202D Aug  
 Oscillogram, trigger adapter for transistor... 159 Apr  
**Over-horizon propagation, see also forward scatter, propagation**  
 Over-horizon radio to link islands... 172D Dec  
 Overseas radiotelephone service links most of world's telephones... 164D Jul  
 Overstaggered doublet amplifier design... 158 Jul

**N**

**P**

Pack set using helmet antenna... 150 Mar  
 Packaging of control circuits... 122 Dec  
**Packaging Techniques**  
 Carton turnover machine... 266D Feb  
 Styrofoam serves as shipping block... 246D Jan  
**Pads, see attenuators**  
 Panel, video patch... 210D Apr  
 PAR, portable... 154 Oct  
 Paralleled beacon lamps serve as dummy load... 162D Jul  
 Parasitic suppressors, power rating... 170 Oct  
 Patch panel, video... 210D Apr  
 Patents, new government... 190D Feb  
 Path, tracing electron... 174 Jun  
 Pattern, helicopter measures antenna... 134 Nov  
 Pentode, triode-connected, dynamic characteristic... 208D Dec  
 Permalloy recording heads... 137 Jun  
 Permanent magnet, impulse magnetizer for... 121 Aug  
**Pertinent patents, see also patents**  
 Pertinent Patents, Chaffin... 210D Jan  
 222D Feb, 256D Mar, 266D Apr  
 198D Jul, 206D Sept  
 Phantastron repetition rate generator... 148 Nov  
 Phase-Controlled Multichannel Oscillator, Hahnel... 164 Apr  
 Phase-linearity nomograph (reference sheet), Sodaro... 178 Apr  
 Phase meter analyzes color tv systems, Houghton... 156 Jan  
 Phase meter, comparison... 188D Jan  
 Phase meter, complex impedance recorder... 167 Sept  
 Phase meter measures water velocity... 128 Sept  
 Phase measurement for color tv and f-m, Schlesinger... 142 Feb  
 Phase shift measurement in color-video... 144 Jun  
 Phase shift nomograph... 178 Apr  
 Phase shifter for industrial control... 188 Mar  
 Phonograph pick-up, capacitive transducer... 161 Jun  
 Photocell label counter... 128 Oct  
 Photoelectric control for television receiver... 204D Dec  
 Photoelectric inspector detects green rot in eggs, Norris... 140 Jul  
 Photoelectric reader feeds business machines, Shepard and Heasley... 134 May  
 Photoetched antennas for supersonic aircraft, Sommers... 130 Jul  
 Photograph transmission by facsimile speeded up... 134 Jul



Photography, submicrosecond shutter 171 Jun  
 Photometer for ionosphere research 212D Mar  
 Photometer tests reflecting road signs, Giovanelli 204D Feb  
 Photometer timer for electron microscope 206 Mar  
 Physiological monitor for anesthesia, Gilford & Broida 130 Oct  
 Picket ship 164D Jul  
**Picture Tube Techniques**  
 Mounting picture tube in color tv cabinet 246D Dec  
 Piercing with squeeze riveter 230D Aug  
 Plastic, dielectric mixture chart 176 Apr  
 Plastic insulation, controlling extrusion of 144 Apr  
 Plating thickness gage, eddy current 146 Nov  
 Plug-in rectifier replaces tube 193D Aug  
 Pogo parachute replaces drones as missile target 180D Jan  
 Portable analyzer measures mobiles 180D Feb  
 Portable precision approach radar, Levin 154 Oct  
 Potentiometer design for minimal loading, Coleman 184D Feb  
 Potting, dielectric mixture chart 176 Apr  
 Power amplifier, linear, for sbb 124 Aug  
 Power amplifier, transistor 174D Sept  
 Power rating of parasitic suppressors (reference sheet), Hule 170 Oct  
 Power rectifier, silicon for a-c line operation 146 Apr  
 Power supply, high-voltage, using electronic filter 154 Aug  
 Power supply, highly-regulated r-f 192D Apr  
 Power supply, ion-gage 210D Feb  
 Power supply, low ripple regulated 164 Nov  
 Power supply, mobile, for 6 and 12 volts 216D May  
 Power supply, regulator for constant-current 170D Aug  
 Power supply, r-f, spectrometer regulated 137 Nov  
 Power supply, using silicon power rectifiers 146 Apr  
 Power supply, vibrating ignitor tube for 248D Mar  
**Preamplifier, see also amplifier**  
 Preamplifier, low-noise input stage 147 Feb  
 Precise measurement of sawtooth linearity 204D Nov  
 Precision approach radar, portable 154 Oct  
 Precision digital delay generator, Perzley 148 Dec  
 Precision time-delay 218D Nov  
 Preferred circuits standardization 182D Nov  
 Preparing high-purity silicon by induction heating 182D Feb  
 Pressure gage for ship-model hulls, Christensen & Funder 196D Jan  
 Precision calibrator checks radar beacons, Sinish 150 Apr  
**Printed Circuit Techniques**  
 Controlling sludge in etched wiring bath 238D Nov  
 Dip-soldering clamp masks tube socket 242D Dec  
 Grounding wiring boards 256D Dec  
 Modular bundles use etched-wiring boards, Roman 230D Dec  
 Plug-in assemblies use standard component bodies 218D Dec  
 Production of curved etched-wiring boards 262D Dec  
 Quality control charts for printed wiring, Heywood 216D Jul  
 Router cuts curves in wiring boards 224D Dec  
 Specifications for printed-wiring production 262D May  
 Stencilled symbols and assembly on etched wiring boards 224D Oct  
 Substitutes for eyelets in etched wiring, Martin & Vavra 250D Dec  
 Test pattern checks printed-circuit panels 224D Jan  
 Tool spreads lugs of socket on etched wiring board 220D Sept  
 Printed film transparencies reduce drafting time 246D Sept  
 Printing, transducer tube changes signals to letters 182D May  
 Private flying, TACAN 174D Jul  
**Process control, see automatic control**  
 Process control, packaging circuits 122 Dec  
 Producing oscillations with a Colpitts circuit, McCusker 184D May  
 Production, automatic assembly with punch card control 122 Nov  
**Production control, see also automatic control**  
 Production control, capacitor sorting 106 Jul  
 Production control, electronic weighing 152 Jun  
 Production control, micrometer sorter 156 May  
 Production, mechanized, for electronic equipment 137 Sept  
**Production Techniques, see type: capacitor; coil; magnetron; printed circuit; etc.**  
 Production testing of audio amplifier, oscillator for 158 May  
 Programming, automatic 135 Oct  
 Propagation, airborne laboratory 164D Aug  
 Propagation, designing communication links 126 Dec  
 Propagation, forward scatter in uhf 122 Oct  
 Propagation, high velocity 180D Sept  
 Propagation in rectangular waveguides 172 Jan

Propagation pattern measured by helicopter 134 Nov  
 Propagation, plotting D-layer static direction 178D Feb  
 Properties of lead sulfide crystals changed 178D Oct  
 Psychoacoustic research, electronic switch for 163 Oct  
 Pulse amplifier 155 Jul  
 Pulse amplifier 170 Sept  
 Pulse amplifier, cathode compensation 156 Nov  
 Pulse-cross display for tv alignment 184D Apr  
**Pulse Generator, see also Generator**  
 Pulse generator, high voltage 222D Apr  
 Pulse generator, transistor 132 Nov  
 Pulse magnetizer for permanent magnets 121 Aug  
 Pulse-series generator, Grisamore & Uyehara 224D Mar  
 Pulse techniques used in waveform generator 149 Jun  
 Pulse transformers used in ferrite core memory 194 Mar  
 Pulsed eddy currents gage plating thickness, Waidelich 146 Nov  
 Pulsed tones control a-m and f-m stations, Michels 132 Sept  
 Pump feeds cement to both sides of mold 254D Sept  
 Punched cards control job-lot assembly system, Gamble, Godwin & Feldheim 122 Nov  
 Punched slots in back cover anchor built-in tv antenna 220D Sept  
 Push-pull oscillator, two-terminal 202D Aug

**Q**

Quartz, crystal, spectrum analyzer 160 Oct

**R**

Radar, AEW planes keep watch 178D Nov  
 Radar aids meteorology 182D Sept  
 Radar and computer track mortar shells back to source 208D Feb  
 Radar cane guides sightless 180D Jun  
 Radar, C-band weather mapping 178D Dec  
 Radar, DEW line 184D May  
 Radar, fan-pencil antenna 142 May  
 Radar, portable precision approach 154 Oct  
 Radar, infrared erasure for dark-trace tubes 170 Feb  
 Radar, local oscillator for c-w 166 May  
 Radar, missile, checked by simulator 127 Jul  
 Radar, models show how to avoid 122 Jan  
 Radar, nomographs for rectangular waveguides 172 Jan  
 Radar movie 198D Dec  
 Radar, optical image superimposed on 214D Mar  
 Radar range calibrator checks beacons 150 Apr  
 Radar ship 164D Jul  
 Radar, short-interval timer for testing 168 May  
 Radar speed meters, accuracy of 132 Dec  
 Radar, tunable X-band cavity 135 Jan  
**Radiation, see also propagation**  
 Radiation pattern measured by helicopter 134 Nov  
**Radio, see also communications, broadcast**  
 Radio astronomy as navigation aid 182D Jan  
 Radio astronomy, spectrum analyzer for sun 174D Oct  
 Radio astronomy, spider antenna 180D Jun  
 Radio, audience survey 126 Jan  
 Radio circuit transmits statistical data from North Africa 184D Jan  
 Radio control gives right-of-way 194D Jun  
 Radio, dynamic receiver selectivity 128 Feb  
 Radio, fifty-kw broadcast transmitter 168 Mar  
 Radio, improving mobile 156 Jun  
 Radio opens garage door 212D Dec  
 Radio receiver a/c for f-m tuning 180D Jun  
 Radio, single-tone calling for mobile 144 May  
 Radioonde, faster 208D Dec  
 Rain gages send radio reports 186D Sept  
 Reactance voltage bias source, Burris 218D Feb

Reactor, linear, design chart 208 Mar  
 Reader, photoelectric 134 May  
 Rebroadcasting, high quality tv receiver for 152 Dec  
 Rebroadcasting uhf 131 May  
**Receivers, see also f-m, television**  
 Receiver, design of transistorized portable 159 Mar  
 Receiver, improving audio in mobile 190D Oct  
 Receiver, Japanese transistor 174D Dec  
 Receiver selectivity, dynamic 128 Feb  
 Receiver, squelch for mobile 143 Jul  
 Receiver, tv, alignment by pulse-cross display 184D Apr  
 Receiver, tv, for rebroadcast 152 Dec  
 Receiver, tv, light beam controls 204D Dec  
 Receiver, tv, used as rebroadcast monitor 131 May  
 Receiver uses a/c for f-m tuning 180D Jun  
 Receiver, wide-band amplifier for uhf 158 Dec  
 Recorded broadcast, automatic 135 Oct  
 Recorder, 14-channel tape, for geophysical 152 Jan  
 Recorder, blood pressure 178D Jun  
 Recorder, complex impedance 167 Sept  
 Recording, alloys improve magnetic 137 Jun  
 Recording and tabulating the radio-tv audience, Brown 126 Jan  
 Recording, seismic, cros display 160 May  
 Rectifier, plug-in, replaces tube 198D Aug  
 Rectifier, power, for a-c line operation 146 Apr  
 Rectifier, trends in metallic 162 Mar  
 Rectifier, vibrating ignitor 248D Mar  
 Reducing hazard of electrical shock in industrial oscillators 180D Jan  
 Reference sheet, design of i-f transistor transformers 156 Aug  
 Reference sheet, dielectric mixture chart 176 Apr  
 Reference sheet, linear reactor chart 208 Mar  
 Reference sheet, microphone nomograph 172 Oct  
 Reference sheet, noise factor nomograph 174 Nov  
 Reference sheet, notch network design 172 Sept  
 Reference sheet, overstaggered doublets 158 Jul  
 Reference sheet, power rating of parasitic suppressors 170 Oct  
 Reference sheet, r-f filter design 176 Feb  
 Reference sheet, rectangular waveguide 172 Jan  
 Reference sheet, standard electronics symbols 176 May  
 Reference sheet, tracing electron paths 174 Jun  
 Refinery, automatic control of 130 Jan  
 Reflection from automobiles in whf tv 166D Jul  
 Reflection-type asymmetrical waveguide, Ishii 192D Dec  
 Reflectorometer for road signs 204D Feb  
**Reflector, see also antenna**  
 Regulated r-f power supply 192D Apr  
 Regulation, low ripple power supply 164 Nov  
 Regulator, current, for van de Graaff generator 151 Oct  
 Regulator for constant current power supplies, Deichert 170D Aug  
 Regulator, motor speed 126 Aug  
 Regulator, spectrometer, stabilizes r-f 137 Nov  
 Relay contact bounce measurements, Jiu 137 Aug  
 Relay design trends 114 Jan  
 Relay, electrostrictive ceramic 226D Mar  
 Relay, microwave, for rural telephone 208D Jan  
 Relay, sensitive thyatron 172D Dec  
 Relay, zero hysteresis 202D Dec  
 Relays, special purpose 150 Feb  
 Reliability, equipment 180D Jul  
**Remote control, see also Telemetering**  
 Remote control for refinery operations 130 Jan  
 Remote tv camera spots forest fires 178D Oct  
 Repeater amplifies in either line direction, Merrill, Smethurst & Rose 164 Jan  
 Repeater, transoceanic telephone 178D Sept  
 Repetition-rate generator has high accuracy, Plemenos 148 Nov  
 Resistor, power rating parasitic suppressors 170 Oct  
**Resistor Production Techniques**  
 Assembly fixture for ganged precision potentiometers 222D Oct  
 Assembly fixtures for precision potentiometers 280D Mar  
 Automatic riveter makes resistor terminal boards 188D Mar  
 Capping resistors 240D Oct  
 Coil-winder for precision potentiometers 248D Apr  
 Cutting and flattening helices for potentiometers 246D Oct  
 Cutting tapered cards for precision potentiometers 266D Nov  
 High-speed color bander 262D Feb  
 Hopper-fed automatic lead cutter for carbon resistors 222D Sept  
 Lacer-insert packaging for boron-carbon resistors 264D Sept  
 Life-testers for precision potentiometers 226D Jul  
 Packaging resistors for automatic unloading 254D Oct  
 Potting with hypo syringe 228D Jan  
 Resistor lead cutter 260D Nov  
 Resistor-spiraling machine is completely automatic 222D Oct  
 Resistor-varnishing setup 252D Oct

Shock-testing machine for precision potentiometers ..... 258D Apr  
 Silvering ends of resistors with conventional painting setup ..... 220D Oct  
 Sorting silvered resistors ..... 232D Oct  
 Welding taps of precision windings ..... 238D Sept

**Resonant-loop antenna for vhf direction finding, Eakin** ..... 172 Feb  
**Response, frequency, improving cathode-follower** ..... 190D Aug  
**Response of transistor amplifiers** ..... 196D Feb  
**Reverse tv program pickup** ..... 176D Jul  
**R-F amplifier for uhf-tv** ..... 112 Jul  
**R-F connectors used in video patch panel** ..... 210D Apr  
**R-F filter design (reference sheet)** ..... Longo & Wolf ..... 176 Feb  
**R-F power supply for bevatron** ..... 164 Feb  
**R-F power supply, highly regulated** ..... 192D Apr  
**Road signs tested by photometer** ..... 204D Feb  
**Robot guidance system for pilotless aircraft** ..... 182D Jul  
**Robot sings new tunes** ..... 200D Apr  
**Rubber band protects panel finish during assembly on bench** ..... 231D May  
**Rural microwave** ..... 208D Jan

**Saturable reactors, see reactors magnetic amplifiers; etc.**  
**Sawmill, uses closed circuit tv** ..... 214D Mar  
**Sawtooth linearity measurement** ..... 204D Nov  
**Sawtooth pulser gives voltage-current curves, Sclar & McPolin** ..... 156 Dec  
**Scaler, see counter**  
**Scanner compares cancer cells against normal cells** ..... 182D Apr  
**Scanning disk improves auto headlight dimmer, Rabinow** ..... 170 Mar  
**Scatter propagation, island radio link** ..... 172D Dec  
**Schematic symbols for electronics** ..... 176 May  
**Scientific electronics markets** ..... 138 Apr

**Screwdriver Production Techniques**  
**Automatic screw feeder for power screwdrivers** ..... 236D Oct  
**Magnet controls torque in new air screwdriver** ..... 242D Oct  
**Seismic recording, cro display** ..... 160 May  
**Selective calling, improving mobile radio** ..... 156 Jun  
**Selective calling, mobile radio** ..... 144 May  
**Selective coupler for uhf multiplexer** ..... 152 Nov

**Selenium Rectifier Production Techniques**  
**Applying selenium to rectifier cells** ..... 242D Jun  
**Assembling cartridge-type selenium rectifiers** ..... 232D Jun  
**Automatic electroplater for selenium rectifier sheets** ..... 260D Jun  
**Automatic turntable tests selenium cells for h-v breakdown** ..... 210D Jul  
**Draining setup for dipped rectifier stacks** ..... 266D Jun  
**Silk-screen machine places insulating paint on selenium rectifiers** ..... 224D Jun  
**Spraying counterelectrodes on selenium rectifier plates** ..... 210D Jul  
**Vacuum metallizing of selenium rectifiers** ..... 258D Nov

**Semiconductor, see diode, transistor, etc.**  
**Sensitive limit detector, Porter** ..... 202D Oct  
**Sensitive thyatron relay operates on microampere, Harris** ..... 172D Dec  
**Series-tube modulates amplifier screen-grid, Bernard** ..... 158 Nov  
**Servo amplifier, autopilot magnetic** ..... 208D May  
**Servo analyzer for wide-range testing, Dickey** ..... 172 Apr  
**Servo control of magnetic drum speed** ..... 140 Aug  
**Servo system, electromechanical net work** ..... 190D Feb  
**Shielded room, air conditioned** ..... 180D Dec  
**Shock hazard in industrial oscillators** ..... 180D Jan  
**Short-interval timer, Moerman** ..... 168 May  
**Shutter, submicrosecond Kerr-cell** ..... 171 Jun

**Signal generator, see also generator, oscillator**  
**Signal generator, audio standard** ..... 161 Dec  
**Signal generator, high voltage** ..... 222D Apr

**Signal generator, transistorized f-m** ..... 133 Feb  
**Silicon diode, using Zener effect in** ..... 182D Dec  
**Silicon power rectifier** ..... 184D Sept  
**Silicon Power rectifiers for a-c line operation, Rudenberg** ..... 146 Apr  
**Silicon prepared by induction heating** ..... 182D Feb

**Silicon transistor, see also transistors**  
**Silicon transistor used in counter** ..... 112 Aug  
**Simple color computer gives tristimulus values, Burr & White** ..... 166 Oct  
**Simulator, sonar target** ..... 167 Mar  
**Simulator tests missile radar** ..... 127 Jul  
**Single-sideband transmitter, linear power amplifier for** ..... 124 Aug  
**Single-tone calling simplifies mobile radio, Hassel** ..... 144 May  
**Single-tube capacitance transducer circuit, Fleming** ..... 182D Oct  
**Slot-array antenna, photoetched** ..... 130 Jul  
**Small airport aid** ..... 184D Jun  
**Solar battery efficiency doubled in year** ..... 182D Jun  
**Solar battery powers telephone carrier** ..... 178D Nov  
**Solar research, spectrum analyzer for sun** ..... 176D Oct

**Soldering Techniques**  
**Automatic soldering gun uses electronic timing** ..... 274D Apr  
**Double-dip soldering uses chassis vibrator, Cass** ..... 226D Dec  
**Jaws on pliers bend digital leads** ..... 260D Feb  
**Masking and fluxing for dip-soldering** ..... 228D Sept  
**Radio is dip-soldered with tubes in sockets** ..... 236D Sept  
**Ultrasonic soldering tools** ..... 246D May  
**Wishbone-shaped soldering staples save space on panels** ..... 232D May

**Solid state, see diodes, transistors, etc.**  
**Sonar target simulator, Cologne & Marriner** ..... 167 Mar  
**Sorting and weighing on production line** ..... 152 Jun  
**Sorting, automatic micrometer for** ..... 156 May  
**Sound, see also audio**  
**Sound, effect of intensity on tubes** ..... 196D Feb  
**Sound level, microphone nomograph** ..... 172 Oct  
**Sound reducer, f-f** ..... 188D Jun  
**Sound reproduction, design factors for audio amplifier** ..... 166 Apr  
**Special-purpose relays gain new uses, Rockett** ..... 150 Feb  
**Spectrometer regulator stabilizes r-f, Donner** ..... 137 Nov  
**Spectrum analyzer for quartz crystals, McDuffie** ..... 160 Oct  
**Speech-music discriminator** ..... 162D Aug  
**Speed control for motor** ..... 126 Aug  
**Speed control, variable, for motors** ..... 162 Apr  
**Speed meters, radar** ..... 192 Dec  
**Speed of propagation, higher** ..... 180D Sept  
**Spectrophotometer, tape-controlled** ..... 136 Feb  
**Spectrum analyzer for mobile radio** ..... 180D Feb

**Spider antenna can beam signals in six directions** ..... 180D Jun  
**Square-law circuit, Lion & Davis** ..... 192D Sept  
**Square-law detector for rms voltages, Sauber** ..... 170 Nov  
**Square-law multiplier, diode bridge** ..... 167 Sept  
**Squelch circuit, compensated, for mobile radio** ..... 143 Jul  
**Squirrel-cage motor speed control system, Spencer** ..... 126 Aug

**SSB, see single-sideband**  
**Stabilization, of r-f for spectrometer** ..... 137 Nov  
**Stabilization of transistor amplifier by feedback** ..... 174 May  
**Stabilizer for ships, computer controlled** ..... 212D Nov  
**Staggered triple-crystal filter, Hill-dreth** ..... 166 Dec  
**Stagger-tuned amplifier design** ..... 158 Jul  
**Standard, gain, microwave horn** ..... 150 Jul  
**Standard symbols for electronics (reference sheet)** ..... 176 May  
**Standards, preferred circuit** ..... 182D Nov  
**Static electricity, formation in thunderstorms** ..... 184D Apr  
**Station operation, automatic broadcast** ..... 135 Oct  
**Statistics transmitted by radio** ..... 184D Jan  
**Storage tube employs secondary emission, Uhlmann** ..... 161 Jan  
**Strip-line, band-pass filter using** ..... 152 May  
**Studio amplifier design for color television, Schroeder** ..... 154 Mar  
**Subaudio oscillator tunes 0-50 cycles, Fleming & Follin** ..... 144 Oct  
**Subharmonic discriminator, delay line** ..... 203 Mar  
**Subharmonic crystal oscillator** ..... 206D Jan

**Supersonic, see ultrasonic**  
**Suppressor power rating parasitic** ..... 170 Oct  
**Surgery, anesthesia monitor for** ..... 130 Oct  
**Survey of 25 years of electronics** ..... 124 Apr  
**Survey of 38 computers for business** ..... 122 Jun  
**Surveying, geodimeter determines base lines** ..... 194D Jul  
**Switch, ionospheric disturbances** ..... 198D May  
**Switch, electronic, eliminates transients** ..... 163 Oct  
**Switch, electronic, for biology** ..... 135 Dec  
**Switch, touch-operated** ..... 200D Oct  
**Switch, ultrasonic, for diversity reception** ..... 169 Nov  
**Switching circuit, double base diode** ..... 198 Mar  
**Switching circuits, transistor** ..... 163 Jan  
**Symbols, standard electronic** ..... 176 May  
**Synchronizing magnetic drum storage speed, Bivans** ..... 140 Aug  
**Synthesizer, electronic music** ..... 200D Apr  
**Synthetic quartz commercially available** ..... 212D Oct

**Table model receiver uses afc for f-m tuning** ..... 180D Jun  
**TACAN, carrier-based** ..... 178D Jun  
**TACAN for private planes** ..... 174D Jul  
**TACAN navigation system shows bearing and distance** ..... 174D Oct  
**Tank capacitor energy storage** ..... 216D Oct  
**Tape-controlled servos speed chemical analysis, Donnor** ..... 136 Feb  
**Tape-covered clips serve as clamps** ..... 252D Feb  
**Tape recorder, geophysical** ..... 152 Jan  
**Tape recording, alloy heads improve** ..... 137 Jun  
**Target discriminator for countermeasures, Weiss & Sixbey** ..... 118 Aug  
**Target for missiles, parachute** ..... 180D Jan  
**Target simulator, sonar** ..... 167 Mar  
**Telemetering, antenna system for missile** ..... 164 Jun  
**Telemetering, data reduction system for missile** ..... 126 May  
**Telemetering for broadcast station** ..... 132 Sept  
**Telephone, all-electronic, using storage tube** ..... 161 Jan  
**Telephone carrier, powered by solar battery** ..... 178D Nov  
**Telephone, military channels increased** ..... 180D Apr  
**Telephone repeater, transoceanic** ..... 178D Sept  
**Telephone, rural microwave** ..... 208D Jan  
**Telephone, two-way repeater amplifier** ..... 164 Jan  
**Telephotograph, facsimile speedup** ..... 134 Jul  
**Television, Albion tries commercial** ..... 180D Nov  
**Television, aligning by pulse-cross display** ..... 184D Apr  
**Television, antenna for WOR-TV** ..... 214D Apr  
**Television, audience survey** ..... 126 Jan  
**Television, automatic damping improves monitor** ..... 230D Mar  
**Television, automobile reflection** ..... 186D Jul  
**Television, British color** ..... 206D Sept  
**Television, British tower** ..... 188D Nov  
**Television, color-burst meter** ..... 149 May  
**Television, color, colorimeter for** ..... 138 Dec  
**Television, color, differential gain test** ..... 114 Aug  
**Television, color, phase meter** ..... 156 Jan  
**Television, color, used for intercity consultation** ..... 261D Mar  
**Television, color-video envelope-delay measurement** ..... 144 Jun  
**Television, feedback clamp circuit** ..... 182D Jul  
**Television flat cathode-ray tube** ..... 214D Mar  
**Television, flying-spot color** ..... 176D Jul  
**Television, high-power grid-control tube for uhf** ..... 130 Apr  
**Television, high-speed facsimile for news photos** ..... 134 Jul  
**Television, Interior Dept. uses underwater** ..... 218D Oct  
**Television, light beam controls receiver** ..... 204D Dec  
**Television, matrixing and encoding color** ..... 140 Nov  
**Television, one-man camera alignment** ..... 214D Dec  
**Television, receiver for** ..... 152 Dec  
**Television, remote, spots forest fires** ..... 178D Oct  
**Television, transistor deflection circuit** ..... 146 Jul  
**Television, uhf, amplifier tube for** ..... 176D Nov  
**Television, uhf, rebroadcasting** ..... 131 May  
**Television, underwater camera** ..... 174D Sept  
**Television, used in sawmill** ..... 214D Mar  
**Television, wide-band amplifier for uhf** ..... 158 Dec

**Television, X-ray, shows inside of engine** ..... 182D Apr  
**Temperature indicator for aircraft engines, Koletsky** ..... 129 Nov  
**Temperature stabilizing transistor amplifier** ..... 174 May

**Terminals, production techniques**  
**Universal holding jig for terminal boards** ..... 242D May

**Testing, see also measurement, ultrasonics**  
**Testing airborne electronic components, Mintz & Levine** ..... 191 Mar  
**Testing, analyzer for servos** ..... 172 Apr  
**Testing color tv, differential gain** ..... 114 Aug  
**Testing, transmission gain** ..... 145 Dec

**Testing techniques**  
**Accelerator tests parts whirling at 100 g** ..... 322D Mar  
**Automatic tester for ferrite memory cores** ..... 244D Dec  
**Calibrating waveguide frequency meters in batches of eleven** ..... 208D Jul  
**Drop test for instruments, McCormick** ..... 254D Sept  
**Gap gage for coaxial tuned stub** ..... 268D Feb  
**Illuminated magnifier aids inspection of missile controls** ..... 256D Jan  
**Life test setup** ..... 234D Nov  
**Locating heater shorts** ..... 264D Dec  
**Mechanized line inspections and tests speaker magnets** ..... 226D Jun  
**Pictorial inspection records expedite flow of quality data, Squires** ..... 234D May  
**Quality control panel shows variations in tested parts** ..... 208D Aug  
**Recorder checks linearity of precision potentiometers** ..... 244D Nov  
**Rotating bolt actuates shake table** ..... 278D Mar  
**Rotational life-tester** ..... 262D Nov  
**Servo amplifier tester for production use, Alman** ..... 310D Mar



Test sets heat plant.....308D Mar  
 Testing seals of coaxial cavities...257D Jan  
 Transparent covers for quality control charts.....230D Jun  
 Turntable aids inspection.....286D Apr  
 Value-averaging device.....246D Jun  
 Testing uhf dx.....200D Dec  
 Theory for formation of thunderstorm electricity.....184D Apr  
 Thermometer for aircraft engines...129 Nov  
 Thickness gage, eddy current plating.....146 Nov  
 Thread-mutilating tool.....256D Sept  
 Threefold gain in military telephone channels.....180D Apr  
 Thunderstorms, formation of static electricity.....184D Apr  
**Thyratron, see also tube**  
 Thyratron relay, microampere....172D Dec  
 Time delay generator, nonlinear...194D Nov  
 Time delay generator.....148 Dec  
 Time delay networks.....176 Jun  
 Time delay nomograph.....178 Apr  
 Time delay, precision.....218D Nov  
 Time signals, Canadian observatory broadcast.....182D, 196D Jun  
 Timer for electron microscope.....206 Mar  
 Timer, short-interval.....168 May  
 Tiny tube amplifies uhf-tv.....176D Nov  
 Tone calling, mobile radio.....144 May  
 Tones, audio, for refinery control...130 Jan  
 Tones control a-m and f-m stations...132 Sept  
 Tower, antenna, installation of f-m antenna on a-m.....130 Aug  
 Tracing electron paths (reference sheet), Spaven.....174 Jun  
 TRADIC computer uses transistors...222D May  
 Traffic, radar speed meters.....132 Dec  
 Traffic, radio control.....194D Jun  
 Transducer, capacitive, low-impedance.....161 Jun  
 Transducer, single-tube capacitance.....182D Oct  
 Transducer tube changes signals to letters.....182D May  
 Transformer, dielectric, for X-band...146 Dec  
 Transformer, design of i-f transistor...156 Aug  
 Transient trigger adapter for oscillogram recording.....159 Apr  
 Transients, eliminated from electronic switch.....163 Oct  
 Transistor amplifier, feedback-stabilized.....174 May  
 Transistor amplifier performance, Williams.....196D Feb  
 Transistor amplifiers for analog computers, Ettinger.....119 Jul  
 Transistor choppers for stable d-c amplifiers, Bright & Kruper.....135 Apr  
 Transistor circuits, d-c.....132 Jun  
 Transistor counter, silicon.....112 Aug  
 Transistor c-r tube deflection circuit, Taylor & Moore.....146 Jul  
 Transistor, design of portable using...159 Mar  
 Transistor, junction, switching circuits.....168 Jan  
 Transistor microphonics.....206D Sept  
 Transistor modulator for flight trainers, Ettinger.....126 Sept  
 Transistor pulse generators, Eckess, Deavenport & Sherman.....132 Nov  
 Transistor receiver, Japanese.....174D Dec  
 Transistor transformer, design of i-f...156 Aug  
 Transistorized f-m signal generator, Hupert & Szubski.....133 Feb  
 Transistors generate multiwaveforms, Keonjian and Suran.....138 Jul  
 Transmission, extended range uhf.....182D May  
 Transmission line calculator, vhf.....168 Dec  
 Transmission test set, Chinski.....146 Dec  
**Transmitter, see also broadcast**  
 Transmitter, fifty-kw broadcast...168 Mar  
 Transmitter monitor, color-burst...149 May  
 Transmitter, multiplexing f-m.....146 Oct  
 Transmitter, pulsed tone controlled...132 Sept  
 Transmitter, series-tube modulator...158 Nov  
 Transmitter, ssb, linear power amplifier.....124 Aug  
 Transmitter using frequency synthesizer.....138 Jan  
 Transmitting, matrixing and encoding color television.....140 Nov  
 Transoceanic telephone cable has built-in repeaters.....178D Sept  
**Trays, for production use**  
 Assembly-line benches are loaded from rear, Prince & Mowll...262D Apr  
 Deep-well bins hold precut leads on tv assembly line.....268D Mar  
 Fibreboard tote boxes for parts use beer-case construction.....240D Feb  
 Heater-storing trays.....282D Apr  
 Trigger adapter for transient oscillograms, Fleming.....159 Apr  
 Triode oscillator, microwave.....184 Mar  
 Triple-crystal filter.....166 Dec  
 Tristimulus computer.....166 Oct  
 Tube, anode-dynode amplifier.....132 Aug  
 Tube, binary adder.....161 Sept  
 Tube, colorimeter for color television.....138 Dec  
 Tube, dark-trace, with infrared erasure.....170 Feb  
 Tube, dynamic characteristics of triode-connected pentodes.....208D Dec  
 Tube, flat cathode-ray.....241D Mar  
 Tube, flat cathode-ray.....186D Nov  
 Tube, high-power uhf-tv.....130 Apr  
 Tube, modulated klystron.....186D Jan  
**Tube Production Techniques**  
 Air-actuated machine makes cath-whiskers for germanium wafers.....210D Aug  
 Automatic aluminizer for television picture tubes.....236D Jun

Burn-in rack cuts early tube failures, Richards.....300D Mar  
 Cam-action grid former.....298D Mar  
 Cathode-shaving tool.....284D Apr  
 Centering fixtures for color TV picture tubes.....296D Mar  
 Detecting cracks in glass-to-metal seals, Staats.....284D Mar  
 Drill-press extrusion of grids for tubes.....250D Jun  
 Electrode-centering jig.....237D Jul  
 Filament-inserting funnel.....256D Nov  
 Flexible drying rods prevent tube breakage.....266D Feb  
 Lint control program reduces tube rejects.....220D Aug  
 Pressurized tube plant.....258D Feb  
 Producing formed and inside-out grids for uhf pencil tubes, Ackerman.....270D May  
 Round-robin noise test for tubes...244D Apr  
 Sliding-average computer for tube quality charts.....276D Mar  
 Soldering crystal diodes.....294D Mar  
 Trenches replace pipes in tube plant.....238D Jul  
 Tube-aging conveyor.....260D Oct  
 V-shaped trough aids threading of cathodes for electropolishing...266D Mar  
 Tube replaced by plug-in rectifier...195D Aug  
 Tube socket spreaders.....224D Jul  
 Tube, storage, secondary emission...161 Jan  
 Tube, vibrating-ignitor rectifier...248D Mar  
 Tubes, effect of intense sound on...196D Feb  
 Tunable cavity for X-band oscillators, Spencer.....135 Jan  
 Tunable microwave triode oscillator...184 Mar  
 Tuning aircraft antenna by a-m system.....152 Aug  
**TV, see television**  
 Tweaks, ionospheric disturbances...198D May  
 Twenty-five years of electronics, Zelfuff & Arnold.....124 Apr  
 Two-terminal push-pull oscillator, Cuddy.....202D Aug  
 Two way radio, improving audio...190D Oct  
 Two-way uhf pack set uses helmet antenna, Jensen & Schwartz...150 Mar

**U**

UHF, amplifier tube for.....176D Nov  
 UHF antenna for aircraft carrier...174D Dec  
 UHF, designing components for...186D May  
 UHF, forward scatter extends range...122 Oct  
 UHF, grid-control tube.....130 Apr  
 UHF radio, military pack set...150 Mar  
 UHF multiplexer uses selective couplers, Carlin.....152 Nov  
 UHF rebroadcasting cuts cost, Root...131 May  
 UHF, testing dx.....200D Dec  
 UHF transmission, extended range...182D May  
 UHF-TV, booster amplifier for.....112 Jul  
 UHF wideband amplifier for receivers.....158 Dec  
 Ultrasonic alarm system, design of...106 Aug  
 Ultrasonic irradiation substitutes for lobotomy.....164D Jul  
 Ultrasonic phase meter measures water velocity, Stull.....128 Sept  
 Ultrasonic ranging speeds cancer diagnosis, Reid & Wild.....174 Mar  
 Ultrasonic switch aids diversity reception, Montgomery.....169 Nov  
 Underwater television camera hovers or cruises.....174D Sept  
 Untitized production benches facilitate assembly-line changes.....232D May

**V**

VHF direction finder.....168D Jul  
 VHF transmission line calculator, Sanderson.....168 Dec  
 Vacuum gage, power supply for...210D Feb  
 Vacuum tube, see tubes  
 Van de Graaff generator, current regulator for.....151 Oct  
 Van de Graaff generator, insect control using.....202D May  
 Variable index of refraction lens for microwave.....142 Aug  
 Variable-speed control for integral-hp motors, Cowie & Gregson.....162 Apr  
 Velocity measurement, phase meter for water.....128 Sept

Velocity of propagation, higher...180D Sept  
 Vibrating-ignitor tube consumes less power, Hatta and Hiraga.....248D Mar  
**Video, see also television**  
 Video amplifier for color television...154 Mar  
 Video patch panel using r-f connectors, Weise.....210D Apr  
 Volscan evaluation.....206D Dec  
 Voltage current curve sawtooth pulser for.....156 Dec  
 Voltage divider, digital.....176D Dec  
 Voltmeter, expanded scale a-c.....164 Dec  
 Voltmeter, square law detector for rms.....170 Nov

**W**

Water-dip solution cleans terminals.....254D Nov  
 Water velocity, phase meter for....128 Sept  
 Waveform generator, transistor...138 Jul  
 Waveform generator uses pulse techniques, Newhall.....149 Jun  
**Waveguide, see also microwave**  
 Waveguide, dielectric transformer for X-band.....146 Dec  
 Waveguide, long distance.....212D Mar  
 Waveguide, nomographs for rectangular.....172 Jan  
 Waveguide, reflection-type asymmetrical.....192D Dec  
 Waveshape generator, high voltage.....222D Apr  
 Weather map recorder.....196D Jul  
 Weather mapping radar uses C-band.....178D Sept  
 Weather warnings.....202D Feb  
 Weighing, electronic production...162 Jan  
 Whistlers, ionospheric disturbances...198 May  
 Wide-angle phase shifter for industrial controls, Brown.....188 Mar  
 Wide-band amplifier for uhf receivers, McWhirt.....158 Dec  
 Wide-band analog function multiplier, Miller, Soltes & Scott.....160 Feb  
 Wings on chassis support 24-inch picture tube.....248D Sept  
 Wire insulation, controlling extrusion of.....144 Apr  
**Wire Production Techniques**  
 Beveling new pliers prevents nicking of wires.....257D Jan  
 Card-controlled machine makes wrapped joints.....224D Nov  
 Constant-tension automatic wire-twisting machine.....220D Oct  
 Cutting plastic sleeving.....248D Jan  
 Grounding shield braid in guided missiles.....240D Apr  
 Induction generator bonds hookup wire strands before stripping...208D Aug  
 Lead length gage.....206D Sept  
 Linotype slugs identify wires...236D Nov  
 Minimizing splices in aircraft radio panel.....272D Apr  
 Potting Techniques for Cable Connectors.....230D Jan  
 Precision photoelectric wire-cutting machine.....252D Feb  
 Pulling cable conductors through plastic sleeve.....238D Jan  
 Spring clips on harness board serve as wire-cutting guides.....222D Jan  
 Stripping nylon jacket from shielded wire.....270D Feb  
 Terminal and marking tools added to wire cutter.....258D Dec  
 Tin reflowing cuts wire-stripping costs.....242D Nov  
 Waterproofing cable connectors...250D Feb  
 Wire-coiling dish.....226D Nov  
 WOR master control.....204D Sept  
 WOR-TV, Empire State antenna...214D Apr

**X**

X-band receiving amplifier, Ishii...202D Apr  
 X-ray television shows inside of operating engine.....182D Apr

**Z**

Zener-voltage breakdown uses in silicon diodes, Wulfsberg.....182D Dec  
 Zero hysteresis relays, Barditch...202D Dec

# AUTHOR INDEX

Items in the author index for which page references are preceded by (letter) are comments from readers, published monthly in the Backtalk department

## A

Abel, F., Adams, Alford, Leach & Rubin, Empire State antenna for WOR-TV ..... 214D Apr  
 Ackerman, H. J., Producing formed and inside-out grids for uhf pencil tubes ..... 270D May  
 Adams, G. J., Alford, Leachm Rubin & Abel, Empire State antenna for WOR-TV ..... 214D Apr  
 Alexander, F. C., Jr., About whistlers (letter) 380D Aug  
 Alford, A., Leach, Rubin, Abel & Adams, Empire State antenna for WOR-TV ..... 214D Apr  
 Alman, J., Servo amplifier tester for production use ..... 310D Mar  
 Applegarth, A. R., Airborne interrogator spots location ..... 170 May  
 Armstrong, H. L., Infinite impedance detector-amplifier ..... 108D Aug  
 Arnold, W. G. & Zeltut, 25 years of electronics ..... 124 Apr

## B

Backman, K., Mobile power supply for 6 and 12 volts ..... 216D May  
 Bagno, S. S., Designing ultrasonic alarm systems ..... 106 Aug  
 Baker, V. H., Taboada & Wiant, Insect control by electron irradiation ..... 202D May  
 Barditch, I., Electronic chopper for d-c amplifiers ..... 192D Nov  
 Barditch, J., Zero hysteresis relays ..... 202D Dec  
 Barnette, W. E. & Giacometto, Differential amplifier for null detection ..... 148 Aug  
 Barry, J. N. & Clarke, Microwave modulator uses ferrite gyrator ..... 139 May  
 Beckwith, H., Flip-flop counter has extended range ..... 149 Jan  
 Begun, S. J., Magnetic tape improves geophysical recordings ..... 152 Jan  
 Bell, R. E. & Ferstle, Electronic weighing on the production line ..... 152 Jun  
 Bernard, W. B., Distortion correction (letter) 480D Mar  
 Bernard, W. B., Series tube modulates amplifier screen-grid ..... 158 Nov  
 Berry, C. E., Noise calculations (letter) 409D May  
 Peter, R. H., Bradley, Brown and Rubinoff, Directly coupled transistor circuits ..... 132 Jun  
 Bibbero, R. J. & Krakauer, Modular simulator tests missile radar ..... 127 Jul  
 Bishop, F. W., Exposure timer for the electron microscope ..... 206 Mar  
 Bivans, E. W., Synchronizing magnetic drum storage speed ..... 140 Aug  
 Blake, R. F. & Morgan, Delay line subcarrier discriminator ..... 203 Mar  
 Blois, M. S., Jr., Evaporated magnetic materials ..... 210D Jun  
 Boesen, G. F. & Schultz, Juke box uses ferrite-core memory ..... 138 Oct  
 Bose, J. H., Multiplexing f-m broadcast transmitters ..... 146 Oct  
 Bower, G. E. & Wynn, Antenna system for missile telemetering ..... 164 Jun  
 Bradley, E. H., Microstrip lines (letter) 322D Jul

## C

Bradley, E. H. & White, Band-pass filters using strip-line techniques ..... 152 May  
 Bradley, W. E., Brown, Rubinoff & Beter, Directly coupled transistor circuits ..... 132 Jun  
 Brantley, J. Q., How accurate are radar speed meters? ..... 132 Dec  
 Braun, E. H., Bias supply design for bolometers ..... 208D Oct  
 Bright, R. L. & Kruper, Transistor choppers for stable d-c amplifiers ..... 135 Apr  
 Broida, H. P. & Gilford, Physiological monitor for anesthesia ..... 130 Oct  
 Brown, A. C. L., Recording and tabulating the radio-tv audience ..... 126 Jan  
 Brown, R. B., Rubinoff, Beter & Bradley, Directly coupled transistor circuits ..... 132 Jun  
 Brown, W. J., Wide-angle phase shifter for industrial controls ..... 188 Mar  
 Brueckmann, H., Helicopter measures antenna patterns ..... 134 Nov  
 Bruene, W. B., Linear power amplifier for ssb transmitters ..... 124 Aug  
 Buesing, R., Improving audio quality of mobile radio ..... 190D Oct  
 Burnett, L. C., Fast tube rate (letter) 408D May  
 Burr, R. P. & White, Simple color computer gives tristimulus values ..... 166 Oct  
 Burris, F. J., Reactance voltage bias source ..... 218D Feb  
 Buss, R. R. & Heland, Low-ripple adjustable regulated power supply ..... 164 Nov  
 Cambrill, R. D., Controlling extrusion of foam plastic on wire ..... 144 Apr  
 Carlin, H. J., UHF multiplexer uses selective couplers ..... 152 Nov  
 Carroll, J. M., Electronic computers for the businessman ..... 122 Jun  
 Cass, W. R., Double-dip soldering uses chassis vibrator ..... 226D Dec  
 Chalfin, N. L., Pertinent patents ..... 210 Jan  
 222D Feb, 256D Mar, 226D Apr  
 198D Jul, 206D Sept  
 Chase, C. E., Direct-reading noise-figure indicator ..... 161 Nov  
 Chen, T. S., Nomographs for rectangular waveguides ..... 172 Jan  
 Chinski, G. R., Transmission test set ..... 145 Dec  
 Christensen, H. & Funder, Pressure gage for ship-model hulls ..... 196D Jan  
 Clarke, W. W. H. & Barry, Microwave modulator uses ferrite gyrator ..... 139 May  
 Colby, N. C., Designing 2,000-mc components for communications ..... 186D May  
 Cole, E. B., Jr., Airplane models reveal how to avoid radar ..... 122 Jan  
 Coleman, E. F., Potentiometer design for minimal loading ..... 184D Feb  
 Cologne, K. M. & Marriner, Sonar target simulator ..... 167 Mar  
 Conover, W. B., Microphone nomograph (reference sheet) ..... 172 Oct  
 Cowie, E. G. & Gregson, Variable-speed control for integral-hp motors ..... 162 Apr  
 Cuddy, E. J., Two-terminal push-pull oscillator ..... 202D Aug

## D

Davidson, D. & Pote, Designing over-horizon communications links ..... 126 Dec  
 Davis, H. G., Jr., Medical electronics and custom construction (letter) ..... 360D Jan  
 Davis, R. H. & Lion, Square-law circuit ..... 192D Sept  
 Day, J. R., Beyond-horizon signals extend communications ..... 122 Oct  
 Deavenport, J. E., Sherman & Eckness, Transistor pulse generators ..... 132 Nov  
 Deichert, R. W., Regulator for constant current power supplies ..... 170D Aug  
 Demars, S. A., Jones & Thomas, Automatic damping improves tv monitor ..... 230D Mar  
 Deming, C. R., Amplifier for fast rise-fall pulses ..... 170 Sept  
 Dessler, A. J. & Robinson, Dynamic characteristics of triode-connected pentodes ..... 208D Dec  
 De Vore, C., More early radar (letter) 382D Jun  
 Diamond, J. M., IM or idp curves (letter) 359D Jan  
 Dickey, F. E., Servo analyzer for wide-range testing ..... 172 Apr  
 Donner, W., Acknowledgement ..... 410D May  
 Donner, W., Spectrometer regulator stabilizes r-f ..... 137 Nov  
 Donner, W., Tape-controlled servos speed chemical analysis ..... 136 Feb  
 Downie, E. G., Magnetic frequency multiplier for fluorescent lighting ..... 224D May

## E

Eakin, J. H., Resonant-loop antenna for vhf direction finding ..... 172 Feb  
 Eckess, W. S., Deavenport & Sherman, Transistor pulse generators ..... 132 Nov  
 Emslie, N. M., Basic chassis for experimental work ..... 166 Nov  
 Epstein, J., Morrison & Woodward, Extending uhf-tv with booster amplifiers ..... 112 Jul  
 Ettinger, G. M., Transistor amplifiers for analog computers ..... 119 Jul  
 Ettinger, G. M., Transistor modulator for flight trainers ..... 126 Sept

## F

Fearon, E. T., Automatic micrometer sorts insulating wafers ..... 156 May  
 Feldheim, F. S., Gamble & Godwin, Punched cards control job-lot assembly system ..... 122 Nov  
 Ferstle, J. A. & Bell, Electronic weighing on the production line ..... 152 Jun  
 Fleming, L., Fixed LC oscillator without taps ..... 216D Mar  
 Fleming, L., Single-tube capacitance transducer circuit ..... 182D Oct  
 Fleming, L., Trigger adapter for transient oscillograms ..... 159 Apr



Fleming, L. & Follin, Subaudio oscillator tunes 0-50 cycles ..... 144 Oct  
 Follin, W. W. & Fleming, Subaudio oscillator tunes 0-50 cycles ..... 144 Oct  
 Fox, R. C., Embedding technique for three-tube plug-in unit ..... 250D May  
 French, H. & Kennedy, Color-video envelope-delay measurement ..... 144 Jun  
 Froemke, D. & Nelson, Electronic load ..... 216D Nov  
 Funder, J. E. & Christensen, Pressure gage for ship-model hulls ..... 196D Jan

**G**

Galman, H., Expanded scale voltmeter for a-c measurements ..... 164 Dec  
 Gamble, G. W., Godwin & Feldheim, Punched cards control job-lot assembly system ..... 122 Nov  
 Geiser, D. T., A-M system tunes aircraft antennas ..... 152 Aug  
 Geist, J. C., Automobile reflection in vhf-tv ..... 166D Jul  
 Giacoletto, L. J. & Barnette, Differential amplifier for null detection ..... 148 Aug  
 Gilford, S. R. & Broida, Physiological monitor for anesthesia ..... 130 Oct  
 Giovanelli, R. G., Photometer tests reflecting road signs ..... 204D Feb  
 Gottleib, C. & Kelleher, Dielectric lens for microwaves ..... 142 Aug  
 Godwin, C. J., Feldheim & Gamble, Punched cards control job-lot assembly system ..... 122 Nov  
 Goldberg, H. B., Local oscillator for c-w radars ..... 166 May  
 Gottlieb, L., Gas glow potentials (letter) 488D Mar  
 Gregson, J. H. & Cowie, Variable-speed control for integral-hp motors ..... 162 Apr  
 Grisamore, N. T. & Ueyehara, Pulse-series generator ..... 224D Mar  
 Groenendyke, G. M. & Lower, Cathode-ray display of seismic recordings ..... 160 May  
 Gruner, R. A., Another staple technique (letter) 410D May

**H**

Hahnel, A., Phase-controlled multi-channel oscillator ..... 164 Apr  
 Hargreaves, W. V., Jr., Compensated squelch for mobile radio receivers ..... 143 Jul  
 Hariharan, M., Ideal world (letter) 380D Feb  
 Harris, J. N., Sensitive thyatron relay operates on microampere ..... 172D Dec  
 Hassel, E. W., Single-tone calling simplifies mobile radio ..... 144 May  
 Hatta, Y. & Hiraga, Vibrating-ignitor tube consumes less power ..... 248D Mar  
 Heasley, C. C., Jr. & Shepard, Photoelectric reader feeds business machines ..... 134 May  
 Heath, W. T. & Lufey, Alloy improves magnetic recording ..... 137 Jun  
 Hetland, G., Jr. & Buss, Low-ripple adjustable regulated power supply ..... 164 Nov  
 Heywood, J. P., Quality control charts for printed wiring ..... 216D Jul  
 Hildreth, D. E., Staggered triple-crystal filter ..... 166 Dec  
 Hilliard, J. K. & Noble, Low-noise input stage for audio preamplifier ..... 147 Feb  
 Hind, J. E. & Ludwig, Electronic switch eliminates transients ..... 163 Oct  
 Hiraga, S. & Hatta, Vibrating-ignitor tube consumes less power ..... 248D Mar  
 Hodowanec, G. & Holborn, Infrared speeds erasure of dark-trace tubes ..... 170 Feb  
 Hogan, J. V., Facsimile speedup enhances usefulness ..... 134 Jul  
 Holborn, F. & Hodowanec, Infrared speeds erasure of dark-trace tubes ..... 170 Feb  
 Holmes, H., Light hydraulic presses cut phono pickup costs ..... 250D Jan  
 Hooper, E. T. & Suozzi, All-magnetic audio amplifier ..... 122 Sept  
 Houghton, R. W., Phase meter analyzes color tv systems ..... 156 Jan  
 Hule, J. A., Power rating of parasitic suppressors (reference sheet) ..... 170 Oct  
 Hupert, J. J. & Szubski, Transistorized f-m signal generator ..... 133 Feb

Ishorn, C. & Swarthe, Counting labels with ferroresonant rings ..... 128 Oct  
 Ishii, K., Reflection-type asymmetrical waveguide ..... 192D Dec  
 Ishii, K., X-band receiving amplifier ..... 202D Apr  
 Ivers, J. H. & Sheehan, Design of transistorized high-gain portable ..... 159 Mar  
 Ives, R. L., Ferrule wrench aids mounting of panel lamps ..... 213D Jul  
 Ives, R. L., Nut starters ..... 236D Jul

**J**

Jensen, D. C. and Schwartz, Two-way uhf pack set uses helmet antenna ..... 150 Mar  
 Jensen, G. K. & McGeogh, Four-decade frequency divider ..... 154 Apr  
 Jiu, R., Relay contact bounce measurements ..... 137 Aug  
 Joffe, M., Meter shows color-burst deviation ..... 149 May  
 Jones, M. E., Thomas & Demars, Automatic damping improves tv monitor ..... 230D Mar

**K**

Kaiser, A. W. & Wolkstein, Anode-dynode beam deflection amplifier ..... 132 Aug  
 Kalmus, H. P., Capacitance transducer has low impedance ..... 161 Jun  
 Kamm, L. J., Digital voltage divider using four resistors ..... 176D Dec  
 Kanagy, M. T., All-magnetic a-f amplifier (letter) 406 Nov  
 Kaufman, A. B., Pot design problem (letter) 403D May  
 Kaufman, B. A., Nonlinear time-delay generator uses diodes ..... 194D Nov  
 Kelleher, K. S. & Goatley, Dielectric lens for microwaves ..... 142 Aug  
 Kennedy, R. C. & French, Color-video envelope-delay measurement ..... 144 Jun  
 Keonjian, E. & Suran, Transistors generate multiwaveforms ..... 138 Jul  
 Kiebert, M. V., Jr., Circuit design factors for audio amplifiers ..... 166 Apr  
 Kleist, L., Rotational life-tester ..... 262D Nov  
 Klink, G., Jr., F-M antenna inside the a-m tower ..... 130 Aug  
 Klywans, L. S., Basic control circuits are packaged ..... 122 Dec  
 Koletsky, H., Temperature indicator for aircraft engines ..... 129 Nov  
 Koros, L. L., High-power uhf-tv uses grid-control tube ..... 130 Apr  
 Koustas, P., Audio-standard generator ..... 161 Dec

Krakauer, M. & Bibbero, Modular simulator tests missile radar ..... 127 Jul  
 Krentzky, F., Decade counter employs silicon transistors ..... 112 Aug  
 Kruper, A. P. & Bright, Transistor choppers for stable d-c amplifiers ..... 135 Apr

**L**

Leach, H. H., Rubin, Abel, Adams & Alford, Empire state antenna for WOR-TV ..... 214D Apr  
 Lee, R., Linear reactor chart ..... 208 Mar  
 Leng, R. B., Controlling dust in microwave tube assembly plant ..... 238D Apr  
 Levin, J. B., Portable precision approach radar ..... 154 Oct  
 Levine, M. B. and Mintz, Testing airborne electronic components ..... 131 Mar  
 Linden, D. L., Chassis design for i-f amplifiers ..... 182D Aug  
 Lindner, M., More pot data (letter) 377D Apr  
 Lion, K. S. & Davis, Square-law circuit ..... 192D Sep  
 Lippke, J. A., Drafting aid (letter) ..... 379D Feb  
 Longo, C. V. & Wolf, R-F filter design (reference sheet) ..... 176 Feb  
 Loper, G. B. & Groenendyke, Cathode-ray display of seismic recordings ..... 160 May  
 Lovell, W. V., Electromagnet removes nonferrous metals ..... 164 Sep  
 Ludwig, H. & Hind, Electronic switch eliminates transients ..... 163 Oct  
 Lufey, C. W. & Heath, Alloy improves magnetic recording ..... 137 Jun  
 Lux, W., German tv transmitters (letter) 482D Mar

**M**

Markowitz, J., Electronic organ uses rotating loudspeakers ..... 116 Jul  
 Markus, J., Mechanized production of electronic equipment ..... 137 Sep  
 Marriner, E. H. & Cologne, Sonar target simulator ..... 167 Mar  
 Martin, L. J. & Vavra, Controlling sludge in etched wiring bath ..... 238D Nov  
 Martin, L. J. & Vavra, Controlling eyelets in etched wiring ..... 250D Dec  
 Maynard, F. B., Binary-adder tube for high-speed computers ..... 161 Sep  
 McCarrell, S., Noise factor nomograph (reference sheet) ..... 174 Nov  
 McCormick, E. M., Data reduction system for missile telemetering ..... 126 May  
 McCormick, S. T., Drop test for instruments ..... 258D Sep  
 McCusker, R. W., Producing oscillations with a Colpitts circuit ..... 184D May  
 McDuffie, T. E., Spectrum analyzer for quartz crystals ..... 160 Oct  
 McFolin, R. L. & Sclar, Sawtooth pulser gives voltage-current curves ..... 156 Dec  
 McGeogh, J. E. & Jensen, Four-decade frequency divider ..... 154 Apr  
 McGhee, R., Review revised (letter) ..... 319D Jul  
 McKenzie, A. A., Getting the most from mobile radio ..... 156 Jun  
 McLaughlin, J. L. A., Dynamic receiver selectivity ..... 128 Feb  
 McWhirt, R. B., Wide-band amplifier for uhf receivers ..... 158 Dec  
 Merrill, J. L., Smethurst & Rose, Repeater amplifies in either line direction ..... 164 Jan  
 Michels, H., Pulsed tones control a-m and f-m stations ..... 132 Sep  
 Miessner, B. F., Patent bill pending (letter) 313D Jul  
 Miessner, B. F., Those early days (letter) 386D Sept  
 Milek, J. T., Market for electronic equipment ..... 138 Apr  
 Miller, J. A., Soltes & Scott, Wide-band analog function multiplier ..... 160 Feb  
 Millman, J. & Taub, Cathode compensation linearizes video stages ..... 156 Nov  
 Mintz, F. & Levine, Testing airborne electronic components ..... 131 Mar  
 Moerman, N. A., Short-interval timer ..... 168 May  
 Montgomery, C. F., Ultrasonic switch aids diversity reception ..... 169 Nov  
 Moore, G. M., Impulse magnetizer for permanent magnets ..... 121 Aug  
 Moore, T. M. & Taylor, Transistor c-r tube deflection circuit ..... 146 Jul  
 Morgan, K. A. & Blake, Delay line subcarrier discriminator ..... 203 Mar  
 Morrison, H., Criss-cross d-c amplifier ..... 198D Aug  
 Morrison, W. C., Epstein & Woodward, Extending uhf-tv with booster amplifiers ..... 112 Jul  
 Mowll, J. U. & Prince, Assembly-line benches are loaded from rear ..... 262D Apr  
 Mural, F., Dynamic-diode limiter for f-m demodulators ..... 146 Aug

**N**

Nelson, V. R. & Froemke, Electronic load ..... 216D Nov  
 Newhall, E. E., Waveform generator uses pulse techniques ..... 149 Jun  
 Nicholson, W. Q. & Ross, Kerr-cell shutter has submicrosecond speeds ..... 171 Jun  
 Nilsen, P. J. & Tuft, Comparator for small phase angles ..... 188D Jan  
 Noble, J. J., Noise calculations (letter) 409D May  
 Noble, J. J. & Hilliard, Low-noise input stage for audio preamplifier ..... 147 Feb  
 Norris, K. H., Photoelectric inspector detects green rot in eggs ..... 140 Jul

**O**

Olin, I. D., Dielectric transformers for X-band waveguide ..... 146 Dec

**P**

Papian, W. N., New ferrite-core memory uses pulse transformers ..... 194 Mar  
 Park, F. R., Microwave system controls fog alarm ..... 122 Jul

Pastor, J. Jr., Staple problem (letter) .....480D Mar  
 Perzley, W., Precision digital delay generator .....148 Dec  
 Plemenos, F. A., Repetition-rate generator has high accuracy .....148 Nov  
 Porter, J. H., Sensitive limit detector .....202D Oct  
 Pote, A. J. & Davidson, Designing over-horizon communications links .....126 Dec  
 Prince, W. & Mowl, Assembly-line benches are loaded from rear .....262D Apr  
 Prugh, T. A., Junction transistor switching circuits .....168 Jan

**R**

Rabinow, J., Scanning disk improves auto headlight dimmer .....170 Mar  
 Rabinowitz, J., Schacher, Star & Taub, Matrixing and encoding color for telecasting .....140 Nov  
 Raible, R. W., Testerman & Sloan, Highly regulated r-f voltage supply .....192D Apr  
 Raible, R. W. & Testerman, Ion-gage supply protects tubes .....210D Feb  
 Reed, J. M., High-voltage waveshape generator .....222D Apr  
 Reid, J. M. & Wild, Ultrasonic ranging speeds cancer diagnosis .....174 Mar  
 Richards, J. A. K., Burn-in rack cuts early tube failures .....300D Mar  
 Richardson, R. L., Precise measurement of sawtooth linearity .....204D Nov  
 Riddle, R. L., High fidelity transistor power amplifier .....174D Sep  
 Robberson, E., How to design sailboat antennas .....140 Jun  
 Robinson, H. G. & Dessler, Dynamic characteristics of triode-connected pentodes .....208D Dec  
 Rockett, F., Metallic rectifiers approach infinite life .....162 Mar  
 Rockett, F., New delay materials improve performance .....144 Jan  
 Rockett, F., Special-purpose relays gain new uses .....150 Feb  
 Rogers, E. J., Current regulator for van de Graaff bagnet .....151 Oct  
 Roman, R. J., Modular bundles use etched-wiring boards .....230D Dec  
 Romander, H. & Watson, Navy transmitter uses frequency synthesizer .....138 Jan  
 Root, H. G., UHF rebroadcasting cuts costs .....131 May  
 Rose, A. F., Merrill & Smethurst, Repeater amplifies in either line direction .....164 Jan  
 Rosenberg, R. S., High-quality receiver for tv rebroadcasting .....152 Dec  
 Ross, I. & Nicholson, Kerr-cell shutter has submicrosecond speeds .....171 Jun  
 Roth, J., Automatic music-speech discriminator silences speaker .....162D Aug  
 Rubin, R., Abel, Adams, Alford & Leach, Empire state antenna for WOR-TV .....214D Apr  
 Rubinoff, M., Beter, Bradley & Brown, Directly coupled transistor circuits .....132 Jun  
 Rudenberg, H. C., Silicon power rectifiers for a-c line operation .....146 Apr

**S**

Sanderson, A. E., VHF transmission line calculator .....168 Dec  
 Sauber, J. W., Square-law detector for rms voltages .....170 Nov  
 Savant, C. A. & Savant, Electromechanical networks for a-c servo-systems .....190D Feb  
 Savant, C. A. & Savant, Notch network design (reference sheet) .....172 Sept  
 Savant, C. J., Jr., & Savant, Notch network design (reference sheet) .....172 Sept  
 Schacher, D., Star, Taub & Rabinowitz, Matrixing and encoding color for telecasting .....140 Nov  
 Scheldorf, M. W. & Klink, F-M antenna inside the a-m tower .....130 Aug  
 Schlesinger, K., Phase measurement for color tv and f-m .....142 Feb  
 Schrock, J. E., Launching control for guided missiles .....122 Feb  
 Schroeder, J. O., Differential gain set tests tv color .....114 Aug  
 Schroeder, J. O., Studio amplifier design for color television .....154 Mar  
 Schultz, C. W. & Roesen, Juke box uses ferrite-core memory .....138 Oct  
 Schwartz, M. & Jensen, Two-way uhf pack set uses helmet antenna .....150 Mar  
 Selar, N. & McFolin, Sawtooth pulser gives voltage-current curves .....156 Dec

Scott, R. E., Miller & Soltes, Wide-band analog function multiplier .....160 Feb  
 Seiter, J. G., Vacuum metallizing of selenium rectifiers .....258D Nov  
 Sharaf, H. M., Automatic recorder for complex impedances .....167 Sept  
 Sheehan, W. E. & Ivers, Design of transistorized high-gain portable .....159 Mar  
 Shepard, D. H. & Heasley, Photoelectric reader feeds business machines .....134 May  
 Shepard, W. L., One-man tv camera aligner .....214D Dec  
 Sherman, K. I., Eckess & Deavenport, Transistor pulse generators .....132 Nov  
 Shuck, L. M., Jeeps and electronics (letter) .....399D Oct  
 Sinish, R. D., Precision calibrator checks radar beacons .....150 Apr  
 Sion, E., Dielectric mixture chart (reference sheet) .....176 Apr  
 Sixbey, S. R. & Weiss, Target discriminator for countermeasures .....118 Aug  
 Slaughter, D. W., Feedback-stabilized transistor amplifier .....174 May  
 Slayton, W. P., Design of microwave gain-standard horn .....150 Jul  
 Sloan, L. G., Raible & Testerman, Highly regulated r-f voltage supply .....192D Apr  
 Smaller, P., Automatic programming cuts broadcasting costs .....135 Oct  
 Smethurst, J. O., Rose & Merrill, Repeater amplifies in either line direction .....164 Jan  
 Sodaro, J. F., Delay-line design (reference sheet) .....176 Jun  
 Sodaro, J. F., Phase-linearity nomograph (reference sheet) .....178 Apr  
 Soltes, A. S., Scott & Miller, Wide-band analog function multiplier .....160 Feb  
 Sommers, D. J., Photoetched antennas for supersonic aircraft .....130 Jul  
 Spaven, W. J., Tracing electron paths (reference sheet) .....174 Jun  
 Spencer, M. C., Squirrel-cage motor speed control system .....126 Aug  
 Spencer, N. A., Tunable cavity for X band oscillators .....135 Jan  
 Squires, F. H., Pictorial inspection records expedite flow of quality data .....234D May  
 Squires, W. K. & Wendt, Feedback clamp circuit for tv .....182D Jul  
 Staats, H. N., Detecting cracks in glass-to-metal seals .....284D Mar  
 Stanford, E., Automatic colorimeter for tv color tubes .....138 Dec  
 Star, M., Taub, Rabinowitz & Schacher, Matrixing and encoding color for telecasting .....140 Nov  
 Stephenson, J. G., Designing stable triode microwave oscillators .....184 Mar  
 Stinehelfer, H. E., Sr. & Vogler, Industrial microwave calibrator .....168 Jun  
 Storm, H. F., Four decades ago (letter) .....377D Apr  
 Struven, W. C., Precision time-delay .....218D Nov  
 Stull, K. S., Jr., Ultrasonic phase meter measures water velocity .....128 Sept  
 Sulzer, P. G., Audio oscillator has low distortion .....158 May  
 Suzzo, J. J. & Hooper, All-magnetic audio amplifier .....122 Sept  
 Suran, J. J., Double base expands diode applications .....198 Mar  
 Suran, J. J. & Keonian, Transistors generate multiwaveforms .....138 Jul  
 Swarthe, E. & Isborn, Counting labels with ferroresonant rings .....128 Oct  
 Szubski, T. & Hupert, Transistorized f-m signal generator .....133 Feb

**T**

Taboada, O., Wiant & Baker, Insect control by electron irradiation .....202D May  
 Taub, H. & Millman, Cathode compensation linearizes video stages .....156 Nov  
 Taub, H., Rabinowitz, Schacher & Star, Matrixing and encoding color for telecasting .....140 Nov  
 Taylor, J. W., Jr. & Moore, Transistor c-r tube deflection circuit .....146 Jul  
 Testerman, M. K., Sloan & Raible, Highly regulated r-f voltage supply .....192D Apr  
 Testerman, M. K. & Raible, Ion-gage supply protects tubes .....210D Feb  
 Thomas, H. E., Aligning tv receivers by pulse-cross display .....184D Apr  
 Thomas, H. E., Demars & Jones, Automatic damping improves tv monitor .....230D Mar  
 Thurston, E. G., Ice detector for lighter-than-air craft .....142 Dec  
 Tooke, P. E., Counting circuit batches components .....157 Feb  
 Traugott, P., More medical electronics (letter) .....382D Jun  
 Trinter, V. E., Fan-pencil antenna for search radars .....142 May  
 Tufte, R. & Nilsen, Comparator for small phase angles .....188D Jan

**U**

Uhlmann, W. E. M., Storage tube employs secondary emission .....161 Jan  
 Upham, J. L., Jr., Automatic a-c bridges sort ceramic capacitors .....106 Jul  
 Uyehara, G. U. & Grisamore, Pulse-series generator .....224D Mar

**V**

Van Wambeek, S. H., Audio tones control refinery operations .....130 Jan  
 Vavra, M. J. & Martin, Controlling sludge in etched wiring bath .....238D Nov  
 Vavra, M. J. & Martin, Substitutes for eyelets in etched wiring .....250D Dec  
 Vogler, J. G. & Stinehelfer, Industrial microwave calibrator .....168 Jun

**W**

Waidelich, D. L., Pulsed eddy currents gage plating thickness .....146 Nov  
 Watson, R. & Romander, Navy transmitter uses frequency synthesizer .....138 Jan  
 Weber, J. P., Home movie sound (letter) .....378D Feb  
 Webb, H. D., How to design overstaggered doublets (reference sheet) .....158 Jul  
 Webster, R. R., How to design i-f transistor transformers (reference sheet) .....156 Aug  
 Webster, R. R., I-F transistor transformers (letter) .....399D Oct  
 Weise, D. M., Video patch panel using r-f connectors .....210D Apr  
 Weiss, M. & Sixbey, Target discriminator for countermeasures .....118 Aug  
 Wendt, K. R. & Squires, Feedback clamp circuit for tv .....182D Jul  
 White, D. R. J. & Bradley, Band-pass filters using strip-line techniques .....152 May  
 White, J. R. & Burr, Simple color computer gives tristimulus values .....166 Oct  
 Wiant, D. E., Baker & Taboada, Insect control by electron irradiation .....202D May  
 Wild, J. J. & Reid, Ultrasonic ranging speeds cancer diagnosis .....174 Mar  
 Williams, C. E., Transistor amplifier performance .....196D Feb  
 Winnigstad, C. N., Generating r-f energy for 6-bev bevatron .....164 Feb  
 Witty, W. M., Modern fifty-kilowatt broadcast transmitter .....168 Mar  
 Wolf, E. & Longo, R-F filter design (reference sheet) .....176 Feb  
 Wolkstein, H. J. & Kaiser, Anode-cathode beam deflection amplifier .....132 Aug  
 Woll, H. J., All-pass amplifier .....155 Jul  
 Woods, R. W., Electronic switch for biological observations .....135 Dec  
 Woods, R. W., Improving cathode-follower frequency response .....190D Aug  
 Woodward, O. M., Jr., Epstein & Morrison, Extending uhf-tv with booster amplifiers .....112 Jul  
 Wouk, V., High-voltage supply uses electronic filter .....154 Aug  
 Wouk, V., Lissajous therapy (letter) .....484D Mar  
 Wulfsberg, K. N., Zener-voltage breakdown uses in silicon diodes .....182D Dec  
 Wynn, J. B., Jr., & Bower, Antenna system for missile telemetering .....164 Jun

**Z**

Zeluff, V. & Arnold, 25 years of electronics .....124 Apr  
 Zucchini, M., Autopilot magnetic servo amplifier .....208D May



**For The**

# Daven Company

**For You:** Progress and Service...

*...through greatly augmented engineering-research personnel, multiplied production facilities, delivery schedules to meet every deadline, far-reaching engineering assistance and new efficiencies in every department...to enhance Daven's reputation for leadership in the design, manufacture and supply of:*

Attenuators • Precision Wire Wound  
and Metal Film Resistors • Rotary Switches •  
Electronic Test Equipment

**THE MOST  
MODERN  
ELECTRONIC  
COMPONENTS  
PLANT  
IN THE  
WORLD...**

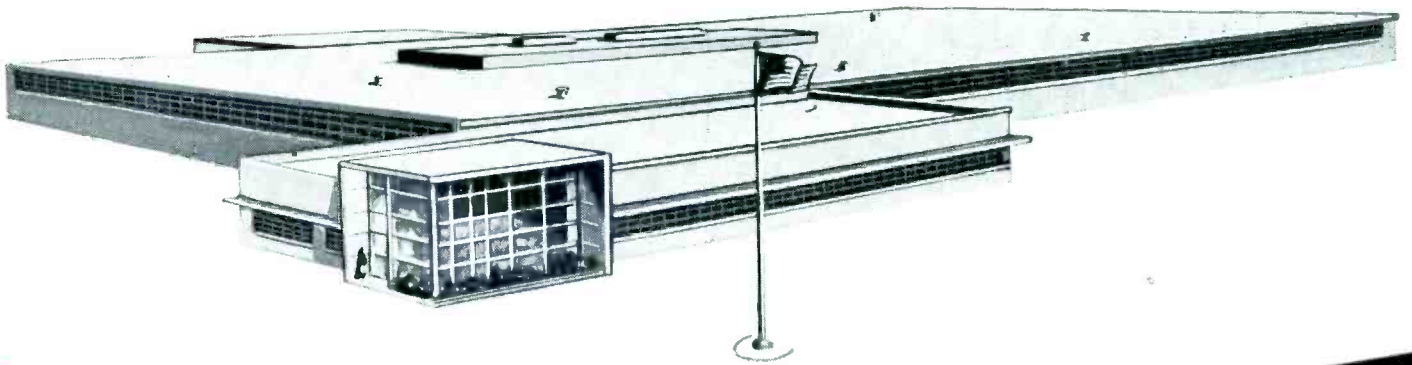

**THE DAVEN CO.**

526 West Mt. Pleasant Avenue,

TODAY, MORE THAN EVER, THE DAVEN <sup>®</sup>  
STANDS FOR DEPENDABILITY!

Route 10, Livingston, New Jersey

# RCA WT-100A Electron-Tube MICROMHOMETER

## NEW VERSATILE TUBE TESTER!

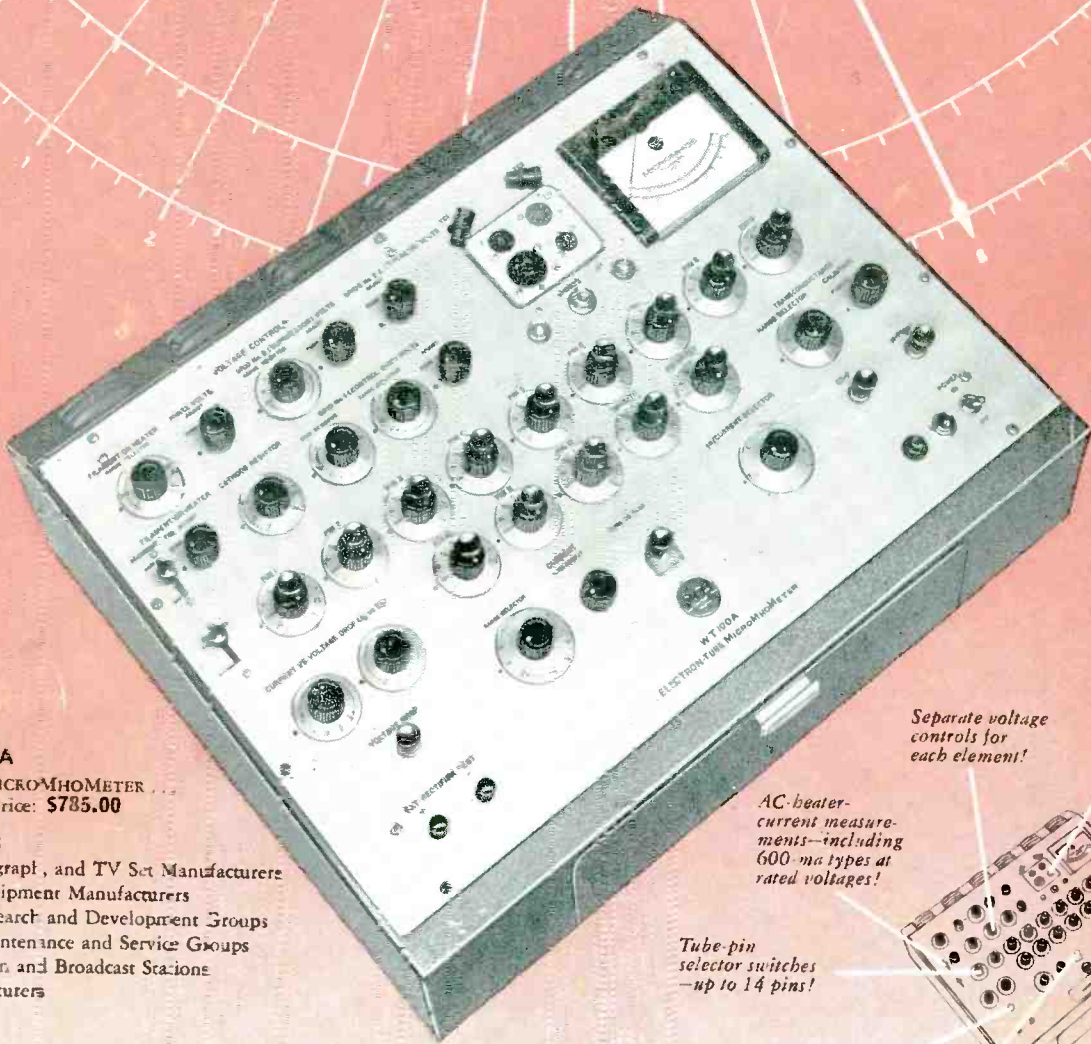

### RCA-WT-100A

Electron-Tube MICROMHOMETER  
Suggested User Price: \$785.00

#### Practical for:

- Radio, Phonograph, and TV Set Manufacturers
- Electronic Equipment Manufacturers
- Electronic Research and Development Groups
- Electronic Maintenance and Service Groups
- Communication and Broadcast Stations
- Tube Manufacturers

**... has accuracy approaching that of tube-factory equipment for measuring true gm**

The new RCA-WT-100A Electron-Tube MICROMHOMETER is especially suited for laboratory and production-line testing, and circuit design engineering. Unique design makes possible the testing of receiving tubes, receiving-type tubes for industry and communications, and small transmitting tubes under actual operating voltage and current conditions. This feature permits *direct correlation* of test results with tube manufacturers' published data—and, in design work, permits the determination of a tube's performance under a given set of current and voltage conditions. The MICROMHOMETER is manufactured in accordance with the same rigid standards of high quality that account for the outstanding reputation of RCA tubes. The WT-100A weighs only 50 pounds; measures 23½" x 3" x 18½".

Plug-in, miniature-socket attachments—new socket types easily added!

Separate voltage controls for each element!

Burn-out proof meter—electronically protected.

AC heater-current measurements—including 600-ma types at rated voltages!

Built-in 2% calibration circuit!

Tube-pin selector switches—up to 14 pins!

Voltage-drop measurements across tubes, dry-disc rectifiers, and crystal diodes!

Measures currents up to 300-ma in 11 ranges—as low as 3 μamp full scale!

Storage compartment for Euc-in multiple-socket attachments!

Control-grid-to-plate and suppressor-grid-to-plate transconductance measurements to 100,000 micromhos!

No inconvenient patchcords—no external null indicators required! Highly accurate, repeatable measurements! Built-in voltage-regulated power supply provides voltages to 300 volts; provides currents to 300 ma!



**RADIO CORPORATION of AMERICA**  
TUBE DIVISION

HARRISON, N. J.

For descriptive information, call or write your RCA Representative or write Commercial Engineering, RCA, Section L-19-a Harrison, N. J.