

JUNE · 1954

PRICE 75 CENTS

electronics

A MCGRAW-HILL PUBLICATION

**Automatic
Astronomer
Finds Stars
Quickly**

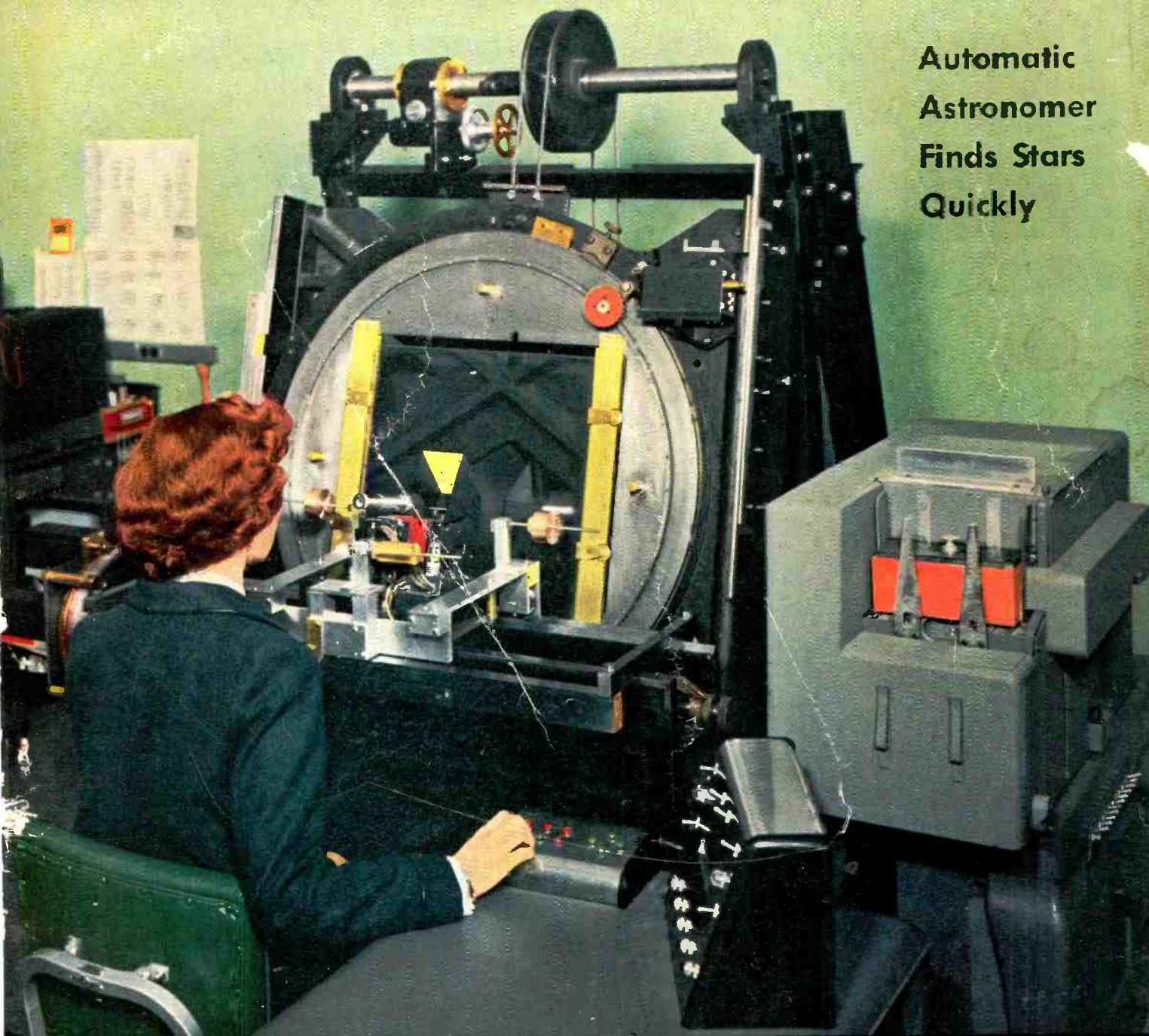



NEW "M" TYPE TOROIDS Maximum Q Minimum Size

UTC Permalloy Dust Toroids have been the standard of the industry for over 15 years. The MQ series of coils provide the highest Q factor in their class (see curves below), with miniaturized dimensions. All units are hermetically sealed to MIL-T-27 Specifications.

The stability is excellent. For the MQE-7 the inductance change is less than 1% for voltages from .1 to 3 volts. The MQA-13 change is less than 1% for applied voltages from .1 to 20 volts. The MQB-5 change is less than 1% for applied voltages from .1 to 50 volts. DC is permissible through the coil (values listed below). Inductance is virtually independent of frequency temperature and vibration.

Mum pickup is extremely low due to the toroidal winding structure, with windings uniformly spread over the core. The case is of high permeability, affording additional shielding such that close spacing of units can be effected, the coupling attenuation being approximately 80 DB.

Other values of inductance than those listed are available on special order at the price of the next higher listed value.

TYPICAL Q CURVES

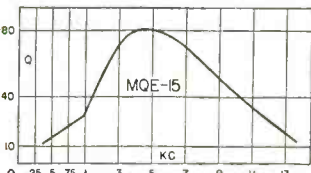
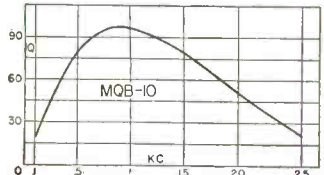
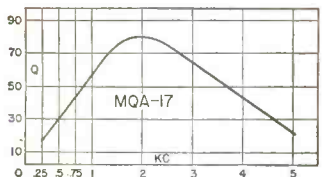
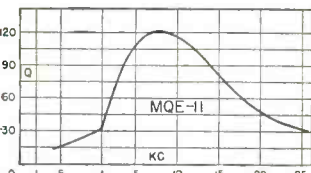
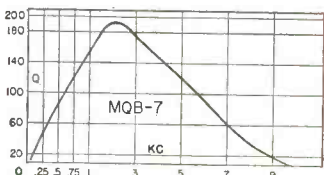
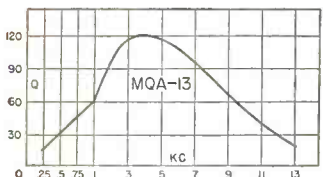
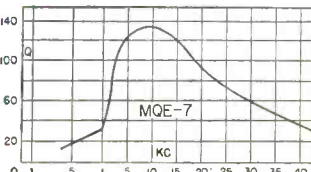
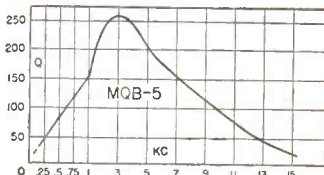
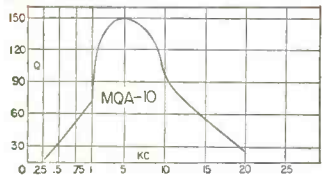
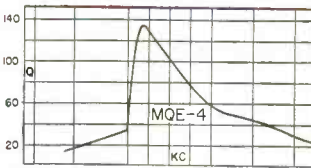
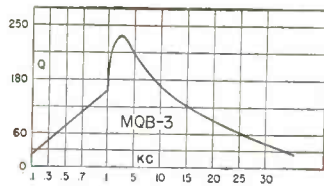
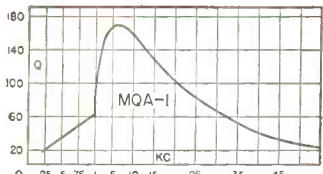

MQA TYPES

Type No.	Inductance	*DC Max.
MQA-1	7 mhy.	250
MQA-2	12 mhy.	200
MQA-3	20 mhy.	150
MQA-4	30 mhy.	125
MQA-5	50 mhy.	100
MQA-6	70 mhy.	80
MQA-7	120 mhy.	60
MQA-8	.2 hy.	50
MQA-9	.3 hy.	40
MQA-10	.5 hy.	30
MQA-11	.7 hy.	25
MQA-12	1 hy.	20
MQA-13	1.5 hy.	17
MQA-14	2.5 hy.	13
MQA-15	4 hy.	10
MQA-16	6 hy.	9
MQA-17	10 hy.	7
MQA-18	15 hy.	5
MQA-19	22 hy.	4

MQB TYPES

Type No.	Inductance	*DC Max.
MQB-1	10 mhy.	400
MQB-2	30 mhy.	250
MQB-3	70 mhy.	170
MQB-4	120 mhy.	120
MQB-5	.5 hy.	60
MQB-6	1 hy.	40
MQB-7	2 hy.	30
MQB-8	3.5 hy.	22
MQB-9	7.5 hy.	16
MQB-10	12 hy.	11
MQB-11	18 hy.	9
MQB-12	25 hy.	8

MQE TYPES

Type No.	Inductance	*DC Max.
MQE-1	7 mhy.	135
MQE-2	12 mhy.	100
MQE-3	20 mhy.	80
MQE-4	30 mhy.	65
MQE-5	50 mhy.	50
MQE-6	70 mhy.	40
MQE-7	100 mhy.	35
MQE-8	150 mhy.	30
MQE-9	.25 hy.	22
MQE-10	.4 hy.	17
MQE-11	.6 hy.	14
MQE-12	.9 hy.	12
MQE-13	1.5 hy.	9
MQE-14	2 hy.	8
MQE-15	2.8 hy.	7.2



MQE CASE

Length 1 1/16"
Width 1/2"
Height 17/32"
Unit Weight 1.5 oz.



MQA CASE

Length 1 9/32"
Width 1 1/16"
Height 1 23/32"
Unit Weight 4 oz.

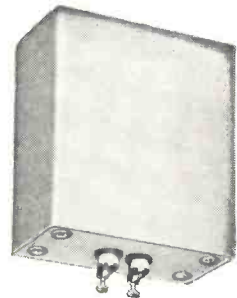

MQB CASE

Length 2 9/16"
Width 1 13/16"
Height 2 13/16"
Unit Weight 14 oz.

*This value of D.C. (MA) will drop the coil inductance 5%. Values of D.C. below this will show proportionately (linear) less inductance drop. For example, MQE-1 will drop 1/2 in L with 13.5 MA.

United Transformer Co.
150 VARICK STREET NEW YORK 13, N. Y.

EXPORT DIVISION: 13 EAST 40th STREET, NEW YORK 16, N. Y., CABLES: "ARLAB"

AUTOMATIC ASTRONOMER FIND STARS QUICKLY—Computer-controlled machine built by Watson Scientific Computing Laboratory of Columbia University locates on photographic plate stars called for by IBM punched card (see p 158)

Figures of the Month	4
Industry Report	5
Field Pulses Produce Nuclear Spin Echoes	by Leonard Malling 134
Cosecant Antenna Aids UHF-TV Coverage	by John E. Martin and John Ruze 138
Color Bar Generator Produces I-Q Signals	by Archie F. Boscia 143
Temperature-Stabilized Transistor Amplifiers	by Harold J. Tate 144
Parachute-Borne Telemetry System	by M. L. Greenough and C. C. Gordon 148
Microwave Relay for Japanese Television	by Tatsuji Nomura, Keiji Suzuki, Shigeru Mita and Norikazu Sawazaki 152
Altitude Corrector for Tracking Radars	by W. R. McQuiston 157
Automatic Measurement of Star Positions	by John Lentz and Richard Bennett 158
Color Demodulators for Television Receivers	by E. G. Clark and C. H. Phillips 164
Delay-Line Dummy Load Has High Power Rating	by H. Brueckmann 167
Improved Demodulator for Radar Ranging	by C. E. Goodell 170
Noncontacting Gage for Microdisplacements	by Harold M. Sharaf 172
Transistor Flip-Flop Uses Two Frequencies	by R. L. Brock 175
Electronic Shake Table	by Pierre M. Honnell 178
Sensitive Receiver for VOR-ILS-Communications	by G. W. Gray 180
Long-Period Timer	by S. Rozenstein and E. Gross 185
Sequentially Gated Automatic Gain Control	by Marcus C. Eliason 186
Frequency Meter Uses Digital Counters	by A. F. Boff 189
TV Lighting Calculator (Reference Sheet)	by Joseph F. Sodaro 192
Power-Level Nomograph (Reference Sheet)	by Theodore Halabi 194
Crosstalk.....133 Electrons at Work.....196 Production Techniques.....246 New Products.....282	
Plants and People.....328 New Books.....368 Backtalk.....378 Index to Advertisers.....415	

W. W. MacDONALD, Editor; **VIN ZELUFF**, Managing Editor; John Markus, A. A. McKenzie, John M. Carroll, Associate Editors; William P. O'Brien, William G. Arnold, David A. Findlay, Haig A. Manoogian, Edmund B. Palmquist, Assistant Editors; Marilyn Wood, Gloria J. Filippone, Arlene Schilp, Editorial Assistants; Keith Henney, Consulting Editor; Gladys T. Montgomery, Washington Editor; Harry Phillips, Art Director; Eleanor Luke, Art Assistant

H. W. MATEER, Publisher; **WALLACE B. BLOOD**, Manager; R. S. Quint, Buyers' Guide Manager; Frank H. Ward, Business Manager; H. E. Hilty, Classified Manager; D. H. Miller, James Girdwood, New York; Wm. S. Hodgkinson, New England; Warren W. Shew, Philadelphia; Charles Wardner, James T. Hauptli, Chicago; J. L. Phillips, Cleveland; T. H. Carmody, R. C. Alcorn, San Francisco; Carl W. Dysinger, Los Angeles; Robert H. Sidur, Atlanta



JUNE, 1954

ELECTRONICS
Member AEC and ABP

Vol. 27, No. 6



Published monthly with an additional issue in June by McGraw-Hill Publishing Company, Inc., James H. McGraw (1860-1948), Founder. Publication Office, 99-129 North Broadway, Albany 1, N. Y.

Executive, Editorial and Advertising Offices: McGraw-Hill Building, 330 W. 42 St., New York 36, N. Y. Donald C. McGraw, President; Willard Chevalier, Executive Vice-President; Joseph A. Gerardi, Vice-President and Treasurer; John J. Cooke, Secretary; Paul Montgomery, Senior Vice-President, Publication Division; Ralph B. Smith, Vice-President and Editorial Director; Nelson Bond, Vice-President and Director of Advertising; J. E. Blackburn, Jr., Vice-President and Director of Circulation.

Subscriptions: Address correspondence to Electronics—Subscription Service, 99-129 N. Broadway, Albany 1, N. Y., or 330 W. 42nd St., New York 36, N. Y. Allow one month for change of address. Subscriptions are solicited only from persons engaged in theory, research, design, production, maintenance and use of electronic and industrial control components, parts and end products. Position and company connection must be indicated on subscription orders.

Single copies 75¢ for United States and possessions, and Canada; \$1.50 for Latin America; \$2.00 for all other foreign countries. Buyers' Guide \$2.00. Subscription rates—United States and possessions, \$6.00 a year; \$9.00 for two years. Canada, \$10.00 a year; \$18.00 for two years. Other western hemisphere countries, \$15.00 a year; \$25.00 for two years. All other countries \$20.00 a year; \$30.00 for two years. Entered as second class matter August 29, 1936, at the Post Office at Albany, N. Y., under act of Mar. 3, 1879. Printed in U.S.A. Copyright 1954 by McGraw-Hill Publishing Co., Inc.—All Rights Reserved. BRANCH OFFICES: 520 North Michigan Avenue, Chicago 11, Ill.; 68 Post Street, San Francisco 4; McGraw-Hill House, London, E.C. 4; Washington, D. C. 4; Philadelphia 3; Cleveland 15; Detroit 26; St. Louis 8; Boston 16; 1321 Rhodes-Haverty Bldg., Atlanta 3, Ga.; 1111 Wilshire Blvd., Los Angeles 17; 738-9 Oliver Building, Pittsburgh 22. ELECTRONICS is indexed regularly in The Engineering Index.

HIGH CURRENT REGULATED DC SUPPLY

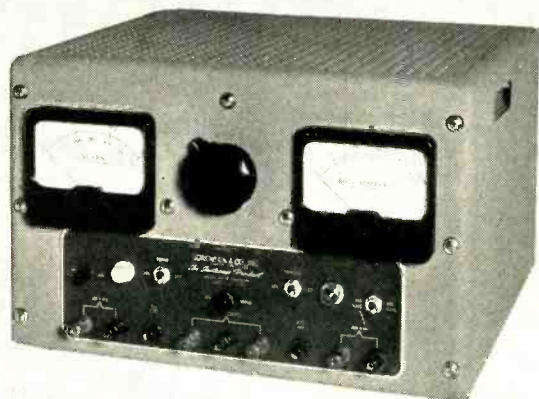

We have been repeatedly advised of the need for a laboratory power supply with current capacity of up to one-half ampere. During the design of the unit it appeared desirable that it should embody characteristics making it suitable for pulse work.

The result is our new Model 600B which we believe merits your attention by its reduced ripple, its internal impedance specifications, and its incorporation of type 5651 tubes to increase long-term stability of output voltage.

Look at these specifications

Output voltage	0-600 VDC
Output current	0-500 Ma
Regulation accuracy	$\pm 0.25\%$ above 100 VDC $\pm 0.5\%$ below 100 VDC
Ripple (mV-RMS)	3 maximum
Bias supply	0-150 VDC
Maximum bias circuit impedance	50000 ohms
Internal impedance, maximum	2.0 ohms
Input range	105-125 VAC, 1 ϕ ; 50-60 \sim
AC voltage unregulated	6.3 VAC, C.T., at 15 amperes

INTERNAL IMPEDANCE

The internal impedance of 2.0 ohms is determined by making measurements in accordance with I.R.E. specifications for the measurement of power supply internal impedance (cf. *The Proceedings of the I.R.E.*, January, 1951). However, this can be expressed in a slightly different manner. The 2.0 ohms impedance applies for frequencies above 20 cycles. Typical measurements indicate that at 10 kc impedance is 0.5 ohms in series with 18 microhenries, and at 20 kc it is 0.5 ohms in series with 8 microhenries.

RECOVERY TIME

Typical measurements indicate a recovery time of 1 millisecond when a load of $\frac{1}{2}$ ampere is applied. It is approximately 0.5 milliseconds when load is decreased from full to no load, and is in the order of 0.2 milliseconds when load is decreased from full to $\frac{1}{10}$ load.

REGULATION ACCURACY

The regulation accuracy applies where

there is load change from zero to full at a fixed input voltage within the rating, or against an input change between 105 and 125 volts at a fixed load within rating. This accuracy applies down to 30 VDC. Below 10 volts the changes due to circuit instability are greater than those due to line or load conditions.

BIAS SUPPLY

The bias supply accuracy is $\pm 0.5\%$ at maximum output voltage and from 0-5 ma.

TUBE COMPLEMENT

OD3 (2), 5651 (1), 5R4 (3), 6L6 (7), 6BQ6 (1), 6SL7 (1), 5Y3 (1).

MECHANICAL SPECIFICATIONS

The instrument is 17" long, 10 $\frac{1}{2}$ " high, and 14 $\frac{7}{8}$ " deep. Net weight is 85 pounds. The unit is self-contained, but a panel is available; its dimensions are 19" long by 12 $\frac{1}{4}$ " high.

PRICE

\$395.00 f.o.b. Stamford, Conn.

Other B Supplies are available in the standard Sorenson line, as well as Nobatrons* (low-voltage, high-current regulated DC sources), AC regulators, frequency changers, and other power regulating equipment. Write for the new general catalog to Sorenson & Co., Inc., 375 Fairfield Ave., Stamford, Conn. In Europe, please correspond directly with Sorenson A.G., Gartenstrasse 26, Zurich 2, Switzerland.

SORENSEN

Sorenson & Company, Inc., 375 Fairfield Ave., Stamford, Conn.

*Reg. U. S. Pat. Off. by Sorenson & Co., Inc.

The scientific approach to vibration measurement



THE D-489
MUIRHEAD - PAMETRADA
WAVE ANALYSER

WITH the Muirhead-Pametrada Wave Analyser the localization of obscure vibrations can be carried out systematically. Designed specifically for such measurements, this instrument covers a range of 19-21,000 c/s with an accuracy of $\pm 0.5\%$. Its high selectivity enables component frequencies close to one another to be measured; the flat top of the tuning characteristic can be varied to simplify measurements of fluctuating frequencies.

In almost every branch of engineering there is a use for this novel instrument.

FEATURES

- Wide frequency band — 19c/s to 21 kc/s in 9 overlapping ranges
- Frequency accuracy $\pm 0.5\%$ over entire range
- Response flat within ± 2 db over entire range
- Flat-topped response curve — narrow or wide bandwidth selected at will
- Off-peak response proportional to percentage mistuning
- Output frequency is that of the selected component, and is available for oscilloscope viewing
- Octave discrimination better than 70db
- Mains operated from a separate stabilized supply unit

MAIL THIS COUPON FOR DESCRIPTIVE BROCHURE

WHICH WILL BE SENT FREE ON REQUEST

NAME _____

POSITION _____

COMPANY _____

MAILING ADDRESS _____

MUIRHEAD & CO. LIMITED · BECKENHAM · KENT · ENGLAND
MAKERS OF HIGH GRADE PRECISION ELECTRICAL INSTRUMENTS

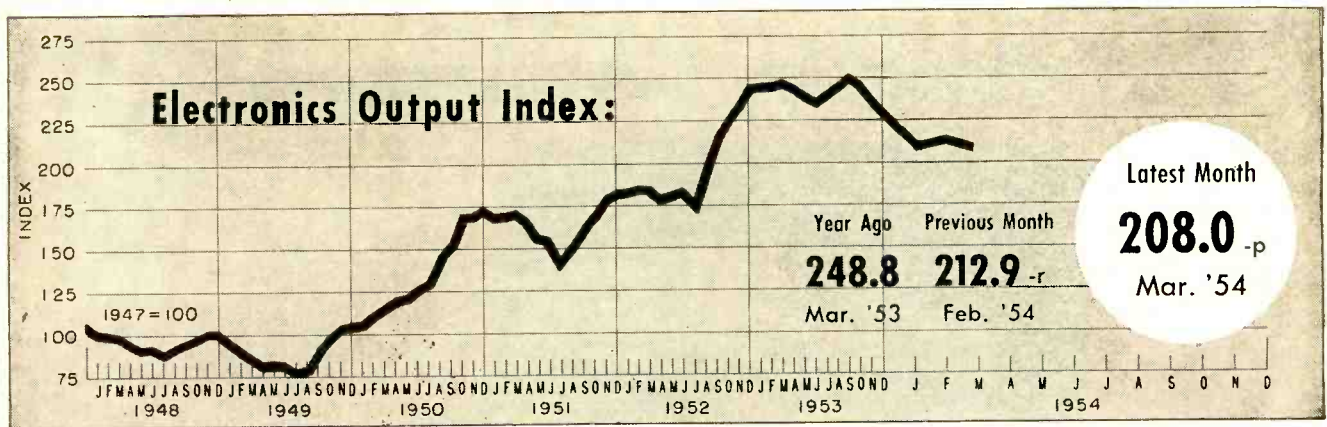

FIGURES OF THE MONTH

	Year Ago	Previous Month	Latest Month
RECEIVER PRODUCTION (Source: RETMA)	Mar. '53	Feb. '54	Mar. '54
Television sets	810,112	426,933	599,606
Home sets	442,101	233,063	244,110
Clock Radios	275,079	105,933	119,863
Portable sets	177,656	98,275	206,130
Auto sets	654,367	331,961	370,249

	Year Ago	Previous Month	Latest Month
RECEIVER SALES (Source: RETMA)	Mar. '53	Feb. '54	Mar. '54
Television sets, units...	603,704	536,017	512,861
Radio sets (except auto)	516,618	262,679	486,034

	Year Ago	Previous Month	Latest Month
RECEIVING TUBE SALES (Source: RETMA)	Mar. '53	Feb. '54	Mar. '54
Receiv. tubes, total units	44,691,200	25,189,147	29,063,484
Receiv. tubes, value...	\$29,978,827	\$18,319,819	\$22,130,627
Pic. tubes, total units...	974,154	645,715	759,468
Picture tubes, value...	\$23,772,801	\$13,916,478	\$15,904,687

	Year Ago	Previous Month	Latest Month
SEMICONDUCTOR SALES (Source: RETMA)	Mar. '53	Feb. '54	Mar. '54
Germanium Diodes	1,172,475	815,824	1,061,010
Silicon Diodes			

	Quarterly Figures		
	Year Ago	Previous Quarter	Latest Quarter
INDUSTRIAL TUBE SALES (Source: NEMA)	4th '52	3rd '53	4th '53
Vacuum (non-receiving)	\$12,790,000	\$9,434,082	\$9,467,331
Gas or vapor	\$3,480,000	\$4,145,018	\$4,854,222
Phototubes	\$760,000	\$510,686	\$405,000
Magnetrons and velocity modulation tubes...	\$10,510,000	\$9,822,600	\$13,073,095
Gaps and T/R boxes...	\$2,090,000	\$1,554,000	\$1,707,730

	Year Ago	Previous Month	Latest Month
TV AUDIENCE (Source: Television Magazine)	May '53	Apr. '54	May '54
TV Homes—Total	29,565,759

	Year Ago	Previous Month	Latest Month
BROADCAST STATIONS Source: (FCC)	Apr. '53	Mar. '54	Apr. '54
TV Stations on Air...	179	385	387
TV Stns CPs—not on air	264	190	190
TV Stns—Applications	612	72	52
AM Stations on Air...	2,430	2,539	2,563
AM Stns CPs—not on air	135	129	112
AM Stns—Applications	249	163	158
FM Stations on Air...	600	555	552
FM Stns CPs—not on air	21	15	16
FM Stns—Applications	9	3	4

	Year Ago	Previous Month	Latest Month
COMMUNICATION AUTHORIZATIONS Source: (FCC)	Mar. '53	Feb. '54	Mar. '54
Aeronautical	38,822	43,682	43,324
Marine	39,425	44,140	44,598
Police, fire, etc.	12,682	15,003	15,065
Industrial	16,232	20,280	20,599
Land Transportation ..	5,660	6,600	6,758
Amateur	112,666	117,427	118,750
Citizens Radio	1,980	5,550	5,612
Disaster	189	257	259
Experimental	415	532	544
Common carrier	1,094	1,490	1,534

	Year Ago	Previous Month	Latest Month
EMPLOYMENT AND PAYROLLS (Source: Bur. Labor Statistics)	Feb. '53	Jan. '54	Feb. '54
Prod. workers, comm. equip.	418.1	352.6 -r	347.4
Av. wkly. earnings, comm. ...	\$65.77	\$65.96-r	\$68.06
Av. wkly. earnings, radio...	\$63.92	\$65.02-r	\$67.03
Av. wkly. hours, comm.	40.6	38.8	39.8
Av. wkly. hours, radio.....	40.2	38.7 -r	39.9

	Year Ago	Previous Month	Latest Month
STOCK PRICE AVERAGES (Source: Standard and Poor's)	Apr. '53	Mar. '54	Apr. '54
Radio—TV & Electronics	298.9	301.9	304.0
Radio Broadcasters ...	290.7	302.1	309.5

p—provisional; r—revised

FIGURES OF THE YEAR

	1953 Total	TOTALS FOR THE FIRST QUARTER		
		1953	1954	Percent Change
Television set production	7,214,787	2,259,943	1,447,110	—36.0
Radio set production	13,368,556	3,834,784	2,581,565	—32.6
Television set sales	6,375,279	1,780,899	1,780,795	—
Radio set sales (except auto)	7,064,485	1,438,866	1,059,336	—26.4
Receiving tube sales	437,091,555	122,058,756	76,385,978	—37.4
Cathode-ray tube sales	7,582,835	2,798,921	1,962,864	—29.9

INDUSTRY REPORT

electronics—June • 1954



DESIGNED for mass production and operation by anyone capable of using an existing business machine, this desk-size computer may prove . . .

Small Brain Can Do Big Jobs Fast

Electronic calculator the size of desk adds two twelve-digit numbers in 2/1,000 second

SUCCESS of computing techniques for business and automation depends upon continual evolution of useful, compact and inexpensive electronic brains. Giant computers needed to solve complex missile guidance, aerodynamic and basic research problems cost anywhere from millions to at least \$500,000. Business needs more equipment intermediate between this and the desk-top calculator.

► **Desk-Size Machine**—One recent approach to fulfilling this need is

suggested by Burroughs, long-time manufacturer of mechanical calculators. Their desk-size machine combines the electrochemical and electronic approach, using some 160 tubes and many germanium diodes. Not yet in production, but operating in prototype form, the machine is expected to sell for \$30,000 in mass production. Initial computers will probably be handled on a rental basis to enable Burroughs to gain practical experience in this field.

► **Simple to Operate**—Data is introduced with a keyboard and answers are printed at 24 characters a second. A magnetic-drum memory stores information like tables of interest rates and logarithms. An op-

erator trained for only an hour and forty minutes computed real estate tax assessments, rate of climb and path of a guided missile and determined power capacity of a hydroelectric system consisting of three dams in the initial demonstration at Detroit.

Diverging Trends Beset UHF Television

Receiver production is substantial but number of stations in operation levels off

THE INDUSTRY is keeping close watch on the uhf television picture. Another appraisal of uhf tv economics was scheduled for late in May by a subcommittee of the Senate Commerce Committee. Representatives of uhf stations, uhf associations and uhf set makers appear at the hearings.

► **Sets**—Factory production of sets with uhf tuning facilities is proceeding at a healthy rate. Since the beginning of 1953 over 1.8 million uhf sets have been produced representing 20 percent of total tv output. At the present production rate the percentage by the end of this year is expected to be substantially higher.

► **Stations**—The number of uhf stations in operation leveled off at the beginning of May. New uhf stations going on the air have taken up the slack of those who have gone off.

About 60 uhf applicants who were granted cp's have withdrawn applications. Two radio stations in New York City are among the latest to do so. One stated the rea-

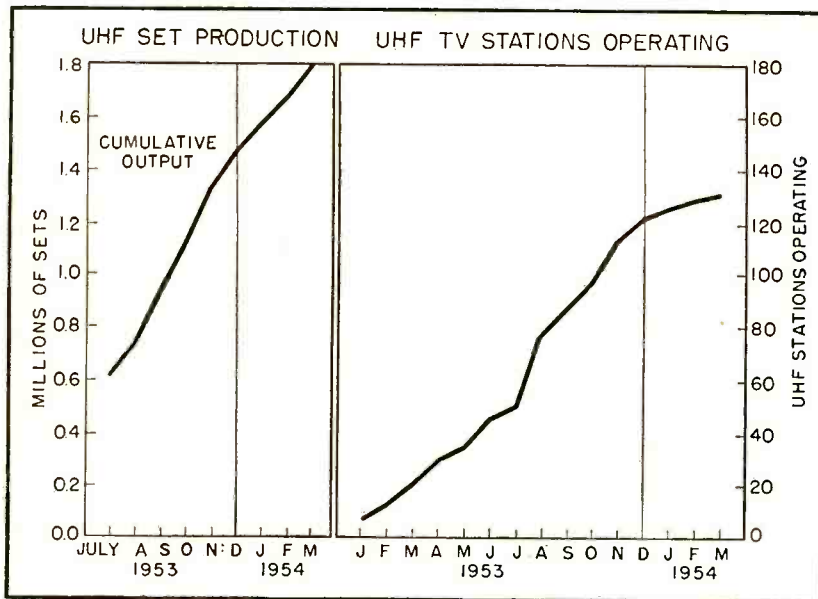

Shadow-Mask Makers Profit With Color

SIZABLE new business developing as a result of color television is aperture-mask manufacturing. In pilot quantities, it is estimated that the price of a finished mask could run as high as \$20 per unit. However, with mass production the cost could drop to \$5 or lower as new techniques are developed.

► **How**—Many of the shadow-masks produced so far have been made in a two-step operation. The holes are etched first in a sheet of cupro nickel made of 70-percent copper and 30-percent nickel by a photo-etching subcontractor. It is then shipped to a precision-metal subcontractor for final finishing and shaping for either the curved or flat form.

Business for these sub-contractors has already been substantial. One photo-etching firm estimates that it produced nearly 8,000 masks in March of this year. In April, however, production dropped sharply as the industry switched to 19-inch color-tube production. However, mask suppliers say they can set up to produce 20,000 masks a month if demand calls for it.

son as being that economic problems involved in starting a uhf station in New York at present seemed insurmountable.

► **Manufacturers** — Experimental field tests of a system that utilizes a low-powered auxiliary transmitter to extend coverage of uhf tv stations to shadowed areas will be made by RCA in cooperation with WJTV in Jackson, Miss.

Six types of 12 kilowatt klystrons have been added by GE to its initial equipment and distributor

sales lines. Since early 1953, GE has equipped 35 stations with the tubes.

Stations use klystrons under direct lease from GE but may now either lease the tubes or purchase them outright. The tubes have been added to the distributor sales line at a list price of \$10,000 each. They operate in uhf band, and each type will provide 12 kilowatts of power output at synchronizing peak level with a power gain of 200 in broadband visual service.

Industry Scores Automation Progress

Methods are reviewed, costs are scrutinized and new advances described at symposium

EVALUATION of the problem of automatizing production lines was made at a symposium in San Francisco on automatic production of electronic equipment co-sponsored by the Stanford Research Institute and the U. S. Air Force.

► **Methods** — Stanford's Research's automatic factory research program, under sponsorship of the Air Force, was described. It proposes a line of single-purpose machines that could be installed one by one in a manual line to enable

gradual conversion to automation in a small factory. The machines would assemble components of conventional construction but with standardized dimensions, in modular increments of 0.1 in., and would use some type of feedback control.

A similar approach to automation, Project Mini-Mach, is being made for the Navy under a Bureau of Ships contract by Melpar of Alexandria, Va.

It uses standard components in a punch-tape controlled assembly line, with a subassembly technique that is basically that of securing component boards together in a deck-like manner, mechanically supported by and spaced from adjacent decks by a special combination of

male-female connectors. Wiring between components and between decks is entirely eliminated.

A modular coordinate system is used to locate the components; the location is coded digitally and recorded on a storage medium. A geometrical description of the entire equipment can be obtained by giving a set of component numbers which choose the component type and size, together with another set of numbers giving the location of the component.

It was explained that a high degree of component accessibility is achieved, since the wafers are detachable for inspection and repair.

(Continued on page 8)

For Improved and More Compact Circuits!

Sylvania's versatile new
POWER TRANSISTOR
2N68

Here's a simple, rugged unit which provides an efficient solution to numerous power requirements including: Servo systems, control applications, and compact radio receivers.

This versatile Sylvania development permits 1.5 watts dissipation with no external heat sink. Its power gain is better than 10 db. And, it may be mounted in any position, with lead wires soldered or clipped for socket mounting. For further details and technical data, write today to Dept. 4E-1606, Sylvania.

Electrical Ratings

Collector to Base Voltage	-25 volts
Collector Current	-1.5 amps.
Dissipation in Free Air	1.5 watts

Typical Operating Conditions

Push-Pull Class B Amplifier ...	Grounded Grid or AC Grounded Collector Circuit.
Power Output	3 watts (MIN)
Collector Voltage	-12 volts
Load Resistance	24 ohms to each transistor.
Collector Current @ Zero Output	-5 ma
Collector Current @ 3 Watts Output	-320 ma
Collector Efficiency @ 3 Watts Output75%
Power Gain	> 10 db
Frequency Response	> 10 KC

Another reason why it pays to specify Sylvania

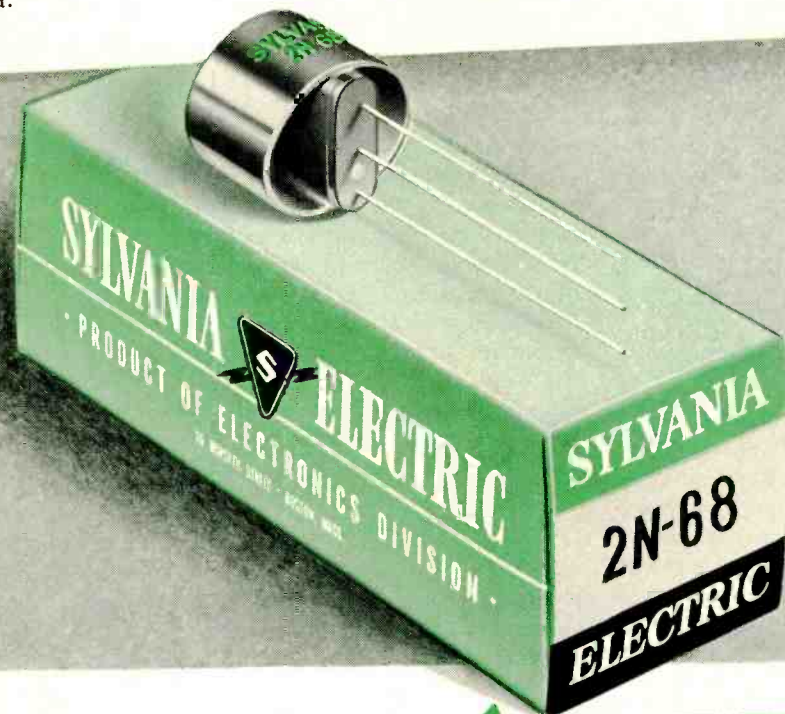

SYLVANIA

Sylvania Electric Products Inc.,  1740 Broadway, New York 19, N. Y.

In Canada: Sylvania Electric (Canada) Ltd., University Tower Bldg., St. Catherine Street, Montreal, P. Q.

LIGHTING • RADIO • ELECTRONICS • TELEVISION

In insertion operations, a tool and anvil combine to effect mechanical fastening of the component to the wafer exclusive of soldering support, and fastening and soldering operations are combined or superimposed. All pertinent conductive surfaces are precoated with solder before entering the assembly machinery so that soldering is reduced to the controlled and precise application of heat by the anvil.

Melpar estimates the machines will produce a two-wafer assembly at a rate of two per minute and that it would be economical to produce as few as 100 of these units between changeovers.

► **Cost**—Attention was focused on the cost factor in automation. It was indicated that major costs in the electronic field were for components, and that automation efforts should be concentrated on standardizing and cutting costs of these.

Cost of assembling typical electronic equipment, it was estimated, included only 10 to 20% for labor, so that little could be saved there. Automation in manufacture of components was described as a fertile field, however, since 60 to 80 percent of equipment assembly costs are for materials.

► **Advances** — Emerson reported that it is working with a conductive adhesive to replace hand soldering operations.

Sylvania Electric Products announced a new high-speed automatic technique for the manufacture of transformer coils. Under the process, the coils are made by rolling together wide sheets of metal foil and insulating paper. The roll is then sliced to form the windings of a transformer or a complete r-f coil.

Sylvania also announced the design of a receiving-tube mount structure adapted to automatic assembly.

The tube mount, developed under a Bureau of Ships contract, uses ceramic to replace mica and glass. The elements are stacked on two ceramic pins, separated by ceramic spacers held to thickness tolerances of 0.0005 inch.

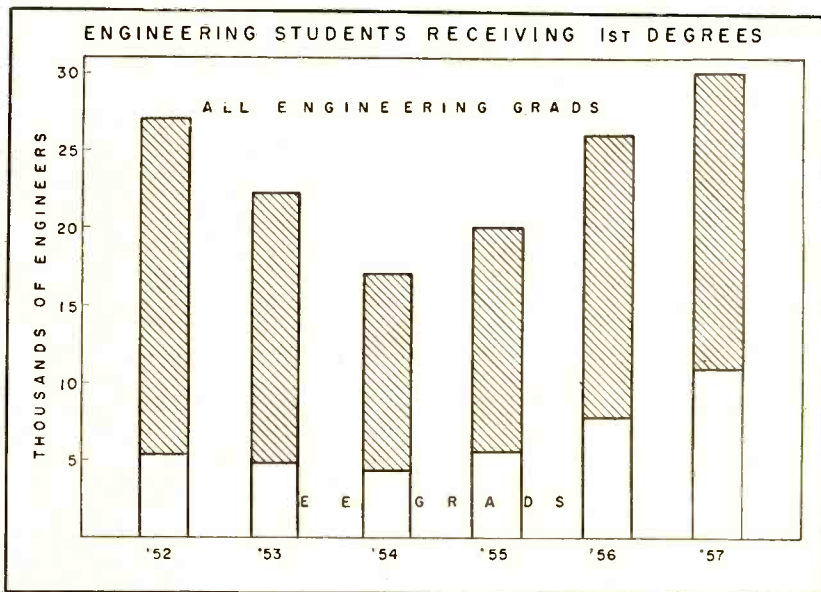

SUPPLY of young engineering graduates hits low point, but . . .

Grads Find Gold Rush Over

Firms besiege top students; low men find little choice; some older engineers are out

ACCORDING TO ELECTRONICS, survey of nearly 80 percent of American engineering colleges and universities, a total of 4,400 students will receive first degree in electrical engineering this June. Of this number, 3,600 indicate that they will be available to accept industrial employment.

Ten percent of the total (440 men) will enter the armed forces by way of R.O.T.C. or regular commissioning while approximately 330 will remain in school for graduate studies.

► **Other Fields**—Although the electronics industry will draw largely from among electrical engineering graduates many mechanical, industrial and chemical engineers and engineering physicists are also sought. Total engineering graduates in all curricula this June will be 22,270.

Engineering educators report that interviewers on college campuses this spring are placing greater stress upon academic standing than at any time since the Korean war began back in 1950. Men

in the top five percent of the class grade-wise can often choose from as many as six offers.

► **Salaries** — Average starting salary for engineers in all fields is \$336 a month. This is up \$10 over June 1953 figures. Top offer made by any of the 50 large companies reporting salary data is \$438 while the low is \$247. Salaries offered depend largely upon the graduates academic grades.

A potential surplus of engineering talent appears to be developing among some engineers in the 45-48 age bracket. Some observers attribute this to cutting of expenses by some firms. This trend presumably has done much towards firming up the demand for recent engineering graduates.

Broadcasters Pool Information at NARTB

TARGET DATE for completion of new broadcasting equipment has now become the annual convention of National Association of Radio and Television Broadcasters, held this year at Chicago, May 23-27. Collectors of data sheets at the exhibit

(Continued on page 10)

IT'S SPRAGUE FOR Ceramic Capacitors

**EVERY TYPE AND RATING FOR
SMALL OR LARGE PRODUCTION RUNS!**

Sprague can provide you with the best capacitors for your requirements. And when it comes to ceramic capacitors, large plants with adequate production and tooling facilities offer prompt delivery for small or large production runs.

In the East, Sprague ceramic capacitors are made at North Adams, Mass., and Nashua, N. H. The Midwest is served by Sprague's wholly owned subsidiary, the Herlec Corporation of Grafton, Wis.

Some of Sprague's newest developments are shown at right. For future developments in ceramic capacitors, look to Sprague for the ultimate in performance, miniaturization, and reliability.

SPRAGUE ELECTRIC CO.

35 Marshall St., North Adams, Mass.

Sprague, on request, will provide you with complete application engineering service for optimum results in the use of ceramic capacitors, and printed resistor-capacitor networks.

NEW! 'RING' CERAMIC CAPACITORS to clean up chassis



Designed to fit around 7-pin miniature tube sockets, these capacitors may contain 2, 3, or 4 sections. They result in a neat physical layout while reducing space to a minimum. Positive positioning of the ultra short leads between the capacitor and socket terminals eliminates lead dress problems and, consequently, allows "hot" circuit designs. Voltage ratings from 100 to 500 d-c. Write for Engineering Bulletin 610.

NEW! FLAT 'PAN' CERAMIC CAPACITORS simplify circuit design



Mounted flat against a chassis with a screw or rivet, these miniature capacitors provide a highly secure mounting. 1 to 4 sections in the shallow pan are insulated and moisture-protected by a phenolic resin. Ideal for military electronics. These units have an unusually high self resonant frequency, and eliminate lead dress problems when mounted adjacent to a miniature tube socket. Available in ratings from 100 to 500 volts d-c. Write for Engineering Bulletin 611.

WIDELY-USED CERAMIC CAPACITORS for electronics, radio, and TV



Shown at left are a few of the many other types of ceramic capacitors available from Sprague. These include:

- Buttons • Discs • Hi-Voltage Moldeds
- Precision Ceramic Trimmers • Plates
- Printed resistor-capacitor networks
- Hermetically sealed, metal cup and tubular precision capacitors

For complete details on any type of ceramic capacitor — it pays to ask Sprague. Write for catalog data on the types in which you are interested.

WORLD'S LARGEST CAPACITOR MANUFACTURER

SPRAGUE

Export for the Americas: Sprague Electric International Ltd., North Adams, Mass. CABLE: SPREXINT.

obtain the equivalent of an annual catalog of radio and television equipment.

► **Accent On Color**—Although broadcast businessmen traditionally discuss, on and off the record, the problems inherent in management of stations, their engineering associates concentrate upon technical aspects of station operation. This year, emphasis is on color tv. The engineering conference committee decided what engineers most needed to know and then sought out expert

authors for about 25 technical papers. Resulting titles might well serve as a checkoff sheet for engineers hard-pressed to make the new medium work successfully.

Engineers from the two networks that have had most experience with live color will serve their colleagues by telling the essential trade secrets on staging, lighting, makeup, costumes and sets.

► **Improved Performance**—Axiomatic among tv engineers is the fact that monochrome performance

must be well-nigh perfect before color can be successfully handled. Loss of quality or dead air have lost the broadcaster some revenue, making reliable operating procedures financially important.

Some of the technical papers reflect these philosophies by telling how to get the best possible performance from black-and-white, how to handle video recordings (backbone of small station programming) how to switch programs without a hitch and how best to perform preventive maintenance.

Authorized Mobile Transmitters Top 433,000

LATEST FCC figures show that 19,322 licensees for industrial, land transportation and public safety radio services are authorized to operate an average of better than 22 transmitters each, or a total of 433,627 transmitters—mobile or fixed. Not included are aeronautical, amateur, citizen, disaster and marine services in which an additional 200,000 licensees are permitted to operate about 600,000 transmitters.

Authorizations shown in the table reflect a trend, but do not show actual stations on the air. The Commission recently voted to determine exactly how many of the authorized stations are now in service.

Class of Station	Number of Licensees		Total
	Fixed	Mobile	
Industrial Services			
Agriculture	1	9	10
Forest Products	277	634	7,894
Low Power Industrial	575		6,911
Motion Picture	12	13	347
Petroleum	505	4,110	19,898
Power	1,786	5,356	59,941
Radiolocation	40	56	94
Relay Press	38	28	691
Special Industrial	2,107	3,309	37,296
	5,341	13,515	132,425
Land Transportation Services			
Auto Emergency	293	253	2,782
Highway Truck	399	549	8,293
Intercity Bus	8	61	768
Railroad	138	942	12,597
Taxicab	5,357	4,156	90,397
Urban Transit	75	80	2,256
	6,270	6,041	117,093
Public Safety Services			
Fire	1,051	1,106	21,170
Forestry Conservation	83	2,397	16,428
Highway Maintenance	34	727	9,122
Police	5,481	6,318	101,594
Special Emergency	1,060	1,079	4,308
State Guard	2	115	189
	7,711	11,742	152,811
Total	19,322	31,298	402,329
			433,627

Manufacturers Adjust C-R Tube Inventory

Factory stocks are still higher than they were last year but are dropping fast

GOOD INDICATOR of the state of business in the tv tube industry is the number of tubes shelved in manufacturers' warehouses. For the past 10 months, c-r tube inventories have been over the million mark each month. However, from a high point of 1.4 million in July of last year, stocks have dropped 400,000.

► **Sales**—One measure of success of inventory management is the

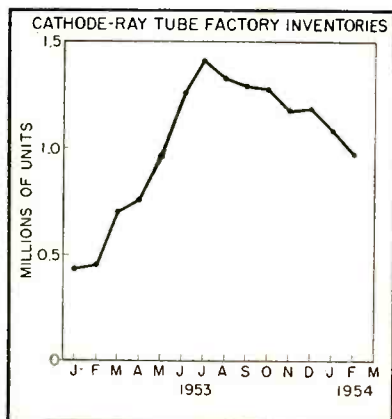

ratio of inventory to sales, with a lower ratio almost always being more desirable. Here are the ratio figures for the past 14 months: Jan. 44, Feb. 53, March 71, April 83, May 127, June 165, July 218, Aug. 150, Sept. 146, Oct. 132, Nov. 166, Dec. 180, Jan. 190, Feb. 149. They dropped nearly 25 percent in February but are still three times as high as they were in February, 1952.

► **Price**—As a result of large stocks price cutting and other symptoms of overstocked warehouses began

(Continued on page 12)

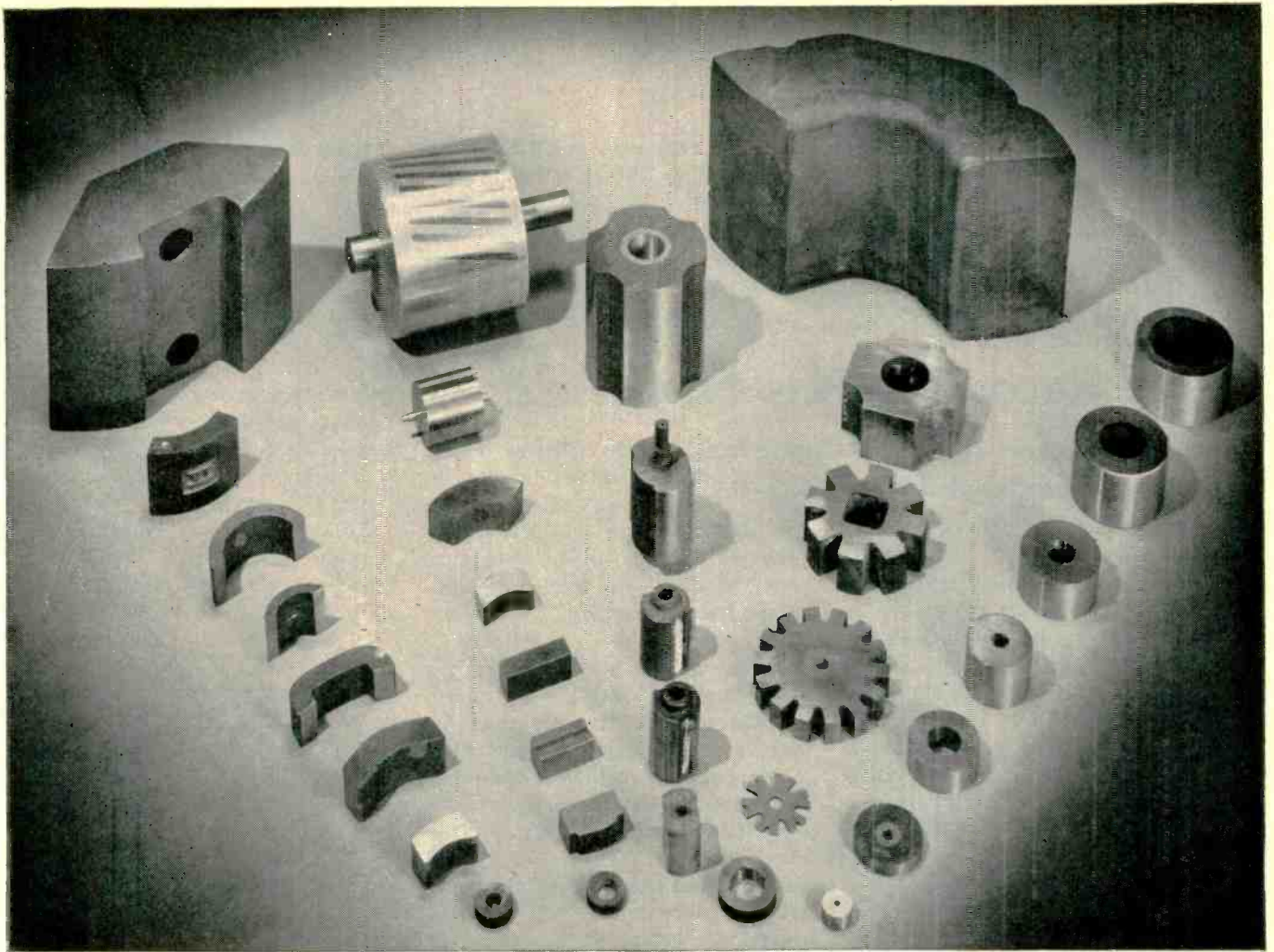

Magnets for rotors or stators ...any design or size you may require



"MAGNETIC MATERIALS CATALOG"

Write for your copy

Contains handy data on various types of Alnico Magnets, partial lists of stock items, and information on other permanent magnet materials. Also includes valuable technical data on Arnold tape-wound cores, powder cores, and types "C" and "E" split cores in various tape gauges and core sizes.

ADDRESS DEPT. E

The use of Alnico permanent magnets in rotor and stator assemblies of motors, generators, magnetoes and tachometers has revolutionized the designs of these devices. Whatever your need may be—from a tiny rotor for a timing device to a large slab for power generators—Arnold can take care of your requirements, either for experimental samples or production quantities.

● *Let us work with you.* You will have the advantage of working with a leading producer of rotor magnets, whose manufacturing and testing facilities—the most modern in the business—give you the best assurance of high quality standards and uniform performance.

W05184

THE ARNOLD ENGINEERING COMPANY

SUBSIDIARY OF ALLEGHENY LUDLUM STEEL CORPORATION

General Office & Plant: Marengo, Illinois

DISTRICT SALES OFFICES . . . New York: 350 Fifth Ave.

Los Angeles: 3450 Wilshire Blvd.

Boston: 200 Berkeley St.



to appear this year. Some leading tube makers reduced prices on c-r tubes to unload excess stocks. This has shown up in some first quarter profit statements. One company, for example, reported net earnings of \$450,304 for the first quarter of

this year compared to \$552,318 for the period in 1953. According to the company, disappointing results in the c-r tube division, which was adversely affected by an unfavorable price situation and instability in the tv industry was a cause.

Market saturation today is put at less than three-quarters of one percent.

Biggest unknown market is business itself, where advantages of storing records and data on tape for automatic access are a challenge to the entire tape industry. Recent announcement by Reeves Soundcraft of a Mylar-base high-fidelity tape that is practically unbreakable can accelerate work in the business field as well as in the other five markets.

Total number of licensees under Armour Research Foundation's basic patents is now 62, of which 14 are foreign concerns.

Tape Recording Hits New Fields

Six major markets emerge; long-playing prerecorded tapes are making debut this year

ALTHOUGH the home entertainment market for magnetic recorders overshadowed all others with its gross sales of over \$50 million last year, two other fields of application battled to a tie in dollar volume of sales last year. One was the long-familiar broadcast station market for high-fidelity tape equipment; the other, a relative newcomer, was the industrial instrumentation field.

Instrumentation recording is used for sound and vibration analysis, telemetering of guided missile performance data, seismic exploration and similar applications where many different channels of data must be recorded faithfully in a short interval for later playback through analyzing equipment. A tape master permits playback over and over again through different filters and equalizers so as to extract the maximum amounts of information from a recording.

► **Sales Reports** — Magne-corder sales for 1953 in this field were about \$1 million, as contrasted to \$1.4 million in studio equipment. Ampex sales of \$1.2 million were divided equally between the two fields in 1953, with an additional \$1.9 million of equipment going to the military for unspecified uses.

► **New Markets**—The three new markets showing promise this year are: (1) taped background music for business and industry; (2) taped music and tape players for home entertainment; (3) specialized tape equipment for office machines and computers.

Potential market for recorded

background music systems using tape is estimated at about 430,000 outlets. Here tape is showing such distinct advantages that Muzak has announced plans for enfranchising firms to duplicate and distribute on tape its library of 7,000 selections.

Magne-cord has finalized arrangements for distributing 8-hour reels of prerecorded magnetic tape especially programmed for factories, offices, restaurants, hotels and other commercial outlets, using over 4,000 selections from RCA Victor's The-saurus library. The tapes will be leased to customers for use on a new tape transcriber that plays automatically either intermittently or continuously.

Magne-Tronics Inc., another recent entry into the taped industrial music field will lease tapes and players in 100 U. S. cities. Source of music here is the 3,000-selection transcription catalog of Capitol Records.

Audio-Video Tape Libraries, a pioneer in the music-on-tape field, has expanded its background music division and also set up a rental plan for 8-hour tapes.

► **Home Market**—At least eight firms are already making prerecorded tapes for home entertainment, and many record firms are actively working on limited tape libraries. The increased availability of taped music has in turn stimulated design and production of tape players. Advantages of players are lower cost and the impossibility of accidentally erasing a recorded tape.

► **Predictions**—Ampro Corp. estimates the market for all types of tape equipment to be 300,000 units for 1954, 540,000 for 1955, 600,000 for 1956 and 800,000 for 1957.

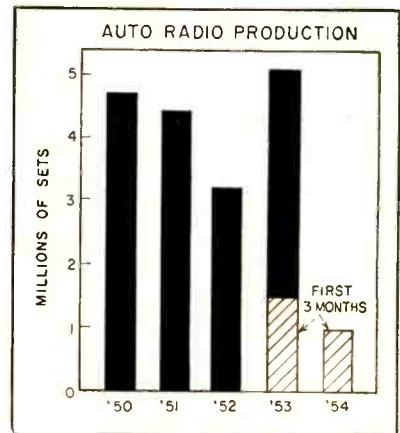

Auto Radio Output Slows Down

Production is off thirty percent in the first quarter as car market changes

BUYERS MARKET that developed in the auto industry this year seems to be having its effect on the automobile radio business.

Nearly a half million less auto radios were produced in the first three months of this year compared to output in the same period in 1953. The drop is partially explained by the decline in auto production since the majority of auto sets are sold direct to car manufacturers and not through retail outlets. In the first two months of this year total passenger car out-

(Continued on page 14)

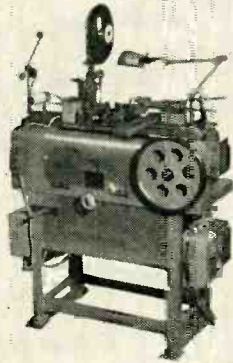

FILAMENT MAKING & TABBING MACHINE

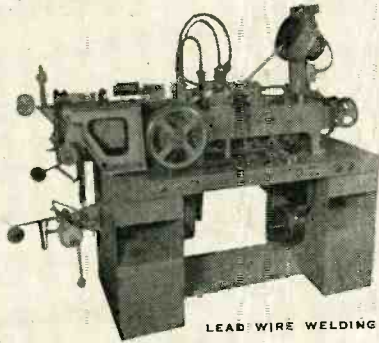

LEAD WIRE WELDING MACHINE

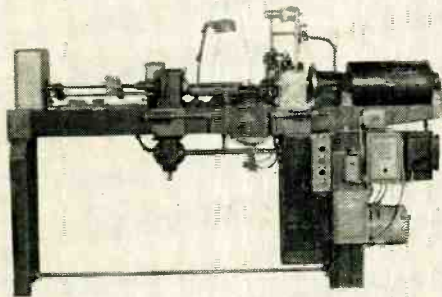

GRID WINDER

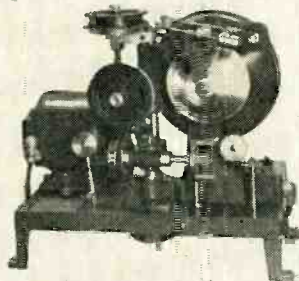

FILAMENT COIL WINDING MACHINE

electronic industry
wire products
at high speeds with

KAHLE MACHINERY

winding—welding—drawing
filament making & tabbing

up to 12,000

3-piece lead wires welded per hour for
miniature receiving tubes!

up to 3,000

filaments per hour, depending on
wire diameter!

up to 2,500

filament coils wound per hour for
miniature lamps!

up to 1,200

RPM on Kahle Grid Winding Machine

Kahle is the largest producer of custom machinery for manufacturing electron tubes from the smallest to the largest size. If you have any difficulties to overcome in tube production . . . exhausting, sealing, stem making . . . write Kahle today and discover how this organization's engineering staff can assist you.

SPECIAL EXPERIMENTAL AND RESEARCH SERVICES OFFERED BY KAHLE INCLUDE:

- Special glass parts and accessories
- Special tools for research
- Special models
- Small lot manufacture of special items for research or development
- Regular industrial engineering at regular fee or contract rates
- Special tubes, lamps, etc. for research purposes including elements and parts
- Any special equipment for manufacture or research for tubes or lamps

Kahle ENGINEERING COMPANY

1310 SEVENTH STREET • NORTH BERGEN, N. J.

put was five percent below that of last year and new car registrations were off 10 percent.

► **Autos**—Automobile manufacturers say that increased competition in the industry is not evoking strip-downs of cars that come factory-equipped with radios. They indicate that it is still the deluxe automobile with all the trimmings that is a large seller. In fact, they point out, the percentage of autos that come factory equipped with radios is pretty much as it was in 1953.

General Motors reports that in the first quarter of this year 94.3 percent of all Oldsmobiles produced were equipped with radios. In 1953 the percentage for the year was 92.2 percent. Accenting the trend to the deluxe auto, 15 percent of all radio-equipped Olds produced in the first quarter used the deluxe

signal-seeking set.

The Pontiac division of GM reports a slight drop for the first quarter with 87-percent factory installed compared to the usual 89 percent. Buick also reports a slight drop to 92 percent of its output that is radio-equipped. It is presently installing 11 percent of new cars with the deluxe model.

► **What's New**—Last year saw the introduction of the signal-seeking car radio. Another move toward more automatic operation was made by Motorola this year with the introduction in its new line of auto radios of a feature called volumatic control. The control circuit uses a tube developed by the firm and Tung-Sol. Motorola plans to include the device in its entire line at no extra cost. It is reported that 18 percent of the firm's sales involve auto radio receivers.

from 6 to 16 points using two sets of negatives.

In the demonstration model, mechanical computing and memory units were used for computing line width and keeping track of spacing information. These units may be replaced in whole or in part by electronic systems by the time full-scale production begins in the fall of 1955. An electronic accessory to the typesetter is a correction unit that slices out lines containing errors and replaces them with corrected lines butt-welded into place in the film strip.

► **Engraving**—Production of plastic halftone cuts by electronic engraving methods has been given added adaptability in a new engraving machine developed by the Fairchild Camera and Instrument Corp. In the present production model, the engraving is produced with exactly the same dimensions as the original photograph. The new unit can vary either or both dimensions of the engraving. Provided on a rental basis, the new engraver will cost from \$300 to \$600 per month.

Printing Trends to Tubes

RECENT DEVELOPMENTS in the printing industry indicate the growing importance of electronics in this field. In preproduction demonstration, the Mergenthaler Linotype Co. showed a two-unit punched-tape controlled photographic typesetter.

The typewriter unit uses a modified electric typewriter to provide a punched paper tape containing

letter and spacing information. When the tape is run through the photographic unit, the punched information automatically sets shutters to uncover the proper letter on one of five glass negative plates. An electronically triggered flash-lamp prints the letter by projection on a strip of photographic film. The typesetter can set type in sizes

West Coast Electronics Spreads Out

Oregon joins California in extolling the industry's growth characteristics

CHAMBERS OF COMMERCE in both California and Oregon recently noted the rising importance of the electronics industry on the west coast.

The Los Angeles Chamber has formed an electronics committee to coordinate industry-wide action on component parts, scientific personnel, industry statistics and recognition and use of new equipment and techniques. According to the group, the electronics industry replaced the aviation industry in 1953 as the second largest in total capital investment in greater Los Angeles.

► **Dark Horse**—Portland, Oregon's Chamber of Commerce character-

(Continued on page 16)



Two-unit typesetter uses electric-typewriter keyboard to punch paper tape for controlling photographic unit at rear. Control panel at side of typewriter is for selecting style of type and word spacing

for control of
SHOCK and VIBRATION

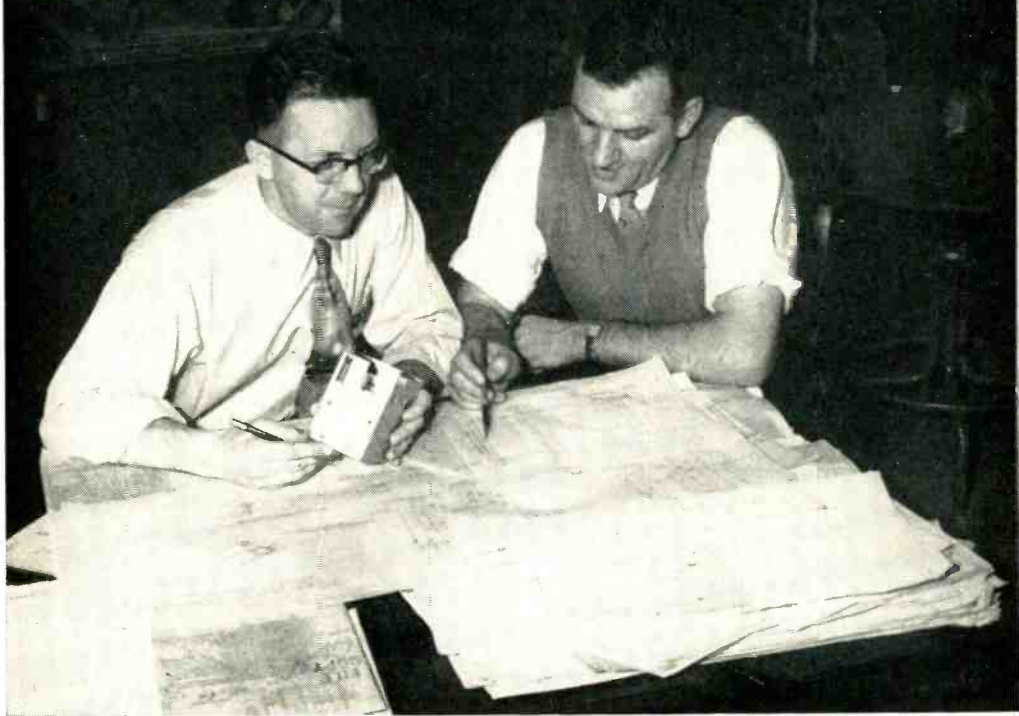

They're YOUR designers - but WE pay them.

You don't have shock and vibration problems every day — but when you *do*, you want them solved promptly. So you want the practical experience of men who've been spending *all* their time in this highly specialized engineering — men who have most likely met and successfully answered questions just like the ones that are bothering you. These men are Barry engineers — ready and able to analyze *your* shock and vibration problems, backed by a laboratory staffed and equipped to *prove* their solutions, and served by model shops geared to produce *your* prototypes whenever you need them.

You'll save time, money, and trouble by using our design and prototype service. Write today for Bulletin DP-54 "This is Barry".



PRODUCTION FACILITIES include such modern equipment as this 100 KVA spot welder, accurately timed for welding aluminum.



LAB-TESTING the performance of Barrymounts protecting delicate electronic equipment.

THE **BARRY** CORP.

707 PLEASANT STREET
WATERTOWN 72, MASS.

SALES REPRESENTATIVES IN ALL PRINCIPAL CITIES

ized the state's electronics business as a sleeper industry. It reports that the industry there has increased 25 percent since 1952 and that employment now totals 1,000 for the state. Sales made out of the state account for 90 percent of total volume.

In 1953, gross sales totalled \$8.6 million and plant space stood at 200,000 sq ft for the 14 concerns that make electronic components and end products in the state. Ten years ago, the report states, only two of the 14 firms were in business. In 1949, seven companies then in business did \$1.8 million in gross sales.

Currently, two companies in Oregon's electronics industry employ over 350 workers, two over 50 and five under 25 people. More than 100 engineers and technicians are employed by these firms.

► **WESCON**—Further indication of the continued growth is the gain made by the Western Electronic Show and Convention. In 1947, exhibitors in the show numbered 50. Last year 370 booths were taken and it is expected that the August show in Los Angeles will fill more than 465 booths. Attendance is expected to reach 20,000.

Company Combats Selenium Shortage

SUPPLY situation in selenium (ELECTRONICS, p. 8, May, 1954) has caused Sarkes Tarzian to request servicemen to turn in used rectifiers to its distributors. They, in turn, have been asked to send them to the company by truck, transportation collect, for credit at the rate of 2.5 cents for those rated at 65 to 150 ma and 5 cents each on rectifiers rated at 200 ma or more.

According to the company, cooperation is vitally needed to insure a continuous supply of replacement rectifiers. A reduction in production would lead to either rationing or the requirement that a replaced rectifier be supplied for each new one purchased.

Manufacturers Break Down Sales

SOME manufacturers in the electronics field have indicated the importance of their various types of products or lines of business in relation to total sales. Following are 1953 percentages of eight companies.

Company	Product or Business	Percent Of Total Sales
GE (Est) 1953 Sales, \$3.1 billion	Affiliated & Foreign	20
	Apparatus	20
	Industrial Products & Lamps	20
	Appliance & Electronic	20
	Defense Products	20
IT&T 1953 Sales, \$362.1 million	Sales From U. S. Manufacturing	43.8
	Sales From Manufacturing Abroad	56.2
Motorola	Television	45
	Communications Products	25
	Auto Radio	18
	Home And Portable Radio	12
RCA 1953 Sales, \$853.0 million	RCA Victor, RCA Labs & RCA International	75.6
	NBC	20.6
	RCA Communications	2.1
	Radiomarine Corp.	2.2
	RCA Institutes	0.1
	Less Intercompany transactions	0.6
Texas Instruments 1953 Sales, \$27.9 million	Engineering, Development & Manufacturing	60.4
	Geophysical Subsidiaries	32.3
	Supply Co. Subsidiaries	7.2
Varian Associates 1953 Sales, \$5.1 million	Research, Development & Engineering Services	39
	Klystrons, electronic systems & Components	61
Western Electric (Est) 1953 Sales, \$1.5 billion	Sales To Bell Telephone	67
	Defense Sales	4
	(82 percent electronic)	29
Westinghouse 1953 Sales, \$1.6 billion	Apparatus & General Industrial	50
	Consumer	26
	Defense	24

► **Companies**—There is little basis for comparison between the various firm's listed in the table but trends for three companies are indicated.

At a recent GE stockholders meeting, it was indicated that a few years ago it had set up the five product groups listed so that each would be roughly equivalent in size. It was stated that the four domestic groups, in general, had maintained the breakdown. In 1953, sales increased in all major product groups and leading increases were in electronics and appliances.

For RCA, shipments to the armed forces accounted for 19 percent of total sales in 1953 and 24 percent in the first quarter of this year. The products and services sold by RCA Victor, RCA Labs and RCA International totaled \$645.1 million in 1953, an increase of 27 percent over 1952. As a result, the division's percentage of total sales jumped from 73.1 to 75.6 in 1953.

Although sales of NBC increased by 8 percent in 1953, its share of total sales dropped from 23.4 percent in 1952 to 20.6 percent last year. Its income was made up of 80 percent tv revenues and 20 percent radio. RCA Communications' share also dropped slightly in 1953 from 2.5 percent to 2.1. The Radiomarine Corp., however, increased its share from 1.7 to 2.2 percent. Its sales increased 57 percent from \$11.8 million in 1952 to \$18.6 million last year. RCA Institutes sales increased from \$742,000 in 1952 to \$960,000 in 1953 and thus maintained the 1952 percentage of total sales at 0.1 percent. RCA reported that tv has accounted for 50 percent of its total volume of business over the past seven years and reached 54 percent in 1953.

► **Changes**—Varying pattern in product groups was also evident from Westinghouse figures. Percentage of total sales accounted for by apparatus and general industrial products dropped from 53 percent 1952 to 50 percent in 1953. Consumer products percentage increased during the period from 23 to 26 percent. Defense sales continued to account for 24 percent.

Phototube Makers Study Market Changes

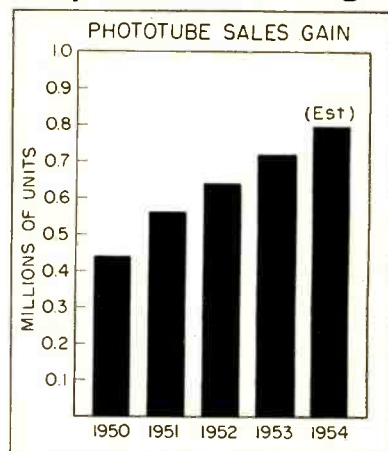

MANUFACTURERS of phototubes have enjoyed constantly rising sales since the end of World War II and ex-

(Continued on page 20)

NEW VARIACs

Standard VARIAC® continuously-adjustable transformers can be operated at line frequencies from 50 to 400 cycles. The new "M" Series are designed for use at frequencies between 350 and 1200 cycles.

Their design is entirely new. They are electrically the high-frequency equivalents of the popular Types V-2 and V-5 units, but are much smaller and lighter than the low-frequency models. At 400 cycles regulation obtained with the "M" units is considerably better than that of the 60-cycle "V"s when operated at 400 cycles. Design and operating features include:

- ★ Cast aluminum construction . . . lighter and even more rugged . . . will withstand vibration tests of 10 to 55 cycles, 1/32 inch total amplitude, 10 to 33 cycles, 1/16 total amplitude. MIL-T-945A. Shock test of 1200 ft.-lb.
- ★ Dynamically and statically balanced radiator
- ★ Excellent thermal conductivity between coil and base, and between base and panel . . . coils bear solidly through thin insulation against cast aluminum base which has annular panel bearing surface.
- ★ Two-ampere model M-2 has 400 turns of wire, giving adequate resolution for many computing and control operations.

- ★ Exclusive DURATRAC contact surface (a protective armor against oxides) provides extra factor of reliability under overload. Instantaneous overloads of ten times normal rating can be handled. Practically no maintenance required. Brush track shows no wear after one million cycles of brush operation
- ★ Unit Brush construction
- ★ Wiring diagram on terminal board
- ★ Ganged assemblies designed for minimum

volume. Coils are mounted back-to-back on a single base for 2-gang assembly.

- ★ ALL VARIAC dials calibrated directly in output voltage at nominal line voltage
- ★ Four corner mounting holes for ganging and special mounting, in addition to three mounting holes identical with standard VARIACs
- ★ On special order, all units can be fungicide-treated to meet military requirements.

... for
350 to 1200 Cycles

Variac

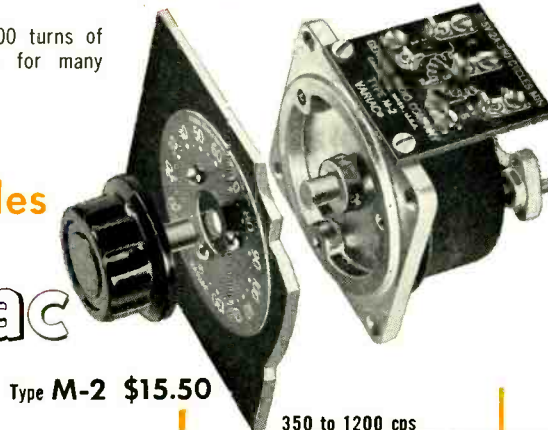

Type M-2 \$15.50

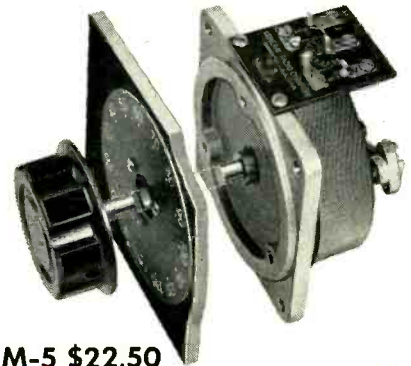

Type M-5 \$22.50

Line Frequency	350 to 1200 cps	350 to 1200 cps
Input Voltage:	115v	115v
Output Voltage:	0 to 135 or 0 to 115	0 to 135 or 0 to 115
Rated Output Current	2 amperes	5 amperes
Maximum Output Current (for line-voltage connection only)	3 amperes	7.5 amperes
No-Load Loss at 400 cps	3 watts	6 watts
Number of Turns on Winding	402	293
D-C Resistance of Winding	6.6 ohms	1.3 ohms
Driving Torque	10-20 in.-oz.	15-30 in.-oz.
Net Weight, Lbs.	1-7/8	3-1/4



Type M-5G2 Variac

Mounting Dimensions Same as Type M-5
Overall Depths Behind Panel are:
M-5G2: 5-1/32" M-5G3: 7-27/32"

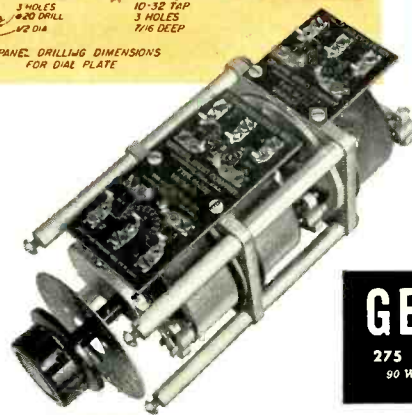
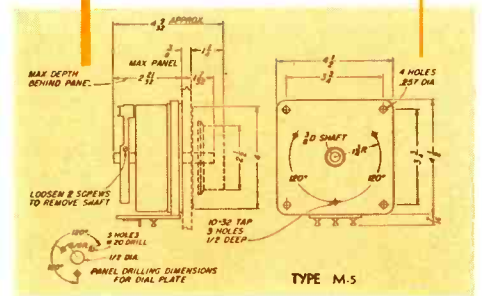
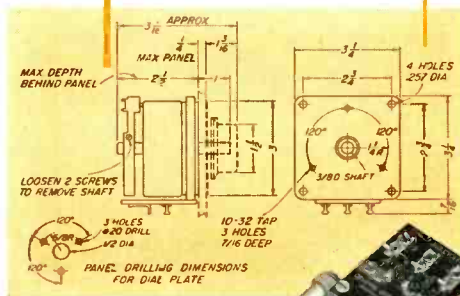

Type M-2G3 Variac

Mounting Dimensions Same as Type M-2
Overall Depths Behind Panel are:
M-2G2: 4-7/8" M-2G3: 7-5/8"

Since 1915

Manufacturers of
Electronic Apparatus
for Science and Industry



GENERAL RADIO Company

275 Massachusetts Avenue, Cambridge 39, Massachusetts, U. S. A.
90 West St. NEW YORK • 920 S. Michigan Ave. CHICAGO 5 • 1000 N. Seward St. LOS ANGELES 28



subminiature

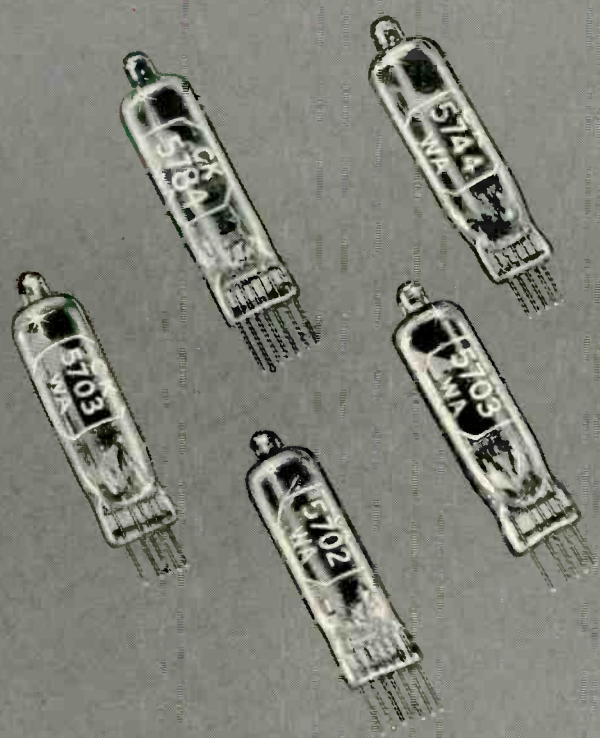

TEST

PLATE VOLTAGE MAXIMUM

PERMISSIBLE HEATER VOLTAGE RANGE

PLATE DISSIPATION

HIGH TEMPERATURE LIFE

1 HOUR STABILITY

100 HOUR SURVIVAL

HEATER CYCLING

MEDIAN CONTROLS

HERE ARE MORE REASONS WHY RAYTHEON SUBMINIATURE TUBES ARE SO RELIABLE:

- ★ Additional Life Test End Points
- ★ Larger Test Samples
- ★ Tighter AQL
- ★ Grouped AQL
- ★ Median and Range Control of Electrical Characteristics
- ★ 100% Microscopic Inspection — pioneered by Raytheon. Forty-seven microscopic tests on each tube
- ★ Narrower Tolerances
- ★ Lower Vibrational Noise Output from CK5702WA and CK5703WA

tubes have always been more
RELIABLE-

CHARTED ARE SOME OF THE ACTUAL MIL SPECIFICATION REQUIREMENTS OF PARTICULAR INTEREST TO THE DESIGNER. MANY OF THESE WERE PIONEERED BY RAYTHEON. COMPARE THE RAYTHEON TUBE DATA WITH THAT OF THE NEAREST COMPETITIVE TYPE, SHOWN IN RED.

A FEW TYPICAL RAYTHEON SUBMINIATURE TUBES

	CK5702WA	CK57C3WA	CK5744WA	CK5784WA
RAYTHEON COMPETITIVE TYPE	200v 165v	275v 165v	275v 165v	200v 165v
RAYTHEON COMPETITIVE TYPE	±10% ± 5%	±10% ± 5%	±10% ± 5%	±10% ± 5%
RAYTHEON COMPETITIVE TYPE	1.85w 1.1w	3.3w 3.3w	1.6w 0.55w	1.85w 1.1w
RAYTHEON COMPETITIVE TYPE	200°C 175°C	200°C 175°C	200°C 175°C	200°C 175°C
RAYTHEON COMPETITIVE TYPE	YES YES	YES NO	YES NO	YES NO
RAYTHEON COMPETITIVE TYPE	YES YES	YES NO	YES NO	YES NO
RAYTHEON COMPETITIVE TYPE	7.5v 7.0v	7.5v 7.0v	7.5v 7.0v	7.5v 7.0v
RAYTHEON COMPETITIVE TYPE	YES YES	YES NO	YES NO	YES NO

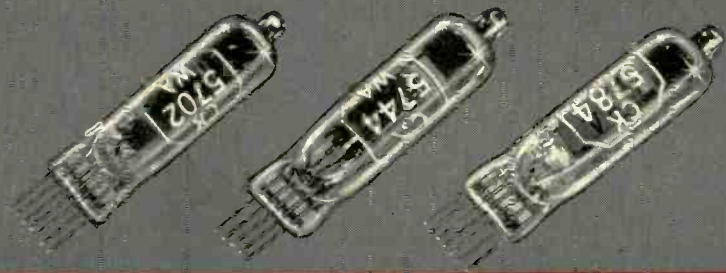
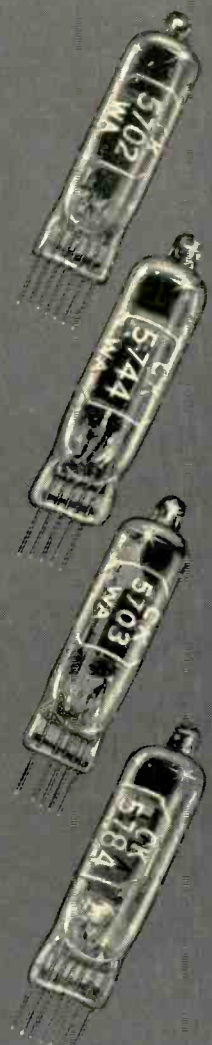

RAYTHEON MANUFACTURING COMPANY

Receiving Tube Division — Home Office: 55 Chape St., Newton 58, Mass.

For Application Information Call: Boston, Blgelow 4-7500 • Chicago, NAional 2-2770 • New York, -Whitehall 3-4980 • Los Angeles, Richmond 7-4321

RAYTHEON MAKES ALL THESE:

RELIABLE SUBMINIATURE AND MINIATURE TUBES • SEMICONDUCTOR DIODES AND TRANSISTORS • NUCLEONIC TUBES • MICROWAVE TUBES • RECEIVING AND PICTURE TUBES

Excellence in Electronics

pect the trend to continue in 1954. With the phototransistor now on the scene, phototube makers are taking another look at the business.

► **Volume**—As shown in the chart, sales of the units have risen at an annual rate of approximately 100,000 units in the past four years and if the rate holds for this year total unit sales will be brought up to 800,000 units.

The steady increase has occurred despite a sizable drop in sales to the government. Last year, only about 12,000 units were sold to the U. S. In 1952, such sales were 40,000, 85,000 in 1951 and 37,000 in 1950. However, sales to equipment manufacturers have evidently risen more than enough to take up the slack in government sales.

► **Transistors**—About four companies have phototransistors commercially available and others plan to make them. Already, units are being made for use in auto headlight dimmers. Their small size is seen as making the units more easily adaptable to many of the present applications of regular-size phototubes.

► **New Markets**—Multiplier phototubes used in nuclear instruments and other applications have been responsible for a substantial part of increased phototube business and manufacturers are increasing sales efforts on the product. Du Mont recently opened two new sales offices to specialize in multiplier phototube sales.

Companies are also bringing out new phototube types in response to market demands. Ten-stage multiplier phototubes have been introduced for use in the nuclear field and other new types have been made for use in headlight dimmer applications.

A new photocell that uses germanium linked to a button of indium is reported to be extra sensitive particularly to infrared radiation and so potentially useful in heat regulation. About $\frac{1}{4}$ inch in diameter and $\frac{3}{8}$ inch long, the cell is reported to be more responsive to light than vacuum photocells a hundred times larger.

Firms Weigh Machinery Expense

New products mean additional investments in machinery and equipment for the industry

INVESTMENTS by electronic manufacturers in new machinery and equipment have steadily increased in the past few years. As shown in the chart, an estimated \$97.5 million was spent for that purpose in 1953. In 1952, according to the Bureau of Census, a total of \$85.5 million was spent representing 65 percent of total capital expenditures.

► **Why**—Constant stream of new products that move from the laboratory to mass production in the factory require, in most cases, a sizable investment by the industry. This is especially true for tube manufacturers. Bigger picture tubes, aluminizing, mass produced transistors and diodes and now color tv tubes have all necessitated large machinery expenditures.

However, not all new products require new equipment. Much tube machinery now used for black-and-white picture tube production, for example, is usable for color tube output. One reason why some color tubes may use metal envelopes is so that manufacturers can utilize metal envelope machinery that has been used for black-and-white tube output.

► **Business**—According to tube machinery makers, demand and inquiries for machinery used to manufacture transistors and diodes seems to be heaviest so far this year. Vacuum equipment manufacturers also report that demand is shaping up for color tube equipment and they expect substantially increased business this year as a result.

Some machinery firms catering to the electronics industry say that they note some hesitancy so far this year on the part of manufacturers to invest in the diode and transistor machinery field because of possible further product design changes that are in the wind. How-

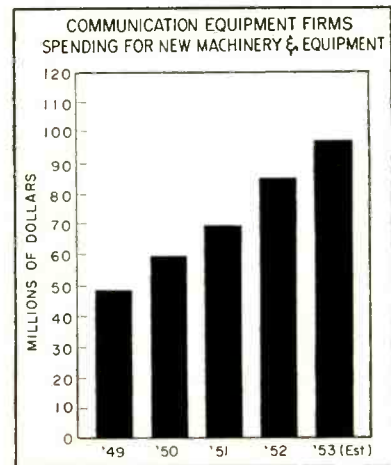

ever machinery makers are not too concerned and expect their volume of business in 1954 will equal that of last year.

TV Antennas Invade Mass Sales Field

Better Business Bureau scores indoor performance claims after product tests

LATEST flurry to hit the tv antenna business industry is a new influx of competition from the indoor tv antenna field. Midget tv antennas are now on sale at dime stores at a retail price of a little over one dollar. Some of them purport to eliminate inside and some outside antennas.

► **Claims**—According to the New York Better Business Bureau, some miniature indoor antennas have also been advertised as able to outperform all others and eliminate ghosts and snow. The Bureau made performance tests of some of them and found that they could not claim better reception on all channels.

It found that no present type of indoor antenna, including the miniature type, could legitimately make any claim of outperforming all others or of outperforming roof antennas, since performance varies with different channels and locations. It recommended that all

(Continued on page 22)

Burnell TOROIDS and FILTERS

"SHRUNK to FIT"



Courtesy of Visart, Inc. Actual Size

Keeping ahead of the game is our specialty and with our newest sub-miniature line of toroidal filters and toroids in actual production, we are living up to our reputation for progressiveness.

The tiny "cheerio" toroids are already being employed in filters small enough to hide with your thumb. Although the applications for these are myriad, the "cheerios" lend themselves perfectly to printed circuit applications as illustrated and are being sold at a cost comparable to standard miniature toroids.

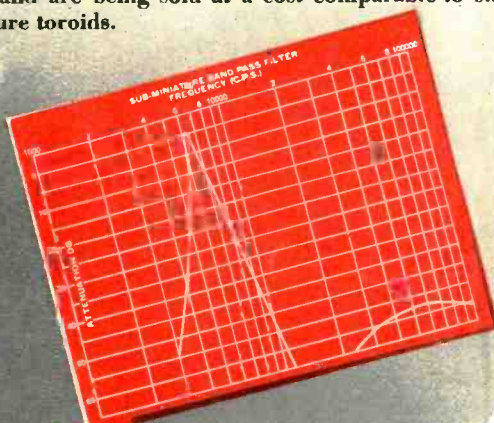
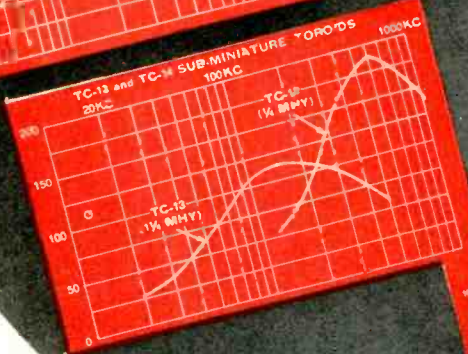

Write for new and enlarged 16 page catalog 102A
Exclusive Manufacturers of Communications Network Components

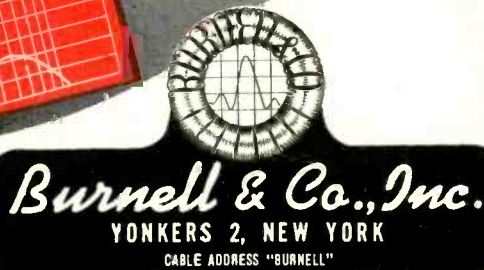

performance claims be limited to provable facts. Questionable claims were discontinued when the Bureau's findings were made known.

► **FTC**—The proposed FTC rules for the tv industry cover the antenna business.

As now proposed, they provide that it is an unfair trade practice to make the unqualified general representation that tv receiving sets equipped with built-in or indoor an-

tennas will perform as satisfactorily as if they were equipped with outdoor antennas when such is not the fact. When the representation is true only in a limited number of locations or within a certain radius of tv stations, or only under specifically favorable conditions, or under other performance limitations, it is unfair trade practice under the rule to fail to make clear and plain disclosures of such limitations.

British Electronics Sets Records

Domestic and foreign sales of electronics products in 1953 reached new high

AN OUTSTANDING production job was done in 1953 by Britain's electronic industry.

Although the most marked increase was in the output of tv receivers, up 35 percent compared to 1952, from 785,000 to 1.1 million units, radio dropped from 1.4 million to 1.1 million sets.

► **Export**—Of the total British production in 1953 of radios and radio-phono combinations, approximately 75 percent was sold to the home market and 25 percent overseas. For tv all but about 7,000 sets were sold in the home market. The 7,000 exported set a record for the industry.

Overseas sales of electronic equipment represent about 25 percent of the total exports of British electrical goods. Of the total \$71.9 million, transmitter and radio communication products group head the list, as in 1952, with exports worth nearly half the total. Components account for just over \$22 million, radio and tv receivers \$12.8 million, and tubes \$6.1 million.

► **Where**—In 1953, India was the principal customer for British components, as it was in 1952, accounting for \$1.8 million of the \$22.1 million total. Australia followed with \$1.6 million and the U.S. moved up to third place buying \$1.4 million worth of components. Overseas sales of record changers and other phonograph parts reached \$5.3 mil-

lion and tape recorder exports neared the \$1 million mark. Principal markets for these products were the U. S. and Australia followed by South Africa, Sweden, Belgium and New Zealand. The largest buyer of loudspeakers and microphones was Canada, followed by South Africa, Belgium, U. S., Netherlands, Australia and India.

► **Show**—A look at what the electronics industry has available product-wise this year was given at the British Radio Component Show held in London in April. The show emphasized tubes and parts designed to operate in the vhf bands because of the possible introduction of commercial tv in the near future and extension of BBC f-m sound broadcasting. It is reported that the initial commercial tv stations will operate around 200 mc and the f-m stations around 100 mc.

Microwave to Aid Wired TV

AFTER two-year delay, a community antenna outfit in Poplar Bluff, Mo. has been given permission to build the microwave relay system needed to extend service by picking up tv broadcasts from stations in Memphis, Tenn. With this grant, the first to any but the Bell System, community-type operators are scurrying to prepare applications for other microwave links.

► **Broad Horizon**—Formerly limited to whatever stations they could pick up on a hill and pipe down into town, the operators sometimes had several programs available, often only one and that one poor. With microwave links, they can now extend their pickup range by receiving the desired broadcast several mountains away and relaying to the local wired system.

Similar service, fed by Bell System relays to Casper, Wyoming and Reno, Nevada has already proved successful. The new non-Bell common carrier system will start with two relay points and provide one channel using a carrier frequency of 6,000 mc. Rates are set at \$2,500 a month for each community system. Organizers of the new enterprise figure the original outlay will come to \$143,000 for the particular system proposed.

Financial Roundup

PROFIT reports in the first quarter of 1954 for companies in the electronics field indicate that, despite sales declines in some cases, many manufacturers experienced increased net income.

According to the National City Bank of New York, the net income after taxes of 20 companies in the radio, tv and electrical equipment field totaled \$83.8 million in the first three months of this year, a 35-percent increase over income in the first quarter of 1953 and a 4-percent increase over that of the fourth

(Continued on page 24)

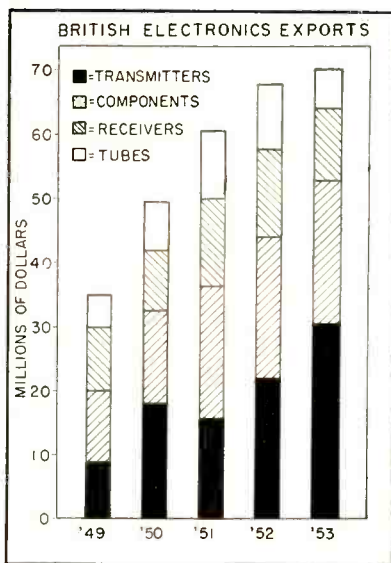

INDUSTRIAL REMOTE CONTROL SYSTEMS CAN GREATLY REDUCE YOUR OPERATING COSTS

Hammarlund equipment centralizes control, ups man-hour output!

A careful review of operations within your plant may disclose the fact that a variety of functions are inefficiently handled manually . . . turning "off" and "on" valves, switches, or operating other controls at remote points. Perhaps the persons performing these functions do so only after receiving telephoned orders from a central dispatch point, and otherwise have little else to do.

Shift these men to more worthwhile activities. Their former duties can be handled direct from the central control point by use of highly-reliable Hammarlund remote control equipment. This all-electronic system requires only one telephone circuit (or microwave or radio circuit) to each remote point for complete control and metering of all your required operations.

Proven Performance

Refineries, pipelines, utilities, railroads and other industrial organizations who have need for centralized control of their wide-spread operations are finding that Hammarlund has a remote control system to fulfill their needs. These systems are now in operation by many progressing industries — a listing is available on request.

Two basic factors, carefully pre-determined for the equipment, were flexibility and versatility. Because it is designed on the building-block principle, using standard service-proven sections in the most efficient combinations, great flexibility has been achieved. For all practical purposes, each customer gets a custom engineered installation at a standard system cost.

Fill out and send the coupon below, or write immediately for detailed information on how you can cut your operating costs by using Hammarlund Remote Control and Signaling Equipment. If you send a brief description of your requirements, Hammarlund engineers will analyze them and suggest the most efficient system. No obligation, of course.

- ✓ PETROLEUM REFINING
- ✓ PIPE LINE OPERATIONS
- ✓ CHEMICAL PROCESSING
- ✓ PUBLIC UTILITY OPERATIONS
- ✓ AIRCRAFT COMMUNICATIONS
- ✓ RAILROAD OPERATIONS

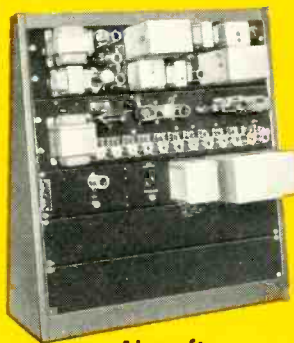

**Aircraft
Communications Control**



**Multi-Gate®
Industrial Control**



**Duplex
Signaling Unit**



Alarm System



Since 1910

THE HAMMARLUND MFG. CO., INC.

460 W. 34th St., New York 1, N. Y.

Midwest Sales Office: 605 No. Michigan, Chicago 11, Ill.

Export Office: 13 East 40th St., New York, N. Y.

Hammarlund Company
460 W. 34th St., New York City

Please send me detailed literature describing your Industrial Remote Control Systems.

I am sending a brief description of my requirements.

Name _____

Title _____

Company _____

Address _____

quarter of last year.

A number of factors are seen as being responsible for the increases. Chief among them is the expiration of the excess profits tax at the end of 1953 which imposed taxes at the rate of 82 percent on income defined as "excess". Now corporate income is taxed at a rate of 52 percent.

Following are the profit reports of 19 companies in the electronics field. The notation 6m refers to first quarter and last quarter figures for the past years indicated. Companies reporting annual profits for 1953 compared to 1952 are listed separately.

Company	1954	1953
Air Associates 6m...	\$184,452	*\$202,000
Burroughs 3m.....	2,315,995	2,525,081
Clevite 3m.....	941,115	932,785
GE 3m.....	48,029,000	33,849,000
W. L. Maxson 6m...	659,412	412,960
RCA 3m.....	10,066,000	9,293,000
Servomechanisms 3m	180,137	
Stewart Warner 3m.	801,469	1,076,344
Stromberg Carlson 3m	571,553	
Sylvania 3m.....	2,121,487	2,773,243
Webster Chicago 3m	205,945	184,773
Zenith 3m.....	827,521	2,109,461

Company	1953	1952
Consolidated Eng. ..	\$510,406	\$501,511
Electronic Eng.	28,400	19,100
Radio Condenser	382,002	525,916
Servomechanisms	305,089	
Standard Coil	2,972,481	2,861,290
Telecomputing	43,622	
Trav-ler	412,000	291,000

* Loss.

► **Filings**—Electronic Associates of Long Branch, N. J., filed with SEC covering 7,500 shares of common stock (par \$1) to be offered by subscription to stockholders of record in May at \$18.50 per share on the basis of one new share for each 15 shares held. Proceeds are to be added to working capital.

I-T-E Circuit Breaker offered 100,000 shares of preferred stock, \$50 par. Proceeds are to be added to general funds and will be available for general corporate purposes to reduce bank loans.

Wired Radio Extends A-M Broadcasting

Of 2,600 a-m radio stations in the United States, 800 operate during daylight hours only and of these, some 530 serve communities without other strong signals. Reason for closing at sundown is that sky-wave signals after dark reach out to great distances and would cause bad interference. There just aren't

enough a-m frequencies to allow full-time operation for all.

► **Money Gimmick** — Since the night-time hours are the favored moments that bring in fattest revenue, day-only operators (who have organized into Daytime Broadcasters Association) have long hankered for a means of getting in on the bigger money. They now have a trick to do the job.

Curt Plummer, head of the FCC Broadcast Bureau, has held discussion with the association on connecting the transmitters to local power lines and feeding programs into receivers. While neither for nor against the scheme, the Commission is willing to let the broadcasters experiment for a year or so under controlled conditions, provided their signals don't escape from the wires.

► **Cleveland Project**—The idea is not new, having been tried abroad

in Italy and elsewhere. It is also used, in modified form, by many a college campus system. Twenty-five years ago, it was tried in Cleveland by Wired Radio, Inc., but failed to pay because of its economic aspects. At that time, the plan was for the power company to furnish programs over its own lines, but the cost of suitable receivers proved too high.

Phonograph Makers Size Up 1954

Business was up last year compared to 1952 and is expected to remain there

ACCORDING to most phonograph producers, sales in 1953 were up from 10 to 20 percent over 1952 totals.

Bureau of Census figures for 1953 place total turntable shipments of

(Continued on page 26)

Tubes Sell Tyrannosaurus



Using 125 high-gain audio amplifiers as portable receiving units, an audio-frequency broadcasting system, installed at the American Museum of Natural History in New York, gives visitors a conducted tour of exhibits. Record players feed descriptive talks to loops around five exhibition halls. An inductor in the input of the amplifier unit carried by the visitor picks up the a-f signal from the loops. Reaction of public will determine whether the system, installed by the Electro-sonic Corp., will be expanded to other sections of the museum

We, too, are interested in intelligent cost reduction!

—for example, this new

General Ceramics

LINE OF SLOTTED ROUND LEG TV FLYBACK TRANSFORMER CORES



**—drastically
reduce TV
power supply
costs!**

and here's why—

- CORES ARE LOWER PRICED
- FASTER, LOWER COST ASSEMBLY
- FEWER INSULATION PROBLEMS
- NO SHARP CORNERS, CLOSE COIL FIT
- BETTER ELECTRICAL DESIGN POSSIBLE
- STANDARDIZED TYPES AND SIZES

General Ceramics research and engineering is geared to pace the industry with advanced designs, perfected to the highest possible degree, produced at absolute minimum cost. Introduction by General Ceramics of round leg transformer cores brings these objectives into sharp focus. Thoroughly engineered, field tested and proven, they have earned the immediate acceptance of leading TV manufacturers. Case histories prove the new cores make better TV flyback power supply units possible at substantially reduced cost. Why not request the facts today?

THESE STANDARD CORES ARE NOT JUST "PARTS"—EACH IS PRECISELY ENGINEERED FOR HIGH EFFICIENCY IN THE FOLLOWING APPLICATIONS:

CORE TYPE	TV PICTURE SIZE
F465	17" ECONOMY MODELS
F492	21" ECONOMY MODELS
F410	21" THRU 27" MODELS
F456	COLOR SETS



General CERAMICS CORPORATION
Telephone VALley 6-5100
GENERAL OFFICES and PLANT: KEASBEY, NEW JERSEY

MAKERS OF STEATITE, ALUMINA, ZIRCON, PORCELAIN, SOLDERSEAL TERMINALS, LIGHT DUTY REFRACTORIES, CHEMICAL STONWARE, IMPERVIOUS GRAPHITE, FERRAMIC MAGNETIC CORES

all types at over 2.9-million units last year. In 1952, 1.8-million turntables were shipped by the industry.

► **Breakdown**—Key to models involved is the Census breakdown of total shipments in 1953. Largest shipments were made of record player units. Over 1.6 million were produced. Accenting the hi-fi trend, 1.0 million of these units were for installation in combination and custom built sets. The remaining 625,000 were plug-in types complete with case for playing through radio and tv sets.

Radio - phonograph - tv combination models represented the smallest market for phonographs in 1953 when only 222,000 were shipped by the industry.

The mechanical or accoustical phonograph with spring or electric motors, was second largest in shipments in 1953 with 709,000 units.

Electronic phonographs, or those with tube amplifiers were the fourth largest shipments in 1953. Coin-operated juke boxes accounted for 61,000 of the total.

► **Future**—Phonograph manufacturers have felt the effect of the buyers market since last fall like most other manufacturers. As a result, price has been a factor not only for the end-product manufacturer but for component makers as well. The industry, as a result, has pressed for lower priced and improved components for its products. To meet this demand, GE recently conducted a survey to see if better tubes could not be designed and built for phonograph manufacturers at a price to meet their requirements. They found that specific tubes for phonographs would be out of step pricewise, at least for the present.

Credit

EXPLANATION and description of the cover photograph of the May 1954 issue of **ELECTRONICS** omitted mention of the Philco Corp., whose engineers developed the jet-etching technique for surface-barrier transistors and in whose laboratories the photograph was taken.

MEETINGS

JUNE 13-18: ASTM 57th Annual Meeting, Hotels Sherman and Morrison, Chicago, Ill.

JUNE 16-18: High Vacuum Symposium, Committee on Vacuum Techniques, Berkeley Carteret Hotel, Asbury Park, N. J.

JUNE 21-25: Summer and Pacific General Meeting, AIEE, Hotel Biltmore, Los Angeles.

JUNE 23-25: First Symposium on Global Communications, IRE, Washington, D. C.

JUNE 29-JULY 3: International Conference on Semiconductors, Netherlands Physical Society and UNESCO, Amsterdam, Netherlands.

JULY 6-9, 1954: International Conference on Electron Microscopy, Joint Commission on Electron Microscopy of International Council of Scientific Unions, London, England.

JULY 8-12: British IRE 1954 Convention, Christ Church, Oxford, England.

AUG. 24-SEPT. 4: National Radio Show of Great Britain, Earls Court, London, England.

AUG. 25-27: 1954 Western Electronic Show & Convention, Los Angeles, Calif.

SEPT. 1-16: Golden Jubilee Meeting of the International Electrotechnical Commission, University of Pennsylvania, Philadelphia, Pa.

SEPT. 13-24: 1954: First International Instrument Congress And Exposition, Commercial Museum and Convention Hall, Philadelphia, Pa.

SEPT. 16-18: Joint Electron Tube Engineering Council, General Conference, Chalfonte-Haddon Hall, Atlantic City, N. J.

SEPT. 1954: International Scientific Radio Union, Amsterdam, Netherlands.

SEPT. 30-Oct. 2, 1954: Second Annual International Sight and Sound Exposition, Palmer House Hotel, Chicago, Ill.

OCT. 4-6: National Electronics Conference, Hotel Sherman, Chicago.

OCT. 6-7: First Annual National Conference, IRE Professional Group on Nuclear Science, Sherman Hotel, Chicago, Ill.

OCT. 14-17: Sixth Annual Convention of the Audio Engineering Society, Audio Fair, Hotel New Yorker, New York.

OCT. 18-20: Radio Fall Meeting, Hotel Syracuse, Syracuse, N. Y.

Nov. 4-5: East Coast Conference on Airborne and Navigational Electronics, IRE, Sheraton-Belvedere Hotel, Baltimore, Md.

Nov. 10-11: Conference on Electronic Instrumentation and Nucleonics in Medicine, Morrison Hotel, Chicago, Ill.

Nov. 12-13: National Symposium on Quality Control Methods in Electronics, IRE and American Society for Quality Control, Hotel Statler, New York, N. Y.

Nov. 18-19: Sixth Annual Electronics Conference, Kansas City IRE, Hotel President, Kansas City, Mo.

Industry Shorts

► **Automobile clubs** have been assigned exclusive use of 452.55 and 457.55 mc and public garages 35.70 and 35.98 mc for mobile radio operation. In localities where both 450-mc frequencies have been assigned, clubs can be assigned the 35-mc channels.

► **Production** of radio and tv receivers in Germany reached 205,884 in January and 214,393 in February compared to a 1953 monthly average of 203,004.

► **Manufacturers' cost** for materials (glass envelope, screen and mask, electron gun) is estimated to be approximately \$72 for the new 19-in. Du Mont color picture tube.

► **Educational tv station** will be established in Puerto Rico by the Department of Education with an appropriation of \$600,000.

► **NIKE missile and control systems** have more than 1.5 million individual parts produced by several hundred contractors in more than 20 States.

► **Raydist crews** flew 30,000 miles to electronically survey the test range for Pacific bomb tests.

► **Television sets** in operation in Puerto Rico total over 8,000 and are expected to increase to over 50,000 by the end of 1954.

► **Radar fire control systems** produced by Hughes since 1945 total over 5,000.

STANDARD
flexlab

TEST PANELS & BENCHES

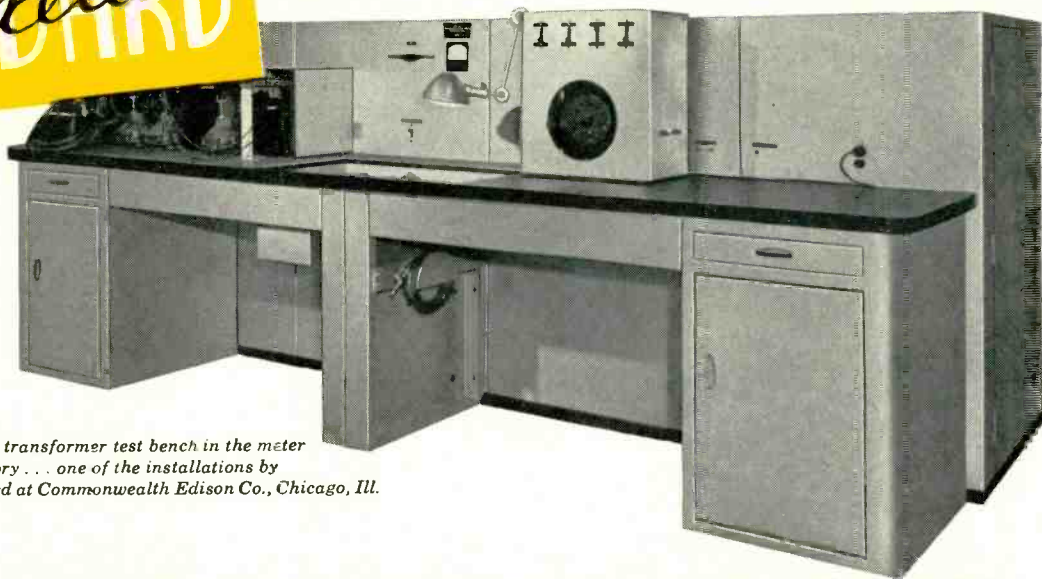

Current transformer test bench in the meter laboratory . . . one of the installations by Standard at Commonwealth Edison Co., Chicago, Ill.

. . . at COMMONWEALTH EDISON



Test benches and control and distribution panels.



Rotating and indicating standards test benches with test lead storage cabinets at each end.



General purpose standardizing and test benches.

Test table with Wheatstone Bridge and Potentiometer.



FLEXLAB

by STANDARD is the hallmark of leadership in custom designed and custom built Test Panels and Benches, Control Panels, Distribution Panels and Pipeline Network Analyzers . . . You will find yourself in the best of company when you have STANDARD design and build your next panel installation . . . Consultation without obligation.

**THE
STANDARD ELECTRIC
TIME COMPANY**

97 Logan St. • Springfield 2, Mass.

SEND TODAY! 

THE STANDARD ELECTRIC TIME COMPANY
97 Logan St., Springfield 2, Mass.

Please send me Flexlab Catalog No. 187

Name _____
Firm _____
Street _____
City _____ State _____

ARE YOU READY FOR

Guaranteed

Core Performance?

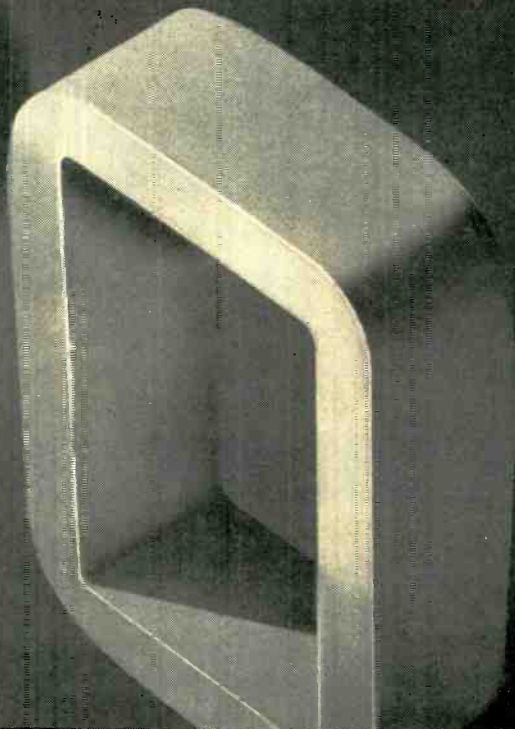

TAPE WOUND CORES

Are you ready for a revolutionary concept in the electrical and electronic industry—the Magnetics, Inc. “Performance-Guarantee” on Tape Wound Cores. Guaranteed

to meet your specifications, and sold at standard prices; these Cores mean truly economical production of high permeability magnetic devices in your plant.

TABLE A
BASIC PHYSICAL CONSTANTS OF
COMMON MAGNETIC MATERIALS

Trade Name	% Ni	% Fe	Other	Grain Structure	Satur. Flux Density Gausses	Resistivity Microhm-Cm	Curie Point °C	Dens. Grams per cc
Hy Mu 80	79	17	4 Mo	“random”	8,700	57	420	8.72
48 Alloy	48	52	...	“random”	16,000	45	500	8.3
Orthonol	50	50	...	oriented	15,500	45	500	8.25
Magnasil	...	97	3 Si	oriented	20,000	48	700	7.65

TABLE B
TRADE NAMES OF SIMILAR MATERIALS

Hy-Mu 80	48 Alloy	Orthonol	Magnasil
4-79 Permalloy	Carpenter 49	Orthonik	Armco Oriented T
Mo-Permalloy	Allegheny 4750	Permeron	Hypersil
Mu Metal*	Hypernik	Deltamax	Orthosil
		Hypernik V	Sifectron

Typical of the unusual scope of the material contained in Catalog TWC-100 are Tables A and B, reproduced from Page 4 of “Performance-Guaranteed Tape Wound Cores.”

GET THE COMPLETE STORY

A wealth of new and unusual material on Tape Wound Cores is available to you in Catalog TWC-100, “Performance-Guaranteed Tape Wound Cores.” Tables A and B of the catalog, reproduced on this page, present a striking illustration of material not to be found compiled together elsewhere.

Data and descriptive details on high permeability materials . . . factory core matching . . . free engineering design services . . . pages of characteristic graphs and tables . . . are yours for the asking. Simply write on your company letterhead.



DEPT. E-7, BUTLER, PENNSYLVANIA

JUST A MATTER OF CONTROL

LORD ENGINEERING CONTROLS VIBRATION

... anywhere!

The difference between a good product and a better one is often just A Matter Of Control—control of vibration and shock which may be damaging your product. Pioneers in solving vibration problems for many industries, Lord Manufacturing Company is well qualified to assure you of better performance from your products through the use of Lord Vibration Control Mountings and Bonded-Rubber Parts. Our Engineers will be pleased to help you in the analysis of the vibration which may damage your product and in the selection of the correct method of control. Lord Engineering means Materials Research—Engineering Research—Product Design—Manufacturing Know-How for your application.

*Over 27,000 designs and their variations
from which to choose.*

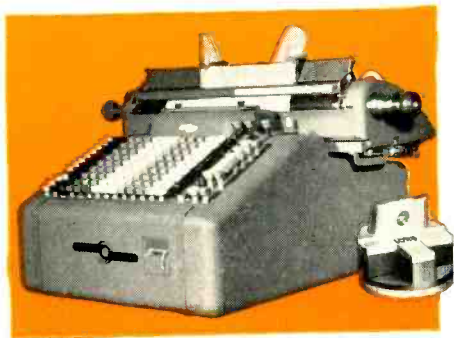

Here is one example of Lord Engineering on sensitive business machines. The Burroughs Sensimatic Accounting Machine is supported on LORD Mountings to reduce noise and cushion shock.

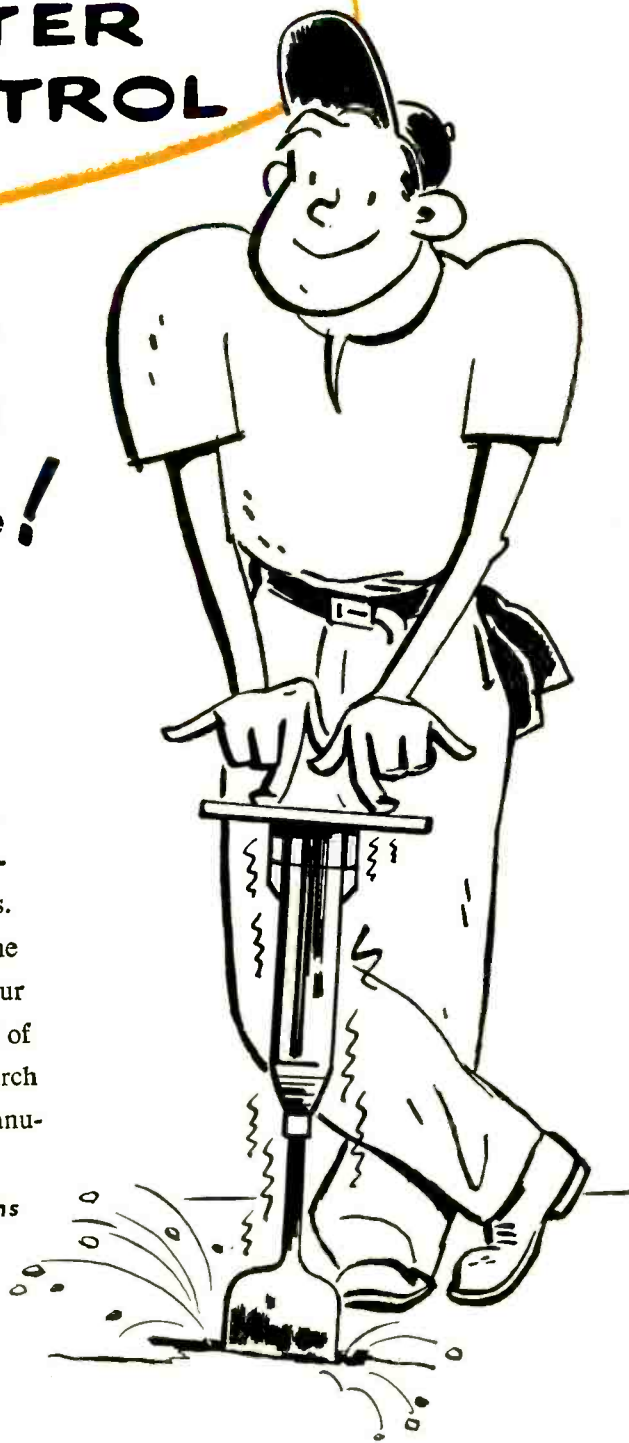

LOS ANGELES 28, CALIFORNIA 7046 Hollywood Blvd.	DALLAS, TEXAS 313 Fidelity Union Life Building	PHILADELPHIA 7, PENNSYLVANIA 725 Widener Building	DAYTON 2, OHIO 410 West First Street
DETROIT 2, MICHIGAN 311 Curtis Building	NEW YORK 16, NEW YORK 280 Madison Avenue	CHICAGO 11, ILLINOIS 520 N. Michigan Ave.	CLEVELAND 15, OHIO 811 Hanna Building

LORD MANUFACTURING COMPANY • ERIE, PA.



Headquarters for
VIBRATION CONTROL
FOR 30 YEARS

A career in

advanced electronic development



Designers for Industry, Inc. is helping many well-known electronics manufacturers meet the "challenge of change" by providing a pool of technical talent unsurpassed by any product development organization.

Our 180-man engineering organization not only generates product ideas. We are also equipped, by experience and facilities, to carry the project through its various stages of development to a final, tested, pre-production model.

In the Electronics field, the DFI organization has built a particularly strong background in miniaturization and modular construction techniques. Some of the many types of development projects we handle are listed below.

Opportunities for unlimited advancement are available at DFI for engineers who have proven records in electronics, electrical, electromechanical, hydraulic and mechanical engineering. Write for further information regarding opportunities in creative engineering work at DFI, as well as DFI employee benefits.

*DFI development
work in electronics
includes:*

COMMUNICATIONS

VHF, UHF, and HF Receivers
Television Receivers
VHF and UHF Transmitters
Microwave Systems
Mobile and Specialized
Military Equipment

MISSILE GUIDANCE

Systems
Servomechanisms

RADAR

Circuitry
Servo Systems
Display Systems
Mechanisms
Beacons
Systems
Fire Control

CONTROLS

Electromechanical
Servomechanisms

COMPUTERS

Test Equipment
Systems Planning
Circuitry
Servomechanisms
Intricate High-speed
Mechanisms

COMPONENT PARTS

Mechanisms
Evaluation Programs
Special Components

DESIGNERS FOR INDUSTRY, Inc.

2915 Detroit Avenue

• CLEVELAND 13, OHIO

Incorporated 1935



It's hot!
in here

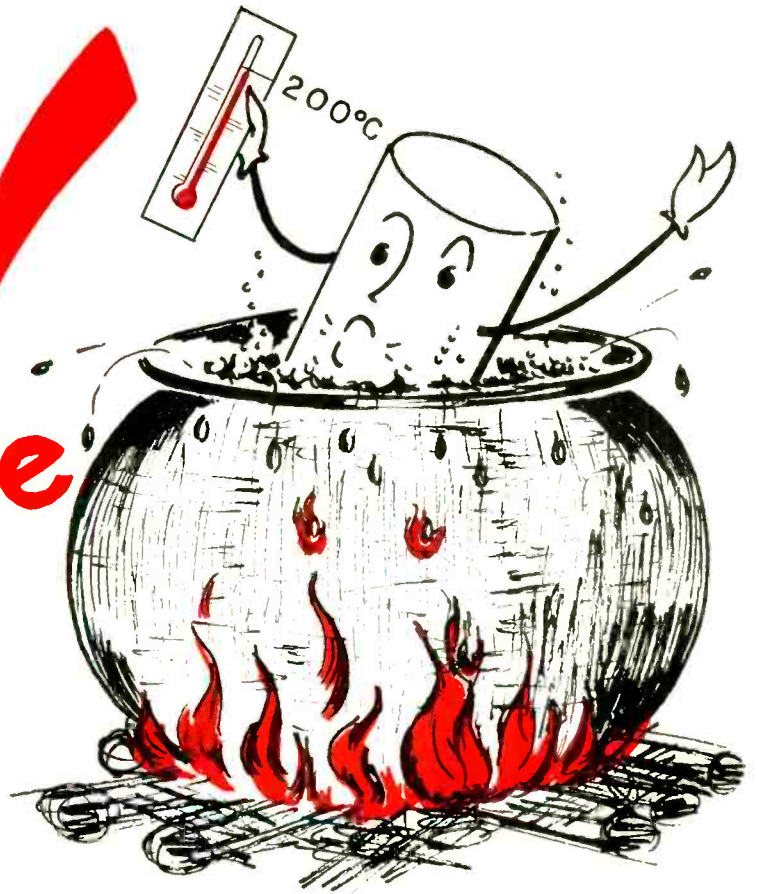

Airpax

proudly announces . . .

MODEL A-100

**400 cycle 6 volt
Chopper**

- • • **for continuous operation
in a 200° c ambient**

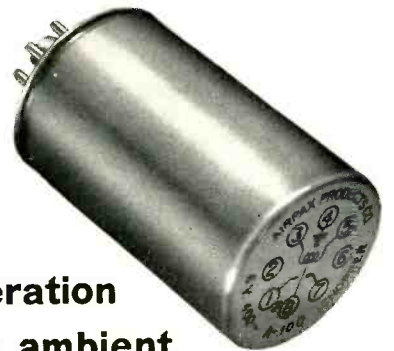

This remarkable Class H adaptation of our standard chopper is at no sacrifice to Airpax quality. In fact operating frequency range is enlarged to 360 to 440 cycles. Drive is 6.3 VAC, 1 watt. Residual noise less than 3 mv. peak to peak at one megohm. Phase lag is 65° between drive voltage and square wave output. Covers the full range of +200°C to -65°C. Will withstand 10g vibration. Contacts SPDT, rated 100 V, 2 ma., max.



MIDDLE RIVER

BALTIMORE 20, MD.

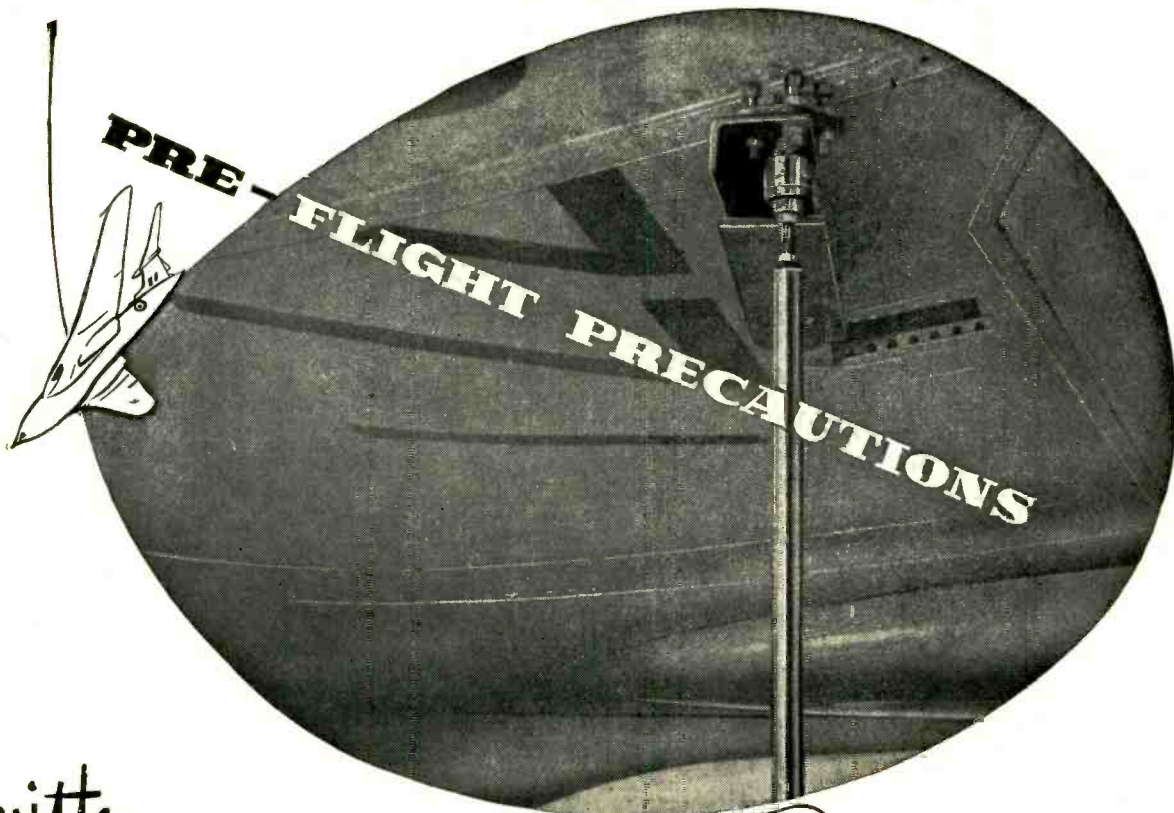

PERMANENT
MAGNET

with
GOODMANS SHAKERS

The flight characteristics of a newly designed aeroplane are the subject of lengthy calculations before the first prototype is built. Whilst the mathematical calculations are themselves accurate, they are based, as in all design work, on several assumptions which have to be verified by a series of pre-flight tests.

One of these essential investigations is the Ground Resonance test, the purpose of which is to determine the various complex modes of vibration of the airframe structure. The frequency of the mode and the dynamic response at remote parts of the aircraft must be accurately determined. The information obtained together with the aerodynamic derivatives is used in predicting the critical 'flutter' speed of the aircraft. The illustration shows one of the two Goodmans Model 8/600 Shakers which were used to excite the Handley Page 'Victor' for this very important test.

For wide frequency range vibration testing and dynamic response investigations, Goodmans Shakers are an obvious choice. These units require no field excitation and provide a faithful reproduction of the input wave form. Industrial applications of controlled vibration are continually increasing; maybe it can serve you—in which case our unique experience is at your service.

Just another of the wide applications of Goodmans Shakers

The range includes models from the 8/600 shown, developing a force of ± 300 lb., to the midget model, with a force of ± 2 lb., for optical cell research and hairspring torque testing, etc.



-----MAIL THIS COUPON-----

TO GOODMANS INDUSTRIES LIMITED
AXIOM WORKS, WEMBLEY, MIDDX., ENGLAND

Please mail me your catalogue and technical data sheets in connection with your PERMANENT MAGNET Shakers.

NAME

COMPANY

CITY..... ZONE..... STATE..... E/U

GOODMANS INDUSTRIES LTD.
AXIOM WORKS • WEMBLEY • MIDDX • ENGLAND

Cables: GOODAXIOM WEMBLEY, MIDDX.



Better Things for Better Living
... through Chemistry

ELECTRICAL ENGINEERING

PROPERTY AND APPLICATION DATA ON THESE
VERSATILE ENGINEERING MATERIALS: "ZYTEL,"
"ALATHON," "TEFLON," "LUCITE."

NEWS

NO. 3

1954

Properties of Du Pont "Teflon" Make It Ideal Insulation for Electrical Equipment

Du Pont "Zytel" nylon gives improved switch performance

Snap switches for machine tools and basic contact mechanisms on industrial instruments often have buttons and stems molded of "Zytel" nylon. This engineering material is used to obtain more efficient production and better performance.

Du Pont "Zytel" is tough and resilient, and resists abrasion. It makes possible the maintenance of critical dimensions. This is particularly important in the manufacture of such parts as timing relays for resistance welding machines, which control the duration of current flow and electrode motion.

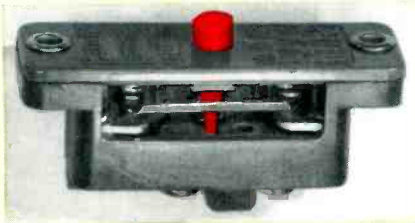

These switches feature one-piece buttons and stems of molded Du Pont "Zytel" nylon.

The lightness of weight and remarkable strength of "Zytel" in thin sections are important factors in such applications. Mass production by injection molding is economical. One molded part often replaces a complex assembly of many parts.

Perhaps "Zytel" nylon can help solve one of *your* design problems. For further information about this or any other Du Pont engineering resin material, clip and mail the coupon on the reverse side.

"Zytel" is the new trade-mark for Du Pont nylon resin.

Dielectric and thermal advantages of "Teflon" are unmatched by any other single material

Du Pont "Teflon" tetrafluoroethylene resin is used for insulation in power distribution equipment because of its unusual combination of properties. In tape form, as wire coating, or molded part, "Teflon" withstands hot-spot temperatures, to 500°F. It is not affected by weather or moisture (zero water absorption by ASTM test D570-42). "Teflon" has a power factor of less than .0005 for the tested range of 60 cycles to 10⁸ cycles. A part molded of "Teflon", when exposed to an arc, leaves no carbonized path.

In addition, "Teflon" has high short-time dielectric strength—with values ranging from 1000 to 2000 volts per mil, depending on thickness. (Recommended working stresses: 50 to 100 volts per mil.) And it is inert to all chemicals normally found in industry.

"Teflon" is tough and flexible

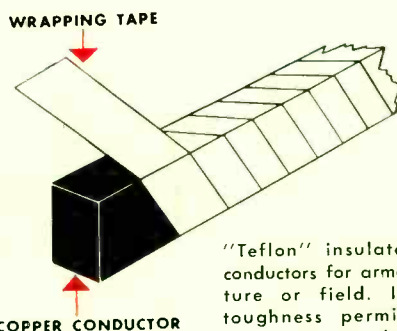

"Teflon" insulates conductors for armature or field. Its toughness permits coils to be formed to shape after taping.

over a wide temperature range, from -450°F. to 500°F. "Teflon" can take a lot of abuse, both during assembly and in use. Parts will not

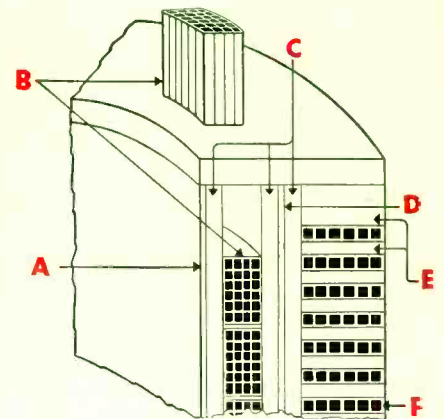

Conductor and layer insulation of "Teflon" in power distribution coils: (A) core insulating barrier (laminate of "Teflon" and glass fiber); (B) low-voltage winding (glass fiber coated with "Teflon"); (C) axial spacers; (D) high-low insulating barrier (laminate of "Teflon" and glass fiber); (E) radial spacers; (F) high-voltage winding (glass fiber coated with "Teflon").

crack if dropped. Cable insulation resists damage from vibration and bending. And tape of "Teflon" conforms easily to sharp corners and odd shapes.

You will find "Teflon" performing with outstanding success . . . not only on power distribution equipment, but in these and other applications as well:

FOR MOTORS AND GENERATORS

The unusual advantages of "Teflon" become apparent when temperatures are too high or atmospheres are too corrosive for other dielectrics. Tape of "Teflon" is particularly suitable for armature or
(Continued, column 3, back side)

OVER



Better Things for Better Living
... through Chemistry

ELECTRICAL ENGINEERING

NEWS

PROPERTY AND APPLICATION DATA ON THESE
VERSATILE ENGINEERING MATERIALS: "ZYTEL,"
"ALATHON," "TEFLON," "LUCITE."

NO. 3

1954

POINTERS ON PROCESSING

**Injection molding
is efficient and
economical**

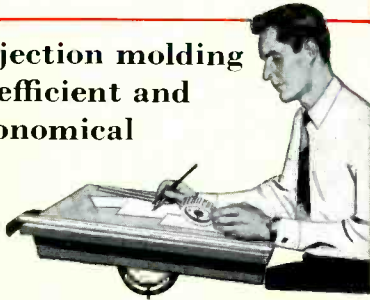

Injection molding, as a method of mass-producing parts made of Du Pont engineering resin materials, has been developed mainly within the past ten or fifteen years. And new improved techniques have accompanied that development.

Investigate Du Pont engineering materials in your product development programs

One of the family of these versatile engineering materials is often a key factor in product improvement or new product design.

The wide range of properties available with "Alathon"* polyethylene resin, "Lucite"* acrylic resin, "Teflon"* tetrafluoroethylene resin, and "Zytel"* nylon resin are helping solve industrial design problems.

NEED MORE INFORMATION?

Clip the coupon for additional data on the properties and applications of these Du Pont engineering materials.

Injection molding offers the advantages of high production rates, low unit cost, and usually does away with finishing operations. One important saving which has been effected by injection molding occurs when the molded piece replaces an assembly of two, three or more parts.

HIGH PRODUCTION RATE

Multi-cavity dies have been made which produce hundreds of identical pieces at a time. Molding time and cycle vary, of course, with the size of the part and its shape. The injection molding process is versatile, and is used to produce a wide variety of quality parts, rapidly and economically.

LOW UNIT COST

Another positive value of injection-molded parts is the low cost of fabrication per part. While the initial cost of the mold itself is high, a mass-production operation makes the cost per piece low. In addition, loss of molding material is generally low.

NO FINISHING OPERATIONS

With good molding techniques, pieces can be injection-molded to close tolerances. In many cases, molded pieces require no finishing operations. Thus, large savings in time and expense can often be realized.

SIMPLIFIED DESIGNS

The versatility of injection molding often permits design simplification.

Du Pont "Zytel" nylon, for example, can be injection-molded into intricate shapes, as well as around metal inserts. Du Pont "Alathon" polyethylene resin and "Lucite" acrylic resin can also be successfully injection-molded into a variety of useful forms. For more information about Du Pont engineering resin materials and how they are being used in industry, clip the coupon.

Du Pont "Teflon"

(continued from other side)

field conductor insulation, coil wrapping, slot lining, lead insulation, and coil separation.

FOR TRANSFORMERS

"Teflon" makes it possible for transformers to operate at hot-spot temperatures as high as 500°F. "Teflon" is used in transformers for conductor, layer, and ground insulation, and for coil separation. At the present time it is used commercially in electronic transformers and experimentally in distribution and power units.

FOR CAPACITORS

Where high ambient temperatures and minimum power loss are essential, "Teflon" gives outstanding service. It is used as the dielectric in many wrapped capacitors.

FOR ELECTRONICS EQUIPMENT

Under conditions of ultra-high frequencies, heavy moisture and concentrated heat, "Teflon" assures efficient operation. Here it takes the form of tape, molded component, or extruded insulation.

Can "Teflon" help you with your design problems? The properties discussed above show why no other single material can match it. And the coupon on the left will bring you whatever further information you need about "Teflon" or any of the other versatile engineering resin materials made by Du Pont.

E. I. DU PONT DE NEMOURS & CO. (INC.)
Polychemicals Department
Room 226, Du Pont Building, Wilmington 98, Delaware

Please send me more information on the Du Pont engineering materials checked:
 "Zytel" nylon; "Alathon"; "Teflon"; "Lucite". I am interested in evaluating these materials for

NAME _____ TITLE _____

COMPANY _____

STREET ADDRESS _____

CITY _____ STATE _____

TYPE OF BUSINESS _____

*"Zytel", "Alathon", "Lucite", "Teflon" are trade-marks of E. I. du Pont de Nemours & Co. (Inc.)

ONE DESIGN
MEETS MANY
REQUIREMENTS →

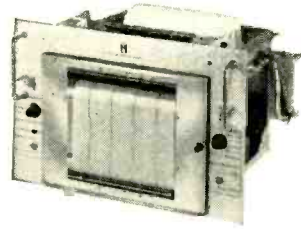

**4
CHANNELS**

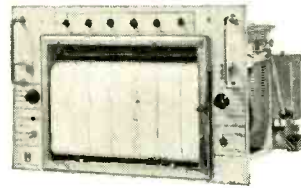

**OR
6**

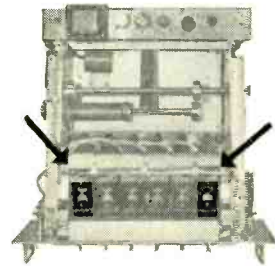

**OR
EXPAND
YOUR 4
CHANNELS
TO 6**

NEW BRUSH OSCILLOGRAPHS

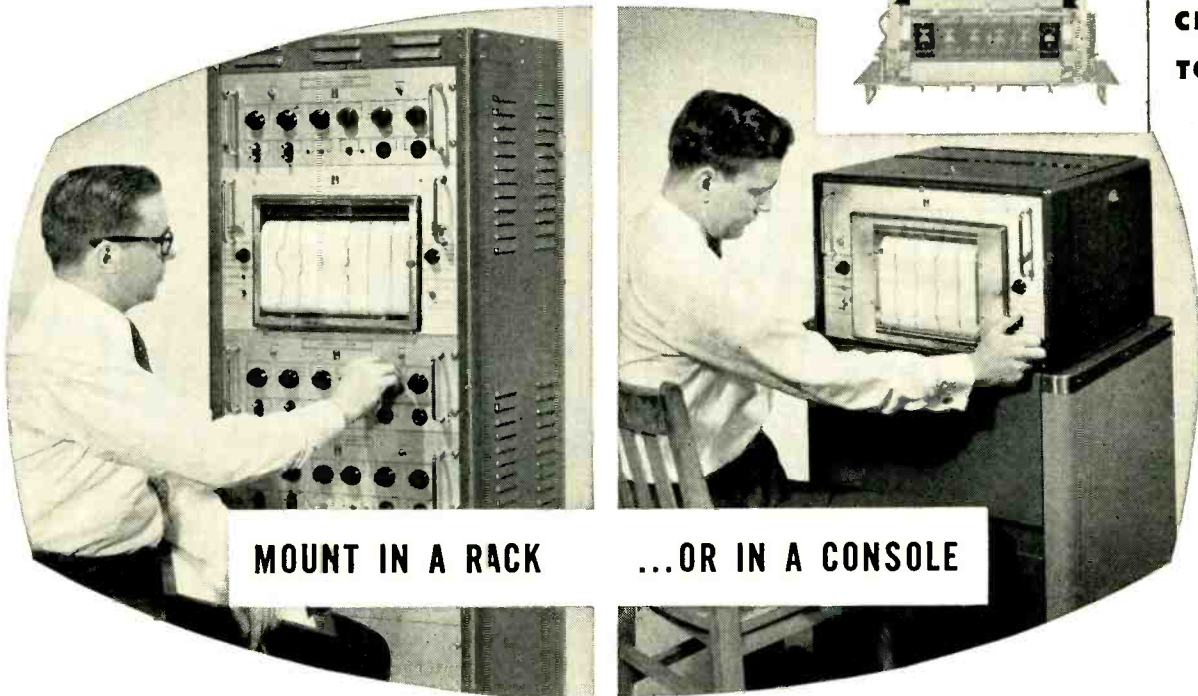

MOUNT IN A RACK

...OR IN A CONSOLE

Standardized design of these new Brush multi-channel oscillographs permits greater flexibility in instrumentation. An identical chassis which can be installed in either a standard 19-inch rack or a console is used for both 4 and 6-channel units. The new electrically-controlled chart drive provides up to sixteen speeds for greater flexibility of speed and operation. The chart can be driven as slow as 1 cm/hour or as fast as 250 mm/sec.—the highest chart speed available on any standard oscillograph. The units can be equipped for local or remote control. Get all the facts—send the coupon today, or call your Brush representative. Brush Electronics Company, Cleveland 14, Ohio. In Canada: A. C. Wickman, Ltd., Toronto.

BRUSH ELECTRONICS

INDUSTRIAL AND RESEARCH INSTRUMENTS
PIEZO-ELECTRIC MATERIALS * ACOUSTIC DEVICES
MAGNETIC RECORDING EQUIPMENT
ULTRASONIC EQUIPMENT



COMPANY

formerly
The Brush Development Co.
Brush Electronics Company
is an operating unit of
Clevite Corporation.

Brush Electronics Company, Dept. K-6B
3405 Perkins Avenue, Cleveland 14, Ohio

Gentlemen:

- Please send bulletin on new oscillographs.
- Please have your representative call.

Name _____

Position _____

Company _____

Address _____

City _____ State _____

NO LOAD RESISTANCE-TEMPERATURE CURVES for GLOBAR® THERMISTORS

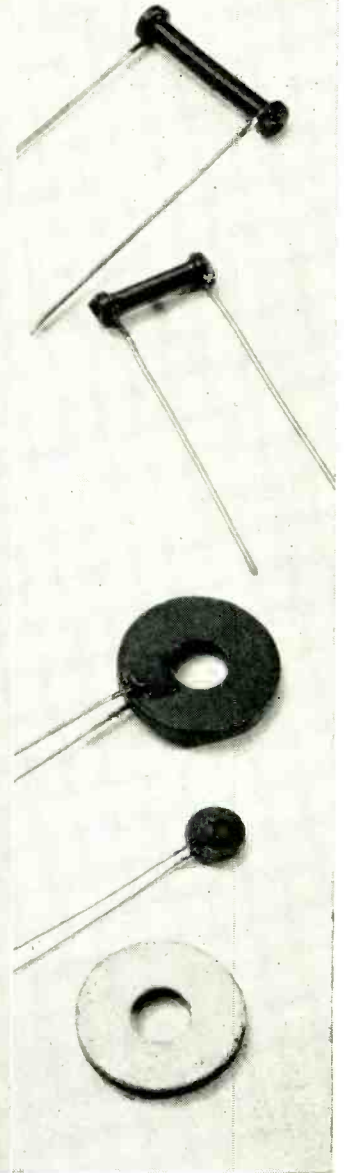
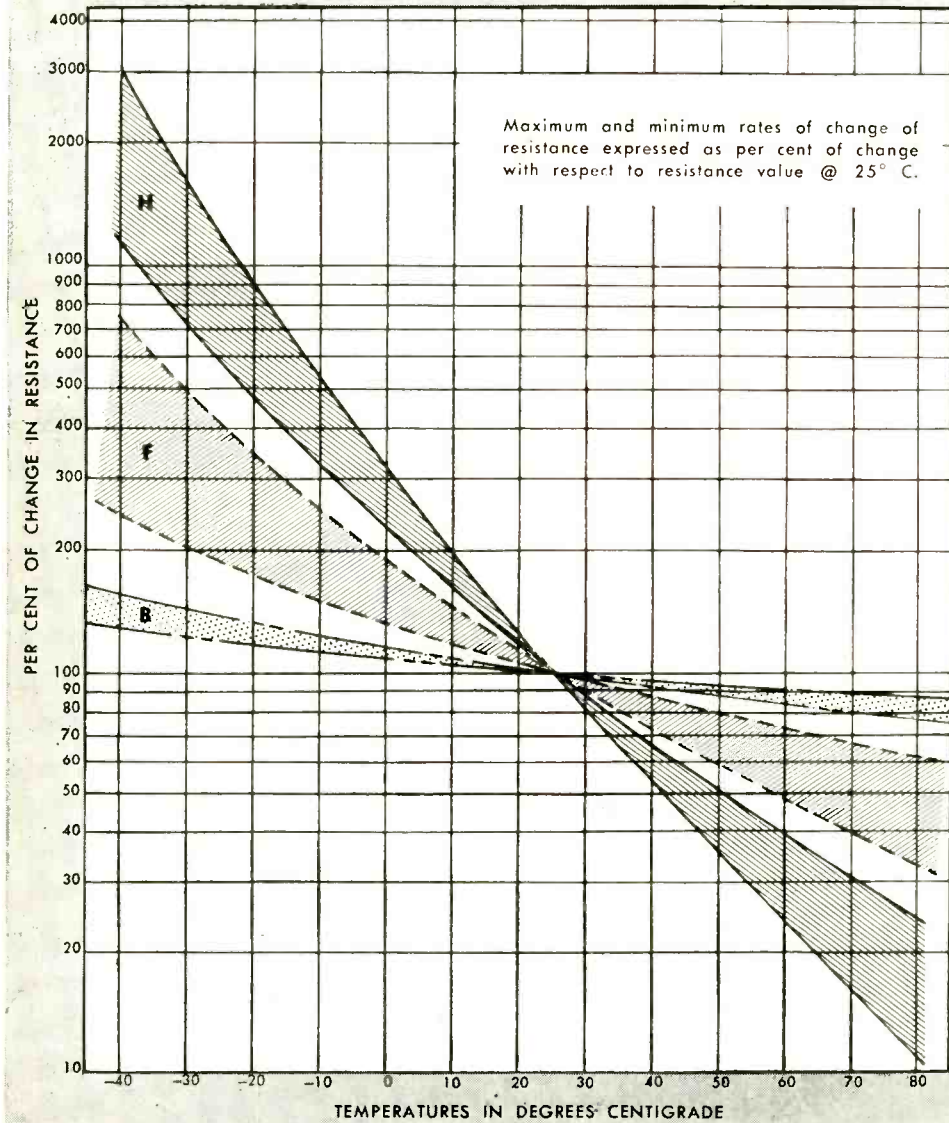

New GLOBAR® TYPE H THERMISTORS can help you solve many circuit problems

Where can you use resistors as sensitive to temperature changes as the new GLOBAR® Type H Thermistors shown on this chart? They offer many challenging possibilities in circuit design... can help you cut costs in the manufacture of radios, television sets, motors, relays, meters, temperature indicating devices, and many other products.

The introduction of the Type H Thermistor, which has a maximum negative temperature coefficient of 4.5%/°C at 25°C, supplementing the range previously obtainable with GLOBAR Types B and F, now provides you a working range from .33%/°C to 4.5%/°C at 25°C.

GLOBAR® Type H Thermistors are engineered to meet your exact requirements—in electrical properties as well as shapes and sizes.

TYPICAL APPLICATIONS
for Type H Thermistors

- To provide time delays in relay, solenoid circuits.
- For temperature compensation in field coils.
- As protective resistors in series filament circuits of radio and television receivers.
- For temperature compensation in meters.
- To control remote temperature indicating devices.
- For temperature compensation in transistor circuitry.

WRITE FOR ENGINEERING BULLETIN ON THERMISTORS

Engineering Bulletin GR-3 gives detailed information on all three types of GLOBAR Thermistors—H, F and B. Write for your copy—and, if you have a circuit problem, send us the basic details. Our engineers will assist you, without obligation. Address: The Carborundum Company, Dept. E 87-47, Niagara Falls, N. Y.

GLOBAR®

Ceramic Resistors

CONVENTIONAL • VOLTAGE SENSITIVE
TEMPERATURE SENSITIVE

by **CARBORUNDUM**

REGISTERED TRADE MARK

87-47

New converters extend range of -hp- 524A Frequency Counter to 220 mc!

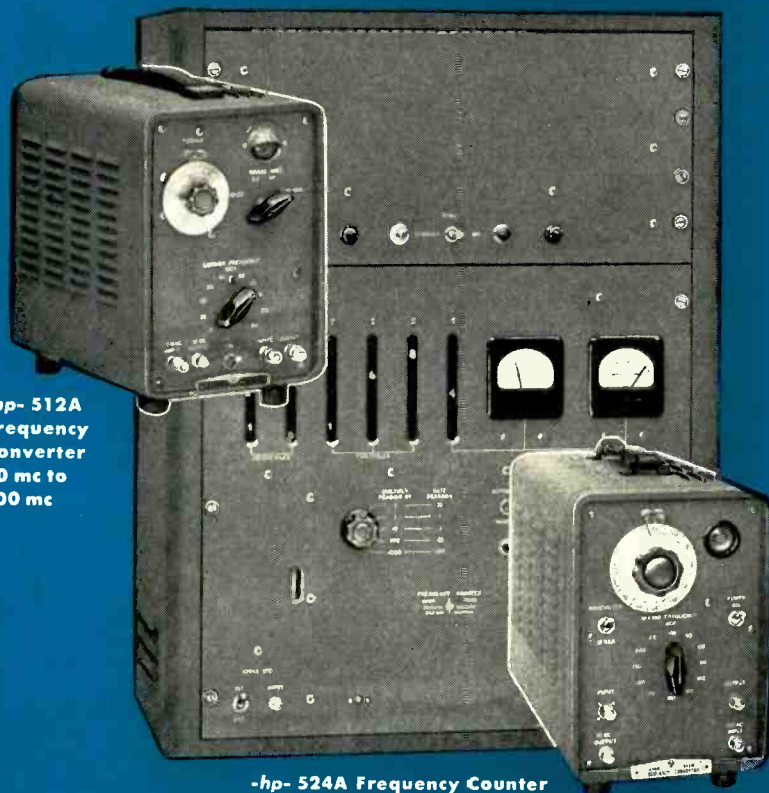

-hp- 512A
Frequency
Converter
10 mc to
100 mc

-hp- 524A Frequency Counter

- Direct readings 10 cps to 220 mc
- Increases sensitivity
- No loss in accuracy
- Instant, automatic measurement
- Easily used by non-technical personnel
- Low cost; eliminates complex setups

-hp- 512B Frequency Converter
100 mc to 220 mc

Now Hewlett-Packard offers two compact, economical Frequency Converters that greatly extend the range and usefulness of your -hp- 524A Frequency Counter—and MATERIALLY INCREASE SENSITIVITY WITHOUT LOSS IN ACCURACY.

The two Converters, -hp- 512A and 512B, increase Counter range from 10 to 100 mc and 100 to 220 mc, respectively. In combination with the Counter, they determine frequencies from 10 cps to 220 mc automatically, instantly, and in direct-reading form without interpolation or calculation. Complex setups and other equipment such as harmonic amplifiers, audio oscillators, multi-vibrators, search wave meters, transfer oscillators and oscilloscopes are completely eliminated. The -hp- Counter-Converter combination is readily used by non-technical personnel since operation consists merely of tuning the Converter to the unknown and selecting the measurement range.

Among the many measurements the Counter-Converter combination makes quickly and easily are crystal checking, oscillator calibration and stability, and broadcast FM and TV transmitter frequency. In addition, -hp- 524A Frequency Counter measures period of low-frequency phenomena by measuring the duration of a complete cycle in microseconds.

Data subject to change without notice. Prices f.o.b. factory.

BRIEF SPECIFICATIONS

-hp- 512A Frequency Converter

Frequency Range: As Amplifier, 100 kc to 10 mc. As Converter, 10 mc to 100 mc.

Input Voltages: 100 kc to 10 mc, 0.1 v R.M.S. minimum; 10 mc to 100 mc, 0.01 R.M.S. minimum (on 50 ohm cable).

Standard Mixing Frequency: Multiplied from 100 kc output of 524A. (Accuracy 1/1,000,000 short term.)

Output Voltage: 2 v minimum (sufficient to operate -hp- 524A over entire range).

Connectors: Standard BNC type.

Power Source: 115/230 v, 50/60 cps, 60 watts.

Size: 7" x 10 $\frac{3}{4}$ " x 14" deep. Weight 20 lbs. Rack mount available.

Accessories Furnished: Cables to interconnect with -hp- 524A.

Price: \$350.00.

-hp- 512B Frequency Converter

Same as above except Frequency Range as Converter, 100 mc to 220 mc; and Input Voltage, 0.25 v R.M.S. minimum.

WRITE TODAY FOR COMPLETE DETAILS

HEWLETT-PACKARD COMPANY

Dept. A, 3032A Page Mill Road, Palo Alto, California, U.S.A.

Field representatives in all principal areas



INSTRUMENTS

Complete Coverage



Technology Instrument Corp., has pioneered in the development of **PHASE MEASURING** and **STANDARDIZING EQUIPMENT** and will continue its contributions in this critical and important field.

- for Measurement
- for Comparison
- for Calibration

These instruments have been designed for sustained, consistent performance. They are as simple and rapid in operation as possible. Full details are available upon request.

Phase measurement and phase reference are the keys to:



TYPE 320-AB PHASE METER

Phase Range: 0-360° without ambiguity
 Frequency Range: 20 cycles to 100,000 cycles
 Absolute Accuracy: 1% of full scale + 3°
 Incremental Accuracy: As close as meter scale can be read.
 Meter Scales: 0-36°, 0-90°, 0-180°, 0-360°



TYPE 322-A PRECISION PHASE METER

Phase Range: 0-360° without ambiguity
 Frequency Range: 20 cycles to 1 Mc
 Absolute Accuracy: ±1° up to 20,000 cycles, slightly decreasing accuracy 20,000 cycles to 1 Mc.
 Incremental Accuracy: ±0.1° up to 20 Kc.
 Meter Scales: 0-360°, 0-30° (any 30° segment 0-360°)



TYPE 324-A VIDEO PHASE METER

Phase Range: 0-360° without ambiguity
 Frequency Range: 20,000 cycles to 4.5 Mc.
 Absolute Accuracy: +4° over entire range
 Incremental Accuracy: ±0.25° over entire range
 Meter Scales: 0-360°, 0-90° (any 90° segment 0-360°)

AMPLIFIERS

As adjuncts to the phase measuring and generating instruments described on these pages, an extensive line of amplifiers is available. These amplifiers have inherently low phase shift which is definitely known and which may be controlled to an accurately fixed value.

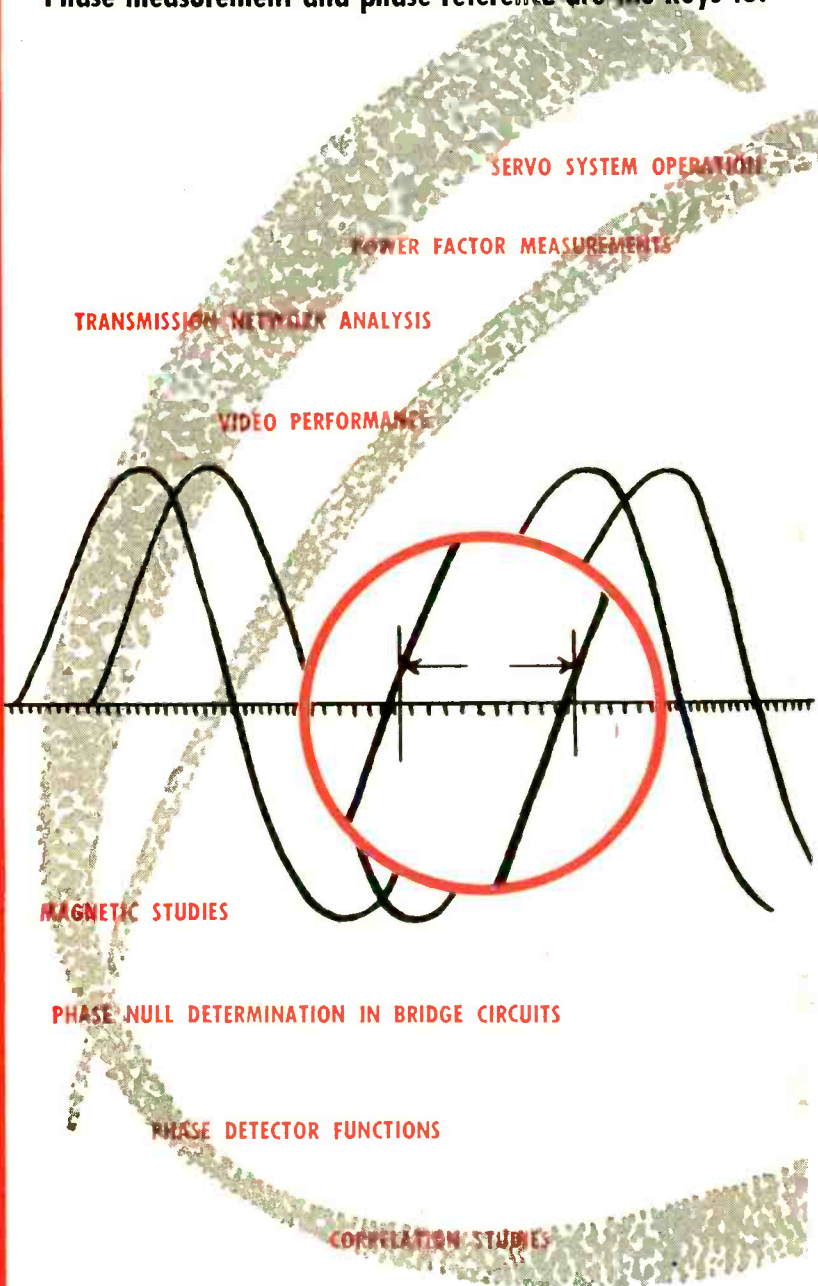

TECHNOLOGY

533 Main St., Acton, Mass. COlonial 3-7711

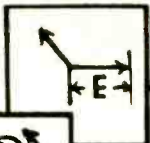

AMPLITUDE

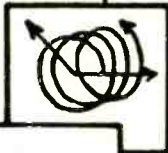

FREQUENCY

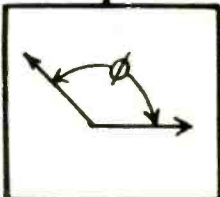

PHASE

It has remained for Technology Instrument Corp.,

to provide superb tools designed exclusively for attack on less familiar problems in the field of PHASE MEASUREMENT. The advance in electronics

technology has, more and more, exploited PHASE relationships and control. Familiarity and understanding of this field, together with techniques based upon measurement devices of greater accuracy, make available a Third Dimension in electronic mastery.

For many years the industry has been well supplied with fine tools from many sources, for the measurement and control of amplitude and frequency. Well trodden paths of experimental procedure, based upon accurate instrumentation, have built up a tremendous body of know-how and familiarity with problems in this area of development.

DATA TRANSMISSION SYSTEMS

RADIO NAVIGATION PROBLEMS

VECTOR ANALYSIS

IMPEDANCE DETERMINATION

SYNCHRONOUS OPERATIONS

HIGH ACCURACY TIMING

SPECIAL ELECTRICAL CONTROL

INVESTIGATION OF FEEDBACK SYSTEMS



TYPE 704-A SECONDARY PHASE STANDARD

Range of Generated Phase Shift: 0-360° variable
Available for any one of the following standard frequencies: 60, 400, 1000, 20,000 cycles or
Available for any one specific frequency between 60 and 20,000 cycles
Absolute Accuracy of Phase Shift: Within 2
Incremental Accuracy of Phase Shift: Within 0.1



TYPE 706-A ULTRASONIC PHASE STANDARD

Range of Generated Phase Shift: 0-360° variable
Available in Standard Model for 82 Kc. or
Available in Special Models for any single frequency between 20,000 cycles and 200 kilocycles
Accuracy of Phase Shift: Within 0.1



TYPE 7000-A PRIMARY PHASE STANDARD

Range of Generated Phase Shift: 0-360° variable
Available for any single frequency between 60 cycles and 20,000 cycles
Absolute Accuracy of Phase Shift: At least 0.05 multiples of 1° established to at least 0.02

CONSULTATION ON PHASE PROBLEMS:

Technology Instrument Corp., as the leader in phase measurement techniques, will welcome the opportunity to assist in any problem in this field. A hand-picked engineering staff is ready at any time to consult with you on your phase problems. This staff has available the finest phase laboratory to be found and its services may be sought for any problem, large or small.

INSTRUMENT CORP.

West Coast Eng'g. Facility, 731 No. LaBrea Ave., Hollywood, Calif., WHitney 0108

THE GREATEST HIGH-TEMPERATURE CAPACITORS EVER DEVELOPED!

Consistently Dependable
Cornell-Dubilier
molded and metal-case Mylar tubulars*

No voltage derating required from -55°C to $+130^{\circ}\text{C}$!

Here are the greatest high-temperature capacitors ever developed—the product of Cornell-Dubilier's manufacturing know-how combined with DuPont's great new Mylar* Polyester film dielectric. Designed in the new Demicon-type *metal-cased* tubular and in the new PM series *molded* tubular styles. This new development results in a capacitor that remains exceptionally stable at temperatures up to 160°C . with no voltage derating required to 130°C . Within these temperature ranges, there is sure to be a capacitor to meet your exact needs. So why not send for individual operating characteristics data—today.

Engineering samples sent on request. For your special design and application problems, use our Technical Advisory Service. No obligation, of course. Write to: *Industrial Division, Cornell-Dubilier Electric Corp., Dept. K-64 South Plainfield, New Jersey.*

THERE ARE MORE C-D CAPACITORS IN USE TODAY THAN ANY OTHER MAKE

CORNELL DUBILIER *Capacitors*

PLANTS IN SOUTH PLAINFIELD, N. J.; NEW BEDFORD, WORCESTER AND CAMBRIDGE, MASS.; PROVIDENCE AND HOPE VALLEY, R. I. INDIANAPOLIS, IND.; FUGUAY SPRINGS AND SANFORD, N. C.; AND SUBSIDIARY, THE RADIART CORPORATION, CLEVELAND, OHIO



ANTENNAS



ROTORS



CAPACITORS



VIBRATORS



CONVERTERS

* DUPONT TRADE MARK

RAYTHEON MAGNETRONS AND KLYSTRONS MEET EVERY FREQUENCY AND POWER NEED

Two of these tubes just declassified

RK6230/QK299B — tunable pulse magnetron (8900-9400 Mc), 1 Kw average peak power



RK6410/QK338 — fixed frequency, pulse magnetron (2750-2860 Mc), 5 megawatt average peak power

RK2J51 — tunable pulse magnetron (8500-9600 Mc), 50 Kw average peak power

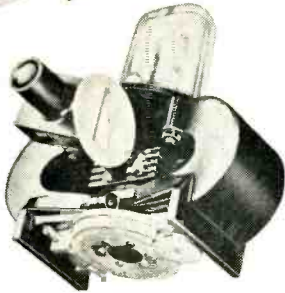

RK5976—mechanically tunable klystron (6250-7425 Mc), average power 100 milliwatts

RK6116 — thermally tuned ruggedized klystron (8500-9660 Mc), average power 25 milliwatts



RK5721—klystron tunable with external cavities from 3600 to 10,500 Mc. Average power 125 milliwatts in the 2 $\frac{3}{4}$ reflector mode (4290-8340 Mc)

Raytheon also manufactures transmitting tubes, storage tubes and square law tubes

VELOCITY VARIATION REFLEX OSCILLATORS

Characteristics of Unclassified
Tube Types

Complete data on tube type available upon request



Raytheon Manufacturing Company
Power Tube Division
Waltham 54, MASSACHUSETTS

MAGNETRON OSCILLATORS

Characteristics of Unclassified
Tube Types

Complete data on tube type available upon request



Raytheon Manufacturing Company
Power Tube Division
Waltham 54, Massachusetts

Now Available —

CONSOLIDATED DATA BOOKLETS FOR RAYTHEON MAGNETRONS & KLYSTRONS

WRITE FOR YOUR COPIES TODAY

These valuable data booklets, which we will be glad to send you, list most principal unclassified types now manufactured — give maximum ratings, typical operating values, frequency ranges. Indispensable to every microwave engineer's file.

Raytheon is the world's largest producer of CW and pulse magnetrons, many tunable mechanically or electrically. A compact, efficient source of

power, magnetrons are being used in an ever increasing number of applications.

Raytheon klystrons, which can be tuned mechanically or thermally, fit the widest range of requirements with tubes available from 550 to 60,000 Mc.

Please feel free to call on us for Application Engineering Service on your microwave problems. There is no cost or obligation.

WRITE TODAY for your data booklets. Please address Raytheon Manufacturing Co., Power Tube Sales — Section PL-02, Waltham 54, Mass., or telephone Waltham 5-5860, Ext. 2443.



Raytheon Manufacturing Company, Power Tube Division, Waltham 54, Mass.

MILLIONS

OF VARIABLE

COMPLETE MILITARY LINE AVAILABLE.

POPULAR MILITARY TYPES ILLUSTRATED.

CORRESPONDING COMPLETE LINE FOR COMMERCIAL APPLICATIONS ALSO AVAILABLE.

5 acres of plant area . . . over 1000 employees . . . making ALL TYPES of variable resistors by the million. . . for ALL your requirements. CTS SPECIALIZES in precision mass production of variable resistors and associated switches . . . makes nothing else.

Most controls available with switches and in concentric shaft tandems or with two controls operating on one shaft. Also available with locking bushing, water sealed bearing and many other special features not illustrated.

Immediate delivery from stock on many JAN-R-94, JAN-R-19 and other types.



WRITE FOR ILLUSTRATED CATALOG—

Describes Electrical and Mechanical characteristics, Special Features and Constructions of a complete line of variable resistors for military and civilian use. Includes dimensional drawings of each resistor

REPRESENTATIVES

Henry E. Sanders
McClatchy Bldg.
59th & Market St.
Upper Darby, Penna.
Phone: Flanders 2-4420

W. S. Harmon Company
121 No. Robertson Blvd.
Beverly Hills, California
Phone: Bradshaw 2-3321

John A. Green Company
6815 Oriole Drive
Dallas 9, Texas

CANADIAN MANUFACTURING AFFILIATE

C. C. Meredith & Co., Ltd.
Streetsville, Ontario

SOUTH AMERICA

Jose Luis Pontet
Buenos Aires, Argentina
Montevideo, Uruguay
Rio de Janeiro, Brazil
Sao Paulo, Brazil

OTHER EXPORT

Sylvan Ginsbury
8 West 40th Street
New York 18, New York

1/2 watt 70°C, 3/4" diameter miniaturized variable composition resistor.

TYPE 65 (Miniaturized)



TYPE C90-65 Tandem



UNPRECEDENTED PERFORMANCE CHARACTERISTICS

Types 65, 90 and 95 are specially designed for military communication equipments subject to extreme temperature and humidity ranges: -55°C to +150°C . . . aridity to saturation.

1 watt 70°C, 15/16" diameter variable composition resistor.

TYPE 90



TYPE GC-90 With Switch



TYPE C2-90 Tandem

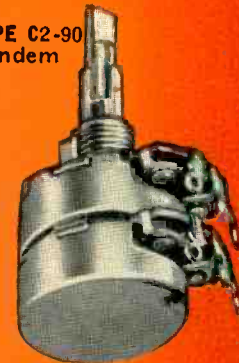

Meets JAN-R-94 type RV4

2 watt 70°C, 1-1/8" diameter variable composition resistor. Also available with other special military features not covered by JAN-R-94.

TYPE 95

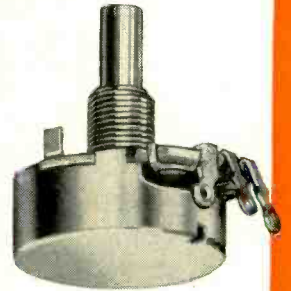

TYPE GC-95 With Switch



TYPE C2-95 Tandem

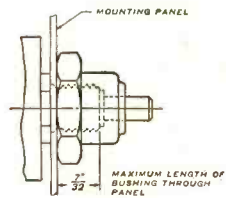

WATER SEALED MOUNTING AND BEARING FOR TYPE 65

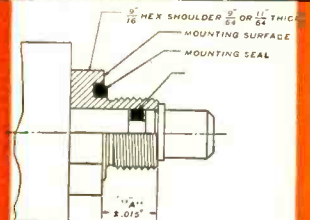
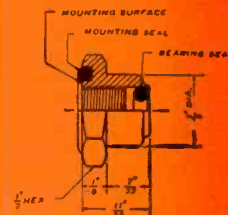

(CAN BE SUPPLIED WITHOUT THE WATER SEALED MOUNTING SHOULDER)
WATER SEALED MOUNTING AND BEARING FOR TYPES 45, 35, 90, 95, 25, 252.



CHICAGO TELEPHONE SUPPLY Corporation

ELKHART • INDIANA

Burton Browne Advertising

RESISTORS... FOR EVERY NEED

Meets JAN-R-94
type RV3

1/2 watt 1-1/8" diameter
variable composition
resistor. Also available
with other special mili-
tary features not covered
by JAN-R-94.

TYPE 35



Meets JAN-R-94
type RV2

1/4 watt 15/16" diameter
variable composition
resistor. Also available
with other special mili-
tary features not covered
by JAN-R-94.

TYPE 45



Meets JAN-R-19
types RA25 and RA30

4 watt 1-17/32" diameter
variable wirewound resi-
stor. Also available with
other special military
features not covered by
JAN-R-19.

TYPE 25

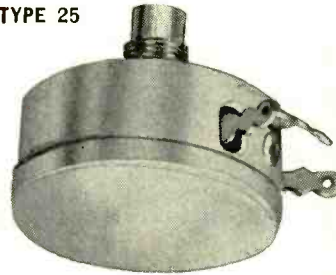

Meets JAN-R-19
type RA20

2 watt 1-17/64" diameter
variable wirewound resi-
stor. Also available with
other special military
features not covered by
JAN-R-19.

TYPE 252

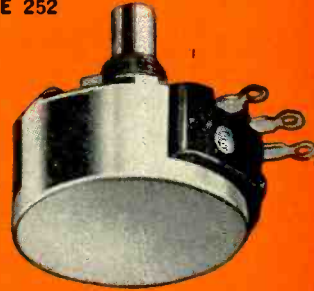

TYPE GC-35
With Switch



TYPE GC-45
With Switch



TYPE GC-25
With Switch

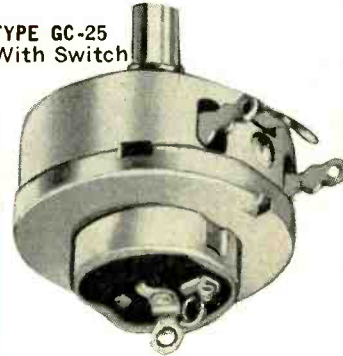

TYPE GC-252
With Switch

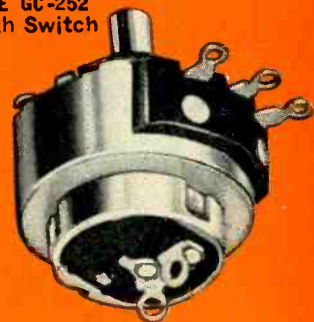

TYPE C2-35
Tandem

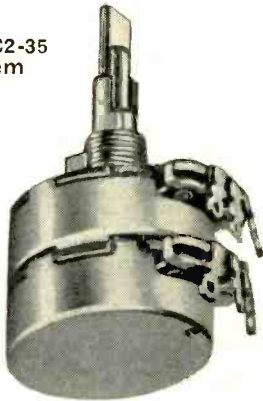

TYPE C2-45
Tandem



TYPE C2-25
Tandem



TYPE C2-252
Tandem

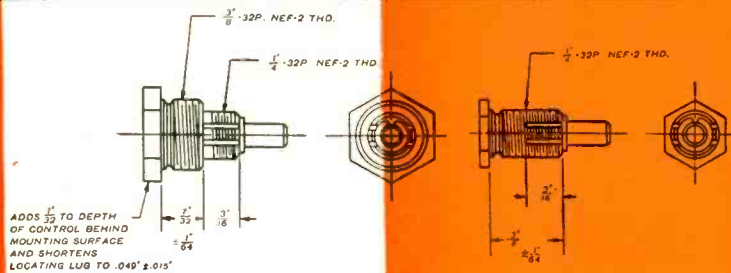
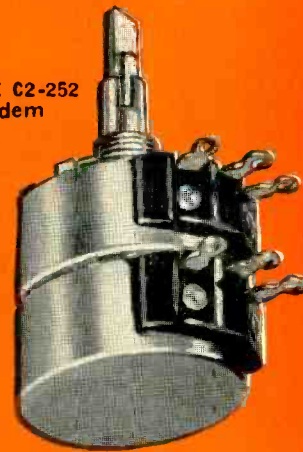

LOCKING BUSHINGS FOR TYPE 65 CONTROL.

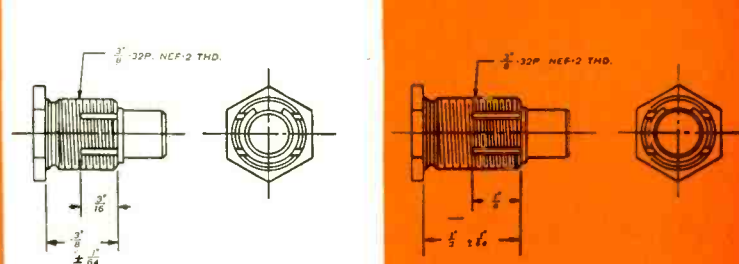

LOCKING BUSHINGS FOR CONTROL TYPES 25, 252, 95, 35, 90, 45.

Specialists in Precision Mass Production of Variable Resistors • Founded 1896

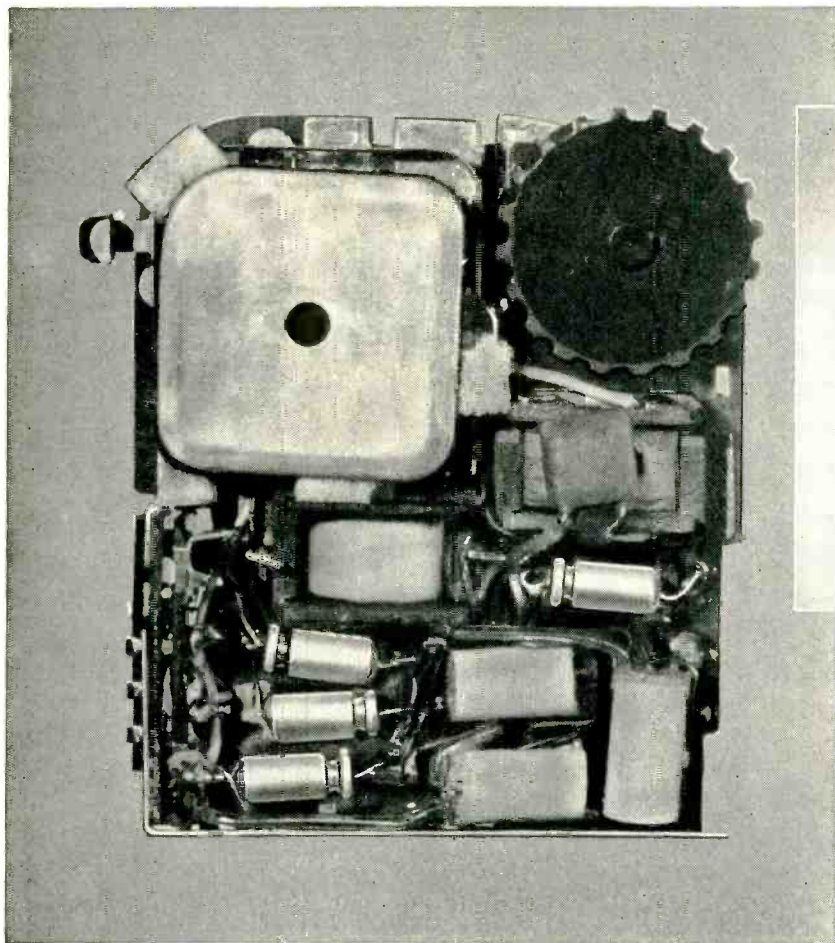

Four G-E Micro-miniature Tantalitic capacitors easily fit into small space provided in this new all-transistor hearing aid. Man above adjusts volume control.

Other applications now being investigated:

- WALKIE-TALKIES
- WRIST RADIOS
- PAGING SYSTEMS

How Tantalitic Capacitors Are Used In Miniaturized Hearing Aids

Four G-E Micro-miniature Tantalitic capacitors are used in this new all-transistor hearing aid. These high-capacitance, small-size units are necessary due to the low-impedance characteristics of transistors, as compared with the vacuum tubes formerly used. Ceramic and paper dielectric capacitors cannot supply sufficient capacitance in the small size desired, according to hearing aid design engineers.

Pictures, circuit diagram, application information courtesy Sonotone Corp.

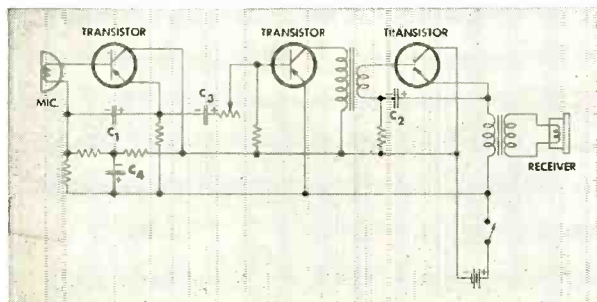

Simplified schematic diagram of Sonotone all-transistor hearing aid, showing location of G-E Micro-miniature Tantalitic capacitors.

Operating at a battery voltage of 2.5 volts, this hearing aid uses two units rated at 2 microfarads each for by-pass, C_1 and C_2 (see diagram). They give a low-impedance signal path from the source to the input of the transistor. Two 1-microfarad units, C_3 and C_4 , are used for coupling and filtering respectively, where their low leakage current of .18 microamperes/uf/volt at 25 deg. C is especially important.

G-E Micro-miniature Tantalitics can be obtained in ratings up to 20 volts, or, up to 8 uf in a $\frac{5}{16}$ -in. long by $\frac{1}{8}$ -in. dia. case size, higher capacitance in a $\frac{1}{2}$ -in. long by $\frac{1}{8}$ -in. dia. case size. Capacitance tolerance is -0% to $+100\%$.

For more information about G-E Micro-miniature Tantalitic capacitors, contact your G-E Apparatus Sales Office or write for bulletin GEA-6065 to General Electric Company, Section 442-15, Schenectady 5, New York.

GENERAL  ELECTRIC

for durable and

dependable vacuum-tight assemblies

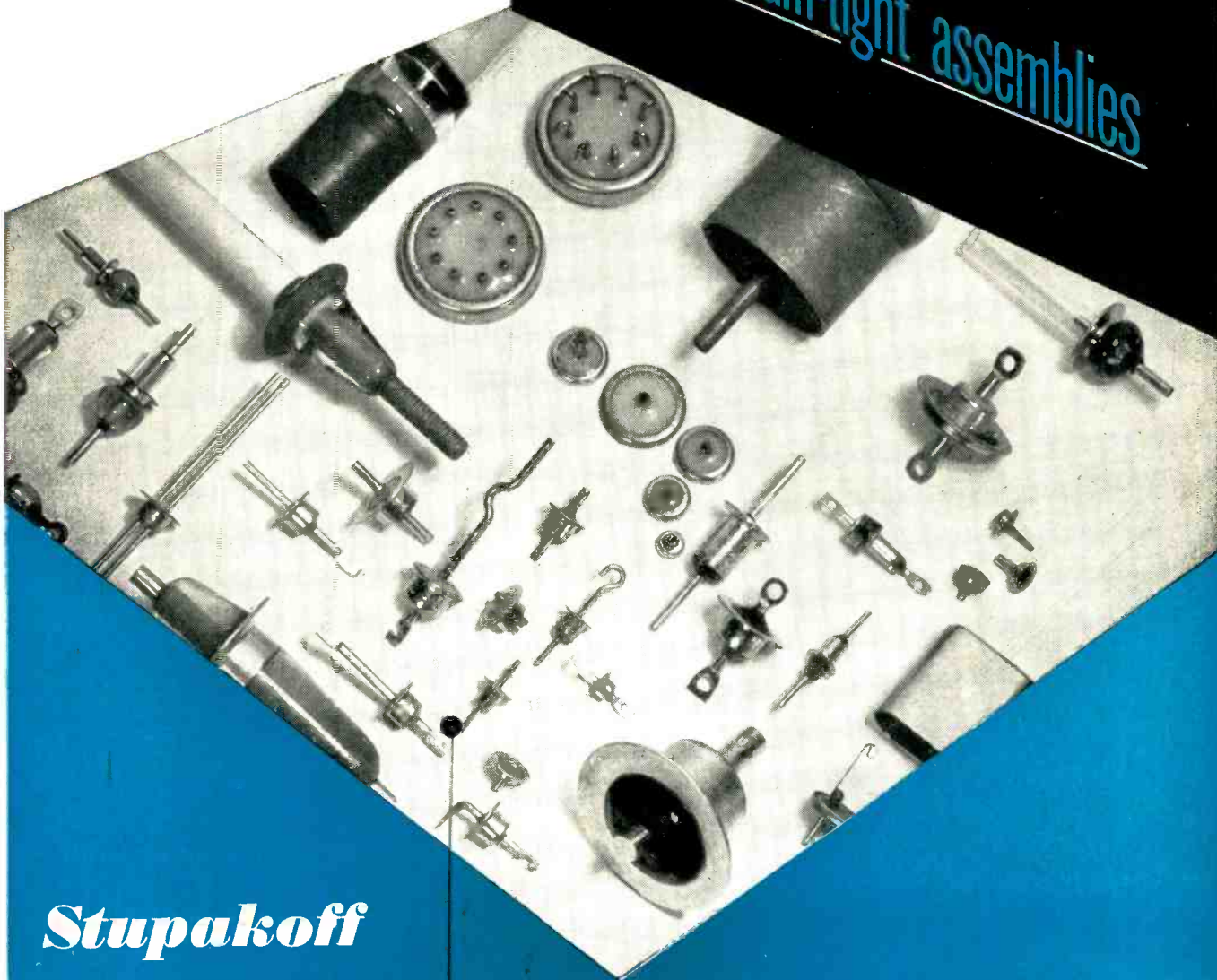

Stupakoff

glass-to-metal
seals

A complete range of sizes and designs of terminals, lead-ins and stand-offs for hermetic sealing is offered by Stupakoff. Made with Kovar metal, the ideal alloy for sealing to hard glass, Stupakoff Seals are durable and dependable. These are not mechanical compression seals, but are permanently fused by chemical interaction. They may be installed by conventional assembly techniques.

Write for a copy of the new Stupakoff Catalog 453, giving details of over a thousand sizes and styles of Stupakoff Seals.

**STUPAKOFF CERAMIC
& MANUFACTURING COMPANY**

LATROBE, PENNSYLVANIA



FACTS YOU SHOULD KNOW ABOUT CELLULAR

Cellular polyethylene power factor and dielectric constant at 1 megacycle vs. temperature. The small effect of temperature change on these two properties indicates that the material will have minimal power losses when subjected to seasonal variations.

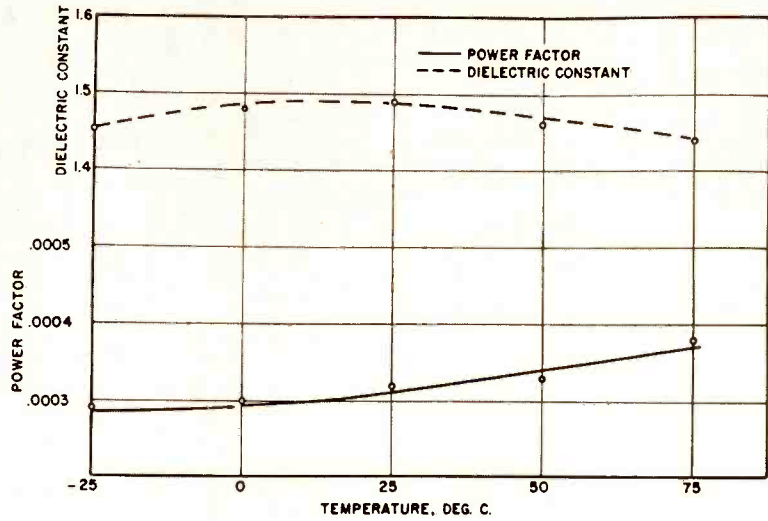

Plot of cellular polyethylene power factor and dielectric constant at 1 megacycle vs. specific gravity shows slight effect of density on power factor but great effect of density on the dielectric constant.

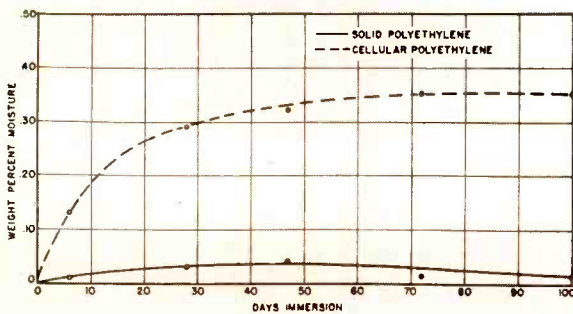
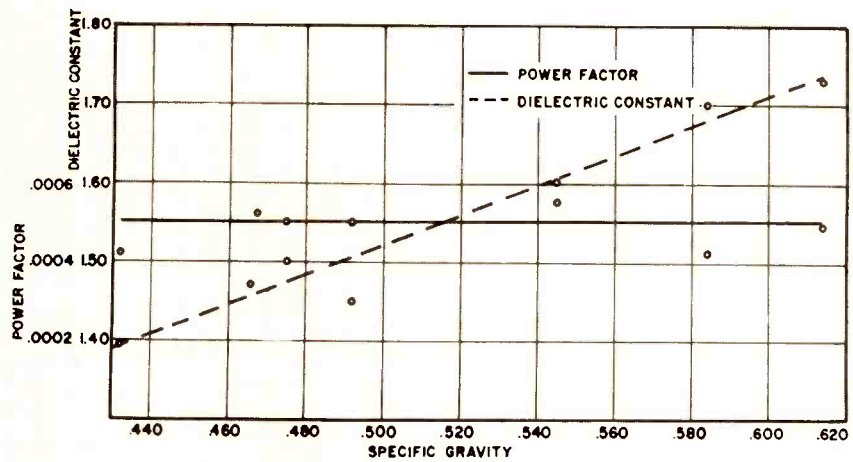

Moisture absorbed vs. days of immersion in tap water at 23 deg. C.

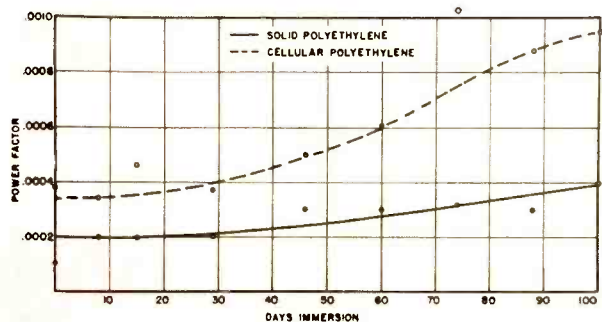

Power factor at 1 megacycle vs. days of immersion in tap water at 23 deg. C.

POLYETHYLENE

NEW BAKELITE MATERIAL FOR LOW-LOSS ELECTRICAL INSULATION

BAKELITE Polyethylene is already known as an outstanding material for electrical insulation. Now Bakelite Company has developed a polyethylene that can be foamed to a cellular form. It is marked by improved low-loss characteristics, and can be used wherever the tensile strength, elongation, and dielectric strength of solid BAKELITE Polyethylene are not of prime importance.

Production of BAKELITE Cellular Polyethylene can be carried out on standard extrusion equipment. Properly extruded, the new material will expand 100 per cent. Structurally, it consists of unconnected hollow cells, so that moisture absorption is of the same low order as solid polyethylene.

Cellular polyethylene is produced by combining polyethylene having a dielectric constant of 2.3 with a blowing agent that yields an inert gas having a dielectric constant of about 1.0. Its own constant lies between the two. Specific gravity is about half that of solid polyethylene. Power factor values are essentially the same. Since the dielectric constant is much lower, it is possible to make insulated conductors with a lower capacitance per foot than with the solid material.

An important application for this material is its use for covering UHF television lead-in wire. As shown in figure 4, there is little or no change in power factor and dielectric constant over a broad frequency range. This absence of irregularities means that power losses will be uniformly low.

BAKELITE Cellular Polyethylene can be formulated for varying degrees of expansion. It has the chemical resistance of polyethylene, and withstands sea water, most acids, alkalies, and oxidizing agents.

For descriptive literature covering BAKELITE Cellular Polyethylene, write Dept. XM-79.

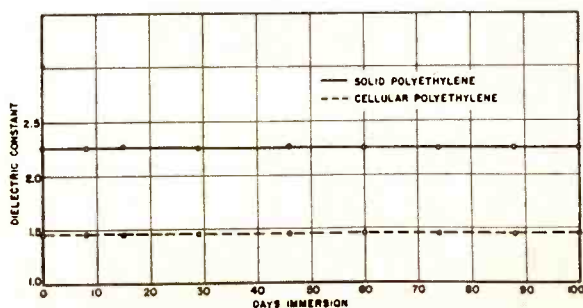

Dielectric constant at 1 megacycle vs. days of immersion in tap water at 23 deg. C.

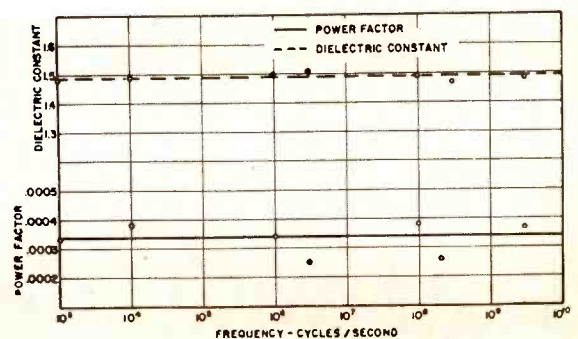

Power factor and dielectric constant of cellular polyethylene vs. frequency.

BAKELITE

TRADE-MARK

POLYETHYLENE



BAKELITE COMPANY

A Division of

Union Carbide and Carbon Corporation



30 East 42nd Street, New York 17, N. Y.

In Canada: Bakelite Company
Division of Union Carbide Canada Limited
Belleville, Ontario

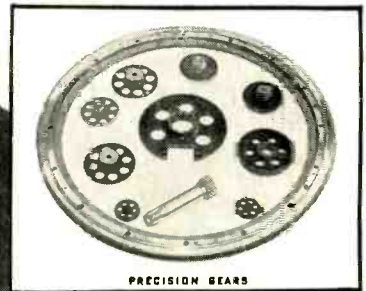
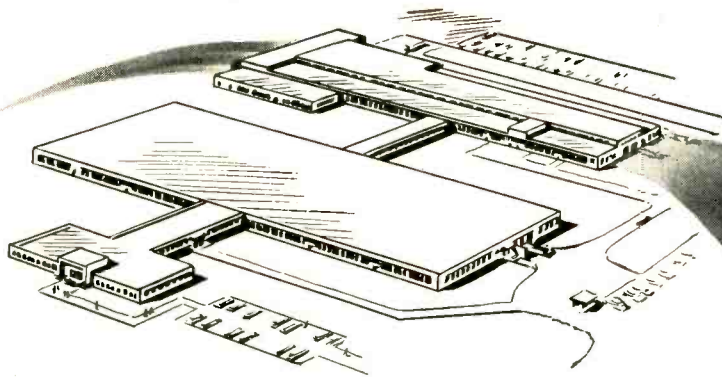

PRECISION GEARS

WHAT DAYSTROM HAS TO OFFER YOU . . .

UNDER ONE ROOF Daystrom Instrument can meet every one of your engineering and manufacturing needs—in their modern 350,000 sq. ft. plant, where a full range of up-to-date equipment is available for manufacturing from raw materials to finished assemblies and systems . . . for complete electro-mechanical and electronic parts and assembly in any quantity . . . for internal, external, surface and centerless grinding; low to high precision turning; jig boring and milling; welding, heat treatment and finishing; precision spur and helical gear shaping, hobbing and shaving; straight and spiral beveled gearing; test and inspection for entire range of gear production.

Daystrom's Research and Development Engineers have special skills in mathematics, radar circuitry, electronic computer design and instrumentations of a similar nature . . . Daystrom's Production Engineers are specialists in the mechanical, electronic and electromechanical fields . . . Daystrom's Manufacturing Engineers are experts in tool design, processing and tooling—with a new, complete toolroom for producing jigs, dies and fixtures.

*Write today for
our facilities report.*

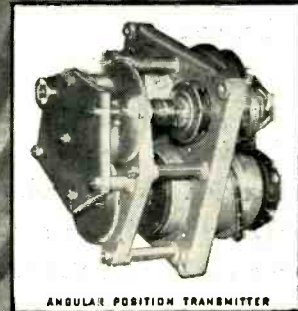

ANGULAR POSITION TRANSMITTER

*DIVISION OF DAYSTROM
INCORPORATED*

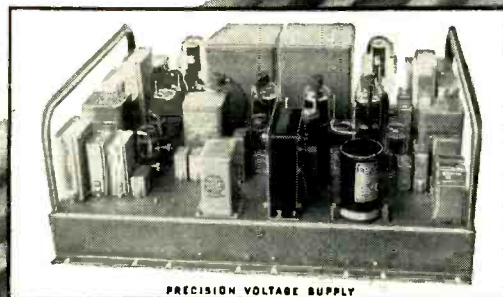

PRECISION VOLTAGE SUPPLY

DAYSTROM INSTRUMENT

ARCHBALD, PENNA.

Affiliates:

American Type Founders, Inc., Elizabeth, N.J.; Daystrom Furniture Div., Olean, N.Y.; Daystrom Electric Corp., Poughkeepsie, N.Y.



For gasketed parts like these . . .



This FREE BOOK CAN HELP YOU CUT COSTS!

There's something new in electronics this year . . .

IT'S THE DAREX Flowed-in GASKET PROCESS!

And this fact-filled brochure gives you the whole Flowed-in Gasket Story. Here are a few samples of the things you'll read in this informative new book:

ABOUT COSTS

Using the DAREX Flowed-in Gasket Process, a major electronics manufacturer is saving \$50,000 per year in labor and materials on a single gasketing operation. As a result of this striking cost reduction, the firm has recommended the DAREX Process for several more gasketing operations.

ABOUT THE PROCESS

The Flowed-in Gasket Process is a new application of a method of sealing developed by Dewey and Almy researchers over 30 years ago, and successfully used in food container manufacture ever since.

The DAREX Flowed-in Gasket Process is more than a sealing compound . . . more than a machine . . . more than an engineering service . . . *it's a complete Process!* So when you switch to Flowed-in Gaskets, you get all three.

Compounds—Over 800 formulations available to meet most needs. Or Dewey and Almy chemists will develop a "job-tailored" compound for you.

Machines—To apply the compound, Dewey and Almy designs and builds machines based on more than 30 years' field experience.

Service—Every machine is precisely adjusted to your specifications before it leaves the shop. When it arrives, a Dewey and Almy Engineer is on hand to install and adjust the machine. Then he trains your operators to full proficiency. And whenever you need him, the Dewey and Almy Man is at your service.

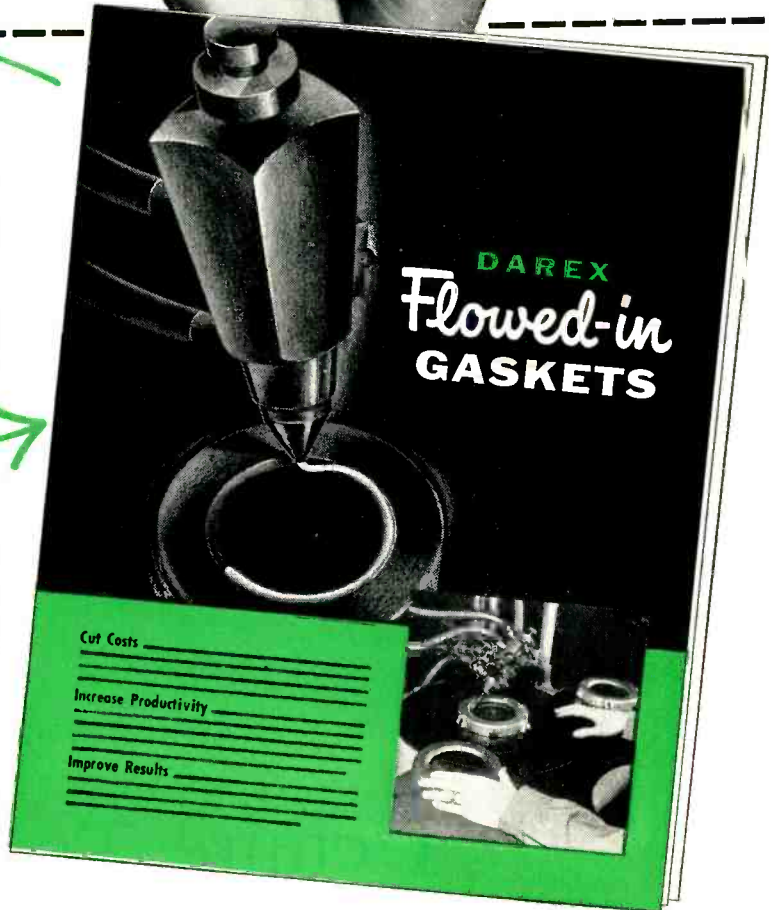

DEWEY and ALMY Chemical Company

Cambridge 40, Mass..

Offices or subsidiaries in Buenos Aires, Chicago, Copenhagen, London, Melbourne, Milan, Montevideo, Montreal, Naples, Paris, San Leandro (Calif.), Sao Paulo, Tokyo.

Discover what DAREX "Flowed-in" GASKETS can do for YOU

MAIL THE COUPON TODAY!

DEWEY and ALMY Chemical Company

Dept. E

Cambridge 40, Mass.

Please send me the new DAREX Flowed-in GASKET Book.

Name

Firm

Street

City State

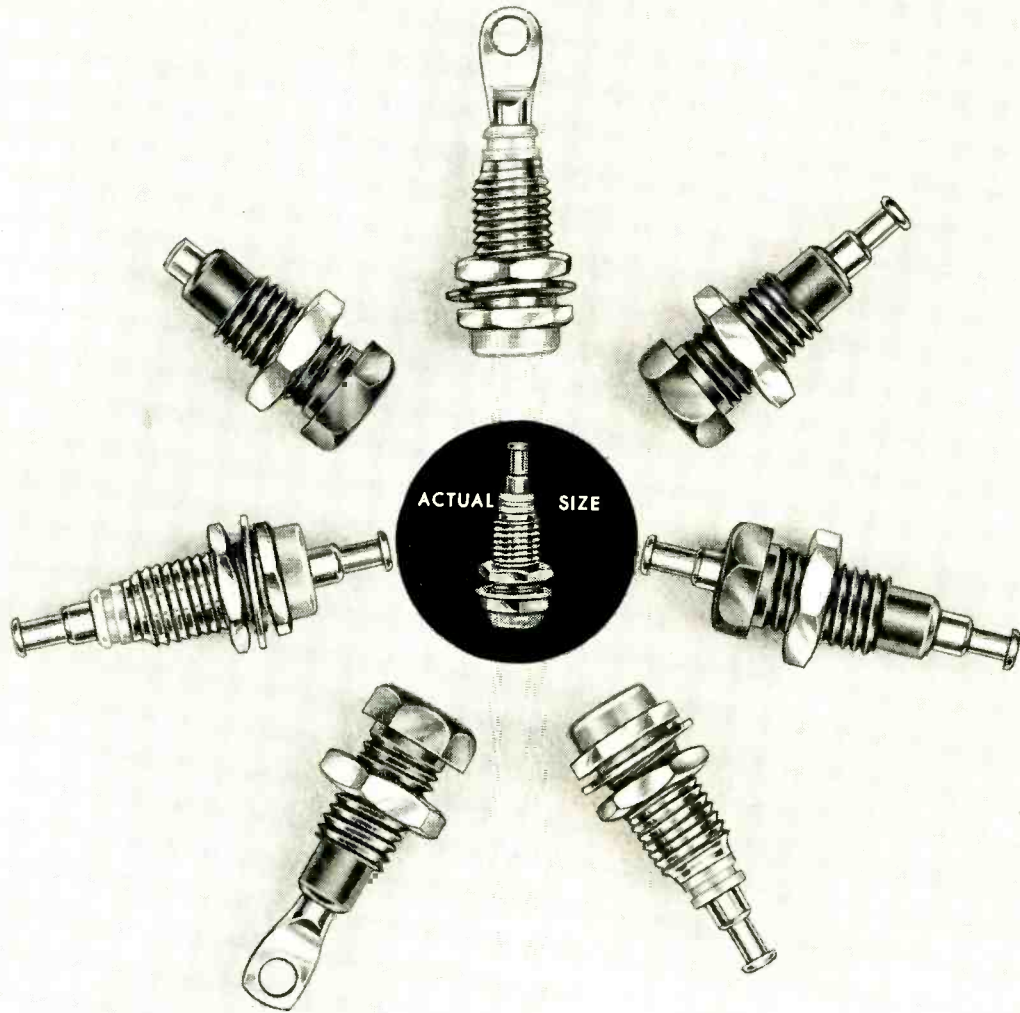

Ucinite Test Jacks

In addition to Test Jacks with a brass, nickel-plated shell and nut with nylon insulator, Ucinite now offers a less expensive version with all-nylon threaded insulator for low capacity to panel and high voltage breakdown.

These Ucinite Test Jacks — designed for standard .080 phone tips — are available in a variety of colors . . . ideally suited to coded application. Silver-plated, heat treated beryllium copper contact is made in one piece with large

terminal ends for easy soldering. The feed through type is provided with a one-piece brass terminal stud, tin-plated.

The specialized abilities and experience of Ucinite's own staff of design engineers are available for work on new and unusual problems. Volume production facilities ensure fulfillment of the largest requirements. For full information, call your nearest Ucinite or United-Carr representative or write directly to us.



The
UCINITE CO.
Newtonville 60, Mass.
Division of United-Carr Fastener Corp.

Specialists in
ELECTRICAL ASSEMBLIES,
RADIO AND AUTOMOTIVE

How many ways can you use

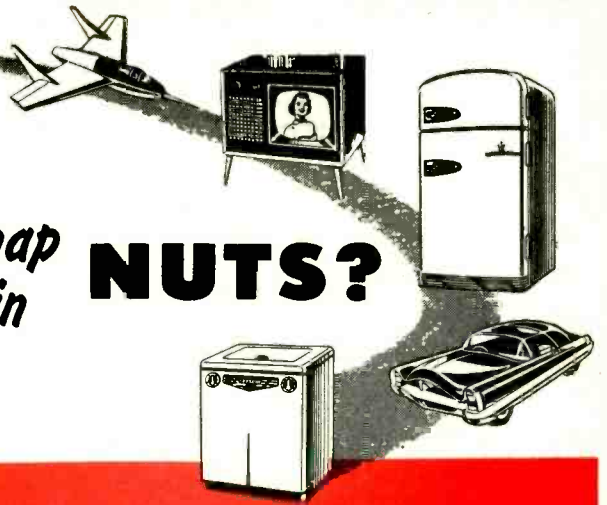

PLASTIC *snap in* NUTS?

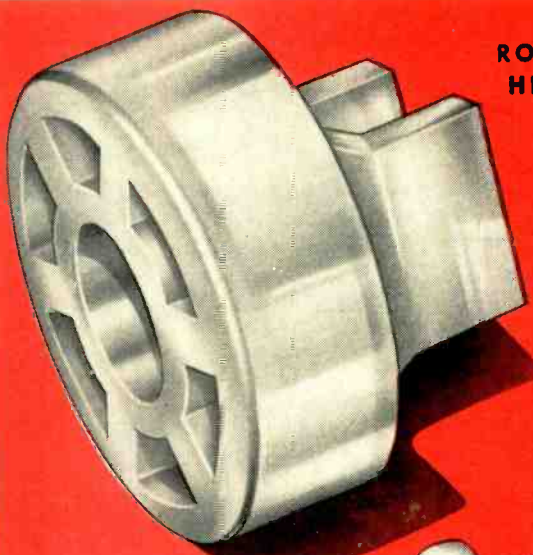

ROUND HEAD

QUICK, EASY ASSEMBLY

Nut is pressed into square hole punched in sheet metal.

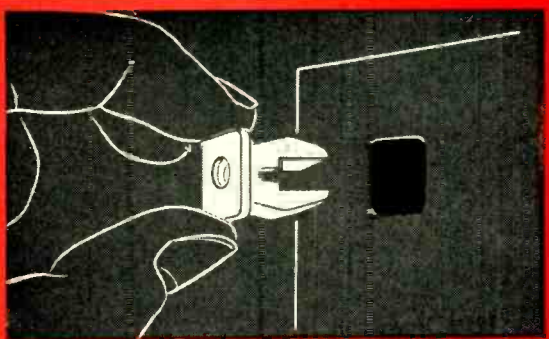



SQUARE HEAD

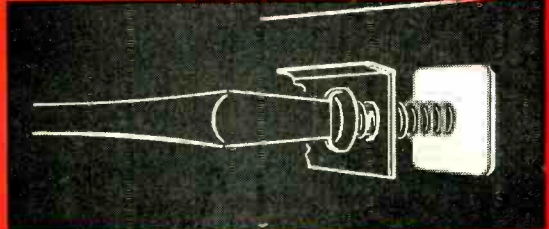

Ordinary sheet metal screw cuts its own threads as it is driven into the nut, expands fingers, locks nut and screw securely.

United-Carr's new self-locking, plastic nut is designed for blind application and can be used with all types of metal finishes without scratching or chipping the surface. Its plastic fingers provide rigid anchorage yet will not mar paint, polished metals or even porcelain.

Inexpensive sheet metal screws cut their own threads and expand the nut's fingers as they are driven, locking both nut and screw tightly in

place. Screws can be removed and replaced several times without damage to the nut.

DOT plastic snap-in nuts are electrically non-conductive and provide a high degree of insulation against heat transfer. For all practical purposes, they also provide an effective vapor seal.

Available in several styles and sizes. Write for full information and samples or contact your nearest United-Carr representative.

UNITED-CARR FASTENER CORP.

CAMBRIDGE 42, MASSACHUSETTS



**New Jobs for One of the World's
Most Useful Metals:
STRAITS TIN from MALAYA**



Concentrating tin ore in Selangor, Malaya. Malayan economy depends heavily on tin exports. Thus a continuing and stable market for tin is as vital to Malaya as a continuing and stable supply is to the United States.

New Tin Alloys---New Techniques Make Soldering Faster, More Efficient

They've been using tin-rich solders for almost 2000 years — and haven't found a real substitute yet! Nothing else is as cheap or easy to use in making corrosion-resistant, impermeable, electrically conductive joints at relatively low temperatures.

Making Solder Still More Efficient

Now, new alloys and new soldering techniques are making tin solders still more useful on production lines.

A solder of tin-indium, for example, is now used for sealing glass to metal or glass to glass—will adhere to mica, quartz, thermosetting plastics, and some glazed ceramics, as well.

For joining aluminum, cerium added to a tin-rich, tin-zinc solder gives both improved salt spray resistance and better wettability.

New techniques for applying solder include ultrasonic methods of soldering and tinning aluminum, and the new mechanized dip soldering process that is saving industry thousands of man-hours.

Tin is, of course, the key ingredient in solder. Over one-third of the world's tin is mined and smelted in Malaya. Known as Straits Tin, this metal is more than 99.87% pure and is world-famous for its absolute reliability of grade.

A New Look at Straits Tin

Today, not only new solders but new tin alloys, new tin-alloy coatings and platings, and new uses for tin chemicals have been discovered that make Straits Tin more valuable than ever to American industry. And continuing research will find still more ways in which tin can serve you in the near future.

Whatever your product or process may be, now is the time to reappraise carefully the unique combination of properties of Straits Tin. For no other metal we know today can do so many different kinds of jobs so economically and so well.



A new booklet, "Straits Tin: A Most Useful Metal for American Industry," tells a factual and intriguing story of the many new ways tin can be used today. A copy is yours for the asking.

THE MALAYAN TIN BUREAU

Dept. 387, 1028 Connecticut Ave., Washington 6, D.C.

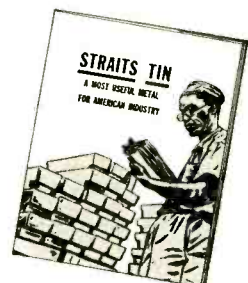

“Retains Flexibility - Resists Abrasion”

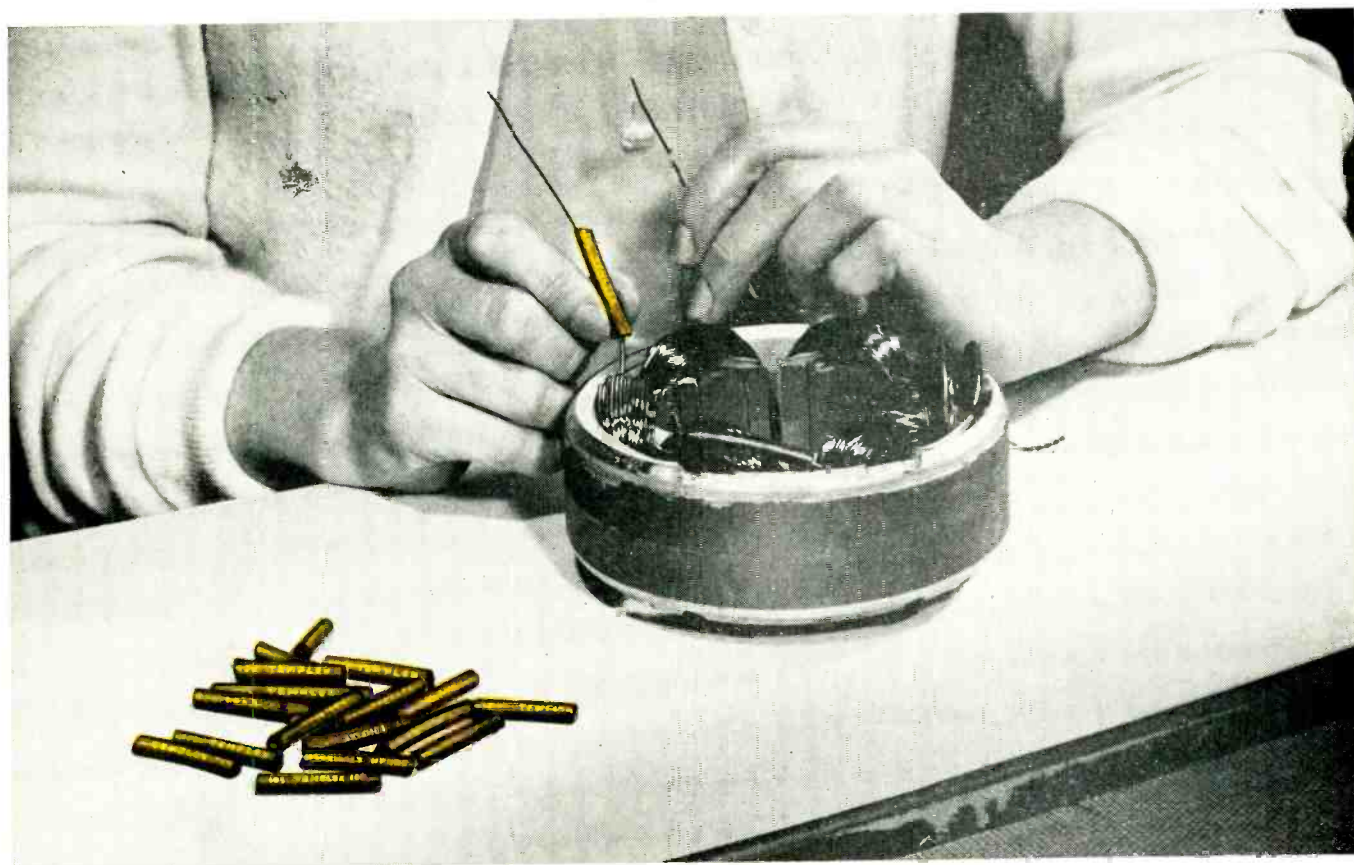

says Redmond Company of **TEMFLEX*** 105 Tubing

In making the field connections for the unique TRI-FLUX shaded pole micromotors built by Redmond Company, Inc., Owosso, Mich., a 1 1/4" length of Irvington's Temflex 105 Tubing is slipped over the lead from one field coil, and the lead is twisted together with the connection from the next field coil. Twisted wires are then welded and bent back, and the Temflex tubing drawn over the welded joint. The entire field is then varnished and baked.

In addition to abrasion resistance and retained flexibility, "resistance to baking heat and high dielectric strength are other reasons for using this material," says Redmond about this flexible plastic tubing. Temflex 105 also carries Underwriters' Laboratories approval for continuous operation in air at 105° C.— and for 90° C. operation *in oil*.

Temflex 105 Tubing is produced by Irvington's Plastics Division in all standard colors, to fit all standard wire sizes. It's identified by the continuously printed name on the tubing surface—look for it when you buy high-temperature tubing. Send for literature and samples.

Look to

IRVINGTON

for Insulation Leadership

INSULATING VARNISHES
VARNISHED CAMBRIC
VARNISHED PAPER
VARNISHED WOVEN GLASS
INSULATING TUBING
CLASS "H" INSULATION



*T.M. Reg. U.S. Pat. Off.

IRVINGTON VARNISH & INSULATOR

DIVISION OF MINNESOTA MINING & MANUFACTURING COMPANY

11 ARGYLE TERRACE, IRVINGTON 11, N. J. • PLANTS: IRVINGTON, N. J.; MONROVIA, CALIF.; HAMILTON, ONTARIO, CANADA

SEVEN YEARS IN SERVICE
This Electronic Calculating Machine
Is a Giant of Precision

✦ Mathematical robot with nearly 18,000 vacuum tubes does in hours what mechanical devices would require years to complete; built for war purposes, it has potentialities of interest to designers and engineers.

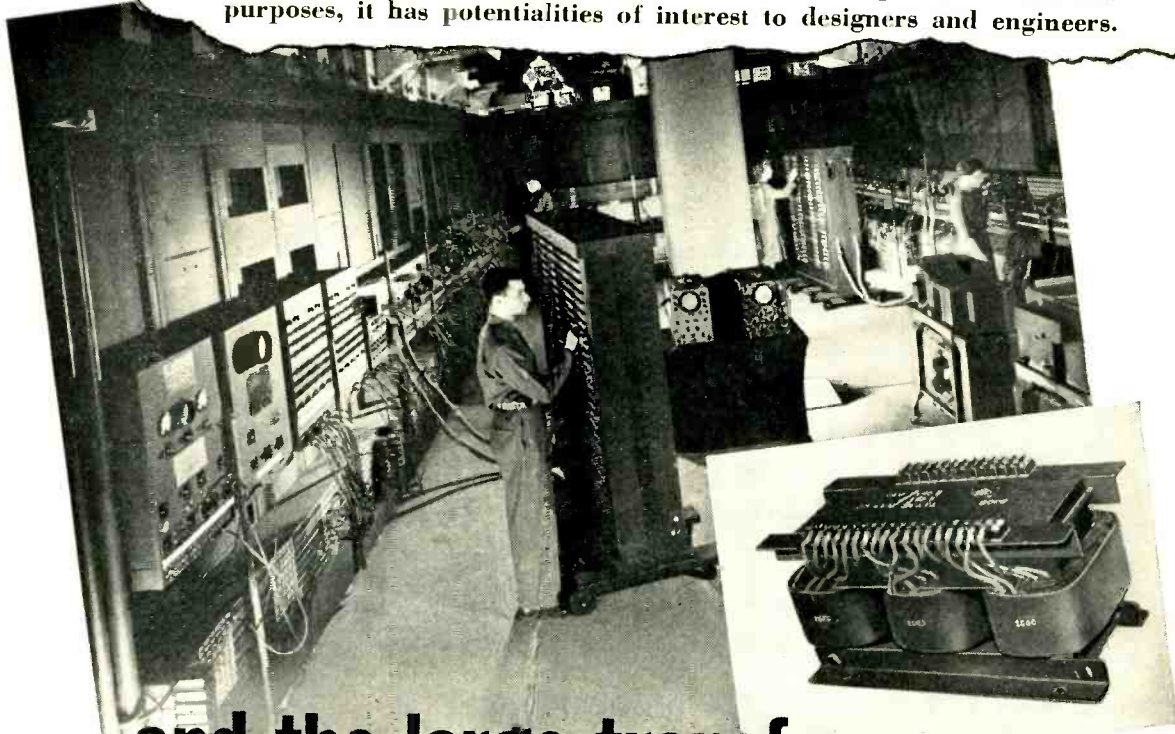

... and the large transformers
 were all furnished by

NOTHELFER

NOTHELFER 3 Phase Plate
 Rectifying Transformer
 240/125 at 12½ KVA
 125

All transformers designed
 for 40° rise.

THE Electronic Numeral Integrator and Computer shown above, designed and constructed in 1946 for the Ordnance Department, U. S. Army, at the Moore School of Electrical Engineering, University of Pennsylvania, is said to be the first all-electronic general purpose computer ever developed.

The design of the TRANSFORMERS among much other complex and expensive equipment, was limited by many unknown factors. However, this 3 Phase Plate Rectifying Transformer is representative of a typical installation by NOTHELFER, whose skill and experience has been instrumental in helping to solve many a difficult winding job.



NOTHELFER WINDING LABORATORIES

9 ALBERMARLE AVENUE • • • TRENTON 3, NEW JERSEY

Waldes Truarc Ring Replaces Nut and Washer ...Cuts Costs \$5.28 Per M...Speeds Assembly by 50%

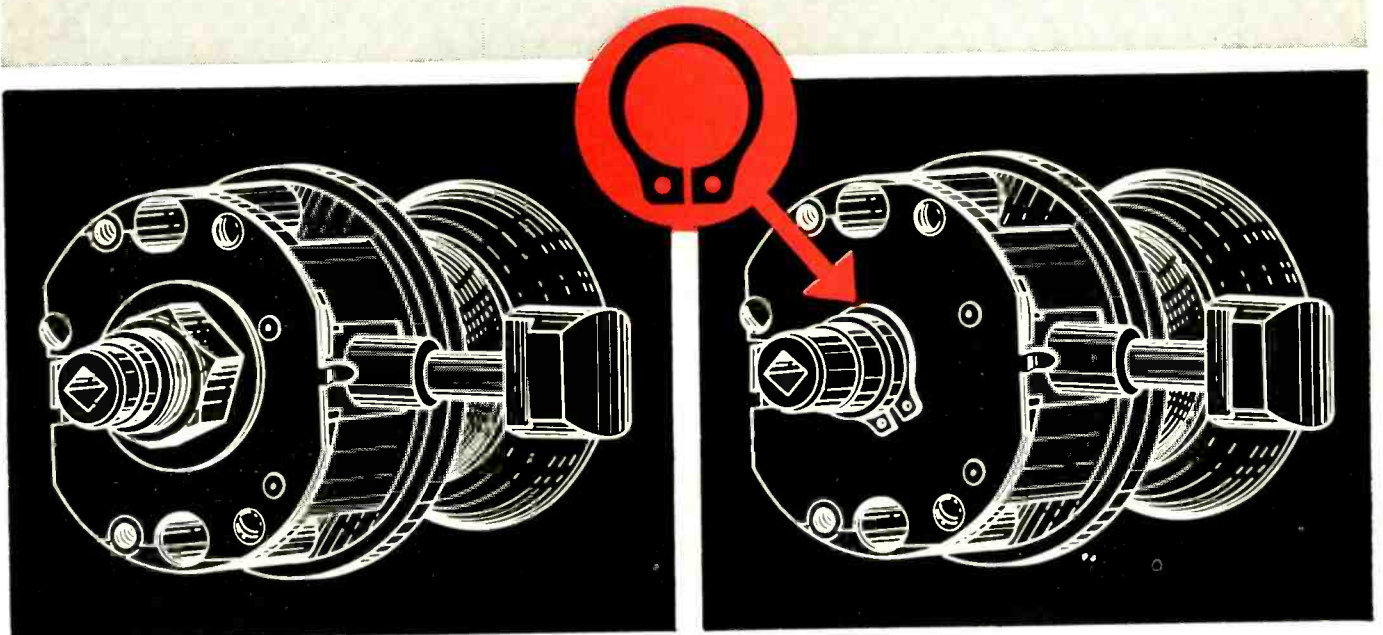

OLD WAY. Main shaft required costly threading. Assembly was slowed by the double application of washer and nut and time-consuming tightening operation.

TRUARC WAY. Truarc Retaining Ring snaps quickly and simply over shaft. Lock assembly is secured in one fast operation. Virtually all play is eliminated from lock.

NEW DESIGN USING WALDES TRUARC RING PERMITTED THESE SAVINGS

OLD WAY

Cost of Nut	\$10.00	per thousand
Cost of Washer	3.80	" "
Labor for Threading	2.00	" "
Assembly	3.00	" "
TOTAL	\$18.80	

TRUARC WAY

Cost of Truarc Ring and Grooving Operation	\$11.52	per thousand
Assembly	2.00	" "
TOTAL	\$13.52	

J. Chesler and Sons, Inc., Brooklyn, N.Y., manufacturers of the pre-assembled "Reddi-Mount" cylindrical lockset, uses a single Waldes Truarc Retaining Ring instead of an old fashioned nut and washer to secure the entire assembly of their lock. This new, improved fastening method enables Chesler to eliminate costly threading . . . save money on material . . . speed assembly time by 50% and produce an improved, more durable product.

You, too, can save money with Truarc Rings. Wherever you use machined shoulders, bolts, snap rings, cotter pins, there's a Waldes Truarc Retaining Ring designed to do a better, more economical job. Waldes Truarc Rings are precision-engineered . . . quick and easy to assemble and disassemble.

Find out what Waldes Truarc Retaining Rings can do for you. Send your blueprints to Waldes Truarc engineers.

For precision internal grooving and undercutting . . . Waldes Truarc Grooving Tool

SEND FOR NEW CATALOG →

WALDES TRUARC
REG. U. S. PAT. OFF.
RETAINING RINGS



Waldes Kohinoor, Inc., 47-16 Austel Pl., L. I. C. 1, N. Y.

Please send me the new Waldes Truarc Retaining Ring catalog.

(Please print)

Name.....

Title

Company

Business Address.....

City..... Zone..... State.....

WALDES KOHINOOR, INC., LONG ISLAND CITY 1, NEW YORK
WALDES TRUARC RETAINING RINGS AND PLIERS ARE PROTECTED BY ONE OR MORE OF THE FOLLOWING U. S. PATENTS: 2,382,947; 2,382,948; 2,416,952; 2,428,341; 2,439,785; 2,441,846; 2,455,165; 2,420,941; 2,483,380; 2,483,393; 2,487,802; 2,487,803; 2,491,306; 2,509,081; AND OTHER PATENTS PENDING.

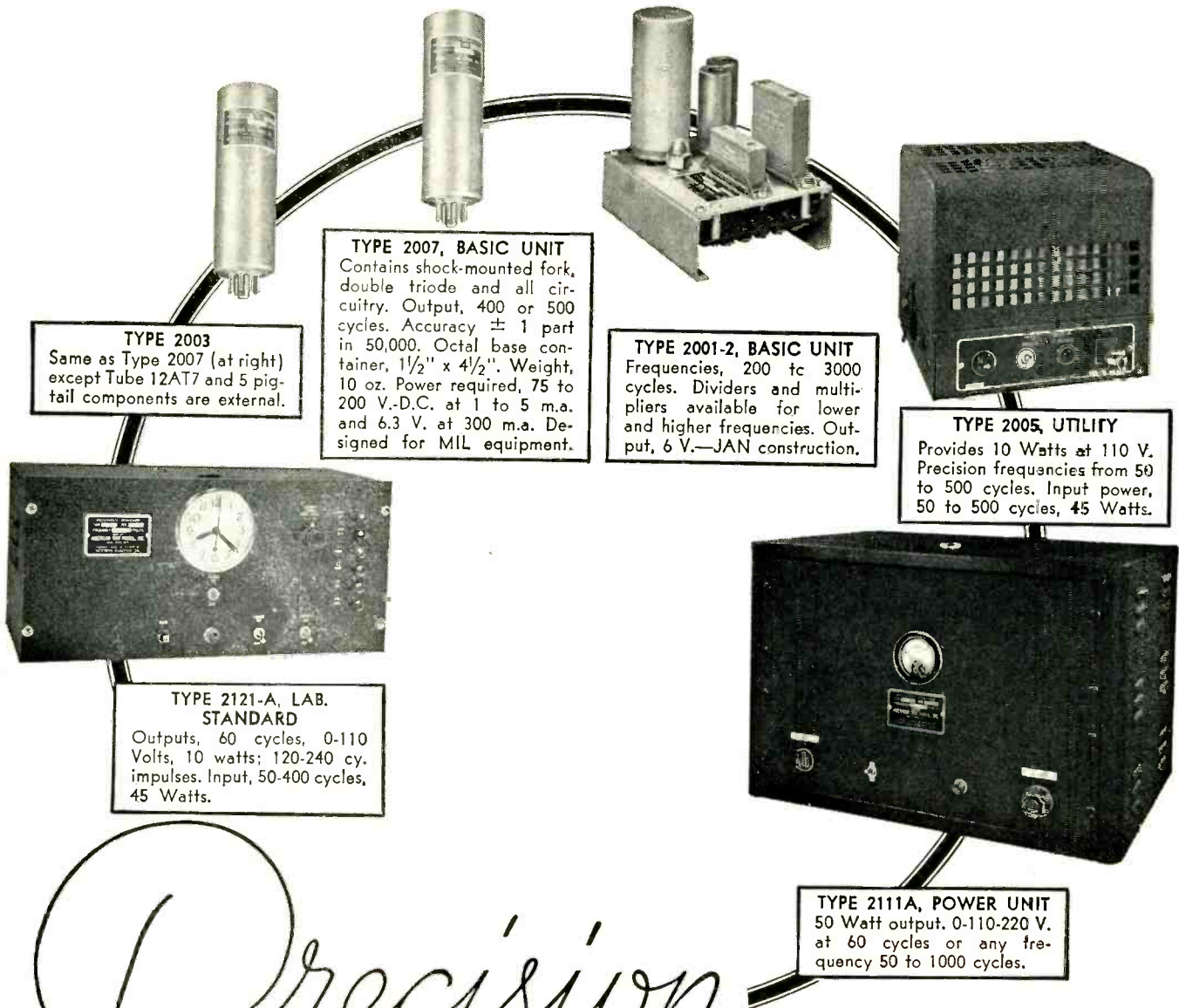

TYPE 2003
Same as Type 2007 (at right) except Tube 12AT7 and 5 pig-tail components are external.

TYPE 2007, BASIC UNIT
Contains shock-mounted fork, double triode and all circuitry. Output, 400 or 500 cycles. Accuracy ± 1 part in 50,000. Octal base container, $1\frac{1}{2}'' \times 4\frac{1}{2}''$. Weight, 10 oz. Power required, 75 to 200 V.-D.C. at 1 to 5 m.a. and 6.3 V. at 300 m.a. Designed for MIL equipment.

TYPE 2001-2, BASIC UNIT
Frequencies, 200 to 3000 cycles. Dividers and multipliers available for lower and higher frequencies. Output, 6 V.—JAN construction.

TYPE 2005, UTILITY
Provides 10 Watts at 110 V. Precision frequencies from 50 to 500 cycles. Input power, 50 to 500 cycles, 45 Watts.

TYPE 2121-A, LAB. STANDARD
Outputs, 60 cycles, 0-110 Volts, 10 watts; 120-240 cy. impulses. Input, 50-400 cycles, 45 Watts.



TYPE 211A, POWER UNIT
50 Watt output, 0-110-220 V. at 60 cycles or any frequency 50 to 1000 cycles.

Precision FREQUENCIES

GUARANTEED ACCURACY
1 PART IN 100,000 (.001%)
except where otherwise noted

The basis of these frequency standards is an electronically actuated high-precision fork, temperature-compensated and hermetically sealed against barometric changes. The partial list of uses at the right not only suggests the broad range of applications but also proven dependability where there can be no compromise with accuracy. Please request details by Type No. Our engineers are available for advice or cooperation on related problems.

- WIDELY USED
IN SUCH FIELDS AS**
- Aviation, Navigation
 - Ordnance, Ballistics
 - High Speed Photography
 - Viscosity Measurement
 - Fluid Flow
 - Nuclear Physics, Telemetering
 - Chemical Reaction
 - Radiation Counting
 - Computers
 - Facsimile
 - Fire Control
 - School and Indl. Research Labs.
 - Accurate Speed Control

American Time Products, Inc.
580 Fifth Avenue
New York 36, N. Y.

OPERATING UNDER PATENTS OF WESTERN ELECTRIC COMPANY

Here's a CLARE RELAY

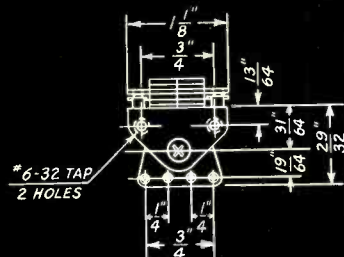
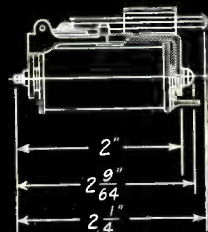
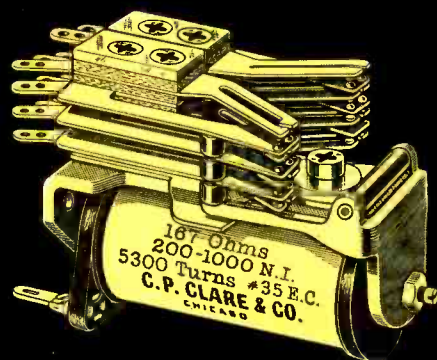

Compare these features of the CLARE Type J Relay with ordinary telephone-type relays

Extremely Small Size—Length: $2\frac{1}{4}$ " , Width: $1\frac{1}{8}$ " , Height (with 10 springs): $1\frac{1}{4}$ " , Net Weight: $2\frac{1}{4}$ oz. (approx.).

Large Current Capacity—Rated current carrying capacity: 4 amperes, 150 watts. Twin contact points (Palladium) standard.

Exclusive New Features—Twin contacts operate independently of each other—minimize chance of contact failure.

Largest possible bearing surface for hinge-type armature.

Armature bearing pin turns in cylinder of different metal which is full width of the heelpiece.

Heelpiece designed and processed for extreme rigidity to take and hold fine adjustments.

Versatile Operation—Standard coils provide for fast operate and fast release (minimum of 1 to 2 milliseconds). Coils may be provided for time delay on operation, time delay on release, or both. Also available, double-wound coils. Operating voltage up to 220 volts d-c.

Armatures may be single (right or left) or double. Residual: lock screw (adjustable) or fixed.

Relays may be mounted on mounting bases or strips as well as upon mounting bars and individual mounting brackets. Also available with plug-in mounting.

Available with slip-on dust-tight covers or hermetically sealed in metal enclosures.

that has changed a lot of design ideas

• No fully acceptable substitute has ever appeared for the conventional telephone type relay. It offers a versatility of performance and flexibility of installation that meet the requirements of the widest variety of industrial designs.

Prior to the introduction of the CLARE Type J Relay, however, designers were handicapped by the comparatively heavy weight, large size and certain operational limitations of this type of relay.

The CLARE Type J changed all this. Here, for the first time, was a light-weight, small-size relay of the telephone type. It not only gave comparable performance advantages but added certain exclusive features which offered a new conception of efficient, long-life relay operation.

This relay, among other features, provided *independent* twin contacts to preclude contact failures; the largest possible armature bearing surface, thus insuring stable operation and little adjustment change over a great number of operations; and an extremely rigid heelpiece to take and hold fine adjustments. (A fine adjustment will shift when a weak heelpiece is distorted by tightening the mounting screws.)

Acceptance of the CLARE Type J Relay has been phenomenal. It has replaced the old style telephone type relays in innumerable designs where small size and light weight were of prime importance. If you are not familiar with the features and characteristics of this relay, we invite you to contact your nearest CLARE sales engineer or write to: C. P. Clare Co., 3101 Pratt Blvd., Chicago 45, Illinois. In Canada: Canadian Line Materials Ltd., Toronto 13. Cable Address: CLARELAY. Write for Engineering Data Book.

CLARE RELAYS

FIRST IN THE INDUSTRIAL FIELD

For
**ENVIRONMENTAL
TEST EQUIPMENT**

see **Tenney**

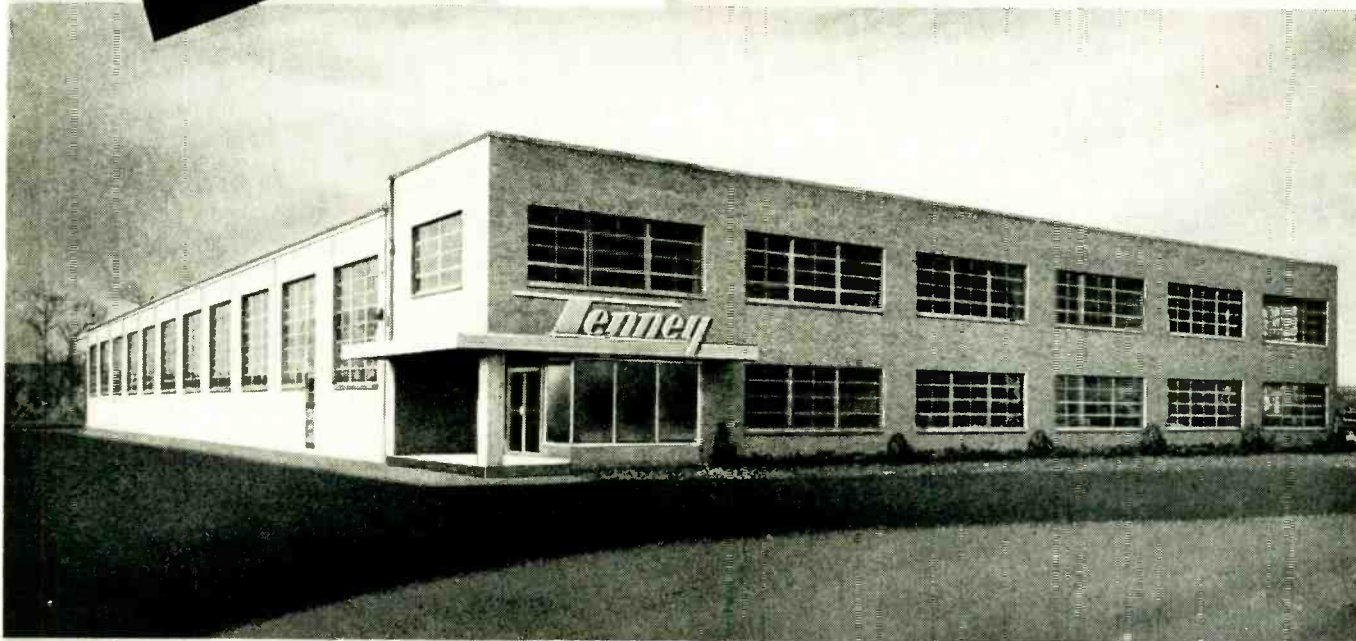

From better facilities

including expanded engineering
new, improved tooling
and faster shipping, comes

a better product

a wide range of "standards" in altitude,
temperature, humidity, sand and dust,
explosion and walk-in chambers*

for you

our customers, whose names* include
the largest firms in America,
the U. S. Government, and Armed Services.

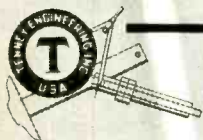

Tenney
ENGINEERING, INC.

1090 SPRINGFIELD ROAD, UNION, N. J.

Plants: Union, N. J. and Baltimore, Md.

Engineers and Manufacturers of Refrigeration and Environmental Equipment

* Information on this equipment
and a purchaser list will be
sent on request.

⊕ 3547



For over **20** years . . .

**A
GOOD PLACE
TO GET
GOOD
RESISTORS**

**JAN-R-11
TYPES**

Styles RC10, RC20,
RC21, RC30, RC31,
RC41, and RC42.

Write for Bulletin J2

$\frac{1}{2}$ -, 1-, and 2-watt fixed composition
types in all RTMA 5%, 10%, and 20%
preferred values.

. . . also voltage regulation; fluorescent
starting; protective surge; and other special purpose
types to your exact specifications.



STACKPOLE

Electronic Components Division
STACKPOLE CARBON COMPANY
St. Marys, Penna.

Now!



K11 ELECTRICAL CONTACTS (RIVETS)



K12 ELECTRICAL CONTACTS (BUTTONS)

General Plate Electrical Contact Kits for Laboratory and Development Use

**A Wide Assortment of Sizes
at Your Fingertips... Simplifies Design, Saves Time**

These two General Plate Electrical Contact Kits are the answer to your contact requirements for development use.

Kit K11 contains a wide assortment of silver rivet contacts. Kit K12 has representative standard button contacts... silver facing on a base metal backing for projection welding. Also included are metal strips for fabrication of contact parts.

Dimensional working drawings are included so that you can duplicate the exact part on your own drawings.

These General Plate kits help you solve design problems by placing standard stock buttons and

rivets at your fingertips. Once a design goes to production, there are no procurement delays... production quantities are available for immediate shipment from General Plate stock. Your contact inventories are minimized, "non-standards" are eliminated, delivery delays are avoided.

Available at a nominal cost... write for complete information and prices today.

**You can profit by using
General Plate Composite Metals!**

**METALS & CONTROLS CORPORATION
GENERAL PLATE DIVISION
36 FOREST STREET, ATTLEBORO, MASS.**

ENTIRELY NEW



POWERSTAT Variable Transformers TYPE 136 AND 236

provide new higher ratings . . . smaller size . . . easier installation and servicing . . . smoother operation and longer life . . . greater overload characteristics.

POWERSTAT types 136 and 236 are all new . . . new design . . . new performance . . . new ratings. Incorporated into each unit are all the features essential for the ultimate in variable transformers. Types 136 and 236 are offered for manually-operated and motor driven duty in 120, 240, 480 volt ratings. Here are the reasons they are superior:

- **Higher Ratings:** Type 136 is rated 120 volts, 50/60 cycles input; 0-120/140 volts, 20.0 amperes output.
- **Smaller Size:** "Pancake" coil design provides compactness for bench or panel mounting.
- **Easier Installation:** Three sets of mounting holes suit all needs. Binding post type terminals provide all connection methods.
- **Easier Service:** Simply remove plate block for access to brush assembly. Brush easily removed

and replaced.
 ● **New Rhodium Plated Commutator:** The one best answer to smooth performance and long life. The contact surface remains forever free of oxides. Corrosion is reduced. Uniform contact drop maintained and greater overload characteristics allowed.

There is a complete standard line of POWERSTAT variable transformers type 136 and 236 to suit individual requirements. Write for Bulletin P354.

The SUPERIOR ELECTRIC COMPANY

Manufacturers of: Powerstat Variable Transformers
 Stabiline Automatic Voltage Regulators • Volt-
 box A-C Power Supplies • Powerstat Light
 Dimming Equipment • Varicell D.C.
 Power Supplies • Superior 5-Way
 Binding Posts

THE SUPERIOR ELECTRIC CO.
 206 Clarke Ave., Bristol, Conn.

Please send Bulletin P354

Name.....

Title.....

Company.....

Address.....

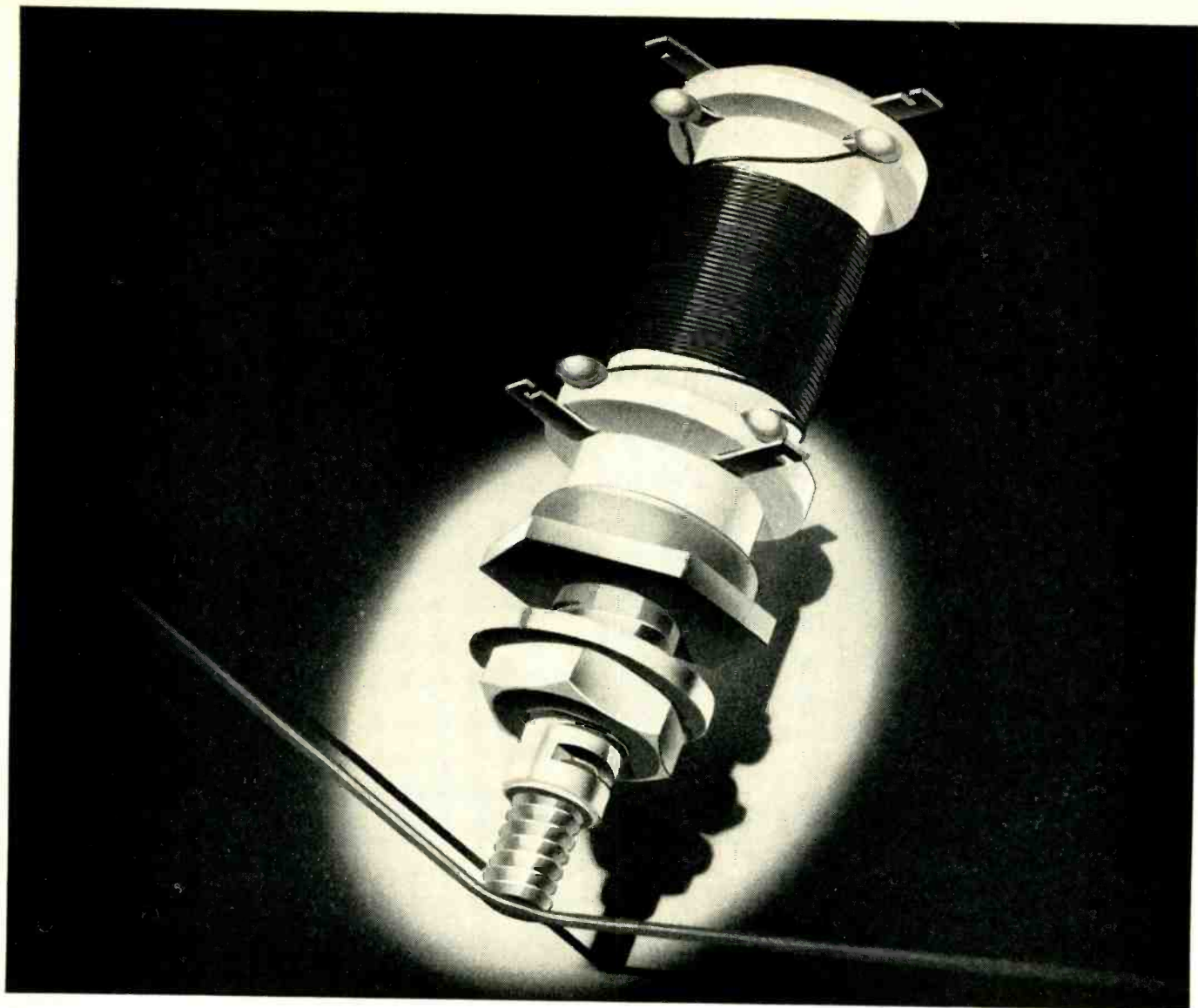

Death-defying performance

You can depend on C.T.C. coils to give a steady, star performance. They won't go dead despite threats of temperature, climate or vibration. And for very good reasons —

The mounting stud of every C.T.C. coil is fastened to the ceramic body in a special way that does away with weaknesses of ordinary coil fastenings. This special fastening makes C.T.C. coils vibration-proof. What's more, their tightness is preserved in hot, cold, dry or damp weather. All C.T.C. coils are precision-made, of course, to meet individual specifications — and to meet, or better, government specifications, as well. And continuous quality control is maintained.

As a result, you get a *guaranteed* electronic component — custom or standard — whose performance you can depend upon.

Precision-made C.T.C. components that benefit from C.T.C. high quality standards include terminals, terminal boards, capacitors, swagers, hardware, insulated terminals and coil forms. For

all specifications and prices, write Cambridge Thermionic Corporation, 437 Concord Avenue, Cambridge 38, Mass. West Coast manufacturers contact: E. V. Roberts, 5068 West Washington Blvd., Los Angeles 16 and 988 Market St., San Francisco, California.

Slug Tuned Coil Data: Single layer or pie type windings to your specifications. Forms of quality paper base phenolic or grade L-5 silicone impregnated ceramic. Mounting studs are cadmium plated brass; ring type terminals are silver plated brass. All units include slugs and mounting hardware. One style (Type C) available with retaining collars of silicone fibreglas which permit 2 to 4 terminals. Windings can be coated with resin varnish, wax or lacquer.

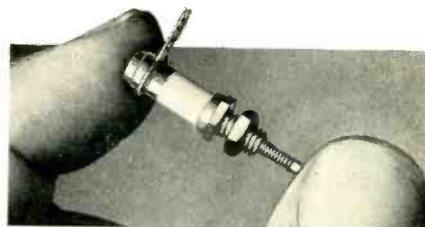

New CST-50 variable ceramic capacitor surpasses range of capacitors many times its size. Stands only $\frac{1}{2}$ " high when mounted, is less than $\frac{1}{4}$ " in diameter and has an 8-32 thread mounting stud. A tunable element of unusual design practically eliminates losses due to air dielectric giving large minimum to maximum capacity range (1.5 to 12MMFD).

C T C

CAMBRIDGE THERMIONIC CORPORATION

*makers of guaranteed electronic components,
custom or standard*



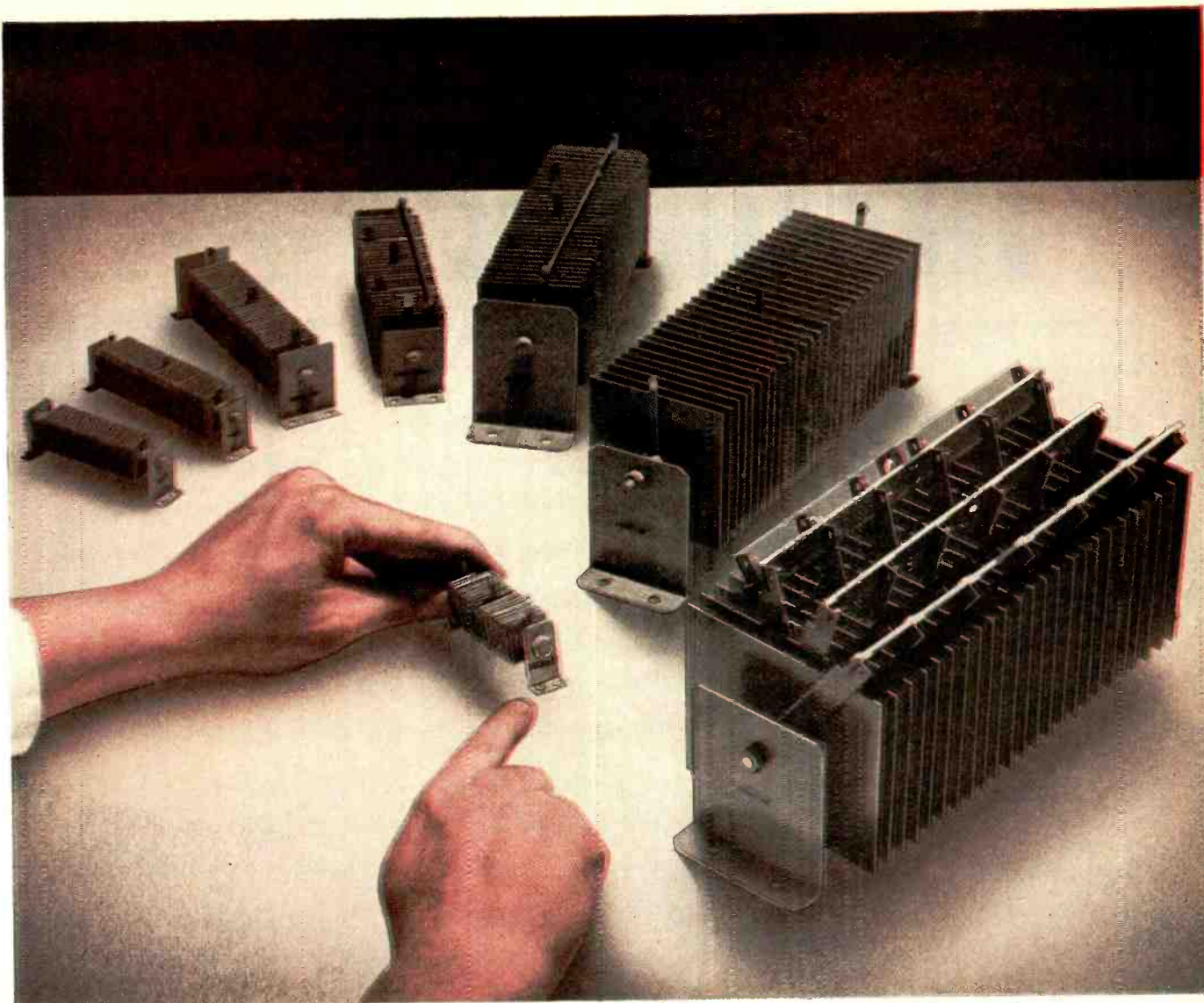

STACKS OF STABILITY

Bradley rectifiers invariably exceed performance requirements, but this quality bonus does not carry a premium price. Our exclusive vacuum process not only assures stability and long life; it also

assures low cost. We would like to prove it by quoting now on your rectifier needs. Please fill out the form below — no obligation, of course. You will get quick action.

VACUUM PROCESSED—for performance as rated

BRADLEY LABORATORIES, INC., 168E COLUMBUS AVENUE, NEW HAVEN 11, CONNECTICUT



DC Output: Volts Min. _____ Amperes Max. _____ Circuit _____	FINISH REQUIRED: _____
AC Input: Volts Max. _____ Phase _____	QUANTITY: _____
LOAD: Res. _____ Ind. _____ Cap. _____ Battery _____	NAME _____
DUTY: Continuous _____ Intermittent _____ On _____ Off _____	ADDRESS _____
COOLING: Convection _____ Forced _____ Ft. Per Min. _____	_____
Max. Ambient Temp. _____ °C	_____

RCA VICTOR Television

CHOOSES

INSUROK®

T-725 INSULATING LAMINATE

The RCA Victor name is a symbol for the highest quality in electronic equipment. To meet their exacting standards, RCA Victor engineers selected INSUROK Grade T-725 phenolic laminate for their television receivers.

INSUROK T-725 provides RCA Victor with a unique combination of electrical properties. It is used in the R.F. tuners, to maintain insulation resistance under high temperatures and humidities . . . in the I.F. tube sockets, to minimize capacity changes with changes in humidity . . . and in the high-voltage compartment, to provide high dielectric strength and surface resistivity.

For the "tough spots" in your product, write or phone about T-725 and the many other grades of INSUROK laminated insulation.

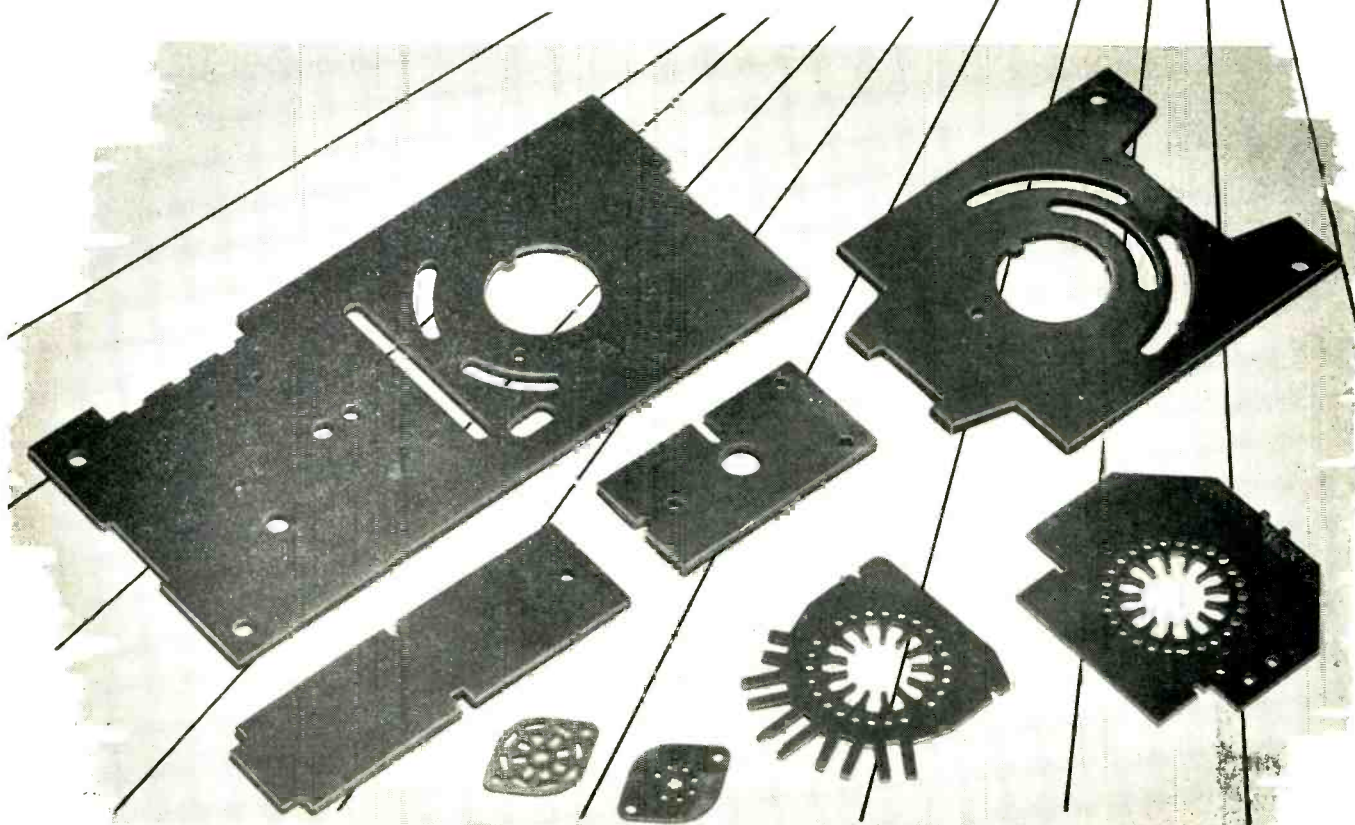
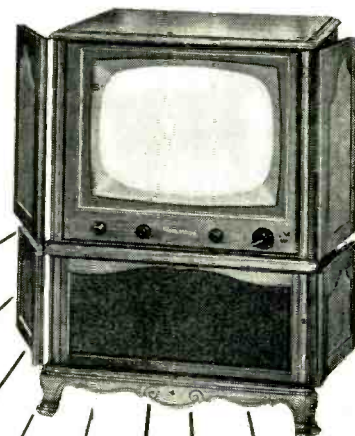

Write Today for Booklet
"LAMINATED
INSUROK"



The RICHARDSON COMPANY

FOUNDED 1858 — LOCKLAND, OHIO

2797-C Lake St., Melrose Park, Illinois (Chicago District)

SALES OFFICES: Cleveland • Detroit • Indianapolis • Lockland, Ohio
Los Angeles • Milwaukee • New Brunswick, (N. J.) • New York • Philadelphia
Rochester • San Francisco • St. Louis

G.E.'s NEW IMPROVED SWEEP TUBES GIVE HIGHER QUALITY AT SAME PRICE!



NEW 6BQ6-GA, 25BQ6-GA (Right)

You can SEE the improvement over prototypes (left)

G-E Design Service brings you . . . constantly . . . new, improved, more dependable receiving tubes at no increase in cost. The 6BQ6-GA and 25BQ6-GA are examples. These sweep tubes cut TV production costs by greatly reducing line rejects . . . also build customer acceptance for your sets, which will require fewer service call-backs.

Other improved G-E tubes are in development, and will be available soon. With the number of tubes per chassis to be at least doubled for Color, builders of sets justifiably are asking for tubes that will stand up—that won't slow TV production by poor performance or high failure rate, and won't make service costs prohibitive.

Better tubes at the same price is an extensive and continuing General Electric program. Get all the facts about these new, improved tubes for television from *Tube Department, General Electric Company, Schenectady 5, New York.*

OUTSTANDING PERFORMANCE! LONG LIFE!

RUNNING HOT" shortened the life of many prototype 6BQ6-GT's and 25BQ6-GT's. G-E designers went to the heart of the problem, and gave the new tubes king-size bulbs that mean cooler operation under all normal conditions. Glass surface area is 89% increased!

Also—because of special mica design and new processing techniques—the 6BQ6-GA and 25BQ6-GA will handle higher pulse plate voltages than their predecessors. The peak rating now is 6,000 v instead of 5,500 v. Internal tube arcing has been reduced substantially.

A further improvement is use of a special high-melting-point solder for the plate cap-terminal. This prevents loosening of the terminal when tubes are removed for testing.

Basing layout is identical with prototypes. The new tubes are fully interchangeable with the old.

GENERAL  ELECTRIC

1G2-1A3

NOPCO[®] LOCKFOAM

Seeking a material light enough yet strong enough to protect their Marker Beacon Antenna against terrific air pressure differentials, Electronics Research, Inc., encountered plenty of obstacles—until they found Nopco Lockfoam.

Today those obstacles are no more. Nopco Lockfoam does the job they needed done . . . offers the light weight and low dielectric constant they need, shields against vibration the delicate electrical apparatus within.

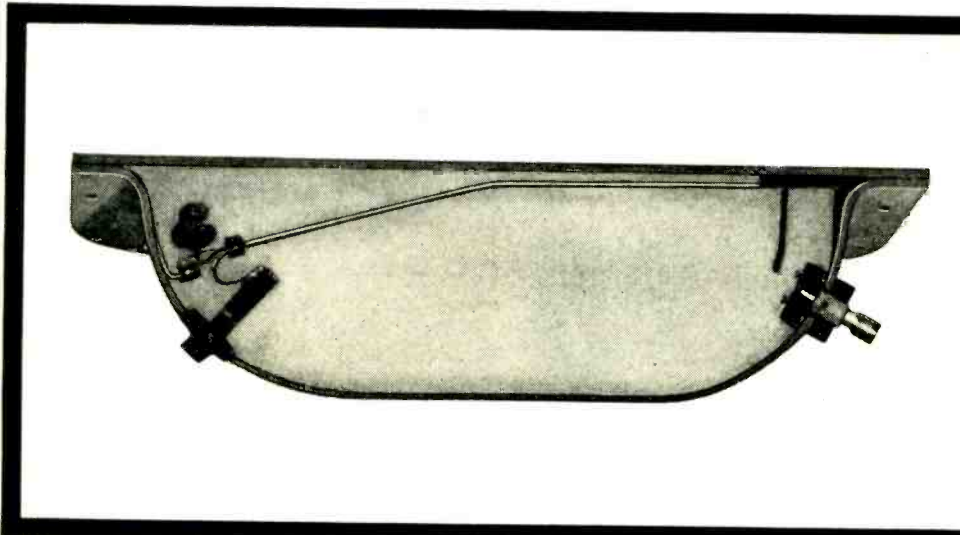

Illustrated is a half cross-section of the Type 140 Marker Beacon Aircraft Antenna made with poured Nopco Lockfoam by Electronics Research, Inc., Evansville, Ind. Before using Lockfoam, this manufacturer was unable to find an ideal reinforcing material which permitted airtight sealing without deformation of the antenna cavity. In its present construction, the difficulties both of deformation and of possible seal rupture are eliminated.

**eliminates
aircraft antenna deformation
caused by air pressures**

Where Can YOU Best Use These Properties?

Near-perfect
Radar Transmission

Ease of Fabrication
It's "poured-in-place"

Great Strength
with Light Weight

Excellent Electrical Properties
6 lb/cu ft Lockfoam tested
at 9.375 KMC
Dielectric Constant 1.05
Loss Tangent .0005

Good Thermal Insulation
"K" Factors

.018 at 8 lb/cu ft
to .025 at 11 lb/cu ft

Wide Range of Densities
From 2 to 35 lb/cu ft

Great Versatility
50 different formulations
available

And from the standpoint of production, states Electronics Research, Nopco Lockfoam has consistent pour characteristics, and bonds strongly to the antenna cavity walls and cover.

Perhaps the rare combination of properties of this versatile foamed-in-place plastic can help with some product you have in mind. At any rate, you'll want the full story. Write today for the Nopco Lockfoam booklet.

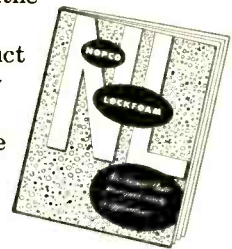

Plastics Division

NOPCO
CHEMICAL COMPANY



Harrison, New Jersey

Cedartown, Ga. • Los Angeles and Richmond, Calif.

NEW LOS ANGELES BRANCH. To aid West Coast manufacturers with complete field service on Nopco Lockfoam, our new office at 4858 Valley Blvd., Los Angeles 32, is now ready to serve you. Drop in and get acquainted, or write.



Potter & Brumfield's MB3D miniature DC power contactor for very high current applications . . .

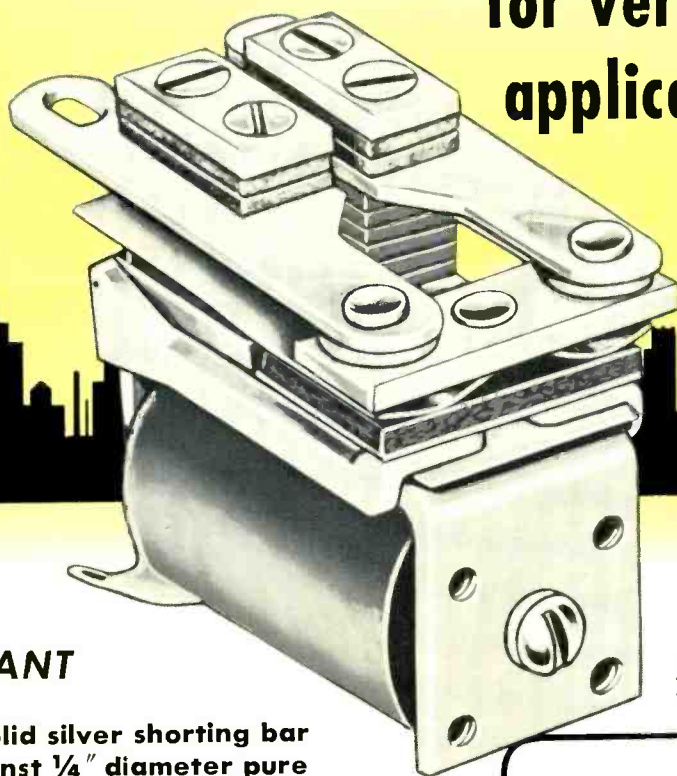

Actual Size only—
1 3/16" x 1 5/8" x 1 3/8" high.

A Little GIANT

- 1 Massive, solid silver shorting bar works against 1/4" diameter pure silver contacts.
- 2 Heavy brass contact arms with large, tinned solder terminals.
- 3 Sturdy over-travel spring made of nickel silver spring temper for maximum contact pressure, long life.
- 4 Magnetic structure utilizes high permeability relay steel for maximum efficiency.
- 5 Varnish impregnated coil for moisture protection.

Also Available Hermetically Sealed

"K" can enclosure—1 13/32" x 1 5/8" x 2 1/8" high. Glass compression type header; solder terminals rated 16 amperes. Mounting: three 6-32 studs on 1 5/16" x 1 3/16" triangular centers.

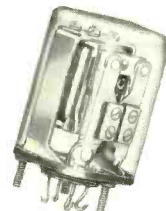

Technical Specifications:

CONTACT ARRANGEMENT: 1 Form X (SPST-NO-DM)

CONTACTS: Pure silver, 1/4" diameter, rated *60 amperes, 28 volts DC, non-inductive load; 100,000 operations, minimum.

*(In dynamotor starting circuits contacts will carry a 150-ampere make surge of 0.3 second duration and will break a 15-ampere steady-state current more than 1,000 times. Contacts also meet tests requiring 250 makes and breaks at peak of surge current. These ratings apply to any contact voltage up to 28 DC nominal with conventional variations—32 volts maximum.)

PULL-IN: 75% or less of nominal coil voltage.

DROP-OUT: 50% or less of nominal coil voltage.

VIBRATION RESISTANCE: 10-500 cps, 10G minimum, three planes—energized and non-energized.

COIL VOLTAGES: 6, 12, 24, 110 DC.

COIL RESISTANCES: 13.3, 62.3, 245, 3670 ohms.

BREAKDOWN VOLTAGE: 500 RMS, minimum.

MOUNTINGS: Four 3-48 holes on 3/8" centers; four 5-40 holes on 3/8" x 7/16" centers or four 4-40 internally threaded bosses 5/32" long on 3/8" x 7/16" centers.

(Stocked by your local Electronics Parts Distributor with one mounting . . . four 3-48 holes on 3/8" centers.)

APPLICATIONS: Ideally suited to dynamotor starting applications in mobile, aircraft or marine equipment. Also readily applicable to other high current, DC circuits. Its small size and light weight make the MB3D a natural for any high current circuit where space and weight are at a premium. Samples and quotations provided on request; specify winding, adjustment, termination and mounting. Write Potter & Brumfield, Princeton, Indiana. Sales offices in principal U.S. and Canadian cities.

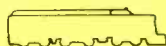

RAILROAD



MOBILE

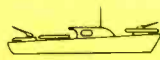

MARINE

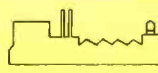

INDUSTRIAL



AVIATION



APPLIANCES

Potter & Brumfield



offers you the benefits of

20 years' custom engineering

... with more than 100 Basic Relay Types!

These basic relay types have been evolved from the design and production of more than 15,000 different custom relays. Used as they are or with slight modifications they will fit most any and all applications.

Thus you are assured of:

1 Proven Design—P & B standard relays have been field tested under all kinds of conditions, thereby giving long, trouble-free service.

2 Lower Costs—Because these relays are already tooled and manufactured in production quantities—a substantial cost saving is passed along to you!

3 Fast Delivery—Orders for standard relays can be filled from stock or with minimum delay.

4 Available through Distributors—Standard types available through P & B franchised Electronic Parts Distributors in all principal cities.

Potter & Brumfield engineers are available for consultation on special relay problems—design or application.

A FEW OF THE MANY P&B BASIC RELAY STRUCTURES



POWER RELAYS
Heavy (PR) and medium (MR) duty. For across the line power circuits, high current switching—SPST to 3PDT.

PR



PLATE CIRCUIT RELAYS—Actuate on few milliwatts. Fit many applications. LM series also available. From SPST to DPDT.

LB



SUPER SENSITIVE RELAYS Operate on less than 10 mW. Dual coils, 10G vibration resistance. Wide versatility. One Form C-SPDT.

SS



LIGHT DUTY RELAYS
Small, light weight, sturdy. Withstand high vibration and shock. From SPST to 3PDT.

KR



IMPULSE RELAYS
Automatic stop prevents backlash. Precise, repetitive switching regardless of operating speed. DPDT or 4PDT.

AP

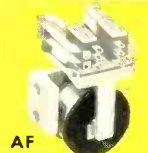

400 CYCLE AC RELAYS
For aircraft or ground equipment. Withstand better than 10G shock. Heavy cast mounting foot. SPST to DPDT.

AF



MULTIPLE CONTACT RELAYS—Longer coil provides power sufficient to actuate additional contacts. For multiple switching—SPST to 4PDT.

KL



TELEPHONE RELAYS
Meet practically all telephone relay requirements. Many contact combinations. MH, MT, LT and ST types also available.

MH



SUPER MIDGET RELAYS—Tiny and rugged—plug-in—SPDT. High degree of resistance to vibration and shock.

SM



MULTIPLE LEAF RELAYS For temperature, indicating or protective circuits. Heavy, tin-coated phosphor bronze contact springs. From SPST to 4PDT.

SU



MOTOR STARTING RELAYS Voltage controlled to insure throwout of starting winding when motor reaches rated speed. SPST-NC or SPST-NC-DB.

MS



SUBMINIATURE SENSITIVE RELAYS
Standard 7 pin plug-in. Ruggedized for vibration and shock. Operating power 25mW. Contact load 2 amps.

PW



LATCHING RELAYS Compact—high utility switching. Coils operate on AC or DC. Voltage or current. From SPST to 4PDT.

LK



HEAVY-DUTY SHOCK-PROOF RELAYS Can be mounted in any position. Particularly resistant to vibration and shock. From SPST to DPDT.

SP



MINIATURE DC POWER CONTACTOR—Heavy duty contacts, rated 60 amperes, 28 V DC, non-inductive load. Rugged construction. Withstands high vibration and shock. SPST-NO-DM.

MB

ALL P & B STANDARD RELAYS CAN BE SUPPLIED WITH DUST COVERS OR HERMETICALLY SEALED CANS WITH SOLDER OR PLUG-IN HEADERS

Write home office in Princeton or phone your local P & B Sales Office for new master catalog describing our wide line of basic relay structures, housings and enclosures. Samples, recommendations and quotations promptly furnished on special applications.

P & B Standard Relays available at your local Electronic Parts Distributor

Potter & Brumfield

PRINCETON, INDIANA

EXPORT: 13 E. 40TH STREET, NEW YORK, NEW YORK

SALES OFFICES IN PRINCIPAL U. S. AND CANADIAN CITIES



50 Watt VHF FIXED STATION

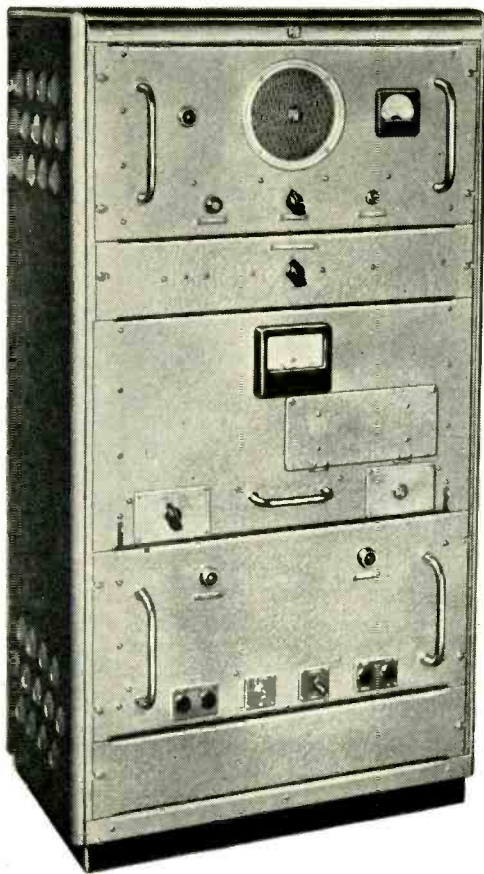
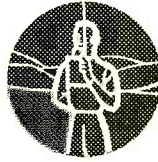

The new Pye 50 watt V.H.F. FIXED STATION is of an advanced design employing the latest techniques. It is ideal for use in normal fixed and mobile schemes where high powered transmitters are required and may also be used for point-to-point radio-telephone links.

A further application is in the aeronautical band where the 50 watt transmitter, together with the standard Pye fixed receiver, provides one of the most efficient ground-to-air control stations at present available in the world.



Pye (New Zealand), Ltd.,
P.O. Box 2839,
Auckland C.I.,
New Zealand.

Pye Canada Ltd.,
Ajax,
Ontario,
Canada.

Pye-Electronic Pty. Ltd.,
65 Park Street,
Abbotsford, Melbourne,
Victoria, Australia.

Pye Ireland, Ltd.,
Manor Works,
Dundrum, Dublin,
Eire

Pye Radio & Television (Pty.) Ltd.,
P.O. Box 10648,
Johannesburg,
South Africa.

PYE LIMITED • • CAMBRIDGE • • ENGLAND

±1% stable voltage in face of 30% line variations

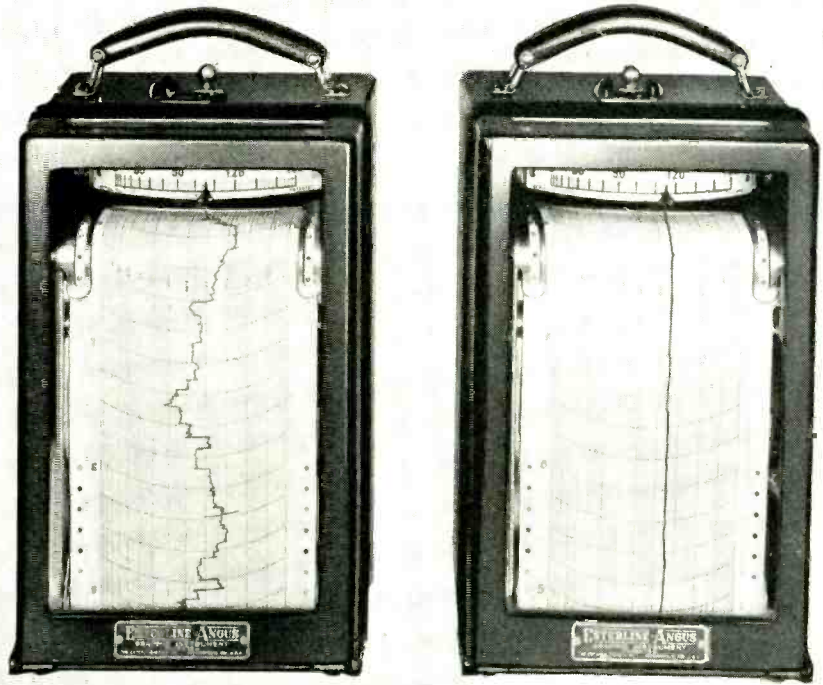

TYPICAL EXAMPLE OF SOLA VOLTAGE REGULATING ACTION. The recording on the left represents a fairly common condition of voltage fluctuation on a 115v line. The chart on the right

was made at exactly the same time from the same line. The primary of the Sola regulator was fed the voltage charted on the left, the voltage charted on the right represents its secondary output, regulated to within ±1% of 115v.

Voltage-sensitive electrical and electronic equipment can not operate to performance specifications under conditions of voltage fluctuation. A source of constant voltage can be easily supplied with a Sola Constant Voltage Transformer . . . built-in as a component, or used externally as an accessory.

Among the chief advantages of Sola regulators are: dependable, automatic operation (static-magnetic regulation) . . . substantially instantaneous response (1.5 cycles or less) . . . no maintenance (no moving or expendable parts) . . . and immediate availability (40 stock units in a wide variety of ratings).

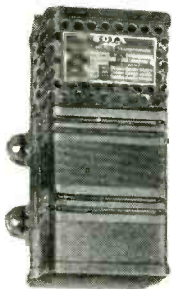

STANDARD TYPE CV

Twenty-nine units from 15va to 10kva in a common power line and filament voltage ratings . . . regulation ±1% or less with a total primary variation of 30% . . . for electronic and electrical equipment requiring close regulation.

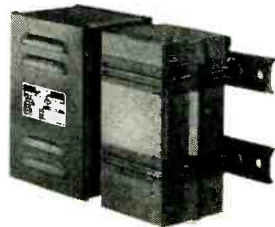

HARMONIC-NEUTRALIZED TYPE CVH

Six units from 60va to 2kva . . . input range 95-125v, output 115v . . . all the features of the Standard Type CV plus a harmonic neutralizer circuit . . . ±1% regulated voltage with less than 3% harmonic distortion.

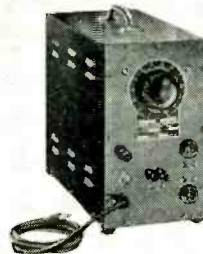

ADJUSTABLE, HARMONIC-NEUTRALIZED TYPE CVL

Two ac voltage supply units, 250va and 500va . . . input range 95-125v, output range adjustable from 0-130v . . . regulated ±1%, harmonic distortion less than 3% . . . for general lab work, testing and other applications.



PLATE AND FILAMENT TYPE CVE

Three units in popular power supply ratings . . . a single, compact source of filament and plate supply voltages . . . regulated to within ±3% or less with line voltage variations of 100-130 volts . . . supplied with separate capacitor for chassis mounting.

SOLA *Constant Voltage* TRANSFORMERS

Write for a 28 page bulletin with complete electrical and mechanical specifications on these Sola units. Request BULLETIN 7F-CV-200.

Transformers for: Constant Voltage • Fluorescent Lighting • Cold Cathode Lighting • Mercury Vapor Lighting • Plastic Signs
SOLA ELECTRIC CO., 4633 West 16th Street, Chicago 50, Illinois, Bishop 2-1414 • BOSTON: 272 Centre Street, Newton 58, Massachusetts
NEW YORK 35: 103 East 125th Street • LOS ANGELES 26: 2025 Sunset Boulevard • PHILADELPHIA: Commercial Trust Building
CLEVELAND 15: 1836 Euclid Avenue • KANSAS CITY 2, MISSOURI: 406 West 34th Street • Representatives in Other Principal Cities

Good-bye

**to all maintenance problems
with ADLAKE Mercury Relays!**

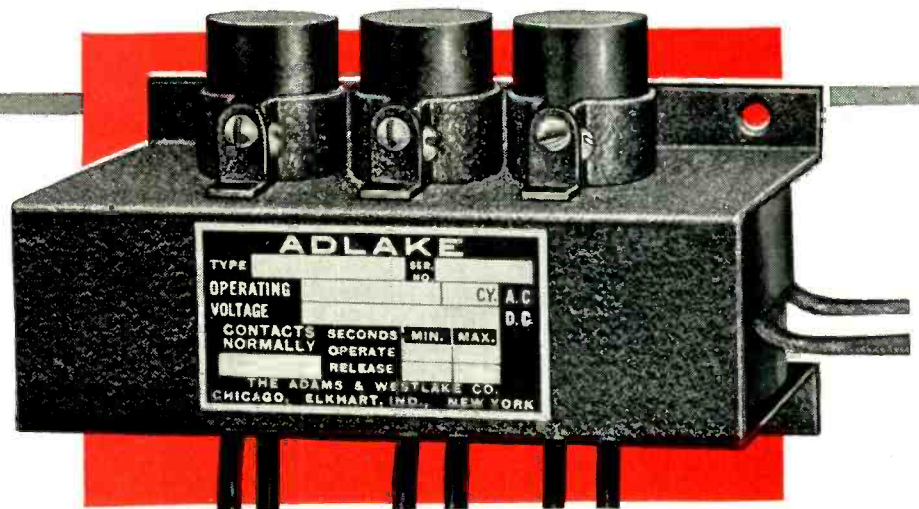

Type 1133 ADLAKE
three pole load relay...
contact normally open

● **Thanks to their positive**, leak-proof sealing... their sure-fire mercury-to-mercury contact ... their immunity to normal vibrations and temperature changes... thousands of satisfied users in every branch of industry can testify that ADLAKE Relays literally *need no maintenance whatever!*

ADLAKE Relays have won their place by *proven* dependability—year in and year out—in jobs that conventional relays can do in an uncertain

manner at best! For every ADLAKE Relay is tested—and guaranteed—to meet specifications!

Yes, in chick incubators or diesel locomotives—for street traffic control or long-range navigation—wherever sensitivity and dependability are required—you can count on ADLAKE. Send for complete ADLAKE Relay catalog today... write The Adams & Westlake Company, 1171 N. Michigan, Elkhart, Indiana. In Canada, write Powerlite Devices, Ltd., Toronto.



**THE
Adams & Westlake
COMPANY**

Established 1857 • ELKHART, INDIANA • New York • Chicago
Manufacturers of ADLAKE Hermetically Sealed Mercury Relays



**ANNOUNCES
A COMPLETE
LINE OF**

Hi-Precision

SERVO COMPONENTS



**DESIGNED TO MEET
EXACTING LINK STANDARDS**



**TESTED AND PROVED
IN PRODUCTION
ELECTRONIC EQUIPMENT**

FRICTION CLUTCHES

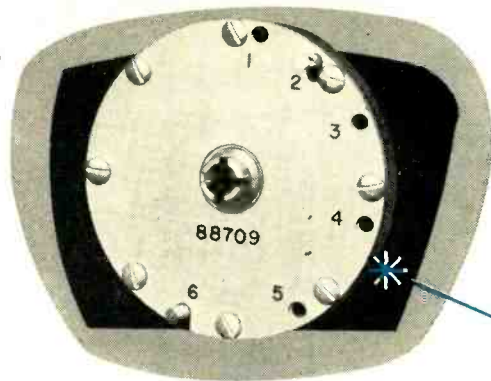

MOUNTING BRACKETS

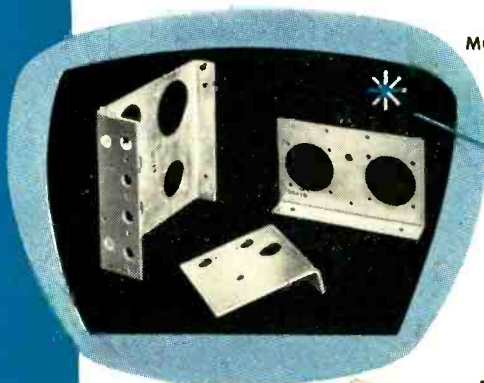

BASE AND UPRIGHT
PLATES

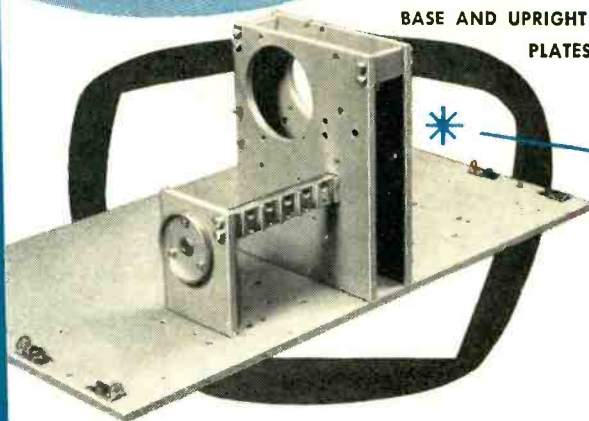

★ Link bridges the gap between laboratory and production with a completely new approach to component design. So skilfully are the servo parts correlated, so precisely are they produced, that the same units—mechanical and electronic—can be used interchangeably in laboratory prototypes and actual production models. This new technique assures in-use performance during research—cuts costs in production design—saves time in tooling-up for new models in the fast-changing electronics field.

- Manufacturers of the world-famous Link Trainers ●
- fractional h.p. wide range variable speed drives ●
- friction and over-drive clutches ●
- ratio voltmeters ● precision potentiometers



GEAR BOXES

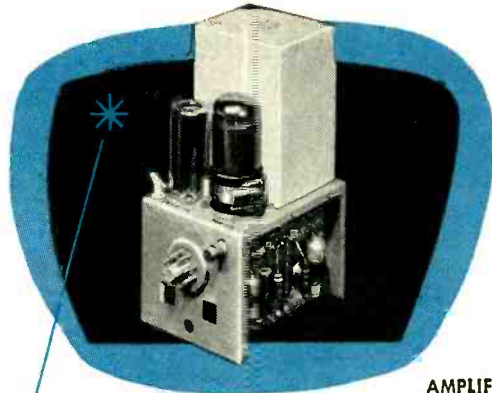

AMPLIFIERS — PHASE DETECTORS

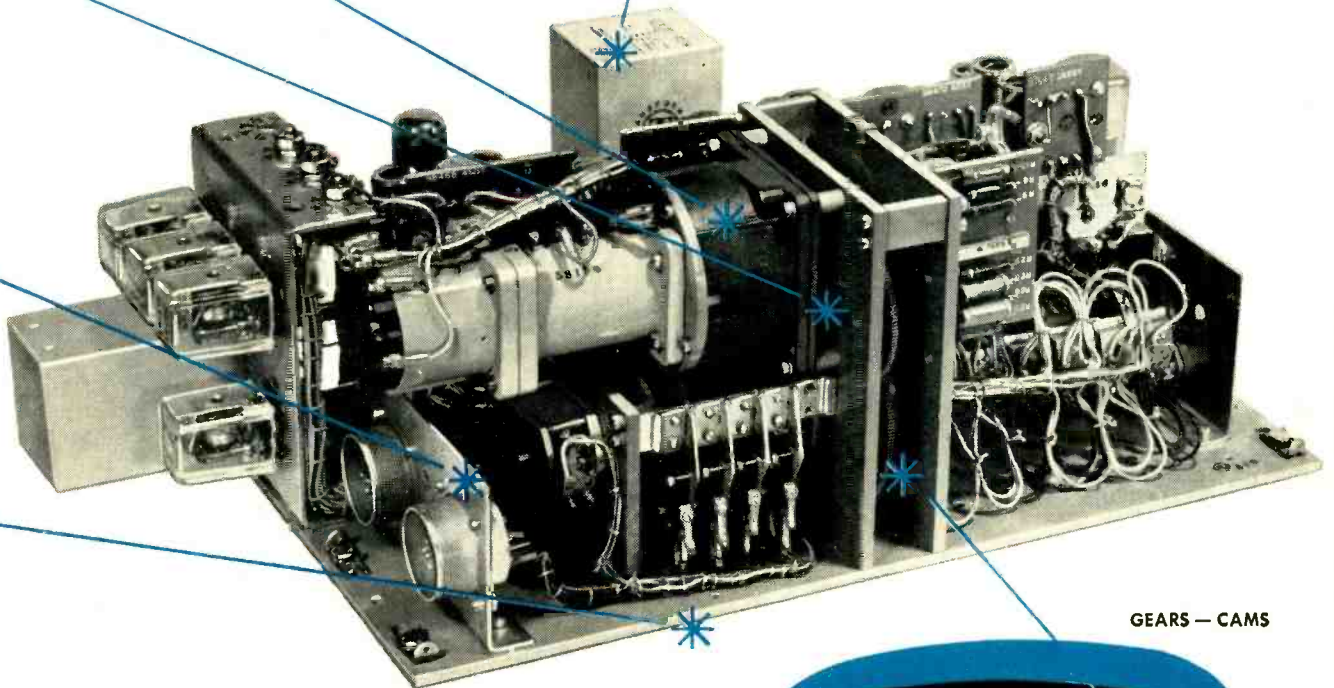

GEARS — CAMS

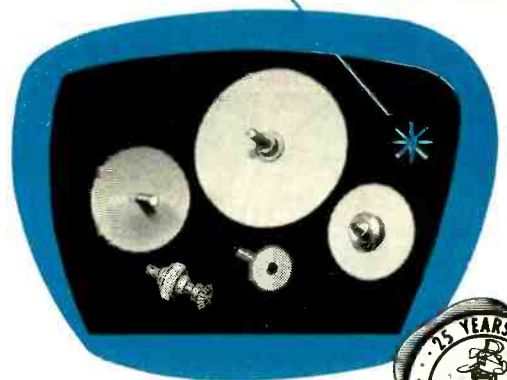

- ★ *Hi-Precision* base plates and brackets *stay* in place, eliminate alignment problems — yet permit full design flexibility.
- ★ Combine servo electronic and servo mechanical units on the same base plate. Provide a single complete packaged unit.
- ★ *Hi-Precision* manufacturing standards that assure accurate servo operations. All mechanical units are held to close tolerance.
- ★ Mount the completed servo unit in an upright position or flat — to best fit specific needs.
- ★ *Hi-Precision* Summing Amplifiers and Servo Amplifiers, plug-in type that offer outstanding reliability in extremely light-weight, compact proportion.
- ★ Phase detectors to switch circuits at specific amplitude — to convert AC voltage to DC voltage.

LINK AVIATION, INC. DEPT. E
BINGHAMTON, N. Y.

Rush me your complete Servo-Component Catalog.

NAME.....TITLE.....
 FIRM.....
 STREET.....
 CITY.....ZONE.....STATE.....



servo-mechanisms • graphic recorders
 spur gear differentials
 index dials • phase angle meters
 and other special electronic devices.



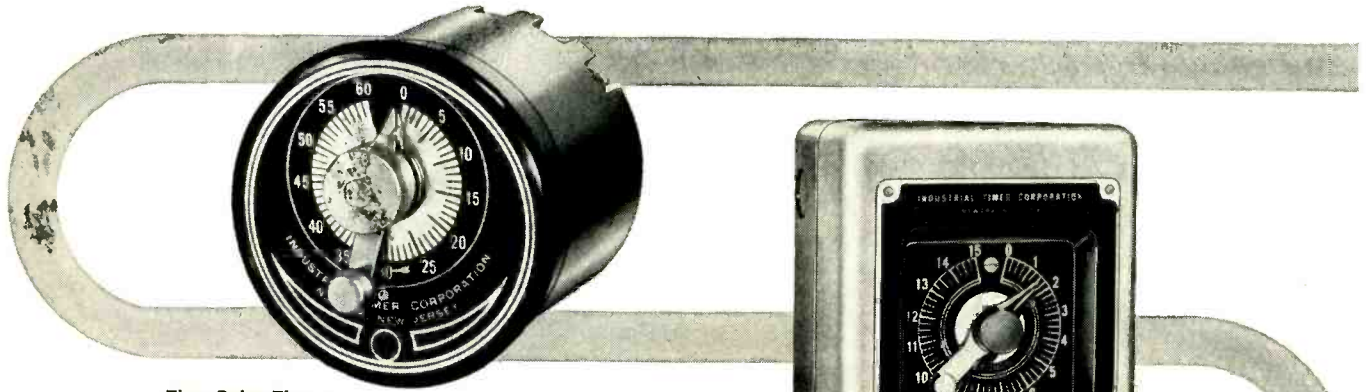

Time Delay Timers

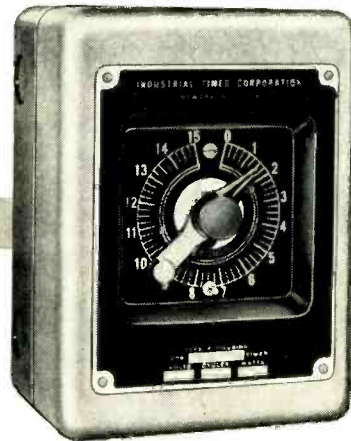

Interval Timers

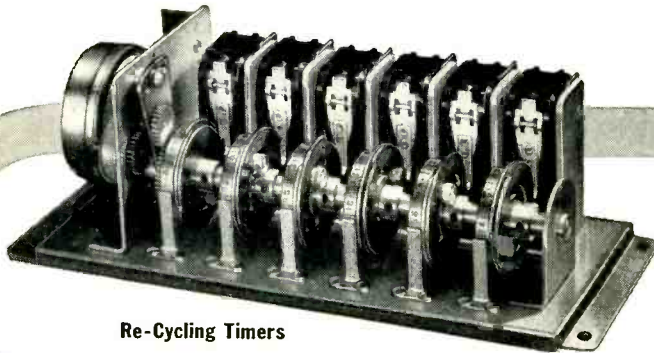

Re-Cycling Timers

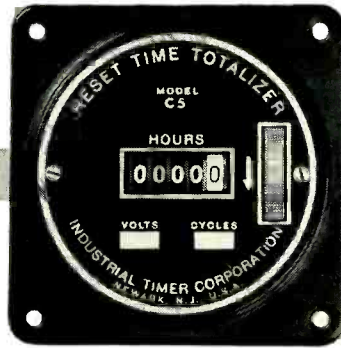

Running Time Meters

MOST COMPLETE LINE OF INDUSTRIAL

TIMERS for automation

The individual requirements of each automation problem are best met by selecting timers designed to perform specific functions. Whatever your timing-control problem, Industrial Timer Corporation can meet it with one of its standard timers, a combination of its standard units, or by designing an entirely new timing element. Our Engineering Department not only originates new designs, but also develops modifications to meet our customers requirements.

We manufacture a complete line of timers in these 4 broad classifications:

**TIME DELAY TIMERS • RE-CYCLING TIMERS
INTERVAL TIMERS • RUNNING TIME METERS**

Our large stocks of 17 basic types from which we have developed over 660 combinations to date, enables us to make rapid deliveries in most cases . . . and excellent deliveries on special orders. Our automation timer specialists will be happy to discuss your automation timer requirements. Your inquiries will receive prompt attention.

*Timers that Control
the Pulse Beat of Industry*



INDUSTRIAL TIMER CORPORATION
131 OGDEN STREET, NEWARK 4, N. J.

BORG MICROPOTS

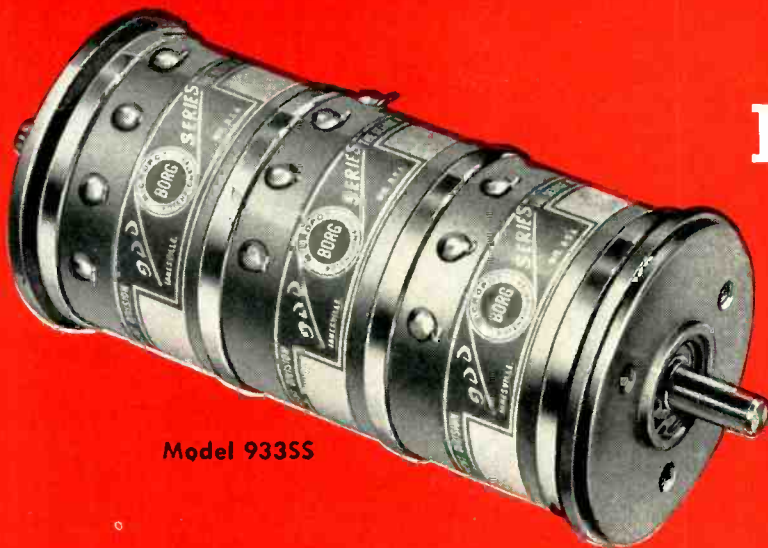

Model 9335S

the
NEW STANDARD
of precision
multi-turn
potentiometers

BORG 900 SERIES 3-TURN AND 10-TURN MICROPOTS

3-TURN MODELS 931-935



931S

932BB

933SK

935S

10-TURN MODELS 901-903



901SK

902B

903BK

903S

Standard models of Borg 900 Series Micropots offer such flexibility that they meet special design needs. Borg has created a new standard for high-precision, multi-turn potentiometers.

Advantages of the Borg 900 Series include greater accuracy, finer resolution, lower torque, longer life, better performance under severe and excessive

vibration, greater adaptability and versatility of application.

Standard models include: 10-turn precision Micropots in 1 to 3 gang models, 3-turn in 1 to 5 gang models, single or double shafts, servo or bushing mounts on either or both ends. Available to designers and engineers in any quantity.

SYNCHRONOUS AND INDUCTION BORG-MOTORS

1000 SERIES 2 POLE AND 4 POLE MODELS With and Without Gear Trains

These Borg-Motors were designed specifically for instrumentation, control and timing devices. They are recommended for all applications where low torque, constant speed and long life are positive requirements.



ATTACH TO YOUR LETTERHEAD

For Complete Engineering Data

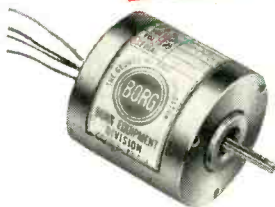

SERVO-CONTROL Borg-Motors

Two phase, 115 volt, 400 cps induction type Borg-Motors for servo control applications. Approximate size 1½" diameter x 2" long with a locked rotor torque of 0.82 ounce-inch.

BORG EQUIPMENT DIVISION
THE GEORGE W. BORG CORPORATION
JANESVILLE, WISCONSIN

BORG EQUIPMENT DIVISION
THE GEORGE W. BORG CORPORATION
JANESVILLE, WISCONSIN

NAME.....

TITLE.....

Please send complete information and engineering data on items checked.

- Precision Multi-Turn Potentiometers, 900 Series
- Borg Standard Potentiometer, 1100 Series
- Precision Multi-Turn Counting Dials
- Servo Control Motors
- Frequency Standards
- Instrument Motors
- Contract Manufacturing

★ ★ ★ ★ ★

IT'S NEW...IT'S NEWS!

...this 360° Bearing Counter

Smaller and more compact than ever, this new 360° Bearing Counter gives users several *bonus* advantages: It can be either base-mounted, or face-mounted flush with a panel surface. It will run at 1500 rpm constant speed or 2500 rpm on intermittent service... and it comes equipped with Geneva Transfer.

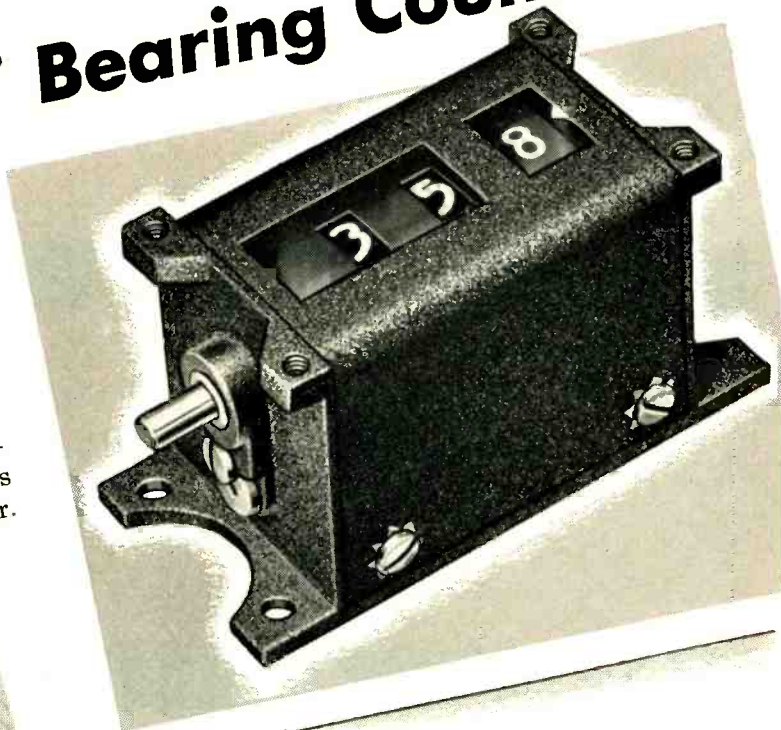

Added Evidence
that —

Everyone Can Count on **VEEDER-ROOT**

This is another Veeder-Root "first" ... the latest of one of hundreds of standard and special Veeder-Root Counters for every mechanical and electrical application. What do you want to count? Write:

ANOTHER NEW VEEDER-ROOT "FIRST"

New *Vary-Tally* Multiple-Unit Reset Counter gives you quick finger-tip count of anything countable. Comes in any combination up to 6 banks high, and 12 units wide (minimum of 2 units wide). Write for news sheet and prices.

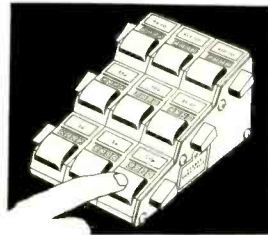

VEEDER-ROOT INCORPORATED • HARTFORD 2, CONNECTICUT

Chicago 6, Ill. • New York 19, N. Y. • Greenville, S. C.
Montreal 2, Canada • Dundee, Scotland
Offices and Agents in Principal Cities



"The Name that Counts"

Takes 22,000 sparks per minute
at 140-mph... **without electrical loss!**



Top of Wells' new "Super Go" ignition coil, C-1850, is molded of Resinox 3700. This coil out-performed all others in racing car tests on Utah salt flats... losing no spark power at speeds up to 140-mph! Manufacturer claims this coil on passenger cars will give same heat and spark at 80-mph as at 40-mph, saving gas and giving same pickup at both high and low speeds.

RESINOX 3700

Wells Manufacturing Company of Fond du Lac, Wisconsin, needed an ignition coil top that combined tremendous arc and heat resistance with outstanding dimensional stability and toughness. After extensive tests, they selected Monsanto's thermosetting molding powder, Resinox 3700. Speed test results proved the wisdom of their choice!

Resinox 3700 is the ideal all-around material for magneto ignition, motor control and electronic circuits, and other electrical applications.

1. It combines high arc-resistance with excellent dimensional stability. Eliminates undesirable after-shrinkage.
2. It has relatively good impact resistance and outstanding moldability, including good transfer molding properties.
3. It offers superior heat resistance.

Perhaps Resinox 3700 is exactly what *you* need to solve an electrical equipment problem. Write today for full information!

Resinox: Reg. U. S. Pat. Off.



SERVING INDUSTRY...WHICH SERVES MANKIND

MONSANTO CHEMICAL COMPANY, Plastics Division, Room 2502,
Springfield 2, Mass.

Please send me complete information on Monsanto's new Resinox 3700 arc-resistant material.

Name & Title _____

Company _____

Address _____

City, Zone, State _____

NRC Rotary Gas Ballast Pumps

*Shave Minutes
Off Pump-Down
Time*

Experience proves NRC high vacuum Rotary Pumps pump down faster. Employing the revolutionary Gas Ballast principle, they're more efficient both mechanically and volumetrically especially at low pressures. They permit minimum blow back and leakage past the pumping members. Since vapors won't condense in this pump, fast pump down time is always maintained.

*Dollars Off Your
Pumping Costs*

The efficiency of NRC Rotary Pumps makes for substantial savings. NRC's special inlet design screens out dust and foreign matter — protects pump parts from undue wear. Dynamic counter-balancing results in minimum vibration. Easier to service. More dependable to operate. Users report long life, low operating costs under the most adverse conditions.

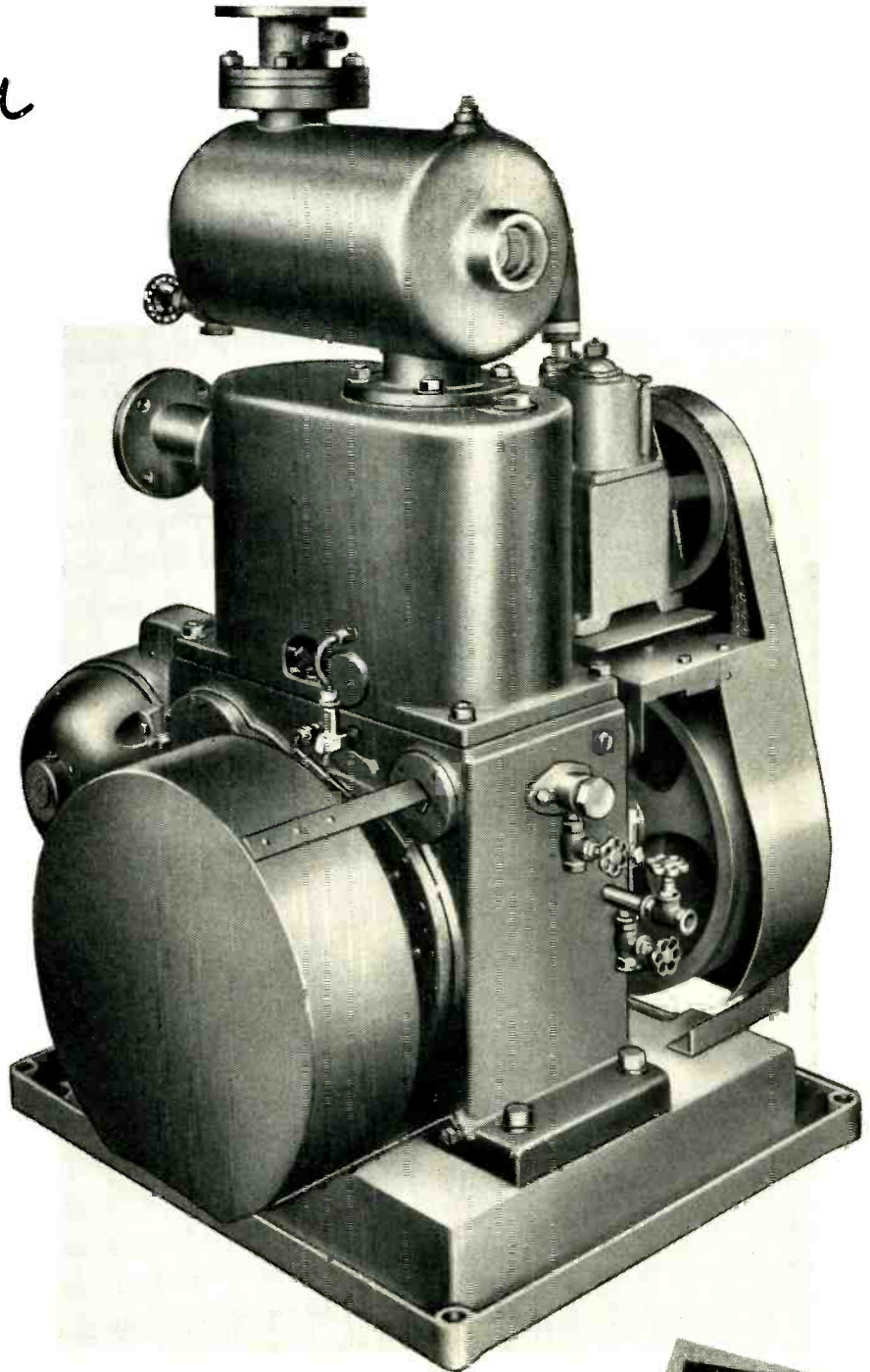

Send today for new Bulletin explaining the Gas Ballast principle plus complete operating and construction data.

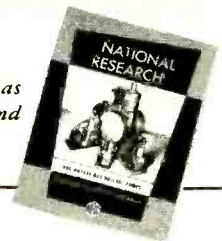

National Research Corporation

Equipment Sales Subsidiary: NARESCO EQUIPMENT CORPORATION

160 Charlemont St., Newton Highlands 61, Mass.

OFFICES: PALO ALTO, CALIF. • CHICAGO • CLEVELAND • NEW YORK CITY

HEADSTART ON TOMORROW

Bendix-Pacific maintains its traditional leadership in aviation by preparing today for tomorrow's engineering demands. From the new Pacific Division Engineering Building will come new developments in hydraulics, electro-mechanics, and airborne radar. It is the first unit in Pacific Division's long range engineering program, representing the newest and one of the most complete development facilities in America.



RADAR



SONAR



HYDRAULICS



TELEMETERING



ELECTRO-MECHANICAL



ULTRA SONICS



PACIFIC DIVISION • Bendix Aviation Corporation
11600 Sherman Way, North Hollywood, California

East Coast Office:
475 5th Ave., N.Y. 17

Export Division: Bendix International
205 E. 42nd St., N.Y. 17

Canadian Distributors:
Aviation Electric, Ltd., Montreal 9



WHAT ARE YOUR SLIP RING ASSEMBLY REQUIREMENTS?

list them on the dotted lines:

size...

Complete PMI Slip Ring Assemblies we have made range in size from .080" diameter by .450" long to 40" diameter by 8' high, weighing as much as 3100 lbs. We can make them smaller or larger — tailored to your exact requirements.

application...

PMI Slip Ring Assemblies surpass severe shock, vibration and water test conditions of MIL-E-2036A and MIL-T-17113 . . . provide trouble-free operation at 60,000 feet, resist fungus and corrosion.

electrical data...

PMI Slip Ring Assemblies have a Voltage Range from microvolts to more than 20,000 volts corona free; Current Range from microamps to more than 600 amps; number of circuits more than 500; typical Brush life 14 million linear feet; Frequency from DC to more than 60 mc.; Noise Level under all customer specifications has been met or bettered.

quantity...

Production on small Synchro Slip Ring Assemblies runs as high as 1000 per day. Ample manufacturing facilities make low-cost large runs possible.

mail this page TODAY for immediate attention to your problem...

NAME POSITION

COMPANY ADDRESS

If your requirements are in the specification stage or in production, PMI engineers will submit, at your request, a design layout or evaluate your present design layout for possible measures of economy or efficiency. Our diversified experience in designing and manufacturing Slip Ring Assemblies can save you time and money. Mail this page today.



P M INDUSTRIES, INC., - STAMFORD • CONN.
DESIGN • DEVELOPMENT • PRODUCTION • ELECTRO-MECHANICAL ASSEMBLIES

WHY generate when you can convert? GET DC DIRECTLY FROM AC

Cut costs, maintenance and replacements with

Federal SELENIUM RECTIFIER EQUIPMENTS

famous for steady, long-life industrial power supply



NO costly, bulky, moving equipment to buy . . . no expendable parts to replace frequently . . . virtually no maintenance!

No wonder Federal's compact, silent, rugged, ever-dependable selenium rectifiers are the economical and efficient way to get DC . . . for chucks, brakes, clutches, drums, pulleys, relays, circuit-breakers, motors and many other applications . . . for all DC needs of the machine tool industry.

Federal Equipments are ready to connect to your AC source . . . ready to deliver uninterrupted service. Powered by Federal's completely inert selenium rectifiers, their life is practically unlimited. All are conservatively rated . . . with a wide margin of safety to withstand momentary heavy overloads.

If the DC output you need is not listed in the table, Federal will gladly design and build to meet any specific requirements. Fill out and mail the attached coupon today!

RATINGS

CODE NUMBER	A-C INPUT			D-C OUTPUT	
	VOLTS	PHASE	CYCLES	VOLTS	AMPS.
FTR 3115-JS	115	1	50/60	115	1
FTR 3116-BS	115	1	50/60	115	5
FTR 3117-HS	115	1	50/60	115	10
FTR 3117-JS	230	1	50/60	115	10
FTR 3152-AS	220 or 440	3	50/60	115 230	4.4 2.2
FTR 3153-AS	220 or 440	3	50/60	115 230	6.6 3.3
FTR 3154-AS	220 or 440	3	50/60	115 230	8.8 4.4
FTR 3155-AS	220 or 440	3	50/60	115 230	13 6.5
FTR 3228-BS	220 or 440	3	50/60	115 230	26 13

MAIL COUPON TODAY for data on available FTR equipments, or any desired rating:

"America's first and largest manufacturer of selenium rectifiers"

Federal
Telephone and Radio Company

A Division of INTERNATIONAL TELEPHONE AND TELEGRAPH CORPORATION
Selenium-Intellin Department: 100 Kingsland Road, Clifton, N. J.
In Canada: Federal Electric Manufacturing Company, Ltd., Montreal, P. Q.
Export Distributors: International Standard Electric Corp., 67 Broad St., N.Y.

Federal Telephone and Radio Company
Selenium-Intellin Dept., Clifton, N. J. Dept. E-313

Send complete data on FTR code numbers indicated below:

Send preliminary data on the following rating:

FTR.....

FTR.....

Company.....

Address.....

Signature.....

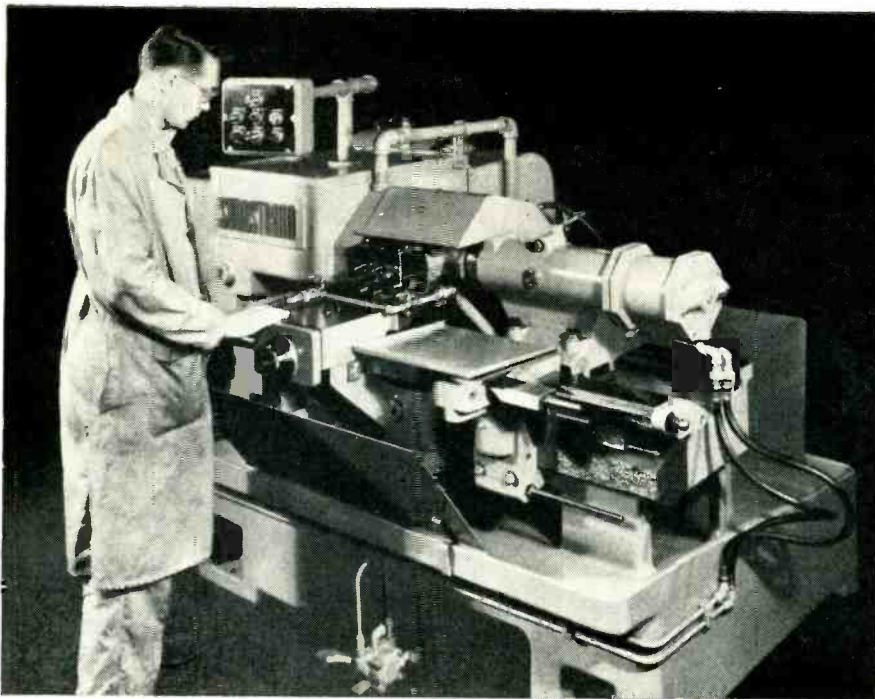

FASTER STARTING AND STOPPING HELPS THIS AUTOMATIC LATHE TO PRODUCE MORE

General Electric Selenium Rectifiers Help Make This Lathe More Productive

Speeding up starting and stopping operations has increased the productivity of many of today's finest machine tools. In the Sunstrand automatic lathe pictured above, an electric brake and clutch combination starts and stops the machine spindle. Another electric brake provides a fast stop when the tool carriage is advanced to the work, or backed off to the unloading position.

D-C POWER to operate the electric brakes and clutch on this lathe is supplied by General Electric selenium rectifiers shown in the smaller photograph. Their high quality (see C.E.

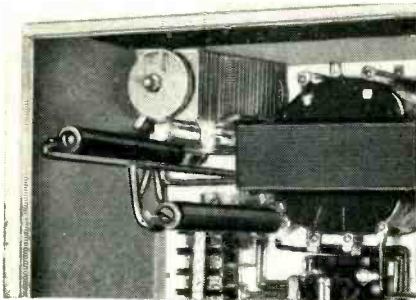

D-C POWER for the lathe's clutch and brakes comes from this selenium rectifier.

Hamann's article at right) makes G-E selenium rectifiers ideal for almost all machine tool applications.

TOP PERFORMANCE of G-E selenium rectifiers is the result of a unique "evaporation" process and careful inspection and testing. Besides providing stacks with exceptionally low forward voltage drop and low reverse leakage, this process assures greater uniformity of these characteristics among different stacks. These qualities last in service. On test in the laboratory, and on-the-job in almost every field of application, G-E selenium rectifiers are demonstrating their extremely slow aging.

OTHER APPLICATIONS for G-E selenium rectifiers include supplying power to operate d-c relays in various control circuits and as components in electronic equipment. A complete range of ratings is available in either open stacks or various types of sealed cases to meet special operating conditions. Contact your nearest G-E Apparatus Sales Office for complete information, or write Section 461-33, General Electric Company, Schenectady 5, New York.

You can put your confidence in—

GENERAL  ELECTRIC

METALLIC RECTIFIER FACTS FOR ENGINEERS

Quality

by C. E. Hamann

One of the most overworked terms used in the selenium rectifier industry is "high quality." Every manufacturer claims "high quality" for his product. Every user wants "high quality" in the selenium components he buys because the quality of the end device can be no higher than that of the components assembled into it.

There are many yardsticks for measuring the quality of a selenium stack. Electrical characteristics, for example: low forward drop and low reverse leakage. Often one is sacrificed in favor of the other.

LOW FORWARD DROP

LOW LEAKAGE

UNIFORMITY

STABILITY

RELIABILITY

Which "yardstick" measures quality?

Real quality insures that both the forward and the reverse characteristics are good.

Uniformity of characteristics is another yardstick. If the characteristics vary from stack to stack the performance of the end equipment will be questionable.

Stability is another important standard in determining quality. The initial characteristics must be good, but they must stay good and not deteriorate with time and use.

Reliability is still another measure of quality. No matter how liberal the manufacturers replacement policy, frequent failures in the field are costly to the equipment manufacturer, and annoying to the equipment user.

All of these yardsticks must be considered carefully in determining quality. To really earn the title of "high quality" a selenium stack must measure up to a high standard of performance by every one of these yardsticks.

C. E. Hamann

General Electric Company

ALSiMAG[®] 576

AN ECONOMICAL HIGH STRENGTH ALUMINA CERAMIC

Meets L-5A Requirements
of JAN-I-70 Specifications

Note These Advantageous Properties

PROPERTY	UNIT	ALSiMAG 576 L-5A
Water Absorption		Impervious
Specific Gravity		3.4
Density	Lbs. per cu. in.	.123
Standard Body Colors		White
Alternative Body Colors		Pink 513 (L-5A)
Safe Temperature at Continuous Heat	°C. °F.	1 100 2 0°2
Hardness	Mohs' Scale	9
Thermal Expansion Linear Coefficient	Per °C. 25-700°C.	7.5×10^{-6}
Tensile Strength	Lbs. per sq. in.	20 000
Compressive Strength	Lbs. per sq. in.	140 000
Flexural Strength	Lbs. per sq. in.	40 000
Dielectric Strength (step 60 cycles) Test discs 1/4" thick	Volts per mil	250
Volume Resistivity at Various Temperatures	25°C. 100°C. 300°C. 500°C. 700°C. 900°C.	Ohms per centimeter cube
		$> 10^{14}$ 2.0×10^{13} 5.0×10^{10} 1.0×10^8 3.0×10^6 4.0×10^5
Te Value	°C. °F.	800 1 472
Dielectric Constant	60 Cycles 1 M.C. 10 M.C. 100 M.C.	8.4
		8.3
		8.2
		8.1
Power Factor	60 Cycles 1 M.C. 10 M.C. 100 M.C.	.0013
		.0007
		.0007
		.0008
Loss Factor	60 Cycles 1 M.C. 10 M.C. 100 M.C.	.011
		.006
		.006
		.006

GAS PRESSURE AND VACUUM TIGHT

UNIFORMLY LOW THERMAL EXPANSION

EXCEPTIONAL STRENGTH

HIGH INSULATING RESISTANCE OVER A WIDE TEMPERATURE RANGE

LOW DIELECTRIC LOSS

QUICK DELIVERY IN ANY DESIRED QUANTITY. ALSiMag 576 parts can be made in the full range of sizes, designs and processes that are normally available in other ALSiMag ceramics.

53RD YEAR OF CERAMIC LEADERSHIP

AMERICAN LAVA CORPORATION

A Subsidiary of Minnesota Mining and Manufacturing Company

CHATTANOOGA 5, TENNESSEE

OFFICES: METROPOLITAN AREA: 671 Broad Street, Newark, N. J., Mitchell 2-8159 • SYRACUSE, N. Y.: 204 Harding Place, Phone 9-0656 • CLEVELAND: 5012 Euclid Avenue, Room 2007, Express 1-6685 • NEW ENGLAND: 1374 Mass. Avenue, Cambridge, Massachusetts, Kirkland 7-4498 • PHILADELPHIA: 1649 N. Broad Street, Stevenson 4-2823 • ST. LOUIS: 1123 Washington Avenue, Garfield 1-4959 • CHICAGO: 228 N. LaSalle St., Central 6-1721 • SOUTHWEST: John A. Green Company, 6815 Oriole Drive, Dallas 9, Dixon 9918 • LOS ANGELES: 5603 N. Huntington Drive, Capitol 1-9114

**DIE PRESSED • EXTRUDED
MACHINED • METALLIZED**

Bulletin 524, sent on request, shows standard metallized hermetic terminals of this material. Custom made items can be supplied promptly. Send blueprint.

MICRO SWITCH Precision Switches

A PRINCIPLE OF GOOD DESIGN

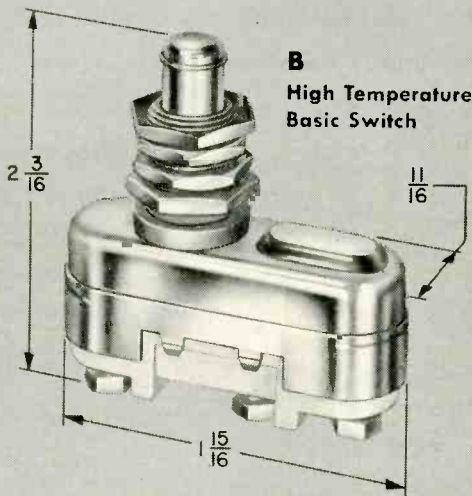

B
High Temperature
Basic Switch

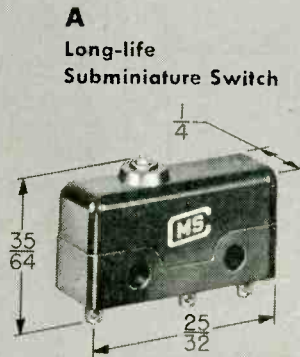

A
Long-life
Subminiature Switch

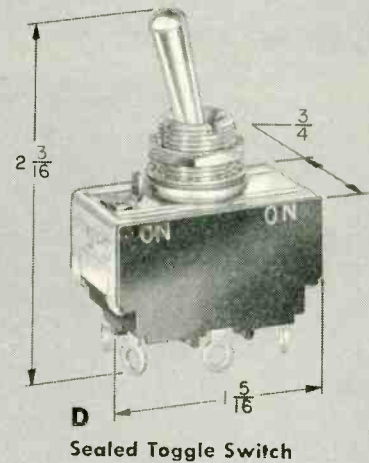

D
Sealed Toggle Switch

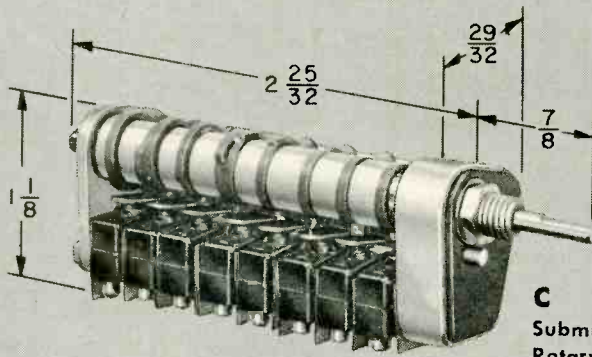

C
Subminiature
Rotary Selector Switch

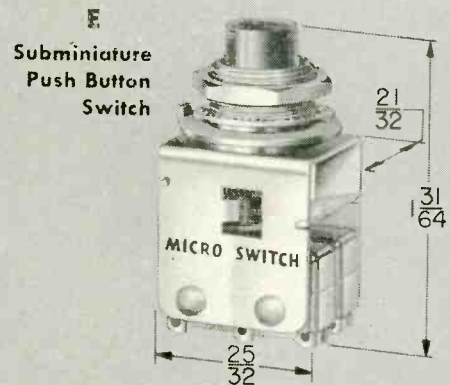

E
Subminiature
Push Button
Switch

There are uses unlimited for these small MICRO SWITCH precision switches in electronic devices and instruments

A This subminiature switch is capable of operations in excess of 20 million. It is an improved type of the basic subminiature switch and is available with either solder post or turret type, wrap-around terminals.

B The high temperature basic switch will operate satisfactorily in a temperature range of from -50° to $+1000^{\circ}$ F. Originally designed for jet aircraft applications, it is equally useful for any application which requires a high-temperature switching component.

C The subminiature rotary selector switch uses from 2 to 8 single-pole, double-throw subminiature switches to control from 2 to 16 electrical circuits. It permits 2

to 8 switching positions with spring or manual return to neutral position.

D This sealed toggle switch is supplied with an external panel seal and an internal bushing seal below the bat handle. It has a bushing for panel mounting and may also be supplied with keying tab.

E The subminiature push button switch assembly is composed of two single-pole, double-throw subminiature switches. The plunger provides an unusually good snap make and break. Available with red or black plastic buttons and either solder post or turret-type, wrap-around terminals.

MICRO SWITCH engineering service, fully experienced in every type of switch use, is available at 16 branch offices to consult with you on your switch application problem. A call to the branch office near you may save time and money. There is no obligation.

MICRO SWITCH provides a complete line of extremely reliable, small-size, high-capacity, snap-action precision switches and mercury switches. Available in a wide variety of sizes, shapes, weights, actuators and electrical characteristics. For all types of electrical controls.

MICRO SWITCH

A DIVISION OF MINNEAPOLIS-HONEYWELL REGULATOR COMPANY
FREEPORT, ILLINOIS



DESIGN and PRODUCTION NEWS

FOR ELECTRICAL AND ELECTRONIC ENGINEERS

Published by TECHNICAL SERVICE, Chemical Manufacturing Division, The M. W. KELLOGG Company

JUNE - JULY, 1954

New Cap Connectors of KEL-F[®] Polymer Widen Tube Service Range... Cut Altitude, Moisture "Arc-Over"!

Exceptional moldability of KEL-F and special equipment permit the "insert" molding of grid cap leads and resistors into a one piece insulated jacket. Conventional wire holes are eliminated, preventing insulation "pull back". Zero moisture absorption of KEL-F polymer and the elimination of wire holes precludes moisture collection which formerly caused "arc over" under high humidity.

The high insulation resistance and dimensional stability of KEL-F polymer over a wide temperature range (minus 320°F to plus 390°F) permits use of these connectors in critical installations subjected to extremes of temperature.

Alden Products Company, Brockton, Mass., uses KEL-F trifluoro-chloroethylene and a special molding technique to produce an entire series of connectors. Variety includes top- or side-connected leads, with or without resistors.

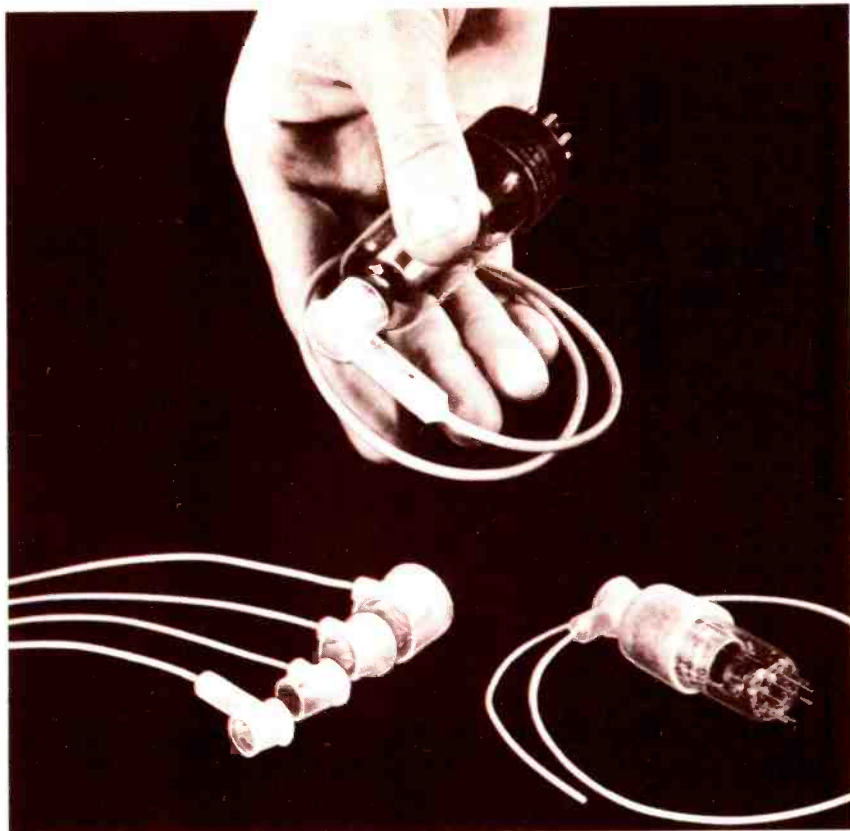

For further information ask for Application Report E-124

**NEW LOWER PRICES
FOR "KEL-F" POLYMERS
OPEN UP MANY
NEW APPLICATIONS
POSSIBILITIES!**

This is the fourth important price reduction since the introduction of KEL-F polymer products in 1948. It cuts prices up to 25% in ton lots, and as much as 42% for small quantities nominally used for experimental work.

The reduction is made possible by the rapidly expanding acceptance of KEL-F polymers and the manufacturing economies achieved in Kellogg's new production facilities.

NEW PRICE SCHEDULE—Effective May 17, 1954

	High Density	Low Density	Plasticized
1-99 pounds	\$10.00	\$9.50	\$11.00
100 - 1999 pounds	9.50	9.00	10.50
2000 pounds and over	9.00	8.50	10.00

F.O.B. Jersey City

(SEE REVERSE SIDE)

® Registered trade-mark for The M. W. Kellogg Company's fluorocarbon Polymers.

KEL-F

TRIFLUORO
CHLORO
ETHYLENE
POLYMERS

KEL-F

MOLDING
POWDERS

KEL-F

FLUORO
CHLORO
CARBON
PLASTIC

KEL-F

DISPERSION
COATINGS

KEL-F

TRIFLUORO
CHLORO
ETHYLENE
POLYMERS

KEL-F

OILS
WAXES
GREASES

KEL-FTRIFLUORO
CHLORO
ETHYLENE
POLYMERS**KEL-F**MOLDING
POWDERS**KEL-F**FLUORO
CHLORO
CARBON
PLASTIC**KEL-F**DISPERSION
COATINGS**KEL-F**TRIFLUORO
CHLORO
ETHYLENE
POLYMERS**KEL-F**OILS
WAXES
GREASES

"Spaghetti", Flexible in Sub-sub-zero Temperature, Protects Against Oils, Chemicals and Moisture!

This smooth extruded "spaghetti" sleeving for aircraft wiring made of KEL-F polymer, is in a class by itself. Not only does it have a high dielectric strength of from 2500 to 3000 volts per mil, and excellent arc resistance, but it will stay pliable and resist cracking and splitting even after prolonged use at temperatures from minus 140° to 300° F. The unique physical and chemical properties of this fluoro-chloro-carbon plastic permits the lightweight but tough sleeving to remain unaffected under constant exposure to chemicals, oils, or aircraft fuels.

Resistoflex Corporation of Belleville, N. J., manufactures several grades of "spaghetti" and rigid sleeving, made from KEL-F polymers, under the name Fluoroflex "C"***.

** Trade mark of Resistoflex Corporation
For further information ask for
Application Report E-105

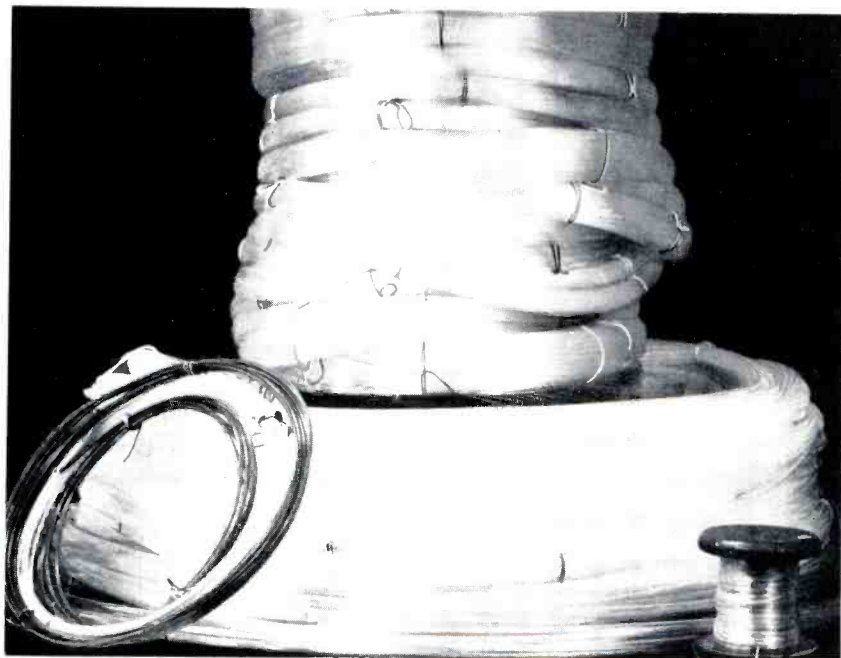

Molders & Fabricators of the Month

Leading molders, extruders and fabricators specialize in the production of materials and parts made of "Kel-F" ... each month this column will spotlight several of these companies with their principal services and products.

International Resistance Company

Philadelphia, Pa.

Extrusion, Compression, Transfer & Injection Molding
Terminals, Resistors, electronic components
Extruded Rod & Tube
Molded Rod, Tube & Sheet

Surprenant Manufacturing Company

Clinton, Mass.

Extrusion
Insulated Wire
Extruded Rod, Tube & Spaghetti
Tape, Strip & Monofilament

Tri Point Manufacturing & Developing Co.

Brooklyn, N. Y.

Machining

The United States Stoneware Company

Akron, Ohio

Corrosion Control
Dispersion Coating

Recent Significant KEL-F Polymer Developments ...

"Lug" type pressure rupture discs now use extruded film not only to protect discs against corrosion damage, but as pressure and vacuum seals.

Wavemeter test probes (microwave control) use molded insulation for consistent performance in high humidity and under thermal cycling.

Heater coils and plates for severe chemical service are protected with "baked on" coatings of KEL-F polymer dispersions.

Indexed commutators for computers now consist of a molded plastic cylinder with intricate conductive inserts. High dielectric and non-carbonization of polymer improves performance.

Visit the **KEL-F POLYMER EXHIBIT** at the **6th Annual Plastics Show**, June 7-10 • Cleveland, Ohio

For complete information regarding any item mentioned in DESIGN AND PRODUCTION NEWS, ask for detailed APPLICATION REPORTS, write

**Technical Service
CHEMICAL
MANUFACTURING
DIVISION**

**THE
M. W. KELLOGG
COMPANY**

P. O. Box 469, Jersey City 3, N. J.
or offices in Boston, Chicago, Dayton,
Los Angeles and New York



SUBSIDIARY OF
PULLMAN
INCORPORATED

To **1954** *Engineers...*

Where will you be in **1964**?

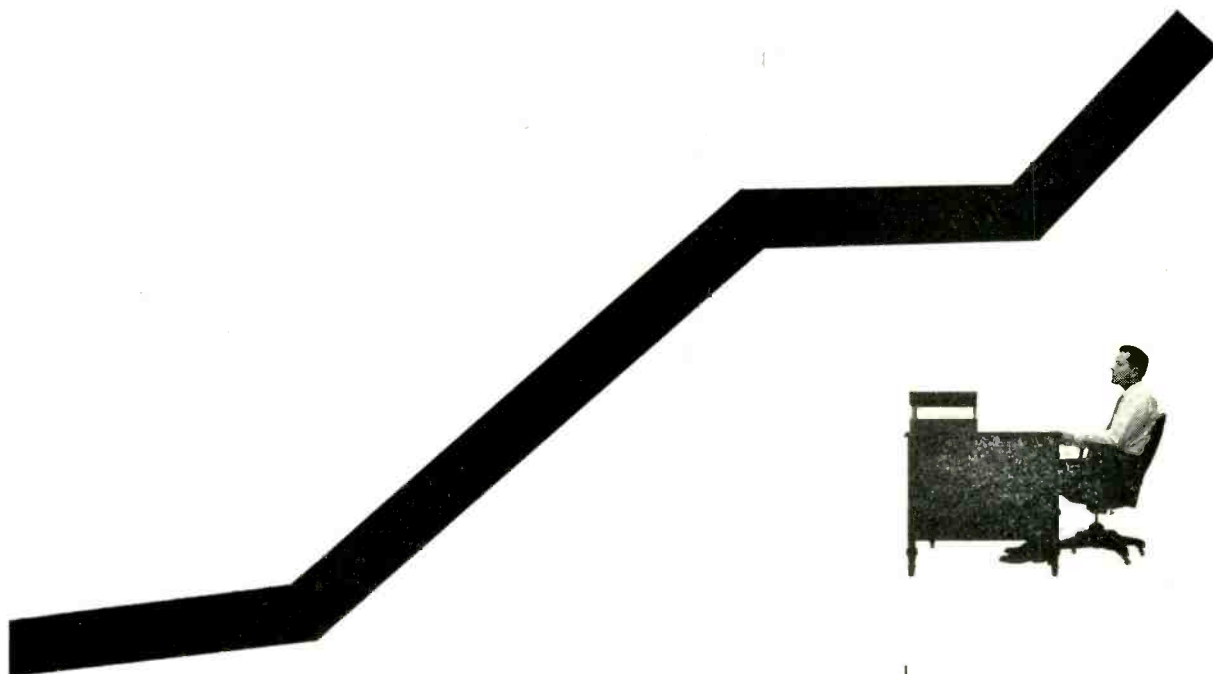

Will you have shifted from job to job, seeking the "right spot" and never finding it? Or will you have moved ahead steadily at one company, gaining recognition and promotion through achievement?

The answer to those questions depends on more than ability and ambition. It also depends on opportunity . . . opportunity to show what you can do . . . opportunity to make hard work and accomplishment pay off in promotion . . . the kind of opportunity you get at Lockheed, working on such diversified projects as huge luxury airliners, jet transports, nuclear energy, fighters, bombers, trainers, vertical rising aircraft and other classified activities.

There are other important yardsticks with which to measure a job: salary, extra employee benefits, living conditions. All standards that tell you *today's* job is a good one; all excellent at Lockheed.

But it is opportunity that makes a Lockheed job a position of the future — a position that in 1964 will enable you to look back on a record of achievement you earned *because you had the opportunity.*

Lockheed invites inquiries from Engineers who seek opportunity for achievement. Coupon below is for your convenience.

Lockheed has career openings for:

- Electro-Mechanical Design Engineers**
with a degree in Electrical Engineering and extensive experience in circuit analysis and design and electro-mechanical experience in servomechanisms and autopilots
- Electrical Design Engineers**
with a degree in Electrical Engineering and experience in aircraft circuit analysis and electrical design
- Electrical Installation Design Engineers**
with a degree in Mechanical or Electrical Engineering and experience in design of electrical equipment installation
- Servomechanisms and Autopilot Research Engineers**
with a degree in Electrical Engineering and experience in research and testing of servomechanisms and autopilots
- Instrumentation Engineer**
with a degree in Electrical Engineering and experience in instrumentation for flight testing
- Thermodynamicists**
with a degree in Aeronautical or Mechanical Engineering and extensive experience in aircraft thermodynamics

Lockheed

AIRCRAFT CORPORATION
BURBANK • CALIFORNIA

Mr. E. W. Des Lauriers, Dept. EE-6
Lockheed Aircraft Corporation
1708 Empire Avenue, Burbank, California

Dear Sir:

Please send me your Lockheed brochure describing life and work at Lockheed in Southern California.

Name _____

Field of engineering _____

Street Address _____

City and State _____

As



sees it...

There's nothing wrong
with **UHF...**
that **COLOR TV**
can't fix!

Now is the time to give UHF a permanent lease on life—while color television is in its infancy. As TV GUIDE sees it, eventual solution of the UHF problem well may be the responsibility of the set manufacturer. The advent of color television would seem to be a most logical and opportune starting point.

TV GUIDE's reason for expressing its editorial opinion is easily understood. We feel safe in assuming that our more than 2,000,000 TV GUIDE families will want their investment in color TV to guarantee complete television enjoyment.

This editorial is reproduced from
the April 30th issue of TV GUIDE



America's Television Magazine.....

as we see it

Now, as we enter the new era of color TV, is the time to establish ultra high frequency television as a major factor in the medium. It can be done, simply and easily, by installing at the factory a combination VHF-UHF tuner in every color set produced.

There is room in the frequency spectrum for only about 500 VHF stations, while the spectrum can accommodate about 1700 UHF stations. The public would be served best by the greatest number of stations. More outlets in each area would mean a wider choice of shows for viewers.

As things stand now, it is difficult for a UHF station to make its way in a region served by a couple of VHF stations. In order to receive new UHF stations, the viewer must install a converter in his set, and that entails expense. So far, UHF outlets have been successful chiefly in areas that have no VHF competition.

The Federal Communications Commission has done almost everything in its power to push UHF. It has yet, however, to urge that manufacturers install tuners capable of receiving both VHF and UHF telecasts in all color sets.

A check of major manufacturers shows that only one specifies VHF-UHF tuners for all its color sets. The others either have made no decision yet or are installing them only as ordered by customers.

This is a golden opportunity, perhaps the only opportunity that ever will arise, to put over UHF television. It is evident that color sets gradually will replace monotone receivers over the next few years. If, during the replacement period, provision can also be made for reception of UHF stations, viewers will benefit two-fold.

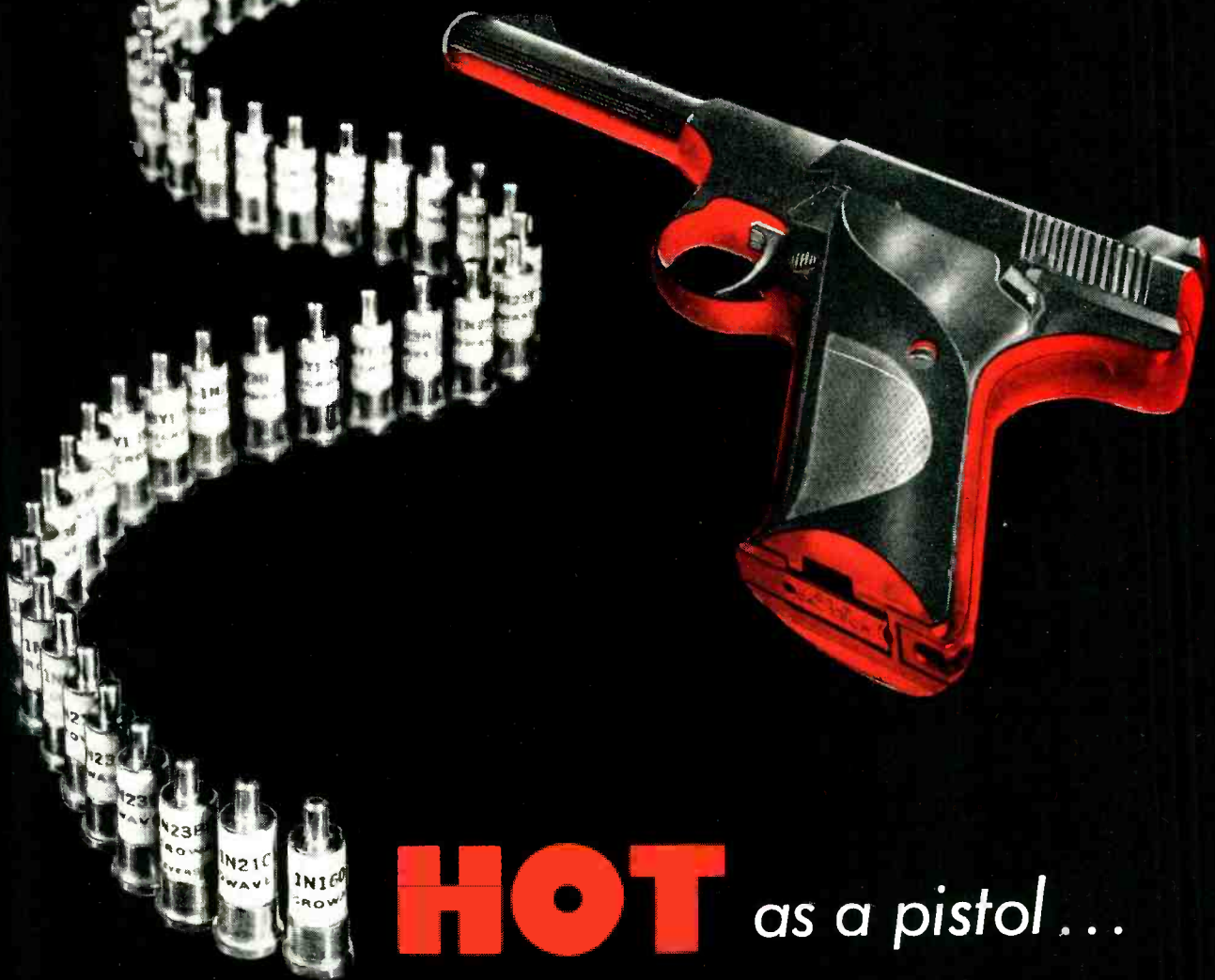

HOT as a pistol...

TYPE	CENTER FREQUENCY (MHz)	MAX. CONVEY. LOSS (dB)	MAX. NOISE RATIO (300Hz)	VSWR (max.)	IMPEDANCE (OHMS)
*1N21B	3060	6.5	2.0	-	200-800
*1N21C	3060	5.5	1.5	-	200-800
*1N190	6750	6.0	2.0	1.5	325-500
*1N160	6750	6.5	2.7	-	200-800
*1N23B	9375	6.5	2.7	-	200-800
*1N23C	9375	6.0	2.0	1.5	325-475
*1N149	9375	5.5	1.5	1.5	325-475
1N78	16000	7.5	2.5	-	325-625
1N26	23984	6.5	2.5	-	300-600
1N53	>30000	8.5	2.5	-	400-800
1N32	3295	Fig. Merit > 85	Video Impedance: 4K-22K		

* Also available with reversed polarity

Designers and producers of microwave receivers are achieving lower noise figures over broader bandwidths plus longer life by specifying Microwave Associates, Inc., silicon diodes. High quality, low cost diodes are available for all microwave bands.

For super low noise performance, specify the 1N149 at X-band and the 1N21C at S-band. The new RF adjusted 1N32 outperforms the field for video use at S-band.

Write for catalog E54S, describing our complete silicon diode line, MICROWAVE ASSOCIATES, Inc., 22 Cummington Street, Boston 15, Mass. Telephone, COpley 7-4441.





Arthur Marquis
Design and Application
Engineer

Arthur R. Kozlowski
Design and Application
Engineer

John H. Smedley
Design and Application
Engineer

George D. Barcus
Design Engineer

Rollin J. Parker
Supervisor—Magnetic
Products Design and
Application

These Carbolyoy® permanent

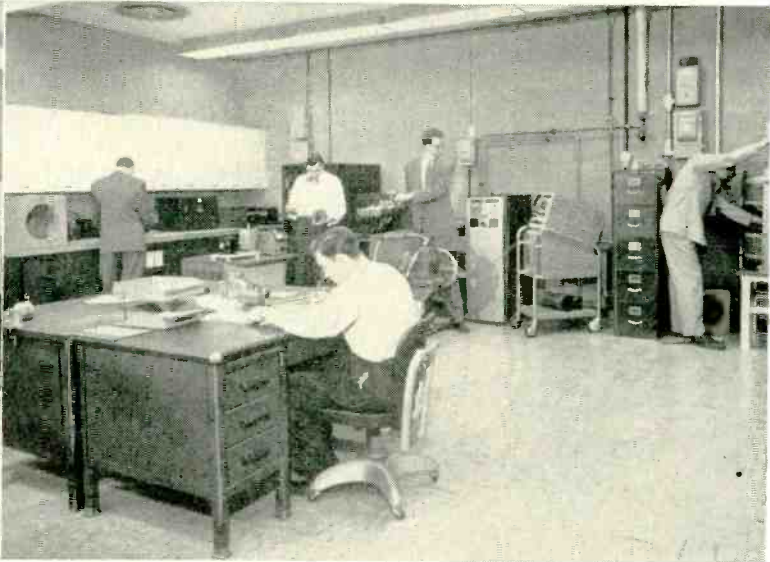
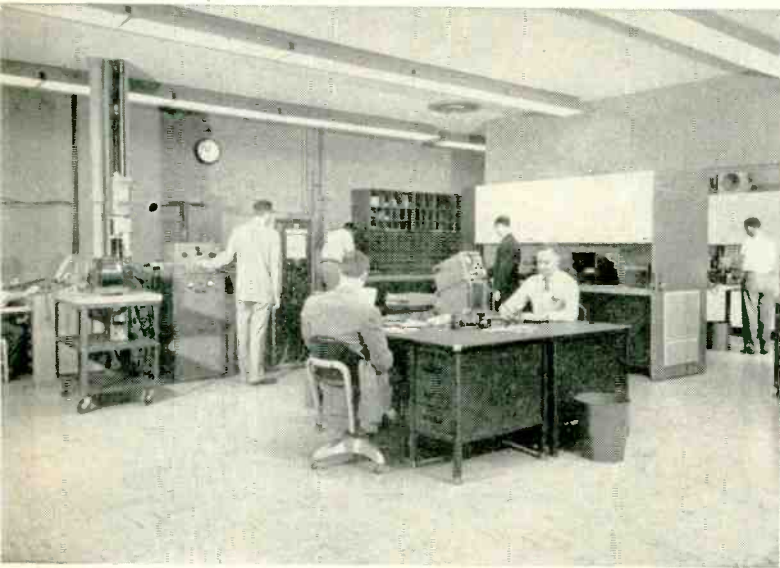

At the modern Carbolyoy magnet laboratory, in Detroit, trained engineers work with the finest equipment. Where necessary, special instruments are often designed by the engineers.

With such complete facilities, Carbolyoy magnet engineers can give you accurate information, quickly. And, they can thoroughly test their designs and the performance of the magnets in your products.

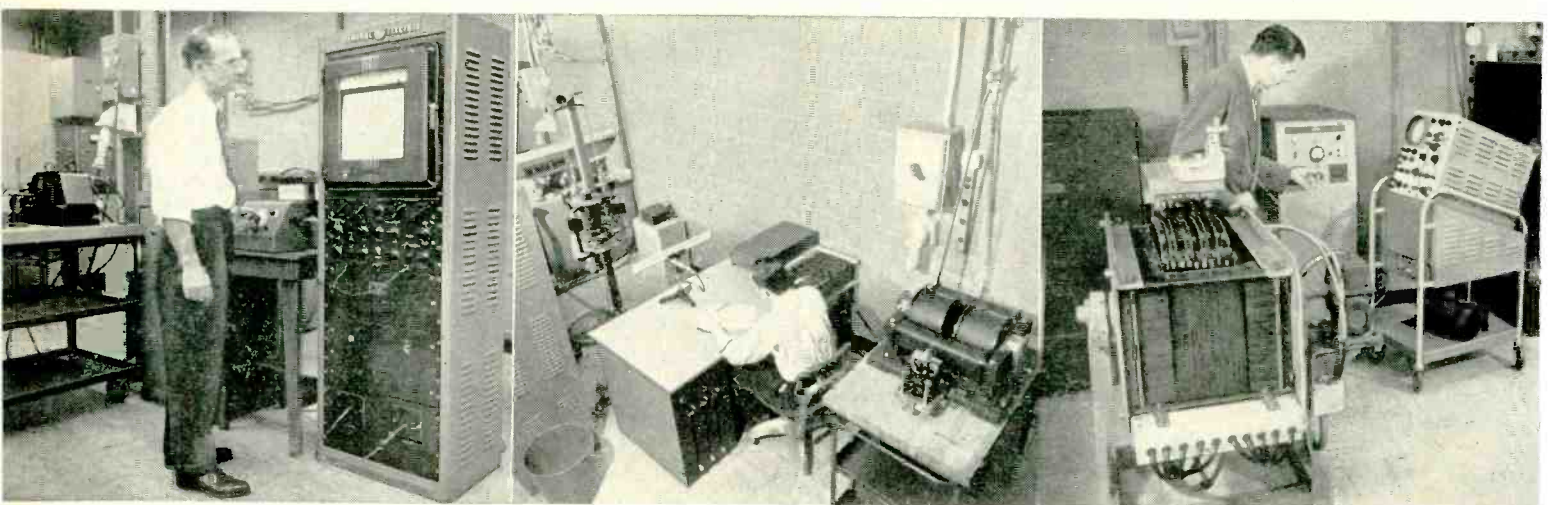

DC Recording Hysteresigraph. Simultaneously plots magnetic force and resulting magnetic induction. Produces complete hysteresis loops, not ordinary point-by-point readings.

High H-Permeameter. Provides point-by-point readings of magnetizing force and induction. Control table and Ballistic Galvanometer also used for general flux measurements.

Condenser Discharge Magnetizer. Produces very large current impulse for magnetizing magnet configurations that can best be accomplished with special field shapes.

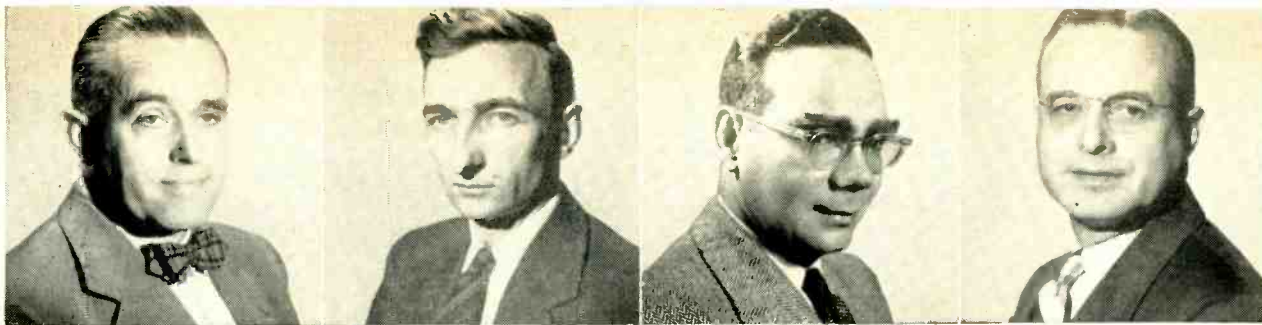

Ernest E. George
*Mgr.—Design and
 Application Engineering*

Robert J. Studders
*Supervisor—Magnetic
 Materials and Process
 Development*

Edgar W. Engle
*Mgr.—Product and
 Process Development
 Engineering*

Edgar L. Hubbard
*Sales Mgr.—Permanent
 Magnets*

magnet engineers can help you improve products, cut costs

Experienced magnet engineers, using the latest test and development equipment, will provide complete engineering appraisal service

You can get valuable technical assistance, without obligation, on the design and application of permanent magnets, from Carboloy magnet engineers . . . men who are leaders in the field.

Only at the Carboloy Department can you obtain engineering appraisal service and sample magnets from separate laboratory facilities devoted exclusively to helping you determine the design and optimum size, shape and strength magnets to fit your particular application. Your product will be tested in the modern Carboloy magnet laboratories, on the latest test instruments, to assure the maximum operating efficiency of the magnets.

PROVED RESULTS

The assistance Carboloy engineers have given other designers and manufacturers has paid off time and again in lower production costs, improved product efficiency, simplified assemblies and reduced product size.

You can rely on their solutions because these engineers, many of whom worked on the original devel-

opment of Alnico, are specially trained and experienced in all phases of permanent magnet design and application.

You can depend on Carboloy magnet sales engineers, too, for authoritative and intelligent answers to your questions. These men have intensive, special training in permanent magnets, supporting their engineering and technical backgrounds.

A COMPLETE SERVICE

Together with the engineers who are working on the development of new magnetic materials and on the improvement of existing Alnico grades, *these men make a complete permanent magnet team.* Their sole job is to help you utilize the tremendous potential of permanent magnets for new and improved products.

This team can start working for you, today. Just fill out the coupon and attach to it your company letterhead, and where possible, blueprints or sketches of the job. Or, if you prefer, the coupon will bring a call by your local Carboloy magnet sales engineer.

Three typical, successful appraisal projects:

INSTRUMENTS. Working with Thomas A. Edison, Inc., Carboloy engineers provided the magnet design that made possible a revolutionary fire detection relay. Use of the proper magnets simplified the design of the relay and reduced its size and weight.

CONTROLS. The development of the hysteresis brake was pioneered by Carboloy magnet engineers. Now widely used in the textile and wire rope industries, this brake eliminates friction, while maintaining the necessary constant tension.

TELEVISION. Carboloy magnet engineers collaborated with tube engineers on the design of a new magnetic internal focusing device. They designed the smaller, more efficient magnets that helped eliminate focusing dials and external assemblies.

CARBOLOY

DEPARTMENT OF GENERAL ELECTRIC COMPANY

"Carboloy" is the trademark for products of the Carboloy Department of General Electric Company

.....

• **CARBOLOY**

• Department of General Electric Company

• 11139 E. 8 Mile Ave., Detroit 32, Michigan

• I would like magnet engineering assistance; I am enclosing necessary information and blueprints.

• Have a Carboloy magnet salesman call.

• Name _____ Position _____

• Company _____

• Address _____

• City _____ Zone _____ State _____

•

SPLITTING HAIRS

TO SPEED CALLS



To triple the voice-carrying capacity of coaxial cable, Bell Laboratories engineers had to create new amplifying tubes with the grid placed only two-thirds of a hair's breadth from the cathode. Furthermore, the grid wires had to be held rigidly in position; one-quarter of a hair's shifting would cut amplification in half.

Working with their Bell System manufacturing partners at Western Electric, the engineers developed precise optical means for measuring critical spacing insulators. On a rigid molybdenum grid frame they wound tungsten wire three ten-thousandths of an inch thick. To prevent the slightest movement they stretched the wire under more tension for its size than suspension bridge cables, then bonded it to the frame by a new process.

The resulting tube increases coaxial's capacity from 600 to 1800 simultaneous voices—another example of how Bell Telephone Laboratories research helps keep your telephone system growing at the lowest possible cost.

This coaxial system electron tube amplifies more voices at the same time because of wider frequency band—made possible by bringing grid and cathode closer together.

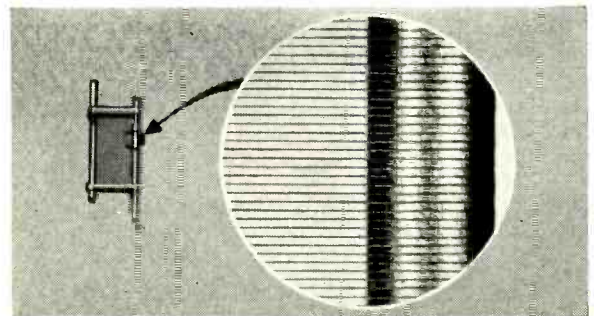

Grid is shown above left, actual size. Picture at right, enlarged 15 times, shows how wires are anchored by glass bond. They will not sag despite nearness of red-hot cathode.

BELL TELEPHONE LABORATORIES

IMPROVING TELEPHONE SERVICE FOR AMERICA PROVIDES CAREERS
FOR CREATIVE MEN IN SCIENTIFIC AND TECHNICAL FIELDS



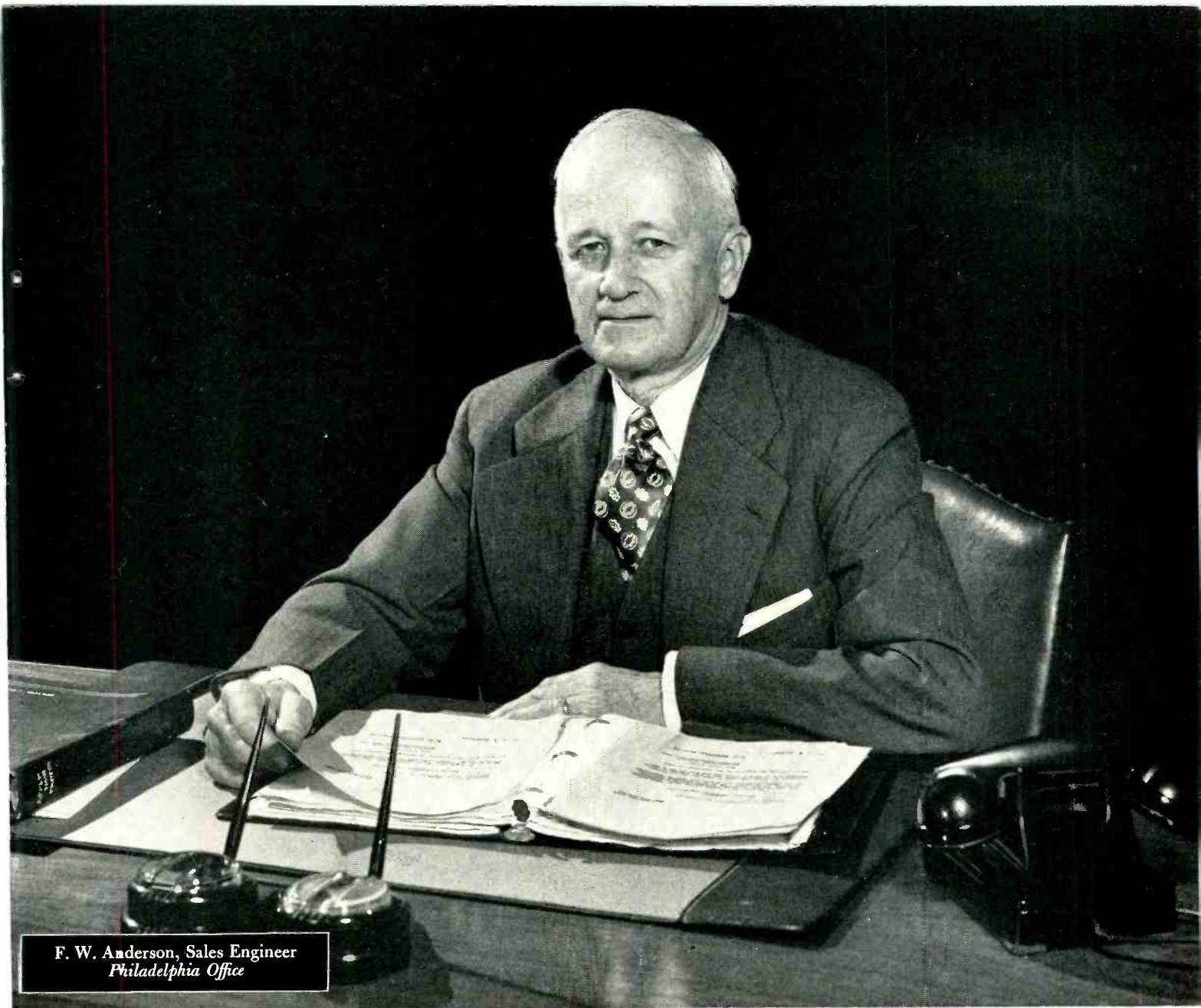

F. W. Anderson, Sales Engineer
Philadelphia Office

“Holtzer-Cabot Motors Ensure Satisfaction”

“My thirty years’ experience in the motor business enables me to fully appreciate the truly outstanding application engineering that goes into every Holtzer-Cabot motor. I know, too, that Holtzer-Cabot motor dependability adds greatly to a product’s performance and reputation.

“Here at Holtzer-Cabot, almost every order results from a sample motor which is designed to meet the customer’s individual specifications. After intensive testing by our own engineers, the sample motor is submitted to the customer for his approval. In every case, our customers have ample opportunity of ‘proving out’ for themselves the advantages of Holtzer-Cabot special design.

“We at Holtzer-Cabot are confident of our ability to

develop special motors that give peak performance and dependable service.

“We know that our motor specialists can solve practically any motor problem given to them and that our sales representatives are thoroughly qualified by training and experience.

“If *you* have a fractional horsepower motor problem, take advantage of Holtzer-Cabot’s 78 years of experience in developing special motors and related electrical apparatus to highest quality standards. Our methods and facilities are yours to command.

“Write, wire or phone. Without obligation on your part, your problem will get expert — and prompt — attention.”

NATIONAL PNEUMATIC CO., INC. AND HOLTZER-CABOT DIVISIONS

125 Amory St., Boston 19, Mass.
Sales Service Representatives
in Principal Cities throughout the World



Designers and manufacturers of mechanical,
pneumatic, hydraulic, electric and electronic
equipment and systems

Quality Components for the Radio-Electronics Industry by **AMPHENOL**

new

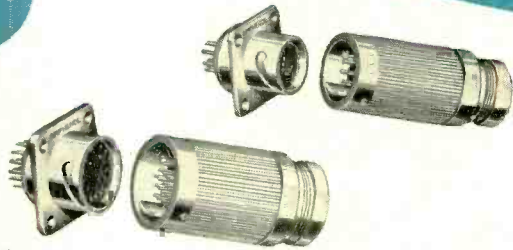

165 SERIES miniature connectors

These new miniature AN-type connectors are obtainable in two connector sizes and six contact configurations. 165 series connectors, besides their very small size, are pressure-proof and completely waterproof.

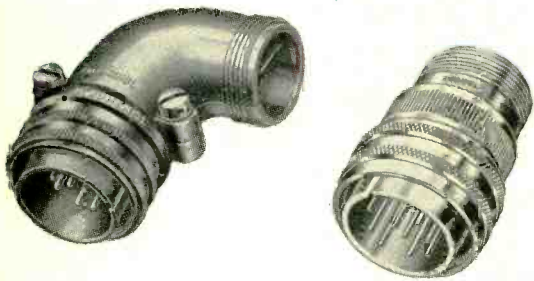

A N connectors

A complete selection of plugs, receptacles and fittings, a wide variety of insert contact arrangements. AMPHENOL AN connectors have many unique features, including gold-plated contacts and famous 1-501 blue dielectric material.



RF connectors

Made in strict accordance with government specifications, AMPHENOL RF connectors are the most efficient link between coaxial cables now available. Series include N, BN, HN, BNC, C, LC, Push-on, and splices, fittings and adapters.



RG cables

Ninety RG-/U coaxial cables are now being precision manufactured in AMPHENOL's up-to-date cable plant. In addition, AMPHENOL makes special cables, including aluminum jacketed ALJAK, miniature, triaxial, and low-noise.



new

26 SERIES miniature connectors

Miniature connectors with 5, 7 or 9 contacts, rack & panel or hex nut sizes. Hood and clamp hardware available for hex nut connectors. Fine materials, electrical efficiency, makes the 26 series ideal in miniaturized application.

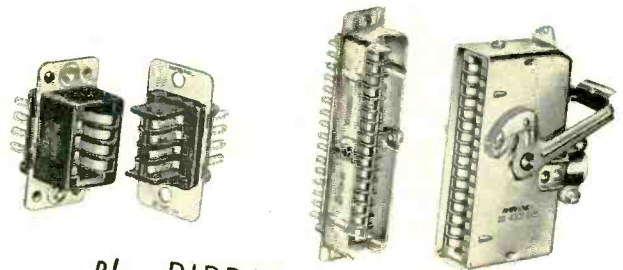

Blue RIBBON connectors

Famous AMPHENOL blue Ribbon connectors now available with pin or barrier polarization. Keyed shells and latch-lock cans are available for the barrier connectors. Both types have gold-plated contacts, AMPHENOL blue dielectric.

new



Qwik microphone connectors

Modern design makes the new QWIKs the most attractive, most efficient microphone connectors for every audio application. QWIKs are lightning-fast to use—plugs click-in to receptacles, disconnection is easily made with one hand.

AMPHENOL

AMERICAN PHENOLIC CORPORATION

chicago 50, illinois

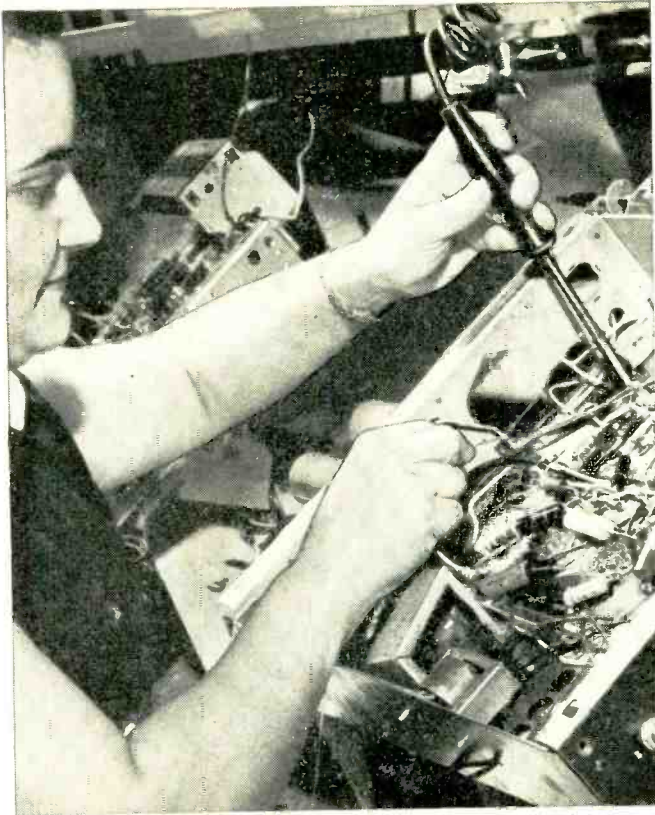

LIGHT-AS-A-PENCIL G-E MIDGET reduces operator fatigue, has longer-lasting Ironclad tip. The Midget solders like a pencil dots an "i."

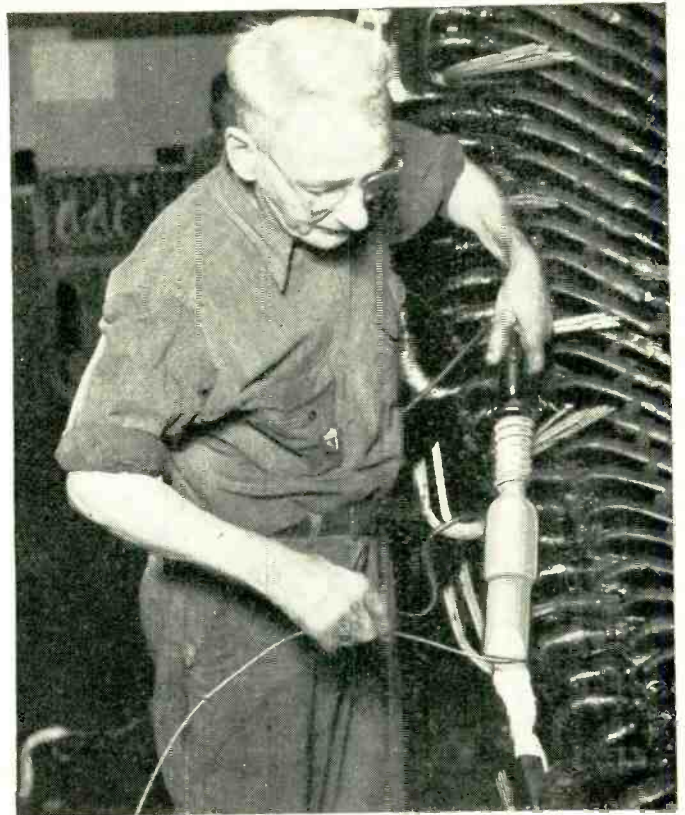

EXTRA-HEAVY-DUTY G-E IRON with long-life calorized copper tip is ideal for soldering heavy-gage cans and armature windings.

You get lower costs, faster soldering with the complete line of long-life G-E irons

Select a soldering iron from General Electric's complete line for easier, faster, cost-cutting soldering. You can choose from 24 different irons with ratings from 25 to 1250 watts.

Long-life G-E Ironclad Copper Tips last up to *ten times as long* as ordinary tips. Ironclad tips combine the durability of iron and excellent heat-transfer of copper.

For Soldering Small Connections, you'll want to try the G-E Midget iron with easily interchangeable $\frac{1}{4}$ -in., $\frac{1}{8}$ -in., and $\frac{1}{16}$ -in. Ironclad tips. This $1\frac{3}{4}$ -ounce, 25-watt iron reduces operator fatigue, makes pinpoint connections. And because the Calrod* heater is *built right into the tip*, you get maximum heat transfer, amazing heat recovery for an iron of this size.

For Medium-sized Jobs, try G.E.'s sturdy Lightweight iron. This high-speed iron

for continuous soldering takes plenty of hard use. Because the iron has a thin shank and interchangeable $\frac{1}{4}$ -in. or $\frac{1}{8}$ -in. Ironclad tips, you can solder tight joints without damaging small connections.

For the Bigger Soldering Jobs, General Electric has larger irons ranging from the 75-watt, $\frac{1}{2}$ -in. tip unit to the heavy-duty 1250-watt, two-inch-copper-tipped model. With a G-E Calrod heater *cast into the heating head*, you get unusually quick heating and high efficiency.

Contact Your General Electric Sales Office or Distributor to solve your soldering problems. Start cutting costs *and* increasing production with long-life, high-speed irons from the complete General Electric line. And for more information mail the coupon at right.

*Reg. Trademark of the General Electric Co.

Sect. 720-126, General Electric Co.,
Schenectady 5, N. Y.

Please send me Bulletin GEA-4519D,
Industrial Soldering Irons.

Name _____

Company _____

Address _____

City _____ State _____

GENERAL  **ELECTRIC**



R, C AND L ACCURATELY MEASURED

RESISTANCE, CAPACITANCE, INDUCTANCE and power factor measured quickly and accurately on this self-contained and robust instrument. Its industrial-designed appearance fits well in modern surroundings and partners its outstanding electrical performance.

UNIVERSAL BRIDGE TYPE TF 868

Resistance from 0.1Ω to $10M\Omega$, Capacitance from $1\mu F$ to $100\mu F$, and Inductance from $1\mu H$ to $100H$.

Single direct reading L.C.R. dial—no multiplying factors involved.

Continuously variable bridge voltage and automatic detector sensitivity control.

Full data and prices of any of the items listed below will be mailed immediately on request:

UNIVERSAL BRIDGE TF 868 · FM DEVIATION METER TF 934
FM/AM SIGNAL GENERATOR TF 995 · STANDARD SIGNAL GENERATOR TF 867
ALSO

VACUUM TUBE VOLTMETERS · FREQUENCY STANDARDS · OUTPUT METERS
WAVEMETERS · WAVE ANALYSERS · Q METERS · BEAT FREQUENCY OSCILLATORS

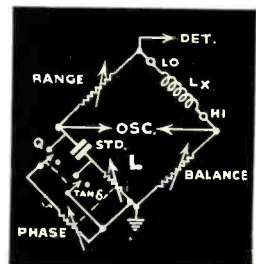
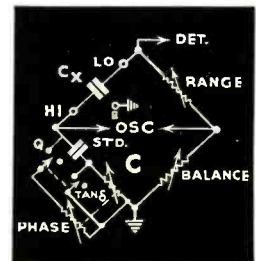
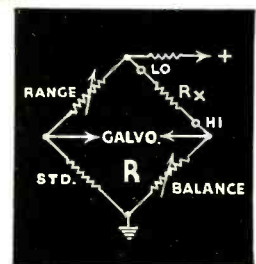

MARCONI INSTRUMENTS

23-25 BEAVER STREET · NEW YORK 4

CANADA: CANADIAN MARCONI CO., MARCONI BUILDING, 2442 TRENTON AVENUE, MONTREAL
ENGLAND: Head Office: MARCONI INSTRUMENTS LIMITED, ST. ALBANS, HERTFORDSHIRE

Managing Agents in Export: MARCONI'S WIRELESS TELEGRAPH COMPANY LIMITED, MARCONI HOUSE, STRAND, LONDON, W.C.2

TC39

Ideas in the making!

ARALDITE® Epoxy Resins developed by Ciba Research are simplifying manufacturing methods, improving product efficiency and opening new fields of product development. The formulator and the end product producer will want to know more about them. We at Ciba want to help you further your development.

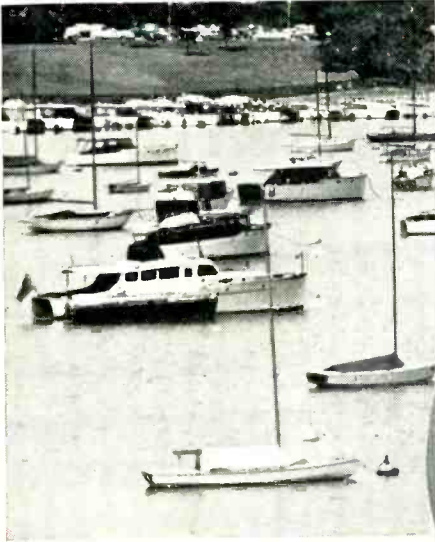

ARALDITE IMPREGNATED MOORING BUOY IS STRONG ... LIGHT ... WEATHER-PROOF AND SINK-PROOF

(Courtesy United Pattern Company)

One-seventh the weight of a steel buoy of comparable size including the unicellular filling beneath the surface skin, this newest idea in modern maritime equipment eliminates hull-scuffing damage and is functionally superior in every other way. Since color is "built-in" with salt-water corrosion resistant laminate, it stays bright and new looking, thereby minimizing maintenance. All these advantages suggest a wide range of new and improved product development in which ARALDITE Resins may prove the answer for you.

SEND THIS COUPON ... or write us on your company letterhead ... for complete technical data on the physical properties and recommended procedures for the successful use of Araldite Resins for your fabricating needs.

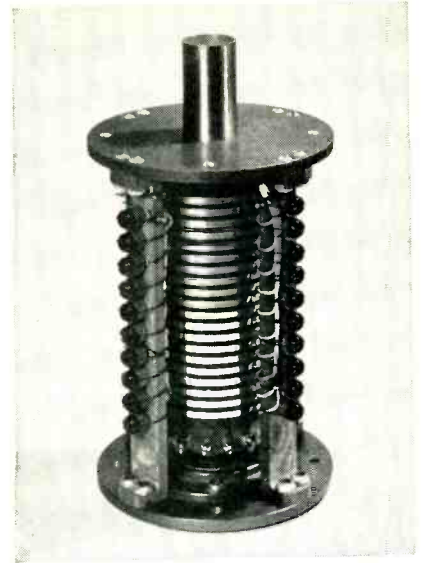
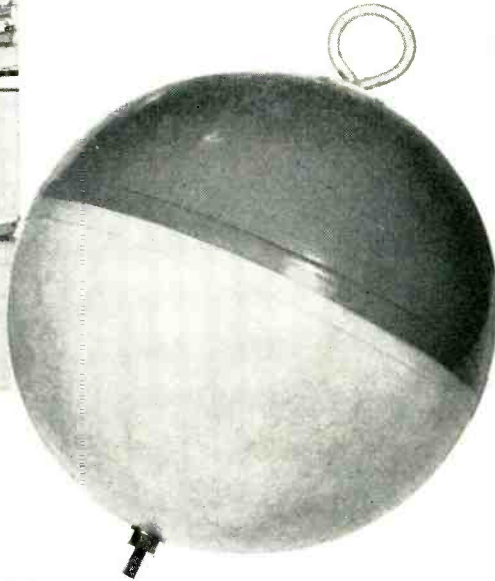

SLIP RING ASSEMBLY

The exceptional casting properties of ARALDITE Resins are demonstrated in this unit designed to operate with strain gauges or radar equipment. ARALDITE Epoxy Resins provide high dielectric strength, arc and humidity resistance which permit a current capacity of 5 amperes per ring.

(Courtesy Airflyte Electronics)



600 VOLT TRANSFORMER TYPE TWM

This example of ARALDITE Resin encapsulating insulation shows how completely it may be applied to encompass coils in housing in an application where rugged use can be expected for the entire life of the unit. (Courtesy Allis-Chalmers)

CIBA

ARALDITE Epoxies

... FOR SUPERIOR BONDING, CASTING, COATING & LAMINATING RESULTS

CIBA COMPANY INC., PLASTICS DIVISION

627 Greenwich St., New York 14, N. Y.
(In Canada: Ciba Co. Ltd., Ciba Bldg., Montreal)

Please send me Ciba Plastics Technical Bulletins
(or, state specific problem.)

Name _____

Company _____ Title _____

Address _____

E-2

HYFLUX for HI-FI

NOW AVAILABLE
No. 9 Speaker Magnets
with
6 MILLION $B_d H_d$ max
GUARANTEED!

Now... for the First Time

the RETMA Standard No. 9 Loudspeaker Magnet is available with a minimum energy product of over 6 million BH max. Made of Hyflux Alnico V HE*, it provides the highest energy product of any commercial Alnico.

The immediate advantages it offers to users of the RETMA No. 9 Magnet are:

- The highest sound level possible.
- A better transient response—resulting from the higher gap density which increases the damping factor—assures a full range of tones and overtones.
- The truest possible reproduction of sound.



High Energy—grain-oriented Alnico V.

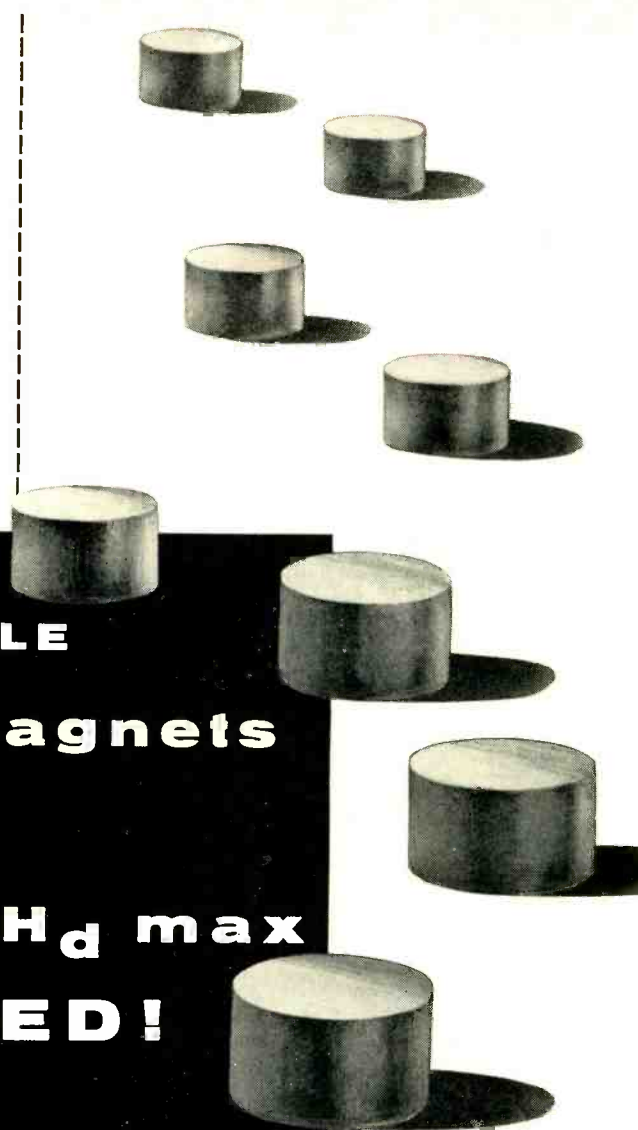

The Indiana Steel Products Company is proud to introduce this improved No. 9 speaker magnet to the audio industry. Investigate its distinct advantages for your speaker. Price and delivery information upon request.

THE INDIANA STEEL PRODUCTS COMPANY
Valparaiso, Indiana

World's largest Manufacturer of Permanent Magnets

INDIANA PERMANENT MAGNETS

A BIG SURPRISE IN A SMALL PACKAGE

*the
new*

AMPEX

600



WEIGHS ONLY 26 LBS.

The most portable truly high fidelity tape recorder ever built.

**PERFORMS LIKE
A TRUE AMPEX**

Frequency response is 30 to 15,000 cycles at $7\frac{1}{2}$ in/sec; signal-to-noise ratio over 55 db; and every machine is tested to meet or exceed specifications.

**SERVES ALL BROADCAST-
CASTING NEEDS**

For recording, editing, dubbing and broadcasting, it's a full time troublefree machine. Major components have been "life tested" for an equivalent of 10 years' normal use.

**COSTS LESS THAN
ANY AMPEX BEFORE**

It's simpler and lighter, but it's all Ampex — and still the best.

AMPEX

CORPORATION

*For full
description and
specifications,
write today
to Dept. E-1695.*

See it at the
**NARTB
CONVENTION**
Chicago, May 23rd to 27th

934 CHARTER STREET • REDWOOD CITY, CALIFORNIA

Distributors in principal cities (listed in the "yellow pages" under "Recording Equipment"); distributed in Canada by the Canadian General Electric Company

Starting here
it's mostly nickel
and chromium...



127 operations
later, it's

Nichrome*

There are several excellent nickel-chrome combinations on the market. But there is only one Nichrome*.

What is it that makes this alloy the universal standard by which engineers judge the properties of heat and corrosion resistance? There is always at least one extra ingredient added to the nickel and chrome. That is . . . the supreme mastery of the Driver-Harris specialists, gained in their 55 years of melting and drawing experience. This hard-won

skill of theirs is reflected in improved heating and quenching techniques . . . in specially developed deoxidizing anneals . . . in expert and precise control of every technical process of the entire manufacturing cycle. Sometimes, indeed, there are as many as 127 distinct operations between melting crucible and the finished wire, strip, or rod.

In recognition of its unique properties, the United States Patent Office in August, 1908, granted solely and exclusively to us the trademark NICHROME. There is only one Nichrome, and it is produced by Driver-Harris.



Driver-Harris Company

HARRISON, NEW JERSEY

BRANCHES: Chicago, Detroit, Cleveland, Louisville,
Los Angeles, San Francisco

In Canada: The B. GREENING WIRE COMPANY, Ltd.,
Hamilton, Ontario.

MAKERS OF THE MOST COMPLETE LINE OF ELECTRIC HEATING, RESISTANCE, AND ELECTRONIC ALLOYS IN THE WORLD

*T. M. Reg. U. S. Pat. Off.

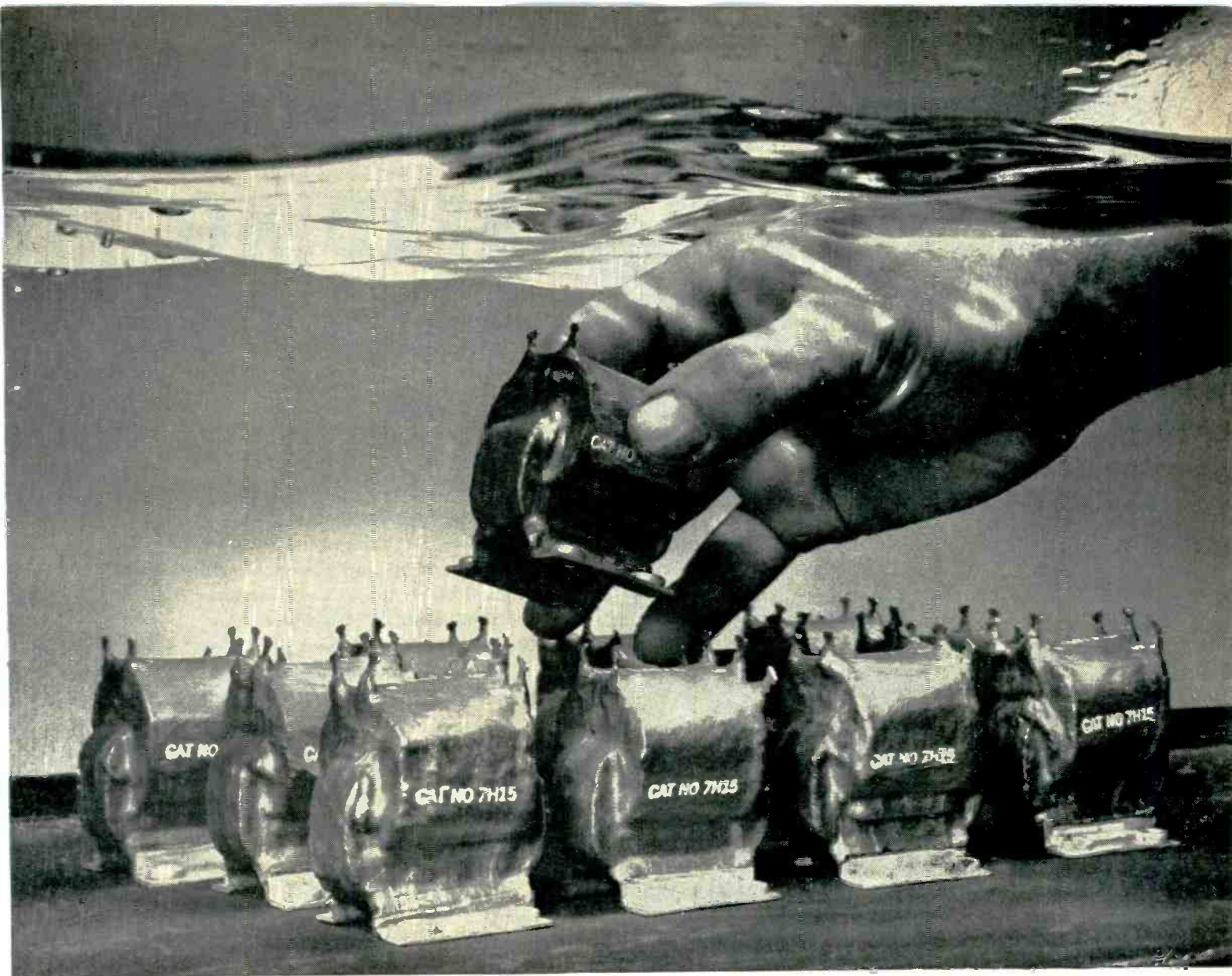

Westinghouse Fosterite[®] Transformers must pass this 4-hour underwater test

If you're looking for a small, open-type transformer, fully protected against moisture, check the line of Westinghouse Fosterite impregnated transformers. This four-hour underwater test proves the point:

All Fosterite-treated transformers are completely submerged in hot water at 60° Centigrade for two hours, after which they are "thermal-shocked" in cold tap water, and soaked there for an additional two hours. An electrical test is then applied, in which each transformer must show an insulation resistance reading of at least 2000 megohms. Fosterite has to be good!

This is just one of many severe tests to which

Westinghouse specialty transformers are subjected. They assure you of quality that will meet your requirements exactly . . . quality that stands up under extreme conditions.

Fosterite impregnated and coated transformers can be made available to meet your most stringent specifications. In addition to moisture protection, Fosterite makes drastic weight reductions possible . . . as much as 30 to 50%, when compared to enclosed types.

Call your Westinghouse representative for further information, or write Westinghouse Electric Corporation, P. O. Box 868, Pittsburgh 30, Pa. J-70678

YOU CAN BE SURE...IF IT'S
Westinghouse



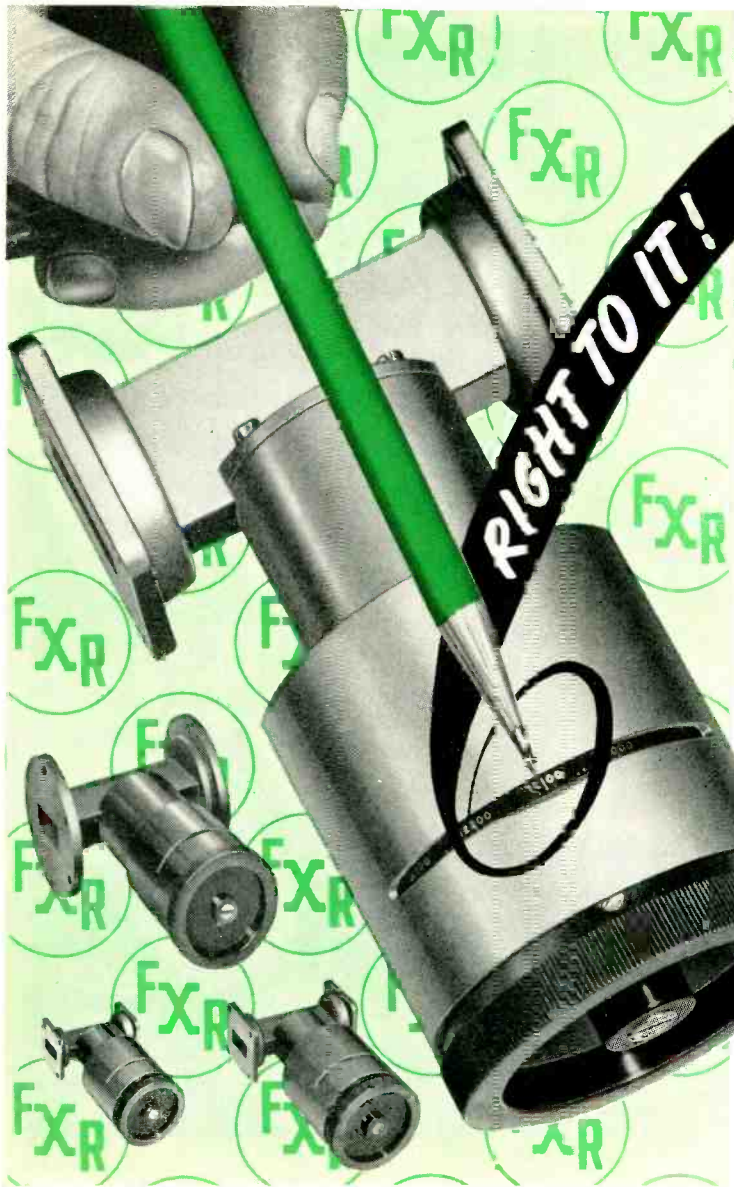

DIRECT READING Frequency Meters

DESIGNED for easier,
more accurate readings...

Tried and true—the FXR Type 410A Direct Reading Frequency Meters give you bull's-eye accuracy, right to the exact reading spot. No more jiggling of many dials, no more complicated calculations. Human error factor is eliminated. These dependable FXR units provide the most convenient means available for determining oscillator frequency in the microwave region.

- .08% ACCURACY
- FULL WAVEGUIDE FREQUENCY RANGE
- DIRECT READING
- HIGH Q
- NOMINAL 30% ABSORPTION DIP
- BACKLASH-FREE OPERATION

TYPE	FREQUENCY RANGE
C410A	5.85 to 8.20 KMC/S
W410A	7.05 to 10.00 KMC/S
X410A	8.20 to 12.40 KMC/S

DELIVERY FROM STOCK • PRICE \$125 EACH*

*Write today for new catalog of complete line of
FXR Precision Microwave Test Equipment*

SLOTTED SECTIONS
PROBES
VSWR AMPLIFIER
SPECTRUM ANALYZERS

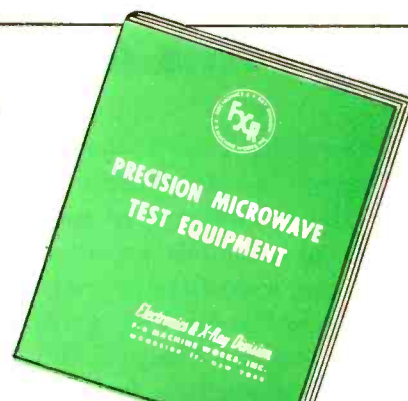

Electronics & X-Ray Division

F-R MACHINE WORKS, Inc.

44-14 ASTORIA BOULEVARD, LONG ISLAND CITY 3, N. Y.

*Data and prices subject to change without notice.

FINANCIAL AID TO HIGHER EDUCATION

Our Colleges and Universities Face Grave Financial Problems

For the past decade the nation's colleges and universities have been caught in a destructive financial squeeze. It is particularly destructive for the independent, privately endowed institutions. Unless extraordinary measures are taken to relieve this squeeze, it promises to become progressively worse. To let it do that is to court a national disaster.

This is the first of two editorials devoted to the financial plight of our colleges and universities. This first editorial deals with the character of the problem, present and potential. The second will indicate some things that need to be done about it, and particularly what American business might do.

Enrollment Soars, Income Lags

In broad outline, the financial problem that afflicts our colleges and universities is simple. The demand for their services has increased rapidly, and promises to keep on increasing even more rapidly. At the same time, their financial capacity to provide these services has lagged behind, primarily because of price inflation.

Between 1940 and 1950, college and univer-

sity enrollment increased from approximately 1½ million to 2½ million—about 75 per cent. Over the same period, the educational income of these institutions, measured in terms of its actual purchasing power, increased only about 64 per cent. Thus, at the end of the decade, our colleges and universities as a group had, on the average, about 6 per cent less to spend per student than they had at the beginning. Meanwhile, the rapid advance of science and technology had made a good college or university course a much more expensive operation than it was in 1940. Since 1950, the latest date for which comprehensive figures are available, the financial squeeze on our colleges and universities has intensified, largely because of another wave of price inflation touched off by the Korean War.

Among the colleges and universities, the independent, privately endowed institutions are particularly hard pressed. In terms of actual purchasing power, the independent liberal arts colleges are now spending at least 20 per cent less per student than they spent in 1940. Public institutions of higher learning, supported out of tax revenues, have managed to increase slightly their expenditure per student. Otherwise, the financial squeeze on higher education as a whole would be even more severe.

Why Independent Colleges Are Hit Hardest

The principal reason why the independent colleges and universities are so hard up is the shrinkage in their income from endowments. These endowments, created in other days by gifts of generous benefactors to help pay the expenses of higher education, have been hit hard from two directions. During the war and post-war years, the tax collector took so large a part of the incomes and estates of wealthy people that this source of endowments has been greatly reduced. Over the same period price inflation cut in half the purchasing power of the income derived from existing endowments. In 1940 income from endowments provided 26 per cent of the total income of the independent colleges and universities. By 1950 it provided only 14 per cent. The figure is still lower today.

The financial plight of the independent colleges and universities is directly reflected in the salary status of their teaching staffs. In mid-1952 a national survey showed that, after adjustment for the increased cost of living, the salaries of those holding full professorial rank in these institutions were 12 per cent lower than they were in 1941-42. Junior teachers, with the rank of instructor, fared somewhat better. In terms of actual purchasing power, their salaries declined only 2 per cent over the 12-year period, largely because there is more direct competition for their services from industry. Over the same period, the real wages of industrial workers increased 55 per cent.

Time Will Not Provide a Cure

The plight of the colleges and universities, which is shared in some degree by all parts of our educational system, is not one that can be left to time for a cure. On the contrary, the financial problems of our institutions of higher learning will be intensified in the years ahead by the pressure of rapidly increasing enrollments. Present prospects indi-

cate that during the next decade college and university enrollment will increase by about one-third, or from 2 $\frac{1}{3}$ million to over 3 million. The problem of increased enrollments will become particularly acute toward the end of this decade when the babies born during the great surge of population in World War II are ready to enter college.

Such an increase in population as that now in prospect can be a tremendous asset to the nation. It is still a truth, even though it is worn a bit thin by frequent repetition at commencement exercises, that a nation has no resource more valuable than the education of its people. And the better the education, the more valuable the asset.

But to realize this, our colleges and universities must have the financial strength to handle the increased enrollments that face them in the years ahead. This means that we must relieve our independent colleges and universities, in particular, from the financial squeeze in which they are now caught and make them full partners in the economic well-being of the nation. Some of the means by which American business might help achieve this will be discussed in a second editorial.

This message is one of a series prepared by the McGraw-Hill Department of Economics to help increase public knowledge and understanding of important nationwide developments that are of particular concern to the business and professional community served by our industrial and technical publications.

Permission is freely extended to newspapers, groups or individuals to quote or reprint all or parts of the text.

Donald C. McGraw
PRESIDENT

McGRAW-HILL PUBLISHING COMPANY, INC.

Outstanding Value

PRESTO SR-II STUDIO CONSOLE TAPE RECORDER

For the first time . . . a precision Presto tape recorder complete with amplifier in studio console cabinet for less than \$1000. Here are the facts about this amazing value:

The R-11* Mechanism Here is the smooth operating, sleekly designed tape transport unit that drew engineers acclaim when it was introduced last year. Embodies the exclusive Presto capstan drive unit where pressure pulley and solenoid are mounted on a single sub-assembly for easy maintenance. Capstan and motor are interconnected by a belt. Two torque motors, each including its own brake system (external contracting type) assure smooth, positive action without the usual hazard of tape breakage. If tape does break, an automatic safety switch instantly stops the mechanism.

The Amplifier Actually there are two separate chassis for amplification. One contains the recording and reproducing channels. The second is the power supply located at the base of the console. This arrangement reduces noise and keeps operating temperature down.

The Console Cabinet Presto's designers have given particular attention to accessibility of every part of the SR-11. The top panel swings upward on a sturdy hinge to expose the underside of the tape mechanism, while the amplifier opens from the front and turns over on gimbals for access to tubes.

Ask your Presto distributor to order your SR-11 today. You'll never match it in value or performance.

*formerly RC-11

\$995 COMPLETE
with amplifier
in console cabinet

PRESTO RECORDING CORPORATION
PARAMUS, NEW JERSEY

Export Division: 25 Warren Street, New York 7, N. Y.

Canadian Division: Walter P. Downs, Dominion Square Bldg., Montreal

- Three triple shielded magnetic heads
- Frequency response: 50 to 15,000 cps. (15"/sec.)
- 55 db signal to noise ratio (at 2% distortion)
- Flutter: less than .15% (15"/sec.)
- Push button function switches
- Will accommodate reels up to 10½"



WORLD'S LARGEST MANUFACTURER OF PRECISION RECORDING EQUIPMENT AND DISCS

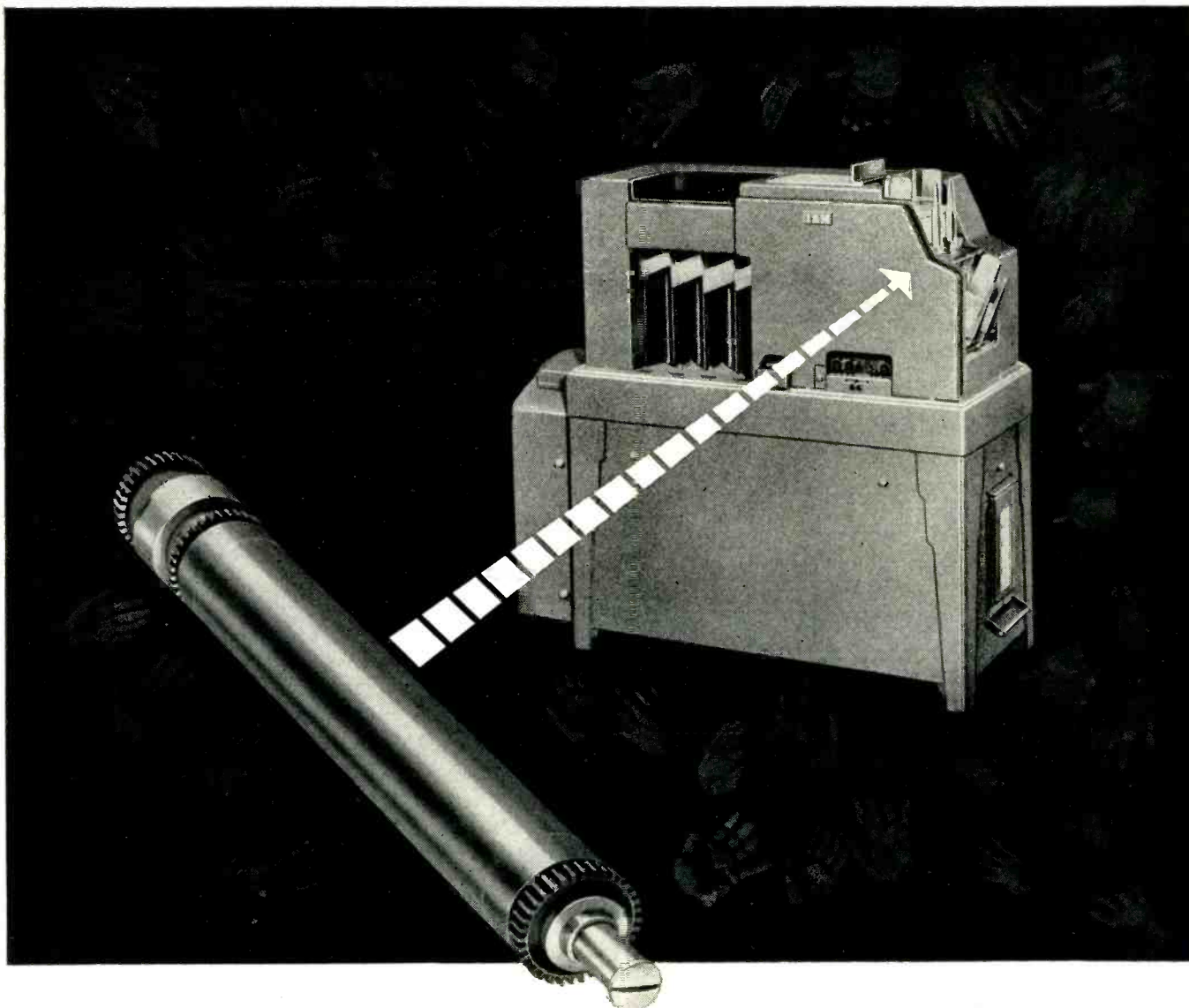

Out of IBM's Collator pops a tubing idea for you!

This is IBM's Collator—a mechanical super-accountant that shuffles, selects, matches and merges punched cards at the rate of four per second!

Heart of this electronic gee-whizzer is an extraordinary kind of tubing—a contact roll over which the cards must pass. Eighty miniature, hard steel brushes finger each card as it skims by—penetrate it through pre-punched holes, touch the contact roll and close the electronic circuit—flipping the card into the right slot.

Collator contact rolls must have good wear resistance to stand this high-speed workout. And they must resist corrosion and be good electrical conductors. So IBM employs Superior WELDRAWN* Beryllium Copper and

low carbon steel composite tubing for Collator contact rolls. This tubing meets IBM's tight specifications for wear resistance, peak hardness and conductivity. Superior supplies the composite tube in $1\frac{1}{8}$ " O.D. with .049" wall.

When tubing troubles put the hex on your plans, call on Superior.

We have years of experience, the modern test and development facilities, and more than 55 analyses in many metals to unravel your problem. Write for a copy of our new Technical Bulletin #7-2 on Seamless and WELDRAWN* Beryllium Copper Tubing. Superior Tube Company, 2500 Germantown Ave., Norristown, Pa.

Round and shaped tubing available in Carbon, Alloy and Stainless Steels; Nickel and Nickel Alloys; Beryllium Copper; Titanium; Zirconium

Superior Tube

THE BIG NAME IN SMALL TUBING

West Coast: Pacific Tube Company

5710 Smithway St., Los Angeles 22, Calif. RAYmond 3-1331

All analyses .010" to
 $\frac{5}{8}$ " O.D.
Certain analyses in
light walls up to
 $2\frac{1}{2}$ " O.D.

...why GUESS
about FLOW CONTROL?



ELECTROFLO VALVE

A solenoid valve for water or air. Provides *AUTOMATIC* control on fluid lines.



MESURFLO CONTROL

Flow Volume Control. *AUTOMATIC*. Maintains one set rate of flow regardless of variable inlet pressures.

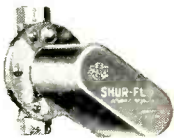

SHUR-FLO AUTOMATIC INTERLOCK

Flow switch. *AUTOMATIC*. Protects equipment against an inadequate rate of flow.



ELECTROMITE VALVE

Small solenoid valve for low flow rates. *AUTOMATIC*. Available with flow volume control.



STRAITFLO STRAINER

Straight line strainer. *AUTOMATIC*. Protects equipment by providing clean un-interrupted flow.



... HAYS has REMOVED
the guesswork!



controls give *AUTOMATIC* control for water and air!



flow controls are *ACCURATE, RELIABLE* and *AUTOMATIC*.

Our engineers will be happy to work with you on your flow problem. Write for folder No. 200 which describes our *AUTOMATIC* controls and gives technical information.



INDUSTRIAL SALES DIVISION

HAYS MANUFACTURING COMPANY

808 WEST 12 ST., ERIE, PENNSYLVANIA.



Complete *AUTOMATIC* Control. Establishes maximum flow rate —*AUTOMATIC* On and Off—Protects Equipment against inadequate rate of flow.

NOW, A REMARKABLE "READY-TO-SOLDER"

PHELPS DODGE

MANY NEW APPLICATIONS POSSIBLE

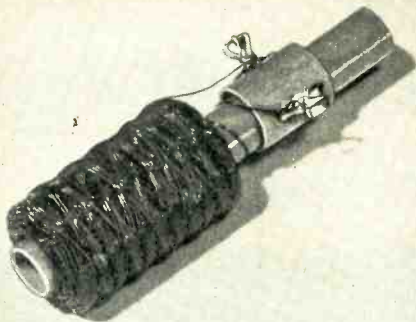

Universal wound TV choke coil

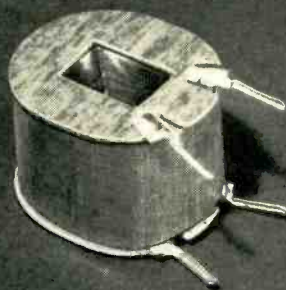

Magnet coil



AC-DC motor coil

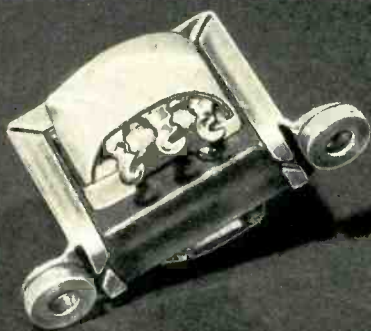

Transformer coil



Solenoid coil

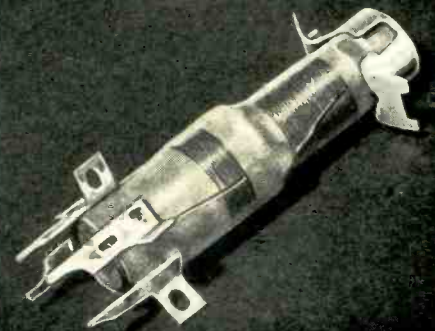

IF-RF coil

First for Lasting Quality—from Mine to Market!

MAGNET WIRE.....



NEW SODEREZE!



- * **Instant Soldering Without Stripping**
- * **Improved Moisture Resistance**
- * **Good Electrical Properties**
- * **Excellent Flexibility and Toughness**

New Sodereze represents a spectacular advance in ready-to-solder magnet wire. It's a new and typical Phelps Dodge development designed to keep pace with industry's growing need for wires that handle easily, save time, reduce overall costs and satisfy a variety of different operat-

ing conditions. The versatility and outstanding properties of New Sodereze not only permit its use wherever solderable wire has been *proved* practical and dependable but suggest its application in unlimited other electronic and electrical fields to replace conventional wires.

Any time magnet wire is your problem, consult Phelps Dodge for the quickest, easiest answer.

*SODEREZE is a Phelps Dodge Trademark.



PHELPS DODGE COPPER PRODUCTS
CORPORATION

INCA MANUFACTURING DIVISION
FORT WAYNE, INDIANA

WHEN MISSING PARTS HOLD UP ASSEMBLY LINES...

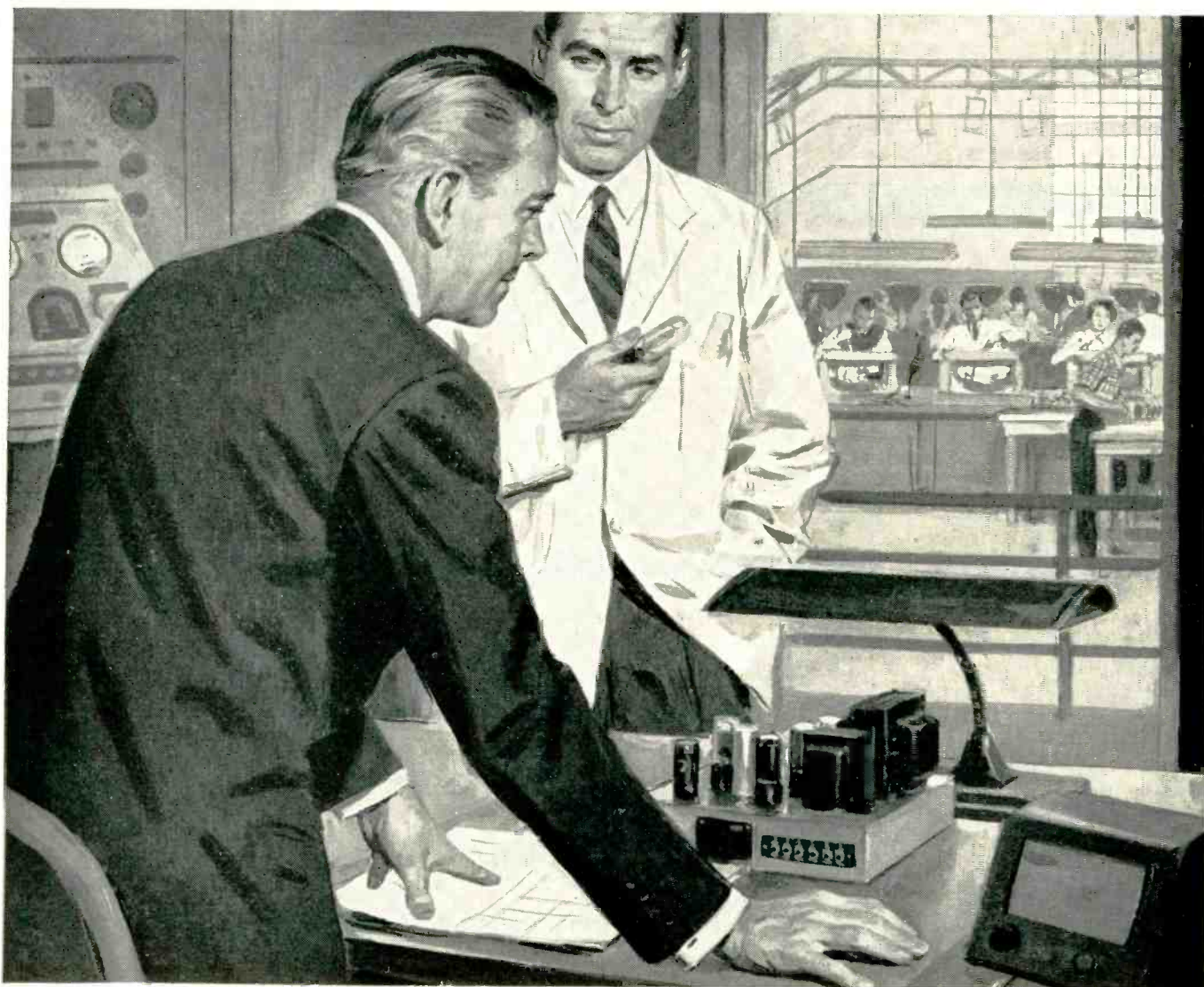

Call on American Airlines AIRFREIGHT

American Specializes In Fast Shipments

When time counts, count on American! The largest air cargo capacity...frequent scheduled departures...and special handling techniques make American your best assurance of prompt forwarding, dependable on-time deliveries.

But last minute rescues are only one of many Airfreight benefits. Another, quite important to manufacturers who regularly ship by air, is reduction in inventory requirements. In addition to saving on warehousing costs, these manufacturers make engineering modifications whenever they wish without fear of obsoleting huge stocks of component parts. American Airlines, Cargo Sales Division, 100 Park Avenue, New York 17, New York.



AMERICAN AIRFREIGHT ALSO LEADS IN

COVERAGE—American serves more leading industrial markets than any other Airline.

CAPACITY—American has the greatest cargo capacity with the right space at the right place.

EXPERIENCE—pioneer in air cargo, American assures you of expert handling.

America's Leading Airline

AMERICAN AIRLINES INC.

IN ITS 21 TOWER MICROWAVE SYSTEM

Western Union uses Sperry Klystrons

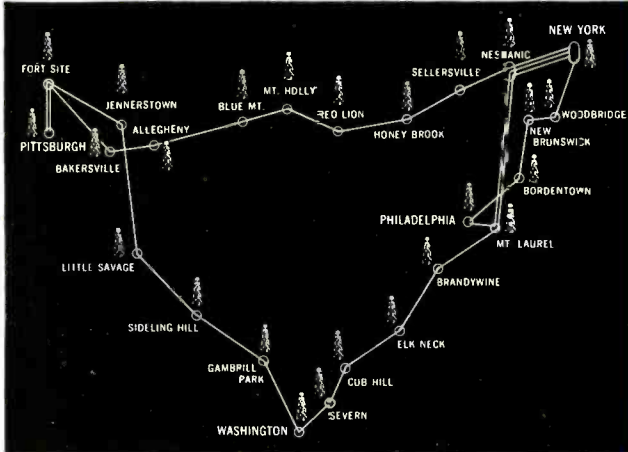
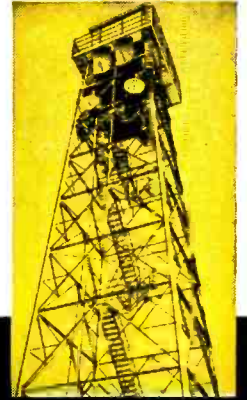

“Dependability has been excellent,” writes H. P. Corwith, Vice President, Development and Research. “Average tube life has been more than 15 months, and some tubes have been in continuous service for almost 3 years.”

■ Installed in 1948, the Western Union microwave system between New York, Philadelphia, Washington and Pittsburgh, consists of 21 towers, varying in height from 60 to 120 feet, and spaced up to 55 miles apart. The system handles hundreds of telegraph circuits—including important government and leased private wire systems as well as circuits for regular message traffic.

■ Through the use of Sperry SAC-41 Klystrons providing power output of 10 watts, Western Union has effectively reduced circuit outages due to fading, and provided dependable service under all conditions. Furthermore, as Mr. Corwith points out above, the average life of Sperry SAC-41 Klystrons has been 15 months—and some tubes have served continuously for almost 3 years.

■ Since 1938, when Sperry sponsored the development of the Klystron, this Company has extended its application to tubes for low, medium and high power applications—and in a frequency range from 750 to 40,000 megacycles. The research, development and specialized production facilities of Sperry in Klystrons—and in accompanying Microline* equipment—are at your disposal to help in solving your problem.

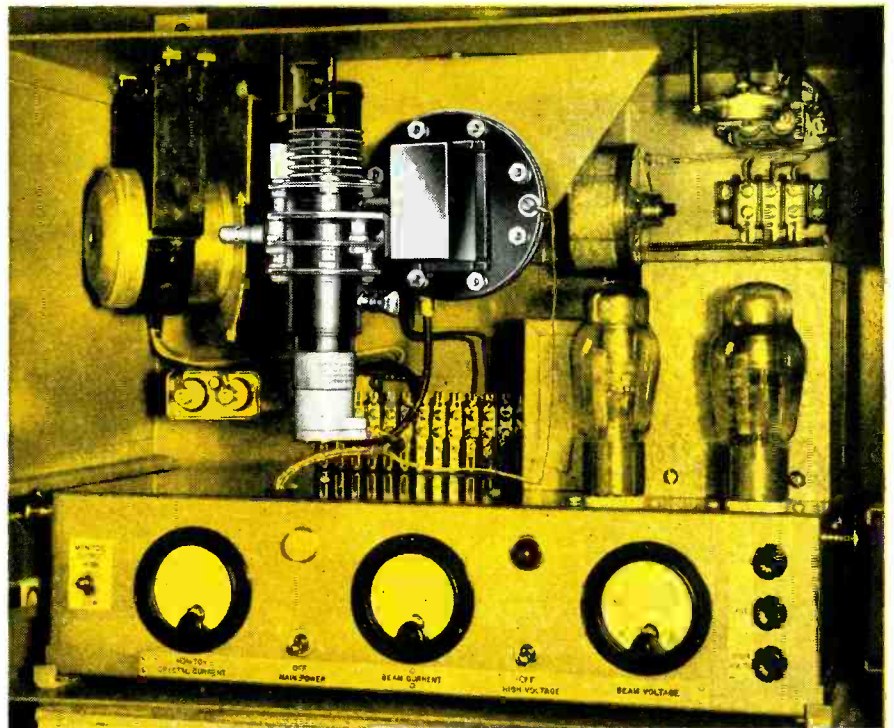

*T. M. REG. U.S. PAT. OFF.

SPERRY **GYROSCOPE COMPANY**
DIVISION OF THE SPERRY CORPORATION

GREAT NECK, NEW YORK • CLEVELAND • NEW ORLEANS • BROOKLYN • LOS ANGELES • SAN FRANCISCO • SEATTLE
IN CANADA • SPERRY GYROSCOPE COMPANY OF CANADA LIMITED, MONTREAL, QUEBEC

MOLDITE CORE "STANDARDS"

For The
**ELECTRONIC
INDUSTRY**

Moldite has taken the initiative in establishing accepted electrical standards long required by the electronic industry. Every coil and set manufacturer, every engineer has designed coils to utilize Moldite "standards".

The reasons are obvious. *Moldite Core Standards Offer . . .*

- | | | |
|--------------|--------------------|-------------|
| ECONOMY | HIGH QUALITY | UNIFORMITY |
| AVAILABILITY | INTERCHANGEABILITY | FLEXIBILITY |

This means a better product backed by years of Moldite leadership in engineering and research. No one has done more than Moldite to give the industry a superlative core or coil form for every electronic application.

So Design with Moldite Core Standards.

- MOLDITE FERRICORES
- MOLDITE MOLDED COIL FORMS
- MOLDITE MAGNETIC IRON CORES

- FERRITE CORES MOLDED COIL FORMS
(iron and phenolic)
- MAGNETIC IRON CORES
- FILTER CORES
- THREADED CORES
- SLEEVE CORES
- CUP CORES

Samples promptly submitted upon request for design, pre-production, and test purposes



... Send for our new
**Catalog No. 110 —
THE MOST COMPLETE
LINE OF CORES
IN THE INDUSTRY!**

**NATIONAL
MOLDITE
COMPANY**

1410 CHESTNUT AVE., HILLSIDE 5, N. J.

- | | | | | |
|--|--|--|--|---|
| Robert T. Murray Co.
604 Central Ave.
East Orange, N. J. | Jerry Golten Co.
2750 W. North Ave.
Chicago 22, Ill. | Arnold Andrews
521 Cumberland Ave.
Syracuse, N. Y. | Perlmuth, Colman & Assoc.
2419 S. Grand Avenue
Los Angeles, Cal. | Jose Luis Ponte
Cardoba 1472
Buenos Aires |
|--|--|--|--|---|

Let **JOY** handle Your **FAN ENGINEERING** on **ELECTRONIC COOLING PROBLEMS**

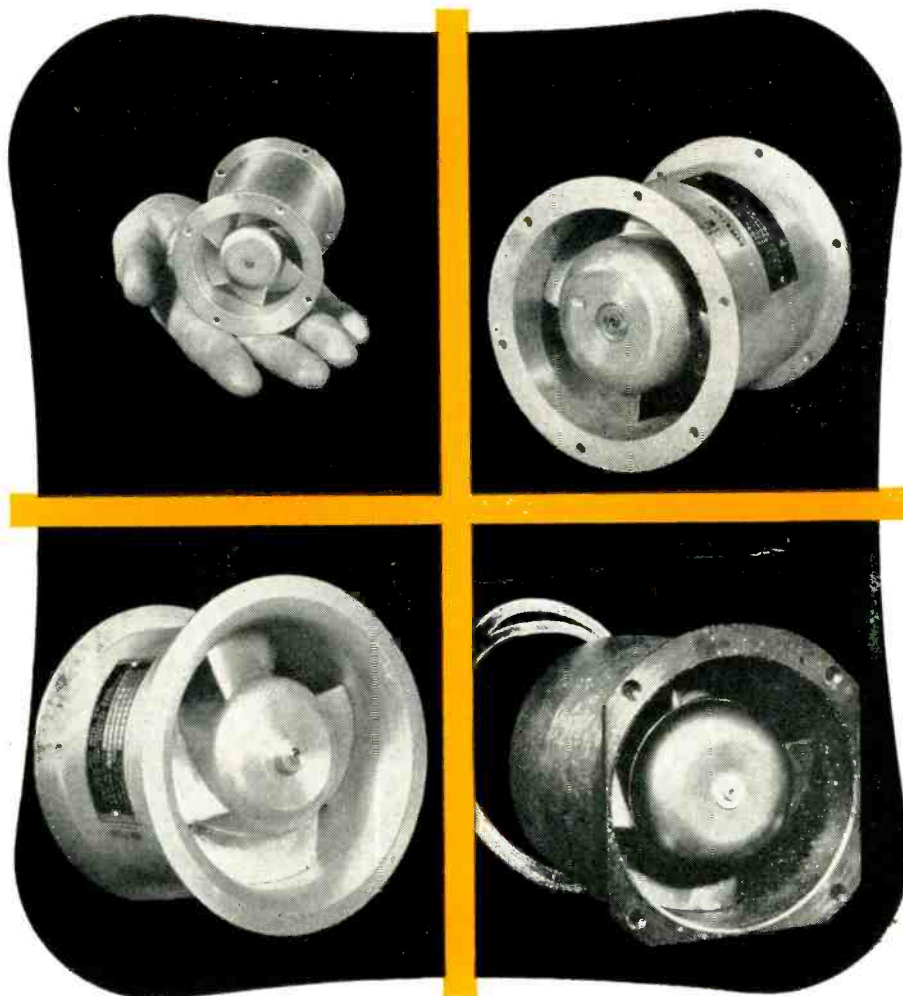

*Reg. U. S. Pat. Office

W&D 1-4010

JOY AXIVANE* Fans offer you advantages in electronic equipment cooling which have been thoroughly proved in service. The higher pressure-output of these vaneaxial blowers generally permits more compact arrangement of the equipment. Additional advantages are: light weight, high strength, high shock and vibration resistance, and high efficiency in low or high pressure service.

For minimum weight, JOY electronic cooling fans are made of aluminum, magnesium, or combinations of these metals. They are designed to meet all present Air Force and Naval electronic specifications, and are available in fan sizes from 2" I.D. up. Totally-enclosed or explosion-proof motors can be furnished where required.

● If you have a problem in heat dissipation from electronic units, no matter what the service conditions may be, let us place at your disposal JOY'S experience as the world's largest manufacturers of vaneaxial-type fans.

*Consult a Joy
Engineer*

Over 100 Years
of Engineering Leadership



JOY MANUFACTURING COMPANY

GENERAL OFFICES: HENRY W. OLIVER BUILDING • PITTSBURGH 22, PA.

IN CANADA: JOY MANUFACTURING COMPANY (CANADA) LIMITED, GALT, ONTARIO

ELECTRICAL
CORDS
KEEP YOUR APPLIANCES
IN SERVICE



MANUFACTURERS AND SERVICE MEN WHOSE PRODUCTS SERVE BEST

Specify

Belden

WIREMAKER FOR INDUSTRY



DESIGNER'S NEWS

—from the RCA Tube Division

New "Premium" Miniature Twin Triodes for Military and Industrial Applications



*6101/6J6WA
Military Control
Type. For
government end
use only.

RCA-6101 and 6101/6J6WA* are medium-mu triodes designed principally for use as class A amplifiers and control tubes in mobile and aircraft equipment where uniformity of characteristics and dependable performance under shock and vibration are essential requirements. The tube can withstand an impact acceleration of 500 G max. and vibrational acceleration of 2.5 G max. Developed from the type 6J6, these "premium" types incorporate many structural improvements, and undergo stringent production controls and rigorous tests during and after manufacture.

Free Paper on Application Considerations for RCA Commercial Transistors

R. M. Cohen's popular technical paper entitled "Application Considerations for RCA Commercial Transistors" is now available on request. Included in the contents are: descriptions of problems involved in the application of RCA point-contact and junction type transistors and typical circuits for af and rf amplifiers, rf oscillators, and "flip-flop" circuits—as well as performance data for these circuits. For your free copy fill out coupon—or write for Reprint ST-817 to RCA, Commercial Engineering, Harrison, N.J.

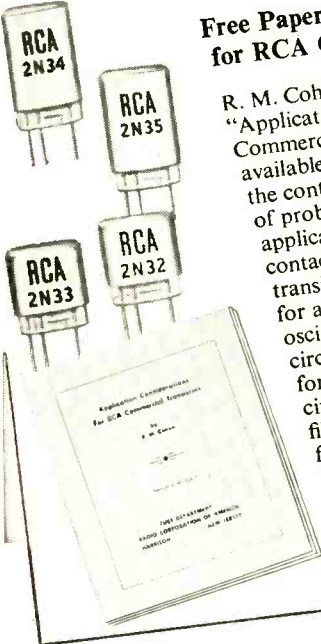

New "Mighty Midget" Speaker for "Pocket-Personal" Radios



Contoured for economy of space, this new RCA-222S1 PM speaker features a 2½-in. cone and measures only 2¼ in. in diameter by 1¼ in. in depth. The weight is only 4.6 ounces, including a 1.0-ounce Alnico V magnet for high efficiency. Frequency range is 300-3500 cps and the voice-coil impedance is 12 ohms. Life-tested at 250 milliwatts, the speaker is designed for long trouble-free service in applications where space is at a premium.

New Dual-Band Oscilloscope for Color and Black-and-White TV

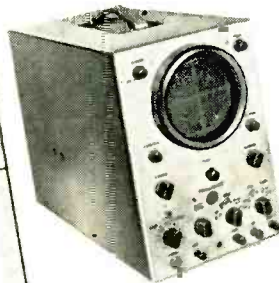

The new WO-78A 5-inch Oscilloscope permits accurate voltage measurements of TV signals throughout the video range in both color and black-and-white receivers. In the wide-band position, the WO-78A has a response flat within -1 db, from 3 cps to 4.5 Mc, with sensitivity of 0.1 volt peak-to-peak per inch (0.035 volt rms per inch). In the narrow-band position, sensitivity is 0.01 volt peak-to-peak per inch. Phase characteristics are excellent throughout entire frequency range.

New 90° Deflecting Yoke for Full Screen Focus

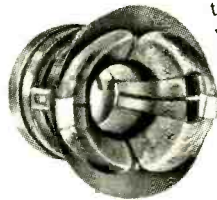

The new RCA-220D1 yoke is designed for rectangular-type 90° kinescopes operating at ultravoltages up to 18 kv. A ferrite core and precision-shaped cosine-type windings, treated with anti-corona silicone resin, provide high efficiency and good side and corner resolution. Molded insulation is employed to withstand the high peak voltage between the horizontal and vertical coils. The 220D1 is designed for use with the RCA-238T1 and RCA-239T1 horizontal-output and high voltage transformers.



RADIO CORPORATION of AMERICA
ELECTRON TUBES

RCA Tube Division
Commercial Engineering, Section F-46, Harrison, N. J.

Please send me technical data on:

- RCA-6101
- Transistor Reprint ST-817
- RCA-222S1 "Mighty Midget" Speaker
- RCA-220D1 Yoke
- WO-78A Oscilloscope

Name _____

Firm _____

City _____ Zone _____ State _____



KEPCO VOLTAGE REGULATED POWER SUPPLIES



MODEL 750

MODEL	VOLTS	CURRENT	REGULATION	RIPPLE
750	0-600	0-750 Ma.	0.5%	10 Mv.
760	0-600	0-1.5 Amp.	0.5%	10 Mv.
770	0-600	0-2.25 Amp.	0.5%	10 Mv.
780	0-600	0-3 Amp.	0.5%	10 Mv.

DC POWER SUPPLY SPECIFICATIONS

KEPCO Voltage Regulated Power Supplies are conservatively rated. The regulation specified for each unit is available under all line and load conditions within the range of the instrument.

REGULATION: As shown in table for both line fluctuations from 105-125 volts and load variations from minimum to maximum current.

***REGULATION FOR BIAS SUPPLIES:** 10 millivolts for line 105-125 volts. ½% for load at 150 volts.

†All AC Voltages are unregulated.

VOLTS	CURRENT	REGU- LATION	RIPPLE	6.3 V.† AC. CT.	MODEL
0-1500	0-200 Ma.	0.5%	20 Mv.		1520
0-1200	0-20 Ma.	0.1%	10 Mv.	10 Amp.	1220
0-1000	0-500 Ma.	0.5%	20 Mv.		1350
200-1000	0-500 Ma.	0.5%	20 Mv.		1250
0-1000	0-50 Ma.	0.1%	10 Mv.	10 Amp.	1020
0-600	0-3 Amp.	0.5%	10 Mv.		780
0-600	0-2.25 Amp.	0.5%	10 Mv.		770
0-600	0-1.5 Amp.	0.5%	10 Mv.		760
0-600	0-750 Ma.	0.5%	10 Mv.		750
0-600	0-300 Ma.	0.5%	10 Mv.	10 Amp.	
0-150 Bias	0-5 Ma.	*	5 Mv.		615
0-600	0-300 Ma.	0.5%	10 Mv.	10 Amp.	500R
#1 0-600	0-200 Ma.	0.5%	5 Mv.	10 Amp.	
#2 0-600	0-200 Ma.	0.5%	5 Mv.	10 Amp.	800
0-600	0-200 Ma.	0.5%	5 Mv.	10 Amp.	
0-150 Bias	0-5 Ma.	*	5 Mv.		815
#1 200-500	0-200 Ma.	0.5%	5 Mv.	6 Amp.	
#2 200-500	0-200 Ma.	0.5%	5 Mv.	6 Amp.	510
200-500	0-200 Ma.	0.5%	5 Mv.	6 Amp.	245
0-400	0-150 Ma.	0.5%	5 Mv.	10 Amp.	
0-400	0-150 Ma.	0.5%	5 Mv.	10 Amp.	2400
0-150 Bias	0-5 Ma.	*	5 Mv.		
0-400	0-150 Ma.	0.5%	5 Mv.	10 Amp.	
0-150	0-5 Ma.	*	5 Mv.		400
0-400	0-150 Ma.	0.5%	5 Mv.	10 Amp.	141
100-400	0-150 Ma.	0.01%	1 Mv.	10 Amp.	2000
0-350	0-3 Amp.	0.5%	10 Mv.		730
0-350	0-2.25 Amp.	0.5%	10 Mv.		720
0-350	0-1.5 Amp.	0.5%	10 Mv.		710
0-350	0-750 Ma.	0.5%	10 Mv.		700
100-325	0-150 Ma.	0.5%	5 Mv.	10 Amp.	
0-150 Bias	0-5 Ma.	*	5 Mv.		131
0-300	0-150 Ma.	0.5%	5 Mv.	5 Amp.	
0-150 Bias	0-5 Ma.	*	5 Mv.		315
0-150	0-50 Ma.	0.5%	5 Mv.		150
3-30	0-30 Amp.	0.5%	0.1%		3030
1-13	0-10 Amp.	0.5%	10 Mv.		3200

MANUFACTURERS OF ELECTRONIC EQUIPMENT • RESEARCH • DEVELOPMENT

KEPCO LABORATORIES

131-38 SANFORD AVENUE • FLUSHING 55, N. Y. • INDEPENDENCE 1-7000

WORKMANSHIP

Workmanship is of a quality with the highest existing production standards and best instrument electronic practices consistent with the intended use of the item as a continuous duty voltage regulated power supply. Oil filled paper condensers and resistor-board construction are included in the design.

FOR NEW POWER SUPPLY CATALOG — WRITE DEPT. No. 789

PERMASEAL®

PRECISION RESISTORS

NOW! ENCAPSULATED AXIAL LEAD STYLES
FOR 85°C, 125°C and 150° AMBIENTS

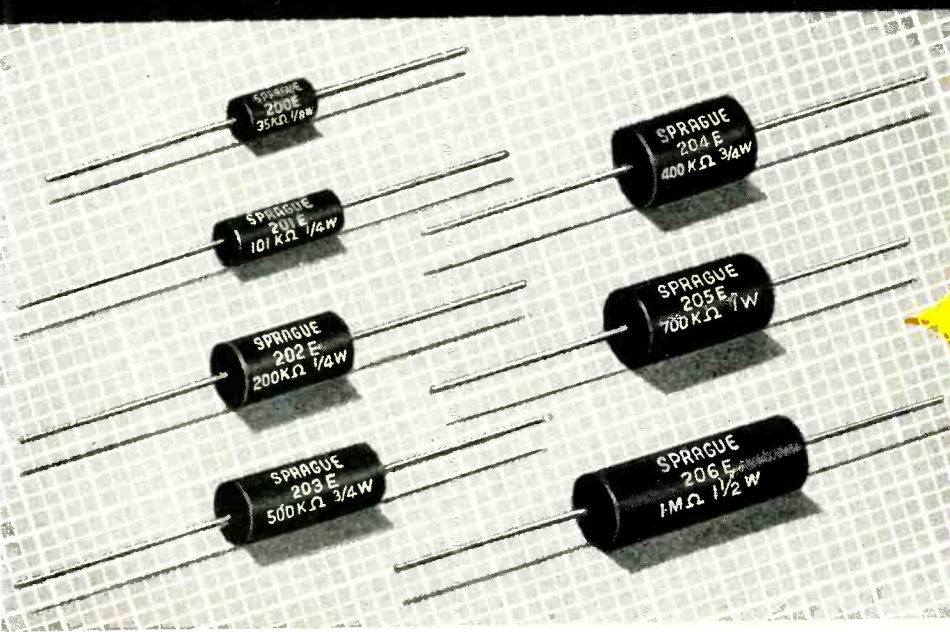

85°C PERMASEAL® RESISTORS					
SPRAGUE TYPE	SIZE		LEAD	RATED WATTS	MAX. OHMS
200E	1/4	1/2	No. 22 AWG	.20	170,000
201E	1/4	3/4	No. 22 AWG	.33	225,000
202E	3/8	3/4	No. 20 AWG	.50	500,000
203E	3/8	1	No. 20 AWG	.75	700,000
204E	1/2	3/4	No. 20 AWG	.75	1.2 MΩ
205E	1/2	1	No. 20 AWG	1.00	1.7 MΩ
206E	1/2	1 1/2	No. 20 AWG	1.50	2.8 MΩ

125°C PERMASEAL® RESISTORS					
SPRAGUE TYPE	SIZE		LEADS	RATED WATTS	MAX. OHMS
300E	1/4	1/2	No. 22 AWG	.10	140,000
301E	1/4	3/4	No. 22 AWG	.15	225,000
302E	3/8	3/4	No. 20 AWG	.25	500,000
303E	3/8	1	No. 20 AWG	.30	700,000
304E	1/2	3/4	No. 20 AWG	.30	1.2 MΩ
305E	1/2	1	No. 20 AWG	.40	1.7 MΩ
306E	1/2	1 1/2	No. 20 AWG	.60	2.8 MΩ

PERMASEAL accurate wire-wound resistors are ideal for point-to-point wiring, for terminal board mounting and for use on processed wiring chassis.

Encapsulated for protection against high humidity, these resistors will stand up in military and industrial electronic service. The protective housing also guards against physical damage during installation and during equipment maintenance.

Standard designs are available in seven different physical sizes for operation at full rated watt-

age at ambient temperatures of 85°C and 125°C. Special units can be made for operation at 150°C ambient with full rated wattage dissipation.

Unusual long-term stability of resistance is another plus feature of Sprague PermaSeal Resistors—as the result of careful matching of winding forms, resistance wire and encapsulating material—together with a thoroughly controlled aging process during manufacture. PermaSeal Resistors are available in resistance tolerances down to 0.1%, when necessary.

SPRAGUE

FOR COMPLETE DATA, WRITE FOR COPY OF SPRAGUE ENGINEERING BULLETIN NO. 122, WITHOUT DELAY.

SPRAGUE ELECTRIC COMPANY,
35 Marshall Street, North Adams, Mass.



PIONEERS IN ELECTRIC AND ELECTRONIC DEVELOPMENT

NORTH ADAMS, MASSACHUSETTS

EXPORT FOR THE AMERICAS: SPRAGUE ELECTRIC INTERNATIONAL LTD., NORTH ADAMS, MASS.

CABLE: SPREXINT



BRIDGEPORT BRASS COMPANY

COPPER ALLOY BULLETIN

BRASS
Bridgeport
CO.

MILLS IN BRIDGEPORT, CONN. AND INDIANAPOLIS, IND.—IN CANADA: NORANDA COPPER AND BRASS LIMITED, MONTREAL



Bridgeport Technical Handbook

To Help Our Customers on Metal Problems

Mass production of tiny but precise metal parts for electronic equipment calls for exacting specifications in brass and copper mill products. The Bridgeport "Technical Handbook" is designed as a ready-reference for product engineers and those responsible for purchasing and fabricating copper and copper-base alloys.

Bridgeport Brass Company recognizes the importance of supplying metal of uniform high-quality for automatic operations. Close cooperation between the fabricator and our technical service department will quickly help with materials to answer performance requirements, cut wasted time and prevent excessive spoilage.

Simplifies Alloy Selection

The Bridgeport "Technical Handbook" is divided into logical, easily read sections covering both general information and specific engineering data.

The first section discusses the numerous coppers and copper-base alloys, their compositions, physical and me-

chanical properties and their uses. It covers in non-technical language such subjects as the copper-zinc alloy system; the effects of additional elements such as lead, tin, aluminum, silicon, manganese, iron, nickel and arsenic on coppers; and the effects of annealing on physical properties. Temper or degree of hardness for sheet, rod, wire and tubing is explained. The causes and prevention of stress corrosion, cracking and hot breaks are discussed.

In addition, the "Technical Handbook" contains information on the importance of the microstructure of rolled and annealed brasses, graphically illustrated by micrographs and curves.

Mill Product Shapes

The following three sections are devoted to mill products—strip and sheet, rod and wire, and tubing. They are further broken down into groups such as Brass and Copper Strip for Drawing, Spinning and Stamping; Rods for Screw Machine Operation; Wire and Rod for Cold Heading; Rods for Hot

Forging; Tubing for Fabrication; and many others.

Each classification lists not only the alloys and their applications, but gives a table of Composition, Mechanical Properties, Physical Constants, Fabrication Properties, as well as the latest specification numbers. By referring to these tables, the purchasing agent and the design engineer can see at a glance the alloys available and their comparative properties. This simplifies alloy selection, saves time and effort.

Hints on Metalworking

The handbook contains a brief but authoritative outline of procedures for working copper-base alloys. There are many diagrams and tables relating to machining, the tools to be used and recommended coolants. Data on Milling, reaming, chasing and sawing are given in concise tabular form with suggested procedures for the different alloys discussed. There are also full sections on drawing and drawing lubricants, annealing, cold heading, soldering, cleaning and dip coloring.

Useful Appendix

To complete the Handbook, almost thirty pages of informative tables are included as an Appendix. These tables cover equivalent weights, temperature conversions, metal melting points, length measurement conversions, and weights of flat products, circles, rod, round wire and copper tubes.

How to Get Your Copy

The Bridgeport "Technical Handbook" is a reliable guide to many problems and situations met by purchasing agents, design engineers and production superintendents in every-day work with copper-base alloys. Your copy will be quickly mailed upon request on company letterhead. And if you are confronted with metal problems not completely answered in the Handbook, do not hesitate to contact our nearest branch office for assistance as well as for your metal requirements. (1593)

FIVE SEVERE TESTS PROVE EXTENDED LIFE... HIGH QUALITY OF G-E GERMANIUM RECTIFIERS FEATURING NEW ALL-WELD SEAM CONSTRUCTION

ABSOLUTE MAXIMUM RATINGS—T-55°C—RESISTIVE LOAD							
DIFFUSED JUNCTION RECTIFIER	1N91	1N92	1N93	1N151	1N152	1N153	1N158
RMS INPUT VOLTAGE (Volts)	—	—	—	35	70	105	30
PEAK INVERSE VOLTAGE* (Volts)	100	200	300	100	200	300	380
PEAK FORWARD CURRENT (Amps)	0.47	0.31	0.25	1.57	1.57	1.57	1.57
D.C. OUTPUT CURRENT* (Ma.)	150	100	75	500	500	500	500
D.C. OUTPUT CURRENT— CAPACITIVE LOAD (Ma.)	—	—	—	350	350	350	350
D.C. SURGE CURRENT (Amps.)	25	25	25	25	25	25	25
FULL LOAD VOLTAGE DROP (volts peak)	0.5	0.5	0.5	0.7	0.7	0.7	1.4
LEAKAGE CURRENT (Ma., @ rated P.I.V.)	2.7	1.9	1.2	2.4	1.9	1.2	0.8
CONTINUOUS REVERSE WORKING VOLTAGE (Volts D.C.)	30	65	100	30	65	100	185
OPERATING FREQUENCY (Kc)	50	50	50	50	50	50	50
STORAGE TEMPERATURE (°C)	85	85	85	85	85	85	85

*Typical absolute maximum ratings.

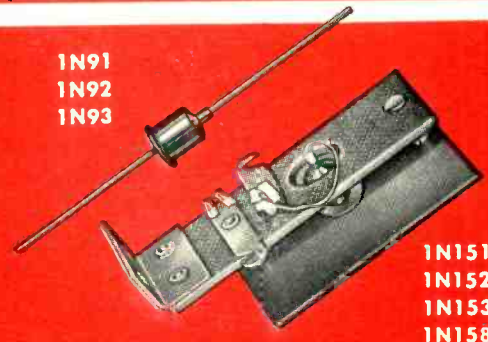

**ORDER IN QUANTITY FOR
IMMEDIATE DELIVERY**

HERE are just five of many severe criteria G.E. insists be met before a diffused junction rectifier is shipped:

1. Life of every day's production is evaluated by sample lot operation at full current, full voltage, and at elevated temperatures under stringent on-off cycle conditions. Acceptance is made only after compliance with 10,000 hour standards.
2. 100% testing of specified characteristics.
3. Full load aging of *all* units.
4. Absolute hermetic seal is checked on *all* units.
5. A 1% quality control level is imposed on *each* shipment.

Your rectifier applications demand nothing less than these standards. Specify General Electric and receive a custom shipment of quality germanium products.

- HERMETICALLY SEALED.
- MINIATURE SIZE made possible by low internal losses.
- DESIGNED to meet all military humidity tests and shock and vibration requirements.
- MULTIPLE ARRANGEMENTS for full wave or bridge circuits.
- VERY LOW LOSSES.

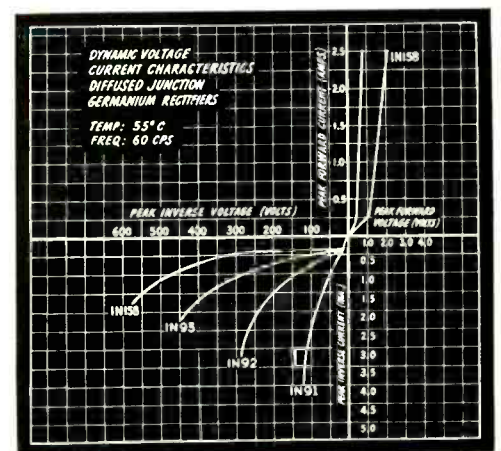

Send for complete G-E Diffused Junction Rectifier Information: General Electric Co., Sec. X464, Electronics Park, Syracuse, N. Y.



GENERAL  ELECTRIC



HAMMER BLOWS

— UP TO
2,000 FOOT POUNDS EACH

yet **WESTON**
RUGGEDIZED INSTRUMENTS
remain operable and accurate!

There's no guesswork about *ruggedizing* instruments at WESTON. Duplicates of *all* the approved equipment for testing — including the High Shock Hammers . . . the Vibrating and Tumbling equipment . . . the Temperature, and Moisture Cycling cabinets — all are here in the WESTON test department continually *proving* the soundness of WESTON'S ruggedized design. Thus you can *be sure* each instrument not only meets the specifications for ruggedized instruments, but will also *prove* its superior ruggedness in service. WESTON Ruggedized instruments now are available for A-C and D-C requirements in 2½", 3½" and 4½" sizes. Bulletin giving complete information sent on request. WESTON Electrical Instrument Corporation, 614 Frelinghuysen Ave., Newark 5, N. J. 6917

**WESTON RUGGEDIZED
INSTRUMENTS ARE AVAILABLE
FOR A-C AND D-C IN
2½", 3½", 4½" SIZES.**

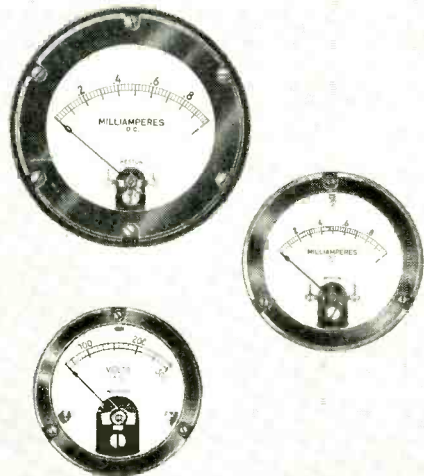

WESTON
Instruments

For Automatic Assembly plus Easy Inventory and Storage



NEW PACKAGING METHOD FOR DISC CERAMICONS®

Pallet-Pak, ERIE's exclusive new packaging method for Disc Ceramicons, answers the need for mechanically pre-aligned capacitors that can be fed into automatic assembly machinery. Hand assembly is also improved because of the ease of handling and the physical uniformity of the capacitor.

ERIE is constantly searching for new ways to assist manufacturers in reducing production costs. Pallet-Pak is a development by ERIE Industrial Engineers with this purpose in mind.

The many other advantages of Pallet-Pak are noted at right. Write for our Pallet-Pak Bulletin with complete illustrations and advantages of this new packaging method that is currently available on a portion of ERIE Disc Ceramicon production.

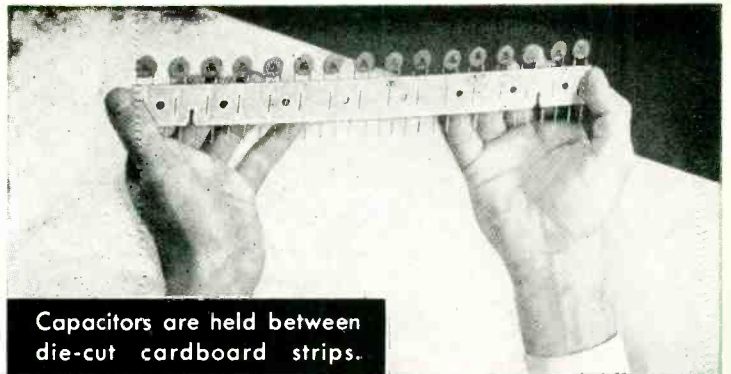

ADVANTAGES FOR INVENTORY AND STORAGE

- Known number in strip makes inventory control easier.
- Count empty strips—multiply by number for usage control.
- Markings all face one direction for easy identification.
- Drawer type disposable pallet for storage and shipping.

ADVANTAGES FOR YOUR PRODUCTION

- Straight lead wires—no tangling—units easily removed by pulling from strip.
- Uniform lead length.
- Carrier insert acts as tote-tray for easy handling.
- Index holes in strip 1½" center to center for use in lead forming and cutting equipment.
- Index holes are above carrier sides—rods can be inserted through holes and entire lot lifted easily in one operation.
- Assurance of uniform quality, resulting from continuous production flow.

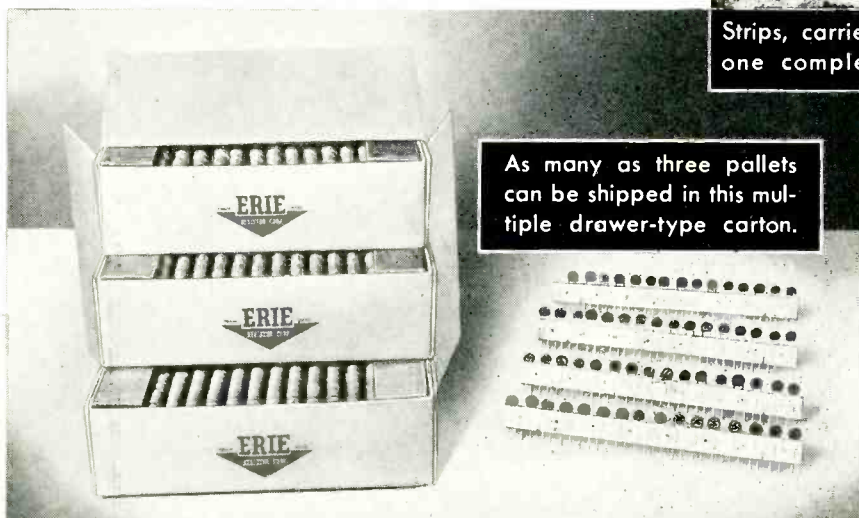

ERIE RESISTOR CORPORATION . . . ELECTRONICS DIVISION

Main Offices and Factories: ERIE, PA.

Sales Offices: Cliffside, N. J. • Camden, N. J. • Chicago, Ill. • Detroit, Mich. • Cincinnati, Ohio • Fort Wayne, Ind. • Los Angeles, Calif. • Toronto, Ontario

Manufacturing Subsidiaries:

HOLLY SPRINGS, MISSISSIPPI • LONDON, ENGLAND • TRENTON, ONTARIO

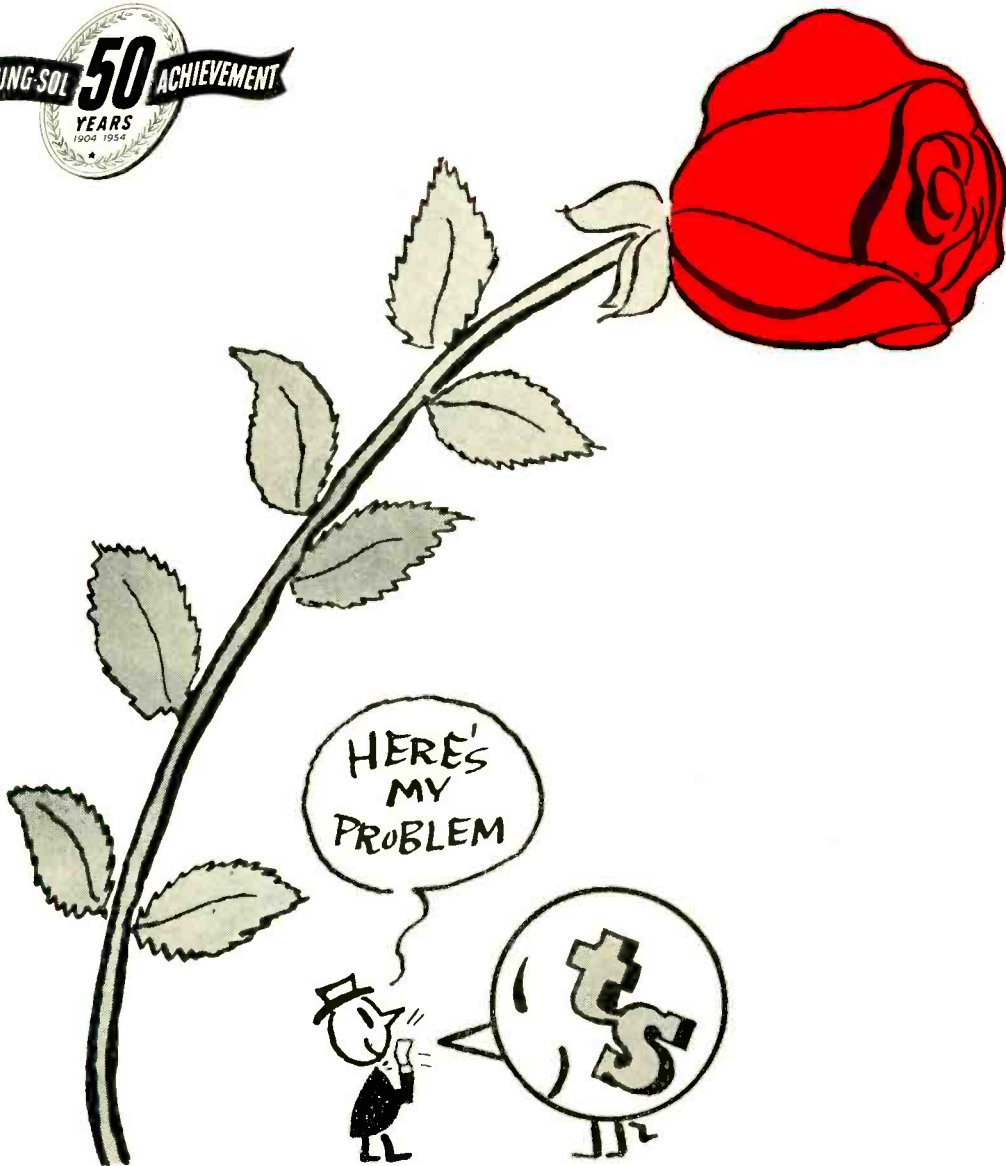

strictly "under the rose"

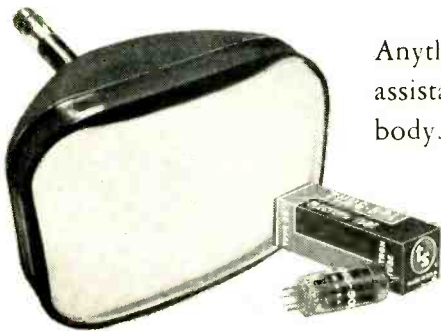

Anything you tell Tung-Sol is absolutely *sub-rosa*. Our engineering assistance to you is completely confidential. Never a peep to anybody. And we make only tubes—no sets—no equipment—just tubes.

TUNG-SOL ELECTRIC INC., Newark 4, N. J.

Sales Offices: Atlanta, Chicago, Columbus, Culver City (Los Angeles), Dallas, Denver, Detroit, Newark, Seattle

TUNG-SOL MAKES All-Glass Sealed Beam Lamps, Miniature Lamps, Signal Flashers, Picture Tubes, Radio, TV and Special Purpose Electron Tubes and Semiconductor Products.

**HIGH ATTENUATION
CONTINUOUS DUTY
HERMETICALLY SEALED**

FILTRON

SCREEN ROOM FILTERS



FILTRON TYPE FA 736
500 VAC/DC
100 AMPS
Frequency Range 1000 to 15,000 MC

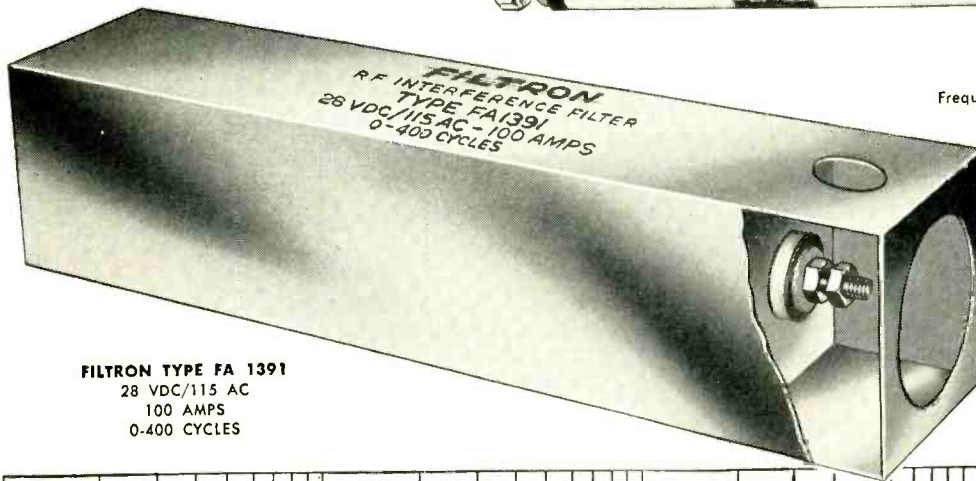

FILTRON TYPE FA 1391
28 VDC/115 AC
100 AMPS
0-400 CYCLES

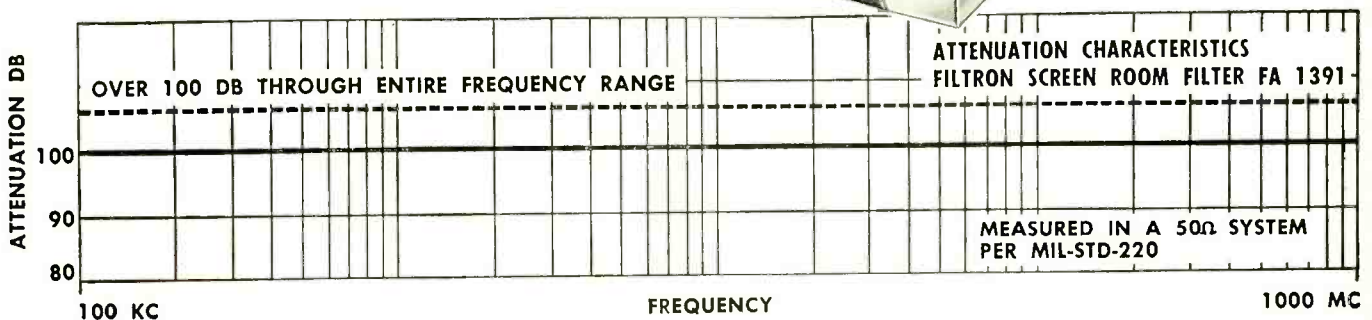

Screen room manufacturers specify and install FILTRON Screen Room Filters as standard equipment.

FILTRON Screen Room Filters are used in the majority of industrial, government and military screen rooms, to meet the requirements of specification MIL-S-4957, and wherever critical RF measurements are required.

FILTRON has over 30 types of Screen Room Filters available, ranging from 1 Amp to 1000 Amps, 28 VDC

to 500 Volt AC/DC, 0 to 1000 cycles. Complete technical information available.

FILTRON RF Interference Filters are also specified in the latest types of Radar, Radio Transmitters, Receivers, Motor Generator Sets, Inverters, Aircraft, Electronic Systems, and numerous other "restricted" equipments.

When you have an RF Interference Filter problem, consult FILTRON — the most dependable name in RF Interference Filters.

SALES REPRESENTATIVES

G. S. Marshall Co., Pasadena, Cal.
Roy J. Magnuson, Chicago, Ill.
Massey Associates, Inc., Narbeth, Pa.,
Washington, D. C.

Holliday-Hathaway, Cambridge, Mass., Canaan, Conn.
Sales Offices at: New York, N. Y., Great Neck, N. Y.
Rochester, N. Y., Binghamton, N. Y.
Wood-Ridge, N. J.

INTERFERENCE FREE
means
FILTERED
by **FILTRON**

An inquiry on your company letterhead will receive prompt attention.

FILTRON CO., INC. • FLUSHING, LONG ISLAND, NEW YORK
LARGEST EXCLUSIVE MANUFACTURERS OF RF INTERFERENCE FILTERS

for your **FREQUENCY SHIFT** Terminal Requirements
Specify **NORTHERN RADIO . . .**



NEW! TWINPLEX COMMUNICATION UNITS



• provide 2 channels of FS communication with existing single channel transmitter and receiving facilities— with performance comparable to the existing single channel system

This Twinplex communication system makes possible a 2-channel radio circuit whereby 2 non-synchronous or synchronous telegraph transmissions modulate a single radio carrier wave by causing the carrier to assume one of four specific frequencies with 400 cps separations.

The transmitting equipment consists of the Twinplex Combiner Type 177 Model 1 and an RF Frequency Shift Keyer such as the Northern Radio Type 105 Model 4. The Combiner converts the four possible conditions of two telegraph signals (M1-M2, M1-S2, S1-M2, S1-S2) respectively into one of four voltages related in a 0-1-2-3 manner. The Combiner output voltage modulates the FS Keyer.

The receiving equipment consists of the Twinplex Converter Type 178 Model 1 and a single or diversity receiver

such as the Northern Radio Type 110 Dual Diversity Receiving System. The Converter demodulates and separates the four audio tones from the radio receiver(s) into two channels each carrying the originally transmitted intelligence. The Twinplex Converter replaces the standard FS Converter for this purpose.

The two telegraph channels provide the same operational flexibility as that of two separate single channel FS systems. One can, for example, simultaneously use channel #1 on 60 wpm teletype and channel #2 on high-speed Morse or Time Division Multiplex. It further permits the reception of channel #1 signals on all standard FS converters (tunable to 400 cps shift) without need for a Twinplex Converter: this is valuable for "Forked Circuit Operation" where the intelligence of channel #1 is intended for pick-up by other receiving stations which are not equipped for Twinplex Reception in addition to the main receiving stations which are so equipped. Reception of channel #2 (or of both channels) requires the receiving end to be equipped with a Twinplex Converter.



Write for complete information.

- Frequency Shift Keyers
- Master Oscillators
- Diversity Receivers
- Frequency Shift Converters
- Multi-Channel Tone Systems
- Tone Keyers
- Demodulators
- Monitors
- Radio Multiplex Systems
- Tone Filters
- Line Amplifiers
- Twinplex Equipment

NORTHERN RADIO COMPANY, inc.
 147 WEST 22nd ST., NEW YORK 11, NEW YORK
 Pace-Setters in Quality Communication Equipment

Send this coupon
today . . .

I want the facts about Collins Microwave.

NAME _____

COMPANY _____

ADDRESS _____

CITY _____ STATE _____

Get this booklet by return mail

and find out why Collins Microwave
will serve you best.

You'll want all the facts in this informative booklet, but this is the story in a nutshell. Collins can do your communications and remote control jobs better because they're *specialists* in radio-electronic design and manufacture. Collins' extensive experience and success in the aviation, broadcast and amateur radio fields supply the required background and facilities to deliver microwave systems that represent the ultimate in dependability. If your plans include the use of Microwave, be sure you get assured performance and quality. Why not mail the coupon now.

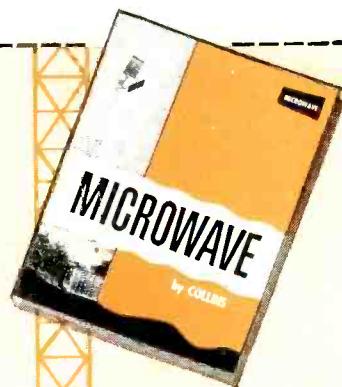

COLLINS RADIO COMPANY Cedar Rapids, Iowa

11 W. 42nd St., NEW YORK 36 1930 Hi-Line Dr., DALLAS 2 2700 W. Olive Ave., BURBANK
Collins Radio Company of Canada, Ltd., 74 Sparks Street, OTTAWA, ONTARIO



J. F. Mandrow (left) and T. W. Connolly prepare a problem in dynamic analysis of an interceptor fire control system for solution on analog computing equipment.



B. D. McVey (foreground) and E. Foxman examine operation of interceptor fire control system with equipment simulating in-flight performance of target, fire control system, and interceptor.



In the development of advanced radar fire control systems for all-weather military aircraft, system design objectives are determined by systems engineering and analysis. To implement these objectives the next step is the detailed analysis, design, and evaluation of the individual subsystems and units.

**PLANNING
PERFORMANCE**

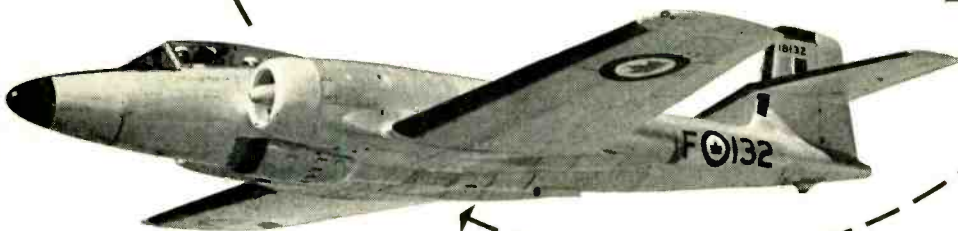

The Avro Canada CF-100 of the RCAF is one of the all-weather interceptors equipped with Hughes radar fire control system.

At Hughes special simulation equipment is used to synthesize aircraft and system performance. The simulator provides a means for examining system performance under laboratory-controlled conditions. In the case of airborne systems such study would otherwise require hundreds of hours of expensive flight testing to achieve comparable results.

Three important aspects of this work are:

Determination of effects on over-all dynamic stability of items such as dynamic range of amplifiers, filtering included to reduce effects of noise, aerodynamic response characteristics of the aircraft, and characteristics of computers.

Evaluation of existing systems, subsystems, or units to determine degree of modification necessary in order to meet new installation or performance requirements.

Assessment of completed systems under simulated operation to establish performance before start of production. Simulator studies are correlated with actual flight tests, helping to predict in-flight performance with reduced flight testing.

SYSTEMS ENGINEERS—CIRCUIT ENGINEERS

Further advancements in the field of radar fire control are creating new positions on our Staff for engineers experienced in the fields of systems engineering and circuit design, or for those interested in entering these areas.

Assurance is required that relocation of the applicant will not cause disruption of an urgent military project.

*Scientific and
Engineering Staff*
HUGHES
RESEARCH
AND DEVELOPMENT
LABORATORIES

Culver City, Los Angeles County, California

Hughes Fusion-Sealed Germanium Diodes

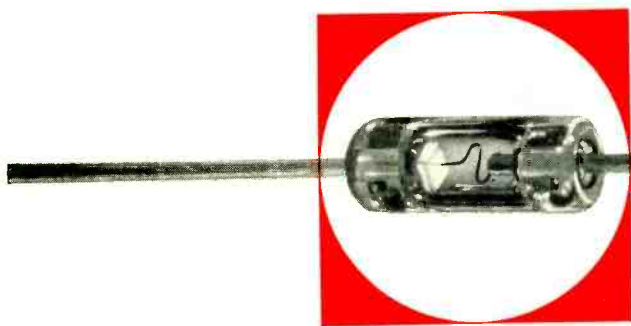

ACTUAL DIMENSIONS
DIODE BODY:
0.265 by 0.130 inches (maximum)
SHUNT CAPACITANCE:
0.5 μ f (maximum)
AMBIENT OPERATING
TEMPERATURE RANGE:
-78°C to +90°C

Hughes Point-Contact Germanium Diodes are fusion-sealed in a one-piece, gas-tight glass envelope . . . impervious to moisture, fumes or other external contaminating agents. The flexible dumet leads are especially suitable for spot-welding; or they can be iron- or dip-soldered as close as 1/4 inch to the diode body—without special precautions.

The germanium crystal is permanently bonded to one lead, the cat whisker is welded to the other, and the point of the cat whisker is welded to the crystal. Hughes diodes are highly resistant to shock and vibration. Positive mechanical stability is achieved without risking contamination from fluxes, waxes or impregnants. And—each diode is thoroughly tested to ensure the stability of

its electrical and physical characteristics. All this means: sturdy, highly reliable diodes.

TYPES—The Hughes line of diodes comprises standard RETMA, JAN, and many special types. Special types are produced according to customer specifications and are tested at high or low temperatures . . . for specific recovery time . . . for matching in pairs or quads.

ELECTRICAL SPECIFICATIONS AT 25° C unless otherwise indicated

DESCRIPTION	RETMA or Hughes Type	Clip-In Hughes Type	Peak Inverse Voltage† (volts)	Absolute Maximum Inverse Working Voltage (volts)	Minimum Forward Current @ +1V (mA)	Maximum Inverse Current		Other Characteristics
						@ -50V (mA)	Other (mA)	
HIGH PEAK	1N55B	HD 2052	190	150	5.0		0.500 @ 150V	
	1N68A	HD 2053	130	100	3.0		0.025 @ 100V	
1 MEG TYPES	1N67A	HD 2054	100	80	4.0	0.050	0.005 @ 5V	
	1N99	HD 2055	100	80	10.0	0.050	0.005 @ 5V	
	1N100	HD 2056	100	80	20.0	0.050	0.005 @ 5V	
500K TYPES	1N89	HD 2057	100	80	3.5	0.100	0.008 @ 5V	
	1N97	HD 2058	100	80	10.0	0.100	0.008 @ 5V	
	1N98	HD 2059	100	80	20.0	0.100	0.008 @ 5V	
	1N116	HD 2060	75	60	5.0	0.100		
	1N117	HD 2061	75	60	10.0	0.100		
GENERAL PURPOSE	1N90	HD 2063	75	60	5.0	0.500		
	1N95	HD 2064	75	60	10.0	0.500		
	1N96	HD 2065	75	60	20.0	0.500		
JAN TYPES	1N126*		75	60	5.0	0.850	0.050 @ 10V	Non-JAN equivalent, HD2070; clip-in, HD2066
	1N127**		125	100	3.0	0.300	0.025 @ 10V	Non-JAN equivalent, HD2071; clip-in, HD2067
	1N128***		50	40	3.0		0.010 @ 10V	Non-JAN equivalent, HD2072; clip-in, HD2068
COMPUTER TYPES	1N191	HD 2077		§	5.0	400K Ω min. between -10 and -50V @ 55°C§ 200K Ω min. between -10 and -50V @ 55°C§ 0.120 @ -3V 0.60 @ -6V	Back resistance recovers to 50K Ω and 400K Ω (200K Ω for 1N192) in 0.5 μ sec and 3.5 μ sec max., respectively. † 0.2 μ sec recovery time. ° 0.2 μ sec recovery time. °	
	1N192	HD 2078		§	5.0			
	HD2013 HD2014				50 @ 1V & 1 @ 0.35V 50 @ 1V & 1 @ 0.35V			
UHF	HD2016A				UHF MIXER DIODE			
MISCELLANEOUS	HD2051		125	100	4.0	0.050	1N63 equivalent.	

†That voltage at which dynamic resistance is zero when back voltage rises linearly at 90v/sec.

‡Back Recovery Time is measured with a forward pulse of 30mA, followed by a reverse pulse of 35 volts. Loop resistance of test circuit 2500 Ω max.

°Recovery time is that point at which the diode voltage reaches -1V after the initiation of a 6V back pulse through 20K Ω from an initial 3 mA forward bias. Total shunt capacitance is 20 μ f.

§Tested at 55°C. Test voltage is a continuous 60 cps sine wave. Peak Reverse Voltage across the diode is 70V. Peak Forward Voltage not less than +2V or Peak Forward Current not less than 20 mA, whichever occurs first.

*Formerly 1N69A.

**Formerly 1N70A.

***Formerly 1N81A.

Descriptive Bulletin SP2A is available on request.

Hughes

SEMICONDUCTOR SALES DEPARTMENT

Aircraft Company, Culver City, Calif.



New York Chicago

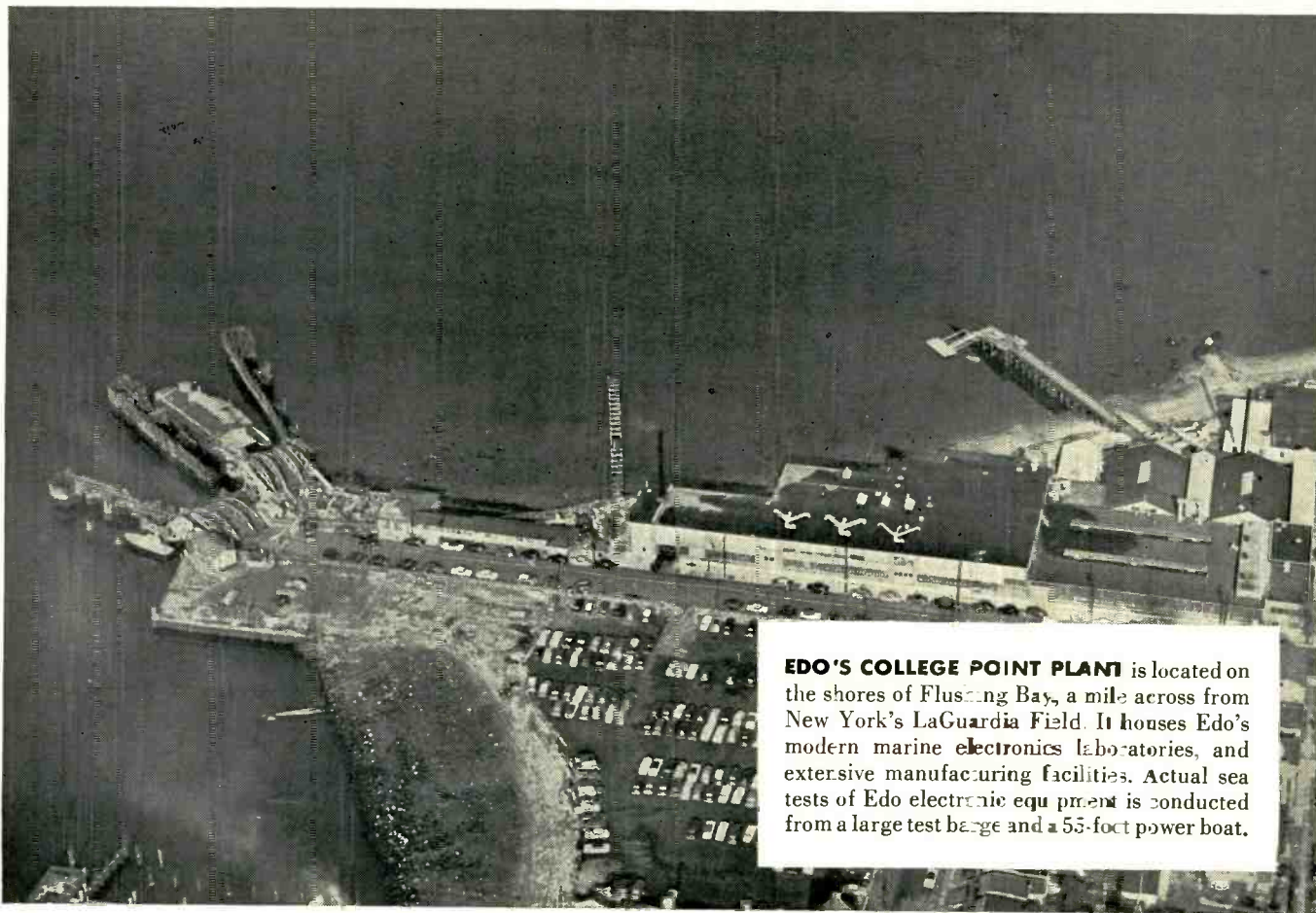

EDO'S COLLEGE POINT PLANT is located on the shores of Flushing Bay, a mile across from New York's LaGuardia Field. It houses Edo's modern marine electronics laboratories, and extensive manufacturing facilities. Actual sea tests of Edo electronic equipment is conducted from a large test barge and a 55-foot power boat.

Miracle(s) at College Point have made EDO Marine Electronics Headquarters

Miracles in electronics—a steady stream of them—have marked Edo's emergence as headquarters for marine electronics development.

Out of Edo's well-equipped plant at College Point have come many *firsts* in marine electronics for a wide range of uses—both naval and commercial—to name a few:

- The first continuously indicating and recording deep depth sounder with a range of 6000 fathoms.
- Many new under-water detection equipments for the Nautilus, the K-1, and other submarines.
- The Edo Fishscope—the fish-finder that assures larger hauls in less time.

These are but a few of the wide range of equipments developed and manufactured by Edo. Through their superior performance, accuracy, range and dependability, they have proved that the Edo flying fish emblem is the symbol of quality and satisfactory operation.

And from this Marine Electronics Headquarters, Edo's home for over a quarter of a century, other new improved equipments will emerge to make navigation simpler, safer and more efficient.



Main electronic assembly of sonar equipments for the United States Navy.

EDO CORPORATION • COLLEGE POINT, L. I., N. Y.  Since 1925

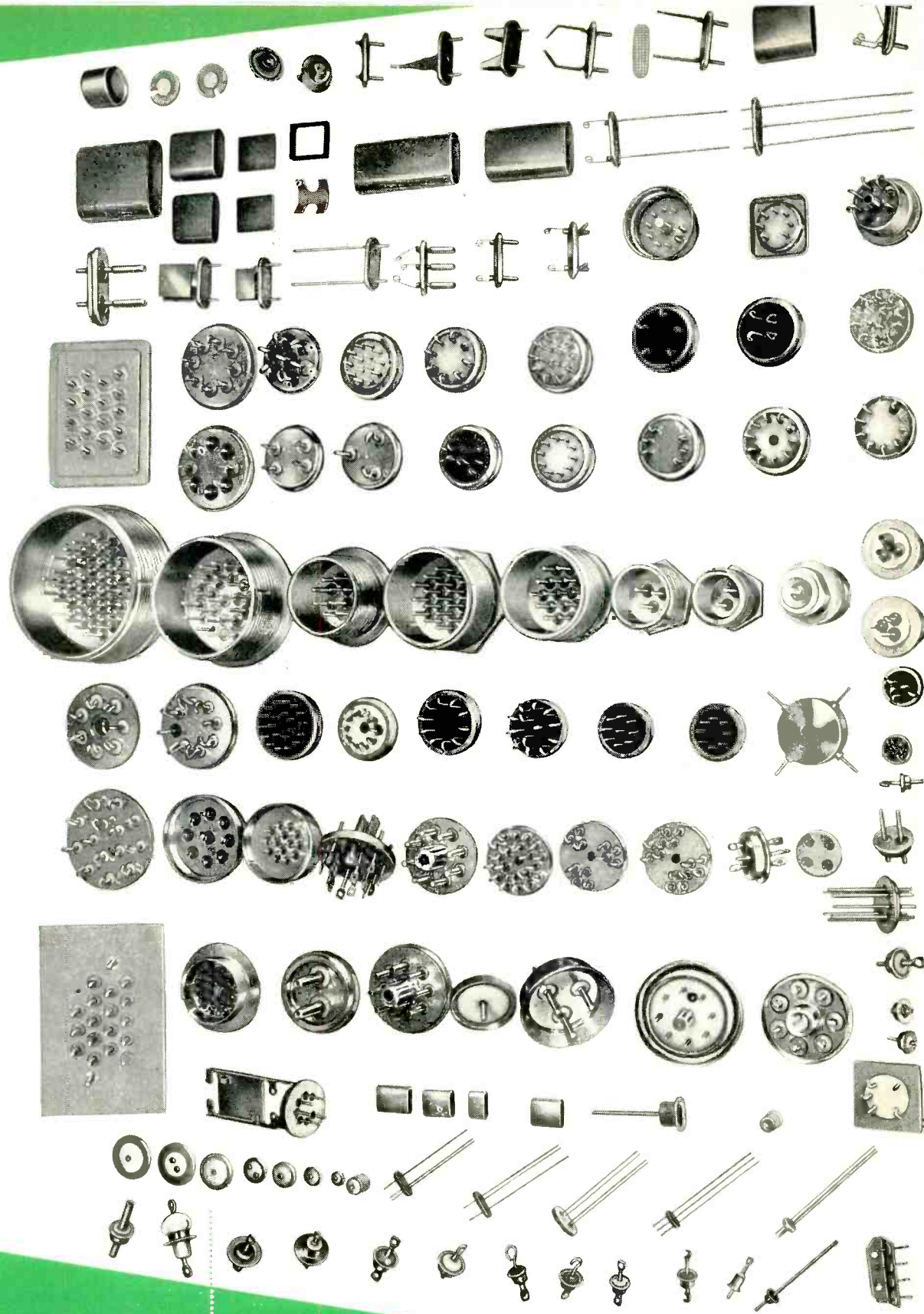

WHAT DO YOU NEED?

SPECIFY

L. L. Constantin & Co.

Glass-to-Metal VACUUM Seals
 Manufacturing Engineers
 Rt. 46, Lodi, N. J.



KOVAR and COMPRESSION HEADERS • AN CONNECTORS • TRANSISTOR MOUNTS • SINGLE TERMINALS • END SEALS • CRYSTAL BASES • MINIATURIZATION

Automatically plots two variables
as a function of a third---

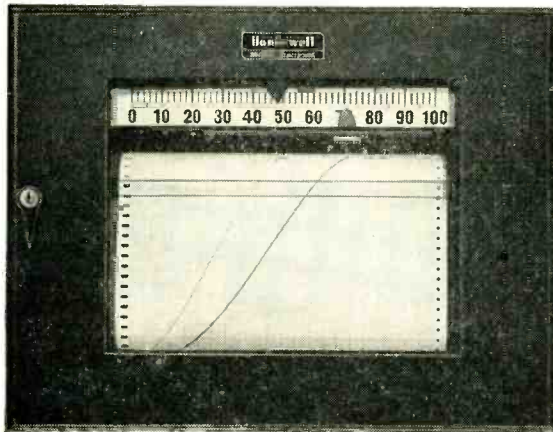

the *ElectroniK*

Duplex Function Plotter

NEWEST of the many modifications of the *ElectroniK* recorder, especially designed for research work, is the Duplex Function Plotter. A two-pen version of the now famous Function Plotter, this instrument has three independent measuring systems; one for each of the horizontally moving pens, and one coupled to the vertically moving chart. The instrument is thus able to draw two simultaneous, continuous curves representing the relationship $x, x' = f(y)$.

In the testing of missiles, engines, nuclear reactions and numerous other studies, the Duplex Function Plotter further helps to accelerate the pace of research. It provides better data by giving scientists a continuous plot of related functions on a single chart, without need for replotting from two sep-

arate records. It helps to lift even more of the burden of routine transcribing and data-taking from the shoulders of trained men . . . and frees them for more complete utilization of their skills.

Input to either pen or to the y-axis can be practically any variable that can be converted to a d-c signal. All three inputs can be of different calibrations.

Your local Honeywell sales engineer will welcome the opportunity to discuss your specific applications for this time-saving instrument. Call him today . . . he's as near as your phone.

MINNEAPOLIS-HONEYWELL REGULATOR CO.,
Industrial Division, Wayne and Windrim
Avenues, Philadelphia 44, Pa.

● REFERENCE DATA: Write for new Data Sheet No. 10.0-17, "*ElectroniK* Duplex Function Plotter."



MINNEAPOLIS
Honeywell
BROWN INSTRUMENTS

First in Controls



MICROWAVE

SIGNAL GENERATORS

Complete coverage of
the range 950-10,800 mcs/sec.

with Polarad single dial operation

Four new Microwave Signal Generators covering the range 950-10,800 mcs/sec. All with famous Polarad single dial operation. Each provides the maximum working range possible in one compact signal generator. And, additional Polarad Signal Generators are available to cover 12.8 to 39.7 kmc.

These features on all MSG units assure fast and simple operation: direct reading, single dial frequency control that tracks reflector voltages automatically . . . direct reading attenuator dial . . . conveniently placed controls, in logical sequence . . . high visibility on the face of each instrument.

Polarad Signal Generators are built to the same high standards required for military equipment. They are practical for the factory assembly line—engineered ventilation assures continuous and stable operation of all instrument functions. Components are readily accessible for easy maintenance. And laboratory accuracy is guaranteed under the most rigorous operating conditions.

Write directly to Polarad or your nearest Polarad representative for details.

	MSG-1	MSG-2	MSG-3	MSG-4*
Frequency Range	950-2400 MCS/sec.	2150-4600 MCS/sec.	4450-8000 MCS/sec.	6950-10,800 MCS/sec.
(Frequency set by means of a single directly calibrated control)				
Frequency Accuracy	±1%	±1%	±1%	±1%
Power Output	1 MW	1 MW	.2 MW	.2 MW
Attenuator Range	120 db	120 db	120 db	120 db
Attenuator Accuracy	±2 db	±2 db	±2 db	±2 db
Output Impedance	50 ohms	50 ohms	50 ohms	50 ohms
Input Power	115V ± 10% 60 cps	115V ± 10% 60 cps	115V ± 10% 50-1000 cps	115V ± 10% 50-1000 cps
Internal Pulse Modulation:				
Pulse Width	0.5 to 10 microseconds			
Delay	3 to 300 microseconds			
Rate	40 to 4000 pulses per second			
Synchronization	Internal or external, sine wave or pulse			
Internal FM:				
Type	Linear sawtooth			
Rate	40 to 4000 cps			
Synchronization	Internal or external, sine wave or pulse			
Frequency Deviation	±2.5 MCS	±2.5 MCS	±6 MCS	±6 MCS
External Pulse Modulation:				
Polarity	Positive or Negative			
Rate	40 to 4000 pulses per second			
Pulse width	0.5 to 2500 microseconds			
Pulse separation	(For multiple pulses) 1 to 2500 microseconds			
Output Synchronizing Pulses:				
Polarity	Positive, delayed & undelayed			
Rate	40 to 4000 pps			
Voltage	Greater than 25 volts			
Rise time	Less than 1 microsecond			
Size	17" long x 13¼" high x 15½" deep		17" long x 15" high x 19½" deep	
Approx. weight	60 lbs.		100 lbs.	

*Also available—MSG 4A: 6,950–11,500 MCS/sec.

"THE FINEST SIGNAL GENERATORS OF THEIR KIND"



ELECTRONICS CORPORATION 100 METROPOLITAN AVENUE,
BROOKLYN 11, NEW YORK

REPRESENTATIVES Albuquerque • Arnprior, Canada • Atlanta • Boston • Chicago • Cleveland • Fort Worth • Kansas City • Los Angeles • New York • Philadelphia • San Francisco • Seattle • St. Paul • Syracuse • Washington, D. C.

ELECTRONICS — June, 1954

125

ESTIMATORS SAY...
"We ALWAYS
Specify

Heldor

BUSHINGS

hermetic-seal, compression type

CANS and COVERS

built to meet MIL-T-27 & Commercial Specifications

ASSEMBLY SERVICE

from assembly of bushings in covers to actual hermetic sealing of your component.

... because, when we 'quote' on a job, we must be sure of **LOW** material- and assembly-costs plus consistent top quality. ”

More and more estimators in the electronic and nuclear fields are experiencing the outstanding advantages of basing their costs on the selection of components from Heldor's line of hundreds of standard and non-standard Cans, Covers and hermetic-seal Bushings . . . (now, lower in cost than ever* because of improved production facilities). These men are also specifying Heldor's Assembly Service because it further reduces costs, speeds delivery and meets rigid inspection standards.

Be Wise! *Economize* . . . the Heldor way! Send specifications or prints of your requirements for a quotation that will tell its own **QUALITY** with **ECONOMY** story! *Do it NOW!*

*Write for your copy of New Price List!

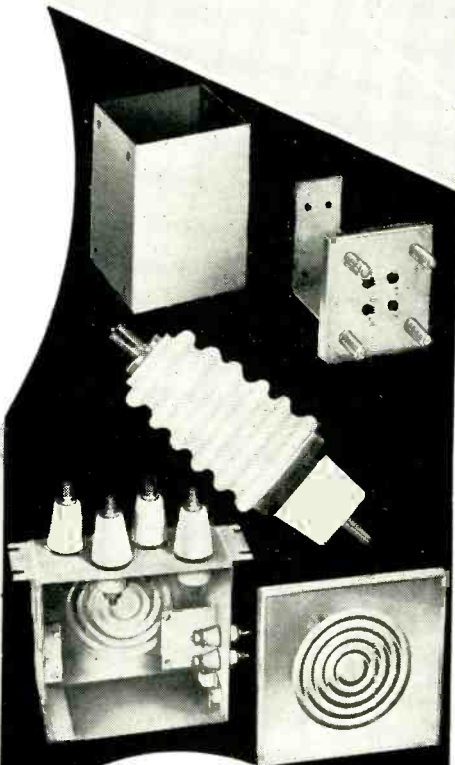

NEW!

**Heldor LOCK-IN,
HERMETIC-SEAL
TERMINAL**



Meets
MIL-T-27 Twist
Test. Improved Elec-
trical Characteristics.
WRITE FOR DATA!

HELDOR MANUFACTURING CORPORATION

HELDOR BUSHING & TERMINAL CO., INC.

238 Lewis Street • Paterson, N. J.

Midwestern Branch: 3821 Montrose Ave., Chicago 18, Ill.



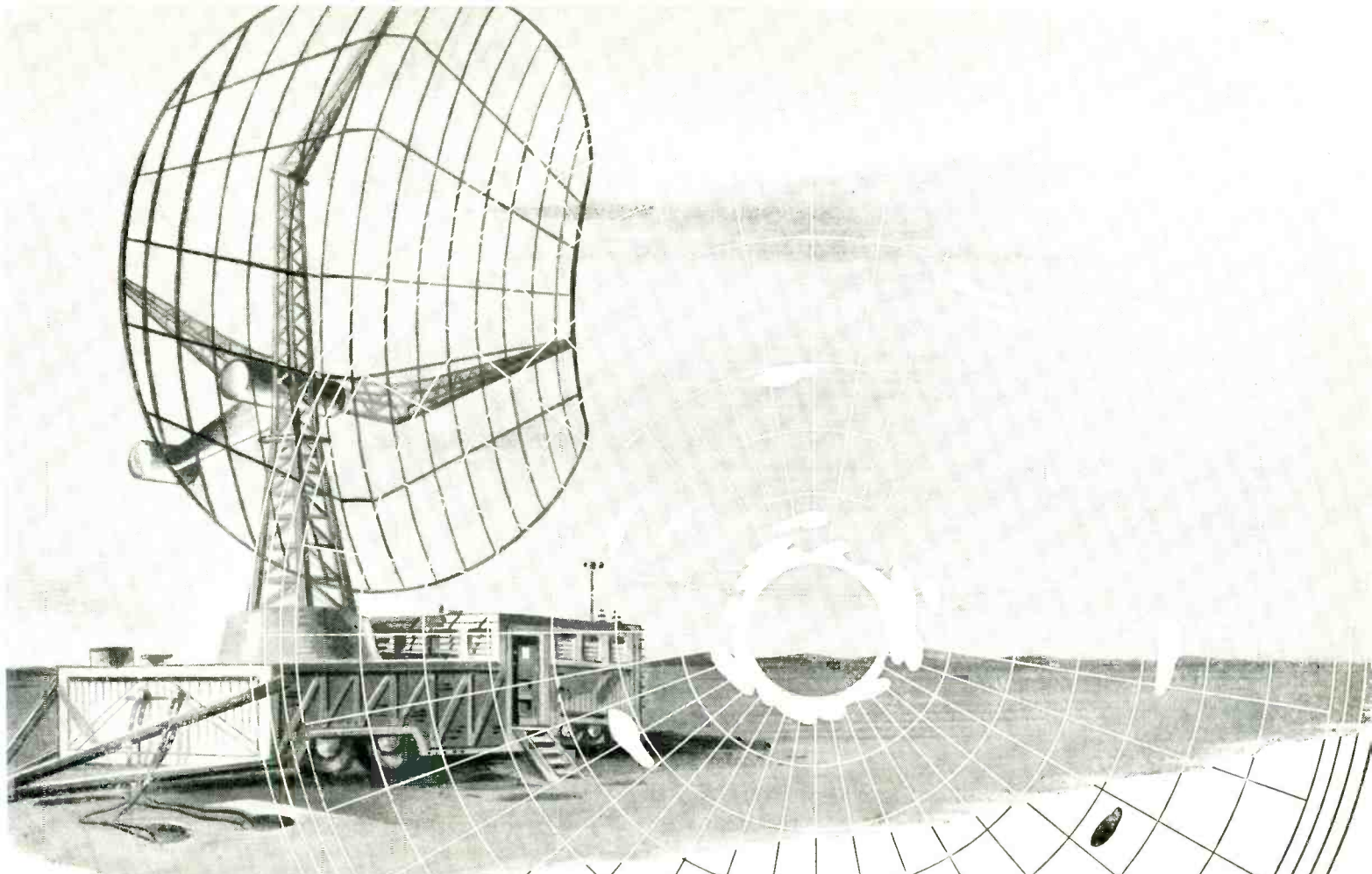

Radar Tubes

by DUMONT

If you need any radar tube, whether for replacement or for initial equipment, Du Mont offers a complete line. Standard Du Mont high-resolution radar tubes range from five inches in diameter to twelve inches with magnetic deflection and either electrostatic or magnetic focus.

Electrostatic-focus tubes are generally intended for initial equipment where the elimination of the focus coil saves cost, weight, and space. Also, their substantially automatic focus feature even eliminates a front-panel focusing control. Electrostatic-focus tubes are usable for replacing magnetic focus equivalents with slight circuit modifications. All Du Mont tubes exhibit the highest standard of quality. The patented Du Mont electron-lens design makes possible precision manufacturing techniques which allow very tight tolerances to be held. In addition, thorough material processing and comprehensive and rigid quality control assure unparallelled tube-to-tube uniformity. *Du Mont will build, to customer specifications, special radar tubes up to 30" screen diameter.

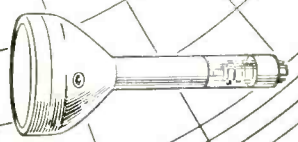

TYPE 5AHP—flat-face, electrostatic focus radar tube

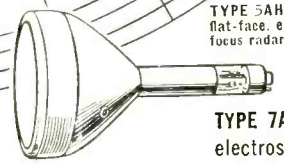

TYPE 7ABP—electrostatic focus radar tube

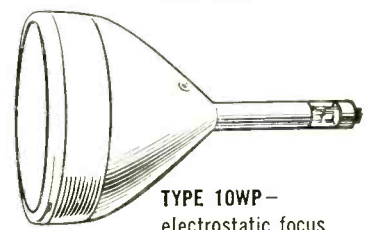

TYPE 10WP—electrostatic focus radar tube

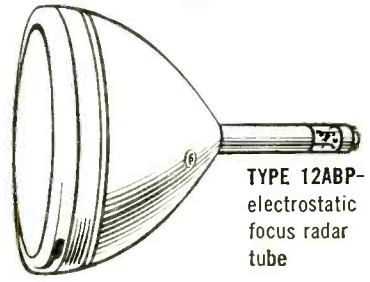

TYPE 12ABP—electrostatic focus radar tube

TYPICAL RADAR TUBES AVAILABLE FROM DU MONT (Not a complete listing)

	5FP-7A	5FP-14A	5AHP-	7BP-	7MP-	7ABP-	10KP-	10WP-	10UP-	12SP-	12ABP-
LENGTH	11 1/8"	11 1/8"	11 1/8"	13 3/4"	12 3/4"	13 3/4"	17 3/8"	16 3/8"	17 3/8"	18 3/8"	18"
ANODE VOLTS	5KV	5KV	5KV	7KV	7KV	7KV	10KV	10KV	10KV	10KV	10KV
TYPICAL LINES/ USEFUL DIAM.	450	550	550	550	600	650	650	675	900	625	700
TYPICAL LINE WIDTH	.0095"	.0077"	.0077"	.011"	.010"	.009"	.014"	.014"	.010"	.018"	.016"
FOCUS	MAG.	MAG.	ELECT.	MAG.	MAG.	ELECT.	MAG.	ELECT.	ELECT.	MAG.	ELECT.
REPLACES		5FP-14	5FP-			7MP- OR 7BP-		10KP-			12DP- OR 12SP-

DU MONT

For full information on any Du Mont radar tubes and their applications, write to: TECHNICAL SALES DEPT.
ALLEN B. DU MONT LABORATORIES, INC., 760 BLOOMFIELD AVENUE, CLIFTON, NEW JERSEY

In Owr Face Red!

Most people have had the experience of moving from one place to another. Most people, therefore, will appreciate our predicament . . . that at such a time, efficient methods of production as well as delivery schedules bog down badly.

That is exactly what has happened to us . . . *and is our face red!* Yes, moving our entire operation to Manchester, N. H. during the past few months has inadvertently caused many disappointments and delays. Our expanding operations were so hampered by our previous space limitations that we've subjected you to uncertain promises and regrettable let-downs. *For this, we apologize deeply.*

Out of all the havoc, however, comes good news! Now, swinging into full production in our great new plant, we will soon be ready to give you the kind of products we can be proud of — the kind of service you deserve!

Yes, with our manufacturing potential quadrupled . . . with new, up-to-the-minute equipment and latest streamlined production methods . . . with an enlarged force of skilled workers and engineers, *you can now be sure of the very best quality and service from Insuline.*

So thank you for bearing with us. From this day on, you can feel assured that your renewed confidence in us will be justified.



insuline

CORPORATION OF AMERICA

186 Granite St.

Manchester, New Hampshire

Eimac Klystron Report

X561

- Power gain of one million
- 5kw power output at 650mc

four cavity klystron

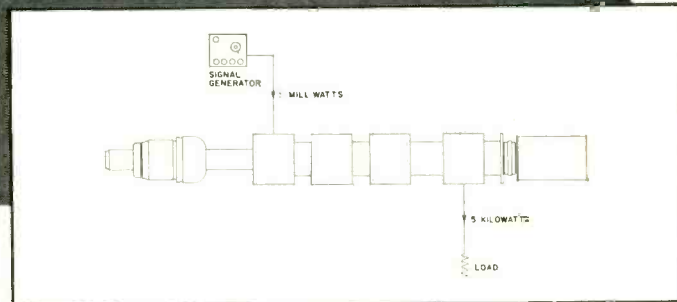
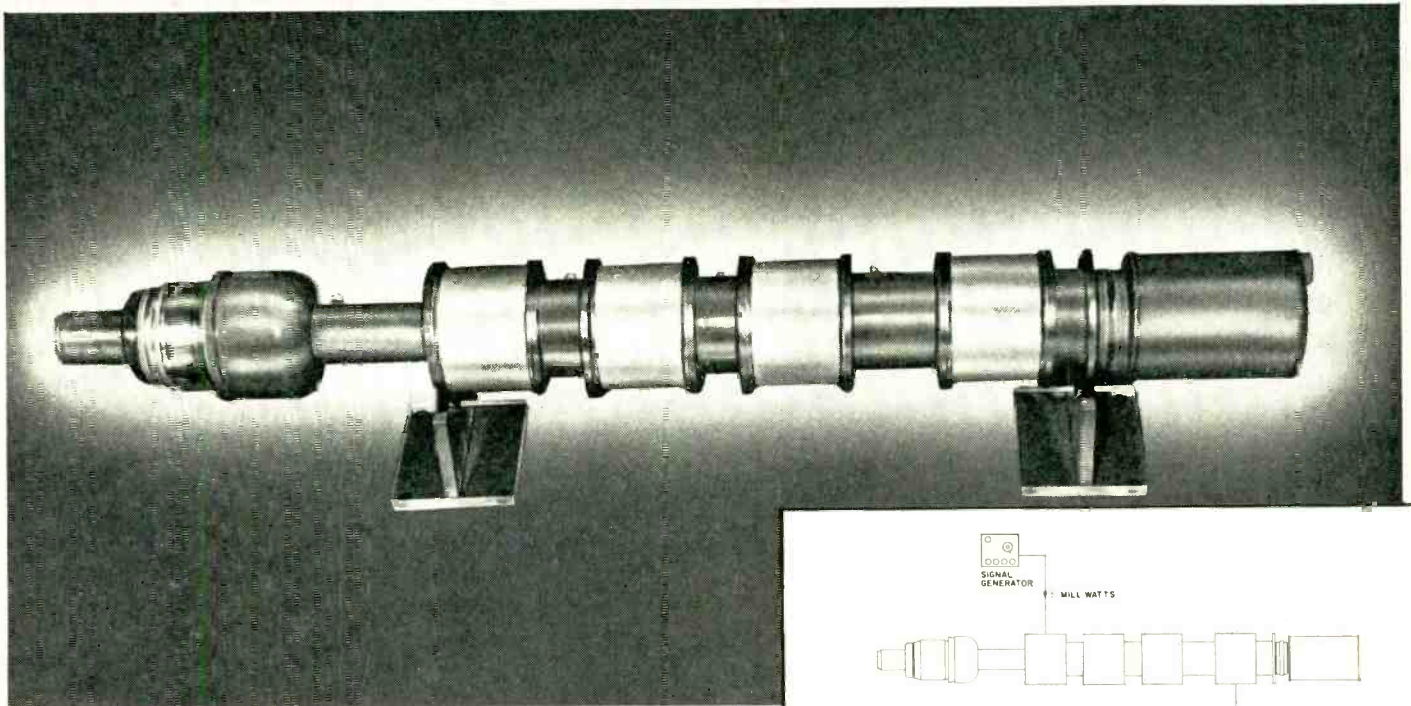

A power gain of one million times, 60db., in CW operation at 650mc has been registered by the Eimac X561 four cavity cascade type amplifier klystron. With only a signal generator driver supplying 5 milliwatts input, the X561 delivers 5kw RF power output. This amazing performance is obtained with complete stability at 38% efficiency. The X561 incorporates the exclusive Eimac klystron power amplifier features of practical design, light weight, ceramic tube cavities and external tuning circuitry. Other Eimac klystron advancements include sturdy reflex klystrons for use in con-

ditions of severe shock, vibration and sustained acceleration at frequencies to 9600mc., as well as high power klystron amplifiers for UHF-TV.

- For a thorough question and answer discussion of klystrons, write our Technical Services department for a free copy of the 20-page booklet, "Klystron Facts."

EITEL-McCULLOUGH, INC.
SAN BRUNO • CALIFORNIA

Eimac
THE WORLD'S
LARGEST TRANSMITTING TUBE
MANUFACTURER

Magnetic

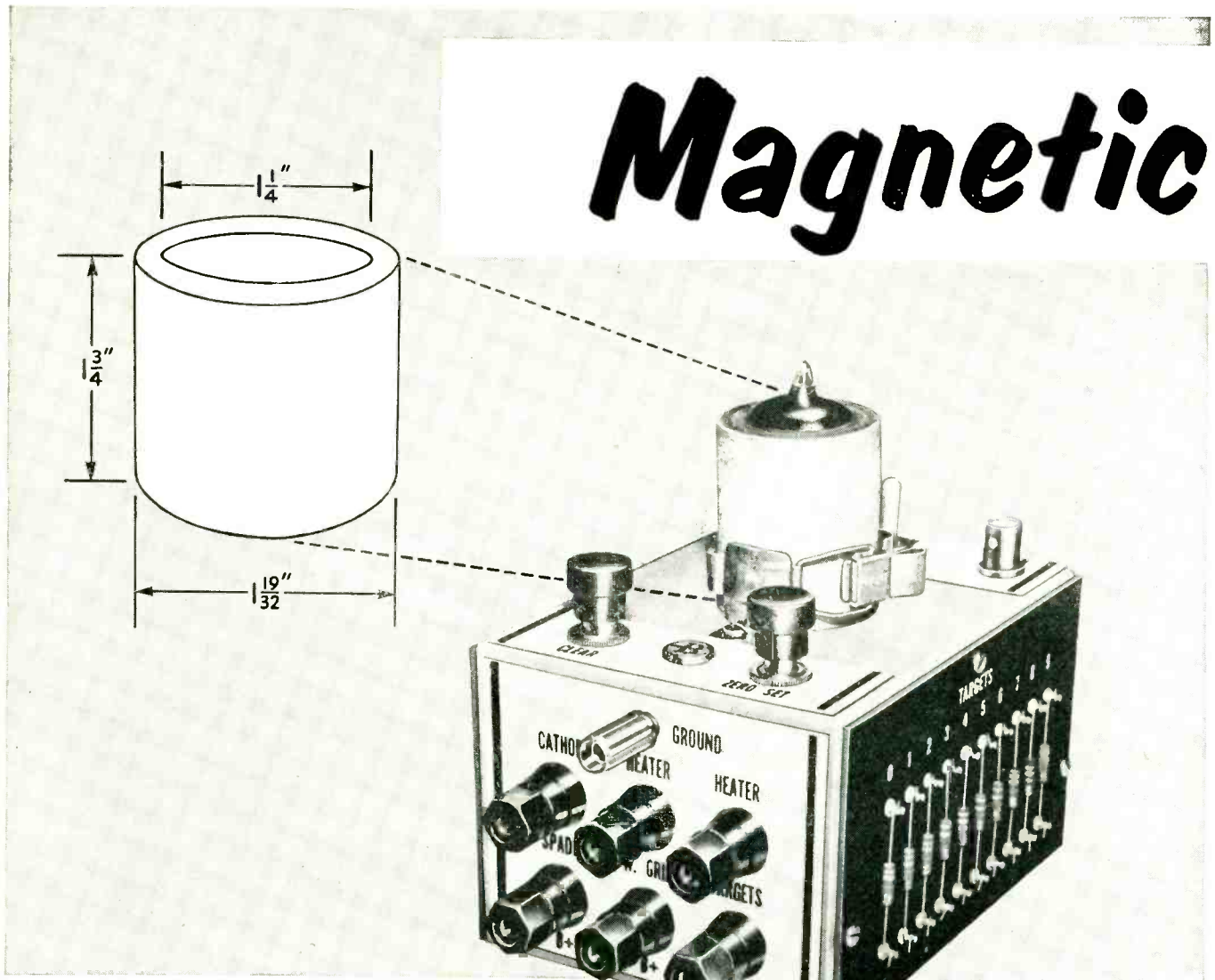

New Burroughs beam switching tube uses Thomas & Skinner permanent magnet

One of the principal problems in designing the new Burroughs Beam Switching Tube—recently announced by Burroughs Electronic Instruments Division—was a means of providing an electron beam, which could be formed, switched, and modulated in any one of 10 discrete automatically locked positions—consecutively or at random.

The solution was a combina-

tion of magnetic and electric fields. . . and to obtain a cylindrical permanent magnet to surround the tube, Burroughs called in Thomas & Skinner engineers. The result was a permanent magnet of the exact-type material needed—and with the specific magnetic characteristics required for successful operation, including maximum energy product, coercive force, residual induc-

tion, and other required characteristics.

It will pay you—as it did Burroughs—to investigate fully the design capabilities of Thomas & Skinner engineers . . . as well as Thomas & Skinner's productive capacity. Write for complete details . . . Thomas & Skinner magnetic materials may be your *short cut to new designs and more profitable production.*

Specialists in magnetic materials, Permanent Magnets, Electrical Laminations and Wound Cores

Materials are our Business



PERMANENT MAGNETS Whatever your needs—Alnico, cobalt, chromium—Thomas & Skinner can meet your specifications for either standard designs or special shapes. Typical of T&S advanced materials is Alnico 5Cb, offering an energy product of 5.70 million *nominal*. And typical of T&S advanced techniques is shell-molding, offering intricate shapes with tolerances as close as $\pm .005$ " without grinding or finishing.

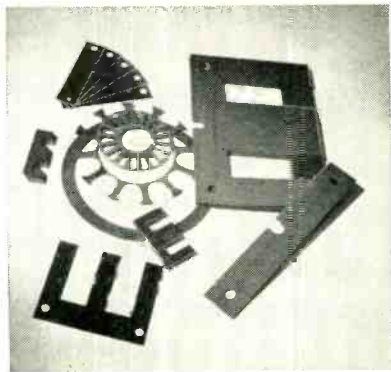

ELECTRICAL LAMINATIONS Geared to high volume production, T&S uses the most modern equipment available to produce high quality laminations in quantity at the lowest prices possible. Rigid quality control is maintained through each phase of production—stamping—atmosphere annealing—every vital step in producing top quality laminations. For every type application, T&S can provide all grades, all gauges to meet your demands for standard or special laminations. T&S's OrthoSil is also available for applications requiring directional electrical characteristics with extreme high permeability and low core loss.

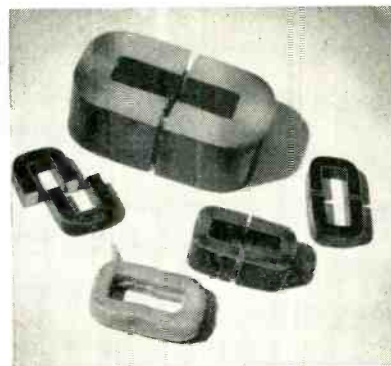

WOUND CORES You can save on both assembly costs and time—and reduce both size and finished weight—with "C" Type and Toroidal Wound Cores made from T&S OrthoSil. The directional magnetic characteristics and extremely rectangular hysteresis loop of oriented OrthoSil have proved advantageous on hundreds of applications, particularly in 400 cycle equipment at flux densities of 15,000 gauss and over.

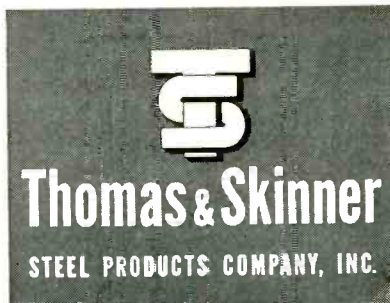

1122 EAST 23RD STREET
INDIANAPOLIS, INDIANA

write today
for free
catalogs!



- Magnet Design—Bulletin 151 (for the design engineer)
- Standard Magnets—Catalog SM-1252 (complete data with dimensional drawings)
- Alnico 5Cb—Bulletin 1253 (details on today's newest Alnico)
- Laminations—Bulletin L-752 (applications, specifications, value graphs)
- Wound Cores—Bulletin WC-353 (specifications, value graphs)

Name and Title _____

Company _____

Address _____

City _____

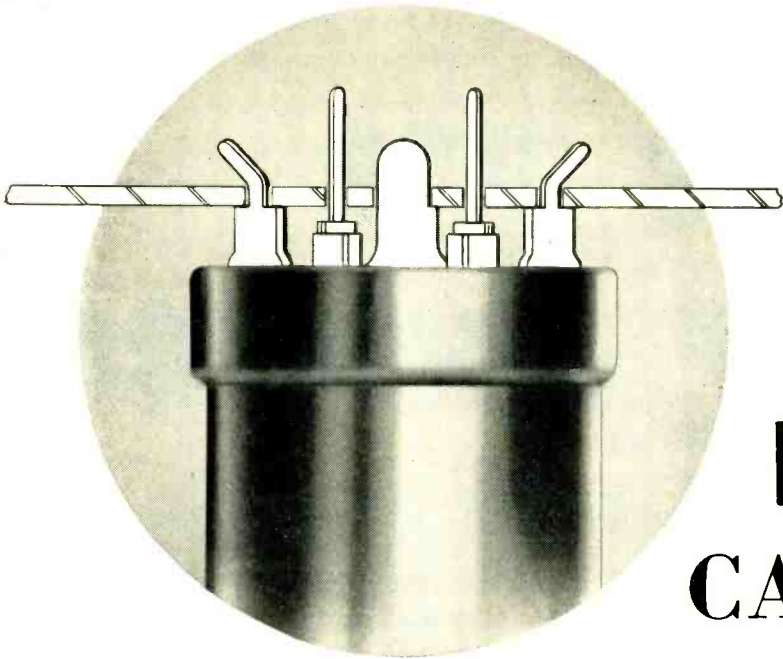

P. R. MALLORY & CO. Inc.
MALLORY
CAPACITORS

designed for easy mounting
 on printed circuits



A new line of Mallory FP Electrolytic Capacitors features mounting prongs and terminals specifically designed for use with printed electronic circuits. These new features give you practical, fool proof mounting—plus the high standards of performance which have earned FP Capacitors outstanding acceptance by leading manufacturers.

Note the shoulders cut in the mounting tabs, to hold the capacitor clear of the chassis. You can print the circuit on *both* sides, without danger of shorting against the case.

Keyed mounting tabs assure correct positioning. Solder terminals are smaller . . . save chassis space, need only a small solder drop to hold securely.

To give a strong mechanical mounting, the prongs can be spread conveniently by means of a simple jig. Aluminum risers from the foil stop short of the soldering area of the terminal . . . can't contaminate the solder.

Write or call us for complete technical information, and for cooperative engineering analysis of your specific capacitor application.

**FOR USE ON
 CONVENTIONAL CHASSIS**



The same special FP Capacitors are also usable on any metal chassis, for service replacement or other applications where they can be individually mounted. For production line use on conventional chassis, the standard Mallory FP Capacitors are recommended.

Expect more . . . Get more from **MALLORY**

Parts distributors in all major cities stock Mallory standard components for your convenience.

Serving Industry with These Products:

- Electromechanical—Resistors • Switches • Television Tuners • Vibrators
- Electrochemical—Capacitors • Rectifiers • Mercury Batteries
- Metallurgical—Contacts • Special Metals and Ceramics • Welding Materials



CROSS TALK

► **NEW ENGLAND . . .** A field trip to the northeast strengthens our belief that this section of the country will continue to exert a major influence upon the design, production and use of electronic equipment despite spectacular gains by other areas.

New England has a number of advantages that cannot be discounted. Its people possess the will to work. They have a high degree of technical skill. Ingenuity is almost the watchword of the Yankee; it flourishes in the shade of fine educational institutions with excellent facilities for research.

While in Boston we had the opportunity of hearing half-a-dozen suppliers of materials and services not in our field speculate, industry by industry, concerning their future markets. In every case electronics was mentioned near the top of the list. We are, it seems, an important industry not only because of what we sell but also because of what we buy, and nowhere is this more evident than in the land of the Pilgrim Fathers.

► **WEIGHT . . .** Sat through a night-spot show with a disc-jockey friend who runs a WCOP remote. This served the double purpose of providing relaxation during a

week on the road and keeping our hand in on broadcasting techniques. Noted that operator used a spool of solder over the turntable spindle to stop record slip. A novel use for the stuff, in our experience.

► **WRITING . . .** The cost of engineering comes up in many conversations with management people these days, perhaps because less of it is financed by the government than a year or so ago.

Several men with whom we have recently explored this subject think the increasing cost is due in large measure to duplication of effort from plant to plant. This reminds us that three separate pieces of printed matter having a direct bearing on this point arrived in the mail this week:

An abstract of a speech says engineering progresses in direct proportion to the number of good published papers. A government experiment station advises that it is starting a course in technical writing for its personnel. And a manufacturer sends us a long letter outlining the opportunities in industry for engineers who can write.

The ultimate importance of technical writing, it seems to us, is simply that by the interchange of information today's work can

begin where yesterday's ended—one need not do again today what was well done yesterday.

► **ROLLING STONES . . .** Widespread pirating of engineers who are up on color television receiver design is reported. Manufacturers are letting no grass grow under their feet in preparing for the new market.

This reminds us that the business of job jumping is not as lucrative in the long run as it was just a few short years ago. Most companies have upped their pay scales, improved working conditions and provided other benefits calculated to hold technical help in a time of shortage. Opportunities for advancement exist in almost every firm in our fast-moving business. Normal obstacles to advancement probably have to be hurdled in the plant across the street too, even though this may not be evident to an outsider. The grass over there is not necessarily greener.

► **HUMAN . . .** On a recent technical program was a paper entitled *The Monte Carlo Method as a Natural Mode of Expression . . .*

We've always suspected that there was a little bit of a gamble in even the most precise branches of engineering.

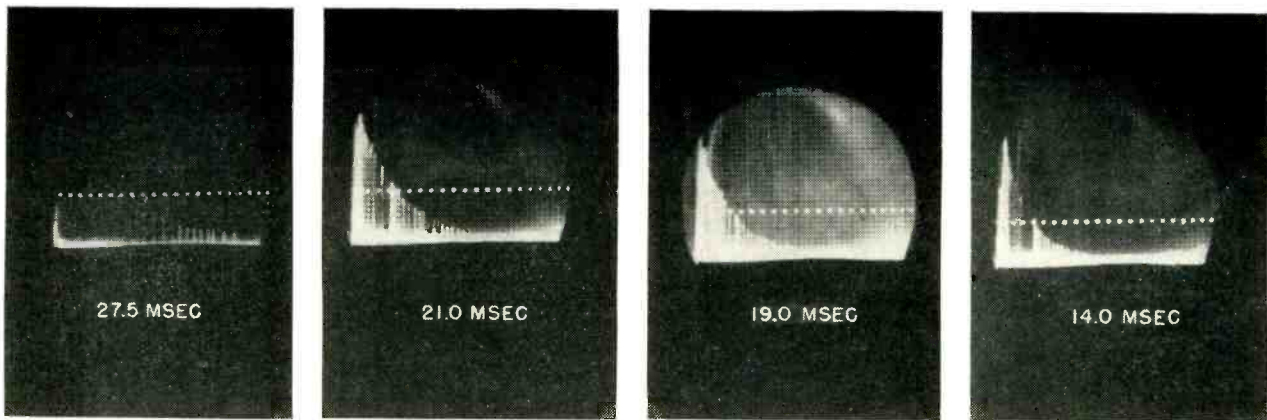

Relaxation times of molecules in oil samples give clue to SAE viscosity

Field Pulses Produce

Pulse transmitter supplies r-f magnetic field for nuclear resonance spectrometer. Study of resulting spin echoes provides additional information about chemical and physical properties of material. Measuring viscosity of lubricating oil is one example

CERTAIN ADVANTAGES of pulse techniques for exciting nuclear resonance become evident when comparisons are made with c-w nuclear resonance systems. The pulse method does not require a homogeneous polarizing field. The received echo signal is obtained when the transmitter is cut off, greatly reducing the effect of the transmitter field at the receiver coil and simplifying probe design. It is in fact possible to use one coil for both transmitter and receiver. However there are advantages in reduction of transient effects in the receiver to be gained by separation of transmitting and receiving circuits. Another advantage of pulsing is that the pulsed signal is readily demodulated and amplified at video frequency and auxiliary sweep fields for producing modulation are not required.

Equipment

Pulse equipment for producing spin echoes is similar to equipment

By **LEONARD MALLING**

*Varian Associates
Palo Alto, Calif.*

used in radar or television. Differences occur mainly in equipment for producing the pulses. Figure 1 is a block diagram of a typical spin echo system designed for proton excitation of liquid chemical samples. A convenient polarizing field and frequency for proton observation is 7,060 gauss and 30 mc, which will satisfy the requirements of the nuclear equation discussed in a previous article.¹ Radio-frequency equipment for proton investigation may be designed for fixed frequency operation and the required nuclear flexibility obtained by varying the polarizing field. Since pulse operation requires wide bandwidths, tuning or searching for signals is relatively simple with magnetic field control.

The sample in its probe is inserted between the pole faces of an electromagnet. The probe uses a

simplified cross-coil arrangement similar to that used in the spectrometer¹; however, since the coils have preset tuning, low-impedance coaxial cables may be used to connect the probe to the electronic apparatus, as shown in the schematic diagram.

Transmitter

Radio-frequency pulses are applied to the probe from a 30-mc transmitter that provides the field for initiating nuclear resonance. The signals generated in the receiver coil are amplified in a 30-mc receiver that has sufficient r-f and video gain to permit observation on an oscilloscope.

A low-frequency function generator supplies continuous pulses to a nuclear timer, which has a flexible control arrangement that provides pulses of the desired characteristics to drive the pulse modulator in the transmitter. The timer ensures also that echo signals are readily observable by supplying suitable con-

USE OF SPIN-ECHO INFORMATION

Main use for equipment of the type described in this article is in measuring certain physical properties of chemicals. Some idea of the applications of spin-echo equipment may be gained from the photographic recordings at the left. These show the experimental results obtained from standard automobile oil samples having different viscosities—from left to right: SAE 10, 20, 30 and 40. The dots on the photos are 5-millisecond time calibration markers.

The physical property measured is the relaxation time, which is a property associated with the motion of molecules in oil samples. The slowly decaying vertical lines are photographic recordings of the change in echo amplitude with change in initiating pulse spacing. As pulse spacing is increased, echo amplitude slowly decreases. With higher viscosities, the decay time is much shorter.

Spin-echo equipment may presently be regarded as a highly specialized tool for the nuclear physicist or chemist. However, as knowledge is gained concerning uses to which nuclear resonance may be put, increasing application of this relatively new phenomenon may be expected—including possible uses in solving purely electronic problems such as memory storage

Nuclear Spin Echoes

trol voltage to the oscilloscope for synchronization and other purposes.

One of the main requirements for the r-f transmitter is that it be capable of producing the required field intensity in the sample enclosed by the transmitting coils. The field intensity should also be continuously controllable to meet the field required depending on the length of the pulse. The field requirement is of the order of 10 gauss and may be readily compared to that for magnetic scanning of television tubes. For nuclear work, however, a sinusoidal r-f field is used.

One effect of the r-f field pulse on nuclei that have already become orientated by the steady d-c polarizing field is to tilt their magnetic moment vectors from the original

direction to some new position. The amplitude of the echo is dependent on the amount of tilt produced by the excitation pulses. The tilt is a function of both pulse width and r-f magnetic field

$$\theta = \gamma H_1 t_w$$

where θ is the angle of tilt of the magnetic moment vectors of the nuclei; γ , a nuclear constant; H_1 , the magnitude of the r-f field; and t_w , the pulse width.

For spin echo equipment, for proton excitation the tilt required may be of the order of 90 degrees. This requires an r-f field of several gauss for a pulse width of the order of 30 microseconds. The r-f field intensity may be provided by an 829A operating as shown in the schematic. Since

one of the major requirements of the transmitter is to provide maximum r-f current in the probe coils, a high Q would appear to be desirable. However, pulse fidelity limits coil Q and sets requirements on output tube operation similar to those for television transmitter output systems.

Receiver Considerations

While one of the primary objectives of spin echo equipment is to produce readily observable echoes, it is sometimes desirable to observe the decay signals that occur immediately after the pulse. A typical presentation of the decay signals may be as shown in Fig. 2. The applied pulses are shown as lines representing relatively narrow

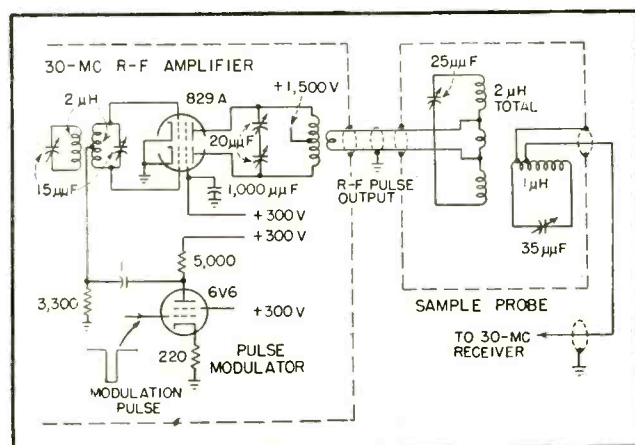

Schematic diagram of probe and transmitter output stages

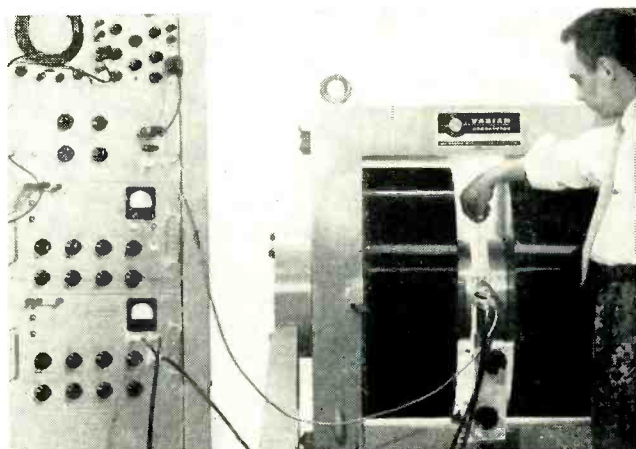

Inserting sample into spectrometer probe

pulses compared to the pulse spacing T . The free decay signals follow immediately after the pulse application and the echo builds up to a maximum after time interval T .

With the simple cross-coil system used on spin echo probes, where no extreme precautions are taken to reduce transmitter pickup at the receiver coil terminals, the transmitter voltage at the receiver coil may be many thousand times greater than the desired signal. Although the free decay signal occurs after the transmitter pulse, the receiver must be capable of presenting the desired information without objectionable transients caused by transmitter pulse overload.

Other receiver considerations such as gain, bandwidth and low signal-to-noise input circuits follow practices now well established in the literature of wide-band amplifier systems.

For a fixed tuned system such as is used here, the signal is brought into resonance by adjusting the magnetic polarizing field to satisfy the resonance equation. The echo signal so obtained may then be maximized by adjustment of the various electronic parameters to suit conditions of the experiment. These parameters include pulse

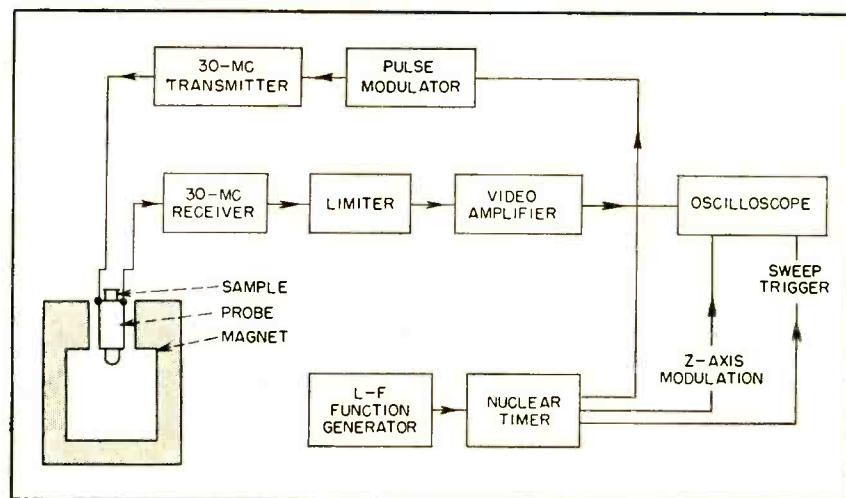

FIG. 1—Pulse operated equipment for studying nuclear spin echoes

spacing, pulse width and transmitter power.

Timer

The nuclear timer for spin echo differs from timers used for radar or television in that extremely slow repetition rates are required due to the long free decay times associated with nuclear resonance of the proton. The repetition rate may vary from 10 to 0.01 cps. However, for convenience of adjustment and ease of observation it is also desirable to have repetition rates as high as 100 cps. As stated above, two r-f field pulses are required to obtain a spin

echo and the pulse spacing may be as short as a few milliseconds or as long as several seconds corresponding to frequencies of from 1,000 to 0.1 cps. The pulse width may be required to vary from 10 to 100 microseconds. In addition, for some nuclear tests a third pulse should be available that may be placed at any desired spacing from the initiating pulse pair.

One of the best ways of securing flexible control and accurate timing in pulse systems is to use a generator of continuous waves or pulses as a driving source. This is the system employed in the spin echo nuclear timer. The block diagram, Fig. 1, shows a low-frequency generator driving the nuclear timer. The function generator has a continuous range of 0.1 to 1,200 cps, corresponding to a pulse pair spacing of one millisecond to 10 seconds.

The system is such that the initiating pulse pair spacing is determined by the frequency of the function generator and all other timing sequences are multiples of the pulse pair spacing. Tuning to maximize the spin echo signal is then readily accomplished by rotating the frequency control dial of the function generator and the time interval between pulses will be known at all times within the accuracy of calibration of the function generator. For some tests the pulse spacing may be quite short—a few milliseconds—whereas the repetition rate may be of the order of once every few seconds.

One way of looking at the nuclear

SPIN ECHOES AND NUCLEAR RESONANCE

The nuclear resonance spectrometer has proved a useful tool for qualitative and quantitative analysis of materials.¹ Study of spin echoes from the nucleus may provide additional important information.

In nuclear resonance spectrometry, a continuous r-f field is applied to a sample immersed in a strong d-c magnetic field. The magnetic moments associated with the nuclei within the sample can be made to precess, producing a small signal that may be amplified and displayed on a recorder. The physical requirements for resonance to occur are $\omega = \delta H_0$ —where $\omega = 2\pi f$ (with f the signal frequency), δ is a nuclear constant, different for each isotope and H_0 is the strength of the polarizing field.

If an r-f pulse is applied rather than a c-w signal, not only does precession occur during the pulse but a steadily decaying signal also persists after the pulse.² This is because energy stored in the orientation of magnetic moments of nuclei during the pulse is dissipated relatively slowly through molecular collisions. This free decay time may be in the order of tenths of a second even though the r-f pulse is only in the order of several microseconds.

If two successive field pulses are applied, then by constructive interference of nuclear-magnetic-resonance signals an echo may be produced after the application of both pulses. This is the spin echo.^{3, 4}

If, before application of the first pulse, the nuclear magnetic moments are oriented in a particular direction by the polarizing field, the first pulse tilts the axis of the nuclei in a new direction. After a period that may be long compared to the pulse width a second pulse is applied and a further shift in orientation produced. The nuclear resonance echo signal is obtained at a time interval equal to the spacing between applied r-f pulses.

In some experiments a third pulse is added to produce further sets of spin echoes. This provides additional information regarding properties of the nuclear spin system

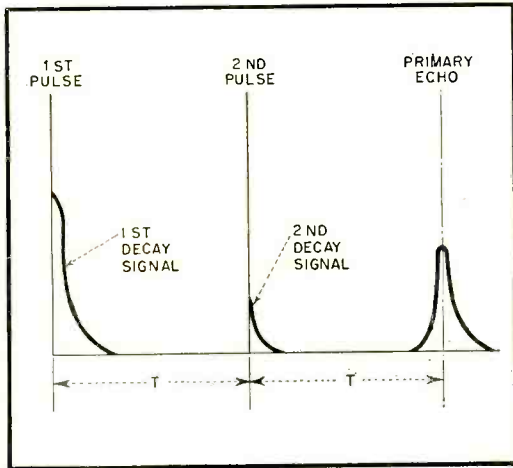

FIG. 2—Free decay signals and echo

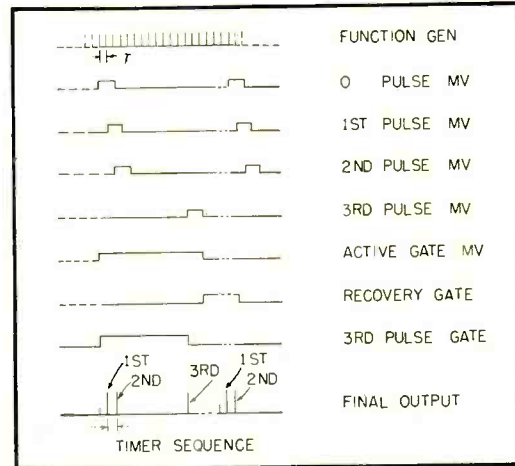

FIG. 3—Relation of pulses and gates

timer is to regard the output as representing a special form of counting, the sequence being, say 1, 2; 101, 102; 201, 202; 201, 302; 401, 402; etc. The 1, 2 count would be the first paired pulse and the interval between 1 and 101 would be the time interval representing the repetition rate, which would be an integral multiple of the spacing between pulses 1 and 2, in this case chosen at 100. This long time interval actually corresponds to the spin recovery rate of the spinning nuclei, or the time required for the spin assembly to return to an equilibrium position in the polarizing field after the application of the r-f pulses. In practice it has been found convenient for oscilloscope synchronization to precede the pulse pair by a synchronizing pulse that does not appear as a r-f pulse. Thus, if in addition a third field pulse is added the counting sequence might be: 0, 1, 2, 21; 100, 101, 102, 121; 200, 201, 202, 221; 300, 301, 302, 321; etc.

Operation

Figure 3 shows the pulse and gate sequences, starting with the continuous pulses delivered by the function generator to the nuclear timer and finishing with the final pulse arrangement at the output. Figure 4 is a simplified block diagram showing the key operation performed by the timer.

Referring to Fig. 4, continuous pulses from the function generator are applied to the control grids of three flip-flop multivibrators V_1 , V_2 and V_3 . Tube V_1 is normally on and V_2 and V_3 are normally off. A

pulse from the function generator will pass directly through V_1 to the output and will simultaneously trip V_1 to cutoff position. As V_1 trips, it trips V_2 through a delay network so that V_2 now passes the next pulse from the input to the output circuit. After the pulse, V_2 drops back to cutoff position and simul-

active gate, which covers the pulse field application and the reception of the echo; and the recovery gate, which covers the period during which the nuclei return to equilibrium. When a third field pulse is required, an extra multivibrator is cut into the pulse selection circuits and is operated by an adjustable

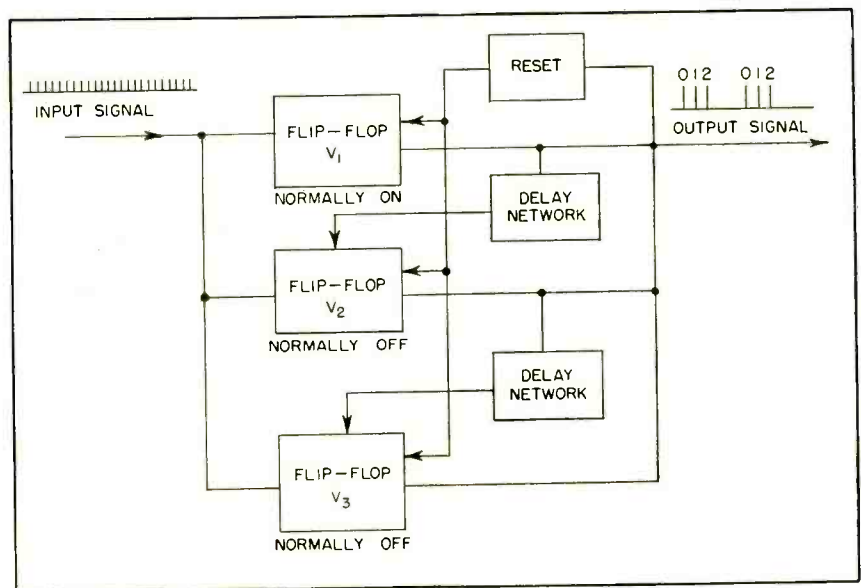

FIG. 4—Obtaining isolated periodic pulse trains from continuous pulse input

taneously readies V_3 for a pulse. After the three pulses have passed, all three flip-flops are in cutoff position so that no further pulses can pass. A reset gate initiated by the first pulse then resets the multivibrators after the desired reset time interval.

Referring once more to Fig. 3, the zero, first and second pulse multivibrators comprise V_1 , V_2 and V_3 in the block diagram, Fig. 4. The reset gate comprises two gates: the

gate that is also initiated by the zero pulse.

Acknowledgments are due the engineers, physicists and technicians associated with this project.

REFERENCES

- (1) L. Malling, Nuclear Resonance Spectrometer, *ELECTRONICS*, Apr. 1953.
- (2) F. Bloch, Nuclear Induction, *Physical Review*, 70, Oct. 1946.
- (3) E. L. Hahn, Spin Echoes, *Physical Review*, 80, Nov. 1950.
- (4) E. L. Hahn, Free Nuclear Induction, *Physics Today*, 6, Nov. 1953.
- (5) See reference 2.

Cosecant Antenna Aids

By JOHN E. MARTIN and JOHN RUZE

*The Gabriel Laboratories
Needham Heights, Mass.*

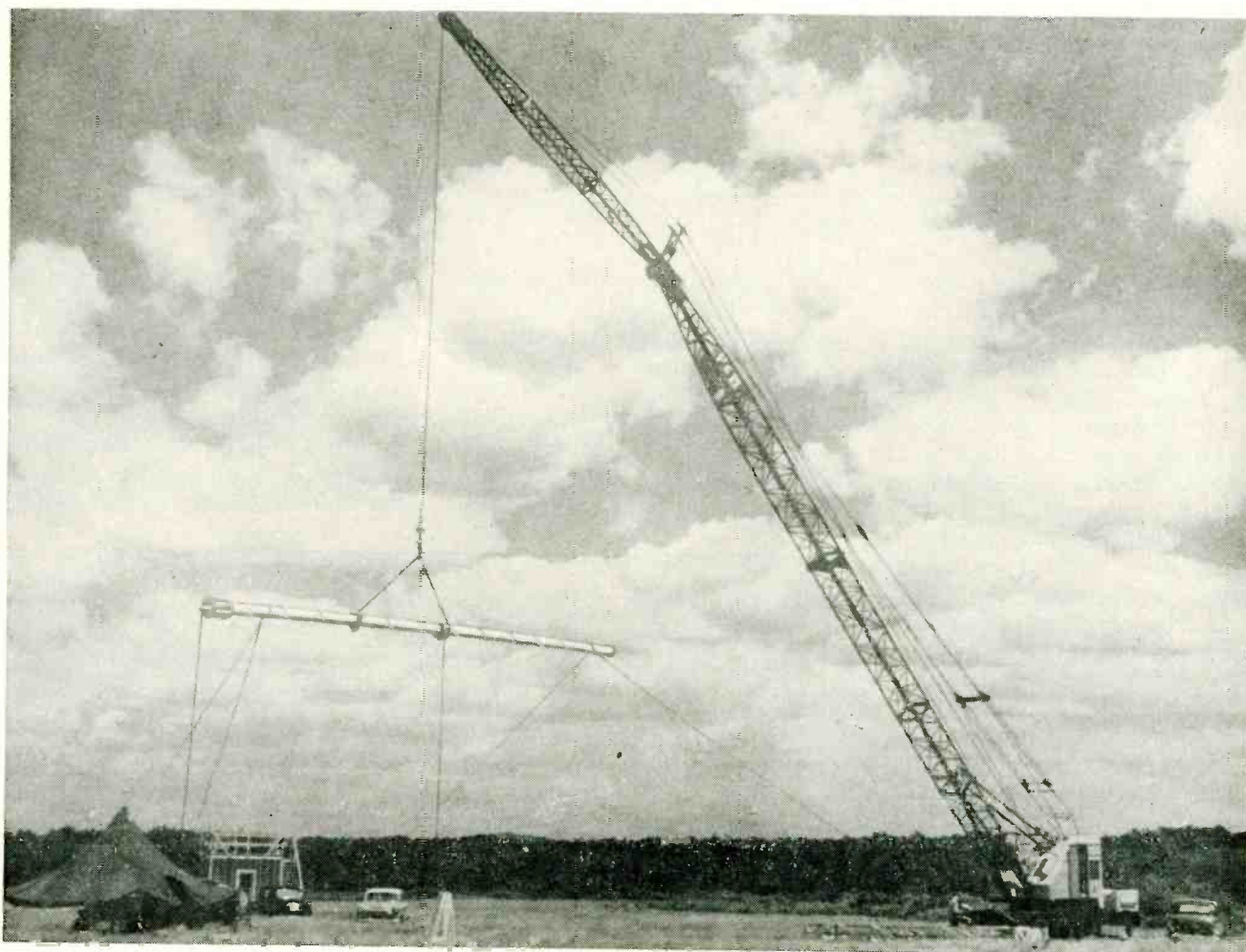

Experimental pattern is verified (see Fig. 10) by suspending antenna and rotating in azimuth while it is illuminated by distant source

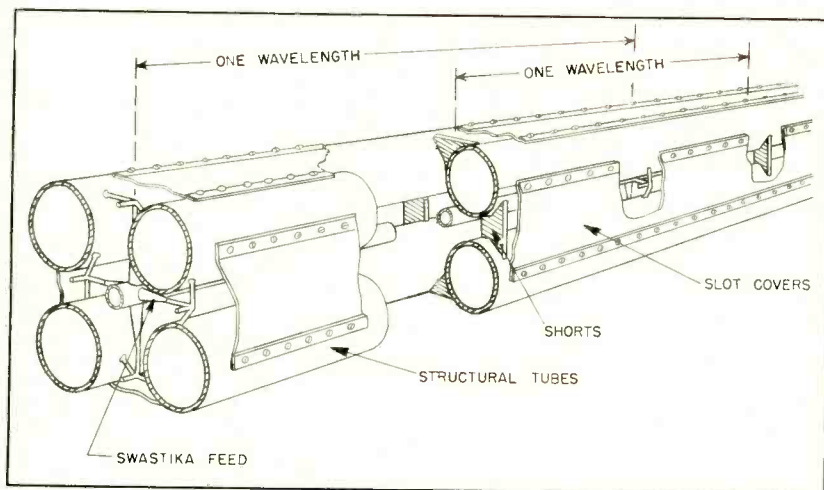

FIG. 1—Sectional view of structural-tube antenna shows shorting members and swastika feeds displaced by a half wavelength

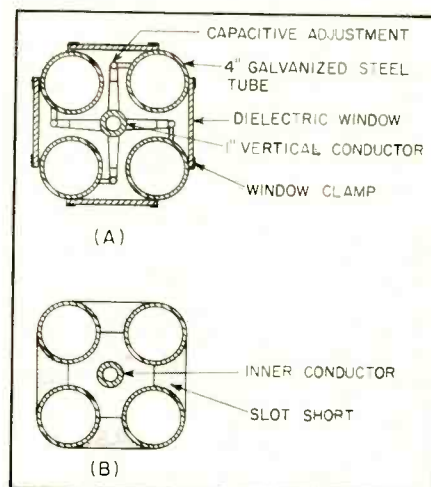

FIG. 2—Cross-section of structure near swastika feed (A) and short (B)

UHF-TV Coverage

Slot-type radiator employs four structural tubes and center conductor to approximate coaxial lines. Advance adjustment permits welding and hot galvanizing. Odd nulls are compensated by unequal power division between top and bottom, while second null is filled by reversing one ring of slots

DESIGN of antennas for uhf television broadcasting presents problems in some ways more stringent than for vhf broadcasting. At uhf, lower transmitter power is available and higher transmission line losses are incurred at both the transmitter and receiver installations. The signal-to-noise ratio of uhf receivers, in general, is less than that obtainable with vhf receivers.

Sharper shadow regions exist at higher-frequency transmission. Furthermore, it is doubtful if larger-aperture receiving antennas actually effect greater gain since they may often be installed in a highly distorted and rapidly varying field. Consequently, for uhf picture quality comparable to vhf standards, greater effective signal strength is required.

Design Problems

Increased signal strength from higher-gain transmitting antennas, obtained with a number of stacked elements, necessarily implies a narrower vertical beamwidth. If the technique of branch-feeding is used, a complex harness greatly increases the cost of manufacture. Alternatively, the simplification afforded by end-feeding makes it more difficult to realize the low vswr required for good picture quality.

Narrower vertical beamwidths also cause the first and second antenna nulls to advance well into the service area, thereby creating circular regions of low field strength. This situation is particu-

larly disconcerting when the antenna is located in a large metropolitan area where deep valleys of low signal intensity are flanked by regions of high field strength. The ideal radiation pattern is a shaped vertical pattern proportional to the cosecant of the depression angle. Such a pattern would lay down a

constant field regardless of range.

Chief problems confronting the antenna designer are: limited bandwidth owing to the larger number of elements and the increased effect of transmission-line discontinuities, irregular coverage resulting from presence of antenna nulls in the primary service area, higher manufacturing costs owing to the increased number of elements and need for a simplified mechanical design affording minimum maintenance and maximum reliability.

These problems have been effectively resolved in a newly developed cosecant uhf antenna that is the subject of this article.

Slot Array

The antenna comprises a vertical array of slot radiators propagating horizontally polarized waves. The slots are formed by the spaces between four vertical tubes of structural steel with four-inch outer diameter and wall thickness of a quarter inch. The tubes are arranged in a square with tube centers five inches apart. The tubes are shorted at intervals by welded steel members, forming a series of rings of resonant slots spaced one wavelength between centers and approximately a wavelength long.

The arrangement shown in Fig. 1 results in a radiating system integral with the supporting structure. The slot apertures are sealed by low-loss plastic covers that envelop a major portion of the external surface of the antenna. The covers are dyed international

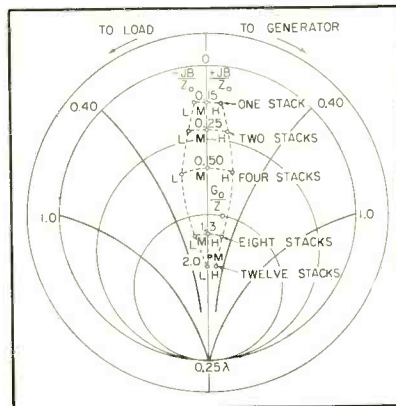

FIG. 3—Optimum bandwidth for twelve stacks is confirmed by plotting

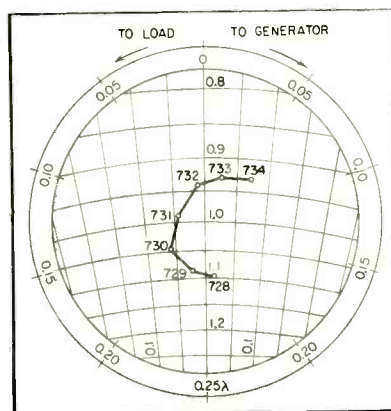
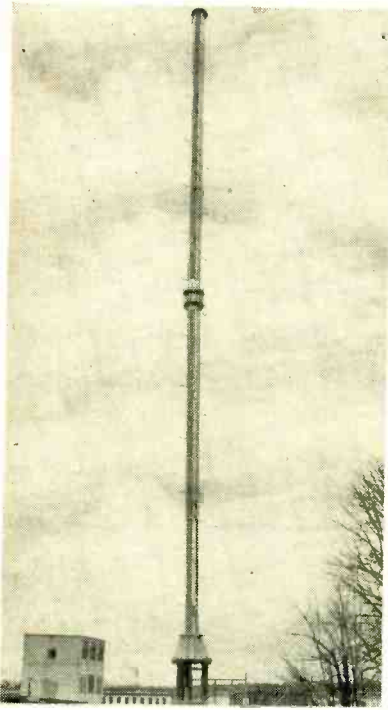

FIG. 4—Admittance curve of the complete antenna



Twenty-four wavelength aperture of uhf-tv antenna is accomplished with no external appendages, thereby minimizing ice formation

orange to obviate maintenance painting of the antenna.

The complete antenna comprises two electrically identical sections of twelve slots each, forming a 24-wavelength aperture.

R-F Feed

The two 12-wavelength sections are center-fed by a standard 3 1/8-in. coaxial line that runs up one of the 4-in. vertical tubes. The individual slots of each section are tapped across the transmission line formed by the inner conductor and the four structural tubes and extending the length of each section. A cross-section of this arrangement is shown in Fig. 2.

A five-wire line is thus formed with the four structural elements acting as the ground; that is, they are equivalent to the outer conductor of a coaxial system. Each ring of slots is energized in phase by the so-called swastika branch-feed arrangement shown in Fig. 1.

The center conductor is rigidly supported by the solid swastikas every wavelength and by the quarter-wave short after the last slot. With the exception of the gas seal at the input, no insulators are used in the antenna proper.

End feeding of an array of many elements is possible only for relatively small bandwidths because the input admittance and the vertical pattern vary considerably with changes in frequency. To obtain the exacting match over the 6-mc channel required for good picture quality, it is necessary to optimize the various antenna parameters for maximum bandwidth.

The antenna can be represented by a vertical transmission line loaded at one-wavelength intervals by equal normalized admittances γ_s , that can be assumed constant over the narrow frequency spread. For a small frequency variation, analysis indicates that the input admittance γ_{IN} is given by

$$\gamma_{IN} = n\gamma_s + j2\pi \frac{\Delta f}{f} \times \left[(n-1) - \gamma_s^2 \sum_{k=1}^{n-1} k^2 \right] + \text{higher order terms} \quad (1)$$

where n is the number of radiators.

At the midfrequency Δf is zero and the input admittance becomes matched to the feeder of character-

istic admittance γ_o when

$$n\gamma_s = \gamma_o \quad (2)$$

The use of this value of γ_s yields a variation of the input admittance with frequency principally owing to the imaginary term. For example, a 1-percent frequency variation results in a mismatch of approximately 1.3.

On the other hand, making

$$\gamma_s = \left[\frac{n-1}{\sum_{k=1}^{n-1} k^2} \right]^{1/2} \quad (3)$$

produces an input admittance constant for small percentage variation in frequency and equal to

$$\gamma_N = n \left[\frac{n-1}{\sum_{k=1}^{n-1} k^2} \right]^{1/2} \quad (4)$$

As an example, for a bandwidth of ± 1 percent the input vswr does not exceed 1.05 and is due to the higher order terms. Under this optimum bandwidth condition, the bandwidth can be shown proportional to the square of the number of slots.

This optimum bandwidth condition can be regarded as minimizing the stored energy in the system and the vswr on the vertical feeder is minimum near the center of the array. In the case where $\gamma_s = \gamma_o/n$, unity vswr occurs at the antenna input and the vswr increases in steps toward the end of the array.

An experimental verification of the optimum bandwidth condition, is illustrated in Fig. 3, where the input admittance variation for one,

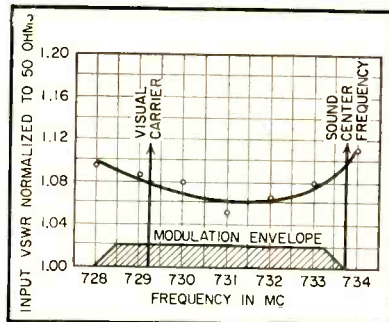

FIG. 5—Input vswr curve plotted against frequency

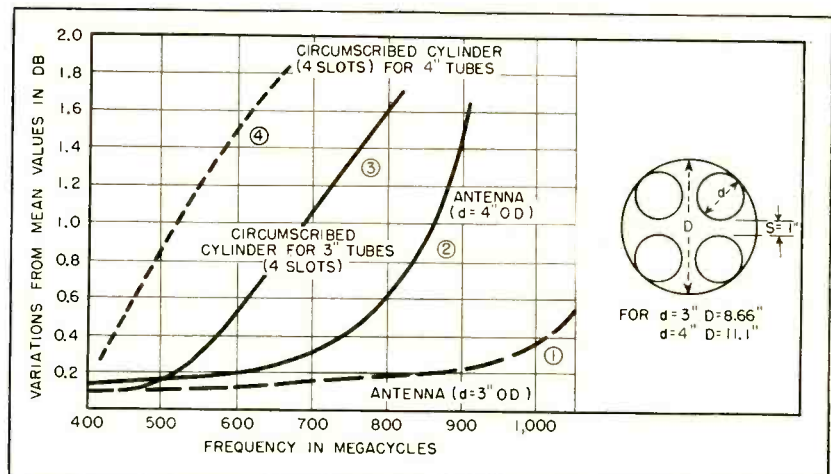

FIG. 6—Measured variations from mean field strength of horizontal radiation

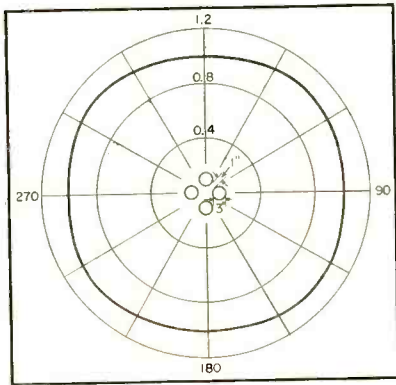

FIG. 7—Horizontal pattern measured at 650 mc

two, four, eight and twelve-element arrays from an optimized twelve-element array is plotted. The measured variations are a maximum for half the array, decreasing to a minimum for the complete array. A simple quarter-wave transformer is used to match the admittance to the input feeder. The final admittance and vswr for the complete antenna consisting of two center-fed sections are shown in Fig. 4 and 5.

To apply the optimum bandwidth condition, it is necessary to adjust the slot admittance to be real and of the magnitude required by Eq. 3. This value is obtained by adjusting the point of contact on the slot and the length of the tuning susceptance. Correct adjustment of the tuning susceptance is determined on a special test section for each channel, permitting the actual antenna to be constructed with no variable adjustments. The entire antenna becomes a welded unit that is hot-dip galvanized after adjustment and welding.

Horizontal Pattern

The horizontal patterns of this structure did not exhibit the theoretical circularity expected of an approximate cylinder having

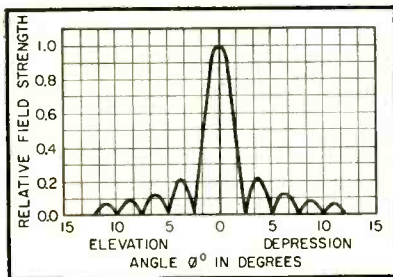

FIG. 8—Vertical pattern of in-phase aperture

four in-phase slots. To illustrate this point the measured and calculated variations from circularity are plotted in Fig. 6. Curves 1 and 2 are plots of measured variation from circularity; curves 3 and 4 are plots of calculated variation based on maximum cross-sectional diameters.

The striking conclusion is that the actual pattern deviation is considerably less than that computed on the basis of a cylinder circumscribing the vertical tubes. Moreover, the equivalent cylinder giving the same circularity as the tube configuration is smaller than the circle joining the tube centers, a circumference on which no radiating current exists.

Circular Pattern

Maximum radiation intensity occurs opposite each slot in a typical measured pattern (Fig. 7). The improved circularity has no special significance apart from the practicability of using fewer slots to obtain a given circularity with a fixed cross-sectional dimension.

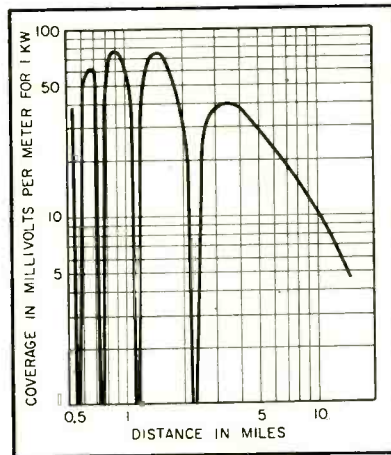

FIG. 9—Predicted coverage of antenna with gain of 27.5

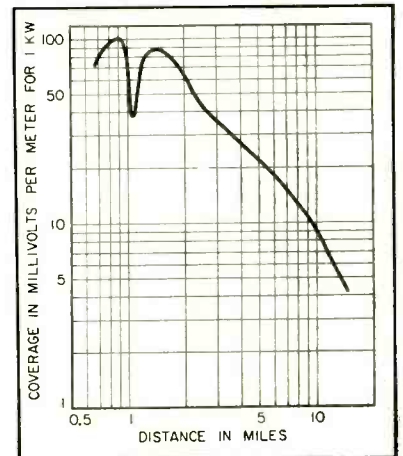

FIG. 11—Predicted coverage of fill-in pattern and gain of 24

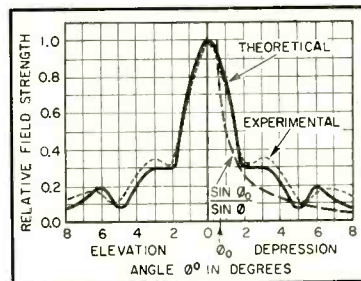

FIG. 10—Vertical pattern with null fill-in

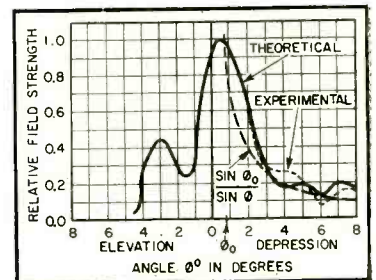

FIG. 12—Vertical pattern with null fill-in and beam tilt

The vertical pattern of a uniform in-phase aperture of 24 wavelengths is given by

$$\frac{\sin(24\pi \sin \theta)}{(24\pi \sin \theta)}$$

which is plotted in Fig. 8. This function has zero values at $\arcsin n/24$, for integer values of n which bracket the subsidiary maxima. The locus of the maximum values follows the cosecant pattern. The power gain of such an antenna is 27.5, after allowing for a 0.3-db copper loss. Figure 9 indicates the coverage diagram to be expected on the basis of the FCC (50, 50) curves when the antenna is mounted on a 500-foot tower. Note the regions of low signal strength caused by the antenna nulls. This antenna should be satisfactory in installations where the service area does not include the region immediately adjacent to the transmitter.

In many installations it is desirable to fill in the antenna nulls. The first, third, fifth and successive odd nulls can be filled by unequal power division between the top and

bottom sections. The radiation pattern then becomes

$$\frac{\sin(12\pi \sin \theta)}{(12\pi \sin \theta)} \times [\cos(12\pi \sin \theta) + jb \sin(12\pi \sin \theta)]$$

where b is related to the power division by power ratio = $[(1 + b)/(1 - b)]^2$.

The second null still remains unfilled. To fill the second null, one of the rings of slots is reversed in phase. The slot chosen is one that contributes quadrature field in the immediate vicinity of the second null. The resulting pattern is shown in Fig. 10 and the predicted coverage diagram in Fig. 11. The antenna gain is correspondingly reduced to 24.

The antenna beam can also be depressed by advancing the phase of the top section. Figures 12 and 13 indicate the pattern and the expected coverage diagram with a phase advance of 60 deg. The peak gain is now reduced to 19.

Pattern Verification

The measurement of the vertical pattern of a horizontal omnidirectional antenna is beset with many difficulties. The antennas for the lower uhf channels are over 50 feet long and weigh approximately 3,000 pounds. The antenna must be properly supported and rotated, using a pattern range in excess of 2,500 feet. It is necessary that the area surrounding the antenna under test be reasonably clear to avoid reflections. Supporting structure reflections are particularly troublesome.

The main body of the pattern can be recorded quite accurately; however, some doubt exists about the data in the null regions. Patterns were taken on several antennas supported four feet above a heavy steel mount by a wooden structure. The data did indicate adequate null fill-in, but the variation of the null structure with a small percentage change of frequency indicated that some field distortion was present.

To obtain a better evaluation of the true free-space pattern, the arrangement shown in the photograph was used. Here the antenna, elevated by a large crane, was connected to a 36-to-1 selsyn arrange-

ment for angular information. As the crane and the recording equipment were located on the antenna axis, in which direction the antenna does not receive radiation, it was felt that the free-space condition was simulated as closely as possible.

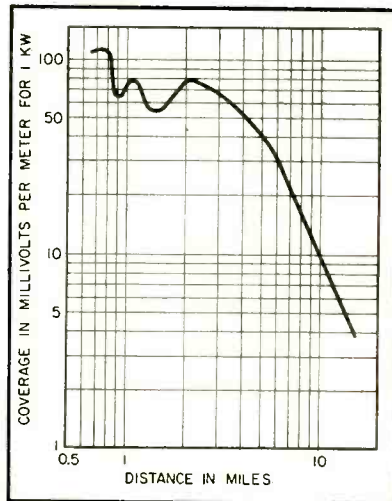

FIG. 13—Predicted coverage with null fill-in and beam tilt. Gain is 19

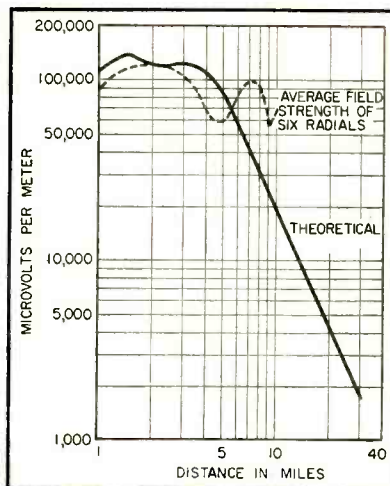

FIG. 14—Observed field strength versus distance for WNOK-TV

The entire test was performed on an abandoned air field, so that reflections from the rear were also minimized. The pattern so obtained is compared with the theoretical in Fig. 10.

Mechanical Design

The antenna is a self-supporting cantilever designed for general tower mounting. The structural rigidity is based on a maximum deflection of less than 0.5 deg at

the radiation center for a wind velocity of 100 mph assuming a pressure of 35 psf. An advantage of the structural configuration is that there are no weakening cut-aways or fragile appendages. The absence of insulators and connectors enables welding and galvanizing the antenna as a complete unit, a process that eliminates practically all subsequent deterioration and failure in service.

Weatherproofing

The antenna is weatherized using strips of dielectric material caulked and clamped over the slots on the tangent planes of the tubes. A specially treated polyethylene or Fiberglas board is suitable. The antenna is allowed to breathe through holes drilled through the base plate, which also serve to drain away moisture during excessive condensation. The gas seal at the antenna input seals off the tower feeder from the antenna.

Elimination of all external appendages and the large ratio of dielectric-to-metal on external surfaces hinder ice formation. Furthermore, each slot layer is essentially a low-Q system with a low slot impedance yielding a low slot voltage. This minimizes the adverse effect of ice layers of high dielectric constant, $\epsilon = 4$. As a result, deicing is seldom required in the majority of applications.

Experimental Survey

To obtain an experimental verification of the predicted coverage diagram and especially to demonstrate the effectiveness of the null fill-in feature, a field-strength survey was conducted on television station WNOK, Columbia, South Carolina. This station operates on channel 67 (790 mc) with a 5-kw transmitter. The survey was conducted by the Allen B. DuMont Laboratories with the consulting firm of Kear and Kennedy participating. Figure 14 indicates the average measured field strength of six radials in comparison to the predicted curve.

This final antenna is based on a design originally developed by H. J. Rowland, formerly of these Laboratories. The development was under the general supervision of L. J. Chu.

Color-Bar Generator Produces I-Q Signals

Signals for alignment of Q and I demodulators obtained from color-bar generator by control of blue-green and blue-red overlap. Simple set-up makes method useful for laboratory alignment work

By **ARCHIE F. BOSCIA***

Senior Test Equipment Engineer
Stromberg Carlson Co.
Rochester, N. Y.

GENERATORS producing red, green, blue and green bars for color tv work can be adjusted to provide I and Q bars for alignment of decoders for these signals. Normally, such a generator is set up to display green, yellow, red, magenta, blue, cyan and green in the most saturated condition possible. Where Q and I bars are needed, it is possible to produce them by proper adjustment of the color-bar overlaps.

The process can be explained by reviewing the equations for Q and I

$$Q = -0.52G + 0.21R + 0.31B \quad (1)$$

$$I = -0.28G + 0.60R - 0.32B \quad (2)$$

In the red-blue overlap, $G = 0$, so

$$I = 0.60R - 0.32B \quad (3)$$

which can be reduced to zero by making $R = (0.32/0.60)B = 0.52B$. This means the magenta overlap can be adjusted to be a bar with $I = 0$, which is a Q bar, by making the red-bar amplitude about $\frac{1}{2}$ the blue-bar amplitude.

Similarly, in the blue-green overlap, $R = 0$, so

$$Q = -0.52G + 0.31B \quad (4)$$

which can be reduced to zero by making $G = (0.31/0.52)B = 0.60B$. Consequently the cyan overlap can be adjusted to be a bar with $Q = 0$, which is an I bar.

Equations 1 and 2 show that

* Work done while with Warwick Mfg. Corp.

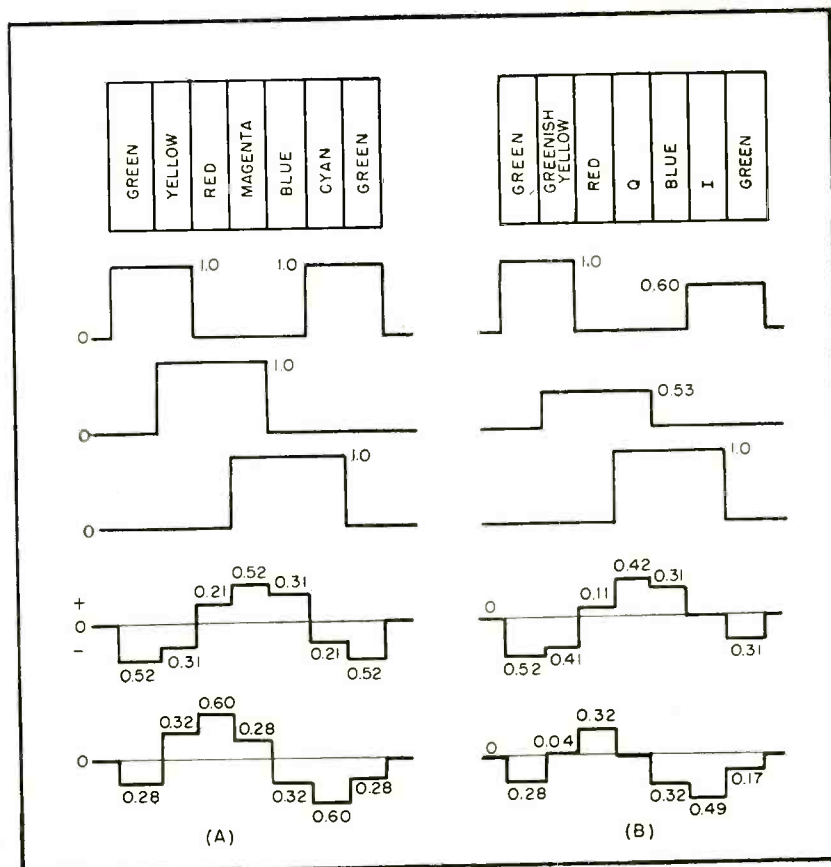

FIG. 1—Generator waveforms for normal display (A) and for I-Q display (B)

the actual bars produced with these adjustments are $+Q$ and $-I$. This does not hamper their usefulness.

In practice the generator is set up for the normal overlapped display of green, yellow, red, magenta, blue, cyan and green. Waveforms at various points in the equipment will appear as in Fig. 1A. Then, observing the Q signal at the matrix adder (or at any other available point) the second green-bar amplitude is reduced until the blue-green overlap shows up as zero

amplitude Q . This adjusts the $-I$ bar in the cyan overlap.

Next, observing the I signal in the matrix adder, the red-bar amplitude is reduced until the blue-red overlap shows zero amplitude. This completes the adjustment of the Q bar. The waveforms with this arrangement are shown in Fig. 1B.

Inspection of Eq. 1 and 2 will show that a similar procedure could have been carried out using the red-green overlap, but the method presented has proved more practical.

Temperature-Stabilized

Design equations and nomograph for determining variation of operating point of junction-transistor amplifiers with temperature provide information for using circuit parameters to stabilize operation. All equation data can be easily measured or calculated

By HAROLD J. TATE

Fairchild Guided Missiles Division
Fairchild Engine and Airplane Corp.
Wyandanch, New York

SEMICONDUCTOR devices are much more sensitive to variations in ambient temperature than electron tubes. In the case of the point-contact transistor, the most temperature sensitive parameters are r_c , the collector resistance, and α , the current gain.^{1,2}

Variations of I_{co} and r_c with temperature can cause marked limitations in the operation of junction-

transistor amplifiers. (I_{co} is the saturation collector current which flows when the emitter circuit is open.) Due to increase in I_{co} , a perfectly stable amplifier at room temperature can shift in quiescent operating point to collector-current saturation if precautions in temperature stabilization are not observed.

With variations in I_{co} alone, stabilization can be achieved by controlling the ratio of equivalent-emitter to equivalent-base series resistance in the bias network.³

The treatment which follows will examine the question of temperature stabilization in the general case, including the possibility of changes in r_c . No assumption is made as to the linearity of these changes with temperature. A relatively simple relationship can be derived to show the effect of variations in r_c and I_{co} on the quiescent collector current of any junction-transistor amplifier.

For convenience, all analyses are carried out in terms of the *pn*p junction transistor. However, the final results apply to the *npn* type as well.

Temperature Effects

Figure 1A shows the collector characteristics of a typical *pn*p junction transistor at room temperature and Fig. 1B shows the collector characteristics of the same transistor at an elevated temperature.

Two effects can be observed

as a result of the rise in ambient temperature: a pronounced shift of the characteristics in the direction of increased collector current caused by an increase in I_{co} and a small tilt or decrease in slope of the characteristics caused by a decrease in r_c .

The temperature coefficient of I_{co} is different for the various transistor types currently available. In addition, it varies among transistors of the same type. However, as better control is exercised over manufacturing processes, more exact information should become available.

For the *npn* grown-junction transistor I_{co} is of the order of 10 percent per deg C.¹

Analysis

In the analysis which follows, R is used for parameters external to the transistor and r for internal equivalent-T parameter⁴. The I_{co} value and its primes refer to quantities described in Fig. 2. All other V 's and I 's refer to values at the operating point. Lower case v 's and i 's are instantaneous values. It is assumed that:

(1) Emitter-base voltage is zero for all values of forward emitter current greater than zero. This voltage will generally be 0.1 volt or less.⁵

(2) Base resistance is negligible compared to collector resistance.

(3) Collector resistance is constant over the entire operating range of currents and voltages. It

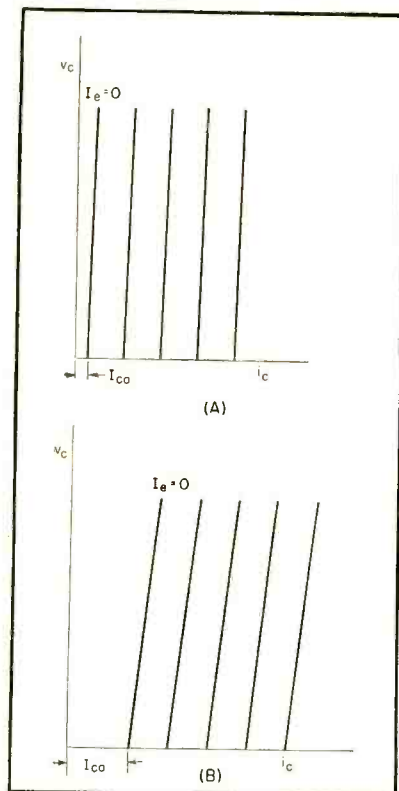

FIG. 1—Typical transistor characteristics at room temperature (A) and at higher temperature (B)

Transistor Amplifiers

is, however, a function of temperature.

(4) Current gain, α , is independent of temperature.

Equivalent Circuit

The d-c equivalent circuit of a *pn*p junction-transistor amplifier is shown in Fig. 3. The biasing network can be reduced to this equivalent circuit by application of Thevenin's theorem.

The loop equations for this network are

$$i_e (R_e + R_b) - i_c (R_b) = E_e + E_b \quad (1)$$

$$-i_e (R_b) + i_c (R_b + R_c) = E_c - E_b - v_c \quad (2)$$

From Eq. 1,

$$i_e = \frac{E_e + E_b}{R_e + R_b} + \frac{R_b}{R_e + R_b} i_c \quad (3)$$

Solving Eq. 1 and 2 for v_c ,

$$v_c = E_{cc} - i_c R' \quad (4)$$

where

$$E_{cc} = E_c + E_e \frac{R_b}{R_e + R_b} - E_b \frac{R_c}{R_e + R_b} \quad (4A)$$

$$\text{and } R' = R_c + \frac{R_e R_b}{R_e + R_b} \quad (4B)$$

Figure 2 shows the load line represented by Eq. 4 superimposed on a typical set of collector characteristics. At the operating point *OP*

$$I_c = \alpha I_e + I''_{co} + I_{co} \quad (5)$$

$$\text{where } I''_{co} = \frac{V_c}{r_c} \quad (5A)$$

Combining Eq. 3, 4 and 5 and solving for I_c

$$I_c = \frac{\alpha(E_e + E_b)}{1 - \frac{\alpha R_b}{R_e + R_b} + \frac{R'}{r_c}} + \frac{E_{cc}}{r_c} + I_{co} \quad (6)$$

Taking the natural logarithm of each side of Eq. 6

$$\ln I_c = \ln \left(\frac{1}{1 - \frac{\alpha R_b}{R_e + R_b} + \frac{R'}{r_c}} \right) + \ln \left(\alpha \frac{E_e + E_b}{R_e + R_b} + \frac{E_{cc}}{r_c} + I_{co} \right)$$

Differentiating and collecting terms,

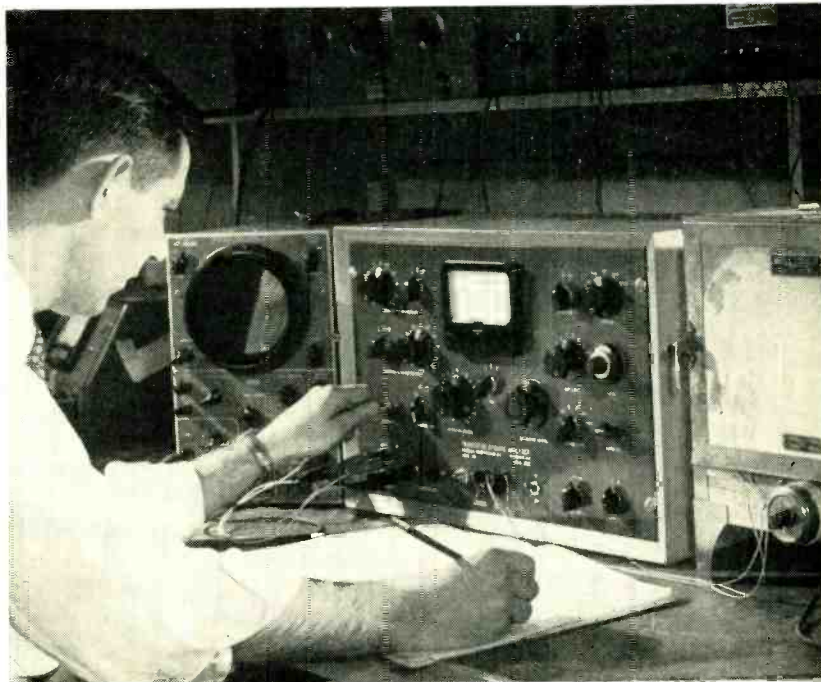

Characteristic variations with temperature are measured with analyzer. Transistor is in oven at right

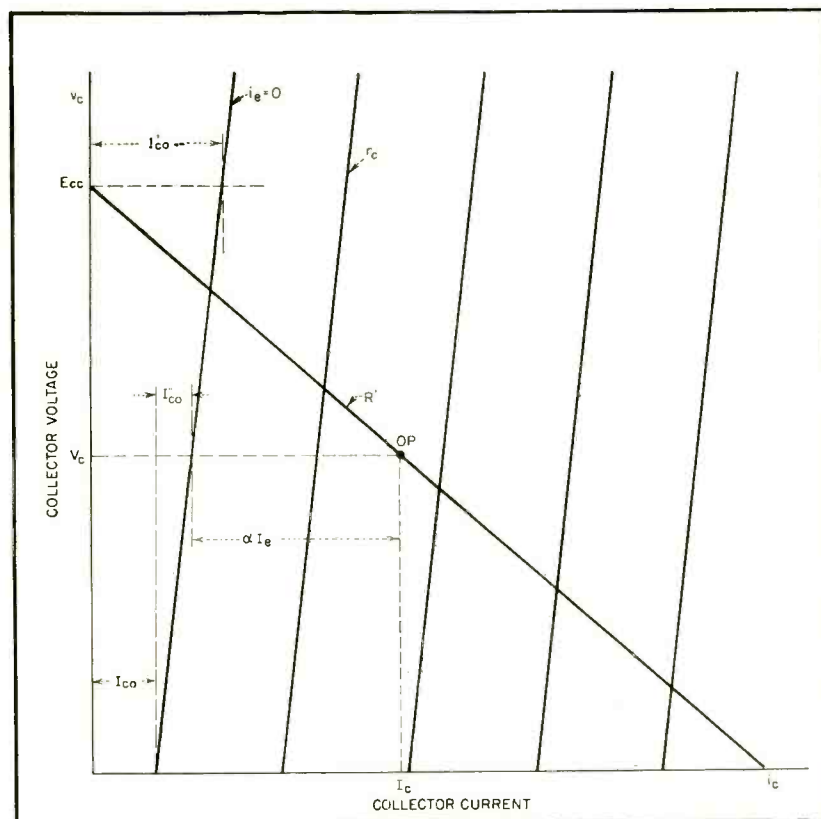

FIG. 2—Graphical definition of terms used in stabilization calculations

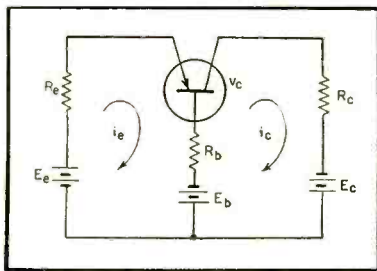

FIG. 3—Direct-current equivalent circuit for pnp junction transistor

where the temperature-dependent variables are r_c and I_{co} , and using $d(\ln v) = dv/v$,

$$\frac{dI_c}{I_c} = \left[\frac{I_{co}}{\alpha \frac{E_e + E_b}{R_e + R_b} + \frac{E_{cc}}{r_c} + I_{co}} \right] \frac{dI_{co}}{I_{co}} + \left[\frac{R'}{R' + r_c \left(1 - \frac{\alpha R_b}{R_e + R_b} \right)} - \frac{E_{cc}/r_c}{\alpha \frac{E_e + E_b}{R_e + R_b} + \frac{E_{cc}}{r_c} + I_{co}} \right] \frac{dr_c}{r_c} \quad (7)$$

After further simplification, using Eq. 4 and 6,

$$\frac{dI_c}{I_c} = \left[\frac{I_{co}}{\alpha I_{co} + I'_{co}} \right] \frac{dI_{co}}{I_{co}} + \left[\frac{I''_{co}}{\alpha I_{co} + I'_{co}} \right] \frac{dr_c}{r_c} \quad (8)$$

where

$$I_{co} = \frac{E_e + E_b}{R_e + R_b} \quad (8A)$$

$$I'_{co} = I_{co} + \frac{E_{cc}}{r_c} \quad (8B)$$

$$I''_{co} = \frac{V_c}{r_c} \quad (8C)$$

$$\frac{dI_{co}}{I_{co}} = \text{fractional increase in } I_{co} \text{ (8D)}$$

$$\frac{dI_c}{I_c} = \text{fractional increase in } I_c \text{ (8E)}$$

$$\frac{dr_c}{r_c} = \text{fractional decrease in } r_c \text{ (8F)}$$

Equation 8 relates the change in collector quiescent operating current to the change in r_c and I_{co} which caused it. Each term in Eq. 8 has a simple physical significance. Terms I_{co} , I'_{co} and I''_{co} appear graphically in Fig. 2.

The most important term in Eq. 8 is αI_{co} , which must be large for good stabilization. The term I_{co} also has a simple physical significance: it is the emitter current which flows if the collector circuit

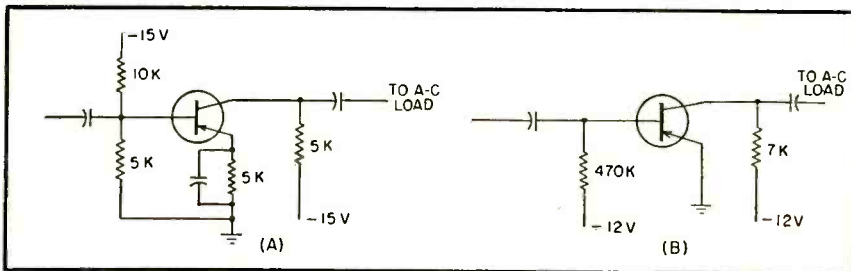

FIG. 4—Stabilized grounded emitter amplifier (A) and unstabilized amplifier (B) used in examples

is opened. Since I_{co} is generally greater than I''_{co} , the form of this equation suggests that a junction-transistor amplifier will be stabilized against temperature variations if the emitter current which flows with the collector circuit open is large compared to I_{co} .

This criterion can generally be applied by inspection. For example, Fig. 4 illustrates two grounded-emitter amplifiers. If the a-c load impedance is small compared to 5,000 ohms, then each amplifier will have about the same input impedance, output impedance and power gain. However, the amplifier of Fig. 4A is stabilized and that of 4B is not.

Circuit Analysis

Consider figure 4A. By Thevenin's theorem, the d-c base circuit is equivalent to a 5-volt battery in series with 3,300 ohms. Current I_{co} is therefore 5 volts divided by 3,300

ohms plus the 5,000 ohms in series with the emitter, or 0.603 ma. This is large compared to I_{co} , which will be of the order of magnitude of 0.02 ma. The stabilization will therefore be good. In Fig. 4B, I_{co} is 12 volts divided by 470,000 ohms or 0.025 ma, which is comparable to I_{co} . The stabilization will be poor.

Examples

To illustrate a complete sample calculation, the amplifiers of Fig. 4 will be examined in more detail. Assume that the transistor is a pnp type having collector characteristics as shown in Fig. 5. For this transistor $\alpha = 0.95$, $r_c = 1$ megohm and $I_{co} = 20$ microamperes.

To assist in making calculations, the nomograph of Fig. 6 is used. Rewriting Eq. 8 in slightly different form

$$\frac{dI_c}{I_c} = \Delta \frac{dI_{co}}{I_{co}} + \Delta' \frac{dr_c}{r_c} \quad (9)$$

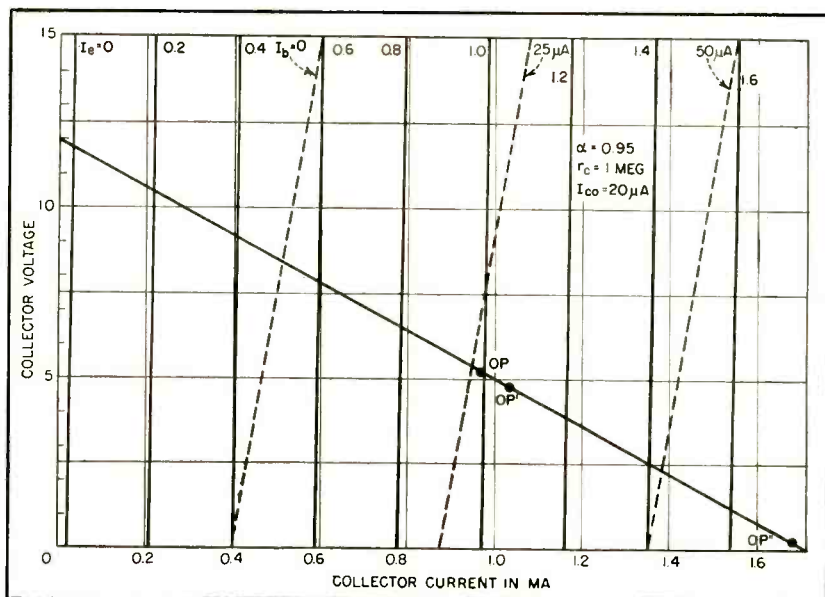

FIG. 5—Collector characteristics for pnp transistor example described in text

$$\text{where } \Delta = \frac{I_{co}}{\alpha I_{co} + I_{co}'}$$

$$\Delta' = \frac{I_{co}''}{\alpha I_{co} + I_{co}'}$$

Equation 9 can now be solved graphically by use of the nomograph in Fig. 6.

Stabilized Amplifier

Considering the amplifier of Fig. 4A, the necessary quantities will be computed for use in stabilization Eq. 9.

- $E_{cc} = 12$ volts (Eq. 4A)
- $R' = 7,000$ ohms (Eq. 4B)
- $I_c = 0.963$ ma (Eq. 6)
- $V_c = 5.3$ volts (Eq. 4)
- $I_{co}' = 0.032$ ma (Eq. 8B)

therefore

$$\alpha I_{co} / I_{co}' = 17.8, I_{co} / I_{co}' = 0.625, I_{co}'' / I_{co}' = 0.166$$

Entering the nomograph with these values

$$\Delta = 0.034$$

$$\Delta' = 0.009$$

and so

$$\frac{dI_c}{I_c} = 0.034 \frac{dI_{co}}{I_{co}} + 0.009 \frac{dr_c}{r_c}$$

To calculate dI_c / I_c assume typical values for dI_{co} / I_{co} and dr_c / r_c . If dI_{co} / I_{co} is 10 parts in 100 per deg C, then for a temperature rise of 20 deg C, $dI_{co} / I_{co} = 2$.

If it is further assumed that $dr_c / r_c = 0.5$

$$\text{then } \frac{dI_c}{I_c} = 0.034(2) + 0.009(0.5) = 0.0725$$

so that I_c increases 7.3 percent for a 200-percent increase in I_{co} , and a 50-percent decrease in r_c . Considerable stabilization is seen to have been achieved. The operating point OP moves to $1.073 \times 0.963 = 1.03$ ma which is represented by OP' in Fig. 5.

Considering the amplifier circuit shown in Fig. 4B:

- $I_{co} = 0.025$ ma
- $E_{cc} = 12$ volts
- $R' = 7,000$ ohms
- $I_c = 0.98$ ma
- $V_c = 5.1$ volts

The d-c load line and quiescent operating point for this calculation are the same as in the previous example.

For this amplifier:

$$\alpha I_{co} / I_{co}' = 0.743, I_{co} / I_{co}' = 0.625, I_{co}'' / I_{co}' = 0.159$$

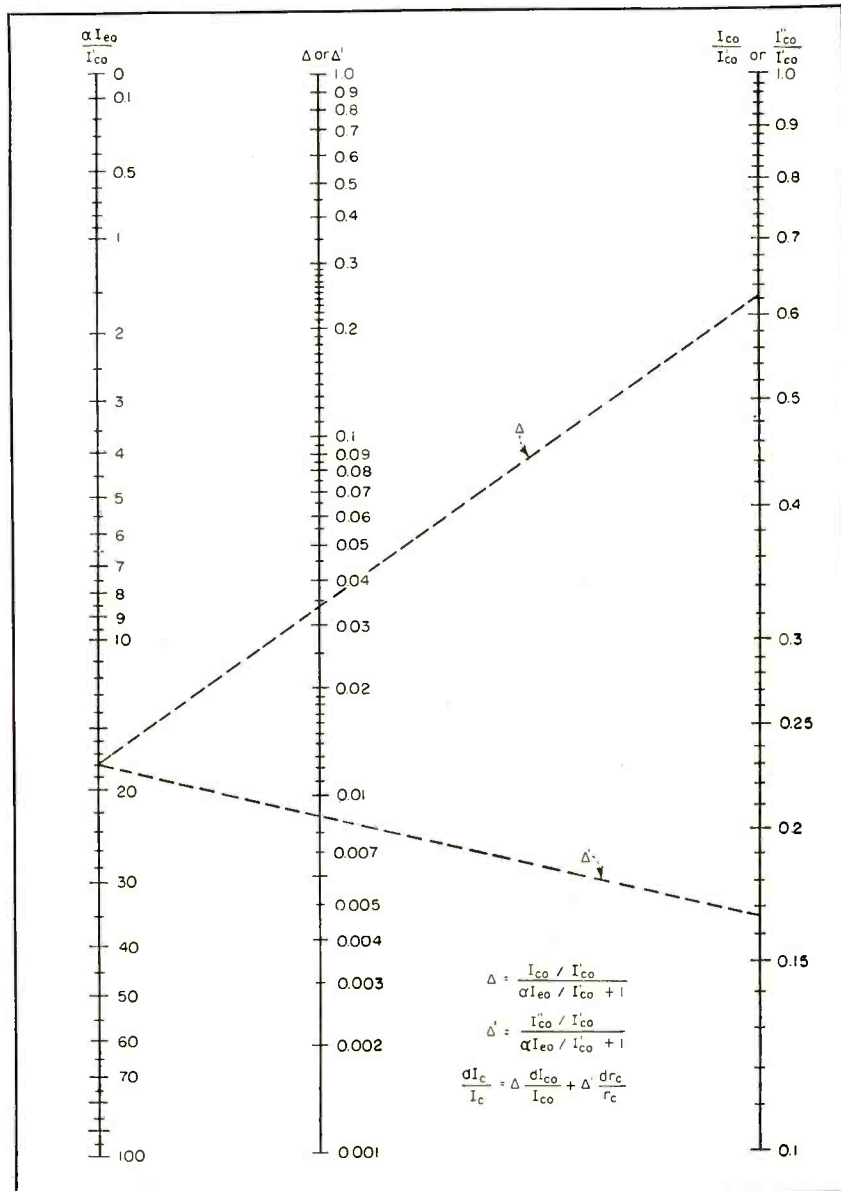

FIG. 6—Nomograph supplies operating point data for variation in temperature of junction transistors

Again entering the nomograph,

$$\Delta = 0.35$$

$$\Delta' = 0.09$$

so that

$$\frac{dI_c}{I_c} = 0.35(2) + 0.09(0.5) = 0.745$$

In this case, I_c increases 75 percent for the same increase in I_{co} and r_c as in the previous example. The operating point has moved to $1.745 \times 0.98 = 1.68$ ma, represented by OP'' in Fig. 5, which is close to collector saturation.

The method described will supply both quantitative and qualitative information concerning the bias-circuit behavior of junction-transistor amplifiers at elevated

temperatures. The technique is easily applied since all quantities in the stabilization formula can be simply measured or calculated in a given design.

REFERENCES

- (1) J. A. Morton, Present Status of Transistor Development, *BSTJ*, 31, May 1952.
- (2) A. Coblenz and H. L. Owens, Variation of Transistor Parameters with Temperature, *Proc IRE*, 40, Nov. 1952.
- (3) R. F. Shea, Transistor Operation: Stabilization of Operating Points, *Proc IRE*, 40, p 1435, Nov. 1952.
- (4) R. M. Ryder and R. J. Kircher, Some Circuit Aspects of the Transistor, *BSTJ*, 28, July 1949. See also L. C. Peterson, Equivalent Circuits of Linear Active Four Terminal Networks, *BSTJ*, 27, Oct. 1948.
- (5) R. L. Wallace and W. J. Pietsenpol, Some Circuit Properties and Applications of n-p-n Transistors, *BSTJ*, 30, July 1951.

EXPERIMENTAL TESTS on parachutes associated with modern high-speed aircraft has resulted in the development of a system for sensing, transmitting and remotely recording parachute data. Seven information channels are provided, permitting simultaneous study of the influence of a number of variables on parachute behavior.

In a typical test procedure, the live jumper is replaced by the rubber and steel torso-shaped dummy, illustrated in Fig. 1, which is weighted to simulate a jumper with his equipment. The dummy is built around a hollow well five inches in diameter in which the electronic equipment is carried. The dummy's head is replaced with the transmitting antenna. The harness, with strain gages inserted into the desired member, is fastened around the dummy in the normal manner.

Information Desired

In the sudden inflation of a parachute, various load-carrying members of the harness and shroud lines are subjected to rapidly applied tensile forces. Knowledge of their maximum values is needed and the duration of the forces is also of significance. Therefore complete time-function plots of the forces at several points in the rigging is the preferred form of output data from the instrumentation system. Altitude information with sufficient accuracy to determine rate of descent is also essential.

Design

The instrumentation system consists of: (1) a series of tensiometer buckles of graduated ranges; (2) altimeters for low and high altitude use; (3) parachute-carried telemetering units for coding and transmitting the data from these pickup instruments to the ground; (4) a ground station assembly for decoding and photographing the telemetered signals; (5) a film reader for producing time graphs of the measured quantities.

The seven information channels have an accuracy of approximately 10 percent. Each channel is sampled 100 times per second. Output information from the overall system is displayed in the form of

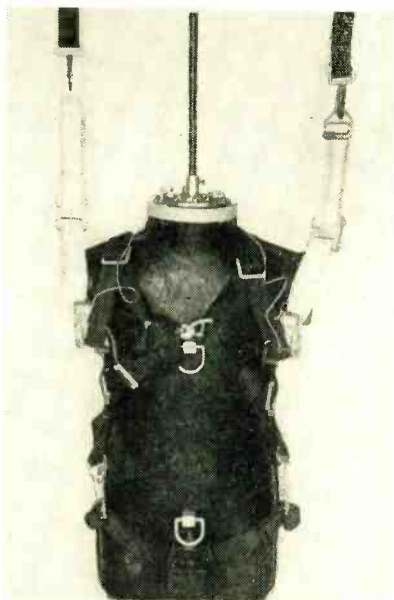

FIG. 1—Test dummy with harness and telemetering equipment installed

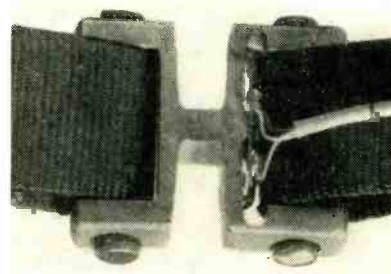

FIG. 2—Tensiometer buckle for sensing tension in harness risers

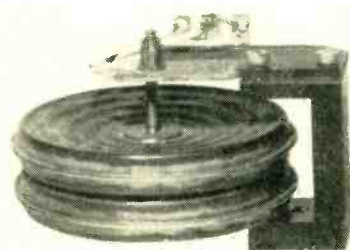

FIG. 3—Aneroid transducer

Parachute-Borne

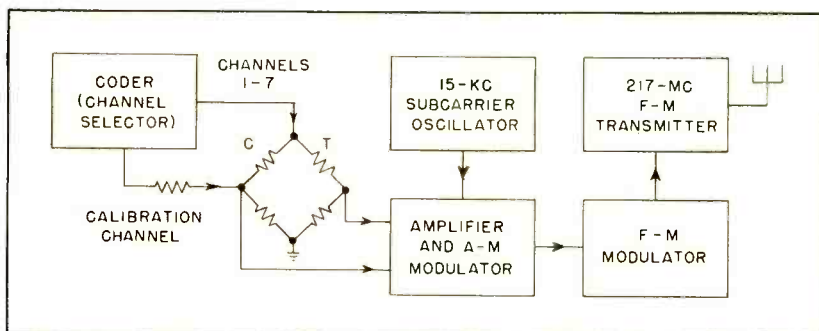

FIG. 4—Block diagram of parachute-borne unit of telemetering system

simultaneous time plots of the seven selected variables on continuous graph paper. The method of modulation employed for conveying the intelligence is pam/f-m.

Transducers

The transducer elements provide for measuring harness tension in ranges of 500, 3,000, 5,000, and 10,000 pounds full scale and altitude in ranges of 20,000 and 40,000 feet. Since the transducers all operate with resistance-wire strain gages, many of the commercially available pressure and acceleration transducers may also be used with the

telemetering system.

The construction of a typical tensiometer buckle for sensing harness forces is shown in Fig. 2. The H-shaped structure is inserted into loops sewn in the webbing and held in place by removable pins. When force is applied to the webbing, the upright members of the H act as cantilever beams. Resistance-wire strain gages are cemented to one elongated and one compressed surface of the cantilever beams, so that strain in the beam surfaces results in proportional resistance changes. Due to the elastic limits of the steel of which the buckle is made,

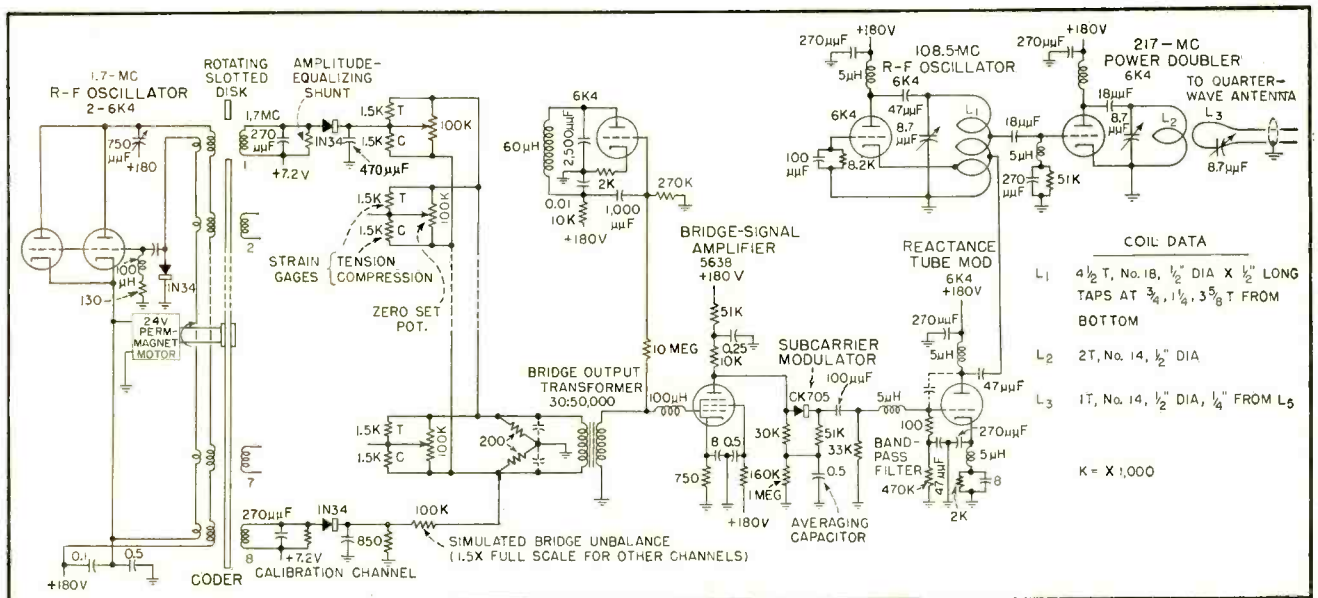

FIG. 5—Circuit diagram of parachute-borne unit. Motor is operated by rectified output of 1.7-megacycle oscillator

Telemetering System

Low-cost, semi-expendable unit transmits data from experimental parachutes during actual descent despite tumbling and shock. System provides seven information channels, each sampled 100 times per second, over an operating range of 2 to 10 miles

By **M. L. GREENOUGH** and **C. G. GORDON**

*Electronic Instrumentation Section
Electronics Division
National Bureau of Standards
Washington, D. C.*

the amount of available resistance change is limited to approximately 0.5 percent. Since the gage resistance is 1,500 ohms, the source of signal is a resistance change proportional to harness tension, whose maximum usable range is ± 7.5 ohms.

Response of this type of buckle possesses a slight degree of non-linearity and hysteresis whose total is within 5 percent of linearity.

A typical altimeter for the airborne units is illustrated in Fig. 3. Its operation is based upon the expansion of an evacuated bellows at lowered atmospheric pressure. A

thin cantilever beam, to which strain gages are attached, is deflected by the bellows motion changing the resistance as a function of altitude.

The bellows is of the radiosonde type in which a nearly linear relationship between altitude and motion is provided. As in the case of the tensiometer buckles, the response approximates a linear relation with sufficient accuracy for practical purposes.

Airborne Equipment

A block diagram of the airborne equipment is shown in Fig. 4, and

a circuit diagram, in Fig. 5. The starting point is the coder, which generates a series of time-sequential pulses at eight circuit points with a repetition rate of 100 pps at each point. Duration of the pulses is slightly less than one-eighth of the 1/100-second period of the complete scan, or about one millisecond. Each of the eight outputs feeds one of the strain-gage bridges, as shown in Fig 5.

The low or inactive side of the bridge is common to all of the transducer elements. Since only one bridge receives an exciting pulse at any instant, there is no over-

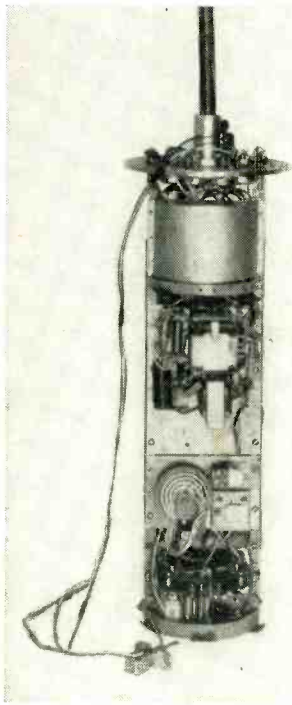

FIG. 6—Parachute-borne unit construction; tensiometer is shown at bottom

lapping or confusion of signals. The bridge output is a repeated series of eight pulses whose amplitudes are proportional to the unbalance of the strain gages on each of the transducers in turn. To assign actual magnitudes to the observed pulses, channel eight is derived from a fixed bridge unbalanced by an amount equivalent to 1.5 times a normal full-scale signal. Then the ratio of channel to calibration signal is indicative of transducer unbalance. Since this ratio is extracted by the output-reading apparatus, system-gain variations do not produce erroneous readings.

The bridge-unbalance signals are raised in level by an amplifier stage and fed to a modulator for conversion to amplitude-modulation of the 15-kc (nominal) subcarrier. The pam subcarrier is then passed to a reactance-tube modulator for applying f-m to the 217-mc transmitter for transmission to the ground station. The transmitting antenna can be seen in Fig. 1.

The entire airborne unit is powered by a self-contained battery pack with capacity for about one hour of continuous operation.

Coder

The coder, visible at the bottom of the airborne unit in Fig. 6, acts

as an inductive commutator to activate each of the eight channels in turn. The essential features of the coder are a r-f oscillator at about 1.7 mc, a permanent-magnet motor which rotates a slotted copper disk at approximately 6,000 rpm, eight pickup coils arranged in a circle and tuned to 1.7 mc and diode rectifiers. As the disk revolves, the oscillator is coupled periodically to each of the eight coils, inducing a voltage pulse in each which is rectified and filtered. The pulse amplitudes are adjusted to 10 volts ± 3 percent across an 850-ohm load by shunting resistors on the pickup coils. In this manner the problems associated with high-speed sliding contacts are avoided.

The motor, instead of being operated on the A-battery supply, is actuated by rectified r-f power supplied by the 1.7-mc oscillator. A better balance of life of A and B batteries is secured by placing the load of the motor, even with its only moderately efficient r-f source of supply, on the B battery. Parallel 6K4's generate the required power for feeding both the motor and the transducers.

Modulation

The subcarrier modulation is achieved by adding the amplified bridge-unbalance signals and the 15-kc subcarrier, then passing the sum through a threshold diode and filter circuit. Thus the subcarrier is allowed to come through whenever a bridge-unbalance signal is present, and in an amount proportional to the unbalance signal. The relative levels are set so that the resultant minimum or zero-signal output at 15 kc is approximately one-quarter the maximum produced by the calibration signal. Full-scale signals from the various transducers therefore amount to 50-percent modulation change in the subcarrier amplitude.

The transmitter and its f-m modulator are conventional in design. The power oscillator, operating at approximately 108.5 mc, feeds a power doubler tuned to 217 mc whose output into a resistive load is nominally 0.75 watt. In the modulator portion the necessary quadrature phase shift from plate to grid is provided by the grid-to-plate ca-

pacitance and a low resistance in the r-f grid return path.

Ground Station

The ground station panel is shown in Fig. 7. The receiver has a bandwidth of 300 kc, video response to 20 mc and includes afc on the local oscillator. As contrasted with f-m/f-m systems, there is no stringent requirement for discriminator linearity. The receiver output is identical to the amplitude-modulated 15-kc subcarrier appearing at the amplifier-modulator output in the airborne unit.

This signal is fed to demodulator and filter circuits which convert the waveform back to the duplicate of the transducer bridge unbalance signals. Equalization to correct for amplifier response, particularly the low-frequency deficiency due to the bridge transformer, is included in this portion of the circuit. The demodulated bridge-unbalance signals are then fed to the camera unit whose function is to record these signals transversely on 16-mm film continuously moving at 10 ips. Provision is made for intermittent film motion to reduce film consumption during the long period of drop after parachute inflation.

The bridge-unbalance signals are also applied to the monitoring crt on the front panel of the ground station for observation of received signals. A low-frequency saw-tooth wave is added to the crt deflection to provide timing indications at

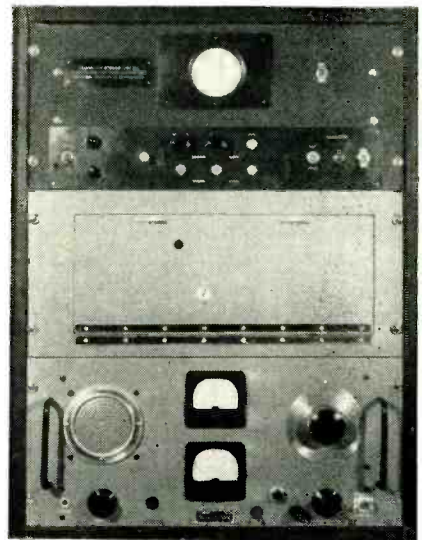

FIG 7—Front panel of ground station equipment. Decoder is at top, camera in center and receiver at the bottom

one-second intervals and for shifting the pattern on the tube screen for longer screen life.

Film Reader

The output of the ground station is a film record of the transducer-unbalance signals, recorded sequentially as each of the eight circuits is pulsed in turn. Before this form of record can be interpreted, it is desirable that it be converted to side-by-side graphs of the individual functions. Such is the purpose of the film reader shown in Fig. 8.

By the time the bridge-unbalance signals have been passed through the entire system the pulses are rounded off somewhat at the base-line corners and have acquired some overshoot. Furthermore, because the pulses are unidirectional, they possess an average value proportional to their amplitudes. This average value cannot be passed by the system and so the occurrence of any one pulse shifts the base line for the immediately succeeding pulses. Clamping at this point is inadvisable because of the loss of small signals. As a result, the magnitude of tension in a given harness section is indicated by the excursion of the peak from the average of the base line at the beginning and end of the individual pulses. Necessary averaging of base lines and subtraction from the peak is performed in the film reader.

The operator turns knobs in the film reader connected to current-

summing potentiometers until pointer lines coincide with the peaks and bases of the pulses. Seventeen potentiometers are provided so that one whole scan of all eight channels may be covered. The operator then adjusts a master gain control until the amplitude of the calibration signal comes to the reference value. Therefore the outputs at the seven other summation points are voltages indicative of the ratios of signal-to-calibration

line which corresponds, for example, to zero tension in the buckles or to zero altitude for the altimeter. Time is indicated by scaling off the intervals between the occurrence of the one-second base-line shifts on the film. Actual amplitudes in terms of force are then assigned by reference to the known scale factor for the buckles employed in the drop. Altitude is determined by marking the altitude of the aircraft beside the corresponding altitude signal.

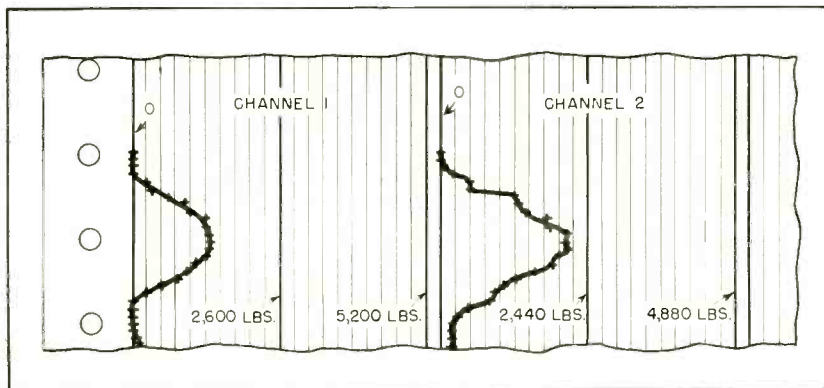

FIG. 9—Sample record showing two channels of system. Curves represent forces on two risers visible in Fig. 1

amplitudes. When the record button is pushed the strip-chart recorder plots all of the seven information channels and stops for the next frame. This procedure is then repeated until all information of interests has been covered.

Test Evaluation

The resultant record consists of seven parallel graphs. Each of the channels starts from its own base

Time-function plots of the forces on two shoulder straps are shown in Fig. 9. The results shown are for a test produced by dropping the dummy from a scaffold, with ropes to provide the decelerating forces. Such a test setup can easily create a given maximum deceleration, however, the dummy does not reach the high velocity encountered before inflation, hence for given peak deceleration the duration of the peak forces is relatively short. The rate of rise however is simulated closely enough to provide an indication of behavior under actual conditions.

In the graph, the rapid rise of the harness forces may be seen. After the peaks, the force remains at a lower level, then finally drops to zero as the dummy effectively bounces on the ropes.

On the basis of experience in actual service the useful range of the equipment is between 2 and 10 miles, depending upon terrain, altitude and relative orientation of transmitting and receiving antennas.

The authors acknowledge the assistance of Paul Selgin, C. Stansbury, F. H. Bayhi, B. K. Hawes, M. L. Kuder and others.

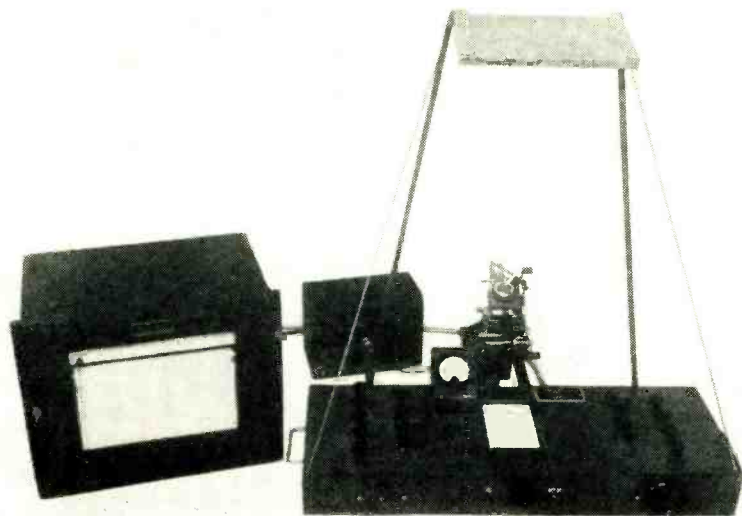
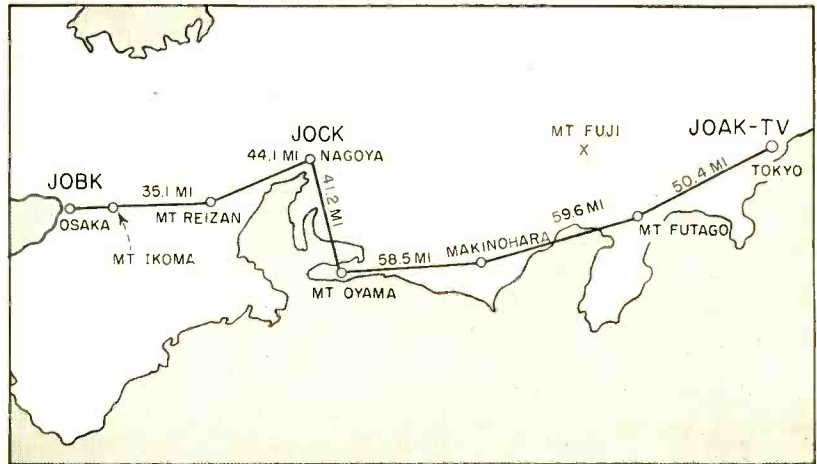

FIG. 8—Film reader converts sequential record on film to seven channels on chart



HIGH-GAIN paraboloidal antennas beam microwave signals over 288-mile mountainous path to provide a . . .

Microwave Relay

Seven-station relay operating in 4,000-mc band links three television outlets of Japanese Broadcasting Company. Traveling-wave tubes used in three-stage microwave amplifier provide three-watt output for hops up to 60 miles between repeaters

MICROWAVE techniques provide network television in Japan. A 4,000-mc tv relay feeds stations in Tokyo, Nagoya and Osaka. The system comprises five repeaters and two terminals. Transmission in either direction is possible by switching waveguide connections.

The relay is 288 miles in length and includes single hops of nearly 60 miles. The terrain is mountainous and as the map shows the system includes two overwater hops.

Propagation difficulties include high free-space attenuation and deep fades. To provide the necessary gain each repeater incorporates a three-stage traveling-wave

Table I—Television Relay System Gain Requirements

Losses	
Waveguide loss at transmitter	1.0 db
Waveguide loss at receiver	1.0 db
Free-space attenuation (60 miles)	114.8 db
Fading	23.0 db
Total	169.8 db
Gains	
Transmitting antenna gain	40.0 db
Receiving antenna gain	40.0 db
Amplifier output—3 watts	34.8 dbm
Total	114.8 dbm
Min. receiving power under worst fading conditions —55 dbm	

amplifier that furnishes about a three-watt output. High-gain paraboloidal antennas 13.1 feet in diameter also are used. These antennas provide 40-db gain. To avoid overshoot the repeaters utilize a double-heterodyne system and alternate transmitting and receiving frequencies between 4,000 and 4,045 mc.

System Requirements

Table I gives the gain requirements for a typical relay link with signal-to-noise ratios expressed in decibels. Table II lists the r-f signal-to-noise ratios of each relay section for both no-fading condi-

Table II—System Performance—R-F S/N for Relay Sections, Video S/N at Terminals

Relay Sections	Distance (miles)	R-F S/N per Section		Video S/N at Terminal	
		(no fading)	(max fading)	(no fading)	(max fading)
Tokyo—Mt. Futago	50.4	55.5 db	34.5 db
Mt. Futago—Makinohara	59.6	53.5	32.5
Makinohara—Mt. Oyama	58.5	53.5	32.5
Mt. Oyama—Nagoya (term.)	41.2	60.5	39.5	56.8 db	35.8 db
Nagoya—Mt. Reisan	44.1	60.5	39.5
Mt. Reisan—Mt. Ikoma (term.)	35.1	62.0	41.0	56.3	35.3

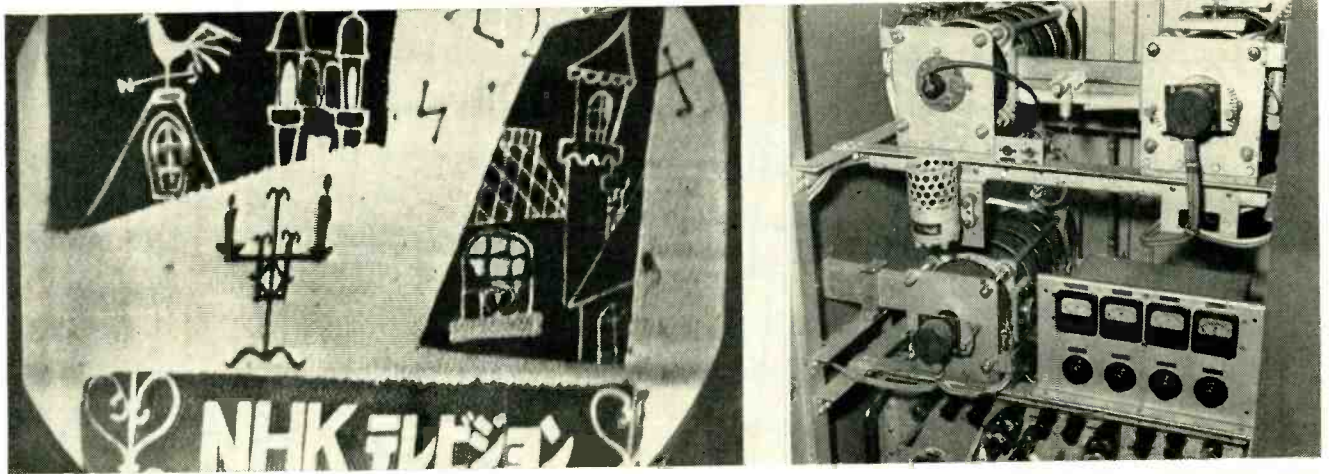

Received picture (left) on monitor illustrates transmission quality. Three-stage traveling-wave amplifier (right) provides high gain

for Japanese Television

By

TATSUJI NOMURA and KEIJI SUZUKI

*Technical Research Laboratory
Broadcasting Company of Japan (NHK)
Tokyo, Japan*

SHIGERU MITA and NORIKAZU SAWAZAKI

*Matsuda Research Laboratory
Tokyo Shibaura Electric Co., Ltd.
Tokyo, Japan*

tions and conditions of maximum fading.

The signal-to-noise ratios given for the video signal at Nagoya and Osaka take into account the fact that here the r-f signal is demodulated and retransmitted over vhf broadcasting transmitters. The f-m improvement factor R is added to the r-f signal-to-noise ratio. This factor is given by

$$R = 3 (B_{1-r} D^2) / 2B_v^2$$

where D is the maximum frequency deviation of f-m, B_{1-r} is the bandwidth of the i-f amplifier and B_v is the bandwidth of the video amplifier.

The tables show that even under the worst expected fading conditions, a signal-to-noise ratio of at least 35 db would be obtained at both terminal stations, Nagoya and Mt. Ikoma (Osaka).

Terminal Equipment

The arrangement of the f-m terminal equipment is shown in Fig 1. The video input is superposed on the repeller voltage of a

klystron to achieve direct frequency modulation. The 3-watt output is obtained in two stages of amplification utilizing traveling-wave tubes.

Frequency modulation by the video signal necessitates stabilization of the klystron oscillator frequency at the peaks of the synchronizing signal.

Thus, on the peaks of the synchronizing signal, a portion of the klystron output is fed back for automatic frequency control. The signal is taken from one arm of a T-junction through a standing-wave microwave frequency discriminator. A switching circuit utilizing a radar-type t-r tube is inserted in the feedback arm of the T-junction. The t-r tube is made to discharge only when afc output is desired—on the peaks of the horizontal synchronizing signal.

However, if the tube was made to discharge on the peak of every horizontal sync pulse, its life would be unduly shortened. A switching pulse generator is used to count down the horizontal sync

pulses and pulse the t-r tube only during every tenth sync pulse.

The schematic diagram, Fig. 2, shows the automatic frequency control circuit including the 10:1 switching pulse generator. The loop gain of the complete afc circuit can be made about 50.

Repeater

As shown in Fig. 3, the television relay repeater operates on the double heterodyne principle. Approximate power levels at various stages are indicated.

The particular repeater shown receives on 4,000 mc and transmits on 4,045 mc. Two local oscillators, three crystal mixers and a 6AK5 i-f mixer perform the conversion.

The input signal received from the paraboloidal antenna is fed into the first crystal mixing circuit through the waveguide. After passing through the input 4,000-mc band-pass filter, it is mixed with a locally generated 3,930-mc signal and converted to the first i-f—70 mc—after which it is amplified by an i-f preamplifier of low noise

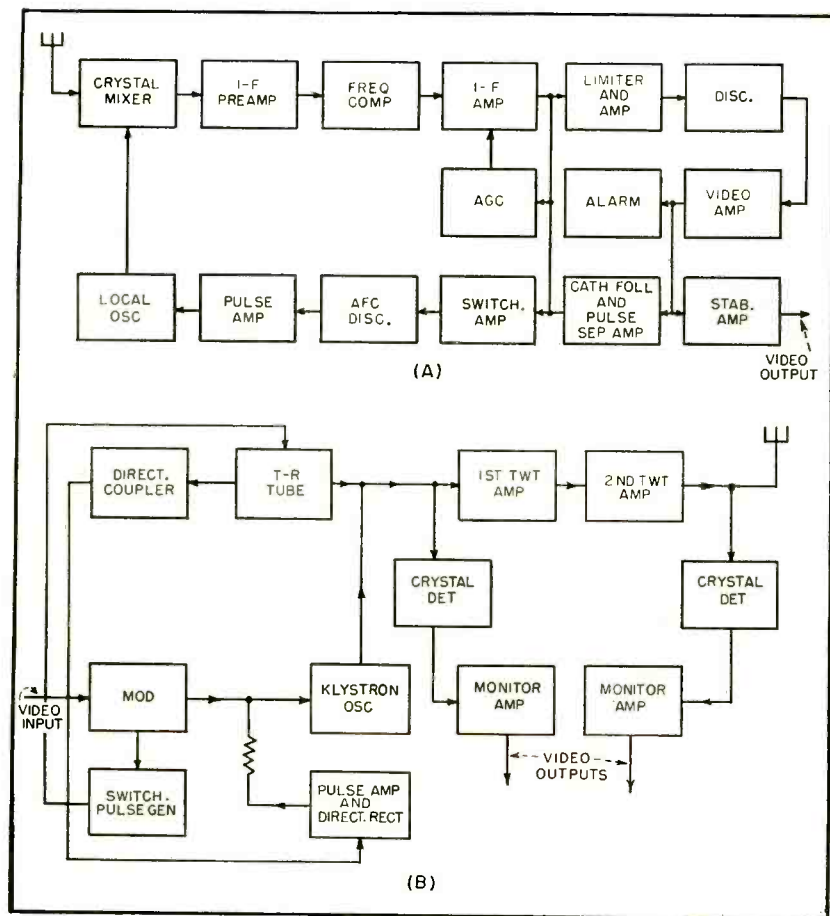

FIG. 1—Terminal station equipment comprises separate microwave receiver (A) and transmitter (B)

figure. This output is then fed into the delay equalizer through a 75-ohm coaxial cable after which it is further amplified by the 70-mc main i-f amplifier. This output and the crystal-controlled second local-oscillator signal (45 mc) are mixed and the second intermediate frequency, 115 mc, is applied to the second i-f amplifier. After it is further amplified by passing through the limiter

circuit, the signal is fed into the third crystal mixer where it beats with the 3,930-mc klystron local oscillator output. The desired microwave output is obtained through the 4,045-mc band-pass filter.

The signal is amplified to the required 3-watt output by a three-stage traveling-wave amplifier and radiated from the transmitting antenna.

Table III—Characteristics of Traveling-Wave Tubes Type 7811 and 7812

Performance Data	Type 7811		Type 7812
	Voltage amplifier	Driver	Power amplifier
Heater voltage.....	6.3 v a-c/d-c	6.3 v a-c/d-c	6.3 v a-c/d-c
1st-anode voltage.....	1,500 v d-c	1,500 v d-c	2,280 v d-c
2nd-anode voltage.....	1,500 v d-c	1,500 v d-c	2,280 v d-c
Grid voltage.....	zero	zero	-60 v d-c
1st-anode current.....	0.5 ma	0.5 ma	3 ma
2nd-anode current.....	2.7 ma	2.7 ma	30 ma
Input power.....	0.5 mw	3.5 mw	200 mw
Gain.....	23 db	20 db	13 db
Output power.....		350 mw	3.8 w
Frequency.....	4,000 mc	4,000 mc	4,000 mc
Magnetic field.....	400 gauss	400 gauss	400 gauss

Facilities for afc, agc and monitoring are also installed.

Crystal Mixer

For the first mixer, a broadband balanced crystal converter is used. The noise figure of the i-f preamplifier is adjusted to a minimum of 11.8 db.

Since the relay repeater is equipped with resonant circuits in each stage of the i-f amplifier, it is necessary to equalize the delay time.

Delay time distortion is two milliseconds at one stage of the M-coupled amplifier of the i-f strip and nine milliseconds at the three-stage stagger-tuned amplifier. To equalize the delay distortion of the repeater, a delay-equalizer circuit is inserted in two stages. The circuit impedance is 150 ohms and buffer amplifiers are placed both at the input and at the output.

Main I-F

The first and second i-f amplifiers are composed of triple-stagger-tuned circuits to achieve their respective bandwidth requirements. Since grid current flows in the limiter circuits and some of the amplifier stages double-tuned, M-coupled circuits are used.

AFC

Since the frequency variation of the klystron oscillator in the repeater has no direct effect on the output frequency, frequency control need be good enough only to make the resulting i-f signals fit into the amplifier passband.

For an f-m signal modulated by a composite video signal, only the frequency at the peaks of the synchronizing pulses is fixed. Thus it is necessary to hold the klystron frequency constant at these sync pulse peaks. The synchronizing pulse is obtained from the monitor output of the repeater. This signal is impressed on the screen grid of a 6AK5 gate tube to pass the second i-f signal for just the duration of the synchronizing pulse. The gate tube output is impressed on the afc frequency discriminator whose output becomes zero when the frequency is lower by 5 mc than the

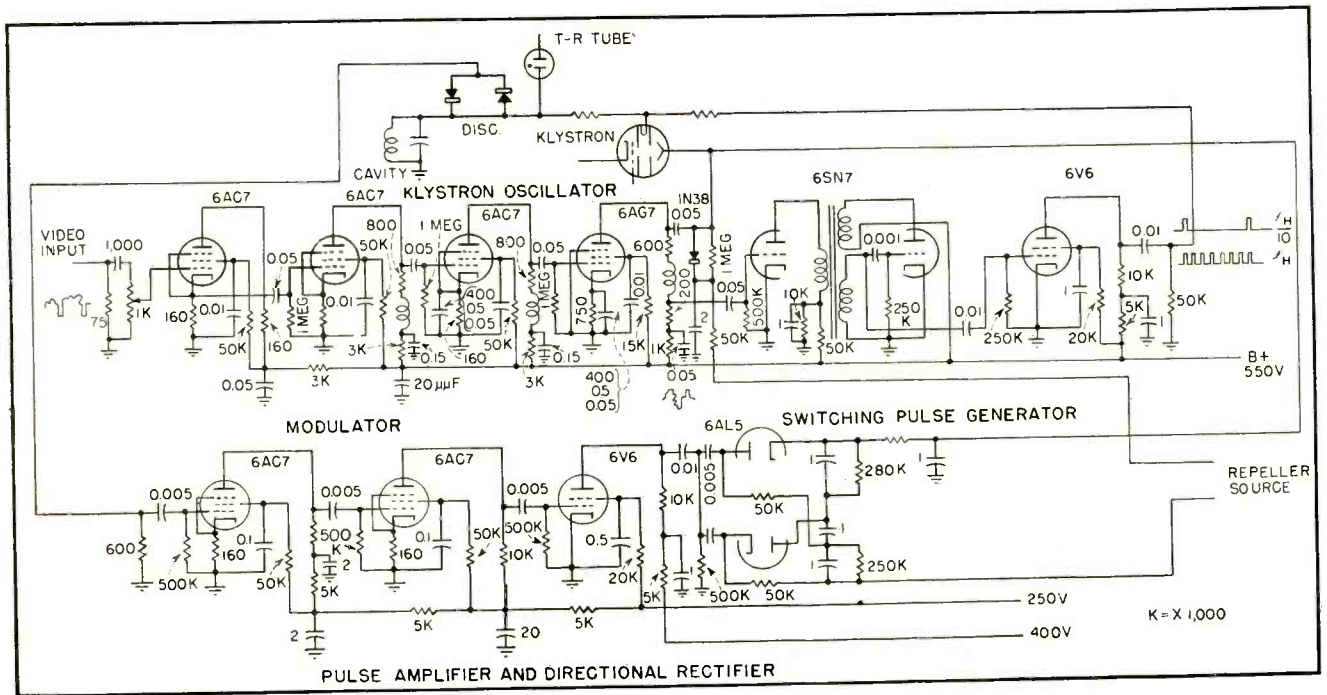

FIG. 2—Automatic frequency control system for terminal station establishes operating frequency

center frequency of the second i-f amplifier. The pulse output is then amplified, rectified and added to the repeller voltage of the klystron oscillator to control its frequency.

The limiter current is used for automatic gain control. This signal is superposed through a d-c amplifier as grid bias on a set of triple-stagger-tuned i-f stages.

To make sure the repeater is operating properly, the picture is

monitored. The monitor input is taken from the second i-f amplifier. In addition, a cavity-type microwave frequency discriminator and video amplifier are installed in the final traveling-wave amplifier stage for monitoring the output signal.

Modulator

As in the first crystal converter, a balanced-type transmitter modulator is used in the repeater

output. The second i-f and the klystron local-oscillator output are mixed and passed through a high-frequency filter to obtain the required microwave output frequency. Maximum output level is approximately 1 mw.

TWT Amplifier

The three-stage traveling-wave-tube amplifier provides a gain of 50 to 60 db and an output of 3

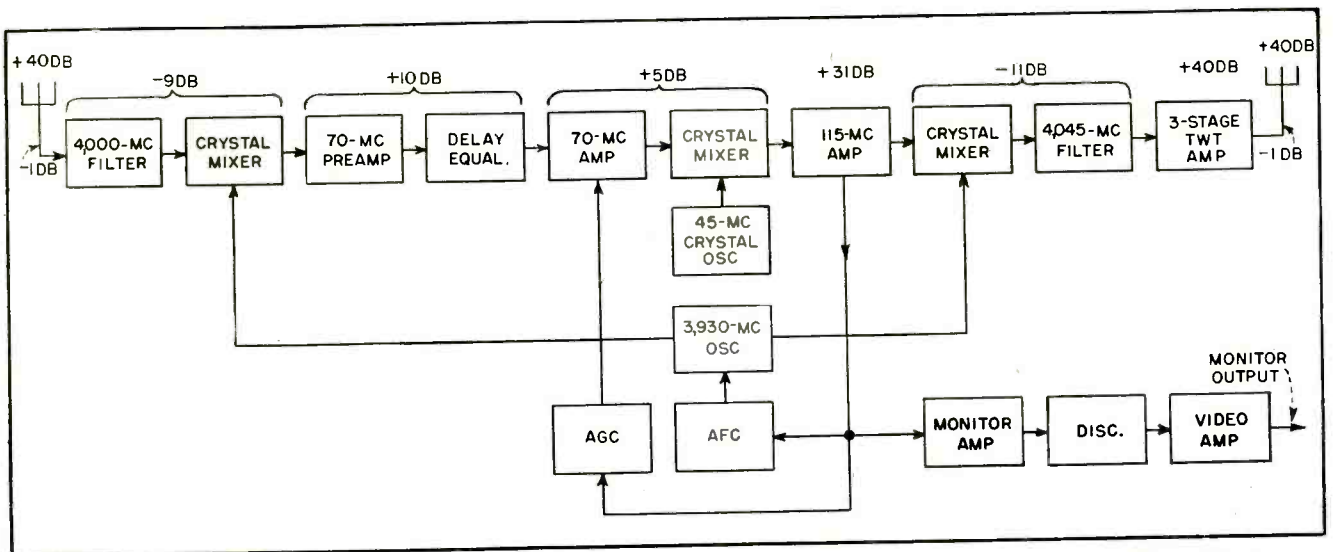

FIG. 3—Relay repeater utilizes high-gain receiving and transmitting antennas and three-stage twt amplifier to achieve 144 db gain

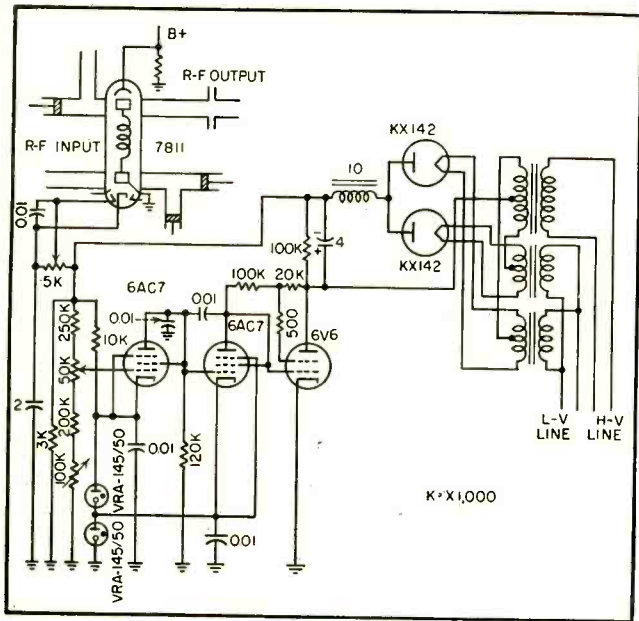

FIG. 4—Regulated high-voltage d-c supply for twt amplifier

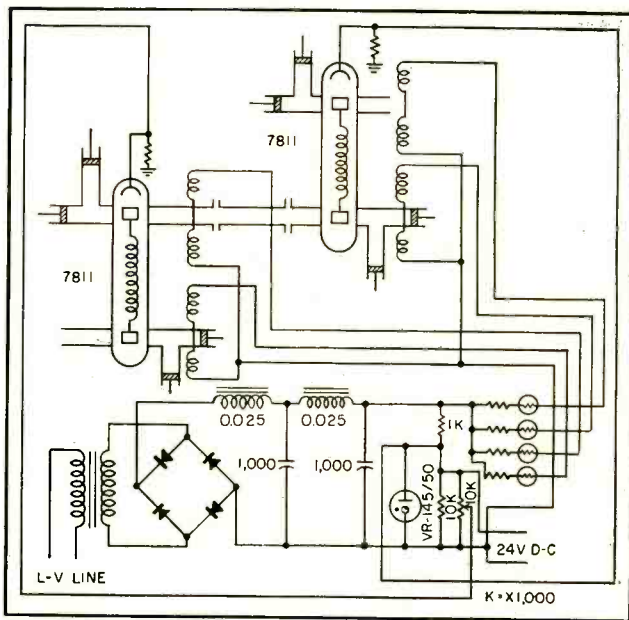

FIG. 5—Current regulator for twt focus coils

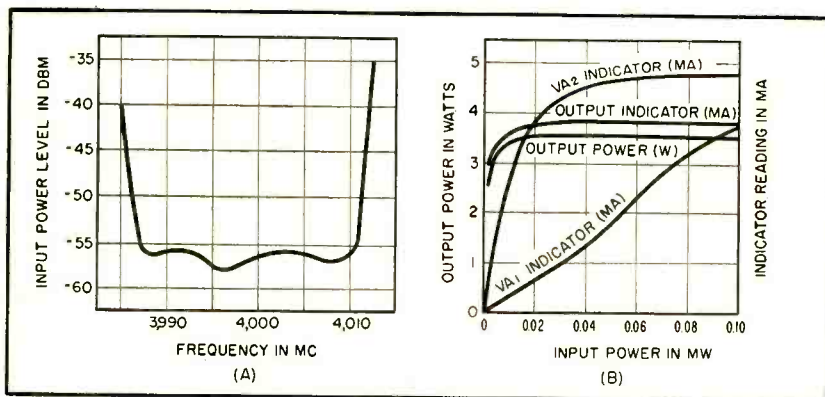

FIG. 6—Overall response of repeater (A) and characteristics of twt amplifiers (B)

watts. Thus, the output level of the third mixer can be small.

The traveling-wave amplifiers have ideal wide-band characteristics, but since the gain and output power are sensitive to voltage variation, the d-c high voltage is held constant by the regulator circuit shown in Fig. 4. Current for the electromagnetic coil is held constant by the circuit shown in Fig. 5. Overall frequency characteristics of the relay repeater including the three-stage traveling-wave amplifier is shown in Fig. 6A.

The characteristics of the twt amplifier are shown in Fig. 6B. The horizontal axis indicates input power in milliwatts and the V_1 output power level indication is proportional to the output power level of the first-stage twt voltage amplifier. Since this output increases in pro-

portion to the input power, the first stage operates as a linear amplifier. The V_2 indication is proportional to the output power level of the second-stage twt amplifier. The second stage begins to saturate around 0.04 mw of first-stage input power level, and the third stage output power indicator shows saturation around 0.01 mw of the first-stage input level. Thus a perfect limiter characteristic is displayed.

The vswr of the standard input waveguide is below 1.5 over the 200-mc range of the amplifier. The same can be said of the output side. Thus frequency response of the amplifier can be kept within 3 db over the band.

Antennas

High-gain paraboloidal antennas are used. The waveguide feeding

the antenna terminates in a horn and a Styrofoam piece is pasted over the open end for waterproofing. Antenna gain is about 42 db. The horizontal half-power beamwidth is 1.34 deg and the vertical: 1.44 deg.

The waveguide is of a standard type and its attenuation is less than 0.1 decibel per meter.

A microwave repeater system of more recent design utilizes all traveling-wave amplifiers and has given satisfactory results.

The input r-f amplifier is a type 7810 low-noise traveling-wave tube. Following the input band-pass filter are two type 7811 twt voltage amplifiers. The signal is then shifted 45 mc and passed to a three-stage voltage amplifier using type 7811 traveling-wave tubes. Output power amplifier is a type 7812.

The authors acknowledge the aid of Yoshitoshi Tanabe, chief of NHK technical research laboratory, Kazuo Murase, chief of the facility department, Mr. Iwao Honjo, director of Matsuda Research Laboratory and Naonobu Shimomura, chief engineer of Tokyo Shibaura Electric Company. Appreciation is also due the engineers of NHK technical research laboratory and the facility department of Matsuda Research Laboratory and Komukai Works of Tokyo Shibaura Electric Company for adjusting and testing the equipment.

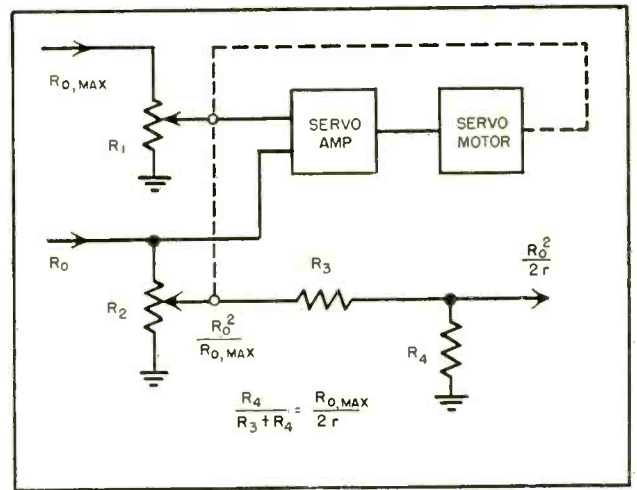
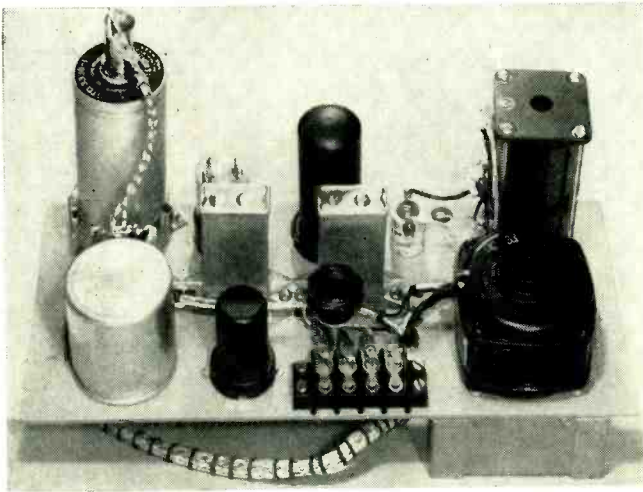

Altitude correction computer (left) uses chopper-type 60-cps servo amplifier with two-phase servo motor to drive two 10-turn helical potentiometers (right)

Altitude Corrector for Tracking Radars

Simple analog computer introduces earth's curvature correction to target-altitude data obtained from tracking radars. Correction permits plotting data from widely separated radars on master board and furnishes accurate information to interceptors

CONVERTING altitude data as determined from a radar to altitude above sea level can be accomplished by a simple analog computer. Conversion is necessary when data from radars separated by as much as 50 miles are displayed on a master plotting board or when data from ground radars are supplied to interceptor aircraft. At 100 miles uncorrected radar altitude data would be in error—about 6,600 feet low.

Radar altitude data is normally available as height above a plane tangent to the earth at the radar. Due to the earth's curvature, altitude data from two separated radars are not compatible.

Using assumptions that do not decrease the desired accuracy of 0.01 percent, altitude above mean sea level becomes $H_c = H_o +$

By W. R. McQUISTON

*Point Mugu Division
Electronic Engineering Co. of Calif.
Los Angeles, Calif.*

$(R_o^2/2r)$ where H_o is altitude observed by the radar, R_o , horizontal range to target and r , radius of the earth.

The analog computer that calculates the term $R_o^2/2r$ is shown in the drawing.

Direct-current voltages proportional to R_o and $R_{o,max}$ are available from the radar computer. The inputs to the 60-cps chopper-type servo amplifier are R_o and a d-c voltage from R_1 . Any difference between the two inputs is converted to 60-cps amplified and used to drive a two-phase servo motor that drives R_1 and R_2 by a gear train until the two inputs are equalized.

When the wiper of R_1 is accurately positioned to match R_o , its physical position on the potentiometer is proportional to $R_o/R_{o,max}$. Since R_2 is mechanically linked to R_1 , R_2 is also positioned in the same ratio and the voltage output of R_2 is $(R_o/R_{o,max}) R_o$ or $R_o^2/R_{o,max}$. Potentiometers R_1 and R_2 are ganged 10-turn Helipot.

Voltage divider $R_3 R_4$ is made proportional to $R_{o,max}/2r$, a constant. The output of R_2 is applied to this divider giving $(R_o^2/R_{o,max}) \cdot (R_{o,max}/2r)$ or $R_o^2/2r$, the desired altitude correction.

The observed altitude H_o and the altitude correction are summed in the radar computer to provide the corrected altitude H_c .

The computer can be used also to solve equations involving division of a squared variable by a constant.

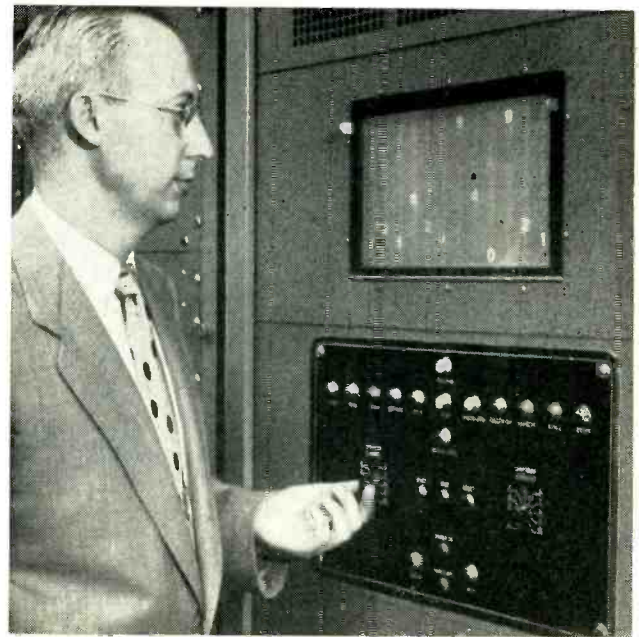

THE FRONT COVER

Automatic astronomer consists of massive measuring engine containing 17-inch-square glass photographic plate made with telescope, punched-card input-output equipment (at right of engine) and two computer and control racks

Sequence control rack, with visual indicator panel that shows, left to right, the star number (1214 here), the X-coordinate of its position on the plate (219.4 mm) and the Y-coordinate (092.1 mm), corresponding to data punched on IBM card

Automatic Measurement

Computer-controlled photoelectric measuring head locates star images one by one on glass photographic plate, measures their coordinates with accuracy better than 1 micron and records results automatically on punched cards for comparison with old data

SINCE THE TIME of Hipparchus, 2,000 years ago, the astronomer has systematically measured the positions of celestial bodies in the sky with the utmost accuracy and recorded them for future study and comparison. The positions of the fixed stars, as distinguished from the planets, or wanderers, are recorded in star catalogs. Positions from early catalogs can be compared with those from later ones for a study of the tiny motions that are gradually unfolding the structure and history of the stellar systems.

Photographic Technique

Methods of measurement have been steadily improved. Today a ten-minute exposure on a photographic plate permits the astrono-

mer to measure as many stars as he could formerly in long hours at the telescope. This ease of collecting data at the telescope aggravated the associated phases of the star catalog program—years of painstaking measurements, stacks of computations and months of proof-reading.

The unique automatic methods described here for doing the computing, printing and proofreading have developed to the point where the outstanding remaining drudgery is that of locating the star image on the plate, measuring its position and recording the results.

To the naked eye the images of stars on a photographic plate appear as tiny black dots on clear glass. Magnification shows that each is composed of a group of iso-

lated silver grains distributed over a roughly circular or elliptic area. For the purposes of the star catalog, it is necessary to measure the coordinates of these star images relative to each other. From these rectangular coordinates can be computed the celestial coordinates of right ascension and declination of each star.

Description of Engine

In the past, a human operator measured the locations of the star images with a measuring engine. Typical of these engines is the one built in 1927 by Heber D. Curtis, made available to Watson Laboratory for modification in the current project. Supported at three points by an angle-iron framework is a massive cast-iron bed that supports

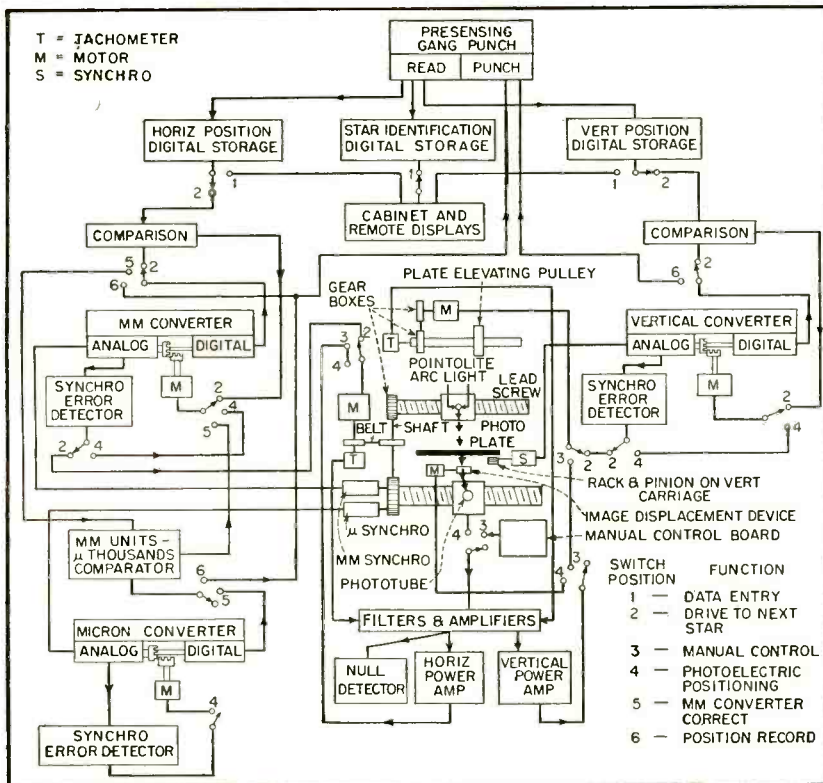

FIG. 1—Simplified block diagram of complete star-measuring system

of Star Positions

By JOHN LENTZ and RICHARD BENNETT

Watson Scientific Computing Laboratory of International Business Machines Corp.
Columbia University, New York, N. Y.

the ways upon which a plate holder moves in the vertical direction. Other ways on the bed provide running surfaces for a horizontal carriage.

A $2\frac{7}{8}$ inch diameter lead screw with 1-mm pitch drives the horizontal carriage by means of a nut affixed thereto by a system of gimbals. The nut is a bronze cylinder with approximately 50 radial wooden plugs providing contact with the screw. At one end of the lead screw is an index head whose circumference is divided into 1,000 equal divisions by ruled index lines. The index head furnishes information as to the angular position of the lead screw and hence, when backlash is removed, information as to the linear displacement of the horizontal carriage. One division

on the head corresponds to 0.001 mm or one micron on the plate.

Requirements for Automatic Measurement

The process of measurement of a given coordinate of a given star image may be divided into three phases. First, out of all the stars whose images are shown on the plate under consideration, the image of the desired star must be found. Approximate plate coordinates can be obtained from earlier star catalogs; these are sufficiently precise to locate unambiguously the desired star. Second, the horizontal carriage of the measuring engine must be moved to a position accurately representative of the coordinate of the star being measured. Finally, the precise new coordinate

value of the star must be recorded.

To make the process of star measurement fully automatic, it was necessary to provide mechanisms and control equipment capable of accomplishing the three phases of the operation automatically in the proper sequence.

To adapt the original measuring engine for an automatic system, a photoelectric scanning device was substituted for the visual microscope. An auxiliary screw and carriage were installed to carry a source of illumination in alignment with the optical scanner for illumination of the photographic plate.

Electrical driving motor assemblies were provided for the horizontal and vertical motions. An auxiliary carriage on ball-bearing wheels on an auxiliary set of horizontal ways was added to remove part of the weight of the microscope carriage from the precision ways.

The original horizontal and vertical scales and graduated head on the lead screw were supplemented by synchro position transmitters.

The engine was enclosed in a case with thermostatic temperature control. A projection system was installed for visual inspection of the field of view of the optical scanner from outside the case.

Three cabinets contain electrical and electronic control and sequencing units. A standard IBM machine for reading and punching cards, called a presensing gang punch, feeds the old star catalog coordinates into the system. Included in the cabinets are analog-digital converters that handle the output from synchro position transmitters on the engine. Since the cards are read while in motion, digital storage is provided so that the data may be compared with the digital output of the converters.

How the Machine Operates

The complete system is shown in Fig. 1. A deck of cards containing the approximate coordinates of the stars to be measured on a given plate, one card per star in order of increasing α , is inserted in the hopper of the gang punch. The cards are fed into the punch one by one, in response to signals from the sequence unit. Numbers in the form

of holes punched in the card are read by sensing brushes making electrical contacts through the holes and this information in the form of electrical impulses is transmitted to digital storage. After the approximate coordinates are read, the card passes to the punching station where it comes to rest temporarily while the measurement of the star position is made.

The coordinates that have been read from the card into digital storage are compared with the outputs of analog-digital converters. The comparison device emits a directional error indication that is applied to the drive motors of the converters, causing them to drive until the converters agree with the storage relays. At this point, the appearance of an error signal in the synchro link between the drive shafts of the measuring engine and the converters causes relays to operate to drive the carriages of the engine to positions that agree with the converters. The star image should now be in the field of the viewing screen.

The machine pauses in its sequence to allow the operator to inspect visually the star image and to move it by push-button control to the center of the screen and within the field of the rotating scanner.

After control has been returned to the sequence mechanism, the error signal derived from the optical scanning head causes the horizontal drive motor and the vertical correction motor to position the carriages so that the optical axis of the scanner will pass through the center of gravity of the star image. The synchro link between shafts and converters furnishes error sig-

nals to drive the converters to new positions corresponding to the precisely measured coordinate of the star image.

Finally, the sequence mechanism causes the new coordinate in the converters to be transmitted to the punch and punched in the appropriate columns of the card that is waiting at the punching station. As the first card is punched, the second card is read and the whole cycle is repeated until the last card of the deck has been read and punched. Save for the stop for inspection just before final positioning, the complete process of measurement of star position is carried out automatically.

The basic sequence control units and analog-digital converters were developed originally by A. H. Dickinson and associates for use in IBM automatic measuring and recording machines installed in wind tunnels during World War II. Subsequently, B. E. Tobin and associates made certain improvements and modifications that were used in the present machine.

The digits from the punched card are stored in stepping switches from which a comparison is made with the analog-digital converters for their positioning. The electrical output from the digital storage and the converters represents the ten digits, 0 to 9, by voltages at 5-volt intervals from 5 to 50. During the stage of setting the converter to the number in digital storage, a comparison unit interprets these voltages, sensing first the highest-order position, then the next lower in succession, and directs the converter motor to drive the converter in the proper direction to bring the two units into agreement.

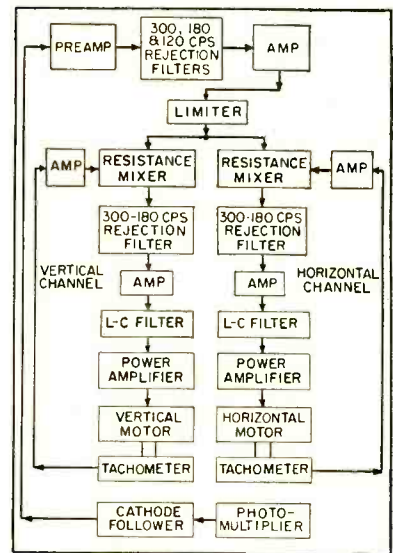

FIG. 4—Photoelectric servo system

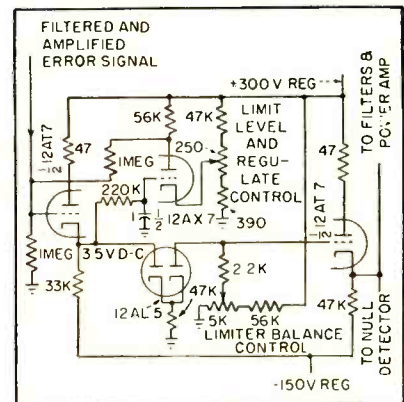

FIG. 5—Series diode limiter with level and balance controls

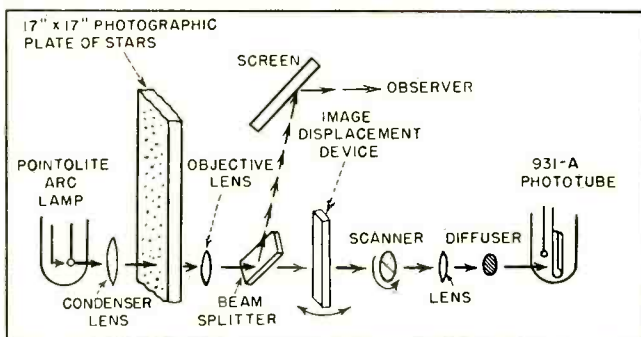

FIG. 2—Optical system employed to locate center of gravity of star image on photographic plate

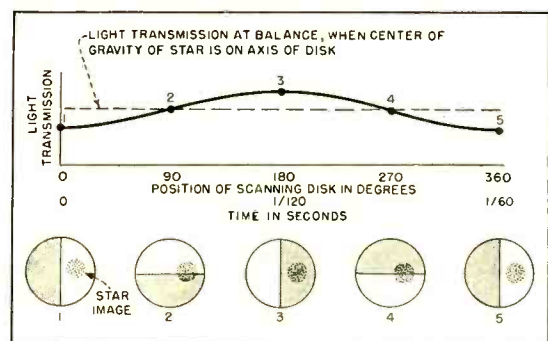
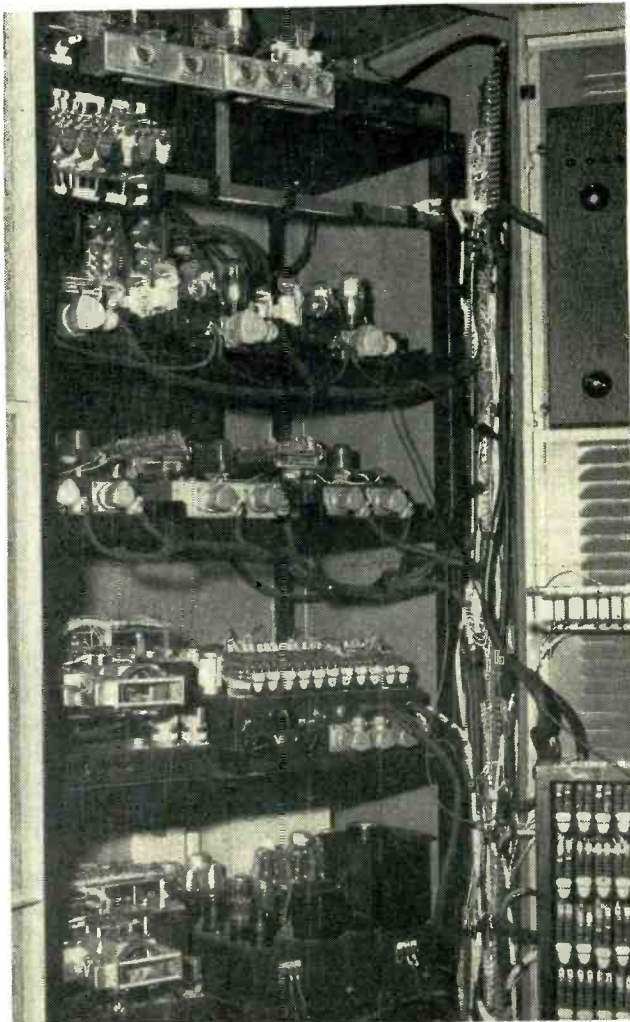
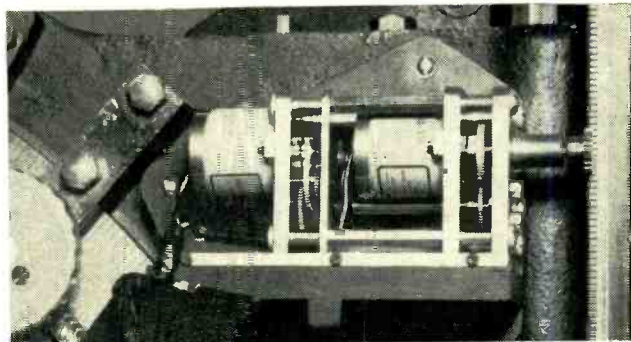

FIG. 3—Operation of scanning disk in relation to magnified opaque image of star



Rear view of sequence control unit



Vertical position-transmitting synchros

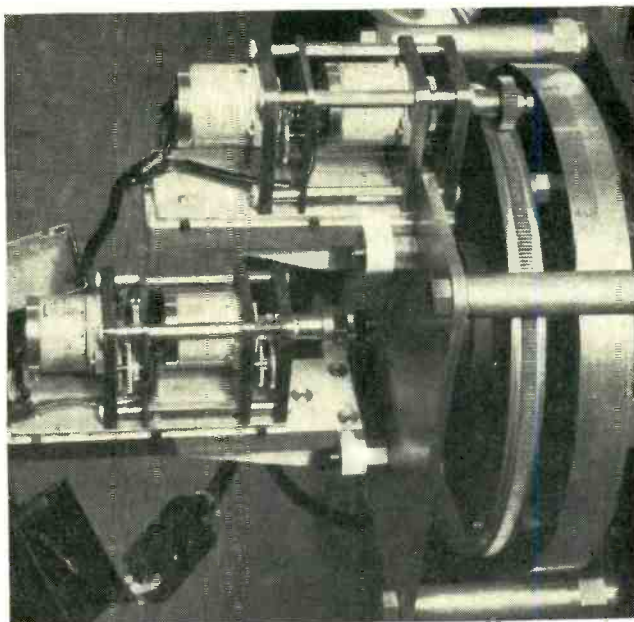

Horizontal position-transmitting synchros

chronism with the digital part and electrically connected to two synchros on the engine. When the converter is made to agree with the number in digital storage, a synchro link indicates an error that is used to drive the engine to agree with the converter.

Analog-Digital Converters

Although four-digit numbers (to tenths of a millimeter) are used in the initial vertical and horizontal positioning of the engine, it is necessary to punch out a seven-digit reading of the screw position (to 0.2μ). The additional three digits are furnished from an auxiliary four-digit or micron converter linked to a pair of synchros connected to the lead screw and so geared as to repeat for every revolution of the screw. The highest-order position of the micron converter corresponds to the lowest-order position of the horizontal converter, but it is exact where the

other may be off by two-tenths of a millimeter.

The necessity for a forced agreement in the overlapping position is shown in the following example. Assume that the horizontal or millimeter converter is positioned at 247.9 mm and the micron converter at 0.0015. The 9 and 0 are in the same decimal position, but 0 is the correct digit. It is not sufficient merely to punch out the 0, since in this case the 9 must be corrected to read 0 to force a carry into the next column and give the correct reading of 248.0015. The correcting device is so designed that, regardless of whether the lowest-order position of the millimeter counter is to be increased or decreased, the change is made in the shortest direction.

Optical System

The optical system of the measuring engine is shown in Fig. 2. Behind the plate is a carriage driven by an auxiliary screw, which is of

the same pitch as the lead screw and rotates synchronously with it. Upon this carriage are mounted the light source, an Edison Pointolite lamp and a lens system that forms a real image of the incandescent sphere of the lamp upon the photographic plate. A substantially uniform illumination of the plate is thereby furnished in the immediate vicinity of the image of the star whose position is being measured. Light from this area is collected by the objective lens and brought to a focus to form a real image of the star, magnified about 20 times, on a rotating scanning disk. On its way from the objective lens to the scanner, the light passes through a thin-film beam splitter, which diverts part of the light to the external viewing screen and through an image displacement device.

The rotating scanning device contains a thin disk through which a semicircular hole is cut. The as-

sembly rotates at 3,600 rpm about an axis perpendicular to the plane of the disk and passing through the center of the diametral edge of the hole. As the disk rotates under the magnified image of the star, the amount of light transmitted through the shutter varies periodically with the fundamental frequency of 60 cps, as shown in Fig. 3. Fourier analysis of this periodic variation of light shows that the amplitude and phase of the fundamental component are measures of the radial and angular coordinates of the center of gravity of the star image with respect to the axis of rotation and an arbitrary angular reference axis.

To obtain an electrical signal suitable for use as an error signal in a servo follow-up system, the light transmitted through the rotating scanner is picked up by a phototube. If the light were to go directly through the scanner to the phototube, the illuminated spot on the cathode of the phototube would move around as the scanner rotated, and variations in sensitivity of different areas on the cathode would give rise to a spurious signal superimposed on the desired error signal. With a lens and diffusing plate in front of the phototube, light is imaged from a point just ahead of the condenser lens on the diffuser and a stationary spot of light is obtained on the cathode. This minimizes any signal due solely to the action of the scanner itself.

Error Signal

The output of the phototube is passed through filtering and limiting units, which deliver to the motors a 60-cps electrical signal, as shown in Fig. 4 and 5. For small amplitudes the amplitude of the signal is proportional to the radial distance of the shutter from the axis of rotation to the center of gravity of the star image. For large amplitudes the amplitude of the signal is constant and independent of the radial error. The phase is at all times proportional to the angular coordinate of the star image.

The error signal, after being limited, is supplied as input to each of two mixer amplifier channels that terminate in hard-tube power

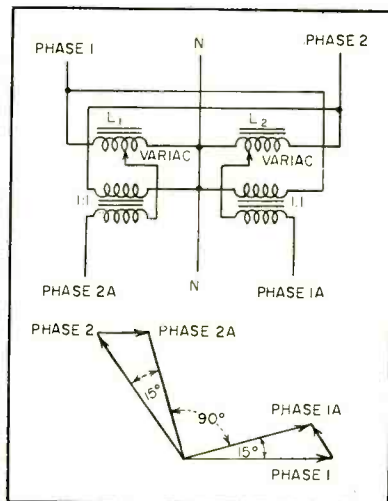

FIG. 6—Variable-phase motor exciter

amplifiers supplying power for the horizontal and vertical drive motors of the engine.

In the horizontal channel the error signal is mixed with a voltage derived from an induction tachometer driven by the horizontal drive motor. This tachometer is mounted on a pivoted bearing in such a manner that the rubber-tired friction wheel on its shaft does not make contact with the driving wheel on the motor shaft. However, by energizing the coil of an actuating solenoid, the tachometer assembly can be tilted so that the rubber wheel on the tachometer shaft comes in contact with the driving wheel and thus causes the armature of the tachometer to rotate. For high-speed slewing of horizontal carriage, the system operates without tachometer feedback. During final approach in positioning star image, the system is stabilized by the feedback from tachometer.

Drive Motors

The outputs of the horizontal and vertical power amplifiers are each applied to one winding of the respective drive motors. These motors are two-phase induction motors whose second windings are excited from independent phaseable sources of 60-cycle voltage. The torque developed by such a motor is proportional to the sine of the electrical phase angle between the voltages applied to the two excited windings.

Assume the error voltage to be resolved into two components, one in phase with the error voltage that would be produced by a purely hori-

zontal error in image position and the second in phase with the error voltage that would be produced by a purely vertical error in image position. It is possible to phase the exciting voltages applied to the second windings of the motors so that the horizontal motor will ignore signals produced by a vertical error in each position, but will develop torque tending to drive the lead screw in such direction as to reduce the horizontal component of error of image position. Conversely, the vertical correction motor can be made to drive in such direction as to reduce vertical errors, but it will ignore horizontal errors.

Since the vertical and horizontal components of the driving signal are 90 deg apart, the exciting voltages for the drive motors must be 90 deg apart. However, to correct for amplifier phase shifts and scanner synchronization, the exciter voltages must be made adjustable in phase. The circuit for the variable phase exciter is shown in Fig. 6. Two legs of the three-phase power lines are added to each other by means of variable inductors and 1-to-1 isolation transformers. From L_1 a portion of phase 1 is added in the isolation transformer to all of phase 2, to give phase 2A. The same operation performed in the other half of the circuit produces phase 1A.

Image Displacement Device

Originally it was planned to center the star image on the axis of the scanner by using the two motions of the original measuring engine. The effect of static friction in the vertical motion made it impossible to position the vertical carriage with sufficient accuracy, however. Although no attempt is made to measure accurately in the vertical direction, proper functioning of the follow-up system requires a precise setting in both coordinates, because the same amplifier channel carries both the horizontal and the vertical error signal.

The image displacement device makes it possible to reduce the vertical error signal to zero. A piece of plane parallel glass mounted in the optical path can be rotated about

an axis parallel to the horizontal ways by a correction motor, which is powered by the signal formerly directed to the vertical drive motor. As this glass sheet rotates, it causes the star image on the scanning shutter to move slightly ($\pm 40\mu$) in the vertical direction and gives a fine control of vertical image position. The device is used solely to achieve a null at the final balance point; during the initial rough positioning in response to the approximate coordinates read from the card and in response to push-button control, the drive motor operates the original vertical motion of the engine.

The effect of static friction when driving the heavy plate holder under manual or pushbutton control was minimized by attaching a mechanical vibrator to the vertical carriage and buzzing whenever a vertical direction button is depressed.

Friction and Lubrication

Sliding friction between the accurate ways and the horizontal carriage was increased when the simple microscope was replaced by a unit containing a periscope, motors, damper, projection screen, cathode follower and a photomultiplier tube. To support the additional weight of 20 pounds, a ball-bearing wheeled carriage was mounted on a set of ways aligned with the precision ways and the two carriages coupled by means of a system of lift rods, self-aligning pivots and counterweights.

Lubrication of the measuring engine is another serious problem. Any lubricant will form a wedge under the horizontal carriage when the carriage has been driven an appreciable distance. The wedge of oil film tends to tilt the optical system, thereby causing errors in measurement. To distribute the oil film in the vicinity of the final setting point, the horizontal servo of the engine is allowed to run undamped so that it hunts back and forth ($\pm 50\mu$) for five oscillations. On the fifth count the tachometer is clutched in, signaling the final approach to the star center. Figure 7 shows the simple circuit used to generate counter impulses.

When signals of forward drive phase are applied to the network,

the total voltage across the terminals will be 230 volts, which provides sufficient current to pick up the impulsing relay. A reverse drive signal presents an in-phase input to the circuit; no voltage appears across the terminals and the relay drops. Forward and reverse signals continue until enough impulses are delivered to the counter for it to cause the operation of the tachometer clutch.

Figure 8 shows the circuit used to advance the sequence control unit when a null point has been reached. The output from a 60-cycle pass filter is rectified and used to bias a thyratron. When a null is reached, no bias is obtained and the thyratron picks up its plate relay. The R-C network in the 2D21 plate supply prevents firing of the tube before bias is developed.

As in any system that uses a 60-cycle carrier, residual hum presented a serious problem. To minimize its effects, each chassis was grounded to a common cabinet point. As a further aid to hum reduction, opposing signals, variable in amplitude and phase, are injected into the system at selected points.

Discussion of Results

The first measurements by the machine in its present form were made on a plate whose star positions had been measured at Yale

for the zone catalog. The 450 star images on the plate were measured automatically on each of three successive days without a change of position of the plate in the engine. After the plate was rotated 180 deg, it was measured on three successive days in the reversed position. Differences in the raw measures of individual stars from the direct runs ($D_2 - D_1$ and $D_3 - D_2$) and from the reverse runs ($R_3 - R_2$) show remarkable consistency. Allowing for a change in zero point of one micron or less from one day to the next, the largest residual is 1.5μ and there are only five as large as 1μ . The average difference from one residual to the next is about 0.4μ , or the probable error of a setting is 0.2μ .

The automatic engine will measure in one working day as many stars as a good observer can measure visually in a week (the observer can measure for only a few hours a day). The weight of an automatic measurement is about four times that of a visual one. Moreover, the precision of the photoelectric setting itself is still higher, the overall accuracy in the present case being limited by the engine rather than the setting.

In the entire process of producing a new star catalog, the only attention given to the individual star is the glance at the image on the screen and the moving of it to the edge of the scanner field. The automatic process includes moving the plate to the precomputed position, measuring, recording, mathematical reductions, statistical analysis and publication. The astronomer plans the program, takes the plates, examines questions that arise from the statistical analysis and discusses interesting results exhibited on the machine records.

The hand adjustment is made because the aperture of the scanner needed for high precision is smaller than the error in the approximate coordinates. An auxiliary device could be used for this adjustment if desired.

The automatic cycle of measurement and control described here is applicable in any circumstances where various control functions are based on the results of measurement and calculations.

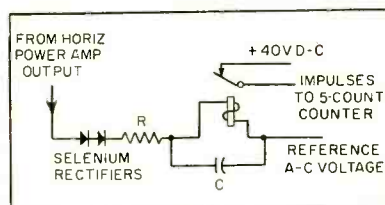

FIG. 7—Counter impulse generator for control of horizontal tachometer clutch

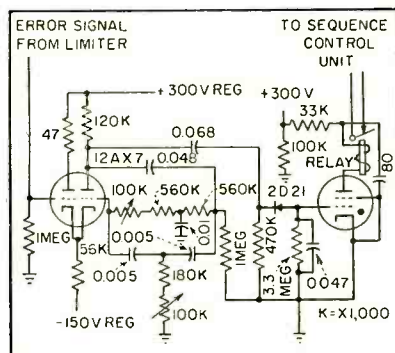

FIG. 2—Photoelectric null detector

Color Demodulators for

By E. G. CLARK and C. H. PHILLIPS

Philco Corporation
Philadelphia, Pennsylvania

DEVELOPMENT is underway on several types of color-carrier demodulation circuits based upon tubes other than the widely used 6AS6. Diode, pentode and beam-deflection systems have recently been described.^{1,2,8} This article covers demodulation circuits based upon heptodes, including a special split-anode version, and dual triodes.

High-Level Demodulation

The 6AS6 is restricted to use as a low-level demodulator and is expensive by receiving-tube standards. Improvement in demodulation circuit design can therefore be realized either by reducing cost of the demodulator tube or by increasing its signal-handling capacity to permit high-level demodulation.

For high-level demodulation to offer any economic advantage, it should allow elimination of the following stages of amplification and permit direct drive of the cathode-ray tube. Addition of the chrominance and luminance signals in the three guns of the tricolor crt is implicit in direct drive schemes.^{3,4} While the potential simplifications of such a system are apparent in Fig. 1A, practical difficulties arising from crt variations make it almost impossible to realize. The circuit shown in Fig. 1B is the basic circuit environment of the color demodulators to be described.

Heptode Demodulators

The suppressor-gated pentode is suited to color demodulator service because it has two grids for injection of color carrier and reference carrier respectively. The 6AS6, in particular, has sharp-cutoff grids, high conversion gain, small interelectrode capacitances and

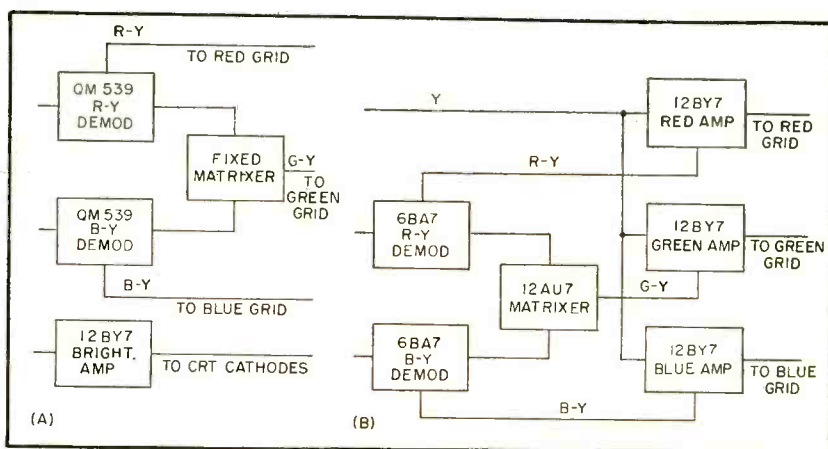

FIG. 1—Block diagram shows essential parts of high-level color demodulator (A) and low-level demodulator (B)

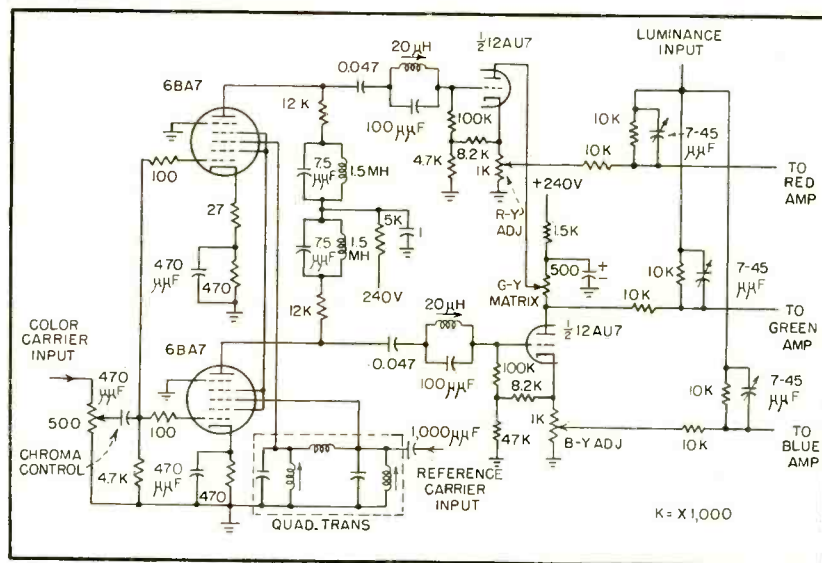

FIG. 3—Complete decoder circuit of receiver used in NTSC color tests. Type 6BA7 heptode demodulators are used

acceptable linearity. The 6BA7 provides characteristics similar to those of the 6AS6 but at approximately one-quarter the cost.

A comparison of the relative linearities, gains and output levels of the 6BA7 and 6AJ8 heptodes with the 6AS6 is furnished by Fig. 2A. The superior linearity and symmetry of the 6BA7 is demonstrated by the curves. The lower

conversion gain of the 6BA7 is not a disadvantage since it is not of sufficient magnitude to reduce seriously the gain reserve of the single color-carrier amplifier that precedes it.

The interaction problem produced both by capacitance and conductance coupling is of the same magnitude for the 6BA7, 6AS6 and split-anode heptode. Figure 2B lists in-

Television Receivers

Heptode and cascode-connected color demodulating circuits achieve economies over circuits using suppressor-gated pentodes. Split-anode heptode provides single tube demodulation. Cascode-connected circuits use dual triodes and pentode-triode combinations

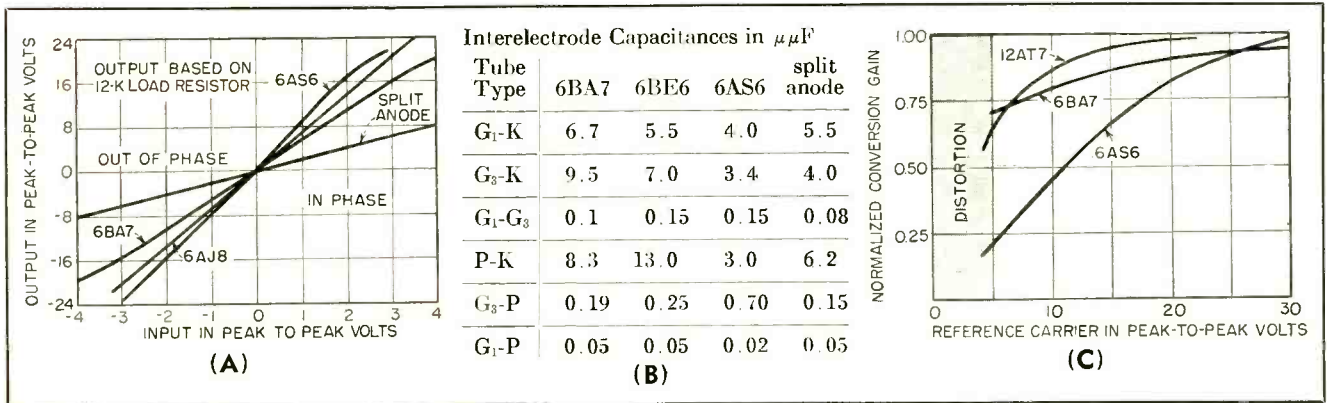

FIG. 2—Properties of some tubes used in color demodulators: conversion gain characteristics (A), interelectrode capacitances (B) and effect of reference carrier input (C)

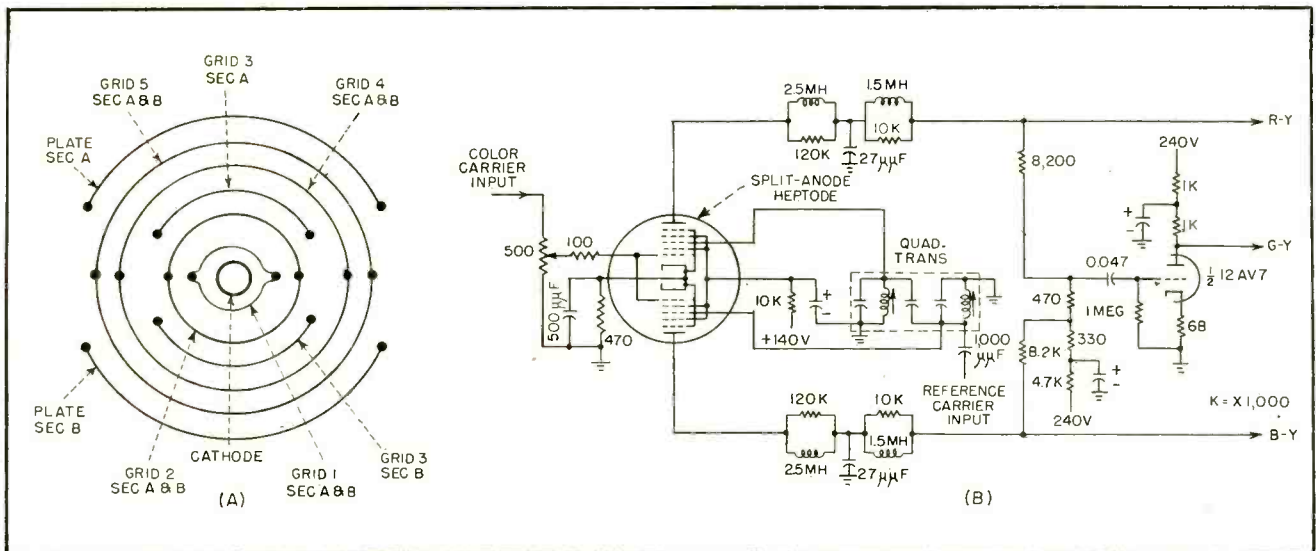

FIG. 4—Plan view of split-anode heptode (A) and demodulator circuit employing it (B)

COLOR TELEVISION RECEIVER ARTICLES

- Compatible Color TV Receiver, Jan. 1953.
- NTSC Color TV Standards for Engineers, Dec. 1953.
- Synchronization in Color TV, May 1953.
- TV Color Detectors Use Pulsed Envelope Method, March 1954.
- Beam-Deflection Tube Simplifies Color Decoders, May 1954.

terelectrode capacitances.

Heptodes were originally designed with a variable-pitch third grid for avc applications. The resulting remote cutoff presents a slight disadvantage for demodulator applications since it requires a higher amplitude of reference carrier to reach gain saturation. The effect on gain of varying reference-carrier amplitude is illustrated

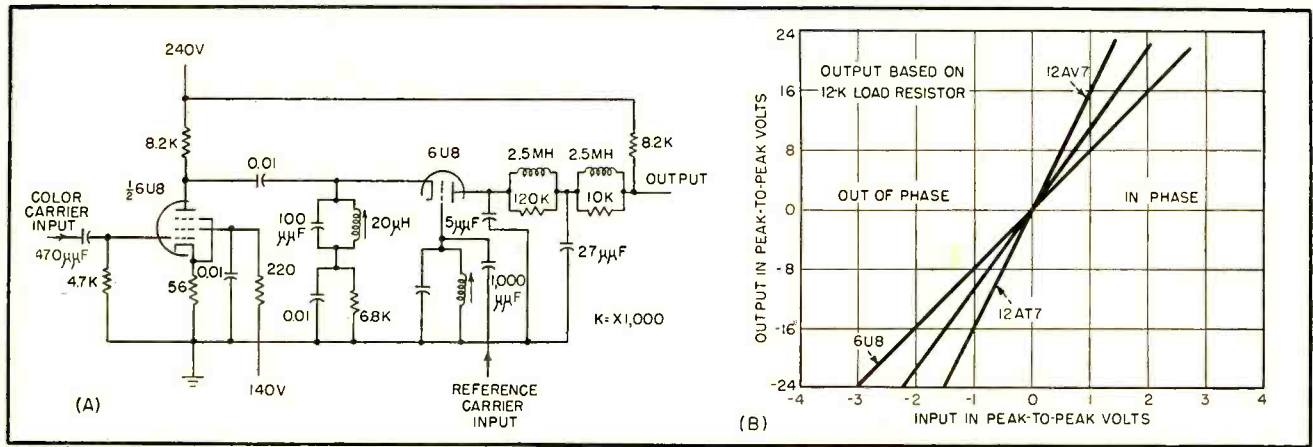

FIG. 5—Cascode-connected demodulator (A) and conversion gain characteristics of some tubes useful in this circuit (B)

in Fig. 2C for various types of tubes. A complete color decoder circuit using type 6BA7 heptode demodulators is shown in Fig. 3.

Simplification of receiver circuits results when two quadrature demodulators are combined in one envelope. Figure 4A illustrates the electrode arrangement for producing dual demodulation in a single nine-pin miniature tube. This tube has been constructed experimentally by splitting the third grid and anode of a conventional heptode and providing them with separate pin connections. Figure 4B illustrates a typical circuit employing the split-anode heptode and a triode G-Y matrixer.

Cascode Demodulators

The advantages of dual control grid demodulators over simple diode or triode demodulators include superior isolation of input signals, immunity to reference carrier amplitude variations or higher conversion gain depending on the form of the particular circuit. A circuit based on dual triode multiplication⁵ can be arranged to provide the advantages of dual control grid operation. Such a circuit, shown in Fig. 5A, has been called a cascode demodulator.

As the curves of Fig. 5B show, the cascode demodulator is characterized by high conversion gain with excellent linearity.

By operating the two sections in parallel across the B supply, sufficiently high peak currents are obtainable to provide true high-level demodulation should it become practical. Series a-c operation provides

the effect of current feedback with its accompanying linearity.

The price paid for the increased efficiency produced by dispensing with the screen grid is higher coupling capacitance between signal injection grids. If a low-impedance drive is not available for the color-carrier, or if neutralization is not feasible, a pentode-triode combination such as the 6U8 can be utilized to minimize coupling of reference carrier into the color-carrier.

One of the advantages of the cascode demodulator is its flexibility. A wide range of characteristics can be obtained through choice and combinations of tube types. The 12AT7 dual triode has a sharp cutoff that reduces the amplitude of reference carrier required to reach saturation.

In one special application,⁶ it was desired to time gate a demodulator at the horizontal sync frequency without having the gating pulse appear in the video load of the demodulator. This would be impossible with a heptode, but with a cascode demodulator a frequency-selective intrastage coupling network provided the required rejection without affecting the demodulated output.

Measurements

Demodulator characteristics are usually plotted from data collected by point-by-point measurements. Test equipment required includes a phase splitter and switching arrangement for obtaining the in-phase and out-of-phase signals. The technique used here provides a

visual display of output symmetry at any given input, expedites gain measurements and removes the need for a phase splitter.

If the color-carrier grid is supplied with a short duty cycle burst of the test frequency, preferably 3.6 mc, and the reference-carrier grid is supplied with a c-w signal of the same frequency, then the burst envelope can be recovered across a suitable output load resistor.

The amplitude is a function of the relative phase of the two input signals, reaching opposite polarity peaks at zero and 180 degrees.

It is necessary only to produce a difference in frequency between the two inputs so that the switching takes place as the signals precess at this frequency. The positive and negative peaks can conveniently be measured with an oscilloscope synchronized at the burst repetition frequency, which should be substantially higher than the difference frequency. Symmetry of output appears directly as positive and negative peaks relative to the base line. Gain is measured in the conventional manner.

REFERENCES

- (1) Pritchard and Rhodes, Color Television Signal Receiver Demodulators, RCA Review, 14, No. 2, June, 1953.
- (2) Donald C. Livingston, Theory of Synchronous Demodulator as Used in NTSC Color Television receiver, Sylvania Technologist, 5, No. 3, July, 1952.
- (3) R. Adler and C. Heuer, Beam-Deflection Tube Simplifies Color Decoders, ELECTRONICS, p 148, May 1954.
- (4) Color Television Receiver for NTSC Specifications, Hazeltine Corp. Bull. No. 7133, Aug. 15, 1952.
- (5) Chance, et al., "Waveforms," p 670, MIT Rad Lab Series, McGraw-Hill Book Co., Inc., New York, 1949.
- (6) E. G. Clark, A Self-Balancing Phase Detector for Color Reference Oscillator APC System, paper at IRE Conv., New York, March 1954.

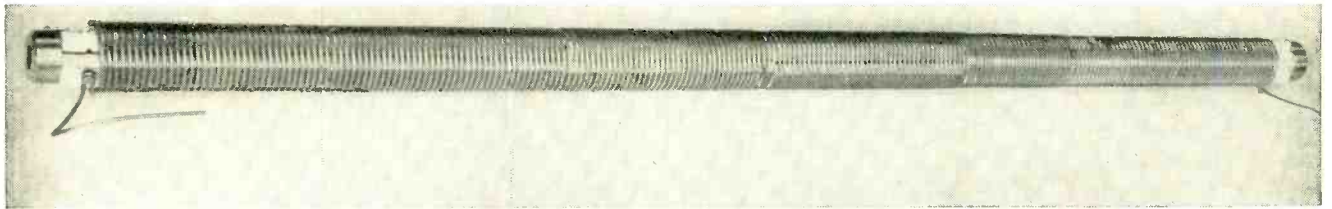

Detail view of delay-line dummy load with outer tube removed showing stainless-steel wire wound on ceramic coil form

Delay-Line Dummy Load Has High Power Rating

Stainless-steel helix wound on coaxial ceramic form functions as dummy load for rhombics or for testing and tuning transmitters. Experimental model rated at 40 kw provides 600-ohm balanced input with swr less than 1.1 over range from 3 to 30 mc

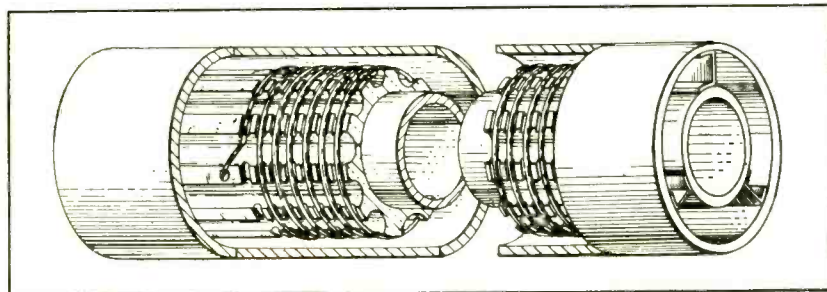

FIG.1 —Construction of delay-line dummy load showing stainless-steel helix

DUMMY LOADS or artificial antennas of high-power capability are needed, for example, as accessories to rhombic antennas. Rhombic antennas must be terminated at the front end in a balanced nonreactive and frequency-independent load of proper resistance to give optimum performance. In transmitting rhombics, the dissipation is often quite high, as in long-range communication at frequencies from about 3 to 30 mc where transmitter power up to several hundred kw is employed. Presently, open-wire dissipation lines of stainless steel are used as such a load. These dissipation lines have limitations.

A dummy load of high power

By H. BRUECKMANN

*Signal Corps Engineering Laboratories
Fort Monmouth, N. J.*

rating is also needed in transmitter testing, particularly transmitters for long-range communication. Requirements are very similar to those for rhombic terminations. The delay line, Fig. 1, is superior as a load of high power rating as compared to other types of loads.

An inner metal tubing supports a coaxial ceramic form of cylindrical shape having on its outside a thread of uniform pitch. Wire made of a material of high resistivity is wound on this form. An outer metal tubing shields the en-

tire helix. This tubing is in electrical contact with the inner tube through brackets at both ends. A stream of air through the gap between the wire and the outer tubing and through the inner tubing serves for cooling. The wire ends are brought out to the side through openings in the outer tubing covered with an insulator.

This configuration differs from others described in recent literature¹ in that it employs an inner metal tubing in addition to an outer tubing.² This inner tubing has greater rigidity and better control over electrical properties.

Basically, this device is a uniform transmission line, inductance, capacitance and resistance being uni-

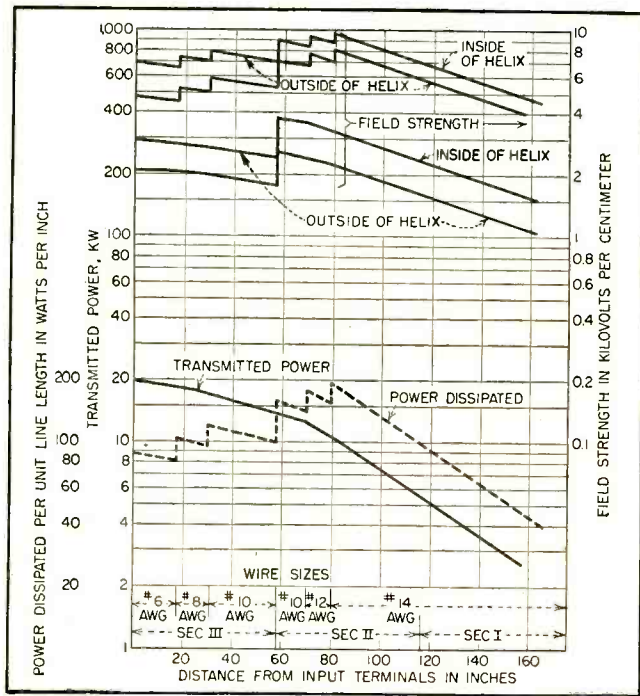

FIG. 2—Operational values at 3 mc with upper two curves computed for single turn and lower two substituting helix

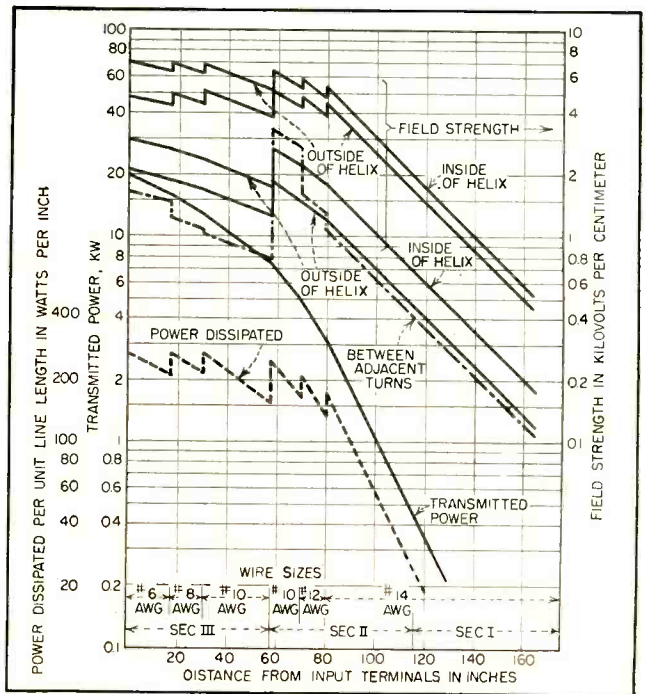

FIG. 3—Operational values of experimental dummy load taken at a frequency of 27 mc show practical frequency limit

formly distributed rather than lumped, and its electrical length is not small compared to the wavelength. More specifically, the device is a delay line because the propagation velocity is greatly reduced compared to that of free space due to the relatively large inductance and capacitance per unit length.

The impedance between one end of the wire and the tubing is non-reactive and frequency independent if the other end is terminated in a matching resistor. Most important, the input impedance is practically independent of wire resistance. If the termination does not match the characteristic impedance, or is a short or open circuit, the input impedance circles in the complex impedance plane with increasing frequency around an average impedance equal to the characteristic impedance of the line. The deviations from the average decrease with the increase in attenuation of the line. If the attenuation is greater than 13.3 db, the swr near the input is smaller than 1.1 and the deviations of the input impedance from the average are smaller than ± 10 percent, regardless of the termination. It is, therefore, a matter of providing enough attenuation to keep the fluctuations

of the input impedance below any specified value.

Wire Size

High breakdown-voltage and large cooling surface are essential in achieving high power-handling capability. This indicates the use of wire sizes greater than a certain minimum diameter, depending upon the power to be handled. On the other hand, the r-f resistance per unit length should be relatively high in order to keep the line as short as possible.

The material which has the highest r-f resistance for a given wire size, consistent with high oxidation-resistance, is stainless steel. Stainless steel not only has fairly high resistivity, about 33 times that of copper, but also has relatively high permeability. Recently tests of No. 410 stainless steel yielded an initial relative permeability of about 50. In the frequency region where skin effect is predominant the resistance is proportional to the geometric mean of resistivity and permeability. Accordingly, stainless steel wire has a resistance 39 times that of copper wire.

The high oxidation-resistance of stainless steel permits continuous operation at temperatures of 1.000

deg F. and more, making cooling by air sufficient. The relatively high temperature coefficient of the resistivity is not detrimental in this particular application because the wire resistance does not affect the input impedance of a terminated line. The same is true for the change of permeability with field strength, which is not small. Stainless steel, although a poor material for ordinary resistors, is an excellent material for use in this delay line.

Assuming the delay line is terminated at one end in a matching resistor and r-f power is fed into the other end, the transmitted power then decreases exponentially with line length. The power dissipated per unit length also decreases exponentially with the distance from the input, if all the dimensions of the line remain constant. This means that the dissipation capabilities of the line are not fully utilized over its entire length.

Fortunately, the ends of two stainless steel wires of different sizes can be butt-welded easily, and the characteristic impedance is affected little by a change in wire diameter if all the other dimensions including the pitch are kept the same. Better utilization of the dissipation capability can be made by

tapering the wire from large to small sizes towards the output.

The helix winding starts with No. 6 AWG wire. After about 20 inches of axial length the wire size is changed to No. 8 which is maintained for about 15 inches.

Wire size is again reduced to No. 10 and maintained for the rest of the length of this unit. Total length is 5 feet. The characteristic impedance of this model is 300 ohms, and propagation velocity is 2.7 percent of the velocity in free space.

Considering the operating temperature of the wire, it is important to keep the dissipation per unit length below the value corresponding to the permissible temperature. The unit dissipation and transmitted power of the experimental model are presented in Fig. 2. At each joint of different wire sizes the unit dissipation rises an increasing amount and falls off in between. Overall, it maintains a fairly constant level, except near the output end, where the wire size is kept constant.

Wire sizes smaller than No. 14 were considered undesirable from the mechanical point of view. It was for this reason that the pitch of the helix was increased from 4 turns per inch to 8 turns per inch in going from section III to section II. This permitted the use of larger wire in section II although higher attenuation per unit length is required than in section III. The diameters of the helix and the tubing had to be changed simultaneously to obtain the same characteristic impedance as in III.

Section I is identical with II, except for the wire size. Propagation velocity of section I and II is only 1.4 percent of the velocity in free space.

One difficulty in the design of this dummy load arises from the fact that wire resistance is proportional to the square root of the frequency. The effect of a change in frequency is shown in Fig. 3. The change of attenuation with frequency puts practical limits to the frequency range that can be covered with one particular delay line. It is possible to reduce this effect by coating the wire with a metal of lower resistivity.

The design of any dummy load

for high power would not be complete without considering the field strength in the dielectric in view of possible voltage breakdown. In this unit the field strength does not come near the breakdown field strength of air, although it is relatively high at certain points.

Figure 4 shows a graph of the measured input impedance as a function of frequency. The values indicated by a dotted line were measured first, indicating the existence of a lumped capacitance at both ends. Such a lumped capacitance can be explained by a decrease in unit inductance and an increase in unit capacitance near the ends of the helix. It was possible to compensate for this end effect by cutting slots in the inner tubing near the terminals and connecting small solenoid coils in series with the line at both ends.

Values measured after these changes were made are shown by solid line. The variation of the input resistance with frequency is within ± 10 percent and input re-

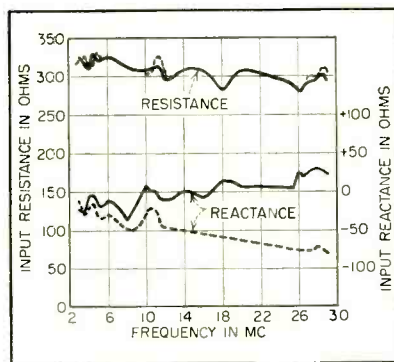

FIG. 4—Curves plotted with and without equalizing coils, terminated into a 307-ohm resistor

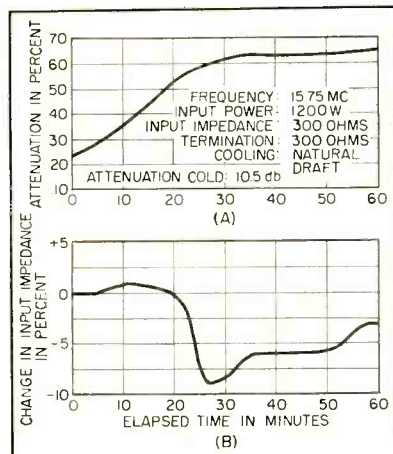

FIG. 5—Effect of input power on input impedance and attenuation

actance is smaller than ± 10 percent of the average resistance. Resistance seems to decrease with increasing frequency. This effect is due to points of phase reversal of the current along the line approaching each other with increasing frequency, resulting in a decrease of the average unit inductance³.

The graph in Fig. 5 A shows attenuation plotted against elapsed time after a certain constant power is applied. The attenuation is normalized on the attenuation in the cold state, that is, measured with very low power and at room temperature.

The curve starts with an attenuation 23 percent higher than in the cold state. This can be interpreted as caused by an increase in permeability of the stainless steel wire with current and, as a result, an increase in resistance of the wire with current. The increase of attenuation with time is due to the increase of resistance with temperature. Both effects have the desirable result of limiting the power dissipated in the terminating resistor, or permitting the omission of this resistor.

The graph of Fig. 5 B shows the effect of temperature on the input impedance referred to cold state. At the end of the test it had reached 1,000 deg F. Measurements with the complete dummy load showed changes smaller than 5 percent. The reason for this is that most of the dielectric in the line, particularly in section III, is air, the dielectric constant of which changes very little with temperature.

This dummy load combines the merit of a dissipation line, in that its input impedance is not affected by changes in input power or temperature, with the compactness of a lumped resistor.

Thanks are due R. E. Lacy and H. F. Meyer of the Signal Corps Engineering Laboratories, for their valuable assistance as well as T. Torretti, D. Lieberman and other personnel of these laboratories.

REFERENCES

- (1) H. E. Kallmann, High-Impedance Cable, *Proc. IRE*, 34, p 348, June 1946.
- (2) Lindenblad, US Patent.
- (3) M. J. Di Toro, General Transmission Theory of Distributed Helical Delay Lines with Bridging Capacitance, 1953 *IRE Nat. Conv.*, New York, March 1953.

Improved Demodulator

By **C. E. GOODELL**

Naval Ordnance Laboratory
White Oak, Md.

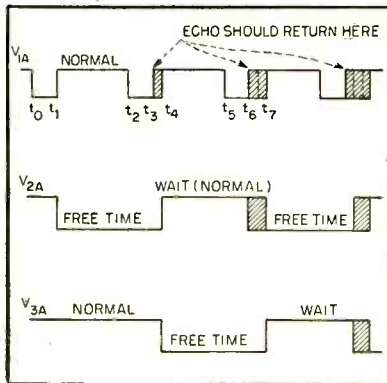

FIG. 1—Waveforms on plates of tubes V_{1A} , V_{2A} , and V_{3A}

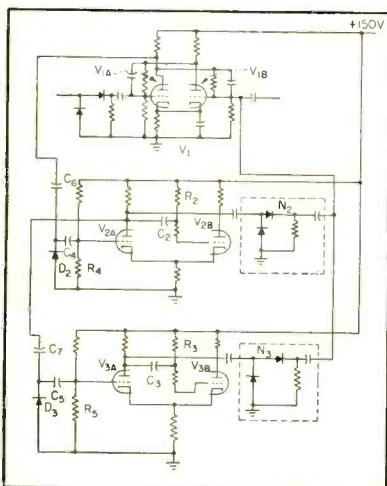

FIG. 2—Simplified schematic of demodulator using Eccles-Jordan trigger circuit

A SIMPLE DEMODULATOR such as a rectangular wave generator and R-C integrator combination which provides a d-c voltage proportional to range can produce either large instantaneous or average errors in range determination if loss of echo occurs. Among other things loss of echo can be caused by temperature stratification, inhomogeneous transmission medium, foreign bodies in the transmission path, secondary absorbers and reflectors.

Demodulator

To realize the simplicity and advantages of a square-wave integration type demodulator, and also

minimize errors due to loss of echo, the delta demodulator has been developed.

Delta demodulation indicates that each time an echo is absent a given known increment of range will be added to the range indication of the previous repetition frame.

If a true echo is received the demodulator action is nonexistent. However, if an echo is subsequently lost the demodulator will sense this loss and cause the square-wave pulse generator, consisting of an Eccles-Jordan trigger circuit, to generate a square wave of width equal to the width of the preceding square wave plus the incremental increase, delta. The time interval, delta, should be as small as possible to introduce the minimum amount of error in any frame. The lower limit on delta is set by the rate at which the target position is varying. Delta cannot be made less than the maximum change in echo transit time corresponding to the maximum change in range of the target during one repetition frame.

Assume that the transmission velocity in the medium is v ft/sec and the maximum rate of change of target range during the interval t sec is r ft/sec, where t is the repetition interval. The minimum value for delta is then tr/v sec.

Percentage-wise this error will be a maximum at the shortest range of interest, but this is not as serious as it might initially appear. For example, assume that every fifth echo is absent. Range is essentially constant and at its minimum value over the interval of interest, and delta is made equal to 10 percent of the pulse width corresponding to

minimum range. If the square wave is integrated to produce an average range value the average error due to the loss of echo sequence is only 2 percent. Without the demodulator and under the same conditions the error would be 20 percent.

In practice it is possible to establish the value of delta at approximately ± 2 percent thereby obtaining a still greater improvement in accuracy. Secondly, and most important, the probability of echo loss at short ranges is negligible. Only when the target is located at a great range do such factors as scattering, absorption and secondary reflections introduce a sizeable amount of echo loss.

Demodulator Operation

Figure 1 shows the waveforms present during a cycle of the demodulator circuit shown in Fig. 2. At time t_0 the same trigger that initiates the transmitted pulse, is fed to the grid of V_{1A} . This positive pulse causes the V_{1A} to conduct and a negative step appears at its plate. This step is passed through C_6 and shorted to ground by D_2 , having no effect on V_{2A} . At time t_1 the detected positive echo is fed into V_{1B} , the tube changes state producing a positive step. This step passes through C_6 , is differentiated by C_4 and R_4 , and applied to the grid of V_{2A} . This action changes the state of V_{2A} where it remains for a free period determined by the discharge characteristics of C_2 and R_2 .

At t_4 , the end of this free period, the tube returns to its normal state with a positive step at the plate of V_{2A} . Meanwhile, at t_3 , another pulse has gone out, and V_1 has changed state with a negative step.

for Radar Ranging

Range errors due to echo loss caused by scattering, absorption and secondary reflections are reduced by pulse demodulator incorporating square-wave generator to fill in lost pulses. Error in correction can be held to less than two percent

This step is again prevented by D_2 from reaching V_2 . The echo from this second pulse, at t_3 , would change the state of V_1 back.

If the echo were lost, at t_1 , V_2 returns to its normal waiting state with a positive step on the plate of V_{2A} . This step is differentiated through network N_3 , and applied to the grid of V_{1B} , returning V_1 to its normal state, indicating a depth delta greater than the depth shown by the previous frame.

At t_1 the positive step from V_2 is also applied through C_7 to the differentiating network C_5 , R_5 , and thence to the grid of V_{3A} changing the state of V_3 . This tube remains changed for a free period determined by the discharge characteristics of C_5 , R_5 . This period is set equal to the free period of V_2 . At t_1 , the end of this free period, V_3 returns to its normal state producing a positive step. This step is differentiated through N_3 and applied to V_{1B} . If an echo has been received, the grid of V_{1B} will already have been driven positive and the positive pulse at t_1 will have no effect. If, however, no echo has been received V_1 will be returned to its normal state again indicating a depth delta greater than the depth shown by the previous frame.

This action of V_2 and V_3 alternately supplying simulated echoes will continue as long as no true echoes are received. The purpose of the two networks N_2 and N_3 is to prevent the positive step at t_1 , t_3/t_1 , t_6/t_1 , from driving V_2 or V_3 positive at the same time this step on the grids of V_2 or V_3 is trying to drive the plates negative. These networks also prevent negative steps from V_2 or V_3 from driving the grid

of V_{1B} negative again at t_1 , t_3 , in the event a true echo has already driven the grid positive. If true echoes are not received the error delta is cumulative. The indicated range is the last true range plus $n \times \text{delta}$, where n is the number of echoes lost.

Simplifying Assumptions

Because it is impossible to predict all the loss of echo sequences and target position variations that can occur, it is difficult to analyze the demodulator behavior under all situations. However, if certain simplifying assumptions are made it is possible to derive relationships useful in determining the best circuit operating criteria.

If repetition rate is fast or target position changes slowly, the range can be considered essentially constant and the following generalized statements are possible:

With constant range no matter how many consecutive echoes are lost, up to the limit defined under Eq. 1 following, upon the receipt of either one or two successive echo pulses the system will reestablish its in-step operation. Only one echo need be received to pull in step if an odd number of successive echoes have been lost, whereas two successive echoes are required to pull the system in step if an even number of consecutive echoes have been lost.

If the range is constant then no matter how many consecutive echoes are lost, up to the limit defined under Eq. 1, the system will always reestablish its in-step operation if a like number of successive echoes are received.

If loss of echo sequence is not

successive the following relationships hold:

If an even number of echoes are initially lost and only one echo received, followed by another sequence of echo loss, sum the total number of echoes lost and subtract the number of echoes received. If this number x is odd then the subsequent receipt of one echo will establish the in-step operation. If the number x is even then the subsequent receipt of two consecutive echoes will establish the in-step operation.

If an odd number of echoes are lost in any sequence followed by the receipt of one echo in-step operation is reestablished.

If range is constant, the maximum number of successive echoes which may be lost before malfunction occurs is stated by the following limit

$$(T - t) \left[1 - \frac{\Delta(M + 2)}{(T - t)} \right] > 0 \quad (1)$$

Where:

T = repetition period

t = pulse width corresponding to the fixed range

Δ = incremental time due to demodulator

N = number of successive echoes lost

$M = f(N)$, tabulated below

$M = 0$ $N = 0, 1$

$M = 2$ $N = 2, 3$

$M = 4$ $N = 4, 5$

If Δ bears a relative prime relationship to the quantity $(T - t)$, the system will automatically reestablish its in-step operation even if the limit defined by Eq. 1 is exceeded. This reestablishment will take place after a time corresponding to the total time during which the loss of echo occurred.

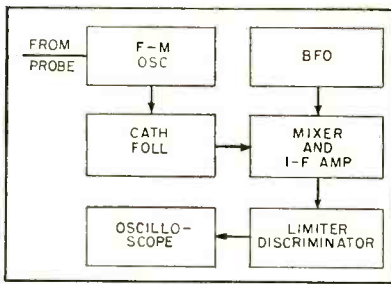

FIG. 1—Frequency deviations of f-m oscillator are controlled by metal-rod probe that is capacitively coupled to face of transducer under examination

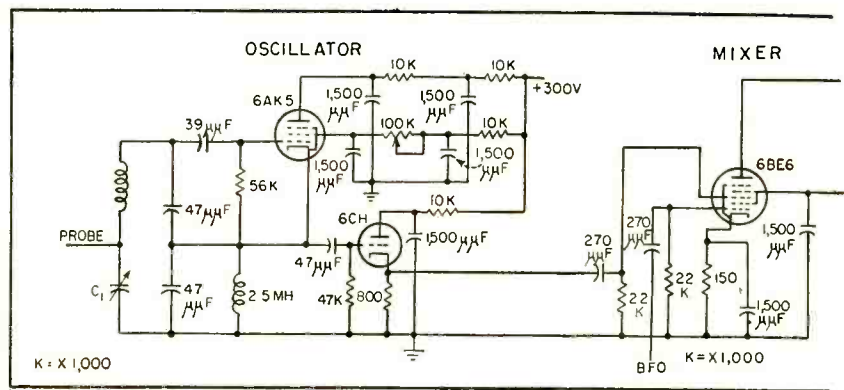

FIG. 3—Circuit of f-m microdisplacement meter uses two-stage stagger-tuned i-f amplifier.

Noncontacting Gage

Frequency-modulation system for point-by-point study of vibrating transducer surfaces. Used in air or liquid medium, the capacitance-coupled probe is capable of responding to displacements of one microinch at vibration rates up to 500 kc

PHYSICAL characteristics of a vibrating transducer can be measured by incorporating the transducer face into an oscillator design so that dynamic displacements of the transducer are translated into a corresponding frequency deviation. The frequency-modulation system described in this article translates these deviations into an amplitude-varying signal that is more easily examined.

The equipment is capable of responding to one-microinch displacement using a 1/16-inch diameter

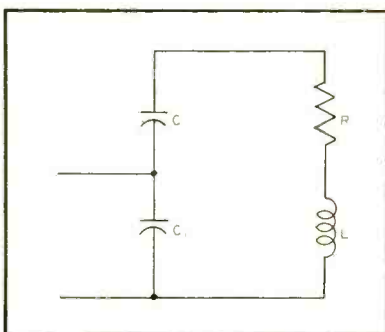

FIG. 2—Equivalent circuit of crystal-controlled oscillator tank circuit

By **HAROLD M. SHARAF**

Laboratory for Electronics, Inc.
Boston, Mass.

probe. The discriminator is capable of detecting a 100-cycle deviation from center frequency at a modulation rate as high as 500 kc, and provides an output signal capable of being measured with an oscilloscope. This last requirement facilitates relative phase measurements of transducer vibrations.

A block diagram of the system is shown in Fig. 1. The probe, a metal rod capacitively coupled to the transducer under examination, is in parallel with the oscillator tank tuning capacitance. The f-m oscillator consists of a stable variable-frequency Clapp-type oscillator whose output is coupled to a mixer stage where the frequency spectrum is translated to an intermediate frequency for amplification and detection. The difference frequency from the mixer is then coupled through an i-f amplifier to the limiter-discriminator stage.

Operation of the probe and transducer in a viscous fluid will increase sensitivity of the equipment since the dielectric constant, K , of most fluids is greater than that of air. For a given transducer deflection, the absolute frequency deviation of the displacement meter will be K times that in air.

The absolute displacement can be found from the relation $f = 1/2 \pi (LC_T)^{1/2}$ where C_T is tuning capacitance plus probe capacitance. The capacitance of the probe is $K\epsilon_0 A/D$, where A is area of plate and D the distance between plates. Differentiating f and C_{probe} implicitly the relation $dD = 2D^2 C_T df/f_0 KA \epsilon_0$ is obtained.

Since df , D , C_T , and f_0 can be measured within a few percent, substitution in these relations will give absolute displacement reading.

Probe

Sensitivity of this equipment can also be enhanced by increasing the effective area of the probe. However, the probe's ability to respond to transducer vibrations in any one

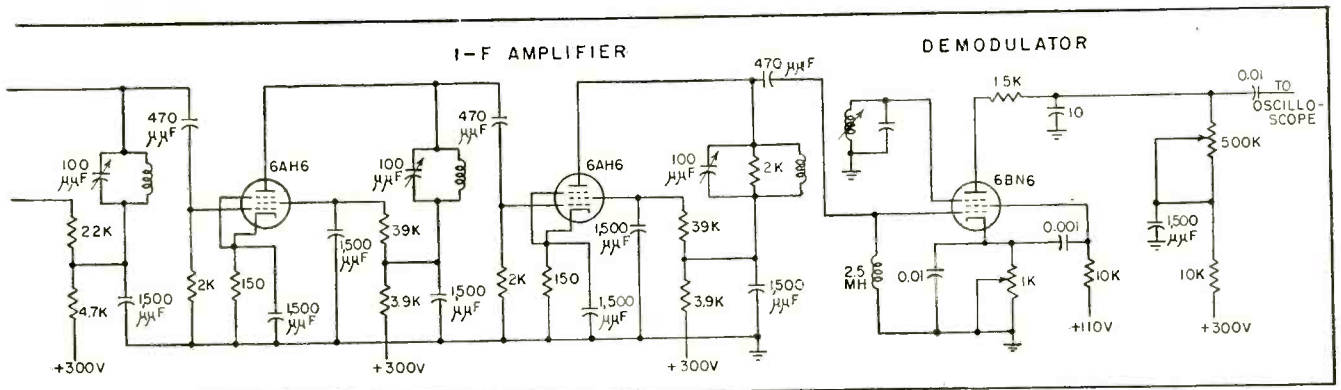

Output is a-m signal for oscilloscope presentation of small area vibrations of transducer surface

for Microdisplacements

segment will be reduced. Some compromise between sensitivity and area response must be made. A maximum probe diameter of 1/16 inch was finally decided on. A smaller diameter probe could be used if the vibration amplitude of the transducer were sufficient to produce reliable detection in the discriminator.

A 1/16-inch probe has an effective area of 0.003 sq in. With a spacing of 0.003 inch between probe and transducer face, the effective probe capacitance in air is 0.229 μf . This is approximately 3 percent of the total tank tuning capacitance.

For a peak deviation of one microinch over the entire surface under investigation the change in tuning capacitance is $dC = 0.765 \times 10^{-3} \mu\text{f}$. Assuming a center frequency of 25 mc and substituting in the relation $df = f dC/2C$, where C is assumed to be 8 μf , then $df = 119$ cycles.

The center frequency of the oscillator should be high with respect to the highest modulation frequency to realize a high-Q oscillator tank circuit. A ratio of 50-to-1 between the center frequency of the oscillator and the maximum modulation frequency has been found to be sufficient.

Oscillator Circuit

As the electrical stability of the oscillator is largely dependent on

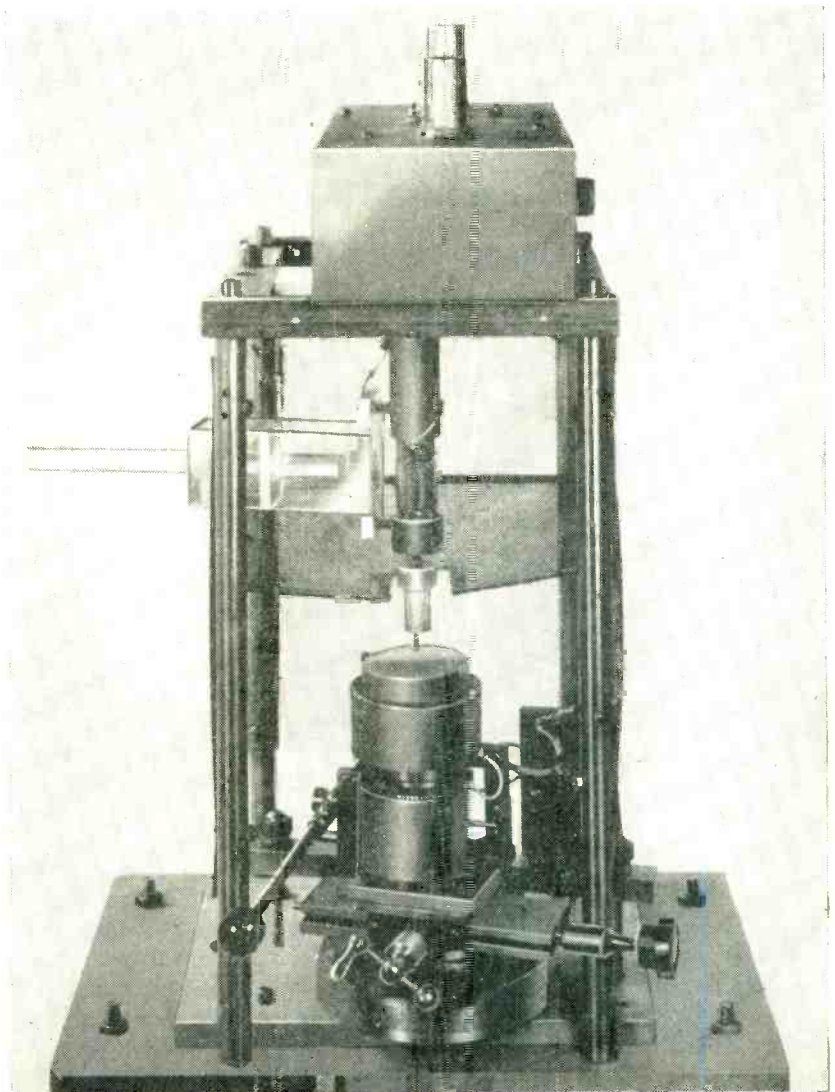

Probe and f-m oscillator are mounted above transducer under examination. Transducer mounting permits accurate placement of transducer under probe

the effective Q of the tank circuits, the L-C ratio should be as low as possible. To secure a maximum frequency deviation, however, C should be as small as possible. A maximum tank tuning capacitance of 4 to 8 μf was used as a compromise between a very sensitive discriminator and an excessively unstable oscillator.

Consider the simplified equivalent electrical network of a vibrating quartz-crystal oscillator tank circuit shown in Fig. 2. The important feature of this circuit is that the ratio of C/C_1 is always minute so that the coupling between the crystal resonator and the external circuit is quite small.

The Clapp oscillator³ circuit provides the isolation necessary for high stability. The probe used for measuring surface displacements is in parallel with the oscillator tuning circuit. The upper side of the transducer under examination is grounded to form the other capacitor plate.

Stray capacitance is negligible in comparison to the relatively intense field existing between the probe and transducer. No efforts were made to shield the probe either mechanically or electrically.

In the complete circuit, shown in Fig. 3, the output of the f-m oscillator is heterodyned to 10.7 mc by a mixer stage and beat-frequency oscillator. The differ-

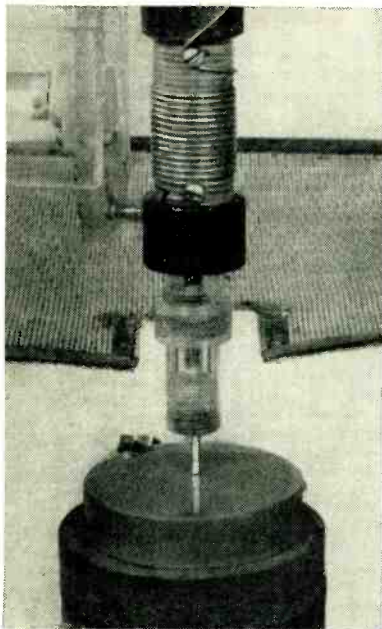

Probe and oscillator coil assembly. Strap on surface of transducer grounds upper face

ence output is coupled to a two-stage stagger-tuned i-f amplifier. Since frequency deviations are quite small, the f-m signal can be treated as an equivalent a-m signal. Thus, the maximum bandwidth of the i-f amplifier should be at least one mc. The stagger-tuned arrangement of broadband amplifiers provides the required bandwidth with a gain sufficient to provide 3-volts output for a one-volt oscillator signal coupled with a 0.1-volt beat-frequency oscillator signal.

Discriminator

A 6BN6 gated-beam tube is used as a discriminator capable of detecting high modulation rates. There are neither R-C time-constant networks to distort the input or output wave nor tuned circuits, barring the quadrature grid circuits, to adjust.

Due to the step-function control action of the limiter and quadrature grids, each grid can independently control the total plate current. The quadrature grid is so arranged that

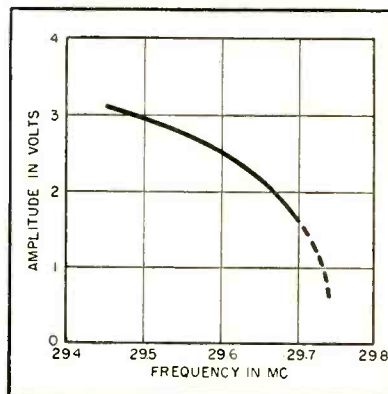

FIG. 4—Plot of amplitude against frequency for displacement meter used as a static measuring instrument

a resonant parallel tank circuit connected to this grid will develop an alternating voltage that lags the limiter-grid voltage by 90 deg. The Q of this quadrature tank must be reasonably high. If the frequency of the input voltage should deviate instantaneously from center frequency, the phase relationship of the limiter and quadrature grids are such that the average plate current will vary in direct relation to the phase difference.

Limiter grid input is 3.0 volts; E_{acc} , 110 volts; and E_{bb} , 300 volts. Frequency-modulation deviation is 20 kc and amplitude-modulation 30

percent. Amplitude-modulation suppression factor is 28 db and output is 0.12 volt per kc. The system provides a linear output for a frequency-deviation range from 1 to 20 kc. Modulation rates of 300 kc have been reproduced faithfully and there are indications that the equipment will respond at 500 kc.

Test Results

With a power amplifier used as the transducer driving source, signals were observed at the resonant frequencies of 30, 57, 167 and in a region of 200 to 300 kc. At 167 kc, the magnitude of displacement L was calculated to be about 4 micro-inches. Signal level was about 20 db above noise level. The transducer was a $\frac{1}{2}$ in. thick, 2 $\frac{1}{4}$ in. diameter disk of barium titanate.

A trial measurement in distilled water provided a reproducible output signal using an earphone as the transducer. Stray modulation of the transducer probe was excessive, however. Careful shielding of components should eliminate this effect.

All readings were secured by decreasing the spacing between the probe and the transducer face until a sizeable output voltage was obtained. A signal generator was set to zero beat with the center frequency of the oscillator. To obtain a relative measurement from one section of the transducer face to another, the transducer was displaced horizontally and probe spacing rechecked by securing a zero beat in the signal generator. In this manner f_0 and D were held constant within the factor of stability of the oscillator.

This instrument will also operate satisfactorily as a static measurement device. The graph in Fig. 4 was taken by varying C_1 to simulate a variation in spacing between the probe and transducer being measured. The d-c voltage was measured by a vacuum-tube voltmeter connected across the 56-K grid resistor in the oscillator circuit. The curve approaches that of a parabola, making it possible to calibrate a meter directly in displacement versus output voltage.

REFERENCE

- (1) J. K. Clapp, An Inductance-Capacitance Oscillator of Unusual Frequency Stability, *Proc IRE*, 36, No. 3, p 356, March 1948.

Transistor Flip-Flop Uses Two Frequencies

Bistable circuit operation is provided by a transistor oscillator with two stable output frequencies. Successive input pulses cause oscillator to shift between frequencies. Scheme avoids undesirable heating effects of current cutoff circuits

TRANSISTOR OSCILLATORS capable of stable operation at either of two frequencies represent a new type of binary computer element.

The two circuits to be described differ from the Eccles-Jordan bistable circuit in that selection between states is according to frequency difference rather than difference in d-c level. Because operation is at a more nearly constant energy level, many undesirable transient heating effects of current on-off transistor circuits are avoided.

Application of successive trigger pulses will alternately change the oscillator frequency from one stable value to the other. Pulses suitable for driving similar units may be derived by passing the oscillator output through a frequency discriminator and differentiating network. Alternatively, the oscillator may be adjusted to give highly unequal amplitudes in the two states. The amplitude difference may then be detected and converted into a suitable driving pulse for a following unit.

Description

Two transistor bistable oscillators exhibiting high performance characteristics are shown in Fig. 1. In each case the primary requirement of the oscillator is that it possess two stable operating frequencies. This may be achieved by employing as the resonant circuit any of the four coupled oscillatory

By **R. L. BROCK**

*Boeing Aircraft Co.
Seattle, Wash.*

circuits shown in Fig. 2.

In the oscillator of Fig. 1A, two stable frequencies, 425 and 500 kc, are possible because of the coupled action between the resonant circuit comprising L_3 and C_3 and that represented by L_2 , C_1 , C_2 and C_4 . This configuration was derived from the cir-

cuit in Fig. 2D according to an inverse transformation associated with transistor-electron triode duality. The transistor, a GE type G11, secures its d-c current bias by R_1 and L_1 . The d-c power source is of the constant-current type and generates approximately 1.8 ma at collector voltages less than 10. Triggering is by positive pulses derived from a low-impedance source and applied through the crystal diode

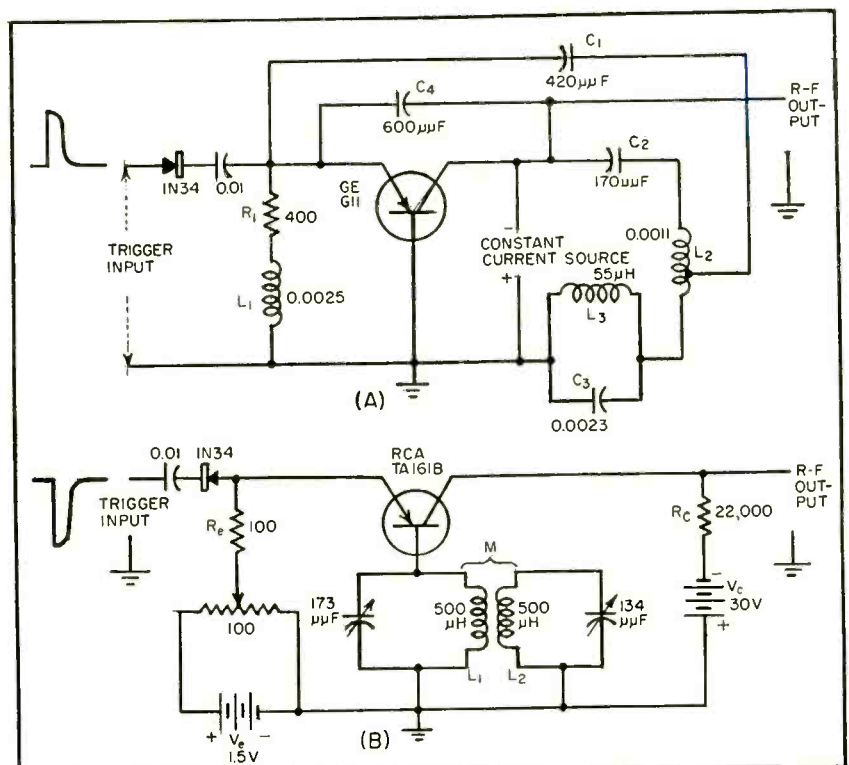

FIG. 1—Two forms of the transistor bistable oscillator. Circuit B utilizes negative resistance transistor

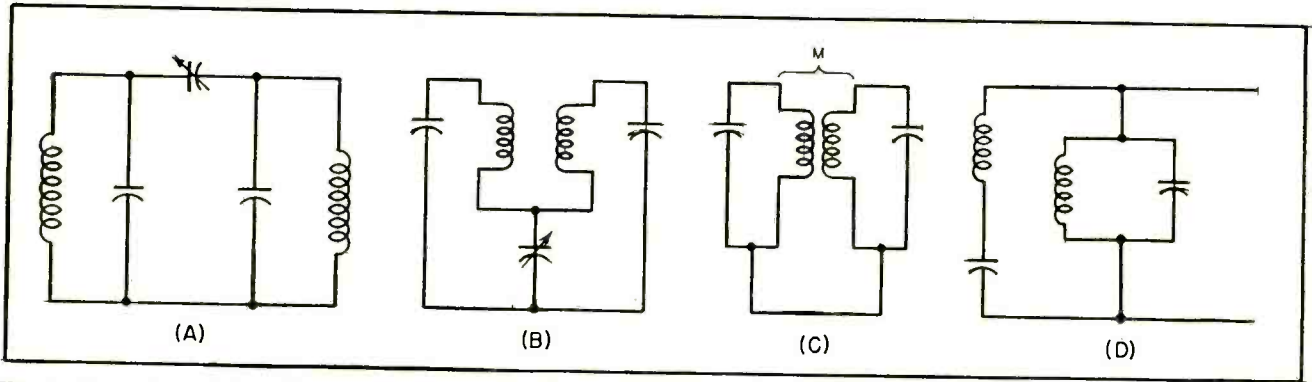

FIG. 2—Several coupled oscillatory circuits suitable for use in bistable oscillators

and capacitor to the emitter. The output may be taken from the collector. The transistor should have low internal base resistance and be capable of operating at low collector voltages.

Operation

Successful operation has been obtained with this circuit for pulse input rates from zero to 5 kc, the highest attempted. Unreliability was not encountered at slow pulse rates such as one every 20 minutes as is often the case in a conventional transistor on-off bistable circuit. This particular circuit was adjusted to given a 2-to-1 ratio between r-f voltage amplitudes for the two states. Tolerances of ± 5 percent appear to be satisfactory for all components and voltages.

The oscillator shown in Fig. 1B is simpler in form although somewhat more critical in operation than the one in Fig. 1A. Here two-frequency operation is attained through a parallel resonant circuit mutually coupled to a similar secondary, as indicated in Fig. 2C. Reliable triggering from one stable frequency to the other may be achieved by applying successive pulses of negative polarity to the emitter circuit. The output may be taken across the 22,000-ohm resistor.

Since external feedback is not employed, this circuit depends on transistors having large internal base resistances. Operation has been achieved with several RCA type TA 161B transistors and only minor circuit adjustments. The stable operating frequencies for the circuit constants chosen are approximately 500 and 550 kc. The operation is reliable for pulse input frequencies from zero to 250 pps.

No attempt has been made to extend the pulse frequency range.

For either of the two circuits in Fig. 1 the oscillator is an electrically coupled circuit externally driven in a sinusoidal manner. The transistor is the driving source and is capable of driving at either of the two stable frequencies of resonance. The transistor is restricted to supplying voltage of limited amplitude and it is this feature that makes it possible to produce the desired shift in frequency with the pulsing networks.

Assume the oscillator is operating at one of the two stable frequencies. Application of the triggering pulse on the emitter temporarily overrides the finite amplitude of the transistor voltage and allows the coupled circuit to go into free oscillation. During this time both stable frequencies coexist and there is a rapid exchange of energy between the coupled circuits. If the time duration of the trigger pulse is of such length that the desired frequency predominates when the transistor regains control of the coupled circuit, the frequency change will have been accomplished as desired. Successive trigger pulses then will alternately shift the oscillator frequency from one stable value to the other.

Design Considerations

The design of a bistable oscillator entails designing an L-C circuit having two frequencies of resonance and combining this circuit with other components to form an oscillator. The circuit of Fig. 1A was designed for an electron triode then transformed to a transistor-circuit according to the duality relation between electron triodes

and transistors. The circuit of Fig. 1B was designed directly for use with transistors.

Figure 3 shows the configuration of the electron-tube oscillator that is transformed according to the duality relations into the circuit of Fig. 1A. The tuned circuits, comprising L_3 and C_3 and L_1 , L_2 and C_2 are each designed to resonate separately at the same frequency. That two distinct frequencies of resonance are present when the two circuits are directly coupled may be shown analytically by an investigation of the impedance of each circuit. Significantly the resulting requirements for existence of two distinct frequencies of resonance are

$$R_p^2 > \omega_0^2 L_3 (L_1 + L_2) \quad (1)$$

$$\left\{ \left[\frac{\pi^2 (L_1 + L_2)^2}{R_p^2} \right] - [(L_1 + L_2)(4f_0^2 L_3)] + (1/f_0^2) \right\} f^2 - (2/f_0) f + 1 = 0 \quad (2)$$

where R_p is the effective parallel resistance in ohms of the L_1 , L_2 , C_2 circuit; $\omega_0 = 2\pi f_0$, the angular frequency of resonance in radians per second of either tuned circuit alone; and L_1 , L_2 and L_3 are inductances in henrys.

Specific numerical calculations are best facilitated by trial and error. Reasonable values of L_1 , L_2 and L_3 are chosen. Then, for a particular frequency f_0 a minimum

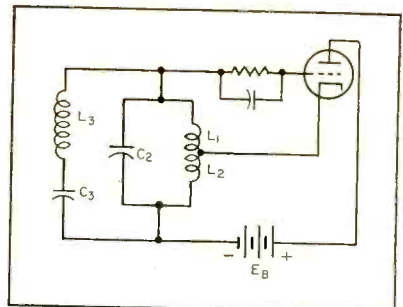

FIG. 3—Basic electron-tube bistable oscillator

value for R_p is determined from Eq. 1 and the two resonant frequencies f_1 and f_2 determined as roots of Eq. 2. Knowing f_0 and the values of inductances for each circuit it is possible to determine values for C_2 and C_3 such that each circuit is independently resonant to the same frequency f_0 .

Having determined the particular requirements for the tuned circuits, the design of the oscillator in Fig. 3 may be completed in the conventional manner. The resulting circuit is then transformed into the transistor bistable oscillator of Fig. 1A.

In designing the circuit of Fig. 1B the inductively coupled L-C circuits are considered first. The analysis leading to conditions under which these coupled circuits exhibit two frequencies of resonance is complex since it is necessary to solve the differential equa-

Analytical study of these circuits under conditions of free oscillation places an upper limit on the value of τ . Since the resulting equations are complex, the value of τ must be considerably less than unity if the two resonant frequencies are to be reasonably close to each other.

For actual design of the coupled circuit, a suitable operating frequency is chosen. Both the primary and secondary must then be separately resonant at the frequency ω_0 . Inductance L_2 is chosen such that its Q will satisfy Eq. 4 for a value of coupling coefficient τ that is reasonably achieved and not too near unity. The remaining constants of the coupled circuits are chosen such that resonance occurs for each circuit alone at frequency ω_0 . The values of the two stable frequencies may be predicted by the results of the analysis for the case of free oscillations or may be de-

under which it is present. However, it is generally sufficient to employ a high-Q tank circuit and adjust the bias conditions until the desired operation is achieved. Careful design will be justified when

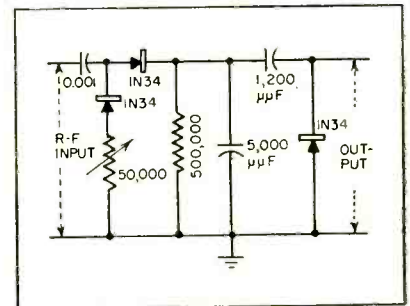

FIG. 5—Counter coupling network

transistor characteristics become more uniform between units.

Both R_s and R_e tend to reduce the regenerative action and hence the amplitude of oscillation, but they also serve as current limiting or protective components. The effect on regeneration of adding R_e is much more pronounced than for adding R_s . Resistance R_e serves as a load across which an output can be taken while R_s acts as a resistance across which the trigger pulse may be applied.

Bistable oscillators need not be restricted to the use of transistors as active elements. Electron triodes will serve just as well. The circuit of Fig. 4 represents one form of bistable oscillator using a CK-5703 triode. Two such circuits each driving a coupling network of the type shown in Fig. 5, have, when operated in tandem, performed reliably as a two-stage binary counter giving one pulse out for every four pulses impressed on the first input.

The author thanks J. E. Maynard of the physical research unit for suggesting this application of double-resonant coupled circuits and for his helpful suggestions during the investigation; also T. Ross for his assistance in the experimental work.

REFERENCES

- (1) D. C. Prince, Vacuum Tubes as Power Oscillators, *Proc IRE*, 11, p 409, 1923.
- (2) G. W. Pierce, "Electric Oscillations and Electric Waves," Chapt. 11, McGraw-Hill Book Co., Inc., New York, 1920.
- (3) Raisbeck, Transistor Circuit Design, *ELECTRONICS*, 24, p 128, Dec. 1951.

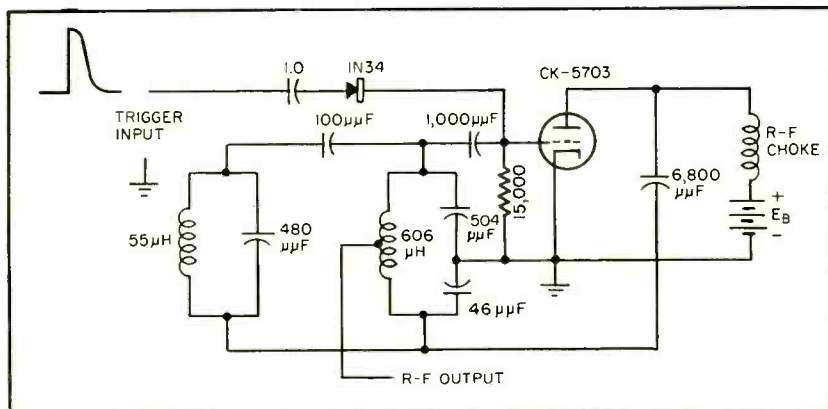

FIG. 4—Bistable oscillator using CK-5703 electron triode

tions describing circuit operation both for no external driving source and for an external sinusoidal driving emf such as operation with a transistor. It is found from the study of forced oscillations that the coefficient of coupling τ between L_1 and L_2 , where

$$\tau = M / (L_1 L_2)^{1/2} \quad (3)$$

must lie between certain fixed limits if two resonant frequencies are to exist. Specifically the treatment of forced oscillations yields the requirement that

$$\tau > (R_2 / \omega_0 L_2) \quad (4)$$

where R_2 is the effective resistance of the secondary circuit and $\omega_0 = 2\pi f_0$ is the angular frequency of resonance in radians per second of either tuned circuit alone.

terminated experimentally. Adjustment of the coupling may then be required to obtain the desired operating characteristics.

The coupled circuit when combined with a suitable transistor circuit results in the oscillator of Fig. 1B. A negative-resistance transistor can be utilized as an oscillator by introducing a parallel L-C circuit in the base lead since the base-circuit regeneration inherent in negative-resistance transistors can overcome the losses of the tuned circuit.

Exact design of such a circuit would entail a study of the negative-resistance base characteristics. Such a study would determine the magnitude of the regenerative effect and the d-c bias conditions

Electronic Shake Table

Highly discontinuous motions having step, ramp, square or triangular wave shapes for testing accelerometers are produced by using three feedback paths from shake table to amplifier which drives moving coil. Inputs include mask-type photoelectric generator

GENERATION of precise mechanical motions is required in testing for microphonics in electron tubes, exciting vibrational modes in propellers or turbine blades, testing air-frames and in dynamic calibration of seismometers, accelerometers and pickups.

Testing these instruments with sinusoidal motions is not too difficult. In studying the response of accelerometers and seismometers, however it is desirable also to have arbitrary transient or discontinuous motions of such wave shapes as steps, ramps and repetitive square and triangular waves.

A transducer system which reproduces discontinuous motions with acceptable fidelity is shown in Fig. 1. The main electromechanical transducer executes the desired vertical motions. The accelerometers on test are clamped to its moving platform. A power amplifier energizes the force coil with varying currents in the image of the desired waveforms. This actuates the main transducer platform. A low-frequency electronic oscillator supplies sinusoidal oscillations; a simple type of wave shaper provides square and triangular waves from the oscillator output.

An arbitrary wave generator of the photoelectric type utilizes a mask cut to the desired mathematical function. The mask intercepts a light beam focused on a phototube to produce electromotive forces of the desired waveform. These are used to drive the power amplifier.

Three feedback circuits are incorporated, one producing a voltage proportional to the moving platform displacement, the second

to its velocity and the third to its acceleration.

A dual-beam cathode-ray oscilloscope provides a display of the platform motions and the electric output of the accelerometer or other device on test.

System Equations

The physical operation of the feedback system in the transducer is portrayed by Fig. 2. The input to the power amplifier μ_o includes not only the arbitrary transient signal voltage $e(t)$, but also voltages proportional to the platform displacement x , to its first derivative and to the second derivative of the platform motion. This arrangement can produce faithful mechanical motions x in the image of the electric signal $e(t)$. The following definitions are used in analysis of the feedback system

- $e(t)$ = applied transient electric signal input
- $x, dx/dt, d^2x/dt^2$ = transducer platform output displacement (vertical), velocity and acceleration
- μ_o = power amplifier gain
- $\beta_1, \beta_2, \beta_3$ = respective feedback loop amplifier net voltage gains (positive or negative)
- T_o = transfer function of main force transducer converting voltage to mechanical displacement: $e_o = T_o x$
- T_1 = transference of photoelectric displacement transducer converting platform displacement to voltage: $e_1 = T_1 x$
- T_2 = transference of velocity feedback transducer converting platform velocity to voltage: $e_2 = T_2 (dx/dt)$
- T_3 = similar device converting the platform acceleration to corresponding voltage: $e_3 = T_3 (d^2x/dt^2)$
- m = total mass of suspended platform, including mass of accelerometer on test
- d = residual velocity damping, due to motion of conducting metal in stray magnetic fields, air damping etc.

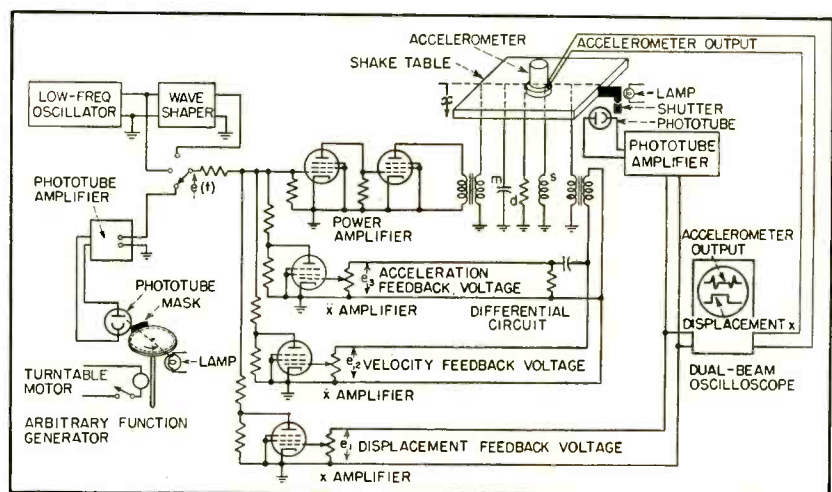
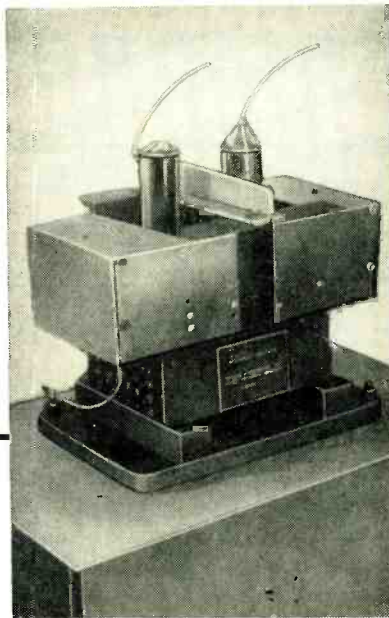

FIG. 1—Power amplifier driving shake table has choice of three input voltage sources. Three feedback paths link table to input of amplifier; two are from an extra coil mounted on the table and the third is from a photoelectric system actuated by a vane mounted on the table

By PIERRE M. HONNELL

Washington University
St. Louis, Missouri



Construction of shake table, showing method of bolting to heavy concrete base as required for faithful generation of wave shapes having steep fronts

s = equivalent stiffness of springs suspending moving platform

The transfer function of the main force transducer is

$$e_o = T_o x = h \left(m \frac{d^2x}{dt^2} + d \frac{dx}{dt} + sx \right) \quad (1)$$

where h is a constant depending upon the electromagnetic parameters of the force coil. The resistance and inductance of the force coil windings are neglected here for simplicity.

Summing the voltages at the input e_{in} of the power amplifier in Fig. 2 gives

$$e_{in} = e(t) + \beta_1 e_1 + \beta_2 e_2 + \beta_3 e_3 \quad (2)$$

Multiplying Eq. 2 by μ_o gives the power amplifier output voltage e_o .

$$e_o = \mu_o e_{in} = \mu_o e(t) + \mu_o \beta_1 e_1 + \mu_o \beta_2 e_2 + \mu_o \beta_3 e_3 \quad (3)$$

Use of Eq. 1 and the appropriate transferred mechanical variables for the feedback voltages yields

$$h \left(m \frac{d^2x}{dt^2} + d \frac{dx}{dt} + sx \right) = \mu_o e(t) + \mu_o \beta_1 T_1 x + \mu_o \beta_2 T_2 \frac{dx}{dt} + \mu_o \beta_3 T_3 \frac{d^2x}{dt^2} \quad (4)$$

Combining terms yields

$$\left(hm - \mu_o \beta_3 T_3 \right) \frac{d^2x}{dt^2} + \left(hd - \mu_o \beta_2 T_2 \right) \frac{dx}{dt} + \left(hs - \mu_o \beta_1 T_1 \right) x = \mu_o e(t) \quad (5)$$

The coefficients of each term of the left hand side of this linear differential equation consists of the algebraic difference of two factors—a constant parameter (such as hm) fixed by an electromechanical magnitude and an adjustable factor (such as $\mu_o \beta_3 T_3$) depending upon a feedback voltage gain. Thus, by a mere change of polarity and gain settings of the feedback voltage

amplifiers, the order of the differential equation can be changed at will, since specified coefficients can be made vanishingly small or very large.

Modes

By appropriate feedback loop gain settings it is possible to make the coefficients of d^2x/dt^2 and dx/dt in Eq. 5 vanish, and the sign of $\mu_o \beta_1 T_1$ positive. Thus, solving for the displacement

$$x = \frac{\mu_o}{hs + \mu_o \beta_1 T_1} e(t) \quad (6)$$

That is, the transducer platform displacement x is in the image of the applied signal $e(t)$, no matter what wave shape the function $e(t)$ may have. This is called the displacement mode of operation of the transducer system.

It is possible to adjust the feedback loop gain settings such that

$$\frac{dx}{dt} = \frac{\mu_o}{hd + \mu_o \beta_2 T_2} e(t) \quad (7)$$

In this event, the transducer platform velocity dx/dt is a replica of the applied electric signal $e(t)$, no matter what the function $e(t)$ may be. This is the velocity mode of operation of the transducer system.

Limitations

Exact accomplishment of Eq. 5 for a physical system is difficult, if

not impossible. Parasitic parameters, such as the driving coil resistance and inductance, are not specifically included in the analysis but are nevertheless present; also, amplifier gains and mechanical network parameters are not constants. The analysis is only an approximation to the physics, but is a useful idealization nevertheless.

Stability of the system is always an important consideration. By improper adjustments of the gain polarities and magnitudes, it is quite easy to obtain an unstable system. For example, by making the coefficient of the velocity term dx/dt slightly negative, electro-mechanical oscillations immediately result. This is not usually desirable, especially if the oscillations are not quickly stopped, as they may damage the pickup on test. However, adjustment of the system to a regenerative state is sometimes useful in sinusoidal calibrations.

Finally, the linear voltage range of electronic amplifiers is limited.

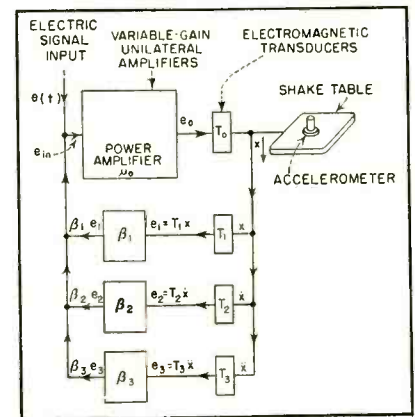

FIG. 2—Feedback representation of electromechanical transducer system

Thus, the maximum available displacement output of the transducer is also limited, although adequate for the precise testing of many electromechanical devices and for fundamental researches.

BIBLIOGRAPHY

- Pierre M. Honnell, An Electromechanical Transducer System for the Transient Testing of Seismographs, *Geophysics*, p 160, Jan. 1953.
- Pierre M. Honnell, Instrumentation for the Transient Testing of Accelerometers, Paper 52-16-2, *Proc Instr Soc Am*, 1952.
- Pierre M. Honnell, Anomalous Transient Response of a Crystal Pick-Up, *Jrl Acous Soc Am*, p 570, May 1953.
- G. G. Gouriet, Spectrum Equalization, *Wireless Engineer*, p 112, May 1953.

Aircraft Receiver for VOR-

Complete navigation and communications equipment, including transmitter on same chassis, provides cro presentation of omnirange signal and c-r indicator for instrument landing system right-left signals. High sensitivity and in-flight calibration are featured

THE OMNIRANGE navigation system for aircraft operates in the frequency range between 112 and 118 mc. There are four separate modulations on the carrier. A 1,000-cycle tone, identifying the station in Morse code, modulates the carrier 10 percent. Voice modulation for weather and communication with aircraft modulates the carrier 30 percent. Third, there is a 30-cycle modulation of 30 percent. Fourth is 9.96-kilocycle modulation of 30 percent. Thus, the carrier may be modulated up to 100 percent.

The navigational features are carried in the 30-cps and 9.96-kc signals. The 30-cps modulation is such that if a receiver north of the station compares the phase of the 30 cps received with that of a similar receiver east of the station, there will be 90 degrees phase difference.

With a receiver south of the station, there will be 180 degrees phase difference and west of the station, the difference will be 270 degrees.

Thus, if there were some way of knowing the phase north of the station without being there, it would be possible to tell the direction of any receiver relative to the transmitter. This reference information is carried in the 9.96-kc modu-

lation by frequency-modulating it at 30 cps in such phase that the 30-cps amplitude modulation will be in phase for a receiver north of the station. Thus, a receiver designed for this type of signal can tell its bearing from the transmitter.

Omnirange Receiver

Figure 1 shows the functions that an omnirange receiver must perform. The tuner and i-f amplifier are conventional. The i-f amplifier is followed by a conventional detector whose output consists of four modulating signals. The 30-cps and 9.96-kc signals are the two required for omnirange operation.

The 30-cps signal is used directly, but the 9.96-kc signal goes into a discriminator to recover its 30-cps frequency modulation. The 30-cps signal from the discriminator is known as the reference-phase signal since its phase is independent of the relative position of receiver and transmitter. The 30-cps signal directly from the detector is known as the variable-phase signal since its phase varies with the position of the receiver relative to the transmitter.

There are two types of phase meters in general use. The first consists of a phase detector giving zero output for 0-degree phase angle and either positive or nega-

tive output if the phase is other than 0 degree. The actual polarity depends upon the sign (positive or negative) of the phase difference. Since such a phase detector will also give a null at 180 degrees, a second phase detector giving nulls at 90 and 270 degrees must also be used to resolve the ambiguity.

A continuously variable calibrated phase shifter is then placed in either the variable or reference-signal channel. The reading of the phase shifter when the first phase detector gives a null thus shows the phase difference between the incoming signals except for a 180-degree ambiguity that is resolved by the second phase detector.

A simpler method is to make a circular deflection on an oscilloscope tube from either the variable or reference-phase signal and then use the other signal to make a sharp pulse that marks a spot on the circular trace. This method has the advantage of being direct reading and does not require the adjustment of a variable phase shifter. There is, likewise, no 180-degree ambiguity to be resolved.

New Design

In designing a receiver for maximum sensitivity, the limit is set by thermal noise at the input. It is important to plan the receiver front end for as good a signal-to-noise ratio as possible. Improvement also results from making the receiver with as narrow a bandwidth as possible, since noise power is proportional to bandwidth. Narrowing the bandwidth seems to offer more room for improvement than any other change because receivers have not so far exploited this possibility.

In a typical commercial receiver, a Wien-bridge type filter is the narrowest element therein; this

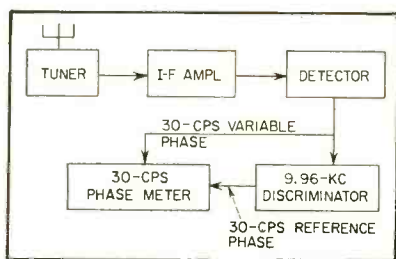

FIG. 1—Principle of phase meter for VOR direction indication

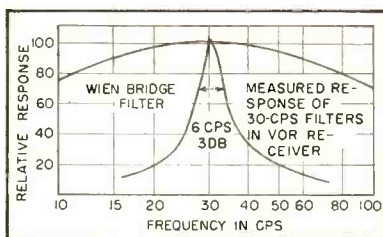

FIG. 2—Comparison of broad Wien-bridge null and measured response of narrow-band filters

ILS and Communications

By G. W. GRAY

Radio Corporation of America
RCA Laboratories Division
Princeton, N. J.

filter commonly has a bandwidth of about 120 cycles at the 3-db points. In the receiver to be described here, a bandwidth of about 6 cycles is used and thus a voltage sensitivity is obtained that is 4 to 5 times better than current commercial sets. Figure 2 compares the band-pass characteristics of these receivers.

A disadvantage of this narrow bandwidth is that it introduces the possibility of phase shift and resultant error. If the tuning of the narrow-band filter should drift slightly, the phase of the 30-cps signal would be shifted a relatively large amount. Since the whole omnirange system is based upon phase measurement, the possibility of such phase shifts cannot be tolerated unless there is some means of checking the filters. Such a method is described by reference to Fig. 3, a block diagram of the developmental receiver.

All the circuits to obtain the 30-cps variable and reference signals are straightforward. In order to measure the phase between the two 30-cps signals, one makes a circular sweep on a cathode-ray tube and a narrow pulse from the second blanks out a portion of the circular sweep. In operation, this gives a presentation whereby the omni station being received is at the center of the circle and the receiver is in the direction of a blanked spot. Tube orientation and circuits are so adjusted that the 12 o'clock position is magnetic north.

Since it is known that the two 30-cps signals will be in phase when the receiver is north of the station, it is possible to feed one of the 30-cps signals into both channels of the phase meter for check purposes. Under these conditions the phase meter should read north. Figure 3 shows the calibration switch that

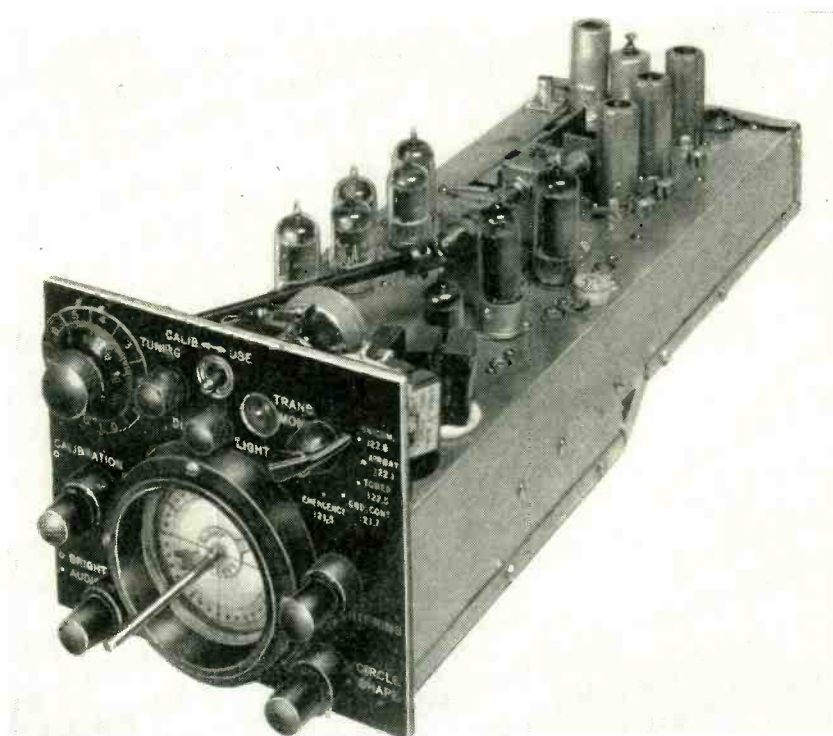

Control chassis shows omnirange presentation, receiving and transmitting adjustments

facilitates adjustment of all circuits likely to shift the 30-cps.

A 1-percent change in the tuning of one of the phase-meter filters will produce approximately five degrees of error. Also, the circuit that makes a narrow pulse from the reference 30-cps signal may be subject to variations in the phase relation between the pulse and the original sine wave. These errors can all be compensated by throwing the switch to CALIBRATE and adjusting the phase of one channel to give a north reading. The switch is thrown to NORMAL for navigation.

Many omnirange receivers employ a left-right meter instead of the circular sweep described here. Such a calibration switch may be employed to advantage with the meter presentation and narrow-

band filters may be used to increase the usable sensitivity.

The 30-cps tuned amplifiers are selective-feedback types to avoid using inductances that are heavy, bulky and costly at these low frequencies. The amplifiers consist of two R-C coupled stages, with all the output being fed back to the first stage by means of a cathode-coupled third stage and in such phase as to be degenerative.

This large amount of feedback reduces the gain of the amplifier to only a little more than unity. A parallel-T R-C filter tuned to reject 30 cps is placed in the feedback path to reduce the feedback at 30 cps to nearly zero. Thus, the amplifier will have nearly full gain at 30 cps and the gain will fall off sharply at both higher and lower frequencies. The result obtained is

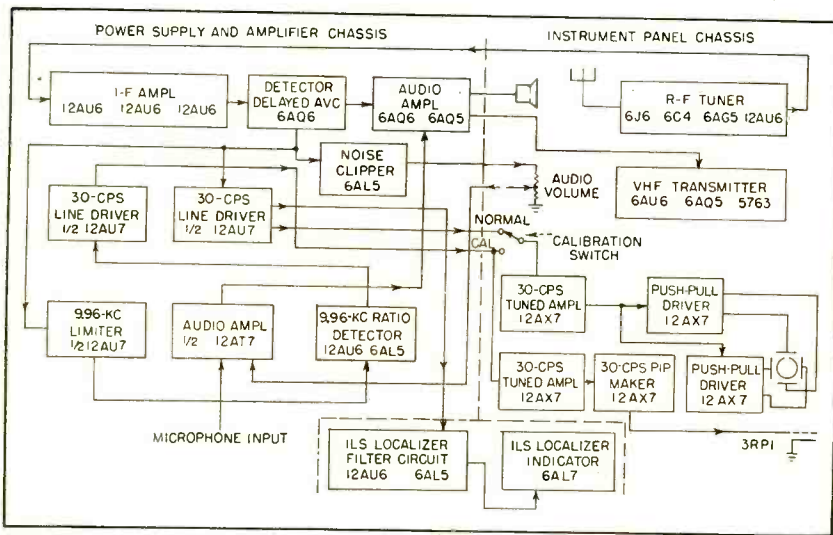

FIG. 3—Block diagram of aircraft equipment shows power chassis (left) that can be stowed anywhere and control equipment (right) mounted near pilot

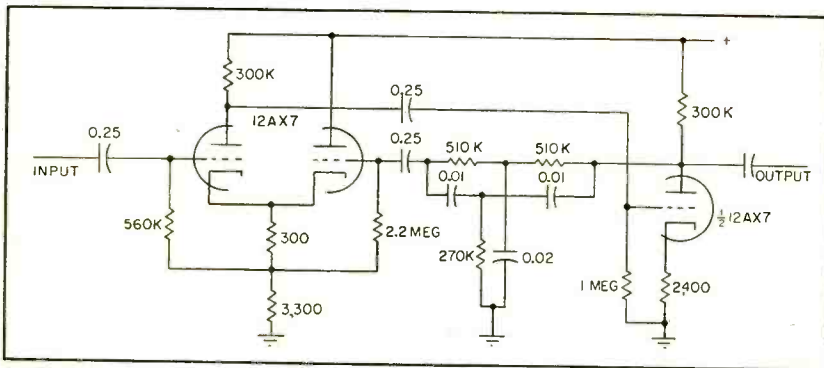

FIG. 4—Tuned amplifier is sharply peaked at 30 cps



Equipment mounted on dashboard of plane

shown in Fig. 2; the circuit is given in Fig. 4, indicating its simplicity.

In the construction of a receiver using these principles a standard f-m tuner and i-f strip manufactured by Collins Audio Products were converted. The original equipment used powdered iron slugs for tuning over the 88-to-108 mc band. Replacing the iron slugs with brass slugs changed the range to 108 to 126 mc. Although the tuner as sup-

plied by the manufacturer is wired for 6-volt filaments, changing one wire modifies it for 12 volts with no changes in tubes. A little extra gain can be obtained from the r-f amplifier by decreasing bias. The only changes made in the i-f strip were removal of limiter and discriminator stages. The tubes were replaced by equivalent 12-volt filament types.

The circuit of the complete receiver is shown in Fig. 5. Circuits

on the right are contained in a chassis designed for the instrument panel and include operating controls. The circuits at the left of the diagram are in a second chassis that may be mounted anywhere, since it has no controls.

Tuning the receiver is accomplished both mechanically and electrically. The mechanical system uses a ten-turn dual dial to actuate the brass slugs of the tuner. Since there is some backlash in the mechanical system, electrical tuning with no backlash is also incorporated. The electrical tuning consists of a neon glow tube connected across the oscillator tube in a circuit allowing direct current through the neon tube to be varied by means of a variable resistor on the front panel.

The neon tube acts as a variable capacitor with the capacitance proportional to direct current through the tube. With the circuit shown, approximately 1-megacycle variation in oscillator frequency is obtained. There are two advantages to this type of fine tuning. The variable resistor has no backlash so the fine tuning of the receiver is easier. This is especially true since the mechanical linkage is long and does have a little backlash.

Second, when contacting a station that is not transmitting continuously, the receiver may be tuned approximately by means of the mechanical linkage and then varied around this frequency with the fine tuning while listening for a reply. Since the fine-tuning range is limited, there is no danger of getting far from the desired frequency even when the dial is not watched.

The i-f strip is conventional. Automatic volume-control voltage is applied to all stages except the last, since this stage operates at a relatively high level and might distort the signal at high bias levels. The detector is biased to provide delayed avc and thus hold the output level nearly constant over wide changes of input level. Output of the detector goes to three places—an audio volume control, an amplifier to amplify and limit the 9.96-kc signal and an amplifier to select the 30-cps variable-phase signal. The 9.96-kc signal goes to a ratio de-

detector circuit for recovery of the 30-cps reference-phase signal.

Wien-bridge coupling circuits are used for the 30-cps signal because of the relatively small capacitors that can be used without introducing phase shift. One of the Wien-bridge coupling circuits incorporates a variable resistor to provide a small amount of phase shift for calibration purposes. The variable-phase 30-cps signal is filtered in a tuned amplifier and then divided into two phases—one phase advanced 90 degrees with respect to the other phase. Each phase goes to a push-pull driver stage for the deflection plates of the cathode-ray tube. A circular sweep is thus produced from the variable-phase omniscinal.

Marker Phase

The reference-phase 30-cps signal goes to a second tuned amplifier and after filtering to a circuit that converts the sine wave to a narrow pulse. Ideally, this circuit should always produce a narrow pulse from the same portion of the sine wave even though the sine-wave amplitude changes. This is not difficult when a transformer is used,

since it has low d-c resistance compared to its 30-cps impedance. Such transformers are bulky and expensive, so the simple circuit of Fig. 6 was devised.

The circuit makes a square wave from the sine wave; it then differentiates the square wave to form positive and negative pulses. Finally, the positive pulses are clipped, leaving one negative pulse per cycle. The pulse obtained by this method is about seven degrees wide. It is important not to build up bias on the grid of the triode as a result of clipping action taking place there.

If bias did build up, it would be proportional to amplitude and this would result in phase shift of the pulse with respect to the sine wave as a function of sine-wave amplitude. Diode D_1 prevents grid current on the positive half of the sine wave; however, the diode must have a finite back resistance for proper clipping. Either a crystal diode or a vacuum diode shunted by approximately 300,000 ohms is used. Thus, the resistance to ground looking into the cathode of D_1 varies depending on whether the voltage is above or below ground. This can be

compensated by putting a second diode D_2 in series with grid resistor R .

Figure 6 shows the expression for the resistance for voltages above and below ground on the assumption that the back resistance of the two diodes is equal. Solving for R shows that R equal to 0.6 of the diode back resistance will result in zero bias being built up on coupling capacitor C . Since the effective back resistance of the diode is not known, the correct value of R is experimentally determined by applying 30-cps sine waves to the pulse-shaping circuit and simultaneously to the horizontal plates of an oscilloscope. The output pulse is applied to the vertical-deflection plates. Changing the amplitude of the input to the pulse maker will cause the pulse on the oscilloscope to move sideways if R is not right. The value of R can be adjusted until the pulse does not move as a function of input amplitude.

Diode Balance

Two precautions obviate the possibility of errors resulting from changing back resistance of the

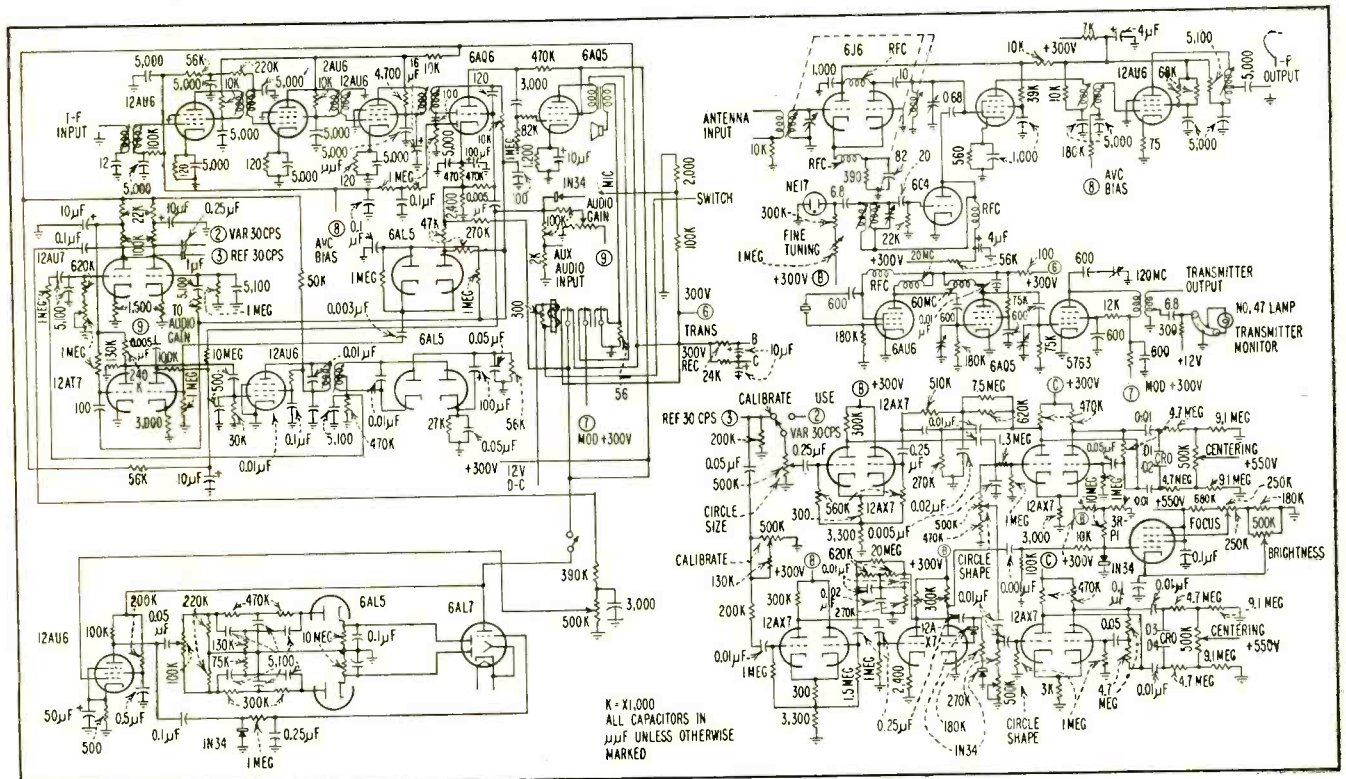

FIG. 5—Complete circuit diagram with vibrator power supply omitted. Interconnections are labeled with number or letter

diodes. The reference-phase signal is put into the pulse maker, since the reference signal derives from the frequency-modulated 9.96-kc signal that went through a limiter and ratio detector. The resulting 30-cps signal is not subject to wide amplitude variations. Second, the pulse-making circuit receives the same signal in both the normal use and calibration positions of the calibration switch. If the pulse maker should introduce phase errors on signals of different strengths, the calibration switch will not only detect the error but also allow in-flight compensation of the circuit.

One criticism of the oscilloscope-type phase meter compared to the course-selector dial and left-right meter is the difficulty involved in figuring which way to turn to get back on course. This problem is easily solved by having some sort of adjustable index on the face of the oscilloscope, as shown in the photograph of the instrument panel chassis. The procedure follows.

If it is desired to fly away from station, the arrowhead is set to the bearing of the radial from the station to be flown. The heading of the plane is that shown at the arrowhead with allowance for the wind. If it is desired to fly towards the station, the tail of the arrow is set to the bearing of the radial from the station to be flown. The heading of the plane is again that shown at the arrowhead with allowance for wind. When flying away from the station, the blanked spot will appear at the arrowhead, and when flying towards the station, at the tail of the arrow.

As shown in the photograph, one side of the arrow may be marked left and the other side right. If the blanked spot on the circle moves to the side of the arrow marked left, the course should be altered to the left in order to get back on the desired course; likewise, if the blanked spot moves to the side marked right, the course should be altered to the right. These corrections apply whether the blanked spot is at the head or tail of the arrow. In practice this device has been found completely satisfactory.

The oscilloscope presentation instead of the left-right meter type

insures virtually fail-safe operation. If the oscilloscope shows a centered circle with a pip that goes to north when calibrating, the 30-cps filters and phase meter are completely checked. The avc circuit is the only other part of the circuit that could produce appreciable 30-cps phase shift; if the avc voltage is not filtered sufficiently, it will grid modulate the i-f amplifier to produce 30-cps phase shift. Even this possible trouble can be made virtually impossible by putting paralleled bypass capacitors on the avc lead.

Since the power supply and modulator are already available, a vhf transmitter is included in the design. The transmitter is crystal-controlled and operates on the eighteenth harmonic of the crystal.

All the controls for operation have been grouped on the front panel without too much difficulty; however, experience has shown that some of the controls are rarely used and probably do not need to be so readily available. Two adjustments

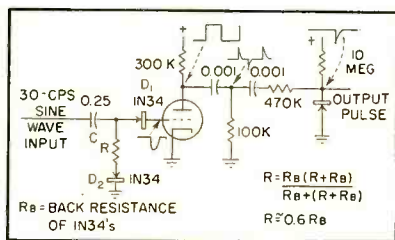

FIG. 6—Pip-making circuit uses matched diodes to prevent phase shift with amplitude

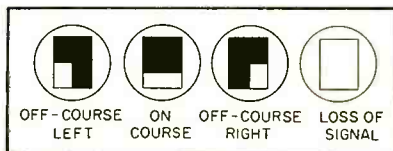

FIG. 7—Patterns of indicator tube for ILS localizer conditions

labeled CIRCLE SHAPE are not required on the front panel. With sufficient magnetic shielding of the cathode-ray tube, the two centering controls can be left off the front panel.

ILS Adapter

Most omnirange receivers include circuits to receive the instrument landing system localizer signal since the carrier frequency is adjacent to the omnirange band. The localizer

signal consists of a carrier with two modulations, 90 and 150 cycles. When the receiver is on course, the two modulations are of equal amplitude; off course on one side the 90-cps signal is larger; off course on the other side the 150-cps signal is larger. In omnirange receivers using left-right meters the same meter can be used for indicating the relative output of detectors tuned to each frequency.

An omnirange receiver using an oscilloscope has no left-right meter available for the ILS localizer. Addition of a meter to an instrument panel is troublesome both for lack of space and because of magnetic effects. In place of a meter a 6AL7 tube may be used. This tube indicates the balance of two voltages and tells which voltage is greater.

Since the 6AL7 uses deflection plates, its input impedance is very high—much higher than that of a meter. With a high-impedance null indicator the filters that separate the 90 and 150-cps signals can be high impedance and thus require less driving power. However, the real advantage of using high-impedance filters is that they require only resistors and capacitors. Expense and bulk of inductors for these low frequencies can be thus avoided. The sharpest R-C filter is a parallel-T rejection type, which is used here. The 90-cps signal is selected by using a 150-cps parallel-T rejection filter and 150-cps signal by 90-cps rejection.

The two signals are rectified by two peak detectors and the resultant voltages applied to the 6AL7 deflection plates. To make the system fail-safe, a third rectifier turns the beam on when a signal is received. If the signal fails, the beam is biased off and no indication is given. The circuit for this 6AL7 indicator is shown on the complete schematic diagram. The type of indication for on-course and off-course is shown in Fig. 7.

BIBLIOGRAPHY

- D. G. C. Luck, An Omnidirectional Radio Range System, *RCA Review*, July 1941.
- D. G. C. Luck, An Omnidirectional Radio Range System—Part II, *RCA Review*, Jan. 1942.
- D. G. C. Luck, An Omnidirectional Radio Range System—Part III, *RCA Review*, Mar. 1946.
- Peter Caporale, Status of VHF Facilities for Aviation, *ELECTRONICS*, p 90, Oct. 1947.
- The Civil Aeronautics Administration VHF Omnirange, *Proc IRE*, Dec. 1951.

Circuit of the voltage-responsive timer uses two relays and three tube envelopes

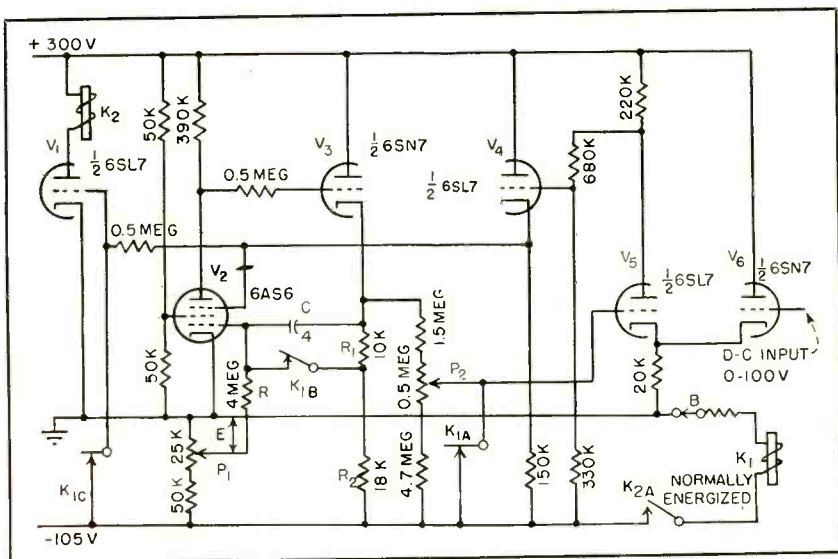

By S. ROZENSTEIN
and E. GROSS

Scientific Department
Israel Ministry of Defense
Haifa, Israel

Long-Period Timer

Miller-integrator sawtooth is compared with input d-c to generate voltage-dependent periods from 0 to 50 seconds with accuracy better than ± 0.25 second. Delays of minutes are possible with device that combines magnetic relays and vacuum tubes

A TRANSDUCER circuit has been designed to convert d-c output of a computer servosystem into a time period starting at any wanted instant. The variable d-c input is between 0 and 100 v, the wanted time period to be linear from 0 to 50 seconds. The accuracy is better than ± 0.25 sec or 0.5 percent of the maximum period if a well-regulated power supply is used. The circuit is practically independent of tube characteristics. Longer time periods can easily be obtained.

A Miller integrator produces a linear sawtooth voltage. Comparison of the slow sawtooth voltage with the input d-c voltage in a triode comparator generates the timing pulse by regenerative switching of the suppressor grid of the Miller integrator pentode. The maximum timing period depends on the R-C constants of the Miller circuit, switching speed being independent of the sawtooth slope, as the feedback circuit is completely d-c coupled. The timing capacitance is the only capacitor in the circuit.

In its quiescent condition K_1 is energized and contacts K_{1A} , K_{1B} and K_{1C} are closed. Tube V_5 is biased

to cutoff through contacts K_{1A} and its plate voltage is high. The grid of cathode follower V_4 is connected to a voltage divider from the plate of V_5 . The cathode voltage of V_4 is approximately +1 v to the suppressor grid of pentode V_2 .

The control grid of V_2 is connected through contacts K_{1B} to a tap on the load resistance R_1 and R_2 of cathode follower V_3 . By means of the d-c coupled negative feedback between V_2 and V_3 plate voltage of V_2 is stabilized at about +50 v. Relay tube V_1 is biased to cutoff through contacts K_{1C} .

To start the timing sequence, pushbutton B is pressed, opening the coil circuit of relay K_1 . With contacts K_{1A} , K_{1B} and K_{1C} open, relay tube V_1 conducts, closing timing relay K_2 . Contacts K_{2A} open, so that K_1 remains open after pushbutton B is released. Tubes V_2 and V_3 now operate as a Miller integrator, the plate of V_2 and the cathode of V_3 rising linearly from +50 v towards the supply voltage, the slope depending on R , C and the voltage E .

The sawtooth voltage continues to rise until the grid of comparator tube V_5 rises above cutoff voltage

produced at the cathode of V_5 and determined by input d-c-voltage on its grid. At that instant V_5 starts to conduct. Because its plate is coupled through V_4 to the suppressor of V_2 , falling plate voltage of V_5 reduces the plate current of V_2 and thus increases the slope of its plate-voltage rise, this change being fed back again to V_5 . The switching action is regenerative and fast.

The negative voltage step at the suppressor grid of V_2 also cuts off relay tube V_1 and timing relay K_2 opens. Contacts K_{2A} close relay K_1 . The circuit returns to its quiescent condition as soon as C is discharged through R_1 . Time T required for the circuit to reach a steady state after closing K_1 is $3R_1C$. In this case, T is 0.12 second.

The slope of the Miller integrator sawtooth voltage and therefore the maximum wanted timing period depend on the choice of components R and C . The exact time is set at 100 v d-c input by adjustment of E on potentiometer P_1 . The minimum time period is adjusted at 0 v input by P_2 in such a way that the switching back occurs immediately after pressing the pushbutton.

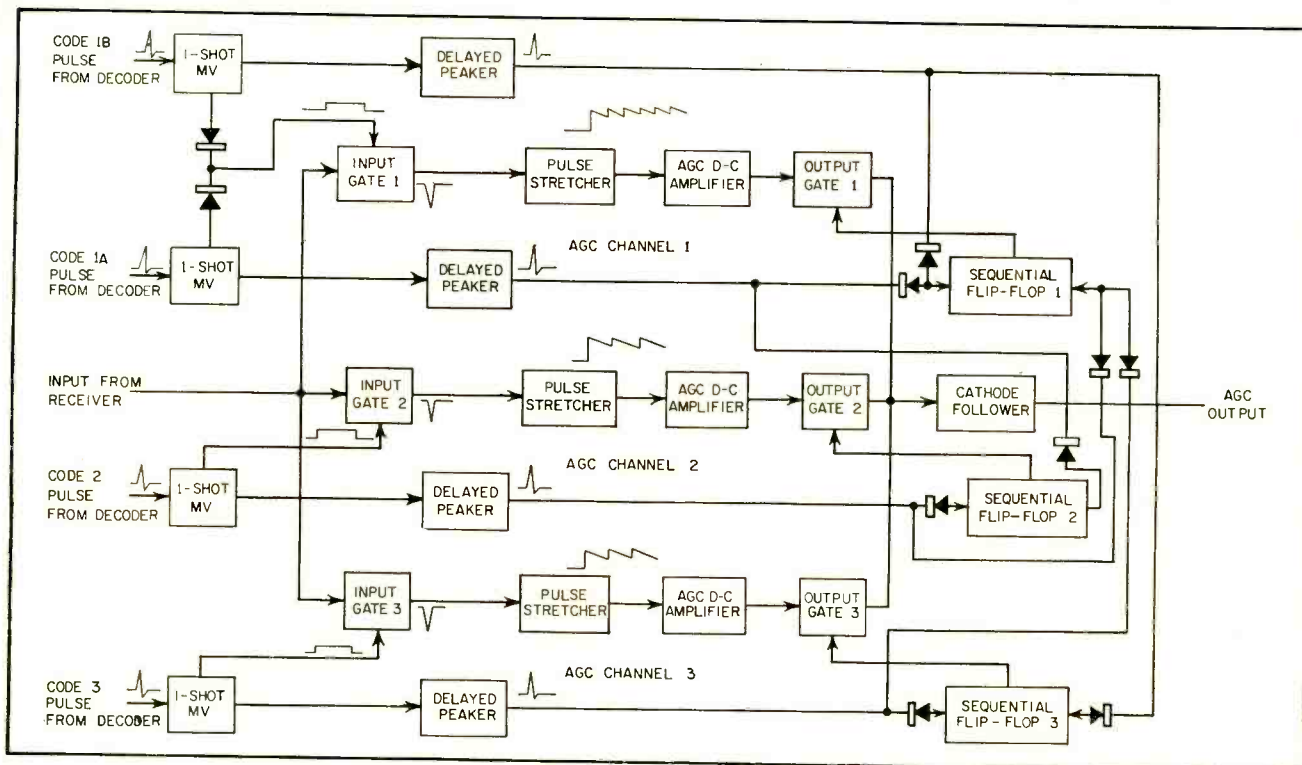

FIG. 1—Block diagram showing stages of three separate agc sections. The input gates are normally off. Control pulses from the decoder activate the multivibrators, which turn on their associated gates

Sequentially Gated

Special agc system equalizes amplitudes of signals from two or more co-channel pulse transmitters differing up to 50 db in intensity. System is applicable in loran, shoran, telemetering and guided missile control receivers

OBJECTIVE of the automatic gain control system to be described is to supply control voltages to a receiver to hold its output constant within ± 1 db while receiving pulsed signals alternatively from two or more transmitters—all operating on the same frequency and varying as much as 50 db in signal intensity. The transmitted pulses have a 0.1-microsecond rise time and a duration of approximately 0.5 microsecond.

Since the leading edge of each pulse must be preserved and the rise time is exceedingly short, an instantaneous automatic-gain-con-

trol circuit is unsatisfactory. In this sequentially gated control, the input and outputs of three agc channels are gated on or off in a specific cyclic sequence.

The main pulses sent out by the three transmitters are preceded by identifying code pulses. The transmitters operate in a one-two-one-three sequence. Pulses are received in the same order. This gives a synchronous cycle to the received signals. The decoded signal tells which transmitter is sending and which transmitter will send next. This information is used to control input and output gating and

a separate automatic-gain-control channel is established for each transmitter.

Pulse Coding

Transmitter 1 has two distinct codes which are transmitted alternately; transmitters 2 and 3 have the same code. Transmitter 1 transmits code A if transmitter 2 is to follow and code B if transmitter 3 is to follow. For simplicity, coding pulses will be referred to as code 1A and 1B for transmitter 1, code 2 for transmitter 2 and code 3 for transmitter 3.

All incoming transmitted pulses

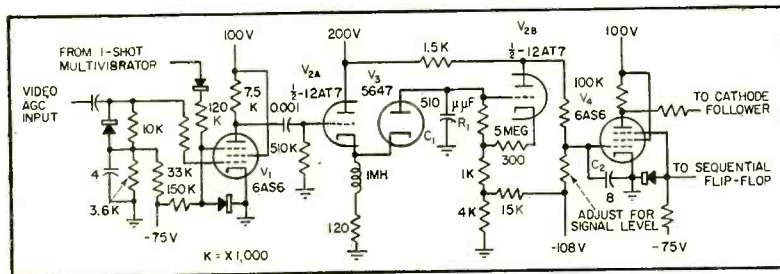

FIG. 2—Typical agc section showing input gate, pulse stretcher, d-c amplifier and output gate. This section is identical to all agc sections in the unit

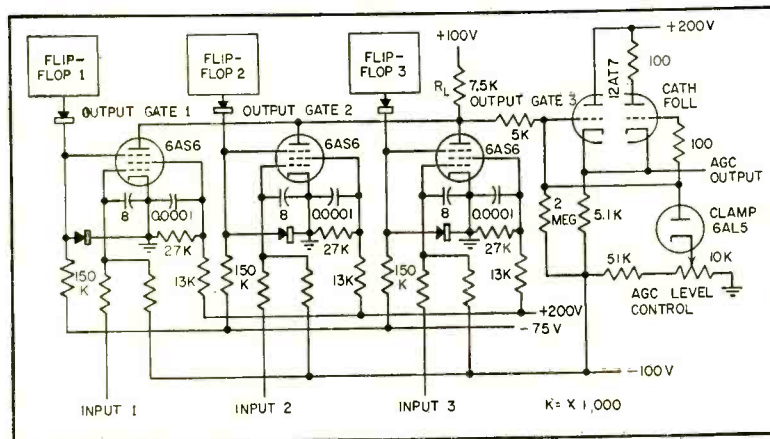

FIG. 3—Output gating circuit including output gates of three agc sections

Table I—Gating Sequence for Automatic Gain Control

Transmitter	Code	Input gate	Output gate
1	1A 1A delayed	open 1 close 1	open 2 close 1
2	2 2 delayed	open 2 close 2	open 1 close 2
1	1B 1B delayed	open 1 close 1	open 3 close 1
3	3 3 delayed	open 3 close 3	open 2 close 3

By **MARCUS ELIASON***
*Sales Manager
 Electronics Division
 Air Associates, Incorporated
 Orange, New Jersey*

Automatic Gain Control

from the detector of the receiver are fed to the video amplifier and then directly to the agc unit. These same video signals are received simultaneously by a decoder.

The main transmitted pulses are preceded by coding pulses identifying the originating transmitters. The agc system is controlled by the coding pulses and the main pulse in each case is used to control receiver gain.

AGC Operation

Figure 1 is a block diagram of the composite agc system. When a signal consisting of coding and main pulses is received, it is fed to the three gates in the agc unit. These circuits are normally off until the proper control pulse from the decoder is fed to a one-shot

multivibrator whose output opens the appropriate gate to pass the main pulse. If the incoming signal is from transmitter 1, the decoder will furnish a code 1A pulse which is fed to a one-shot multivibrator whose time constant is 12 microseconds. The output of this multivibrator is impressed on the suppressor of input gate tube 1. Since the coding pulse arrives approximately 10 microseconds before the main pulse, there is time for the code 1A pulse to trigger the gating multivibrator before the main pulse arrives. The gate closes at the end of the 12-microsecond multivibrator pulse.

The main pulse is amplified in the first gate tube and fed through a pulse-stretching circuit that lengthens it from 0.5 microsecond to approximately 15 milliseconds. The output of the pulse stretcher is

fed through the d-c amplifier and output gate to the cathode follower which feeds the i-f amplifier.

When the one-shot multivibrator shuts off input gate 1, its output is also fed to a delay-peaker network which emits a pulse 12 microseconds after the code 1A control pulse. This code 1A delayed pulse is fed to flip-flop 1 which in turn deactivates output gate 1.

The code 1A delay pulse also feeds flip-flop 2 turning on output gate 2. The voltage stored in the pulse stretcher from previously received pulses is now applied to the cathode follower. This furnishes the proper agc voltage to the i-f amplifier, anticipating the proper agc level for the next set of pulses to be received from transmitter 2 because of the sequential operation of the transmitters.

When the next group of pulses

*Formerly with the Hughes Aircraft Co., Culver City, Calif.

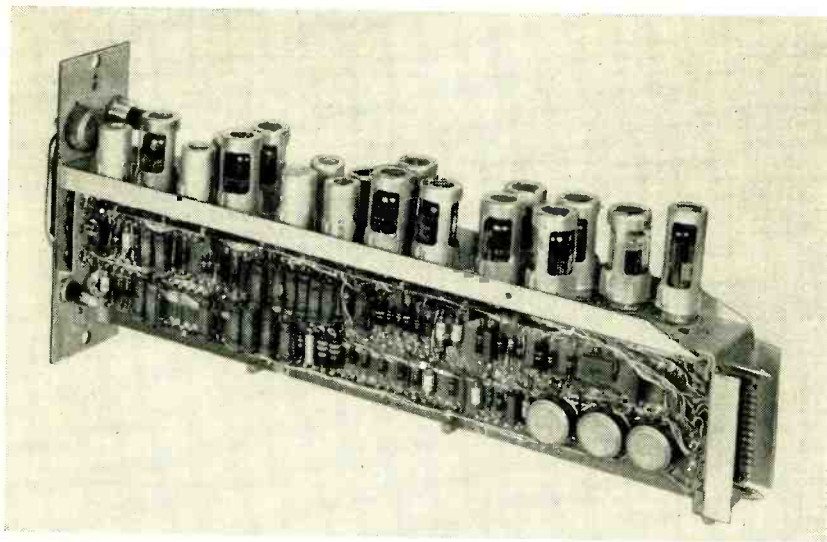

Complete age circuit assembled on plug-in type chassis

is received from transmitter 2, the decoder decodes the pulses and furnishes the code 2 control pulse. This pulse is fed to its one-shot multivibrator whose time constant is also 12 microseconds. The output from this multivibrator is fed to input gate 2 and holds it open 12 microseconds allowing the main pulse from transmitter 2 to pass before it closes. This pulse is also lengthened to 15 milliseconds, amplified and stored. The one-shot multivibrator triggered by the code 2 control pulse also feeds a peaker network. The output of this peaker emits a code 2 delay pulse which feeds flip-flop 2 turning off output gate 2.

The code 2 delay pulse also triggers flip-flop 1 turning on output gate 1. This allows the voltage stored in circuit 1 to be fed to the cathode follower and the receiver i-f strip. The receiver now has proper bias applied to the i-f strip awaiting the pulses from transmitter 1. The next group of pulses received and decoded are from transmitter 1. As this is the alternative output of transmitter 1, the decoder furnishes a code 1B control pulse. This pulse is fed to the one-shot multivibrator. The output of the multivibrator is delivered to input gate 1 which allows the main pulse from transmitter 1 to pass. This pulse is lengthened and amplified. The one-shot multivibrator also feeds a peaker. This

peaker network emits the code 1B delay pulse to flip-flop 1 which shuts off output gate 1. The delayed pulse is also fed to flip-flop 3 to turn on output gate 3 allowing the voltage stored in age channel 3 to pass to the cathode follower and the i-f strip of the receiver. The age level is now correct for receiving pulses from transmitter 3.

When the signal is received from transmitter 3, the output of the receiver activates the decoder generating a code 3 pulse which is fed to its one-shot multivibrator which also has a time constant of 12 microseconds. This multivibrator output is connected to input gate 3 so the main pulse from transmitter 3 can pass, be lengthened and amplified. The output one-shot multivibrator associated with the code 3 pulse also feeds its peaker. This peaker network emits its code 3 delay pulse to flip-flop 3 for turning off output gate 3. Simultaneously the code 3 delayed pulse operates flip-flop 1 which turns on output gate 1 allowing voltage to pass to the cathode follower and the i-f strip of the receiver.

Operational Details

The entire operation represents one sequential age cycle. Output gates 1, 2 and 3 are flip-flop controlled and remain off or on until triggered. This sequential operation is shown in Table I.

The period for each set of trans-

mitter pulses is approximately 2,000 microseconds for transmitter 1 and 4,000 microseconds for transmitters 2 and 3. Because the pulse stretcher lengthens each pulse to approximately 15 milliseconds, there is sufficient amplitude information from about 8 pulses for transmitter channel 1 and 4 pulses for transmitter channels 2 and 3 for setting the levels in each of the age circuits at any time. Since the transmission repetition rate is approximately 500 per second for transmitter 1 and approximately 250 per second for transmitters 2 and 3, a 15-millisecond pulse-stretching network is necessary for setting average levels and storing sufficient age voltage to be applied to the receiver i-f strip the next time a transmission is received.

A typical age section is shown in Fig. 2. Tube V_1 is the input gate. When the 12-microsecond square-wave from the one-shot multivibrator is applied to the suppressor of this tube, the pulse is clamped to approximately zero potential allowing the tube to conduct. During this period, however, the main pulse arrives at the control grid, is amplified and coupled to cathode follower V_{2A} to drive pulse stretching network V_3 , C_1 and R_1 .

The suppressor of V_1 is controlled by one of the three sequential flip-flops. Capacitor C_2 smoothes out the pulse peaks on the age voltage. The plate of this stage is direct-coupled to the grid of the cathode follower whose cathode is tied directly to the age bias line in the receiver i-f strip. Direct-current output gating between the three separate age channels is obtained by connecting the plates of output gates 1, 2 and 3 as shown in Fig. 3. Since only one gate operates at one time, the plates of the three output gates are tied to a common load resistor. The voltage developed at the grid of the cathode follower stage is due to only one of the age channels. When one output gate is turned off, another gate tube is simultaneously turned on thus assuring correct bias on the receiver i-f strip at all times. A common-cathode resistor network in the three sequential flip-flops assures that only one output gate can be on at one time.

Frequency Meter Uses Digital Counters

Direct readings of frequencies from 0 to 42 mc are obtained using counter techniques. Simple operating procedure enables unskilled personnel to make highly precise measurements. Instrument incorporates self-checking feature

TECHNIQUES of digital counting and heterodyning are combined in a frequency meter that is as simple to operate as basic counters and has a frequency range of 42 mc. In contrast to heterodyne systems alone, there is no ambiguity, no searching or adjustment, no possibility of falsely identifying harmonics and a measurement is completed in a few seconds.

Figure 1 is a block diagram of the frequency meter. Fundamental and harmonic frequencies of the crystal oscillator are applied to the harmonic amplifier. Reference harmonics are selected in 1-mc steps over a frequency range of 2 to 41 mc and beat against the input signal in the mixer stage to obtain a beat frequency less than 1.2 mc. The unbalanced mixer circuit is followed by a low-pass filter which has its cutoff frequency below that of the input signal and also below the lowest harmonic. When a beat frequency below 1.2 mc is produced, the SET LEVEL meter will be deflected. This signal is then applied through the gate circuit to the counter which displays the answer.

Operation

To make a measurement, the selector switch is turned in the direction of increasing frequency (clockwise) until a position is reached where the SET LEVEL meter is deflected. The full answer is then displayed on the eight banks of decade lights. There are two adja-

By **A. F. BOFF**

*Berkeley Division
Beckman Instruments, Inc.
Richmond, California*

cent positions of the selector switch which will produce a beat frequency below 1.2 mc with consequent deflection of the meter. One position uses a reference frequency lower than the signal and the other a higher reference frequency. The lower reading is in all cases correct.

Circuit Design

The circuits of the counter and time-base sections of the instrument are conventional.

The circuit diagram of the heterodyne section is shown in Fig. 2. Crystal controlled oscillator V_1 is a

triode amplifier with two separate feedback paths. The series network containing thermistor R_2 provides loop gain and automatic amplitude control. Resistor R_3 provides a negative feedback path to prohibit oscillation except when the grid resistor is shunted by the series resonance of the crystal and its trimmer capacitor C_2 . This circuit is extremely stable due to its relative immunity to changes in tube characteristics and has the added advantage of allowing the trimmer capacitor to have one side at ground potential thereby avoiding the effect of hand capacitance during standardization of crystal frequency.

Capacitor C_2 is a piston type con-

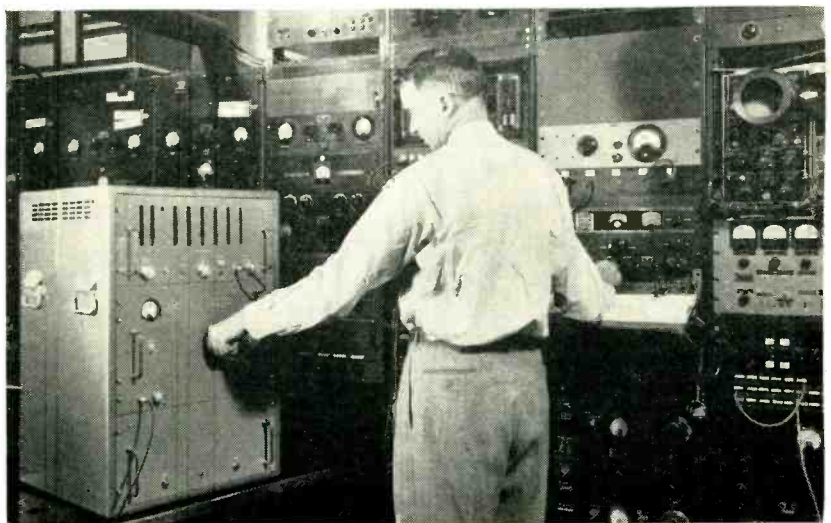

Frequency meter in use at RCA communications center, Bolinas, California to measure frequency of transmitters

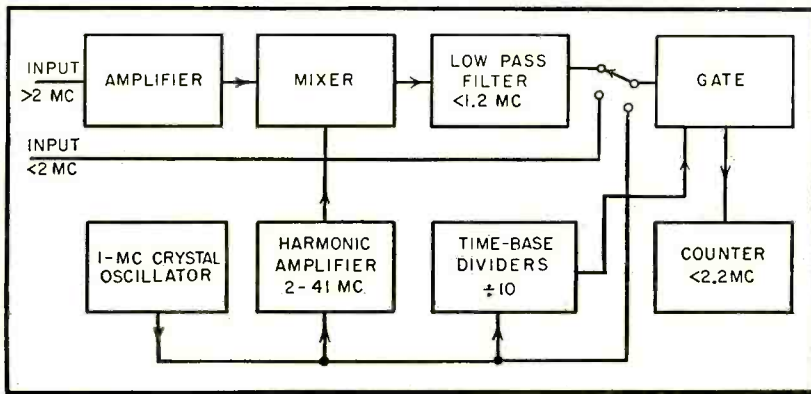

FIG. 1—How heterodyne and counter techniques are combined

structured of invar and quartz. It has very little dielectric loss and a nominally zero temperature coefficient of capacitance.

Cathode follower V_2 provides a convenient take-off point for synchronizing the time base dividers in the counter section.

The output from the oscillator is amplified by V_3 and applied at high level to the grid of V_4 . A large bias is built up on C_3 by the grid current of V_4 and consequently V_4 passes plate current during only a small part of each cycle of the oscillator waveform.

The current pulse causes a damped oscillation in L_1 at a frequency in the region of 10 mc. Since the process is concerned only with producing a pulse of proper shape and polarity, the exact frequency is of no consequence. The first positive going cycle of this waveform is larger than all subsequent cycles until the next 1-mc impulse is received.

Negative bias is built up on C_1 by grid current in V_5 causing this tube to be completely cut off except during the peaks of the largest positive cycles of its input waveform. The input to V_5 is a fast, narrow pulse at a repetition rate of 1 mc precisely controlled by the crystal oscillator. Such a waveform contains harmonics of 1 mc at practically constant amplitude to an order dependent upon the width and rise time of the pulse.

Harmonic Selector

The tuned circuit comprised of L_2 and its associated capacitors selects individual harmonics from 2 to 41 mc. The response of this circuit to harmonics adjacent to that selected is so small that the input circuits reach a limiting condition before sufficient energy at a false frequency can be forced through to the meter circuit. Inductance L_2 is tuned by capacitors mounted on the turret switch and maintains a

Q in the neighborhood of 400 over the complete range 2 to 41 mc. This value of Q is obtained by high quality capacitors, low loss dielectric material for the switch and a physically large inductor. Plate damping by V_5 is negligible since the tube conducts for only a very short interval of time.

Response

At the most critical frequency—41 mc—the response to 42 mc is more than 26 db down. Since the input amplifier is designed to limit at about 15 db above normal signal level, it is virtually impossible to obtain false answers due to this cause, even allowing substantial detuning of the selective circuit. Excessive variation in sensitivity over the range is corrected by signal input amplifier V_6 . Stray capacitances shunting the resistance plate load cause a rapid decline of amplification at high frequencies.

The resonant selector circuit is loosely coupled to mixer V_7 . In typical heptode mixers, the signal grid has a characteristic which is considerably more linear than the injection electrode. The customary positions of signal and reference frequencies with respect to the injection electrodes are reversed to minimize demodulation of 1-mc sidebands inevitably present in the reference frequencies.

The three-section filter following the mixer tube is a conventional M-derived, constant-K type having nominal cutoff at 1.2 mc and infinite attenuation at 2 mc. Stray capaci-

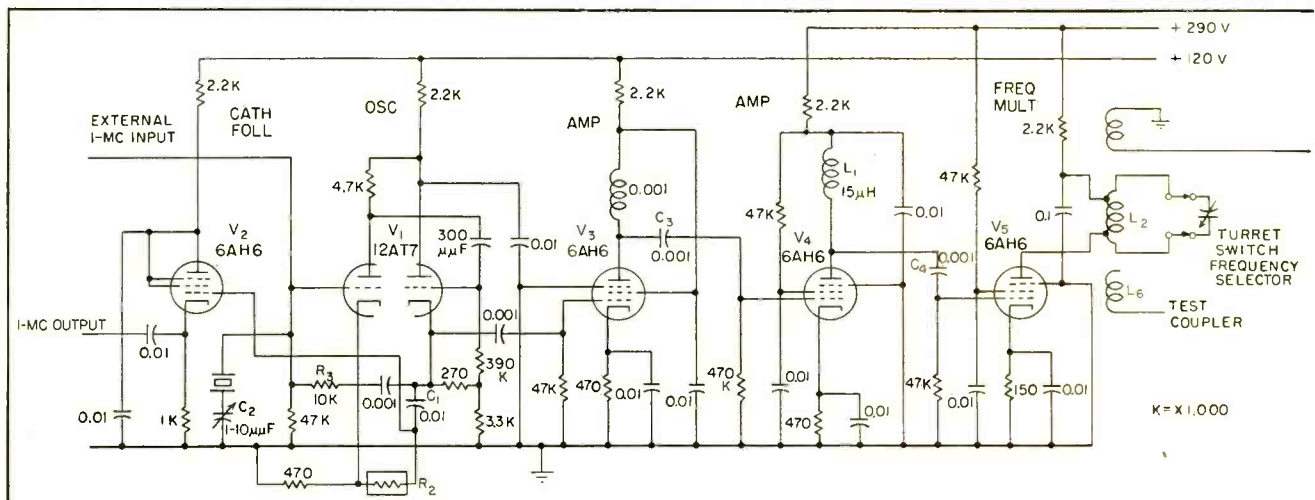

FIG. 2—Schematic diagram of heterodyne section of frequency meter. Mixer output is applied through gate to counting unit for display.

tances across L_3 , L_4 , and L_5 are effective as additional elements normal in an M-derived design. Pentode V_8 is a low-impedance output stage connected by coaxial cable to the counter section of the instrument. Further amplification to drive the meter circuit is provided by V_9 and V_{10} .

Coil L_6 is a pickup probe brought to a socket on the front panel. A small amount of energy at all harmonic reference frequencies is available here. By coupling to a radio receiver, a beat note may be obtained with a standard WWV transmission and the frequency of the crystal oscillator adjusted to zero beat using trimmer C_2 , which is accessible on the front panel.

Counters

A decimal counter unit with neon light indication is illustrated in Fig. 3. Several of these units are used in cascade to form the counter illustrated in the block diagram. Every pulse which passes through the gate circuit to the counter is precisely registered. For frequency measurement, the gate must be opened for a precisely known time interval. This time interval is obtained by dividing the output from a crystal controlled oscillator operating at 1 mc. Additional circuits must be provided to allow time for adequate display of the total reading and resetting to zero.

Accuracy

There are three separate contributions to error in the measure-

ment of frequency by this method. All counting instruments which measure the number of impulses in a finite time introduce an irreducible error of ± 1 count, dependent upon the instant the gate opens in relation to the phase of the signal. Also, a small amount of jitter is produced in the processes of division in the time base. Finally, the frequency of the crystal oscillator is not exactly correct.

In this instrument, the error due

to jitter is less than $0.1 \mu\text{sec}$ and is not therefore significant in the measurement of beat frequencies of the order of 1 mc. The crystal is housed in a thermostatically controlled oven and it has been found practicable to obtain short-term stability of 1 part in 10^7 . Regular comparison with a standard is necessary to maintain this accuracy.

Overall accuracy at all frequencies from 0 to 42 mc is ± 1 part in $10^7 \pm 1$ cps.

Calibration

The circuit complexity makes self-checking indispensable. A simple but thorough method is readily available. When the input selector switch shown in Fig. 2 is thrown to the TEST position, consistent correct readings can be obtained only if all the decimal counter units are functioning correctly, the time base dividers are dividing in the proper ratio and in a stable fashion and the gate and control circuits are operating correctly. Absolute accuracy of the crystal oscillator is the only factor not checked by this test.

The author is indebted to his associates at Berkeley Division for design of sections of this instrument and for assistance during its development.

BIBLIOGRAPHY

- George J. Kent, Production-Line Frequency Measurements, *ELECTRONICS*, 24, p 97, Feb. 1951.
 L. R. M. Vos de Wael, Direct-Reading Frequency Measuring Equipment for the Range of 30 cps to 30 mc, *Proc IRE*, 40, p 807, Jul. 1952.
 John M. Shaull, Adjustment of High-Precision Frequency and Time Standards, *Proc IRE*, 38, p 6, Jan. 1950.

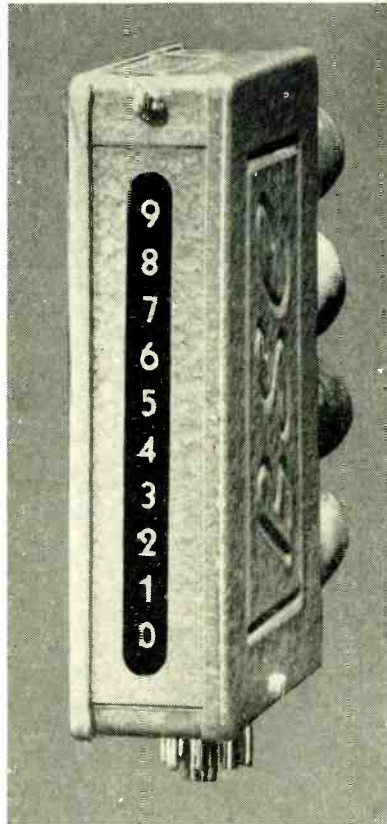
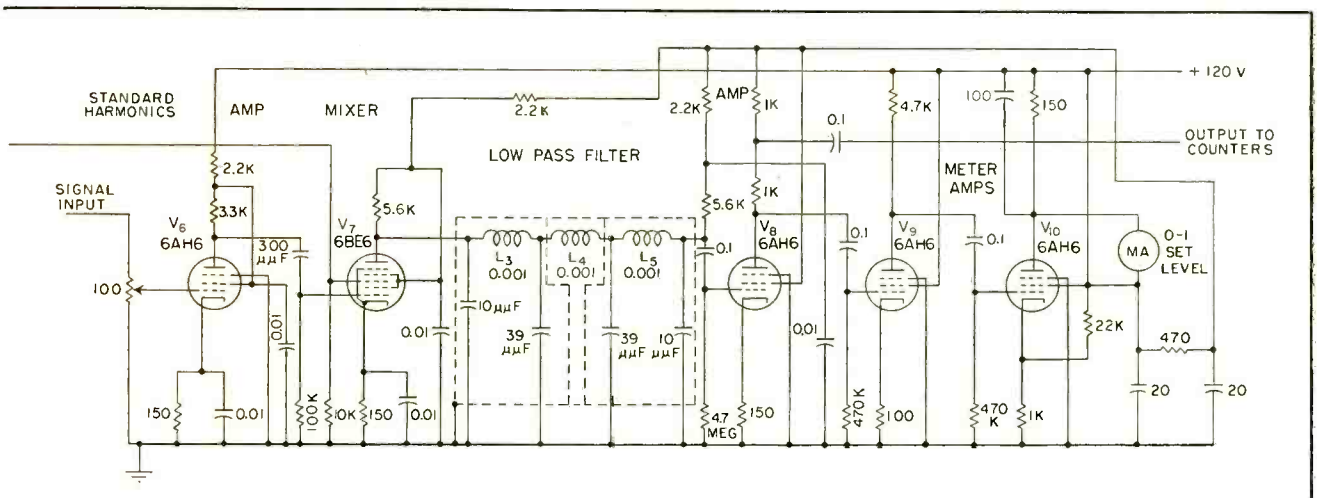

FIG. 3—Direct-reading decimal counter



Crystal oscillator output is applied to time-base dividers

TV Lighting Calculator

Chart permits graphical determination of illumination on photosensitive surface of camera pickup tube when scene brightness and lens aperture are given. May also be used to find required scene brightness if other factors are known

By **JOSEPH SODARO**

Los Angeles, Calif.

ILLUMINATION INTENSITY on the photosensitive surface of a tv camera pickup tube is given by $E = \pi BT \cos^2\theta/4f^2$ where E is in foot-candles, B is scene brightness in candles per square foot, T the lens transmission coefficient, f the lens aperture and θ the angle between the direction of the light and the optical axis of the system.¹ For practical use this formula is simplified by assuming 15 degrees as an average value of θ and 0.75 as an average value of T .² The calculator is based upon the equation after simplification for average values.

Use

Camera pickup tube illumination is determined from this nomograph by selecting scene brightness in candles per square foot on the B scale and the lens aperture on the f scale. Join these points with a straight line. At the intersection of this line with the E scale read camera pickup tube illumination. This value can be multiplied by the pickup tube photosensitive surface area in square feet to obtain lumens.

As an example, determine the camera illumination for a scene brightness of 10 candles per square foot for an $f/3$ lens. From 10 on B draw a straight line to 3 on f . Read 0.55 foot-candles at the point where this line crosses the E scale.

To determine required scene illumination, enter the nomograph on the E scale with the required camera pickup tube

illumination in foot-candles and on the f scale with the aperture stop value. A straight line through these points extended to the B scale will indicate the necessary scene brightness.

The nomograph is not applicable directly to close-up work in which the pickup tube image is greater than one-tenth the

actual size of the object. For these cases, divide the value obtained on the E scale by $(m + 1)^2$ in which m is the magnification ratio.

REFERENCES

- (1) W. N. Goodwin, Jr., The Photronic Photographic Exposure Meter, *Jour SMPPE*, p 95, Feb, 1933.
- (2) D. G. Fink, "Principles of Television Engineering", p 70, McGraw-Hill Book Co., New York, 1940.

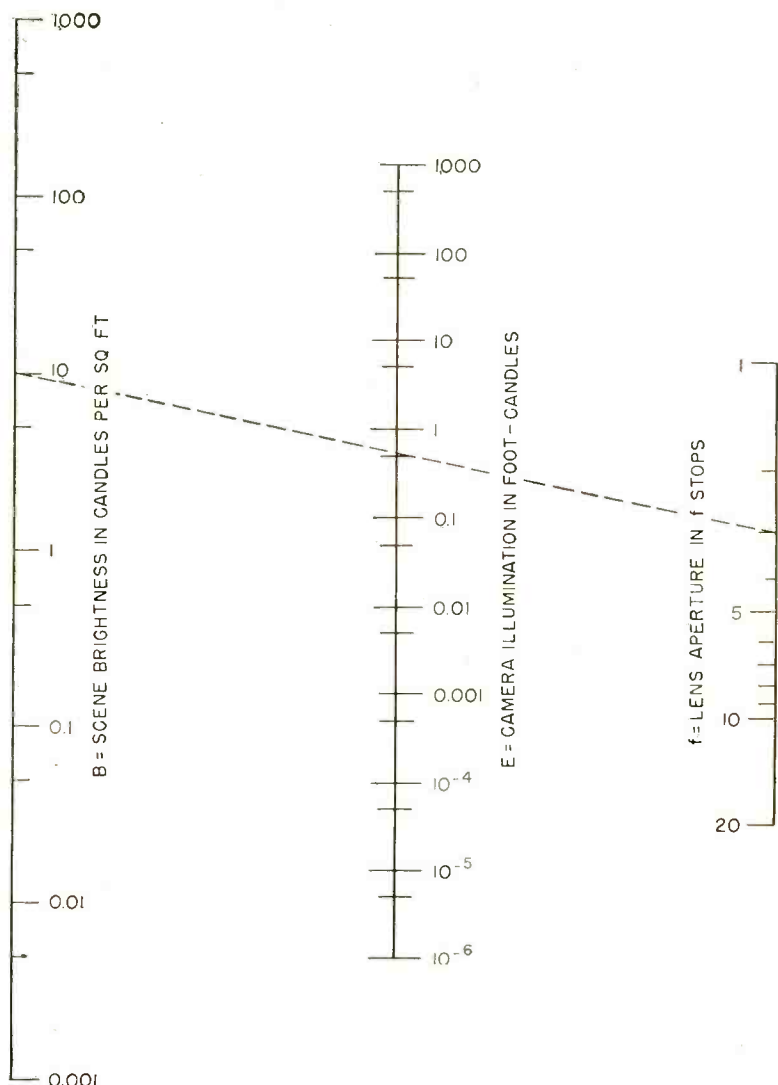

CONSULT CINCH —

ELECTRONIC COMPONENTS *plus* SERVICE . . .

the utmost in service assured by the most modern, adequate facilities, the production methods and experience that have made CINCH the standard in electronic components.



To produce the intricate assemblies of metal and plastic so essential in electronics, CINCH facilities include a combination of metal stamping and plastic production . . . and an experienced skilled staff.



Centrally located plants in Chicago, Shelbyville, Indiana and St. Louis.

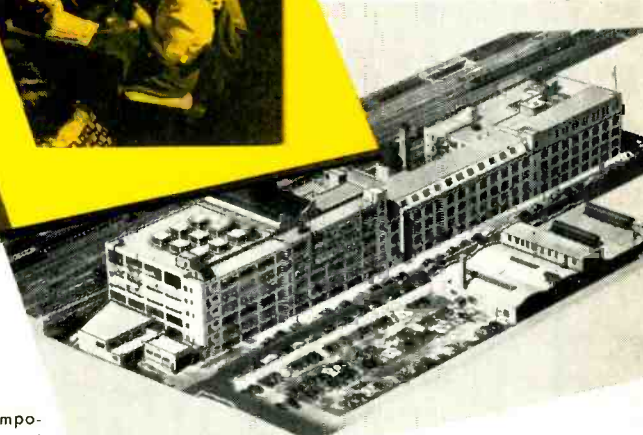
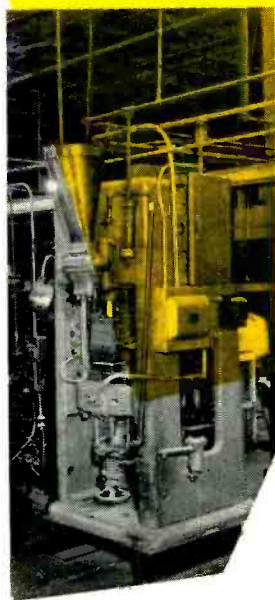

CINCH electronic components are available at leading jobbers — everywhere.

CINCH is available for the production of any component assembly needed in electronic mobilization that falls within its experienced, skilled engineering and extensive production facilities. For the past quarter of a century the record has shown the organization to be extremely flexible; readily adapted to the requirements.

CONSULT CINCH

CINCH MANUFACTURING CORPORATION

1026 South Homan Ave., Chicago 24, Illinois

Subsidiary of United-Carr Fastener Corporation, Cambridge, Mass.



Cinch
ELECTRONIC
COMPONENTS

Power Level Nomograph

By THEODORE HALABI

Atlantic Transformer Co.
Groton, Conn.

Conversion chart gives voltage and power levels for db or dbm across any normal value of impedance from one to one million ohms. Scale extension covers any level not directly intersecting on graph

POWER LEVELS are commonly expressed in db or dbm instead of directly in watts. With a given level of +20 db across an impedance of 600 ohms, it is relatively simple to calculate the corresponding voltage level. Since +20 db is a gain of 20 db of power over a reference of 0 db or 6 milliwatts, $P = 0.006 \times \text{antilog } 20/10 = 0.6$ watt. Then using $\text{Power} = E^2/R$, $E = \sqrt{0.6 \times 600} = 19$ volts. The same computation can be made whenever the power is given in multiples of 10 db, such as -50 dbm or +40 db, utilizing the fact that the log of multiples of 10 is an integer.

However, when the power level is some number indivisible evenly by 10 such as -75 dbm, the input level of a high-gain amplifier, or +35 db, the output of an audio amplifier, it is necessary to find the voltage across an impedance by looking up the antilog of the power level, a decimal number.

To use the nomograph, draw a straight line from the impedance at left through the power level and read volts directly at the right. For example, a 250-ohm audio line is transmitting +10 dbm of power from which 1.58 volts is read off the graph.

The scale extension value, 40 db, allows calculation of any level not intersecting directly on the nomograph. For instance, a 5,000-ohm plate load impedance at a +42 db level intersects off the graph. However, read 6.9 volts at +2 db (42-40). The multiplying factor for 40 db is 100 and therefore, the level is $6.9 \times 100 = 690$ volts.

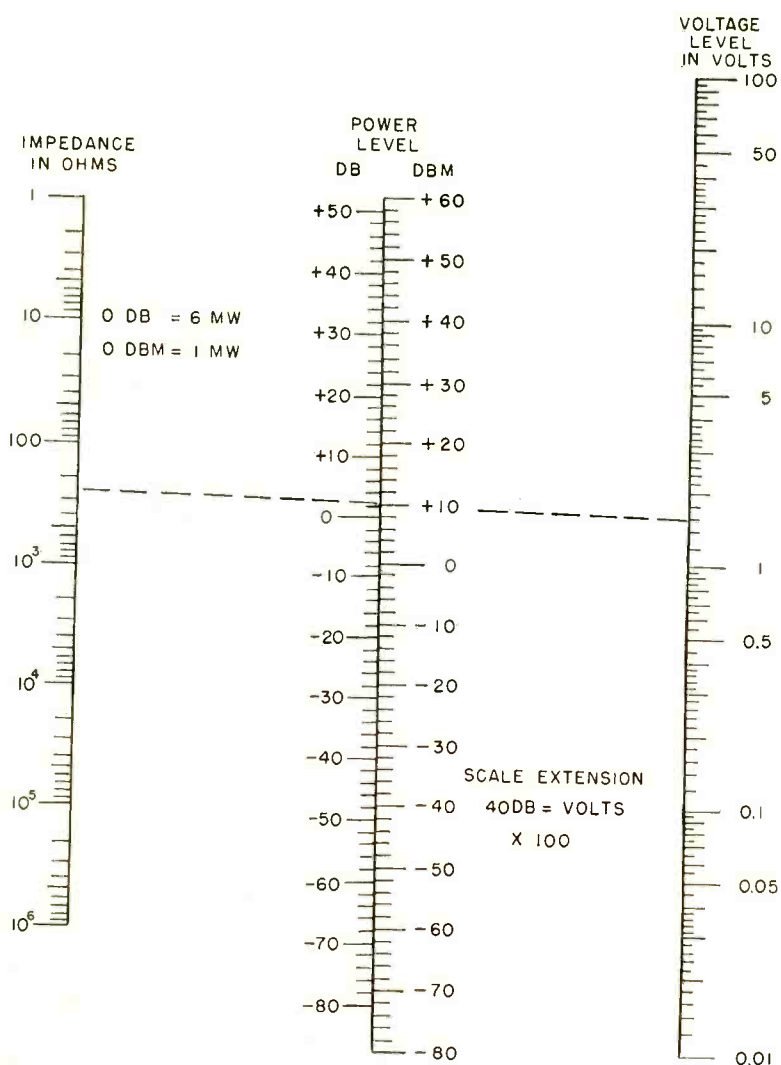

To avoid vibrator troubles...



Call on MALLORY in the design stage

Power supplies will meet the toughest requirements of battery operated equipment if experienced engineering goes into the selection of each element... vibrator, transformer, and buffer capacitor... so that electrical characteristics are balanced to give maximum vibrator performance.

Call Mallory in the design stage and put an end to your vibrator problems. Mallory engineers will help you translate your power needs into a precisely engineered design... you'll save engineering time... you'll get the power performance your equipment needs.

In Vibrator design and production, Mallory offers you...

EXPERIENCE gained through years of working with leading manufacturers on a broad variety of vibrator applications.

VIBRATORS for civilian and military use... produced by the organization which pioneered the development of commercial Vibrators over 20 years ago and has supplied more Vibrators for original equipment than all other makes combined.

ENGINEERING AND PRODUCTION FACILITIES... to your most exacting requirements for vibrators or complete power supplies.

Whether your equipment is in production or still on the drawing board, write or call us today for complete information on our facilities.

Expect More...

Get More from

P. R. MALLORY & CO. INC.
MALLORY

Parts Distributors in all major cities stock Mallory standard components for your convenience.

Serving Industry with These Products:

Electromechanical—Resistors • Switches • Television Tuners • Vibrators
Electrochemical—Capacitors • Rectifiers • Mercury Batteries
Metallurgical—Contacts • Special Metals and Ceramics • Welding Materials



ELECTRONS AT WORK

Edited by ALEXANDER A. MCKENZIE

Sun Powers Telephone 196	Signal Detector for High Noise Levels . . . 210
Fungi Attack Army Equipment 198	Robot Controls Aircraft 218
Electronic Store Dick 198	VHF Transistor Oscillators 220
Radio Controls Traffic Signals 200	Measuring TV Sound Modulation 226
Bias Control for I-F Limiters 200	Increasing Validity of Shock Tests 236
Single Tube Square-Wave Generator . . . 206	Tester for Transistor Selection 240

OTHER DEPARTMENTS

featured in this issue

	Page
Production Techniques	214
New Products	282
Plants and People	328
New Books	368
Backtalk	378



Mobile f-m transmitter powered by sun's rays falling on developmental silicon solar battery has possible range of several miles

Sun Powers Telephone

LOW-POWER demands of transistorized telephone equipment (ELECTRONICS, p 192, May 1954) and development of *p-n* junctions in silicon have made feasible a practical solar battery.

The battery illustrated comprises a number of silicon strips each measuring about a half inch by two inches, which when connected together, produce power from sunlight at a rate of 50 watts per square yard of surface.

Heart of the development is a technique, useful in the manufacture of transistor devices, of introducing controlled amount of impurity beneath the surface of extremely pure silicon. Introduced

at a precise rate under carefully controlled conditions, the impurities reach a depth of less than one ten-thousandth of an inch.

Wires, through which useful current may flow, are connected to the surface layer and to the body of the silicon. In full sunlight, current flows at a rate of 24 milliamperes per square centimeter at a voltage of approximately half a volt. In practice, the silicon strips, which can stand much higher temperatures than comparable germanium devices, are encapsulated in a clear high-resistance plastic.

Bell Labs scientists estimate that this type of energy conversion unit, operating on the light rather than

the heat of the sun, can never convert more than 22 percent of total incident solar energy. They believe that it may be possible to attain practical efficiencies as high as 10 percent. The present solar battery has an efficiency of 6 percent, which is many times that of comparable devices, such as thermocouples and photocells.

Although many interesting experiments can be performed with the solar batteries constructed in the laboratory, using either sunlight or artificial illumination, they are not yet in a stage of development for high-power applications.

First practical employment of the sun for telephone service may be with transistor equipment now undergoing field tests near Americus, Ga. Prime source of power must be storage batteries, as is true generally in telephone plant. By determining the probable incidence of sunshine a solar battery of

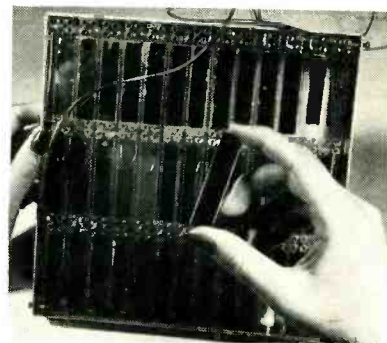

Solar battery is made up of special silicon strips like that held in hand. Units are encapsulated in clear plastic

You can get complete FM-AM coverage

100 KC to 216 MC

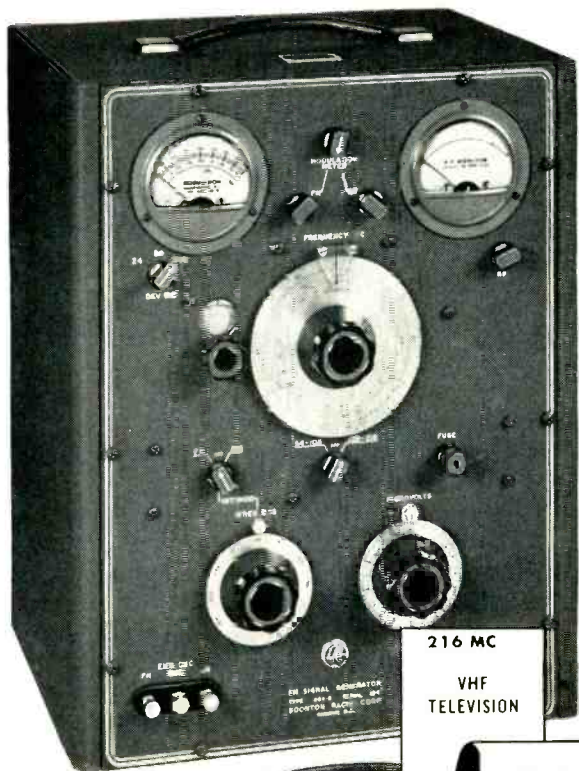

PRICE: \$975.00
F. O. B. Boonton, N. J.

FM-AM SIGNAL GENERATOR

Type 202-B

SPECIFICATIONS

FREQUENCY RANGE: 54—216 MC = 0.5%
 FM MODULATION: 0—240 KC continuously variable.
 FM DISTORTION: Less than 2% at 75 KC.
 AM MODULATION: 0—50% continuously variable.
 AM DISTORTION: Approximately 5% at 50% AM.
 INTERNAL MODULATING FREQUENCIES: 50, 100, 400 cycles; 1, 5, 7.5, 10, 15 KC.
 R. F. OUTPUT VOLTAGE: 0.1 to 200,000 microvolts continuously variable from source impedance of 26.5 ohms.
 POWER SUPPLY: 105—125 volts, 50/60 cycles (internally regulated)

UNIVERTER Type 207-A

(When used with 202-B)

SPECIFICATIONS

FREQUENCY RANGE: 100 KC—55 MC.
 FREQUENCY RESPONSE: Flat within ± 1 db. over frequency range.
 FM-AM MODULATION: See 202-B.
 FM DISTORTION: No appreciable distortion at any level.
 AM DISTORTION: No appreciable distortion at carrier levels below 0.05 volt and modulation of 50%.
 RF OUTPUT VOLTAGE: 0.1 to 100,000 microvolts continuously variable from source impedance of 26.5 ohms; also approximately 1.5 volts from 330 ohms into open circuit.
 POWER SUPPLY: 90—130 volts, 60 cycles (internally regulated).

The Type 202-B FM-AM Signal Generator and the Type 207-A Univerter provide complete FM-AM signal coverage from 100 KC continuously through 216 MC in two compact portable units.

The Type 202-B FM-AM Signal Generator was designed to meet the exacting requirements set forth by leading engineers throughout the country and has found widespread acceptance as the essential laboratory instrument for receiver development and research work.

The Type 207-A Univerter was designed to provide additional frequency coverage of commonly used intermediate and radio frequencies and enables the modulation and attenuation calibration features of the 202-B to be utilized at these lower frequencies.

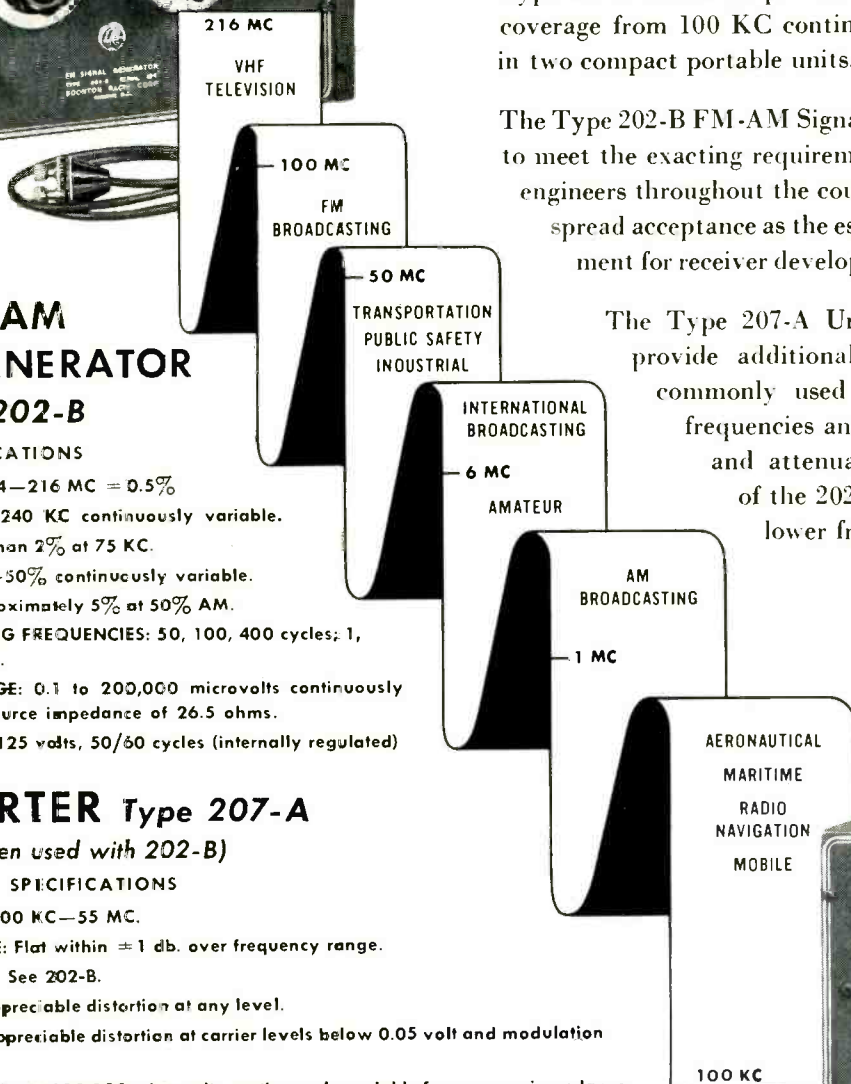

Write for CATALOG "J"

PRICE: \$345.00
F. O. B. Boonton, N. J.





Bell Labs research team, G. I. Pearson (physicist), D. M. Chapin (engineer) and C. S. Fuller (chemist) who invented the solar battery check samples for photoelectric efficiency

sufficient size may be installed to keep the storage battery charged. This solar battery would probably have from three to five times the energy of one required for service under continuous illumination.

At a recent demonstration, the solar battery was used to power a portable transistor f-m transmitter and turn the motor to run a toy Ferris wheel.



Two-week exposure in tropic test chamber at Signal Corps Engineering Labs, Fort Monmouth, N. J. has left untreated leather case covered with fungus. Specifications for manufactured equipment now reflect experience of tests.

Fungi Attack Army Equipment

DAMAGE by fungus to electronic equipment and carrying cases has been reduced to a fraction of that suffered during the war. Tests in the mycological laboratory at Fort Monmouth under precision control

of temperature and humidity are likely to reduce the deleterious effects of fungi still further.

Conditions in the South Pacific area gave similar results.

A test room ten feet long and



Electronic Store Dick

California market owner has installed three small television cameras (like that near ceiling at right) to scan 22,000 square feet of floor area. Shoplifters can be detected by viewing displays on three receiver screens (at left). Each camera is suspended four feet below ceiling and can be completely rotated or turned downwards at 45 degrees. Controls are located at the receivers

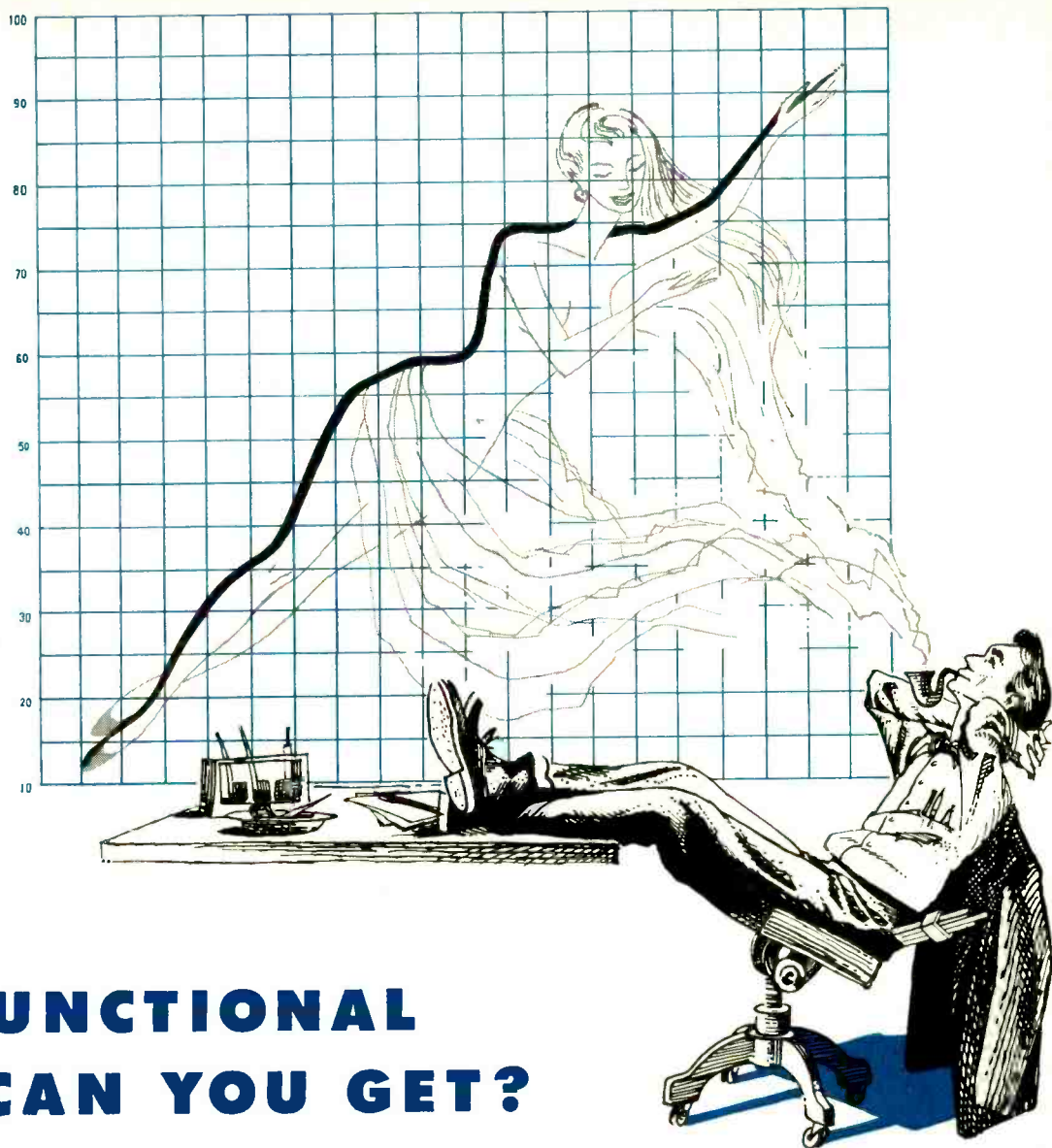

HOW FUNCTIONAL CAN YOU GET?

Need a sine-cosine pot?...or one that will solve $Y = X^2 + \sqrt{X}$... or do you desire those dreamy curves above?

Whatever your need...there's a HELIPOT* precision potentiometer to put out the curve you want...to do computations for you...or to compensate for inequalities of input.

Small or large...continuous-rotation or multi-turn...single units or ganged up to 25 sections (and each can produce a different function) on a common shaft. You get an extremely wide choice of resistances...with extremely close conformities...and a choice of mounting styles. Helipot makes non-linear potentiometers to your exact specifications.

Helipot's manufacturing methods also afford you the widest choice of coil-winding techniques for functional potentiometers.

If the curve you need is most precisely and economically reproduced by spacewinding on a copper mandrel...by a shaped card...by padding and tapping...or by a combination...come to Helipot first!

And, of course, we have non-linear HELIPOTS in a variety of

standard functions... available for prompt delivery.

Write for detailed information and specifications of HELIPOT functional potentiometers. Ask for Data File 602

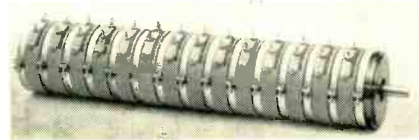

14-gang Series YN non-linear HELIPOT

Helipot *first in precision potentiometers*

Helipot Corporation/South Pasadena, California
Engineering representatives in principal cities
a division of BECKMAN INSTRUMENTS, INC.



*REG. U.S. PAT. OFF. 346

five feet wide can be operated at a temperature of 82 F and relative humidity of 95 percent. In this muggy climate, harmful fungi flourish.

The Signal Corps is interested in the general type of fungus known as saphrophytic, which utilizes dead organic material such as cellulose, leaf mold, dead insect bodies and other matter as nutrient. Other food sources include untreated leather (used in pole climbers' safety belts and field telephone cases). Web carrying straps and cotton-braid wire and cable insulation are also vulnerable.

While fungi are unable to obtain nutrition from glass or metals, they often spread from adjoining nutrient surfaces and accelerate corrosion. The acids produced by fungus mycelium and alkaline products of metabolism have been known to etch glass.

Some of the plastics have a high natural immunity to fungus damage that make them attractive for the design of new equipment. After the effectiveness of fungicidal varnishes or sprays and antifungus impregnations has been tested, equipment specifications for Signal Corps materials are included in contracts.



Radio Controls Traffic Signals

AUTOMATIC CONTROL of traffic lights by emergency vehicles has been accomplished with a device called NATECS, developed by North American Aviation, Inc. at Downey, Calif.

In the experimental system, a small radio transmitter mounted on the emergency vehicle activates receivers connected to traffic light controls. The warning signal causes all lights a quarter of a mile ahead to turn red for fifteen seconds. After the emergency, regular tim-

ing is re-established.

A somewhat similar device developed by the Aetco Co. of Downey has an added feature. When another fast-moving emergency vehicle is approaching, a red dashboard light flashes. This automatic feature is included to prevent accidents that might be caused when two emergency vehicles, each with the same frequency siren, approach an intersection at right angles.

Still in the developmental stages, these equipments are not available.

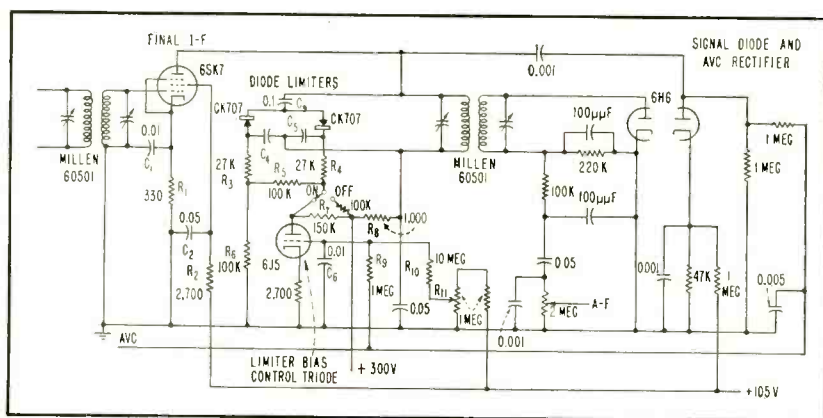

Noise limiter circuit uses crystal diodes taking advantage of low forward resistance to improve limiting action

Bias Control for I-F Limiters

BY NATHANIEL BISHOP
Time, Inc.
Springdale, Conn.

has been eliminated since the comparatively low back resistance of conventional crystal diodes is not a factor in the design. Advantage is taken of the comparatively low forward resistance provided by crystal diodes to give improved limiter performance.

The diagram illustrates the application of the circuit to the last stage of a 5-mc i-f strip in a mobile vhf receiver. Three stages of i-f are used with delayed avc applied only to the first two stages. The bandwidth of the i-f strip is approximately 40 kc for effective noise

ADVANTAGES of limiting impulse noise in the i-f system of an a-m receiver has been pointed out (ELECTRONICS, p 164, June 1953). Further development work has re-

sulted in a new circuit that provides for better limiting action and less distortion on all grades of a-m signals. Restriction of the choice of limiters to vacuum-tube diodes

TIME-TRIED TETRODE



LOS GATOS 4D21/4-125A

MODERN in every respect—
with exclusive Sintercote black-
body high-dissipation anode and
emission-free grids—the Los
Gatos 4D21/4-125A provides a
new source of supply for a widely-
applied tetrode type. Check
Los Gatos for your requirements
in other types with emphasis
on long service life.

LEWIS and KAUFMAN, Ltd.

LOS GATOS 1

CALIFORNIA



REG. U. S. PAT. OFF.

Export Representatives:
MINTHORNE INTERNATIONAL CO., INC.
15 Mocre St., N.Y. 4, N.Y., Cable: Minthorne

In Canada:
THE RADIO VALVE COMPANY OF CANADA, LIMITED
189 Dufferin Street, Toronto 1, Ontario, Canada

EXTREMELY HIGH "Q"

insures
minimum frequency
affect
over a wide spectrum



For
precision
circuitry
in:

Frequency Generators
Analyzer Circuits
Wave Metering Apparatus
Countless Other Electronic
and Industrial Devices

For complete information on capacitor performance characteristics and recommended applications, write for Catalog 1117. To get the help you need for special requirements, consult Industrial Condenser Corporation's highly experienced engineering staff. They will provide specific recommendations, plus the design and engineering "know how" to meet your needs.

INDUSTRIAL
CONDENSER CORPORATION



3249 North California Avenue

Chicago 18, Illinois

Outstanding Operating Characteristics

Insulation resistance at +20° C. after three minutes charge: 900,000 megohm microfarads

Insulation resistance at +75° C.: 78,000 megohm microfarads

Insulation resistance at -75° C.: In excess of one million megohm microfarads

Change in capacitance from +25° C. to -80° C.: +0.76%

Self time constant of 10 mfd. capacitor: 4800 hours

Q at 50 kilocycles: 10,000

Power Factor at 1 kc: 0.00025

limiting and ease of tuning in mobile operation.

The values shown, while successfully used in one receiver, are subject to modification depending upon the design of the particular receiver. As in all types of receivers employing limiters, the gain must be high up to the point of limiting or effective limiting will not be possible when receiving weak signals.

Limiter bias in the original circuit depended upon the rectified voltage developed by the limiters themselves, which in turn tended to follow the peak of the applied voltage at a syllabic rate. Signals with poor positive-modulation characteristics failed to provide sufficient limiter bias to prevent serious loss of intelligibility. In this circuit, however, limiter bias does not depend upon rectification of the limiters but is derived from an independent source under control of the avc system.

Limiter Bias

Bias for the two crystal limiters is derived from the B+ supply by the series combination of R_1 , R_6 and R_9 . Resistor R_7 also serves as the plate load resistor of the triode control tube. Variable negative bias applied to the grid of the control tube, therefore, will control the limiter bias. This variable negative bias is obtained from the avc circuit and is fed to the grid of the control tube through a low-pass filter consisting of R_8 and C_6 . To allow application of the full range of avc voltage to the grid of the control tube and at the same time provide for optimum bias in the absence of a signal, a small positive voltage is applied to the grid to buck down the avc voltage appearing at this grid in the absence of a signal.

This adjustment is provided for by the potentiometer R_{11} , the arm of which is connected to the control grid through the 10-megohm resistor R_{10} . This is usually adjusted in the absence of a signal or impulse noise and the adjustment is gaged by a slight diminution in receiver noise in the output of the receiver indicating that limiting is taking place on receiver noise peaks. When a signal is applied to the receiver, the bias on the control tube

Plain Pointers on Projection

ONE of the claims we make concerning the Kodak Contour Projector is that once an object is brought into focus at any given magnification it will remain in focus when magnification is changed. (This freedom to change magnification is made possible through the use of a lens turret, mounting six lenses, and speeds inspection procedures.) An operator only need flick a dial to switch from one magnification to another; no time is lost refocusing.

Occasionally, however, one of our customers writes to question our claim and declares that he has found it necessary to refocus when changing magnification. This does not upset us. Almost invariably the difficulty can be traced to the phenomenon of optics called "depth of field." This refers to the distance between the nearest and farthest points sharply defined by a lens and is aptly illustrated by the picture below. It is apparent that when a lens is focused on one object, other objects—nearer and farther from the lens—may appear in acceptable focus.

One of the characteristics of this phenomenon of depth of field is that it decreases sharply as magnification is increased. This is equally true when a lens is focused on an actual object, as with a camera, or on an image of that object, as is the case with our contour projector. The result is that when working at higher magnifications depth of field is considerably less than when working at lower powers.

Consequently, it is possible that an object in focus at 10 power may appear out of focus when magnification is changed to 100 power, where depth of field is less and the need for precise focusing correspondingly

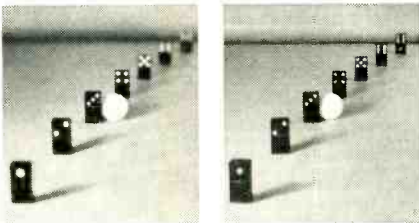

greater. Because of this, we recommend that, when inspecting parts at several magnifications, the part first be focused at the highest magnification to be used. This insures focusing within the narrowest tolerances and, when magnification is changed to a lower power, the part remains in sharp focus on the screen. When this recommendation is followed, complaints on the need for refocusing vanish.

Incidentally, it should be mentioned that neither focus nor depth of field affects accuracy of magnification with the Kodak Contour Projector. This remains as rated irrespective of the precision of focus, thanks to what our optical people call a telecentric stop. Which, in itself, is subject for another in this series of columns.

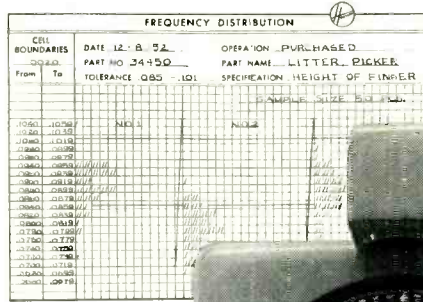

Frequency distribution chart of part size based on optical measurement.

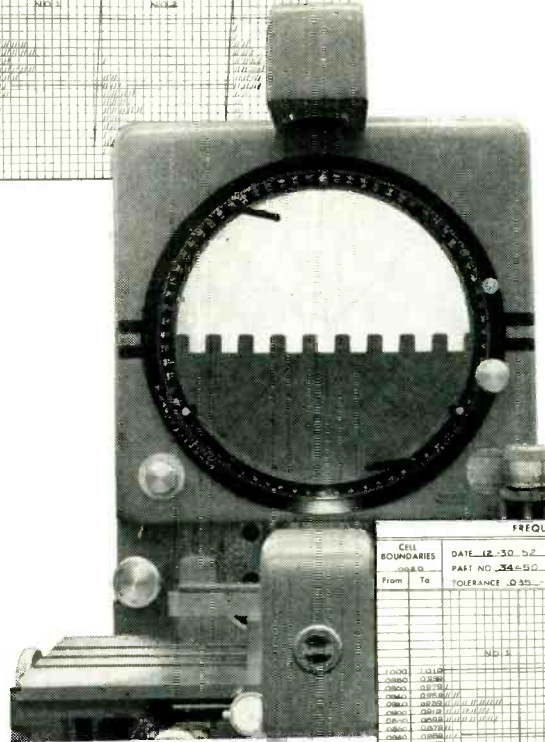

Frequency distribution chart of part size after tool alterations.

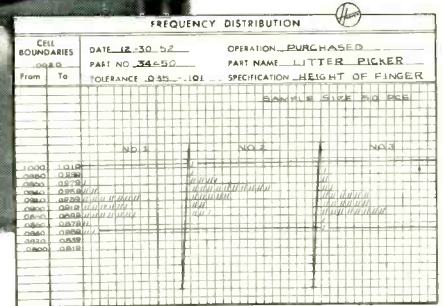

Saved...296 pieces per thousand!

Like many another manufacturer, the Hoover Company, Canton, Ohio, has its rejection problems. A typical one involved a flexible, rubber-like "litter picker" used in its vacuum cleaners. Although tolerances ranged from .085" to .101", rejects ran as high as 30%.

To solve this problem, Hoover employed a Kodak Contour Projector to measure the parts, plotted results in accordance with modern methods of statistical quality control. Based on these studies, alterations were made in the cutting tool and the holding fixture for the part. Rejects dropped from 30% to less

than 1/4 of 1%. Savings amounted to 296 pieces per thousand.

"Optical gaging with the Kodak Contour Projector," say Hoover engineers, "eliminated incorrect readings caused by mechanical distortion of the parts. In addition, optical methods of measurement proved from 4 to 5 times faster than conventional gaging techniques."

Your own production measurement or inspection problem may similarly be solved by optical gaging with a Kodak Contour Projector. To find out more about it, send the coupon for your copy of "The Kodak Contour Projector."

EASTMAN KODAK COMPANY

Special Products Sales Division, Rochester 4, N. Y.

Please send me a copy of your booklet, "The Kodak Contour Projector."

NAME _____ TITLE _____

COMPANY _____

ADDRESS _____

CITY _____ STATE _____

(Zone)

Kodak
TRADE-MARK

48

For high precision operations on hard, brittle materials



THE *S.S. White* INDUSTRIAL "AIRBRASIVE" UNIT

If you perform delicate drilling, shaping and cutting operations on hard, brittle materials, it will pay to investigate the "Airbrasive" Unit.

The "Airbrasive" Unit's tiny, high-speed jet of gas-propelled abrasive particles makes extremely fine, precise cuts and does it without the shock, heat or vibration usually associated with conventional methods. The process has proved highly successful in producing many precision parts and devices.

We'll be glad to advise you on the advantages of using the "Airbrasive" Unit in your production, if you'll send us a sample part and give us details of the job you wish performed. There's no obligation.

THE "AIRBRASIVE" UNIT DOES MANY JOBS

It's been demonstrated that the Unit can do jobs considered impossible or impractical by previously known methods, such as:

- Trimming resistance elements on printed circuits
- Internal threading of glass and ceramic tubing
- Cutting spiral bands on deposited carbon resistors
- Cutting germanium
- Drilling fine holes in glass

Bulletin 5307 has details. Send for a copy.

THE *S.S. White* INDUSTRIAL DIVISION
DENTAL MFG. CO.



Dept. EB, 10 East 40th St.
NEW YORK 16, N. Y.

Western District Office • Times Building, Long Beach, California

swings negative, thereby increasing the limiter bias as it appears across R_5 . Resistors R_3 and R_4 isolate intermediate frequencies from the control system.

The time constant of response of the bias-control system to changes in avc voltage is established partially by the low-pass filter R_5 and C_5 in the grid circuit of the control tube, but to a greater degree by the time constant of the limiter-bias circuit consisting of the two miniature 1- μ f capacitors C_4 and C_5 in series in combination with the resistors R_3 , R_4 and R_5 .

The necessity for limiter-bias control results from the fact that few if any receivers have essentially flat avc. If such were the case, limiter bias could be fixed. The addition of amplified control of the limiter bias makes provision for the fact that the voltage appearing at the limiter terminals is not independent of signal strength over the wide ranges of input encountered in mobile service.

Since the bias conditions may be established for limiting at any desired percentage of modulation, the system becomes independent of the modulation characteristics of the incoming signal insofar as limiter operation is concerned. In addition, a continuous series of high-amplitude pulses can increase the bias on the limiter only to the point where the control tube is cut off. Hence, excessive limiter bias in the presence of such interference is minimized.

Construction

Care must be exercised in placement and shielding of the limiter components, in particular C_3 , C_4 , C_5 , the crystal diodes and R_3 and R_4 to prevent feedback in the i-f system. Excessive coupling between the primary and secondary of the last i-f transformer may prevent adequate limiting owing to a reduction in the primary impedance by the loading of the signal diode circuit. A slight detuning of the secondary of the last i-f transformer will suffice to handle this situation if a tightly coupled i-f transformer is used, without noticeably impairing the overall frequency characteristic of the i-f strip. A better solution is

VAC-TITE* COMPRESSION SEALS

To improve the quality of their products
and to keep them competitive cost-
wise, more manufacturers are turning
to HERMETIC SEAL... for headers
for critical applications, airborne use,
maintenance-free operation and for
the arc resistance of glass insulation.

V a r i a t i o n s

With production and variety increasing steadily, HERMETIC SEAL offers an unparalleled selection of multi-terminal headers, miniature plugs, individual terminals, rectangular plugs and connectors of every shape and size... plus condenser seals and crystal bases. These units are available in VAC-TITE* Compression Seals as well as conventional kovar designs. Try HERMETIC first because HERMETIC has always been first and foremost in its field.

*VAC-TITE is HERMETIC's new, vacuum-proof, compression-construction, glass to metal seal. In addition to special shapes, many standard sizes such as .800 O.D. and .900 O.D. multi-terminal headers and a large variety of individual terminals are available in VAC-TITE Compression Seals.

In addition to those shown, HERMETIC produces a wide variety of multi-headers with individual glass insulations.

*Write for samples, data, prices.
We welcome the opportunity to work with
you on special problems.*

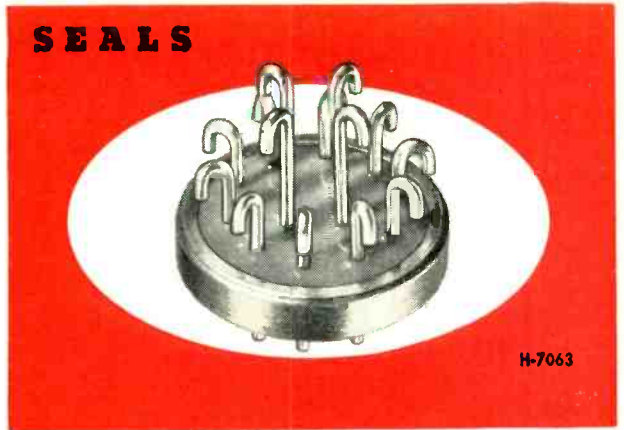

H-7063

on a vital theme

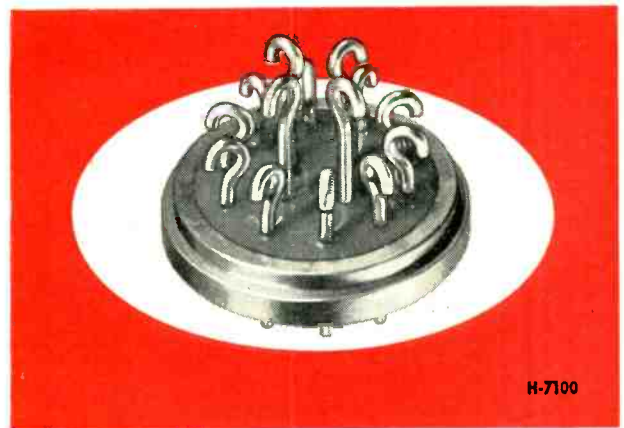

H-7100

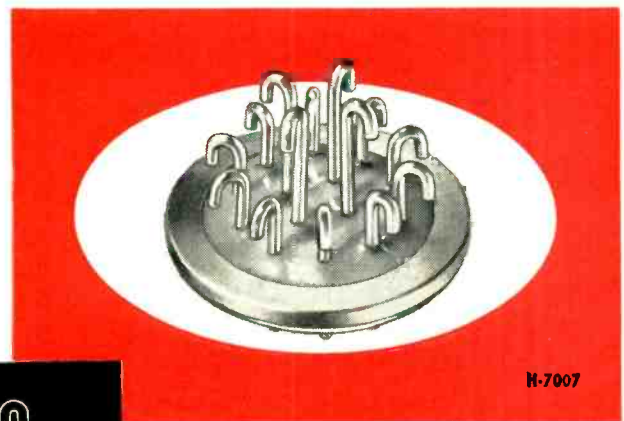

H-7007

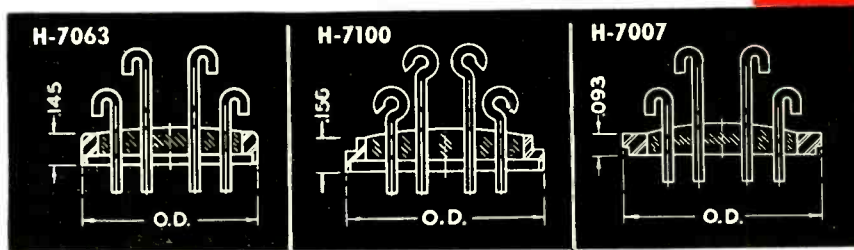

H-7063

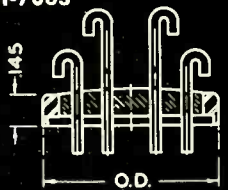

HIGH FLANGE BODY

O.D. available—1.000, .966, .900, .800, .750, .600, .500

H-7100

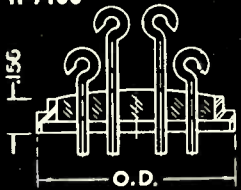

NOTCH BODY

O.D. available—1.000, .966, .900, .800, .750, .600, .500

H-7007

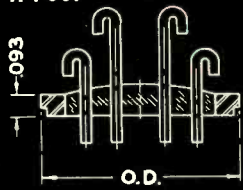

LOW FLANGE BODY

Also available with flange reversed.
O.D. available—1.062, 1.000, .900, .730, .640, .600, .375

All parts shown available up to 21 terminals depending on O.D. Integral exhaust tubulation, color codes, alternate terminations may also be had. Terminal diameters up to .093 dia. depending on O.D.

HERMETIC SEAL PRODUCTS CO.

31 South Sixth St.
Newark 7, N. J.



F I R S T A N D F O R E M O S T I N M I N I A T U R I Z A T I O N

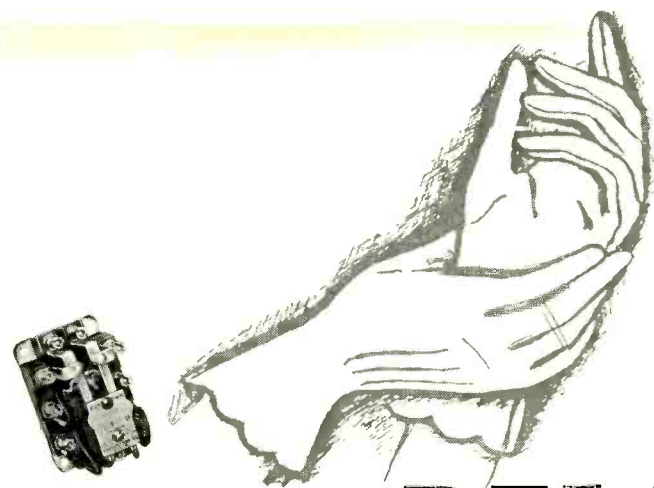

RELAYS THAT FIT

electrically
mechanically
costwise

Over 5,348 standard Struthers-Dunn relay and timer types—each designed for a specific purpose—spell maximum efficiency and economy for the great majority of applications.

Equally important, more than 30 years of specialization in relays exclusively, means that Struthers-Dunn is uniquely fitted to recommend as well as to supply types that fit your particular application like the proverbial glove.

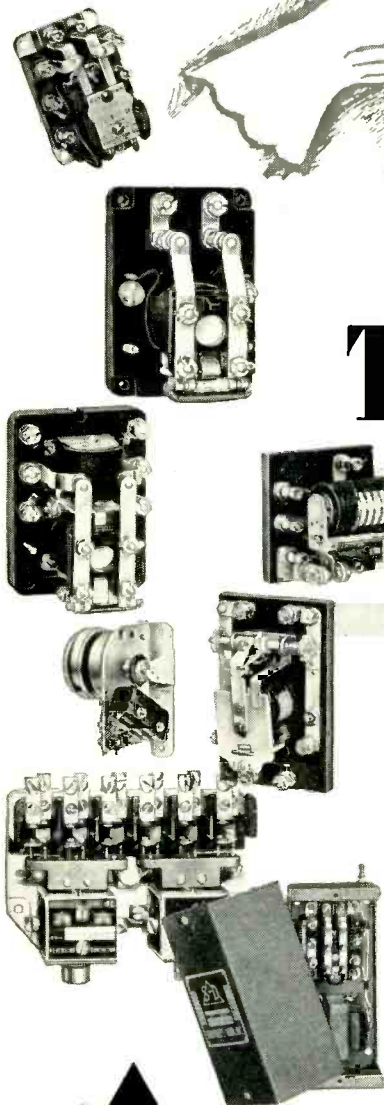

STRUTHERS-DUNN

NEW ADDRESS

OVER 5,348 RELAY TYPES

STRUTHERS-DUNN, INC., LAMB'S ROAD, PITMAN, N. J.

ATLANTA • BALTIMORE • BOSTON • BUFFALO • CHARLOTTE • CHICAGO • CINCINNATI
CLEVELAND • DALLAS • DETROIT • KANSAS CITY • LOS ANGELES
MINNEAPOLIS • MONTREAL • NEW ORLEANS • NEW YORK • PITTSBURGH
ST. LOUIS • SAN FRANCISCO • SEATTLE • SYRACUSE • TORONTO

to reduce the coupling between primary and secondary to prevent excessive reduction of the primary impedance.

Field experience with this noise limiting system has proved satisfactory under all conditions of mobile operation. Its performance on weak signals in the presence of heavy ignition noise is excellent owing to the fact that the AVC system is protected from excessive noise peaks, thereby preserving maximum receiver sensitivity in the presence of high-level impulse noise. The distortion produced by this type of controlled i-f limiter appears to be insignificant in terms of maintaining excellent speech intelligibility.

Single Tube Square-Wave Generator

BY SERGIO BERNSTEIN AND
WILLIAM J. SPAVEN

Government Division
Fada Radio and Electric Co., Inc.
Belleville, N. J.

A RELATIVELY simple, one-tube clipper circuit has been designed which is capable of developing square waves by properly shaping a sinusoidal input waveform.

Basically the circuit consists of a

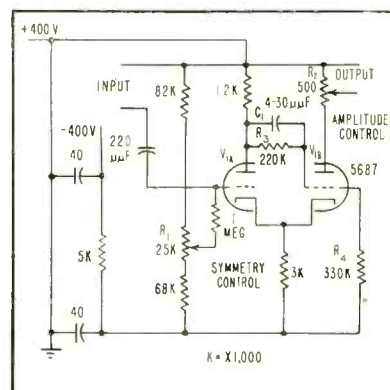

FIG. 1—Generator uses Schmitt trigger circuit to produce square waves from sine-wave input

high-speed, cathode-coupled bistable multivibrator known as the Schmitt trigger circuit.

In Fig. 1, the grid of the first triode V_{14} is connected to a d-c voltage source which can be varied in amplitude. When this voltage is

SPECIFY THESE

Dependable Standard



LUG-TYPE, LEAD-THRU INSULATORS

LUG-TYPE, LEAD-THRU INSULATORS

For condensers, transformers, other applications requiring voltage ratings from 2000 to 4000 (rms.). Compression sealed, super rugged. Inside or outside mounting; lead wires up to .060

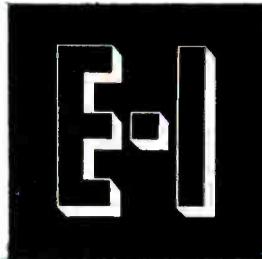

hermetically-sealed terminations

TO SOLVE DESIGN PROBLEMS QUICKLY AND ECONOMICALLY!

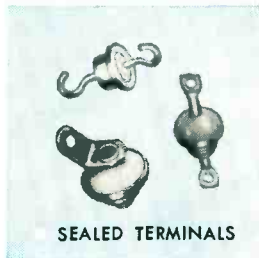

SEALED TERMINALS

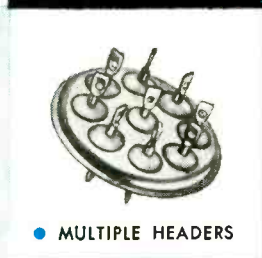

MULTIPLE HEADERS



COMPRESSION TYPE

SEALED TERMINALS

Featuring cushioned glass construction, high thermal shock resistance. Available in economical preferred types and special designs.

MULTIPLE HEADERS

Vacuum tight, cushioned glass construction. Strain-free, tin dipped for easy soldering and silicone treated for maximum dielectric strength.

COMPRESSION TYPE HEADERS

Super rugged, absolutely rigid, practically indestructible multiple headers. Exclusive E-I development offers greatly increased resistance to shock and vibration.

END SEALS

For condensers, resistors and other tubular components. Completely strain-free and provide a permanent hermetic seal. Standardized, economical types.

OCTAL HEADERS

Plug-in and multiple types. Feature new principle of hermetic sealing.

COLOR-CODED TERMINALS

Feature glass inserts in standard, easily identified RMA color codes. Coloring is in the glass.



END SEALS

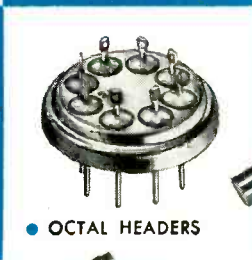

OCTAL HEADERS

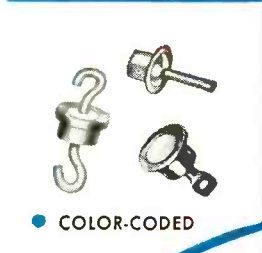

COLOR-CODED



E-I... Your headquarters for hermetically-sealed multiple headers, octal plug-ins, terminals, color coded terminals, end seals and lug-type lead thru insulators. New bulletins are available now on E-I hermetically sealed terminations. Call, or write on company letterhead, for the complete engineer-designer file portfolio including data on all E-I standard types. Samples of the new STANDARD TRANSISTOR CLOSURE are available on request made on your company letterhead.

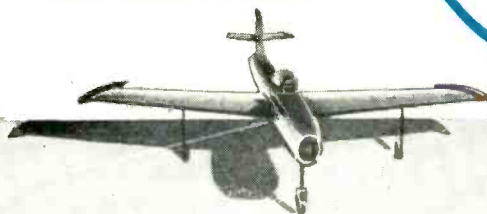

DIVISION OF AMPEREX ELECTRONIC CORPORATION

*PATENT PENDING ALL RIGHTS RESERVED

ELECTRICAL INDUSTRIES

44 SUMMER AVENUE, NEWARK 4, NEW JERSEY

EXPORT AGENTS: PHILIPS EXPORT CORP., 100 EAST 42nd STREET, NEW YORK 17, N. Y.

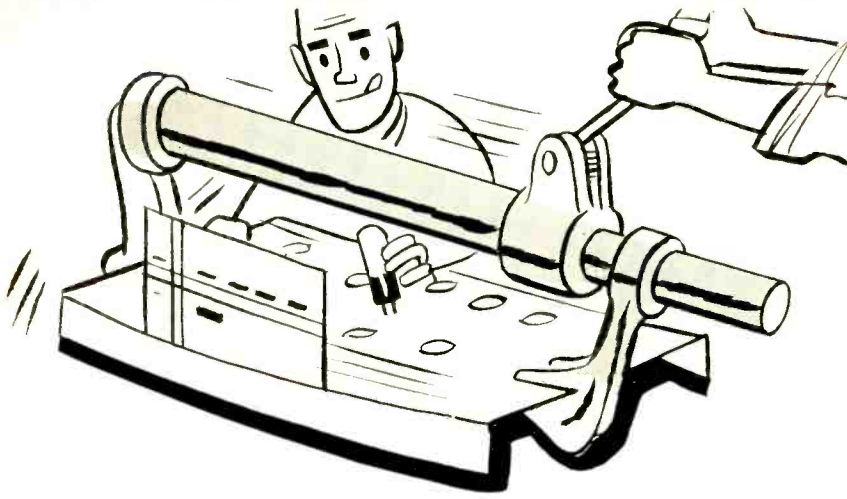

This is a chassis stretcher ... but don't buy it, use Centralab miniature switches instead

- Reduce chassis crowding
- Cut down size and weight
- Cut costs
- Most complete line of switches available
- Diameter only 1-5/16"
- Widest variety in poles, positions and sections
- Double wiping quiet contacts
- One source for all your switch needs
- Phenolic (Grade LTS-E5)
- Steatite (Grade L-5).

DON'T TURN THIS PAGE until you write for technical Bulletins 42-156 and 42-157.

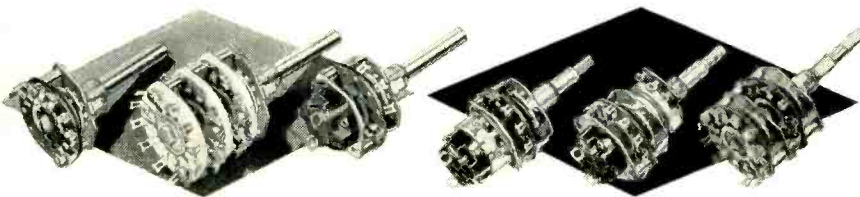

SERIES 20 — Staked or bolted types. Available with Steatite or phenolic insulation . . . 2 to 12 positions . . . 30° or 60° positive indexing. Steatite is grade L-5, meets JAN-I-10 specifications. Phenolic is grade LTS-E5, JAN P-13.

SERIES 30 — Switch and control combinations with concentric shafts. Furnished in three types: rotary switch mounted forward, control in rear; control in front, rotary switch in rear; two rotary switches operating independently.

Centralab

A Division of Globe-Union Inc.
914-F E. Keefe Avenue • Milwaukee 1, Wisconsin
In Canada: 804 Mt. Pleasant Road, Toronto, Ontario



zero V_{1A} is nonconducting. The plate voltage is direct-coupled through a frequency compensated voltage divider, R_s , R_i , and C_i , to the grid of the second triode causing V_{1B} to conduct. When the grid voltage of V_{1A} approaches a voltage equal to the cathode potential minus the grid bias, V_{1A} starts to conduct. At a slightly higher voltage, a critical point is reached and regeneration takes place causing a sudden transfer of current from V_{1B} to V_{1A} . In this second state, V_{1A} is conducting and V_{1B} is cut off.

As the grid voltage is reduced no change in state will occur until the input voltage approaches a second critical potential. A regenerative condition again results, and the circuit returns to its previous stable state with V_{1A} cut off and V_{1B} conducting.

Rectangular Wave

By introducing a varying waveform at the grid of V_{1A} it is possible to develop a rectangular waveform at the plate of V_{1B} . The signal to be clipped is coupled to the grid through a large blocking capacitor. Any waveform may be used at the input to provide a rectangular waveform of constant amplitude at the output.

With the parameters indicated, a waveform having a peak-to-peak amplitude of approximately 5 volts is required to trigger the circuit. The input impedance is 1 megohm. Maximum output waveform amplitude is approximately 20 volts peak-to-peak. The output impedance varies from zero to 500 ohms depending on the setting of the amplitude control. A negative power supply is used so that no output coupling capacitor is required. This feature is necessary if long pulses with perfectly flat tops are to be obtained. The measured rise time between 10 and 90 percent amplitude points of the output wave-shapes is 0.25 microsecond. It is important that the 3,000-ohm cathode resistor be noninductive. If a wire-wound resistor is used, the rise time of the output waveform will be greater than specified.

Two controls are included in the design. Symmetry control R_s , var-

Now you can have high precision

dynamic data recording

on a **limited budget**

Priced competitively with inexpensive pen-type recording oscillographs but offering far greater frequency range and improved accuracy, Consolidated's new low cost 6-channel Type 5-117 Recording Oscillograph now takes its place in the CEC precision instrument line. Using CEC's new, improved series 7-300 galvanometers, the 5-117 now brings to industry accurate dynamic measurement which only a precision, photographic type recording oscillograph can provide. The 5-117 Oscillograph produces accurate recordings with flat response over the frequency range of 0 to 300 cps. Galvanometers are available for use in the 5-117 which permit strain gage measurements with flat response from 0 to 90 cps *without amplification*. For full details about this high-precision, low-cost instrument write for CEC Bulletin 1533A-X3.

Consolidated's 5-117 Recording Oscillograph

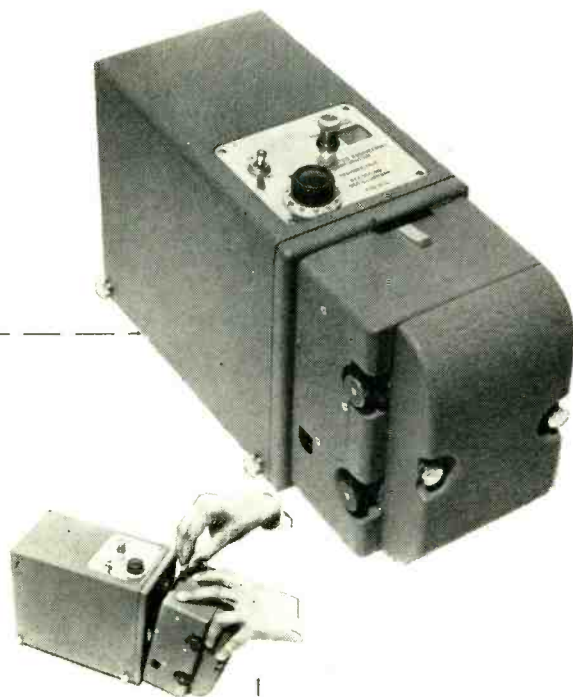

The Consolidated 5-117 Recording Oscillograph features a detachable magazine which accommodates 100 foot rolls of recording paper 70 millimeters wide. An integral footage indicator shows the remaining or unexposed record length. The record is positively driven through change gears, and any one of six speeds from $\frac{3}{4}$ inch to 24 inches per second may quickly be selected. The CEC Type 5-117 Recording Oscillograph gives you precision dynamic data recording for the price of a pen-type recording oscillograph.



"Spot setting" of six CEC Type 7-200 or 7-300 Galvanometers is made easy by a calibrated ground glass screen brought into position by swinging a pivoted bracket.



Data input from transducers to the oscillograph is through six individual locking-type electric connectors on a rear panel. Integral 6-foot power cable is standard equipment.

Active data channels	6 active and 1 static reference trace.
Galvanometers employed	CEC Type 7-200 or 7-300 magnetically damped types, providing 0 to 300 cps range.
Record material	70 mm wide photographic record paper or film.
Record magazine	Daylight loading, 100 foot capacity.
Record speeds	6 steps from $\frac{3}{4}$ " to 24" per second.
Time indication	$\frac{1}{2}$ inch lines photographed along edge of record at 1/10th and 1/100th second intervals.
Record identification	5 digit number automatically advanced and photographed at start of each run.
Controls	Recording Switch, Galvanometer Illuminator Rheostat, Power On-Off Switch.
Viewing screen	Calibrated ground glass screen for initial spot setting and observation of galvanometer traces.
Connectors	Individual locking-type connector for each galvanometer input.
Power requirement	115 volt, 60 cycle ac, 90 watts maximum.
Weight	24 pounds.
Dimensions	Width 5 $\frac{1}{2}$ "—Height 8 $\frac{1}{2}$ "—Length 14 $\frac{1}{8}$ ".

Consolidated Engineering

ANALYTICAL INSTRUMENTS FOR SCIENCE AND INDUSTRY

CORPORATION

300 North Sierra Madre Villa, Pasadena 15, California Sales and Service through **CEC INSTRUMENTS, INC.**,

a subsidiary with offices in: Pasadena, Atlanta, Chicago, Dallas, Detroit, New York, Philadelphia, Washington, D. C.



3-speed PHONOMOTORS

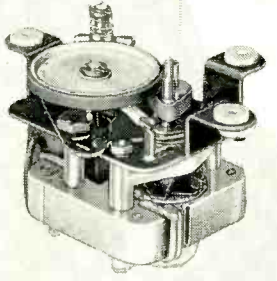

Single belt-type 3-speed
record-changer phonomotor

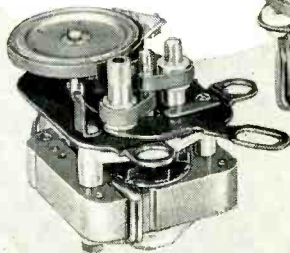

Double belt-type 3-speed
record-changer phonomotor

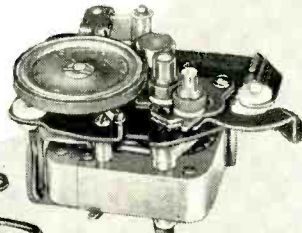

Turret-type 3-speed
record-changer phonomotor.

FIRST CHOICE of America's Leading Record-Changer Makers

There are good reasons why America's leading record-changer manufacturers rely on General Industries to furnish their phonomotor requirements. Engineering... design... manufacturing skill... dependable, trouble-free performance... all contribute to the high quality of GI *Smooth Power* products.

Each of the above 3-speed record-changer phonomotors was designed and engineered by General Industries to meet the specific requirements of a leading national manufacturer. For complete information about General Industries phonomotors — for both record-changer and manual application — write to:



THE GENERAL INDUSTRIES CO.
DEPARTMENT MA • ELYRIA, OHIO

ies the d-c bias applied to the grid of V_{1A} . When a sine wave is applied to the input grid, it is possible to obtain an assymmetrical output waveform, the duty cycle of which may be varied from 20 to 80 percent.

The amplitude control, R_2 , varies the amplitude of the output waveform from 0 to 20 volts peak-to-peak. The device is capable of developing square waves varying in frequency from 20 to 200,000 cycles.

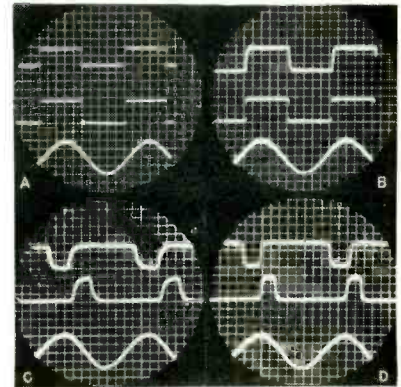

FIG. 2—Output waveforms obtained using a 20 cps input (A), 10 kc input (B), 200 kc input (C) and 200 kc with capacitive loading (D)

Figure 2 shows the output waveforms obtained with sine-wave input signals. Effect of capacitive loading is also shown. Pulses as short as 1 microsecond can be obtained with a repetition rate of 200 kc.

BIBLIOGRAPHY

- Vin Zeluff and John Markus, "Electronics Manual for Radio Engineers", First Ed., p 407, 708, McGraw-Hill Book Co., Inc., N. Y.
- Valley and Wallman, "Vacuum Tube Amplifiers", MIT Rad. Lab. Series, Chap. 18, McGraw-Hill Book Co., Inc., N. Y., 1949.
- J. F. Rider, "Encyclopedia on Cathode Ray Oscilloscopes and Their Uses", p 542, John F. Rider Publisher, Inc., N. Y., 1950.
- O. H. Schmitt, "A Thermionic Trigger", *Jour Sci Inst.*, p 24, 1938.
- Elmore and Sands, "Electronics", p 99, McGraw-Hill Book Co., Inc., N. Y., 1949.

Signal Detector for High Noise Levels

BY SCOTT L. SHIVE

Signal Corps Engineering Laboratories
Fort Monmouth, N. J.

A DEVICE useful for detecting a small sine-wave signal of known frequency masked by random electrical noise of relatively high amplitude consists essentially of a gating



*Molded by Mechanical Institute
Boonton, New Jersey*

When RCA was doing its pioneering research in color television, it needed a very special material for tube bases. Arc resistance and great dielectric strength were essential, as well as resistance to heat and atmospheric humidity. PLASKON Alkyd offered these features—plus affording an extremely high rate of production due to its ready moldability. Under a test potential of 12,000 volts, the electrical leakage between pins is so low as to be insignificant. The choice was an obvious one. PLASKON Alkyd molding material guaranteed a safe, speedily manufactured component.

Why not find out what PLASKON products can do for you? Our technical staff is ready at all times to discuss your problems, help you find the right product for your needs. Write today for information or call your nearest Plaskon Man.



For further information on PLASKON plastics and resins, address Barrett Division, Allied Chemical & Dye Corporation, 40 Rector Street, New York 6, N. Y. Whitehall 4-0800



Lapp

ANTENNA TOWER INSULATORS

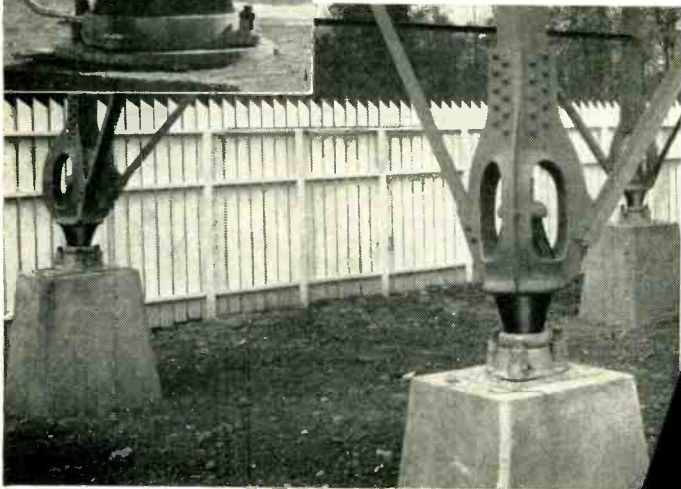

● Insulation of antenna structures is a field pioneered by Lapp. The first insulated broadcasting tower, erected more than 30 years ago, was on Lapp insulators. Today, most of the world's radio towers are supported by Lapp insulators—including the tallest guyed mast ever built, more than 1200 feet high.

Through the Lapp "compression cone," immense loads can be carried by electrical porcelain—single Lapp base insulator units of the type shown here having been design-tested to strengths in excess of 3,500,000 lbs.

Write for description and specification data on units for any antenna structure insulating requirement. Lapp Insulator Co., Inc., Radio Specialties Division, 226 Sumner St., Le Roy, N. Y.

TOWER FOOTING INSULATORS FOR SELF-SUPPORTING RADIATORS

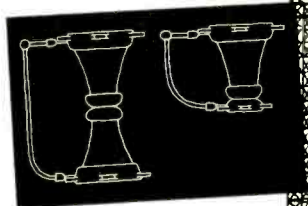

MAST BASE INSULATORS

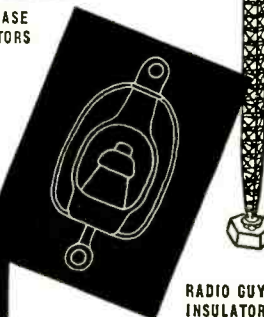

RADIO GUY INSULATOR

Lapp

circuit which alternately presents high and low impedance for equal periods of time to the source. When the frequency of the switching coincides exactly with the frequency and phase of the signal, the signal voltage is rectified and appears as a d-c component, with an average value proportional to signal level. It may be detected by placing a d-c ammeter in the line carrying the signal-plus-noise currents.

Although the rms value of the total noise-voltage spectrum may be many times greater than the rms value of the signal, noise voltage components existing at any frequency other than exactly that of the switching frequency will produce no net average direct current. The frequencies to which the d-c meter will respond determine the bandwidth of noise voltages above and below the switching frequency which may produce meter oscillation.

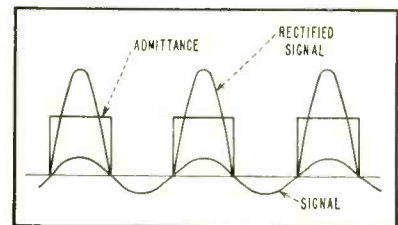

FIG. 1—Rectified signal resulting from combination of a-c signal with square admittance wave of detector circuit

For example, if the meter responds to frequencies from zero to 5 cycles per second, then noise voltages in a frequency band 5 cycles on either side of the switching frequency may produce oscillatory meter response. However, the meter may be damped to any desired degree and made to respond to no frequency greater than a small fraction of one cycle per second. In this sense the circuit may be considered to be an extremely selective detector circuit, or a filter circuit with extremely narrow band response whose center frequency may be varied over any desired range by changing the switching frequency, and whose bandwidth of response may be controlled to any desired degree by regulating the meter damping.

One form of gating circuit for

Really



Reliable

HERMETICALLY SEALED Germanium Transistors



Vanquish vacuum tubes in computer circuits AFTER 3000 GRUELING TEST HOURS

NOT A SINGLE FAILURE! More than 200 of Radio Receptor Co.'s PNP diffused junction transistors, Type RR87, are giving tangible evidence they are really reliable. All the original units are still performing after 600,000 transistor hours in a computing machine development project now underway at one of the country's largest research centers.

Where short-lived vacuum tubes used to conk out one by one at a prohibitive rate, tiny RRco. transistors are proving their life-span far exceeds the bulky tubes in flip-flop, gates and other pulse circuits. What's more, these efficient transistors are "potted" in sub-assemblies, not removeable from the computer mechanism except as a unit. They *have* to be good!

When the RRco. trademark appears on transistors, diodes or selenium rectifiers you can always be sure they are *really reliable* . . . if you'd like guidance from our engineering group specializing in transistor circuitry, just write us now.

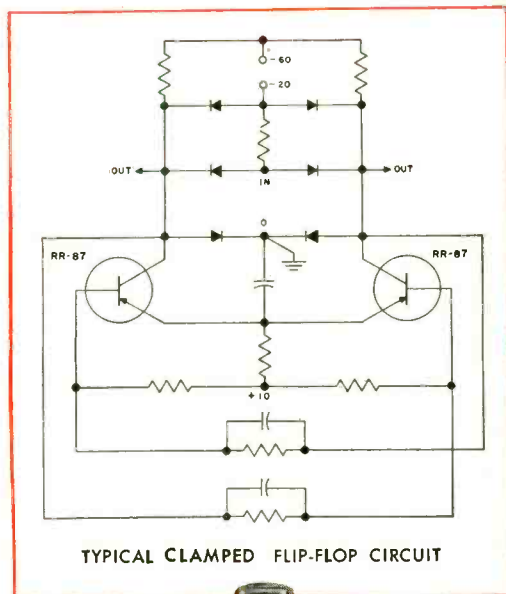

TYPICAL CLAMPED FLIP-FLOP CIRCUIT

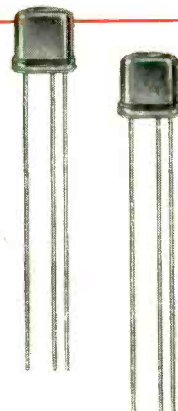

Another RRco. computer transistor recently developed is Type RR83. Ask for complete information regarding this as well as RR87.

RADIO RECEPTOR COMPANY, INC.
Seletron and Germanium Division

SALES OFFICES: 251 WEST 19th STREET, NEW YORK 11, N. Y., WATKINS 4-3633, FACTORIES IN BROOKLYN, N. Y.

ELECTRONICS — June, 1954

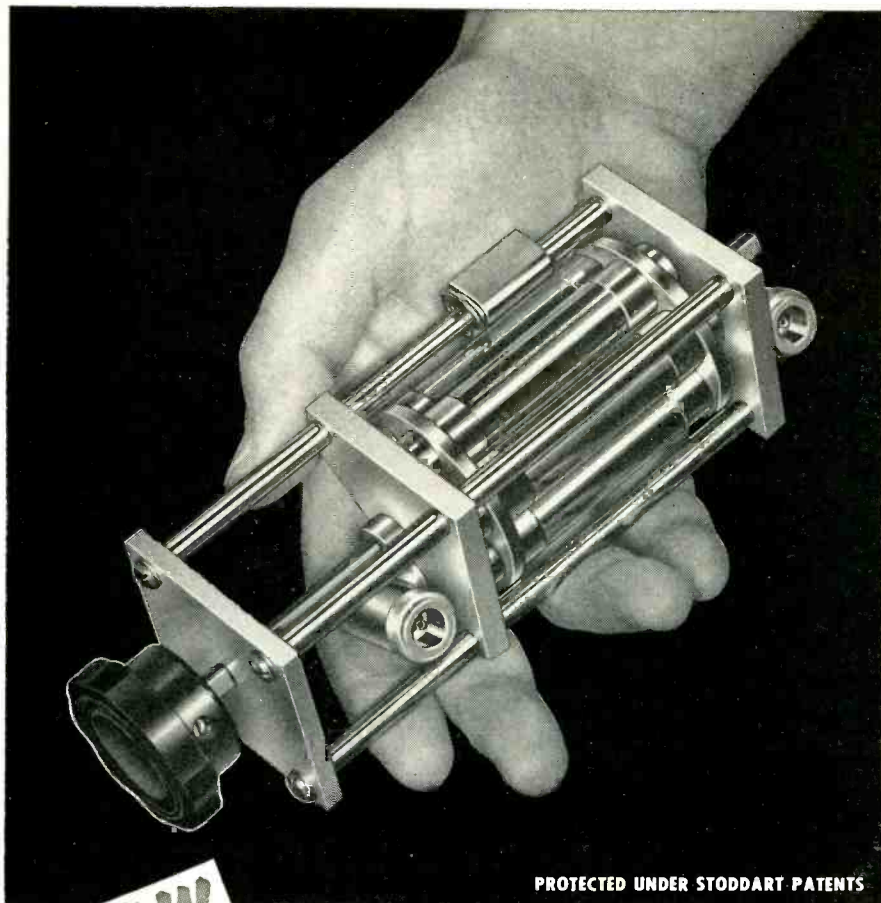

PROTECTED UNDER STODDART PATENTS

Precision Attenuation to 3000 mc!

TURRET ATTENUATOR featuring "PULL-TURN-PUSH" action

**SINGLE "IN-THE-LINE"
ATTENUATOR PADS
and
50 ohm COAXIAL
TERMINATION**



FREQUENCY RANGE:
dc to 3000 mc.

CHARACTERISTIC IMPEDANCE:
50 ohms

CONNECTORS:
Type "N" Coaxial female fittings each end

AVAILABLE ATTENUATION:
Any value from .1 db to 60 db

VSWR:
< 1.2, dc to 3000 mc., for all values from 10 to 60 db
< 1.5, dc to 3000 mc., for values from .1 to 9 db

ACCURACY:
±0.5 db

POWER RATING:
One watt sine wave power dissipation

*Send for free bulletin entitled
"Measurement of RF Attenuation"*

*Inquiries invited concerning pads or
turrets with different connector styles*

single frequency detection consists of the mechanically driven commutator. Driven at a speed equal to one-half that of the signal to be detected, the commutator presents an open circuit for one quarter revolution and no current flows through the ammeter. For the next quarter revolution the commutator presents a short circuit and current flows through the ammeter limited only by the source impedance. Since current can flow only for alternate half cycles of the signal, half-wave rectification of the signal occurs and is evidenced by a net average d-c reading on the ammeter proportional to signal voltage amplitude.

The signal voltage to be detected is a sine wave alternating at the switching frequency, and the resulting current is equal to the product of the sinusoidal signal voltage wave and the zero-based square admittance wave as shown in Fig. 1.

D-C Components

A d-c term, equal to the value of the rectified signal voltage, results only from the product of the signal voltage and the fundamental of the admittance wave, because the product of two sine functions contains a constant, or d-c term, only when the frequencies are identical. However, because of the harmonic content of the admittance wave, small d-c currents may result from the products of the harmonics of the admittance wave with components of the noise voltage existing at those same frequencies. Such d-c currents, however, will be extremely small because any single frequency component of a random noise voltage is theoretically infinitely small, but low frequency voltages within the response band of the d-c meter will be produced by the combined sum of noise-voltage components within that narrow frequency band around each of the specific harmonic frequencies of the admittance wave. These low-frequency voltages will produce random fluctuations of the d-c ammeter. The products of higher harmonics of the admittance wave and noise voltages of those higher frequencies will give rise to progressively lower amplitudes of fluctuation voltages, however, because the amplitude of

STODDART AIRCRAFT RADIO Co., Inc.

6644-A Santa Monica Blvd., Hollywood 38, California • Hollywood 4-9294

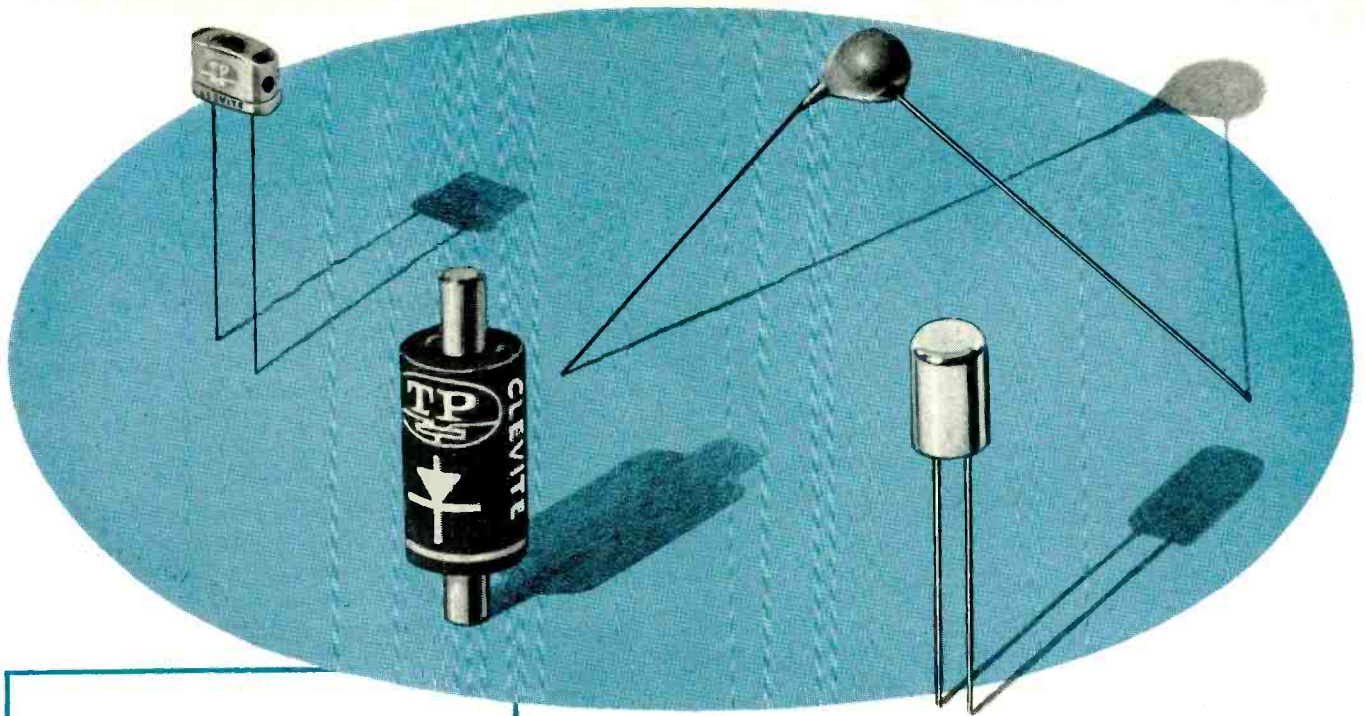

Clevite Germanium Diodes

CARTRIDGE TYPE			
1N34	1N65	1N98	1N147
1N34A	1N66	1N99	1N174
1N38	1N67	1N100	1N190
1N38A	1N67A	1N105	4A
1N48	1N68	1N107	4B
1N51	1N68A	1N108	4C
1N52	1N69	1N109	4D
1N54	1N70	1N110	4E
1N54A	1N72	1N111	4F
1N55	1N75	1N112	4G
1N55A	1N81	1N113	4H
1N55B	1N86	1N114	4I
1N56	1N87	1N115	4J
1N56A	1N88	1N116	4K
1N58	1N89	1N117	4L
1N58A	1N90	1N118	4M
1N60	1N95	1N124	4N
1N63	1N96	1N132	
1N64	1N97	1N133	

"DIOMITE" BEAD TYPE			
D1N34	D1N65	D1N108	1C
D1N34A	D1N69	D1N109	1D
D1N48	D1N86	D1N116	1E
D1N51	D1N88	D1N117	1F
D1N54	D1N90	D1N118	1G
D1N54A	D1N95	D1N174	1H
D1N56	D1N96	1A	1J
D1N56A	D1N107	1B	

"MICROTEMP" DIODES			
M1N38	M1N55B	M1N68A	M1N108
M1N38A	M1N58	M1N70	6A
M1N54A	M1N58A	M1N75	6B
M1N55	M1N63	M1N81	
M1N55A	M1N67	M1N107	

SPECIAL CASE TYPES			
S1N39	1N188	1N189	5B

For data sheets and complete information on CLEVITE transistors, diodes and transistor test sets, write Dept. E6.

Only Clevite Germanium Diodes are available in 127 types!

Cartridge—Bead—Can—Special Case Types—For All Applications

Nowhere else can you get this wide range of diode types — suitable for so many applications! Basically point contact or junction crystal rectifiers, CLEVITE Germanium Diodes offer numerous advantages over conventional vacuum tube diodes — including extremely long operating life and no filament or heater power requirements.

CLEVITE DIODES Offer All These Features!

- Universal Lead Mounting
- 30 different pigtail lead mounting positions on cartridge types permit design versatility and easy installation — *at no extra cost!*
- Positive Electrical Stability through precious metal electro-bonding
- Advanced Hermetic Sealing
- Provides moisture resistance and wide ambient temperature range operation at full ratings
- Uniformly Low Inter-Electrode Capacitance
- Micro-sized — Precision Tested — Rugged

LOW COST — HUNDREDS OF APPLICATIONS

As Rectifiers — Detectors — Discriminators — Limiters — Multipliers — Modulators — Switches — and many new, important uses that are being discovered daily!

TRANSISTOR PRODUCTS, Inc.

TELEPHONE: WALTHAM 5-9330
CABLE ADDRESS: TRANSISTOR
CODES: UNITED TELEGRAPH-HOUSE



241-257 CRESCENT STREET, WALTHAM 54, MASSACHUSETTS
AN OPERATING UNIT OF CLEVITE CORPORATION

TRANSISTORS • DIODES • SEMI-CONDUCTOR MEASURING EQUIPMENT

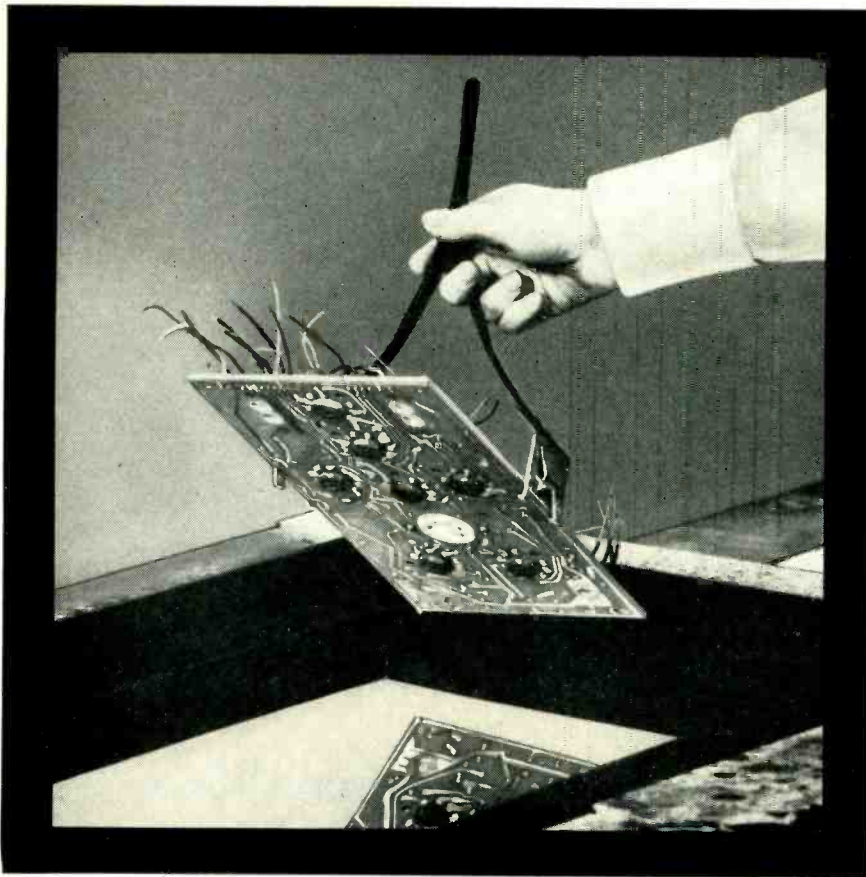

Subject: solder

As far as cost is concerned, solder is a relatively small item in any manufacturing operation.

But solder does a big job. You should have the best solder you can buy... Federated solder.

For printed circuits — Federated CASTOMATIC®

bar solder, the machine-cast solder with *no dross*, with *uniform composition* throughout each bar.

For joining work — Federated Rosin Core

(RTS 200) wire solder in all commercial gauges and compositions.

Photo courtesy Photocircuits Corp., Glen Cove, N. Y.

Federated Metals Division

AMERICAN SMELTING AND REFINING COMPANY
120 BROADWAY, NEW YORK 5, N. Y.

In Canada: Federated Metals Canada, Ltd., Toronto and Montreal

Aluminum, Magnesium, Babbitts, Brass, Bronze, Anodes, Zinc Dust,
Die Casting Metals, Lead and Lead Products, Solders, Type Metals



any of the square wave harmonics is inversely proportional to the order of the harmonic. Fluctuation voltages due to all harmonics of the admittance wave except fundamental may be eliminated by a low-pass filter in the ammeter circuit cutting out all noise-voltage frequencies above the signal frequency. The harmonics could also be eliminated if the admittance-time function were a perfect sinusoid instead of a square wave.

If only the sine-wave signal voltage and the square pulsed admittance wave with base on the zero axis are considered, the damped ammeter which reads the average of the product of these two functions could be taken to indicate one point on the cross correlation curve of the sine wave and the square wave of this specific type. If the signal frequency shifts phase slowly and continuously with respect to the switching frequency, the ammeter reading relative to the phase represents a plot of the cross correlation function.

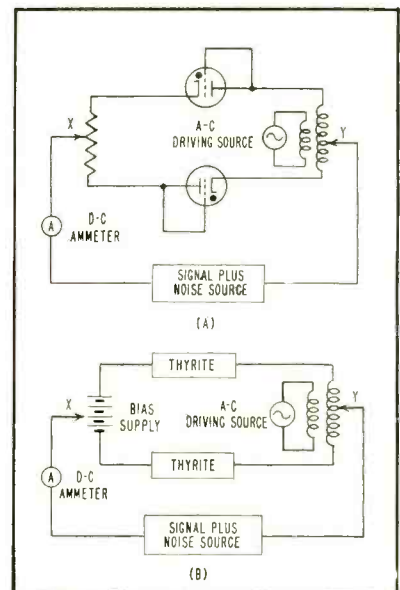

FIG. 2—Detector circuit using thyratrons (A) and thyrite resistors with bias source (B)

The magnitude of the average d-c current for a given a-c signal voltage and given maximum circuit admittance is greater for a square wave admittance-versus-time function than for any other wave shape.

An electronic gating circuit which provides the desired off-on,

Ultra-Stable Microwave Oscillator



MODEL 804

The LFE Model 804 Microwave Oscillator provides a source of highly stabilized microwave frequencies suitable for use as a local oscillator for microwave measurements, or in many other applications where a high degree of stability is required, such as Q measurements, SWR measurements and general narrow band design work. A dial accurately calibrated directly in frequency is an important feature. The main elements of the unit are a klystron oscillator, a stabilizing monitor loop which consists of a calibrated dual-mode reference cavity, a feedback amplifier and a self-contained power supply. Means are provided for modulating the oscillator.

Specifications

Frequency Coverage

8,500 – 10,000 Mc – X-Band

Dial Calibration

Calibrated directly in frequency –
1 Mc per division

Frequency Stability

Short Term Deviation – less than one part in 10^8
Long Term Drift – negligible after complete warm-up

Modulation

Can be modulated 25% when stabilized;
100% modulation possible when stabilization is removed

Power Output

80 – 100 milliwatts
Output flange – UG 40/U

Power Consumption

160 watts

Size

12-7/32" x 19" front panel, 19-1/4" deep,
cabinet or rack mounting

Weight

100 lbs.

For complete information,
see your LFE engineering
representative or write –



LABORATORY for ELECTRONICS, INC.

75-3 PITTS STREET • BOSTON 14, MASS.

PRECISION ELECTRONIC EQUIPMENT • OSCILLOSCOPES • MAGNETOMETERS • COMPUTERS • SOLID DELAY LINES

ANOTHER PROBLEM SOLVED by *Tubular Rivet*

RE: **ELECTRONICS COMPANY**

problem Set three rivets simultaneously in small triangular pattern:

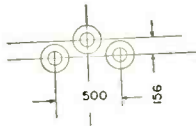

Space Between Rivet Heads
.015 and .218 — Rivet
Head Diameter: .281" —
Rivet Length: $\frac{5}{8}$ " — Work:
Stack of 13 components

solution

Our style 203 Machine with specially designed rivet cutoff and tube type delivery to special rivet positioners applied to Standard machine frame.

P.S.

Let us see what we can do with your close center problems. Drop your prints and/or samples in the mail. No obligation, naturally.

Tubular Rivet

© STUD COMPANY

WOLLASTON 70, MASSACHUSETTS

BRANCH OFFICES: Buffalo, Chicago, Detroit, Indianapolis,
Los Angeles, Nashville, New York City, Philadelphia, San Francisco, St. Louis

square wave, admittance-versus-time characteristic, is shown in Fig. 2A. The a-c driving signal applied to the primary of the transformer builds up potential between plate and cathode in the two thyratrons in series with the transformer secondary. When the potential is in the forward direction they ionize and become conducting at a relatively low voltage and remain so for virtually the duration of that half cycle. When the potential across the tubes changes from the forward to the reverse direction, the tubes extinguish and remain so for the duration of that half cycle. During this process, the admittance of the circuit, as seen between points X and Y, is zero during the half cycle that the tubes are extinguished and relatively high during the half cycle that the tubes are conducting. The grids of the thyratrons, instead of being tied to the plates as shown, may be separately driven by a timed pulse to insure simultaneous ionization of both tubes.

The thyratrons in this circuit may be replaced by any rectifier elements including vacuum tubes or solid-state devices connected in



Robot Controls Aircraft

Electrical brain called automatic master sequence selector (AMSS) developed by Minneapolis-Honeywell for the Air Force memorizes flight plan and takes over routine normally performed by human pilot. The previously determined flight plan, for which information is obtained by sensing pins making contact through punched holes in paper tape, is followed. A plane under its control can fly along a radio beam or the pilot can take over absolute control in an emergency

for critical voltage applications ...

RMC HIGH VOLTAGE DISCAPS®



Discaps with a dielectric of 1200 K or over are not recommended for deflection yokes or other 15,750 cycle applications.

CAPACITY	DIELECTRIC	SIZE	AVAILABLE CAPACITY TOLERANCES	
2-KV				
331-470	120C-K	5/16"	± 20%	GMV
471-1000	120C-K	3/8"	± 20%	GMV
1001-2700	HI K	9/16"		GMV
2701-5000	HI K	3/4"		GMV
5001-10000	HI K	3/4"		GMV
3-KV				
220-500	1200-K	5/8"	± 20%	GMV
501-1000	1200-K	5/8"	± 20%	GMV
1001-5000	HI K	3/4"		GMV
4-KV				
181-680	1200-K	3/4"	± 20%	GMV
681-1000	HI K	5/8"		GMV
5-KV				
131-330	1200-K	7/8"	± 20%	GMV
331-1000	HI K	7/8"		GMV
6-KV				
101-220	1200-K	3/4"	± 20%	GMV
221-470	1200-K	7/8"	± 20%	GMV
221-1000	HI K	7/8"		GMV
471-1000	HI K	7/8"		GMV

POWER FACTOR: 1.5% Max. @ 1 KC (initial)
INSULATION: Durez phenolic—vacuum waxed

CAPACITY	DIELECTRIC	SIZE	AVAILABLE CAPACITY TOLERANCES	
2-KV				
5-47	N-750	5/16"	5-10-20%	GMV
48-68	N-750	1/2"	5-10-20%	GMV
69-82	N-750	5/8"	5-10-20%	GMV
83-130	N-750	5/8"	5-10-20%	GMV
131-200	N-1500	5/8"	5-10-20%	GMV
201-250	N-1500	3/4"	5-10-20%	GMV
251-330	N-1500	7/8"	5-10-20%	GMV
3-KV				
5-15	N-750	5/16"	5-10-20%	GMV
16-20	N-750	1/2"	5-10-20%	GMV
21-56	N-1500	5/8"	5-10-20%	GMV
57-180	N-1500	5/8"	5-10-20%	GMV
181-240	N-1500	3/4"	5-10-20%	GMV
241-330	N-1500	7/8"	5-10-20%	GMV
4-KV				
5-68	N-1500	7/8"	5-10-20%	GMV
69-180	N-1500	7/8"	5-10-20%	GMV
5-KV				
5-30	N-1500	5/8"	5-10-20%	GMV
31-60	N-1500	3/4"	5-10-20%	GMV
61-130	N-1500	7/8"	5-10-20%	GMV
6-KV				
5-20	N-1500	3/4"	-10-20%	GMV
21-100	N-1500	7/8"	-10-20%	GMV

POWER FACTOR: .1% Max. @ 1M C (initial)
INSULATION: Durez phenolic—vacuum waxed

HIGH VOLTAGE DISCAPS for yoke and other applications

RMC DISCAPS assure the voltage safety factor required in deflection yoke or special electronic applications. These RMC high voltage DISCAPS are rated at 200C, 3000, 4000, 5000, and 6000 volts DC.

Now available in any capacity between 5 MMF and 10000 MMF, their smaller size and lower initial cost offer definite production ease and overall savings.

If you want proof that DISCAPS are the outstanding ceramic capacitors write us about your specific requirements and we will forward samples.

DISCAP
CERAMIC
CAPACITORS



RADIO MATERIALS CORPORATION

GENERAL OFFICE: 3325 N. California Ave., Chicago 18, Ill.

FACTORIES AT CHICAGO, ILL. AND ATTICA, IND.

DISTRIBUTORS: Contact Jobbers Sales Co., P. O. Box 695, Fairlawn, N. J.

new! Integral core and coating design

castohm[®]

FIXED WIREWOUND POWER RESISTORS

**OUTPERFORMS ALL CONVENTIONAL
POWER RESISTORS**

- Higher Wattage Ratings — smaller sizes
- 25 % lighter in weight
- 350°C hot spot operation
- Closer Tolerances — to 1 % (5 % standard)
- Better heat conductivity
- Exceptional resistance to thermal shock
- Designed to MIL-R-10566 specifications



New Shallcross Castohm power resistors surpass all previous standards for high wattage fixed power resistors. Thoroughly tested and designed to MIL-R-10566 specifications, Castohms offer unique opportunities for saving space and weight while improving the reliability and efficiency of modern industrial and military equipment. Specifications on all types from 8 to 225 watts are yours for the asking. SHALLCROSS MANUFACTURING COMPANY, 522 Pusey Ave., Collingdale, Pa.

Shallcross

series such that they are both in the same direction relative to the driving voltage and both have approximately similar impedance-voltage characteristics.

Virtually any device with a non-linear impedance-voltage characteristic, not necessarily a rectifying device, might be used by the introduction of a d-c bias voltage source. A circuit utilizing nonlinear elements, such as thyrite, with symmetrical forward and reverse impedance characteristics, is illustrated in Fig. 2B. In this circuit, the battery furnishes a constant bias voltage across the thyrite elements, and the a-c driving voltage superimposed upon this bias, raises and lowers the unidirectional potential such that the impedance of the elements is alternately lower and higher. The admittance of the circuit alternates and selective rectification of the signal voltage will result.

VHF Transistor Oscillators

BY H. E. HOLLMANN

*U. S. Naval Air Missiles Test Center
Point Mugu, Calif.*

THE DUAL OF a conventional vacuum tube is the positive-grid or retarding-field tube at an aperiodic condition of operation¹. The conventional tube is based on an electrostatic control of its space charge around the grid and the positive grid tube exhibits a control of the current distribution and has a current gain $\alpha_c = -1$.

The positive-grid tube is a perfect example for an ideal transistor that, with semiconductors, can only be approached to a degree. The analogy between transistors and retarding-field tubes is so complete that the latter can be measured and investigated in transistor testers². The ideal form, however, results in the fact that the positive-grid tube is characterized only by a single parameter, input impedance, instead of a multiplicity of transistor parameters.

Only under peculiar conditions of operation can the alpha be less or



HIGH SPEED SWITCHES

for High Power Pulsed Modulators

for High Power Electron Tube Protection

Machlett Hydrogen Thyratrons

ML-5949/1907 • ML-5948/1754

Hydrogen Thyratrons answer the need for high speed switching of high peak power combined with simplified circuitry: zero bias . . . broad hold-off voltage range . . . extremely rapid change from non-conducting to conducting state . . . broad ambient temperature range.

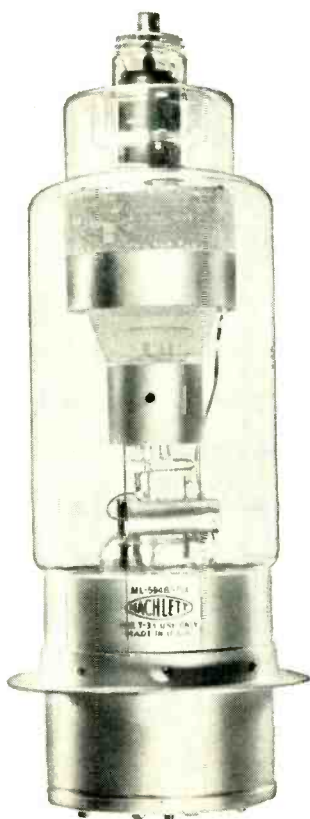

Typical Operation

	ML-5949/1907	ML-5948/1754	
Plate voltage, forward, epy	25	25	KV max.
Plate voltage, inverse	5	5	KV max.
Peak current, ib	500	1000	amps max.
Pulse repetition rate, prr	450	360	pps
Pulse duration (nominal)	2.0	2.5	usec
epy × prr × ib*	6.25×10^9	9.0×10^9	

* epy × prr × ib is the product of maximum forward plate voltage by pulse repetition rate by maximum pulse current. The maximum limit is determined to hold average tube dissipation to a reasonable maximum value.

Protective Circuits Described

Hydrogen thyratrons as high speed shunting switches are described in Cathode Press, Vol. 11, No. 1, 1954. Write for a copy.



For complete data write to:
MACHLETT LABORATORIES, INC.
Springdale, Connecticut



Over 55 years of electron tube experience!

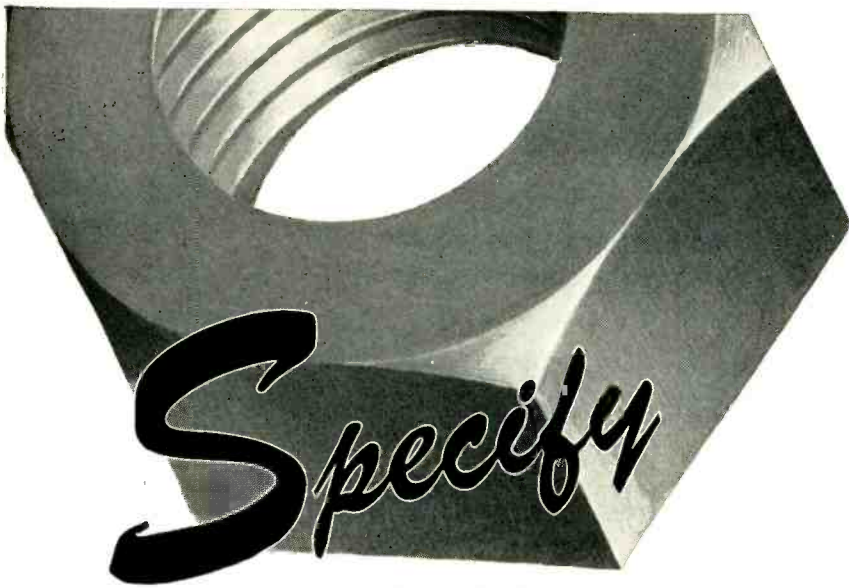

STAINLESS STEEL FASTENINGS by Anti-Corrosive

because



1 PROPERTIES YOU NEED! Whether it's strength, non-magnetic quality, resistance to corrosion, abrasion or high temperatures, Anti-Corrosive has your fastening answer — made to the closest of specifications!



2 AVAILABILITY! From machine screws as small as #0-80, Anti-Corrosive's IN STOCK inventory of more than 9,000 varieties and sizes of stainless steel fastenings means *immediate delivery* of your requirements! Streamlined special order service, too!



3 LOWER COST! Superior production capacity and know-how means *lower costs*, helps you stay within production budgets!

Write for FREE Product List 54I — lists complete range of items, sizes and analyses available from stock or by special order.

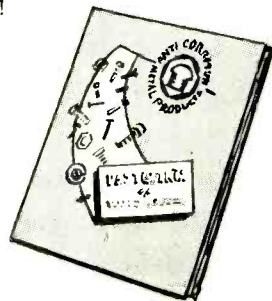

**ANTI-CORROSIVE
METAL PRODUCTS CO., INC.**

Castleton-on-Hudson,
New York

greater than one, namely if electron oscillations or secondary emission occurs. On the other hand, an imperfect retarding-field tube, such as a pentode with imperfect saturation, simulates junction transistors and requires some additional parameters.

Retarding Field

With this analogy in mind, almost all transistor circuits can be simulated with aperiodic retarding-field tubes as in the Hartley oscillator³, and the transistor audion⁴.

Retarding-field tubes exhibit a peculiar phenomenon that is not possible in present transistors, namely the electron-oscillations around the grid. Their frequency is determined by the Barkhausen

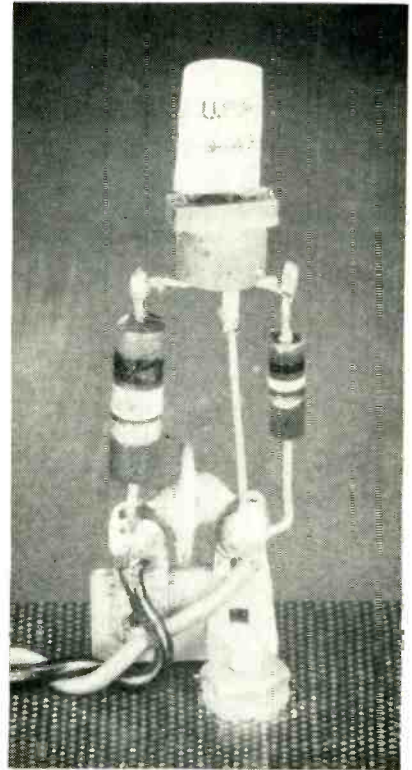

FIG. 1—Simple circuit uses internal oscillations of transistor to reach very-high frequencies

relation $\lambda^2 V_0 = K$ or $f_0^2/I_0 = K$, where V_0 denotes the positive-grid potential. Extending the analogy into the transit-time region where the transit time of the charge carriers determines the performance of the tubes as well as of transistors, it can be seen that a type of internal transistor oscillations is to

NEW HIGH ACCURACY

SIZE #10 SYNCHRO SERIES ...



THESE PHOTOS REPRESENT ACTUAL SIZE

The same engineering team that designed and put into production the Size #15 high precision synchro ten years ago now has in production their Size #10 synchro series of equal accuracy at less than half the size and weight.

At a saving of 3.2 ounces and almost 2 cubic inches and at comparable cost, we guarantee in our new 0.937" diameter series to equal or better the accuracy of current 1.437" diameter units.

SYNCHRO PROGRESS

Year	Error Spread	Weight	Cost
1917	6°	5 lbs.	? Marks
1934	6°	10 oz.	\$65.00
1941	2½°	5 oz.	\$20.00
1944	20'	5 oz.	\$35.00
1954	10'	1¾ oz.	\$25.00
Coming	5'	5 oz.	?
Coming	15'	1¼ oz.	?

For full engineering information, drawings, electrical characteristics, etc., volume and experimental quantity prices, write or telephone A. E. Hayes, Sales Department, Clifton Heights, Pennsylvania. Telephone (Philadelphia) MAdison 6-2101.

eppc
CLIFTON PRECISION PRODUCTS COMPANY, INC.
 CLIFTON HEIGHTS, PENNSYLVANIA

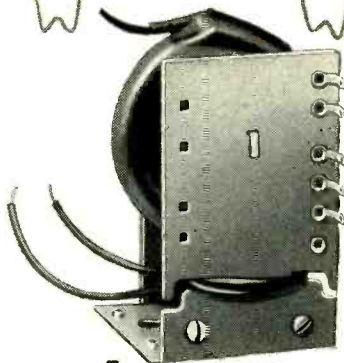
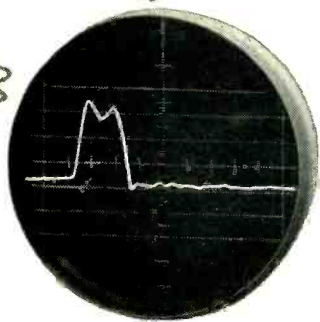

measuring
re-trace time
assures
FLYBACKS designed to your
exact specifications—
built for *EXTRA* years of trouble-free performance.

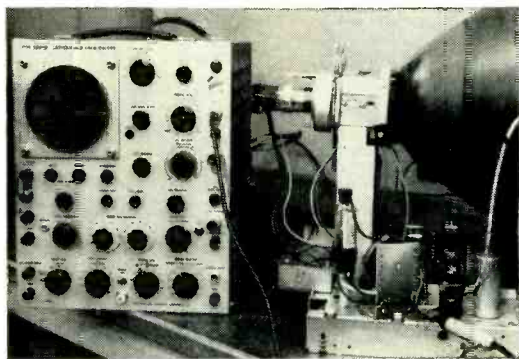

FAST SERVICE

on your requirements: Heppner has



2 airplanes and 6 pilots in the

Sales and Engineering Departments.

SPECIALISTS IN ELECTRO-MAGNETIC DEVICES

HEPPNER
MANUFACTURING COMPANY

Round Lake, Illinois (50 Miles Northwest of Chicago)
Phone: 6-2161

Representatives: **John J. Kopple**
60 E. 42nd St., New York 17, N. Y.

James C. Muggleworth
506 Richey Ave., W. Collingswood, N. J.

Ralph Haffey
R. R. 1, U. S. 27, Coldwater Rd.,
Ft. Wayne 8, Indiana

Irv. M. Cochran Co.
408 So. Alvarado St., Los Angeles, Calif.

be expected even if they are based on a different mechanism.

A significant difference between the retarding-field oscillator and self-oscillating transistors must be pointed out. Whereas the electrons themselves represent the resonator of a positive-grid tube, transistors incorporate a resonator in the form of an induced inductance resonating with the cold transistor capacitances.

To explain the origin of the induced inductance, consider the Miller effect. In a vacuum triode, grid voltage and plate voltage are in phase-opposition so that the displacement current passing the grid-plate capacitance is superimposed upon the displacement current charging the grid capacitance.



FIG. 2—Cavity resonator transistor oscillator operates at frequencies as high as 350 mc

The result is an effective input capacitance proportional to voltage amplification. In transistors, the opposite phenomenon takes place. Input and output voltages of a grounded-base connection are in phase so that the emitter sees the collector capacitance with a negative sign or in the form of an inductance. This may be attributed to a dual Miller effect and, in connection with the cold capacitances, forms a series-resonant circuit. At the same time, the transistor may exhibit such a large α_0 that the resistive component of the input impedance becomes negative so that self-excitation of the internal tank circuit takes place.

Figure 1 shows an extremely

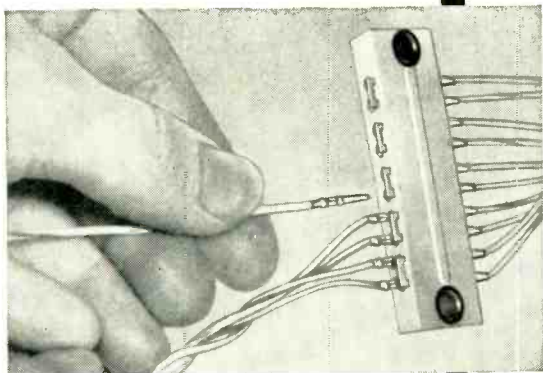

BASIC 10 CONNECTOR TAPER-BLOK WITH DUAL CONTACTS

Photo shows TAPER-BLOK with A-MP TAPER PINS in place. Strip measures only .610" x 2". Blocks, made of NYLON 10001, can also be stacked to accommodate hundreds of circuits.

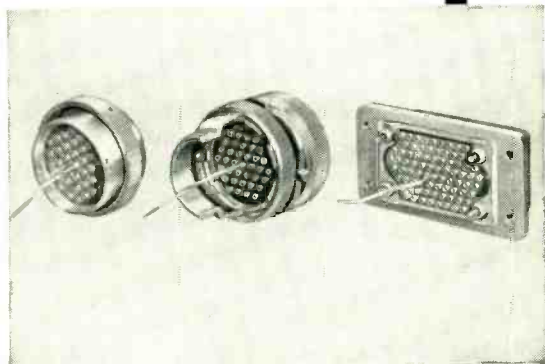
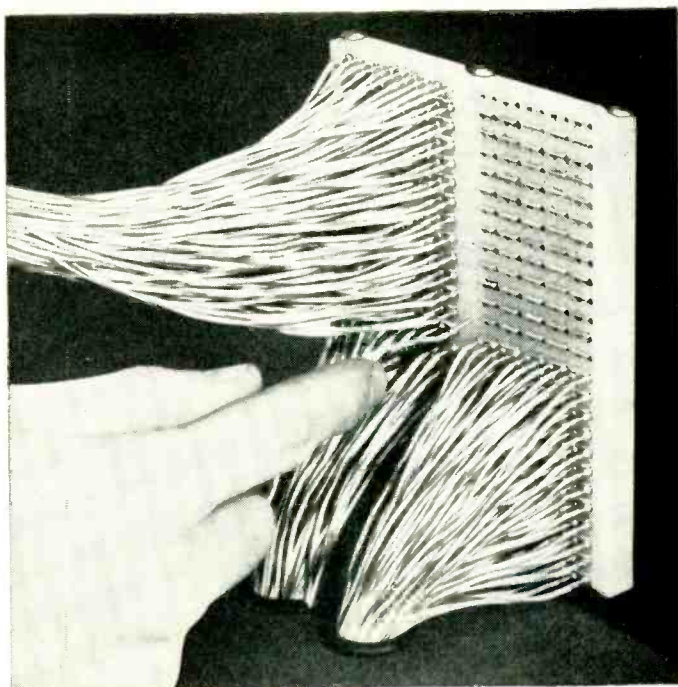

TAPER PINS FOR MULTIPLE CONNECTORS, AN AND OTHER TYPES

Amphenol, Cannon, Continental and Winchester Connectors now are available with tapered receptacles for A-MP self-locking TAPER PINS. Saves over 80% of your wire assembly time and provides uniformly higher quality connections at lower cost.

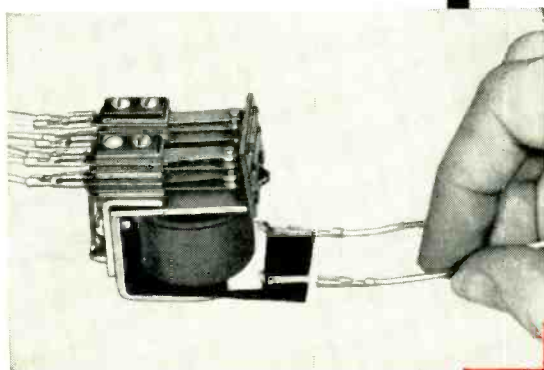

TAPER TAB RECEPTACLE APPLICATIONS

More and more flat tabs on relays, switches and other components are being tapered to receive A-MP TAPER TAB RECEPTACLES. Fast easy assembly reduces costs and provides higher quality connections.



NEW

MINIATURE

TAPER-BLOK

For AMP Taper Pins

(Wire Ranges: #26 to #16)

NEW TAPER-BLOK FOR A-MP'S TAPER PINS HELPS YOU SAVE SPACE AND WEIGHT, SPEEDS UP WIRING ASSEMBLY, SIMPLIFIES DESIGN, AND REDUCES COST!

The TAPER-BLOK shown has receptacles for 1000 connections, yet measures only 4" x 5" x 3/8"! Receptacles are designed to receive A-MP self-locking Taper Pins which can be easily pushed in place with A-MP's CERTI-LOK measured energy insertion tool.

Extremely high contact pressure assures dependable, uniform, low resistance connections for electric and electronic circuits.

Assembled TAPER-BLOKS are available in 10 and 20 connector sizes with single or dual receptacles. TAPER-BLOK strips can be assembled by stacking to provide the number of connections required for your design. Write for specific information and latest prints.

AMP Trade Mark Reg. U.S. Pat. Off. © AMP



AIRCRAFT-MARINE PRODUCTS, INC.
2100 PAXTON STREET, Harrisburg, Pennsylvania

In Canada — AIRCRAFT-MARINE PRODUCTS, INC.
1764 Avenue Road, Toronto 12, Ontario, Canada

Pick 'DIAMOND H' RELAYS

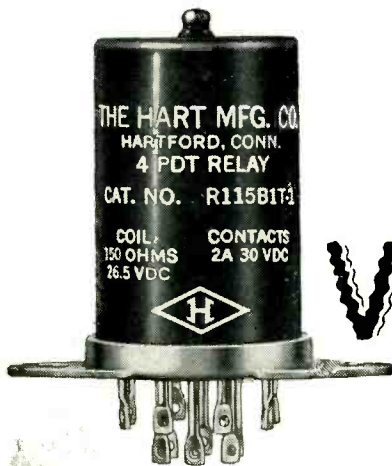

Shown Actual Size



... FOR HIGHER
VIBRATION
RESISTANCE

Vibration resistance range of "Diamond H" Series R Relays has been more than doubled, extending now from 0 to well over 1,000 cycles per second at 15 "G's."

Continuing engineering developments such as this are constantly broadening the adaptability of Series R Relays for a wide variety of applications . . . guided missiles, jet aircraft, fire control and detection, radar, communications, high speed camera, geophysical and computer apparatus . . . and similar applications requiring positive operation under critical conditions.

Hermetically sealed, miniature aircraft relays, Series R devices are basically 4PDT, but are also available in DPDT and 4PDT with two independent coils, either or both of which will operate the unit. Available with all standard mounting arrangements, including ceramic socket for interchangeability. Their design permits unusually compact grouping and provides a firm bond between relay and chassis. See us for special arrangements.

In their field still the smallest and lightest, (1.6 cu. in., 3.76 oz.) combining highest operating shock resistance (to 50 "G" and higher), widest temperature range (-65° to +200° C.) and greatest ability to break high currents and high voltages, Series R Relays consistently operate over 400,000 cycles without failure at 5 A. and go 3,500 or more under 30 A. at 30 V., D.C., resistive. They carry voltages up to 300 D.C. at 4/10 A. for more than 400,000 cycles. With low

contact loading, life expectancy is 10 million cycles or better.

Operating time is 10 ms. or less; drop out time 3 ms. or less. Coil resistances up to 35,000 ohms are standard; to 50,000 ohms available for special units. Sensitivity approaches 100 mw. at 30 "G" operational shock resistance. Inter-electrode capacitance is less than 5 mmf. contacts to case—less than 2½mmf. between contacts, even with plug-in type relay and socket.

Designed to meet all requirements of USAF Spec. MIL-R-5757B, they far surpass many. Bulletin R-150, giving basic performance data under varying conditions, is yours on request. Our engineers are prepared to work with you to develop variations to meet your specific requirements. Tell us your needs.

THE HART MANUFACTURING COMPANY

202 Bartholomew Avenue • Hartford, Connecticut

simple transistor transmitter producing the described internal oscillations. The transistor is supported by two precision resistors of 10,000 ohms in the emitter and collector circuit which stabilize the supply currents and secure proper operating conditions. The internal oscillations have sufficient power to permit their frequency to be measured with a grid-dip meter.

Since the induced inductance depends on transistor parameters, frequency f_o varies with the operating point and in particular with the collector current. The relationship between f_o and I_c follows the formula $f_o^2/I_c = K$, which is the dual of the Barkhausen relation in that the collector current replaces the grid voltage.

With r-f transistors combining a large α_o with a high cutoff frequency, oscillations as high as 75 mc have been measured. Much higher frequencies, however, may be expected if the transistors are pulsed. Harmonics run as high as 600 mc and are utilized to drive a cavity resonator.

Figure 2 shows a vhf transistor oscillator whose cavity reaches as high as 350 mc. Frequency modulation is produced by superimposing a minute modulating current upon the supply or bias value. For example, in the 100 mc range, the output voltage of a record player with a piezoelectric pickup has been found to produce a 100 percent modulation with good fidelity.

REFERENCES

- (1) H. E. Hollmann, Vacuum Tube Analogy of Transistors, *ELECTRONICS*, p 156, July 1952.
- (2) H. E. Hollmann, Transistors in Terms of Vacuum Tubes, *Tele-Tech.* p 14, May 1953.
- (3) H. E. Hollmann, Transistor Oscillators, *Tele-Tech.* p 82, Oct. 1953.

Measuring TV Sound Modulation

BY ROBERT F. WOLFSKILL

Commercial Radio Monitoring Co.
Kansas City, Mo.

FREQUENCY SWING or deviation of a television sound transmitter can be measured with portable equipment. Required are a good quality

INTERNATIONAL RECTIFIER

C O R P O R A T I O N



EL SEGUNDO
CALIFORNIA

"RED DOT"

Germanium Diodes

for

High

Temperature

For complete information on "RED DOT" high temperature germanium diodes to meet your particular specifications, write Dept. C for Bulletin ER-191.

**Applications
from
-60°C to +100°C**
AVAILABLE NOW!
INTERNATIONAL RECTIFIER CORPORATION's newly developed "RED DOT" series of germanium diodes with superior forward and reverse characteristics at temperatures to 100°C.

INTERNATIONAL RECTIFIER
C O R P O R A T I O N

Executive Offices: 1521 E. Grand Ave., El Segundo, Calif. · Phone: OREGON 8-6281
Chicago Branch Office: 205 West Wacker Drive · Phone: Franklin 2-3889
New York Branch Office: 501 Madison Avenue · Phone: Plaza 5-8665

GOT A JOB FOR THE WORLD'S MOST SENSITIVE GYRO?

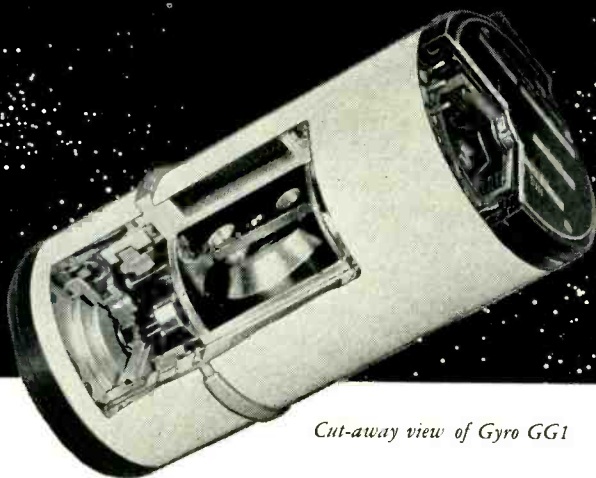

Cut-away view of Gyro GG1

THAT cylinder you see above should soon be causing a lot of excitement, now that we're permitted to take the security wraps off.

Its name is the Honeywell Integrating Gyro, called HIG for short. To date we've made over 10,000 of these amazing gyros.

Their moving parts rotate in a fluid on a gimbal that is jewel-mounted. Because of this nearly frictionless mounting, the HIG can measure things as minute as a speed 1/100th that of the hour hand on a watch.

And it's so rugged it can do such precision jobs even after being used as a hammer to drive a nail.

Up to now, major uses of the HIG have been in missile guidance systems and in radar stabilization and fine control systems. You may have a very different application of the HIG in mind. If so, we'd like to hear from you. The address is Honeywell Aero Division, Dept. 658 (E), Minneapolis 13, Minn. We'll be glad to send full details—on the HIG, and on our full gyro line as well.

Besides the HIG, Honeywell, a leader in gyro production, manufactures Vertical Gyros, Cageable Vertical Gyros and damped and undamped Rate Gyros—all available on a mass production basis to industry.

Specifications of Honeywell Integrating Gyro GG1

Pickoff Resolution: Better than 0.00001 radians of arc.

Pickoff Sensitivity: 34 mv/milliradian with 100 ma. excitation at 400 cps.

Angular Momentum: 100,000 gm cm²/sec.

Rotor Speed: 12,000 rpm.

Gimbal Travel: ± 6.0°

Transfer Ratio $\frac{\text{Output Angle}}{\text{Input Angle}} = 1$

Characteristic Time Constant: 0.0028 seconds.

Spin Motor Power Requirement: 10 volts, 400 cps, three phase, 0.65 amperes per phase.

Weight: less than 3 lbs.

Dimensions: length 6"; diameter 2.75".

audio oscillator and a communications-type receiver, with S meter, capable of tuning 4.5 mc.

Basis of the technique is the fact that, depending upon frequency and amplitude of modulation, the varying carrier amplitude of a frequency-modulation transmitter often goes through zero. The particular application is possible because a 4.5-mc signal is generated by the difference in frequency between the picture and sound carriers of a standard television transmission.

In practice, with both picture and sound carriers present, there is a strong 4.5-mc signal in the vicinity of the transmitter. Frequency swing is checked by modulating the sound transmitter with a specified tone until at a given amplitude the power in the center-frequency carrier is all dissipated in the sidebands. The magnitude of the frequency-modulated center-frequency carrier will theoretically reach zero when the peak frequency swing is 2.40, 5.52 and 8.65 times the audio frequency used to modulate the f-m transmitter.

Receiver Placement

The receiver should be located in the transmitter room near the modulation monitor. The antenna on the receiver need be only a short wire five to ten feet long. Receiver and antenna should be kept away from the transmitters proper to avoid picking up signals from lower-power multiplier stages. The modulation should be removed from both the picture and sound transmitters so the 4.5-mc signal will be at maximum amplitude and as sharp as possible.

The receiver is tuned to the center of the frequency where the S meter will be at maximum reading. Adjust the r-f gain control or antenna length until the reading is about 9 to 10 db over S 9. With either the picture or sound carrier turned off the S meter reading with no 4.5 mc signal should be near zero or not more than S 2 or S 3.

The frequency of the audio oscillator is set to 5.2 kc with the output control of the oscillator at minimum. Slowly increase the output of the oscillator until a minimum

MINNEAPOLIS
Honeywell

Aeronautical Controls



You can simplify purchasing . . . improve design . . . speed production

with improved **C-D-F DILECTO** laminates

Only C-D-F, the Continental-Diamond Fibre Company, makes Dilecto laminated plastic, just as only Cadillac makes a Cadillac. Dilecto is 50 different materials with more combinations and variations in desired properties than we can tell you here.

But Dilecto has three important qualities that you should think about if you buy, design, or machine laminated plastics.

DILECTO HAS HIGH MECHANICAL STRENGTH

Mechanical strength is frequently an important determining factor in the selection of an insulating material. Insulating parts used in large electrical power equipment are frequently bulky. The high mechanical strength of Dilecto helps reduce size-dimensions of insulating parts without danger of failure. Instruments, meters and small motors frequently require very small insulating parts which must withstand comparatively large mechanical stresses. Insulation for use in high frequency circuits should have a minimum bulk factor for minimum dielectric losses. Dilecto fulfills these requirements with a combination of high mechanical strength and low loss factor, characteristic of the better C-D-F electrical grades.

So C-D-F selects for your Dilecto insulation grade the correct, highest quality base material, paper, cotton, nylon, glass. These are used in combination with improved penetrating resins: Improved Phenolic, New Melamine, New Sili-cone, New Teflon, all synthetic, well polymerized resins.

Both the base and the resin are good insulators by themselves. But C-D-F sells them to you in an improved, practical form . . . Dilecto. Uniform sheets, tight tubes, strong rods, close tolerance machined and formed specialties, high bond strength metal clads.

Why does Dilecto combine so well mechanical strength with dielectric strength and dimensional stability? Because Dilecto is almost homogeneous, a true blend of resin and base.

DILECTO IS ALMOST HOMOGENEOUS

A poor laminate absorbs moisture at its edges, loses its insulating properties fast. Entrapped moisture and other volatiles within the cured structure causes inconsistent dielectric strength, with ultimate puncture and breakdown.

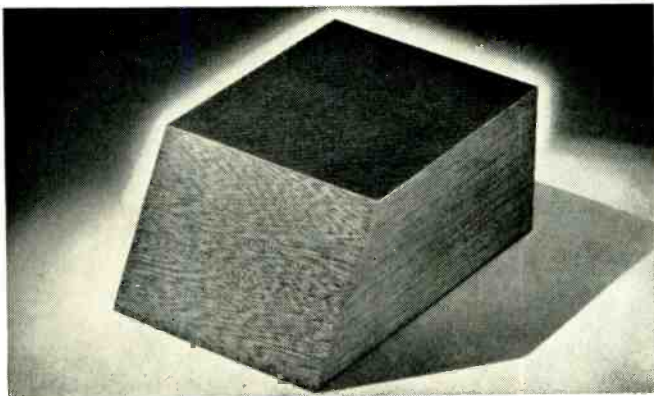

Punch press and bench saw operators know how much time and material is saved when the laminated plastic is *uniform* and *homogeneous* in nature like Dilecto.

DILECTO IS IMPROVED

Yes, C-D-F Dilecto is an improved laminated plastic, due to high standards and advances in resin and manufacturing techniques. It is watched by skilled workers in our modern plants, checked against rigid standards . . . C-D-F standards . . . by our quality control people. It is easy to machine, and the C-D-F shops are doing a booming business in specialties.

Table I—Typical Improved Phenolic Laminates

Commercial designation ^a	Resin	Filler	Improved properties	Improvement due to:
MEC-5	Phenolic	Nylon fabric	Insulation resistance; moisture resistance	Filler
XXHV-2 ^b	Phenolic	Paper	High dielectric strength parallel to laminations	Resin and manufacturing technique
CRD	Phenolic	Cotton mat	Better machining	Filler
XXXP-26 ^b	Phenolic	Paper	Insulation resistance; moisture resistance	Resin and manufacturing technique
C-92	Xylenol ^c	Cotton fabric	Alkali resistance	Resin
CF	Modified phenolic	Cotton fabric	Postforming	Resin

^a All grades are Continental-Diamond Fibre Company.

^b Resins have improved penetrating properties and the manufacturing techniques use these properties to provide better impregnation of the filler. Since thorough impregnation eliminates entrapped moisture and air, greater moisture resistance and better dielectric properties are attained. Manufacturing techniques also provide suitable temperature control during the curing stage to assure uniform quality and optimum property values in the finished laminate.

^c Xylenol is essentially a dimethyl phenol.

—from Electrical Manufacturing Article "Wider Design Opportunities with the NEW Phenolics", Part II.

The next time you think of laminated plastics, the name to remember is C-D-F Dilecto. The improved, high strength, uniform material that makes insulation buying and using more a science, less a puzzle. New grades, new applications, new savings are just part of the Dilecto success story. Look up the facts in Sweet's Design File, or write for catalog. Send us your blueprint for quotation . . . tell us your design dream . . . C-D-F wants to work with you.

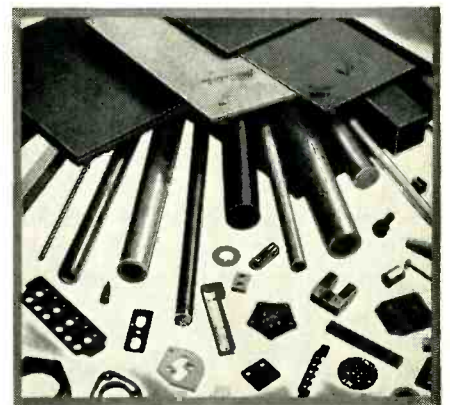

Continental-Diamond Fibre

CONTINENTAL-DIAMOND FIBRE COMPANY
NEWARK 16, DELAWARE

... for aircraft

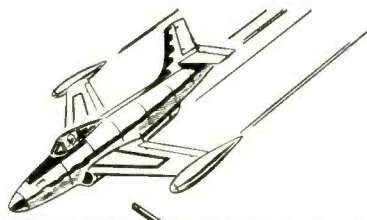

... for gunfire control

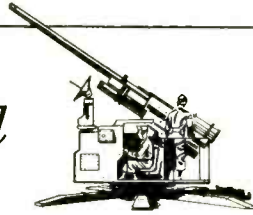

... for
servo-mechanisms

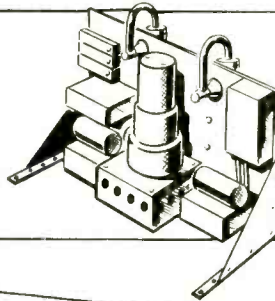

get the
facts about



PRECISION POTENTIOMETERS

For prompt service on prototypes that meet your specifications, get in touch with Gamewell.

Linear and non-linear Gamewell Precision Potentiometers can be made to meet your exact requirements. And they are made by a firm with over 98 years of experience in the manufacture of precision electrical products.

Write today for a copy of the Gamewell Precision Potentiometer booklet. It contains a convenient glossary of terms used in working with precision potentiometers.

THE GAMEWELL COMPANY
NEWTON UPPER FALLS 64, MASSACHUSETTS

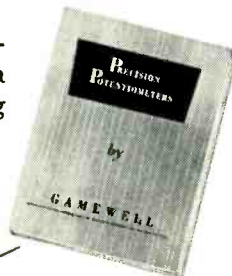

PRECISION POTENTIOMETERS

Manufacturers of precision electrical equipment since 1855

reading is obtained on the S meter. At this point the aural transmitter is being modulated 50 percent or about 12.5-kc swing. This first null will appear when the amplitude of the audio-tone frequency modulates the transmitter to a frequency swing equal to 2.4 times the frequency of the audio tone being used, in this case 5.2 kc. Since 25 kc swing on the aural transmitter equals 100 percent modulation, 12.48 kc will equal 50 percent modulation.

After rechecking the tuning of the receiver to make sure it is still peaked on the 4.5 mc signal, set the frequency of the audio oscillator to 4.55 kc. Increase the output of the audio oscillator until the S meter reaches a null and increases to a maximum as the output of the audio oscillator is increased. Continue to increase the output of the audio oscillator until the S meter indicates a second null. Slowly increase and decrease the output of the audio oscillator until the S meter is at a minimum reading on the second null.

Full Modulation

At this point the aural transmitter will be modulated 100 percent. In this case where the second null is being used, the factor to determine frequency swing in kc is 5.52 times the frequency of the tone being used. Since the frequency of the tone in this case was 4.55 kc and the factor is 5.52, the frequency swing is 4.55 times 5.52 or 25.2 kc. Since 25 kc swing equals 100 percent modulation, the modulation monitor should read 100 percent under these conditions.

Another test that can be used to determine 100 percent modulation is to modulate the sound transmitter with a 10.4-kc tone. With this higher-frequency tone, the 100 percent modulation condition will be reached on the first null. However when using higher audio frequencies, there may be some error in the reading of the modulation monitor owing to error in the pre-emphasis and de-emphasis pads in the transmitter and monitor. If the output of the audio oscillator can be kept constant, the 100 percent modulation reading can be determined and then the frequency of

**TOPS for
All Electrical Uses**



CLEVELITE*

LAMINATED PAPER BASE PHENOLIC TUBING

Outstanding for many years as the Top Performer, Clevelite is unmatched in its ability to meet unusual specifications.

Built-in Dimensional Stability, High Dielectric Strength, Low Moisture Absorption, Great Mechanical Strength, Excellent Machining Qualities and Low Power Factor make Clevelite Tubing outstanding.

Available in diameters, wall thicknesses and lengths as desired, for Collars, Bushings, Spacers, Cores and Coil Forms.



Our new Torkrite internally threaded and embossed tubing affords better control of adjustments in coil forms using threaded cores.

Write for your copy of the latest Clevelite brochure.

WHY PAY MORE? For Good Quality . . . call CLEVELAND!

*Reg. U. S. Pat. Off.

The **CLEVELAND CONTAINER Co.**
6201 BARBERTON AVE. CLEVELAND 2, OHIO

PLANTS AND SALES OFFICES at Chicago, Detroit, Memphis, Plymouth, Wisc., Ogdensburg, N. Y., Jamesburg, N. J.
ABRASIVE DIVISION at Cleveland, Ohio
CANADIAN PLANT: The Cleveland Container, Canada, Ltd., Prescott, Ontario

REPRESENTATIVES

NEW YORK AREA R. T. MURRAY, 604 CENTRAL AVE., EAST ORANGE, N. J.
NEW ENGLAND R. S. PETTIGREW & CO., 62 LA SALLE RD., WEST HARTFORD, CONN.
CHICAGO AREA PLASTIC TUBING SALES, 5215 N. RAVENSWOOD AVE., CHICAGO
WEST COAST IRV. M. COCHRANE CO., 408 S. ALVARADO ST., LOS ANGELES



Take advantage of our
Fast Dependable Delivery.

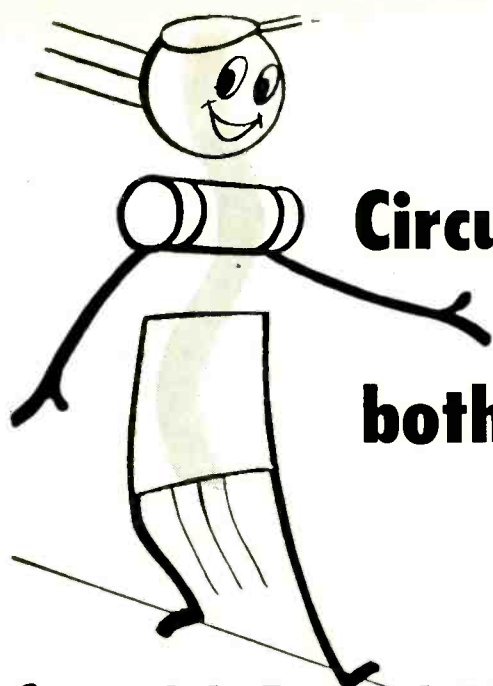

Circuit stability

bothering you?

Centralab Printed Electronic Circuits take YOU off the wire!

- Reduce stray capacities where not wanted.
- One part instead of 9 or 10.
- Saves up to 80% of soldered connections.
- Combine capacitance, resistance and wiring on one plate.
- 100 or 1,000,000 plates all identical — all tested.
- Save stocking space, ordering, handling time, and paper work.
- 30 standard plates stocked for immediate delivery.
- Special plates on order.

*Here's an example of
Centralab engineering*

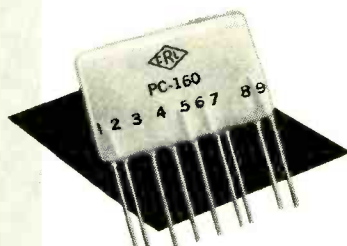

NEW PENDET

— a complete pentode detector and audio coupler circuit that replaces 9 parts . . . 9 soldered connections.

There are actually 4 resistors and 5 capacitors screened and fired to a single Ceramic-X plate. Unit is only $1\frac{9}{16} \times \frac{7}{8} \times \frac{11}{64}$ " thick. Leads are $2\frac{1}{2}$ " long.

Trademark —
*Printed Electronic Circuits

the audio oscillator can be lowered to 1 kc watching the monitor to see if the modulation-percentage reading changes. This will give an indication of how flat the combination of the pre-emphasis in the transmitter and de-emphasis in the monitor is. To make this test the output of the audio oscillator must be flat over the frequency range.

There are some other factors that must be considered in making measurements where no modulation monitor is available and the 50-percent and 100-percent readings are to be established on a vu meter. The pre-emphasis should be removed at the transmitter. If this is not possible, it will be necessary to take into consideration the amount of pre-emphasis at the frequency of the tone being used. Referring to the standard pre-emphasis curve for a time constant of 75 microseconds will give specified increases in db over the curve referred to 1 kc.

For example, if the 100-percent modulation condition is obtained by using a tone of 4.55 kc on the second null, it would be necessary to increase the input to the transmitter about 6.5 db to obtain 100-percent modulation at an audio input of 1 kc.

Third Null

If oscillator tone is about 2.89 kc the sound transmitter can be modulated until the third null is obtained on the S meter. This would give a reference point on the vu meter for 100-percent modulation, since a tone of 2.89 kc times a factor of 8.65 (third null) equals 25-kc swing. Referring to the standard pre-emphasis curve will show that it would take about 3 db more signal from the audio oscillator to modulate the aural transmitter 25 kc (100 percent) with a 1-kc tone than it takes with a 2.89 kc tone.

While additional nulls will be obtained as the audio oscillator output is increased, the nulls become less predominant and it is harder accurately to determine and count on the S meter. Also the receiver must be very selective to prevent the selection of first and second-order sidebands that occur at about factors of 3.0 and 5.0 times the modulation-



"Now!
Dictate a letter for
a complete package of
Centralab's technical
sheets on PECs."

Centralab

A Division of Globe-Union Inc.
914-F E. Keefe Avenue • Milwaukee 1, Wisconsin
In Canada: 804 Mt. Pleasant Road, Toronto, Ontario



INTRODUCING - the new

CHATHAM

TYPE 6337

LOW-MU POWER

TRIODE

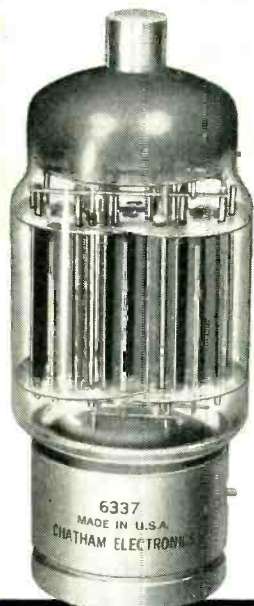

Featuring:

- LOW MU, HIGH PERVEANCE
- PLATE CURRENT WITHIN $\pm 10\%$
- COMPACT PHYSICAL DESIGN
- WITHSTANDS 500 G SHOCK

..an outstanding regulator tube for DC power supply units

Specifically designed as a regulator tube, Type 6337 features plate current held within $\pm 10\%$, and complete absence of plate current drift. A hard glass envelope and a button stem that strengthens the mount, provide high immunity to extreme shock and vibration. Wide inter-lead spacing practically eliminates electrolysis. These and many other special features make the Type 6337 a tube of utmost dependability in critical regulating circuits. Call or write today for full information.

CHARACTERISTICS:

PLATE SUPPLY—225 volts	TRANSCONDUCTANCE—
BIAS RESISTOR—100 ohms	45,000 μ mhos
AMP. FACTOR—2.7	PLATE CURRENT—450 ma
PLATE RESISTANCE—60 ohms	HEATER VOLTS—6.3 (AC or DC)
PLATE DISSIPATION—80 watts	HEATER AMPS—7.25

NEW LITERATURE ON REQUEST — Call or write today on company letterhead for new brochure and data sheets — no obligation.

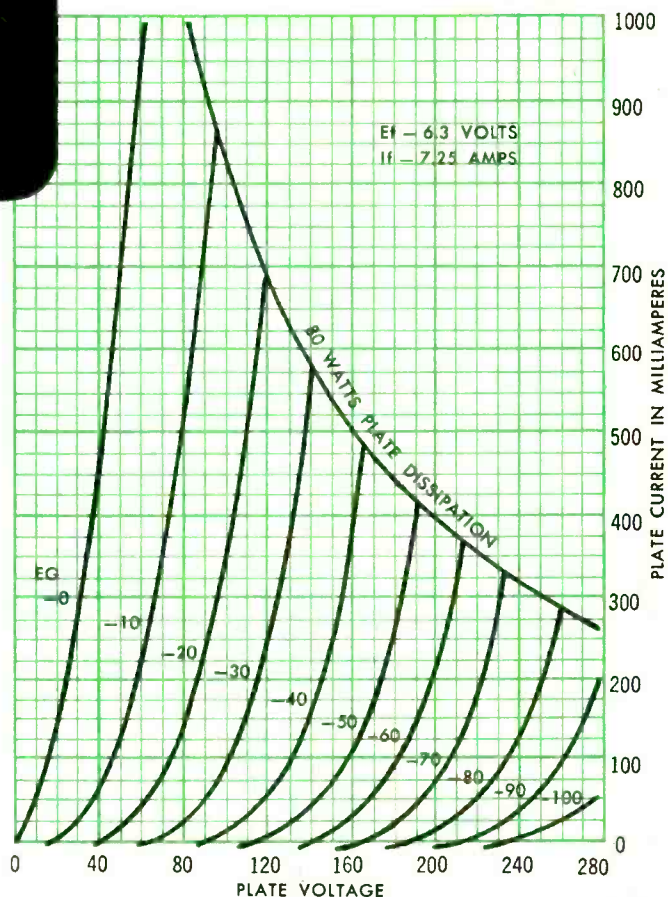

CHATHAM ELECTRONICS CORP.

Executive and General Offices: LIVINGSTON, NEW JERSEY
Plants and Laboratories: NEWARK and LIVINGSTON, NEW JERSEY

LONG BEACH

in Southern California

OFFERS INDUSTRY

COMPETITIVE

ADVANTAGES

Looking for a new plant site?

Many firms have moved to Long Beach to be close to the concentrated markets with a high per capita purchasing power.

Others are here, near their suppliers, saving time and money in transportation. Still others are moving here from congested centers—to obtain cheaper land for expansion, room for more efficient plant layout, and better living and working conditions.

Here, too, industry avoids intense and costly competition for skilled workers—and there is an excellent pool of skilled labor in this area.

Other Advantages

There are many other reasons for locating your plant in the Long Beach area. Low taxes, cheap utilities, low-cost construction and operation, and good housing are some.

Write today for full, free information. Inquiries are confidential, of course.

CHAMBER OF COMMERCE • DEPARTMENT OF INDUSTRY

200 East Ocean Boulevard, Long Beach 2, California

tone frequency. When using low modulating frequencies, these might be counted along with the first and second nulls unless the receiver is extremely selective.

Similarly, with low modulating frequencies the first and second nulls occur with such a low level of audio signal that it is difficult to control the increase in output of the audio oscillator slowly enough not to miss either or both the first two nulls. If the fourth or fifth nulls are used, the factors are about 11.8 and 15.0 respectively. For 100-percent modulation (25-kc swing) using the fourth null, the tone should be about 2.12 kc. For the fifth null the tone should be about 1.66 kc. Another disadvantage of using the lower audio frequencies is that the accuracy of the audio tone used must be greater to determine the kilocycle swing accurately, owing to the higher multiplying factor.

Pre-emphasis

If the station has a modulation monitor or if the pre-emphasis circuit is removed from the transmitter (where the monitor is not available) it is not necessary to consider the above. The modulation monitor contains a de-emphasis circuit that will cancel the effect of the pre-emphasis circuit in the transmitter.

In making these measurements it is important that the picture and sound carriers be unmodulated so that a clean sharp signal will be received at 4.5 mc with both carriers on. The picture carrier can be operated at reduced power if that is necessary to use the transmitter unmodulated. The sound carrier should have as little residual modulation as it is possible to have.

The receiver should be selective enough to reject carriers in the order of 5 kc either side of 4.5 mc to the extent that they will not read on the S meter. With the 4.5-mc carrier off, the noise level at the receiving location should not read over S 2 or S 3 at the most. With the 4.5-mc carrier on, the r-f gain and antenna pick-up should be adjusted so the meter reading is about S 9 or 10 db over S 9.

Several readings of the modulation percentage can be taken and the average of all the readings can

MOLONEY *HiperCore* ELECTRONIC CORES

Products of Painsstaking Precision

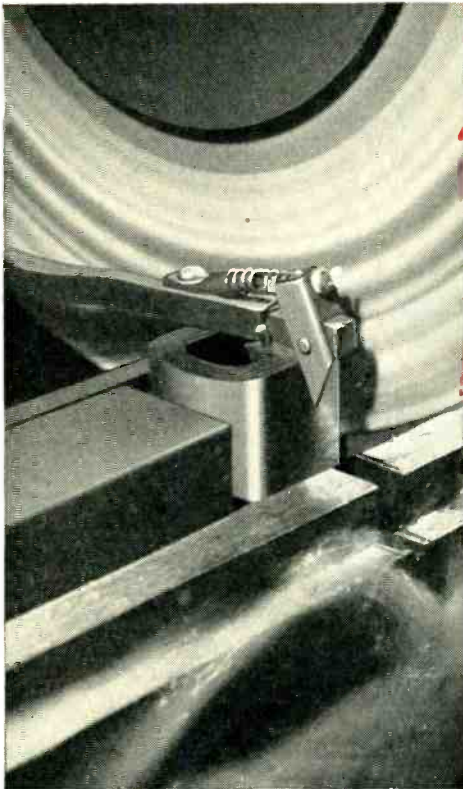

The painstaking precision with which Moloney Electronic Cores are produced is perhaps best demonstrated by the methods used in marking and cutting the cores.

Each core is stamped with diagonal lines assuring quick, positive identification between core halves after cutting. Accurate cutting-grinding machines cut the cores to such close tolerances that the resulting core faces can be reassembled with a maximum air gap of only .0005" per leg.

All this care and precision results in uniform electrical characteristics which assure you of greatly improved efficiency of core performance for your products. Moloney HiperCore Electronic Cores are wound cores of cold-rolled oriented silicon steel, and give better performance with important savings in size and weight, and have greater flux carrying capacity with lower losses... and they are *uniform* in these advantages.

ME53-35



Rigid production controls guarantee the high quality of Moloney HiperCore Electronic Cores. Available in any quantity in any of more than 1000 standard sizes or to your own special specifications if desired. Write today for Bulletin SR-205 containing specifications, performance data and prices.



MOLONEY ELECTRIC COMPANY

Manufacturers of Power Transformers • Distribution Transformers • Load Ratio Control Transformers • Step Voltage Regulators • Unit Substations

SALES OFFICES IN ALL PRINCIPAL CITIES • FACTORIES AT ST. LOUIS, MO. AND TORONTO, ONT., CANADA

ELECTRONICS — June, 1954

235

PRODUCT PERFORMANCE AND ACCEPTANCE REQUIRE CAREFUL COMPONENT COMPARISON

Compare RELAYS

OPEN OR CAN TYPE
MIDGETS AND SUB-
MIDGETS.

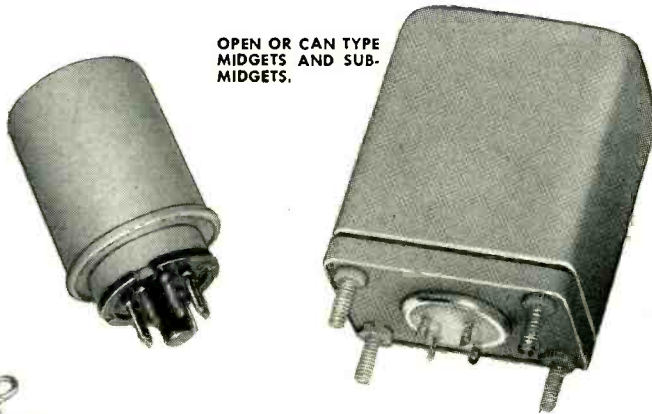

A WIDE VARIETY OF
SPRING AND COIL COM-
BINATION, OPERATING
POTENTIALS AND CON-
TACT RATINGS.



How do you compare relays? Comparison can be made on the basis of craftsmanship, uniformity of performance, dependability . . . and AEMCO invites such comparison. Comparative quality is relative but absolute quality is more certain!

We believe that the long and continuous servicing of more than one hundred top names of American Industry establishes the uniform dependability of AEMCO 'Engineered' RELAYS.

If one of the hundreds of stock AEMCO Relays does not exactly fit your requirements, we will design and manufacture to meet your particular needs . . . to exceed your specifications!

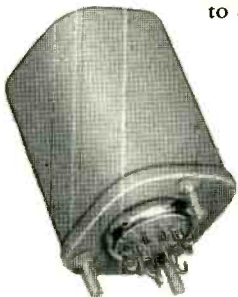

- ★ POWER RELAYS
- ★ DELAYED MAKE OR BREAK
- ★ CIRCUIT CONTROL
- ★ CURRENT AND POTENTIAL RELAYS



WRITE TODAY for complete information on AEMCO Relays
to meet your requirements and exceed your expectations!



Automatic Electric MFG. CO.

62 STATE STREET • MANKATO, MINN.

be used for absolute reference. However if extreme care is used in making these measurements, the accuracy is good enough that very little variation will be noticed.

Increasing Validity of Shock Tests

By CHARLES E. CREDE

Chief Engineer
Barry Corporation
Watertown, Mass.

LIKELIHOOD of damage to equipment increases as the maximum stress in structural members increases. A typical equipment may be considered to consist of many structures each with its characteristic natural frequency. The equipment may be simulated by a device known as a multifrequency reed gage.

Such a gage is made up of a chassis, a number of reeds of different natural frequencies and means to indicate the maximum deflection of each reed during shock. If the deflections of identical reeds are compared for different conditions of shock, the relative severity of the respective shocks may be estimated by comparing the deflections of identical reeds.

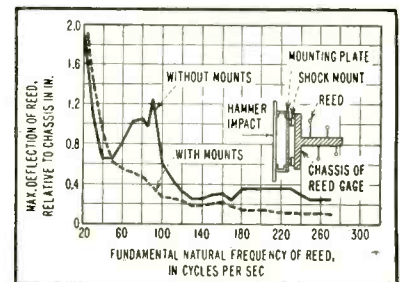

FIG. 1—Data from multifrequency reed gage using five foot hammer drop on high impact shock testing machine for lightweight equipment

Shock tests were made on a high impact shock testing machine first with a reed gage attached rigidly to the mounting plate of the testing machine and then with the gage attached to the mounting plate by shock mounts. By varying the natural frequency of the reeds the effect of this shock upon structures of different natural frequencies was determined.

Figure 1 shows the maximum deflection of the reeds and Fig. 2 shows the maximum acceleration of



New Taylor laminates are premium in everything but price

YOU'LL LIKE everything about this new family of Taylor paper-base laminates—including their price. They're a new kind of hot-punch laminate, uniform all the way through, with no surface overlay of resin.

In insulation resistance, water absorption, power factor, flame retardance and dimensional stability, they'll meet or exceed your strictest specifications. And they punch and stake so well . . . with smooth surfaces and clean edges . . . that you can produce complex parts with maximum utilization of each sheet.

Four different grades are available in production quantities, in standard sheet size of approximately 49" by 49":

XXXXP-301 . . . *the top grade laminate* with unusually high insulation resistance, lowest water absorption . . . excellent punching and staking.

XXP-351 . . . a high grade laminate with most of the properties of XXXP-301, at lower price.

Grade 353 . . . a quality grade laminate priced for economy, with outstanding electrical and physical properties.

Grade 354 . . . an easily fabricated grade having low water absorption and good stability . . . priced for real savings.

Taylor Fibre Co. Plants in Norristown, Pa.; and La Verne, Calif. *Branch offices in Atlanta; Boston; Chicago; Cleveland; Dayton; Detroit; Indianapolis; Los Angeles; Milwaukee; New York City; Philadelphia; Rochester; San Francisco; St. Louis; and Tolland, Connecticut. Distributors in Grand Prairie and Houston, Texas; Jacksonville, Florida; New Orleans, Louisiana; and Toronto, Ontario.*

WRITE TODAY FOR FULL SPECIFICATIONS, AND FOR ENGINEERING ASSISTANCE IN APPLICATION

TAYLOR
Laminated Plastics
Vulcanized Fibre

**IMMEDIATE
DELIVERY...
FROM STOCK!**



ACTUAL SIZE



CHICAGO

Molded TOROIDS

- **UNIFORM** ● **COMPACT**
- **EASILY COMBINED TO GIVE
DESIRED INDUCTANCE**

These plastic encapsulated toroid coils are wound on high density, high permeability, powdered molybdenum permalloy cores. Designed to provide the utmost in stability and ruggedness, CHICAGO toroids are extremely well insulated and have low temperature coefficients. Additional features include:

- High Q over a wide frequency range
- Close tolerance of plus, minus 1%
- High stability over temperature range of -55°C to 85°C
- Unaffected by humidity
- Minimum pickup from external magnetic fields
- Easily stacked, mounted with a single screw
- 1-1/16" diameter, 1/2" high, 90° spacing of terminals



SPECIAL TOROIDS

... engineered and built to exact specifications of inductance and Q. either cased or uncased, are available from Chicago Standard. Write today, outlining your requirements.

SPECIAL AUDIO FILTER NETWORKS



Audio filters for any specific application, band pass, band elimination, high pass, low pass, etc. can be designed to meet the characteristics you require.



**CHICAGO STANDARD
TRANSFORMER CORPORATION**
3501 ADDISON STREET ● CHICAGO 18, ILLINOIS

EXPORT SALES: Roburn Agencies, Inc., 431 Greenwich Street, New York 13, N. Y.

the same reeds, calculated from their maximum deflections, both expressed as a function of the fundamental natural frequency of the reed.

The amplitudes of the curves indicate the relative severity of the shock experienced by the equipment. The solid curves are generally somewhat above the level of the dotted curves indicating the extent of the protection that is afforded by the mounts. The difference between the two curves is relatively modest and it is possible that this difference could be compensated by designing the equipment to have greater strength. If no other considerations were involved, it would be difficult to justify the use of shock mounts except for use on equipment of marginal strength.

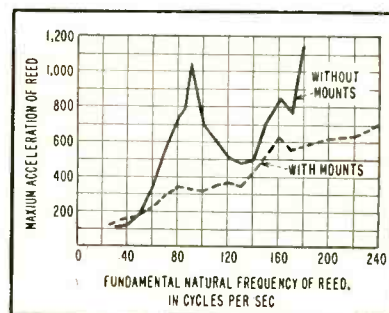

FIG. 2—Response spectra showing large excursions of maximum acceleration characteristic

However, the relatively high peaks in the solid curves at a frequency of approximately 90 cps are significant. These peaks occur because the mounting plate of the shock testing machine had a natural frequency of 90 cps and the reed whose natural frequency is 90 cps experienced a large amplitude as a result of resonance between reed and mounting plate. The curves representing tests with mounts show little evidence of the peak at 90 cps. The mountings thus function as vibration isolators to isolate the transient vibration of the plate resulting from the hammer impact of the shock machine.

The mounting plate of the shock testing machine may be considered simulating one particular type of mounting for the equipment. When the equipment is installed in a vessel, it will probably be mounted

GET LONGER . . . TROUBLE-FREE LIFE
AT NO EXTRA COST WITH CBS-HYTRON

CTS-RATED* 6CU6

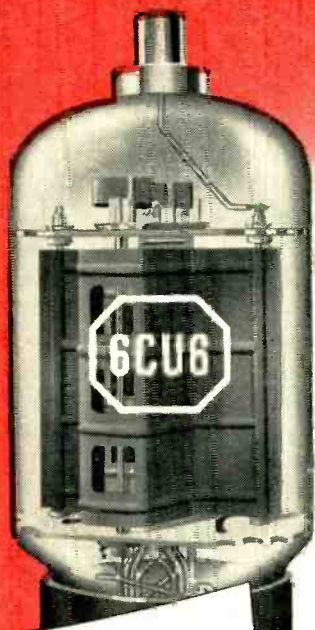

FLASH!
NEW CTS-RATED 12CU6-25CU6
... with all the 6CU6's
features ... at no extra cost
... now available for
series-string operation.
Combined data sheet for
6CU6, 12CU6, and 25CU6
free on request.

Why the CTS-Rated* 6CU6? The 6CU6 horizontal amplifier is rated the same as the 6BQ6GT . . . is electrically interchangeable with it. *But . . .* because the 6CU6 is rated for continuous television service, it will *live* under 6BQ6GT maximum ratings.

The 6BQ6GT is a good tube. (Heck, CBS-Hytron originated it.) But, it was designed for 10- and 12-inch TV sets. Today it carries the load in 21-inch sets. Furthermore, it must combat the accumulated dissipation caused by: 1. Line-voltage variations. 2. Faulty receiver adjustments. 3. Shifting values of components due to age

and overload. Result: The 6BQ6GT is often operated above maximum ratings.

Obviously, a brand-new design . . . not just an improved 6BQ6GT . . . was needed. The husky CBS-Hytron 6CU6 (See Mechanical Features) is the answer: a premium-performance tube *at no extra cost*. CTS-Rated, it offers generous safety margins for plate dissipation . . . high-voltage insulation . . . and high-line protection. Note also the bar graph showing much larger plate and envelope areas of CBS-Hytron 6CU6.

In the 6CU6 . . . another CBS-Hytron first . . . high voltage and heat meet their match. You forget run-away plate current, high-voltage arc-overs, and shrinking TV pictures. You gain by longer life . . . minimized service . . . happier customers. Try the CBS-Hytron 6CU6 today.

MECHANICAL FEATURES OF 6CU6

1. Heavier-gauge plate with large radiating fins.
2. Vents in beam plates and plate aligned for maximum radiation of heat from grids.
3. Anti-arc rings for uniform distribution of electrostatic field.
4. Anti-arc mica eyelets.
5. T-12 transmitting-type bulb.
6. Plate connection "hard-soldered" and positioned to reduce heat conduction and arcing.

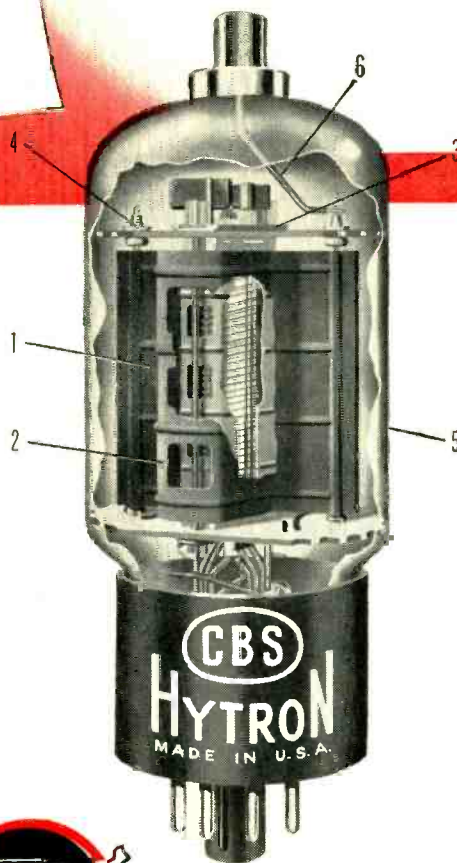

*Rated for Continuous Television Service

6CU6 OFFERS GREATER DISSIPATION RESERVES

6BQ6GT
6CU6
WITH 48.5% MORE BULB AREA

6BQ6GT
6CU6
WITH 31.5% MORE PLATE AREA



Manufacturers of
Receiving Tubes Since 1921

CBS-HYTRON Main Office: Danvers, Massachusetts

A Division of Columbia Broadcasting System, Inc.

A MEMBER OF THE CBS FAMILY: CBS Radio • CBS Television • Columbia Records, Inc.
CBS Laboratories • CBS-Columbia • CBS International • and CBS-Hytron

RECEIVING • TRANSMITTING • SPECIAL-PURPOSE • TV PICTURE TUBES • CRYSTAL DIODES AND TRANSISTORS

ELECTRONICS — June, 1954

239

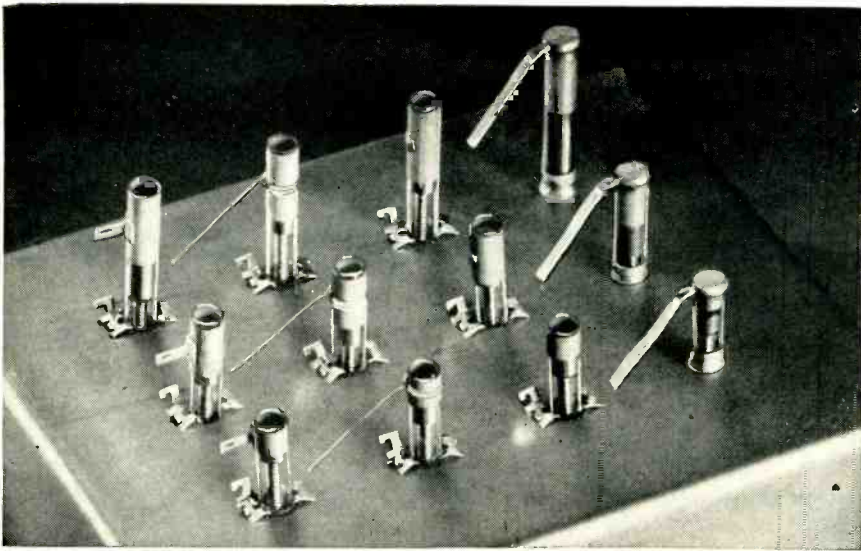

NEW LOW PRICES on CORNING Metallized Glass Trimmer Capacitors

They're the same tough, stable trimmers we've been making for years, but with new terminations, new mountings, and *new low prices*. And, they're available in standard types from .3 to 12 u.u.f., or can be designed to meet your specific requirements.

CORNING Metallized Glass Midget Trimmer Capacitors are produced by permanently bonding metal to tubes made of glass with practically zero

temperature coefficients in the VHF range. This means negligible capacity shift, even with widely variable ambient temperatures. Produced on automatic machinery, they can be manufactured in quantity with electrical characteristics held to very close tolerances.

For complete information on the new CORNING Trimmers, including the new prices, mail the coupon below.

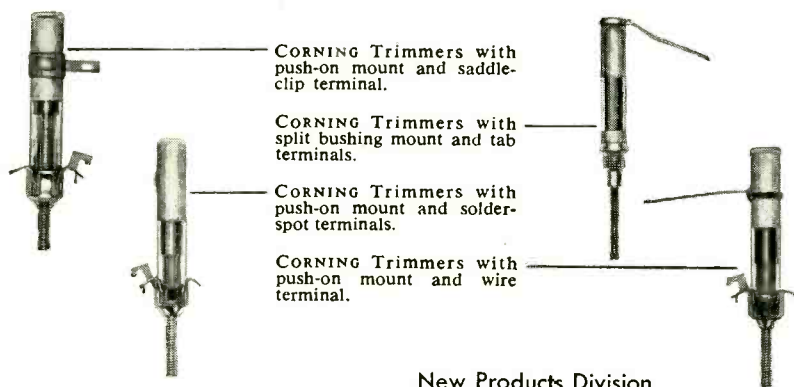

New Products Division



Corning means research in Glass

CORNING GLASS WORKS

DEPT. E-6, CORNING, N. Y.

Please send me information on CORNING Metallized Glass Trimmer Capacitors

Name..... Title.....

Company.....

City..... Zone..... State.....

on a bracket whose natural frequency is different from the natural frequency of the mounting plate on the shock testing machine. The resonance will then occur at a different frequency. A structure of the equipment that did not experience such resonance during the shock test may experience resonant conditions when installed within the vessel.

The shock test without shock mounts thus tends to become invalid, because it fails to predict the failure that may occur as a result of resonance between the structures of equipment and the mounting brackets.

The use of shock mounts almost completely eliminates the effect of these resonances and creates a condition in which the natural frequency of the mounting brackets is unimportant. The natural frequencies of mounting brackets are difficult to predict. In many installations no effort is made to control such natural frequencies.

Tester for Transistor Selection

By NOAH H. KRAMER
Engineering Laboratory
International Business Machine Corp.
Endicott, N. Y.

ULTIMATE TEST of a transistor is its behavior in an actual circuit, but it is usually beneficial to have some tests to ascertain if the transistor meets minimum requirements. These requirements must be intelligently chosen to select proper transistors for specific applications.

The tester described here is designed to check two characteristics of a junction transistor that are significant in amplifier applications. They are, I_{co} , the collector current with zero emitter current and $I_{co}/(1 - \alpha)$, the collector current with zero base current. Provision is made to test either *pn*p or *np*n transistors.

The first test measures the saturation current of the collector-base diode I_{co} . On a small signal basis, the I_{co} is indicative of the magnitude of the collector resistance r_c of the equivalent circuit. This current is temperature sensitive and in the usual operating ranges, will double

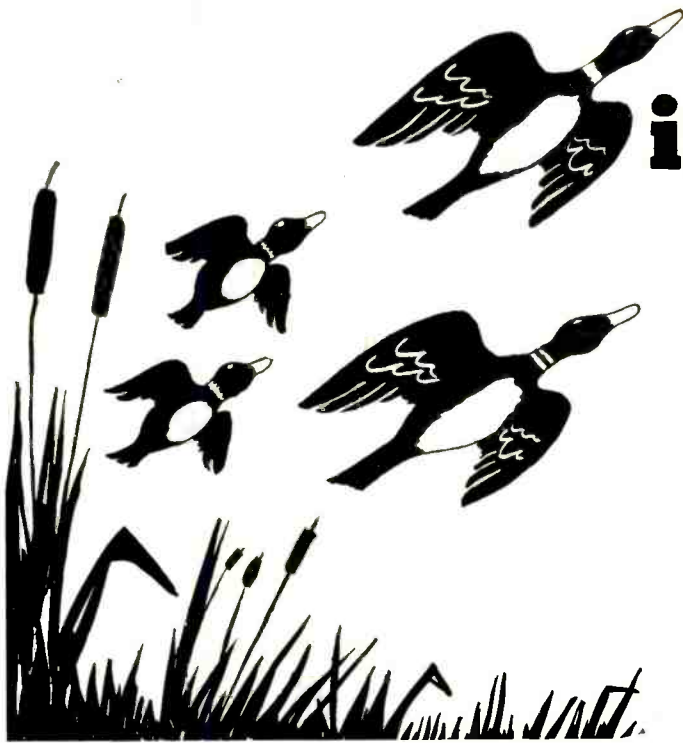

it takes two

DISPLAY ADVERTISING

- AROUSES INTEREST
- CREATES PREFERENCE

DIRECT MAIL

- GETS PERSONAL ATTENTION
- TRIGGERS ACTION.

After your prospect has been convinced by DISPLAY ADVERTISING, he still must take one giant step. *He must act.* A personalized mailing piece direct to his desk, in conjunction with a display campaign, is a powerful action getter.

McGraw-Hill has a Direct Mail Division ready to serve you with over 150 specialized lists in the Industrial Field.

To get your copy of our free INDUSTRIAL DIRECT MAIL CATALOGUE (1954) containing complete, detailed information about our services, fill in the coupon below and mail it to McGraw-Hill.

Do it now! The best advertising programs are planned well in advance.

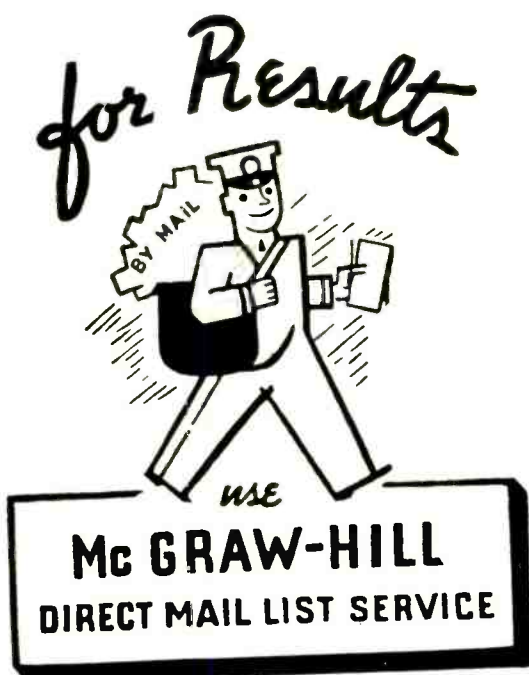

Direct Mail Division,
McGraw-Hill Publishing Co., Inc.
330 West 42nd St., N. Y. 36, N. Y.

Please forward my free copy of the McGraw-Hill
"Industrial Direct Mail Catalogue."

NAME _____

COMPANY _____

ADDRESS _____

CITY _____ STATE _____

A CORDIAL

INVITATION

Brilliantly, year after year, Britain's Radio Show has proved to be the most comprehensive exhibition of its kind in the world. This year's show already promises to be the most important yet. For now, more clearly than ever, Britain has the lead in radio design and manufacture. In every field—Radio, Television, Telecommunications and Electronics—there are new developments, vital to the markets of the world and essential for you to see. We invite you to make your arrangements *now* for this most valuable visit.

..to the

BRITISH NATIONAL RADIO SHOW

London August 24 — September 4

Information brochures may be obtained from
THE RADIO INDUSTRY COUNCIL 59 Russell Square,
London WC1 England Telegrams: Oidarion, Westcent, London

APPLY TO YOUR LOCAL B.O.A.C. OR B.E.A. AGENT FOR TRAVEL INFORMATION

for about every 8-deg-C rise.

To avoid the use of a sensitive microammeter, currents are measured by the voltage drop across a 5,000-ohm resistor, R_1 , as shown in Fig. 1.

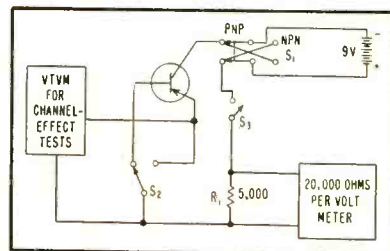

Transistor tester measures saturation current of collector-base-circuit and short-circuit gain

The second test determines the short-circuit gain of the transistor. With zero base current, the collector and emitter current will stabilize at the value $I_e = I_{co}/(1 - \alpha)$. Such a circuit, with no d-c path in the base, is extremely sensitive to temperature change and therefore is seldom recommended. However, the measurement obtained representing $5,000 I_{co}/(1 - \alpha)$ volts is used to determine the short-circuit current gain of the transistor, $1/(1 - \alpha)$, in the following manner.

The result of the first test ($5,000 I_{co}$ volts) is divided into the result of the second test [$5,000 I_{co}/(1 - \alpha)$ volts] obtaining $1/(1 - \alpha)$. This result is independent of the actual value of the 5,000-ohm resistor.

The low resistance of R_1 was chosen so that a 20,000 ohm-per-volt meter could be used for measurements without degrading the accuracy more than twenty percent. A ten microampere I_{co} would then develop a reading of about fifty millivolts.

Provision is made to choose the proper battery polarity by double-pole double-throw switch S_1 .

To test for I_{co} , voltage is applied to the collector and the circuit is completed through R_1 to the base. The emitter is left unconnected.

When it is desired to test for $I_{co}/(1 - \alpha)$, the base is left open and the circuit is completed through the emitter. Single-pole double-throw switch S_2 completes the circuit to either the base or the emitter.

To avoid the possibility of

HIGH QUALITY—LOW COST

MYLAR* DIELECTRIC CAPACITORS

Good-ALL CAPACITORS

IN COMMERCIAL TYPE CONSTRUCTION—Type 620 and 621

*DuPont Trademark for its polyester film

Especially Adaptable to Your Own Requirements

Enclosed in Plastic Thermo-setting Impregnated Paper Tube.

MYLAR Dielectric *Miracle X Impregnated*. Same excellent properties obtainable in our hermetically sealed Mifilm Capacitors.



Type 620

Marbelite Plastic End Seal provides life-time sealing — stops costly pull outs. Cannot soften or drip at high temperature.



Type 621

Extended Foil Construction.

Tab Construction.

Excellent Humidity Resistance • Highest Insulation Resistance
• Low Capacitance Change With Temperature — Operating Temperatures —65°C to +125°C • Sizes equal or smaller than metalized paper capacitors yet with greatly improved properties as to insulation resistance and life expectancy .173 dia. × 9/16" long (.001 Mfd, 600 VDC) to 1,050 dia. × 2 3/16" long (1 Mfd, 600 VDC) Power Factor less than .5%.

We custom-build to your specified sizes. We can supply your needs in metal or vinylite cases and still provide the same small space factor.

Our Engineers are always ready to work with you on any capacitor problem.

Write for complete catalog covering all types of Good-All long-life capacitors. We invite sample orders for your evaluation.

Good-ALL CAPACITORS

SO SUPERIOR they are being specified and used extensively by Electronics, Radio and TV Manufacturers throughout America.

GOOD-ALL ELECTRIC MFG.CO.

114 W. First St., Good-All Bldg., Ogalalla, Nebr. Phone 112 or 113 — Cable address "Goodalla"

Only Precision OFFERS YOU HIGHEST QUALITY, LOW COST PAPER TUBING

in
any shape
every size
any length
plus
any ID
every OD
any quantity



**DIELECTRIC KRAFT • FISH PAPER • CELLULOSE ACETATE
COMBINATIONS • PHENOL IMPREGNATED**

Round, square, rectangular, triangular, any shape, any size—Precision Paper Tube Co. can provide *all* your paper tubing needs. Your specifications are met to the most exacting tolerances. Precision Paper Tubes are sturdy, crush resistant, have high tensile strength and excellent dimensional stability.

Send in your specifications for samples. Request Arbor List of over 2000 sizes.

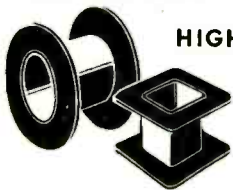

HIGH DIELECTRIC BOBBINS FOR BETTER COILS

Precision-made on specially designed equipment, using the finest materials, to provide maximum tensile strength, light weight, more winding space and other essential electrical and

mechanical characteristics.

Furnished in any size or shape. Supplied plain or fitted with leads, slots or holes. Flanges cut to specification, plain or embossed. Tube ends swaged to lock flanges.

Send Specifications for samples. Ask for illustrated folder.

Sales Representatives in:

New England:
Framingham, Massachusetts, Framingham 7091

Metropolitan New York, New Jersey:
Jersey City, New Jersey, Journal Square 4-3574

Upstate New York:
Syracuse, New York, Syracuse 76-8056

Northern Ohio, Western Pennsylvania:
Cleveland, Ohio, Atlantic 1-1060

Indiana, Southern Ohio:
Logansport, Indiana, Logansport 2555

Missouri, Southern Illinois, Iowa:
St. Louis, Missouri, Sterling 2318

Maryland:
Baltimore, Maryland, Plaza 2-3211

Philadelphia, Camden:
Philadelphia, Pa., Chestnut Hill 8-0282

California:
Pasadena, California, Sycamore 8-3919

Canada:
Montreal, Quebec, Canada, Walnut 2715



PRECISION PAPER TUBE CO.

2041 W. CHARLESTON ST.

CHICAGO 47, ILL.

Plant No. 2: 79 Chapel St., Hartford, Conn.

transients owing to plugging the transistor into a circuit with an applied voltage, the momentary normally open switch S_a is installed. This switch applies voltage to the transistor only when measurements are required.

A third test, pertinent to *n-p-n* grown-junction transistors, can be made with a modification of this equipment. This test is for the so-called channel effect. In this test, a vacuum-tube voltmeter must be used to read the emitter voltage when the S_2 switch is positioned for the I_{co} test. For transistors without the channel effect, the reading will be in millivolts. However, most of the present grown-junction transistors will show a voltage that increases with time. This measurement reaches a few volts in a matter of minutes. The cause of this phenomena is attributed to impurities that create a channel across the very thin base layer of the transistor.

Table I—Typical Data Obtained from Transistor Tester

Transistor (<i>n-p-n</i>)	$5,000I_{co}$ in volts	$5,000I_{co}$ $1 - \alpha$ in volts	$\frac{1}{1 - \alpha}$
1	0.033	1.6	42
2	0.038	2.5	66
3	0.08	3.1	39
4	0.04	1.8	45
5	0.02	1.0	50
6	0.04	1.5	37
7	0.03	2.1	70
8	0.04	2.5	62
9	0.05	3.1	62
10	0.06	2.8	47

Typical data concerning the actions of different transistors is presented in Table I. This data could be used, for example, to choose transistors 8 and 9 for push-pull circuits because of their equal gains. Transistor 3 might be rejected for some circuits because its I_{co} is high ($5,000 I_{co} = 0.08$ volt, $I_{co} = 16$ microamperes) and would cause excessive currents as temperature was increased. On the other hand, the low I_{co} of transistor 5 could make it desirable in an application involving extreme ranges of temperature.

silicon transistors now in production!

silicon transistors — long awaited by the electronics industry — are finally out of the laboratory and on the market... brought to you *first* by Texas Instruments, a leading transistor manufacturer. A new and unrivalled degree of design freedom is created by the TI n-p-n grown junction **silicon transistor**, now available in production units with glass-to-metal hermetic sealing. **silicon transistors** radically improve temperature stability and power handling while retaining the best amplification and frequency characteristics of previous semiconductor devices.

write *today* for detailed information on the **silicon transistor!**

TEXAS INSTRUMENTS
INCORPORATED

6000 LEMMON AVE. DALLAS 9, TEXAS

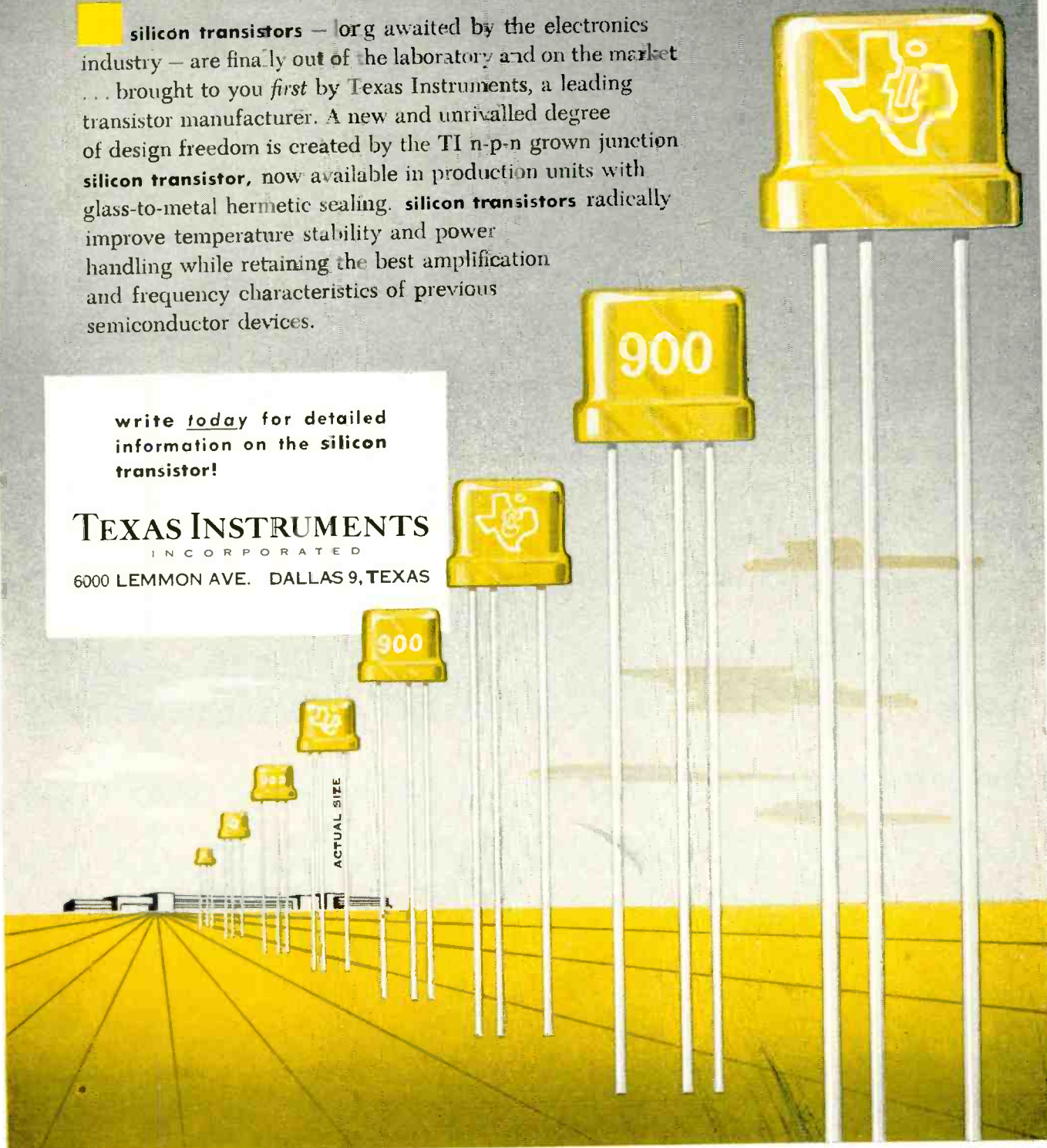

Production Techniques

Edited by JOHN MARKUS

Soldering Crystal Diodes.....	246	Punched Mounting for Metal-Can Electrolytics	266
Induction Heater Bonds Wire Strands Before Stripping	246	Reaming Fixtures for Radar Antenna Units	267
Motorized Neck Sparker for Picture Tubes	248	Induction Sealing of Magnetron Pulse Plug	269
Conveyor Belt Speeds Induction Brazing	248	Zone-Melting Setup for Refining Germanium	271
Lever-Operated Press Installs Tiny C Washers	248	Painting Insides of 1B3 High-Voltage Tubes	272
Graphite-Spraying Machines for Tube Anodes	252	Installing Shock Mounts	274
Painting Picture Tubes with Knuckle-Joint Brushes	254	Self-Balancing Bridge Checks Parts Automatically	275
Lead-Staking Machine for Printed I-F Transformers	256	Maintenance Tool Dolly	277
Machining Printed Circuits	258	Applying Doliflex Coating to Toroidal Coils	278
Aluminizing TV Tubes	260	Plastic-Top Assembly Bench	281

OTHER DEPARTMENTS featured in this issue

	Page
Electrons At Work.....	196
New Products	282
Plants and People	328
New Books	358
Backtalk	378

Soldering Crystal Diodes

SOLDERING CRYSTALS to a resistor board is a critical job because the heat of the soldering iron can damage the delicate construction of the crystal. A crystal soldering jig devised by Hewlett-Packard, Palo Alto, Calif., solved the problem. It holds the crystal in place for soldering to the resistor board and at the same time dissipates the heat of the soldering operation so it will not harm the crystal.

Copper jaws soldered to spring clamps hold crystal in position on terminal board and conduct soldering iron heat away from crystal. Arm on heavy metal plate holds clamp in position

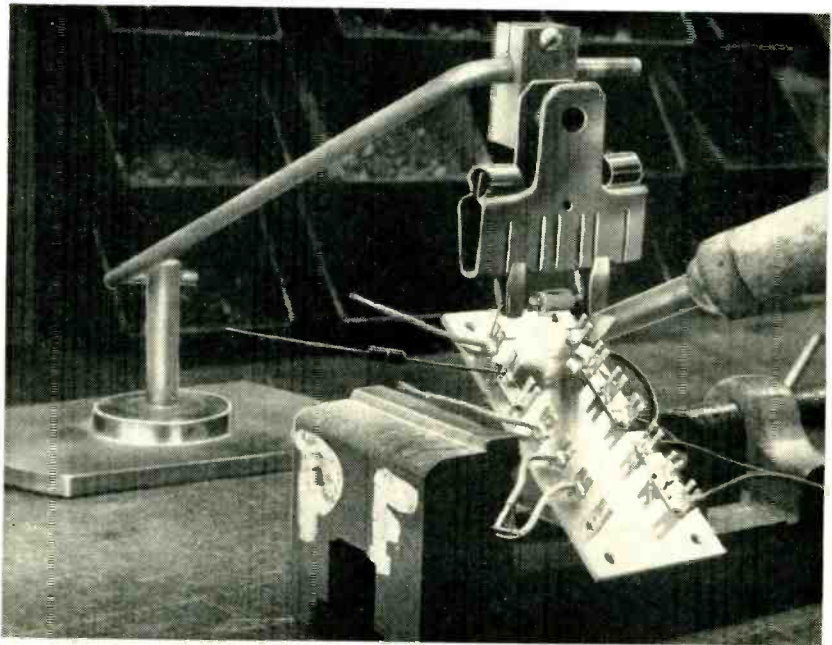

Induction Heater Bonds Wire Strands Before Cutting and Stripping

A TUBE-OPERATED high-frequency induction heater used in conjunction with an Artos automatic wire cutting and stripping machine at Federal Telephone and Radio Corp. serves to bond together the individual tinned strands in the regions to be stripped. This eliminates the necessity of tin-dipping the ends after cutting and stripping.

The heater is located between the reel of insulated wire and the Artos machine, so that the cutting machine mechanism draws the wire

through the work coil of the heater. The heating cycle is synchronized with the stroke of the wire cutter so that heating and bonding occurs

only in regions where subsequent cutting and stripping operations occur. Manufacturer of the heater is Lepel High Frequency Labora-

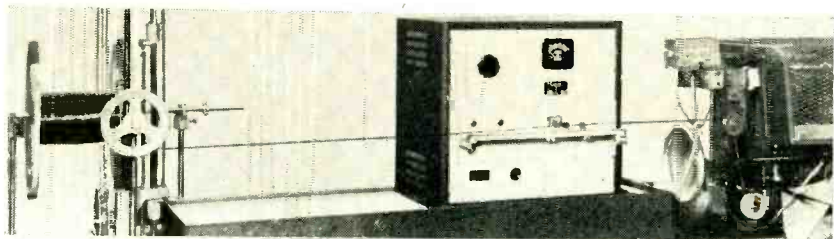

Setup for automatic bonding, stripping and cutting of stranded insulated wire

*S'matter, Swami,
won't it work?*

Near-sighted or not, our snake charmer friend should know he can get more out of a wire if it has a well soldered connection. How do we know that? Well, making the right kind of flux core solder for every application has been Kester's sole business for more than 50 years. There's no mystery about Kester Solder, no secret ingredients either. With Kester, quality is the paramount feature . . . the same today as it's always been.

TRIPLE-PLAY! Kester "44" Resin . . . "Resin-Five" . . . Plastic Rosin-Core Solder . . . your best bets . . . with exact core size or flux-content and alloy "tailored" to your requirements.



KESTER

S O L D E R C O M P A N Y

4204 WRIGHTWOOD AVENUE, CHICAGO 39, ILLINOIS
NEWARK 5, NEW JERSEY • BRANTFORD, CANADA

tories, Inc., Woodside, New York City. A stepless power control permits selection of proper power output for heating various sizes of wire.

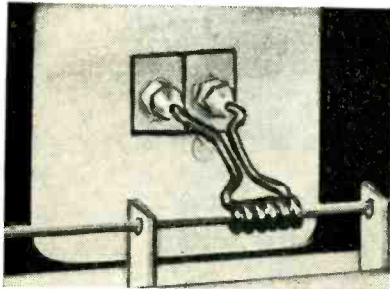

Method of guiding insulated stranded wire through work coil of heater

Motorized Neck Sparker for Picture Tubes

REMOVAL of sharp points from surface areas inside the necks of picture tubes, which might cause difficulty in later high-voltage field installations, is accomplished at General Electric's picture-tube plant at Electronics Park, Syracuse, N. Y., by an automatic sparking process. The metal arm and spring assembly, mounted on top of the high-voltage insulator, is rotated in a horizontal plane while being alternately raised and lowered by an electric motor and gear box over the bench. This mechanical movement gives complete coverage in the tube neck and base while a high-frequency generator provides the necessary power for the sparking operation.



Pushing start button of timer to initiate automatic sparking during final processing of picture tubes

Conveyor Belt Speeds Induction Brazing

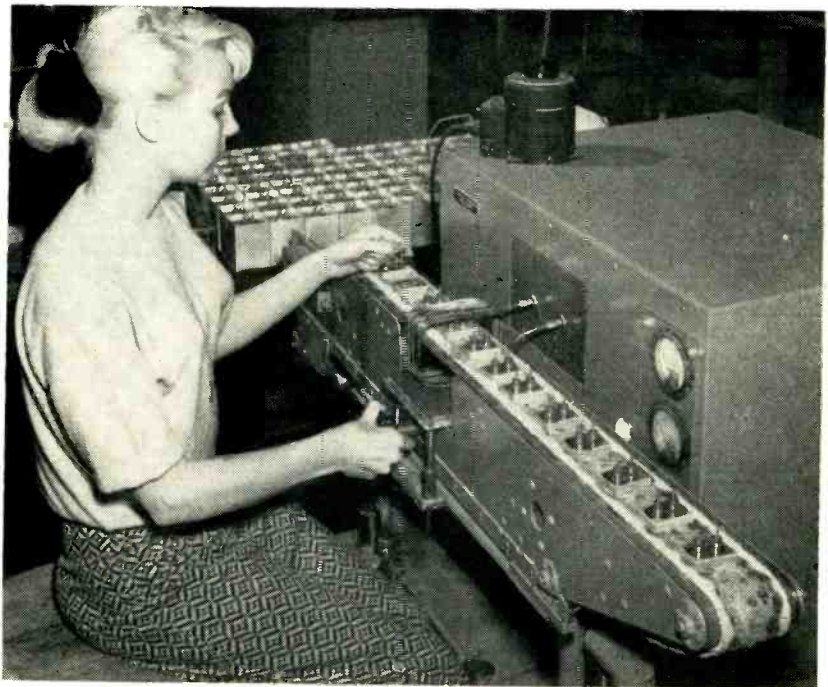

Conveyor belt carries transformer headers through induction heating coil from left to right for soldering of terminal seals. Finished parts drop off into tote box at right. Right hand of operator is on knob which raises or lowers conveyor-belt for centering parts in work coil

SOLDERING and brazing of small transformer parts is speeded up greatly by a belt conveyor attached to an induction heater at Triad Transformer Co., Venice, Calif. The endless asbestos-covered canvas belt moves parts through heating coils at easily controlled speeds (regulated by a Powerstat on top of the heater). A simple hand control positions the belt up or down as required for various sizes of parts.

In soldering hermetic seals to transformer lids, the operator simply places the terminals in the lids and drops a preformed ring of soft solder around each terminal.

When the lid has passed the coil, soldering is complete.

Original setup time for an operation is fairly lengthy, requiring experimentation with speed of belt, height of belt and power through the work coil. A log of settings for each operation reduces subsequent setup time to a minimum. For operations of 25 or more parts, economy is great. A four-minute hand operation takes 12 seconds per assembly on the conveyor. Use of preformed rings of solder eliminates waste solder and permits use of a non-skilled operator. The conveyor was added to a standard Salesmaster Corp. electronic heater.

Lever-Operated Press Installs Tiny C Washers

A SIMPLE hand-operated tool installs and locks $\frac{1}{8}$ -inch C washers in shaft grooves with one movement of the operating lever. Automatic feed is incorporated, similar to that of a stapling machine, so that the operator does not have to touch the washers during assembly. An addi-

tional feature is a lever-operated die for removing C washers easily from faulty components. The tool was developed in the television plant of E. K. Cole Ltd., Southend-on-Sea, England.

The C washers are first placed on a loading mandrel by hand. When

COMPRESSING TIME

In any security program *time* is the one irreplaceable element. Making the most of time is particularly vital in guided missiles projects. Fairchild's Guided Missiles Division has demonstrated its ability to "spend" time effectively. Its completely integrated engineering and production organization can, in effect, *compress time*.

With a balanced engineering team and an experienced production staff housed together in a facility built specifically for the development and manufacture of missiles, Fairchild can cut down lags in moving a missile project from the design and development phase into the production phase.

It has done so.

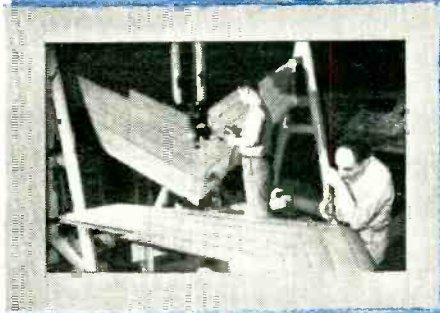
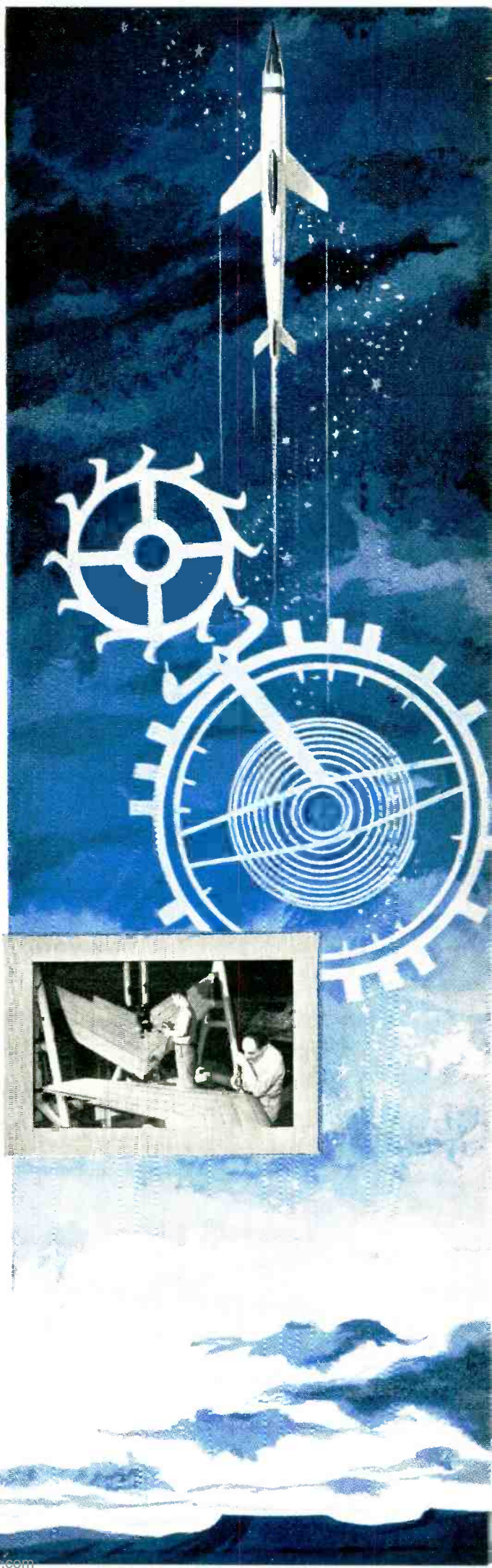

ENGINE AND AIRPLANE CORPORATION
FAIRCHILD

Guided Missiles Division

WYANDANCH, N. Y.

Aircraft Division, Hagerstown, Maryland • Engine Division, Farmingdale, N. Y.
Speed Control Division, Wickliffe, Ohio • Stratos Division, Bay Shore, N. Y.

Koiled Kords* permit EASY SERVICING of In-a-Door or Sliding Units . . .

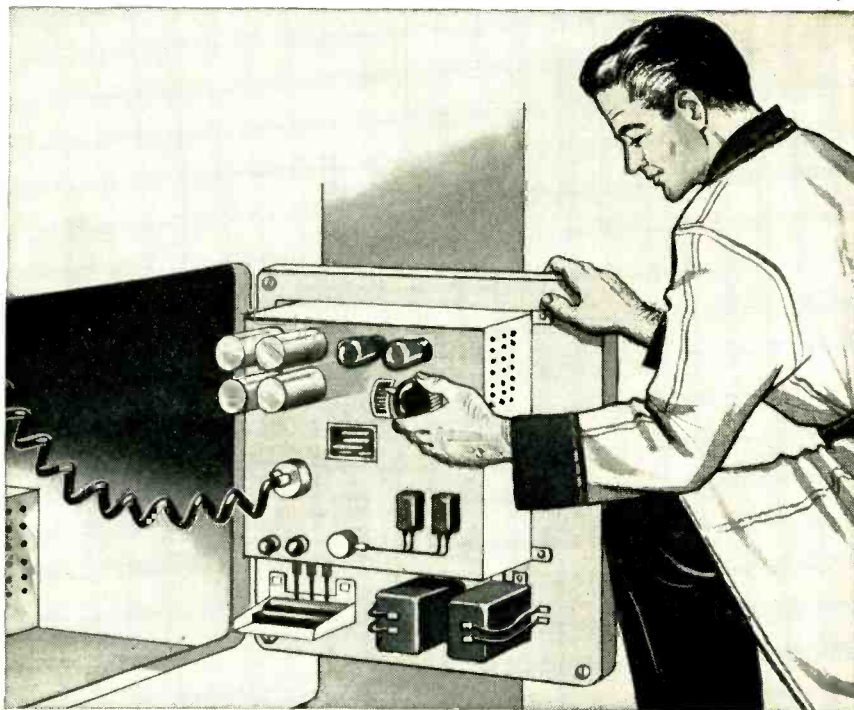

A six inch section of KOILED KORDS retractile cord will extend to more than two feet when pulled and when released will retract immediately to its original neat, compact, spring-like shape. KOILED KORDS solve the problem of carrying current to movable units without having a long trailing cord to foul in the mechanism. They make it possible to retain electrical contact between units when they are pulled out for servicing, facilitating trouble location and correction.

KOILED KORDS extend as needed without looping, dangling or tangling.

KOILED KORDS are compact, neat, attractive, built to withstand continued flexing.

KOILED KORDS are available on special order to your specifications in multi-conductor types up to 37 conductors. Stocked types include 2, 3, 4 and 5 conductor #23 AWG communications cords and 2, 3 and 4 conductor Underwriters' Laboratories approved SO, SJO and SV-neoprene jacketed power cords. KOILED KORDS can be supplied in 48 inch mandrel lengths or prepared into cord sets for attachment to equipment.

WRITE FOR KOILED KORDS APPLICATION BULLETIN SHOWING MANY USES.

Koiled Kords

INCORPORATED

Box K, New Haven 14, Conn.

*KOILED KORDS is the trademark of Koiled Kords, Inc.

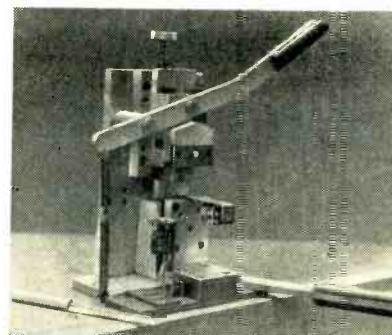

Combination fixture for installing and removing C washers from rotating spindles of adjustable television coils. Loading mandrel is on bench at left

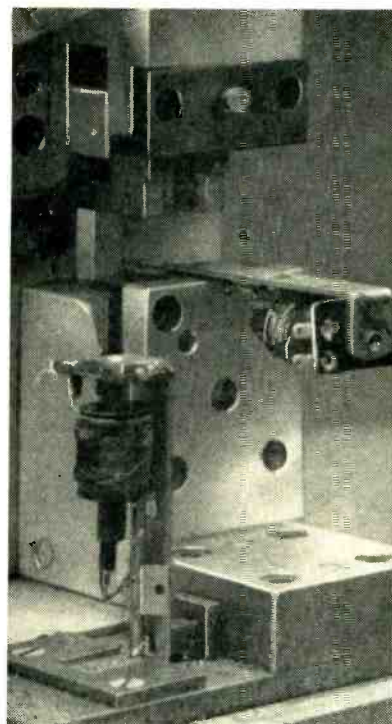

Details of C washer fixture

the mandrel is loaded, its end is held against the back of the magazine on the fixture, so that the washers slide off the end of the blade into the magazine. A feed saddle behind the washers in the magazine forces them toward the front under spring pressure, much as in an ordinary paper-stapling machine, so that the foremost washer is pushed into a pocket in the ram blade.

The rotating spindle of the component is positioned in a recess on the anvil of the fixture and the top hand lever is pulled down. This causes the ram blade to descend and force its C washer into the groove of the spindle. Immediately under the spindle is a die for closing the



SENDZIMIR MILLS FOR PRECISION ROLLING OF ALLOY STRIP

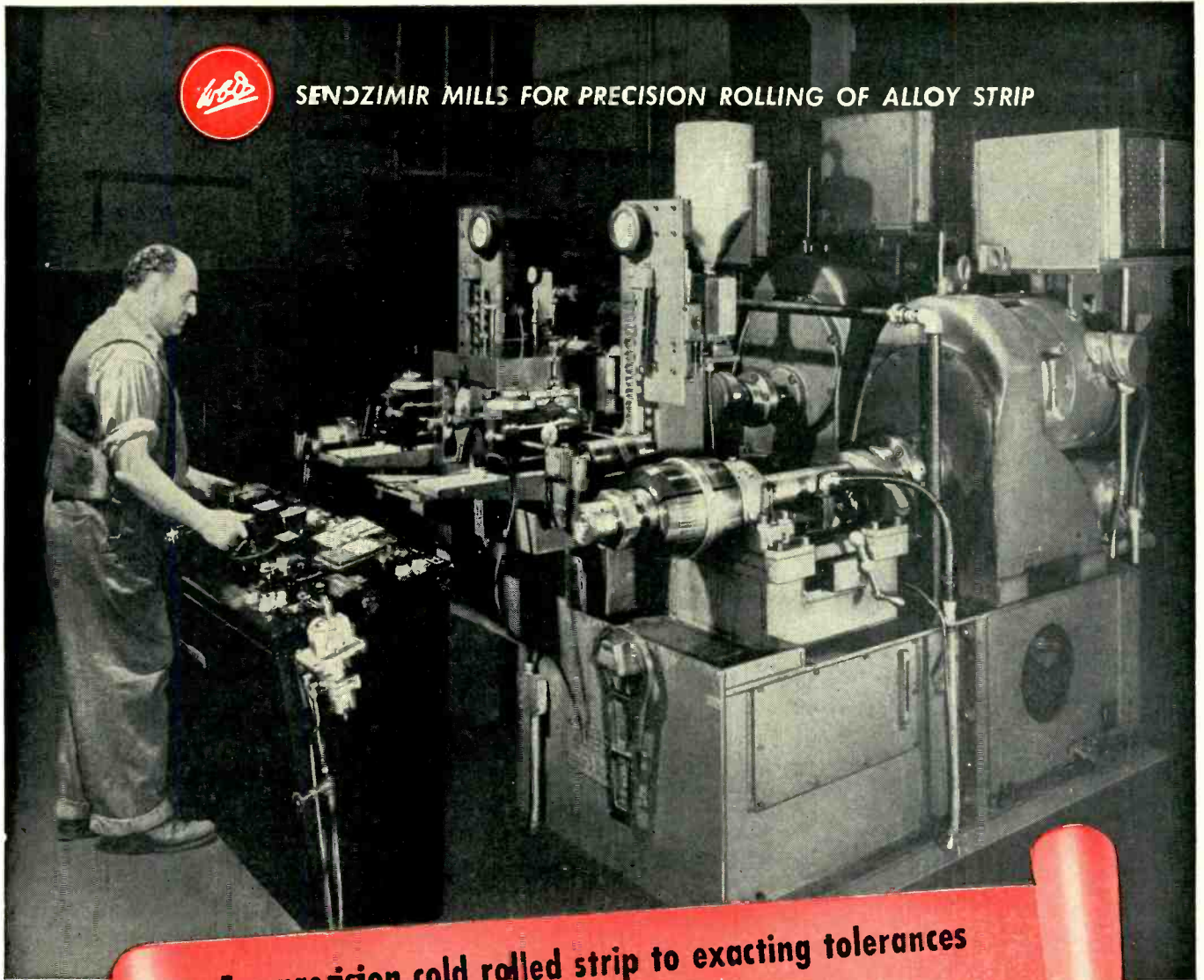

For precision cold rolled strip to exacting tolerances
-specify W.B.D. Alloys

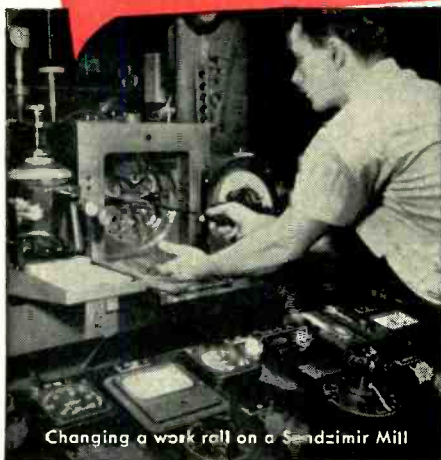

Changing a work roll on a Sendzimir Mill

-For electric, electronic, instrument and other critical applications

These Sendzimir mills represent the latest development in cold rolling technique and assure uniformity across the strip width. The expert operators are accustomed to close size tolerances and excellent finishes. A completely new and modern plant incorporates the latest production facilities. For resistance alloys, Rodar, Nickel, Beraloy, and custom alloys to specification, contact an experienced WILBUR B. DRIVER Sales Engineer.

WILBUR B. DRIVER CO.

NEWARK 4, NEW JERSEY





introducing the miniature
EPSYLON MULTITRACK
TAPE RECORDING SYSTEM
for special instrumentation

MULTITRACK MAGNETIC HEADS for 2, 3, or 4 tracks on ¼ in. tape, 8 tracks on ½ in. tape, and 16 tracks on 1 in. tape. Designed with a separate unit head for each track. Meticulously precision engineered. High performance from audio through ultrasonic range. Special head to grid transformers. Unit-type, section-built record/playback miniature amplifiers with plug-in correctors for all tapes at all speeds. Accurate tape transport mechanisms for all tape sizes with tape speeds from 1 in./sec. to 60 in./sec.

further particulars from

**EPSYLON RESEARCH
 AND DEVELOPMENT
 CO. LTD.**

The Barons • St. Margarets
 Middlesex • England
 Telephone
 Popesgrove 4451-5
 Cables:
 Erd. Twickenham, Middlesex

ends of the washer as the ram forces it down. The spring-loaded hand lever then returns to its original position and the magazine feeds another C washer into the ram in readiness for the next assembly.

When manufacturing faults in components necessitate dismantling of the spindles, the spindle is inserted in a vertical hole in the base of the fixture. The other hand lever is then operated, forcing a blade against the C washer to spread it open and push it out of the groove. Here the operator must position the open end of the washer correctly before inserting the spindle in the hole.

**Graphite-Spraying
 Machines for Anodes**

BOTH rotary turntable and inline conveyor machines are used in Tung-Sol's Bloomfield, N. J. plant to move anodes through the beam of a spray gun and then through a baking oven. The spray solution is graphite in a suspension of butyl acetate with some nitrocellulose binder. Baking evaporates the butyl acetate, leaving a hard carbonizing coating that serves to suppress secondary emission.

Both setups provide for rotation of the anodes during spraying, so that all sides receive an even coating. Operating speed is high enough to permit running the gun continuously. Over the spray area is a sheet-metal hood connected to a pipe stack that draws out fumes.

The smaller machine, with a six-head rotary turntable, is used for small anodes that can be dried in a relatively short distance of travel; the oven here occupies an arc of



Rotary turntable setup for carbonizing small anodes of tubes

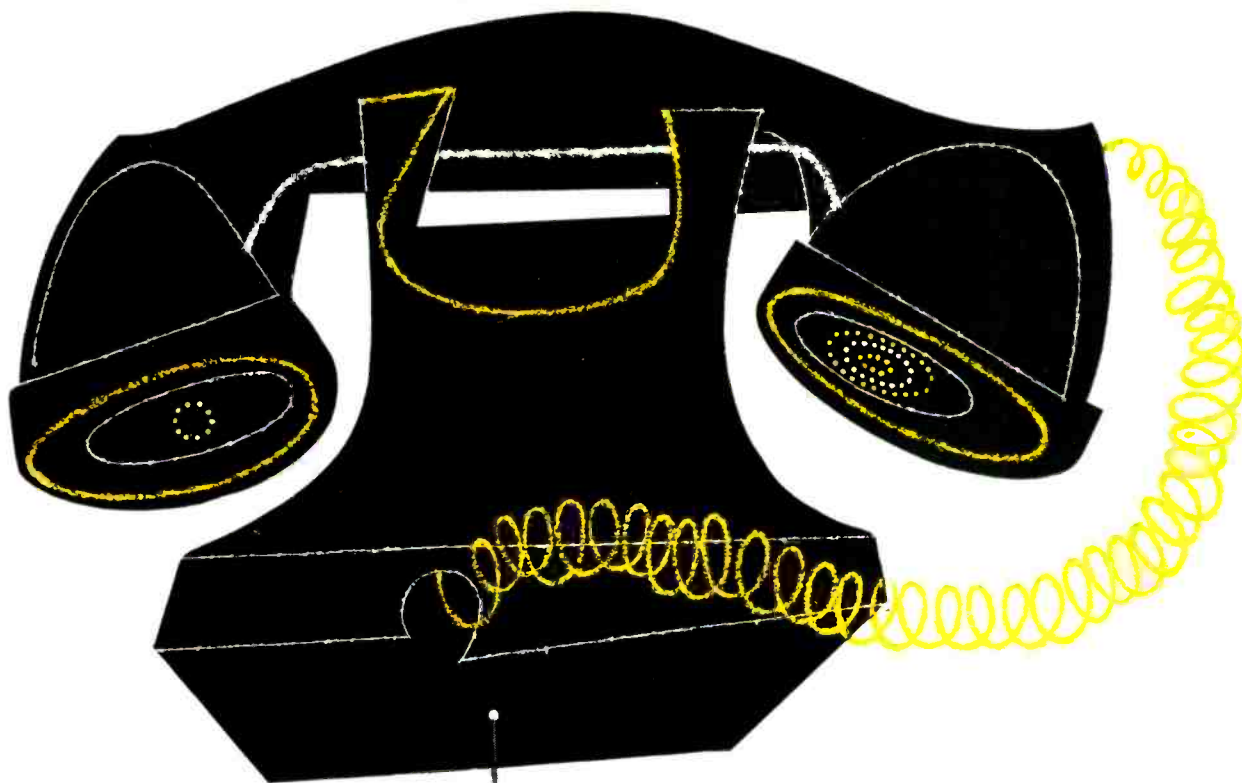

CRUCIBLE PERMANENT MAGNETS

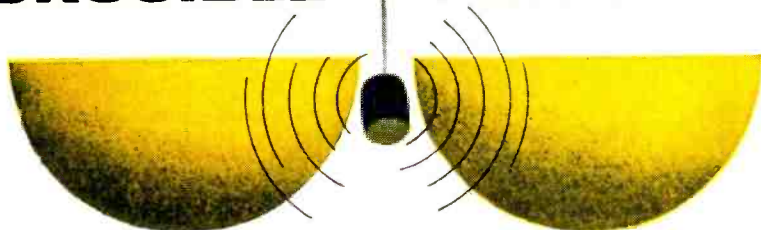

provide maximum energy . . . minimum weight

No matter what your permanent magnet application may be — galvanometer, speedometer, television or telephone — you'll find that Crucible alnico magnets have a *consistently higher* energy product. This means more energy from a smaller magnet.

Since alnico alloys were first developed, Crucible has been a leading producer of this superior type of permanent magnet. And Crucible alnico permanent magnets are made by the nation's foremost specialty steelmaker.

For alnico magnets that are unsurpassed in quality — *call Crucible.*



CRUCIBLE

first name in special purpose steels

54 years of *Fine* steelmaking

ALNICO PERMANENT MAGNETS

CRUCIBLE STEEL COMPANY OF AMERICA, GENERAL SALES OFFICES, OLIVER BUILDING, PITTSBURGH, PA.
 REX HIGH SPEED • TOOL • REZISTAL STAINLESS • ALLOY • MAX-EL • SPECIAL PURPOSE STEELS

Heiland **MULTI-(to 60) CHANNEL**

**RECORDING
OSCILLOGRAPHS**

(Model 700)

AMPLIFIER SYSTEMS

(Model 119)

BRIDGE BALANCE UNITS

(Model 82-6)

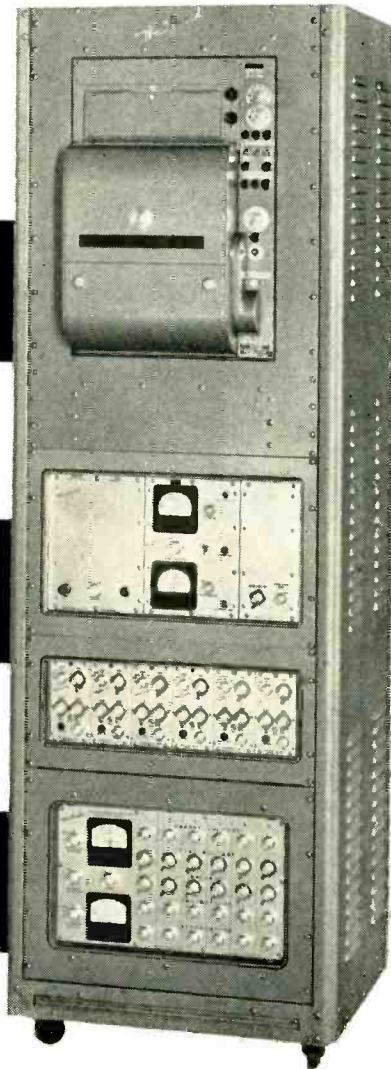

... designed for fixed or mobile
relay rack mounting

Write for complete details on the instruments shown above, as well as Heiland galvanometers and portable recording oscillographs.



Heiland Research Corporation

130 East Fifth Avenue • Denver 9, Colorado

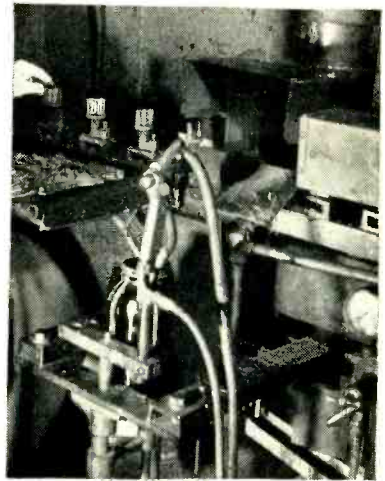

Inline conveyor and spray setup for carbonizing large anodes. Bake oven is at right

about 90 degrees along the turntable.

The inline conveyor employs anode holders bolted to a chain conveyor running horizontally. After passing through the spray area, the anodes move through a long baking oven and fall off into a bin when the conveyor chain goes over the end sprocket wheel to return underneath. Rotation during spraying is achieved by mounting each head on a shaft having a gear that meshes with a stationary rack running the length of the spray area.

Painting Picture Tubes with Knuckle-Joint Brushes

APPLICATION of a conductive coating to the inner surfaces of rectangular glass picture tubes is expedited through use of specially designed paint brushes in the General Electric tube plant at Elec-



Operator demonstrates how squeezing of finger lever makes brush bend

Midland

leads again...this time in



far in Advance

in the development of
Frequency Control Crystals
and Circuits for COLOR TELEVISION,
Midland is prepared NOW
to supply you in quantity with
Color TV Crystals to
your exact specifications...
and to counsel on all
matters concerned with this subject.

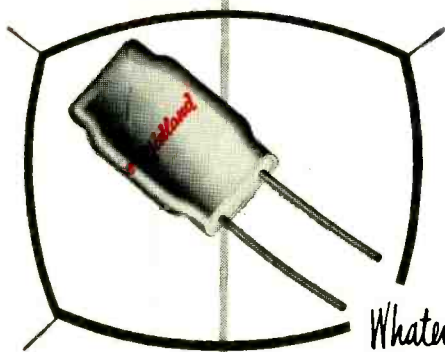

*Whatever your Crystal need, conventional or specialized
When it has to be exactly right, contact*



Midland

MANUFACTURING COMPANY, INC.
3155 Fiberglas Road, Kansas City, Kansas

WORLD'S LARGEST PRODUCER OF QUARTZ CRYSTALS

WHAT ARE YOU LOOKING FOR in a paper tubular capacitor?

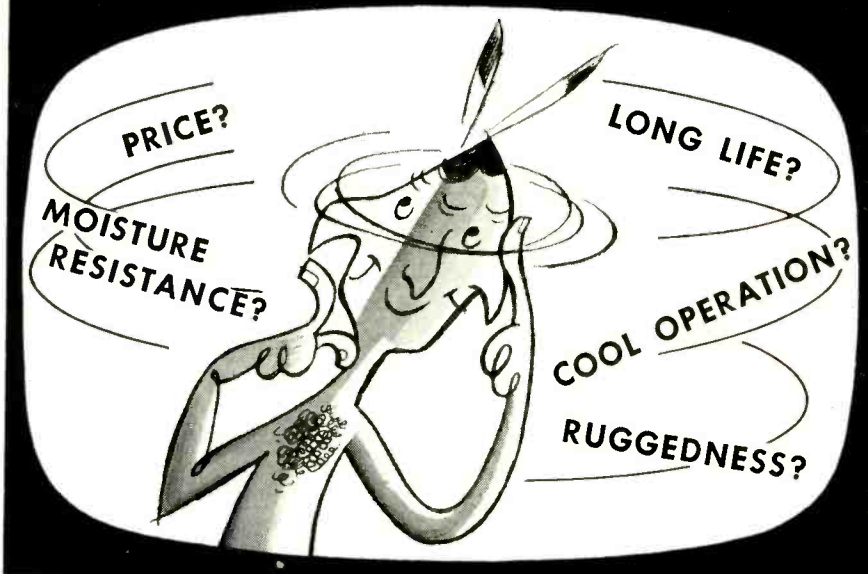

No matter what your particular applications problem in paper tubular capacitors—Sangamo can meet your need. You can choose from the following types:



TELECHIEF—The *premium* tubular. Molded in Humiditite . . . the Telechief offers amazing moisture resistance—satisfactory high temperature operation up to 85° C. (Contact our engineers about operating problems in the 100°—125° C range).

REDSKIN—An industry standard. Gives dependable *long life* operation at 85° C. The thermo-setting plastic case stands rough handling and the especially designed, flexible leads resist breakage—they can't pull out.

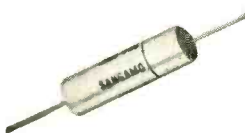

CERAMICHIEF—A ceramic-encased paper tubular. Here's quality at a price. Try it for high moisture resistance—long life. Wax, Resinex, or Mineral Oil impregnated. 85° C operation. The Ceramichief is ideal for plastic imbedment circuitry.

BUCKSKIN—An economical cardboard-encased paper tubular. Gives full Sangamo quality in applications where costs are a problem. Wax, Resinex, or Mineral Oil impregnation. Built to pass requirements of RTMA Spec. REC-118A.



P.S. For extremely critical applications—don't overlook Sangamo Types SA through SM. These hermetically-sealed, metal cased tubulars are built to MIL-C-25A Specs. Engineering Bulletin TS-105 gives full information.



SANGAMO ELECTRIC COMPANY

SC54-10

MARION, ILLINOIS

tronics Park, Syracuse, N. Y. For maximum efficiency, different lengths of brushes are used for different areas to be painted. A knuckle joint in the handle permits the brush unit to be straightened for insertion in the long, small-diameter neck. When the brush is inside the tube, the operator operates the joint by a lever, and the brush bends to cover the necessary area while the bulb is rotated by the motor-driven vacuum chuck.

Lead-Staking Machine for Printed I-F Transformers

UP TO FOUR separate wire leads are simultaneously applied to the terminals of an etched coil strip by a special lead forming and staking machine used by one manufacturer of printed-circuit components.

Wire for the leads is pulled out from reels mounted at the rear of



Loading sheet on machine in preparation for attachment of leads through rectangular slots at right on copper-clad plastic strip

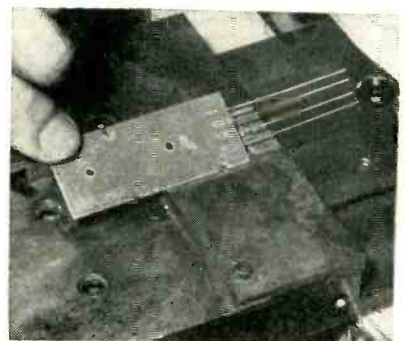

Removing the etched coil strip after applying four leads simultaneously to the coil terminals



Mr. Milton Kaufman, President of Aquatogs, Inc., tells how:

He makes sales go up in a downpour

"Women, weather and fashion are fickle," says Milton Kaufman. "Put 'em together and you have our business—all-weather garments.

"When a town is hit by heavy rain — especially without warning — the demand for Aquatogs shoots up.

"We call on Air Express, ship and deliver in a matter of hours—and cash in on this peak demand. As you might guess, our customers are flattered by this service.

"We regularly send orders out Air Express every week in the year throughout the country.

"We also depend on Air Express to move goods without a hitch from our door to the retail store receiving room.

"Yet, practically all of our orders cost us less with Air Express than with other air services."

It pays to express yourself clearly. Say Air Express! Division of Railway Express Agency.



Air Express



GETS THERE FIRST via U.S. Scheduled Airlines

CALL AIR EXPRESS . . . division of RAILWAY EXPRESS AGENCY

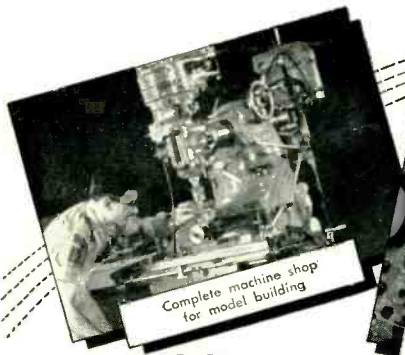

Complete machine shop for model building



Finest Electronic Equipment

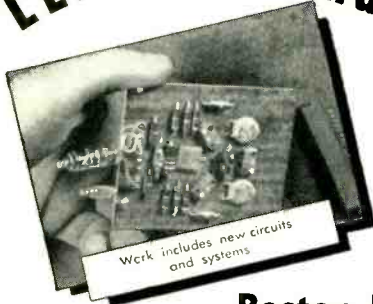

Work includes new circuits and systems

LEADERS and SPECIALISTS in ENGINEERING

offered splendid opportunities in **Boston Engineering Laboratory!**

Men qualified to handle high level assignments in electronics are offered a challenging opportunity in Boston, under ideal working conditions divorced from production. The laboratory provides stimulating projects, an atmosphere of scientific progress and provides assistance towards your personal advancement or professional recognition. You will work with a top level technical staff possessing the finest facilities. Administrative positions are open to men qualified to guide the efforts of others.

MICROWAVE ENGINEERS

Senior engineers to handle design and development projects and provide technical direction of other top-level engineers working on microwave circuits and microwave plumbing in the development of military airborne electronic equipment. Should have 5 years' experience in such work and at least a BS degree.

ELECTROMECHANICAL ENGINEERS

Senior engineers to direct groups of top level engineers working on mechanical designs of airborne electronic equipment. Should be able to estimate operating and development expenses to judge and coordinate staff work. Should have 5 years' experience in the field and at least a BS degree.

ELECTRONIC Engineer-in-Charge

To plan, direct and control the activities of engineers engaged in design and

Sylvania provides financial support for advanced education as well as a liberal insurance, pension and medical program. Investigate a career with Sylvania.

INTERVIEWS BY APPOINTMENT

Charles D. Kepple, Professional Placement
Boston Engineering Laboratory

SYLVANIA

ELECTRIC PRODUCTS INC.



70 Forsyth Street • Boston, Massachusetts • KENmore 6-8900

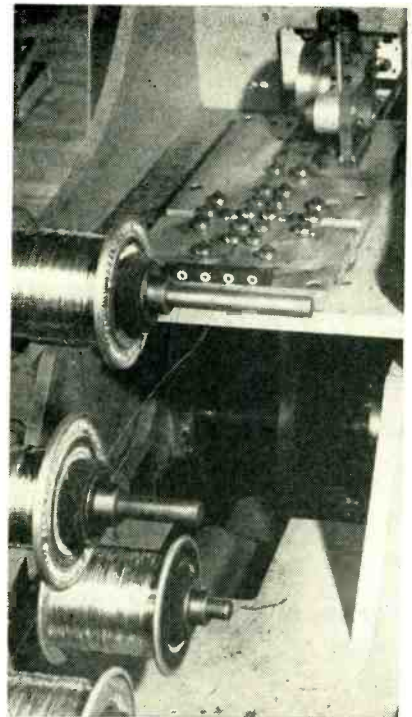

Rear of lead forming and staking machine, showing friction-drag mountings for the wire reels. Each wire runs around five straightening rollers mounted on steel bed plate

the machine and each wire is run through a series of five straightening rollers. The wires then go through four grooves in a large steel drive drum, to emerge at the front of the machine. Here small metal fingers push each lead wire up through its slot in the etched strip which has previously been placed in position by the operator.

Next, head hammers come down from above and flatten the loops so as to lock the leads in the slots. Simultaneously, a rotating knife cuts the leads to length to complete the operation.

New wire feeds forward while the operator unloads the finished piece and places a new one in position. This technique is used for at least six different types of 40-mc i-f transformers, coils and traps employing photo-etching as a production process.

Machining Printed Circuits

A NEW METHOD of producing copper-foil printed circuits, announced by Erie Resistor Corp., involves embossing the foil in laminated Bakelite sheets in such a way that

the switch is ON to
**GUARDIAN[®]
 CONTACT
 SWITCH
 ASSEMBLIES**

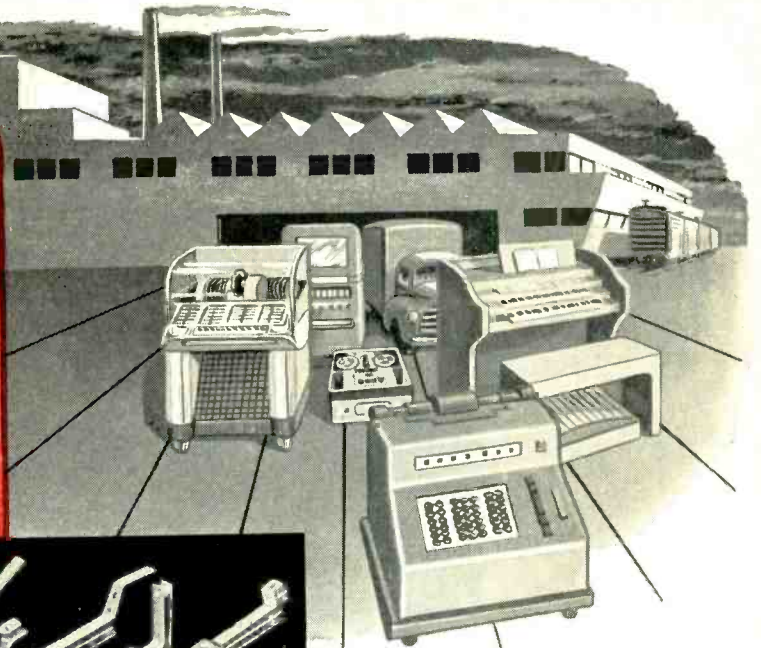

UNIT A

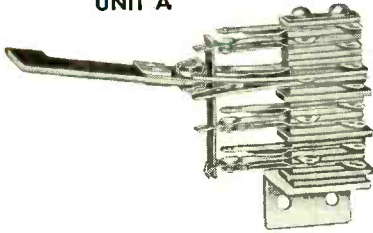

SNAP-ACTION
 REVERSING SWITCHES

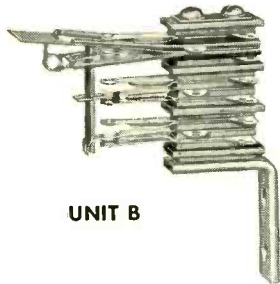

UNIT B



You're looking at performance and low cost that have never been so efficiently combined when you study these new Guardian Contact Switches. Use them independently or in combination with Guardian Relays, Steppers, Solenoids, or special controls and you will soon discover these Guardian Contact Switches make no compromise with quality and performance despite their reasonable price. They are quickly available in a vast variety of contact combinations and in all popular materials from Guardian's enormous stocks of standard and special blades, lug adaptors, insulating separators and bushings ready for immediate assembly. Fine silver, silver alloy, platinum-ruthenium and Fasloy #7 contacts with blade materials of all types are available.

GUARDIAN SNAP-ACTION REVERSING SWITCHES

Unit "A" controls reversing of 10 amp., 115 v., non-inductive loads in automatic equipment. 4 P.D.T. contacts are of Fasloy #7. Life tests up to 5,000,000 operations. Unit "B" has automatic return with 3 P.D.T. combination. Both units U. L. approved.

GUARDIAN ENGINEERS' KIT

Indispensable to those who design, build or test electrical controls. Kit contains a generous supply of standard Guardian contacts for various blade dimensions and includes all parts necessary for complete switch assemblies. Order yours today.

GET BULLETIN CS-1

It illustrates contacts, contact blades, lug adaptors and insulating separators. Yours for the asking . . . no cost . . . write today.

- ELECTRONIC ORGANS
- TELEPHONE ANSWERING SERVICE
- ADDRESSING EQUIPMENT
- BUSINESS MACHINES
- VENDING MACHINES
- COIN CHANGERS
- THERMOSTATS
- DICTATING EQUIPMENT
- WIRE RECORDERS
- AUTOMATIC RECORD CHANGERS
- LIE DETECTORS
- INTERCOM SYSTEMS
- EMERGENCY PRODUCTION CONTROL
- TAPE RECORDERS
- CONVEYOR CONTROLS
- FACSIMILE SIGNATURE TRANSMISSION
- ANIMATED SIGNS AND DISPLAYS
- TRAFFIC SIGNALS
- ELECTRONIC BRAINS
- TRANSPORTATION
- AUTOMATIC SELECTION
- GUIDED MISSILES
- RADAR
- PHYSIO-THERAPY
- GUN-FIRING
- ROCKET-FIRING

GUARDIAN  ELECTRIC
 1625-G W. WALNUT STREET CHICAGO 12, ILLINOIS

A COMPLETE LINE OF RELAYS SERVING AMERICAN INDUSTRY

Miniaturization
presents problems
solved only by

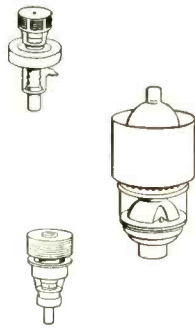

TUNGSTEN TANTALUM MOLYBDENUM

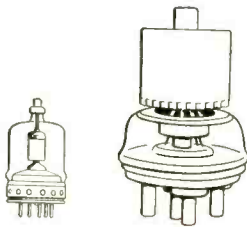

Miniaturization of electronic tubes has presented an entire new group of problems including intense localized heating, spacing tolerances, and thermal expansion.

Tantalum, tungsten and molybdenum all have extremely high melting points, low vapor pressure, and good strength at high temperature. All three have very low coefficients of expansion.

But it's important that you select the right one. In this selection, Fansteel's long and specialized experience can be of inestimable help. In addition, Fansteel engineers, experts with every possible facility at their command, can aid you in part design and economical fabrication methods. Save time, money and the likelihood of production headaches by calling on Fansteel now, before your problems begin.

Write for free informative booklet
"FANSTEEL TUNGSTEN and MOLYBDENUM"



Fansteel Metallurgical Corporation

NORTH CHICAGO, ILLINOIS, U.S.A.

42502C

the depressed portions represent the wiring desired. This embossing operation is performed during the Bakelite curing process. The unwanted part of the copper foil is then removed mechanically. Advantages are expected to be in economy of production and in elimination of chemicals in contact with the insulating material during manufacture.

Aluminizing TV Tubes

A REFLECTIVE aluminum coating is applied to the inner surface of a picture tube to reflect the light which otherwise would be absorbed



Picture tube aluminizing area, showing individual vacuum buggies

by the black interior. In producing aluminized tubes at the G-E tube plant at Electronics Park, Syracuse, N. Y., the aluminum coating is applied in three different ways. For black-and-white tubes, one method involves use of individual aluminizing buggies and the other a 24-head rotary machine called a merry-go-round. For color tubes a three-at-a-time stationary bell-jar setup is used.

Each buggy contains a vacuum pumping system, a vacuum connection to the tube being processed and a suitable means for melting the aluminum strip within the tube while it is under vacuum. The aluminum first is melted and then vaporized, after which it condenses on the inner surface of the tube. Automatically controlled, the aluminizing equipment goes through a cycle which includes exhausting the air in the tube to produce the vacuum, preheating the aluminum slug, flashing the aluminum and then re-

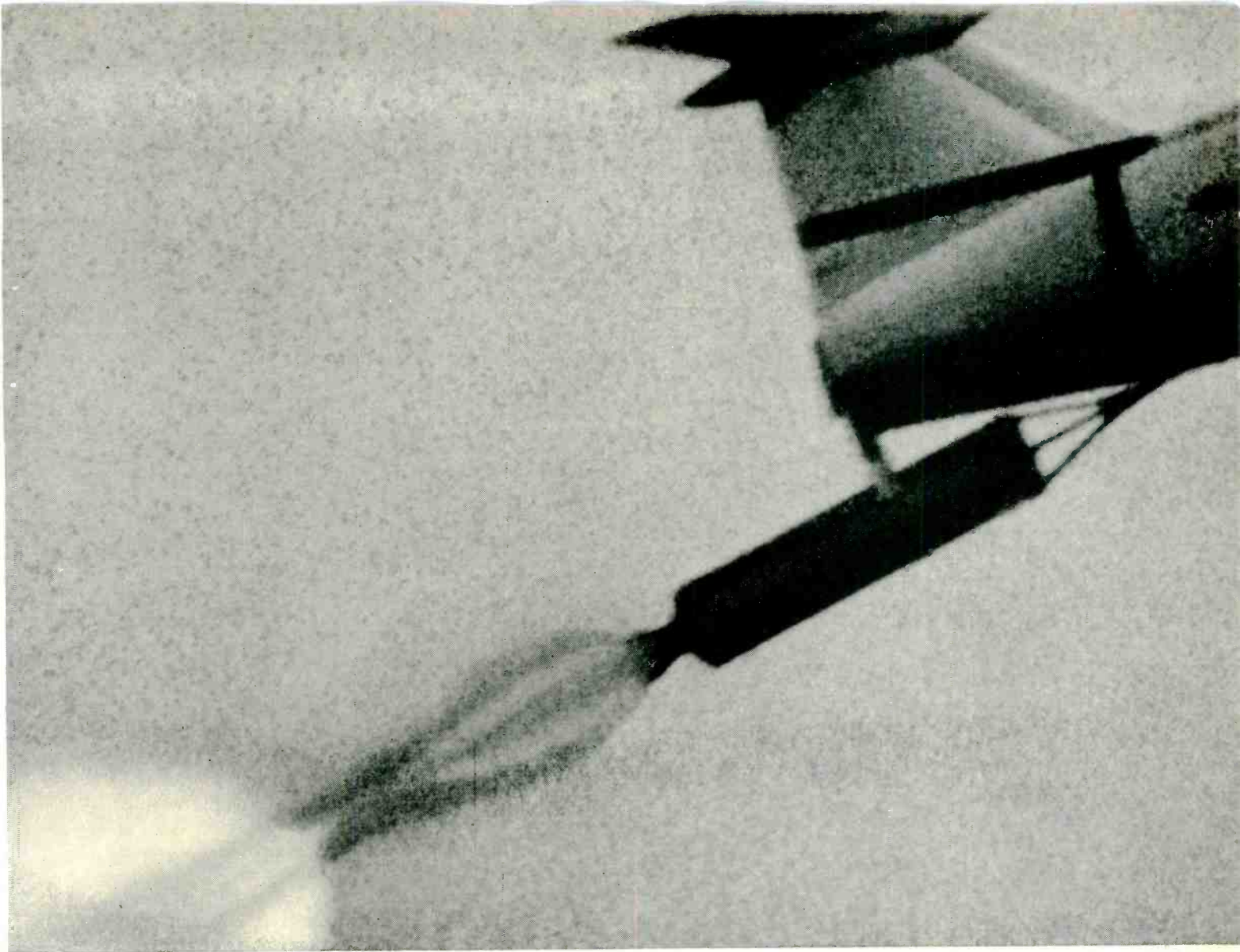

moment in history

You are looking at 1/1000 of a second in the history of aviation. It occurred at a fraction past 4:31 p.m. on January 20, 1949.

This was the Zero moment which marked the official launching of the first successful pilotless bomber to be approved by the U.S. Air Force—the Martin B-61 Matador.

The picture is historic for a very significant reason: it records the tradition-shattering payoff of an entirely new development in the aircraft industry, known as Martin Systems Engineering. This is a science and a method of

developing spaceborne systems as total solutions of Operations problems.

The Martin Matador is far more than the thing you glimpse here. Behind it is an integrated network of facilities designed to give this important new weapon simplicity of operation and extreme mobility. These components add up to the total solution of one of the most formidable security problems of our time.

They also add up to one of today's most important developments: the full story of Martin Systems Engineering.

You will hear more about Martin!

Martin
AIRCRAFT



THE GLENN L. MARTIN COMPANY
BALTIMORE • MARYLAND

DO YOU USE OR MAKE ANY OF THE PRODUCTS IN THIS LISTING?

List of Users

The types of industries listed are all repeat users of **Tru-Lay Push-Pull Controls**. Experimental applications are not shown.

Agricultural Equipment
 Air Conditioning Equipment
 Aircraft & Parts Automobiles
 Bakery Equipment Boats & Ships
 Bottling Machinery
 Brewing & Distilling Equipment
 Business Machines
 Buses & Motor Trucks
 Candy Making Machinery
 Canning Machinery
 Ceramics Machinery
 Chemical Processing Machinery
 Coal Mining Machinery
 Coin Operated Machines
 Construction Machinery
 Dairy Products Machinery
 Dental & Surgical Equipment
 Die Casting Machinery Diesel Engines
 Drinking Water Coolers
 Electrical Appliances
 Electrical Generating Equipment
 Electrical Machinery
 Electrical Transmitting Equipment
 Electronic Equipment
 Elevator Control Panels
 Fire Protection Equipment
 Food Processing Equipment
 Forging Machinery
 Foundry Equipment
 Gas & Oil Production (Test Stands)
 Glass Making Machinery
 Grain Processing Equipment
 Hat Machinery Heating Equipment
 Hydraulic & Pneumatic Equipment
 Ice Cream Making Machinery
 Laundry & Dry Cleaning Equipment
 Leather Working Machinery
 Lumber & Saw Mill Machinery
 Marine Equipment
 Materials Handling Equipment
 Metal Mining Machinery
 Metal Working Machinery—Machine Tools
 Military & Naval Equipment
 Motorcycles & Bicycles
 Nuclear Science Equipment
 Oil Refinery Equipment Ordnance
 Packaging Machinery
 Paint Making Machinery
 Paper Making Machinery
 Photo Equipment (manufacture)
 Plastics Fabricating Machinery
 Plastics Producing Machinery
 Power Plant Equipment
 Printing & Binding Machinery
 Quarrying Machinery
 Radio & Television (manufacture)
 Railroad Equipment
 Road Building & Maintenance Equipment
 Rubber Processing Equipment
 Safety Locks on Fuse Panels
 Sanitation Plumbing (Floor Valves)
 Shoe Machinery Steel Mill Machinery
 Telephone & Telegraph Machinery
 Textile Machinery
 Waterworks Equipment
 Welding Equipment
 Wire Making Machinery
 Woodworking Equipment
 X-Ray Machines

Whether your interest is in a single application of this versatile

PUSH-PULL CONTROL

or in its inclusion as a component of the product you manufacture, we would welcome your request for our **DATA FILE** for your further study.

Because **TRU-LAY PUSH-PULL CONTROLS** are "SOLID as a rod but FLEXIBLE as a wire rope" their use has simplified the design and improved the operation of literally hundreds of products as indicated in the accompanying list of repeat users.

These fine controls are designed, and painstakingly built, to have the qualities of **ACCURACY, HIGH LOAD CAPACITY, FREEDOM FROM TROUBLE, LONG LIFE, FLEXIBILITY . . .** they are frequently and successfully used in conjunction with electrical, hydraulic and air controls . . . they are thoroughly effective under almost any operating condition.

Here are some of the jobs they handle well . . . **HOT** jobs on jets and industrial furnaces . . . **COLD** jobs down to -70°F . . . **WET** jobs in food processing and marine applications . . . **DIRTY** jobs in cement mills and coal mines . . . **CORROSIVE** jobs in chemical processing . . . **HEAVY, TOUGH** jobs on construction machinery . . . **LIGHT DUTY** jobs on business machines, drinking water coolers . . . **REMOTE** jobs 150 feet or more from control point . . . they **DAMPEN VIBRATION** to protect delicate instruments . . . and **LUBRICATION** of the inner, working member is taken care of *for life* during assembly.

• The six booklets and bulletins in this **DATA FILE** will answer further questions you may have about this versatile and dependable tool, and will also provide you with the means of defining to us the application you may be interested in.

Write
for a copy
without obligation

DATA FILE

ACCO

**AUTOMOTIVE and AIRCRAFT DIVISION
AMERICAN CHAIN & CABLE**

601-B Stephenson Bldg., Detroit 2 • 2216-B South Garfield Ave., Los Angeles 22
929-B Connecticut Ave., Bridgeport 2, Conn.

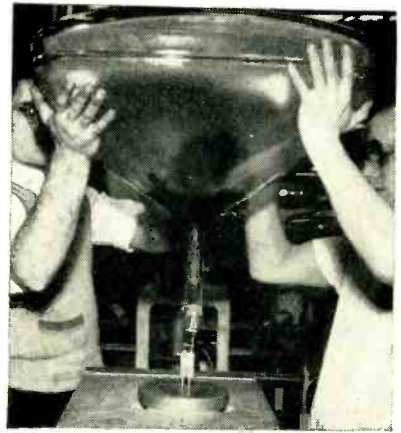

Lowering 27-inch rectangular picture tube into aluminizer

turning the tube to atmospheric pressure. The equipment is manually loaded and unloaded. Canvas safety curtains normally cover tubes during aluminizing.

Two men are required to lower a 27-inch all-glass picture tube bulb into position on the aluminizing equipment. At the top of the aluminizing unit is the vaporizing shield, and just below is the filament holding the aluminum slug. The dark inside conductive coating does not cover the entire surface area of the bulb, as in non-aluminized tubes, since the aluminum coating will serve as a return path for the screen excitation currents.

Aluminizing Merry-Go-Round

The automatic 24-head rotary aluminizing machine was made by the Equipment Development Works, General Electric Company, Schenectady, N. Y. It consists of 24 complete self-contained aluminizing buggies mounted on a continuously revolving turntable. Each buggy



Rotary aluminizing machine

Do you have any of these problems?

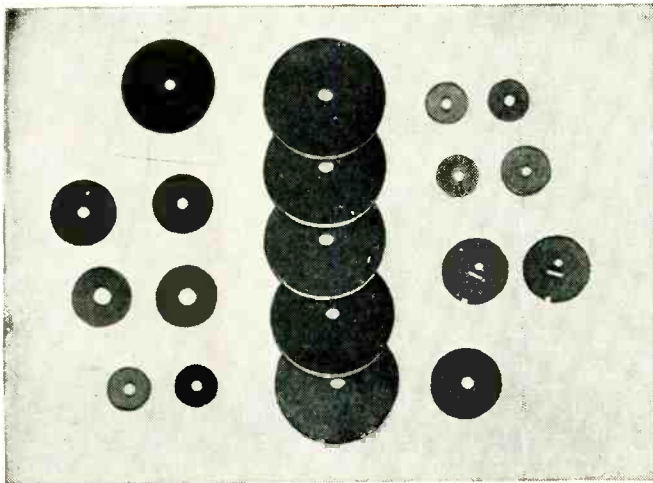

1. Need a combination of gasket sealing and mechanical and electrical properties? Various grades of LAMICOID®—laminated plastic made with organic and inorganic binders—are combined with natural or synthetic rubber to obtain the excellent insulating and mechanical properties of LAMICOID and the sealing properties of rubber.

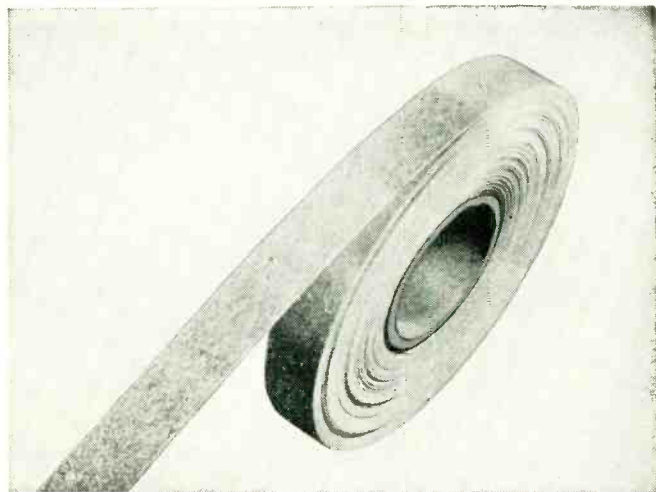

2. Need a mica tape that can be run on taping machines at high speed? ISOMICA® tapes are made from long rolls of thin continuous mica sheet... are more uniform in mechanical and dielectric strength... have no high spots or voids. For electrical insulation of class B or class H motors, generators and transformers.

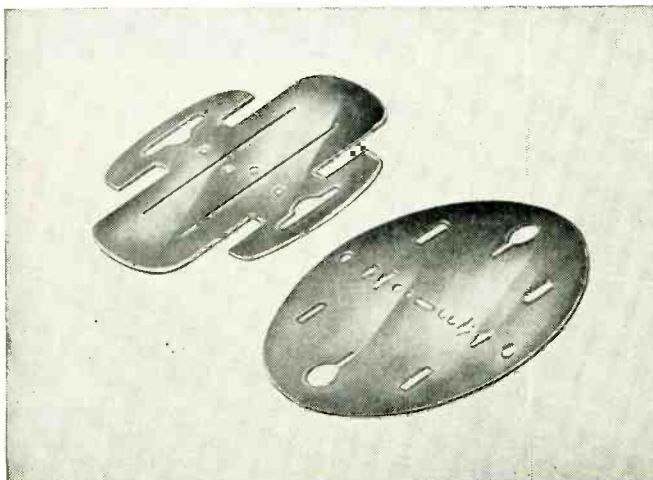

3. Need accurately punched mica stampings for filament, grid and plate supports? MICO produces mica stampings to extremely fine tolerances. Whenever you need precision-fabricated mica parts of the highest quality, call on MICO. We have 60 years of experience in this field.

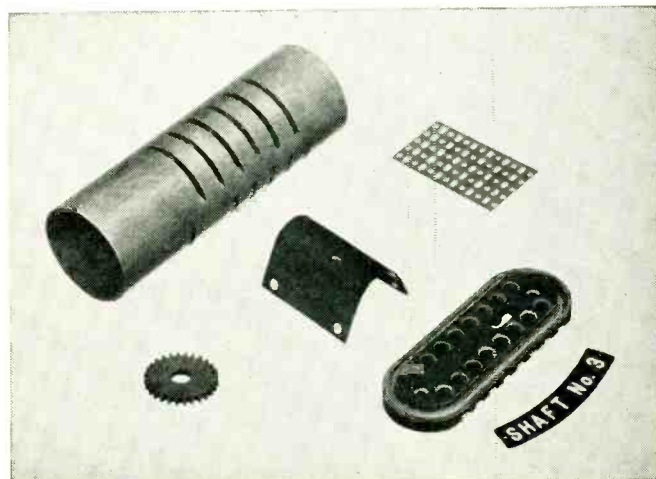

4. Need special mechanical and electrical properties for brackets, terminal blocks, access panels, etc.? LAMICOID® is half as heavy as aluminum and, weight for weight, stronger than steel. Offers high impact strength, high dielectric strength, excellent abrasion and moisture resistance.

Whatever electrical insulating materials you need, MICO makes them best. We manufacture all standard types and many special materials, and fabricate parts to your specifications. Send us your blueprints or problems today.

**Trademark*



MICA Insulator COMPANY

Schenectady 1, New York

Offices in Principal Cities

LAMICOID® (Laminated Plastic) • MICANITE® (Built-up Mica) • EMPIRE® (Varnished Fabrics and Paper) • FABRICATED MICA • ISOMICA®

MOTOR DATA
No. 126

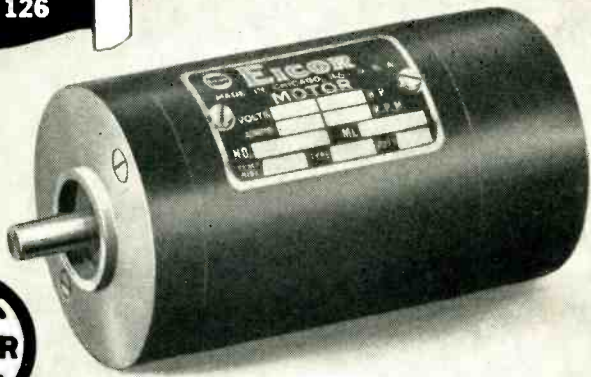

2300 FRAME MOTOR
1/5 HP at 3800 RPM

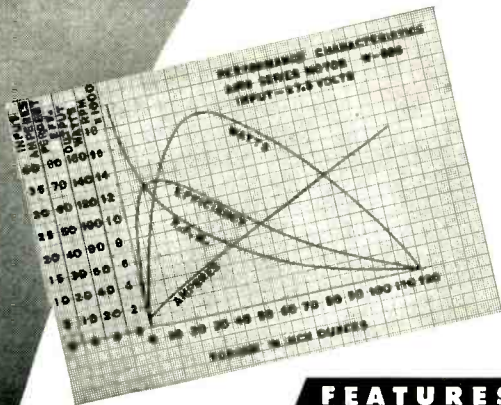

The basic design of the 2300 Frame Motor has been used in scores of individual modifications. Many of these designs are complete and available—others for new equipment can readily be developed.

FEATURES

ELECTRICAL

- Series or shunt wound
- High starting torque
- Low starting current
- High efficiency
- Low RF interference
- Unidirectional or reversible
- Armature and field windings varnish impregnated and baked

MECHANICAL

- Low weight factor
- Unusual compactness
- Completely enclosed
- Base or flange mounting
- Laminated field poles
- Precision ball bearings
- Segment-built commutator
- Permanent end play adjustment

2300 FRAME MOTORS		2318 Series	2310 Shunt
Watts Output, Int.	(max.)	160	50
Torque at 6000 RPM	(in. oz.)	40	10
Torque at 3800 RPM	(in. oz.)	57	—
Lock Torque	(in. oz.)	120	14
Volts Input	(min.)	5	5
Volts Input	(max.)	110	28
Temperature Rise	(int.)	50°C	50°C
Diameter		2 ⁵ / ₁₆ "	2 ⁵ / ₁₆ "
Length less shaft		4 ⁵ / ₃₂ "	2 ³ / ₄ "
Shaft Dia.	(max.)	.312"	.312"
Weight	(lbs.)	2.4	1.5

contains a roughing and fine vacuum pump, power supply, electrodes for flashing the aluminum slugs, and a fixture for supporting and sealing the bulb in position during the process.

At the start of a new cycle, the operator loads a filament and aluminum charge assembly into the filament holder and places the bulb in position in its fixture atop the buggy. The vacuum seal is obtained



Tri-cornered bell jar for aluminizing three phosphor plates at a time for 15-inch round color television picture tubes

by use of a large rubber seat in the fixture, which makes contact with the bulb funnel just above the yoke reference line. The self-contained vacuum system then starts to work, first roughing out the bulb with the mechanical pump and finally pulling a high vacuum by means of a large oil diffusion pump. Power is applied to the pumps at the proper time by means of a commutator located in the center of the machine.

When the bulb reaches the proper vacuum condition, voltage is applied to the filament assembly, thereby melting and vaporizing the aluminum charge. This vaporized aluminum condenses on the inner surface of the bulb, producing the desired mirror-like effect. Safety drapes around the machine are used to minimize the hazard from any glass breakage during processing. The equipment is capable of aluminizing bulbs at a rate of over 100 per hour.

Color Tube Setup

Only the phosphor plate is aluminized in a color picture tube. Aluminizing is essential in even a

Eicor, Inc. 1501 W. Congress St., Chicago 7, Illinois

DYNAMOTORS • INVERTERS • ELECTRONIC CONTROLS • ALTERNATORS • MOTORS

QUALITY FERRITE CORES *by* ALLEN-BRADLEY

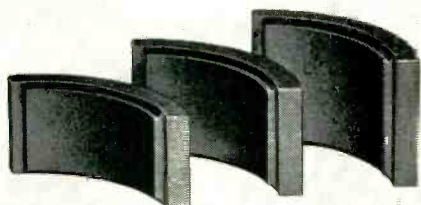
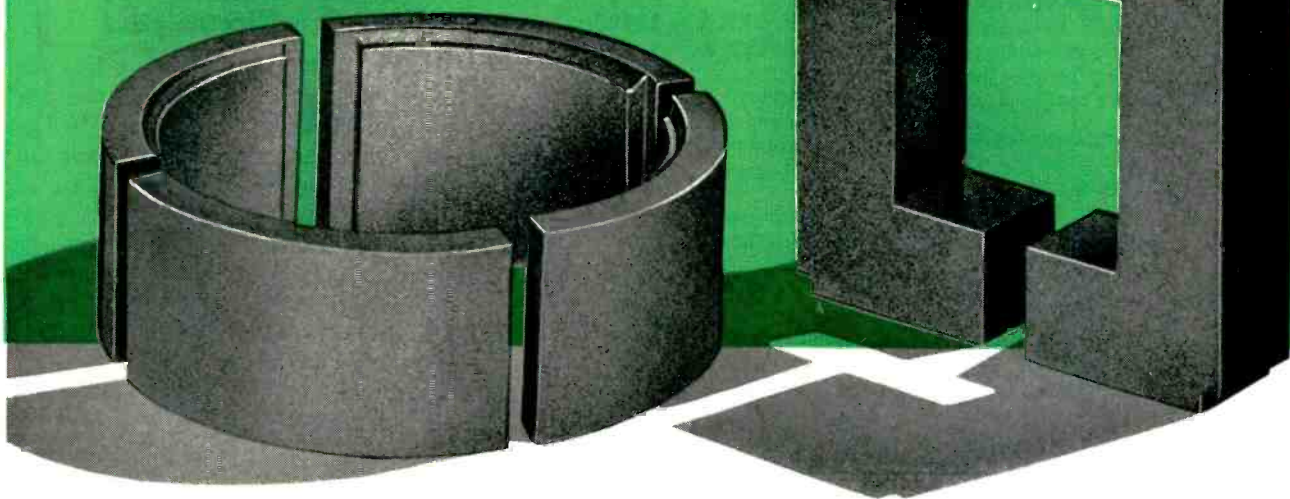

Deflection Yoke Cores in Six Widths

Allen-Bradley yoke cores are all made with an inside radius of 1.027 inches and in six widths as follows: — 0.960 in., 1.125 in., 1.188 in., 1.225 in., 1.250 in., and 1.407 in. Samples for qualification tests can be furnished on request.



The modern Allen-Bradley main plant in Milwaukee, Wisconsin.

UNIFORM IN DIMENSIONS AND PERFORMANCE

The production of Allen-Bradley QUALITY ferrite parts is held to the same close manufacturing standards as all other Allen-Bradley radio and television components . . . such as Bradleyunits, Bradleyometers, and Allen-Bradley ceramic capacitors . . . long recognized as TOP QUALITY. Television equipment manufacturers already consider Allen-Bradley as a desirable source of ferrite cores.

These ferrite cores are now listed in ten part numbers for the U cores and in nine part numbers for the quarter ring cores.

Write for blueprints or samples, today.

Allen-Bradley Co.
110 W. Greenfield Ave., Milwaukee 4, Wis.



ALLEN-BRADLEY

RADIO & TELEVISION COMPONENTS

QUALITY



DEPEND on

Deposited Carbon Resistors

for

ACCURACY and STABILITY!



DC-2 —
2 Watts



DC-1 —
1 Watt



*DCS 1/2 —
1/2 Watt



DC-1/2 —
1/2 Watt



*DC-1/4 —
1/4 Watt



*DC-1/8 —
1/8 Watt

*For Miniature Installations

Dalohm deposited carbon resistors are manufactured under rigid controls to deliver matchless performance and economy in any high-low resistance range.

Dalohm resistors are sealed against moisture with special silicone coating having high dielectric strength, excellent thermal conductivity, and high resistance to abrasion.

From 1 Ohm to 200 Megohms, depending on type.

Temperature coefficient 200 PPM per degree C for lower resistance ranges up to 500 PPM per degree C for higher ranges.

1% accuracy. 2%, 5%, and 10% tolerances also available.

Write, Wire or Call

1300 28th Ave. Phone 2139

DALE PRODUCTS, INC. Columbus, Nebraska, U.S.A.
In Canada — Teletronics Corp., Ltd., Toronto and Montreal

small color picture tube, to provide a conductive layer that maintains a uniform potential on the phosphor screen. This prevents deterioration of color purity and also increases the light output from the screen. The aluminizing station at the GE color picture tube development laboratory aluminizes three screens at once in a special bell jar, to coat the rear of the phosphor screens.

Punched Mounting for Metal-Can Electrolytics

BY FORMING the mounting lips for an electrolytic capacitor from the metal that would normally be punched out of the chassis hole for the component, mounting time is reduced from 1.3 minutes to only 0.18 minute and mounting cost is reduced approximately 2 cents in the television receiver plant of E. K. Cole Ltd., Southend-on-Sea, England.

Punching of the mounting tabs is included in the first punching operation on the chassis. Upward

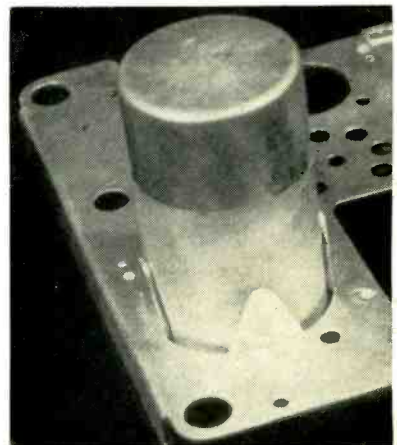

New capacitor mounting method, requiring no additional parts. Capacitor is inserted from underneath

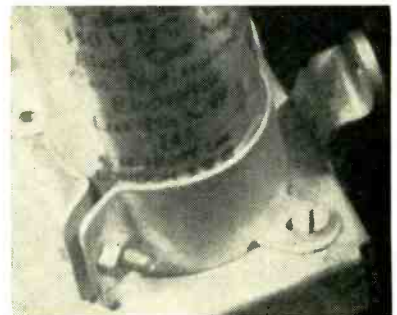

Conventional mounting method formerly used, involving seven additional parts

New aids for Thermistor use

Send for application kits and 52-page manual

Two special application kits of Carboloy® Thermistors (negative temperature coefficient resistors) are now available for design and application work. Each kit contains a selection of the most widely used styles and sizes.

The new, free 52-page technical manual includes latest information on the use of Thermistors in the automatic detection, measurement and control of energy.

The manual also contains comprehensive descriptions of Thermistors' properties, revised static and dynamic characteristic curves, specifications and order information. Send coupon, today.



New Carboloy Thermistor Manual TH-13

Kit #1, \$20.00 FOR ENGINEERING APPRAISAL

Contains 18 Thermistors: two of each, in three styles and three sizes.



Kit #2, \$125.00 FOR APPLICATION DEVELOPMENT

Contains 104 Thermistors: twenty-six sizes and four styles. Also contains steel, lead and fibre washers, and tubing for building assemblies.

CARBOLLOY

DEPARTMENT OF GENERAL ELECTRIC COMPANY

"Carboloy" is the trademark for products of the Carboloy Department of General Electric Company

CARBOLLOY
 DEPARTMENT OF GENERAL ELECTRIC COMPANY
 11139 E. 8 Mile Ave., Detroit 32, Michigan

Send me the following: New Thermistor Manual TH-13
 Kit No. 1, \$20.00, plus applicable state taxes
 Kit No. 2, \$125.00, plus applicable state taxes

Enclosed is Check Money order for \$_____. Please invoice us

Name _____ Title _____
 Company _____
 Address _____
 City _____ Zone _____ State _____

forming of the tabs is combined with the second piercing tool if it is the spring stripper type, or in the chassis bending tool, and thus no additional punching operations are involved for producing the mounting.

The new method holds the capacitor in place securely by friction alone, as the mounting tabs are bent slightly inward during forming.

Reaming Fixtures for Radar Antenna Units

PRODUCTION bottlenecks on airborne radar antenna units have been eased at Dalmo Victor Co., San Carlos, Calif. largely through development and use of precision hand-operated reaming fixtures. These reduced the previous time-consuming operation on jig boring machines by nearly 75 percent, at only 10 percent of the former cost. Improved accuracy is another benefit, permitting complete interchangeability of parts with near-zero dimensional limits. Formerly the components making up the housing for the azimuth drive gear had to be preassembled and aligned with specially ground plug gages,

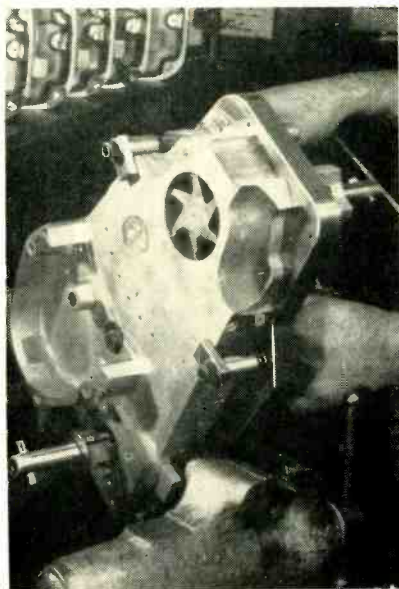

Using master hand reaming fixture on azimuth drive gear housing. Fixture is clamped in vise on bench, a casting is placed on the fixture and anchored with mounting tabs, and each reamer in turn is then turned in by hand to complete the final finishing of four holes, one of which is counter-bored and faced

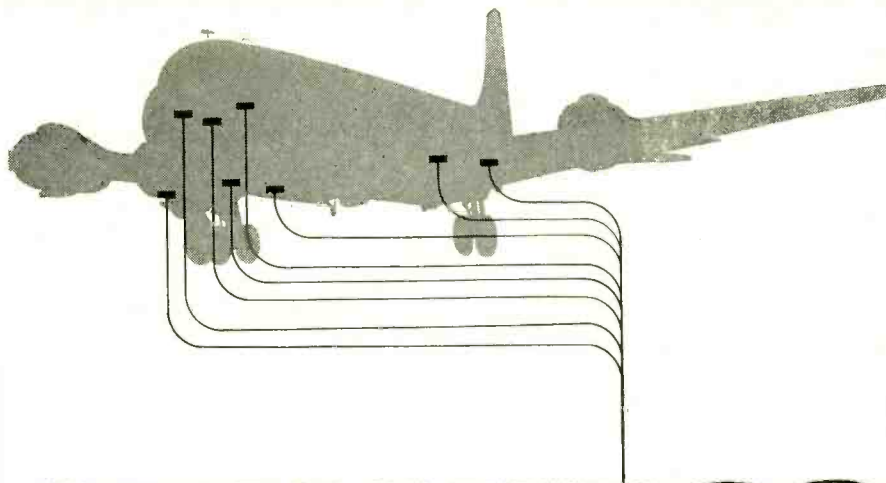

SYNCHROS

Nerve ends for sky giants!

Rotors of these super-sensitive synchro torque transmitters duplicate or interpret the rotation or position of other rotors in remotely placed counterparts. In this way they give accurate, visual information on the action or angle of control surfaces, gear, fuel flow, auxiliaries, etc.

They are widely used in closed loop control systems where they demonstrate the precision quality of Oster Avionic Products.

They conform to military specifications for altitude, high and low temperature, life, shock, vibration, humidity and fungicidal treatment.

You can depend on Oster quality in rotating components for automatic control.



OSTER lightweight Synchro Transmitters, type 2G. Accurate to .25° or less, in angular definition. Has many applications in the avionics industry, where angular or linear position indications must be accurately interpreted.

Other OSTER Avionic Products include:

- Special motors: Servos, Drive Motors, Blowers and Fans for use with D-C and A-C supply voltages in common usage on aircraft and ground equipment.
- Synchro Generators, Control Transformers, Transmitters, Differentials, Receivers, Resolvers and Two-Speed Synchros.
- Tachometer Generators and Reference Generators.
- Aircraft Actuators, both linear and rotary.

Insure dependability... specify **Oster**



Mail this coupon for your copy of our illustrated pamphlet No. 974 on Oster Avionic Products.



JOHN OSTER MANUFACTURING CO. AVIONICS DIVISION
Dept. 436, Racine, Wisconsin, U.S.A.

Please send, postpaid, your catalog of OSTER Avionic Products.

Name _____
 Company _____
 Address _____
 City _____ Zone _____ State _____



New! Printed Circuit CONNECTORS

HHB SERIES EC

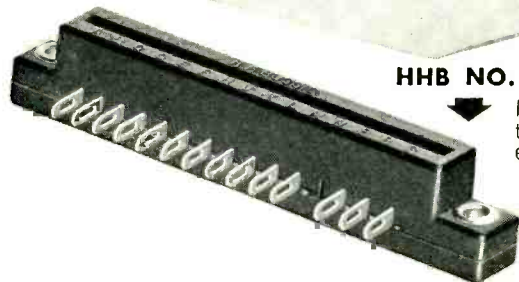

HHB NO. 3370 CARD RECEPTACLE

Fifteen beryllium copper pressure contacts with solder tabs protruding from either the bottom, right or left side, or combinations. Polarizing key positions to suit requirements. Material: No. 3700 green mineral filled phenolic. Plating: gold on silver. [Also available in other materials and platings.] Overall 3 5/16-in. x 3/8-in. wide x 5/8-in. high.

HHB NO. 3371 CARD RECEPTACLE

Fifteen beryllium copper pressure contacts equipped with terminal pins at bottom only for quick solder dip assembly. Polarizing key positions to suit requirements. Material: No. 3700 green mineral filled phenolic. Plating: gold on silver. [Also available in other materials and platings.] Overall 3 5/16-in. x 3/8-in. wide by 5/8-in. high.

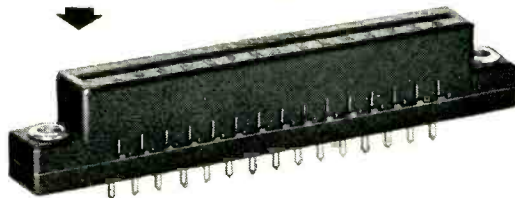

HHB NO. 3366 TERMINAL STRIP

—for periphery assembly of printed or etched cards. Fifteen terminal pins of phosphor bronze provided in lengths to accommodate 1/16-in. thick cards. Also available for 1/8-in., and 1/4-in. card thickness. Fast assembly by dip method of solder points. Material: No. 3700 green mineral filled phenolic. Plating: gold on silver. [Also available in other materials and plating.] Overall 2 21/64-in. x 5/16-in. wide x 5/16-in. high.

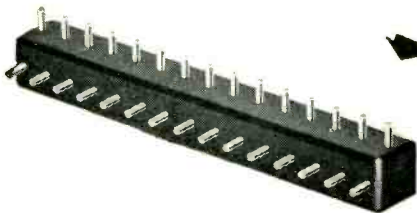

HHB NO. 3367 CONTACT STRIP

Same materials, dimensions, etc., as No. 3366 Terminal Strip. Pin contacts on one side mate with connector strip HHB 3372.



HHB NO. 3372 CONNECTOR STRIP

A female mating strip for male connectors HHB No. 3367, and No. 3369. Fifteen pressure type sockets of beryllium copper. Solder tabs for No. 20 wire. Two holes for permanent base mounting. Material: No. 3700 green mineral filled phenolic. Plating: gold on silver. [Also available in other materials and plating.] Overall 2 1/2-in. x 17/32-in. wide x 7/16-in. high.

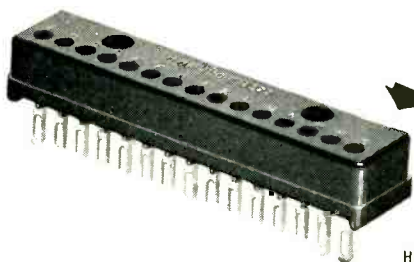

HHB 3368 Terminal Strip and HHB 3369 Terminal Connector Strip available for stack assembly of printed or etched cards. Similar to HHB 3366 and HHB 3367 with straight through terminal pins.

Write for 8-page catalog bulletin.

H. H. BUGGIE, Inc.
726 Stanton Street
Toledo 4, Ohio

Sales Engineers in All Principal Cities

Skilled in Electronic Component Parts
**RESEARCH • DESIGN
ENGINEERING
MANUFACTURING**

along with hand drilling and reaming of mating parts.

Mechanite castings are used as a supporting foundation for the fixture assembly. The castings are rough-machined, stress-relieved and ground true for face location of parts to be reamed. Bores for reamer journal guides and locators

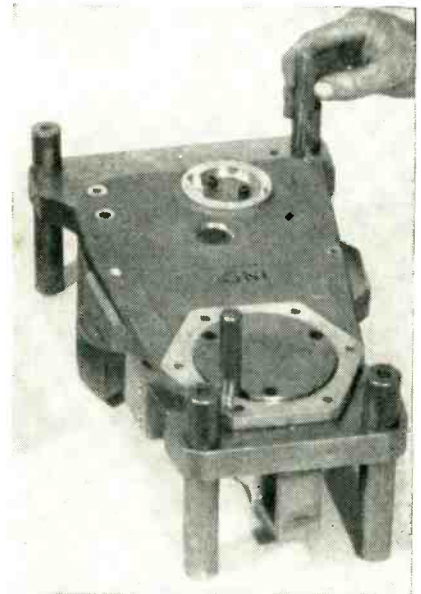

Alignment-checking fixtures for azimuth drive gear housing proves out correct location of bores and dowel pin holes and determines face squareness. Any casting distortion will show up here

are held within very close dimensional limits on a jig borer. Where production drawings allow plus or minus 0.0005 inch jig boring tolerances on the fixtures are held to practically zero limits.

Journal guides and caps, reamer bodies and shanks are fabricated of high-carbon steel, rough-machined, normalized and carburized. Guides and caps are ground, honed or lapped on all critical surfaces, maintaining extreme concentricity and face squareness.

Tungsten carbide inserts are brazed to reamer flutes and the entire unit ground on centers to near-zero concentricity and to the nominal diameter of the production part to be made.

All critical dimensions are checked with precision gage blocks and special gaging equipment. An additional check is made by using a jig borer to inspect the fixture and the first part run.

Several types of these master

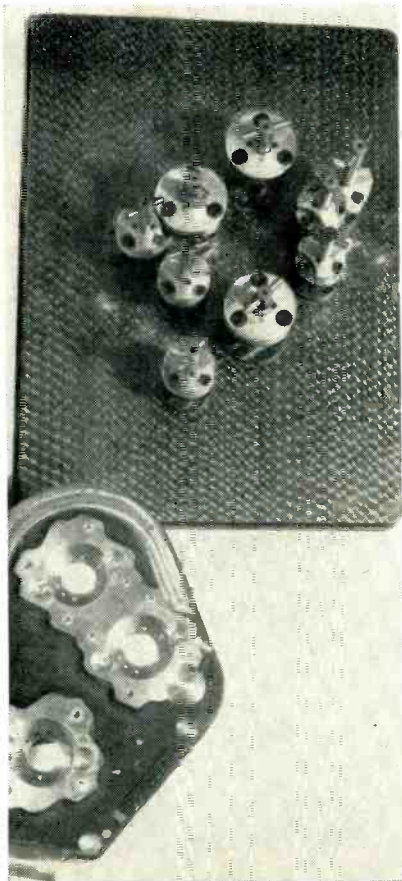

Example of reaming fixture for gear housing cover

reaming fixtures are currently in use, including those producing individual finished surfaces on external and internal diameters, face and shoulder dimensions, or a combination of these operations.

Besides providing precise alignment and interchangeability of parts, the fixtures eliminate match markings formerly used, hold scrap parts to a minimum and greatly reduce bench inspection time.

Induction Sealing of Magnetron Pulse Plug

FUSING of the metal pulse plug assembly to the glass envelope section of a type 4J52 high-power X-band search radar magnetron is achieved with a single-turn work coil during production of this tube in the Hicksville, N. Y. plant of Amperex Electronic Corp.

The water-cooled work coil is connected to a Ther-Monic r-f heating transformer having a single-turn secondary. The ring-shaped



when the going gets
ROUGH
VARIAN klystrons can take it

The true test of a production klystron is the ability to operate successfully when subjected to severe vibration and shock under field conditions. That's why manufacturers of mobile radar insist on VARIAN klystrons—klystrons that stand up when the going gets rough.

VARIAN KLYSTRONS ARE RUGGED

Varian makes **sure** that its klystrons meet field performance requirements by testing each one under severe high amplitude vibration. This production test, accurately duplicating field conditions, is rough — so rough that **ordinary** klystrons can't take it.

VARIAN MEANS PROVED PERFORMANCE

From design to finished product, Varian builds quality into every klystron. And quality means dependability — the reason why leading system manufacturers specify Varian when klystron performance is a critical factor in the operational reliability of their product.

For rugged, dependable, production klystrons, specify:

- VA-6310/V-260
- VA-6312/V-270
- VA-6313/V-280
- VA-6314/V-290
- VA-6315/V-153
- VA-6316/V-151

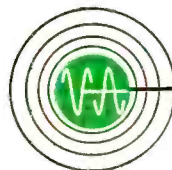

IN KLYSTRONS, THE MARK OF LEADERSHIP IS
VARIAN associates
PALO ALTO 1, CALIFORNIA

Representatives in all principal cities.

15 Horsepower in a 7"x11" case!

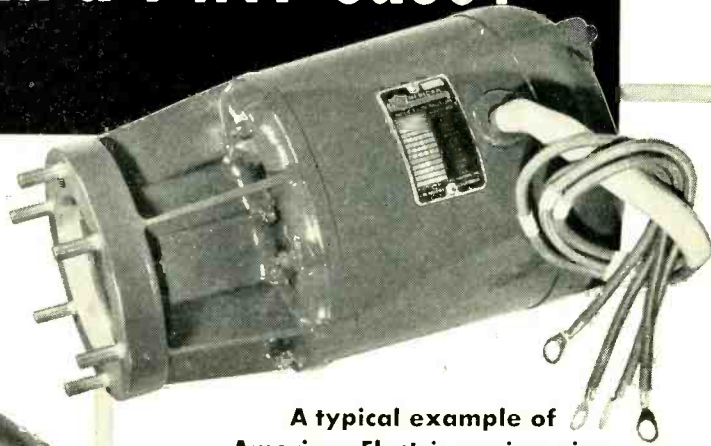

A typical example of American Electric engineering

This 400 cycle 3 phase motor for driving a hydraulic pump is a special aircraft design, custom-developed by American Electric Motors Inc. Rated at 15 h.p. continuous duty at 11,500 r.p.m., it actually produces 19 h.p. on intermittent duty, yet occupies less than 1/4 cubic foot. A special case made of magnesium holds weight down to a mere 32 lbs. or approximately 1/2 h.p. per pound. This motor is fungus-proof, corrosion resistant, meets AND 20002 type XIIB mounting specifications and is sealed against hydraulic oil. It operates within a temperature range of -67° to +131° F. Overall length of the motor unit is 7" with a 4" coupling extension.

MINIATURE MOTORS for all PURPOSES

In addition to engineering such "specials" described above, American Electric makes an almost unlimited range of miniatures for 60 and 400 cycle, and variable frequency operation. These feature low weight and compact size, meeting high temperature requirements. With our wide variety of completed tooling, laminations are available for almost any miniature motor requirement without design compromise or delay.

INDUCTION OR SYNCHRONOUS TYPES—Both reluctance and hysteresis motors are available in the synchronous type.

APPLICATIONS—American Electric Miniatures are available for all *drive requirements*, for *propeller fans* and *centrifugal blowers*. Let us quote on your requirements. Wire, write or phone today!

Variable frequency motors in these blowers and fans operate at minimum watts loss over the full range of frequencies encountered with aircraft power supplies—from 320 to 1000 c.p.s. CFM output of blowers is substantially uniform over full frequency range at atmospheric pressure. RPM rises at high altitude, increasing velocity and cooling ability.

Also Manufacturers of High Cycle Motor-Alternators and A.C. Industrial Motors.



4811 Telegraph Road,
Los Angeles 22,
California

FIELD ENGINEERING REPRESENTATIVES:

TRAVCO ENGINEERING COMPANY—Silver Spring (Md.) • Boston • Buffalo • New York City • Chicago
Dallas • Kansas City • Wright Field • Minneapolis • Seattle • Montreal • Toronto
JOE DAVIDSON & ASSOCIATES, Los Angeles

work coil has a rectangular cross-section, made by brazing together two washer-shaped pieces and two bands of copper. A solid inner ring fitting tightly inside the work coil adapts its large size to a specific smaller heating job. This solid center section is cooled by conduction from the hollow water-cooled outer ring. A single saw cut breaks



Rotating knurled sleeve to move pulse plug up and down during sealing to glass section of magnetron by induction heating

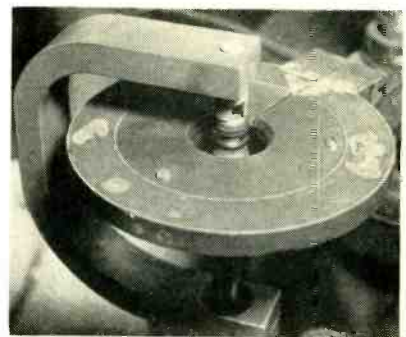

Construction of single-turn work coil, and details of pulse plug support

up the rings for connection to the transformer.

The operator first raises the C-shaped support bracket and inserts the pulse plug in the upper end of the bracket. She then places the mating glass section on the rod which comes up through the lower end of the bracket, and adjusts a knurled sleeve to adjust the joint up or down into the plane of the work coil. A touch of the start button then turns on the r-f generator for an interval controlled

by a preset timer. During heating, the operator can move the plug and the glass up and down independently to work the molten glass as required for obtaining a vacuum-tight metal-to-glass seal. This is done by manipulating the concentric supports, as shown in the photo.

Zone-Melting Setup for Refining Germanium

A NEW zone-melting method for refining germanium and other materials to practically perfect purity—99.9999999 percent pure—has been developed by W. G. Pfann at



Zone-melting setup for refining germanium

Bell Telephone Laboratories.

The new process is based on the fact that impurities are not equally soluble in the solid and liquid states of a substance; usually, impurities are more soluble in the liquid. To take advantage of this, a narrow molten zone is moved slowly along an ingot of relatively impure material to sweep the impurities to one end of the ingot.

This is accomplished by passing the ingot through a circular induction heater which, in the case of germanium, brings it to the molten state at a temperature of about 1,760 F. As the ingot is passed slowly through the heater, the

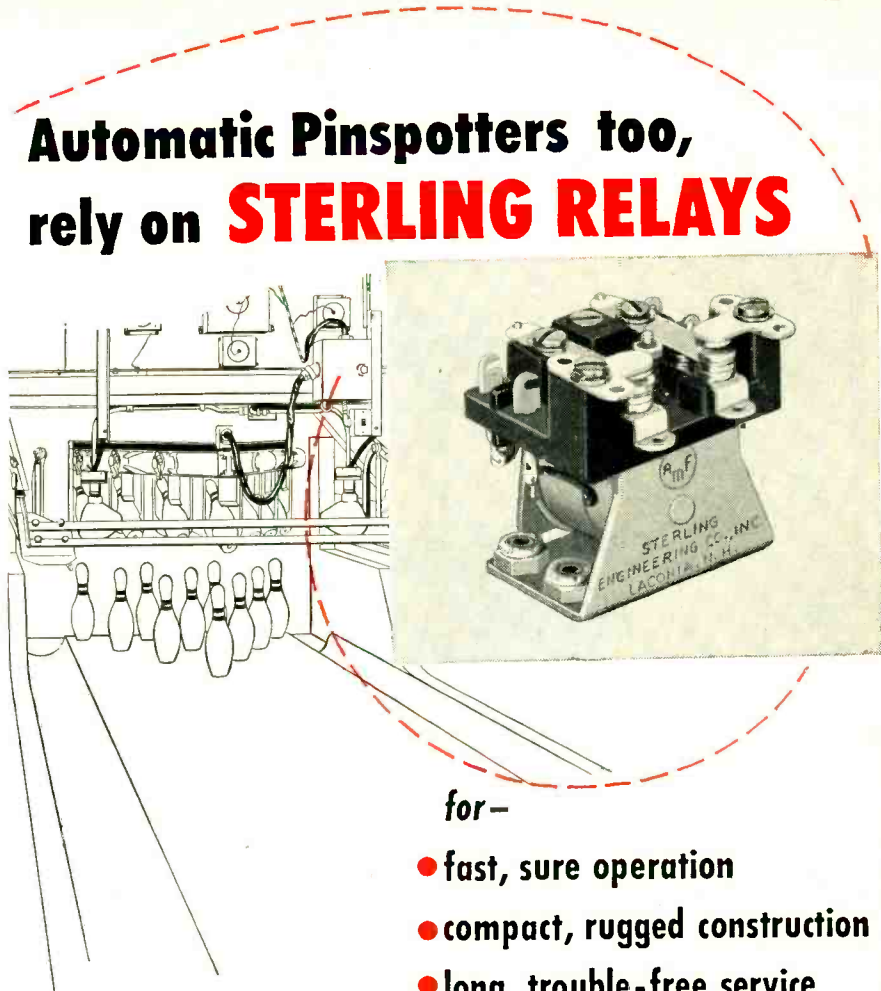

for—

- fast, sure operation
- compact, rugged construction
- long, trouble-free service

These amazing machines perform *automatically* every pit function in bowling, on a 17-second cycle, 24 hours per day! Six **STERLING** Relays in the machine's "brain" reliably coordinate a multiple series of electric and electronic circuits which actually enable it to "remember" and act with almost human intelligence... and superhuman accuracy!

To meet their exacting requirements, the manufacturers of Pinspotters rely on **STERLING** Type PS Relays—one of the many types of **STERLING** Relays used by leading manufacturers of electrically- and electronically-controlled equipment.

General Specifications: Sterling Type PS Relay

- COIL—single wound to 220 volts AC or DC
- POWER CONSUMPTION—2.5 watts DC—4.5 V. A. AC
- OPERATE TIME—approx. .025 sec.
- RELEASE TIME—approx. .010 sec.
- SPRING COMBINATION—2C (DPDT).
- #10 (1/4" silver) contact is standard. Contact Codes 3, 9, 11 and 12 are also available.
- MOUNTING—4 #6-32 stop nuts on 1/2" x 1-5/16" centers; four 7/32" clearance holes on same centers also available.
- DIMENSIONS—1 1/2" x 1 1/8" x 1-13/16" high.
- WEIGHT—approx. 4 oz.

May we send you the **STERLING** Relay Catalog or make up a test relay to fit your specific needs? Write **STERLING ENGINEERING COMPANY, INC.**, 54 Mill St., Laconia, N. H. (Subsidiary of American Machine & Foundry Company, New York.)



Make your next move...

to industry's greatest variable resistor value...

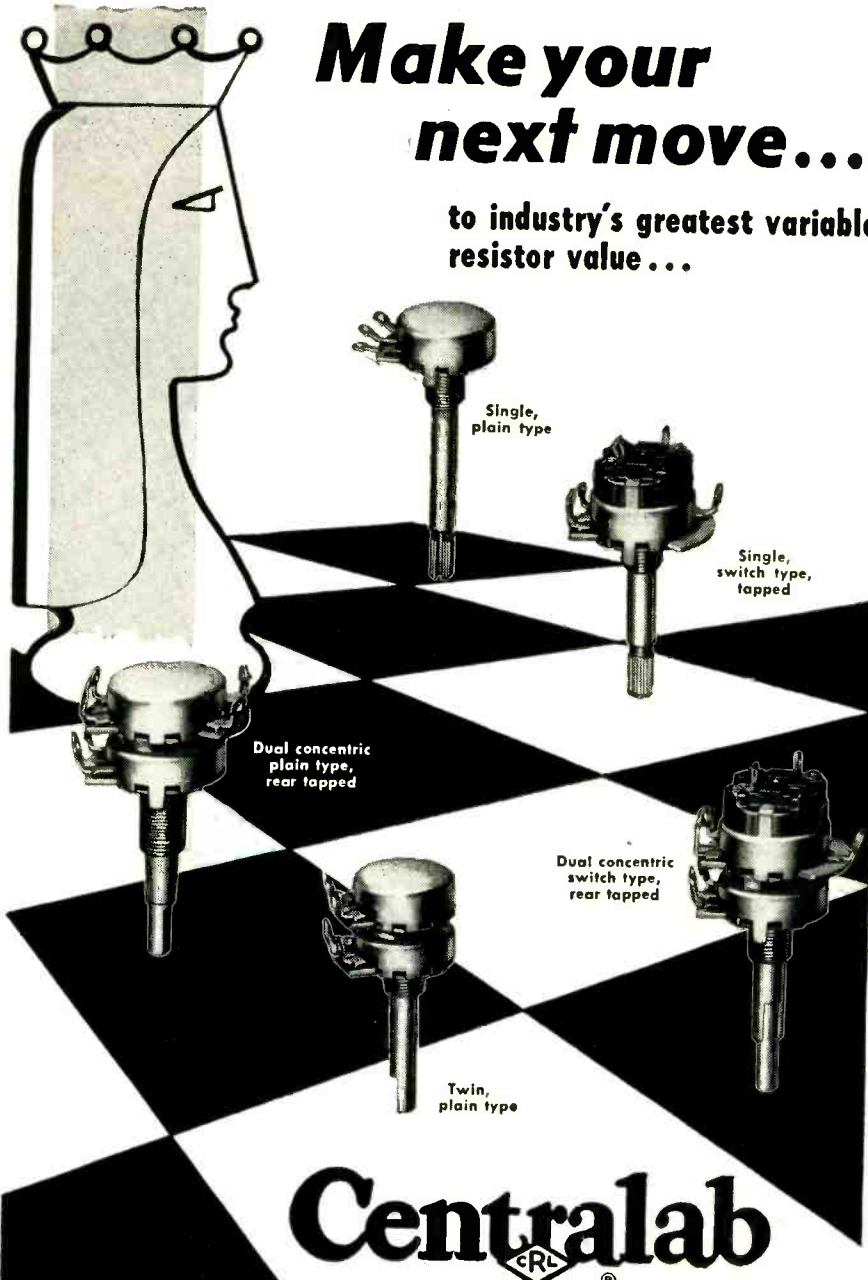

Centralab

Model 2 Radiohm®

SPECIFY Centralab Model 2 Radiohms — it's a move in the *right direction* to new production simplicity... new, finer performance. Model 2's are only $1\frac{5}{16}$ " in diameter, and rated at $\frac{1}{2}$ watt. You get lower noise level, longer life, more value for your money.

Imagine the larger variety of uses in TV, radio, sound and test applications. Available in two switch ratings — 5 amps @ 125 volts a-c and 8 amps @ 125 volts a-c. There are six different switching combinations for real flexibility and greater circuit simplification.

For complete technical data, write for Bulletin 42-164.

Centralab

A Division of Globe-Union Inc.
914-F E. Keefe Avenue • Milwaukee 1, Wisconsin
In Canada: 804 Mt. Pleasant Road, Toronto, Ontario

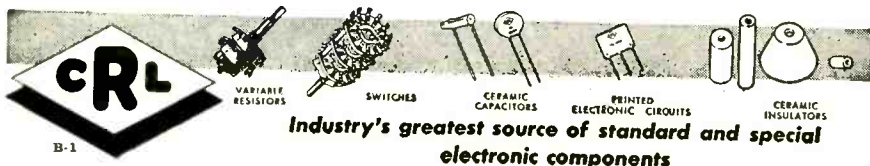

molten zone tends to hold the impurities while the ingot solidifies into a purer state on the other side of the heater.

In actual practice, a series of such circular heaters is used and each molten zone extracts its share of impurities from that left by the preceding zone. At the end of the run, substantially all the impurities have been swept to one end of the ingot. Here they are trapped when the tip of the ingot passes out of the heater and solidifies. This section, loaded with the impurities swept into it from the entire ingot, may then be cut off.

The zone-melting technique, adapted to the requirements of production operation, is now used to make the ultra-pure germanium required in the manufacture of transistors by Western Electric Co.

Painting Insides of 1B3 High-Voltage Tubes

Two different motorized setups are used to apply a band of insulating paint on the inside of glass envelopes for type 1B3 high-voltage tubes, in the Bloomfield, N. J. plant of Tung-Sol Electric Inc. The paint serves to break up the leakage path from the top to the bottom of the tube on the inside surface of the glass envelope. This path is provided by a barium oxide deposit resulting from getter flash. Painting material used is green in color, applied in a smooth thin layer.

The first setup uses one motor to rotate the glass envelope of the tube and another to drive a paint-

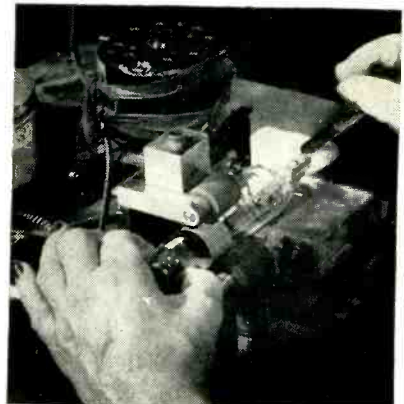

Setup using manually operated brush

mixing paddle and a wheel that runs in the paint and automatically applies the paint to the brush. Both motors operate through gear reduction systems.

The tube envelope rotates between three rubber rollers, one of which is driven by friction with a steel shaft on the gear system of the first electric motor. The upper rubber roller is mounted on a hinged and weighted arm that can be flipped up out of the way for unloading and loading tubes. A stop is provided for the top cap of the tube and the driven-rubber roller is skewed just enough to keep the tube pressing against the stop.

When an envelope has been loaded, the operator moves in a spring-mounted brush by bringing up a slide with her right hand. This slides the brush over the rotating paint wheel, making it pick up the required amount of paint. The slide is moved inward to a stop, bringing the brush in position. The operator then depresses the spring blade of the brush to apply the band of paint. The brush clears the en-

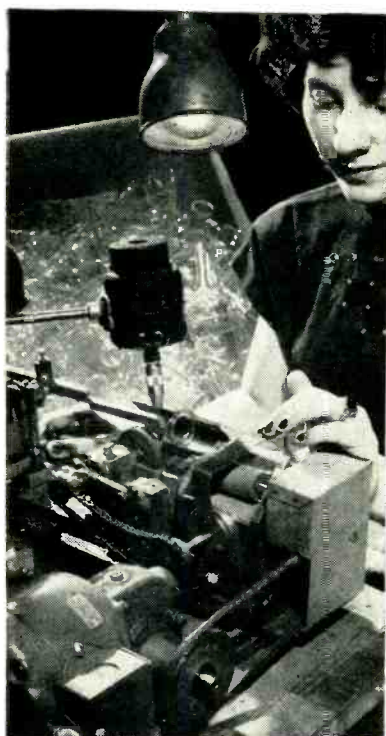

Setup using cam-operated brush for applying paint automatically in desired band inside envelope when operator moves in brush slide with right hand. Left hand is pressing down spring metal strip that holds envelope against its drive rollers

Precision WHEATSTONE BRIDGES

Highest Accuracy... Minimum Size for Field, Lab, and Production Use

There's a Shallcross Bridge for measuring resistance to any desired precision—indoors or out. Field models have aluminum cases with controls easily adjustable even with a gloved hand. Models for lab, production, and school use feature high readability and simple operation—even for unskilled users.

Accuracy, Stability, and Ruggedness—unsurpassed in any instrument of comparable price.

Selections from the complete Shallcross line are described below. Additional specifications on these, and many other types, are available from SHALLCROSS MFG. CO., 522 Pusey Ave., Collingdale, Pa.

Deliveries
from
Stock ✓

WHEATSTONE—FAULT LOCATION BRIDGE No. 6100:

5-dial field model. Locates grounds, crosses, opens, and shorts by Murray, Varley, Hilborn, or Fisher Loop and Capacitance tests. Range: 1 to 1,011,000 ohms. Accuracy: $\pm 0.1\%$, + 0.01 ohm. $8\frac{7}{8}'' \times 7\frac{3}{8}'' \times 5\frac{3}{4}''$. 8 lbs. Price: \$175.

KELVIN-WHEATSTONE BRIDGE No. 638-R:

Shallcross has pioneered this compact combination of two bridges in one. Range: 0.001 to 11,110,000 ohms. Accuracy: $\pm 0.3\%$ - 1 to 111,100 ohms. $12\frac{1}{2}'' \times 10\frac{1}{2}'' \times 6\frac{3}{4}''$. 9 lbs. Price: \$260.

WHEATSTONE-LIMIT BRIDGE No. 6320: C o m b i n e s

5-dial Wheatstone and Percent-Limit features. Range: 0.1 to 111,110,000 ohms. Accuracy—Ratio resistors: $\pm .01\%$, Rheostat: $\pm (.01\%$ to $.05\%$ + .005 ohms). $15\frac{3}{4}'' \times 9\frac{1}{4}'' \times 5\frac{1}{2}''$. 15 lbs. Price: \$700.

Shallcross

Now for the first time ...a Magnecorder under \$300



the new M30 professional tape recorder

The M30 Magnecorder is the first tape recorder to offer you professional quality at so low a price. The accepted leader in tape recording the world around, Magnecorders are used by more engineers than all other professional tape recorders combined.

complete in one case

The M30 Magnecorder is mounted in a handy portable case, with high fidelity output for external amplifier. Model M33, slightly higher, includes power output stage and integral PM speaker. Your dealer is listed under "Recorders" in the classified telephone directory.

magnecord, inc.

225 WEST OHIO STREET, DEPT. E-6
CHICAGO 10, ILL.

NEW LOWER PRICES ON STANDARD MAGNECORDER

See your dealer for
new reduced prices
on PT6 and PT63
gear.

velope when there is no pressure on the blade, to permit insertion and removal of the brush without causing streaks.

A newer and more automatic set-up which gives higher production rates has a cam arrangement for lowering and raising the brush automatically as the slide is moved in and out. Here both paddle and paint wheels are driven by the main drive motor through a sprocket and chain linkage, and a separate electric mixing motor with stirrer paddle is mounted overhead in the paint box to give additional mixing. Only two rubber rollers are used; the operator presses down a piece of spring steel over the top of the rotating envelope to keep it in position during the painting operation. This strip springs up out of the way automatically when released, permitting quicker removal and reloading of envelopes.

Installing Shock Mounts

FITTING RUBBER SHOCK MOUNTS into the chassis of electronic apparatus is usually an awkward hand operation. Hewlett-Packard, Palo Alto, Calif., uses a collet-type screw holder for quick and simple insertion of the shock mounts used for supporting a tube socket plate on a chassis.

The three mounts are first in-



Collet-type tool in position for pulling shock mount through chassis hole for socket plate held in hand

served one by one in the socket plate with the aid of the tool. The plate is then held in position against the bottom of the chassis and the tool is inserted through each mounting hole in turn from the top of the chassis to grip each mount and pull its other end through the chassis hole.

Self-Balancing Bridge Checks Parts Automatically

By DESMOND E. S. ISLE
Isle of Wight, England

A MOTORIZED Wheatstone Bridge, connected in the conventional manner but provided with fully automatic indication and control features, speeds testing and sorting of resistors in a British electronic plant. The unit is arranged to give an almost immediate output reading after connecting the component to be tested. Insofar as no controls are used by the operator, the possibility of maloperation is zeroed. No vacuum tubes are needed.

Values of bridge components vary with the resistance range of the products under test, hence no values are given. At balance $R_1 = R_x$ if the preset R_2 is adjusted to equal the resistance of relay K_1 . Rheostat R_1 is rotated by a permanent-magnet motor M at a speed of about 10 rpm during operation of the unit. This type of motor is

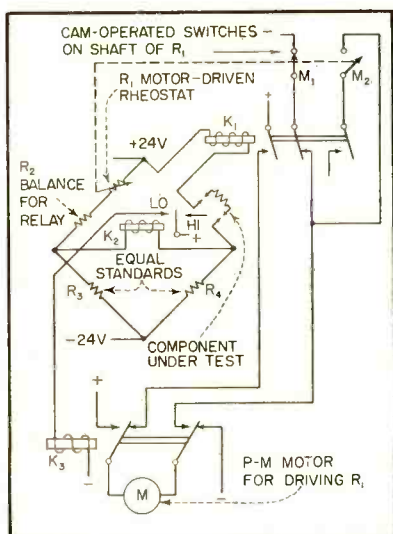

Circuit of bridge for production-testing all types of resistors

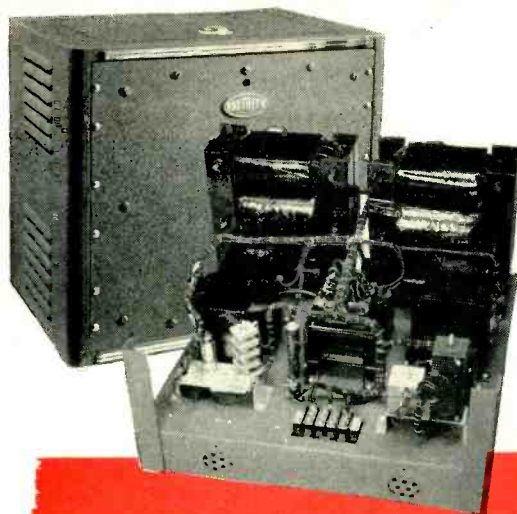

new
RAYTHEON
2KVA

VOLTAGE STABILIZER

with Magnetic Amplifier Control

This latest advance in voltage stabilizer design by Raytheon gives you these outstanding advantages of Magnetic Amplifier Control: (1) lower harmonic content (2) better no load to full load regulation (3) less cubic space required and (4) ability to take heavy overload without damage.

Write for complete information.

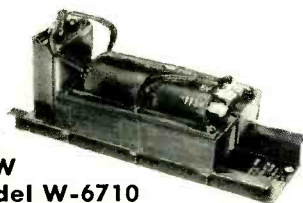

NEW Model W-6710 Voltage Stabilizer

OPEN TYPE CONSTRUCTION FOR CHASSIS MOUNTING

Insures constant 6 volts output at 25 watts, stabilized to $\pm 1/2\%$ from an input of 95 to 130 volts. Designed for 6-volt incandescent reference lamps; for colorimetric or spectrophotometric instruments and for stabilized filament voltages to tubes used in electronic apparatus within its rating.

SPECIFICATIONS

- Input: 115 volts, $\pm 10\%$, 58-62 cycles, single phase.
- Output: 115 volts, 2000 va.
- Output voltage stabilizations:
Fixed load, $\pm 1/2\%$ for line change.
 $\pm 1\%$ for frequency change.
No load to full load (85% P. F.), 1% maximum.
- Temperature rise of components; 50°C maximum.
- Harmonics (at 60 cycles input); less than 5% total.
- Efficiency at full load (100% power factor); 90% minimum.
- Mounting: Bench, floor, wall or relay rack.

RAYTHEON MANUFACTURING COMPANY EQUIPMENT SALES DIVISION

DEPT. 6270A WALTHAM 54, MASSACHUSETTS
DISTRICT OFFICES: BOSTON, NEW YORK, CLEVELAND, CHICAGO, NEW ORLEANS, LOS ANGELES (WILMINGTON), SAN FRANCISCO, SEATTLE
INTERNATIONAL DIVISION: 589 FIFTH AVE., NEW YORK CITY

RAYTHEON PRODUCTS INCLUDE: WELDPower* welders; Voltage stabilizers (regulators); Transformers; Sonic oscillators for laboratory research; Standard control knobs; Electronic calculators and computers; Radio, television, subminiature and special purpose tubes and other electronic equipment. *Reg. U.S. Pat. Off.

BUILD



Excellence in Electronics

DEPENDABILITY INTO YOUR PRODUCTS

The *Right Formula* For Solving Complex Problems...

HUBBELL
Interlock TRADE-MARK **CONNECTORS**
 + *New* **MAGNETIC**
DECISION ELEMENTS!

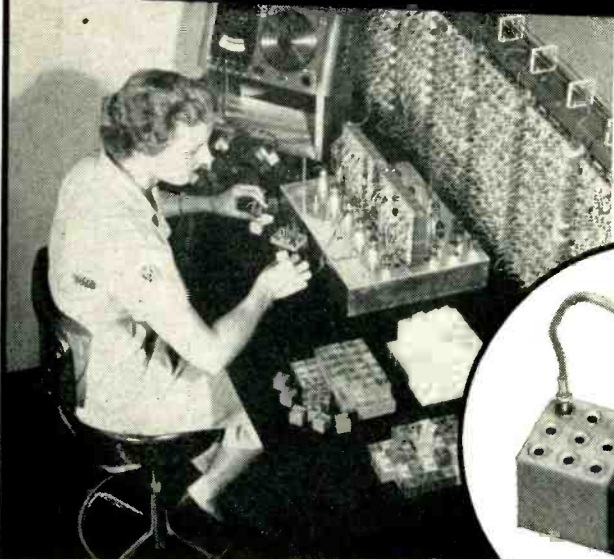

Inset shows closeup of computer blocks connected by wired Interlock Plugs.

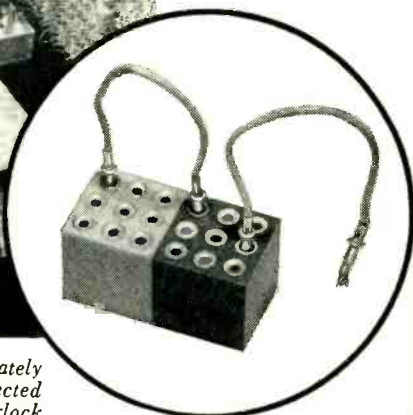

Plugboard (above) contains approximately 1,000 Magnetic Decision Elements, connected in various configurations by Hubbell Interlock Type "B" Automatic Locking Plugs to form basic computing structures.

Magnetic Decision Elements, designed by Minnesota Electronics Corp. and developed in collaboration with the U. S. Naval Ordnance Laboratory, White Oak, Silver Spring, Md., are basic computer blocks for building the entire arithmetic, program, control, and memory sections of any digital computer.

Hubbell Interlock connectors were selected to provide a low contact resistance for each block, necessary for accurate results in computations. Automatic locking . . . quick disconnect feature makes possible rapid cascading in any desired performance pattern. *Plugs cannot disconnect accidentally from blocks, yet can be quickly disconnected when intended.*

. . . Another example of Hubbell Interlocks's many applications in the field of electronics. Our development laboratory will cooperate with your engineers to adapt Interlock for your specific applications.

For Further Information, Write Dept. A:



HARVEY HUBBELL, INC.
 Interlock Dept., Bridgeport 2, Conn.

HUBBELL INTERLOCK DEVELOPMENTS

- Types A, B, C & S Plugs and Connectors • Flexible Terminal Strips
- Test Prod Kits • Laminated Terminal Strips

used to reduce overshoot time, as well as for its good acceleration qualities.

Relay Operation

Across the balance points of the bridge is connected a sensitive side-stable relay K_2 , which moves its armature to the LO or HI contact depending on the direction of the out-of-balance current in its coils. As motor M drives R_1 from its high value to its low value, the armature of K_2 will change over to LO shortly after balance is passed. In doing so, relay K_3 is operated.

During the period of search, relay K_1 is operated by the current passing through the component under test, and the motor for R_1 is driven through the contacts of K_1 and the normal-position contacts of K_2 . At the operation of relays K_2 and K_3 , the motor is halted as there is no path to minus for the motor while all three relays are pulled in. The value of the component is now read off a scale whose calibration is staggered slightly in advance of the value of R_1 to account for overshoot.

On removing the component, relay K_1 releases, causing the motor to continue driving R_1 and the indicator pointer. Rotation continues to an unmarked portion of the scale where a cam on the indicator shaft operates the mechanical contacts M_1 and M_2 . In opening, M_1 stops the unit in the ready position. Relay K_3 is still held operated by relay K_2 , although the test component has been removed.

On application of another test component in position, relay K_1 re-operates and completes the motor circuit through cam contact M_2 which is now closed. Driving once more on to the useful arc of R_1 , relay K_2 changes over and ensures release of K_3 . Control of the equipment now rests again with the finding of a balance condition. Thus, the complete sequence is repeated automatically.

If the test component is of higher value than can be normally indicated, relay K_2 will not pull over to HI, and due to the opening of the mechanical contact M_2 , an obvious fault condition will be shown up.

Similarly, if the test component

is shorted, relay K_2 will not pull in to LO, and the unit will continue to run for as long as the offending component is connected.

Mechanical Construction

The motor-driven resistor R , is driven via a 600-to-1 reduction gear box, with the indicating pointer moving at the same speed as the resistor wiper arm. About 70 percent of the indicator scale is calibrated, the remainder of the rotation being used for interlock purposes. When batching components having a particular tolerance, a colored Plexiglas arc of the required size is used to cover the permissible area of indication for the particular end values. Other similar aids may be devised locally.

Relay K_2 is a telegraph relay operating at about 2 ma, while K_1 and K_3 are standard K-3000 Inter-Services relays. Total size of the unit complete with rectifier-transformer assembly is about a 10-inch cube.

Performance

With regard to maintenance while in use, dust, particularly of the silica-base variety, is the main offender. Therefore, if ventilation is necessary, louvers should be carefully placed. Trouble from other sources is rare, as the majority of relays are given an adjustment-free life expectation of 10⁷ operations. The mechanical contacts should be constructed to give a small measure of self-cleaning action, by using about $\frac{1}{16}$ inch over-travel on the lifting cams.

The positive action of the equipment commends itself readily to use in quantity. Total cost of manufacture is about \$45. Production of a quantity would be assisted by the provision of a common d-c power supply serving all units in parallel.

Maintenance Tool Dolly

PORTABLE maintenance dollies for on-the-spot repairs, alteration and installation work cut travel time to the maintenance shop in General Electric's picture-tube plant at Electronics Park, Syracuse, N. Y. The dollies are used by plumbers,

PRECISION COMPONENTS tuned to tomorrow

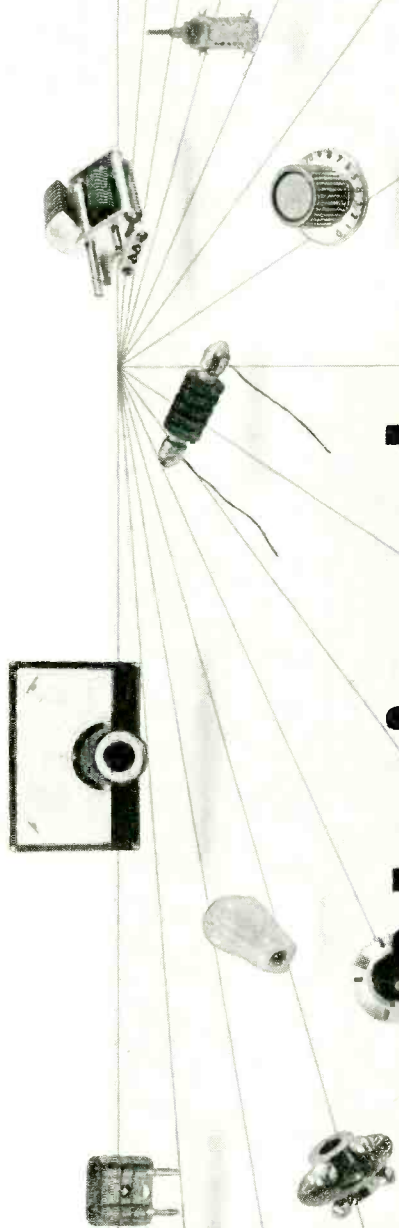
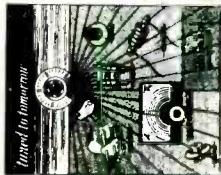

NEW CATALOGS

Write on your business letterhead, (or give your amateur call-sign) for your free copy of National's new catalogs of quality knobs, dials, spreaders, couplings, tube caps, grips and sockets, coils, coil forms, condensers and multi-band tank assemblies. Specify items in which you are interested. Write to Dept. E-654

National

NATIONAL COMPANY, INC., 61 SHERMAN ST., MALDEN 48, MASS.

IRON FIREMAN SENSITIVE RELAYS



Model No. MSR-300

Another new Iron Fireman product! These small current-sensitive DPDT relays operate positively where very little power is available, such as in vacuum tube circuits. Yet, their contacts will handle upwards of 200 watts. They are especially designed for dependable performance under adverse conditions of vibration, shock, temperature.

- Exclusive new design
- Resistant to shock and vibration
- Hermetically sealed
- Wide temperature range
- Long life

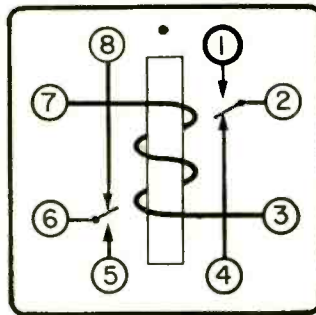

Typical relay circuit diagram

For more information on Sensitive Relays, as well as Choppers and High-Speed Relays, write to:



Iron Fireman Electronics
2800 S. E. 9th Ave., Portland 2, Ore. **DIVISION**



Plumber's maintenance dolly in picture tube plant

electricians and machine maintenance personnel.

The plumber's dolly includes pipe fittings, hand tools, plumbing compounds and other commonly used items. Mounted on top is a pipe vise. When a new shift begins, each maintenance man moves his dolly to the assigned area in the plant to be ready for rapid service.

Applying Dolflex Coating to Toroidal Coils

PLASTIC coating of toroidal coils was speeded and quality of work improved greatly when Lenkurt Electric Co. of San Carlos, Calif. designed a special conveyor for the operation. In early experiments without the conveyor and without automatic heating, two production workers were able to coat only 125 toroids a day and the rejects averaged 20 percent. Using the conveyor system, the same two workers now can produce at least 250 coated coils a day and the rejection rate is less than 1/2 percent.

The plastic material, Dolflex, is thermosetting, providing a fungus-resistant and fire resistant coating that is satisfactory electrically. It needs high and even heat to cure properly, and it must be handled rapidly before curing because it begins setting within a few seconds after touching a preheated object. Since the coating on toroids is only 0.015 to 0.020 inch thick, it must be perfect if it is to seal properly.

The oval-shaped conveyor de-



As first step in plastic coating, operator removes preheated mold from conveyor and preheated toroid from oven. Toroid is dipped in plastic and permitted to drain while mold is filled with plastic to the three-quarter mark

signed for the coating operation has a circumference of 10 feet and moves at a speed of three inches a minute. One section of the conveyor has a radiant heater above it that preheats metal molds and their lids to 275 F. Toroids are preheated in an oven at the same temperature at least 2 hours to drive out most of the air and moisture in them.

At the start of the operation a hot toroid is removed from the oven, dipped into the liquid plastic at room temperature, then removed and allowed to drain for a few seconds. While this is draining, a hot mold and lid are removed from the conveyor and sprayed with mold release. The operator then opens a faucet and permits the plastic to enter the hot mold to the three-fourths full mark. The toroid—on

NEW

FOR FIELD
FACTORY OR
SERVICE
USE

**THE ONLY PORTABLE GENERATOR
THAT PROVIDES ALL THE SIGNALS
REQUIRED FOR**

COLOR TV

Chromalyzer

by **TELECHROME**
INCORPORATED



Chromascope
(Signal
Certification)



Phase Slope
(Envelope Delay)
Curve Tracer

Accurately aligns and checks color TV receivers, monitors and checks video systems. Push button selection of Blue, Red, Magenta, Green, Cyan, Yellow, G-Y $\angle 90^\circ$, R-Y, B-Y, Q, I as well as Black, White, Luminance, Chrominance, Burst and Sync. Output is either Video or R.F. picture with sound carrier on channels 2 to 6. Specifically designed for servicemen, engineers and maintenance personnel. Portable. Can be locked into a system.

Complete equipment for generating color bars; creating encoded and composite pictures from transparencies; color signal certification; transmission, reception, monitoring, and analysis of color pictures — literature on these and more than 100 additional instruments for color TV by TELECHROME are available on request.

TELECHROME
INCORPORATED

The Nation's Leading Supplier of Color TV Equipment
88 Merrick Road Amityville, N. Y.
Amityville 4-4446

NO EXTERNAL CHANNELLING EQUIPMENT !

Standard
8
channel

Very **H**igh **F**requency
radio link
type
FP11

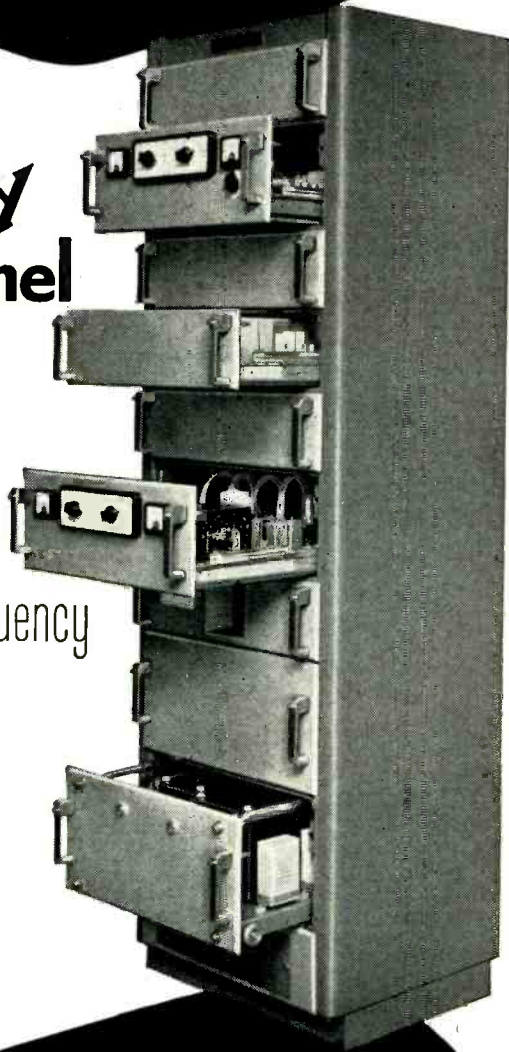

complete in one cabinet

Six Telephone or Teleprinter Channels, plus Independent Order Wire Circuit. Full Supervisory and Control Facilities. Alternative Radio Frequency Bands.

Write for leaflet No. 198/10

available for early delivery



Standard Telephones and Cables Limited

Registered Office: Connaught House, Aldwych, London, W.C.2

RADIO DIVISION • New Southgate • London • N.11 • England

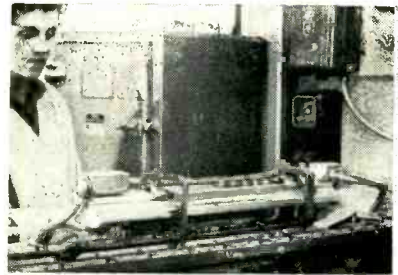

Conveyor used in plastic coating operation for small toroids

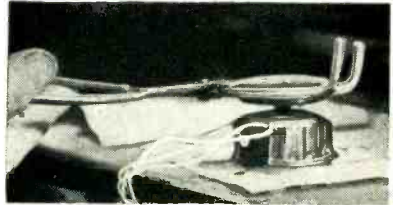

Preheated lid is partially filled with plastic and then pressed quickly in place on mold. Excess air and coating material are squeezed out as lid is pressed down firmly. Toroid leads extend through notches in wall of mold

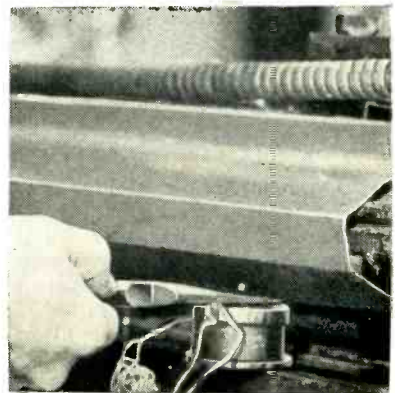

Placing mold in conveyor for heating 10 minutes at 310 F with radiant heaters above and below conveyor

which the coating has already begun to set—is immersed in the filled mold and pushed down with the fingers.

Wires or leads are threaded through notches in the wall of the mold. The hot lid is then picked up with tongs, partially filled with the plastic and quickly put into position on the mold. It is pressed down firmly to squeeze out excess material and any air trapped in the mold. The excess solidifies immediately and can be peeled off the outside of the mold easily.

The entire operation described above must be done quickly—in 12 to 15 seconds—to prevent imperfec-

tions forming in the plastic before it is cured.

The operator places the mold containing the toroid and coating on the conveyor where, for the next 10 minutes, it is cured by being heated to 310 F with radiant heaters both above and below the conveyor. A voltage regulator on the radiant heaters prevents spoilage resulting from voltage variations. A 30-second repeat interval timer is used to control on-off time for the radiant heaters.

After going through the 10-minute heating area (30 inches on the conveyor), the mold passes through a cool 30-inch area for another 10 minutes. It is then removed by a second operator who takes the mold apart, ejects the coil, trims it as needed and inspects it. The mold, now empty, is placed back on the conveyor and will pass through the preheat area before again reaching the first operator and being re-used.

Plastic-Top Assembly Bench

A SPECIALLY DESIGNED assembly bench is used at Helipot Corp., South Pasadena, California, for assembly of precision potentiometers. The design was carefully planned as a result of time and



Bench setup having recesses for parts pans. Assembly jig is fastened to bench

motion studies, and is custom built in the firm's own carpentry shop. The laminated sheet plastic top is glued to plywood, and holes are then drilled or cut to accommodate the small metal pans used in assembly operations. The gleaming plastic top contributes to cleanliness in producing precision components.

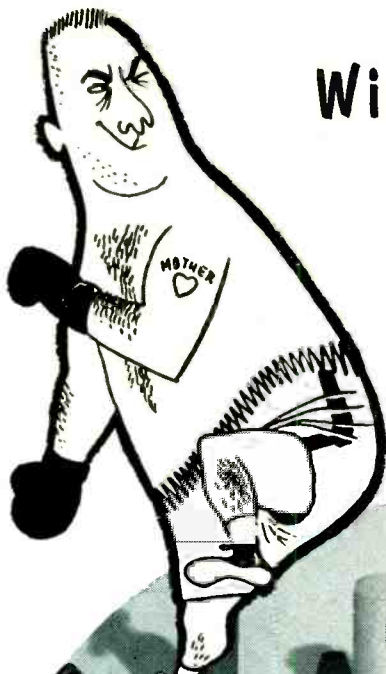

Willie Can
Only
PUNCH
'EM!

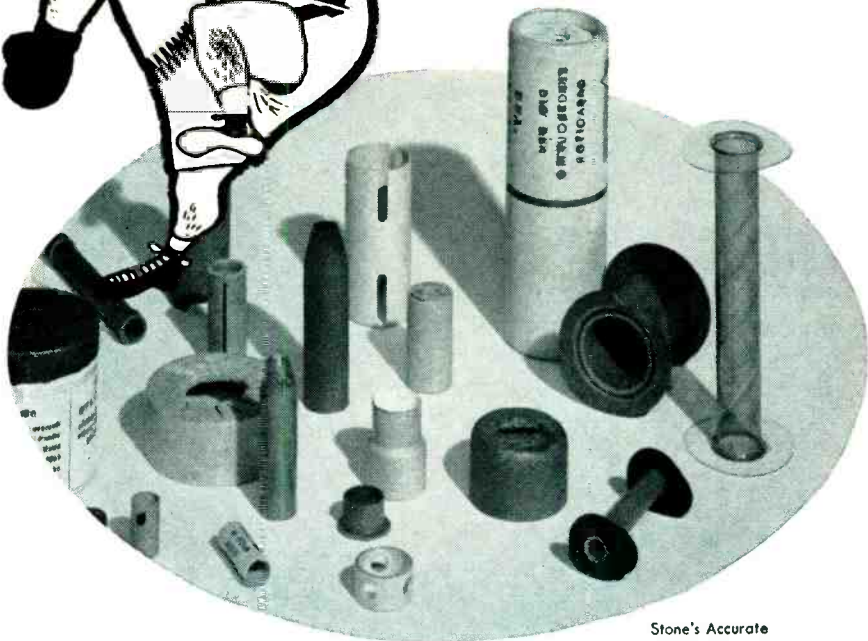

Stone's Accurate Fabrications

Stone is much more versatile than our friend Willie, ring warrior of repute.

We not only can punch our spiral wound small diameter paper tubes—we can notch 'em, slot 'em, fabricate 'em, and imprint 'em.

It's also common knowledge that Stone's custom-made yet mass-produced low cost tubes of kraft, fish paper, and plastic films are especially noted for hi-dielectric strength and close tolerances.

Stonized, a phenolic impregnated spiral tube, is best known for its low moisture absorption and good dimensional stability qualities.

When you need small diameter tubes, Stone's greater versatility and longer experience means better service at lower cost.

Phone or write us today.

Stone

PAPER TUBE CO.

AFFILIATED WITH

STONIZED PRODUCTS CO. INC.

900-922 Franklin Street, N.E., Washington 17, D. C.

NEW PRODUCTS

Edited by WILLIAM P. O'BRIEN

50 New Products and 65 Manufacturers' Bulletins Are Reviewed . . . Control, Testing and Measuring Equipment Described and Illustrated . . . Recent Tubes and Components Are Covered

MILLIVOLTMETER

useful in transistor studies

INDUSTRIAL CONTROL Co., Wyandanch, L. I., N. Y. The 213-A is a d-c millivoltmeter with high sensitivity, stable zero and direct polarity indication. It features full scale deflection of 1.00 mv d-c, a zero center movement with plus or minus deflection, and internal noise and drift kept below 10 μ v d-c. In addition, a d-c amplifier channel is made available with a maximum gain of 1,000, low output resistance, and stable zero and gain. No warmup time is necessary other than tube

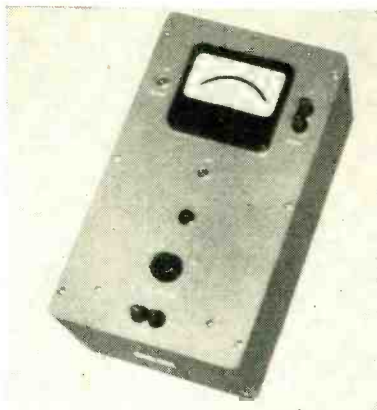

heating. Operation is from the 117 v, 60 cps line. No damage results from heavy input overloads. The 213-A is especially useful in semiconductor and transistor studies, circuit design, microwave and radiation work, transducer calibration, bridge measurements and as a low-level amplifier driving c-r and mechanical oscillographs, pen recorders and alarm relays.

COLOR CAMERA

televises films and slides



RADIO CORP. OF AMERICA, Camden, N. J., has announced the 3-V camera for televising color motion pic-

ture film and slides. It employs three Vidicon pickup tubes and a light-splitting optical system of dichroic mirrors. With the 3-V, many broadcasters can use present black-and-white film and slide projectors with only minor modification. Equally important, they can use a single 3-V camera to select up to three picture sources and shift from one to another simply and instantaneously. The new camera will be used with a special 3-V optical multiplexer. Into this unit may be fed

the output of two motion picture projectors—either 16 mm or 35 mm—and a dual-disk, single-lens, 2 x 2 slide projector. Controls on the multiplexer will permit instantaneous shifting of the camera pickup among these sources. The dichroic mirror system divides the color image into three parts. It does this by light-splitting lenses which reflect light of a given primary color while transmitting light of the other primary colors. Each of the three resulting images is fed to a corresponding Vidicon tube, which then generates a signal representing only that part of the image.

POWER RESISTORS

in 5 and 10 watt sizes

SPRAGUE ELECTRIC Co., 35 Marshall St., North Adams, Mass. Two miniaturized self-mounting wire-wound power Blue Jacket resistors for use in tv and industrial electronic production where space is a factor have been announced. These axial-lead vitreous-enamel units, types 27E

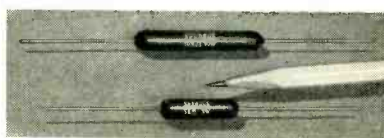

and 28E, are designed specifically for applications where reliability is a must, and are ideal for point-to-

point wiring, terminal board mounting, and processed wiring boards, fitting ideally in dip-soldered sub-assemblies.

TINY CONNECTORS

feature reduced weight

AMERICAN PHENOLIC CORP., Chicago 50, Ill. A reduction of weight

OTHER DEPARTMENTS

featured in this issue:

	Page
Electrons At Work	196
Production Techniques	214
Plants and People	328
New Books	368
Backtalk	378

Big Savings Ahead

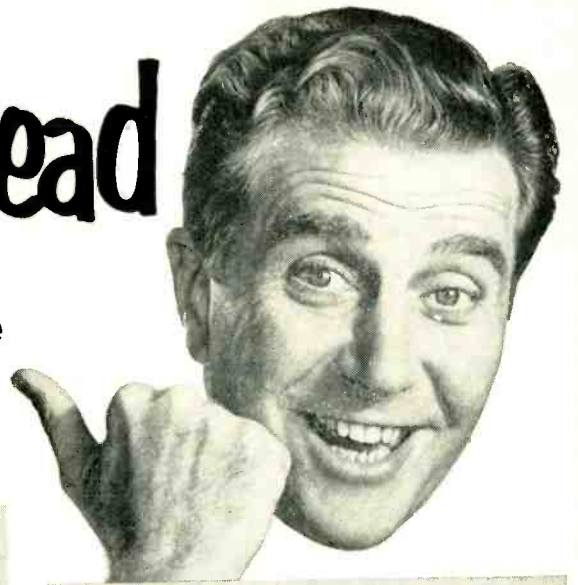

2 New SYLVANIA SOCKETS save Assembly Time ... Cut Costs ... Improve Performance!

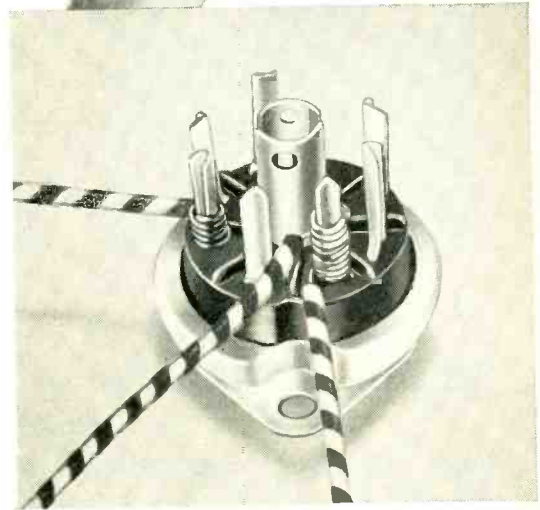
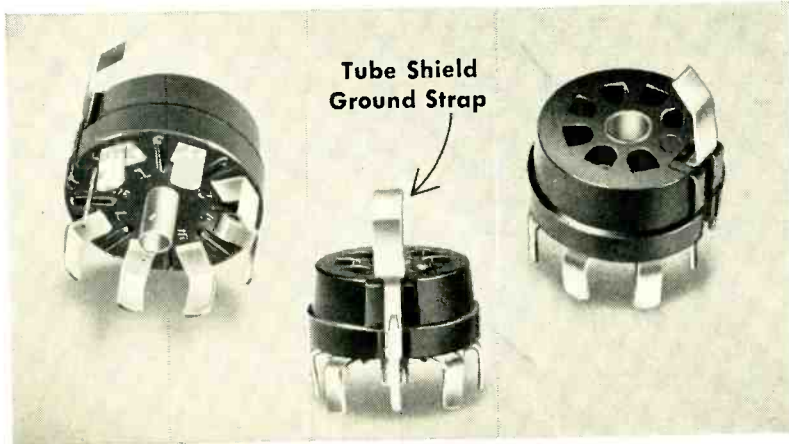

1. New Sylvania 7-pin Miniature Printed-circuit Sockets. Contacts and center shield are shaped so that sockets can be stacked one upon another for automatic feeding and assembly. Small slots are used on the circuit board to receive the contacts, resulting in stronger chassis construction. Only one socket assembly need be stocked since terminals can be interconnected by printing the circuit on the chassis board rather than using a metallic connector on the socket itself.

Insulator is molded of general-purpose or low-loss phenolic. Contacts are brass or phosphor bronze, plated to suit your specification. Supplied with or without center shield. Now available in 7-pin construction with 9-pin miniature and other types to follow. Tube Shield Ground Strap can also be furnished.

2. New Sylvania Solderless-type Sockets for wire-wrapped connections are now being made in all 7 and 9-pin miniature sizes. Contacts are shaped to provide reliable connections with the use of present wire-wrapping tools.



See the full story of Sylvania's Fabricating Services in Sweet's Catalog — Product Design File. Look for **1b** **Sy**

For full information concerning these or other Sylvania parts, or special quality components engineered to your own specifications, write to Dept. 4A-1606, Sylvania today.

SYLVANIA

Sylvania Electric Products Inc., 1740 Broadway, New York 19, N. Y.
 In Canada: Sylvania Electric (Canada) Ltd., University Tower Building, St. Catherine Street, Montreal, P. Q.

LIGHTING • RADIO • ELECTRONICS • TELEVISION

is a feature of the new 165 series of miniature AN connectors. These miniatures are used extensively in modern aircraft and guided missiles. The new connectors are available in two sizes, six configurations—with 5, 9, 11, 12, 14 or 24 gold plated contacts. They are

pressurized but not hermetically sealed and will far exceed the government-required 50-hour salt-spray test. Female connectors feature a sandwich-type construction for the inner seal with the containing cartridge spun over, thus being sealed at the factory with

no chance of leakage. The outer seal is accomplished with a silicone O ring. Other features include a hard-coat finish anodically formed on the aluminum shell; the blue 1-501 dielectric; and interchangeable inserts (contact sizes No. 20 and No. 16).

INSULATED TERMINAL

for heavy-duty wire use

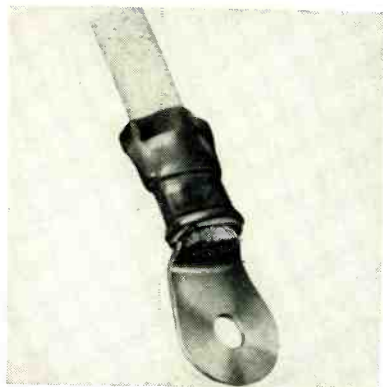

AIRCRAFT-MARINE PRODUCTS, INC., 2100 Paxton St., Harrisburg, Pa., has developed the Ampli-Bond insulated terminal for users of heavy-duty wire. It gives a positive and complete bond of the insulation to the terminal sleeve, insures uniform insulation thickness under confined crimping pressures, and therefore transmits the pressure evenly to the center of the crimp area. Insulation is designed to extend minimum distance beyond terminal barrel,

provides maximum permanent support and allows the use of large-size wire in restricted areas. Completely separate metallic ring grips wire insulation, prevents exposure of conductor during sharp bends and cable fatigue caused by excessive flexing and vibration. This nonconducting ring forms a barrier to foreign objects coming in contact with current-carrying members. A tough vinyl insulation is used that will withstand a minimum of 6,000 v, which is four times the military specification for insulated terminals.

PRESSURE TRANSDUCER

for high-range use

NORTH AMERICAN INSTRUMENTS, INC., 2420 N. Lake Ave., Altadena, Calif. Model GP-8 high-range pressure transducer has ranges extending from 200 to 5,000 psi gage and all are rated at 100-percent safe overload. The instrument is suitable for both static and dynamic measurements. Dynamic response is more than sufficient for most measurements involving transient

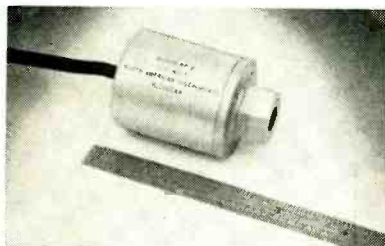

pressure phenomena. The natural frequency runs from 2,000 cps to

10,000 cps. The unit has been designed with particular emphasis on resistance to mechanical vibration and shock excitation. Electrical characteristics of the model GP-8 are the same as those of the company's other transducers. Any excitation frequency from 60 to 50,000 cps may be used, the maximum input voltage at 3,000 cps being 30 v. Full scale output is 40 mv per v input in bridge circuit operation. Rated accuracy including linearity is 1 percent full scale or better.

WAVE ANALYZER

for vibration analysis

THE DAVIES LABORATORIES, INC., 4705 Queensbury Road, Riverdale, Md. Completely automatic reduction of vibration, seismic, power line transient, noise, shock and the like can be made on the heterodyne type, series 901 automatic wave analyzer. The analysis is a Fourier analysis—amplitude vs frequency. Covering the frequency range of 3 to 2,000 cps, it has the following features: variable bandwidth $\frac{1}{2}$ to 45 cps, analysis down to 3 cps, amplitude

accuracy ± 5 percent of reading on logarithmic scale, frequency accuracy $\frac{1}{2}$ percent of reading, input voltage range 60 db and input impedance $2\frac{1}{2}$ megohms. Analysis is recorded and up to 14 inputs are handled and selected completely automatically, including if desired the simultaneous analysis of from two up to the total number of inputs. The analyzer consists of 6 basic units, which are available individually as well as in an as-

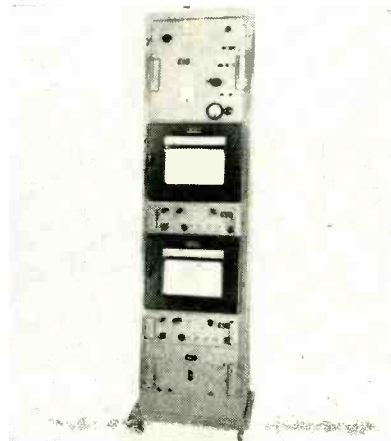

FAMOUS KINGS IN HISTORY



RICHARD I—affectionately surnamed “the Lion-Hearted”—was King of England from 1189 until his death in battle ten years later. In the first year of his reign he started on the Third Crusade. A major figure in English romance, Richard Coeur de Lion is a symbol of chivalry and famous for many deeds of valor.

In this scientific age, Connectors by Kings are a symbol of the most modern progress in engineering ingenuity and precision manufacture. Electronics engineers everywhere accord them a valued recognition earned by years of research and product development. For the finest “Solid Contact” Connectors make Kings your prime source.

FAMOUS KINGS CONNECTORS



UHF SERIES

 **KINGS**
Electronics
40 MARBLEDALE ROAD, TUCKAHOE 7, N. Y.

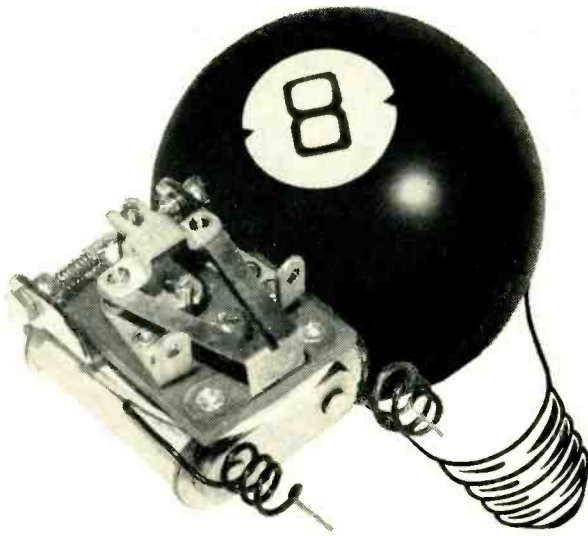

NEW LIGHT ON THE LAMP LOAD PROBLEM

This relay was developed for use in photoelectric street light controls, where, to the problem of handling an incandescent load without contact welding, is added the requirement of doing so on normally closed contacts.

The cold starting current drawn by an incandescent lamp bulb is many times greater than its running (hot) current. When, as in our testing procedures, the circuit is connected over heavy gauge wires direct to a "stiff" power line, and when the bulbs are allowed to cool fully between cycles, the starting current is 10 times the running current. Although it varies with different sizes and voltages

of bulb, a figure of 10 is conservative on 120 volt circuits.

The Type 51 Sigma Relay is a sensitive SPST contactor, normally closed. It operates at 100 milliwatts D. C. (3.2 ma, 10,000 ohm coil). Switches 10 Ampere Incandescent lamp load at 120 V. A. C. for a life expectancy of 5,500 times, or once per day for 15 years.

The Type 51 Relay should be given a try when 100 milliwatts coil signal must switch 10 to 25 Amps (24 V. D. C. or 110 V. A. C.) 10,000—100,000 times, on resistive or inductive loads.

SIGMA

SIGMA INSTRUMENTS, INC.

62 PEARL ST., SO. BRAintree, BOSTON 85, MASS.

sembly-input switching panel, oscillator-controller, modulator-filter, recorder, power supplies and rack.

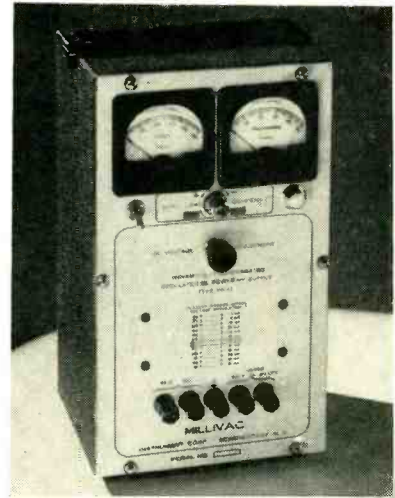

D-C POWER SUPPLIES have unusual stability

MILLIVAC INSTRUMENT CORP., 444 Second St., Schenectady 6, N. Y., has developed a series of RP supplies to meet the demand for regulated d-c power supplies that have high stability at a reasonable cost. They are dynamically compensated to provide zero or slightly negative internal impedance to compensate for voltage drops in lines between the power supply and the consumer. These new small supplies range in voltage from 250 to 400 v and in current from 50 ma to 100 ma.



POWER SUPPLY features a high-gain circuit

CONSOLIDATED ENGINEERING CORP., 300 N. Sierra Madre Villa, Pasadena 8, Calif. Zero to 15 v d-c at a maximum of 1 ampere is the output furnished by the type 3-132 power supply. Designed for the excitation of multiple strain gages and other resistance type transducers, it may be used as a second-

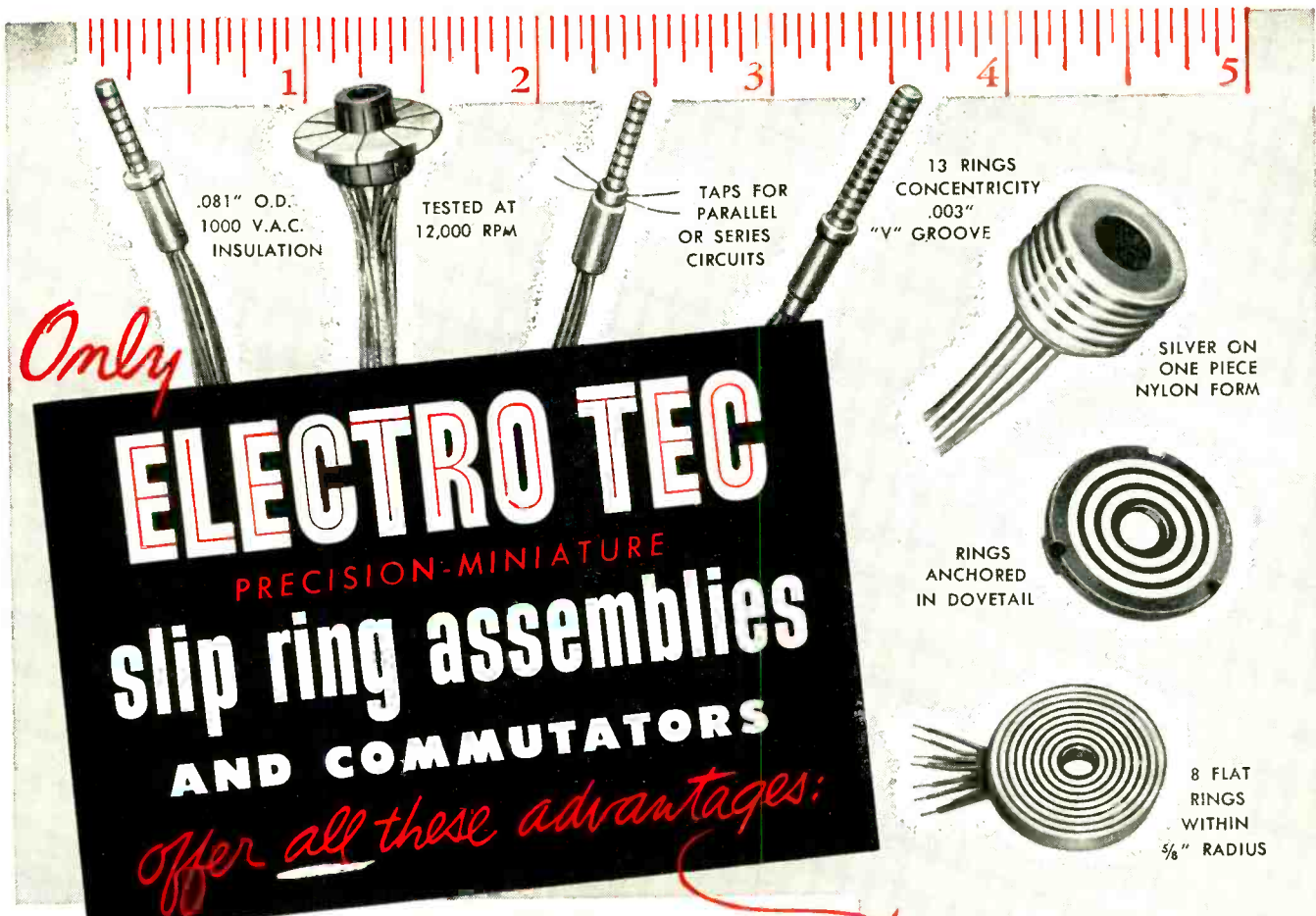

Only

ELECTRO TEC

PRECISION-MINIATURE

slip ring assemblies

AND COMMUTATORS

offer all these advantages:

EXCLUSIVE* ELECTRO TEC TECHNIQUES

insure closer tolerances, absolute uniformity, and the ultimate in miniaturization

Electro Tec units are the product of an exclusive manufacturing technique that results in accuracy unattainable by conventional fabricating methods. In this process a plastic is moulded around the wire leads. Accurate machining reduces this blank to the proper shape, complete with grooves. Hard silver is deposited into the grooves by electroplating to produce the required rings. Final machining insures concentricity and dimensional accuracy. The result is one-piece, unitized construction with conducting rings of 60 to 70 Brinell hardness.

Diameters of these assemblies range from .045" to 24" cylindrical or flat. Cross-sections may range from .005" to .060" or more. Rings are polished to a jewel-like finish and can be held to 4 micro-inches or better. Even the smallest sizes withstand a 1000 V.A.C. breakdown test. Most types easily withstand rotational speeds up to 12000 rpm.

ELECTRO TEC Assemblies are Specified by the Nation's Leading Precision Instrument and Equipment Manufacturers for Proven Greater Dependability, Longer Life, Smoother Functioning.

The uniformly superior performance of Electro Tec slip ring and commutator assemblies in thousands of industrial and governmental applications has resulted in wide adoption of these component units by most leading manufacturers of precision instruments and equipment. Although these products provide improved performance and extra dependability, prices are strictly competitive. Write today for fully illustrated literature.

ELECTRO TEC CORPORATION
 SO. HACKENSACK NEW JERSEY

PRODUCTS OF PRECISION CRAFTSMANSHIP BY A NEW AND REVOLUTIONARY PROCESS

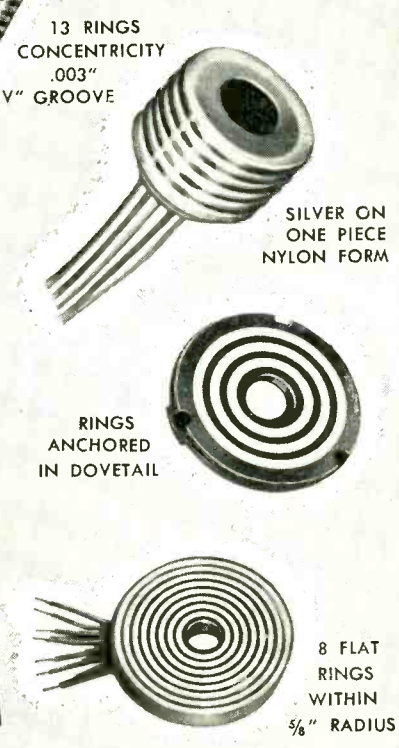

- ONE PIECE, UNITIZED CONSTRUCTION
- ABSOLUTE MINIMUM TORQUE FRICTION
- DIAMETERS FROM .045" TO 24.0"
- MINIMUM 1000 V.A.C. HI-POT INTER-CIRCUIT
- UNIFORMLY HARD SILVER RINGS PLATED INTO GROOVES ON PRECISION MACHINED ONE PIECE PLASTIC FORM
- SPECIAL SURFACE DEPOSITS PREVENT TARNISH, MINIMIZE FRICTION, BRUSH NOISE AND PRACTICALLY ELIMINATE WEAR

ACTUAL SIZE

ULTRA-MINIATURIZED SLIP RING ASSEMBLY

6 Insulated Contact Rings	Rings 60-70 Brinell Fine Silver
Ring Width .030"	Tarnish Resistant
Barrier Width .015"	Friction Minimizing
Ring Diameter .045"	Surface Deposits
Weight 5.5 Grains (1/80 Ounce)	1000 Volt Hi-Pot Between Rings
	Color Coded Leads

*PATENTS PENDING

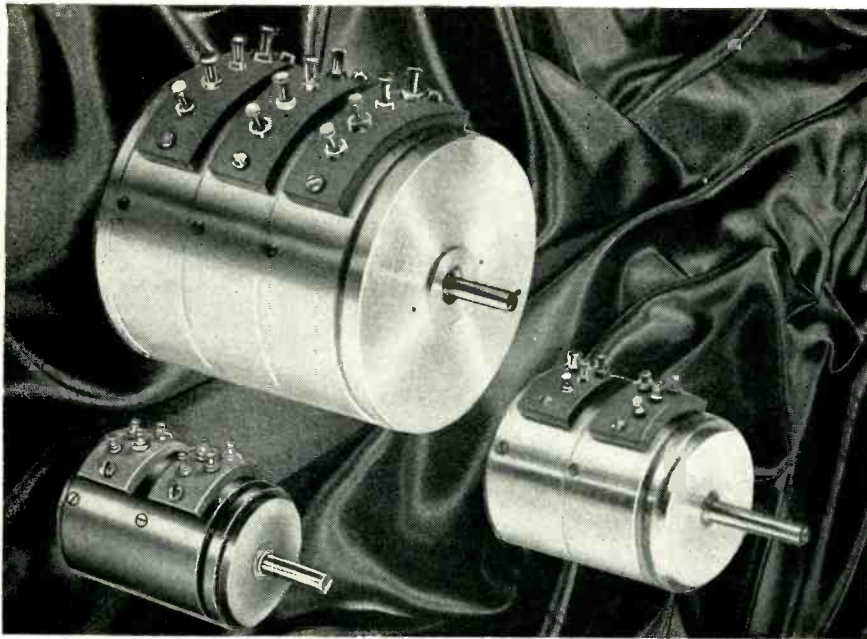

Three NEW Fairchild Precision Potentiometers

TYPE 751 7/8"

TYPE 741 1 1/8"

TYPE 754 2"

LINEAR

Type 751, resistance range 400 to 20,000 ohms, linearity $\pm 0.5\%$ or better; Type 741, resistance range 500 to 25,000 ohms, linearity $\pm 0.5\%$ or better; Type 754, resistance range 800 to 100,000 ohms, linearity $\pm 0.15\%$ or better. All are extremely compact and are available with servo mounts. Internal clamp rings permit ganging without increasing overall diameter. All have gold-plated terminals for reduced contact resistance and easier soldering. Standard resistance values Types 741 and 751—500, 1000, 5000, 10,000, 20,000 ohms; Type 754—1000, 5000, 10,000, 20,000, 50,000 ohms.

Three more reasons why Fairchild can supply ALL your precision potentiometer needs

Fairchild makes a complete line of precision potentiometers to fill all your needs—linear and nonlinear potentiometers, single or in ganged combinations . . . single-turn, helical and linear motion . . . with servo or threaded bushing mounts . . . and with resistance elements to meet your requirements.

Fairchild guarantees accuracy of $\pm 1\%$ in nonlinear types and $\pm 0.5\%$ in linear types. Highly accurate production methods and close mechanical tolerances, plus thorough type-testing and quality control, assure high resolution, long life, low torque and low electrical noise level in every Fairchild potentiometer. For more information, or for help in meeting your potentiometer problems, call on Fairchild Camera & Instrument Corp., Potentiometer Division, 225 Park Avenue, Hicksville, L. I., N. Y., Department 140-53A.

FAIRCHILD

PRECISION POTENTIOMETERS

any reference voltage source in many other research, production, calibration and measurement applications. It is also a convenient voltage supply for sensitive filaments in d-c amplifiers. Continuously adjustable over the 0 to 15-v range, output voltage is indicated on a front-panel meter and may be varied with a 10-turn voltage-setting control. Output impedance is less than 0.1 ohm; output drift, less than 5 mv per hour; and ripple, less than 1 mv peak-to-peak. A 10-v change or transient in a 105 to 125-v a-c line voltage causes less than 10-mv change in the output; a 0 to 1-ampere change in load causes less than 20-mv change. The unit's outstanding performance results from its high-gain circuit, a portion of which continually compares the output against a stable internal reference voltage to insure absolute regulation.



S-S FILTER for amateur receivers

BURNELL & Co., 45 Warburton Ave., Yonkers 2, N. Y. Type S-15000 single-sideband filter for amateur receivers utilizes a toroid coil instead of the costly crystal filters formerly required. The S-1500 ssb filter features compact size and ease of installation. Fixed-tuned and hermetically sealed, it requires no adjustment, is rugged and trouble-free. It may be installed in any existing amateur receiver now in use, and is also suitable for incorporation into new designs by set manufacturers. It utilizes 50 kc as a 2nd i-f and provides a narrow-band, sharp cutoff response which insures maximum intelligibility and maximum signal intensity. Descriptive

information, including schematic and response curve, is available in a single-sheet bulletin.

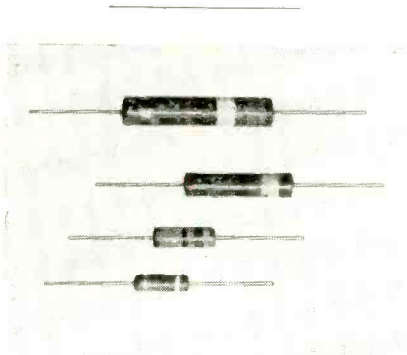

INSULATED CHOKES
for many applications

INTERNATIONAL RESISTANCE Co., 401 North Broad St., Philadelphia 8, Pa., has available a line of chokes in four sizes, all protectively insulated against high humidity in molded plastic housings. Identified as types CL1/2, CLA, CL1 and CL2, they offer a wide range of size and characteristic combinations, and permit accurate specification to individual space and electrical requirements. The chokes offer numerous circuit applications, such as: filament chokes, plate loads, wave traps, parasitic suppressors, line terminating impedances, cathode chokes, antenna chokes and grid chokes.

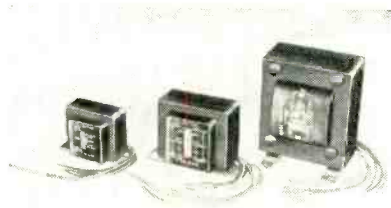

TRANSFORMERS
are plastic-molded

TELECTRO INDUSTRIES CORP., 35-18 37th St., Long Island City 1, N. Y., announces the introduction of Telectrans, the new custom plastic-molded transformers and reactors for the electronic industry. Through the use of a novel method of plastic encapsulation, Telectrans improve upon the conventional hermetically sealed transformer and the use of hermetically sealed solder terminals. Telectrans are manufactured

from Melt to Mechanism
Help for you
... with
micro-precision production

No. 602
the case of
The Mirror-Surfaced Spring

Our Customer's Problem
To obtain a corrosion-resistant spring with a mirror-finish; tensile strength required 200,000/250,000 psi; capable of being bent cold through an angle of 180° without fracture; thickness tolerance $+ .00000, -0.00003$ "

Our Solution
Laboratory-controlled diamond-die drawing equipment developed by Hamilton to produce super-tough ribbon-like hairspring wire permitted quantity production of this exceptionally high quality spring, at reasonable cost.

Your Problem
When you need fast production of small precision screws, "problem" parts, jewel bearings, or complex devices—machined to microscopic tolerances when necessary—assembled in any quantity—checked by extra-expert inspectors—guaranteed to do the job designed every time... call on Hamilton. Send your prints—we'll be glad to help you.

Hamilton Precision Service for all Industry
Turning
Milling
Threading
Recessing
Profiling
Assembly
Inspection and Testing
backed by
Metallurgy
Engineering
Design Help

Allied Products Division
Hamilton Watch COMPANY
930 WHEATLAND AVE., LANCASTER, PA.

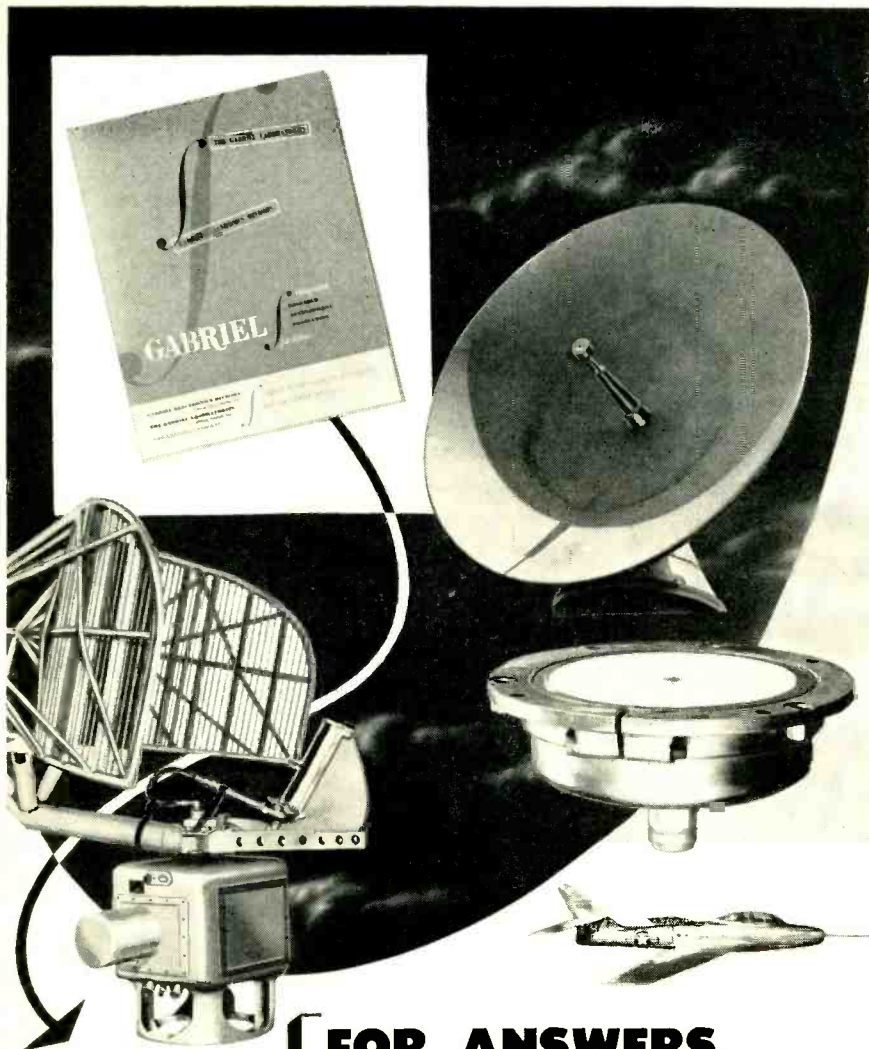

Look here

FOR ANSWERS TO YOUR* ANTENNA PROBLEMS

Facing new antenna problems?

Find important new ideas and advanced techniques leading to the ultimate answers in Gabriel's new Facilities Report. For design . . . development . . . or production, you need this 24-page well illustrated brochure.

It is, we believe, by far the most complete in the field. A few of the projects described—typical of Gabriel experience that can help you—are:

RADAR—Design and production of search antennas; IFF parasitic antennas; conical scan for gunlaying and tracking.

MISSILES—Flush-mounted antennas for intelligence transmission; beacon antennas for tracking.

AIRCRAFT—Blade, flush mounted, and block antennas for navigational radar, Shoran, communications, and homing.

MICROWAVE RELAY—For mobile military communications, railroad, TV network, and public utilities.

*Executives and Engineers at Management Level.

SEND FOR YOUR COPY. Write on your letterhead, please, indicating antenna problem involved. Address Consulting Engineering Department.

GABRIEL ELECTRONICS DIVISION

Formerly Workshop Associates Division

THE GABRIEL COMPANY, 300 Endicott Street, Norwood, Mass.



with sealed, flexible leads that can be supplied to any length and with any type of termination. These transformers and reactors have been approved by the Signal Corps Engineering Laboratories and meet the requirements of MIL-T-27, grade 1, class A. Using special techniques, custom designed transformers and reactors for all types of audio, power and low-frequency r-f applications, can be supplied at savings in size, weight and cost.



DIGITAL COMPUTER with magnetic-drum memory

CONSOLIDATED ENGINEERING CORP., 300 N. Sierra Madre Villa, Pasadena 8, Calif. Model 203 general purpose digital computer is not limited to any specific field of activity but is adaptable to almost any problem reducible to numerical terms. The numerical notation used is an easily understood, binary-coded decimal system in which four binary digits form each decimal digit. The four binary digits are operated upon in parallel, while each successive decimal digit is handled serially. Progress of a problem can be quickly checked, for contents of all internal registers are displayed as arrays of neon lights which can be directly read as decimal digits. A magnetic drum rotating at 3,600 rpm, along with the associated reading-writing heads and electronic circuits, serves as the computer's memory. Capacity of 4,080 words of 10 decimal digits each plus the speed at which the computer can extract the words from the memory gives the overall system an appreciable speed advantage. All additions, subtractions, logical shifts and transfers are performed at an average rate of 500 per second,

while multiplications are accomplished at 120 per second and divisions at 85 per second. Complete description is given in bulletin 3100.

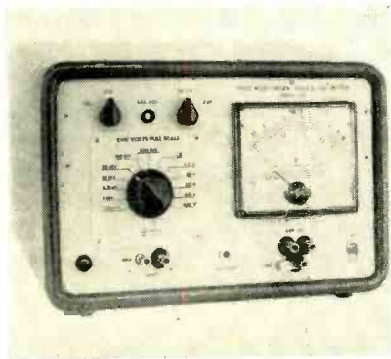

VOLTMETER
measures true rms values

BALLANTINE LABORATORIES, INC., Boonton, N. J. Model 320 Voltmeter of the ultrasensitive type measures true rms values of highly complex waveforms in addition to sinusoidal waves. It operates over a range of 100 μ v to 320 v and in a band of 5 cps to 500 kc. Accuracy is better than 3 percent between 15 cps and 150 kc for any reading regardless of scale position. Other features include 10-megohm input impedance, provision for simultaneously observing the voltage reading and monitoring the amplified signal with phones or cro, and a built-in calibrator unit for correcting the effects of advanced aging of tubes. Accessories are available for extending voltage range to 20 μ v and 10 kv and for measuring rms currents from 0.1 μ a to 10 amperes.

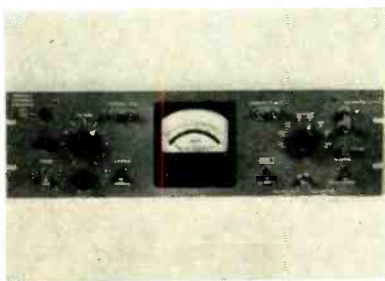

CALIBRATOR
has iron vane type meter

NORTHEAST ELECTRONICS CORP., Municipal Airport Building, Concord, N. H. Model 3 calibrator is designed to facilitate calibration of

NOW...the new

CANNON
AN-"E"
PLUGS

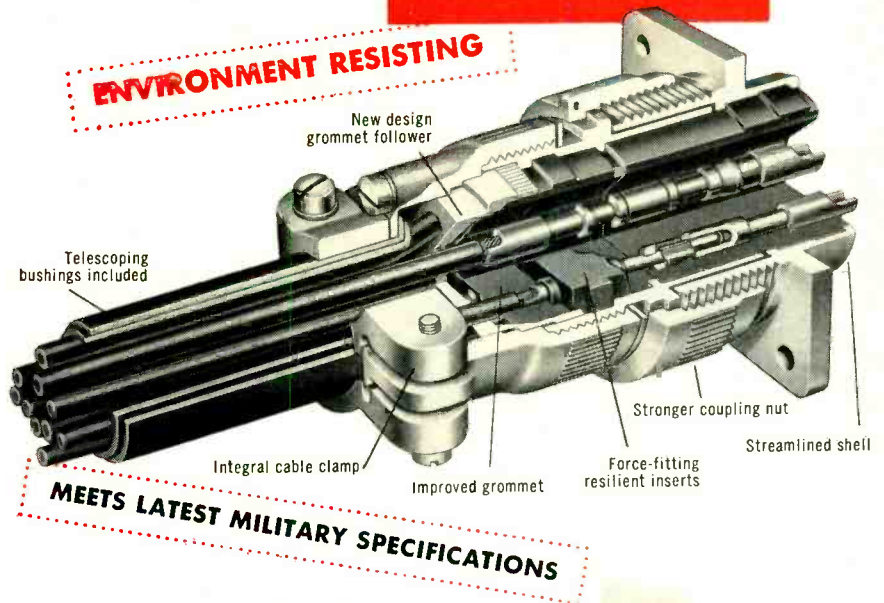

Streamlined Shell
Approximately 25% lighter than previous design.

Stronger Coupling Nut
Improved strength features.

New Grounding Lugs
Integral; convenient.

Integral Cable Clamp
Space saving, fewer parts.

New, lighter polychloroprene... or
Cannon's new exclusive premium Silcan 63, optional, featuring resilience, increased tensile strength, and long-lasting dimensional stability.

Closed-entry socket contacts, machined from solid high-conductivity copper alloys, silver-plated; hand tinned solder pots.

Telescoping Bushings
Standard Equipment



AN3108E Plug mated with AN3102E Receptacle

Moisture proof!
...Vibration resisting!
...Resilient insulation!

Just what you've been waiting for!

The new high-quality, streamlined, simpler, smaller, and lighter Cannon AN-"E" meets today's military specifications (MIL-C-5015A ASG) with improved connector performance. *Completely sealed from cable to cable.* A multi-service unit designed to meet your moisture condensation, flashover, corona, and vibration problems.

Write for "AN-E" Bulletin... TODAY!

Refer to Dept. 120

CANNON ELECTRIC COMPANY, 3209 Humboldt St., Los Angeles 31, California. Factories in Los Angeles; East Haven; Toronto, Canada; and London, England. Representatives and distributors in all principal cities.

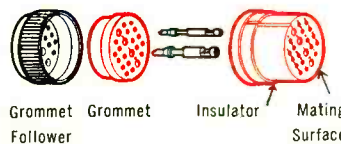

No moisture condensation trap

The Cannon AN-"E" Connector grommet provides positive seal against the rear of the resilient insulator. Mating surfaces of resilient insulators of connectors are sealed by compressing the insulators 3/32" during mating.

AN-"E" Connectors have 3 times the flashover value of similar connectors, sealed.

An important feature for high altitude and other applications.



CANNON ELECTRIC

THIS BOOK DOESN'T

tell all



**... but it's full
of ideas
you can use**

SUCCESSFUL developments in the electronics field depend mainly on three things: ideas . . . experience . . . facilities. *This book is full of all three.*

Just a short request on your letterhead . . . or the coupon below . . . will bring this valuable book in the mail to you at once.

Thompson Products, Inc.

ELECTRONICS DIVISION • 2196 CLARKWOOD ROAD, CLEVELAND 3, OHIO

Thompson Products, Inc.
Dept. EE, Electronics Division
2196 Clarkwood Road, Cleveland 3, Ohio

Please send me a copy of Electronic Advancement.

Name _____ Title _____

Company _____

Address _____

City _____ Zone _____ State _____



vtvm's and oscilloscopes in the low voltage ranges. It provides a calibrated a-c output voltage from 0.50 mv to 7.50 v with an rms accuracy of 1.5 percent or better over the frequency range of 25 cps to 1,000 cps. A 60-cps variable voltage supply is contained in the instruments; other frequencies can be applied to the external terminals. It uses a meter with an iron-vane movement to insure permanent calibration. The calibrator is available for standard relay rack mounting or for portable use. It is 5½ in. high, 4 in. deep and weighs 7 lb.

PLATED FINE WIRE for the electronic industry

NORTH AMERICAN RESEARCH LABORATORIES, INC., 275 Lexington Ave., Kenilworth, N. J., announce their own high quality product of gold, silver and platinum and other plated wire, available now directly to the user. The wire is shipped on new throw-away type plastic spools. A 2-page brochure discusses the company's services and such products as continuous wire plating, strip plating and plating of small parts such as electrical connectors, contacts and Tinkertoy components.



POWER BRIDGE covers 10-1,000 mc range

ELECTRO-METRIC INSTRUMENT CO., 241 Center St., New York 13, N. Y., has available a vhf-uhf power bridge that covers a frequency range of 10 to 1,000 mc. It can measure power levels from 2 µw to 30 mw in 6 ranges—0.1 mw through 30 mw, full scale. A self-balancing circuit is used, requiring a minimum of manual operation. Input

impedance is 300 ohms balanced and vswr is better than 1.3 in the range specified. Total error is less than 5 percent. The extensive range of applications includes speedy and accurate gain measurements on tuners and converters, transmission measurements of active and passive networks, and calibration of signal generating equipment. Recorder connections are made available. Continuous recording should prove of interest to transmitter engineers and in propagation studies.

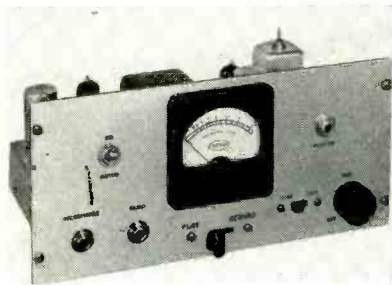

TAPE PREAMPLIFIER
has 50-12,000 cps response

PENTRON CORP., 221 E. Cullerton, Chicago 16, Ill. Model HFP-1 high-fidelity tape preamplifier offers frequency response of 50 to 12,000 cps ± 3 db, with an absolute minimum of distortion. Used with the company's intermatching 9T-3M tape transport mechanism, the preamplifier provides an inexpensive tape recording and playback system. The HFP-1 controls are: an illuminated v-u recording meter, gain control and power switch, record-play switch and compensation switch.



PULSE TRANSFORMERS
useful in computer systems

MAGNETICS RESEARCH Co., 142 King St., Chappaqua, N. Y. The MDT series of transformers are designed for use in driving magnetic drum

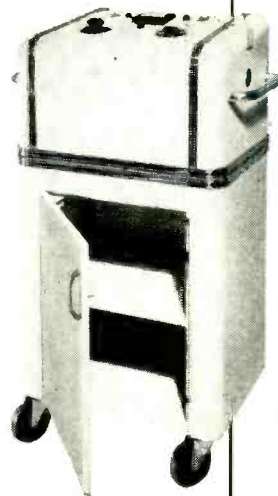

Only Karp
can offer you
these deep
cuts in your
enclosure
costs

- Over 3000 stock tools and dies to cut your new tooling costs.
- Modern 88,000 sq. ft. plant and facilities make possible *mass production techniques*...cut your costs to the bone.
- Complete "one-stop" service: fabrication, finishing and assembly done in *one* plant—eliminates extra hidden handling costs.
- Our production output can be geared to your needs—cutting your inventory needs.
- Competent engineering and design counsel available.

Whether you need ten or ten thousand units, we can prove to you that our initial cost is low, and all the extra hidden costs are eliminated. Send us your blueprints, samples or sketches. Phone or write. A prompt quotation will follow.

KARP METAL PRODUCTS CO.
Division of H & B American Machine Company
215 63rd Street, Brooklyn 20, New York

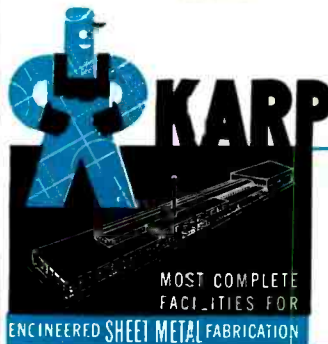

enclosures reflect the skills within

FACILITIES FOR ENGINEERED SHEET METAL FABRICATIONS: In aluminum or steel • long run or short • spot, arc, gas or hellarc welding • any type finish.

- Modern plant—3 city blocks long
- Thousands of dies available
- Most modern of sheet metal fabricating equipment
- U. S. Air Force Certified Welding Facilities
- Air-conditioned spray room... complete baking facilities
- Complete sub-assembly facilities

Where the

INFINITESIMAL .001"

is **IMPORTANT**

AS IN INSTRUMENT DIALS

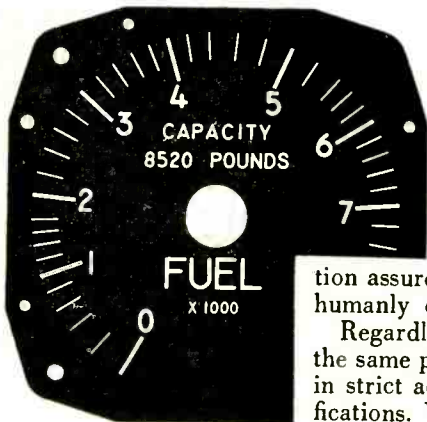

"MICROSCOPIC-PRECISION"

actually defines the minute accuracy of dials by U. S. Radium (instrument, clock, or watch), for "microscopic" checks and painstaking inspections in every step of production assure the *highest degree of perfection* humanly or mechanically possible.

Regardless of size of the order, we take the same pains to assure a finished product in strict accordance with prints and specifications. You are welcome to avail yourself of our engineering and designing experience toward the end that your product may be both *functionally satisfactory* and *less costly* in production.

where **FUNCTIONAL DESIGN**
is **IMPORTANT**
AS IN INSTRUMENT PANELS

Special equipment and specialized personnel, plus our rigid controls, constant checking and inspection guarantee the fine finished product your order merits. Whether flat or curved, we can produce your panels edge-lighted, and either luminous or non-luminous engraved, etched, screened or lithographed, with the *ultimate in uniformity and legibility.*

where **APPEARANCE AND ECONOMY**
are **IMPORTANT** — AS IN NAMEPLATES

The same engineering skill and same plant facilities are yours for the production of nameplates. For years we have been the major source of supply for many industries and our reputation has been built on *attention to detail, prompt deliveries,* and the *economy* effected for our customers.

FOR COMPLETE INFORMATION on items of interest to you, address —
United States Radium Corporation, 535 Pearl St., New York 7, N. Y.
attention Dept. E-6



or magnetic tape recording heads or for any application requiring moderately high power pulses. They have two primary windings and one secondary and are characterized by fast rise and fall times and relatively long allowable on time. Available in primary (each winding) to secondary turns ratios of 1 to 2, 1 to 1, 2 to 1, 3 to 1, 4 to 1, 5 to 1 and 6 to 1, these units will match any recording head to any driving tube. Typical figures for the MDT-1 (1 to 1 ratio) being driven by a pair of type 5881 tubes and driving a Raytheon magnetic drum recording head are: record current, 200 ma; peak voltage across record head, 200 v; maximum pulse width for less than 20-percent peak current falloff, 6 μ sec; and current overshoot, less than 5 percent with critical damping.



BEAM POWER TUBE
for uhf color tv use

RADIO CORP. OF AMERICA, Harrison, N. J. Type 6448 beam power tube, developed for uhf tv broadcasting, is capable of 12,000 w of power output at 900 mc. The tube measures only 7 $\frac{1}{4}$ in. in height and 11 $\frac{1}{4}$ in. in diameter, and features a novel built-in canal system for water-cooling. In color or black-and-white tv service, the 6448 can deliver a synchronizing-level power output of 15,000 w at 500 mc. As a c-w amplifier in class C telegraphy, the tube can generate useful power output of 14,000 w at 400 mc or 11,000 w at 900 mc. Construction of the water-cooled tube described minimizes circuitry, reduces tuning requirements, results in rugged,

simple mechanical arrangements, and makes possible small overall cavity size. Only one set of cavities is required to tune the entire uhf tv frequency band.



PLUG-IN NETWORKS for impedance matching

THE DAVEN CO., 191 Central Ave., Newark, N. J., has available the 690 series of plug-in attenuation networks. The plug-in feature permits input and output impedance to be changed to any value by substituting plug-in pads of the particular impedance desired. The networks are intended for use in general laboratory and production testing; are extremely rugged, flexible and reliable. They are available in either T or balanced H circuits. A range of 110 db in 1-db steps can be obtained on the 2-dial series, or a range of 111 db in 0.1-db steps on the 3-dial series. A special card-type, noninductive winding is used, giving a frequency range of from 0 to 50 kc. Resistor units are calibrated to ± 1.0 -percent accuracy and operate at a ± 20 -db (0.6 w) maximum input level. To insure low contact resistance and uniform contact pressure, knee-action switch rotors are used. Silver alloy rotors, slip-rings and contacts insure finest performance.

SOLDER POTS with controlled heating

VULCAN ELECTRIC Co., Danvers 10, Mass., has available a line of thermostatically controlled rectangular solder pots, designed specifically for tinning printed circuits or dipping small chassis assemblies. Shallow cast iron crucibles are designed with wide lips and come in any inside dimensions

CALIDYNE'S

latest advance

IN
LARGE SHAKER SYSTEMS
FOR
PRODUCT
VIBRATION-TESTING

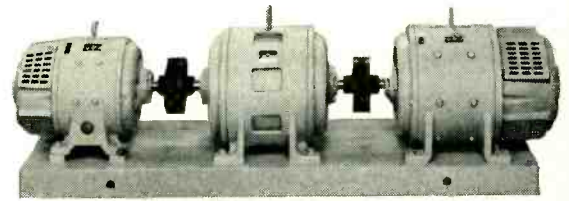
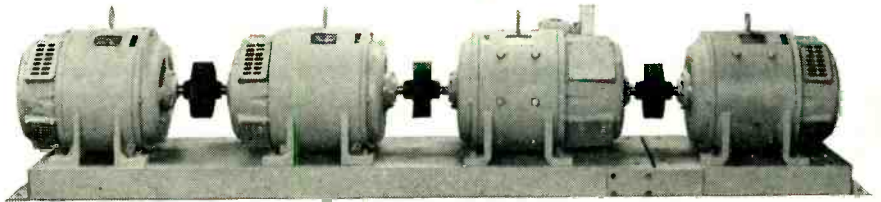

the new m47

ROTARY POWER SUPPLY

FOR USE WITH THE
MODEL 48A SHAKER

PROVIDES WIDE UNBROKEN FREQUENCY RANGE

One alternator, in place of three in earlier power supply designs, provides the 5 to 500 cps frequency range. This wide, unbroken range is especially useful in vibration-testing products and parts to MIL-E-5272 and similar requirements. A second dual alternator supplies a range of 500 to 2000 cps.

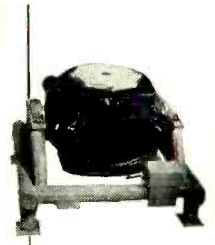

ELIMINATES POWER FACTOR CORRECTION

The new power supply has sufficient reserve, even under adverse loads, to permit maximum operating efficiency *without power factor correction*. Thus the important advantage of uninterrupted testing, through the ranges 5 to 500 cps, and from 500 to 2000 cps.

REDUCES OVERALL SHAKER SYSTEM COSTS

The elimination of power factor correction and previously required alternators, reduces the overall price of the basic 2000 cps Shaker System by approximately 10%. The new Calidyne System itself is composed of the Model M47 Rotary Power Supply, the new Model M119 Control Console and the Model 48A Shaker. A full line of accessories — signal monitor, frequency cyler, servo control and degaussing coil and controls — is available for this new system. For technical data and information on standard or special Calidyne Shaker Systems to meet your requirements, call on Calidyne today.



THE CALIDYNE COMPANY

120 CROSS STREET, WINCHESTER, MASSACHUSETTS

SALES REPRESENTATIVES:

NEW YORK CITY AREA
G. C. Engel
Reclor 2-0091

EXPORT

Rocke International Corp., N. Y. C.
Murray Hill 9-0200
NORTHERN NEW YORK
Technical Services Co., Boston
Capitol 7-9797

NEW JERSEY

G. C. Engel, Ridgewood 6-7878

PHILADELPHIA, PA.

G. C. Engel, Chestnut Hill 8-0892

CLEVELAND, OHIO

M. P. Odell Co., Prospect 1-6171

DAYTON, OHIO

M. P. Odell Co., Oregon 4441

WASHINGTON, D. C.

F. R. Jodon, Inc., Woodley 6-2615

CHICAGO, ILLINOIS

Hugh Marland Co.
Ambassador 2-1555

DALLAS, TEXAS

John A. Green Co., Dixon 9918

WALTHAM, MASS.

Robert A. Waters, Inc.
Waltham 5-6900

HOLLYWOOD, CALIFORNIA

G. B. Miller Co., Hollywood 9-6305

SEATTLE, WASH.

F. R. Miller Co., Lander -3320

ALBUQUERQUE, NEW MEXICO

G. B. Miller Co.
Albuquerque 5-8606

SAN FRANCISCO, CALIF.

G. B. Miller, Lyell 3-3438

MINNEAPOLIS, MINN.

H. W. Richardson and Co.
Geneva 4078

ARNPRIOR, ONTARIO, CANADA

Measurement Engineering Limited
Amprior 400

NEW HAVEN, CONN.

Robert A. Waters, Inc.
Fulton 7-6760

VLF

... Very Low Frequencies



• **RADIO INTERFERENCE**
• **and FIELD INTENSITY***
• **measuring equipment**

• **Stoddart NM-10A • 14kc to 250kc**
• **Commercial Equivalent of AN/URM-6B**

VERSATILITY.... The NM-10A is designed to meet the most exacting laboratory standards for the precise measurements, analysis and interpretation of VLF radiated and conducted radio-frequency signals and interference. Thoroughly portable, yet rugged, the NM-10A can be supplied with accessories to fulfill every conceivable laboratory and field requirement.

EXCELLENT SENSITIVITY.... The NM-10A sensitivity ranges from one micro-volt-per-meter to 100 microvolts-per-meter, depending upon whether rod or shielded loop antennas or line probe are used.

ACCURACY.... Each equipment is "hand calibrated" in the Stoddart Test Laboratories by competent engineers. This data is presented in simplified chart form.

DRIPPROOF.... Sturdy dripproof construction allows long periods of operation in driving rain or snow without adverse effects.

FLEXIBLE POWER REQUIREMENTS.... The ac power supply permits operation from either 105 to 125 volts or 210 to 250 volts ac, at any frequency between 50 cps and 1600 cps.

Stoddart RI-FI* Meters cover the frequency range 14kc to 1000mc

HF NM-20B, 150kc to 25mc
Commercial Equivalent of AN/PRM-1A. Self-contained batteries. A.C. supply optional. Includes standard broadcast band, radio range, WWV, and communications frequencies. Has BFO.

VHF NM-30A, 20mc to 400mc
Commercial Equivalent of AN/URM-47. Frequency range includes FM and TV bands.

UHF NM-50A, 375mc to 1000mc
Commercial Equivalent of AN/URM-17. Frequency range includes Citizens band and UHF color TV band.

STODDART AIRCRAFT RADIO Co., Inc.
6644-A Santa Monica Blvd., Hollywood 38, California • Hollywood 4-9294

from 6 in. × 12 in. to 12 in. × 12 in., with depths of from 1 in. to 4 in. Replaceable electric heating elements are clamped to the under surfaces of crucible castings and are well insulated from the sheet metal casing. Both pot and thermostat are mounted on the same heavy metal base.

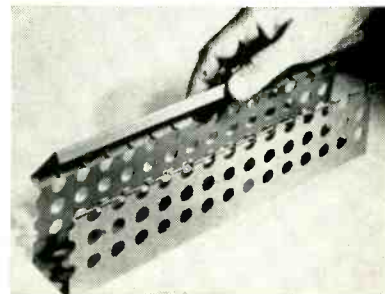

WIRING DUCT
eliminates lacing

TAYLOR ELECTRIC INC., 15460 Dale, Detroit 23, Mich. To hold, protect, and distribute a harness, this newly designed duct has important time-and-labor-saving advantages. Made from a thermoplastic material, its chemical and physical properties are similar to those of machine tool wire insulation. Cover snaps on and off. Clips, inserted at regular intervals, hold wires firmly and eliminate costly lacing or harness in wiring and maintenance. It will not support combustion, and will not warp under damp or moist conditions. It is available in lengths up to 45 in., and is easily cut into sections with a knife.

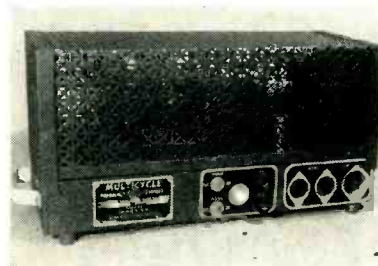

FREQUENCY CHANGER
makes ideal bench supply

BLISS SCIENTIFIC INSTRUMENTS, 107 Elmwood Ave., Ithaca, N. Y., is introducing a line of electronic frequency changers of which the Multi-cycle model 281 is typical. Operating from the 115-v, 60-cycle line, the

unit delivers 115 v, 400 cycles constant duty. Voltage regulation is ± 2.5 percent, and waveform distortion is practically negligible from zero to full load. It makes an ideal all-around 400-cycle bench supply for use with servomechanisms, magnetic amplifiers, testing airborne equipment and the like. Model 281 is available in a wide range of frequencies. Frequency may be readily changed at any time through simple internal adjustments.



S-W AMPLIFIER
has vswr range to 100

F-R MACHINE WORKS, INC., 44-14 Astoria Blvd., Long Island City 3, N. Y. The FXR type B810A standing wave amplifier is designed to provide full utilization of the latest precision slotted sections and probes when measuring the impedance or vswr in a coaxial or waveguide transmission line. Some features are: (1) noise level less than 0.03 μ v; (2) variable, metered bolometer bias, 3.5 to 9 ma constant current; (3) automatic bolometer protective circuit; and (4) narrow and wide-band operation.

WWV MONITOR
for local standards

MATAWAN ELECTRONICS Co., INC., 236 Creek Road, Keansburg, N. J., has available a new WWV receiver, model ME-117. It compares a local standard to the WWV 5-mc standard. After demodulation, the 5-mc carrier is doubled to 10 mc and displayed on a 2-in. crt as a circular pattern. A 10-mc multiple of the local standard modulates the inten-

Teflon... SHEET*

Your Best Source Is

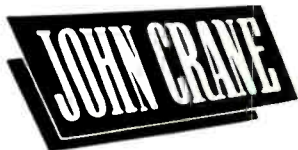

Thickness Inches	Nominal Size
1/16	12 x 12
1/32	18 x 18
1/8	24 x 24
3/16	36 x 36*
1/4	48 x 48*
3/8	
1/2 & Up	

* Can be furnished in 1/2 sheets



ROD

DIAMETER INCHES	
1/4	1
5/16	1 1/8
3/8	1 1/4
1/2	1 3/8
5/8	1 1/2
3/4	1 3/4
7/8	2
	2 1/4
	2 1/2
	3

Other diameters on specification

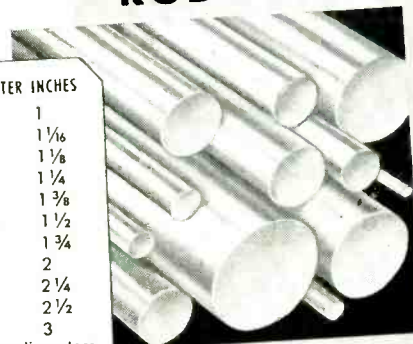

TUBING

TYPICAL SIZES INCHES	
O. D.	I. D.
3/8	1/4
1/2	3/8
3/4	1/2
1	3/4
1 1/2	1
2 1/2	1 1/2
3	1 3/4



HERE'S WHY: You can order in quantity and in a wide variety of sizes—and be certain of complete uniformity throughout. Our strict density control assures you thoroughly non-porous Teflon—free from any flaws which might possibly affect your end use or product. Dimensions are accurate to your most critical tolerances—no rejects, waste of material or loss of time. You get product purity—Teflon at its best in every one of its remarkable characteristics. Delivery is prompt—you get the quantity you want when you want it.

Since the availability of Teflon, "John Crane" engineers have worked with Industry to successfully solve innumerable problems and develop new applications. *You can benefit from their experience and know-how.*

Characteristics of Teflon

- CHEMICAL**
Completely inert.
- ELECTRICAL**
Very high dielectric strength.
Extremely low power factor.
- THERMAL**
Temperature range
-300° to +500° F.
- MECHANICAL**
Strang, flexible, weather resistant.
- LOW COEFFICIENT OF FRICTION**
Absolutely non-stick.

* DuPont Trademark

Request full information and ask for our bulletin, "The Best in Teflon." Crane Packing Co., 1802 Cuyler Ave., Chicago 13, Ill.

In Canada: Crane Packing Co., Ltd.,
617 Parkdale Avenue, N., Hamilton, Ont.



CRANE PACKING COMPANY



PRESENTING

POLYPENCO[®] Q-200.5

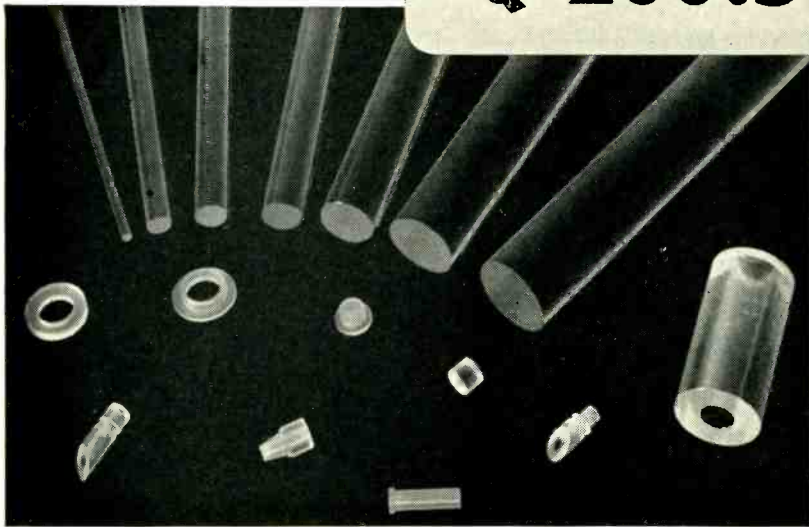

- excellent UHF insulation
- good machining qualities
- dimensionally stable to 400°F
- available in standard shapes

POLYPENCO Q-200.5 is ideal for coaxial spacers, connector beads, stand-off insulators, coil forms, UHF antennae insulators, etc. Its low dissipation factor (less than .0002 at 30 megacycles) remains practically constant over the entire frequency range. It is transparent, light, and resists most chemicals.

POLYPENCO Q-200.5 now joins the family of high quality industrial non-metallic materials supplied by The Polymer Corporation of Penna. It meets the requirements of specification MIL-P-77A (Type E2). Polymer quality controls assure uniform high quality in piece after piece and lot after lot. You can get POLYPENCO Q-200.5 in centerless ground rod up to 1" diameter in 6-8 feet lengths for your own fabrication or we will fabricate it for you.

Write for technical bulletin giving data and properties of POLYPENCO Q-200.5.

POLYPENCO Q-200.5

nylon and teflon*
stock shapes, finished parts
also available to your specifications

The POLYMER CORPORATION of Penna. • Reading, Penna.
Warehouse stocks:
Chicago, Ill. • Newton, Mass. • Branford, Conn. • Los Angeles, Calif.

*Trademark for Du Pont tetrafluoroethylene resin

NEW PRODUCTS

(continued)

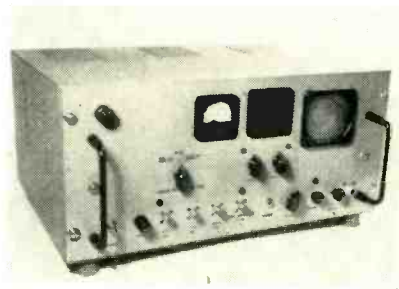

sity of this pattern. Speed and sense of rotation of the pattern indicate the amount and direction of the deviation from the WWV standard. The receiver will accommodate any local standard frequency in the range from 50 kc to 10 mc equal to a subharmonic of 10 mc, 2 mc or 400 kc. A second channel receives the audio modulation and time signals of the WWV standard.

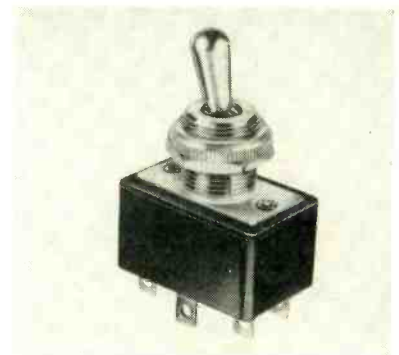

TOGGLE SWITCH rated at 3,000 v flash test

BRITISH ELECTRONIC SALES Co., 23-03 45th Road, Long Island City 1, N. Y. Type T622 is the latest addition to a broad line of electronic instrument switches using unusually heavy plated beryllium wiping contacts in a unique design. This dpdt quick-make-and-break toggle switch features very small overall size with relatively high current handling ability of 6 amperes on a-c or d-c. It is rated at 3,000 v flash tests, and uses standard U. S. threads. Handle style is made to customer's sample or specification.

CRYSTAL DETECTOR with detachable crystal

F. W. SICKLES DIVISION, General Instrument Corp., Chicopee, Mass. Type 17036 is a miniature 45.75-mc

picture i-f crystal detector with filter assembly and detachable, snap-in crystal and shielding cover to reduce radiation. The unit is $\frac{3}{4}$ in. sq \times 2 in. high. It contains either single or double tuned transformer and crystal, tweet network and silvered mica capacitors.

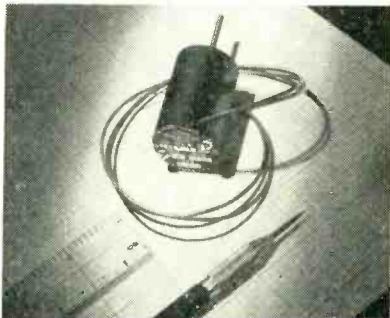

TINY P-M MOTOR rated at 1/400 h-p.

DALMOTOR Co., 1375 Clay St., Santa Clara, Calif. Type PM-47 miniature permanent-magnet motor, rated at 1/400 horsepower with operating rotor speed of 10,500 rpm, is suggested for application to small fans, blowers and other similar light-weight-load applications. Designed for continuous duty, it draws 0.18 ampere at 27 v d-c, and has a total weight of 5 oz. Dimensions are $1\frac{3}{16}$ in. long \times $1\frac{1}{8}$ in. diameter and the $\frac{1}{8}$ -in. diameter shaft has an extension length of $1\frac{1}{16}$ in. Other lengths and special arrangements can be provided where required.

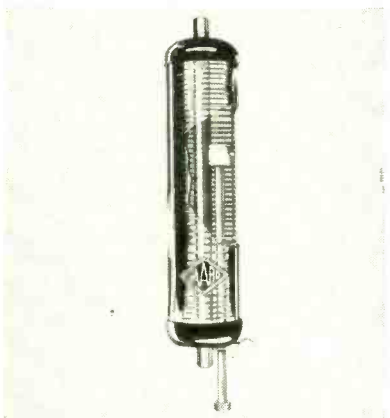

VARIABLE COIL for mobile use

VAARO ELECTRONIC ENGINEERING Co., Box 5035, Long Beach, Calif., has announced a new variable

THE SOLUTION...



...to your R-F noise
suppression problem



AEROVOX R-F noise suppression FILTERS*

Ideal for R-F noise suppression in military and commercial aircraft, vehicular low-voltage DC applications, and for special usages such as shield rooms and critical equipment. Maximum reliability. High attenuation. High current ratings. Still smaller hermetically-sealed metal-case housings. Advanced pi-type construction for greatest efficiency. Definitely the solution to your R-F noise suppression problem.

FEATURING...

- Aerolite† metallized-paper sections provide maximum reliability and life factors.
- Unique "fault-isolation" characteristic offers added protection against surge voltages.
- High attenuation of R-F currents. Maximum attenuation available, from .15 mc to 400 mc.
- Low DC resistance assures minimum heating and low voltage drop.
- Operating temperature range from -55°C to $+85^{\circ}\text{C}$. At full rating (150 v.d.c.), operating temperature range is from -55°C to $+70^{\circ}\text{C}$. All units rated for continuous duty.
- Test voltage for all units, 200 v.d.c. at room temperature for period not exceeding 1 minute.
- Case construction of non-magnetic metal suitably protected for severest service requirements.
- Available with special terminals, special mountings and other special considerations for specific needs.

*WRITE FOR LITERATURE. Screen-room filters also available with extra-high attenuation (120 db) for AC and DC applications. Send us your R-F noise-suppression problem.



AEROVOX CORPORATION

NEW BEDFORD, MASS.

HI-Q DIVISION CINEMA ACME
ENGINEERING CO. ELECTRONICS, INC.
OLEAN, N. Y. BURBANK, CALIF. MONROVIA, CALIF.

†trade-mark

In Canada: AEROVOX CANADA LTD. Hamilton Ont. JOBBER ADDRESS: 740 Belleville Ave. New Bedford, Mass.
Export: Ad. Auriema, Inc., 89 Broad St. New York, N. Y. • Cable: Auriema, N. Y.

Considering Environmental Test Equipment?

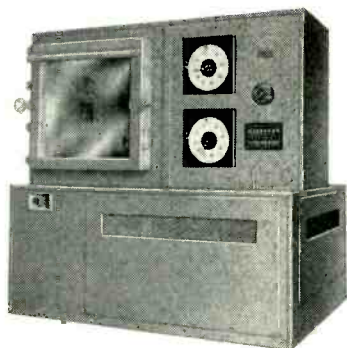

Be sure to look beyond the unit . . .

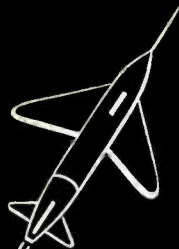

Bowser Technical Refrigeration pioneered the development and manufacture of environmental test equipment.

Bowser's complete engineering staff is available (at no obligation) to help in solving YOUR difficult test problems. Design engineers and production facilities are available to construct test equipment to meet your specialized requirements.

Typical of Bowser's standard test chambers are the Laboratory Unit and Walk-In Room shown above.

The Laboratory Unit has a temperature range from +200° F to -100° F, relative humidity range from 20% to 98%, altitude from sea level to 100,000 feet.

Standard Walk-In Rooms simultaneously produce altitude to 100,000 feet, temperature range from -100° F to +200° F, relative humidity from 20% to 98%.

Bowser also builds explosion chambers, sand and dust chambers, humidity simulation units, and environmental simulation chambers to meet any desired specifications.

Write for free descriptive bulletins or request a Bowser field engineer to consult on YOUR environmental test problem.

BTR
DEPENDABILITY

BOWSER TECHNICAL REFRIGERATION

DIVISION BOWSER, INC. TERRYVILLE CONNECTICUT

single-unit mobile coil for use in the 75, 40, 20, 15, 11 and 10-meter band range. It incorporates a slider that can be moved up or down until the transmitter loading is obtained, and then the slider remains exactly in place through a shaft lock feature. The single-unit coil is built in two models: model V-102 for rigs developing from 0 to 250-w input, and the model V-103 for rigs developing from 0 to 500-w input. Outstanding features and information on construction details are given in bulletin VC-1.

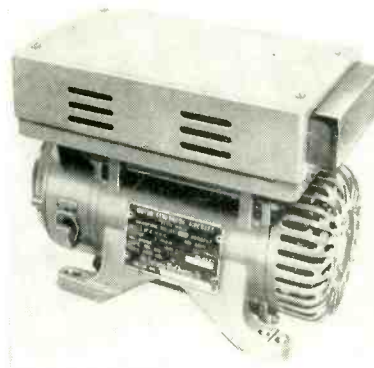
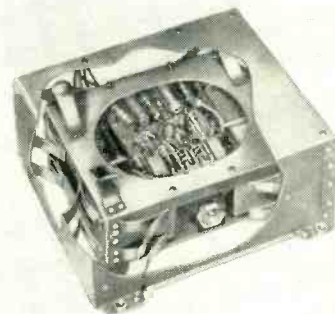

INVERTER has shock-mounted control

THE LELAND ELECTRIC Co., Division of American Machine & Foundry Co., Dayton 1, Ohio. A new 1,500 v-a inverter for operation up to 50,000-ft altitude is in production.

It features light weight (40-lb) and compactness (13½ in. long × 7½ in. wide × 9¼ in. high). The electronic voltage and frequency control package utilizes a new concept of vibration and shock isolation consisting of stainless steel folded springs mounted on the six faces of the regulator chassis and slide on graphitized phenolic sheet fastened to the inner surfaces of

the outside package. Adequate isolation of the regulator is accomplished while the complete inverter is subjected to vibration (to 10 g) from 0 to 500 cps.



D-C POWER SUPPLIES use no vacuum tubes

MAGNETIC RESEARCH CORP., 318 Kansas St., El Segundo, Calif. Utilizing no vacuum tubes or moving parts, the Stabvolt type A line of power supplies is designed for ruggedness, reliability and years of maintenance-free operation. It features dual magnetic regulation which effectively isolates line voltage transients from the d-c output voltage. The response to a-c line variations of 95 to 135 v is practically instantaneous with dynamic line regulation better than 0.2 percent. The transient free feature permits an all magnetically regulated power supply to be used as a transient free d-c power source in the field of d-c measurement and instrumentation for strain gages, comparators, potentiometers, tungsten lights and recording lamps. Standard sizes are available in 6, 12 and 28 v at current ratings up to 100 amperes. From no-load to full-load, regulation is better than ± 1 percent, and response to extreme conditions of loading is faster than 0.2 second. Ripple is less than 0.5 percent, rms.

INSTRUMENT CABINET permits handy maintenance

ELGIN METALFORMERS CORP., 906 N. Liberty St., Elgin, Ill., has introduced an instrument cabinet designed for maintenance and production assembly men. Top, bottom, back and both end panels are

New

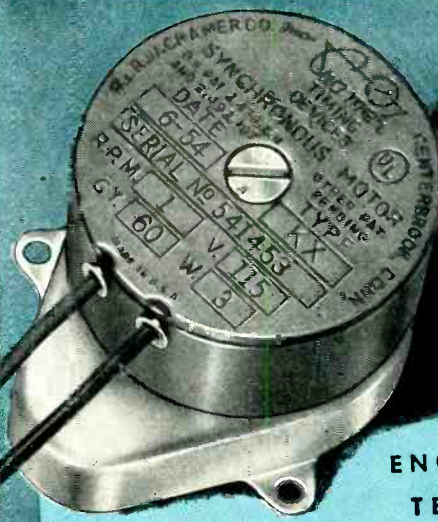
KX SYNCHRONOUS MOTOR



ENGINEERING TEST MEMO

Jim - Here's the dope on the KX

TO: *J.C. Smith Prod Mgr*

SUBJ: *New Motor*

- ✓ Extra Reserve Strength (30 in. oz. torque at 1 rpm.)
- ✓ Instant start-stop
- ✓ Runs in any position
- ✓ Truly synchronous speed
NO SLIP
- ✓ Highly versatile
- ✓ Temperature rise only 43°C
- ✓ Rugged - mechanically & electrically

Exceeds test specs all the way - Roy

This does not tell the whole story by any means, but it does indicate the growing acceptance of this powerful motor for all types of instrument and control applications which require constant speed and dependability even under adverse environmental conditions. The complete story is yours for the asking. Write today.



SPECIALISTS IN TIME CONTROL

the R. W. CRAMER CO., Inc.

BOX 3, CENTERBROOK, CONNECTICUT

For lighter, more compact, Servo Systems

THE NEW

KEARFOTT PENNY SIZE SYNCHROS



Accurate . . . Rugged
Dependable

PERFORMANCE DATA

	TRANSMITTER	CONTROL TRANSFORMER
PRIMARY EXCITATION	26 VOLTS 400 CYCLES	11.8 VOLTS 400 CYCLES
INPUT CURRENT	95 Ma	137 Ma
INPUT IMPEDANCE	274/75° Ohms	82/68° Ohms
OUTPUT SECONDARY	11.8 VOLTS	23.5 VOLTS
RESIDUAL (NULL) VOLTAGE	40 Mv RMS 20 Mv Fund	40 Mv RMS 20 Mv fund
SENSITIVITY	200 Mv/Degree	400 Mv/Degree
WEIGHT	1.75 Oz.	1.75 Oz.
MAXIMUM ERROR from EZ	10 Minutes	10 Minutes

Kearfott now offers from production the smallest, accurate line of Synchros available. These Transmitters and Control Transformers, Resolvers and Differentials, conform to Navy BuOrd. Size 8. Integrally cast stator and stainless steel housing assemblies permit straight through bores, eliminating the fundamental errors of eccentricity; providing ruggedness and environmental resistance to these components.

KEARFOTT COMPONENTS INCLUDE:

Gyros, Servo Motors, Synchros, Servo and Magnetic Amplifiers, Tachometer Generators, Hermetic Rotary Seals, Aircraft Navigational Systems, and other high accuracy mechanical, electrical and electronic components.

Technical Data Sheets on these and other Synchros in various size ranges and for special applications available. Send for them today.



KEARFOTT COMPANY, INC., LITTLE FALLS, N. J.

Sales and Engineering Offices: 1378 Main Avenue, Clifton, N. J.
Midwest Office: 188 W. Randolph Street, Chicago, Ill. South Central Office: 6115 Denton Drive, Dallas, Texas
West Coast Office: 253 N. Vinedo Avenue, Pasadena, Calif.

A GENERAL PRECISION EQUIPMENT CORPORATION SUBSIDIARY

NEW PRODUCTS

(continued)

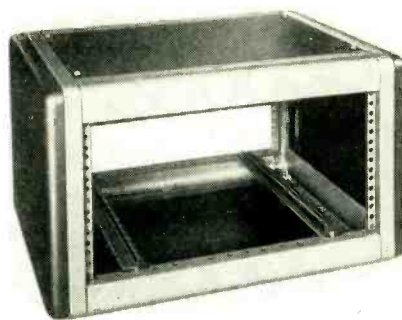

quickly removed with only a screwdriver, allowing complete accessibility to the interior. It is constructed throughout of smooth, premium-quality cold-rolled steel, fabricated with electronically controlled welds. The cabinets can be stacked vertically or horizontally, locked together in minutes with Tinnerman Speed Nuts and a screwdriver. They can accommodate chassis with 8 3/4 in. x 19 in. front panel, 15 in. depth. Chassis guide supports are adjustable to chassis of any width up to 17 in.

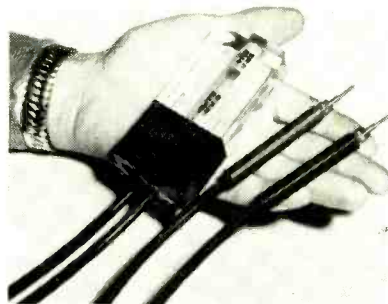

VOLTAGE TESTER is rugged and light

CRAFT LABORATORIES, 214 E. Broad St., Westfield, N. J., has available the model AP1 voltage tester, for testing circuits from 90 to 600 v. By substituting an electronic means for a mechanical one, the voltages can be separated by large, easily distinguished marks. The operating section is transparent, so that it can be seen from any angle; a low voltage lighting only the bottom part, the higher voltages causing the light to climb up the tube, giving the voltage indication the way a thermometer shows temperature. It will give an accurate voltage indication on all frequencies from d-c to 400 cycles on the same scale, and indicate polarity on d-c. In addition, it has the standard fea-

tures of the mechanical types such as 30-in. leads made of 10,000-v wire, and a place to bury the prod tips for the protection of the one carrying it.

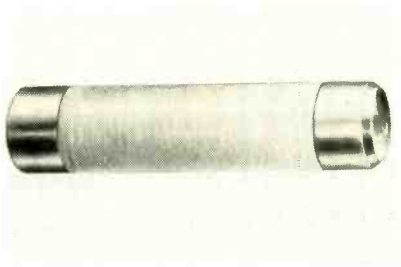

BOLOMETER
is of the hot wire type

NARDA—NASSAU RESEARCH & DEVELOPMENT ASSOCIATES, INC., 66 Main St., Mineola, N. Y. The N-821B bolometer for detection of microwave and ultrahigh frequencies is of the hot wire type, requiring a bias current of 8.75 ma to obtain the operating resistance of 200 ohms. The detection is square law for power levels within any 40-db interval. Burnout power is over 15 mw, and sensitivity is 4.5 ohms per mw. The bolometer is made by a new process that permits the use of a continuous plastic sleeve enclosing the hot wire, resulting in a higher tensile strength than previously available.

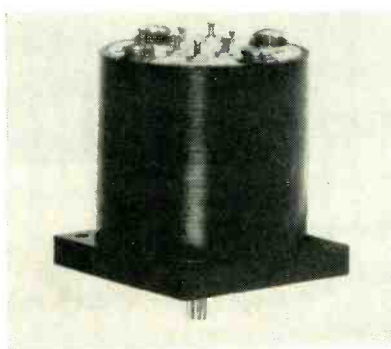

SERVO MOTOR
is two-speed unit

RAYTHEON MFG. Co., 148 California St., Newton 58, Mass. This motor was designed for a servo unit which required two-speed operation of its components. The two speeds are obtained by pole changing which is accomplished by simple connection changes. Speeds of 11,000 and 5,500

It's here...

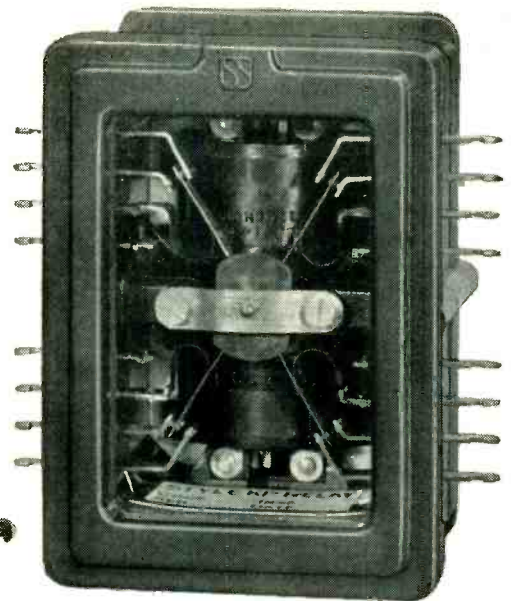

a reliable, long-life, high-speed relay

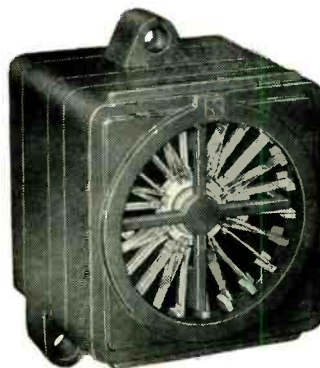

UNION RD RELAY

A sensitive, high-speed, rotary-type relay that operates with a minimum of contact bounce.



UNION TYPE M RELAY

A hermetically-sealed miniature relay that meets all requirements of MIL-R-5757 A & B.

The UNION KP rotary-type relay is an ideal control component for those circuits where reliability, sensitivity and high speed are essential.

Compact, yet ruggedly constructed, this precision instrument under rigid test operated more than 500,000 times without failure or breakdown. A number of these relays, installed in a critical code control circuit, have been operating as many as 500,000 times per day—pulsing 25 to 30 times a second.

Power requirements for the KP relay can vary from 5 to 150 milliwatts with operating time of 5 to 15 milliseconds—depending upon application. It is available in various contact combinations and ratings for either plug-in or solder-lug connections.

The KP and other Union quality relays, including the RD and type M, are available for many applications. Send for literature.

General Apparatus Sales, Dept. E-67
Union Switch & Signal
Division of Westinghouse Air Brake Co.
Pittsburgh 18, Pennsylvania

Send further information on KP relays
 RD relays Type M relays.

Name Title.....
Company
Address
City Zone... State.....

GENERAL APPARATUS SALES

UNION SWITCH & SIGNAL

DIVISION OF WESTINGHOUSE AIR BRAKE CO.
PITTSBURGH 18, PENNSYLVANIA

NEW YORK · CHICAGO · ST. LOUIS · SAN FRANCISCO

**A NEW
SUB-MINIATURE
PRECISION
QUARTZ CRYSTAL**

**THAT
USES
ONLY 1/5th
THE
SPACE**

**FORMERLY
REQUIRED**

The McCoy M-20 "McMite" has a frequency range of 5.0 mc. to 110 mc. It's a sub-miniature hermetically sealed unit, adaptable to multi-channel design for communications and frequency control equipment. Can be plugged into a sub-miniature tube socket, wired into miniature selector switch assembly or can be soldered to a printed circuit terminal board. Meets Military Specification requirements for fundamental operation above 5 mc. and overtone operation above 15 mc. The "McMite" does not sacrifice stability or dependability but meets same characteristics and performance requirements as larger crystal units used by the Military.

Send for **FREE** catalog today on the McCoy line of high quality, precision made quartz crystals.

McCoy ELECTRONICS CO.
MT. HOLLY SPRINGS PENNSYLVANIA

McCoy M-20 "McMite"

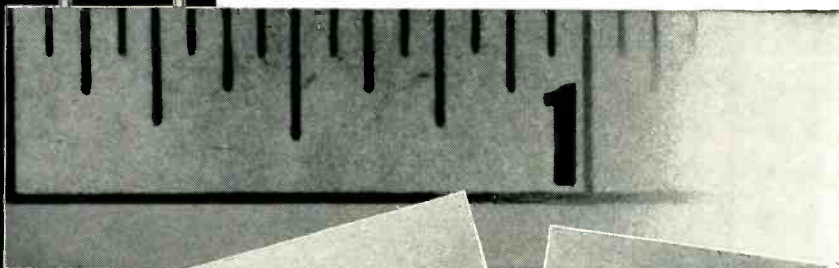
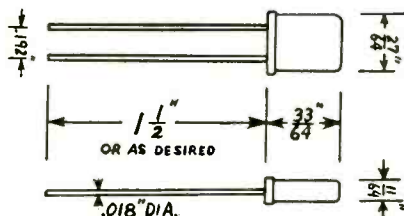

The switching assemblies shown here (2" diameter and 1 1/4" diameter) are illustrative of the space saving qualities of our M-20 "McMite" crystals.

rpm are available with a 400-cycle motor. The stalled torque is 0.13 oz in. with the high-speed connection and 0.35 oz in. with the low-speed connection. This motor eliminates the need for gear ratio changing devices in applications when two-speed operation is essential. For complete technical information, write for bulletin DL-Y-15.

**POTTING COMPOUNDS
with many applications**

ISOCYANATE PRODUCTS, INC., P. O. Box 1681, Wilmington, Del. IPI-Isofoam is a new foamed-in-place, polyisocyanate expansible resin, which is self-cured to produce a low density product with a multiplicity of applications. The strength and electrical properties of the compound can be effectively utilized as a core material for radomes in aircraft and guided missiles. These same properties can also be used to provide space saving through potting of radio and other electronic circuits.

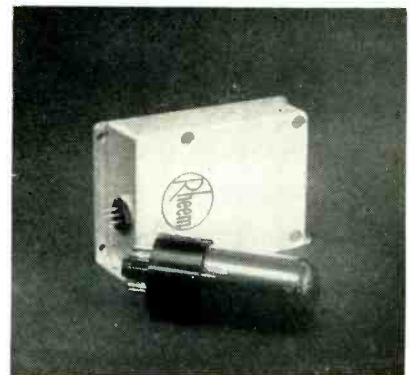

**AUDIO AMPLIFIER
for instrumentation**

RHEEM MFG. Co., 9236 East Hall Road, Downey, Calif. This subminiature, wide-band audio amplifier is designed for a wide variety of applications in the instrumentation field. Its circuitry, which includes the use of overall feedback, together with minor feedback loops, results in very stable operational characteristics. The major feedback loop is independent in the input and output circuits. The amplifier is a versatile unit capable of furnishing gains of 30,100, 300 or 1,000. It

has an input impedance of 2 or 100 megohms and either a 6 or 24-v filament supply may be utilized. The unit may be subjected to extreme shock and vibration and still maintains constant output.



DELAY LINES
designed for color tv

OSSIAN MFG. CO., Box 151A, Ossian, Ind., has added the designs illustrated to its stock delay lines. These distributed constant lines are available with impedances of 3,300, 2,700, 2,000, 1,500 and 1,100 ohms. The rise time for a 1- μ sec delay is 0.1 μ sec for the 3,300-ohm type. The lines are designed primarily for color tv.

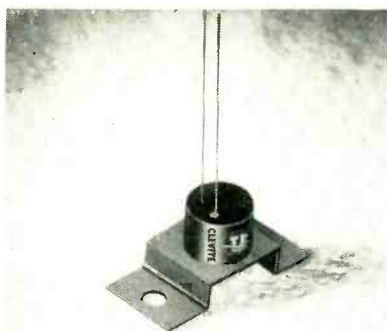

TRANSISTOR
is experimental type

TRANSISTOR PRODUCTS, INC., Snow & Union St., Boston 35, Mass., has available an experimental high-power transistor, type X78. It is a *mp* diffused junction transistor, useful principally when used in matched pairs in class-B audio amplifier applications. Subminiature matching transformers have been made available for use in such a circuit. Although the unit is derated when operated at tempera-

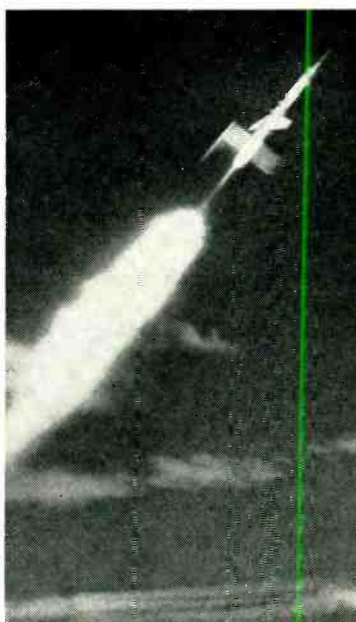

*Career-chance
of a lifetime for*

**RESEARCH
and DESIGN
SPECIALISTS**

in LOCKHEED'S expanding Missile Systems Division

Recently formed from other Lockheed engineering organizations to prepare for the era of automatic flight, Lockheed's Missile Systems Division has a few openings for highly-qualified specialists in research, design and proposal work.

The type of work involved in the Division's contracts—along with its expansion program—makes these openings outstanding opportunities for achievement. The positions call for engineers of senior or group leader level. Engineers who qualify probably have worked on missile, radar-computer, counter-measure, IFF, AMTI or similar projects.

LOCKHEED has openings for:

Research Specialists

with broad experience in missile guidance problems, missile proposal work, control system analysis and evaluation, and servomechanisms. Strong electronics and electro-mechanical background needed.

Design Specialists

with broad experience in missile proposal work and systems analysis. The positions also require experience in missile design, electronics, communications, microwave techniques, systems evaluation, airframe design, aerodynamics, structures and mechanics.

In addition to outstanding career opportunities, the Missile Systems Division offers you excellent salaries commensurate with your experience, generous travel and moving allowances, an unusually wide range of employee benefits and a chance for you and your family to enjoy life in Southern California.

Coupon below is for your convenience.

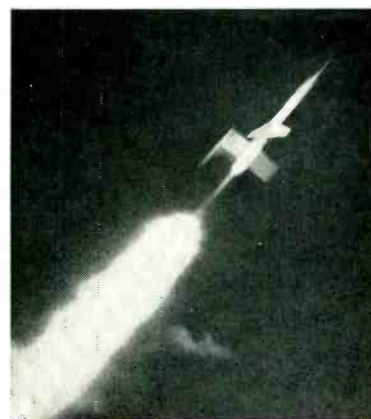

L. R. Osgood Dept. E-M-6

LOCKHEED MISSILE SYSTEMS DIVISION

7701 Woodley Avenue, Van Nuys, California

Dear Sir: Please send me information on the Missile Systems Division.

name _____

field of engineering _____

street address _____

city and state _____

For U. G. CONNECTORS

rely on
ALLIED INDUSTRIES
for
Prompt Delivery
and
Highest Quality

Adequate plant facilities make possible immediate delivery on the majority of connectors. The consistent gearing of our production to meet customers' schedules has helped establish Allied Industries as a prime source for connectors.

Quality control is rigid. Constant inspection and sensitive testing devices help maintain high standards of accuracy and quality. Diligent attention to all details, as weight and texture of silver plating and other such items often overlooked or neglected, has been set as our goal. Our coaxial cable connectors meet all government specifications.

The price is right. For further information request the price list on our connectors—or send us your specifications for quotation.

- 1 A1-11022—High voltage quick disconnect plug.
- 2 UG-154U—A1-11070—Type LC Plug for use with RG-17/U cable.
- 3 UG-21D/U—A1-11072 Improved Type N Plug.
- 4 MX-554/U—A1-11039—Type BNC Resistive Termination.
- 5 A1-11047—High voltage quick disconnect right angle adapter.
- 6 UG-355/U—And UG-356/U—A1-11006 Klystron Coupler.
- 7 UG-37A/U—A1-11032—Ceramic insert, pressured, high voltage receptacle.

ALLIED INDUSTRIES, Inc

2500 Woodland Ave.
Louisville 10, Kentucky

NEW PRODUCTS

(continued)

tures above 80 F, it has still found widespread usefulness in the laboratory. Minimum power gain is 10 db at room temperature when used in the recommended circuit.

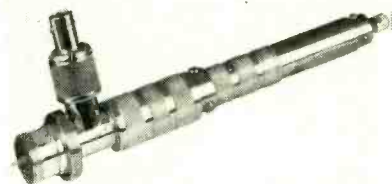

R-F PROBE with dual tuning control

F-R MACHINE WORKS, INC., 44-14 Astoria Blvd., Long Island City 3, N. Y. High sensitivity and convenient, broadband tuning are achieved in the FXR type B200A broadband probe. The dual tuning control provides optimum matching from the probe pickup to the easily replaceable crystal or bolometer detector. An adaptor is provided for the type 821 barreters. A BNC output connector permits easy connection to a standing-wave amplifier. The probe is tunable over the frequency range of 1 to 12.4 mc.

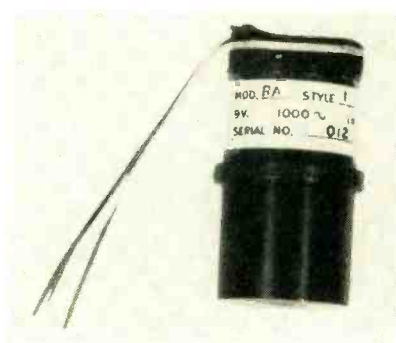

TINY GYRO and miniature accelerometer

RAYTHEON MFG. CO., 148 California St., Newton 58, Mass. The miniature gyro will indicate angular rates from 0.05 deg per sec to 120 deg per sec. An accelerometer in an identical package measures accelerations from 0.01 g to 25 g. These instruments are approxi-

mately 2 in. long and 1 in. in diameter, and meet very high standards for reliability under shock and vibration. A variety of models of both devices is available having different performance characteristics, and for operation from power supplies of frequencies of either 400 or 1,000 cycles. For complete details write for bulletin DL-Y-21 on the gyro or DL-Y-20 on the accelerometer.

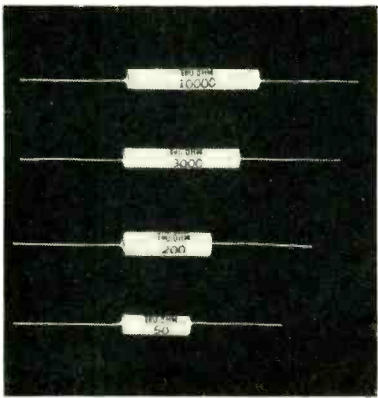

RESISTORS of the axial lead type

TRU-OHM PRODUCTS, DIVISION OF MODEL ENG. & MFG., INC., 2800 N. Milwaukee Ave., Chicago 18, Ill., has available axial-lead resistors wound on fiber glass cord in a continuous length. The cord is cut to required length and then the leads are securely clamped to each end. The core is then coated with silicone cement and inserted in a ceramic tube which affords maximum mechanical protection and high dielectric strength. The ends of the resistors are then sealed with silicone cement, which precludes any possibility of moisture coming in contact with the resistance element. Axial-lead resistors are supplied in standard watt ratings of 5, 7 and 10 w and to maximum resistance values of 1,000 ohms, 5,000 ohms and 7,500 ohms respectively.

HYDRAULIC VALVE features low phase shift

RAYTHEON MFG. Co., 148 California St., Newton 58, Mass. This high-performance hydraulic valve has a phase shift of only 2 deg per cps. It has two stages—a pilot and a

INDUSTRIAL POCKETSCOPE

by

Waterman

MODEL S-11-A

DC-COUPLED
WORK-HORSE OF
INDUSTRY

Size:
11" x 5" x 7"
8¾ Pounds



ANOTHER EXAMPLE OF *Waterman* PIONEERING...

The INDUSTRIAL POCKETSCOPE, model S-11-A, has become America's most popular DC coupled oscilloscope because of its small size, light weight, and unique flexibility. This compact instrument has identical vertical and horizontal amplifiers which permit the observation of low frequency repetitive phenomena, while simultaneously eliminating undesirable trace bounce. Each amplifier sensitivity is 0.1 Volt rms/inch. The frequency responses are likewise identical, within -2 db from DC to 200 KC. Their total undistorted outputs permit effective trace expansion of twice the screen diameter. The internal sweep generator is continuously variable from 3 cycles to 50 KC and can be synchronized from positive going signals. Return trace blanking is optional. Intensity modulation is accomplished by connecting either directly to the grid of the three-inch cathode ray tube or thru an amplifier having a gain of approximately 10 and a flat response to 500 KC. Direct intensity modulation threshold voltage is approximately 1 volt rms. Additional provisions for direct access to all the deflection plates, the second anode, and the amplifier output terminals extend the usefulness of the S-11-A many fold.

WATERMAN PRODUCTS CO., INC.

PHILADELPHIA 25, PA.

CABLE ADDRESS: POKETSCOPE

WATERMAN PRODUCTS INCLUDE

S-4-C SAR PULSESCOPE®
S-5-A LAB PULSESCOPE
S-6-A BROADBAND PULSESCOPE
S-11-A INDUSTRIAL POKETSCOPE®
S-12-B JANized RAKSCOPE®
S-14-A HIGH GAIN POKETSCOPE
S-14-B WIDE BAND POKETSCOPE
S-15-A TWIN TUBE POKETSCOPE
RAYONIC® Cathode Ray Tubes
and Other Associated Equipment



WATERMAN PRODUCTS

The *IMPROVED* Model 310A BALLANTINE Sensitive Electronic Voltmeter

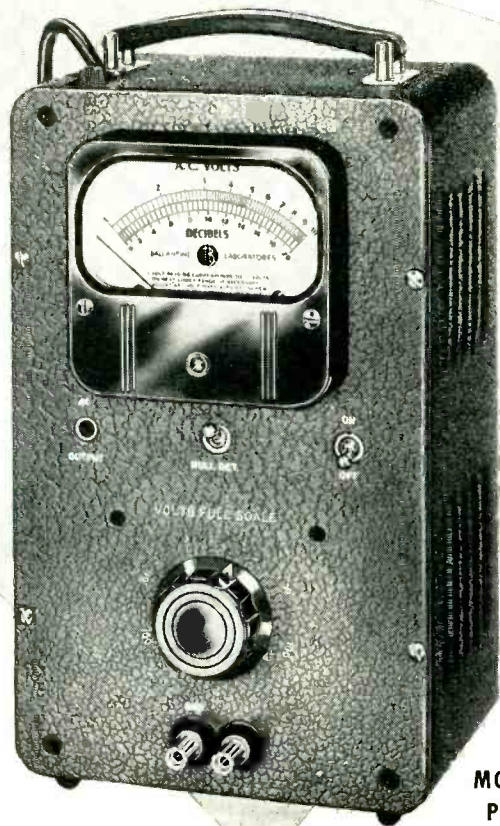

MODEL 310A
Price \$235

To measure 40 microvolts to 100 volts
from 10 cycles to 2 megacycles
with accuracy ($>100 \mu v$) . . . 3% to 1 mc; 5% above
Input impedance 2 megohms shunted by 15 mmfd
below 10 mv; and by 8 mmfd above

Usable as null detector sensitive to $10 \mu v$ from 5 cps to 4 mc

Improvements include lower noise level; enhanced frequency response; reduced susceptibility to line voltage variations; incorporation of premium tubes throughout amplifier system, etc.

Featuring Customary BALLANTINE
SENSITIVITY — ACCURACY — STABILITY

Write for catalog for more information about this and other BALLANTINE voltmeters, calibrators, amplifiers and accessories.

BALLANTINE LABORATORIES, INC.

100 FANNY ROAD, BOONTON, NEW JERSEY

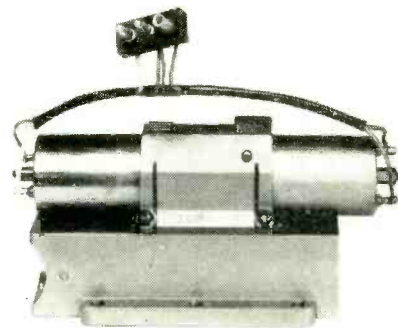

control stage—which results in a valve that can produce up to 5 hp at a hydraulic pressure of 3,000 psi from very small electrical signals. The control sleeve is removable and can be obtained with various size ports for individual requirements. Freedom from the effects of Bernoulli forces at high flow rate is made possible by the inherent design of this valve. For complete details, write for bulletin DL-Y-17.



DELAY LINES with variety of mountings

TECHNITROL ENGINEERING Co., 2751 N. Fourth St., Philadelphia 33, Pa. Very compact delay lines can be obtained in a tubular shape or a package, with a wide choice of mountings. The delay can be varied from 0.01 to 1.6 μ sec. Characteristic impedance can be had from 400 to 2,500 ohms. There is a wide frequency response. For instance in a line with 0.5- μ sec delay at 1,200-ohms impedance, the frequency response is 3 db down at 5 mc, 6 db down at 8 mc and 10 db down at 10 mc. Continuously wound delay lines provide minimum pulse distortion and are extremely stable

with temperature variations. All lines are covered and impregnated to protect the winding from moisture and mechanical damage.

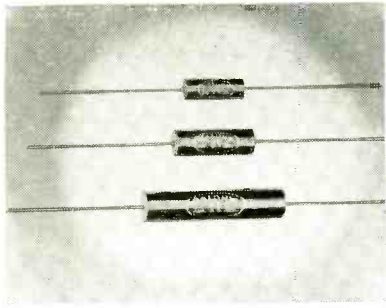

POWER RESISTORS are tiny, ruggedized type

DALE PRODUCTS, INC., Columbus, Neb., has announced production of a new Dalohm ruggedized miniature power resistor designed to withstand the utmost in shock conditions. Type RSE resistors are available in 2, 5 and 10-w sizes. They are sealed in a special silicone coating and housed in black metal tubing. They are impervious to moisture; have complete welded construction from terminal to terminal; and have a temperature coefficient of 0.00002 per deg C. Ranges are from 0.05 ohm to 55,000 ohms. Tolerances of 0.05, 0.1, 0.25, 1.0 and 3.0 percent are available.



POTENTIOMETER is sine-cosine type

FAIRCHILD CAMERA & INSTRUMENT CORP., 225 Park Ave., Hicksville, N. Y. Type 753 is a 3-in. continuous sine-cosine potentiometer utilizing two wipers spaced 90 deg apart to furnish full function sine-cosine outputs. It is also available as a straight sine function with a single wiper. It is 1 1/2 in. long from the front of the servo flange to the

RESEARCH

brings you a

compact, light, economical

new oven

THE JKO9 CRYSTAL OVEN

- Only 1.28" dia.x1.70" high and weighs only 1.5 oz.
- Minimum temperature gradient at crystal.
- Rapid warm up with no overshoot.
- Will meet a specification of $75^{\circ} \pm 1^{\circ} \text{C}$ over a temperature range of -55° to $+70^{\circ} \text{C}$.
- Economical and reliable because design permits tooling for uniform production.



STABILITY

Thru "Thermaflow" Design*

Temperature, like water, seeks its own level. Instead of trying to "dam up" heat within the oven, by use of massive heat retaining elements, the JKO9 oven is designed to permit a uniform loss and uniform replacement of heat. Heat is simply replaced as it is lost from the low mass, high conductivity shell. And within this shell the crystal unit remains wrapped in a blanket of warm air. Because sufficient heat is always lost by the shell none need be yielded by the crystal.



Symbol of Service

THROUGH RESEARCH STABILITY AVAILABILITY

The compact, light, inexpensive JKO9 matches the performance of many ovens employing multistage heaters and massive heat-retaining elements. It houses one or two crystals, plugs into an octal tube socket, is available with a choice of heater voltage from 6 to 28 volts. It is another JK step in the advancement of miniaturization and extreme stability. Write us for complete engineering information.

The James Knights Company Sandwich, Ill.

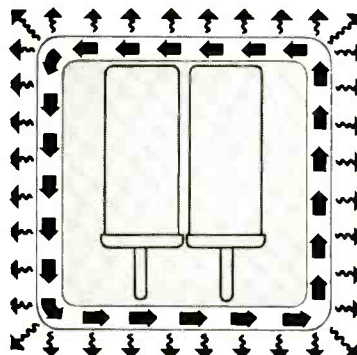

JK09 Heat Exchange Pattern

AVAILABILITY

A COMPLETE LINE

The JKO9 is the newest of the many frequency control units that comprise the JK line of Crystals for the Critical.

*A James Knights Patent

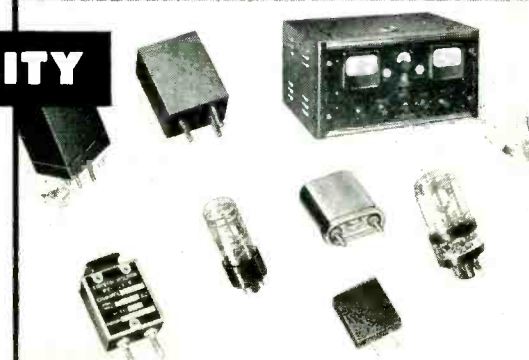

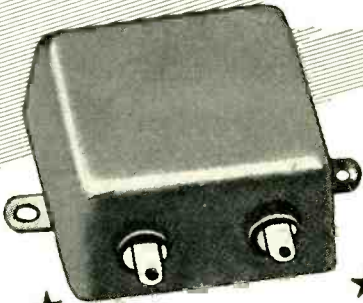

DUMONT MILITARY CAPACITORS

*Supplied in
Accordance with*

**JOINT
ARMY • NAVY • AIR FORCE**

SPECIFICATION

MIL-C-25A

Write for Bulletin No. 38 . . .

DUMONT AIRPLANE & MARINE INSTRUMENTS, Inc.

OFFICE
15 William Street
New York, N. Y.

FACTORY
Clearfield
Pennsylvania

rear of the cup. Type 753 is easily ganged up to 6 cps. Standard resistance value is 20,000 ohms per quadrant. Standard linearity tolerance of ± 0.5 percent of the peak-to-peak output is offered. Torque of shaft per cup section is 1.5 oz in. for single wiper and 2.0 oz in. for dual wiper at 25 C. All terminals are gold plated for reduced contact resistance, low corrosion factor and faster soldering.



CAPACITOR for use in amateur field

JENNINGS RADIO MFG. CORP., P. O. Box 1278, San Jose 8, Calif., has introduced a new vacuum variable capacitor designed for service in the amateur field. Type VAC has a capacitance range of 4 to 40 μf with a nonlinear variation that makes tuning easier at the low capacitance end. Its rating of 42 amperes rms at 10 kv peak (and 22 mc) also makes it highly useful as a neutralizing capacitor in commercial applications. The voltage rating of 10 kv peak is determined at maximum capacitance and increases rapidly as the plates are separated at lower capacitances. The unit is 5 in. long and 2 $\frac{3}{8}$ in. in diameter, with a $\frac{1}{4}$ -in. diameter tuning shaft.

I-F TRANSFORMERS are small, bifilar type

LABORATORY FOR ELECTRONICS, INC., 75 Pitts St., Boston 14, Mass. is introducing a line of new, small bifilar type i-f transformers. They are wound on special ceramic forms and are given a thorough vacuum impregnation with silicone varnish

to increase moisture resistance. The units are adjustable in that they are slug tuned. Small fixed-tuned and slug-tuned solenoids and peaking coils are also available. Another new product is a line of custom-built pulse transformers of both the small interstage type and the high-power output type. These transformers can be supplied in cases per customers' specifications or in the small sizes that can be made up as encapsulated units.

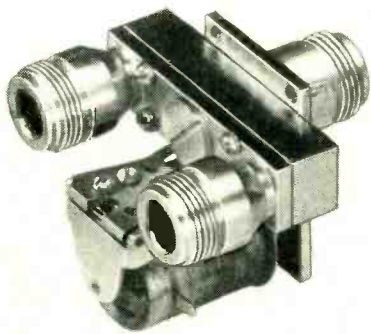

COAXIAL SWITCH
has low vswr

DANBURY-KNUDSEN, INC., P. O. Box 170, Danbury, Conn. Type CR25N, with type N connectors, is one of a new series of coaxial switches recently introduced. This 2-position coaxial switch has a maximum vswr of 1.25 and a minimum crosstalk figure of 42 db at frequencies up to 3,000 mc. Electrical performance at lower frequencies is considerably better. Minimum expected life is 1,000,000 operations. It can be supplied for remote operation with a-c or d-c operating coils for any standard voltage and is available with a control knob for manual operation.

Literature

Microphones and Acoustic Devices. Shure Brothers, Inc., 225 W. Huron St., Chicago 10, Ill. The revised general catalog No. 44B contains illustrations and data on Shure microphones for all applications; microphone accessories; magnetic

a **UNIQUE** application . . . of a **NEW** principle
for a **BETTER** instrument

Doelcam

D-C Indicating Amplifier



Type
2HLA-3

Write for Bulletin IA-7

- ▶ **High Stability**
Less than 10 microvolts long term drift
- ▶ **Wide Dynamic Response**
Flat from 0 to greater than 20 cps
- ▶ **Magnetic Input**
Second-Harmonic Magnetic Converter for input stage
- Linearity within 1%**
- High input impedance**
- Zero-center meter**
- Will drive recorders**

THE DOELCAM D-C Indicating Amplifier is a completely self-contained instrument for the amplification and measurement of d-c voltages and currents of minute magnitude. A new design concept employing the remarkable sensitivity and inherent stability of the second harmonic magnetic converter is used in the input stage of the amplifier. This design feature, by eliminating all moving parts such

as mechanical choppers, makes this instrument ideally suited for applications where accuracy, reliability and insensitivity to changing ambient conditions are of prime importance.

Doelcam CORPORATION

SOLDIERS FIELD ROAD, BOSTON 35, MASS.
West Coast Office: 304 Tejon Pl., Palos Verdes, Calif.
Instruments for Measurement and Control
Synchros • Gyros • Servos • Microsyns • Servo Motors

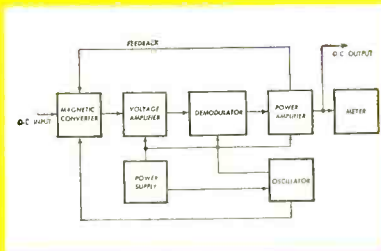

MAGNETIC INPUT . . . Block Diagram showing DOELCAM Second Harmonic Magnetic Converter as input stage . . . a new design concept

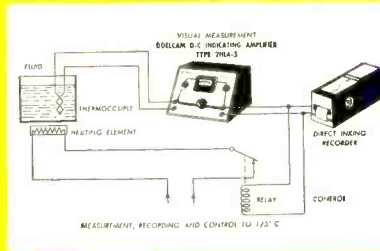

MEASUREMENT - RECORDING - CONTROL to 1/5° C. A typical Process Control application showing high accuracy of DOELCAM Type 2HLA-3

STOP RF LEAKAGE ON THE DRAWING BOARD



... WHEN YOU DESIGN METEX ELECTRONIC WEATHERSTRIPPING INTO YOUR EQUIPMENT YOU GET ITS POSITIVE SHIELDING EFFECTIVENESS — AT MAXIMUM OVERALL ECONOMY

Plan now to take full advantage of *Metex Electronic Weatherstripping's* unusual effectiveness in shielding all types of electronic equipment. Because it is made of knitted wire mesh, *Metex Electronic Weatherstripping* is both conductive and resilient. It assures positive metal-to-metal contact between all mating surfaces. And being resilient it accommodates itself positively to surface inequalities.

In reality, *Metex Electronic Weatherstripping* can do more for you than just shield RF leakage. It can cut the cost of machining mating surfaces to close tolerances. It can eliminate the need for extra fasteners and many other costly means of making joints RF tight.

To get the best results and lowest production costs, design with *Metex Electronic Weatherstripping*, available in 3 basic forms:

- 1 Continuous lengths in various cross sectional shapes with or without fin for attachment.
- 2 Die-formed shielding gaskets, and
- 3 Sealing gaskets where the knitted wire gasket is combined with a sealing medium.



For detailed information on METEX ELECTRONIC PRODUCTS, write for FREE copy of "Metex Electronic Weatherstrips" or outline your SPECIFIC shielding problem — it will receive our immediate attention.

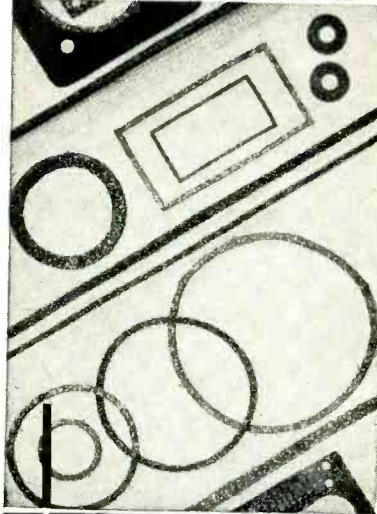

METEX ELECTRONIC WEATHERSTRIPPING

For shielding on all types of electronic and electrical equipment

Each of these is made in various sizes and shapes which are readily adaptable to practically any equipment. The resiliency can be varied where necessary to meet specific requirements.

Applications in which *Metex Electronic Weatherstripping* has already proved its effectiveness include pulse modulator shields, wave-guide choke-flange gaskets, local oscillators on TV sets, dielectric heaters, etc.

tape and wire recording heads (with replacement chart); crystal and ceramic pickup cartridges (with replacement chart); and crystal phonograph pickups and needles.

Crystal Units. Reeves-Hoffman Corp., Cherry and North Sts., Carlisle, Pa. A 4-page bulletin describes the company's most used crystal units which range in frequency from 16 kc to 100 mc, and include the new RH-7BTV designed specifically for use in color tv. Comprehensive data pertaining to dimensions, frequency range and corresponding military specifications are given.

Contact Materials. P. R. Mallory & Co., Inc., 3029 E. Washington St., Indianapolis 6, Ind., has published a 59-page catalog devoted to electrical contacts and contact assemblies. It contains detailed specifications of the company's contact materials; numerous photographs and descriptions of manufacturing facilities and processes; and sketches, line drawings, charts and tables. An outstanding feature is a contact material selector guide, containing descriptions, applications and advantages of each material.

Toroidal Coils. Torwico Electronics, Inc., 961 Frelinghuysen Ave., Newark 5, N. J. A 4-page bulletin entitled "Toroids by Torwico" describes the fine wire winding technique range to No. 46 gage as used in the 18,000 turns on 20-henry chokes. Other coils and finished components that can be furnished from stock or on a contract order basis are illustrated and details given. They include miniature magnetic amplifier coils, high temperature coils, high-Q chokes, large coils, miniature chokes, oscillator coils and low-pass filters.

Oscilloscope Handbook. The Hickok Electrical Instrument Co., 10527 Dupont Ave., Cleveland 8, Ohio, has released a 24-page handbook on cathode-ray oscilloscopes. It contains explanation and illustration of the basic characteristics of the oscilloscope, how it

METAL TEXTILE CORPORATION

KNITTERS OF WIRE MESH FOR MORE THAN A QUARTER CENTURY

Roselle, New Jersey



works and tips on its more general uses. It also lists technical features and performance specifications of models ranging from 3-in. portable scopes up to large technician bench models and includes the highly accurate industrial-electronic laboratory types.

Coil Winding Machines. Geo. Stevens Mfg. Co., Inc., Pulaski Rd. at Peterson, Chicago 30, Ill., has just issued the 46-page catalog No. 54. It illustrates and completely describes machines for winding practically every kind of coil, including toroidal, transformer, bobbin, repeater, solenoid, resistor, armature, variable pitch, space wound, lattice-wound universal and field coils. A variety of accessories are also pictured and described. One page is devoted to winding formulas.

Microwave Equipment. Bogart Mfg. Corp., 315 Seigel St., Brooklyn 6, N. Y. A 4 page folder illustrates and describes five types of microwave equipment. Information is given on the S-band rotary joint, a waveguide to coaxial to waveguide structure employing doorknob transitions; the type 130 magnetron coupler; type 466 reaction frequency meter; type 834 duplexer; and type 535 shielded tube mount.

Magnetic Amplifiers. Magnetic Amplifiers, Inc., 632 Tinton Ave., New York 55, N. Y. A 6-page folder illustrates push-pull magnetic amplifiers, adjustable magnetic servo amplifiers, saturable transformers, demodulators, magnetic voltage regulators and variable speed drives. Included are tabular technical data on 60-cps magnetic amplifiers, 400-cps magnetic amplifiers and magnetic amplifier position servo systems.

Power Transistor. Minneapolis-Honeywell Regulator Co., 2753 Fourth Ave. South, Minneapolis 8, Minn. A 4-page data sheet gives preliminary specifications on the 2N57 power transistor. It includes general information, maximum ratings, information on total transistor dissipation, maximum

NEW Berkeley 1 MEGACYCLE-1 MICROSECOND Universal Counter & Timer

Four extended-range precision instruments at the size and price of one! Drives digital printer, IBM card punch converter, or digital-to-analog converter!



Berkeley's new Model 5510 Universal Counter and Timer provides the functions of counter, time interval meter, events-per-unit-time meter and frequency meter in one compact instrument. It will:

- ① — Count at speeds to 1,000,000 counts per second.
- ② — Count events occurring during a selectable, precise time interval.
- ③ — Measure time intervals in increments of 1 microsecond over a range of 3 microseconds to 1,000,000 seconds.
- ④ — Determine frequencies and frequency ratios, from 0 cps to 1 megacycle.
- ⑤ — Provide a secondary frequency standard (stability, 1 part in 10^6).
- ⑥ — Operate directly into (a) the new Berkeley Model 1452 single-unit printer, (b) Berkeley digital-to-analog converter, or (c) Berkeley data processor driving IBM card punches, electric typewriters, or teletype systems.

CONDENSED SPECIFICATIONS

Input Sensitivity: 0.2 v. rms (Freq. meas.); 1.0 v. peak to peak (other functions)

Input Impedance: 10 megohms shunted by 35 mmf.

Time Bases: 1 mc, 10, and 1 kc; 100, 10 and 1 cps.

Gate Times: .00001, .0001, .001, .01, 0.1, 1.0 and 10 seconds

Crystal Stability: 1 part in 10^6 (temp. controlled)

Display Time: 0.2 to 5 seconds

Accuracy: ± 1 count, \pm crystal stability

Power Requirements: 117 v. ($\pm 10\%$), 50-60 cycles, 400 watts

Dimensions: 20 $\frac{3}{4}$ " wide x 10 $\frac{1}{2}$ " high x 15" deep; panel, 8 $\frac{3}{4}$ " x 19"

Price: Model 5510, \$1,100.00 (f.o.b. factory).

Available for prompt delivery. Wire or write for technical bulletin, application data; please address dept. G-6

Berkeley

M32

division

BECKMAN INSTRUMENTS INC.
2200 WRIGHT AVE., RICHMOND, CALIF.

YOUR BEST SOURCE FOR ELECTRONIC CABINETS

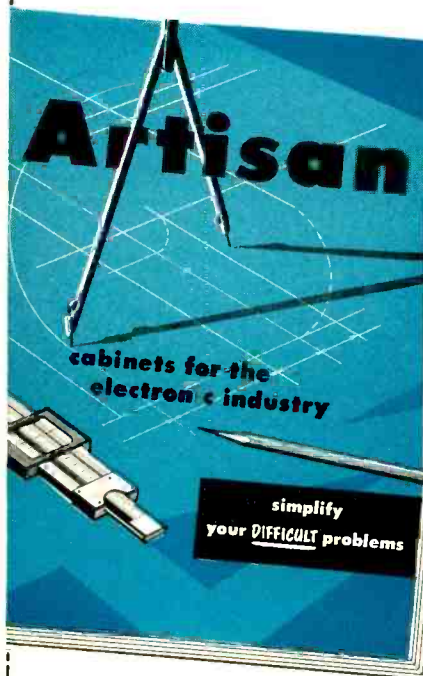

OUR NEW
CATALOG NO. EC-354
WILL GIVE YOU
THE DETAILS

Artisan
Metal Works Company

11410 MADISON AVE.
CLEVELAND 2, OHIO

NEW PRODUCTS

(continued)

power output, typical operating conditions and typical values. Also available is a single sheet (RD-53-002) showing characteristic curves.

Potentiometers and Rheostats. P. R. Mallory & Co., Inc., 3029 E. Washington St., Indianapolis 6, Ind., has available a catalog devoted exclusively to carbon and wire-wound potentiometers and rheostats. It tells the equipment design engineer how to specify control requirements to facilitate quotation and sample preparation and to assure production without delay. The catalog consists of 19 pages containing electrical and mechanical characteristics of available designs in the forms of description, line drawings with dimensions, and large clear photographs. Also illustrated are numerous charts and graphs as well as available hardware. The catalog also contains descriptions and values of potentiometers which can be manufactured in compliance with military specification JAN-R-19.

Portable Insulation Tester. Milwaukee Electronics Corp., 5231 N. Hopkins St., Milwaukee 9, Wisc. A single-sheet catalog bulletin covers the model ME-5KV portable high-potential a-c insulation tester. Included are operational information, technical specifications and descriptive data on the unit's 11 built-in features.

Transfer Volt-Ammeter. Charles Engelhard, Inc., 850 Passaic Ave., East Newark, N. J., has published a 4-page folder dealing with the new Hermach-Engelhard transfer volt-ammeter, a precision a-c multirange instrument with an accuracy of 0.05 percent through a frequency range from 20 to 20,000 cps. The folder describes and illustrates the unit, outlining its features. One page is devoted to information on how to use the unit.

Insulated Chokes. International Resistance Co., 401 North Broad St., Philadelphia 8, Pa. Bulletin H-1 gives comprehensive data on new sizes and extended ranges, construction, insulation, humidity,

HERE'S WHAT
We
MEAN BY -



Miniature

BEARINGS!

TYPE RF

FILMOSEAL

from 0.1969" O.D.

Smallest Sealed Retainer Type Radial
Ball Bearing

An RMB First

This is a miniature bearing! It looks like a big bearing, doesn't it? That's because it has all the features of a big bearing, such as—

- Deep groove races
- Balanced two-piece or snap-type ball retainer
- Non-rubbing capillary oil seal
- Removable and replaceable dust shield
- Precision tolerances

RMB Type RF Filmoseal bearings (illustrated) are available in sizes from 0.1969" O.D.

Type RF now available in R2 size (ABEC-1, 3, 5)
($\frac{1}{8}$ " bore— $\frac{3}{8}$ " O.D.)

**Bring your Miniature
Bearing Problems to RMB**

A complete line of over 250 miniature and instrument bearings including radial and roller types available for prompt delivery. Experimental quantities from stock.

Write for catalog 12
Or see our catalog in Sweet's Files.

RMB LANDIS & GYR,

INCORPORATED

45 WEST 45TH ST. • NEW YORK 36, N. Y.

aging, applications and color coding for a line of insulated chokes. The 4-page catalog contains detailed charts and graphs.

Seals Catalog. Minnesota Rubber and Gasket Co., 3630 Wooddale Ave., Minneapolis 16, Minn., has published a new 16-page brochure documenting in detail the production and application of rubber O-ring seals. Included are sections on end products, O-ring sizes, dash numbers and variable tolerances, dimensional data for installation of standard size O-rings, cross-sectional drawings of correct and incorrect installations and methods of utilizing O-ring sealing properties.

Mounting Systems. Robinson Aviation, Inc., Teterboro, N. J. Advanced design features of all-metal mounting systems are described and illustrated in a new 4-page bulletin, No. 800. The special types of all-metal (Met-L-Flex) mountings described have been developed after extensive research and laboratory work, collaboration with missile designers and service experience. The bulletin offers the answer to many exacting and unusual problems of mounting electronic equipment in guided missiles, rockets and jet aircraft. It includes engineering data and specific examples of various types of mounts and mounting systems.

Electric Actuators. AiResearch Mfg. Co., Los Angeles 45, Calif. A 64-page catalog of electric actuators is now available. The descriptive booklet outlines the applications and specifications of 20 basic types of linear and rotary actuators, power units, jacks, gear boxes and ammunition boosters. The company manufactures some 300 different models in these fields. Illustrated with photographs, charts and engineering drawings, the booklet is designed to help potential users choose the model that will best suit their needs.

Tube Sockets. Remler Co. Ltd., 2101 Bryant St., San Francisco 10, Calif. A one-sheet bulletin illustrates and describes medium base

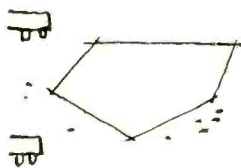
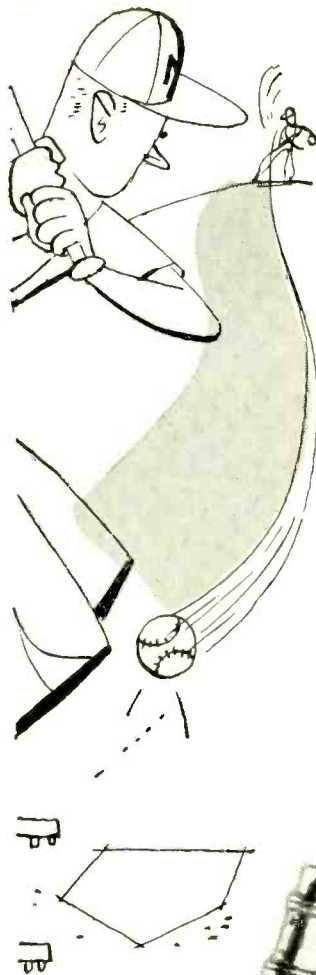

Curves belong in the right places!

Centralab ceramic BC Hi-Kap[®] tubular capacitor leads end tricky bending or fitting...

Centralab BC's help take the fuss and cuss out of assembly. Sturdy 1½" leads are straight and true — solder coated for rapid installation. They'll make a big hit with you every time!

The facts prove BC's are your best buy

- ⌚ **Low weight per capacity** — heaviest is only .082 oz.
- ⌚ **Small size** — smallest is a fraction of an inch long, only .200" in diameter.
- ⌚ **Broad capacitance range:** from 1 mmf to .01 mfd.
- ⌚ **Impervious to moisture** — Ceramic-X body is non-hygroscopic. Absorption .007% or less.

... Here are more facts to prove why Centralab's BC's out-perform all others!

- ⌚ **Two types of insulation**—1. Moisture-proof, low-power-factor resin lacquer. 2. Durez phenolic dipped—prevents shorting possibilities. Color-coded to RETMA specifications.
- ⌚ **Low power factor** — .3 to 1.5%, max.
- ⌚ **High leakage resistance** — Initial — 5000 megohms, minimum.
- ⌚ **Maximum dependability** — Moisture- and puncture-proof. Will not short or become intermittent.
- ⌚ **100% factory tested** for voltage and capacity, and power factor.

LET BC'S END YOUR FIELD TROUBLES — WRITE NOW FOR BULLETIN 42-3R!

Standard items available at your local (CRL) distributor — see Catalog 28.

Centralab

A Division of Globe-Union Inc.
914F E. Keefe Avenue • Milwaukee 1, Wisconsin
In Canada: 804 Mt. Pleasant Road, Toronto, Ontario

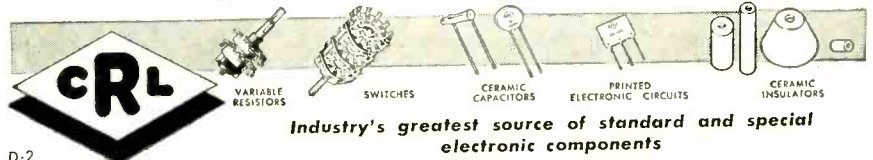

D-2

**Where dependability,
long life and uniform
performance are
all-important . . . select**

Bendix
Red Bank

HARD GLASS Miniature Beam Power Amplifier



Here's another advance in the Bendix Red Bank "Reliable" Vacuum Tube program. Featuring a hard glass bulb and stem with gold-plated pins . . . plus a conservative design center of cathode temperature . . . the Bendix Red Bank RETMA 6094 can operate at temperatures up to 300° C. compared to an average of only 175° C. for soft glass bulbs. Thus, this new tube ideally meets aircraft, military and industrial applications where freedom from early failure, long service life, and uniform performance are essential.

The Bendix 6094 uses pressed ceramic spacers, instead of mica, for element separation. In other tubes, deterioration of mica in contact with the hot cathode causes loss of emission which is greatly accelerated under shock and vibration. Ceramic eliminates this problem and greatly reduces damage caused by fatigue failure of parts.

For complete details on our special-purpose tubes, write today.

ELECTRICAL RATINGS*

Heater voltage (AC or DC)**	6.3 volts
Heater current	0.6 amps.
Plate vptage (maximum DC)	275 volts
Screen voltage (maximum DC)	275 volts
Peak plate voltage (max. instantaneous)	550 volts
Plate dissipation (absolute max.)	12.5 watts
Screen dissipation (absolute max.)	2.0 watts
Cathode current (max. instantaneous peak value)	100.0 ma
Heater-cathode voltage (max.)	±450 volts
Grid resistance (max.)	0.1 megohm
Grid voltage (max.)	+5.0 volts
(min.)	-200.0 volts
Cathode warm-up time	45 seconds
(Plate and heater voltage may be applied simultaneously.)	

*To obtain greatest life expectancy from tube, avoid designs where the tube is subjected to all maximum ratings simultaneously.

**Voltage should not fluctuate more than ±5%.

MECHANICAL DATA

Base	9 pin miniature hard glass— gold plated tungsten pins
Bulb	Hard glass—T6½
Max. over-all length	2¾"
Max. seated height	2¾"
Max. diameter	¾"
Mounting position	any
Max. altitude	80,000 feet
Max. bulb temperature	300°C.
Max. impact shock	500g
Max. vibrational acceleration	50g
(100-hour shock excited fatigue test, sample basis.)	

NEW PRODUCTS

(continued)

4-pin and octal tube sockets. Specifications and dimensional drawings are given for these heavy duty industrial type components that are designed for rugged service and applications subject to vibration and shock.

Trimmers. Arco Electronics Inc., 103 Lafayette St., New York 13, N. Y. A 1-page bulletin announces two new Elmenco trimmers—the type 40 (miniature) and type 42 (midget). Sizes and guaranteed ranges are given.

Low Inertia Servo Motor. Infra Electronic Corp., 553 Eagle Rock Ave., Roseland, N. J. A recent bulletin deals with the type M100 low inertia servo motor. It lists motor characteristics, and contains a performance data curve and a schematic diagram showing fixed phase and control phase. A dimensional drawing is also included.

Power Supplies. Kepco Laboratories, 131-38 Sanford Ave., Flushing 55, N. Y., has available a folder illustrating and describing 20 models of voltage regulated power supplies. Tabular material lists output, volts, current, regulation and ripple for each.

Thermal Time Delay Relay. Elly Electronics Corp., P.O. Box 395, Fair Lawn, N. J., has issued a bulletin illustrating and describing its positive snap-action spdt thermal time delay relay that features small size, light weight, low heater current and low operating temperature. Technical specifications and ordering information are given.

High-Vacuum Pumps. Consolidated Vacuum Corp., 735 Ridge Rd., W., Rochester 3, N. Y. Data sheet 6-55 contains complete physical dimensions, operating data and performance curves for each of the type MCF high-vacuum oil diffusion pumps. The smallest of the eight fractionating metal pumps in the series described has a 2-in. diameter and a peak speed of 60 liters per sec; the largest has a 32-in. diameter and a peak speed of 19,000 liters

Bendix
Red Bank

Manufacturers of Special-Purpose Electron Tubes, Inverters, Dynamotors, Voltage Regulators, Fractional D.C. Motors and A.C. and D.C. Generators.

DIVISION OF



EATONTOWN, N. J.

West Coast Sales and Service: 117 E. Providencia Ave., Burbank, Calif.
Export Sales: Bendix International Division, 205 E. 42nd St., New York 17, N. Y.
Canadian Distributor: Aviation Electric Ltd., P.O. Box 6102, Montreal, P. Q.

per sec. The pumps discussed will produce an ultimate pressure of 5×10^{-7} mm Hg at 25 deg C.

Electronic Typewriter. Shepard Laboratories, 480 Morris Ave., Summit, N. J. A 4-page bulletin deals with the model 134 high-speed typewriter, an electronically operated printing device, capable of producing hard copy from the output of an electronic computer or magnetic tape. The machine described is adaptable to a wide variety of applications, such as data handling, inventory control or the production of subscriber labels. Illustrations, specifications and dimensional drawings are included.

Data Processing Equipment. International Business Machines Corp., 590 Madison Ave., New York 22, N. Y. The significant principles and components of electronic data processing equipment are described in "Light On The Future", an illustrated booklet now available. After a brief comparison of the construction and applications of analog and digital computers, the booklet explains the organization of digital computers and describes briefly the functions of the input, storage, arithmetic, control and output components. A glossary is included.

Time Delay Generator. Rutherford Electronics Co., 3707 S. Robertson Blvd., Culver City, Calif. A single-sheet catalog bulletin illustrates, describes, outlines special features and the many uses of the model A-5 time delay generator, a precision electronic device for the generation of accurate and variable time intervals. Complete technical specifications are given.

Color Broadcast Equipment. Radio Corp. of America, Camden, N. J., recently released a catalog of standard color broadcast equipment. It contains detailed descriptions and specifications covering all essential items of color networking and test equipment. Included are RCA's color stabilizing amplifier, color monitor, color signal analyzer, linearity checker, color monitor analyzer, burst con-



THE PROBLEM

SENSITIVITY, DISTANCE AND CONVENIENCE

The microprojector shown below is designed to project an enlarged image of the microscope's field on a ground glass screen in back of the bellows. In developing this equipment, the designer needed a control set-up which would allow the operator to stand in front of the screen and focus the microscope and center the image. He found the answer in

THE LOW-COST SOLUTION

AN S.S. WHITE REMOTE CONTROL FLEXIBLE SHAFT

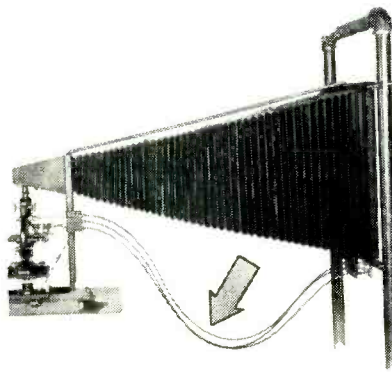

In fact, three shafts, 4 feet long, did the trick. One end of each shaft was attached to the appropriate control on the microscope and the other end to a control knob at the operator's station. Despite their length, the shafts met all requirements by providing the close, delicate adjustment needed.

If you'd like to get the full story on the money-saving advantages offered by S.S. White flexible shafts for both power drive and remote control send for

This Important Data for Economy-Minded Designers

The 256-page Flexible Shaft Handbook has details on flexible shaft selection and application. Copy sent free if you request it on your business letterhead.



THE S.S. White INDUSTRIAL DIVISION
DENTAL MFG. CO.



Dept. E, 10 East 40th St.
NEW YORK 16, N. Y.

Western District Office • Times Building, Long Beach, California



"Your Blueprint In Plastics"

ALL MATERIALS • ALL PROCESSES

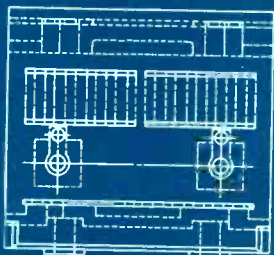

Custom
Molding

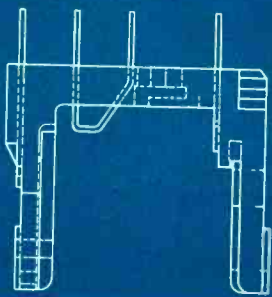

CONSOLIDATED
MOLDED PRODUCTS CORPORATION

SCRANTON 2, PENNA.

trolled oscillator, color frequency standard, burst flag generator, color bar generator and colorplexer. The catalog is accompanied by a complete price list.

Power Oscillator. Industrial Test Equipment Co., 55 E. 11th St., New York 3, N. Y. A single-sheet bulletin illustrates and describes the model 1040 power oscillator, a compact precision oscillator providing 3-w output. Included in the bulletin are applications, features and complete technical specifications.

Precision Potentiometers. The Gamewell Co., Newton Upper Falls 64, Mass., has issued an 8-page folder on its precision potentiometers which are electro-mechanical devices containing a resistance element that is contacted by a movable slider. Included are illustrated descriptions and specifications on the RL-270 series linear potentiometers and the RL-14MS and RL-11C non-linear group. Also given are data on toroidal (sometimes referred to as type RL-257) linear potentiometers. The company's materials and methods are described. Ordering and pricing information are given.

Galvanometers. Edin Co., Inc., 207 Main St., Worcester 8, Mass. Descriptive bulletin B-1 outlines in considerable detail the characteristics and features of a line of ink-writing galvanometers for research and industrial instrumentation. Response curves and complete specifications for eight models are given.

Evaluating Shielding Enclosures. The Ace Engineering and Machine Co., 3644 N. Lawrence St., Philadelphia 40, Pa., has announced publication of an engineering study entitled "Evaluating Shielded Enclosures." It devotes considerable space to such things as: attenuation vs insertion loss; how each is measured and what they mean in terms of actual performance; screen rooms vs solid sheet enclosures, and where each should be used in terms of both physical and electrical considera-

LARGE TRANSFORMERS



FOR ELECTRONIC APPLICATIONS

For electronic applications requiring special or experimental transformers of large capacity Acme Electric can supply custom-built units designed to exact electrical characteristics and performance requirements.

We invite your inquiry.

ACME ELECTRIC CORPORATION

Main Plant: 316 Water Street • Cuba, N. Y.

West Coast Engineering Laboratories: 1375 W. Jefferson Blvd., Los Angeles, Cal.

In Canada: ACME ELECTRIC CORP. LTD. • 50 Northline Rd. • Toronto, Ont.

Acme Electric
TRANSFORMERS

tions. Filters and filter performance, structural factors, contacting of components, air inlets—all are covered at length and in a highly objective manner.

Thermistors. Carboloy Dept. of General Electric Co., Detroit 32, Mich. A new manual that enables a user to understand easily what thermistors are, how they are applied, what functions they perform and what benefits industry derives from them in detecting and compensating temperatures, and providing time delay or surge control in electrical equipment, is announced. The 52-page publication includes considerable new information on thermistors, tests supplied by an independent laboratory, characteristic curves for a thermistor carrying current in thermal equilibrium with the ambient, and for one where the time delay function is of primary interest. Illustrations are keyed so a user can tell at a glance which style or type thermistor is best adapted to his application.

Precision Resistors. The Daven Co., 191 Central Ave., Newark, N. J. A 32-page catalog is intended as a guide to basic data on precision wire-wound resistors for the application and design engineer. The catalog is divided into sections starting with broad general data on all of the company's precision wire-wound resistors and continuing into complete detailed specifications of each type. Where applicable, latest government specifications are cross-referenced.

Electronic Temperature Control. Fielden Instrument Division, Robertshaw-Fulton Controls Co., 2920 N. Fourth St., Philadelphia 33, Pa. A bulletin on the new electronic temperature control, series 97, is now available. The control discussed is applicable in production processes for electric, steam and hot water heaters; baths of all kinds; ovens, kilns and dryers; plastic extrusion presses and a number of other uses. The series 97 described is available for wide ranges in temperature and operates on the principle of the change

TIC's tiny duo..

Similar in appearance - different in application!

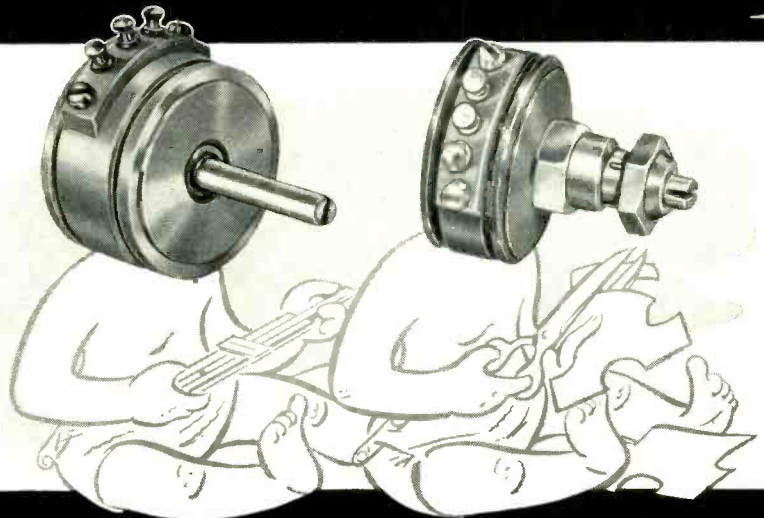

**RVP7/8 Precision
Potentiometer
for Computation**

**RV7/8 Trimmer
Potentiometer
for Adjustment**

TIC's tiny duo — for your needs in diversified applications of miniature potentiometers.

Type RVP7/8 provides accuracies approaching those of larger potentiometers commonly used in computing and control instrumentation. TYPE RV7/8 provides reliability, stability and positive setting for calibration and trimming adjustments.

TIC characteristic quality is embodied in both miniature potentiometers.

Rugged Aluminum Base
Corrosion Resistant Finish
Patented Ganging Method

Wide Resistance Range
High Resolution
Low Noise

Specifications common to both RVP7/8 and RV7/8:

Resistance Range: 100 ohms — 40,000 ohms
Resistance Tolerance: $\pm 5\%$ Standard
Power Rating: 2 watts at 25° C
Ambient Temperature Range: -55°C to +80°C.
Temperature Coefficient of Resistance Wire: .00002 per degree C.
Resolution: Optimum for each resistance value

RVP7/8 Specific data:

Linearity: $\pm 2\%$ of total resistance standard less than 1% of total resistance on special orders.
Electrical Rotation: 320° $\pm 5\%$ Standard
Rotational Life: 1,000,000 complete cycles at 60 rpm
Mounting: Precision servo-type.

RV7/8 Specific data:

RV7/8 Mounting: Threaded bushing with locking device for maintaining precise setting under extreme environmental conditions.

Write for new RV7/8 Bulletin 12-3.

ENGINEERING REPRESENTATIVES

Chicago, Ill. — Uptown 8-1141
Rochester, N. Y. — Monroe 3143
Canaan, Conn. — TAYlor 4-7215
Dayton, Ohio — Michigan 8721
Baltimore, Md. — Plaza 7694
Great Neck, L. I., N. Y.
Great Neck 2-9406

Amprrior, Ont., Can. — Amprrior 400
New York, N. Y. — MURray Hill 8-5858
Cambridge, Mass. — ELiot 4-1751
Hollywood, Cal. — HOLlywood 9-6305
Dallas, Texas — Dixon 9918
Binghamton, N. Y. — Binghamton 3-1511
Wood-Ridge, N. J. — Webster 9-7217

TECHNOLOGY INSTRUMENT CORP.

533 MAIN STREET • ACTON, MASS. • TELEPHONE COLonial 3-7711

West Coast Engineering Facility: 731 North LaBrea Ave., Hollywood 38, California—WHITney 0108.

this TEFLON* gives you uniform parts...

electrically... dimensionally

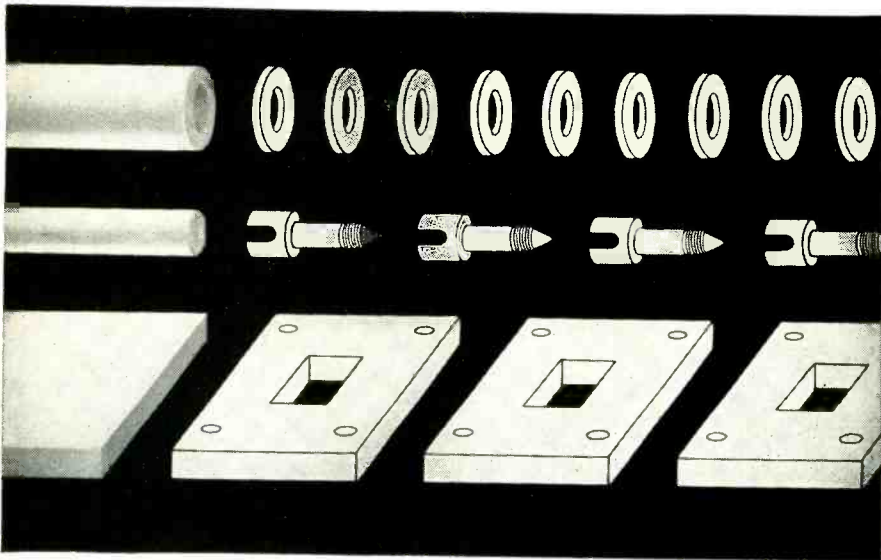

*Non porous FLUOROFLEX®-T assures electrical stability.
It's stress relieved for uniform machinability.*

It's in the processing—not in the appearance—that the real difference in Teflon shows up. Natural discolorations don't mean a thing to performance. But variable properties do.

That's why Fluoroflex-T products are extruded or molded under rigid control. Specially designed equipment compacts Teflon powder to the critical density—which not only prevents porosity, but also assures highest tensile strength. Resistoflex processing relieves internal stresses to provide better dimensional stability without any porosity. In short, Fluoroflex-T rods, tubes and sheets offer *uniformly* optimum properties.

All this means non absorbent insulators, for optimum UHF performance... and also uniform machining with fewer rejects. Why not specify Fluoroflex-T for *your* Teflon parts? For more information write for Bulletin FT-1.

*DuPont trade mark for its tetrafluoroethylene resin.
© Resistoflex trade mark for products from fluorocarbon resins.

RESISTOFLEX

corporation

Belleville 9, N. J.

SPECIALLY ENGINEERED FLEXIBLE RESISTANT PRODUCTS FOR INDUSTRY

of resistance of a wire-wound sensing element with changes in temperature. The company will recommend and supply a complete range of control elements for use with the unit.

Power Plants. Kupfrian Mfg. Co., 395 State St., Binghamton, N. Y. Bulletin 5464 illustrates and outlines chief features of the model MGA-600 portable 600-w power plant. The unit described could have applications for transmitters, p-a systems, civil defense and other possibilities. Complete specifications are included.

Tubular Paper Capacitors. The Gudeman Co., 340 W. Huron St., Chicago 10, Ill. Catalog X-100 contains engineering data, electrical characteristic curves, available mounting styles and tabular material giving technical specifications for a wide line of miniature tubular paper capacitors. Ordering information is included.

H-V Half-Wave Vacuum Rectifier. CBS-Hytron, Danvers, Mass. Bulletin E-225 is devoted to the type 3A3 high-voltage half-wave vacuum rectifier for color television. Mechanical and electrical data, a basing diagram, maximum ratings and an average plate characteristics curve are included.

Microwave Balanced Mixers. Airtron, Inc., 1103 W. Elizabeth Ave., Linden, N. J. A 6-page technical bulletin on the relatively new art of microwave balanced mixer design has been published. Technical bulletin T-2600 provides much of the basic theoretical and design information needed by the radar or commercial microwave relay engineer in choosing the proper waveguide mixer for his particular application. Each mixer is individually described as to construction, operating characteristics and applications.

Information Storage System. Logistics Research, Inc., 141 S. Pacific Ave., Redondo Beach, Calif. A revolutionary method of electronic information storage that provides users with an open door to complete automation is described in

detail in a 4-page illustrated pamphlet. The pamphlet describes technical functions of the Magnetic Library System, and outlines its practical application in such varied operations as accounting, production and inventory control, and preparation of detailed reports. The system described consists of an electronic digital computer and a memory wheel working in conjunction with commonly-used office machines.

Flexible Shafts and Couplings. Kupfrian Mfg. Co., 395 State St., Binghamton, N. Y. Catalog 5495 covers a wide line of light duty flexible shafts and couplings. Included are typical applications, technical descriptions and dimensional drawings. A section is devoted to special assemblies dealing with a variety of shaft fittings, casings, casing ferrules and casing nuts.

Relays. Advance Electric and Relay Co., 2435 North Naomi St., Burbank, Calif. A recent 6-page brochure lists 48 of the company's relays designed for a wide variety of applications. The relays shown are grouped in accordance with their primary function, such as: antenna, coaxial, delay, power and telephone types. Complete technical specifications and ordering information are given.

X-Y Plotter. Librascope, Inc., 1607 Flower St., Glendale, Calif., has available a 6-page folder illustrating and describing the X-Y plotter and recorder, a compact, desk-size unit designed for plotting two independent variables from either analog or digital inputs. Included are data on the even-flow ink supply, floating gear train and full-visibility plotting surface. The folder also gives information on the mechanical, power amplifier and removable input sections. Accessory converters are illustrated and described.

Microwave Communication Equipment. Collins Radio Co., Cedar Rapids Iowa. A 12-page booklet illustrates and describes a line of microwave communication equipment that can be used in conjunction with existing wire lines

ONE SOURCE

for every Wire and Cable requirement

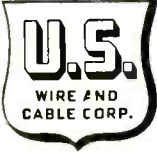

U.S.
WIRE AND
CABLE CORP.

Electronic and Communication... Electrical and Industrial . . . in every field *U.S. Wire and Cable* plays an active part as a dependable manufacturer. Products of our new enlarged factory surpass all standard field and laboratory tests. Of our extensive line, the items shown here are only representative. We invite your inquiries for our Catalogue and further information.



No. RHF-11
High Frequency Cable



No. ML-18
Instrument Wire



No. M-20
Microphone Cable



U.S. WIRE & CABLE CORP.



No. LR-5900
Radio Hook-Up Wire



No. M-22
Microphone Cable



No. 1500
Tabular Twin Lead

HIGH FREQUENCY COAXIAL CABLES: These cables not only conform to, but in most cases surpass, JAN-C-17-A specifications for RG type cables. Our continual laboratory tests assure you that these cables will exceed your requirements in the Electrical, Electronic, and Industrial uses to which they will be applied.

INSTRUMENT and RADIO HOOK-UP WIRES: Furnished with Nylon, Polyethylene, Vinyl or other types of plastic insulation, or without jacket. UNDERWRITERS' LABORATORIES approved, these wires are used for Control Wiring, Automatic Dispens-

ing Machines, and in Radio & TV Equipment.

MICROPHONE and INTERCOM CABLES: A complete selection of Shielded and Unshielded types which can be used for Lead-in, Phono Pick Ups, Speaker Installations, and Public Address purposes in the Radio industry.

TV ANTENNA WIRES: Designed in all shapes (*Flat, Round, Twin Leads, Tubular*) to fulfill the requirements of Television, Mobile Communications, UHF, VHF, Community Antenna Systems, Antenna Rotor Leads, and other Electronic purposes.

UNITED STATES WIRE & CABLE CORP.

22 PROGRESS STREET
UNION, NEW JERSEY

Consult us about your
wire and cable problems.

Catalog on request.

Representatives in Principal Cities

- MECHANICAL ENGINEERS
- ELECTRONICS ENGINEERS
- ELECTRICAL ENGINEERS
- X-RAY ENGINEER
- PHYSICISTS
- AERODYNAMICISTS
- MATHEMATICIANS



WORK ON THE FRONT LINE OF THE NATION'S VITAL

DEFENSE PROGRAM. Sandia Corporation is engaged in the development and production of atomic weapons—a challenging new field that offers opportunities in research and development to men with Bachelor's or advanced degrees, with or without applicable experience. Here you can work with able colleagues, eminent consultants and superior facilities on advanced projects of high importance — and also build a permanent career in a rapidly expanding field with a company that recognizes individual ability and initiative.

LIVE IN ALBUQUERQUE, THE HEART OF THE SUNNY

SOUTHWEST. Located in the historic Rio Grande Valley at the foot of the Sandia Mountains, mile-high Albuquerque is famous for its climate—mild, dry and sunny the year around. A modern, cosmopolitan city of 150,000, Albuquerque offers unique advantages as a place in which to live. Albuquerque's schools, churches, theaters, parks, and modern shopping facilities afford advantages of metropolitan life—yet hunting, fishing, skiing and a multitude of scenic and historic attractions may all be found within a few hours' drive of the city. New residents have little difficulty in obtaining adequate housing.

ENJOY THESE OTHER IMPORTANT ADVANTAGES.

These are permanent positions with Sandia Corporation, a subsidiary of the Western Electric Company, which operates Sandia Laboratory under contract with the Atomic Energy Commission. Working conditions are excellent, and salaries are commensurate with qualifications. Liberal employee benefits include paid vacations, sickness benefits, group life insurance, and a contributory retirement plan. This is not a Civil Service appointment.

Make Application to:

PROFESSIONAL EMPLOYMENT
DIVISION C

SANDIA
Corporation

SANDIA BASE • ALBUQUERQUE, NEW MEXICO



or other facilities to provide communication circuits suitable for telephone, teletype, telemetering, supervisory control, facsimile and video transmission. Included are microwave and multiplex block diagrams together with illustrations of various units and typical racks. A diagram shows a typical microwave station listing no-standby and with-standby r-f and multiplex equipment.

Test and Measuring Equipment.

The Clough-Brengle Co., 6014 Broadway, Chicago 40, Ill. Complete specifications and data on a line of test equipment are presented in catalog No. 54-A. Listed are the model 603 i-f sweep generator; models 179A and 405 beat frequency oscillators; models 182-A and 282-A audiomatic generators; model 217H transmission measuring set; models 299A and 552 r-f signal generators; model 712 capacity-resistance-inductance bridge; and model 411 extended range audio oscillator. The 12-page publication with price list included is available on request.

High-Power Rotary Joint. Microwave Development Laboratories Inc., 220 Grove St., Waltham 54, Mass. Bulletin RJ-1 illustrates and describes model B172, a high-power rotary joint. Operational characteristics and specifications are given.

Solenoid Catalog. West Coast Electrical Mfg. Corp., 233 W. 116th Place, Los Angeles, Calif., has available a new a-c solenoid catalog. It presents easy-to-read solenoid design information, engineering drawings, solenoid performance charts, work and temperature curves. This information is necessary to assist the engineer in selecting the right solenoid for his application.

Regulated Power Equipment.

Sorenson & Co., Inc., 375 Fairfield Ave., Stamford, Conn., manufactures of electronic a-c voltage regulators, regulated d-c sources and B-supplies, electronic frequency changers, inverters, magnetic-amplifiers d-c sources and

related equipment, now have available a new general catalog including their entire standard line of instruments. The catalog provides abundant general information on the operating principles of the company's instruments and complete specific data on each instrument, including pictures, general descriptions, electrical and mechanical specifications. Request catalog No. 254.

Resistors. Atlas Resistor Co., 24 E. Coulter St., Philadelphia 44, Pa., has published a 4-page folder illustrating and describing a line of fixed (pack wound) and adjustable resistors. Complete technical data includes wattage, size, mountings and range in ohms.

Precision Noninductive Resistors. K-F Development Co., 2634 Spring St., Redwood City, Calif. A new leaflet describes a series of 9 resistor types providing standard values over the range of 0.1 ohm to 1 megohm in values exact to 1 percent, 0.5 percent or 0.1 percent accuracies. The series is illustrated, identified by type number, and tabulated in a compilation of data which includes wattage, diameter, length and net prices. Ordering information as well as data on alloys of wire used for standard and special resistors are also included.

Transformers and Reactors. Thor-darson-Meissner, Seventh and Belmont, Mt. Carmel, Ill. Now available is catalog 400-L covering the company's line of transformers and reactors. It features a new, complete television replacement section, new output transformer chart and complete cross reference.

Automatic Controls. J. B. Rea Co., 1723 Cloverfield Blvd., Santa Monica, Calif. A new 16-page brochure covers the company's products and automatic control engineering services. Some of the products discussed in the brochure are a hovering control for rotary wing aircraft, an automatic cruise control system, a digital strain gage recording system, an automatic control for cold blankets and

SPACE TIGHT?

USE JOHNSON TYPE "E" AND "F" CAPACITORS

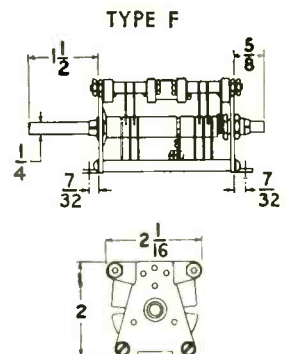
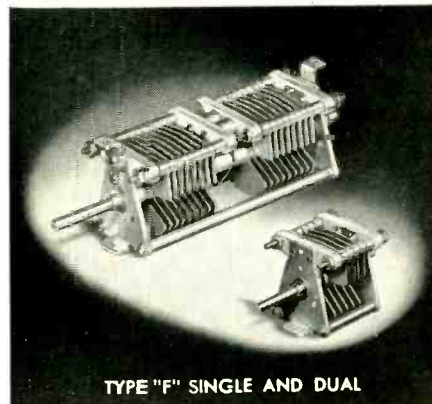
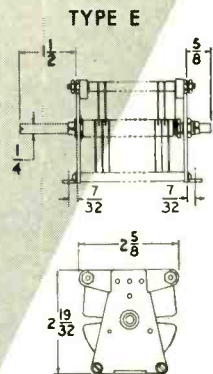
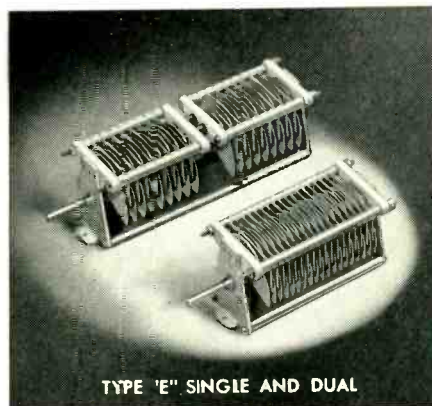

LESS PANEL AREA—MORE CAPACITY PER CUBIC INCH!

Rugged and compact, JOHNSON Type "E" and "F" Capacitors for medium and low power transmitters have more capacity per cubic inch and occupy less panel space for their ratings than any other capacitor on the market.

In addition, their simple, functional design provides extremely good mechanical rigidity and exceptional electrical performance. Points of superiority include steatite insulation, heavy aluminum plates with rounded edges, $\frac{1}{4}$ " tie rods, efficient cadmium plated phosphor bronze

contacts and stainless steel shafts. Designed for chassis mounting with stator up to reduce capacity to ground, they have unusually low minimum capacity ratings.

Available in 40 different models, single and dual sections with plate spacings from .045" to .125" and maximum capacities from 35 to 500 mmfd.

Quotations on standard models or "specials" to meet your requirements are available on request. Investigate Johnson's "E" and "F" Capacitors for your application today!

Write for the **NEW** Johnson General Products Catalog #975.



E. F. JOHNSON COMPANY

CAPACITORS • INDUCTORS • SOCKETS • INSULATORS • PLUGS • JACKS • KNOBS • DIALS AND PILOT LIGHTS

2315 SECOND AVENUE SOUTHWEST • WASECA, MINNESOTA

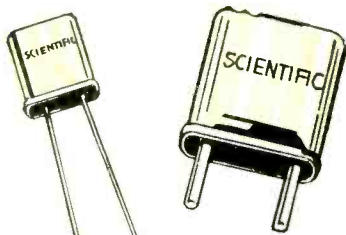

CRYSTALS

FOR EVERY PURPOSE



- AIRCRAFT
- MOBILE TWO-WAY
- LAW ENFORCEMENT
- TAXI
- RAILROAD
- BROADCAST
- AIR FORCE
- ARMY — SIGNAL CORPS

- NAVY
- HOBBY MODELS
- AMATEUR
- TELEVISION
- PIPELINE
- MARINE
- INDUSTRIAL
- CAA Type Certification



CONSULT OUR RESEARCH AND ENGINEERING LABORATORY. IT IS AT YOUR SERVICE.

One of the Oldest Manufacturers of Crystals in the United States.

ORDERS PROMPTLY FILLED



SCIENTIFIC

CRYSTALS OF THE HIGHEST QUALITY

SCIENTIFIC RADIO PRODUCTS, INC.

215 South 11th St.,
Omaha, Nebr., U.S.A.

Be Specific - Say Scientific

NEW PRODUCTS

(continued)

a digital autopilot for fighter aircraft.

Insulators. Fluorocarbon Products, Inc., a division of the U. S. Gasket Co., Camden 1, N. J., has issued a 12-page catalog on a complete line of Teflon insulated Chemelec stand-off and feed-through insulators—designed for low-loss, high-frequency service, unaffected by a wide range in ambient temperatures, pressures, altitudes, humidity and mechanical shock and vibration. Two series of miniature and subminiature stand-off insulators are illustrated and described: (1) with stud, screw or rivet mounting hardware and (2) compression mounting type. Four series of feed-through insulators are shown: (1) hermetic solder-seal type, (2) moisture and oil-proof gasket type, (3) miniature threaded metal body type and (4) miniature and subminiature compression mounting type. Ask for bulletin No. EC-1153.

Slide Wire Rheostats. Herman H. Sticht Co., Inc., 27 Park Place, New York, N. Y., has issued bulletin No. 551 which shows their complete line of Standco slide wire rheostats with graduated percentage scale. Of particular interest are the new type double rheostats shown on page 3 which are suitable for series or parallel connection and are designed to cover a particularly long range in resistance, and have a large amount of current capacity. Also shown are fixed resistors-potentiometers with one or more adjustable bands. The graduated percentage scale attached to all rheostats discussed has a feature which enables the user to calculate approximate resistances very quickly and to vary the resistances and current intelligently.

Magnetic Recording Head Replacement. Shure Bros., 225 W. Huron St., Chicago 10, Ill., have issued a magnetic recording head replacement chart. This chart lists the exact Shure replacement for the tape head used in the manufacturer's original equipment. Illustrations of the types of recording

CRYSTAL CALIBRATOR

MEASUREMENTS CORPORATION
Model 111

FREQUENCY RANGE: .25Mc.—1000 Mc.

FREQUENCY ACCURACY:

±0.002%



A Dual-Purpose Calibrator

- CRYSTAL-CONTROLLED OSCILLATOR
- BUILT-IN DETECTOR
- 2 Microwatt Sensitivity

Designed for the Calibration and Frequency Checking of Signal Generators, Transmitters, Receivers, Grid-Dip Meters and other equipment where a high degree of frequency accuracy is required.

Harmonic Range:

.25 Mc. Oscillator: .25-450 Mc.

1 Mc. Oscillator: 1-600 Mc.

10 Mc. Oscillator: 10-1000 Mc.

117 volts, 50/60 cycles; 18 watts, 6" wide, 8" high, 5" deep; 4 lbs.

MEASUREMENTS CORPORATION



Boonton

New Jersey

heads, recording head dimensions, technical data, and a numerical listing of Shure type heads, may be found on the reverse side of the chart.

Communication Tape Monitor System. Magnecord Inc., 225 W. Ohio St., Chicago 10, Ill., has available a folder dealing with its communication tape monitor system for the automatic and continuous recording of radio and phone intercommunication. The system described permits simultaneous and continuous recording of 4 individual intelligence signals on standard $\frac{1}{4}$ -in. tape. Illustrated descriptions are given for: (1) a multichannel recording tape transports system; (2) a multichannel reproduce transport; (3) a mobile storage table; (4) a portable bias-record indicating meter; and (5) a portable erase unit.

Selenium Rectifiers. Radio Receptor Co., 251 W. 19th St., New York 11, N. Y., has issued bulletin No. 177, a comprehensive 24-page catalog describing Seletron selenium rectifiers—both radio and industrial types. Fully illustrated with voltage curves, circuitry, tabular matter and product applications, it devotes considerable space to an expanded tabulation of power rectifiers up to 260 v input and 30 amperes. Among the rectifiers discussed are those special ones for magnetic amplifier application, hermetically sealed and high temperature types, as well as embedded stacks.

Waveform Simulator. The Newton Co., 55 Elm St., Manchester, Conn., has available a folder discussing the Synthescope, an instrument which will reproduce waveforms on an oscilloscope from patterns that have been drawn manually. The instrument described is comprised of 3 basic components: waveform generator, intermediate electronic circuitry and oscilloscope. Applications of the unit are included.

Frequency Meter. Colortone Electronics, Inc., 238 William St., New York, N. Y. A single-page bulletin deals with the model TS-175A/U frequency meter. It illustrates the

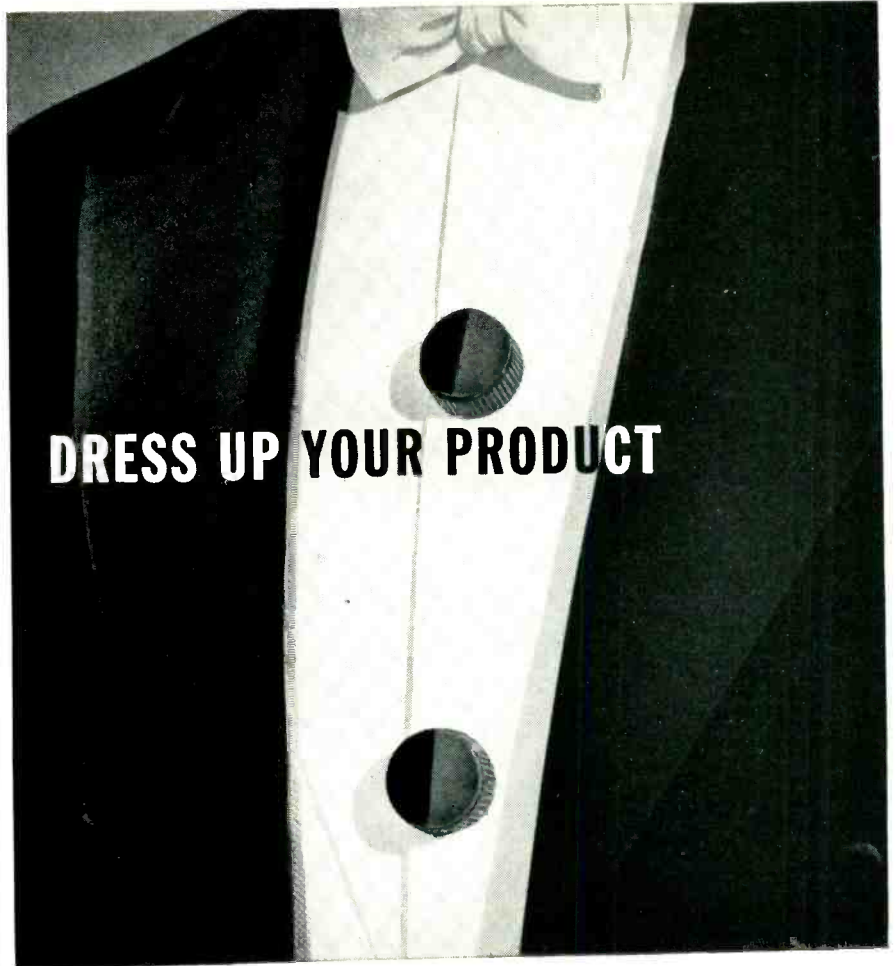

DRESS UP YOUR PRODUCT



Make the *outside* of your fine electric and electronic equipment look like the quality *inside* — with standard control knobs by Raytheon.

These injection molded knobs add the appeal of custom styling at standard cost. They are available in an integrated family of 54 items — in a choice of *six* basic types and *five* widely used sizes.

Made of tough, durable "Tenite II" (cellulose acetate butyrate) with anodized aluminum inserts and dual setscrews. All types and sizes available in black with gleaming *mirror finish* or with non-reflecting *matte finish* for government applications. Unlimited color variation is also available including knob parts assembled in different color combinations.

Write for complete information. Address Dept. 6270-KA, Raytheon Manufacturing Company, Equipment Sales Division, Waltham 54, Massachusetts.



**STANDARD
CONTROL
KNOBS**

PRICE IS RIGHT! DELIVERY IS RIGHT!

ECLIPSE-PIONEER AUTOSYN* SYNCHROS

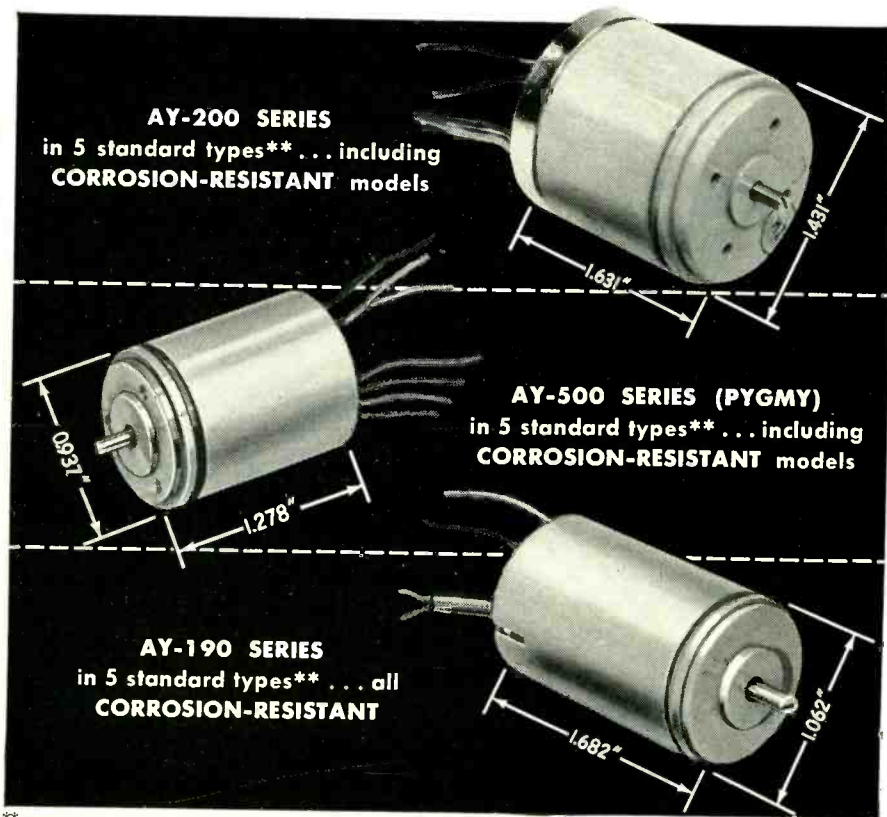

**TRANSMITTERS, RECEIVERS, CONTROL TRANSFORMERS, DIFFERENTIALS AND RESOLVERS

And there's a type to meet every need!

Our Autosyns provide the perfect answer to synchro requirements for three good reasons. First, they're priced attractively to keep down your initial cost. Second, they can be delivered in prototype quantities *at once*. Third, they're available in all standard types in production quantities . . . as well as practically any special type you could ever need. And, of course, military specifications are used as design objectives in all cases. Only at Eclipse-Pioneer can you find the combination of

experience, facilities, and production techniques that make possible all these important advantages. So, *whatever* your synchro requirements, it will pay you to see Eclipse-Pioneer.

OTHER STANDARD AND SPECIAL ECLIPSE-PIONEER AUTOSYN SYNCHROS INCLUDE models 1, 11, 15, 18, 23 and 2R as well as high temperature, high frequency, linear, and other types for special needs.

*REGISTERED TRADE-MARK BENDIX AVIATION CORPORATION.

WRITE DEPARTMENT C

ECLIPSE-PIONEER

TETERBORO, NEW JERSEY

West Coast Office: 117 E. Providencia Ave., Burbank, Calif.
Export Sales: Bendix International Division, 205 E. 42nd St., New York 17, N. Y.



NEW PRODUCTS

(continued)

unit and outlines its frequency range, calibration accuracy, stability, environmental conditions passed and applications.

Meter Calibrator. Kalbfell Laboratories Inc., 1090 Morena Blvd., San Diego 10, Calif., has available a mailing piece that illustrates and describes its meter calibrator, a compact unit that produces an absolutely calibrated d-c voltage, independent of input line voltage and output load variations. Specifications and applications are included.

Electrometer Voltage Dividers. Keithley Instruments, 3868 Carnegie Ave., Cleveland 15, Ohio. A loose-leaf perforated catalog sheet illustrates and describes the models 2006 and 2007 voltage dividers that clip onto electrometers to extend their voltage ranges. Typical applications of the units discussed include measuring voltages on c-r tubes, photomultiplier tubes, tv picture tubes, x-ray and radiation equipment, leakage of high-voltage insulators, and testing the voltage breakdown of cables. Specifications are given.

Stacked Retaining Rings. Industrial Retaining Ring Co., 8 W. Sidney Ave., Mt. Vernon, N. Y. A 4-page folder illustrates and describes the company's method for cutting costs and speeding assembly with its stacked open-type retaining rings. The booklet shows how these retaining rings work to eliminate waste motions, nonproductive time and ring loss. A free offer is included.

Disk Thermostats. Stevens Mfg. Co., Inc., 69 South Walnut St., Mansfield, Ohio. Bulletin F-2009 describes the line of type M bimetal disk thermostats for appliances, electronic devices and apparatus. Hermetically sealed and semienclosed styles are covered. Punched for insertion in standard three-ring binders, the bulletin describes the operating principle and illustrates it with a schematic diagram. Ratings, typical performance curve, dimensions, construction, and various available terminal arrangements and mounting provisions are

shown in diagrams, tabular data and photographs.

Toggle Switches. Micro Switch, a division of Minneapolis-Honeywell Regulator Co., Freeport, Ill. Catalog No. 73a covers 19 precision snap-action toggle assemblies and over 90 AN and JAN approved designs, including assemblies that will control anywhere from 1 to 24 separate electrical circuits. The catalog has complete dimensions, operating characteristics, electrical ratings and contact arrangements on each switch, as well as an illustration of one representative switch from each group or family of switches. There is also general information on each family of switches to aid in selecting just the right switch for any specific application. The toggle switches described are designed for aircraft, mobile, marine, railway and other low-voltage d-c applications.

Subminiature Blower. Sanders Associates, Inc., Nashua, N. H. A tiny folder discusses subminiature blower featuring a motor and blower complete in a 1-in. cube. Weight of the unit described is 1 oz.; input—400 cps, 2 phase 4 w; and output—3 cu ft of air per minute. Dimensional data, characteristics and environmental conditions for the Minicube are included.

Power Supplies. Allied Engineering Division, Allied International, Inc., Connecticut & Richards Aves., South Norwalk, Conn. An 8-page brochure contains technical information on five of the company's power supplies. Clear illustrations and specifications are provided for each model. A detachable sheet is included for filling in specifications of special design.

Portable Analog Computer. Dynamic Analysis, Inc., Box 2188 South Annex, Van Nuys, Calif. An illustration and outstanding features of the Dyalzyer are given in a single-page mailing piece. The unit described is a new low-cost, portable analog computer for analysis, synthesis and simulation of dynamic systems.

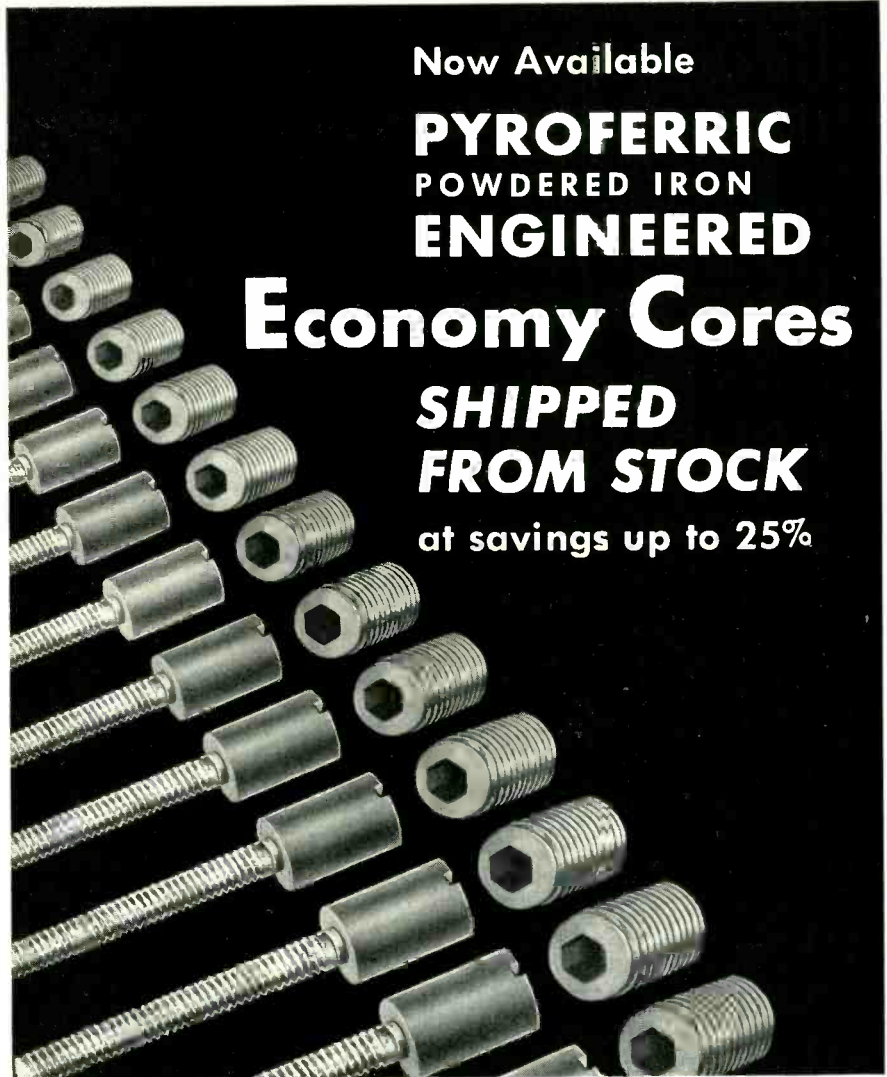

Now Available
PYROFERRIC
 POWDERED IRON
ENGINEERED
Economy Cores
SHIPPED
FROM STOCK
 at savings up to 25%

PYROFERRIC INSERT CORES
 Diam: .245 to .250 • Insert: 4-40 x 1" Extending
 Slot in Core: 1/32 x 1/32

PYROFERRIC THREADED CORES
 Material: PY 1A (Carbonyl E)

Part No.	Material	Length
EE 5001-P	PY 12A (IRN-8)	3/8"
EE 5002-P	PY 1A (Carbonyl E)	3/8"
EE 5003-P	PY 1A (Carbonyl E)	1/2"
EE 5004-P	PY 14A (Carbonyl TH)	3/8"
EE 5005-P	PY 14A (Carbonyl TH)	1/2"

Part No.	Diameter	Length	Thread	Adjusting Slot
EE 5101-P	.248-.250	3/8"	28 T.P.I. Shallow	Hex Hole .103-.105
EE 5102-P	.237-.239	3/8"	32 T.P.I. Shallow	Hex Hole .103-.105
EE 5103-P	.180-.182	5/16"	32 T.P.I. Shallow	Screwdriver slots both ends

All Pyroferic products are produced to conform to the strictest engineering standards of uniformity, controlled quality of materials, and performance that lives up to the most exacting specifications.

PYROFERRIC
 PYROFERRIC BLDG. BRONX BOULEVARD
 at 216th St., N.Y.C. 67

Please send me specification sheets on Pyroferic Economy Cores

Write on your letter-head for latest Catalog No. 23 Ju.

NAME _____ TITLE _____
 FIRM _____
 ADDRESS _____ CITY _____ STATE _____

PLANTS AND PEOPLE

Edited by WILLIAM G. ARNOLD

New plant expansions are announced by manufacturers . . .
Associations plan conventions, shows and meetings . . . Engineers
are named to new positions . . .

OTHER DEPARTMENTS

featured in this issue:

	Page
Electrons At Work	196
Production Techniques	246
New Products	282
New Books	368
Backtalk	378

Frequency Symposium Fetes Engineers



AMONG THE ENGINEERS attending the eighth annual Frequency Control Symposium at the Berkeley-Carteret Hotel in Asbury Park, N. J. were, from left to right, Col. F. F. Uhrhane, Commanding, Signal

Corps Engineering Laboratories; W. L. Doxey, chief, Frequency Control Branch, Squire Signal Laboratory, Fort Monmouth, N. J.; J. L. Greber, RCA and Lt. Col. J. V. Fill, director, Squire Signal Lab.

RETMA Plans 30th Anniversary Celebration

THE RADIO-ELECTRONICS-TELEVISION MANUFACTURERS ASSOCIATION attained its 30th birthday in April. Celebration of the event will be deferred until the Association's annual convention June 15-17 in Chicago.

The trade association for the radio-tv and electronics industry was founded in April, 1924, in Chicago, by a small group of component manufacturers who foresaw

some of the potentialities of the new industry and the need for cooperative action to guide it.

H. H. Frost was elected the Association's first president.

Besides Frost, the first board of directors of RMA consisted of A. J. Carter, A. A. Howard, Frank Reichmann, Philip Lenz, Jr., J. McWilliams Stone and E. N. Rauland, the latter three of whom are still active in the industry.

The Association was known as the Radio Manufacturers Association until 1950 when it became the Radio-Television Manufacturers Association. In 1953 "Electronics" was added to the name in recognition of the expanding scope of both the Association and the industry it represents.

The first major reorganization of the Association occurred in 1933 with the establishment of four major divisions. These were the Set, Tube, Parts and Amplifier & Sound Equipment Divisions. The Transmitter Division, now known as the Technical Products Division, was formed in 1942.

As the industry has grown and more services have become necessary, the Association has established statistical, government relations and international departments.

The latest reorganization took place in 1953 with the formation of the two committees of the Board of Directors—the Radio-Television Industry Committee and the Electronics Industry Committee.

Sixteen industry leaders have served as president of the Association between 1924 and 1954. In 1951 the Association for the first time employed a paid president, Glen McDaniel, and elected an industry executive as chairman of the board of directors. Robert C. Sprague became the first board chairman and holds the same office today.

Leslie F. Muter, of Chicago, holds the record of having held office in RETMA longer than any other industry representative. In addition to serving four terms as president,

RECORD FEATURES

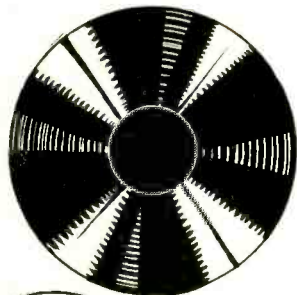

BEAUTIFULLY
STYLED SMOOTH
MODERN LINES—
POLYCHROMATIC
FINISH

PLAYS
10 MIXED
DIAMETER RECORDS
AT
33 $\frac{1}{3}$, 45 OR 78
R.P.M.

'MAGIDISK'
AUTOMATICALLY
SELECTS
7", 10" OR 12"
DISCS

P.U.
RETURNED
AND MOTOR
SWITCHED OFF
AFTER LAST
RECORD

10"
DIAMETER
HEAVY STEEL
RECESSED
TURNABLE
WITH RUBBER
MAT

TURNABLE
RIM DRIVE BY
VIBRATION-DAMPED
INDUCTION MOTOR
ELIMINATING
RUMBLE AND
'WOW'

COMPACT
OVERALL
DIMENSIONS IDEAL
FOR RADIOGRAM
OR T.V.
CONSOLE

FITTED
ANTI-ACOUSTIC
FEED BACK
SUSPENSION
SPRINGS

EXTENDED
FREQUENCY
RANGE REVERSIBLE
SAPPHIRE STYLI
CRYSTAL
P.U.

SIMPLE
UNIT CONTROL
'ON,' 'OFF,' 'REJECT'
AND RECORD
SPEED



Only the Monarch Autochanger has *all* these features. Its record performance, fidelity reproduction and absolute reliability are acclaimed by music lovers and record enthusiasts everywhere—it's the first choice of the experts.

WORLD'S FINEST AND MOST WANTED AUTOCHANGER

Birmingham Sound Reproducers Limited, Claremont Works, Old Hill, Staffs.

he has been treasurer for 18 years, a position he still holds.

Forty-six manufacturers organ-

ized RMA in 1924. Today the Association's membership exceeds 370.

Of the charter members, all but a

few have disappeared as corporate entities either through mergers, dissolutions or for other reasons.

Raytheon Opens Electronics Lab, Appoints Personnel

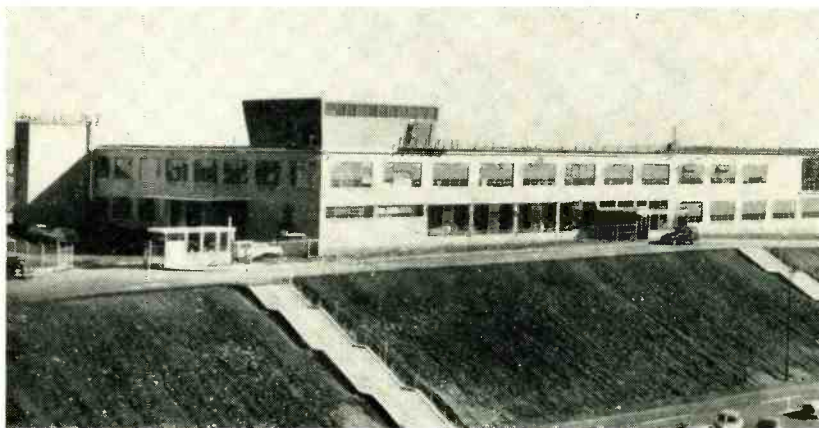

A NEW TWO-MILLION DOLLAR electronics laboratory was opened near Hanscom Air Force Base in Bedford, Mass.

The U. S. Navy began construction of the building late in 1952, when it was planned that Raytheon would use the structure as a Navy research and development center. It has 100,000 sq ft of floor space on two floors, and will house approximately 700 workers. There are 21 specially designed bays for

operating and testing radar equipment.

The personnel of the new laboratory comprise an establishment which has been engaged in missile and radar work since 1944.

David D. Coffin, manager of Raytheon's missile and radar division, has been named an assistant vice-president of the firm.

He manages the group of more than 700 employees based in the new laboratory building; a large

manufacturing plant in South Lowell and the Raytheon plant at the Naval Air Missile Test Center, Point Mugu, Calif.

He joined Raytheon in 1934, where he has served as design and supervisory engineer for the transformer division, chief engineer of the commercial division, and in other positions of increasing responsibility in the engineering operations of the company.

Sidney A. Standing has been appointed manager of Raytheon's cathode ray tube division.

In 1941, Standing was employed by North American Phillips, subsequently becoming manager of its electronic tube division in Dobbs Ferry, N. Y. He later went to Tung-Sol where he set up and managed the cathode ray tube division. From that position he has rejoined Raytheon specifically to direct the engineering, manufacturing, and quality control of black-and-white, color, and industrial cathode ray tubes.

Wescon Hosts Set For 1954 Convention

THE WESTERN ELECTRONIC Show & Convention (Wescon) is getting set to receive the thousands of engineers who will attend the show in August.

The event takes place in Los Angeles' Pan-Pacific Auditorium and the Ambassador Hotel on August 25, 26, and 27 and more than 465 booths will be occupied—nearly 100 more than last year. And overall attendance is expected to approach 20,000.

Hosts for this year's Wescon will be the Los Angeles Section of the IRE, and the Los Angeles Council of WCEMA. With a membership of only 830 in 1946, the Angeles Section of IRE today is composed of



Ellis F. King

more than 2,880 engineers. It is second only to the New York Section in number of members.

Chairman of the section is Ellis F. King, of the University of California at Los Angeles; vice-chairman is Bruce S. Angwin of GE; secretary is Walter E. Peterson of



E. P. Gertsch

Northrop Aircraft and treasurer is Charles E. Rutherford of Rutherford Electronics.

Chairman of the Los Angeles Council of WCEMA is E. P. Gertsch of Gertsch Products; vice-chairman is R. G. Leitner of Packard-Bell and secretary-treasurer is

"FUSES?"



There's BUSS — the one Source for all FUSES."

For your exact fuse needs, there's a BUSS fuse. A complete line of fuses for the Electronic Industries — in sizes from 1/500 amperes up . . . plus a companion line of fuse clips, blocks and holders.

Besides meeting your specifications, BUSS fuses are known for their ability to give accurate and dependable electrical protection under all service conditions.

To make sure that a BUSS fuse will never let you down — every BUSS fuse normally used by the Electronic Industries is tested in a sensitive electronic device that rejects any fuse that

is not correctly calibrated, properly constructed and right in all physical dimensions.

That's why manufacturers and service organizations throughout the nation rely on BUSS as the one source for fuses of unquestioned high quality.

Should you have a special problem in electrical protection, let BUSS save you engineering time. The world's largest fuse research laboratory and its staff of engineers are at your service to help you select the fuse best suited for your device — and if possible, a fuse available from local wholesalers' stocks.

Makers of a complete line of fuses for home, farm, commercial, electronic and industrial use.



For more information
mail this Coupon ►

BUSSMANN Mfg. Co. (Division of McGraw Electric Co.)
University at Jefferson, St. Louis 7, Mo.

Please send me bulletin SFB containing facts on BUSS small dimension fuses and fuse holders.

Name _____

Title _____

Company _____

Address _____

City & Zone _____ State _____ ELRC

654

NOW

**NEW YORK —
73 RUTLEDGE ST., BROOKLYN 11, N. Y.**

**CARGO PACKERS
EAST & WEST COAST
PACKAGING
SERVICE!**

**CALIFORNIA —
2050 BROADWAY, SANTA MONICA**

Individually-engineered
CLIMATE-PROOF, SHOCK-PROOF PACKAGING

To meet the increased, country-wide demands of the electronics industry. Cargo Packers has now inaugurated complete facilities in the West Coast area also, for packaging protection of delicate instruments, equipment and components, including



12-PAGE BROCHURE tells how to avoid the pitfalls, gives complete detailed information on C-P methods of protective packaging.

- Special Assembly Equipment
- Experts in Military Specifications
- Economical Production line methods
- Full Compliance in Every Detail
- Competent Consulting Service

Whether in storage or in transit anywhere, absolute protection against strain, stress, shock, vibration, temperature or humidity fluctuations, moisture — or even skin damage — is assured by Cargo Packers' individual attention to every job. For recommendations on specific packaging problems, call or write our Sales-Engineering Department today.

CARGO PACKERS

INCORPORATED

New York — 73 RUTLEDGE ST., BROOKLYN 11, N. Y.
California — 2050 BROADWAY, SANTA MONICA

CLIMATE-PROOF PACKAGING

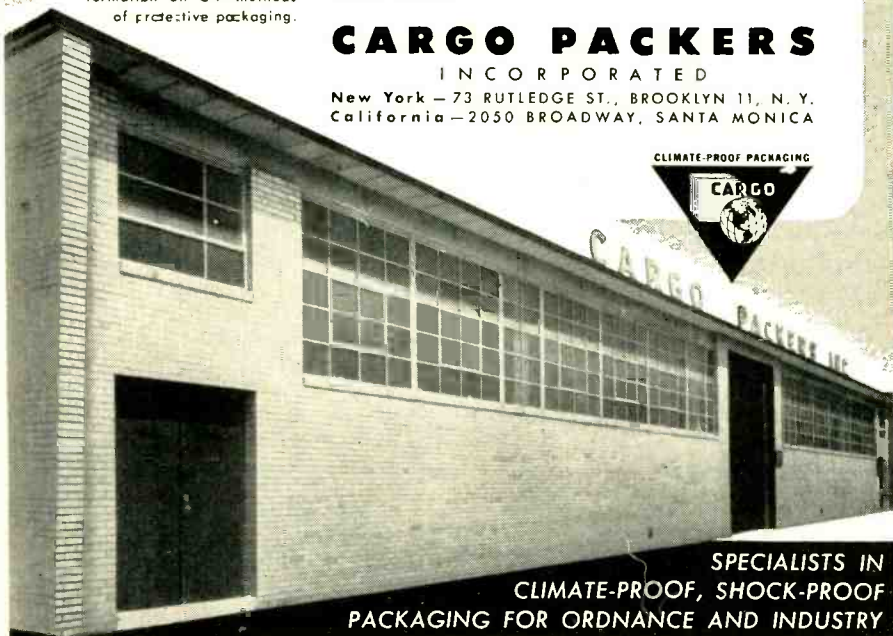

**SPECIALISTS IN
CLIMATE-PROOF, SHOCK-PROOF
PACKAGING FOR ORDNANCE AND INDUSTRY**

Gramer Yardbrough of American Microphone. Its present membership includes more than 110 electronic firms in Southern California.

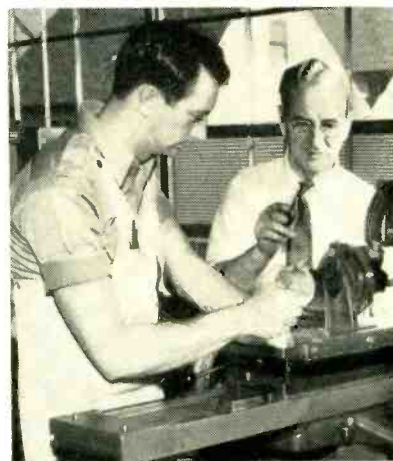

**Volkert Launches
Apprenticeship Program**

JOHN VOLKERT METAL Stampings has allotted part of its newly-constructed plant in Queens Village, N. Y., to the exclusive use of tool-and-die-maker apprentices.

Working under a veteran tool and die maker, employed as a full-time instructor, the apprentices get constant instruction from him and, in addition, specialized instruction from other Volkert craftsmen.

"We recognize that high-precision tooling skills are in great demand in our mass-production economy," Jack Kleinoder, general manager, said, "and we've stepped up our apprenticeship program. We have been training apprentices on a small scale since our company was founded in 1934, but we now hope to have about a dozen or more at all times. Six are already taking the course." Kleinoder is chairman of the apprenticeship committee of the National Tool & Die Manufacturers Association.

The program, covering four years for each apprentice, has the approval of both the New York State Apprenticeship Council and of the National Tool & Die Manufacturers Association. It is planned that graduates of the course will be eligible for credits toward an engineering degree at Pratt Institute.

Francis Beck, a veteran of al-

most 50 years as a tool and die maker, has been appointed Volkert's supervisor of apprentice training. Working under Beck, apprentices will get training in their own shop for three years. In the fourth year, they will spend most of their time in the Volkert toolroom under actual working conditions.

Related classroom instruction, supervised by Professor Bergin of Pratt and approved by the Board of Education of the City of New York, is being given to the apprentices in the Volkert plant two evenings a week.

All applicants, who must be at least high school or trade school graduates, must pass aptitude, qualification and physical examinations. Apprentices sign an agreement under which they are hired for a 90-day probationary period.

NBS Members Receive Commerce Award

SIX MEMBERS of the staff of the National Bureau of Standards have received the Department of Commerce Gold Medal Award for Exceptional Service. The awards were made for "outstanding contributions, as a member of a group, in the field of production technology for electronics with important implications for the electronics industry and for national defense". The men receiving the award were: J. G. Reid, Jr.; Robert L. Henry; Benjamin L. Davis; Charles C. Rayburn; James G. Black, Jr. and Harold S. Horiuchi.

These six men were the primary scientists responsible for the development of an automatic method for mechanical production of electronics and for the design and construction of machinery to mass produce electronic components on a pilot plant scale. This program was formerly known as "Project Tinkertoy".

J. Gilman Reid, Jr., joined the staff of NBS in 1937. In 1941 he became a project engineer at the Bureau working on the design and development of electrical and electronic control equipment for uranium isotope separation. In 1943 Reid joined the program for devel-



Mixed and ready to perform design miracles!

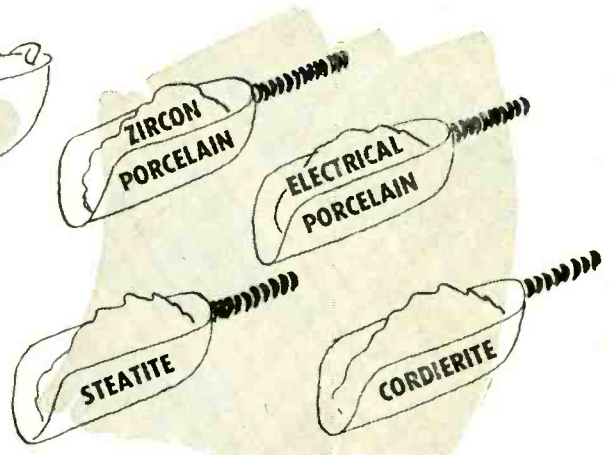

Centralab

offers you engineered ceramics for all types of structural and electrical use.

4 BASIC TYPES TO CHOOSE FROM:

	1 Steatite Body 302	2 Cordierite Body 401	3 Zircon Porcelain Body 452	4 Electrical Porcelain Body 501
Grade (JAN-1-10)	L-5	L-3	L-4	L-2
Dielectric Constant	5.76	6.23	8.99	5.91
Power Factor (at 1 Megacycle)	.0012	.0048	.0014	.0090
Loss Factor (at 1 Megacycle)	.0069	.0299	.0126	.0535
Dielectric Strength (Volts per Mil)	265	228	210	260
Coefficient of Linear Expansion:				
20-200° C.	7.0x10 ⁻⁶	2.1x10 ⁻⁶	3.8x10 ⁻⁶	4.6x10 ⁻⁶
20-400° C.	7.4x10 ⁻⁶	2.7x10 ⁻⁶	4.3x10 ⁻⁶	5.1x10 ⁻⁶
20-600° C.	7.9x10 ⁻⁶	3.1x10 ⁻⁶	4.7x10 ⁻⁶	5.7x10 ⁻⁶
Moisture Absorption (%)	0-0.010	0-0.010	0-0.010	0-0.010
Apparent Specific Gravity	2.69	2.65	3.68	2.53
Modulus of Rupture (lbs/sq. in.)	19,000	17,000	20,000	13,300
Compressive Strength (lbs/sq. in.)	70,000	95,000	82,200	71,400
Impact Strength (ft. lbs/sq. in.)	1.95	1.80	2.21	1.55



WRITE NOW! Let Centralab solve your ceramic problems!

- Thousands of formulae "ready to go".
- Largest staff of ceramic and electronic engineers available for consultation.
- All parts produced under strict quality control after each major operation with the industry's most modern, mechanized production facilities.

Standard ceramic insulators available at your local (CRL) distributor—see catalog 28.

Centralab

A Division of Globe-Union Inc.
914F E. Keefe Avenue • Milwaukee 1, Wisconsin
In Canada: 804 Mt. Pleasant Road, Toronto, Ontario

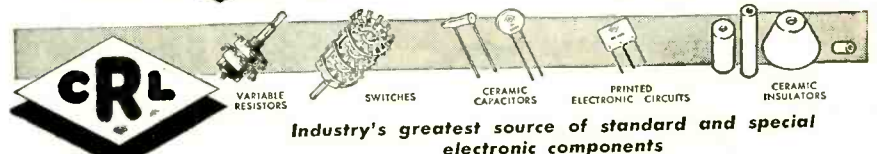

Industry's greatest source of standard and special electronic components

X-2

PHALO

Molded Plugs



M-1007 Octal



F-1001

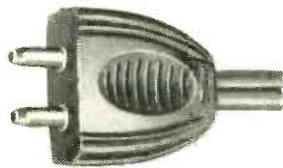

1005 Connectors

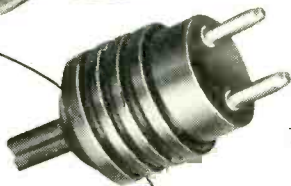

1002 Connectors

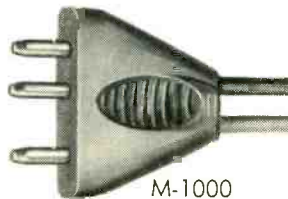

M-1000

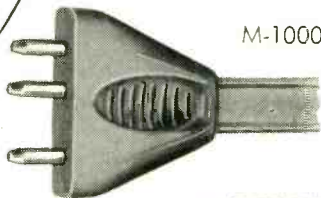

M-1000

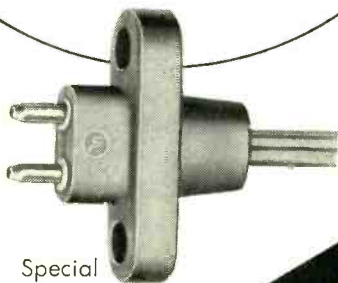

Special Interlock



M-1002 Plug



Special Strain Relief



Standard Strain Relief



Recognized leaders in molding specialty plugs for the electronics and electrical manufacturing industries.

Insulated Wires, Cables and Cord Set Assemblies

Complete catalog



material request

PHALO

PLASTICS CORPORATION
Corner of Commercial St.
Worcester, Massachusetts

opment of radio proximity fuzes and from 1944 he directed a major project in this field. Following this work he served as chief engineer for the Electronic Instrumentation Laboratory. From 1950 to 1953 he was chief of the NBS Electronics Division.

Henry joined NBS in 1946 and worked in the field of printed electronic circuits, conducting research on materials and technique associated with special electronic production processes. After conception of the Modular Design of Electronics system, he was chosen to lead "Project Tinkertoy" in its development into a method for the Mechanical Production of Electronics. Henry was technical and administrative director of the project and was also responsible for coordinating the efforts of the private contractors involved. He received the Fleming Award as an outstanding young man in the Federal Government.

Benjamin L. Davis was basically responsible for the general development of organic materials and the processes for their use in the mechanized production of electronics. He was especially responsible for development of the tape resistor and a protective coating for the tape resistor. He came to the NBS in 1937 after serving with the Department of Agriculture and the Office of Technical Services of the Department of Commerce.

Charles C. Rayburn came to NBS in 1951. Previously he designed and constructed an apparatus which he used to detect the presence of short-lived nuclear isomers. He also had worked for GE.

While in the Air Force he specialized in communications and engineering.

James G. Black, Jr., came to the Electronics Division of the National Bureau of Standards in 1952. He was previously assistant professor in industrial arts at Morehead State College.

Harold S. Horiuchi came to the National Bureau of Standards in 1948. He has been closely connected with the miniaturization program of electronic equipment employing printed circuit techniques.

All of these men except Dr. Davis

are now connected with ACF Electronics of Alexandria, Virginia.



Clary Multiplier Names Oldenburg

KENNETH F. OLDENBURG has been appointed supervisor of the electronic laboratory of Clary Multiplier in a move to effect closer coordination between development work on new products and electronic manufacturing operations.

Oldenburg joined Clary as an engineering designer for the company's business machines in 1947 and for the past two years has been a supervisor in charge of the development of new electro-mechanical equipment, including input keyboard machines and automatic readout printers. He was previously with Ohmite in research. In his new position he will head research and development on all the company's electronic data handling products in addition to the input and readout machines.

Milton Scozzafava will take over Oldenburg's specialized projects in the office equipment division and will continue his own work as engineering supervisor for Clary adding machines and cash registers.

Sylvania Establishes Guided Missile Lab

SYLVANIA established a new laboratory that will analyze and evaluate the scientific and engineering problems associated with guided

THE 10-MEGACYCLE SCOPE

MODEL

OL-23A

- Expansion of any image detail is possible up to the maximum writing rate of the 'scope.
- AND the sweep maintains its accurate calibration independent of the degree of expansion.

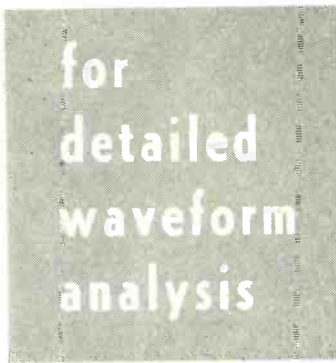

REALLY IMPORTANT
image expansion
by means of stable
SWEEP DELAY

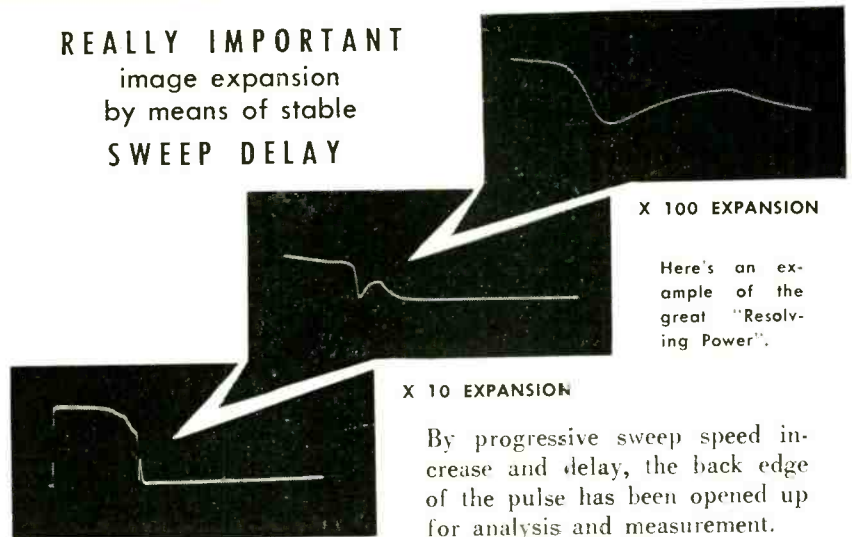

X 100 EXPANSION

Here's an example of the great "Resolving Power".

X 10 EXPANSION

By progressive sweep speed increase and delay, the back edge of the pulse has been opened up for analysis and measurement.

NORMAL PRESENTATION

"Sweep-Lok" synchronization
- easy to set - locks in and stays locked over broad ranges

SPECIFICATIONS

- 5 cycle to 10 mc vertical amplifier with signal delay line — .035 μ sec rise time
- Accurately calibrated triggered or recurrent sweeps 0.1 μ sec/cm to .011 sec/cm
- Vertical calibration voltage variable to 100 peak-to-peak
- Built-in trigger generator with positive and negative outputs
- Continuously variable sweep delays up to 10,000 μ sec without jitter

MODEL OL-23A
OSCILLOSYNCHROSCOPE

\$890.⁰⁰

f.o.b. Winchester



BROWNING
Laboratories, Inc.
Winchester, Mass.
ENGINEERED FOR ENGINEERS

Write for descriptive literature

For easier-to-tie knots that will not slip!



**HEMINWAY
& BARTLETT**

Fungus-Proof

NYLON

LACING CORDS and FLAT BRAIDED TAPES

- Revolutionary synthetic resin coating prevents knots from slipping.
- Laces faster and tighter with less effort. Unique "plastic memory" actually causes lacing to tighten *itself* after knot is made!
- Its greater strength means minimum breakage — minimum rejects.
- The synthetic resin coating retains the desirable malleability of wax and yet has a melting point of over 190°F. It is non-toxic to humans.
- Complies with *ALL* construction and fungus-proof requirements of Govt. Spec Jan-T-713 and Jan-T-152.

Cords and tapes are also available with wax finish.

For **FREE SAMPLES** and prices write:

The Heminway & Bartlett Mfg. Co., ELECTRONICS DIVISION, 500 Fifth Ave., New York 36, New York
Sales Offices: Chicago, Philadelphia, Boston, St. Louis, Cincinnati, San Francisco, Los Angeles, Charlotte, N.C.,
Gloversville, N.Y. Foreign Agent: Turner, Halsey Co., Inc., 40 Worth St., New York. Cable Address: THECOTEX

missiles. The facility, known as the Missile Systems Laboratory, is located in Queens County, N. Y.

Howard L. Richardson, vice-president in charge of engineering operations, said the activity's first project is a long-range advanced study of missile problems for the Army Ordnance Corps.

Scientists at the laboratory, according to Richardson, will stress the "systems" approach to missile problems.

The value of a missile must be judged on the basis of how well it accomplishes some useful military purposes, he said. In addition to the design of the missile itself, scientists must determine how a target is to be located and identified, how and when the missile is to be fired, how many missiles are required to accomplish a certain purpose, where the missiles are needed, and how many men are required to keep a military missile activity in a state of readiness. The work of the missile group will embrace this entire system of missile development, Richardson added.

Oliver G. Haywood, Jr., has been appointed manager of the Missile Systems Laboratory. Before his present assignment, Dr. Haywood was manager of engineering planning. A former colonel in the U. S. Air Force, he was at one time head of the Air Force Office of Scientific Research in Baltimore, Md.

Members of Dr. Haywood's staff will include Frank S. Manov, manager of the systems analysis department, who formerly was chief of the operations analysis directorate of the Allied Air Force in Central Europe; Maurice E. Bell, manager of the laboratory's plans department, who until recently was scientific director of the U. S. Office of Naval Research in London, England; and Ernest Schlieben, manager of the electronics department, formerly with the Navy at Sands Point, N. Y.

Link Aviation Plans Affiliation

THE AFFILIATION of Link Aviation with General Precision Equipment Corp. has been planned.

The operation of Link will con-

HIGH CAPACITY DUO-SEAL® VACUUM PUMP

5 Cubic Feet (140 Liters) Per Minute

GUARANTEED VACUUM 0.0001mm Hg. or 0.1 Micron

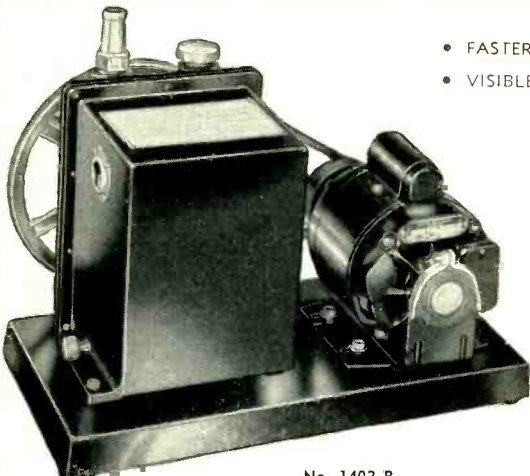

No. 1402-B

The 1954 edition of the Welch Catalog on Duo-Seal Vacuum Pumps is now available.

This 48-page book lists many new items of interest. A complete description, includ-

- FASTER PUMPING
- QUIET OPERATION
- VISIBLE OIL LEVEL
- COMPACT DESIGN

Overall dimensions for pump and motor 15½" high and 11" wide x 19⅝" long.

1402B. DUO-SEAL PUMP, MOTOR-DRIVEN. A No. 1402 Pump mounted on a base with a ½ H.P. 115-volt A.C. motor. Complete with pulleys, belt, and cord. **Each \$295.00**

1402G. BELT GUARD for 1402B Duo-Seal Pump. **Each \$15.00**

1402. DUO-SEAL TWO STAGE VACUUM PUMP. Pump unit only, not mounted on a base, but with a 10 inch grooved pulley, a supply of oil, and directions for use. **Each \$225.00**

ing performance curves of the Duo-Seal Pumps ranging from 21 liters per minute to 375 liters per minute, is given, as well as a greatly enlarged listing of Diffusion Pumps, Vacuum Gauges and accessories.

Manufacturers of
Scientific Instruments and
Laboratory Apparatus

W. M. WELCH SCIENTIFIC COMPANY
DIVISION OF W. M. WELCH MANUFACTURING COMPANY
ESTABLISHED 1880
1515 Sedgwick St., Dept. H, Chicago 10, Illinois, U.S.A.

tinue under its present management and expansion of operations in Binghamton is expected.



Reeves Soundcraft Receives Award

THIS IS THE MAGNA-STRIPER machine developed by Reeves Soundcraft. The firm recently received an award from the Academy of Motion Picture Arts and Sciences "for developing the process of applying stripes of magnetic oxide to film for sound recording and reproduction." Ernest W. Franck, chief engineer of Soundcraft for development and research, is pictured checking a reel of film that has just been striped at Soundcraft's Springdale, Conn., plant.



Bogue Electric Opens New Plant

OVER ONE THOUSAND visitors attended the new plant opening of Bogue Electric Manufacturing Company in Paterson, N. J.

Principal speaker was Vice Ad-

America's Leading Manufacturers of Unusual VTVM-S



Our exceptionally sensitive, stable vacuum tube voltmeters for DC, low frequency and high frequency, our micro-microammeters and our multi-meters are considered almost indispensable in any modern electronic laboratory engaged in fundamental research and development work. These instruments are also in extensive use for production testing and other applications requiring the ultimate in ruggedness and reliability.

MV-17c DC mV-meter, 0-1mV, DC

MV-12b AC mV-meter, 0-3mV, 20 cps to 250 KC

MV-22b AC mV-meter, 0-300uV, 20 cps to 10MC

and others . . .

We also manufacture dynamically compensated DC power supplies with adjustable positive, negative or zero output impedance.

MILLIVAC INSTRUMENT CORPORATION

P. O. Box 997, Schenectady 6, N. Y.

Ultra Sensitive Oscilloscopes

We manufacture the series VS-900 ultra sensitive DC oscilloscopes which were one of the main sensations of the IRE show in New York, in the Spring of 1954. They are rated to have a maximum sensitivity of 700 uV per cm DC to 500 KC and 10 uV per cm rms AC, 1 cps to 500 KC. Their drift is well below 3 mV.

We also manufacture very stable DC amplifiers for high frequency oscilloscopes. They are rated 20 or 40 db gain over a frequency range of 0-10 MC. Their drift is well below 10 mV.

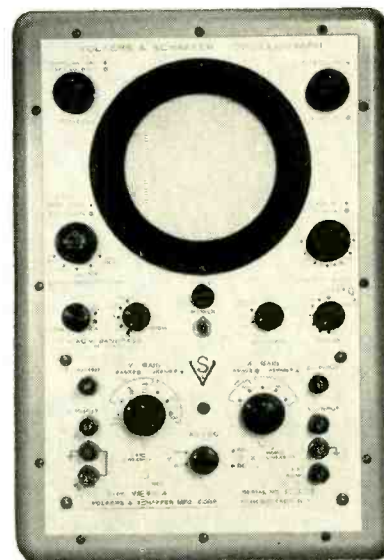

VOLKERS & SCHAFFER MANUFACTURING CORP.

P. O. Box 996, Schenectady 6, N. Y.

TERMALINE COAXIAL LOAD RESISTORS

50 ohms DC to 4000 mc—5 watts to 2500 watts

The constant resistance (Low VSWR) of the TERMALINE resistor make it the ideal dummy load and standard resistor at UHF and VHF. Design is such that normal reactance is put to work producing a pure resistance over an extremely wide frequency range. Acting as a "bottomless pit" for RF energy, thousands of TERMALINE units are in daily use in high frequency applications.

Model	Cont. Power Rating	Input Connector
80F	5 watts	UG-23B/U
80M	5 watts	UG-21B/U
80A	20 watts	UG-23B/U
81	50 watts	UG-23B/U
81B	80 watts	UG-23B/U
82	500 watts	} Adaptor to fit UG-21B/U supplied
82A	500 watts	
82C	2500 watts	

Adaptors or cable assemblies for standard coaxial line available.

ALL TERMALINE units, except Model 82C, are self-cooled. Substantial quantity discounts.

LITERATURE UPON REQUEST



Size 3 3/8" x 3/4" dia.



6" x 8 1/2" x 17"



**BIRD
ELECTRONIC CORP.**
1800 EAST 38TH ST., CLEVELAND 14, OHIO
TERMALINE Coaxial Line Instruments

NEELY
ENTERPRISES
Hollywood • San Francisco
Albuquerque
EARL LIPSCOMB
ASSOCIATES
Dallas • Houston

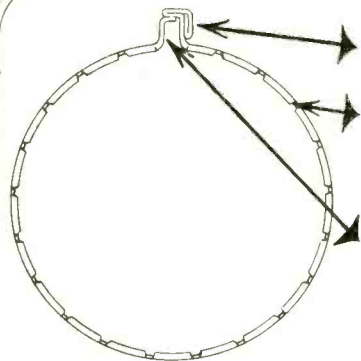

THREADED TRIPLE-FOLD RING HEAD, .075" thick eliminates nuts . . . avoids loosening.

SERRATED EDGES on large size clamp ring circumference allow for maximum and minimum tolerances between the two cups . . . provide greater holding power to cup walls.

When clamp screw is tightened to lock the ends in position, any added take-up on screw brings all pressure to bear on cup circumference . . . prevents slippage.

BE SURE . . . USE AUGAT "GRIP-TITE" CLAMP RINGS

The Augat clamp ring is a *sure* grip in multiple ganging of precision potentiometers.

Grip-tite potentiometer clamp rings are made of 302 stainless steel, are corrosion resistant and have withstood rigid 200-hour salt spray tests.

All rings normally supplied without screws.
Samples, specifications and prices on request.

For smaller diameters, use Augat standard double-fold non-serrated clamps.

AUGAT BROS. INC.
31 PERRY AVENUE — ATTLEBORO, MASS.

miral John E. Gingrich, Chief of the Office of Naval Material and former commander of the largest task force operating in Korean waters.

Other speakers included Governor Robert E. Meyner; Brigadier General William T. Hudnell, Office of the Deputy Chief of Staff, Materiel, U. S. Air Force; Major General Francis H. Lanahan, Deputy Assistant Chief of Staff, G-4, U. S. Army; Ora W. Young, Regional Administrator, Civil Aeronautics Administration; Edward J. MacEwan, Executive Vice-President, Paterson Chamber of Commerce; Mayor Lester F. Titus of Paterson, and Edward P. Schinman, President of Bogue.

The new plant will increase present Bogue plant facilities by approximately thirty percent, and is part of an extensive program of continuing diversification.

California County Sets Communications

LOS ANGELES COUNTY'S Board of Supervisors has voted to establish a separate department of communications to be headed by an electronics engineer. Among the factors that led the board to coordinate all communications activities in one administrative unit are the largest telephone switchboard operated by any local governmental unit in the country; six departments with radio communications systems; traffic problems indicating a need for radar speed timers and electronic traffic controls and electronics needs for Civil Defense.

Westinghouse Names Two To New Posts

FRANKLIN P. HINMAN has been named acting manager of manufacturing for the Westinghouse electronic tube division in Elmira, N. Y. and Harry F. Pully has been appointed to the newly-created position of acting manager of the Division's Elmira plant.

Hinman, who replaces John M. Smith, assumes his new position after serving as product manager of power tube manufacturing for

the past year. He joined Westinghouse at the electronic tube division in September 1951 as a general foreman. Later he became superintendent of maintenance and installation of equipment.

Hinman came with Westinghouse from the Lancaster, Pa., plant of RCA where he held various manufacturing and engineering positions from 1942 to 1951.

Pully assumes his new managerial duties after serving as product manager of cathode-ray tube manufacturing. He joined the tube division in September 1951 as a general foreman. In December 1951, he was made a division staff supervisor and later was appointed superintendent of cathode-ray tube manufacturing.

Prior to joining Westinghouse, Pully held various supervisory positions in the Lancaster, Pa., plant of RCA.

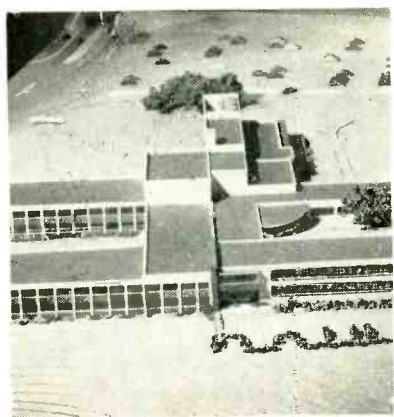

Burroughs Moves Into New Research Center

THE 22-MILE move from downtown Philadelphia to its new research center in Paoli, Pa., was completed by Burroughs Corp.

The Research Center with 105,000 sq ft of space is concerned primarily with research and development work in electronics, electro-mechanics and magnetics. In addition to building two "giant brain" electronic computers, the laboratory has developed specialized tubes, pulse control equipment, magnetics components and a number of electronic

Amerac's new, versatile . . .

"C" BAND WAVEMETER

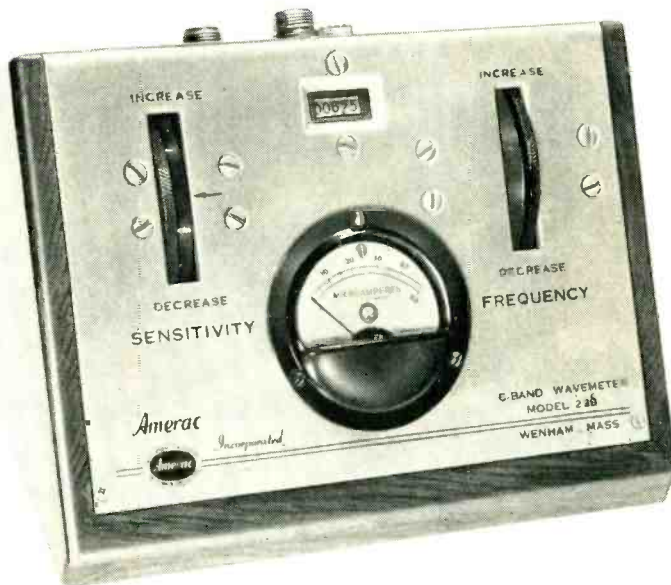

Precision manufactured—just like its sister model for the "S" Band—Amerac's new, Model #230, "C" Band Wavemeter is a co-axial line instrument covering the frequency range from 3500 MC to 6500 MC, by either the transmission or absorption method.

— FEATURES —

- High frequency stability through the temperature range 10° C to 40° C.
- Extreme mechanical stability.
- High accuracy of measurement ($\pm .02\%$).
- Sloping panel for easy observation.
- Tri-plating of all surfaces.
- Large knurled control knobs, for simple operation.
- Rugged components, for long service life.
- Golden anodized aluminum panel and cabinet of fine hand-rubbed walnut, for pleasing appearance.

SPECIFICATIONS

- Type N constant impedance input connectors.
- BNC or UHF co-axial fitting for external video connection.
- Power handling capability (absorption)—0.5mw to 1 watt.
- Power handling capability (transmission)—1mw to 1 watt.
- Peak power—up to 25 watts (transmission).
- Approximate loaded Q 2500.
- Cabinet size—8" wide, 6 1/2" deep, 5" high.
- Net weight 4 3/4 pounds.

This unit can be modified for your own specific requirements. Send for bulletin E.



Amerac Incorporated

116 TOPSFIELD ROAD
WENDHAM, MASSACHUSETTS

the pioneer
is the leader

applications in punched paper tape for improving and speeding the performance of business machines.

More than half of the personnel now working in the new Paoli building are electrical engineers, physicists, mathematicians, mechanical engineers and technicians; the balance are administrative and office personnel.

Du Mont Appoints Three Engineers

Leonard A. Bayer, Rudolf Leopold and Joseph A. Hatchwell have been appointed to new posts at Du Mont Laboratories.

Bayer has been appointed to the new position of manager of the product engineering department of the Communication Products Division.

Bayer, whose 18 years of engineering experience includes 12 years in the television and radio fields, will translate blueprint plans and working models into products ready for mass assembly.



Leonard A. Bayer

Since joining Du Mont in 1946, Bayer's activities have included work on government radar projects, commercial television equipment, and industrial color television systems.

Rudolf Leopold was appointed manager of the newly formed specifications and records department of the Communications Products Division. He will be in charge of drawing up final plans and specifications for the firm's line of television broadcast transmitters, studio equipment and mobile communication products.

Leopold, who joined Du Mont in

IT COSTS YOU LESS TO DO IT FASTER with PANORAMIC EQUIPMENT

NEW

Panoramic Model

SPA-1

A Convenient Single Package VHF-UHF Spectrum Analyzer 50MC-950MC with Two RF Tuning Heads

The Model SPA-1 Panoramic Spectrum Analyzer incorporates a superior panoramic indicator, power supply and optional tuning heads, RF-2 and RF-3, which cover the ranges between 50MC to 250MC and 220MC to 950MC, respectively. The SPA-1 is exceptionally simple to operate, lending itself to production tests as well as laboratory usage.



- Direct Frequency Reading, 50MC-950MC to almost OKC
- Variable resolution 9KC-100KC
- Sweep Rates: 1cps, 5cps, 30cps and 25-35 cps, variable
- High inherent stability • Low cost

Model SG-1 Panoramic's NEW Sweep Generator

for Accurate Inspection of Responses of Sonic and Ultrasonic Systems and Devices

- Direct Frequency and Amplitude Reading Screen for Slave Scopes
- Frequency Range: 40cps-20KC, 400cps-200KC, selectable
- Frequency scales: logarithmic or linear, selectable
- Amplitude scales: linear of 2 decade logarithmic, selectable
- Variable linear sweep range
- Internal frequency markers
- Scan rate cps internal; 60-0.04cps external with Model TW-1 Triangular Wave Generator



Panoramic's NEW Model FM-1 FM Monitor

A Low Cost Portable Package for Rapid Visual Measurement of Actual Bandwidth of Mobile FM Transmissions

- Instantaneous panoramic presentations of carrier and sidebands of voice transmissions
- Helps prevent channel spillover
- Indicates modulation symmetry
- Accurately measures deviation by constant tones
- Has band limit markers
- Simple to operate



Write today for full information.

Inquiries invited on Panoramic Spectrum Analyzers for Special Problems.

10 South Second Avenue • Mount Vernon, N. Y.
MOunt Vernon 4-3970



1945, has handled designs for new electronic equipment including a 3-D television camera for the Atomic Energy Commission and Du Mont's image orthicon camera.

Joseph A. Hatchwell, Mid-Atlantic regional sales manager for the television receiver division, has been promoted to director of service.

Hatchwell's new responsibilities include the administration, supervision, and direction of the technical activities of the division's Service Department on a national basis. Prior to joining Du Mont in 1952, he served with RCA from 1946 to 1952. He was one of the staff that initiated that company's tv service organization. Earlier, he served as RCA's foreign technical manager on government contracts with headquarters in Tokyo, and was also a technical advisor to the Armed Forces in Korea.

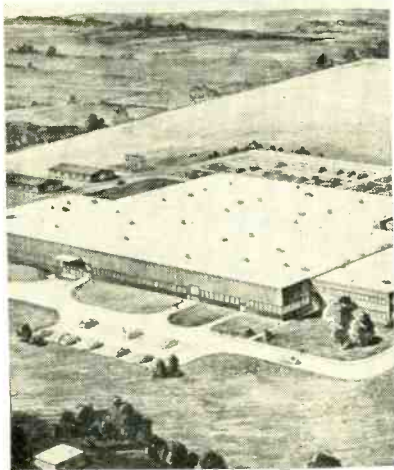

GE Breaks Ground For New Controls Plant

CONSTRUCTION has started on a new GE plant in Waynesboro, Va. which will manufacture electronic controls for industrial and aviation use.

The new factory is being built "in anticipation of projected heavy demands for such equipment as electronic drives, adjustable speed drives, speed regulators, aircraft and regulating equipment, and similar devices."

Expected to be in full operation some time next year, it will employ about 550 people. Facilities on the 70-acre site will include a large

Announcing...quick deliveries on **COMCO'S New** **FLEETCOM 1/2 Volt 2-Way Radio**



MODEL 400 - 6/12 MOBILE PACKAGE

\$ **460**

F.O.B. Coral Gables, plus State and Federal taxes. Price subject to change.

25- 50 MC - 25 WATTS OUTPUT } 8/4 Amps.
152-174 MC - 15 WATTS OUTPUT } Standby (6/12)

- ★ Change from 6 to 12 volts by merely reversing voltage selector plug.
- ★ Rugged construction with heavy duty power relay and fuse for engine compartment mounting.
- ★ Dual frequency provisions built in every unit.
- ★ Readily obtainable 6 volt tubes and vibrator used. 6146 Final amplifier.
- ★ Can be mounted under dash or almost anywhere. Case 11"x12 1/2"x5 1/2".
- ★ Low cost maintenance with COMCO color code tuning.
- ★ Standard manufacturers parts extensively used and identified for easy replacement at your local supplier.
- ★ Plus many other outstanding features described in bulletin 454 available upon request.

NOTE: Over 150 different COMCO VHF-FM models now certified with U.S. Federal Civil Defense Administration.

ATTENTION DEALERS!
Liberal discounts. Write for available territories.

MANUFACTURERS OF RADIO  & ELECTRONIC EQUIPMENT

COMMUNICATIONS COMPANY, Inc.
CORAL GABLES, MIAMI 34, FLORIDA



ZINC ALLOY FASTENINGS



GRC WING NUTS
Exclusive, finger-grip design; easy to assemble, disassemble; brightly finished; clean threads.



GRC CAP NUTS
Die Cast, not turned! Free of tool marks, and cut-off burrs; class 2 threads tapped square with face of nut.



NEW! GRC WING SCREWS
A steel screw combined with GRC's attractive finger-grip wing-nut.



GRC SMALL TUBULAR RIVETS
Die cast, not headed! Closer tolerances, more uniform heads for greater riveting efficiency. Dia. up to 9/16"; lengths to 5/16".

- RUSTPROOF
- DEPENDABLE
- DURABLE

—and Profitable for You!

Gries die cast zinc alloy fastenings are durable, rustproof . . . economical, too! All Gries fastenings may be used without protective finishes in most applications. Furnished in all commercial finishes when desired. Prompt delivery on standard sizes—specials to order.

WRITE TODAY FOR SAMPLES AND PRICES



GRIES REPRODUCER CORP.
World's Foremost Producer of Small Die Castings
151 Beechwood Ave., New Rochelle, N. Y. • Phone New Rochelle 3-8600



manufacturing area, warehouse, laboratory, personnel facilities, and offices.

Collins Names Five Executives

ORGANIZATIONAL CHANGES at Collins Radio Company have been announced by Arthur A. Collins, president.

R. S. Gates was named executive vice-president; L. E. Bessemer, vice-president, manufacturing; R. T. Cox, vice-president, research & development; J. G. Flynn, Jr., vice-president, sales, and M. W. Burrell, second vice-president.

Other officers of the company are L. M. Craft, vice-president; W. J. Barkley, senior vice-president; S. J. Storm, secretary-treasurer; L. E. Wiles, controller, and L. M. Schoon, assistant treasurer.

NBC Begins Color Studio Construction

CONSTRUCTION OF THE NATIONAL Broadcasting Company's first West Coast color television studio was started in Burbank, Calif.

Programs from the new studio, part of NBC's Television Center, will go on the air in January, 1955. The color studio, to be known as Studio 2, will be built exclusively for colorcasting. It will be 90 by 140 ft. in area and 42 ft. high.

In addition to the studio proper, there will be an adjoining dressing room section and a technical building.

The technical building will house three rehearsal rooms and a storage room for equipment. On the second floor will be a film projection room, video control room and central control.

ASC Cable Appoints New Process Engineer

JAMES M. CAMPBELL, JR., was appointed process engineer for the ASC Cable division of Radio Apparatus. The firm specializes in wire harnesses and cable assemblies used in electronics apparatus.

Prior to joining the ASC staff,

VHF COMMUNICATIONS RECEIVER



S220A

SPACE ECONOMY!

SAVE MORE THAN 40% RACK SPACE!
A standard 66" rack will hold only 7 ordinary VHF receivers. 12 SCHUTTIG S220A receivers will fit in this same rack! The SCHUTTIG receiver requires only 5 1/4 inches of vertical rack space as contrasted with 8 3/4 inches for other VHF receivers. The S220A is competitive in price, too!

SELECTIVITY: Bandwidth is ± 20 Kc 6 db down; ± 100 Kc 60 db down.
SENSITIVITY: 1 MICROVOLT modulated 30% provides 1 watt with 10 db S/N ratio!
OUTPUT: 3 WATTS; feeds either built-in speaker or 600 ohm line.

UNSURPASSED PERFORMANCE

SCHUTTIG and CO. INCORPORATED



**5005 Calvert Road
College Park, Md.**

MAGNETIC-AMPLIFIER CIRCUITS

Just Published!

This practical treatment of fundamental principles, characteristics, and applications logically develops the various kinds of basic and more complex magnetic amplifier circuit arrangements without extended mathematical considerations. Descriptive and graphical methods are used to give qualitative and quantitative interpretation of essential facts. Material is systematically classified according to circuit functions so you can compare and select solutions best suited to your special problem. By William A. Geyger, U. S. Naval Ord. Lab. 277 pp., 135 illus., \$6.00



PROBABILITY AND INFORMATION THEORY WITH APPLICATIONS TO RADAR

Just Published!

Shows in easy stages how the theory of probability applies to electronics, communication, and particularly radar. Using basic mathematics, it discusses the theory of probability distribution, mathematical description of waveforms, Shannon's information theory, applications of inverse probability to problems of signal and noise, etc. By P. M. Woodward, Telecomm. Research Establishment, Malvern, England. 128 pp., \$4.50

TELEVISION BROADCASTING

Practical manual for radio engineers, operations personnel, and others interested in the technical aspects of television broadcasting. Covers in detail the equipment, facilities, and techniques involved in the running of a television studio—topics such as lighting, staging, television recording, and color television equipment. Gives a valuable insight into the whole field without the use of complex mathematics. By Howard A. Chinn, Columbia Broadcasting System. 688 pp., 346 illus., \$10.00

ELECTRONICS FOR COMMUNICATION ENGINEERS

Saves research time and effort on electronic problems in communications. Its 252 articles from *Electronics* contain a wealth of design equations, charts, nomographs, tables, etc. Covers amplifiers — antennas — audio — cathode-ray tubes — components — electronic music — filters — measurements — microwaves — oscillators — power supplies — propagation — pulses — receivers — transmission lines — transmitters. Edited by John Markus and Vin Zeluff, Assoc. Editors, *Electronics*. 624 pp., hundreds of illus., \$10.00



SEE THESE BOOKS 10 DAYS FREE

McGraw-Hill Book Co., 330 W. 42 St., NYC (36)

Send me book(s) checked below for 10 days' examination on approval. In 10 days I will remit for book(s) I keep, plus few cents delivery, and return unwanted book(s) postpaid. (We pay for delivery if you remit with this coupon—same return privilege.)

- Geyger—MAG. AMP. CIRCUITS—\$6.00
- Woodward—PROB. & INFORM. THEORY WITH APPLICATIONS TO RADAR—\$4.50
- Chinn—TELEVISION BROADCASTING—\$10.00
- Markus & Zeluff—ELEC. FOR COMM. ENGRS.—\$10.00

(Print)

Name

Address

City Zone.....State.....

Company

Position FL-4

This offer applies to U. S. only

MICROWAVE FREQUENCY METERS for K_u BAND

MODEL 807B 12,400 to 18,000 mc

Features:

- Frequency range: 12,400 to 18,000 MC
- Accuracy: 0.1%
- Precision: 0.05%
- Loaded Q: 4000
- Reactive dip: 10% minimum
- Insertion loss: 0.1 db maximum
- Waveguide: RG - 91/U
- 0.05% accuracy available on special order.

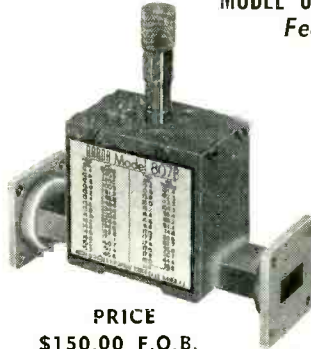

PRICE
\$150.00 F.O.B.

Write for complete bulletin TR-6

MODEL 802

FREQUENCY METER
2400 to 10,200 mc
0.2% accuracy

\$785.00 F.O.B.

MODEL 810

FREQUENCY METER
8200 to 12,400 mc
0.1% accuracy

\$110.00 F.O.B.

MODEL 333 THERMISTOR

ELIMINATES THE NEED FOR SPECIAL MOUNTS

- For measuring pulsed power having low duty cycle.
- Consists of a 32A5/32A26 thermistor element encapsulated in a cartridge having the same size as a 1N23 crystal.
- May be used with all wattmeters designed for thermistors.
- Extremely high burnout power due to self-fusing.



PRICES IN
U. S. ONLY

Write for complete bulletin BR-6

Also available as Model 331 for use in barretter mounts

NARDA

MICROWAVE TEST EQUIPMENT & BOLOMETERS

66 MAIN ST. • MINEOLA, N. Y. • GARDEN CITY 3-3570

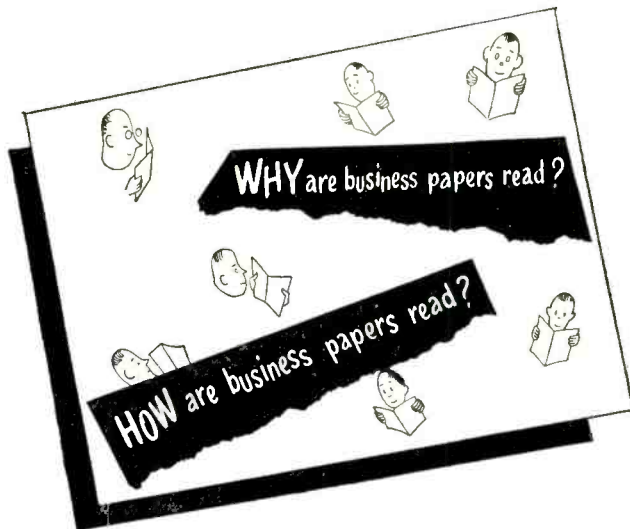

A copy of this quick-reading, 8-page booklet is yours for the asking. It contains many facts on the benefits derived from your business paper and tips on how to read more profitably. Write for the "WHY and HOW booklet."

McGraw-Hill Publishing Company, Room 2710, 330 West 42nd St., New York 36, N. Y.



MICROWAVE DEVELOPMENTS

Wheeler Laboratories is an engineering organization offering consulting and engineering services in the fields of radio and radar.

Our "Slide Rule Lending Library" shown above has proved to be a practical method for providing our engineers with the most suitable tools for their specialized problems, and for increasing their familiarity with a variety of computing devices.

At present, Wheeler Laboratories comprises a staff of twenty engineers under the personal direction of Harold A. Wheeler, with supporting facilities including a group of designers and a model shop.

A brief summary of our work will be sent on request, and comprehensive engineering reports on some of our developments are available. Inquiries are welcomed regarding your particular problems in microwave design and development.

Wheeler Laboratories, Inc

122 Cutter Mill Road, Great Neck, N. Y.
HUNter 2-7876

NEW MULTIMETER KIT
\$26.50

SIGNAL TRACER KIT
\$23.50

NEW SCOPE KIT
\$59.50

CONDENSER CHECKER KIT
\$19.50

VACUUM TUBE VOLTMETER KIT
\$24.50

TUBE CHECKER KIT
\$29.50

SIGNAL GEN. KIT
\$19.50

GRID DIP METER KIT
\$19.50

Heathkit TEST EQUIPMENT

BUILD YOUR OWN — INCREASE KNOWLEDGE — SAVE MONEY — BUY DIRECT FROM MANUFACTURER . . . Top quality instruments in kit form featuring latest design and circuit developments. Completely detailed step-by-step construction manual — clear pictorials — complete schematics. All sheet metal work punched, formed and finished. Low kit prices include tubes, chassis, cabinet and all necessary constructional components.

Kits for the school — service shop — industrial laboratory — hobbyist, etc.

Write for free catalog for further information.

HEATH COMPANY
BENTON HARBOR 14,
MICHIGAN

Campbell was in the service and repair department of P. R. Mallory Co. of Indianapolis.

Pentron Names Chief Engineer

JAY T. NICHOLS has been appointed Chief Engineer of Pentron Corp. His present projects with Pentron include the development of magnetic recorders for both the commercial market and the government services.

Previous to joining Pentron, he served on the staff of the Armour Research Foundation in the development and use of instrumentation. He was in charge of various programs studying effects and causes of shock and vibration phenomena both in the laboratory and in the field. He also participated in the development of automatic weapons and in tests of atomic weapons at Eniwetok and in Nevada.

Before joining Armour Research, Nichols was manufacturing engineer with Western Electric Co. in the production of central office equipment.



Boyers Heads New National Division

JOHN S. BOYERS joined the National Company as chief engineer of the magnetic memory devices division.

Until recently, Boyers was vice-president of Magnecord which he helped organize in 1946. Since that time, he had held various positions

R. F. AND I. F.
COILS
 OPEN TYPES OR SHIELDED
for Television, Radio, Communications Applications

LOWER PRICE
QUICKER DELIVERY
HIGHEST QUALITY



1. **RATIO DETECTOR**
Iron Core Tuned complete with Shield Can.

Coil is carefully impregnated for stability. Built to withstand drastic temperature changes. Mechanically stable. It has excellent linearity. Once set—remains in adjustment—vibration-resistant. Has room for additional tie-lug on terminal base.



2. **HORIZONTAL OSCILLATOR COIL**
 Mechanically stable winding structure. Iron core tuned. Single hole mounting. Machine staked terminals.



3. **HORIZONTAL LINEARITY CONTROL COIL**—Very stable winding structure. Instantly adjustable with pullout shaft. Clip mounted. A favorite with leading T-V set manufacturers. Sturdy. Vibration resistant. Trouble free.

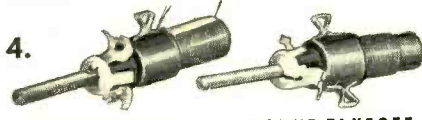

4. **PICTURE I. F. TRANSFORMER**
 Bifiler Winding. Iron Core Tuned. Excellent electrical and mechanical ability. Carefully controlled "Q". Single hole mounting.

SOUND TAKEOFF COIL
 Iron Core Tuned. Machine Staked terminals. Excellent electrical and mechanical stability. Single hole mounting.



6. **ANTENNA COIL** Rigidly controlled high "Q". Inductance easily adjustable. Machine staked lugs. Good electrical and mechanical stability. Easily mounted. Small size.

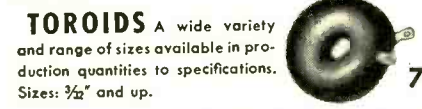

7. **TOROIDS** A wide variety and range of sizes available in production quantities to specifications. Sizes: 1/2" and up.

Above units are specified as standard equipment by leading manufacturers.

Your inquiry is invited. Write

JOHNSON ELECTRONICS DIVISION



2734 NORTH PULASKI ROAD - CHICAGO 39, ILLINOIS

ELECTRONICS — June, 1954

from chief engineer to president. Prior to Magnecord, he had been associated with Armour Research Foundation, Chicago, in the development of magnetic recording systems. During the war, he was with the U.S. Navy Underwater Sound Laboratory at New London, Conn., and the Radiation Laboratory at MIT.

Forst Receives Canadian GE Award

FOR THE FIFTH consecutive year, Canadian GE presented its engineering award "to stimulate interest in technical development con-



Bill Forst, left, & Don Schofield

tributing to the betterment, in any way, of Canadian Broadcasting; and to increase recognition of the value and essential function of radio broadcasting and television technical personnel."

The award was conferred upon William Forst of radio station CKOM, Saskatoon, "in recognition of his pioneering efforts in the field of unattended operation of broadcast transmitters." It was presented by Don Schofield of Canadian GE.

Brooklyn Polytechnic To Buy New Building

THE POLYTECHNIC INSTITUTE OF BROOKLYN contracted to purchase for \$2,000,000 the eight-story, block-long plant building of American Safety Razor in downtown Brooklyn.

The building fronts on Brooklyn's

WET OR DRY
Resistance is high

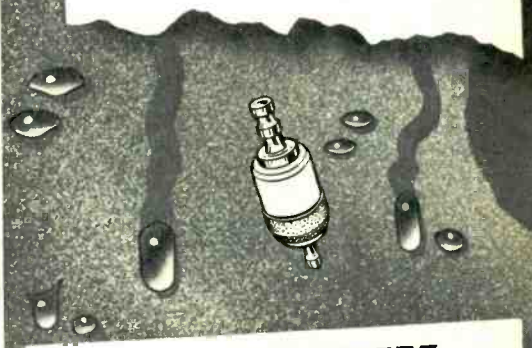

... with LUNDEY
miniature hermetic terminals!

TESTS PROVE—Lundey series #199 miniature hermetic terminals give excellent performance under conditions of high humidity.

In an average test the following results were tabulated:

Relative Humidity	Temp.	Insulation Resistance
90%	80°F	1,000,000 megohms
50%	80°F	3,000,000 megohms

OTHER FEATURES

- Mounting in simple drilled or punched holes . . . no extrusion needed.
- Effective spring loading
- Teflon external member
- Silicone or neoprene core
- Minimum mounting — 15/64" on centers
- Voltage rating — 500V RMS operating
- Current rating — 8 amperes
- Three electrode styles available
- Production-proved
- Meets MIL-T-27 specifications

If humidity creates a problem for you, let Lundey terminals help you solve it. Write for Bulletin #199, Dept. E.

LUNDEY ASSOCIATES

694 Main Street, Waltham 54, Mass.

Designed for



Application

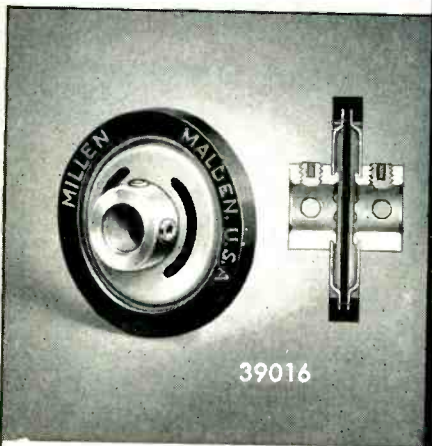

39016

**A Really NEW
FLEXIBLE COUPLING
No. 39016**

Incorporating features which have long been desired in a flexible coupling. No Back Lash—Higher Flexibility—Higher Breakdown Voltage—Smaller Diameter—Shorter Length—Higher Alignment Accuracy—Higher Resistance to Mechanical Shock—Solid Insulating Barrier Diaphragm—Molded as a Single Unit.

**JAMES MILLEN
MFG. CO., INC.**

MAIN OFFICE AND FACTORY
**MALDEN
MASSACHUSETTS**



\$80,000,000 Civic Center and is opposite the site of the proposed Supreme Court Building soon to be erected.

Harry S. Rogers, president of the century-old Institute, declared that acquisition of the building will enable Polytechnic to bring its widely dispersed facilities together in one suitable modern structure.

He said it cannot be determined at this time when the Institute will move into the new quarters. The date depends upon a number of factors, particularly the success of efforts to raise the required funds.

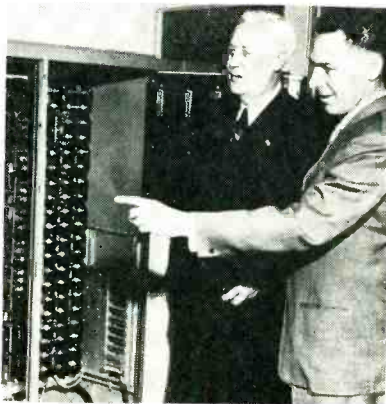

**Swedish Industrialist
Backs New Computer**

AXEL L. WENNER-GREN, left, Swedish industrialist and philanthropist, inspected ALWAC, the new low cost general purpose electronic digital computer developed with his financial backing by Logistics Research of Redondo Beach, Calif. Glenn E. Hagen, LRI's physicist-president, is at the right.

**Slutz Appointed
To NBS Post**

RALPH J. SLUTZ has been appointed assistant chief of the central radio propagation laboratory of the National Bureau of Standards. Dr. Slutz was formerly a consultant to NBS in the fields of electronic computers and mathematics.

From 1949 to 1953 Dr. Slutz was assistant chief of the NBS electronic computers laboratory.

In his new position, he will assist in the direction of the research pro-

If . . .

**YOU CHANGE
YOUR ADDRESS**

Be sure to notify us at once, so future copies of **ELECTRONICS** will be delivered promptly.

Also make certain you have advised your local Post Master of your new address so other important mail doesn't go astray.

Both the Post Office and we will thank you for your thoughtfulness. Mail the information below to: Subscription Dept., **ELECTRONICS**, 330 W. 42nd St., New York 36, N. Y.

New

Name

Address

City..... Zone..... State.....

Company..... Title.....

Old

Name

Address

City..... Zone..... State.....

ELECTRONICS

330 W. 42nd St.

New York 36, N. Y.



he's working for you

THIS FELLOW IS TRAINED IN YOUR BUSINESS. His main duty is to travel the country — and world — penetrating the plants, laboratories and management councils . . . reporting back to you every significant innovation in technology, selling tactics, management strategy. He functions as your all-seeing, all-hearing, all-reporting business communications system.

THE MAN WE MEAN IS A COMPOSITE of the editorial staff of this magazine. For, obviously, no one individual could ever accomplish such a vast business news job. It's the result of many qualified men of diversified and specialized talents.

AND, THERE'S ANOTHER SIDE TO THIS "COMPOSITE MAN," another complete news service which complements the editorial section of this magazine — the advertising pages. It's been said that in a business publication the editorial pages tell "how they do it" — "they" being all the industry's front line of innovators and improvers — and the advertising pages tell "with what." Each issue unfolds an industrial exposition before you — giving a ready panorama of up-to-date tools, materials, equipment.

SUCH A "MAN" IS ON YOUR PAYROLL. Be sure to "listen" regularly and carefully to the practical business information he gathers.



McGRAW-HILL PUBLICATIONS

what is

available from **Pyramid**

The security of experience.

Pyramid has more experienced personnel (in years of actual designing and manufacturing of capacitors) than any other manufacturer.

The control of specially designed facilities. Pyramid is the only manufacturer of capacitors whose plants were planned and built specifically for the entire manufacturing process of capacitors from drawing board conception through reception of raw materials, fabrication, packaging and shipment.

The guarantee of one standard.

All Pyramid capacitors are one quality, made of the same quality materials demanded by rigid military specifications. Pyramid capacitors have a low leakage factor due to the non-hygroscopic insulating material used on all production. Pyramid delivers the best at no premium.

A complete line of capacitors—full ranges in all ratings and types.

Burton Browne advertising

PYRAMID

1445 HUDSON BOULEVARD • NORTH BERGEN, N. J., U. S. A.

ELECTRIC COMPANY

NEW "PARAFORMED" SPIRAL WOUND PAPER TUBES

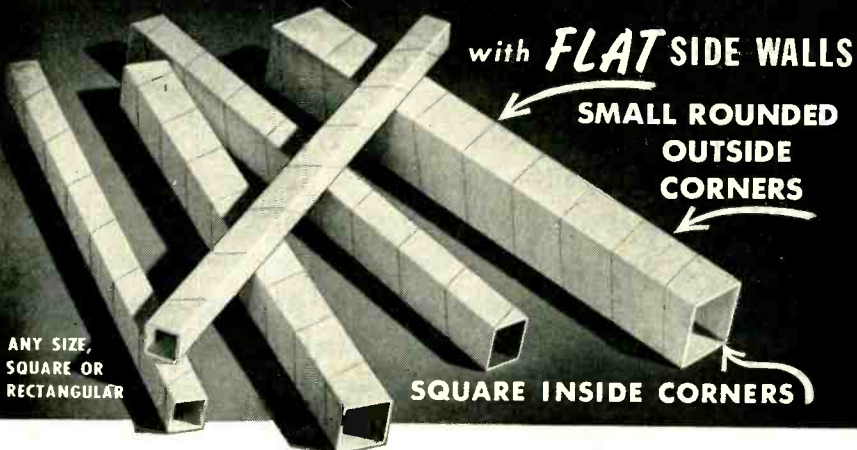

ANY SIZE,
SQUARE OR
RECTANGULAR

DO YOU HAVE A SPACE PROBLEM?

Eliminates squeezing operation of finished coil and possibility of shorts due to fractured enamel insulation.

For the first time, a paper tube like this—developed and perfected by PARAMOUNT after years of research! No artificial heat or pressure is used in its manufacture—“PARAFORMING” takes place at the time of actual winding. No sharp outside edges to cut the wire during winding of coils. Has great rigidity and physical strength. Permits coil manufacturers to hold *much closer tolerances*. No need for wedges to tighten the winding on the laminated core. Coils can be automatically stacked much faster, too. The new “PARAFORMED” tubes are approved and used by leading manufacturers. *And they cost no more!*

Paramount

PAPER TUBE CORP.
616 LAFAYETTE ST., FORT WAYNE 2, IND.

Standard of the Coil Winding Industry for Over 20 Years

WRITE ON COMPANY
LETTERHEAD FOR
STOCK ARBOR LIST
OF OVER 2000 SIZES

gram of the Central Radio Propagation Laboratory, which serves as the primary agency of the government for radio wave propagation research and for the centralization and coordination of information in this field.

Dr. Slutz was a design engineer at the Institute for Advanced Study from 1946 to 1948, doing research on input-output mechanisms and high-speed electronic digital arithmetic circuits. From 1942 to 1945 he was a member of Division 2 of the Office of Scientific Research and Development, investigating the effects of bomb and projectile explosion and impact, and in 1937 and 1938 he was with the Bell Telephone Laboratories.

Philco Names Skinner TV Vice President

JAMES M. SKINNER, JR., was appointed vice-president of the television division of Philco.

For the past two years, he has been vice-president in charge of distribution for the firm.

Skinner will help coordinate all activities of the television division including product planning, manufacturing, engineering, advertising, sales promotion and sales.

Kelly Honored By Research Institute

MERVIN J. KELLY, president of Bell Telephone Laboratories, received the Industrial Research Institute's 1954 Medal at the Institute's annual meeting.

The medal was presented to Dr. Kelly “for distinguished leadership in industrial research, joining the mind of the scientist and the hand of the technologist to serve the security and well being of mankind, and for outstanding personal contributions to national security.”

Air Force Opens Research Center

THE NEW LABORATORIES of the Air Force Cambridge Research Center were opened at Bedford, Mass.

The five million dollar research and development buildings were re-

cently accepted by the Air Force and will be the site of important work involving the air defense of the nation.

The Air Force Cambridge Research Center is one of eleven installations that are engaged in the vital mission of keeping the United States Air Force the most modern and powerful in the world through the development of new and improved weapons, weapons systems, and guided missiles.

The Center is charged with administrative and logistical support of Lincoln Laboratories as well as the conduct of long-range projects in electronics and geophysics.

A number of laboratories, libraries, machine shops and supporting administrative offices already have moved into the new Center buildings.

MB Manufacturing Acquired by Textron

TEXTRON ACQUIRED its third non-textile business, the MB Manufacturing Co. of New Haven, Conn. A few months ago, the firm purchased the entire stock of Dalmo Victor of San Carlos. In 1953, Burkhart Manufacturing was acquired.

MB specializes in engineering and producing vibration equipment for military and civilian planes and ships, guided missiles and other defense and civilian items.

These non-textile operations have been acquired by Textron as a part of its program to protect stockholders against the severe fluctuations in the textile industry.

It was pointed out that if Dalmo Victor Company, Burkhart Manufacturing Company, and the MB Manufacturing Company continue at their past earning rates, they are expected to produce combined earnings before taxes of approximately \$6,000,000 in 1954.

Clarostat Mid-West Plant in Full Swing

NOW ENTERING its third year of operation, the Mid-West plant of Clarostat Mfg. is reported to be in full

"The TOUGHER the BETTER"
WEMPY

says
the KING
of NUTS

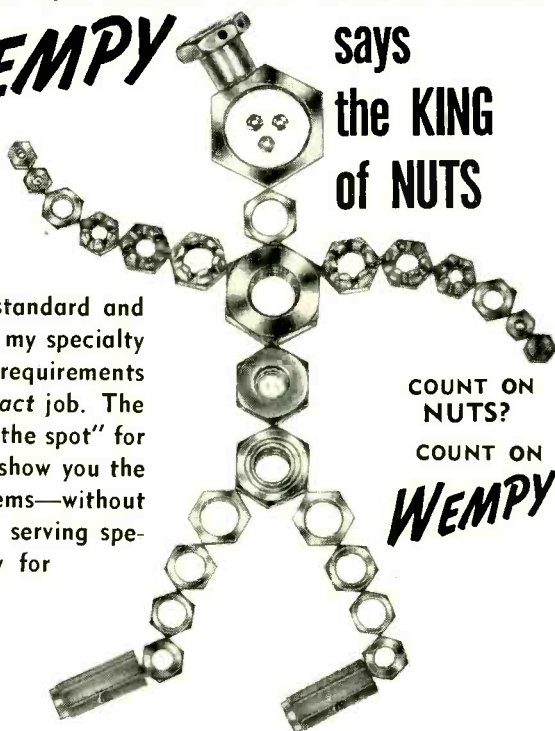

Sure, I come in all standard and ready-made sizes but my specialty is the Tough-Nut requirements you need to do an exact job. The next time you're "on the spot" for special nuts, let me show you the answer to your problems—without obligation. I've been serving special nuts to industry for many years.

COUNT ON NUTS?

COUNT ON

WEMPY

Write Dept A
for
Complete Catalog

WESTFIELD METAL PRODUCTS CO., INC.
WESTFIELD, MASS.



★ **ULTRA LOW**

capacitance
& attenuation

TYPE	μμF/ft	IMPED.Ω	O.D.
C1	7.3	150	.36
C11	6.3	173	.36
C2	6.3	171	.44
C22	5.5	184	.44
C3	5.4	197	.64
C33	4.8	220	.64
C4	4.6	229	1.03
C44	4.1	252	1.03

WE ARE SPECIALLY ORGANIZED TO HANDLE DIRECT ORDERS OR ENQUIRIES FROM OVERSEAS
SPOT DELIVERIES FOR U.S.
BILLED IN DOLLARS—
SETTLEMENT BY YOUR CHECK
CABLE OR AIRMAIL TODAY



NEW **MX and SM** SUBMINIATURE CONNECTORS
Constant 50Ω-63Ω-70Ω impedances

TRANSRADIO LTD. 138A Cromwell Rd. London SW7 ENGLAND CABLES: TRANSRAD, LONDON



SQUARE WAVE GENERATOR

Combined Voltage Calibrator and Source of Square Waves

This precision instrument provides square waves suitable for testing the transient and frequency response of wide band amplifiers, and for accurately measuring their amplitude. A wide range of output levels is available. Attenuator settings do not affect the output wave shape.

MODEL 183

SPECIFICATIONS — Frequency Range: 10 cps to 1 mc continuously variable over decade steps; Rise time: 0.02 μ sec for 100 ohms output, 0.05 μ sec for 1200 ohms output; Max. output: 10 volts p-p across 100 ohms, 100 volts p-p across 1200 ohms.

VHF-UHF NOISE SOURCE

Accurate, Simplified Operation

Ideal for measuring receiver noises in television tuners, receivers and other applications between 50 and 900 mc. Designed for operation with 300 ohm receivers with less than 0.5 db error. Noise figure 0-19 db.

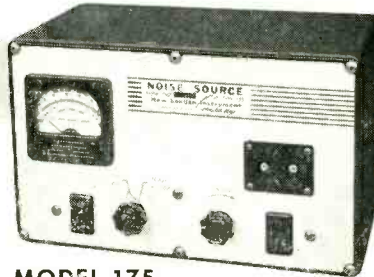

MODEL 175

Write for specifications and catalog on our complete line of measuring equipment.

NEW LONDON INSTRUMENT Company

P. O. BOX 189E
NEW LONDON, CONN.

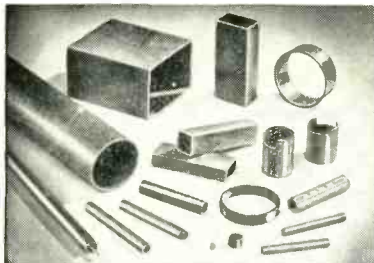

RESINITE

GIVES YOU THE HIGHEST INSULATION RESISTANCE OF ANY RESINATED PRODUCT

Performance data—compiled from laboratory tests, actual field operations and reports from manufacturers—prove the outstanding operating characteristics of Resinite. In volume resistivity . . . low moisture absorption . . . excellent thermal properties . . . low power factor . . . and resistance to voltage breakdown . . . Resinite outperforms all other resinated products.

Resinite Coil Forms are available with inside or outside threads—slotted, punched or embossed. Special three-row threaded design permits axial pressure in excess of 25 lbs. Torque controllable to + or -1 inch oz.

Write today for full details and technical information

RESINITE CORPORATION

DIVISION OF PRECISION PAPER TUBE

2035E West Charleston Street, Chicago 47, Illinois
79 Chapel St., Hartford, Conn.

- RESINITE 8104
very high dielectric properties under extreme humidity.
- RESINITE "AC"
very high dielectric properties—completely immune to electrolytic corrosion.
- RESINITE 104
for stapling, severe forming and fabricating.

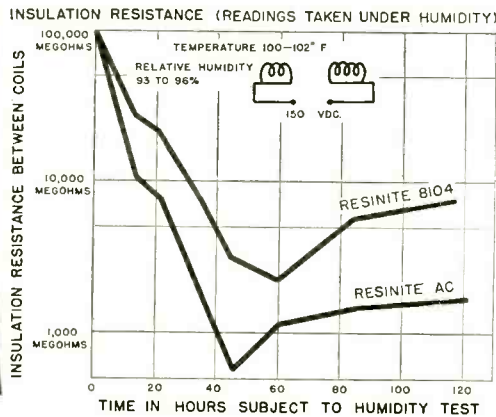

Tests conducted on .253 I.D. x .283 O.D. tubes used on coil forms for television receivers.

production. Supplementing the output of the main plant in Dover, the Mid-West plant now produces power resistors, power rheostats, metal-clad strip resistors, carbon and wire-wound controls, and aircraft controls.

The Mid-West plant maintains a complete inventory of distributor items.

Superior Tube Names Richard

C. D. RICHARD, JR. was appointed supervisor of the electronic laboratory of Superior Tube. The laboratory is responsible for the development and control of materials and products for the radio and television industry. He joined Superior in 1946.



Smith Appointed Control President

STANLEY J. SMITH is the president of Control Laboratories, a new company recently formed by Avien. He was formerly director of engineering and development at Simmonds Aerocessories. He is an inventor in the aircraft instrument field and particularly in the field of fuel quantity gages, in which he is credited with a number of key patents.

Fubini Appointed Harvard Lecturer

EUGENE G. FUBINI has been named a Gordon McKay Visiting Lecturer on applied science at Harvard University and will be in residence for

DANO COILS

Serve
Modern Industry

Behind the scenes come Dano Coils—made to exact customer specifications to perform an exact electrical function . . .

- Molded Coils
- Form Wound
- Paper Section
- Acetate Bobbin
- Bakelite Bobbin
- Cotton Interweave
- Coils for High Temperature Application

Also, Transformers
Made to Order

The DANO Electric Co.
MAIN ST., WINSTED, CONN.



Mark your own symbols, numbers, lettering, on your small parts, tools, identification and name plates . . . easily, simply, quickly . . . tracing from a master with the GREEN ENGRAVER.

Widely used in electronic and plastic fields, in machine tool shops and wherever permanent marking is needed. The GREEN ENGRAVER engraves equally well on metals, plastic, wood, hard rubber and glass.

✓ Fact-filled folder on request . . . showing how economies in costs, labor and time are achieved with the GREEN ENGRAVER.

✓ Routs ✓ Models ✓ Profiles ✓ Engraves Etching attachment and other special equipment for industrial uses are available.

Green Instrument Co.
INCORPORATED
363 PUTNAM AVE., CAMBRIDGE, MASS.

JELLIFF

ALLOY 800 RESISTANCE WIRE

for miniaturized precision-instrument components

the ideal resistance wire for

fixed and variable resistors of high ohmage — resistance boxes and bridges — voltmeter and wattmeter multipliers — and other miniature wire-wound units.

Where space is at a premium and performance is a "must" — these outstanding qualities of Jelliff Alloy 800 will assure that your products conform to the tightest specs.

High resistivity, 800 ohms/cm² — Low Temperature Coefficient, ±20 ppm per °C—Non-Magnetic—Highly Stable Electrically and Mechanically — Diameters from 0.0009" to 0.0056" — Bare, enameled or oxidized, or insulated with silk, Nylon or cotton — Solders and Winds easily.

For Complete Data Address
Department 17

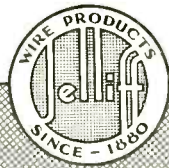

THE C. O. JELLIFF
MANUFACTURING CORP. SOUTHPORT, CONN.

NOW...SOLVE YOUR HIGH VOLTAGE PROBLEMS with BETTER EQUIPMENT

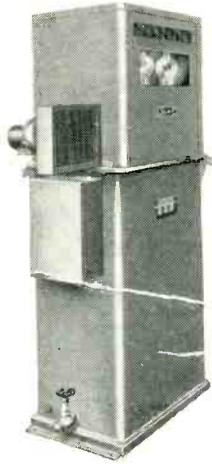

34 KW 17,000 V.D.C.



Our years of experience gives you MAGNATRAN Heavy Duty High Voltage products . . . built for longer life and rugged performance

← NEW UNITIZED RECTIFIERS

For high voltage D.C. sources . . . lower initial cost . . . minimum upkeep . . . convenient — ready to connect to AC. line and D.C. load . . . compact — requires minimum floor space.



Askarel Immersed Filter Reactor 50,000 Volt Test

AIR . . . OIL . . . ASKAREL

Plate Transformers . Filament Transformers . Filter Reactors . Modulation Transformers . Distribution Transformers . Pulse Transformers . Testing Transformers . Precipitation Transformers . General Purpose Transformers . Hi-Voltage Transformers.

WRITE FOR DETAILED INFORMATION MEETS STANDARDS OF AIEE-NEMA

A NAME SYNONYMOUS WITH EXPERIENCE

MAGNATRAN INCORPORATED

TRANSFORMERS AND ELECTRICAL EQUIPMENT
WALTER GARLICK, JR., PRESIDENT
246 SCHUYLER AVE., KEARNY, NEW JERSEY



THESE

RESINITE

VINYL

LACING CORDS

KNOT EASIER!

WON'T SLIP!

Easier Tying. Resinite EP-1 and EP-69 Vinyl Lacing Cords knot by simple methods and stay knotted because of high coefficient of friction. Will not slip on the assembly.

High Elasticity. Allows wires to be replaced in an assembly without unlacing.

Fungus Resistant. EP-69 is made from same fungus-resistant material as tubing manufactured under military specifications (MI-1-7444).

Many Sizes and Shapes. Available in round and square shapes from 1/32" to 1/4" dia. Also rectangular. Breaking strength from 2 to 160 lbs.

300% Elongation. Permits less to be used. Economical.

High Dielectric Strength. Offers additional protection.

High Compatibility with most insulating materials, will not bite through.

Highest Quality. Rigidly controlled during manufacture by the most modern machinery and equipment. Write for complete information, prices and samples.

Eastern shipments direct from our Chicago warehouse.

Resinite

RESIN INDUSTRIES, INC.

315 Olive St. • Box 1589 • Santa Barbara, Calif.

SPECIALISTS IN VINYL SLEEVING AND TUBING FOR THE AIRCRAFT, ELECTRONICS AND PHARMACEUTICAL FIELDS

the first half of the academic year 1954-55.

From 1938 to 1943 Dr. Fubini was acting engineer for the design and installation of vhf links for CBS. During the war he was a research associate at the Radio Research Laboratory of Harvard and became technical observer in countermeasure work with the Air Force in charge of operational analysis, radar countermeasures section of the Eighth Air Force in England. From 1945 to date he has been with Airborne Instruments, Mineola, L. I., N. Y. In 1947 he was appointed supervising engineer of the special devices section.

He has recently specialized in the development of microwave strip lines which make use of printed circuit techniques and which transmit power at microwave frequencies with low loss. Present plans call for Dr. Fubini's giving two courses, one concerned with the practical aspects of noise in electrical circuits, the other dealing with special topics in microwave antennas and circuits.

Jensen Opens New Loudspeaker Plant

JENSEN MANUFACTURING acquired a new plant in Guttenberg, Iowa, that will concentrate on a standardized line of speakers, in six-inch sizes and smaller, for volume industrial customers.

The space made available in the Jensen Chicago plant by the move has been devoted to expanded production of hi-fi speakers.

The new plant encompasses 25,000 sq ft of space on a 15-acre plot.

Four Engineers Receive Commerce Award Medal

SAUL R. GILFORD, Peter B. Haas, Arthur W. Holt and Robert K-F Seal of the National Bureau of Standards have received the Department of Commerce Silver Medal for Meritorious Service.

Saul R. Gilford received the award for "very valuable contributions to electronic instrumentation in the field of biophysics".

He joined the staff of NBS in 1948 and since that time has de-

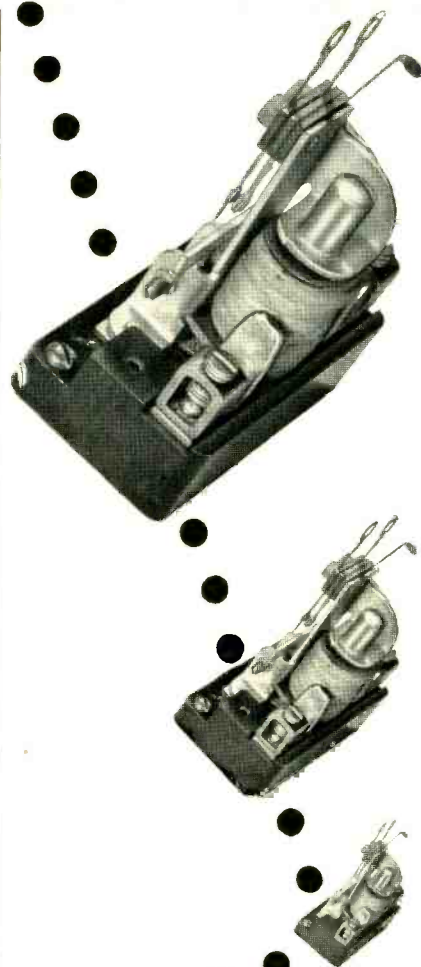

This remarkable relay protects against overloads . . . has inverse time delay . . .

Here is an overload relay that combines extremely high speed operation under dangerous conditions with inverse time delay to allow for starting inrush or harmless, momentary overloads.

HEINEMANN Silic-O-Netic® Overload Relays put protection on a definite basis. They always carry the rated load regardless of ambient temperature . . . always actuate with time delay at 125% of rating . . . always actuate instantaneously at eight times rating.

This degree of performance available only in HEINEMANN Silic-O-Netic Overload Relays allows you to build-in the positive protection of your products.

Send for Bulletin 5101.

HEINEMANN

ELECTRIC COMPANY

97 PLUM STREET • TRENTON 2, N. J.

veloped a number of instruments for use in the medical field. Among these are a physiological monitor, developed in cooperation with Dr. H. P. Broida of NBS, which can give immediate warning of unfavorable changes in a patient undergoing an operation.

Peter H. Haas received the Medal for "outstanding contributions in the field of magnetic measurements and standards at radio frequencies".

He joined the staff of NBS in 1949 and is presently a member of the high frequency standards laboratory of NBS. In his work he has developed standards for measuring commercial magnetic materials, and a precise and accurate secondary standard developed by him has been adopted by an instrument manufacturer, making the standard available commercially.

Arthur W. Holt received the award for "a major contribution of unusual value to science and technology in the original design and construction of a new high-speed memory for electronic data processing machines".

Holt joined the staff of NBS in 1949 to carry out research on the Bureau's first high-speed automatic electronic computer, SEAC. He has made several contributions to the improvement of that machine and has taken part in the development of a second computer, DYSEAC.

Robert K-F Scal received the Medal for "an outstanding contribution to electronic engineering in the development of a miniaturized airborne radar".

Since 1947, Scal has been associated with the Electronics Division of the Bureau, where he has been engaged in development of new techniques, materials and components for electronic miniaturization.

Radio Plant Planned for Iran

ESTABLISHMENT OF a Swedish factory in Iran for manufacturing radio equipment is being planned. Production is expected to start before the end of 1954.

It is reported that the factory is

ENGRAVE

NAME PLATES • PANELS • DIALS

in your own shop

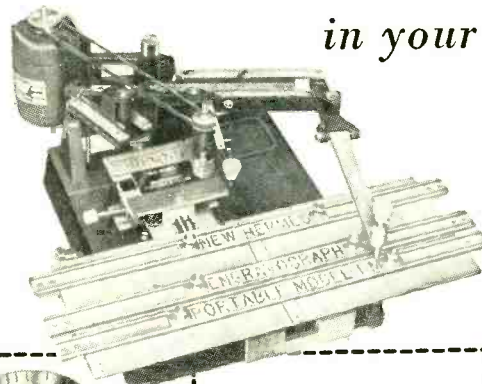

Lowest set-up time for unskilled labor



CALIBRATIONS



PROFILES



CURVED SURFACES

10,000 IN USE Accepted by all leading manufacturers as the speediest, most versatile portable engraver. Only the NEW HERMES has these patented features:

- Adjustable for 15 ratios.
- Self-centering holding vise.
- Automatic depth regulator.
- Adjustable copy holders.

SEND FOR BOOKLET 1M - 29

NEW HERMES ENGRAVING MACHINE CORP.
13-19 University Pl. New York 3, New York

DEPENDABILITY PROVED !!

In Thousands of Installations

SWITCHCRAFT
INC.

"MT-JAX"



Designed especially for use in high quality communication equipment

- Rugged Steel Frame provides rigidity and dimensional stability.

Long frame type, commonly referred to as a Telephone Switchboard Jack. Rugged steel frame, produced in specially designed dies—press welded to provide the rigidity and dimensional stability so important in Communication Jack Panels.

- Maximum Life Springs—corrosion resistant.
- Palladium contacts.

Springs of special alloy of nickel silver, produced in precision design dies, insure maximum spring life.

Welded cross-bar palladium contacts. Finishes and insulations meet the exacting requirements of the military specification JAN-J-641.

WRITE FOR SPECIAL BULLETIN NO. S-520.

SWITCHCRAFT
INC.

1336 N. Halsted St., Chicago 22, Ill.

CANADIAN REPRESENTATIVE
ATLAS RADIO CORP. LTD.,
560 King St. W., Toronto 2B, Canada
Phone: Waverly 4761

AVAILABLE AT ALL LEADING RADIO PARTS JOBBERS •

For improved performance
in high vacuum systems

"WESGO"

ALUMINA INSULATORS

- ultra high purity
- made to any design
requirements

For details on
properties, write
for illustrated
brochure.

WESTERN GOLD & PLATINUM WORKS
589 BRYANT STREET, SAN FRANCISCO 7, CALIFORNIA

expected to produce 3,000 to 4,000 receiving sets per month. Manufacture will be on a license basis with AGA, a Swedish firm, with component parts delivered from Sweden. The plant will be staffed with Swedish engineers and will draw on the Iranian labor force.

The market for radios in Iran is said to be good because of the large portion of the population who cannot read.



Bruce Coffin Elected Victoreen Chairman

BRUCE A. COFFIN, formerly vice-president and a director of CBS, has been elected chairman of the board of directors of Victoreen Instrument of Cleveland, Ohio.

The company also appointed E. W. Glasenapp as general manager of its resistor department. He was previously associated with Service Equipment and was instrumental in organizing Wilcor Products.

New Capacitor Firm Organized

CONDENSER MANUFACTURERS was recently formed in Nashville, Tenn., for the manufacture of electrolytic capacitors of the etched foil type.

The company is in production at its 10,000 sq ft factory.

Personnel of the new firm include:

Hampton Lackey, president, who was formerly half-owner and president of Industrial Products of Nashville.

Howard W. Gates, vice-president & chief engineer, was formerly con-

Microwave
Assemblies,
Radar Components,
and Precision
Instruments . . .
manufactured to
your Blueprints
and Specifications.

N.R.K. MFG. & ENGINEERING CO.
4601 WEST ADDISON STREET • CHICAGO 41, ILL. • Spring 7-2970

For HIGHEST ELECTRICAL & MECHANICAL EFFICIENCY!

New
JONES

SERIES 2400 PLUGS & SOCKETS

• Improved Socket Contacts—4 individual flexing surfaces. Positive contact over practically their entire length.

• Cadmium plated Plug and Socket, Contacts mounted in recessed pockets, greatly increasing leakage distance, **INCREASING VOLTAGE RATING.**

• Interchangeable with 400 Series.



P-2406-CCT



S-2406-SB

Send for complete Catalog No. 20. Plugs, Sockets, Terminal Strips.

Howard B. Jones Division
CINCO MANUFACTURING CORPORATION
CHICAGO, ILLINOIS
SUBSIDIARY OF UNITED CARB FASTENER CORP.

IT'S NEW

GRAYHILL

Series 24 Miniature Tap Switch

with **IMPROVED DETENT ACTION!**

- Available 1 to 6 Decks
- 2 to 10 Positions Per Deck
- Same construction in all deck combinations

RETAINS ALL THE FEATURES OF THE SERIES 5000 AND SERIES 12... **PLUS MORE POSITIVE DETENT AND BETTER ACTUATING "FEEL".** SLIGHTLY LONGER BEHIND PANEL LENGTH TO ACCOMMODATE NEW DETENT DESIGN AT THE FRONT OF SWITCH (SHAFT END).



Grayhill

523 Hillgrove Avenue
La Grange, Illinois
Phone: Fleetwood 4-1040

for the **ELECTRONIC INDUSTRIES**
Quality
Ribbons
STRIPS

**MOLYBDENUM
TUNGSTEN
TANTALUM
FORMED PIECES**

Your Special Metals Rolled to Thin Sizes & Close Tolerances

YOUR INQUIRIES WILL RECEIVE PROMPT ATTENTION

H. CROSS CO.

15 BEEKMAN ST., N. Y. 39, N. Y.
WOrth 2-2044 and COrt andt 7-0470

IN-RES-CO
TYPES SM-15 & SM-30 WIRE WOUND
RESISTORS

SUB-MINIATURE
weather-tested midgets

Type SM-15 and SM-30 Resistors offer three vital advantages—sub-miniature size, weather resistant construction and high resistance. The elimination of center hole mounting and the inclusion of axial leads increases winding area and results in 25% greater resistance value than resistors of standard design. Special coating is moisture and fungus proof and designed to meet JAN-R-93 specifications. Sealed in Eakelite construction affords additional climatic protection. As ratings are conservative, types SM-15 and SM-30 can be specified with confidence for service under rigorous conditions.



TYPE SM-15
5/16" DIA. x 3/8" LG.



TYPE SM-30
5/16" DIA. x 3/4" LG.

ASK FOR THE NEW **RESISTOR HANDBOOK**—

Contains complete data on resistors for every purpose and their recommended applications. Please make request on company letterhead.



INSTRUMENT RESISTORS CO.

COMMERCE AVENUE



UNION NEW JERSEY

APPLICATION-DESIGNED RESISTORS FOR ELECTRONICS AND INSTRUMENTATION

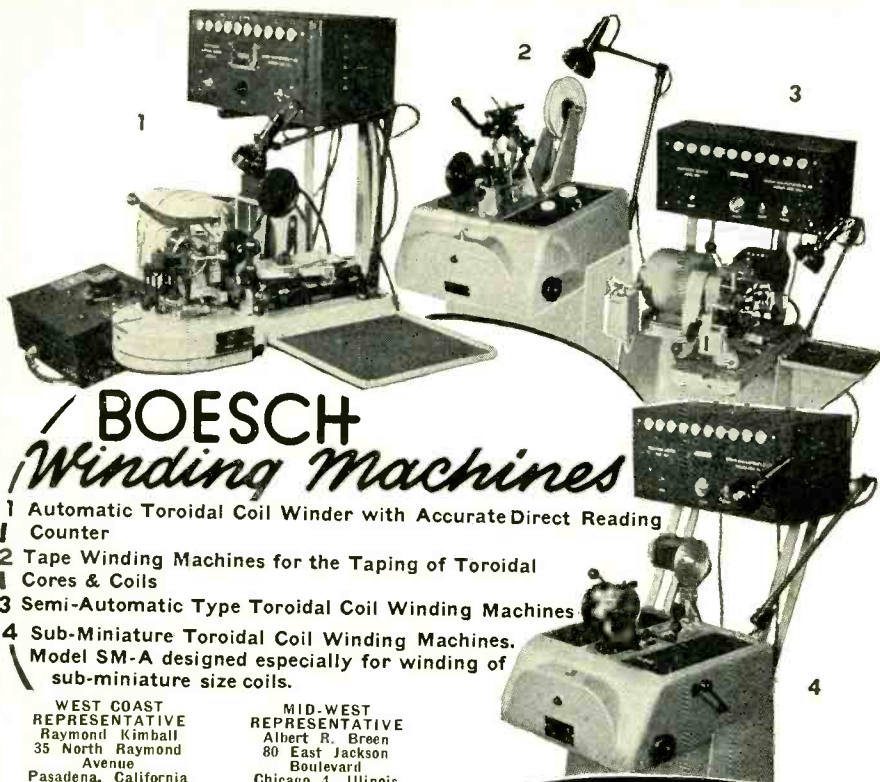

BOESCH Winding Machines

- 1 Automatic Toroidal Coil Winder with Accurate Direct Reading Counter
- 2 Tape Winding Machines for the Taping of Toroidal Cores & Coils
- 3 Semi-Automatic Type Toroidal Coil Winding Machines
- 4 Sub-Miniature Toroidal Coil Winding Machines. Model SM-A designed especially for winding of sub-miniature size coils.

WEST COAST
REPRESENTATIVE
Raymond Kimball
35 North Raymond
Avenue
Pasadena, California

MID-WEST
REPRESENTATIVE
Albert P. Green
80 East Jackson
Boulevard
Chicago 4, Illinois

EXPORT MANAGER—F. E. Koscherak
75 Central Park West, New York 23, New York

**WORLD'S MOST VERSATILE
WINDING MACHINES**



STERLING

A DEPENDABLE SOURCE
FOR

TRANSFORMERS MIL-T-27 & COMMERCIAL



- Pulse
- Audio
- Power
- Filter Choke
- Filament
- RF Coils

Custom Built to
your Specifications



**WE SOLICIT
SAMPLES AND SHORT
RUN PRODUCTION**

297 North 7th St., Brooklyn 11, N. Y.

nected with Western Electric, Bell Labs and U.S. Signal Corps. He also owned and operated Lectrex, electrolytic capacitor manufacturers for the hearing aid trade.

J. C. Carlin, director of research, also held that position with Tennessee Products & Chemical Corp. and was general manager of engineering of Warwick Mfg. Corp.

Armour Research Names Lerner

IRWIN S. LERNER has been promoted to supervisor of the computer systems section in the electrical engineering department at Armour Research Foundation of Illinois Institute of Technology, Chicago.

He formerly held the post of electrical engineer in the department and has been with the Foundation since 1951.

Lerner's section is concerned with design, development, and construction of special and general purpose digital and analog computer equipment.

From 1948 to 1951, he was with the geophysics exploration research department of Continental Oil.



Levinthal Forms Electronics Firm

ELLIOTT C. LEVINTHAL, former chief engineer at Century Electronics, Los Angeles, has established his own company—Levinthal Electronic Products, in Redwood City, Calif. The new firm will develop, produce and merchandise electronic medical instruments, microwave devices and other electronic equipment.

The company has two medical in-

Caltech Jet Propulsion Laboratory

... is now offering select engineering positions requiring a considerable degree of initiative, creative ability and responsibility.

System Analysis Engineer

For analysis, study, and evaluation of guided missile systems.

Radar, Doppler, Antenna Engineers

Several responsible positions are available for engineers experienced in micro wave, audio, pulse, antenna, and other circuits relevant to radar and doppler systems.

Gyro Engineer

Position involves the development and design of gyros, accelerometers and gimballed systems. Experience with precision instrumentation techniques is desirable.

Computer Engineers— Analog and Digital

With development experience in circuit design, logical design, transistors or theory of automatic control computers.

Mechanical Engineers

For design and development of small auxiliary power supplies. Experience with air turbines, reciprocating gasoline engines, gas turbines or electric alternators is desirable.

Electronic Physicist

For investigation into the basic physical phenomenon occurring in electronics. An immediate problem is the investigation of ammonia absorption oscillators.

Experience in the respective fields is required.

Send your resume today to:

JET PROPULSION LABORATORY

California Institute of Technology
4800 Oak Grove Drive
Pasadena 3, California

struments on the market. Both were developed by Albert J. Morris, vice-president of the firm.

Before joining Century Electronics, Levinthal was research director and member of the board of Varian Associates, Palo Alto; research associate at Stanford University and project engineer at Sperry Gyroscope.



Daven Promotes J. P. Smith

J. P. SMITH, JR., formerly chief engineer of the Daven Co., has been promoted to director of engineering for the company.

Radio City Products Expands Plant

RADIO CITY PRODUCTS has awarded a contract and construction has already started on a new and additional building at Easton, Pa. It will add about 5,000 sq ft to the present 28,000 sq ft now occupied.

The new building will be used for shipping and warehousing. The company recently moved its engineering and development labs to Easton.

Leeds & Northrup Plans New Plant

LEEDS & NORTHRUP plans to construct an instrument plant on a 129-acre tract adjacent to North Wales, Pa.

Estimated cost of the 250,000

POLYSTYRENE- CAPACITORS



Insulation-Resistance

at 100 V = 20°C

$R > 1 \cdot 10^7 \text{ M}\Omega$

Loss angle at
800 Hz 20°C

$\text{tg } \delta < 1 \cdot 10^{-4}$

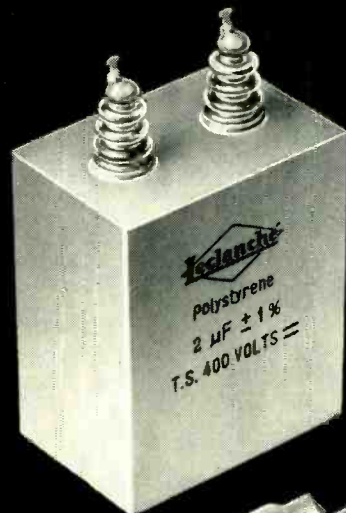

LECLANCHÉ S.A.

YVERDON

SWITZERLAND

ATTENTION!!
Executives and Salesmen!

*Shave in the
Comfort of
Your Own Car,
Boat or Plane!*

WITH **ATR**

SHAV-PAK



Specially Designed for
Operating Standard A.C.
Electric Shavers in
Automobiles, Buses,
Trucks, Boats, and
Planes.

Keep in
Glove
Compartment



PLUGS INTO
CIGARETTE LIGHTER
RECEPTACLE
ON DASH

\$12.95

LIST PRICE

TYPE	INPUT D.C. VOLTS	A.C. OUTPUT 60 CYCLES	OUTPUT WATTAGE	LIST PRICE
6-SPB	6	115 volts	15	12.95
12-SPB	12	115	15	12.95

**DICTATE REPORTS
ACCURATELY-PROMPTLY!**

*make your car, boat or plane
a "rolling office"*

WITH **ATR**

INVERTERS



for changing your
storage battery
current to A. C.

Household
ELECTRICITY

Anywhere
in your own car!

Plugs into
Cigarette Lighter
Receptacle on Dash

\$2250
AND UP
LIST PRICE



ATR INVERTERS . . .

especially designed for operating
standard 110 volt A. C. . . .

- TAPE RECORDER
- WIRE RECORDERS
- DICTATING MACHINES
- ELECTRIC RAZORS

See your jobber or write factory today
for complete information



AMERICAN TELEVISION & RADIO CO.
Quality Products Since 1931
SAINT PAUL 1, MINNESOTA—U. S. A.

PLANTS AND PEOPLE

(continued)

sq ft building, additional equipment, utilities and landscaping is in excess of \$4 million.

Present schedules call for construction to start in the early Fall, with occupancy in latter 1955. Approximately 1,300 of the firm's 3,100 employees will be at the new location.

The building will provide facilities for the manufacture of Micro-max and Speedomax recorders and controllers, panels and cubicles for load frequency control, as well as space for supporting units engaged in engineering, industrial engineering, order control, inspection, receiving, warehousing and shipping.

Gudeman Expands

THE GUDEMAN CO. announced the opening of additional facilities in the Los Angeles area for the manufacturer of pulse transformers and delay lines.

Fairchild Recording Forms New Division

A NEW MOTION PICTURE sound division has been established by Fairchild Recording of Whitestone, Long Island to manufacture Perspecta Stereophonic Sound Integrators for theaters. The new unit is a 'compatible' theatre sound system that produces three-speaker stereophonic sound from a single optical sound track.

Ray Crews, vice-president of Fairchild and formerly supervisor of sound recording under Loren L. Ryder at Paramount, will direct this new division. Crews was manager of a Westrex subsidiary installing and servicing theatre equipment for many years.

Marconi Promotes Top Engineers

WITH THE RETIREMENT OF G. M. WRIGHT, engineer-in-chief of Marconi Wireless, B. N. MacLarty takes over that position. His deputy will be R. J. Kemp, formerly chief of research.

E. Eastwood, deputy chief of re-

**INCREASED
ADAPTABILITY!**

GIANNINI

PRESSURE SWITCH

Designed for use as a standard gauge pressure switch or as a pressure differential control, the Giannini Pressure Switch provides genuinely dependable service—especially in aircraft or industrial applications involving control system actuation or pressure warning.

GIANNINI

Pressure Switch

44517

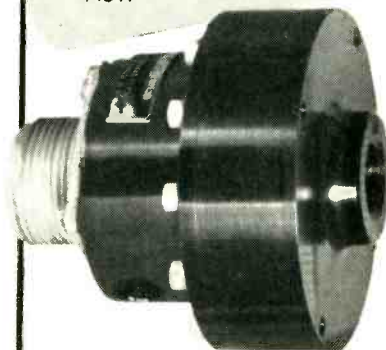

Actuating tolerance will not exceed 1% of actuating pressure at 25°C. Contact life of at least 25,000 operations at rated loads. Overpressures up to 3000 psi without affecting operating tolerance. Will not vary more than 3% between -55°C and +71°C. Pressure range factory-set anywhere between 10 psi and 200 psi.

We'll be pleased to furnish additional information on this pressure switch—or on a variation to meet your individual needs. Write us, without obligation, of course.

Giannini

G. M. GIANNINI & CO., INC.
ElectroMechanical Division
East Orange • New Jersey

UNLIMITED OPPORTUNITIES for . . . Electrical Engineers and Physicists to do Digital Computer Engineering

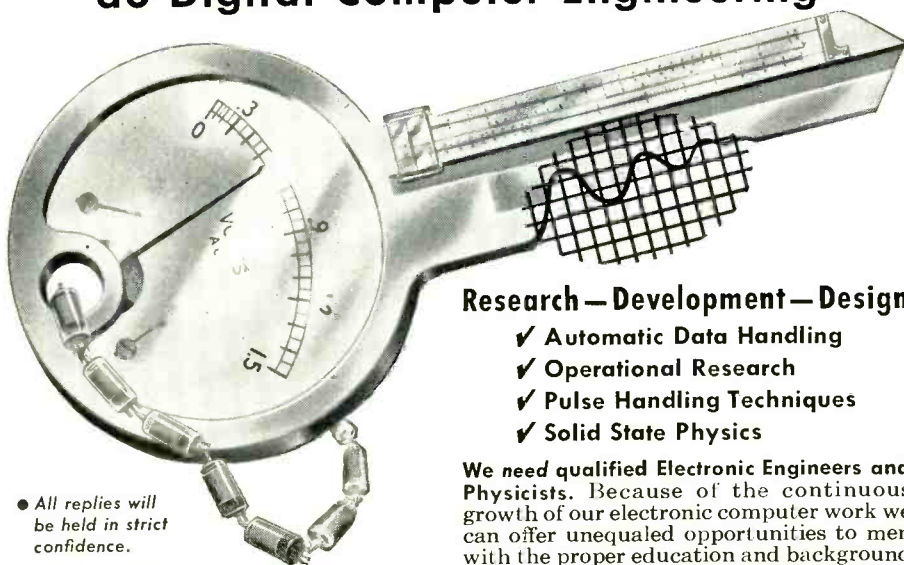

- All replies will be held in strict confidence.
- Interviews will be arranged at our expense.

Research — Development — Design

- ✓ Automatic Data Handling
- ✓ Operational Research
- ✓ Pulse Handling Techniques
- ✓ Solid State Physics

We need qualified Electronic Engineers and Physicists. Because of the continuous growth of our electronic computer work we can offer unequalled opportunities to men with the proper education and background in the Electronics field . . . permanent positions, financial security, professional development.

HERE IS THE KEY TO YOUR FUTURE...

ENGINEERING RESEARCH ASSOCIATES

DIVISION OF **Remington Rand**

1902 West Minnehaha Avenue, Dept. E-00, St. Paul W4, Minnesota

Stycast® 2850GT

Casting Resin for Electronic Embedments

WIDE TEMPERATURE RANGE
-100°F to +400°F
(for Short Periods to +500°F)

COEFFICIENT of THERMAL EXPANSION
Approximately the same as Aluminum and Brass

GOOD ADHESION to Most Materials
LOW SHRINKAGE
CAN BE CURED AT ROOM TEMPERATURE

Write for More
Information on
Other Stycast
Plastics for Electronics



Emerson & Cuming, Inc.
PLASTICS for ELECTRONICS
869E Washington Street, Canton, Mass.

IT TAKES TWO

DISPLAY ADVERTISING • AROUSES INTEREST • CREATES PREFERENCE
DIRECT MAIL • GETS PERSONAL ATTENTION • TRIGGERS ACTION

After your prospect has been convinced by Display Advertising, he still must act. A personalized mailing piece, is a powerful action-getter. Send for our Industrial Direct Mail Catalogue, 150 lists available.

for Results



Mc GRAW-HILL
DIRECT MAIL LIST SERVICE

Direct Mail Division,
McGraw-Hill Publishing Co., Inc.
330 West 42 St., N. Y. 36, N. Y.

Please forward my free copy of the McGraw-Hill Industrial Direct Mail Catalogue.

Name _____
Company _____
Address _____
City _____ State _____

let **WILLIAMS**
help you apply

ferric oxides

to the manufacture
of your

FERRITES

You'll be well repaid by getting the facts on a special group of Pure Ferric Oxides, developed by Williams especially for use in the manufacture of ferrites.

Williams Ferric Oxides analyze better than 99% Fe₂O₃. They contain a minimum of impurities. They are available in a broad range of particle sizes and shapes. Among them, we're certain you'll find one that's "just right" for your requirements. The proper application of Ferric Oxides to the manufacture of Ferrites is our specialty.

Tell us your requirements . . . we'll gladly send samples for test. Chances are good that our Ferric Oxide "Know How" can save you considerable time and money. Address Dept. 25, C. K. Williams & Co., Easton, Pa.

WILLIAMS
COLORS & PIGMENTS

C. K. WILLIAMS & CO.
Easton, Pa. • East St. Louis, Ill.
Emeryville, Cal.

P.S. We also produce IRN Magnetic Iron powders for the Electronic Core Industry, the Magnetic Tape Recording Industry and others. Write for complete technical information.

search, replaces Kemp as chief at the company's research establishment at Great Baddow, England.

New French Tube Company Planned

A GROUP OF FOUR French companies producing electronic and cathode ray tubes plan to form a new company to handle the entire production of the group. The new concern will be called Compagnie Industrielle Francaise des Tubes Electroniques and will have an initial capital of 300 million francs. Founders are Cie des Lampes Mazda, Cie Claude-Paz et Silva, Lampes Fotos and Lampes Visseaux.

Co-operation between the plants of the four companies is expected to result in increased French production of electronics and cathode-ray tubes, which totalled 14 million in 1953.

Zenith Plastics Consolidates Facilities

ZENITH PLASTICS Co. of Gardena, Calif. has consolidated all its aircraft engineering and fabrication facilities into a new division, to be known as Zenith Aircraft.

The company is producing plastic fuselage assemblies for Lockheed P2V5 Neptune bombers and a series of radar housings for the Navy WV-2 and Air Force RC 121C Constellation.

Telectro Industries Names Grossner

NATHAN GROSSNER has been appointed chief engineer and sales engineer for Telectro's transformer division.

He has been associated with a number of transformer manufacturers over the last seven years.

Vulcanized Fibre Plans Research Laboratory

NATIONAL VULCANIZED FIBRE has announced plans for a modern research laboratory to enlarge the facilities of the company's research and development section.

The laboratory will be housed in

RECORDS TWO INDEPENDENT VARIABLES FROM ANALOG OR DIGITAL INPUTS

A compact, desk-size unit designed for general purpose graphic recording from analog or digital inputs with standard Librascope converters or special modifications engineered to customer requirements. Unique pen travel, fast and dependable. Full chart visibility allowing curve generation to be observed at all times. Write for detailed catalog information.

Mechanical and electrical analog computers, digital computers, input-output devices and components.

Computers and Controls

LIBRASCOPE

A SUBSIDIARY OF GENERAL PRECISION EQUIPMENT CORPORATION

1607 FLOWER ST., GLENDALE, CALIF.

X-Y PLOTTER AND RECORDER

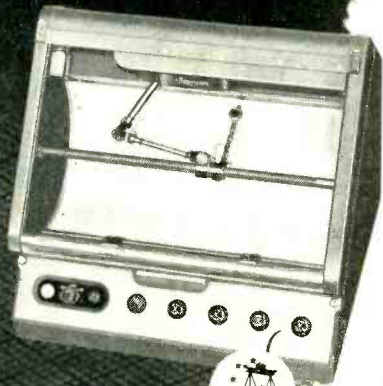

LIBRASCOPE, INCORPORATED

Why Minnesota Rubber parts have longer life

Actual use in many of the finest electrical systems proves Minnesota Rubber O-rings and rubber parts last longer. Made by Minnesota Rubber's exclusive injection molding process, all parts have extremely high density, tolerances within $\pm .001$ inch, no flash on sealing surfaces—and may be bonded to metals. Result: longer flexing life at a cost lower than the industry average!

Now *anyone* can find better rubber parts—if he remembers the name *Minnesota Rubber*. Write today for information and prices. For complete O-ring installation data, request the new free catalog 9-B.



Minnesota Rubber and Gasket Company

3630 Wooddale Avenue, Minneapolis 16, Minnesota, Dept. 310, Phone Mohawk 9-6781

what is currently a large stone warehouse at Yorklyn, Del., near Wilmington. Formerly used for storage of raw materials employed in the manufacture of Vulcanized Fibre, the building will be completely renovated at an estimated cost of nearly a quarter of a million dollars. It will embrace 20,000 sq ft of floor space.

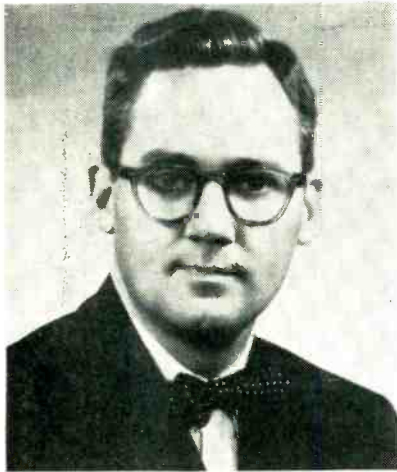

Blackstone Named U. S. Consultant

HENRY BLACKSTONE, president of the Servo Corporation of America, has been appointed a member of the National Council of Consultants of the Small Business Administration.

Blackstone, who founded Servo in 1945, has invented and developed electronic components for national defense. He is now serving as a national director of the Young Presidents Organization and advisor to its committee to encourage new business.

Thompson Products Elects Engineers

DEAN E. WOOLDRIDGE AND SIMON RAMO were elected to the board of directors of Thompson Products.

Both men resigned top management jobs with Hughes Aircraft last year and, with financial backing provided by Thompson Products, organized the Ramo-Wooldrige Corporation to specialize in new advanced system developments involving the general field of guided

SENSITIVE RELAYS that R-E-S-I-S-T



SHOCK

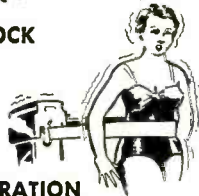

VIBRATION



TEMPERATURE

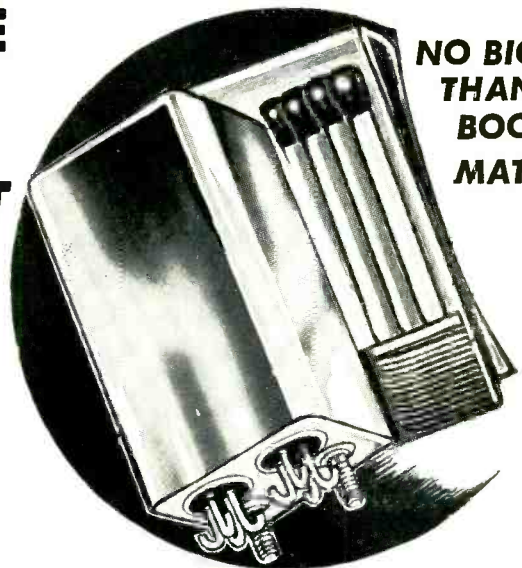

NO BIGGER THAN A BOOK OF MATCHES

Here are miniature sensitive relays—single or double-pole types—which fulfill the most rigid requirements of space, shock, temperature and vibration in both commercial and military applications. The Series 100-105-106 relays are hermetically sealed and have a long life expectancy. Write for Bulletin SR-6

Engineering representatives in principal cities.



Measure FREQUENCY AND FM DEVIATION To 500 MC!

For development . . . production . . . and communication testing!

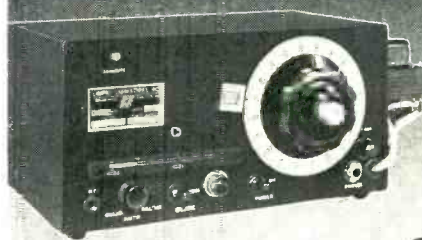

LAMPKIN 105-B MICROMETER FREQUENCY METER

Heterodyne-type, uses one crystal to measure all transmitters from 0.1 to 175 mc., and crystal-controlled transmitters to 500 mc. Accuracy better than 0.005%. Readings in absolute frequency, or percentage of error from desired frequency. Useful as precision, low-level, CW signal generator, 20 mc. up. Price \$220.00.



LAMPKIN 205-A FM MODULATION METER

Direct indication of peak deviation on voice modulation, 0-25 kc. positive or negative. Tunable 25 to 500 mc. in one band. Doubles as relative field-strength meter. Built-in speaker. Jack for oscilloscope. Price \$240.00.

MEET FCC SPECS—for mobile-radio maintenance. SMALL SIZE—less than 13" wide, less than 14 lbs., apiece.

For technical data, mail coupon today!

LAMPKIN LABORATORIES, INC.
Bradenton, Florida

LAMPKIN LABORATORIES, INC.
INSTRUMENTS DIVISION
BRADENTON, FLORIDA

Without obligation, please send me data on Lampkin meters.

Name _____
Street _____
City _____ State _____

missiles, radar, computers, electronic controls and automatic intelligence devices.



Webster-Chicago Elects Owen

NORMAN C. OWEN was elected president of Webster-Chicago. He was vice-president in charge of sales.

E. J. Moritz, general manager of the laminations division, was elected vice-president in charge of manufacturing. Other officers who were re-elected are Walter P. Altenburg, vice-president and general counsel; G. W. Wallin, vice-president in charge of engineering; C. B. Dale, vice-president in charge of research; Herman Biechele, secretary and Edward R. Johnson, treasurer.

Trav-Ler Expands TV Set Plant

TRAV-LER RADIO CORPORATION will be in production in a new 70,000 sq ft modern addition to its plants in Orleans, Ind., to handle an anticipated twenty-five percent increase in billing for the current year over 1953, according to Joe Friedman, president.

The new plant, specially equipped to handle production of television and high fidelity products will occupy a 3½ acre section adjoining the present plants in Orleans and has been specifically designed for continuous production line operation. The addition will give Trav-



CHECK AUDIO FREQUENCY RESPONSE QUICKLY

with the Brue! & Kjaer Automatic Frequency Response Tracer

This instrument is a "package" unit for audio frequency checks and adjustment of amplifiers, radios, filters, loudspeakers, hearing aids, etc. An audio oscillator and a special oscilloscope are combined in one unit. The horizontal sweep of the oscilloscope and the frequency scan of the oscillator are synchronized.

Response curves are presented visually on the cathode ray tube screen, calibrated in both decibels and millivolts versus frequency. The Model BL-4707 has an automatic gain control circuit to maintain the desired oscillator output voltage for constant sound pressure, voltage, or current, for testing microphones, hearing aids, etc. The Model BL-4708 has an audio-modulated RF signal source in place of the automatic gain control circuit for testing radio frequency devices as well.

For complete specifications on this and other Brue! & Kjaer instruments, write Brush Electronics Company, Dept. K-6A, 3405 Perkins Avenue, Cleveland 14, Ohio.

ACOUSTIC AND TEST INSTRUMENTS

Brue! & Kjaer instruments, world famous for their precision and workmanship, are distributed exclusively in the United States and Canada by Brush Electronics Company.

- BL-1012 Beat Frequency Oscillator
- BL-1502 Deviation Test Bridge
- BL-1604 Integration Network for Vibration Pickup BL-4304
- BL-4304 Vibration Pickup
- BL-2002 Heterodyne Pickup
- BL-2105 Frequency Analyzer
- BL-2109 Audio Frequency Spectrometer
- BL-2304 Level Recorder
- BL-2423 Megohmmeter and D. C. Voltmeter
- BL-3423 Megohmmeter High Tension Accessory
- BL-4002 Standing Wave Apparatus
- BL-4111 Condenser Microphone
- BL-4120 Microphone Calibration Apparatus and Accessory
- BL-4708 Automatic Frequency Response Tracer

BRUSH ELECTRONICS COMPANY

formerly The Brush Development Company. Brush Electronics Company is an operating unit of Clevite Corporation.

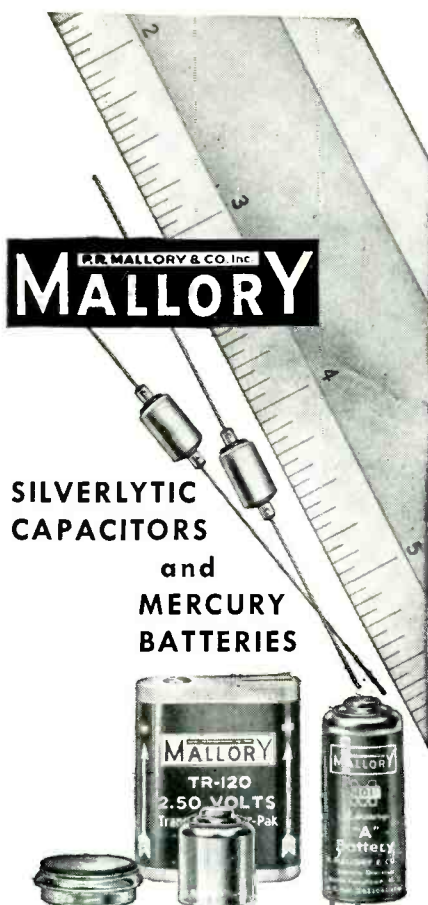

P. R. MALLORY & CO. Inc.
MALLORY

SILVERLYTIC CAPACITORS and MERCURY BATTERIES



Ideal for TRANSISTOR CIRCUITS

If you are designing equipment around transistor circuits, Mallory Mercury Batteries will deliver the constant-current, constant-voltage needed for best performance. There is no significant deterioration or loss of energy even after long periods of storage.

Mallory Silverlytic Capacitors are also designed to meet the special requirements of transistor and other low voltage circuits.

For complete data, write to P. R. Mallory & Co. Inc., Indianapolis 6, Indiana.

Available NOW in production quantities

P. R. MALLORY & CO. Inc.
MALLORY



SPADE BOLTS

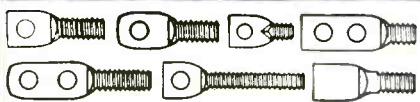

Specialists in designing and manufacturing All-Purpose Fasteners and Mounting Lugs. Tooled to produce over 1,000 sizes and styles of Spade Bolts in any finish, material or quantity.

OTHER PRODUCTS

Simplex WIRE STRIPPERS & CUTTERS

- TOOLS AND DIES
- METAL STAMPINGS
- WIRE SPECIALTIES
- REPLACEMENT TIPS for Electric Soldering Irons

Send samples or specifications for quotations. Descriptive bulletin on request.

WENCO MANUFACTURING CO.
1133 W. Hubbard St., Chicago 22, Ill., U.S.A.

the NEW

1/8" MECHANICAL DIFFERENTIAL from FORD INSTRUMENT COMPANY

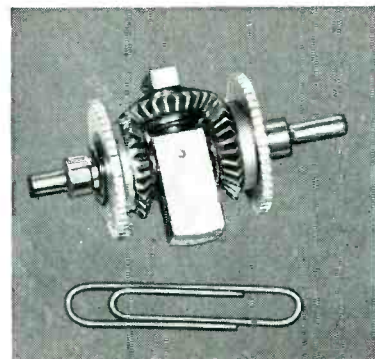

- Operates in working circle of 1.000" max. diameter
- Lost motion does not exceed 12 mins.
- High sensitivity
- Stainless steel throughout; resistance to wear and corrosion
- Uses Zerol bevel gears.
- Weight, with typical end gears, is less than one ounce

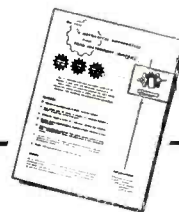

The 1/8" differential is the latest and smallest addition to the Ford Instrument line of single spider gear differentials. Engineered to highest military and commercial standards, this highly reliable unit provides extreme accuracy in additive and subtractive operations, while functioning with minimum friction and backlash.



FORD INSTRUMENT COMPANY
31-10 THOMSON AVENUE
LONG ISLAND CITY, N. Y.

WRITE FOR FULL DETAILS

Fully illustrated data sheet gives performance curves and characteristics. Please address Dept. EL.



TRANSFORMERS

" Fill Your Need to a "

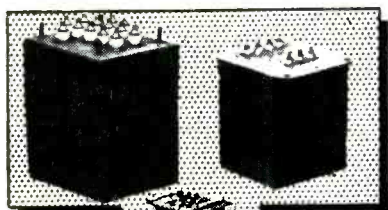

For INDUSTRIAL and ELECTRONIC EQUIPMENT

SAMPLE SHORT and LONG RUNS

Let us quote on your Specifications, no obligation

Delivery as Promised!

DESIGNED TO COMMERCIAL AND MILITARY SPECIFICATIONS (MIL-T-27 and AN-E-19)

EPCO Products Inc.
2500 Atlantic Ave.
Brooklyn 7, New York

Specification Coils



—for every requirement—radio, FM, TV and Government Applications!

Including Universal, Bank Wound, Universal Progressive and Solenoid. All are precision-built to highest engineering standards and conform exactly to specifications. For uniform high quality, prompt delivery and economical unit costs, specify coils by Fugle-Miller. Radio, TV and JAN specifications are a specialty. Phone, wire or write for quotations.

ADDRESS INQUIRIES TO DEPT. E6



FUGLE-MILLER LABORATORIES
MAIN STREET, METUCHEN, NEW JERSEY
Telephone: Metuchen 6-2245

IF IT'S NEW . . . IF IT'S NEWS . . . IT'S FROM *ELCO*

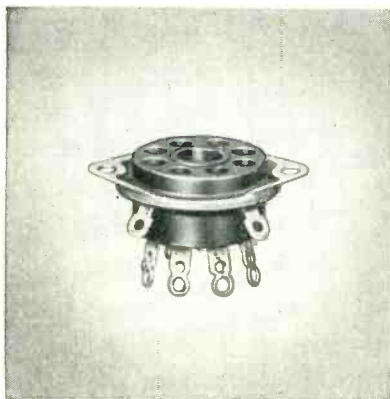

The need for a high-quality octal socket for commercial applications has been answered with the new Elco socket illustrated here. Elco's "commercial octal" offers an all-molded body of general purpose or mica material, equipped with fully-floating brass or phosphor-bronze contacts. The steel saddle is available with or without ground-lugs, cadmium-plated or hot-tinned for ease of soldering. This octal socket is also available for printed circuits and solderless connections. Full information concerning this newest Elco quality-product is yours upon request; as is data about Elco's complete quality-line of miniature and sub-miniature tube-sockets, shields and the world-famous Varicon connector—now available with brackets, handles and covers.

The need for a high-quality octal socket for commercial applications has been answered with the new Elco socket illustrated here. Elco's "commercial octal" offers an all-molded body of general purpose or mica material, equipped with fully-floating brass or phosphor-bronze contacts. The steel saddle is available with or without ground-lugs, cadmium-plated or hot-tinned for ease of soldering. This octal socket is also available for printed circuits and solderless connections. Full information concerning this newest Elco quality-product is yours upon request; as is data about Elco's complete quality-line of miniature and sub-miniature tube-sockets, shields and the world-famous Varicon connector—now available with brackets, handles and covers.

For Catalog Sheets, Call GARfield 6-6620 or Write ELCO Corp., 190 W. Glenwood, Phila. 40, Pa.

Let a total of 210,000 sq ft of production space in Orleans.

Veeder-Root Names Burton

ALLAN L. BURTON has joined Veeder-Root to carry out market research and electronic development work with the company.

Burton comes to Veeder-Root from RCA where he specialized in new product administration. He previously had been associated with the American Optical in research and new business activities, and had been manager of industrial sales for Tracerlab.

During World War II he was associated with the Underwater Sound Laboratories at Harvard University where he worked on the development of underwater weapons.

Navy Needs Engineers

ENGINEERS, TECHNOLOGISTS, physicists, physiologists and metallurgists are needed by the U. S. Navy. The Naval Air Material Center, located in the U. S. Naval Base at the extreme south end of Broad Street in Philadelphia, Pa., has vacancies in the above positions for qualified eligibles. These vacancies are at grade GS-5 to GS-12 level with salary ranging from \$3,410 to \$7,040 per annum.

The Naval Air Material Center (the Air Center is divided into three major branches—the Naval Aircraft Factory, the Naval Air Experimental Station and the Naval Auxiliary Air Station) is engaged in research (applied), development, manufacture, modification, test evaluation and overhaul of aircraft, aircraft components and aeronautical materials, including launching and arresting devices.

Interested persons should file an application for Federal Employment, Standard Form 57, with the Industrial Relations Department, Naval Air Material Center, Naval Base, Philadelphia 12, Pa. Applications may be obtained from the Industrial Relations Department,

AGF FISH TAIL BURNERS



581-E(OS)



420-CNS



420-DNS



104-NS



332-NS



81-ANS



81-BNS



81-WNS



228-NS



228-FNS

SPECIAL BURNERS OR MODIFIED STANDARDS MADE TO ORDER

AGF Fishtail Burners are widely used in glass working machines that manufacture ELECTRONIC TUBES, ELECTRIC LIGHT BULBS, VACUUM BOTTLES, etc.

Rigid adherence to specifications proven as best since 1878, are your assurance of satisfaction when you buy from the PIONEERS.

Write for New Burner Catalog of wide variety.



AMERICAN GAS FURNACE Co.
130 SPRING STREET - ELIZABETH 4, N. J.

Naval Air Material Center, or any first or second class post office or from any Civil Service Regional Office.

Schulman Named By CBS-Columbia

HAROLD J. SCHULMAN has been named director of service for CBS-Columbia.

In the newly established post, he will have supervision of all CBS-Columbia service and field engineering activities.

Schulman resigned as director of service for Du Mont Laboratories, a position he held for more than three years, to accept his new post. Prior to his Du Mont affiliation, he was for three years service manager for Admiral distributors of New York City.

Schulman is chairman of the service committee of RETMA.

Bennett Named General Cable Chairman

IRVING T. BENNETT was elected chairman of the board of General Cable Corporation. He will continue also as the company's chief executive officer, a position he has held since August, 1953. As chairman, he succeeds D. R. G. Palmer who is retiring after 35 years with the firm.

Mr. Bennett came to General Cable Corporation in April, 1953 as a director and chairman of the executive committee. Previously, he had been vice president and general manufacturing manager as well as a director of Revere Copper and Brass Incorporated which he joined as sales promotion manager in 1929. From 1944 to December, 1952, he had been vice president in charge of the Baltimore and Aluminum Divisions of Revere.

RETMA Membership Increases

THE FOLLOWING companies were admitted to membership in RETMA: Central Sales & Manufacturing Co., Denville, N. J.;

ZOPHAR

WAXES

COMPOUNDS

Zophar Waxes, resins and compounds to impregnate, dip, seal, embed, or pot electronic and electrical equipment or components of all types; radio, television, etc.

Cold flows from 100°F. to 285°F.

Special waxes non-cracking at -76°F.

Compounds meeting Government specifications plain or fungus resistant.

Let us help you with your engineering problems.



ZOPHAR MILLS, INC.
112-130 26th Street,
Brooklyn 32, N. Y.

NOISE and FIELD INTENSITY METER Model NF-105

(Commercial Equivalent of AN/URM-7)

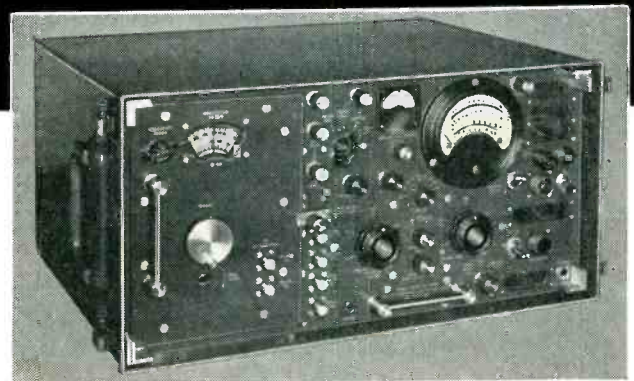

CONFORMS TO
MIL-I-6181B
MIL-I-16910

ENGINEERING DATA

- Frequency range 20 MC to 1000 MC by means of three quick-change tuning heads. At least one RF amplifier with tuned input is employed for each tuning range.
- Easy frequency scanning by means of single tuning knob.
- Built-in impulse noise calibrator flat to 1000 MC (Output externally available).
- 4 1/2" logarithmic indicating meter reads carrier or true peak.
- Aural slideback operation.
- Input VSWR better than 1.2 to 1.
- Built-in regulated "A" and "B" supply.
- Complete line of accessories available.

Write today for additional information and our complete catalog

edp **EMPIRE DEVICES PRODUCTS CORPORATION**
38-15 BELL BOULEVARD • BAYSIDE 61, NEW YORK

MANUFACTURERS OF
FIELD INTENSITY METERS • DISTORTION ANALYZERS • IMPULSE GENERATORS • COAXIAL ATTENUATORS • CRYSTAL MIXERS

**YOU CAN'T
SHAKE 'EM LOOSE!
BUT YOU CAN COOL 'EM OFF...**



With BIRTCHER

KOOL KLAMPS

BIRTCHER KOOL KLAMPS will help keep your subminiature tubes COOL... and hold them firm and secure, regardless of how they are shaken, or vibrated.

KOOL KLAMPS are made of a specially developed heat treatable alloy 99 1/2% pure silver of high thermal conductivity.

KOOL KLAMPS under certain conditions are able to reduce bulb temperatures as much as 40° C. KOOL KLAMPS have proved of particular value in miniaturized electronic equipment.

Where heat conditions are less critical, beryllium copper KOOL KLAMPS are available.

The BIRTCHER CORPORATION
4371 Valley Blvd.
Los Angeles 32, California
Dept. E-6-4



Please send Bulletin which describes and illustrates Kool Klamps in detail.

Company
Attention of
City State

Electronic Tube Corp., Philadelphia, Pa.; International Rectifier Corp., El Segundo, Calif.; Jackson Electronics & Television, Inc., Chicago, Ill.; Klipsch & Associates, Hope, Ark.; Magnex Corp., Jamaica, N. Y.; McCoy Electronics Co., Mt. Holly Springs, Pa.; Onondaga Pottery Co., Syracuse, N. Y.; Orradio Industries, Inc., Opelika, Ala.; Rectifier Corp. of Puerto Rico, Fajardo, P. R.; Reiner Electroncis Co., Inc., New York, N. Y.; The Tetrad Co., Yonkers, N. Y.; Waters Conley Co., Rochester, Minn.

Raytheon Expands Marine Radar School

RAYTHEON'S radar training school for instructing ship's officers in the operation of marine radar and other electronic aids to navigation has been expanded. The action came with the closing of the Maritime Administration's Radar and Loran School in New York.

A three-day course in Waltham, Mass. will be offered without cost to merchant mariners. The curriculum will include operating instructions for the firm's marine equipment. Instructions in making minor repairs and adjustments will also be given.

The company also announced that Captain John N. Boland, USN (ret.), has been appointed manager of its office in Washington, D. C. He became associated with Raytheon in 1951. From 1945 to 1948 Capt. Boland was in charge of the fire control radar research and development section of the Navy's Bureau of Ordnance.

New York Central Names Auerbach

THE NEW YORK CENTRAL RAILROAD announced the appointment of Al Auerbach as electronics engineer succeeding the late George M. Brown.

In addition to teaching tv and electronics, Auerbach has been associated with Emerson, Radio Receiver and most recently with Fada Radio as a tv engineer.



have you
thought about
Florida
for plant
location?

Florida offers decided advantages to manufacturers in certain fields of electronics such as...

- Tubes
- Resistors
- Coils
- Expensive Transformers
- Light weight electro-mechanical components
- Specialized instruments and equipment

Key personnel, engineers and good production workers are available, employee morale is high and the labor climate is excellent. More than 1,965 new residents move to Florida every week.

Florida's sunny year-round good weather assures reduced construction, plant maintenance and heating costs.

Florida is strategically situated for serving Southern and Latin-American markets.

In Florida you pay no state income taxes, no state ad valorem tax, no state inheritance tax.

Florida already has well established electronics research and development facilities—with room for more.

A MANUFACTURER SPEAKS

Quoting the president of a Florida electronics company:

"We are firmly convinced that our firm could not have made the strides it has made in the last three years in any other state in the Union."

For further information write: Industrial Development Division, State of Florida, 3306 E Caldwell Building, Tallahassee, Florida.

**you'll always
do better in**

Florida

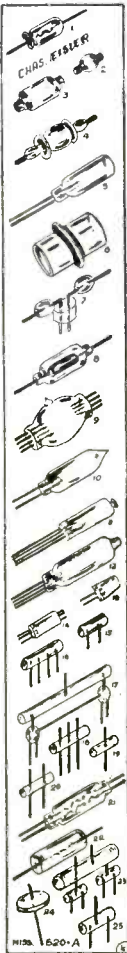

You Name It EISLER Makes it...

GLASS TO METAL

ELECTRONIC GLASS WORKING EQUIPMENT for RADIO, TELEVISION TUBES, INCANDESCENT LAMPS, GLASS LATHES for TELEVISION TUBES

We make Transformers, Spot and Wire Butt Welders, Wire Cutting Machines and 500 other items. Indispensable in your production. Eisler Engineers are constantly developing New Equipment. If you prefer your own designs, let us build them for you. Write to Charles Eisler who has served The Industry over 34 years.

Machines for small Radio Tubes of all kinds.
SEND YOUR GLASS PROBLEMS TO EISLER
 24 POSITION BARREL CAM INDEXING TYPE
 TURNTABLE FOR GLASS BUTTONS
 MADE BY EISLER

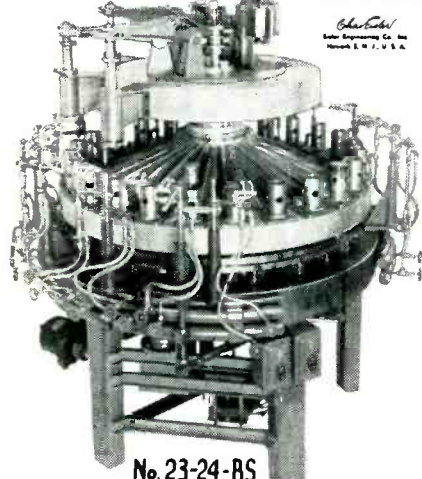

No. 23-24-BS

World Famous
 for Over 33 Years
 Charles Eisler M.E.

DR. CHAS. EISLER M.E. PRES.
EISLER ENGINEERING CO., INC.
 751 So. 13th St., NEWARK 3, N. J.



Dual-Trace Applications

with the
Tektronix Type 535 Oscilloscope and Type 53C Dual-Trace Plug-in Preamplifier

Here is a combination ideally suited to most applications involving accurate comparisons of two signals.

The Type 53C Dual-Trace Unit contains two identical amplifier channels that can be electronically switched either by the oscilloscope sweep or at a free-running rate of approximately 100 kc. When amplifier switching is triggered by the sweep, and time-delay characteristics of the two amplifier channels are closely controlled, time comparisons accurate within 1 μ sec can be made. Two simultaneous transients may be viewed by free-running the switching. Transients of as little as 1 msec duration are well delineated, having about 100 elements in each trace. For many purposes, shorter transients can be adequately observed.

The Type 535 Oscilloscope is designed to use plug-in preamplifiers. It has an exceptionally wide sweep range, high accelerating potential, new accurate sweep-delay circuitry, and many other important features. Four Plug-In Preamplifiers have been developed for use with the Type 535, to provide an unusually high degree of flexibility in a single oscilloscope.

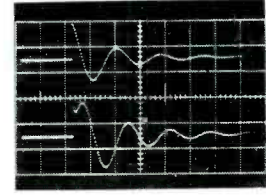

SINGLE-SWEEP PRESENTATION
 Response of two networks excited by a single pulse shows free-running operation of the Dual-Trace Unit in a one-shot application. A single 200- μ sec/cm sweep is used for this display.

ALTERNATE-SWEEP PRESENTATION

Output of an RC network superimposed on the input pulse. Both waveforms appear on alternate 0.04 μ sec/cm sweeps, accurately measuring the risetime deterioration caused by passage through the network.

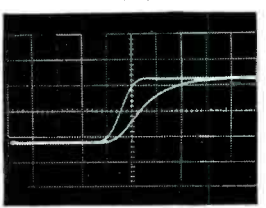

MAIN OSCILLOSCOPE FEATURES
 600,000,000 to 1 Sweep Range—0.02 μ sec/cm to 12 sec/cm, continuously variable. Calibrated—0.02 μ sec/cm to 5 sec/cm, accurate within 3%.

10 KV Accelerating Potential—Brighter display at low repetition rates.
Flexible Sweep Delay—1 μ sec to 0.1 sec, jitter-free, incremental accuracy within 0.2% of full scale.
 Type 535 Oscilloscope—\$1300 plus price of desired plug-in units.

DUAL-TRACE PLUG-IN PREAMPLIFIER
 Type 53C Specifications

Two Identical Amplifier Channels
 Frequency Response—DC to 8.5 mc.
 Rise-time—0.04 μ sec.
 Sensitivity—0.05 v/cm to 20 v/cm calibrated, continuously variable to 50 v/cm.
Electronic Switching
Triggered—actuates alternate sweeps.
Free-running rate—100 kc, approximately.
 Type 53C Dual-Trace Unit—\$275.

OTHER PLUG-IN PREAMPLIFIERS
 Type 53A Wide-Band DC Unit—\$85.
 Type 53B Wide-Band High-Gain Unit—\$125.
 Type 53D High-Gain Differential Unit—\$145.
 Prices f.o.b. Portland (Beaverton), Oregon.

Please write for complete specifications



Tektronix, Inc.
 P. O. Box 831A
 PORTLAND 7, OREGON
 Cable: TEKTRONIX

Subminiature Voltage Regulator Tubes

NEW!	DEPENDABLE!	INEXPENSIVE!	
TYPE	STARTING VOLTAGE	OPERATING VOLTAGE	MAXIMUM CURRENT
65ST2-32	67VDC	65VDC	1.5MA
90ST2-32	110VDC	90VDC	1.5MA
140ST-32	150VDC	140VDC	1.5MA

Other Voltages & Currents to your Specifications
 Complete Technical Data Furnished on Request

Actual Sizes Shown
SIGNALITE INC.—37 Neptune H'wy.—Neptune, N. J.

Cunningham
 ESTABLISHED 1929

crossbar

A truly superior switch for MASTER CONTROL AND MONITOR SWITCHING OF AUDIO & VIDEO CIRCUITS Also COMPUTERS • TELEMETERING TELEPHONY • DELAY LINES ETC.

Extreme flexibility
 Fast quiet switching
 Crosstalk down 60 Db at 10 MC
 Any group of setups may be held intact while setting up others
 Provision for spot or remote control
 Strapwiring eliminated
 Excellent HF characteristics
 Palladium contacts
 Reduced cost
 Compact design, small size
 Low operating power—2.5 watts
 Simple "package" installation

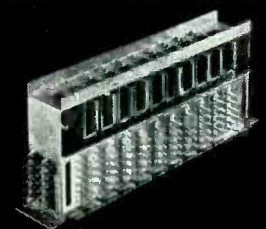

- Individual magnets at each cross-over.
- Maximum, six conductors per circuit.
- Life-tested to 100 million operations.

JAMES CUNNINGHAM, SON & CO., INC.
 Dept. T-1, Rochester, New York Tel: BAker 7240

536K Multimeter Kit \$12.90
Wired \$14.90
1000 ohms/volt



425K 5" Scope
Kit \$44.95
Wired \$79.95



470K 7" Push Pull Scope
KIT \$79.95. WIRED \$129.50.

YOU BUILD

EICO

**KITS
IN ONE
EVENING-**

**but they
last a lifetime...
and you
save 50%**

**38 Kits and 42 Instruments —
the Industry's most complete
line of MATCHED
TEST INSTRUMENTS**

1/4 - million EICO In-
struments are now in use
the world over! That's the
proof of EICO's leader-
ship in Value.

For latest precision engi-
neering, finest compo-
nents, smart professional
appearance, lifetime per-
formance and rock-bot-
tom economy — see and
**compare the EICO
line at your Jobber
before you buy any
higher-priced equip-
ment!** You'll agree with
over 100,000 others that
only EICO Kits and In-
struments give you the in-
dustry's greatest values
at lowest cost

Prices 5% higher on West Coast.



1050K Battery Elim.
Kit \$29.95. Wired \$39.95

525K Tube Tester
Kit \$34.95
Wired \$49.95



377K
Sine & Square Wave Audio Gen.
Kit \$31.95. Wired \$49.95

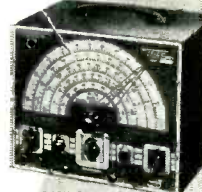

565K Sweep Gen.
Kit \$34.95. Wired \$49.95

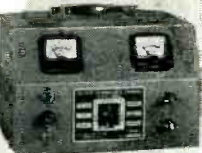

221K VTVM Kit \$25.95
Wired \$36.95

565K Multimeter Kit \$24.95
Wired \$29.95
20,000 ohms/volt

Write NOW for FREE latest Catalog E-6

EICO
Laboratory Precision at lowest cost

©1954
ELECTRONIC INSTRUMENT CO., Inc.
84 Withers Street, Brooklyn 11, N. Y.

NEW BOOKS

The Electronic Musical Instrument Manual

BY ALAN DOUGLAS, Senior Scientific Officer, British Iron and Steel Research Association. Pitman, 221 pages, 2nd Ed., 1954, \$6.00.

THIS is not primarily for the beginner. While it is not a mathematical book, when equations are needed they are given and explained. The first two chapters on "Sound" and "Music and Noise" are reviews of fundamentals rather than being elementary in treatment. However, any electronic engineer would feel completely at home, and an average high school student of physics would understand just about all of it.

There are seven chapters, 187 figures, 3 appendices, 57 references and a 5-page index. One appendix indicates the twelve half-tone musical notations for vibrations from 16.353 to 16.744.032 vibrations per second (excessive digits, no doubt). Two of the chapters are enlarged from the first edition: "IV. The Production And Mixing Of Electrical Oscillations" (68 pages) and "VII. Experimental Methods" which in 18 pages indicates three broad fields for future experiment and improvement.

In Chapter "VI. Commercial Electronic Instruments" (65 pages, 54 figures) the author has done a fine job of integration. Each of thirteen instruments has been allotted adequate space. Since this is not a book on what organ to buy, there is perhaps no reason to indicate preference of one organ over another. In this chapter, the illustrations were chosen to show "differences between two basic schools of thought. . . (a) should the originally-generated waveform contain all the required harmonics, subsequent analysis or control being effected by removing unwanted harmonics and modifying others: or (b) should pure sine waves be independently generated for each required fundamental and harmonic frequency, and control or synthesis achieved by adding numbers of these pure waves of varying frequencies and amplitudes?"

The figures are uniformly excel-

How to whip your relay problems!

Just call **ADVANCE...**
we're ready and
willing to make the
relays you need.

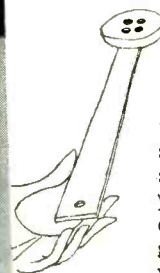

CONTACTS,
for example

Say the word and we'll up the sizes... switch from fine silver to tungsten, palladium, silver-cadmium oxide, gold contacts, or... you name it!

INSULATION

Laminated phenolic, silicone glass, ceramic, steatite, linen-base bakelite, or... you name it!

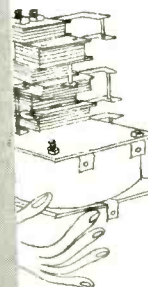
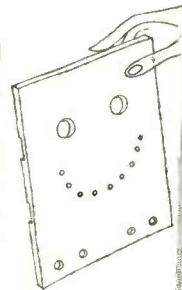

ANYTHING SPECIAL...

ADVANCE will engineer, develop and produce the custom relays you need in minimum time. Call **ADVANCE** for action.

For ELECTRONIC USES

We build a vast variety of sensitive, reliable relays...create superior new designs quickly. You'll find our quality control is now the tightest in the industry.

Write—and let us solve your relay problems



ADVANCE ELECTRIC AND RELAY CO.

2435-F NORTH NAOMI STREET
BURBANK, CALIFORNIA

how DIELECTRIC are...

ENGINEERED CERAMICS?

If it's a question of building better insulation characteristics into your product, take a look at Frenchtown Engineered Ceramics. The alumina bodies, particularly, offer excellent electrical resistance at high temperatures. Take, for instance Frenchtown ALAMNOX charted below:

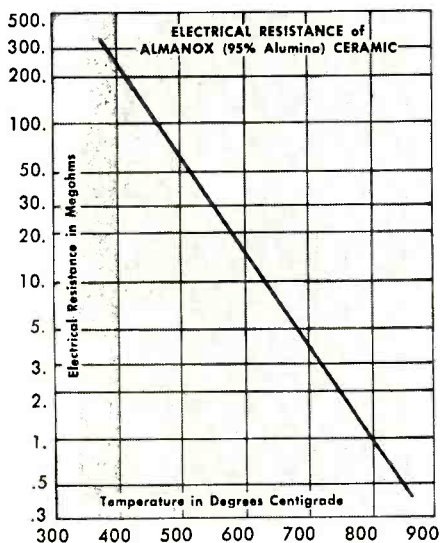

High dielectric strength is only one of the many desirable properties. Low thermal expansion, good thermal conductivity, excellent mechanical strength and wear resistance have enabled many manufacturers to improve over-all performance of their products.



For complete information, send for this bulletin on Design Principles and chart of electrical and mechanical properties of FRENCHTOWN ENGINEERED CERAMICS.



lent. In two cases, folded inset pages of adequate size are used: "Part circuit of the Novachord" and "Complete circuit of the Solovox". The latter gives all circuit constants, though these are lacking in the former. In addition the "Hammond mixing circuit" occupies a two-page spread. All waveforms are clear line drawings. The publisher is to be congratulated on his courage and enterprise in reproducing these figures. The paper is good quality, and no misprints were found.

Some confusion may exist for readers not familiar with British terms. Two important examples occur repeatedly; our unwieldy micromicrofarad is the picofarad or pF, and h.t. is plate voltage. There should be no trouble in identifying a high magnification valve as a high- μ tube, and screening is, of course, shielding. Gas tubes, like 884, are shown cross-hatched, instead of by the familiar dot. L. F. Oscillator is an a-f oscillator, speech coil is voice coil, but what is sorbo rubber (page 113) and a paxolin strip (page 204)?

In general it isn't too hard to think of our own tube equivalent when a circuit is shown, as it usually is. Some of the tubes (valves) are international, but to open the book at random, on pages 50-51 four circuits of one-tube oscillator circuits show: 6A8G, AC/SG and L 63, EF50, 7A8. The first and last are readily identified, but the others are not likely to be familiar.

There will be no argument to the author's discourse on distortion, but immediately following, he says that a practical amplifier range is "30 to 10,000 cycles/sec., which will still allow a substantial percentage of signals of higher frequencies being heard". (argument!)

A couple of minor faults: (page 106) output transformers "should not have taps"; the secondary winding must be matched to the load. He should know that sectionalized secondaries can be paralleled or otherwise connected. On page 11 a slight recasting of the definition of the decibel would be desirable.

Some examples of the author's style and knowledge: (page 26) "the form of vibration in a piano



NEW Allenpoint Set Screws

WITH
SCIENTIFICALLY-DESIGNED
SMALLER CUP POINTS

Smooth, deep point penetration for greater holding power and resistance to vibration; precision formed threads and accurate thread lead for maximum locking action. Comparative tests by leading laboratory prove Allen Set Screws unmatched in performance. Write to Advertising Department for Bulletin C-33A.

When ordering through your local industrial distributor, specify Genuine Allenpoint Set Screws.



ALLEN

MANUFACTURING COMPANY
Hartford 2, Connecticut, U.S.A.





1 MFD. 2 1/2" x 2 1/2" x 1 1/2"



0.5 MFD. 1 3/4" x 1 3/4" x 1 1/8"



0.25 MFD. 1 3/4" x 1 1/4" x 7/8"



0.1 MFD. 1 3/4" x 1 1/4" x 7/8"



0.05 MFD. 1 3/4" x 7/8" x 1 1/16"

ULTRA-HIGH PRECISION POLYSTYRENE CAPACITORS

as low as 0.1% tolerance in most values

CAPACITANCE AVAILABLE—0.05 to 10.0 MFD.
 VOLTAGE AVAILABLE—100 to 400 VDC
 INSULATION RESISTANCE—10⁶ MEG./MFD.
 TEMP. COEFF.—100 P.P.M. per °C (—20° to 140°F)
 DIELECTRIC ABSORB.—.015%
 DISSIPATION—.0002

Special Values to Close Tolerances—Our Specialty

SOUTHERN ELECTRONICS CORP.

239 W. Orange Grove Avenue, Burbank, Calif.

NOW!

accurately controlled electric heat

for

HEATING LIQUIDS
 MELTING SOLIDS
 in Tanks and Vessels

with

WATLOW
 IMMERSION HEATERS

The most efficient method of heating fluids in tanks, kettles, steam tables, boilers, etc. Watlow Units are designed for low internal operating temperatures—which results in maximum life. Available in brass, steel or nickel alloy, also stainless steel sheaths, for maximum corrosion resistance. Standard sizes: 3/4" to 2" dia., 3 1/2" to 60" lengths; 10W-35W densities. Special sizes and shapes built to your specifications.

Send for your free copy of Watlow Electric Heating Units Catalog.

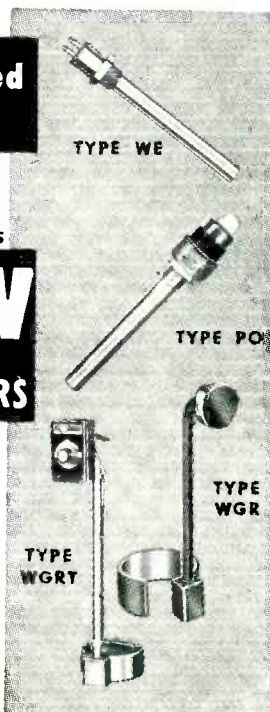

WATLOW

SINCE 1922—DESIGNERS AND MANUFACTURERS OF ELECTRIC HEATING UNITS

ELECTRIC MFG. CO.
 1390 FERGUSON AVE.
 SAINT LOUIS 14, MO.

is very interesting. There is no other instrument quite like it, and it cannot be exactly simulated by electrical means. The principal reason for this is the very strong characteristic starting tone which is almost of a transient nature, having a very steep wave front containing many frequencies"; (page 43) "Beat tones do, in fact, contribute much more to music than is generally realized. For example, the ear detects a fundamental tone in the lower tones of a violin. The real fundamental is very weak, because it lies below the fundamental resonance of the violin body, and any sound output lower in pitch than the resonance is very small. Adjacent, strong upper harmonics produce the beat tones which sounds to the ear like the actual fundamental or pitch tone of the sound being produced"; . . . (page 35) "The square wave is exceedingly useful in musical synthesis, as all "hollow" sounding tones consist principally of odd harmonics; . . . (page 37) "it might be said that the successful imitation of orchestral tones demand both square and sawtooth wave forms, as well as sine waves".

The reviewer would like to see added a glossary listing British and American terms, also a list of similar tubes and valves mentioned in the text.

If music is your vocation or avocation, and you know something about electronics, you will get a great deal from this book. It is well worth careful reading. It is also valuable as an authoritative reference.—RICHARD C. HITCHCOCK, *Syntron Company, Homer City, Penna.*

Industrial Electronics

By R. KRETZMANN. *Philips' Technical Library, Eindhoven, Holland, 236 pages, 1954, \$5.50.*

THIS book adds to the expanding series of Philips' Technical and Scientific Publications, of which there are already a considerable number in the field of radio and electronics. The author is German and the translator of the present book is a Londoner. The translation of a technical text is difficult, in

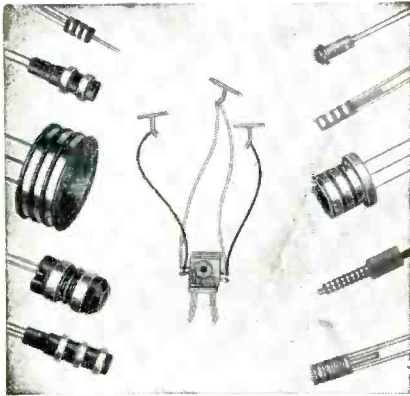

Miniature and Sub-Miniature
SLIP RING ASSEMBLIES
BRUSH BLOCK ASSEMBLIES
COMMUTATORS

and other
 Electro-Mechanical Components

PRECISION MADE
TO YOUR OWN SPECIFICATIONS

Precision molded products with exacting tolerances in precious and non-precious solid metals of all alloys. All types of Thermo-Plastic and Thermo-Setting materials.

Slip Ring Assemblies fabricated or one-piece precision molded to your specifications in Nylon, Kel-F, Mineral filled Mellamine, Phenolic, and other materials. Rings and leads spot welded or brazed together for positive electrical circuit.

Our Swiss methods and techniques are geared to meet exacting requirements. We invite your inquiries.

COLLECTRON CORPORATION

MUrray Hill 2-8473 • 216 East 45th Street • New York 17, N. Y.

PULSE TRANSFORMERS INTERSTAGE • MAGNETRON BLOCKING OSCILLATOR

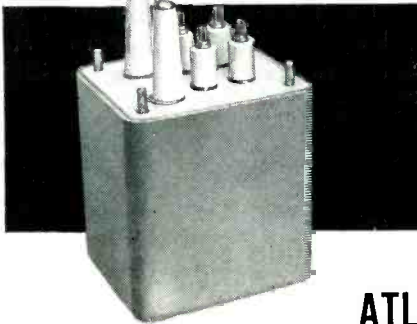

Write for detailed information

We have facilities for complete electrical and environmental testing to 20,000 volts. Design facilities also available.

50 KW MAGNETRON TRANSFORMERS

(Now in production)

INPUT — 1250 V, 28 ohms; OUTPUT — 7500 V, 1100 ohms; PULSE WIDTH — 0.85 to 2.4 Microseconds; DUTY CYCLE — .002. 5% Max. Droop; .1 Microsecond Rise Time; 0.7 Amp. Bifilar Filament.

All units completely tested to these specifications.

ATLANTIC TRANSFORMER CORP.

30 Hynes Avenue, Groton, Connecticut

Stycast Hi-k

Plastic Rod and Sheet Stock for RF and Microwave.

Any Dielectric Constant 3 through 20

DISSIPATION FACTOR below 0.001
 TEMPERATURE RANGE -75°C to +125°C
 MACHINEABILITY Excellent

Emerson & Cuming, Inc.
 PLASTICS for ELECTRONICS

869 E Washington Street, Canton, Mass.

Write for More Information on Other Stycast Plastics for Electronics

New components, designs and techniques for HIGH VOLTAGE and CORONA SUPPRESSION

Here's a brand new technique . . . makes possible connectors and cables wherein insulation is molded right around contact and lead . . . to give you an integral unit that licks the problems of high voltage and corona suppression at new low cost, by —

- 1 Eliminating need of leakage paths at wire holes.
- 2 Utilizing materials more inert to ozone attack than conventional materials.
- 3 Sealing high voltage potential sources from air except at the point of contact mating, where there is a natural damping of corona.

This new technique just worked out for Color TV can give you connectors and cables for solving many problems involving high voltage and corona suppression.

NEW SOCKET TECHNIQUE

As illustrated in this Alden 2201TSC Color TV Tube Connector, the new technique permits a



jacket of high voltage insulation to be integrally molded around each high voltage contact and lead, while the low voltage leads take the resilient "figure 8" clips in the regular isolated pockets providing air space leakage.

NEW CABLE TECHNIQUE



This new technique makes possible completely molded cables having all connectors and wire insulation sealed into an integral unit that licks the problems of high voltage and corona suppression. For example, the 30,000-volt anode cable illustrated has in-line tube cap, high voltage disconnect and anode clip all molded together as one integrated unit tailored for a Color TV set.



8101FP/M
 High Voltage Disconnect for 20,000 volt anode cable.



8111FP/M
 High Voltage Disconnect for 30,000 volt anode cable.



91-1S2L-1BC
 Molded in-line Tube Cap.

ADDITIONAL ADVANTAGE—this new technique gives a solidly molded unit that eliminates common cable problems of: wire fatigue under vibration; insulation pullback; strain relief for leads.

TO GET STARTED

write for Spec Sheets on Color TV—and let us plan these techniques to your special needs in ANY field involving high voltages and corona suppression.



ALDEN PRODUCTS CO.

6127 N. Main St., Brockton 64, Mass.-



Radio Telemetering Equipment

Airborne and commercial transmitting installations for pulse width and FM radio telemetering. Ground station equipment for the reception, handling and reduction of telemetered data. We are prepared to furnish standard units from production or to develop and produce special equipment to your specifications.



ASCOP

WE PROVIDE ▲ THE LEVER YOU MOVE THE WORLD

Your Inquiries are Invited. Write Today.
or call Plainsboro 3-4141

APPLIED SCIENCE CORPORATION OF PRINCETON

Also: High Speed Sampling Switches and Special Components and Equipment

45 Wallace Road, Princeton, N. J.



SHOCK PROOF VACUUM TUBE RETAINERS

These retainers are used to secure Vacuum Tubes and to resist side motion of Vacuum Tubes used in radio equipment which is subject to shock and vibrations. These retainers meet the requirement of all JAN specifications. The insulated portion is made of a melamine base Fibre Glass Phenol which provides 300 volts insulation to ground and withstands a temperature of 350 F. The insulated plate can readily be fastened or released by hand.

Manufacturers of Electronic Components

Available for envelope types T7, T8, MT8, T9, T12, ST12, T12ZDL, ST14, S14, ST16, T5½, T6½, MT-1C, ST19, T14, ST128CT-9.

JAMES IPPOLITO & CO., INC.

401 CONCORD AVENUE, BRONX 54, N. Y.

general, and in a relatively new science such as electronics it is even more difficult. Therefore, unfamiliar phrases are bound to occur and minor errors as well as none-too-clear explanations inevitably creep into the text. Thus, it is not too well suited for use in this country as practically all of the tubes and equipment referred to are naturally those made or sold by the Philips Company. This lack of familiarity with our techniques is indicated by the book's sub-title "Introduction to Modern Industrial Electrical Practice." There are a number of other terminologies that are a little strange to us, such as enneode, senditron, zero point anode arrangement and pulsation welding.

The book is divided into two parts. The first, comprising about one-third of the text, is devoted to the tube types used in the industrial field and their basic circuits. Part II is devoted to circuit details and applications. Diagrams are used extensively but in only a few cases are the numerical values of components given. Its greatest value in this country is undoubtedly to engineers interested in the line of industrial tubes and equipment built and sold by the Philips Company. For instance, the Senditron tube for welding control is apparently a commercial product of the Philips Company, but it is quite different in its principle of operation than anything available in the U. S. A. Thus, it might well be interesting reading to those competing in foreign countries, particularly South and Central America, with the able engineers and export representatives of this highly successful firm.—W. C. WHITE, *General Electric Research Laboratory.*

Microwave Spectroscopy

By M. W. P. STRANDBERG. *John Wiley and Sons, Inc., (Methuen's Monographs on Physical Subjects), New York, 1954, 140 pages, \$2.50.*

THIS IS THE SECOND book on the subject that has come out within the last year. (The first, by Walter Gordy et al and having the same title, was reviewed in *ELECTRONICS* last October.) The present volume is a much less ambitious monograph, being restricted to the

microwave spectroscopy of rotating molecules.

Like most of the books in the Methuen series, Dr. Strandberg's contribution comprises a concise, rather advanced treatment of the subject. The book is intended either as a fundamental text for someone interested in specializing in the field or, as the author puts it, as "a second course in quantum theory whose framework consists of the many problems which may be precisely illustrated experimentally by microwave spectroscopic methods."

The subject of microwave spectroscopy dates back no further than the end of World War II. The good start which American scientists obtained in the field was due largely to a poor guess on the part of the radar designers toward the end of the war. In their efforts to produce a narrow searchlight radar beam which could be handled by antennas of convenient size and yield more detailed information, the designers went from wavelengths of 10 cm to 3 cm, and finally 1.25 cm. To their amazement they found that contrary to all expectations the range of the 1.25-cm radar was limited to a few miles. This limitation was due to the absorption of microwaves in water vapor in the atmosphere at that frequency. Many of the radars were discarded, and the surplus equipment thus created became a ready source of apparatus suitable for microwave instrumentation at research centers all over the United States.

Perhaps the most outstanding of these centers today are at Columbia and Duke University, MIT and the National Bureau of Standards. (The abovementioned book by Gordy was the contribution of the Duke group.) Dr. Strandberg (an MIT professor) is a physicist, a fact which is evident from his approach to the subject. The book presupposes a knowledge not only of matrix methods, but of quantum mechanics as well. The larger part of the text is devoted to the physics of the subject, with experimental considerations remaining unmentioned until Chapter 10. However, this chapter, as well as the following chapters (on sources of radia-

SECON

- round •
- oval
- flat •
- grooved
- ribbon •

precision small wire

- bare •
- insulated
- plated •

for highly engineered applications

- all metals •
- all alloys

Round Wire to 0.00015" diameter. Ribbon rolled to 0.0001" in thickness. Close tolerances held on all specifications.

SECON

... wherever the element calls for **PRECISION**

development and production metallurgists
SECON METALS CORPORATION
 7 Intervale Street, White Plains, New York
 White Plains 9-4757

Write for Pamphlet E.

DC-7 NEVER BEFORE such Magnificence . . . such Power such Performance!

and NEVER BEFORE has the A. W. HAYDON COMPANY been so proud of its contribution . . .

In the never-ending conquest of the vast barriers of space and time, Douglas goes ever forward meeting every challenge that men and machines must face. The newest — and brightest — star in the aviation firmament, the Douglas DC-7, is truly a miracle of the mastery of men over machines . . . and in this great work sixteen A. W. Haydon timing devices play an important part. We at A. W. Haydon take pride in our contribution toward bringing a mass of metal and machinery into integrated performance which meets Douglas' high standards. Integrated performance is born of a multitude of small component parts, working in perfect mechanical and electrical coordination. The A. W. Haydon precision timing instruments are a vital part of this vast network.

DOUGLAS DC-7, the ultimate in comfortable and safe air travel. Swift, luxurious, dependable — the new DOUGLAS DC-7 justly deserves the accolades it is receiving.

A. W. Haydon Time Delay Relay is a very important component of the automatic prop feathering system.
 A. W. Haydon Time Delay Relay times duration of prop feathering.
 A. W. Haydon Repeat Cycle Timer is a vital part of the prop deicing equipment.
 A. W. Haydon D.C. Timing Motors are used in the cabin pressurization systems.

The A.W. HAYDON COMPANY
 235 NORTH ELM STREET
 WATERBURY 20, CONNECTICUT
 Design and Manufacture of Electro-Mechanical Timing Devices

when timing poses a problem — consult

(Catalog sent on request)

you could make your own suit...



But it's better business to have an experienced tailor do it — right!

Coils are the same way. Maybe you make your own — but usually we at Coto-Coil can make them for you faster, better and at lower cost. It's our business to know the best types of materials for each type of coil. We have time-saving automatic equipment, the most modern testing devices. And we bring to your job nearly 40 years of coil design and manufacturing experience.

Find out how this combination can save costs for *you*.

Coto-Coil Company, 65 Pavilion Avenue, Providence 5, R. I. New York Office: 10 East 43rd Street, New York 17, N. Y.

Coto  **Coils**

tion, sample cells, detectors and electronic apparatus), are in themselves very complete, though they could have been profitably supplemented by a more voluminous bibliography.

Studies of the electronic hyper-fine structure and paramagnetic materials are not treated in the present volume, but within the limitations that the author set himself, he has produced an excellent contribution to this expanding new field.—
CHARLES SUSSKIND, *Stanford University, Stanford, Calif.*

Television Receiver Design— Flywheel Synchronization of Sawtooth Generators

By P. A. NEETESON. *Philips' Technical Library. Elsevier Press, New York and Houston, 1953, 156 pages, \$4.50.*

THIS is the second of the excellent series of monographs on television receiver circuits produced by Philips engineers, of which the first (on i-f stages, by A. G. W. Uitjens) was reviewed in these pages in the August, 1953 issue. The first part of the book sets the stage by a detailed treatment of the circuit to be synchronized, that is, the sawtooth-wave generator. Capacitive and inductive sawtooth circuits are treated from the theoretical and practical standpoints. A separate chapter is devoted to tubes specially developed for such circuits.

Then follow three chapters, the meat of the book, on the general principles of synchronization, the particular forms of storage-stabilized (flywheel) sync circuits, and the automatic-phase-control circuits. The latter chapters are models of compact presentation and clarity, well worthy of the close scrutiny of the experienced designer as well as the tyro. The former class of reader well knows that the control of second order effects in stabilized sync circuits requires knowledge of many terms in the equations. These are all faithfully set down, with liberal use of the operational symbolism (further developed in two Appendices). The book is very well illustrated with explicit circuits and their significant waveforms, as well as tabular presentations of fre-

for maximum economy... 5KW VACUUM TUBE BOMBARDER OR INDUCTION HEATING UNIT

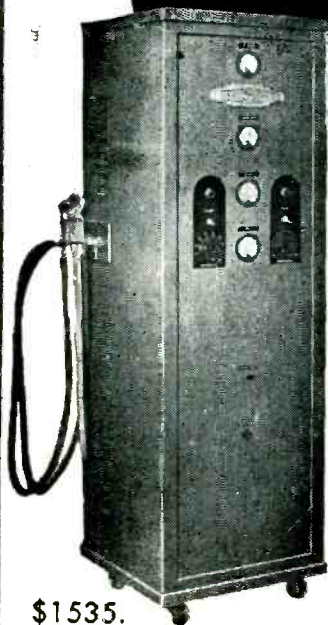

\$1535.

Simple... Easy to Operate... Economical
Standardization of Unit Makes This New Low
Price Possible.

Maximum economies can be obtained only by use of correct frequency and power combinations when applying the techniques of induction heating to manufacturing processes.

It is significant that only Scientific Electric in the present market, can offer you a selection of frequencies depending on power required, in wide power range. 2-3½-5-6-7½-10-12½-15-18-25-40-60 KW (all units above 60 KW are considered custom built). This means that electronic heating equipment produced by Scientific Electric is tailored to your needs... fitted perfectly to the task entrusted to it, enabling you to keep your initial investment in equipment to a minimum while affording you all the proven advantages of electronic heating.

Write now for complete information or send samples of work to be processed. Specify time cycle for your particular job. We will quote on proper size unit for your requirements.

DESIGNERS AND MANUFACTURERS OF HIGH FREQUENCY AND HIGH VOLTAGE EQUIPMENT SINCE 1921

Scientific Electric

105-119 MONROE ST  GARFIELD, N. J.

For consistently high purity...

"LINDE" M.S.C. RARE GASES
Trade-Mark
 (Mass Spectrometer Controlled)

- Helium
- Argon
- Neon
- Krypton
- Xenon

In radar electronic equipment, nuclear radiation counters, cosmic ray cloud chambers, and thyratrons, where the purest rare gases are demanded, LINDE M.S.C. Grade gases meet the specifications. They are produced under continuous mass spectrometer control to assure you of gases of *known* purity and consistently high quality. LINDE, the world's largest producer of gases from the atmosphere, can meet your individual needs of volume, mixture, and container.

For information on the physical, chemical, and electrical properties of these gases, send for the booklet, "LINDE Rare Gases."



LINDE AIR PRODUCTS COMPANY

A Division of
 Union Carbide and Carbon Corporation
 30 E. 42nd Street  New York 17, N.Y.
 In Canada:
 Dominion Oxygen Company, Division
 of Union Carbide Canada Limited, Toronto
 The term "Linde" is a registered trade-mark of Union Carbide and Carbon Corporation.

AEROCOM MEANS TROUBLE-FREE SERVICE!
 From Ground To Air or Point to Point



The model 12GLX-M, 1KW Beacon Transmitter illustrated, operates on a single frequency in the range 200-415 Kcs. Oscillator coil can be supplied crystal-controlled or self-excited. Tone oscillator provides 30% high level modulation for identification when keyed with Aerocom's model AK-3B automatic keyer. The unit can also be voice modulated. Power supply . . . any stable voltage in the range 200-240 volts, 50/60 cycles, single phase. Overall dimensions in CM, 56W x 62D x 177H. Net weight 286 kilos.



3090 DOUGLAS ROAD

MIAMI 33, FLA.

NEW HORIZONS

Today's horizons in electronic engineering are limited only by the vision of the individual himself. To those qualified men who desire to stand on the constantly changing frontiers of electronic development, we offer a chance to pioneer and grow with a soundly-established, yet young and progressive company.

• **Electronics Field Engineers**

Local & Field Assignments Available

At least 5 years' experience in any one of these fields: Servo Mechanisms; Special Weapons; Microwaves; Antennas; Circuit Design; Flight Simulators; Radio Propagation; Electronic Computers and Communications.

Qualified to instruct in the operation and supervise installation, maintenance and repair of Radar, Sonar, Flight Simulators and allied electronic equipment in the field.

Salary and advancement commensurate with ability; liberal vacation, sick leave, 9 paid holidays, group life, sickness and accident insurance plans, and a worthwhile pension system.

STAVID ENGINEERING, INC.

Personnel Office, 312 Park Avenue
 Plainfield, N. J.—Plainfield 6-4806

VULCAN
ELECTRIC HEATING UNITS

CARTRIDGE



Concentrated electric heat for small areas.
 Brass sheath for temperatures up to about 750°. Other metals for higher temperatures.
 Standard sizes and types listed in the Vulcan catalog, or size, sheath, terminals and lead wires adapted to your specific problems.

VULCAN
ELECTRIC COMPANY
 DANVERS 70, MASS

SAVE TIME and COST
BUY 58 BRANDS FROM
ALMO'S SINGLE SOURCE
LEADING ELECTRONICS
DISTRIBUTOR IN THE EAST



FREE INFORMATION

ALMO RADIO COMPANY
 412 North 6th St. Philadelphia 23, Pa.

Write to ALMO RADIO CO. for These Free Industrial Catalogs.

- Triplet
- GE
- Simpson
- Stancor
- Amphenol
- Almo Industrial News

Your Name
 Company Name
 Address
 City Zone State

Branch Stores: Wilmington, Del., Atlantic City & Camden, N. J., Salisbury, Md., Norristown, Pa.



**MAGNETIC
AMPLIFIERS**
for
**Improved Circuit Performance,
Life and Reliability**

- Rugged ● Dependable
- Available in three ranges
- Hermetically sealed LB case
- Eliminates need for reference voltage source
- Three control windings
- Simplifies wiring

These outstanding Series RG-60-D Magnetic Amplifiers by ATLAS provide extreme ruggedness and unfailing dependability for many voltage control applications. By improving the performance and life of circuits in which they are used, costly maintenance and repairs can be reduced. Competitive in price with other voltage control methods, ATLAS Magnetic Amplifiers have *all* the features you have always desired.

WRITE to Dept. AD for Bulletins for complete specifications.

ATLAS

ATLAS ENGINEERING CO., Inc.

3 EDGEWOOD ST., ROXBURY, MASS.

Quality...



is Standard with Standard Piezo

Standard Piezo guarantees accurate and dependable quartz crystals to meet all private plane or commercial air carrier requirements.

Whether they are high or low in frequency, for use at low or high altitudes, you'll find Standard Piezo quality is consistently superior.

For your crystal requirements, standard or custom, write or call us.



Standard Piezo Co.
CARLISLE, PENNA.
Phone 1495

quencies, voltages and circuit constants.

This book clearly illustrates the value of the specialized monograph. It takes careful study, but it rewards the effort well.—DONALD G. FINK, *Philco Corp., Philadelphia, Pa.*

THUMBNAIL REVIEWS

Dielectric Constants and Electric Dipole Moments of Substances in the Gaseous State. NBS Circular 537. By Arthur A. Maryott and Floyd Buckley. U. S. Government Printing Office, Washington 25, D. C., 29 pages, 1953, 20¢. A tabulation of data for approximately 350 substances in the vapor state derived from consideration of microwave, radio-frequency and optical data.

Reference Data for Orienting Quartz Plates by X-ray Diffraction. NBS Circular 543. By Catherine Barclay and Leland T. Sogn. U. S. Government Printing Office, Washington 25, D. C., 7 pages, 1953, 15¢. Considerable information useful to the technician in checking crystal orientation.

Electrodeposition Research, Proceedings of the NBS Semicentennial Symposium, December 4-6, 1951, NBS Circular 529. Government Printing Office, Washington, D. C.; 129 pages, 1953, \$1.50. Cross section of research currently being conducted in electrodeposition by industrial, university and government laboratories in Europe and the United States.

Tables of Normal Probability Functions, NBS Applied Mathematics Series 23. (Supersedes MT14), 344 pages, 1953, \$2.75, Government Printing Office, Washington, D. C. Tables of two functions to fifteen decimal places and tables of two functions to seven places, useful to a wide variety of statistical applications.

Stability Theory of Differential Equations. By Richard Bellman. McGraw-Hill Book Co., New York, N. Y., 166 pages, 1953, \$5.50. A theoretical book for the mathematician.

Protection against Betatron-Synchrotron Radiations up to 100 Million Electron Volts. NBS Handbook 55, 52 pages, 1954, \$0.25, Government Printing Office, Washington, 25, D. C. Protection requirements for operating personnel, hospital patients, and the public against the potential hazards of accelerators. The hazards resulting from the various radiations produced by the sources are included, as well as those due to certain associated effects, such as noise, electricity and ozone protection. Recommendations are also given on a consistent system of units and of measurement procedures that

XCELITE Hand Tools

PREFERRED BY THE EXPERTS

WHY GAMBLE
ON UNTRIED TOOLS?

YOU'RE
ALWAYS
RIGHT
WITH

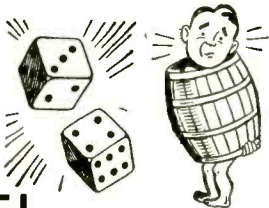

XCELITE!



No. 64 Standoff Insulator Pliers

Heavy-duty, all-purpose, super-tough with special forged rib lock design. Ideal for opening and closing standoff insulators. Part of a full line of XCELITE pliers, screwdrivers and nut drivers servicemen swear BY—not at.

Ask your supplier for the brand-new XCELITE catalog, or write:

XCELITE, INCORPORATED
(Formerly Park Metalware Co., Inc)
Dept. C
Orchard Park, N. Y.

For Originality
LOOK TO XCELITE

Precision
Unlimited

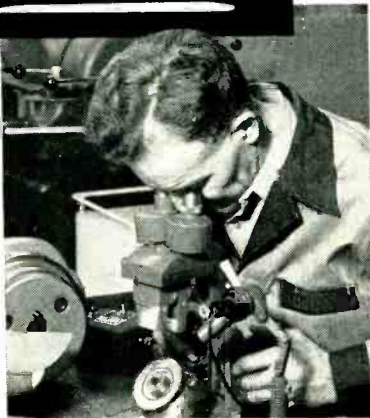

The breeding of Fine Pitch Instrument Gears involves both science and artmanship. Requires craftsmen—not just machinists.

Why? Because these little animals have complex personalities—sometimes hard to deal with.

Now, here we have done nothing else, day after day for some 20 years.

The point is: if you need Fine Pitch Gears—GET THEM HERE.

6854

Dexter MACHINE PRODUCTS, INC.
CHELSEA, MICHIGAN Box 328
Phones: Detroit WO. 5-2399—Chelsea: GREENWOOD 9-1797

NEW BOOKS

(continued)

can be applied to radiations with energies above 5 Mev.

Selenium Rectifier Handbook. Sarkes Tarzian, Inc., Bloomington, Ind., 72 pages, 1954, \$1.00. Manufacturing processes, characteristics, how-to-use, guide for replacements in radio and tv chassis, with many circuits and much practical matter.

Tables of Lagrangian Coefficients for Sexagesimal Interpolation. NBS Applied Mathematics Series 25, 157 pages, 1954, \$2.00. Tables for interpolation when the arguments are expressed in sexagesimal measure, such as degrees (or hours), minutes and seconds. Useful in many branches of engineering.

Tables of 10^x. NBS Applied Mathematics Series 27, 543 pages, 1953, \$3.50, U. S. Government Printing Office, Washington 25, D. C. Antilogarithms to the base 10, or 10^x, in the form of two tables, a readily interpolable table for 10 decimal accuracy and a basic radix table for 15-figure accuracy. Used in conjunction with logarithmic tables in any extensive computations involving logarithms and antilogarithms, these tables will save considerably more labor than will logarithmic tables used alone. The only similar table is J. Dodson's "Antilogarithmic Canon," published over 200 years ago.

Crystal Handbook. James Knights Co., Sandwich, Illinois, 36 pages, 1953, \$1.00. Handy reference of crystal and oscillator theory for the design engineer using crystals, outlining important factors that should be considered in equipment design if maximum crystal performance is to be realized. A bibliography is included.

Circular and Hyperbolic Sines for Radian Arguments. NBS Applied Mathematical Series 36, 407 pages, 1953, \$3.00. U. S. Government Printing Office, Washington 25, D. C. Tables of sin x , cos x , sinh x and cosh x , $x = 0(0.0001) 1.9999, 9D$; sinh x and cosh x , $x = 0(0.1) 10, 9D$; a conversion table of degrees, minutes, seconds \leftrightarrow radians and a table of multiples of $\pi/2$.

Les Filtres a Cristaux Piezoelectriques. By D. Indjoudjian and P. Andrieux. Gauthier-Villars, 55 Quai des Grands-Augustins, Paris, France, 177 pages, 1953, 3,300 francs or \$10.00. A treatise on crystal filters, in French.

Magnetic Fields of Cylindrical Coils and Annular Coils. By Chester Snow. NBS Applied Mathematics Series 38, 30 pages, 1953, U. S. Government Printing Office, Washington 25, D. C., 25 cents. Axial and radial components of the magnetic field at any point in space of a cylindrical or an annular coil carrying an electric current, expressed in terms of complete elliptic integrals or of Legendre functions which involve ratios of the significant dimensions of the coils. Applications range from laying-out of large current-limiting reactors in electric power stations to design of coils for studying paramagnetic resonance in atomic nuclei.

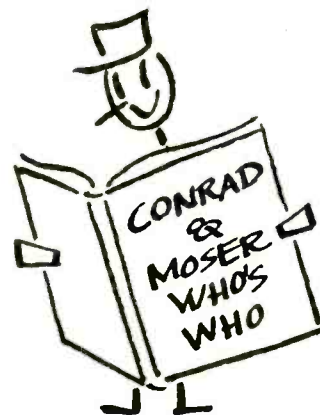

WHO USES US?

Some of our customers have only engineering facilities, and use us for manufacturing.

Other of our customers have both engineering and manufacturing facilities, and use us for special manufacturing assignments.

Both types use us for new products or to produce complete difficult assemblies, or to create intricate, finely-made parts.

CONRAD & MOSER

Workers in Aluminum,
Brass, Steel & Plastics

DESIGNING

ENGINEERING • MANUFACTURING

MECHANISMS • MACHINES

PARTS • TOOLS • DIES • MOLDS

STAMPINGS • CASTINGS

MACHINING • SHEET METAL

ENCLOSURES & CHASSIS

1/8 to 1/2 NAVY SPEC ALUMINUM

SPOT WELDING AND HELIARC

WELDING.

2 Borden Ave.

Long Island City 1, N.Y.

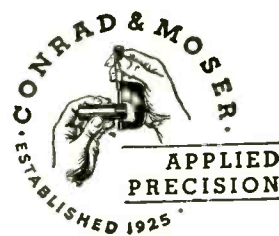

60-DAY FREE TRIAL

of America's most popular
bench assembly stool



A tired worker costs **MUCH**
more than a good chair

- 4-way adjustable backrest
- Scroll shaped posture seat
- Tamper-proof tubular all-welded construction
- Adjustable height ranges from 17" to 25" or 24" to 32"

Now test Royal's famous No. 515 stool in your own plant without cost or obligation. See why the country's top firms choose it for superior versatility and durability. Write for free trial stool today!

metal furniture since '97



Royal Metal Manufacturing Co.

175 North Michigan Avenue, Dept 2106, Chicago 1

Factories: Los Angeles • Michigan City, Indiana
Warren, Pa. • Walden, N. Y. • Galt, Ontario
Showrooms: Chicago • Los Angeles • San Francisco
New York City • Authorized Dealers Everywhere

MAIL TODAY

Royal Metal Mfg. Co., 175 N. Michigan Ave.,
Dept. 2106, Chicago 1, Ill.

- We want to test your No. 515 stool for 60 days without obligation. Send short _____ tall _____ model.
- Please send your new catalog of industrial seating.

Name _____

Firm Name _____

Address _____

City _____ Zone _____ State _____

BACKTALK

Audio Feedback

DEAR SIRs:

REGARDING the article "Multiple Feedback Audio Amplifier." (ELECTRONICS, p148, Nov. 1953) we have received a number of technical inquiries. . . .

In his letter in the Jan. 1954 issue, W. B. Bernard indicates he has obtained excellent results using tetrode tubes with 20 db of feedback, and expresses concern with respect to the critical nature of balance, etc in a 36-db feedback amplifier of this type.

The potential difficulties he mentions were carefully considered in the development of the amplifier, but proved to be of no real consequence. On the contrary, the design combines the efficiency and high power output of tetrodes with exceptionally low distortion and complete stability under all load conditions.

Mr. Bernard considers triodes and pentodes comparable in producing distortion. This is surprising . . . since it is commonly accepted that higher-order distortion is greater in pentodes (see Langford-Smith, "Radiotron Designer's Handbook," 5th Ed. p546), so that pentodes require more feedback to equal the distortion performance of triodes. Since advanced triode amplifiers (Williamson) generally use 20 db of feedback, it was considered essential to use a good deal more in a tetrode design to achieve substantially negligible distortion. As mentioned in the article, the design employs 36 db of feedback split into three loops to achieve low and high frequency stability.

Mr. Bernard doubts that the local feedback introduced into the output stage by the 480K resistors is effective around the output stage. It is true that the effect of the output stage feedback is to reduce the interstage impedance, and that the voltage gain of the output stage from grid to plate is not altered. However, the reduction of interstage impedance is simply the mechanism through which feedback operates.

For example, a doubling of gain in one 6L6 will cut the interstage



New pre-production
Kit for Design-in
and experiment

See that your products are design competitive . . . feature Microdot advantages. Order Microdot Kit #553 today . . . and save valuable experiment time by having the precise parts you need for multi-stage tests. Satisfaction is assured. Simply clip this advertisement to your letterhead with P.O. or check for \$60. Mail to address below.



MICRODOT

DIVISION OF FELTS CORP.
1826 Fremont St., So. Pasadena, Calif.



Both Connector and Cable in
this box are actual size!

Over 85% of the torque wrenches
used in industry are

STURTEVANT TORQUE WRENCHES

Read by Sight, Sound or Feel.

- Permanently Accurate
- Practically Indestructible
- Faster—Easier to use
- Automatic Release
- All Capacities

in inch grams...inch
ounces...inch pounds
...foot pounds
(All sizes from
0-6000 ft. lbs.)



Every
manufacturer,
design and
production man
should have
this valuable
data. Sent upon
request.

P.A. STURTEVANT CO.
ADDISON QUALITY ILLINOIS

**PRECISION • STABILITY •
LOW NOISE LEVEL
S.S. WHITE TYPE 65X
MOLDED RESISTORS**

Rating—1 Watt.
Temperature Coefficient—From approx. + 0.1 % / °F for 5000 ohm resistors to approx. - 0.2 % / °F for 10 megohm resistors.
Voltage Coefficient—Less than 0.02 % / Volt.
Upper Temperature Limit—170 °F for continuous operation.
Standard Range—1000 ohms to 9 megohms. For general commercial service.
Noise Level—A low noise level is inherent in all 65X resistors. Where noiseless operation is essential, we are equipped to test and guarantee standard range resistors with "less noise than corresponds to a resistance change of 1 part in 1,000,000, for the complete audio frequency range."

Send for Bulletin 4906. It gives full details on S.S. White Molded Resistors. Write for a copy.



**EXTREME
HIGH VALUE
RANGE**
Up to 10,000,000 megohms for specialized scientific and industrial service.

**THE S.S. White INDUSTRIAL DIVISION
DENTAL MFG. CO.**



Dept. R, 10 East 40th St.
NEW YORK 16, N. Y.

Western District Office • Times Building, Long Beach, California

A COMPLETE LINE OF INSULATED STAPLES

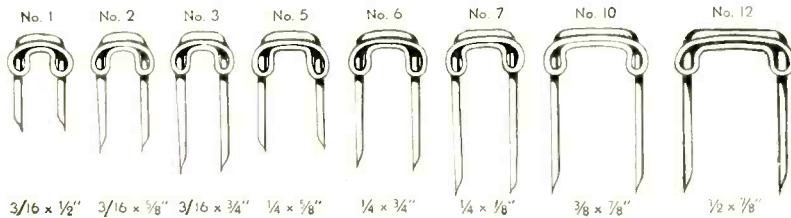

3/16 x 1/2" 3/16 x 5/8" 3/16 x 3/4" 1/4 x 5/8" 1/4 x 3/4" 1/4 x 1/2" 3/8 x 7/8" 1/2 x 7/8"

The Insulated Staple is the most satisfactory cleat or carrier for low voltage wiring that has ever been devised.

Emerson Apparatus Co. 187 TREMONT ST.
MELROSE, MASS.



• 31 1/2" high, 18 3/4" wide, 27" long.

LAB DOLLY MODEL A

- ... with 8 power outlets (1500 watts, 110 VAC) and a 10 foot heavy duty extension cord.
- Ball Bearing Swivel Rubber Tired Casters.
- Recommended by Laboratories wherever used.
- Constructed of Aluminum. Features 2 Shelves for Equipment and a pan for test leads, notebooks, etc.

Price 4950

FOB Louisville, Ky.

TECHNICAL SERVICE CORP.

1404 W. Market St. Louisville 3, Kentucky

Roanwell
Standard Navy
Hand-Held
MICROPHONE



Style #044

USED IN
SMALL AIRCRAFT



AND
MOTORCYCLES



**OUT-OF-STOCK
DELIVERY**

Beginning May, 1954

Designed to rigid Navy specifications, this dependable, lightweight microphone features long-life, high output, and all-position response. Incorporates use of long-life detent switch. Cord is reinforced by a rubber protector for maximum flexure life. Available also with coil cord—on made-to-order basis.

HANGER STYLE 035

Designed for use with Style #044



Roanwell hand-held microphone. Made of hardened steel, finished in cadmium plate. Resilient heat-treated



spring grip holds microphone securely, prevents vibration.

WRITE FOR COMPLETE DATA

ROANWELL CORPORATION
27 SIXTH AVE., BROOKLYN 17, N. Y.

For PILOT LIGHTS

CONSULT

DIALCO

Your product benefits 3 ways from the use of a DIALCO Pilot Light:

Enhanced appearance: The glow of light and sparkle of a lens add colorful visual attraction.

Greater safety: A timely warning flashed by a pilot light can prevent damage to equipment.

Added service: Discs inserted behind lenses can be used to deliver specific messages, such as "FUEL LOW", "ON", "OFF", etc.

Let the Dialco engineering department assist you in selecting the right lamp and the most suitable pilot light for your needs.

Dialco offers the complete line of pilot lights, from sub-miniature types to giant units with 1½" lenses.

Every assembly is available complete with lamp.

SAMPLES ON REQUEST AT ONCE — NO CHARGE

Illustrations are approx. 70% actual size . . . (A) No. 8-1930-111 sub-miniature pilot light . . . (B) No. 521308-991, with multi-vue cap . . . (C) No. 922210-111, dimmer type . . . (D) No. 47901 with light shield cap.

Write for Catalogues L-151, L-153, and L-154

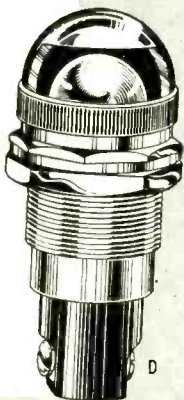
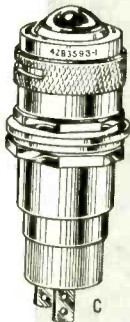
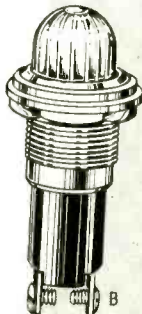

Foremost Manufacturer of Pilot Lights

DIALIGHT CORPORATION

60 STEWART AVE. • BROOKLYN 37, N. Y.

HYACINTH 7-7600

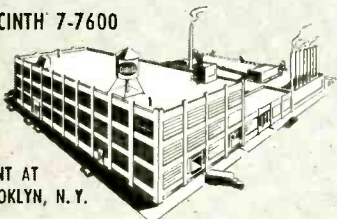

PLANT AT
BROOKLYN, N. Y.

BACKTALK

(continued)

impedance in half, thus halving the gain of the 6AU6 and keeping the output constant. The local feedback, therefore, is actually effective in stabilizing the gain of the output stage, and reducing its distortion.

Mr. Bernard is concerned with the rather large plate current excursions required of the 6AU6's in driving the 6L6's. The current swing required in the 6AU6 is only 0.88 ma peak at full power (0.20 ma due to the 15-v swing across the 100K plate load of the 6AU6 and the 330K grid leak of the 6L6, plus 0.68 ma due to the 325-v swing across the 480K feedback resistor). This leaves a comfortable margin in the 1.5-ma plate current of the 6AU6.

The low voltage swing required of the 6AU6 (15 v) is very favorable for low-distortion production . . . the distortion product is virtually pure second harmonic which is cancelled by the push-pull connection and by opposite second-harmonic distortion in the output stage. This low voltage swing is one of the advantages of pentode drivers. Triode drivers applied to a multiple-feedback amplifier would have to supply about 75-v peak swing.

Mr. Bernard expresses concern regarding the accurate balancing required using push-pull feedback, referring to a previous article and correspondence in *ELECTRONICS* covering an amplifier which employed 40 db of push-pull feedback. In the reference article, the authors reported that unbalance had no audible effect on their circuit, in spite of 40 db of push-pull feedback.

The multiple-feedback amplifier uses only 24 db of push-pull feedback, and is so little sensitive to unbalanced tubes that one 6AU6 can be replaced by a 6CB6, or one 6L6 by a 6V6, with only negligible effect on power output and distortion. The reasons include the feedback loops themselves, which stabilize the gains of each half of the push-pull system, and the individual cathode resistors of the 6AU6's. The latter result in a considerable stabilization of transconductance—because of plate current stabilization in the first place, and local signal-frequency feedback in the second.

Consider the balance problem as

Don't be afraid to change that Package Design

BRADLEY

has a rigid plastic box
for your product . . .

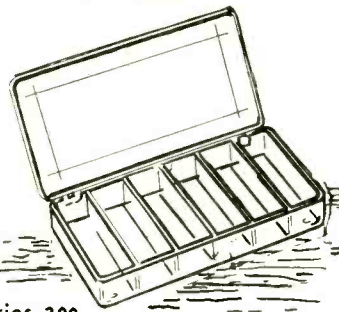

Series 300

8¼" x 4¼" x 1¼"
(assorted compartments)

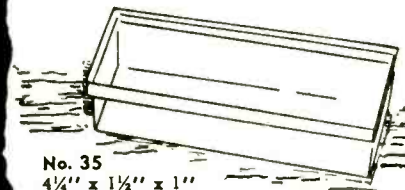

No. 35

4¼" x 1½" x 1"

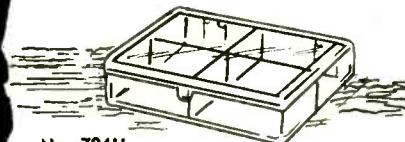

No. 704H

2 7/8" x 2" x ½"

4 compartments.

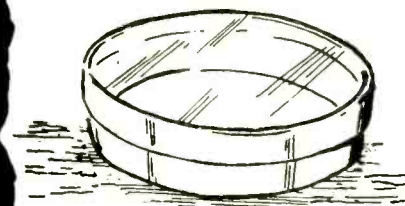

No. 32

2¼" diam. x 5/8" deep

Industrial manufacturers, especially of components, are utilizing our boxes for packaging. We have over 500 rigid polystyrene boxes available FROM STOCK MOLDS, or we will design a box to meet your specific requirements.

Send for illustrated catalog, showing box dimensions . . . you're cordially invited to visit our new factory and showrooms when in Chicago.

World's Largest Assortment of Rigid Plastic Boxes



BRADLEY INDUSTRIES

1656 North Damen Ave
Chicago 47, Ill.

one of operating two low-impedance generators in parallel. The generators are then halves of the push-pull system, which are closely coupled by the output transformer. The output impedance at each 6L6 plate, due to push-pull feedback, is 300 ohms. While this figure is fairly low, and calls for reasonably correct setting of the signal balance control (1,000-ohm cathode pot of 6AU6), it is no lower than that of a 6AS7G output stage without feedback, which would certainly not be considered impractical because of considerations of balance.

To answer other inquiries regarding the published amplifier circuit we add the following information:

Full output is obtained with about 0.9 v rms input.

The 7,500 and 25,000-ohm resistors in the output stage are of 5-watt rating. The 270-ohm cathode resistors are 2 watts and one-watt resistors are recommended for all other cases.

We use our LS-63 output transformer, connected 10,000 ohms plate-to-plate. The power supply uses our R-105 transformer and R-20 choke. The input capacitor should be 600-volt rating.

The 1,000-ohm pot in the 6AU6 cathode is a signal balance control. It can be set either for minimum second-harmonic distortion if a distortion meter is available, or for maximum output at clipping level if only a scope is available. If neither can be had, a method suggested by Arthur Hansen can be used. The amplifier is loaded with its rated impedance, as shown in the accom-

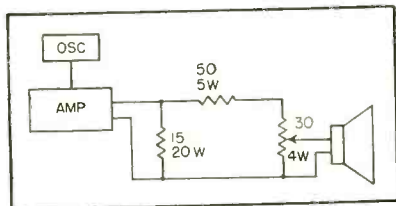

panying diagram, and a small portion of the output is fed to a loudspeaker. The amplifier can then be run at full power, with the output at a comfortable level. The signal balance control can be set for minimum distortion by ear. If no oscillator is available, a 60-cps signal is adequate.

The twin-T at the input is an op-



FOR
MAGNETIC
RECORDING

BRUSH REDHEADS GIVE TOP PERFORMANCE

The high fidelity performance of Brush Redheads has won them wide acceptance from makers of magnetic recording equipment. The record-reproduce head, designed for dual-track recording on 1/4-inch tape, has unusually high resolution, which provides an extended frequency range. The Redhead is dimensionally stable, is unaffected by moisture, and provides freedom from

microphonics. The companion erase head has the same basic construction, and is outstanding for efficient operation at very low power consumption.

For information on the complete line of Brush magnetic heads—single and multi-channel, write Brush Electronics Company, Dept. K-6, 3405 Perkins Avenue, Cleveland 14, Ohio.

BRUSH ELECTRONICS

INDUSTRIAL AND RESEARCH INSTRUMENTS
PIEZO-ELECTRIC MATERIALS • ACOUSTIC DEVICES
MAGNETIC RECORDING EQUIPMENT
ULTRASONIC EQUIPMENT



COMPANY

formerly
The Brush Development Co.
Brush Electronics Company
is an operating unit of
Clevite Corporation.

ILSCO

CONNECTORS

LO 7 SIZES

1000 MCM — 14

CAN NEUTRAL

60, 100 & 200 AMPS.

SLU 11 SIZES

1000 MCM — 14

FUSE CLIPS

MANY SIZES AND TYPES

XT 6 SIZES

500 MCM — 14

TERMINAL BLOCKS

VT 6 SIZES

600 MCM — 14

MU 3 SIZES

500 MCM — 6

WRITE FOR 80-PAGE CATALOG

ILSCO 5753 MARIEMONT AVE., CINCINNATI 27, OHIO

Finest
CLOSELY-REGULATED
PRECISION
DC POWER SUPPLIES

HIGH VOLTAGE—HIGH CURRENT

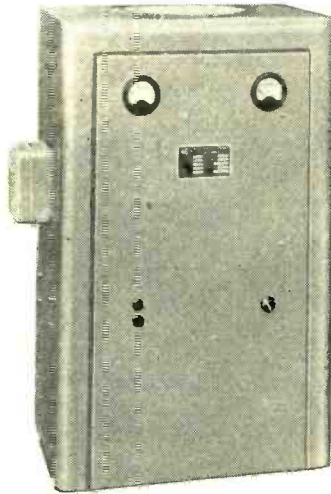

Write for Technical Bulletin—Contains
Complete Engineering Specifications



Division of
LEACH CORPORATION

4441 Santa Fe Avenue
Los Angeles 58,
California

CONTROL—Magnetic Amplifier.
OUTPUT: 6 to 500 VDC at 5 to 200
Amps. continuous.
RIPPLE As low as 0.01% RMS.—or
to customer's specification.
REGULATION—Steady State. $\pm 0.15\%$
no load to full load.
Dynamic. $\pm 0.2\%$ under ex-
treme load or line change.

PRECISE REGULATION . . . for Labora-
tory or Production work.

Designed to meet the most exacting
requirements of the Electronics
industry, INET Precision Power
Supplies combine the long-life per-
formance of selenium rectifiers with
the rugged dependability of mag-
netic amplifier controls.

PROTECTED . . . Engineered for long,
trouble-free operation, Units are
fully protected against overloads
and static elements eliminate main-
tenance.

COMPACT—Simple to Install and
Operate . . .

Requires minimum space, housed in
steel cabinets with meters and con-
trols mounted for quick visibility
and operation. Available in wall,
floor-standing or caster mounted
models.

BACKTALK

(continued)

tional rumble filter. It results in a
3-db loss at 45 cps and a null at 9
cps, and is a desirable addition
when a record changer is used.

The 3.3- μ f capacitor shown in
the phase inverter depends upon the
wiring capacitance, and in some
cases can be omitted. If a small
trimmer is used, it should be set
for maximum clipping-level power
at 5 kc.

The 8- μ f capacitors in the push-
pull feedback loops are 450-v tubu-
lar electrolytics.

JOSEPH DIAMOND
United Transformer Company
New York, N. Y.

Source Impedance

DEAR MR. ONDER:
I READ with interest your article
"Audio Amplifier Matches Voice-
Coil Impedance", p 176, February
issue of ELECTRONICS. As a physi-
cist, it occurred to me that the value
of source impedance you gave for
your amplifier (400 ohms) was not
in keeping with elementary bridge
theory. That is, for a resistive
bridge with four equal legs the
source impedance is equal to one
of the legs. I built your circuit
using four different tube types
keeping all parameters constant.
This entailed changing the voltage
amplifier ladder so as to keep equal
grid-cathode excitation on all tubes.

The source impedances shown by
the four tube types were plotted on
log paper and, rather surprisingly,
fitted a line with the equation

$$R_s = 50 \sqrt{R_p}$$

How this could be predicted from
theoretical considerations, I have
not yet determined.

If we are to assume that the equa-
tion is true for all values of R_p and
then enter the equation with $R_s =$
16 ohms, we obtain the ridiculous
plate resistance of 0.033 ohm. Thus
it seems impractical to reduce the
source impedance by paralleling
tubes. Feedback was used to reduce
the source impedance but reduc-
tions of only about 50 percent
seemed practical.

Do you know any other method by
which the circuit can be modified in
order to reduce the source im-
pedance? I think that some method
can be devised by which low-im-

ELECTROPLATED

Wires

Preferred for:

- ✓ Corrosion Resistance
- ✓ Better Solderability
- ✓ Suppression of Grid Emission
- ✓ Improvement of Electrical Characteristics

SINCE 1901

GOLD, SILVER, RHODIUM,
PLATINUM and other metals,
applied to many different
types of wire to meet your
specifications. Uniform plat-
ing, scientifically controlled.
Write for latest list of products.

SIGMUND COHN MFG. CO., INC.
121 So. Columbus Avenue • Mount Vernon, N.Y.

PROFESSIONAL SERVICES

Consulting—Patents—Design—Development—Measurement

in

Radio, Audio, Industrial Electronic Appliances

ALPHA ENGINEERING LABS

TROUBLE-SHOOTING SPECIALISTS

Wareguide tube twisting, bending and forming, Broaching, Tooling design, improvements and methods.

ANDRE TEMPE

P. O. Box 107 Phone Budd Lake, N. J.
Hackettstown 340

ELECTRONIC RESEARCH ASSOCIATES, INC.

"TRANSISTORIZE" YOUR PRODUCT!

Complete Service in consulting, research, development, and production on Transistor circuitry, products and instrumentation.

715 Main Street North Caldwell, N. J.
Caldwell 6-6729

NEW ROCHELLE TOOL CORP.

FOR CERTIFICATION OF INDUCTION AND DIELECTRIC HEATING EQUIPMENT IN ACCORDANCE WITH F. C. C. RULINGS

Mobile Test Unit Available Entire U. S.

320 Main St. New Rochelle, New York
Phone NE 2-5555

ANNIS ELECTRIC RESEARCH LABORATORY, INC.

CONSULTING — RESEARCH — DEVELOPMENT AND DESIGN OF RADIO AND ELECTRONIC EQUIPMENT

Antennas, Wave Propagation, Information Storage, Computers, Impedance Matching and Variable Speed A-C Motors.

P. O. Box 581 1401½ S. Neil St.
Champaign, Ill. Tel. 6-1780

ERCO RADIO LABORATORIES, INC.

Radio Communications Equipment

Engineering - Design - Development - Production
Pioneers in Frequency Shift Telegraph

Garden City • Long Island • New York

NIAGARA ELECTRON LABORATORIES

CONSULTATION - DESIGN - CONSTRUCTION MFG. THE THERMOCAP RELAY

Specializing in solution of problems of electronic and electro-physical instrumentation for the research or analytical laboratory. Industrial plant problems also invited.

Andover, New York Cable Address: NIATRONLAB

ROGER BARRETT BROSS

Consulting Engineer

SPECIAL ELECTRIC MACHINES
ELECTROMAGNETIC COMPONENTS
Design - Development - Manufacture
Testing - Application

25 Curtis Rd. OL 3-9235
Box 157, Natick, Mass.

HANSON-GORRILL-BRIAN INC.

Products & Mfg. Development

ELECTRICAL - ELECTRONIC
HYDRAULIC - MECHANICAL

One Continental Hill Glen Cove, N. Y.
Glen Cove 4-7300

PICKARD & BURNS, INC.

Consulting Electronics Engineers

Analysis and Evaluation
of Radio Systems

Research, Development and Production
of Special Electronic Equipment

240 Highland Ave. Needham 94, Mass.

W. J. BROWN

Registered Prof. Engr. Connecticut, Ohio, England

ELECTRONIC CONTROL SYSTEMS
Consulting — Research — Development

INTERNATIONAL CLIENTELE
71 Gurley Road Stamford, Conn.
Stamford 4-4876

HIGHLAND ENGINEERING CO.

William R. Spittal & Staff

DESIGN, DEVELOPMENT AND MANUFACTURE
OF TRANSFORMERS, CHOKES, ETC.

FOR THE
ELECTRONIC, INDUSTRIAL & ALLIED FIELDS
Main & Urban, Westbury, L. I., N. Y.
WE-7-2983

ALBERT PREISMAN

Consulting Engineer

Television, Pulse Techniques, Video
Amplifiers, Phasing Networks,
Industrial Appliances

Affiliated with
MANAGEMENT-TRAINING ASSOCIATES
3224-16th St., N. W. Washington 10, D. C.

CODETYPER LABORATORIES

PRINTED CIRCUITS, EMBEDMENT CELLS
AND MINIATURIZATION ENGINEERS

Design your standard product using cost and labor saving Printed Circuits. We perform all engineering and supply you with Master Plans for your production. Reasonable, fast service.

550 Flith Avenue, New York 19. JU6 4487

HOGAN LABORATORIES, INC.

John V. L. Hogan, Pres.

Applied Research, Development, Engineering

Est. 1929. Electronics, Optics, Mechanisms, Fac-
simile Communication, The Circle Digital Computer,
Electro-sensitive recording media, Instrumentation.
155 Perry Street, New York 14. CHelsea 2-7955

JOSEPH RACKER COMPANY

Radar Consultants & Editors

Technical Manuals
Research and Development

140 Nassau Street New York 38, N. Y.
Worth 4-1463

CROSBY LABORATORIES, INC.

Murray G. Crosby & Staff

Radio - Electronic
Research Development & Manufacturing
Communications, FM & TV

Robbins Lane, Hicksville, N. Y.
Hicksville 3-3191

INTERFERENCE MEASUREMENT LABORATORY

Interference Study per Government Specifications
Shielded Space for Interference Investigation
Field Surveys for F. C. C. Certification of Induction
and Dielectric Heating Equipment

1844 Utica Avenue Brooklyn 34, New York
Navarre 8-1248

THE TECHNICAL MATERIAL CORPORATION

Communications Consultants

Systems Engineering
General Offices and Laboratory

700 Fenimore Rd., Mamaroneck, N. Y.

EDGERTON, GERMESHAUSEN & GRIER, INC.

Consulting Engineer

Research Development and Manufacture
of Electronic and Stroboscopic Equipment
Specialists in High-speed Photography

160 Brookline Avenue Boston 15, Mass.

THE KULJIAN CORPORATION

Consultants • Engineers • Constructors

Electronic Control
Specialists

Utility • Industrial • Chemical

1200 N. Broad St., Phila 21, Pa.

WHEELER LABORATORIES, INC.

Radio and Electronics

Consulting — Research — Development
R-F Circuits — Lines — Antennas

Microwave Components — Test Equipment

Harold A. Wheeler and Engineering Staff
Great Neck, N. Y. HUunter 2-7876

Eldico of New York, Inc.

Pioneers of Television Interference Elimination from
Transmitters, Induction Heaters, Diathermy and etc.

Donald J. S. Merten & Engineering Staff

72 E. Second St. Mineola, L. I., N. Y.

Measurements Corporation

Research & Manufacturing Engineers

Harry W. Houch Martial A. Honnell
John M. van Beuren

Specialists in the Design and
Development of Electronic Test Instruments

Boonton, New Jersey

YARDNEY LABORATORIES, INC.

Research - Design - Development

Electro-Chemical Generators of Energy

105 Chambers Street Worth 2-5500
New York 7, N. Y.

pedance devices can be used with the circuit and still have appreciable power output and acceptable efficiency.

WILLIAM E. BLUMBERG
 Chemical Corps Biological Laboratories
 Frederick, Maryland

DEAR MR. BLUMBERG:
 THANK YOU for your letter . . . forwarded to me by ELECTRONICS magazine.

You state that the source impedance of 400 ohms is not in keeping with elementary bridge theory and yet in your next sentence you mention the fact that for a resistive bridge with four equal legs the source impedance is equal to one of the legs. The figure of 400 is correct; and is the plate resistance of a single 6AS7 triode unit under those operating conditions. Please also note that the load impedance and not the source impedance is mentioned in the article and on Fig. 6A.

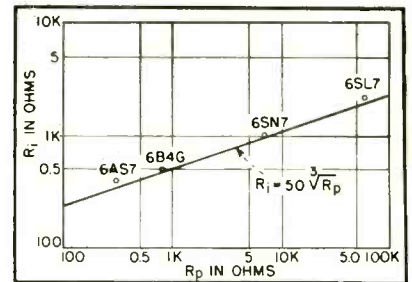

Source impedance versus plate resistance for bridge-type amplifier

As far as power transfer is concerned, I do not know of any method whereby the generator impedance can be reduced. Therefore your equation and your curve are a mystery to me and I can not see how the 7K plate resistance of a 6SN7 triode unit can be reduced to 940 ohms as you show it.

In my experiments with this particular tube it was necessary to use a load resistance of 7,000 ohms for maximum power with or without feedback. With the 9-watt amplifier, a loudspeaker of 400 ohms is required, whereas the 18-watt unit calls for 200 ohms for maximum power transfer. These are in agreement with basic theory.

I trust that this information will clear any misunderstanding.

KERIM ONDER
 Circuit Research Laboratory
 New York, N. Y.

CONTACTS

FOR THE FIELD OF ELECTRONICS

Auricon Hollywood

16mm SOUND-ON-FILM EQUIPMENT FOR TELEVISION NEWSREELS, TV FILM INSERTS AND KINESCOPE RECORDINGS... SOLD WITH A 30-DAY MONEY-BACK GUARANTEE. YOU MUST BE SATISFIED!

CINE-VOICE \$695.00	AURICON-PRO \$1310.00	SUPER 1200 \$4652.15	TRIPOD \$325.00	PORTABLE POWER UNIT \$269.50	SOUND RECORDER \$1149.50

WRITE FOR FREE ILLUSTRATED INFORMATION

BERNDT-BACH, Inc.
 7373 Beverly Blvd., Los Angeles 36, Calif.

MANUFACTURERS OF SOUND-ON-FILM RECORDING EQUIPMENT SINCE 1931

EISLER MANUFACTURES COMPLETE EQUIPMENT

- WELDERS FOR SPOT & WIRE BUTT
- RADIO, TV TUBE EQUIPMENT & REPAIR UNITS
- INCANDESCENT, FLUORESCENT MFG. EQUIPMENT
- NEON SIGN MAKERS EQUIPMENT, GLASS LATHES
- ELECTRONIC EQUIPMENT, VACUUM PUMPS, Etc.
- Wet Glass SLICING & CUTTING MACHINES for Lab Use
- TRANSFORMERS, SPECIAL & STANDARD TYPES

EISLER ENGINEERING CO., INC.
 751 So. 13th St. Newark 3, N. J.

Shorted Turn Indicator
 now \$175 f.o.b.

Karttron
 HUNTINGTON BEACH, CALIF.

EST. SINCE 1914

FLUXES
 SODERING
 BRAZING & WELDING

L. B. ALLEN CO. INC. Chicago 31, Ill.
 6751 BRYN MAWR AVE.

400 CYCLE SUPPLIES

MODEL 281 MULTICYCLE

115V CAPACITY 100 V.A.

Send for bulletin E6

Scientific **Bliss** Instruments
 167 ELMWOOD AVENUE
 ITHACA, N. Y.

One inexpensive modern device . . .

can frequently help speed up operation and maintenance or production.

One product advertised in the "Contacts" Section may be the answer to your problem . . . a real money-saver.

To be informed—and reminded—on modern aids to economical operation, maintenance and production, check "Contacts" advertising regularly . . . every issue.

Precision

BLACK ANODIZING

Specializing in black anodizing, both sulphuric and chromic, on all alloys and castings.

All other colors as well.

GOVERNMENT CERTIFIED

Contact us for special service.

HENRY and MILLER INDUSTRIES, INC.
 675 Garfield Ave., Jersey City, N. J.
 Henderson 4-4200

UNDISPLAYED RATE

\$1.80 a line, minimum 3 lines. To figure advance payment count 5 average words as a line. POSITION WANTED undisplayed advertising rate is one-half of above rate, payable in advance.

BOX NUMBERS count 1 line additional.

INFORMATION

DISCOUNT 10% if full payment is made in advance for four consecutive insertions of undisplayed ads (not including proposals).

EQUIPMENT WANTED OR FOR SALE Advertisements acceptable only in Displayed Style.

DISPLAYED—RATE PER INCH

The advertising rate is \$16.10 per inch for all advertising appearing on other than a contract basis. Contract rates quoted on request. AN ADVERTISING INCH is measured $\frac{7}{8}$ inch vertically on one column, 3 columns—30 inches—to a page. ELECT.

Send NEW ADVERTISEMENTS to N. Y. Office, 330 W. 42 St., N. Y. 36, for the July issue closing June 4th. The publisher cannot accept advertising in the Searchlight Section, which lists the names of the manufacturers of resistors, capacitors, rehostats, and potentiometers or other names designed to describe such products.

PURCHASING AGENT—ASSISTANT

Minimum of six years experience buying electronic components. Prefer an electrical engineer, but will consider other electrical background or experience.

K. A. Cruise Bendix Aviation Corporation
Post Office Box 1159 Kansas City 41, Missouri

REPLIES (Box No.): Address to office nearest you
NEW YORK: 330 W. 42nd St. (36)
CHICAGO: 520 N. Michigan Ave. (11)
SAN FRANCISCO: 68 Post St. (1)

POSITIONS VACANT

ELECTRONIC RESEARCH and Development positions are available to men with intelligence, imagination, and the desire to produce significant work. Our firm is devoted entirely to research and development, numbers about 1000, and is owned by one of the nation's leading universities. Our salary and benefit programs are competitive with industry. Almost every branch of electronics is covered in our program, and internal funds are available for research on promising individual ideas. Additional information on current openings will be sent upon request. Cornell Aeronautical Laboratory, Inc., Buffalo 21, New York.

CALIFORNIA STATE Polytechnic College plans additions to its staff in the Electronic and Radio Engineering Department to teach (1) courses in fields, waves and antennas, and (2) intermediate level courses in circuits. For information write: Harold P. Hayes, Dean of Engineering, San Luis Obispo, California.

PROGRESSIVE COMPANY needs mechanical engineer with creative ability—1 to 2 years experience in development or design of intricate mechanisms, electro-mechanical devices, or similar products desirable but graduate considered. Address inquiries to Sie Research and Development Corp., Attn: J. J. Houghton, P.O. Box 13053, Houston 19, Texas.

POSITIONS WANTED

CHIEF ENGINEER or engineering director. Cleared for secret military contracts. Prefer suburban location. Clarence Lundy, 215 Elberon Blvd., Elberon, N. J.

ELECTRONICS SCIENTIST—Interested in position in electronics field with good opportunity for advancement. A.A. degree in Physics, and six months at Harvard and M.I.T. wartime radar schools. Experience includes three years army radar officer, one and a half years instrumentation in nuclear research, three years electronics research, two years analyst and consulting engineer in military communications intelligence agency and one and a half years owner of general electronics service company. PW-2591, Electronics.

Don't forget the

BOX NUMBER

When answering the classified advertisements in this magazine don't forget to put the box number on your envelope. It's our only means of identifying the advertisement you are answering.

SALES REPRESENTATIVE

WANTED

COIL WINDING

Eastern electrical coil winder established over 35 years requires sales representatives contacting manufacturers. State territory covered and lines carried.

RW-2624, Electronics
330 W. 42 Street, New York 36, N. Y.

REPRESENTATIVES WANTED

Manufacturer of electronic test equipment for military and commercial applications needs technically qualified representatives. Write giving qualifications, lines handled, territory covered.

RW-2178, Electronics
1111 Wilshire Blvd., Los Angeles 17, Calif.

Rep wanted

contacting industry for instrumentation or/and calling on coil manufacturers to handle line of ultrasonic equipment and coil winding machines.

RW-2595, Electronics
330 W. 42 St., New York 36, N. Y.

POSITIONS WANTED

SYSTEMS ENGINEER, BSCE, 10 years total experience, 4 years supervision design and development of analog computers. Presently self-employed. Desire permanent position. Send replies to PW-2607, Electronics.

GOOD TECHNICAL training with twenty four years experience building and designing electronic apparatus recent experience in Ultra Sonic generators seeking position where experience is the primary requirement further information to Box PW-2696 Electronics.

SELLING OPPORTUNITY WANTED

PHYSICIST-SALESMAN now manufacturer representative, Philadelphia, desires additional line—Experienced in phy-chem, processes, nuclears, electro-mech, control systems. Outstanding sales record. RA-2727, Electronics.

CAPITAL TO INVEST

Capital through stock issues, loans, mergers. Small business financed for expansion. Sy Field, 1008 5th Ave., NYC 28, BU-8-5792

WANTED

ANYTHING within reason that is wanted in the field of Electronics can be quickly located through bringing it to the attention of thousands of men whose interest is assured because this is the business paper they read.

MANUFACTURERS

Aggressive sales organization in Middle Atlantic States can provide representation for additional electronic or electrical equipment or parts.

MACLEN CORPORATION
Manufacturers Representative
3226 Ninth Street, N.E. Washington 17, D. C.

OPPORTUNITY

If you have
ELECTRONIC EXPERIENCE
plus
SALES PERSONALITY
and are
AN ORGANIST
and are
YOUNG and ENERGETIC

Your unusual combination of abilities may qualify you for a TOP sales engineering position with a famous manufacturer of electronic organs.

SW-2533, ELECTRONICS
330 W. 42nd St., New York 36, N. Y.

PHYSICIST

Research and development on light sources, and in particular on gaseous discharge devices. Requires good mechanical aptitude. Excellent working conditions in research laboratory of a well-established firm located in the Newark area. Liberal employee benefits. Write giving full details including personal data, age, education and experiences in this or other fields, salary expectations, availability. Do not apply if colorblind or chain smoker.

P-2658, Electronics
330 W. 42 St., New York 36, N. Y.

ENGINEER or PHYSICIST

For research and product development of thermistors. Direct experience required. Should be capable of taking complete responsibility. Good opportunity in new plant of midwestern electrical components manufacturer. Reply in confidence giving education, experience and salary desired.

P-2735, Electronics
520 N. Michigan Ave., Chicago 11, Ill.

ELECTRONIC ENGINEERS

for design & development work
WITH A YOUNG PROGRESSIVE COMPANY

✓ digital techniques

✓ computers

✓ radar

SEND RESUME OF EXPERIENCE AND EDUCATION, WITH SALARY REQUIREMENTS, TO

Electronic Engineering Company



180 SOUTH ALVARADO STREET,
LOS ANGELES, 37, CALIFORNIA
DUNKIRK 2-7353

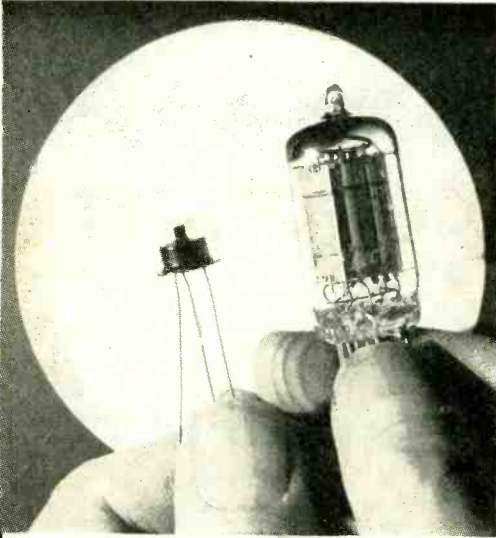

General Electric hermetically-sealed, evacuated junction transistor (left), contrasts sharply with standard miniature vacuum tube.

**GENERAL ELECTRIC
OFFERS OPPORTUNITIES TO...**

**ENGINEERS
PHYSICISTS
CHEMISTS**

WORK ON THE NEW DEVELOPMENTS IN ELECTRONICS AS AN ENGINEER WITH GENERAL ELECTRIC

Few developments today can match the importance and versatility of the tiny transistor, which has vast possibilities for both industrial and consumer use.

General Electric engineers are at work now on new improvements, new applications and advances. As always, they are aided by the finest facilities . . . by the cooperation and encouragement of recognized leaders in the field . . . by the opportunity to take on increasingly challenging assignments.

These factors, combined with stability, excellent salary and benefits, provide the engineer with the ideal environment for achievement and growth.

Experience required in the following fields:

*Advanced Development, Design, Field Service
and Technical Writing in connection with:*

**MILITARY RADIO & RADAR MULTIPLEX MICROWAVE
MOBILE COMMUNICATION COMMUNICATIONS
ELECTRONIC COMPONENTS
TELEVISION, TUBES & ANTENNAS**

Bachelor's or advanced degrees in Electrical or Mechanical Engineering, Physics, Metallurgy or Physical Chemistry and/or experience in electronics industry necessary.

Please send resume to: Dept. 6-4-E, Technical Personnel

GENERAL  ELECTRIC

ELECTRONICS PARK, SYRACUSE, N. Y.

ENGINEERS

EE and ME

PHYSICISTS

DESIGNERS

For Work in
Design & Development of:

1. Airborne navigational instruments
2. H.F. pulse magnetic recording systems
3. R.F., I.F., video and microwave circuits



In the friendly Kollsman organization you'll work with intriguing problems concerning the design and development of America's finest aircraft instruments.

Please submit resumes to: Employment Manager

KOLLSMAN Instrument Corp.

80-08 45th Ave., Elmhurst, Long Island, N. Y.

Bendix Aviation Corporation

● **YORK Division . . .**

This NEW division of our nationally-famous corporation has openings for

**ENGINEERS
PHYSICISTS**

Top-flight men in advanced fields of electronic research, development and product engineering are needed for challenging work under ideal conditions in our new, modern plant.

You benefit at Bendix York from our location in the heart of a beautiful suburban area, from high wages, paid vacations and holidays . . . and excellent opportunities for advancement.

Openings at all levels.

Write, Wire or Phone
Department Y-1



**AVIATION CORPORATION
YORK DIVISION**

Phone: York 5521

York, Penna.

For Engineers . . .

Clear Horizons ahead

. . . at Goodyear Aircraft Corporation

BUILD YOUR CAREER and help build tomorrow's world with the pioneer and leader in lighter-than-air craft. There's a clear, bright future at Goodyear Aircraft for engineers with talent, aptitude and ambition.

FORCEFUL, CREATIVE THINKING is the key to Goodyear's progressive research and development programs in missiles, electrical and electronic systems, servomechanisms, new special devices and fiber resin laminates. Design and development engineering opportunities are many and varied . . . are now available to capable and imaginative men and women in the field of airships, aircraft and aircraft components.

POSITIONS ARE OPEN in several fields with salaries based on education, ability and experience.

Physicists	Civil engineers
Mechanical engineers	Welding engineers
Aeronautical engineers	Electrical engineers

Openings also exist for personnel with ability and experience in technical editing and writing, art, and motion pictures.

AKRON, HOME OF GOODYEAR AIRCRAFT, is located in the lake region of northeastern Ohio. Cosmopolitan living, year-round sports and recreation, cultural and educational advantages make this thriving city an ideal spot for a pleasant home.

THE TIME TO PLAN A CAREER IS - NOW! Write, giving your qualifications, or requesting an application form.

C. G. Jones, Salary Personnel Department

GOODYEAR AIRCRAFT CORPORATION

AKRON 15, OHIO

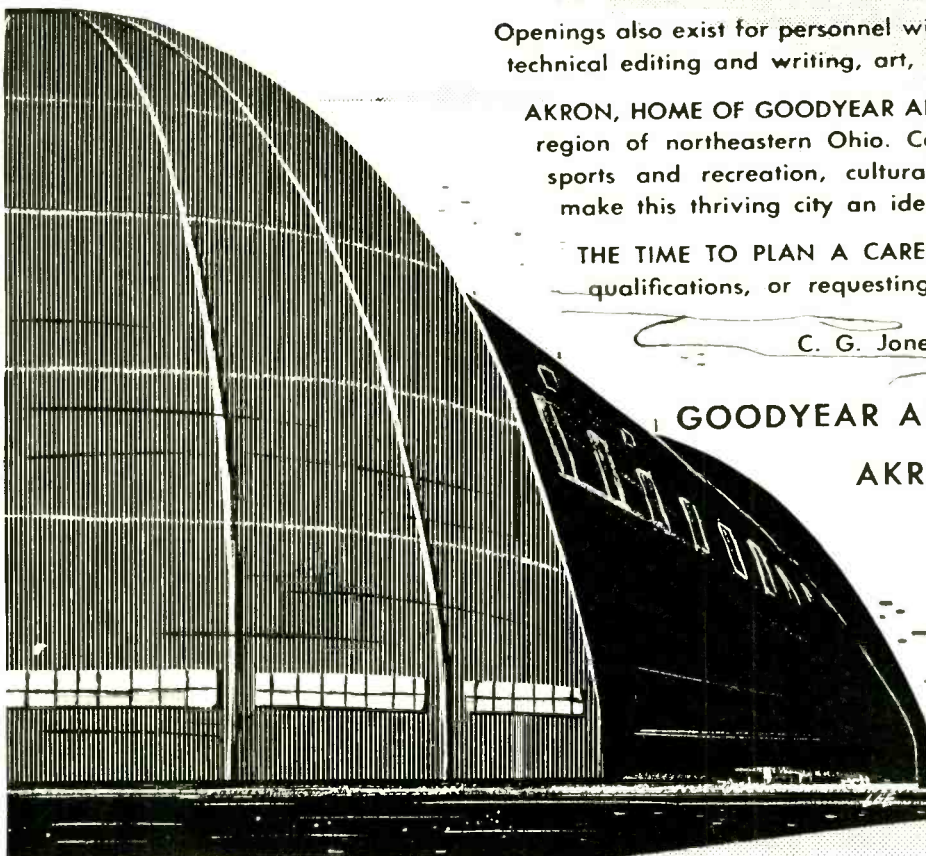

M. I. T.

LINCOLN LABORATORY

Staff research positions available for exceptional **electrical engineers** with advanced training or experience in **electronics** as applied to . . .

Radar,
Communications
and
High Speed
Digital Computers.

Please reply to:
Personnel Department, P. O. Box 73,
Lincoln 73, Mass.

**production and design
ENGINEERS
FOR TV COMPONENTS**

One of the world's largest manufacturers of electronic components since 1921 — plants in the east and midwest — offers you the opportunity to grow in a dynamic organization.

Are you a qualified engineer, preferably experienced in TV tuners and sweep circuit components?

We invite you to write to us today, detailing your experience in this field.

Address all replies to: Director Industrial Relations
General Instrument Corporation
829 Newark Avenue, Elizabeth, New Jersey

RECEIVER ENGINEERS
With Experience in VHF
and UHF Frequencies

Career Opportunities
With Old Established
Central Connecticut Firm
Interesting Projects
Top Salaries
Suburban Living

Replies Held in Strict Confidence
Wire or Phone Collect
Personnel Mgr. SHERWOOD 7-2741

**THE ALLEN D. CARDWELL
ELECTRONICS PRODUCTIONS
CORPORATION**
Plainville, Connecticut

**SENIOR-PROJECT
ELECTRO-ACOUSTIC ENGINEER**

We need a man with 10 years background in the fields of electronics, electromagnetics and acoustics.

Salary high in proportion to background experience.

Dyna-Labs, Inc.

1075 STEWART AVENUE,
GARDEN CITY, N. Y.
GArden City 3-2700

**MAN WHO CAN CREATE
A STRONG ELECTRONICS DEPT.**

Missile manufacturer having large mechanical design staff but small electronics group is seeking a man capable of creating and heading an expanding electronics department. Will be responsible for design of electronic systems which are optimum for a given missile, and the choice, coordination, and packaging of component equipment. Salary range \$10,000 to \$15,000 per year.

Please send resume of background including a snapshot, if available, and details of related experience to

P-2405, Electronics
520 N. Michigan Ave., Chicago 11, Ill.

RCA OPENS NEW HORIZONS ***in AVIATION ELECTRONICS!***

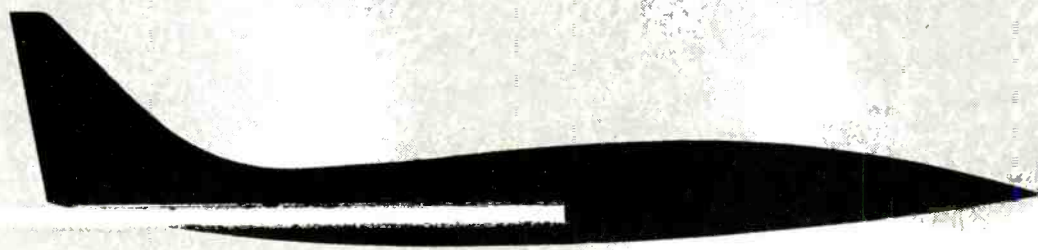

ADVANCE THE SCIENCE OF

**FIRE CONTROL • PRECISION NAVIGATION
COMMUNICATIONS**

***You'll find challenge in: Systems, Analysis,
Development or Design Engineering***

And You Can Specialize In: Radar • Analog Computers • Digital Computers • Servo-Mechanisms • Shock & Vibration • Circuitry • Heat Transfer • Remote Controls • Sub-Miniaturization • Automatic Flight • Transistorization • Design for Automation

You Should Have: Four or more years' professional experience and your degree in electrical or mechanical engineering, or physics

You'll find unlimited opportunities for professional advancement in RCA's broadened aviation electronics program! Suburban or country living nearby. Relocation assistance available.

And at RCA, you'll move ahead through *learning* as well as *doing* . . . for RCA encourages you to take engineering *graduate* study with company-paid tuition. You'll also enjoy professional status . . . recognition for accomplishment . . . unexcelled facilities . . . *many* company-paid benefits.

Your RCA career can start now! Begin by sending a resume of your education and experience to: **Mr. John R. Weld, Employment Manager**
Dept. B454F, Radio Corporation of America
Camden 2, New Jersey



RADIO CORPORATION OF AMERICA

Tmks. ®

It's the Individual that counts at MELPAR...



NO ENGINEER becomes just a "cog in the wheel" at Melpar. Instead, everybody has his own responsibility — is rewarded and advanced for a job well done. That's why so many young engineers hold the top jobs here. Melpar is growing and new top jobs open up regularly. Maybe you're just the man for one of them. Why not find out — now!

Experience desired in one or more of these or allied fields: Data Handling Equipment (magnetic cores, magnetic recording equipment, analogue to digital conversion, shaft digitizers) • Flight Simulation (servomechanisms, pulse circuitry, electronic cabling) • High Frequency Antennas • Audio and Video Circuit Design • Small Mechanisms Design • Mechanical Packaging and Electronic Components • Heat Transfer and Thermodynamics • Design of reciprocating compressors, hot gas generators and diesel engines

Address: Personnel Director, Dept. E-6



melpar
INCORPORATED

Galen Street, Watertown, Mass. • 440 Swann Ave., Alexandria, Va.

A SUBSIDIARY OF THE WESTINGHOUSE AIR BRAKE COMPANY

An Opportunity

is offered for intelligent, imaginative engineers and scientists to join the staff of a progressive and self-sustaining, university-affiliated research and development laboratory. We are desirous of expanding our permanent staff in such fields as electronic instrumentation, missile guidance, microwave applications, design of special-purpose electronic computers, and in various other applied research fields of electronics and physics.

Salary structure and benefit programs are on a par with industry. In addition, there are many tangible advantages, such as our self-sponsored internal research policy, of interest to men with ingenuity and initiative.

CORNELL AERONAUTICAL LABORATORY, INC.



BUFFALO 21, NEW YORK

WHITE-RODGERS ELECTRIC CO.

ARMAMENT ENGINEERING DIVISION

NEEDS

ENGINEERS

for

RESEARCH, DESIGN, DEVELOPMENT

of
**MISSILE GUIDANCE SYSTEMS
AUTOMATIC FLIGHT FORMATION
SYSTEMS and ASSOCIATED COMPONENTS**

To formulate dynamics and computer equations, and to design and develop experimentally electro-mechanical computers and instrument servo-mechanisms

SEND RESUME TO EMPLOYMENT MANAGER
1201 CASS AVE. ST. LOUIS 6, MO.

ELECTRONIC AND MECHANICAL ENGINEERS!

Motorola Research Laboratories, located in the healthful climate of Arizona's Valley of the Sun, has several openings for experienced engineers in the following fields:

Electronic research and development for missile guidance, radar and VHF communications.

Mechanical design of missile-borne and vehicular electronics equipment.

Analysis and laboratory work involving development of new types of airborne and ground radiators and waveguide components.

VHF and microwave antenna waveguide circuitry.

Transistor development.

Desire men with B.S. degree or above. Salary commensurate with education and experience. Free health, accident and life insurance. Free hospitalization. Profit Sharing. Paid holidays. Sick leave. Vacations. Ideal working conditions. Plenty of housing, reasonably priced. Excellent schools. Exceptionally mild and dry winter climate.

WRITE: J. A. Chambers, Manager
Motorola Research Laboratory
3102 North 56th Street
Phoenix, Arizona

*important
engineering
opportunities*

WITH

MAGNAVOX

Permanent positions to Senior and Project Engineers, with mechanical or electrical design experience, are offered by Magnavox, creative leaders in the electronics industry.

OPPORTUNITIES

IN:

SYSTEMS
DIGITAL COMPUTERS
SERVO SYSTEMS
COMMUNICATION
NAVIGATIONAL AIDS
FIRE CONTROL
MICROWAVE
ANTENNAE
SONAR
RADAR

Please forward complete resume to:

MR. FRANK H. GOLDSMITH

THE
MAGNAVOX
COMPANY

Fort Wayne, Indiana

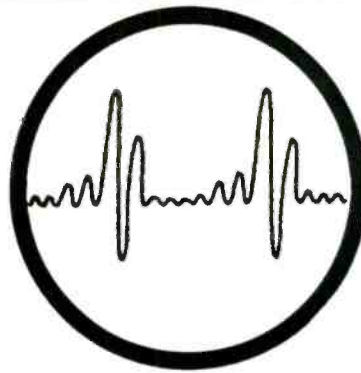

**SPECIAL OPPORTUNITIES FOR
SENIOR ENGINEERS**

Convair in beautiful, sunny San Diego invites you to join an "engineers" engineering department. Interesting, challenging, essential long-range projects in commercial aircraft, military aircraft, missiles, engineering research and electronics development. Positions open in these specialized fields:

Electrical Design	Servo-mechanisms
Mechanical Design	Aerodynamics
Structural Design	Thermodynamics
Structures	Operation Analysis
Weights	System Analysis

Generous travel allowances to those accepted. For free brochure, write Mr. H. T. Brooks, Engineering Dept. 900

CONVAIR
IN BEAUTIFUL
SAN DIEGO

3302 PACIFIC HIWAY
SAN DIEGO 12, CALIFORNIA

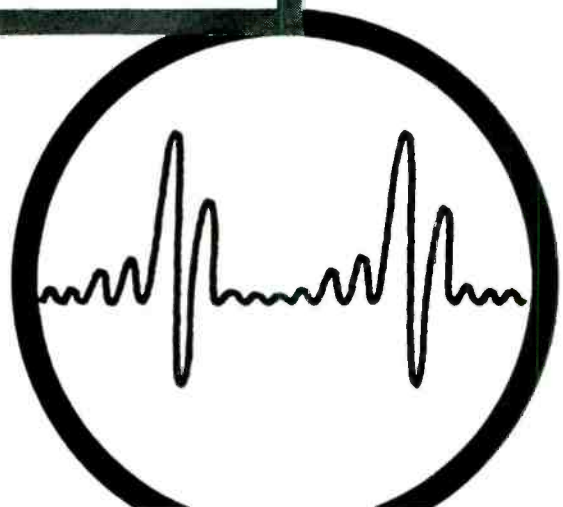

Why?

ELECTRONICS ENG.

PHYSICISTS

MECHANICAL ENG.

Here Is Why Bendix Radio Is The Place For YOU To Work

Challenging work in The development of:

- Radar (Airborne and Ground)
- Auto Radio and Test Equip.
- Airborne & Mobile Comm. Equip.
- Missile Guidance Systems
- Computer Applications
- Research & Development
(Incl. Transistors and Printed Circuitry)



- Excellent salaries.
- Semi-annual work reviews with advancement on merit.
- Modern, air-conditioned plant located in beautiful suburban area with ample housing, good schools, attractive shopping centers, major league sports.
- Numerous employee benefits.

Call, wire or write Mr. L.H. Noggle, Dept. J

Bendix Radio

DIVISION OF BENDIX AVIATION CORPORATION
BALTIMORE-4, MD. Phone Valley 3-2200

PROGRESSIVE ENGINEERS LOOK WEST

Qualified Electronic and Electro-Mechanical engineers find happy association with a Western electronics pioneer and leader.

*design
development
production*

Commercial and military projects. Radar, DME, Communications, Noise, Test Equipment including color T.V. — Many others with real interest & challenge. Relocation expenses — excellent working conditions — Central location. Scheduled reviews & advances. Fine insurance plan. Move should not disturb urgent military projects.

Send complete resume, income history & requirements to engineering employment mgr.

Hoffman LABORATORIES, INC.

(A SUBSIDIARY OF HOFFMAN RADIO CORP.)

3761 SO. HILL ST.

LOS ANGELES 7, CALIF.

ELECTRICAL ENGINEER

Our Engineering and Developing Department needs a recent Electronic engineering Graduate, preferably with a Master's Degree, to work on Electronic Digital computing equipment. Computing experience desirable but not essential. Location will be in Chicago. In reply please state age, education, past employers, salaries earned, address and phone number for early interview. Replies will be kept in strictest confidence. P-2391, ELECTRONICS, 520 N. Michigan Ave., Chicago 11, Ill.

TUBE ENGINEERS FOR SYLVANIA



Five or more years' experience on tube development. Familiarity with Microwave Tube development particularly desirable.

Work in Sylvania's expanding Traveling Wave Tube Development Program at the

Research Laboratories
SYLVANIA

ELECTRIC PRODUCTS INC.
Bayside, Long Island, N. Y.

... where you can live and work in New York's finest residential area

Please send resume of experience to
E. W. Doty
Manager of Personnel

ENGINEER—Heavy experience in Mercury electrical discharge lamps; qualified for experimental and design work.
PHYSICIST—Experienced in electrical discharge lamps; qualified for experimental and development work. Long established Newark, N. J. Lamp Manufacturer.

P-2660. Electronics
330 W. 42 St., New York 36, N. Y.

ENGINEERS

SYSTEMS
RADAR
SERVO
COMPUTER

BACKGROUND: Responsible positions open for top level development and project engineers with practical and research experience in:

Advanced Electronic Circuits and Systems
Microwave Radar
Microwave Receivers and Transmitters



Requirements emphasize advanced analytical and/or management experience on highly complex electronic and electro-mechanical systems.

Kindly send resume and salary requirements to

The W.L. MAXSON Corp.
460 W. 34th ST., NEW YORK 1, N.Y.

If you have design
experience in

**MAGNETIC
AMPLIFIERS
CRYSTAL and
L-C FILTERS
MINIATURE
TRANSFORMERS
PLASTIC
ENCAPSULATION
TECHNIQUES**

(or if you are an engineer
desiring experience in these
fields)

... you owe yourself an investigation of the career advantages offered by Communication Accessories Company, Hickman Mills, Missouri . . . located in South Suburban Kansas City, where you and your family can enjoy advantages of:

1. Management-owned expanding organization.
2. Rural atmosphere — 25 minutes to metropolitan Kansas City.
3. Newly developed housing facilities, schools and shopping centers.

For confidential negotiations,
address inquiries to
W. S. Bonebright, V. P.,

**COMMUNICATION
ACCESSORIES
COMPANY**

Hickman Mills, Missouri

EVERY ELECTRONIC ENGINEER

Should Measure the Chances

FOR A
FUTURE
WITH

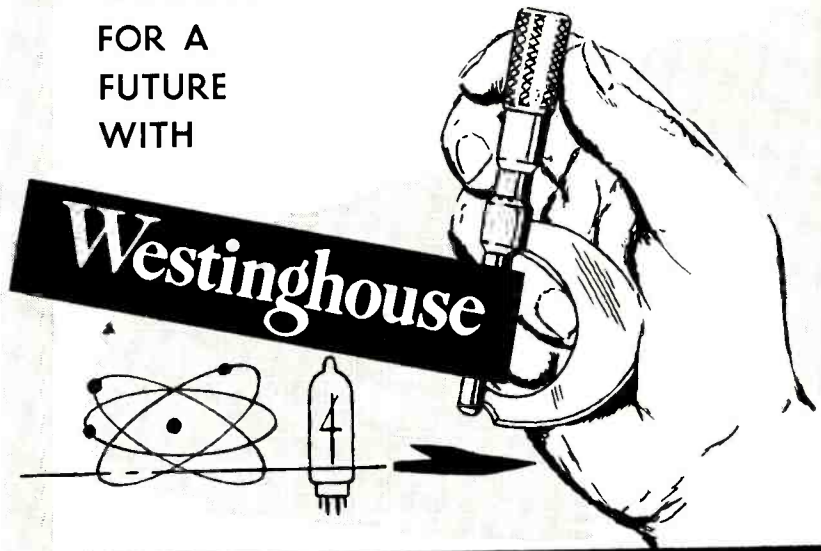

SEND FOR OUR NEW BROCHURE TODAY!

At Westinghouse, you'll find industrial stability, progress and professional recognition. Our new illustrated 20-page brochure will provide you with a complete description of the operations and opportunities at the Westinghouse Baltimore Divisions, where electronics and aviation-electronics work is setting the pace for the industry. Among

the subjects fully discussed in the brochure are:

- PROFESSIONAL RECOGNITION
- OPPORTUNITIES FOR ADVANCEMENT
- FACILITIES
- COMPANY ORGANIZATION
- HOUSING CONDITIONS
- EMPLOYE BENEFITS
- WORKING CONDITIONS

WRITE TODAY FOR YOUR COPY

ELECTRICAL ENGINEERS • MECHANICAL ENGINEERS
PHYSICISTS • MATHEMATICIANS • FIELD SERVICE
ENGINEERS • ENGINEERING TECHNICAL WRITERS

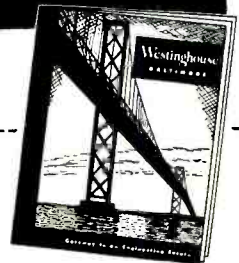

Mr. R. M. Swisher, Jr.
Employment Supervisor, Dept. JE - 1
Westinghouse Electric Corporation
109 West Lombard Street
Baltimore 1, Maryland

Please send me a copy of "Gateway to an Engineering Future."

Name

Address

City Zone State

Engineering Field

YOU CAN BE SURE...IF IT'S

Westinghouse

Air Arm and Electronics Divisions
Baltimore, Maryland

**HIGH CYCLE GENERATOR
Dual Voltage**

115 volts AC; KW 1.5; PF 1.0, Single Phase, Cycles 800; DC; Volts 28.5; watts 500; r.p.m. 2666; mfgd. by D. W. Onan & Sons; frame No. 19533B\$99.50

**SINE-COSINE GENERATORS
(Resolvers)**

Diehl Type FJE-43-9 (Single Phase Rotor). Two stator windings 90° apart, provides two output equal to the sine and cosine of the angular rotor displacement. Input voltage 115 volts, 400 cycle\$30.00 ea.
Diehl Type FPE-43-1 same as FJE-43-9 except it supplies maximum stator voltage of 220 volts with 115 volts applied to rotor\$25.00 ea.

VOLTAGE GENERATORS (RATE)

ALNICO MIDGET D.C. VOLTAGE GENERATOR Type B-35-D\$17.50
ALNICO MIDGET D.C. VOLTAGE GENERATOR Type B-44-D\$17.50
A.C. GENERATOR: 67 V. 20 Cyc., 2-Phase, .015 Amps. Type PM-1, 1200 R.P.M.\$15.00

**SYNCHRONOUS
SELSYNS**

110 volt, 60 cycle, brass cased, approx. 4" dia. x 6" long. Mfg. by Diehl and Bendix.

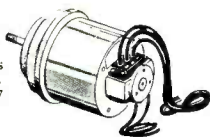

Quantities Available.

REPEATERS\$20.00 ea.
TRANSMITTERS\$20.00 ea.

AUTOSYN MOTOR TYPE 1

115 VAC; 60 cycle; 1-phase; DR. #4279 Foot mounted; Mfg. Bendix Aviation Corp.\$15.00 ea.

SYNCHROS

General Electric MOD. 2J15M1: 115-57.5 Volts 400 Cycle\$22.50 ea.
AUTOSYN MTR. KOLLSMAN Type #403; 32 VAC; 60 cycle; single phase\$22.50 ea.
AUTOSYN MTR. BENDIX Type #851; 32 VAC; 60 cycle; single phase\$22.50 ea.
REPROSYN UNIT, Type IC-006-A\$15.00 ea.
IF Special Repeater (115V-400 Cyc.)\$10.00 ea.
2J1F 3 Generator (115-400 cyc.)\$10.00 ea.
5CT Control Transformer: 90-50 Volt; 60 Cy.\$45.00
5F Motor (115/90 Volt-60 cyc.)\$45.00
5SG Differential Generator (90-94 volts - 400 cyc.)\$30.00 ea.
TRANSMITTER, BENDIX C-78248: 115 Volt, 60 Cycle\$25.00 ea.
Differential-C-78249: 115 V., 60 Cy.\$5.00
REPEATER, BENDIX C-78410: 115 Volt, 60 Cycle\$37.50 ea.
REPEATER, AC synchronous 115 V., 60 cycle, C-78868\$15.00 ea.
REPEATER, DIEHL MFG. No. FJE 22-2; 115 Volt; 400 Cy., Secondary 90 V.\$27.50
5G GENERATOR (115/90) 60 cycles\$45.00
7G Synchro Generator (115/90 volts; 60 cycle)\$75.00
6G Synchro Generator (115/90 volt; 60 cycle)\$60.00
6DG Synchro Differential Generator (90/90 volt; 60 cycle)\$50.00
2J5F1 Selsyn Control Transformer: 105-55 Volts; 60 cycle\$22.50
2JD5HAI Selsyn Generator: 115-105 Volts, 60 cycle\$50.00
2J1F1 GENERATOR: 115-57.5 Volt; 400 cycle\$12.50 ea.
2J1H1 DIFFERENTIAL GENERATOR: 57.5-57.5 Volt; 400 cycle\$12.50 ea.
2J1G1 CONTROL TRANSFORMER: 57.5-57.5 Volt; 400 cycle\$7.50 ea.
2J5H1 SELSYN GENERATOR: Mfg. G. E., 115-105 Volts, 60 Cycle\$27.50

**PANORAMIC
ADAPTER
Model AN/APA-10**

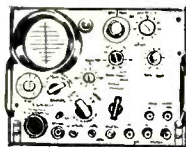

Provides four types of presentation (a) Panoramio (b) Aural (c) Oscillographic (d) Osciloscopic. Designed for use with AN/ARR-7, AN/ARR-5, AN/APR-4

SCR-587 or other equipment with I.F. or 455 kc., 5.2 mc or 30 mc. Includes 21 tubes with 2" scope tube. PRICE\$99.50

Immediate Delivery

ALL EQUIPMENT FULLY GUARANTEED

All prices net FOB Pasadena, Calif.

INVERTERS

10563 LELAND ELECTRIC

Output: 115 VAC; 400 cycle; 3-phase, 115 VA; 75 PF. Input: 28.5 VDC; 12 amp.\$59.50

PIONEER 12117

OUTPUT: 26 volts; 400 cycles; 6 volt amperes, 1-Phase. INPUT: 24 VDC; 1 amp.\$25.00 ea.

ALTERNATOR, CARTER

Mfg. Carter Motor Co.; OUTPUT: 7 VAC; 9.7 amp.; 650 cycles, and 295 VDC, 200 amps. INPUT: 26.5 VDC; 10.5 amps; 6500 rpm.\$49.50 ea.

PE 218 LELAND ELECTRIC

Output: 115 VAC; Single Phase; PF 90; 380/500 cycle; 1500 VA. INPUT: 25-28 VDC; 92 amps; 8000 RPM; 1/2" Dia. Volts, 27.5\$39.95 ea.
BRAND NEW

PE 109 LELAND ELECTRIC

Output: 115 VAC, 400 cyc; single phase; 1.53 amp; 8000 RPM. Input: 13.5 VDC; 29 amp.\$65.00

MG 153 HOLTZER-CABOT

Input: 24 V. DC, 52 amps. Output: 115 volts - 400 cycles, 3-phase, 750 VA. and 26 Volt - 400 cycle, 250 VA. Voltage and frequency regulated.\$95.00 ea.

PIONEER 12130-3-B

Output: 125.5 VAC; 1.5 amps, 400 cycle single phase. 141 VA. Input: 20-30 VDC, 18-12 amps. Voltage and frequency regulated\$75.00

12116-2-A PIONEER

Output: 115 VAC; 400 cyc.; single phase; 45 amp. Input: 24 VDC 5 amp.\$65.00

10285 LELAND ELECTRIC

Output: 115 Volts AC, 750 V.A., 3 phase, 400 cycle, .90 PF, and 26 volts, 50 amps, single phase, 400 cycle, .40 PF. Input: 27.5 VDC, 60 amps, cont. duty, 6000 R.P.M. Voltage and Frequency regulated.\$95.00

10486 LELAND ELECTRIC

Output: 115 VAC; 400 Cycle; 3-phase; 175 VA; .80 PF. Input: 27.5 DC; 12.5 amp; Cont. Duty.\$90.00 ea.

PIONEER 10042-1-A

DC INPUT 14 Volts; OUTPUT: 115 Volts; 400 Cycle 1-Phase; 50 Watt.\$75.00

94-32270-A LELAND ELECTRIC

Output: 115 Volts; 190 VA; Single Phase; 400 Cycle; .90 PF, and 26 Volts; 60 VA; 400 Cycle, .40 PF. Input: 27.5 Volts DC 18 amps cont. duty, voltage and freq. regulated\$95.00

PIONEER 12147-1

OUTPUT: 115 VAC 400 cycle; Single phase. INPUT: 24-30 VDC; 8 amps.\$79.50

MG 149F HOLTZER CABOT

OUTPUT: 26 VAC @ 250 VA; 115V @ 500VA; Single Phase; 400 cycle. INPUT: 24 VDC @ 36 amps.\$49.50

EICOR CLASS "A" NO. 1-3012/08-7

OUTPUT: 125 VAC; 400 cycle; single phase; 100 VA. INPUT: 24-30 VDC; 11 amps; Duty Int. Voltage and Frequency Regulated\$99.50

**HAZELTINE PULSE GENERATOR
MODEL 1017**

Electrical Characteristics: Pulse Freq: initiating and sliding pulse-external. Pulse Width: initiating and sliding pulses, 10 microseconds. Pulse Amplitude: initiating and sliding pulses, plus 150 volts. Sliding Pulse Delay: variable over full trace length. Sweep Duration: 50, 200, and 1000 microseconds. TUBES: 16-6S47; 3-6AG7; 3-6L6; 2-6J5 gt; 2-6SN7 gt; 1-5U4 G; 1-6SK7; 1-6Y6G; 1-991; 1-9002. Power input: 110-125 volts, 60 cyc. single phase; batteries none. Dimensions: 13 1/2" x 20 1/2" x 23". Weight 85 lbs. PRICE\$79.50

ALNICO FIELD MOTORS



(Approx. size overall . . . 3 3/4" x 1 1/2" diameter)
DELCO TYPE #5069600: 27.5 volts DC; 250 RPM\$15.00
DELCO #5069230: 27.5 VDC; 145 rpm.\$15.00
PM Motors Delco Type #5069371: 27.5 volts; DC Alnico Field; 10,000 R.P.M.; dimensions 1" x 1" x 2" long; shaft extension 1/2" diameter 0.125"\$8.00

**BODINE GEAR
HEAD MOTORS**



10:1 Gear Ratio; Motor operates: 24 VDC, 2 Amps, 1/50th H.P., 5000 RPM.
NEW\$9.95

400 CYCLE MOTORS

EASTERN AIR DEVICES #133 Synchronous Motor 115 Volt; 400 cycle\$17.50
PIONEER: TYPE CK5 2 Phase; 400 cycles \$25.00 ea.
EASTERN AIR DEVICES TYPE J49A: 115 V; 0.1A; 7000 r.p.m. Single phase 400 cycle.\$17.50 ea.
AIRESEARCH: 115V; 400 CPS; Single phase 6500 RPM; 1.4 amp; Torque 4.6 in. oz.; HP. .03.\$10.00 ea.
EASTERN AIR DEVICES TYPE JM6B: 200 VAC; 1 amp; 3 phase; 400 cycles, 6000 RPM.\$12.50 ea.
EASTERN AIR DEVICES, TYPE J31B: 115 V; 400 1200 Cycle, Single Phase.\$42.50 ea.
AIRESEARCH: AC induction, 200 V; 3 Phase, 400 Cycle, 2 H.P.; 11,000 RPM; 8 amps.\$79.50 ea.
AIRESEARCH: AC Induction, 200 V; 3 Phase, 400 Cycle, 12 H.P., 6500 RPM; 1.5 amps.\$25.00 ea.
Electric Motor, PNT-1400-A-1A Serial No. 207, 208 V., 400 Cycles, 3 Phase Kearfott Co., Inc.\$17.50 ea.

**SERVO MOTOR 10047-2-A; 2 Phase;
400 Cycle, with 40-1 Reduction Gear
\$17.50**

SMALL DC MOTORS

GENERAL ELECTRIC #5BA10AJ18 . . . 27 VDC; RPM 110; 1 oz. FT.\$12.50
DELCO #5069625 . . . 27 VDC; 120 RPM; Governor controlled\$22.50
EMERSON #75: 12 Volt DC; 1/6th HP; 10 amp; 3800 RPM; Approx. size: 2 3/8" x 5"\$9.95 ea.
DELCO #5068750: 27 VDC; 100 RPM; built in reduction gears\$12.50 ea.
J. OSTER: series reversible motor 1/50th H.P.; 10,000 RPM; 27 1/2 VDC; 2 amps; SPERRY #806609; approx. size 1 1/2" x 3 3/4"\$7.00 ea.
General Electric Type 5AB10AJ37; 27 volts, DC; 5 amps; 8 oz. inches torque; 250 RPM, shunt wound; 4 leads; reversible\$12.50
General Electric, Mod. 5BA10F33; 12 oz. inches torque, 12 DC 56 RPM, 1.02 amp.\$15.00 ea.
General Electric Type 5BA10AJ52C; 27 volts DC; 5 amps, 8 oz. inches torque; 145 RPM; shunt wound; 4 leads; reversible\$12.50
GENERAL ELECTRIC DC MOTOR Mod. 5BA10AJ-64, 100 r.p.m.; 65 amp; 12-oz.-in. torque 27V DC\$12.50
2 1/2 H.P. MOTOR-Mfg. LEECE-NEVILLE Co; Type 1454-MO; 24VDC; 4000 RPM; 100 amp\$35.00

115 VOLT GENERATORS

Brand new Eclipse generators: 115 VAC; 9.4 amp; 1000 watts; single phase; 800 cycles; 2400-4200 rpm. DC output is 30 volts at 25 amp. Unit has spindle drive shaft and is self-excited. \$29.95



BLOWER

Eastern Air Devices, Type J31B: 115 volt; 400-1200 Cycle; single phase; variable frequency; continuous duty; L & R #2 blower; approx. 22 cu. ft./min.\$15.00



BLOWER: Mfg. John Oster; Type C2A-13; 27 VDC, 63 amps; 1/100 H.P.; 7000 RPM; Series Wound\$9.95 ea.

BLOWER ASSEMBLY

115 Volt, 400 Cycle, Westinghouse Type FL 17CFM, complete with capacitor. New\$9.95 ea.

TEST EQUIPMENT

TS 13/AP	\$650.00
TS 35/UP	495.00
TS 45/APM	195.00
TS 51/ATG	95.00
TS 59	69.50
TS 61/AP	69.50
TS 76/APM	79.50
TS 80/U	14.95
L-96-A	195.00
TS 251	650.00
LZ Signal Generator	149.00

C & H SALES CO

2176 East Colorado Street • Pasadena 8, California • RYAN 1-7393

We STOCK for IMMEDIATE SHIPMENT one of the MOST COMPLETE inventories of SPECIAL-PURPOSE, TV, & RADIO TUBES. We offer fully guaranteed, STANDARD BRANDS at the LOWEST PRICES, consistent with HIGHEST QUALITY. SPECIAL ATTENTION to EXPORT ORDERS. WATCH FOR NEW TYPES EACH MONTH!

OA2	5.38	2J54	62.95	5J22	11.50	6J5	.55	50C5	.72	403-A(WE)	1.50	72A	1.35	Type	1.35	Type	1.29	Price	.24
OA3/VR-75	1.04	2J54-B	95.00	5JP7	20.00	6J6	.60	50L6GT	.70	403-B	3.45	722-A	1.50	722-A	1.50	1930	.60		
OA4-G	1.15	2J55	22.00	5R4G	1.45	6K6GT	.55	55	.40	404-A/5847	write	723A/B	15.75	723A/B	15.75	1951	1.25		
OB2	.78	2B61	22.00	5TP4	30.00	6K5	.59	QK50	60.50	407-A(WE)	2.50	724-B	1.75	724-B	1.75	2059	1.10		
OB3/VR-90	.78	2K22	18.50	5U4-G	.59	6S47GT	.63	QK51	60.50	408-A(WE)	2.50	725-A	7.50	725-A	7.50	5516	7.25		
OC3/VR-105	.88	2K22	17.50	5V4-G	.63	6SN7GT	.79	QK72	250.00	416-A(WE)	write	726-A	55.00	726-A	55.00	WL-5550	44.10		
OD3/VR-150	.75	2K25	24.50	5Y3-GT	.48	6SO7GT	.63	81	.95	417-A(WE)	write	728-C	18.00	728-C	18.00	WL-5552	110.00		
OZ4	.55	2K28	25.00	6CJ	7.25	6T8	.99	82	1.11	418-A(WE)	18.00	728A Y, BY, CY, DY, EY, & FY	13.00	728A Y, BY, CY, DY, EY, & FY	13.00	5536	5.75		
1B3GT	.90	2K28	25.00	6C6	5.00	6U8	1.05	83-V	.98	421-A(WE)	5.00	750TL (JAN)	65.50	750TL (JAN)	65.50	5642	1.00		
1B22	1.20	2K29	23.00	6AB4	135.90	6AT5	.58	HF100	3.00	422-A(WE)	5.00	801-A	3.30	801-A	3.30	5647/SN949	9.50		
1B23	4.95	2K30 410R	135.90	6AF4	1.39	6W4GT	.55	100-E(Collins)	2.50	GL-434-A	12.00	WL-802	805	WL-802	805	5648	7.75		
1B24	6.75	2K33-A	135.90	6AG5	.78	6W6GT	.82	100-TH(JAN)	5.95	GL-446A	77.00	807	805	807	805	5651	2.30		
1B26	1.50	2K41	139.50	6AH4GT	.89	7C25	85.00	FG-104	25.00	GL 451	7.00	807W/5333	4.95	807W/5333	4.95	5654	1.45		
1B27	9.95	2K45	.38	6AM5	.93	9JP1	12.50	F-128A	70.00	464-A	3.00	809	3.50	809	3.50	5670	3.25		
1B32/532-A	1.25	2K45	write	6AK5	.60	12AT6	1.60	VXR-130	1.50	GL 471-A	2.20	WL 810	15.95	WL 810	15.95	5676	4.25		
1B35	7.00	2X2-A	write	6AL5	.90	12AT7	1.05	117Z3	.75	WL 431-A	4.30	811	2.90	811	2.90	5683	1.15		
1B63A	37.50	3A5	.90	6AN5	3.65	12AV7	.55	117Z6GT	1.00	CK-501LX	1.25	812	2.95	812	2.95	5694	2.25		
1C6	.10	3B24	4.50	6AN5	3.65	12AV7	.72	CK-501LX	25.00	WL530	1.65	812A	3.55	812A	3.55	5719/SN980D	5.50		
1H4	.16	3B25	3.40	6AN5	3.65	12AV7	.72	WL530	19.95	WL 531	4.75	813	17.75	813	17.75	5725	4.10		
1L4	.43	3B26	2.75	6AN5	3.65	12AX7	.75	RX215	7.00	WL 531	4.75	813	9.95	813	9.95	5726	1.50		
1L6	1.35	3B28	3.70	6AS5	2.65	12AY7	1.75					816	1.40	816	1.40	5732	3.95		
1N21-B	1.93	3BP1	7.09	6BP1	7.09							826	6.65	826	6.65	5749	1.90		
1N23-A	1.90	3BP11	7.09									829B	9.95	829B	9.95	5750	2.00		
1N34-A	.55	3C23(GE)	1.00									830B	2.75	830B	2.75	5751	2.85		
1N38-A	1.25	3C24/24G	1.00									WL-833A	49.00	WL-833A	49.00	5780(WE)	350.00		
1N44/400B	1.10	3C27	3.25									834	8.00	834	8.00	5784	3.00		
1N45/400C	1.20	3C31 C1B	2.25									837	2.50	837	2.50	5793(WE)	350.00		
1N48	.45	3C45	11.75									838	2.50	838	2.50	5793	4.75		
1N52	.55	3CP1	2.50									WL-845	13.50	WL-845	13.50	5812	1.50		
1N54	.75	3D21A	6.95									851	34.00	851	34.00	5814	1.75		
1N54-A	.83	3D22	8.95									860	2.00	860	2.00	5819	45.00		
1N63	1.90	3D24	8.95									861	13.50	861	13.50	5829	2.75		
1N69	.75	3DP1	2.25									865	.95	865	.95	5849	6.00		
1N70	.30	3DP1-A	5.25									869B	1.20	869B	1.20	5844	1.50		
1P21	29.95	3EP1	3.50									872A	55.00	872A	55.00	5879	1.40		
1P23	2.50	3FP7	2.30									872A(GE)	2.40	872A(GE)	2.40	5945	395.00		
1P28	7.75	3GP1	2.30									874	2.95	874	2.95	6021	7.75		
1P40	1.50	3HP14	6.50									874	.75	874	.75	6080	3.50		
1R5	.75	3J30	85.90									884	1.50	884	1.50	6090	2.00		
1S5	.75	3J31	write									WL-891	237.00	WL-891	237.00	6095	1.50		
1T4	.70	3S4	.55									892R	225.00	892R	225.00	6096	1.85		
1U4	.75	4A1	1.15									918	11.70	918	11.70	6097	1.75		
1U5	.70	4B22	7.50									921	26.90	921	26.90	6098	1.95		
1V	.50	4B24	4.50									922	11.00	922	11.00	6099	1.90		
1X2-B	.90	4B25/EL6CF	7.95									931A	19.50	931A	19.50	6101	1.90		
1Y2	2.75	4B28/CE-225	3.95									954	34.30	954	34.30	6136	1.80		
2B22	2.00	4B32	9.39									955	52.25	955	52.25	6146	4.65		
2C39 (JAN)	12.50	4C27	10.00									957	47.90	957	47.90	6201	5.00		
2C39-A (JAN)	17.50	4C35	17.50									958A	.60	958A	.60	8011	.75		
2C40 (RCA)	9.95	4-85 A	20.00									959	6.50	959	6.50	8012	2.20		
2C43	write	4-125 A	30.25									1000T (JAN)	95.00	1000T (JAN)	95.00	8014	write		
2C44	.93	4-250 A	41.25									CK1005	.95	CK1005	.95	8020	2.50		
2C51 396-A	3.75	4D22	21.50									CK1027	5.00	CK1027	5.00	9002	.95		
2C52	3.75	4D32	22.50									1701	2.75	1701	2.75	9003	1.45		
2D21	1.00	4E27/257B	11.25									1203A	.30	1203A	.30	9004	.25		
2E22	1.70	4J32	220.90									1512	2.00	1512	2.00	9005	.25		
2E24	2.75	4J36	125.00									1613	.75	1613	.75			AND MANY	
2E25	3.70	4J37	195.00									17H12	2.90	17H12	2.90			OTHERS	
2E25	3.40	4J63	195.00									715-A	3.00	715-A	3.00	1620	4.50		
2E30	2.20	4X150A (JAN)	29.95									1713	4.00	1713	4.00	152?/SL5M	1.93	complete line of	
2J21/2J21A	2.99	4X150G (JAN)	29.95									715C	15.90	715C	15.90	1524	1.50	receiving tubes and	
2J22	2.50	4X500F (JAN)	62.50									1525	.35	1525	.35	1525	.30	crystal diodes not	
2J26	6.90	5A4W	1.50									1626	1.95	1626	1.95	1626	.20	listed	
2J27	0.30	5BP4	3.00																
2J31	19.75	5CP1	4.75																
2J32	19.75	5CP1-A	7.95																
2J33	20.90	5D21	11.00																
2J34	27.75	5P7	1.00																
2J37	12.00	5J29	10.90																
2J39	3.39	5J30	23.50																
2J50	13.45	5J33	11.90																
2J51	259.00	5JP1	13.00																

Remember! We Ship No Seconds or Rehased "Bargains." You can Place Your Confidence in Our Dependable NEW Tubes. We Ship the Best—First Quality RCA, GE, SYLVANIA, WESTINGHOUSE, HYTRON and RAYTHEON TUBES Insure Repeat Orders From You—Our Customers.

AUTHORIZED FACTORY DISTRIBUTORS FOR EIMAC, WESTINGHOUSE (WL), CBS-HYTRON (CBS), CETRON and LEWIS & KAUFMAN TUBES

NEW RECTIFIER TRANSFORMERS

PR1: 115 V., 60 cycles in. 4 Amps 58.75
 SEC: 9, 12, 18, 24, and 30
 Volts 12 Amps 16.75
 24 Amps 35.75
 30 Amps 45.00
 Continuous Ratings 50 Amps 59.75

FILTER CAPACITORS

Capacity	W. Voltage	Ea.
500 MFD.....	50 V.	.85
1000 MFD.....	15 V.	.35
2000 MFD.....	50 V.	2.25
6000 MFD.....	15 V.	1.50

SELENIUM RECTIFIERS FULL-WAVE BRIDGE TYPE

Max. Amps	18/14 Volts	36/28 Volts	54/42 Volts	72/56 Volts	130/100 Volts
1	1.40	2.40	3.80	4.60	8.50
2	2.10	3.00	5.40	6.00	10.50
2 1/2	3.00	4.20	6.00	8.00	13.00
4	3.75	7.50	11.50	14.50	25.25
6	4.50	9.00	13.00	17.50	33.00
10	6.00	12.75	20.00	25.00	42.50
12	8.20	16.25	22.50	30.00	46.00
20	13.25	25.50	38.00	49.00	79.50
24	16.25	32.50	45.00	58.00	86.50
30	20.00	38.00	57.50	72.00	100.00
36	25.00	48.50	66.00	88.00
50	32.00	62.50
100	60.00	120.00

INVERTERS

Onan MG-215H. Navy type PU13. Input 115/230, 60 cy, 1 Ph. Output: 115, 480 cy, 1 Ph., 1.2KW and 26 V DC at 4 amps. New. \$295.00
 Onan MG-0-75. Navy type PU11 Input 115/230, 60 cy, 1 Ph. Output: 115, 480 cy, 1 Ph., 5.3 amps, and 26 VDC at 3.8 Amps. New. \$225.60
 Leland Elec. Co. PE206A. Input: 24 Ph. at 28 Amps. Output, 80V, 800 cy, 1 Ph. 185W. New. \$22.50
 PE218H. Input: 28DC. Output: 115, 400 cy, 1 Ph., 1.5KVA. New. \$32.50
 G.E. 5A51315511A. Input: 28DC. Output: 115, 400 cy, 1 Ph., 1.5 KVA. Regulated. New. \$89.50
 Eleor. 32VDC to 110AC. 60 cy, 1 Ph. at 2.4 Amps. New. \$39.70

DYNAMOTORS

Navy type CA10-211444. Input: 105 to 130VDC. Output: either 26VDC at 20 amps, or 13VDC at 40 amps. Radio filtered and complete with line switch. New. \$89.50
 Type PE94CM. For SCR-522. Brand new in overseas cases. Has wide band input and output filters. \$19.50

AMPLIDYNES

5AM211J7. Input 27 VDC @ 15 A. Output 60 VDC @ 2.5A 4600 RPM. New. \$34.50
 5AM31N9A. Input 27 VDC @ 44 A. Output 60 VDC @ 8.8 A. 7500 RPM. New. \$23.50
 5AM31N18A. Input 27 VDC @ 44 A. Output 60 VDC @ 8.8 A. 8300 RPM. New. \$12.50

SMALL DC MOTORS

G.E. 5BA50LJ2A. Armature 60VDC at 8.8 Amps. Field 27.5VDC at 2.5A RPM 4600. H.P. 0.5. New. \$27.50
 Oster E-7-5. 27.5DC. 1/20 HP. 3600 RPM Shunt Wound. New. \$9.50
 Dumore Co. type ELBG. 24 VDC. 40-1 gear ratio. For type B-4 Intervalometer. New. \$3.75

RADAR ANTENNAS

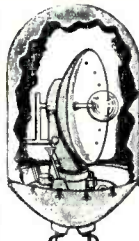

TYPE SO-13 ILLUSTRATED

Type SO-1 (10CM) assembly with 24" reflector, waveguide nozzle and drive motor with condition. New. \$279.50
 Type SO-3 (3 CM.) Surface Search type with reflector and drive motor, but less plumbing. New in original cases. \$99.50
 Type SO-13. (10CM.) Complete assembly with 24" dish, dipole, drive motor and gearing. New. \$89.50

RADAR SETS

MODEL SQ. Portable radar set, 10CM. Operates on 90-130 volt, 60 cy, 1 Ph. "A", "B", and "PP" presentation. Complete with technical manual and full set of operating spare parts. Using top grade condition. New. \$749.50
 MODEL ASG-1 Radar unit consisting of transmitter and converter assembly CPR-42ARC. Antenna Assembly CRP-ACZ. Mounting Base CPR-10ABE, etc. New in original case. \$279.50

SCR-545A RADAR

Removed from trailer. Includes: Azimuth and Elevation Control Units: 214A and 154A Indicators; Input and Output Servo Amplifiers; Three BC-1035A Scopes; Power Panel and LA-65A Power Supply; Range Cont. Unit; Range Converter; Search Rec. and Cont. Unit; Search Trans; Track Rec. and Control Unit; Track Trans; Range Unit; Auto. Controller; no Antenna included. In good condition. A terrific value at \$1375.00 Only one set available.

REPAIR PARTS For BC 348 MODELS H, K, L, R, ONLY

Main Tuning Capacitor. \$ 4.50
 1st I F Transformer Assembly. 2.60
 2nd I F Transformer Assembly. 2.00
 3rd I F Transformer Assembly. 2.00
 4th I F Transformer Assembly. 2.00
 Crystal Filter Assembly. 6.50
 C. W. Oscillator Assembly. 2.00
 915 Kc Crystal mounted. 2.75
 Antenna Unit Assembly. 12.50
 R. F. Unit Assembly. 12.50
 Resistor: Volume Control. 2.75
 Knob for Main Tuning Condenser. .50
 Band #1 Coils - per set of 6. 3.50
 Band #2 Coils - per set of 4. 2.00
 Band #3 Coils - per set of 4. 2.00
 Band #4 Coils - per set of 4. 2.00
 Band #5 Coils - per set of 4. 2.00
 Band #6 Coils - per set of 4. 2.00

G. E. SERVO AMPLIFIERS

Used in B29 planes for Central Station Fire Control Systems B2, B3 and B4. Used to drive Amplidyne 5AM31N9A and Control Motor 5BA50LJ2A listed in 1st column. New less tubes. \$29.50

9 CONDUCTOR CABLE

Army spec. CO-215 Weatherproof 9 Cond. No. 20 AVG stranded tinned copper, plastic ins., color coded, double vinyl jackets with tinned copper braid between. Dia. 9/16" made by G.E. Available 1000, 1500, 2000 ft. reels. Price \$1.15 ft.

SCR-522 EQUIPMENT

Complete BC-624C receivers and BC-625AM Transmitters including mounting racks, plugs, connectors, dynamotor. Brand new equipment with instruction manuals. Write for full details.

BARGAINS IN TRANSMITTING MICA CAPACITORS

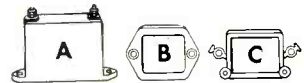

MFD	DCWV	Style	Price
.00003	2000	A	\$.29
.00003	3000	A	.39
.00005	3000	A	.39
.00009	3000	A	.39
.0001	3000	A	.39
.0002	3000	A	.39
.00035	2500	A	.29
.00036	5000	A	1.79
.000375	5000	A	1.79
.0004	2500	E	.29
.0004	3000	A	.39
.0005	3000	A	.39
.00056	5000	A	1.79
.0006	2500	A	.39
.0007	3000	A	.39
.00075	2500	A	1.79
.00075	5000	A	1.79
.0008	4500	A	1.79
.001	500	A	.19
.002	3500	A	1.29
.003	2000	A	.39
.003	3000	A	.39
.005	1200	C	.29
.005	2000	A	.39
.006	1200	C	.19
.006	2500	A	.39
.01	600	C	.19
.01	1200	C	.29
.015	1500	A	2.49
.02	600	C	.19
.025	1250	A	1.10
.025	2500	A	1.79
.12	500	A	2.49

High voltage transmitting types. Thousands in stock. Wide selection of sizes, types and ratings. All new and made by top manufacturers.

FREQUENCY METER 375 to 725 MCS



Model TS-127/U is a compact, self-contained, battery powered, precision (± 1 Mc) frequency meter which provides quick, accurate readings. Requires a standard 1.5V "A" and 45V "B" battery. Has 0-5 Min. time switch. Contains sturdily constructed "H-Q" resonator with average "Q" of 3000 working directly into detector tube. Uses 957, 186 and 3S4 Tubes. Complete new with inst. book, probe and spare bit of batteries. Less \$47.50

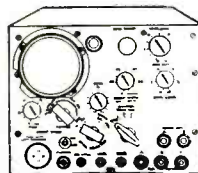

Complete with 21 tubes including 3" CRT scope tube. For operation on 115V, 400 Cy. Price. \$99.50
 For operation on 115V, 60 Cy. Price. \$145.00
SPECIAL OFFER!
 AN/APA-10 TECH. MANUAL. 80 pages. Postpaid in U.S.A. \$1.00

PANADAPTER and SCOPE AN/APA-10

A combined Panoramic Adapter and Oscilloscope. Has 3 coax input connectors for feeding in from receivers having I.F. of 455kc., 5.2 mc or 30mc. Designed also to be used as regular oscilloscope for testing other equipment. Has both vertical and horizontal push-pull amplifier inputs, etc.

FLUXMETER

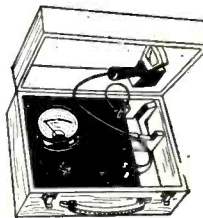

Used to calibrate field strength of magnets from 500 to 4000 gauss and indicate polarity. Probe has gap of 1/4". Beautifully built in hardwood case with hinged cover. Instructions for operation on under side of cover. Size 12 1/2 x 9 x 6 in. Ideal for lab and school use. New. An exceptional value at \$24.50

400 CY. BLOWERS

Westinghouse Type FL. 115V. 400 cy. 0-700 RPM. Airflow 17C.P.M. New \$3.95

SYNCHROS

Ford Inst. Co. Synchro Differential Generator. Mod. 3 Type 5SDG. 90/30V. 400 cy. Ord. Dr. 173020. New. \$6.50
 Armor. Synchro Differential Generator. Type 6DG. New. \$29.50
 Hobart Mfg. Co. Synchro Dif. Generator Type NLS. 115V. 60 Cy. New \$4.95
 5F, 5G, 5CT Also in Stock

D.C. SELSYN MOTOR

Step by step type for use with potentiometer in D.C. Selsyn Control Systems. Bendix - Type CAL14810 (MK1 Mod 0). 70 Volts DC input. \$4.95

MOTOR GENERATORS

2 KVA O'Keefe and Merritt. 115DC to 120AC. 50 cy. 1 Ph. Export Crated. New. \$125.00
MOTOR GENERATOR, TYPE CGU-2
 Unit of U. S. Navy TCR 7 Transmitter Motor. 2 H.P. 230V. D.C. 10 amps. Generator: 1800V. D.C. 0.4 A. 500V. H.P. 0.35A. 115V. D.C. 1.5A. 12 V. D.C. 2A. 3480 RPM. Self excited. Brand new including spare armature. \$65.00
ALLIS-CHALMERS 23010C to 115AC
 60 cy. 1 Ph. 1.25 KVA. \$149.50

FREQUENCY STANDARD

Complete self contained, dual 100/1000 kc crystal, multi-vibrator and harmonic amplifier. Calibrates with WWV and provides 1000, 100, and 10 kc check points from 100 to 45,000 kc. 115V. 60 cycles. New with instructions. \$23.95



Radar Repeater Adapters NAVY TYPE CBM-50AFO

A repeater unit for video signals and trigger pulses designed to work in conjunction with standard Navy radar equipments wherein provision is made for operation of remote P.P.L. sets. This adapter provides four video and trigger pulse lines for operations one or more remote P.P.L. control installations. 115 Volt, 60 cycles A.C. Dimensions are 3 1/2" x 2 1/2" x 1 1/2". New \$97.50

HIGH POT TRANSFORMER

Westinghouse. Pri. 115, 60 cy. Sec: 15,000V. C.T. @ 0.30A. C.T. ungrounded. Excellent for high-potting tests. Size OA 12 1/2" x 8 1/2" W x 9 1/2" D. Weight 67 lbs. Fully enclosed steel case. Price. \$29.50

30-100,000 CYCLE MODULATION TRANSF.

For RCA Type 250-K Broadcast Transmitter (M1-7212) P to P Primary Imp. 15,000 ohms. Secondary Load 3,000 ohms. Size 1 1/2" x 3 1/2" x 1 3/4". Wt. 142 lbs. New. \$49.50

60 CYCLE TRANSFORMERS

G. E. Step-Down. 6KVA. Pri: 230/450. Sec: 115/125, 60 cy. Size: 20" x 10" x 14 1/2". Weight 225 lbs. Navy grey finish. Integral junction box and mounting brackets. \$69.50
 Plate Trans. Raytheon. U-5815. Pri: 440/220, 60 cy. 3 phase. Sec: each phase 130/0V @ 0.67A test 6000V. \$59.50
 Plate Trans. Pri: 115V. 60 cy. 1 Ph. Sec: 1470V. C.T. @ 1.2A. Tested at 5500V. RMS. Raytheon. Size 12 1/2" x 10" x 10". Shipping wt: 150 lbs. New. Price. \$27.50

ALTITUDE INDICATOR

Type ID-1A, APN-1. Brand New in original cartons. Special. \$2.95

SPECIALS

ATTENUATOR. Daven Type T-800 Circuit: TPE. Imp. 50,000, 0.5 DB. per step. New. \$2.75
 CRT Shields for 3" Tube. \$2.75
FIRE DETECTOR. Designed for use on aircraft, tanks, armored vehicles. Heating of outside casing as by fire causes inside snap blade switch to close. Good Experimenters Item. 3 for \$1.00
JACK BOX. BC-1366M. Band New \$6.65
JACK PLUG ASSEMBLY. 787Q. New. 10 for \$1.00
PARABOLOIDS. 1 1/2" dia. spun magnesium, 4" deep, 1 1/2" x 1 1/2" opening at apex. Per pair. \$12.50
SAWTOOTH POTENTIOMETER. Continuous winding, 2 rotating and 2 take-off brushes. GF251N35. \$2.75
GLENDIOL. 24V DC, 2 lb. pull, 3/4" stroke. New. \$1.45
SWEEP GENERATOR CAPACITOR. 5/10 mfd., split stator coax type. Hi-speed ball bearings. \$1.95

HIGH VOLTAGE OIL CAPACITORS

Mfd.	Volts	Price
.001	50 KV	\$22.50
.01	5 KV	2.50
.02	8 KV	4.50
.02	20 KV	9.75
.025	50 KV	34.50
.025-.025	50 KV	34.50
.1	3 KV	1.75
.1-1	4.5 KV	3.50
.135	7.5 KV	6.95
.2	50 KV	47.50
.25	15 KV	17.50
.25	20 KV	19.50
.25	50 KV	67.50
1	7.5 KV	6.95
1	15 KV	47.50
2	5.5 KV	9.50
2	6 KV	12.50



SPECIAL \$6.95

METER SPECIALS

G.E. Type DO-50, 3" Sq. Scale reads 0-3 D.C. Basic Mov. 10 MA. F.S.V. = 3. New. Price \$2.45
 G.E. Type DO-50, 3" Sq. Scale reads 0-3/0.0 V. D.C. Basic Mov. 10 MA. F.S.V. = 3. New. Price \$2.45
 G.E. Type DO-50, 3" Sq. Scale reads 0-80 Amps. D.C. and F.S.V. = 0.50. New. Price \$2.45
 G.E. Type DO-50, 3" Sq. Scale reads 0-100 Amps. D.C. and F.S.V. = 0.50. New. Price \$2.45

TERMS: Rated Concerns Net 30, FOB Bronxville, New York. All Merchandise Guaranteed. Prices Subject to Change.

PHONE: BRONXVILLE 2-0044

ELECTRONICRAFT INC.

27 MILBURN ST. BRONXVILLE 8, N. Y.

Cable Address: Electcraft, N.Y.

COMMUNICATIONS EQUIPMENT CO.

MICROWAVE COMPONENTS

10 CM.—RG48/U Waveguide

- 10 CM ECHO BOX: Tunable from 3200-3333 Mc. For checking out radar transmitters, for spectrum analysis, etc. Complete with pickup antenna and coupling devices. \$27.50
- 10 CM ANTENNA ASSEMBLY: 3000-3300 Mc. Parabolic Dish, 20 inch Diam. Fed from dipole. Rotation: 360 Deg. Azimuth at speeds of 20 and 10 RPM. Tilt: 20 deg. above and below horizontal. Motor Driven by 2-28V motors, 1.5 A Total Drain. Azimuth input is fed to servo mechanism, and elevation data is obtained from Azimuth potentiometer. Net Weight 65 lbs. \$78.50
- POWER SPLITTER for use with type 726 or any 10 CM Shepherd Klystron. Energy is fed from Klystron antenna through dual pick-up system to 2 type "N" connectors. \$22.50 EACH
- DIRECTIONAL COUPLER. Broadband type. "N" output. Coupling, 20 db, with sid flanges. Navy CABV4A-AN-2 \$37.50
- LHTR. LIGHTHOUSE ASSEMBLY. Parts of RT39 AP4 5 & APG 15, Receiver and Trans. Cavities w/assoc. Tr. Cavity and Type N CPLG. To Reviv. Uses 2C40, 2C43, 1B27. Tunable APX 2400-2700 MGS. Silver Plated. \$32.50
- BEACON LIGHTHOUSE cavity p/o UFN-2 Beacon 10 cm. Mfg. Bernard Rice, each. \$32.50
- MAGNETRON TO WAVEGUIDE Coupler with 721-A Duplexer Cavity, gold plated. \$45.60
- 721A TR BOX complete with tube and tuning plungers. \$12.50
- MENALLY KLYSTRON CAVITIES for 707B or 2K28 \$4.00
- WAVEGUIDE to 7/8" Rigid Coax "Doorknob" Adapter Choke Flange Silver Plated Broad Band. \$32.50
- AS14A AP-10 CM Pick up Dipole with "N" Cables \$4.50
- HOLMDELL TO-TYPE "N" Male Adapters. W. F. #D167284 \$2.75
- I.F. AMP. STRIP: 30 MC. 30 db. gain, 4 MC Bandwidth, uses 6AC5's—less tubes. \$24.00
- BEACON ANTENNA. AS31/APN-7 in Lucite Ball. Type "N" feed. \$22.50
- ANTENNA. AT49A/APR. Broadband Conical, 3000-3300 MC Type "N" Feed. \$12.50
- "E" PLANE BENDS, 90 deg. less flanges. \$7.50

3 CM.—RG 52/U Waveguide

- FLEX. WAVEGUIDE SECTION, 1 ft. long. With UG-40/UG-39 flanges. Attenuation is less than 0.1 db. at 9375 mc. and VSWR is less than 1.02. Rubber covered. \$7.50
- 3 CM ANTENNA ASSEMBLY: Uses 17" paraboloid dish, operating from 24 vdc motor. Beam pattern: 5 deg. in both Azimuth and elevation. Sector Scan: over 160 deg. at 35 scans per minute Elevation Scan: over 2 deg. Tilt: over 24 deg. \$85.00
- Cross-Guide Directional Coupler, UG-40 output flange. Main Guide is 6" Long, with 90 Deg. "E" Plane bend at one end, and is fitted with Std. UG 39/UG 40 flanges. Coupling figure: 20 db Nominal. \$22.50
- HORN FEED, Mounted at end of 1' run. Designed to be used with dish reflector. \$15.00
- VSWR Measuring Section. Consisting of 6" straight section, with 2 pick-up. Type "N" Output Jacks, mounted 1/2 Wave apart. \$8.50
- RG52/U waveguide in 5' lengths, fitted with UG 39 flanges to UG40 cover. \$7.50 per length
- Rotating-joints supplied either with or without deck mounting. With UG40 flanges. each, \$17.50
- Bulkhead Feed-Thru Assembly. \$15.00
- Pressure Gauge Section with 15 lb. gauge. \$10.00
- Directional Counter, UG-40/U Take off 20db. \$17.50
- TR-ATR Duplexer section for above. \$8.50
- Rotary joint choke to choke with deck mounting. \$17.50
- 90 degree elbows. "E" plane 2 1/2" radius. \$12.50
- Microwave Receiver, 3 CM. Sensitivity: 10-13 μ Vdcs. Complete with L.O. and AFC Mixer and Waveguide Input Circuits. 6 I.F. Stages give approximately 120 DB gain at a bandwidth of 1.7 MC. Video Bandwidth: 2 MC. Uses latest type AFC circuit. Complete with all tubes, including 723A/B Local Oscillator. \$175.00
- ADAPTER, waveguide to type "N", UG 81/U, p/o TS 12. TS-13. Etc. \$14.50
- ADAPTER, UG-163/U round cover to special htl. Flange for TS-45, etc. \$2.50 ea.

3CM Motor-Driven Echo Box

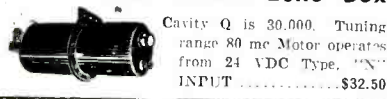

Cavity Q is 30,000. Tuning range 80 mc Motor operates from 24 VDC Type. "N" INPUT \$32.50

K Band—1/2" x 1/4" W.G.

- Right Angle Bend E or H Plane, specify combination of couplings desired. \$12.00
- 45° Bend E or H Plane, choke to cover. \$12.00
- Mitered Elbow, cover to cover. \$4.00
- TR-ATR Section, Choke to cover. \$4.00
- Flexible Section 1" choke to choke. \$5.00
- "S" Curve Choke to cover. \$4.50
- Adapter, round to square cover. \$5.00
- Feedback to Parabola Horn with pressurized windows for APS-34. \$27.50

MAGNETRONS

Type	Freq. Range (MC)	Peak Power Out (KW)	Duty Ratio	Price
2212A	3345-9405	50		58.75
2212	3267-3333	265		7.50
2126	2992-3019	275		7.49
2127	2965-2992	275	.002	19.95
2129	2914-2939	275	.002	49.95
2131	2820-2860	285	.002	24.50
2132	2780-2820	285	.002	28.50
2138*	3249-3263	5		16.50
2139*	3267-3333	5	8.7	24.50
2148	9310-9320	50		24.50
2149	9000-9160	50	.001	59.50
2158*	9215-9275	50	.001	132.50
2161†	3000-3100	35	.002	34.50
2162†	2914-3010	35	.002	34.50
3431	24-27KMC	50	.001	85.00
4134	2740-2750	900		125.00
4142†	670-730	30	.003	169.50
5123	1044-1056	475	.001	49.00
700B	690-700	40	.002	22.50
700D	710-720	40	.002	39.75
706EY	3038-3069	200	.001	32.50
706CY	2976-3097	200	.001	32.50
725-A	9345-9405	50	.001	Write
730-A	9345-9405	50	.001	24.00
4J38	3550-3600	750	.001	169.45

*—Packaged with magnet.
†—Tunable over indicated range.

KLYSTRONS

723A	\$12.50	2K25/723A/B	\$27.50
723A/B	19.50	417-A	17.50

70 WATT MAGNETRONS

These tubes provide a simple, rugged, inexpensive source of C.W. energy. An inexpensive power supply is all that's required.

CHARACTERISTICS:

Heater: 6.3 V, 3.8 A	Power out: 70 W. Cw
Anode V. 1250 V	Anode current: 125 ma.
Pk. Input: 200 Watts	Av. input: 100 W
Each tube is packaged with an integral magnet, and is tunable over the range shown below.	
TYPE RANGE (MC.)	TYPE RANGE (MC.)
QK 60 2810-3005	QK 61 2975-3170
QK 62 3135-3330	

Price \$85 ea.

15 KV CONTACTOR

Rugged contactor assembly: Coil: 115V 60 cps, 1 phase. Contacts: SPST NO, 15,000 V., 1.0 amp. plus 2-SPST NO contacts in parallel rated 100 amp per contact. Contactor has 2 auxiliary contact ass'y's. For operating accessory pilot equipment. Equipped with flash barriers. Size 1 1/2" x 1 1/4" x 1 1/4" Overall

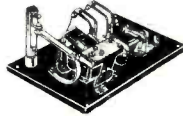

\$37.50

VARISTORS

D-167208	\$1.35	D-171812	\$1.63
D-171858	\$1.42	D-172155	\$1.50
D-168687	\$1.35	D-167176	\$1.25

THERMISTORS

D-164699	Bead Type DCR: 1525-2550 Ohms @ 75 Deg. F. Coefficient: 2% Per Deg. Fahr. Max. Current 25 MA AC/DC. \$2.50
D-167332	Bead Type. DCR is 1525-2550 Ohms. Rated 25 MA at .825-1.175 VDC. \$1.35
D-167613	Disk Type DCR: 355 Ohms @ 75 Deg. F. P.M. 2.5% I Watt. \$1.35
D-166228	Disk Type 7120 Ohms @ 60°F. 4220 Ohms @ 80°F. 2500 Ohms @ 100°F. 1640 Ohms @ 120°F 1/35

—IN STOCK—

A1A	APS-4	APT-4	SJ-1
APA-9	APS-6	MKV	TAJ
APA-10	ASD	MKX	TBK
APN-3	ASH	RC145	TBL
APN-7	BG	RC148	SCR520*
APN-9*	DAS†	SO-1	SCR521
APS-2	DBS†	SO-8	SCR518
APS-3	APT-2	SG-1	

*COMPONENTS. †LORAN EQUIPMENT

—TEST SETS—

TS-10	TS-12	TS-159
TS-36	TS-56	TS-268
TS-47	TS-34	TS-270

JAN WAVEGUIDE FLANGES

UG 39/U	\$1.10	UG 51/U	\$1.65
UG 40/U	\$1.25	UG 52/U	\$3.40
UG 40A/U	\$1.65	UG 52A/U	\$3.40

MICROWAVE ANTENNAS

- AT49/APR—Broadband Conical. 300-3300 MC. Type N Feed. \$8.95
- AS-31/APN-7. 10cm. Polyrod in Lucite Ball. Type N Fitting Coax Feed. \$22.50
- Relay System. Parabolic reflectors approx. range 2000 to 6000 Mc. Dimensions 4 1/2" x 3". New. \$100.00
- Dipole for above. \$12.00
- Cone Antenna. AS 125 APIT. 1000-3200 mc. Stub supported with type "N" connector. \$14.50
- AS14A/AP. 10 CM pick up dipole assy, complete w/length of coax and "N" connectors. \$4.50
- AS46A/APG-4 Yagi Antenna, 5 element array. \$22.50
- 30" Parabolic Reflector Spun Aluminum dish. \$4.85
- APS-34 Millbox Antenna, waveguide input. 24,000-27,000 MC. \$22.50
- SCR 584, Dishes Perforated, Metal Construction \$185.00

PULSE TRANSFORMERS

- Westinghouse 4P37: Primary: 50 ohms imp, 750 v. Sec. 15 kv, 1000 ohms imp. Bilhar filament trans. built in, delivers 12.6 v at 2.5 amp. (pri. 115 v. 400 cps.) \$37.50
- RAYTHEON WX 4298E: Primary 4KV, 1.0 USFC. SEC. 16KV-16 AMP. DUTY RATIO: .001 400 CYCLE PUL. TRANS. "BUILT-IN" \$42.50
- WECO: KS 9948: Primary 100 ohms; Sec. 50 ohms; Plate Voltage: 18 KV, Part of APQ-13. \$12.50

GE #K-2449A



Primary: 0.33 KV, 50 ohms Imp.
Secondary: 28 KV, 450 ohms.
Pulse length: 1.0/5 usec @ 635/120 PPS. Pk Power Out: 1.740 KW
Bihar: 1.5 amps (as shown) \$62.50

- GE #K2748-A. 0.5 usec @ 2000 Pps. Pk. Pwr. out is 32 KW impedance 40:100 ohm output. Pri. volts 2.3 KV Pk. Sec. volts 11.5 KV Pk. Bihar rated at 1.3 Amp. Fitted with magnetron well. \$39.50
- K-2745 Primary: 3.1/2.8 KV, 50 ohms Z. Secondary: 14/12.0 KV 1025 ohms Z. Pulse Length: 0.25/1.0 usec @ 600/600 PPS. Pk. Power: 200/150 KW. Bihar: 1.3 Amp. Has "built-in" magnetron well. \$42.50
- K-2461-A. Primary: 3.1/2.6 KV—50 ohms (line). Secondary 14/11.5 KV—1000 ohms Z. Pulse Length: 1 usec @ 600 PPS. Pk. Power Out: 200/130 KV. Bihar: 1.3 Amp. Fitted with magnetron well \$39.75
- UTAH X-1517-1: Dual Transformer. 2 Wdgs. per section. 1:1 Ratio per sec 13 MH inductance 30 ohms DCR. \$7.50
- UTAH X-1507-1: Two sections, 3 Wdgs. per section. 1:1:1 Ratio. 3 MH, 6 ohms DCR per Wdg. \$7.50
- 68G711: Ratio: 4:1 Pri: 200V. Sec. 53V, 1.0 usec Pulse @ 2000 PPS. 0.016 KVA. \$4.50
- TR1049: Ratio 2:1 Pri. 220 MH, 50 Ohms. sec. 0.75 H. DCR 100 Ohms. \$6.75
- K-901695-501: Ratio 1:1. Pri. Imp. 40 Ohm, Sec. Imp. 40 Ohms. Passes pulse 0.6 usec with 0.05 rise. \$8.95
- Ray UX 7896—Pulse Output Pri. 5v sec. 41v. \$7.50
- Ray UX 8442—Pulse inversion—40v + 40v. \$7.50
- PHILCO 352-7250, 352-7271, 352-7287
- RAYTHEON: UX8493, UX5986 \$5 ea.
- W.E.: D-166310, D-166638, KS9800, KS9948.
- UTAH #9262, with Cracked Beads, but will operate at full rated capacity. \$5.00
- UX 8693 (SCS #270627-51): 3 Wdgs. 32 turns #18 wire. DCR is: 362/372/4 ohms. Total voltage 2500 vdc. \$5.00
- D-166173: Input: 50 ohms Z. Output: 900 ohms Z. Wdgs. Freq. range 10 kc-2mc. P/O AN/ATQ-13 \$12.50
- K-2450: Pulse-inversion auto-transformer: primary 13 kv, 4 usec. Output: 14 kv @ 100 kw peak. \$34.50

PULSE NETWORKS

- 15A-1-400-50: 15 KV. "A" CKT. 1 microsec. 400 PPS. 50 ohms imp. \$37.50
- G.E. #3E (3-84-810) (8-224-405) 50P4T. 3KV "E" CKT. Dual Unit. Unit 1, 3 sections. 0.84 Microsec. 810 PPS. 50 ohms imp. Unit 2, 8 Sections. 2.24 microsec. 405 PPS. 50 ohms imp. \$6.50
- 7-5E3-1-200-67P. 7.5 KV "E" Circuit. 1 microsec. 200 PPS. 67 ohms impedance 3 sections. \$7.50
- 7-5E1-16-60. 67P. 7.5 KV "E" Circuit. 4 sections 16 microsec. 60 PPS. 67 ohms impedance. \$15.00
- 7-5E3-3-209-67P. 7.5 KV "E" Circuit. 3 microsec. 200 PPS. ohms imp. 3 sections. \$12.50
- H-615. Sprague 10KV, 2.2 usec., 375 PPS. 50 ohms imp. Philco #358-2754. \$27.50
- H-615. Sprague 10KV, 0.85 usec., 750 PPS. 50 ohms imp. Philco #358-2754. \$27.50
- #754: 10KV, 0.85 usec., 750 PPS. 50 ohms imp. \$27.50
- KS8865 CHARGING CHOKE: 115-150 II @ .02A. 32 -10II @ .08A. 30,700V Corona Test. 21KV Test. \$37.50
- G.E. 2-EE3-1-350-50 P2T. "E" CKT. 1 Microsec. Pulse @ 350 PPS. 50 OHMS Impedance. \$69.50
- G.E. 6E3-5-2000-50 P2T. 6 KV. "E" Circuit 0.5 usec /2000 PPS/50 ohms/2 sections. \$7.50

PULSE EQUIPMENT

- MIT. MOD. 3 HARD TUBE PULSER: Output Pulse Power 141 KW (12 KV at 12 Amp.) Duty Ratio: .001 max. Pulse duration: 5, 1.0, 2.0 microsec. Input voltage: 115 v. 400 to 2400 cps. Uses: 1 71B, 4-80 T, 3 72, 1 73. New. \$350.00
- ASD Modulator Units, mfd. by Sperry. Hard tube pulser delivers Pk. pulse of 144 kv. Similar to Mod 3 unit. Brand new, less tubes. \$85.00
- Airborne RF head, model A1A, delivers 50 Kw peak output at 9000 mc. at .001 duty. Complete with pulser unit and all tubes. Used, excell. \$185.00

MAIL ORDERS PROMPTLY FILLED. ALL PRICES F.O.B. NEW YORK CITY. 25% DEPOSIT WITH ORDER. BALANCE C.O.D. RATED CONCNS SEND P O

131 Liberty St., New York 7, N. Y. Dept E-6 Chas. Rosen Phone: Dlgy 9-4124

POWER TRANSFORMERS

COMB. TRANSFORMERS 115V/50-60

CPS INPUT

CT-479	7000V/.018A (2 X Ind. V. Test) 2.5V	537.50
CT-138	520-0-520V 500MA, 6.3V/3A, 6.3V/17A, 2 X 5V/3A	14.75
CT-013	450-0-450V @ 200MA, 10V/1.5A, 2.5V 3.5A 5V/3A	6.95
CT-341	1050V/10MA—625V @ 5MA, 26V @ 4.5A 2x2.5V/3A, 6.3V @ 3A	9.95
CT-403	350VCT .025 A 5V/3A	2.75
CT-931	585VCT .086 A 5V/3A, 6.3V/6A, 4.25	4.25
CT-442	525VCT 75 MA 5V/3A, 1CT/2A, 50V/200 MA	3.85

FILAMENT TRANSFORMERS 115V/50-60 CPS INPUT

Item	Rating	Each
FT-140	5VCT @ 10A 25KV Test	\$22.50
FT-157	4V/36A, 2.5V/2.75A	2.95
FT-101	6V/25A	1.79
FT-924	5.25A/21A, 2x7.75V/6.5A	14.95
FT-824	2x26V/2.5A, 16V/1A, 7.2V/7A, 6.4V/10A 6.4V/2A	8.95
FT-463	6.3VCT/1A, 5VCT/3A, 5VCT/3A	5.49
FT-55-2	7.2V/21.5A, 6.5V 6.85A, 5V/6A, 5V/3A	8.95
FT-38A	6.3/2.5A, 2x2.5V/7A	2.79
FT-650	2.5V/10A-3KV Test LO-CAP	7.50

PLATE TRANSFORMERS, 115V/60 CY INPUT

PT 175	550-0-550VAC (400VDC) @ 150MA	\$6.30
PT 157	660-0-660 VAC (500VDC) or 550-0-550 VAC (400VDC) at 125MA	8.70
PT 158	1080-0-1080V (1000VDC) at 125MA Plus 500-0-500VAC (400VDC) at 150MADC Simult. Ratings	10.80
PT 159	900-0-900 VAC (750VDC) or 800-0-800 VAC (600VDC) at 225 MADC	10.35
PT 167	1400-0-1400 VAC (300MADC) or 1175-0-1175 VAC (1000VDC) at 300MADC	25.50
PT 168	2100-0-2100 VAC (1750VDC) or 1800-0-1800 VAC (1500VDC) at 300 MADC	33.00
PT 371	210-0-210V at 2.12 Amp	9.45
PT 133	3340-0-3370V, 2.5 KVA	\$105.00
PT 801	22,000V/234 MA., 5.35 KVA, "Lo-Cap" Donut	\$135.00
PT 521	7500V/.06A, Half-Wave	\$85.00
PT 579	3100-0-3100V/2KVA, 15KV.INS.	\$135.00

C. T. Grounded (case)



GE #M-7470689 Input: 115 V, 60 Cycle, Single Phase
1 WDG 3700 V Tapped at 710V
1 WDG 1700V Primary
Rated .0377KVA
Lo-Cap Donut Construction \$24.75

FILTER CHOKES

Stock	Description	Price
CH-187	Swing, 4-16H, 150MA, 210 ohms, 3KV Test	\$3.90
CH-189	Swing, 4-16H, 250MA, 125 ohms, 3KV Test	6.60
CH-190	Swing, 3-14H, 300MA, 80 ohms, 3KV Test	6.90
CH-CEC117	9-60H/.05-400MA, 10KV Test	14.95
CH-366	20H/3A	6.95
CH-322	.35H/350MA—10 Ohms DCR	2.75
CH-141	Dual 7H/75 MA, 11H/60 MA	4.69
CH-119	8.5H/125 MA	2.79
CH-69-1	Dual 120H/17 MA	2.35
CH-8-35	2/.5H/380 MA 25 Ohms	1.79
CH-776	1.28H/130 MA 75 ohms	2.25
CH-344	1.5H/145MA/1200V Test	2.35
CH-43A	1.5H/15MA—850 ohms DCR	1.75
CH-366	20H/300MA	6.95
CH-999	15HY/15MA—400 ohms DCR	1.95
CH-445	0.5 HY/200 MA, 32.2 OHMS, 3000 V.T.	1.39
CH-914	12 HY-250 MA SCS 3C1987-14	3.69
CH-533	13.5H, 1.0 AMP DC, 13.5 KV INS	29.95

DYNAMOTORS

TYPE	INPUT		OUTPUT		Price
	VOLTS	AMPS	VOLTS	AMPS	
DM 416	14	6.2	330	.170	\$6.75
DM 33A	28	7	540	.250	3.95
BD AR 93	28	3.25	375	.150	7.50
23350	27	3.75	285	.075	3.95
B-19 Pack	12	9.4	275	.110	8.95
DA-3A*	28	10	500	.050	6.95
			300	.260	
			150	.010	
PE 73 CM	28	19	1000	.350	22.50
BD 691	14	2.8	220	.08	12.95
D-402†	13.5	12.2	300	.200	
			8.8VAC		12.50
SP 175	18	3.2	450	.06	4.49
DM 25†	12	2.3	250	.0	6.95

† Less Filter. * Replacement for PE 94.
† Used. Excellent.

INVERTERS

800-1B Input 24 vdc, 62 A. Output: 115 V, 800 cy, 7A, 1 phase. Used, excellent \$18.75
 PE-218H: Input: 25/28 vdc, 92 amp. Output: 115V, 350/500 cy 1500 Volt-ampere. NEW \$37.50
 PE-286: Input: 28 vdc, 36 amps. Output: 80 v 800 cy, 500 volt-amps. Dim: 13" x 5 1/2" x 10 1/2" \$22.50
 NAVY COR-211095: Input 22-30 VDC/75-60A OUTPUT: 115V/400 CY, 1 KVA/8.7A. RPM: 4800 with coupling provision for Spark Gap. Brand New. Original packing. \$150.00
 ALTERNATOR: Belt-Driven, Output 80V/600 Watts/1200 CPS \$49.50

Send M.O. or Check. Shipping Chgs. C.O.D.
COMMUNICATIONS EQUIPMENT CO.
 131 Liberty St. Dept. E-6 New York City 7, N.Y.

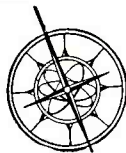

COMPASS COMMUNICATIONS CO.

A Division of COMPASS ELECTRONICS CORP.

A WELL-INTEGRATED ORGANIZATION WITH FACILITIES AND TRAINED PERSONNEL FOR—

- DESIGN, MODIFICATION, PRODUCTION, AND TESTING OF COMMUNICATIONS AND RADAR EQUIPMENT
- SUPPLY AND DISTRIBUTION OF ALL TYPES OF EQUIPMENT AND TUBES

We Maintain Our Own Fully Equipped Testing Laboratory to Test and Guarantee Anything We Sell

SPECIAL RADAR AND MICROWAVE ACCESSORIES

TS-35A/AP—(LATE MODEL) X-BAND SIGNAL GENERATOR AND POWER METER—Input 115/1/50-1200 CPS. Generates and measures RF power. Produces (CW or pulsed, int. or ext. synchronized) signal of known frequency and power. Generates FM signal for trouble shooting radar. NEW—\$475.00

SN—RADAR—10 cm—Compact, light and portable, ranges of 5 and 20 miles. Uses 5CPI scope. Operation is from 115 volts, 60 cycle, but we can supply converter for dc operation. \$850.00 ea

ANTENNA ASSEMBLY—10 cm Radar—Reflector is a lightweight parabolic cylinder, Ass'y

has both manual and motor drive. Ideal unit for labs, classroom demonstration, small craft, etc. \$99.50 ea

MAG—10 cm. remarkable link radar, portable, operated from 6 volt battery, uses folding antenna and tripod. A pair at \$1,750.00

APS-3—3 cm—Airborne radar for search and homing, 5-in. scope. 10 brand new sets at \$750.00 ea

APQ-13—Very late model airborne radar set, complete and new. One only at \$2,950.00

SCR-545—Complete radar set, less vehicle, antenna and power plant, pretty fair condition, sold as-is at \$1,375.00

MOTOR GENERATORS CONVERTERS • INVERTERS DYNAMOTORS

We Have One of the Largest Stocks of Electrical Conversion Equipment in the East, including All Types of Rotating Machinery and a Variety of DC and AC Magnetic Starters and Controllers from 100 Watts to 100 Kilowatts

MOTOR GENERATOR, in 115 vac, out 220-250 vdc, @ 1/2 KVA \$65.00

ESCO ROTARY CONVERTERS — Mounted in Steel Drip-Proof Boxes—Type R-1-41. Filtered Input 110 volts, 2.5 amps, 3600 rpm. Output 110/1/60 @ 1.8 amps, 200 watts \$45.00

ESCO MOTOR GENERATORS—Dual unit (a) Input 32 v dc @ 8 amp. Output 110/1/60 @ 1.5 amps, 165 va 150w, 1800 rpm. (b) Input 32 volts dc @ 16 amps. Output 260 volts, 1500 cycles @ 4 amps. Rating 1.05 kva, 3,000 rpm. Filtered. These two units are mtd. together on bed plate, complete with control panel containing switch & 0-50 v dc meter. \$32.50 ea. part.

MOTOR - GENERATOR - ALTERNATOR—Migr.—Quality Electric Co. Ltd. Input 115/1/60 ac @ 22.5 amps, 1800 rpm. Outputs: #1.500/1000 v dc, 0.25/0.3 amp., 0.125/0.3 kw #2 150 v dc, 0.667 amp., 0.1 kw. #3. 115 v ac 0.87 amp., 3000 cycles. 0.1 kva. PF-1. \$245.00

ESCO CONVERTER—Input 110 volts dc. output 110 volts ac @ 1.2 amps. Brand new. \$35.00

ALLIS CHALMERS CONVERTER 110 volts dc to 110 volts ac @ 1.25 kva output \$165.00

PINCOR ROTARY CONVERTER — Input 110 volts dc. Output 220/1/60, 0.300 kva; 90 pf; 3000 rpm; cont. duty; 40°C. Filtered for Radio use \$60.00

CONTINENTAL MOTOR - GENERATOR — 350 watts. Type CC-21991—Wt. 148 lbs. Input 115 volts dc @ 5.7 amps, 0.625 hp. Output 115 volts ac, 1 ph., 60 cycles @ 3.04 amps, 1800 rpm, 0.85 pf, 40°C temp. rise, sep. excited. Filtered \$95.00

WESTINGHOUSE ELECTRIC GENERATOR — 10 KVA—AC. Output 115/1/60 @ 108.5 amps; .80 pf; 50°C; cont. duty 1800 rpm, sep. excited, 125 dc. DC generator Output 125 volts dc @ 8 amps. This generator is mounted on bed plate with room for motor mounting. It can be driven by any mechanically coupled motor, dc or ac or other drive \$459.00

MOTOR GENERATOR 800-1D — Input 24-28 volts dc, Output 115 v, 800 cycles at 10.5 amps. Small and compact \$29.50

M-209—Holtzer-Cabot—Filtered. Input 115/1/60. Output 115 volts, 3φ, 233 cycles; at 0.4 amps and 24 volts dc at 6.5 amps. 3500 rpm. \$125.00

MG-149—Holtzer-Cabot Inverter ... \$49.50

21F1 SELSYN—115-57.5v. 400 cycles \$44.45

SF, 5G—SYNCHRO—115 v, 60 cycles \$39.50

POWER UNIT TYPE 23 — Rotary transformer, filtered. Input 24 vdc. Output 6.3 volts at 2 amps and 200 volts at 30 ma \$19.50

And, of course, PE-73, PE-94, PE-98, BM-25, -28, -32, -33, etc.

SA-2-RADAR. Used for air traffic control, tracking and search, both land-based and ship-borne. 5 microsec. pulse, PPI indication, operates at 200mcs, peak power of 150 KW. Input 110/120 volts a.c. 4 complete installations in stock.

We Have Equipment in Quantity:

- 500 Sets SCR 510 and 610
- 200 Sets SCR-269
- 250 Sets SCR 508-528
- 200 Sets SCR-284
- 250 Sets SCR 608-628
- 30 Sets TCS
- 50 Sets SCR 808-828
- 200 Sets BD-71, 72 Switchboards
- 200 Sets MN-28
- Etc. Etc.

SPECIAL PURPOSE and TRANSMITTING TUBES

MARINE AND AIRCRAFT COMMUNICATIONS AND NAVIGATION EQUIPMENT
 OUR EXPORT DEPARTMENT AVAILABLE FOR SPECIAL SERVICE TO OVERSEAS CUSTOMERS

393 GREENWICH STREET NEW YORK 13, N. Y.
 All phones: BEEKMAN 3-6510 Cable Address: COMPRADIO, N. Y.
 WHOLESALE, INDUSTRIAL AND INSTITUTIONAL SALES ONLY

SAVE ON TUBES BRAND NEW TUBES GUARANTEED TUBES

OA2	\$95	2J34	17.50	4C35	17.50	5J33	7.50	250TH	14.50	707B	13.55	832A	6.50	5633	8.95
OA3	VR75 1.00	2J36	89.00	4J26	99.50	5MP1	3.95	250TL	12.50	708A	1.95	836	2.95	5634	8.95
OA5	3.50	2J42	105.00	4J28	99.50	5NP1	3.95	251A	49.50	713A	.95	837	1.45	5636	5.25
OB2	1.00	2J49	59.50	4J29	99.50	5R4GY	1.25	274B	2.75	715A	3.00	838	2.98	5637	4.00
OC3	VR105 .90	2J51	195.00	4J30	149.50	5R4WGY	1.60	304TL	6.95	715B	4.00	851	35.00	5639	8.95
OD3	VR150 .85	2J56	89.50	4J31	99.50	C6L/5528	6.50	307A	RK75 2.95	715C	13.00	852	12.50	5643	6.95
1B22	1.20	2J61	24.50	4J34	75.00	C6J	7.25	310B	8.95	717A	.90	860	3.50	5646	8.95
1B23	4.00	2J62	11.00	4J36	99.50	6AL5W	1.60	312A	2.95	719A	19.00	861	12.00	5651	2.50
1B24	6.75	2K22	17.50									865	.98	5654	1.75
1B26	1.75	2K23	19.95									866A	1.30	5656	14.95
1B27	11.00	2K25	20.00									869B	35.00	5657	150.00
1B32	532A 1.75	2K26	50.00									872A	1.95	5670	3.50
1B35	5.50	2K28	25.00									874	1.10	5672	1.29
1B42	8.25	2K33A	65.00									878	1.95	5676	1.29
1B63A	42.50	2K34	139.50	4J42	79.50	6BL6	60.00	316A	1.25	720BY	125.00	880	300.00	CK5678	1.00
1D21	SN4 3.75	2K39	115.00	4J52	199.50	69M6	69.50	323B	7.95	720CY	125.00	884	1.40	5687	3.75
1N21B	2.00	2K41	125.00	4J57	299.50	6C21	24.50	327A	4.50	720EY	125.00	889R-A	175.00	5693	4.25
1N23B	2.90	2K42	139.50	4-1L5A	19.00	6F4	3.00	328A	3.95	721A	2.95	891R	125.00	5694	2.60
1N34A	.79	2K45	110.00	4X150A	27.50	6J4	4.50	336A	write	722A	1.95	GL893A	295.00	5702	2.95
1N35	1.95	2K48	99.50	4X500A	7500	6SU7GTY	2.75	337A	6.00	723A	7.95	922	1.25	5704	2.50
1N38	1.50	2X2A	1.40	5AP1	2.95	7C22	99.50	349A	8.50	723A/B	12.00	931A	4.95	5718	6.00
1N44	1.10	3B22	1.95	5BP1	3.95	7C24	99.50	350A	4.50	724B	2.00	935	5.00	5719	8.95
1N47	4.50					12DP7	13.00	368AS	4.00					RK5721	189.50
1N55	2.75					12GP7	17.50	383A	write					5750	3.10
1N63	K63 1.95					12HP7	13.50	393A	5.95					5787	6.00
1P28	7.75					15E	1.75	394A	3.50					CK5787	4.95
1P29	2.00					KC4	39.50	417A	8.50					5814	1.75
1P36	2.75					D42	write	434A	9.95					5844	4.50
1P39	1.20					35TG	5.95	446A	1.19					5876	14.95
1Z2	2.75					FG57 5559	15.00	446B	3.50					5893	12.50
VS-2	7.50					QK60	59.00	450TH	40.00					5902	8.95
2B22	2.25					RK60 1641	1.95	450TL	40.00					5905	12.50
2C21x1642	.69					RK72	.95	WL456	59.50					5907	9.00
2C36	25.00					RK73	.95	464A	4.95					5908	9.00
2C39	12.50					75T	6.95	WL530	16.95					5916	9.00
2C39A	13.00	3B23	4.05	5BP2A	4.95	75TL	7.95	CK536AX	.95					5932	
2C40	7.25	3B24	4.25	5BP4	3.25	83V	1.10	GL562	write	725A	4.50	955	.49	6L6WGA	4.95
2C42	10.00	3B26	3.50	5CP1A	14.50	FG95 5560	22.50	GL605	write	726A	12.00	957	.49	5972	4.50
2C43	13.95	3B28	5.95	5C22	27.50	ML-100	write	WL616	99.50	726B	32.00	958A	.69	6005	2.75
2C44	.89	3C22	72.50	5CP7	9.50	100TH	7.50	GL623	write	730A	20.00	959	1.50	6026	2.25
2C46	10.00	3C23	6.50	5D21	9.50	HF120	9.95	KU627	17.50	803	3.75	CK1005	.69	6110	8.95
2C51	3.69	3C24	24G 1.10	5FP7	1.95	FG104	29.50	KU628	write	804	10.95	CK1006	1.95	6111	9.50
2C52	3.00	3C27	3.75	5FP1 4	7.50	FG105	17.50	WL-651	39.50	805	2.95	1616	.90	6121	9.95
2D21	1.15	3C33	9.95	5HF1	3.95	F-123A	7.79	WL652	65739.00	807	1.50	1619	.30	6201	4.50
2D21 W	2.49	3C45	9.50	5HF4	3.95	VI-127A	2.75	F660	write	808	2.75	1625	.30	8005	4.95
2E24	3.30	3EP9	9.50	5JP1	17.50	FK159	149.60	F661	write	809	2.75	1629	.30	8012	1.95
2E26	3.25	3FP7	1.95	5JP2	17.50	FG172	22.50	700 B C D	16.50	810	2.95	1630	.89	8013	4.95
2E31	1.40	3GP1	1.95	5JP4	17.50	HF200	14.50	703A	2.95	811A	3.50	1636	1.25	8020	1.25
2E35	1.40	3JP1	12.50	5JP5	17.50	WL900	write	705A	1.50	812	2.95	2050	1.30	8025	3.95
2J26	5.00	3K27	199.50	5J23	29.50	207	75.00	706AY	27.50	813	7.95	2051	.80	8025A	5.95
2J27	7.50	3K30	199.50	5J26	120.00	211 VTAC	.80	706BY	27.50	815	3.50	ZB3200	100.00	9001	1.15
2J31	17.50	4B24	6.95	5J29	10.00	217C	4.95	706CY	27.50	828	9.95	5516	5.50	9002	.98
2J32	17.50					221A	.98	706DY	27.50	829	6.00	5586	200.00	9003	1.30
2J33	20.00	4C27	CV22 9.00	5J30	19.95	QK249	200.00	706FY	27.50	899B	9.50	5591 403B	3.00	9004	.49
						250R	6.95	706GY	29.50	830B	1.95	5611	115.00	9005	1.50

NOW—NEW LOW PRICES!

SPECIAL!
Vacuum Capacitors



50 mmfd. 15,000 v. \$7.50
12 mmfd. 32,000 v. \$10.00
50 mmfd. 32,000 v. \$12.50
100 mmfd. 20,000 v. \$14.00

5" DUAL GUN TUBE SPECIAL!

Long persistency face. Valued at \$200.00. This tube has been rejected for military use.

Fully guaranteed. Only **\$17.95**

WRITE FOR FREE CATALOG!

All Prices F.O.B. Los Angeles, subject to change without notice. Minimum order \$5.00. Orders for \$5.00 should be prepaid in full.

Jsh SALES CO. **ELECTRONICS**
Dept. EF
7552 Melrose Ave.
Los Angeles 46, California

Thousands of other types in stock. Send us your requirements. RECEIVING TUBES? We carry a complete line in stock. Standard brands only.

New Sola Const. Volt. Transformers

Input 95-125VAC, Output 118VAC 60 cycles
165VA \$24.95, 225VA \$32.95, 310VA \$42.50,
475VA \$47.50, 750VA \$68.50, 6.3VAC @2.7
Amp. \$6.95

LAPIROW BROS.

1649 Hoffner St. Kirby 1285 Cincinnati, Ohio

GLASS TUBING

PYREX - NONEX - URANIUM
BULB & CYLINDERS
WRITE FOR FREE MONTHLY LIST
HOUE SUPPLY COMPANY
PHONE KEYPORT 7-1286
M. R. #1 Box 86X Keyport, N. J.

Transmitters: ART-13, BC-610-E, TCS-12
Receivers: BC-312, BC-342, BC-348, AR-88
Transmit-Rec: ARC-1, SCR-694-C, SCR-284
Frequency Meters: BC-221, LM, TS-174.
Oscilloscopes: Dumont #241
Amateur Transmitters: Collins 30-J, 32V-2,
32V-3

ALLTRONICS
Electronic Equipment
BOX 19, BOSTON 1, MASS.
Telephones: Richmond 2-0048, 0916

SPECIAL!

Quantity—100—30" Flyback
TRANSFORMERS \$4.95
Used by DuMont on Model #RA119
Original Boxes EACH

Quantity—500 R.C.A. Flyback
TRANSFORMERS \$2.19
No. 75585 EACH

Quantity—100—Three Tube
PHONO AMPLIFIERS \$2.69
Uses 50L6—35Z5—12SQ7 Less Tubes

Quantity Prices on Request

WANTED! ELECTRONIC TUBES AND PARTS
PLEASE SEND LIST AND LOWEST PRICES

ADAMSON ELECTRONICS CO.
591 E. TREMONT AV. N. Y. 57, N. Y.

K-RK-ARC-UG-PL-AN

CONNECTORS

In Stock for Immediate Delivery

Connector Corporation

—OF AMERICA—

137 Hamilton St., New Haven 11, Conn. Phone: Spruce 7-2513

New York Phone: Lexington 2-6254

CRYSTALS

Guaranteed to oscillate!
Your choice of frequencies!
Largest selection in the world!

NOTE! EVERY CRYSTAL TESTED FOR ACTIVITY BEFORE SHIPMENT!
 All numbers listed are FUNDAMENTAL FREQUENCIES with fractions omitted.

FT-243 HOLDER

Lots of 10 or more. Each.....		69c
Lots of 5 or more. Each.....		79c
Individually. Each.....		99c
1015	2135 2480 2630 2775 2940 3085 3230 6073 6405 7140 7590	8066
1110	2140 2485 2635 2780 2945 3090 3235 6078 6410 7145 7595	8070
1129	2145 2490 2640 2785 2950 3095 3240 6083 6415 7150 7600	8073
1150	2155 2495 2645 2790 2955 3100 3290 6106 6440 7175 7620	8075
1195	2165 2505 2655 2795 2960 3105 3300 6125 6450 7200 7630	8083
1215	2175 2510 2655 2815 2965 3110 3310 6140 6473 7206 7640	8100
1800	2180 2515 2660 2825 2970 3115 3320 6142 6475 7225 7650	8110
1915	2195 2520 2665 2830 2975 3120 3340 6150 6500 7240 7660	8120
1930	2300 2525 2675 2835 2980 3125 3340 6150 6500 7240 7660	8120
1940	2305 2530 2675 2840 2985 3130 3340 6150 6500 7240 7660	8125
1950	2320 2535 2680 2845 2990 3135 3345 6155 6505 7245 7670	8130
1965	2350 2545 2685 2850 2995 3140 3345 6155 6505 7245 7670	8133
1977	2355 2550 2690 2855 3005 3145 3350 6160 6510 7250 7675	8140
1980	2360 2557 2695 2860 3005 3150 3355 6165 6515 7255 7680	8150
1985	2365 2560 2700 2865 3010 3155 3360 6170 6520 7260 7685	8150
2010	2370 2565 2705 2870 3015 3160 3365 6175 6525 7265 7690	8163
2015	2375 2570 2710 2875 3020 3165 3370 6180 6530 7270 7700	8166
2017	2390 2575 2715 2880 3025 3170 3375 6185 6535 7275 7705	8170
2020	2415 2580 2720 2885 3030 3175 3385 6190 6540 7280 7710	8173
2025	2430 2585 2725 2890 3035 3180 3390 6195 6545 7285 7715	8180
2035	2435 2590 2730 2895 3040 3185 3395 6200 6550 7290 7720	8183
2040	2440 2595 2735 2900 3045 3190 3398 6315 7025 7510 7783	8025
2060	2450 2603 2745 2910 3055 3200 6000 6335 7075 7530 7800	8033
2065	2455 2605 2750 2915 3060 3202 6006 6340 7075 7540 7810	8200
2090	2460 2610 2755 2920 3065 3205 6025 6350 7075 7550 7820	8041
2105	2465 2615 2760 2925 3070 3210 6040 6362 7100 7560 7830	8050
2125	2470 2620 2765 2930 3075 3220 6042 6373 7106 7570 7840	8058
2130	2475 2625 2770 2935 3080 3225 6050 6375 7125 7580 7850	8063

FT-243 HOLDER

Lots of 10 or more. Each.....		34c
Lots of 5 or more. Each.....		39c
Individually. Each.....		49c
4035	4300 4635 4930 5295 5645 5785 5906 6275 6706 66306 67625 7975 8475	8500
4045	4330 4660 4950 5320 5675 5815 5936 6306 6740 6940 7675 8250 8525	8500
4080	4340 4695 4965 5335 5685 5825 5940 6325 6750 6950 7706 8275 8550	8500
4095	4395 4710 4995 5325 5685 5825 5940 6325 6750 6950 7706 8275 8550	8500
4110	4395 4715 5030 5335 5700 5825 5950 6340 6773 36732 37725 8275 8575	8500
4135	4445 4780 5035 5385 5706 5840 5955 6350 6775 6975 7773 8300 8600	8500
4165	4450 4785 5090 5395 5725 5850 5973 36373 36800 7450 7775 8306 8625	8650
4175	4490 4815 5127 5435 5730 5855 5975 6375 6806 67473 7806 8325 8650	8650
4190	4495 4820 5165 5435 5740 5860 5995 6400 6825 7475 7825 8340 8675	8650
4215	4535 4840 5180 5485 5750 5875 6026 6406 6840 7506 67873 8350 8690	8690
4220	4540 4845 5205 5500 5760 5875 6225 6425 6850 7525 7875 8375	8690
4255	4880 4852 5235 5545 5773 5880 6240 6673 36873 37906 8400	8690
4280	4510 4860 5245 5582 5775 5892 56250 6675 6875 7575 825 8425	8690
4295	4620 4900 5285 5587 5780 5900 6273 56700 6900 7506 67973 83450	8690

DC-34 & DC-35 CRYSTALS

Your Choice. Ea. only 99c

1690	1890 2010 2275 2446 2643 2853 3117 3412 3680 3825 3985 4135 4335	4255
1705	1910 2105 2290 2455 2665 2894 3149 3425 3695 3830 3995 4145 4345	4275
1720	1930 2106 2295 2467 2685 2915 3166 3442 3710 3850 4012 4155 4355	4280
1738	1950 2131 2300 2478 2685 2929 3161 3480 3855 4015 4155 4350	4285
1746	1970 2170 2315 2491 2710 2955 3190 3485 3870 4020 4175 4370	4300
1770	1990 2155 2326 2500 2711 2926 3201 3500 3885 4030 4175 4380	4315
1790	2010 2335 2510 2725 2960 3270 3520 3890 4035 4195 4397	4325
1810	2030 2375 2540 2752 2971 3279 3540 3895 4050 4210 4415	4335
1830	2050 2395 2555 2765 2990 3280 3550 3750 3905 4055 4215 4435	4340
1850	2070 2420 2580 2790 3010 3297 3575 3760 3920 4065 4235 4445	4350
1870	2082 2215 2375 2559 2775 3010 3311 3580 3765 3925 4080 4240	4355

FT-171 HOLDER

Lots of 10 or more. Each.....		79c
Lots of 5 or more. Each.....		89c
Individually. Each.....		99c
2123	2280 2415 2582 3010 3422 53660 3812 53980 4245 5225	5492
2125	2282 52435 2630 3010 53500 3667 53825 3995 4255 5492	5492
2131	2290 2442 52665 3175 3510 3682 53870 4012 54280 6000	6000
2145	2300 2467 2725 3202 53520 3695 3889 4037 54310 6210	6210
2150	2305 2470 2780 3205 53550 3700 3945 4050 4345 7165	7165
2155	2320 2500 2810 3235 5362 3712 53950 4080 4350 7950	7950
2165	2350 2520 2840 3285 5369 3760 3955 4097 54360 8000	8000
2185	2380 2550 2870 3330 5376 3800 3965 4110 4400 9200	9200
1738	2030 2082 2258 2390 2550 2967 3322 53580 3807 53979 4112 4735 9590	9590
1746	2040 2105 2260 2405 2557 2990 3400 3637 53810 3975 4177 55200	5200

DISCOUNTS FOR QUANTITY PURCHASES

WE INVITE INQUIRIES FROM FOREIGN BUYERS, AIRLINES, MILITARY AND EXPORT PURCHASERS, MANUFACTURERS, JOBBERS, WHOLESALE AND VOLUME DEALERS.

NOTE! All items subject to prior sale and change of price without notice. MINIMUM ORDER \$2.50. All orders MUST be accompanied by check, cash or M.O. WITH PAYMENT IN FULL. NO C.O.D. CALIFORNIA BUYERS add sales tax. INCLUDE APPROXIMATELY 5% PER CRYSTAL FOR POSTAGE. **DEALERS & JOBBERS: WRITE FOR SPECIAL QUANTITY DISCOUNTS.** All buyers invited to write for FREE crystal catalogue giving complete list of frequencies.

COMPLETE SETS

SCR-508	Individually tested and Guaranteed to operate! Channels 0-79. FT-241 HOLDERS. Fundamental crystal frequency range: 370.370 to 516.667 KC. Set of 80 crystals.	\$25.00
SCR-509 & SCR-510	Channels 0-79. FT-243 HOLDERS. Fundamental crystal frequency range: 570.67 to 8340 KC. Set of 80 crystals.	\$32.00
SCR-608	Channels 270-389. FT-241 HOLDERS. Fundamental crystal frequency range: 375.000 to 510.277 KC. Set of 120 crystals.	\$48.00
TRC-1	Channels 700-999. In 2 types of holders; TRANSMITTER CRYSTALS in FT-211 HOLDER. Fundamental crystal frequency range: 729.167 to 1040.625 KC. RECEIVER CRYSTALS in FT-253 HOLDER. Fundamental crystal frequency range: 7500 to 8750 KC. MATCHED PAIR (1 transmitter crystal and 1 receiver crystal).	\$1.50 \$300.00
SCR-609 & SCR-610	Channels 270-389. FT-243 HOLDERS. Fundamental crystal frequency range: 5675-8000 KC. Set of 120 crystals.	\$48.00

FUNDAMENTAL OUTPUT FREQUENCIES

4035	4280	4495	4710	4930	5205	5397	5587	5780	5950
4080	4330	4540	4780	4980	5245	5437	5645	5820	5995
4165	4397	5480	4840	5030	5285	5470	5687	5860	
4240	4445	4635	4880	5127	5327	5545	5730	5907	

SCR-536 Matched pairs of Transmitter-Receiver crystals in FT-243 HOLDER. Receiver crystal is 455 KC. higher than the frequency of Transmitter crystal.

YOUR CHOICE OF ANY MATCHED PAIR. PER PAIR..... \$1.00

NOTE: For individual crystals, see frequencies and prices in the chart on the left.

MISCELLANEOUS & SHIP BAND FREQUENCIES

81.05 KC. Octal tube type (Used in SCR-581 & SPM-1)	2638	KC. in FT-243 holder.....	\$2.99
200 KC. in FT-241 holder.....	1.99	2670 KC. in FT-243 holder.....	2.99
200 KC. Type DG-18 in octal tube base type holder.....	1.99	2670 KC. in FT-243 holder.....	2.99
327.8 KC. No. D-168342 (used in ES-102/AP)	9.95	2738 KC. in FT-243 holder.....	2.99
500 KC. in FT-241 holder.....	1.99	3000 KC. in FT-243 holder.....	2.99
1000 KC. in FT-241 holder.....	2.49	3038 KC. in FT-243 holder.....	2.99
1000 KC. Type HG-18 in octal tube base type holder.....	3.45	3038 KC. in FT-243 holder.....	2.99
2000 KC. in FT-243 holder.....	1.99	3103 KC. in FT-243 holder.....	2.99
2142 KC. in DG-34 holder.....	2.99	3188 KC. in FT-243 holder.....	2.99
2174 KC. in DG-34 holder.....	2.99	3197 KC. in FT-243 holder.....	2.99
2182 KC. in FT-243 holder.....	2.99	3198 KC. in FT-243 holder.....	2.99
2300 KC. in FT-243 holder.....	2.99	3203 KC. in FT-243 holder.....	2.99
2632 KC. in FT-243 holder.....	2.99	5030 KC. in FT-243 holder.....	1.99
2637 KC. in FT-243 holder.....	2.99	10,000 KC. Type S-60 Bliley, in CR-1 holder.....	1.99
2638 KC. in DG-34 holder.....	2.99		

CR-1A HOLDERS

Lots of 10 or more.....		69c
Lots of 5 or more.....		74c
Individually. Each.....		79c
5980	6670 7120 7460 7930 8032 8116 8172 8272 8340 8423	8423
6181	6700 7130 7470 7960 8050 8126 8176 8284 8351 8428	8430
6350	6740 7160 7550 7980 8060 8126 8193 8290 8357 8430	8430
6380	6750 7180 7570 8007 8080 8132 8194 8297 8373 8438	8438
6450	6800 7230 7590 8010 8090 8137 8200 8308 8374 8475	8475
5020	5700 5590 6510 7010 7350 7670 8013 8092 8140 8205 8317 8380 8502	8502
5041.6	5520 5677 6530 7020 7360 7730 8018 8103 8142 8216 8320 8392 8528	8528
5108	5550 5700 6550 7040 7400 7790 8020 8110 8146 18220 8328 8400 8554	8554
5280.3	5722 6650 7080 7440 7810 8025 8115 8152 8260 8335 8404 8580	8580



AR7-W
169 to 3400 KC.
Ea. \$2.99



FT 164
201 to 4300 KC.
Ea. \$3.99



FT-241 or CR 4
400 Freqs. from 729.167 to 1040.625 KC. in steps of 0.675 KC.
Ea. 99c



RCA Model MI-8412
A or B
5818 to 5805 KC.
Ea. \$1.99

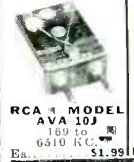

COLLINS TYPE I-C
1335 to 4407.5 KC.
Ea. \$1.99

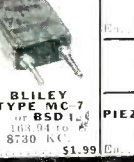

AVA 53
2035 to 6010 KC.
Ea. \$2.45

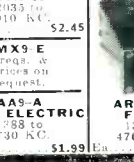

MX 9 E
Freqs. as Price on request.



RCA Model AVA 10J
169 to 6510 KC.
Ea. \$1.99



BLILEY TYPE MC-7 or BSD
104 to 8730 KC.
Ea. \$1.99

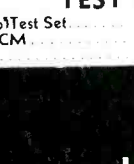

PIEZO ELECTRIC
8730 KC.
Ea. \$1.99

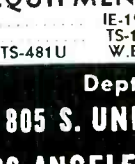

AR-4W or FT-249
1398 to 4765 KC.
Ea. \$1.99

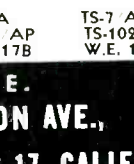

BSD 180G
156.875 to 1300 KC.
Ea. \$1.99

TEST EQUIPMENT

Measurement Corp Test Set	TS-428 (XM-2) PCM	TS-35A AP	IE-19A	TS-14 AP	W.E. 17B	TS-7 ASQ	TS-102A AP	W.E. 19C (SP)
---------------------------	-------------------	-----------	--------	----------	----------	----------	------------	---------------

U.S. CRYSTALS, INC.,

Dept. E.
 805 S. UNION AVE.,
 LOS ANGELES 17, CALIF.

CONDENSERS

4 mfd.—600 V \$1.10
 16 mfd.—600 V \$1.89
 Dual 8 mfd oil filled cond. hermetically sealed and packed. Type PT #1. 3 1/2" x 2 1/2" x 2 1/2". Stud mnt. centers 2". Plugs into standard four prong socket.
 5 mfd.—400 V # 416 MCT. \$1.19
 80 mfd.—4 KV \$49.50
 .00025 mfd.—1200 V \$1.19
 Trans. Mica Type #4. 10% disc lots of 100.

10 mfd.—600 v \$98
 Three term, bot. mtg. channel type. Dims. 3 1/2" x 2 1/2" x 2 1/2". Two 5 mfd. sections rated 400 V at 72 deg. "C". 1800 V test. Meets commercial specs. for 600 V operation up to 40 degs "C". Ideal for filter or power factor application. Repeat sales prove this rugged high quality condenser to be of outstanding value. Carton of 24, weight \$89.42 lbs. Large qua. available.

1 mfd.—25 KV \$59.95
 1 mfd.—2500 V \$99
 6 mfd.—150 V \$35
 Three term, dual 3 mfd oil cond. with brackets. 4 1/2" x 1 3/4" x 1 1/4". Ideal for audio crossover networks.
 4 mfd.—600 V Type TLA 6040 \$1.45
 2 x 1 mfd.—230 VAC \$49
 2 St Bath Tub Type
 400 m mfd. S. Mica. \$4.00 "C"

Mfd.	Volts	Price	Mfd.	Volts	Price
.00014	15KV	55.75	2	1000V	.85
.00023	16KV	5.95	2	1000V TLA	1.25
.01	10KV	4.75	2	1500V	1.69
.012	25KV	22.50	2	2000V	2.80
.02	10KV	5.25	2	2500V	3.95
.02	20KV	17.90	2	3000V	5.80
.025-.025			2	4000V	7.95
.03	60KV	34.50	2	5000V	12.50
.03	7500V	4.95	2	6000V	15.95
.03	16KV	15.95	2	7500V	29.95
.035	10KV	12.95	2	82KV	P.U.R.
.05	5KV	2.95	2	3000V	3.35
.05	7500V	2.95	3	600V	1.59
.08	12.5KV	15.95	3	4000V	11.95
.1	1500V	1.95	3	1000V	1.25
.1	2000V	1.95	3	1500V	1.45
.1	2500V	1.39	4	600V TLA	1.40
.1	3000V	1.45	4	600V TLA	1.40
.1	4000V	1.95	4	100V	1.95
.1	7500V	1.75	4	150V	1.95
.1	10KV	3.50	4	2000V	4.35
.1	10KV	12.95	4	2500V	5.95
.1	12KV	14.95	4	3000V	7.55
.1	12KV	14.95	4	4000V	13.95
.1	25KV	29.50	4	5000V	24.95
.1-1	2000V	3.84	4	7500V	52.60
.1-1	7500V	3.50	4-4	600V	2.40
.1-1	7500V	1.95	5	330VAC	1.75
.15-15	8000V	10.55	5	600V	1.75
.2	10KV	17.95	5	1000V	1.99
.2	15KV	17.95	5	1500V	2.98
3x2	2000V	2.85	5	1500V	3.45
.25	2500V	1.95	6	600V	1.85
.25	4000V	1.75	6	1000V	2.49
.25	4000V	3.25	6	1500V	3.95
.25	3000V	1.45	6	2000V	1.45
.25	15KV	15.95	7	600V	1.35
.25	20KV	19.95	8	500V	1.25
.25	25KV	29.95	8	800V	2.25
.25	32.5KV	59.50	8	600V RG	3.50
.25	50KV	67.50	8	600V VAC	3.50
.3	2000V	1.95	8	1000V	3.25
.4	10KV	19.95	8	1500V	4.25
.4	1500V	1.80	8	2000V	7.25
.4	2000V	1.95	8	800V	2.95
.5	2500V	2.20	8-8	600V	2.75
.5	3000V	2.39	8-8	600V	5.90
.5	4000V	2.59	8	1000V	6.25
.5	5000V	4.15	10	1500V	6.75
.5-1	2000V	.90	10	600V	8.25
.5-5	800V	.60	10	1500V	8.25
.5-5	1000V	.69	10	600V	4.95
.5-5	25KV	55.50	12	1500V	3.25
1	400V	.59	12	1500V	6.35
1	500V	.59	12	2000V	6.35
1	1000V	.59	15	400VAC	4.95
1	1500V	.91	15	600V	3.25
1	2000V	1.95	15	1000V	6.35
1	2500V	2.50	15	1500V	6.35
1	3000V	2.50	15	1500V	6.35
1	6000V	6.85	15	5000V	63.50
1	6000V	8.25	15	1500V	5.85
1	7000V	11.25	20	600V	5.85
1	10KV	27.95	20	330VAC	4.69
1	15KV	49.50	20	1000V	5.25
1	18KV	49.50	20	330VAC	5.25
1	20KV	59.50	30	2500V	14.50
1	25KV	70.00	30	2200VAC	12.95
2	600V	55-.75	80	4000V	49.50

CHANNEL COND.

Mfd.	Wvdc	Price	Mfd.	Wvdc	Price
.025	600	\$19	.25	1000*	.45
.05	400	.21	.4	600	.30
.05	1000*	.22	.5	400*	.19
1	500	.28	.5	500*	.33
1	600	.32	.5	300	.42
1	2500	1.25	2x.5	600	.49
3x.1	400	.34	2x.5	400	.59
3x.1	400	.40	5-1	1000*	.49
3x.1	400	.40	5-1	600*	.39
3x.1	600	.43	1	500	.58
3x.1	1000	.51	1	500	.58
.25	400V	.34	1	800	.63
.25	600V	.39	1	800	.63

Trans. MICA CONDENSERS

Mfd.	Wvdc	Price	Mfd.	Wvdc	Price
.000015	2500	.35	.001	2500	.49
.000024	2500	.38	.001	4500	1.70
.00025	1200	.30	.001	5000	2.50
.00003	600	.24	.0015	600	.23
.00003	1200	.29	.0015	2500	.53
.00004	2000	.29	.0015	5000	2.50
.00003	2000	1.30	.002	600	.27
.00004	2000	.23	.002	1200	.39
.000047	2500	.31	.002	2500	.63
.00005	600	.23	.002	5000	2.95
.00005	1200	.29	.0024	5000	2.25
.00005	2500	.33	.0025	600	.28
.000068	5000	1.35	.0025	1200	.43
.000068	2500	.27	.003	600	.31
.00007	2500	.23	.003	800	5.95
.00008	2500	.33	.003	2500	.74
.00009	2500	1.35	.003	3000	1.85
.0001	600	.23	.003	800	5.95
.001	1200	.29	.004	600	.29
.001	2500	.36	.004	1200	.49
.0015	600	.23	.005	600	.48
.0015	2500	.33	.005	1200	.45
.0015	2500	1.35	.005	2500	.99
.002	600	.23	.005	3000	1.90
.002	1200	.29	.006	600	.36
.002	600	.23	.006	1200	.45
.0025	600	.23	.008	1200	.55
.0025	2500	.40	.008	600	.35
.0025	5000	1.95	.01	1200	.73
.0025	5000	1.95	.01	2500	1.15
.0027	1200	.28	.01	8KV	7.95
.0027	2500	.36	.015	600	.55
.003	600	.23	.015	1200	.78
.003	600	.23	.015	2500	1.25
.004	2500	.29	.02	600	.57
.0047	2500	.40	.02	600	.21
.005	600	.23	.02	600	.48
.005	1200	.29	.02	1200	1.15
.005	2500	.33	.02	2000	1.50
.005	3000	.36	.03	600	.67
.0068	2500	.28	.03	1200	1.34
.0089	1200	.28	.03	1200	1.34
.009	600	.23	.115	2000	6.35
.001	1200	.32	.4	600	6.50

BATHTUB CONDS.

Mfd.	Volts	Price	Mfd.	Volts	Price
.01-.01	600	\$25	3x.25	1000	.70
.02-.02	600	.25	3x.25	1000	.70
.04-.04	600	.25	.25	1000	.48
.05	800	.20	.3	400	.15
.05	1000	.39	.5	400	.37
.05-.05	1000	.44	.5	600	.47
.05-.05	1000	.44	.5	1000	.52
.08-.08	800	.25	2x.5	800	.59
.1	1000	.39	3x.5	600	.69
.1	1000	.42	1	200	.25
.1	1200	.45	1	400	.30
.1-1	400	.29	1	600	.45
.1-1	600	.39	1	600	.59
.1-1	1000	.51	1-1	230VAC	.39
3x.1	600	.40	1-1	600	.95
3x.1	1000	.55	2	400	.69
2	1000	.21	2	600	.95
.25	800	.19	4	100	.49
.3	2000	4.00			
.25	600	.41			
.25-25	600	.49			

Special Mica Kit

100 @ \$3.50

Available in Other Sizes

W.E. CONDENSERS

Mfd.	Type	Price	Mfd.	Type	Price
5	141-B	.95	.01	F40C	.18
1	D161884A	1.25	1	D160800	1.25
			1	WE147	1.75
.000195	D82383	.15	2-2	1-137C	I 2.25

—WANTED—
 Condensers of all Types in any quantity. Also other standard components.

Write ART HANKINS, Owner

MONMOUTH RADIO LABORATORIES

BOX 159 Long Branch 6-5192 OAKHURST, N. J.

Type "G" Mica Condensers

Mfd.	Volts	Price	Mfd.	Volts	Price
.00005	3KV	5.95	.0013	15KV	34.95
.00005	10KV	19.95	.002*	6KV	11.95
.0001	6KV	12.50	.002*	20KV	37.90
.00015	10KV	15.95	.0025	12KV	35.95
.00024	6KV	9.95	.0025	25KV	39.50
.00024	8KV	11.95	.0025	30KV	43.95
.00025	10KV	19.95	.00575	10KV	37.50
.00025	20KV	33.95	.011	4KV	9.95
.0004	20KV	33.95	.02	2KV	10.85
.0005	20KV	35.00	.045	2KV	37.50
.0006*	35KV	49.90	.09	1.5KV	7.95
.001	6KV	11.50	.016	2KV	5.95
.001	25KV	57.50			
.001	30KV	61.50			

MICA CONDENSERS

Mfd.	Volts	Price	Mfd.	Volts	Price
6	10, 15, 27, 30, 34, 39, 50, 51, 60, 70, 75, 85, 100, 140, 150, 200, 230, 240, 250, 300, 350, 390, 400, 500, 510, 600, 650, 750, 1000, 1200, 1400, 1500, 1600, 2000, 2400, 2500, 3000, 3300, 3700, 3900, 4000, 4700, 5000, 5100, 6000, 6200, 6500, 7900, 8000 & 9100 mfd.				
8	to 75mfdmfd	5c	2000 to 5100mfd	10c	
1000 to 1600mfd	6c	6000 to 9100mfd	13c		

SILVER MICA CONDENSERS

Mfd.	Volts	Price	Mfd.	Volts	Price
7	8, 10, 15, 24, 25, 27, 35, 50, 75, 100, 120, 150, 170, 200, 240, 250, 300, 330, 400, 450, 500, 750, 1000, 1100, 1200, 1300, 1450, 1500, 2000, 2200, 2300, 2700, 2900, 3000, 3300, 3600, 4300, 4700, 5100, 5600, 6200, 7500, 8200 & 9100 mfd.				
7	to 75mfdmfd	8c	2200 to 5100mfd	22c	
100 to 750mfd	9c	2500 to 8200mfd	24c		
1000 to 2000mfd	17c	9100mfd	30c		

TUBULAR OIL CONDS.

Mfd.	Wvdc	Price	Mfd.	Wvdc	Price
.0025	400	.15	.03	400	.15
.005	1600	.10	.05	200	.09
.01	300	.12	.05	600	.16
.01	600	.16	.05	1600	.21
.01	2000	.25	.05	2000	.26
.02	100	.10	1	600	.22
.02	400	.14	.28	600	.22
.02	600	.17	.5	600	.25

CERAMIC CONDS.

Mfd.	Wvdc	Price	Mfd.	Wvdc	Price
10, 27, 56 & 100 mfd					
1000 & 5000 mfd					

MOLDED PAPER CONDS.

Mfd.

Biggest & Best in Surplus Communications

JUST RECEIVED

LARGE QUANTITY:
BC-669 RADIOTELEPHONES,
NEW—UNUSED, 45 WATTS
OUTPUT ON PHONE,

6 Channels (Crystal-controlled) for Transmitter & Receiver.

LARGE QUANTITY:
SCR-300 (BC-10003 Walkie-Talkies; SCR-536 (BC-611) Handy - Talkies. SPARE PARTS for both eqpts.

All units reconditioned to LIKE NEW, thoroughly tested.

BIGGEST & BEST STOCK IN:
TCS Transmitters & Receivers
with 12, 24, 110 DC or 110 AC Power Supplies.

BEACHMASTER & OTHER BATTLE ANNOUNCING PA SYSTEMS.

SCR-284; BC-224; BC-312; 342 & 348. SCR-510, SCR-511, SCR-610.

VHF EQUIPMENT:
SCR-522, BC-797, SCR-624, TDQ, RCK, & VHR-401A RECEIVERS.

BC-221 FREQUENCY METERS, LIKE NEW—CHECKED OUT WITH MATCHING CALIBRATION BOOK

EACH \$99.50

With Non-Matching Calibration Book \$69.50

Finest Stock of X'MTTRS & RADIOTELEPHONES for FIXED STATION INSTALLATION, 50 Watts to 10 KW.

Write for Prices & Literature.

EXPORTERS, GOVERNMENT AGENCIES, INDUSTRIALS!

We have a large stock of Transmitters, Receivers, Walkie-Talkies, VHF Equipment, Ship & Shore Communications, FM Broadcast Stations, Radar, Accessories, etc. Write and tell us of your requirements. Descriptive literature and prices available upon request.

ALL MATERIAL SUBJECT TO PRIOR SALE!
 CABLE ADDRESS: TELEMARINE, N. Y.

—TELEMARINE—
COMMUNICATIONS CO.
 3040 W. 21st Street, Brooklyn 24, N. Y.
 Phone: ES 2-4300

POWER RHEOSTATS



"Be Right with" Famous Make
 MODELS H-J-G-K-L-N-P-R

Ohm	Watt	Each	Ohm	Watt	Each	Ohm	Watt	Each	
150(L)	5.34	50	50	25	1.47	500	100(K)	3.55	
1	1.50	100	80	25	1.30	500	150(L)	6.98	
1.1	50(J)	2.34	75	25(H)	1.86	500	150	4.20	
1.1	50	1.64	75	25	1.30	500	300(N)	8.42	
2	25(H)	1.86	75	75(G)	3.15	750	25(H)	1.86	
2	100(K)	3.79	75	300	6.30	750	150	4.20	
2	300(N)	8.42	80	50(J)	2.10	750	100(K)	3.55	
3	100(K)	3.79	80	500(R)	12.18	800	25	1.30	
3	225(P)	6.99	100	25(H)	1.86	1000	25(H)	2.10	
3	50(J)	2.10	100	25	1.00	25	1.47	1000	
3	100(K)	3.79	100	100(K)	3.55	1200	225(P)	6.99	
3	75(H)	1.86	100	150(L)	5.05	1200	50(J)	2.22	
3	50(J)	2.10	125	25(H)	1.86	1250	50(J)	2.22	
3	75(G)	3.15	125	25	1.30	1250	150(L)	5.34	
3	7.5	225(P)	150	50(J)	2.10	1500	25(H)	2.10	
3	7.5	75(G)	175	25(H)	1.86	1500	25	1.30	
3	7.5	50(J)	6.99	175	500(R)	12.18	1500	50(J)	2.22
3	8	50	1.47	200	25	1.86	1800	30(J)	2.22
3	8	500(R)	12.18	200	25	1.30	1800	150(L)	5.62
3	10	25(H)	1.86	200	25	1.47	2000	25(H)	2.10
3	10	50	1.47	200	100(K)	3.55	2000	50(J)	2.22
3	10	100	2.97	200	150(L)	5.05	2250	150(L)	5.62
3	12	50	1.86	250	25(H)	1.86	2500	25	1.47
3	12	50	2.10	250	50(J)	2.10	2500	100(K)	3.71
3	12.5	500(R)	12.18	300	50(J)	1.47	2500	150(L)	5.62
3	13	100(K)	3.55	300	50	1.47	2500	150(L)	5.62
3	15	25(H)	1.86	300	75(G)	3.15	3000	25	1.47
3	15	25	1.30	300	100(K)	3.55	3000	100(K)	3.79
3	15	75(G)	3.15	350	25(H)	1.86	5000	25(H)	2.22
3	16	50	2.10	350	150(L)	5.05	5000	100(K)	4.04
3	16	50	1.47	350	150(L)	5.05	5000	100(K)	4.04
3	20	25(H)	1.86	370	25	1.30	7500	50(J)	2.34
3	20	50(J)	1.47	370	150(L)	5.05	7500	100(K)	4.30
3	25	25(H)	1.86	400	25	1.30	10K	50(J)	2.50
3	30	50	1.47	400	75(G)	3.15	10K	50	1.75
3	30	50	1.47	500	25(H)	1.86	10K	100(K)	4.34
3	40	225(P)	6.99	500	25	1.30	15K	25	1.93
3	50	25	1.30	500	50	1.47	20K	4	1.75
3	50	50(J)	2.10	500	75(G)	3.15	20K	150(L)	6.98

AVAILABLE IN ALL SHAFT SIZES—
 Knob Type or 1/8" Screw driver.
 Specify type shaft required.

SPECIAL DISCOUNT TO QUANTITY USERS



SPECIAL SALE
15 MFD 600 VOLTS D.C.
 Famous Make Oil Filled Condenser
 3" wide x 2-1/2" thick x 4-1/2" high, 3-1/2" mounting centers
 Production Quantity 79 ea.
 Available At Lowest Prices



HIGH POWER TRANSMITTING MICAS

G-1 TYPE			
0001	6 KV	12.18	0008
00015	5 KV	12.18	001
00015	6 KV	12.18	0015
0002	6 KV	12.18	02
00024	6 KV	12.76	032
00025	6 KV	12.76	032
0004	6 KV	13.31	051
0005	6 KV	14.00	08
00075	6 KV	14.00	09
0001	10 KV	19.67	0005
00015	10 KV	19.67	00085
0002	10 KV	19.67	001
00027	12 KV	19.67	001
0003	10 KV	19.67	01
000375	10 KV	19.67	045
0004	5 KV	19.67	045
00005	20 KV	33.27	0011
0001	20 KV	36.30	0012
0001	25 KV	37.80	00124
00015	20 KV	37.80	0015
00025	20 KV	39.33	0016
0003	20 KV	39.33	002
0004	20 KV	41.15	0025
00045	15 KV	41.15	004
00047	20 KV	41.15	005
0005	20 KV	41.15	006
0008	20 KV	41.15	015
00095	5 KV	42.35	015
001	15 KV	42.35	05
001	20 KV	42.35	25
00025	30 KV	66.35	0025
0003	25 KV	66.35	005
00032	25 KV	66.35	006
00032	30 KV	66.35	006
0005	30 KV	66.35	0075
0006	35 KV	67.50	01
00062	30 KV	66.35	01083
00065	35 KV	67.50	01163
0008	30 KV	66.35	03
001	25 KV	68.73	056
0015	25 KV	68.73	05668
000155	30 KV	139.20	000533
0004	30 KV	139.20	001
0001	6 KV	14.00	0008
00015	5 KV	14.00	0015
0002	6 KV	14.47	02
00024	6 KV	15.44	032
00025	6 KV	15.44	032
0004	6 KV	17.55	051
0005	6 KV	18.00	08
00075	6 KV	18.00	09
0001	10 KV	19.67	0005
00015	10 KV	19.67	00085
0002	10 KV	19.67	001
00027	12 KV	19.67	001
0003	10 KV	19.67	01
000375	10 KV	19.67	045
0004	5 KV	19.67	045
00005	20 KV	33.27	0011
0001	20 KV	36.30	0012
0001	25 KV	37.80	00124
00015	20 KV	37.80	0015
00025	20 KV	39.33	0016
0003	20 KV	39.33	002
0004	20 KV	41.15	0025
00045	15 KV	41.15	004
00047	20 KV	41.15	005
0005	20 KV	41.15	006
0008	20 KV	41.15	015
00095	5 KV	42.35	015
001	15 KV	42.35	05
001	20 KV	42.35	25
00025	30 KV	66.35	0025
0003	25 KV	66.35	005
00032	25 KV	66.35	006
00032	30 KV	66.35	006
0005	30 KV	66.35	0075
0006	35 KV	67.50	01
00062	30 KV	66.35	01083
00065	35 KV	67.50	01163
0008	30 KV	66.35	03
001	25 KV	68.73	056
0015	25 KV	68.73	05668
000155	30 KV	139.20	000533
0004	30 KV	139.20	001

Many other sizes and types in stock — All Perfect.

HEADQUARTERS FOR:
 • BATHUBS & CHANNEL BRACKETS
 • TYPE J—JL—JJ—JJJ POTS
 • MICAS: transmit & receive
 • JONES CONNECTORS & STRIPS
 • POWER RESISTORS

A. MOGULL CO.
 17 Warren St., N. Y. 7, N. Y.
 Phone: WORTH 4-0865

Universal General- "A DEPARTMENT STORE FOR YOUR ELECTRONIC SUPPLIES"

General Electric AUTOMATIC VOLTAGE STABILIZER

Made for Western Electric by G. E. G. E. Part #69G869-KS14209. Voltage regulation within 1% with full load at input of 95-135V, output 115 volts—30 VA. With unity power factor load. Supplied with plug and cord on input side and female receptacle on the output. Metal case 3 1/4" w. x 8 1/2" l. x 2 3/4" h. Shipping weight 12 lbs.

T162..... 9.95 each
 90.00 for 10 units

VOLTAGE REGULATOR

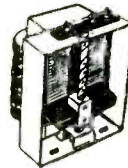

Amertran Transtat
 PRI: 115V 60 Cyc
 Sec: 105-250V
 7.83 Amp .9KVA

Special 14.50

10 for 137.50

6 V. VIBRATOR POWER SUPPLY



Lightweight unit supplies following d-c voltages from 6V d-c source:

Volts	Amps	Volts	Amps
+1.5	0.3	+67.5	.005
-6	0.02	+135	.02

Current can be exceeded by 50% for intermittent use. Brackets are provided for use with 3" x 1 1/2" x 2 1/2" plastic 6V storage battery. Power supply is self contained and includes vibrator, transformer, relay, neon indicator, and filter units. Dimensions: 4 1/2" x 3 3/4" x 1 1/2". Net wt. 2 1/2 lbs 6V d-c Power Supply #PS101 \$5.95 less battery

10 for \$50.00 less batteries



110V 60 Cyc TIMING MOTORS

INGRAHAM 8 RPM Fully Enclosed. \$1.75
 TELECHRON 3.6 RPM..... 1.95
 GILBERT With Gear Train—6 RPD Day 1.75
 GILBERT 60 RPM (1 RPM)..... 1.50
 HAYDON: 1/12 RPM, 24V AC..... 1.50

400 CYCLE MOTOR



Eastern Air Devices J31-E17:
 115V, 0.65 Amp; Single Phase;
 1500 RPM..... \$2.50

Orders Under \$10 Remittance With Order. Plus Approximate shipping charges (coverage will be returned).

TERMS:—All prices F.O.B. Our Plant.
 Rated Firms Net 10 Days;
 All Others Remittance with Order.
 Merchandise returnable within 10 days for full credit

324 CANAL ST. (Near B'way) N. Y. — WA 5-9642
Universal general corp.

Brings you What you Need and Want at **Harjo LOWEST PRICES!**

RADAR EQUIPMENT

APS-4 complete Radar Set	5550.00
SN complete	400.00
Y25/TPS-2	75.00
R5/APN-9	650.00
AN/PPN-1 (Eureka)	75.00
AN/PPN-2 (Eureka)	75.00

TS45/APM X BAND SIGNAL GENERATOR

June Special! **\$195**
Priced low for small labs, schools and service shops. While they last!

Western Electric HANDSET \$395

Standard type as used on telephones. Complete with cord. Suitable and home telephone systems.

POWER SUPPLIES INVERTERS

MG-149F Rotary converters, Certif.	549.50
RA-34 Hi-voltage for BC-291, etc.	149.50
RA-62 Hi-voltage for SCR-522	150.00

HI-VOLTAGE POWER SUPPLIES

119V, 60cy. In. 1250-1500V, at 350 ma out. Hvy. duty potted transformers. Oil condensers relay controlled. Orig. made for navy radar. FB for xmtr. \$22.50 and lab use. Shp. wt., 100-lbs. A steel at	
---	--

CHOKES

13H 250MA, new	\$3.95
20H 300MA, 5KV ins.	4.95
7H 420MA, 90 ohms	5.95
50H 580MA, 17.5MV, New Shp. wt., 300lb.	\$85.00

TRANSFORMERS

HI-VOLTAGE DONUT TYPE FILAMENT TRANSFORMER. Primary 110V, 60-cy. Secondary 5V @ 10 amps, 20KV ins. With mounted socket for 872 rectifier tube. Famed donut type, practically extinct. FB for labs. xmtrs. \$12.95 Shp. wt., 15-lbs. New.

AUTOMATIC VOLTAGE REGULATOR. Thoradon. Primary 95, 135, 190, 270 V. Secondary 115 V, 60 cy. @ 250 VA

CLASS B DRIVER. Primary 500/125, secondary 6800/1700 Amertan \$7.50

MORE CASH for your surplus equipment. Get what you want without red tape. Write today for immediate reply!

TRANSMITTERS & RECEIVERS

ARC-3 complete, certified	5580.00
BC-640 & BC-639, RA-42	750.00
AN/TRT-1 Mine Trans.	100.00
ART-13	350.00
BC-797 ground stas.	750.00
SCR-384	100.00
BC-1338 Marker Rcvrs. Certif.	75.00
BC-733D CAATC	35.00
BC-648	145.00
ARG-8 Search Jam Equip. Rcvr-Xmtr control box (less tubes & blower)	\$35.00
ASB-7 Xmtrs with tubes. FB for 420 MC and TV relay work.	7.95
ANDREW TYPE 876 DRY AIR PUMP for use with coax transmission lines. New	\$9.95

RCA Surplus TV CAMERA

Special! **\$225**

With 1848 Iconoscope and 6-stage video amplifier and clipper. For use in movie pickup chains and training and experimental work. **UNBEATABLE BARGAIN.** Write for complete information.

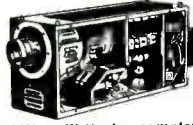

TEST EQUIPMENT

TS-11	\$45.00	TS-184	45.00
TS-13	695.00	TS-268	37.50
TS-34	300.00	IE-19	5200.00
TS-47/APR	225.00	I-222	89.50
TS-50/U	14.95	I-139A	12.50
TS-89	32.50	I-183A Freq. Meter	22.50
TS-100	85.00	I-185A Oscillator	24.50
TS-101	7.50	BC-721 Meter	85.50
TS-126	75.00	BC-1287A (S band)	125.00
TS-131	14.95	LM	85.00

SOUND POWERED HEAD & CHEST SET. Navy type, no batteries required. Ideal for TV antenna installations etc. 20' cord. New 525 Value. **\$7.95**

VARIABLE CONDENSER. Broadcast Station type. Cardwell PK 544, QD1, split stator. 50-540 MMF per section. 250 spacing. Dimensions 2 3/4" x 8 3/4" x 7 1/4". **\$49.50**

FREE CATALOG Thousands more items in stock. All shipments F.O.B. Warehouse and subject to prior sale!

Check These Money-Saving METER BARGAINS

PORTABLE KILOWATT HOUR METER KIT contains brand new standard kilowatt meter, and heavy duty lab type case with handle. Complete with instructions \$70 value—yours for just \$49.50

3-INCH BLACK DIALFACE 0 750 MA. \$4.00

500-0-500 MICRO WESTON FREQ. METER. Model 814, 350 to 450 cycles 100 to 125V. Removed from new equipment. Reg. price \$100—our price \$24.95

PANEL METERS, 3" square Weston 0-2.5 amp DC \$4.95

RCA TUBE HANDBOOK TYPE HB-3 IN 3 VOLUMES

these books may be registered so that supplements can be received regularly from RCA. **A MUST FOR EVERY \$13.50 \$495** ENGINEERING DEPT.

TUBES! TUBES! TUBES!

DuMONT 3GP1 Cathode Ray Tube. Brand new. Boxed with schematic and parts list. \$1.79

701A Kilowatt Screen Grid Transmitting Tube. Just right for that new AM or SSB. New. \$4.95

FILAMENT TRANSFORMER for 701A, 8V at 7 1/2 amps. \$3.95

Hundreds of other Tube Values—Check us!

WILLARD 6-V. BATTERIES, \$1.29 or 4 for \$1

BULLSEYE & DIAL-LITE SOCKETS, 39c ea. Candelabra type (removed from new equip).

220 V. CANDELABRA BULBS to fit above 19c each or 7 for \$1

MICRO SWITCHES, brand new 4 for \$1

SCOPE TRANSFORMERS. Prim. 110V, 60 cycl. Sec. 3500 V, 25 MA, 10 KV ins. Shp. wt. 15 lbs. \$3.95

RESISTORS, insulated, Standard brands, 5% 100 for \$1.79

TV TUNERS, Standard coil. Cascade with \$807-616. New \$13.95

CERAMIC CONDENSERS. Kit of 100 ass't. Brand new, standard brand, \$10 value! \$1 postpaid

NEW POWER TRANSFORMER, 110V, 60 cy. primary, 150 V, 30MA secondary, 6.3-1 amps. Fil. FB for grid dip kits, test equip, etc. 79c ea. or 4 for \$3

1000's MORE ITEMS IN STOCK. Write for information—or VISIT OUR RETAIL SHOWROOMS

Harjo Sales Co.

Dept. EE

4109 BURBANK BLVD.—BURBANK, CALIF.
P. O. Box 1187 MAGNOLIA PARK STA.
Cable: HARJO Phone: VICTORIA 9-2411

2 1/2" ROUND PANEL METERS

0-1 MA DC G.M. Lab Spec black scale	\$3.50
0-150	3.50
0-3 MA DC Hickok 56	3.50
0-5 MA DC Gruen G.W. 508	3.50
0-80 MA DC Marion MR25W 80 DC MA	3.50
0-300 MA DC G.E. DW 55	4.95
0-15 Amp. DC Hoyt =17-3, Metal Case	3.95
0-300 Volts DC Sun 2 AP 380	4.95
0-150 Volts AC Hickok MR 26150 ACV	4.95
0-300 VAC Triplett Metal Case 232	4.95

3 1/2" ROUND PANEL METERS

0-50 Micro Amp DC Electrolech	\$8.50
0-30 VDC Weston 301 Metal Case	7.50
0-300 VDC G.E. DO 41 1000 ohms/volt	7.50
0-500 VDC G.E. DO 41 1000 ohms/volt	9.50
0-1 K.V. G.E. DO 41 1000 with 1 RC Res	16.50
0-10 VDC G.E. 100 ohms/volt DO 41	5.95
0-5 Amp DC Simpson 25	6.00
0-50 Amp DC Weston, Metal Case 301	7.50
0-100 Amp DC Hoyt 531 L Int. Sh. Surf. Mid.	2.00
0-300 Amp DC WH EI with Shunt black Scale	8.50
0-50 MA DC Weston 301	6.50
0-150 MA DC Weston 301	6.50
0-800 MA DC DeJur 310	3.00
0-1.5 V AC Hickok 47M	3.50
0-15 V AC Roller Smith TAS	5.50
0-130 V AC Westinghouse NA35	10.50
0-150 V 400 Cy G.E. AO-22	7.50
0-3 Amp AC Weston 476	7.50
0-5 Amp AC Weston 476	5.00
0-5 Amp Simpson 57 3" sq.	5.00
0-30 Amp Weston 476	7.50
0-75 Amp Simpson 57 - 3" sq. with C.T.	7.50
0-2.5 ARF McClintock 35	4.00

* Unless otherwise specified the above items all have white scales, round bakelite cases, and are brand new and in original cartons.

MARITIME SWITCHBOARD

Instrument & Accessories
336 CANAL STREET, NEW YORK 13, N. Y.
WOrth 4-8216 (7)

LOOK! FABULOUS LOW PRICES—EVEN FOR RADIO SHACK

Industrial, Receiving, Special-Purpose

FREE!

New 1954 electronic parts mail-order catalog! Better than ever!

OC3/VR-105	.79	71A	.45
OD3/VR-150	.69	QK-72	50.00
1A3	.78	RK-72/CRP72	.85
1A5GT	.62	FG-90	2.50
1822	1.11	100TH	7.50
1824	7.95	VR-105	.79
1827	9.95	112A	.39
1832/532A	1.75	211/VT4C	.79
1N21	.69	227A	3.50
1N22	.95	274B	1.95
1N27	.95	EL-302.5	1.00
1P23	1.95	304TH	9.95
1R4	.39	GL-316A	1.69
1T4	.49	350A	2.95
2A3	.75	371A	1.95
2AP1	7.50	388A	1.95
2B22	1.50	394A	2.50
2C33	2.75	WL-417A	12.50
2C40	9.95	GL-434A	12.50
2E22	1.50	GL-446A	1.50
2J21	4.95	464A	3.95
2J21A	5.95	CK-501X	.59
2J22	6.50	532A	1.95
2J27	8.95	GL-605	35.00
2J34	19.95	WL-653B	45.00
2J50	49.50	7P-653	35.00
2J55	65.00	705A	1.50
2X2	.39	706AB	12.50
2X2A	1.10	706AY	16.50
3A4	.59	7P-653	35.00
3B7/1291	.62	721A	1.50
3C23	8.50	723AB	14.95
3C24	1.95		
3DP1	2.50		
3D6/1299	.39		
3EP1	3.50		
3FP7	1.69		
3GP1	2.50		
3JP12	4.50		
4B22/EL5B	3.50		
4B25/EL6CF	3.50		
EL/C5B	3.50		
EL/C6A	3.50		
4J36	95.00		
4J37	95.00		
5BP1	4.69		
5D21	11.50		
5FP7	1.65		
5JP2	12.50		

**T
U
B
E
P
R
I
C
E
S
D
R
O
P
D
R
O
P**

6AG7	.79	724A	1.25
6AJ5	.95	724B	1.50
6AJ6	.49	725A	5.50
6BA6	.55	803	3.10
6C6	.55	805	2.50
6C8G	.55	807	1.35
6H6	.49	810	9.95
6K7	.45	811	2.10
6SC7	.75	813	8.95
6SH7GT	.59	814	2.25
6SH7	.59	815	3.00
7C4/1203A	.39	816	1.10
7E5/1201	.69	826	.90
7E6	.45	830B	1.95
10Y	.79	832	6.95
12A6	.69	832A	7.95
12C8	.59	838	2.50
12J5GT	.40	866A	1.00
12SJ7	.40	872A	1.95
14H7	.49	884	1.00
14J7	.49	902P1	4.50
15R	.55	954	.29
CE22	.69	CK-1089	.45
RK-25	2.10	957	.29
23D4	.45	1616	.75
FG-27A	4.90	1619	.49
30SP	.39	1624	1.00
455P	.35	1625	.35
53A	1.00	1629	.55
QK-59	50.00	1655/6SC7	.75
QK-60	50.00	1846	50.00
QK-61	50.00	2051	.79
		8005	4.25
		9001	.95
		9002	.85
		9003	.99
		9004	.39
		9006	.34

RADIO SHACK CORPORATION

167 Washington St., Boston 8, Mass.

JUNE SPECIAL
FG-27
\$4.90

SEARCHLIGHT SECTION

RECORDER, SIGNAL GENERATOR—AMPLIFIER, & Voltage REGULATOR

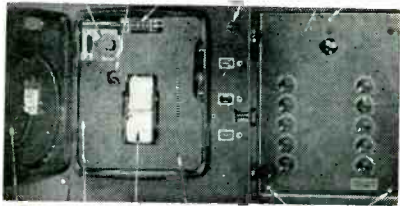

RECORDER, SIGNAL GENERATOR—AMPLIFIER, AND VOLTAGE REGULATOR UNIT of BC-968 TRAINER—Used for assimilated Radar identification when used with BC-412 Scope. Signal Generator generates various AC wave forms. Recorder was used to record difference in scope and generator wave forms as guided by operator. 110 Volt 60 cycle operation—with Manual. Shipping Weight: 270 lbs. Complete Unit. NEW: **\$59.50**

OR AVAILABLE AS SEPARATE ITEMS:
SIGNAL GENERATOR—AMPLIFIER: Can be adjusted for various wave forms. 110 Volt 60 cycle operation. Voltage regulated supply 300 Volt 100 MA. 6.3, 5 A.; 5 Volt 3 A. Power Supply. 15 Tubes: 17A6, 3/7A8, 3/7FT, 3/7N7, 1/5Y3GT, and 4/VR1150. With Tubes and Manual. **\$19.95**

RECORDER—Complete with 115 V, 60 cycle 1/125 HP Gear Head Motor, Feeder Counter, Pen, etc. and with Manual. \$19.95
CONSTANT VOLTAGE REGULATOR—115 V, 60 cycle, #30726. \$14.95

BLOWERS:

115 Volt 60 cycle **BLOWER** (pictured)—approx. 100 CFM Dis. 2 1/4" Intake; 2" outlet. Quiet running. Motor size: 2 1/2"x3 1/4". NEW — Not Govt. surplus. **\$8.95**
 Order No. 1C939.
DUAL BLOWER—Same as RN-520 above, except has blower assembly in each side of motor. Order No. 1C890. **\$13.95**
COMPACT TYPE—108 CFM, motor built inside squirrel case, 4-1/2" Intake; 3-3/4" x 3" Dis. Complete size: 4-1/2" W. x 9-3/4" H. x 8-1/2" D. Order No. 2C067. **\$14.50**
FLANGE TYPE—140 CFM, 3-1/2" Intake; 2-1/2" Dis. Complete size: 8-1/2" W. x 7-3/4" H. x 6-3/4" D. Order No. 1C890. **\$13.95**
FLANGE TWIN—275 CFM, 4-1/2" Intake; 3-1/2" x 3" Dis. Complete size: 11-3/4" W. x 9-3/4" H. x 8-1/2" D. No. 2C069. **\$21.95**
MINIATURE BLOWERS—24 VDC; ohmng Outlet 1" x 3/8". Dual 20 CFM \$7.95. Single 10 CFM \$5.95

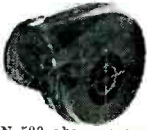

SOUND POWERED HEAD AND CHEST SET

NAVY TYPE—No Batteries required. Ideal for TV Antenna Installations, and many other uses. 20 Ft. Cord. Used—Tested. Each: \$5.95
WIRE — COMBAT TYPE: 2 Cond. twisted, rubber covered, medium weight, W-130 @ 1¢ per ft. **FIELD WIRE:** 2 Cond. twisted, weatherproof, heavy duty. W-110, 525 Ft. Roll \$4.75



TRANSFORMERS:

110 VOLT 60 CYCLE PRIMARIES:
5 VOLT CT-25A—10,000 V. Ins. OPEN FRAME—3" x 5" x 4 1/2". **\$5.95**
 Sec. Two 12 V. 4 A Winding — gives 12 V. 8 A., or 24 V. 4 A. **\$1.50**
 Sec. 24 V. 1/2 A. **\$1.50** Sec. 24 V. 1 A. **\$4.95**
 Sec. 24 Volt 6 Amps. **\$3.95**
 Sec. 6-24 or 30 Volts, 8 Amps. **\$5.95**
AUTO—TRANSFORMERS:
 230 Volt to 115 Volt 60 cycle 20 KVA. Stock = 3115620-25 Jeffries Type EA. Price: **\$69.50**
 230 Volt to 115 Volt 60 cycle 250 Watt. Jefferson = 352-7093. Price: **\$5.95**

ADDRESS DEPT. E • All Prices Are F.O.B. Lima, Ohio • 25% Deposit on C.O.D. Orders

INVERTERS & GENERATORS:

5D21N3A—27 VDC input; output 110 Volt 400 cycle. 1 Phase 485 VA. **\$39.50**
PE-109D—Input 13.5 VDC 29 A.; output 115 V 400 cycle. 1 Phase 1.53 Amps. **\$59.50**
PU-7/AP—Input 28 VDC 160A; output 115 V 21.6 A 400 cycle 2500 VA. **\$89.50**
PE-118—Input 28 VDC 100 A.; output 115 V 400 cycle. 1 Phase 1500 VA. **Used: \$14.95**
PE-218—Input 28 VDC 100 A.; output 115 Volt 400 cycle. 1 Phase 1500 VA. **Used: \$24.95**
NEW: \$49.95
PE-115 or PE-206—Input 28 VDC 36 A.; output 80 Volts 800 cycle 7.2 Amps. **Like New: \$12.95**
TYPE 800-1-D—Input 28 Volts 62 A.; output 115 V 7 Amps. 1 Phase 800 cycle. **Used: \$39.95**
NEW: \$75.00
MOTOR AMPLIDYNE—Input 115 Volt 60 cycle 1 Phase; Output 250 Volts .6 Amps. GE # 5AM450815 **\$89.50**
MOTOR GENERATOR POWER SUPPLY—Model BK, Set type CCL 211014—Input 115 VDC, 3/4 HP Motor—Output Generator: 27 VDC 250 Watts. **Price: \$59.50**
GASOLINE ENGINE GENERATOR—PU-6/TPS-1 Generator Output 120 Volt 400 cycle 1 Phase 1400 Watt, & 27 VDC 400 Watt. Direct drive by single cyl. air-cooled two cycle gas engine. **Price: \$175.00**

COAXIAL CABLE & CONNECTORS:



CO-1071 CORD—With PL-259 Plugs each end. Renewable Vinylite Covering over Plugs, 50 ohm coax. 2 Ft. long. Price: 59¢ Each — Or Lots of 10 @ 50¢ Ea.
PL-259—Plug ea. end & 32" RG-54/U—58 ohm 50¢
UG-21/U—Plug ea. end & 32" RG-11/U75 ohm 50¢
UG-22/U—with 4" Coaxial Cable. **\$1.50**
RG-8/U (SPECIAL) 51.5 ohm. Same size as RG-8/U. Prices: 1 to 100 ft. @ 8¢ per ft.—100 to 500 ft. @ 7 1/2¢ per ft.—500 to 1000 ft. @ 7¢ per ft.—1000 ft. RLL (or more) @ 6 1/2¢ per ft.
RG-34/U—71 ohm, 145 ft. length. **\$15.00**

MOTORS: 24 VDC Reversible

MOTOR—3.7 RPM, 40 lb. Torque. Motor Size: 5-1/2" x 4-1/32" 3-5/16" Shaft size: 21/32" x 5/16". Also operates 24 VAC. Philco No. 441. **\$10.08**
27.5 VDC—6000 RPM, 1.5 oz. In. Shaft Size: 1-3/8" x 1/4". Motor Size: 2-3/8" x 1-1/2". No. 5069-267. **\$6.95**
27 VDC—1-10 HP—3500 RPM. Shaft Size: 3/8" x 1/4". Motor Size: 4" x 3-1/2". Air Assoc. No. EE-763. **\$6.95**
80 VDC—1/50 HP—3000 RPM. Shaft Size: 3/8" x 1/4". Motor Size: 5" x 3". G.E. No. 5 PN881A10. **\$8.95**
28.5 VDC—1/35 HP—2200 RPM. Shaft Size: 1-1/8" x 1/4". Motor size: 4-1/2" x 3-3/4". Electrolux No. 16876. **\$5.95**
24 VAC OPEN FRAME—20 RPM Double Shaft Back Gear Motor with Disengage Clutch. Shaft size: 1-1/2" x 3/16". **\$3.95**
24 VAC OPEN FRAME—3 RPM Back Gear Motor. Shaft size: 3/8" x 3/16". Price: **\$2.95**
24 VDC REVERSIBLE—5000 RPM with Magnetic Brake. Flange Mount Spine Shaft—size: 3/8" x 3/16". Motor: 4" L. x 2-1/2" Dia. GE Motor only = 5B-A25A32A. Price: **\$4.95**
24 VDC AIRWAY MOTOR—Model #Z-350, Approx. 5000 RPM. Motor size: 2-1/2" x 1-5/8". Shaft size: 1/2" x 1/4". Price: **\$2.95**
26 VOLT 60 CYCLE—60 RPM Synchronous Cramer Motor #1147. Shaft size: 1" x 1/2". **\$1.95**
110 VDC 1/70 HP, 1550 RPM. Motor size: 4" x 2-1/2". Shaft size: 1" x 3/16". Redmond #157. **\$4.95**
6 VDC 1/20 HP, 4000 RPM. Motor size: 5" x 3". Shaft size: 3/4" x 1/4". Redmond #12-56. Price: **\$4.95**
12 VDC 1/30 HP, 4500 RPM. Motor size: 3" x 2-1/4". Shaft size: 1" x 3/16". Delco #5047520. **\$4.95**
A.C. INDUCTION MOTOR—115 Volts 60 cycles 1.9 RPM—Torque Oz. In. 75; Watts—9; with variable Multiple Disc Cover Wheel and Micro Switch mounted on Bracket Assy. Holtzer Cabot Motor Type RW2 2505. **\$9.95**
GEARED HEAD MOTOR—Heavy Duty, 24 VDC 8 Amp, 2-1/2 lb. Torque; 100/200 RPM Shaft size: 5/16" x 1". Right Angle Drive. **\$8.95**



RCA SURPLUS TV CAMERA!

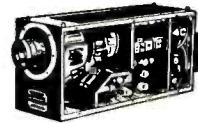

\$275.00
 Frequency—264-372MC complete with 1818 Iconoscope, and 6 stage Video amplifier and clipper—scanning: vertical 40-60 FPS, Horizontal 13,500, 15,800CPS—Ideal for use in movie pick up chains and for training and experimental work.

MAGNETRON TUBES

2J-21	56.00	718 AY	\$19.50
2J-21A	5.00	718 BY	19.50
2J-22	3.50	718 CY	19.50
2J-62	14.50	718 EY	19.50
2K-55	42.50	723A B	20.00
250 TL	58.00	750 TL	\$75.00

PLATE TRANSFORMERS

Amer Trans Spec. 29108; Pri. 115 V., 10.4 Kva., 60 cycles, Sec. 17,600 v., 35 Kv. test. For RA-38 Power Supply. Like new condition. **\$49.50**

CONDENSERS

.25 mfd. @ 20,000V	1 mfd. @ 10,000V	\$19.50
per	517.50	
.25 mfd. @ 32,500V	3 mfd. @ 7,500V	24.50
	50.00	1x1 mfd. @ 3,000V 6.50
1 mfd. @ 6,000V	7.50	1 mfd. @ 3,000V 3.50
2 mfd. @ 20,000V	49.50	

SPRAGUE 15A-1-400-50P

15 KV "A" Circuit 1 Microsec. **\$14.50**
 400 PPS 50 ohms impd.

Test Equipment

RECEIVERS—TRANSMITTERS

OSCILLOSCOPE SPECIALS!

DUMONT	*224	3 in.	\$149.50
DUMONT	*208	5 in.	225.00
DUMONT	*168	5 in.	87.50
R.C.A.	*158	5 in.	87.50
BROWNING	*PAE	5 in.	195.00

Radar

Ask for complete listing of our Radar Equipment

NEW CATALOGUE NO. 113
 LISTS INVENTORY OF AIRCRAFT, INDUSTRIAL AND MILITARY ELEC. TRONICS EQUIPMENT. NOW OFF THE PRESS. SEND FOR YOUR COPY TODAY!

ARROW SALES INC.

Mailing Address: P. O. BOX 3878-E, N. HOLLYWOOD, CALIF.
 Office-Warehouse: 746D VARNA AVENUE, N. HOLLYWOOD, CALIF.
 POplar 5-1810 • Stanley 7-6005 • Cable Address: ARROWSALES

SURPLUS
 ANY STANDARD RANGE
 *5MA & UP

This Month's SPECIAL OFFER

PANEL METERS \$249 ea.
 *Milliammeter
 Voltmeter 2" SQ. WESTON
 Ammeter 2" SQ. WESTON SANG.

0-50 Microamps Weston Model 600 8.95
 0-150 Volts A.C. Weston Model 476 10.95
 0-2.5 Amps R.F. Weston Model 425 6.95
 Other Weston - Simpson - General Electric Ranges and Models in Stock

METERS FOR TEST EQUIPMENT

as used in
 BC-610 • BC-191 • BC-375 • I-100
 SCR Numbers 284, 508, 510, 610 • RA-34
 AN/TRC1 • TS268/U • and others
 Correspondence Invited

METERS FOR AIRCRAFT

GENERAL ELECTRIC • WESTON • WESTINGHOUSE
AMMETERS VOLT-AMMETERS SHUNTS
C.A.A. CERTIFIED—GUARANTEED
 (prices on request)

METER REPAIRS

Our standard laboratory with its highly skilled personnel has complete facilities for designing, calibrating, scaling and repairing panel meters. Stock panel meters converted and rescaled to your specifications.

INSTRUMENT SERVICE

455 B. 67th St. Arverne, New York
 Neptune 4-8594

FAIR RADIO SALES • LIMA, OHIO

AN/APR-4 LABORATORY RECEIVERS

Complete with all five Tuning Units, covering the range 38 to 4,000 Mc.; wideband discone and other antennas, wavetraps, mobile accessories, 100 page technical manual, etc. Versatile accurate, compact—the aristocrat of lab receivers in this range. Write for data sheet and quotations.

We have a large variety of other hard-to-get equipment, including microwave, aircraft, communications, radar; and laboratory electronics of all kinds. Keleket alpha scalars and chambers, dosimeters and other nucleonics now in stock. Quality standards maintained.

NEW TS-13/AP X-BAND SIGNAL GENERATORS with manual \$575.00; TS-175/U Frequency Meter 85-1,000 Mc. \$485.00; H-P, Boonton, G-R, Measurements, many others in stock.

ENGINEERING ASSOCIATES

434 PATTERSON ROAD

DAYTON 9, OHIO

AVAILABLE FROM STOCK THE TS-250 ALTIMETER TEST SET

Complete with Accessories and Instructions

This set is designed to provide an accurate signal source for calibrating all ranges of AYB, AYD, AN/ARN-1 or AN/APN-1 Radio Altimeters. The TS-250 may also be used for measuring over-all loop sensitivity.

As compared with standard delay line type of calibrators, the 250 is better because of greater accuracy and because it provides a means of calibrating both the high and low altitude ranges. Provision for alignment of the counter circuits is also included. Operating from a 24-29 VDC source, the TS-250 is the logical instrument for all Airline maintenance personnel. The calibration accuracy of the TS-250 is within 1%, while the attenuator accuracy is within 3 db.



Housed in an attractive St. James grey enameled splash proof case, the weight of which, complete, is 20 lbs., the over-all dimensions are 12 x 12 x 15.

The net price of this instrument F.O.B. Harvard, Massachusetts, complete as per illustration, \$660.00.

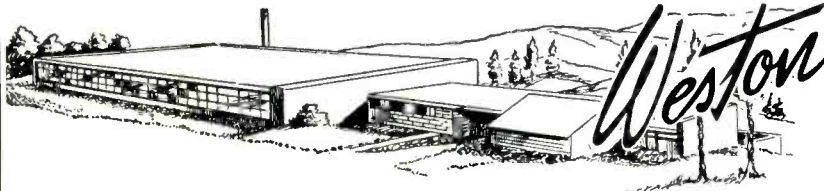

LABORATORIES, INC.
HARVARD, MASS.

Tel: HARVARD APR-426 250-AYER 300-TWX
HARV 193 Cable: WESLAB

ATTENTION QUANTITY BUYERS!

Lowest prices in the industry on these transmitting and special purpose rectifier tubes.

872A-\$1⁷⁵ ... 866A-75¢

FG81A-\$2⁴⁹ ... 705A-75¢ ... 1616-59¢
8013A-\$1⁹⁵ ... 9004-20¢

All new, standard brand tubes. JAN specifications. Original manufacturers' boxes.

Stock up now, while quantities are available at these fabulous prices. Correspondingly low prices on all other types of tubes.

Escriban En Espanol

Ecrivez-Nous En Francais

Schreiben Sie Uns Auf Deutsch

MARITIME INTERNATIONAL CO.

11 STATE ST., N. Y. 4, N. Y.
DIGBY 4-3192
CABLE ADDRESS—FOXCROFT.

SEARCHLIGHT SECTION

REVERSIBLE GEARED-MOTOR

Delco-PM-Permanent Magnet Alnico Field Motor



#5071895 1/4" SHAFT or 11/16 GEAR... \$17.50
 #5069600 \$18.50
 Clamps to hold motor. \$1.50 ea.

GRAIN OF CORN LAMPS

28 VOLTS

#328 #321
 10 for \$3.00 100 for \$25.00

#318 3V
 Amber or Clear
 10 for \$1.80
 100 for \$15.00

LM32 10 for \$4.50
 Bausch & Lomb 10 for \$6.50
 EXTENSION SOCKET ON CORD & TRANSFORMER FOR LM 32 \$3.50

#326
 2 1/2 Volts
 10 for \$3.00

Ford Spark Coil by Delco-Remy 1/2".....\$2.75

MARKTIME
5 HOUR SWITCH
 A 10 amp. timing device. Pointer moves back to zero after time elapses. Ideal for shutting off radios and TV sets when you go to bed. Limited supply at this special PRICE. \$4.90
 Also available in 15 min., 30 min., 1 hr. at \$5.90

Genuine TELECHRON Motors
 2 RPM \$2.90
 3 RPM 3.90
 4 RPM 2.90
 3.6 RPM 3.15
 1 RPM 3.95
 60 RPM 4.30
 3 R.P. Hr. 2.85
 1 R.P. 2 Hr. 2.80
 1 R.P. 12 Hr. 3.25
 Laboratory Special 1 of Each Above \$25.00

HAYDON SYNCHRONOUS TIMING MOTOR
 110v. 60 cycle 30 RPM... \$2.60
 110v. 60 cycle 1 RPM... \$2.85
 230V (1 RPM)..... 1.00
 60C 12 RPM..... 1.00

ALL PRICES F.O.B. N. Y.
EST. 1923 BLAN EST. 1923
 64M Dey St. New York 7, N. Y.

IN STOCK

TS10	IE 19A	BC376-H
TS16	TS251	BC1155
TS34	EE65	APS4
TS35A	TG34	APS3 components
TS59	VT158	R132/TPS10
TS184	ID80-APA-17	RA34
BC191	I-83	A-5 Auto Pilot Amplifier
BC375		

AN/APR5A Airborne superhet radar search rec. Freq. range 1000 to 3000MC. Rec. has a 10MC RF band width operating from 80/115VAC. Single phase 60 to 2600 cps and one amp. at 26VDC complete with tubes... like new... \$250.00

AN/APT5 TRANSMITTER... operates over a freq. of 300 to 1400 MC; output 30 watts. The carrier freq. is noise-modulated with effective random noise freq. up to 2MC. Complete with tubes... like new... \$99.50

I-122 SIGNAL GENERATOR RF signal 15 to 25 MC and 90 to 125 MC; modulated at 400 cps. or 625 cps. Power Supply 100 to 135 VAC, 25 to 60 cps. like new... \$39.50
 Spar parts kit for above... \$9.95 (new)

Write for prices and bulletin.
RW ELECTRONICS, Dept. EL
 2430 S. Michigan Ave. Chicago 16, Ill.
 Phone: CA lument 5-1281

Call on Columbia for Cut-Cash buys!

Everything goes in this hot, value-packed Sale. Order Now!

ASSORTED RESISTORS NEW!
 Long pig-tails. American made—not Japanese.
 Kit of 1,000... \$7.50
 Kit of 500... 4.25
 Kit of 100... 2.98
 Kit of 50... .65

RA-105 POWER SUPPLY
 115 V. 60 cycle input. Output ranges from 110 V. to 2400 V. Consists of 4 transformers, 2 diodes, 7 oil-filled filter condensers & hundreds of other useful items. Parts alone worth \$75.00. BRAND NEW.
 Special at **13.95** only (Wt. Approx 100 lbs.)

OIL-FILLED CONDENSERS
 All brand New!
 8 MFD @ 600 VDC... 89c
 2 for... \$1.75
 8 MFD @ 1,000 VDC... \$1.89
 2 for... 3.50
 10 MFD @ 600 VDC... 1.89
 2 for... 3.50

PE-103 DYNAMOTOR
 0-12 V. input. 500 VDC @ 200 MA output.
 Excellent. **22.95** each

RA-34 RECTIFIER
 AC power supply for IC-121 transmitter. Input 110 V. 60 cycle. Output: 1,000 VDC @ 500 MA. Brand New. Good con. **\$9.50**

POWERSTAT TYPE #1126
 Input 115 VAC 50/60 cycles. Output: 0-135 VAC. 15 amp. New in original boxes. **\$33.95** each

NEW SIGNAL CORPS RELEASE!
 Latest Field Telephone. Made of light-weight aluminum. Waterproof. Long range. Has bell or neon indicator for call signal. Uses a handset with F-1 button. Easily converted to terrific phone patch. Complete with batteries. BRAND NEW. **PAIR \$19.50**

MAGNETO GENERATOR TYPE
 20 cycle, 100 V. For ringing telephone circuits, igniting dynamos, experiments and many other uses. JUST RELEASED. Brand new **\$5.95**

All items F.O.B. Los Angeles. 25% deposit required.
COLUMBIA ELECTRONICS
 2251 W. Washington Blvd.
 Los Angeles 18, Cal.

NEW SIGMA RELAYS
 DPDT. Hermetically sealed octal base. No better value!
 15,000 OHM. Each... \$2.99
 2 for only... 5.00
 5,000 OHM. Polarized. Ea. 1.99
 3 for... 5.00

PRECISION TEST EQUIPMENT
 Only a sample of our vast stock
SIGNAL GENERATORS
 TS 13-AP I-72 I-196
 TS 35-AP I-96 I-208
 TS 45-AP I-122 I-147
 TS 120-UP I-130 804C
 Measurements No. 78 Ferris No. 188
RANGE CALIBRATORS
 TS 5-AP TS 19-AP
 TS 102-AP
FREQUENCY METERS
 BC 221 LM TS 174
POWER METERS
 TS 33 TS 36 TS 125 I 203

TUBE SPECIALS! BOXED!
 304TL Ea. \$1.75
 2 for 9.00
 3C24/24G Ea. \$1.49
 2 for 2.75
 1625 Ea. 2.96
 4 for \$1.00
 5BP4 Ea. \$2.95
 5BP1 Ea. 2.49
 725A Ea. \$6.95
 730A Ea. 7.95

TG-10 KEYS
 Automatic Code Training Keyer, originally used for class instruction. Includes a push-pull 6L6 amplifier. Variable speed synchronous drive motor and rewind. Tube complement 3-6SJ7, 1-6SN7, 1-5Y3. Dimensions 25"x19"x11" **\$22.50**
 Limited Quantity

SPLIT STATOR CONDENSERS
 New! 2 meter. Silver plated. Original box. Ea. **49c**

WESTERN ELECTRIC HANDSET
 With F-1 button. Like new. Special this month only. Ea. **\$2.95**

YOUR NAME WANTED
 Get on our mailing list to receive FREE copies of our famous Best Buy Bulletins

FOR SALE
FACTORY TEST INSTRUMENTS
 RCA TG1A television sync generator, rack and power supply
 General Radio, Type 724A Precision Wavemeter —16KC to 50 Mc.
 General Radio, Type 650A Impedance Bridge
 Leeds & Northrup #4286 Kelvin Bridge .0001 to 11 ohms
 Brown Potentiometer Model 126W3 0-71 Millivolts DC
 Shallcross Milliohmeter Type 671 .0001 to .3 ohms
 Measurements Model 62 AC-DC VTVM
 Solar Exam-Eter (Production type capacitor & resistance checker)
 50 U.T.C. 5 Amp Varitrans. (Good Condition)
 70 Isolation Transformers 250 V.A.

TECH-MASTER CORPORATION
 443 Broadway, New York 13, N. Y.
 Telephone: WOrth 6-2323

UNEQUALED COVERAGE!!!
 The SEARCHLIGHT SECTION offers advertisers unequalled coverage of the three fields which ELECTRONICS penetrates.
 The first being the designers, manufacturers, and users of electronic and allied equipment.
 The second field, Communications,—Electronics serves the operation and maintenance engineer in every type of wireless and wire communication.

In Electronics' third field, namely the Industrial, there is horizontal penetration to all types of industry where users of industrial electronic equipment for control, measurement and safety are found.

The SEARCHLIGHT SECTION can be used at a small cost to announce all kinds of business wants and needs to other men in the Electronic industry.

When you want additional employees, want to buy or sell used or surplus new equipment, components or other allied products, seek more capital—in fact, for almost any business need or want, put the SEARCHLIGHT SECTION to work for you.

For more information write to the Classified Advertising Division, McGraw-Hill Publishing Company, Inc. 330 West 42nd Street, New York 36, N. Y.

WHOLESALE ONLY
ELECTRONIC COMPONENTS
AIRCRAFT EQUIPMENT
HYDRAULICS
RADIO & ELECTRONIC SURPLUS
 13933-9 BRUSH STREET
 Detroit 3, Mich. TO 9,3403

SPECIAL PURPOSE TUBES

• 304TL-5.00 • 807-1.00 • 815-2-50 • 872A-2.00

1B24..... 6.00	3B25..... 2.50	6G4..... 3.00	282A..... 6.00	631-P1..... 4.00	833A..... 35.00
1B27..... 8.75	3B26..... 2.50	7BP7..... 2.75	283A..... 3.00	701A..... 3.00	837..... 1.00
1B42..... 7.75	3B28..... 3.50	9GP7..... 3.75	286A..... 5.50	702A..... 1.95	838..... 9.25
2AP1..... 5.00	3C23..... 5.00	9LP7..... 3.75	304TH..... 6.75	702B..... 2.50	846..... 125.00
2C33/RX-233A..... 2.00	3C24/24G..... 1.00	12GP7..... 9.50	304TL..... 5.00	703A..... 2.50	849..... 15.00
2C40..... 4.75	3DP1..... 2.00	FG-17 5557..... 4.75	305A..... 3.50	707A..... 4.50	850..... 20.00
2D21..... 1.00	3EP1..... 3.00	RK-19..... 1.50	307A..... 2.00	707B..... 7.75	860..... 9.00
2E22..... 1.50	3GP1..... 2.00	RK-21..... 1.25	310A..... 3.00	708A..... 2.00	861..... 10.00
2J21A..... 4.75	4B26..... 4.50	RK-23..... 1.50	311A..... 5.00	709A..... 1.50	866A..... 1.00
2J22..... 4.75	4B27..... 5.00	HK-54..... 3.50	313C..... 3.00	715A..... 2.50	869B..... 50.00
2J26..... 6.00	4C22/HF-100..... 7.50	RK-62..... 1.75	316A..... 1.00	715B..... 3.50	872A..... 2.00
2J27..... 8.00	4C27/CV-92..... 9.00	RK-73..... 1.00	323B..... 5.75	715C..... 16.00	878..... 1.00
2J29..... 25.00	4E27..... 13.00	C-100D..... 2.00	328A..... 3.25	719A..... 10.00	884..... 1.00
2J31..... 19.00	4J34..... 75.00	F-128A..... 35.00	329A..... 5.50	721A..... 1.50	885..... 1.35
2J32..... 19.00	4J35..... 100.00	HK-154..... 4.00	348A..... 6.00	723A/B..... 14.00	891R..... 190.00
2J33..... 23.00	4J42..... 100.00	VT-158..... 20.00	349A..... 6.50	724A..... 1.00	892R..... 190.00
2J34..... 17.50	5BP1..... 2.75	FG-190..... 5.00	350A..... 2.50	724B..... 1.25	902P1..... 4.25
2J36..... 75.00	5BP4..... 2.75	HF-200..... 12.50	354A..... 10.00	725A..... 5.00	913..... 9.00
2J37..... 10.00	5CP1..... 3.75	C-202..... 10.00	355A..... 10.00	726A..... 8.50	923..... 1.00
2J38..... 8.00	5C30/C5B..... 3.00	204A..... 10.00	F-375A..... 10.00	726B..... 35.00	931A..... 3.75
2J40..... 25.00	5D21..... 8.50	205B..... 1.00	393A..... 5.50	726C..... 35.00	959..... 1.35
2J55..... 55.00	5FP7..... 1.00	F-207..... 50.00	394A..... 2.00	803..... 9.75	CK-1006..... 1.35
2J56..... 80.00	5FP14..... 6.00	217A..... 2.50	WL-417A..... 6.50	805..... 2.50	1500T..... 100.00
2J61..... 23.00	5JP1..... 9.00	WL-218..... 20.00	GL-434A..... 10.00	807..... 1.00	1624..... 1.00
2J62..... 17.00	5JP4..... 9.00	250R..... 4.50	446A..... 1.00	808..... 1.50	1904..... 12.00
2J-B51..... 4.50	5J26..... 75.00	251A..... 50.00	446B..... 1.00	811..... 2.00	9050..... 1.00
2K33A..... 50.00	5J30..... 20.00	252A..... 15.00	WL-460..... 10.00	815..... 2.50	ZB-3200..... 85.00
2K54..... 50.00	5J32..... 50.00	253A..... 5.00	464A..... 3.50	822..... 15.00	8002R..... 35.00
2K55..... 50.00	5R4GY..... 1.00	257A..... 3.00	WL-468..... 15.00	826..... 1.00	8012..... 1.50
3AP1..... 4.00	C6A..... 6.00	267B..... 6.00	521..... 19.50	828..... 8.75	8013..... 2.00
3BP1..... 3.00	C6L/5528..... 5.00	271A..... 5.00	WL-530..... 8.00	830B..... 1.75	8020..... 1.00
3B24..... 3.50	6BM6..... 50.00	274B..... 1.50	WL-531..... 4.50	832..... 6.00	8025..... 2.75
3B24W..... 6.75	6C21..... 15.00	276A..... 5.00	559..... 1.00	832A..... 7.00	PD8365..... 50.00

western engineers

• Prices do not include transportation

ELK GROVE, CALIFORNIA
GEORGE WHITING, OWNER

• Fully guaranteed

4 PDT

MIDGET RELAY



26.5 vdc 125Ω..... \$2.95
12 vdc 70Ω..... 1.65
26.5 vdc 280Ω..... 2.75
6 vdc 18Ω dpdt..... 1.50
12 vdc 180Ω dpdt..... 1.35
5.3 vdc 15Ω sust NO 10A bridge cont..... \$1.50
RELAY 3 PDP 24 vdc 250 ohm Clare K..... 2.50
MOTOR 400-1800 cyc 115v EAD J31C..... 4.95
ERIE 557 silver trimmers 3-12 NPO, 8-50 N750
TS2A 1.5-7 NPO, 4-30 N500, 7-45 N500, etc.
Thousands of other items. Write for Bulletin

EMPIRE ELECTRONICS COMPANY

400 Avenue L, Brooklyn 30, N. Y. Cloverdale 2-4000

INSTRUMENTS and METERS

RADAR TEST UNIT, Echo Box, 150-240 MC, 115 Volt AC, Liebel-Flarsheim Co.
TEST SET for IMC Block Mica Elect. Qual., Boonton Radio # 130, AWS C 75.3 Cap. MKDDE.
TEST UNIT, I-176..... \$42.50
INDICATOR ID-101/MRN-3, st. # 3F2877..... \$30.50
TEST SET TS-32A/TRC-1..... \$17.50
SERVO POT., S-167500, st. # 6583808, W.EL. \$39.50
FREQUENCY METER, 58-62, 100-130V, 11PT 21PX, 2 1/2" case..... \$13.50
FREQ. METER, 55-65, 100-150V, Frahm, 3 1/2" case..... \$14.50
ELAPSED TIME METER, 110 volt 60 cycle, registers to 9,999.9 and repeats, Cramer RT-21H, 3 1/2" rd case..... \$13.50
ELAPSED TIME METER, 200-240 Volts 60 cycle, to 9,999.9 hrs. and repeats, Cramer RT-3H, 3" square case..... \$13.50
DC MICROAMMETER, 0-50, Electrotech #350, AWS type MR34W050DCUA, 3 1/2" case..... \$ 8.50
DCMA, 0-500, SC type IS-122, st #3F222, G.F. 2 1/2" bl sc..... \$ 5.50
RF Amp, 0-3, for Navy XMTR, Weston 507, 2 1/2" case, black scale..... \$7.50
RF AMP, 0-8, SC type IS-89, GE DW-44, 2 1/2" case, bl. sc..... \$6.50
DCMA 0-200, for TCS XMTR, Weston 506, \$ 8.50
RF Amp, 0-3, for Navy XMTR, Weston 507, 2 1/2" case, black scale..... \$ 7.50

Items Brand New and Guaranteed Net FOB warehouse. Send for additional listings, details.

AVIONIC ASSOCIATES

124 Birchwood Road Paramus, N. J.
Ridgewood 6-6336

PRECISION RESISTORS

BARGAIN PRICES WIREWOUND SPOOL TYPE



Type WW3 or Equal, 1/2 Watt . . . Your Choice 35¢

Ohms	Tol.	Ohms	Tol.	Ohms	Tol.	Ohms	Tol.	Ohms	Tol.	Ohms	Tol.
.250	1%	9.1	1%	55.10	1%	366.6	1%	6500	1%	33.30K	1%
.334	1%	10.48	1%	62.54	1%	400.0	1%	7000	1%	35.00K	1%
.502	1%	10.84	1%	75.00	1%	434.3	1%	7300	1%	35.83K	1%
.557	1%	11.10	1%	79.81	1%	705.0	1%	7500	1%	37.00K	1%
.627	1%	11.25	1%	87.00	1%	723.1	1%	8000	1%	37.00K	1%
.760	1%	11.74	1%	97.80	1%	750.0	1%	8500	1%	40.00K	1%
1.00	1%	12.32	1%	105.8	1%	855.0	1%	8800	1%	45.00K	1%
1.01	1%	13.0	1%	123.8	1%	1000	1%	10.00K	1%	47.00K	1%
1.53	1%	13.02	1%	125.0	1%	2193	1%	12.00K	2	50.00K	1%
2.00	1%	13.15	1%	130.0	1%	2200	1%	14.82K	1	59.00K	1%
2.5	1%	13.3	1%	147.5	1%	2250	1%	15.00K	1	59.15K	1%
2.04	1%	13.52	1%	180.0	1%	2500	1%	15.75K	1	68.00K	1%
3.0	1%	13.89	1%	210.0	1%	2850	1%	16.70K	1	100K	5
3.5	1%	14.98	1%	220.4	1%	3427	1%	17.00K	1	125K	1
4.0	1%	16.37	1%	235.0	1%	4000	1%	20.00K	1		
5	1%	25.00	1%	260.0	1%	4300	2%	25.00K	1		
5.26	1%	30.00	1%	270.0	1%	4451	1%	30.00K	1		
5.5	3%	46.00	1%	298.3	1%	5000	1%	32.70K	1		
7.4	1%	52.54	1%	331.8	1%	5900	1%	32.89K	1		

Type WW4 or Equal, 1 Watt . . . Your Choice 45¢

.861	1%	12.0	1%	120	1%	1100	1%	6000	1%	25K	1%
1.02	1%	20.0	1%	150	1%	1250	1%	6800	1%	40K	1%
2.55	1%	28.0	1%	250	1%	1750	1%	8000	1%	55K	1%
2.58	1%	38.0	1%	270	1%	2000	1%	9000	1%	80K	1%
3.39	1%	50.0	1%	420	2%	2200	1%	10K	2	84K	2
8210	1%	75	1%	425	1%	3300	1%	12K			
5.21	1%	82	1%	800	1%	4800	1%	20K	1		

Type WW4 or Equal, 1 Watt . . . Your Choice 60¢

100K	1%	128K	1%	150K	1%	250K	1%	500K	1%	600K	1%
120K	1%	130K	1%	240K	1%	320K	1%				

Type WW5 or Equal, 1 Watt . . . Your Choice 65¢

84K	2%	522K	1%	590K	2%	645K	1%	700K	1%	1 Meg	5%
-----	----	------	----	------	----	------	----	------	----	-------	----

1 Megohm 1% WW5 or Equal \$1.50

RELIANCE MERCHANDIZING CO.

Arch St., Cor. Croskey Phila. 3, Pa. Telephone Rittenhouse 6-4927

TELEPHONE RELAYS

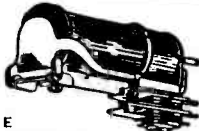

Large Stock of
CLARE, TYPES C D & E
COOKE, AUTOMATIC—ELECTRIC
ALL TYPES OF COILS and PILE-UPS
Send Us Your Specs. for Our Quote

CLARE TYPE C STANDARD SIZE SENSITIVE TELEPHONE RELAYS

Coil	Contracts Will Close at	Price
1) 6500 ohms 1C	4 MA	\$2.50 ea.
2) 6500 ohms 1B-1C	3.5 MA	2.75 ea.
3) 6500 ohms 2A	4 MA	3.00 ea.
4) 6500 ohms 2A-1B	4 MA	3.00 ea.
5) 6500 ohms 5A	5 MA	3.25 ea.
6) 6500 ohms 5A-2D	5 MA	3.50 ea.

CLARE TYPE G HALF SIZE SENSITIVE TELEPHONE RELAYS

Coil	Contracts Will Close at	Price
1) 6500 ohms 2A	5 MA	\$2.50 ea.
2) 5800 ohms 3A	4 MA	2.50 ea.
3) 5800 ohms 2B-1C	5 MA	2.50 ea.
4) 4850 ohms 1C	4 MA	2.50 ea.
4) 3600 ohms 1C	6 MA	2.00 ea.
5) 4850 ohms 1A	5 MA	2.00 ea.
6) 3300 ohms (None)	ACTUATOR	1.50 ea.
7) 3300 ohms 1A	Micro-Switch	2.50 ea.

All above Relays may be used for continuous duty operation on 110V. D.C.

OTHER TYPE C TEL. RELAYS

1) 1300 ohms 2A-1B	24 or 48V	\$2.75 ea.
2) 1300 ohms 1B	24 or 48V	2.25 ea.
3) 2500 ohms 1A	24-48V	2.25 ea.
4) 400 ohms 5A1C	24V	2.75 ea.
5) 400 ohms 5B1C	24V	2.75 ea.

OTHER TYPE G TELEPHONE RELAYS

1) 1300 ohms 1A-1C	24 or 48V	\$2.50 ea.
2) 400 ohms 1A	24V	1.65 ea.
3) 500 ohms 1D	24V	1.65 ea.
4) 200 ohms 1A	24V	1.50 ea.

CONTACT SYMBOLS

A=Norm. Open B=Norm. Closed C=S.P.D.T.
D=Make Before Break

CLARE TYPE A Tel. Relay. Coil—110 Volts A.C. 60 cy. Contacts—3PDT (3 form C) Price—\$3.50 ea.
SIGNAL Wheellock Relays #KS9665 Coil—2,000 ohms Contacts—1A, 1B, 1C Oper. at 9 Ma Price—\$2.75 ea.
GM #13017 Relays. 24 volts 150 ohm. Contacts—3PDT 10 Amp. Price—\$2.00 ea.
MINIATURE TEL. RELAY. 300 ohm, 24 volt SPDT \$1.65 ea.
FIVE Prong CR-2791 G.E. Plug In Relays.
1) C-103C25 2200 ohms SPDT 4.5 MA... \$4.00 ea.
2) C-104B28 700 ohms SPDT 6 MA... \$3.00 ea.

Bulletin #700 Allen Bradley Contactors 110V AC 60 cy. D.P.S.T. N.O. 25 Amps... \$7.50 ea.

ALLIED BJD36 MINIATURE RELAYS

1) 24V.	260 ohms DPDT	\$1.25 ea.
2) 24V.	100 ohms DPST NO	1.00 ea.

Clare SK-5032 (Herm. Sealed) Plug-In Relays. Coil—30 ohms 6 volts Contacts—DPDT. Price \$4.00 ea.

SIGMA TYPE 5F SENSITIVE RELAYS. Has two 70 ohm coils. Contacts—SPDT... Price—\$3.00 ea.

Leach Relays Type 1025-SN-BF. Coil—24V. 425 ohms. Contacts—D.P.S.T. Norm. closed. Rated at 10 Amps... Price—\$1.25 ea.

STROM. CARL. TEL. RELAY Coil—100 ohm 6 Volts. Contacts—1A... Price—\$1.35 ea.

Chase

Electronic Supply Co.
105-07 225 St.
Queens Village, N. Y.
HOLLIS 4-5033

CARRIER EQUIPMENT

Western Electric CF-1A 4-channel carrier telephone terminals.
EE-101-A 2-channel 1000/20 cycle carrier ringers.
CFD-B 4-channel carrier pilot regulated telephone terminals complete with four channels 1000/20 cycle ringing.
CFD-B 4-channel pilot regulated telephone repeaters.
C-42-A V. F. telegraph in from 2- to 12-channel terminals.
FMC 1 or 2 channels carrier telephone terminals, automatic regulation, duplex signaling each channel. Carrier frequencies above 35 KC. Ideal for adding channels above type "C".
Complete engineering and installation services offered.

RAILWAY COMMUNICATIONS, INC.

Raytown, Missouri
Telephone: FLeming 2121

X-RAY

All types for industrial and experimental applications. Tubes, cables and components.

MEDICAL SALVAGE CO., INC.
217 E. 23rd St. New York 10, N. Y.
Murray Hill 4-4267

THESE ARE JUST THE FACTS!

We Sell More Electron Tubes, for Lower Prices than any Dealers in the Trade; ALL TUBES ARE STANDARD BRANDS AND FULLY GUARANTEED: RCA, G.E., PENNSYLVANIA, ETC.

RAYTHEON ORIGINAL BOXED JAN
706B 18.50

OA2	.85	3A4	.55	316A	.85	921	1.40	8012A	1.95	Diodes****	
OA3	.85	3A5	.79	394A	2.50	923	1.75	8013A	3.50	1N21	1.55
OB2	.85	3B2A	4.50	GL434A	10.75	931A	3.95	8025	1.95	1N21B	1.55
OB3	.85	3B2B	2.75	446A	1.00	954	.25	9001	.85	1N23A	2.25
OC3	.85	3B28	3.75	450TH	44.00	955	.25	9001	.85	1N23B	2.50
OD3	.85	3C24	1.00	506AX	1.10	956	.35	9002	1.25	1N26	7.75
1B24	6.75	3C24	8.75	507AX	1.00	957	.35	9003	1.25	1N43	1.50
1B29	2.40	3E29	11.50	702A	1.75	CK1005	.35	9004	.25	1N43	.64
1B32/532	1.00	4C22	17.50	704A	2.50	CK1006	.45	9005	1.95	1N43	1.50
1N21B	1.65	4D22	13.50	705A	1.50	2050	.95	9006	.25	1N81	1.35
1N23B	2.40	4E27	150.00	707A	1.50	2050	.95	SCOPE TUBES**			
1N26	7.75	4F52	1.45	715A	2.95	2051	1.20	85ZAP1	6.95	Receiving Tubes	
1N34	1.64	5R4G	1.45	715A	2.95	591	1.20	85ZAP1	4.95	1A7GT	.60
1N43	1.35	6CJ	6.50	715C	15.85	5636	5.75	8AP1	6.95	1CSGT	.45
1N81	1.35	6A56	1.75	717A	85	5636	5.75	8BP1	3.50	1E7G	.85
1P23	2.50	6C21	18.00	722A	9.95	5642	1.00	8DP1	2.75	1L4	.45
1P36	3.95	10Y	45	801A	35	5641	1.45	8JP1	2.75	1Q5GT	.60
1P40	1.50	FC34	4.00	807	1.45	5654	1.65	8JP1	1.95	1P5	.60
2C39	12.50	2D7	8.95	812	2.00	5670	3.25	8BP1	3.50	1T4	.45
2C39A	15.00	FG32	1.95	815	4.25	5725	4.10	8HP1	4.25	3B7	.33
2C40	4.75	RM60/1641	60.50	816	1.40	5726	1.90	8HP1	4.25	3Q4	.60
2C42	7.50	QM60	60.50	829	6.65	5745	1.50	8P7	4.25	574	.85
2C43	14.50	QM61	17.50	829B	9.95	6080	1.50	9P7	4.25	574	.85
2C46	7.50	FC98	25.00	832	7.25	6097	1.50	Write for other	.45	types.	
2C52	3.50	FG105	6.95	832A	7.50	753					
2D21	.75	F123A									
2J33	20.00										
2J34	17.75										
2J39	12.50										
2J54	47.50										
2J62	17.50										
2M22	17.50										
2M23	15.50										
2M28	25.00										
2M34	65.00										
2M33A	65.00										
2K55	65.00										
2X2/879	.45										

F127A 17.50 837
HF200 13.50 845 12.25
204A 37.50 860 1.75
21V VTAC 1.75 865
RX233A 3.25 866A
250TH 19.00 872A GE. 2.75
304TL 6.95 878 1.25
307A 2.25 918
313C 2.85 919 2.00
313C 2.85 921

6SH7
6V6G
12SL7GT
LOTS OF 100 OR MORE .40

AMPEREX IN ORIGINAL PACKING
ZB3200 135.00

BEAM POWER PENTODE FULLY GUAR'D.
813 8.50

WE BUY YOUR SURPLUS TUBES
• SEND LIST WITH DETAILS •

ALLIED ELECTRONIC SALES
Specialists in ELECTRONIC TUBES
Barclay 7-5839
74 Cortlandt St., New York 7, N. Y.

Partial Listing. Query us for other types. F.O.B. N.Y.C. Rated (D&B) Firms Open Account. Attractive Discounts To Quantity Buyers.

WANTED

WANTED

TRANSMITTER EQUIPMENT
Highest prices paid for BC610 Transmitter, JB-70 Junction Box, BC939 or BC729 Ant. Tuning Units, BC614 Speech Amp & all BC610 Coils & Tuning Units.

TEST EQUIPMENT

TS184/AP Spectrum analyzer, G. R. VTVM Model 180A, Dumont 381A Scope, Boonton Q Meter Model 260A and 190A with accessories.

TRANSMITTING TUBES

2C51, 2J, 2K, 3K, 4J, 4K series, 3C45, 3D21A, 3E29, 4C35, 4D21, 4-125A, 5C22, 450TL, 728AB, 810, 813, 820B, 832, all W.E. tubes. We buy all types, RECEIVING, TRANSMITTING, INDUSTRIAL.

"TAB"

111 Liberty St. N. Y. 6, N. Y.
Phone Rector 2-6245

WILL BUY ALL

ART-13/type T-47A \$200.00 BC-348 modified \$50.00
ART-13/type T-47 \$150.00 ARCI Radio \$200.00
APN-9 \$200.00 BC-312 Receiver \$60.00
BC-342 Receiver \$60.00
SHIP VIA EXPRESS C.O.D.
SUBJECT TO INSPECTION TO.
H. FINNEGAN
49 Washington Ave. Little Ferry, N. J.

New "SEARCHLIGHT" Advertisements

received by June 4th will appear in the July issue subject to limitations of space available.
Classified Advertising Division
ELECTRONICS
330 West 42nd St. New York 36, N. Y.

"SEARCHLIGHT" Can Help You!

Hundreds of miscellaneous business problems that confront you from time to time, can be quickly solved through the use of the SEARCHLIGHT SECTION of ELECTRONICS.

When you want to buy or sell used or surplus new equipment and/or components, want additional capital or have other business wants—advertise them in the SEARCHLIGHT SECTION for quick, profitable results!



RADIO - RADAR - INSTRUMENTS
AIRCRAFT - PHOTO EQUIPMENT

AIRLINES •
GOVERNMENTS
RESEARCH •
LABORATORIES

We carry a large inventory of **NEW and Guaranteed overhauled U.S. Signal Corps and U.S. Navy Surplus Equipment.**
 We solicit your inquiries.

TRANSMITTERS
RECEIVERS
RADAR
DYNAMOTORS
INSTRUMENTS
SELSYNS. PLUGS
AERIAL PHOTO EQUIPMENT
SPARE PARTS

WE WILL NOT BE UNDERSOLD!

Send for **FREE** catalogues on

- Communication Equipment
- Inverters - Dynamotors
- Radio-Radar Test Equip.
- Aerial Photographic Equip.

EQUIPMENT WANTED

Semler Industries, Inc.
 6853 Lankershim Blvd., North Hollywood, Calif.

FOR SALE

HEADSETS, HS-30/U
 REMOTE CONTROL UNITS, RM-29
 ANTENNA EQUIPMENT, RC-173
 DYNAMOTORS, DY-12
 DYNAMOTORS, DM-32A
 DYNAMOTORS, DM-36
 DYNAMOTORS, PE-86

VICTOR-BERNARD INDUSTRIES, INC.
 1511 N. 26th St., Phila. 21, Pa.

FOR SALE

Four New Regulated POWER SUPPLIES
 300 Volts at One Ampere
 Complete lot or singly
 FS-2778, Electronics
 330 W. 42 St., New York 36 N. Y.

Your inquiry will have Special value . . .

If you mention this magazine, when writing advertisers. Naturally the publisher will appreciate it . . . but, more important, it will identify you as one of the men the advertiser wants to reach with this message . . . and help to make possible enlarged future service to you as a reader.

ALPINE ELECTRONICS

"The Peak in Tube Deals"

RADAR—INDUSTRIAL—ELECTRONIC

OA285	2J5020.00	6AR62.50	715B4.00	57631.50
OA395	2J51215.00	6AS61.75	722A1.50	58141.85
OB275	2J5450.00	6AS7G3.45	723AB18.00	58404.50
OC380	2J6122.00	6CJ6.75	728AY, BY, CY	60951.00
OD380	2J6225.00	6J44.60	DY, EY, FY	611011.25
1B246.75	2K2215.00	91P72.95	Price upon Request	801180
1B271.70	2K2311.25	15R45		8913A3.00
1B279.75	2K2523.50	FG175.00		80201.25
1B427.00	2K2825.00	FG27A7.40	8001.50	80253.75
1B63A40.00	2K2922.50	28D71.25	8053.00	XTAL DIODES
1P2127.50	2K33A90.00	35T3.00	829B11.00	1N21A1.50
1P232.55	2K34120.00	5C10518.00	830B2.00	1N21B2.00
1P288.50	2K55A75.00	FG17225.00	832A7.50	1N221.20
1P401.50	3B244.00	215A5.00	8371.00	1N22A1.85
1Z21.90	3B24W7.50	249C4.50	8382.50	1N23B2.00
2AP18.50	3B253.40	274B2.00	86595	1N254.95
2B221.75	3B262.75	316A80	866A1.25	1N268.50
2C332.00	3B284.50	394A2.50	872A3.00	1N271.50
2C38A17.50	3CP11.75	GL434A11.75	8841.50	1N3460
2C404.90	3C236.50	GL464A95	8851.50	1N34A85
2C4314.50	3C24/24G90	GL464A7.00	9211.75	1N351.60
2C4495	3C4511.50	471A2.50	16121.50	1N38A1.25
2C513.65	3DP12.25	505A1.75	16205.00	1N418.90
2C5311.65	3E299.50	KU52716.50	16361.50	1N4216.90
2D2195	3P71.75	700A9.50	20501.40	1N431.70
2J213.75	4B225.00	700B9.50	55575.00	1N451.40
2J21A3.75	4B257.75	700C9.50	56365.50	1N4665
2J225.00	4B3210.50	700D9.50	56421.00	1N473.95
2J266.75	4C3519.00	701A4.50	56457.50	1N4845
2J2721.00	4J32175.00	702A1.50	56467.50	1N5140
2J3195	4J36130.00	703A2.50	56512.50	1N5475
2J3235.00	ELCSB2.75	704A85	56541.65	1N54A95
2J3337.50	5BP12.80	705A1.00	56703.50	1N58A1.10
2J3425.00	5C2237.50	706B15.00	56863.00	1N6055
2J3712.00	5D2111.50	706C15.00	56873.00	1N6465
2J3817.00	5J299.00	707A4.75	57022.95	1N6990
2J3935.00	5J3311.95	707B9.00	57031.90	1N7080
2J4029.00	5R4GY1.25	708A3.50	57185.00	1N7285
2J4846.50	(JAN)6AK51.85	709A1.75	57195.00	
2J4960.00	6AK5W1.35	713A85		

—Subject To Prior Sale—

UNCONDITIONALLY GUARANTEED—STANDARD BRANDS ONLY

ALPINE ELECTRONICS

"The Peak in Tube Deals"

P. O. Box 979
 Grand Central Station
 New York 17, N. Y.

Sigma SENSITIVE Relays

HERMETICALLY SEALED—STANDARD OCTAL PLUG
 RECENT MFG.—LARGE QUANTITIES—1-19/32x1-19/32x2-9/16
 BRASS CASE

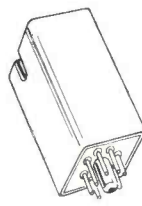

COIL: 5000 ohms; polarized; max. current 0.9 ma. (either polarity)
 CONTACTS: SPDT; 2 amp., 28V DC or 110V AC; silver cont.; fast acting

COIL: 16,000 ohms; max. pick up 0.9 ma.; min. drop out 0.1 ma.
 CONTACTS: SPDT & SPST (1A1C); 1 amp., 28V DC or 110V AC; silver cont.; fast acting

\$3.75
 Either type

Miniature RELAY CONT: DPDT, 2A. COIL: 24V DC 300 ohm
 Open frame, Approx. 1 1/2 x 1 x 3/4 **37¢**

TUBE—ZP-623 (893)
 20 KW Plate Dis. to 5mc.
 UNUSED & TESTED **\$150.00**

ARC-3 TRANS.-REC.
 10 Channel Certified **\$580.00**

C-H SPDT SWITCH
 Sglt Hole Mtg. w/hdwe;
 Bat Hdle. 15 A—125V;
 JAN-S-32, ST42D
 Min. Order 100 **35¢**

Avionic Supply

Electronics for Industry

1223 VENICE BLVD. • LOS ANGELES 6, CAL. • TEL. DU-80508

FOR SALE

FIVE NEW AND TWO SLIGHTLY USED
 50 KILOVOLT, 100 MA. G. E. POWER
 SUPPLIES. FOR DETAILS WRITE

FS-2650, Electronics
 520 N. Michigan Ave., Chicago 11, Ill.

FOR SALE 1000 KLIXON THERMOSWITCHES

#C4351-17-97
 50¢ Ea.

NATIONAL SURPLUS SALES
 MIDWEST'S LARGEST SURPLUS DEALER
 719-23 E. 18th K. C., Mo.

CERAMIC BELOW FACTORY CONDENSERS

Standard Brand,
 All Styles, Types and
 T.C. Large Quantities
 in Stock, Immediate Delivery.

CAP ELECTRONICS INC.
 102 WARREN ST., N. Y. 7, N. Y.
 RECTOR 2-8078



SAVE ON SURPLUS

Check and compare our complete stocks. All equipment is overhauled, tested and guaranteed unconditionally! We can supply spare parts for most all electronic equipment. Write for complete information!

AN/ART-13 EQUIP.

ATC, T-47, T-47A XMTRS.
DY-11, DY-17 DYN.
CU-25, SA-22 ANT. BOXES
O-16, O-17 LFO UNITS
MT-284, MT-283, MT-164,
MT-163

FOR BEST COMPETITIVE
AND QUANTITY PRICES
PHONE Republic 0215 —
ASK FOR BEN SANETT!

PARABOLIC REFLECTOR

4' dia. circular. Heavy duty construction. Part of SCR-682. New. **\$22.50**

RC-224 RADAR ANT.

Complete with Parabolic reflector drive motor and mechanism. Used for S band radar. **\$1995**
Complete, unused

AN/APS-4 RADAR \$235

Used, good condition — Complete

INVERTER SPECIAL!

PU-43—Eclipse type 800 in Rev. out 110 V. 800 cy. 7 A. **\$4.95**

ECLIPSE 800-17

in 28V out 110 V. 800 cy. 10A. **\$5.95**

Complete ILS Systems RC-103 & AN/ARN-5A both for \$150

New, orig. cartons. Consists of BC-733, RB9/ARN-5. Ant. Cables, Mounts, Ind. Dyn. Etc. Complete, ready for use. FOR WHOLESALE QUANTITY DISCOUNTS, write Ben Sanett

MX 595-6SQ-1A Speech Scrambler

A very compact speech conversion unit designed for radio and telephone circuits to scramble or unscramble speech or code. Utilizes numbered code cards which insures complete privacy. This equipment can be used with any field or airborne communication equipment. **\$45**

A COMPLETE STOCK OF TUBES

OA2 5.75 3C33	9.95 TZ40	Write 454H	Write 725A	4.95 889RA	195.00
OA3 3C45	12.95 RK60	15.95 726A	12.95 726B	35.00 920	250.00
VR75 1.05 3E29	10.50 1641	1.95 531	5.00 726C	45.00 923	3.50
OB3/VR90 1.00 3EP1	8.50 RK 72	.95 559	2.00 726C	45.00 923	1.25
OC3/VR105 .85 1806P1	3.50 757L	8.50 WL651	70.00 803	3.00 930	Write
OD3/VR150 .65 3FP7	3.75 8R90	7.00 WL652	45.00 805	2.95 931A	4.50
1B22 7.50 3HP7	2.95 217C	6.00 7007	45.00 807	7.50 955	4.5
1B27 11.50 3JP1	14.50 220B	149.50 C O	16.50 810	1.50 956	.45
1B32 1.95 4C25	18.50 250TH	15.95 703A	3.25 811	2.95 957	.45
1B42 9.95 4E27	13.75 250TH	34.95 704A	1.00 812	9.50 958A	.75
1N21 1.05 4J34	89.50 250TH	34.95 704A	1.00 812	2.95 959	1.50
1N21B 2.35 4J42	175.00 250TH	34.95 704A	1.00 812	2.95 959	1.50
1N22 1.25 4J50	Write	34.95 704A	1.00 812	2.95 959	1.50
1N23A 2.50 4-65A	17.50 250TH	34.95 704A	1.00 812	2.95 959	1.50
1N23B 2.95 4-125A	20.00 250TH	34.95 704A	1.00 812	2.95 959	1.50
1N31 6.50 5C22	40.00 250TH	34.95 704A	1.00 812	2.95 959	1.50
1N38 1.25 5C21	7.00 250TH	34.95 704A	1.00 812	2.95 959	1.50
2C36 27.50 5CP1A	14.00 250TH	34.95 704A	1.00 812	2.95 959	1.50
2C26 39.50 5GP1	2.95 250TH	34.95 704A	1.00 812	2.95 959	1.50
2C39 12.50 5FP7	1.95 250TH	34.95 704A	1.00 812	2.95 959	1.50
2C39A 15.95 5DP1	11.50 250TH	34.95 704A	1.00 812	2.95 959	1.50
2C40 7.00 5J29	10.00 250TH	34.95 704A	1.00 812	2.95 959	1.50
2C41 1.19 5J30	27.50 250TH	34.95 704A	1.00 812	2.95 959	1.50
2C51 3.75 5J32	55.00 250TH	34.95 704A	1.00 812	2.95 959	1.50
2D21 1.25 5B8	2.50 304TH	6.95 706	45.00 843	5.00 734	16.95
2D21W 2.50 5L5B	Write 304TL	6.45 707B	12.50 845	5.95 880	Write
2126 12.50 5R4GY	1.25 708A	3.75 801A	5.00 860	5.00 883	Write
2127 8.95 6AL5W	1.75 RK75	3.50 710A	1.50 852	15.95 8011	7.5
2131 20.00 6BL6	70.00 316A	1.00 713A	1.25 854A	Write 8025	4.50
2K22 18.95 6B16	70.00 316A	1.00 713A	1.25 854A	Write 8025	4.50
2K25 21.00 6C21	22.50 342A	Write 717A	.90 861	12.50 9001	1.25
2K33A 125.00 6J4	5.50 350A	3.95 715B	16.50 864	.35 9002	.95
2K54 Write 7CPI	9.95 38AS	5.50 719A	2.00 860	1.00 9003	1.25
2K55 45.00 12AY7	1.75 371B	.69 720CY	866A	1.25 9004	.60
2K24 4.50 12DP7	5.50 380A	9.50 DY	150.00 869B	60.00 9005	1.50
2K25 3.50 12GP7	19.95 434A	12.00 721A	1.50 870A	2.95 9006	.60
2K28 1.95 15E	1.70 446A	1.25 723A	8.95 884	1.25	
2C29 75.00 15P7	5.50 446B	3.75 723A/B	14.95 880	375.00	
3C21 1.35 35TG	5.50 450TL	37.50 724B	2.50		

MFGR'S QUANTITIES TUBES at attractive prices
1629 316A 6J6
IP30 5B8 VT127A
7CPI 3EPI 314A

MISC. EQUIPMENT

Prices on Request.
TBS VHF XMTR. RCVR. & Accessories
TDQ MG SETS & Starters
BC-318 All Models
RCV. VHF Xtal Cont. Revr.
ARC-3 VHF Transceiver
ARC-3 VHF
APN-9, BC-312, 342
APN-4
CRT-3
BC-611 Handie Talkies
RTA-1B BC-1306
RAIB SCR-509
AN/ARN-7
C-1 Auto Pilot Gyro.

AN/APG-13A RADAR

2700 MC. Complete. New with all accessories and cables. **\$1495.00**
Ready for use.

TOP \$ FOR YOUR SPARE EQUIPMENT

Send full description for our generous offer

TEST EQUIPMENT

TS-3	\$200.00	TS-129	5.00
TS-12 X Band SWR Unit, box 1 & 2	215.00	TS-143	75.00
TS-13	475.00	TS-226	22.00
TS-19	125.00	TS-203	20.00
TS-23	100.00	APA-23	149.50
TS-34	Write	APR-1	175.00
TS-45	180.00	APR-2	175.00
TS-51	20.00	APR-5	215.00
TS-56	39.50	BC-221	89.50
TS-78	16.50	APA-6	62.00
TS-92	30.00	IE-19	195.00
TS-127	45.50	I-95	35.00

POWERSTAT TYPE NO. 1126

New original boxes. Input 115V. AC 50/60 cycles. Output voltage 0-135 V AC. Max. amps output 15 amps, 2 KVA. Overall size 8-3/16" x 8-1/16". Complete with knob and scale. Write for quantity discounts **\$33.95**



Send 25% deposit with all orders. Minimum order \$10! Shipped best way unless otherwise specified. All items subject to prior sale. Write for FREE CATALOG!

RADIO & ELECTRONICS

Dept. E-1—2033 W. Venice Blvd. Los Angeles 5, Calif.

Phone: Republic 0215

INDEX TO THE SEARCHLIGHT ADVERTISERS

JUNE, 1954

This index is published as a convenience to the readers. Care is taken to make it accurate but ELECTRONICS assumes no responsibility for errors or omissions.

SEARCHLIGHT SECTION
(Classified Advertising)

H. E. Hilty, Mgr.

EMPLOYMENT	385-393
EMPLOYMENT ADVERTISERS INDEX	420
EQUIPMENT	394-414

Adamson Electronics	400
Allied Electronic Sales	410
Alltronics Electronic Equipment	400
Alpine Electronics	411
Arrow Sales Inc.	406
Avionic Associates	409
Avionic Supply	411
Barry Electronics Corp.	395
Blan	408
Cap Electronics	411
C & H Sales Co.	394
Chase Electronic Supply Co.	410
Columbia Electronics	408
Communications Equipment Co.	398, 399
Compass Communications Co.	399
Connector Corp. of America	400
Cramer Electronics, Inc.	403
Electroncraft Inc.	397
Empire Electronics Co.	409
Engineering Associates	406
Fair Radio Sales	406
Fay-Bill Distributing Co.	402
Finnegan, H.	410
General Baking Company	403
Harjo Sales Co.	405
Houde Supply Co.	400
Instrument Service	406
JHS Sales Co.	400
Joe's Radio Shop	403
Lapirow Bros.	400
Lelectronic Research Laboratories	396
Liberty Electronics	413
Maritime International Co.	407
Maritime Switchboard Co.	405
Medical Salvage Co.	410
Mogull Co., Inc.	404
Monmouth Radio Laboratories	403
National Surplus Sales Co.	411
Radalab	402
Radio & Electronic Surplus	408
Radio Shack Corp.	405
Railway Communications Inc.	410
Reliance Merchandising	409
R. W. Electronics	408
Semler Industrie Inc.	411
"TAB"	410, 414
Tech-Master Corp.	408
Telemarine Communications Co.	404
Universal General Corp.	404
U.S. Crystals Inc.	401
V & H Radio & Electronics	412
Victor-Bernard Industries, Inc.	411
Western Engineers	409
Weston Laboratories	407

NEW YORK'S RADIO TUBE EXCHANGE

TYPE	PRICE	TYPE	PRICE	TYPE	PRICE	TYPE	PRICE	TYPE	PRICE	TYPE	PRICE	TYPE	PRICE	TYPE	PRICE
OA2	51.00	2131	24.00	3C21	1.50	5BP1	3.95	122A	1.75	450TH	32.50	801A	9.9	931A	5.00
OA3	1.10	2132	29.00	3C31	2.95	5BP2A	12.00	203A	7.50	464A	7.50	802	2.95	954	.35
OB2	.95	2133	32.00	3D1	7.50	5BP1	3.95	211	.95	471A	1.25	803	5.95	955	.50
OB3	1.10	2134	36.00	3D1A	10.00	5CP1	7.50	217C	12.00	527	18.00	805	4.95	956	.75
OC3	.96	2136	90.00	3D1A-52	10.00	5CP7	6.95	212C	10.00	WL530	23.00	807	1.50	957	.25
OD3	.89	2138	8.95	3EP1	5.00	5CP7A	14.00	244A	9.50	WL531	22.50	808	1.95	958A	.60
CU1	2.95	2139	8.95	3EP2	15.50	5D21	18.00	249C	4.25	WL532	1.75	809	2.9	959	2.25
1B21	1.50	2140	29.00	3FP7	5.00	5FP7	1.95	250TH	15.95	WL533	15.00	810	10.50	E114A	.25
1B22	1.50	2142	135.00	3HP7	5.00	5HP1	27.50	250TL	12.00	HK651	35.00	811A	3.75	1280	.95
1B23	6.95	2149	60.00	4A21	2.75	5HP2	19.50	274B	2.75	700A/D	10.00	812A	3.9	1500T	135.00
1B24	12.00	2150	55.00	3CP1	5.00	5HP4	27.50	30TH	1000.	701A	4.50	813	13.75	HK1551	75.00
1B26	1.75													1603	5.00
1B27	12.50													1612	1.50
1B32	2.95													1613	1.25
1B38	35.00													1616	1.25
1B50	23.00													1619	.45
1B51	7.50													1622	1.50
1B56	35.00													1624	1.75
1B60	35.00													1625	.35
1N21	1.25													1626	.25
1N21A	1.75	2155	150.00	4B26	5.40	5J23	45.00	304TL	10.00	703A	3.95	814	3.75	1851	1.80
1N21B	2.75	2156	110.00	4C27	22.50	C6A	11.00	307A	3.50	704A	1.95	815	6.25	2000T	150.00
1N21C	19.50	2161	35.00	4C28	35.00	C6J	7.50	310A	4.50	705A	21.75	816	1.45	2050	1.80
1N22	1.00	2162	35.00	4E27	16.00	7BP7	5.00	310B	4.95	706A/Y	5.00	829	11.00	2051	1.00
1N23	1.95	2K22	15.00	4J25	150.00	7DP1	9.00	311A	6.50	707A	9.75	829A	12.00		
1N23A	2.75	2K23	15.00	4J26	150.00	12A14	50.00	312A	3.50	707B	15.00	829P	15.00	Various 5000 and 6000 series of new production	
1N23B	7.75	2K25	27.50	4J27	150.00	12DP7	24.00	323A	15.00	714A Y	18.00	830H	2.00	8012	2.00
1N23C	7.75	2K26	68.00	4J28	150.00	1M15	225.00	327A	3.75	715A	4.50	832A	9.95	8012A	2.50
1N25	4.50	2K28	35.00	4J29	150.00	15E	1.75	328A	6.75	715B	9.00	833A	45.00	8013	3.00
1N26	6.75	2K29	35.00	5J30	150.00	15R	.75	350A	10.00	715C	22.50	834	7.50	8013A	3.50
1N27	3.50	2K33A	75.00	4J31	150.00	NE16	.59	350B	5.95	717A	30.00	837	2.75	8019	1.75
1N34A	.79	2K39	140.00	4J32	150.00	20A	.75	352A	3.00	719A	22.50	838	5.95	8020	1.80
1N43	2.25	2K41	135.00	4J33	150.00	KY21A	8.25	HK351C	15.00	720A Y	150.00	849	35.00	8025	3.75
2B4	1.25	2K45	80.00	4J34	100.00	HX21	8.00	357A	15.00	721A	3.50	860	3.50	14335	96.00
2B22	1.75	2K50	275.00	4J35	150.00	HK240	1.50	368AS	4.95	722A	1.50	861	25.00	9001	1.25
2C34	.15	2K51	125.00	4J36	150.00	25T	2.95	371B	1.50	723A	1.50	866A	1.50	9002	.90
2C40	9.00	2K55	125.00	4J37	159.00	45 Special	.35	388A	4.50	723B/R	18.00	869E	67.50	9003	1.25
2C42	12.00	2K56	72.00	4J38	150.00	HK39	2.75	388A	1.80	721A	1.95	869L X	50.00	9004	1.50
2C43	14.50	3A1A	1C.00	4J39	150.00	HP50	1.75	393A	7.50	721B	2.25	872A	3.50	9005	2.75
2C44	6.00	3BP1	1.20	4J40	150.00	VT52	.35	391A	3.95	725A	9.00	878	1.50	9006	.25
2C46	7.50	3B24	4.50	4J41	150.00	HK54	4.50	MX40H	.50	726A	18.00	879	.50		
2E22	2.25	3B25	5.50	4J42	190.00	HK72	1.00	417A	15.00	726B	3.50	880	250.07		
2J21A	12.00	3B26	5.00	4J51	190.00	HK73	1.00	446A	15.00	728A	45.00	881	1.50		
2J22	9.00	3B29	8.00	4J52	225.00	FC95	19.95	446A	1.95	728A Y/GY	15.00	885	1.50		
2J26	15.00	EL3C	5.50	4J53	225.00	100TH	7.95	446B	3.95	730A	22.50				
2J27	15.00	3C22	95.00	45B	250.00	FC105	20.00	450TL	45.00	750TL	99.00	914A	75.00		

TERRIFIC SLASHES in PRICE
up to 70% from PREVIOUS LOW PRICES

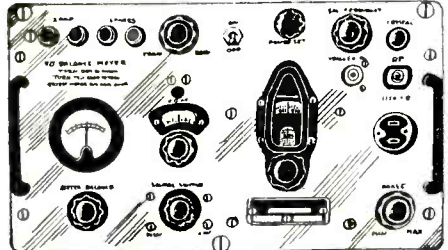

SPECIAL!
5,000 V. Power Supply
For IP25 Infrared Image Converter from 3 V. Battery Source.
NEW, Complete with RCA 1654 Tube **\$990**



NEW TS-147 C/UP TEST SET
NEW TS-147 B/UP TEST SET
Hard-to-get
X-Band SIGNAL GENERATOR
Now Available

Test Set TS 147 UP is a portable Microwave Signal Generator designed for testing and adjusting beacon equipment and radar systems which operate within the frequency range of 8500 MC to 9600 MC.

NEW MICROWAVE TEST EQUIPMENT TS148/UP SPECTRUM ANALYZER

Field type X Band Spectrum Analyzer, Band 8430-9580 Megacycles.
Will Check Frequency and Operation of various X Band equipment such as Radar Magnetrons, Klystrons, TR Boxes. It will also measure pulse width, c-w spectrum width and Q or resonant cavities. Will also check frequency of signal generators in the X band. Can also be used as frequency modulated Signal Generator etc. Available new complete with all accessories, in carrying case.

Other test equipment, used checked out, surplus

- | | | |
|--|-------------------------------------|---|
| TSK1/SE K Band Spectrum Analyzer | TS47/APR 40-400 MC Signal Generator | TS226 Power Meter |
| TS3A/AP Frequency and power meter S Band | TS69/AP Frequency Meter 400-1000MC | TS239A-TS239C Synchroscope |
| RF4A/AP Phantom Target S Band | TS100 Scope | TF890/1 X Band Spectrum Analyzer |
| TS12/AP VSWR Test Set for X Band | TS102A/AP Range Calibrator | 834 General Radio Frequency Meter |
| TS13/AP X Band Signal Generator | TS108 Power Load | |
| TS14/AP Signal Generator | TS110/AP S Band Echo Box | SURPLUS EQUIPMENT |
| TS33/AP X Band Power and Frequency Meter | TS125/AP S Band Power Meter | APA10 Oscilloscope and panoramic receiver |
| TS34/AP Western Electric Synchroscope | TS126/AP Synchroscope | APA38 Panoramic Receiver |
| T35/AP X Band Signal Generator | TS147 X Band Signal Generator | APS 3 and APS 4 Radar |
| TS36/AP X Band Power Meter | TS270 S Band Echo Box | APR4 Receiver and Tuning Units |
| 1-96A Signal Generator | TS174/AP Signal Generator | APR5A Microwave Receiver |
| TS45 X Band Signal Generator | TS175/AP Signal Generator | APT2-APT5 Radar Jamming Transmitter |

MINIMUM ORDER
25 Dollars

YOU CAN REACH US ON TWX NY1-3235

SPECIAL
Wide Band S Band Signal Generator 2700/3400MC using 2K47 or PD 8365 Klystron, Internal Cavity Attenuator, Precision individually calibrated Frequency measuring Cavity. CW or Pulse Modulated, externally or internally.

Large quantities of quartz crystals mounted and unmounted.
Crystal Holders: FT243, FT171B others.
Quartz Crystal Comparators.
North American Philips Fluoroscopes Type 80.
Large quantity of Polystyrene beaded coaxial Cable.



LIBERTY ELECTRONICS, INC.
135 LIBERTY STREET
NEW YORK 6, N. Y.
Phone WOrth 4-8262

INDEX TO ADVERTISERS

Aame Electric Corp.	318	Bradley Laboratories, Inc.	61
Adams & Westlake Company	67	Bridgeport Brass Co.	112
Advance Electric & Relay Co.	368	British National Radio Show	212
Aeronautical Communications Equipment, Inc.	375	Browning Laboratories	335
Aerovox Corporation	299	Brush Electronics Co.	33
Aircraft-Marine Products, Inc.	225	Brush Electronics Co.	33, 362, 381
Airpax Products Co.	31	Buggie, Inc. H. H.	268
Alden Products Company	371	Burnell & Co.	21
Allen-Bradley Co.	265	Bussmann Mfg. Co.	331
Allen Co., Inc., L. B.	384		
Allen Manufacturing Company	369		
Allied Industries, Inc.	306	CBS-Hytron, a Div. of Columbia Broadcasting System, Inc.	239
Almo Radio Company	375	Calidyne Company, The	295
Amerac, Inc.	339	Cambridge Thermionic Corporation	60
American Airlines, Inc.	102	Cannon Electric Co.	291
American Chain & Cable	262	Carboloy Dept. of General Electric Co.	84, 85, 266
American Electric Motors	270	Carborundum Company	34
American Gas Furnace Co.	364	Cargo Packers, Inc.	332
American Lava Corporation	79	Centralab Division of Globe-Union, Inc.	208, 232, 272, 315, 333
American Phenolic Corporation	88	Chatham Electronic Corp.	233
American Television & Radio Co.	358	Chicago Standard Transformer Co.	238
American Time Products, Inc.	54	Chicago Telephone & Supply Corp.	40, 41
Ampex Corporation	93	Ciba Company, Inc.	91
Anti-Corrosive Metal Products Co., Inc.	222	Cinch Manufacturing Co.	193
Applied Science Corporation of Princeton	372	City of Long Beach, Chamber of Commerce	234
Arnold Engineering Co.	11	Cleveland Container Co.	231
Artisan Metal Works Company	314	Clare & Co., C. P.	55
Atlantic Transformer Corp.	371	Clifton Precision Products Company, Inc.	223
Atlas Engineering Co., Inc.	376	Cohn Mfg. Co., Inc. Sigmund	382
Augat Bros., Inc.	338	Collectron Corporation	371
Automatic Electric Mfg. Co.	236	Collins Radio Company	119
		Communications Company	341
Bakelite Company, a Div. of Union Carbide & Carbon Corp.	44, 45	Conrad & Moser	377
Ballantine Laboratories, Inc.	308	Consolidated Engineering Corp.	209
Barrett Division, Allied Chemical & Dye Corp.	211	Consolidated Molded Products Corp.	318
Barry Corporation	15	Constantin & Co., L. L.	123
Belden Manufacturing Company	108	Confidential-Diamond Fibre Co.	229
Bell Telephone Laboratories	86	Cornell-Dublier Electric Corporation	38
Bendix Aviation Corporation, Eclipse-Pioneer Division	326	Corning Glass Works	240
Pacific Division	75	Coto-Coil Company	374
Red Bank Division	316	Cramer Co., Inc., R. W.	301
Berkeley Div., Beckman Instruments, Inc.	313	Crane Packing Co., John	297
Berndt-Bach, Inc.	384	Cross Co., H.	355
Bird Electronic Corporation	338	Crucible Steel Co. of America	253
Birmingham Sound Reproducers Ltd.	329	Cunningham, Son & Co., Inc., James	367
Bircher Corporation	366		
Boesch Manufacturing Co., Inc.	356	Dale Products Inc.	266
Boonton Radio Corporation	197	Dano Electric Co.	351
Borg Corporation, George W.	71	Daven Co., The	3rd Cover
Bowser, Inc.	300	Daystrom Instrument, Div. of Daystrom, Inc.	46
Bradley Industries	380		

NEWLY DEVELOPED SUB MINIATURE TYPE 10

HYCOR

**TYPE 10
PRECISION
RESISTOR**

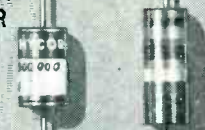

**TYPICAL
1 WATT
CARBON
RESISTOR**

H - SERIES

Hermetically
SEALED

PRECISION WIRE-WOUND

RESISTORS

The new Hycor "H" Series Precision Resistors incorporate unique design features that make it possible for the resistors to meet performance requirements far beyond those required by military specification.

The "H" Series Precision Resistors are encapsulated in a tough plastic compound. The result is a solid, homogeneous unit with unparalleled ruggedness, impervious to the effects of moisture, thermal shock and mechanical shock. The plastic is filled with heat conducting mineral which dissipates the heat and equalizes the "hot spots" in the resistor winding. The sealed-in terminal connections are welded.

SPECIFICATIONS...

MILITARY SPECIFICATIONS: Performance characteristics satisfy all requirements of MIL-R-93A and JAN-R-93.

TEMPERATURE COEFFICIENT: $\pm 0.0022\%$ per deg. C.

OPERATING TEMPERATURE: -65°C. to $+125^{\circ}\text{C.}$
RESISTANCE ACCURACY: Standard resistance tolerances are 1%, 0.5%, 0.25% and 0.1%.

Type 10 (illustrated):
1/4" dia x 13/32" long;
Resistance range: 1.0 ohm - 0.35 meg.

Send for Bulletin H for complete description on other physical sizes and wattage ranges.

REPRESENTATIVES:

Beebe Associates, 1155 Waukegan Rd., Glenview, Illinois
Burlingame Associates, 103 Lafayette St., New York City
Harrison J. Blind, 1616 Cord St., Indianapolis 24, Indiana
G. M. Howard & Assoc., 734 Bryant St., San Francisco 7, California

EXPORT DIVISION

Morhan Exporting Corporation, 458 Broadway, New York 13, New York, U.S.A.
Cable: "MORHANEX"

HYCOR SALES COMPANY
of California

11423 Vanowen St., No. Hollywood, Calif.

**ALL TYPES
ALL SIZES**

Ultrasonics

**WE ALSO MAKE A COMPLETE LINE OF
QUARTZ FREQUENCY CONTROL CRYSTALS**

E. B. LEWIS COMPANY

E. HARTFORD 9, CONN.

Designers for Industry, Inc.	30
Dewey & Almy Chemical Company	47
Dexter Machine Products, Inc.	377
Dialight Corporation	380
Doolean Corporation	311
Driver Co., Wilbur B.	251
Driver-Harris Company	94
Dumont Airplane & Marine Instruments, Inc.	310
Dumont Laboratories, Inc., Allen B.	127
duPont de Nemours & Co. (Inc.) E. I.	32A, 32B

Eastman Kodak Co., Special Products Sales Div.	203
Edo Corporation	122
Eicor, Inc.	264
Eisler Engineering Co., Inc.	367, 381
Eitel-McCullough, Inc.	129
Eleo Corporation	364
Electrical Industries, Div. of Amperex Electronic Corp.	207
Electro Tee Corp.	287
Electronic Instrument Co., Inc.	368
Emerson Apparatus Co.	379
Emerson & Cuming Inc.	359, 371
Empire Devices Products Corp.	365
Engineering Research Associates, Div. of Remington Rand, Inc.	359
Epeco Products, Inc.	363
Epsilon Research & Development Co., Ltd.	252
Erie Resistor Corporation	115

F-R Machine Works, Inc.	96
Fairchild Camera & Instrument Corp.	288
Fairchild Engine & Airplane Corporation	249
Fansteel Metallurgical Corp.	260
Federal Telephone & Radio Corp.	77
Federated Metals Div. American Smelt- ing & Refining Company	216
Filtron Co., Inc.	117
Ford Instrument Company	363
Frenchtown Porcelain Company	369
Fugle-Miller Laboratories	363

Gabriel Electronics Div., Gabriel Co.	290
Gamewell Company	230
General Radio Company	17
General Electric Company Apparatus Dept.	42, 78, 89
Electronics Dept.	113
Tube Dept.	63
General Ceramics Corp.	25
General Industries Co.	210
Giannini & Co., Inc., G. M.	358

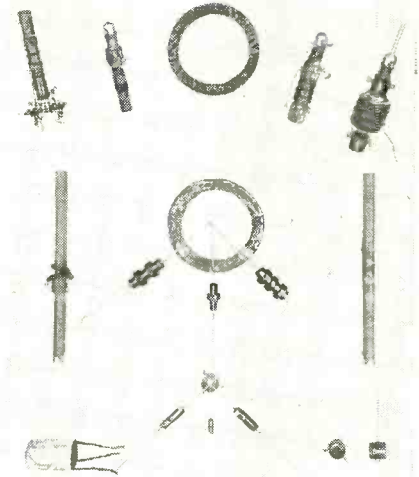

Coils of Special Order to the Customer's prints are wound at Moran Electronic Components Inc. to a high quality at reasonable cost — with best possible delivery.

Moran Electronic Components Inc. offers a standard line of most used Chokes of the Solenoid and Universal Pie types, ranging in Inductance from .47 Micro-Henry to 25 Milli-Henry.

Complete Data available on request.

MORAN ELECTRONIC COMPONENTS INC.
10515 Metropolitan Ave., Kensington, Md.

What Makes a Mailing Click?

Advertising men agree . . . the list is more than half the story. McGraw-Hill Mailing Lists, used by leading manufacturers and industrial service organizations, direct your advertising and sales promotional efforts to key purchasing power.

In view of present day difficulties in maintaining your own mailing lists, this efficient personalized service is particularly important in securing the comprehensive market coverage you need and want. Investigate today.

for Results



Mc GRAW-HILL
DIRECT MAIL LIST SERVICE

McGraw-Hill Publishing Co., Inc.
DIRECT MAIL DIVISION
330 West 42nd Street, New York, 18, N. Y.

Good-all Electric Mfg. Co.	243
Goodmans Industries Limited	32
Gramer Transformer Corp.	345
Grayhill	355
Green Instrument Co., Inc.	351
Gries Reproducer Corporation	342
Guardian Electric Mfg. Co.	259

Hamilton Watch Company	
Allied Products Div.	289
Hammarlund Manufacturing Co., Inc.	23
Hart Manufacturing Company	226
Harvey Hubbell, Inc.	276
Haydon Company, A. W.	373
Hays Manufacturing Company	99
Heath Company	344
Heiland Research Corp.	254
Heinemann Electric Co.	252
Heldor Mfg. Corporation	126
Helipot Corporation, a Div. of Beckman Instruments, Inc.	199
Hemingway & Bartlett Mfg. Co.	336
Henry & Miller Industries, Inc.	381
Heppner Manufacturing Co.	224
Hermetic Seal Products Co.	205
Hewlett-Packard Company	35
Hughes Aircraft Company	121
Hughes Research & Development Labs.	120
Hycor Sales Co. of California	415

Ilseco Copper Tube & Products, Inc.	381
Industrial Condenser Corp.	202
Industrial Development Div., State of Florida	366
Industrial Timer Corp.	70
Indiana Steel Products Co.	92
Inet Div. of Leach Corp.	382
Instrument Resistors Co.	355
Insuline Corp. of America	128
International Rectifier Corp.	227
International Resistance Co.	104, 105
Ippolito & Co., Inc., James	372
Iron Fireman, Electronics Div.	278
Irrington Varnish & Insulator Div. of Minnesota Mining & Mfg. Co.	51

Jelliff Mfg. Corp., C. O.	351
Jet Propulsion Laboratory	357
Johnson Co., E. F.	323
Jones Div., Howard B. Cinch Mfg. Corp.	355
Joy Manufacturing Co.	107

Kable Engineering Co.	13
Karp Metal Products Co., Div. of H & B American Machine Co.	293
Karltron	384
Kearfott Co., Inc.	302

WAVELINE

MICROWAVE NOISE SOURCE

model 2200 2600 to 26,000 mcs.
level 16.0 db above KTB at 290°K
independent of operating temperature

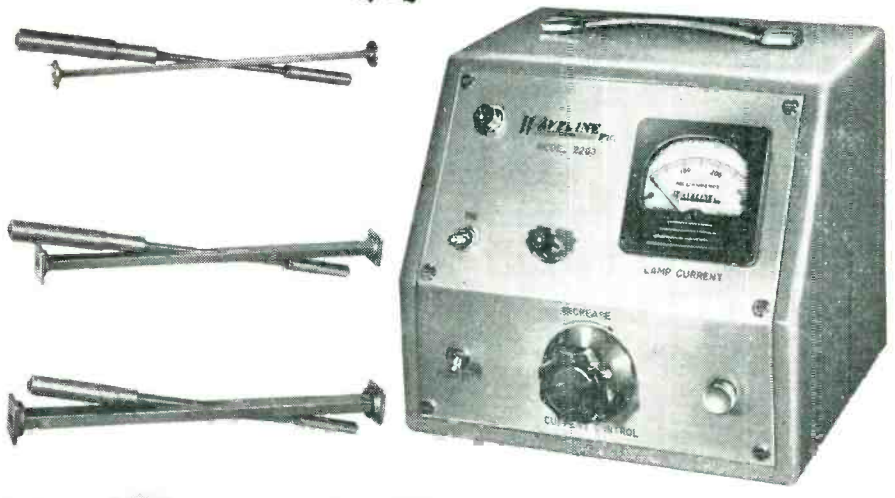

The WAVELINE Model 2200 microwave noise source—gas noise tube in combination with its Waveguide mount and power unit—provides a random noise source of known output level in the frequency range from 2,600 to 26,000 MCS. Throughout this range it also functions as an untuned termination.

The noise power of 16.0 db ±0.5 db above KTB at 290°K is available without warm-up time—and is *completely independent of operating temperature.*

The gas noise tube provides an average VSWR over the frequency range of the tube of approximately 1.07; maximum is approximately 1.13. Insertion loss of the unlighted tube is negligible; maximum inserted VSWR is 1.17. Full VSWR plots for active and inactive tube conditions are supplied with the unit.

MODEL 2200 POWER SUPPLY AND CABLES.....\$150.00

To find out how the Model 2200 can work effectively for you, contact WAVELINE today.

©NTI



replacing GLASS with TEFLON

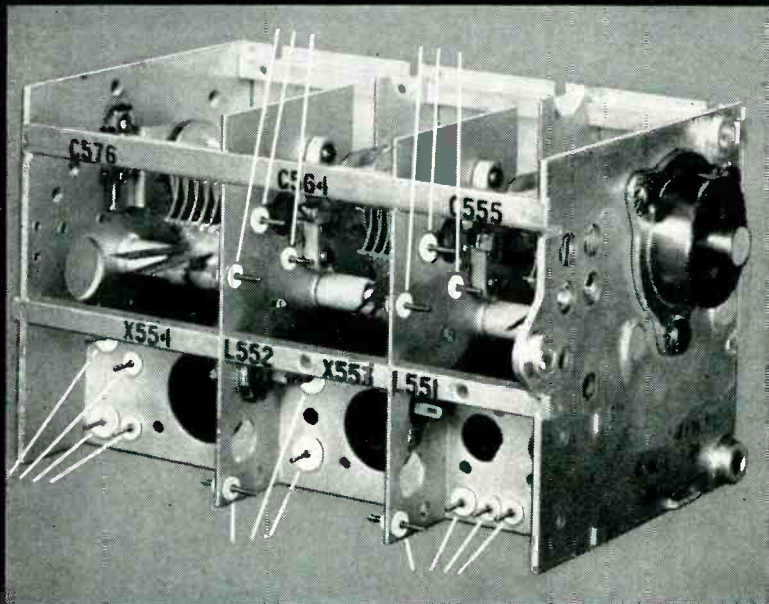

Chemelec Stand-Off and Feed-Through Insulators

● Tough, resilient TEFLON made these miniatures possible —and **BETTER**— than glass-insulated components.

COMPRESSION MOUNTING, without breakage.

WITHSTAND SHOCK and vibration in service.

NO ADDITIONAL HARDWARE NEEDED.

ASSEMBLY COSTS GREATLY REDUCED.

THE PLASTIC'S "MEMORY" securely locks insulators permanently in place. Minimum pull test 10 lbs., insulator to deck, hardware to insulator.

MINIATURIZATION is easily accomplished.

SEVEN STOCK SIZES, including sub-miniatures, in both Stand-Off and Feed-Through types. Other dimensions feasible.

WRITE for Chemelec Bulletin EC-1153.

UNITED STATES

FLUOROCARBON PRODUCTS INC. DIVISION
CAMDEN 1, NEW JERSEY

Kellogg Company, M. W.	80A, 80B
Kepeco Laboratories	110
Kester Solder Company	247
Kings Electronics Co., Inc.	285
Knights Co., James	309
Koiled Koids, Inc.	250

Laboratory for Electronics, Inc.	217
Lampkin Laboratories, Inc.	361
Landis & Gyr, Inc.	314
Lapp Insulator Co., Inc.	212
Leclanche, S. A.	357
Lewis Company, E. B.	416
Lewis & Kaufman, Ltd.	201
Librascope, Inc.	360
Linde Air Products Co., a Div. of Union Carbide & Carbon Corp.	375
Link Aviation, Inc.	68, 69
Lockheed Aircraft Corp.	81
Lockheed Missile Systems Div.	305
Lord Mfg. Co.	29
Lundey Associates	345

Machlett Laboratories, Inc.	221
Magnatran, Inc.	351
Magnecord, Inc.	274
Magnetics, Inc.	28
Malayan Tin Bureau	50
Mallory & Co., Inc. P. R.	132, 195, 362
Marconi Instruments	90
Martin Company, Glenn L.	261
McCoy Electronics Co.	304
McGraw-Hill Book Co.	343
Measurements Corporation	324
Metal Textile Corp.	312
Metals & Controls Corp., General Plate Div.	58
Mica Insulator Co.	263
Microdot Div., Felts Corp.	378
Microswitch, a Div. of Minneapolis- Honeywell Regulator Co.	80
Microwave Associates, Inc.	83
Midland Mfg. Co., Inc.	255
Millen Mfg. Co., Inc. James	346
Millivac Instrument Corp.	337
Minneapolis-Honeywell Regulator Co. Aero Div.	228
Industrial Div.	124
Minnesota Rubber & Gasket Co.	360
Moloney Electric Co.	235
Monsanto Chemical Co., Plastics Div.	73
Muirhead & Co., Ltd.	3
Moran Electronic Components, Inc.	416

N.R.K. Mfg. & Engineering Co.	354
Nassau Research & Development Associates	343
National Company, Inc.	277
National Moldite Co.	106

National Pneumatic Co., Inc. & Holtzer-Cabot Divisions	87
National Research Corp.	74
New Hermes Engraving Machine Corp.	353
New London Instrument Co.	350
Nopeo Chemical Co.	64
Northern Radio Company, Inc.	118
Nothlefer Winding Laboratories	52
Oster Mfg. Co., John	267
Panoramic Radio Products, Inc.	340
Paramount Paper Tube Corp.	348
Phalo Plastic Corporation	334
Phelps-Dodge Copper Products Corp., Inca Mfg. Div.	100, 101
PM Industries, Inc.	76
Polarad Electronics Corp.	125
Polymer Corp. of Penna.	298
Potter & Brumfield	64A, 64B
Precision Apparatus Co., Inc.	420
Precision Paper Tube Co.	244
Presto Recording Corp.	97
Pye Ltd.	65
Pyramid Electric Co.	318
Pyroferrie Co.	327
Radio Corporation of America	109
Back Cover	
Radio Materials Corp.	219
Radio Receptor Co., Inc.	213
Railway Express Agency, Air Express Div.	257
Raytheon Manufacturing Co.	18, 19, 39, 275, 325, 352
Resin Industries, Inc.	352
Resinite Corporation, Div. of Precision Paper Tube Co.	350
Resistoflex Corporation	320
Richardson Co., The	62
Roanwell Corporation	379
Royal Metal Mfg. Co.	378
Sandia Corp.	322
Sangamo Electric Co.	256
Shuttig & Co., Inc.	342
Scientific Electric Div. of "S" Corrugated Quenched Gap Co.	374
Scientific Instruments	384
Scientific Radio Products, Inc.	324
Secon Metals Corp.	373
Shallcross Mfg. Co.	220, 273
Sigma Instruments, Inc.	286
Signal Engineering & Mfg. Co.	361
Signalite, Inc.	367
Sola Electric Co.	66

...for superior service
and economy

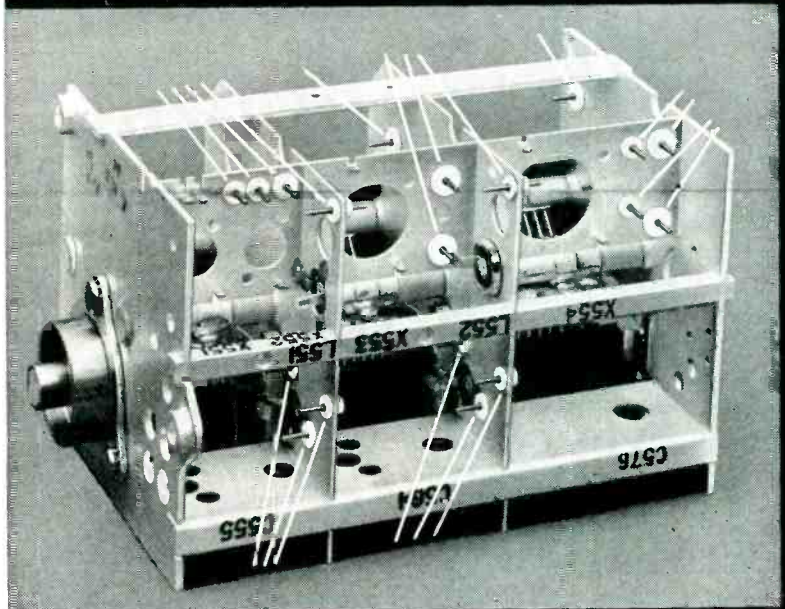

Chemelec Stand-Off and Feed-Through Insulators

● TEFLON's superior insulating characteristics made these miniatures possible—and **BETTER**—especially for high frequency, high voltage or current, high temperature service.

HIGHER surface and volume resistivity.

LOWER loss factor and dielectric constant.

HIGHER dielectric strength.

WIDER service temperature range (−110°F to +500°F).

ZERO water absorption (A.S.T.M. Test).

WON'T CARBONIZE under arcing.

WON'T DC-plate.

NON-FLAMMABLE, non-gassing, chemically inert.

INVESTIGATE Chemelec Stand-Off and Feed-Through Insulators for superior service and lower assembly costs.

SEVEN STOCK SIZES, including sub-miniatures. Other dimensions feasible.

WRITE for Chemelec Bulletin EC-1153.



GASKET COMPANY

FABRICATORS OF *du Pont* TEFLON, *Kellogg* KEL-F
AND OTHER PLASTICS

DAVEN TURNS TO AIR

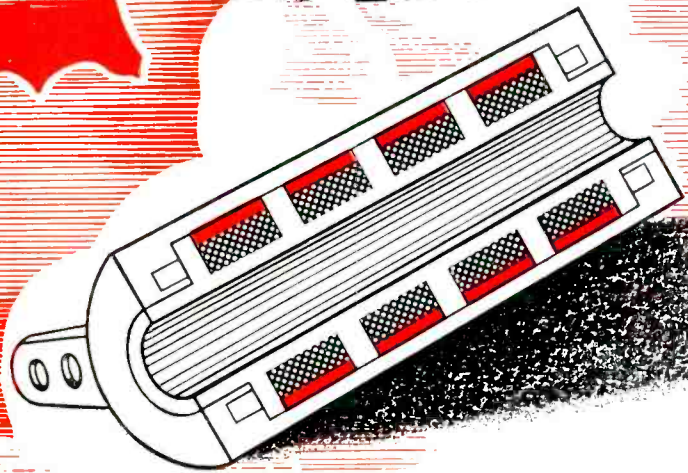

in a completely new approach

to the production of Encapsulated Seald-Ohm Wire Wound Resistors

Only DAVEN turns to air to keep the molding material absolutely separated from the resistance wire in its new line of Super Davohm Encapsulated Seald-Ohm Resistors. The wire is maintained in a slot filled with dry air . . . no external pressures are applied to it. These air pockets, between the wire and the plastic coating, guarantee absolute stability . . . eliminate shorted turns.

Only DAVEN matches the temperature coefficient of expansion of the molding compound with the ceramic bobbin, the resistance wire and the metal terminals. This removes the possibility of cracks or strains on the wire during cycling.

Because of the special construction used, Daven can furnish Encapsulated Wire Wound Resistors with temperature

coefficients below ± 20 P.P.M./ $^{\circ}$ C. when required, and with accuracies to $\pm .05\%$.

These exclusive Daven precision, wire wound resistors are completely hermetically sealed . . . yet are no larger than standard lug-type resistors.

In addition, these units are made in accordance with MIL-R-93A specifications, and are substantially more rugged than conventional resistors. They will withstand the JAN-R-93, characteristic A, salt-water immersion test, and, in addition, temperature cycling from -65° C. to $+125^{\circ}$ C. The strong molding material will resist pressures equivalent to 75,000 ft. altitude, and will not cold flow at temperatures up to 150° C.

Write for latest Resistor Brochure

THE **DAVEN** ^{CO.} 191 Central Ave.
Newark 4, N. J.

WORLD'S LARGEST MANUFACTURERS OF ATTENUATORS

NEW for

UHF

RCA-6BC4

high gain, low noise RF amplifier



RCA-6BC4
UHF Medium-Mu Triode
(actual size)

Here's an excellent combination of important tube characteristics for UHF tuner designs. The new RCA-6BC4, for rf amplifier service, provides high gain combined with low noise factor . . . thanks to its high transconductance of 10,000 micromhos at relatively low plate current.

You also get the advantages of low lead inductance, low lead resistance, and low interelectrode capacitances . . . plus good isolation

of input and load circuits. In addition, silver-plated base pins are used to reduce UHF skin-effect losses.

A well-tried companion for top UHF performance is the RCA-6AF4 for local oscillator service. This tube features *good* frequency stability as well as low lead inductance, low rf lead resistance, and low interelectrode capacitances.

And, for your VHF tuner applications, you can make an excellent choice of RCA tubes for this service

from the group shown below. Ask your RCA field engineer for details. Call your nearest RCA field office:

(EAST) Humboldt 5-3900
415 S. 5th Street
Harrison, New Jersey

(CENTRAL) Whitehall 4-2900
589 E. Illinois Street
Chicago 11, Illinois

(WEST) Madison 9-3671
420 S. San Pedro Street
Los Angeles 13, California

RCA-6AF4 for local
UHF oscillator service



RCA TUBES FOR VHF TUNERS

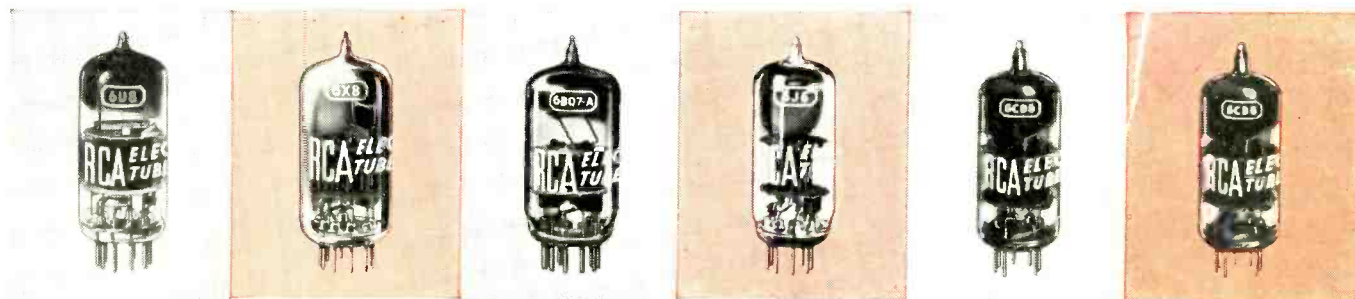

RCA-6U8 Triode-Pentode Converter RCA-6X8 Triode-Pentode Converter RCA-6BQ7-A Medium-Mu Twin Triode RCA-6J6 Medium-Mu Twin Triode RCA-6BC5 Sharp-Cutoff Pentode RCA-6CB6 Sharp-Cutoff Pentode



RADIO CORPORATION of AMERICA

ELECTRON TUBES

HARRISON, N. J.