

JULY · 1952

PRICE 75 CENTS

electronics

A MCGRAW-HILL PUBLICATION



FREQUENCY COUNTER
PRODUCTION-TESTS CRYSTALS



FOR MINIATURIZATION

The miniaturization of transformers has been a UTC specialty ever since the development of the Ouncer series in 1937. The importance of this engineering "know how" is reflected by the large number of UTC Miniature components in present military equipment. Some examples of this engineering leadership are illustrated below.

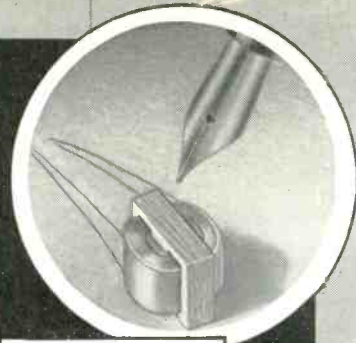

SM Unit ACTUAL SIZE
— As photographed
with normal pen for
comparison.

DC CONTROLLED OSCILLATOR INDUCTORS

The curves below illustrate oscillator frequency variation using two types of RF inductors varied by the amount of DC through the controlled windings. These units are available in ounce size and smaller.

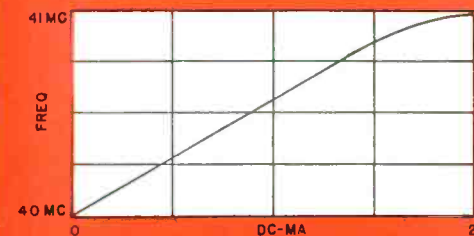

MINIATURIZED AIRCRAFT FILTERS

The standard 90-150 cycle aircraft filters have been reduced in size and weight in UTC's miniaturization program. The curves below illustrate the frequency characteristics of these units.

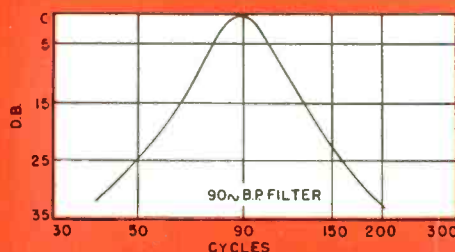
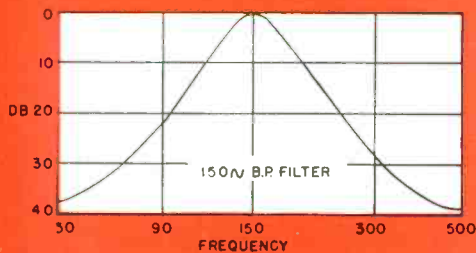

Ouncer case, non hermetic, is $\frac{7}{8}$ " diameter x $1\frac{1}{8}$ " height. Weight — .06 lbs.



Ouncer case, hermetic, is $1\frac{5}{16}$ " diameter x $1\frac{3}{8}$ " height. Weight — .11 lbs.

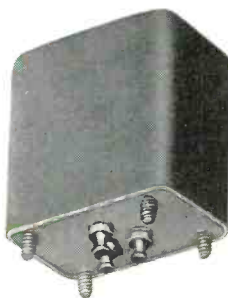

Miniaturized filter case is $1\frac{11}{16}$ " x $1\frac{13}{16}$ " x $1\frac{1}{8}$ " height. Weight — .3 lbs.



SM sub-miniature audio components, $\frac{7}{16}$ " x $\frac{1}{2}$ " x $\frac{7}{16}$ " height. Weight — .009 lbs.

OUNCER FILTERS

Filter miniaturization is a specialized art. The curves below show a low pass filter and a high pass filter being supplied in the UTC ounce case.

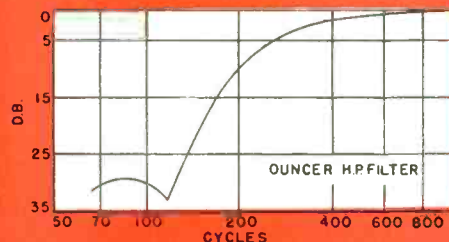
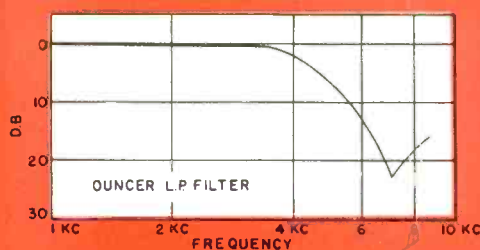

EXTREME MINIATURIZATION

Through the use of specialized materials, extremely compact designs are possible. The curve below illustrates the Q characteristics of a 7500 hy. low frequency reactor housed in the UTC ounce case.

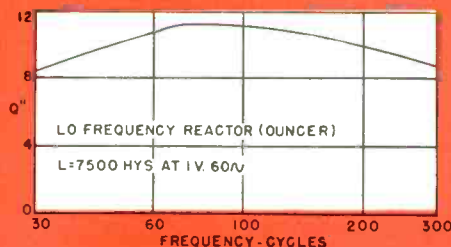

The sub-miniature audio transformer whose frequency curve is shown above, weighs less than one-seventh of an ounce yet provides wide range frequency characteristics. Its impedance ratio is 500 to 50,000 ohms for operation into a $\frac{1}{2}$ meg. Loaded grid.

United Transformer Co.

150 VARICK STREET

NEW YORK 13, N. Y.

EXPORT DIVISION: 13 EAST 40th STREET, NEW YORK 16, N. Y.

CABLES: "ARLAB"

FREQUENCY COUNTER PRODUCTION-TESTS CRYSTALS — Hewlett-Packard direct-reading instrument speeds finishing operation at Mare Island Naval Base in California (see p 156)..... **COVER**

FIGURES OF THE MONTH	4
Includes Electronics Output Index, a business barometer for management	
INDUSTRY REPORT	5
Top-level news, trends and market interpretations	
REMOTE-CONTROL AUTOMATIC WEIGHING , by Enrico Klein.....	98
Dial settings control remote proportioning of industrial-process ingredients	
BINARY COUNTER USES TWO TRANSISTORS , by Robert L. Trent.....	100
General-purpose circuit may be triggered by either positive or negative pulses	
TRANSMITTERS FOR UHF TELEVISION	102
Improved designs result in higher power but not megawatts deemed essential in 1948	
INTERNAL ELECTROSTATIC DEFLECTION YOKE , by Kurt Schlesinger.....	105
Beam experiences simultaneous deflection with equal horizontal and vertical sensitivities	
INDUSTRIAL YARN CLASSIFIER , by Fred P. Strother.....	110
Phototube device is used for measuring textile yarn diameters	
DISTRIBUTED AMPLIFIER COVERS 10 TO 360 MC , by Howard Scharfman.....	113
Nine 6AK5 tubes provide 8-db gain within 2 db over entire range	
REDUCING TV RECEIVER OSCILLATOR RADIATION , by E. W. Chapin and Willmar K. Roberts.....	116
Additional shielding and filtering needed to eliminate interference costs little extra if designed into tuner	
PRECISION PREAMPLIFIER , by George E. Beggs, Jr.....	121
Gives 6-db-per-octave rise from crossover frequency down to 10 cps, with choice of five high-frequency rolloffs	
PULP-LOG METAL DETECTOR , by Marcel Grobtuch and D. J. Williams.....	124
Single-coil system prevents damage to multiblade log chippers by ferrous tramp metal	
RECORDING COCHANNEL BROADCAST INTERFERENCE , by Mal Mobley, Jr.....	127
Measures interfering station's field intensity before desired station leaves the air	
CONSTANT-CURRENT D-C AMPLIFIER , by Donald McDonald.....	130
Double-ended output stage allows for simplification and economy in power supply	
tone-BURST GENERATOR CHECKS A-F TRANSIENTS , by Marshall C. Kidd.....	132
Transient distortion of networks and loudspeakers is measured directly	
ULTRASONIC RANGING FOR CANCER DIAGNOSIS , by John M. Reid and John J. Wild.....	136
Modification of AN/APS-T3 radar trainer gives promising results	
NONDISTORTING CRO SWITCH , by William L. Firestone and Richard M. Bloniarz.....	139
Simple circuit provides high performance at low cost	
PROTECTING SENSITIVE CURRENT METERS , by L. J. Giacoletto.....	142
Three electronic circuits used to avoid overload of meters measuring microamperes	
SCRIPTOSCOPE SHOWS MESSAGES ON C-R TUBE , by A. G. Hubby and R. B. Watson.....	144
Permits reproducing handwriting electronically at a distance, using simple four-channel amplifier	
MAXIMUM COVERAGE FOR VHF-UHF TV , by Frederick W. Smith.....	146
Simplified curves derived from FCC data facilitate choice of frequency and site	
CROSSTALK.....97	ELECTRONS AT WORK.....152
PLANTS AND PEOPLE.....302	NEW BOOKS.....312
PRODUCTION TECHNIQUES.....228	BACKTALK.....328
NEW PRODUCTS.....258	INDEX TO ADVERTISERS (Last Page)

W. W. MacDONALD, Executive Editor; John Markus, Vin Zeluff, A. A. McKenzie, James D. Fahnestock, Associate Editors; William P. O'Brien, Ronald K. Jurgen, John M. Carroll, Assistant Editors; Ann Mastropolu, Marilyn Wood, Mary J. Johnson, Editorial Assistants; Gladys T. Montgomery, Washington Editor; Harry Phillips, Art Director; Eleanor Luke, Art Assistant

KEITH HENNEY, Editorial Director

H. W. MATEER, Publisher; WALLACE B. BLOOD, Manager; R. S. Quint, Buyers' Guide Manager; N. F. Cullinan, Promotion & Research Assistant; H. E. Hilty, Classified Manager; D. H. Miller, James Girdwood, New York; Wm. S. Hodgkinson, New England; Warren W. Shew, Philadelphia; C. D. Wardner, Chicago; J. L. Phillips, Cleveland; T. H. Carmody, R. C. Alcorn, San Francisco; Carl W. Dysinger, Los Angeles; Ralph C. Maultsby, Atlanta



July, 1952

ELECTRONICS

Vol. 25, No. 7



Member ABC and ABP

Published monthly with an additional issue in June by McGraw-Hill Publishing Company, Inc., James H. McGraw (1860-1948), Founder. Publication Office, 99-129 North Broadway, Albany 1, N. Y.

Executive, Editorial and Advertising Offices: McGraw-Hill Building, 330 W. 42nd St., New York 36, N. Y. Curtis W. McGraw, President; Willard Chevallier, Executive Vice-President; Joseph A. Gerardi, Vice-President and Treasurer; John J. Cooke, Secretary; Paul Montgomery, Senior Vice-President, Publication Division; Ralph B. Smith, Editorial Director; Nelson Bond, Vice-President and Director of Advertising; J. E. Blackburn, Jr., Vice-President and Director of Circulation.

Subscriptions: Address correspondence to Electronics—Subscription Service, 99-129 N. Broadway, Albany 1, N. Y., or 330 W. 42nd St., New York 36, N. Y. Allow ten days for change of address. Subscriptions are solicited only from persons engaged in theory, research, design, production, maintenance and use of electronic and industrial control components, parts and end products. Position and company connection must be indicated on subscription orders.

Single copies 75¢ for United States and possessions, and Canada; \$1.50 for Latin America; \$2.00 for all other foreign countries. Buyers' Guide \$2.00. Subscription rates—United States and possessions, \$6.00 a year; \$9.00 for two years. Canada, \$10.00 a year; \$16.00 for two years. Other western hemisphere countries, \$15.00 a year; \$25.00 for two years. All other countries \$20.00 a year; \$30.00 for two years. Entered as second class matter August 29, 1936, at the Post Office at Albany, N. Y., under act of Mar. 3, 1879. Printed in U. S. A. Copyright 1952 by McGraw-Hill Publishing Co., Inc.—All Rights Reserved. BRANCH OFFICES: 520 North Michigan Avenue, Chicago 11, Ill.; 68 Post Street, San Francisco 4; McGraw-Hill House, London, E.C. 4; Washington, D. C., 4; Philadelphia 3; Cleveland 15; Detroit 26; St. Louis 8; Boston 16; 1321 Rhodes-Haverty Bldg., Atlanta 3, Ga.; 1111 Wilshire Blvd., Los Angeles 17; 738-9 Oliver Building, Pittsburgh 22. ELECTRONICS is indexed regularly in The Engineering Index.

marion methods

die-cut, process and print
each dial individually

Because the accuracy of an indicating instrument is completely dependent upon the accuracy of its dial, Marion takes extraordinary care with each dial . . . from the simplest black and white type to a fluorescent type of seven colors.

Marion dials are never printed in sheets and then stamped out, as are ordinary dials. Each Marion dial is die-cut, prepared and printed *separately*. This individual handling guarantees finished painted edges, which reduces high voltage corona; it also assures accurate mechanical registration of the dial with the pivot center of the instrument.

Precision and dependable performance are built into every Marion dial . . . in each step of manufacture.

Preliminary Operations . . . Dial data furnished by the customer is carefully checked by Marion's Engineering Department. After Engineering OK, data and suggested layout are sent to the Art Department.

The dial scale is drawn 4 to 6 times "life size," then the drawing is photographed and reduced to the proper size.

Preparation of Plates . . . After photography, a positive print is made. Color separations are made by hand, and deep-etched zinc plates for offset lithography are produced. The offset process is used to assure sharp printing definition and good color.

Preparation of Dial Blank . . . Each metal dial blank is thoroughly rinsed and vapor de-greased. Then, three separate coats of special fume and age-proof eggshell-white lacquer are applied. This lacquering technique gives a surface that will not chip, flake, fade or discolor.

Registering . . . After careful inspection, dial blanks are securely mounted on the printing press. Each blank is individually adjusted, and the printing plate is positioned exactly. This step ensures perfect registration for multi-color printing.

Printing and Drying . . . Each dial is then printed separately. After special inks of each color are applied, dials are baked for 15 to 20 minutes to set the ink. This process eliminates smudging, and minimizes the amount of lint picked up during drying. Dials are thoroughly inspected again before they are mounted on Marion instruments.

Other Marion Methods. Marion's method of assuring the top accuracy and service of each dial by individual handling is only one of a number of methods which Marion is presenting in the hope that some of them will help you as they have helped us. We will be pleased to send more information if desired.

MARION ELECTRICAL INSTRUMENT CO., 401 CANAL ST., MANCHESTER, N. H.

marion meters

MANUFACTURERS OF MARION



uggedized PANEL METERS

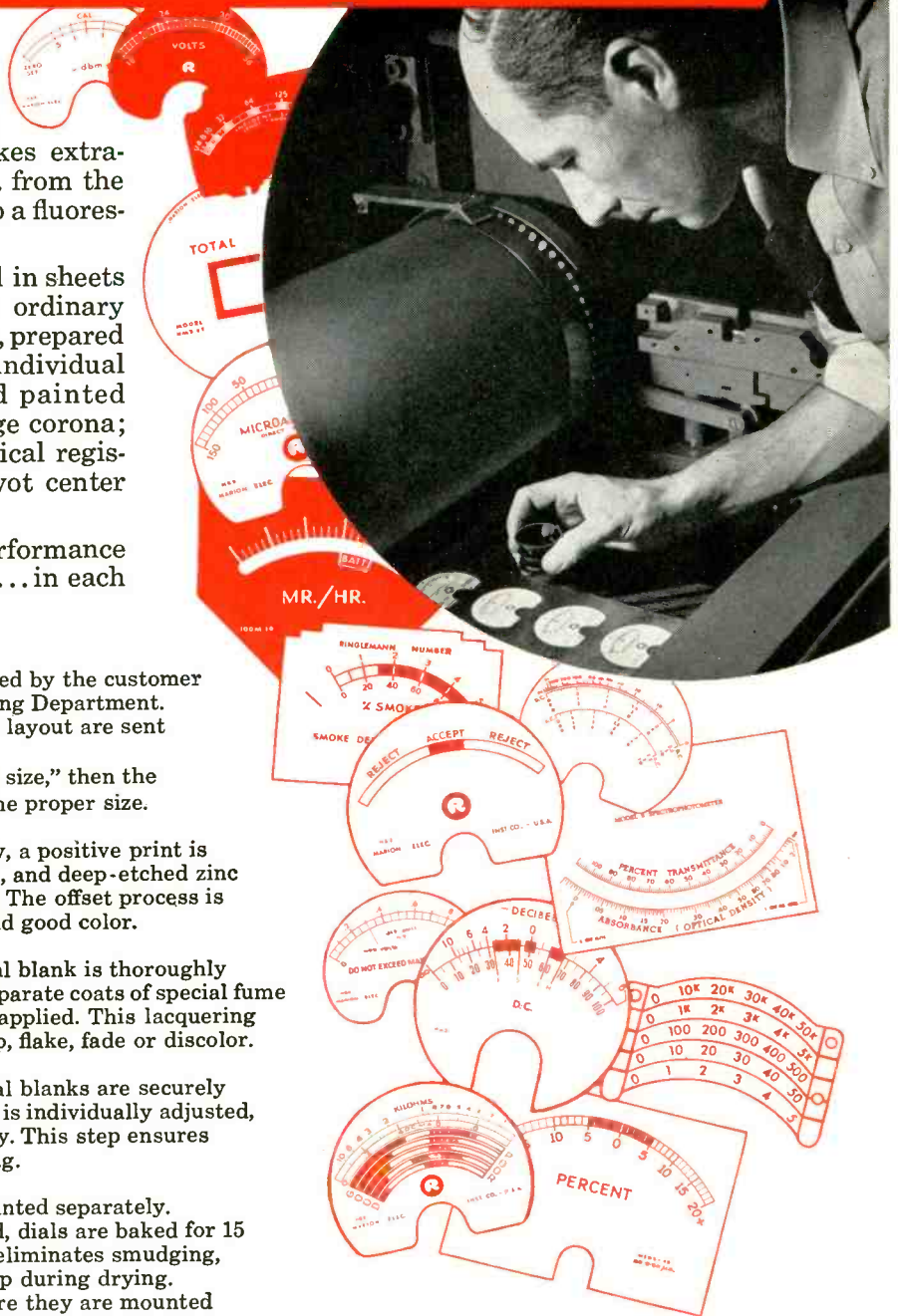

MUIRHEAD MAGSLIP RESOLVER NO. 2



Given R & θ
find h & r

$$h = R \sin \theta$$

$$r = R \cos \theta$$

Change of axes.

$$x' = x \cos \alpha + y \sin \alpha$$

$$y' = y \cos \alpha - x \sin \alpha$$

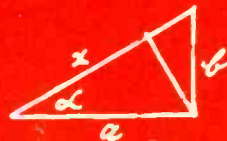

$$x = \sqrt{a^2 + b^2}$$

$$x = a \cos \alpha + b \sin \alpha$$

Given N & E
determine R & θ

$$R = E \cos \theta + N \sin \theta$$

$$Zero = E \sin \theta + N \cos \theta$$

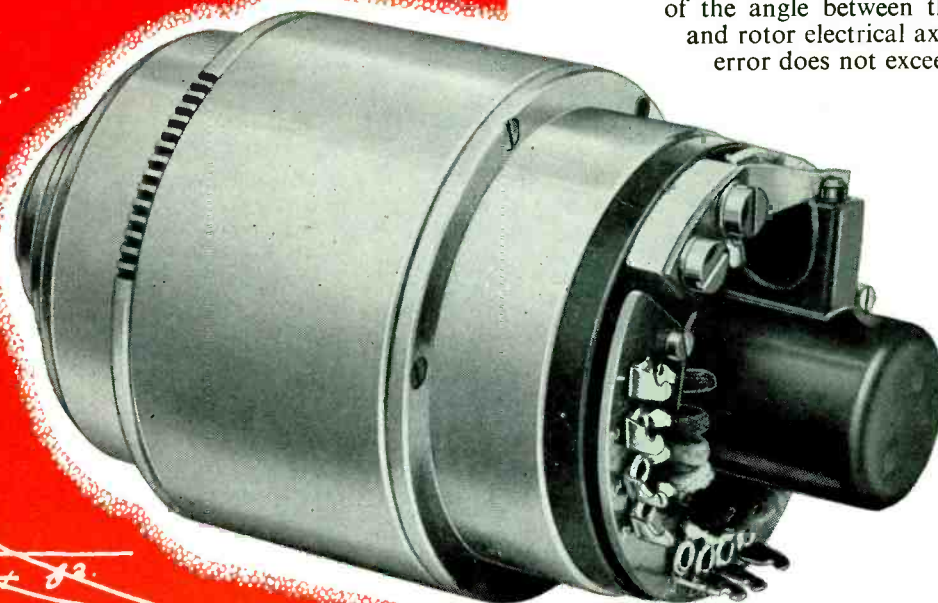
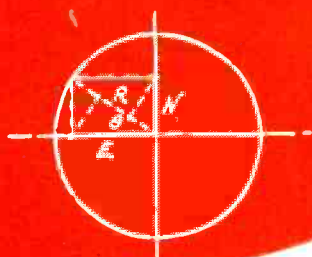

THE RESOLVER No. 2 is a special type of Magslip used for the solution of trigonometrical problems, such as the conversion of polar to Cartesian coordinates.

Each stator phase is energized in accordance with an applied computing voltage. No power is taken from this source, energization being obtained by means of an amplifier and a second (feedback) stator winding. The rotor voltages are proportional to the exciting voltages and to the sine and cosine of the angle between the stator and rotor electrical axes. The error does not exceed 0.1%.

MAIL THIS COUPON FOR DETAILS

Please mail Bulletin B-690 fully describing
MUIRHEAD MAGSLIP RESOLVERS

NAME _____

POSITION _____

COMPANY _____

ADDRESS _____

ELECTRONICS 75

MUIRHEAD & CO. LTD. BECKENHAM • KENT • ENGLAND

PRECISION ELECTRICAL INSTRUMENT MAKERS



FIGURES OF THE MONTH

	Year Ago	Previous Month	Latest Month
RECEIVER PRODUCTION			
(Source: RTMA)			
	Apr. '51	Mar. '52	Apr. '52
Television sets	469,157	510,561	322,878-p
Home Radio sets	619,651	532,858	462,167-p
Portable sets	150,494	99,720	110,529-p
Auto sets	542,021	343,314	275,250-p

	Year Ago	Previous Month	Latest Month
RECEIVER SALES			
(Source: Licensee figures)			
	Mar. '51	Feb. '52	Mar. '52
Television sets, units . . .	718,986	410,280	370,905
Electric radio sets, units	768,083	344,008	380,846
Battery sets, units	135,300	43,638	68,339
Auto sets, units	273,130	195,689	204,990
Television sets, value . . .	\$142,035,675	\$71,835,056	\$62,988,663
Electric radio sets, value	\$21,565,687	\$6,488,686	\$7,963,825
Battery sets, value	\$2,656,750	\$844,091	\$1,332,640
Auto sets, value	\$8,696,203	\$5,539,061	\$5,912,217

	Year Ago	Previous Month	Latest Month
RECEIVING TUBE SALES			
(Source: RTMA)			
	Apr. '51	Mar. '52	Apr. '52
Receiv. tubes, total units	35,883,627	30,935,220	26,247,258
Receiving tubes, new sets	25,284,390	19,513,454	15,334,092
Rec. tubes, replacement.	9,052,251	7,231,186	6,095,641
Receiving tubes gov't. . .	229,339	2,776,796	3,257,119
Receiving tubes, export.	1,317,647	1,413,784	1,560,406
Picture tubes, to mfrs. . .	278,955	370,206	270,781

	Year Ago	Previous Month	Latest Month
BROADCAST STATIONS			
(Source: FCC)			
	May '51	Apr. '52	May '52
TV Stations on Air	107	108	108
TV Stns CPs—not on air	2	0	0
TV Stns—Applications . .	408	536	541
AM Stations on Air	2,271	2,347	2,352
AM Stns CPs—not on air	105	68	66
AM Stns—Applications . .	267	324	323
FM Stations on Air	648	632	630
FM Stns CPs—not on air	14	14	17
FM Stns—Applications . .	9	9	10

	Year Ago	Previous Month	Latest Month
NETWORK BILLINGS			
(Source: Pub. Info. Bureau)			
	Apr. '51	Mar. '52	Apr. '52
AM/FM—ABC	\$2,980,183	\$3,355,715	3,244,146
AM/FM—CBS	\$6,487,717	\$5,154,077	\$4,943,400
AM/FM—MBS	\$1,539,801	\$1,826,527	\$1,677,748
AM/FM—NBC	\$4,897,882	\$4,184,074	\$4,078,593
TV—ABC	\$1,432,319	\$2,076,782	\$1,686,583
TV—CBS	\$2,906,891	\$5,643,123	\$5,641,831
TV—DuMont	\$574,025	\$758,763	\$738,926
TV—NBC	\$4,758,309	\$7,357,305	\$6,946,751

	Year Ago	Previous Month	Latest Month
TV AUDIENCE			
(Source: NBC Research Dept.)			
	May '51	Apr. '52	May '52
Sets in Use—total	12,499,900	16,939,100	17,290,800
Sets in Use—netw'k conn.	10,608,300	16,024,900	16,352,300
Sets in Use—New York.	2,350,000	2,930,000	2,970,000
Sets in Use—Los Angeles	918,000	1,155,000	1,185,000
Sets in Use—Chicago . . .	921,000	1,135,000	1,155,000

	Year Ago	Previous Month	Latest Month
COMMUNICATION AUTHORIZATIONS			
(Source: FCC)			
	Apr. '51	Mar. '52	Apr. '52
Aeronautical	32,531	32,176	32,147
Marine	28,722	34,843	35,116
Police, fire, etc.	8,825	10,592	10,787
Industrial	8,852	12,475	12,766
Land Transportation . . .	4,112	4,847	4,886
Amateur	90,691	106,832	108,648
Citizens Radio	497	878	971
Disaster	0	29	31
Experimental	482	458	349
Common carrier	827	922	942

	Year Ago	Previous Month	Latest Month
EMPLOYMENT AND PAYROLLS			
(Source: Bur. Labor Statistics)			
	Mar. '51	Feb. '52	Mar. '52
Prod. workers, electronic	273,200	273,100-r	272,900-p
Prod. wkrs., radio, etc. . .	183,200	171,000-r	171,100-p
Av. wkly. earnings, elect.	\$60.58	\$65.14-r	\$64.99-p
Av. wkly. earnings, radio	\$57.13	\$61.28-r	\$60.84-p
Av. weekly hours, elect. . .	41.1	41.2-r	41.0-p
Av. weekly hours, radio. . .	40.4	40.8-r	40.4-p

	Year Ago	Previous Month	Latest Month
STOCK PRICE AVERAGES			
(Source: Standard and Poor's)			
	May '51	Apr. '52	May '52
Radio—TV & Electronics	222.0	292.5	281.8
Radio Broadcasters	208.7	286.2	273.9

	Year Ago	Quarterly Figures Previous Quarter	Latest Quarter
INDUSTRIAL EQUIPMENT ORDERS			
(Source: NEMA)			
	1st '51	4th '51	1st '52
Dielectric Heating	\$520,000	\$560,000	\$150,000
Induction Heating	\$4,270,000	\$3,400,000	\$2,400,000

	Year Ago	Quarterly Figures Previous Quarter	Latest Quarter
INDUSTRIAL TUBE SALES			
(Source: NEMA)			
	1st '51	4th '51	1st '52
Vacuum (non-receiving). . .	\$6,550,000	\$14,300,000	\$11,320,000
Gas or vapor	\$2,230,000	\$3,170,000	\$3,100,000
Phototubes	\$410,000	\$400,000	\$500,000
Magnetrons and velocity modulation tubes	\$1,400,000	\$6,670,000	\$8,460,000

p—provisional; r—revised; e—estimated

INDUSTRY REPORT

electronics—JULY • 1952

Atomic Energy Contracts Rising

Electronics industry equipment 'take' totalled \$39.5 million in '50-'51; more coming

IMPORTANT to the national economy as well as to the national defense are government expenditures on the atomic energy program. They have totalled \$6.5 billion in the last ten years, according to the McGraw-Hill magazine *Nucleonics*.

In the fiscal years 1950 and 1951 the Atomic Energy Commission spent \$521 million with 41 American industries for equipment and supplies alone, exclusive of expenditures for construction, research and development and raw materials.

Of this \$521 million, \$39.5 million (8 percent) went to the electronics industry.

► **Electronics' Share** — Between June 31, 1949 and June 31, 1951

electronics industry contractors received 146 contracts making up the \$39.5-million. Subcontractors handled \$8.5 million (22 percent) of this business.

Prime contractors obtained 96 percent of their equipment and supply business through negotiations, 4 percent by bidding competitively. Firms having more than 500 employees received 97 percent of the dollar volume, those with fewer employees 3 percent.

Subcontractors negotiated 67 percent of their business, obtaining 33 percent by bidding. Companies with over 500 employees got 65 percent of it, smaller ones 35 percent.

► **Future Prospects**—No estimate of the amount of money to be spent by the AEC on equipment and supplies and, in particular, electronic

equipment and supplies, in the fiscal year 1953 (beginning July 1, 1952) is yet available.

The Commission has, however, asked for an overall \$4.5-billion appropriation (including a supplemental request), and this is 246 percent higher than in 1952.

Wanted: More Electronic Engineers

\$4,000 starting salaries clean up crop of June grads; pirating is costly; last reserve is Europe

THE law of supply and demand determines pay rates. With the shortage of electronic engineers, salaries are rising.

To attract badly-needed engineers, many firms are surveying the industry-wide salary situation almost monthly and adjusting their own rates accordingly.

► **Fledgling Pay**—June graduates with a B.S. degree are signing up at about \$320 a month, in a range of \$280 to \$350.

Some factors affecting the figure are company size and location, fringe benefits, extent of job security, amount of practical industrial or military experience obtained before graduation.

To offset high starting salaries, more complex work is being assigned to graduates right from the start. This includes responsibility for paper work, easing the burden of such work on more experienced engineers.

A Master's degree today rates little or no automatic boost in starting pay. Instead, salary upping is based on ability to analyze circuits and understand theory. A maximum of \$50 extra per month for an M.S. generally goes to those having

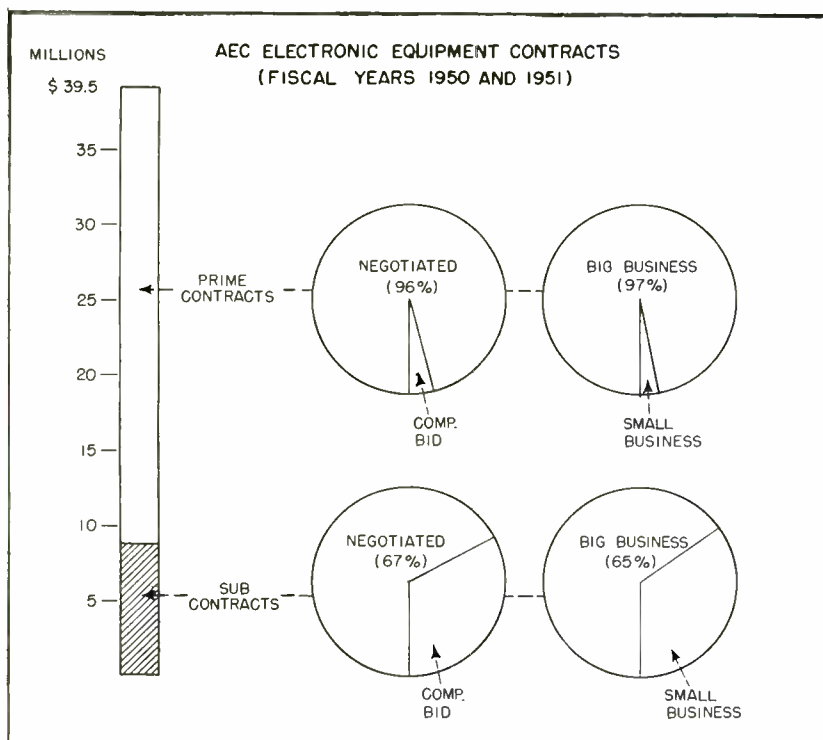

a thesis directly related to the work they will do.

► **Pirating**—The limited supply of June grads is just about gone. There is now practically universal agreement that pirating of engineers eventually hurts the pirating firm along with the rest of the industry, hence engineer job-changing today is principally for reasons other than salary.

Reserve of engineers in Europe appears to be greater than our own. Already a few U.S. firms are importing these men, despite language difficulties, expenses of moving and delays in getting security clearances.

► **Holding Their Own**—Turnover is a major factor in the engineering picture. At least one large electronic firm is now holding engineering turnover below 0.1 percent per month, without paying above-normal salaries, but 1 percent per month is considered good by other companies in the industry.

Car-Card Radio Wins Decision

BY A 7-to-1 vote the Supreme Court of the United States has decided that broadcast reception in buses and streetcars does not violate the constitutional rights of passengers.

This was good news for Transit Radio, Inc., chief proponent of the system. Its next hurdle will be to gain unqualified approval by FCC, which has never actually disapproved.

► **Counting Sheep**—Advertisers like the idea of broadcasting to a captive audience that can be accurately counted (ELECTRONICS, p 72, June 1948). A musical program available to the general listening public can be hopped up during commercials by a special ultrasonic tone that raises the volume on the bus receivers.

Transit Radio now operates in nine cities and has equipment installed in 3,200 vehicles, according to Richard C. Crisler, president.

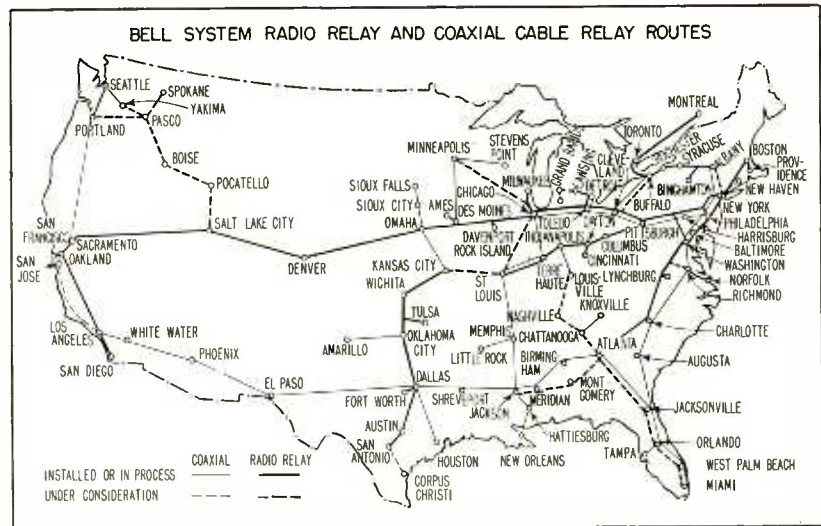

Microwave Telephone Expands

Bell System adds new facilities. Several independents enter field

LARGEST OPERATOR of microwave telephone equipment is the Bell System, with 5,350 miles of radio-relay links in operation and an additional 1,560 miles under construction. This represents a total capital outlay of \$75 million.

The map shows Bell's microwave network, including 407 miles operated by Bell of Canada. Coaxial cable routes supplementing these facilities are shown as light lines.

Major radio-relay links provide six broad-band communication channels. Each broad-band channel can carry either one television program or upwards of 600 telephone conversations. At present, Bell's microwave facilities largely carry television programs. However the amount of telephone traffic carried by microwave will be doubled by the end of 1952.

► **Selling to Bell**—Western Electric, AT & T's manufacturing subsidiary, builds the bulk of the Bell System's microwave equipment, including all major radio-relay links. However, where the great traffic-handling capacity provided by WE equipment is not required, Bell often buys microwave equipment manufactured by outside concerns.

Philco has supplied 218 miles of

microwave radio relay for single-channel tv service.

Chief suppliers of so-called "skinny" route equipment that provides up to 24 telephone channels between toll centers include Federal, Philco and REL; 642 miles of such equipment are operated by the Bell System.

► **Independent Companies**—Destruction of outside plant by ice, windstorm or rockslide can be disastrously costly to the telephone industry's little fellow. So independent companies, totaling 5,300, are also eyeing microwave favorably.

Peninsular Telephone of Tampa, Fla., Tidewater of Warsaw, Va., and Citizens' Utilities of Redding, Calif., have installed Federal 24-channel links for toll-center hookup.

Outside continental U. S., Maritime Telephone and Telegraph of Canada and the Puerto Rico Telephone Co. use Federal links. In Hawaii, Mutual Telephone has installed Link Radio equipment for intra-island use.

Silicon Transistors?

ONE MAJOR DRAWBACK of germanium transistors, both point-contact and junction, is that above 75 or 80 degrees centigrade they become un-

(Continued on page 8)

SYLVANIA CHALKS UP

Another First

*Now
an Instant-
Firing
ATR TUBE*

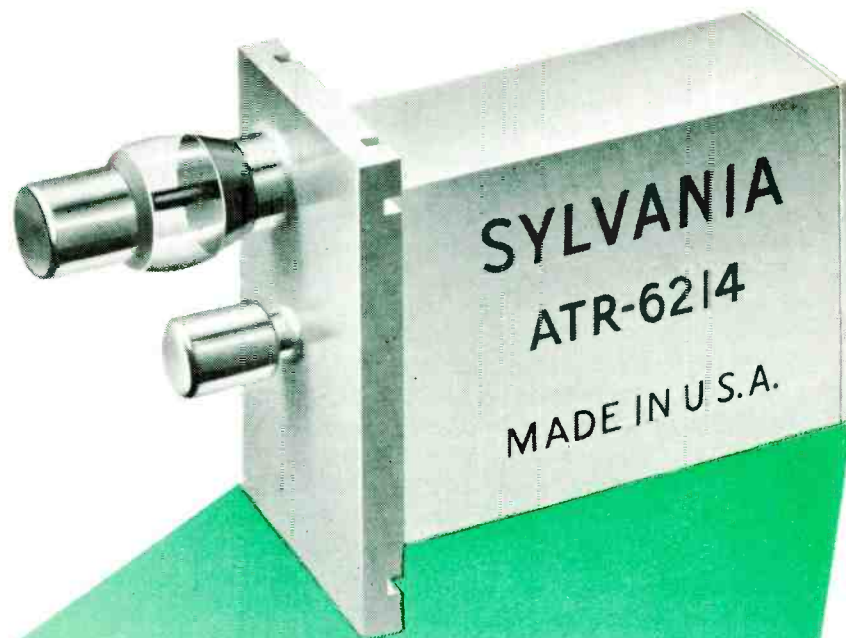

Sylvania proudly announces a new Instant-Firing ATR Tube, Type 6214.

This tube now makes possible for the first time, the operation of a Beacon Radar from a single antenna. Previously, reliable Beacon operation required use of two separate antennae—one for receiving and one for sending.

The New Sylvania Tube permits a Beacon to "clear its throat" immediately and answer a received signal instantly by transmitting a reply signal—OVER THE SAME ANTENNA. It opens

the way to new and more compact designs resulting in worthwhile savings in equipment manufacture.

This new component is just one more example of the constant research and engineering skill which has established Sylvania's leadership in electronic development.

For data concerning the ATR-6214 or any other Sylvania Microwave Tube, write today to: Sylvania Electric Products Inc., Dept. E-2507, 1740 Broadway, New York, N. Y.

SYLVANIA



ELECTRONIC DEVICES; RADIO TUBES; TELEVISION PICTURE TUBES; ELECTRONIC TEST EQUIPMENT; FLUORESCENT TUBES, FIXTURES, SIGN TUBING, WIRING DEVICES; LIGHT BULBS; PHOTOLAMPS; TELEVISION SETS

stable or may not operate. Reports from the field indicate that silicon, abandoned in early transistor development for more promising germanium, remains stable at higher temperatures.

'Silver Ear' Speaker Due In Few Months

'GOLDEN EAR' high-fidelity audio enthusiasts who are accustomed to pay three and four-figure prices for their equipment recently heard a reasonably high-fidelity loudspeaker destined to sell for \$20 to \$25.

Using four \$1.25, five-inch speaker units in a specially constructed plywood cabinet, Jordan J. Baruch of MIT's Acoustics Lab has obtained a speaker system that is reasonably flat from 40 to 11,000 cycles. He could really please the Golden Ears, using similar techniques, but the end product would cost more.

► **Availability**—Good news for Silver Ears (who like high-fidelity but can't afford premium prices) is the fact that Ultrasonics Corp. of Cambridge, Mass., has already taken out a license, made a production prototype and will be in production in a few months.

NARTB Seeks to Ease Federal Operator Requirements

FCC proposal might free needed technicians for coming tv activity

FOLLOWING on the heels of several individual grants to f-m broadcasters, the National Association of Radio and Television Broadcasters has petitioned the Federal Communications Commission for industry-wide relaxation of rules on station operations.

For an f-m transmitter perched upon a mountain accessible only by jeep or skis, remote-control untended operation may mean the difference between f-m programs or no programs. Any station carrying a high percentage of commercial programs might find a full complement of \$85-a-week operators good insurance against a blowup in the middle of a revenue-producer. But most f-m stations are not in the big money.

► **Standard Broadcasting**—FCC, nudged by NARTB, now proposes that all nondirectional a-m stations (as well as f-m) with power less than 10 kw shall be allowed to

operate by remote control. Moreover, it would relax the requirement calling for a first-class licensee to run the equipment, although NARTB suggests that one operator of this grade be kept on call. Actually, routine station operation by men of lesser license grade under a top-licensed man is already permitted because of personnel shortages. The new proposal would standardize a temporary measure.

Operator unions will file lengthy dissents by the Commission's deadline for comments on August 4, 1952. Labor groups that are usually in bitter competition are united in opposition to what they consider the industry's bid for 'cheap help'. Pointing out that a good operator is paid as much for what he knows as for what he does, the unions feel that by keeping standards high both operating engineers and broadcasters get needed protection.

► **TV Squeeze**—Strongest motivation for the NARTB petition stems from the economic pressures of

(Continued on page 10)



Tank Trucks Use Electronics to Facilitate Passing

When a motorist wants to pass this truck, his horn signal is picked up by a microphone at the rear of the truck, amplified and fed to a loudspeaker in the cab. The driver then operates the pass or don't pass signal light switch at his fingertips. Designed to increase road safety, the warning device is being installed on Shell tank trucks in Sweden

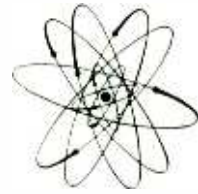

PERMANENT CAREER OPPORTUNITIES

FOR
ENGINEERS • PHYSICISTS • CHEMISTS

The Sprague Electric Company, one of the basic companies in the electronics industry, offers permanent employment to qualified personnel. Sprague-made components are used by the millions, not only in military electronics, but in peace-time radio, television, electronic computers, and in all the phases of industrial electronics.

You can grow with Sprague!

Pleasant working conditions in modern, well-equipped laboratories and plants in the heart of New England's Berkshire Hills, famous summer and winter resort area—just 45 miles from Albany, N. Y.

PRESENT OPENINGS INCLUDE:

PHYSICISTS: All grades, for research and development on transistors and solid state problems.

ELECTRICAL ENGINEERS: All grades, for research, development, and application engineering on resistors, capacitors, radio interference filters, and pulse-forming networks.

ELECTRICAL ENGINEERS: All grades, for complex test equipment design and production.

PHYSICISTS: All grades, for experimental research involving highly accurate measurements in properties of new materials.

PHYSICAL CHEMISTS: All grades, for research on dielectrics, resistance elements, and thin metal films.

CERAMICISTS and ELECTRICAL ENGINEERS: All grades, for research and development on printed circuits.

CHEMISTS and CHEMICAL ENGINEERS: Junior, for research and product development in ceramics, resistance elements, and dielectrics.

ORGANIC CHEMIST: Ph.D., for investigation of mechanisms of organic reactions and structures of organic compounds.

MECHANICAL ENGINEERS: All grades, for design and development of production machinery.

METHODS ENGINEERS: All grades, for factory planning and methods work.



PIONEERS IN ELECTRIC AND ELECTRONIC DEVELOPMENT

Please send your full
qualifications to:

Engineering Department
SPRAGUE ELECTRIC COMPANY
NORTH ADAMS, MASSACHUSETTS

television. In New York City, where salaries in most fields are highest, operators are getting as much as \$150 for a 5-day, 40-hour week. Here, the income from f-m is inconsequential and a-m rates are being forced down. Many a-m broadcasters anticipate embarking upon tv's ocean of red ink. They see the engineer market being inflated by the very fact that they must then double their own licensed-operator employment. And this is but a fraction of the nonlicensed technical personnel necessary.

The Commission asks one \$64 question: how is it proposed that remotely controlled stations or those using nontechnical operators put into immediate effect, after an alert, the Conelrad (ELECTRONICS, p94, Aug. 1951) frequency-changing program that denies navigational information to enemy aircraft?

Parts Distributors Score Bypassing

DISTURBING to industrial distributors of electronic parts is bypassing by manufacturers dealing directly with large plants. Affected distributors have recently become vocal enough on the subject to induce at least a few parts manufacturers to protect them with respect to price.

Not so readily reduced is the bypassing of radio-tv replacement-part distributors by set makers selling components to servicemen direct or through their own distributors. This part of the distribution picture is complicated by the fact that there are (1) set makers doing a legitimate business in 'original replacement', (2) those that have inadvertently bought more parts than they can use in receiver production and, (3), those that deliberately overbuy to hammer down price and plan to dump the surplus.

Several industry groups are studying the last-mentioned situation but so far the most concrete suggestion reported involves somewhat vague 'monitoring' of suspected factory accounts.

'Community' TV Antennas Big Business

Even applicants for uhf-tv-station licenses are wooing operators; 'built-in' audience easily captured

COMMUNITY TV antenna systems have quietly become a very respectable equipment market.

These systems, which simply pick up distant tv stations on a master antenna and distribute the signals to homes of subscribers via cable, require neither heavy manufacturing facilities nor extensive staff. Thus the new field may very well attract many companies which couldn't possibly consider entering, say, the manufacture of tv transmitters.

► **Expansion Plans**—Though only 70 to 80 systems are operating today, serving perhaps 10,000 to 15,000 homes, at least twice that many more are being planned. And the planners seem to have little fear, even though the late unlamented freeze on new stations is over, that the advent of new stations will dry up their future.

Investment per system can be quite substantial. The largest system in operation today, Trans-Video, Pottsville, Pa., has invested \$300,000

to serve 1,600 subscribers—and it plans to expand to serve 3,000 or more. Many other companies have even more ambitious plans, in such cities as Harrisburg, (5,000 subscribers) and Williamsport, Pa. (4,000).

► **Cable is Key**—Early company in the business was Jerrold Electronics, Philadelphia. RCA, Philco, and Technical Appliance are active and latest is Spencer-Kennedy, Cambridge, Mass. The price differential between companies is as great as 2-to-1.

Such systems are proving a boon to coaxial-cable manufacturers, since each installation uses miles of high-quality lines. To date, most systems have employed cable such as RG/59U and RG/11U. Operators are constantly pushing cable makers to develop lower-loss lines, so that amplifiers may be spaced farther apart—substantially reducing costs.

► **UHF 'IN'**—Applicants for uhf-tv stations are wooing community-system operators, for the simple reason that they can provide a 'built in' audience the day a uhf station begins telecasting.

One converter at the master antenna can bring a uhf signal down to a vhf channel to be fed to the entire system—obviating the need for each set owner to buy a converter and uhf antenna at \$50 or more.

New Battery Designs Hit Market

Alkaline electrolytes used in B batteries for personal portables

ALKALINE dry-cell batteries have received widespread publicity in recent weeks by virtue of their use as B batteries in personal-portable radios. Two companies, RCA and Emerson, have already announced new sets using such batteries. Others are expected to follow suit.

► **Content**—Design of a flat-type alkaline dry cell, according to the Ray-O-Vac Company, centers about the use of sodium-hydroxide (caustic soda) electrolyte, with a



Rear view of the new RCA personal portable, showing the new alkaline B battery at the left

zinc anode and a manganese-dioxide mixture for the cathode material. With usage of the battery,

(Continued on page 14)

Through the years
 with one of the
 electronic industry's
 First Families

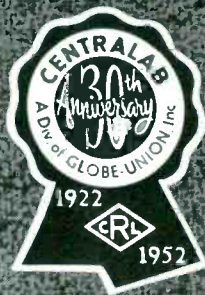

EARS

made
 good in peacetime)



ry's first Tubular
 coupling
 capacitors -

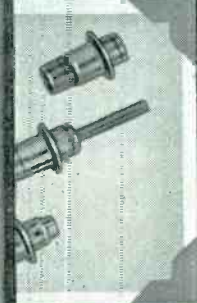

Panel Mounted
 Ceramic Capacitors

anything
 (w
 them)



CENTRALAB'S ELECTRONIC FAMILY

Many members have made electronic history!

Today, many of the most advanced developments in electronic equipment -- from modern hearing aids to television, radar and X-ray -- are built around the revolutionary components pioneered and introduced by Centralab.

Tangible evidence of the ceaseless research that gives fresh

emphasis to the fact that many products bearing your trademark serve better -- last longer ... thanks to the continuing engineering advances of Centralab.

As in the past -- so in the future -- you can look to Centralab for leadership in electronic component research.

Variable Resistors

(Great granddad)



1922 First composition variable resistor ever built



1929 First combination variable resistor and switch

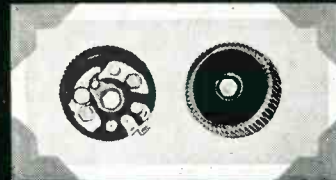

1946 Model 1 - World's smallest switch type variable resistor

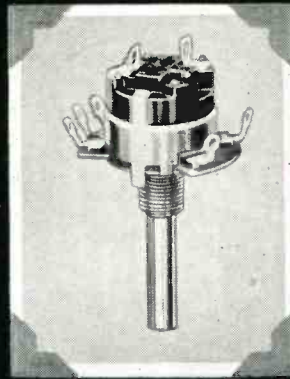

1949 Model 2 Radiohm the most modern high quality variable resistor

(Latest addition to this part of the family)

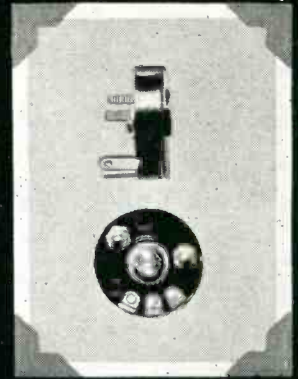

1951 New High Torque Variable Resistor - world's smallest - no bigger than a dime!

(She started this branch of the family)

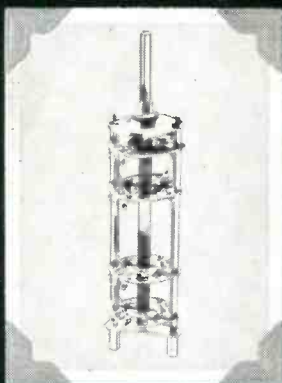

1936 A new and complete line of wave band switches

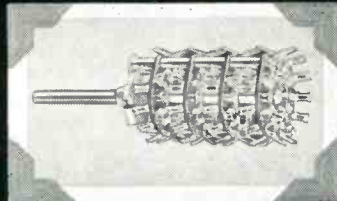

1938 The industry's first 24 contact per single section switch

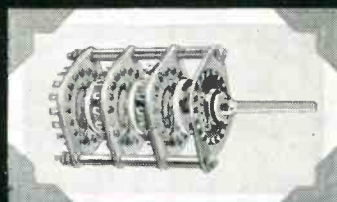

1943 The industry's first low-loss, high frequency medium duty powerswitch

Switches



1939 First multiple contact lever action switch

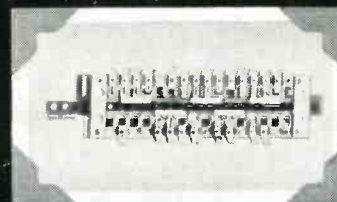

1947 The first slide switch introduced to the industry

(our most beautiful babies!)

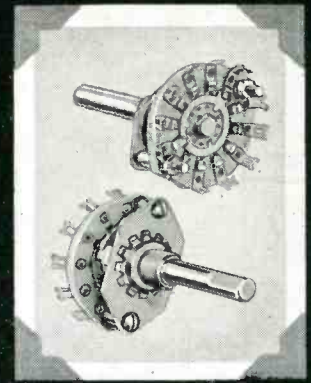

1951 New miniature rotary switch (1 1/16" dia.)

HAS BEEN GROWING FOR 30 YEARS

Capacitors

(War babies who made more than good in peacetime) ←

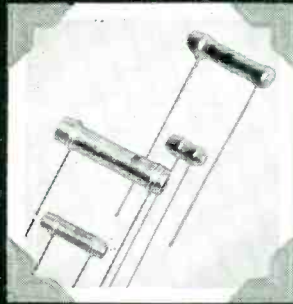

1935 Temperature Compensating Ceramic Capacitors

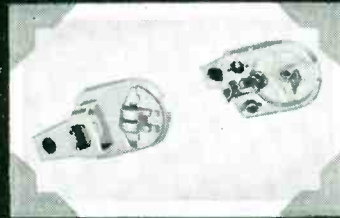

1939 Industry's first Ceramic Trimmer Capacitors



1941 Industry's first High Voltage Transmitting Ceramic Capacitors

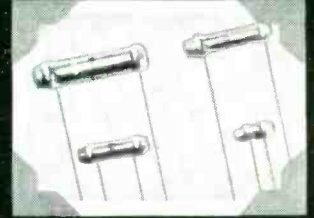

1945 Industry's first Tubular Type, By-Pass coupling Ceramic Capacitors -

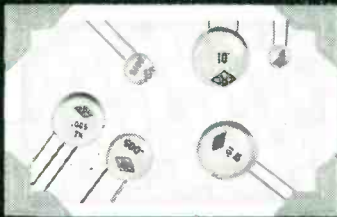

1946 The first Disc-Type By-Pass coupling ceramic capacitors introduced to the electronic industry

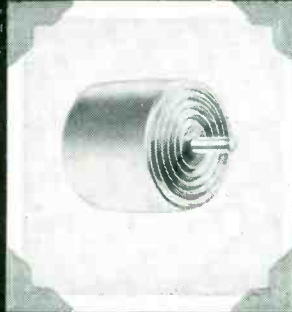

1947 Industry's first TV High Voltage Ceramic Capacitors

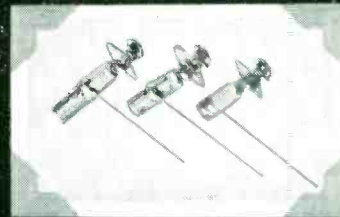

1949 Industry's first Ceramic Tubular Trimmer Capacitors

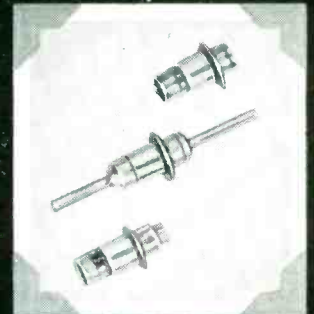

1951 New Eyelet Mounted Feed-Through Ceramic Capacitors

Printed Electronic Circuits

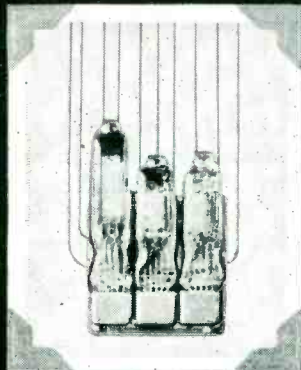

1943 Centralab originated the industry's first printed ELECTRONIC circuit

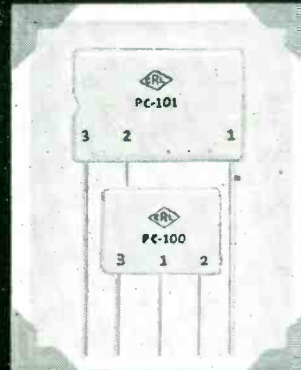
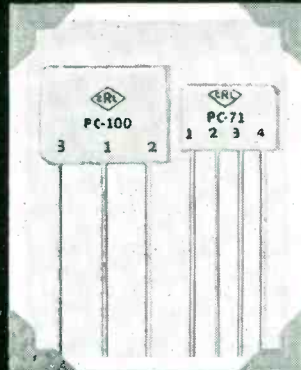

(Nobody ever saw anything like these, but now everybody wants them.) ←

Ceramics

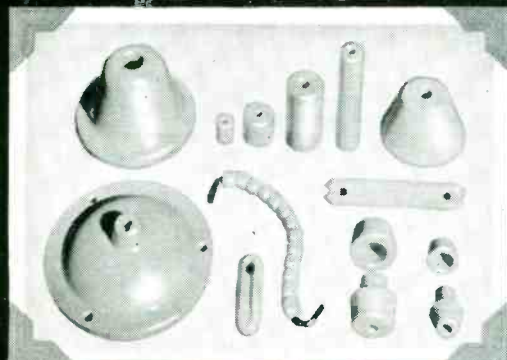

1942 First offered fine ceramics to industry. Actually, Centralab had been making ceramics for its own use since 1928... but in 1942 developed a grade L-5 Steatite Ceramic superior to the then existing Navy grade "G" specification

Centralab was the first to metalize ceramics. By 1945 Cordierite and Zirconite bodies with grade L-4 rating were developed.

(This branch of the family just grows and grows and grows and there's no room for all their pictures)

Centralab

A Division of Globe-Union Inc.

900 EAST KEEFE AVENUE

MILWAUKEE

the electrolyte becomes absorbed gradually.

For portable-radio use, the batteries are light-drain devices, rated at about 500 milliampere hours and able to withstand up to 15-milliampere current drain. The same basic design, changed slightly by the addition of mercuric oxide to the electrolyte, gives a heavy-drain battery for other uses.

Several new radios are using two 1½-volt A batteries connected in parallel. These are of the conventional zinc-carbon construction but with a special mix of manganese dioxide for the depolarizer. Leak-proof steel containers seal in the ingredients for longer life.

► **Mercury Cell**—The new alkaline batteries are somewhat similar in action to the mercury cell of the P. R. Mallory Company, in which a solution of potassium hydroxide and zinc oxide forms the electrolyte, a pressed zinc pellet or a roll of thin corrugated zinc strip forms the anode and pure mercuric oxide with graphite added forms the depolarizing cathode. Mercury cells have long shelf life because there is little or no internal cell reaction until electrical energy is drawn from the cell.

Batteries of the carbon-zinc type, for portable-radio use, are being revamped by the National Carbon Company and improved designs are expected to be on the market at low cost early in July. The new carbon-zinc B battery will be of the flat-type, and the new cylindrical A battery will be twice the length of the usual 1½-volt cell.

TV Manufacturers Fight Summer Slump

New line introductions plus special convention promotions may boost summer sales

NEW television models and new advertising campaigns are usually introduced in the fall. This year, however, because of the July political conventions, manufacturers have

been virtually forced to promote tv sales in what has nearly always been a month of very low buying activity.

► **Plans**—Westinghouse, Admiral and Philco are engaged in twin summer promotions. Each is sponsoring convention coverage on television and introducing new tv sets. Other manufacturers such as RCA, Crosley, Zenith and CBS-Columbia are unveiling new tv models during the slow season.

For some companies, this is the third time in 1952 that new set debuts have taken place. There may be more this year. Normally, new models are introduced twice a year.

In addition, many special promo-

tions are planned. Free phonographs with each console sold, free use of a set during the convention and special contests for cash prizes are some of them.

► **Outlook**—Consensus of opinion is that price is the really important consideration in today's market. In fact, some companies expect a trend toward greater production of low-priced 17-inch models.

One manufacturer sees 1952 sales by tube size reaching the following percentages: Consoles: 60 percent 20-inch tubes, 40 percent 17-inch tubes; Combinations: 85 percent 20-inch tubes, 15 percent 17-inch tubes; Table Models: 40 percent 20-inch tubes, 60 percent 17-inch tubes.

R-F Heater De-Bugging Slow

Industry struggles to meet FCC's June 30 deadline on radiation and interference

ON JUNE 30 FCC rules limiting radiation from radio-frequency heating equipment go into effect. At the time of this writing, it appears that a substantial percentage of the country's r-f equipment will then be operating illegally, or shut down.

A survey among specialists engaged in de-bugging industrial equipment and issuing FCC-required certificates showing compliance with FCC rules shows that many are flooded with jobs and will not be able to take on additional ones (or even complete those con-

tracted for) by June 30.

Estimates of the percentage of equipment that will be operating legally after June 30 run between 30 and 90 percent, with several expressing concern over industrial production interruptions caused by shutting down equipment that has not been or cannot be certified.

► **Relaxations**—Certain of the FCC rules have been eased.

A multi-unit installation covering an area that can be contained in a 500-ft. circle may be covered by one certificate.

Medical diathermy users have been granted a year extension to June 30, 1953.

► **Field Findings**—Each installation (Continued on page 16)

R-F Heater Interference Experience

Equipment Type	Freq. Range	Recommended Steps
High-frequency motor-generator sets	up to 3,000 cps	Usually no corrective measures necessary, unless harmonic radiation is high
Vacuum-tube generators	100 to 500 kc	Shielding and power-line filtering
Quenched-gap	200 to 500 kc	Shielding often needed if manufactured prior to July 1, 1947
Mercury-hydrogen gap	20 to 70 kc	Most units already provided with steel shielding. May require extra shielding and some line filtering
Plastic-sealing	6 to 160 mc	Shielding of both vacuum-tube oscillator and electrodes essential
Plastic-preheaters	6 to 50 mc	Usually provided with oscillator and electrode shielding. If not, shielding essential
Wood-gluing, rubber, chemical heating and drying	2 to 50 mc	Usually necessary to improve shielding to meet requirements
Foundry core baking		Most units manufactured after July 1, 1947, and thus certified by manufacturer

an **ounce**
(and 1/4) →

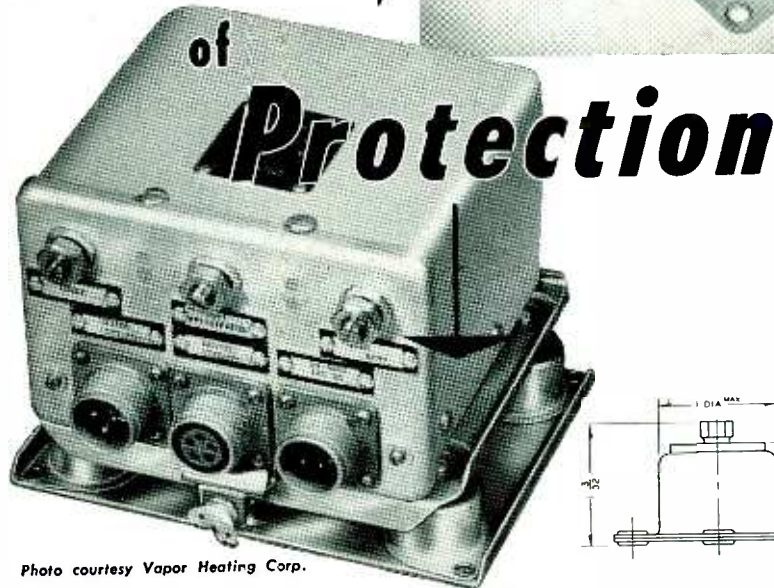
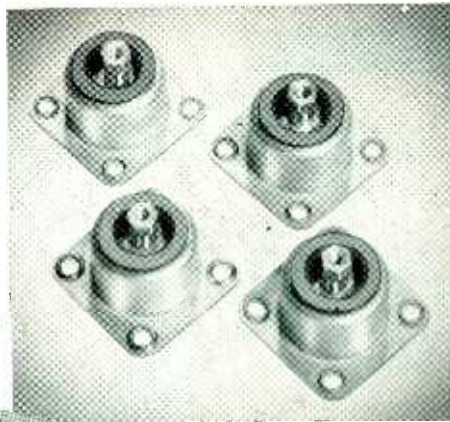

Photo courtesy Vapor Heating Corp.

insures the reliability of your equipment.

Miniature air-damped Barrymounts were developed specifically to help you with your miniaturization projects. They give you these advantages:

1. Less space — reduced height cuts cubage of mounted equipment.
2. Less weight — only 5/16 ounce per unit isolator.
3. Wide load range — 0.1 to 3.0 pounds per isolator.
4. Satisfy temperature (-67 to +170F), vibration, and other performance requirements of JAN-C-172A — special models available for extreme high or low temperatures.
5. Ruggedized models — available for equipment that must meet shock-test requirements of AN-E-19, MIL-E-5272, and MIL-T-5422.
6. Four styles — available as unit isolators or assembled with mounting bases built to your needs.



TYPE 6475



TYPE 6695



TYPE 6465



TYPE 6690

For complete information, ask for Barry Catalog 523-A; it's free on request. And for greatest benefits with miniature Barrymounts, let our Field Engineering Service share our experience with you in the early stages of your designs.

THE **BARRY** CORP.

707 PLEASANT ST., WATERTOWN 72, MASSACHUSETTS

SALES REPRESENTATIVES IN

Atlanta Chicago Cleveland Dallas Dayton Detroit Los Angeles Minneapolis New York Philadelphia
Phoenix Rochester St. Louis San Francisco Seattle Toronto Washington

presents different problems to engineers and technicians doing the debugging and making certification measurements.

It takes 20 to 40 man hours to add required screening and filtering to make an offending piece of equipment operate properly, and 10 to 20 hours to make certification measurements.

Cost usually runs between \$300 and \$500. Figures are subject to wide variations.

One specialist saves multi-unit customers money by de-bugging one piece of equipment and letting company employees perform like operations on other units.

In difficult cases, many companies have been forced to use elaborate screen rooms to house heating equipment.

Some firms move equipment into basement locations to take advantage of the natural shielding afforded by the earth.

Electronics Firms Lead In Defense Contracts

Sixteen electronics companies are among top 100 listed by Munitions Board

ELEVEN PERCENT of the \$44 billion spent on defense contracts from July, 1950 to December, 1951 went into the coffers of sixteen electronics and related-industry manufacturers.

These firms were among the top 100 military contractors who received 59.9 percent or \$26 billion of all military prime contracts for the period.

General Electric again topped the electronic firms on the list but a large percentage of its contracts are for jet engines. Along with GE, Westinghouse and AT&T were other major electronic manufacturers in the first 20 companies. Principal upward change is for Sylvania, which moved from 91 on the previous list to 71st place on the present one.

► **Top Firms**—Following are the electronics and related-industry

firms on the list of 100 military prime contractors:

	Position	Millions	Percent of Total
General Electric	5	\$976.8	2.2
Westinghouse	12	674.4	1.5
AT&T	13	657.3	1.5
Sperry	17	479.0	1.1
Bendix	18	473.4	1.1
IT&T	22	286.8	0.7
RCA	27	211.3	0.5
Avco	33	184.6	0.4
Philco	40	160.7	0.4
Raytheon	42	142.7	0.3
Collins	44	138.7	0.3
Hazeltine	56	93.1	0.2
American Bosch	59	91.4	0.2
Sylvania	71	76.9	0.2
Stewart-Warner	78	63.3	0.2
Gilfillan	87	53.3	0.1

What's Behind the Figures— Network Billings

Fifth of a series explaining items reported on statistical page each month

NETWORK BILLINGS, the fifth category of statistics reported each month in *Figures of the Month* (p 4), represent the gross time charges billed to advertisers and agencies each month by the major radio and tv networks, as compiled by the Publishers Information Bureau of New York.

Only *network* charges are included; billings for time sold by individual stations, not carried as network programs, are not reported.

The accompanying charts, which

Kaiser-Frazier Eyeing Electronics

AUTOMOBILE-MAKER Kaiser-Frazier is studying the electronics field, may manufacture power tubes.

Negotiations are reported to be under way with another company that would provide plant facilities and electronic engineers.

show the trend in billings for each network from October 1950 to the present, reveal that tv is forging steadily ahead of sound radio in gross billings. For the first four months of 1952 network radio (ABC, CBS, MBS, and NBC) produced billings of \$56.5 million while tv (ABC, CBS, DuMont, NBC) accounted for \$60.7 million.

This is a sharp reversal of position from the previous year. In 1951 network radio billings were \$174.7 million for twelve months, against \$128.0 million for tv.

► **Competition**—NBC has pushed ahead in tv, capitalizing on its early promotion of video as a net-

(Continued on page 18)

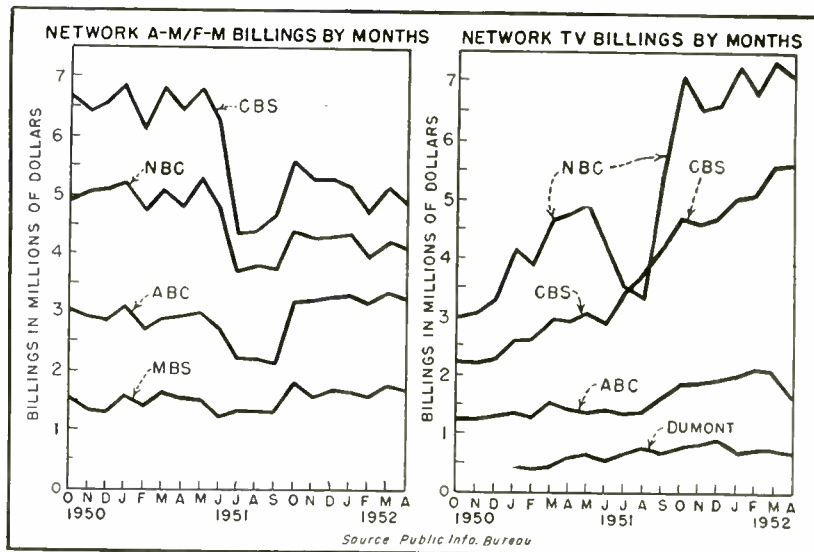

Source: Public Info. Bureau

ALL in ONE PACKAGE...

**Distortion Analyzer
Noise Indicator Frequency Meter
and a Highly Sensitive
Voltmeter**



the  type 1932-A Distortion and Noise Meter \$595.00

Here is a highly accurate, easily operated instrument widely used for the measurement of audio fidelity, distortion and noise. This instrument is very valuable for production-checking and adjusting attenuators, audio amplifiers, audio oscillators and radio receivers, and checking envelope distortion of oscillators up to 900 Mc. Among Its Many Uses Are:

- ★ Complete, continuous and accurate wave analysis of fundamentals from 50 to 15,000 cycles; with harmonic range up to 45,000 cycles when used with an oscilloscope — invaluable for checking hum, noise and distortion
- ★ Rapid selection of frequency — only one main tuning control and push buttons used
- ★ Indication of frequency with accuracy of better than 3%, making it a reliable frequency meter
- ★ Direct audio voltage measurements of 600-ohm systems over a range of +20 to -40 dbm
- ★ Highly sensitive voltage measurements from 1 mv to 100 volts, if calibrated first
- ★ Detection of noise levels down to 200 μ v — inherent noise of instrument considerably less
- ★ Visual observation of distortion components with an oscilloscope; the distortion components at the output jack and the input to the analyzer are applied to the horizontal and vertical plates of a scope. The resulting lissajous figures give visual indication of the prevalent distortion harmonics. Simply by tuning through the frequency spectrum, a continuous visual indication of distortion present is obtained.

The accuracy, rapidity and ease with which a wide variety of measurements can be made has ideally adapted this instrument to the production checking of radio receivers, electronic instruments and components, as well as for everyday measurements in the communications laboratory.

Abridged Specifications

- Distortion Range:** Push buttons select full-scale meter deflections of .3, 1, 3, 10 or 30 per cent distortion
- Noise Range:** Noise measurements made to 80 db below reference calibration level
- Audio-Frequency Range:** 50 to 15,000 cycles for fundamental in distortion measurements; 30 to 45,000 cycles for noise and hum measurements
- Required Input Voltage:** between 1.2 and 30 volts for 100,000-ohm input; between 0.8 and 30 volts for 600-ohm input
- Residual Distortion Level:** 100,000-ohm input — .05% (maximum distortion) below 7,500 cycles; 0.10% above 7,500
- Residual Noise Level:** Less than 80 db
- Accuracy:** Essentially $\pm 5\%$ of full scale for distortion, noise and dbm measurements

GENERAL RADIO Company

275 Massachusetts Avenue, Cambridge 39, Massachusetts, U. S. A.
90 West Street NEW YORK 6 920 S. Michigan Ave. CHICAGO 5 1000 N. Seward St. LOS ANGELES 38



work medium, but is below CBS in radio. The combined billings (radio and tv) of these two networks are about on a par: \$111.2 million for CBS vs \$113.5 million for NBC during the year 1951, and \$41.5 million for CBS vs \$44.9 million for NBC in first third of 1952.

Both networks now get more gross income from tv than from radio, whereas ABC still makes its major revenue from radio.

Converters Hold UHF-TV Fort

Present price problem defers production of complete-coverage receivers

ALTHOUGH coverage of 82 channels will be provided in the ultimate tv receiver, a survey of 30 receiver manufacturers reveals that the need to maintain present low prices prevents immediate production of such sets.

Only two receiver models so far announced provide complete coverage of vhf and uhf channels without additional parts or accessories. However, some companies have engineering models built, and at least one front-end manufacturer offers a tuner covering channels 2 to 83.

The present uncertainty of when and where stations will open on the uhf channels is reflected in the receiver industry. Manufacturers are more concerned with holding down the cost of a receiver than providing maximum utility in the near future. In the words of one, "We will not use a complete 82-channel tuner until forced to. Some of our new models use strips, others converters."

► **Biggest Market**—Manufacturers are most concerned with sales in presently served areas which will get additional stations. In such areas 17 million receivers now operate. Any of these can be used with a converter to receive uhf channels, and those equipped with turret tuners can usually be modified with strips to receive a few uhf channels. As a result, nearly all manufacturers are planning

Primes Off W-H Hook

LABOR DEPARTMENT plan to hold government contractors responsible for the wage and hour policies of their subcontractors (p 20, June) under the Walsh-Healey act has been indefinitely postponed.

Secretary Maurice Tobin cancelled a June 10 hearing which was to have led to a July 1 regulation, has announced no new dates.

to push the sale of converters.

For the oldest receivers, the converter sets on top of or alongside the receiver cabinet. Some models made since 1949 have had space provided in the design of cabinet and chassis for the converter to be fitted in. Some of these cover only a few selected uhf channels, other tune all uhf channels from 14 to 83.

Some manufacturers will produce their own design of converter, others plan to purchase from front-end makers, as complete chassis or as subassemblies like vhf tuners.

Separate-unit converters covering uhf channels range in price from \$29.95 (Teleking) to \$49.95 (GE), most companies say "will be under \$50." Strips for old sets having turrent tuners cost from \$2 up, are given free during 1952 to viewers in cities getting uhf channels by Sparton and Admiral.

Coin-Box Television Will Show on Wire

TELEMETER is Paramount's version of subscription television, whereby the home viewer may hope to see first-run movies from his easy chair. Zenith (Phonevision), NBC and Skiatron also have systems for the same purpose but use different methods of denying the program to nonsubscribers and other ways of collecting.

International Telemeter Corp., of Los Angeles, places a coin box beside the television set and wires in

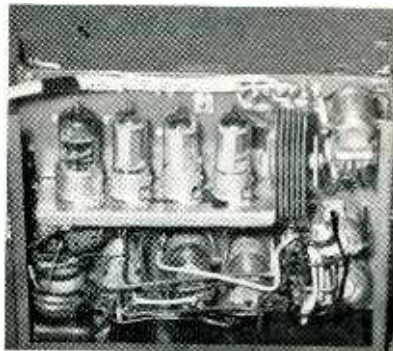

Telemeter coin box that shows program price is connected by cable to chassis within television cabinet. When sufficient coins are deposited, the movie is seen and the sound track heard. An electronic tape recorder notes the show and amount paid

a sealed chassis connected by armored cable. When the receiver is switched to a Telemeter band, a dial on the coin box is lighted and soon clicks out the price of the program. At the same time, a 'barker' audio channel starts advertising the attraction persuasively. The screen shows a futuristic pattern of lightning flashes, with an occasional tantalizing glimpse of a close-up or still scene.

► **Nickel-in-the-Drum**—When coins are dropped into the box, the dial revolves to show the balance due. When the full viewing price has been deposited, the show comes on bright and clear. The set automatically switches to the program sound channel. Other sets, unequipped for Telemeter, see only the darting flashes, while two sound channels fight, the barker being somewhat the stronger.

Whether FCC will ever license any subscription tv system over the protests of film exhibitors and constitutionalists is a moot question now. For a field test, Telemeter

(Continued on page 20)

International RECTIFIER

CORPORATION

EL SEGUNDO
CALIFORNIA

Selenium

Diodes

D-1224

1/8" diameter
1/4" length
Potted in thermo-
setting compound.

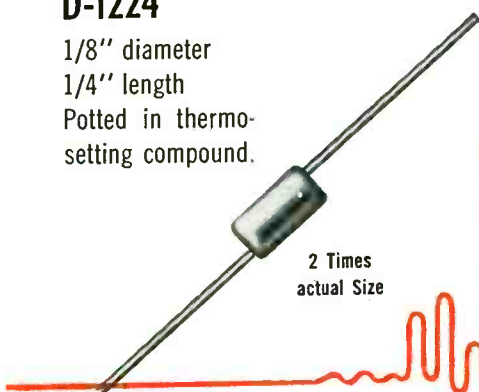

2 Times
actual Size

D-1224

RMS applied voltage, max. 26 volts per cell
Peak inverse voltage 60 volts per cell
RMS input current, max. 500 microamperes
DC output voltage 20 volts per cell
Voltage drop at full load 1 volt per cell
DC output current, avg. 200 microamperes
DC output current, peak 2.6 milliamperes
Max. surge current 10 milliamperes
Reverse Leakage at 10V RMS ... 0.6 microampere
Reverse Leakage at 26V RMS ... 3 microamperes
Frequency max. CPS 200 KC

Also available in 2-cell Diodes.

D-1290

RMS applied voltage, max. 26 volts per cell
Peak inverse voltage 60 volts per cell
RMS input current, max. 3.75 milliamperes
DC output voltage 20 volts per cell
Voltage drop at full load 1 volt per cell
DC output current, avg. 1.5 milliamperes
DC output current, peak 20 milliamperes
Max. surge current 80 milliamperes
Reverse leakage at 10V RMS ... 2.4 microamperes
Reverse leakage at 26V RMS ... 12 microamperes
Frequency max. CPS 100 KC

Also available in 2, 3 and 4-cell Diodes.

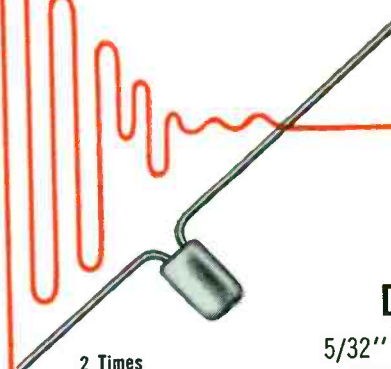
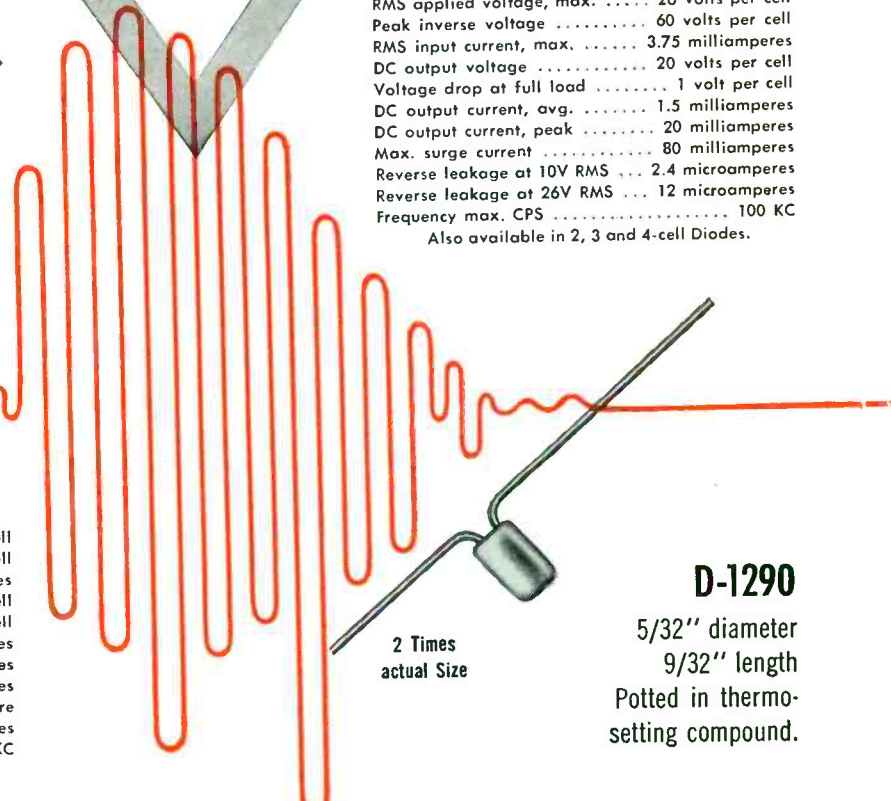

2 Times
actual Size

D-1290

5/32" diameter
9/32" length
Potted in thermo-
setting compound.

International RECTIFIER CORPORATION

GENERAL OFFICES:
1521 E. Grand Ave.
El Segundo, Calif.
Phone El Segundo 1890

CHICAGO BRANCH OFFICE:
205 W. Wacker Dr.
Franklin 2-3889

proponents expect to tie their idea into a wired-television system serving Palm Springs, Calif. Telemeter programs will be connected into the local cable at certain hours for viewing on one of the receiver channels. By avoiding going on the air, the system can be home-tested without embarrassment to FCC.

Military Parts Orders Momentarily Slow

Recent end-equipment contracts have not yet been reflected to the component-maker's level

PRESENT LULL in placement of component-part orders by holders of military-equipment contracts is temporary, according to Washington sources.

The military started to 'stretch out' placement of equipment contracts in late 1951 and, seeing less new business immediately ahead, prime contractors tightened up on parts purchases. Parts manufacturers, in turn, became reluctant to expand production facilities and in

some instances this resulted in a delivery slowdown even on existing orders.

Military end-equipment orders stepped up a little in May and June, 1952. This should be felt at the component-manufacturing level by August or September.

► **'Spares' Too**—Further complicating the planning of component-part makers is the reluctance of the military to commit itself for quantities of spare parts when it places initial end-equipment orders. Government officials, remembering the vast quantities of spare parts stored up during World War II and the criticism which this later invoked, are moving cautiously. "How," they say, "can we determine spare parts needs until a reasonable number of new equipments are field tested?"

Relatively few spare parts are at present manufactured along with those needed for assembly of new military equipment. Thus economies that might be achieved by volume production must be foregone. Several possible solutions are currently under consideration. One of them involves placement of spare parts orders concurrently with equipment reorders.

New Director For NPA Electronics Division

NAMED to a dual post, R. W. Cotton succeeds J. A. Milling as Director of NPA's Electronics Division and Chairman of the Electronics Production Board. He directs the electronics phases of the mobilization program and is responsible for obtaining critical materials and allocating them to electronic producers.

Now on leave from Philco, where he is Assistant to the President, and Vice President of Philco International Cotton was formerly Managing Director and Chairman of the Board of British Rola Ltd., loudspeaker manufacturers. During World War II, he was Controller of Signal Equipment for the British Air Commission. He has been serving as consultant to the U.S. Munitions Board.

California Surveys Electronics Potential

Parts and equipment markets growing but there are cost hurdles

HIGH MARKET POTENTIAL is weighed against high costs in a new survey of California as a location for electronics manufacturing made by the state's Chamber of Commerce.

► **Growing Market**—The study indicates that one of the most vitally needed areas of expansion is component parts. Manufacturers need more local production of capacitors and resistors in particular. Only 10 to 25 percent of such parts are available from nearby suppliers.

Industrial electronic equipment is also needed by the state's mushrooming aviation and experimental military installations.

Television and radio market potential is between 300 and 400 percent greater than the state's present productive capacity. One out of five radio and television sets

(Continued on page 22)



Audio Ordnance

Rated at 300-watts firepower, this University loudspeaker is mounted atop the turret of a U. S. tank and used by Army 'loudspeaker and leaflet companies' to broadcast surrender invitations and news to the enemy

Production Men like

TAYLOR VULCANIZED FIBRE



Here's a production man's dream—a uniform easy-to-work material that can be readily machined in any manner in which it is possible to machine metal. Yes, Taylor Vulcanized Fibre, which weighs only half as much as aluminum, is a real time and trouble saver for production men in nearly every branch of the manufacturing industry.

And another advantage in using this workable material is that it is available in numerous forms including sheets, strips, rods, and rolls, and in a wide range of sizes and thicknesses.

When production schedules call for the purchase of *fabricated* parts, made to your specifications, Taylor can furnish them, too—on time—ready for your assembly lines.

It will be well worth your while to get all the facts about Taylor Vulcanized Fibre. You may find new ways and means to use it in making your products better, faster, and cheaper. Let us also give you the details about other Taylor products, such as Phenol, Silicone, and Melamine Laminates, as well as Taylor Insulation.



*In the
railroad
field...*

Rail-joint insulation—which must withstand, year-after-year, the brutal pounding of locomotive and car wheels—offers conclusive proof of the inherent "toughness" of Taylor Vulcanized Fibre.

This 62-page fact-filled Taylor Catalog describes how the many Taylor Laminated Plastics are made, how and when they're used, and more important, how you can use these basic materials to make your product better... at lower cost! Write today for a copy of Catalog E7.



TAYLOR FIBRE CO.

NORRISTOWN, PA. • LA VERNE, CALIF.

VULCANIZED FIBRE • TAYLOR INSULATION

PHENOL, SILICONE & MELAMINE LAMINATES • FABRICATED PARTS

purchased west of the Rocky Mountains is made in California.

► **High Costs**—Balanced against these good market prospects are the state's relatively high manufacturing costs. Electronics manufacturers there pay about 5 percent more for materials than do similar producers in Pennsylvania-New Jersey and Chicago areas.

Labor and shipping costs are also higher in California's electronics industry. The survey's figures show that the average hourly wage for assemblers and technicians is about \$1.65, while the average in the Chicago and New Jersey areas is near \$1.44.

Employment in the industry has jumped from less than 4,000 to a total of 36,000 in the last ten years.

TV "Saturation-Plus" Seen In Eight Years

NUMBER of television receivers in operation in the United States may exceed the number of homes with electricity by 1960. That is the prediction of W. R. G. Baker, General Electric vice president and general manager of its Electronics Division.

GE market research indicates that 53 million sets will be in operation by 1960, more than three times the present number and five million more than the number of homes expected to have electricity by that time.

Between seven and 10 million homes will have two television sets.

Computers Used To Predict Weather

QUICKER and more exact weather forecasts may result from use of BARK, the Swedish binary computing machine which can retain one hundred 7-digit numbers in its brain.

The application is being worked out by a group of research scientists from eight nations under the auspices of UNESCO.

MEETINGS

- AUG. 11-21: Congress of U.R.-S.I. Sydney, Australia.
- AUG. 12-15: 1952 APCO Conference, Hotel Whitcomb, San Francisco, Calif.
- AUG. 15-16: Emporium Section, IRE, Annual Summer Seminar, Emporium, Pa.
- AUG. 19-22: AIEE Pacific General Meeting, Phoenix, Ariz.
- AUG. 22-31: Grand German Radio and Television Exhibition, Dusseldorf, Germany.
- AUG. 26-30: Australian IRE Radio Engineering Convention, Sidney, Australia.
- AUG. 27-29: Western Electronic Show and Conference, Municipal Auditorium, Long Beach, Calif.
- AUG. 27-SEPT. 6: British National Radio Show, Earls Court, London.
- SEPT. 8-10: American Standards Association, Third National Standardization Conference, Museum of Science and Industry, Chicago, Ill.
- SEPT. 8-12: National Instrument Conference and Exhibit, Cleveland, Ohio.
- SEPT. 20: Cedar Rapids Section, IRE, Communications Conference, Roosevelt Hotel, Cedar Rapids, Iowa.
- SEPT. 22-25: NEDA Third Annual Convention and Manufacturers' Conference, Ambassador, Atlantic City, N. J.
- SEPT. 29-OCT. 1: Eighth Annual National Electronic Conference and Exhibition, Hotel Sherman, Chicago, Ill.
- OCT. 1-3: Canadian Electrical Manufacturers Association, General Brock Hotel, Niagara Falls, Ont.
- OCT. 6-8: NAED, Fall Meeting of the Pacific Zone, Hotel del Coronado, Coronado, Calif.
- OCT. 13-17: AIEE, Fall General Meeting, New Orleans, La.
- OCT. 20-22: Radio Fall Meeting, RTMA Engineering Department, Hotel Syracuse, Syracuse, N. Y.
- OCT. 26-29: NAED, Meeting of Board of Governors, Grove Park Inn, Asheville, N. C.
- Nov. 10-13: NEMA, Haddon Hall, Atlantic City, N. J.
- Nov. 10-30: International Radio and Electronics Exhibition, Bombay, India.
- Nov. 17-18: AIEE, Technical Conference on Recording and Controlling Instruments, Benjamin Franklin Hotel, Philadelphia, Pa.
- Nov. 19: American Standards Association, 34th Annual, Waldorf Astoria, New York.
- JAN. 14-16, 1953: Joint AIEE-IRE Conference on High Frequency Measurement, Washington, D. C.

Business Briefs

► **Electronics** and communication equipment production and delivery for the armed forces is now five times greater than it was in January, 1951, according to General Omar N. Bradley.

► **21 Servicemen** strategically located about the country form a field advisory board serving the Standard Transformer Corp. They advise the firm on replacement problems, are consulted concerning new products and new technical literature.

► **Industry** now leads educational institutions and government agencies as the largest customer for scientific instruments and apparatus, according to the Scientific Apparatus Makers Association.

► **Two Contracts** for television equipment have been signed by Bogota, Columbia. One for 6,000

tv sets at \$840,000 goes to E. K. Cole Ltd., London. The other, for a tv transmitter and associated equipment costing \$230,971, goes to Marconi's Wireless Co. Ltd., London.

► **West German** market for radio receivers is expected to increase this year. In 1951, manufacturers there produced 2,500,000 sets, of which 200,000 were exported.

► **Magnetic Amplifiers** are being used to regulate current and voltage in a new type of railway passenger car lighting generator system developed by Bogue Electric Mfg. Co.

► **Electronics** may eliminate one of the solid institutions of the electrical age, the meter man. Devices that read household meters and automatically transmit the information to distant electronic business machines for billing and complete record keeping are forecast by W. R. G. Baker of GE.

ELECTRONIC ENGINEERS, DESIGNERS, MANUFACTURERS:

They're here! *super-rugged*



E-I PLUG-IN HEADERS

PRECISION HERMETICALLY SEALED

— with solid metal blanks that withstand extraordinary punishment

Here's a completely new line of plug-in headers that represent an entirely new principle of hermetic sealing—a type more rugged than any design previously available anywhere. In these headers a great increase in mechanical strength as been achieved by substituting solid metal blanks in place of the usual metal stamping. The result is effective sealing with vastly improved ability to withstand stress, strain and shock.

— many standard types for economical problem solutions

Available in an extended range of types, these headers incorporate all the time-proven features that have made E-I headers and terminals the standard of quality for more than 10 years. These include low expansion, high temperature glass, tin-dip for easy soldering, silicone treatment to combat spray and humidity, individual testing, and many others. Why not call, wire or write today for full particulars.

— available in 8 to 11 pins with or without flange

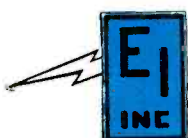

ELECTRICAL INDUSTRIES • INC

MANUFACTURERS OF SPECIALIZED ELECTRONIC EQUIPMENT

44 SUMMER AVENUE • NEWARK 4, NEW JERSEY

New (40X) Amplifier and

BROWN
INSTRUMENTS
ACCELERATE
RESEARCH



Electrical Characteristics

- EQUIPMENT INPUT IMPEDANCE—3000 ohms.
- STABILITY—(after warmup)
—within 1.0 μ v.
- DEAD ZONE (with 76750-3
motor)—0.1 μ v.
- OVERALL VOLTAGE GAIN
— 40×10^6 .
- 60 CYCLE OUTPUT CUR-
RENT—0-12 MA.
- 60 CYCLE OUTPUT VOLT-
AGE—0-154.

New (40X) amplifier combines high gain and sensitivity with good stability.

Specially designed to reduce thermal potentials and stray pickup, the new Brown 40X servo amplifier incorporates an extra stage of amplification to provide increased sensitivity . . . permitting motor drive from signals as low as 0.05 microvolts.

Pictured with the amplifier is the rectifier which provides d-c filament voltage for the first amplifier tubes. It can be used as the basic link in a closed servo loop (where great sensitivity is required) . . . to translate electrical signals into directional motion . . . to provide corrective action in conjunction with minute error signals . . . for null detection . . . or for remote positioning.

Narrow Span Potentiometer

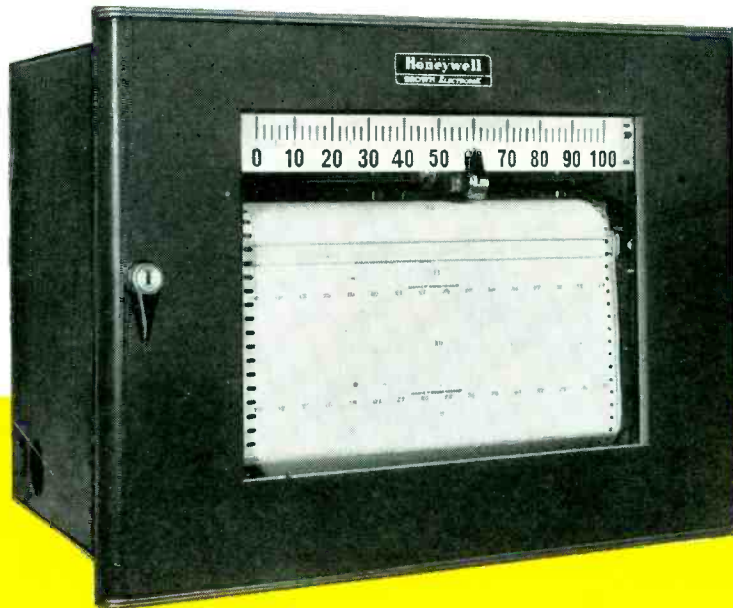

Self-contained *ElectroniK* narrow span potentiometer, incorporating new (40X) amplifier, is ideal for measuring low level potentials.

Electrical Characteristics

- RANGES—Recorders: 0-100, 0-200, 0-500 microvolts, 0-1 millivolts. Indicators: 0-500 microvolts and 0-1.1 millivolts.
- STABILITY (after warmup)—1 microvolt or less for all ranges.
- LIMIT OF ERROR— $\frac{1}{4}\%$ of span.
- SENSITIVITY—0.1 microvolt.
- DEAD ZONE—0.1 microvolt or 0.006% of span (whichever is greater).
- PEN SPEEDS—24 or 12 seconds full travel.
- CONTROL FORMS—Any standard pneumatic form, circular chart only.
- CHART SPEEDS—Any standard speed.
- POWER SUPPLY—115 volts, 60 cycles only.
- RANGE OF INPUT SIGNALS TO RECORDER—(approx.) 0.05 μ v. to 1 mv.

Important Reference Data

Send for Data Sheet No. 10.20-4 on the (40X) Amplifier . . . Data Sheet No. 10.0-8 on the *ElectroniK* Narrow Span Potentiometer . . . and Bulletin No. 15-14, "Instruments Accelerate Research"

Now, with the development of a new high gain amplifier and potentiometer circuit, extremely low level potentials can be measured, recorded and controlled in this new self-contained instrument. The sensitivity of this instrument is so high that a change in signal as low as one-tenth of a microvolt can be determined. Spans as narrow as 100 microvolts provide a high degree of resolution. Internal design practically eliminates thermal emf's and stray a-c pickups.

The new *ElectroniK* Narrow Span Potentiometer may be used wherever the accurate measurement of d-c potentials of the order of microvolts is required . . . it is available as a Strip Chart Recorder (illustrated), as a Multi-Point Precision Indicator, and as a Circular Chart Recorder with pneumatic control.

MINNEAPOLIS-HONEYWELL REGULATOR Co., *Industrial Division*, 4428 Wayne Ave., Philadelphia 44, Pa.

MINNEAPOLIS
Honeywell
BROWN INSTRUMENTS



First in Controls

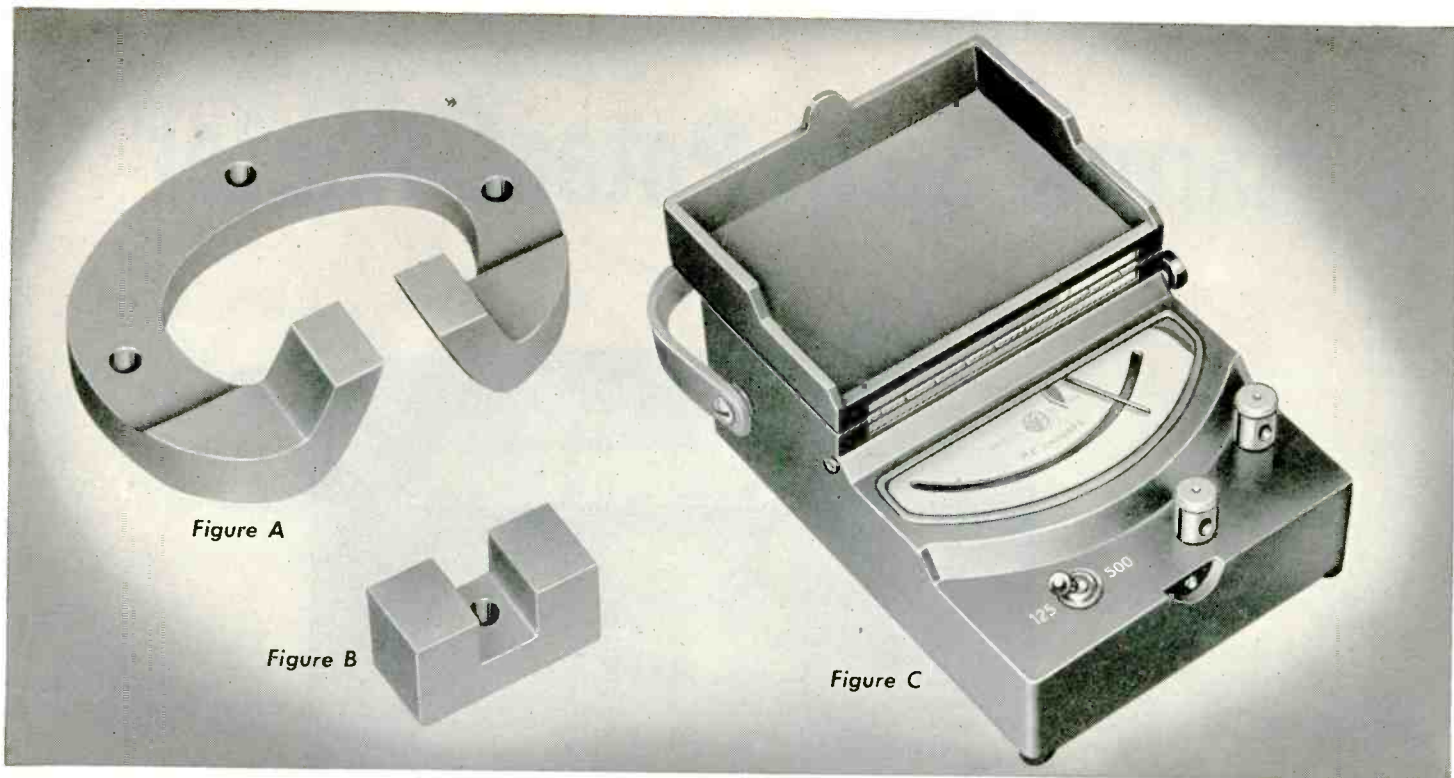

Figure A

Figure B

Figure C

INSTRUMENTS—Fig. A is a damping magnet formerly used in GE portable indicators. Fig. B is the new Carboloy Alnico magnet now used. Its smaller size permitted improved instrument design and lower

magnet cost with no decrease in efficiency. Fig. C. New magnet also speeds assembly, makes faster and easier calibrations.

How Carboloy permanent magnets improve electrical products

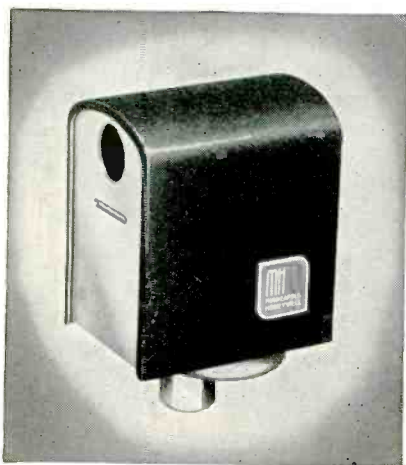

CONTROLS—Switches in compact Minneapolis-Honeywell controls use permanent magnets to give safer snap action, help quench arcs. The magnets are exceptionally stable; provide uniform high energy for the life of the control.

Want to cut down product size, weight? Build a better-performing product for less money?

Then check the possibility of using Carboloy Alnico permanent magnets wherever you need *lasting* magnetic energy.

Carboloy permanent magnets are simple, self-containing sources of energy that *never* fail. They are powerful in small sizes. Need no outside power supply, no maintenance. They help reduce fabrication costs by eliminating wires, coils and operating parts. Above all, they let you simplify design . . . build a lighter, more compact, finer-performing product at a saving.

On these pages you'll see how others got the jump on competitors by using permanent magnets. Perhaps you'll get an application idea from reading about them.

FREE SERVICES

If so, check Carboloy magnet engineers for free, expert advice and an assist in design and application. Look to Carboloy production lines, too, for the uniform, high-energy Alnico magnets you'll need for best results — all sizes, all shapes; cast or sintered to your specifications.

Send coupon for free Magnet Design Manual PM-101 and Standard Stock Catalog PM-100.

CARBOLOY

DEPARTMENT OF GENERAL ELECTRIC COMPANY

11139 East 8 Mile Road, Detroit 32, Michigan

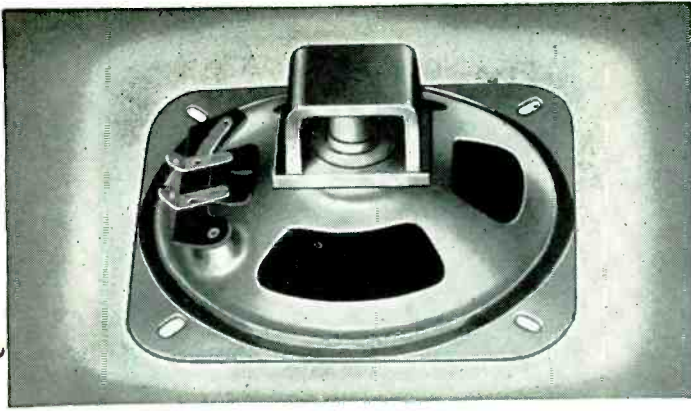

SPEAKERS—In speakers, permanent magnets replace larger electro-magnets in field structure. Current passing through Alnico's *uniform* field makes voice coil and cone vibrate in proportion to voltage; tone is truer.

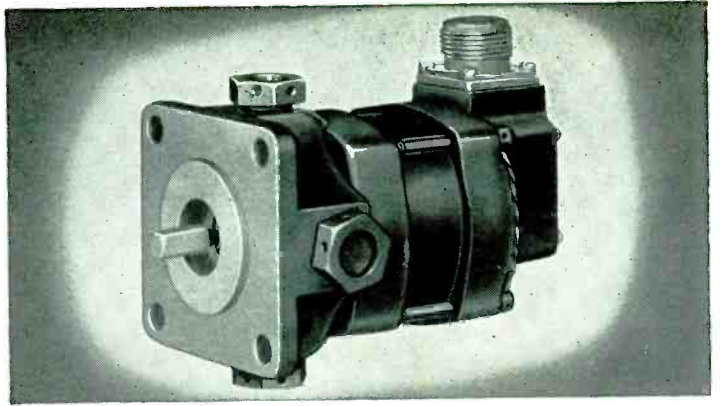

GENERATORS—When GE engineers had only 6" x 6" area for jet's tachometer generator, they whipped design problem with a tiny permanent magnet. It eliminated coils and wires, supplied the powerful energy required.

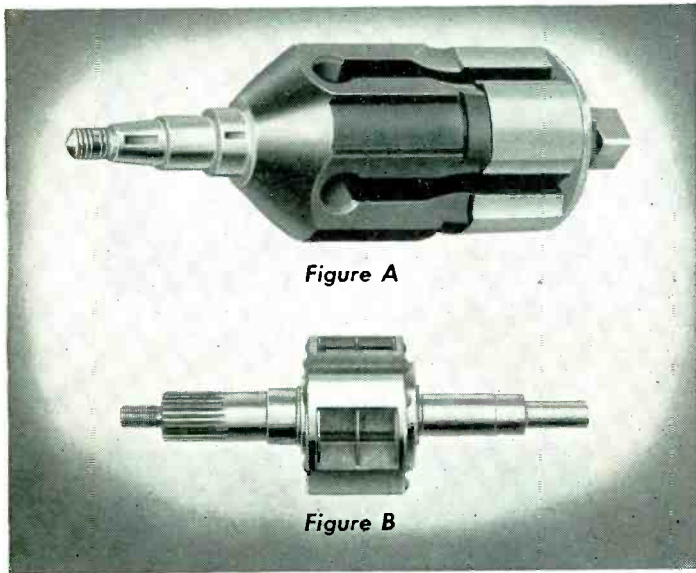

Figure A

Figure B

MAGNETOS—To Scintilla Magneto Division, Bendix Aviation Corp., weight savings are vital in their aircraft products. Fig. A shows chrome rotor weighing approximately 4 lbs. 9 ozs. Fig. B shows newer model rotor using Alnico. It weighs only 2 lbs. 4 ozs.

ADVANTAGES OF CARBOLOY PERMANENT MAGNETS

- | | |
|--------------------------------------|---|
| 1 Simple — no operating parts | 7 No power failures |
| 2 Uniformly powerful | 8 Combine electrical and mechanical features |
| 3 Last forever | 9 Simplify mechanical assemblies |
| 4 No coils to wire | 10 Uninterrupted operation |
| 5 Cool-running | 11 Moisture-resistant |
| 6 No operating costs | 12 Create savings |

"Carboloy" is the trademark for the products of Carboloy Department of General Electric Company

Plants at Detroit, Michigan; Edmore, Michigan; and Schenectady, New York

**CARBOLOY
ALNICO
PERMANENT
MAGNETS**

*Mail
Coupon
Today*

Corboloy Department of General Electric Company
11139 East 8 Mile Road, Detroit 32, Michigan

Gentlemen:

Please rush me, without cost or obligation, copies of Permanent Magnet Design Manual PM-101 and Standard Stock Catalog PM-100.

NAME _____

POSITION _____

COMPANY NAME _____

ADDRESS _____

CITY _____ ZONE _____ STATE _____

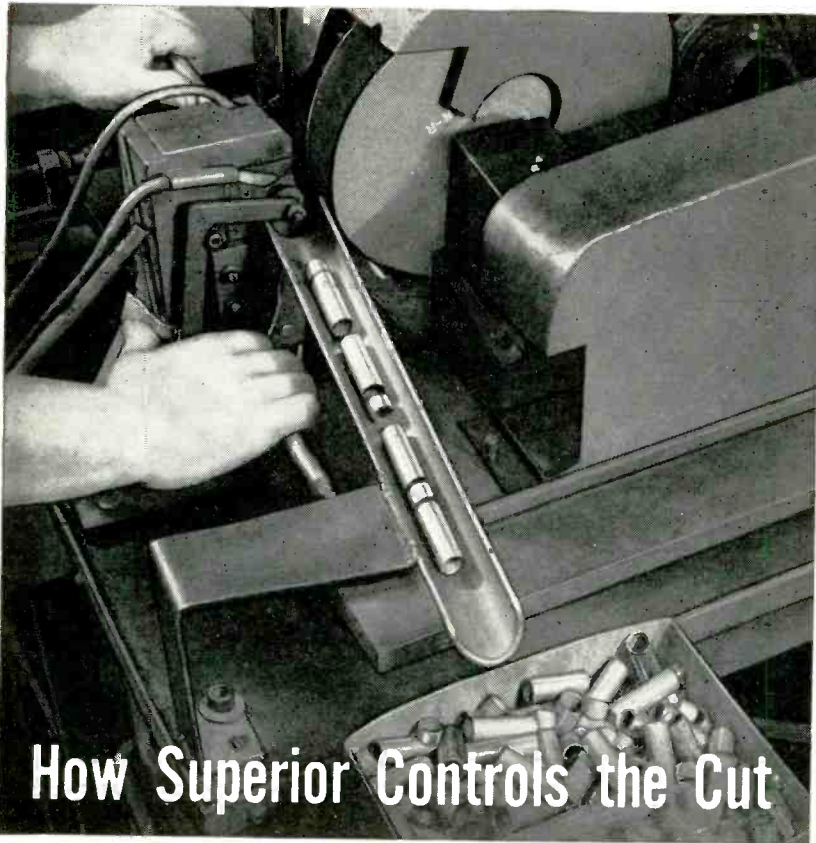

How Superior Controls the Cut

to give you better tubular parts

● Cutting tubing into exact lengths as the first step in the fabrication of tubular Electronic parts is a simple operation. Or is it?

Complications set in when the temper of the tubing is changed to meet customer specifications; when the tubing to be cut has a wall .010" or thinner; when length tolerances as close as .010" are required; when a 3° to 10° angle cut with a tolerance of $\pm \frac{1}{2}^\circ$ is called for; and when flattening, denting or other distortion must be prevented.

But overcoming complications in simple operations . . . and finding ways around them in other basically more difficult ones, is a specialty of the Electronics Division of Superior.

Our customers for Electronics parts have come to expect us to deliver the goods, exactly to specifications, whether standard production or complex experimental parts. What's more, they frequently ask us for suggestions about improvement on their designs and specifications . . . and they get them.

There is nothing unusual about all this—it's our job and we know how to do it. If you are a manufacturer or experimenter in the Electronics Industry and you need a tubular part that presents a problem, tell us about it. We'll probably be able to help and will gladly do so. Write The Superior Tube Company, 2500 Germantown Ave., Norristown, Pennsylvania.

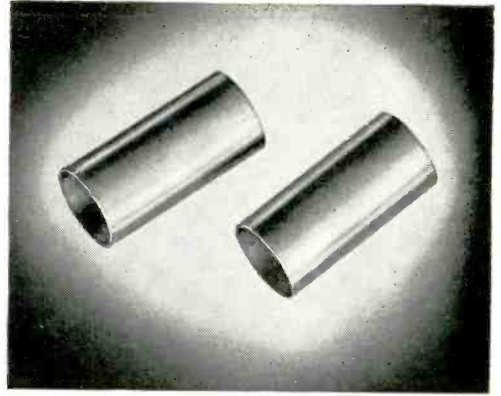

Cutting and Tumbling. Cutting machines and jigs of many types and sizes are combined with extensive tumbling equipment to permit fast accurate production of quantities of parts at Superior.

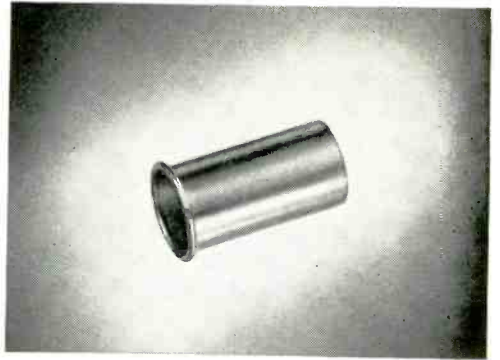

Fabrication: Parts can be readily rolled at either or both ends, flared, flanged, expanded, or beaded (embossed) as required. The anode above is one of many such parts we produce at high speed and low cost.

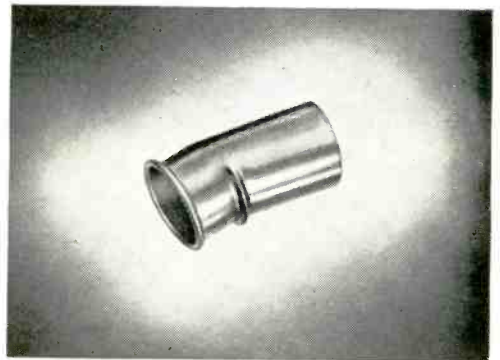

The Finished Part. Final stage in the fabrication of the part shown above at three stages of production is a bend nicely controlled for both precise angle and freedom from other, unwanted distortion.

**This Belongs in Your Reference File
... Send for It Today.**

NICKEL ALLOYS FOR OXIDE-COATED CATHODES: This reprint describes the manufacturing of the cathode sleeve from the refining of the base metal. Includes the action of the small percentage impurities upon the vapor pressure, sublimation rate of the nickel base; also future trends of cathode materials are evaluated.

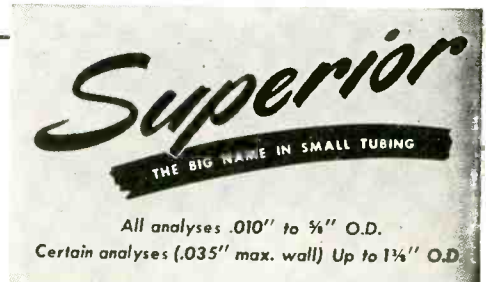

SUPERIOR TUBE COMPANY • Electronic products for export through Driver-Harris Company, Harrison, New Jersey • Harrison 6-4800



Lapp

GAS-FILLED CONDENSERS

More than 15 years service on thousands of Lapp Gas-Filled Condensers proves them to be completely reliable—electrically and mechanically. They offer the advantages of extreme compactness for high voltage and high current ratings... low loss... high safety factors... puncture-proof design... constant capacitance under temperature variation.

In construction, the condenser assembly is supported on a top aluminum ring, the steel tank serving only as a support for this ring and as a leak-proof gas container. The high potential plates are stationary, carried on a rigid aluminum center stud, supported by a ceramic bowl. Rotor plates are grounded, carried on ball-bearings in a race almost the full diameter of the tank. This construction provides a grounded tuning shaft on variable models, makes possible efficient and complete water cooling for high current operation, and results in direct and short current paths to condenser plates.

Write for complete description and specifications. Radio Specialties Division, Lapp Insulator Co., Inc., Le Roy, N. Y.



MODEL 24IF
Fixed only

Capacitances up to 60,000 mmf.; 1 mc. current ratings: 175, 350, 525 amps.; Safety gap settings: 14, 25, 38 Kv peak.



MODEL 18IF—*Fixed only*
MODEL 18R—*Fixed or Variable*

Capacitances up to 30,000 mmf.; 1 mc. current ratings: 120, 240, 360 amps.; Safety gap settings: 6, 14, 25, 38, 50, 63, 72 Kv peak.



MODEL 12R—*Fixed or Variable*
MODEL 12IF—*Fixed only*

Capacitances up to 15,000 mmf.; 1 mc. current ratings: 105, 210, 315 amps.; Safety gap settings: 6, 14, 25, 38, 50, 63 Kv peak.



MODEL 9R
Fixed or Variable

Capacitances up to 8000 mmf.; 1 mc. current ratings: 85, 170, 255 amps.; Safety gap settings: 6, 14, 25, 38, 50 Kv peak.



MODEL 7R
Fixed or Variable

Capacitances up to 8000 mmf.; 1 mc. current ratings: 70, 140, 210 amps.; Safety gap settings: 2½, 6, 14, 25, 38 Kv peak.

BRASS
for "Bridgeport" Service
CO.



BRIDGEPORT WAREHOUSE SERVICE

The Bridgeport warehouses are designed to supply from stock limited quantities of sheet, rod, wire or tubing. It is the policy of the company to maintain adequate warehouse stocks at all times so that small orders can be filled without delay.

The fabricator is in a position to obtain promptly metal to fill orders for experimental work or to start production runs, while waiting for mill shipments.

Bridgeport warehouses make every effort to carry the variety of alloys, sizes and gages which fulfill the requirements of the locality they serve.

To take care of the maximum range of widths of strip metal, slitting service is available—not only to serve warehouse stocks, but also to make customers' stocks of non-ferrous strip metal more flexible.

Bridgeport's Warehouse Stocklist carries weight tables and a technical digest giving the properties of the most popular copper-base alloys. If you do not have a copy, ask your nearest Bridgeport office.

Mills in Bridgeport, Conn. and Indianapolis, Ind.
In Canada: Noranda Copper and Brass Limited, Montreal

BRIDGEPORT BRASS COMPANY



30 GRAND STREET, BRIDGEPORT 2, CONNECTICUT

Make Light

of SIZE and WEIGHT
PROBLEMS



with

ASTRON

SUBMINIATURE

Metalite* Capacitors

Astron METALITE* metallized paper capacitors, distinguished by their extremely small size and light weight, are currently serving commercial and military users who must meet strict government specifications. Their unique self-healing property, long life and *precision manufacture* have made them the accepted standard for quality metallized paper capacitors throughout the world. If you have a capacitor problem of any kind, our engineers will be glad to consult with you.

For complete information on Astron METALITE and other standard capacitors, write for Catalog AC-3.

*Trademark

Export Division: Rocke International Corp., 13 E. 40th St., N. Y. C.

In Canada: Charles W. Pointon, 1926 Gerrard St. East, Toronto

Depend On—Insist On



255 Grant Avenue, E. Newark, N. J.

**SILETRON
"C" CORES**
*for quick
delivery*
**IN
PRODUCTION
QUANTITIES**

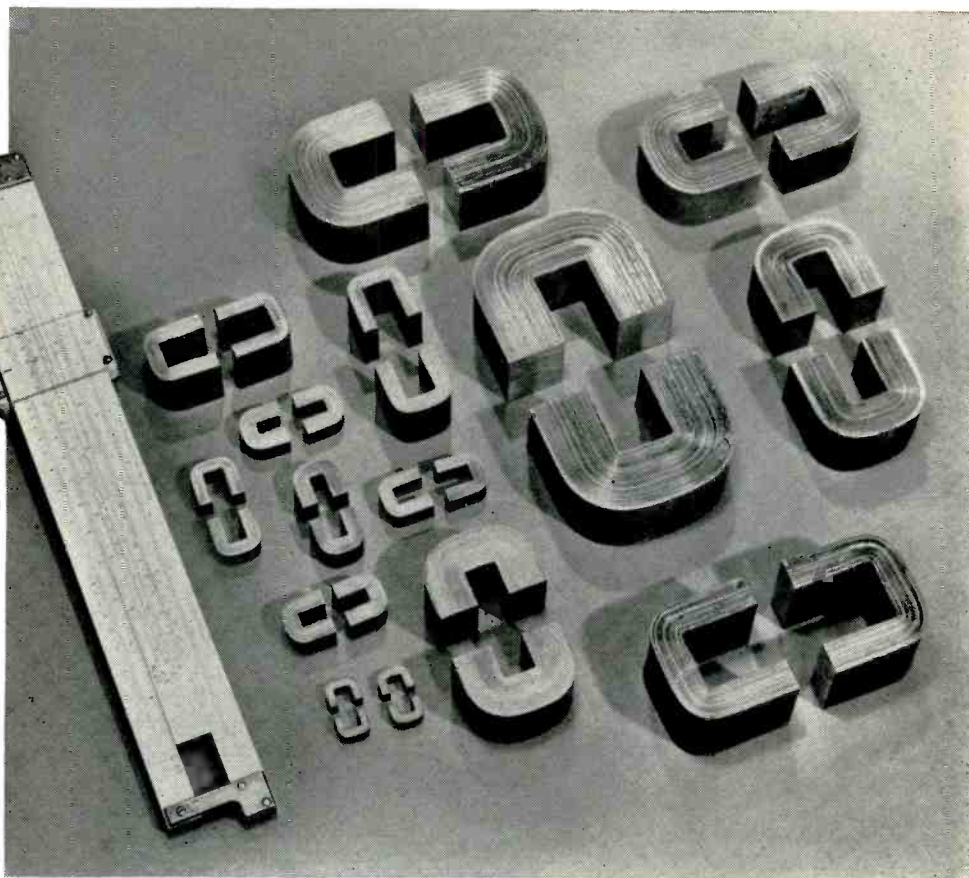

... wound from strip as thin as 0.00025"

*Quality-Tested
and Proved*

- ★ Arnold "C" Cores are made to highly exacting standards of quality and uniformity. Physical dimensions are held to close tolerances, and each core is tested as follows:
- ★ 29-gauge Siletron cut cores are tested for watt loss and excitation volt-amperes at 60 cycles, at a peak flux density of 15 kg.
- ★ 4-mil cores are tested for watt loss and excitation volt-amperes at 400 cycles, at a peak flux density of 15 kg.
- ★ 2-mil cores are tested for pulse permeability at 2 microseconds, 400 pulses per second, at a peak flux density of 10 kg.
- ★ 1-mil cores are tested for pulse permeability at 0.25 microseconds, 1000 pulses per second, at a peak flux density of 2500 gauss.
- ★ 1/2 and 1/4-mil core tests by special arrangement with the customer.

Now available—"C" Cores made from Siletron (oriented silicon steel) thin-gauge strip to the highest standards of quality.

Arnold is now producing these cores in a full range of sizes wound from 1/4, 1/2, 1, 2 and 4-mil strip, also 29-gauge strip, with the entire output scheduled for end use by the U. S. Government. The oriented silicon steel strip from which they are wound is made to a tolerance of plus nothing and minus mill tolerance, to assure designers and users of the lowest core losses and the highest quality in the respective gauges. Butt joints are accurately made to a high standard of preci-

sion, and careful processing of these joints eliminates short-circuiting of the laminations.

Cores with "RIBBED CONSTRUCTION"* can be supplied where desirable.

Ultra thin-gauge oriented silicon steel strip for Arnold "C" Cores is rolled in our own plant on our new micro-gauge 20-high Sendzimir cold-rolling mill. For the cores in current production, standard tests are conducted as noted in the box at left—and special electrical tests may be made to meet specific operating conditions.

● We invite your inquiries.

*Manufactured under license arrangements with Westinghouse Electric Corp.

W&D 4211

THE ARNOLD ENGINEERING COMPANY



SUBSIDIARY OF ALLEGHENY LUDLUM STEEL CORPORATION

General Office & Plant: Marengo, Illinois

HELMHOLTZ

... First in electromagnetic induction

Hermann Ludwig von Helmholtz
1821 - 1894

This distinguished German mathematician, teacher, physicist, and physiologist made great contributions in many scientific fields. While lecturing in 1847, he stated, "... the discharge of a (Leyden) jar is not a simple motion of electricity in one direction, but a backward and forward motion between the coatings." Helmholtz developed the fundamental equation for the current in an inductive circuit. He also was the first to measure the velocity of the propagation of electromagnetic induction. His research in this field inspired Hertz, his pupil, into later discovery and measurement of electromagnetic waves.

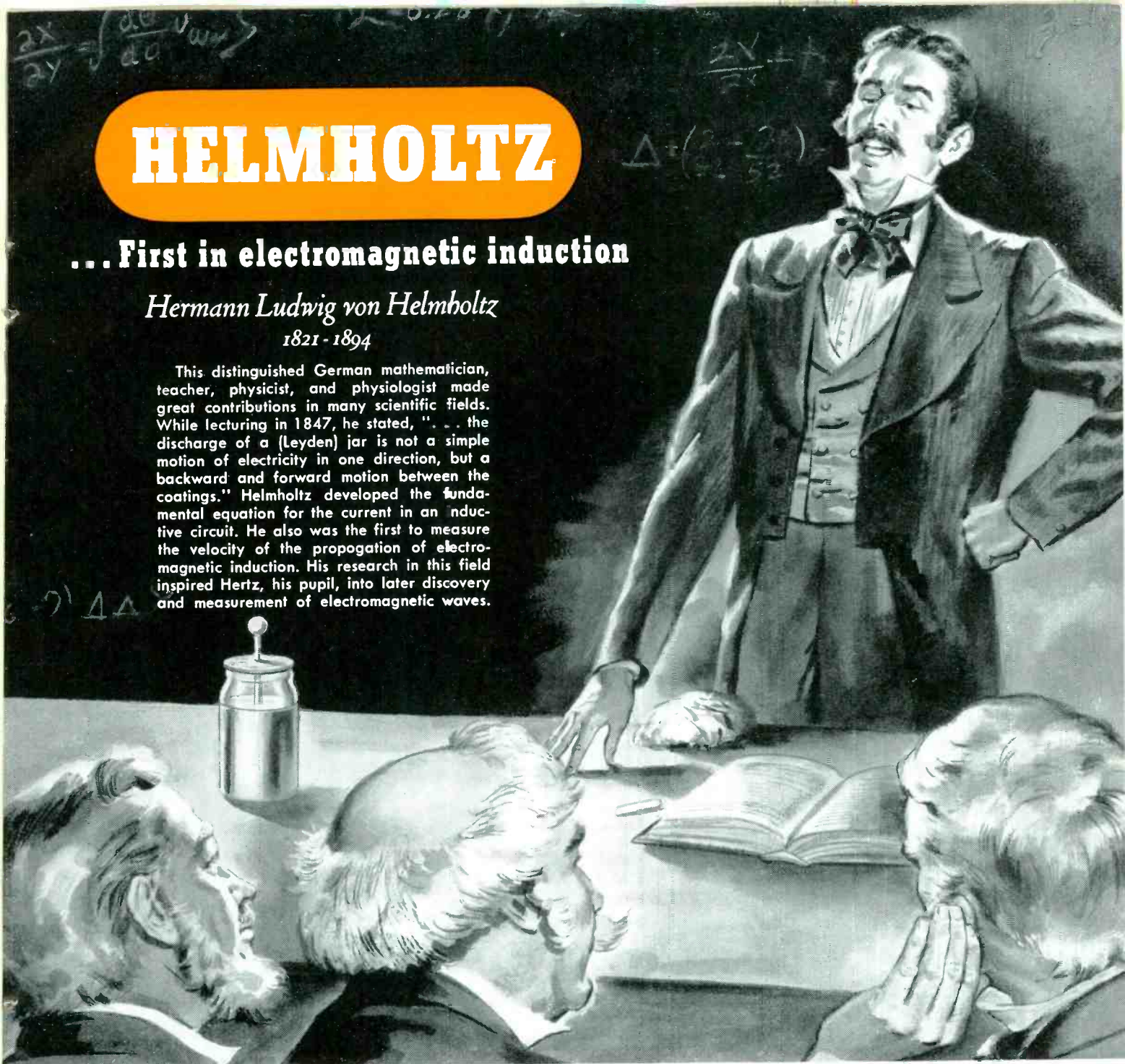

From an original drawing made for OHMITE.

OHMITE®

FIRST in resistors

...today



Be Right with OHMITE

RHEOSTATS • RESISTORS • TAP SWITCHES

More manufacturers have standardized on Ohmite wire-wound resistors than on any other make. These preferred resistors have a world-wide reputation for *dependability* . . . the ability to give unflinching performance under adverse operating conditions. Furthermore, the Ohmite resistor line is the most extensive available. Investigate these fine units for your product.

OHMITE® Wire-Wound RESISTORS

Built FOR LONG LIFE
AND DEPENDABLE
OPERATION

VITREOUS ENAMEL COVERING



Acts as both heat conductor and electrical insulator. Holds the winding rigidly in place, and protects it against mechanical damage, moisture, and fumes.

EVEN, UNIFORM WINDING

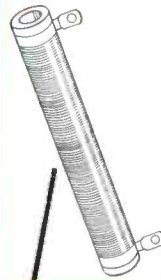

The unsurpassed uniformity of the resistance winding prevents "hot spots" and resultant failures. This uniformity is permanent — locked in by vitreous enamel.

TINNED TERMINALS

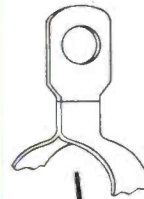

Terminal lugs are tinned for ease in soldering to connecting wires. Resistance wire is welded or brazed to the lug, assuring perfect electrical connection.

STRONG CERAMIC CORE



The high-strength ceramic tube provides a sturdy insulating base for the resistance winding. It is unaffected by cold, heat, fumes, or high humidity.

RESILIENT MOUNTING BRACKETS

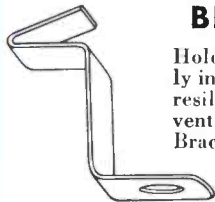

Hold resistor firmly in place, yet have resilience to prevent shock damage. Brackets are simple to attach; can be easily removed by a slight upward pressure at the base.

OHMITE MANUFACTURING CO.
4816 Flournoy Street, Chicago 44, Ill.



Write on Company
Letterhead for
Complete Catalog.

Be Right with

OHMITE®

RHEOSTATS • RESISTORS • TAP SWITCHES

One-thousand miles of Y3 Grid Wire

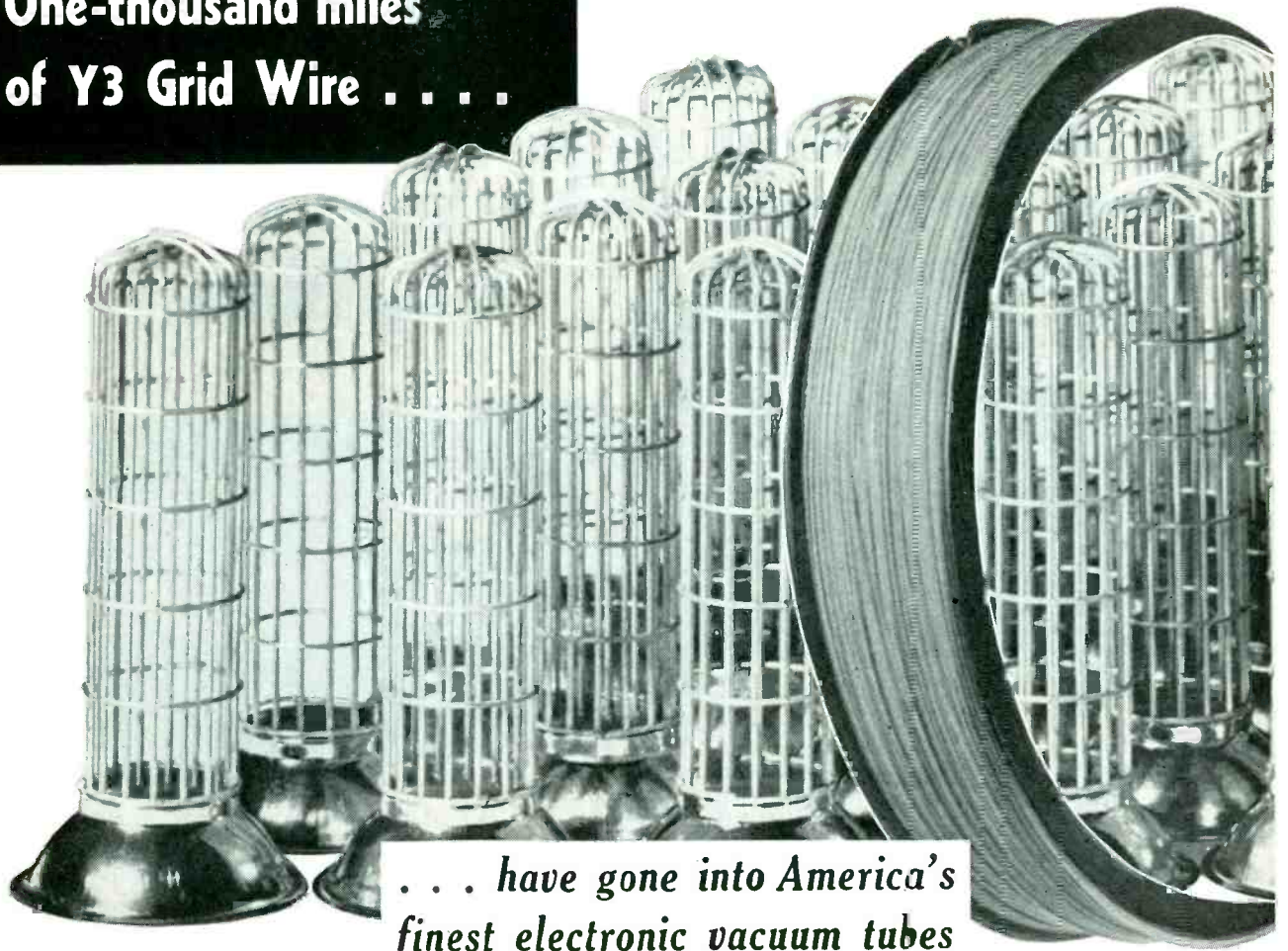

*. . . have gone into America's
finest electronic vacuum tubes*

- ***Withstands high temperatures***
- ***Adaptable to hand or machine winding***
- ***No substantial primary emission***

Outstanding performances by many, many thousands of electronic vacuum tubes utilizing Y3 grid wire have followed years of research by Eimac engineers. Uniquely treated Y3 grid wire suppresses primary emission by nullifying thorium contamination. It maintains rigidity at high temperatures—has a ductility that makes it adaptable for hand or machine winding and is ideal for spot-welding techniques. Eimac's Y3 is superior to molybdenum or tantalum grids operated in similar tubes and conditions. Intended for use with thoriated tungsten filaments, Y3 has long life and no substantial primary emission up to 1300° centigrade brightness temperature. Type Y3 grid wire is produced by Eimac and is available in quantity lots of 100, 500, 1000, 5000 and 10,000 meters.

**Write our application engineering
department for further information**

EITEL-McCULLOUGH, INC.
SAN BRUNO, CALIFORNIA

Export Agents: Frazer & Hansen, 301 Clay St., San Francisco, California

Follow the leaders to

Eimac
TUBES

For low-level d-c measurements use these new, L&N triple-purpose Amplifiers

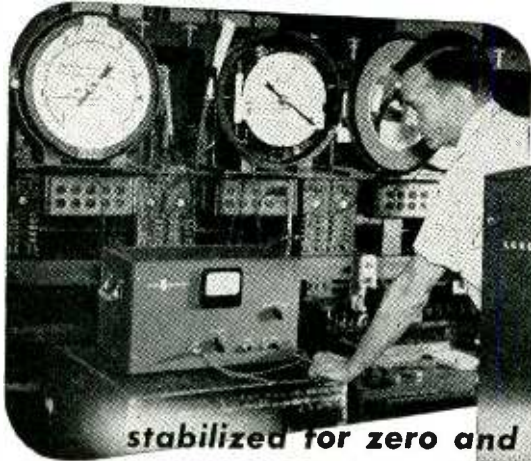

High precision checking and calibrating under factory conditions using D-C Indicating Amplifier as null detector for accurate bridge and potentiometer circuits. Through combination of a-c amplification and balanced feedback network, zero and gain stability are designed right into instrument. Trimmer controls are eliminated.



can be used as . . .

- ✓ DIRECT-READING MICROVOLT METER OR MICRO-MICROAMMETER
- ✓ RECORDER PREAMPLIFIER
- ✓ NULL DETECTOR

THESE new D-C Indicating Amplifiers are the answer for all your low-level measurements with thermocouples, strain gages, bolometers—bridge and potentiometer circuits—ionization, leakage, and phototube currents—almost any measurement of extremely small direct current or voltage.

Actually 3 instruments in 1, Amplifiers can be used as:

✓ Direct-reading instruments—Scale multiplier knob lets you select the range in which you want to work.

✓ Recorder preamplifiers—with broad flexibility. One or two degrees temperature difference can be spread right across a 10" Speedomax recorder chart.

✓ Null detectors—more sensitive than most reflecting galvanometers, yet with full scale response time of only 2 to 3 seconds. Leveling is unnecessary; the instrument is not affected by vibration. At the turn of a range knob, you have available a wide choice of sensitivities. And when using non-linear response, not only does the instrument stay on scale at extreme unbalance; sensitivity increases automatically as the null point is approached.

For details, send for Folder EM9-51(1). Write our nearest office, or 4979 Stenton Ave., Phila. 44, Pa.

SPECIFICATIONS	
MICROVOLT UNIT No. 9835	MICRO-MICRO-AMPERE UNIT No. 9836
FULL SCALE RANGES WITH BUILT-IN 4" METERS 0 to 50 or -25 to +25 Microvolts; scale multipliers: 1, 2, 4, 10, 20, 40	0 to 1000 or -500 to +500 Micro - Microamps; scale multipliers: 1, 2, 5, 10, 20, 50, 100, 200, 500, 1000, 2000
ACCURACY	
Of amplifier: $\pm 0.4\%$ of reading; Of meter: $\pm 1\%$	Of amplifier: ± 0.5 to 0.8% * of reading; Of meter: $\pm 1\%$
ZERO OFFSET	
Max. offset: ± 0.5 Microvolt	Max. offset: $\pm 2\%$ of scale
*SOURCE RESISTANCE	
Up to 10,000 ohms.	0.1 megohm or more.
REPOSE TIME	
2 to 3* sec.	2 to 3* sec.
OUTPUT	
For full scale input on any range: 10 millivolts at output impedance of 500 ohms for null recorder, 1 volt for 20,000-ohm external meter.	
Front panel fits standard 19" relay rack.	
*Accuracy and Response Time depend on Source Resistance.	

Jrl. Ad EM9-51(2)

MEASURING INSTRUMENTS TELEMETERS AUTOMATIC CONTROL HEAT-TREATING FURNACES
LEEDS & NORTHRUP CO.

When **SPECIFICATIONS** call for
STANDARD CASES & COVERS

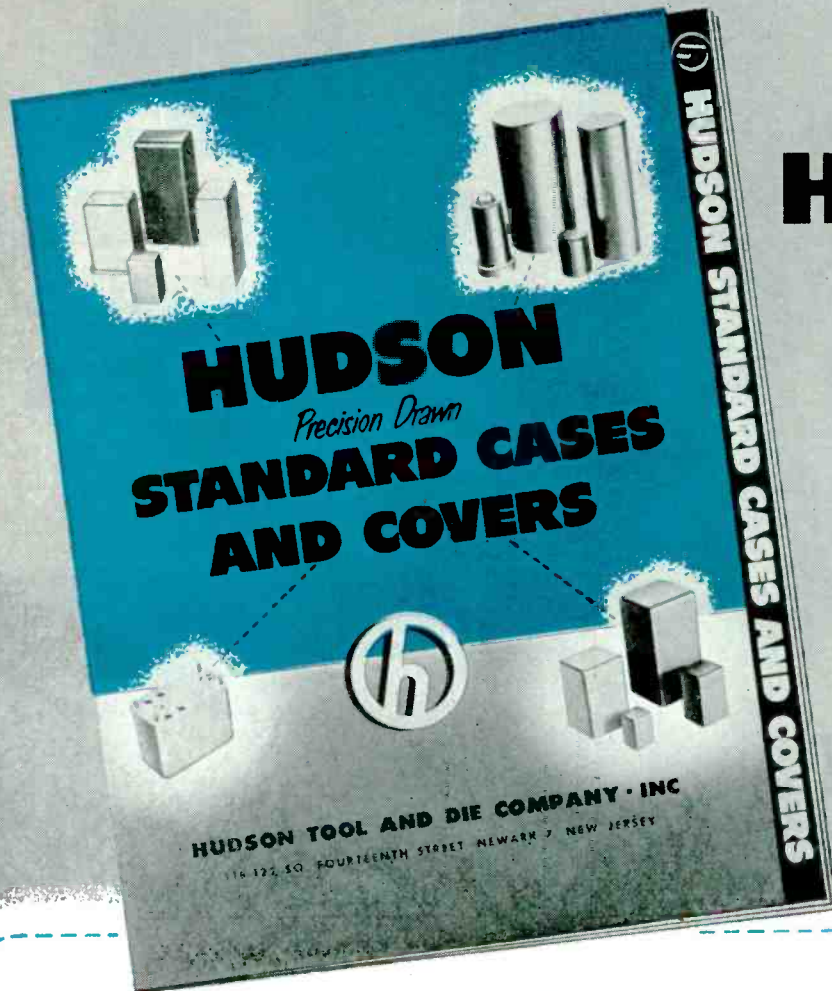

—consult the new

**HUDSON
DATA
FILE!**

—including

- STANDARD DRAWN CASES & COVERS
- SPECIAL METAL STAMPINGS
- SPECIAL COVER & CAN ASSEMBLIES

—the complete guide to precision metal parts

The new Hudson Handbook contains full engineering data and specifications on hundreds of standard cases and covers. All are craftsmen-made to provide a quick, economical solution to component problems. Keep a copy of the Handbook on file in your engineering and purchasing departments. Request yours now!

—plan your production around Hudson

All drawn cases and covers in the new Hudson Data File are standard and orders are filled promptly from regular factory stocks. Quality metal stampings are precision made to your exact specifications. For complete information on standard components, consult the Hudson Data File—for specification metal stampings, call or write Hudson for prompt service! Address inquiries to Desk 210.



HUDSON TOOL AND DIE COMPANY · INC

118-122 SO. FOURTEENTH STREET, NEWARK 7, NEW JERSEY

MINUTE
IN SIZE...
GIANTS
IN PERFORMANCE!

MYCALEX 410

8-PIN SUB-MINIATURE TUBE SOCKETS

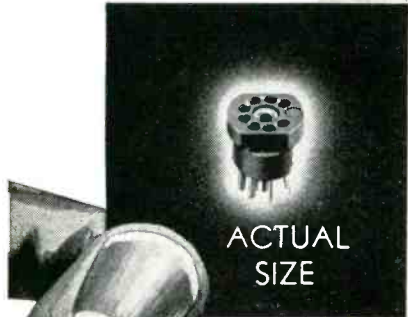
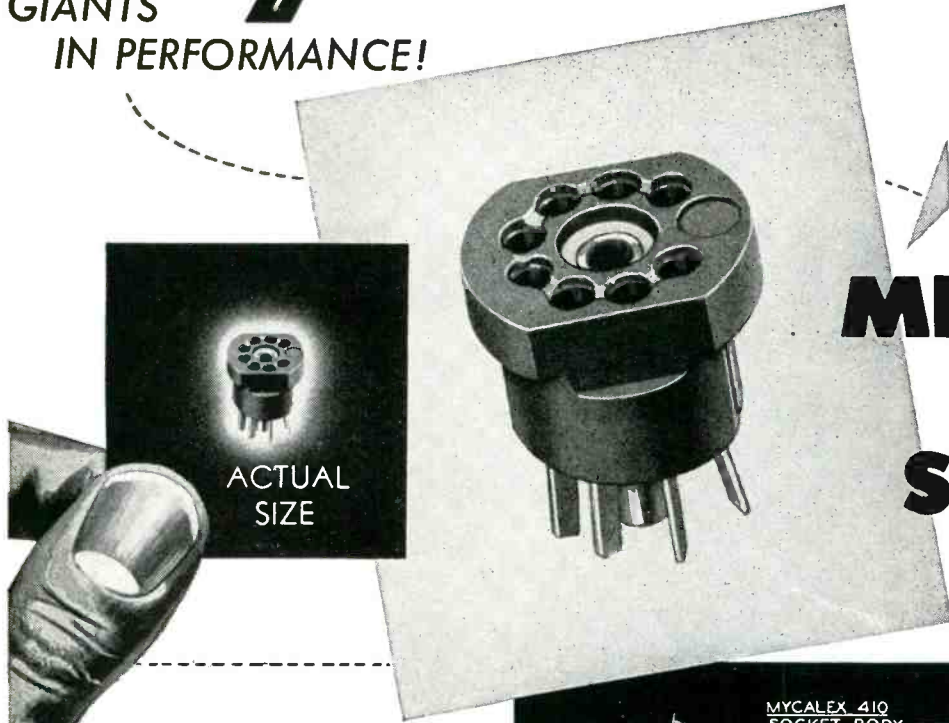

TOP
VIEW



BOTTOM
VIEW

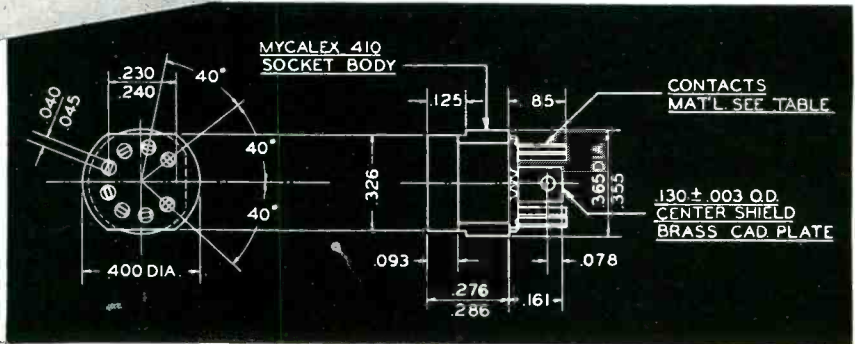

- LOW LOSS FACTOR OF .015 at 1 MC.
- INSULATION RESISTANCE (min.) 50,000 Megohms
- ARC RESISTANCE, ASTM SECS. 250+
- OPERATING TEMPERATURE 135°C (limitation due to contact metal)
- Q-value at 40°C—50% RH—not less than 1000
- Q-value at 40°C—90% RH min.—not less than 333

WRITE FOR DATA SHEETS

Mycalex 8-Pin Sub-Miniature Tube Sockets are fully described in the new Data Sheets. Other catalogs are available on Mycalex Insulation for every electronic or electrical application.

New MYCALEX 410 Sub-Miniature Tube Sockets are designed for use in electronic and electrical equipment where space is at a premium. Because they are extremely compact, these sockets offer a ready solution to numerous design problems involving spatial limitations. Installation is simple, mounting being accomplished without screws or rivets in shaped chassis holes.

Improved electrical performance and greater mechanical protection for the tube than are available with ordinary insulating materials are afforded by this socket through the use of MYCALEX 410 glass-bonded mica. MYCALEX 410 is rated Grade L-4B insulation under N.M.E.S. JAN-I-10. It offers superior electrical and mechanical properties in combination with practical cost per unit.

MYCALEX TUBE SOCKET CORPORATION

Under Exclusive License of
MYCALEX CORPORATION OF AMERICA
30 ROCKEFELLER PLAZA, NEW YORK 20, N. Y.



MYCALEX CORPORATION OF AMERICA

Owners of 'MYCALEX' Patents and Trade-Marks

Executive Offices: 30 ROCKEFELLER PLAZA, NEW YORK 20 — Plant & General Offices: CLIFTON, N. J.

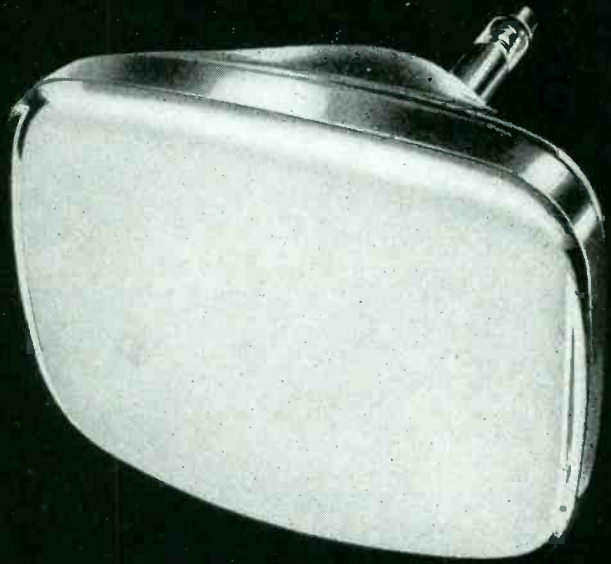

THERE'S ALWAYS ONE LEADER...

DU MONT

*Fine receivers can be
made finer through the use of Du Mont Teletrons.*
Available in all popular screen sizes.*

Cathode-ray Tube Division, Allen B. Du Mont Laboratories, Inc., Clifton, N. J.

*trade mark

C D

onsistently
ependable

CORNELL-DUBILIER CAPACITORS

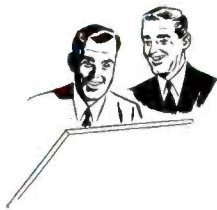
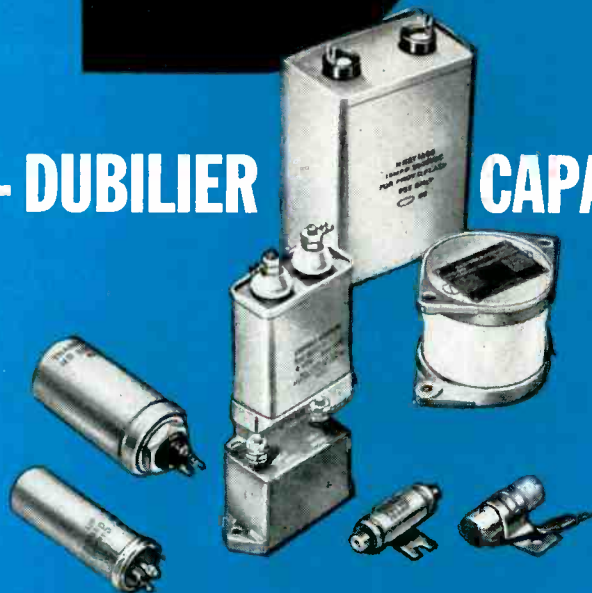

"Let's take this capacitor problem to C-D" About 3 times out of 4, we find that a capacitor problem submitted to us has come up before, and the solution is ready and waiting.

Coincidence? No, just that C-D is usually called on to tackle the capacitor problems of other companies engaged in the same type of work as your own.

If your problem is new or old, our engineers will be glad to collaborate with you. Dept. K-72, Cornell-Dubilier Electric Corporation, South Plainfield, New Jersey.

CORNELL-DUBILIER

world's largest manufacturers of capacitors



SUBSIDIARY



CAPACITORS



VIBRATORS

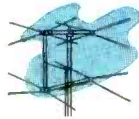

ANTENNAS



CONVERTERS



ROTATORS

SOUTH PLAINFIELD, N. J. • NEW BEDFORD, WORCESTER AND CAMBRIDGE, MASS. • PROVIDENCE, R. I. • INDIANAPOLIS, IND. • FUQUAY SPRINGS, N. C. • SUBSIDIARY, THE RADIART CORP., CLEVELAND, O.

Noise Suppression?



Engineers think of **FILTRON** for RF Noise Suppression!

FILTRON engineers haven't licked Barber Interference Suppression, yet, but we can solve all your problems of RF Interference Suppression on electronic equipment.

FILTRON will *custom design* the filter for your circuit conditions to meet size, weight and overall configuration—and meet military RF Inter-

ference Suppression limits and specifications.

FILTRON's advanced engineering, due to constant research and development, together with FILTRON's production know-how, insures quality components to meet your delivery requirements. Your inquiries are invited.

RF INTERFERENCE SUPPRESSION FILTERS FOR:

Motors	Dynamotors
Generators	Power Plants
Inverters	Actuators
Electronic Controls	Gasoline Engines
And other RF Interference producing equipment	

filtered by **FILTRON**

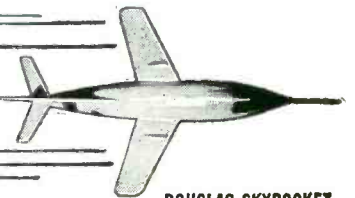

DOUGLAS SKYROCKET

Send for our LATEST CATALOG on your company letterhead

THE FILTRON CO., INC.
FLUSHING, LONG ISLAND, NEW YORK

LARGEST EXCLUSIVE MANUFACTURERS OF RF INTERFERENCE FILTERS



*Which part
interests
YOU?...*

Perhaps that's one question that rightfully belongs with your future planning.

For, like ourselves, your manufacturing divisions may be toiling night and day in the interests of America's safety.

But to research scientists—seeking the solution to some intricate problem of instrumentation and control—Kollsman offers an experienced hand. A reputation based on inventive ingenuity, precision craftsmanship and world-over acceptance of its products.

In manufacture or research, there is no finer name than Kollsman—designers, developers and makers of:

- Aircraft Instruments and Controls
- Miniature AC Motors for Indicating and Remote Control Applications • • • Optical Parts and Optical Devices
- Radio Communications and Navigation Equipment



KOLLSMAN INSTRUMENT CORPORATION

ELMHURST, NEW YORK

GLENDALE, CALIFORNIA

SUBSIDIARY OF
Standard COIL PRODUCTS CO. INC.

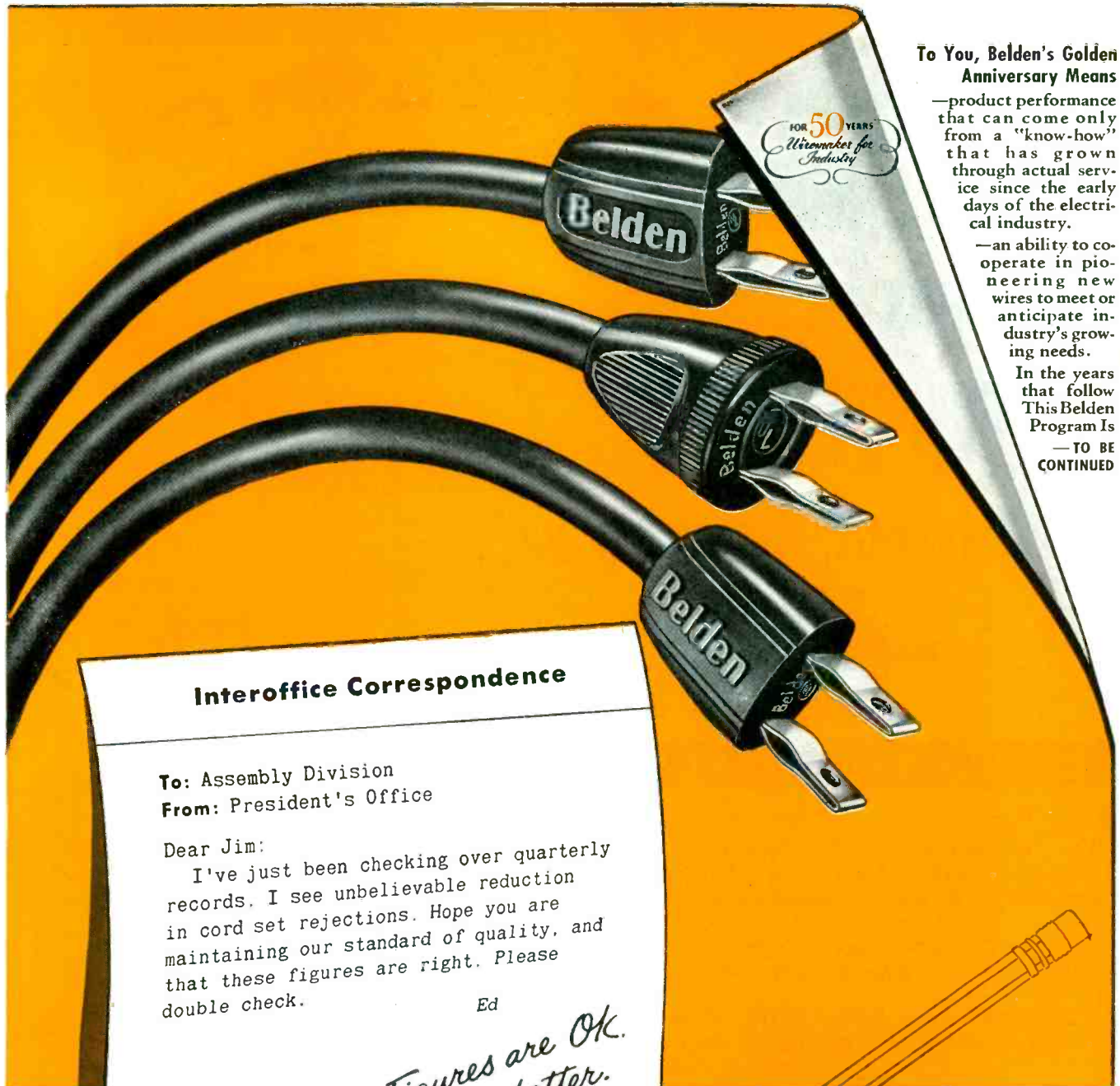

To You, Belden's Golden Anniversary Means

—product performance that can come only from a "know-how" that has grown through actual service since the early days of the electrical industry.

—an ability to cooperate in pioneering new wires to meet or anticipate industry's growing needs.

In the years that follow This Belden Program Is

—TO BE CONTINUED

FOR 50 YEARS
Wiremaker for Industry

Interoffice Correspondence

To: Assembly Division
From: President's Office

Dear Jim:

I've just been checking over quarterly records. I see unbelievable reduction in cord set rejections. Hope you are maintaining our standard of quality, and that these figures are right. Please double check.

Ed

*Dear Ed- Figures are Ok.
Quality is actually better.
Answer simple - we
changed to Belden Cords.
Jim*

1. Low Installation Cost
2. Low Inspection Cost
3. Fewer Rejects
4. Less Returned Goods
5. Less Failures in Service
6. Satisfied Customers

WRITE: Belden Manufacturing Co.
4625 West Van Buren Street
Chicago 44, Illinois

CORDITIS-FREE CORDS BY...

Belden WIREMAKER FOR INDUSTRY

Because
product leadership
depends on
component quality

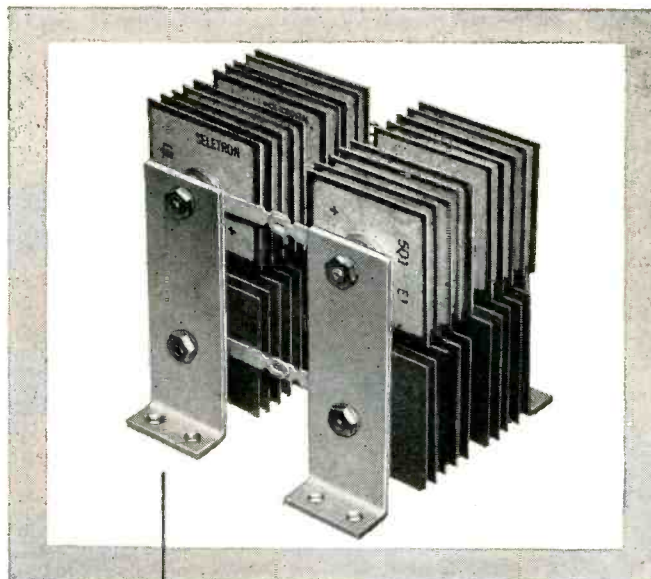

Tektronix, Inc. relies on...



SELENIUM RECTIFIERS

The Tektronix Cathode-Ray Oscilloscope, recognized leader in its field, is a high precision instrument and light in weight because of essential mobility. Since it is urgent that sweep rates and deflection sensitivities remain constant in spite of line voltage variations, all critical voltages are electronically controlled.

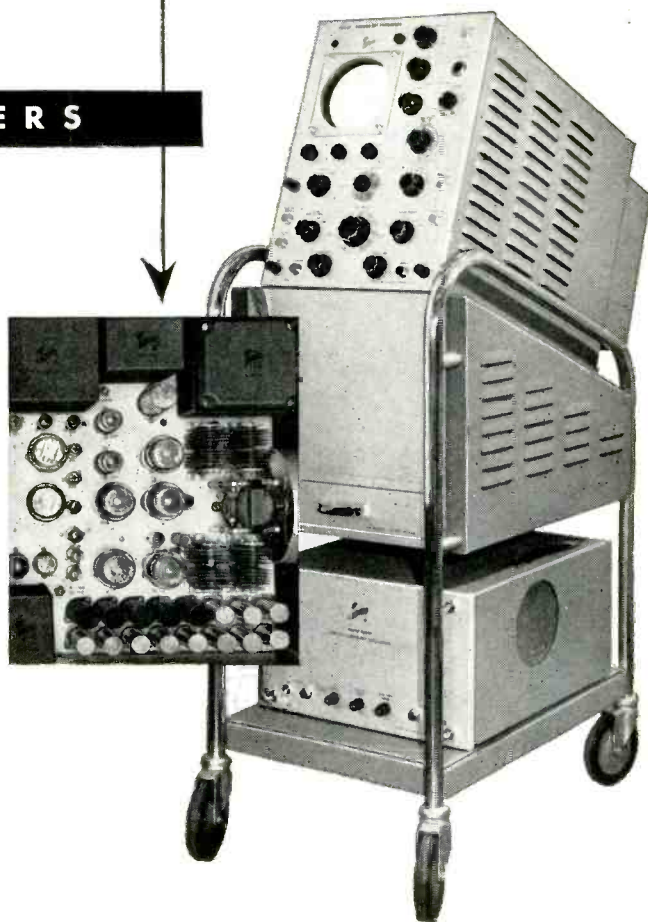

Specified for the power supply, of course, are SELETRON Selenium Rectifiers to help maintain Tektronix standards. In the type 517 Oscilloscope, SELETRON 5Q1 rectifiers are combined to furnish 750 milliamps at 150 volts and 500 milliamps at 225 volts. Their ruggedness and dependability aid materially in maintaining the stability of this wide band high voltage instrument.

Versatile SELETRON Selenium Rectifiers are available in a complete range of sizes for every electronic circuit—from a few mils up to thousands of amps. Whatever your problem in rectification—whether in radio, communications or for heavy industrial use, count on our engineers to be of real assistance. Your correspondence is invited . . . Remember, product quality depends on *component* quality!



**Seletron
and Germanium
Division**

RADIO RECEPTOR COMPANY, INC.

 Since 1922 in Radio and Electronics 
Sales Dept.: 251 W. 19th St., New York 11, N. Y. • Factory: 84 N. 9th St., Brooklyn 11, N. Y.

Bottle Neck Buster!

...KARP

"Accurated" Fabrication OF SHEET METAL CABINETS, HOUSINGS, CHASSIS, ENCLOSURES

Production is rolling and costs stay down in hundreds of plants, thanks to KARP "Accurated" Fabrication. Here is insurance that every dimension is accurate... every hole drilled clean, correctly sized and positioned... openings accurately spaced... all units uniform, and finish perfect.

That adds up to smooth, fast assembly that ends lost motion and builds volume output!

Why not let Karp Design Engineers study your assembly requirements for a fabricated sheet metal unit? Whether it's a liberal or close-tolerance job—whether it calls for simple or intricate forming, drawing, bending, welding, finishing, or all combined... "Accurated" Fabrication the Karp way means real insurance of assembly ease, speed, and economy. Send us your blueprints.

**Jobs are rated for required tolerances—liberal or close—with quality maintained at its best.*

See us at the
WESTERN ELECTRONIC SHOW
AND CONVENTION, Booth 423
August 27th, 28th and 29th
Long Beach, Calif.



KARP METAL PRODUCTS CO., INC.

215 63rd STREET, BROOKLYN 20, NEW YORK

Specialists in Fabricating Sheet Metal for Industry

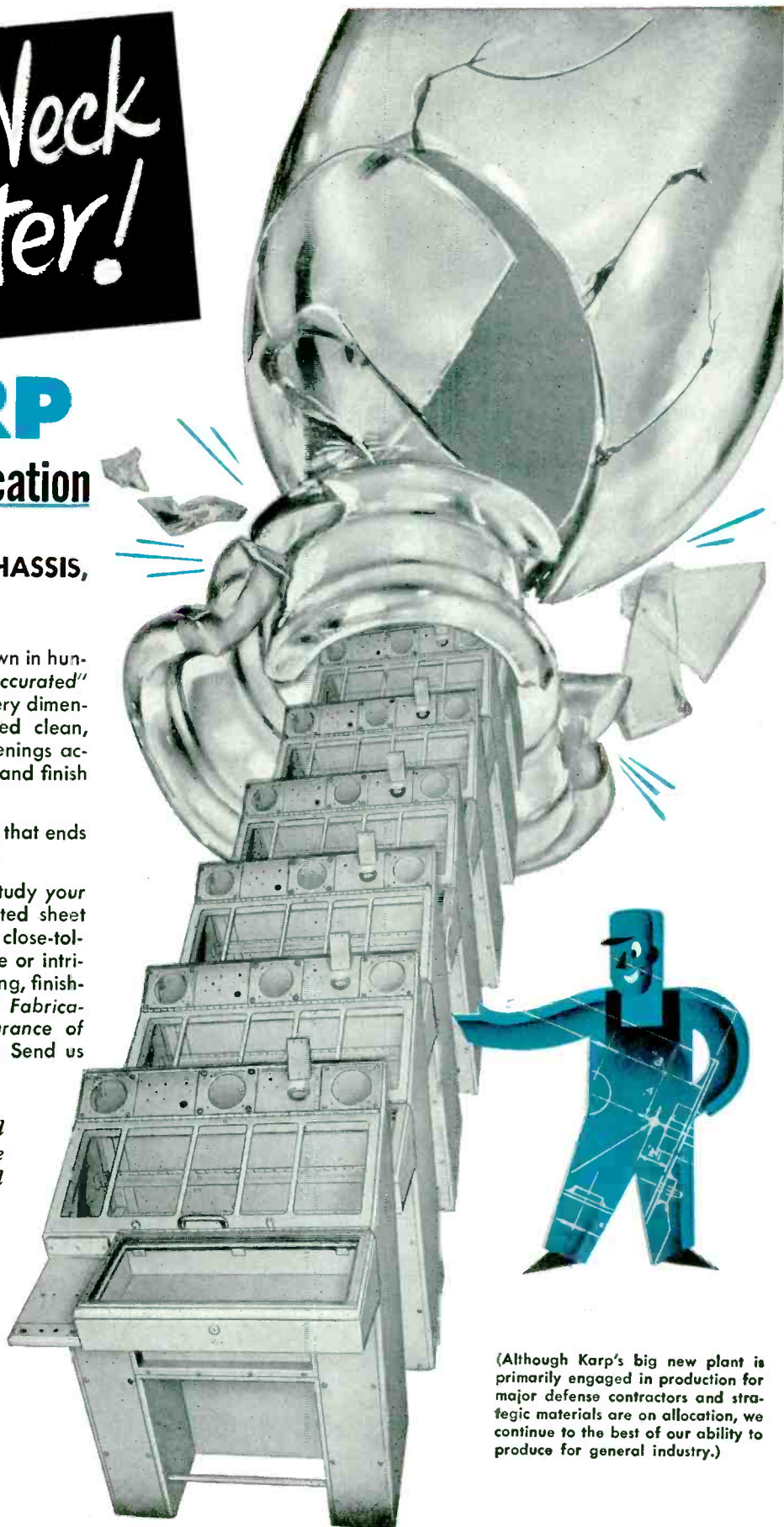

(Although Karp's big new plant is primarily engaged in production for major defense contractors and strategic materials are on allocation, we continue to the best of our ability to produce for general industry.)

SCINFLEX ASSURES YOU PEAK PROTECTION AGAINST CIRCUIT FAILURE

When operating conditions demand an electrical connector that will stand up under the most rugged requirements, always choose Bendix Scinflex Electrical Connectors. The insert material, an exclusive Bendix development, is one of our contributions to the electrical connector industry. The dielectric strength remains well above requirements within the temperature range of -67°F to $+275^{\circ}\text{F}$. It makes possible a design increasing resistance to flashover and creepage. It withstands maximum conditions of current and voltage without breakdown. But that is only part of the story. It's also the reason why they are vibration-proof and moisture-proof. So, naturally, it pays to specify Bendix Scinflex Connectors and get this extra protection. Our sales department will be glad to furnish complete information on request.

- Moisture-Proof • Radio Quiet • Single Piece Inserts •
- Vibration-Proof • Light Weight • High Insulation Resistance
- High Resistance to Fuels and Oils • Fungus Resistant •
- Easy Assembly and Disassembly • Fewer Parts than
- any other Connector • No additional solder required.

The Finest
**ELECTRICAL
CONNECTOR**
MONEY CAN
BUY!

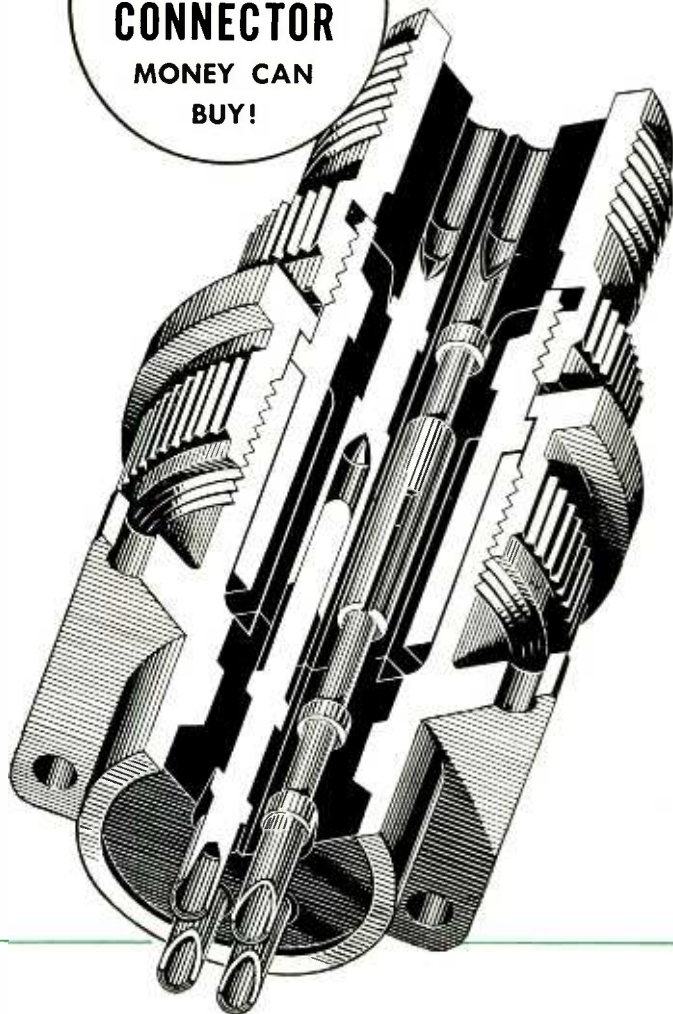

BENDIX SCINFLEX

**ELECTRICAL
CONNECTORS**



SCINTILLA MAGNETO DIVISION of
SIDNEY, NEW YORK



Export Sales: Bendix International Division, 72 Fifth Avenue, New York 11, N. Y.

FACTORY BRANCH OFFICES: 118 E. Providencia Ave., Burbank, Calif. • Stephenson Bldg., 6560 Cass Ave., Detroit 2, Michigan • Brauer Bldg., 176 W. Wisconsin Avenue, Milwaukee, Wisconsin • 582 Market Street, San Francisco 4, California

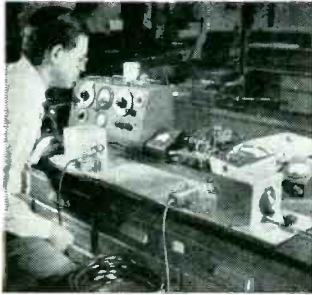

LABORATORIES: Experimental and development work requires extremely close voltage control for accurate and dependable results.



MANUFACTURING: To achieve maximum rated performance of electrically powered equipment, the input nameplate voltage must be maintained.



TESTING: Constant voltage must be maintained when testing or inspecting your product to obtain a valid check.



MAINTENANCE: By maintaining constant voltage to lamp loads and electrically operated equipment, productive life is increased and maintenance costs reduced.

ELECTRICAL OPERATIONS IN *Your Plant* REQUIRE

STABILINE

Automatic

VOLTAGE REGULATORS



TYPE EM4115

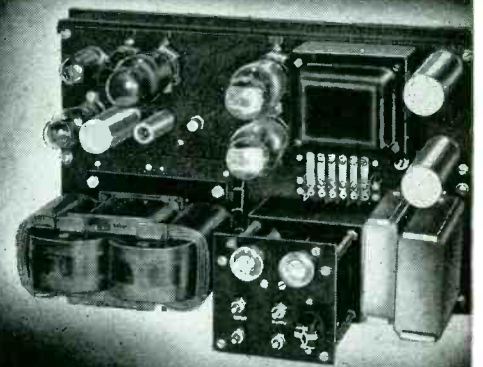

TYPE IE5101R

THERE IS NO BETTER WAY TO MAINTAIN CONSTANT OUTPUT VOLTAGE *Automatically*

TYPE

IE

INSTANTANEOUS ELECTRONIC

Completely electronic automatic voltage regulators with no moving parts. Offer instantaneous correction . . . excellent stabilization and regulation. Waveform distortion does not exceed 3%. Particularly adapted for use in laboratories . . . test lines and for all other applications where the most exacting voltage regulation is necessary.

TYPE

EM

ELECTRO MECHANICAL

Consists basically of a very sensitive detector controlling a motor-driven POWERSTAT variable transformer and auxiliary transformer. Correction is not instantaneous but is faster than most automatic voltage regulators. Features zero waveform distortion and high efficiency. Ideally suited for controlling large industrial loads.

FOR YOUR ELECTRICAL OPERATIONS . . .

. . . there is a STABILINE Automatic Voltage Regulator right for the job . . . to maintain constant voltage regardless of line or load changes. Send today for complete information.

WRITE TO — 207 THURE AVENUE, BRISTOL, CONNECTICUT
ASK FOR — SECO BULLETIN S351



THE SUPERIOR ELECTRIC CO.
BRISTOL, CONNECTICUT



- STABILINE AUTOMATIC VOLTAGE REGULATORS
- POWERSTAT VARIABLE TRANSFORMERS
- VARICELL D-C POWER SUPPLIES
- VOLTBOX A-C POWER SUPPLIES
- SUPERIOR 5-WAY BINDING POSTS
- POWERSTAT LIGHT DIMMING EQUIPMENT

PRECISION RESISTORS... FOR PRECISION ELECTRONICS



MEPCO

- Precision Wire Wound Resistors:
JAN-R-93, and Commercial
- External Meter Multiplier Resistors:
JAN-R-29
- Pre-Wired Resistor Switch Assemblies
- Other Types to Your Specifications

MEPCO, INC., MORRISTOWN, NEW JERSEY

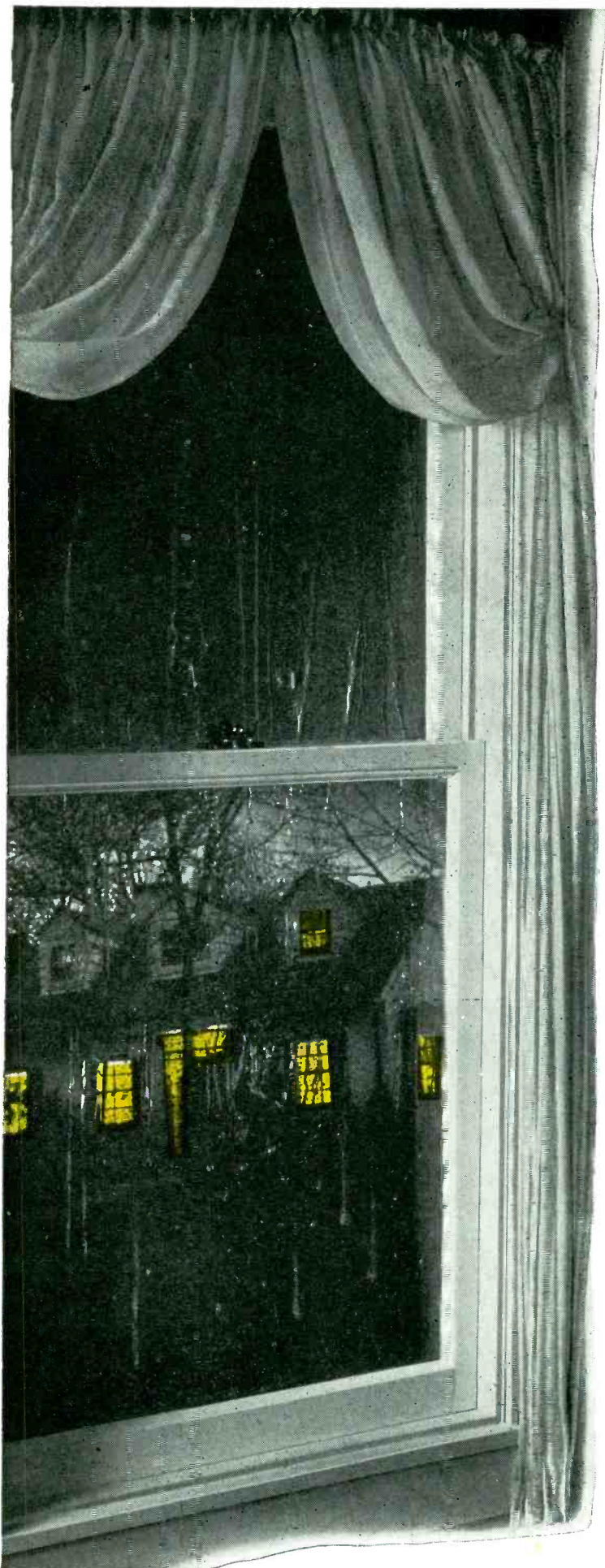

Gloom chaser . . . that works



Fair weather or foul, when you flip a light switch you *expect* light. You take it for granted. Actually, like a touchdown in football, the result is the triumph of teamwork in electrical apparatus.

The power company is the captain. The players include the manufacturers of generators, transformers, switch gear, and electrical fixtures. But an *unseen essential* called *Synthane* is present, too.

Synthane is a laminated plastic. It is an excellent electrical insulator. It is also a mechanical material that combines light weight and strength, a chemical-resistant material that machines easily.

Send for the complete Synthane Catalog. Then, if you find Synthane a material you can use, we will be glad to help you with design, sheets, rods, tubes or fabricated parts. Synthane Corporation, 6 River Road, Oaks, Pennsylvania.



Insulator (left) made from Grade X Black Synthane for Square D Company and switch mounting plate made for Cutler-Hammer Inc. of Grade GLCC-M Synthane. Both parts require good electrical characteristics.

Synthane—one of industry's unseen essentials

SYNTHANE

S

LAMINATED PLASTICS

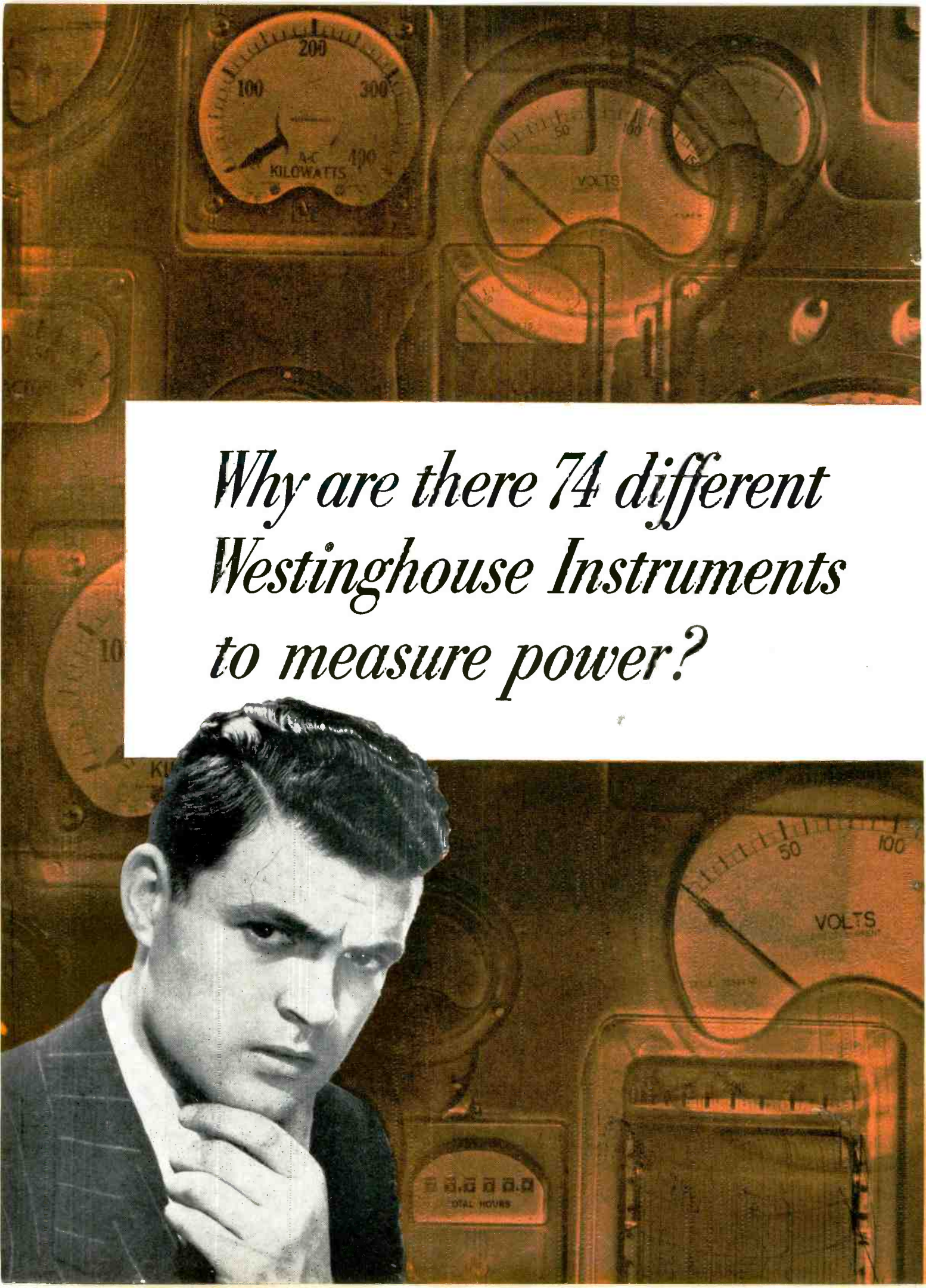
A black and white photograph of a man in a suit, looking thoughtful with his hand on his chin. He is positioned in the lower-left foreground. The background is a dimly lit control room filled with various electrical instruments and gauges. A prominent gauge in the upper left shows 'AC KILOWATTS' with a scale from 0 to 300. Another gauge to its right shows 'VOLTS' with a scale from 0 to 100. Below the man, a panel is labeled 'TOTAL HOURS'. The overall atmosphere is industrial and technical.

*Why are there 74 different
Westinghouse Instruments
to measure power?*

If you produce a product

The wider choice you get in Westinghouse Instruments offers you new opportunities to improve your product's performance, appearance, salability. Whether you want to measure amperes, volts, watts, vars, power factor, frequency or synchronism, there's a Westinghouse Instrument to meet the precise requirements of your customers. And the performance of *all* Westinghouse Instruments meet ASA Standards.

pilot a plant

If your job is supervision of production or plant operation, getting just the *right* instrument can help you gain closer control of a process or more efficient operation of plant facilities. Moreover, Westinghouse offers you competent application assistance to help you employ instruments most effectively.

or probe the unknown

If your job is research, this complete line of instruments serves all your needs for the measurement of electrical values. The diversity of types, for any given measurement, includes many variations in size, types or mounting, types of scale, range, accuracy and styling, as well as instruments to measure position, time, temperature and speed.

you gain benefits like this:

Take the case of a leading electronic equipment manufacturer. They needed to equip tube test stations with a variety of instruments having co-ordinated styling for best appearance; small enough to permit close grouping and accurate enough to serve as "standards". Standard Westinghouse Instruments answered every requirement! Next time *you* need instruments to improve a product, perfect a process or probe a problem . . . specify Westinghouse!

J-40419

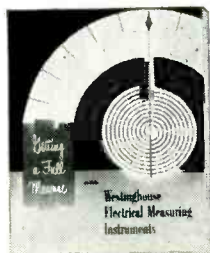

For complete information about Westinghouse Instruments, write for Booklet B-4696. Address: Westinghouse Electric Corporation P. O. Box 868, Pittsburgh 30, Pennsylvania.

YOU CAN BE SURE... IF IT'S
Westinghouse

INSTRUMENTS



RCA VICTOR Television

CHOOSES

INSUROK®

T-725 INSULATING LAMINATE

The RCA Victor name is a symbol for the highest quality in electronic equipment. To meet their exacting standards, RCA Victor engineers selected INSUROK Grade T-725 phenolic laminate for their television receivers.

INSUROK T-725 provides RCA Victor with a unique combination of electrical properties. It is used in the R.F. tuners, to maintain insulation resistance under high temperatures and humidities . . . in the I.F. tube sockets, to minimize capacity changes with changes in humidity . . . and in the high-voltage compartment, to provide high dielectric strength and surface resistivity.

For the "tough spots" in your product, write or phone about T-725 and the many other grades of INSUROK laminated insulation.

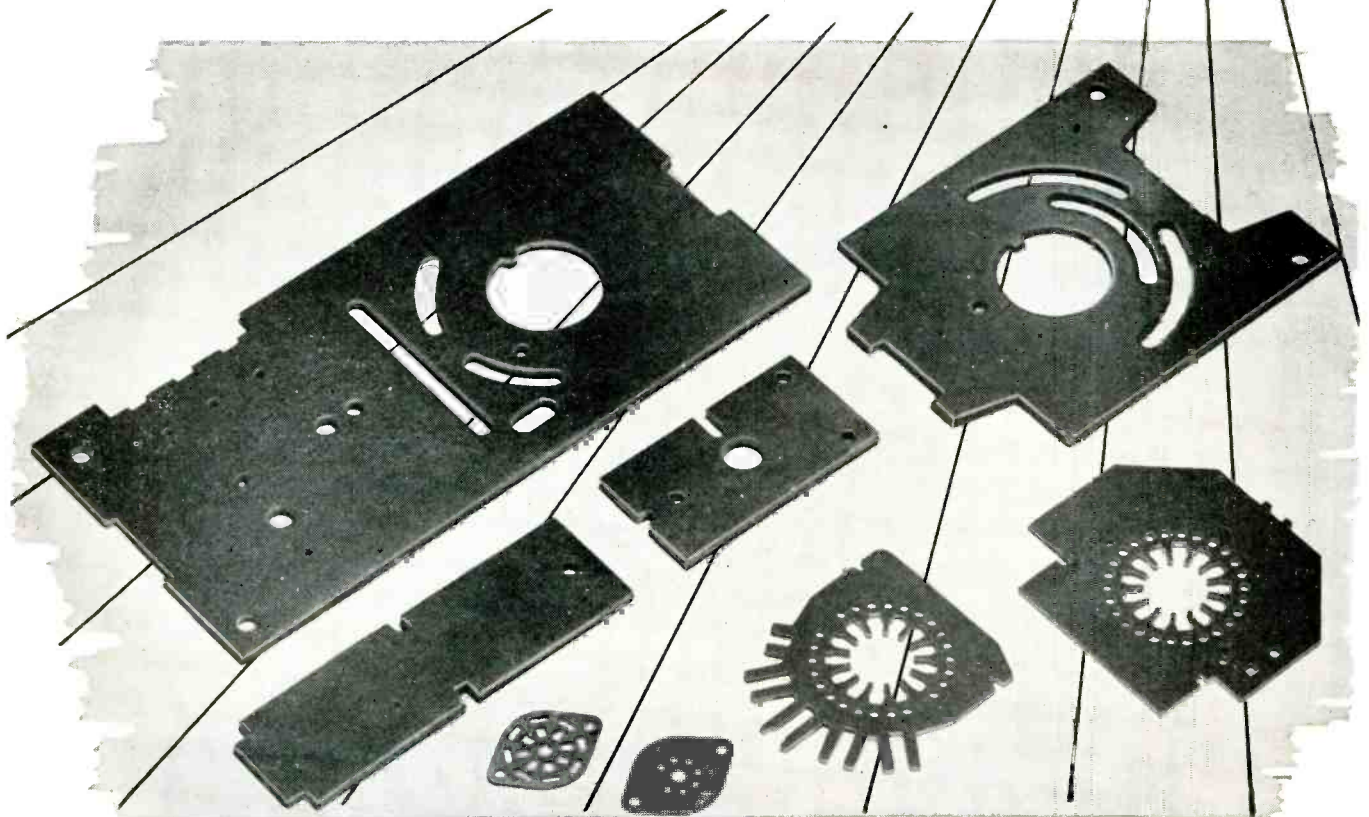
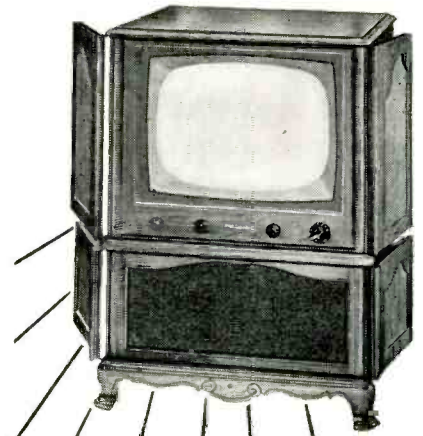

Write Today for Booklet
"LAMINATED
INSUROK"

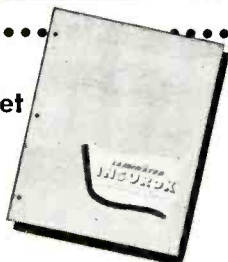

The RICHARDSON COMPANY

FOUNDED 1858—LOCKLAND, OHIO

2797 Lake St., Melrose Park, Illinois (Chicago District)

SALES OFFICES: Cleveland • Detroit • Indianapolis • Lockland, Ohio
Los Angeles • Milwaukee • New Brunswick, (N. J.) • New York • Philadelphia
Rochester • San Francisco • St. Louis



LEADER...

IN PRODUCTION FACILITIES

Delco Radio is the world's largest builder of automobile radios—the leader in production and assembly of component parts.

LEADER...

IN ENGINEERING

Delco Radio developed many of the most important advances in automobile radios . . . has outstanding experience in this field.

LEADER...

IN QUALITY

Each and every step in the manufacturing of Delco Radio products is closely supervised to maintain high, uniform product quality.

LEADER...

IN MANUFACTURING CONTROL

Completely integrated for efficient production from raw material to finished product, Delco Radio meets any customer need.

Here at Delco Radio, we are keenly aware of national defense requirements and of the necessity for further accomplishment in the field of radio. Delco Radio is even now developing and producing—on time—superior devices that meet the test of modern military needs.

You can depend on Delco Radio for on-time delivery of products with uniformly high quality.

DELCO RADIO

DIVISION OF GENERAL MOTORS
KOKOMO, INDIANA



40.109
240.65
1174.6
20000.
— OR ANY OTHER

precision

FREQUENCY

FROM 40 TO 20,000 CYCLES
CONSERVATIVE ACCURACY UNDER USUAL CONDITIONS
1 PART IN 100,000—(.001%)

Have you a need for any specific number of cycles in precision frequencies?

Can a source of such frequency solve your design problem or increase its factor of safety?

Have you a system that requires great accuracy, stability and dependability?

The frequencies shown at the top of the page are but a few among hundreds furnished for precision application in industries, laboratories and Government departments.

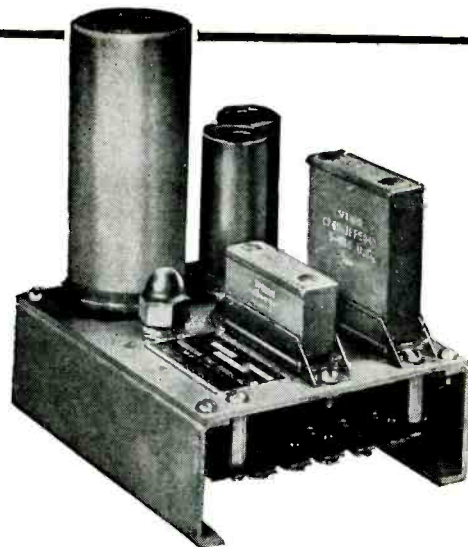

CALIBRATED AGAINST A STANDARD ACCURATE TO 1 PART IN 10-MILLION

The basic unit of this frequency standard is an electronically driven fork,—temperature compensated and hermetically sealed against changes of humidity and barometric pressure. Through its use, any frequency or multi-frequencies between 40 and 20,000, fractional or otherwise, are obtainable.

**OUR ENGINEERS
ARE AVAILABLE
TO COOPERATE
ON ANY PROBLEM**

American Time Products, Inc.

580 Fifth Avenue

New York 19, N. Y.

MANUFACTURING UNDER PATENTS OF WESTERN ELECTRIC CO.

AMERICAN LAVA CORPORATION

Spotlights **ALSIMAG[®]**

METALLIZED CERAMICS

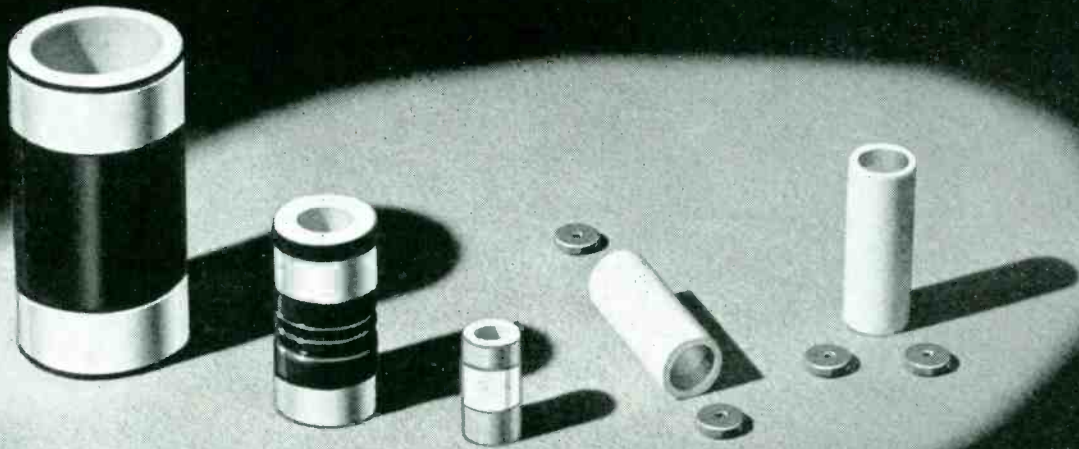

ALSIMAG METALLIZED CERAMIC CASES FOR HERMETICALLY SEALING ELECTRONIC COMPONENTS.

Where a permanently moisture proof envelope for components is required, use an Alsimag metallized ceramic case with Alsimag metallized ceramic cap.

Alsimag ceramics have high mechanical strength. The excellent bond between metal and ceramic form a lasting seal against moisture when soft soldered.

Metal-ceramic combinations provide stable performance under wide variations of temperature and humidity.



Our broad experience in working with metal-ceramic combinations is available to you at any time.

50TH YEAR OF CERAMIC LEADERSHIP

AMERICAN LAVA CORPORATION

CHATTANOOGA 5, TENNESSEE

OFFICES: METROPOLITAN AREA: 671 Broad St., Newark, N. J., Mitchell 2-8159 • PHILADELPHIA, 1649 North Broad St., Stevenson 4-2823
SOUTHWEST: John A. Green Co., 6815 Oriole Drive, Dallas 9, Dixon 9918 • NEW ENGLAND, 1374 Massachusetts Ave., Cambridge, Mass., Kirkland 7-4498
LOS ANGELES, 5603 North Huntington Drive, Capital 0901 • CHICAGO, 228 North LaSalle St., Central 6-1721 • ST. LOUIS, 1123 Washington Ave., Garfield 4959

Besto-Hire[®]

JAN-C-76 Type SRIR, Unbraided, Spiral Striped

JAN-C-76 Type SRRF, Plain or Braided

JAN-C-76 Type SRIR, Braided — Cotton, Rayon, Glass

Wire and Cable

AN-J-C-48a Braided — Cotton, Glass, Nylon Jacket

JAN-C-76 Type WL with Nylon Jacket

JAN-C-76 or AN-J-C-48a Shielded

JAN-C-76 Type SRHV, Plain or Braided

For Aviation and Electronics

Tell us the type of wire or cable you need — the chances are excellent that it is one of our regular production numbers. If it isn't already in our extensive line, we will design the wire especially for you. We have had long experience in coming up with the right answers in wire and cable for many leading manufacturers in the fields of aviation and electronics. Try us. You Specify — We Supply!

Ask us for our new complete catalog. We'll gladly send you a copy.



RHODE ISLAND INSULATED WIRE CO., Inc.

50 BURNHAM AVENUE

CRANSTON, RHODE ISLAND

National Sales Offices: 624 S. Michigan Blvd., Chicago, Ill.

BRING THROUGH EQUIPMENT FAST!

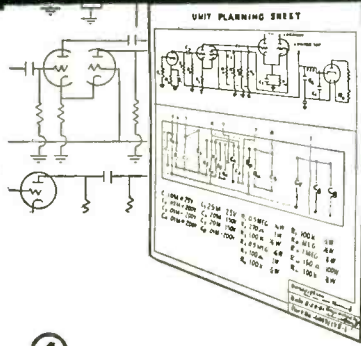

**FROM STANDARD STOCK COMPONENTS
YOU CAN SIMPLIFY DESIGN —
SPEED PRODUCTION — AND CUT
SERVICE COSTS**

① ORGANIZE CIRCUITS QUICKLY

Schematics of most electronic equipment can be broken down into circuit blocks of logically associated functions. These functional circuit blocks can be mounted readily either in the Alden "20" plug-in packages or Basic Chassis unit. Tube sockets and associated components quickly lay out on full scale Unit Planning Sheets for mounting on terminal cards. These special pre-punched, multi-hole terminal cards have wide flexibility to take an infinite variety of circuit variations. Both sides of card can be used to obtain maximum component density area. Using the Unit Planning Sheets, functional circuit units are all planned in one step.

IT'S AS SIMPLE AS THIS!

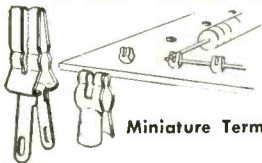

Miniature Terminals — 650 Series

Terminal cards have been designed to accommodate tremendous number of circuit variations — to make neat tube and component sub-assemblies with a minimum of wiring and simplified assembly techniques. Special Alden Miniature Terminals are new and radical punch press configuration — ratchet slot holds various size component leads for soldering — no twisting of leads with pliers. Figure "eight" shape accommodates cross wiring and buss leads. Terminals are punch press parts — so take a minimum of solder, reduce solder time, eliminate danger of cold solder joints.

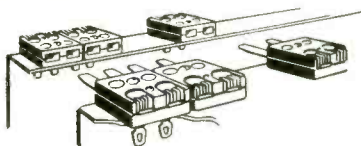

Back Connectors — 462MIN Series

Alden Terminal Card System means minimum of inter-cabling — but even this cabling can be laid out easily and proceed as simple sub-assembly. Open sided chassis construction makes cable easy to wire to front panel, terminal cards and back connectors. The Alden Back Connectors are units that can be discretely positioned on the back of the chassis — isolating lines with incompatible voltages, currents, or frequencies. This design insures accessible solder terminals for soldering — avoids rat nests of congested conventional back connector wiring. Color coded, the Alden back connectors provide beautiful operational or service check points for all leads to and from chassis.

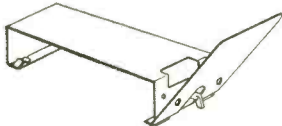

Hinged Front Panel Design

Hinged front panel design of chassis allows rheostats, indicator lights, jacks, etc. to be mounted on panel as another easy-to-work sub-assembly. This panel attaches easily to chassis — is wired — swung up and fastened with Alden Target Screws.

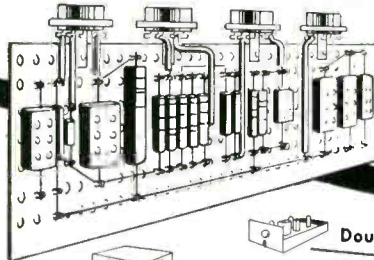

② GET EASY SUB-DIVISION OF LABOR

Solder terminals and sockets quickly rivet to Alden terminal card according to layout on Unit Planning Sheet. Components snap into the special Alden Miniature Terminals which hold them for soldering — (No twisting or wrapping of leads necessary) — With all tube sockets and their associated components mounted on one card — the wiring and soldering of circuits is an open, easy-to-work sub-assembly operation.



ALDEN BASIC CHASSIS

③ CUT SERVICE AND MAINTENANCE COSTS IN FINAL EQUIPMENT

In field, shop, or office your equipment maintenance is reduced to 30 second changeovers. Basic replacement elements are small enough in weight and size to be shipped by parcel post for repair.



Target Screws

These screws have concave head with arced notch so power screw driver locates head quickly, no danger of it slipping out and marring panel surface — yet same screw can be unfastened with coin in order to hinge forward the front panel for servicing and check in the field.

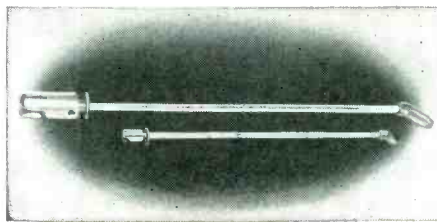

"Serve-A-Unit Lock"

Assembled — the Basic Chassis simplifies operation of equipment — Slashes service and maintenance time. Smooth, positive insertion and removal of the chassis is provided by the Alden "Serve-A-Unit Lock." A simple twist of the handle and the chassis backs off with finger tip ease. It also pilots the chassis back into place — securely locking it for operation with the same facility.

WIDE VARIETY OF APPLICATIONS

ON AIRCRAFT EQUIPMENT — Large manufacturers of aircraft equipment are using the Alden Method of unit construction to simplify design and save engineering time.

ON COMPUTERS — Recent large scale digital computer for Air Corps uses Alden "20" Plug-in Bases and Sockets throughout. One of country's largest manufacturers is building two large computers using Alden "20" Plug in Packages.

ON BUSINESS EQUIPMENT — Leading business machine manufacturers are designing with Alden components for greater accessibility and ease of servicing of their equipment.

FOR SMALLER UNITS ALDEN "20" PLUG-IN PACKAGES

Here is a plug-in package unit using the above method of converting schematic into finished assembly quickly. Simply mount the completed terminal card sub-assembly on the Alden "20" Non-Interchangeable base, dip solder the leads — add cover or housing and handle and it's completed — In operation, visual or instrument checks are easily made — if trouble occurs doubtful units are quickly isolated — these units easily unplug and a comprehensive inspection made. Spare units can be plugged in so equipment doesn't have to be inoperable while repairs are in process.

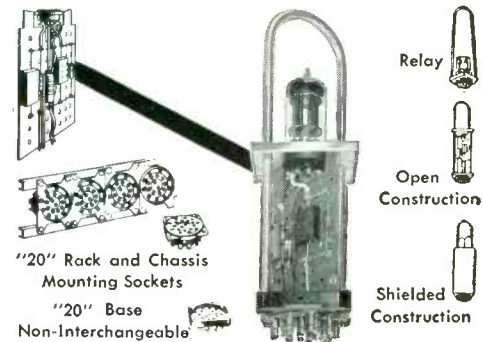

"20" Rack and Chassis Mounting Sockets
"20" Base Non-Interchangeable

Relay
Open Construction
Shielded Construction

TO GET STARTED QUICKLY!

Send for these tremendously useful Laboratory Work Kits and have them in your lab for use on present equipment or immediately ready for next new project:

- Kit #4 Alden "20" Plug-in Packages.....\$10.00*
- Kit #24 Alden Basic Chassis.....\$26.50*
- Kit #25 Terminal Card Mtg. System.....\$11.50*
- Kit #26 Basic Terminal Staking Tools.....\$15.00*
- Kit #8 Target & Cap Captive Screws.....\$ 3.00*
- Kit #29 Color Coded Back Connectors.....\$ 4.50*

or send for free booklet, "Basic Chassis and Components for Plug-in Unit Construction."

*Prices shown are for sample kits only — For production runs send us your schedule.

MILITARY

dehydrators

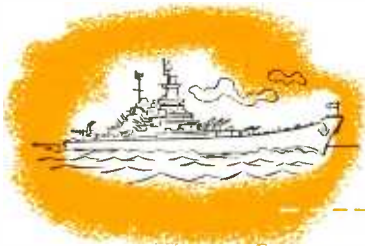
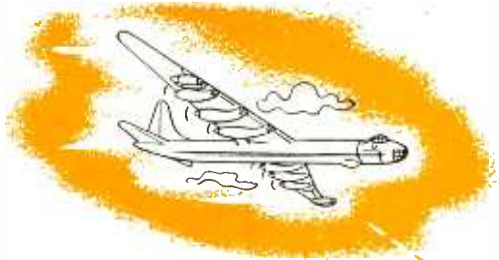

FOR AIR, LAND AND

TYPICAL APPLICATIONS IN WHICH CP DEHYDRATORS PROVIDE YEAR 'ROUND TROUBLE-FREE AUTOMATIC SERVICE:

- Purging and pressurizing transmission lines, waveguides and associated apparatus.
- Pressurizing large cavities and other radio and radar equipment enclosures.
- Fog prevention in precision optical systems.
- Corrosion prevention in precise servo amplifier assemblies.
- For raising and maintaining the power handling capacity of high voltage systems and apparatus and innumerable other similar applications.



CP DEHYDRATORS OFFER THE FOLLOWING UNIQUE FEATURES:

Low dewpoint • operating pressure up to 100 lbs. per square inch
fully automatic operation • continuous duty performance • low noise level • minimum vibration • long service life with minimum maintenance

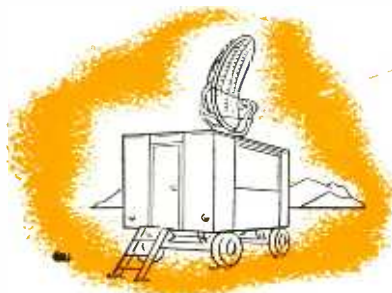

MANUFACTURERS OF COAXIAL TRANSMISSION LINE, TOWER HARDWARE,



SEABORNE SERVICE

... **Custom
Designed
for every
Government
and Military
Application**

CP dehydrators are readily adaptable to the critical requirements of the Armed Forces. Standardized parts permit rapid assembly of equipments suitable for practically any specialized need at minimum cost and without prolonged delay. Over a decade of CP experience in dehydrator design and manufacture insures products of long life and dependable service with an absolute minimum of maintenance. Inquiries are invited.

**COMMUNICATION PRODUCTS
COMPANY • Inc**



MARLBORO, NEW JERSEY
Telephone: FReehold 8-1880

DIPOLE ANTENNAS, SWITCHES, Q-MAX LACQUER AND CEMENT

HAMMARLUND

PRECISION-BUILT CAPACITORS

Hammarlund Capacitors, backed by 42 years of design, engineering and production experience, are today recognized by the military services, electronic manufacturers and research engineers, as the finest quality capacitors available. Since the founding of the Hammarlund Manufacturing Company in 1910, it has designed and developed capacitors that today are standard in industry. Millions of them are in use by almost every important manufacturer of electronic equipment.

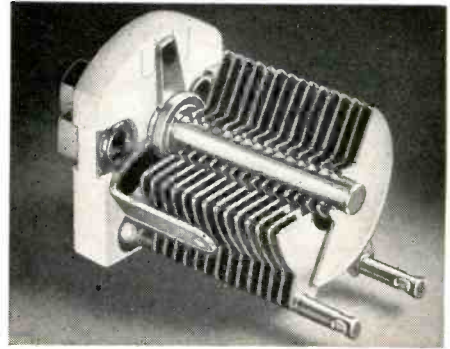

NOW AVAILABLE!

1952

CAPACITOR CATALOG

This detailed and illustrated 12-page catalog is yours for the asking. It will be a valuable addition to your library of radio parts suppliers, for it includes complete diagrams and electrical and mechanical specifications covering the broadest selection of standard variable air capacitors available to the electronic industry.

FOR YOUR FREE COPY of the 1952 Hammarlund Capacitor Catalog write us today. All capacitors listed in this catalog are stock items which can be purchased from jobbers, dealers everywhere.



HAMMARLUND

MORE THAN 40 YEARS EXPERIENCE COUNTS!
THE HAMMARLUND MANUFACTURING CO., INC.
460 WEST 34th STREET • NEW YORK 1, N. Y.

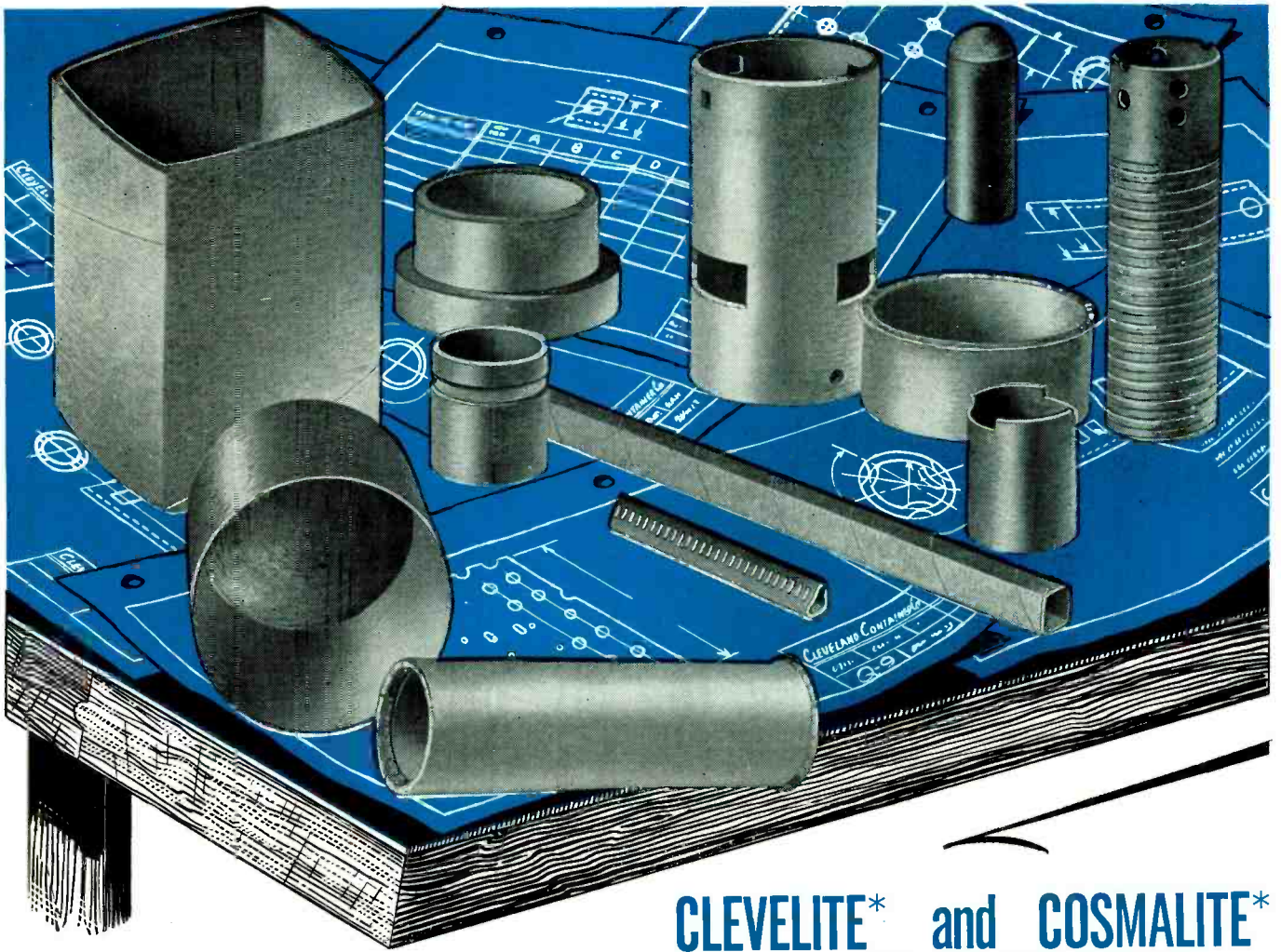

A GRADE FOR EVERY NEED!

Diameters—wall thicknesses and lengths to meet regular or special adaptations.

IN RADIO AND TELEVISION their use is almost universal. They have high insulation resistance and low moisture absorption. Their low dielectric loss is suitable for ultra high frequency applications.

IN ELECTRIC MOTORS for armature shaft spacers, insulators, brush holders, and many similar force-fit applications requiring machining, Clevelite is particularly suitable.

IN RELAYS, CONTROLS, SELENIUM RECTIFIERS, the various grades of Clevelite Phenolic Tubing have special properties that guarantee complete satisfaction.

CLEVELITE* and COSMALITE* LAMINATED PHENOLIC TUBING

are more than ever before—the first choice in the electronic and electrical industries.

They combine proven performance with low cost and excellent service!

Wherever high dielectric strength, low moisture absorption, physical strength, low loss and good machineability are of prime importance . . . the combined electrical and physical properties of

CLEVELITE and COSMALITE
are essential

IMMEDIATELY AVAILABLE
Tell us your needs.

* Reg. U. S. Pat. Off.

Why Pay More?
For the best . . .
Call CLEVELAND!

The **CLEVELAND CONTAINER Co.**
6201 BARBERTON AVE. CLEVELAND 2, OHIO

PLANTS AND SALES OFFICES at Plymouth, Wis., Chicago, Detroit, Ogdensburg, N. Y., Jamesburg, N. J.
ABRASIVE DIVISION at Cleveland, Ohio
CANADIAN PLANT: The Cleveland Container, Canada, Ltd., Prescott, Ontario

REPRESENTATIVES

NEW YORK AREA R. T. MURRAY, 604 CENTRAL AVE., EAST ORANGE, N. J.

NEW ENGLAND R. S. PETTIGREW & CO., 62 LA SALLE RD., WEST HARTFORD, CONN.

CHICAGO AREA PLASTIC TUBING SALES, 5215 N. RAVENSWOOD AVE., CHICAGO

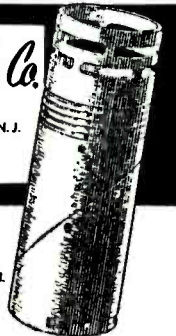



What's the big attraction?

The same brilliance that catches Mr. Trout's eye is also found on a wide range of brass and copper products, from costume jewelry to the gleaming brightwork on a ship.

The clean, bright surface of Chase metals doesn't just happen . . . it is controlled in research laboratories by Chase metallurgists . . . it is checked and tested every step along the way to the finished sheet, rod, wire or tube.

Chase brass and copper products are available, subject to government controls, through dealers, and jobbers across the nation and through Chase's 23 convenient mill warehouses.* Chase Brass & Copper Co., Incorporated, Waterbury 20, Conn.



Chase brass and other copper alloys range in color from rich red to bright yellow. The right color for each product and use is one of the features of Chase research and quality control.

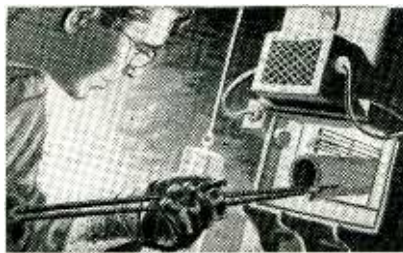

When the Chase Technical Advisory Service is asked to solve a problem by a manufacturer, Chase metallurgists will often find the right answer in this research laboratory test furnace.

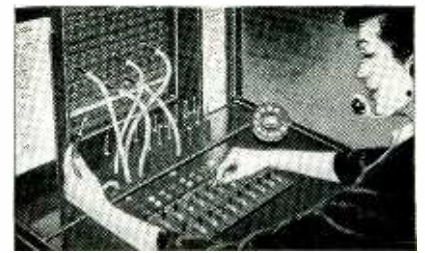

Patented Chase Telnic[®] Bronze makes better switchboard parts. Chase research developed Telnic for high strength, excellent machinability, corrosion resistance, and conductivity.

Chase

**The Nation's Headquarters for
BRASS & COPPER**

Chase Brass & Copper Co. is a subsidiary of KENNECOTT COPPER CORPORATION

*Albany† Atlanta Baltimore Boston Chicago Cincinnati Cleveland Dallas Denver† Detroit Houston† Indianapolis Kansas City, Mo. Los Angeles Milwaukee Minneapolis Newark New Orleans New York Philadelphia Pittsburgh Providence Rochester† St. Louis San Francisco Seattle Waterbury (†Sales Office Only)

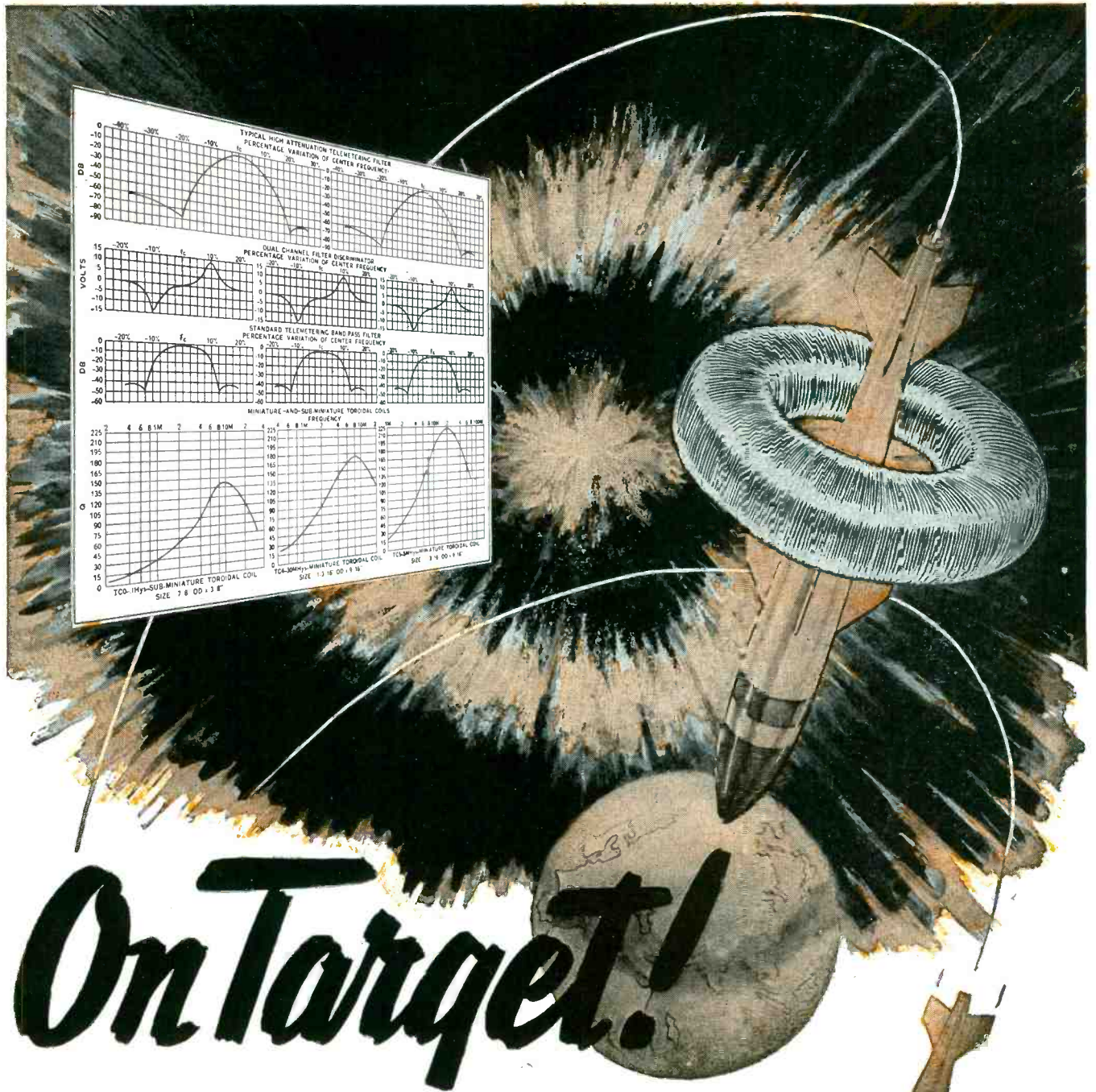

On Target!

THE TERM "GUIDED MISSILE" TO THE UNINITIATED USUALLY INDICATES AN AIRBORNE PILOTLESS PLANE DEVICE. HOWEVER, TO THE WELL INFORMED, THIS CONNOTES MANY OTHER POSSIBLE FORMS OF MISSILES; SOME OF WHICH ARE PHYSICAL REALITIES AND SOME DRAWING BOARD PROJECTS. NOT ALL OF THESE "CONTROLLED FLIGHT" DEVICES HAVE SPECIFIC USES AS ATTACK MISSILES. MANY ARE VALUABLE RESEARCH AIDS IN THE ANALYSIS OF THE BEHAVIOUR OF AIRCRAFT UNDER EXTREME OPERATING CONDITIONS. (TELEMETERING).

THE ENGINEERS WHO DESIGN THE CONTROL APPARATUS FOR MISSILES KNOW THAT IN ORDER TO ANTICIPATE THEIR EXACT BEHAVIOUR EVERY TIME AND THE SELECTIVE CIRCUITS AND FILTERS USED MUST BE UP TO THE HIGH STANDARDS OF PERFORMANCE FOR WHICH BURNELL'S TOROIDS AND FILTERS ARE SO WELL KNOWN.

THE NATURAL RESULT OF THIS REPUTATION IS THAT MANY THOUSANDS OF OUR PRODUCTS ARE IN SOME WAY PLAYING THEIR PART IN KEEPING THE MILITARY ELECTRONIC PROGRAM "ON TARGET."



Burnell & Company
 YONKERS 2, NEW YORK
 CABLE ADDRESS "BURNELL"

EXCLUSIVE MANUFACTURERS OF COMMUNICATIONS NETWORK COMPONENTS



DESIGNER'S

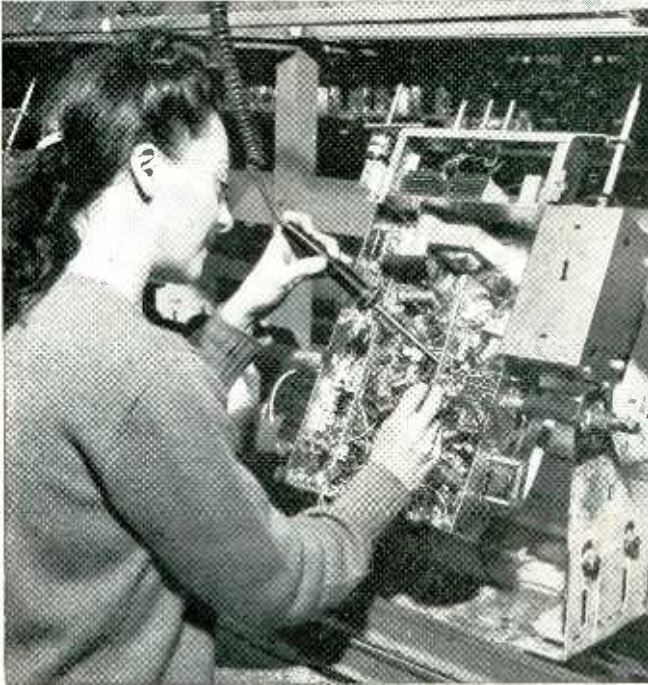

1. New, fast-heating G-E iron weighs only 8½-oz.

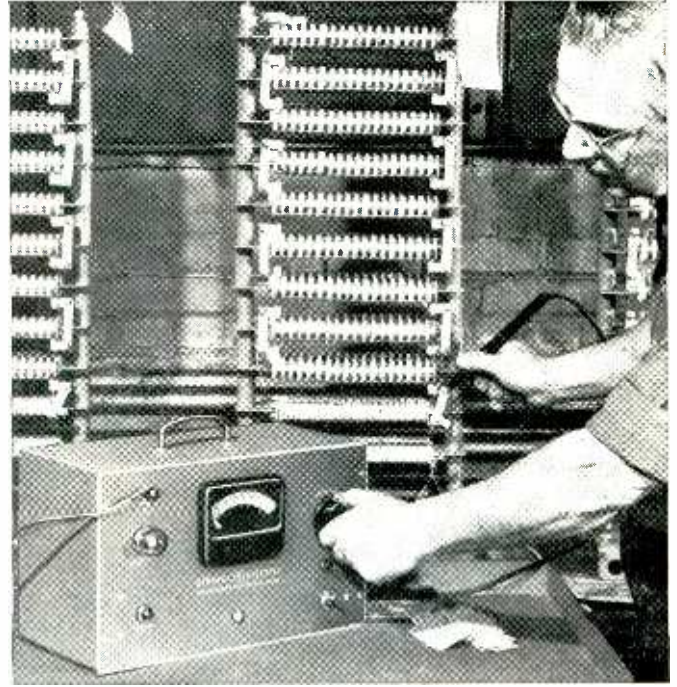

2. New G-E portable hi-pot tester is easy to operate.

Two ways to speed your production

Reach hard-to-solder places with this new thin-shank iron

"As easy to use as a pencil," say operators who use General Electric's new lightweight soldering iron.

Its thin, $\frac{5}{16}$ -inch-diameter shank lets the $\frac{1}{4}$ -inch tip into places a regular iron can't touch. Operators can solder more joints per minute—and with fewer rejects—because the iron's lightness, balanced design and comfortable handle all reduce fatigue.

Long-lasting G-E Calrod* heater provides quick heat-recovery properties, gives plenty of heat for uniformly strong soldered joints. Maintenance of this 60-watt, 120-volt iron is low because the long-life Ironclad tip need not be filed or dressed. Send for Bulletin GED-1583.

*Reg. Trade-mark

Eliminate cages and barriers with this new insulation tester

Now you can perform high-potential tests on your equipment with minimum danger to personnel. That's because the current output of General Electric's new high-potential insulation tester is limited to 5 milliamperes—well below the "let go" value.

Testing time is cut, too—no need to set up cages, barriers, or tape. Tester is portable, weighs only 22 lbs. Simply plug it into any 115-volt a-c outlet and start testing.

Line surges are virtually eliminated in output. Flash-overs can't burn insulation. Neon light on panel gives warning *before* insulation breaks down. Output is adjustable from 0 to 3500 volts, with test capacitance up to .006 muf. Bulletin GEC-700.

GENERAL ELECTRIC

Four ways G-E selenium rectifiers meet your d-c power requirements

Selenium rectifiers provide the electrical designer with versatile and flexible means of getting the right quantity of d-c power. But not all selenium rectifiers are alike. Here are four important "quality points" you'll find in G-E units in comparison with competitive equipment:

1. Lower forward resistance—for higher output and cooler operation—plus lower costs in other circuit components.

2. Less back leakage—for higher efficiency as well as higher output.

3. Cooler operation—the result of the above characteristics—since there is less heat to dissipate, less ventilation is needed.

4. Slower aging—which extends expected life at rated output to over 60,000 hours.

And of course the G-E line is complete, to meet all your design needs.

For a complete refresher on rectifier fundamentals, circuits, and applications, send for the new 28-page G-E booklet prepared to aid the design engineer. Check Bulletin GET-2350.

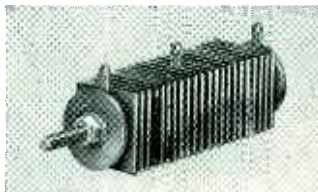

Standard stack construction



Tube-mounted construction

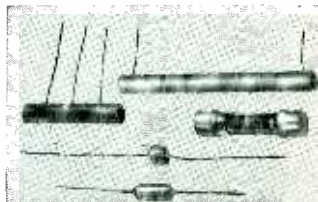

Miniature cell assemblies

Dual-rated capacitors simplify design problems

Meet your design needs, standardize, and cut inventories with these G-E fixed paper-dielectric capacitors. Equally applicable to a-c and d-c, they come in many case styles, with ratings from 236 through 660 volts a-c and 400 through 1500 volts d-c. All units are treated with Pyranol* and hermetically sealed to prevent leakage or contamination. Check Bulletin GEC-809.



Current-sensitive relays stand severe vibrations

G-E current sensitive d-c relays are available with d-c pickup ratings in steps from 4 to 1500 ma. They are especially applicable to circuits using limited power for energizing coils—as in aircraft. Lightweight and corrosion-proof, these relays withstand severe vibration and operate at rated current through a wide range of altitudes. See Bulletin GEC-834.



EQUIPMENT FOR ELECTRONIC MANUFACTURERS

A partial list of the thousands of items in the complete G-E line. We'll tell you about them each month on these pages.

Components

Meters and Instruments	Timers
Capacitors	Indicating lights
Transformers	Control switches
Pulse-forming networks	Generators
Delay lines	Selsyns
Reactors	Relays
*Thyrite	Amplidyne
Motor-generator sets	Amplistats
Inductrols	Terminal boards
Resistors	Push buttons
Voltage Stabilizers	Photovoltaic cells
Fractional-hp motors	Glass bushings
Rectifiers	Dynamotors

Development and Production Equipment

Soldering irons
Resistance-welding control
Current-limited high-potential tester
Insulation testers
Vacuum-tube voltmeter
Photoelectric recorders
Demagnetizers

*Reg. trade-mark of General Electric Co.

**General Electric Company, Section A667-21
Schenectady 5, New York**

Please send me the following bulletins:

Indicate: ✓ for reference only
× for planning an immediate project

- GEC-700 High-Potential Tester
- GEC-809 Paper-Dielectric Capacitors
- GEC-834 Current-Sensitive D-C Relays
- GED-1583 Lightweight Soldering Iron
- GET-2350 Selenium Rectifiers

Name _____

Company _____

City _____ State _____



Raw Stock or Complete Fabricated Assemblies . . .

General Plate has the Facilities to meet all your Electrical Contact Requirements

There are many advantages for using General Plate composite contact materials and completely fabricated assemblies. Among the more important are better performance, longer operating life and lower fabricating costs.

But that's not all — here at General Plate you have a single source that can supply your contact requirements be it raw stock or complete assemblies. General Plate contacts and stock are available in a wide range of alloys designed to meet your specific requirements.

Raw stock is supplied in various combinations, in overlay, single or double inlay, single or double edgelay, and Top-Lay stock. The precious metal is clad to your required base metals such as brass, bronze, nickel, monel, copper, beryllium copper, etc. In addition General Plate provides composite buttons, rivets, stampings, welded or brazed assemblies.

General Plate fabricated assemblies including assemblies requiring stampings, screw machine or

headed parts with contacts attached, etc. are made to your exact specifications.

Make General Plate your headquarters for solid or composite contacts, contact material and fabricated contact assemblies.

GENERAL PLATE PRODUCTS INCLUDE

Precious metals clad to base metals, Base metals clad to base metals, Silver solders, Composite contacts, buttons and rivets, Truflex® Thermostat Metals, Alcuplate®, Platinum fabrication and refining, #720 Manganese Age Hardening Alloy. Write for technical data bulletins.

*Have You a Composite Metal Problem?
General Plate can solve it for you*

GENERAL PLATE

Division of Metals & Controls Corporation

37 FOREST STREET
ATTLEBORO, MASSACHUSETTS

TUNG-SOL®

dependable electron tubes

5687



6AX4
GT



5881



6U8



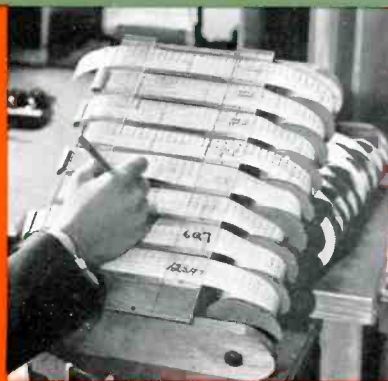

Mica specifications checked to thousandth-inch accuracy.

Completed mounts are inspected for visual defects.

Statistical control assures uniformity of quality and performance.

Life tests prove Tung-Sol Tubes can take it.

complete control of materials— and manufacturing procedures makes Tung-Sol Tubes Dependable!

TUNG-SOL engineering has produced tubes of matchless performance, which Tung-Sol manufactures in large quantities with infinite precision. If you have a product or a problem involving electron tubes—let Tung-Sol help you. You'll like Tung-Sol Tubes—and you'll like Tung-Sol service.

TUNG-SOL ELECTRIC INC., Newark, N. J.

SALES OFFICES: ATLANTA • CHICAGO • CULVER CITY • DALLAS • DENVER • DETROIT • NEWARK

TUNG-SOL MAKES ALL-GLASS SEALED BEAM LAMPS, MINIATURE LAMPS, SIGNAL FLASHERS, PICTURE TUBES, RADIO, TV AND SPECIAL PURPOSE ELECTRON TUBES



Bradleyunits are available in all standard R. T. M. A. values.

**This
HONEYCOMB RESISTOR CARTON
is a Time- and Laborsaver
in the Production Line**

**Differentially
tempered leads**

The leads of all Bradleyunits are differentially tempered. This graduated softness of leads near the body of the resistor prevents sharp bends and avoids damage to resistor.

SIZES OF UNITS

Rating	L	D
1/2-w	3/8"	9/64"
1-w	9/16"	7/32"
2-w	11/16"	5/16"

IMPORTANT NOTICE

The tremendous demand for Bradleyunits has, in the past, resulted in disappointments due to extended deliveries. Our production facilities have been substantially increased, and your demands for Bradleyunits can now be satisfied quite promptly.

Give your assemblers the laborsaving advantage of Allen-Bradley honeycomb packaging. This unique container keeps resistor leads straight and free from tangling. It makes it easy to pick up a Bradleyunit from the patented Allen-Bradley carton, which holds the resistors in perfectly spaced rows. The removal of one or even fifty resistors does not affect the alignment of the remaining units.

Bradleyunits have permanent characteristics because they are rated to operate continuously at 70 C ambient temperature and not at 40 C. Therefore, they can withstand extremes of temperature and humidity. Bradleyunits need no wax impregnation to pass salt water immersion tests.

Allen-Bradley Co.
110 W. Greenfield Ave., Milwaukee 4, Wis.



ALLEN-BRADLEY
FIXED & ADJUSTABLE RADIO RESISTORS

Sold exclusively to manufacturers

QUALITY

of radio and electronic equipment

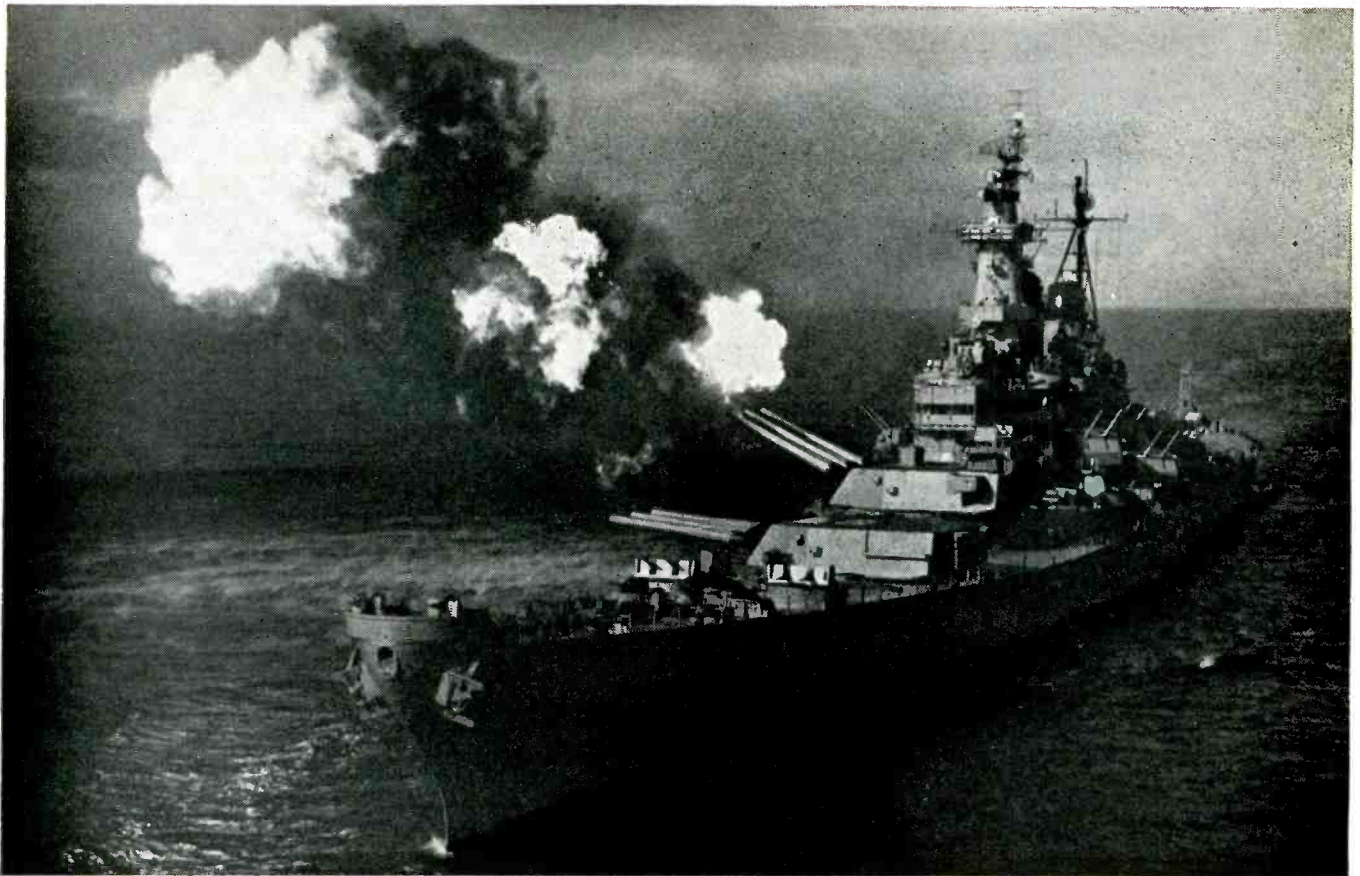

Official U. S. Navy Photo

range...

The range of these big guns exceeds anything else afloat. In a like manner, Edo echo-sounding equipment now being installed on ships of the U. S. Navy gives far greater range and accuracy than other types of sonar previously used. This superior performance promises important advances in both ocean navigation and naval tactics.

For instance, the Edo Model 185 deep sounder continuously measures and records any known ocean depths giving the navigator a new means of plotting his course by ocean bottom contours. Other Edo sonar devices search out and detect distant vessels with a range and accuracy never before believed possible.

Such successful results come only from a research and engineering staff endowed with imagination, ingenuity and the ability to apply the latest developments in the whole field of electronics to any specific problem — a characteristic Edo trait for over a quarter of a century.

A SYMBOL KNOWN AND RESPECTED FOR OVER A QUARTER OF A CENTURY

Twenty-seven years of experience are behind the leadership which Edo enjoys in the field of sonar development, research and manufacture. Members of the Edo engineering staff have pioneered many of the developments which make the use of echo-ranging underwater detection equipment an increasingly important function not only in anti-submarine warfare but also in the safe and efficient operation of modern ships.

The exceptional performance of Edo equipment brings to the famous flying fish emblem increasing recognition as the symbol of superior equipment.



EDO CORPORATION · COLLEGE POINT, N. Y.

2 WALDES TRUARC RINGS REPLACE COTTER PINS AND WASHERS... SAVE \$.0219 PER UNIT



OLD WAY

Cam shaft for breathing roll ironer mechanism required: drilling 2 holes; 2 cotter pins; 2 washers. Inaccuracy in locating holes for cotter pins caused frequent rejects.

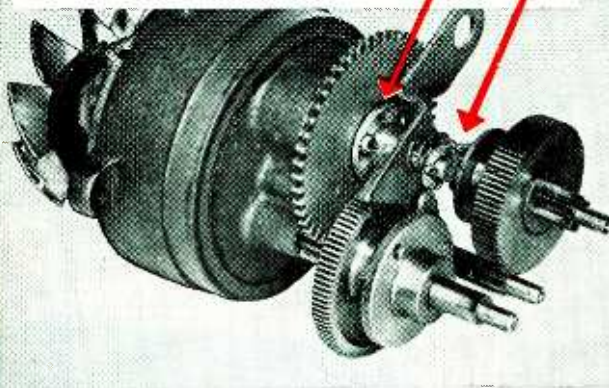

NEW WAY

2 simple grooves to accommodate 2 Waldes Truarc Rings, are cut in shaft during regular screw machine cycle—at no extra cost. Waldes Truarc Rings are applied quickly, easily.

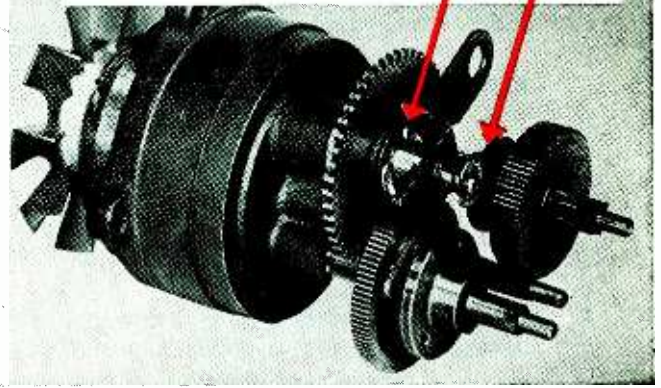
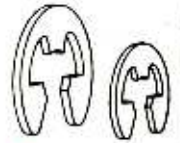

Using 2 Waldes Truarc "E" Retaining Rings in their Automatic Cabinet Ironer, saved The Horton Manufacturing Co., Fort Wayne, Ind., \$.0219 per unit. Truarc Rings saved 50% in assembly time... cut down on rejects... increased efficiency of the unit... eliminated risk of damage to hands and clothing of workers in assembly.

Redesign with Truarc Rings and you, too, will cut costs. Wherever you use machined shoulders, bolts, snap rings, cotter pins, there's a Waldes Truarc Retaining Ring designed to do a better job of holding parts together.

Truarc Rings are precision-engineered... quick and easy to assemble and disassemble. Remain circular to give a never-failing grip. They can be used over and over again.

Find out what Truarc Rings can do for you. Send your blueprints to Waldes Truarc engineers for individual attention, without obligation.

COMPARATIVE COSTS—

WITH COTTER PINS	WITH TRUARC RINGS
MATERIAL:	MATERIAL:
2 washers0045	2 Truarc E Rings . .0283
2 cotter pins0017	
OPERATIONS:	OPERATIONS:
drilling 2 holes	Cutting 2 grooves . .0000*
in shaft0223	
ASSEMBLY TIME . . .0485	ASSEMBLY TIME . . .0268
Total cost \$0.0770	\$0.0551

TOTAL SAVINGS WITH TRUARC RINGS \$.0219 PER UNIT

*Grooves are cut in shaft during regular screw machine cycle

For precision internal grooving and undercutting... Waldes Grooving Tool.

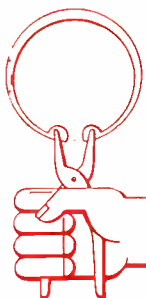

SEND FOR NEW BULLETINS →

WALDES
TRUARC
REG. U. S. PAT OFF
RETAINING RINGS



Waldes Kohinoor, Inc., 47-16 Austel Place, L. I. C. 1, N. Y.
Please send engineering specifications and data on Waldes Truarc Retaining Ring types checked below. E-074

- Bulletin #5 Self-locking ring types
- Bulletin #6 Ring types for taking up end-play
- Bulletin #7 Ring types for radial assembly
- Bulletin #8 Basic type rings
- Send me information about the Waldes Grooving Tool.

Name _____
Title _____
Company _____
Business Address _____
City _____ Zone _____ State _____ 3678

WALDES KOHINOOR, INC., LONG ISLAND CITY 1, NEW YORK

WALDES TRUARC RETAINING RINGS AND PLIERS ARE PROTECTED BY ONE OR MORE OF THE FOLLOWING U. S. PATENTS: 2,382,947; 2,382,948; 2,416,852; 2,420,921; 2,428,341; 2,439,789; 2,441,846; 2,455,189; 2,483,380; 2,483,383; 2,487,802; 2,487,803; 2,491,308; 2,509,051 AND OTHER PATENTS PENDING.

Honeywell Mercury Switches

PROTECTED FOR
USE UNDER SEVERE
OPERATING CONDITIONS

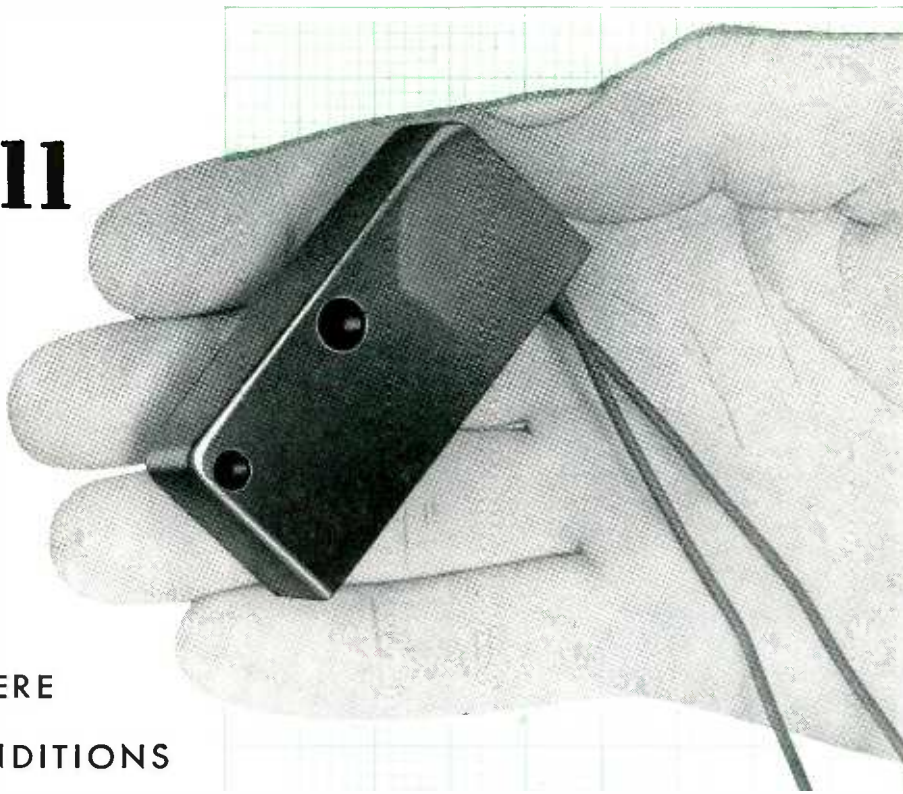

Honeywell Mercury Switch 1MP1 embedded in plastic case held in hand to indicate size and compactness of design.

HONEYWELL glass-enclosed mercury switches are durable enough to meet every "normal" operating condition. For applications where mechanical shock and impact are present, MICRO has designed added protection for these glass-enclosed mercury switches. This consists of embedding the switches in plastic "potting" compounds.

Pictured here is the new 1MP1 Mercury Switch. This unit provides less than 1 degree differential angle, with a basic 2 ampere, 115 volt a-c; 1 ampere, 115 volt d-c rating. The contact arrangement is single-pole, single-throw. Mounting holes accommodate a $\frac{1}{4}$ " mounting screw and pin. This allows for simple assembly and adjustment which can be locked in position.

There are more than 90 Honeywell mercury tube designs with many variations in size, differential angles, electrical ratings and contact arrangements. MICRO field engineers are located near you to provide full information on Honeywell Mercury Switches, either glass-enclosed or embedded. Contact your nearest MICRO SWITCH branch office.



Cut open view of embedded Honeywell Mercury Switch illustrates switch embedded in plastic "potting" compound.



Let a MICRO SWITCH Engineer show you how you can "use Honeywell Mercury Switches as a principle of good design"

MICRO SWITCH

FREEPORT, ILLINOIS

MICRO Snap-Action Switches . . . Honeywell Mercury Switches



A DIVISION OF MINNEAPOLIS-HONEYWELL REGULATOR COMPANY

A Molehill of Difference Can Make a Mountain of Trouble in Waveguides

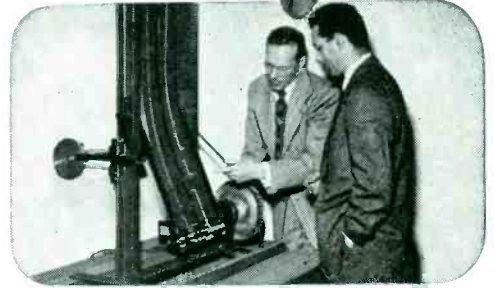
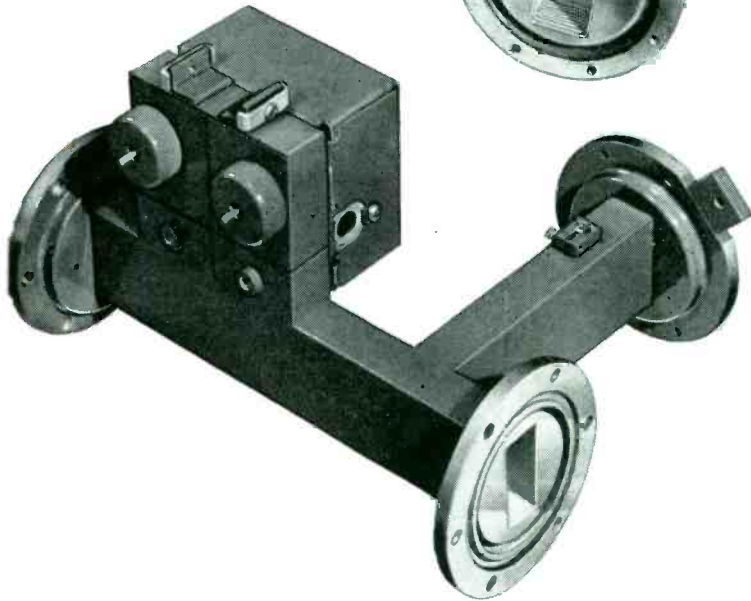

Remember this traffic-stopper at the 1952 IRE Show in Grand Central Palace? It's a torture test. Flexed well over 1,000,000 times, Waveflex flexible Waveguides gave no evidence of failure or loss of physical or electrical properties.



Fabricated to precision methods, Titeflex flexible and rigid Waveguides are produced to the closest tolerances and to exacting specifications. Titeflex maintains strict quality control and inspection from raw materials to finished products.

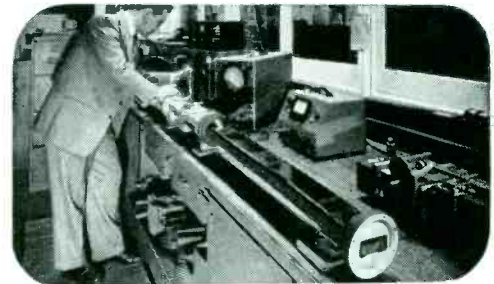

No Waveguide gets by this department without a thorough electrical check-up. Every single Titeflex Waveguide is tagged before shipment with its test score on JAN-W-287 specifications for flexible Waveguides or JAN-W-85A for rigid Waveguides.

... A little difference in waveguides—imperceptible to the eye—can jeopardize a costly investment.

If you want to be sure of your electronic equipment, if you want to reduce operational failures, insist upon Titeflex microwave components.



Send for free catalog of uses, properties, and specifications.

Let Our Family of Products Help Yours

Titeflex

✓ Check products you are interested in.



SEAMED AND SEAMLESS METAL HOSE



PRECISION BELLOWS



IGNITION HARNESS



IGNITION SHIELDING

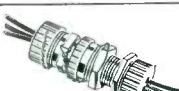

ELECTRICAL CONNECTORS



RIGID AND FLEXIBLE WAVE GUIDES

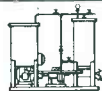

FILTERS



FUSES

TITEFLEX, INC.
524 Frelinghuysen Ave.
Newark 5, N.J.

Please send me without cost information about the products checked at the left.

NAME _____
TITLE _____
FIRM _____
ADDRESS _____
CITY _____ ZONE _____ STATE _____



FOR

FASTER

SERVICE

GREATER VARIETY

HIGHER QUALITY



ALLMETAL "AN"

STAINLESS STEEL FASTENERS

MACHINE SCREWS • NUTS • BOLTS • WASHERS • PINS • RIVETS

AVAILABLE IMMEDIATELY FROM STOCK, an endless stream of first quality "AN" stainless fasteners is Allmetal's answer to the exacting demands of defense production . . . in aircraft, electronics, ordnance, in industry everywhere. Always remember Allmetal, to get the fasteners you want—when you want them.

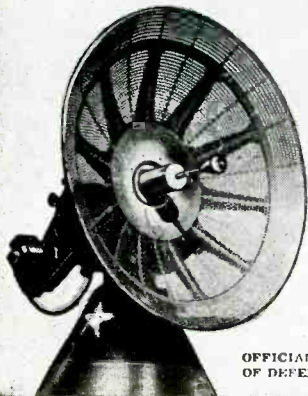

OFFICIAL DEPT.
OF DEFENSE PHOTOGRAPHS

WRITE FOR
CATALOG,
ON YOUR
LETTERHEAD,
TODAY!

FOR EMERGENCY ORDERS:
WIRE Allmetal Screw Products Co.
WUX, New York
or PHONE WOrth 4-6444



MANUFACTURERS SINCE 1929

ALLMETAL

SCREW PRODUCTS COMPANY, INC.

33 GREENE STREET NEW YORK 13, N. Y.

ANOTHER CBS-HYTRON FIRST YOU'LL BE BUYING SOON



CBS-HYTRON 1AX2

NEW HEAVY-DUTY TV HIGH-VOLTAGE RECTIFIER CAN TAKE IT!

TV high-voltage rectifiers take a beating: Terrific variations occur in applied filament voltage . . . 0.8 to 2.4 volts! Sudden arcs in the rectifying system place destructive electromechanical stresses on the filament. And the increasingly larger TV picture tubes demand peak emission and peak inverse voltage simultaneously. The new CBS-Hytron 1AX2 was especially designed to take such rough treatment and come up smiling.

1AX2 DATA

The CBS-Hytron 1AX2 is a compact, 9-pin miniature TV pulse rectifier. Plate is brought out to top cap and filament is oxide-coated. Absolute maximum ratings are: peak inverse plate voltage, 25,000 volts; d-c load current, 1.0 ma.; and steady-state peak plate current, 11.0 ma.

Typical Operation — TV Pulse Rectifier

Filament voltage	1.4 v \pm 10%
Filament current	650 ma
Positive-pulse plate voltage	20,000 v
Negative-pulse plate voltage	5,000 v
Peak inverse plate voltage	25,000 v
D-c output voltage	20,000 v
D-c load current	300 μ a

BOTTOM VIEW
OF SOCKET

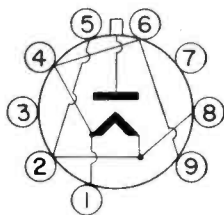

ADVANTAGES OF NEW CBS-HYTRON 1AX2

- 1 Rugged, high-wattage filament of CBS-Hytron 1AX2 has adequate peak emission for the new, larger TV picture tubes. 1AX2 may be run simultaneously at both its peak inverse voltage and maximum d-c current.
- 2 Higher load of 1AX2 filament on transformer tends to regulate filament voltage. Eliminates need for limiting resistor. Yet lower plate-to-filament capacitance (0.7 μ mf) of 1AX2 prevents loss of high voltage.
- 3 Insulated tension bar (patent applied for) through center of 1AX2 coiled filament limits destructive movement of filament by electromechanical stresses.
- 4 Filament of 1AX2 is located in base and shielded to eliminate bombardment of cool ends of filament by gas molecules.
- 5 An overloaded 1X2A may be replaced with its big brother, the CBS-Hytron 1AX2, by simply removing the limiting resistor. In rare cases, it may be necessary to add another turn to the secondary of the filament transformer to obtain the required 1.4 volts for the 1AX2.



MAIN OFFICE: SALEM, MASSACHUSETTS



TYPE 252, JAN-R-19, Type RA20

2 watt, 1 1/4" diameter variable wirewound resistor. Also available with other special military features not covered by JAN-R-19. Attached Switch can be supplied.

Resistance	CT5 Part	JAN-R-19 TYPE
50 ± 10%	B8079	RA20A1SD500AK
100 ± 10%	W6929	RA20A1SD101AK
250 ± 10%	X3497	RA20A1SD251AK
500 ± 10%	W6931	RA20A1SD501AK
1000 ± 10%	W6932	RA20A1SD102AK
1500 ± 10%	W6933	RA20A1SD152AK
2500 ± 10%	W6934	RA20A1SD252AK
5000 ± 10%	W6935	RA20A1SD502AK
10,000 ± 10%	W6936	RA20A1SD103AK

CT5 Part	JAN-R-19 TYPE
X3496	RA20A2SD500AK
L9388	RA20A2SD101AK
M9879	RA20A2SD251AK
X3498	RA20A2SD501AK
X3499	RA20A2SD102AK
M9809	RA20A2SD152AK
L9103	RA20A2SD252AK
L9104	RA20A2SD502AK
H8979	RA20A2SD103AK



TYPE 25, JAN-R-19, Type RA30 (May also be used as Type RA25)

4 watt, 1 1/2" diameter variable wirewound resistor. Also available with other special military features not covered by JAN-R-19. Attached Switch can be supplied.

Resistance	CT5 Part	JAN-R-19 TYPE
50 ± 10%	X3502	RA30A1SD500AK
100 ± 10%	X3503	RA30A1SD101AK
250 ± 10%	X3505	RA30A1SD251AK
500 ± 10%	X3507	RA30A1SD501AK
1000 ± 10%	X3508	RA30A1SD102AK
1500 ± 10%	X3509	RA30A1SD152AK
2500 ± 10%	X3511	RA30A1SD252AK
5000 ± 10%	Q1409	RA30A1SD502AK
10,000 ± 10%	X3513	RA30A1SD103AK
15,000 ± 10%	X3514	RA30A1SD153AK

CT5 Part	JAN-R-19 TYPE
W2837	RA30A2SD500AK
X3504	RA30A2SD101AK
X3506	RA30A2SD251AK
M7566	RA30A2SD501AK
S2444	RA30A2SD102AK
X3510	RA30A2SD152AK
S2736	RA30A2SD252AK
X3512	RA30A2SD502AK
R1561	RA30A2SD103AK
L9107	RA30A2SD153AK

Immediate delivery from stock

JAN-R-94 AND JAN-R-19 TYPE MILITARY VARIABLE RESISTORS

Preference given to orders carrying military contract number and DO rating. Other JAN items or special items with or without associated switches can be fabricated to your specifications. Please give complete details on your requirements including electrical and mechanical specifications.

UNPRECEDENTED PERFORMANCE CHARACTERISTICS
Designed for use in military equipment subject to extreme temperature and humidity ranges including jet and other planes, guided missiles, tanks, ships and submarines, telemetering, microwave, portable or mobile equipment and all other military communications.

For further information, write for Stock Sheet No. 162



NEW 38-PAGE ILLUSTRATED CATALOG—Describes Electrical and Mechanical characteristics, Special Features and Constructions of a complete line of variable resistors for military and civilian use. Includes dimensional drawings of each resistor. Write today for your copy.

REPRESENTATIVES

Henry E. Sanders
John B. McClatchy Bldg.
69th & Market St.
Upper Darby, Penna.
Phone: Flanders 2-4420

W. S. Harmon Company
1638 So. La Cienega Blvd.
Los Angeles 35, Calif.
Phone: Bradshaw 2-3321

John A. Green Co.
6815 Oriole Drive
Dallas 9, Texas

IN CANADA

C. C. Meredith & Co.
Streetsville, Ontario

SOUTH AMERICA

Jose Luis Pontel
Buenos Aires, Argentina
Montevideo, Uruguay
Rio de Janeiro, Brazil
Sao Paulo, Brazil

OTHER EXPORT

Sylvan Ginsbury
8 West 40th Street
New York 18, N. Y.



CHICAGO TELEPHONE SUPPLY
Corporation

specialists in precision mass production of variable resistors

FOUNDED 1896 • ELKHART, INDIANA

SHAFT TYPES
AVAILABLE
ON STOCK CONTROLS

CTS SHAFT TYPE LT-2 LOCKING BUSHING

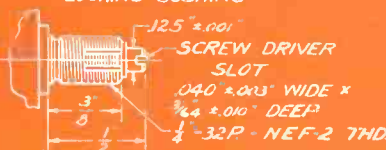

MOUNTING HARDWARE ASSEMBLED
MOUNTING NUT 3/8 HEX. x 1/2
LOCK NUT 3/8 HEX. x 1/2
LOCK WASHER #1914A

CTS SHAFT TYPE RE

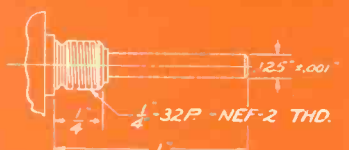

MOUNTING HARDWARE ASSEMBLED
MOUNTING NUT 3/8 HEX. x 1/2
LOCK WASHER #1914A

Resistance
250 ±10%
500 ±10%
1000 ±10%
2500 ±10%
5000 ±10%
10,000 ±10%
25,000 ±10%
50,000 ±10%
100,000 ±10%
250,000 ±10%
500,000 ±10%
1 Meg ±20%
2.5 Meg ±25%

CTS Part	CTS Shaft Type RE
X3516	
X3517	
X3518	
X3519	
X3520	
X3521	
X3522	
X3523	
X3524	
X3525	
X3526	
X3527	
X3528	

CTS Part	Locking Bushing	CTS Shaft Type LT-2
X3530		
X3531		
X3532		
X3533		
X3534		
X3535		
X3536		
X3537		
X3538		
X3539		
X3540		
X3541		
X3542		

TYPE 65
 1/2 watt 70° C, 3/4" diameter miniaturized variable composition resistor.

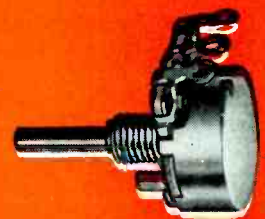

TYPE 95, JAN-R-94, Type RV4

Resistance
100 ±10%
250 ±10%
500 ±10%
1000 ±10%
2500 ±10%
5000 ±10%
10,000 ±10%
25,000 ±10%
50,000 ±10%
100,000 ±10%
250,000 ±10%
500,000 ±10%
1 Meg ±20%
2.5 Meg ±20%
5 Meg ±20%

JAN-R-94 TYPE RV4	JAN Shaft Type SD
RV4ATSD101A	
RV4ATSD251A	
RV4ATSD501A	
RV4ATSD102A	
RV4ATSD252A	
RV4ATSD502A	
RV4ATSD103A	
RV4ATSD253A	
RV4ATSD503A	
RV4ATSD104A	
RV4ATSD254A	
RV4ATSD504A	
RV4ATSD105B	
RV4ATSD255B	
RV4ATSD505B	

JAN-R-94 TYPE RV4	JAN Shaft Type RJ
RV4ATRJ101A	
RV4ATRJ251A	
RV4ATRJ501A	
RV4ATRJ102A	
RV4ATRJ252A	
RV4ATRJ502A	
RV4ATRJ103A	
RV4ATRJ253A	
RV4ATRJ503A	
RV4ATRJ104A	
RV4ATRJ254A	
RV4ATRJ504A	
RV4ATRJ105B	
RV4ATRJ255B	
RV4ATRJ505B	

CTS Part	Non-JAN Locking Bushing	CTS Shaft Type LT-1
W3160		
W3161		
W3162		
W3166		
W3163		
W3164		
W3167		
W3168		
W3169		
W3170		
W3171		
W3172		
W3173		
W3165		
W3159		

2 watt 70°C, 1 1/8" diameter variable composition resistor. Also available with other special military features not covered by JAN-R-94. Attached Switch can be supplied.

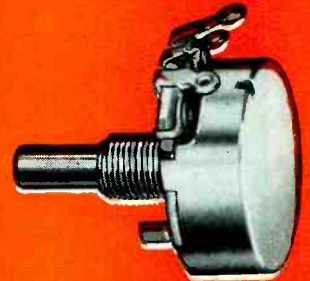

TYPE 45, JAN-R-94, Type RV2

Resistance
100 ±10%
250 ±10%
500 ±10%
1000 ±10%
2500 ±10%
5000 ±10%
10,000 ±10%
25,000 ±10%
50,000 ±10%
100,000 ±10%
250,000 ±10%
500,000 ±10%
1 Meg ±20%
2.5 Meg ±20%

RV2, JAN Shaft Type SD	CTS Part	JAN-R-94 TYPE
	A5876	RV2ATSD101A
	A5877	RV2ATSD251A
	A5878	RV2ATSD501A
	A5879	RV2ATSD102A
	A5880	RV2ATSD252A
	A5881	RV2ATSD502A
	A5882	RV2ATSD103A
	A5883	RV2ATSD253A
	A5884	RV2ATSD503A
	A5885	RV2ATSD104A
	A5886	RV2ATSD254A
	A5887	RV2ATSD504A
	A5888	RV2ATSD105B
	A5889	RV2ATSD255B

CTS Part	Non-JAN Locking Bushing	CTS Shaft Type LT-1
A5922		
A5923		
A5924		
A5925		
A5926		
A5927		
A5928		
A5929		
A5930		
A5931		
A5932		
A5933		
A5934		
A5935		

1/4 watt, 1 5/16" diameter variable composition resistor. Also available with other special military features not covered by JAN-R-94. Attached Switch can be supplied.



TYPE 35, JAN-R-94, Type RV3

Resistance
100 ±10%
250 ±10%
500 ±10%
1000 ±10%
2500 ±10%
5000 ±10%
10,000 ±10%
25,000 ±10%
50,000 ±10%
100,000 ±10%
250,000 ±10%
500,000 ±10%
1 Meg ±20%
2.5 Meg ±20%
5 Meg ±20%

RV3, JAN Shaft Type SD	CTS Part	JAN-R-94 TYPE
	A5861	RV3ATSD101A
	A5862	RV3ATSD251A
	A5863	RV3ATSD501A
	A5864	RV3ATSD102A
	A5865	RV3ATSD252A
	A5866	RV3ATSD502A
	A5867	RV3ATSD103A
	A5868	RV3ATSD253A
	A5869	RV3ATSD503A
	A5870	RV3ATSD104A
	A5871	RV3ATSD254A
	A5872	RV3ATSD504A
	A5873	RV3ATSD105B
	A5874	RV3ATSD255B
	A5875	RV3ATSD505B

CTS Part	Non-JAN Locking Bushing	CTS Shaft Type LT-1
A5907		
A5908		
A5909		
A5910		
A5911		
A5912		
A5913		
A5914		
A5915		
A5916		
A5917		
A5918		
A5919		
A5920		
A5921		

1/2 watt, 1 1/8" diameter variable composition resistor. Also available with other special military features not covered by JAN-R-94. Attached Switch can be supplied.



JAN SHAFT TYPE SD

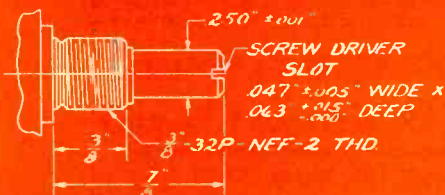

MOUNTING HARDWARE ASSEMBLED
 MOUNTING NUT 1/2" HEX. X 3/2"
 LOCK WASHER #1920A

JAN SHAFT TYPE RJ

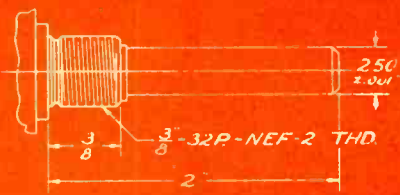

MOUNTING HARDWARE ASSEMBLED
 MOUNTING NUT 3/16" HEX. X 3/2"
 LOCK WASHER #1920A

CTS SHAFT TYPE LT-1
 LOCKING BUSHING

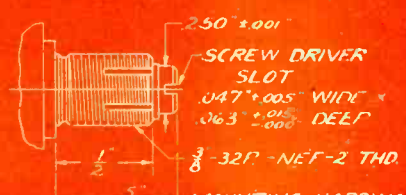

MOUNTING HARDWARE ASSEMBLED
 MOUNTING NUT 1/2" HEX. X 3/2"
 LOCK NUT 1/2" HEX. X 3/2"
 LOCK WASHER #1920A



Application Report #2

... how POLYTRIFLUOROCHLOROETHYLENE has been used to solve tough design problems.

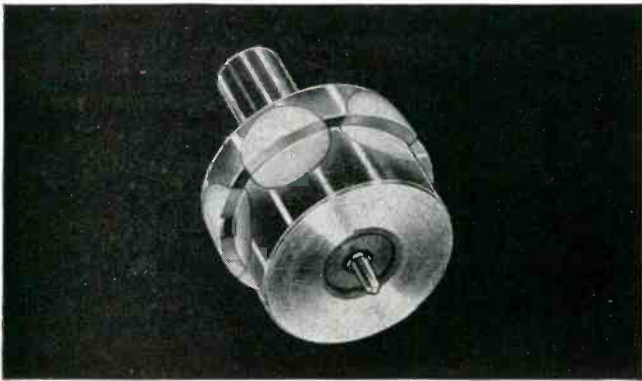

1. This rotary switch demonstrates several of the unusual properties that are winning a leading place for Kel-F in electronic applications. In production, Kel-F is injection molded into the metal switch case around an intricate insert . . . result—an hermetic seal between plastic and metal, plus high electrical resistance and dimensional stability.

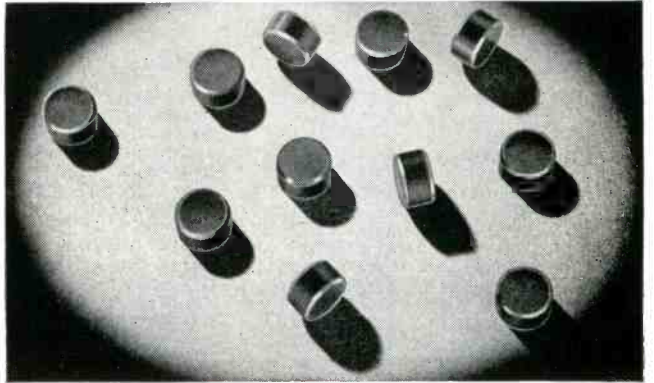

2. Glass fiber and Kel-F are combined to produce these compression-molded valve seats for compressed-gas tanks. Kel-F's chemical inertness eliminates chance of corrosion problems. Its dimensional stability combines with that of the glass fiber to deliver finished parts that have minimum deformation over an extremely wide temperature range.

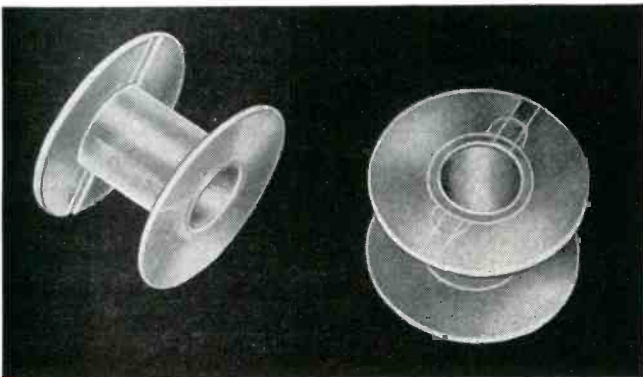

3. These coil forms are molded on standard injection equipment at very favorable production rates, again pointing up Kel-F's superior molding properties. Further reasons for specification of Kel-F in a rapidly growing list of such high frequency electronic applications are—performance at high temperature; excellent insulating properties; and zero moisture absorption.



4. Machined to close tolerance from solid rod, on an ordinary automatic screw machine, these bushings illustrate Kel-F's versatility. Such ready machinability combines with physical strength, chemical inertness, dimensional stability and electrical resistance to make Kel-F a sound specification for many types of chemical and electrical fittings.

A Capsule Report on the Properties of KEL-F

- ★ Chemical Inertness
- ★ Wide temperature range —minus 320 F to 390 F
- ★ High electrical resistance
- ★ Low Cold Flow
- ★ Zero Moisture Absorption
- ★ Variable transparency and flexibility properties
- ★ Readily molded, extruded and machined

Basic Kel-F Products Available

MOLDING POWDERS

Unplasticized

#300 . . . for high temperature service

#270 . . . for less severe temperatures

Plasticized (in either #300 or #270)

P 20 . . . with 20% plasticizer

P 25 . . . " 25% "

P 30 . . . " 30% "

DISPERSIONS

NW-25 . . . flows readily at fusion temperatures

N-1 . . . High molecular weight

OILS, WAXES and GREASES

#1 . . . Light Oil

#3 . . . Medium Oil

#10 . . . Heavy Oil

#40 . . . Waxy Oil (pour point 80-90 F)

#150 . . . Hard Wax at 70 F (Greases compounded to order)

Standard Fabricated Kel-F Materials and Parts Available from Commercial Sources

Molded Sheets★ Extruded and Molded Rod★ Extruded Tubing
Thin Film (extruded as lay-flat tubing)

Gasket★ Washer★ Valve Disc★ "U" Packing

"O" Ring★ Kel-F coated Resilient-core "O" Rings

Valve Diaphragms

Transformer Terminal★ Rotary Electric Switch★ Hook-up Wire

Electronic Terminals, Tube Bases and Coil Forms

For full information on various molders, extruders and fabricators of Kel-F products; also technical data on detailed properties, molding and application techniques—write

Chemical Manufacturing Division



THE M. W. KELLOGG COMPANY

A SUBSIDIARY OF PULLMAN INCORPORATED

P. O. Box 469, Jersey City 3, N. J.

**Motorola
Announces**

**Another Best-Choice
for You**

NEW

450-470 Mc.

2-Way Radio Communication Equipment
for New Public Safety, Land Transportation,
Industrial, and Citizen Bands

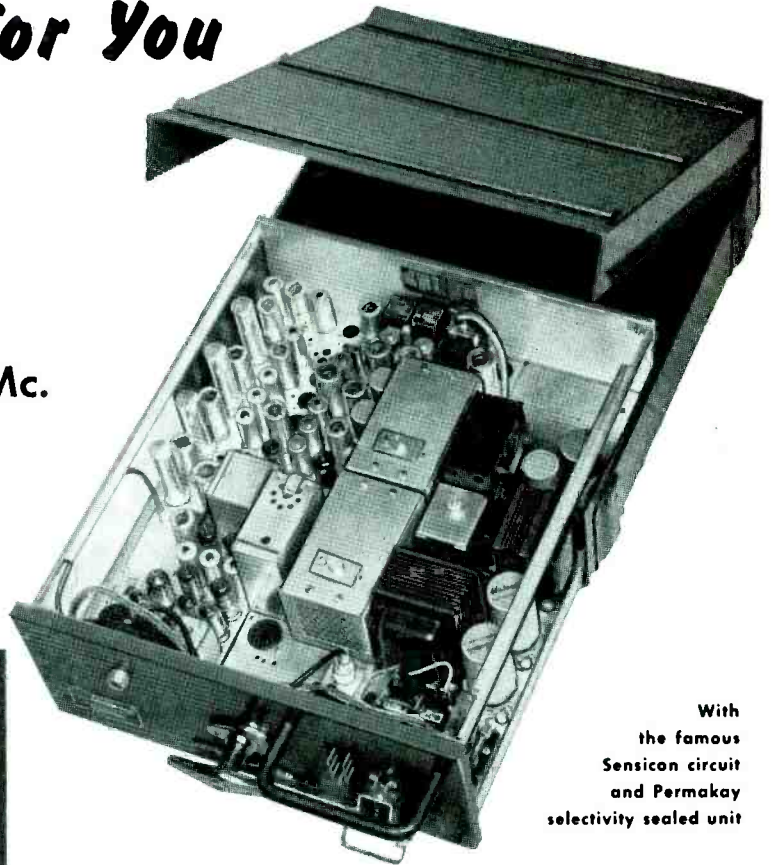

With
the famous
Sensicon circuit
and Permakay
selectivity sealed unit

**2-WAY
RADIO**

BROUGHT TO FULL SUCCESS

BY

Motorola

WORLD LEADERS IN 2-WAY RADIO

Now you can have all the advantages of uncongested non-interference operation up in the 450 megacycle range . . .

. . . for F.C.C. has given you the space, and Motorola has built for you the quality tool for best results. It is now released for sale to you after more than 2 years of rigorous testing and service in the field.

Here, once again, Motorola has put your best long-term *value* ahead of everything. It will save you up to 25% in maintenance alone.

This completely new design has the same guaranteed, obsolescence-free features that make Motorola equipment *all-ways* your best buy!

— the one others always try to copy

Motorola, Inc.

Communications &
Electronics Division
4545 Augusta Blvd.
Chicago 51, Ill.

PLEASE DISPATCH LITERATURE AND HAVE YOUR ENGINEERS CONTACT.

(Name).....

(Company).....

Address.....

City..... State.....

20 BY-PASS ERIE CERAMICONS[®]

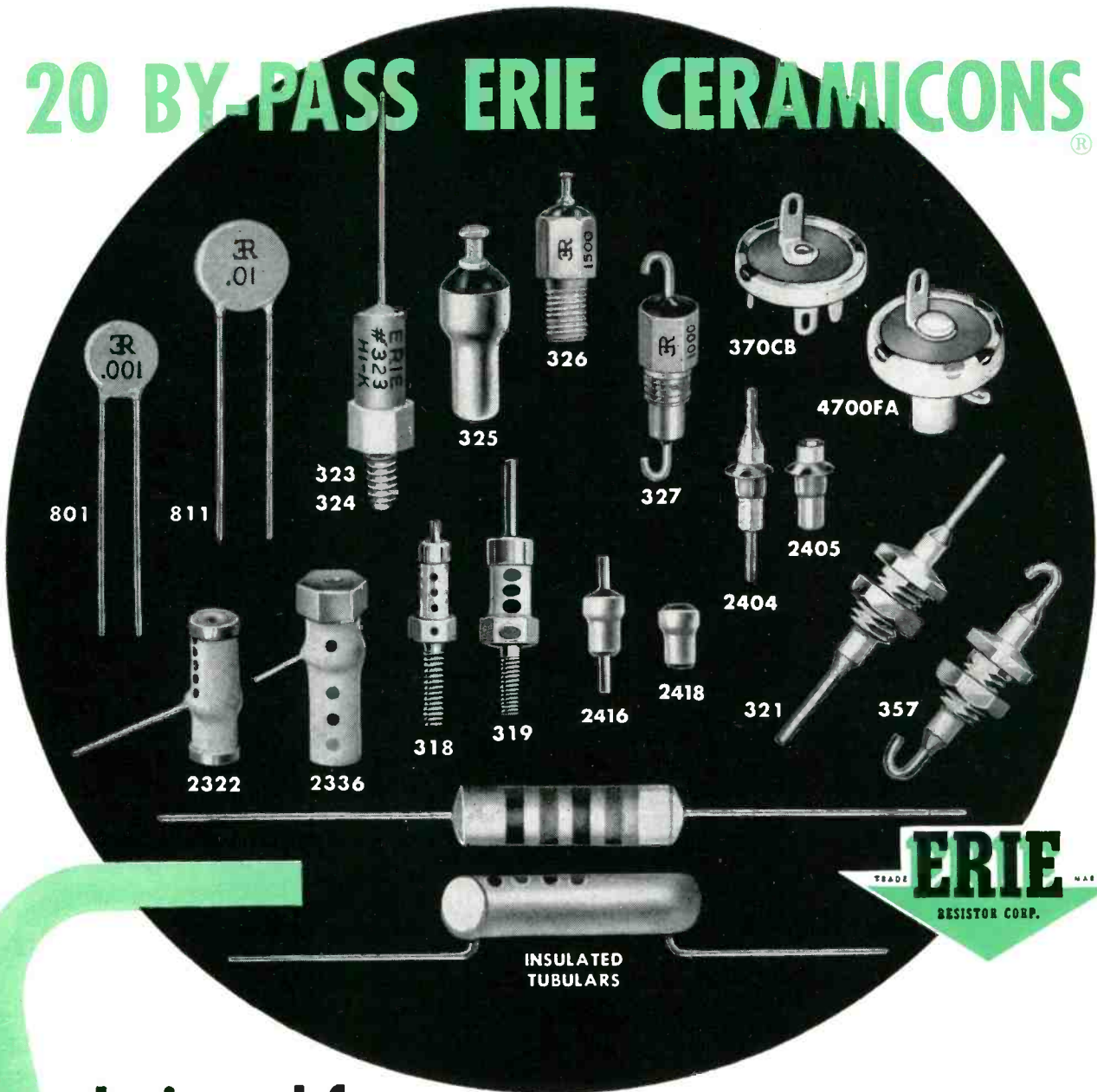

designed for MINIATURIZATION, RUGGEDIZATION

Erie Ceramicons fulfill all the requisites for efficient by-passing—compact design, low inductance, and conservative 500 volt D. C. rating. Erie Resistor offers the most complete line of ceramic by-pass units available. Each design has been thoroughly proven in domestic and military equipment.

Eighteen popular styles in ceramic ca-

pacitors are shown above. Feed-Thru's are supplied in values up to 2000 mmf, Stand-Off units up to 5000 mmf, Tubular and Disc units up to .01 mfd. Also shown above are two Silver Button Micacs representing the 370 series for values up to 1000 mmf and the 4700 series for values up to 6000 mmf. Write for samples to meet your specific requirements.

Electronics Division
ERIE RESISTOR CORP., ERIE, PA.
LONDON, ENGLAND • • • TORONTO, CANADA

Cliffside, N. J. • Philadelphia, Pa. • Buffalo, N. Y. • Chicago, Ill.
Detroit, Mich. • Cincinnati, Ohio • Los Angeles, Calif.

For the Answer to Your Insulation Problem

Look Through *this* Line...



● Can't guarantee that the Varflex Line will solve every insulation problem—large, small, unusual—that Varflex Electrical Sleeving or Tubing has solved. The Varflex range of application is vast—chances are you'll find the solution to your Electrical insulating problem somewhere in the Varflex line.

● **VARGLAS SILICONE.** That's the insulating sleeving and tubing—pioneered by Varflex—that takes temperatures ranging from 500° F above to 85° F below in its efficient, resistant stride. Lead wire and treated cord too.

● **VARGLAS TUBING IMPREGNATED WITH GENERAL ELECTRIC PERMAFIL.** Tough, flexible, heat-resistant—available in coils. Premium tubing at a reasonable price.

● **VARGLAS SLEEVING AND TUBING.** Numerous types and grades—including synthetic treated, varnished, lacquered, saturated, litewall and others.

● **VARGLAS NON-FRAY SLEEVING.** Three types—may be subjected to temperatures up to 1200° F—for applications where dielectric requirements are not primary.

● **VARFLO TUBING AND SLEEVING.** New, low-priced—for applications where unusually high temperatures are not a factor. A real economy line, this.

● **VARFLEX COTTON TUBING AND SLEEVING.** Varnish or lacquer impregnants—for applications where Fiberglass products are not required.

● **SYNTHOLVAR EXTRUDED PLASTIC TUBING.** Low temperature flexibility—high dielectric and tensile strength—made from a standard formulation of vinyl polymers.

SAMPLES? All you want with our compliments. For free folder of our complete line, just clip and mail this coupon.



**VARFLEX
CORPORATION**

**MAKERS OF ELECTRICAL INSULATING
TUBING AND SLEEVING**

VARFLEX Corporation, 308 N. Jay St., Rome, N. Y.

Please send me information as well as free samples of your electrical Sleeving and Tubing.

I am particularly interested in samples suitable for _____

Name _____

Company _____

Street _____

City _____ Zone _____ State _____

FOR RADIO



AND

TV

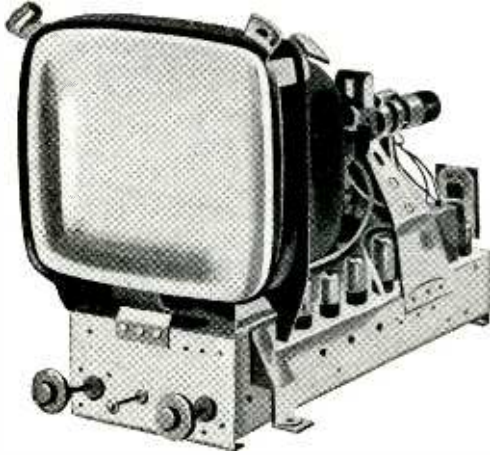

SOLDERING THAT LASTS...

USE...

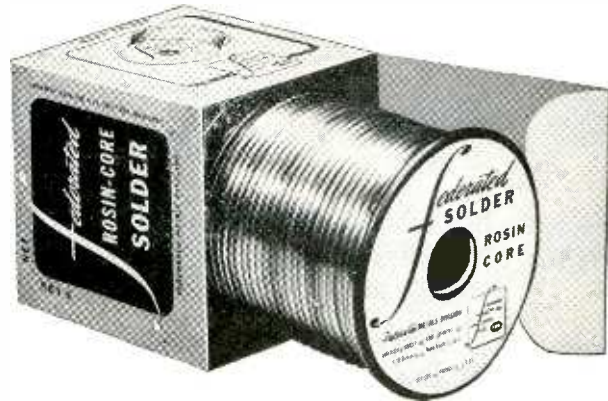

For any soldering job that demands freedom from corrosion and conductive flux residue . . . for ease of working and unequalled consistency . . . there is nothing better than Federated Rosin Core Solder.

Each Rosin Core Solder composition . . . there is a variety for different purposes . . . is a tin and lead alloy with a rosin flux that is effective but not corrosive. Because the rosin residue is chemically inactive, current leakage at radio and television frequencies is prevented.

Federated Rosin Core Solder is a quality product that is unsurpassed for the permanence of the bond it produces . . . for the consistently easier soldering job it does! Look for it in 1, 5, 20, 25, and 50-pound sizes on the familiar orange and black metal spool. Listed by Underwriters' Laboratories Inc.

Federated Metals Division



AMERICAN SMELTING AND REFINING COMPANY • 120 BROADWAY, NEW YORK 5, N. Y.

NEW, 10 Mc Wide Band Oscilloscope . . .

for precise, quantitative studies of pulse waveforms, transients and other high or low speed electrical phenomena

**LFE Model 401 Oscilloscope . . .
A high gain, wide band, versatile,
general purpose instrument**

Advances in electronics have placed greater demands on the time, frequency, and amplitude measuring capabilities of laboratory oscilloscopes. LABORATORY FOR ELECTRONICS, INC., recognizing the ever-increasing requirements of the rapidly expanding electronics industry, and using specifications set forth by electronic engineers, has developed the Model 401 oscilloscope to provide the features and conveniences required in a medium price, general purpose instrument.

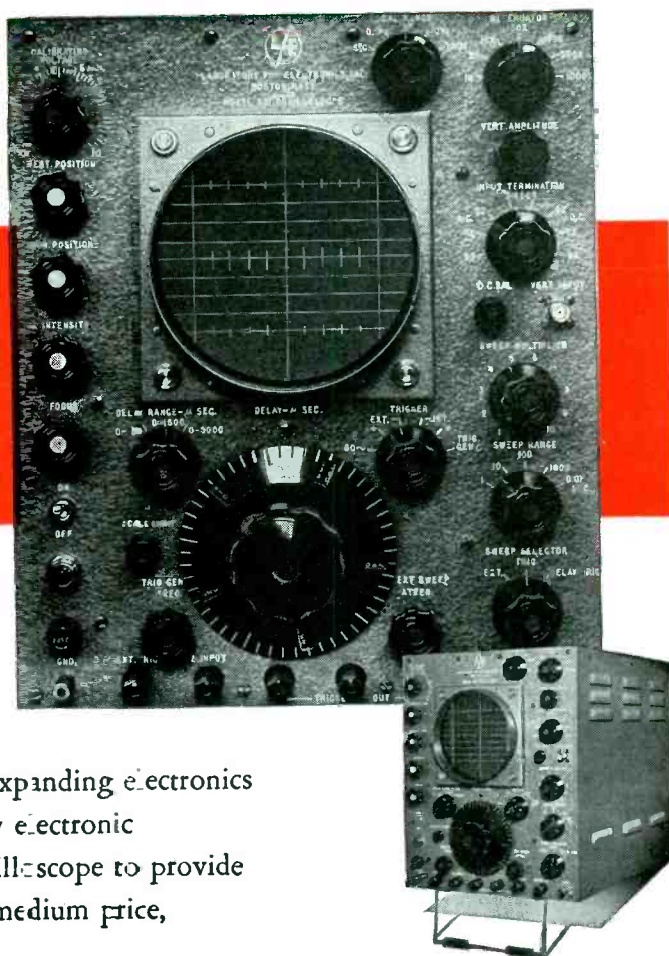

SPECIFICATIONS

Y-Axis

Deflection Sensitivity — 15 millivolts peak-to-peak/cm
Frequency Response — DC to 10Mc
Transient Response — Rise Time — 0.035 microseconds
Signal Delay — 0.25 microseconds
Input line terminations — 52, 72, or 93 ohms, or no termination, for either AC or DC input
Calibrating Voltage — 60 cycle square wave.
Input Imp. — 1 megohm, 30 mmf.

X-Axis

Sweep Range — 0.01 sec/cm to 0.1 microseconds/cm
Delay Sweep Range — 5-5000 microseconds in three ranges — continuously adjustable
Triggers — Internal or External, + and -, or 60 cycles, or delayed trigger outputs are available at suitable binding posts.
Built-in trigger generator for triggering external circuits and sweeps.

General

Low capacity probe
Functionally colored control knobs conveniently grouped
Folding stand for better viewing
Adjustable scale lighting
Facilities for mounting oscilloscope cameras
Dimensions — 12½" wide, 15" high, 19" deep
Weight — 55 lbs.
Price — \$895. F. O. B., Boston



**LABORATORY
ELECTRONICS, INC.**

Write for full color booklet with complete information.

75 PITTS STREET BOSTON 14, MASS.

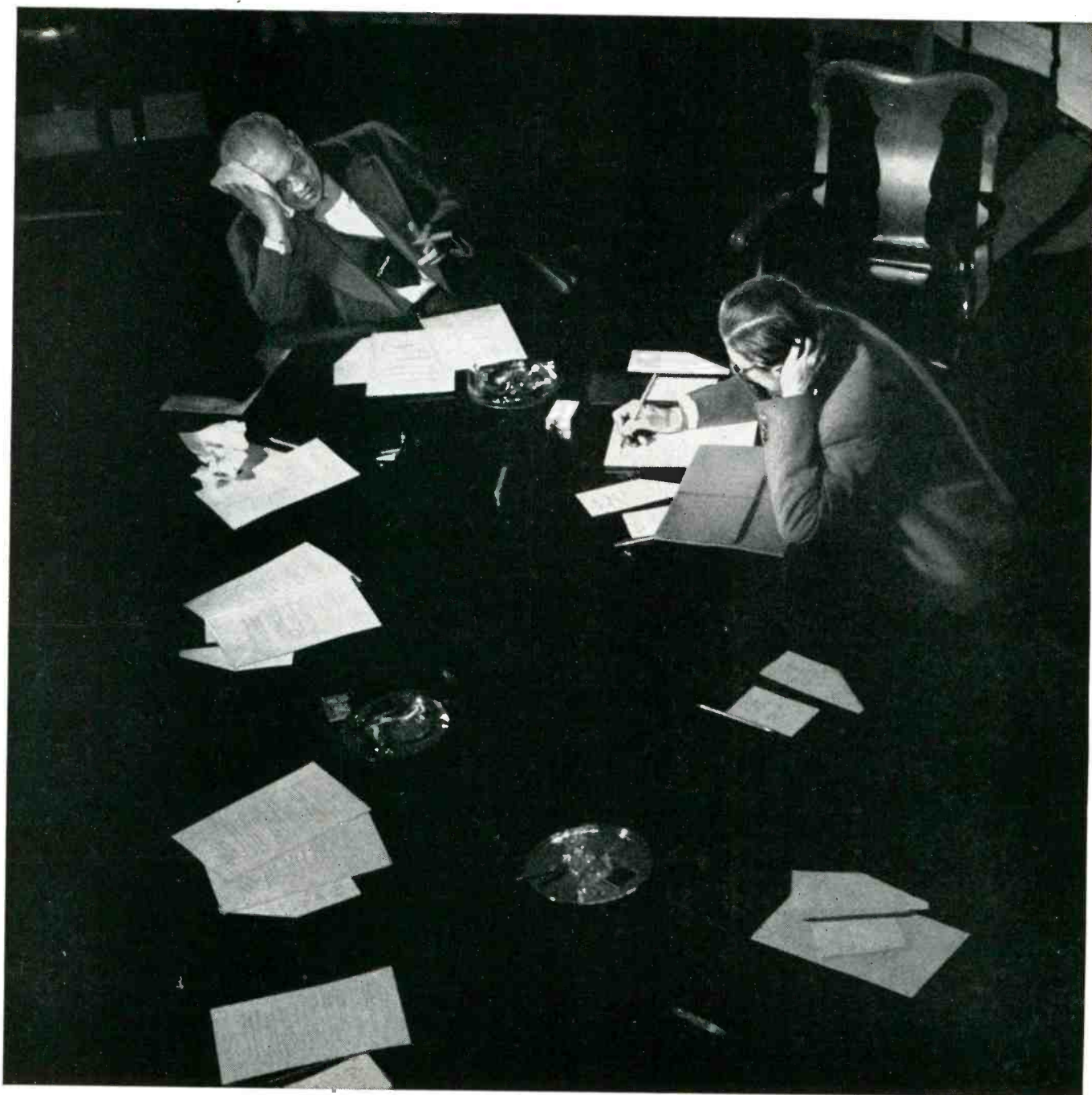

\$50,000 a day— for waiting!

These manufacturers are waiting.

In their factory, the production line has halted, the men are idle. And every day of this inactivity is costing them \$50,000—and more!

What happened? One small breakdown in an important machine has stopped the works!

Even though replacement parts are hundreds of miles away, there's one

way they could cut those days of waiting to *hours*. It's an answer that is saving thousands of manufacturers thousands of dollars every day.

That answer is—Air Express!

Air Express speed means *production* line speed. Whether your business is factories, films, or food, you can profit from regular use of Air Express. Here's why:

IT'S FASTEST — Air Express gets *top priority* of all commercial shipping services — gives the fastest, most complete door-to-door pick-up and delivery service in all cities and principal towns at *no extra cost*.

IT'S DEPENDABLE — Air Express provides one-carrier responsibility all the

way and gets a *receipt upon delivery*.

IT'S PROFITABLE—Air Express service costs less than you think, gives you many profit-making opportunities.

Call your local agent of Air Express Division, Railway Express Agency.



AIR EXPRESS
GETS THERE FIRST

Here's How BUSS FUSE "Know How" Helps Protect Your Reputation

The BUSS Fuses you buy today are the result of the production of millions upon millions of BUSS Fuses during the past 37 years. These years of specializing have taught BUSS engineers how to make fuses of unquestioned high quality — and still maintain a competitive price.

To make sure that a BUSS Fuse will always operate properly under service conditions . . . each and every BUSS Fuse is tested in a highly sensitive electronic device that records: — the fuse has the right capacity, is properly constructed and right in all physical dimensions.

Behind the established reputation of BUSS Fuses is the world's largest fuse research laboratory and the world's largest fuse production capacity.

If you have a special problem concerning electrical protection, let our engineers help you select or design the right fuse, or fuse mounting, to meet your needs. Our staff of engineers and laboratory are at your service.

BUSSMANN MFG. CO.
University at Jefferson St. Louis 7, Mo.
Division of McGraw Electric Company

BUSS offers a complete line of fuses for Radio • Television • Controls • Avionics • Radar • Instruments • PLUS a companion line of fuse clips, fuse blocks and fuse holders.

SEND THE COUPON FOR COMPLETE FACTS

BUSSMANN Mfg. Co. (Division of McGraw Electric Co.)
University at Jefferson, St. Louis 7, Mo.

Please send me bulletin SFB containing complete facts on BUSS small dimension fuses and fuse holders.

Name _____

Title _____

Company _____

Address _____

City & Zone _____ State _____

ELRC-752

It counts
your
"UPS and
DOWNS"

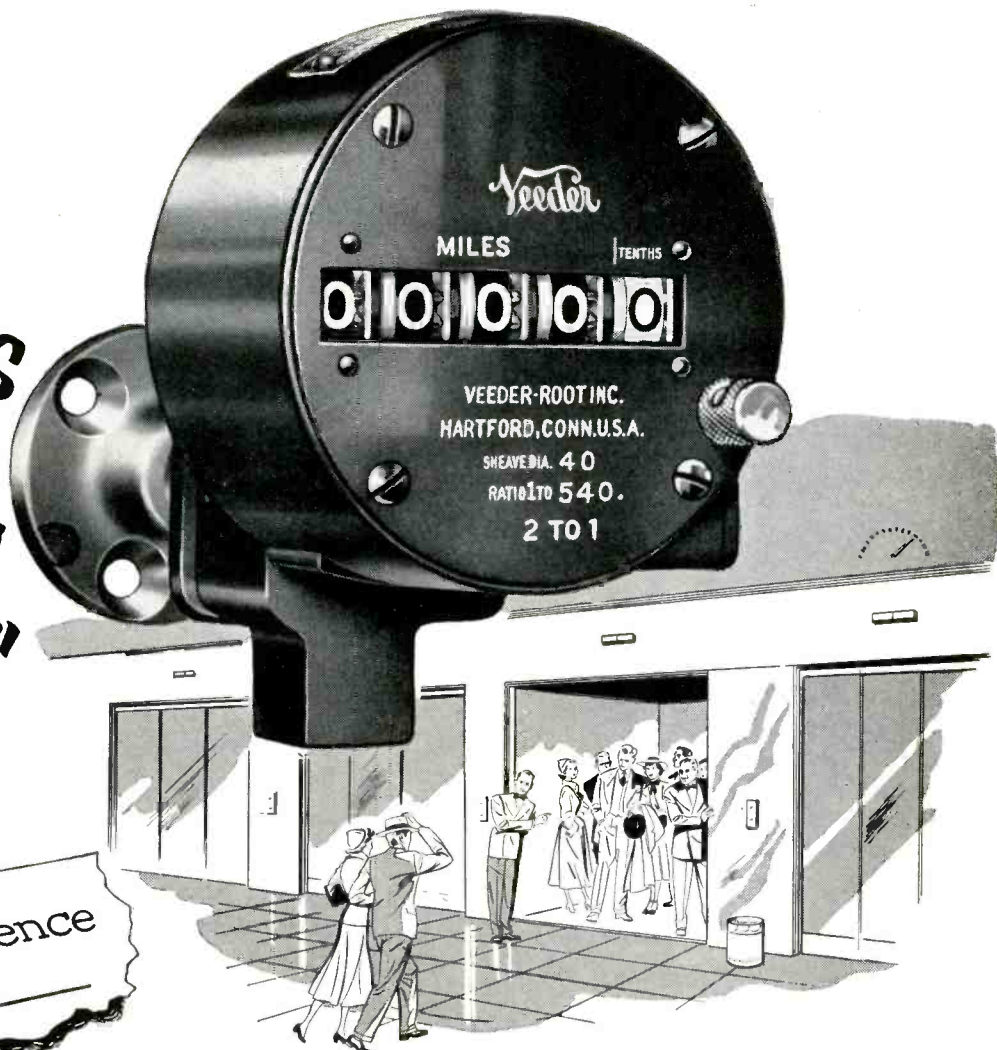

Added Evidence
that _____

Everyone Can Count on VEEDER-ROOT

Elevator Mileage Recorders give accurate figures on vertical miles . . . so that it can be plainly seen . . . *in advance* . . . when it's time to replace cables, overhaul cars, motors, and what have you . . . *including your life*.

Yes, the V-R wheelmark monogram protects millions of people daily, from the depths of the sea to the stratosphere. Of course, not all V-R Products and services are available nowadays



. . . but if your work counts importantly in defense, then you can count on Veeder-Root to help you, as soon as rush commitments permit.

VEEDER-ROOT INCORPORATED
"The Name That Counts"
HARTFORD 2, CONN.

Chicago 6, Ill. • New York 19 • Greenville, S. C.
Montreal 2, Canada • Dundee, Scotland

Offices and agents in principal cities

"Counts Everything on Earth"



HiVolt Power Supplies*

where size and weight must be kept to a minimum



These hermetically-sealed, self-contained power supplies are designed to transform AC to high voltage—low current DC for many applications. Our exclusive engineering techniques and oil-filled construction assure smaller, lighter, more flexible units.

Applications:

radiation counters

photoflash devices

spectographic analyzers

projection television sets

dust and electrostatic precipitators

oscilloscopes

display tubes

etc.

Send us your requirements and we will recommend the best HiVolt Power Supply.

MANUFACTURERS
Glassmike Capacitors
Plasticon Capacitors
HiVolt Power Supplies
Pulse Forming Networks

Condenser Products Company



7517 North Clark Street • Chicago 26, Illinois

* HiVolt Power Supplies . . . occupy as little as 1/3 the space; weigh as little as 20% of conventional supplies

Military Performance and Dependability

THE SX-73 COMMUNICATIONS RECEIVER

"A Gibraltar of Stability"

It is the ultimate in all-wave receivers . . . this jewel of precision craftsmanship. Refined in even the smallest detail, the SX-73 meets the tough military communications specifications.

Hallicrafters is proud to place its name on the SX-73.

PRECISION

hallicrafters

SX-73

Frequency Range:

540 kc to 54 Mc in six turret-selected bands.

20 tubes, including rectifier, voltage regulation and ballast tubes.

Dual conversion, 455 kc and 6 Mc crystal controlled.

Receiver type: Single superheterodyne in tuning ranges of 540 kc to 7.0 Mc and dual conversion on tuning ranges from 7.0 to 54.0 Mc.

Types of signals: AM, CW, MCW, ICW, and Carrier Shift Tele-typewriter.

Frequency calibration: 2 tenths of one per cent or less at all frequencies.

Image rejection: Not less than 80 db at any frequency.

Front panel controls: R.F. gain, AC on/off; b.f.o. pitch; audio gain; crystal phasing; selectivity; V.F.O./Crystal; crystal vernier; band selector; frequency; receiver/sound; CW/modulation; A.G.C./manual; A.N.L./off antenna adjust.

FRONT VIEW,
SX-73

HALLICRAFTERS • WORLD'S LEADING MANUFACTURER OF PRECISION RADIO & TELEVISION
CHICAGO 24, ILL.

MINIATURE PRECISION

CONNECTORS

Meeting EXACTING REQUIREMENTS FOR ELECTRONIC INSTRUMENTATION

POSITIVE POLARIZATION
FLOATING CONTACTS
PRECISION MACHINED CONTACTS
VIBRATION PROOF
MINERAL FILLED MELAMINE BODY
FLAME RESISTANT
HIGH DIELECTRIC AND
MECHANICAL STRENGTH

Our laboratory facilities, plus our vast experience in designing connectors and terminals, are available to develop designs according to your individual requirements.

The following products, illustrated here, are now in production:—

- Cable to Panel Connectors — 4 to 100 contacts
- Rack to Panel Connectors — 4 to 100 contacts
- Stand-off Terminals
- Miniature Stand-off Terminals
- Feed-thru Terminals
- Terminal Boards

HERMETICALLY

SEALED. Pin contacts with body plate to customer's specification and design.

The only standard for connectors ...

CONSTANT RELIABILITY

CONTINENTAL CONNECTORS

CATALOG #E-7
AVAILABLE ON REQUEST



Exclusive Sales Agents

DeJUR AMSCO CORPORATION
45-01 NORTHERN BOULEVARD, L. I. C. T., N. Y.
MANUFACTURERS OF SCIENTIFIC PRECISION EQUIPMENT FOR OVER A QUARTER OF A CENTURY
• CAMERAS • PROJECTORS • ENLARGERS • EXPOSURE METERS •

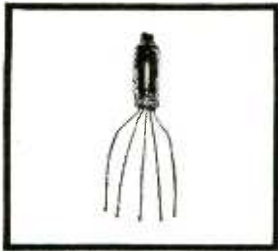

Nickel grid wire and strip, furnished in this case by Driver-Harris Company, Harrison, N. J. and Sigmund Cohn & Co., N. Y., N. Y. are components in this tiny (1" long) pentode amplifier tube used in hearing aids.

Peanuts to Power

...tubes perform better with **NICKEL**

From the tiny peanut tube in hearing aids to the tremendous power producer in transmitting equipment... in almost every tube... electronics manufacturers turn to Nickel to improve performance.

In cathodes, side rods, lead wires, grids, sleeves, connecting straps... in virtually every part... it's Nickel's special qualities that make that part do its special job... and do it better.

What are these qualities?

- Excellent forming quality. Simplifies production of precision parts.
- Strong, spot-welded joints practically free of oxidation.
- Strength to maintain precision despite handling in mounting parts.
- Rustproof in handling and storage. Corrosion resisting to solvents in cleaning.
- Lower gas content. Faster evacuation because gas can be removed at higher temperatures.
- Greater strength at high evacuation temperatures without crystal change, means less change in dimensions and tube constants.
- Better electron emission from coated nickel cathodes.
- Better carbon coating adherence with less embrittlement of strip.
- Conducts heat better at elevated temperatures.
- Good damping characteristics minimizing microphonic effects.

All of which means an electronic tube made with Nickel and Nickel Alloy components can perform better, whatever its application.



Low carbon Nickel was the choice for the spun anode sleeve and other critical parts in this 40 million watt power tube produced by the Chatham Electronics Corp., Newark 2, N. J.

Perhaps there's a Nickel or a Nickel Alloy that will help improve your product's performance. There's a concise booklet available—"Inco Nickel Alloys for Electronic Uses" which may answer your questions. Send to Bruce Winter for your copy today. Also, if you have a special metal selection problem, just write giving full details.

Nickel and Nickel Alloys are on extended delivery, so anticipate needs. It pays to order well in advance, always giving NPA rating and full end-use information.

The International Nickel Company, Inc.

67 Wall Street, New York 5, N. Y.

MONEL® • "R"® MONEL • "K"® MONEL
 "KR"® MONEL • "S"® MONEL • NICKEL
 LOW CARBON NICKEL • DURANICKEL® • INCONEL®
 INCONEL "X"® • INCOLOY® • NIMONICS

NICKEL  ALLOYS



*Maybe you're
missing a bet on*

HASH and INTERFERENCE SUPPRESSION!

Recent experience indicates that Stackpole molded iron cores and Ceramag® cores (ferrites) help materially in minimizing "hash" and r-f interference when used in the filter systems of electrical tools and equipment. Their advantages include

- ✓ **Less IR Drop** because of lower d-c resistance
- ✓ **Greater R-F Attenuation** because of less distributed capacitance
- ✓ **Concentrated Field** with consequent reduction in coupling to other coils
- ✓ **Reduced Space Requirements**
- ✓ **Increased Inductance** for a given amount of wire or, conversely
- ✓ **Less Wire** for the same inductance

As one of the earliest pioneers in core production, and backed with a complete line of materials, sizes, shapes and production facilities, Stackpole welcomes the opportunity to cooperate in adapting suitable cores to particular noise suppression problems.

Your inquiry entails no obligation and will receive prompt, skilled attention. Write to Electronic Components Division, Stackpole Carbon Company, St. Marys, Pa.

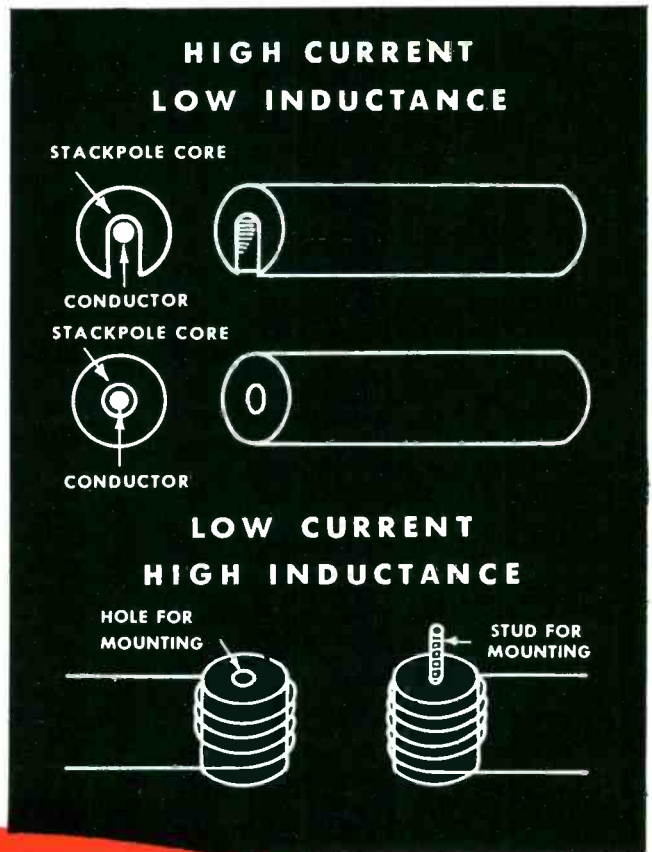

STACKPOLE
MOLDED IRON *Cores* CERAMAG® (FERRITES)

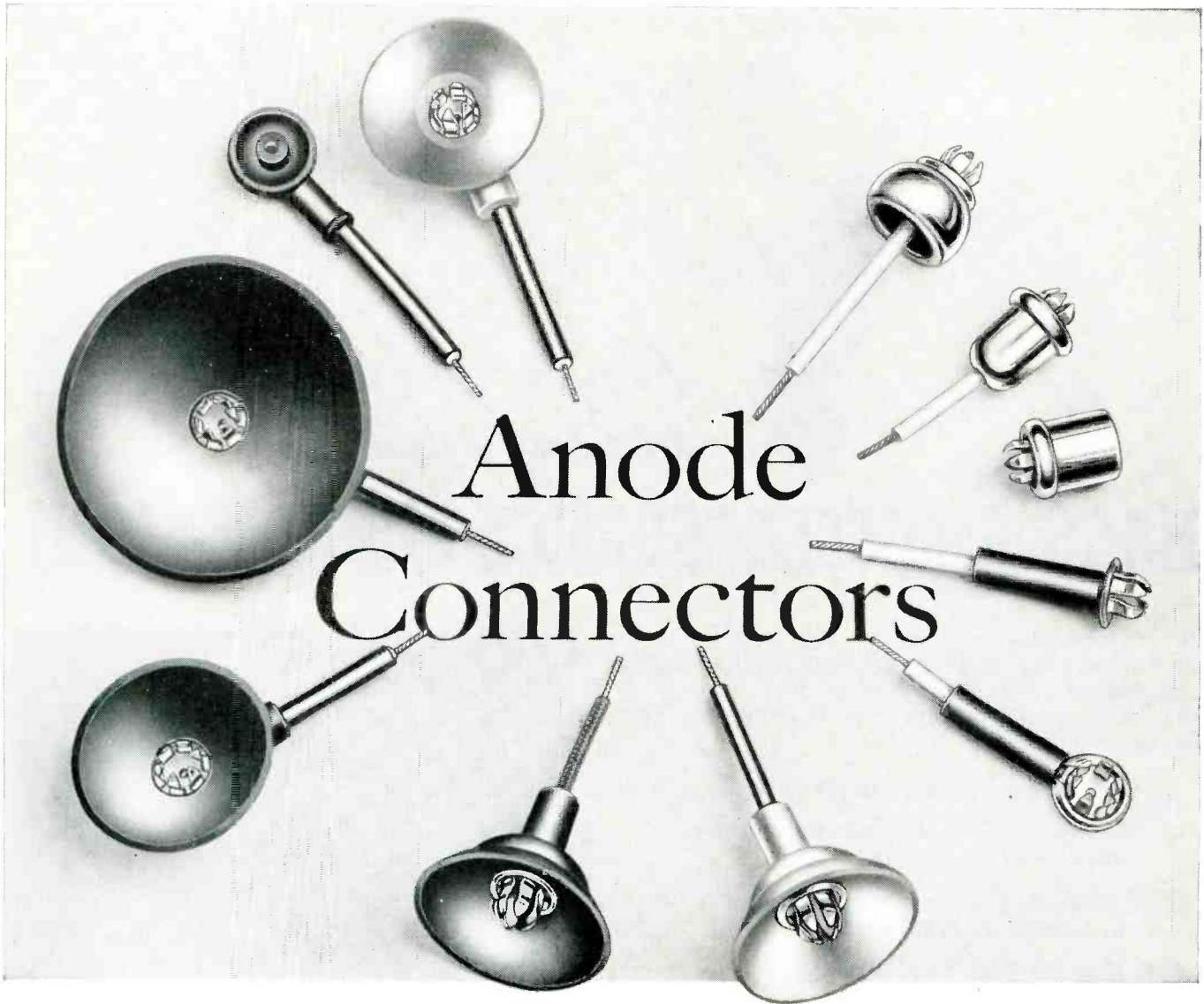

Anode Connectors

Ucinite Anode Connectors are available in several types for standard recessed small cavity caps in cathode ray tubes. Straight or right angle lead connections can be made with or without insulating shields. Shields are made from corona resistant neoprene or silicon.

Good contact and firm holding power are assured by silver plated, heat treated steel United-Carr Plug Buttons. Metal parts are designed to keep corona at a minimum.

Also available is the right angle connector with rubber suction cup shield for recessed small ball caps.

Other special corona resistant connectors and adaptors are available or can be readily designed for specific requirements.

Wire leads are furnished to customer's specifications.

Ucinite offers complete design and engineering services as well as volume production facilities.



The

UCINITE CO.

Newtonville 60, Mass.

Division of United-Carr Fastener Corp.

Specialists in

**ELECTRICAL ASSEMBLIES,
RADIO AND AUTOMOTIVE**

OFFERS COMPLETE COVERAGE

1. ..in electronic test instrumentation..

Today, *-hp-* offers complete instrumentation for virtually every type of electronic measuring. For audio work, *-hp-* oscillators and generators, ½ to 10,000,000 cps. For voltage measurements, vacuum tube voltmeters (ac and battery) 2 to 700,000,000 cps. For VHF, UHF and SHF, signal generators 10 to 7,600 mc. For microwave, a broad-band line covering all coaxial and 6 most-used waveguide frequencies. For microwave impedance and power measurements, complete new instrumentation, 10 to 12,400 mc. For frequency measurement, standards, monitors and cycle counters, .01 to 200 mc. These and more—over 200 fast, accurate, easy-to-use instruments—the world's most complete coverage of electronic measuring needs.

2. ..in convenient, "next-door" service..

-hp- has selected the best independent organizations in America to give you person-to-person help with your measuring problems. You are served by electronic specialists—men trained by Hewlett-Packard, fully informed about all *-hp-* instruments. These men save your time by helping select exact instrumentation you require. They can offer expert counsel on your measuring problems. They are located in major business centers, as near to you as your telephone. Call them whenever, *wherever* you need personal help, in your plant, *today!*

The *-hp-* field service program saves time!

The *-hp-* direct-to-you sales policy saves money!

HEWLETT-PACKARD COMPANY

2309A PAGE MILL ROAD • PALO ALTO, CALIFORNIA, U.S.A.

There is a trained *-hp-* representative near you!

Albuquerque, New Mexico
Neely Enterprises
107 S. Washington St.
Albuquerque 5-8731

Boston 16, Massachusetts
Burlingame Associates
270 Commonwealth Ave.
KENmore—6-8100

Chicago 40, Illinois
Alfred Crossley & Associates
4501 N. Ravenswood Ave.
UPTown 8-1141

Cleveland 15, Ohio
M. P. Odell Co.
2536 Euclid Ave.
PROspect 1-6171

Dallas 5, Texas
Earl Lipscomb Associates
P. O. Box 8042
Elmhurst 5345

Dayton 2, Ohio
Alfred Crossley & Associates
410 W. First St.
Michigan 8721

Denver 3, Colorado
Ronald G. Bowen Co.
852 Broadway
AComa 5211

Detroit 5, Michigan
S. Sterling Company
13331 Linwood Ave.
TOWnsend 8-3130

Fort Myers, Florida
Arthur Lynch & Associates
P. O. Box 466
Fort Myers 5-6762

High Point, North Carolina
Bivins & Caldwell
Security Bank Bldg.
High Point 3672

Houston 5, Texas
Earl Lipscomb Associates
2420-B Rice Blvd.
P. O. Box 6573
LInden 9303

Los Angeles 46, California
Neely Enterprises
7422 Melrose Ave.
WEBster 3-9201

New York 13, New York
Burlingame Associates
103 Lafayette St.
DIGby 9-1240

Philadelphia (Upper Darby), Pennsylvania
Burlingame Associates
7060 Garrett Road
FLanders 2-1597

Phoenix, Arizona
Neely Enterprises
32 West Jefferson St.
PHOenix 4-7311

Sacramento, California
Neely Enterprises
309 Ochsner Bldg.
GILbert 3-7461

Salt Lake City, Utah
Ronald G. Bowen Co.
P. O. Box 2215
MURray 900

San Francisco 18, California
Neely Enterprises
2830 Geary Blvd.
WALnut 1-3960

Seattle 9, Washington
Ron Merritt Company
217 Ninth Avenue North
SEneca 4948

St. Louis 9, Missouri
Harris-Hanson Company
5506 S. Kingshighway
SWEetbrier 5584-85

Syracuse 2, New York
Burlingame Associates
712 State Tower Bldg.
SYracuse 2-0194

Toronto 2-B Ontario, Canada
Atlas Radio Corporation, Ltd.
560 King St., West
Waverley 4761

Washington 9, D. C.
Burlingame Associates
2017 S Street N. W.
DEcatur 8000

HEWLETT-PACKARD  INSTRUMENTS



100% INSPECTION

.....assures top performance of
JEFFERS
 high voltage capacitors

Other Jeffers Products

ceramic capacitors • disc capacitors
 high voltage condensers • capristors

**Other Speer Products
 for the Electronics Industry**

anodes • contacts • resistors • iron
 cores • discs • brushes • molded
 notched* coil forms • battery carbon
 graphite plates and rods

*Patented

Other Speer Divisions: Speer Resistor,
 International Graphite & Electrode

You can be sure of maximum results from Jeffers high voltage television capacitors for two reasons:

FIRST—every unit is 100% inspected for capacity, power factor, leakage, and voltage. The testing device is adjustable, permitting each capacitor to be held at high test voltage for any specified length of time. Thus there is no chance for a defective part to get by.

SECOND—these high voltage capacitors are extremely well made. They are completely encased in a special thermosetting molding material of exceptional strength. All terminals are securely soldered to the high dielectric constant ceramic body. The entire unit is impregnated under vacuum with a micro-crystalline wax to give extra protection against moisture.

Jeffers high voltage capacitors are ideal in circuits for filtering or by-passing, where the AC component is small. Why not put them to work for you? Write today for our specification sheets.

Jeffers Electronics Division
 Speer Carbon Company
 Du Bois, Pennsylvania



GUARD RING SEAL

Clearly Nuclear

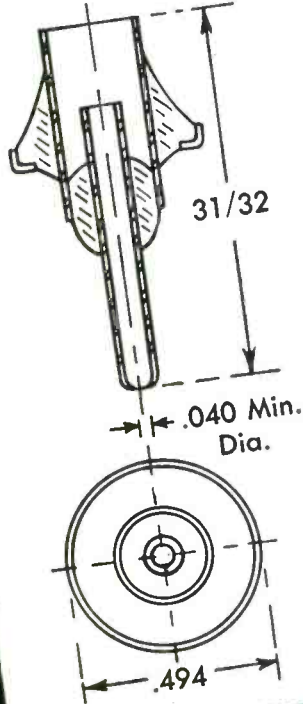

Clearly nuclear and definitely an achievement in precision production, the Guard Ring Seal is typical of Hermetic Seal's daily accomplishments. Currently used for boron trifluoride filled neutron counters, Geiger counters, etc., the Guard Ring Seal gives improved operation under conditions of high humidity and contamination. It also gives freedom from micro-second surface breakdown pulse when pin to body voltage is 2000 V.

For your requirements in hermetic seals, for information and help in planning a product, consult the experienced source for quality hermetic seals and be right every time.

Visit Hermetic's booth #418 at the Western Electronic Show and Convention, Long Beach, Cal., August 27, 28 and 29.



Hermetic Seal Products Co.

31 South Sixth St., Newark 7, N. J.

Write

for your copy of our new 32-page brochure, the most complete and informative presentation ever made on hermetic seals.

The Triumph Manufacturing Co.

*“Galley duty in the Navy requires
a motor control as rugged
as the machine”*

say Sheldon B. Storer (right) and Samuel T. Bryant (left), Sheldon Storer & Associates, Cincinnati, Ohio, representatives, Ward Leonard Electric Company.

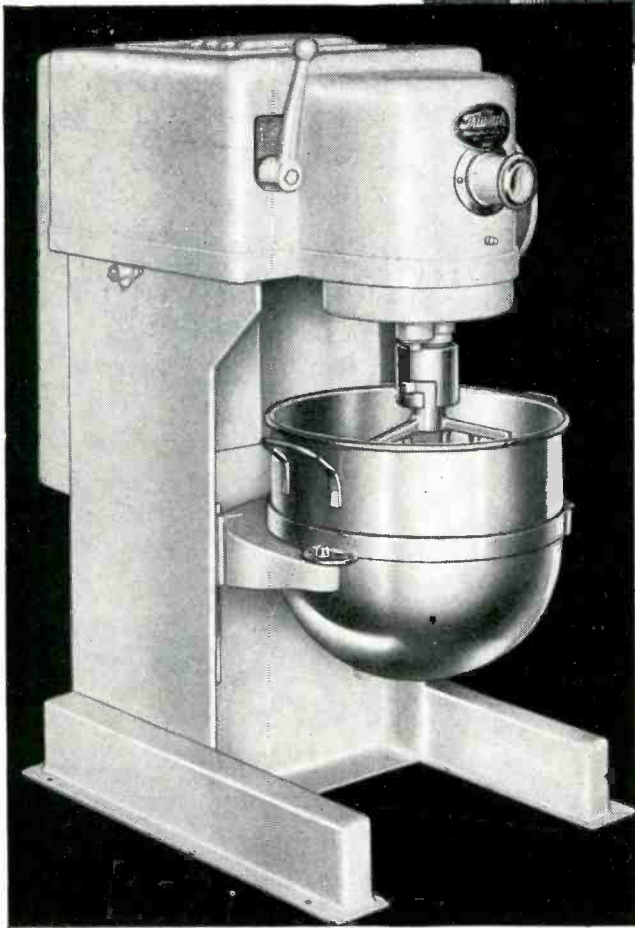
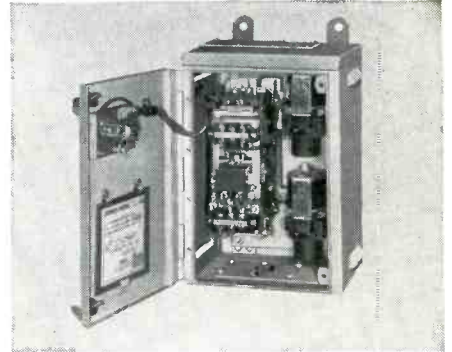
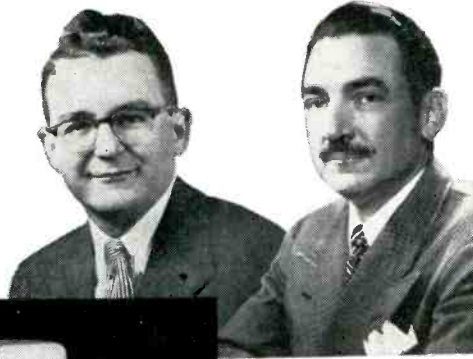

This Triumph vertical “kitchen” machine is used by the Navy for everything from mixing dough to cutting French-fried potatoes, grinding coffee, sharpening cutlery.

Such machines are operated by a wide variety of people wherever naval vessels or installations are found and it is essential to keep them in operation with a minimum of down-time.

In order to meet exacting Navy standards, Triumph consulted Ward Leonard for a motor control. Because of their long experience and excellent record in the production and development of Navy controls of many types, Triumph was assured that Ward Leonard could supply them with sturdy, trouble-free equipment which would match the construction of their ruggedly built machines.

The Ward Leonard controllers used by Triumph vary only depending on whether the power supply is a-c or d-c. For d-c applications they are Ward Leonard, Bulletin 4556, across-the-line starters, magnetic type, continuous duty, semi-automatic operation with overload and low voltage protection, drip-proof enclosure and spraytight pushbutton station; Bulletin 4651 is the equivalent for a-c applications.

Complete operating and maintenance instruction books were supplied the Navy as a result of the team work of William Leuze, chief engineer of Triumph, and Samuel Bryant of Ward Leonard.

Ward Leonard field engineers are always ready to work with you to solve your electrical control problems. When your production demands exact engineering, quality manufacturing, prompt, efficient handling and shipping, call on Ward Leonard.



WARD LEONARD ELECTRIC COMPANY

MOUNT VERNON, NEW YORK

Result-Engineered Controls Since 1892



TO INSURE HIGH METAL QUALITY, Frank DePaola, chemist, studies samples microscopically for grain and crystal structure.



MAGNETIC OVERLOAD RELAYS are tested for tripping time by Anthony J. Bellitto before they are installed on motor control panels.

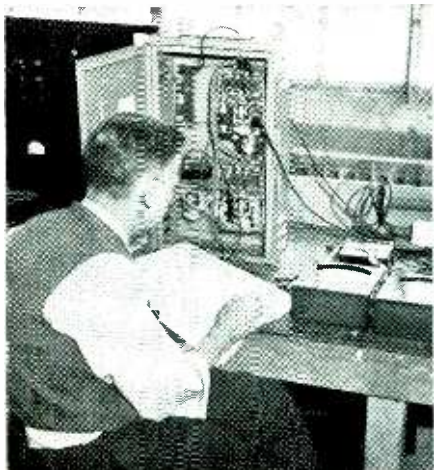

AN A-C MOTOR CONTROLLER undergoes a careful wiring check by Donald A. Parsons of Ward Leonard's Test Department.



COMPONENTS OF A-C SOLENOID STARTERS are being assembled in Ward Leonard's plant in Mount Vernon, New York.

From PT Boats to Battle Wagons — Ward Leonard Designs Controls to Meet Exacting Specifications

At sea, electrical controls or components must meet exacting service conditions involving mechanical shock, vibration, salt spray, plus pitch and roll.

The Ward Leonard control line includes devices designed especially for Navy, Coast Guard and Maritime use, as well as the well-known industrial control line. For example, Ward Leonard makes pushbutton stations for the Navy and Maritime applications, and a comprehensive line of commercial pushbutton stations. This holds true for a great variety of components.

Ward Leonard frequently builds special control items which involve contactors, starters, rheostats, relays, resistors, and other major electric components.

Ward Leonard controls are of unit construction. Each component is manufactured and tested independently. These components are then combined and mounted to suit customer's exact requirements.

Consult Ward Leonard on the extreme flexibility and adaptability of Ward Leonard controls and components to meet your special needs.

DISTRICT OFFICES AND REPRESENTATIVES

Atlanta 5, Georgia	C. B. Rogers and Associates
Baltimore 18, Md.	Durling Electric Co.
Charlotte 1, N. C.	James L. Highsmith & Co.
Chicago 4, Illinois	Ward Leonard Electric Co.
Cincinnati 2, Ohio	Sheldon Storer and Assoc.
Cleveland 14, Ohio	The Ambos-Jones Co.
Corpus Christi, Texas	Branco-Kracy Co., Inc.
Denver 2, Colorado	Mark G. Mueller
Detroit 21, Michigan	Jesse W. Eakins Co.
Hartford 6, Conn.	Ward Leonard Electric Co.
Houston 1, Texas	Branco-Kracy Co., Inc.
Kansas City 2, Mo.	Maury E. Bettis Co.
Knoxville, Tennessee	John G. Pettyjohn
Los Angeles 13, Calif.	Ward Leonard Electric Co.
Memphis 3, Tenn.	E. E. Torkell
Minneapolis 5, Minn.	Marvin H. Kirkeby
Newark 2, N. J.	Ward Leonard Electric Co.
New Orleans 13, La.	Electron Engineering Co.
Philadelphia 2, Pa.	Ward Leonard Electric Co.
Pittsburgh 16, Pa.	W. A. Bittner
Roanoke, Virginia	Lynn H. Morris
Rochester 7, N. Y.	Ward Leonard Electric Co.
St. Louis 10, Mo.	Ward Leonard Electric Co.
Salt Lake City 1, Utah	Leonard M. Slusser
San Antonio, Texas	Branco-Kracy Co., Inc.
San Francisco 3, Calif.	L. F. Church Co.
Seattle 4, Wash.	Northwestern Agencies, Inc.
Tucson, Arizona	Central Station Equipment Co.
Washington 5, D. C.	Federal Engineering Co., Inc.

CANADA

Edmonton, Alta.	D. M. Fraser, Ltd.
Halifax, N. S.	D. M. Fraser, Ltd.
Montreal 25, P. Q.	D. M. Fraser, Ltd.
Toronto 1, Ont.	D. M. Fraser, Ltd.
Vancouver, B. C.	D. M. Fraser, Ltd.
Winnipeg, Man.	D. M. Fraser, Ltd.

EXPORT

New York 4, N. Y. | Ad. Auriema, Inc.



RHEOSTATS



RELAYS



MOTOR CONTROLS



CHROMASTER



Ward Leonard's complete engineering textbook, "Handbook of Power Resistors," \$3. per copy.

Unusual NON-LINEAR voltage resistance sensitivity

These unretouched photos of oscilloscope screens show the effect obtained by connecting a GLOBAR type BNR resistor in series with a fixed resistor across a 115 volt 60 cycle supply.

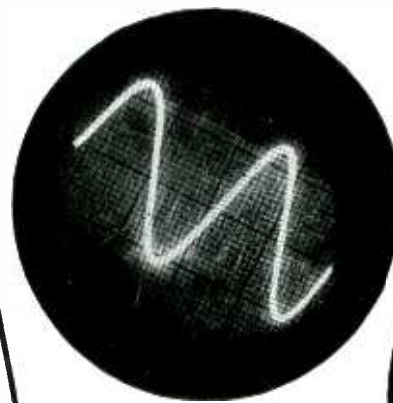

← Wave form of applied voltage



Wave form of current flowing in circuit →

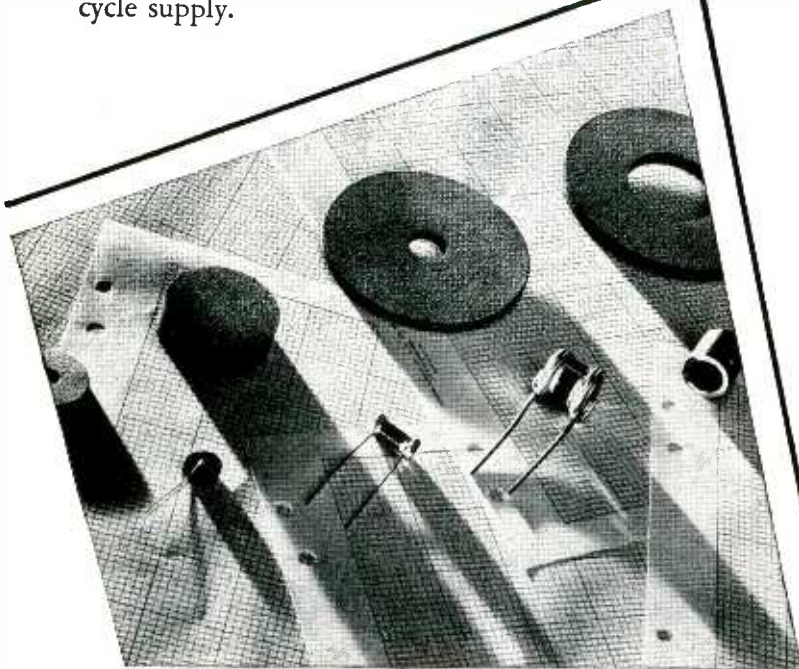

GLOBAR Type BNR conductive ceramic body resistors

Dampen the effect of transient voltages and provide instant protection for electrical circuits.

➔ **THESE ADVANTAGES** are realized in magnetic solenoid valves, motor governors, relay contacts and other surge absorbing applications as:

Write for Bulletin GR-2 which contains detailed engineering data. Address The Carborundum Company, GLOBAR Division, Dept. EL 87-113, Niagara Falls, N. Y.



1. Oil burner ignition transformers to prevent high voltage feed back into line.
2. Small motors to prevent arcing of governor contact points.
3. Stabilizing rectifier circuits by limiting peak voltages.

"Carborundum" and "Globar" are registered trademarks which indicate manufacture by The Carborundum Company



PUSH-ON SPEED NUTS®

Make New Record

FOR GRAY AUDOGRAPH

Here's how SPEED NUTS made a 50% savings in time, and a 75% material savings in the assembly of Gray AUDOGRAPH Dictating Machines . . .

Engineers at Gray Manufacturing Company took a second look at the index strip on their Audograph Machine and this is what they found. Five standard Tinnerman Push-On Type SPEED NUTS could be zipped over plain studs to attach the complete Index Strip Holder Assembly in half the time . . . replacing hex nuts, lock washers and eliminating special threaded studs.

This is just one of the many SPEED NUT Savings Stories being reported every day in a wide variety

of industries. Take a second look at some of your assembly operations with an eye to keeping costs down and quality production UP; your Tinnerman representative is prepared to help. SPEED NUTS are the most economical fasteners ever developed — to prove the point, we'd like to make a comprehensive Fastening Analysis of your product line. In the meantime, write for your copy of SPEED NUT Savings Stories, TINNERMAN PRODUCTS, INC., Box 6688, Cleveland 1, Ohio. *In Canada:* Dominion Fasteners, Ltd., Hamilton. *In Great Britain:* Simmonds Aeroaccessories, Ltd., Treforest, Wales. *In France:* Aeroaccessoires Simmonds, S. A. — 7 rue Henri Barbusse, Levallois (Seine) France.

The Gray Executive Model AUDOGRAPH machine pictured here is one of a complete line of dictating and sound-writing equipment. Above, right, sketch shows how Index Strip Holder is attached with Push-On Type SPEED NUTS. 5 SPEED NUTS and studs replace 5 special threaded studs, 5 Bronze Lock Washers and 5 Brass Hex Nuts.

TINNERMAN *Speed Nuts*
*Trade Mark Reg. U. S. Pat. Off.
FASTEST THING IN FASTENINGS®

Built for the toughest service



Mallory Q Series Wire Wound Controls

If you need a wire wound control that will stand up under the most severe conditions, here's the answer to your problem—Mallory Series Q controls. These new features make the Q series your best choice for military and other exacting applications:

- IMPERVIOUS TO MOISTURE AND FUNGUS:** all insulation used in this control is made of high resistance material which has exceptionally low moisture absorption . . . treated to prevent fungus growth.
- WEATHERPROOF FINISH:** nickel plated case, stainless steel shaft, and all other metal parts will pass a 100-hour salt spray test.
- LONGER LIFE:** hard nickel-silver contacts withstand the wear of thousands of rotations.
- SELECTION OF TAPERS:** all standard JAN tapers are available.

In addition to these standard features, Q series controls can be supplied in a number of special variations invaluable in applications requiring complete waterproofing or extreme resistance to vibration:

- WATERPROOF SHAFT BUSHING:** a waterproof gasket between shaft and bushing, sealed with silicone grease, prevents leakage along the shaft.
- WATERPROOF PANEL SEAL:** gasketed seal prevents leaks at the point of panel mounting.
- BUSHING LOCK:** a split bushing, when tightened, prevents shaft rotation even under severe shock and vibration.

Mallory carbon controls—with all the construction features of the wire wound units—are also available in the Q series design.

For full information on Q series controls, call or write Mallory today.

Series	Watts	Diameter	Similar JAN Type
QC	2	1 $\frac{1}{8}$ "	RA15
QR	2	1 $\frac{1}{4}$ "	RA20
QM	4	1 $\frac{1}{2}$ "	RA25 & RA30

P. R. MALLORY & CO. Inc.
MALLORY

SERVING INDUSTRY WITH THESE PRODUCTS:

Electromechanical—Resistors • Switches • Television Tuners • Vibrators
Electrochemical—Capacitors • Rectifiers • Mercury Dry Batteries
Metallurgical—Contacts • Special Metals and Ceramics • Welding Materials

P. R. MALLORY & CO., INC., INDIANAPOLIS 6, INDIANA



CROSS TALK

► **AGE . . .** Electronics is often called a young man's business, despite the fact that it is now well out of swaddling clothes.

Our field continues to attract young men, and profits from their freshness and virility. It does so for two reasons. First, the potential applications of electronics still seem boundless. Second, the field now also represents one of the country's most important going businesses. Mere newness is no longer the sole attraction.

The industry itself is frequently fascinated by youth alone and, currently desperate for technicians, sometimes robs the cradle. There are signs of returning good sense in Help Wanted ads. Several companies are deliberately bidding for the engineering experience found side by side with age. Others are welcoming older engineers into management.

A good oldster is better than a bad youngster. A good youngster is better than a bad oldster. The yardstick is ability, not age.

► **BOATS . . .** In the approaching summer season we will spend what is laughingly called spare time cruising Long Island Sound under power and sail.

Marine radiophone WC2600, aboard "Dolphin," taxes the rarely-charged storage battery. Amateur station W2TY normally remains silent for this reason, and because two hobbies overtax weekend recuperative powers. The idea of installing an electronic depth

finder is nevertheless appealing. But there is a bug.

Units we've seen tell how much water is *under* the boat. Since we normally puddle-jump close in-shore, what is needed is one that puts out a nice narrow pencil of ultrasonic energy *ahead*. This would enable us to duck unlighted buoys on night runs and safely grope our way into tight and shallow little harbors.

There's a market for a different kind of design.

► **PARTS . . .** As transistors develop commercially, electronic circuitry will change. This is widely recognized. Among other things, input and output impedances are quite different from those involved in conventional tubes.

Not so widely appreciated is the certainty that other component parts will change too. Consider several publicized virtues of the transistor. It is small. It requires no heater current. It operates at low voltages. So associated parts will also have to be small, and their ability to handle watts may be a minor rather than a major design consideration.

Maybe we are in for an era of sub-subminiature components. Or do you prefer micro-miniature?

► **DEFINITION . . .** Making the rounds in Washington to sort out the facts and fictions that so obsess this and other industries, we picked up a phrase about the city that explains why such checking

of rumors is necessary.

Washington, it is said, is "the only place in the country where sound travels faster than light."

► **SPECIALIZATION . . .** Engineering is a highly specialized field of endeavor. Don't look now, but right in your own shop it is rapidly becoming even more so.

There are administrative engineers, development engineers, systems engineers, project engineers, product engineers, standards engineers, production engineers, quality control engineers, test engineers, packaging engineers, field engineers and even publication engineers. Probably we've left out a few.

Electronic applications of one kind or another are becoming so complex that engineers are subdividing right in their own bailiwick.

► **SHOPTALK . . .** Many readers have found "Industry Report" (p 5) interesting and valuable, if not downright indispensable. Others have found "Production Techniques" (p 228) ditto. But some are apparently so far behind in their reading that they are not yet aware of these two innovations running regularly since February.

A piece of our editorial hide adheres monthly to these two new departments. So, we can't resist planting this sixth-month call-up.

Not even electronically do we know a way to put a steam whistle on the contents page.

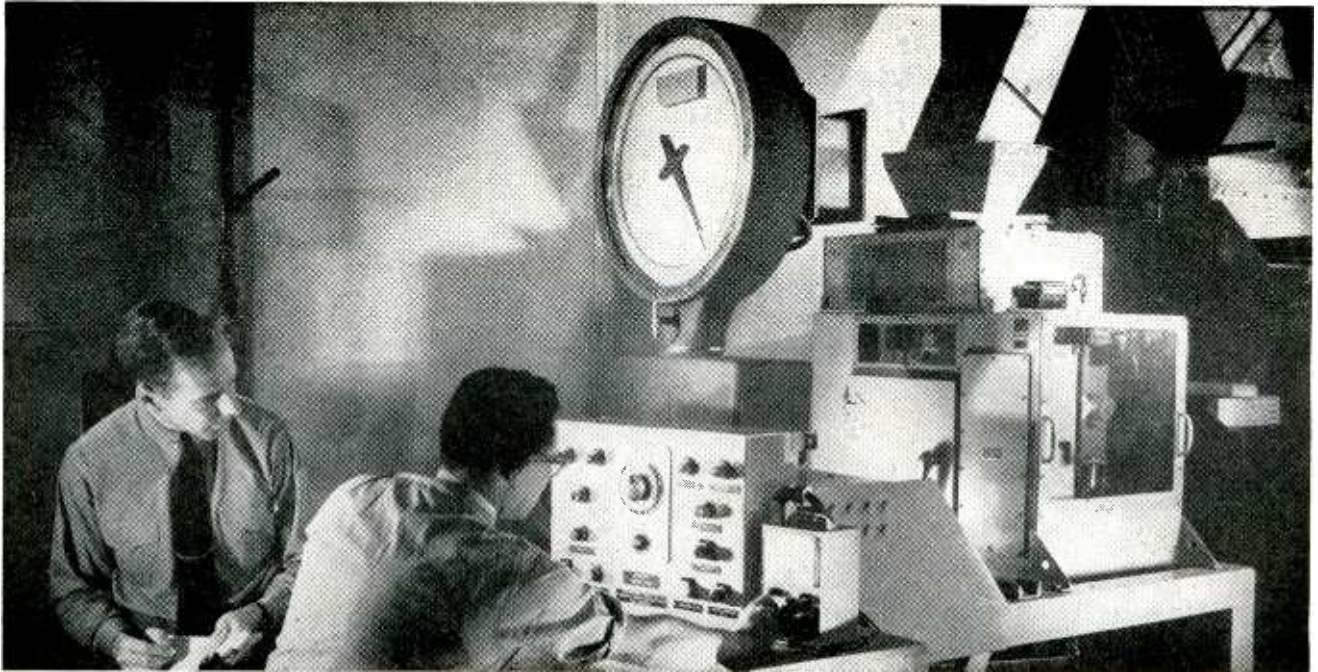

Weighing industrial-process ingredient by electronic control. Equipment shown is manually sequenced. Fully automatic controls handle several ingredients

Remote-Control Automatic Weighing

AUTOMATIC PROPORTIONING of solid and liquid ingredients for industrial processes is accomplished electronically by the Richardson Select-O-Weigh. This device permits remote control of one or more automatic scales to deliver an unlimited number of commodities into a continuous process either cumulatively or consecutively. For example, a proportioning system installed in a rubber-processing plant allows four different grades of carbon blacks to be weighed accumulatively into a single scale-hopper according to preselected schedules. Upon completion of the required accumulation, the machine discharges its load and is ready to begin a new cycle.

The system comprises a dial scale, a remote weight-setting vernier dial, and an electronic cut-off switch to stop the various feeders when the correct weight of an ingredient has been attained. The cut-off switch is actuated by proximity of a metal flag on the weight-scale pointer to

By **ENRICO KLEIN**

*Chief Electrical Engineer
Richardson Scale Co., Clifton, N. J.*

a plastic-enclosed metal flag remotely positioned on the periphery of the weight-scale dial by means of a servomechanism.

Figure 1 shows schematically the

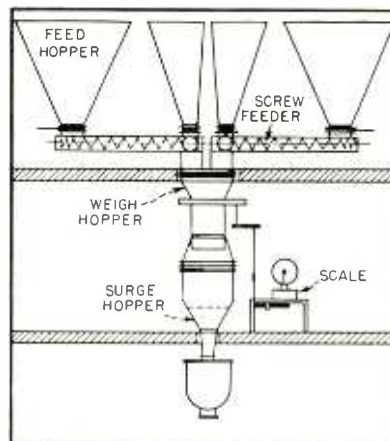

FIG. 1—System schematic showing screw feeders, weigh hopper, and weighing machine

physical arrangement of the weighing mechanism and feeders. The loading cycle of the scale is as follows: The electronic proximity-switch flag advances to the position pre-established on the servo pickup coil scheduling the first weighing. The first feeder, indexed by selection, starts. When the flag mounted on the dial-scale pointer, in advancing, meets the proximity flag, the feeder stops. The proximity flag then proceeds immediately to the position pre-established by the setting of the pick-up coil scheduling the second weighing and the second feeder starts.

Adequate time lags introduced into the cycle permit the flag to position itself before the feeder initiates. At the conclusion of the second feed, the remaining ingredients are added proportionally as scheduled. When the weighing cycle is complete, the machine rests awaiting the discharging impulse. The order of feeder selection is not critical and several pick-up coils

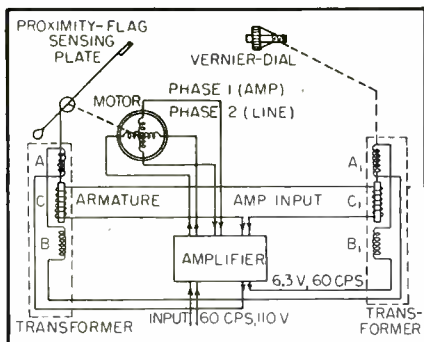

FIG. 2—Servomechanism positions proximity-switch sensing plate to program desired weight

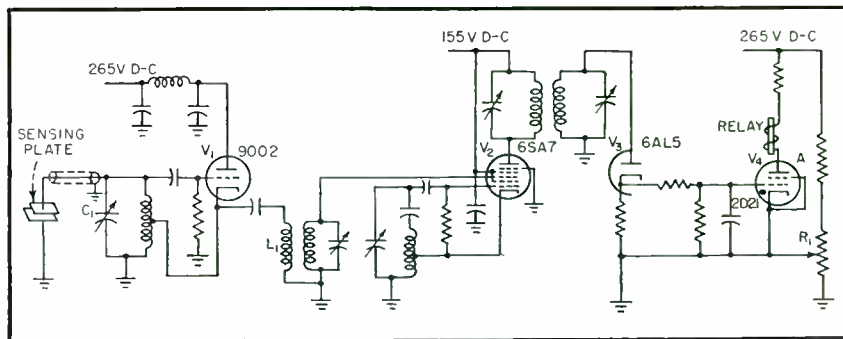

FIG. 3—Proximity flag-to-scale pointer capacitance tunes r-f oscillator of sharply-resonant switch circuit. Diode output voltage fires thyatron with 10,000-ohm relay in plate circuit

Industrial control circuits applied to automatic weighing facilitate remote batching of process ingredients. Desired weights set up on vernier dial are automatically obtained in proper sequence from storage bins by servomechanism

may be sequenced to operate the same feeder.

Each time the scale is discharged, a permanently adjusted pick-up coil is switched into the servomechanism. This compels the proximity switch to position itself at the zero or tare balance position on the weight-scale dial. The proximity-switch circuit is then actuated and a signal indicates complete evacuation of the scale's weigh hopper before the next cycle is initiated. An alarm pilot light indicates failure of the tare-check circuit to the operator.

Servomechanism

The proximity-flag positioning servo consists of two linear variable-differential transformers connected as shown in Fig. 2. Each transformer consists of three coils wound on a single spool with a free-moving armature of magnetic material mounted inside the spool. Alternating current is supplied to the center, or primary coil *C* and the magnetic flux generated by this coil is distributed by the armature so that a voltage is induced in the secondary coils *A* and *B*. If the armature is symmetrically located, the induced voltages will be equal, but if the armature moves to the left (up) the induced voltage in coil *A*

will be greater than the induced voltage in coil *B*. If the armature moves to the right (down) the voltage in coil *B* will be greater than that induced in coil *A*. In normal operation the coils are connected in a series bucking relationship so that, when the armature is centered and both coils have equal voltages induced, the resulting output is zero. If the armature moves to the left a voltage of one phase, *A*, will predominate and if the armature moves to the right a voltage of the other phase, *B*, will predominate. Phase *A* will differ from phase *B* by 180 degrees.

The pick-up transformer is connected to the vernier dial, which is graduated in pounds and installed on the control panel. This manual control is so calibrated that 0.1 inch motion of the servo pick-up coil armature represents full-scale displacement of the weighing-scale dial. Since the vernier-dial graduations are therefore proportional to the peripherally located weight markings on the weight-scale dial, the servomechanism can be used to position the proximity-switch flag at the desired ingredient weight.

The electronic proximity switch consists of a frequency-drift, proportional-output triggering circuit shown schematically in Fig. 3.

Oscillator tube *V*₁ is tuned to the broadcast frequency that will deliver highest power output through the i-f transformer at 455 kc and through the conventional mixer-oscillator circuit of *V*₂. Tuning is performed by *C*₁ and the fixed setting of the sensing plate in proximity to the scale-pointer flag.

Circuit Details

Coupling coil *L*₁ is a Meissner-type 14-1022 broadcast antenna transformer. The mixer-oscillator stage is a conventional arrangement. Output voltage through diode *V*₃ when the oscillator swings at the calibrated radio frequency of approximately 1,650 kc with the flag in proper proximity to the scale pointer is approximately 100 volts, while it is only 0 to 10 volts when off resonance. The voltage gradient between these two conditions is due to the sharply tuned i-f transformer.

The rectified output is fed into a 2D21 thyatron *V*₄, the triggering point of which is adjusted by biasing potentiometer *R*₁. Automatic-timed interlocks in the process-control circuit reset the thyatron plate circuit, dropping out the plate relay, by interrupting it at point *A*. A 10,000-ohm, plate-circuit, plug-in relay is used.

Binary Counter

By **ROBERT L. TRENT**

Member of Technical Staff
Bell Telephone Laboratories
Murray Hill, N. J.

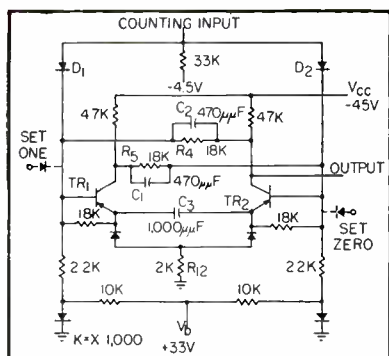

FIG. 1—Schematic diagram of the stabilized binary counter. The two transistors are point-contact type

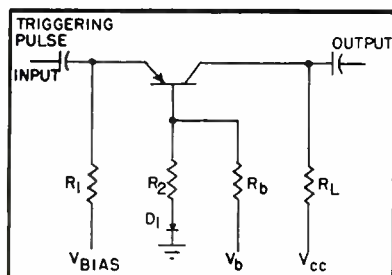

FIG. 2—Stabilized single transistor for triggering pulse input

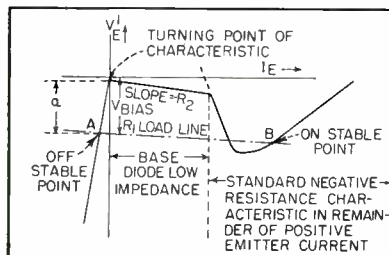

FIG. 3—Characteristic and load line for circuit of Fig. 2

TWO TRANSISTORS are employed in the general-purpose binary counter with two stable d-c equilibrium points described herein. The counter may be triggered from one stable point to the other by the application of pulses of the same polarity to a common input terminal.

Figure 1 is a schematic diagram of the counter. Two balanced transistor stages with back couplings between collectors and bases, consisting of C_2 and R_4 , C_1 and R_5 , are used. Direct d-c coupling is obtained by load resistor R_{12} and direct a-c coupling between emitters by C_3 .

Regenerative paths for a-c signals are provided by the couplings as well as d-c paths to achieve stability once the transient effects have

subsided. A diode steering circuit consisting of D_1 and D_2 impresses triggering pulses upon the transistor bases. The steering circuit gives direction by the difference of potential existing between the bases when one unit is in the ON condition and the other in the OFF condition.

The common emitter resistance R_{12} eliminates the necessity for a separate biasing supply for the emitters because it always passes the emitter current of the ON stage to provide the biasing potential for the OFF stage. The circuit also utilizes base stabilization and a feature insuring low triggering requirements.

Stabilization Feature

Triggering sensitivity and stable operating points of transistor trigger circuits may be affected markedly by variations among transistors and by variations in the operation of a single transistor at different temperatures. Transistors, at present, vary widely from one another in the amount of base current I_{co} , which flows when the emitters are biased negatively in the nonconducting region.

The variable base current, when flowing through the large base resistance added in the base circuit to obtain the desired negative resistance characteristic, causes variations in the turning point of the characteristic. By adding a biased diode in the base lead, a low shunting impedance is provided in the negative emitter current range.

This feature is illustrated in Fig. 2. The low impedance keeps variations in I_{co} from unit to unit from causing a wide range of voltages to be developed across the base resistances. The remainder of the standard negative resistance characteristic is obtained over a range of positive emitter current because of the high impedance condition.

To insure at least a minimum value of negative resistance as soon as positive emitter current is obtained after triggering, a small resistor has been added in series with the shunting diode. This resistor also gives a sharply defined turning point in the characteristic, resulting in ease of triggering and less loading of the triggering source. Higher frequency response is obtained because the transition time is decreased.

Effects of variations in I_{co} on the turning point may be kept within practicable limits by proper proportioning of the added resistance. The characteristic resulting is shown in Fig. 3. The stabilization feature has been applied to both transistors in the circuit under discussion.

Triggering Sensitivity

A binary counter stage should be stable enough so that when set to one condition, it maintains that

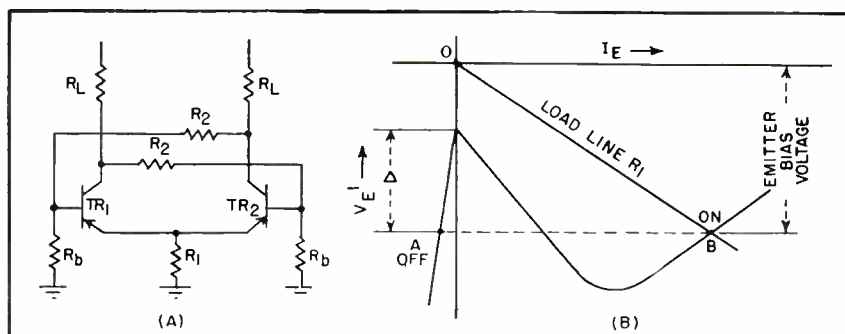

FIG. 4—Trigger circuit with lockup feature (A) and emitter characteristic (B)

Uses Two Transistors

Various timing and registry functions are provided by transistorized counter with repetition rate from 0 to 50 kc. It has stability without the usual sacrifice in sensitivity and it permits either positive or negative triggering pulses to be used

condition indefinitely until the next incident pulse is impressed upon the input lead. Unfortunately, satisfaction of this requirement often leads to poor triggering sensitivity. The counter under discussion uses circuits enabling both stability and sensitivity to be secured.

The simplified circuit of Fig. 4A shows the required lockup feature as performed by the common emitter coupling resistance R_1 and the cross-coupling resistors R_2 . Figure 4B is the characteristic for such a circuit, assuming that both transistors have identical characteristics and that each transistor acts separately as a two-terminal device. The ON unit is assumed to be stable at point B where the characteristic curve and the load line R_1 intersect. The OFF unit must be stable at the same emitter potential as in the previous case because of the coupling action of R_1 . The positive triggering pulse must have an amplitude greater than Δ .

When R_2 and the diodes are added, Fig. 5A, the effect on the characteristic and load line is shown in Fig. 5B. The ON unit has the same operating point B as before but the OFF unit no longer operates at point A . The diode in series with the OFF unit emitter is biased in the reverse direction to

give a new load line $E-E_1$ for the OFF unit.

The new load line intersects the normal characteristic at point C . The triggering pulse amplitude decreases from a value greater than Δ , as in the previous case, to greater than δ . A further decrease in the required positive triggering amplitude is obtained by use of shunt resistor R_3 to give intersection at point D . Triggering occurs in this case when the pulse is greater than γ . The sensitivity has been increased without sacrificing stability of the circuit.

Triggering Mechanism

The counter circuit, Fig. 1, may be triggered with either positive or negative pulses if the proper steering diode polarity is observed. With the circuit as shown, the diodes are connected for positive-pulse triggering. Steering is accomplished by the difference of potential between ON and OFF unit base connections. The ON unit base is always 5 to 10 volts more negative than the OFF unit base with the result that a positive pulse at the input will be impressed upon the ON unit base. This pulse also appears on the emitter of the ON unit because of the low impedance from base to emitter in the ON condition.

Coupling capacitor C_3 passes the pulse to the OFF unit emitter which is at a high impedance. The OFF unit is then triggered because it is stable at a point close to the turning point in the characteristic. A sharp pulse, 20 volts in amplitude with a rise time of 0.2 to 0.3 μsec , appears at the collector of TR_1 because of the triggering action. This pulse is passed back to the base of the ON unit by means of capacitor C_1 . The characteristic of the ON unit shifts abruptly in a positive direction.

If the characteristic shifts enough so that the emitter load line no longer intersects the characteristic, the only remaining stable point is in the OFF stable region. Following the time constant of C_2 and its discharging resistor, the collector voltage becomes more negative. This time constant sets the upper limit on the repetition rate of the counter.

Capacitor C_3 performs another function in keeping the potential difference existing between the emitters, during the triggering interval. This insures that the steering diodes will remain polarized correctly until the end of the transition period.

Triggering with negative pulses is accomplished by reversing the steering diodes. A negative pulse at the input is then impressed upon the base of the OFF unit.

Triggering pulse requirements for the counter are that the polarity may be either negative or positive, amplitude from 3 to 6 volts and duration greater than 0.6 μsec . Repetition rate is from 0 to 50 kc. Output pulse amplitude is from 16 to 25 volts with a rise time of 0.2 to 0.4 μsec and a fall time of from 2 to 4 μsec . Power input is about 0.5 watt.

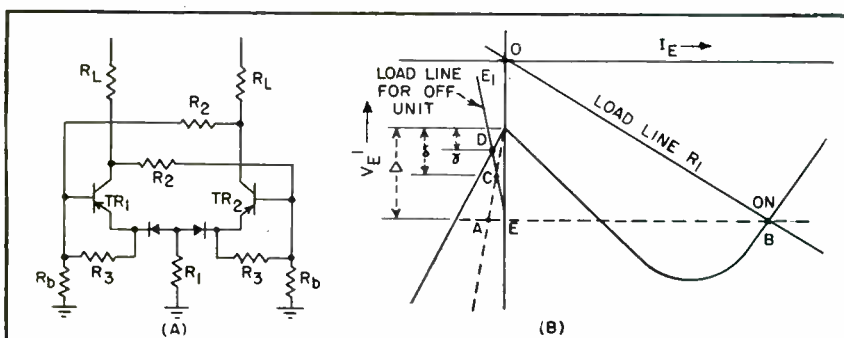

FIG. 5—Modified trigger circuit (A) and emitter characteristic (B)

TRANSMITTERS for

Design techniques have progressed since the 1948 JTAC report but the necessary megawatts then anticipated have yet to be realized. Transmitter powers to be commercially available in Fall and Winter will not exceed ten kilowatts but substantially higher power may be feasible in 1953

NOW THAT the FCC has officially unscrambled the television broadcasting situation in this country there remains the problem of engineering equipment for useful operation in the channels between 470 and 890 mc. The problem of delivering the required power levels is proving difficult.

When the uhf-tv band was first considered, the FCC asked the Joint Technical Advisory Committee (JTAC) to study the propagation characteristics of the proposed allocations. The resulting JTAC report showed that field strengths as much as ten times those normally required on the vhf channels would be necessary at uhf.¹

The FCC established a field strength of 500 microvolts per meter as adequate for residential-rural service on the 54 to 216-mc channels. The JTAC report estimated that 5,000 microvolts per meter would probably be required for same grade of service on the uhf channels.

The Norton propagation formula indicates that a signal of 5,000 microvolts per meter from an antenna height of 500 feet can be maintained at 40 miles only if an effective power of 214 kilowatts is radiated. An experimental trans-

mitter on the Empire State Building, operating on 510 and 910 mc showed that an effective radiated power of as much as 5 to 20 megawatts might be required in actual practice for such coverage.

Existing Equipment

At the time the new channels were proposed in 1948, the RMA Television Transmitter Committee reported that the maximum power available from existing tubes over a 6-mc channel was 2,000 watts at 475 mc and 500 watts at 890 mc. Antenna power gains of ten were then considered tops.

To evaluate the practical service possibilities of the uhf frequencies, NBC has operated station KC2XAK at Bridgeport, Conn. since December, 1949.² The transmitter comprises a 500-watt commercial vhf unit, providing picture and sound output on 176.75 and 178.25 mc, plus a tripler and power amplifier for each service. Final picture output frequency is 530.25 mc at a power output of one kw on sync signal peaks.

Both tripler and output amplifiers employ cavities with eight 4X150 tubes in each cavity. A slot antenna is employed at this station. A horizontal circular pattern is ob-

tained with 22 sets of four slots alternately arranged at 45-deg intervals about the supporting pole. The measured pattern of such an antenna 40 feet long shows a power gain of 17.

Tubes in parallel as the final amplifier have been operated on 609.25 and 709.25 mc by DuMont. Six 2C39A lighthouse tubes were mounted in a so-called beer-barrel cavity.³ This is formed of two coaxial-line cavities with the tubes mounted in the center of half-wave foreshortened lines and connected as a grounded-grid amplifier. One cavity becomes the cathode-grid circuit and the other is the plate-grid circuit. Fed to an antenna having a gain of 20, an output of 8 kw erp can be expected.

Another experimental DuMont setup used eighteen tubes in a similar beer-barrel cavity arrangement. About 750 watts of c-w power was available with good modulation characteristics at 600 mc.

To avoid parallel operation of several small tubes, General Electric has used a high-power klystron in a five-kw transmitter.⁴ The tube operates single-ended as a linear amplifier and can provide a power gain of 50. Using a helical antenna having a power gain of 20, an effective radiated power of 100 kw can be obtained.⁵ Recently, G-E filed specifications with the FCC for a 60-kw uhf transmitter designed around a higher-power klystron. This would produce about 1,000 kw of effective radiated power, the maximum presently authorized for uhf by FCC.

Commercial Equipment

For channels 14 to 83, RCA offers commercially the TTU-1B transmitter which provides 1-kw peak picture power and 500 watts of

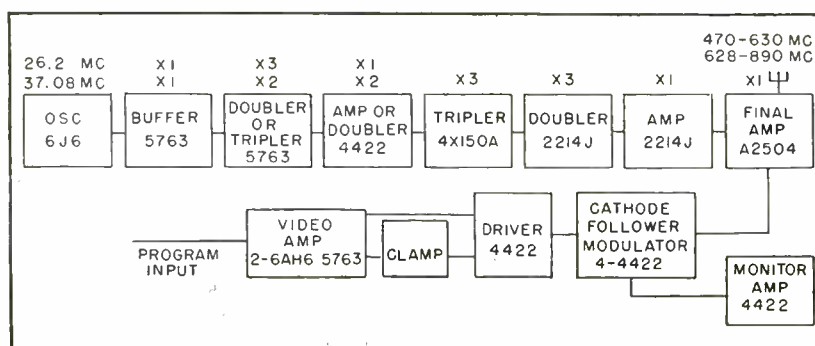

FIG. 1—Tube line-up of RCA one-kw picture transmitter

UHF TELEVISION

aural power out of the sideband filter and diplexer. A block diagram of the video transmitter is shown in Fig. 1.

Overtone crystals having output frequencies in the order of 26 to 37 megacycles are used. This permits a low multiplying factor between 18 and 24 (18 from 470 to 630 mc). At station KC2XAK, the crystal frequency of the video transmitter was 4,909.7 kc, and a multiplying factor of 108 provided 530-mc output. On a similar basis, a 6-mc crystal and a multiplying factor of 144 would be required to reach a final operating frequency in the order of 850 mc.

Proper operation of intercarrier receivers requires that the beat frequency between picture and sound carriers be 4.5 mc. The RTMA recommends that the maximum difference between the carriers not exceed 5,000 cycles. At vhf fre-

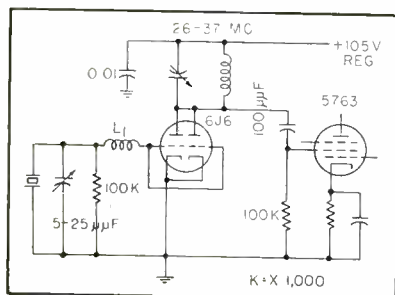

FIG. 2—Oscillator circuit for third-overtone crystal

quencies, this can be achieved by using crystals with a tolerance of 0.0005 percent for the picture carrier and 0.001 percent for the sound carrier. At uhf, a tolerance of 0.0001 percent for the visual carrier and 0.0004 percent for the aural carrier maintain the difference between the two carriers to an acceptable value.

The difference has been maintained in some designs by using the beat between the carriers to control an afc system in the transmitter but this requires common circuits between picture and sound transmitter. The use of overtone crystals in the transmitter described permits the two transmit-

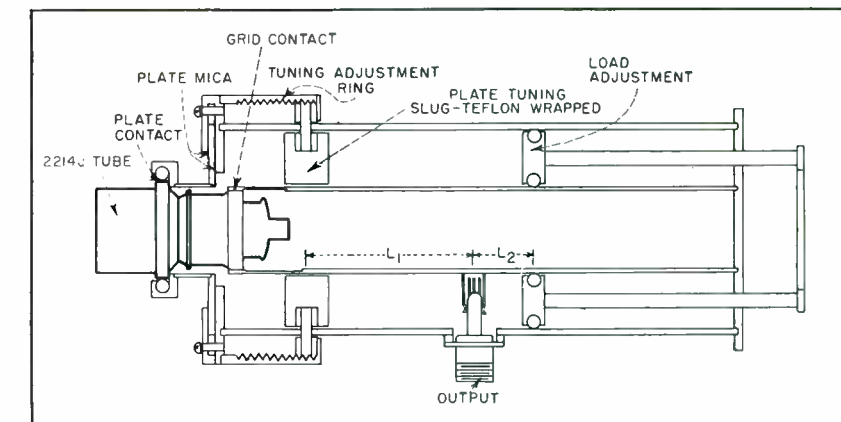

FIG. 3—Quarter-wave plate cavity for 2214J tube

ters to operate independently.

A schematic of the oscillator circuit is shown in Fig. 2. The crystal-holder capacitance and the tube input capacitance combine with coil L_1 to provide a high impedance in the grid circuit necessary to permit the crystal to operate on its third overtone.

Stage Lineup

Following the crystal there is a buffer stage using a 5763 tube. A second 5763 operates as a doubler for transmitter output frequencies between 630 and 890 mc or as a tripler for frequencies between 470 and 630 mc.

A 4422 tube acts as an amplifier for the lower group of channels or as a doubler for the upper group of channels.

The next stage is a 4X150A which operates as a frequency tripler and provides an output of 50 watts in the region of 235 to 445 megacycles. Up to this point, conventional circuitry and lumped-constant plate circuits are employed. The following stages contain coaxial cavities. The remainder of the r-f unit includes two 2214J tubes and the A2504 final output stage.

The first 2214J operates as a frequency doubler and produces an output of about 80 watts. The second 2214J is a straight-through amplifier and develops 180 watts. The 4X150A and the two 2214J cavities are supplied with a plate

voltage of approximately 1,100 volts.

A coaxial cavity circuit for the 2214J tubes with a quarter-wavelength plate circuit is shown in Fig. 3 in cross-section. The cavity sketch is simplified to show only the plate circuit. The metallic tuning slug is wrapped with Teflon tape. The portion of the tape parallel to the long dimension of the cavity and the slug and cavity cylinders, both inner and outer, form the output coupling capacitor. The r-f currents flowing between plate and grid must flow through these two capacitors. In effect, the slug capacitor is in series with the tube output capacitance across an equivalent inductance.

Movement of the slug changes the resonant frequency of the plate circuit. Except for a small voltage drop across the Teflon capacitors, the moving slug arrangement can be thought of as a noncontacting short circuit.

The r-f voltage drop across the Teflon capacitors excites the lower portion of the cavity. The distance L_1 , between the output connector and the nominal setting of the tuning slug, and L_2 , the distance between the load adjustment and the output connector, determines the actual loading across the equivalent plate circuit. Looking into the cavity at the output connector, the distance L_2 determines the amount of inductive reactance placed in parallel with the 50-ohm load. Dis-

tance L_1 is chosen so that the impedance at the output connector position appears as resistance shunted across the equivalent output tank at the tuning slug.

The grid circuits of the 2214J cavities are also of coaxial construction. A simplified sketch is illustrated in Fig. 4. The tuning slug which is wrapped with Teflon tape to form a capacitor acts to tune out the reactive component of impedance that the grid of the tube presents. This matches the 50-ohm input line to the grid of the tube and acts as the input tuning control. The knurled grid tuning adjustment moves the Teflon screw which in turn moves the Teflon concentric capacitor.

A cross-section view of the A2504 final amplifier tube appears in Fig. 5. An air-cooled tetrode, it employs a cavity plate circuit like that of the 2214J but larger in diameter.

Video Modulator

Five video stages are used in the modulator portion of the transmitter. The arrangement of stages is shown in Fig. 1. The output stage is a cathode-follower modulator which drives the grid of the A2504 final power amplifier tube directly.

Inverse feedback is used between the first 6AH6 and the second 6AH6 to help reduce distortion, noise and to increase stability.

The 5763, a cathode follower, acts as a phase inverter to drive the first 4422 with a signal of the proper polarity. The 4422 is a conventional video amplifier and its plate circuit contains the only set of peaking coils in the video chain. The clamp circuit operates on the grid of this stage, and the d-c component of the video signal is maintained from this point on.

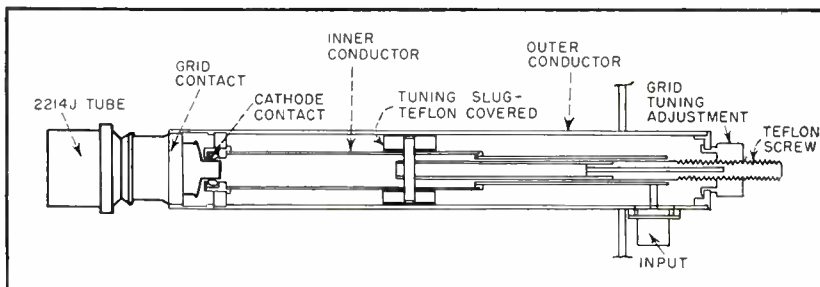

FIG. 4—Simplified drawing of grid cavity for 2214J tube

The output voltage of the cathode-follower modulator is produced across a capacitance of about $225 \mu\text{f}$. To reproduce fine detail in the picture, the voltage across this output capacitance must change in an extremely short period of time. For design purposes, a figure of $0.08 \mu\text{sec}$ is used. For steep-fronted waveforms, a peak current from the modulator tubes is required that exceeds the current normally required to produce the output voltage across the cathode resistor for relatively slow signal changes. The four 4422 tubes in parallel provide peak plate current of about 800 ma with the grid well in the negative region.

When the grid is driven in the negative direction, the charge across the stray capacitance may not follow the grid signal and distortion will result. Some minimum current is kept flowing through the modulator tubes to keep the equivalent time constant of the R-C discharge circuit fast enough. White-level current through the tubes is not allowed to drop below a certain level and all signal excursions are above this value.

Sound Transmitter

In the sound transmitter, an f-m exciter takes the place of the crystal oscillator and buffer stages of the picture transmitter.

A crystal oscillator and pulse generator produce a series of narrow pulses which are used to synchronize a saw-tooth generator. The saw-tooth output is clipped at a level corresponding to the instantaneous audio modulation applied. A series of pulses from the modulator that have been shifted in phase or timing according to the instantaneous modulation applied are fed to a series of frequency multipliers

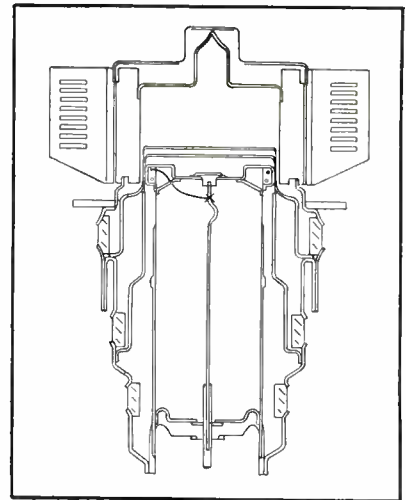

FIG. 5—Cross-section of one-kw final amplifier tube, type A2504, an air-cooled tetrode having ceramic seals

and restored to sine-wave form. The second crystal oscillator and mixer translates the f-m signal to a new portion of the spectrum without altering the initial deviation. The following amplifiers increase the signal level and act as selective filters.

This unit is a phase modulator and a frequency-selective device is provided at the audio input terminal to make the audio output of the second audio amplifier vary inversely with frequency. This is done to maintain a frequency deviation independent of the modulating frequency.

Other r-f stages of the sound transmitter are similar to the units in the video transmitter.

10 Kilowatts

For higher-power operation, a 10-kw amplifier is planned to be added to the picture transmitter described. This consists of an A2500 tetrode as a linear amplifier using a coaxial plate circuit like that of the 2214J tube. Another A2500 provides sound channel output of five kw.—V.Z.

REFERENCES

- (1) D. G. Fink, The Prospects for UHF Television, *ELECTRONICS*, p 68, Nov. 1948.
- (2) R. F. Guy, UHF Television Field Test, *ELECTRONICS*, p 70, April 1950.
- (3) W. H. Sayer, Jr. and E. Mehrbach, UHF Transmitter Uses Beer-Barrel Cavity, *ELECTRONICS*, p 125, Dec. 1951.
- (4) H. M. Crosby, Five-KW Klystron UHF Television Transmitter, *ELECTRONICS*, p 108, June 1951.
- (5) Lloyd O. Krause, Sidfire Helix UHF-TV Transmitting Antenna, *ELECTRONICS*, p 107, Aug. 1951.

Internal Electrostatic Deflection Yokes

Equal horizontal and vertical deflection sensitivities result from simultaneous deflection. Confinement of fringe fields provides greater freedom from scan distortion and defocusing and permits wider angles of deflection

WHEN COMPARING conventional electrostatic and magnetic deflections in their present forms, it is found that the former is basically sequential and the latter simultaneous in operation. The crossed-pair system of deflector plates delivers first one component of deflection and then the other, whereas the modern magnetic yoke handles both components at once. Undoubtedly, it is desirable to do the same with electric fields.

The resemblance between the physical laws for static electricity and magnetism holds a clue for the construction of an electrostatic yoke. Assuming cylindrical geometry, that analogy demands that we should provide two crossed sets of boundary potentials, each of them with a cosine distribution around either axis of deflection. On the basis of these considerations, the present form of deflection electrode was developed. Since this is a separate unit, structurally and functionally, within the tube, the designation Deflectron was coined for it.

Early Efforts

There have been earlier attempts to solve the problem of simultaneous electrostatic deflection in two dimensions. For instance R. R. Law suggested resistive material to obtain the correct boundary potentials;¹ H. Salinger used, for the same purpose, a 12-wire cage connected to a mixing network outside of the tube;² and F. Gray applied V.

By **KURT SCHLESINGER**

*Television Research Dept.
Motorola, Inc.
Chicago, Ill.*

Ardenne's principle of distributed shielding,³ to perform various electronic functions, including deflection.⁴

However, none of these earlier efforts seems to have resulted in a practical device suitable for use in modern cathode-ray tubes. To be useful, such a unit should have no more than four terminals, high sensitivity, low admittance, a rigid, lightweight structure and it should be easy to produce and to reproduce. The Deflectron meets all of these requirements.

Figure 1 explains the principle of composite electrodes, which are the basic elements of the Deflectron. In Fig. 1A metallic areas of different width are connected, alternately, to separate voltages V_1 and V_2 . An electron flying in the Z direction across the strips at an altitude d , will see a resultant potential V as described by

$$V = \left[V_1 \frac{l_1}{\lambda} + V_2 \frac{l_2}{\lambda} \right] + 0.64 (V_1 - V_2) \sin \left(\frac{\pi l_1}{\lambda} \right) e^{-2\pi \frac{d}{\lambda}} \cos \left(2\pi \frac{z}{\lambda} \right)$$

This effective potential consists essentially of a constant term and an

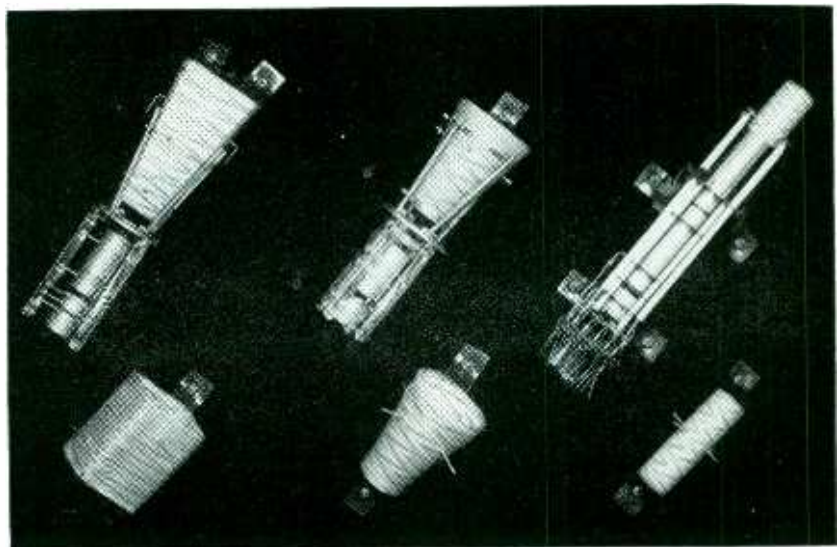

Typical electrostatic deflection units for tv (left) circular (center) and 30-degree pencil (right) yokes

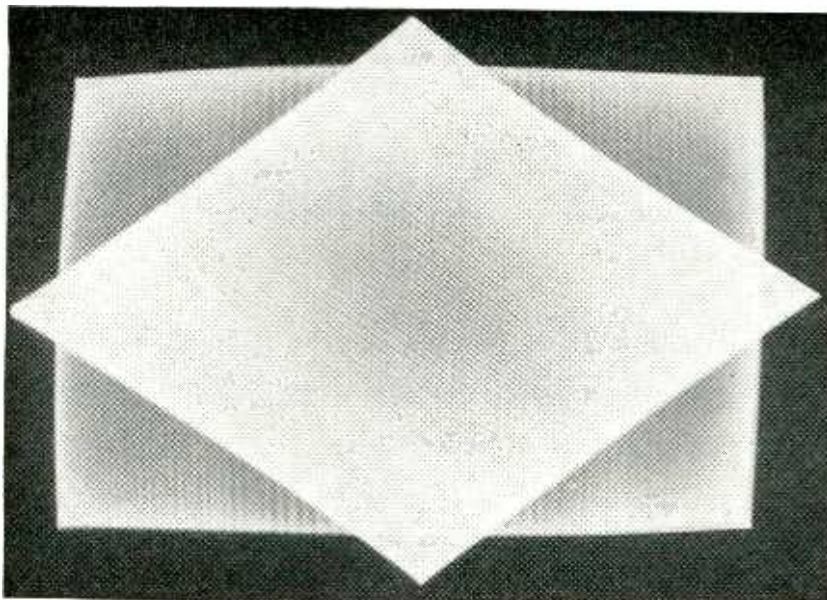

Sweep patterns from rectangular unit with and without matrix network. Matrix provides almost double scanning area

alternating term. The constant term indicates an average potential which is the sum of the two bias voltages, each weighed by the effective length of the strip, to which they are applied. This term does not change with distance.

The alternating term on the other hand is proportional to the bias-difference between strips, and it is found to decrease rapidly with distance from the electrode. Figures 1B and 1C show the potential-functions at the surface and approximately $\frac{1}{2}$ wavelength away, respectively. An observer who is more than one-half a wavelength away will therefore see less than 4 percent of the alternating component, but all of the average potential.

$$V_{av} = V_1 l_1/\lambda + V_2 l_2/\lambda$$

Since the relative strip width may be varied, across the surface by design, we are in a position to realize many desirable potential distributions including the case of a constant gradient parallel to the surface of the electrode. This is illustrated in Fig. 2.

Rectangular Deflectron

Figure 2A shows the conventional sequential type of electrostatic deflection using two crossed pairs of plates as contrasted to an equivalent Deflectron which performs biaxial deflection, simultane-

ously. The deflection box is only half as long as the crossed-plate structure. The sides of the box are formed by composite electrodes with triangular boundaries. Each coating is continuous along an edge so that there are four terminals.

Center of deflection R is the same for all rays. In the conventional structure, there are two separate deflection centers R_v and R_h and two different sensitivities for the two axes. In the crossed-plate arrangement, the fringe field between pairs has to be traversed by the beam thus giving rise to defocusing and keystone distortion. In the box system, these fringe fields are confined to the vicinity of the composite surfaces. The beam passes through the central region where the field is uni-

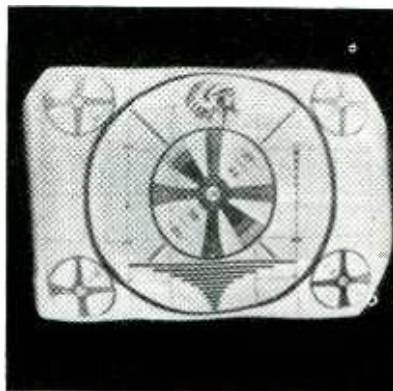

Television test pattern scanned with circular electrostatic deflection unit

form. This provides greater freedom from scan distortion and defocusing so that wider angles of deflection become practical.

Figure 3A shows what happens if the corner terminals are directly connected to two balanced sweep generators V and H . If the box is cut for an aspect ratio of 4×3 , the figure of scanning becomes a rhombus, standing on one point and including an angle of 74 degrees.

Figure 3B shows how to obtain a rectangular television scan parallel to the sides of the box. A matrix R-C network is inserted between the generators and the tube. Two arms of this matrix are reactances and the other two are resistances. If designed for a crossover frequency of 1,000 cps, the network will behave at the line and field frequency as if R or C , respectively, did not exist. As shown in the crt face by the use of the matrix the scanning area is almost doubled.

Deflection Sensitivity

A box in matrix connection is the equivalent of a matched pair, that is, a set of parallel plates cut for the same exit angle. The ultimate deflection sensitivity of such plates depends only on their aperture and the beam voltage as indicated by

$$e_d = 4E_A \tan^2 (\frac{1}{2} \alpha)$$

where E_A is the beam voltage at the point of deflection, e_d the peak-to-peak voltage between plates and α the total deflection angle.

This expression shows that at 52 degrees, deflection requires as much voltage as acceleration and, at 72 degrees, twice as much.

Fortunately, only one-half of this total has to be supplied to each plate, if push-pull operation is used. This high voltage demand, rather than functional deficiencies, seems to draw a line beyond which the use of electrostatic deflection becomes increasingly difficult. The practical limit appears to be reached at 50 degrees total deflection angle.

Figure 4 gives a general idea of the sweep circuit techniques for television. The system, when sealed into a bulb type 16LP4 run at 15,000 volts, requires 4,500 volts

for vertical and 7,900 for horizontal deflection, if no use is made of post acceleration. The vertical sweep voltage may be readily derived from two small triodes type 6SF5, running in push-pull off a plate supply of 2,700 volts and drawing 600 microamperes apiece.

The line sweep comes from a pulse amplifier with reactive load. It uses a power pentode type 6AU5 and a step-up transformer, whose secondary is tuned to approximately one-sixth of the line frequency (2,500 cps.). An early model of this sweep unit consumed 10 watts which is only a fraction of the power input used for conventional magnetic sweep circuits.

The need for a matrix network

with its attending frequency restrictions is obviated by the use of Deflectrons with rotational sym-

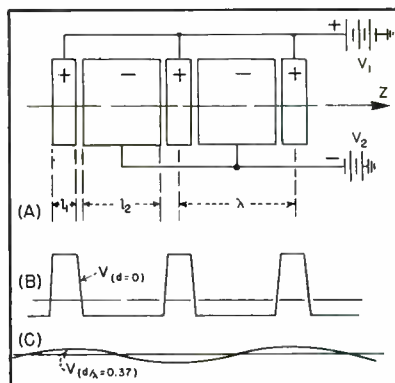

FIG. 1—Typical composite electrode configuration (A) and theoretical potential functions at (B) and at a distance d (C) from electrode surface

metry. The circular unit may be used with or without matrix, in a great variety of applications including tv picture tubes, radar indicators and oscilloscopes. The cylindrical form has the advantage of providing greater spacing between beam and electrode surface for most of the scan, thus minimizing deleterious wall effects. This advantage is largely maintained but the sensitivity is increased, if the cylinder is tapered off to a cone.

Circular Analysis

Figure 5 illustrates the basic conditions under which a uniform field with an inclination of ϕ degrees is properly reproduced in a

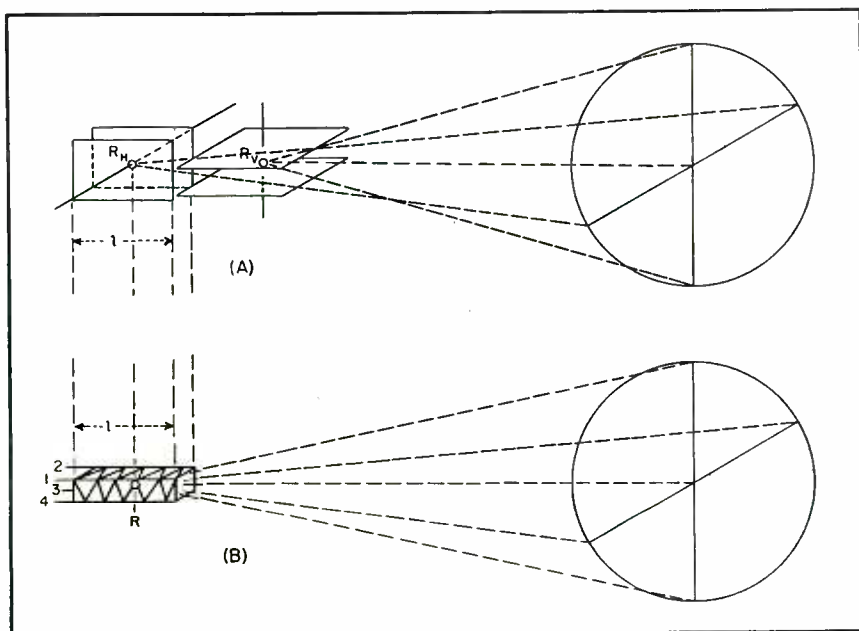

FIG. 2—Biaxial electrostatic deflection system (B) has advantage over conventional sequential type (A) of equal deflection sensitivities and common center of deflection

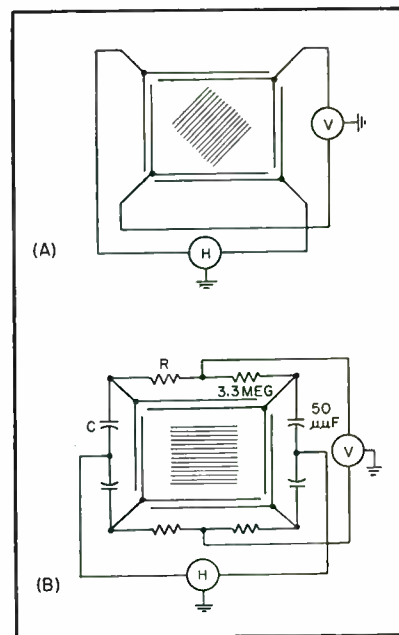

FIG. 3—Matrix connection (B) corrects for rhombic geometry

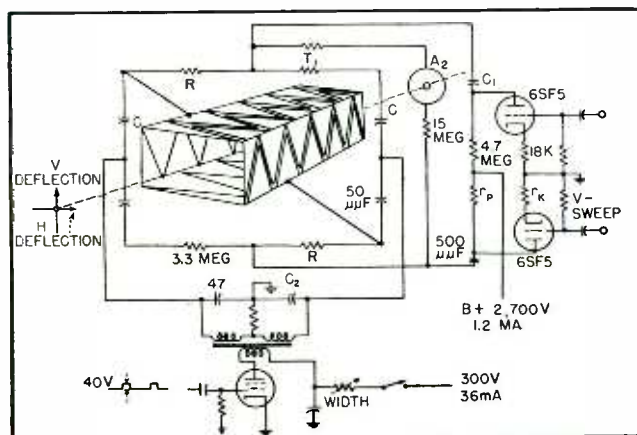

FIG. 4—Rectangular deflection box with matrix and sweep circuits

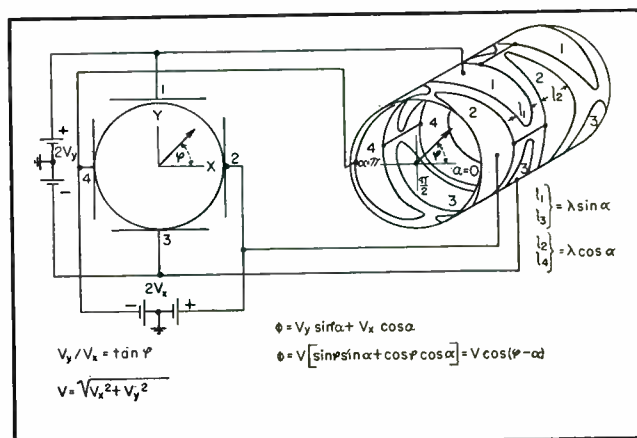

FIG. 5—Circular deflection unit offers production advantages

circular deflectron. Suppose two voltages V_x and V_y are applied to the plates of a conventional oscilloscope in ratio of

$$V_y/V_x = \tan \varphi$$

To reproduce that angle correctly, with the same voltages, a circular deflectron has to be printed in such a way that the active length of the pattern is a sine and/or cosine function of the angle. In Fig. 5 this is accomplished by metallic areas which are bounded by half waves of sine and cosine, respectively. The boundary potential then is the sum of the applied voltages weighed by their respective lengths

$$\Phi = V_y \sin \alpha + V_x \cos \alpha$$

From the voltage ratio equation we find this to be the equivalent of a new cosine distribution.

$$\Phi = V \cos (\varphi - \alpha)$$

where $V^2 = V_x^2 + V_y^2$. The potential described by this equation generates, within the cylinder, a uniform field of the desired inclination. This reveals, moreover, that it is mandatory to keep the deflection voltages balanced at all times, including any d-c shift and positioning voltages. In this respect, the Deflectron is more touchy than its counterpart, the plate deflector, which may be operated from single-ended sources without too much trouble, at least at small angles.

There is apparently more than

one way to meet the required cosine distribution of potential in circular configurations. Figure 6 shows three geometries which are equivalent at least to a first approximation. Figure 6A shows the sinusoidal area distribution just mentioned. This pattern has the disadvantage of requiring conducting bridges which spoil the potential distribution and introduce points of high voltage gradient involving insulation difficulties.

The pattern of Fig. 6B shows the offset sine, which has inherent continuity thus avoiding one of the above defects. Figure 6C, or the arrow pattern, offers both continuity as well as good voltage stability. It consists of four groups

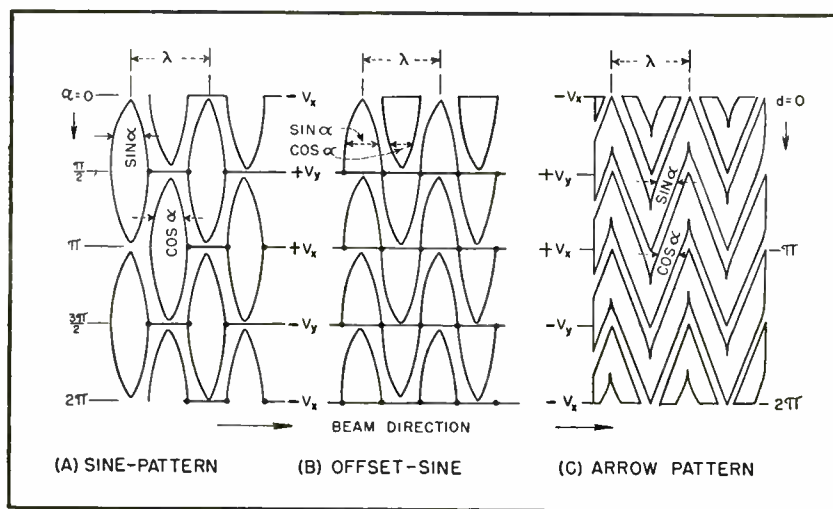
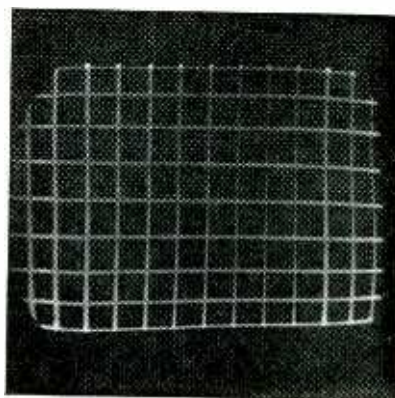

FIG. 6—Pattern geometries for circular Deflectrons



Bar pattern obtained with conical deflection unit

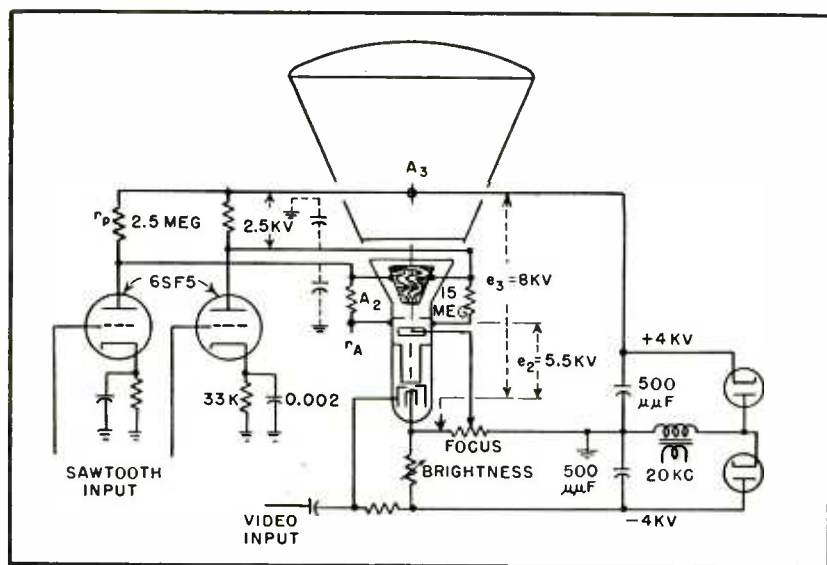

FIG. 7—Circuit illustrates extreme simplicity of conical deflection unit for ppi radar displays. Two 6SF5's generate 7,200-volt deflection signals

of metallic ribbons, whose width in axial direction varies as a sine-function of the angle. Each ribbon covers one-half of the perimeter.

The center of the photograph of various configurations shows a conical Deflectron of the offset-sine variety. Below it is a conical electrode with arrow pattern. These cones are cut for a 60-degree opening and have a 2 to 1 taper, which results in a sensitivity increase of 30 percent. The positive lens effect caused by the taper is negligible.

The gun used in all these Deflectron tubes is short and straight since no ion trap is required. Focus is done electrostatically at voltages between zero and 300 volts.

The conical unit has been successfully employed for radar applications. Figure 7 shows the extremely simple circuitry required

for ppi displays. Two pairs of 6SF5 triodes generate the required 7,200 volts of clipped sawtooth wave in push-pull out of a B-supply of 4 kv. With an input of 45 volts per phase, we obtained 50-degree deflection of an 8,000-volt beam using a moderate amount of post-acceleration (1.4 to 1).

The combined power supply for preamplifiers and tube employs a pulse-operated voltage doubler at a repetition rate of 20 kc. Since balanced d-c deflection is provided for, the spot may be shifted permanently toward the perimeter without defocusing. The small Deflectron capacitance (25 μf per phase) permits fast sweeps with negligible plate power.

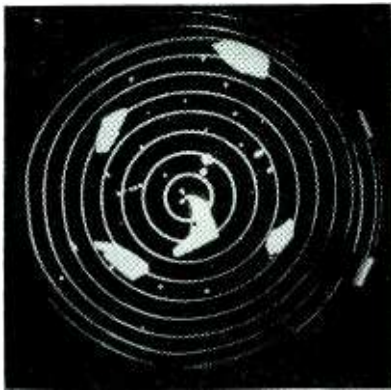

Radar ppi obtained using conical deflection circuit shown in Fig. 7

To illustrate an oscilloscope application, a 30-degree pencil unit was developed and mounted on top of a standard electron gun type 5CP1-A.

The pencil-Deflectron electrode shown at right in the composite of different types is a glass-cylinder two inches long and $\frac{1}{2}$ inch wide with an arrow pattern. Similar pencil units may also be produced inside of a 1-inch cylinder with $\frac{3}{4}$ inch diameter.

In its present form, the deflection factor of this tube is about twice as high as that of a conventional 5CP1, but both axes have identical characteristics. The mechanical ruggedness, simplicity of mounting and alignment, and the ease of reproduction may outweigh the loss of sensitivity for many applications.

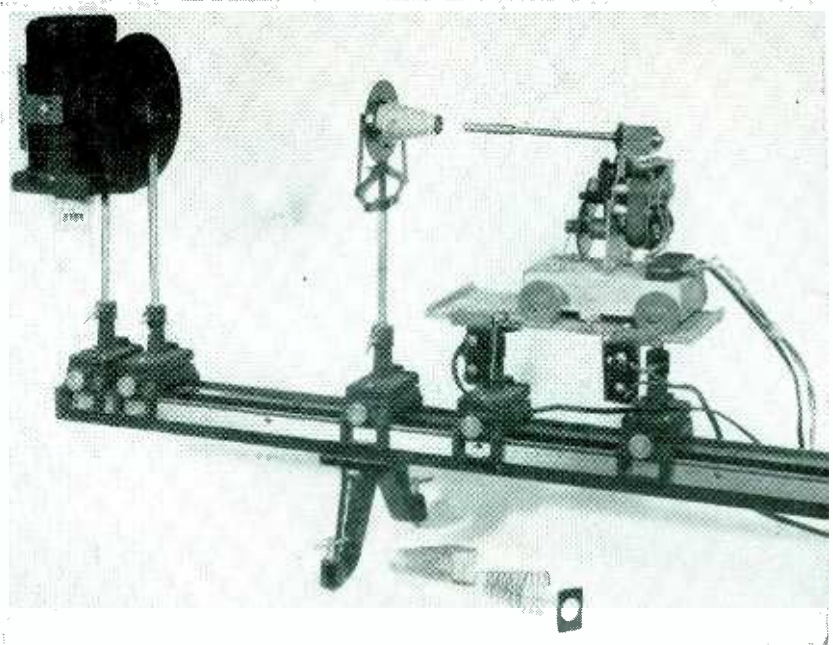

Flying-spot illuminator for photoengraving electrostatic deflection yokes

One of the advantages of the Deflectron over the conventional crossed-pair system is the ease by which it may be reproduced with high accuracy. The Deflectron uses a glass base with narrow inside, but with wide outside, tolerances. Such a body may be readily produced by pressing glass around a precision graphite filler in a mold. The accurate reproduction of the metallic pattern is assured by using methods of photo-engraving. With this technique, all units are printed from a single master negative which is, itself, a photographic copy from an enlarged pattern design drawing.

Production Techniques

In production, a film carrying the master pattern is inserted on the inside of the glass envelope and illuminated by a concentrated arc lamp. The small size of this light source insures sharp contours, in spite of the fact that contact between glass and film may be as far off as 20 mils.

To obtain constant and uniform exposure all along the inside of the electrode, it was found necessary to use a flying-spot method of illumination, rather than a stationary lighthouse setup. A small motor rotates a surface-silvered 45-degree mirror around the axis of the elec-

trode, so that the reflected light hits the film glass surface under almost normal incidence. At the same time, the motor carriage rolls slowly back and forth, so that the inside is scanned in a helix. The rest of the procedure follows the established methods of photo engraving. The etched silver base is built up by electro-plating of copper.

When placed inside the evacuated envelope, the units are able to withstand the high sweep voltages without arc-over. On a glass base, the phase to ground capacitance averages 20 μf , while the surface insulation after processing regularly exceeds 100 megohms, thus permitting the use of high-impedance sweep circuits with low power consumption.

The project has been supported by D. E. Noble, vice-president of Motorola, Inc. and Director of Research, and benefitted from the assistance of Gerald C. Hoffman, V. Graziano and James H. Grigg.

BIBLIOGRAPHY

- (1) U. S. Patent 2,179,097.
- (2) H. Salinger: The electro-static Dissector *Proc. NEC*, p 82, 1946.
- (3) U. S. Patents 2,185,239 and 2,080,449.
- (4) U. S. Patents 2,293,539 and 2,302,118.
- (5) W. D. Buckingham and C. R. Deilbert: Characteristics and Applications of Concentrated Arc Lamps, *Jour. SMPE*, p 376, 47, Nov. 1946.

INDUSTRIAL

By **FRED P. STROTHER***

*Head, Electronics Department
Research Division
West Point Manufacturing Company
Shawmut, Alabama*

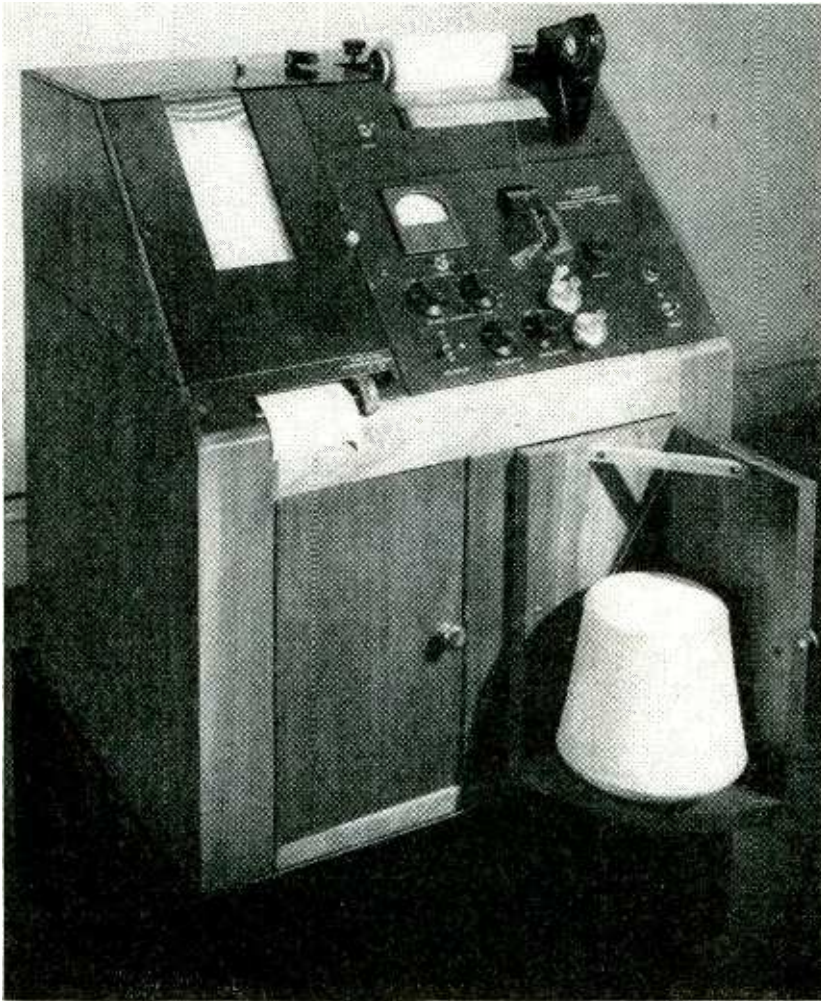

The complete instrument used for measuring and recording diameters of yarn and other filamentary materials

MEASUREMENT OF YARN and similar materials by means of their shadows in a beam of light falling on a phototube is not new. Most of the instruments designed for this purpose in the past, however, have suffered from a number of faults.

Instability of the d-c amplifiers, lack of provision for a suitable method of passing the yarn or material being measured through the measuring gap and poor choice of the basic method by which the yarn is to be measured are a few of the difficulties often encountered.

Instruments on the market today

* Work done by the author while in the employ of Deering Milliken Research Trust in Greenwich, Conn.

that utilize the shadow method are entirely satisfactory when the material being measured is perfectly round. In the case of textiles, however, there is reason to measure yarns that may tend to band, ribbon or twist and give erroneous readings due to the apparent change in diameter. Actually, the weight or total amount of material being measured has not changed.

In the instrument to be described, known as the Filometer, this difficulty has been overcome by employing a high-intensity beam of light so arranged that light is actually transmitted through the material being measured. The changing amount of light reaching the phototube is a measure of the

amount of material present and not of the physical size alone.

Measurements by this method may cause apparent errors for different-colored yarns but corrections can be introduced to take care of this in most types of yarn.

Instrument Description

The instrument is complete in itself. Within one cabinet are included a small creel or holding arrangement for the yarn to be measured, the actual measuring head with its associated mechanical and electronic equipment, the recorder with the necessary drives and a three-speed winder for spooling the measured yarn. This enables the operator to measure yarn without any auxiliary equipment or special setup.

The yarn to be measured is unreel from the quill, or spool, and fed continuously through the measuring unit on the instrument. After that it is rewound on a package that may be used on standard textile machinery. The recording pens make a record on chart paper driven by a synchronous motor. The chart is exactly in step with the yarn as it is fed through the machine. At any point on the chart, the size of the corresponding point on the yarn being measured can be read.

From the chart one can calculate the percentage variation existing in the yarn and discover any waves or cyclic variations that may appear. A fairly complete analysis of the quality of the yarn can be made relative to its size.

The instrument is arranged with a sloping panel on which are located all of the controls necessary for easy operation and a window through which the chart may be viewed while the recording is being made.

YARN CLASSIFIER

Instrument for use in textile industry measures and records diameters of filamentary materials such as yarn. Device is more accurate and has better stability than other similar instruments using phototubes

Figure 1 is a mechanical drawing of the functional parts. The yarn is unwound from bobbin *B* at a constant speed by means of the synchronously driven drum winder *W* and repackaged for further use.

While traveling from bobbin to drum, the yarn passes through the gap between the prisms mounted on the measuring head *H*. The head contains a light source *I*, light beams that are directed on the measuring phototube *V*₁ and the balancing phototube *V*₂, the latter through the adjustable shutter *K*.

The purpose of the second phototube is to correct to a first order for variations in the light output of *I*. Balance is achieved initially by adjustment of the shutter *K*. It can also compensate to a degree for variations in the phototubes due to aging and other reasons.

Any material lying within the measuring-head light beam causes the bridge, Fig. 2, to be unbalanced. The resulting signal is fed through the sensitivity control to the channel-one amplifier, its recorder and then to the channel-two amplifier and its recorder.

Integrating Circuit

An integrating circuit located between amplifiers one and two is used to level out the fine short-term variations existing in the yarn in order that the long-term variations may be more easily seen. These are recorded in channel two. A balancing meter *M*₁, Fig. 1, is included with a switch allowing it to be used on either of the two amplifiers.

Particular attention has been given to make the design of each unit stable and sound. The proper location of each item, with respect to the rest of the instrument, is such that operation requires a min-

imum of effort. There is no interaction between the various elements or circuits.

Calibration is effected by means of a block on which are fastened four wires of suitable sizes so arranged that when the block is placed in the measuring gap, a

wire of a certain size is interposed in the beam of light.

Sizes of the wires are chosen so that the shadow they cast will bear a specified relationship to a given yarn size. As the wire casts a solid shadow compared to the integrated reduction in light caused by the

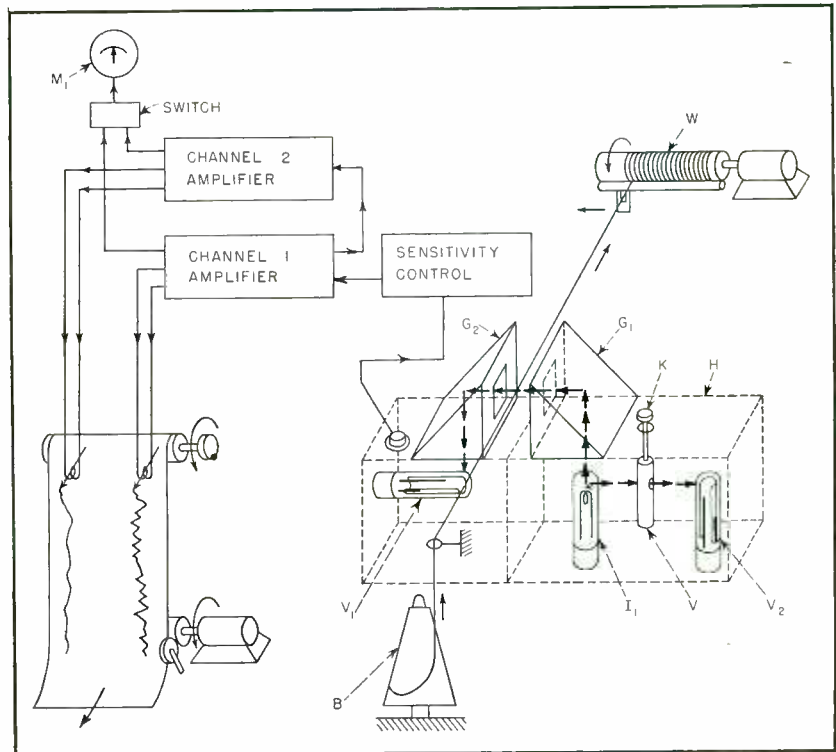

FIG. 1—Principal elements used in the Filometer

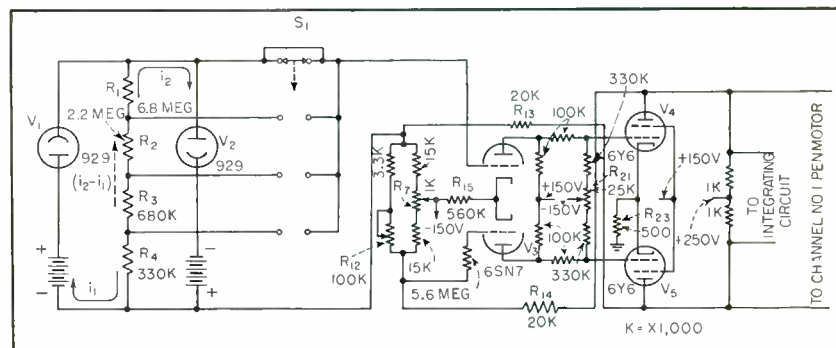

FIG. 2—Simplified schematic of the measuring circuit, coarse-sensitivity control and channel-one amplifier

yarn, a calibration is necessary to establish the relationship between the two.

Calibration is done when the measuring block is fabricated. Different calibration blocks are required for colored yarns. Generally, the percentage variation is the important thing and this does not require absolute calibration. The sensitivity is set so that the recorder pen writes above or below any desired line on the chart. When the chart is finished, the percent variation can be calculated.

If absolute calibration is desired, the yarn is temporarily removed from the measuring slot, the gauge substituted and centering checked. The instrument is then calibrated by means of the gain control R_{12} , Fig. 2. The calibrating block is removed, the yarn replaced and the machine is ready for operation.

Circuitry

Figure 2 is a simplified schematic of the phototube and coarse-sensitivity circuits. Figures 2, 3 and 4 show channels one and two and the integrating circuit interposed between them. It may be seen from Fig. 2 that the coarse-sensitivity control consists of a switch that shorts out progressively R_1 , R_2 and R_3 . In this manner, the value of load resistance is reduced and, as a result, the maximum voltage appearing across it is also reduced.

When yarn is being measured, the amount of light reaching V_1 , Fig. 2, is less than that reaching V_2 because the yarn lies in the light path between the exciter lamp I_1 and the phototube V_1 . This in turn reduces the current flowing in V_1 proportional to the amount

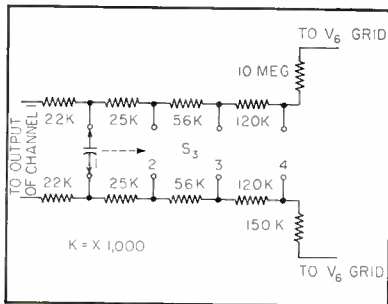

FIG. 3—Simplified schematic of the integrating circuit

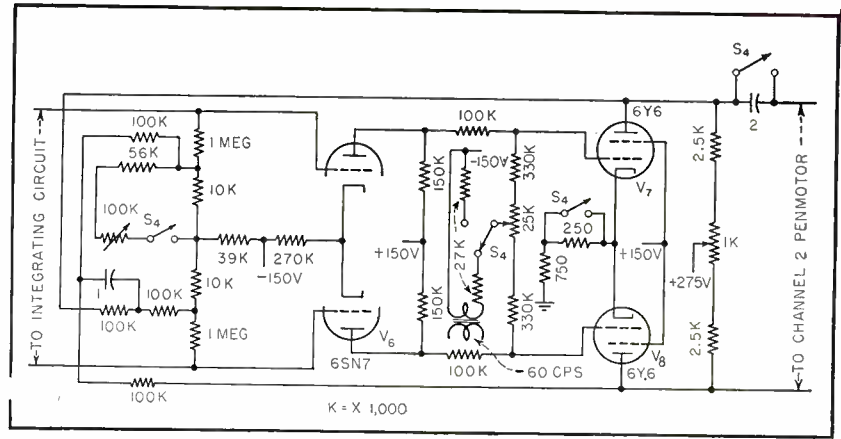

FIG. 4—Schematic of amplifier used in channel two

of yarn present in the beam of light and reduces the current i_1 . The difference in i_1 and i_2 now causes a voltage drop across the resistor chain, constituting the signal sent to the channel-one amplifier. This signal is proportional to the yarn size.

A fine-sensitivity control is also provided in the amplifier shown in Fig. 2 and allows adjustment to be made between the positions obtained on the coarse-sensitivity control switch.

Design of the amplifier for channel one, Fig. 2, is standard with a phase inverter and amplifier stage V_3 .

Push-pull output tubes V_4 and V_5 drive the pen motor. Negative feedback from the plates of V_4 and V_5 to the grids of V_3 is secured through R_{13} and R_{14} . This feedback in conjunction with the unbypassed cathode resistor R_{23} tends to stabilize the circuit with respect to both gain and drift.

The network of resistors connected to -150 volts reduces the plate voltage from V_3 to a value suitable for the grid circuit of V_4 and V_5 .

The cathode of V_3 is also connected to -150 volts through R_{15} . Resistors R_7 and R_{21} provide suitable balancing voltages. With the circuit shown, the impedance of the plate circuit of the output tubes V_4 and V_5 is reduced sufficiently to be used for driving a pen motor.

Output from the channel-one amplifier is also fed into the integrating circuit shown in Fig. 3. This

circuit consists merely of suitable series resistors and a capacitor in what is essentially a low-pass filter combination.

The channel-two amplifier, as shown in Fig. 4, is very similar to the amplifier used in channel one with feedback utilized. A modulating circuit consists of a transformer and its switch, which introduces a 60-cycle modulating voltage in series with the negative supply to the center tap of the grid circuit of the output tubes V_4 and V_5 .

Other switches modify the rest of the circuit so that the pen motor will operate about a center line on the chart rather than biased to one side as is the case when the unit is used for measuring size.

The pattern produced is similar to that of a modulated r-f pattern on an oscilloscope. It may be thought of as a greatly magnified shadow picture of the yarn but compressed in length.

Extensive tests have proved that the measurements made by the machine have sufficient accuracy for practically all textile research and production work.

The writer is indebted to Dr. Norman C. Armitage, president of the Deering Milliken Research Trust, for permission to publish this article, to Walter Frere for his assistance in compiling the necessary data, to Dr. W. C. Anderson and the entire staff of the Research Trust for their contributions, and especially to Dr. D. G. C. Hare, for his suggestions that made these d-c amplifiers practical.

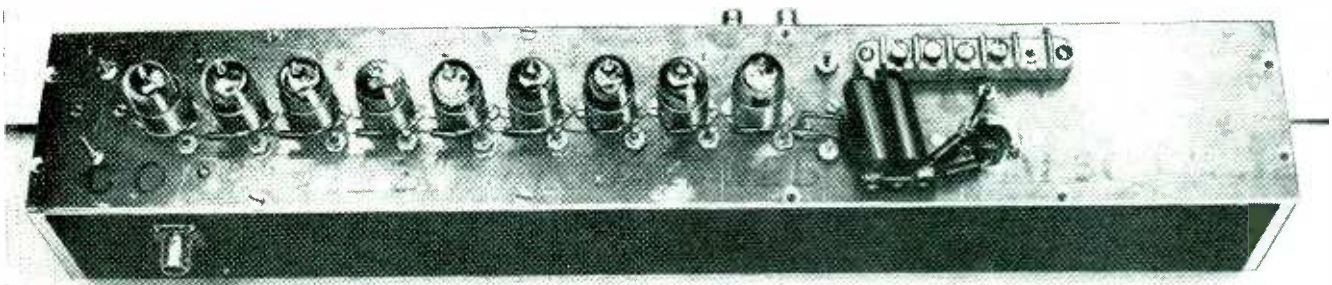

Top view of distributed amplifier shows placement of nine 6AK5's

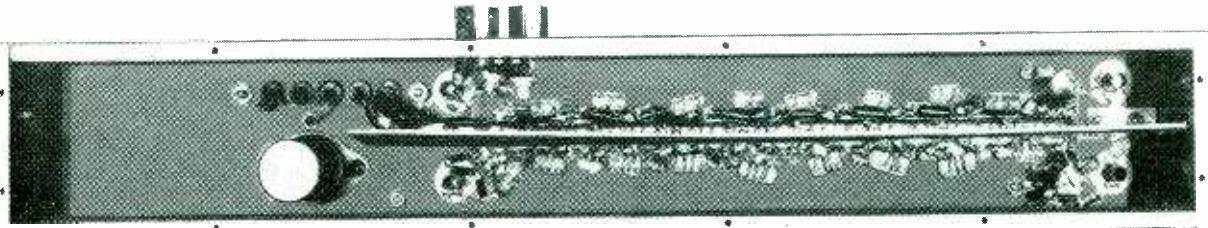

Bottom view reveals size, shape and position of grid and plate line coils

Distributed Amplifier Covers 10 to 360 MC

Provides 8-db gain, ± 2 db, using readily available or easily fabricated parts. Applications include millimicrosecond oscillography, wideband i-f and r-f amplification and any other requiring extremely wideband amplification

CONSIDERABLE PROGRESS has been made in extending the band width of amplifiers through the use of distributed amplification. Indications that amplification was possible to frequencies approaching 400 mc have been made, and for such applications as millimicrosecond oscillography, wideband i-f amplifiers and r-f preamplifiers, a need exists.

A distributed amplifier with a gain of 8 db flat to ± 2 db over the 10 to 360-mc band is shown in the photograph. The amplifier employs readily available parts except for the inductors of the grid and plate lines. These are easily constructed. The grid and plate artificial trans-

By **HOWARD SCHARFMAN**

*Research Associate
The Johns Hopkins University
Radiation Laboratory
Baltimore, Maryland*

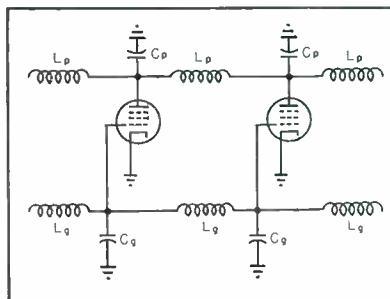

FIG. 1—Two sections of constant-k type circuit used in distributed amplifier

mission lines are of the constant-k type with m-derived half sections ($m = 0.6$) matching the lines to the terminating resistors. This type of distributed amplifier has been analyzed to some extent^{2,3} and based on an extension of this analysis, the present amplifier was designed and built.

Two sections of the constant-k type of distributed amplifier are shown in Fig. 1. The impedance level of the grid line is 50 ohms and for the plate line it is 93 ohms. The grid-to-cathode and plate-to-cathode capacitances as well as the associated socket capacitances are incorporated in the lumped C's required for the lines. For the low-

pass constant-k line employed,

$$C'/\text{per section} = \frac{2}{R\omega_c}$$

$$L/\text{per section} = \frac{2R}{\omega_c}$$

where $R = \sqrt{L/C} =$ characteristic resistance of line and $\omega_c =$ angular cutoff frequency. The 6AK5 was chosen since it has a high figure of merit, is readily obtainable, and is physically small. It was operated with $E_b = E_{sc} = 120$ v, and $E_c = -1.5$ v (fixed bias).

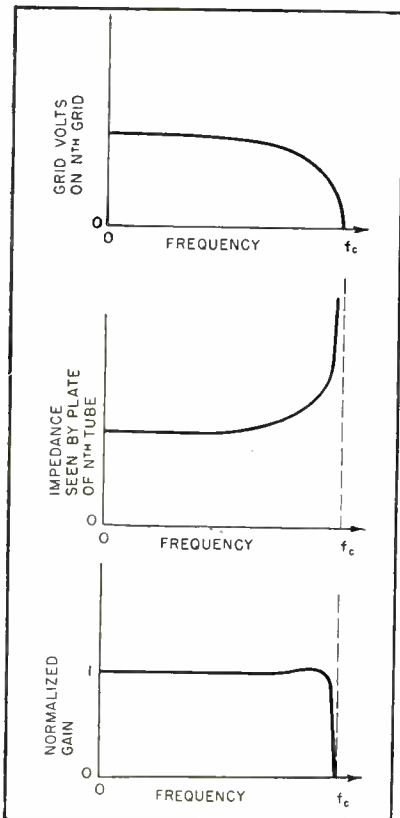

FIG. 2—Curves show grid-line loss compensation at high frequencies

Analysis of the distributed amplifier using constant-k lines in grid and plate circuit has been carried out previously. However, past investigations have been primarily concerned with cascaded distributed amplifiers where grid and plate lines having the same impedance level are desirable. If only a single stage of amplification is necessary (gains of 10 db or less), considerably higher cutoff frequencies are attainable if the plate-line impedance is made larger than the grid-line impedance.

Response

An extension of the analysis made in reference 2 indicates that for maximally flat amplitude response, with a gain of $e = 2.718 = 8.68$ db, the upper cutoff frequency is given as

$$f_c = 0.607 f_i \sqrt{\frac{g_m R_p}{g_i R_g}}$$

where $f_c =$ upper cutoff frequency, $g_m =$ transconductance of tube, $R_p =$ characteristic resistance of plate line, $R_g =$ characteristic resistance of grid line and $g_i =$ input shunt conductance at a frequency f_i .

Thus, if $R_p = 2R_g$, an increase of over 40 percent in upper cutoff frequency over the case of $R_p = R_g$ is predicted. The maximum R_p is limited by the output capacitance (plus socket capacitance) of the tube used and the chosen upper cutoff frequency through the relationship stated above for constant-k lines, C_p per section $= 2/R_p\omega_c$.

Due to transit-time effects, the

input shunt conductance varies proportional to the square of the frequency. Thus, at high frequencies (above 100 mc), the grid line becomes lossy. This is compensated by an increase in the impedance seen at the plate of each tube as the frequency increases as shown in Fig. 2. If the parameters of the circuit are properly chosen, these two effects can be made to cancel yielding a flat response over almost the entire band. This maximally flat response is achieved when $N C_c/\omega_c C_g = 1$, where $N =$ number of tubes, $C_g =$ grid-to-cathode capacitance, $\omega_c =$ angular upper cutoff frequency and $g_c =$ shunt conductance at f_c .

In addition to the shunt conductance variation with frequency, there is also some increase in input capacitance due to transit-time effects. This variation in capacitance with frequency combined with differences in input and output capacitance among a batch of the same tube type introduces mismatch and therefore reflections along the grid and plate lines. These effects are most noticeable at the higher frequencies for the phase shift per section increases sharply as the cutoff frequencies are approached. The gain-frequency curve will then have a rapidly varying form near cutoff. Tube capacitance and lead lengths, as well as any undesired mutual inductance between adjacent inductances, add to this effect.

Impedance Variation

Another serious difficulty arises from the variation of impedance with frequency of the terminating resistors for the lines. Tests on composition resistors indicate that values of resistance below 50 ohms remain more nearly constant with frequency than those above 50 ohms. Consequently, the 93-ohm terminations were made of three resistors in series. Comparison with results using a 93-ohm resistor showed a substantial improvement in flatness of the gain-frequency characteristic.

The m-derived terminating half sections were built with variable capacitors to compensate for reflections and mismatch arising from the aforesaid variables. Trimming of these capacitors had a consider-

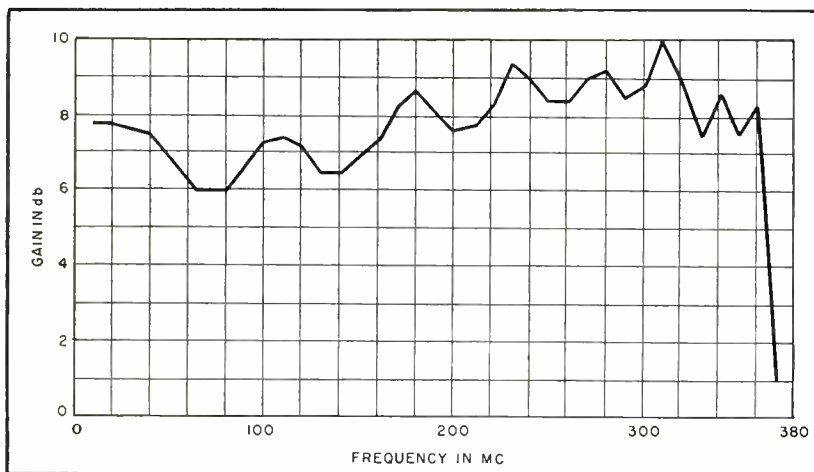
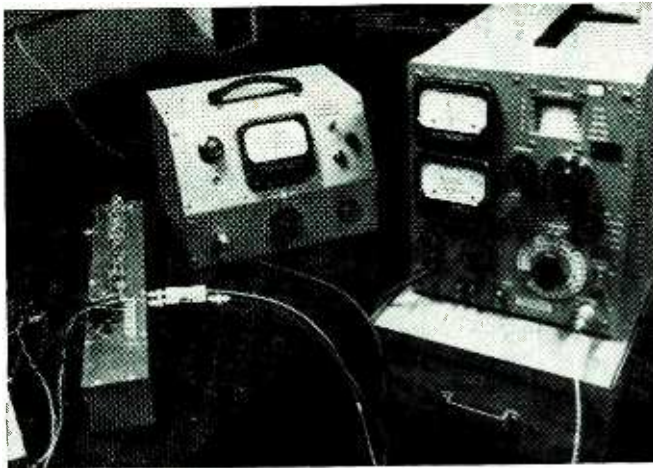

FIG. 3—Gain-frequency curve shows response of amplifier to be flat within ± 2 db from 10 to 360 mc



Gain of distributed amplifier is measured by comparing with accurately-calibrated amplifier-attenuator combination

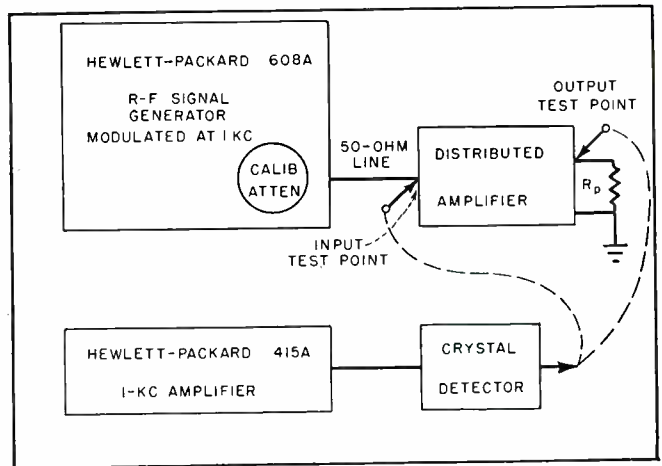

FIG. 4—Measuring system for obtaining gain-frequency curve shown in Fig. 3. Actual setup is pictured at left

able effect on the response curve, especially near cutoff.

In dealing with such a wideband amplifier, oscillation due to undesired feed back is possible despite the nominally low gain. This is particularly true at frequencies just below cutoff where it is possible for the gain to rise sharply due to reflections and increased plate impedance. Any small feedback path through the tubes, through radiation, or through ground currents, can cause oscillation. It was therefore necessary to use $\frac{1}{4}$ -inch 24-ST aluminum sheet for the chassis, place an aluminum shield plate between grid and plate lines, and carefully adjust the inductance of each section to minimize reflections on the lines. The resultant gain-frequency characteristic is shown in Fig. 3.

Test Setup

The system used for the measurement of the gain-frequency curve is shown in Fig. 4. A calibrated r-f signal generator modulated at 1,000 cps feeds the input of the distributed amplifier. The amplifier is terminated in its characteristic plate resistance and the input terminals are also properly terminated as the output impedance of the signal generator matches the grid line impedance. Two fittings permanently mounted on the chassis connect to the input and output points through 0.001- μ f ceramic capacitors. A type 1N45 crystal and its associated peak detecting circuit is mounted in a small copper box

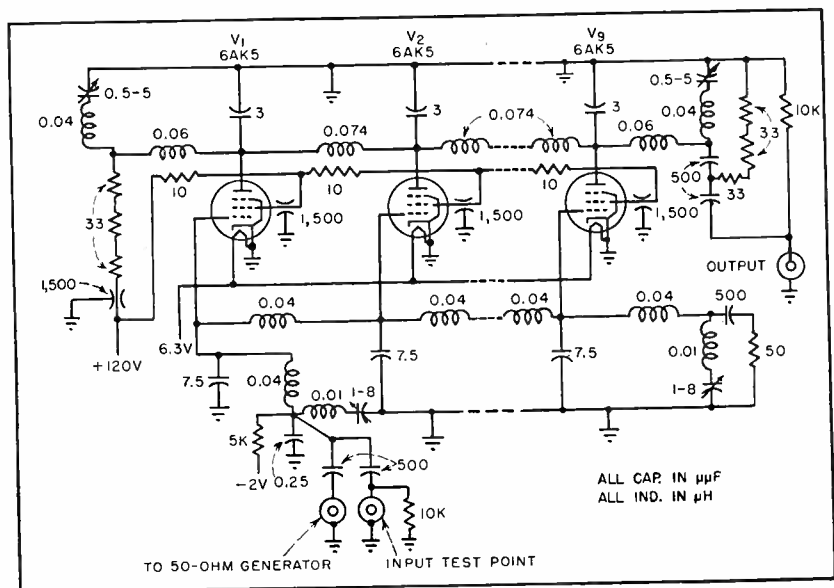

FIG. 5—Partial circuit shows component values for 360-mc distributed amplifier

such that the crystal end can be directly connected to either the input or output test point through a male fitting. The crystal output is determined by using a Hewlett-Packard 415A-1KC amplifier and reading the calibrated input attenuator directly in db after adjusting it for the same amplifier output reading at the input and output test points. If the r-f signal is kept small (less than 10 mv), the crystal will operate in the square-law region, and the difference in amplifier output resulting from connecting the crystal circuit to the input and output test points can be read off the output meter, which is also calibrated in db. These two methods yielded readings that had a maxi-

mum difference less than 0.2 db.

It should be noted that the results of the first method are independent of the crystal constants, and that the second method requires only that the crystal characteristics be square law.

The writer wishes to thank D. D. King for his many helpful suggestions pertaining to the measurement procedure, and to M. Brodwin, H. M. Watts and G. de Socio for their help in writing this paper.

REFERENCES

- (1) Y. P. Yu, H. Kallmann, P. S. Cristaldi, *Millimicrosecond Oscillography*, *ELECTRONICS*, p 106, July 1951.
- (2) W. R. Hewlett, J. H. Janberg, J. D. Noe, *Distributed Amplification*, *Proc. IRE*, p 956, Aug. 1948.
- (3) W. H. Horton, J. G. Jasberg, J. D. Noe, *Distributed Amplification—Practical Considerations and Experimental Results*, *Proc. IRE*, p 748, July 1950.

Reducing TV Receiver

By **E. W. CHAPIN** and **WILLMAR K. ROBERTS**

*Chief, Laboratory Division Assistant Chief, Laboratory Division
Federal Communications Commission, Laurel, Maryland*

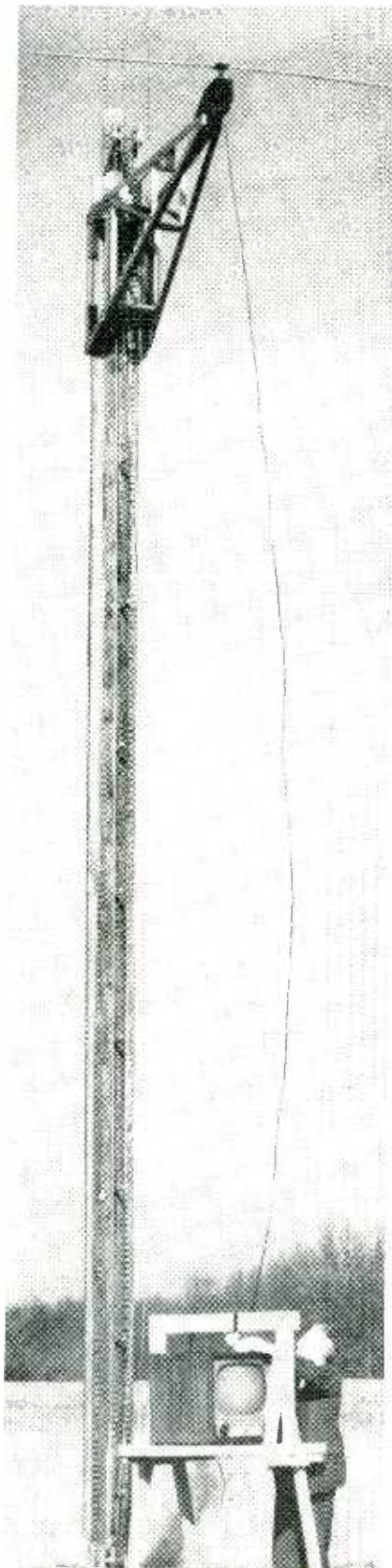

Receiver on turntable, with its antenna 30 feet above ground

INTERFERENCE caused by nearby receiver local oscillator radiation cannot usually be corrected at the receiver which has the interference. Furthermore, the preponderance of oscillator radiation on some channels may place one station in an unfair competitive position with regard to another in the same area. This type of interference has led at least one station to request a frequency reassignment.

Radiations from f-m receivers have seriously interfered with the use of certain air navigation frequencies. This problem has been solved by changing the frequency of the station to which the offending receivers were tuned, but the solution is not fundamentally sound and will become increasingly difficult or impossible as the spectrum becomes more fully utilized.

The choice of a particular intermediate frequency to alleviate oscillator radiation interference may conflict with other important considerations which also are involved in this choice, such as direct pickup of signals on the intermediate frequency and the necessity for obtaining a satisfactory image ratio.

Reverse TVI

When an i-f value is such that the oscillator radiation does not fall in a tv channel, it may fall on a channel occupied in the same locality by some other service that can get along with a field intensity as low as 0.1 microvolt per meter. It is thus possible that relatively more interference can be caused to a service essential to the public interest by the choice of oscillator frequencies outside of tv channels.

The fundamental solution is therefore considered to be a reduction in the level of the oscillator radiation produced by new receivers. This matter is related to costs, but only a small additional cost is

required for a considerable degree of suppression. The present lack of shielding may be partly blamed on a lack of an appreciation of the order of magnitude of the radiation and the degree to which radiation can easily be reduced. The lack of appreciation in turn may stem from the dearth of suitable measurements of the strength of the radiations.

Measurement Technique

Spurious radiation may come from the receiver chassis itself, acting as an antenna, or from individual circuit components and wiring. It may also result from coupling of a certain part of the oscillator power into the antenna circuit and its subsequent radiation by the antenna. The field arriving at a distant point is the vector sum of the radiations coming from different parts of the receiver and antenna structure.

Minor changes in the location of components and leads may result in large changes in the field measured at a distant point, not so much as a result of an actual increase or decrease in the total radiation, but as a result of a change in the distribution of the several components which add vectorially at the measuring point. Recognizing these difficulties of measurement, the Institute of Radio Engineers recently agreed upon and published a standard method of measurement.¹

The oscillator test range constructed at the laboratory of the Federal Communications Commission permits measurements in accordance with the IRE Standard, as well as other types of measurements. The test site is a level space clear of obstructions for at least 100 feet in all directions from both the receiver and the measuring point.

The receiver whose oscillator

Oscillator Radiation

Interference with other receivers can be reduced substantially by simple shielding and filtering of the tv tuner, at little extra cost if incorporated in initial design. Examples of modifications for two types of tuners are given and radiation measuring setup is described

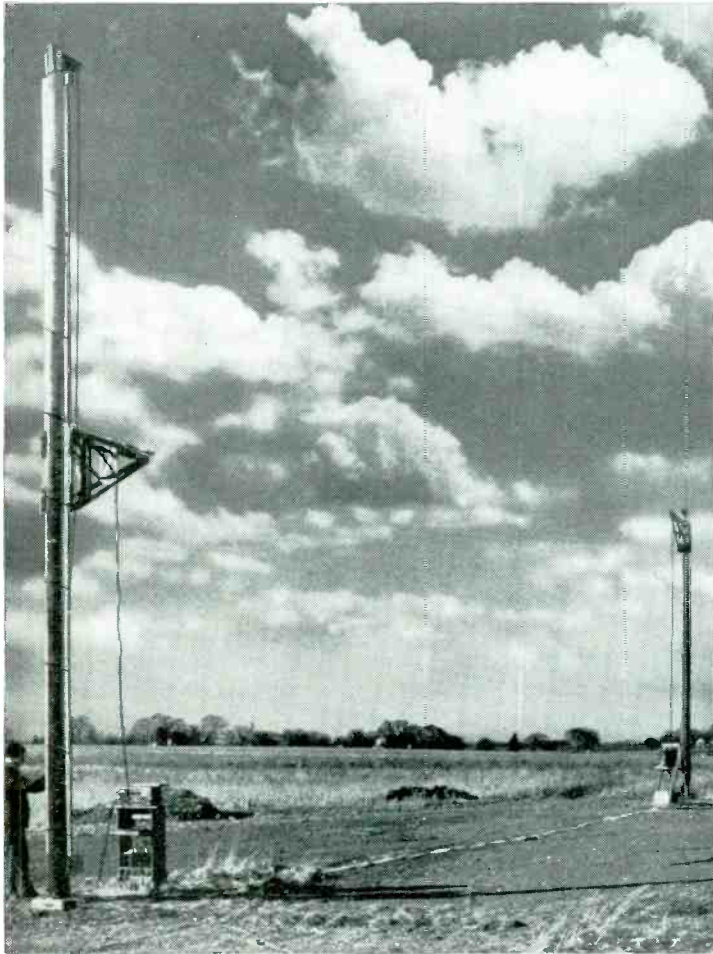

Test range for measuring radiation from oscillator of tv receiver, with field intensity meter and antenna in foreground and receiver 100 feet away at right

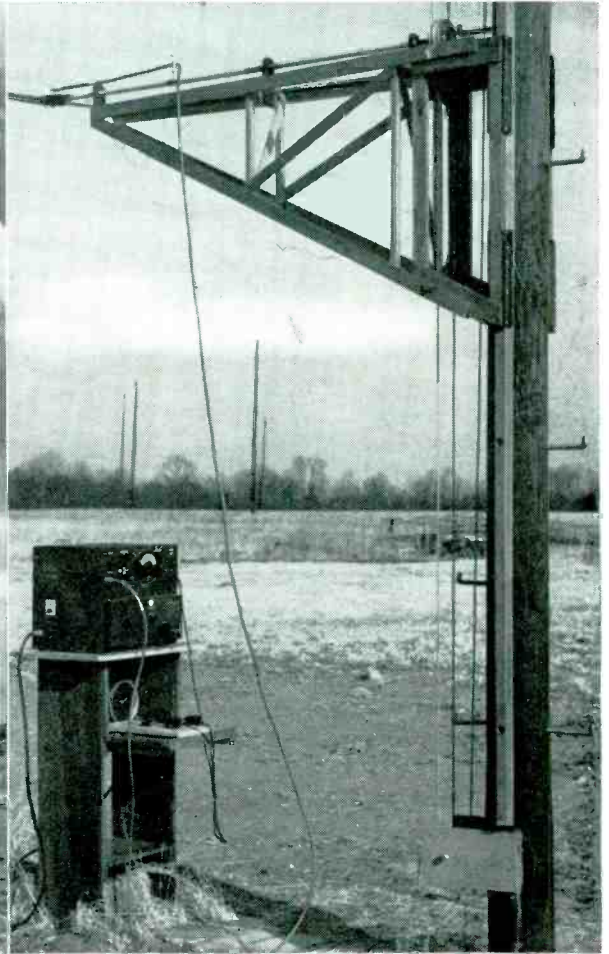

Field intensity meter uses antenna mounted so that antenna elevation and polarization can be changed by manipulating ropes

radiation is to be measured is placed on a turntable, the rotation of which is controlled from the measuring point. The electric power for both ends of the system is fed through buried cables. No metallic object greater than 6 inches in length exists in any part of the setup above ground level, with the exception of the receiver being tested, the field intensity measuring set and the associated antennas.

Provision is made to raise and lower the measuring dipole of the field intensity set and to change its polarization. The azimuthal orien-

tation of the horizontal dipole of the receiver is adjustable, independently of turntable rotation, or may be revolved with the turntable. The distance between the two antennas is 100 feet. The elevation of the receiver antenna is 30 ft, and the height of the field intensity meter antenna is continuously variable from 7 to 20 feet. All of the variables are manipulated independently to obtain the maximum possible indication.

Several f-m and tv receivers of post-war manufacture have been tested, employing substantially the

methods set forth in the IRE standard. The results are tabulated in Table I.

The conclusion from these measurements is that receiver radiation difficulties can exist and will occur in the future as frequencies occupied by the radiations are assigned for use by licensees in the same area. Frequency evasion is not alone satisfactory as a means of controlling the interference.

Shielding Problem

The usual local oscillator has a plate power input of the order of

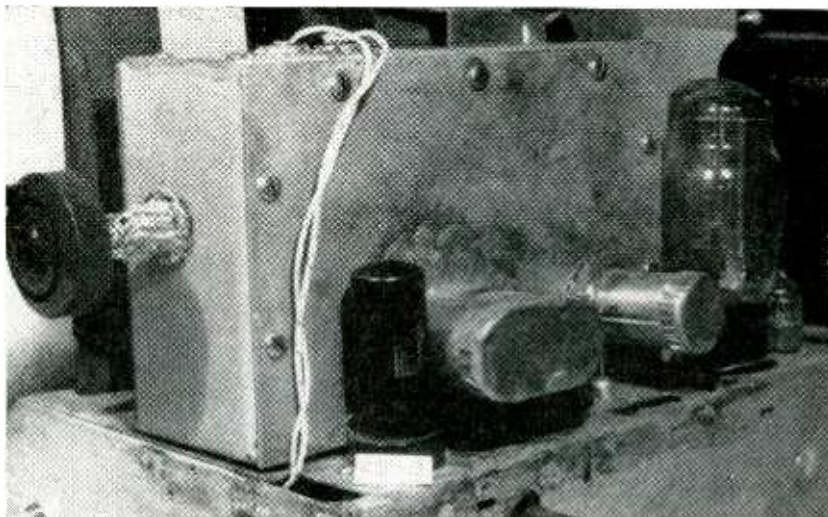

Example of continuous type of tv tuner, modified to reduce oscillator radiation below 10 microvolts per meter at 100 feet. Soldered cylindrical enclosures cover the three tubes

1 watt and available output power of $\frac{1}{4}$ to $\frac{1}{2}$ watt. If all of this power were efficiently radiated by a dipole antenna, a field of 160 millivolts per meter could be produced at a distance of 100 feet in free space. Fortunately, as shown in Table I, only a fraction of this oscillator power is typically radiated from the chassis and from circuit components and wiring.

Most of the measured radiation from f-m and tv receivers is stray radiation from the chassis. This can be demonstrated by short-circuiting the antenna terminals and completely eliminating the antenna and transmission line. It is only when the radiation has been reduced to levels considerably below those originally measured that any substantial radiation from the dipole antenna can be noticed.

More satisfactory shielding enclosures around the receiver or around the tuner itself (since the tuner generally is a separate unit assembled into the receiver chassis) offer the greatest possibility for improvement. Such enclosures should provide feed-through capacitors for power supply leads. Signal leads that must pass through the wall of the shielding enclosure may be equipped with filters, preventing the escape of oscillator energy.

The use of a low-pass filter in the video i-f lead of a wide-band stage may not be desirable because it increases circuit capacitance to ground and thereby reduces the

maximum amplification for a given bandwidth. Instead, the video i-f lead may be made very short and covered with a partial or complete shield. In f-m receivers, where the circuit bandwidth requirement is not great, either feed-through capacitors or suitable low-pass filters may be used for the mixer output lead.

The antenna input circuit of the tuner can be shielded from the rest of the unit by using suitable barrier walls and using a pentode or grounded-grid triode r-f amplifier (with the possible exception of the uhf band, where r-f amplifier tubes may not yet be economical). If a pentode is used, the screen should be grounded carefully for r-f potentials. The use of inductance in the screen circuit, as is sometimes done to obtain desirable input impedance characteristics for the r-f amplifier, will largely offset the value of the r-f amplifier as a radiation suppressor.

Fixed or switched low-pass filters may be employed in the antenna input circuit, or an additional tuned circuit may be included to provide further isolation for oscillator frequencies between the antenna and the input stage.

Indoor Tests

While an outdoor test site is preferable for radiation measurements, weather conditions may be unfavorable during a period when a particular tuner design is being

tested. An indoor test setup that gives related results is therefore desirable. It can use a field intensity meter (or a receiver with suitable indicator) whose dipole antenna is mounted at some arbitrary position in the room, plus a simple turntable on which the tuner or complete receiver may be placed. A shielded room is not essential. The antenna of the field intensity meter may be placed near a wall, well above the floor. The turntable may be at any convenient point in the room.

The turntable is particularly useful when checking leakage from the chassis. Minor adjustments and modifications may merely shift the distribution of field intensity in the room, without changing the level of leakage. Without a turntable, the impression may be gained that a particular change in the receiver has desirable results, whereas only the angle of peak radiation was changed.

By comparison of indoor and outdoor results, it is possible to arrive at an approximate relationship between the two that will serve as a useful guide in establishing the degree to which suppression must be achieved in the laboratory room before it is worthwhile to measure out of doors.

Certain field intensity meters are equipped by the manufacturers with small magnetic probes that have electrostatic shielding. These probes are useful in searching for leaks and other deficiencies in the enclosure of the receiver or tuner.

Desirable Radiation Limits

While it would be desirable to suppress oscillator radiation completely, there is probably an economic balance between the probability of interference at a given maximum radiation level and the cost of achieving that level in the large number of receivers that are to be manufactured. A goal of about 15 microvolts per meter at 100 feet seems reasonably attainable below about 250 mc. This may still cause interference to the reception of otherwise useful tv signals as strong as 1,500 microvolts per meter, as well as to signals of other services which may use much lower intensities. However, the test conditions are related to the maximum

radiation condition; the probability is that certain channels of the receiver will have much lower radiation than the maximum, and the direction of radiation of the maximum signal may not coincide with the location of the nearest receiver. Also, if the limit of 15 microvolts per meter is met in receiver production, most of the receivers will radiate less than the specified maximum and cause less interference.

At frequencies above about 250 mc, other man-made and natural interference is less, permitting the utilization of lower field strengths, and propagation difficulties may require an appreciable portion of listeners to use weak fields. Suppression of oscillator radiation will therefore be important for uhf television tuners and receivers.

Modification of Continuous Tuner

To determine the extent to which existing tuners could be modified to reduce oscillator radiation, two representative types of tuners that have had considerable production were selected for a laboratory experimental program.

The first tuner modified was continuously tunable in frequency over the 12 television channels from 54 to 216 mc. The modifications may be considered extreme in that they include use of a complete metallic covering around the entire tuner, including its tubes. Joints in this covering were soldered except where it was necessary to leave provision for access.

The end of the tuning shaft that projects directly into the oscillator compartment had to be grounded effectively to keep the stray radiated field below the desired 15 microvolts per meter. The mere ungrounding of this one shaft and its protrusion about 2 inches outside the shield resulted in fields at some frequencies of the order of 100 microvolts per meter at 100 feet. An insulated shaft would be desirable.

To reduce the escape of oscillator energy through the i-f output path the first i-f grid coil was moved into the tuner shield box inside a small separate shield. This i-f coil was coupled to a second i-f tuned circuit

in the grid of the first i-f amplifier by a capacitive coupling network which included a feed-through capacitor to ground having an impedance of about 200 ohms at the intermediate frequency and proportionately less at the oscillator frequencies.

Power supply leads were brought into the tuner from the top through button-type feed-through capacitors and r-f chokes which were enclosed in a separate shield inside the main shield.

Reduction of the antenna component of radiation was effected by placing a cylindrical shield around the r-f amplifier tube socket. This cylindrical shield has an additional wall across it to isolate the input and output circuits of the r-f amplifier. Bypassing of the screen, filament and cathode leads was done with button-type capacitors placed as close as possible to the socket.

The modified tuner was tested in the standard outdoor test setup and found to produce a maximum field of 10 microvolts per meter at 100 feet at the worst frequency. It is considered that although the intended goal had been met, certain parts of the work had not been done in the most economical manner; also it would be desirable to provide more satisfactory access to the tuner, especially for replacement of tubes and for alignment adjustments. Therefore, on the basis of the experience already gained, work was begun on a second tuner.

Modification of Turret Tuner

The second tuner used had 12 channel strips, each supporting the necessary r-f, mixer and oscillator coils for one vhf channel. Zinc-coated steel was used for shielding, to stay away from copper or other metals which might be difficult or expensive to obtain. The modifications were as follows.

(1) An assembly of three 500- μ f button-type feed-through capacitors was arranged to cover the slot in the side of the tuner through which the power supply and i-f leads originally came, and to filter the power supply leads. These capacitors should have low impedance at the oscillator frequencies as compared to the impedance of conven-

Table I—Radiation Measured on Typical Receivers

Channel (mc for UHF)	Osc Freq in mc	μ v per met r at 100 ft	
1948 TV Receiver	2	63	
	3	116	
	4	145	
	5	185	
	6	235	
	7	627	
	8	273	
	10	476	
	11	362	
	12	298	
	13	552	
	1949 TV Receiver	3	176
		6	65
8		587	
10		600	
11		762	
13		269	
1950 TV Receiver	2	84	
	4	64	
	5	88	
	7	220	
	9	360	
	13	175	
1951 TV Receiver	2	356	
	3	90	
	4	151	
	5	74	
	6	83	
	7	87	
	8	89	
	9	95	
	10	125	
	11	117	
	12	131	
	13	198	
	1951 UHF TV Converter	500	512
550		612	
600		650	
650		645	
700		900	
750		1,160	
800		805	
850		900	
1951 UHF TV Converter	900	555	
	500	1,500	
	550	2,340	
	600	2,840	
	650	1,300	
	700	1,310	
	750	890	
	800	560	
	850	1,000	
	890	1,300	

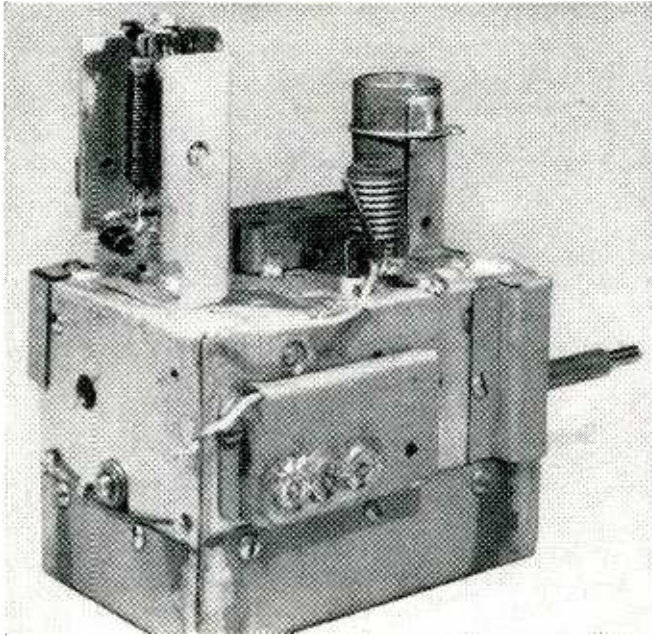

Modified version of turret-type tuner. Main openings are covered by zinc-coated steel, with button-type feed-through capacitors for filament, plate and avc leads

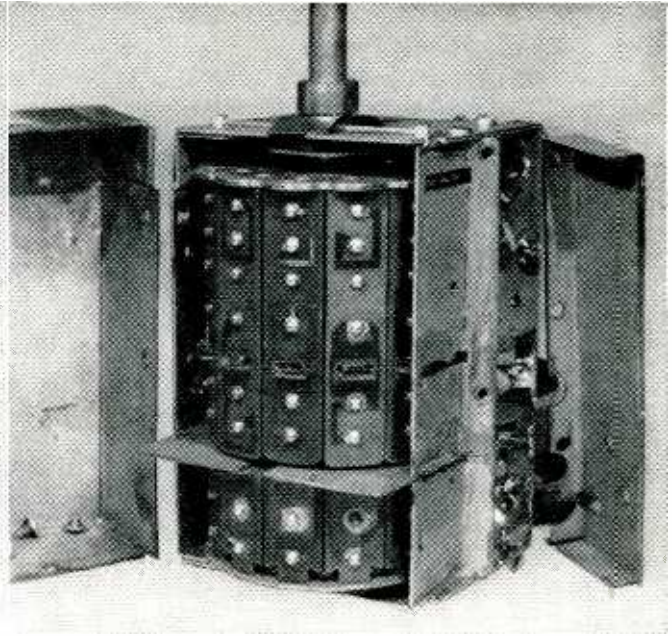

Method of cutting channel strips and mounting additional shield wall through turret assembly. Tuning shaft at top is grounded by adding collar and spring

tional bypass capacitors.

(2) A cover was folded out of one piece of metal and fastened to the open bottom of the tuner with self-tapping screws.

(3) A bent metal cover was placed over the side opening of the tuner chassis.

(4) A small metal cover was fitted over that part of the top of the chassis where aligning screw adjustments come through. Some of these screws are mounted in Bakelite and are therefore quite hot. Alignment adjustments may be made through holes in the top of the new shield cover.

(5) A single metal shield wall was put through the tuner at the center of the r-f amplifier tube socket, to isolate the r-f input circuit. This required cutting each of the channel strips.

(6) A bent metal piece was used to cover the detent spring, which projects partly through a slot in the chassis.

(7) A grounding spring and shaft collar were used to reduce oscillator leakage through the fine-tuning shaft. (An insulated shaft is indicated.)

(8) The extra screen inductance in the r-f amplifier was eliminated, to further isolate the r-f input.

(9) The picture i-f lead was

rearranged so that only about 2 inches of it are exposed to reach the first i-f grid.

(10) The 47- μf capacitor in the sound trap tank circuit was moved to a point on the surface of the chassis where the sound i-f lead comes through. A feed-through capacitor would be more satisfactory mechanically.

(11) The flanges of tube shields were soldered to the chassis, instead of relying on rivets only.

Conclusions

These modifications serve to cover the entire outer surface of the tuner as completely as practical with a metallic covering and to isolate the antenna input circuit from the remainder of the tuner. There are still numerous joints and connections between the metal parts and there are holes. However, if the holes are kept small and if the joints are tied in such a manner that they are not over two inches in length, no particular difficulty results. A new tuner could very likely be designed and manufactured that would achieve these modifications in a much simpler manner at a cost but little higher than that of the original tuner.

The modified turret-type tuner was installed in a tv receiver, tested

for oscillator radiation, and found to produce a maximum of 9 microvolts per meter at 100 feet on the worst channel. Most of the 9 microvolts are still obtained when the antenna and its feed line are completely removed from the tuner, showing that if further suppression were desired it should be sought in the direction of improving the shielding around the chassis.

While the work reported in this paper was performed in the course of official duties, the opinions are those of the authors and do not necessarily represent the position of the Federal Communications Commission.

Valuable contributions to this work have been made by other members of the Laboratory staff, especially F. D. Craig, who did much of the development work, and M. C. Mobley, who constructed the outdoor test range. The work was performed under the direction of the Chief Engineer of the Federal Communications Commission, as a result of a suggestion made by Commissioner G. E. Sterling.

REFERENCE

- (1) Subcommittee on Spurious Radiation, IRE Receiver Standards Committee, Standards on Radio Receivers: Open Field Method of Measurement of Spurious Radiation from Frequency Modulation and Television Broadcast Receivers, 1951, *Proc. IRE*, p 803, July 1951.

Precision Preamplifier

New circuit gives 6-db-per-octave rise in response from crossover frequency down to 10 cps to match recent improvements in other components of high-fidelity sound systems. Passive network compensator gives choice of five high-frequency rolloffs

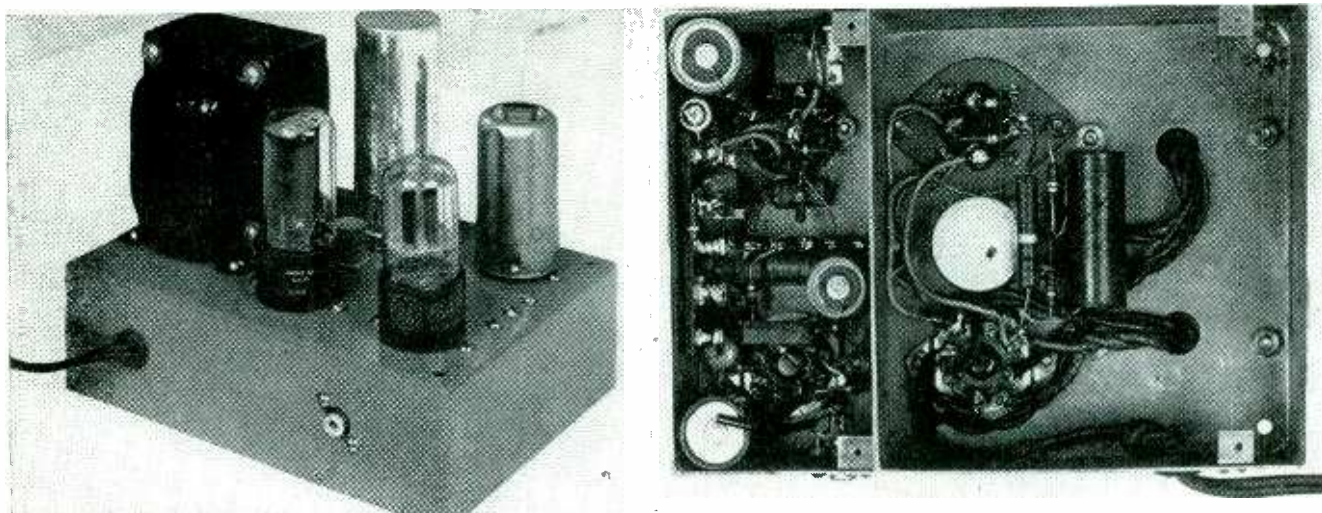

Top and bottom views of preamplifier, showing partition shielding between power supply and amplifier section

THE DEVELOPMENT of a modern preamplifier leads to many problems from the standpoint of hum, noise, stability and overload characteristics. In addition, the preamplifier should accurately match the 6-db-per-octave rise in response below the turnover frequency, to frequencies as low as 20 cps, to fully justify the use of speakers and amplifiers capable of good response in this region, and greatly improve low-frequency transient response when used with tonearms having little or no arm response.

The preamplifier design presented here meets these requirements for a high-quality sound system. Midfrequency gain is 39 db, maximum input for less than 0.7 percent harmonic distortion is 0.25 v and maximum output is 22 v. Equivalent grid noise at 60 cps is 3.1 μ v. Required input for 1.0 v output at 2,000 cps is less than 15 mv.

If a complete radio-phonograph system is under consideration, the preamplifier may be used as a con-

By **GEORGE E. BEGGS, Jr.**

*Continental Sound Consultants
Warrington, Pa.*

sealed unit, power being switched on and off by a radio tuner. The output of the preamplifier, properly attenuated by means of a gain control initially preset to give matching levels of radio and phonograph program material, is fed into the uncompensated phonochannel of the tuner. The tuner volume and tone controls, a-c line switch and input switching then centralize and simplify the complete operation of the home system without the use of a separate preamplifier control panel.

The low output source impedance of the preamplifier allows its use adjacent to a phonograph turntable, which in itself may be placed remote from the other amplifier stages. Assuming the cable capacitance to be of the order of 40 μ mf per foot, it will have little effect upon the high-frequency performance of the unit up to 500 feet. A shunt capacitance of 20,000 μ mf

on the output will attenuate 15 kc only 3 db.

For broadcast applications, the preamplifier may be fed into a 600-ohm isolating pad if desired and thus into the input channel of a standard program console.

Performance

A preamplifier-equalizer meeting the requirements outlined would ideally have flat response from a selected turnover frequency, say 500 or 600 cps, up to the top end of the desired range, say 30 or 40 kc. Below the crossover, the response would rise uniformly at 6 db per octave down to the lowest frequency desired, at which point the response would fall off rapidly.

The actual measured response of the unit shown in the circuit diagram of Fig. 1 is presented in Fig. 2. Other crossover frequencies can be provided by changing the capacitance values in the two selective networks of the 7F7 plate circuits, or by the use of external networks as described below. The deviation curve shown is a plot of

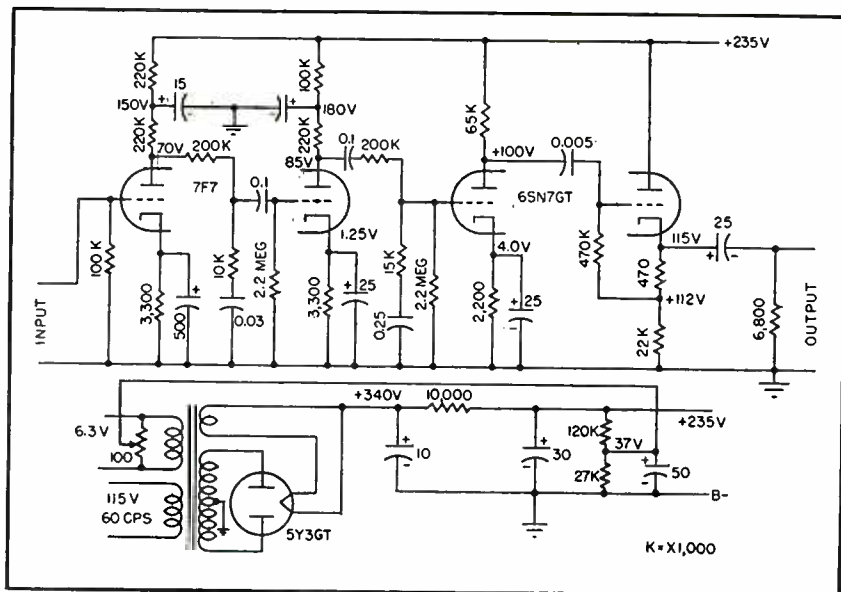

FIG. 1—Complete circuit of new preamplifier-equalizer with self-contained power supply

the difference between the desired curve and the measured characteristics obtained with the unit. It will be noted that the deviation curve is flat within less than one db from approximately 15 cps to over 20,000 cps, providing excellent low and high-frequency transient response.

Circuit Details

The circuit of the preamplifier is relatively straightforward. Cathode bias is used in all cases to minimize distortion which arises from the contact bias used in some preamplifiers. The separation of the two cathodes of the 7F7 is essential to maintain stability in the system, otherwise motorboating will occur regardless of the size of the cathode capacitor utilized to bypass a common cathode resistor.

The 7F7 is operated with positive heater bias derived from the B+ supply. A variable heater center-tap potentiometer, adjusted for minimum noise, is also employed. Wiring of the input stage is point to point, with a common ground return point for the grid circuit, cathode circuit and frequency-discriminating circuit in the plate of each section of the 7F7. This common ground point is the center point on the loctal socket.

The input ground is also returned directly to this point, the input

jack being isolated from the chassis. Furthermore, the input magnetic loop is kept small. Loom shielding is unnecessary. Independent decoupling is used in the two low-level plate supplies, although it is omitted from the third stage and cathode follower circuits. This decoupling also provides adequate filtering of the B supply ripple.

Where pickups generating output voltages greatly in excess of 10 millivolts are utilized, it is desirable to provide a gain control in the system so that the output voltage from the cathode follower will be of the same order of magnitude as that derived from a detector in an a-m or f-m tuner. Accordingly, a 10,000-ohm gain control is suggested in place of the 6,800-ohm fixed output resistor in the output circuit of the cathode follower stage. Since the system will tolerate input voltages as high as 250 mv without producing distortion in excess of 0.7 percent, an output gain control is feasible and desirable to maintain the highest signal-to-noise ratio.

Low-impedance output (without the gain control) is not very susceptible to capacitive or resistive loading, hence the preamplifier may be fed directly into any high-impedance input channel or into a 600-ohm input line (unbalanced) if the 6,800-ohm output resistor is

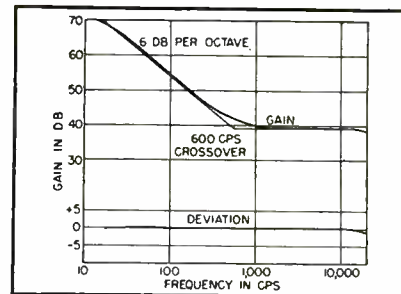

FIG. 2—Frequency response curve of preamp

retained. A 600-ohm termination results in about 5 db loss at all frequencies in the response range.

The amplifier section is completely isolated from the power supply section, being placed across one end of the chassis and shielded from the power supply components. In-line construction is utilized. Where vibration may be encountered, the two amplifier tubes should be mounted on a cushioned or floated plate sufficiently large to accommodate most of the circuit elements, making necessary only connection of B supply, heater leads and input and output lines.

Response Measurement

A Hewlett-Packard 202D oscillator covering the frequencies from below 10 cycles to above 70,000 cycles was utilized for response tests.

An output attenuator which reduced the output voltage by 200 to 1 was placed across the terminals of the oscillator; the output voltage was developed across 50 ohms. A signal of about 10 millivolts at 2,000 cps was fed to the input of the preamplifier. As the input frequency was varied, the output voltage of the preamplifier was maintained constant regardless of input frequency, the level being read with a Hewlett-Packard 400A vacuum-tube voltmeter. The variations in oscillator voltage as developed across the oscillator terminals were measured with the same vacuum-tube voltmeter by switching it from output to input, and the variations in required input voltage were inversely plotted to measure the overall response of the system.

This method of measurement eliminates any errors present in

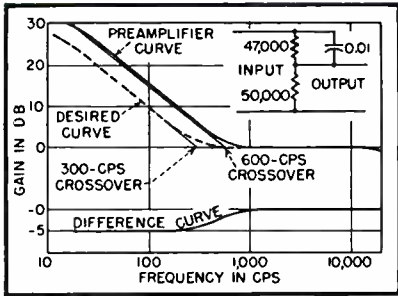

FIG. 3—Method of designing network to give desired high-frequency rolloff

the frequency response of the vacuum-tube voltmeter and errors which might arise due to variation of oscillator output voltage with frequency, since the same errors are present in the measurement of both the input and output voltages.

Noise Distortion

Distortion and noise measurements were made by using a General Radio low-distortion model 1301-A oscillator as a source and a General Radio model 1932-A noise and distortion analyzer as a measuring instrument.

The equivalent noise at 60 cps, including nonsinusoidal bounce and flicker noise as well as hum, is computed by measuring the output voltage with the input open-circuited, then measuring the 60 cps gain, which is 60 db. Since this is a factor of 1,000 (voltage gain) the output voltage in millivolts is equivalent to the effective 60-cps input voltage in microvolts at the input grid. The measured output voltage is 3.1 mv (50 db below 1.0 v); the effective 60-cps input noise is thus 3.1 μ v.

Distortion measurements were made in the same manner as response measurements, the output voltage being maintained constant at all input frequencies. The distortion of the preamplifier, measured at 0.070 v input, is less than 0.1 percent. Oscillator distortion of the order of 0.1 percent makes measurements below this level difficult. Maximum input limitations are well above the outputs of magnetic cartridges now available.

It is possible, and perfectly feasible, to provide networks external to the preamplifier which will provide various high-frequency rolloff

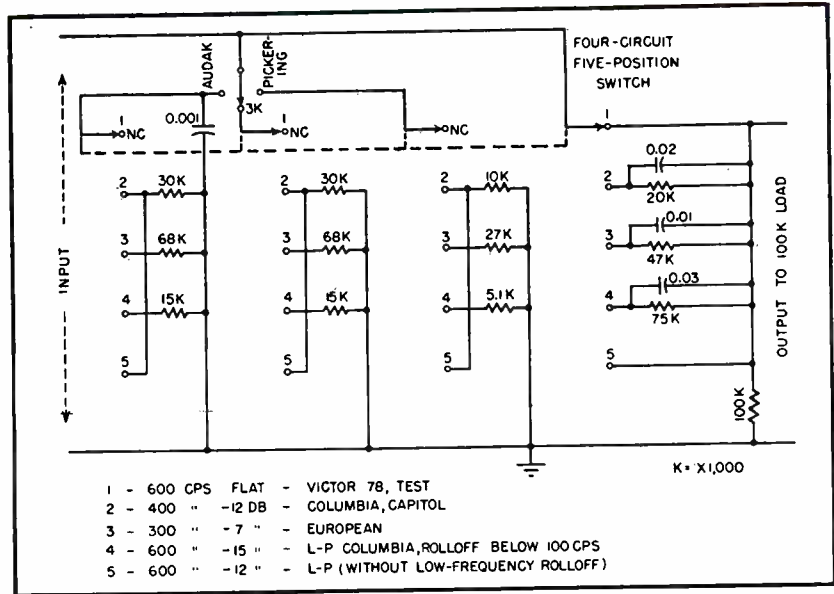

FIG. 4—Recording characteristics compensator

characteristics and change the crossover frequency. Initially this seems a bit difficult, but the basic philosophy of the circuits required is simple.

Crossover Frequency

In Fig. 3 the curve of the preamplifier with its 600-cps crossover frequency is drawn in conjunction with the desired curve for a 300-cps crossover. The difference curve is then derived, resulting in the curve shown at the lower half of Fig. 3.

A network to satisfy such a response characteristic is also shown. Basically, the network must produce the desired loss below the sloped portion of the difference curve. A simple voltage divider network will solve the problem. Above the sloped portion of the curve, no loss is desired. The voltage divider must thus be short-circuited at these frequencies. A capacitor shunting one section of the divider, selected to have an impedance equal to the resistance it shunts in the slope frequency region, preferably near the lower end of the slope, satisfies the requirement. Below the slope-frequency region, the network gives the desired fixed loss.

The circuit components needed to produce crossover frequencies of 400 cps and 300 cps in association with the preamplifier 600-cps cross-

over are given in Fig. 4. To these are added various shunt resistors on the first three switch decks to give rolloffs for various recording characteristics. The rolloffs are produced by these shunts as a result of the inductance of the cartridge with which they are used. Since various makes of cartridges are different, different shunt circuits are provided. Where the inductive impedance and the shunt impedance are equal, there will be 6-db loss and frequencies above this point will be further reduced, approaching a loss curve of 6 db per octave.

More rapid attenuation may be produced by shunting capacitors across the loss resistors. Little change in level results from these shunts, as the effective source impedance of the pickups is relatively low compared to the shunt values of the capacitors.

The philosophy behind the passive network compensator is that the buried preamplifier should have its circuits intact, without need to extend any of the networks by remote cable and switch. The passive network compensator allows centralization of all controls at the tuner in a small space, or the compensator may be adjacent to the turntable. Since all components of the compensator are small, they may be mounted on the switch itself.

Pulp-Log Metal Detector

Designed specifically to detect relatively large pieces of tramp metal in work areas subject to great vibration. Immunity to strong electromagnetic fields from nearby induction motors and to fluctuating line voltage is provided

By **MARCEL GROBTUCH** and **D. J. WILLIAMS**

*Correspondent
McGraw-Hill World News
Melbourne, Australia*

*Research Division
Australian Paper Manufacturers Ltd.
Melbourne, Australia*

DESIGNED FOR the pulp and paper industry, this detector protects multiblade chippers from damage by pieces of ferrous metal. The device has been installed in the Maryvale pulp mill of the Australian Paper Manufacturers Ltd. of Melbourne, Australia.

In its first months of operation, the new detector has located several pieces of tramp metal which could have caused considerable damage and possible substantial loss of production.

The detector is immune to the effects of fluctuating line voltage and it is automatically compen-

sated against drift from the balance condition.

At the mill where it is now installed, the tramp metal encountered comprised mainly steel wedges used for timber splitting. Other metal encountered was in the form of pickaxe heads and pieces of metal dislodged from the conveyors and barking drums ahead of the chippers.

The layout of the plant at the only available site of installation is somewhat cramped and a considerable quantity of mild steel structure is in the immediate vicinity. All surroundings are subject to

heavy vibration, a factor which would seriously affect the operation of the usual metal detector. For these reasons a single-coil method has been adopted, although mutual-inductance systems generally offer somewhat better stability and sensitivity.

Frequency of Operation

A frequency of 1,000 cycles is used. The bridge initially tried was of the Maxwell type. This system proved impractical due to the presence of strong interfering electromagnetic fields varying in intensity with the rapidly fluctuating loads

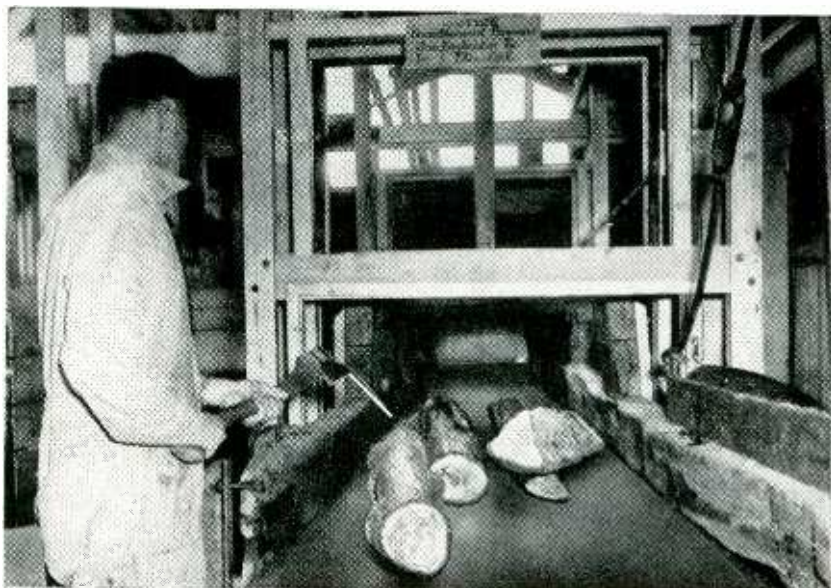

Search coil of the detector is located around the conveyor carrying billets to the chipping machines. Typical pieces of tramp metal encountered were in the form of steel wedges and pickaxe heads



Detector and recorder. Second panel from top has resistance-adjusting knobs for bridge circuit

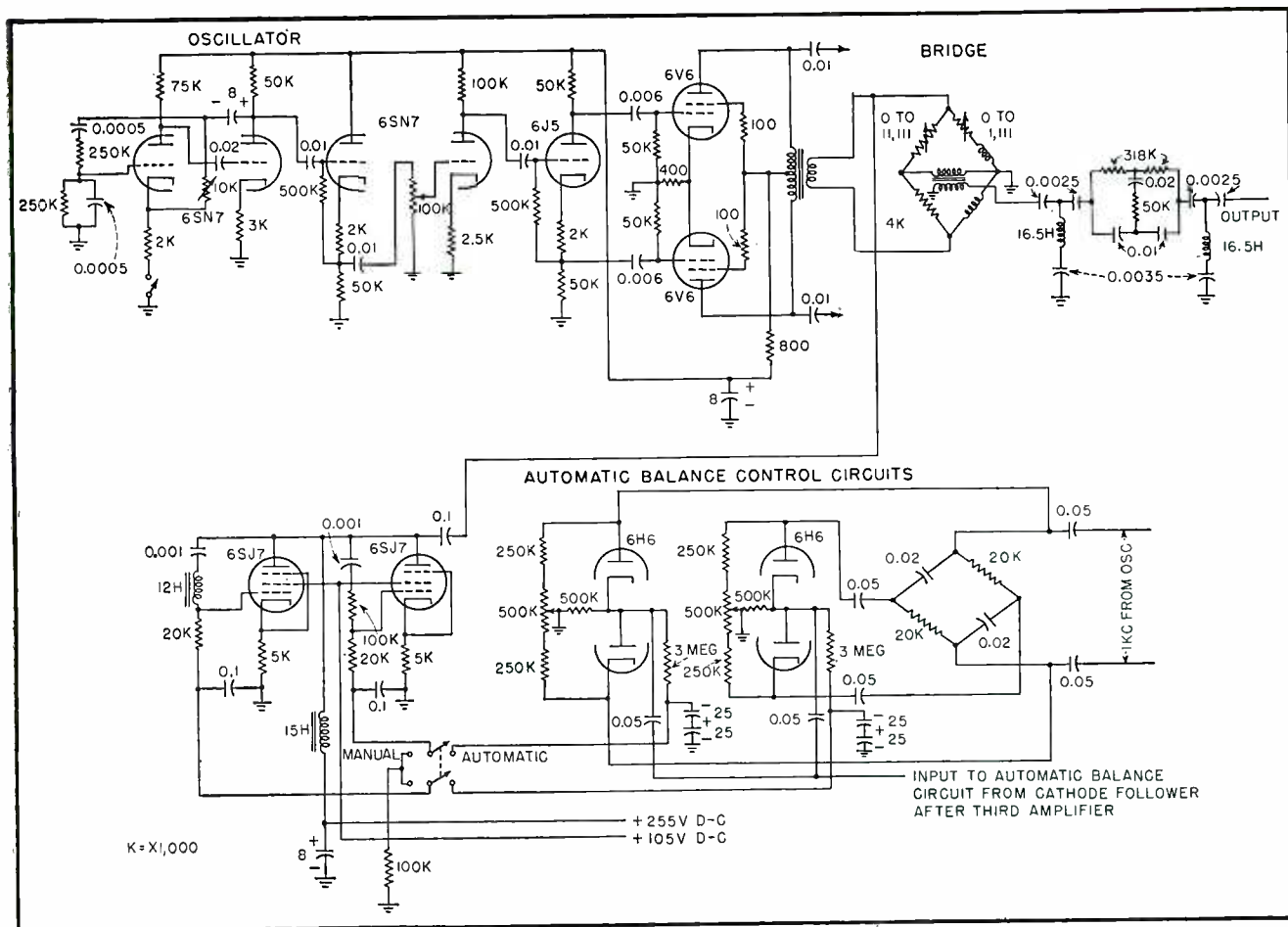

FIG. 1—Oscillator, bridge and automatic balance control circuits for the metal detector

on the induction motors driving the chippers. There are three such motors with an aggregate of 1,000 hp in the vicinity of the equipment installation.

A special inductance bridge using two similar 370-turn coils, each on a wooden form 3 feet 8 in. wide by 2 feet 10 in. high, was used. One coil was wound around the conveyor and the other was placed immediately above in the same plane to assure a like orientation to the interfering electromagnetic fields.

The coils are connected in the bridge so that the unwanted induced voltages are of opposite polarity and therefore cancel each other out.

Further improvements in eliminating the effects of this interference were made by increasing the power input to the bridge from 3.5 to 8 watts and by decreasing

the sensitivity of the unbalance detector amplifier.

Because of the vibration present at the site of the search coil, the instrument is located some distance away where the effect is greatly reduced. The 60-foot lead used for connecting the coils is shielded, with the braided metal shield used as a common ground return.

Circuit Description

The 1,000-cycle oscillator used, shown in Fig. 1, is of the Wien-bridge type using a 6SN7. Output of good stability with respect to amplitude and frequency, is fed to the first section of the second 6SN7 used as a cathode follower, from which it is amplified by the second section to drive the 6J5 phase-splitter and pushpull 6V6 vacuum tubes.

Tapped secondary impedances are used on the output transformer so

that the bridge impedance, approximately 3,500 ohms, may be well matched. Power output is about eight watts.

The two coils are in opposite arms of the bridge. A Q balance control of 1,111 ohms, adjustable in steps of 0.1 ohm, is in series with one coil. The two ratio arms of the bridge are resistive, and one is variable from 0 to 11,111 ohms in steps of 0.1 ohm. For convenience, the junction of the two coils is maintained at ground potential.

The unbalance is transformer-coupled to a filter system consisting of two 850-cycle high-pass filters separated by a bridged-T network tuned for maximum attenuation at line frequency. This system reduces the interfering voltages to less than 150 μ v at the input to the three-stage amplifier.

The first two stages of the am-

the strongest and weaker signals.

During summer 1948, measurements were made wherein all signals involved were skywaves. From time to time the desired or strongest signal on the channel varied widely in intensity, upsetting the reference voltage ratio of desired versus undesired signals. Under these circumstances, the equipment provided very little useful information.

Narrow-Band Recorder

The narrow-band recorder, which was developed in the fall of 1948, is shown with its associated calibration gear in the photograph and the block diagram. The receiver consists of four stages of tuned r-f, a diode detector, and an audio stage tuned to 13.5 cycles that actually constitutes the first stage of the i-f system. The selective amplifier follows the receiver. The output of the selective amplifier is connected to a diode detector and also to a cathode follower, which supplies the i-f to a frequency-discriminator circuit. The discriminator provides an afc voltage that is applied to a reactance tube in the crystal oscillator, thereby maintaining the output frequency in such a manner as to sustain the i-f at 13.5 cycles. Figure 1 is the overall i-f selectivity curve.

The crystal oscillator also introduces a voltage ahead of the detector for stabilizing the avc voltage produced by the desired signal. The output of the second detector supplies avc voltage to the first two r-f stages in the receiver and excites a d-c amplifier and graphic recorder. The narrow-band recorder incorporates both primary a-c power regulation and regulated d-c power supplies.

Calibration of the narrow-band recorder is accomplished by using a crystal-controlled signal generator to feed increments of power into the receiver antenna input terminals while maintaining a frequency difference of 13.5 cycles with respect to the receiver oscillator.

Figure 2 shows the response curve of signal input voltage versus recorder output in chart ma. This receiver response curve is corrected for the effective height of the receiving antenna to obtain an

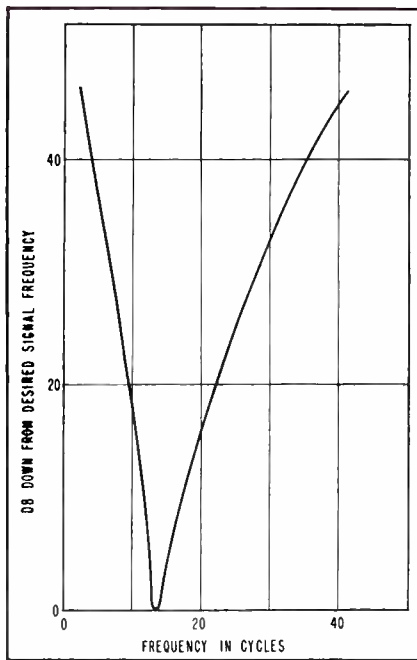

FIG. 1—Overall i-f selectivity curve shows high degree of rejection of signals differing from 13.5 cycles

output response in millivolts per meter versus chart ma.

After calibration of the narrow-band recorder, the antenna is connected and the signal to be measured is tuned in by adjustment of the local oscillator.

During operation of the recorder, the intermediate frequency is constantly monitored by a frequency meter that operates from the discriminator circuit. A Brush high-speed oscillograph is connected into the i-f system for frequent graphic checks of the intermediate frequency. A vacuum-tube voltmeter reads diode detector voltage, indicating the magnitude of oscillator injection voltage and the beat frequency between the local oscillator and any unwanted signals.

Field Tests

During 1949, the narrow-band recorder was field tested, making skywave studies of clear channel interference problems. Figure 4 shows three charts in terms of sunset hour. The narrow-band chart, Fig. 3A shows the drop in the undesired station's field intensity as operation is switched from nondirectional. Also shown are charts of desired signal, Fig. 3B, and the monitor signal, Fig. 3C.

Figure 4 shows three charts at

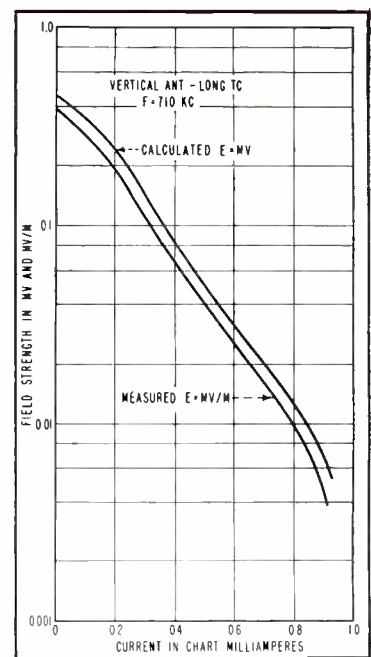

FIG. 2—Basic recorder response curve (right) and the same curve corrected for antenna effective height

ss + 4 and ss + 5. Figure 4B is the standard field-intensity recording of the desired station leaving the air with the undesired station remaining on. Figure 4A is the narrow-band recording of the undesired station. The monitor station field-intensity recording is shown in Fig. 4C. Also shown is the frequency check chart, Fig. 4D.

Supplementary Recordings

Cochannel skywave measurements made with the narrow-band recorder were supplemented by recordings of monitor and desired signals on separate recorders since the narrow-band recorder recorded only the undesired signal.

The monitor and desired stations were recorded using converted Command receivers. These receivers operated from regulated power supplies, with avc added for logarithmic recording, and d-c amplifiers driving Esterline-Angus recorders. Vertical antennas were used on all recorders. A Federal field-intensity meter calibrated by the Bureau of Standards was used to correct the recorders' output response curves to read directly in mv per meter versus chart ma.

One-minute time constants were

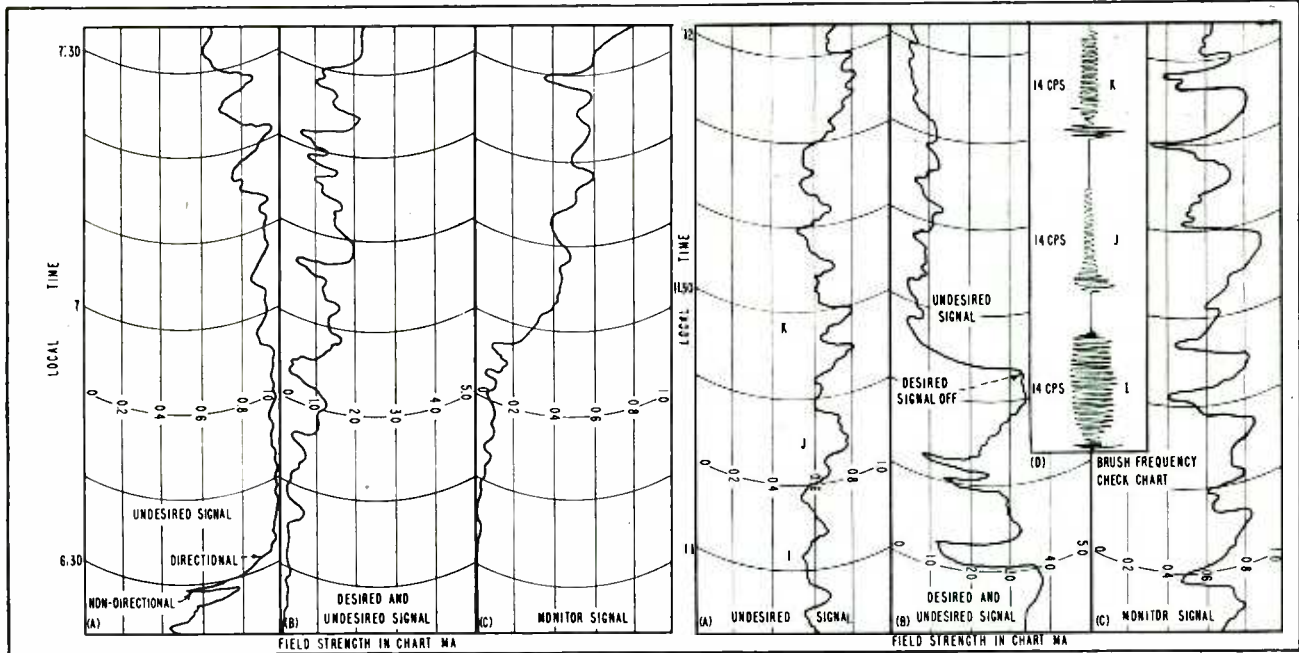

FIG. 3—Field intensity recordings made during sunset hour. Undesired signal (A) shows effects of changeover from non-directional to directional antenna operation

FIG. 4—Field-intensity recordings made at desired station's signoff time. Trace (B) shows interfering station's field-intensity after desired station signs off

used on all three recorders as this value is generally used in skywave studies. Measurements were usually limited to a certain bearing, centered around the desired station's 0.5 mv per meter contour.

Analysis of Data

In an analysis of skywave measurements between two stations, field-strength or interference ratios are determined with respect to sunset time. This is the time of sunset at midpoint of the transmission path between the station measured and the point of measurement. This time is obtained from FCC or Naval Observatory charts showing sunset time with respect to location. Analysis of skywave charts is made, determining the field strength exceeded for either 10 percent or 50 percent of sunset hour and each hour following.

Since skywave transmission varies from night to night, measurements are normally made over a thirty-day period. At the conclusion of the month's recording, the field intensities exceeded for either 10 percent or 50 percent of every hour during each night's operation are plotted against midpath sunset time, resulting in an average skywave curve during the thirty-day test. From this curve, it is possible to determine the average field in-

tensity for $ss + 2$ or any other time.

Figure 5 shows a thirty-day summary curve of fifty-percent values for the undesired station, desired station, and the monitor station.

In conclusion, it may be of interest to note that nondirectional-to-directional antenna skywave ratio tests showed very poor correlation with calculated and ground-plane measurements. FCC nondirectional-to-directional antenna skywave ratio tests, involving approximately twenty-five radio stations showed similar results.

It appears that many existing directional systems, adjusted by ground-plane measurements, are not giving adequate skywave protection. Improved engineering standards are needed if the growth of cochannel skywave interference is to be kept to the same order of magnitude as that intended.

Credits

The narrow-band cochannel recorder is based upon the ideas of G. F. Leydorf, vice president and chief engineer of WJR. R. K. Clark, C. W. Jones, and G. L. Mills of WJR and R. A. Fox, and W. G. Hutton, of WGAR, developed the equipment under Mr. Leydorf's direction. Field testing was done by Mal Mobley. Mr. Leydorf assisted in the preparation of this paper.

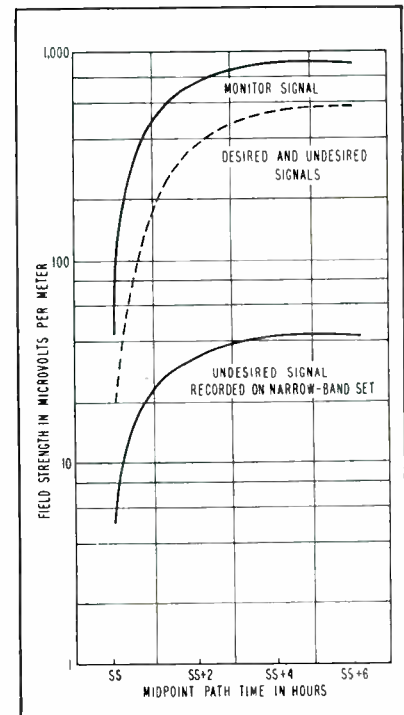

FIG. 5—Thirty-day summary of 50-percent hourly median values recorded both on narrow-band set and by conventional techniques

REFERENCES

- (1) Federal Communications Commission, "Standards of Good Engineering Practice Concerning Standard Broadcast Stations", p 11, Washington, D. C., 1947.
- (2) Glenn D. Gillett, U. S. Patent 2,079,265, May 4, 1937.
- (3) R. A. Fox, A System for Continuously Recording Co-Channel Interference, NAB Convention, Los Angeles, 1948.

Constant-Current

Design reduces power-supply requirements because amplifier does not present varying load as do conventional circuits. Costs are cut by using only one high-voltage winding, one rectifier tube and minimum of filtering components in power supply

ONLY a simple, light power supply is required for the direct-current amplifier to be described. It does not present a variable load to the B supply, therefore the supply needs regulation only for line variations. Since line variations require a much smaller percentage of regulation control, a resulting overall system simplification is achieved.

The circuit of the newly developed amplifier shown in Fig. 1 differs from conventional d-c amplifier circuits only in the final push-pull stage. One-half of this stage serves as the output stage delivering power to the load. The other half delivers out-of-phase current to ground through an equivalent load, neutralizing both the flow of load current to ground and the accompanying drain on the B power supply.

The double-ended output stage acts like a single-ended output without the usual load current change in B-supply current. Consequently, the supply shown in Fig. 1 for the

amplifier is considerably simpler than a conventional one for a d-c amplifier.

In particular, the simplified supply of Fig. 1 requires only one high-voltage winding and one rectifier tube instead of the two high-voltage windings and two rectifier tubes of the conventional supply. Because the load current does not change, neither voltage amplifier nor power amplifier tubes are required for voltage regulation and a resistor may be used in the place of a choke for filtering.

The divider formed by the two regulator tubes provides a satisfactory ground return because no load current flows to the mid-point of this divider.

Although the quiescent current from the B supply of Fig. 1 is twice the quiescent current of a conventional supply the maximum capacity of a conventional supply must be the same as that of Fig. 1 because at full load it delivers just as much current as does the supply shown in Fig. 1.

Drift of the amplifier of Fig. 1 is comparable to that of conventional, stable d-c amplifiers and averages one mv referred to the input grid. Over its rated operating range this amplifier is linear to $\pm\frac{1}{2}$ percent. Although no choke is used in the B-supply filter, the 60-cycle hum appearing across the output terminals is less than one mv referred to the input grid. Response of the amplifier is flat from zero to 20 kc for gains from 1 to 15.

The operating range of the output for which the amplifier of Fig. 1 retains its linearity of $\pm\frac{1}{2}$ percent is ± 10 ma into a load of 50 to 1,000 ohms. By changing the cathode resistor in the output stage, the amplifier can be made to develop ± 50 volts into loads greater than 50,000 ohms with a linearity of $\pm\frac{1}{2}$ percent.

Adjustment

There are only three points of adjustment; R_a , R_b , and R_n in the amplifier of Fig. 1 and two of these are used infrequently. Potentiom-

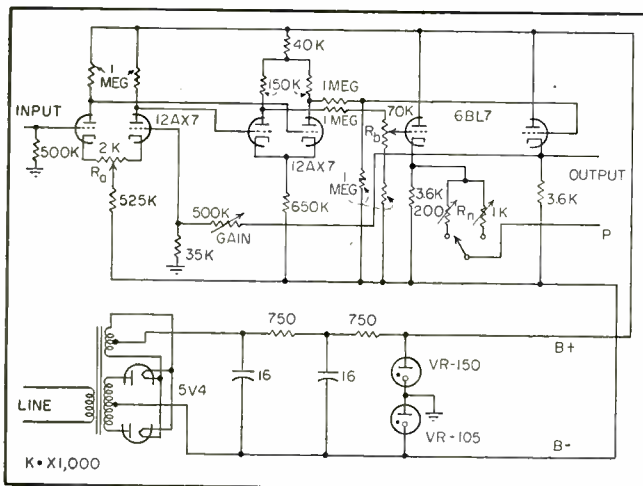
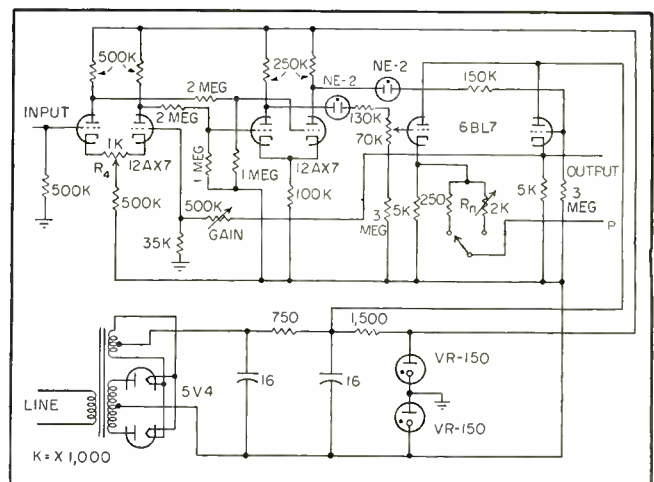

FIG. 1—Schematic diagram of the d-c amplifier. Double-ended output stage acts like single-ended output without the usual load current change



Modified version of the amplifier and power supply shown in Fig. 1. This circuit is designed for driving both photographic recorders and direct-writing recorders

D-C Amplifier

By DONALD McDONALD

Chief Engineer
Cook Research Laboratories
Chicago, Illinois

eter R_n is a zero adjustment used to bring the output to ground. Potentiometer R_b is adjusted infrequently and is used to bring the cathode of the left-hand half of the output stage to ground. Potentiometer R_n is touched only when the output load of the amplifier is changed and it is then adjusted for neutralization of the load current flowing to ground. Proper adjustment of R_n is accomplished by inserting a milliammeter at point P and adjusting R_n until the meter reading is less than 0.5 ma for full-scale output. Fortunately, this adjustment of R_n is not very critical.

These new d-c amplifiers were developed by the author for driving galvanometer elements of photographic oscillograph recorders used

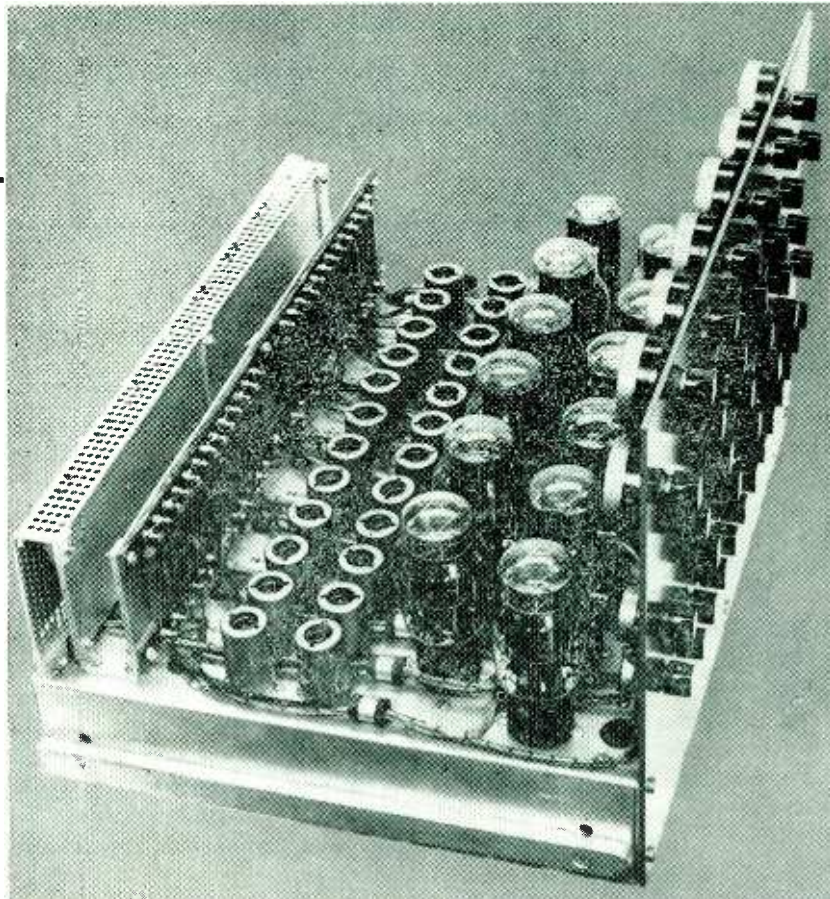

Bank of 12 driver amplifiers capable of delivering ± 50 ma into 100 ohms used for driving 12 galvanometer elements

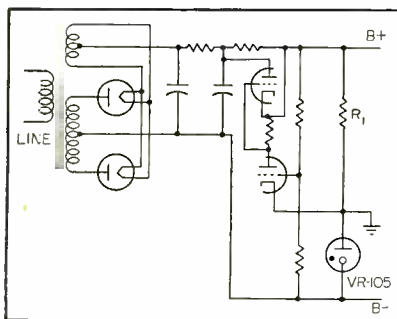

FIG. 2—Schematic diagram of power supply for driving ten or more amplifiers with outputs of about ± 50 ma each

in the playback of multiple-channel magnetic recording systems. In the playback of these systems, permanent visible records were made of as many as 12 channels at one time. This required 12 d-c amplifiers to drive the 12 galvanometer elements.

When the d-c amplifiers use output tubes capable of delivering about ± 50 ma and ten or more such amplifiers are powered from one B supply, the load current flowing

to ground may cause distortion unless considerable care is taken in adjusting R_n . If it is difficult to adjust R_n satisfactorily then a B supply of the type shown in Fig. 2 will supply these amplifiers without accompanying distortion.

The supply of Fig. 2 also uses a voltage divider to provide a ground return. This voltage divider is composed of a resistor R_1 and a VR tube. A regulator circuit is employed, but, as will be noted, the regulating tube is shunted by a resistor which carries the majority of the supply current, because the regulator tube must correct for only small variations in load current.

If excessive unneutralized load current flows to the center of the voltage divider, the voltage across the VR tube may increase. This increase is sensed by the regulating circuit, and the total supply voltage

correspondingly increases so that the mid-point or ground return of the divider still remains at the same relative position between B- and B+. Because of the balanced stages used throughout the amplifier, such an increase in the overall supply voltage does not produce appreciable drift or distortion when the ground point remains at the same relative position between B+ and B-.

A modified version of the amplifier and B supply of Fig. 1 makes the fullest use of the power capacity of the 6BL7 output tube. In this circuit, the second stage was redesigned to increase the drive of the output stage. The B supply has been increased to permit a larger swing of the output stage. This amplifier can deliver ± 20 ma into a load of 50 to 1,500 ohms, with a linearity of $\pm \frac{1}{2}$ percent.

Tone-Burst Generator

Transient distortion of loudspeakers, enclosures, microphones and networks can be measured quickly and easily by system reducing such distortions to numbers for comparison.

Information supplements sound-pressure curves for better evaluation

OF MANY FACTORS involved in reproduction of sound, transient distortion is the one measured most rarely. The loudspeaker-enclosure combination is the most serious contributor to this type of distortion.

The three basic driving-force or input functions used in transient work are the suddenly applied sine wave, the unit step function and the unit impulse or delta function. For loudspeaker considerations, it was felt that the simplest and most convenient automatic transient recording system should use the tone-burst type of input signal, a form of the suddenly applied sine-wave method.¹

A tone consisting of a given number of cycles is applied to the loudspeaker and then turned off for an equal period. All sound coming from the loudspeaker during the time the burst is turned off is recorded on a level recorder as transient distortion. For such a signal, the buildup and decay transients are

By **MARSHALL C. KIDD**

*Advanced Development Section
Home Instruments Department
RCA Victor Division
Camden, New Jersey*

essentially the same so it does not matter which is measured.

With this recording system, transient and steady-state curves are drawn with the same recorder on the same sheet of paper since both systems measure the full-wave rectified average value of the wave form. Results are expressed in the db difference between the sound pressure and transient curves. This can easily be converted to percentage values.

Equipment Description

The block diagram of the system is shown in Fig. 1. An oscillator of the beat-frequency type is applied to a gate in which the signal is interrupted to produce bursts of tone 4, 8 or 16 cycles long, followed by equal off periods. The bursts feed

a power amplifier which drives the loudspeaker. The loudspeaker and a microphone are placed in an acoustically dead room and the microphone develops a voltage proportional to the sound-pressure output from the loudspeaker. This voltage is amplified and applied to a second gate circuit which eliminates that portion of the transient output corresponding to the original burst portion of the signal. The hang-over, or transient distortion, corresponding to the sound output when the input signal is turned off, is then applied to the recorder.

To generate the pulses necessary to operate the two gates, the oscillator output is fed to a limiting amplifier where the sides of the wave are made steep enough to trigger a binary counter.² Output from the counter operates a flip-flop circuit driving the gate of the tone-burst generator. Two delay networks are driven by the square-wave output from the flip-flop but the waves are 180 deg out of phase.

Two paths of the delay network are adjusted to delay the gating pulses applied to the tone-burst eliminator by the time required for the sound to travel from the loudspeaker to the microphone. Waveforms at each point of the block diagram show how this is done with the use of differentiators, clippers and delay multivibrators. Output of the delay network then feeds the second flip-flop circuit driving the gate of the tone-burst eliminator.

The circuit diagram in Fig. 2 shows the limiting amplifier and the five-stage counter. All voltages are given for normal operating conditions. The limiting amplifier uses four 6AH6 tubes driven into the

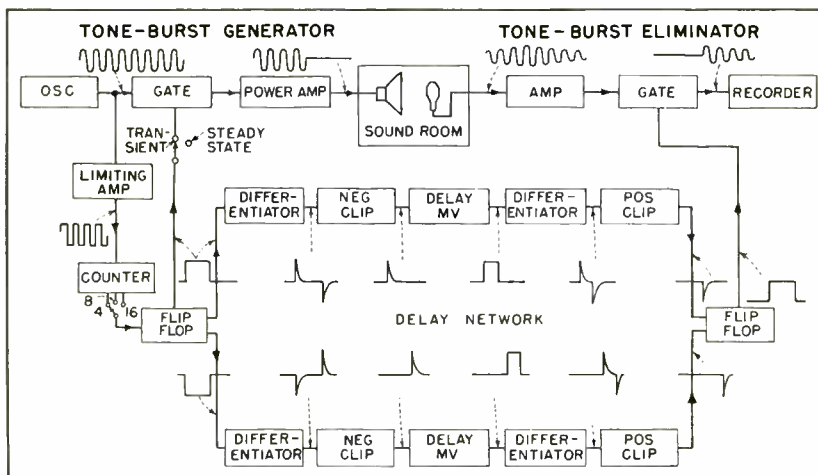

FIG. 1—Block diagram of the transient recorder

Checks A-F Transients

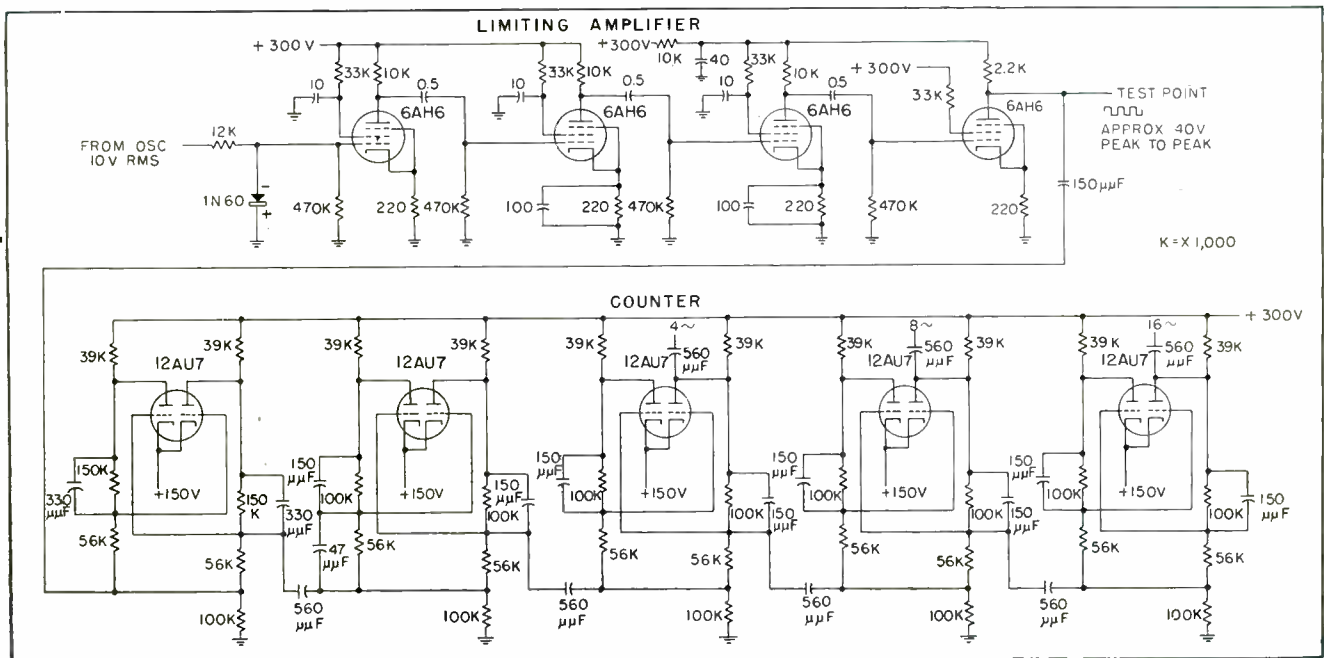

FIG. 2—Schematic diagram of the limiting amplifier and the five-stage counter

grid-current region. These tubes were chosen to get the greatest gain for a given bandwidth. It was found necessary to use four stages of amplification to obtain a square-wave output with a rise time fast enough to trigger the counter at low frequencies.

The square-wave output from the limiting amplifier drives the first tube of the binary counter, which operates like a frequency divider. For every two pulses into each counter tube one pulse comes out. The binary counter is essentially a multivibrator with two stable states. Operation of all five counter tubes is the same except that each one operates at one half the frequency of the tube ahead.

The points marked 4, 8, and 16 cycles are pick-off points for the square-wave signal operating the flip-flop tube. The square-wave period is determined by the number of cycles (4, 8, or 16) of the original sine wave from which all the pulses are derived. Slight variations in the first two counter circuit elements were made to increase the stability of operation.

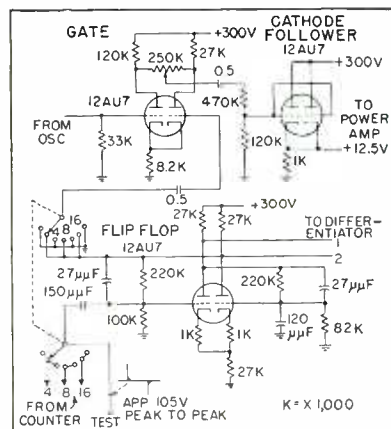

FIG. 3—Tone-burst generator schematic diagram

The circuit for the tone-burst generator is shown in Fig. 3. The 12AU7 gate tube normally has the right side conducting, thus bringing the cathode voltage up and cutting off the left half of the tube. When a negative square wave from the flip-flop is applied to the right-hand grid, the right side of the gate is turned off and the left side conducts. This allows the left half of the tube to operate as a class-A amplifier. The grid is allowed to

float and set its own bias.

The right-hand grid bias varies the tube from saturation to cutoff. The potentiometer in the plate circuit of the gate balances out the d-c component. The output is then attenuated with a voltage divider to prevent overloading the cathode follower operating into a 500-ohm load.

Delay Network

The delay network circuits are shown in Fig. 4. Square-wave inputs are applied to the differentiators to produce sharp pulses. The crystal-diode clippers remove the positive pulses. The negative pulses are applied to the grids of the limiting amplifier, which inverts and amplifies the pulses. The combination of the diodes and limiting-amplifier stage is therefore equivalent to a negative clipper. The amplified positive pulses are used to trigger the delay multivibrators. The delay time is adjusted by the variable 5-meg resistor in the grid circuit.

Normally, the right half of the delay multivibrator tube is conduct-

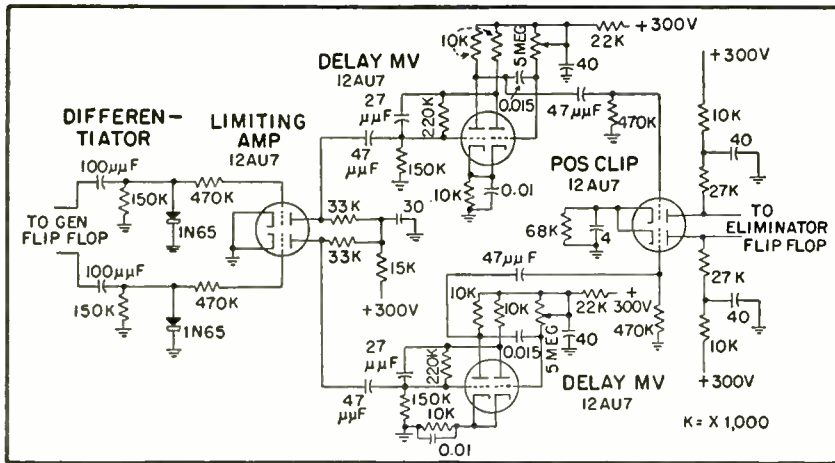

FIG. 4—Schematic diagram of the delay networks

ing and the left half is cut off. When a positive input pulse is applied to the left grid, the left half of the tube fires and the right half is cut off. This firing time is determined by the R-C time constant of the 0.015- μ f capacitor and 5-megohm variable grid resistor. The delay is normally set for about 2 milliseconds since sound-pressure curves are drawn with a microphone distance of two feet.

The differentiated output of each multivibrator is then fed to the grid of the 12AU7 positive clipper. Clipping is obtained by the use of a large cathode resistor which cuts off both tubes so that after inversion in the tube only negative pulses can be produced in the output.

The tone-burst eliminator is shown in Fig. 5. The negative pulses from the positive clipper cause the 12AU7 flip-flop circuit to operate in the same manner as the tone-burst-generator flip-flop. The output square wave of this flip-flop then opens and closes the 12AU7 gate tube of the eliminator. The generator and eliminator circuits operate in essentially the same manner. The amplified signal from the microphone is observed at the test point.

Equipment Operation

When the transient distortion of a system is measured, three curves are drawn. The steady-state or sound-pressure curve is always drawn for a reference. To make

this curve directly comparable with the transient curves it is drawn in exactly the same way as the transient curves except that the speaker is not pulsed with the tone-burst but has a steady tone of variable frequency applied to it.

Microphone Channel

The microphone channel is gated with the tone-burst eliminator so that the recorder receives a signal 50 percent of the time, the same as when the transient curves are drawn. The rectified average value of this wave is recorded and experience shows that the resultant curve shape is always within 0.5 db of the curve obtained when the recorder is fed with an ungated signal, but is 6-db down. To obtain the best presentation of the transient distortion of loudspeakers, the transient distortion curve is drawn in two parts to cover the range of 30 to 15,000 cycles.

The low-frequency end of the spectrum is measured with four cycles on and four off and the high-frequency end is measured with 16 cycles on and 16 off. The change-over frequency at which one curve stops and the other starts is not critical but 200 cycles is normally taken since this frequency is between the fundamental resonance and the cone-breakup resonances for most loudspeakers.

Below 200 cycles the recorder tends to follow the 16-cycle burst instead of averaging it. For enclosure studies the four-cycle burst

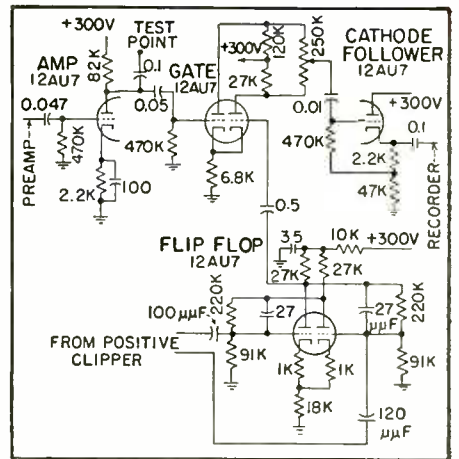

FIG. 5—Circuit of the tone-burst eliminator

can be used throughout the range since there are few resonances above 1,000 or 2,000 cycles in most enclosures.

The equipment is designed to operate only when the delay time is less than 85 percent of the period of the highest frequency burst. The delay network has no memory and as the period of the incoming wave approaches the delay time at high frequencies, instability will result. This is because the delay multivibrator cannot be triggered again until it has returned to its previous stable-state condition.

In the initial setup of the equipment, it is necessary to adjust the delay multivibrators so that the beginning and the end of the original

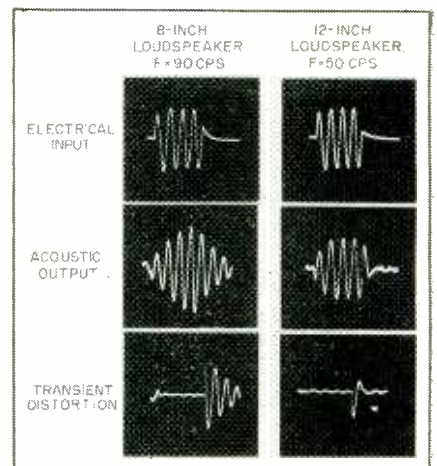

FIG. 6—Voice-coil current, acoustic output and transient distortion for two loudspeakers each operating at the fundamental low-frequency response

burst are just eliminated by the tone-burst eliminator. This can be done most accurately at the high-frequency end of the range of the particular loudspeaker being tested. It is also necessary to carefully balance out any d-c component in the signal fed to the recorder by means of the balancing potentiometers in the plates of the gate circuit since an unbalance will record as transient distortion. Once these adjustments are made, they need be checked only occasionally during the operation of the equipment.

Experimental Results

The oscillograms of Fig. 6 show the voice-coil current, acoustic out-

some acoustic damping. These units show the two extremes in low-frequency transient response of loudspeakers.

Figure 7 shows the sound-pressure and transient-distortion curves of the same 12-inch loudspeaker. The ordinate is in db for all curves and zero db is arbitrary. Note the lack of rise in either curve at the low-frequency resonant frequency of 50 cycles. This is characteristic of all expensive large-magnet units. The 16-cycle transient curve always has lower amplitude than the four-cycle transient curve since the decay is averaged over a period four times longer.

The cone begins to act as a trans-

associated with the 2,750-cycle resonance. A simple tuned circuit with approximately the same transient response is shown for comparison. Note that the Q of the equivalent tuned electrical circuit is eight.

Conclusions

It is now possible to draw loudspeaker transient distortion curves quickly and easily. The system described isolates and reduces transient distortion to numbers for comparison purposes. Any speaker with less than 10 to 12.5 percent transient curves, 18 to 20 db down, over its useful range is comparable to the best loudspeakers measured. It is felt that this information supplements sound-pressure curves and enables a better evaluation of the variations in these curves, including diffraction effects. The equipment is also useful in measuring transient distortion of enclosures, microphones and networks. It is a very helpful design tool for studying loudspeaker cones.

The author wishes to acknowledge the helpful advice and suggestions of Murlan S. Corrington in preparing this paper.

REFERENCES

- (1) Murlan S. Corrington, Transient Testing of Loudspeakers, *Audio Eng.*, 34, No. 8, p 9, Aug. 1950.
- (2) John T. Potter, A Four-Tube Counter Decade, *ELECTRONICS*, 17, p 110, June 1944.
- (3) Murlan S. Corrington and Marshall C. Kidd, Amplitude and Phase Measurements on Loudspeaker Cones, *Proc. I.R.E.*, 39, p 1,021, Sept. 1951.

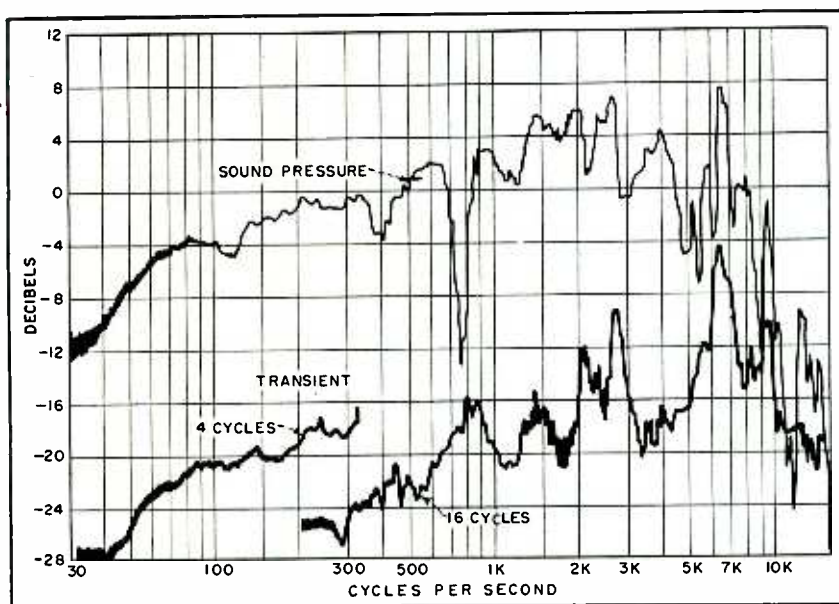

FIG. 7—Sound-pressure and transient-distortion curves for the 12-inch loudspeaker of Fig. 6

put and transient distortion for two loudspeakers, each operating at the fundamental low-frequency resonance.

The electrical input to each shows a slight distortion of the wave due to the limited bandwidth of the amplifier but the waveform is still reasonably good.

The eight-inch loudspeaker is a conventional one with a small magnet and low flux density in the air gap. The 12-inch loudspeaker has a very large ring magnet and the mechanical design also incorporates

mission line at about 700 cycles and the first major vibrational mode occurs at 800 cycles.³ This is associated with a dip in the sound-pressure curve and a peak in the transient curve. The next major mode, shown by the transient curve, occurs at 1,400 cycles. This peak corresponds to a peak in the sound-pressure curve. At 2,100 and 2,750 cycles, respectively, two more peaks occur. At higher frequencies the transient response becomes progressively worse.

Figure 8 shows the waveforms

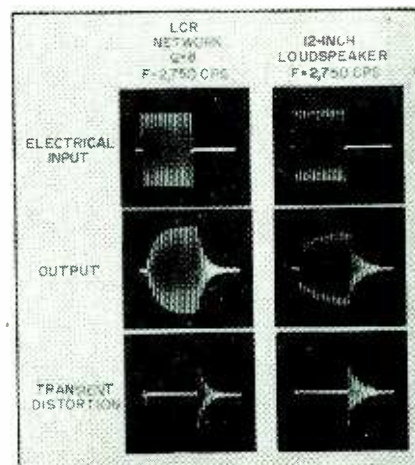

FIG. 8—Waveform associated with 2,750-cycle resonance

Ultrasonic Ranging

Equipment showing increased echo amplitude from cancerous tissue has been used in cancer diagnosis. Results have been confirmed in 20 operations. Crystal transducer is coupled to tissue by water column

X-RAY IS OF LITTLE USE in very early diagnosis of cancer, the existence of which can be confirmed definitely only by microscopic examination of removed suspect tissue. However, ultrasound, since it is a form of mechanical energy, may be employed to investigate tissue properties.

The instrument shown in the photographs detects reflections of ultrasonic energy from acoustic impedance discontinuities between tissue elements of differing elastic properties. Termed the Echograph, it has been used with promising results in efforts to diagnose cancer in 20 human breast tumors before operation, to examine a brain tumor during operation and for laboratory studies.

Preliminary work¹ was carried out using an ultrasonic radar trainer, AN/APS-T3, at its operating frequency of 15 mc.² Discovery that internal reflections from cancerous tissue were of greater amplitude than those from surrounding normal tissue prompted development of the portable instru-

ment to be described.

The same crystal transducer is used both to transmit pulsed ultrasound and to pick up reflected echoes. By displaying echoes from a narrow sound beam on a linear time-base sweep, confusion from the presence of many structures is greatly lessened.

Frequency Considerations

Frequencies in the megacycle range are necessary to keep wavelength short at the mean velocity of 1,540 meters per second³ for human muscle tissue. As the frequency is raised, trouble with diffraction effects is lessened and resolution is improved. However, since attenuation by tissue increases with frequency, range is decreased at higher frequencies.

Since crystal transducers must be operated at mechanical resonance to obtain sufficient sensitivity, the frequency of operation depends

also upon the crystals available. The limited bandwidth of resonant crystals also affects resolution, placing a lower limit on the length of the transmitted pulse. Damping of the crystal may be used to increase bandwidth.

The crystals used,⁴ X-cut, quartz discs thickness-resonant at 15 mc, have a minimum pulse length of about 0.5 microsecond. The crystals are operated undamped, one face radiating into a water coupling column and the other air backed. Mismatch between the acoustic impedance of quartz and air prevents radiation in the back direction.

System Operation

Referring to Fig. 1, the repetition-rate oscillator produces timing pulses at a rate variable from 400 to 4,000 pps. A rapid rate is used to permit short exposures when photographing the oscilloscope screen, minimizing blurring from breathing and other motion of the patient.

Brought to the desired width at sufficient amplitude, actuating pulses are applied to the clamp-tube-controlled oscillator which generates r-f pulses. Output pulses as short as 1.5 cycles at 15 mc can be generated by this circuit. However, the crystal stretches the acoustic pulse to at least 0.5 microsecond. This corresponds to a crystal Q of about ten. It is therefore important to avoid use of high Q circuits in the transmitter if further stretching is to be prevented. This is accomplished using non-resonant impedance coupling in a class-A voltage amplifier, and using the crystal itself as the only resonant element in the output power amplifier. This latter stage is operated class C with fixed bias so that advantage can be taken of the low duty

This investigation was supported by a research grant from the National Cancer Institute of the National Institutes of Health, U. S. Public Health Service.

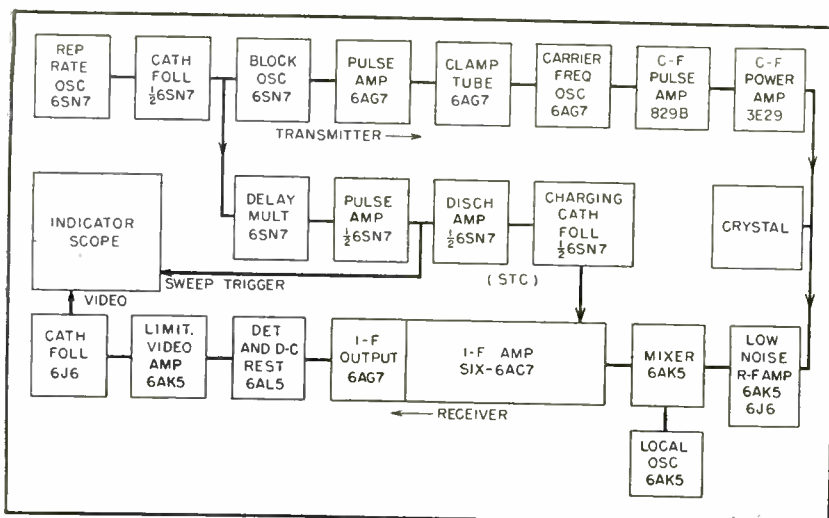

FIG. 1—Block diagram of ultrasonic echo-ranging equipment

for Cancer Diagnosis

By JOHN M. REID

and JOHN J. WILD

*Department of Electrical Engineering
University of Minnesota
Minneapolis, Minn.*

cycle by using a high plate voltage to obtain a high peak-power output. A peak power of about 1 kw is used.

Details of the crystal coupling network are shown in Fig. 2. The coupling network allows both the transmitted pulse and the signals from reflected echoes to be applied through a matching L section to the grid of a low-noise, receiver-input stage.

Receiver blocking by the transmitter pulse is minimized by use of single-tuned, coupling coils connected from grid to ground. These provide a low-resistance path for grid current. Thus, the receiver recovers from the transmitted pulse more rapidly than the crystal, which produces a detectable voltage for about 30 microseconds after the applied pulse ends. The remainder of the receiver is conventional. Overall bandwidth is 4 mc with a gain of about 100 db. A wide-band oscilloscope is employed for presentation of reflected signals on a linear time-base sweep.

Zero Range

The problem of working to zero range is met by interposing a column of water between the crystal and the tissue, and sealing the assembly with a thin rubber membrane. The signal returned from this membrane becomes the zero-range marker, and arrives after both the transmitted pulse and the crystal's hangover have ceased. The delay multivibrator (Fig. 2) produces a pulse which starts the oscilloscope trace just before the membrane signal is received. The display thus utilizes the entire screen.

The water column conducts the acoustic pulse away from the crystal, and since it does not return

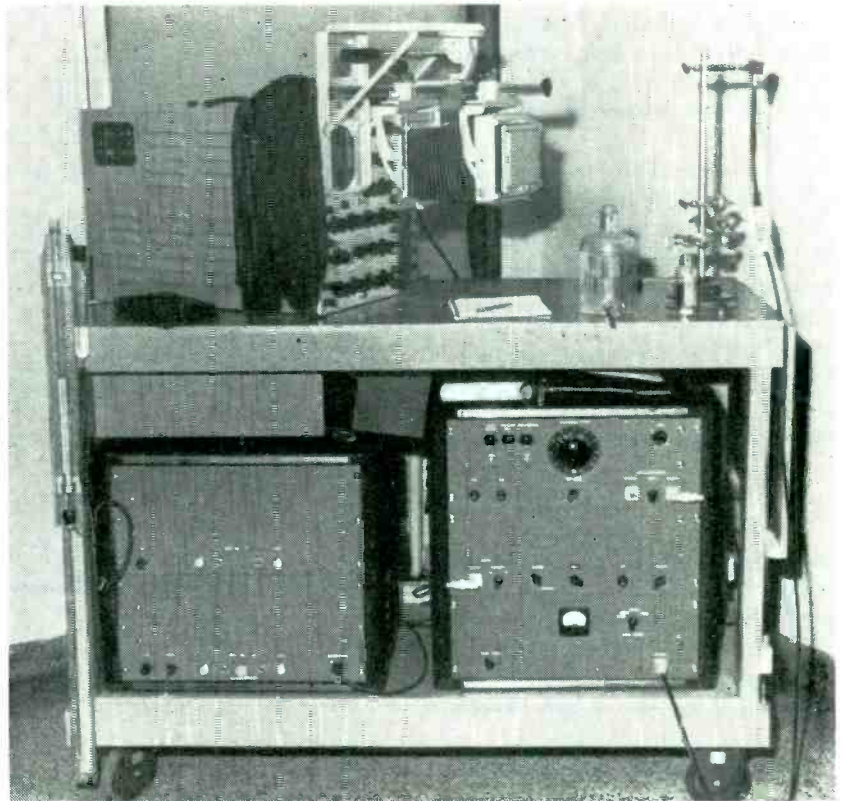

Ultrasonic echo-ranging equipment in use during laboratory examination of removed tissue specimens

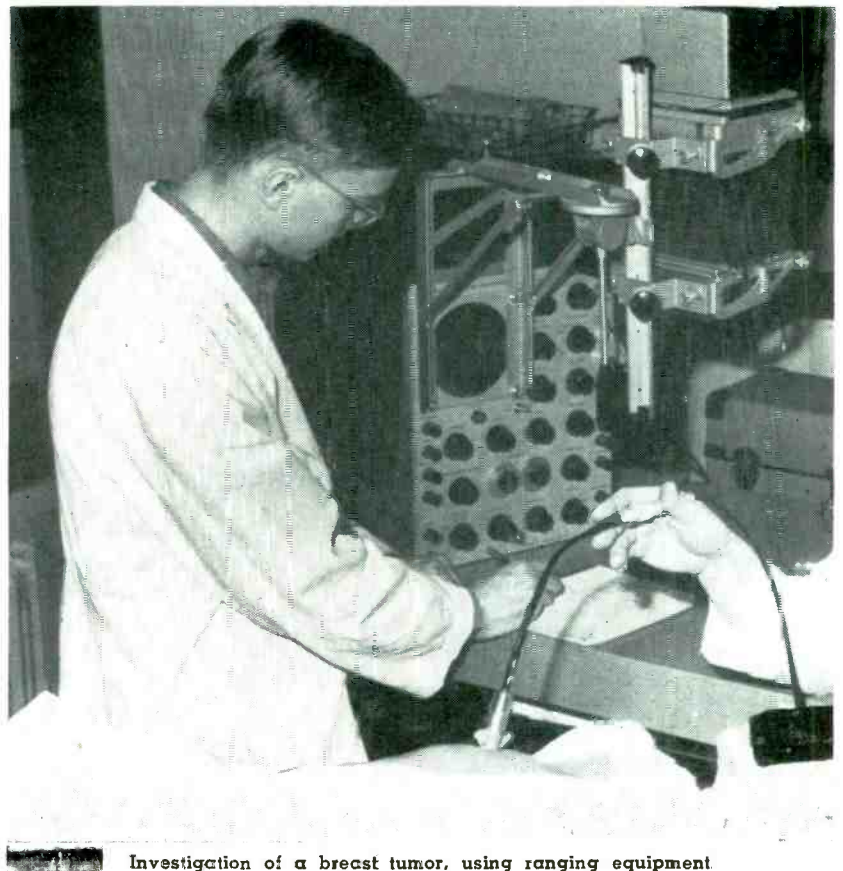

Investigation of a breast tumor, using ranging equipment

from the membrane until after the applied pulse ends, the crystal is effectively loaded at all times. When the load is removed during handling of the probe, the crystal is not in danger of fracture. The water attenuates the signal somewhat, but a part of the loss can be made up by increasing the pulse power.

This solution to the problem of achieving zero range has the disadvantage that multiple reflections of transmitted energy take place between the sealing membrane and the crystal face. The water column must therefore be long enough to make the second reflection arrive at the crystal later than the deepest signals of interest.

Depth of Penetration

The factor limiting the depth from which echoes can be received is the attenuation offered by intervening tissue. This effect is noticeable at 15 mc for only a few centimeters of depth, appearing as a large dynamic range between early and deep echoes with the result that echoes on the first part of the time base saturate the oscillograph screen.

Attenuation effects may be compensated for by making receiver gain an increasing function of time across the time base, synchronized with the operating cycle. This is the same solution used in radar systems to minimize close-in land or sea return, usually termed sensitiv-



Crystal probe applied to brain coverings after removal of the skull during a brain-tumor operation

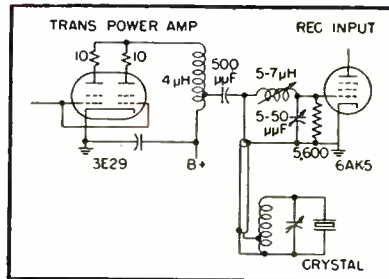

FIG. 2—Crystal coupling networks

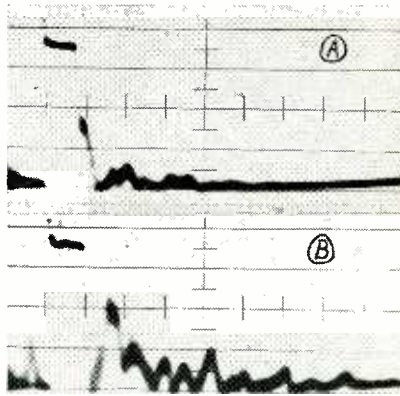

FIG. 3—Oscilloscope traces, showing echoes from normal brain tissue (A) and from a cancerous tumor in the same brain (B)

ity time control. This circuit (see Fig. 1) is actuated by the same delayed pulse that starts the time-base sweep and uses the buildup of voltage across a capacitor to obtain an exponential waveform. Voltage is impressed on the negative voltage used for gain control in the i-f amplifier. Receiver gain is therefore decreased coincidentally with receipt of the membrane echo and rises exponentially across the time base.

Present range of about two cm can be extended by further use of stc until the limit imposed by random noise in the receiver is reached. Increasing depth by the use of greater pulse power should be approached with caution, since the damage threshold on a pulse basis at 15 mc has not been definitely determined. Present power was checked by direct experiments on the living brains of laboratory animals, without producing detectable damage.⁵ The present range has allowed examination of practically all breast tumors encountered.

For greater depths, where loss in definition could be tolerated, advantage could be taken of the

reduced attenuation of lower frequencies.

Example

Typical oscilloscope traces are shown in Fig. 3. These particular records are from the first known attempt to localize and diagnose a brain tumor in a live human being by this method during an operation. The crystal probe, in a sterilized holder, was applied to the brain coverings after the skull had been removed.

Figure 3A shows echoes from normal brain tissue following the saturated signal received from the water-column sealing membrane. Figure 3B shows signals returned from suspected tissue. The subsequent operation confirmed the location of the tumor, and that it was cancerous (Glioblastoma Multiforme).

The differences illustrated in Fig. 3 have been found almost consistently with cancerous tissues of various types from different parts of the body. Comparison of normal and tumor echoes removes factors such as variation in system sensitivity, differences in crystal efficiency and variations from patient to patient.

Acknowledgement is due Henry E. Hartig of the University of Minnesota and Finn J. Larsen of Minneapolis-Honeywell for their kind help and advice, and to medical photographer Lloyd Wolf of the University of Minnesota.

REFERENCES

- (1) J. J. Wild, The Use of Ultrasonic Pulses for the Measurement of Biologic Tissues and the Detection of Tissue Density Changes, *Surgery*, 27, p 185, Feb. 1950.
- (2) Lyle A. French, John J. Wild and Donald Neal, Detection of Cerebral Tumors by Ultrasonic Pulses, *Cancer*, 3, p 705, July 1950.
- (3) Lyle A. French, John J. Wild and Donald Neal, The Experimental Application of Ultrasonics to the Localization of Brain Tumors, *Journal of Neurosurgery*, 8, p 198, 1951.
- (4) J. J. Wild and Donald Neal, Use of High-Frequency Ultrasonic Waves for Detecting Changes of Texture in Living Tissues, *The Lancet*, p 655, March 24, 1951.
- (5) Finn J. Larsen, Ultrasonic Trainer Circuits, *ELECTRONICS*, 19, p 126, June 1946.
- (6) George D. Ludwig, The Velocity of Sound through Tissues and the Acoustic Impedance of Tissues, *The Journal of the Acoustical Society of America*, 22, p 862, Nov. 1950.
- (7) John F. Blackburn, *Components Handbook: Radiation Laboratory Series*, Vol. 17, p 180, McGraw-Hill Book Co., N. Y.
- (8) Lyle A. French, John J. Wild and Donald Neal, Attempts to Determine Harmful Effects of Pulsed Ultrasonic Vibrations, *Cancer*, 4, p 342, March 1951.

Nondistorting CRO Switch

Oscilloscope accessory uses miniature receiving-type tubes and permits simultaneous viewing of two signals from subaudio to ultrasonic frequencies. Distortion of signals is low, and internal amplifiers provide gain up to 28 for stepping up low-voltage signals

By WILLIAM L. FIRESTONE and RICHARD M. BLONIARZ

*Motorola, Inc.
Chicago, Illinois*

IN MOST LABORATORIES, the simultaneous study of two separate phenomena is required only occasionally, but when the need does arise there is no simple substitute for an electronic switch. It is therefore desirable to have one available, but its cost and complexity should be held within reasonable limits since it is usually regarded as a stand-by piece of equipment.

The electronic switch shown in the photograph performs satisfactorily and yet its design is such that only a few hours and a handful of parts are required for its construction. A brief review of the reasoning behind its design is given prior to actual circuit description.

There are two basic methods of alternately sampling two signals for simultaneous display on the face of a single cathode-ray oscilloscope.

Slow Switching

The first method¹, one which has been in use for many years, is to present on the oscilloscope face several cycles of one of the signals and then by switching to present several cycles of the other signal. By continuous repetition of the process both signals appear as continuous phenomena. Even though the switching rate is rather slow the picture may appear continuous because of the persistence of the cathode-ray screen and be-

cause of the persistence of vision. This process usually requires a reasonably low switching frequency, particularly when low-frequency phenomena are to be observed. This switching rate is usually made variable and must normally be synchronized with one of the input signals.

Fast Switching

The second method², which has found application in more recent

times, has a high switching rate of fixed frequency and samples both signals continuously. Each signal is sampled many times during each cycle. This of course necessitates a switching rate which is much higher in frequency than the signal to be viewed. For example, if the switching rate is 25 kc and it is assumed that at least 10 samples per cycle are necessary to have reasonably good reproduction, then the highest signal frequency that

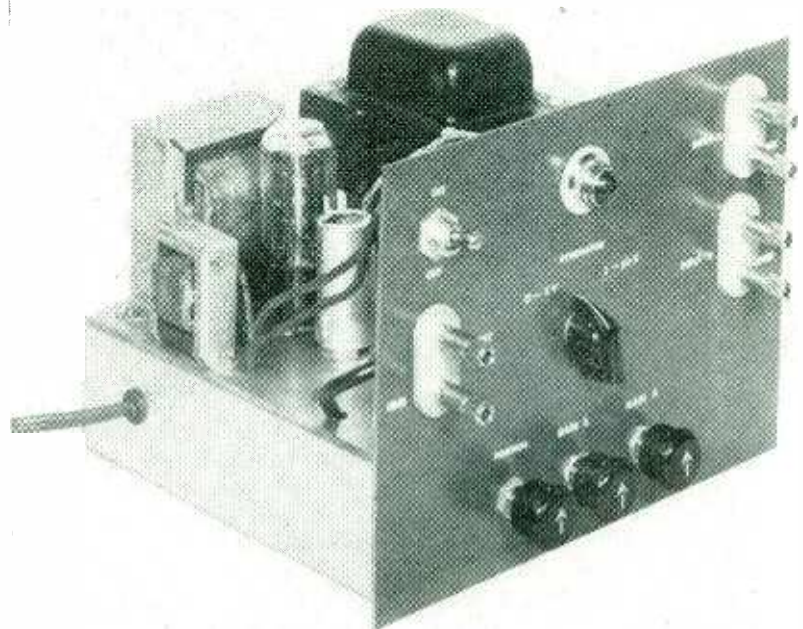

Simplified electronic switch employs readily-available tubes. Signals up to 20 kc can be displayed with almost no distortion

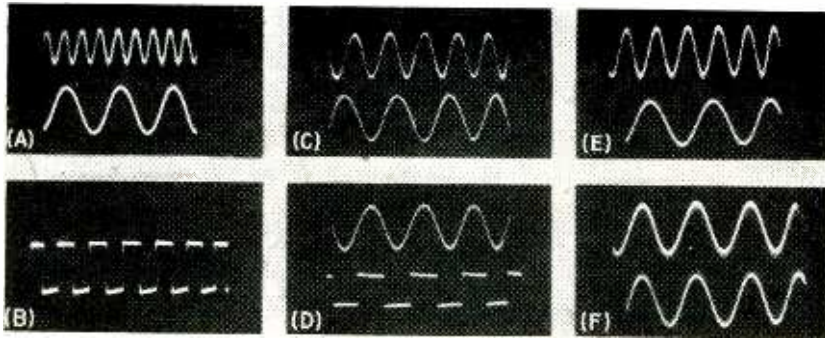

Oscillograms show (A) comparison of 180 and 60-cps sine waves, (B) 7,500-cps switching wave, (C) comparison of 120 and 60-cps sine waves, (D) 60-cps sine and square waves, (E) 5 and 10-kc signals and (F) 20-kc signals applied to each input

may be expected to be observed is approximately 2.5 kc. This second method of switching is normally considered to be primarily for the observation of low-frequency phenomena.

It has not been commonly realized that this second method of switching need not have so high a fixed switching rate nor be limited to viewing phenomena having signal frequencies much lower than the switching frequency.

The switch to be described has several distinct advantages. It uses a minimum number of tubes, namely three, and it permits viewing of all frequencies in the pass band of the gated amplifiers with only two fixed switching frequencies which are not harmonically related. Good signal amplification is provided.

Circuit Details

The circuit is shown in Fig. 1. The output of the 12AT7 square-wave generator alternately cuts off and allows conduction of the 6BE6 amplifiers at a rate of approximately 7,500 cps. Although the frequency is not critical, this value was chosen on the following basis:

Since this device was originally designed for the study of low-frequency signals, a maximum oscilloscope sweep frequency of 75 cps was arbitrarily set. Assuming a trace length of 4 inches and a sampling width of 1/50th inch, a square-wave is required whose period corresponds to a width of 1/25th inch. The switching frequency is therefore $4 \times 25 \times 75$ or 7,500 cps.

The particular square-wave gen-

erator³ used provides an excellent waveshape of sufficient amplitude and does so with a minimum of components. A good waveshape is essential to minimize the switch-over time of the amplifiers and keep each sampling as clean as possible for faithful reproduction.

In keeping with the idea of simplicity of design, a minimum number of tubes was used, and pentagrid tubes were employed because of their great versatility. Positive switching is assured by impressing the square waves on the control grids of the 6BE6's. Separation of the signals on the oscilloscope is accomplished by the difference in screen voltage obtained by the position control.

The gain controls and 10-to-1 attenuator permit input signals of up to 10 volts to be examined. Fixed bias of approximately 6 volts is required to prevent grid current flow and to minimize distortion. The maximum voltage gain of the amplifiers under these conditions is 28. Separation of the signals by varying the screen voltage should be kept to a reasonable amount, since the gain of the amplifiers is a function of the screen grid voltage.

Operation

When possible, the gain of the oscilloscope should be used as an aid to the separation of the signals. Since the screen circuits are symmetrical the signals may be positioned in any manner; either signal may be placed above or below the other or the two signals may be superimposed.

To view two periodic signals of

different frequencies, a harmonic relation must exist between these signals, since the oscilloscope may be synchronized to only one frequency. This is a limitation imposed upon any type of electronic switch. No harmonic relation need exist, however, between the switch frequency and the signal frequencies. It will be shown later that it is actually undesirable that such a harmonic relation exist between the switch frequency and signal frequencies.

Although this switch was primarily designed for the viewing of low-frequency phenomena, it is possible to view signals of all frequencies within the response characteristics of the gated amplifiers. This may be explained as follows:

All frequencies passed by the amplifiers fall into two categories relative to the switching frequency: (a) Signal frequencies less than the switch frequency, and (b) signal frequencies greater than the switch frequency.

For signals under category (a), the simultaneous viewing is the result of sampling each signal many times per cycle, resulting in waveforms composed of a number of closely-spaced points. Examples of this type of operation are shown in the oscillograms. As the signal frequency increases, the number of samples per cycle decreases, which would suggest an upper limit on the signal frequency. This apparent upper limit would be determined by the minimum number of samples per signal cycle which would provide an acceptable presentation. Such an upper limit, however, does not exist except for the frequency limitations of the amplifiers. This can be seen by considering a signal frequency of say 5.02 kc and a switching frequency of 7.5 kc. With these frequencies the switch would sample $5.02 / (2 \times 7.5)$ or 0.334666 . . . cycles of the signal each time.

Synchronization

If the oscilloscope is externally synchronized by the signal under observation, but not synchronized with the sampling rate, then the sampling of the signal would be at a different place on each cycle.

With external synchronization the sweep would start at the same point on the oscilloscope and always be in synchronization with the signal. However, because the samples occur at different places on the signal they would run on the oscilloscope and consequently blend together, presenting a smooth and continuous waveform. The oscilloscope has in effect integrated the waveform.

Exceptions to the above occur when the signal frequency F , or any of its harmonics, namely nF , is equal to the switch frequency F_0 or any of the switch frequency harmonics mF_0 . In other words, whenever the following equation is satisfied a signal might not be presented in an acceptable manner:

$$nF_s = mF_0 \quad (1)$$

where F_s = signal frequency, F_0 = switch frequency, $n = 1, 2, 3, 4, \dots$ and $m = 1, 2, 3, 4, \dots$

This may be shown by considering the case where one signal frequency F_{s1} is $2/3$ of the switch frequency, so that $n_1 = 3$ and $m_1 = 2$. Since $F_0 = 7,500$ cps it follows that F_{s1} becomes 5,000 cps. Since the input signals must be harmonically related, the second signal is 10,000 cps and $2F_{s1} = F_{s2}$. Using Eq. 1 again, for the second signal $n_2 = 3$ and $m_2 = 4$. By choosing the signal frequencies in this manner it is possible to examine two cases at one time; that is, signals above and below the switch frequency and harmonically related to it. The waveforms of Fig. 2 indicate the

type of presentation to be expected with this condition.

Drift

It should be remembered that if the switch frequency F_0 or the signal frequencies F_{s1} and F_{s2} vary, the samples will drift on the oscilloscope. If this drift is fairly rapid the picture presented will be smooth and continuous. Under these conditions the vertical traces created during switchover will decrease in brilliance and become barely noticeable. If two switching rates, not harmonically related, are employed, whenever a combination of switching rates and signal frequencies gives a poor presentation, it is merely necessary to change to the other switching rate. Since the two switching rates are not harmonically related the new sampling rate will result in drift of the samples on the oscilloscope and hence a complete presentation will occur. Since the frequency of the multivibrator is controlled only by a single capacitor C , it is possible to obtain a two-frequency multivibrator by adding one capacitor and one switch.

On the other hand, if the signal frequencies are much lower than the switch frequency, so that $n > 10m$, a good waveform will result even with harmonic relationships being present, because there are a sufficient number of samples occurring in each signal cycle to give the illusion of a continuous trace.

The accompanying oscillograms

show waveforms taken under actual test conditions. It has been found that if the input signal at the grids of the gated amplifier is limited to one volt the distortion is kept low even with full gain. However, higher quality reproduction is possible if the signals on the grids are kept somewhat below this level.

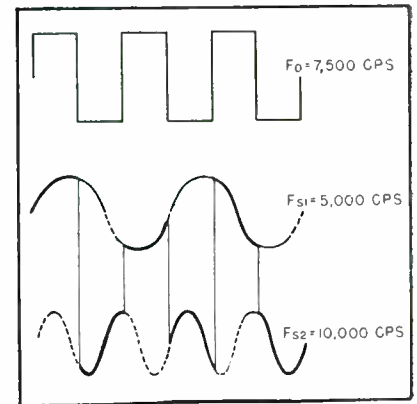

FIG. 2—Relationship between switch and signal frequencies

Operating experience with the instrument has shown that it is possible to view all recurrent-type phenomena within the pass band of the gated amplifiers by using only two fixed switching rates. By using fixed switching rates the multivibrator may be simplified as compared with a variable-frequency type of multivibrator. The switching rates may be close in frequency if desired, but must not be harmonically related.

The signals to be viewed may be either higher or lower in frequency than the switching rates and preferably not harmonically related to it. The switching rates need not be synchronized to any other signal; in fact it is desirable not to do so.

For best viewing conditions the oscilloscope sweep oscillator should always be externally synchronized to one of the signals.

REFERENCES

- (1) H. K. Hughes and R. F. Koch, Combination Vacuum Tube Switch for Double-Trace Cathode-Ray Oscillograph, Audio-Amplifier and Mixer, *Rev. Sci. Instr.*, Apr. 1941.
- (2) N. A. Moerman, Four-Channel Electronic Switch, *ELECTRONICS*, Apr. 1946.
- (3) G. W. Gray, An Inexpensive Square-Wave Generator, *ELECTRONICS*, Feb. 1952.
- (4) J. R. Cosby and C. W. Lampson, An Electronic Switch and Square-Wave Oscillator, *Rev. Sci. Instr.*, Apr. 1941.
- (5) H. J. Reich, An Electronic Switch for the Simultaneous Observation of Two Waves with the Cathode-Ray Oscilloscope, *Rev. Sci. Instr.*, Apr. 1941.

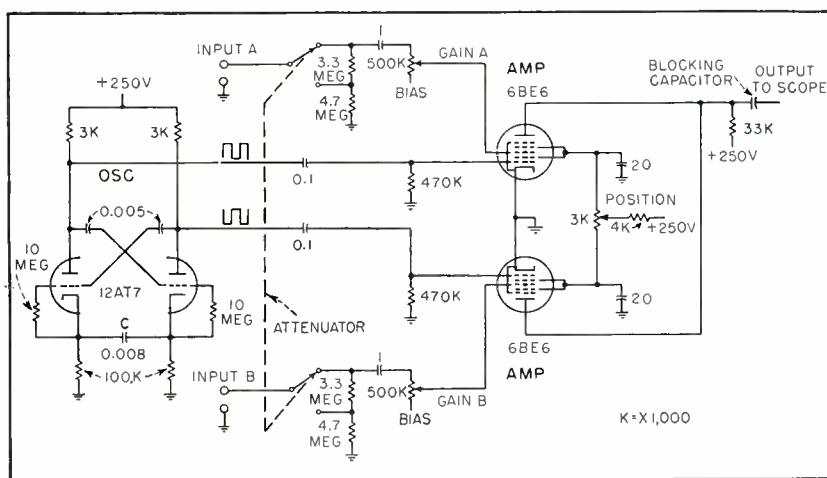

FIG. 1—Electronic switch uses 12AT7 square-wave oscillator to gate two 6BE6 amplifiers

Protecting SENSITIVE

MOVEMENTS of meters having full-scale readings of less than one ma can be protected against overload by electronic means. Fuses are not readily available for such sensitive meters.

Figure 1 shows an electronic protection circuit¹ that has been used previously in some test equipment. The circuit consists of a triode amplifier whose input is connected across the meter to be protected and whose output is d-c connected to a thyatron grid. When the voltage across the meter exceeds a predetermined value, the thyatron conducts and actuates a relay which opens the load circuit.

Current meters used in test equipment are often connected in the positive side of the load circuit in which case a separate power supply is necessary to operate the protection circuit.

The circuit of Fig. 1 does not provide protection against overload currents in the reverse direction through the meter. Also, the protection provided is not fail-safe in operation. The circuit of Fig. 2 was developed to overcome these deficiencies. The mechanical size and power consumption were also reduced.

The operation of the circuit of Fig. 2 is basically the same as that of Fig. 1. The following paragraphs explain points of differences.

Neon glow tubes are used as d-c coupling elements to reduce the overall voltage required. Protection against overload in the reverse direction is provided by the following means. For reverse current, the triode grid goes more positive. The plate voltage drops to a point where neon tube V_4 ceases conduction. The thyatron grid voltage then drops to ground potential and neon tube V_5 conducts. The resulting thyatron grid voltage is sufficient to cause the tube to conduct. Proper operating voltages are required to obtain equal protection in both directions.

To reset the circuit of Fig. 1, a reset switch is used to short-circuit the thyatron causing it to cease conduction. When the reset switch is opened, the thyatron may again be triggered to conduction by an anode-voltage surge generated by the stored energy in the relay coil. Reconduction is eliminated by connecting, with the aid of an auxiliary pair of relay contacts, a 20- μ f capacitor and series resistor in shunt with the reset switch.

Resetting of the circuit of Fig. 2 or 3 is accomplished by opening the thyatron circuit. The load circuit is opened simultaneously to prevent meter overload while the protection circuit is inoperative. The contacts on the reset switch are mechanically interlocked so that the load circuit is opened before the thyatron circuit and closed in the reverse order. Either of the above methods of resetting appears satisfactory.

To provide fail-safe operation, the load circuit of Fig. 2 is open until current flowing through the relay coil closes the relay. This occurs at about the same time the protection circuit becomes operative.

With universal shunt multirange meters, the terminal voltage corresponding to full-scale deflection changes with the different ranges. In order to get the same protection, independent of range setting, the voltage across the meter coil is monitored by the protection circuit.

A voltage-regulator tube V_2 was introduced in order to improve reliability and stability particularly against line-voltage surges producing erroneous operation. The voltage-regulator tube may not be required in all cases.

Operation

Grid current flowing in the d-c amplifier tube V_3 is a potential source of error in the meter reading. Measurements were made to ascertain the magnitude of the grid current. Using a 1- μ a full-scale

By **L. J. GIACOLETTO**

Research Department
RCA Laboratories Division
Princeton, N. J.

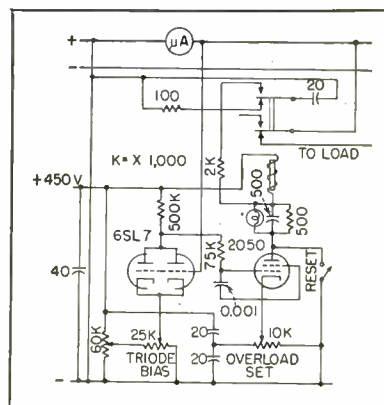

FIG. 1—Basic electronic protection circuit for low-current meters

d'Arsonval-type instrument, no deflection was noticeable for several 6AQ6 tubes operating with plate voltages of 85v and grid voltages of -0.75v. It was concluded that error from this source could normally be neglected.

The protection circuit has been successfully employed to protect meters having 30 to 50 mv corresponding to full-scale deflection. Resetting difficulties were encountered when employed to protect some 10- μ a meters. These difficulties, due to stored mechanical energy in the meter movement, can be eliminated by placing a resistor of suitable value in series with the meter and using the voltage drop across this resistor to operate the protection circuit.

Adjustment of meter zero setting can be used to compensate for constant circuit leakage that cannot be eliminated.

The NE51 neon tubes are sufficiently nonuniform that the circuit will usually have to be readjusted when a tube is changed. The neon tubes should be aged several hours initially before adjusting the circuit. With these precautions, after a few minutes initial warmup, the

CURRENT METERS

Damage due to overload of microammeters and milliammeters can be prevented by use of electronic monitor circuit. Thyatron-operated relay opens the load circuit when voltage across the meter exceeds a predetermined value

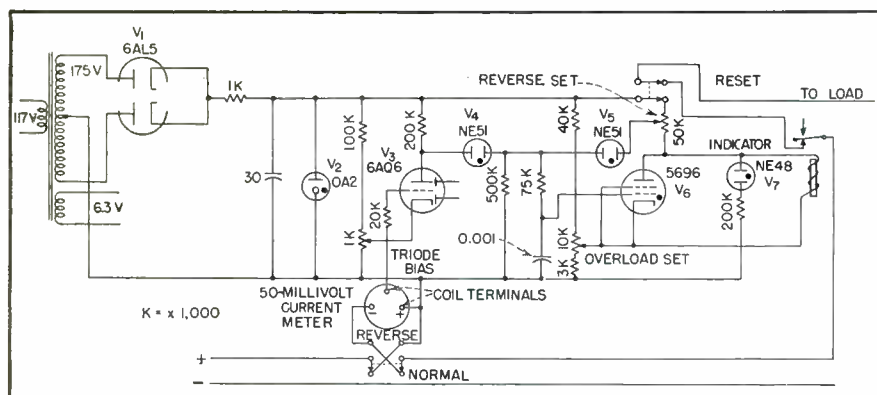

FIG. 2—Improved circuit with reverse-current protection and fail-safe operation. Voltage regulator V_2 prevents damage from line voltage surges

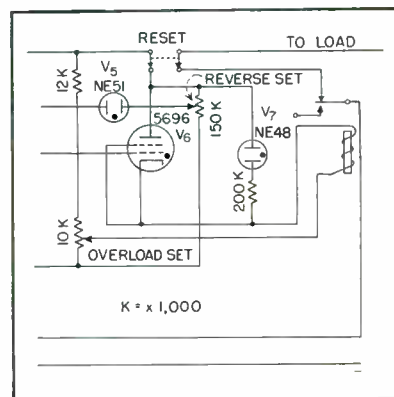

FIG. 3—Revised portion of circuit of Fig. 2 for fast operation

operation of the circuit is reliable and stable even with the overload point set at 1.5 times full load current. A more typical adjustment is to have the relay operate for 2 x forward current and 5 x reverse current. Reverse current protection need not be as good as forward current protection since it is much less likely to occur and since the meter movement is immediately brought to rest in the reverse direction. By careful adjustment, the same protection in both directions can be obtained if desired. For some operating conditions the neon tube will oscillate. This situation is not serious and has not caused improper operation.

Short-circuit protection is of considerable importance for meter safety. It is dependent in part upon the speed with which the relay coil is deenergized through the thyatron. The mechanical and electrical constants of the meter movement and the internal impedance of the power source are also important in determining short-circuit protection. The circuit of Fig. 2 provides reasonably good short-circuit protection.

To improve short-circuit opera-

tion, the time required to open the relay must be decreased. The circuit of Fig. 3 was developed to improve short-circuit operation by decreasing the relay operation time.

In this circuit the relay is normally nonenergized until overload occurs. By overdriving the relay, fast operation can be obtained. The time required to open the relay may be further reduced by changing the adjustment of the relay for more sensitive operation at the expense of less open contact pressure, and by increasing the relay overdrive.

Since the overload protection circuit is practically instantaneous in operation, some load-current surges, as for instance capacitor charging current, may operate the relay although the meter would not be in danger of damage. Relay operations caused by very rapid surges are eliminated by the R-C elements in the thyatron grid circuit. The R-C time constant must not be made too large, however, since meter protection against short-circuit overload conditions becomes worse.

Adjustment

The TRIODE BIAS, OVERLOAD SET, and REVERSE SET controls permit

initial adjustment of the protection circuit. With V_6 and V_7 nonconducting and no load current, the TRIODE BIAS control is adjusted so that V_4 just conducts. The load current is then increased to correspond with the maximum overload current, and the OVERLOAD SET control adjusted to cause V_6 to conduct. If desired, the maximum overload current can be simulated by connecting a suitable d-c potential at the coil terminal leads.

To adjust the REVERSE SET control, reverse current is passed through the current meter of sufficient magnitude to cause V_4 to cease conduction. The REVERSE SET control is then adjusted so that V_5 conducts sufficiently to cause V_6 to conduct. Normally with this procedure of adjustment the reverse current required to produce relay operation will be comparable to the forward current required to produce relay operation. If this is not the case, the controls can be adjusted slightly to achieve the desired operation.

REFERENCE

- (1) C. W. Cain's adaption of circuit developed by G. D. Hanchett, Jr., An Electronic Multicircuit Breaker, *QST*, p 34, Aug. 1947.

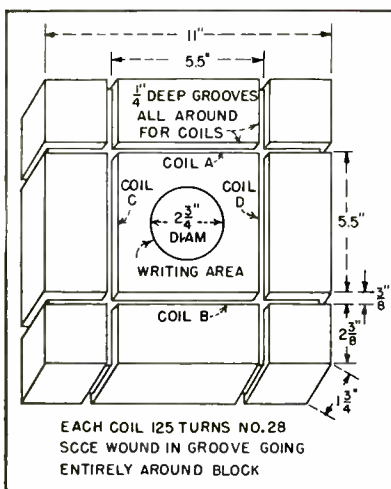

FIG. 1—Construction of wood form for the four rectangular pickup coils

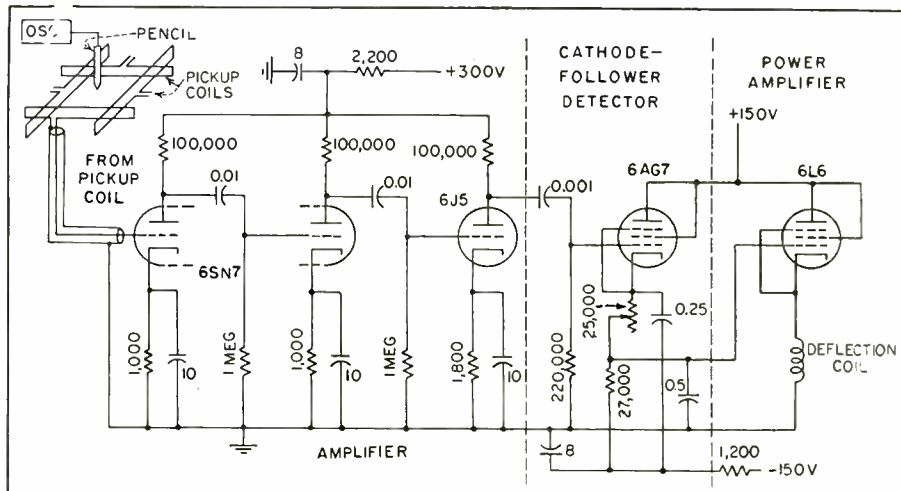

FIG. 2—Circuit of one of the four identical channels that amplify the 10,000-kc signals from the writing-table coils before and after detection

Scriptoscope Shows

Coil surrounding tracing pencil is fed by 10-kc oscillator, producing moving magnetic field that induces varying voltages in the four rectangular coils surrounding the writing board. Output currents are amplified separately and changed to varying direct current for c-r deflecting coils to give exact reproduction of handwriting on long-persistence screen

By **A. G. HUBBY** and **R. B. WATSON**

*Department of Physics, University of Texas
Austin, Texas*

WHEN HANDWRITING is to be reproduced electronically on a cathode-ray tube screen, this reproduction must take place simultaneously with the act of writing. The appearance of the trace on the screen should be a proper likeness of the handwriting of the particular individual operating the instrument, though the trace may be in any desired ratio to the original size of the writing.

The Scriptoscope utilizes the process of induction of voltages in suitably disposed coils to achieve this effect. A magnetic field alternating at a frequency of about 10 kc is produced by a small circular coil which is wound on the stylus or pencil used for the writing.

The desired writing is traced on the surface of a square wooden block having four long, rectangular

coils wound around it, as shown in Fig. 1. The alternating magnetic field from the pencil induces, in these four coils, voltages whose magnitudes and phases depend on the position of the pencil.

Construction Data

The coil for generating the magnetic field consists of about 200 turns of No. 36 DSC wire wound in a groove 1 inch long and $\frac{3}{8}$ inch deep near one end of the pencil. The coil fills only part of this groove, and is covered with a layer of insulating tape for protection.

The exact number of turns for the coils is not critical. Small wire was used for the generating coil to allow production of a considerable magnetic field by a coil of relatively small size. The number of turns on the coils in the box is a

compromise that avoids hum pickup while giving reasonable voltage at the coil terminals.

The difference between the induced voltages in the two side coils varies nearly linearly with the side-to-side position of the pencil (and generating coil) in the neighborhood of the center of the surface of the box. The difference voltage from these two coils on the edges of the box is thus representative of the component of the motion of the pencil in the lateral direction.

To make use of the region of linearity, only a small region in the center of the box is used.

The resultant voltages from the four coils are separately amplified, rectified and applied to the deflection circuits of a cathode-ray tube, as indicated in Fig. 2.

It was found convenient to am-



Example of writing as seen on cathode-ray screen

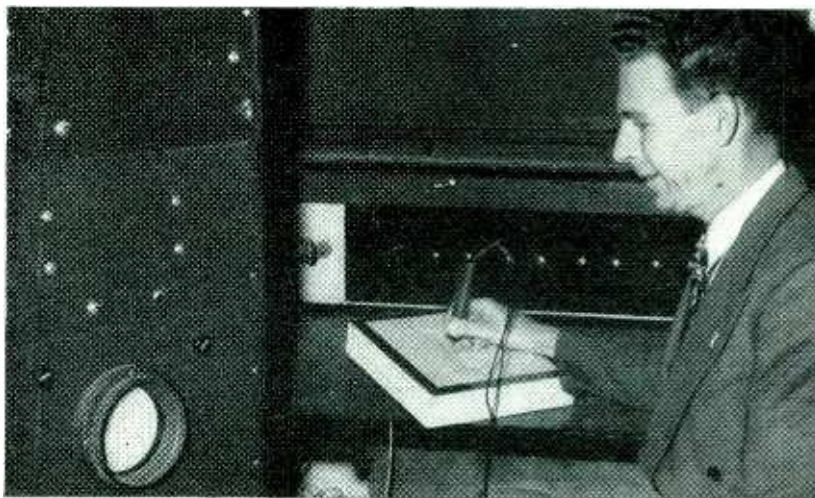

Using Scriptoscope pencil while watching resulting handwriting on rack-mounted cathode-ray tube

Messages on C-R Tube

plify and rectify the signal from each coil separately, since the deflection coils are arranged in pairs for both vertical and horizontal deflection in the cathode-ray section of the radar remote indicator unit used in the first model. A long-persistence screen on the cathode-ray tube allows easy viewing of the trace. The trace is blanked out between words or symbols by means of a switch on the pencil which operates as the pencil is removed from the box. This switch impresses a negative voltage on the grid of the cathode-ray tube which is of sufficient magnitude to cut off the electron beam.

Circuit Details

All four electronic channels employ the circuit of Fig. 2. The three amplifier stages have a gain of about 15 each. The output from the 6J5 final amplifier stage is applied to a linear detector having a resistor-capacitor combination in the cathode return. Direct coupling from this detector to the cathode-ray tube deflection coil is required to handle slow variations and steady deflections. Sufficient power for deflection is obtained from a 6L6 cathode-follower power stage driven from the detector,

using the cathode-ray tube deflection coil as a cathode load.

The power stage has its grid voltage centered about zero as a quiescent operating point by returning the detector cathode to a negative voltage supply. The use of the 6L6 as a cathode follower gives a good match to the deflection-coil load and quenches any tendency to oscillate arising from the distributed capacitance of the deflection coil.

A simple 6V6 Hartley electron-coupled oscillator (not shown) provides a signal for the generating coil of the pencil. Four separate conventional power supplies are used for the various parts of the system. A negative supply is used for the cathode-ray tube blanking voltage and for the return from the cathode-follower detector stages. A second supply provides +150 volts for the power output stages, the cathode-follower detectors and the Hartley oscillator. A third supply provides +450 volts (unregulated) for the plate potential and focus coil current for the cathode-ray tube and +300 volts (regulated) for the amplifier stages. The fourth supply is a conventional half-wave rectifier providing 4,000 volts accelerating potential for the cathode-ray tube.

The region of linearity on the box occupies a space of about 6 square inches at the center, at which point the coils are separated by about 5.5 inches. The gains of the four channels are kept approximately equal by choice of components. Centering of the spot on the cathode-ray tube to correspond to the center position of the pencil is secured by adjusting taps on the 25,000-ohm voltage dividers in the cathodes of the detector stages.

The ratio between the size of the actual handwriting and the writing appearing on the cathode-ray tube is adjusted by changing the amplitude of the current into the generating coil, thereby affecting the signal applied to all four channels in an identical way.

This article is drawn largely from a thesis, *Scriptoscope*, presented for the degree of Master of Arts in August, 1948 by A. G. Hubby, who is now with Magnolia Petroleum Co., Dallas, Texas. The authors acknowledge the loan of the cathode-ray tube assembly and other electronic components from the Defense Research Laboratory at the University of Texas operating under Contract No. NOrd-9195 with the Bureau of Ordnance, Navy Department.

By FREDERICK W. SMITH

*Radio and Allocations Engineering
National Broadcasting Co.
New York, N. Y.*

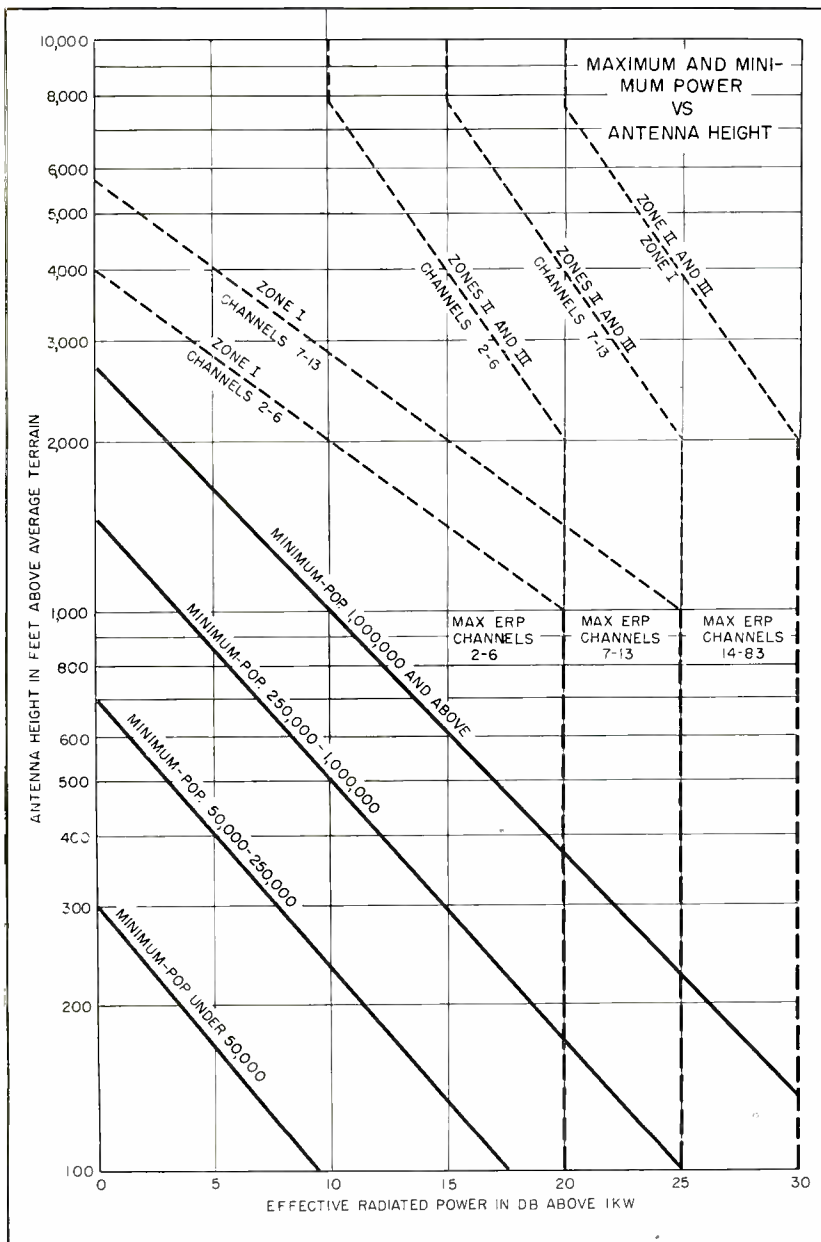

FIG. 1—Maximum and minimum power vs antenna height for all channels and zones

Table I—Required Median Field Strength in db Above 1 $\mu\text{v}/\text{m}$ ($\text{db}\mu$) at Outer Limits of Service

Grade of Service	Channels 2-6	Channels 7-13	Channels 14-83
A	68	71	74
B	47	56	61

cycles. Of the important changes to be made in the engineering standards, one of the most significant is an upward revision of the maximum effective radiated power that may be transmitted by television broadcast stations, which will make pos-

sible substantial increases in the service radii of existing stations.

The maximum and minimum powers that will henceforth be used in television broadcasting depend on transmitting antenna height and the population of the city to

be served as shown in Fig 1. For channels 2 to 6 (54 to 88 mc) a maximum of 20 db above 1 kw (dbk) of power may be transmitted for antenna heights of 1,000 feet or less; for channels 7 to 13 (174 to 216 mc) 25 dbk for antenna heights of 1,000 feet or less; and for channels 14 to 83 (470 to 890 mc) 30 dbk for antenna heights of 2,000 feet or less. For greater antenna heights, radiated power of a station must be derated as shown in Fig. 1, according to the particular zone of the country in which the transmitter is to be located. The zone divisions established by the FCC are shown in the map.

It will be noted that in the new standards, transmitted effective radiated power (erp) is expressed in terms of decibels above a reference level of one kilowatt or dbk. The maximum levels of 20, 25, and 30 dbk, therefore, represent power levels of 100, 316, and 1,000 kilowatts, respectively. Likewise, the FCC will henceforth specify field strength levels in terms of decibels above a reference level of one microvolt per meter or $\text{db}\mu$. This convention has the advantage that transmission-line losses and antenna gains may be directly subtracted and added to transmitter power output levels. A power increase of one decibel at the transmitter will result in an increase of a decibel in received field strength.

Coverage Prediction

Under the old standards that have been superseded, the coverage of television stations was described in terms of contours based on a median field strength of 5.0 and 0.5 millivolts per meter. In the new standards, the coverage of television stations is expressed in terms of two grades of service, which are defined in Table I. The grade A and B service classifications are essentially specifications

of the extent of signal penetration that will prove to be satisfactory to the average urban or rural observer equipped with an average television receiving system, both from a subjective and a time-availability standpoint. According to the propagation characteristics of uhf and vhf, and considering the performance capabilities of the average television receiver and receiving antenna system, if the field-strength levels specified in Table I are provided, then the re-

quirements for Grade A and B service will be met.

Another innovation is the inclusion in the standards of television field-strength curves that are based on a statistical analysis of the service rendered by the existing television stations. These replace field-strength charts, such as those in the old standards, or previously published elsewhere², which were based on the theoretical propagation to be expected over a smooth, spherical earth, and which did not

take into account the statistical effects of terrain losses, or provide median field strengths. Figures 2, 3 and 4 represent condensed versions of these curves and are arranged to permit convenient and rapid computation of the distances to the Grade A and B service contours when the antenna height above average terrain and the effective radiated power of a station in dbk are known.

Typical Case

Figures 2, 3 and 4 are used as follows: Assume that an antenna site has been selected for a station to be located in Zone II, and that the radiation center of the antenna will be 1,500 feet above mean sea level. A topographic map, such as prepared by the U. S. Geological Survey, is then secured and eight or more radials are drawn on it, each extending to a distance of ten or more miles from the proposed transmitter location, as described in the FCC standards. One or more of these radials must extend through the major city or cities to be served. A profile graph for each of these radials is then constructed, which also shows the elevation of the antenna radiation center, as shown in Fig. 5. This represents a hypothetical profile that might be obtained along a N 30° E radial from a proposed television site.

Once such a profile has been obtained, average elevation of the profile graph of the radial for the eight-mile distance between two and ten miles from the proposed transmitter location is determined by means of a planimeter or by averaging successive points in the interval.

In the case of the radial profile graph shown, this proves to be 305 feet above mean sea level. The height of the radiation center of the antenna above the average elevation of the radial between two and ten miles, the antenna height above average terrain, is 1,500 feet minus 305 feet, or 1,195 feet. This height is taken as 1,190 feet because the FCC specifies antenna height to the nearest 10 feet, taking the lower alternative for midway figures. The antenna height above average terrain is

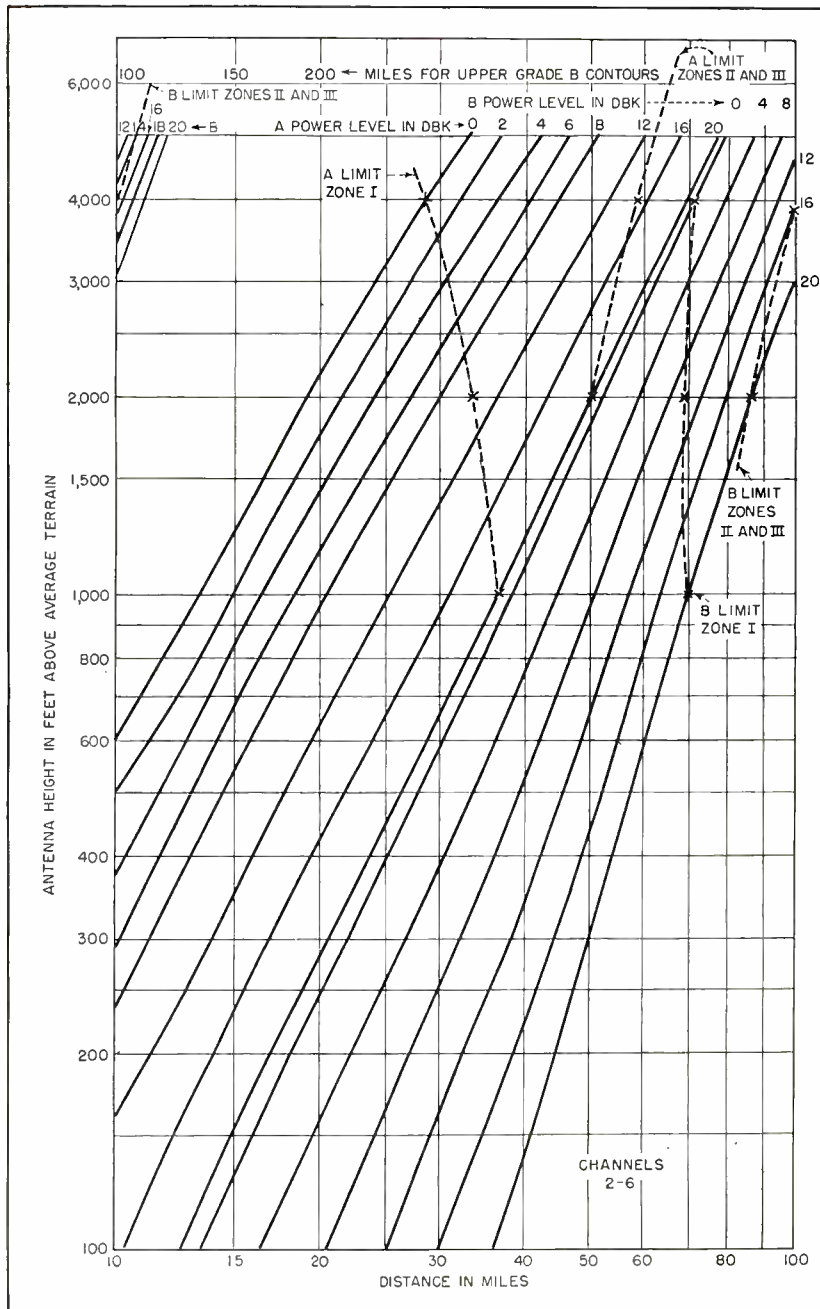

FIG. 2—Grade A and B contour distance for channels 2 through 6

CONSULT CINCH FOR THE PRODUCTION OF ANY COMPONENT ASSEMBLY FOR COMMERCIAL OR MILITARY USE THAT FALLS WITHIN THE GENERAL CATEGORY OF ELECTRONICS PARTS MANUFACTURE



Cinch sockets and shields to JAN specifications:

DESCRIPTION	MAT.	JAN S-28	JAN S-28-A	JAN S-28-A AMEND 1	
7 Pin Miniature	Mica	SO-10-M (T9365-1)	TSE7T101 (9356)	TS102P01 (9356)	
7 Pin Miniature	Ceramic	SO-10-C (T9316-1)	TSE7T102 (9355)	TS102C01 (9355)	
8 Pin Octal	Mica	See Note #1	TSB8T101 (51B16203)	TS101P01 (51B16203)	
8 Pin Octal	Mica	See Note #1	See Note #1	TS101P02 (51B16758)	With Mtg. Nuts
8 Pin Octal	Ceramic	See Note #1	TSB8T102 (51B16220)	TS101C01 (51B16220)	
8 Pin Octal	Ceramic	See Note #1	See Note #1	TS101C02 (51B16759)	With Mtg. Nuts
9 Pin Noval	Mica	See Note #1 (53F12875)	TSE9T101 (53F13373)	TS103P01 (53F13373)	
9 Pin Noval	Ceramic	See Note #1 (53F12776)	TSE9T102 (53F13381)	TS103C01 (53F13381)	
7 Pin Shield	*	SOS-3 (8660-1)	TSF0T101 (8690-1)	TS102U01 (8690-1)	1 3/8"
7 Pin Shield	*	SOS-6 (8661-1)	TSF0T102 (8691-1)	TS102U02 (8691-1)	1 3/4"
7 Pin Shield	*	See Note #1 (16G12564)	TSF0T103 (8698-1)	TS102U03 (8698-1)	2 1/4"
9 Pin Shield	*	See Note #1 (16G12626)	TSF0T104 (16G13375)	TS103U01 (16G13375)	1 1/2"
9 Pin Shield	*	See Note #1 (16G12627)	TSF0T105 (16G13376)	TS103U02 (16G13376)	1-15/16"
9 Pin Shield	*	See Note #1 (16G12628)	TSF0T106 (16G13377)	TS103U03 (16G13377)	2 3/8"

*JAN S-28 Shields—Steel—Cadmium Plated
 JAN S-28-A Shields } Brass—Nickel Plated
 JAN S-28-A Amend 1 } Brass—Nickel Plated
 Note #1. Not Included in Jan. Spec.
 Numbers Shown in Parentheses () Indicate Cinch Part Numbers

Cinch is producing many variations of standard electronic components for military use. An organization that is flexible, readily adapted to any requirement . . . in military or commercial emergency. Ample physical properties . . . space and production facilities.

Consult Cinch today!

CINCH MANUFACTURING CORPORATION

1026 South Homan Ave., Chicago 24, Illinois

Subsidiary of United-Carr Fastener Corporation, Cambridge, Mass.

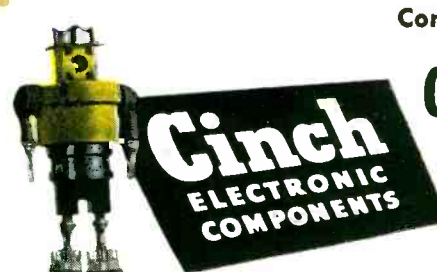

Cinch components are available at leading electronic jobbers — everywhere

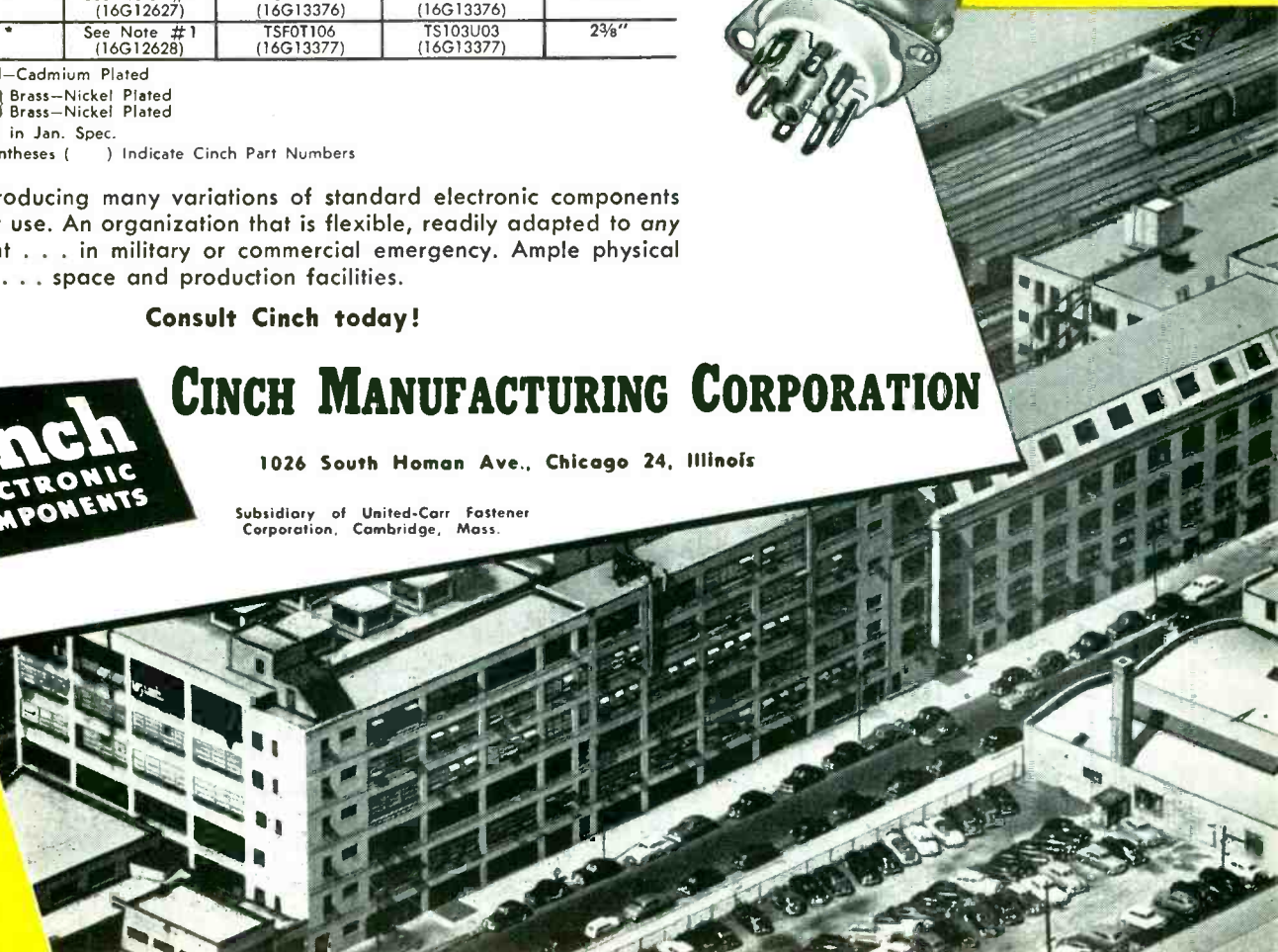

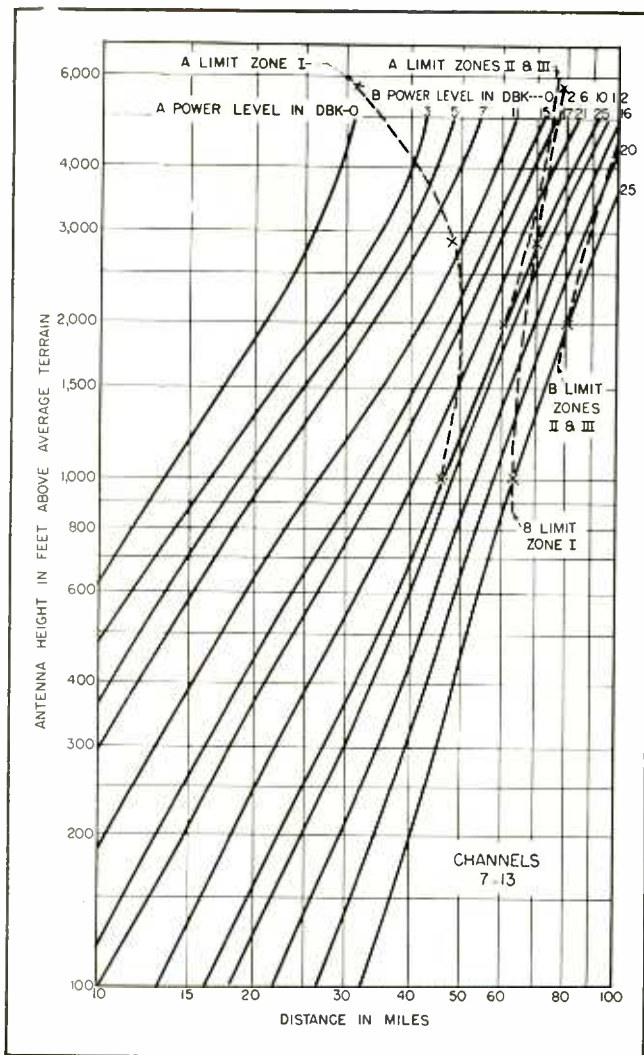

FIG. 3—Grade A and B contour distances for channels 7 through 13

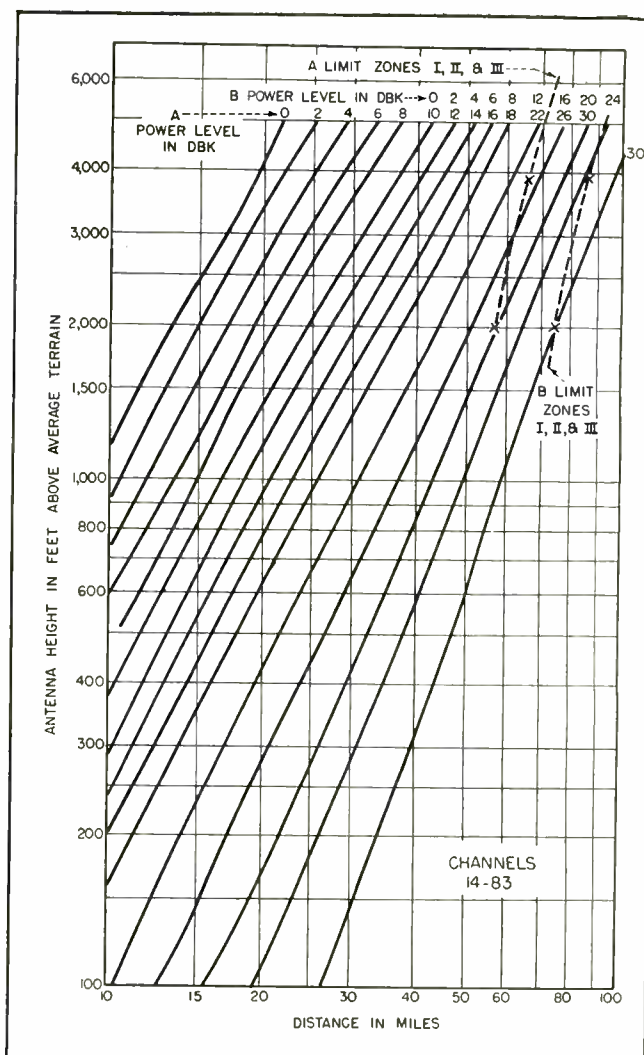

FIG. 4—Grade A and B contour distances for channels 14 through 83

usually taken as 100 feet where it proves to be less than 100 feet or negative.

According to Fig. 2, the coverage for an effective radiated power of 20 dbk on channel 2 at this site, and along this particular radial, will be about 40 miles, A, and 73.5 miles, B. If the station were to be located in Zone I, the coverage limit would be set by the maximum power curve in Fig. 1 as indicated by the dashed lines ("A Limit Zone I" and "B Limit Zone I" in Fig. 2) and would be 36 miles, A, and 69.5 miles, B.

The complete contours for the station are then secured by repeating the above process for each of the radials and by marking off the distances obtained for all of the radials on a suitable map. A smooth curve that joins the appropriate points then represents the

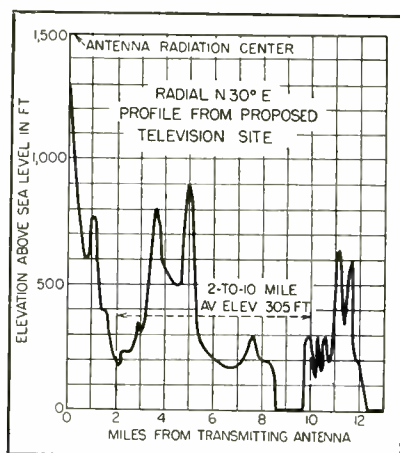

FIG. 5—Representative radial showing method of determining average elevation

contour at which the specified service is obtained. If the coverage map is to be submitted to the FCC as part of an application for construction permit, the contours

should be constructed on the Sectional Aeronautical Chart for the area.

The effective radiated power of a television station is the sum of the transmitter power output in decibels above one kilowatt, and the transmitting antenna gain over a half-wave dipole in decibels, less the loss in decibels incurred in the diplexer, triplexer (if used), and transmission-line feed system. When the transmitter power output rating already incorporates the diplexer loss, the latter need not be considered.

REFERENCES

- (1) Sixth Report and Order; Amendment of the Rules, Regulations and Engineering Standards Concerning the Television Broadcast Service, Appendix D, Federal Communications Commission, Washington 25, D. C., April 14, 1952.
- (2) F. W. Smith, Calculating UHF Field Intensities, *ELECTRONICS*, p 110, Oct. 1950.

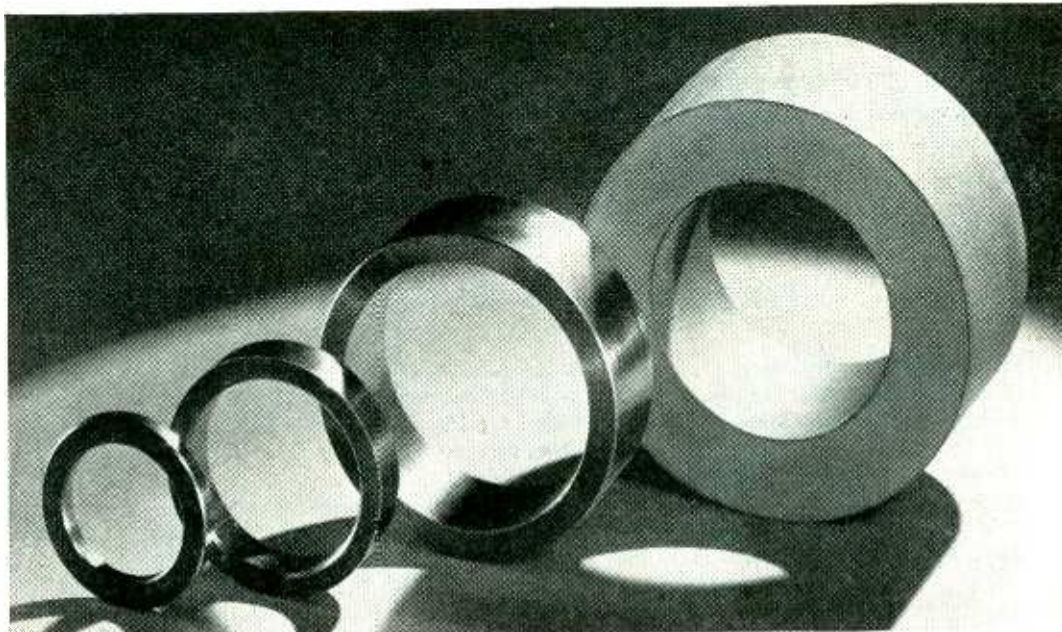

Get more
of the properties you want in a high density metal
with **MALLORY 1000 METAL**

Expect More . . .
Get More From Mallory

At your service when you bring your metallurgical problems to Mallory is a well-rounded, skilled organization with years of specialized research and practical production experience.

Many have found that the combination of Mallory products and Mallory technical service results in product betterment . . . production economy—value beyond expectation.

It may well be to your advantage to see what the Mallory "team" can do for you.

Today designers are finding wide use for Mallory 1000 Metal—a sintered Tungsten-base alloy—because it possesses properties which other high density metals cannot offer. Mallory 1000 Metal gives you . . .

- HIGH DENSITY . . .** Mallory 1000 Metal has a density of 16.8 to 17.0 grams per cubic centimeter.
- GREAT STRENGTH . . .** Mallory 1000 Metal has a tensile strength of more than 80,000 lbs. per square inch.
- EASY MACHINABILITY . . .** Mallory 1000 Metal machining is like that of grey iron in operation and chip.
- DRIFT RESISTANCE . . .** Mallory 1000 Metal shows no objectionable drift or shift at rotational speeds as high as 35,000 RPM.

You'll find Mallory 1000 Metal at work wherever high density and great strength are required—as in rotors, flywheels, balance weights . . . or as a shield for radium and x-rays. Write today for technical information about versatile Mallory 1000 Metal.

*In Canada, made and sold by Johnson Matthey and Mallory, Ltd.
 110 Industry Street, Toronto 15, Ontario*

Metallurgical Products and Alloys

P. R. MALLORY & CO., Inc.
MALLORY

SERVING INDUSTRY WITH

- Electromechanical Products**—Resistors • Switches • TV Tuners • Vibrators
- Electrochemical Products**—Capacitors • Rectifiers • Mercury Dry Batteries
- Metallurgical Products**—Contacts • Special Metals • Welding Materials

P. R. MALLORY & CO., INC., INDIANAPOLIS 6, INDIANA

ELECTRONS AT WORK

Including INDUSTRIAL CONTROL

Edited by RONALD K. JURGEN

Preamplifier for Medical Use.....	152	Alarm Signal Generators	204
Electronic Projectile Test Range.....	152	Television Spot Wobbler.....	212
Visual Tracking of Front Ends.....	154	Simple Capacitance Alarm System....	214
Sorting Coins Electronically	154	Ultrasonics Aids Diathermy	
Vacuum-Tube Analogy of Transistors.	156	Experiments	216
Life Testing Reliable Tubes.....	169	Radio Hazard with Electric Blasting	
Voice and Sound-Operated Relays....	176	Caps	220
Design of a Low-Noise Pentode.....	194	Spark Speeds in the Audio Region....	222
Electronic Elevator Touch Button.....	224		

OTHER DEPARTMENTS

featured in this issue:

	Page
Production Techniques.....	228
New Products.....	258
Plants and People.....	302
New Books	312
Backtalk	328

Preamplifier for Medical Use

By J. L. MURPHY and H. W. PAVELA
*Assistant Chairman Electrical Engineer
 Electrical Engineering Research
 Armour Research Foundation
 Chicago, Illinois*

ELECTROMYOGRAPHY is the electrical recording of the potentials arising in muscle tissue. The preamplifier and amplifier described herein are used with a magnetic recorder for that purpose.

Referring to Fig. 1, a pair of electrodes is inserted into, or near, an area of the muscle of interest. These are the active and reference points and are connected to the two input grids of the differential preamplifier. A third electrode attached to the subject in an inactive area serves as a ground for the system.

The differential action of the am-

plifier is defined as the ratio of the in-phase voltage to the signal potential for equal outputs. The signal applied between the two grids tied together and ground for a given output should be larger by a factor of over 2,000 than a signal applied between the two grids.

In this amplifier, the first stage consists of two tubes connected in the Toennies differential circuit which provides good in-phase rejection. This input stage consists of a cathode-follower pentode 6AU6 coupled to the cathode of a single-ended amplifier. Test were conducted on tube types 6AU6, 5693, 6SJ7, 6BA6 and 6AG5 for the input circuit and led to the selection of the 6AU6 from the standpoint of low inherent noise, high amplification and high differential ratio. This

type of input stage gives a high differential ratio which is further improved by adjustment of C_1 and R_1 .

Regardless of tube type tested, selection for gain, low noise and differential ratio was necessary. However, it was found that 20 percent of stock 6AU6's were suitable for input pairs.

The single-ended output of the differential stage is fed into two stages of amplification, each consisting of a 12AX7 dual triode. The first section of each tube is connected as a conventional triode amplifier and is direct-coupled to the second section which functions as a cathode follower, providing good high frequency response and low output impedance.

The preamplifier has a frequency response of 0.5 cycles to 10 kc between 3-db points, a noise level of approximately three microvolts rms referred to the input grids and an overall gain of 16,000. High and low frequency cut-off filters are provided for reducing the bandwidth.

The complete paper entitled "A Magnetic Recorder for Medical Application" was presented by the authors at the 1951 National Electronics Conference.

Electronic Projectile Test Range

IN A NEW PROJECTILE test range at the Naval Ordnance Laboratory, White Oak, Md., guns up to 40 mm will be fired through the muffler partly seen at right in the photo-

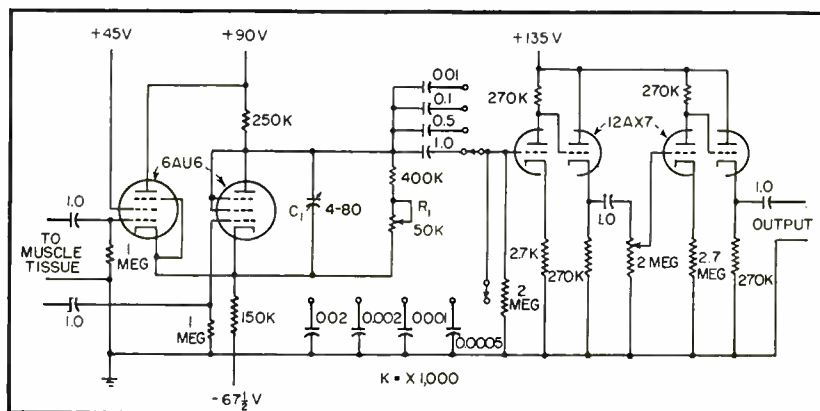

FIG. 1—Schematic diagram of the preamplifier for magnetic recording in medical applications

**Type
206-A**

FM SIGNAL GENERATOR

for Mobile Communications Receivers

Frequency Range

146 mc to 176 mc



PANEL A

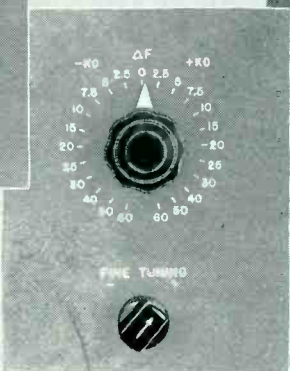

PANEL B

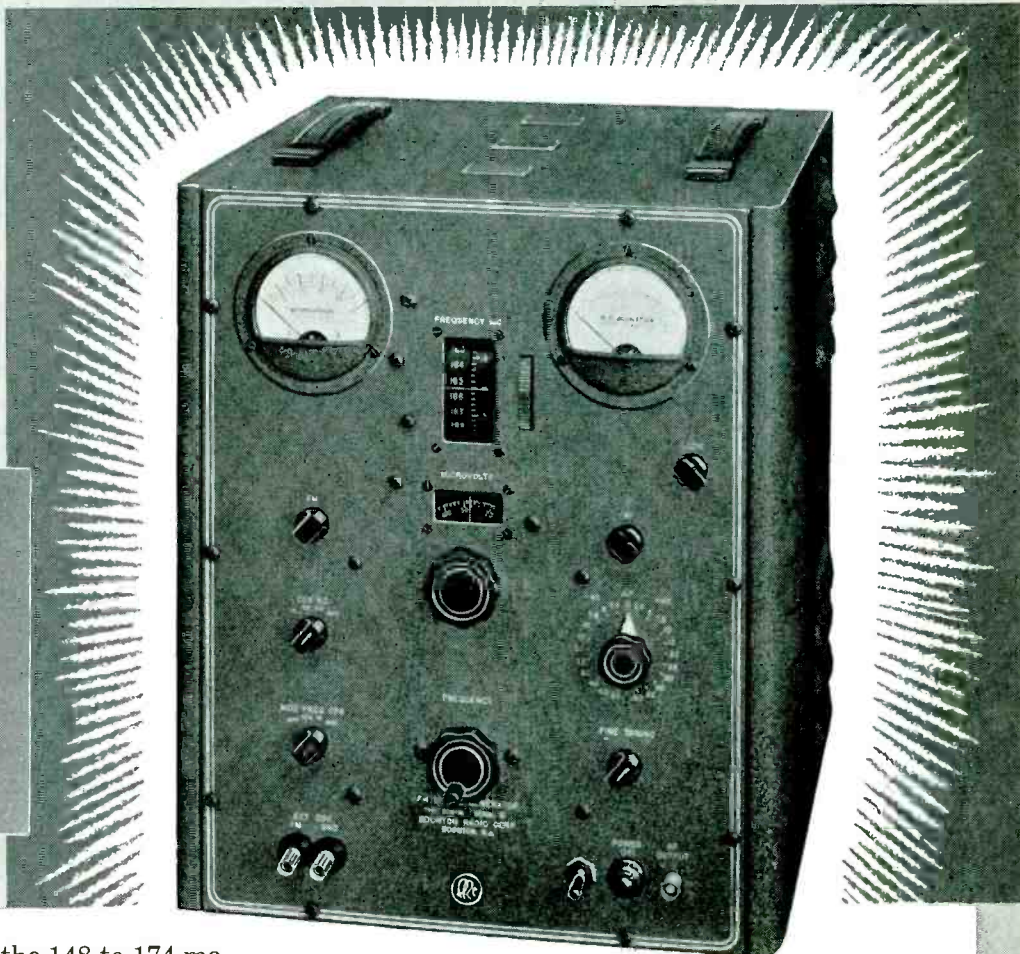

Mobile communications receivers in the 148 to 174 mc range have high sensitivity and rigid selectivity specifications. The receivers must not drift nor suffer detuning from variations in signal level. To be certain that these important requirements are met, laboratories and manufacturers must have a test instrument with capabilities at least an order better than receiver requirements.

The Type 206-A FM Signal Generator meets these needs. Output frequency is adjusted by a mechanism with a fast and vernier drive which is marked in 1.0, 0.1, and 0.01 mc divisions (see panel A). The dial mechanism position can be changed with respect to the tuning condenser shaft by a lock mechanism to calibrate any single point. Tuning in discrete steps for selectivity measurements may be carried out rapidly by a switched electronic tuner (see panel B). Very fine tuning corrections can be made by an additional electronic vernier. Drift of oscillator output with time is very low and variation in output frequency with attenuator setting negligible. A wide range of output levels is available (see panel A). The instrument is characterized by low microphonism and low leakage.

SPECIFICATIONS (Type 206-A)

- FREQUENCY RANGE:** 146 mc to 176 mc in one range.
- FREQUENCY CONTROLS:** Main dial marked in 1 mc divisions.
Vernier (mechanical) marked in 0.1 and 0.01 mc divisions.
 Δ F Switch: \pm 60 kc in small discrete increments.
Fine Tune: Continuous electronic tuning over \pm 10 kc range.
- FREQUENCY ACCURACY:** \pm 0.2% after warmup.
- FREQUENCY STABILITY:** With temperature variations: \pm 0.001% per degree centigrade.
With line voltage variation: \pm 0.002% for \pm 10% line variation.
- RF OUTPUT VOLTAGE:** 0.1 to 200,000 microvolts into a 53 ohm load.
- RF ATTENUATOR ACCURACY:** Approximately \pm 10%.
- RF OUTPUT IMPEDENCE:** 53 ohms resistive looking into panel connector.
- FREQUENCY MODULATION:** Frequency deviation ranges (continuously variable) 0-10, 0-25, 0-100 and 0-250 kc.
Frequency deviation accuracy: Can be calibrated to \pm 5% by internal standard.
- FM DISTORTION:** Less than 2% at 100 kc and less than 10% at 250 kc deviation.
- MODULATING SOURCES:** Internal AF oscillator at 400 and 1000 cps.
External AF oscillator may be used.
Output from internal AF oscillator available for synchronizing or other purposes.
- POWER SUPPLY:** Provides electronically regulated filament and B voltages.

Write for complete information

PRICE \$910.00 F.O.B. BOONTON, N. J.

BOONTON RADIO

BOONTON · N · J · U · S · A

Corporation



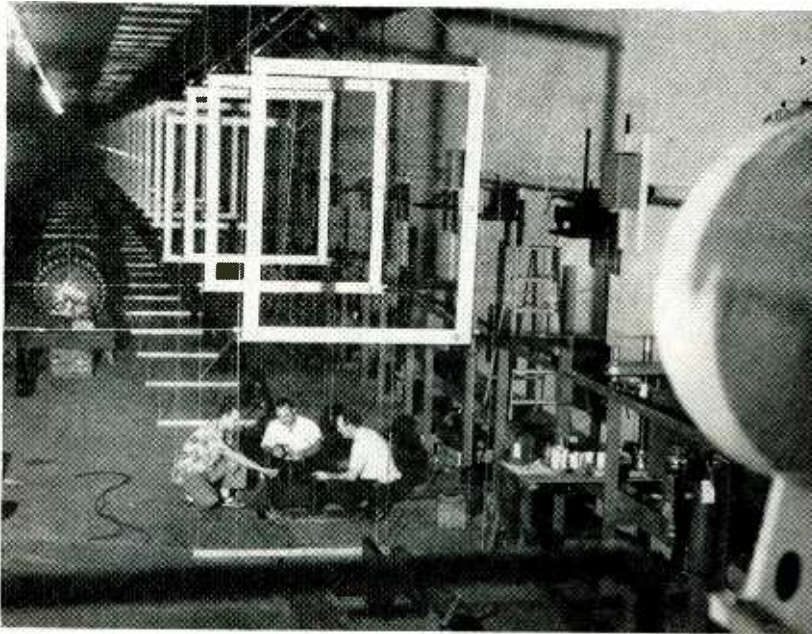

Workmen shown putting finishing touches on new Naval projectile test range

graph. A line of 25 frames will automatically set off a battery of cameras to record the flight of a missile.

Purpose of the range is to carry on stability and drag investigations on spinning and finned projectiles. The range allows for the use of larger missiles and lower mach

numbers than is possible in a pressurized range.

Two possible electronic means under consideration for setting off the cameras are the use of a photoelectric beam to be cut by the projectile and use of a magnetic field in which a magnetized steel bullet is fired through a magnetic coil.

Visual Tracking of Superheterodyne Front Ends

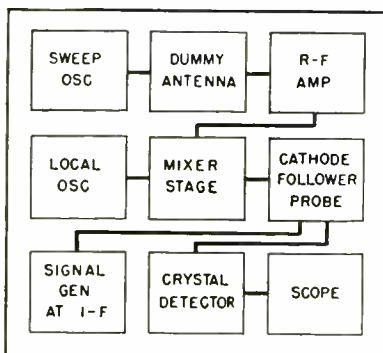

FIG. 1—Block diagram of the setup for aligning superheterodyne front ends

By PHILIP S. WESSELS

*Electronic Scientist
Federal Communications Commission
Laboratory Division
Laurel, Maryland*

NUMEROUS articles in the literature have presented the mathematics of tracking in superheterodyne receivers, but little has been published on methods of checking possible solutions. The equipment

shown in Fig. 1 provides rapid and accurate checking means.

The output of a sweep oscillator is coupled to the antenna in a manner that its effect on the first tuned circuit is minimized. A standard dummy antenna probably would be used in most cases. This signal is taken off the grid of the mixer tube with a cathode follower and detected in a manner that gives a presentation of the response curve of the r-f amplifier on the screen of an oscilloscope.

It is standard procedure to place markers on such a picture by injecting an r-f voltage of appropriate frequency into the circuit. These markers occur when the beat note between the sweep oscillator and the injected signal fall within the pass band of the oscilloscope. In general there will be enough stray pickup from the local oscillator to give such a marker appropriately

placed relative to the r-f response curve.

If a third signal is mixed into the system, additional beat notes will appear. Two of these will occur at points on the sweep which represent frequencies equal to the sum and difference of the local oscillator and the third signal. If this third signal is set equal to the intermediate frequency, one of these markers should fall somewhere on the response curve of the r-f amplifier, depending on the tracking error at this particular point.

The r-f amplifier now can be tuned from one end of the band to the other and tracking error and changes in the response curve can be observed at the same time. Additional markers could be introduced to designate the desired frequency of either end of the band and perhaps the crossover point.

This system makes it possible to check quickly the solution of any tracking problem. It could be used on the production line where all bands of a receiver could be checked in a matter of minutes.

Sorting Coins Electronically

WHEN THE United Kingdom began issuing cupronickel coins and withdrawing from circulation those coins containing silver, an electronic device for sorting the coins was developed. Experimental work indicated that the two types of alloy could be separated by measuring their relative conductivities. The



The coin sorting machine

THE FRONT COVER

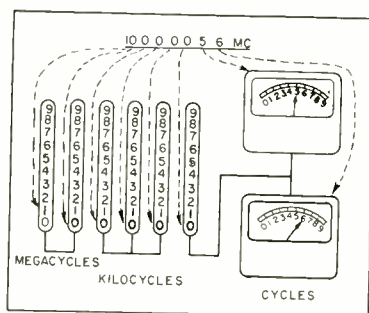

THE FREQUENCY COUNTER shown in the cover photograph in a crystal-testing application, measures and displays directly the crystal frequency.

Range of the instrument is from 0.01 cps to 10 mc. The accompanying drawing shows the display arrangement of the counter. Neon tubes behind the panel slots illuminate the proper numerals for direct indication.

Pulse techniques are used in the device manufactured by the Hewlett-Packard Company. The complete counting circuit consists of eight cascaded scalars with indicating systems. Each scalar is a decade type and generates one output pulse for every ten pulses received.

equipment is shown in the accompanying photographs.

The mixed coins are placed in the rotary hopper which feeds them down a vertical chute. The chute guides the coins through a sensing head consisting of a gapped iron-core inductance. The effect the coins have on the flux present in the gap is taken as an indication of their composition.

If the flux variation shows the coin to be of cupronickel composition, the coin falls uninterruptedly down the guide to a receptacle. Silver coins cause accurately-timed pulses to be fed to an ejector unit. The pulses energize a small solenoid causing an inclined deflector, attached to the plunger, to move

across the chute and into the path of the falling coins. Upon hitting the deflector, the silver coins are conveyed to a special receptacle.

The machine will handle a range of denominations if the guide in the hopper is changed and the right switch position on the control unit is selected. The machine has a capacity of about eight coins per second.

The information in this article was abstracted from *Electronic Engineering* for January 1952. Teledictor Limited of Dudley, England, did the developmental work on the unit. This description is published with the permission of the Superintendent, Royal Mint, London, England.

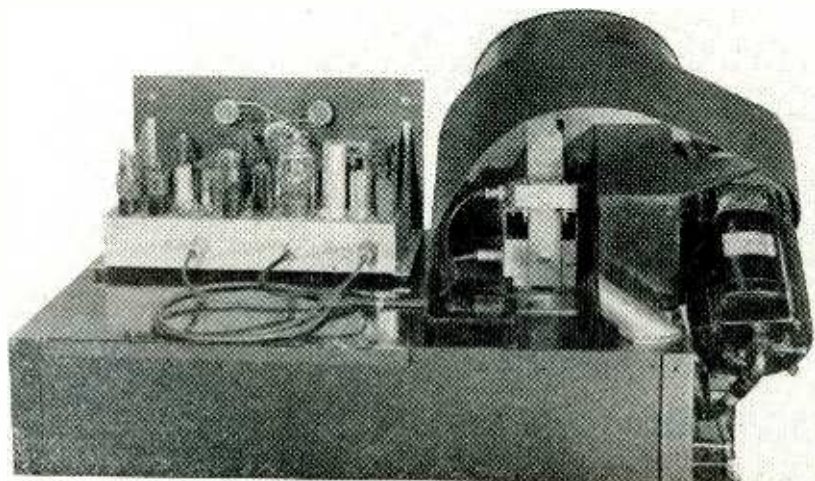

Rear view of the instrument with covers removed. The sensing head and ejector unit are on the vertical chute behind the rotary hopper

Vacuum-Tube Analogy of Transistors

BY HANS E. HOLLMANN

U. S. Naval Air Missile Test Center
Point Mugu, California

ACCORDING TO DUALITY, the transistor requires a constant bias current instead of a constant bias voltage, reactances in vacuum tube circuits are equivalent to admittances, resistors to conductances, and so forth. Although somewhat tricky in complex circuits, the duality principle has been found to be very useful in practical circuitry design.

If the general rule is followed that the duality principle requires every significant element to be replaced with its dual, this concept may be applied not only in the direction from common vacuum tubes to transistors but also conversely.

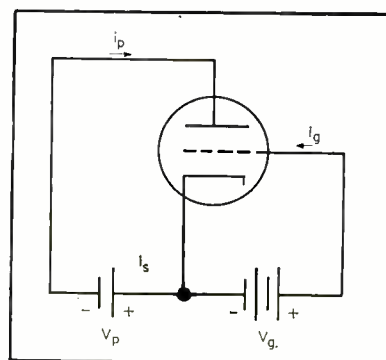

FIG. 1—Basic schematic of the retard-ing-field tube

The final step would be the exchange of grid and plate of a triode, that is, let the plate carry the input or control energy while the grid is the output electrode.

Such a tube will not operate on the principle of space-charge control. A highly positive grid and a plate potential in the vicinity of zero, however, leads directly to a retarding-field tube. Since this peculiar vacuum tube may not be well known, its basic performance briefly is summarized in modern terminology.

The retarding-field tube has been utilized as a generator and detector for microwaves and has been found to operate successfully beyond the region of electron oscillations. As shown in Fig. 1, the cathode may be assumed to be a tungsten filament and the grid potential to be above



You'll find more Career Opportunities at RCA

UNUSUAL career-building openings await experienced

ELECTRONIC ENGINEERS . . .
ELECTRICAL ENGINEERS . . .
MECHANICAL ENGINEERS . . .
COMMUNICATION ENGINEERS . . .
COMPUTER ENGINEERS . . .
PHYSICISTS . . .
and **METALLURGISTS**

Positions open offer lifelong career opportunities to men who expect more from their work than is provided by an ordinary engineering assignment.

RCA IS A GOOD PLACE TO WORK

At RCA you receive recognition for your accomplishments. You work in close collaboration with distinguished scientists and engineers. You enjoy highest professional recognition among your colleagues. You have unexcelled facilities for creative work. The surroundings in which you work are pleasant and stimulating. You and your family enjoy outstanding employee benefits. Opportunities are excellent for advancement in position and income. Unlike "feast-or-famine" businesses, RCA has forged ahead regardless of war or depression.

Immediate Openings in
RESEARCH • DEVELOPMENT • DESIGN • APPLICATION
in the following fields:

RADAR • MISSILE GUIDANCE • SERVO MECHANISMS
ANALOG COMPUTERS • TRANSFORMERS AND COILS
NAVIGATION AIDS • TELEVISION • ELECTRON TUBES
COMMUNICATIONS • TECHNICAL SALES
ELECTRONIC EQUIPMENT FIELD SERVICE

Send a complete résumé
of your education and experience.
Personal interviews
arranged in your city.

Send résumé to:
Mr. ROBERT E. McQUISTON, Manager
Specialized Employment Division,
Dept. 46G
Radio Corporation of America
30 Rockefeller Plaza, New York 20, N. Y.



RADIO CORPORATION of AMERICA

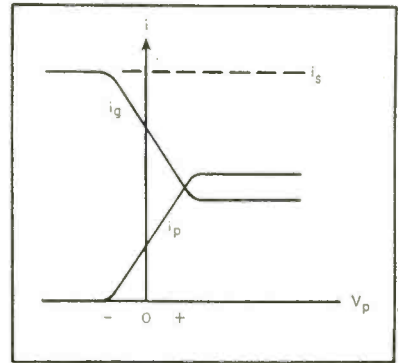

FIG. 2—Idealized grid and plate characteristics of the retarding-field tube at aperiodical conditions of operation

Quantity PRODUCTION OF THE HIGHEST Quality

AMPHENOL RG CABLES set the standard for quality in a field where quality and dependable performance are a "must." Frequent laboratory and production tests insure uniform quality and performance. Users of Amphenol RG Cables know that they will perform as specified!

AMPHENOL R F CONNECTORS provide an efficient connecting link between coaxial cables. They feature never-failing continuity, extremely low R F loss and the assurance of a long life of sustained quality. The design, materials and finishes of each type connector are carefully chosen to give the best possible performance under the required conditions.

AMPHENOL A N CONNECTORS are strong! They have a tensile strength of 53,000 pounds. Engineered to meet the rigid Army-Navy Specifications, these connectors insure lowest millivolt loss. The non-rotating solder pockets cut soldering time and reduce operator fatigue. Amphenol has the widest selection of A N Connectors to meet MIL-C-5015 Specifications.

Now Available . . . Catalog B-2—A General Catalog of Amphenol Components—will be sent on request.

AMERICAN PHENOLIC CORPORATION
1830 SOUTH 54TH AVENUE • CHICAGO 50, ILLINOIS

AMPHENOL

the saturation value.

The grid current is composed of two groups of electrons. One group strikes the grid immediately on its way from the cathode, the other group passes through the grid meshes and is slowed down by the retarding field in the grid-plate space. Depending on whether the plate has a negative or slightly positive potential, these electrons are either repelled or caught by the plate. As a result, the saturation current can easily be seen to be split into grid and plate current. There exists a current transfer in that the grid characteristic i_g versus plate voltage V_p is the mirror image of the plate characteristic i_p versus V_p as shown in Fig. 2. Hence $di_g = -di_p$, or the current gain $\alpha = -1$.

An alternate explanation is the retarding-field tube acting as a constant-current resistance transformer. The input or plate voltage is loaded with the internal plate resistance $r_p = dV_p/di_p$, while the output resistance $r_g = dV_g/di_g$ is almost infinitely high because of saturation. The result is a power gain which asymptotically approaches infinity. Since perfect saturation is not possible, this is only an idealized extreme. If the saturation filament is replaced with the first electrodes of a conventional multigrid tube, for example, with a saturated pentode, the saturation becomes less perfect and the power gain approaches a finite value.

In some types of tubes, particularly characterized by very fine and homogeneous grids, the electrons arrange themselves into groups or bunches that oscillate together. This bunching effect builds up

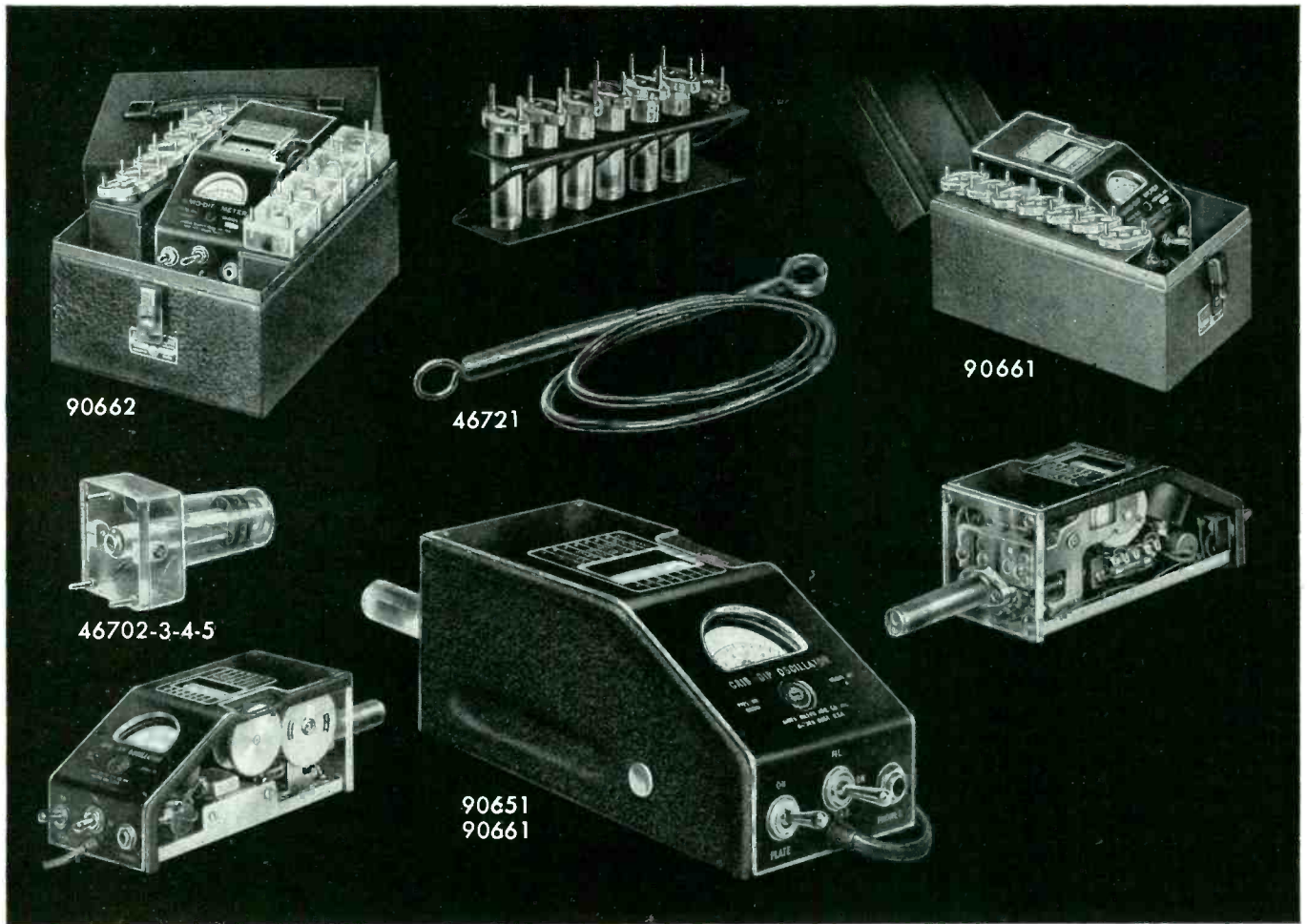

Designed for Application

Grid Dip Meters

Millen Grid Dip Meters are available to meet all various laboratory and servicing requirements.

The 90662 Industrial Grid Dip Meter completely calibrated for laboratory use with a range from 225 kc. to 300 mc. incorporates features desired for both industrial and laboratory application, including three wire grounding type power cord and suitable carrying case.

The 90661 Industrial Grid Dip Meter is similar to the 90662 except for a reduced range of 1.7 to 300 mc. It likewise incorporates the three wire grounding type cord and metal carrying case.

The 90651 Standard Grid Dip Meter is a somewhat less expensive version of the grid dip meter. The calibration while adequate for general usage is not as complete as in the case of the industrial model. It is supplied without grounding lead and without carrying case. The range is 1.7 to 300 mc. Extra inductors available extends range to 220 kc.

The Millen Grid Dip Meter is a calibrated stable RF oscillator unit with a meter to read grid current. The frequency determining coil is plugged into the unit so that it may be used as a probe.

These instruments are complete with a built-in transformer type A.C. power supply and interterminal terminal board to provide connections for battery operation where it is desirable to use the unit on antenna measurements and other usages where A.C. power is not available. Compactness

has been achieved without loss of performance or convenience of usage. The incorporation of the power supply, oscillator and probe into a single unit provides a convenient device for checking all types of circuits. The indicating instrument is a standard 2 inch General Electric instrument with an easy to read scale. The calibrated dial is a large 270° drum dial which provides seven direct reading scales, plus an additional universal scale, all with the same length and readability. Each range has its individual plug-in probe completely enclosed in a contour fitting polystyrene case for assurance of permanence of calibration as well as to prevent any possibility of mechanical damage or of unintentional contact with the components of the circuit being tested.

The Grid Dip Meters may be used as:

1. A Grid Dip Oscillator
2. An Oscillating Detector
3. A Signal Generator
4. An Indicating Absorption Wavemeter

The most common usage of the Grid Dip Meter is as an oscillating frequency meter to determine the resonant frequencies of de-energized tuned circuits.

Size of Grid Dip Meter only (less probe): 7 in. x 3½ in. x 3½ in.

JAMES MILLEN

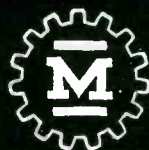

MFG. CO., INC.

MAIN OFFICE

AND FACTORY

MALDEN, MASSACHUSETTS, U. S. A.

MEGOHMS
 MEGOHMS
 MEG
 MEG
 MEGOHMS
 MEGOHMS
 MEGOHMS
 MEGOHMS
 MEGOHMS

Cheaper by the dozen with

**JELLIFF
 ALLOY 1000
 RESISTANCE WIRE**

This new material packs 1000 ohms/cm—48% more than the widely-used nickel-chromium alloys.

And what's more, there's no loss of other important physical and electrical properties. High tensile strength—excellent solderability—TC of Resistance is 20—EFM vs Copper + 7 micro-volts—Coefficient of Expansion 13.9—remarkable Surface-Corrosion Resistance—and many more vital characteristics make ALLOY 1000 a money-making, prestige-building component of compact, precision resistors. For complete data get Bulletin 17.

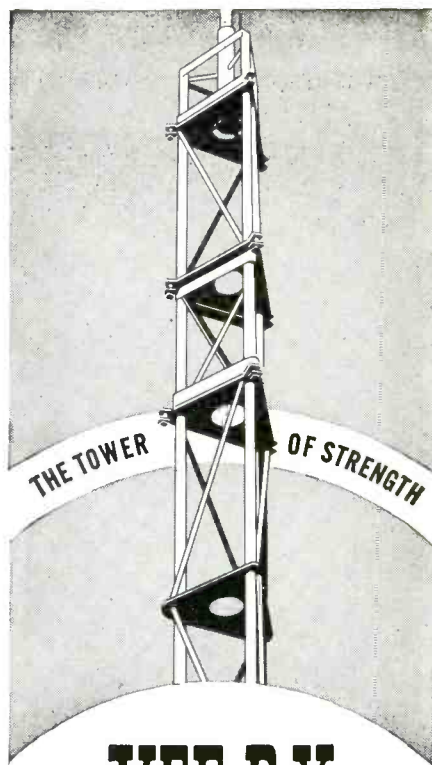

**VEE-D-X
 Sectional Tower**

**MOST ECONOMICAL FOR
 MICROWAVE • FM • TV
 COMMUNICATIONS • RADAR**

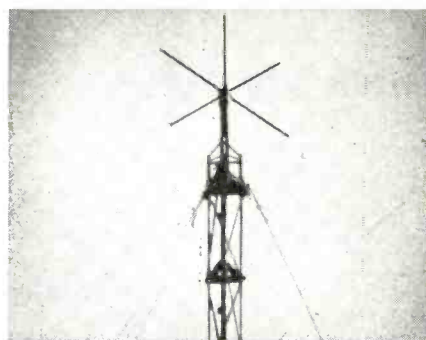

Actual photograph of VEE-D-X Sectional Tower installation showing 152 MC ground-plane antenna suited for ground-to-plane, ship-to-shore, and mobile communications.

**THE LaPOINTE-PLASCOMOLD CORP.
 WINDSOR LOCKS, CONN.**

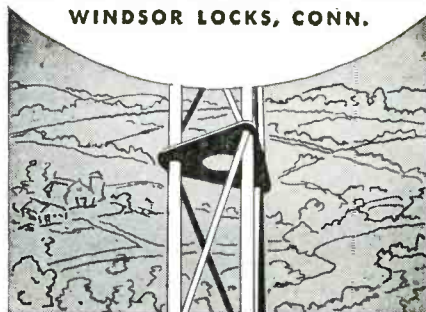

AMPERITE

Thermostatic Metal Type

Delay Relays

**PROVIDE DELAYS RANGING
 FROM 1 TO 120 SECONDS**



FEATURES: — Compensated for ambient temperature changes from -40° to 110° F . . . Hermetically sealed; not affected by altitude, moisture or other climate changes . . . Explosion-proof . . . Octal radio base . . . Compact, light, rugged, inexpensive . . . Circuits available: SPST Normally Open; SPST Normally Closed.

PROBLEM? Send for "Special Problem Sheet"

Regulators

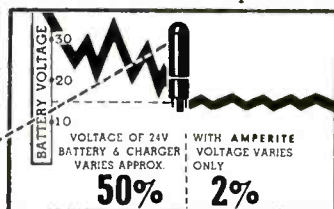

Amperite regulators are the simplest, lightest, cheapest, and most compact method of obtaining current or voltage regulation . . . For currents of .060 to 6 Amps. . . Hermetically sealed; not affected by altitude, ambient temperature, humidity.

Write for 4-page Illustrated Bulletin.

AMPERITE CO., Inc., 561 Broadway, New York 12, N. Y.

In Canada: Atlas Radio Corp., Ltd., 560 King St., W. Toronto

Stupakoff

KOVAR-GLASS
SEALS

*for Sealed
Assemblies*

Perfectly closed and durable airtight assemblies are made with Stupakoff Kovar-Glass Seals. The use of hard glass for these seals provides the highest degree of protection against thermal shock and weathering. Kovar is the ideal metal for such seals because its expansion characteristics closely match those of the hard glass to which it is readily bonded. The resulting seals are uniform and easily assembled.

Stupakoff Seals are available in a wide variety of standard sizes and designs, and can be made in many special forms, as indicated by the illustration above. Extensive experience has given Stupakoff the engineering and manufacturing knowledge and skill to produce Kovar-Glass Seals that are made accurately, uniform and dependable. We will gladly submit samples and quotations.



SEND for Stupakoff Bulletin No. 851, containing photographs, drawings and specifications on many standard seals.

STUPAKOFF *Products for Electrical and Electronic Applications*

ASSEMBLIES—Metallized ceramic induction coils and shafts; metallized plates for fixed rigid assemblies; ceramic trimmer condensers.

CERAMICS—Precision-made ceramic products for electrical and electronic applications, all voltages, frequencies and temperatures.

RESISTOR CERAMICS—Used for temperature indicating or measuring equipment, for infrared light source and for heating elements. Complete with terminals, in the form of rods, tubes, discs, bars, rings, etc.

CERAMIC DIELECTRICS—For by-pass, lead-through, blocking, stand-off and trimmer applications. Temperature compensating Ceramic Dielectrics and high K materials. Tubes, discs and special shapes, plain or silvered.

PRINTED CIRCUITS—Amplifiers, couplings, filters, integrators.



STUPALITH—Will withstand extreme thermal shock. May be made to have zero, low-positive or negative expansivities. Safely used at temperatures up to 2400° F.

SEALS, KOVAR-GLASS—Terminals, Lead-ins; Stand-offs—for hermetically sealing and mechanical construction in radio, television, electronic and electrical apparatus. Single or multiple terminal units, in a wide variety of sizes and ratings.

KOVAR METAL—The ideal alloy for sealing to hard glass. Used for making hermetic attachments. Available as rod, wire, sheet, foil—or as cups, eyelets and other shapes.

STUPAKOFF CERAMIC & MFG. CO., Latrobe, Pennsylvania

Stable as a Wirewound Resistor*

MODEL "R" VOLTMETER

SIE

DC VOLTS
DC MILLIVOLTS
AC VOLTS
AC MILLIVOLTS
OHMS
MEGOHMS
STANDARD CELL
DC AMPLIFIER

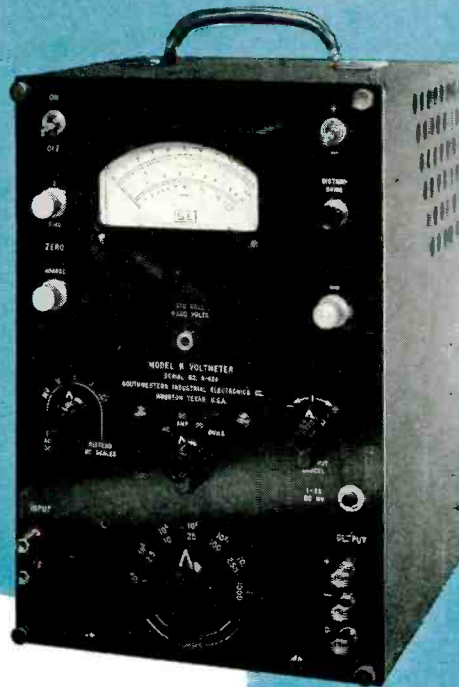

THE MODEL "R" VOLTMETER

The Model "R" is primarily intended for the precise measurement of DC potentials, providing DC voltage ranges from one volt full scale to 1,000 volts full scale; however, to allow the instrument its greatest possible utility, the following auxiliary functions have been included in its design:

Distended DC Voltage Ranges: Bucks out 99% of measured voltage and indicates 1% of measured voltage full scale.

DC Millivolt Ranges: One millivolt full scale to 1,000 millivolts full scale.

AC Volt and Millivolt Ranges: One Millivolt full scale to 1,000 volts full scale.

Self-Contained Standard Cell: For instant check of voltmeter calibration.

Ohms Ranges: Times one to times 10^6 .

Distended Ohms Ranges: Reads bottom half of ohms scale full scale.

DC Amplifier: Will drive a one ma recorder, has gain of 200, and frequency range of zero to 100 kc.

*This statement refers to the fact that precision wire-wound resistors are used for all attenuators and range resistances, and that the DC Amplifier is a highly degenerative system employing wirewound resistors for the beta network. It has been found that changes in gain with warm-up are in the order of .1 of 1% and are primarily due to the temperature coefficient of the resistors in the beta network

SIE

SOUTHWESTERN INDUSTRIAL ELECTRONICS CO.

2831 Post Oak Road

HOUSTON, TEXAS, U.S.A.

under the influence of an external or internal resonance system or even of resonating electrodes. Such electron oscillations cause deformations of the aperiodic characteristics in that they may reduce the current gain but, on the other hand, they also may cause α to be greater than one.

Irrespective of this phenomenon, retarding-field amplifiers and retarding-field oscillators have been built, particularly a retarding-field audion in which the nonlinear plate characteristic provides the detector action or rectification while the current transfer produces the amplification of the a-f energy.

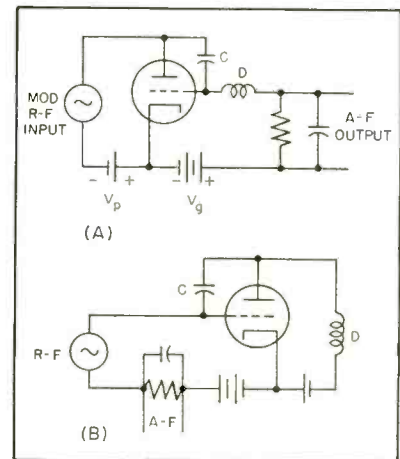

FIG. 3—Retarding-field audion with short-circuit of the current transfer. Plate input (A) and grid input (B)

The input load of the r-f source has been reduced considerably by the so-called "short-circuiting of the current transfer"^{1,2}. According to Fig. 3A, grid and plate are bridged over by a capacitor C while the r-f choke D in the grid lead prevents r-f energy from penetrating into the output circuit. The input source can clearly be seen as being loaded with the saturation resistance so that only very low r-f power is dissipated.

Since grid and plate, for the r-f, are short-circuited, it makes no difference whether the r-f voltage is introduced into the plate or grid circuit. This conclusion leads to the diagram portrayed in Fig. 3B. Both circuits, in modern terminology, are grounded-plate circuits, at least for the r-f.

A current gain greater than one, as resulting from electron oscilla-

You can bring crystals to frequency quickly, accurately . . . by high vacuum coating

Here's a way to bring piezo-electric crystals to an exact frequency without the usual time-consuming grinding, testing, grinding method.

It works like this: In a high vacuum coating chamber, silver is evaporated on a number of crystal blanks simultaneously through masks used to build the metal up solidly in the center. Then, in another vacuum unit, each crystal is individually brought down rapidly to required frequency by further coating. Frequency can be checked continuously during the second operation—there's no grind-and-try experimentation required.

DPI makes the high vacuum equipment you need to set up a complete crystal coating system. Units are easy to operate and capable of turning out highly accurate crystals on an economical mass-production basis. For complete information on this, or any application of high vacuum in the electronics industry, write to *Distillation Products Industries*, Vacuum Equipment Department, 727 Ridge Road West, Rochester 3, N. Y.

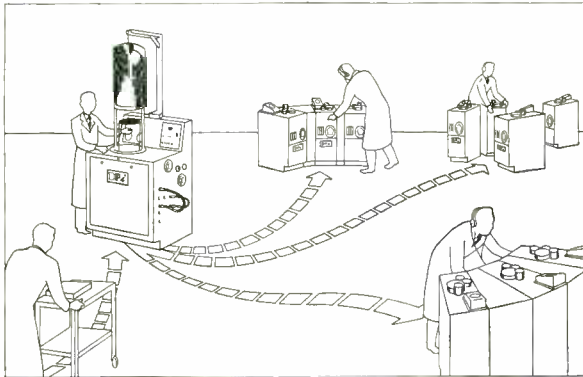

Typical layout for a complete crystal coating system. Work flows through a base coating unit which handles a number of crystals at a time to final coating units which bring each crystal down to exact frequency.

DPI base coating unit Model LC1-14. Completely self-contained with mechanical pump and operating controls, it uses a highly efficient DPi oil diffusion pump. Vacuum is quickly achieved, coating is rapid.

**high vacuum research
and engineering**



DIALS OR NAMEPLATES OF ANY TYPE — at savings that will surprise you!

Because of our company name, you may think of U. S. Radium Corporation as a source of only *luminous* dials or nameplates. Actually we make self-luminous, fluorescent, phosphorescent, and *nonluminous* types, including Alumilite, lithographed or etched aluminum, brass, steel, or stainless steel — finished in lacquer, nickel, chromium, or silver — with black, color, or luminescent markings. In other words, you name it — we make it!

Moreover, having produced millions of dials and nameplates for all kinds of instruments, timepieces, and other uses, we've learned to combine mass-production techniques

with our traditional standards of accuracy and fine quality. Result: you get exactly the dials or nameplates you want — at lower costs than you are likely to think possible.

We are, of course, equipped to meet Government specifications . . . and to produce large quantities of routine-type dials or nameplates, or small runs of special, high-accuracy scientific ones.

To find out how we can provide your apparatus with better-designed or lower-cost dials or nameplates, write to Department E7, United States Radium Corporation, 535 Pearl Street, New York 7, New York.

Other Products of U. S. Radium

RADIOACTIVE FOILS
(alpha-ray ionization sources)

IONOTRON STATIC ELIMINATORS

RADIUM LOCATORS:
lenses, buttons, screws, markers

LUMINOUS RETICLES
and other specialties

POWDERS:
cathode-ray tube and television tube

SILHOUETTE ILLUMINATION
of clocks, watches, and instruments

RADIATION MATERIALS:
radiation, neutron, and standard-light sources



**UNITED STATES RADIUM
CORPORATION**

BETTER DIALS AND NAMEPLATES AT LOWER COST

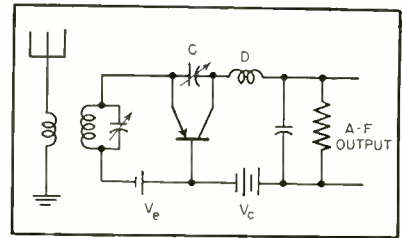

FIG. 4—Transistor audion equivalent to Fig. 3

tions, makes the retarding-field tube unstable. On the other hand, the resulting negative plate resistance produces self-excitation of a tank circuit connected to the plate so that the electron oscillations are self-modulated with a-f or i-f.

By means of this example, it can be seen that the retarding-field tube is the perfect analog of the transistor. This analogy makes it possible to change the retarding-field audion immediately into a transistor audion provided the supply voltages have the right polarity as well as suitable magnitudes in order to cause the transistor to operate in a nonlinear region. In this way the basic schematic of a transistor audion as shown in Fig. 4 is obtained. Depending on whether self-excitation is desired for heterodyning purposes or not, the bridge capacitor *C* must be properly adjusted. Hence, a variable bridge capacitor may serve for the adjustment of damping reduction, similar to the vacuum tube audion with controllable feedback.

Other transistor circuits may be derived from retarding-field technique, for example: oscillators and amplifier cascades in which each base-resistance loads the output circuit of the preceding stage. From such a multistage retarding-field amplifier, the transistor cascade portrayed in Fig. 5 may be derived in which the input stage is the grounded-emitter type, whereas the next stages follow alternately in-

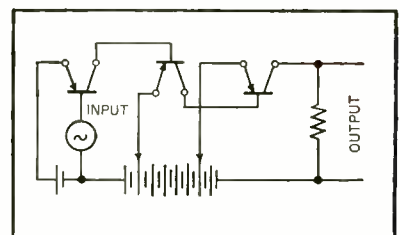
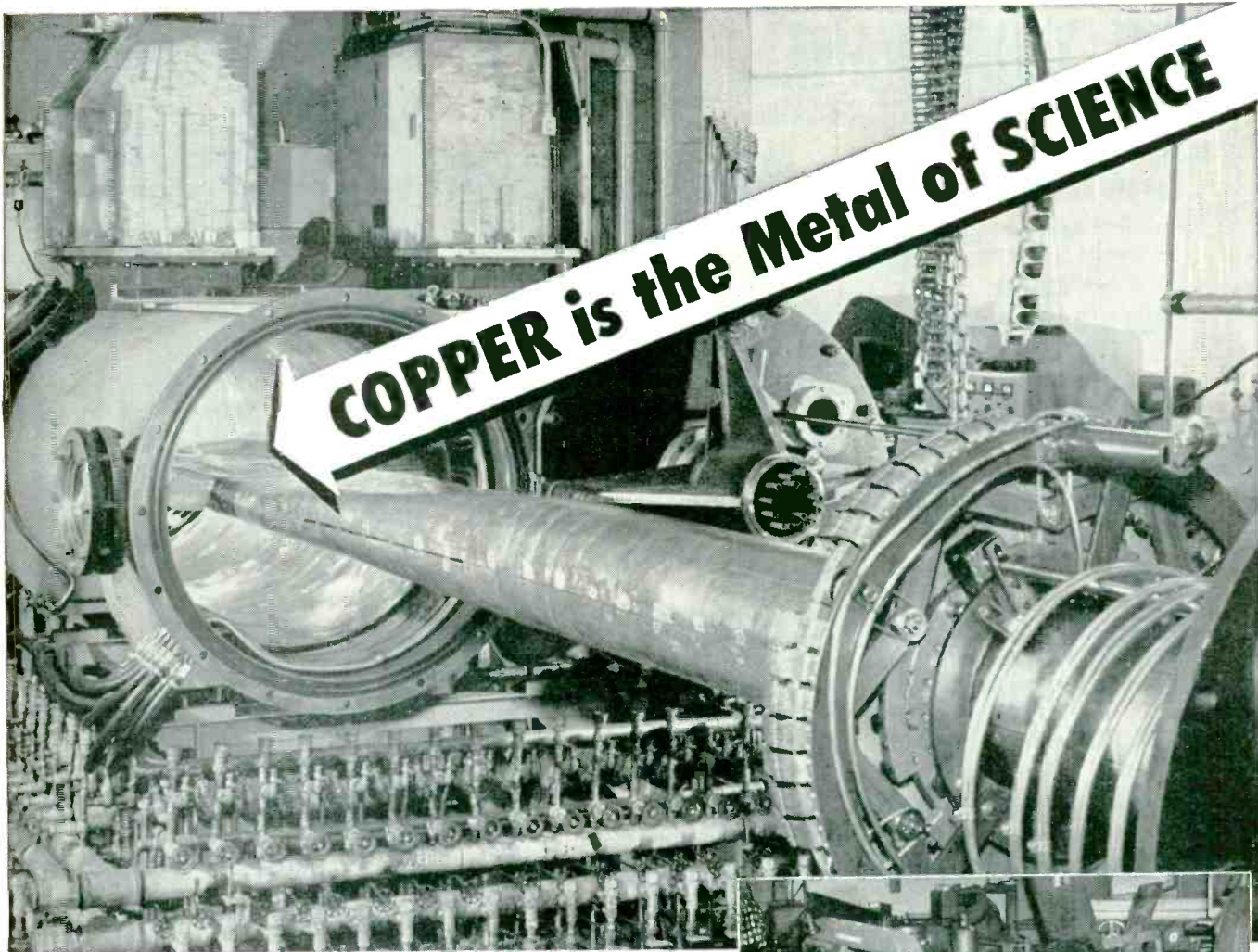

FIG. 5—Transistor cascade equivalent to a multistage retarding-field amplifier



D and D Stem being inserted in Cyclotron; made of Revere Electrolytic high-conductivity copper, set rolled and annealed, 1/8" thick. Note also large number of bronze valves to control flow of cooling water through brass pipe.

● For many years Revere has been saying that "Copper is the metal of invention." It has high electrical and heat conductivity, excellent resistance to corrosion, is easily fabricated and formed, so that it is attractive to designers and inventors, as well as to manufacturers. Now we say it is also "The metal of science," because it is so essential to the operation of most scientific devices.

The pictures on this page illustrate some of its uses in a cyclotron, built by and for the Nuclear Physics Laboratory of the University of Washington in Seattle. The instrument was designed and constructed so far as possible by University personnel, who were completely successful in working copper into the most complicated shapes.

Revere collaborated on the project in various ways, and furnished copper bar, sheet, rod and tube to the University's high specifications. Remember that Revere will be glad to consult with you on your problems concerning copper and copper alloys, and aluminum alloys.

REVERE

COPPER AND BRASS INCORPORATED

Founded by Paul Revere in 1801
230 Park Avenue, New York 17, N. Y.

Mills: Baltimore, Md.; Chicago and Clinton, Ill.; Detroit, Mich.;
Los Angeles and Riverside, Calif.; New Bedford, Mass.; Rome, N. Y.—
Sales Offices in Principal Cities, Distributors Everywhere

SEE "MEET THE PRESS" ON NBC TELEVISION EVERY SUNDAY



Photo taken in the University of Washington shop during fabrication of the two Ds and D Stems.



Seven miles of Revere copper bus bar were wound into great coils for the cyclotron electromagnet. The University built the winding machine itself, and wound the coils in its own shop. The special Revere bar is soft temper, free from scale, with rounded edges.

FOR YOUR PANEL

A NOVEL and UNIQUE CIRCUIT INDICATOR

DIALCO

DESIGNED FOR NE-51 NEON LAMP

For 110 or 220 volt circuits

The required resistor is an integral part of this assembly — "built-in."

**RUGGED • DEPENDABLE
LOW IN COST**



PATENTED: No. 2,421,321
Cat. No. 521308-997

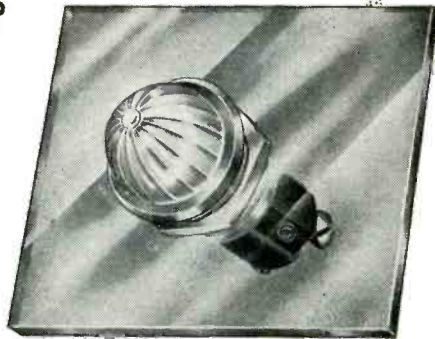

WILL YOU TRY A SAMPLE?

Write on your company letterhead. We will act at once.
No charge, of course.

SEND FOR THE 192 PAGE HANDBOOK OF PILOT LIGHTS

Among our thousands of Pilot Light Assemblies there is one which will fit your special conditions. Many are especially made and approved for military use. We pride ourselves on prompt deliveries—any quantity.

ASK FOR OUR APPLICATION ENGINEERING SERVICE

Foremost Manufacturer of Pilot Lights

The DIAL LIGHT COMPANY of AMERICA

900 BROADWAY, NEW YORK 3, N. Y. SPRING 7-1300

Century MODEL 408

RECORDING OSCILLOGRAPH

FOR VIBRATION, TEMPERATURE, STRESS, STRAIN ANALYSIS

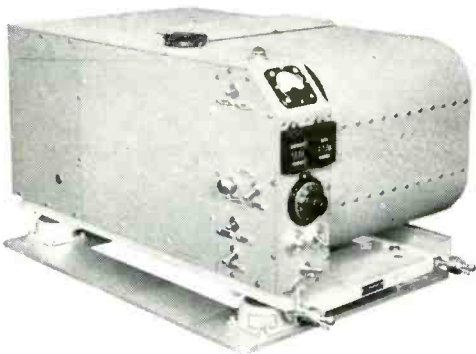

After conducting a nation-wide survey among the users of oscillograph equipment and carefully considering the problems which have confronted them for a number of years, Century is proud to offer the Model 408 Oscillograph. This Oscillograph has been designed and built expressly for mobile and airborne operation. As with all Century products,

this oscillograph incorporates the utmost in modern design and workmanship, yet it remains simple in its operation and maintenance.

Write for Bulletin CGC-302

REGISTER and VOTE—it's YOUR country

Century GEOPHYSICAL CORPORATION

TULSA, OKLAHOMA

1505 Race Street
Philadelphia, Pa.

238 Lafayette St.
Dayton, Ohio

EXPORT OFFICE:
149 Broadway, New York

SILVER GRAPHALLOY

BRUSHES



AND

CONTACTS

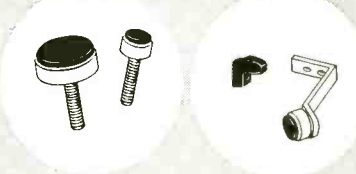

... for applications requiring low electrical noise, low and constant contact drop, high current density and minimum wear.



EXTENSIVELY USED IN

**SELSYNS
ROTATING THERMOCOUPLE and
STRAIN-GAGE CIRCUITS
ROTATING JOINTS
GUN-FIRE CONTROLS
DYNAMOTORS etc.**

Wide range of grades available for standard and special applications.

Brush holders and coinsilver slip rings available for use with Silver Graphalloy Brushes.

OTHER GRAPHALLOY PRODUCTS:

Oil-free self-lubricating Bushings and Bearings, Oil-free Piston Rings, Seal Rings, Thrust and Friction Washers, Pump Vanes.



Write us for Data Sheets and further information. Outline your problem and we will apply our years of accumulated experience toward its solution.

GRAPHITE METALLIZING CORPORATION

1055 NEPPERHAN AVENUE • YONKERS, N. Y.

SIMPSON MODEL 480 GENESCOPE FOR ACCURATE TESTING

approved by
service managers of:

- admiral**
- zenith**
- motorola**
- emerson**
- hoffman**
- hallicrafters**

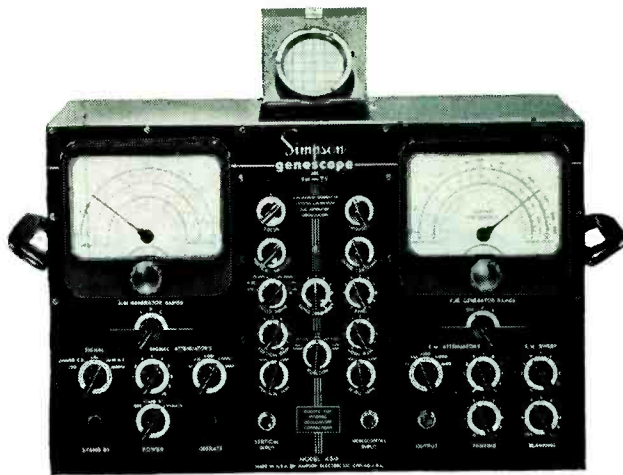

- Provides all the necessary signal sources for proper alignment and servicing of FM and TV receivers • Includes the Simpson High Sensitivity Oscilloscope, complete in every detail and equipped with a high frequency crystal probe for signal tracing • Independent, continuously variable attenuators and step attenuators for both AM and FM units offer complete control of output at all times—from the high level required for front end adjustment to extremely low levels for fringe area peaking operations • Multiple shielding, generous bypassing and adequate line filtering reduces signal leakage to a negligible factor • A 0-15 megacycle sweep is provided by means of a noiseless specially designed sweep motor based on the principles of the D'Arsonval meter movement for fine control and lasting accuracy • The exclusive Simpson output cable (illustrated on the right) includes a variable termination network which is quickly adapted to provide open, 75 or 300 ohm terminations—the addition of a pad provides attenuation and isolation. The use of appropriate resistors across certain terminals will provide any other termination required. A .002 MFD blocking condenser can be added on any termination for use on circuits containing a DC component • The FM generator output voltage is constant within .2 DB per MC of sweep. Model 480 \$395.00

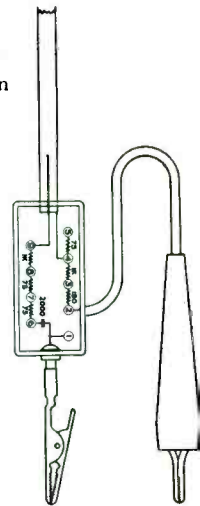

Also available without the oscilloscope as Simpson Model 479 TV-FM Signal Generator. Model 479 \$269.00

Simpson Instruments That Stay Accurate Are Available From All Leading Electronic Distributors

SIMPSON ELECTRIC COMPANY

5200 W. Kinzie St., Chicago 44, Illinois • Phone: COlumbus 1-1221 • In Canada: Bach-Simpson, Ltd., London, Ont.

BURTON BROWNE ADVERTISING

signs

of



quality

**QUALITY
IS
BUILT
INTO
EVERY**

WHEELER TRANSFORMER

manufactured with

HELDOR CANS & TERMINALS

PRECISION production techniques enable Wheeler to manufacture hermetically-sealed transformers to meet MIL-T-27 Specifications. To accomplish this, all components must be of consistent high quality. That is why Wheeler uses Heldor transformer cans and terminals for their products.

Whether your products must conform to MIL-T-27 specifications or not, it will pay you to standardize on Heldor transformer cans, compression-type hermetic seal bushings or complete can assemblies that save headaches, time and money. Get the facts!

MAIL THIS COUPON TODAY!

Name.....

Title.....

Company.....

Address.....

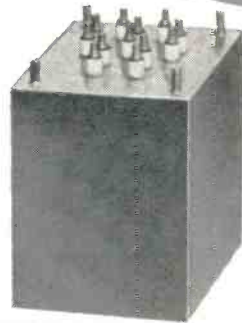

WHEELER NO. 14-313
HELDOR CAN NO. 113-NB
HELDOR TERMINAL NO. 375-A



WHEELER NO. 14-285
HELDOR CAN NO. 109-JA
HELDOR TERMINAL NO. 250-A



WHEELER NO. 14-280
HELDOR CAN NO. 108-FA
HELDOR TERMINAL NO. 250-A



WHEELER NO. 14-283
HELDOR CAN NO. 107-HA
HELDOR TERMINAL NO. 250-B



HELDOR MANUFACTURING COMPANY
Division of **HELDOR BUSHING & TERMINAL CO., INC.**
225 Belleville Avenue, Bloomfield, New Jersey

verted. If necessary, stability may be secured by inserting damping resistors in the input circuit or between the stages, thereby introducing negative feedback.

REFERENCES

- (1) H. E. Hollmann, The Retarding-Field Tube as a Detector for any Carrier Frequency, *Proc. IRE*, 22, p 630.
 (2) H. E. Hollmann, Positive-Grid Valve as a Detector, *Exp. Wireless*, May 1934, p 245, June, p 309.

Life Testing Reliable Tubes

By HERBERT A. HAMMEL
 Sylvania Electric Products Inc.
 New York, N. Y.

DURING the last decade there has been a trend towards the use of more complex electronic equipment. This trend has been most evident in the field of military operations. The vital nature of these operations and their reliance upon electronic equipment have brought about the need for vastly increased reliability in such equipment.

A definition currently proposed for reliable tubes is: "Reliable tubes are those tubes so designed and manufactured as to give continuity of operation superior to ordinary commercial tubes." A supplier may submit to the Armed Services as "reliable" only those tubes which have been specifically produced as "reliable" tubes.

The rate of tube failure (inoperative and characteristic failures) must not exceed that stated on the tube specification.

To judge any life test, one must study the distribution of tube failures. Data from many tests run by Sylvania show that the distribution of life test failures with time is a complex curve. Figure 1 shows a typical rate of failure curve (curve 1) and its various components. The first component (curve 2) is a con-

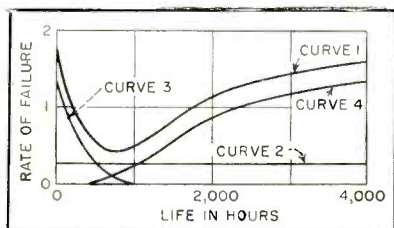

FIG. 1—Typical failure curves for tubes operating under normal conditions

Announcing *A SPECIAL New Type Recorder* for **HIGH FREQUENCY TELEMETERING**

HIGHEST accuracy ever attained
 ...
LESS THAN 0.1 PERCENT PEAK-TO-PEAK FLUTTER 3 WOW

- WILL RECORD ALL RDB TELEMETERING BANDS (up to 100 kc)
- WILL RECORD THE OUTPUT OF 4 RECEIVERS
- FOUR INDEPENDENT DATA TRACKS
- OVER-ALL PLAYBACK ERROR LESS THAN 0.7% ON FINAL DATA
- COMPLETE SHOCK AND VIBRATION PROTECTION
- 16 MINUTES RECORDING TIME AT 60 INCH TAPE SPEED

Model **500**

Complete Information on Request

AMPEX *Magnetic Tape* **RECORDERS**

AMPEX ELECTRIC CORPORATION Redwood City, California

Yesterday's
"impossible"
designs

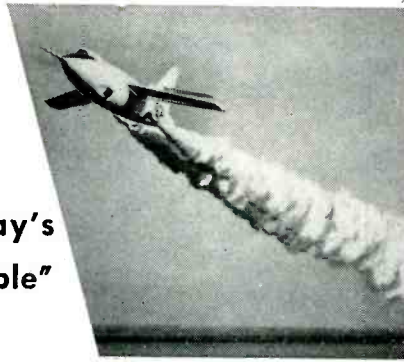

are being executed successfully with
Micro Ground Miniature Ball Bearings



America's first and only fully *ground* miniature ball bearings, Micro makes possible design refinements unheard of only a few years ago. With 85 sizes and types from $\frac{3}{8}$ " down to $\frac{1}{8}$ " o.d. and in tolerance ranges of ABEC-5 and above, Micro bearings offer tremendous opportunities to minimize space, weight and friction and at the same time to retain high capacity. Yet Micro precision ground bearings actually cost less than comparable *unground* miniatures.

Write for Technical Bulletin No. 50

MICRO

New Hampshire

Ball Bearings, Inc.

5 Main Street, Peterborough 1, N. H.



Aerophysicists,
Designers,
Engineers

**YOUR IDEAS
WILL COUNT AT
NORTH AMERICAN**

North American encourages advanced thinking, because they know looking ahead is the only way to maintain leadership in the aviation industry. That's why North American needs men of vision. If you like hard thinking and would like to work for a company that will make the most of your ideas, you'll find real career opportunities at North American. North American offers you many extra benefits, too.

North American Extras —

Salaries commensurate with ability and experience • Paid vacations • A growing organization • Complete employee service program • Cost of living bonuses • Six paid holidays a year • Finest facilities and equipment • Excellent opportunities for advancement • Group insurance including family plan • Sick leave time off • Transportation and moving allowances • Employees Credit Union • Educational refund program • Low-cost group health (including family) and accident and life insurance • A company 24 years young.

Write Today

Please write us for complete information on career opportunities at North American. Include a summary of your education, background and experience.

IS YOUR FIELD LISTED HERE?

Airborne Electronic Equipment
Equipment Flight Tests
Precision Instruments
Automatic Controls
Propulsion Systems
Servo-Mechanisms
Airframe Studies
Radar Devices
Instrumentation
Micro Wave Techniques
Metallurgical
Electroplating
Engineering Planning

**NORTH AMERICAN
AVIATION, INC.**

*Aerophysics, Electro-Mechanical Research
Division*

Dept. 3, Personnel Section,
12214 Lakewood Blvd., Downey, California
*North American Has Built More Airplanes
Than Any Other Company In The World*

**DUAL REGULATED
DC SUPPLY**

New

FEATURES

- ✓ A turn of a switch will:
Series for higher voltage.
Parallel for higher current.
- ✓ Each output independently metered.
- ✓ Continuously variable, 0 to 350 volts.
- ✓ Ripple voltage less than 10 millivolts.
- ✓ Regulation better than .5%.
- ✓ Maximum current 200 milliamperes.
- ✓ Stabilized variable bias supply.
- ✓ 6.3 volts AC at 5 amperes.



MODEL D4 POWER SUPPLY

**Two Completely
Independent
Sources of Regulated Power**

REQUEST BULLETIN NO. 54
FOR DETAILED SPECIFICATIONS

**Oregon
Electronics**

2232 E. BURNSIDE STREET,
PORTLAND 15, OREGON

MFG. CO.



C - D - F makes all three!

low cost Spiral Tubing

• Designers, engineers, production men everywhere are changing their thinking (and specifications) over to economical C-D-F spiral tubing. Whether it's round, square, or rectangular, C-D-F tubing is stiff, sturdy, crush resistant. It has good tensile strength, along with good dimensional stability under varying atmospheric conditions.

Above all, it is low in cost. C-D-F experts in insulation, recommend spiral tubing for coils and structural spacers. For transformers, switches, selenium rectifiers.

The round tubing ranges from $\frac{1}{8}$ " to 6", with wall thicknesses from .0075" to $\frac{1}{8}$ ". The minimum ID of the square and rectangular tubing is $\frac{3}{8}$ ", with $2\frac{1}{8}$ " the maximum ID. $\frac{1}{16}$ " is the maximum wall thickness. All tubing can be supplied in lengths from 2' to 4'. From our own fabricating experience, we know you will find this sturdy material easy to drill, tap, rivet, flute or thread.

Think it over . . . then talk to the man from C-D-F, a skilled plastics engineer. C-D-F has sales offices in principal cities with modern test laboratories at all plants. C-D-F spiral tubing. The man from C-D-F. *Both* are good to know!

FOR LITTLE COILS . . .

• C-D-F puts notches in so that cores can be inserted and accurately adjusted. Hard to crush, this tube withstands prolonged heat of 190°F., 240°F. intermittently. Write for samples and complete specifications. For availability, economy, adaptability . . . buy your spiral tubing from C-D-F.



Continental-Diamond Fibre Company

NEWARK 16, DELAWARE

THIS is Precision Silver Plating

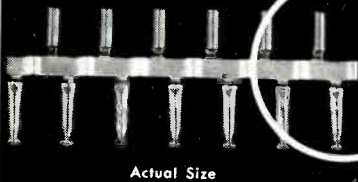

Actual Size



Enlarged approx. 2½ X

PIECE . . . Double end connectors
METAL . . . Beryllium copper
SPECS . . . Uniform deposit over entire surface, including interior surfaces of tiny hole and crimping end; perfect adhesion; had to pass bend test; all pieces uniform in deposit; batches reproducible

For a long time, our business has been Precision Plating in the precious metal field and we number among our customers leading manufacturers in the electronics and the electrical fields. We have turned out plated parts in the face of some of the most severe specifications ever confronting platers, as for example, the connectors illustrated above. The specifications tell the story.

Precision Plating and ordinary commercial plating are as far apart as the poles. Precision Plating insists upon:

- 1 . . . high uniformity of deposit on interior as well as exterior surfaces
- 2 . . . high uniformity piece by piece
- 3 . . . exceptionally strong bond or adhesion
- 4 . . . reproducibility, batch by batch

Yes, Precision Plating is our business. We go even further. In a number of cases, we have suggested minor changes in design of the piece in order to assure desired plating results. Perhaps you have been looking for just such a plating service as we can offer.

Donham Craft, Inc.

SPECIALISTS IN SILVER, GOLD, AND OTHER PRECIOUS METAL FINISHES

THOMASTON, CONN.

Plating-Wise . . .
 YOUR Design
 is Safe
 with Us.

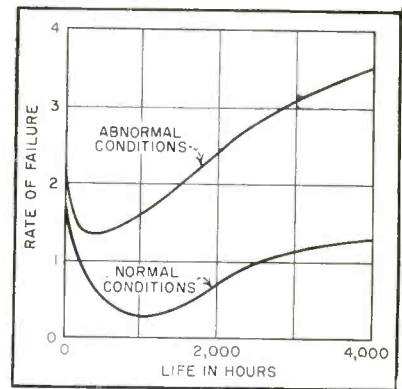

FIG. 2—Typical failure curves for tubes operated under normal and abnormal conditions

stant low rate of failure. These failures are usually of the inoperative type and are due to random failures of welds or heaters.

The second component (curve 3) is a high initial transient resembling an exponential curve. These failures are also of the inoperative type, however, they are due primarily to faulty manufacturing. Finally, there is a distribution (curve 4) of failures, resembling the gaussian or normal distribution, which is due to the wearing out of the tubes. If tubes are operated under normal conditions of voltage and temperature, the lowest point of the overall failure curve (curve 1) generally occurs somewhere between 500 and 1,000 hours. This point will vary widely with the tube type.

High ambient temperature, excessive plate dissipation, or any other unusual operating condition will result in an increased rate of tube failure. This increase causes the wear-out component of tube failures to start earlier in life and to affect a greater number of tubes. Figure 2 shows what may happen to the rate of failure curve when tubes are used beyond their rated conditions.

Subcommittees of the Joint Electron Tube Engineering Council and the Armed Services Electro Standards Agency have developed a life test procedure for reliable tubes which is currently receiving the favorable consideration of both industry and government. The proposed life test is basically a two-step procedure. The first step limits failures to the prescribed rate. The



OF
CENTIMETER AND MILLIMETER WAVE
 MAGNETRONS — GAS DISCHARGE TUBES — WAVEGUIDE COMPONENTS
 TEST EQUIPMENT — SILICON DIODES — THE NEW TRANSISTOR

MICROWAVE ASSOCIATES, Inc. combines specialized production techniques with the latest research in vacuum tubes, microwave gas discharge phenomena and solid state physics. Our excellently equipped and capably staffed Boston plant can fill many of your microwave component needs. All of our production is to exacting military and commercial specifications.

SEMICONDUCTORS

MICROWAVE is establishing new production facilities to supply a complete semiconductor line including 1N21B, 1N21C, 1N23B, 1N25, 1N26, and special millimeter wave silicon diodes. Production will commence shortly on — n-p-n **TRANSISTORS** under license to The Western Electric Company.

LOOK FOR THE TRADEMARK

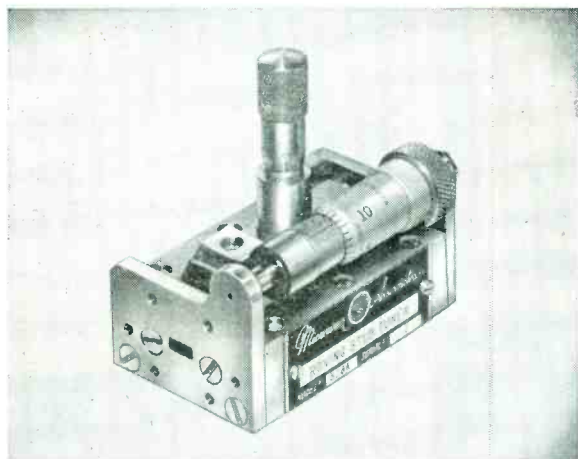
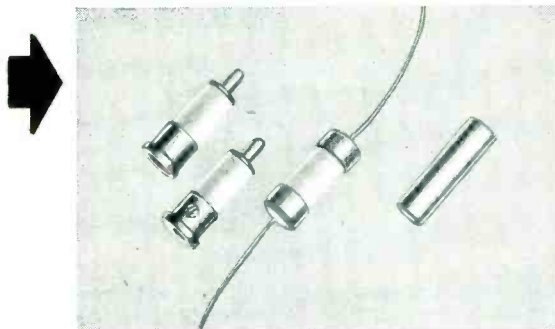

**WAVEGUIDE COMPONENTS
 AND TEST EQUIPMENT**

Our competent MICROWAVE component group specializes in the 3 cm and millimeter region producing duplexers, mixers, attenuators, roving stub tuners, frequency meters, standing wave detectors, dry and water loads and other excellent components.

**MAGNETRONS AND
 GAS DISCHARGE TUBES**

The seasoned MICRO-WAVE tube engineering and production teams are now producing several magnetron types including the popular 2J42 and 2J42A. High level TR microwave gas discharge switching tubes are available for several bands. Our research personnel in this field are always ready to assist in special microwave tube design problems.

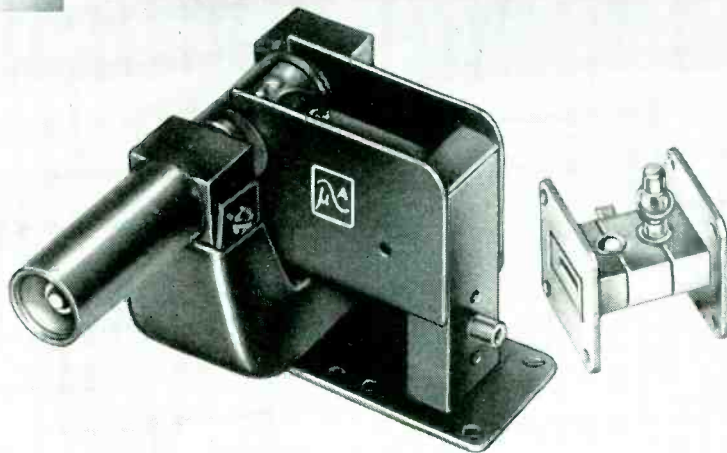

WRITE FOR THE LATEST CATALOG INFORMATION A-1
 ON THIS RAPIDLY EXPANDING LINE

Microwave
Associates INC.

22 CUMMINGTON STREET BOSTON 15, MASSACHUSETTS

Microwave Associates, Inc.
 22 Cummington Street
 Boston 15, Massachusetts

Name _____
 Dept. _____
 Company _____
 Street _____
 City _____ Zone _____ State _____

IT'S **rpc** FOR



HIGH VOLTAGE RESISTORS

Stable, dependable resistors made in sizes from one inch to 18½ inches long. Power Rating 1 watt to 90 watts. Resistance values to 100,000 megohms. Designed for easy mounting on a panel or stand-off insulator. Can be assembled to make tapped combinations. Matched pair resistors with 2% accuracy available for high voltage instrumentation. **rpc High Voltage Resistors** are used in quantity by leading Manufacturers, Instrument Makers, Universities and Laboratories.

ALSO MANUFACTURERS OF HIGH QUALITY PRECISION WIRE WOUND RESISTORS. HIGH FREQUENCY RESISTORS AND HIGH MEGOHM RESISTORS. WRITE TODAY FOR CATALOG.

rpc RESISTANCE PRODUCTS CO.
714 RACE STREET • HARRISBURG 2, PA.

Bardwell & McAlister's Line of Television Lights TV SPOTS • Designed for Television Studios and Stages

Drawing upon their sixteen years of experience in the production of studio lights used by the motion picture industry, Bardwell & McAlister, Inc. now offers a complete new line of lights especially designed and engineered for TV stage and studio lighting.

Paint with Light

Painting with light is the ability to control the light source, in order to emphasize the necessary highlights and the all-important shadows. Only through controlled light can the scene or subject be given the desired brilliance, beauty and third dimensional effects.

Our Specialists...

are always ready to assist and advise your engineering staff, so that your studios and stages will be fully equipped to properly "Paint with Light."

Write for complete specifications and prices of these TV SPOTS. Address Dept. 68.

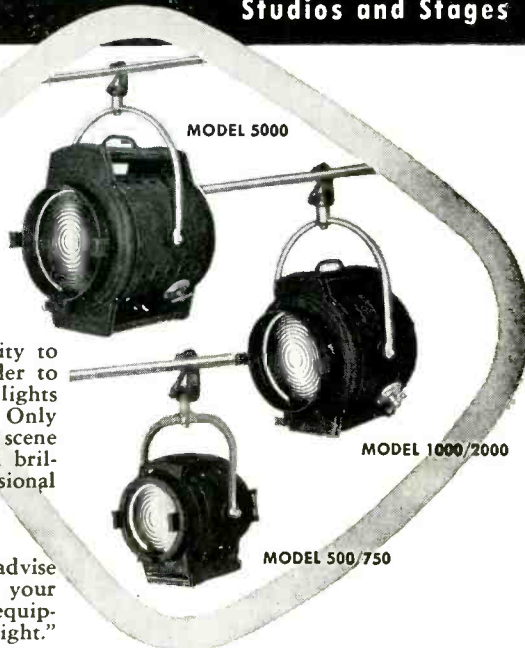

BARDWELL & McALISTER 2950 ONTARIO STREET
BURBANK, CALIFORNIA

The Nonmelting Silicone Insulating and Waterproofing Compound that is stable from -70° to over 400° F.

Meets all Requirements of AN-C-128a

DOW CORNING
4 COMPOUND

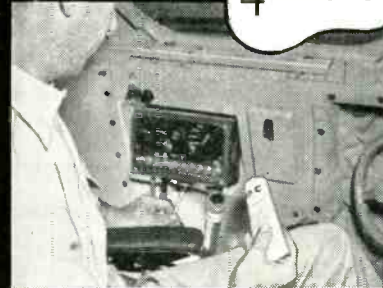

Dow Corning 4 applied by brushing to AN connector receptacle of pilot's "jack box" prevents interference caused by moisture at this critical junction in aircraft communications system.



Dow Corning 4 applied by brushing to AN connector on V. H. F. Transmitter/Receiver excludes moisture without appreciable change in resistance across properly mated pin and socket connections.

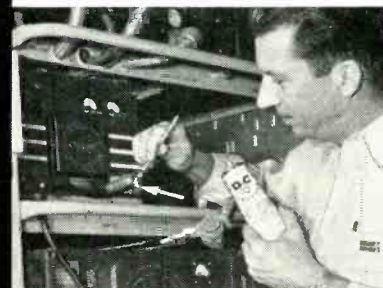

Arrows show where Dow Corning 4 is used on variable inductance rollers in a Collins-Western Electric V. H. F. Transmitter/Receiver to lubricate, minimize resistance and reduce leakage losses.

Photos courtesy Braniff International Airways.

More water repellent than paraffin, Dow Corning 4 Silicone Compound is highly resistant to oxygen, ozone and deterioration caused by corona discharge.

Write Today! for your copy of our new booklet on Dow Corning 4 Compound. Address Department BD.

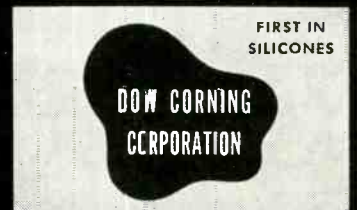

FIRST IN SILICONES

MIDLAND, MICHIGAN



Kenyon

TRANSFORMERS

**for standard and
special applications**

Kenyon quality transformers have always represented the highest standards of performance and durability. For more than a quarter century discriminating engineers who will settle for nothing but the best have consistently specified Kenyon.

KENYON TRANSFORMERS FOR

MIL Applications

Radar

Broadcast

Atomic Energy Equipment

Special Machinery

Automatic Controls

Experimental Laboratories

Write for details

KENYON TRANSFORMER CO., Inc.

840 Barry Street, New York 59, N. Y.

BALLANTINE

STILL THE FINEST IN ELECTRONIC VOLTMETERS

Ballantine pioneered circuitry and manufacturing integrity assure the maximum in

SENSITIVITY • ACCURACY • STABILITY

- All models have a single easy-to-read logarithmic voltage scale and a uniform DB scale.
- The logarithmic scale assures the same accuracy at all points on the scale.
- Multipliers, decade amplifiers and shunts also available to extend range and usefulness of voltmeters.
- Each model may also be used as a wide-band amplifier.



MODEL 314

MODEL	FREQUENCY RANGE	VOLTAGE RANGE	INPUT IMPEDANCE	ACCURACY	PRICE
300	10 to 150,000 cycles	1 millivolt to 100 volts	1/2 meg. shunted by 30 mmfds.	2% up to 100 KC 3% above 100 KC	\$210.
302B Battery Operated	2 to 150,000 cycles	100 microvolts to 100 volts	2 megs. shunted by 8 mmfds. on high ranges and 15 mmfds. on low ranges	3% from 5 to 100,000 cycles; 5% elsewhere	\$225.
305	Measures peak values of pulses as short as 3 microseconds with a repetition rate as low as 20 per sec. Also measures peak values for sine waves from 10 to 150,000 cps.	1 millivolt to 1000 volts Peak to Peak	Same as Model 302B	3% on sine waves 5% on pulses	\$280.
310A	10 cycles to 2 megacycles	100 microvolts to 100 volts	Same as Model 302B	3% below 1 MC 5% above 1 MC	\$235.
314	15 cycles to 6 megacycles	With probe, 1 millivolt to 1000 volts. Without probe, 100 microvolts to 1 millivolt	With probe, 11 megs. shunted by 6 mmfds. Without probe, 1 meg. shunted by 25 mmfds.	3% except 5% above 3 megacycles	\$265

For further information, write for catalog.

BALLANTINE LABORATORIES, INC.

100 FANNY ROAD, BOONTON, NEW JERSEY



second serves as a small check on the tube failure rate and protects the buyer against shifts in electrical characteristics greater than those permitted by the specification.

The first part of the proposed life test is an attributes type of sampling plan. This means that each tube in the sample is tested after an appropriate period of time and classified as either good or bad. The Services have recently issued a series of such sampling plans entitled Sampling Procedures and Tables for Inspection by Attributes.

The second portion of the life test protects the buyer against epidemics of failures which occur late in life and against excessive shifting of electrical characteristics. To do this, a sample of 20 tubes is continued on life for 400 hours after the completion of the first portion of the life test. This sample is treated on both an attributes and a variables basis. That is, not more than a given number of actual tube failures of any type are permitted, and the average values of the electrical characteristics are not permitted to shift more than the specified amounts.

Voice and Sound-Operated Relays

BY KARL GREIF
Norwich, New York

SOUND and voice-operated relays have appeared in various publications from time to time, usually relatively involved, using three or four tubes. An attempt is made here to provide two simple sound-operated switches from which a multiplicity of applications might be filled.

The primary element making possible the simplified circuitry discussed here is the use of carbon microphones and efficient sounding boxes or resonant diaphragms. Since there are no problems of fidelity, the carbon microphone with its characteristic high output decreases the gain required in the amplifier. Any sounding board arrangement which might be introduced makes it

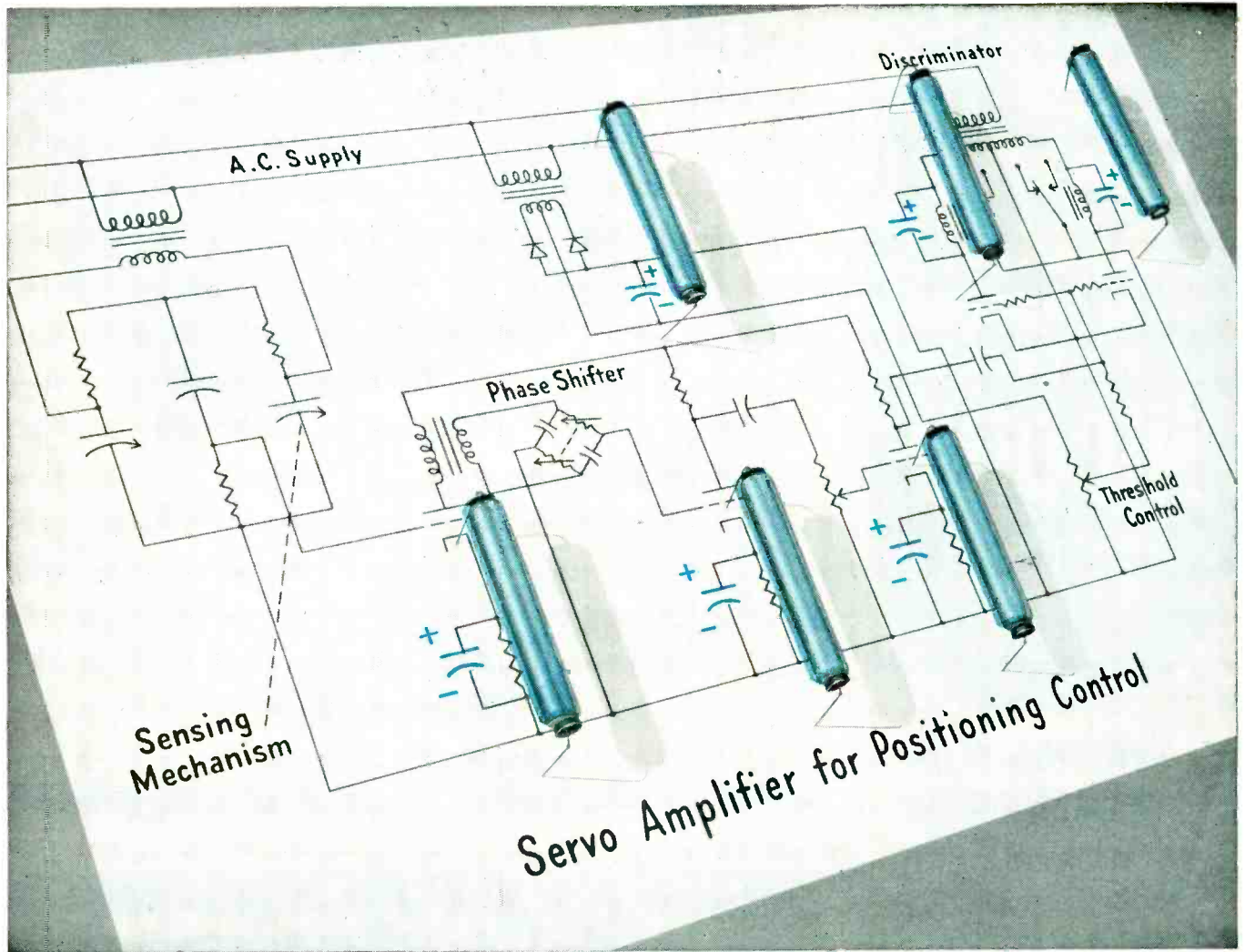

Tantalytic Capacitors get key role in "servo" circuit for positioning control

This servo-amplifier circuit controls the positioning of equipment which operates in high altitudes. Its capacitors must provide stable operation in widely varying temperatures. They must withstand considerable vibration. And their size and weight have to be kept to a minimum—without sacrificing operating life.

To meet these requirements, our capacitor application engineers recommended General Electric Tantalytic capacitors. These capacitors offer an operating temperature range from -55°C to $+85^{\circ}\text{C}$ —with at least 65% capacitance at -55°C . They contain a non-acid electrolyte—making them chemically stable and providing long operating life. They combine large capacitance with small size and weight. And they have the ability to withstand

severe physical shock.

Other features of G-E Tantalytic capacitors include: exceedingly low leakage currents, extremely long shelf life and complete hermetic sealing. They're presently available in ratings from .1 muf to 12 muf at 150 volts d-c.

If you have a similar large-volume application where a low price is secondary to a combination of small size and superior performance—it will pay you to get in touch with us. You can get more complete information on the outstanding characteristics of Tantalytic capacitors from your local G-E representative. Or write General Electric Company, Section 407-309, Schenectady 5, New York. Ask for Bulletin GEC-808.

General Electric Company, Schenectady 5, N. Y.

GENERAL  **ELECTRIC**

407-309

NEW
BRAZING ALLOY
 for VACUUM TUBE COMPONENTS
"NICORO"
 Alloy of Nickel, Copper and Gold
 ... our exclusive development

✓ SUPERIOR FLOW CHARACTERISTICS
 ✓ MINIMUM "LEAKERS"
 ✓ GREATER STRENGTH

WRITE FOR FACTUAL DATA AND PRICES

--- MAIL THIS COUPON ---

Your name

Firm name

Address

City State

WESTERN GOLD & PLATINUM WORKS
 Smelters • Refiners • Manufacturers
 589 BRYANT STREET
 SAN FRANCISCO 7, CALIF.



A NEW SOLUTION TO OLD PROBLEMS

AEROCOM'S NEW ARTIFICIAL ANTENNA, SIMULATING ACTUAL OPERATING CONDITIONS, SAVES TIME ON TRANSMITTER AND RECEIVER TUNING

It is no longer necessary to final tune transmitters or receivers aboard aircraft. With the new Artificial Antenna (Model DA200) you can precisely simulate, electrically, any normal aircraft antenna. All this without leaving the test bench. This equipment will accept any transmitter power up to 200 watts -- coaxial fitting provides direct 52 ohm metered load. Sturdily constructed for hard usage, can be mounted in standard rack cabinet or used on bench top.

A letter or wire from you will bring descriptive literature

AER - O - COM
 3090 DOUGLAS ROAD MIAMI 33, FLA.
 Reg. U. S. Pat. Off.

Build YOUR OWN TEST EQUIPMENT Heathkit

Heathkits are completely engineered instruments supplied unassembled. Every kit goes together smoothly and easily. All drilling, punching, and painting has already been done for you.

It's easy and fun to build a Heathkit. All parts are furnished and are of highest quality for years of trouble-free, dependable operation.

Save money by constructing your own. All expensive wiring and assembly costs are completely eliminated.

Detailed construction manual shows clearly where each wire and part goes and tells exactly how to build the kit. Write for free catalog.

Heathkit AUDIO GEN. KIT \$34.50
Heathkit TUBE CHECKER KIT \$29.50
Heathkit TELEVISION GENERATOR KIT \$39.50
Heathkit SIGNAL TRACER KIT \$19.50
Heathkit CONDENSER CHECKER KIT \$19.50
Heathkit IMPEDANCE BRIDGE KIT \$69.50
Heathkit HANDITESTER KIT \$13.50
Heathkit PUSH-PULL...5 OSCILLOSCOPE KIT \$43.50
Heathkit ELECTRONIC SWITCH KIT \$19.50
Heathkit BATTERY ELIMINATOR KIT \$24.50
Heathkit R.F. SIGNAL GEN. KIT \$19.50
Heathkit VACUUM TUBE VOLTMETER KIT \$24.50

HEATH COMPANY
 BENTON HARBOR 14, MICHIGAN

REPORT AGENT
 ROCKE INTERNATIONAL CORP.
 83 E. 40th St.
 NEW YORK CITY (14)

NOW

**Fully automatic Leesona[®]
No. 107 Coil Winder turns out
accurate coils faster than ever before**

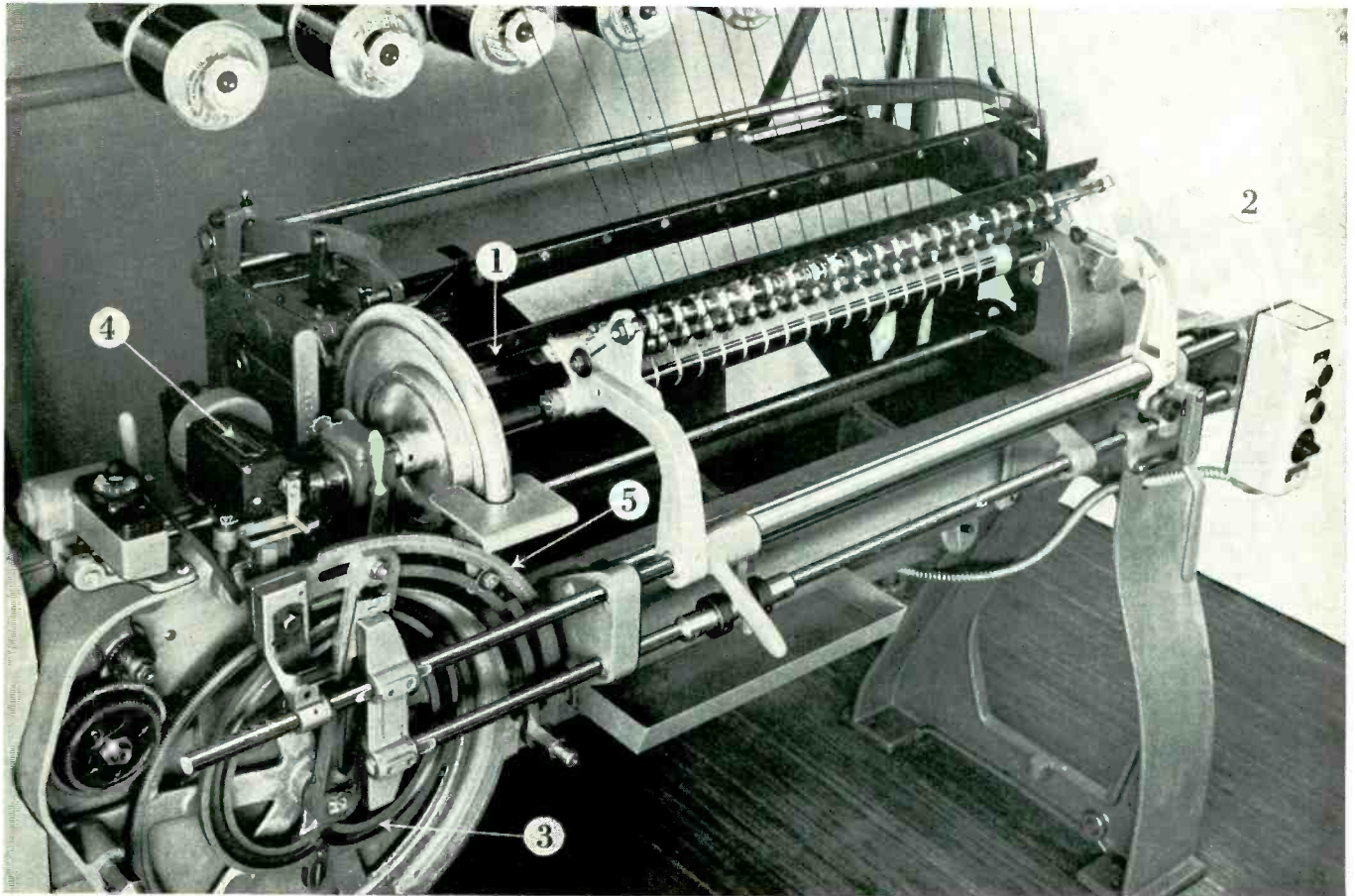

Because:

1. New Automatic Delivery Shelf accurately feeds paper inserts to the coils . . . tensionizes paper upon insertion to minimize finished coil diameters . . . staggers overlaps to prevent egg shaped coils. Individual paper inserts are automatically measured and cut to the required lengths gradually increasing as the coil grows in diameter.

2. Electronic Speed Control gives a slow, cushioned start . . . gradually accelerates

to full speed . . . then, maintains constant rate of winding speed for uniform wire tension and coil density.

3. Positive Traverse . . . Large cam surface insures absolute traverse accuracy even on long coil lengths. Cam groove assures "quick-return" . . . eliminates crossed turns at the ends of wire layers.

4. Automatic Counter stops the machine when the *exact* number of turns has been reached.

NO CAMS TO CHANGE!

5. Graduated Quadrant eliminates changing cams. You get the winding length and turns per layer you want merely by adjusting the quadrant and changing 3 gears. Only 68 gears cover the entire range from 20 to 500 turns per layer.

Bulletin 107 shows you how this fully Automatic Leesona No. 107 Interleave Coil Winder gives you paper-insulated or acetate-insulated coils with the electrical characteristics you want at highest speeds and lowest costs. Write for Bulletin 107.

UNIVERSAL WINDING COMPANY

P. O. Box 1605, Providence 1, R. I.

238.1.2

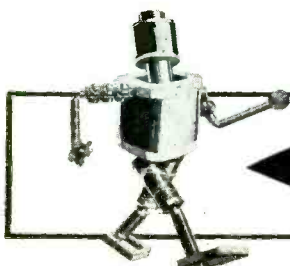

For winding coils in quantity
accurately . . . automatically
use Universal Winding Machines

high gain

LOW COST



Andrew Omnidirectional Antenna for VHF Communications

No, this new High Gain Communications Antenna isn't cheap, but it does offer the most economical solution to your coverage problem. Whether you want maximum coverage for a specific transmitter power, minimum power or shortest tower for a specific coverage, or freedom from dead spots, the ANDREW Type 3000 Antenna is the least expensive solution. Why? Because talk-back is the limiting factor in mobile communications. Gain in the central station antenna costs less than increased power in every mobile unit.

ANDREW Type 3000 High Gain Communications Antenna offers better than 6 db gain in the 148-174 MCS band. This means that the power delivered to the receiver on both talk-out and talk-back is increased four times. The horizontal radiation pattern is circular.

Write for the ANDREW High Gain Antenna bulletin today!

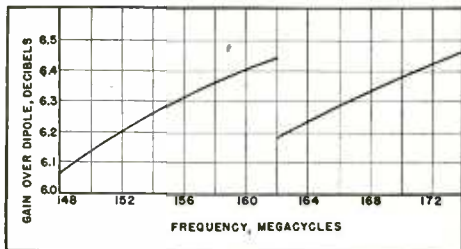

Andrew
CORPORATION

363 EAST 75TH STREET, CHICAGO 19

ANTENNA SPECIALISTS

TRANSMISSION LINES FOR AM-FM-TV-MICROWAVE • ANTENNAS • DIRECTIONAL
ANTENNA EQUIPMENT • ANTENNA TUNING UNITS • TOWER LIGHTING EQUIPMENT

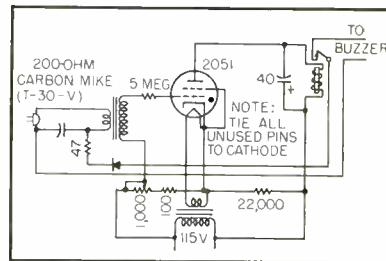

FIG. 1—Sound-operated alarm circuit for actuating a relay. Pickup is through a carbon microphone

simple to obtaining effective amplification.

Such is the case with the circuit shown in Fig. 1. The throat-type carbon microphone is mounted directly in contact with a plastic miniature radio-type cabinet. With such an acoustical arrangement, it is possible to cause the relay to pick up with a snap of the fingers, 15 to 20 feet distant.

One disadvantage in long-term use of any carbon-type microphone is the inherent packing of the granules with time, causing an attendant decrease in sensitivity. This fault can be corrected by giving the microphone, or entire unit if attached as described, a slight shake when turning the unit on. When a hand microphone is used, normal use keeps the granules free.

The unit is called the Baby-Larm, and is intended for use in the nursery. It can be placed on a stand or dresser near the crib and whenever the baby cries or whimpers, a buzzer sounds in the living room, garden or other convenient location. If the relay is to be mounted integral with the microphone unit, some provisions must be made to avoid a cycling phenomena caused by the sound of the relay



Chassis of the baby-watching alarm circuit

Presenting

*A beautiful new
multi-turn dial
that adds distinction
to the finest
instrument panels*

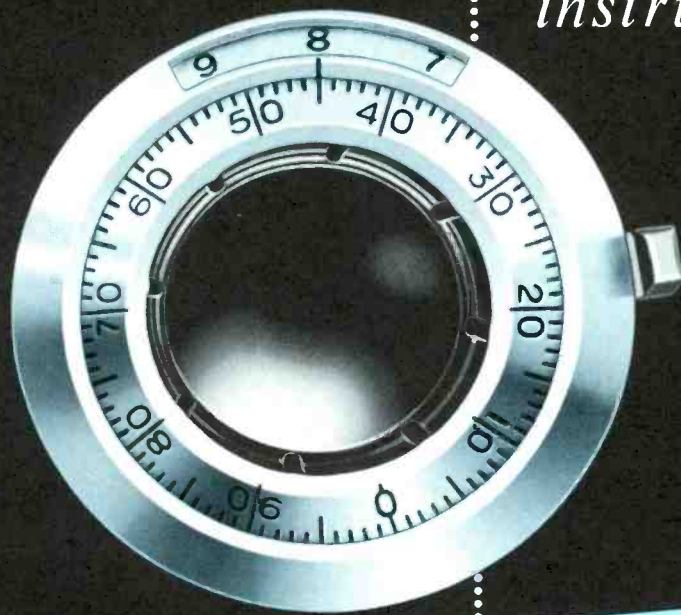

THE MODEL "RA"

Precision **Duodial**

(For dimensions and details turn page)

Another development of THE **Helipot** CORPORATION South Pasadena, California

Save Time,
Eliminate Errors,
with the new multi-turn

model **RA**
precision **Duodial**

Instant, accurate readings
distinctive beauty... quality "feel"... simple installation!

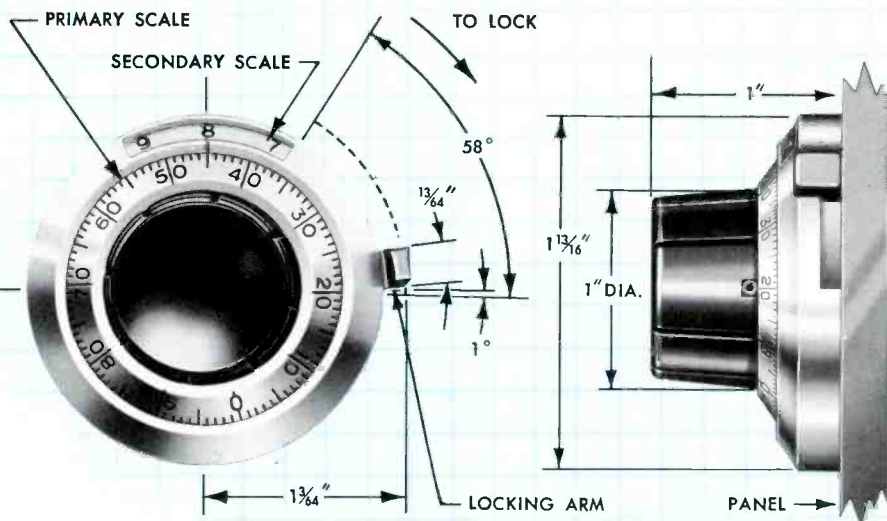

The new RA DUODIAL—product of the world's largest manufacturer of precision potentiometers—establishes a new standard of beauty and quality in multi-turn indicating dials. Finished in satin-chrome, with non-metallic parts of black nylon, the unit adds a distinguished appearance of quality and excellence to the finest instrument panels—and its precise operation gives a smooth "feel" that is unequalled. From every standpoint—readability, appearance, operation, construction—here is a dial worthy of the highest quality electronic instruments!

Unique Jump Mechanism

With its glare-proof satin finish and recessed black numerals that will not wear off, the RA DUODIAL is not only beautiful but is unusually easy to read. Moreover, the secondary dial is driven by a unique jump mechanism that keeps the dial stationary until the primary dial has completed a full revolution—then the turns-indicating dial "jumps" to the next numeral. Thus, the index always points *directly* to the number showing the particular helical turn on which the slider is positioned, eliminating errors in dial readings and settings.

Another convenience feature—three numbers show in the window at all times so that the operator knows instantly in which direction the dial is to be rotated to make the next setting. And with 10 turn potentiometers, readings are made directly in decimal equivalents of the slider position on the resistance winding—simply, accurately, and with maximum convenience for any resistance range.

Vibration-Proof Lock

All RA DUODIALS are equipped with a positive *vibration-proof* locking mechanism that can be easily and instantly set by the same hand that is adjusting the knob. Locking is accomplished by means of a cam actuated brake shoe which acts radially against an inner drum. This arrangement eliminates any possibility of dial movement during or after setting.

Easy To Mount On Panel

The RA is unusually compact—only 1-13/16" diameter (the same as a Model A HELIPOT)—and comes completely assembled, with mounting parts and hex wrench included. Installation is extremely simple. Set the dial and potentiometer at zero. Place the shaft through panel hole. Place lug plate over shaft, and mounting nut on potentiometer bushing. Then place the RA dial over shaft, lining up the register hole with lug—and tighten set screws. *It's as easy as that!*

In addition, the mounting nut is so designed that it is adaptable to thin (1/8" and under) or thick panels by simply reversing ends. No problems of adapting the unit to your particular panel requirements!

Finest Construction Throughout

In all respects the RA DUODIAL is built to maintain its attractive appearance and quality "feel" throughout its long life. Metal parts are machined from die-cast alloy and plated in accordance with specifications MIL P6871 and QQ P416 (1) for corrosion resistance. Non-metallic parts are made of long-lived nylon, with nylon jump gear to assure smooth quiet operation of the

secondary dial. And since the primary dial is connected directly to the potentiometer shaft, no wear or backlash can affect the accuracy of the settings.

Two allen-head set screws—positioned at 90°—lock the dial to the potentiometer shaft, and the black nylon knob insulates the instrument from hand capacity.

The RA DUODIAL is primarily designed for use with the 10-turn Model A HELIPOT. However, it is equally ideal for use with the 3-turn Model C or the ultra-precision models AN and CN when these potentiometers are equipped with bushing mounting. Additional numerals provided on the secondary dial make the RA adaptable for readings up to 15 turns for special applications.

An RAJ version of the RA Precision DUODIAL is available for use on the miniature Model AJ 3/4" 10-turn HELIPOT. The RAJ also fits other multi-turn devices with 1/8" shafts.

Contact your nearest HELIPOT representative for complete details—or write direct.

THE Helipot CORPORATION

SOUTH PASADENA 2, CALIFORNIA

Field Offices: Boston, New York, Philadelphia, Rochester, Schenectady, Cleveland, Detroit, Chicago, St. Louis, Los Angeles, Seattle, Dallas and Fort Myers, Florida. In Canada: Cossor Ltd., Toronto and Halifax. Export Agents: Frathom Co., New York 18, New York.

For *Critical* Applications
Triplett 630-A Has No Counterpart

Accuracy
to 1½%

Readability
with a Mirror-Scale

Adaptability
with ½% resistors

Try it at your distributor's

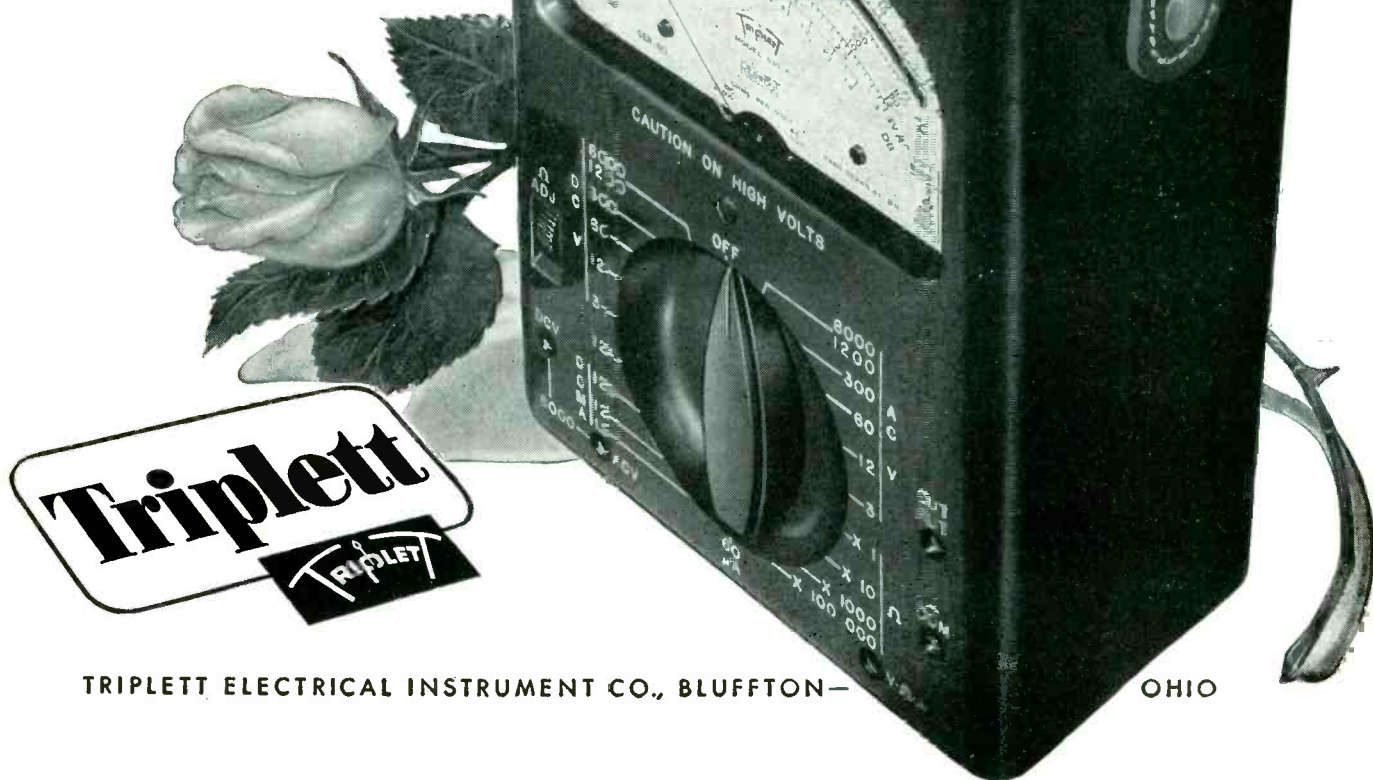

TRIPLETT ELECTRICAL INSTRUMENT CO., BLUFFTON—

OHIO

A Quality Relay for RUGGED DUTY!

AMRECON
TYPE: DO
A.C. or D.C.



WITH CONTACT ARRANGEMENTS
UP TO 4-POLE, DOUBLE THROW

Wherever severe shock and vibration are encountered, this rugged little relay can be relied upon to give *dependable* service. Originally designed for aircraft and mobile equipment, the versatile AMRECON Type DO is adaptable to many other uses where maximum protection against mechanical injury is required. Small in size (2 1/4" high, 2 1/8" wide, 1 1/8" deep) it is available in contact arrangements up to four-pole, double throw. Coils are normally rated at 3 watts d.c., or 6 watts, 60-cycle a.c.—for voltages up to 230 volts d.c., or 440 volts a.c. Contact rating: 10 amps—at 115 volts a.c. non-inductive, or 32 volts d.c. Weight: approximately six ounces.



WRITE FOR
COMPLETE INFORMATION
American Relay & Controls, Inc.
4911 W. Flournoy St., Chicago 44, Ill.

GREATER RESOLUTION

SLOWER SWEEP RATE



PANADAPTOR SA-8a PANALYZOR SB-8a

More Valuable Than Ever!

New Panoramic engineering achievements embodied in these improved instruments open important new applications involving modulation and interference problems.

SA-8a and SB-8a enable spectrum analysis of signals so close in frequency that their corresponding indications would normally mask one another.

- IMPROVED RESOLUTION down to 50 cps for RF spectrum analysis where maximum resolution is a "must"
- LOW SWEEP RATES down to 1 scan per second for analysis of pulsed RF signals with low p.r.f.'s
- LONG PERSISTENCE DISPLAYS
- CONTINUOUSLY VARIABLE SCANNING WIDTH

3 types available with maximum sweepwidths of 200 KC., 1 MC. and 10 MC.

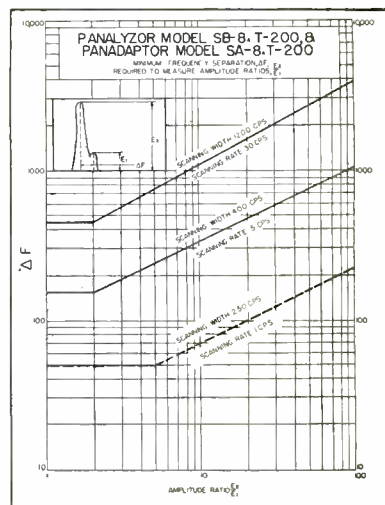

WRITE TODAY
FOR COMPLETE
SPECIFICATIONS
AND PRICES



10 South Second Avenue, Mount Vernon, N. Y.
Mount Vernon 4-3970

ELECTRIC INSTRUMENT & CONTROL HEADQUARTERS

YES, OFF-THE-SHELF SERVICE



Electro-Tech maintains one of the largest and most complete stocks in the country of electrical meters, instruments and industrial control equipment—representing over 250 top lines.

Yes, our warehouse is bulging with standard stocks of

- | | | |
|--------------------------|--------------|---------------------|
| Counters | Solenoids | Toggle Switches |
| Panel Meters | Tachometers | Shunts (Electrical) |
| Transformers | Thermometers | Meggers |
| Switchboard Meters | Thermostats | Solenoid Valves |
| Micro Switches | Rectifiers | Pyrometers |
| Photo Electric Equipment | Rheostats | Multimeters |
| Relays | Timers | Oscilloscopes |

and Laboratory Standard Instruments

In addition, we manufacture and stock *Special Test Equipment* • *Electric Heating Units* • *Current Transformers* • *Pyrometers* • *Thermocouples* • *Rectifiers*.

Our laboratory is available for repair work, rescaling, recalibration and special calibration of your electrical and industrial instruments. Often months are saved by rescaling and calibrating stock instruments to your specifications.

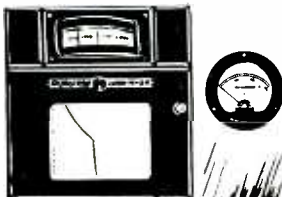

FOR SPEED
Wire — Code RDL
Teletype — NY 1-2906
Phone — BArlay 7-4209

CONSULT US ABOUT YOUR REQUIREMENTS

"The
Industries
Buying Guide"
our
GENERAL
CATALOG E-7
FREE

ELECTRO-TECH EQUIPMENT CO.

55 LISPENARD ST., NEW YORK 13, N. Y.

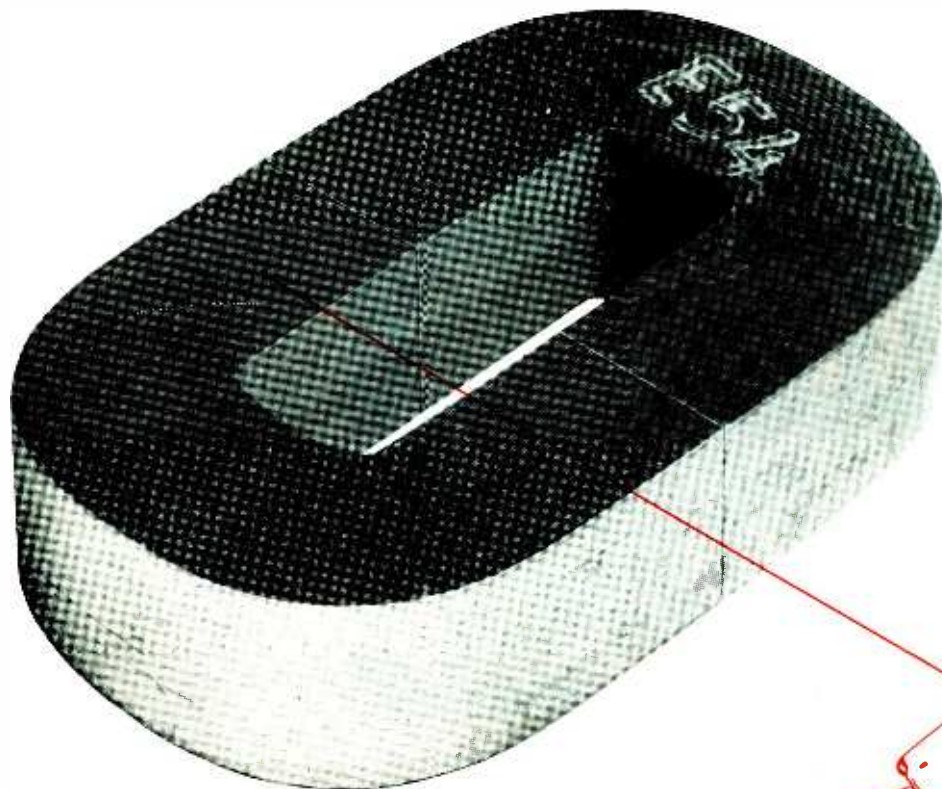

HIPERSIL® CORES

help revolutionize this soldering gun!

In designing their new Versa-Tool soldering gun, Phillips Manufacturing Company wanted a power unit that would provide instantaneous heat for off-on operation, yet operate on household voltage. A transformer was needed to build adequate amperage. But it had to be small, to fit into the handle . . . lightweight, for balance . . . reasonable in cost, to insure competitive pricing of the assembled unit.

Westinghouse Type RC Hipersil Cores provided the complete answer.

Because Hipersil Cores have greater flux-carrying capacity, Phillips engineers were able to cut size and weight of the transformer, effecting considerable savings in coil as well as core costs. But, better still, because the two-piece cores simplified assembly, manufacturing costs were slashed.

Hipersil Cores can cut cost, size and weight in all types of electrical and electronic transformers. Available in a wide range of sizes and shapes for low or high-frequency applications. Greater flux-carrying capacity, compact construction, plus the savings they effect in your manufacturing costs make them the best transformer cores on the market today. For more technical information on applying Hipersil Cores to your product, write to Westinghouse Electric Corporation, P. O. Box 868, Pittsburgh 30, Pennsylvania.

J-70628

YOU CAN BE SURE...IF IT'S
Westinghouse

HIPERSIL CORES



Here's the NEW

TAYLOR

8013-A

... It's a Rugged High-Voltage Rectifier

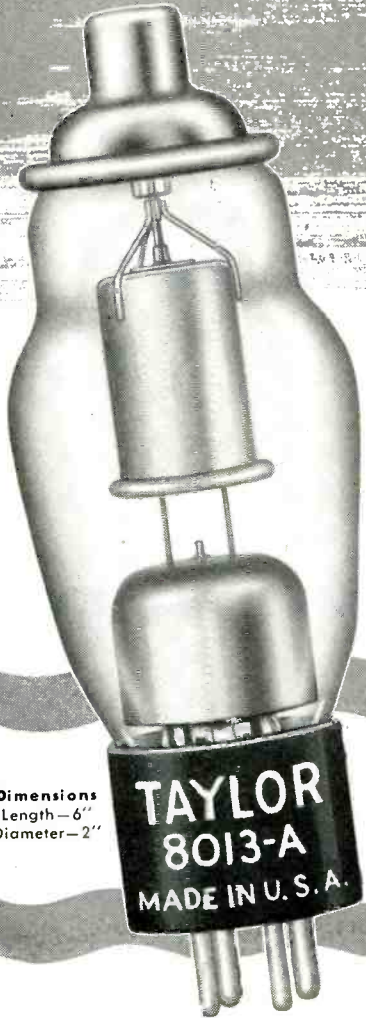

Dimensions
Length—6"
Diameter—2"

The new Taylor Custom Built 8013-A rectifier gives a fine account of itself in either air or oil operation. From its 2.5 Volt—5 Ampere long-life thoriated filament to the special oil resistant silicone compound used to permanently bond the base to its nonex glass envelope, the 8013-A is a champion in all respects. It's reasonably priced too, which gives every user the advantage of low operating cost.

TAYLOR 8013-A RATINGS

The 8013-A is rated at 40 KVP inverse or forward in air, 55 KVP in oil. Average current: 20 MA continuous in air—30 MA continuous in oil; with instantaneous peak current capacity of 450 MA.

★ TRANSMITTING
★ RECTIFIER

★ INDUSTRIAL
★ ELECTRONIC

As always, Taylor is producing tubes of superior quality and outstanding performance. The Taylor Representative nearest you is ready and willing to discuss your particular requirements. Call on him for information any time.

Taylor HEAVY CUSTOM BUILT DUTY **Tubes**

TAYLOR TUBES INC., 2312-18 WABANSIA AVE., CHICAGO 47, ILL.

Canada: Atlas Radio Corp., Ltd.
560 King St., W., Toronto 2-B
Cable: ATRADCO

Export: Royal National Company
75 West St., New York 6, N. Y.
Cable: NATVARNCO

armature dropping out. The relay must be shock-mounted on soft rubber grommets in the manner of nonmicrophonic tube sockets. It was also necessary to slip a soft rubber sleeve over the armature stop to silence the click made by the armature when it snaps against the stop.

The circuit makes use of a 2051 thyratron and is a-c operated. An adjustable bias is provided by the 1,000-ohm potentiometer. Although such an adjustment is usually sufficient, other uses requiring a continuous sensitivity control from zero can be controlled by placing a 1,000-ohm rheostat directly across the microphone.

A standard carbon-microphone transformer drives the grid. Microphone excitation voltage is derived from the 6.3-volt filament transformer and a single-plate selenium rectifier. Phasing of the microphone transformer was found to be important in that both the thyratron and the microphone are operating substantially half wave. A hold-over delay, consisting simply of a capacitor across the relay, is provided to continue the buzzer circuit for at least one second for any sound.

Other applications of this circuit are as an aid in the home of deaf persons, utilizing a signal light instead of a buzzer, automobile-operated garage-door openers, keying transmitters and call systems automatically, timers and remote triggering of scientific apparatus by a shout, shot or other shock wave. It could be useful at unattended airports, to light the field lights whenever a flyer buzzed the field desiring to land, the sound of his engine could trip the sound-operated relay. A five-minute time-delay tube

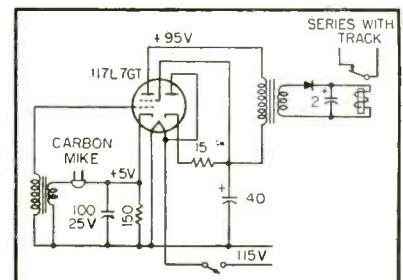
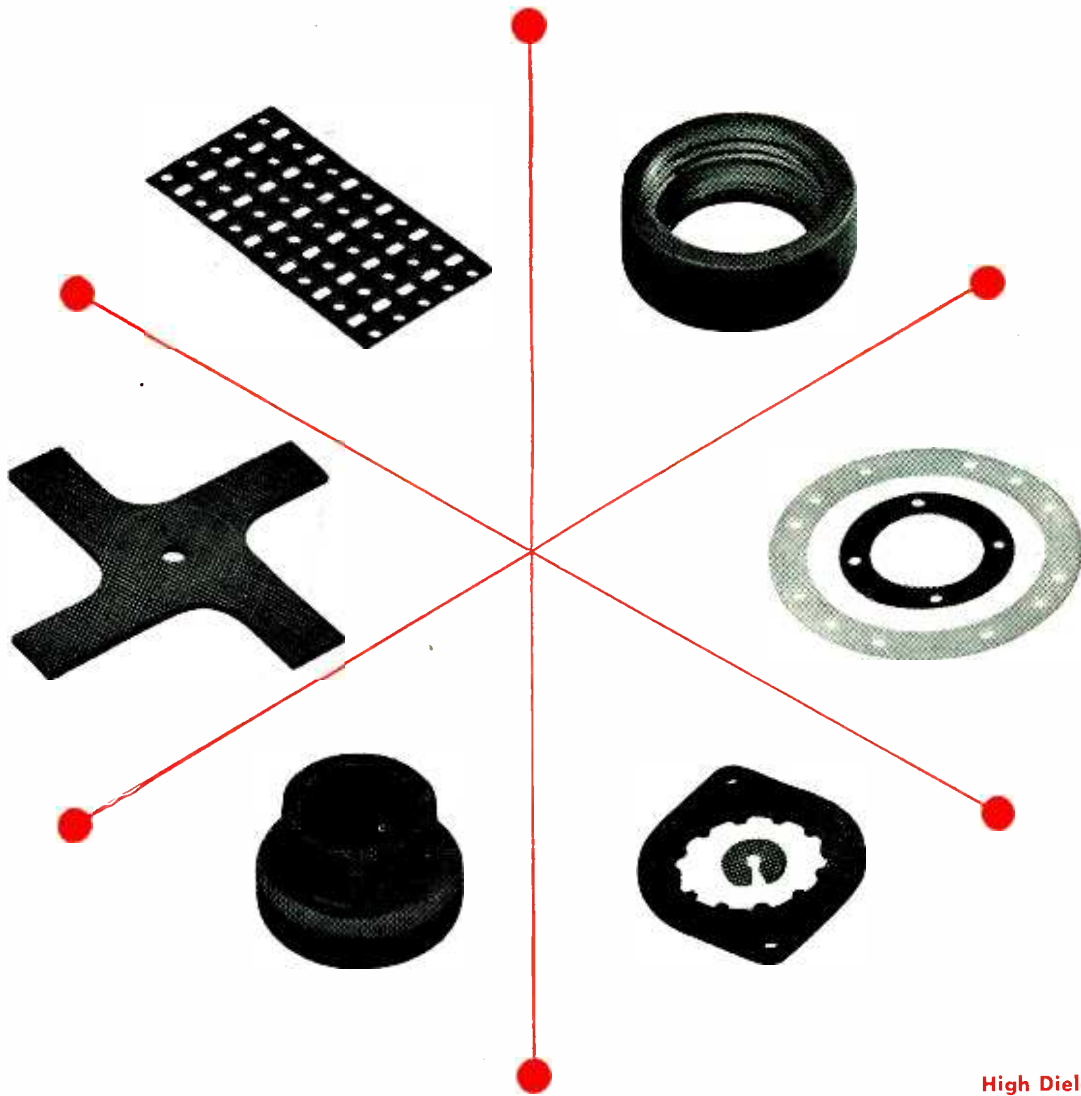

FIG. 2—Voice-operated circuit designed for remote-control toy electric trains



High Dielectric Strength
 Low Power Factor
 Heat Resistance
 Low Moisture Absorption
 High Impact Resistance
 Dimensional Stability
 Light Weight
 Tensile Strength
 Abrasion Resistance

new uses for an old friend... *Lamicoid*[®]

You probably know LAMICOID (Laminated Plastic) as an old friend for such uses as tube socket supports, coil forms, dials, panels, antenna parts and many other applications.

The same qualities that make it adaptable to these uses may also provide practical answers to your material shortage problems . . . and perhaps even bring you savings or improvements!

LAMICOID is made with fillers such as glass, nylon,

paper, fabric, etc. and a variety of resins. This wide range of materials makes it almost certain that LAMICOID can give you the essential mechanical, structural, or insulating characteristics your product requires.

LAMICOID is supplied as standard sheets, rods and tubes, or fabricated into parts to your specification. Why not let us put our 58 years of experience to work on your electrical insulation problems. Send your blueprints and specifications to us today for prompt quotation.



MICA *Insulator* **COMPANY**

Schenectady 1, New York

Offices in Principal Cities

LAMICOID (Laminated Plastic) • MICANITE (Built-up Mica) • EMPIRE (Varnished Fabrics and Paper) • FABRICATED MICA



Be a **BOEING** Engineer!

If you meet Boeing's exacting standards, you will share the prestige of Boeing's engineering leadership. And you'll work with men famous for their pioneering contributions to both civil and military aviation. You'll be aided by the finest research facilities in the industry.

At Boeing you'll work on such challenging projects as supersonic research, guided missiles, the B-47 (world's fastest jet bomber), the still-classified B-52, and other exceptional programs. You'll find a rewarding, long-range career here, in a company that has been growing steadily for 35 years.

There are opportunities at Boeing, right now, for experienced and junior engineers for aircraft

- DESIGN
- DEVELOPMENT
- RESEARCH
- PRODUCTION
- TOOLING

also for servo-mechanism and electronics designers and analysts, and for physicists and mathematicians with advanced degrees.

Openings are available at Seattle, Washington, and at Wichita, Kansas. Boeing provides generous moving and travel allowances, gives you special training, and pays a good salary that grows with you.

You'll be proud to say, "I'm a Boeing engineer!"

Write today to the address below or use the convenient coupon

JOHN C. SANDERS, Staff Engineer—Personnel
DEPT. H-7
Boeing Airplane Company, Seattle 14, Wash.

Engineering opportunities at Boeing interest me. Please send me further information.

Name _____

Address _____

City and State _____

SERVOTHERM PRODUCTS

BOLOMETER AND PREAMPLIFIER

Thermistor bolometers are FAST, sensitive INFRARED and HEAT detectors. Especially RUGGED for industrial, scientific, and military applications. PREAMPLIFIER provides NOISE-FREE initial amplification and mount.



THERMISTOR POWER SUPPLY

Provides voltages required by BOLOMETER bridge and PREAMPLIFIER. Regulated and filtered permitting THEORETICAL NOISE LIMITS of amplification, while operating from 60 CYCLE line.



SERVO CORPORATION OF AMERICA

DEPT. E-7

NEW HYDE PARK, N.Y.



FS MICROMETER HEAD

for the Electronics Industry

ELECTRONIC ENGINEERS PRAISE FS MICROMETER HEADS FOR THEIR PRECISE ACCURACY EVEN AFTER LONG HARD USAGE. THIS ACCURACY IS MADE POSSIBLE BY A PATENTED THREAD-FORM WITH RADIALLY-LOADED NUT FOR ELIMINATION OF BACK-LASH, AND AUTOMATIC WEAR COMPENSATION . . . OTHER FEATURES AND SPECIFICATIONS ARE DESCRIBED IN OUR NEW BULLETIN, OBTAINABLE ON REQUEST.

2

FREQUENCY STANDARDS

P. O. BOX 66, EATONTOWN, N. J. • TELEPHONE ASBURY PARK 1-1018

MIL-P-7788

SPECIFICATION

AN-P-89

PANELS-DIALS-ETC.

BODNAR INDUSTRIES, INC.

19 RAILROAD AVE., NEW ROCHELLE, N.Y.

COMPLETE TESTING FACILITIES

FOR 'GOVERNMENT INSPECTION AT SOURCE'

★ MOLDED - FABRICATED ★

PLASTIC LIGHTING PLATES

PLASTIC LIGHTING PLATES

★ DESIGN - PRODUCTION ★

NOW . . . FIBERGLAS *plus* SILICONE RUBBER

Note supporting
Fiberglas braid

BH "1151"

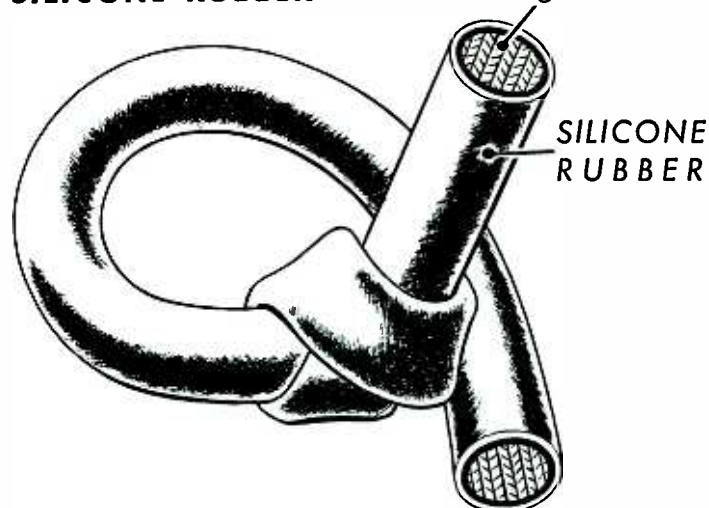

. . . for longer electrical equipment life

BH "1151" is a new electrical sleeving that provides the unique combination of permanent flexibility and high dielectric strength at Class "H" temperatures. It offers a long-lasting union of two great inorganic materials — Fiberglas and Silicone Rubber.

BH "1151" shows no change in physical or dielectric properties after 15 minutes at 600°F.; 4 hours at 500°F.; or 96 hours at 450°F. It is applicable for continuous operation through a temperature range of -90°F. to 400°F.

BH "1151" can be twisted, knotted or bent without crazing, cracking, or loss of dielectric strength. Available in rated grades up to 7,000 volts. Electrical

resistance is unusually high. It will not support fungus growth. Offers excellent chemical resistance. Meets all applicable NEMA specifications for Class H insulations.

BH "1151" is available in colors, for circuit tracing and coding, in continuous coils, 36 inch lengths, or in short lengths cut to individual specifications. It is made in Grades H-A-1, H-B-1, H-C-1 and H-C-2. Get all the facts on this superior electrical insulation — write for data sheets today.

Address Dept. E-7

Bentley, Harris Manufacturing Co.
Conshohocken, Pa.

BH *Fiberglas*^{*} SLEEVINGS

*BH Non-Fraying Fiberglas Sleeveings are made by an exclusive Bentley, Harris process (U. S. Pat. No. 2393530). "Fiberglas" is Reg. TM of Owens-Corning Fiberglas Corp.



ELECTRONS INCORPORATED

127 SUSSEX AVENUE

NEWARK 4, N. J.

We will gladly mail ratings and circuit design data concerning these neon gas grid controlled rectifiers.

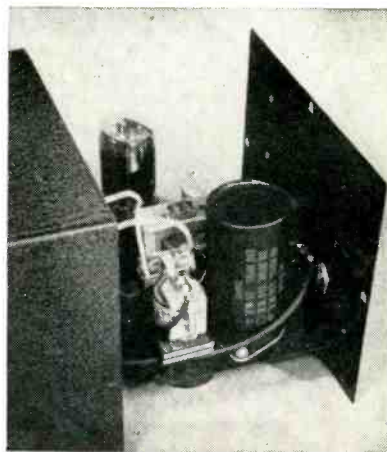

Chassis of the voice-operated relay control

would hold the lights on for a maximum of five minutes without reenergizing the thyatron. This would prevent the lights from burning all night after a clap of thunder for instance. The circuit obviously could also be applied to an automobile parked advantageously near a private runway, to turn on the car headlights for marker illumination in landing.

The second circuit, although less sensitive, has interesting uses. It is designed to trip a relay once for each word or syllable spoken, or for each sound impulse of a given duration and repetition rate. The Voice-Trol, a unit making use of this circuit is shown in Fig. 2. It was designed primarily to provide a voice control for standard remote control electric toy trains. Since these trains come equipped with a built-in stepping relay to control their direction, no alterations are necessary.

Normally a button is pressed twice for a moving train to reverse; the current to the track being interrupted twice, causing the stepping relay to move to the reverse position. The two terminals of the Voice-Trol are simply connected in series with the track feeders. The words, "Back-up" are spoken into the microphone, the current is interrupted twice, and the train reverses. "Stop" brings the train to a halt with one pulse, and "Forward" causes it to move forward again. Various combinations of commands were derived which presented a very convincing display. It can be used by the hobbyist, and

Part Instead of 3

The modified Dome-Type SHAKEPROOF® Lock Washer is held on the screw by the rolled thread—it can't drop off but is free to rotate.

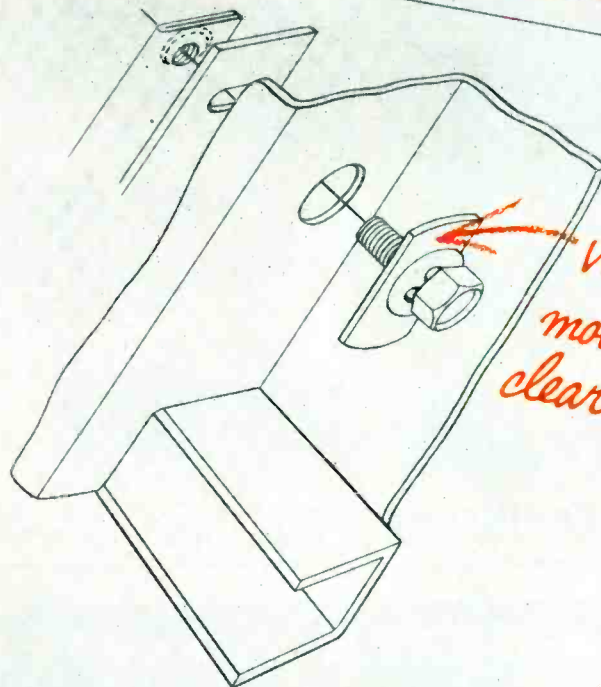
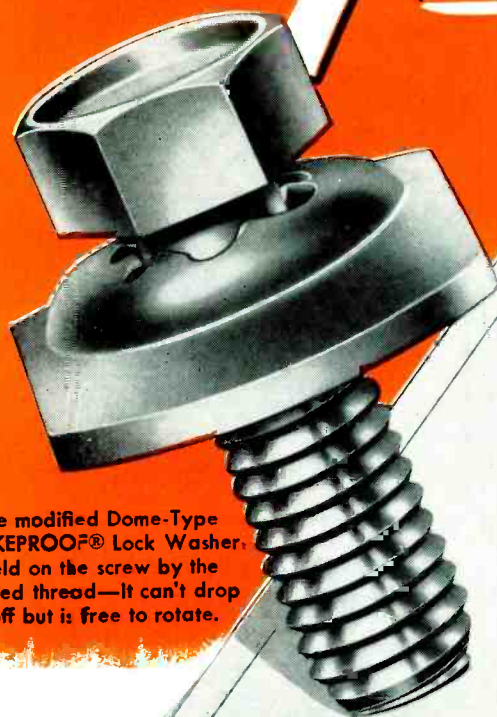

Washer shape modified to clear side wall!

ASSEMBLY DETAIL ON RADIATOR GRILLE TO FRAME ASSEMBLY. MODIFIED STANDARD SEMS-by-SHAKEPROOF REPLACES STAMPED SPANNER PLATE, LOCK WASHER AND SCREW.

SHAKEPROOF inc.
Div. of Illinois Tool Works

PROJECT 235X

Typical of SHAKEPROOF Leadership in Fastening Engineering . . .

. . . are the *three* outstanding features of this modified Sems unit.

First, the Dome-Type SHAKEPROOF Lock Washer spans elongated or enlarged clearance holes providing great resilience and locking power.

Second, Shakeproof pre-assembly combines washer and screw as a single easy-to-handle unit.

Third, special modification of the washer shape permits application in restricted space.

Shakeproof fastening engineering like this can give you better fastenings and reduce your costs too!

SHAKEPROOF inc., Division of Illinois Tool Works, Elgin, Illinois. In Canada: Canada Illinois Tools Limited, Toronto, Ontario.

for Better Fastenings and Lower Assembly Costs!

SHAKEPROOF inc.

"Fastening Headquarters"

T.M. REG. U.S. PAT. OFF.



ELECTRONIC GLASS WORKING EQUIPMENT for RADIO, TELEVISION TUBES, INCANDESCENT LAMPS, GLASS LATHES for TELEVISION TUBE REPAIR. We make Transformers, Spot and Wire Butt Welders, Wire Cutting Machines and 500 other items, indispensable in your production. Eisler Engineers are constantly developing New Equipment. If you prefer your own designs, let us build them for you. Write to Charles Eisler who has served The Industry over 30 years.

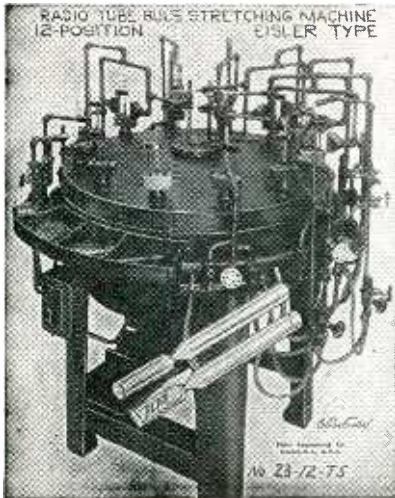

Machines for small Radio Tubes of all kinds; 24 Head Stem, 24-Head Sealing and 24-Head Exhaust Machines, Spot Welders, etc.

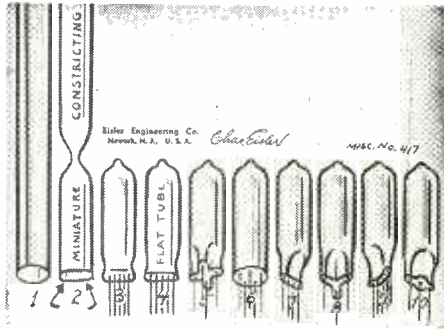

EISLER ENGINEERING CO., Inc.

751 So. 13th St.
Newark 3, N. J.

PRIMARY BATTERIES for your Specialized Needs

DRY TYPES

78 Standard Industrial, Laboratory and Government Types.



LAB-BILT BATTERIES

Our engineers will design and create to your requirements. Send us your specifications.

HI-DRIVE MINIATURE MOTOR



Precision-built, low-cost, battery-operated—available for delivery now.

RESERVE TYPES

Water activated "One Shot" Batteries.



Send for **FREE** Catalog

SPECIALTY BATTERY COMPANY

A Subsidiary of the **RAYO-VAC** Ray-O-Vac Company

MADISON 10, WISCONSIN

JUST PUBLISHED

ELECTRONIC ANALOG COMPUTERS

1. Gives aid in the design and operation of electronic computers of the d-c analogy type used as differential analyzers and equation solvers. Shows procedure for setting up problems that lessens chief error of faulty assignment of scale factors. Gives samples of practical applications. Covers design of computer circuits, auxiliary components, and complete installations to meet specific needs. By Granino A. Korn, Staff Engr., Lockheed Aircraft Corp., and Theresa M. Korn, formerly Engr., Boeing Aircraft Co. 378 pp., 70 illus., \$7.00



ELECTRONIC MEASUREMENTS

2. Covers measurement fundamentals in many fields beyond conventional radio, including television, radar, and other pulsed systems, microwave techniques, and techniques of value to engineers in other areas who use electronics in their instrumentation. Treats circuit constants and lumped circuits; waveform, phase, and time interval measurements; receiver and antenna measurements; generators of special waveforms; attenuators and signal generators, etc. By F. E. Terman, Dean, School of Engr., Stanford U., and J. M. Pettit, Assoc. Prof. of Elec. Engr., Stanford U. Second Ed., 683 pp., 450 illus., \$10.00

RADIO ANTENNA ENGINEERING

3. Provides guidance in the design and construction of receiving and transmitting antennas used in point to point, ground-to-air, and military communications, as well as broadcasting. Deals with wires, masts, and towers, with frequencies up to 30 megs. Treats radiation, circuit, and mechanical engineering, operational requirements, bandwidth, propagation and system engineering for each type of antenna. Includes advanced designs suggested by very-high frequency and ultra-high-frequency techniques, emphasizing their growing importance. By Edmund A. Laport, Chief Engr., RCA Int. Div. 563 pp., 386 illus., \$9.00

MUSICAL ENGINEERING

4. Explains the theory and practice of interrelated phases of musical engineering—including speech, music, musical instruments, acoustics, and hearing. Treats the construction, range, characteristics, vibrating and resonating systems of musical instruments. Analyzes each aspect of sound reproducing and pickup systems. Gives help toward better production of vocal and instrumental music, in acoustic design of studios, and problems in recording, transmission, and broadcasting of music and speech. By Harry F. Olson, Dir. Acoustical Laboratory, RCA Laboratories, Princeton, N. J. 309 pp., 303 illus., 28 tables, \$6.50

SEE THESE BOOKS 10 DAYS FREE

McGraw-Hill Book Co.,
330 W. 42nd St., NYC 36

Send me book(s) checked below for 10 days' examination on approval. In 10 days I will remit for book(s) I keep, plus few cents for delivery, and return unwanted book(s) postpaid. (We pay for delivery if you remit with this coupon; same return privilege.)

- 1. Korn & Korn—ELECTRONIC ANALOG COMPUTERS \$7.00
- 2. Terman & Pettit—ELECTRONIC MEASUREMENTS \$10.00
- 3. Laport—RADIO ANTENNA ENGINEERING \$9.00
- 4. Olson—MUSICAL ENGINEERING \$6.50

(Print)
Name

Address

City Zone State

Company

Position L-7-52

This offer applies to U. S. only.



Connector Problem?

...We'll take it from **HERE**

Good ideas for electronic circuitry sometimes run afoul of connector problems. Maybe existing connector units won't hold air pressure gradients, won't stand the heat, aren't rugged enough for the job. Or maybe it's a question of altitude, or under-water application. But if you can sketch the circuit, we'll take it from there. We've engineered so many special connectors, solved so many "impossible" problems, that whatever the requirements are, we can usually provide the answer.

WRITE TODAY for specific information, or send us your sketches. We'll forward recommendations promptly.

BREEZE Special CONNECTORS

BREEZE CORPORATIONS, INC.

41 South Sixth Street

Newark, New Jersey



Lightweight actuators for any requirement.



Job engineered, welded-diaphragm bellows.



Flexible conduit and ignition assemblies.



Aero-Seal vibration-proof hose clamps.

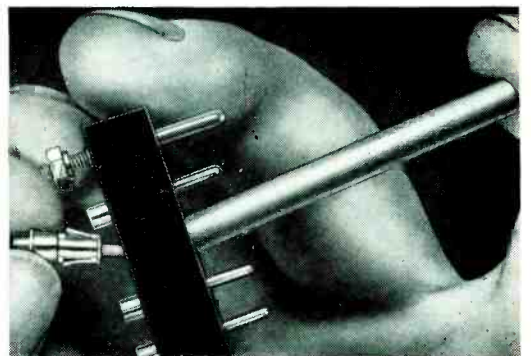

Removable pins in Breeze connectors speed soldering, save time, trouble. Pins snap back into block.

MEET

JAN-I-225, 16E4 (Ships) and MIL-I-6181

Specifications for Radio Interference Suppression!

ACE *Pre-built* SCREEN ROOMS



Features

1. Attenuation of 100 DB and higher from 0.15 to 10,000 MC.
2. Prebuilt, immediate installation, easy to relocate or to enlarge.
3. Standard and special types and sizes to meet practically any requirement.
4. Special filter entry and door construction.
5. Special service entrance for gas, air, water, etc., when required.

Write, wire or 'phone for details

ACE ENGINEERING and MACHINE CO., Inc.

3644 N. Lawrence St., Philadelphia 40, Pa.

Telephone: REgent 9-1019

as a novelty attraction as well.

The circuit shown in Fig. 2 is built around a 117L7 tube, the diode section making possible one-tube operation. Microphone current is obtained in the cathode circuit and standard carbon-microphone transformer supplies the signal to the grid. The tube is operating relatively cut-off until a word is spoken. The positive half cycle at the grid turns the tube fully on. This large amplitude square wave is fed through a matching transformer and is rectified to provide the d-c relay excitation. A capacitor, across the relay, was chosen to provide the proper holding characteristics to obtain a relay pick-up once for each normally spoken word or syllable.

The output winding must be so phased as to provide rectification of the negative-going plate signal. Ringing, found to be present with strong signals, during the positive

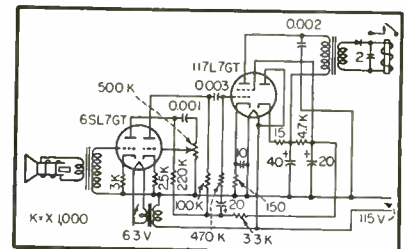

FIG. 3—Modified form of Fig. 2 using a dynamic loudspeaker as a microphone

peaks (when the tube is completely cut off) was of no consequence since that half cycle is unused.

Numerous stepping relay functions can be achieved with the basic circuit to deduce any predetermined intelligence from groups of sound impulses. This circuit lends itself readily to exhibits and demonstrations.

By increasing the relay holding capacitor to approximately 40 μ f, and connecting the grid to the voltage amplifier of a public-address call system or transmitter, automatic keying can be obtained with this circuit. Also, a counter could be made to total the number of times any audio equipment is used or any sound has occurred.

A third circuit is shown in Fig. 3 which is used in instances where a carbon microphone would be unde-

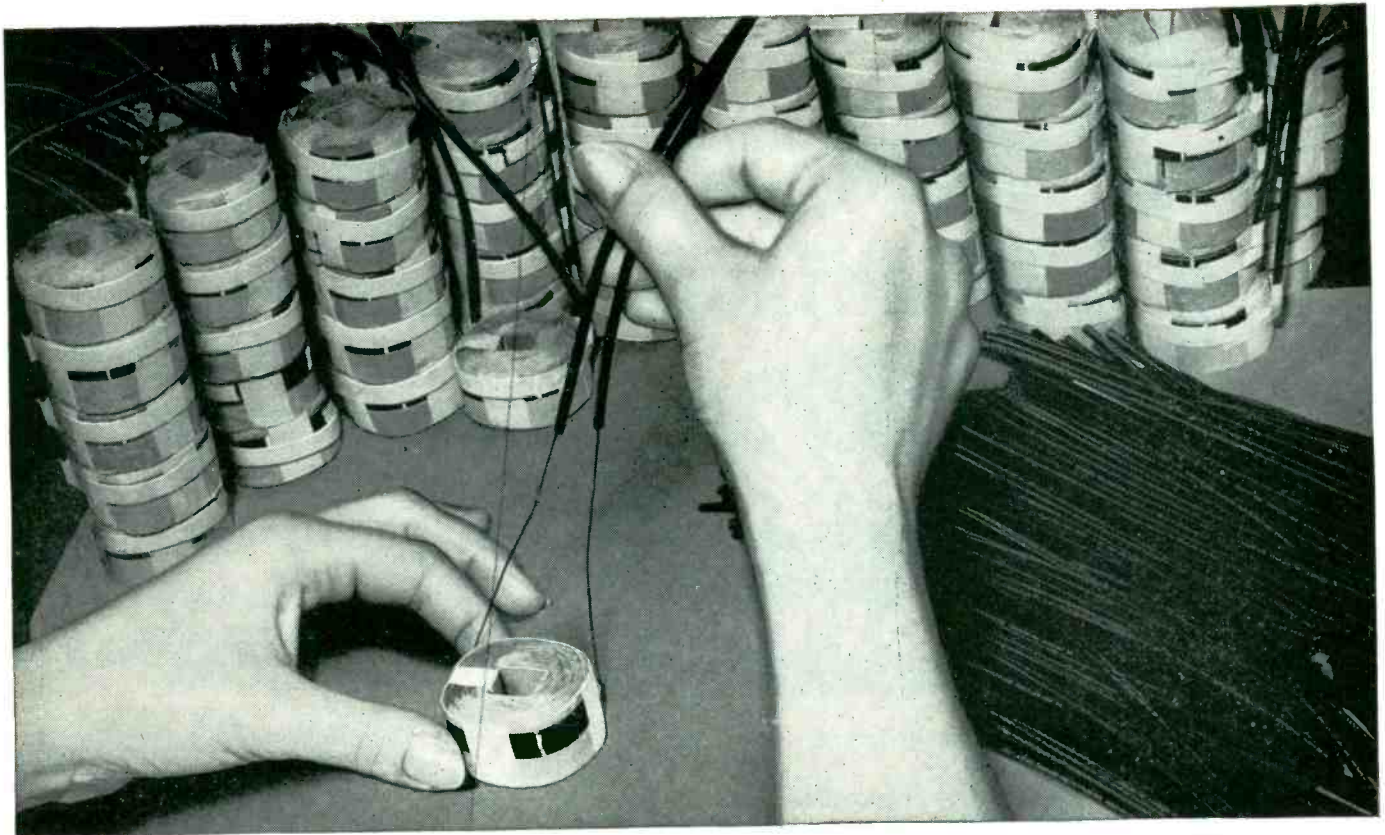

Minneapolis-Honeywell eliminates soldering operations . . . by slipping **TEMFLEX 105** over coil leads

Quantity use of Temflex 105 flexible plastic tubing effects substantial savings in assembly costs of the RA 117 Protectorelay oil burner control, according to Minneapolis-Honeywell Regulator Company, makers of the famous MH Control Systems and Brown Instruments.

Assembly of the control calls for suitable insulation of two lead wires from each of two coils of the type shown in the illustration. Conventional methods would call for clipping off the lead wires close to the coils, and making soldered joints to insulated wires — calling for four soldering operations for each control.

But Minneapolis-Honeywell merely slips a length of Temflex 105 over each lead. **RESULT:** Soldering operations are eliminated . . . leads are thoroughly insulated, remain flexible . . . assembly costs are cut down.

Service advantages of Temflex 105 — in this and many other applications — are even more outstanding. This Irvington tubing is approved by Underwriters' Laboratories for 90° C operation in oil — *as well as* for continuous operation at 105° C. In addition to this superior oil resistance, Temflex 105 offers good resistance to mineral and coal tar solvents — and prolonged exposure to acids and alkalis has little effect on its initial high dielectric strength of 1200 vpm.

Get the full facts on Temflex 105 — mail the coupon for free technical data sheet.

Send this convenient coupon now

Irvington

VARNISH & INSULATOR COMPANY

Irvington 11, New Jersey

Plants: Irvington N. J.; El Monte, Calif.; Hamilton, Ontario, Canada

Look to
IRVINGTON
for insulation leadership
INSULATING VARNISHES
VARNISHED CAMBRIC
VARNISHED PAPER
VARNISHED FIBERGLAS
INSULATING TUBING
CLASS "H" INSULATION

EL-7/52

Irvington Varnish & Insulator Co.
11 Argyle Terrace, Irvington 11, N. J.

Gentlemen:

Please send me your technical data sheet on Temflex 105 Plastic Tubing.

Name.....Title.....

Company.....

Street.....

City.....Zone.....State.....

3 CLEAN-CUT ADVANTAGES

OF *Seamless* [PATENTED] RADIO PINS

- 1** Extreme Uniformity
- 2** Superior Staking Qualities
...ends will roll without splitting
- 3** Better for Molded Parts
...closed end keeps compound out

If you use pins for vacuum tubes, adapters, fluorescent lamps, plugs, or electrical equipment of any kind, the chances are you'll save time, money and rejections by using these super-smooth, *seamless*, patented Radio Pins. They are available in a wide variety of styles and sizes, with staking end either closed or open. For a quotation, simply send a sketch, sample or description and state the quantity and finish you need.

SHEET METAL STAMPINGS?

In addition to Radio Pins, we produce large quantities of top caps, base shells and adapter shells for vacuum tubes; also a wide variety of other metal products, including deep-drawn shells and cups, blanks and stampings, ferrules, grommets, washers, vents, fasteners—and, for almost every manufacturing requirement, the world's largest assortment of eyelets.

We invite your inquiry to the Waterbury Brass Goods Branch of The American Brass Company, Waterbury 20, Connecticut.

49407



FOR QUALITY BRASS GOODS— **ANACONDA**

sirable. Although using a dynamic loudspeaker as a microphone, and two stages of amplification, the circuit is still moderately simple, using only two multipurpose tubes. The circuit is essentially that of Fig. 2 with the addition of the two-stage preamplifier. Sensitivity is controlled by the input to the second stage. It is advantageous to mount the loudspeaker pickup on some sounding board or resonator.

Design of a Low-Noise Pentode

BY P. WELCH

*Engineering Division
Brimar Valve Works
Standard Telephones and Cables Ltd.
Kent, England*

TUBES required for service in the first stage of high-gain amplifiers and similar equipments using very low signal input levels set a special problem in thermionic tube design. The main requirement for a tube of this type is that it should produce very little extraneous noise in relation to the signal level.

Three main sources of tube noise are microphony, hum and hiss. Besides limitation of these noises as much as possible, the tube must be capable of giving a reasonably high gain because if the first stage amplification is not high enough, the noise output from the second tube becomes appreciable.

The 6BR7 has been designed with low noise requirements in mind. The high gain required limited the choice of tube type to a pentode although this structure does introduce certain undesirable noise features. The most natural choice of

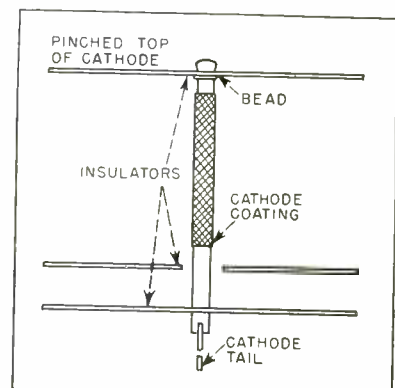

FIG. 1—Means for locking the cathode in the insulating member

EDISON selects NICHROME* V WIRE

for new, high-accuracy, long life MINIATURE RELAYS

Edison's new space-saving miniature thermal time-delay relays, scarcely larger than a door key, are built to handle big jobs—accurately and dependably, day in and day out.

They offer the simplest, most trouble-free, and least expensive way of introducing delay periods into electric circuits. Thus they are ideal for control functions relating to cathode protection, motor starting, "hold-overs," overload protection, automatic cycling, and numerous applications where magnetic relays have hitherto been used.

Since accuracy of operation depends, essentially, upon the consistent performance of the extremely small heater, wire of this winding must be *exceptionally stable*—be capable of retaining its physical and electrical characteristics *indefinitely*.

Nichrome V alloy, unique product of Driver-Harris, fulfills these all-important conditions. With a temperature co-efficient of resistance that remains constant between 20°C. and 500°C.—a considerably wider temperature range than actually here involved Nichrome V assures uniform, precision performance. And being highly resistant to heat and corrosion, it assures *outstanding stability for a lifetime*.

This particular application serves to emphasize other desirable properties which make Nichrome V wire extremely suitable for heating, or resistance units required to occupy very limited space. For example: Only a few milliamperes of current are utilized by the Edison miniature thermal relay. The heater winding must, therefore, have high resistance in order to produce sufficient heat to deflect the bi-metal contact strip. The electrical resistivity of Nichrome V (650 ohms/cm) permits a short length of one-mil-diameter wire to be used, thus saving space; and the high tensile strength of

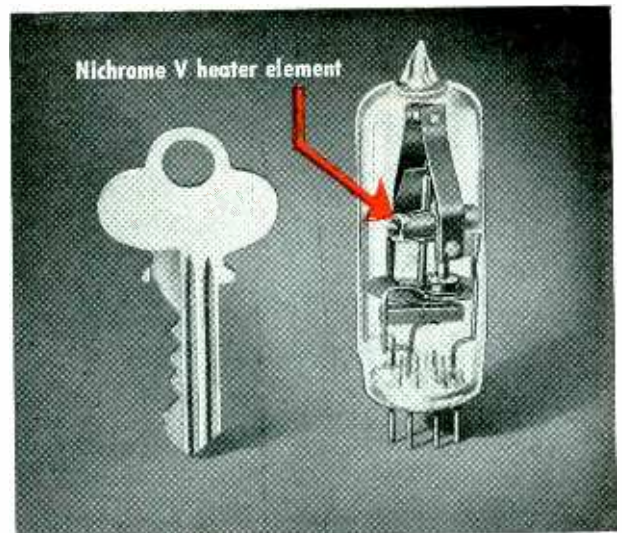

New Edison Time-Delay Relay — Model 207
Standard Voltages 115—27.5—6.32 Hermetically sealed. Vibration and shock proof. Ambient compensated -60°C. to +85°C. Wide range of delay periods available.

Nichrome V (200,000 p.s.i. at 20°C.) eliminates breakage in winding operation.

For products whose successful operation depends upon application of stable electrical alloys, highly resistant to heat and corrosion, you'll find Nichrome and Nichrome V offer *plus values* that are unequalled. At the present time, these alloys are on allocation; but if you will let us have your specifications, we shall be glad to make recommendations and serve you to the best of our ability.



Nichrome* is manufactured only by

Driver-Harris Company

HARRISON, NEW JERSEY

BRANCHES: Chicago, Detroit, Cleveland, Los Angeles, San Francisco

*T. M. Reg. U. S. Pat. Off.

Sold in Canada by The B. GREENING WIRE COMPANY, LTD., Hamilton, Ontario, Canada

MAKERS OF THE MOST COMPLETE LINE OF ELECTRIC HEATING, RESISTANCE, AND ELECTRONIC ALLOYS IN THE WORLD

let WILLIAMS help you
apply ferric oxides to
the manufacture
of your

ferrites

You'll be well repaid by getting the facts on a special group of Pure Ferric Oxides, developed by Williams especially for use in the manufacture of ferrites.

Williams Ferric Oxides analyze better than 99% Fe_2O_3 . They contain a minimum of impurities.

They are available in a broad range of particle sizes and shapes. Among them, we're certain you'll find one that's "just right" for your requirements. The proper application of Ferric Oxides to the manufacture of Ferrites is our specialty. So write today, stating your requirements. We'll gladly send samples for test. Chances are good that our Ferric Oxide "Know How" can save you considerable time and money. Address Dept. 25, C. K. Williams & Co., Easton, Pa.

WILLIAMS

COLORS & PIGMENTS

C. K. WILLIAMS & CO.

Easton, Pa. • East St. Louis, Ill. • Emeryville, Cal.

P. S. We also produce IRN Magnetic Iron powders for the Electronic Core Industry, the Magnetic Tape Recording Industry and others. Write for complete technical information.

existing characteristics was that of the h-f pentode type 6J7 and in order that the 6BR7 should be fully equivalent it was designed with a low anode-to-grid capacitance.

The tube is of the nine-pin jumbo miniature type. This size of single-ended tube has advantages and disadvantages for low noise design.

Reduction of Microphony

The use of the nine-pin miniature construction allowed the tube elements to be mounted close to the glass base. This lowered the center of gravity of the tube, as compared with a conventional octal-based type, and it was therefore less prone to movement under conditions of vibration.

In the design of the 6BR7, the size and shape of each electrode was carefully chosen so that it should not have a low frequency fundamental resonance. This insured that the vibration of the element should not give rise to regenerative feedback at low values of gain in the amplifying equipment. As previously explained, this effect is usually the limiting factor to the tube performance and therefore every effort was made to effect improvements over previous designs.

In order that the general resonance value should be of relatively high frequency and low amplitude, the structural length of the tube was kept as short as possible. Individual electrodes were then studied in turn.

To prevent movement, the cathode of the 6BR7 was locked in the insulating member. This was done by making a small bead in the round wall of the cathode, inserting it through the insulator and then

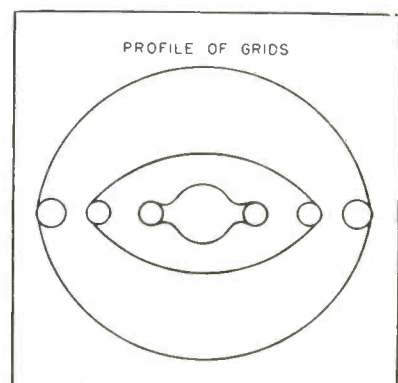

FIG. 2—Grid profile for the 6BR7



Buttoned-up and navigating blind

Operating tanks with full effectiveness in featureless arctic or desert terrain presents a new problem in "blind" navigation.

Dead reckoning and navigating under such conditions requires electronic and electro-mechanical systems that are highly complex yet simple to operate and maintain.

This growing field of vehicular navigation is

another place where Arma is a leader in basic research, design, development and production. Over 34 years of close cooperation with the Armed Forces—and more recently the Atomic Energy Commission—stand behind Arma's reputation. *Arma Corporation, Brooklyn, N. Y.; Mineola, N. Y.; Subsidiary of American Bosch Corporation.*

ARMA

ADVANCED ELECTRONICS FOR CONTROL



Revolutionary

MINIATURIZATION

of

VARIABLE CAPACITORS

Jennings Vacuum Capacitors are revolutionary. They combine small physical size with high KVA.

JENNINGS first miniaturized the function of variable capacity by bringing out its vacuum variables.

NOW, JENNINGS is miniaturizing its own vacuum capacitors in order to reduce the space required in modern high frequency radio and television transmitters.

Relative proportions of an air variable and three Jennings Vacuum Capacitors

Literature mailed on request

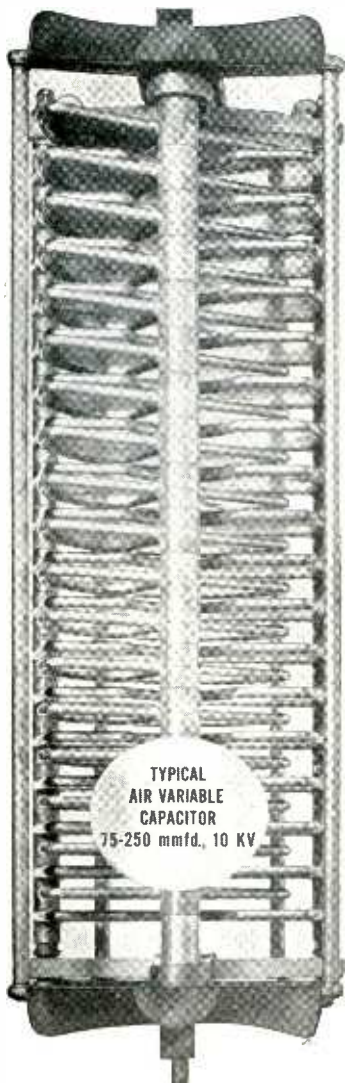

TYPICAL AIR VARIABLE CAPACITOR
 75-250 mmfd., 10 KV

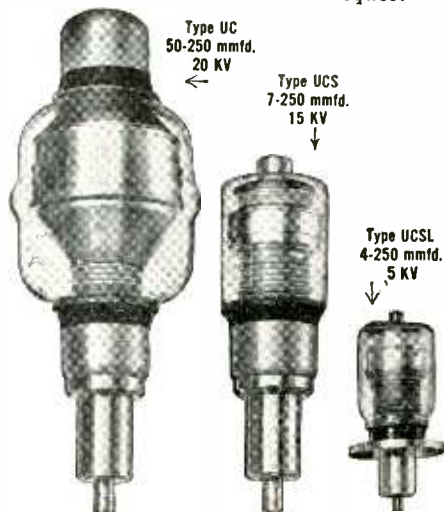

Type UC
 50-250 mmfd.
 20 KV

Type UCS
 7-250 mmfd.
 15 KV

Type UCSL
 4-250 mmfd.
 5 KV

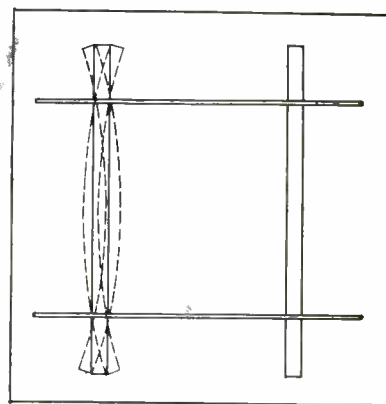

FIG. 3—Conventional insulator and grid assembly

clamping the end together on the other side of the insulator. This is shown in Fig. 1.

The grids of the 6BR7 were made with either a keyhole or an oval type of profile, Fig. 2. This was done so that the grid wires could expand during the heating associated with tube manufacture and yet return to their original shape when they cooled. It was not necessary therefore to provide expansion slots in the insulators for the supporting members, which could then be held by very tight fitting holes.

The most serious cause of grid movement was found to be the resonance of the supporting member itself. Figure 3 shows a conventional insulator and grid assembly. If the beam could be supported at two points. If the beam could be supported at either end the frequency of resonance would increase and the amplitude for a given accelerating force would be less. The 6BR7 therefore incorporates a double-insulator system at each end with the two insulators separated by a small distance, Fig. 4. This type of construction achieves the results of clamping at both ends and yet allows the grid-supporting member to expand.

Experiments showed that by using the double-insulator construction the fundamental resonance of the suppressor grid could be increased from 700 to 1,700 cps with a decrease of noise output under conditions of constant acceleration of about 10 to 1. This construction was applied to all the grids except the control grid. In this case the

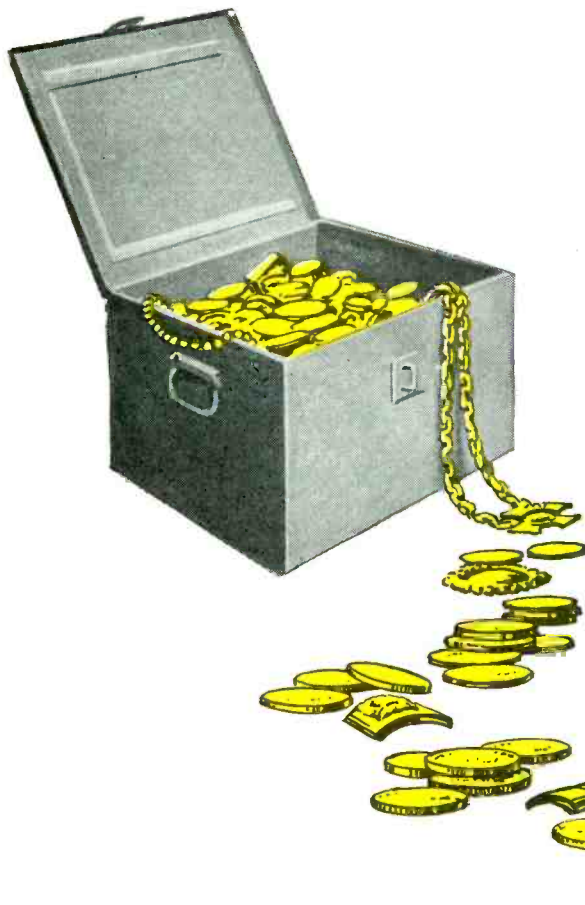

METAL CABINETS ARE "GOOD AS GOLD" *when fabricated by* **BALTIC**

Let our craftsmen give your products the golden touch that makes them look worth their price. We fabricate sheet metal cabinets, racks, panels, chassis or other formations to the most exacting requirements.

We work with any metal, any gauge and any dimensions or quantity, adhering to the same high standards whether the job is simple or challenging to our skill and ingenuity.

You can rely on us for perfection of construction details that insures complete uniformity and interchangeability of units or parts. This saves you money, because it makes your assembly easier and faster. You enjoy the extra benefits of custom work at little or no premium, because our large stock of tools and dies saves you high tooling costs.

We do careful, skillful welding of all types on any metal and have complete up-to-date finishing department. Compare our quality and our quotations.

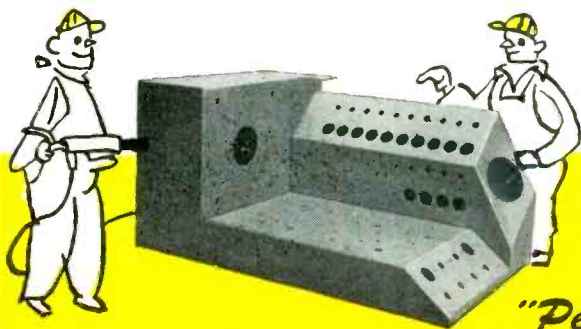

BALTIC METAL PRODUCTS CO.
120 SUTTON ST., BROOKLYN 22, N. Y.

"Perfectioneers" in Sheet Metal Fabrication

BRUSH

and
the future
of
ultrasonics



Laboratory Model Ultrasonic Transducer

● The Science of Ultrasonics, today, is in about the same relative position as that of electricity 75 years ago. In 1877 it was known that electricity, activating the arc lamp, would create light but there were few other practical uses for it.

Today, preliminary investigations of Ultrasonics indicate many possible applications. Among the fields worthy of exploration are the application of Ultrasonics to the processing of foods, chemicals and metals. Also of interest is the application to the cleaning of small precision parts.

In addition to carrying on extensive Ultrasonic investigations in their laboratories, The Brush Development Company has recently introduced a line of standard **HYPERSONIC*** equipment. This equipment has been designed to permit research staffs everywhere to join in the exploration of the potentialities of Ultrasonics.

Brush engineers welcome the opportunity to discuss with you the application of Ultrasonics to your specific problems. For further information, write The Brush Development Co., Department 3405 Perkins Avenue, Cleveland 14, Ohio.

*T. M. Reg.

THE **Brush**
DEVELOPMENT COMPANY



Piezoelectric Crystals and Ceramics
Magnetic Recording Equipment
Acoustic Devices
Ultrasonics
Industrial & Research Instruments

3405 Perkins Avenue • Cleveland 14, Ohio

grid was clamped at the top end but the connecting member to the stem wire at the bottom end achieved the same results.

As a further feature in structural design the four insulators of the 6BR7 were held by four wires which passed through holes near the periphery. The shielding members were all welded to these wires insuring that the insulators were all firmly held.

The anode of the 6BR7 was designed to reduce vibration. Besides the usual strengthening ribs it was supported between the insulators in three places preventing movement in any direction, Fig. 5.

Finally the tube assembly was located in the glass bulb very tightly by virtue of the four-insulator construction. This is important because as a rule the glass bulbs are of irregular internal diameter and a structure which is held by two insulators cannot always accommodate these variations.

Reduction of Hum

Hum is caused by the a-c heating of the cathode. It may be due to the capacitance between heater and grid, the induction effect between heater and grid, the magnetic effect, heater emission and/or by poor insulation between heater and cathode.

Insulation hum is rarely serious with the modern techniques of heater coating and in any case its effects can be largely countered by the cathode by-pass capacitor used in the circuit.

Magnetic hum is always met when faggot-type heaters are used and it may be almost completely avoided by using a double helical heater with a low heater rating be-

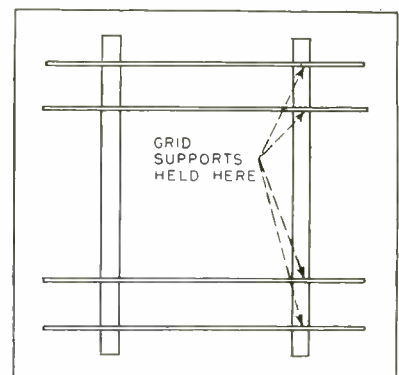
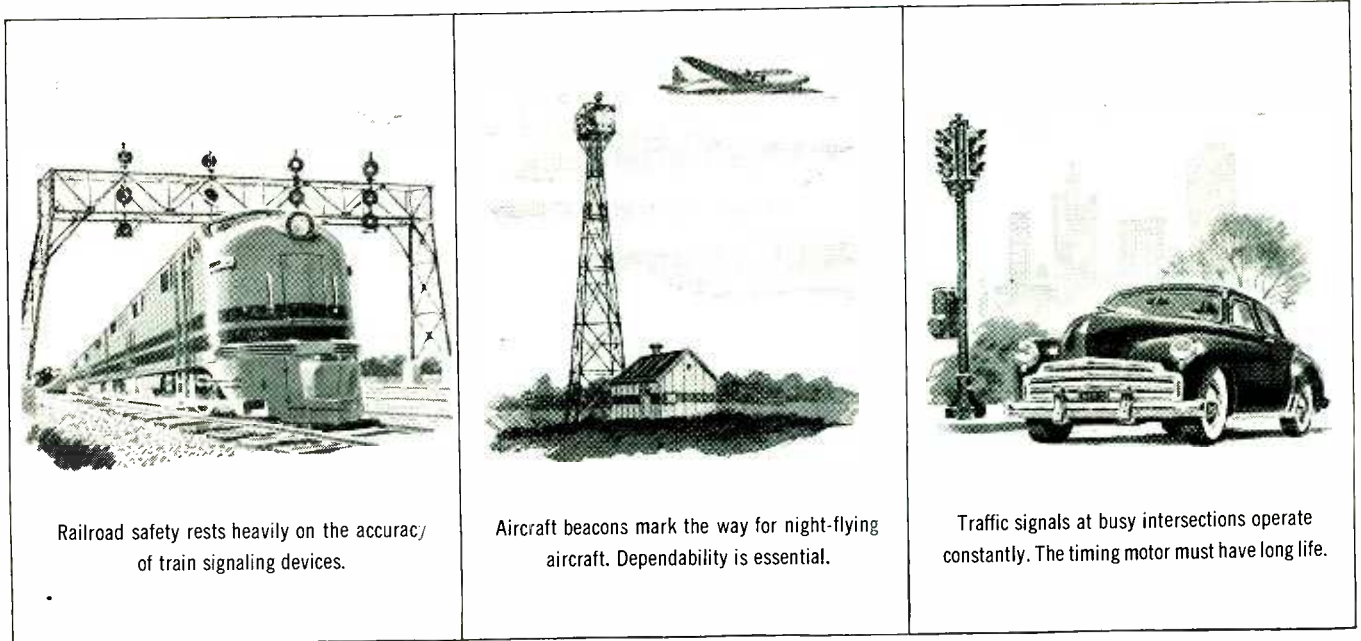

FIG. 4—Double-insulator system

Precious cargos!

—with *Telechron*[®] **motors** on guard
where accuracy, dependability, and long life are essential



Railroad safety rests heavily on the accuracy of train signaling devices.

Aircraft beacons mark the way for night-flying aircraft. Dependability is essential.

Traffic signals at busy intersections operate constantly. The timing motor must have long life.

Modern safety devices for high-speed transportation help assure safe arrival of loved ones who travel. And Telechron synchronous timing motors play a big part in making these safety devices reliable.

Because of design and the reservoir of specially compounded oil, all moving parts are continuously lubricated. The rotor shaft itself literally floats on a film of oil, and the entire mechanism turns quietly and with minimum friction. Even under the wide extremes in temperature and humidity common in the transportation field, Telechron motors — with their superior lubrication — have demonstrated consistent, year-in, year-out dependability.

Investigate the extra advantages of quality Telechron motors for your new product designs. They're available in a wide range of sizes and characteristics. For complete details, write for catalog IS-120. Telechron Department, General Electric Company, 47 Homer Ave., Ashland, Mass.

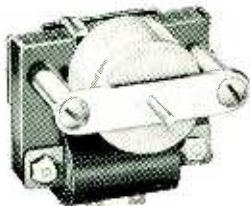

Type B3 Motor. A medium-duty motor for such applications as switches, combination recording and controlling mechanisms, and various types of control equipment.



Type C-5X Motor. A high-torque motor for operation in heavy-duty applications involving timing, switching, and controlling. Sturdy gear train construction. Reversible.

Telechron[®]

**FOR DOWNRIGHT
RECORDING
VERSATILITY**

*Current
Voltage
Pressure
Temperature*

*You can't beat the
system* **WHEN IT'S A
SANBORN**

*Stress
Strain
RPM
Displacement*

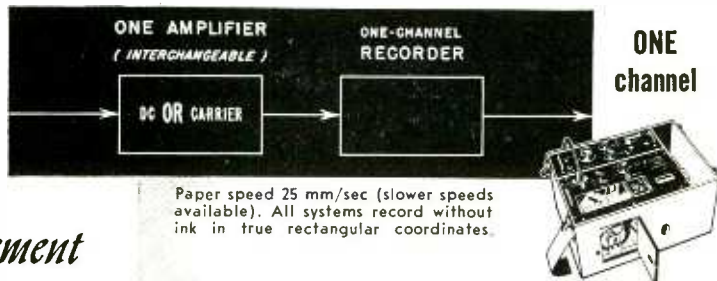

*Torque
Force
Flow
Shock*

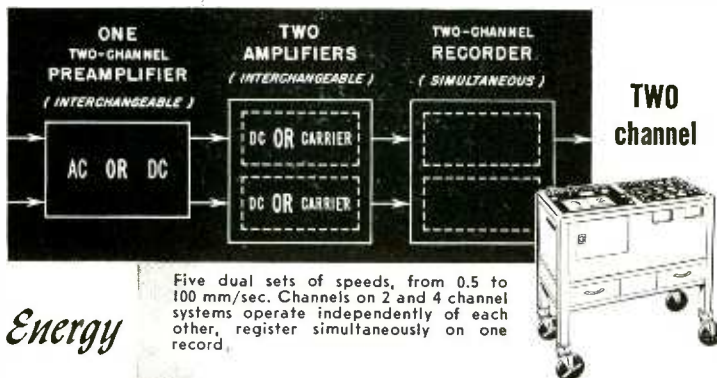

*Radiant Energy
Light
Tension
Load
Velocity
Vacuum*

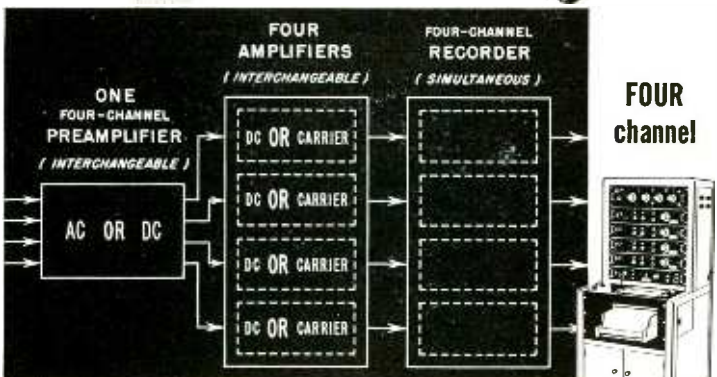

*Vibration
Gas Analysis
Humidity
Acceleration
Thickness
Sound Pressure*

For complete catalog
address Industrial Division.

**SANBORN
COMPANY**
CAMBRIDGE 39, MASS.

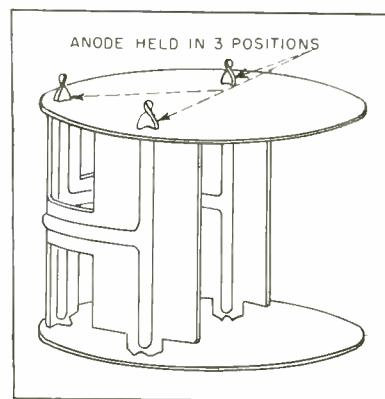

FIG. 5—Means for securing the anode to prevent movement

cause in such a heater design the return helix balances out the magnetic effect of the first helix. The 6BR7 uses a heater of this type with a rating of 6.3 volts at 0.15 ampere.

The static hum, caused by the capacitive effect and induction hum may be reduced by suitable screening between grid and heater. The more serious of these two is that due to the capacitive effect. The 6BR7 incorporates shielding devices so that the capacitance between grid and heater within the tube envelope is practically zero, Fig. 6. The disadvantage of the single-ended tube is apparent, as there must always be a capacitance effect in the glass base. Experiments show that nearly all of the hum produced in the 6BR7 is due to this.

Lastly the conduction effect due to heater emission is nonexistent since the cathode is pinched at the top and the heater shielded at the bottom, Fig. 6.

Reduction of Hiss

It has been explained that hiss noise due to electron emission is of a fundamental nature. The effect can be aggravated, however, if there are gas molecules present within the tube. These will ionize and change the nature of the space current. In the manufacture of the 6BR7, every effort is made to produce a tube with a very good vacuum. Surface texture of the cathode coating, in extreme cases, is also responsible for noise effects. If the emission is limited to isolated patches, the motion of the electrons becomes sporadic. By insuring



HERMETIC SEALING FOR EVERY REQUIREMENT

- NEO-SIL** HERMETIC SEAL TERMINALS — Applicable on MIL requirements. Will withstand thermal shock, vibrations, mechanical strains, and excessive pressures with no impairment of the seal or other functional characteristics. E-3LW terminals are now being used at 1000 psi static oil pressure and undergo 5000 psi tests for two minutes.
- NEO-SIL** OCTAL TYPE PLUG IN HEADERS — Applicable for MIL requirements. These units can undergo sustained vibrations, large temperature changes, and other strains without impairment to the seal or other functional characteristics. Available with eight and twelve pins.
- NEO-SIL** MULTIPLE PIN HEADERS — Applicable for MIL requirements. Presently being used on MIL-T-27 transformers. These units are available with 2 to 10 pins. These units can undergo conditions mentioned above with no impairment to the seal or other characteristics.
- NEO-SIL** FUSE HOLDERS, HERMETICALLY SEALED — Available for 3-AG and 4-AG fuses. These units are completely sealed from moisture with or without the cap or fuse inserted. They are applicable on pressurized and gas filled components.
- NEO-SIL** CABLES, HERMETICALLY SEALED — The cables are hermetically sealed at the plug on thru to the panel.
- NEO-SIL** ROTARY WATERSEAL PANEL ASSEMBLIES — These units have an excellent five year customer history on gas filled pressurized components. They are available for 1/4" shafts and for potentiometers and switch bushings.
- NEO-SIL** LINE CORDS WITH PLUGS FOR EUROPEAN USE, HERMETICALLY SEALED — These units are completely sealed at the plug and are being used on pressurized units.
- NEO-SIL** GASKETS, METER, PANEL, COVER, ETC. — Molded from Neoprene for complete sealing.
- NEO-SIL** ADAPTERS, U. S. TO EUROPEAN, AFRICAN, SOUTH AMERICAN SOCKETS — Our 200A and 300A together will adapt virtually all standard plugs, sockets, and lamp sockets of the above mentioned areas.
- NEO-SIL** COIL FORMS, CRYSTAL CONTACTS, and other molded bakelite and Neo-Sil rubber units.

PLUG IN TYPE HEADERS

MULTIPLE TYPE HEADERS

NEO-SIL HERMETIC SEALS INDIVIDUAL TYPE TERMINALS

TEST DATA

The result of the Electrical Testing Laboratories Inc., Report #330655, dated March 18, 1949, on this material shows the following:

Volume Resistivity at 800 Volts d-c
 Room Temperature 25°C R.H. 30 percent
 Megohm-inches okm centimeters
 1.4×10^8 35×10^{17}

Dielectric Constant and Dissipation Factor

Dielectric Constant	Dissipation Factor	Loss Factor
9.22	@ 60 cycles per second .058	5.32
6.17	@ 1 megacycle per second .0455	.28
5.35	@ 50 megacycles per second 0.20	1.1

Dielectric Strength at 60 cycles Volts per mil — 270

Durometer Average — 80 ± 5
 Temperature — Rated as a Class A material conservatively + 175° to -70° cent grade.

The Flashover Voltages indicated were taken at a temperature of 68° Fahrenheit, and 47% Relative Humidity.

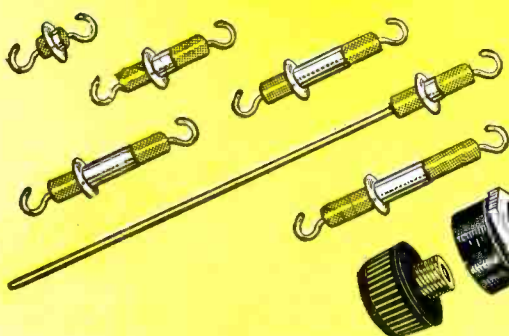

24 CORNELISON AVE., JERSEY CITY 4, N. J.

We welcome your inquiries on any phase of design, development or production.

CHICAGO REPRESENTATIVE: GASSNER & CLARK COMPANY
 6349 North Clark St., Chicago 26, Ill.

for LONGER battery LIFE

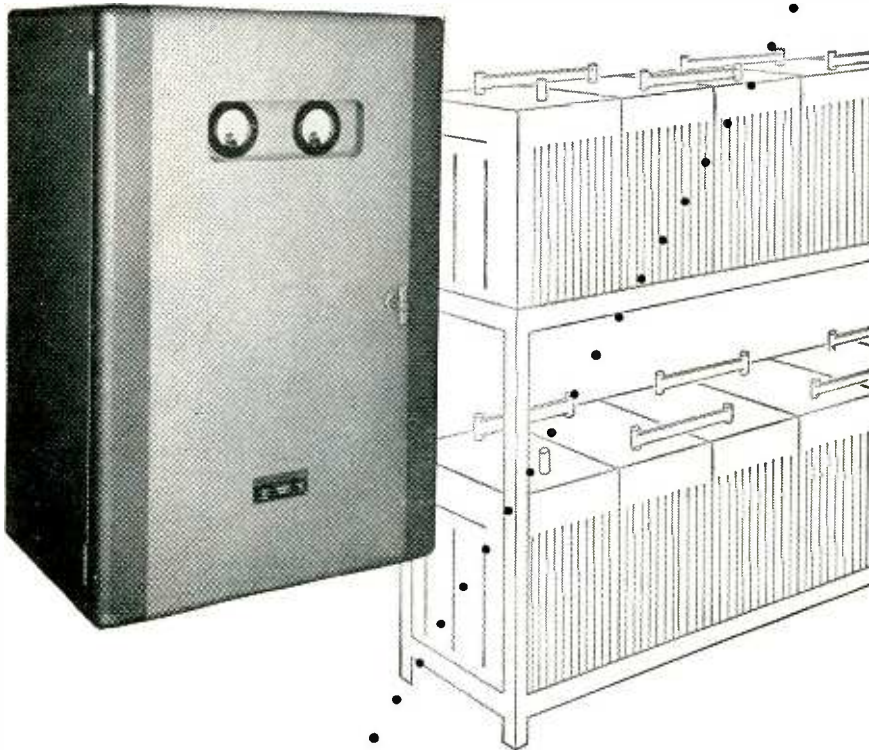

keep the floating voltage constant with PECO Automatic Battery Chargers

The PECO Battery Chargers accurately float the control battery of any power station or substation which has a reasonably constant switchboard load; furnishes power to the load and maintains a fully charged battery, ready for any emergency.

To provide extreme accuracy of electronic control and the exceptional reliability demanded by this type of service, Power Equipment engineers designed this PEC-626 Automatic Battery Charger by starting with the rugged components of a manual charger, then added a magnetic system for coarse voltage control and a simplified electronic system for fine voltage control.

As an illustration of the accuracy of the PECO charger, this example can be

used: the DC output is sufficient to maintain 60 lead acid battery cells at 129 volts; it will also furnish power to switchboard loads within the rating of the charger, and at all times the output voltage is automatically regulated to within ± 0.5 percent, for AC line voltage fluctuations of ± 5 volts on a 230 volt circuit.

Exceptional reliability is shown by the fact that if the electronic control section should be disconnected, the magnetic control section will still automatically hold the output voltage to within ± 3 percent of nominal voltage.

Write for complete specifications today.

POWER EQUIPMENT Company

Battery Chargers • Battery Eliminators •
D.C. Power Supply Units • Regulated Exciters
• and other Special Communications Equipment

55 ANTOINETTE STREET DETROIT 2, MICHIGAN

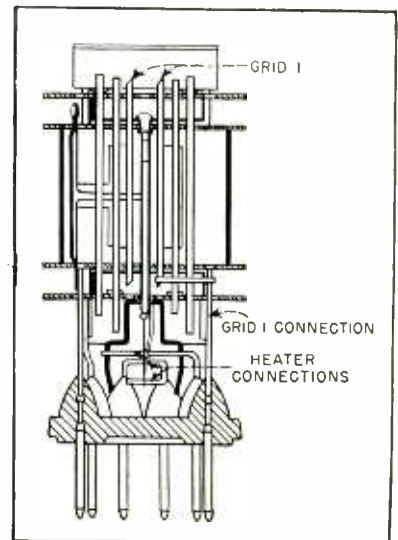

FIG. 6—Section of tube showing shielding (heavy lines) to reduce grid-to-heater capacity

that all the cathodes have a smooth coating and that the processing involved in manufacture is closely controlled, this trouble has been avoided in the 6BR7.

Finally, the insulators of the 6BR7 are all coated with a preparation that insures a very high resistance between electrodes. This is essential because the tube is normally used with a very high grid resistor which would produce a noise voltage at the grid if the leakage current were high. Values of grid current due to this cause for the tube structure alone, vary from 1.0×10^{-8} to 1.0×10^{-10} amperes.

Alarm Signal Generators

By M. B. FREEDMAN and T. E. ROLF

Special Devices Engineering Section
Engineering Products Department
RCA Victor Division
Camden, New Jersey

FIGURE 1 shows a circuit using the gas tube type VR75-30 to produce a simulated motor-driven horn. Constants were chosen to provide a fixed frequency of approximately 600 cps for the fundamental tone with a very short initial voltage delay to simulate the motor starting time. The tone was roughened by introducing a 60-cycle voltage into the network to simulate the ratchet frequency.

The maximum leakage current of the tube was not a factor in this

This is the second and final section of the paper. The first section appeared in the June issue, page 200.

Brilliant and
Steady

**BACKGROUND
PROJECTION**



for World-Wide Settings in YOUR TV Studios

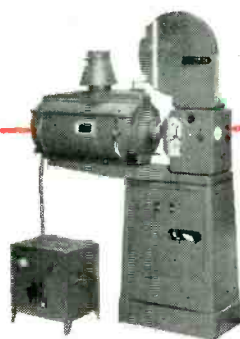

**First Professional 16 mm
TV Background Projector
Provides 2,000 Lumens**

46 ampere arc lamp, $f/1.5$
20 mm lens, air-cooled
film gate, sprocket inter-
mittent that ends film
wear and holds old film
steady.

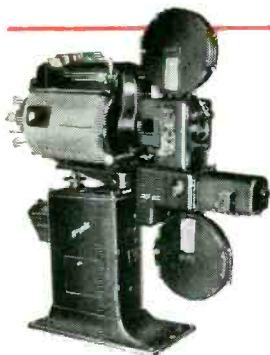

**TV Version of Famous
Simplex X-L 35 mm
Projector: 7,000 Lumens**

An incomparable projec-
tor used in 80% of all
theatres; now equipped
for TV use with "2-3"
intermittent. 80-110 am-
pere arc; $f/1.9$ 2" lens.

Here, at last, is background projection made practical for any TV studio or network . . . brilliant, steady motion pictures that make any action scene in 16 mm or 35 mm film libraries available as a setting for TV programs.

No complex phasing needed with TV cameras. Simply focus camera on the background screen for a perfect picture. The GPL "2-3" intermittent pulldown, coupled with a 60 light-pulse per second shutter, automatically meets the camera's requirements. Special optical systems for each projector reduce "throw" required, save studio space.

Get full details on these outstanding projectors, now in use on major networks. Consider them in your new studio planning; add to the utility of your present equipment.

WRITE, WIRE or PHONE . . .

General Precision Laboratory

INCORPORATED

PLEASANTVILLE NEW YORK

GPL

TV Camera Chains • TV Film Chains • TV Field and Studio Equipment • Theatre TV Equipment

ENGINEERS...TECHNICIANS!..here is your

New!

B&W

Dip Meter
Model 600

PRICE
\$48 net



VERSATILITY, COMPACTNESS, QUALITY

Few instruments will prove so handy in so many ways as this versatile B&W Model 600 Dip Meter! Ideal for lab, production, service or ham shack use, it provides a quick, accurate means for measuring resonant circuit frequencies, spurious emissions and many other tuned circuit characteristics. Shaped for easy use in today's compact electronic assemblies, highly sensitive and accurately calibrated, it incorporates many features previously found only in higher-priced instruments. You'll find dozens of uses for it as ...

A Grid Dip Oscillator for determining resonant frequencies of tank circuits, antennas, feed line systems, and parasitic circuits; align-

ing filters and traps; peaking coils, neutralizing and tuning transmitters before power is applied.

An Absorption Wave Meter for accurately identifying the frequency of radiated power from various transmitter stages; locating spurious emissions causing troublesome TV and radio interference, and many similar uses.

An Auxiliary Signal Generator providing a signal for tracing purposes and for preliminary alignment of receivers, converters, and I-F stages.

An R-F Signal Monitor for audible observation of hum, audio quality, and other audible characteristics of radiated power.

For Capacity, Inductance, and "Q" measurements in conjunction with other components of known value.

TECHNICAL FEATURES

- ✓ Covers 1.75 to 260 mc. in 5 bands.
- ✓ Adjustable sensitivity control.
- ✓ Size 3" x 3" x 7". Weight 2 lbs.
- ✓ Handy wedge-shape for easy access in hard-to-get-at places.
- ✓ Monitoring jack and B+ OFF switch.
- ✓ Rust-proofed chassis, aluminum case.
- ✓ Built-in power supply for 110 volts A.C.

Sold by leading distributors throughout U. S. A. and Canada
Data bulletin sent on request.

BARKER & WILLIAMSON, Inc.

237 Fairfield Avenue

Upper Darby, Penna.

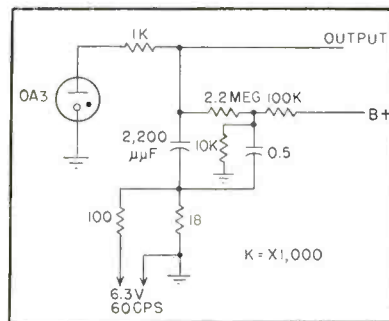

FIG. 1—Gas-tube simulated horn

circuit since the resistance values are relatively low. However, since one multivibrator oscillator could be used for both the siren and horn signals by changing voltage conditions, the gas tube was eliminated entirely.

The multivibrator oscillator has proven to be a versatile tool for the designer of alarm and attention signals because of the ease with which its frequency can be changed by voltage variation. It has been substituted for the gas tube in the siren and horn circuits as shown in Fig. 2 which shows a circuit used to obtain both signals from one oscillator by switching the circuit elements.

The multivibrator oscillator has been further applied in the production of signals for timing the bell repetition rate and the recurrence rate of a siren signal which cycles approximately every three seconds. In these cases a pulsing relay in one of the multivibrator plate circuits applies or varies the frequency control voltages.

Recently, the building-block principle has been applied in the development of a new audio generator for producing alarm signals in an announcing system. Two phase-shift oscillators, two multivibrators

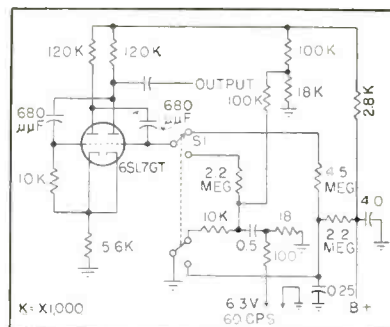
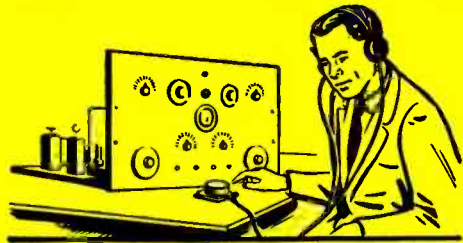

FIG. 2—Siren horn circuit, Switch S_1 is shown in the siren position

As old as
RADIO
yet as young as
ELECTRONICS...

AEROVOX CAPACITORS



1922 At the very dawn of radio—30 years ago, Aerovox came into being to meet capacitor needs. Pioneer radiophone transmitters and earliest radio receivers specified Aerovox capacitors. Such collaboration has continued down through the first three decades of radio-electronic progress.

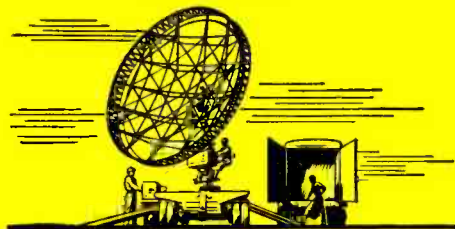

1952 Today, giant atom-smashing betatrons . . . radar gear spotting unseen targets . . . transoceanic radio-guided rocket bombs . . . world-wide radio communications . . . electronic computers reducing thousands of calculation man-hours to mere seconds . . . the modern miracle of television — for all facets of the Electronic Age, Aerovox capacitors are still engineered to customer specifications.

Indeed, from tiny precision “ceramics” and metallized-paper “space-savers,” to giant power-handling “oils” and “micas,” Aerovox remains the time-proven source for ALL capacitor needs.



Sub-miniature vitrified ceramic terminal end-seal Type P123ZN Aerolene-impregnated metallized-paper tubular capacitor.



AEROVOX CORPORATION

NEW BEDFORD, MASS.

Hi-Q® DIVISION OLEAN, NEW YORK **WILKOR** DIVISION CLEVELAND, OHIO

JOBBER ADDRESS: 740 Belleville Ave., New Bedford, Mass.

Export: 41 E. 42nd St., New York 17, N. Y. • Cable: AEROCAP, N. Y. • In Canada: AEROVOX CANADA LTD., Hamilton, Ont.

for MILLIMICROSECOND Pulse Observation

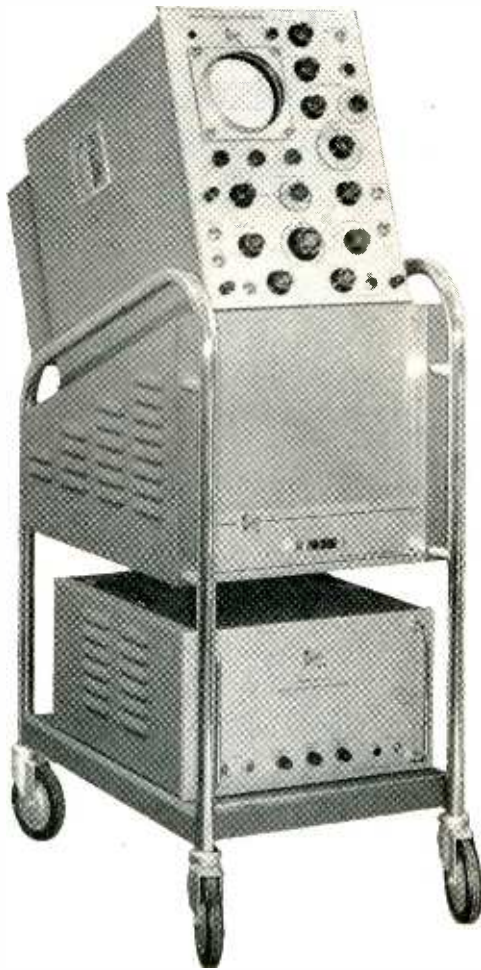

The **TEKTRONIX Type 517 Cathode-Ray Oscilloscope** is a specialized instrument designed primarily for the observation and photographic recording of very fast rising wave forms having a low duty cycle. Vertical amplifier risetime of 7 m μ sec and sweeps as fast as 10 m μ sec/cm permit step-function reproduction with an accuracy never before attainable in a commercial oscilloscope. Sufficient delay is incorporated in the vertical amplifier to permit the observed signal to trigger the sweep. Built-in rate generator can be used to trigger the circuit under study.

SENSITIVITY—0.1 v/cm

RISE TIME—0.007 μ sec or less

TIME BASES—11 fixed, 0.01 μ sec/cm to 20 μ sec/cm, accurate within 2%

NET SIGNAL DELAY—(Total delay minus sweep starting time) 20 to 50 m μ sec

ACCELERATING POTENTIAL—24kv

METALLIZED CRT

REGULATION—All critical voltages electronically regulated

AMPLITUDE CALIBRATOR—25 kc pulse, 0.15 v to 50 v full scale, accurate within 4%

TEKTRONIX Type 517 Cathode-Ray Oscilloscope
\$3500 f.o.b. Portland, Oregon



TEKTRONIX, Inc.

P. O. BOX 831A, PORTLAND 7, OREGON • CABLE: TEKTRONIX

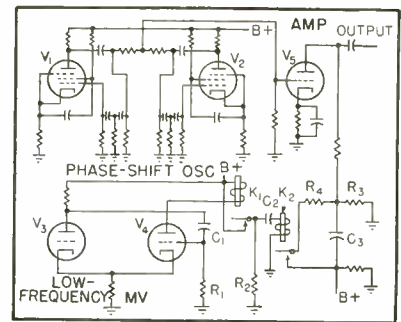

FIG. 3—Bell-generator circuit

and an amplifier connected in various combinations by external switching arrangements comprise all the circuitry needed to create the bell, siren and horn signals.

Figure 3 shows the bell circuit minus the switching setup. The phase-shift oscillators apply a continuous tone signal to the amplifier. The exponential amplitude decay is introduced in the plate circuit of V_5 , where C_3 is seen to be in series with the B supply. The charging rate of C_3 through V_5 and R_3 determines the decay characteristic of the bell.

Relays K_1 and K_2 and multi-vibrator V_3 , V_4 comprise the cycling actuator. Relay K_2 is pulsed by the surge of charging current in C_2 each time K_1 is energized by V_4 . Contact K_{2A} remains closed only a small fraction of a second, but long enough to discharge C_3 completely through R_4 , a small resistor. The pulsing of K_2 thus results in the momentary application of full $B+$ voltage to V_5 , hence momentary full output. With K_{2A} open again and C_3 charging, the amplitude diminishes in accordance with the decay of potential on the tube side of C_3 .

The time constant is adjusted so that the signal voltage amplitude is about one-fifth of maximum value when recycling occurs. The type of multivibrator shown in Fig. 3 was chosen to insure that when $B+$ is turned on to start the generator, V_4 would always conduct immediately so that the closing of K_{2A} would always coincide with the initial application of $B+$ to V_5 . If this were not done, application of $B+$ to the previously "dead" circuit would start a bell cycle which would be reactivated prematurely when the relay tube did conduct, thus producing a double-strike at the outset.

The siren circuit, shown in Fig.

Let **MONOWATT** help you with your ORDNANCE CONNECTOR REQUIREMENTS

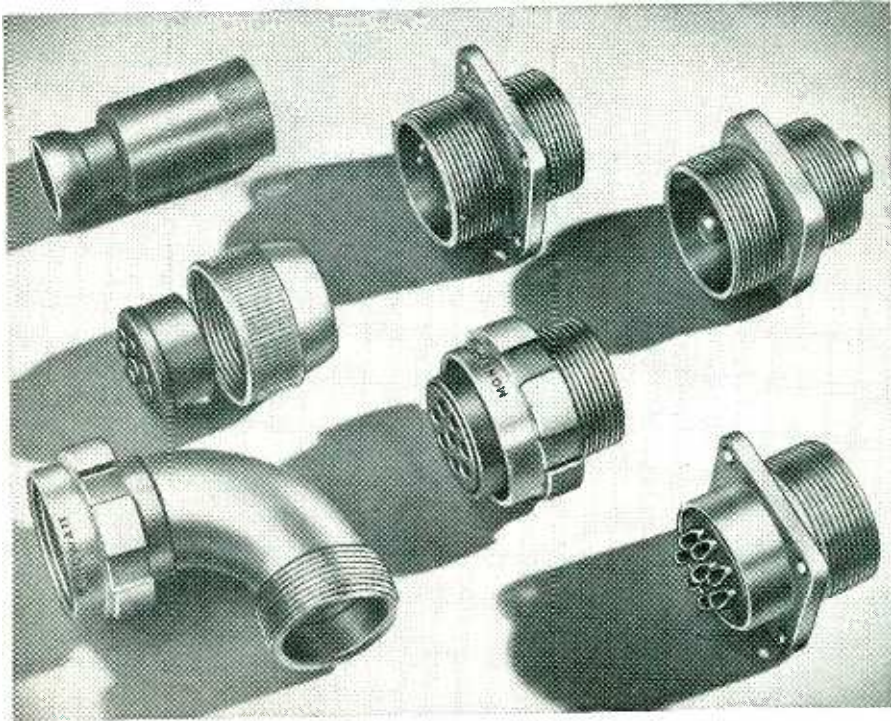

Pictured here are the basic styles of ordnance connectors made by Monowatt, with several accessories. What the camera cannot show is the organization back of the product—the sound engineering, expert workmanship, and facilities for mass-production.

Monowatt is now supplying ordnance connectors for such companies as American Locomotive (for tanks), Auto-Lite (for vehicle generators and voltage regulators), as well as Detroit Tank Arsenal (for spare parts for tanks).

If you use ordnance connectors—or any of the wiring components shown below—you will be interested in what Monowatt can do for you.

↑ Connectors made to Government specifications, for ordnance vehicles. Includes a complete line of accessories which provide moisture-proofing, radio shielding, prevention of wire breakage, and use under special applications.

For complete information, mail the coupon.

And you can count on **MONOWATT** for all types of electrical components — made to your specifications



Harness Assemblies
Made to your specifications



Wiring Devices
For mass-produced electrical equipment and appliances



Wiring Components
Made to your specifications

Monowatt Department C-7, General Electric Company
95 Hathaway St., Providence 7, R. I.

- Please send Catalog D-1 — Electrical Connectors and Wiring Assemblies for Aircraft, Ordnance and Electronic Equipment.
- Please quote on attached specifications.

Name.....

Title.....

Company.....

Address.....

MONOWATT
A DEPARTMENT OF GENERAL ELECTRIC COMPANY, PROVIDENCE 7, R. I.

MARCONI

was

first

first radio patent 1896.

first radio Company.

first to span Atlantic with a radio signal.

first ship to shore radio transmissions.

first commercial air radio service.

first short wave directional beam.

These are but a few of the vital contributions which the Company, founded by Guglielmo Marconi has, in the course of half a century, given in the service of mankind.

MARCONI of England

serves mankind

MARCONI'S WIRELESS TELEGRAPH COMPANY LTD., CHELMSFORD, ENGLAND

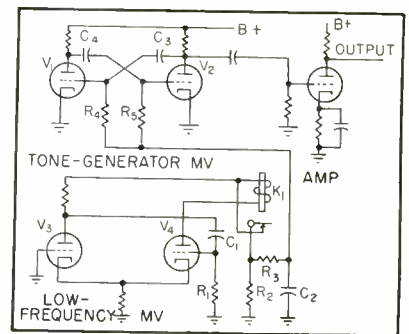

FIG. 4—Siren-generator circuit

4, uses two of the three blocks used for the bell. The tone generator, however, is now a multivibrator. The amplifier is now directly powered by B+. The circuit operation is as follows: Initial application of B+ power starts both multivibrators and the amplifier. Relay K_1 is energized immediately, preventing application of B+ to the tone generator grid circuits. Capacitor C_2 is charged negatively by current from V_1 and V_2 grids and the gradual accumulation of this bias on the grids gradually reduces the plate waveform amplitudes, resulting in lesser grid swings and consequently shorter multivibrator periods.

The frequency rises exponentially toward a much higher value. The decreasing amplitude is not in evidence at the output because of the amplifiers limiting effect. Exponential return of the frequency to the lower value is initiated by the reversal of multivibrator V_3 - V_4 , whereupon K_1 is deenergized and B+ is applied to C_2 through R_3 . Capacitor C_2 must now charge from its negative potential toward the B+ potential, retracing approximately the path it followed in going negative. The charge is never permitted to start positive, for when

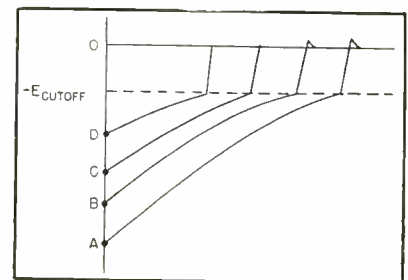

FIG. 5—Grid-circuit waveforms for siren tone-generator multivibrator. Explanation of curves is in text



THEY'RE NEW...



AND THEY'RE THOMPSON TOO!



Model CA-26, 1P6T, 115 volt, 60 cycle, AC motor-actuated Coaxial Switch for use with RG-9/U cable.

COAXIAL SWITCHES

designed, engineered, manufactured ...

by **Thompson**



Model CA-36, 1P3T manually-actuated RG-17/U Coaxial Switch with electrical and mechanical interlock.



Model CA-31, 2P2T Sensing or Lobing Switch, 115 volt, 380-1000 cycle AC motor actuator. Switching speed, 15-35 Rev/sec. For use with RG-58/U cable.

EVERY INCREASE in the scope and tempo of electronics creates new and stringent demands. Keeping abreast through development and manufacture of a reliable line of special-purpose electronic equipment is the business of Thompson experimental laboratories and manufacturing plants.

Like many other Thompson electronic developments, the three new coaxial switches illustrated were designed, engineered and manufactured to meet the rigid requirements of modern microwave components and accessories. Complete technical information is, of course, available upon request.

Whatever your problems may be—in coaxial switches, antennae, specialized test equipment or wave guide and coaxial components and accessories—Thompson's experience-proved research, development and production facilities at both Cleveland and Columbus, Ohio are at your service.

Thompson Products, Inc.

ELECTRONICS DIVISION • 2196 CLARKWOOD RD. • CLEVELAND 3, OHIO

for exclusive

**2-way
switch
timing
at Low Cost**



Buy } **SESSIONS
SWITCH TIMERS**

Only Sessions Switch Timers provide the exclusive, two-way switching feature that can double the buy appeal of your radio and television sets.

Sessions Timers not only feature the popular, automatic *switch-on* control—used to awaken or remind—but an exclusive *shut-off* switch as well. Thus, a Sessions-equipped clock radio may be set to turn off automatically 1½ to 2 hours after set turn-on . . . can be used as a Sleep Switch or as safety Shut-off. That's just *one* fast-selling Sessions feature available at an amazing *low cost*.

Advanced design brings split-second accuracy and kitten-quiet operation to all fully-guaranteed Sessions movements. Custom styling enables you to specify dial, hands and bezel characters to fit your exact requirements. Timers are available with separate, adjustable "Sleep-Slector" switches, and other features. These important considerations make it worth your while to buy the better buy . . . **SESSIONS SWITCH TIMERS**. Write for technical details. The Sessions Clock Company, Timer Div., Dept. 44, Forestville, Conn.

See Sessions Products at
The
National Housewares Show,
Atlantic City, N. J.
Spaces 1302-1303,
Lower Level July 7-11

Sessions
SWITCH TIMERS

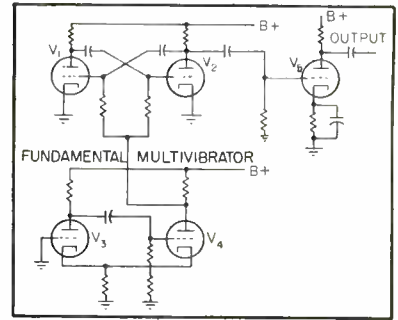

FIG. 6—Horn-generator circuit

the negative potential has been reduced nearly to zero, K_1 is energized again and the cycle repeats. Figure 5 illustrates a series of grid waveforms, A-D taken in that order as the frequency rises.

The horn circuit, Fig. 6, utilizes all three of the blocks which were used in the siren. The modulation of the tone generator is now direct, a resistor replacing the relay coil in the V_1 plate circuit. The composite signal appears as a fundamental tone of about 400 cps roughened by a lower frequency tone at about 30 cps, the latter corresponding to the ratchet frequency. The amplitude of the modulating component is about one-fourth the fundamental amplitude and appears both as frequency-modulation and as a mixed-in amplitude component.

Television Spot Wobbler

THE CIRCUIT diagram shown in Fig. 1 is of the "spot-wobble" portion of the Ekco Model TC165 television receiver, designed for the reception of 405-line transmissions as used in Great Britain.

The purpose of the device is to fill in the spaces between the lines on the normal television picture. It is thus of greatest value in receivers employing large picture tubes with a small, well-focused spot.

It will be seen that the circuit comprises a Colpitts oscillator in which the oscillator coil takes the form of an extra pair of vertical deflection coils. These coils are mounted on the neck of the picture tube, adjacent to the focus magnet.

From the point of view of achieving the required result in the picture, the exact oscillator frequency

Sensational Advancements In Science & Industry

Created the Need for **THE NEW** *Stabelex "D"* **CAPACITORS**



YOUR FREE
INDUSTRIAL CONDENSER CORPORATION
Stabelex "D" Capacitor Catalog
may prove to be the most important
new single piece of literature for
you this year!

The low power factor is shown on Curve #1108. It is to be noticed that the losses over a wide range of temperature are practically negligible.

Performance curves illustrating various characteristics of the Stabelex "D" Capacitor will appear in this magazine each month.

OUTSTANDING FEATURES

INSULATION RESISTANCE AT 20° C. AFTER THREE MINUTES CHARGE—900,000 megohm microfarads

INSULATION RESISTANCE AT 75° C.—78,000 megohm microfarads

INSULATION RESISTANCE AT -75° C.—In excess of 5 million megohm microfarads

CHANGE IN CAPACITANCE FROM 25° C. TO -80° C; +0.76%

SELF TIME CONSTANT OF 10 MFD CAPACITOR—4800 hours

Q AT 50 KILOCYCLES—10,000

POWER FACTOR AT 1 KC—0.00025

SEND FOR CATALOG 1117 TODAY

After a long period of research, Industrial Condenser Corporation now offers to industry for the first time the first of their family of Stabelex capacitors, stabelex "D", which has been produced for special applications for some time.

Complete information performance curves, characteristics, and suggested applications of the various types now available will be found in this catalog.

Mfrs. of OIL, WAX, ELECTROLYTIC, PLASTIC

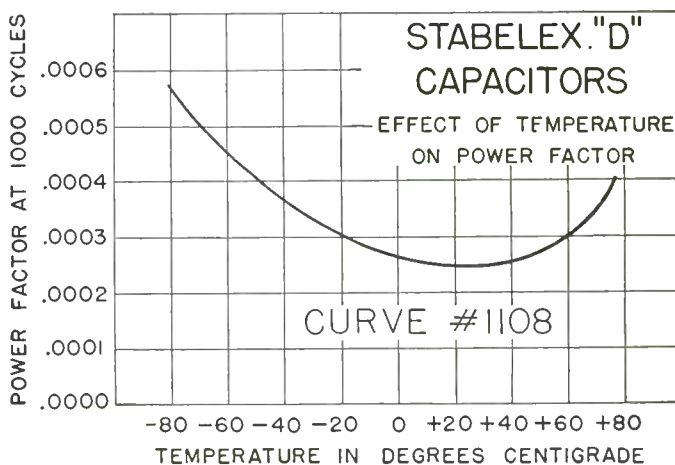

INDUSTRIAL CONDENSER CORPORATION

3244 N. California Avenue
Chicago 18, Illinois, U.S.A.

Please send me my FREE copy of your new Catalog 1117 on Stabelex "D" Capacitors.

Name

Company Position

Street

City Zone State

CAPACITORS and RADIO INTERFERENCE FILTERS



GYROS

Designed, Developed, and
Produced by

ECLIPSE-PIONEER



● Eclipse-Pioneer, one of the world's largest producers of Gyros, has developed a series of direct reading and remote transmitting Gyros for radar stabilization, navigation, remote compass, automatic pilot, and other similar airborne applications.

Typical of these Gyros is the type 14104, a two axis, gravity erected Vertical Gyro Transmitter designed for use as a remote vertical reference where vertical stabilization is required. The instrument is essentially an electrically driven, vertical-seeking gyro with separate Autosyn* transmitter pick-offs on the pitch and bank axes. Sealed in an aluminum case, protection against environmental conditions is accomplished by means of a double "O" ring labyrinth air tight seal. Signals are brought out on sealed headers (terminal panels) and caging and uncaging is obtained thru D.C. solenoids. Provisions are incorporated within the case to reduce bank error encountered in turns. A means of sensing turns is required in order to employ this feature.

*REG. TRADE MARK OF BENDIX AVIATION CORPORATION

LOOK FOR THE PIONEER MARK OF QUALITY
REG. U. S. PAT. OFF.

Specifications for Eclipse-Pioneer Gyro Type 14104

Dimensions: 6 $\frac{3}{4}$ " diam., 6 $\frac{3}{4}$ " high • Weight: 6 $\frac{1}{4}$ lbs.

Operational limits: 360° in roll and pitch with controlled tumbling of the pitch axis at near 90°.

Erection device: A gravity sensitive erection system maintains the gyro in a vertical position to within $\pm\frac{1}{4}$ ° of vertical.

Caging: From any position at full rotor speed in less than 45 seconds.

Power Requirements

Gyro rotor: 115 volts, 400 cycle, 3 phase, 25 VA • Gyro caging: 28 volts DC, 5 amperes.

Gyro turn error compensation: 115 volts, 400 cycle, Single phase 40 MA.

Pickoff excitation: 26 volts, 400 cycle, Single phase, 0.34 watts each.

Bank and Pitch Pickoff Information

Input voltage: (Nominal rotor excitation): 26 volts, 400 cycle, Single phase.

Input current: 50 milliamperes.

Input impedance (stator open): 139 + j510 ohms.

Stator resistance—DC (line to line): 34 ohms.

Rotor resistance—DC: 48 ohms.

Stator output—max. (line to line): 11.8 volts.

Sensitivity: 220 millivolts x degree sine of displacement angle.

Null voltage—max.: 70 millivolts.

Phase shift (rotor to stator): 4°

For detailed information, write to Dept. C

ECLIPSE-PIONEER DIVISION of

TETERBORO, NEW JERSEY

Export Sales: Bendix International Division, 72 Fifth Avenue, New York 11, N. Y.

Bendix
AVIATION CORPORATION

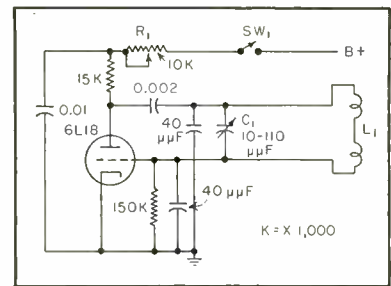

FIG. 1—British circuit uses Colpitts oscillator. Oscillator coil is used as an extra pair of vertical deflection coils

is not very critical but, for normal size picture tubes, should be such as to produce about 1,000 complete cycles or wobbles in each line. As in the British system, the visible portion of each line represents 83.5 percent of the whole, 1,000 wobbles per line will produce 835 visible wobbles across the width of the picture. The "wavelength" of each wobble in a 13-in. wide picture is thus 13/835 in. which is roughly 0.015 in. The required amplitude of wobble is related to the line-pitch of the picture.

For the British 405-line, 25 image-per-second system, 1,000 wobbles per line entails an oscillator frequency of slightly over 10 mc but in practice this frequency is adjusted within this region to a value which eliminates the possibility of harmonic interference with the receiver. This adjustment is carried out in relation to the reception channel to which the receiver is tuned.

Referring to Fig. 1, L_1 is the combined oscillator coil and wobble deflection coils and C_1 adjusts the operating frequency. Resistor R_1 is the amplitude control which is preset and SW_1 permits the device to be switched out of circuit to facilitate adjustment of focus.

Simple Capacitance Alarm System

THE CIRCUIT shown in Fig. 1 is for a simple capacitance alarm device known as the Intrudalarm and manufactured by Harvey-Wells Electronics, Inc., Southbridge, Mass.

Essentially, the circuit consists of a weak oscillator and a relay tube biased to cutoff by some of

PRECISION

Controls

At the *very heart* of highly critical equipment such as electronic computers, electronic gunsights and radar assemblies, the control requirements call for outstanding electrical and mechanical precision. Indeed, from single section to as many as twenty sections, the precision controls must track with mathematical accuracy.

Clarostat Series 42 Controls fully meet these requirements. Thus *the climax in precision controls*.

Clarostat has made the major portion of such precision controls in use today. Many were supplied to the armed forces in World War II. Many more have been supplied for civilian purposes since then. And now, *based on an unparalleled experience background*, Clarostat engineers offer you further refinements in their latest Series 42 design.

You can stand pat with CLAROSTAT

Engineering Bulletin No. 142 sent on request. And remember, when your control or resistor requirements call for *quality, quantity and economy*, you can meet them with Clarostat's engineering and production facilities. *Submit that problem!*

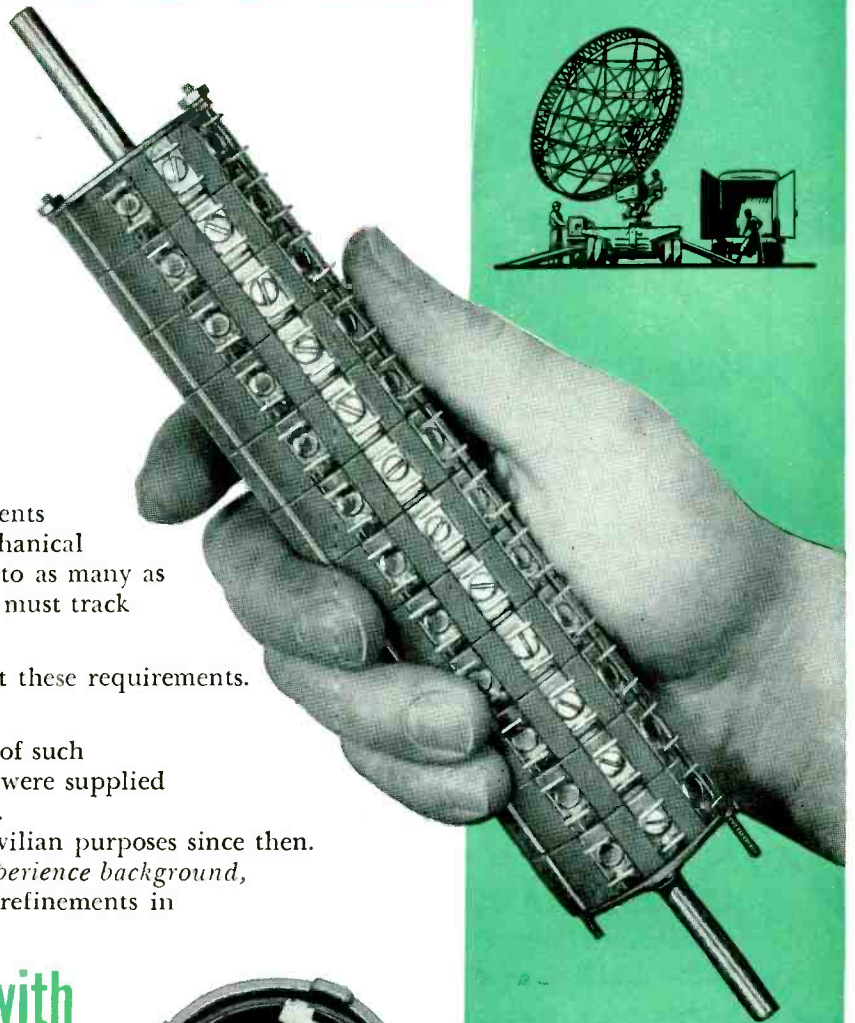
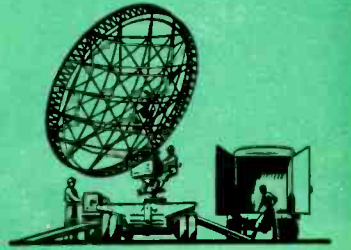

New Clarostat Series 42 potentiometer. Available in single and multiple assemblies up to 20 sections. Precision windings to plus/minus 0.5% and better. Positive contact rotor, smooth rotation, minimum wear. Perfect tracking of all units in assembly. No backlash or play. Rotor of each potentiometer mounted on centerless-ground shaft passing through all sections.

Controls and Resistors

CLAROSTAT MFG. CO., INC., DOVER, NEW HAMPSHIRE
In Canada: Canadian Marconi Co., Ltd., Toronto, Ontario



WHEN YOU NEED A MINIATURE TRANSFORMER

CHECK THESE FEATURES OF THE HORNET

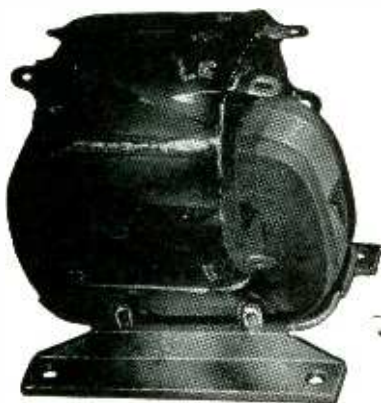

- ✓ **SIZE AND WEIGHT** Because they are designed for high operating temperatures, Hornet Transformers and Reactors have only about one-fourth the size and weight of Class A units of comparable rating.
- ✓ **VOLTAGE RATINGS** Designs are available for RMS test voltages up to 10,000 volts at sea level, and up to 5,000 volts at 50,000 feet altitude. Power ratings from 2VA to 5KVA.
- ✓ **POWER FREQUENCIES** These units are designed to operate on 380/1600 cps aircraft power supplies, 60 cps power supplies, and any other required power frequency.
- ✓ **AMBIENT TEMPERATURES** Hornet Units can be designed for ambient temperatures up to 200 deg. C. Size for any given rating depends upon ambient temperature and required life.
- ✓ **LIFE EXPECTANCY** Extensive tests indicate that the life expectancy of Hornet units at continuous winding temperatures of 200 deg. C. is over 50,000 hours.
- ✓ **MOISTURE RESISTANCE** Since Hornet Transformers and Reactors contain only inorganic insulation, they are far more moisture resistant than conventional Class A insulated units.
- ✓ **EFFICIENCY** Regulation and efficiency of Hornet Transformers compare favorably with Class A units.
- ✓ **SPECIFICATIONS** Hornet Transformers meet the requirements of Government specifications covering this type of equipment.



Bulletin B300, containing full electrical and dimensional data on Hornet units, is now available. Write for it, or tell us your specifications for special units.



**NEW YORK
TRANSFORMER CO., INC.**
ALPHA NEW JERSEY

ELECTRONS AT WORK

(continued)

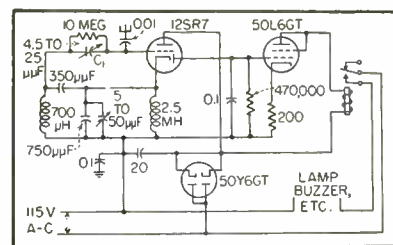

FIG. 1—Schematic of the intruder alarm system

the output voltage from the oscillator. In normal operation, any additional capacitance caused by a person or object coming close to the antenna will cause the oscillator to stop oscillating. When this happens, the bias on the 50L6GT is removed, the tube conducts and actuates the relay which closes the circuit of the warning device.

Ultrasonics Aids Diathermy Experiments

By HERMAN P. SCHWAN and
EDWIN L. CARSTENSEN

*Department of Physical Medicine
Moore School of Engineering
University of Pennsylvania
Philadelphia, Pennsylvania*

IN THE INVESTIGATION of the heating of tissue by high-frequency sound, relatively little work has been reported on the acoustic impedance of tissue. There has been evidence, however, to show that frequencies in the order of one mc are of interest for diathermy.

The first biological material chosen for investigation was blood. Figure 1 is a diagram of the mechanical arrangement used in the measurements. The test vessel is divided into two compartments by a rubber diaphragm. One half is filled with degassed water and the other with the liquid under investigation.

Transducers are mounted on a sliding assembly source in the water chamber and the receiver is located in the test liquid. The separation between the transducers is held constant and the transducer assembly is moved along the axis of the test tank.

Variation of receiving intensity with assembly position is used to obtain the absorption coefficient of the sample liquid. Barium titanate

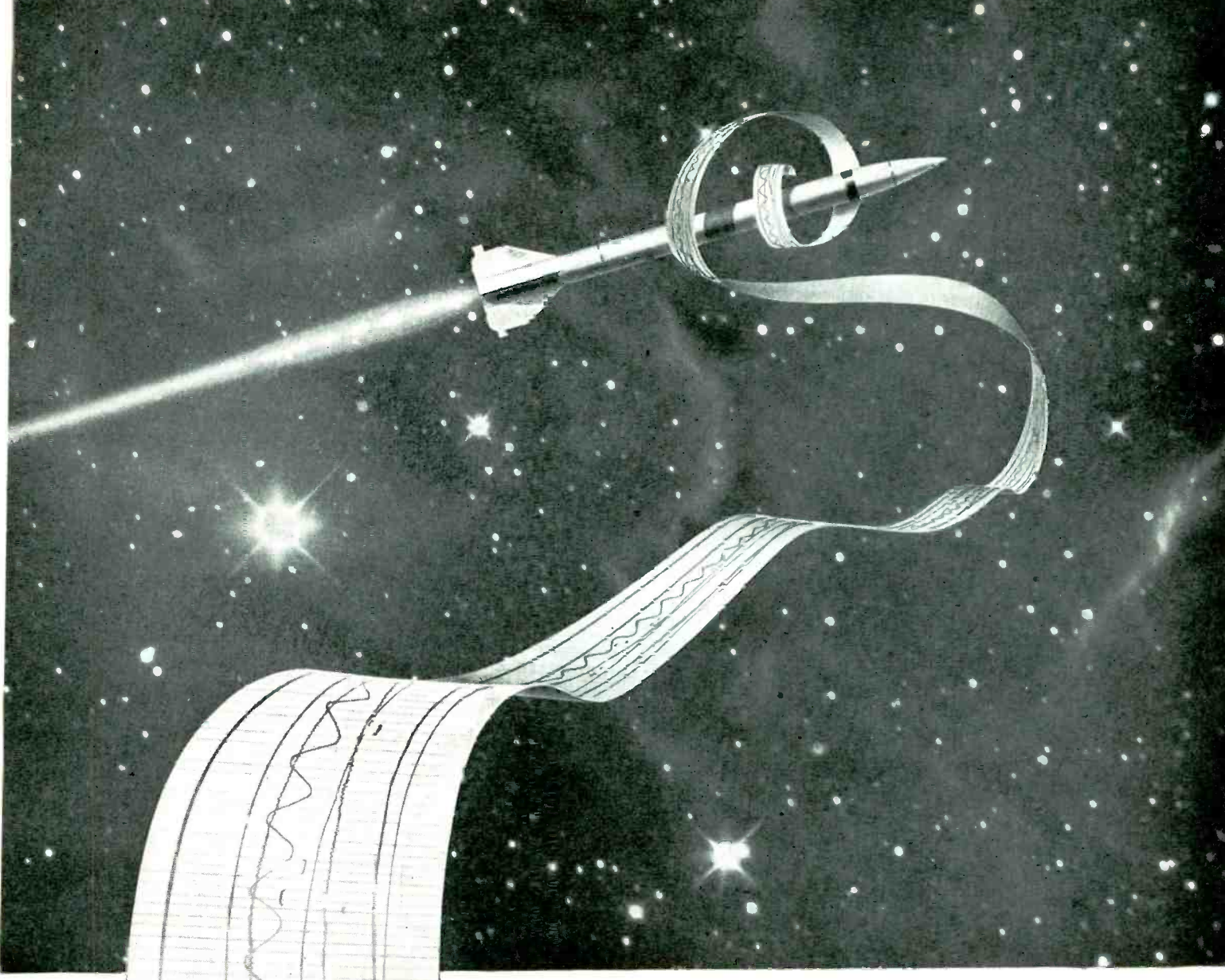

REPORT CARD...from Space!

STRUCTURE	A-
AERODYNAMICS	B+
PROPULSION	B-
ELECTRICAL SYSTEM	B
CONTROLS	C
GUIDANCE	C-
PR	B+
SI	

Guided missiles send their "report cards" home in the form of complex radio signals which are received and recorded permanently at the ground station. These records inform the missile engineer if his foster-child flunked its final exams or passed at the head of its class. Bendix-Pacific airborne telemetering systems and ground-based receiving stations have been transmitting and recording accurate "report cards" for guided missiles continuously since the kindergarten era of pilotless flight.

The great number of Bendix-Pacific electronic components used in present-day guided missiles and aircraft attest to this company's leadership in the field of airborne electronics. Bendix-Pacific standard telemetering assemblies, radar equipment, radio-control systems and electronic servo components are recognized for their advanced design, ultra-compactness and reliability.

Your company, too, can profit from the years of diversified experience built into every piece of electronic equipment bearing the Bendix-Pacific nameplate. You are invited to write for a free copy of the booklet illustrating Bendix-Pacific electronic developments.



Production "Problem-Children" LICKED!

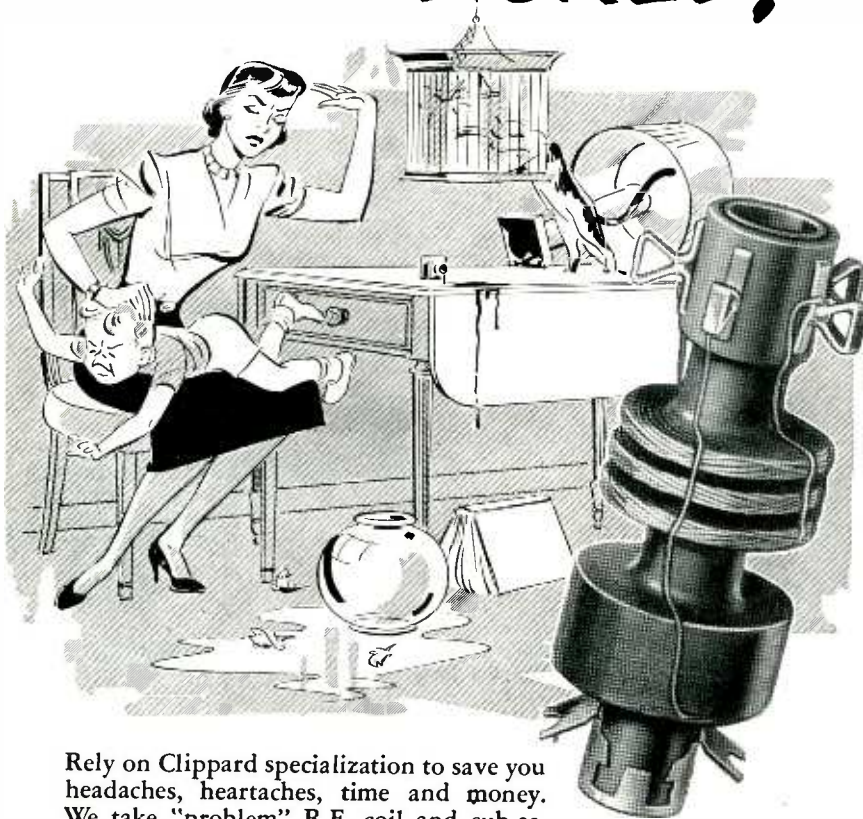

Rely on Clippard specialization to save you headaches, heartaches, time and money. We take "problem" R.F. coil and sub-assembly children off your hands, replacing "snafu" operations with smooth-sailing production and profits.

In many instances the creative thinking of Clippard design, production and control engineers also results in significant mechanical and electrical improvement. We produce windings and sub-assemblies that save size, weight, critical materials, money, assembly problems and production delays for some of the foremost names in electronics, and can do the same for you.

A manufacturers' manufacturer, Clippard specializes in production runs of 1,000, 10,000, 10,000,000 or more units of laboratory accuracy. High speed coil winding and control equipment of our own design plus a staff of skilled technicians assure you the quality coils and sub-assemblies you want, when you want them, with a minimum of rejects, fuss or bother.

Call on Clippard to free your production facilities for more profitable work...to get precision coils and sub-assemblies quickly and economically. Send us a sample, specifications or other details for a prompt solution or quotation, NOW!

Want to save TIME and MONEY Testing Resistors and Condensers?

Send for catalog sheets describing our P.R. 5 Resistance Comparator or P.C. 4 Capacitance Comparator. Both quickly pay for themselves by allowing unskilled operators to check 30 or more components per minute with laboratory accuracy!

Clippard

INSTRUMENT LABORATORY INC.

7350-90 Colerain Road • Cincinnati 24, Ohio

MANUFACTURERS OF R. F. COILS AND ELECTRONIC EQUIPMENT

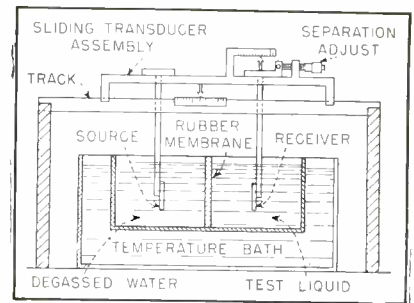

FIG. 1—Mechanical drawing of the setup for ultrasonic diathermy measurements

plates were used for transducers to cover the range from 300 to 2,400 kc. Magnitudes of acoustic impedance for water and blood are approximately equal. There are only small reflections from the liquid interface and refraction effects at this boundary are negligible.

One of the greatest difficulties associated with conventional techniques for measuring absorption in liquids is that the output of the receiving transducer depends not only on the absorption of the liquid but is also a complicated function of transducer separation. This method avoids these difficulties by maintaining a constant transducer separation.

For velocity of sound determinations, the wave length in the test liquid is measured by comparison of phase of the r-f output of the receiver with a direct signal from the generator while the transducer separation was varied by micrometer control.

Effectively free field conditions are obtained through the use of pulsing techniques. A pulse of r-f is applied to the source, Fig. 2. The output of the receiver is amplified and presented on an oscilloscope. The relative output inten-

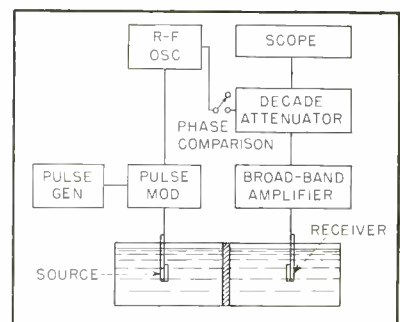

FIG. 2—Block-mechanical drawing of r-f pulse equipment



X-BAND KLYSTRON AMPLIFIER

for mopa
operation

VARIAN V-27
9.1 to 11.0 kmc

5 watts c-w
500 watts pulsed

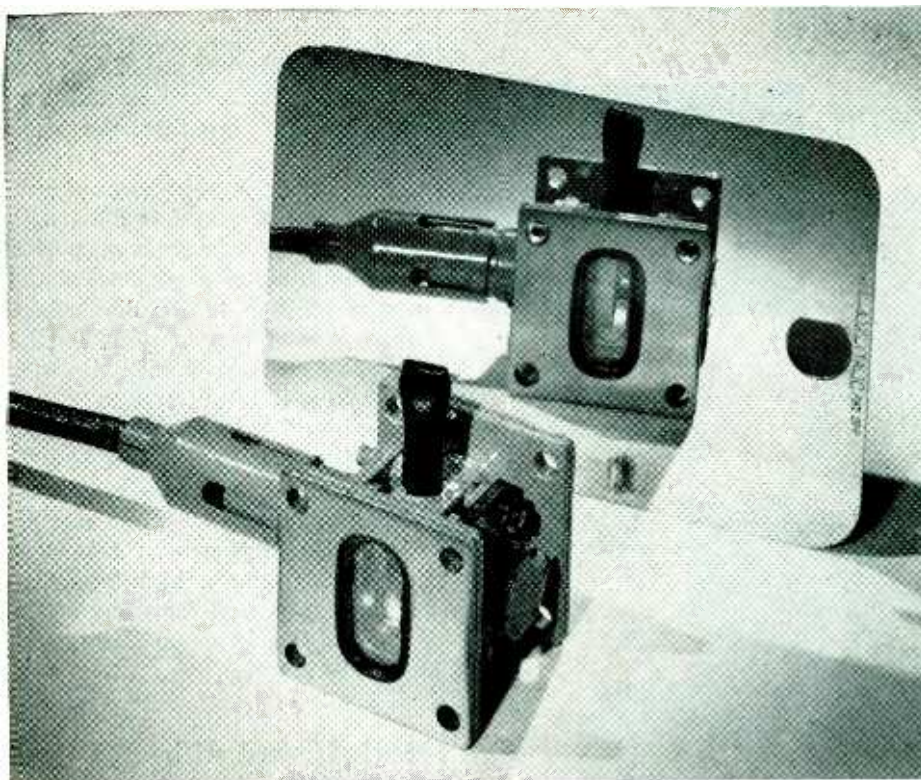

ALL THE ADVANTAGES of master-oscillator-power-amplifier operation in the x-band are made practical by the new Varian V-27 amplifier. This is another of the compact two-resonator tubes derived from the outstanding Varian X-21, and can utilize any of the Varian x-band oscillators as driver.

IN APPLICATION, the new V-27 serves as a buffer amplifier to prevent oscillator frequency changes caused by varying load impedances; as a linear amplifier; or as a phase-modulated amplifier; in relay service and in certain types of radar and beacons.

FEATURES OF THE V-27 include the unusually light weight of six ounces; a space factor less than that of a two-inch cube; a convenient new integral pigtail termination for leads; a special rugged cathode construction; and wideband Varian mica-seal flange windows.

OPERATIONALLY, the V-27 provides output powers of 4 to 8 watts c-w or 100 to 500 watts with 3- to 5-kv pulses on a 3 per cent duty cycle. It is rated with a beam voltage of 1350 volts, beam current of 100 ma. Both input and output flanges fit inch by half-inch waveguide.

SEND FOR FULL DETAILS on these or other Varian klystrons. Your particular microwave problem may find a solution in one of the Varian commercial klystrons—or in one of the many developmental types which cannot be publicized.



VARIAN associates

990 VARIAN STREET · SAN CARLOS 1, CALIFORNIA

FIELD ENGINEERING
REPRESENTATIVES
IN PRINCIPAL CITIES

Here's why those in the know

—demand

CANNON PLUGS

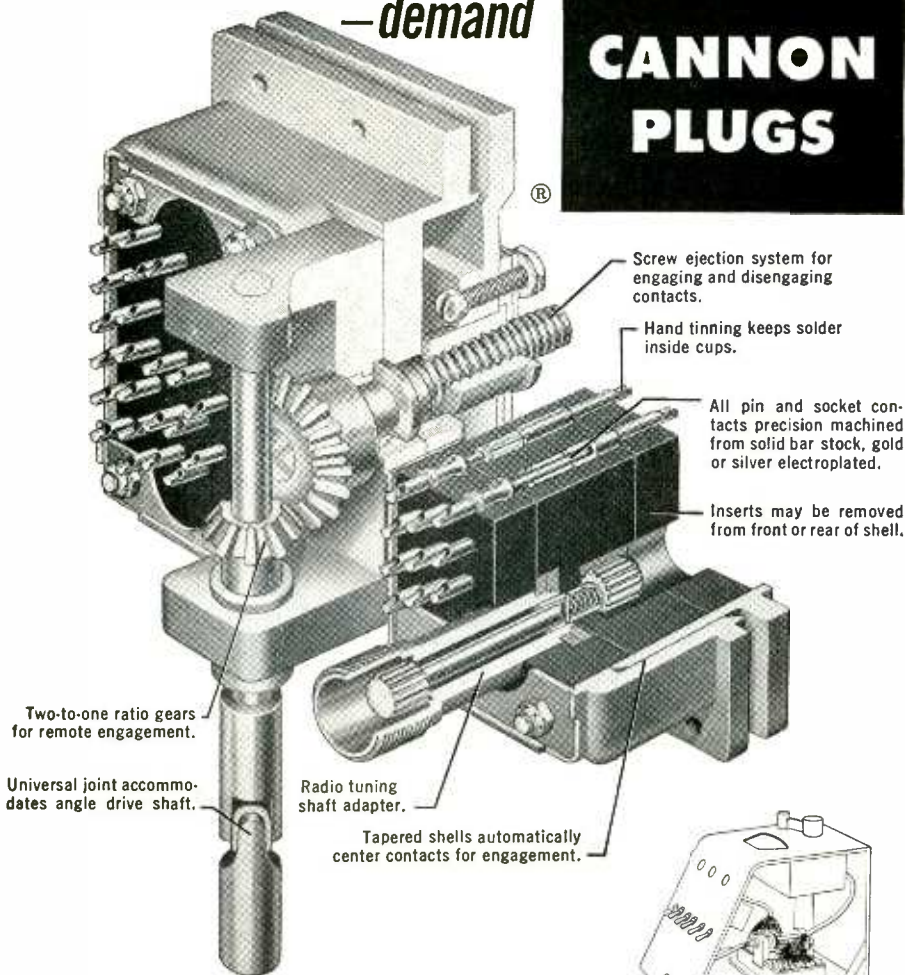

This highly specialized DPD2 Cannon Plug, a member of the DP Series, has its principal use in aircraft instrument panels and remote radio control equipment. But, like many other Cannon Plugs, it has found its way into other fields where the highest quality is needed and where the value of long, trouble-free performance is recognized.

Originally this 2-gang connector was designed to assist in the standardization of radio and instrument assemblies so that such equipment might be interchanged between similar aircraft. It allows for compact design in close quarters with access from the front only. This type of application and variations of the fittings are shown at right. Any Cannon DPD insert may be placed within the shell, with or without tuning shaft, coax, twinax, large or small contacts, provided the separation forces of both halves are similar.

This plug typifies the close attention to important detail that distinguishes every Cannon Plug—the world's most extensive line. If you are looking for real value, regardless of the field you work in, your best bet is Cannon.

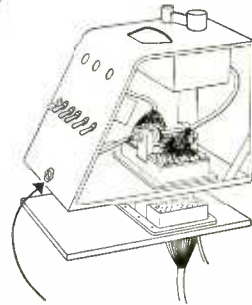

Connector is separated by turning slotted shaft here. Complete unit may then be removed from pedestal, shown below.



CANNON ELECTRIC

Since 1915

CANNON ELECTRIC COMPANY
LOS ANGELES 31, CALIFORNIA

Factories in Los Angeles, Toronto, New Haven. Representatives in principal cities. Address inquiries to Cannon Electric Company, Dept. G-120, P. O. Box 75, Lincoln Heights Station, Los Angeles 31, California.

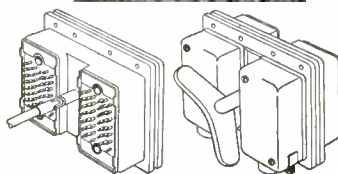

(Left) Same Cannon Plug without tuning shaft. Straight drive instead of 90° gear. (Right) Similar DPD2 with Dzus wing nut extraction method and junction shells. There are several other variations. Write for details.

sity is measured by use of a decade attenuator which can be adjusted for constant signal at the oscilloscope.

For solid tissue measurements the entire test vessel is filled with water and the sample is supported between thin plastic windows placed at the position of the diaphragm. Transmission loss is measured by comparison of output intensity with and without tissue sample.

Depths of penetration for solid tissues are of the order of four to eight cm at one mc. Frequencies up to approximately two mc can be useful for diathermy. According to clinical reports, high-frequency sound can be used for many of the same applications as electromagnetic diathermy.

Radio Hazard with Electric Blasting Caps

RADIO-FREQUENCY HAZARDS may exist in the use and transportation of electric blasting caps and similar electrically actuated devices such as delay electric blasting caps and electric squibs.

Amplitude-modulated radio stations are the greatest hazard because of their high power, relatively low frequencies and presence in open country where blasting operations are apt to take place. Television and f-m stations are less hazardous because of their high frequencies and antenna locations.

Induced currents may also come from mobile radio, although because of low power, vertical antennas and high frequencies, chances are slim that premature explosions would be caused.

Intensity of r-f energy normally

Table I—Safe Distances for Various Transmitted Powers

Power (watts)	Distance (feet)
5— 25	100
25— 50	150
50— 100	220
100— 250	350
250— 500	450
500— 1,000	650
1,000— 2,500	1,000
2,500— 5,000	1,500
5,000— 10,000	2,200
10,000— 25,000	3,500
25,000— 50,000	5,000
50,000—100,000	7,000

RMC DISCAPS

...the standard of performance throughout the entire radio and television industry

APPROVED AND USED BY LEADING MANUFACTURERS

"HEAVY DUTY" By-Pass DISCAPS

GMV Type .. Rated at 1000 V. D. C.

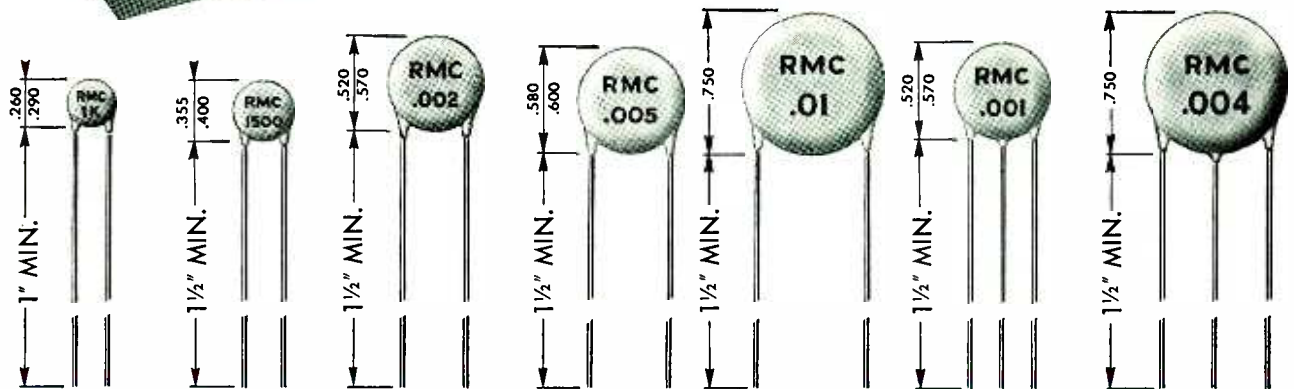

SPECIFICATIONS

POWER FACTOR: INITIAL 1.5% @ 1 KC
AFTER HUMIDITY 2.5% @ 1 KC
WORKING VOLTAGE: 1000 VDC—TEST VOLTAGE: 2000 VDC
INSULATION: DUREZ PHENOLIC—VACUUM WAXED

LEAKAGE RESISTANCE: INITIAL 7500 MEG OHMS
AFTER HUMIDITY 1000 MEG OHMS
LEADS: #22 TINNED COPPER (.026 DIA.)

When Ordering Specify "HEAVY DUTY" Type DISCAPS

DEPENDABLE

RMC HI-VOLTAGE DISCAPS



Molded Plaston Case

TYPE F-500

TYPE E-500

CAPACITY.....	.500 MMF +50% -20% at 22° C.....	.500 MMF +50% -20% at 22° C
WORKING VOLTAGE.....	25,000 VDC.....	20,000 VDC
FLASH TEST VOLTAGE.....	37,500 VDC.....	30,000 VDC
POWER FACTOR.....	Less than 1% at 1000 CPS.....	Less than 1% at 1000 CPS
LEAKAGE RESISTANCE.....	Guaranteed higher than 25,000 Meg Ohms	Guaranteed higher than 25,000 Meg Ohms
BODY SIZE.....	.1" Dia. x 2 1/4" Long.....	.1" Dia. x 2" Long

DISCAP CERAMIC CONDENSERS



RADIO MATERIALS CORPORATION

GENERAL OFFICE: 3325 N. California Ave., Chicago 18, Ill.

FACTORIES AT CHICAGO, ILL. AND ATTICA, IND.

Two RMC Plants Devoted Exclusively to Ceramic Condensers

Phaostron

RUGGEDIZED, HERMETICALLY SEALED ELECTRICAL INDICATING INSTRUMENTS



PROVIDE ENVIRONMENT FREE PERFORMANCE

To preclude possibility of elements changing beyond predictable tolerances, precautionary measures are required.

... Assembly, adjustment, testing and sealing takes place in our Air-Conditioned, Temperature-Controlled plant.

... All jewels and pivots are cleaned during microscopic inspection.



... All meters are baked at 180° F. for 16 hours to remove possible moisture and stabilize all components.



... Only after stabilization is accomplished are the meters balanced and calibrated.

... Uncontaminated environment is then sealed into the meter by means of glass-to-metal hermetic sealing. All meters are tested to determine the integrity of the hermetic seal.



New York
Blair-Steinberg Co.

... REPRESENTED BY ...

Chicago
Walter Berggren & Assoc.

An illustrated Brochure #PM1 is available on request.

ENVIRONMENT FREE
ELECTRICAL EQUIPMENT by

Phaostron

PHAOSTRON CO. 151 PASADENA AVE. SOUTH PASADENA, CAL.

decreases as the square of the distance from the transmitter. Table I shows distances beyond which there would seem to be no possibility of a premature explosion for the transmitted powers shown. The distances given are based on the worst possible conditions such as wire length and position of the circuit. A substantial margin of safety is also included.

The induced energy picked up by the blasting cap circuit may be reduced substantially by application of a few rules of thumb. If the wire lengths are made to be other than half or one-quarter the radio wave length, induced currents will be small. The wires should not be parallel to the transmitter antenna nor in its zone of maximum radiation. Induced current is less if the wires are on the ground rather than suspended a few feet above it. Additional information on safe handling of such devices is presented in the E. I. DuPont de Nemours and Company Technical Service Bulletin No. 13.

Spark Speeds in the Audio Region

BY JOSEPH F. SWINGLE, JR.

Rouss Physical Laboratory
University of Virginia
Charlottesville, Va.

IN MANY CASES where a triggered spark gap is used as a source of light the question arises as to when the spark ceases to follow the input signal. This usually occurs because of too fast an input signal. Figure 1 illustrates the setup for a situation of this type.

In Fig. 1, a light beam from the spark-gap light source *S* is reflected from a revolving mirror located on the ultracentrifuge shaft and triggers a multiplier phototube. The output is amplified and drives a thyatron trigger circuit which fires the

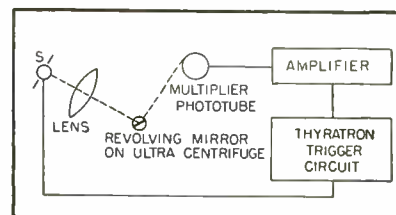
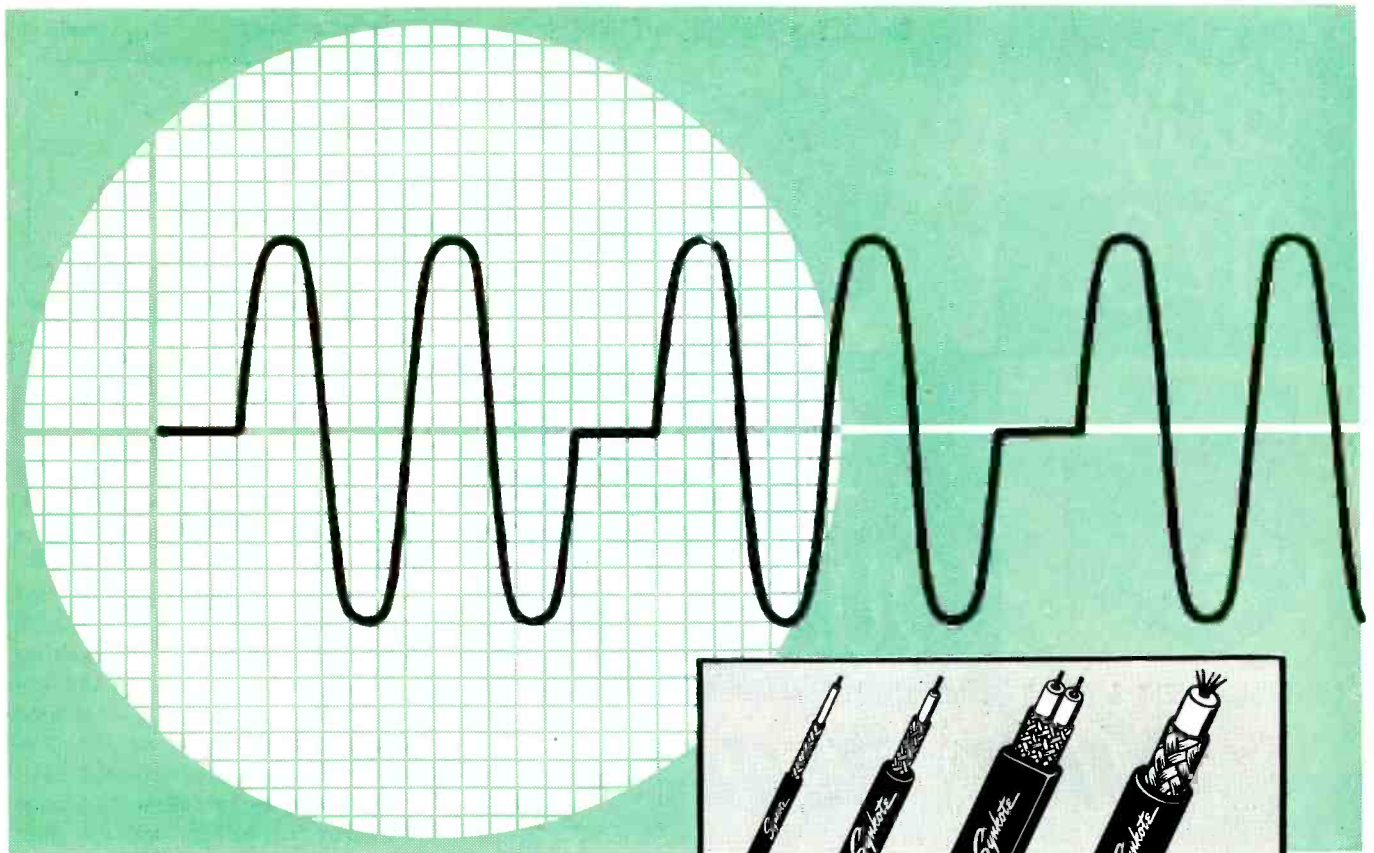

FIG. 1—System using triggered spark gap as a source of light



Several Things Less to Worry About... When You Specify Synkote Coax Cable

Attenuation, impedance, shielding, insulation, velocity of propagation, *all* the worrisome wire factors affecting your final signal are *dependably constant* in SYNKOTE Coaxial Cables.

Manufactured to 10 standard specifications, SYNKOTE Coax Cables are available in impedances from 50 to 300 ohms . . . insure minimum attenuation and maximum dependability at all frequencies and under most conditions.

For specifications other than standard, our engineering service department

will be glad to work with you. Write today — your inquiry will be given prompt attention.



**DEPENDABLE
Coaxial Cable**

"Made by the mile — tested by the inch"

P L A S T O I D C O R P O R A T I O N
42-61 24th STREET, LONG ISLAND CITY 1, NEW YORK

**HOOK-UP WIRE • AIRCRAFT CABLE • TV WIRE • COAXIAL CABLE •
NYLON JACKETING • HIGH TEMPERATURE WIRE • MULTI-CONDUCTOR CABLES**



CUBICLES • HOUSINGS • CABINETS

any size...

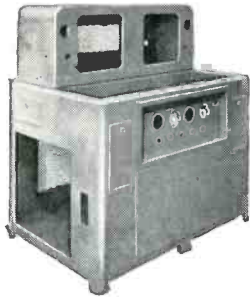

CONTROL PANELS & DESKS

any quantity

KIRK AND BLUM

CUSTOM BUILT ELECTRICAL ENCLOSURES

One unit . . . hundreds . . . or thousands, in any shape or size, KIRK & BLUM has the men, equipment and experience to fabricate sheet metal enclosures to exacting specifications. Put our 45 years of experience to work for you in building custom parts and assemblies of sheet steel, light plate, stainless, aluminum, monel and other alloys in gauges to 3/8".

Write today for your copy of the latest KIRK & BLUM Electrical Enclosures Catalog. For prompt quotation, send your prints to The KIRK & BLUM MFG. CO., 3211 Forrer Street, Cincinnati 9, Ohio.

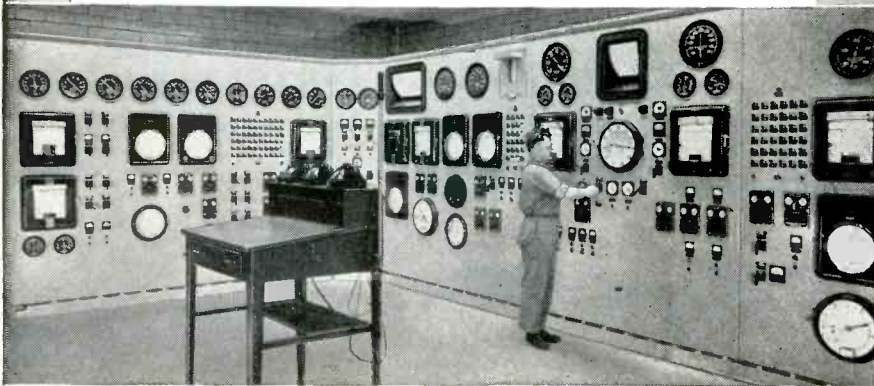

Control Desks • Cubicles • Electrical Cabinets and Enclosures
Outdoor Electrical Enclosures • Instrument Panels • Control Panels
Transformer Tanks • Test Stands • Switch Gear Housings • Louvres

KIRK AND BLUM

METAL FABRICATION

ELECTRONS AT WORK

(continued)

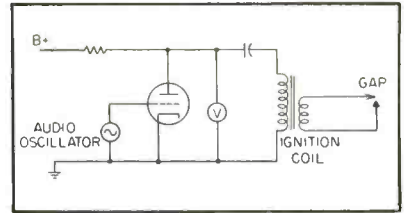

FIG. 2—Circuit for checking to see when the spark gap ceases to follow the input signal

spark gap at the same rate. The problem is to determine when the spark gap ceases to follow the input signal and fires at some other rate lower than the input signal.

An accurate check may be had by driving the thyatron with an audio oscillator and by measuring the voltage to ground of the capacitor, see Fig. 2. The capacitor voltage will decrease as the frequency of the input increases until the gap ceases to follow the trigger. The capacitor voltage then rises.

Another possible method is to observe the output of a communications receiver on an oscilloscope while the gap is firing. This signal is the radiation of the spark gap. The signal may be measured by Lissajous figures and the point where following ceases is easily determined.

Electronic Elevator Touch Button

AN INTERESTING USE of electronics developed in recent years and known as the electronic touch button has been installed in the new Chrysler Building East in New York City by the Otis Elevator Company.

Figure 1 shows a sketch of a typical elevator fixture. An insulating material with a high dielectric constant is used to cover the face of the button. An electrically conductive material coats the back of the button and makes contact through a spring with a similar coating on the top of the tube. The button forms one plate and the dielectric of a capacitor.

The tubes used are neon diodes. Referring to Fig. 2, as long as current flows through the tube, a



VITREOUS ENAMELED RESISTORS

The resistor line which is specified by engineers employed by the nation's foremost manufacturers of original equipment.

DELIVERY

... two separate self-contained resistance plants guarantee prompt delivery.

QUALITY

... as the world's leading manufacturers of wire wound resistors, we assure you that only the finest engineering techniques and material are utilized.

PRICE

... our tremendous manufacturing capacity enables us to offer resistors ... in any quantity ... at exceptionally attractive prices.

ENGINEERING

... our factories include the most modern machine shops and engineering facilities. Our experienced engineering department is at your service to assist in designing any resistance unit to meet your requirements and to meet JAN Specifications.

We invite your inquiries.

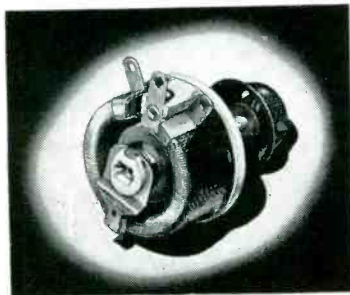
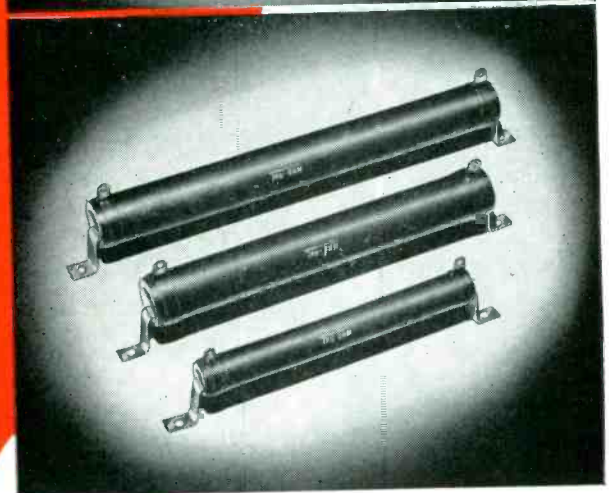
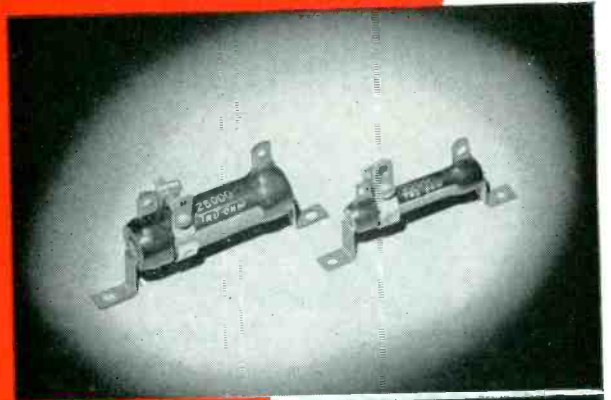

Our new multi-colored catalog, complete with engineering data and illustrations, is yours without obligation. **WRITE TODAY!**

The New TRU-OHM Power RHEOSTAT

... the practical rheostat in its most exacting form, with a compensating constant pressure contact brush ... designed to meet JAN Specifications. Write for complete technical literature.

TRU-OHM PRODUCTS

Division of Model Engineering & Mfg., Inc.

General Sales Office: 2800 N. Milwaukee Avenue, Chicago 18, Ill.
Factory: Huntington, Indiana

MANUFACTURERS: Power Rheostat, Fixed Resistors, Adjustable Resistors, "Econohm" Resistors

Here's how

ELECTRO TEC

miniature slip ring and commutator assemblies

Solve TOUGH DESIGN PROBLEMS

- 6 INSULATED CONTACT RINGS
- RING WIDTH .030"
- BARRIER WIDTH .015"
- RING DIAMETER .045"
- WEIGHT 5.5 GRAINS (1/80 OUNCE)
- RINGS 60-70 BRINELL FINE SILVER
- TARNISH RESISTANT, FRICTION MINIMIZING SURFACE DEPOSITS
- 1000 VOLT HI-POT BETWEEN RINGS
- COLOR CODED LEADS



PROBLEM: ULTRA MINIATURIZATION — Design and mass produce an extremely miniaturized slip ring assembly. Reduce diameter of rings to absolute minimum to lessen torque friction. Maintain micro-tolerances; eliminate accumulated errors common to "assembled" slip rings.

SOLUTION: ELECTRO TEC EXCLUSIVE* METHOD of unitized, one piece construction provided a prompt, economical solution to this problem. Final design was even smaller than was originally specified and tolerances were held to closer limits.

Same Exclusive* One-Piece Construction Used in All Electro Tec Assemblies

Diameter of Electro Tec assemblies range from .045" to 24" cylindrical or flat. Cross sections of the rings may range from .005" to .060" or more. Rings are polished to a jewel-like finish... can be held to four micro-inches or better. Regardless of size, the same exclusive Electro Tec manufacturing technique is used to guarantee precise concentricity, higher dielectric strength, longer life and closer tolerances.

WRITE FOR LITERATURE!

A completely illustrated, four page folder contains full information on Electro Tec Miniature Slip Rings and Commutators. Describes the Exclusive* method of construction that has made Electro Tec the leading supplier to America's major instrument manufacturers. Send for your free copy today on company letterhead.



TESTED AT 12,000 RPM

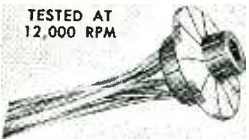

SILVER ON ONE PIECE NYLON FORM



8 FLAT RINGS WITHIN 3/8" RADIUS



*PATENTS PENDING

ELECTRO TEC

SO. HACKENSACK



CORPORATION

NEW JERSEY

PRODUCTS OF PRECISION CRAFTSMANSHIP
BY A NEW AND REVOLUTIONARY PROCESS

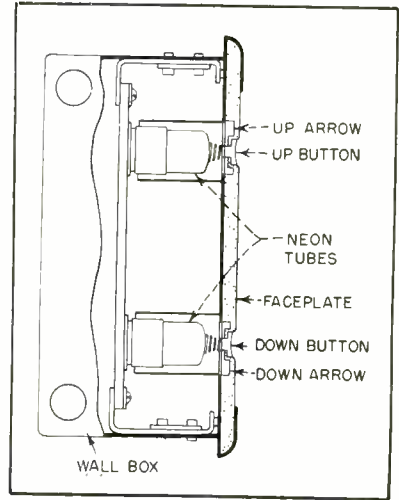

FIG. 1—Sketch of a touch-button fixture

call remains registered. No call is registered when current flow ceases.

If no call is registered and, consequently, no current is flowing through the tube, a 135-volt d-c potential exists across the gap between the anode and cathode of the tube.

This potential is not large enough to cause conduction. However, there is also a 150-volt a-c potential between anode and ground. When a person's finger touches the button, the distribution of electrostatic fields inside the tube is changed sufficiently for the tube to ionize and start conducting current. Current continues to flow after the person's finger is removed because the d-c potential will then maintain the flow of current after it has once started.

A negative pulse of voltage is applied to the circuit when an elevator answers the call. This reduces the voltage across the tube, current flow ceases and the call is no longer registered.

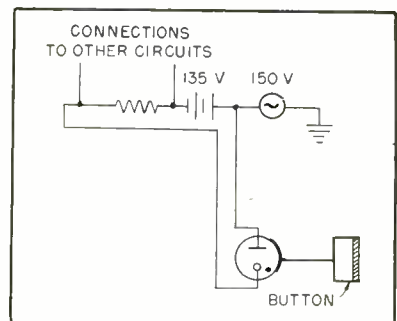
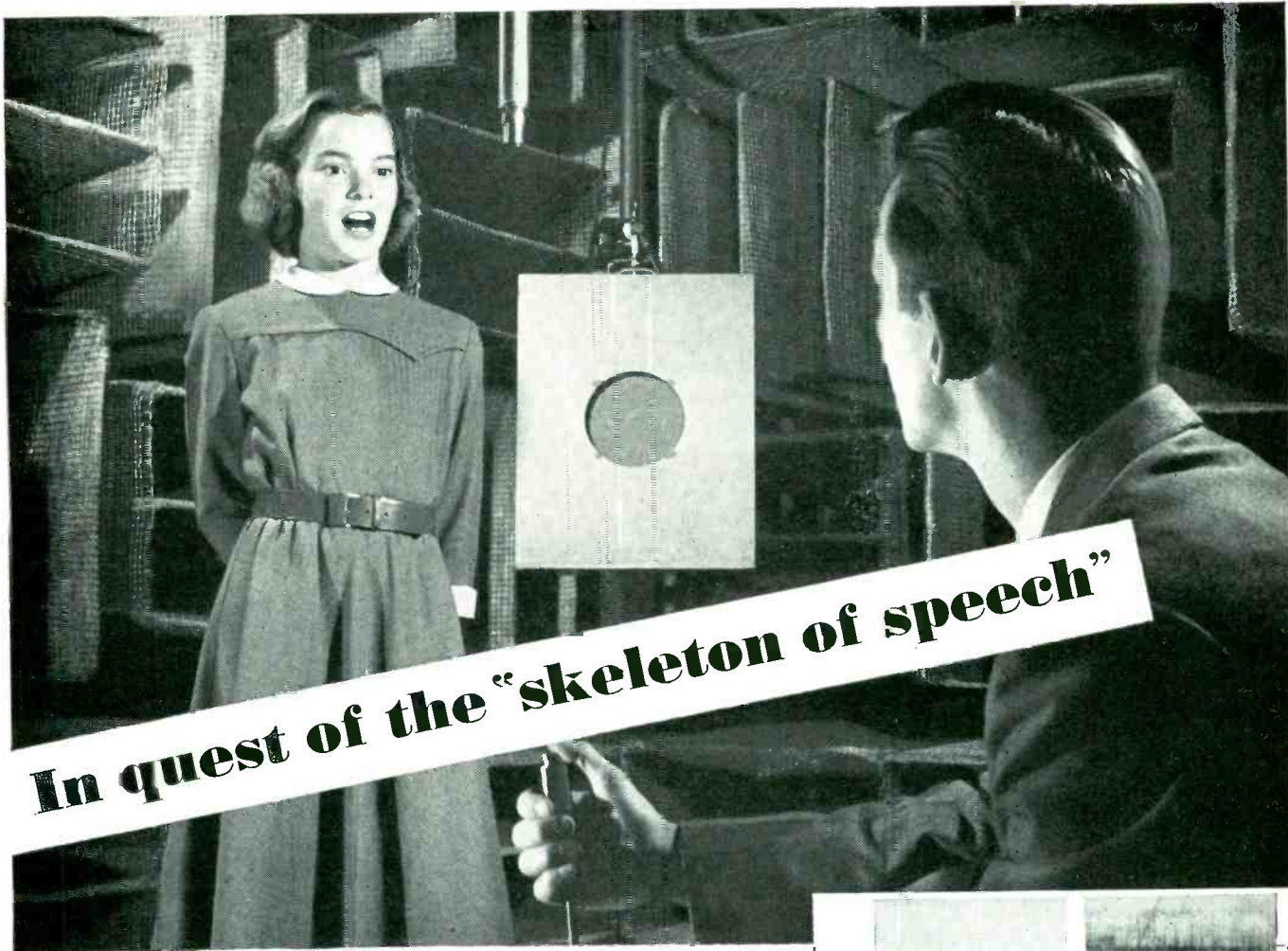

FIG. 2—Simplified schematic diagram of the touch-button circuit



In quest of the "skeleton of speech"

In the famous Quiet Room at Bell Laboratories, this young volunteer records speech for analysis. Scientists seek to isolate the frequencies and intensities which give meaning to words . . . stripping away non-essential parts of word sounds to get the basic "skeleton" of speech.

A child or an adult . . . a man or a woman . . . an American or an Englishman—all speak a certain word. Their voices differ greatly. Yet listeners understand the word at once. What are the common factors in speech which convey this information to the hearer's brain?

Bell scientists are searching for the key. Once discovered, it could lead to new electrical systems obedient in new ways to the spoken word, saving time and money in telephony.

Chief tool in the research is the sound spectrograph which Bell Telephone Laboratories developed to make speech visible. Many kinds of persons record their voices, each trying to duplicate an electrically produced "model" sound. While their voice patterns are studied, a parallel investigation is made of the way human vocal cords, mouth, nose and throat produce speech.

Thus, scientists at Bell Laboratories dig deeply into the fundamentals of the way people talk, so that tomorrow's telephone system may carry your voice still more efficiently—offering more value, keeping the cost low.

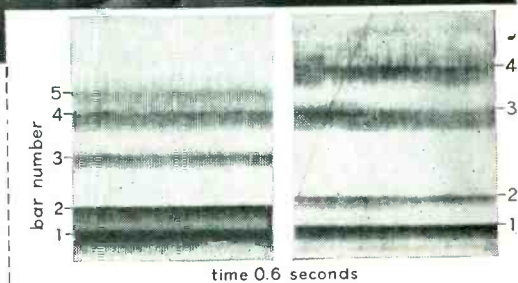

Spectrograms of young girl's voice (right) and man's voice making "uh" sound as in "up." Horizontal bars reveal frequencies in the vocal cavities at which energy is concentrated. The top of the picture is 6000 cycles per second. Pictures show how child's resonance bars are pitched higher than man's.

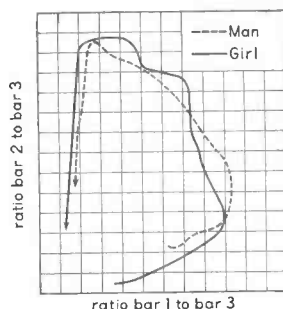

The word "five." Graph shows ratio of frequency of spectrogram bars. The solid line is for a girl and the dotted line is for a man. Note the similar patterns despite pitch differences. Human hearing extracts the speech sounds from this sort of pattern in the identification of words. Scientists aim at machines that can do the same.



BELL TELEPHONE LABORATORIES

Improving telephone service for America provides careers for creative men in scientific and technical fields.

Production Techniques

Edited by JOHN MARKUS

OTHER DEPARTMENTS

featured in this issue:

Tape-Cutting Fixtures Speed Production of Transformers.....	228	Magnet-Wire Container.....	244
R-F Coil Winder.....	228	Steel-Wool Pad on Bench Discharges Capacitors	246
Lamination Stacker For Magnetic Amplifiers	230	Far-Infrared Baking.....	246
Cart for Pass-Along TV Line.....	232	Spaghetti Chopper.....	248
Magnifying-Glass Holders.....	234	Lead-Positioning Springs.....	250
Salvaging Tungsten.....	238	Serial-Number Disk	252
Production-Floor Carts.....	240	Core-Banding Tool.....	252
Output Transformer Tester.....	242	Diode Clip Boards.....	254
Hookup Wire Rack.....	256		

	Page
Electrons at Work.....	152
New Products	258
Plants and People.....	302
New Books	312
Backtalk	328

Tape-Cutting Fixtures Speed Production of Transformers



Winding adhesive tape spirally on drum made from removable U-channels, for cutting into tabs at Keystone Products Co.

TABS of adhesive tape or cloth, widely used for anchoring coil leads and many other purposes in the production of electronic equipment, present a cutting and dispensing problem that can be solved in various ways depending on the speed and volume of the assembly-line operation.

Where large quantities of tabs are needed for anchoring leads of the coils for miniature amplifiers, the elaborate cutting fixture and dispensing rack arrangement used by Keystone Products Co. in Union City, N. J. becomes economically feasible. Here quarter-inch-wide U-shaped channels fit into slots arranged $\frac{1}{4}$ inch apart on two aluminum disks. A friction fit keeps the channels in position, forming a drum that can be turned by a crank

on one end of the shaft.

The tape to be cut is wound spirally on the channels until the drum is full. A razor blade or sharp knife is then run alongside each channel in turn to cut the tape quickly into tabs. Cutting on one side of each channel gives $\frac{1}{2}$ -inch tabs, which are the shortest that can be obtained with the setup. Tab length can be increased in $\frac{1}{4}$ -inch intervals by appropriately spacing the cuts.

After the tabs have been cut, the channels are lifted out one by one and placed over metal pegs on the dispensing rack. For a half-inch tab, half its length projects above the channel and can easily be pulled off for use.

A simpler wood cutting drum is



Wood fixture used at Utility Electronics for cutting tape into tabs

in use at Utility Electronics in East Newark, N. J. for smaller production runs. Slots are cut lengthwise in the square drum at the desired tab distance. Dowel rods serve as the shaft and handle. The base and frame are also wood. The tape is spirally wound over the arbor, then cut into tabs by running the razor blade along each groove in turn.

R-F Coil Winder

COILS for television tuners and similar high-frequency applications are wound more efficiently and accurately with a simple hand-operated gear-train arrangement than with elaborate motor-driven equipment in the Television Receiver Division of Allen B. DuMont Labs.,

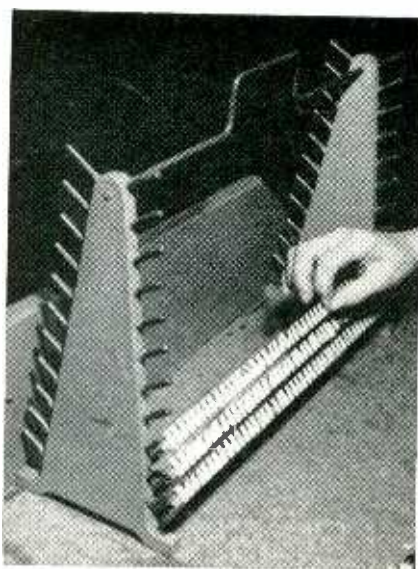

Rack for supporting U-channels with tape tabs alongside coil-winding machine

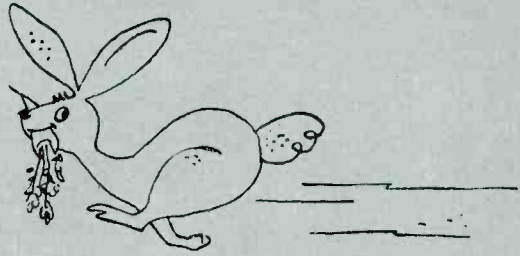

FAST



KESTER FLUX-CORE SOLDER

FAST . . . FASTER . . . FASTEST

FAST . . . Kester Plastic Rosin-Core, the old reliable, always does a fast job.

FASTER . . . Step up the tempo with Kester "Resin-Five" and still retain flux stability.

FASTEST . . . For high-speed soldering, unbelievable flux mobility. You'll want Kester "44" Resin-Core the newest of all Core Solders.

Free Technical Manual—write for your copy of
"SOLDER and Soldering Technique."

Over 100,000 types
Kester Flux-Core Solder
available

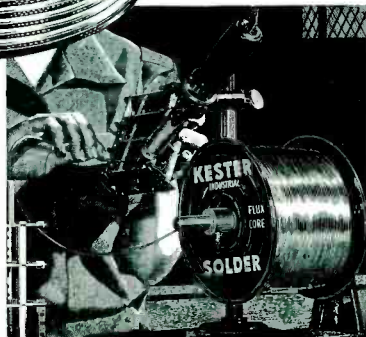

KESTER SOLDER COMPANY
4204 Wrightwood Ave., Chicago 39
Newark 5, New Jersey • Brantford, Canada

**KESTER
SOLDER**

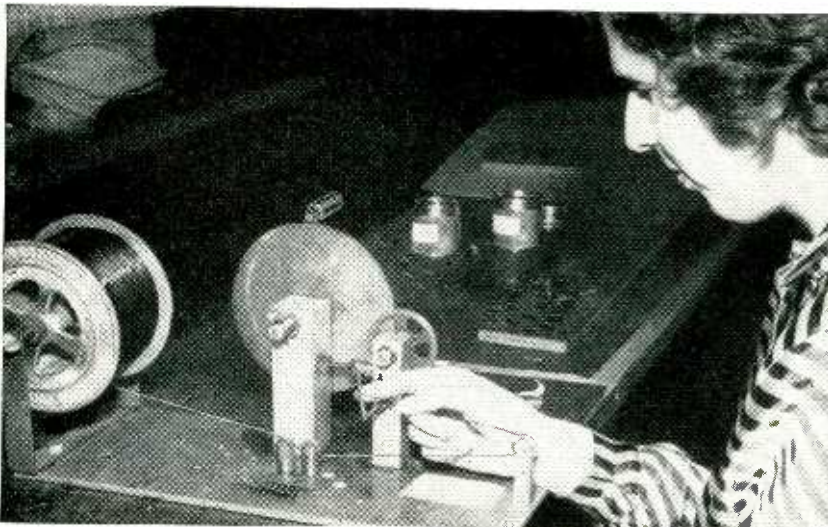

Inserting wire in hole in hinged lever of mandrel. Pulling handle of large gear forward to stop winds complete r-f coil in few seconds

Inc., in East Paterson, N. J.

Metal pegs inserted in the large drive gear are located to hit against the gear bearing supports or other stops, limiting the motion of the gear to the exact angle needed to give the desired number of turns on the coil mandrel. A convenient handle is attached to the large gear for moving it through this angle to wind a coil. By changing positions of stops and/or changing gear ratios, coil turns can be changed.

The entire mechanism, including the axle for the spool of wire, is

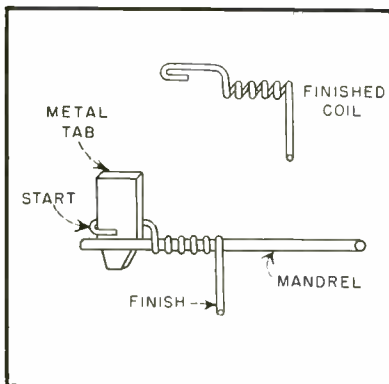

Modification of mandrel for obtaining preformed hook in coil lead

mounted on a heavy metal plate. From the spool, the wire goes over three straightening pulleys to a mandrel having on its end a hinged lever. The end of the wire is inserted in a hole in the lever, the hole being positioned far enough away from the mandrel to give the desired lead length. With the wire in position, the operator presses against the hinged lever lightly to keep it at right angles to the mandrel, then pulls the gear handle forward to its stop to wind the coil. The wire is clipped at both ends with side-cutting pliers, and the hinged lever is straightened out so the completed coil can be slipped off.

In another setup, a hook is formed in the starting lead of the coil by using a modified mandrel without the hinged lever. The end of the wire is bent around a metal tab inserted in a hole in the mandrel, as shown, and the coil is wound as before. The tab is pulled out after winding so the coil can be removed, then put back in readiness for the next coil.

Laminated Stacker for Magnetic Amplifiers

USE of a Lamator automatic E-I lamination stacker speeds production of magnetic amplifiers at Keystone Products Co. in Union City, N. J. As designed for this particular application, the machine takes three coils (one for each leg

of the core) and stacks in the laminations from the bottom rather than from the top. The vertical storage racks each contain both E and I laminations. When the left-hand rack releases an E for feeding under the stack already in the coils,

the right-hand rack releases an I; on the next pass an I comes from the left and an E from the right, for alternate stacking just as would be done manually.

A split pulley on the motor gear box permits adjusting the speed of the machine for optimum operation without jamming. In event of a jam, the operator moves a lever that slides the rotor forward to ease belt tension, then removes the jammed laminations. Bent, off-size or burred laminations are commonest causes of jams.

A snap-action switch is actuated

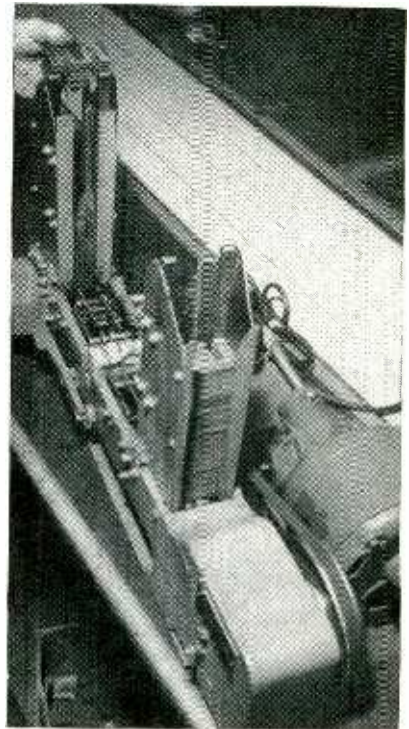

Loading E laminations into one of vertical racks of stacker for magnetic amplifiers. Jams due to imperfect laminations are minimized by feeding in laminations from the bottom of the stack, so weight of stack aids operation



Partly stacked coils of magnetic amplifier. Spring-loaded cover plate of machine hides laminations. The snap-action switch has a button that is pushed by the cover plate to stop the machine when the coils are full



• **WITHSTANDS
250°C**

- **HAS HIGH SPACE FACTOR**
- **EXCELLENT ELECTRICAL PROPERTIES**

A NEW MAGNET WIRE

If smaller, lighter electrical components are needed in the military electronic gear or aircraft controls you are concerned with, investigate the use of CEROC ST, the newest Sprague magnet wire.

Application of a single Teflon overlay to the base ceramic insulation results in a magnet wire which has many of the best properties of both Sprague's CEROC 200 silicone-coated ceramic-insulated wire and CEROC T double-Teflon ceramic-insulated wire.

Complete details of this important new development are given in Engineering Bulletin 404, available on letter-head request.

For latest information on CEROC 200 and CEROC T, write for Bulletins 401-B, 402-H, and 403-C.



SPRAGUE ELECTRIC COMPANY

35 Marshall Street, North Adams, Massachusetts

CEROC[®]

ST

QUICK DELIVERY

Immediate deliveries from stock on small sample quantities of all CEROC wires as well as short delivery cycles on production runs are now in effect.

There is plenty of room for your orders on the production schedules of our North Adams, Mass. and Bennington, Vt. plants with their newly-expanded facilities.

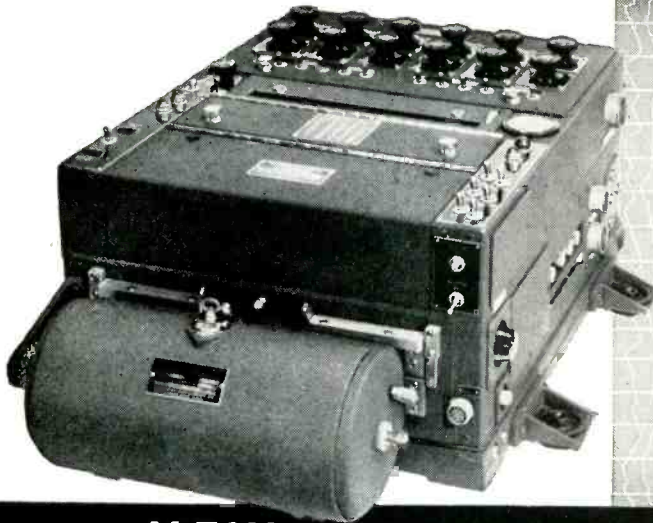

the **NEW** S-8 Oscilloscope

Here, in a versatile instrument of advanced design, are all the things you need for complete oscillographic recording. The Hathaway Type S-8 Oscilloscope, which has long been the standard of oscillographic recording, has been improved to meet the rapidly expanding demands of modern research. Whether your measurement problems are simple or complex, the **NEW** Type S-8 Oscilloscope has the inherent capabilities necessary to measure vibration, pressure, acceleration, and strain with new ease and accuracy.

The newest features include:

QUICK-CHANGE TRANSMISSION fully enclosed with gears running in oil to provide instantaneous selection of 16 record speeds over the range of 120:1

CHART TRAVEL INDICATOR provides continuous indication of chart motion. Operator knows instantly by flashing lamp if anything should happen to interfere with chart motion

FULL-RESILIENT MOUNTING FOR MOTOR AND TRANSMISSION isolates all possible vibration and makes possible the use of modern super-sensitive galvanometers

NEW GALVANOMETER STAGE accommodates all Hathaway galvanometer for recording milliamperes, microamperes, or watts

NEW RECORD-LENGTH CONTROL AND NUMBERING SYSTEM designed for long, trouble-free service under all kinds of ambient conditions

All the other valuable features are retained, such as **PRECISION TUNING-FORK-CONTROLLED TIMING SYSTEM** produces either 1/10-second or 1/100-second time lines across sheet

WIDE RANGE OF GALVANOMETER TYPES AND CHARACTERISTICS provide for almost any recording requirements. Natural frequencies to 10,000 cps. Sensitivities to 50,000 mm per ma, single and polyphase watts

DAYLIGHT LOADING AND UNLOADING RECORDS TO 200 FT. IN LENGTH, width to 10 inches

SIMULTANEOUS VIEWING AND RECORDING

AUTOMATIC BRILLIANCY CONTROL

12 TO 92 ELEMENTS

Whatever your needs may be, investigate the **NEW** Type S-8 Oscilloscope and its 170 types of galvanometers — the most versatile equipment in existence for general-purpose applications.

WRITE FOR BULLETIN 2B1-K FOR DETAILS

Hathaway
INSTRUMENT COMPANY
 1315 SO. CLARKSON STREET • DENVER 10, COLORADO

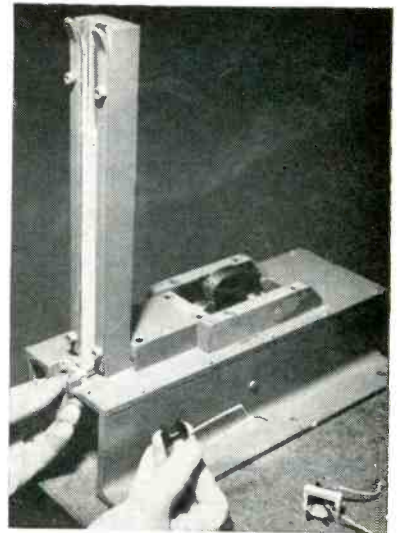

Plunger of butt stacker is here delivering correct number of E-E laminations for half of core for single-coil unit

by the rising stack in the coils, to stop the machine automatically when the desired thickness of stack is attained. The stacker is made by LaCesa Engineering Corp., 5910 W. Division St., Chicago, Ill.

For smaller transformers using butting E-E stacks without interleaving, Keystone speeds assembly of cores with a special LaCesa butt stacker operated by a foot lever. This delivers exactly the correct number of laminations for each half of the core.

When the foot lever is pressed, an accurately machined plunger moves forward under cam action to push the laminations out to the fingers of the operator, for immediate insertion in the single coil. A similar stack is inserted from the other side of the coil to complete the core. An accurately positioned stop bar prevents unwanted laminations from coming out when the plunger moves forward.

Cart for Pass-Along TV Line

EITHER an ordinary surfaced bench or angle-iron rails can be used with the furniture-caster cart developed for Tele-tone's television receiver assembly line. With rails, the free-swiveling casters and the flat plywood base of the cart keep it moving straight down the line. On a flat bench, a fifth ball-bearing wheel mounted vertically under the cart

MITCHELL-RAND

electrical insulation
headquarters

miraglas* tapes

HIGH
TENSILE
STRENGTH

GREAT
DIMENSIONAL
STABILITY

MOISTURE
OVERLOAD
EXCESSIVE HEAT
ACID · DIRT
RESISTANCE

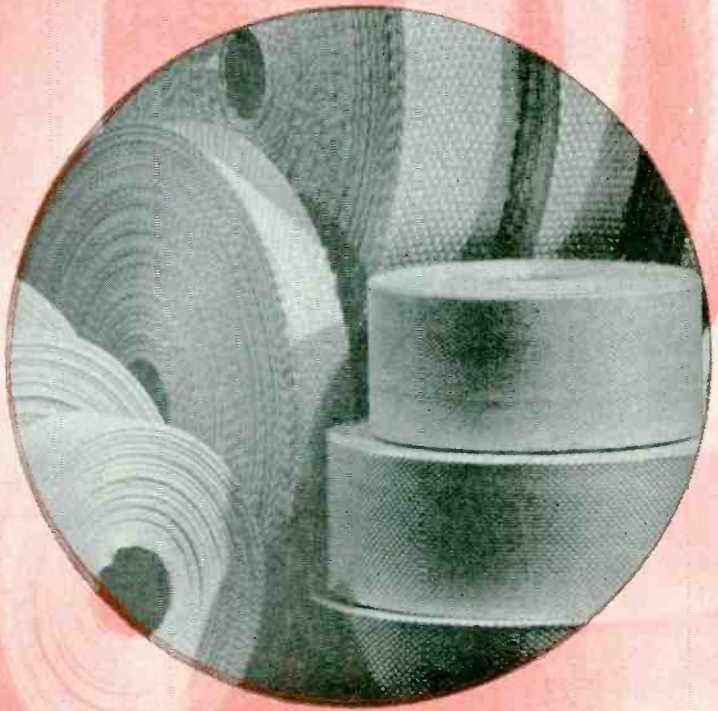

* woven of FIBERGLAS

... to provide the ultimate in electrical insulation

MIRAGLAS TAPES are available in a wide variety of widths, thicknesses and styles, for practically every electrical insulation requirement where high dimensional stability and tensile strength are desired. Continuous filament MIRAGLAS TAPES are supplied in thicknesses ranging from .003" to .015" and in widths from 3/8" to 1 1/2". Medium weave tapes, for machine taping, range in thicknesses from .005" to .015" while tight weave tapes for manual taping, range in thicknesses from .003" to .007" only. Staple fiber tapes in thicknesses from .010" to .025" and widths from 1/2" to 1 1/2" are also available for applications where space is not a primary consideration or where a more resilient wrapper is wanted.

Write for a copy of the **MIRAGLAS TAPE BULLETIN**

... also for a **FREE TEST SAMPLE**



MITCHELL-RAND INSULATION COMPANY, INC.

51 MURRAY STREET

CORLEON 7-9264

NEW YORK 7, N. Y.

A PARTIAL LIST OF M-R PRODUCTS: FIBERGLAS VARNISHED TUBING, TAPE AND CLOTH · INSULATING PAPERS AND TWINES · CABLE FILLING AND POTHEAD COMPOUNDS · FRICTION TAPE AND SPLICE · TRANSFORMER COMPOUNDS · FIBERGLAS SATURATED SLEEVING · ASBESTOS SLEEVING AND TAPE · VARNISHED CAMBRIC CLOTH AND TAPE · MICA PLATE, TAPE, PAPER, CLOTH, TUBING · FIBERGLAS BRAIDED SLEEVING · COTTON TAPES, WEBBINGS AND SLEEVINGS · IMPREGNATED VARNISH TUBING · INSULATING VARNISHES OF ALL TYPES · EXTRUDED PLASTIC TUBING



Quality control of the components of EICOR products is maintained by innumerable inspections and tests. And such thoroughness pays—it assures reliable motors and dynamotors for our Armed Forces—it helps us produce perfect units, faster.

For example, the insulation tester illustrated was designed and built by EICOR engineers expressly for applying high potential stresses between certain insulated components. Such tests are made between high or low voltage windings and ground; from high to low voltage windings; from field coils to ground, and between other parts, depending on the type of the unit. *Every motor and every dynamotor,* large or small, must “take it” at a specified voltage as a routine part of production testing.

Long experience in this highly specialized field has helped earn an enviable reputation for EICOR products. This experience may be of considerable assistance to you when rotary electrical equipment is a factor in your post war planning.



Eicor, Inc. 1501 W. Congress St., Chicago 7, Illinois

DYNAMOTORS · INVERTERS · ELECTRONIC CONTROLS · ALTERNATORS · MOTORS



Three-purpose chassis cart for television receiver assembly line

runs between two closely spaced angle-iron strips screwed to the bench. This wheel is at the leading end of the cart.

For a powered conveyor line, a roller-chain conveyor can be run behind or under the line, with rods projecting from the chain to engage some part of the cart.

Magnifying-Glass Holders

FOR inspecting connections and checking clearances in intricate subminiature assemblies for military and commercial electronic units, magnifying lenses are becoming more and more essential. Varieties of holders for these lenses are becoming almost as numerous as for soldering irons, in commercial as well as homemade versions. Three examples are shown, along with a modification of one holder

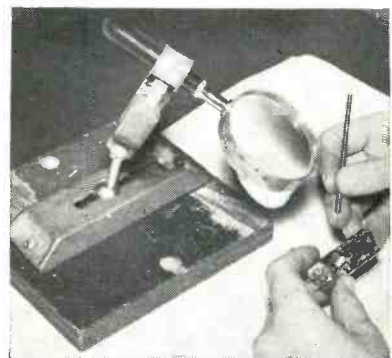

Lens holder devised by RCA engineers to aid inspector in checking clearances between parts on subminiature plug-in i-f amplifier stage

Want an oscilloscope camera NOW?



Scope Image

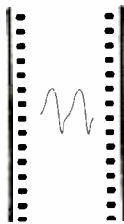

Film Recording

1. Single-frame photography of stationary patterns using a continuously running sweep.

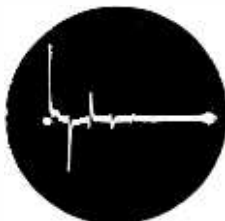

Scope Image

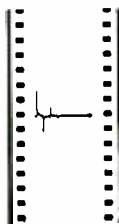

Film Recording

2. Single-frame photography of single transients using a single sweep.



Scope Image



Film Recording

3. Continuous-motion photography employing film motion as a time base.



Scope Image

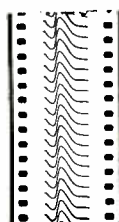

Film Recording

4. Continuous-motion photography employing oscilloscope sweep as a time base.

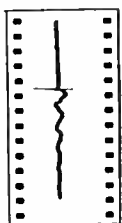

FILM MOTION
TIME BASE

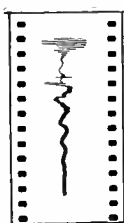

FILM MOTION
AND SCOPE SWEEP

5. Continuous-motion photography employing combination of film motion and oscilloscope sweep as a time base.

Complete information about applications and operation of both the Fairchild Oscillo-Record Camera and the Fairchild-Polaroid Oscilloscope Camera is available. Write today to Fairchild Camera and Instrument Corporation, 88-06 Van Wyck Boulevard, Jamaica 1, New York, Department 120-18A-1.

Fairchild Oscillo-Record Cameras are now available *from stock* for immediate shipment. With these units you can make *permanent* photographic records of oscilloscope traces, thereby eliminating possible errors in making hand sketches from memory. In time-saving and convenience alone, these cameras will pay for themselves many times over.

FAIRCHILD OSCILLO-RECORD CAMERA IS UNUSUALLY VERSATILE

Users of the Fairchild Oscillo-Record Camera like its versatility. Designed for both still and continuous-motion photography on 35-mm film, it records non-recurring phenomena that are too rapid for visual study, others that are so slow that continuity is lost, and the occasions where very high-speed transients are combined with very slow-speed phenomena. For some idea of the types of jobs this instrument can do, study the examples at the left. Each solves a particular problem. Oscillo-Record camera users especially like its:

- CONTINUOUSLY VARIABLE SPEED CONTROL — 1 in./min. to 3600 in./min.

- TOP OF SCOPE MOUNTING that leaves controls easily accessible.

- PROVISION FOR 3 FILM LENGTHS—100, 400 or 1,000 feet.

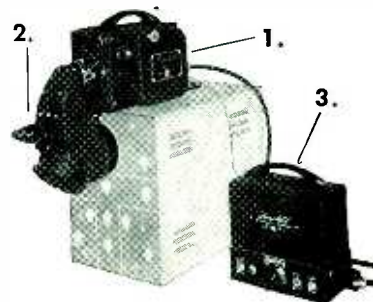

1. Camera, 2. periscope, 3. electronic speed control. Accessories include 400- and 1,000-ft. film magazines, magazine adaptor and motor, universal mount for camera and periscope, binocular split-beam viewer.

FAIRCHILD TAKE-UP CASSETTE FOR SHORT RUNS

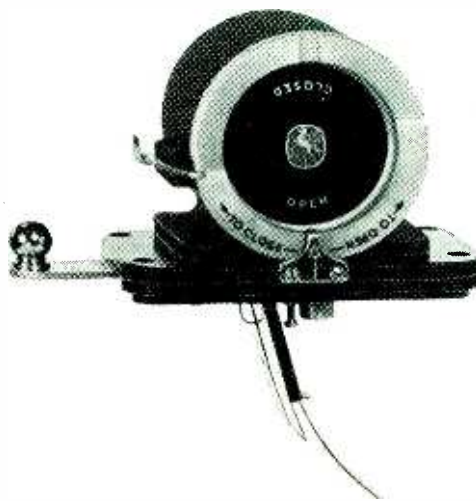

Where only a few pictures are required for quick development and study, a small Take-up Cassette is available as an accessory. The convenience afforded by this unit results in the saving of considerable time in handling short runs and reduces film wastage to a minimum. It is easily attached to the top of the camera by means of an adapter. A built-in knife permits short lengths of exposed film (up to 10 feet) to be cut off and removed with the cassette for developing.

FAIRCHILD
OSCILLOSCOPE RECORDING CAMERAS

JOHNSON TYPES "E" and "F" CAPACITORS

TYPE F DUAL

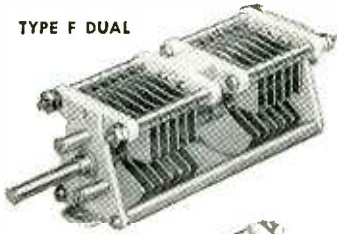

TYPE E SINGLE

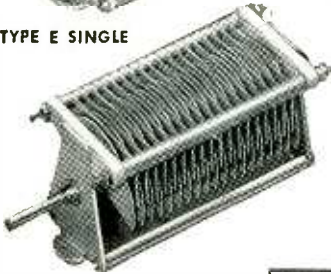

Presenting JOHNSON E and F capacitors. Designed to have the best possible capacity/volume ratio for their ratings, they waste no space. Rigidity, quality materials and low losses qualify them for the most exacting applications.

CONSTRUCTION

Aluminum plates, .032" thick with rounded edges. Heavy aluminum end frames with 1/4" aluminum tie rods. Dense molded Steatite insulators combine strength and minimum electrical losses. Shafts are 1/4" stainless steel with 5/8" rear extensions. Cadmium plated, phosphor bronze rotor contacts; dual models have center rotor contact for electrical symmetry. Normal mounting is with stator up providing low capacity to ground and effectively reducing the minimum. Both end frames drilled and tapped 6-32 for optional panel mounting. Brackets supplied for inverted mounting or mounting of accessories.

PANEL SPACE REQUIRED:

Type E, 2 5/8" wide x 2-19/32" high; Type F, 2-1/16" wide x 2" high. "L" dimension is nominal length excluding shaft extensions. Mounting dimension is 7/16" more than "L" dimension.

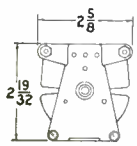
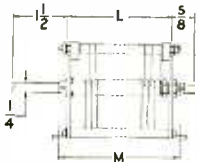

TYPE E

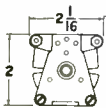
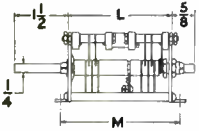

TYPE F

TYPE E SINGLE SECTION						
Cat. No.	Type No.	Cap. per Sect.*			Number Plates	L
		Max.	Min.	Spacing		
154-1	250E20	244	12	.045"	23	2 5/8"
154-2	350E20	353	15	.045"	33	3 1/8"
154-3	500E20	488	19	.045"	45	4 1/8"
154-4	35E30	39	8	.075"	6	1 3/8"
154-5	50E30	52	9	.075"	8	1 7/8"
154-6	70E30	73	9	.075"	11	2 3/8"
154-7	100E30	100	11	.075"	15	2 9/16"
154-8	150E30	154	14	.075"	23	3 7/16"
154-9	250E30	251	20	.075"	37	4 7/16"
154-10	350E30	347	25	.075"	51	6 7/16"
154-11	35E45	38	9	.125"	9	2 3/16"
154-12	50E45	53	11	.125"	12	2 8/16"
154-13	70E45	74	13	.125"	17	3 3/16"
154-14	100E45	101	16	.125"	23	4 1/16"
154-15	150E45	145	20	.125"	33	6 3/32"
154-16	250E45	241	32	.125"	55	9 9/16"
TYPE E DUAL SECTION						
154-501	200ED20	200	10	.045"	19	5 1/8"
154-502	300ED20	312	13	.045"	29	6 21/32"
154-503	50ED30	52	8	.075"	8	4 3/8"
154-504	70ED30	72	8	.075"	11	4 17/32"
154-505	100ED30	99	10	.075"	15	5 3/8"
154-506	150ED30	153	13	.075"	23	7 1/16"
154-507	200ED30	196	15	.075"	29	8 3/8"
154-508	50ED45	52	10	.125"	12	6 3/32"
154-509	70ED45	74	12	.125"	17	7 1/16"
154-510	100ED45	100	15	.125"	23	9 3/32"
TYPE F SINGLE SECTION						
155-1	35F20	35	7	.045"	6	1 15/32"
155-2	50F20	54	8	.045"	9	1 5/8"
155-3	70F20	66	8	.045"	11	1 25/32"
155-4	100F20	106	10	.045"	17	2 1/4"
155-5	150F20	154	12	.045"	25	2 7/8"
155-6	250F20	252	17	.045"	41	4 3/32"
155-7	35F30	36	8	.075"	9	1 7/8"
155-8	50F30	52	9	.075"	13	2 3/16"
155-9	70F30	67	11	.075"	17	2 23/32"
155-10	100F30	99	14	.075"	25	3 15/32"
155-11	150F30	148	18	.075"	37	4 7/8"
TYPE F DUAL SECTION						
155-501	50FD20	53	7	.045"	9	3 1/2"
155-502	70FD20	66	7	.045"	11	3 27/32"
155-503	100FD20	104	9	.045"	17	4 11/16"
155-504	150FD20	153	11	.045"	25	6
155-505	200FD20	202	14	.045"	33	7 5/32"
155-506	50FD30	51	8	.075"	13	4 5/32"
155-507	70FD30	66	10	.075"	17	5 23/32"
155-508	100FD30	99	13	.075"	25	7 1/16"

* Nominal Values

Many variations from standards are available where the quantities justify special production. These variations include: special capacitances, .030 spacing, special shafts and bearings, dynamically balanced rotors, special contacts, etc.

For additional description of E and F capacitors as well as the complete JOHNSON line of outstanding capacitors, write for catalog 701-A7



E. F. JOHNSON CO.
WASECA, MINNESOTA



Modification of RCA battery-clip fixture for holding plug-in stage

for supporting the subminiature chassis itself.

A large battery clip screwed to the rod of a ball-and-socket base serves as holder for a conventional reading glass used at an AN/PRC-10 inspection position in RCA's Camden, N. J. plant. The inspector here uses a piano-wire feeler to check clearance between the components and the chassis of a plug-in stage. Holding pressure on the steel ball can be adjusted by loosening or tightening one of the screws that fasten the socket casting to the wood base.

By brazing semicircular pieces to the jaws of the battery clip, RCA methods engineers modified this same holder to support the plug-in chassis during assembly. The circular jaws permit rotating the plug-in base readily for work on both sides, and the fixture itself can be



Large Bausch & Lomb magnifier and stand used by RCA for inspecting sub-miniature chassis

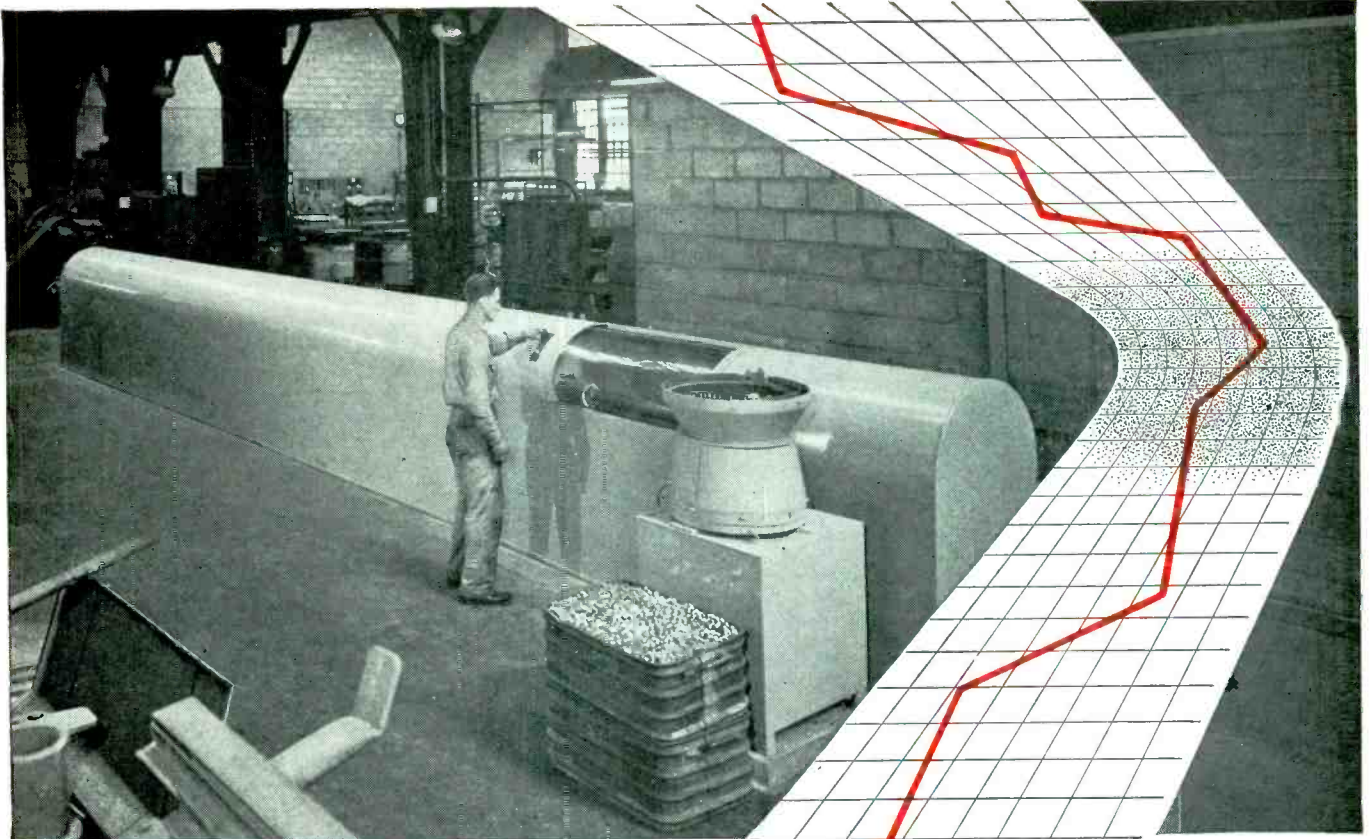

An automatic heat treat machine. Production is about 3 times that possible with manual methods while quality is held within very close limits.

CRUCIBLE ALNICO MAGNETS

KEEP COSTS DOWN . . . through
automatic production that gives quality control

Alnico magnets have been getting smaller and lighter, thanks to production techniques in use at Crucible. Automatic machinery cuts the possibility of human error to a minimum, so rejections are low. This helps to maintain stable price levels in the face of rising material and labor costs. At the same time, Crucible's rigid inspection standards and attention to quality have developed a magnet with the *highest gap flux per unit weight of any on the market.*

Today, Crucible can offer lighter, magnetically stronger Alnico magnets because of these automatic production techniques developed over the sixteen years that we have been producing the Alnico alloys. And behind our familiarity with permanent magnets lies more than 52 years' experience with specialty steelmaking. Let us advise you on your magnet problem.

CRUCIBLE

first name in special purpose steels

52 years of *Fine* steelmaking

PERMANENT ALNICO MAGNETS

CRUCIBLE STEEL COMPANY OF AMERICA, GENERAL SALES OFFICES, OLIVER BUILDING, PITTSBURGH 30, PA.
STAINLESS • REX HIGH SPEED • TOOL • ALLOY • MACHINERY • SPECIAL PURPOSE STEELS

Pyroferric

IRON CORES

PYROFERRIC IRON CORES are scientifically manufactured, under strictest quality controls and rigid maintenance of close electrical and mechanical tolerances.

PYROFERRIC services are available for the engineering of your core production requirements . . . write for catalog 22, which gives complete powdered iron core information such as the manufacture of iron cores, their electrical properties, materials, design considerations, standardization data, uses, and contains other useful information.

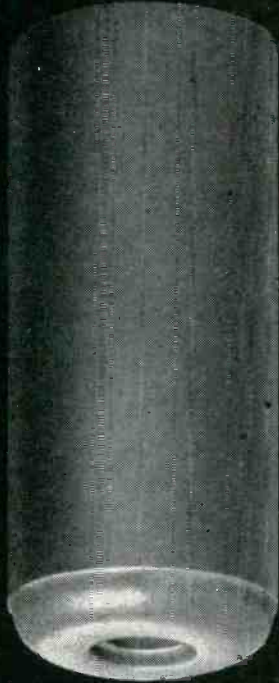

PYROFERRIC

621 EAST 216 ST.,

NEW YORK 67, N. Y.

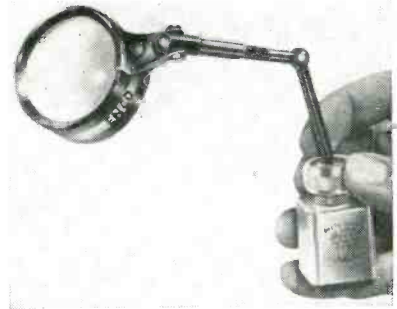

Magnetic holder for supporting 4-power two-inch magnifying lens on ferrous surface

set at the most convenient angle for each stage of assembly work.

At another inspection position in the same RCA plant, a standard Bausch and Lomb magnifying-lens holder is used to obtain a greater range of height adjustment.

For greater magnification, a two-lens 4-power magnifier is now available from Enco Mfg. Co., 4524 W. Fullerton Ave., Chicago 39, Ill., along with a magnetic base holder that grips to any ferrous surface and has a magnetic pull of about 50 lb.

Salvaging Tungsten

AN ultrasonic vibrator operating at 27,000 cycles per second is used to remove glass beads from tungsten rods taken out of defective vacuum tubes at Raytheon's Waltham, Mass. plant. When the tungsten



To remove adhering glass, operator inserts rod in hole in end of ultrasonic vibrator

**The FIRST all-band
direct reading**

SPECTRUM ANALYZER

10 MCS to 21,000 MCS

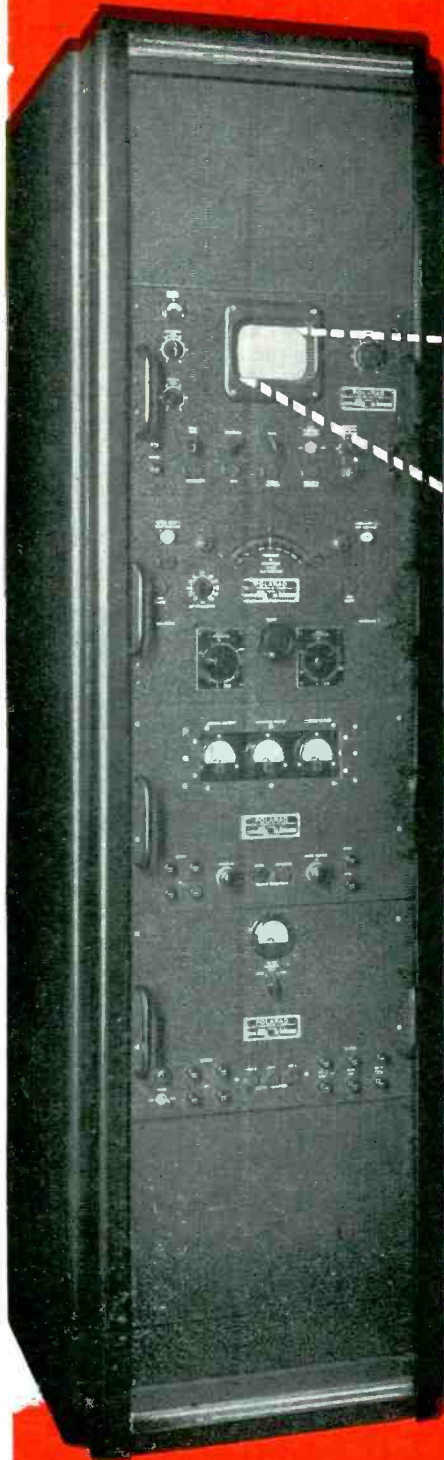

Polarad's Model LSA Spectrum Analyzer is the result of years of research and development. It provides a simple and direct means of rapid and accurate measurement and spectral display of an r.f. signal.

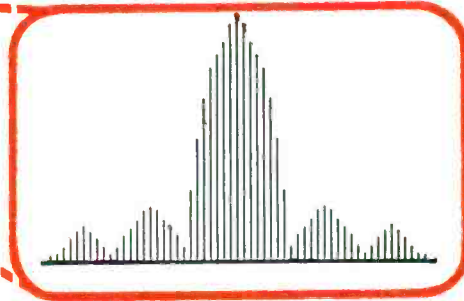

Outstanding Features:

- Continuous tuning.
- One tuning control.
- 5 KC resolution at all frequencies.
- 250 KC to 25 MCS display at all frequencies.
- Tuning dial frequency accuracy 1 percent.
- No Klystron modes to set.
- Broadband attenuators supplied with equipment from 1 to 12 KMC.
- Frequency marker for measuring frequency differences 0-25 MCS.
- Only four tuning units required to cover entire range.
- Microwave components used latest design non-contacting shorts for long mechanical life.
- Maximum frequency coverage per dollar invested.
- 5 inch CRT display.

Where Used:

Polarad's Model LSA Spectrum Analyzer is a laboratory instrument used to provide a visual indication of the frequency of distribution of energy in an r.f. signal in the range 10 to 21,000 MCS.

Other uses are:

1. Observe and measure sidebands associated with amplitude and frequency modulated signals.
2. Determine the presence and accurately

measure the frequency of radio and/or radar signals.

3. Check the spectrum of magnetron oscillators.
4. Measures noise spectra.
5. Check and observe tracking of r.f. components of a radar system.
6. Check two r.f. signals differing by a small frequency separation.

Write for Complete Details

**the instrument consists of
the following units:**

Model LTU-1 R.F. Tuning Unit—10 to 1000 MCS.
Model LTU-2 R.F. Tuning Unit—940 to 4500 MCS.
Model LTU-3 R.F. Tuning Unit—4460 to 16,520 MCS.
Model LTU-4 R.F. Tuning Unit—15,000 to 21,000 MCS.
Model LDU-1 Spectrum Display Unit.
Model LPU-1 Power Unit.
Model LKU-1 Klystron Power Unit.

Polarad

Electronics Corporation

100 Metropolitan Ave.

Brooklyn 11, N. Y.

Manufacturers of broadband microwave laboratory instruments.

GET THE INSIDE STORY

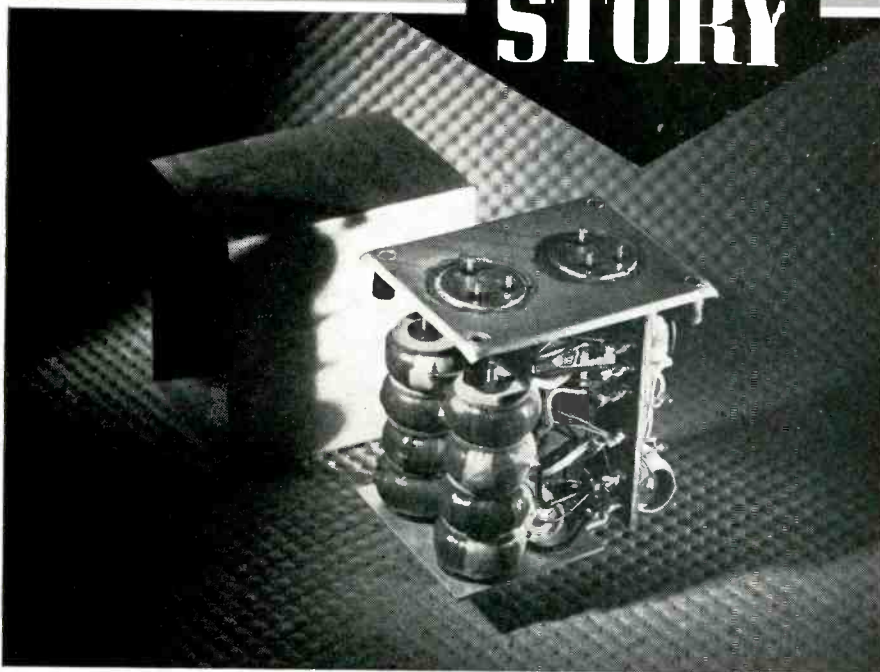

...WHEN YOU BUY FILTERS

RESPONSE CURVES and cases may look alike, but component quality and internal construction are the things that determine dependability—in a filter, and in the associated equipment.

TO BE SURE components are the best, Lenkurt presses its own cores, winds the coils, and subjects all parts to the most rigorous checks possible.

IN A LENKURT FILTER, parts are firmly fastened to sturdy headers, connections made to rigid terminal boards. Units are impregnated, cased, and/or hermetically sealed as required.

LENKURT FILTERS are engineered and built to your most exacting specifications on delivery schedules to meet any quantity need by Lenkurt Electric Company—largest independent manufacturers of telephone toll transmission equipment.

**LENKURT ELECTRIC
SALES COMPANY**
San Carlos 1 California



rod is inserted in a small hole at the end of the vibrator all glass on the rod disintegrates instantly. The former manual hammering-off of the glass was much slower and often resulted in cracked pieces of tungsten that were unfit for further use.

Other glass-sealing alloys can be salvaged by the same method, with similar savings in critical materials such as cobalt and nickel.

Production-Floor Carts

REMOVABLE steel shelves almost double the capacity of carts used for transporting and storing finished chassis units and larger components on the production floor at Utility Electronics in East Newark, N. J.

Metal brackets were welded to



Inserting extra shelf in cart to increase capacity

Again it's SYLVANIA!

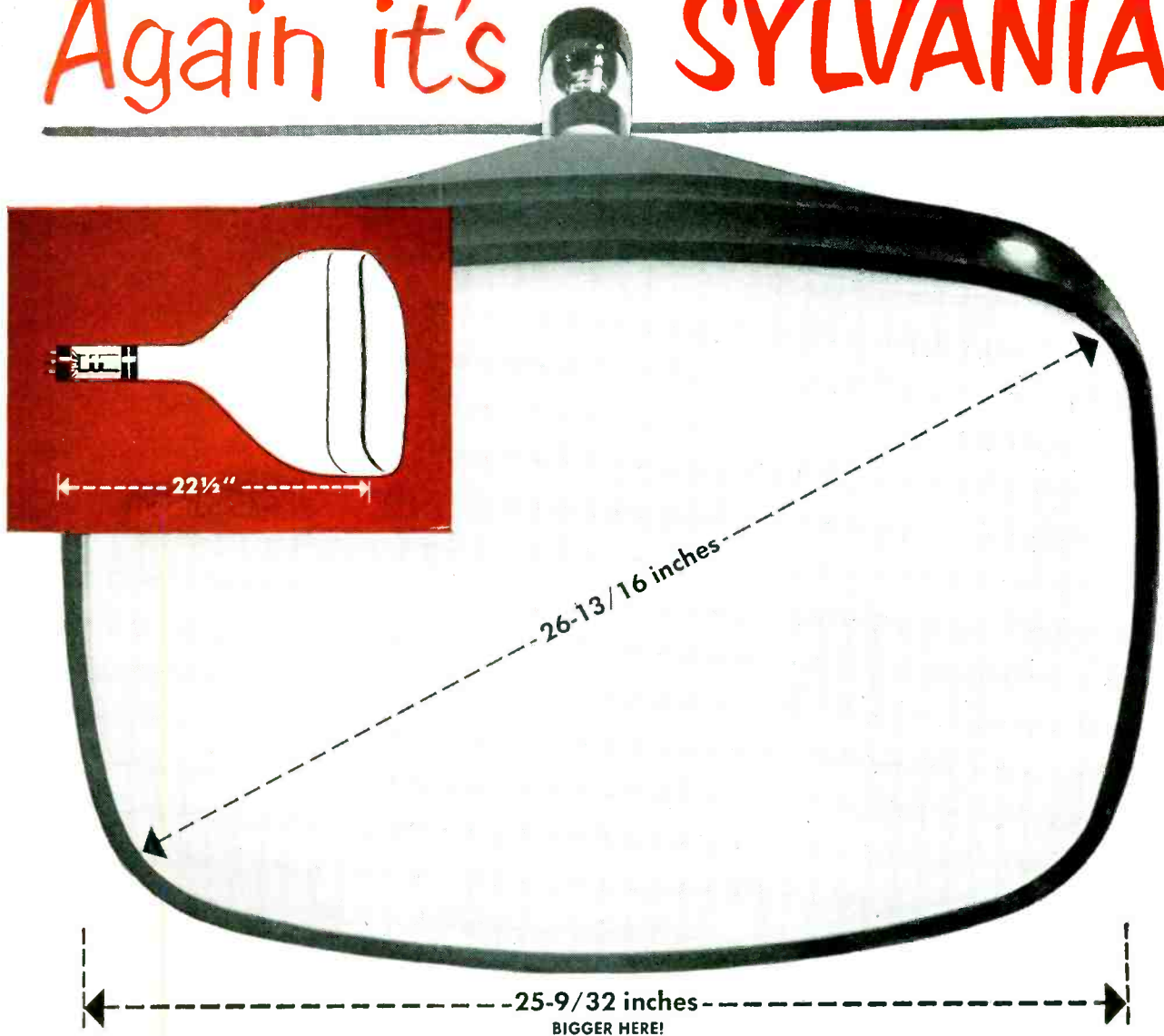

Now with a New 27-inch Rectangular Picture Tube

Again Sylvania steps ahead with a big all-glass picture tube to meet your demands for larger sets and larger screens.

This tube is designed for easier, more comfortable viewing. It employs a neutral-density, gray filter face plate. The tube is magnetically focused and deflected. Equipped with an ion trap gun . . . no external conductive coating.

NEW COMPACT DESIGN

Here is a big tube that's actually shorter in depth to overcome many cabinet design problems. By employing a deflection angle of 90

degrees, the over-all, front-to-rear dimension of this tube has been held to only $22\frac{1}{2}$ inches.

For full detailed data and characteristics of this latest Sylvania picture tube, write today to Sylvania Electric Products Inc., Dept. R-1407, Emporium, Pa.

SYLVANIA





NEW ENGLAND DIVISION MILFORD, CONN.



ILLINOIS DIVISION AURORA, ILL.



OHIO DIVISION ELYRIA, OHIO



PENN. DIVISION ALLENTOWN, PA.

NOW **4** MODERN PLANTS

on industry's doorstep to expedite service of your needs for **QUALITY** tubular and split rivets, rivet setting machines and special cold-headed fasteners

★ WRITE FOR CATALOG

Est. 1919

the **MILFORD RIVET & MACHINE CO.**

855 BRIDGEPORT AVE., MILFORD, CONN.

MILFORD

the name to RIVET in your memory for faster firmer better fasteners

the angle-iron framework of the cart to serve as supports for three additional shelves, centered between the four original shelves, for use when handling smaller units. An added advantage of the technique is reduction in the total number of carts and hence of floor space needed for cart storage. The technique was introduced by J. P. Breickner, production manager of the plant.

Output Transformer Tester

BY CURTIS R. SCHAFER
The Liquidometer Corp.
Long Island City, N. Y.

FIVE electrical characteristics of a servo-system output transformer are checked automatically by the production-type test setup shown. When the operator inserts a transformer in the test fixture, plate and screen voltages are automatically applied by means of a switch built into the fixture.

Correct phasing of the transformer is checked by noting the di-



Hermetically sealed output transformers, used to couple the electronic amplifier to the two-phase motor of a self-balancing bridge used in capacitance-type aircraft gasoline gages, are checked completely in a few seconds when inserted in socket on box in foreground



keeping communications ON THE BEAM

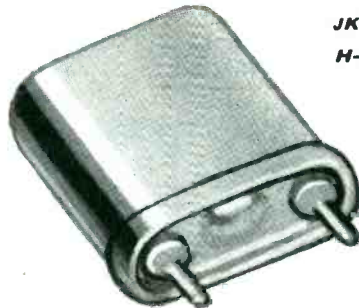

**JK STABILIZED
H-17 CRYSTAL**

CRYSTALS FOR THE CRITICAL

The small, compact H-17 is designated as a military type crystal for its use in mobile units common to the military. Frequency range: 200 kc to 100 mc. Hermetically sealed holders; wire-mounted, silver-plated crystals.

*the JK
FD-12*



**FREQUENCY AND
MONITOR MODULATION**

Monitors any four frequencies anywhere between 25 mc and 175 mc, checking both frequency deviation and amount of modulation. Keeps the "beam" on allocation; guarantees more solid coverage, too!

"High Gear" Response to High Power Maintenance!

Dawn or dusk, it doesn't matter. These heroes of the high wires arrive to stop power trouble before it starts. Their "nose for disaster" is in the service truck, in the mobile radio unit which often relies on JK crystals and monitors to keep their assigned radio frequency on the beam.

THE JAMES KNIGHTS COMPANY
SANDWICH 3, ILLINOIS

inside this package on your Jobber's shelf...



is the world's toughest transformer

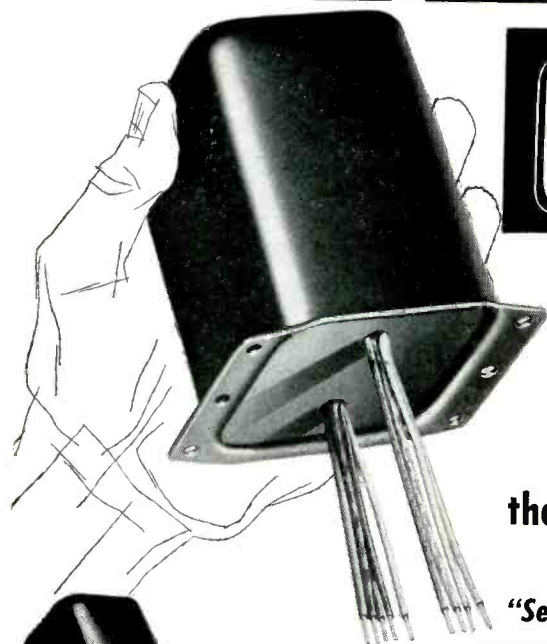

CHICAGO

C-TYPE

With 10" color-coded leads brought out through fibre board base cover. Lead ends are stripped and tinned for easy soldering. Flange-mounted unit.

there's nothing tougher than **CHICAGO**

"Sealed-in-Steel" construction

CHICAGO "New Equipment" transformers (available in 3 mountings) feature one-piece drawn-steel cases—the strongest, toughest, best-looking units you can buy. The one-piece seamless design, enclosing an electronically perfect construction, provides the best possible electrostatic and magnetic shielding, with complete protection against adverse atmospheric conditions. For every application: Power, Bias, Filament, Filter Reactor, Audio, MIL-T-27, Step-down—ask your electronic parts distributor for CHICAGO "Sealed-in-Steel" Transformers—the world's toughest with that extra margin of dependability.

Free "New Equipment" Catalog

Get the details on CHICAGO'S New Equipment Line—covering "Sealed-in-Steel" transformers for every modern circuit application. Write for your Free copy of this valuable catalog today, or get it from your distributor.



H-TYPE

Hermetic sealing meets all MIL-T-27 specs. Steel base cover is deep-seal soldered into case. Ceramic bushings. Stud-mounted unit.



S-TYPE

Steel base cover fitted with phenolic terminal board. Convenient numbered solder lug terminals. Flange-mounted unit.



CHICAGO TRANSFORMER

DIVISION OF ESSEX WIRE CORPORATION

3501 ADDISON STREET • CHICAGO 18, ILLINOIS



TRADE MARK REG.

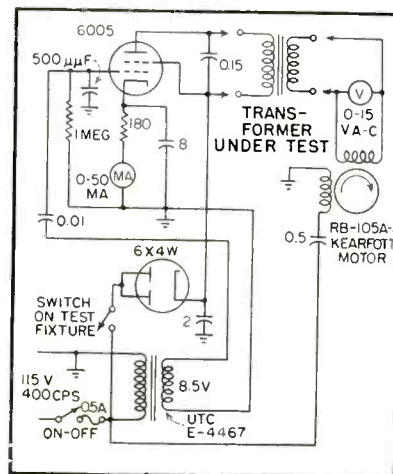

Output transformer test circuit

rection of rotation of a pointer attached to the shaft of the panel-mounted load motor. The primary inductance with d-c flowing, the insertion loss, the turns ratio and the power-handling ability are all checked by noting the a-c voltage across one phase of the motor, as all four characteristics will effect this voltage.

The milliammeter in the cathode circuit of the type 6005 Arinc tube serves as a built-in tube checker, providing a continuous check on the test setup itself. The equipment was constructed by Arthur Hull of The Liquidometer Corp.

Magnet-Wire Container

Two identical parts of molded fiber comprise a new method of packaging spools of magnet wire for shipment. Weight is only one-third that of the old-style wooden shipping box. Sharp corners, nail hazards



Molded fiber carton for wire shipment

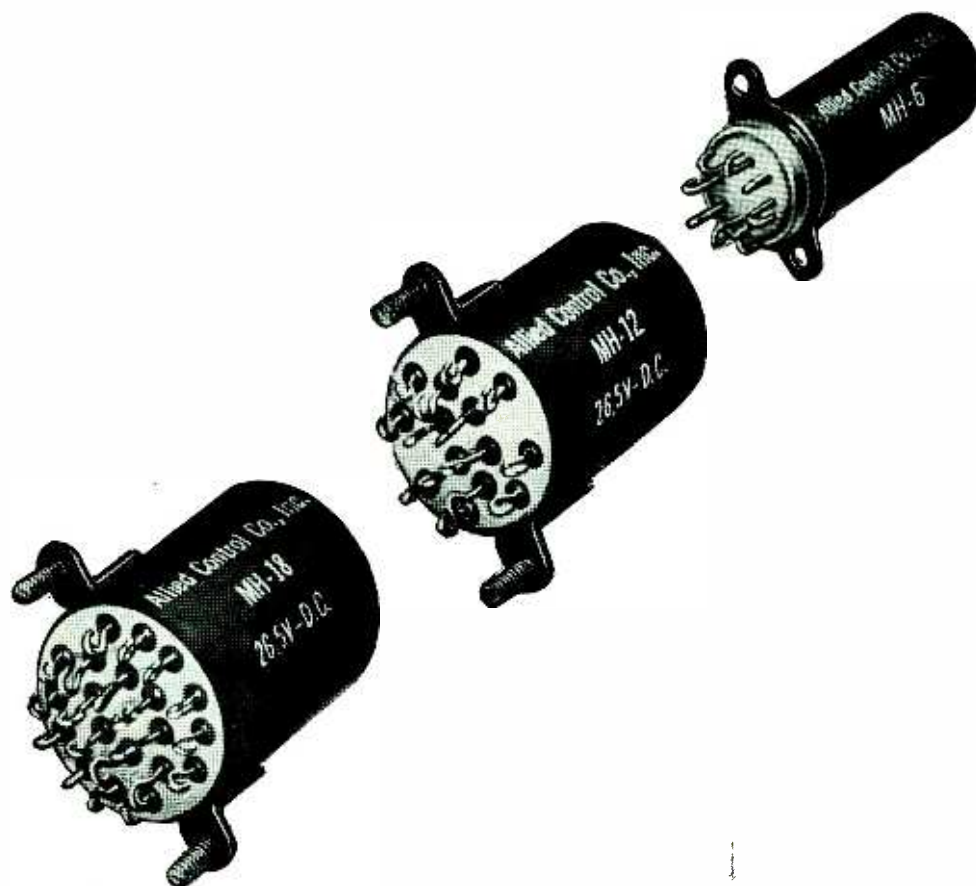

ALLIED'S NEW 50 G SUB-MINIATURE RELAYS

Developed specifically to meet the rigid requirements of U.S.A.F. Spec. MIL-R-5757A, the new Allied line of sub-miniature double throw relays includes the MH-18 (6-pole), the MH-12 (4-pole), and the MH-6 (2-pole) will follow.

Contacts are rated at 2 amps resistive or 1 amp inductive at 28 volts D.C.

The high performance of these relays has been achieved in an extremely compact, unitized construction and parallels the most recent advances in airborne equipment design.

Complete details in Bulletin 1002.

1ST

**Sub-miniature relays
to be developed**

ALLIED CONTROL COMPANY, INC., 2 EAST END AVENUE, NEW YORK 21, N. Y.

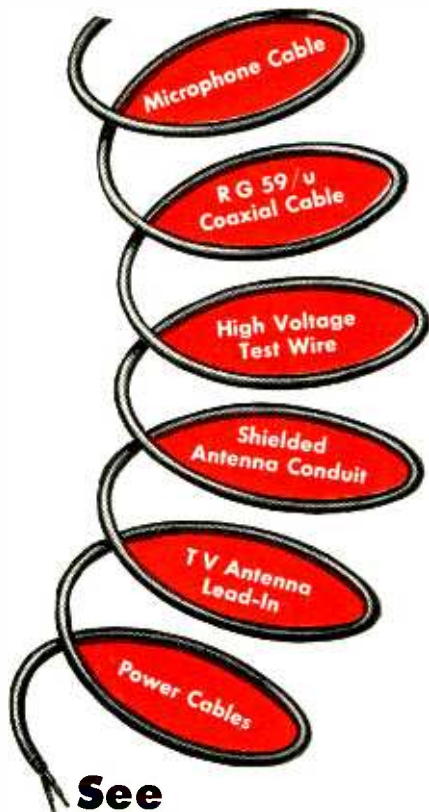

See
CAROL CABLE

... for prompt service

Carol Cable's complete manufacturing facilities assure you efficient service and prompt delivery. We draw our own wire, and formulate our own insulation from all modern synthetic rubbers and plastics. Your orders are engineered and manufactured by an organization that operates as an integrated, independent unit, without intermediate profits.

Constant laboratory control over raw materials, work in process and finished cable is your guarantee of dependable performance of all Carol products.

Your wire and cable problems will receive our immediate attention. Write to us today!

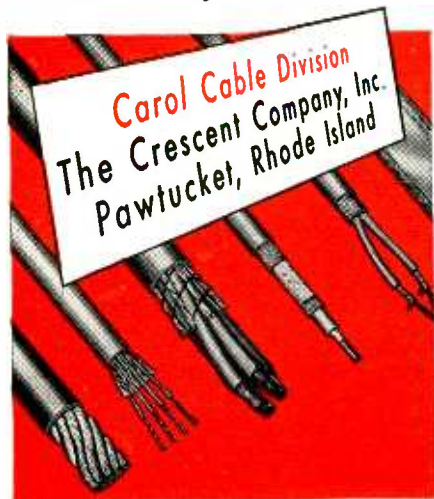

and slivers are eliminated.

After removing the top cover, the customer can lift the lower tray to storage shelves or use it directly alongside coil-winding machinery on production floors, without unpacking.

The new container was developed under the sponsorship of Anaconda Wire & Cable Co. as a solution to the serious problem of damage to magnet wire during shipment.

Steel-Wool Pad on Bench Discharges Capacitors

AFTER testing four-section electrolytic capacitors for capacitance and for leakage current at rated voltage, the units are discharged simply yet completely by jabbing the terminals



Discharging electrolytic capacitor in steel wool after leakage test

into a pad of fine steel wool at Astron Corporation's East Newark, N. J. plant.

Tiny individual wads of the steel wool are also used behind the holes provided for the capacitor terminals in the test fixture, to make positive contact with the terminals when a unit is slid into the fixture.

Far-Infrared Baking

BREAKAGE loss caused by uneven heating during baking of the interior graphite coating of television picture tubes was reduced more than 80 percent and production stoppages cut in half by changing filament-type infrared heat sources in the baking oven to far-infrared electric radiant heaters. The glass



ARC SIGNAL GENERATOR

ARC Signal Generators permit quick, accurate check-out of aircraft before take-off, as well as fast, dependable bench checks and trouble shooting.

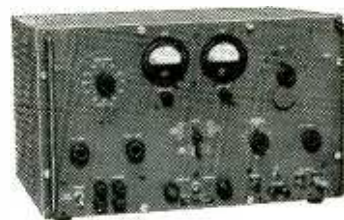

TYPE H-14 108-132 Megacycles

Standard signal source for complete testing of VHF Airborne omnirange and localizer receivers in aircraft or on the bench. Checks up to 24 omni courses, omni course sensitivity, to-from and flag-alarm operation, left-center-right on 90/150 cycle and phase-localizers, and all necessary quantitative bench tests. For bench checks, 0-10,000 microvolts; for ramp checks, RF output 1 volt into 52 ohm line. Equal to Mil. SG-66/ARM-5.

Price: \$885.00 net, F.O.B. Boonton, N. J.

TYPE H-12 - VHF Signal Generator, a

900 to 2100 mc source of cw or pulse amplitude-modulated RF. Power level 0 to -120 dbm. Internal pulse circuits with controls for width, delay, and rate, and provision for external pulsing. Frequency calibration better than 1%. Built to Navy specs for research, production testing. Equal to Military TS-419/U.

Price: \$1,950.00 net F.O.B. Boonton, N. J.

Write today for complete details



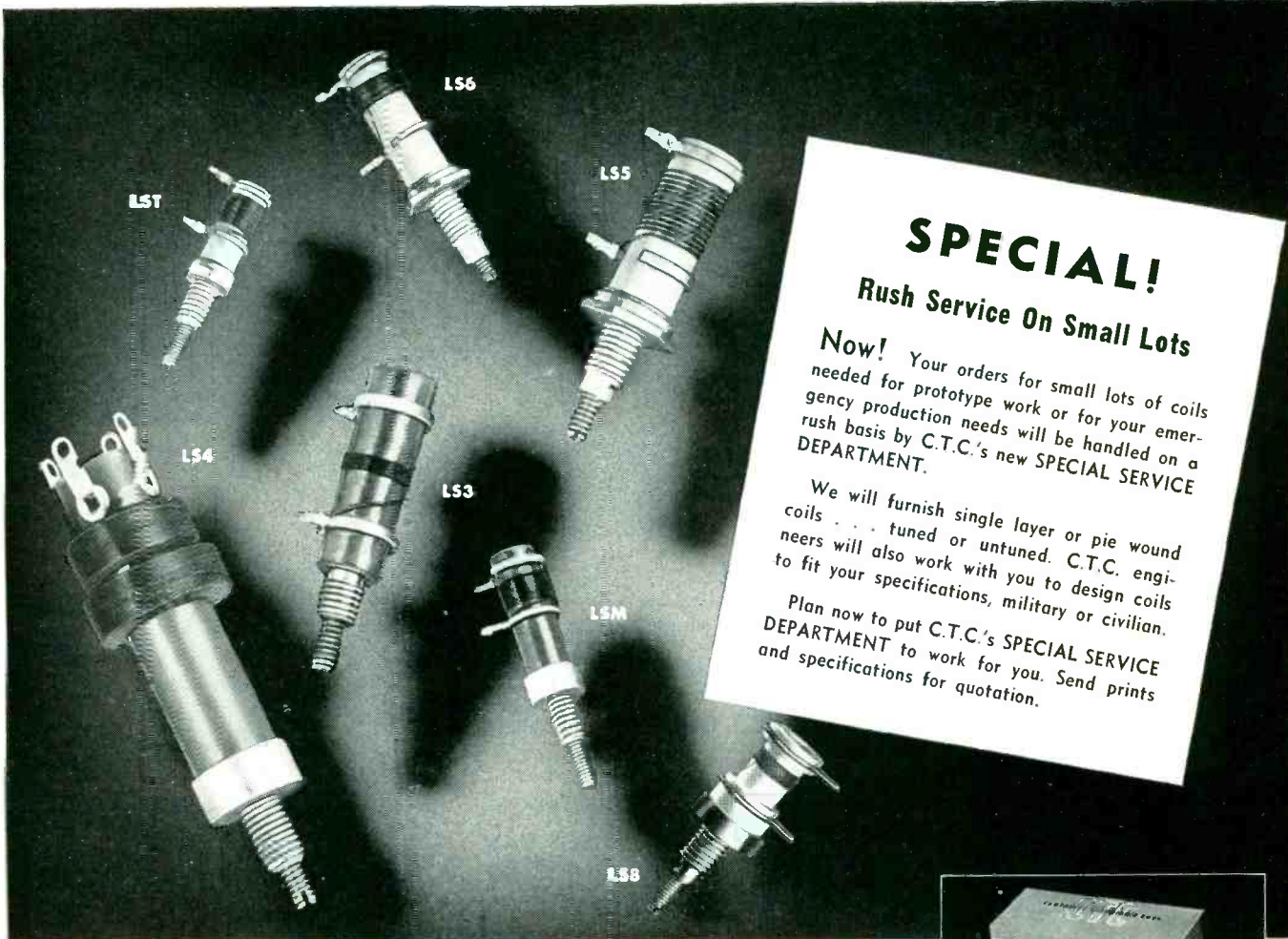

SPECIAL!
Rush Service On Small Lots
Now! Your orders for small lots of coils needed for prototype work or for your emergency production needs will be handled on a rush basis by C.T.C.'s new **SPECIAL SERVICE DEPARTMENT**.
 We will furnish single layer or pie wound coils . . . tuned or untuned. C.T.C. engineers will also work with you to design coils to fit your specifications, military or civilian.
 Plan now to put C.T.C.'s **SPECIAL SERVICE DEPARTMENT** to work for you. Send prints and specifications for quotation.

**Here are the coils you want
 ...the way you want them!**

Take advantage of one of C.T.C.'s most popular and useful services . . . the winding of slug tuned coils to exact specifications. Single layer or pie types furnished. You can be sure your specs — military or personal — will be faithfully followed to the last detail of materials and methods, and with expert workmanship.

C.T.C. coil forms are made of quality paper base phenolic or grade L-5 silicone impregnated ceramic. Mounting bushings are cadmium plated brass and ring type terminals are silver plated brass. Terminal retaining collars of nylon-phenolic also available in types LST, LS5, LS6.

Wound units can be coated with durable resin varnish, wax or lacquer. Both

coils and coil forms are furnished with slugs and mounting hardware — and are obtainable in large or small production quantities. Be sure to send complete specifications for specially wound coils.

All C.T.C. materials, methods, and processes meet applicable government specifications. For further information on coils, coil forms or C.T.C.'s special consulting service, write us direct. *This service is available to you without extra cost.* Cambridge Thermionic Corporation, 437 Concord Avenue, Cambridge 38, Mass. West Coast manufacturers, contact: E. V. Roberts, 5068 W. Washington Blvd., Los Angeles 16, and 988 Market Street, San Francisco, California.

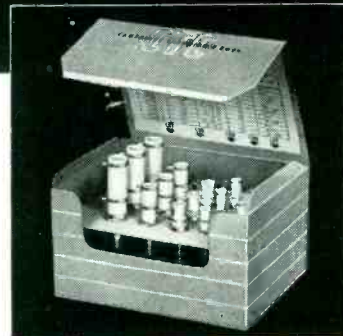

NEW CERAMIC COIL FORM KIT. Helps you spark ideas in designing electronic equipment or developing prototypes and pilot models. Contains 3 each of the following 5 C.T.C. ceramic coil form types: LST, LS5, LS6, LS7, LS8. Color-coded chart simplifies slug-identification and gives approximate frequency ranges and specifications. Nylon-phenolic collars to replace metallic rings available with kit for all ceramic coil forms except LS7 and LS8.

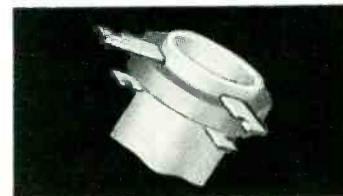

NEW NYLON-PHENOLIC COLLARS. Terminals held securely; soldering spaces doubled; excellent for both bifilar and single pie windings. Show an increase in Q and many new benefits over metallic rings — without impairing in any way the moisture- and fungus-resistant qualities of coil form assemblies.

CAMBRIDGE THERMIONIC CORPORATION

custom or standard . . . the guaranteed components



New Catalog! Send for your copy now.



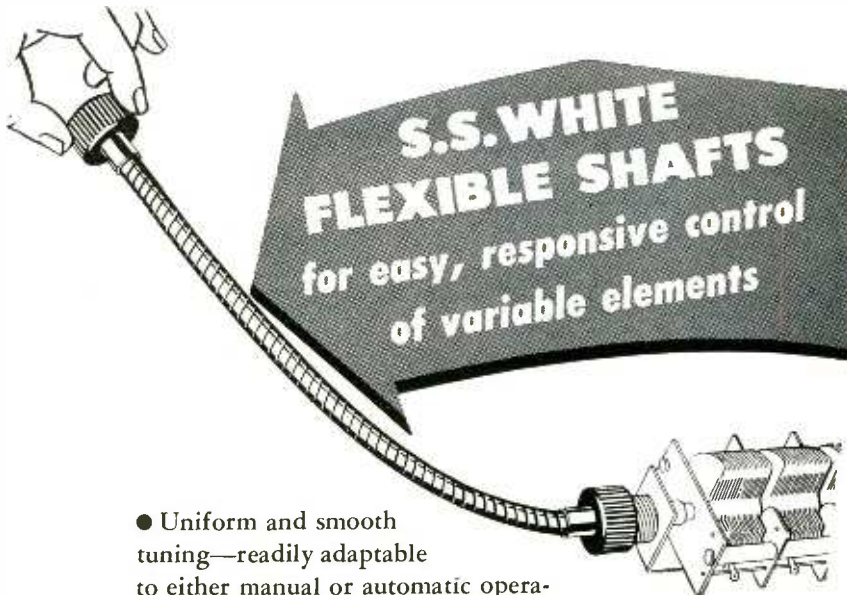

● Uniform and smooth tuning—readily adaptable to either manual or automatic operation is always assured with S.S.White remote control flexible shafts. Designed and built just for this service, S.S. White flexible shafts operate with a minimum of backlash and practically equal deflection in either direction of rotation. What's more, they won't slip, wear out or lose their sensitivity.

Use S.S.White flexible shafts to couple variable elements to their controls. You'll find they make it easier to meet space, wiring, servicing and overall design requirements—and they allow you to do it without having to worry about intervening turns, congested conditions, distance or alignment.

You'll find it easy to satisfy the conditions of almost any remote control application from their wide selection of sizes, types and characteristics.



ENGINEERING COOPERATION

Want help in selecting and applying flexible shafts to your needs? S.S.White engineers are always ready to cooperate with you in working out the solution. Their assistance entails no obligation, and all details are held in strictest confidence.

SEND FOR THIS 256-PAGE HANDBOOK

This authoritative reference manual gives a comprehensive picture of flexible shaft construction, selection and application. Get your copy by writing to us on your company letterhead.



THE S.S. White INDUSTRIAL DIVISION
DENTAL MFG. CO.



Dept. E, 10 East 40th St.
 NEW YORK 16, N. Y.

Western District Office • Times Building, Long Beach, California

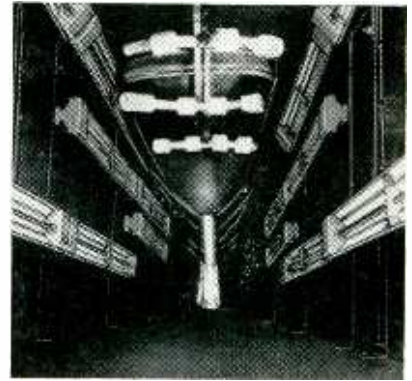

Baking coating inside picture tubes with far-infrared heaters in oven through which overhead conveyor runs

absorbs far-infrared energy (between the limits of 1 and 16 microns), speeding up the baking of the coating on the glass, whereas it transmits most of the near-infrared radiation (between about 0.4 and 5 microns). The change also permitted reducing oven power consumption from 66 to 54 kw. Tubular-type Chromalox far-infrared heaters are made by Edwin L. Wiegand Co., 7500 Thomas Blvd., Pittsburgh 8, Pa.

Similar heaters are focused on the bases of kinescopes moving past on a belt conveyor, to dry out the sealing cement.

Spaghetti Chopper

A STANDARD bare-wire cutting machine is being used successfully without modification for cutting many different types of spaghetti and plastic tubing into short lengths required for television receiver production at the CBS-Columbia plant in Brooklyn, N. Y. The operator merely pushes into the feed rollers a handful of long



Examples of variety of materials that can be chopped into short lengths

"What audio tubes can I substitute, to trim our TV price another \$3.00?"

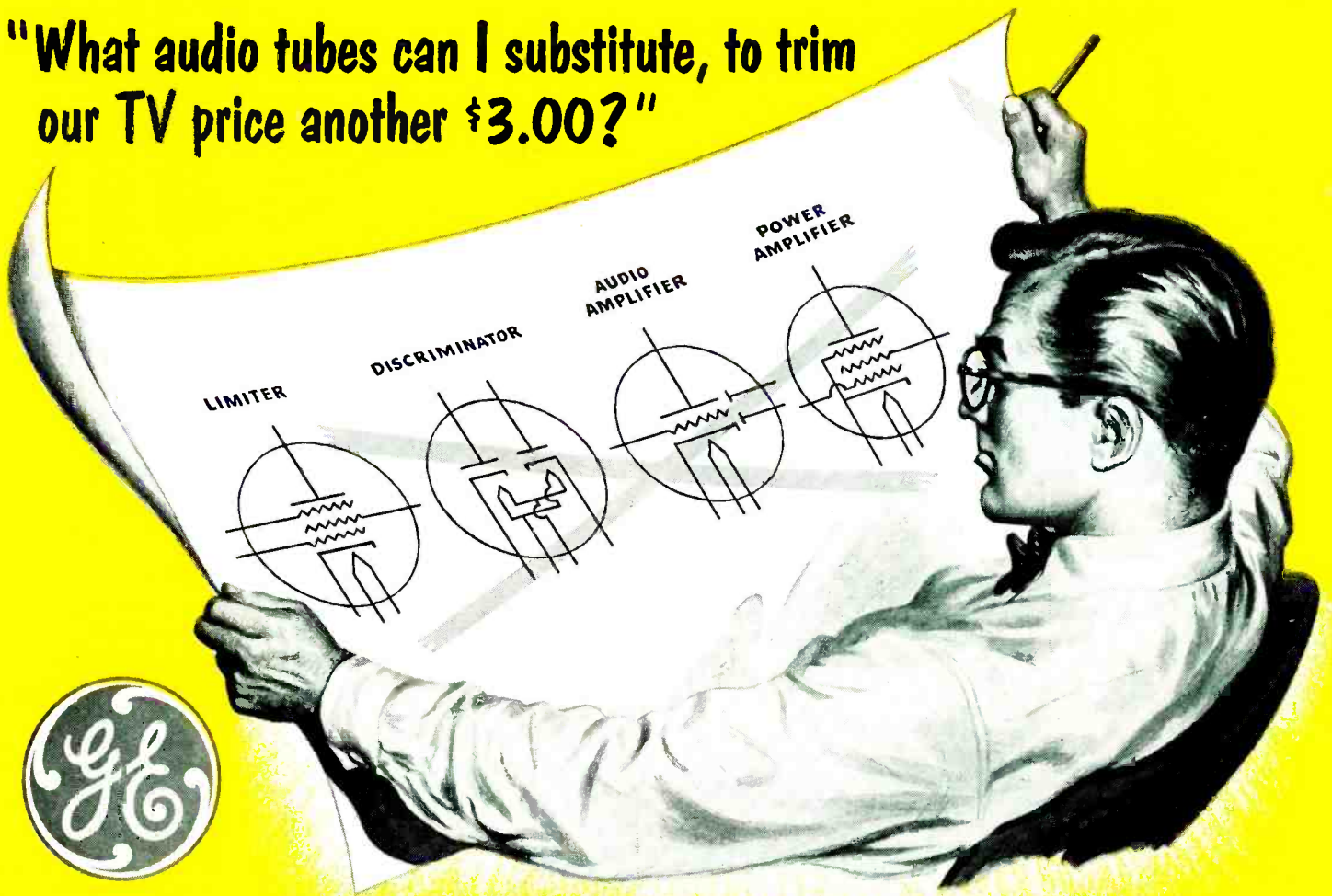

6BN6

Combined limiter, discriminator, and audio amplifier

6BK5

High-sensitivity power tube, designed for use with 6BN6



New G-E pair does work of 4 tubes! SAVES TV COST, MAINTAINS QUALITY PERFORMANCE!

● The 6BN6-6BK5 audio pair helps solve your chief problem, Mr. Designer—how to bring prices *down*, keep performance *up*, in a TV market that's strongly competitive.

Fine reception: you retain it because General Electric custom-designed the new 6BK5 power pentode to team up with its companion, the 6BN6. High sensitivity . . . plenty of clear audio output . . . are 6BK5 features. The new pentode will produce up to 3½ watts of audio, yet is so sensitive that only 5 volts peak is needed to drive the tube into distortion.

Cost saving—both in tubes and components—is a product of the 6BN6's versatility. This gated-beam tube is a real "triple-threat" performer, serving simultaneously as limiter, discriminator, and audio amplifier.

More TV sets sold, better-satisfied customers . . . that's how the 6BN6 and 6BK5 pay off for you! Booklet ET-B35 describes the tubes fully. Phone, wire, or write for it! *General Electric Company, Tube Department, Schenectady 5, New York.*

GENERAL  ELECTRIC

small

OPEN GEAR TRAINS made to your specifications

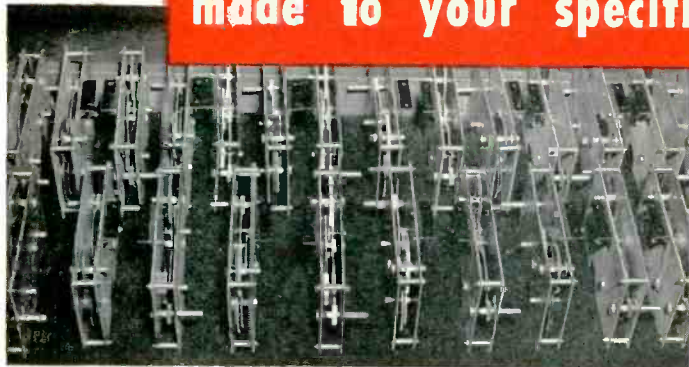

Many units, such as timers, transmitters, vending mechanisms, and similar devices require the adoption of small open gear trains for intermittent duty.

Beaver Gear Works is equipped to make these trains to any degree of accuracy required. Beaver Gear engineers, knowing what is expected, and qualified to assist in details of fine-pitch gear applications, can advise you as to what will work best under various conditions and can specify the correct design.

THE *Finest*



IN GEARS

Beaver Gear Works Inc.

1021 PARMELE STREET, ROCKFORD, ILLINOIS



BECO
IMPEDANCE BRIDGE

for measurement of
**RESISTANCE ♦ CAPACITANCE
INDUCTANCE**

- ♦ Compact—9" x 11" x 11" over-all
- ♦ Exceptionally accurate ♦ Wide ranges
- ♦ Convenient operation from battery, or AC power line accessory amplifier
- ♦ Features exclusive DEKADIAL for high precision readings.

BECO

BROWN ELECTRO-MEASUREMENT CORP.
4635-37 S. E. HAWTHORNE BLVD. PORTLAND 15, OREGON

Shown: Model 250-C. Many laboratories now install several compact Beco Bridges for flexibility and utility. Write to factory for costs, details, and an analysis of your needs. No obligation.

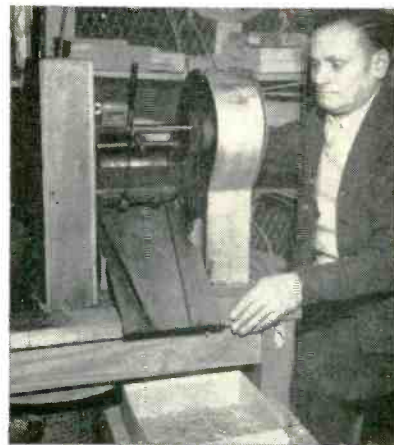

Chopping spaghetti with motor-driven wire-cutting machine

lengths of the material to be cut.

The cutting blade is coupled through a variable-speed linkage to the feed rollers. The rate at which the blade moves up and down in its chopping action thus determines the length of cut, which can be up to 9 inches. Polyethylene tubing up to 5/8 inch in diameter is cleanly cut, as are other materials heretofore considered difficult to cut accurately into short lengths.

Lead-Positioning Springs

STIFF coil springs hold top-cap connectors directly over their respective tube sockets on a 12-tube aging rack built by Chatham Electronics Corp., Newark, N. J., for aging high-voltage industrial and communications tubes. Plastic strips

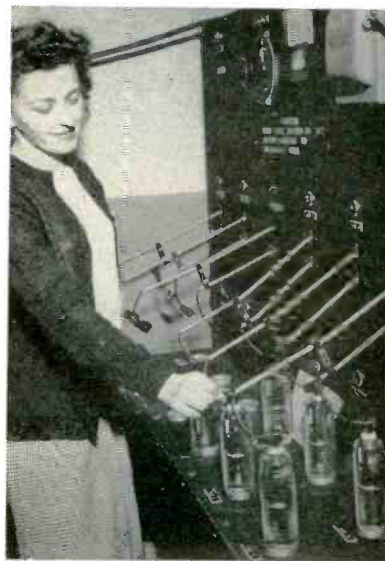

Use of springs around top-cap leads to speed up connections on tube aging rack

Quality...in quantity



PRECISION RESISTORS

JAN R-93 or MIL R93A SPECS.

CHECK THESE FEATURES

LOW-EXPANSION WINDING FORMS

(non-hygroscopic) prevent distorted windings, breaking of seal, breakdown of dielectric.

HIGH-STABILITY RESISTANCE WIRES

—pure, carefully selected, pretested alloys.

PRECISION WINDING

—uniformly wound, mechanically tied under scientifically controlled conditions.

NON-CORROSIVE, ANCHORED TERMINALS

—strong, tin-dipped copper terminals, securely and permanently attached to winding form.

HERMETIC SEALING

A special process, employing chemically inert compounds, seals winding against destructive effects of salts, moisture, and atmospheric conditions.

PRETESTED FOR ACCURACY

—quality assured by temperature cycling, salt water immersion, humidity, and overload tests.

If finding reliable, lightweight, precision wire wound resistors is your problem, investigate the I-T-E product. I-T-E precision resistors have been developed by experts to meet the exacting requirements of the electronics industry.

Simple basic design, engineering skill, extensive production facilities, and close quality control are all combined to give you lightweight resistors that far exceed requirements of JAN R-93 or MIL R93A specifications. You get quality—close tolerance in every unit—in any quantity you need.

RATINGS:

I-T-E precision wire wound resistors can be supplied in quantity all the way from 0.01 ohms to 10 megohms—0.125 to 5 watts. Standard tolerances $\pm 1\%$. Available in specified tolerances down to $\pm 0.05\%$. Ideal for all JAN "A" and "B" as well as MIL applications.

FOR DETAILED INFORMATION—Get in touch with your nearest I-T-E representative or write direct to:

I-T-E RESISTOR DIVISION

1924 Hamilton Street

Philadelphia 30, Penna.

specify



RESISTORS

I-T-E CIRCUIT BREAKER COMPANY • RESISTOR DIVISION • PHILADELPHIA 30, PA.

Guthman products

maintain a reputation of quality
for military
as well as civil application

DELAY LINES

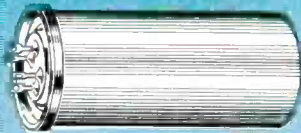

COILS
FOR MILITARY, RADIO & TELEVISION

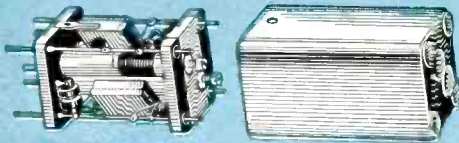

YOKES



FLYBACKS

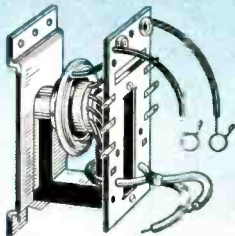

- SHIELD CANS
- ANTENNA COILS
- OSCILLATOR COILS
- HORIZONTAL SWEEP TRANSFORMERS
- COMPRESSION TYPE MICA TRIMMERS
- I.F. TRANSFORMERS
- LOOP ANTENNAS
- R.F. TUNERS



edwin i. guthman & co., inc.

15 s. throop st. chicago 7.. CH 3-1600

also attica, indiana . . 394J BURTON BROWNE ADVERTISING

PRODUCTION TECHNIQUES (continued)

are bolted to the front and rear springs of each row to provide further stiffening and positioning.

Top-cap connectors can be removed quickly, without leaving loose leads in the way when inserting the next batch of tubes. Connections to new tubes are made almost as fast, for the connectors all stay within an inch or so of the position where they are needed.

Serial-Number Disk

A REDUCTION in the cost of applying individual serial numbers to each Tele-tone television receiver chassis was achieved by stamping the numbers beforehand on left-over brass

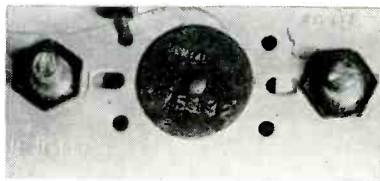

Use of scrap brass disk for serial number of tv set

punchout disks and riveting a disk to each chassis. The disk can be attached after assembly of the chassis if desired, as when running models having the same chassis but different picture-tube assemblies.

Core-Banding Tool

AFTER two-section Hypersil cores have been assembled around their coils and banded with a special Westinghouse core-banding tool, the banding clip is soldered for extra locking during production of

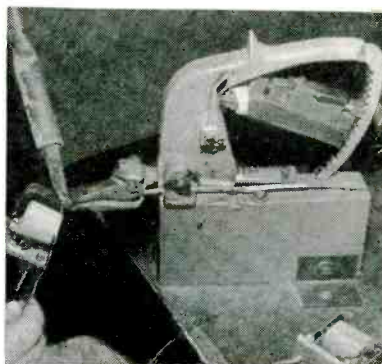

Fixed mounting of core-banding tool to facilitate soldering of banding clamp. Solder is brought up through hole in bench so it is always conveniently within reach

BIRTCHEr TUBE CLAMPS

Hold Tubes in Sockets
under all Vibration,
Impact and
Climatic
Conditions

83
VARIATIONS
FOR
STANDARD
TUBES



NEW
CLAMP
FOR
MINIATURE
TUBES



You can't shake, pull or rotate a tube out of place when it's secured by a Birtcher Tube Clamp. The tube is there to stay. Made of Stainless Steel, the Birtcher Tube Clamp is impervious to wear and weather.

BIRTCHEr TUBE CLAMPS can be used in the most confined spaces of any compact electronic device. Added stray capacity is kept at a minimum. Weight of tube clamp is negligible.

Millions of Birtcher Tube Clamps are in use in all parts of the world. They're recommended for all types of tubes: glass or metal—chassis or sub-chassis mounted.

**THERE'S A BIRTCHEr TUBE CLAMP
FOR EVERY STANDARD AND
MINIATURE TUBE!**

Write for samples, catalogue and price lists.

THE BIRTCHEr CORPORATION
4371 Valley Blvd.
Los Angeles 32, Calif.

What YOU can do... Must do

*to ease the critical
iron and steel
scrap problem*

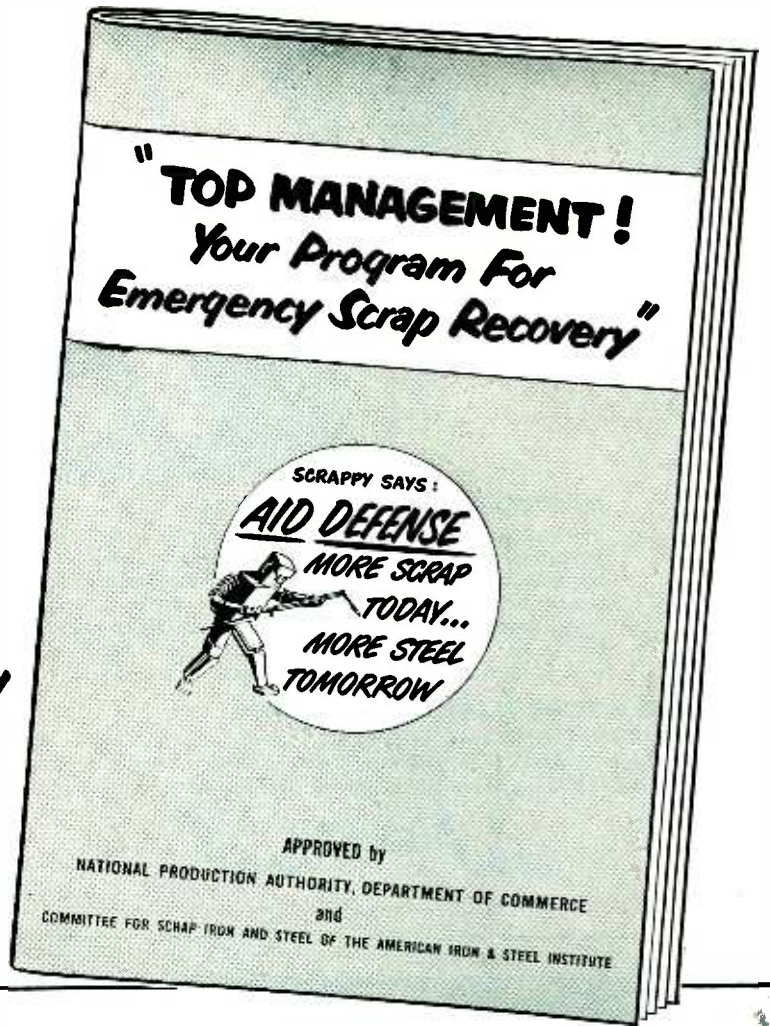

It's a problem calling for the assistance of every thoughtful business man—now.

Unless the steel mills get more scrap . . . furnaces may have to be shut down.

Shut down—at a time when our armed forces need more and more equipment . . . when civilian demands for steel are greater than ever . . . when our economy is fighting desperately against inflation!

You Can Help. Yes . . . regardless of the business you're in . . . you're in the scrap business, too.

If you're in the steel-fabricating bus-

iness, you have extra *dormant* scrap to be added to your *production* scrap.

If you're in any other business, you surely have idle metal that will do you—and America—more good being fed into furnaces than cluttering up your premises.

Write for Suggestions. The booklet shown here tells how to set up a Scrap Salvage Program with least amount of effort and minimum interference with your regular operation. It tells where to look for scrap, what to do with it when you get it.

You are urged to send for the booklet

now. Use the coupon.

FACTS ABOUT SCRAP SALVAGE

Steel production	1950 — 97,800,000 net tons
Estimated capacity	1952 — 119,500,000 net tons
Purchased	
scrap used*	1950 — 29,500,000 gross tons
Estimated purchased	
scrap requirement*	1952 — 36,200,000 gross tons

*All consumers

Where will the extra tonnage come from? Mostly from your *dormant* metal—obsolete machines and structures, tools, jigs, fixtures, gears, wheels, chains, track.



**This advertisement is
a contribution, in the national interest, by**

NON FERROUS METAL NEEDED, TOO:

McGRAW-HILL PUBLISHING COMPANY, INC.

330 WEST 42nd STREET

NEW YORK 36, N. Y.

Advertising Council
25 W. 45th St.
New York 19, N. Y.

Please send me a copy of the free booklet: "Top Management: Your Program for Emergency Scrap Recovery"

NAME.....
COMPANY..... TITLE.....
ADDRESS.....
CITY..... ZONE..... STATE.....

M
M
MARKEM
marks
them all

**FROM ARTILLERY SHELLS
TO MEDICAL AMPULES**



MASTERS OF MARKING—Since 1911

Markem methods, machines, type and inks have been marking the products of industry for forty years. Markem machines can mark up to many thousands of pieces per hour. They make clear, durable imprints on flat, curved or irregular surfaces of paint, paper, wood, glass, metal, leather, plastic, rubber, fabric, composition and pressure sensitive tapes. No special skill is needed for their operation. Legend and color of imprint may be quickly and easily changed.

MAKE YOUR MARK WITH MARKEM

When your products need marking for Identification, Control or Market — ask Markem. Submit your problem, together with a sample of the item to be marked. Markem Machine Company, Keene 5, New Hampshire.



GOLD PLATED TUNGSTEN & MOLYBDENUM

Gold Plated Nickel Alloy
and Molybdenum Alloy
Grid Wire

Grid Wire



• Made to meet your specifications . . . for gold content, diameter and other requirements.

Write for details and list of products

SIGMUND COHN MFG. CO., INC.

131 SOUTH COLUMBUS AVENUE • MOUNT VERNON, NEW YORK



interstage transformers for radar antenna stabilizers at the Union City, N. J. plant of Keystone Products Co.

Though normally hand-held, the banding tool is here mounted on a wood block which in turn is fastened to the bench, so as to leave the operator's hands free to hold the soldering iron and solder.

Diode Clip Boards

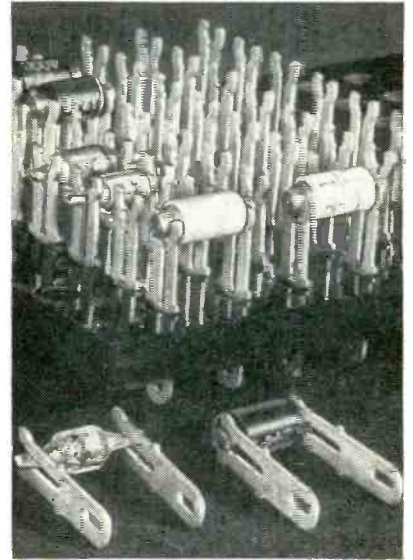

Holders for crystal diodes

SIMPLE clips stamped out of flat sheet metal are inserted in round drilled holes in an insulating board to form holders for the 1,200 crystal diodes used in the Maddida computer made by Northrop Aircraft,

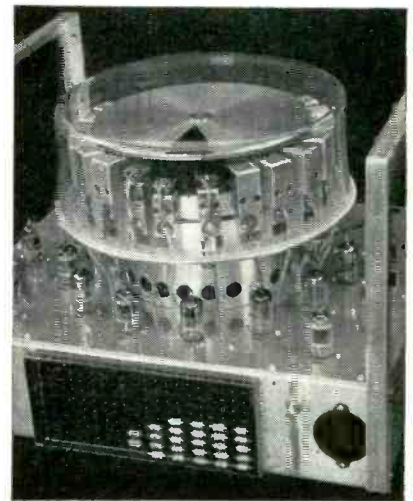

Diode clip board mounted on front of magnetic drum memory chassis for Maddida computer

MAGNETIC AMPLIFIERS and *Custom-Built* TRANSFORMERS

The select list of Keystone customers is enough to convince you that we build quality units and *only* quality units. Let us see your prints and specifications. Chances are we'll be able to build your units at lower cost, while exceeding even your fondest hopes as to quality and uniformity. No obligation to consult our engineering department.

KEYSTONE PRODUCTS COMPANY

UNION CITY 2, N. J.

Telephone: UNION 6-5400

Send us your name and address
KEYSTONE; request "THE
interesting little magazine
we're sending to trans-
former users every month.

● MORE THAN 27,000

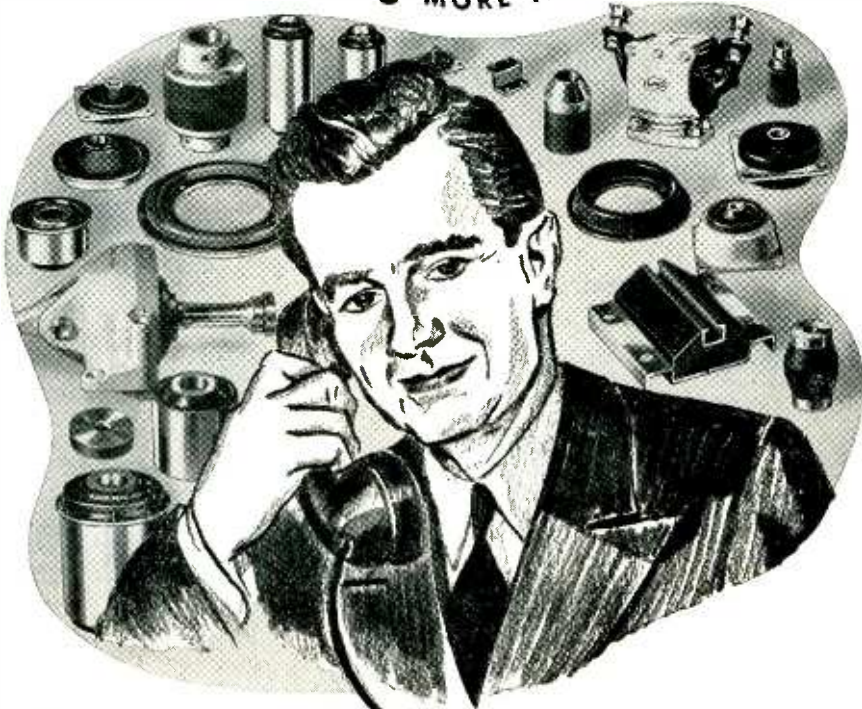

Inc., of Hawthorne, California. Two different sizes of indentations accommodate the two terminal sizes on these diodes. The holders fit snugly in the drilled holes, and are anchored in place by the soldered connections made on the other side of the board.

Hookup Wire Rack

A CONVENIENT rack for spools of hookup wire was constructed from steel bar and rod stock at the Bogue Electric Company's Paterson, N. J. plant. The wire from each spool is threaded through a hole in the wood front-panel boards of the rack just above a white tape strip on which the wire sizes and other specifications are lettered. Holes for the wires are made just large enough to prevent the wires from slipping back onto the spools.

THERE IS AN EASY WAY TO CONTROL VIBRATION

The easiest way to solve your vibration problem is to put it up to your nearest Lord Field Engineer. He will analyze it and recommend the specific type of Lord Mounting necessary. By drawing upon complete data files of more than 27,000 Lord Mountings and their variations, it is probable that he can solve your problem from this reservoir of available Lord Mountings.

If your vibration trouble involves circumstances which have not been encountered before, your Lord Field Engineer will work closely with you and with engineers at the Lord Factory to design the type of specific Lord Mounting most profitable to you.

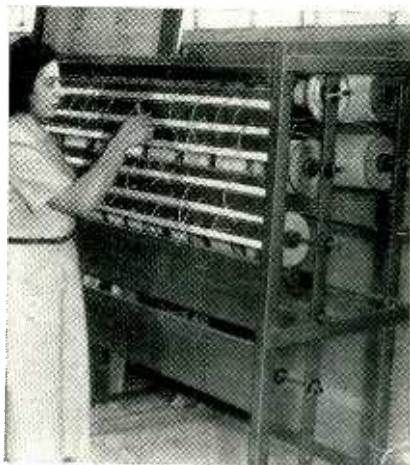

Simple rack holds up to 100 large spools of wire and provides convenient access to ends of wires

For immediate attention to your problem call or write to

BURBANK, CALIFORNIA 233 South Third Street ROckwell 9-2151 CHarleston 6-7481	CHICAGO 11, ILLINOIS 520 N. Michigan Ave. Michigan 2-6010	DALLAS, TEXAS 1613 Tower Petroleum Building PRospect 7996
--	--	--

DAYTON 2, OHIO 238 Lafayette Street Michigan 8871	DETROIT 2, MICHIGAN 7310 Woodward Ave. TRinity 5-8239	NEW YORK 16, NEW YORK 280 Madison Avenue MUrray Hill 5-4477
--	--	--

PHILADELPHIA 7, PENNSYLVANIA 725 Widener Building LOcust 4-0147	ERIE, PENNSYLVANIA 1635 West 12th Street 2-2296
--	--

LORD MANUFACTURING COMPANY • ERIE, PA.



HEADQUARTERS FOR
VIBRATION CONTROL MOUNTINGS
... **BONDED RUBBER PARTS**

Thick washers are placed between the spools on each shaft, to insure that each spool will turn freely. Shafts are held in position by cotter pins at the ends. Empty spools can be replaced from either end of a shaft after first slipping the shaft out of its bearing hole, but generally all spools on a given shaft have the same type of wire. Replacement of spools is then not necessary until all are empty. The rack saves operator time, conserves floor space and improves the general appearance of the shop.

Announcing the **NEW** *Federal* SELENIUM RECTIFIER... with

36 VOLT (RMS) CELLS

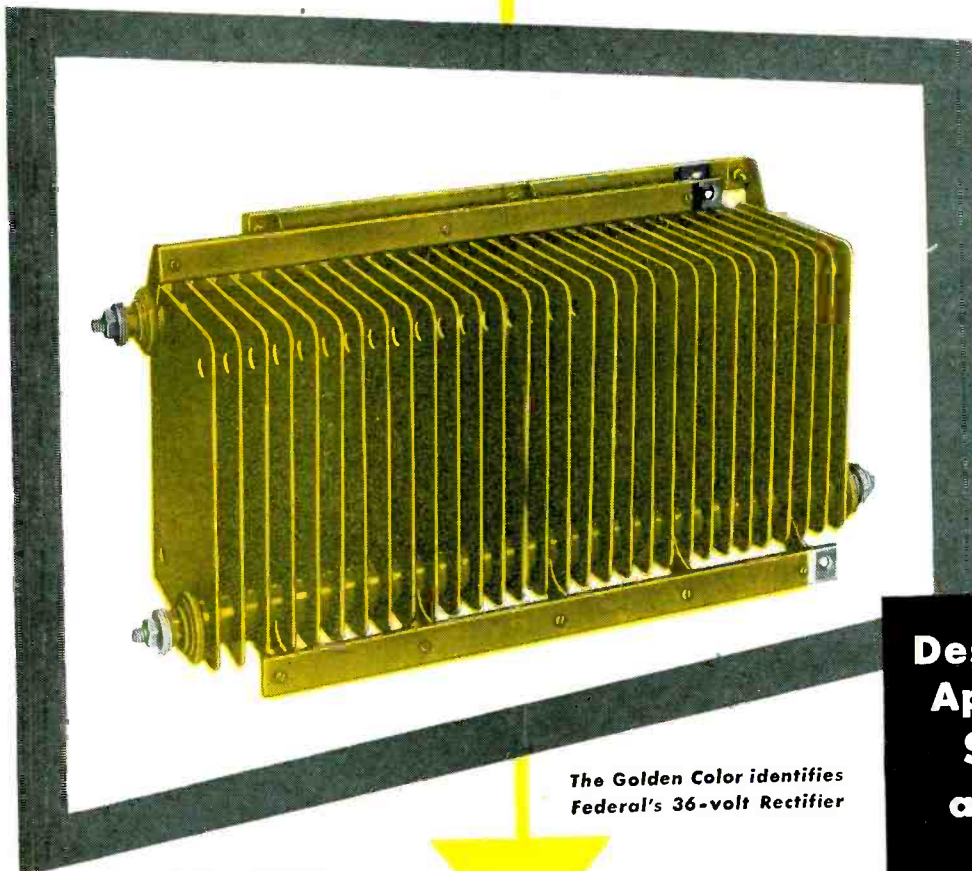

The Golden Color identifies
Federal's 36-volt Rectifier

Designed for Special
Applications where
SIZE—WEIGHT
and **EFFICIENCY**
are **TOP**
CONSIDERATIONS

ANOTHER *Federal* CONTRIBUTION

- Fewer plates
- Lighter weight
- Smaller size
- Greater Over-all Efficiency
- Dependable
"Federal Performance"

HERE'S THE ANSWER to your selenium rectifier stack requirements . . . for applications where *space* is at a premium . . . where *weight* is of prime importance. This is the ideal rectifier for many military end-use equipments . . . for aircraft . . . for compact, portable units.

Developed by America's *first* manufacturer of selenium rectifiers, you can depend on its quality, efficiency and economy.

Wherever you need DC from an AC source—look to Federal . . . *from milliwatts to kilowatts!* For details on Federal's new 36-volt rectifier cells of various sizes—or any other DC power requirement—write to Dept. F-113.

America's oldest and largest manufacturer of selenium rectifiers

Federal Telephone and Radio Corporation



FEDERAL TELECOMMUNICATION LABORATORIES, Nutley, N. J. . . . a unit of IT&T's world-wide research and engineering organization.

SELENIUM-INTELIN DIVISION
100 KINGSLAND ROAD, CLIFTON, NEW JERSEY

In Canada: Federal Electric Manufacturing Company, Ltd., Montreal, P. Q.
Export Distributors: International Standard Electric Corp., 67 Broad St., N. Y.



NEW PRODUCTS

Edited by WILLIAM P. O'BRIEN

Control, Testing and Measuring Equipment Described and Illustrated . . . Recent Tubes and Components Are Covered . . . Thirty-Five Trade Bulletins Reviewed



Dynamic Pressure Indicator

RUTISHAUSER CORP., 490 So. Fair Oaks Ave., Pasadena 1, Calif. Model ST-12 electronic pickup indicator measures transient, recurrent and static pressures. Operation is based on phase modulation principle using capacitance-type pickup. Carrier frequency of about 12.5 mc, with only $\frac{1}{8}$ in. free diameter pickup diaphragm, enables uniform response to pressure transients having frequency components much higher than heretofore measurable. The unit uses long-life sub-miniature tubes, takes up less than $\frac{1}{2}$ cu ft of space and weighs 13 lb. Multichannel installations are available for rack mounting.

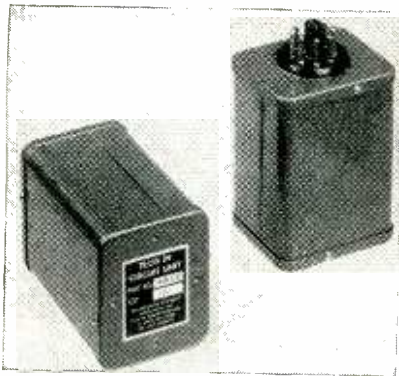

Plug-In Amplifier

ENGINEERING RESEARCH ASSOCIATES, INC., 1902 W. Minnehaha Ave., St. Paul W4, Minn., has developed

a new miniature plug-in amplifier characterized by exceptionally high gain and relative independence of power supply voltage fluctuation. The unit, measuring $1\frac{1}{2}$ in. \times $2\frac{1}{4}$ in. \times 3 in., is potted in a steel case, thus reducing microphonics. Specific characteristics include a maximum gain of 9,000 and a flat frequency response from 2 to 1,000 cps. Power supply requirements consist of 600-ma, 6.3-volt filament supply and a 0.5-ma, 250-volt plate supply. Maximum output voltage is 20 v. Applications include use in wide-range integrating circuits in which integration is achieved by a stabilizing negative feedback circuit.



Measuring Bridge

THE HERMAN H. STICHT Co., 27 Park Place, New York, N. Y. Type Z measuring bridge is designed to take the place of a large Wheatstone bridge for measuring resistances in the field, workshop or laboratory. Its small dimensions make it convenient for carrying in coat pocket or briefcase. Range is 0.05 to 50,000 ohms over six ratios. The source of supply, a standard flashlight battery, is contained in the case. Accuracy of the instrument is approximately ± 1 percent. The bridge comes for d-c measurements

OTHER DEPARTMENTS featured in this issue:

	Page
Electrons At Work	152
Production Techniques	228
Plants and People	302
New Books	312
Backtalk	328

with galvanometer and flashlight battery and can also be used for d-c and a-c current by means of an auxiliary plug-in buzzer and head phone.



Wide-Band Voltmeter

BALLANTINE LABORATORIES, INC., Boonton, N. J. Model 314 wide-band electronic voltmeter measures a-c voltages from 100 μ v to 1,000 v in the frequency range of 15 cycles to 6 mc. Its accuracy of 3 percent up to 3 mc and 5 percent above is the same at all points on the single logarithmic voltage scale. With its probe, the input impedance is 6 μ f shunted by 11 megohms and the voltage range is 1 mv to 1,000 v in 6 decade ranges. Without its probe it may be used to measure down to 100 μ v but the input impedance is reduced to 25 μ f shunted by 1.1 megohms. The unit may also be used as a wide-band amplifier with maximum gain of 60 db vari-

READIN'-'RITIN'-'RITHMETIC

**KNOW YOUR
THREE Rs**

when it comes to
**Tubes for Industrial,
Military and
Transportation
service**



RAYTHEON

RELIABLE

RUGGEDIZED

Look at the chart. Keep it for reference. It tells you better than a thousand words why RAYTHEON may be regarded as the No. 1 source of Reliable and Rugged Tubes of all kinds.

Type	Description	Controlled Characteristics								Proto- type	Heater		Plate		Grid Volts	Screen		Amp. Fac- tor	Mut. Cond.
		Shock	Fatigue vibration	Vibration output	Stabilization	Centrifugal acceleration	5,000 hour life	Heater cycle life	High temperature life		Median control	60,000 foot altitude	Volts	Ma.		Volts	Ma.		
Reliable Miniatures																			
CK5654	RF Amplifier Pentode	✓	✓	✓	✓	✓	✓	✓	✓	6AK5	6.3	175	120	7.5	-2.0	120	2.5	—	5000
CK5670	Medium Mu Dual Triode	✓	✓	✓	✓	✓	✓	✓	✓	2C51	6.3	350	150	8.2	$R_k = 240$ ohms	—	—	35	5500
CK5686	AF-RF Output Pentode	✓	✓	✓	✓	✓	✓	✓	✓	—	6.3	350	250	27.0	-12.5	250	5.0	—	3100*
CK5725	RF Mixer Pentode	✓	✓	✓	✓	✓	✓	✓	✓	6AS6	6.3	175	120	5.2	-2.0	120	3.5	—	3200
CK5726	Dual Diode	✓	✓	✓	✓	✓	✓	✓	✓	6AL5	6.3	300	Max. Peak Inv. 330 volts. $I_0 = 9$ ma. dc per plate		—	—	—	—	—
CK5749	RF Amplifier Pentode	✓	✓	✓	✓	✓	✓	✓	✓	6BA6	6.3	300	250	11.0	$R_k = 68$ ohms	100	4.2	—	4400
CK5751	High Mu Dual Triode	✓	✓	✓	✓	✓	✓	✓	✓	12AX7	6.3/12.6	350/175	250	1.1	-3.0	—	—	70	1200
CK5814	Low Mu Dual Triode	✓	✓	✓	✓	✓	✓	✓	✓	12AU7	6.3/12.6	350/175	250	10.5	-8.5	—	—	17	2200
Reliable Subminiatures																			
†CK5702WA (6148)	RF Amplifier Pentode	✓	✓	✓	✓	✓	✓	✓	✓	5702	6.3	200	120	7.5	$R_k = 200$ ohms	120	2.5	—	5000
†CK5703WA (6149)	High Frequency Triode	✓	✓	✓	✓	✓	✓	✓	✓	5703	6.3	200	120	9.0	$R_k = 200$ ohms	—	—	25	5000
†CK5744WA (6151)	High Mu Triode	✓	✓	✓	✓	✓	✓	✓	✓	5744	6.3	200	250	4.0	$R_k = 500$ ohms	—	—	70	4000
†CK5784WA (6150)	RF Mixer Pentode	✓	✓	✓	✓	✓	✓	✓	✓	5784	6.3	200	120	5.2	-2.0	120	3.5	—	3200
CK6021	Medium Mu Dual Triode	✓	✓	✓	✓	✓	✓	✓	✓	—	6.3	300	100	6.5	$R_k = 150$ ohms	—	—	35	5400
CK6110	Dual Diode	✓	✓	✓	✓	✓	✓	✓	✓	—	6.3	150	Max. Peak Inverse 420 volts. $I_0 = 4.4$ ma. per plate		—	—	—	—	—
CK6111	Low Mu Dual Triode	✓	✓	✓	✓	✓	✓	✓	✓	—	6.3	300	100	8.5	$R_k = 220$ ohms	—	—	20	4750
CK6112	High Mu Dual Triode	✓	✓	✓	✓	✓	✓	✓	✓	—	6.3	300	100	0.8	$R_k = 1500$ ohms	—	—	70	1800
CK6152	Low Mu Triode	✓	✓	✓	✓	✓	✓	✓	✓	5975	6.3	200	200	12.5	$R_k = 680$ ohms	—	—	15.8	4000
Rugged Miniatures																			
6AK5W	RF Amplifier Pentode	✓	✓	✓	✓	✓	✓	✓	✓	6AK5	6.3	175	120	7.5	-2.0	120	2.5	—	5000
6AL5W	Dual Diode	✓	✓	✓	✓	✓	✓	✓	✓	6AL5	6.3	300	Max. Peak Inv. 420 volts. $I_0 = 9$ ma. dc per plate		—	—	—	—	—
6AS6W	RF Mixer Pentode	✓	✓	✓	✓	✓	✓	✓	✓	6AS6	6.3	175	120	5.2	-2.0	120	3.5	—	3200
6C4W	RF Power Triode	✓	✓	✓	✓	✓	✓	✓	✓	6C4	6.3	150	250	10.5	-8.5	—	—	17	2200
6J6W	Dual AF-RF Triode	✓	✓	✓	✓	✓	✓	✓	✓	6J6	6.3	450	100	8.5	$R_k = 50$ ohms	—	—	38	5300
6X4W	Full Wave Rectifier	✓	✓	✓	✓	✓	✓	✓	✓	6X4	6.3	600	Max. Peak Inv. 1250 volts. $I_0 = 70$ ma. dc.		—	—	—	—	—
Rugged GT Types																			
6J5WGT	General Purpose Triode	✓	✓	✓	✓	✓	✓	✓	✓	6J5GT	6.3	300	250	9	-8.0	—	—	20	2600
12J5WGT	General Purpose Triode	✓	✓	✓	✓	✓	✓	✓	✓	12J5GT	12.6	150	250	9	-8.0	—	—	20	2600
6SN7WGT	Dual Triode	✓	✓	✓	✓	✓	✓	✓	✓	6SN7GT	6.3	600	250	9	-8.0	—	—	20	2600
6X5WGT	Full Wave Rectifier	✓	✓	✓	✓	✓	✓	✓	✓	6X5GT	6.3	600	Max. Peak Inv. 1250 volts. $I_0 = 70$ ma. dc.		—	—	—	—	—

The above listing of Controlled Characteristics is based on the requirements and test limits of the applicable JAN-1A test specification.
 Note: All dual section tube ratings are for each section. *2.7 watts Class A output. 10 watts Class C input power to 160 mc.
 †For simplicity of identification with the prototypes, the type numbers with a "WA" suffix were established at the request of the Armed Services to replace the type numbers in parenthesis previously announced for these types.

Over 300 Raytheon distributors are at your service on these tubes. Application information is readily available at Newton, Chicago, Los Angeles.



RAYTHEON MANUFACTURING COMPANY

Receiving Tube Division

Newton, Mass., Chicago, Ill., Atlanta, Ga., Los Angeles, Calif.

RELIABLE SUBMINIATURE AND MINIATURE TUBES • GERMANIUM DIODES AND TRANSISTORS • RADIAC TUBES • RECEIVING AND PICTURE TUBES • MICROWAVE TUBES

Excellence in Electronics

able in 20-db steps and flat within 0.5 db from 100 cycles to 3 mc and within 1 db from 50 cycles to 6 mc.



UHF Oscillator Triode

RADIO CORP. OF AMERICA, Harrison, N. J. The 6AF4 miniature triode is designed to operate as an oscillator in uhf tv receivers covering the frequency range from 470 to 890 mc. It features good frequency stability; short mount structure with small elements to provide low interelectrode capacitances; short internal leads to reduce lead inductance and r-f resistance; silver-plated base pins to minimize losses caused by skin effect at ultrahigh frequencies; and double base-pin connections for both plate and grid. A technical bulletin is available.

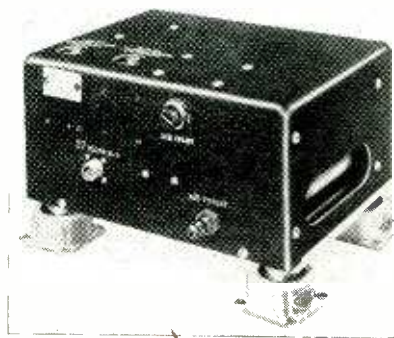

Pressurizing Kit

LEAR, INC., Romec Division, Elyria, Ohio. Model RR-9650 pressurizing kit is designed for use on aircraft powered by gas turbine engine. The object is to take air with elevated pressure from the compressor section of the engine and convert it into dry, oil-free air for pressuriz-

ing radar or other electronic plenums of jet aircraft; also to discharge a uniform pressure regardless of gas turbine pressure. Included with the equipment is a 1/15-hp, 27-volt, d-c air compressor with rated capacity of 300 cu. in. per minute at 8 psi absolute inlet pressure and 20 psi absolute discharge pressure. Overall dimensions are $11\frac{1}{2} \times 9\frac{1}{2} \times 7\frac{1}{2}$ in. high. Weight is 13.9 lb. Control of discharge pressure is fully automatic as is the control of inlet pressure fed from the gas turbine, so excessively high pressure is never passed on into the electronic equipment.



Oscilloscope Calibrator

SIMPSON ELECTRIC Co., 5200 W. Kinzie, Chicago, Ill. Model 276 oscilloscope calibrator just over 2 lb in weight, is completely self contained and operates from 117 v, 50-60 cycles and can be used with any oscilloscope. It has a sine-wave output which is used directly on the $4\frac{1}{2}$ -in. meter. The meter is calibrated directly in rms, peak, and peak-to-peak values. Six ranges are provided with peak-to-peak full scale values of 1, 2.5, 10, 25, 100 and 250 v with an accuracy of 3 percent. Each range is continuously adjustable from zero to full scale value. A 12-position function switch provides the range positions. Alternate positions of the switch provide for feeding the signal under test to the oscilloscope. External pickup is eliminated by providing power shut-off in these feed-through positions.

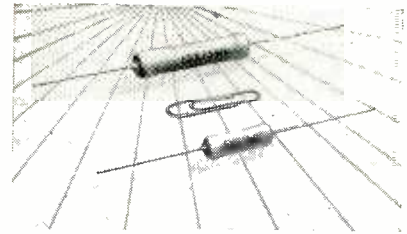

Power-Type Resistors

WARD LEONARD ELECTRIC Co., 115 MacQuesten Parkway South, Mt. Vernon, N. Y., has developed the Axiom miniature power type resistors with axial leads. They are made with special alloy resistance wire of low temperature coefficient of resistivity wound on tough miniature ceramic cores. Sturdy No. 20 B&S tinned axial leads are mechanically anchored and silver brazed to end caps. The entire assembly is encased in Vitrohm enamel forming a hard, crazeless, heat conducting hermetic seal. The resistors are available in conservatively rated 5 and 10 watt sizes. Standard resistance tolerance is ± 5 percent.

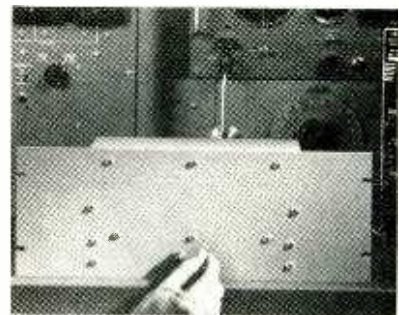

Harmonic Generator

SIERRA ELECTRONIC CORP., 810 Brittan Ave., San Carlos, Calif. Fed by a 10-kc square wave at 5 volts minimum, the model 133 harmonic generator supplies harmonic voltages of this input at every 10-kc point up to 15 mc. Containing its own power supply, it operates from standard 115-v, 50 or 60-cps power, consuming 25 w. Designed for use in an instantaneous frequency-comparison arrangement, the unit has application possibilities wherever such a harmonic frequency source is needed. In frequency-comparison work, an unknown frequency is beaten against an adjacent and identifiable harmonic voltage and the beat frequency meas-



Behind the familiar blue label of WOR recording studios...

the finest in modern sound recording methods and equipment

Radio stations from coast to coast recognize this label as the mark of a top quality transcription. One that can be depended on to meet or exceed the extremely high broadcast standards of sound quality.

To maintain this reputation, WOR Recording Studios, one of the largest in the world, use the finest and most costly tape and disc recording equipment obtainable. And—what's equally important—their engineers have found that Audiotape and Audiodiscs are an ideal combination for meeting the exacting requirements of broadcast transcription and commercial recording work. This same record-making combination is also being used with outstanding success by America's leading producers of fine phonograph records.

With Audiotape and Audiodiscs, you can achieve this same sound perfection in *your* recording work, too. Their consistent, uniform quality is the result of more than 12 years of specialized experience by the only company in America devoted solely to the manufacture of fine recording media, both tape and discs.

AUDIO DEVICES, Inc.

444 MADISON AVE., NEW YORK 22, N. Y.
Export Dept.: 13 East 40th St., New York 16, N. Y., Cables "ARLAB"

...including

audiotape*



and **audiodiscs***



*Trade Mark

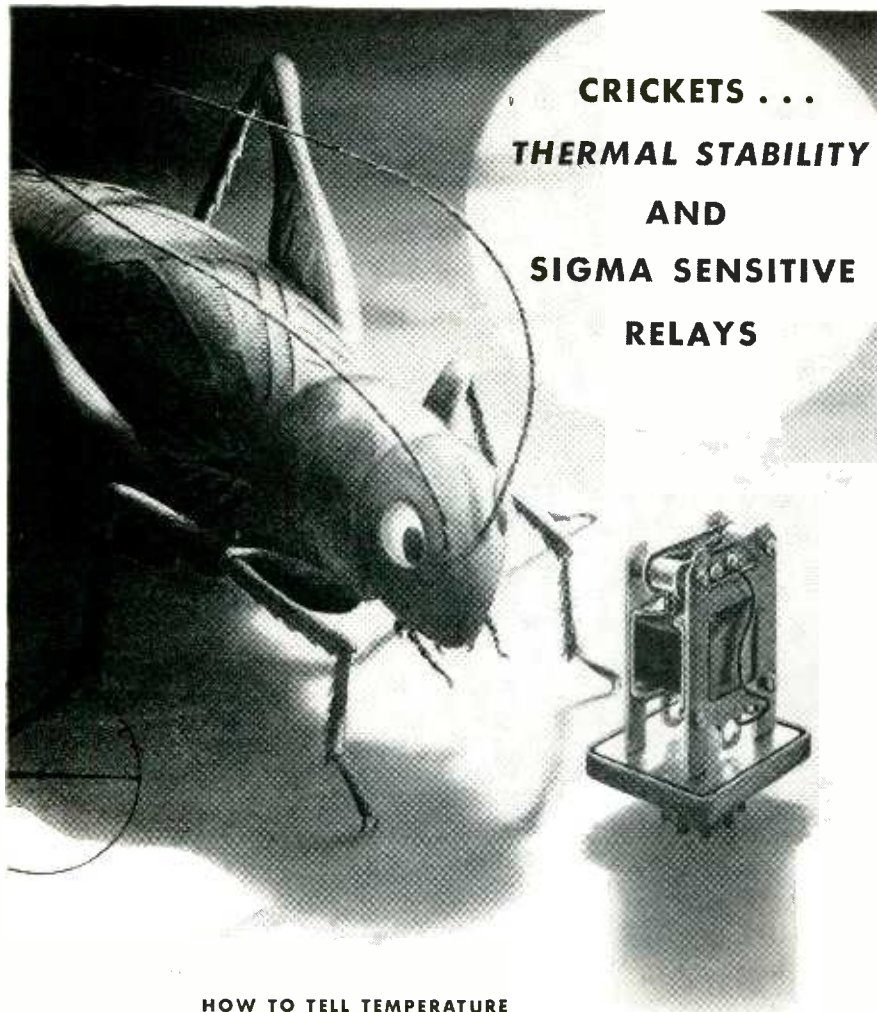

**CRICKETS . . .
THERMAL STABILITY
AND
SIGMA SENSITIVE
RELAYS**

HOW TO TELL TEMPERATURE

Temperature affects the chirping of crickets. In fact, you can actually tell temperature with a chirping cricket and a watch. Count the number of chirps in 15 seconds, add 37 — and there is your answer in degrees Fahrenheit! Try it some time.

TEMPERATURE vs. ADJUSTMENT

Years of work on the thermal behavior of many relay designs has yielded a broad grasp of the principles of stability. For example, springs with a high negative thermoelastic coefficient cause a decrease in magnetomotive force values at the limits of the work stroke. A negative expansion coefficient of the air gap will do the same thing. These facts are typical, except in the presence of noise, which, obscuring the Bellows factor, shows up graphically as a hysterical expression. At the design level, it is desirable to replace frictional individuals with compliant constituents, matched to the thermal density of the environment ambient propensity.

Recent tightening of military specifications has forced us to study microstructures, for which the tri-stable two-stage Caloriferer* with Biased Viewpoint adjustment now in use is a most useful tool. The interrelated variables of the Barkhausen effect, gyrotechnesis, and low-expunction refractifiers are thus coming under closer scrutiny and control than ever before.

Scientific study and attention to detail are the keystones.

OUR CONCLUSIONS

As a result (somehow or other) certain Sigma Relays have relatively good thermal stability. If you have a problem of this nature there's no telling what Sigma can do for you.

** Particulars of this equipment available free when requested on your company letterhead.*

SIGMA

SIGMA INSTRUMENTS, INC.

62 PEARL ST., SO. BRAintree, BOSTON 85, MASS.

ured on an oscilloscope or with a frequency counter.



R-F Coax Connectors

DAGE ELECTRIC Co., INC., 62 N. Second St., Beech Grove, Ind. Type C r-f coaxial connectors are designed for use up to 1,000 v under strict military specifications. They are of constant impedance and are to be used with 50-ohm medium size r-f cables. The connectors provide for easy connect-disconnect operations through a bayonet lock top coupling. A minimum of cable indentation is maintained through an improved cable clamping mechanism. Silicone rubber gaskets are used to make the connector waterproof.



Voltage-Regulator Tube

RADIO CORP. OF AMERICA, Harrison, N. J. Type 6073 cold-cathode, glow-discharge tube of the 7-pin miniature type is intended for voltage-regulator service critical as to excessive shock and vibration. It is a premium version of the OA2 and OB2, and is constructed and processed to meet military requirements. The tube can withstand an instantaneous impact acceleration

NEW ELECTRO

*filtered DC
power supply*

1%

LESS THAN

**RIPPLE at
TOP LOAD**

Continuously
Variable
0 - 28 Volts
up to 15 Amperes



**Test, Service DC
Equipment from AC Lines
Faster . . . at Less Cost!**

NEW MODEL "NF" meets most requirements in a DC power supply . . . extremely low AC ripple or hum, at this output range . . . low price . . . dependability. One control gives you adjustable output voltage over its rated range. Exclusive "Electro" application of selenium rectifiers increases rectifier power rating and lowers cost per ampere output. Top quality components and special design withstand high overloads.

\$195
Net

For Aircraft, Tank, Marine Electronic Equipment, Laboratory Instruments, Research, Relays, Solenoids, Phone Circuits.

Model "B" 6 Volts, 1-20 Amps . . . \$49.80

Model "BJ" 6 Volts, 1-12.5 Amps . . . \$37.50

Send for Details Today!



Electro Products Laboratories

4501-Ef North Ravenswood Ave. Chicago 40, Ill.
In Canada

ATLAS RADIO CORP., LTD., TORONTO
PRECISION INSTRUMENTS SINCE 1944

ELECTRONICS — July, 1952

new

development in—

SOLDER PREFORMS

lower cost
more exacting precision standards

● The new Art Wire Solder Preforms reduce your costs, eliminate variability in soldering, insure sounder, stronger joints, and minimize hand labor. Precision made to every specification including Military and Federal for soft solder . . . in shapes that meet the requirements

Complete information on request. Send blueprints or samples for estimates.

of your induction soldering operation.

ART WIRE & STAMPING CO.

1 Boyden Place

Newark 2, N. J.

**MAKE IT
ARROW!**

**Single Source
INDUSTRIAL
ELECTRONICS
SUPPLIER**

**FREE!
1100-PAGE
GENERAL
CATALOG!**

**Purchasing
Agents! Chief
Engineers!**
Write today on your company letterhead for your copy of our gigantic buying guide. Address Dept.

**Suppliers for
RESEARCH • PRODUCTION
DEVELOPMENT • PROCESSING
CONTROL and MAINTENANCE**

For **FAST SERVICE** • Teletype: NY1-472
Western Union: WUX-N.Y. • Cable: "AROELECTRO-N.Y."

ARROW ELECTRONICS INC.

82 CORTLANDT ST., NEW YORK 7, N. Y. • DIGBY 9-4714

**SAME DAY
SHIPMENTS**
of over 75,000
different items!

**COMPLETE
STOCKS**
of over 300
National
Brands

**ONE
ORDER**
brings you
Everything
in the
INDUSTRY

**ONLY
1 INVOICE**
•
**SAVE TIME,
BILLING,
SHIPPING
COSTS**

**COMPETENT
TECHNICAL
STAFF —
AT YOUR
SERVICE**

Everything
in
ELECTRONICS
including JAN EQUIPMENT



GRID AND PLATE CONNECTORS



High quality grid and plate connectors of both the insulated ceramic (meeting JAN 1-10 specifications) and the non-insulated spring clip types for use on tubes having contacts of $\frac{1}{4}$ ", $\frac{3}{8}$ ", and $\frac{9}{16}$ " diameters. All lugs are designed to provide strong mechanical connection. Write for drawings.

TURRET SOCKET ASSEMBLIES

Designed for National's 7-pin and 9-pin miniature tube sockets. Permit compact sub-assembly wiring at base of socket. Cadmium-plated brass center support has a standard length of two inches. Silver-plated brass terminal studs. Available with holes through which leads can be drawn or with solid studs.

Center supports of varying lengths and other types of terminals can be supplied to manufacturers in quantity.

Write for drawings.



Write for drawings



of 900 g, and a vibrational acceleration for extended periods of 2.5 g. Operating-current range is from 5 to 30 ma. It regulates at an average value of 108 v.

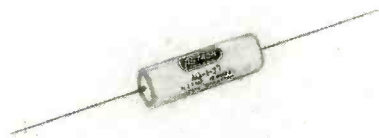

Small Paper Capacitor

ASTRON CORP., 255 Grant Ave., E. Newark, N. J., has a new type AQ subminiature paper capacitor designed for operation at temperatures through 125 C. Capacitance stability over a wide temperature range is from -65 C to $+125$ C, without derating, plus high insulation resistance, low power factor and high test voltage. These capacitors are supplied in the extended foil, noninductive-type construction. Hermetically sealed, they are capable of meeting all military requirements.

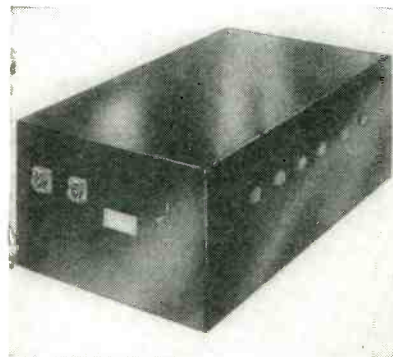

Magnetic Transient Recorder

MAGNE-PULSE CORP., 140 Nassau St., New York, N. Y. Aperiodic or "one-shot" waveforms can now be permanently recorded and displayed at any desired repetition rate on an oscilloscope through the use of the type 102 magnetic transient recorder. Providing a recording rate of up to 1,000 pulses per inch—or a bandwidth of 1 mc—this low cost, lightweight unit, which can also record and display recurrent waveforms, should find wide application

in laboratories conducting research on radar, tv, atomic phenomena, computers and allied fields.



Laboratory Power Supply

ALCO ELECTRONICS MFG. Co., 102 Marston St., Lawrence, Mass. Model 400-A comprises two independently regulated power supplies with extremely low ripple and output impedance. Each of the 200-ma regulated outputs may be operated independently and simultaneously, and by front-panel switching may be combined in parallel to provide double output current (400 ma) over the voltage range of 0 to 425 v. The outputs are floating, permitting operation with other than negative ground. Stabilized negative bias voltage is provided with continuous adjustment from 0 to -150 v. Heater voltages (unregulated) of 6.3 v at 10 amperes are available at binding posts.

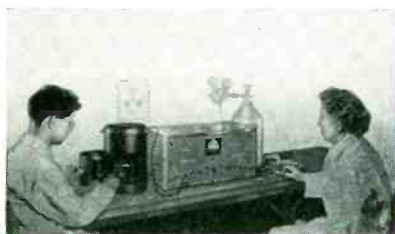

Twin Scaler

RADIATION COUNTER LABORATORIES, INC., 5122 W. Grove St., Skokie, Ill., has designed a Higinbotham binary scaler with two input connectors, two scales of 16 and two recorders. Each scale of 16 and its recorder operates independently from the other, using a single h-v power supply. The single h-v power supply employs two separate regulating circuits so the voltage avail-



**the only
VHF
receiver
in the
low-priced
field!**



- 27 mcs. — 250 mcs.
in 6 Bands
- Receives AM-FM-CW
- Mobile or Fixed Operation
- Can Be Used As Receiver
or Converter

Here is the perfect answer to the need for compact, dependable, versatile and low-priced VHF reception. Can be operated from power supply or batteries for fixed or mobile use. Can be used as a complete receiver in itself or as a VHF converter with any receiver tuning to 10.7 mcs. As converter makes features of connected receiver usable on VHF.

\$142⁰⁰* Incl. all coils
Power supply, \$22.43*

*Slightly higher west of the Rockies



Now your Screen-rooms can be

RADIO-SILENT

from 0.150 to 25,000 mc.

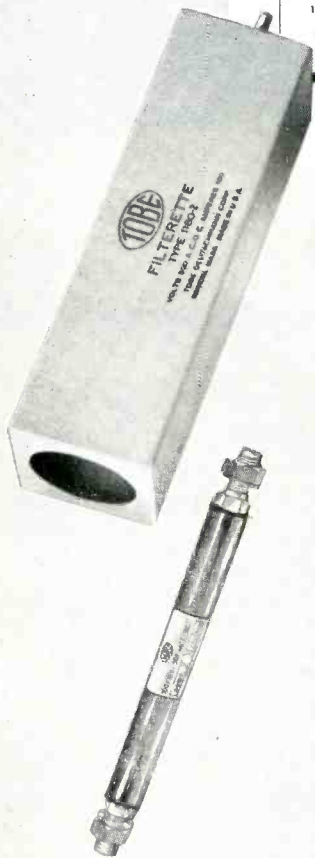
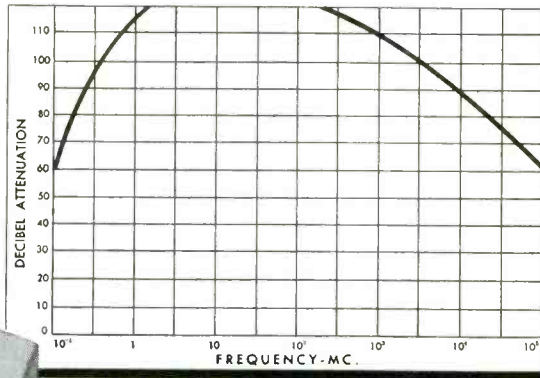

TOBE FILTERS

for screen-booth power lines cover the entire spectrum from the LF through the SHF range with high attenuation at all frequencies.

The performance curve above shows the combined attenuation of a double-shielded test room, a Tobe #1180-2 medium-range filter, and a Tobe #1457-1 high-range filter. The filters, rated at 100 amperes 500 volts a.c./d.c., have a total line drop of only 0.2 volts per circuit at full load; others available at lower and higher ratings.

Catalog E-201 giving electrical characteristics, dimensions, mounting provisions, weights, terminal data, and recommendations for your use of wide-range line filters is free on request. **WRITE TODAY.**



TOBE DEUTSCHMANN
CORPORATION
NORWOOD, MASSACHUSETTS

able at each G-M tube may be regulated to the desired value. A switch enables one to check the voltage on first one and then the other G-M tube. Counting rates up to and in excess of 20,000 counts per minute can be independently registered on each Veeder-Root recorder.

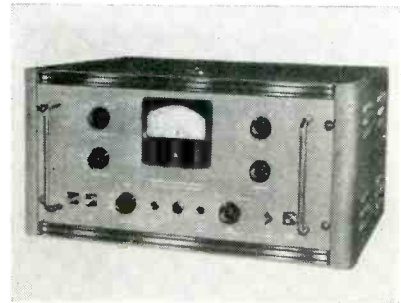

Standing-Wave Amplifier

POLYTECHNIC RESEARCH AND DEVELOPMENT Co., 55 Johnson St., Brooklyn, N. Y. Type 275 amplifier is a high-gain linear audio amplifier designed to accurately indicate vswr's over the full scale ranges of 1 to 1.3, 1 to 3, 3 to 10, 10 to 30 and 30 to 100. A normalizing gain control channel minimizes the effect of power drift on the r-f source. The unit may be operated as either a broadband amplifier over the range of 300 to 3,000 cps or as a narrow-band amplifier at 500, 1,000 and 1,300 cps with a 25-cps pass band. Noise level is 0.03 μ v. Full-scale narrow-band sensitivity is 0.1 μ v. The input circuit provides for either crystal or bolometer operation with a variable bolometer bias of 2.5 to 8 ma.

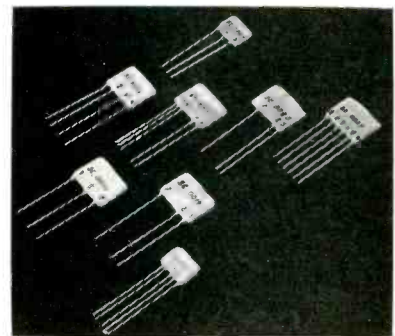

Printed Circuits

STUPAKOFF CERAMIC AND MFG. Co., Latrobe, Pa., has developed a line of printed electrical circuits some of

which incorporate as many as six separate resistors and capacitors in a permanent circuit. In their production patterns for resistors, capacitors and conductors are printed on vitreous, high-dielectric ceramic plates by a silk-screen process. The dielectric properties of the ceramic are used for the capacitors, while silver is used for conductors and carbon graphite or other resistance materials for resistors. After the patterns are printed they are bonded permanently to the ceramic surface by controlled curing; then are protected from abrasion and humidity by the application of an impervious plastic covering. One printed circuit replaces from two to six individual components. Typical circuits are described in bulletin 1151.

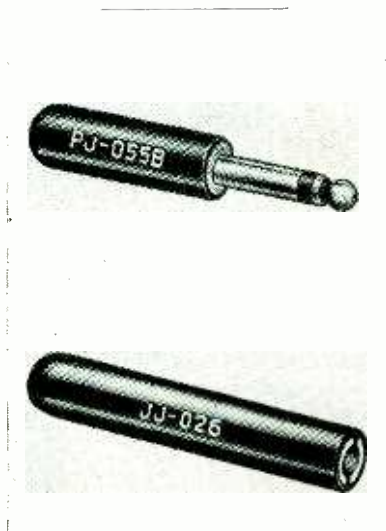

Plug and Jack

SWITCHCRAFT, INC., 1328 N. Halsted St., Chicago 22, Ill., has announced two new related products most commonly used in military communication and industrial equipment. The No. 440 "Little Plug" (PJ-055B) features a one-piece tiprod which together with the sleeve are assembled into the mold as an insert; providing a finished plug with complete continuity of thermoplastic insulation between this tiprod and the sleeve of the plug. Design and material are in accordance with specification JAN-P-642. The No. 820 "Extension Jax" (JJ-026) features spring tempered nickel silver springs assembled into a rigid stack assembly, insulated by phenolic spacers and

GLASS - TERMINAL TUBULAR CAPACITORS

midget • metal-cased • hermetically-sealed

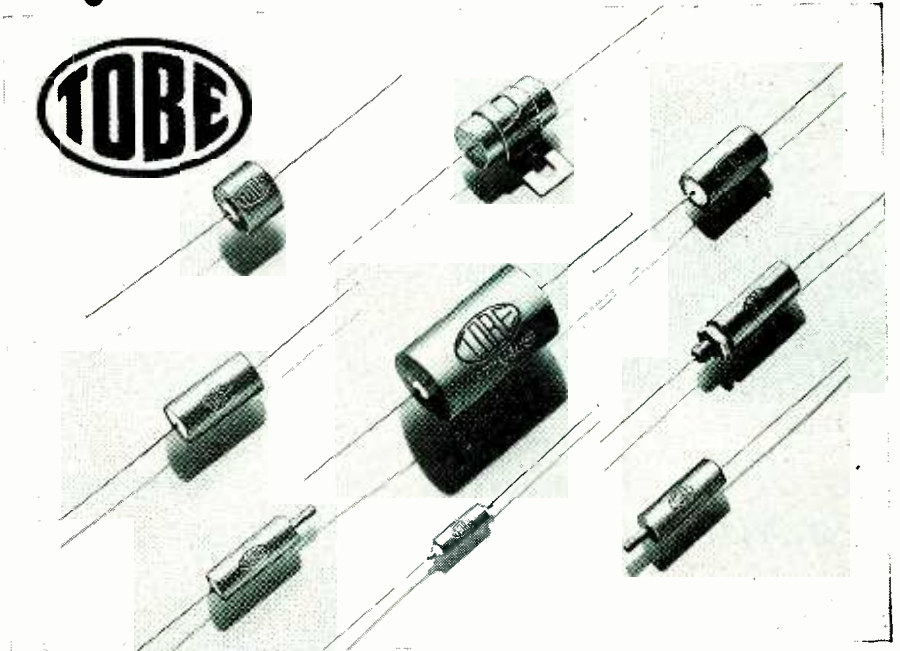

For miniaturized apparatus and where the self-healing characteristic is desirable, specify Tobe metallized-paper glass-terminal tubulars. Capacitance ratings from 0.01 to 10 mfd. Voltage ratings from 150 to 600 volts d-c. Mineral-wax or mineral-oil impregnation for temperatures - 55 to + 85C; silicone-fluid impregnation for - 55 to + 105C range.

For the "hot spots" where space is limited, specify Tobe silicone-fluid-impregnated glass-terminal tubulars. These units are built to work over a range of - 55 to + 125C. Capacitances 0.001 to 1.0 mfd. Working voltages 200 to 1000 volts d-c.

For cramped space in circuits whose surge characteristics prevent use of metallized-paper units, specify Tobe foil-paper capacitors with stabilized-Halowax impregnation. Capacitances 0.001 to 1.0 mfd. Voltage ratings 200 to 400 volts d-c. Temperature range - 40 to + 85C.

For general service specify Tobe glass-terminal tubulars with mineral-oil impregnation. Capacitances 0.001 to 1.0 mfd. Working voltages 200 to 1000 volts d-c. Temperature range - 55 to + 85C.

All types available with windings insulated from or grounded to case. Extended-foil windings for low-voltage high-frequency service; tabbed windings for minimum size. Standard capacitance tolerance $\pm 20\%$; can be furnished $\pm 5\%$. Write for catalog giving complete list of sizes and ratings.



TOBE DEUTSCHMANN
CORPORATION
NORWOOD, MASSACHUSETTS

- DESIGNED
 - ENGINEERED
 - MANUFACTURED
- for
PRECISION
PERFORMANCE

Burlington

RUNNING TIME METER



• Designed for use on AC lines where successful servicing of electronic or electrical equipment depends upon the regular servicing of such equipment based on actual operating (or idle) time. Unit has a range of 9999.9 hours and resets automatically at 10,000 hours. Can be supplied for either 120 or 240 volts. 60 cycle operation and has operating temperatures of -55 to $+55^{\circ}$ C.

• The Running Time Meter is housed in Burlington's attractive, black bakelite 3" square or $3\frac{1}{2}$ " round case.

- 9999.9 hour range
- 10,000 hour automatic reset
- -55 to $+55^{\circ}$ C. operating temperature.

Write Dept F-72 for further details.

BURLINGTON INSTRUMENT COMPANY
BURLINGTON, IOWA

They can take it!

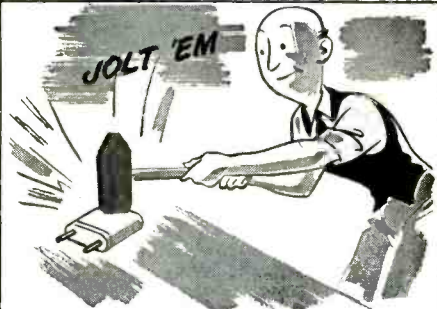
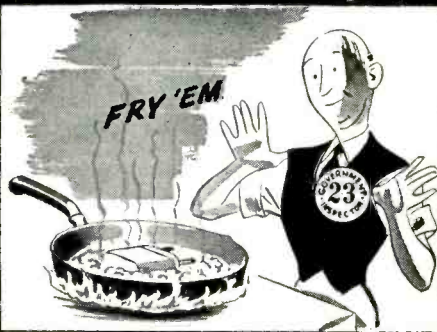
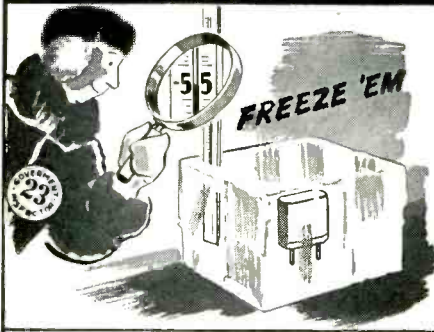

DX
XTALS

THE HEART OF A GOOD TRANSMITTER

-and dish it out!

DX RADIO PRODUCTS CO.
GENERAL OFFICES: 2300 W. ARMITAGE AVE., CHICAGO 47, ILL.

NECO
VICTORY
Thermistors

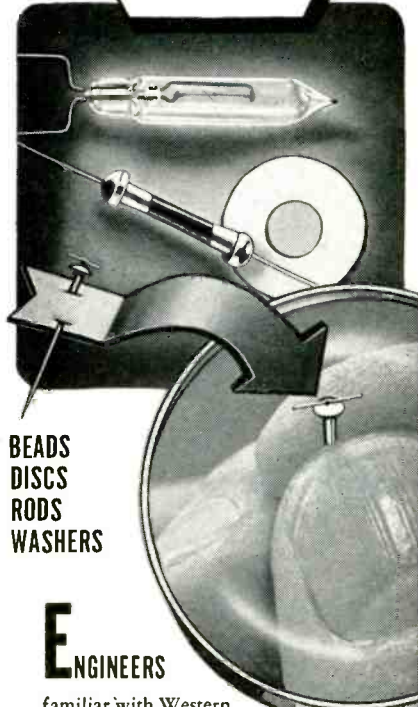

BEADS
DISCS
RODS
WASHERS

ENGINEERS

familiar with Western Electric thermistors will welcome this new source. Victory is licensed under all Western Electric thermistor patents.

These thermistors have exceptionally high temperature-coefficient and stability.

You may have used thermistors for time delay, temperature compensation, control, or measurement. Did you know they are being used for voltage regulation, volume limiting, surge protection, oscillator stabilization, radar power measurement, vacuum manometry, gas analysis, flow measurement, and a host of new applications being developed every day?

Send for free literature.

Victory

ENGINEERING CORPORATION
Springfield Road
UNION, NEW JERSEY

tubing, firmly assembled to long brass body by stainless steel screws. Materials and finishes are in accordance with specifications JAN-J-641.

Humidity Control

BARBER-COLMAN Co., Rockford, Ill. Two-position or proportioning, humidifying or dehumidifying, for process or comfort control, the new electronic humidity control features supersensitive, instant response with plug-in elements, wide range and simple adjustments. A moisture-sensitive element changes resistance instantly with minute changes in relative humidity. In spaces supplied by a central fan the sensing element is mounted either in the duct or the conditioned space, remote from the amplifier and adjustments. For controlling the relative humidity in spaces not completely air conditioned, the control is available with all operating adjustment mechanisms mounted in a convenient cabinet.

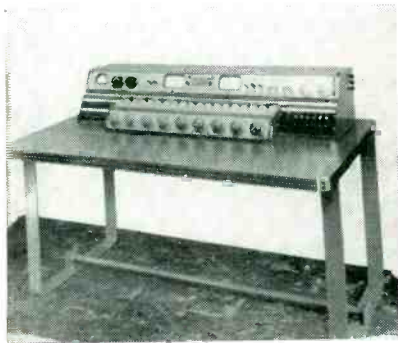

Broadcast Console

ALTEC LANSING CORP., 9356 Santa Monica Blvd., Beverly Hills, Calif. Model 250A console is a completely self-contained a-c operated unit designed for high quality control in a-m, f-m or tv broadcasting. Especially featured in the console is the use of newly designed miniature plug-in preamplifiers, line amplifiers, monitor amplifiers and power supplies. Available input impedances are 30, 150, 250 or 600 ohms with a nominal output impedance of 600 ohms. Frequency response is ± 1 db from 20 to 20,000 cycles and the signal-to-noise ratio is 70 db. Overall dimensions of the con-

REPUBLIC WATCHES THE LITTLE THINGS THAT MEAN BIGGER PRODUCTION FOR YOU

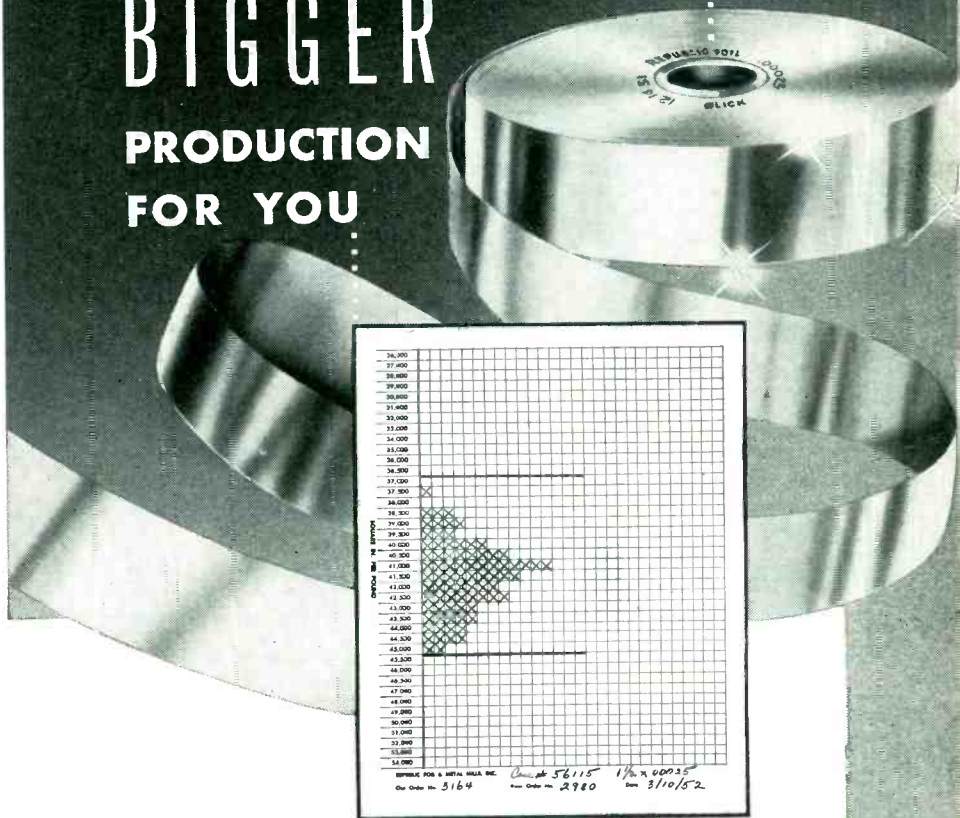

Take the matter of quickly identifying coils of Republic Aluminum Foil. Republic coils are clearly marked with the customer's code, the gage and the packaging date. Because the marking is on the edge of the coil, close to the core, a partially used coil is as quickly and readily identified as a new one.

As an added service, Republic is always glad to furnish their customers with an inspection chart covering each order. This chart tells at a glance the detailed yield factors of any given order. It is a pictorial representation of what can be anticipated in production.

But the most significant characteristic of Republic capacitor foil is its consistently good quality. Accurate gage, clean, straight edges and individual boxing mean more production, less down time, and fewer rejects.

Republic capacitor foil is available in widths of 1/4" and wider, and in gages from .00017" to .005".

REPUBLIC FOIL & METAL MILLS INCORPORATED

DANBURY

CONNECTICUT

Branch Sales Offices: 209 W. Jackson Blvd., Chicago 6, Ill.
666 Mission St., San Francisco 5, Cal.



INSULATION

FORMVAR • FORMEX • ENAMEL

STRIPPED CLEAN IN SECONDS

with **X-VAR**

IN



1. DIP WIRE in X-VAR for 3 seconds.

OUT



2. WITHDRAW and watch coating disintegrate.

WIPE

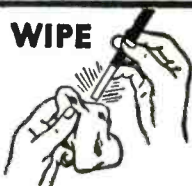

3. WIPE CLEAN. Operation completed in seconds.

X-VAR is non-corrosive, non-creeping — leaves wire ready for soldering. Now in use by leading manufacturers of electrical products. Write for FREE SAMPLE for testing.

FIDELITY CHEMICAL PRODUCTS CORP.
472 Prellinghuysen Avenue, Newark 5, New Jersey

MICROWAVE RESISTORS TELEWAVE TYPE R

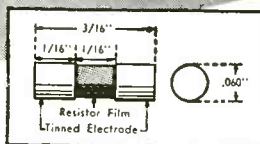
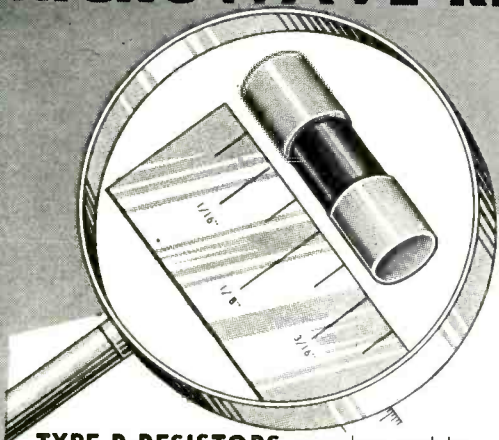

TYPICAL APPLICATIONS

- Power measurement at any frequency
- Matched terminations for waveguides or coaxial lines
- Resistive power pickup loops
- RF pads or attenuators
- Dummy loads
- Temperature measurements
- Impedance matching

SPECIFICATIONS

Resistance: 50 ohms standard, other values on request.
 Tolerance: 5% or 10%
 Wattage: 1/4 watt continuous duty at 25°C
 Size: 1/16 inch diam. x 3/16 inch long
 Terminals: Tinned sections 1/16 inch long
 Film Length: Type R-063 — 1/16 inch
 Type R-093 — 3/32 inch
 Temperature Coefficient: approx. 0.0019 ohms/ohm/°C.
 Power Sensitivity: Approx. 10 ohms/watt

TYPE R RESISTORS employ noble metal film deposits on specially selected heat resistant glass.

FILM THICKNESS offers negligible skin effect, at microwave frequencies.

POWER CAPACITY of 1/4 watt provides high power handling ability.

PHYSICAL STRUCTURE is ideally suited to impedance matching in standard coaxial line and waveguides.

FINISH. Coated with a special silicone varnish to protect the film.

TELEWAVE LABORATORIES, INC.
100 Metropolitan Ave. • Brooklyn 11, New York

AVAILABLE
FOR
IMMEDIATE
DELIVERY



INFORMATION on positions at NORTHROP

Northrop Aircraft, Inc. is engaged in vitally important projects in scientific and engineering development, in addition to aircraft production. The program is diversified, interesting and long-range. Exceptional opportunities await qualified individuals.

The most responsible positions will go to top-caliber engineers and scientists. However, a number of excellent positions exist for capable, but less experienced, engineers. Some examples of the types of positions now open are:

ELECTRONIC PROJECT ENGINEERS...
 ELECTRONIC INSTRUMENTATION ENGINEERS...
 RADAR ENGINEERS...
 FLIGHT-TEST ENGINEERS...
 STRESS ENGINEERS...
 AERO- AND THERMODYNAMICISTS...
 SERVO-MECHANISTS...
 POWER-PLANT INSTALLATION DESIGNERS...
 STRUCTURAL DESIGNERS...
 ELECTRO-MECHANICAL DESIGNERS...
 ELECTRICAL INSTALLATION DESIGNERS.

Qualified engineers and scientists who wish to locate permanently in Southern California are invited to write for further information regarding these interesting, long-range positions. Please include an outline of your experience and training.

Allowance for travel expenses.

Address correspondence to
Director of Engineering,

**NORTHROP
AIRCRAFT, INC.**

1009 E. BROADWAY
HAWTHORNE, CALIFORNIA

sole including table are 36 in. high, 55 in. long and 31 in. deep and weight is 280 lb.



Toroidal Windings

D&R, LTD., 402 E. Gutierrez St., Santa Barbara, Calif., announce the availability of toroidal coils characterized by improved winding techniques. High-Q inductor requirements of miniaturized apparatus may be readily met by the use of these coils. Both powdered-iron and continuous strip-wound core materials are utilized, depending upon the particular application.

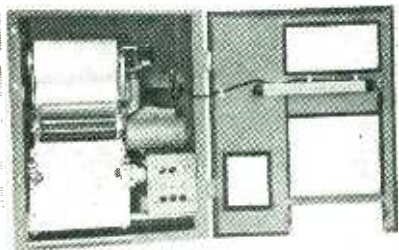

High-Speed Printer

ANELEX CORP., Concord, N. H. The Synchroprinter, a high-speed printer developed for recording the output of analog or digital computers in directly readable form on standard paper, may be used in any application where data is available in electrical or mechanical form. It is capable of printing 15 lines of 40 characters each in one second, or a rate of 600 characters per second. Printing is accomplished by means of continuously rotating type wheels and cooperating print hammers. The device features independent control of printing and

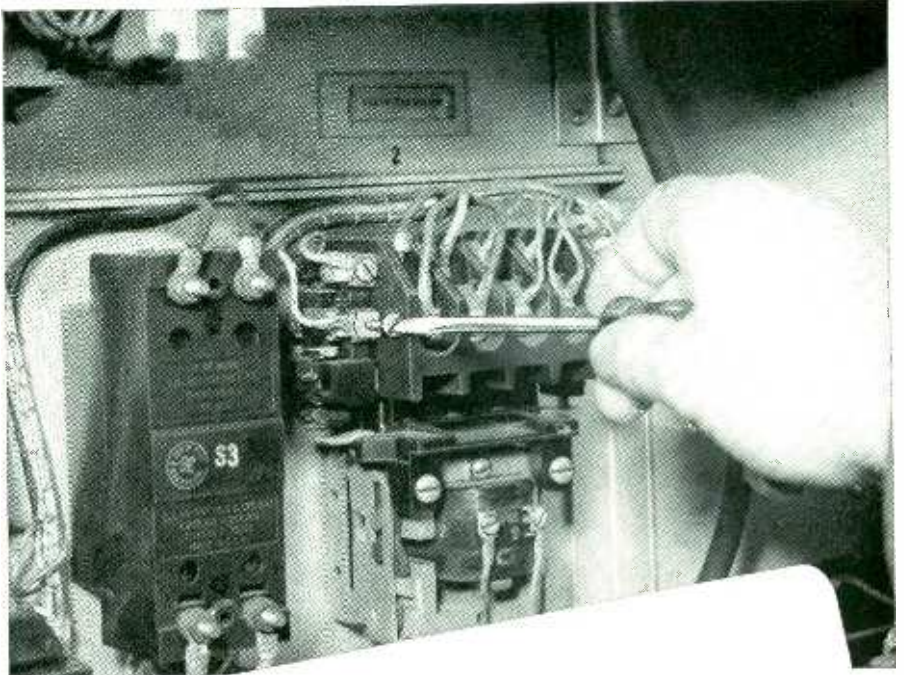

THE HIGH QUALITY EQUIPMENT YOU BUILD DESERVES FASTENINGS by HARPER

If you manufacture any type of electronic equipment, you know how important high quality, non-corrosive fastenings can be to your production.

H. M. Harper is the largest manufacturer specializing in fastenings of non-ferrous metal and stainless steel. Over 7,000 items carried in stock.

Harper Everlasting Fastenings offer manufacturers of electronic equipment:

- fastenings of brass, naval bronze, silicon bronze, Monel, nickel, aluminum, all stainless steel—many non-magnetic materials
- high quality and extreme accuracy
- a vast metallurgical and engineering background capable of solving any fastening problem
- twenty-nine years of manufacturing experience
- one source of supply for all your needs, with the added advantages of one source of responsibility, one account to handle, one bill to pay.

There is a Harper distributor near you with stocks to fill your order. Harper engineers and metallurgists will be glad to assist you in the solution of any fastening problem.

THE H. M. HARPER COMPANY
8244 Lehigh Avenue, Morton Grove, Ill.

Mail the coupon below for complete catalog of Harper Everlasting Fastenings. There is a Harper distributor near you with stocks to fill your requirements.

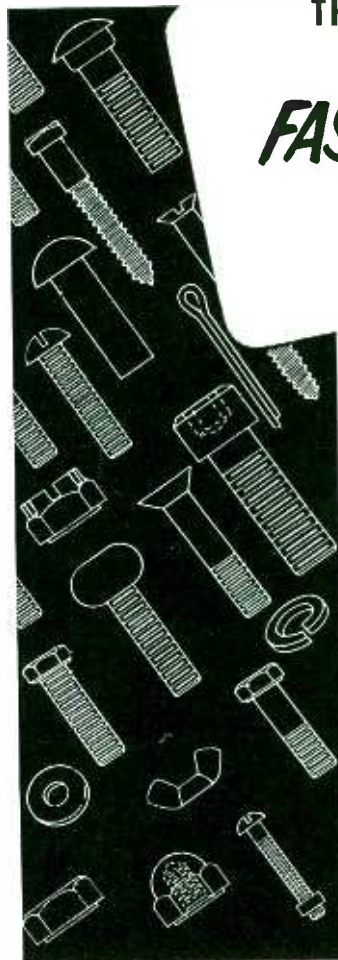

Specialists in all Non-Corrosive Metals

The H. M. Harper Company
8244 Lehigh Avenue
Morton Grove, Illinois
Please send the complete catalog of Harper Everlasting Fastenings.

Name.....
Position.....
Company.....
Address.....
City.....Zone.....State.....

PRECISION POTENTIOMETERS

Type RL-270:

Wedding ring type . . . five sizes charted below. Gamewell Potentiometers are precision instruments in every respect. They feature close limits in electrical characteristics and mechanical construction, low electrical noise, low torque, and long life. All types operate at -55°C. to $+55^{\circ}\text{C.}$, 95% relative humidity at altitudes up to 50,000 ft. Non-linear windings are available.

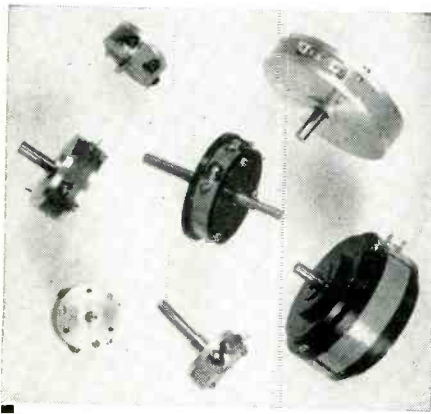

CONDENSED SPECIFICATIONS

	RL-272	RL-270	RL-271	RL-275	RL-277
Diameter (in.)	5	3	2	1 1/8	1 1/4
Rating (watts)	12	6	3	2	1.5
Torque, max. (oz. in.)	1	1	1	1/2	1/2
Weight (oz.)	15	6	3	2	1
Mounting: 3 holes 1/8" deep	#8-32	#8-32	#8-32	#6-32	#4-40
Mounting circle diam. (in.)	3.250	1.750	1.250	1.000	1.000
Max. resistance (ohms) $\pm 10\%$	500,000	275,000	160,000	105,000	64,000
Min. resistance (ohms) $\pm 10\%$	460	250	150	105	80
Max. useful angle (deg.)	358 $\pm 1/2$	356 $\pm 1/2$	354 $\pm 1/2$	352 $\pm 1/2$	350 $\pm 1/2$
Max. resolution (%)	0.05	0.08	0.15	0.2	0.25
Min. resolution (%)	0.01	0.015	0.025	0.04	0.05
Linearity (%)	± 0.10	± 0.10	± 0.15	± 0.25	± 0.30

Standard Shaft: single end, 1/4" extension, specify if otherwise.
 Double ended shaft special: specify diameter and length.
 Multiple sections can be ganged, add 1/4" to the overall length for each additional section.
 Terminals will be positioned on the circumference as required for taps and winding angle.
 Expected life of all types over 1,000,000 cycles.

FOR COMPLETE DETAILS SEND FOR BULLETIN F-68-A



THE GAMEWELL COMPANY
 NEWTON UPPER FALLS 64, MASSACHUSETTS

DANDUX

specification designed

**CANVAS
 and leather
 PRODUCTS**



CARBINE CLIP BAG



PADDED INSTRUMENT CASE

TOOL ROLLS—BAGS & CASES
 BG BAGS—CW BAGS
 RADIO EQUIPMENT
 ELECTRONIC EQUIPMENT
 RADAR EQUIPMENT

C. R. DANIELS, INC.
 DANIELS, MD.

75 West St. New York 6, N. Y.
 549 W. Randolph St. Chicago 6, Ill.

PHALO

"Current's Favorite Conductor"

Provides Versatile Quality for Mobile Communication!

Year after year, hundreds of thousands of feet of shielded connecting cables bearing the famous "Current's Favorite Conductor" trademark, find their way into the nation's best mobile radio and telephone communication systems.

Phalo builds shielded cables that are as versatile as the systems they connect . . . whatever the purpose, you couldn't find a better quality answer. Next time specifications call for shielded communication cable, call for PHALO and be certain!



PHALO
 Plastic Corporation

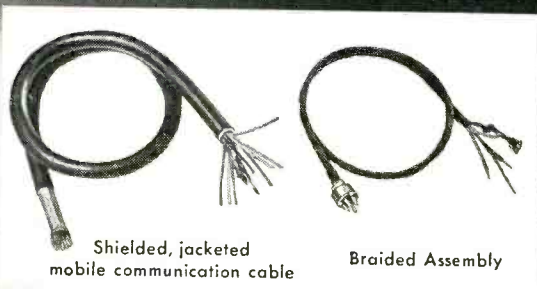

Shielded, jacketed mobile communication cable

Braided Assembly

Manufacturers of Thermoplastic Insulated Wire, Cables, Cord Sets and Tubing to Government Specifications

CORNER OF COMMERCIAL STREET, WORCESTER, MASSACHUSETTS

ROBINSON

All-Metal MOUNTS



are used in

UNITED'S

NEW CONVAIR-LINER 340'S

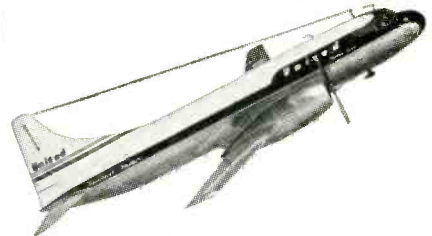

for the permanent protection of vital electronic equipment, instruments and controls against vibration and shock.

Write for Robinson's new catalog today.

ROBINSON AVIATION INC.
 TETERBORO, NEW JERSEY
Vibration Control Engineers

paper feed. This permits data produced at irregular time intervals to be consolidated into adjacent lines of print.



Electrical Delay Lines

GULTON MFG. CORP., 212 Durham Ave., Metuchen, N. J., is offering electrical delay lines for use in computers, radar, tv and other electronic applications where delays are required ranging up to 100 μ sec. These feature low-loss, excellent temperature stability through the use of specially engineered temperature compensating capacitors, and small physical size. All of these delay lines are custom engineered to the exact mechanical specifications and electrical characteristics required by the customer. Typical characteristics are delay time, 1.1 μ sec; rise time, 0.1 μ sec; bandwidth 2.0 mc; attenuation, less than 1 db and characteristic impedance, 460 ohms.

Volt-Ohm-Milliammeter

AMERICAN CHRONOSCOPE CORP., 316 W. First St., Mt. Vernon, N. Y. Model 601 portable v-t volt-ohm-milliammeter is a self-contained, universal test instrument that is battery operated and requires no external source of power supply. The meter accurately measures a wide range of a-c and d-c voltages, resistances and currents. It has six d-c voltage ranges from 3 to 1, 200 v full scale, 13-megohm input impedance; 5 a-c voltage ranges from 3 to 300 v full range, 6-megohm input impedance; 6 ohm ranges from 1 to 100 megohms; and 6 current ranges from 3 to 1,200 ma. Designed for all types of radio, electronic or industrial work, the unit is extremely useful when ex-

Where there are **DOUBTS**
instead of **FACTS**
... **LABEL IT**

with **Kum-Kleen** labels



WHY LABEL WITH Kum-Kleens — Wherever there's an unanswered question, a guess instead of a know, or a hesitation on identification or procedure, that's the place for Kum-Kleen labels. One electronic manufacturer records assembly and testing steps on Kum-Kleen labels, which are easily peeled off and filed for future reference.

Kum-Kleens are EASILY APPLIED — Avery Kum-Kleen, pressure-sensitive labels are just *laid-on* with a finger-touch. They're self-adhesive — easy to apply — stick to any clean, smooth surface . . . require no moistening, soaking, heating.

Kum-Kleens CUT LABELING COSTS — The patented Avery Dispensers—manual or electric—feed die-cut labels off roller tape, ready for quick, clean labeling. Many users report labeling speeds *5 times faster* than conventional methods.

Kum-Kleens are MORE PRACTICAL — Kum-Kleens *stay stuck* even in extremes of temperature and humidity with no pop, peel or curl. No excess glue or moisture to clean up! **THEY SAVE TIME, LABOR AND COSTLY MISTAKES!**

WHAT TO LABEL WITH Kum-Kleens: Nameplates—Trade-marks — Guarantees — Instructions — Approval Seals — Diagrams — Inspection — Caution — Repairs — Prices — Masking — Routing — How to use Copy . . . and many others.

Kum-Kleen — the original pressure-sensitive label — is a product of **AVERY** ADHESIVE LABEL CORP.

117 Liberty St., New York 6 • 608 S. Dearborn St., Chicago 5 • 1616 So. California Ave., Monrovia
Offices in other principal cities.

Please send case histories, free samples and prices
 Have the Avery label man call

Name _____
Title _____
Company _____
Address _____

ATR

For
**AC CURRENT
ANYWHERE**



**STANDARD
AND HEAVY DUTY
INVERTERS**

For Inverting D. C. to A. C. . . .
Specially Designed for operating A. C.
Radios, Television Sets, Amplifiers, Ad-
dress Systems, and Radio Test Equip-
ment from D. C. Voltages in Vehicles,
Ships, Trains, Planes and
in D.C. Districts.

ATR ✓ NEW MODELS
✓ NEW DESIGNS
✓ NEW LITERATURE

"A" Battery Eliminators, DC-AC
Inverters, Auto Radio Vibrators

See your jobber or write factory

AMERICAN TELEVISION & RADIO CO.
Quality Products Since 1931
SAINT PAUL 1, MINNESOTA-U. S. A.

IF YOUR D. O. CONTRACTS CALL FOR: . .

CONTACTS AND CONTACT ASSEMBLIES
BRUSHES • WIPERS • SLIP RINGS
COMMUTATOR SEGMENTS • RESISTANCE WIRES
NON-CORROSIVE WEAR RESISTANT PARTS . . .



CALL NEY . . . TODAY!

FOR years Ney Research has covered not only the development of specialized precious metal alloys for applications such as these, but also the design of both standard and special contacts, brushes, wipers and other component parts. Our increased facilities are now geared to economical production of these important precious metal components . . . in large or small quantities. Consult us.

THE J. M. NEY COMPANY, 179 Elm Street, Hartford 1, Connecticut
Specialists in Precious Metal Metallurgy Since 1812.

SCOPE DOLLY
Model 1

Convenient Height and Viewing Angle
Adjustable to Hold Portable Scopes
Ball Bearing Swivel Rubber Tired Casters
Lightweight Aluminum Construction
Recommended by Laboratories Wherever Used

\$35.00 FOB LOUISVILLE, KY.
Formerly manufactured by UNIQUE DEVICES
Now manufactured and sold by

TECHNICAL SERVICE CORPORATION
3116 Michigan Drive Louisville 5, Kentucky

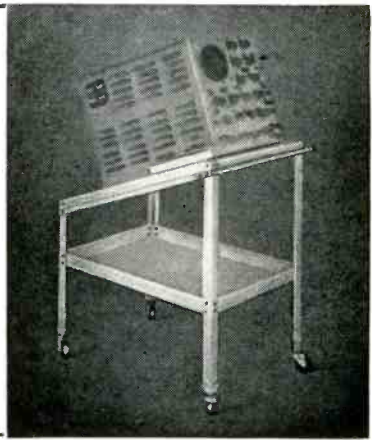

WASHERS—ALL KINDS

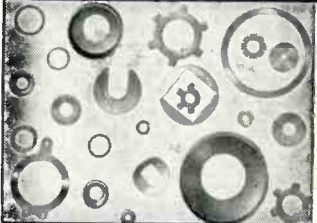

WASHER SPECIALISTS for nearly half-a-century. Dies in stock will produce most sizes. Big runs made with automatic presses. An economical, accurate, and highly reliable source for washers, also all kinds of metal stampings. **HAVE WHITE-HEAD'S CATALOG ON FILE;** write for it.

- BEVELED CUP
- D-HOLE RETAINER LOCK
- SPACERS
- SPRING TENSION SQUARE HOLE
- STAR LOCK THRUST TONGUE



EST. 1903

WHITEHEAD STAMPING COMPANY

1691 W. LAFAYETTE

DETROIT 16, MICH.

ternal power is not available; when limitations are imposed by grounds; or to prevent small amounts of 60-cycle hum.

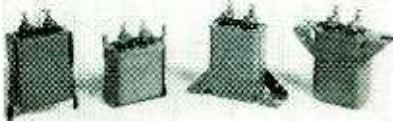

Capacitors

INDUSTRIAL CONDENSER CORP., 3243 N. California Ave., Chicago 18, Ill. Illustrated are the type D of the Stabelex "D" hermetically sealed capacitors that hold a charge for as much as 200 days or longer. Case material is lead-coated steel. Terminals are specially prepared and treated glass, standoff type. Type of winding is noninductive. Operating temperature is -80°C to $+75^{\circ}\text{C}$. Capacitance tolerance is ± 10 percent. Catalog 117 gives complete details and applications for the entire Stabelex "D" line.

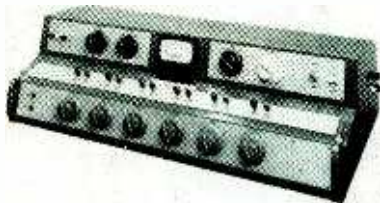

Station Console

ALTEC LANSING CORP., 9356 Santa Monica Blvd., Beverly Hills, Calif. Model 230B console is designed for two-studio station use and is equally suited for use in elaborate p-a and recording installations. In the self-contained, a-c operated unit there are four separate preamplifiers, two booster amplifiers, a line amplifier and a monitor amplifier, all mounted on one chassis. Available input impedances are 50, 150, 300 or 600 ohms and output impedance is 600 ohms. System gain is 100 db (including a 6-db isolation pad). Frequency response is ± 1 db, 20 to 20,000 cycles, and the signal-to-noise ratio is 74 db. Measure-

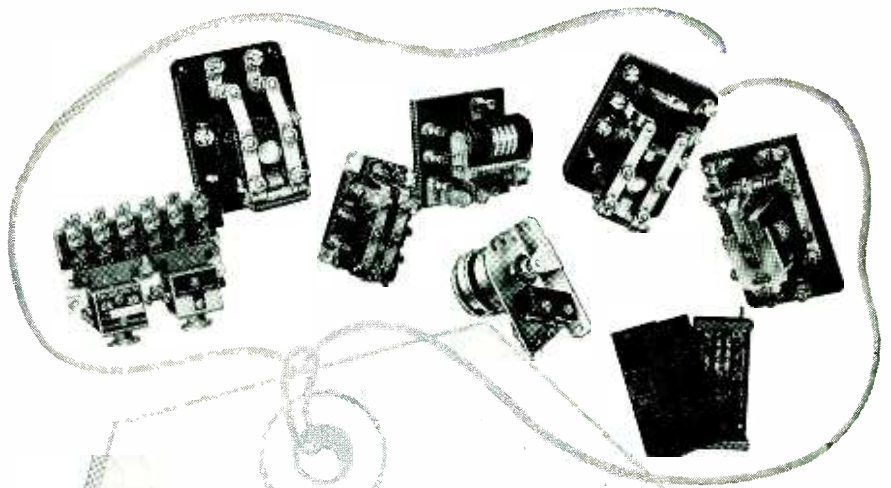

STRUTHERS -DUNN

*is making more
relays of more types,
for more critical
control applications
than
ever before*



A 640-page guide to relay selection and use

Let "RELAY ENGINEERING", the famous Struthers-Dunn handbook, help solve your problems of relay selection, application, circuitry and maintenance! Over 17,000 copies in use. Price \$3.00.

STRUTHERS-DUNN

5,348 RELAY TYPES

Struthers-Dunn, Inc., 150 N. 13th St., Philadelphia 7, Pa.

BALTIMORE • BOSTON • BUFFALO • CHARLOTTE • CHICAGO • CINCINNATI
CLEVELAND • DALLAS • DETROIT • KANSAS CITY • LOS ANGELES
MINNEAPOLIS • MONTREAL • NEW ORLEANS • NEW YORK • PITTSBURGH
ST. LOUIS • SAN FRANCISCO • SEATTLE • SYRACUSE • TORONTO

TEFLON MAGNET WIRE

FOR HIGHEST TEMPERATURE APPLICATIONS

We invite inquiries where requirements call for:

- small SPACE FACTOR**
- HIGHEST ABRASION RESISTANCE**
- FLEXIBILITY AND ADHERENCE**
- DIELECTRIC STRENGTH**
- RESISTANCE TO CHEMICALS**

capable of withstanding temperatures of 250 centigrade.

WARREN WIRE COMPANY

POWNAI

VERMONT

Producers of Nylon, Plain Enamel, and Served Magnet Wire
Tinned and Bare Copper Wire.

SYNTRON

SELENIUM RECTIFIERS

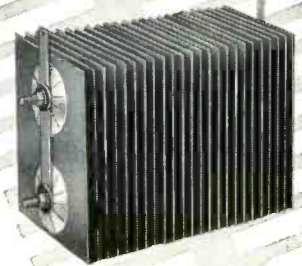

Made by a new process to a uniform, high quality for continuous, heavy-duty service.

1" sq. to 12"x16" cells—in stacks, or single cells for customer assembly.

Write For Illustrated Folder

SYNTRON CO.

241 Lexington Ave. Homer City, Pa.

ATTENUATORS

by
TECH LABS



MIDGET
TYPE
600

"Midget" model is especially designed for crowded apparatus or portable equipment.

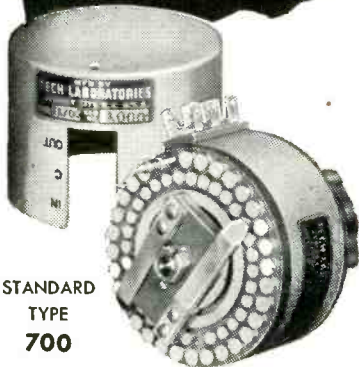
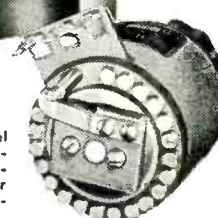

STANDARD
TYPE
700

- Solid silver contacts and stainless silver alloy wiper arms.
- Rotor hub pinned to shaft prevents unauthorized tampering and keeps wiper arms in perfect adjustment.
- Can be furnished in any practical impedance and db. loss per step upon request.
- TECH LABS can furnish a unit for every purpose.
- Write for bulletin No. 431.

Exclusive Canadian Dist.: RCA Victor, Ltd



Manufacturers of Precision Electrical Resistance Instruments
PALISADES PARK • NEW JERSEY

ENGRAVING and MARKING

The Green Engraver



**ENGRAVES,
ROTS,
PROFILES and MODELS**

A real money saver for industry. Proven by the experience of tool and die, electronic machine, radio, electrical and instrument manufacturers.

The Green Engraver zips out precision work on metal, plastics, wood, glass, hard rubber, etc. . . . engraves panels, name plates, scales, dials, molds, lenses, instruments, instruction plates, directional signs . . . by simple tracing. Routing, profiling and three dimensional modeling indicate its versatility. Electronic etching attachment available.

Specify the Green Engraver for the best in low cost performance. Special attachments and engineering service available for production work.

FREE — Fact-packed folder yours upon request.

Green Instrument Co.
INCORPORATED

363 Putnam Ave., Cambridge, Mass.

ments of the unit are 9 $\frac{3}{8}$ in. high, 36 $\frac{3}{4}$ in. long and 17 in. deep.

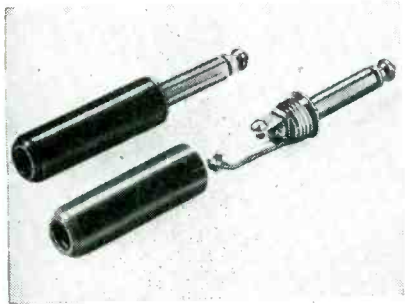

Tiny Phone Plug

CARTER PARTS Co., 213 West Institute Place, Chicago 10, Ill., has introduced a new "imp" phone plug. The tip and sleeve of the new plug fit standard 2-conductor jacks but the molded Bakelite handle has been reduced to about one-half normal size. The new design makes for added convenience and savings in space.



Control Relay

AUTOMATIC TEMPERATURE CONTROL Co., 5200 Pulaski Ave., Philadelphia 44, Pa., has developed an electronic control relay designed to operate in conjunction with a differential transformer transmitter. To obtain control of any variable the differential transformer is adjusted so that its zero position is at the exact point at which it is desired to obtain control. This position is sensitive to less than 0.0001 in., and as the armature of the transformer is moved off this null point by a change in the variable, a signal is generated having amplitude and phase definition. The control relay is sensitive to this minute signal and either pulls in or drops out depending on the direction of the

ANOTHER MOLDITE ENGINEERING TRIUMPH

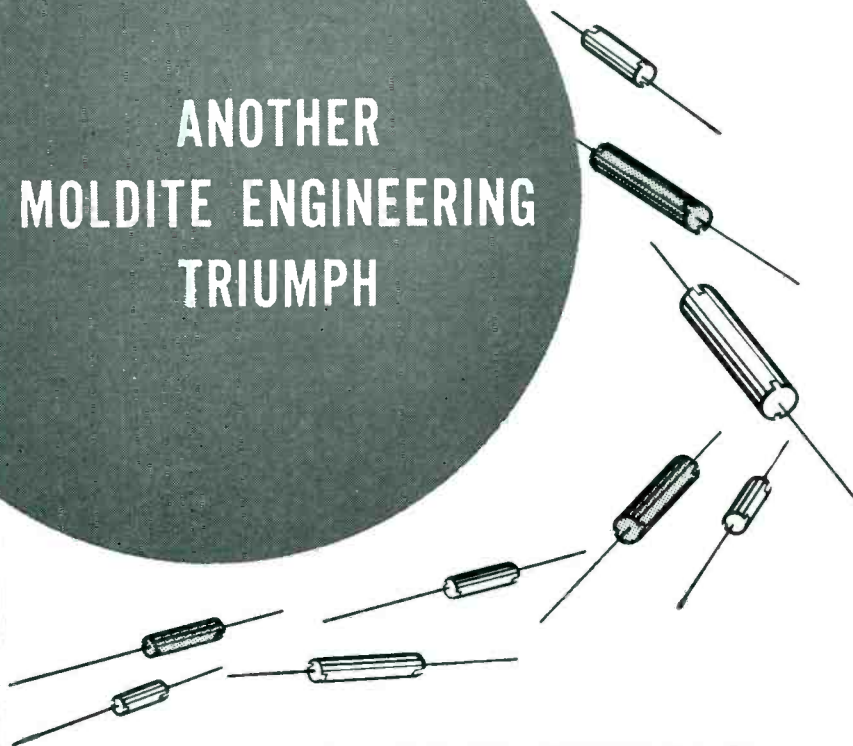

MOLDED COIL FORMS

After years of development, the NATIONAL MOLDITE COMPANY has engineered and built an automatic machine for making molded coil forms held to the most exact dimensions for length and O.D. This new machine is geared for high speed production, thus providing prompt shipment on most popular sizes.

Here is another example of MOLDITE pioneering in order to provide the radio, television, and communication industries with quality engineered components.

Yes, look to MOLDITE for precision engineered magnetic iron cores, RF filter cores, and now MOLDED COIL FORMS.

**MAGNETIC IRON CORES • FILTER CORES • MOLDED COIL FORMS
THREADED CORES • SLEEVE CORES • CUP CORES**

NATIONAL

MOLDITE

COMPANY

1410 Chestnut Ave., Hillside 5, N. J.

Samples promptly
submitted upon request
for design, pre-production,
and test purposes

SEND FOR CATALOG 110

Robert T. Murray
614 Central Ave.
East Orange, N. J.

Jerry Golten Co.
2750 W. North Ave.
Chicago 22, Ill.

Martin P. Andrews
Mott Road
Fayetteville, N. Y.

Perlmuth-Colman & Assoc.
1335 South Flower
Los Angeles, Cal.

Jose Luis Pontet
Cardoba 1472
Buenos Aires

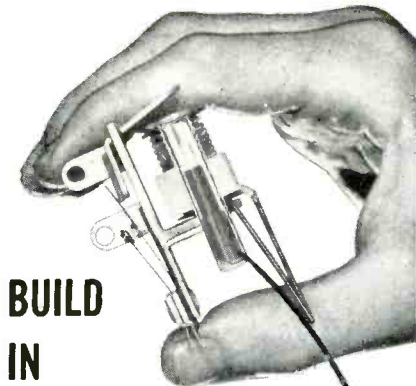

**BUILD
IN
OVERLOAD PROTECTION**
... or prevent single-phasing

This tiny, low cost Heinemann Silic-O-Netic Relay puts overload protection right into your circuits... or it can prevent single-phasing on three-phase motor applications.

TIME DELAY to allow for starting in-rush or temporary overloads is provided by a hydraulic-magnetic principle... and the complete time element is hermetically sealed, forever free of dirt and atmospheric conditions. Delay characteristics are inversely proportional to overload. They are unaffected by ambient temperature... and available with curves to suit your requirements.

Send for informative Bulletin 5001A.

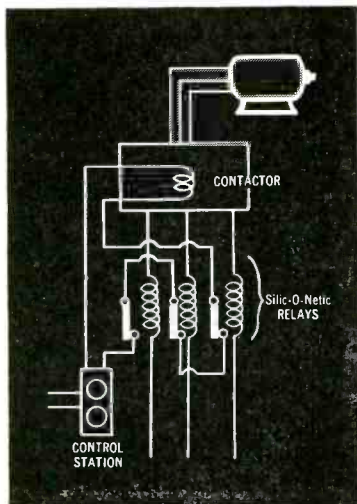

HEINEMANN

ELECTRIC COMPANY
97 Plum Street, Trenton 2, N. J.

Eliminate **CRYSTAL
TEMPERATURE
CONTROL COSTS...**

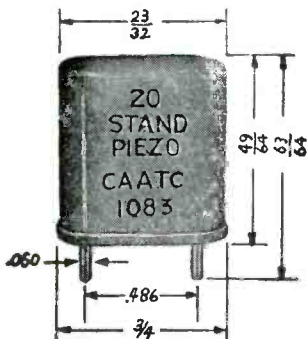

Now you can forget temperature control. Just specify Standard's Type 20 Crystal Unit for your products.

In addition to lowering power requirements and weight, it increases compactness, durability and dependability. Type 20 meets all Government specifications, too.

Discover how the Standard Type 20 can cut costs and increase sales for you. A letter will bring Engineering data and complete details by return mail.

Standard Piezo
COMPANY
CARLISLE, PENNSYLVANIA

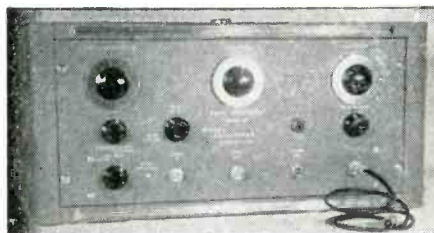

NEW PULSE GENERATOR
FEATURES

- Pulse Height:** 0-50 v. continuously variable, positive or negative polarity.
- Pulse Width:** 0.07 to 7 μ s. continuously variable.
- Repetition Frequency:** 50-5000 cycles, controlled from an internal or external oscillator.
- Output Impedance:** 75 ohms or less.

- Pulse Shape:** 0.02 μ s. rise and fall times. Top flat within 2%.
- Synch Out:** 50 v. into 200 ohms, 1 μ s. wide, 0.1 μ s. rise time.
- Pulse Phasing:** Output pulse can be delayed 100 μ s. or advanced 10 μ s. with respect to the synch output.

Other laboratory pulse generators also available.

For full details write for Bulletin PG-50

76 STAGE STREET

MANSON LABORATORIES

STAMFORD CONN.

PIX

**WIRE FORMING
SPECIALISTS**

Precision Parts to meet your Production and Engineering needs. From .002" dia. to .125" dia. Radio tube parts—Stampings—Drawings Modern facilities, high-production equipment.

Metal Crystal Holder Parts

Send sketch or print for quotation.

PIX MANUFACTURING CO., Inc.
24-B Bedford St., Newark 3, N. J.

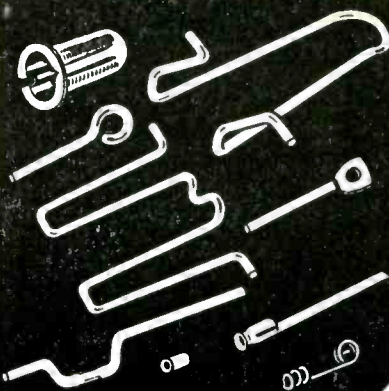

signal. The relay can be installed up to 5,000 ft away from the source of the measured variable.

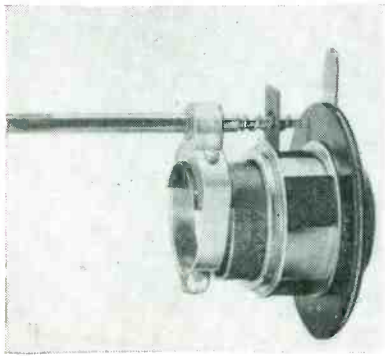

Focusing Device

HEPPNER MFG. Co., Round Lake, Ill., has available a tv p-m focusing device designed for use with the new low-energy magnetic focus tube. It is installed in two seconds by simply slipping over the tube's neck and tightening the clamp. No brackets or special mounting contrivances are required. Because the entire device weighs only 5 oz, including the 1½ oz Alnico permanent magnet, it cannot damage the neck of the tube. Two turns of the adjusting screw are sufficient to cover the entire focus range.

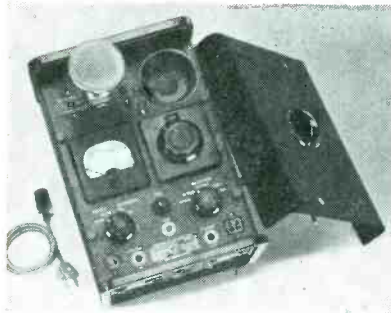

Sound-Level Meter

GENERAL RADIO Co., 275 Massachusetts Ave., Cambridge 39, Mass. Type 1551-A sound-level meter measures product noise and working-area noise levels. Its stable circuit uses a two-stage preamplifier as well as a three-stage main amplifier. Overall frequency response of the amplifiers is flat from 20 cycles to 20 kc so that full advantage can be taken of new high-fidelity microphones. Direct measurement of sound pressure levels can be made over a range from 24

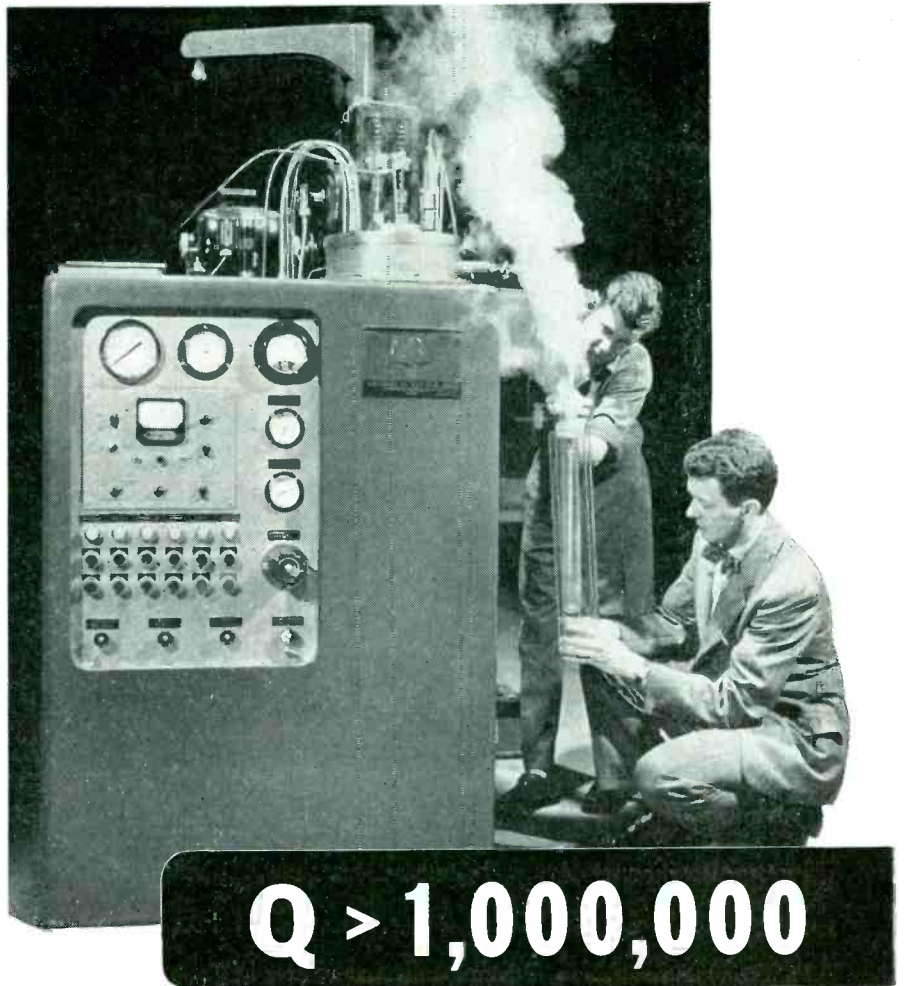

Q > 1,000,000

Resonant circuits with Q's in the range of millions are one of the many practical applications of low-temperature techniques and phenomena being studied by laboratories equipped with our Collins Helium Cryostat. With this reliable equipment for the production of liquid helium, phenomena known to occur in the neighborhood of Absolute Zero are now being exploited for useful purposes.

Various industrial low-temperature laboratories are studying the very low energy effects, masked by thermal noise at normal temperatures, for their application to communications and control processes. Other potential uses of low-temperature phenomena include the development of sensitive bolometers, perfect conductors, magnetic shields, and insulators which will hold a charge for unusually long periods.

Your industry, equipped for low-temperature research, can expand the growing list of practical uses for these low-temperature effects.

For further information on the Collins Helium Cryostat and other potential applications of low-temperature research write for Bulletin E-3.



ARTHUR D. LITTLE, Inc.
Mechanical Division

30 MEMORIAL DRIVE • CAMBRIDGE, MASS.

to 140 db, a power range of 400 billion to 1. The unit weighs 11 lb and its overall size is 470 cu in.

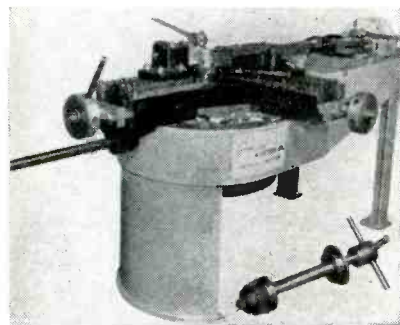

Waveguide Bender

GENERAL RIVETERS, INC., 785 Hertel Ave., Buffalo 7, N. Y., has developed a hand-operated tube bender fitted with specially designed dies for bending waveguides. Capacity of the hand bender using the compound gear is 2-in. standard pipe, 8-in. radius. The dies shown are for bending $\frac{1}{2}$ in \times 1 in. 0.065-wall copper tubing. Dies for larger size tubing can be furnished. The machine is arranged to travel 210 degrees for bending parts requiring 203 degrees, allowing for spring back on large radius.

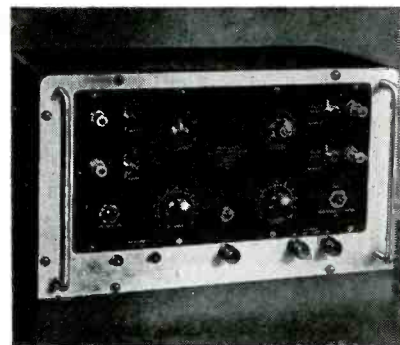

D-C Preamplifier

A. C. COSSOR LTD., Cossor House, Highbury Grove, London, England. Model 1430 d-c preamplifier is a unit of laboratory equipment used for preamplification of minute potentials for the presentation to the input of standard oscillograph amplifiers. The instrument is designed to cover the frequency range from d-c to 30 kc, the response being 15 percent down at 30 kc. Literature giving complete description and specifications is available from

EAD ENGINEERING
gives you
"2 for 1"



MODEL J31E-23



(5) LEADS, 10" LONG

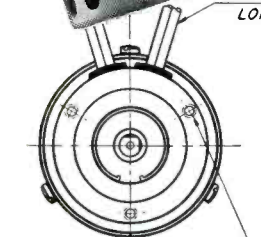

(3) #6 (138)-32 NC 2 TAP,
 $\frac{7}{32}$ DEEP EQUALLY SPACED
AS SHOWN ON 1.500 DIA.

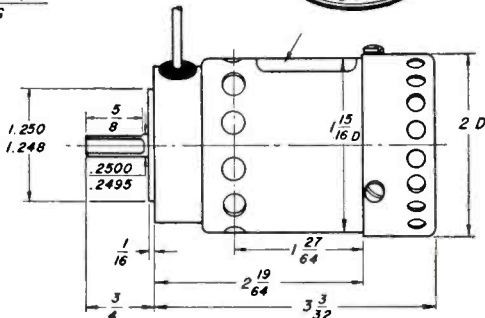

Here, designed into one small frame, is a variable frequency capacitor motor capable of operating at dual frequency ranges of 50/60 cycles or 360/1600 cycles. Another outstanding EAD engineering achievement . . . one motor that does the work of two!

SPECIFICATIONS

Continuous duty • single phase • 115 volts AC • Ambient temperatures: -55°C to $+85^{\circ}\text{C}$ • Weight: 1 lb., 1 oz. • Meets military specifications for humidity, salt, shock, vibration and tropicalization.

Applications: Airborne equipment (fans, blowers, pumps and other suitable uses.)

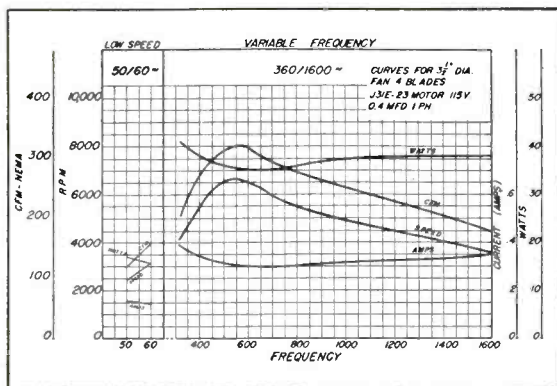

Solving special problems is routine at EAD

If your problem involves rotating electrical equipment, bring it to EAD. Our completely staffed organization will modify one of our standard units or designs and produce a special unit to meet your most exacting requirements.

EASTERN AIR DEVICES, INC.

585 DEAN STREET, BROOKLYN 17, NEW YORK

the company's U. S. agent, Beam Instruments Corp., 350 Fifth Ave., New York, N. Y.

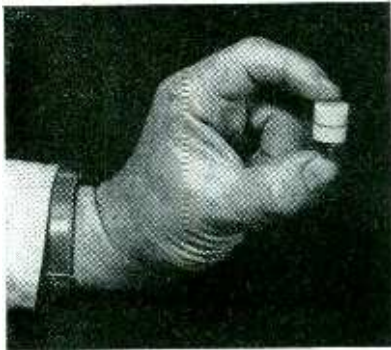

H-V Tip Jack

INSULINE CORP. OF AMERICA, 3602 35th Ave., Long Island City 1, N. Y., has announced the No. 1899 high-voltage tip jack, designed expressly for stability in sensitive electronic test equipment. The insulation is nylon, withstands 10,000 volts and has negligible moisture absorption. The spring contact is made from one piece of phosphor bronze and takes all standard phone tips and test prods. The jack is furnished with a molded washer that affords positive protection against shorts to a metal panel.

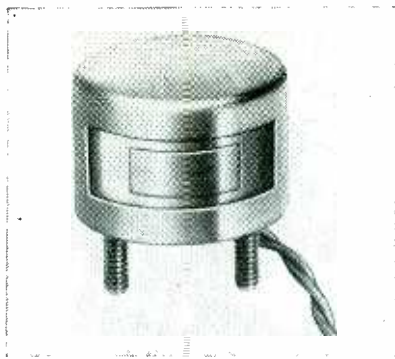

Tape Recorder Head

THE INDIANA STEEL PRODUCTS CO., Valparaiso, Ind. The TD-704 high output record-playback head has a frequency response flat within 1 db from 100 cycles to 7,000 cycles at a tape speed of 7.5 in. per second. At a tape speed of 15 in. per second maximum frequency response is increased to nearly 12,000 cycles. Signal output is in the order of 5 mv. The head utilizes a track width of 0.200 in. assuring maximum out-

High Temperatures? Small Space? Severe Conditions?



Today's trend towards miniaturization makes severe demands on electronic wiring. That is why so many leading electronic equipment manufacturers specify Rome Synthinol 901. A resin plasticized polyvinyl chloride thermoplastic compound, it is Underwriters' approved for temperatures up to 105° C., as a special small-diameter type with no assigned voltage, as well as for regular 300 and 600 volt ratings.

Where space is a problem, Rome Cable engineers have developed a small-size hook-up with with an 8 mil wall of Rome Synthinol 901 insulation and an exceptionally small over-all diameter. With nylon sheath maximum diameters run from as small as .051" for 24 AWG to .100" for 16 AWG.

What's more Rome Synthinol 901 has greater resistance to heat deformation, baking embrittlement, shrinkage, cracking, solvents, moisture and flame, plus improved solderability. It is available in distinct, permanent colors, either plain or with outer coverings.

MILITARY TYPE HOOK-UP WIRE

Rome Cable is an approved manufacturer of military types SRIR, SRHV and WL, complying with Army-Navy Joint Specification JAN-C-76, as well as shipboard types SRI and SRIB conforming to Specification MIL-C-915. Insulated with Rome Synthinol thermoplastic compound, these wires are manufactured in the complete range of specification sizes.

Whatever your requirements, you can depend on Rome for electronic wires of the highest quality. The coupon will bring you descriptive literature.

MAIL IT TODAY.

ROME CABLE CORPORATION
DEPT. E-7, ROME, N. Y.

Please send me information on Electronic Wiring.

Name

Company

Address

City State

IT COSTS LESS TO BUY THE BEST

ROME CABLE CORPORATION
ROME, NEW YORK and TORRANCE, CALIFORNIA



THE MOST COMPLETE LINE IN THE INDUSTRY...

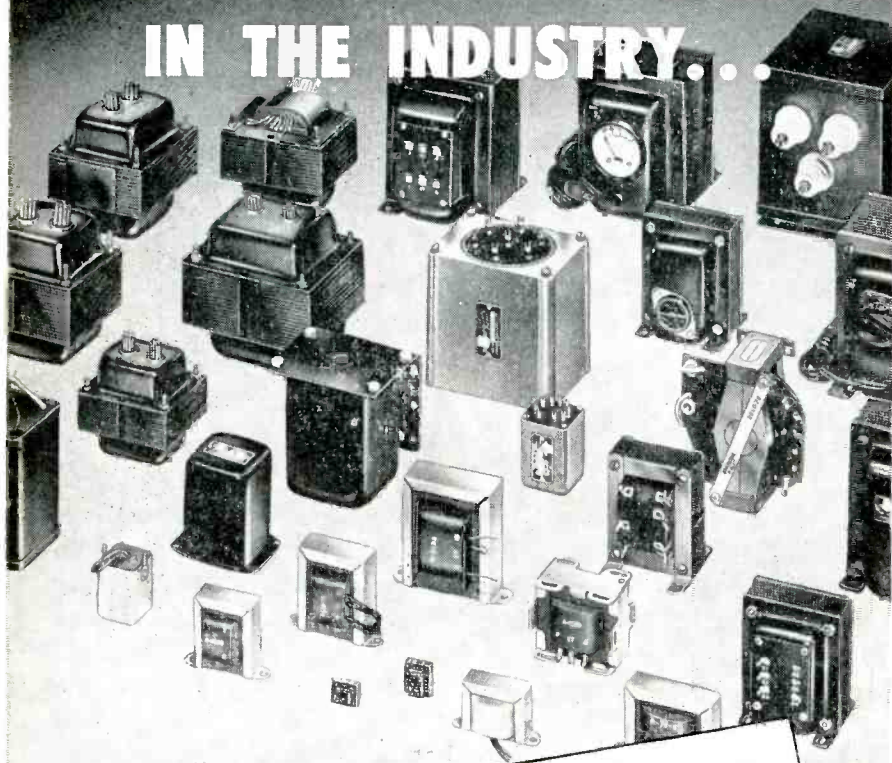

TRANSFORMERS AND RELATED COMPONENTS

For Industrial, Military, TV, Radio and
other Electronic Applications



Stancor is, of course, one of the world's largest producers of special design transformers for use in all types of electronic equipment.

In addition, Stancor has the most complete stock line in the industry for use in your prototypes or lab equipment. If you need one or a hundred transformers in a hurry, you can probably find the type you need in the Stancor catalogued line. They are quickly available through the Stancor parts distributor in your locality.

The new 24 page Stancor catalog lists 475 transformer and related components. Ask your Stancor distributor for a FREE copy, or write us directly.



JUST PUBLISHED!

STANDARD TRANSFORMER CORPORATION

3578 ELSTON AVENUE, CHICAGO 18, ILLINOIS

put and signal-to-noise ratio and a constant overall level of the playback signal. Impedance is 1,000 ohms at 1,000 cps. The unit is designed for single track recording on $\frac{1}{4}$ -in. tape.



F-M Phonograph Cartridge

WEATHERS INDUSTRIES, 510 Richey Ave., West Collingswood, N. J., has introduced a new f-m phonograph cartridge operating on a unique variable-capacitance principle. With a good transcription arm it tracks at a stylus pressure of one gram. When installed in modern Webster and RCA-45 record changers the stylus pressure can be adjusted to 3 grams or less. Frequency response is 20 to 20,000 cps. The cartridge operates with an oscillator unit using one 6AT6 tube. Filament and plate current may be taken from the audio amplifier, or from a power supply sold separately.



Timer

NUCLEAR INSTRUMENT & CHEMICAL CORP., 229 W. Erie St., Chicago 10, Ill., has introduced the model T100 timer designed to measure elapsed time in one-hundredths of minutes for greater accuracy in radioactive sample counting. The unit operates on standard 110-volt, 60-cycle current and has a convenient off-on switch in the line cord. It can be quickly reset to zero when counting

is completed. Measurements are 3 3/8 in. high x 3 3/8 in. wide x 4 in. deep.



Portable Recorder

AUDIO & VIDEO PRODUCTS CORP., 730 Fifth Ave., New York 19, N. Y. The portable Wagner-16 Micro Disc recorder, model P16-450 is a professional instrument enabling one to record and play back a full hour of speech or music on a single unbreakable vinylite disc that is only 4 1/2 in. in diameter, operating at 16 rpm and at a pitch of 448 lines per in. Contained within the portable carrying case is the complete mechanism and recording head, amplifier and power supply, play-back pickup and loudspeaker for recording and playing back instantaneous Micro Discs. The equipment operates from 115 v, 60 cycles a-c.

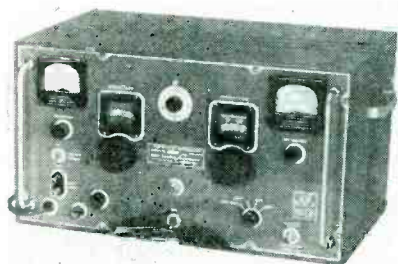

F-M Signal Generator

NEW LONDON INSTRUMENT CO., P. O. Box 189, New London, Conn. Type 100B f-m signal generator covers the frequency range from 20 to 110 mc. At 150-kc deviation typical distortion is 2 percent at 1,000 cycles modulation to a maximum of 4.5 percent at 15,000 cycles modulation. Distortions are proportionately lower for deviations smaller than 150 kc. In addition to a fine



THREADED I. F. CORE

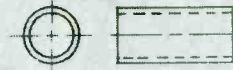

SLEEVE CORE



"E" CORE



TOROID

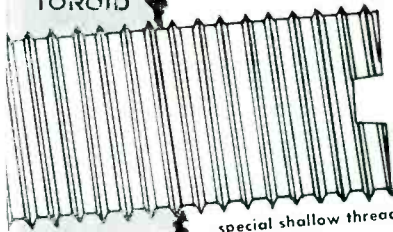

Threaded Core Advantages

THREADED CORES COST LESS THAN ANY OTHER TYPE OF ADJUSTABLE CORES

1. Reduced cost per core
2. Smaller assemblies (less space necessary)
3. Simplest IF transformer core design
4. Higher "Q" by elimination of metal inserts
5. Hexagonal hole design permits top tuning
6. Saving of critical material

Television, Electronic and Radio set designers are considering the advantages of the Threaded Core. Where Threaded Core substitutions for Insert Cores are indicated as more practicable design, greater economy, stability and better performance have been the result. Part and labor cost reductions can easily be visualized through the elimination of brass screw inserts and simplified assembly.

Threaded Iron Cores are blank-formed with screwdriver slots or hex holes. The blank is then externally threaded on a centerless thread grinder. Your threaded core self-taps itself through the serrated paper coil form.

Threaded core permeability is effected by the type of threads selected. The table illustrates the advantages of selecting finer and shallower threads.

PERMEABILITY VS THREAD FORM		Diameter Tolerance vs. Permeability	
Thread Form	Per Cent Change	O. D. tolerance	Permeability tolerance
20 pitch	-22	±0.001 in.	±4%
28 pitch	-14	±0.002	±2%
32 pitch	-13		
28 shallow pitch	-7		
32 shallow pitch	-6.5		

The "Q" potential: Threaded Cores having the least permeability drop during threading usually provide the highest "Q" as smaller coils (less copper) are required to achieve the given inductance.

Threaded Core Size and Strength

Greater physical strength is attained in the Threaded Core with the use of finer threads because of the effective larger diameter. The ratio of length to diameter shall not be less than 1 1/2 to 1, nor more than 4 to 1, for economical core design. (Standard Diameters: 0.159; 0.181; 0.238; 0.249; 0.304.)

Radio Core Quality Control

All Radio Cores manufactured, are produced with special attention to both mechanical and electrical tolerances resulting in lower incoming inspection and assembly costs on the part of the customer.



CUP CORE



DUMBBELL CORE



IRON CORE COIL FORM



PLAIN CORE



INSERT CORE



TUNING CORE



For more detailed Threaded Core information—Write for: Samples, designs and Specific Costs, Dept. E5752, Technical Data Booklet, "Engineered Radio Cores" No. E752.

Radio Cores, Inc.

9540-50 Tulley Avenue Oak Lawn, Illinois



Do you know this fact about Germanium Crystal Diodes?

Ordinary test methods reveal all there is to know about the static characteristics of germanium crystal diodes. However, an important but little known characteristic shows up to plague the engineer when the diode is actually operating in the circuit.

Under dynamic operation some diodes have a much higher forward resistance than under static conditions. A finite time, measured in microseconds, is needed for the diode to recover its normal static resistance after the voltage changes from back to forward.

This dynamic characteristic, if not within allowable limits, would affect the performance of the circuit. For example, if two diodes are to be matched for a bridge circuit, the static forward resistance of both may be 200 ohms, while the dynamic forward resistance at 500 kc might be 300 ohms for one, and 1,000 ohms for the other.



New CRC Diode Tester

tests dynamic characteristics.

The new CRC Diode Tester tests both forward and back characteristics under static and dynamic conditions... telling you how the diode will perform before you mount it in the circuit. Where large numbers of diodes are used in plug-in form, the Diode Tester can also be used for periodic circuit checks to detect potential diode failures before they occur.

If you are using germanium crystal diodes, the CRC Dynamic Crystal Diode Tester will be a valuable addition to your electronic test equipment.

Write today to the
Director of Applications for
a helpful information sheet.



Forward resistance of a good germanium crystal diode under dynamic conditions.



Forward resistance of a bad diode under dynamic conditions showing excessive overshoot.

tuning knob the single-band frequency range can be even more precisely adjusted with an incremental frequency dial that changes the carrier up to ± 100 kc. It also features a precision piston attenuator—100,000 to 0.02- μ v output, and external and internal (100 to 15,000 cycles) modulation.

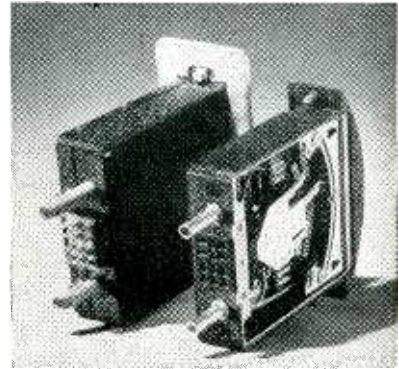

Edgewise Fader

PAINTON & Co. LTD., Kingsthorpe, Northampton, England, has designed a miniature edgewise fader for tv applications where the video signal actually passes through the fader. Features of the instrument include: coaxial plugs and sockets for the incoming and outgoing video signal; provision for a 30-step bridged-T network, insuring smooth video fade; and changeover contacts providing cueing facilities. Attenuations up to 34 db are possible and frequency response is substantially flat up to 5 mc for all attenuations.

Dual Regulated Power Supply

OREGON ELECTRONIC MFG. CO., 206 S. W. Washington St., Portland 4, Oregon. Model D6 is a versatile heavy-duty regulated power supply. It supplies two regulated outputs continuously variable from 0 to 600 v at a maximum current of 200 ma each, with regulation better than 0.5 percent from 10 v to a maximum and ripple of less than 10 mv peak to peak. A turn of a knob combines the two outputs to give a maximum output current of 400 ma. Other outputs are 6.3 v a-c at 10 amperes center-tapped, 650 v d-c unregulated with less than 2 v ripple, 0 to



Computer Research CORPORATION

3348 W. EL SEGUNDO BLVD. HAWTHORNE, CALIFORNIA... OSBORNE 5-1171

Brush Magnetic Recording Components

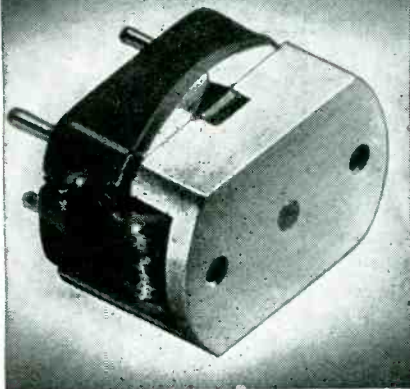

Model BK 985

**Better Performance—
Uniformity—Stability—Because
of 5 Precision Lapping Operations**

THE MODEL BK 985 narrow channel recording cartridge is typical of the advanced design and production quality of Brush Magnetic Recording Components. Brush engineering leadership in this field means improved basic design. Brush experience and skill in precision production means a product you can count on to do its job efficiently.

Brush Magnetic Recording Components include a full line of single and multiple recording heads applicable to every type of tape recording.

Write us for help on your magnetic recording problems. Your inquiries will receive the attention of capable engineers. Address Dept. E-7.

THE **Brush**



DEVELOPMENT COMPANY
3405 Perkins Ave. • Cleveland 14, Ohio
Piezoelectric Crystals and Ceramics
Magnetic Recording Equipment
Acoustic Devices • Ultrasonics
Industrial & Research Instruments

MIDGET TELEPHONE TYPE RELAYS in hermetically sealed containers

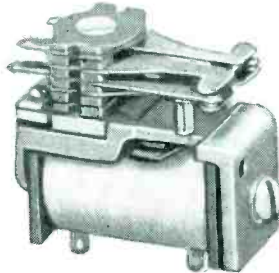

Surface mounting, open type, Series 80 Relay — size: $1\frac{15}{32}$ " l. x $\frac{5}{8}$ " w. x $1\frac{25}{64}$ " h.

Compact, multiple contact with vibration and shock-proof characteristics. Designed to meet various operating requirements typical of Armed Services applications.

Unique pile-up arrangement reduces width below the conventional relay, thereby reducing over-all space volume.

Coils are varnish-impregnated to resist high humidity conditions. All ferrous parts are treated to pass salt-spray tests.

Engineering Representatives in Principal Cities

WRITE FOR
BULLETIN
MTR-6

Wheelock RELAYS
SIGNAL
ENGINEERING & MFG. CO.
154 WEST 14TH ST. NEW YORK 11, N.Y.

SHOCKPROOF VACUUM TUBE RETAINERS

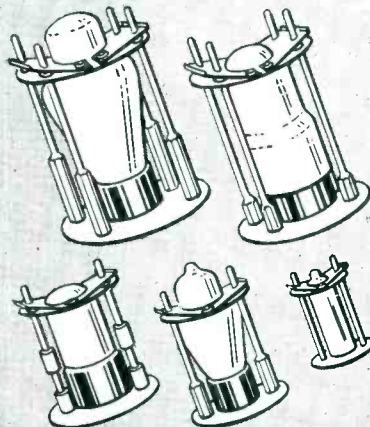
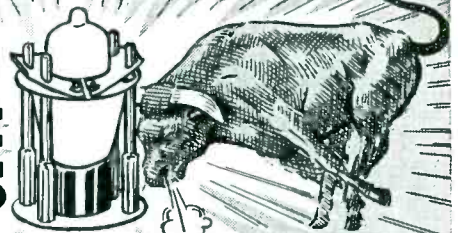

These retainers are used to secure Vacuum Tubes and to resist side motion of Vacuum Tubes used in radio equipment which is subject to shock and vibrations. These retainers meet the requirement of all JAN specifications. The insulated portion is made of a melamine base Fibre Glass Phenol which provides 300 volts insulation to ground and withstands a temperature of 350 F. The insulated plate can readily be fastened or released by hand.

Available for envelope types T7, T8, MT8, T9, T12, ST12, T122DL, ST14, S14, ST16, T5 $\frac{1}{2}$, T6 $\frac{1}{2}$, MT-IC, ST19, T14, ST128CT-9.

*Manufacturers of
Electronic Components*

JAMES IPPOLITO & CO., INC.
401 CONCORD AVENUE, BRONX 54, N. Y.

FLOW MEASUREMENT

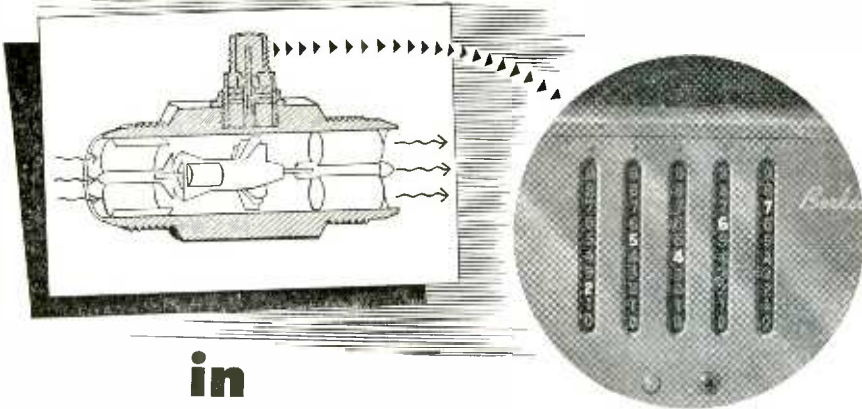

in High-Pressure Systems

- ★ DIRECT READING
- ★ REMOTE INDICATION
- ★ ACCURACIES TO 0.1%

RAPID, ACCURATE determination of rate of flow of volatile or explosive fluids in high-pressure systems is provided by the Berkeley EPUT (Events-Per-Unit-Time) Meter in conjunction with magnetic flowmeter mounted in the fluid line. Rotation of the flowmeter impeller produces electrical pulses at a

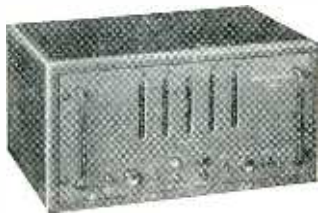

frequency directly proportional to rate of flow. These impulses are counted by the EPUT during a precise predetermined time interval and the results are displayed in direct-reading digital form on the illuminated front panel. The unit may be recycled either manually or automatically. Remote indication, maximum safety, accuracy of measurement and ease of operation are important features of this system.

MODIFICATIONS: Variable presettable time base can be provided for direct indication of rate of flow in the desired units of measurement. The entire equipment can be supplied in explosion-proof housings if required.

APPLICATIONS: Fuel consumption measurements in engine and gas-turbine test cells; precise flow measurement for accurate control in chemical, petro-chemical and general industrial research and manufacture.

SPECIFICATIONS

	MODEL 554	MODEL 556
RANGE	20-100,000 cps	20-100,000 cps.
ACCURACY	± 1 cycle	Line voltage stability (approx. 0.1%)
TIME BASE	1 second	1 second
SHORT TERM STABILITY	Standard crystal—1 part in 10 ⁵ Oven crystal—1 part in 10 ⁶	Line voltage stability
POWER REQUIREMENTS	105v.-130v., 60c., 175w.	105v.-130v., 60c., 125w.
INPUT (any wave form)	0.2-50 volts rms (pos.)	0.2-50 volts, rms (pos.)
DISPLAY	Direct reading digital—variable 1-5 seconds	
DIMENSIONS	20¾" x 10½" x 15"	16¾" x 10¼" x 12¾"
PANEL	Standard rack 19" x 8¾"	15¾" x 8¾"
PRICE	\$775	\$560

This is one of many broad applications wherein Berkeley instruments can provide direct reading digital presentation of information at extremely high orders of accuracy.

For complete data, please write for Bulletin F554

Berkeley Scientific Corporation

2202 WRIGHT AVENUE • RICHMOND, CALIFORNIA

-150 v d-c at 5 ma variable and stabilized. Both voltmeter and milliammeter may be switched to monitor any of the regulated or stabilized outputs.

Literature

Snap-Acting Thermostats. Stevens Mfg. Co., Inc., 69 S. Walnut St., Mansfield, Ohio. Bulletin L-4144 covers a line of snap-acting thermostats for operation on wide or narrow differentials. In addition to suggested applications the bulletin describes the operating principle and illustrates it with schematic diagrams. Ratings, typical performance curves, dimensions and construction data are included.

Potentiometers. DeJura-Amsco Corp., 45-01 Northern Blvd., Long Island City 1, N. Y., has issued bulletin 101-E covering its new line of series C-200 external phasing potentiometer. The series described has been engineered and designed to fulfill the exacting requirements of contemporary instrument, computer and similar electronic equipment. Complete specifications are furnished, and a wide variety of applications for single and multiple-ganged units is shown.

Transformers. Crest Laboratories, Inc., Whitehall Building, Far Rockaway, N. Y., announces the availability of an eight-page catalog describing their new hermetically sealed transformers. Complete technical specifications are given on the line of miniature, sub-miniature and microminiature transformers. Catalogs may be obtained upon letter head request.

Radioactivity Glossary. Radiation Counter Laboratories, Inc., 5122 W. Grove St., Skokie, Ill. Fifty-eight terms commonly used in radio activity measurements are listed and defined in a single-page glossary now available.

Resistor Data. The Daven Co., 191 Central Ave., Newark 4, N. J., has completed a 6-page brochure con-

cooling
breezes

FOR

electronic
hot spots!

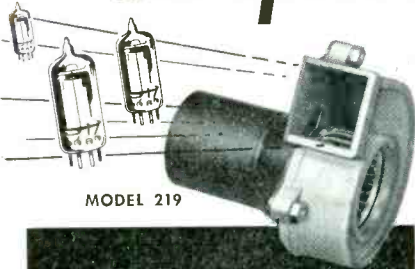

MODEL 219

American
Electric

Variable Frequency

MOTOR-
BLOWERS

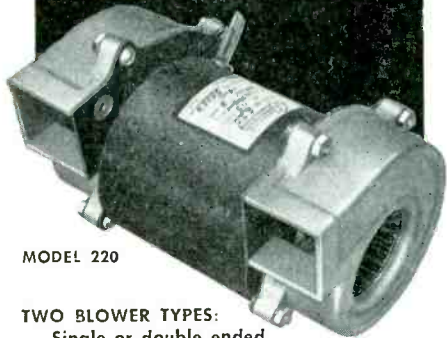

MODEL 220

TWO BLOWER TYPES:
Single or double ended.

Especially designed for spot cooling electronic equipment aboard aircraft. Unique design insures minimum watts loss over full frequency range of 320 to 1000 cycles.

In spite of wide frequency variations, the cfm output remains essentially constant at sea level. As pressure is reduced, the rpm increases, providing additional velocity of cooling air.

AIR DELIVERY: Blower heads available for any direction of air delivery.

Write for literature!



4811 Telegraph Rd.
Los Angeles 22,
California

THANK YOU

McGraw-Hill

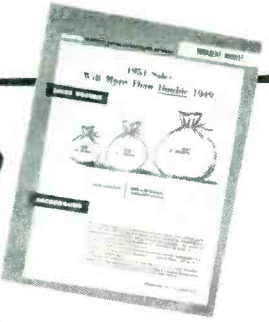

for recently calling the attention of industry to the substantial growth of UNILELECTRIC'S volume in your advertising in Business Week, Advertising Age, Advertising Agency, Printers' Ink and Sales Management, and by direct mail.

Your featuring of our company in your folder of "Examples of Successful Business Paper Advertising" is deeply appreciated. We will strive to maintain the precision standards and cost saving features of UNILELECTRIC WIRING SYSTEMS responsible for the progress that called forth your generous comments.

UNITED MANUFACTURING & SERVICE CO.

409 South 6th St., Milwaukee 4, Wis.

**Copies of the McGraw-Hill report are available on request. Send today for this additional evidence that UNILELECTRIC WIRING SYSTEMS will reduce your product wiring costs — and improve your products.*

Now! A Complete New Line of

STANDARDIZED COILS

for Radio, FM and TV Receivers

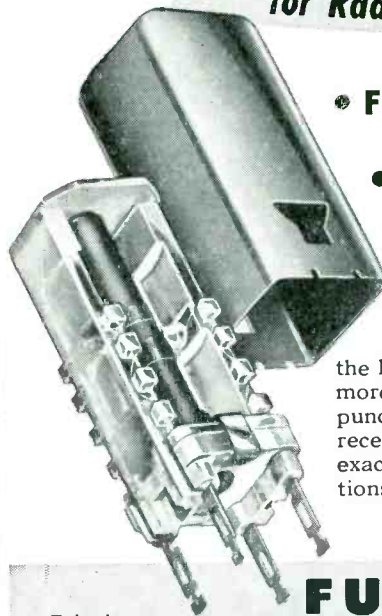

- FIT STANDARD CHASSIS PUNCHINGS AND AREAS
- HIGHEST QUALITY AT NO EXTRA COST
- PROMPT, DEPENDABLE DELIVERY DATES

These standardized coils are manufactured to the highest standards of the industry—yet cost no more. They fit the most commonly used chassis punchings—are made for all Radio, FM and TV receiver applications. Windings can be supplied to exactly meet your requirements. For prompt quotations and firm delivery dates, call, wire or write.

ADDRESS INQUIRIES TO DEPARTMENT E-7

Telephone:
Metuchen 6-2245

FUGLE-MILLER
LABORATORIES
MAIN STREET, METUCHEN, NEW JERSEY



DESIGNED for UHF

TARZIAN TUNER, Model TT-7

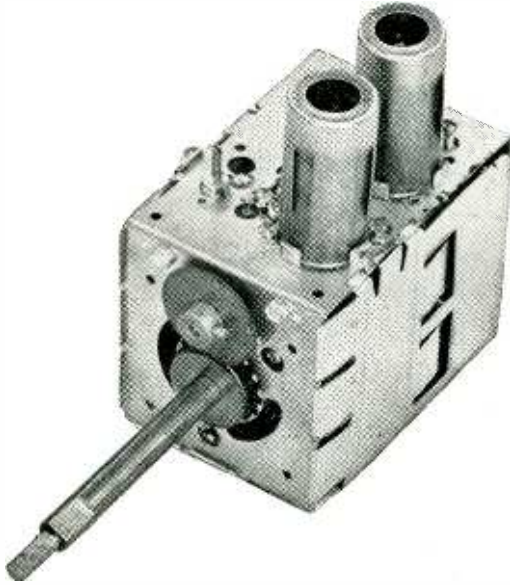

The Model TT-7 features 12 VHF channels plus 1 or 2 UHF inputs with appropriate UHF power switching built in. Available for 41 mc. IF systems. (Can be supplied for 21 mc. IF systems.)

SPECIFICATIONS:

RF AMPLIFIER:	6BQ7
OSC. MIXER:	6X8
POWER SUPPLY:	135 volts at 10 ma. 250 volts at 14 ma. 6.3 volts at 0.85 amps.
GAIN:	Into a 5 mc. 6 db Δ f IF grid— High channels 23 db min. Low channels 26 db min.
NOISE FACTOR:	As measured into a 3.0 to 3.5 mc. Δ f IF— 9.5 db max. for high channels 8.0 db max. for low channels
IMAGE REJECTION:	40 db min. high channels 46 db min. low channels
IF REJECTION:	50 db min.*
RF BALANCE:	20 db min.
VERNIER RANGE:	Plus or minus 1 mc. min. Plus or minus 2 mc. max.

* Except channels 2-3 and 4 of 41 mc. tuners.

* In the UHF position, the tuner is changed to an amplifier for the UHF I.F. Power is applied to the UHF tuner which may be either a FULL-RANGE CONTINUOUS TUNER or a single channel UHF tuner. In either case, a separate UHF antenna input is provided.

SARKES TARZIAN, Inc.

Tuner Division
Bloomington, Indiana

taining full descriptive material on precision wire-wound resistors, hermetically sealed resistors and miniature resistors. The resistors are individually charted, diagrammed and tabled to provide valuable information, such as wattage dissipation, tolerances, temperature coefficients and maximum resistance values with different types of wire, physical dimensions and types of mounting.

Identification Tape. Labelon Tape Co., Inc., 450 Atlantic Ave., Rochester 9, N. Y. A folder in four colors tells the story of the newly developed pressure-sensitive plastic tape that can be written upon. Many of its countless uses include the identification of circuits in panel boards and the labeling of component parts of electronic testing equipment. Labelon may be applied to any smooth surface, written on with pencil or stylus, and is resistant to dirt, oil, water or acids, and unaffected by temperatures from -40 to 160 F. Data on the many colors and widths are included.

Tube Data. Hytron Radio & Electronics Co., Salem, Mass. Five recent engineering bulletins give mechanical and electrical data on the 5Y3WGT fullwave rectifier, the 12BY7 video pentode amplifier, the 12BZ7 high-mu dual triode, the 12A4 medium-mu triode and the 12B4 low-mu triode.

Servo Stabilizer. Kalbfell Laboratories, Inc., P. O. Box 1578, San Diego 10, Calif., has available a descriptive pamphlet on the Twin-T servo stabilizer, a device that contains a phase-shifting network to compensate for the lag caused by motors or other inertial elements. The unit described overcomes hunting while maintaining fast response time.

Signal-Splitters. J. L. A. McLaughlin, La Jolla, Calif. A recent 6-page folder gives complete specifications on the series 10 signal splitters that eliminate adjacent channel and heterodyne interference. The units described can be used with standard type communications receivers and are



Development Engineers

*This is the age of
Automatic Control*

Play your part in the development of *Automatic Controls* with Honeywell, long established leader in the control industry.

Help solve today's problems in some of the fields listed below as they pertain to automatic control, and help pave the way to a better future.

- Electronics
- Servo Mechanisms
- Hydraulics
- Electro-Magnetics
- Gyros
- Computers
- Electro-mechanical devices
- Electrical contact phenomena

If you are interested, please write giving a resume of your qualifications to Mr. Ross Wagner, Minneapolis-Honeywell Regulator Co., Dept. EL-1, Minneapolis 8, Minn. Your correspondence held in strict confidence, of course.

If you are now utilizing your highest skill in a defense industry, please do not apply.

MINNEAPOLIS
Honeywell
First in Opportunity



XCELITE Hand Tools
PREFERRED BY THE EXPERTS



XCELITE SCREWDRIVER

WORK EASIER and FASTER

WITH XCELITE COMBINATION TOOLS!

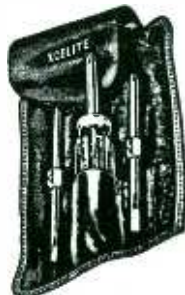

CK-3 SET

XCELITE tools give you instant selection of the correct size and save you money over cost of individual tools.

XCELITE CK-3 Set of 3 most used screwdriver sizes.

1. Nos. 1, 2 and 3 Phillips, reversible to 3/16", 1/4" and 5/16" regular.
2. New spring-type fastener master handle. Without blade, becomes 7/16" nutdriver.

XCELITE 99 Set

1. 9 Detachable chrome-plated nut driver blades from 3/16" to 1/2".
2. 2 Standard blade screwdriver sizes.
3. Nos. 1 and 2 Phillips Screwdriver blades plus big master handle. 13 tools in 1, all in durable plastic roll kit.

See your dealer today or write for complete XCELITE tool catalog!

XCELITE INCORPORATED
Formerly Park Metalware Co., Inc.
Dept. C Orchard Park, N. Y.

For Originality
LOOK TO **XCELITE**

sub-miniature
AND
moisture-proof

IN-RES-CO
S-15 & S-30
WIRE WOUND
RESISTORS

THE ECONOMICAL SOLUTION where moisture proof resistive elements of comparatively small size are required for commercial applications. Type S-15 is 3/8" long by 1/4" diameter; type S-30 measures 3/4" by 1/4" diameter. Both types are moisture proof and capable of high performance over long periods of continuous service. IN-RES-CO Resistors for every ordnance or civilian requirement are available at a cost that solves circuit design problems both performance-wise and cost-wise. Check up now, on the complete line of IN-RES-CO quality wire wound resistors.

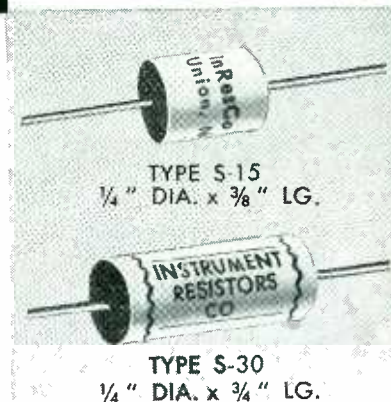

TYPE S-15
1/4" DIA. x 3/8" LG.

TYPE S-30
1/4" DIA. x 3/4" LG.

**INSTRUMENT
RESISTORS CO.**

COMMERCE
AVENUE



UNION
NEW JERSEY

APPLICATION-DESIGNED RESISTORS FOR ELECTRONICS AND INSTRUMENTATION

FOR JAN SPECIFICATION RESISTORS — consult the new illustrated literature describing the complete In-res-co line. Write for your copy today!



AUTOMATIC CYCLING

Simplified by EDISON Relay

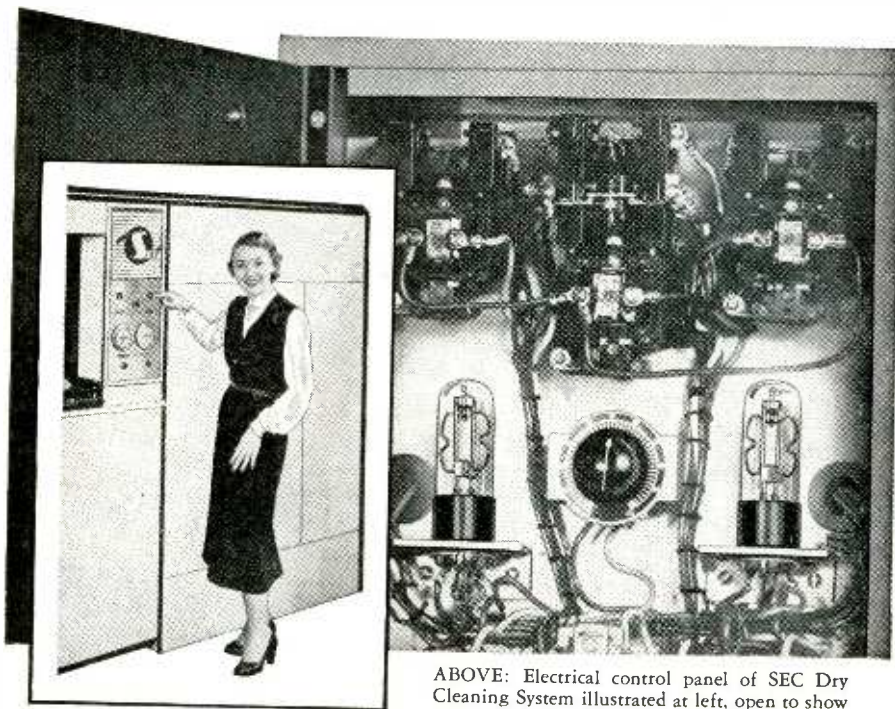

ABOVE: Electrical control panel of SEC Dry Cleaning System illustrated at left, open to show position of EDISON Thermal Relays.

THE SEC-O-MATIC CORP. chose the EDISON Model 501 Time Delay Relay to provide an automatic delay period in the washer and extractor cycles of their SEC automatic dry cleaning system.

THE EDISON TIME DELAY RELAY was selected because of its long dependable service record in many industrial applications, its low cost, and plug-in feature.

HOW IT WORKS—The heater of the EDISON delay relay is in the circuit between the washing timer and the washing motor starter relay. When the timer is set, the heater of the delay relay is energized and a valve is opened allowing the cleaning fluid to reach its level in

the washing tank. The delay relay then closes its contacts and the washing motor begins its agitating cycle.

AT THE END of the washing cycle, the washing timer closes the extractor circuit which energizes the heater of the second delay relay and reverses the valve to drain the washing tank. When the contacts close, the centrifugal dryer is set in motion.

AUTOMATIC DELAYS are only one of the many uses found for this EDISON relay. Send now for further details. Bulletin E8-3007 will be sent free.

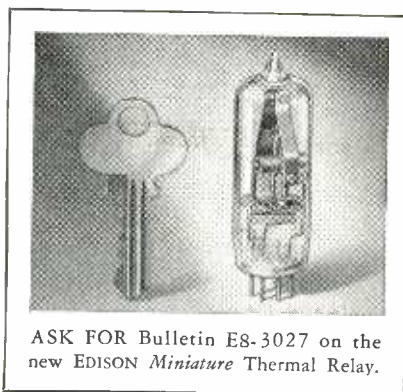

ASK FOR Bulletin E8-3027 on the new EDISON Miniature Thermal Relay.

Thomas A Edison
INCORPORATED

Instrument Division

51 Lakeside Avenue, West Orange, N. J.

MANUFACTURERS OF

Electrical Resistance Bulbs

Temperature Indicating and Alarm Systems

Sealed Thermostats

YOU CAN ALWAYS RELY ON EDISON

NEW PRODUCTS

(continued)

normally supplied with inputs for receivers having i-f amplifiers of 455 kc but can be modified to match other frequencies.

Packaged Pulse Control Units. Control Instrument Co., Inc., 67 Thirty-Fifth St., Brooklyn 32, N. Y., has released a new bulletin on the Burroughs line of unitized pulse generating and control apparatus for use in the fields of tv, radar, digital computers, telemetering and nuclear physics. It contains detailed information, specifications, characteristics and some typical applications.

High-Temperature Magnet Wire. Sprague Electric Co., North Adams, Mass. Engineering bulletin 404 deals with Ceroc ST single-Teflon, ceramic-insulated, high-temperature magnet wire. Standard sizes and performance characteristics are shown. Also included is a guide for application and operation.

Electrical Tapes. Industrial Tape Corp., New Brunswick, N. J., has published a four-page folder covering its line of Permacel electrical tapes. Technical data and prices for thirteen different types are given.

Quartz Crystals. Bliley Electric Co., Union Station Building, Erie, Pa. Bulletin No. 43 is a 16-page catalog dealing with a wide line of quartz crystal units. Descriptions, photographs and mechanical drawings for each are given. Included are a two-page specification index for military crystal units and concise ordering information.

Soldering Hints. Federated Metals Division, American Smelting and Refining Co., 120 Broadway, New York 5, N. Y., has published a new 16-page booklet on the fundamentals of soldering, entitled "How to Solder." It contains simple instructions and illustrations aimed at making soldering more successful and easier to do.

UHF TV. Allen B. DuMont Laboratories, Inc., 1,000 Main Ave., Clifton, N. J. Written in nontech-

**PRODUCE
PROFESSIONAL
COMMERCIALS
AT LOW COST WITH
the New Gray TELOP II**



• Now, with the new versatile Gray TELOP II you can produce and broadcast an amazing variety of professional-quality commercials at surprisingly low cost. Local sponsors will marvel at the way TELOP II presents their selling message with opaque cards, photographs, art work and transparencies. And you get the real effect of superimposition, lap-dissolve and fade-out. Only limitation is your imagination. Takes up very little space. One operator does it all!

Write for full information on the new exciting Gray TELOP II.

GRAY RESEARCH

and Development Co., Inc.,
598 Hilliard St.,
Manchester, Conn.



Walter E. Ottaviano President

Division of The GRAY MANUFACTURING COMPANY
—Originators of the Gray Telephone Pay
Station and the Gray Audiograph

ZOPHAR

WAXES

COMPOUNDS

Zophar Waxes, resins and compounds to impregnate, dip, seal, embed, or pot electronic and electrical equipment or components of all types; radio, television, etc.

Cold flows from 100°F. to 285°F.

Special waxes non-cracking at -76°F.

Compounds meeting Government specifications plain or fungus resistant.

Let us help you with your engineering problems.



ZOPHAR MILLS, INC.
112-130 26th Street,
Brooklyn 32, N. Y.

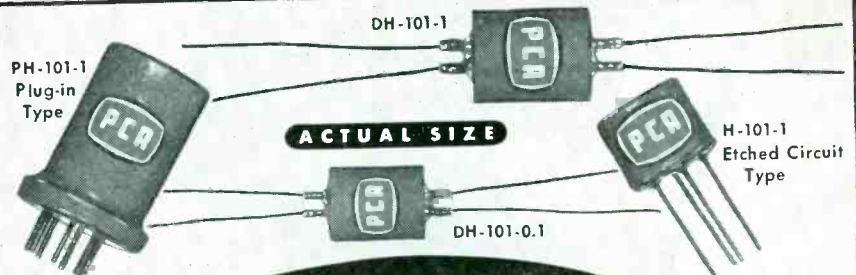

HERMETICALLY SEALED MINIATURE PULSE TRANSFORMERS

Designed for PLUG-IN or wiring into etched, printed or conventional circuits. Models available with two, three or four windings for producing pulses from .1 μ sec. to 10 μ sec. when connected in standard blocking oscillator circuit.

Write for bulletins describing over 30 of our hermetically sealed and standard plastic impregnated and embedded transformers.





INCORPORATED
6368 DeLongpre Avenue
Hollywood 28, California
Granite 2196

Research, development
and manufacture of
miniature electronic
components and
assemblies

Precision ATTENUATION to 3000 mc!

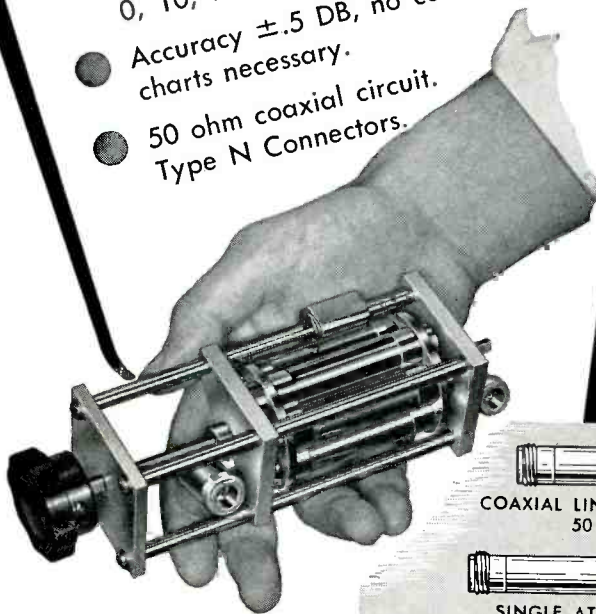
- VSWR less than 1.2 at all frequencies to 3000 mc.
- **TURRET ATTENUATOR** featuring "Pull - Turn - Push" action with 0, 10, 20, 30, 40, 50 DB steps.
- Accuracy $\pm .5$ DB, no correction charts necessary.
- 50 ohm coaxial circuit. Type N Connectors.



 COAXIAL LINE TERMINATION
 50 ohms

 SINGLE ATTENUATOR PAD
 50 ohms

VSWR ± 1.2 to 3000 mc.
 One watt c.w. power dissipation

Inquiries are invited concerning single pads and turrets having other characteristics

STODDART AIRCRAFT RADIO CO.
 6644-A SANTA MONICA BLVD., HOLLYWOOD 38, CALIFORNIA
 Hillside 9294

nical language, a recent booklet (while primarily directed at the broadcasters) will be of assistance in providing some background on uhf for everyone. In it are discussed how uhf is different, what a uhf station would cost and how it should be laid out.

Directional Coupler. Hewlett-Packard Co., 395 Page Mill Road, Palo Alto, Calif. Volume 3, No. 7-8 of the Journal presents a technical article dealing with a precision directional coupler that uses multihole coupling. Units described in this well-illustrated article are useful in many types of applications such as mixing and isolation.

Dynamic Pressure Indicator. Rutishauser Corp., 490 So. Fair Oaks Ave., Pasadena 1, Calif. A seven-page bulletin illustrates and describes the new model ST-12 electronic pickup indicator having very high frequency response. It includes construction and specifications.

Microwave Components. Technicraft Laboratories, Inc., Thomaston-Waterbury Road, Thomaston, Conn., have released their 1952 catalog for general distribution. Subject matter includes illustrations and detailed description of their flexible and rigid waveguide assemblies and other components. In addition, it describes the many laboratory facilities and services offered by the company.

Photoelectric Equipment. De-Tec-Tronic Laboratories, Inc., 1711 Terra Cotta Place, Chicago 14, Ill., has published a new catalog of photoelectric equipment for industry. It illustrates and describes a complete line of amplifier-relays and light source and phototube units with design standardized to eliminate the high cost of specially engineered apparatus.

Loudspeakers. The Plessey Co Ltd., Ilford, Essex, England. Publication No. 542 is a 16-page catalog describing in detail a new line of shrouded loudspeakers. The line described includes four of circular units, and one



REXOLITE 1422

(FORMERLY G. E. TEXTOLITE 1422)

COMBINES EVERY DESIRABLE
PHYSICAL, CHEMICAL, &
ELECTRICAL
PROPERTY IN ONE INSULATING
MATERIAL FOR U. H. F.



REXOLITE 1422

- Specifically designed to meet the growing need for a U. H. F. insulating material that's low in cost.
 - Meets JAN-P-77 and MIL-P-77A specifications.
 - Withstands high temperature due to its thermosetting nature.
 - Has outstanding electrical properties.
 - Has low specific gravity — is strong and rigid with unusually high compressive and tensile strengths.
 - Has excellent impact strength and hardness allowing its use under highly abusive conditions.
 - Its dimensional stability and unusual chemical inertness allow its use where other materials fail.
 - Readily machinable to extremely close tolerances.
 - Available as centerless ground rods in any diameter up to 1". Also cast in larger diameter rods and sheets.
- Write today for technical bulletins and samples. Our engineering staff is always at your disposal.

Manufacturers of Non-strip wire, High Temperature Electrical Tubing and other extruded plastic products.

THE REX CORPORATION
60 LANDSDOWNE STREET
CAMBRIDGE 39, MASS.



Estab.
1920

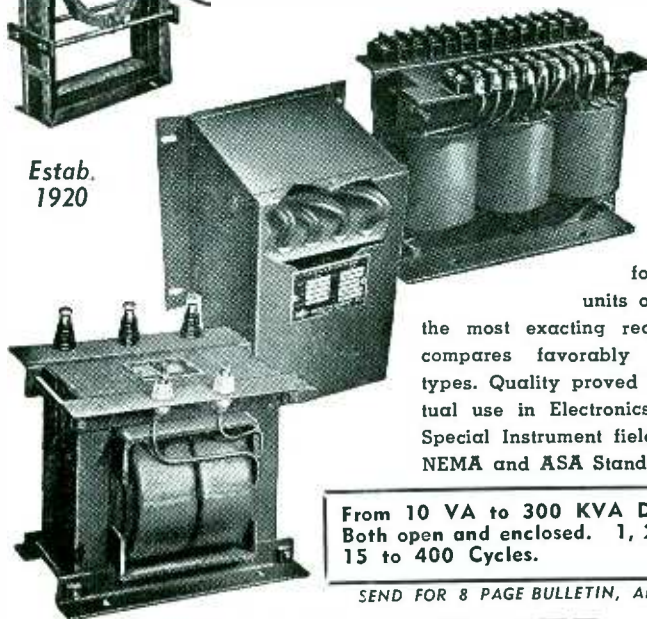

Special TRANSFORMERS

*Individually Built
To YOUR Specifications*

IN
SMALL
QUANTITIES

●
For 31 years we have been building transformers in single units or in quantity to the most exacting requirements. Cost compares favorably with standard types. Quality proved by years of actual use in Electronics, Research and Special Instrument fields. Built to meet NEMA and ASA Standards.

From 10 VA to 300 KVA Dry-Type only.
Both open and enclosed. 1, 2 and 3 Phase
15 to 400 Cycles.

SEND FOR 8 PAGE BULLETIN, AND PRICE LIST



NOTELFER

WINDING LABORATORIES

9 ALBEMARLE AVE., TRENTON 3, N. J.



New G-E Hermetically-Sealed Relay Protected from Breakdowns

Cuts Down on Relay Replacements

General Electric's new air-craft relay is more highly arc-resistant, has non-tracking stack insulation, because of a revolutionary technique for directly molding contact arms into a polyester compound.

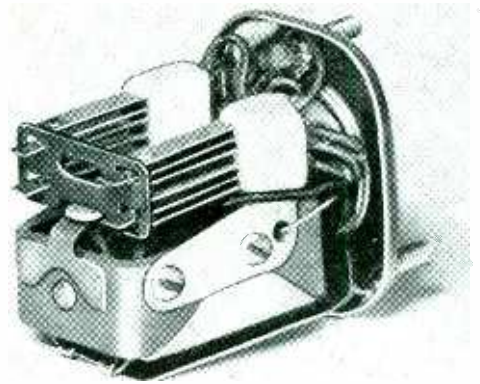

A more powerful magnet structure yields a higher tip pressure, adds to the surety of making contacts. And the relay is available for quick shipment. Write Section 730-38 for Bulletin GEA-5729.

General Electric Co., Schenectady 5, N. Y.

730-38



Rated at 28 volts d.c., the relay withstands surges up to 1500 volts.

GENERAL ELECTRIC

HIGH SPEED



ELECTRONIC

COUNTING

TIMING

CONTROL

INSTRUMENTS

FOR APPLICATIONS INVOLVING THESE BASIC MEASUREMENTS

CALCULATION $+ - \div \times$

For business, industrial and scientific applications requiring computation, data handling, memory and high speed printing, the Potter Instrument Company can supply complete systems. Some of the newly developed equipments include simplified electronic arithmetic units, multipurpose shift registers, storage devices, photoelectric readers, tape handlers and high speed line-at-a-time printer.

QUANTITY



Pills, buttons, bottle caps, hardware, etc., can be counted and batched in precise predetermined quantities at speeds up to 60,000 per minute. Important savings in labor and overages are assured by the speed and accuracy of the Potter Electronic Counter. Count Detectors for any product are available.

LENGTH



Wire or strip material can be automatically sheared or marked in precise predetermined lengths at high rates of speed, and if required, automatically stacked in predetermined quantities. Practically any definition of measurement can be obtained.

TIME



Time intervals can be easily measured or generated with extremely high accuracy through the use of Potter Counter Chronograph Interval Timers. Registration of measurement is retained until reset. Accuracy of one part in 8,000,000 can be provided.

SEQUENCE



Since the electronic counters can be arranged to predetermine any sequence of selected counts, they can be readily and advantageously substituted for cams, gears, patterns, chains and other systems of timing control. Control by absolute count assures high accuracy, faster operating speeds, since there are no moving parts to wear.

FREQUENCY

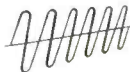

Potter Electronic Counters provide an exact ratio of division which is maintained even though the input frequency is varied. If the input frequency is stopped the output also stops. Frequencies can be measured or generated with high precision. Square waves of variable frequency, pulse-width and number can be easily generated.

REVOLUTION



Through electromagnetic or photoelectric pickup, shaft rotation can be accurately counted or timed without physical contact. Fractional parts of a revolution can be measured or used to control automatic machine processes as a function of predetermined counts.

PROBLEMS ?

Your specific counting, timing or control problem, explained on our data sheet, will result in a prompt and efficient solution by our engineers.

WRITE FOR DESCRIPTIVE CATALOG NO. 38

POTTER INSTRUMENT COMPANY

INCORPORATED
117 CUTTER MILL ROAD, GREAT NECK, NEW YORK

NEW PRODUCTS

(continued)

tical, each available in a choice of four flux densities, and each providing a choice of cones having performance characteristics adapted for various classes of receivers.

Capacitor Catalog. John E. Fast & Co., 3101 N. Pulaski Road, Chicago 41, Ill. Catalog No. 27 lists an entire line of power-factor-correction capacitors. Section 1 gives general information on their applications and locations, with general standards and specifications; section 2 details individual units; section 3 is devoted to rack-type assemblies; and section 4 lists pole types.

Semiconductors. Carboloy Department of General Electric Co., Detroit 32, Mich. Catalog TH-5 contains 30 pages of general basic information relating to physical and operating characteristics of thermistors, which are electronic semiconductor control elements whose electrical resistance responds negatively to minute temperature changes. Typical applications and wiring diagrams are listed. Graphical data of temperature-resistance ratio characteristics for rod, disk and washer-types are included. The last page gives suggested applications for thermistors in various industries.

Drawn-Oval Capacitors. General Electric Co., Schenectady 5, N. Y. Bulletin GEA-5777 covers the new line of dual-rated capacitors in drawn oval containers. The units described, designed to replace case styles CP53 and CP70, are lighter, smaller, mechanically stronger, 10 to 20 percent lower in cost, and constructed so as to save critical materials. Dimensional drawings and a table of prices and data are included.

Differential Transformers. Automatic Temperature Control Co., 5200 Pulaski Ave., Philadelphia 44, Pa. Bulletin R-31 explains the principles of differential transformers. It covers in detail the characteristics of linear transducers and their wide and varied use in industry. Profusely illus-

ACME MAKES BOTH!

... FILTERS WITH TOROIDS
... FILTERS WITH LAMINATIONS



Depending on what frequency is required, Acme can supply standard or miniaturized filters with either toroidal or laminated inductors.

Where required, these filters can be manufactured to hold very close phase shift tolerances and close output requirements over wide temperature ranges.



Write for complete catalog on this and other Acme standard and custom designed electronic products.



300 NORTH LAKE AVENUE, PASADENA 4, CALIF.



ETC

MULTI-GUN
C-R TUBES
and
MULTI-CHANNEL
OSCILLOSCOPES

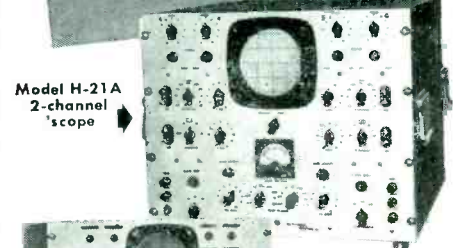

Model H-21A
2-channel
scope

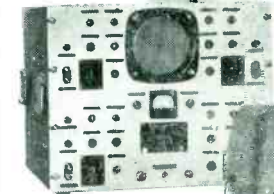

Model H-43
4-channel
scope

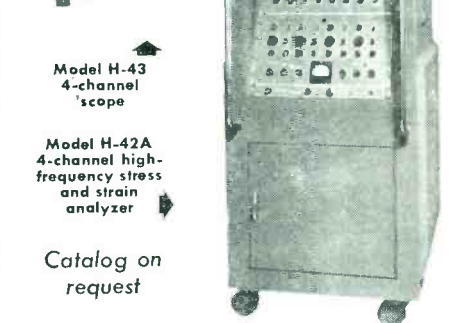

Model H-42A
4-channel high-
frequency stress
and strain
analyzer

Catalog on
request

Only with CO-AX

AIR SPACED ARTICULATED
R.F. CABLES

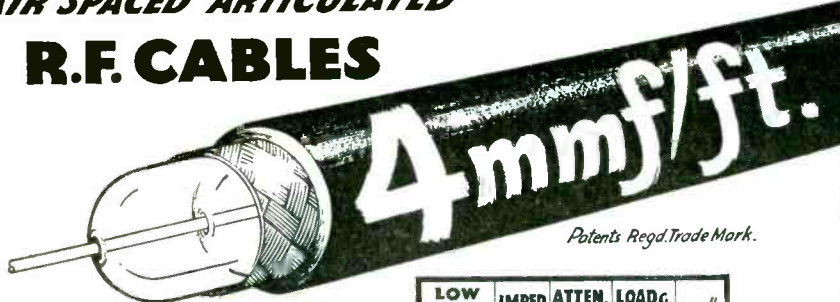

Patent's Regd. Trade Mark.

THE LOWEST EVER
CAPACITANCE OR
ATTENUATION

We are specially organized to handle direct enquiries from overseas and can give IMMEDIATE DELIVERIES FOR U.S.A. Billed in dollars Settlement by your check.

TRANSRADIO LTD

CONTRACTORS TO H.M. GOVERNMENT.
138A CROMWELL ROAD LONDON SW.7 ENGLAND
CABLES: TRANSRAD LONDON.

LOW ATTN. Types	IMPED. Ohms.	ATTEN. db/100ft. of 100 Mc.s	LOADG. Kw.	OD" of 100 Mc.s
A.1.	74	1.7	0.11	0.36
A 2	74	1.3	0.24	0.44
A34	73	0.6	1.5	0.88
LOW CAPAC. Types	CAPAC. mmf/ft.	IMPED. Ohms.	ATTEN. db/100ft. of 100 Mc.s	OD" of 100 Mc.s
C1	7.3	150	2.5	0.36
PC1	10.2	132	3.1	0.36
C11	6.3	171	3.2	0.36
C2	6.3	171	2.15	0.44
C22	5.5	184	2.8	0.44
C3	5.4	197	1.9	0.64
C33	4.8	220	2.4	0.64
C44	4.1	252	2.1	1.03

HIGH POWER FLEXIBLE

PHOTOCELL CABLE

VERY LOW CAPACITANCE

electronic tube

CORPORATION
1200 E. MERMAID LANE
PHILADELPHIA 18, PA.

1st with machines
for winding heavy
wire on small
cores

1st with machines
licensed under
Western Electric
Patents

1st in the application
of toroids to sonar
requirements



LEADS IN

**ENGINEERING, DESIGN AND PRODUCTION
OF PRECISION WOUND**

MAGNETIC COMPONENTS

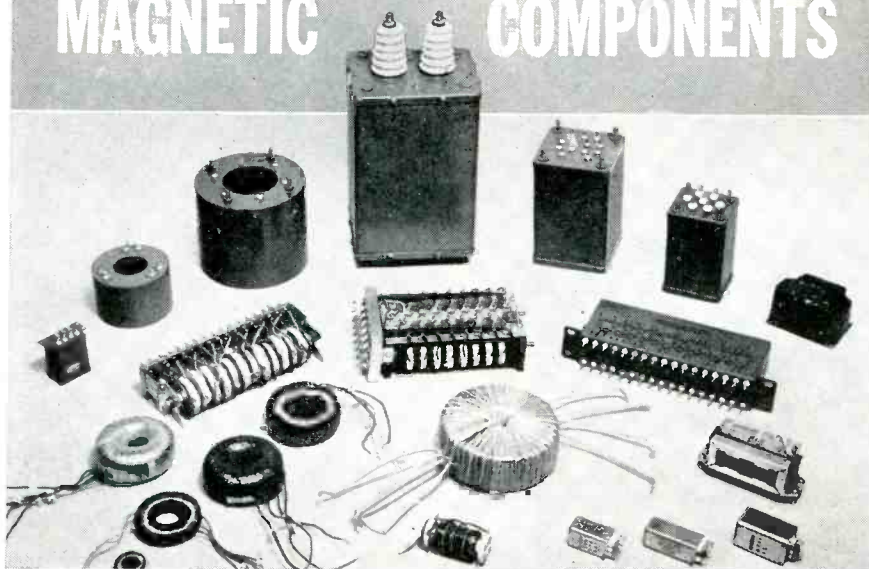

Raytheon offers you all of the newest Toroid winding facilities plus a rich background of experience in the design and production of Toroid coils for military and commercial applications. As a pioneer in the field of precision-wound Toroidal inductors and transformers, Raytheon has led the way in the development of advanced techniques for combating moisture and maintaining high values of Q . . .

in meeting today's needs for special audio and ultra high frequency transformers . . . and in the development of special high-precision deflection coils for military applications.

In every way Raytheon is completely equipped to serve you as your reliable source of supply for all types of highest quality precision wound Magnetic Components. Write for complete information.

RAYTHEON

MANUFACTURING COMPANY
EQUIPMENT SALES DIVISION

DEPT. 6470-A WALTHAM 54, MASSACHUSETTS

DISTRICT OFFICES: BOSTON, NEW YORK, CLEVELAND, CHICAGO, NEW ORLEANS, LOS ANGELES (WILMINGTON), SAN FRANCISCO, SEATTLE
INTERNATIONAL DIVISION: 19 RECTOR ST., NEW YORK CITY

RAYTHEON PRODUCTS INCLUDE: WELDPower* welders; Voltage stabilizers (regulators); Transformers; Sonic oscillators for laboratory research; Standard control knobs; Electronic calculators and computers; Radio, television, submarine and special purpose tubes and other electronic equipment.

*Reg. U. S. Pat. Off.

BUILD



Excellence in Electronics

**DEPENDABILITY
INTO YOUR
PRODUCTS**

trated, it includes all the various types of indicators, recorders, pressure transmitters, control relays, servomechanisms, load cells, demodulators, amplifiers, micrometer positioners and many other industrial instruments.

Moisture & Fungus-Resistant Varnish. Brooklyn Paint & Varnish Co., Inc., 50 Jay St., Brooklyn 1, N. Y. A 4-page brochure deals with the TUF-ON 747-S moisture and fungus-resistant varnish that conforms to government specification MIL-V-173A. The varnish described is designed for the treatment of communications, electronic and associated electrical equipment. Included are a table of test requirements, methods of application, safety precautions and drying information.

Airborne Mounting Bases. T. R. Finn & Co., Inc., 333 Jackson Ave., New York 54, N. Y. Catalog MB-110 is a four-page illustrated brochure on airborne electronic mounting bases; vibration isolators for these mounting bases to JAN-C-172A specifications; type M shock mounts to Signal Corps specifications; and fire control shock mounts for Naval vessels. Included are diagrams showing specifications, technical characteristics and explanatory notes.

Interference Filters. Photovolt Corp., 95 Madison Ave., New York 16, N. Y. Bulletin No. 180 deals with G.A.B. interference filters for the isolation of narrow spectral bands in colorimetry, fluorimetry, microscopy, photomicrography, flame photometry and color densitometry. The units described are also used in reflectometry, light-scattering measurements, microcolorimetry, refractometry, polarimetry, and in all other fields requiring monochromatic light in the visible and near-infrared range.

Low-Voltage Vehicular Capacitors. Sprague Electric Co., 35 Marshall St., North Adams, Mass. Bulletin No. 217 gives full details on type 131J line of hermetically-sealed corrosion-resistant capacitors for

**2 KW
VACUUM TUBE
BOMBARDER
OR
INDUCTION
HEATING UNIT**



For Only \$650.

Never before a value like this new 2-KW bench model "Bombarder" or high frequency induction heater . . . for saving time and money in surface hardening, brazing, soldering, annealing and many other heat treating operations.

Simple . . . Easy to Operate . . . Economical Standardization of Unit Makes This New Low Price Possible.

This compact induction heater saves space, yet performs with high efficiency. Operates from 220-volt line. Complete with foot switch and one heating coil made to customer's requirements. Send samples of work wanted. We will advise time cycle required for your particular job. Cost, complete, only \$650. Immediate delivery from stock.

Scientific Electric Electronic Heaters are made in the following ranges of Power: 1-2-3½-5-7½-10-12½-15-18-25-40-60-80-100-250KW.

*Scientific
Electric*

Division of

"S" CORRUGATED QUENCHED GAP CO.

107 Monroe St., Garfield, N. J.

U. G. CONNECTORS

*Our Coaxial Cable
Connectors Meet All
Government Specifications*

★ ALL ORDERS DELIVERED PROMPTLY ★

*Manufacturers of
Highest Quality Connectors*

ALLIED INDUSTRIES, INC.

1023 S. 21st STREET
LOUISVILLE 10, KY.

Phone Arlington 4640

FOR THOSE *TIGHT* SPECIFICATIONS



Miniature
**POWER
RESISTORS**



25-Watt
Type RH-25



50-Watt
Type RH-50

EVERY DESIRABLE
CHARACTERISTIC

- Smallest in size.
- Sealed in Silicone.
- 100% impervious to moisture and salt spray.
- Complete welded construction from terminal to terminal.
- Temperature coefficient 0.00002% per degree C.
- Ranges from .05 Ohms to 55,000 Ohms, depending on type.
- Tolerance .1%, .5%, 1%, 3%, and 5%.
- RH Types—Silicone sealed in a die-cast, black anodized radiator finned housing and mounts on sub-panel for maximum heat dissipation.
- Prompt Delivery.
- Let us quote on your immediate needs.

Phone, wire or write George Risk
Telephone 2139—2500 13th Street
For Price & Delivery
(We also manufacture deposited carbon resistors)

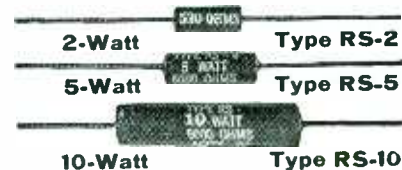

"DALOHM"
MINIATURE PRECISION
RESISTORS

MANUFACTURED IN
ACCORDANCE TO
JAN-R-26A Specifications
Characteristic G'

DALE PRODUCTS, INC. Columbus, Nebraska

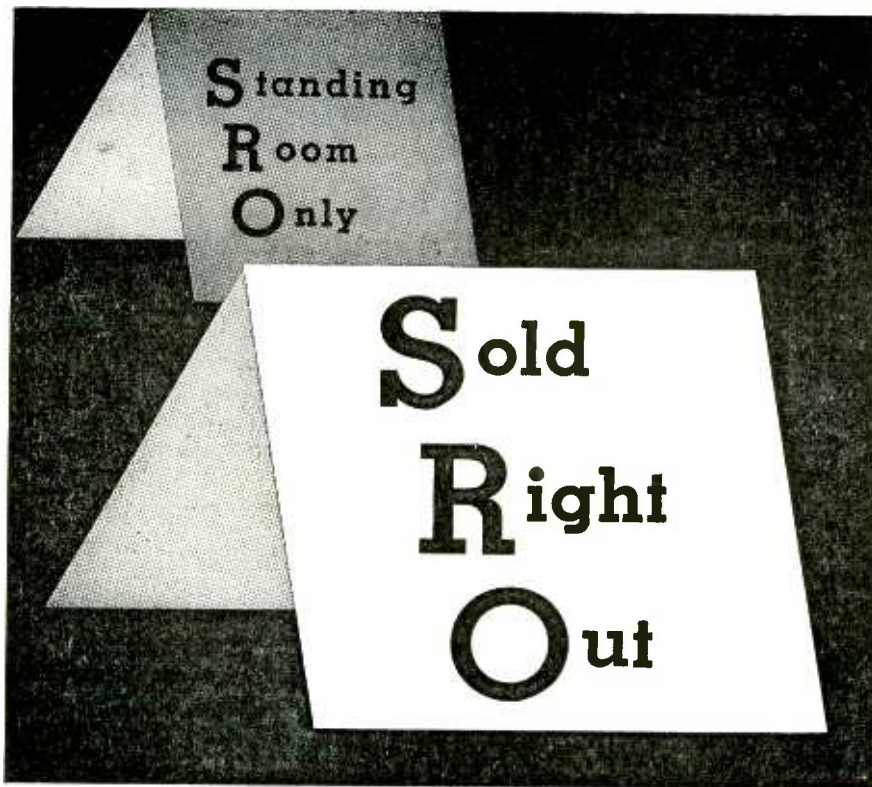

We're sorry, but we think it's only fair to tell possible new customers our Standing Room Only sign must be changed to Sold Right Out!

The design and production facilities of our microwave department are now taken over by the increasing requirements of our present customers. Because of our responsibility to them, this situation may continue quite a while.

We are sorry to say this because we enjoy making new friends. But we feel that we should tell those who might be interested in our engineering and manufacturing facilities, that for some time we may not be able to serve them.

Any change in the situation will be announced in this publication.



radio-interference suppression on the low-voltage electrical systems of military vehicles and portable gasoline-driven power plants. The metal-encased capacitors described, designed to meet U.S. Army Specification 71-1667 and Ordnance Drawing DQBX1, withstand severe shock and vibration as well as atmospheric moisture and salt spray.

Damage Control. The Brinnell Co., Simsbury, Conn. Bulletin 252 fully describes the Protectron, an electronic device for preventive maintenance and increased production efficiency. The catalog points out that Protectron-equipped plants have been able to step up production of present equipment by 12.5 to 22 percent, have reduced tool and die breakage up to 86 percent, and have been able to effect a manpower gain up to 300 percent, since one man can safely handle four Protectron-equipped automatic machines.

Picture-Tube Data. Allen B. Dumont Laboratories Inc., 1,000 Main Ave., Clifton, N. J., has announced distribution of the latest edition of the "Picture Tube Data Chart." The chart, printed on heavy stock and suitable for wall mounting, lists the electrical and physical characteristics for any modern RTMA-registered tv picture tubes.

Pressure-Sensitive Tapes. Insulation Manufacturers Corp., 565 W. Washington Blvd., Chicago 6, Ill. Detailed information on characteristics, uses and technical data for Permacel pressure-sensitive electrical tapes is provided in a new 16-page catalog. Descriptions of nonelectrical Permacel and Texcel tapes are included. Cotton cloth, crepe paper, flatback paper, acetate cloth, acetate film, acetate cloth-film combination and vinyl film electrical tapes are covered. A special section is devoted to nonelectrical paper, cloth, glass-reinforced paper, cellophane, and acetate fiber tapes.

Subminiature Terminals. Garde Mfg. Co., 588 Eddy St., Providence 3, R. I. A single-page bulletin



The Victoreen 5886 Quality subminiature electrometer pentode has unusually low filament current and high emission stability. It's structure is designed to reduce microphonics, an improvement of prime importance in portable equipment. The tube has a high ratio of transconductance to control grid current, a feature which makes it especially useful in single stage circuits in portable equipment.

DATA	Pentode Connected	Triode Connected
TYPICAL SERVICE	Electrometer	Electrometer
PLATE VOLTAGE (volts)	+12	+10.5
ACCELERATOR GRID VOLTAGE (volts)	+4.5	—
CONTROL GRID VOLTAGE (volts)	2.0	3.0
PLATE CURRENT (μ a)	6	200
CONTROL GRID CURRENT (μ a)	3×10^{-16}	2×10^{-13}
μ	1	—
G_m (μ mhos)	14	160
FILAMENT	1.25 volts at 10 ma	

Write our Technical Service Department for further details.



TUJEDD 9-2020

RESEARCH DESIGN DEVELOPMENT PRODUCTION

Televiso Corporation

GENERAL OFFICES AND PLANT
7466 WEST IRVING PARK ROAD - CHICAGO 34, ILL.

To: Chief Engineer
Subject: Radio Interference

Gentlemen:

The problem of Radio Interference reduction is coming into greater prominence, with greater emphasis being given in Military specifications, and more stringent rules being enacted by the Federal Communications Commission. In the past, many manufacturers neglected to consider interference in the design of new equipment, and as a result, few companies have adequate measuring equipment or personnel trained to use it.

Televiso has been a pioneer in the Interference Reduction field, and for some time has been performing research and acting as consultant to the United States Navy. We are one of only four companies in the United States - and the only one in the middle-West - authorized to make acceptance tests, and issue certificates of compliance with Military specifications that are recognized by the Navy.

Our facilities include Government approved measuring instruments covering the range from 11 kc to 1000 mc and a screen room 12' by 11' by 7 1/2'. The instruments are portable, and we can make measurements outside our plant when necessary. Our engineering staff has been trained by the Bureau of Ships, U. S. Navy, at Annapolis, and has had extensive experience in the measurement and reduction of Radio Interference.

Whether you are a manufacturer, operator, or repairman of electronic or electro-mechanical equipment, Televiso can solve your Radio Interference problems.

For complete details, please contact the writer.

Very truly yours,
TELEVISIO CORPORATION

Fredrick A. Hamilton
Fredrick A. Hamilton
Radio Interference Division

FAH:LG

special-type...

special terminal arrangement

proportional

double head

remote push button control

AN AGASTAT TIME DELAY RELAY for every requirement

DIVISION OF ELASTIC STOP NUT CORPORATION OF AMERICA
1027 NEWARK AVE., ELIZABETH 3 NEW JERSEY

AGASTAT TIME DELAY RELAY

AGASTAT

STIMSONITE REFLECTORS

AGASTAT

AIRPORT LIGHTING

AGASTAT

MARINE LIGHTING EQUIPMENT

TIE-TALKS FEATURE

Technology Instrument Corporation potentiometers are designed for application in computing devices, instrumentation, electronic control and servo mechanisms — wherever extreme electrical and mechanical precision is an essential requirement.

As a result of years of custom manufacturing a complete line of standard sizes is available ranging from 7 inches in diameter to the sub-miniature $\frac{7}{8}$ " in diameter.

Custom design both mechanical and electrical is a featured TIC service. Precision non-linear pots may be designed to meet customer's requirements from either empirical data or implicit functions. Taps and special winding angles anywhere up to 360° continuous winding can be incorporated into both linear and non-linear precision potentiometers. Greatly expanded facilities plus mass production techniques meet customer volume needs yet maintain precision tolerances in both linear and non-linear potentiometers.

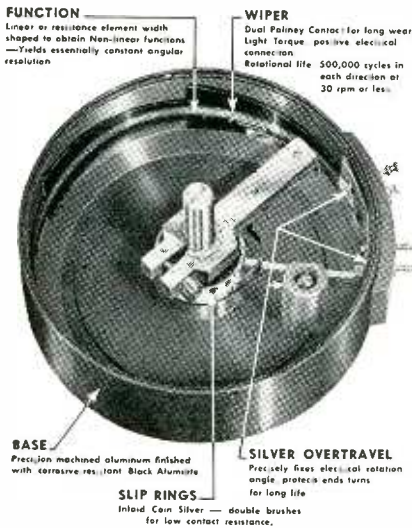

Type RVP3 tapped hole and precision pilot mounting

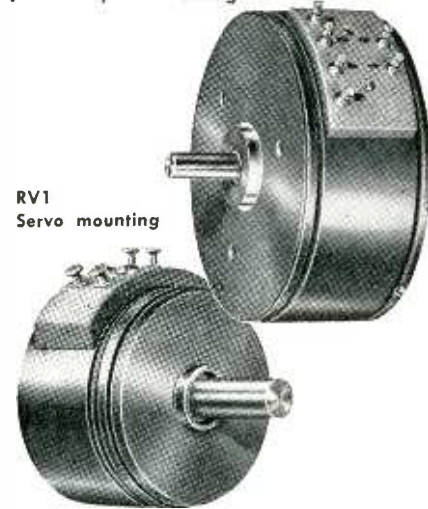

RV1 Servo mounting

TYPE	DIAM.	RESISTANCE	ELECTRICAL ANGLE	LINEARITY	POWER RATING	MOUNTING	EXAMPLE OF NON-LINEAR FUNCTION AVAILABLE AS STANDARD
RVP-7	7"	1,500,000 Ω tol. to ± 1%	330° tol. to ± 5°	As low as ± 0.5%	6 watts at 25° C.	Servo	Type RVP7-52 function: $E_{out} = \sin \Theta \pm 0.1\%$ peak amplitude
RVP-3	3"	Std. values to 200,000 Ω tol. to ± 1%	320° tol. to ± 5°	As low as ± .1%	4 watts at 25° C.	Servo—tapped hole and precision pilot or threaded bushing	Type RVP3-54 function: 50 db logarithmic; conformity: ± 2% constant fractional accuracy
RV-3	3"	Std. values to 200,000 Ω tol. to ± 1%	315° tol. to ± 1°	As low as ± .35%	8 or 12 watts	3 tapped hole	Available for non-linear functions Note: Phenolic base precision potentiometer, stainless steel or bakelite shaft
RV2	2"	Std. values to 100,000 Ω tol. to ± 1%	320° tol. to ± 5°	As low as ± 2%	4 watts at 25° C.	Servo—tapped hole and precision pilot or threaded bushing	Type RV2-5112 function: $R = KC\Theta$ conformity: ± .5% over 44° to 320°
RV1- $\frac{3}{4}$ "	$\frac{3}{4}$ "	Std. values to 100,000 Ω tol. to ± 1%	320° tol. to ± 1°	As low as ± .25%	3 watts at 25° C.	Servo—tapped hole and precision pilot or threaded bushing	Type RV1-5104 function: $E_{out} = \sin \Theta \pm 4\%$ peak amplitude per quadrant
RV1	1- 1/16"	Std. values to 50,000 Ω tol. to ± 1%	320° tol. to ± 2°	As low as ± .3%	2 watts at 25° C.	Servo or threaded bushing	Type RV1-57 function: $E_{out} = \sin \Theta / 1.78 \pm 4\%$ of peak amplitude
LINEAR TYPES ONLY:							
RV- $\frac{3}{4}$ "	$\frac{3}{4}$ "	Std. values to 40,000 Ω tol. to ± 1%	320° tol. to ± 3°	As low as ± .5%	1 watt	Servo or threaded bushing	
RVT	Translatory 10,000 Ω 3% ± 1% ± 15%		Stroke* 2 1/2"	± 1% total resistance	1 watt	Provides output proportional to a linear displacement rather than a rotary motion of a shaft	

* Special resistance values and stroke lengths from .5 inches to 18 inches can be provided on a custom basis.

Engineering Representatives

Cleveland, Ohio — PProspect 1-6171
Chicago, Ill. — UPTown 8-1141
Rochester, N. Y. — Monroe 3143
Canaan, Conn. — Canaan 649
Dayton, Ohio — Michigan 8721

Arnprior, Ont., Can. — Arnprior 400
New York, N. Y. — Murray Hill 8-5858
Cambridge, Mass. — Eliot 4-1751
Hollywood, Cal. — HOLLYWOOD 9-6305
Dallas, Texas — Dixon 9918

TECHNOLOGY INSTRUMENT CORP.

533 Main Street, Acton, Massachusetts, Telephone: Acton 600

NEW PRODUCTS

(continued)

illustrates and describes the sub-miniature insulated standoff terminals featuring a voltage breakdown of 3,500 v a-c, rms, 60-cycle test. The molded Melamine insulation included in the units described is in accordance with latest revisions of MIL-P-14 specification.

Test Equipment. Communication Measurements Laboratory, Inc., 120 Greenwich St., New York 6, N. Y. A recent 12-page catalog contains illustrated descriptions and specifications for the following instruments: models 1430, 1435 and 1420 variable frequency electronic generators; models 1115-A, 1100, 1110, 1130 and 1135 regulated power supplies; model 1010 automatic inspector Rotobridge; models 1060 and 1061 Rotobridge cable test stands; model 1210B stroboscope; and model 1500 megohmmeter. Prices for each are included.

Control Selection. General Electric Co., Schenectady 5, N. Y., offers an eight-page selection guide for a wide range of electric and electronic controls, devices and accessories. Bulletin GEA-5781 contains quick-reference selection data, photographs and listings of additional publications that give complete information on each of the equipments. Products included are: manual, magnetic, combination and reversing motor starters; pushbutton stations; relays; limit switches; solenoids; photoelectric relay; electronic relay; electronic timer; pressure and vacuum switch; float switch; pressure governor; reduced-voltage starter; Thy-mo-trol drive; and smoke density indicator and control.

Mobile Antennas. Ward Products Corp., Division of The Gabriel Co., 1523 E. 45th St., Cleveland 3, Ohio. A new catalog sheet gives complete specifications on model SPPC-88. The sheet describes a special mobile antenna used to eliminate the frequent breakage that occurs when antennas for the 30 to 50-mc bands are mounted on a high vehicle such as a bus or truck.

CLIMATE-PROOF PACKAGING



Here's a quick solution to

MILITARY PACKAGING

**CARGO PACKERS
CLIMATE-PROOF
PACKAGING**

Meets all Specifications for Signal Corps, Navy and Air Force Shipments of Electronic Equipment with Facilities that include—

- SPECIAL PACKAGING EQUIPMENT
- EXPERTS IN MILITARY SPECIFICATIONS
- ECONOMICAL ASSEMBLY LINE METHODS
- FULL COMPLIANCE IN EVERY DETAIL
- COMPETENT CONSULTING SERVICE

NEW ILLUSTRATED BROCHURE explains in detail how Cargo Packers can economically handle all details of your military packaging problems. You save valuable plant space, costly equipment and the need for experienced specification packaging experts. Find out now, how Cargo Packers production line methods save you time, money, endless detail work, and costly errors. Request your copy, now!

CARGO PACKERS
INCORPORATED
73 RUTLEDGE STREET
BROOKLYN 11, NEW YORK

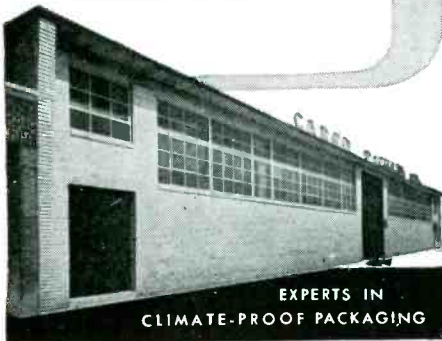

EXPERTS IN
CLIMATE-PROOF PACKAGING

drawn cases

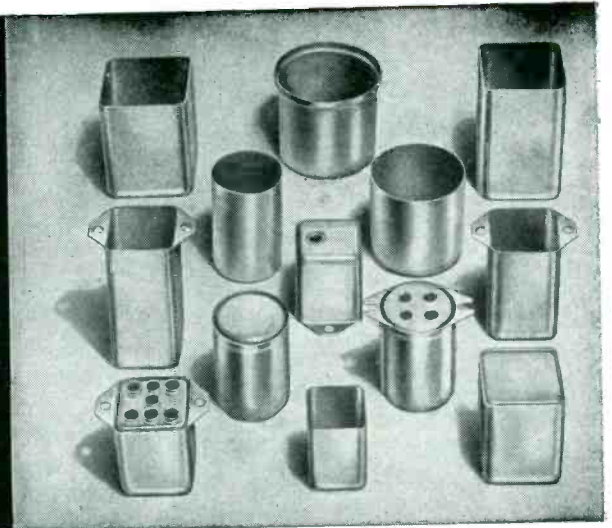

also
OLYMPIC
Fabricated cases
End shields
Channel frames
Mounting brackets

hot tin dipped . . . fabricated terminal and vent holes . . . smooth, one-piece construction using cold rolled steel . . . draw depths up to 2½" . . . inside fit covers for easy hermetic sealing in all sizes . . . available as stock sizes and as special fabrications.

OLYMPIC METAL PRODUCTS COMPANY, INC.
P. O. BOX 71A
PHILLIPSBURG, N. J.

IMMEDIATE DELIVERY

Federated offers industry's most useful testing instrument!

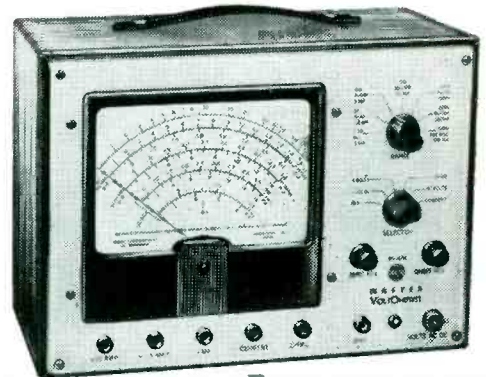

THE NEW RCA MASTER VOLTOHMYST

For direct measurement of:

- peak-to-peak values of unsymmetrical complex waves from 0.2 volt to 2,000 volts
- peak-to-peak values of symmetrical complex waves from 0.2 volt to 4,200 volts
- rms values of sine waves from 0.1 volt to 1,500 volts
- dc voltages from 0.02 to 1,500 volts
- resistance over the range of 0.2 ohm to 1,000 megohms
- small currents from 10 microamperes to 500 milliamperes, dc
- large currents from 500 ma up to 15 amperes, dc

For servicing, production, research: Accurate 8½" meter.
Complete specifications on request.

Federated Purchaser
INCORPORATED

THE ONLY COAST TO COAST ELECTRONICS DISTRIBUTOR

New York City
66 Dey St.
Digby 9-3050

Newark, N. J.
114 Hudson St.
Market 3-9035

Allentown, Pa.
1115 Hamilton St.
Phone 3-7441

Easton, Pa.
925 Northampton St.
Phone 4259

PLANTS AND PEOPLE

Edited by WILLIAM P. O'BRIEN

Engineers Form New Company

AN electronics development and manufacturing organization in Baltimore, to be known as Phebcoc, Inc., was recently set up by J. M. Pearce, P. A. Hoffman and T. T. Eaton, previously with the Glenn L. Martin Co. as chief electronics engineer, assistant chief electronics engineer and section head of the missile guidance group respectively. They are specializing in electronic instrumentation, special test equipment and telemetry for the missile and radar fields.

Kupfrian Doubles Plant Space

THE KUPFRIAN MFG. CO., producers of flexible shafting, universal joints, wire shielding and remote controls,

announce the recent purchase of a five-story brick building at 395 State St., Binghamton, N. Y., containing over 12,000 sq ft of floor space.

With the new space Kupfrian more than doubles the area in which operations were started in 1950. During this first two years, the number of employees has increased from the initial ten to forty-five. Much of the current production is for military requirements.

Antenna Test Range

ON THE SITE of their new Natick, Mass., laboratory, Workshop Associates, Division of The Gabriel Co., has completed a new antenna pattern-measuring range. The range will be used for measuring antenna radiation patterns over a distance

OTHER DEPARTMENTS

featured in this issue:

	Page
Electrons At Work.....	152
Production Techniques..	228
New Products	258
New Books	312
Backtalk	328



Transmitting tower for Workshop's new antenna pattern-measuring range

GETTING READY FOR EXPANDED TV

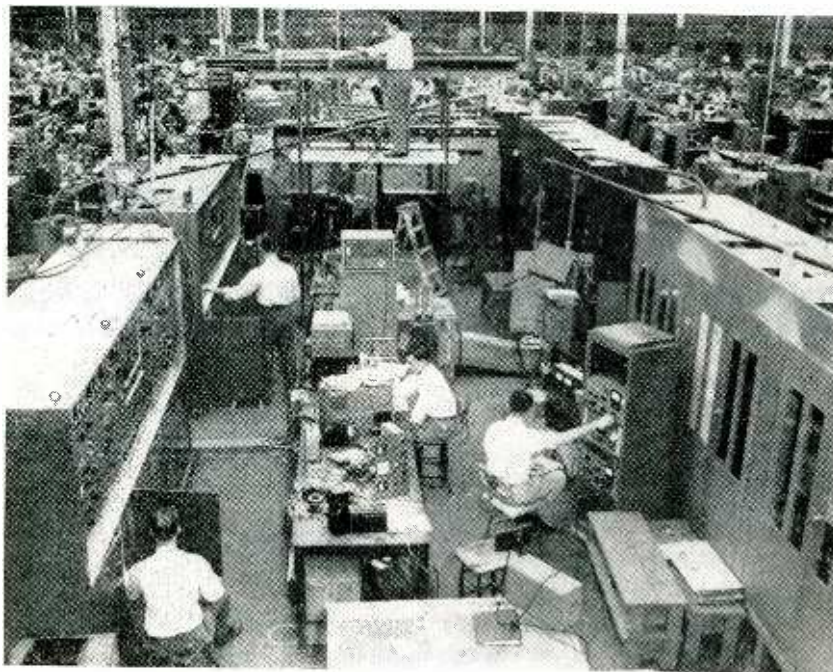

Television transmitters and amplifiers undergoing final testing at GE's Electronics Park plant, Syracuse, N. Y. Pictured are five-kw units for vhf channels 2 through 13 and 35-kw amplifiers for increasing the range and improving the picture quality of present and future tv stations. General Electric anticipated the end of the freeze on new tv construction to make possible the delivery of transmitting equipment this year. The company also has in production low-power transmitters for the new ultra-high frequencies, some of which will be delivered this year

of about 1,200 feet. It consists of a transmitting tower (illustrated) and a receiver 1,200 feet away where the actual measuring is done.

The transmitter is 35 ft above the ground, on the top of a knoll, and the terrain is clear and sloping to the receiver. The enclosure has a 20 ft x 12 ft floor area and provision for transmitting four frequencies simultaneously.

The new range is now in operation and supplements the 3,200-ft range Workshop has been using for several years at its Needham, Mass., plant.

Poole Expands UHF TV

C. F. ROTHROCK, JR., field engineer with Link Radio Corp., has joined the John H. Poole Broadcasting Co., Hollywood, Calif., as uhf television development supervisor to direct equipment improvement in the company's experimental station on channel 22, KM2XAZ.

Rothrock's most recent assignments for Link have included a uhf



electronic wire and cables for standard and special applications

Whether your particular requirements are for standard or special application, choose *LENZ* for the *finest* in precision-manufactured electronic wire and cable.

GOVERNMENT PURPOSE RADIO AND INSTRUMENT HOOK-UP WIRE,

plastic or braided type, conforming to Government Specification JAN-C-78, etc., for radio and instruments. Solid or flexible conductors, in a variety of sizes and colors.



RADIO AND INSTRUMENT HOOK-UP WIRE,

Underwriters Approved, for 80° C., 90° C. and 105° C. temperature requirements. Plastic insulated, with or without braids.



RF CIRCUIT HOOK-UP AND LEAD WIRE

for VHF and UHF, AM, FM and TV high frequency circuits. LENZ Low-Loss RF wire, solid or stranded tinned copper conductors, braided, with color-coded insulation, waxed impregnation.



SHIELDED MULTIPLE CONDUCTOR CABLES

Conductors: Multiple—2 to 7 or more of flexible tinned copper. Insulation: extruded color-coded plastic. Closely braided tinned copper shield. For: Auto radio, indoor PA systems and sound recording equipment.



SHIELDED COTTON BRAIDED CABLES

Conductors: Multiple—2 to 7 or more of flexible tinned copper. Insulation: extruded color-coded plastic. Cable concentrically formed. Closely braided tinned copper shield plus brown overall cotton braid.



SPECIAL HARNESES,

ords and cables, conforming to Government and civilian requirements.



SHIELDED JACKETED MICROPHONE CABLE

Conductors: Multiple—2 to 7 or more conductors of stranded tinned copper. Insulation: extruded color-coded plastic. Closely braided tinned copper shield. Tough, durable jacket overall.



JACKETED MICROPHONE CABLE

Conductors: Extra-flexible tinned copper. Polythene insulation. Shield: #36 tinned copper, closely braided, with tough durable jacket overall. Capacity per foot: 29MMF.



TINNED COPPER SHIELDING AND BONDING BRAIDS

Construction: #34 tinned copper braid, flattened to various widths. Bonding Braids conforming to Federal Spec. QQ-B-575 or Air Force Spec. 94-40229.



PA AND INTERCOMMUNICATION CABLE

Conductors: #22 stranded tinned copper. Insulation: textile or plastic insulated conductors. Cable formed of Twisted Pairs, color-coded. Cotton braid or plastic jacket overall. Furnished in 2, 5, 7, 13 and 25 paired, or to specific requirements.



Lenz Electric Manufacturing Co.

1751 N. Western Ave., Chicago 47, Illinois

ords, cable and wire for radio ♦ p. a. ♦ test instruments ♦ component parts

radio-telephone link for a large war plant, the first highway truck radio system in the west and several police radio departments.

His engagement is the latest stage in Poole's uhf developmental program, which has included establishment of KM2XAZ on Signal Hill, Long Beach, in 1949; creation of improved transmission facilities in cooperation with Stanford Research Institute; and enlargement of coverage by moving the station to Mt. Wilson early this year.

WCEMA Addition

NEWEST corporate member elected to the Los Angeles Council of the West Coast Electronic Manufacturers' Association is Franklin C. Wolfe Co., 11,723 Mississippi Ave., Los Angeles, Calif., makers of terminals and other electronic products, and serving also as design engineers and consultants.

Speer Carbon Consolidates

SPEER CARBON Co., St. Marys, Pa., and its subsidiaries, Jeffers Electronics, Inc., DuBois, Pa., Inter-

national Graphite and Electrode Corp., Niagara Falls, N. Y., and Speer Resistor Corp., St. Marys, Pa., have consolidated into one company, the Speer Carbon Co., with headquarters at St. Marys. The various subsidiaries henceforth will operate as divisions of Speer Carbon Co.

National Union Forms Transistor Division

FORMATION of a transistor division, to be engaged in the manufacture of germanium and silicon diodes and transistors of both the point contact and junction types, has been announced by National Union Radio Corp., Orange, N. J.

Edmund G. Shower has been appointed head of the new division. He was for many years with the Bell Telephone Laboratories where he set up the initial transistor production line. On leave of absence from Bell Labs from 1943 to 1946, he served in the Navy, where as a member of the Bureau of Ships, Electronics Division, he had charge of coordination of electron tube design for the Naval Establishment

with the Army, Air Force, Marine and allied agencies.

RDB Appointment

APPOINTMENT of C. Guy Suits as a civilian member of the Committee on Electronics of the Department of Defense Research and Development Board was recently announced by D. A. Quarles, committee chairman.

Dr. Suits, who is vice-president and director of research for the General Electric Co., Schenectady, N. Y., was formerly a member of the Committee on Ordnance of the Research and Development Board, and is presently a member of the Special Technical Advisory Group of the Board and the Joint Chiefs of Staff.

Civilian members in addition to Mr. Quarles, vice-president of Western Electric Co. and president of the Sandia Corp., and Dr. Suits, are Dr. E. W. Engstrom, research director of RCA Laboratories, Princeton, N. J., and Dr. William L. Everitt, dean of engineering at the University of Illinois, Urbana, Ill.

Three representatives from each of the military departments complete the membership of the group.

ELECTRONICS LANDMARKS INSPECTED

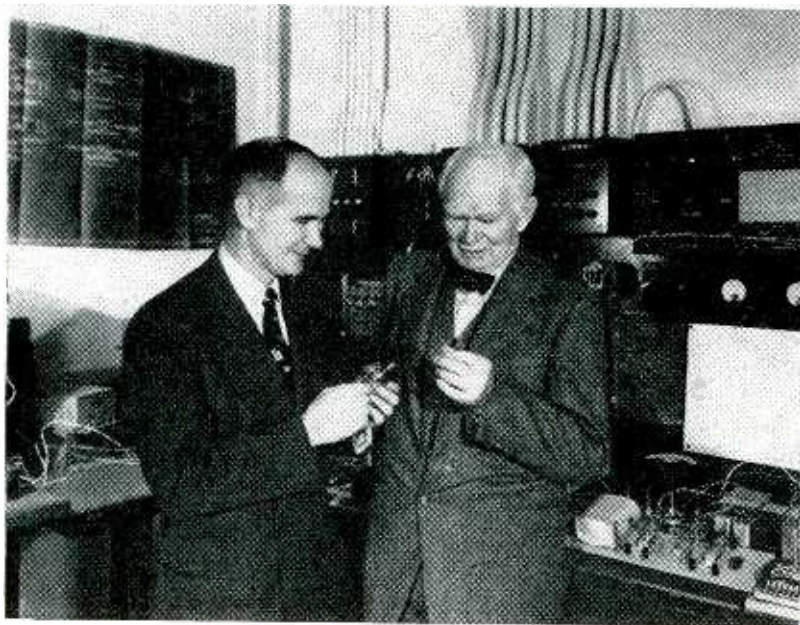

Two major landmarks in the history of electronics are represented by the devices in the hands of the men pictured above. On the left is William Shockley of Bell Telephone Laboratories, who directed the research program leading to the invention of the transistor. On the right is Lee deForest, who in 1907 invented the audion, forerunner of modern vacuum tubes, and the cornerstone of modern electronics. The photo, made during a recent visit to Bell Laboratories by Dr. deForest, shows him holding the transistor and Dr. Shockley holding the audion

West Coast Company Expansions

FOUR companies have recently announced plant expansion on the west coast:

The Pacific division of Bendix Aviation Corp., North Hollywood, Calif., has purchased the Photo-Electric Pilot Corp., Seattle, Wash., and Photo-Electric president A. B. Dickison is joining the Bendix organization in an executive capacity. Manufacture of Photo-Electric marine pilots will be continued temporarily at the Seattle plant, and will be moved to North Hollywood in late summer. Pacific division of Bendix first entered the marine field in 1947 with its electronic depth recorder.

Varian Associates, San Carlos, Calif., has awarded a contract for construction of its new research and development laboratory to be built on a 10-acre land tract leased from

A PRIMARY STANDARD FOR NOISE FIGURE MEASUREMENT IN THE MICROWAVE SPECTRUM FAST • SIMPLE • ACCURATE

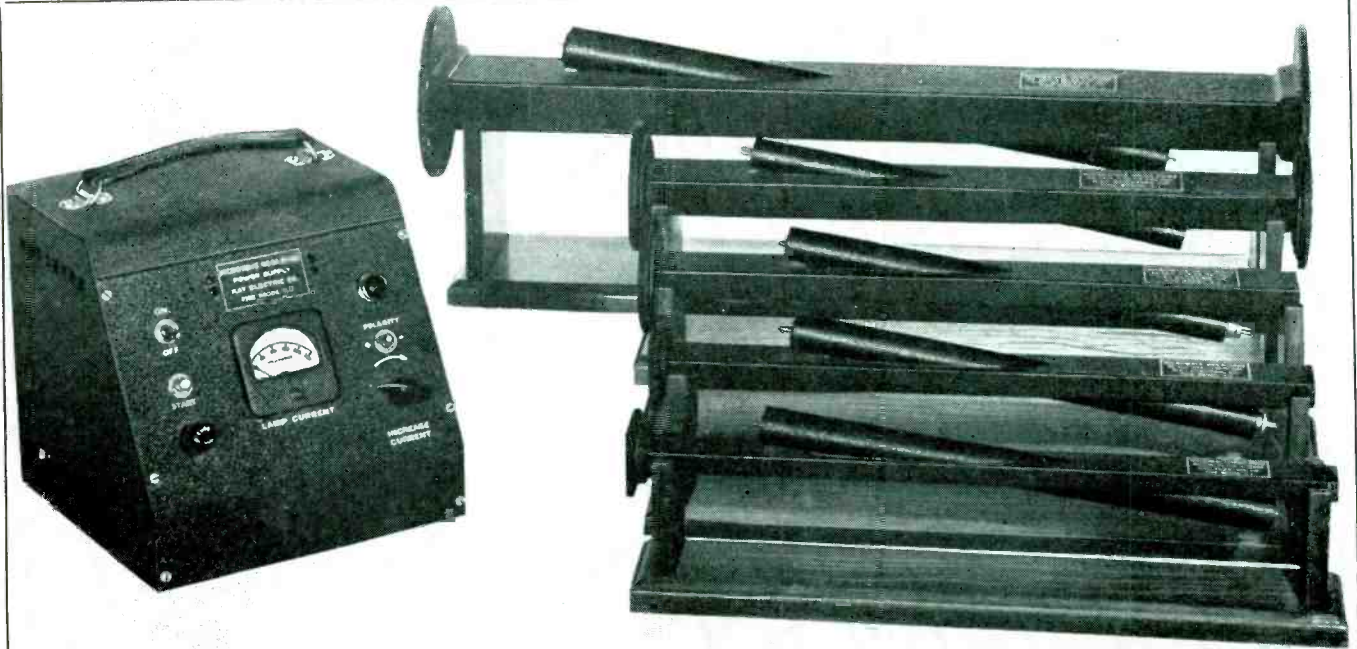

THE MICROWAVE MEGA-NODES NOISE OUTPUT (All Guides) 15.8 db Accurate to ± 0.25 db

USES: The Microwave Mega-Nodes are sources of random noise provided in six waveguide sizes. The Microwave Mega-Nodes may be used for the measurement of noise figure, receiver gain, and for the calibration of standard signal sources. The noise figure is obtained by comparing the noise output of a system with the amount of noise introduced by the Microwave Mega-Node. Comparative receiver sensitivity measurements may be easily made unless excessive noise is present in the systems under comparison. In radar systems the Microwave Mega-Node is particularly useful in checking the over-all performance.

DESCRIPTION: The Microwave Mega-Nodes employ a gas discharge which is radiating substantially monochromatic light. The Mega-Nodes are available in the following waveguide sizes and cover the following ranges:

RG 69/U	1,200 to 1,400 megacycles
RG 48/U	2,600 to 3,950 megacycles
RG 49/U	3,950 to 5,850 megacycles
RG 50/U	5,850 to 8,200 megacycles
RG 51/U	7,050 to 10,000 megacycles
RG 52/U	8,200 to 12,400 megacycles

One end of each waveguide is terminated in a standard flange.

A thermometer is attached to each waveguide to correct for temperature variations.

The standing wave ratio is less than 1.2 over the entire range and is usually less than 1.1 over most of the operating region.

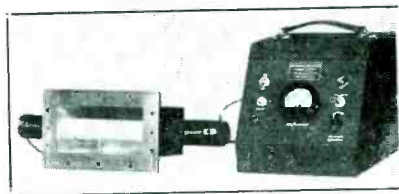

RG-69/U
Microwave Mega-Node

PRICE:

Single waveguides RG-48/U,
RG-49/U, RG-50/U, RG-51/U,
or RG-52/U\$195.00

Standard power supply for any
of above\$100.00

RG-69/U (L-Band) Waveguide ..\$400.00

Special power supply for RG-
69/U guide\$120.00

Set consisting of standard power supply and one each
of the following waveguides: RG-48/U, RG-49/U,
RG-52/U\$600.00

Prices are F.O.B. Factory
Export charges: Add 10% for outside U. S. and Canada.



KAY ELECTRIC COMPANY

25 Maple Avenue

Phone CAldwell 6-4000

Pine Brook, New Jersey

Put dependable **MOSINEE** Forest Fibres to work for you!



Remember . . . MOSINEE means more than "paper" in the field of electronics and electrical products. MOSINEE stands for FIBRES that have scientifically controlled electrical, chemical and physical properties, to perform specific functions . . . fibres of dependable technical uniformity vital to your quality standards and production requirements.

MOSINEE fibres can be made to your specifications, with

- good dielectric strength, high tensile or tear strength . . .
- specified pH for maximum-minimum acidity or alkalinity . . .
- accurate caliper or density . . .
- proper impregnation characteristics for resin, wax or other substances . . .
- proper characteristics for plastics operations and parts . . .
- uniform softness, stiffness, flexibility, toughness . . . or other vital technical characteristics.

MOSINEE has its sources of quality forest fibres, practical experience, laboratory facilities, and scientific production controls to create and produce the type of fibres your operations require. Contact MOSINEE.



MOSINEE PAPER MILLS COMPANY
MOSINEE, WISCONSIN

MOSINEE

makes fibres work for industry

Stanford University. The new laboratory will be ready for operation by April 1953. At the same time, San Carlos facilities will be expanded to include a staff of about 500 to manufacture klystrons and other electronic products.

The Walkirt Co., designers and manufacturers of electronic pulse circuitry, have moved into their new and expanded quarters at 145 W. Hazel St., Inglewood, Calif. Offices and enlarged production facilities are available for custom engineering and manufacturing, with emphasis placed on miniaturization, resin encapsulation and pulse circuitry for all types of high-speed or high-precision counting or measurement of time, frequency and rotational speeds. The Walkirt Co. was formerly located in Culver City, Calif.

The Ajax Condenser Co., Inc., of Chicago, Ill., has announced the opening of a capacitor factory at 10905 Chandler Blvd., North Hollywood, Calif. The new factory will soon be able to offer to the electronic and electrical industries on the west coast the same complete lines of electrolytic and paper capacitors and noise filter units produced by the Illinois corporation.

Majestic Appoints Vice-Presidents

FRANK J. DIELI has been appointed vice-president and chief engineer of Majestic Radio & Television, Division of The Wilcox-Gay Corp., Brooklyn, N. Y. He heads the engineering and research staffs for Majestic Radio & Television, Garod Radio, and recently assumed charge of engineering for Wilcox-Gay re-



F. J. Dieli

RELIABILITY

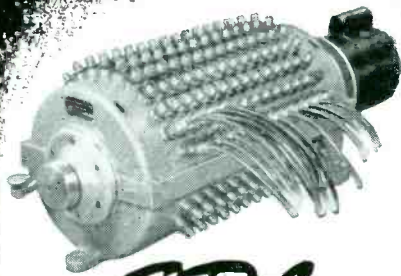

ERA

MAGNETIC DRUM STORAGE SYSTEMS

Ruggedly designed to rigid specifications, operationally proved by tens of thousands of hours of operation in a variety of applications, ERA Magnetic Drum Storage Systems are fully engineered, operationally reliable systems.

Large storage capacity, proven dependability, alterable yet non-volatile storage, and high speed are among the important characteristics which make these systems the optimum choice for many high-speed data-handling problems.

ERA's experienced engineers will be pleased to assist you in the application of ERA Magnetic Drum Storage Systems to your particular system requirements.

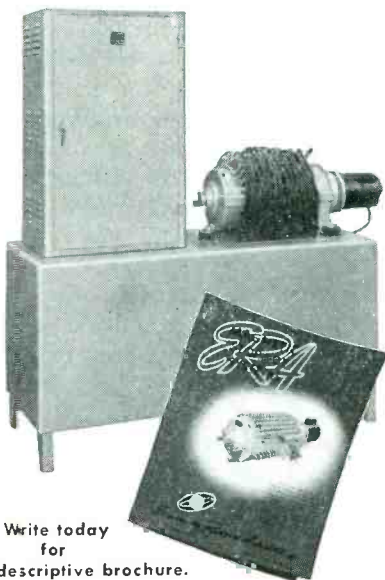

Write today for descriptive brochure.

Engineering Research Associates, Inc.

Department E-1, 1902 West Minnehaha Avenue
St. Paul 4, Minnesota

Digital Computers • Data-Handling Systems • Magnetic Storage Systems • Instruments • Analog Magnetic Recording Systems • Communications Equipment.

hermetically sealed

actual size



miniature and sub-miniature

audio transformers

CREST

LABORATORIES, INC.

Whitehall Building, Far Rockaway, N. Y. • FA 7-2732

- MANUFACTURED to meet most exacting MIL-T-27 specifications.

- STYPOL impregnation prior to potting assures quiet operation and long life under all adverse conditions.

- MU-METAL core assures a light weight, compact unit with full efficiency and wide frequency response.

- MIL FAMILY TYPE AVAILABLE:
Input—10, 11; Drives—12;
Output—13; Modulation—14;
Interstage—15;
Matching—16, 17;
Audio Oscillator—18;
Multi-Purpose—19;
Audio Inductor—20.

- PRODUCTION SAMPLES: Submitted for your inspection and approval.

- TRANSISTOR APPLICATION: Stock items designed for transistor circuitry.

- JOBBER LINE: Immediate delivery on full line of uncer and subuncer type miniatures.

this you **MOISTURE and** must **FUNGUS PROOF** read **your PARTS?**

PRODUCTION Engineering's complete Moisture- and Fungus-Proofing Process (Hot Wax, Varnish and Dow Corning 200) is already saving more and more electronic component manufacturers substantial sums and hours. You, too, can effect the same type of DOLLAR and time savings.

Our process—vacuum centrifuging, etc.—passing all government specifications—is complete . . . for rugged or delicate parts of practically any type of material.

We guarantee that it will be satisfactory. It will accurately fulfill your specifications and banish moisture- and fungus-proofing headaches. It will pay you to investigate the money and time saving features of our service. Get the FACTS.

WE CAN SAVE YOU

- money
- time
- worry

MAIL COUPON NOW!

Production Engineering Corp. Dept. E, Clifton, N. J.
Please send me details of your Moisture and Fungus Proofing Process.

Name Title

Company

Address

PRODUCTION ENGINEERING CORP.

173 SARGEANT AVENUE, GREGORY 3-5161 CLIFTON, N. J.

ording products. He joined Garod ten years ago and was made chief engineer in 1950.

The company has also announced the appointment of Robert J. Leykum to vice-president in charge of



R. J. Leykum

manufacturing. He joined Garod in 1935 and prior to his new appointment served as plant superintendent in the company's Brooklyn tv and radio receiver plant.

OTHER NEWS

New Radio Disturbance Warnings

BEGINNING July 1, 1952, the National Bureau of Standards will broadcast new short-wave radio disturbance forecasts via the NBS standard frequency broadcasting station WWV. This new service will replace the radio disturbance warning notices that have been transmitted by WWV since 1946. The broadcasts will tell users of radio transmission paths over the North Atlantic the condition of the ionosphere at the time of the announcement and also how good or bad communication conditions are expected to be for the next 12 hours.

The NBS radio disturbance forecasts, prepared four times daily, will be transmitted in Morse code twice each hour—19½ and 49½ minutes past the hour—on WWV standard frequencies of 2.5, 5, 10, 15, 20, and 25 mc, as was done prior to July 1. As in the past, the notices will include a letter indicating present radio reception conditions. However, the new notices will also contain a digit indicating the expected quality of future reception. As be-

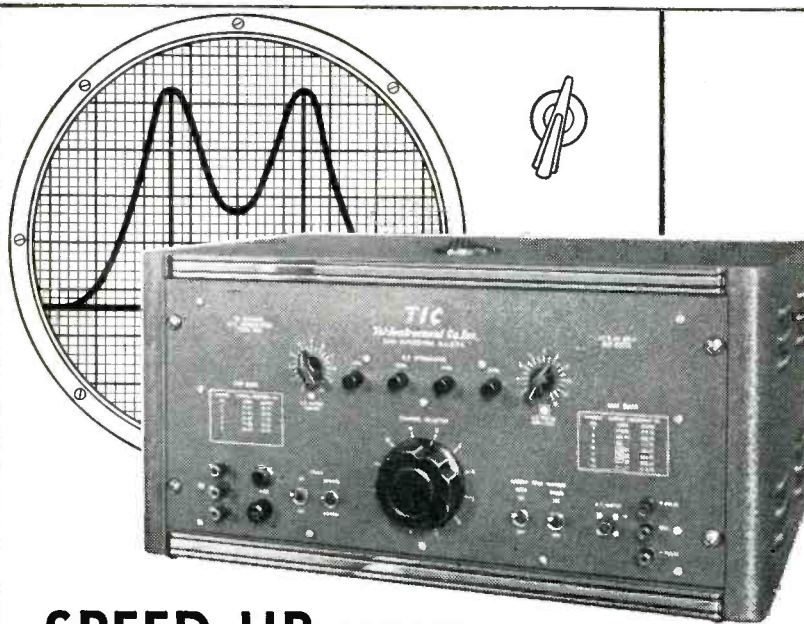

SPEED UP your PRODUCTION TESTING with the Type 1210 R.F. Sweep Generator

Here is a highly efficient, easily operated, sweep generator that eliminates many production test headaches.

Any one of 12 T.V. Channels can be instantly selected by means of a prominent front panel dial. R.F. tuning alignment is greatly accelerated and simplified through the use of a pre-set 15 MC. sweep for each channel, complete with crystal sound and video markers.

These features, plus the added advantage of continuous maintenance-free operation, warrant your immediate investigation.

Plan ahead for your instrument requirements, now!

SPECIFICATIONS

FREQUENCY COVERAGE:

Television channels 2 to 13 inclusive on fundamental oscillator frequency.

BANDWIDTH:

15 MC. on all channels. May be adjusted to greater or lesser bandwidth. Return trace blanking to provide reference baseline.

OUTPUT:

At least 0.5 volt peak across 75 ohm terminated cable. Amplitude of sweep constant within $\pm 5\%$ over entire band. Output probes furnished for 75 and 300 ohm receiver inputs.

ATTENUATOR:

Push button constant impedance type. Four fixed steps of 20, 20, 20, and 10 db plus 10 db variable.

AUXILIARY OUTPUT SIGNALS:

Sawtooth sweep signal automatically phased for "X" axis of oscillograph.

Monitor output derived from germanium crystal rectifier connected across output cable. Marker pulses both positive and negative in polarity and variable in amplitude when connected externally.

PRICE: \$695.00 F.O.B. factory.

TIC

Manufacturers of a complete line of TV and Radar Test Equipment

Tel-Instrument Co. Inc.

50 PATERSON AVENUE • EAST RUTHERFORD, N. J.

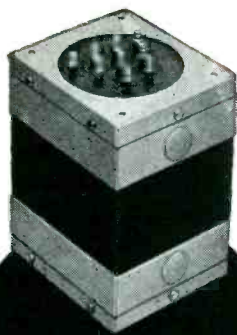

*where precision
matters...*

THERMADOR



*Transformers for Television
... Radar ... Aircraft ...
Geophysics ... Radio*

You will find Thermador ready, willing and fully qualified to handle your transformer requirements. Engineering experience and manufacturing know-how, developed over a period of 35 years, form the hard core that makes Thermador today's largest West Coast manufacturer of electrical appliances and transformers. We would like to work with you on your next project involving the design and production of transformers for specific requirements...including joint Army-Navy specifications.

transformers:

Audio Auto	Geophysical
Driver Filament	High-Fidelity Audio
Input-Output	Midget Plug-In
Plate Power	Television
Tube to Line	

... also Chokes and Reactors



**THERMADOR ELECTRICAL
MANUFACTURING CO.**

3-320

5110 District Boulevard • Los Angeles 22, Calif.

Make a **GM**

PORTABLE D'ARSONVAL

GALVANOMETER

*the Heart
of Your
Instrument*

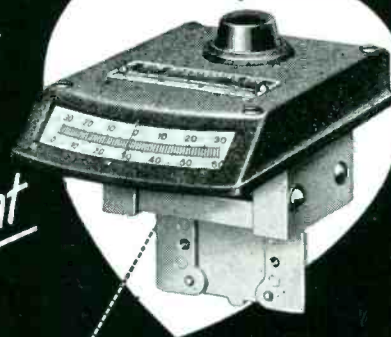

FOR MEASURING LIGHT reflectance and color, the Photovolt Corporation of New York uses a Model 600 G-M Galvanometer for its popular Reflection Meter (left). Whatever your own particular instrument field, you can achieve this same self-contained portability, ruggedness and high sensitivity with G-M Galvanometers. Complete catalog on request.

GM LABORATORIES-INC.

In Canada: Cossor (Canada) Ltd.,
301 Windsor St., Halifax, N. S.

4336 NORTH KNOX AVE., CHICAGO 41

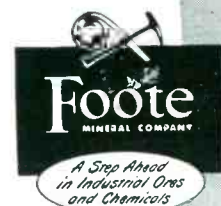

PURE DUCTILE

ZIRCONIUM

- Iodide processed Zirconium of highest purity for commercial use.
- 20% lighter than steel.
- outstanding resistance to corrosive attack by both acids and alkalis.
- remarkable gas absorption properties.

Zirconium is ductile and malleable. Its use in atomic reactors... as a "getter" in electronic tubes... as an additive in metal alloying... as an igniter in flash bulbs and as a non-corrosive metal in surgical specialties are a few of Zirconium's applications. Investigate Zirconium, the metal with a future.

Price reductions averaging 50% have been made on Foote Zirconium rods, sheets and wire.

Write now for the new Foote Zirconium price schedule and data. Experimental samples are available upon request.

FOOTE MINERAL COMPANY

426 Eighteen W. Cheltenham Building
Philadelphia 44, Pennsylvania

PATENT ATTORNEYS

An unusual situation has developed at Hughes. In the last few years, our Laboratories have grown to a population of more than three thousand men and women, who cover a wide range of research and development. New electronics products we have developed support a manufacturing organization of thousands of additional people.

And yet today our patent attorneys can be numbered on the fingers of two hands!

The explanation is, of course, that our growth has been very rapid and we have gotten a late start in trying to build an appropriately large patent department. The situation has not been made any easier for us by a current rapid expansion of our commercial, nonmilitary interests. As a result, however, we believe that the opportunities for patent attorneys are now unusually attractive at Hughes.

To keep abreast with the work being done in our Laboratories, our patent department must be greatly enlarged; this means that today's openings carry unusual potentialities for rapid advancement. On the other hand, the fact that the Research and Development organization to be served has already established itself as one of the largest and most productive electronics laboratories in the country provides a degree of security not usually associated with opportunities for rapid individual growth.

*Inquiries should be addressed to:
Engineering Personnel Department*

HUGHES

**RESEARCH and
DEVELOPMENT
LABORATORIES**

Culver City, Los Angeles County, California

Assurance is required that re-location of the applicant will not cause disruption of an urgent military project.

fore, the letters used will be N, U, and W, signifying that radio propagation conditions are normal, unsettled or disturbed, respectively. The digit will be the forecast of expected quality of transmitting conditions on the NBS-CRPL scale of 1 (impossible) to 9 (excellent).

Digit (Forecast)	Propagation Condition	Letter (Current)
1	Impossible	W
2	Very Poor	W
3	Poor	W
4	Fair to Poor	W
5	Fair	U
6	Fair to Good	N
7	Good	N
8	Very Good	N
9	Excellent	N

If, for example, propagation conditions at the time the forecast is made are normal but are expected to be only "fair to poor" within the next 12 hours, the forecast statement would be broadcast as N4 in Morse code, repeated five times; that is, "N4, N4, N4, N4, N4."

The New NBS radio disturbance forecasts refer only to North Atlantic paths, such as Washington to London or New York to Berlin. The forecasters assume that the most suitable radio frequencies for communications are available and in use along these paths. Because of this assumption, their notices must be interpreted on a relative scale in terms of experience on each radio circuit in use. It is impossible to rate conditions on an absolute scale because the varied effects of transmitter power, type of communications traffic and procedure, antennas and receivers prevent an evaluation that will be valid for all systems and all circuits. One purpose of broadcasting both a description and a forecast is to show more clearly whether propagation conditions are expected to deteriorate or improve in the 12-hour period.

For the past 18 months, the NBS Radio Warning Service has been making continuous 24-hour daily studies of the North Atlantic circuits by specialized techniques. The new disturbance information to be transmitted by WWV is one of the results of this investigation. Other radio disturbance forecasts which NBS has supplied regularly for almost ten years are forecasts of propagation conditions 1 to 25 days in advance and daily 24-hour forecasts.

PREMAX

Get These Bulletins!



PREMAX ANTENNAS for mobile, RACES, CAP, CD, Marine and other installations are fully explained in these new Bulletins, just off the press. Low-cost Antennas that increase range. Send for yours today!

PREMAX PRODUCTS
DIVISION CHISHOLM-RYDER CO., INC.

5201 Highland Ave., Niagara Falls, N. Y.

Quality COMES FIRST

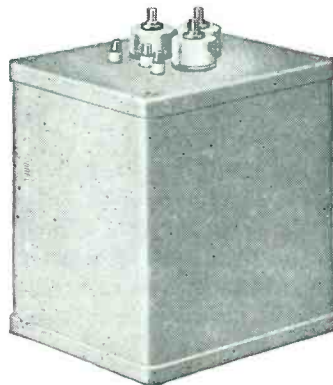
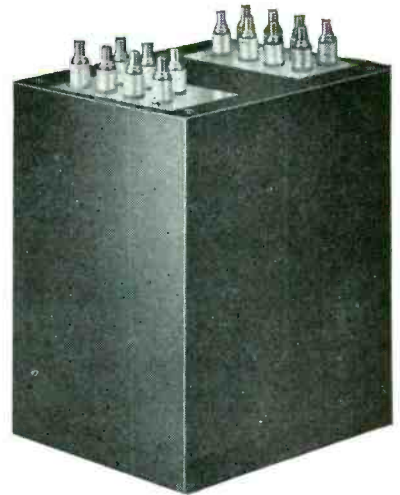

• If performance and long life are the primary factors in your application of transformers, then submit your specifications to Acme Electric. Quality comes first in every Acme Electric transformer.

ACME ELECTRIC CORPORATION
317 WATER STREET • CUBA, N. Y.

Acme Electric
TRANSFORMERS

BE SAFE WITH
Q-max
A-27
LOW-LOSS LACQUER & CEMENT

- Q-Max is widely accepted as the standard for R-F circuit components because it is chemically engineered for this sole purpose.
- Q-Max provides a clear, practically loss-free covering, penetrates deeply, seals out moisture, imparts rigidity and promotes electrical stability.
- Q-Max is easy to apply, dries quickly and adheres to practically all materials. It is useful over a wide temperature range and serves as a mild flux on tinned surfaces.
- Q-Max is an ideal impregnant for "high" Q coils. Coil "Q" remains nearly constant from wet application to dry finish. In 1, 5 and 55 gallon containers.

Communication Products Company, Inc.

MARLBORO, NEW JERSEY (MONMOUTH COUNTY)
Telephone: FReehold 8-1880



SHIELDING PROBLEMS

effectively and economically solved with
METEX
electronic "Weather Strips"

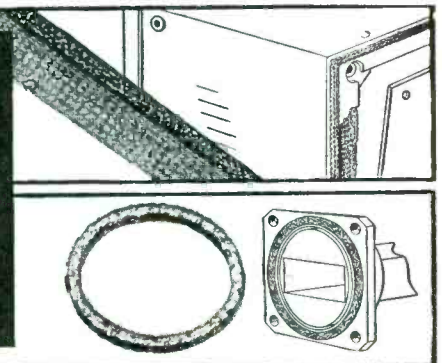

Resilient... Conductive... Compressible... Cohesive

From closures for cabinets to gaskets for waveguide couplings, Metex Electronic Shielding assures lasting metal-to-metal contact to prevent leakage, without the need for costly machining to secure precise surface-to-surface contacts. Metal wire — knitted, not woven or braided — gives Metex Electronic Strips and Gaskets that combination of conduc-

tivity and resiliency which makes them so effective and economical for shielding.

For a more detailed picture of the scope of utility of Metex Electronic Products, write for free copy of "Metex Electronic Weather Strips." Or outline your specific shielding problem—it will receive immediate attention.

METAL TEXTILE CORPORATION
KNITTERS OF WIRE MESH FOR MORE THAN A QUARTER CENTURY

641 East First Avenue

Roselle, N. J.



Shallcross

DECADE RESISTANCE BOXES



for fast, accurate laboratory
or production testing

36 Standard Types

1,2,3,4,5 and 6-dial

Accuracy: 10 ohms and above, 0.1%; 1.0 ohm, 0.25%; 0.1 ohm, 1% and 0.01 ohm, 5%. Closer tolerances on special order.

Ask for Engineering Bulletin L-17

**Shallcross Manufacturing
Company**
Collingdale, Pa.

NEW BOOKS

Nomography and Empirical Equations

BY LEE H. JOHNSON, *Tulane University.* John Wiley & Sons, Inc., New York, 1952, 150 pages, \$3.75.

THIS interesting and useful book is divided into two broad parts: first, the technique of constructing nomographs or alignment charts for equations containing more than two variables, and, second, the technique of determining the mathematical equation which expresses the relations existing between several variables.

The chapter headings show the range of subject matter:— parallel-scale nomographs, Z-charts, parallel and perpendicular index lines, concurrent scales, recurrent variables, combined nomographs, methods of curve fitting, curves of two, three and four constants.

For anyone who uses alignment charts (and who in this field does not?) and who wishes to know how they are made, this is a good way to find out. Not only will the reader learn the techniques but he will learn much about the accuracy of such charts, how to determine the scales, and other necessary facts—and he need not be a mathematician to do it.—K.H.

Electronics For Communication Engineers

BY JOHN MARKUS AND VIN ZELUFF. McGraw-Hill Book Co., New York, 1952, 610 pages, \$10.

THIS is the third of a series of books by these two authors comprising a collection of previously published articles grouped by subject matter. This book is really a second volume of the authors' "Electronics Manual For Radio Engineers." The first volume covered the years 1940-1948.

The current one covers a period of five years. A total of 252 articles, all from ELECTRONICS, are included. Chapters are: (1) Amplifiers; (2) Antennas; (3) Audio; (4) Cathode-Ray Tubes; (5) Components; (6) Electronic Music; (7) Filters; (8) Measurements; (9) Microwaves; (10) Oscillators; (11) Power Supplies; (12) Propagation; (13) Pulses; (14) Receivers; (15)

TEST-ADJUST TELEVISION SETS AT *Your* CONVENIENCE

Even without station test pattern or in remote, weak signal areas!

A television set will produce a picture only when it is supplied with a COMPOSITE VIDEO SIGNAL. To check any TV set properly, you must have a COMPOSITE VIDEO SIGNAL.

Every TV station sends a COMPOSITE VIDEO SIGNAL when telecasting a program or a test pattern. This COMPOSITE VIDEO SIGNAL is composed of—(1) a synchronizing and blanking signal to lock the free running raster into a frame of two interlaced fields, and—(2) a video signal to control the amount of light and produce the picture (which may be a program scene or a test pattern for analysis purposes).



SUPREME MODEL 665

The SUPREME COMPOSITE VIDEO GENERATOR provides the same type of sync and blanking signal as the TV station—even the equalizing pulses. In addition, it incorporates a video section which generates a special test pattern for analysis and adjustment of TV sets. Other patterns or pictures can be presented by using auxiliary equipment connected to the special "gated" video input section of this versatile instrument. The Model 665 should not be confused with the cross-hatch or bar-pattern generators. The Supreme Model 665 supplies a COMPOSITE VIDEO SIGNAL.

Why lose time and money waiting for that ideal scene or test pattern to check a TV set? In fringe or weak signal areas, you are strictly in the "driver's seat" with a SUPREME COMPOSITE VIDEO GENERATOR. Write SUPREME, Inc., Dept. P-7, GREENWOOD, MISSISSIPPI for descriptive folder.

Our 25th Year

SUPREME

Testing Instruments

"SUPREME BY COMPARISON"

TUBE TESTERS • OSCILLOSCOPES
SIGNAL GENERATORS • MULTI-METERS
FOR RADIO AND TELEVISION

MAILING LISTS THAT WORK . . .

McGraw-Hill Industrial Mailing Lists are a direct route to today's purchase-controlling executives and technicians in practically every major industry.

These names are of particular value now when most manufacturers are experiencing constantly increasing difficulty in maintaining their own lists.

Probably no other organization is as well equipped as McGraw-Hill to solve the complicated problem of list maintenance during this period of unparalleled changes in industrial personnel. These lists are compiled from exclusive sources, based on hundreds of thousands of mail questionnaires and the reports of a nationwide field staff, and are maintained on a twenty-four hour basis.

Investigate their tremendous possibilities in relation to your own product or service. Your specifications are our guide in recommending the particular McGraw-Hill lists that best cover your market. When planning your industrial advertising and sales promotional activities, ask for more facts or, better still, write today. No obligation, of course.

for Results



Mc GRAW-HILL
DIRECT MAIL LIST SERVICE

McGraw-Hill Publishing Co., Inc.

DIRECT MAIL DIVISION

330 West 42nd Street

New York, 36, N. Y.

Call on *Lewis*

when you need

DEPENDABLE



SPRINGS



WIREFORMS



STAMPINGS



**QUALITY, ECONOMY and PROMPT SERVICE
on Every Order—Large or Small!**

There is never any letdown in Lewis quality or service. Your order will be given prompt, efficient attention regardless of size. You can be sure that the springs, wireforms or stampings you order will be fairly, economically priced. What's more, Lewis has the extensive, modern facilities, the long-experienced engineers and skilled production craftsmen to supply you with springs, wireforms and stampings tailored to your exact needs.

If you have any tricky or tough problems involving springs, Lewis's engineers will be glad to help you solve them. Or, if you need large or small quantities of standard springs in a hurry—just call on Lewis! Send us your drawings, specifications or samples today!

LEWIS SPRING & MANUFACTURING CO.
2656 W. NORTH AVENUE, CHICAGO 47, ILLINOIS

Lewis **PRECISION SPRINGS**

The Finest Light Springs and Wireforms of Every Type and Material

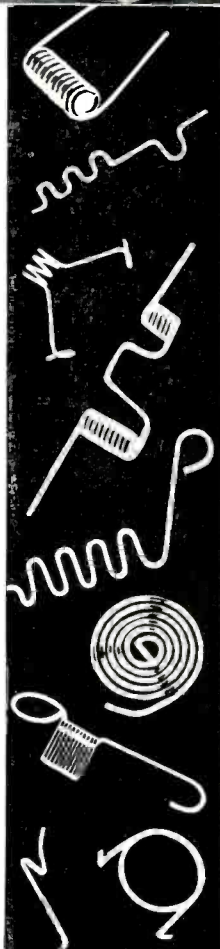

Transmission Lines; (16) Transmitters. The chapter on electronic music consists of 10 articles; although not strictly in the communications field, this is a subject in which a considerable number of electrical engineers have become interested of late.

In addition to the chapter article index, there are an author index and a comprehensive subject index that lists many features of the contents that may not be apparent from the titles. Some of the articles have been condensed but the issue of *ELECTRONICS* in which each appeared is given so that reference to the original source is a simple matter. The many drawings, graphs and wiring diagrams (they average several per page), which added so much to the value of the original articles, have been retained. Any references included in the original articles have also been included so that further information is easily obtainable.

This book makes a valuable addition to the communication engineer's library. His text books are the source of basic information while this book supplies the details and practical aspects of the latest applications and practices.—W. C. WHITE, *Research Laboratory, General Electric Co., Schenectady, N. Y.*

Introduction to Electronic Circuits

BY R. FEINBERG. *Longmans, Green and Co., New York, 1952, 163 pages, \$3.50.*

THIS book moves at a fairly high rate from the first page on. Maximum use is made of symbols to represent physical and electrical phenomena, and very few words are wasted.

Such a feature should be very appealing to some, but may bring objection from others. The work is complete, but to derive maximum benefit, a great deal of careful analytic reading is required. For the graduate student, this terse writing is usually desirable, but for the second or third year student (for whom the book is intended) it may be difficult to absorb.

Being British, the book naturally

MICO

Precision Apparatus

TOROID COIL

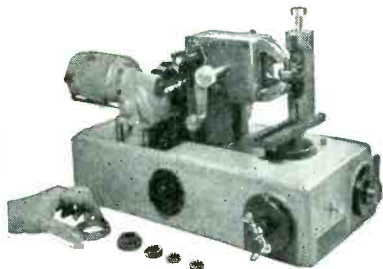

WINDERS

Flexible machines for your laboratory prototype development work.

Production machines built for volume manufacturing of specific coils.

MICO INSTRUMENT CO.

76E Trowbridge St., Cambridge, Mass.

Miniature

THERMOSTATS & THERMAL TIMERS



THE ULANET ORGANIZATION SPECIALIZES IN THE DESIGN AND MANUFACTURE OF THERMAL UNITS

FOR ALL TYPES OF TIMING & THERMOSTATIC CONTROLS

It will pay you to compare our units — contact us and you'll save time & money by using engineered Ulanet Controls.

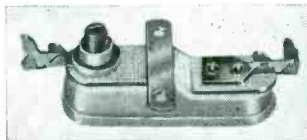

MODEL 13 THERMOSTAT

Designed so precision calibration is unaffected by extreme temperatures. Totally enclosed and mechanically rugged, easily mounted and readily wired. Electrolytic silver contacts.

MODEL PB THERMAL TIMER

Here's a rugged unit with timing ranges of 2 seconds to 3 minutes. Ceramic base provides stability — Bakelite bracket insures full insulation. Made to accepted Ulanet specifications. Clinch bracket secures adjustment screw. Contact rating is 100 watts, 115-230 V. ac.

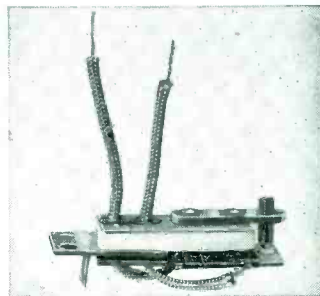

Your requirements for Timing or Thermostatic Control can readily be met with a Ulanet unit. Please state application and desired operation when writing.



GEORGE ULANET COMPANY

417 MARKET ST., NEWARK 5, N.J. ★ ★ ★ ★ ★

Over 85% of the torque wrenches used in industry are

STURTEVANT

TORQUE WRENCHES

Read by Sight, Sound or Feel.

- Permanently Accurate
- Practically Indestructible
- Faster—Easier to use
- Automatic Release
- All Capacities

in inch ounces . . . inch pounds . . . foot pounds
(All Sizes from 0-6000 ft. lbs.)



Every manufacturer, design and production man should have this valuable data. Sent upon request.

A STURTEVANT CO. ADDISON QUALITY ILLINOIS

"IMPROVED"

MODERN HORIZONTAL HYDRAULIC DRAWING

... for your coin silver slip rings

This "IMPROVED" modern equipment assures faster production and more accurate slip rings in sizes up to 1". Coin silver or standard inlay coin silver .025" thick bonded to a brass base. Tolerances — ± .001 outside and inside diameters.

Your inquiries will be appreciated and replied to promptly.

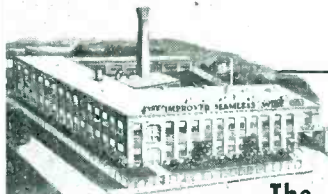

The Home of **IMPROVED Service**
Rhode Island's largest manufacturer
of Laminated Metals.

The **IMPROVED SEAMLESS WIRE COMPANY**
INCORPORATED 1898
775 Eddy Street, Providence 5, Rhode Island

refers to valves instead of tubes. This difference no longer represents any trouble in the globe-wide information-sharing programs in effect today. Typical tube characteristics are discussed, rather than typical tubes, which makes the material useful to those familiar with British or American types.

For the student who can apply himself, the book is recommended for its direct approach. Analogies used are well chosen and serve fully to explain the concepts that lend themselves to such treatment. The numerous examples given, though brief, are also helpful in understanding ideas.

Main emphasis is directed toward tube construction and internal operation, and typical application of tubes in oscillators, amplifiers and other simple circuits. Some attention is given to industrial tubes and circuits. Since no specific design details (circuit values, tube types, etc.) are given, the book is not recommended for designers, but rather as a text book for a college course on fundamentals of electron tubes.—J.D.F.

Tubes a Modulation Vitesse

BY R. WARNECKE AND P. GUENARD.
Gauthier-Villars, Paris, 800 pages, 1951.

MANY of the older generation of tube engineers believe that too few comprehensive publications exist on many important aspects of vacuum tube theory and design. The need for having assembled in book form technical information which has been accumulated over a period of years is particularly felt at this time when many young engineers are being introduced to the field of electron tube techniques. The book on velocity-modulation tubes by Warnecke and Guenard represents a very complete and systematic presentation of the subject. Both authors are well known for their original contributions in this field and for their skill in presenting technical material. This reviewer believes that their present effort in preparing a book on velocity-modulation tubes will be greatly appreciated both by junior and senior engineers concerned with efficient utilization of engineering talent in

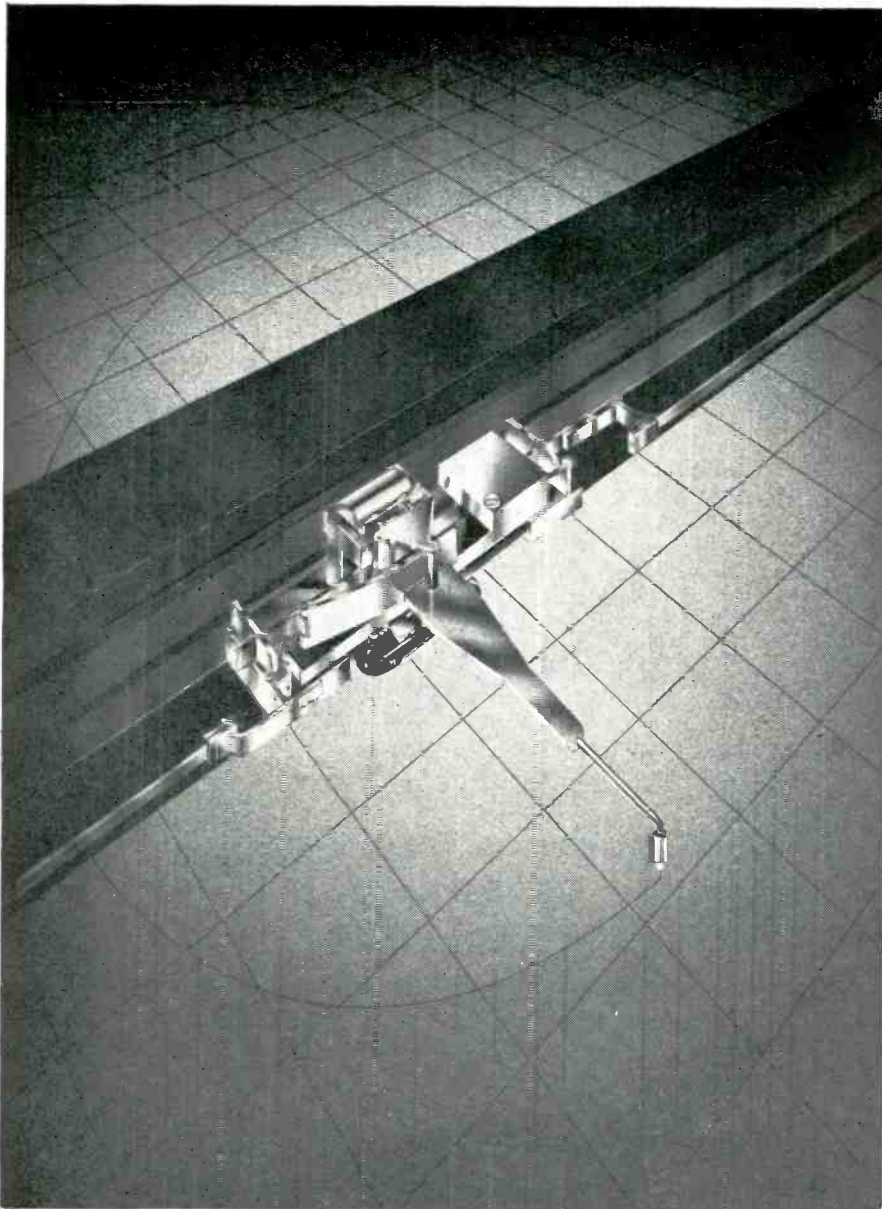

This is a pen of a Variplotter plotting board.
Function: Plots D.C. voltages x vs. y or x_1 vs. y_1 and x_2 vs. y_2 .
Surface: Thirty inch square plotting surface.
Accuracy: .05% static. .1% dynamic.
Information: Contact Electronic Associates, Inc.
Long Branch, N. J.

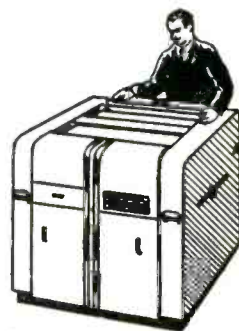

Variplotter
MODEL 205 SERIES PLOTTING BOARDS

LONG BRANCH, NEW JERSEY



LABORATORY POWER SUPPLY



- Excellent electronic regulation.
- Two independent regulated outputs continuously variable 0 to 425 volts at 200 ma. Positive or Negative ground.
- 0 to 425 @ 400 ma if the two sources are combined.
- Stabilized bias supply 0 to -150 volts.
- 6.3V AC @ 10 amps.
- Low Ripple Voltage.
- Compact. Fits standard rack.
- Moderately Priced.

WRITE FOR BULLETIN B

ALCO ELECTRONICS MFG. CO.
102 Marston Street
Lawrence, Massachusetts

For HIGHEST ELECTRICAL & MECHANICAL EFFICIENCY!

New JONES SERIES 2400 PLUGS & SOCKETS

● Improved Socket Contacts—4 individual flexing surfaces. Positive contact over practically their entire length.

● Cadmium plated Plug and Socket, Contacts mounted in recessed pockets, greatly increasing leakage distance, INCREASING VOLTAGE RATING.

● Interchangeable with 400 Series.

Send for complete Catalog No. 18. Plugs, Sockets, Terminal Strips.



P-2406-CCT



S-2406-SB

Jones HOWARD B. JONES DIVISION
CINCH MANUFACTURING CORPORATION
CHICAGO 24, ILLINOIS
SUBSIDIARY OF UNITED-CARE FASTENER CORP.

FOR WIRING DIAGRAMS
FOR INSTRUCTION PANELS
FOR LUBRICATING CHARTS

MEETS GOVERNMENT SPECIFICATIONS

IMPORTANT DATA

PROTECTION

—LAMINATING BY TRIMOUNT

SAFE-GUARDS charts, diagrams, technical illustrations, and any other type of printed material. PROTECTS against moisture, oils and greases, resists many chemicals. Aging does not alter the transparency. Withstands tough handling. The Trimount laminating process applies a tough, lustrous, transparent film of plastic to the surface of paper, fabric, or just about any material. Engineered to the most exacting specifications.

Write, Phone or Send Samples for Specific Recommendations
For technical data or consultation — consult

TRIMOUNT PLASTIC CO., INC. 71 DUDLEY ST., ARLINGTON 74, MASS., TEL. ARLINGTON 5-9023

Pulse Generator and Calibrator

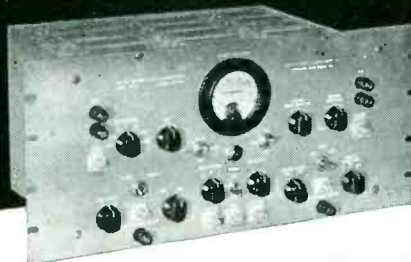

Model PC-100 R illustrated here

- The Teletronics Model PC-100 Pulse Generator and Calibrator was designed as an accessory for general use with triggered oscilloscopes.
- However, the variety of waveforms generated and the flexibility of operation provided make it a valuable instrument for many other purposes.

Incorporates design of HAZELTINE ELECTRONICS CORP. Model 1456 Senior Pulser

For further information, write or wire

- The Pulse Calibrator produces two rectangular pulses of short duration whose amplitudes and polarities can be independently controlled.
- Their repetition frequency and the time interval between them are also adjustable. Accurate marker pulses and square-waves are generated for making both time and amplitude measurements. The unit can be synchronized from an external source or it may be operated self-synchronous in which case a pulse for synchronizing other equipment is generated.

TELETRONICS LABORATORY
INC.
WESTBURY, L. I., N. Y.

MANUFACTURERS OF ELECTRONIC INSTRUMENTS AND PRODUCTION TEST EQUIPMENT

ELECTRONIC and MECHANICAL ENGINEERS

As a leader in the field of electronic research and development, MELPAR constantly deals in new ideas and works with skilled men whose initiative and ability are an active factor in the development of these ideas.

We want to add to our distinguished group of engineers men whose background entitles them to the substantial salaries, advancement and recognition that is an integral part of MELPAR policy. Work is in pleasant Alexandria, just outside Washington, D. C., in a modern plant with extensive laboratory facilities.

If you have had Research, Development and Manufacturing experience in any of the following fields we would like to hear from you:

• FLIGHT SIMULATORS

- Computers
- Radar Beacons
- Telemetry
- Sub-Miniaturization
- Microwave Receivers
- Microwave Transmitters

Send resume to:

PERSONNEL DIRECTOR, Dept. E.

MELPAR, INC.

Subsidiary Westinghouse Air Brake Co.

452 Swann Ave. Alexandria, Virginia
or

10 Potter Street Cambridge, Mass.

the field of tube development.

In the preface the authors state that in reviewing literature on velocity-modulation tubes they were greatly helped by having at their disposal the unpublished lecture notes by Professors Hansen and Feenberg, which contain a summary of most important results of research and development in the United States during the war. The authors' own studies and experiences in the laboratories of the Compagnie Generale de Telegraphie sans Fil naturally served as a guide and influenced the choice of material included in the book.

The book comprises almost 800 pages and is divided into seven parts. After an introduction containing a brief history of the invention of velocity-modulation and allied tubes, the first big chapter is devoted to a review of fundamentals of interaction between electrons and radio-frequency fields and the exposition of the velocity modulation principle involving conversion of electron velocity modulation into current modulation. Bunching and debunching effects, and the influence of finite electron transit time on effectiveness of energy interchange are also discussed.

The second part develops the theory and presents methods of design of cavity resonators suitable for velocity-modulation tubes. The third part describes different types of v-m tubes, such as two and three cavity amplifiers, reflex oscillators and frequency multipliers. The fourth part presents experimental results and technical data on practical tubes. It also describes some special forms of v-m tubes and gives design data on tube components, such as cathodes, guns, cavities, collectors, repellers, etc. The fifth part is devoted to the extension and refinement of the theory and discusses such topics as the behavior of electrons in non-uniform fields, multipactor effect, focusing of electron beams, effects of space charge in drift space, hysteresis effects, tube noise, relativity corrections, scaling methods, and gives examples of design of tubes to specified characteristics. The sixth part is concerned with the problems of frequency limits, bandwidth, modulation, impedance

THE WIDE BAND POCKETSCOPE

BY WATERMAN



MODEL
S-14-B

Wt. 14 lbs.
12" x 6" x 7"

Another Waterman **POCKETSCOPE** confirming the obsolescence of conventional oscilloscopes. Characterized by wide band amplifier fidelity without peaking as well as amazing portability. S-14-B **POCKETSCOPE** is ideal for laboratory and field investigation of transient signals, aperiodic pulses, or recurrent electrical wave forms.

Vertical channel: 50mv rms/inch, with response within -2DB from DC to 700KC, and pulse rise of 0.35 μ s. Horizontal channel: 0.3v rms/inch with response within -2DB from DC to 200KC, and pulse rise of 1.8 μ s. Non-frequency discriminating attenuators and gain controls, with internal calibration of trace amplitude. Repetitive or trigger time base, with linearization, from 1/2cps to 50KC, with \pm sync. or trigger. Trace expansion. Filter graph screen. Mu metal shield. And a host of other features.

WATERMAN PRODUCTS CO., INC.

PHILADELPHIA 25, PA.
CABLE ADDRESS: POKETSCOPE

WATERMAN PRODUCTS INCLUDE:

S-4-A SAR	PULSESCOPE
S-5-A LAB	PULSESCOPE
S-10-B GENERAL	POCKETSCOPE
S-11-A INDUSTRIAL	POCKETSCOPE
S-14-A HIGH GAIN	POCKETSCOPE
S-15-A TWIN TUBE	POCKETSCOPE

Also **RAKSCOPES**, **LINEAR AMPLIFIERS**, **RAYONIC TUBES** and other equipment



S.S. White MOLDED RESISTORS

The All-Weather Resistors



TYPE 65X
(Actual Size)

The resistors that give you . . .

- Inherent low noise level
- Good stability in all climates

STANDARD RANGE

1,000 OHMS TO 9 MEGOHMS

These resistors are used extensively in commercial equipment, including radio, telephone, telegraph, sound pictures, television, etc. They are also used in a variety of U. S. Navy equipment.

HIGH VALUE RANGE

10 TO 10,000,000 MEGOHMS

This unusual range of high value resistors has been developed to meet the needs of scientific and industrial control, measuring and laboratory devices — and of high voltage applications.

SEND FOR BULLETIN 4906

It gives details of Standard and High Value Resistors, including construction, characteristics, dimensions, etc. Also described are S.S. White 80X Resistors, designed for extremely high voltage equipment. Copy with Price List sent on request.



THE **S.S. White** INDUSTRIAL DIVISION
DENTAL MFG. CO.



Dept. R, 10 East 40th St.
NEW YORK 16, N. Y.

WESTERN DISTRICT OFFICE: Times Building, Long Beach, Calif.

When Time is Unimportant



Its control is anybody's job. But when it involves an intricate problem, the concern that may be depended upon to correctly solve it is the **A. W. Haydon Company**

Thoroughly experienced timing engineers assure prompt, accurate solutions to the most difficult of proposed applications.

WRITE FOR CATALOG



The **A.W. HAYDON**
COMPANY

235 NORTH ELM STREET
WATERBURY 20, CONNECTICUT
Design and Manufacture of Electrical Timing Devices

Are YOUR Recordings Accurate?

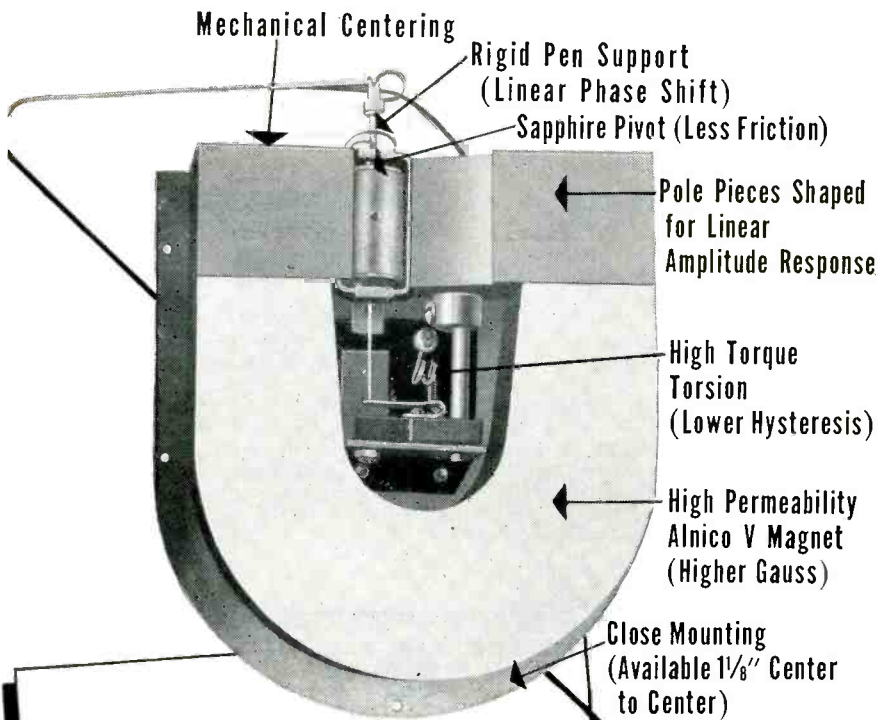

Edin recorders with ink-writing galvanometers assure rapid, accurate recording for frequency responses from D.C. to 300 cycles per second. Designed for multiple operation in recorders up to 12 channels, with 1, 3 or 9 speeds as high as 625 mm/sec. Whatever your recording requirements, there is an Edin instrument to meet them. Mail the coupon today for complete facts.



THE EDIN COMPANY
207 Main St., Worcester 8, Mass., Dept. B

Gentlemen: Send complete information on Edin recording instruments Companion amplifiers.

Name.....
No..... Street.....
City..... State.....
Position.....

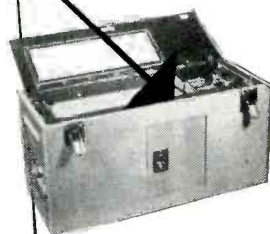

Standard catalogued units available in 1, 2, 4, 6 and 8 channels. Companion amplifiers for all applications.

matching, stability of power supplies, etc. The seventh and final part is devoted to the discussion of future possibilities of velocity-modulation tubes such as achieving greater bandwidth, higher power, lower noise, etc.

The book contains 476 illustrations and a bibliography comprising 385 items including a list of books, review articles, papers on specialized topics, and a list of pertinent patents. This reviewer, who possesses only a limited knowledge of technical French, believes that many tube engineers, even with little familiarity with the language, will be able to follow the presentation and make effective use of the great deal of information contained in the book.—ANDREW V. HAEFF.

Alternating Current Machines

By GEORGE V. MUELLER. McGraw-Hill Book Co., New York, N. Y., 1952, 502 pages, \$7.50.

IN SPITE of the inroads of electronic techniques into established areas of electrical engineering, and the creation of new areas, the basic electrical-mechanical energy-conversion process in industry is still accomplished by rotating electrical machinery. Moreover, the use of regulator- and servo-controlled machines is growing, largely through the coordinated application of electronic equipment with electrical machinery. For these reasons, training in the fundamental principles of electrical machinery is a necessity for engineers working in many of the areas now constituting electrical engineering.

There are other aspects of electrical machinery that are important to the electrical engineer and the electrical-engineering student aside from machinery for machinery's sake. For example, the principles of torque and force production through the interaction of electromagnetic fields, and the principles of voltage generation through relative movements of conductors and fields, apply equally well to the conventional rotating machinery as to the wide variety of microphones, recorders, loudspeakers, meter movements, pickup devices, and the like, that serve as the ter-

for accurate

TORQUE

measurement

5 lb./in. to 750 lb./in.

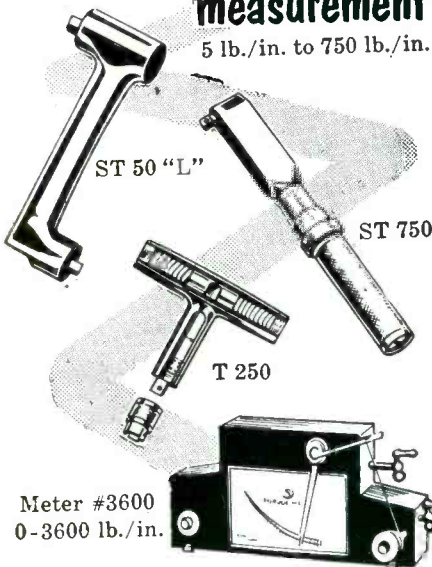

Meter #3600
0-3600 lb./in.

All wrenches meet Spec. #MIL-H 4034A.
Write For Catalog

Skyway
PRECISION TOOL CO.
1107A So. Fremont Ave.
Alhambra, Calif.

SENIOR ENGINEERS

Opportunities Western Connecticut

Opportunities for personnel experienced in the following fields. Our present operations require us to be concerned with the following materials, processes, specifications and equipment: Fosterite, Hermetically sealed transformers, Casing resins, Vacuum impregnation, MIL-T-27 and AN-E-19, Precision testing equipment, Oil filling.

Our record of over 40 years of successful business operation indicates the security of this company. If you are experienced in the design of audio transformers, power transformers, reactors, pulse transformers, please send resume to Director of Personnel.

THE WHEELER INSULATED WIRE CO.
Division of Sperry Corporation
150 E. Aurora St., Waterbury, Conn.

Kahle

SPECIALISTS IN
HIGH-SPEED

electron tube machinery

Kahle's 40 years of experience eliminate trial orders and experimental set-ups. Standard toolings for all tube manufacturing eventualities *already* have been tested and approved. This means that Kahle can assemble machines for everything from sub-miniature to largest TV picture tubes to your exact specifications . . . at lower costs!

Kahle

ENGINEERING CO.

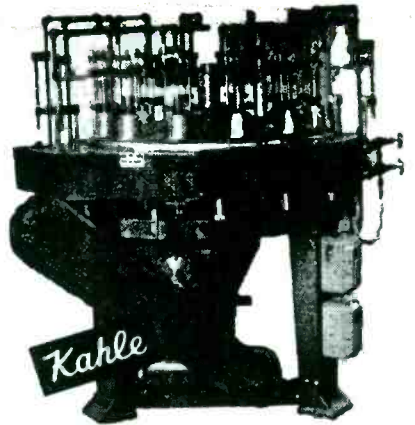

#1384 12-HEAD BUTTON STEM MACHINE. FOR SUB-MINIATURE TUBES. Upper and lower molds on every head. Dual motor drive. Indexing and head rotation are by separate motors. For oblong, square, round buttons, etc.

Machinery for all types of electron tubes and related glass products.

Consultations invited. Write today for our new catalog with complete details.

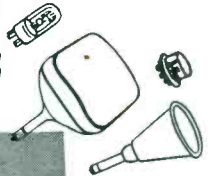

1309 Seventh St., North Bergen, N. J.



HEAT RESISTANT WIRES FOR EVERY APPLICATION . . .

Just a Reminder!

Now is the time to install Lewis heating cable on those outside pipe lines that caused you trouble last winter. Nickel Chrome conductor with special insulation designed for 500°F operation.

Write for details

Send your electronic control, communications or appliance wiring specifications for a recommended solution by our engineers.

FOR A TRIAL ORDER OR A CARLOAD consult

- HEATING UNITS
- HEATING ELEMENT
- RESISTANCE LINE CORD
- THERMOCOUPLE WIRE
- ASBESTOS LEAD & FIXTURE WIRE
- INSULATED RESISTANCE WIRE
- FIBERGLAS INSULATED WIRE
- WIRE TO ANY SPECIFICATIONS



THE LEWIS ENGINEERING CO.

Wire Division
NAUGATUCK CONNECTICUT

Announcing THE NEW C-200

DeJUR External Phasing Potentiometer

The new C-200 high precision potentiometer has been engineered and designed by DeJur-Amsco to fulfill the exacting requirements of contemporary instrument, computer and similar electronic equipment.

Designers are invited to submit their applications to DeJur engineers for recommendations and suggestions.



- 2" Diameter
- 4 Watts Fully Enclosed
- 10 to 200,000 Ohms Accuracy up to 1%
- Linearity up to 0.3%
- Non Linear Windings
- 360° (Continuous) Mechanical Rotation
- 320° Electrical Rotation
- Taps as Required
- High Resolution 1,000,000 Cycles Operational Life
- Precious Metal Contacts
- Low Torque 1 oz. inch
- Centerless Ground Stainless Steel Shafts
- Ball Bearings to Special Order
- Single or Ganged Units
- Servo Type Mounting or Single Hole Threaded Bushing
- Numerous Shaft Designs

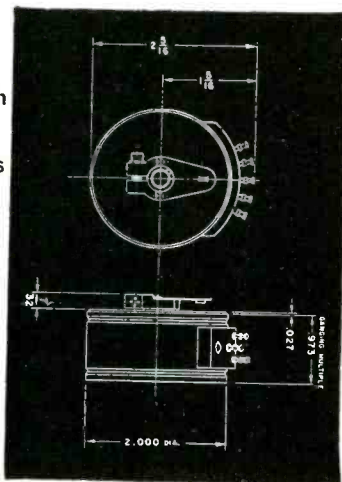

WRITE FOR BULLETIN 100-E

DeJUR AMSCO CORPORATION
 45-01 NORTHERN BOULEVARD, L. I. C. 1, N. Y.
 MANUFACTURERS OF SCIENTIFIC PRECISION EQUIPMENT FOR OVER A QUARTER OF A CENTURY
 • CAMERAS • PROJECTORS • ENLARGERS • EXPOSURE METERS •

minating devices of electronic and communications systems. The concepts of sinusoidal space and time waves of B and H that are used to explain the operation of induction motors and synchronous machines apply equally well to the wave picture for open-wire transmission lines and wave guides. Finally, the idea that an equivalent circuit represents a physical device only within specified assumptions is equally important in the analysis of electrical machinery as in the analysis of vacuum-tube circuits.

Professor Mueller's book is designed for fourth-year electrical-engineering students. As such, it covers material on transformers, single-phase and polyphase induction motors, synchronous machines, synchronous converters, and rectifiers.

The section on transformers utilizes 210 out of the 502 pages in the book, and covers not only single-phase and polyphase-connected power transformers, but instrument transformers, constant-voltage transformers, induction regulators, and so forth. The section on polyphase induction motors shows the best balance of content between principles and details and between length of the section to length of the book. In addition to the conventional induction-motor material, the section has interesting discussions of speed control and induction-generator action. The section on synchronous machines includes introductory material on the two-reaction theory. The single-phase-motor material is largely qualitative. The synchronous-converter treatment is conventional, while the rectifier section is short and applied largely to waveforms of the single-phase two-anode rectifier and the three-phase rectifier.

The book is liberally illustrated with oscillograms that provide convincing representations of waveform phenomena. However, they lose their effectiveness where several traces are crowded onto one axis with inadequate labeling. The photographs illustrating equipment types appear up to date and informative. Plots of air-gap flux waves are used relatively little; vector diagrams are apparently the more-

Fine Wire Specialists

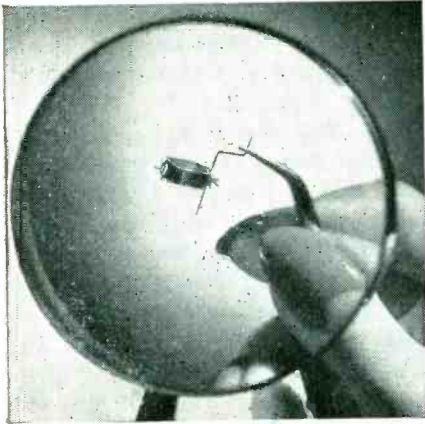

1700 Inches of No. 50 Wire on This Meter Coil

Want really micro-fine wire? Write for price list on our full line of highest quality enameled magnet and Litz wire. Immediate delivery. All sizes—Numbers 44 to 52 (.002" to .0008").

INSTRUMENT WIRE COMPANY

150 Church Street • Guilford, Conn.

ELECTRONICALLY REGULATED LABORATORY POWER SUPPLIES



• STABLE
• DEPENDABLE
• MODERATELY PRICED

MODEL 28
STANDARD
RACK
MOUNTING

PANEL SIZE
5 1/2" x 19"
WEIGHT 16 LBS.

- **INPUT:** 105 to 125 VAC, 50-60 cy
- **OUTPUT #1:** 200 to 325 Volts DC at 100 ma regulated
- **OUTPUT #2:** 6.3 Volts AC CT at 3A unregulated
- **RIPPLE OUTPUT:** Less than 10 millivolts rms

For complete information write for Bulletin E



LAMBDA ELECTRONICS
CORPORATION
CORONA NEW YORK

LICK SOLDERING FATIGUE!



—with the new **HEXAACON FEATHERWEIGHT MODEL 30H**

So light its weight is hardly noticeable, but more powerful than its wattage rating indicates. Hatchet design makes it more comfortable and practical to use than a soldering pencil. No transformer required.

WEIGHT—5 1/2 OUNCES (LESS CORD); WATTS—40 OR 60; TIP DIA.—BOTH 1/8" AND 1/4" TIPS FURNISHED WITH EACH IRON; PRICE— **\$5.50**

Write today for catalog describing the complete line of screw tip, plug tip and hatchet irons.

HEXAACON ELECTRIC CO.

130 WEST CLAY AVE.,
ROSELLE PARK, N. J.

HEXAACON

The confidence vote in coils goes to **DANO**



- Form Wound
- Paper Section
- Acetate Bobbin
- Bakelite Bobbin
- Cotton Interweave
- Coils for High Temperature Applications

ALSO,
TRANSFORMERS
MADE TO ORDER

Dano for coil performance! Dano for coil dependability! From simple electrical coil windings to specially treated coils—Dano is the confident choice everytime.



THE DANO ELECTRIC CO.
MAIN ST., WINSTED, CONN.

DIGITAL COMPUTER ENGINEERS

ELECTRICAL ENGINEERS and PHYSICISTS

needed for circuit design and development. Engineers and Physicists with 1 to 4 years experience in pulse circuits, pulse handling techniques, and systems development. Openings also for recent graduates.

- Replies strictly confidential
- Interviews arranged at our expense

Engineering Research Associates, Inc.



Leaders in the Development of Digital Computers

1902 W. Minnehaha, St. Paul 4, Minn.

• "You Will Enjoy Living In Minnesota"

MICROPOT

PRECISION TEN-TURN POTENTIOMETER

1. You get permanent accuracy because the resistance wire is locked in place. It is precision positioned and moulded integrally with the housing.
2. You get permanently accurate settings, smooth action and low uniform torque provided by the stainless steel, precision ground, double thread lead screw guiding the moving contact.
3. You get precise positioning of the moving contact because of the two bearings supporting the rotor assembly.
4. You get good rigid terminals because they are moulded integrally with the housing.
5. Terminals soldered to ends of resistance element before moulding. Entire resistance circuit is an integral part of the housing.
6. You get accurate setting and re-setting due to anti-backlash spring in contact guide.
7. You get a fine resolution because of the $43\frac{1}{2}$ " length of resistance wire in the spiral element.
8. You get a resistance output directly proportional to shaft rotation within $\pm 0.1\%$ of the total resistance. Every potentiometer is automatically machine tested for linearity at 101 points.

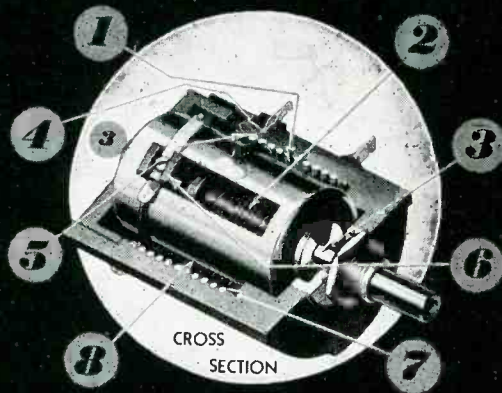

**LINEARITY
ACCURACY $\pm 0.1\%$**

Units for immediate shipment:
1,000 to 30,000 ohm range.
Special resistance values made to order.

WRITE TODAY FOR
ENGINEERING INFORMATION



BORG EQUIPMENT DIVISION
THE GEORGE W. BORG CORPORATION
JANESVILLE • WISCONSIN

NEW BOOKS

(continued)

avored graphical teaching aid. In general, the presentation of physical concepts of machine behavior could be improved.

Examples appear frequently in the text; they serve the triple purpose of illustrating particular points, providing additional subject material, and demonstrating typical sizes and orders of magnitude. As a teaching text, the book has other features. It has a plentiful supply of problems at the end of each chapter. In addition, it has instructions in the appendix for 22 experiments on a-c machinery. The text material is apparently keyed to the experiments to such an extent that parts of the text read like instructions for laboratory work, rather than explanations of particular topics. Nevertheless, this book has advantages for the busy teacher who must be concerned with the combination of class work, problems, and laboratory.—ALEXANDER KUSKO, *Department of Electrical Engineering, Massachusetts Institute of Technology.*

Measurements at Centimeter Wavelength

BY DONALD D. KING, *Johns Hopkins University.* Van Nostrand, 327 pages, \$5.50, 1952.

THIS is an excellent book for people who have a nodding acquaintance with the properties of centimeter waves. The book is so written that should more theory of microwave propagation be needed, more than adequate references are given in each chapter.

Chapter 1 is introductory, outlining the general scope of the material. It sets the limitations in the use of lumped network elements and ordinary electronic devices at centimeter wavelength.

Chapter 2 discusses methods of transmitting power at centimeter wavelengths. Two-conductor transmission lines and hollow pipes are correlated and normalized transmission formulas are explained. The properties of the more common uniconductor wave guides are completely tabulated. Transmission-line charts are presented along with a discussion about the properties

FEATURING

Hermetically sealed quartz crystal holders and all types of Hermetic Seals, built to meet critical government specifications.

Hermetic Seals made to most exacting standards in one of New Jersey's most modern equipped plant with latest manufacturing facilities.

Our engineering staff is ready to serve your needs promptly.

Write for prices and complete data sheets.

• **L. L. Constantin & Co.** •
Route 6 and Franklin Ave., Lodi, N.J.

RECORDERS

RECORD TIME · COUNT QUANTITY AND WEIGHT

Actuated by an electrical impulse . . . operates on the output of a scaler, photo tube, limit switch or any similar device. Records counts with relation to time and quantity on a roll of tape . . . automatically resets to zero.

In *Radioactive Research*, it saves precious man hours and results in greater economy and efficiency.

In *Industry*, it maintains a permanent record automatically, recording production and time each hour.

Whatever your counting problems, our Engineering Department can adapt these Recorders to meet your particular need.

Write for interesting Booklet SC34

WEIGHT RECORDERS
SCALES
HI-SPEED COUNTERS

AUTOMATIC WEIGHT
RECORDERS SINCE 1888

STREETER-AMET COMPANY
4101 RAVENSWOOD AVENUE
CHICAGO 13, ILLINOIS

MICRODIAL

TEN TURN-COUNTING DIAL

Microdial is composed of two concentrically mounted dials . . . one for counting increments of each turn and the other for counting turns. The incremental dial has 100 equal divisions and is attached rigidly to the shaft so there is no backlash. Thus the contact position is indicated to an indexed accuracy of 1 part in 1000. Rotation is continuous in either direction. There are no stops on the Microdial assembly.

COMPACT . . . Microdial has same O.D. as Micropot . . . requires no more panel space.

CLEAR READING . . . Forced fast-reading tests showed only 1/20th as many errors with Microdial open window as with next most legible dial. Turn counter distinguishes between 0 and 10 turn readings, and accelerates to avoid confusion on readings near integral turns. Precise readings are made from larger dial with maximum separation of graduations and wide angle visibility.

CONVENIENT . . . delivered completely assembled with dials synchronized. Easily mounted in a few seconds. All dials may be locked.

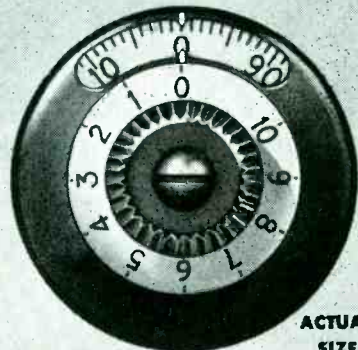

ACTUAL SIZE

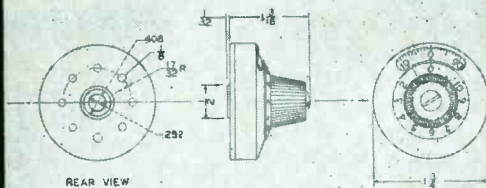

Microdial . . . turn-counting dial, primarily designed for use on Micropot ten turn linear potentiometers . . . use it on any multiturn device having ten turns or less.



BORG EQUIPMENT DIVISION
THE GEORGE W. BORG CORPORATION
JANESVILLE • WISCONSIN

for the **ELECTRONIC INDUSTRIES**

Quality Ribbons STRIPS

**MOLYBDENUM
TUNGSTEN
TANTALUM
FORMED PIECES**

Your Special Metals Rolled to Thin Sizes & Close Tolerances

YOUR INQUIRIES WILL RECEIVE PROMPT ATTENTION

H. CROSS CO.

15 BEEKMAN ST., N. Y. 38, N. Y.
WOrth 2-2044 and COrtlandt 7-0470

FOR QUALITY • QUANTITY — QUICKLY

SPECIFY

DAGE

RADIO FREQUENCY CONNECTORS

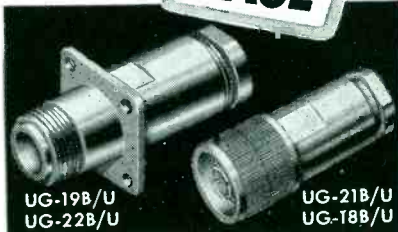

UG-19B/U
UG-22B/U

UG-21B/U
UG-18B/U

● Dage specializes in the manufacture of the *finest* in Type BNC, Type N and special radio frequency connectors. Your requirements for radio frequency connectors will be met quickly and efficiently by Dage. All Dage connectors are manufactured in strict accordance with military specifications. Write Dage today.



QUALITY
QUANTITY
QUICKLY

DAGE

DAGE ELECTRIC COMPANY, INC.
67 North Second Street • Beech Grove, Indiana

Electronics Mfrs... See Birnbach!



Cut production costs, speed operations, by specifying BIRNBACH—your **DEPENDABLE** Source of Supply!

COMPLETE WAREHOUSE STOCKS
Write for Catalog 52

BIRNBACH RADIO CO. INC.
145 HUDSON STREET
NEW YORK 13, N. Y.

For All Your Needs in
Radio - Electronic - Television

- Gov't Specification
- Hook-Up Wire
SRIR-SRHV
JAN-C-76
- Thermoplastic
WL-Glass Braid
Nylon Jacket
105° C. UL
Approved
- Wire—Cable
- Guy Wire
- Aluminum Wire
- Magnet Wire
- Jacks—Plugs
- Insulators
Steatite-Ceramic
- Hardware
- Accessories
- Test Leads
- Vinyl Extruded
and Radio
Grade Tubing

Manufacturers of Quality Products
for the Electronics Industries—
Serving since 1923



Try Remler for Service-Tested
"Hard-to-Get" Components

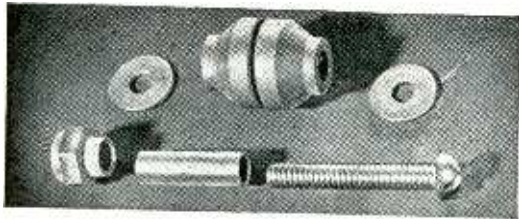

SILASTIC RUBBER SHOCK MOUNTS

① Ideal for sub-panel mounting. Isolates tubes from shock and vibration. Mount retains compliance from *minus* 70° to *plus* 480°F. Invaluable for military and airborne equipment.

Custom Components

Metal-plastic components designed and manufactured to order. Write for quotations specifying electrical and mechanical characteristics. Describe application. No obligation.



MINIATURE TUBE CLAMP

② Corrosion resistant. Holds miniatures in sockets under severe conditions of shock and vibration without restricting air circulation. Easy to insert and withdraw tubes. Three sizes.

Remler Company Ltd.
2101 Bryant St. San Francisco 10, Calif.

Remler

Since 1918 PIONEERS IN ELECTRONICS AND PLASTICS



Coil with cotton yarn covering

Here at Coto-Coil . . .

. . . the High Speed Covering Department winds outer covers of natural or synthetic yarns over Coto Coils. These top quality yarns position and hold down leads according to specifications, provide electrical insulation and physical protection. Here power winders and expert operators insure maximum production output of the highest quality. These

modern production facilities, plus 35 years of experience, combine to make Coto Coils the first choice for engineered coils. Coto-Coil Company, 65 Pavilion Avenue, Providence 5, R. I.



of each chart and a key as to which chart is the best for a particular type of problems. The physical construction of transmission guides is treated along with methods of suppressing reflections due to physical supports. Matching sections, baluns, switches and attenuators are presented.

Chapter 3 discusses the devices used for converting high frequency power to power at frequencies more amenable to measurement with instruments. Bolometers, thermocouples, load lamps, crystals, electron tubes, barreters and their associated circuitry are described. Methods of coupling these components to lines and guides and ways of calibrating the system as a detector are given. Wattmeters, attenuation and noise measurements terminate the chapter.

Chapter 4 covers the measurement of frequency, wavelength and wave form. Comparison with the harmonics of a known frequency, tuned resonant circuits (lumped and cavities) and measurement of velocity are used for frequency measurements. Methods of panoramic displays are given. The methods of measurement are compared in a table which gives the limitations of each.

Chapter 5 presents the more common centimeter-wave generators. Methods of modulation and stabilization are discussed. Tests on oscillators are outlined. Frequency pulling due to loading is discussed.

Chapter 6 covers impedance measurement by means of lines, bridges and combinations of the two. Standing-wave or resonance ratios, curve width and multiple fixed probes are used on lines. Lumped as well as wave guide bridges are used as impedance comparator devices. Measurement of dielectric properties is accomplished by using wave guides and resonators.

Chapter 7 describes methods of measuring antenna fields. The basic construction of the equipment for making such measurements and its properties are discussed in some detail.

This book fills the need of those who wish to learn the general technique of centimeter-wave measure-

ments without wading through a sea of introductory words and mathematics. The pertinent facts are well presented. No words are wasted. There is no unnecessary mathematical manipulation. Sufficient references are given for the reader who wishes more detail.—CHARLES A. HACHEMEISTER, *Brooklyn Polytechnic Institute.*

THUMBNAIL REVIEWS

CALIBRATION OF COMMERCIAL RADIO FIELD-STRENGTH METERS. By Frank M. Greene, National Bureau of Standards, Circular 517, 5 pages, 10 cents, Government Printing Office, Washington 25, D. C. Describes standards and methods used in calibrating meters in the range 10 kc to 300 mc.

RADIO AMATEUR'S HANDBOOK, 29th Edition. American Radio Relay League, West Hartford, Conn., 1952, \$3.00. 784 pages, 93 charts, 459 tube base diagrams, 85 basic formulas. This hardy perennial continues to grow. This new edition containing material published in QST during the past year involves new gear and up-to-date modifications of older radio equipment, plus history, basic theory and a vast quantity of data useful to all practicing radio people.

AN ADHESIVE TAPE-RESISTOR SYSTEM. By B. L. Davis, National Bureau of Standards, Circular 530, 83 pages, 30 cents, 1952, Government Printing Office, Washington 25, D. C. Complete description of NBS development of carbon-film resistor in form of adhesive tape as a useful component in the miniaturization program. Description of ovens, switching equipment, recorder for life tests and data on each of the carbons studied plus sources of supply are included.

TRAITE D'ELECTRICITE THEORIQUE; Vol. 1, Electrostatics. By Marc Jouguet, Gauthier-Villars, Paris; 359 pages, \$11.75, 1952. First of what promises to be several volumes of a profound and rigid analysis of all electrical theory.

ELECTRICAL ENGINEERING, Volume 1, Direct Currents. By Chester L. Dawes, McGraw-Hill Book Co., 736 pages, \$7.00, 1952. For the beginning student of electrical engineering, a new edition including recent developments in applied electrical science; electrical, magnetic and physical phenomena.

INDUSTRIAL CARBON & GRAPHITE PRODUCTS. A vest pocket handbook giving properties and dimensions of carbon and graphite electrodes of all sorts. National Carbon Company, 30 East 42 St., New York 17, N. Y.

RADIOTELEPHONE LICENSE MANUAL. By Woodrow Smith, Editors and Engineers, Ltd., Santa Barbara, Calif., 1952, 197 pages, \$3.75. Answers are given to questions taken from the latest FCC Study Guide for Elements I through IV as preparation for all grades of commercial radiotelephone license. An appendix gives formulas, Q signals, miscellaneous abbreviations and excerpts from laws and regulations. No questions on radiotelegraph operating practice, advanced radiotelegraph, aircraft radiotelegraph or ship radar techniques are included.

SUBCONTRACTING FOR DEFENSE. Chamber of Commerce of the United States, Washington, 6, D. C., 36 pages, 1952, 50¢. A how-to pamphlet on getting subcontract orders on the vast number of items which go into defense end-products.

CORRECTION. By error, the price of "High Frequency Transmission Lines" by Willis Jackson, published by John Wiley & Sons, Inc., was stated in May 1952 **ELECTRONICS** to be \$0.75 whereas the correct price is \$1.75.

Winchester Electronics
INCORPORATED

NEW SMALL SIZES

available for immediate shipment

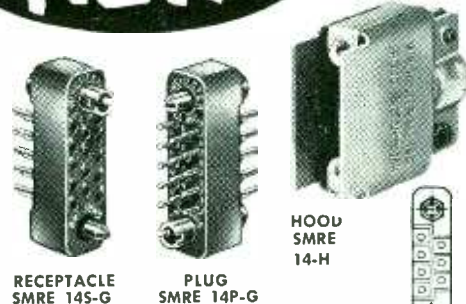

DIAGRAMS OF CONNECTORS SHOWN ARE ACTUAL SIZE

SUB-MINIATURE RECTANGULAR "SMRE" CONNECTORS

MONOBLOC* CONSTRUCTION eliminates unnecessary creepage paths, moisture and dust pockets and provides stronger molded parts.

MOLDED MELAMINE BODIES (in accordance with MIL-P14a)—mineral filled—are fungus-proof and provide mechanical strength as well as high arc and dielectric resistance.

CONTACTS and GUIDES are precision machined: pins from brass bar (QQ-B611) and sockets from spring temper phosphor bronze bar (QQ-B746a). They are gold plated over silver for consistent low contact resistance, reduction of corrosion and aid in soldering.

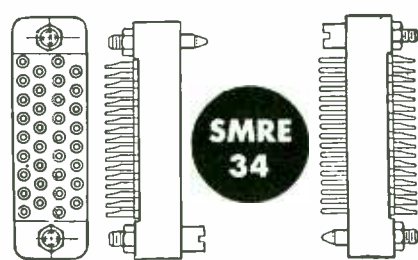
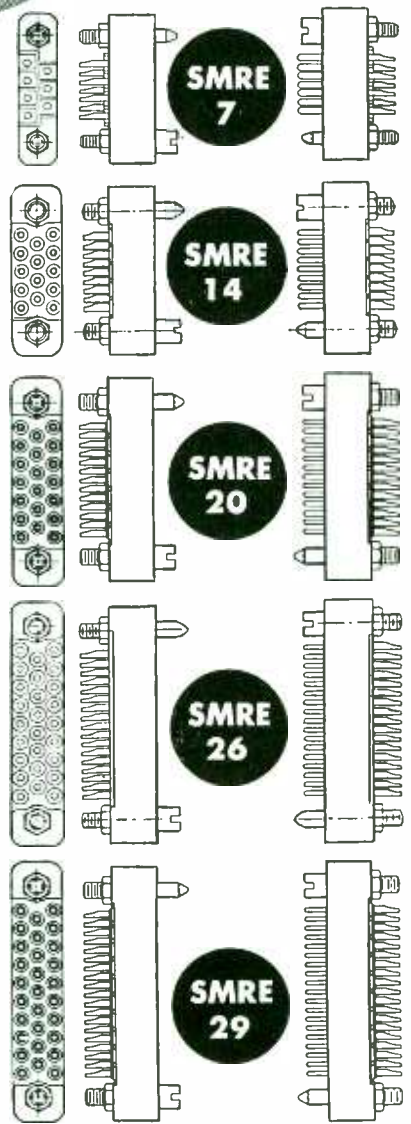

SMRE HOOD SIZES VARY TO FIT THE RESPECTIVE CONNECTORS ABOVE.

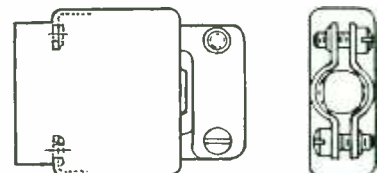

WINCHESTER ELECTRONICS
INCORPORATED

GLENBROOK, CONN., U.S.A.
West Coast Branch:
1729 Wilshire Blvd. Santa Monica, Calif.

*TRADE MARK REG. U. S. PAT. OFF.

WRITE OR WIRE TODAY FOR FULL DETAILS

potentiometers



Syncomount

Linear and functional output, rugged construction, ball bearings, small size, low torque, synco-type mount.



Rectipot

Push-pull motion, linear and functional output, high resolution, rectilinear potentiometer.



Gangpot

Functional and linear outputs, coils independently adjustable, variety of flexible assemblies.



Microtorque

Linear output, minimum torque, potentiometer and selsyn outputs, most ultra sensitive of them all.

These potentiometers are available in a variety of resistance values and circuits. For details on these and other fine instruments, write:

G. M. GIANNINI & CO., INC.
Pasadena 1, Calif.

Giannini

BACKTALK

Networks

DEAR SIRs:

IN the January 1952 issue of *ELECTRONICS* appeared an article by Mr. Peter G. Sulzer (p 95, "Single-Band Audio Generator") in which reference is made to an R-C network (reference 8, p 97) that "... has been described in the German and Japanese literature, but suitable reference is not available".

On page 66 of the January 1945 issue of the *Proceedings of the IRE*, I give myself credit for having developed the circuit (network E, Fig. 1 in Mr. Sulzer's paper).

As the development of this network is a rather simple matter it is possible that someone else found the circuit before I did. Such a thing, I understand, happened in the case of the Ginzton and Hollingsworth network (Sulzer's reference 3).

On the other hand, the Sulzer network can be readily shown to be an unsymmetrical twin-T network which may be transformed into an equivalent pi. Examination of the resulting impedance equations do not seem to throw any light as to the manner in which the network meets these conditions. Use of the approximations (according to Mr. Sulzer's circuit constants) $R \gg R_3$; $R_1 \gg R_3$; $R_1 = R_2$ does not give any additional information. The question arises as to the desirability of a network that does not lend itself to design by means of pencil and paper.

BRAULIO DUENO

Physics Department
Universidad de Puerto Rico
Mayaguez, Puerto Rico

(Editor's Note: Space limitations forced us to omit Dueno's elegant mathematical verification of his contentions as outlined above.)

Audio Generator

DEAR SIRs:

SERGEANT H. B. Kendall, of the Royal Canadian Air Force Station at Clinton, Ontario, has called to my attention an error that appeared in one of the figures in my recent article, "Single-Band Audio Generator" (*ELECTRONICS*, p 95, Jan. 1952).

In Fig. 2C and 2D the vector E_n should be drawn downward and

- ELECTRONIC DESIGN ENGINEERS
- TECHNICAL WRITERS
- DESIGN DRAFTSMEN
- PHYSICISTS

Westinghouse

offers you

SECURITY AND OPPORTUNITY

EE's and ME's with over 3 years experience . . . a number of excellent positions are now available in our Electronic & X-ray and Air-Arm Divisions for work on:

- Broadcast Transmitters
- Power Line Carrier Communication Equipment
- Railroad Radio
- Radio Frequency Heating
- Medical and Industrial X-ray
- Commercial Radar
- Balancing Equipment
- Military Radar (ship, ground, airborne)
- Military Transmitters
- Specialized Electronic Equipment
- Fire Control Systems
- Automatic Pilots
- Guided Missiles

Check These Outstanding Benefits: Top pay, ideal working conditions, advancement on merit, graduate study opportunities, employee scholarships, paid relocation expenses, Baltimore location.

Send resume of experience and education to: Manager of Industrial Relations, Westinghouse Electric Corp., 2519 Wilkens Ave., Baltimore 3, Md.

If you are using your greatest skill in a defense industry, do not apply.

YOU CAN BE SURE... IF IT'S
Westinghouse



development
and production.

METALLURGISTS

BASE, RARE AND PRECIOUS
METALS AND ALLOYS

SMALL UNITS

SMALL SIZES

CLOSE TOLERANCES

Nickel alloy, filament wire and
ribbon: flat, grooved, crowned.

Grid wire electroplated.

Alloys for special requirements,
bare or enamelled.

Further details upon request.

SECON

METALS CORPORATION
228 East 45th Street, New York 17, N. Y.
MUrray Hill 7-1594

Runzel WIRE CORD and CABLE



"Products of
Science"

The Runzel Lab-
oratory insures
that every inch of
Runzel wire, cord
and cable is
thoroughly tested before shipping.
Your wiring needs in hook-up,
lead-in, shielded wire and cords,
speaker cords and all types of in-
sulated wire products, in almost
endless variety of colors, sizes and
specifications, are available from
this centrally located plant.

WRITE FOR
SAMPLES

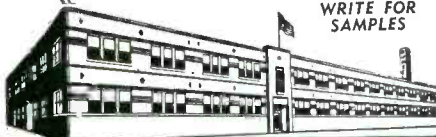

RUNZEL CORD & WIRE CO.
4723 Montrose Avenue
Chicago 41, Illinois.

ENGRAVE

PANELS OF ANY DIMENSIONS IN
YOUR OWN SHOP

with the **Engravo** graph

PORTABLE MODEL I-S



TRACER
GUIDED FOR
UNSKILLED
LABOR

Send for Booklets
I-S 29 —portable model
H-29 —heavy duty model

NEW HERMES, Inc. 13-19 University Place, N.Y. 3
CANADA: 359 St. James St., Montreal

new hermes

Engravo

 graph

- The only portable machine which reproduces 15 sizes from one master alphabet.
- The only one with adjustable copy holding slides for multiline engraving in one set-up.
- Self-centering holding vise for nameplates.

NEW HERMES, Inc. 13-19 University Place, N.Y. 3, N.Y.

In Canada: 359 St. James St., Montreal

World's Largest Manufacturer of Portable Engraving Machines

SEALING
DIPPING
POTTING
IMPREGNATING



INSULATING
FUNGUSPROOFING
MOISTUREPROOFING
HEAT CONDUCTING

WAXES BIWAX COMPOUNDS

Developed and produced for manufacturers of electronic components and other electrical units.

Specifications and samples available on request.

Information relative to your problem or application will enable us to make suggestions and recommendations.

BIWAX CORPORATION

3445 HOWARD STREET
SKOKIE, ILLINOIS

Simplifying HF Power Measurement
Model 67 TERMALINE
DIRECT-READING R-F WATTMETER

30 mc to 500 mc
 (to 1000 mc if specified)

50 ohms

Triple Range 0-25 watts
 0-100 "
 0-500 "

Type N Input Connector
 (Adaptor for PL-259 supplied)

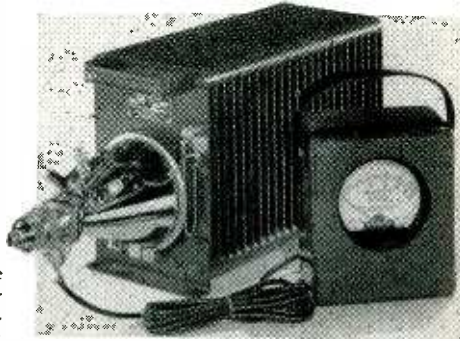

● Model 67 is a larger type Wattmeter than the well-known AN-ME-11/U (our Model 611) R-F Wattmeter. Specifically designed for fixed station transmitters to 500 watts output, it may be used nicely on low range for mobile gear. Provided with an aluminum cased, shock-mounted meter, Model 67 is as simple to use as a DC voltmeter. Now in general use throughout the industry, TERMALINE Wattmeters may be depended upon for fast, accurate and repeatable power readings.

NON-RADIATING
 ... Accuracy - 5%
RUGGED CONSTRUCTION
 ... Size - 17" x 9" x 6"
 Wght. - 30 pounds



BIRD
ELECTRONIC CORP.
TERMALINE COAXIAL LINE
 INSTRUMENTS

1800 EAST 38TH ST.
 CLEVELAND 14,
 OHIO
 West Coast:
 NEELY ENTERPRISES
 HOLLYWOOD 46, CAL.

HUGHES

Research and Development

Laboratories

invites inquiries from

Engineers and Physicists

Culver City, Los Angeles County, California

ASSURANCE IS REQUIRED THAT RE-LOCATION OF THE APPLICANT
 WILL NOT CAUSE DISRUPTION OF AN URGENT MILITARY PROJECT.

BACKTALK

(continued)

to the right, and the markings of E_c and E_R should be interchanged. These changes do not alter the explanation in the text.

PETER G. SULZER

*Ionospheric Research Section
 Central Radio Propagation Laboratory
 National Bureau of Standards
 Washington, D. C.*

More on Phase

DEAR SIRS:

THE ARTICLE by John L. Glaser entitled, "Accurate Phase Difference by Lissajous Figures" (ELECTRONICS, p 206, Mar. 1952) leads me to mention still another method of determining phase angle between two sinusoidal voltages of the same frequency. The method is so obvious that it might be overlooked. The accuracy possible with this method is particularly good for values of phase angle around 90 degrees, so that it might very well supplement the methods mentioned in Glaser's article.

The horizontal and vertical amplifications are adjusted so that the ellipse is tangent to a pair of vertical lines distant $2X$ apart and to

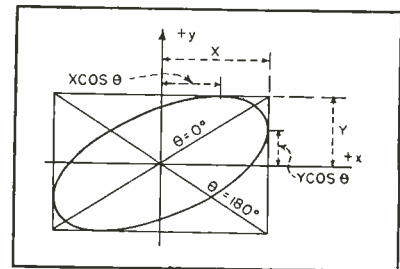

Additional method for measuring phase between sinusoidal voltages with maximum accuracy around 90 degrees

a pair of horizontal lines distant $2Y$ apart as shown in the accompanying diagram. Then the distances from the coordinate axes to the points of tangency are $X \cos \theta$ and $Y \cos \theta$ as shown.

If the positive x and y directions are to the right and up as shown then θ is the angle by which the X signal laps the Y signal. For θ equals zero the ellipse degenerates into a straight line in the first and third quadrants. With increasing θ the axes of the ellipse rotate clockwise. At θ equals 90 degrees they are horizontal and vertical. With increasing θ the clockwise rotation continues until

at θ equals 180 degrees the ellipse becomes a straight line in the fourth and second quadrants.

The average of four values of $\cos \theta$ may be used for any ellipse to improve the accuracy in determining θ .

Justification for the method is easily provided by considering the projections of two rotating vectors of lengths Y and X separated by phase angle θ . When one is projected true length, say X , the projection of the other is $Y \cos \theta$. This gives one point of tangency on the ellipse. Vice versa for the other tangent point.

E. E. WEIBEL

Professor of Mechanical Engineering
University of Colorado
Boulder, Colorado

Military Justice

DEAR SIRs:

IN THE March issue of *ELECTRONICS* there appeared some paragraphs (*Industry Report*, p 16) entitled "What Happens to Drafted Engineers?" There are some glaring errors, or rather omissions in this piece that I feel bear illumination because of your widespread circulation throughout the industry and the possible misconceptions that might be formed, and because I have yet to read an article on engineers in service in any publication which accurately portrays the situation.

The picture you paint of OCS is quite accurate as far as it goes. But it implies that OCS grads are utilized in technical endeavors. To quote your context, "... receive assignments in line with their civilian occupations." Nothing could be further from fact. Upon receiving his commission, the new 2nd lieutenant is placed upon the nearest boat to the Far East. He might delay his departure thirteen weeks by undertaking more extensive training in a particular field (radar, radio, wire, photo). Or he might possibly be sent to Germany. But in any case, he winds up as an *administrative officer*, usually in a signal company or service company, or if he's exceptionally lucky, in a signal repair depot. I have yet to hear of the need for an en-

DO MORE IN LESS SPACE!

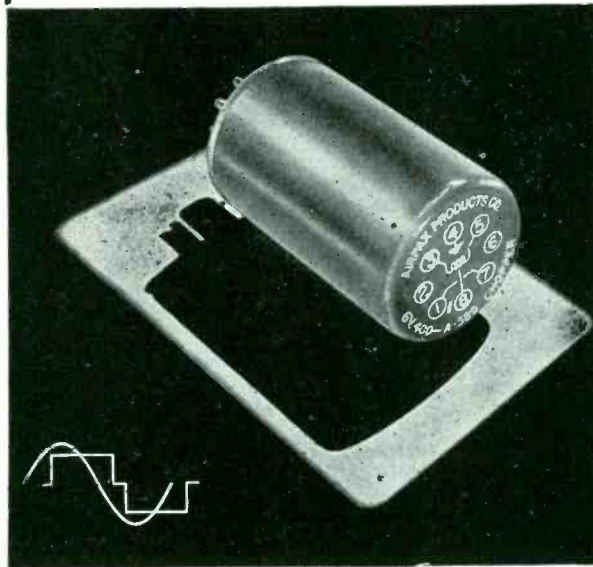

Model A589, a rugged 400 cycle chopper, 5 volt. Will withstand 10G vibration operating, 50G non-operating and can be used reliably over temperatures of -70°C to 100°C . This chopper has a phase lag of 65° between the drive voltage and the square wave output. Adjusted for 380 to 420 cycles, can be operated over much wider ranges. The residual noise is less than 1.5 mv peak at one megohm circuit impedance. Hermetically sealed, built in accordance with exacting military specifications and adjusted precisely to very close tolerances. Constructed per AN-E-19 employs silicone shock mounting, silicone glass insulation for maximum stability.

For more than five years, AIRPAX has blazed a trail in the chopper and miniature power supply field which is now clearly marked by acceptance in the nation's most prominent electronic concerns. Phone, wire or write, we can offer field proven experience, reliable units, quick sample delivery and volume production to meet your schedules.

AIRPAX
PRECISION-BUILT
CHOPPERS
AND
INVERTERS
YOU CAN DEPEND ON!

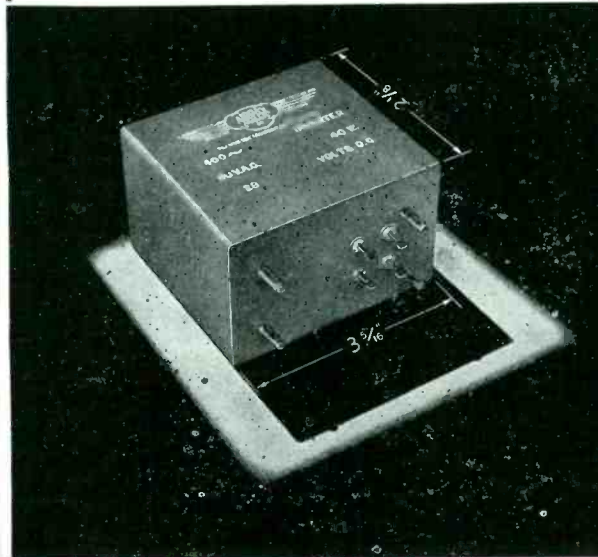

Model A702 heavy duty miniature 400 cycle vibrator inverter, specifically designed to operate 400 cycle gyro motors. The nominal rating is 110 volts, 30 watts, but it will deliver 45 watts for short duty. Most motors require power factor correction as vibrator loads, this model has power factor correction built in to operate 4 small motors. Discuss your application with our engineering department. They may find it wise to make changes to accommodate your load. Will operate at temperatures down to -70°C , up to 85°C . can be subjected to violent vibration, acceleration and shock. Completely hermetically sealed. Weight 1 lb., 6 oz.

AIRPAX
DESIGNERS PRODUCTS COMPANY ENGINEERS
MIDDLE RIVER BALTIMORE 20, MD.

CONTACTS

FOR THE FIELD OF ELECTRONICS

BACKTALK

(continued)

gineer's talents in any of these places.

Incidentally, if your engineers have college degrees, they are eligible for direct commissions. This has the advantage of eliminating twenty-two weeks of OCS, but the ultimate assignment is still the same—administration.

On the other hand, what's happening to the EM (enlisted man) who was an engineer in civilian life? Believe it or not, he is getting a break. A great many of the electronics people are being sent to Ft. Monmouth, New Jersey, where the majority are working in SCEL (Signal Corps Engineering Laboratories) on research and development projects. But lo, the poor officer—he sees SCEL only on guided tours; guides, by the way, are EM's.

This, gentlemen, is the picture as seen through the eyes of a young engineer who is a mere corporal (said rank attained on the basis of military proficiency—not technical ability). Ev all means check my statements. I hope this letter will cause you to do so. Print it in *Backtalk* if you think it worthy but don't advise unsuspecting people to get into Signal Corps OCS. You're doing them a terrible injustice.

CORPORAL
Signal Corps

(Editor's Note: The above letter expresses a viewpoint different from that of most service personnel in letters to this office. As far as we can determine, the true officer experience lies somewhere between that outlined in our original article and the situation described above. Since we have, in the Corporal's letter, documentary proof that there is at least one enlisted man who is satisfied that his civilian talents are being used, we must conclude that progress is being made. May the trend continue.)

Transistor Supply Increases

IN the item entitled "Transistor Supply Increases," appearing on page 10 of the June issue, the table containing production and delivery figures was based upon information presented by Lt. Col. William F. Starr but also contained other data gathered by the Editors. The text of the item, as well, contained data gathered from several sources.

GRC WING NUTS TOP QUALITY PRICED LOWER



Rust-proof zino alloy with GRC's recessed-wing finger-grip. All commercial finishes, all popular thread sizes. Special threads or untapped wing nuts; special designs to order.

Write today for samples and prices—and compare!

GRIES REPRODUCER CORP.
100 Willow Ave., N. Y. 54 • Phone: MO 5-7400

ELECTRICAL COILS

Bobbin, spool, form, layer, interleaved, interwoven types. Made of any material, any finish, for any application.

Send blue-prints and specifications for prompt quotation.



THE FIVE STAR COMPANY
West Main Street
Plantsville, Conn.

ELECTRO PLATING

SPECIALISTS IN
Silver, Cadmium & Zinc
Barrel Plating

Iridite and Cronak
Processes

To Government Specifications
Government Certified

EVEREADY PLATING CO.
1790 FIRST AV. N.Y.C.
EN 9-1222

ELECTROACUSTIC G.m.b.H.
Westring 425-429, Kiel, W. Germany

Electronic Research, Development & Production—Prime & Subcontracting

Highly qualified staff specializing in Underwater Sound Engineering (Sonar, etc.), Radio Communication (HF, VHF Radar, etc.), & Air Sound Equipment. Interested in cooperating with U. S. electronics firms in development work, licensed manufacture and representation in Europe; willing license own patents in U.S.A. (Radar, Sonar Underwater Sounding, Ships Radio).

U. S. Rep.:
American and Foreign Enterprises, Inc.
521 Fifth Avenue New York 17, N. Y.

Shorted Turn Indicator
for unmounted coils
MODEL 101C BULLETIN 42
HUNTINGTON BEACH, CALIF.

KARTRON

FLUXES
SODERING
BRAZING & WELDING



L. B. ALLEN CO. INC. Chicago 31, Ill.
6751 BRYN MAWR AVE.

SUB-CONTRACTING
MILITARY AND COMMERCIAL
receivers—test equipment
transmitters—controls
sub-assemblies

TELETRONICS LABORATORY, INC.
Westbury, L. I., N. Y. Westbury 7-1028

EL-TRONICS, INC.
Research—Development—Manufacture

A single unit to large production quantities. Specialists in Nuclear Instruments, Test Equipment and Instrumentation

Send for Free Resume of our Facilities
2657 N. Howard St. Philadelphia 33, Pa.
GARfield 5-2026

WALKIE-RECORDALL 16 miniature BATTERY RECORDER-PLAYBACK

Continuous, permanent, indexed recording, up to 4 hrs., only 3c hr. Instantaneous, permanent playback. Picks up sound up to 60 ft. Records conferences, lectures, dictation, 2-way phone & sales talks; while walking, riding or flying. Records in closed briefcase with "hidden mike"! Write for Detailed Literature.

MILES REPRODUCER CO., INC.
812 BROADWAY Dep't E-7 NEW YORK 3, N. Y.

FM MODULATION METER

Measures maximum modulation deviation on mobile-system FM transmitters, all frequencies, 25 to 200-MC. Price \$240.00.

LAMPKIN LABORATORIES, INC.
BRADENTON, FLORIDA

We do **Sub-Contracting**
for Military & Commercial
sub-assemblies • test equipment • receivers

MICHEL MANUFACTURING CO.
227 North Water Milwaukee, Wisconsin

TRANS-WIND CO.
Research—Development—Manufacture

Master Precision Potentiometers & Ferro-magnetic Components. Single units & limited production of Transformers, Reactors, Magnetic Amplifiers our specialty. Master potentiometers, linear & non-linear, single & multirun, designed & constructed. Linearity better than .01%.

603 Amboy Street Brooklyn 12, N. Y.

EISLER Manufactures Complete Equipment for:



SPOT WELDERS, Electric for 1/2 to 250 KVA.
TELEVISION TUBE GLASS WORKING EQUIPMENT.
TRANSFORMERS, Special and Standard Types.
INCANDESCENT LAMP Manufacturing Equipment.
FLUORESCENT TUBE Manufacturing Equipment.
NEON SIGN MAKERS EQUIPMENT.
ELECTROLYC EQUIPMENT, Vacuum Pump, etc.
WET GLASS SLICING and Cutting machines for Laboratory Use

EISLER ENGINEERING CO., Inc. 751 So. 13th St., Newark 3, N. J.

PROFESSIONAL SERVICES

Consulting—Patents—Design—Development—Measurement

in

Radio, Audio, Industrial Electronic Appliances

CROSBY LABORATORIES, INC.

Murray G. Crosby & Staff
Radio - Electronic
Research Development & Manufacturing
Communications, FM & TV
Robbins Lane, Hicksville, N. Y.
Hicksville 3-3191

R. W. HODGSON

RESEARCH & DEVELOPMENT ENGINEERS SPECIALIZING IN ELECTRONICS, NUCLEONICS, INSTRUMENTATION, SERVOMECHANISMS & CYBERNETICS
Office—6600 Lexington Ave., Hollywood 38, Calif.
All Mail to Box 874, Sherman Oaks, Calif.
GLadstone 9680

JOSEPH RACKER COMPANY

Radar Consultants & Editors
Technical Manuals
Research and Development
140 Nassau Street, New York 38, N. Y.
Worth 4-1463

DATA ENGINEERS, INC.

Engineering that "Counts"
Designers & Manufacturers of
Data Recording Instruments
4608 Ravenswood Ave., Chicago 40, Ill.

R. W. HODGSON

PATENT AGENT SPECIALIZING IN ELECTRONICS
Registered to Practice Before the U. S. & Foreign Patent Offices
Office—6600 Lexington Ave., Hollywood 38, Calif.
All Mail to Box 874, Sherman Oaks, Calif.
GLadstone 9680

W. C. ROBINETTE CO.

MOTRON DEADBEAT HIGH GAIN SERVOS
Speed control of any Prime Mover $\frac{1}{2}$ % to .001% average. Electric Transmissions $\frac{1}{2}$ to 50 HP plus controls—Zero droop—No load to full load.
802 Fair Oaks Ave. South Pasadena, Calif.
Py 11594

DUBROW DEVELOPMENT CO.

Design — Development — M
Quality Electronic Equipment
347 High St. Burlington, N. J.
Burlington 3-0446

HOGAN LABORATORIES, INC.

John V. L. Hogan, Pres.
Applied Research, Development, Engineering
Est. 1929. Electronics, Optics, Mechanisms, Facsimile Communication, Digital Computers, Electro-sensitive recording media, Instrumentation.
155 Perry Street, New York 14. CHelsea 2-7855

SKINNER, HARLAN AND IRELAND, INC.

Consulting Engineers
Specializing in Magnetic Materials and Their Application
Office and Laboratory Indianapolis 7, Indiana

EDGERTON, GERMESHAUSEN & GRIER, INC.

Consulting Engineers
Research, Development and Manufacture of Electronic and Stroboscopic Equipment
Specialists in High-Speed Photography
180 Brookline Avenue, Boston 15, Mass.

THE KULJIAN CORPORATION

Consultants • Engineers • Constructors
Electronic Control Specialists
Utility • Industrial • Chemical
1200 N. Broad St., Phila. 21, Pa.

THE TECHNICAL MATERIEL CORPORATION

Communications Consultants
Systems Engineering
General Offices and Laboratory
121 Spencer Place, Mamaroneck, N. Y.

Eldico of New York Inc.

Pioneers of Television Interference Elimination from Transmitters, Induction Heaters, Diathermy and etc.
Donald J. S. Merten & Engineering Staff
44-31 Douglaston Pkwy Douglaston, N. Y.
Bayside 9-8686

MEASUREMENTS CORPORATION

Research & Manufacturing Engineers
Harry W. Houck Jerry B. Minter
John M. van Beuren
Specialists in the Design and Development of Electronic Test Instruments
Boonton, N. J.

TELECHROME, INC.

Electronic Design Specialist
COLOR TELEVISION EQUIPMENT
Flying Spot Scanners, Color Synthesizers, Keyers, Monitors, Oscilloscopes and Related Apparatus
J. R. Popkin-Churman, Pres. & Ch. Engr.
88 Merrick Rd. Amityville, L. I. N. Y.

FRANK J. EPSTEIN

Registered Patent Agent
General Patent Practice
Specializing in
Radio, Radar and TV Electronics
837 So. Sycamore Ave., Los Angeles 36, Calif.
Whitney 9317

Eugene Mittelman, E.E., Ph.D.

Consulting Engineer & Physicist
High Frequency Heating—Industrial Electronics
Applied Physics and Mathematics
549 W. Washington Blvd. Chicago 6, Ill.
State 2-8021

HARRIS A. THOMPSON

Microwave Electronic Radar
Electro-Mechanical
Consulting
MFG. & DEVELOPMENT PROBLEMS
2525 Penn., Boulder, Colorado, Phone 1202W

ERCO RADIO LABORATORIES, INC.

Radio Communications Equipment
Engineering - Design - Development - Production
Pioneers in Frequency Shift Telegraph
Garden City • Long Island • New York

NIAGARA ELECTRON LABORATORIES

CONSULTATION - DESIGN - CONSTRUCTION
MFG. THE THERMOCAP RELAY
Specializing in solution of problems of electronic and electro-physical instrumentation for the research of analytical laboratory. Industrial plant problems also invited.
Andover, New York Cable Address: NIATRONLAB

WHEELER LABORATORIES, INC.

Radio and Electronics
Consulting—Research—Development
R-F Circuits—Lines—Antennas
Microwave Components—Test Equipment
Harold A. Wheeler and Engineering Staff
Great Neck, N. Y. Great Neck 2-7806

HANSON-GORRILL-BRIAN INC.

Products & Mfg. Development
ELECTRICAL - ELECTRONIC
HYDRAULIC - MECHANICAL
One Continental Hill Glen Cove, N. Y.
Glen Cove 4-1922

ALBERT PREISMAN

Consulting Engineer
Television, Pulse Techniques, Video
Amplifiers, Phasing Networks,
Industrial Appliances
Affiliated with
MANAGEMENT-TRAINING ASSOCIATES
3308-14th St., N. W. Washington 10, D. C.

YARDNEY LABORATORIES, INC.

Research - Design - Development
Electro-Chemical Generators of Energy
105 Chambers Street Worth 2-3534, 35, 36
New York 7, N. Y.

RELY ON THE NATION'S CLEARING HOUSE FOR

**URGENTLY NEEDED
ELECTRONIC TUBES**

AMERICA'S
INVENTORIES
AT YOUR
FINGERTIPS

**MORE THAN
4,000 TUBE TYPES
MORE THAN
10,000,000 TUBES
LEADING BRANDS**

AMPEREX • BOMAC • CHATHAM • CETRON
DUMONT • EIMAC • FEDERAL
GENERAL ELECTRIC • HYTRON • INDUSTRO
LEWIS & KAUFMAN • MACHLETT
NATIONAL • NATIONAL UNION
NO. AMERICAN PHILIPS • PHILCO
RAYTHEON • R C A • SYLVANIA • SPERRY
TAYLOR • TUNG-SOL • UNITED
WESTERN ELECTRIC • WESTINGHOUSE

TUBE TYPES

RECEIVING • SUBMINIATURES • CRT
TRANSMITTING • SPECIAL PURPOSE
CRYSTAL DIODES • GLOW MODULATOR
GAS PRESSURED MEASURING
STROBOTRONS • TR & ATR • ROCKET
MAGNETRONS • KLYSTRONS • THYRATRONS
FLASH • PHOTRONS • PHOTOTUBES
KENOTRONS • IGNITRONS • PHANOTRONS

State Labs. Inc.,

"The Nation's Clearing House for Electronic Tubes," is, today, the world's largest organization specializing exclusively in buying and selling electronic tubes and crystals.

Purchasing agents of leading companies, distributors, and manufacturers in every industry—are depending on State Labs Inc. for their needs on electronic tubes, large or small.

Through our "clearing house" service, you are often able to buy your tube requirements below distributors' prices . . . even below the manufacturers' prices. You buy at the true market value—determined by trained electronic tube specialists maintaining a constantly changing record of prices and inventories throughout the nation.

**PROMPT QUOTATIONS
IMMEDIATE DELIVERY
FROM STOCK**

FREE! WEEKLY MARKET GUIDES

. . . gathered from hourly quotations and from over 1,000 sources. Each week you receive a compilation of availability and prices of the tube inventories of the nation. Helps you pay the least when buying—get the most when selling. Send for this free service today!

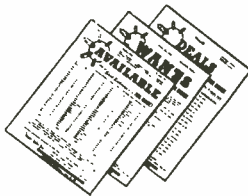

State Labs Inc.

ADDRESS: 37 East 28th Street, New York 16, N. Y., U. S. A.

PHONE: MUrray Hill 3-9802

TELETYPE: NY 1-1807

WIRE: STATE LABS, WUX, N. Y.

CABLE: STATELABS

AS THE MAN-POWER SHORTAGE

becomes more acute.

You may be facing the problem of finding enough engineers or highly technical men to keep your production up to the new demands growing out of the defense effort.

In a recent advertisement, one of the leading aircraft manufacturers restated a well-known but seldom practiced principle: "a trained, experienced engineer in one specialty can be retrained in almost any other engineering specialty with a minimum of time and effort expended".

Engineers follow with intense interest the publication devoted to their particular field. And so they are gathered into convenient groups whenever you wish to reach them — as readers of America's industrial publications.

Let us help you select the proper publications in order to reach just the type technical men you need.

Classified Advertising Division

McGRAW-HILL PUBLICATIONS

330 W. 42nd St.

N. Y. 36, N. Y.

Development Engineer

We have an opening for an experienced Engineer to develop laboratory quality electronic test equipment.

This position requires both practical and theoretical ability and only those with a real interest and aptitude should apply.

We are a stable, well-established small firm, located in a desirable residential area. Our laboratory is modern and well-equipped. You will find an outlet for all your talents.

Please send resume and salary requirements to Director of Development.

BOONTON RADIO CORP.

Intervale Road
Boonton, New Jersey

NEW PRODUCTS WANTED

Do you have a new or improved device or component with broad sales possibilities in the electronic or mechanical field?

One of our clients—a progressive, experienced and well-equipped manufacturer—is interested in developing, volume-producing, and marketing additional products for industry.

Outright purchase, royalty or license arrangement will be considered.

Write, giving preliminary details. Strict confidence is assured.

MICHENER & HOLLAND
2100 Lincoln Liberty Bldg.
Philadelphia, Pa.

COMMERCIAL PRODUCT Wanted

At present 90 percent on defense work, we are looking to the future with long range plans.

Electro-Mechanical in character, we employ approximately 200 people. Facilities include complete engineering department, with research laboratory and competent technical staff, model shop and complete machine shop, assembly department and related services.

We are interested in any practical item with open market possibilities of an Electrical, Mechanical or Electro-Mechanical nature, in any condition of development from idea to production model.

BO-4044, Electronics
330 W. 42 St., New York 36, N. Y.

Contract Work Advertising
See page 363

REPLIES (Box No.): Address to office nearest you
NEW YORK: 330 W. 42nd St. (36)
CHICAGO: 520 N. Michigan Ave. (11)
SAN FRANCISCO: 68 Post St. (4)

POSITIONS VACANT

RUSSIAN TECHNICAL translators—permanent employment—preferably with good background in electronics and aeronautics. Applicants must have a good current knowledge of technical English as well Russian. Must pass U. S. Government security regulations. Good starting salary and excellent possibilities for additional earnings. Also possibility for advancement to editor. Free-lance available for those not interested in permanent position. Reply to Box 183, Nyack, N. Y.

SYSTEM PLANNING Engineers. Graduate electrical engineers wanted to assist in planning the electrical development of a large metropolitan electric utility in the northeastern part of the United States. Work consists of determining the location, size, and method of connections for additional generating capacity, and associated transmission lines and switching; distribution lines and associated substations. This work involves many electrical calculations to determine load distribution, short circuit current, stability, voltage regulation, and involves the use of AC and DC Calculating Boards. Applicants to be not over 30 years old, with BS in EE from an accredited college or university. Salary range \$3600 to \$5200, depending upon experience and education. Experience record, education, salary expected, and recent photograph should be submitted with the letter of application. P-4301, Electronics.

WANTED—B.S.E.E. graduate, 25-35 years for radio, TV, radar Transformer design and development. Should be experienced, three to five years. Attractive salary range with top fringe benefits. Our modern plant is located in Midwest in good living area. Give full details covering your experience. All replies confidential. Our engineering staff knows of this advertisement. P-4345.

WANTED—GRADUATED electrical engineer for work in Connecticut. A man having approximately 3 years experience in design of transformers or electrical machinery could qualify. Salary commensurate with ability. The Superior Electric Company, Connecticut.

EMPLOYMENT SERVICE

SALARIED PERSONNEL, \$3,000-\$25,000. This confidential service established 1920, is geared to needs of high grade men who seek a change of connection under conditions assuring, if employed, full protection to present position. Send name and address only for details. Personal consultation invited. Jira Thayer Jennings, Dept. L, 241 Orange St., New Haven, Conn.

POSITION WANTED

ELECTRONIC ENGINEER BSEE 20 years experience design, application, ship installation planning, admin. engineering, program coordination. Desire position of responsible administration in East. PW-4425, Electronics.

SELLING OPPORTUNITY WANTED

SALES REPRESENTATIVE Engineers are seeking additional lines in electronics and allied fields. Metropolitan N. Y. location. Organization offers over 20 years experience in field. RA-4191, Electronics.

BUSINESS OPPORTUNITIES

Basic Component—

We have developed a new low cost patentable process for manufacturing molded insulated Carbon Resistors. Production equipment is near completion. Additional capital is required and a partnership or outright sale will be considered. BO-4341.

We Need more products.

Aggressive Electronics Manufacturer desires to manufacture and distribute parts and equipment on a royalty basis. We have complete research and development facilities, and nation wide representation. Also can do contract assembly and wiring work. Replies held strictly confidential. Send inquiries to BO-4563, Electronics.

TO ENGINEERS

who will be vacationing in

NEW YORK



Your chance of a lifetime...
apply for a CAREER JOB in
Engineering with CURTISS-WRIGHT

Make your vacation pay off. Talk to our engineering representative while in N.Y., learn how you can broaden your life, expand your future with one of the nation's great industrial organizations.

► **Start at good pay.** Work in suburban New Jersey just minutes from Manhattan via express highways. Live in the beautiful lake area of fine homes, modern schools. Enjoy nearby ocean beaches, deep-sea fishing, year-round big league sports, 7 TV channels.

Here are jobs in one of the best areas of the U.S. for good living, combined with a real career. For you work on new frontiers of science, make headline engineering news. You pay no state income tax. And there's long-range security in the growing diversity of products at Curtiss-Wright.

► **Set up Your Interview** in advance. If your engineering field is listed below, send us your resume and this notice today.

CURTISS-WRIGHT

Corporation • Wood-Ridge, N. J.

"A GOOD PLACE TO WORK"

CLIP NOW AND MAIL!

Simply attach this reminder to a resume, giving the following information: Personal background; Education in detail; Work experience in detail; Salary requirements.

I will be in New York on _____

Name _____

Street _____

City _____ State _____

I am interested in the following field of engineering Aeronautical, Electrical, Electronic, Mechanical, Metallurgical.

MAIL TO: Mr. Leo Sweeney, Dept. ERB-31
Curtiss-Wright Corporation
Wood-Ridge, N. J.

Please advise address and phone where you can be reached while in New York.

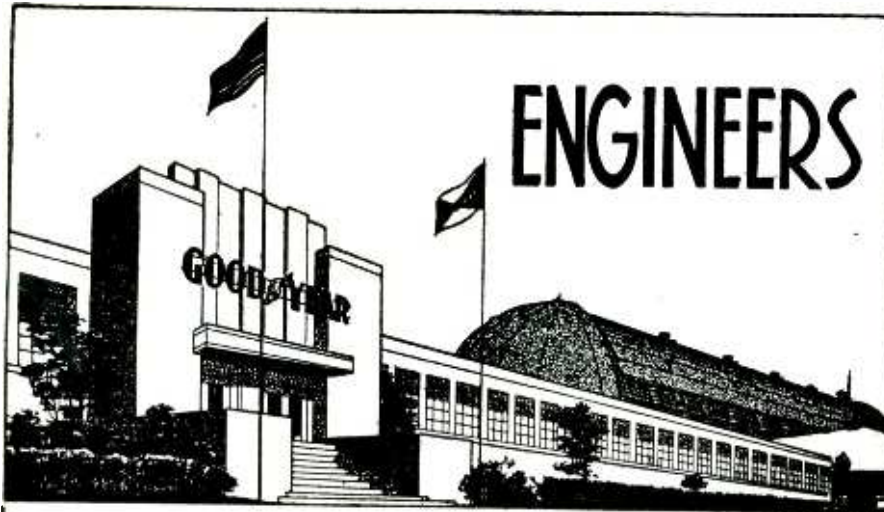

ENGINEERING WITH A FUTURE

RESEARCH • DEVELOPMENT • DESIGN

The continued and steady growth of established research and development projects has opened a number of unusual opportunities for outstanding and experienced men.

ENGINEERS • SCIENTISTS • PHYSICISTS

Positions are available in our organization for qualified personnel in the following fields:

- | | |
|------------------|---------------------|
| Circuit Analysis | Aerodynamics |
| Microwaves | Applied Mathematics |
| Analog Computers | Physics |
| Servomechanisms | Flight Test |
| Dynamics | Design |

Openings exist at several levels, and inquiries from recent graduates are also invited. Salaries are based on education, ability, and experience. Liberal salary, vacation, insurance, and retirement plans are yours if you qualify.

If you are interested in a secure future in these experimental fields, write and give full details to Mr. C. G. Jones, Salary Personnel Department.



Akron 15, Ohio

ENGINEERS
ELECTRONIC
and
Electro-Mechanical



MAKE
YOUR MOVE
IN THE
RIGHT
DIRECTION

POSITIONS THAT POINT TO
A SUCCESSFUL FUTURE!

Minimum Requirements

Four years' experience in advanced research and development on Radar Systems, Computers, Wave Guide and Antennas, Servo-mechanisms, Pulse Techniques Gyroscopic Equipment and Related Fields.

If your skills are now being fully utilized in a vital defense industry, please do not apply.

Kindly send resume and salary requirements to

The **W. L. MAXSON**
CORPORATION

460 W. 34th St. New York 1, N. Y.

ENGINEER!

- IS YOUR WORK STIMULATING?
- ARE YOU CHALLENGED BY YOUR JOB?
- ARE YOU RECEIVING PROFESSIONAL RECOGNITION?

SYLVANIA

believes in building men

The company now in its 51st year is expanding rapidly. Net sales this year exceed 1938 by 16 times. Additional high caliber men are needed with training and experience in all phases of electronics, physics and mechanics.

Write us about yourself, if your experience and future plans fit into this picture.

William B. Seiniger
Department 501

SYLVANIA ELECTRIC PRODUCTS, INC.
Radio & Television Division
254 Rano Street, Buffalo 7, New York

ELECTRONIC ENGINEERS

Degree in Electrical Engineering
Plus Maintenance or Repair Experience on SCR-584 Radar

**ELECTRONIC ENGINEERING COMPANY
OF CALIFORNIA**

180 SO. ALVARADO STREET
LOS ANGELES, CALIFORNIA

**HOUSTON, TEXAS
TRANSFORMER ENGINEER**

Precision equipment manufacturer needs qualified, experienced engineer for audio and sub-audio transformer design and development. Experience with the high permeability alloys desirable. Knowledge of magnetic circuitry must be sufficient for development work on magnetic amplifiers. Salary commensurate with ability.

P-4510, Electronics
520 N. Michigan Ave., Chicago 11, Ill.

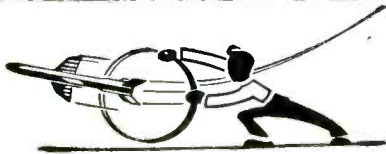

... An invitation to

ELECTRONIC ENGINEERS

MCDONNELL AIRCRAFT CORPORATION

Offers attractive opportunities to engineers experienced in the missiles field. If technological impact and challenge to ability are features you look for in an assignment, study these classifications and "square off."

SENIOR and JUNIOR ENGINEERS for:

Package Design
 Microwave Design and Development
 Radar Design and Development
 Auto-Pilot Design and Development
 Instrumentation Development
 Control Systems
 Servomechanisms design and Development
 Systems Analysis and Synthesis
 Fire Control Computation and Development
 Reeves Electronic Analogue Computers
 Aircraft Antenna and Radome Design
 Laboratory Testing and Evaluation

CONTACT:

TECHNICAL PLACEMENT SUPERVISOR
 MCDONNELL AIRCRAFT CORPORATION
 BOX 516, ST. LOUIS 3, MISSOURI

You'll Like Working for M.A.C.!

MCDONNELL
Aircraft Corporation
 ST. LOUIS 3, MO

ENGINEERS

LOCATE IN THE

Healthful Southwest

FOR
 ATOMIC
 WEAPONS
 INSTALLATION

Mechanical Engineers, Electronics and Electrical Engineers, Physicists, and Mathematicians. A variety of positions in research, development and production open for men with Bachelors or advanced degrees with or without applicable experience.

These are permanent positions with Sandia Corporation, a subsidiary of the Western Electric Company, which operates the Laboratory under contract with the Atomic Energy Commission. The Laboratory offers excellent working conditions and liberal employee benefits, including paid vacations, sickness benefits, group life insurance and a contributory retirement plan.

Land of Enchantment

Albuquerque, center of a metropolitan area of 150,000, is located in the Rio Grande Valley, one mile above sea level. The "Heart of the Land of Enchantment," Albuquerque lies at the foot of the Sandia Mountains which rise to 11,000 feet. Cosmopolitan shopping centers, scenic beauty, historic interest, year 'round sports, and sunny, mild, dry climate make Albuquerque an ideal home. New residents experience little difficulty in obtaining adequate housing in the Albuquerque area.

Make application to the

PROFESSIONAL EMPLOYMENT DIVISION

SANDIA
Corporation

SANDIA BASE
 ALBUQUERQUE, N. M.

ENGINEERS
PHYSICISTS
CHEMISTS
METALLURGISTS

Your Professional Future
AND
General Electric



An element you can count upon for continuing satisfaction and security.

Satisfaction — through the challenging and diversified nature of your work, the prestige and stimulation of your professional associates.

Security — through the singular importance of General Electric's role in the American economy and the recognition of your contribution.

Positions now open in Advanced Development, Design, Field Service, and Technical Writing in connection with:

MILITARY RADIO & RADAR
 MOBILE COMMUNICATION
 MULTIPLEX MICROWAVE
 COMMUNICATIONS
 ELECTRONIC COMPONENTS
 TELEVISION, TUBES & ANTENNAS

Bachelor's or Advanced Degree in Electrical or Mechanical Engineering, Physics, Metallurgy or Physical Chemistry and/or experience in the electronics industry necessary. Do not apply, please, if your best skills are being used for vital defense work.

Please send resume to:
 Dept. 72-E, Technical Personnel
 ELECTRONICS PARK

GENERAL  ELECTRIC

SYRACUSE, N. Y.

ELECTRONIC ENGINEERS

Mechanical Designers for Research and Engineering

To work in the design and development of new electronic equipment. Excellent working and living conditions, good salaries and exceptional employee benefits. Write, giving full details including education and experience. Personal interviews will be arranged.

THE NATIONAL CASH REGISTER COMPANY
 Main & K Sts., Dayton 9, Ohio

**CORNELL
 AERONAUTICAL
 LABORATORY, INC.**

We are continually seeking men of outstanding ability who are willing and able to add to our research efforts. Typical fields include:

**RADAR
 COMPUTERS
 INSTRUMENTATION
 SERVOMECHANISMS
 SYSTEMS ANALYSIS**

For additional information write, referencing this advertisement. Due to clearance problems it is impossible to consider non-citizens.

**Employment Manager
 Cornell Aeronautical
 Laboratory
 4455 Genesee Street
 Buffalo 21, New York**

**ENGINEERS
 AND
 PHYSICISTS
 BS - MS - Ph.D:**

Responsible positions in mechanical, electrical or electronic engineering, physics or engineering physics for advanced development and design of special equipment and instruments. Prefer men with minimum of two years' experience in experimental research design and development of equipment, instruments, intricate mechanisms, electronic apparatus, optical equipment, servomechanisms, control devices and allied subjects. Positions are of immediate and permanent importance to our operations. Southwestern location in medium sized community. Excellent employee benefits. Reply by letter giving age, experience and other qualifications. All applications carefully considered and kept strictly confidential.

**Ind. Rel. Manager,
 Research & Development Dept.**

**PHILLIPS
 PETROLEUM COMPANY**
 Bartlesville • Oklahoma

HELICOPTER INSTRUMENTATION ENGINEER

Instrumentation Engineer to solve theoretical and practical instrumentation problems involved in wind tunnel, whirlstand and flight testing of helicopters and convertiplanes. Desirable background would include aeronautical or mechanical engineering course (including instrumentation theory) and several years of industrial dynamic instrumentation work. Will you please state training, experience and salary requirements. All replies will be confidential. Write:

Technical Placement Supervisor

McDONNELL AIRCRAFT CORPORATION

Post Office Box 516
St. Louis 3, Missouri

STAVID ENGINEERING, INC.

has openings for
Graduate

ELECTRONIC ENGINEERS MECHANICAL ENGINEERS

Experience in Design and Development of Radar and Sonar necessary.

Broad knowledge of Search and Fire Control Systems; Servo Mechanisms, Special Weapons, Microwave, Antenna and Antenna Mounts, etc.

Mechanical Engineer should have experience in packaging of Electronic Equipment to Gov't specifications including design of complex cabinets, shock mount and sway brace structures, Servo Mechanisms.

Positions are available in Field Service and Technical Writing.

Liberal personnel benefits including life, sickness and accident insurance, and a worthwhile pension system. Paid holidays and vacations.

Personnel Office
200 W. Seventh St.
Plainfield, N. J.
Telephone Plainfield 6-4806



**Senior Engineers
SEE PAGE 342
FOR OPENINGS IN
CONVAIR'S COMMERCIAL
CHARACTRON PROJECT**



SPECIAL OPPORTUNITIES FOR SENIOR ENGINEERS

Convair in cool, clean, beautiful San Diego invites you to join an "engineers" engineering department. Interesting, challenging, essential long-range projects in commercial aircraft, military aircraft, missiles, engineering research and electronics development. Positions open in these specialized fields:

Radar Systems Missile Guidance Systems
Servo-mechanisms
Electronic Circuits
Microwave Components and Systems

Generous travel allowances to those accepted. For free brochure, write Mr. H. T. Brooks, Engineering Dept. 900

CONVAIR IN BEAUTIFUL SAN DIEGO

3302 PACIFIC HIWAY
SAN DIEGO 12, CALIFORNIA

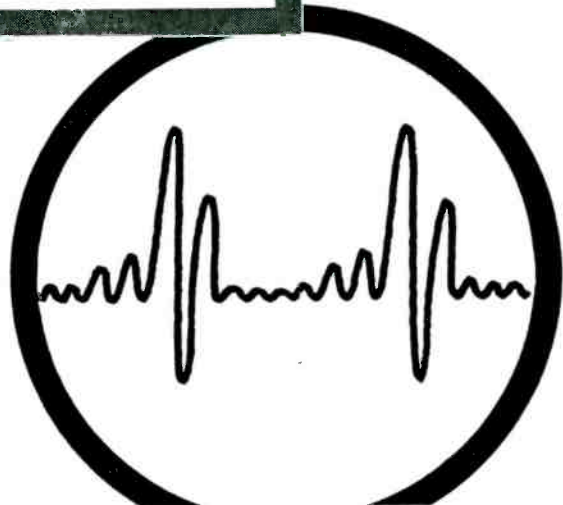

**MAKE THIS YOUR HOME
FOR IMPORTANT WORK
UNDER IDEAL CONDITIONS**



- TV RECEIVER DESIGN ENGINEERS
- ELECTRONICS ENGINEERS
- FIELD ENGINEERS
- TEST & INSPECTION ENGINEERS
- LAB. TECHNICIANS

NEEDED TO WORK ON: Radar, G.C.A., Mobile Radio, Auto Radio, Airborne Communication & Navigation Equipment, Television, Antennas, Microwave Equipment, Servo Mechanisms, Guided Missiles and Test Equipment Design.

YOU BENEFIT AT BENDIX RADIO: from high wages, a modern, air-conditioned plant, paid vacations and holidays, group insurance and a good chance for advancement.

Housing immediately available in the beautiful suburban and country areas that surround the Bendix Radio plant.

Write, Wire or phone
MR. E. O. COLE, DEPT. J.

Bendix Radio

DIVISION OF BENDIX AVIATION CORPORATION

BALTIMORE-4, MD. Phone: TOWSON 2200

*Makers of the World's Finest
Electronic Equipment*

MALE HELP WANTED

- ENGINEERS
SCIENTISTS
MATHEMATICIANS
STATISTICIANS
TECHNICIANS
DESIGNERS
COMPUTERS
MACHINISTS, Precision**

Specialties: electronic, optical, mechanical, servo-mechanisms, etc.

Fields: measurement, recording, transcription, computation and analysis of guided missile and guidance systems performance.

Work Types: operation, maintenance, design, development, construction, research, study.

Work at: lab, shop and/or outdoors.

INSTRUMENTATION

**of guided missiles and aircraft
blind navigation systems.**

Equipment worked with: cine-theodolites, special optical instruments, recorders, radars, telemeters, data transcription devices, digital computers, many types of IBM equipment.

Locations: Air Force bases near Alamogordo, New Mexico and Dayton, Ohio.

Other openings: throughout U. S. A. and world.

Advantages: excellent opportunity for advancement, rapidly expanding organization. Personnel and family transportation reimbursed, company paid insurance, and other benefits.

Salary: you'll be interested! Write for application form to:

LAND-AIR, INC.

Holloman Air Force Base New Mexico

**COMPONENT APPLICATION
ENGINEERS**

Collins Radio Company needs experienced component application engineers. Experience in component application or testing and specifications is required. EE degree desirable but equivalent additional experience will be considered. Immediate need is for men familiar with motors, dynamotors, vacuum tubes, transistors, meters, relays, transformers, capacitors and resistors.

Salary commensurate with ability.

Write fully—today. Address letter to

COLLINS RADIO COMPANY

CEDAR RAPIDS, IOWA

POSITIONS OPEN

| Location
| KANSAS CITY, MO.

**Electronic & Mechanical
Engineers**

ELECTRONIC ENGINEERS: Must have considerable development experience in radio transmitting and receiving equipment. Ability to fill position of Senior Project Engineer a requisite.

MECHANICAL ENGINEER: Must have development experience in mechanical design of electronic or similar precise equipment. Practical and theoretical knowledge of materials, finishes, sheet metal, and machine shop design are basic requirements. Position is one of considerable responsibility.

SALARY: Open.

These positions are permanent.

Write stating educational and professional history direct to:

Jay V. Wilcox, President
WILCOX ELECTRIC COMPANY, INC.
1400 Chestnut St. Kansas City 1, Mo.

Dependable communications since 1931

SALES ENGINEER

Old established Toronto firm in radio and electronics industry requires the services of a sales engineer, with college degree in Communications Engineering or Electronics, to handle one of the world's leading lines of laboratory test equipment. Should have at least two or three years practical engineering experience. Must have ability to meet and handle people. Permanent position. Live in Toronto, but willing to travel throughout Canada. Please submit all pertinent information, including salary required to:

SW-3989, Electronics
330 W. 42nd St., New York 36, N. Y.

**4-CHANNEL
CHART RECORDER**

Rahm 4-channel hot wire direct recording oscillograph, model RO4C (1951). Used approx. 2 mo. In med. res. lab. Complete with accessories and 22 rolls of chart paper.

LIST (INCL. PAPER): \$1,305.00
PRICE \$650 F.O.B.

THE UNIVERSITY OF MINNESOTA
PURCHASING DEPARTMENT
MINNEAPOLIS 14, MINN.

STANDARDS ENGINEER

To establish and direct engineering and manufacturing standards program for the manufacture of military and commercial electronic equipment. Education required: BS in ME or EE or equivalent. Experience: 6 years minimum in electrical engineering or manufacturing including at least 2 years as standards engineer.

P-4866, Electronics
1111 Wilshire Blvd., Los Angeles 17, Calif.



ATTENTION!

Former Field Engineers

We urgently need men with electronic background, and preferably radar or computer experience, to supervise, instruct and assist in installation—maintenance of electronic equipment.

Excellent starting salary during factory training, plus overtime premium in field. Substantial insurance program. Domestic & overseas assignments available. Salary will be commensurate with experience.

Please forward your personal experience record to:

Personnel Supervisor
Field Eng. Div.

Reeves Instrument Corp.
215 East 91st St.
New York, 28, N. Y.

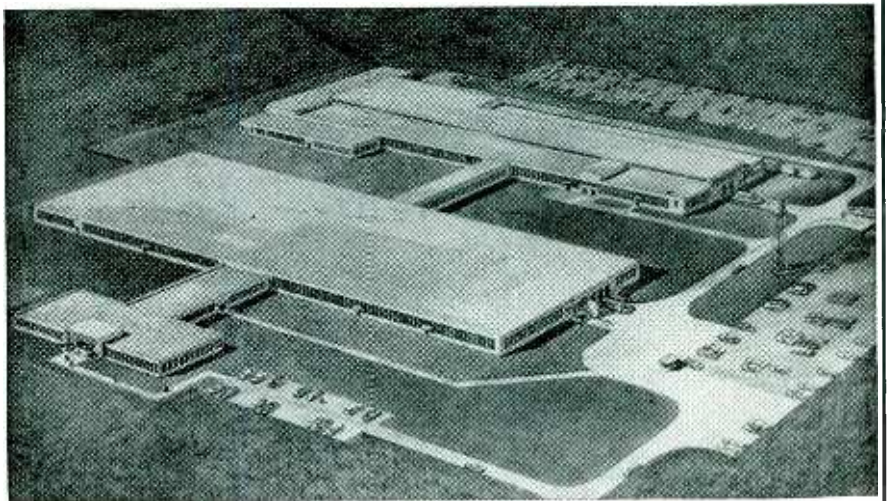

electronic engineers

A new plant now under construction with a major Navy contract for electronic gunfire control units and a progressive management. Job opportunities are open for Electronic Engineers for Navy Fire Control work involving computers, gyros, radar, and engineering positions at all levels.

Daystrom offers a sound chance of advancement, a post-defense future in one of the most modern plants in the country.

AC SPARK PLUG DIVISION

of

GENERAL MOTORS CORPORATION

PRECISION INSTRUMENT PLANT

Positions now available for highest caliber personnel in the field of airborne automatic electro-mechanical control equipment.

MECHANICAL DESIGN ENGINEERS
ELECTRONIC ENGINEERS
SERVO ENGINEERS
ELECTRONIC DESIGNERS
MECHANICAL DESIGNERS

New and expanding division of an established firm with 20 years of successful experience in the instrument field. Work involved deals with the manufacture and development of highly complex equipment of the most advanced type.

Write or Apply

AC Spark Plug Division
GENERAL MOTORS CORPORATION
1925 E. Kenilworth Place
Milwaukee 2, Wisconsin



WRITE

OR

PHONE

PERSONNEL DEPARTMENT OF DAYSTROM, INCORPORATED
ARCHBALD, PA.

JERMYN - 1144

PRINTED CIRCUIT ENGINEER

We require an engineer, electrical or chemical, experienced in printed carbon resistors to set up this process and take complete charge of developing printed circuits. Location, Virginia. This is an unusual opportunity with a successful and progressive components manufacturer. Our small engineering staff will grow considerably creating responsible positions for qualified men. Write your qualifications and salary requirements. All replies will be kept strictly confidential.

P-4542, Electronics
330 W. 42 St., New York 36, N. Y.

ELECTRONIC ENGINEERS ALL GRADES

Small electronic research and development laboratory, located 8 miles outside of Washington, D. C., has several openings for junior and senior electronic engineers. Degree essential. Varied projects include analog computers, servo mechanisms, special test equipment, etc. All Defense work. Liberal salaries dependent upon experience.

THE DAVIES LABORATORIES
Incorporated
4705 Queensbury Road, Riverdale, Maryland

SENIOR ENGINEERS - DEVELOP NEW COMMERCIAL USES FOR CONVAIR CHARACTRON

Convair's new commercial charactron project has openings for Senior Engineers in Pulse Circuitry, Electronic Storage Systems, High Speed Printing and Electron Optics.

Write: H. T. BROOKS

ENGINEERING DEPARTMENT 910

CONVAIR SAN DIEGO 12 CALIFORNIA

URGENTLY NEEDED TECHNICAL WRITERS

FOR

COLLINS RADIO'S ENGINEERING PUBLICATIONS DEPARTMENT

Collins Radio Company's ever-growing leadership in the fields of communications, navigation and broadcasting is placing an increasing importance upon the completeness and quality of the technical literature required to support its equipment in the field. If you are qualified to write such material, join us and watch electronics progress with Collins.

Collins' facilities include a complete, self-sufficient publications organization, including writers, editors, artists, draftsmen and a well-equipped offset printing plant.

DUTIES—Preparing and editing copy for commercial and government operating and maintenance manuals, engineering reports and equipment specifications.

QUALIFICATIONS—Degree in electrical engineering or degree in journalism and several years of practical radio experience.

Write us fully about yourself—today. The jobs are open now! Address your letter to Merrill S. Smith, Collins Radio Company, Cedar Rapids, Iowa.

ELECTRONIC ENGINEER

for

Challenging Opportunity in

ATOMIC ENERGY

Tracerlab, Inc., the foremost commercial firm in the development of peacetime applications of atomic energy and electronic instrumentation for measuring radioactivity seeks an outstanding Electronic Engineer to take complete responsibility for a group of major projects.

Position requires a B.S. in Electronic Engineering, with an M.S. preferred. Minimum of 5 years industrial experience. Familiarity with applications and limitations of manual and machine tools used in sheet metal work, good knowledge of drafting practice and complete understanding of electronic test equipment necessary.

Unparalleled opportunities await the qualified applicant. Salary commensurate with training and experience. Please send resume to:

Industrial Relations Department

TRACERLAB, INC.

130 High Street Boston 10, Mass.

TAKE ADVANTAGE OF These Opportunities Today! Positions Open NOW for: ENGINEERS and TECHNICIANS

Here's a real chance to gain valuable experience in the field of **ELECTRONICS!**

You will be working on the vital problem of electron tube reliability for an established aeronautical communications firm.

We need men of good educational background and experience who can handle either field or laboratory assignments, men who understand circuits and the mechanical aspects of electronics, engineers with electron tube design and application background. We will consider men who do not have a college degree if they have comparable experience. Salaries commensurate with ability.

Our personnel have been informed of this advertisement. Replies will be kept in strict confidence. Send a resume of your education and experience to:

P-4459, Electronics
330 W. 42 St., New York 36, N. Y.

RESEARCH OPPORTUNITIES

The University of Michigan is expanding its research organization and will have a number of excellent opportunities open in important research programs for **ENGINEERS, PHYSICISTS and MATHEMATICIANS**. Work classifications are in the fields of:

ELECTRONICS

(Experience in circuit development and design on analog and digital computers, telephone switching equipment or cathode ray displays preferred.)

SYSTEMS ANALYSIS

SIMULATION

OPERATIONAL ANALYSIS

OPTICS

MECHANICAL ENGINEERING (Icing Research)

Researchers have an opportunity to complete their requirements for graduate degrees while employed.

Salaries are commensurate with training and experience. Applicants are invited to send a resume of education and experience to:

Personnel Office
University of Michigan
Ann Arbor, Michigan

TEACHING POSITIONS IN ISRAEL

The Hebrew Institute of Technology, Haifa, Israel, proposes to appoint 1 professor in power engineering, with special qualifications in electric machines; 1 professor in telecommunications; 2 associate professors in electric engineering (electric machines, telecommunications, and electronics).

Applicants should have first-rate professional and academic qualifications, be willing to integrate themselves into the life of the country and, in due course, to teach in Hebrew.

Applications with full details should be sent, for transmission to Haifa, to:

The American Technion Society
80 Fifth Avenue New York 11, New York

TRANSFORMER ENGINEER TO HEAD DEVELOPMENT

Rare opportunity to join staff of nation's leading manufacturer of specialty transformers as head of development section. Company has lowest turnover in the industry. Background should include at least three years in responsible position as project or development engineer with experience in at least three of the following lines: fluorescent lamp ballasts,—transformers for luminous tube, ignition, mercury lamp, power circuit, control and radio. Age preferred, 30 to 40 years.

Attractive salary range. Midwest location in area of good living conditions. Give complete data regarding past and present work. All replies confidential. Our engineers know of this advertisement.

P-4287, Electronics
520 N. Michigan Ave., Chicago 11, Ill.

INSTRUMENT ENGINEERS

Research and Development Engineers experienced in pneumatic and electrical instruments. Also openings for recent engineering graduates, Mechanical preferred. Excellent opportunity with rapidly growing Research and Development Department. These are permanent positions with stable organization. Send resume to:

AMERICAN METER CO.
Personnel Department
10th & Payne Avenue
Erie, Pa.

HOUSTON, TEXAS TRANSFORMER ENGINEER

Precision equipment manufacturer needs qualified, experienced engineer for audio and sub-audio transformer design and development. Experience with the high permeability alloys desirable. Knowledge of magnetic circuitry must be sufficient for development work on magnetic amplifiers. Salary commensurate with ability.

P-3864, Electronics
520 N. Michigan Ave., Chicago 11, Ill.

ENGINEERS WITHOUT COLLEGE DEGREES...

We put no limits on your engineering future!!

● Are you capable of doing real professional-level engineering work? If you have demonstrated your ability to do first class engineering work but feel you are being handicapped by the lack of a college degree, get in touch with this company.

WE ARE a large manufacturer of Electronic Equipment (Military, Aviation, Automotive, Television) and have over 100-million-dollar backlog. Located on Eastern Seaboard.

● There are many responsible positions open in our organization which offer unlimited opportunity. We want them filled by competent men, regardless of their formal educational backgrounds.

P-4214, Electronics
330 W. 42 St., New York 36, N. Y.

ELECTRONIC ENGINEERS & PHYSICISTS

OUR STEADILY EXPANDING LABORATORY OPERATIONS
ASSURE PERMANENT POSITIONS AND UNEXCELLED
OPPORTUNITY FOR PROFESSIONAL GROWTH IN

RESEARCH & DEVELOPMENT

GUIDED MISSILES

TELEVISION

ELECTRONIC NAVIGATION

SOLID STATE PHYSICS

VACUUM TUBES

RADAR

ADDRESS **CAPEHART FARNSWORTH CORP.**
INQUIRIES TO FORT WAYNE, IND.

ENGINEERS! PHYSICISTS!

We have openings in research, development and production at our Newark and Livingston, New Jersey plants for engineers and physicists in the following fields:

- Vacuum Tubes
- Gas Tubes
- Hydrogen Thyratrons
- Computer Tubes
- Computer Circuits
- Nucleonic Instruments
- Pulse Circuits
- Electronics Equipment

Excellent opportunities for men with ability and experience. Openings exist for recent graduates. Write giving full details to:

Personnel Department

**CHATHAM
ELECTRONICS CORP.**

475 Washington Street
Newark, New Jersey

KAMAN AIRCRAFT'S

entrance into the field of ELECTRONIC DEVICES for HELICOPTER use has created an immediate need for

RADIO ENGINEERS

Minimum of 5 years experience in the design and development of high frequency FM transmitters and receivers. Engineering graduates with advanced degrees preferred.

RADIO and ELECTRONIC TECHNICIANS

3 to 5 years experience in the construction testing and operation of high frequency FM transmitters and receivers. Engineering graduates preferred.

ELECTRO-MECHANICAL TECHNICIANS

3 to 5 years experience in aircraft servo-control systems. Engineering graduates preferred.

Please send detailed resume to

W. M. TYNAN

Administrative Engineer

Department E

KAMAN AIRCRAFT CORPORATION
Windsor Locks, Connecticut

OIL FILLED CONDENSERS

MFD	VDC	Price	MFD	VDC	Price	MFD	VDC	Price	MFD	VDC	Price
2	400	\$.55	1	1500	.59	1-1	7000	5.95	125	27KV	37.50
5-5	400	1.65	.5	1500	1.25	1	7500	2.85	.001	50KV	24.50
1	600	.55	3	1500	2.50	.5	7500	8.95	.025	50KV	42.50
2	600	.69	4	1500	2.95	1-1	7500	22.50	.2	50KV	85.00
600R'd	1.65	1-5	2000	.95	.075-.075	8KV	6.50	.25	50KV	95.00	
2-2	600R'd	1.65	.25	2000	1.50	1	10KV	16.50	7.5	220VAC	1.95
3	600	1.30	5	2000	1.30	1	10KV	29.50	1-3	330VAC	1.95
4	600	1.65	1	2000	1.95	1	12KV	8.95	10	330VAC	3.95
4	600R'd	1.65	3	2000	3.75	1	15KV	37.50	12.75	330VAC	4.10
5	600	1.75	12	2000	8.95	.045	16KV	4.70	15	330VAC	4.50
6	600	1.85	1	2500	2.75	.05	16KV	4.95	5	440VAC	3.10
600R'd	1.85	1-1	2500	3.85	.075	16KV	8.95	2.9	660VAC	3.24	
8	600	1.95	32	2500	15.80	.25	20KV	19.95	7	660VAC	4.25
4-4-4	600	2.50	5	3000	2.40	1	20KV	54.00	8	660VAC	4.50
4 x 3	600	2.50	1	3000	3.40						
10	600	3.25	2	3000	4.50						
1	1000	.65	.03	4000	1.25						
2	1000	.90	3 x 2	4000	1.95						
2	1000R'd	1.85	2	4000	6.95						
3.5-.5	1000	1.85	1	5000	1.60	.02	600	OM-6002			\$.45
4	1000	1.95	.2	5000	2.50	.05	600	OM-6005			.48
6	1000	2.50	1	5000	4.88	.1	600	OM-610			.51
8	1000	3.25	.2	5000	18.50	.25	600	OM-625			.55
1200	1.85	.01-.03	6000	1.65	.5	600	OM-650				.60
1-1-1	1200	1.85	.1	7000R'd	1.79	1.0	600	OM-601			.85

OILMITES

MFD	VDC	TYPE	Price
600	600	OM-6002	\$.45
600	600	OM-6005	.48
600	600	OM-610	.51
600	600	OM-625	.55
600	600	OM-650	.60
600	600	OM-601	.85

COAXIAL CONNECTORS



FULL LINE OF JAN APPROVED COAXIAL CONNECTORS

IN STOCK
UHF-N-PULSE-BN-BNC

UG-7/AP \$6.30	UG-23C/U \$1.90	UG-58A/U \$1.15	UG-106/U \$.15	UG-191/AP \$.80	UG-262/U \$1.20
UG-12/U .95	UG-24/U 1.30	UG-59A/U 2.25	UG-108/U 2.60	MX-195/U .75	UG-273/U 2.25
UG-15/U 1.50	UG-25/U 1.35	UG-83/U 2.25	UG-109/U 2.60	UG-197/U 2.80	UG-274/U 2.75
UG-18/U 1.25	UG-27/U 1.30	UG-85/U 1.75	UG-146/U 2.55	UG-201/U 2.25	UG-275/U 5.60
UG-19/U 1.80	UG-27A/U 2.95	UG-86/U 2.60	CW-159/U .60	UG-203/U .85	UG-276/U 2.75
UG-21/U 1.95	UG-28A/U 3.75	UG-87/U 1.60	UG-166/U 32.50	UG-206/U 1.30	UG-290/U 1.20
UG-21A/U 1.50	UG-29/U 1.55	UG-88/U 1.10	UG-167/U 2.85	UG-224/U 1.20	UG-291/U 1.35
UG-21B/U 1.35	UG-30/U 2.30	UG-89/U 1.35	UG-171/U 5.50	UG-226/U 3.85	UG-306/U 2.95
UG-22/U 1.35	UG-34/U 16.60	UG-90/U 1.60	UG-173/U .40	UG-245/U 2.30	UG-414/U 3.25
UG-22B/U 1.65	UG-36/U 17.60	UG-98/U 1.85	UG-175/U .15	UG-254/U 2.75	UG-625/U 1.35
UG-22C/U 1.65	UG-37/U 17.50	UG-102/U .90	UG-178/U .15	UG-255/U 2.45	
UG-23/U 1.20	UG-37/U 17.50	UG-103/U .98	UG-177/U .24	UG-280/U 1.20	
UG-23B/U 1.90	UG-58/U .80	UG-104/U 1.40	UG-185/U 1.35	UG-261/U 1.20	

QUOTATIONS UPON REQUEST ON ANY CONNECTORS NOT LISTED HERE

M-358	MC-277	PL-259A	FL-325
M-359	MC-320	PL-274	SO-239
M-359A	PL-258	PL-284	SO-264
M-360	PL-259	PL-293	TM-201

COAXIAL CABLE

Type	Price Per M Ft.	Type	Price Per M Ft.	Type	Price Per M Ft.	Type	Price Per M Ft.
RG-5/U	\$140.00	RG-13/U	\$216.00	RG-28/U	\$475.00	RG-57/U	\$325.00
RG-6/U	180.00	RG-17/U	650.00	RG-29/U	50.00	RG-58/U	60.00
RG-7/U	85.00	RG-18/U	900.00	RG-30/U	300.00	RG-58A/U	70.00
RG-8/U	100.00	RG-19/U	1250.00	RG-35/U	900.00	RG-59/U	60.00
RG-9/U	250.00	RG-20/U	1450.00	RG-54A/U	97.00	RG-62/U	75.00
RG-9A/U	275.00	RG-21/U	220.00	RG-55/U	110.00	RG-77/U	100.00
RG-10/U	240.00	RG-22/U	150.00				
RG-11/U	100.00	RG-24/U	675.00				
RG-12/U	240.00						

ADD 25% TO PRICES SHOWN FOR QUANTITIES UNDER 500 FT.

METERS

1 MA DC 3 1/2" R DeJur Mod 310 (0-4KV scale)	\$5.75
500 Microamps, DC-2 1/2" round-Sun	4.30
1ma. DC Fan type-4" scale (rem. from eqpt)	3.95
500 ma. DC 2 1/2" R-General Electric	2.95
2 amp. RF 2 1/2" Sq-Simpson	3.15
5 amp. AC 4 1/2" R-JBT	4.11
30 V DC 2 1/2" R-General Electric	3.95
3 amp. RF 3 1/2" R-Weston	6.00

OIL-FILLED 35 KV AND 50 KV ISOLATION TRANSFORMERS

Pri. 460V 60 cy. Sec. 115V 200 VA Insulated for 50KV	
DC-G. E. Form E1R-36" H x 13" D	\$125.00
Pri 115V 60 cy. Sec. 115V 250 VA Insulated for 35 KV	
DC-G. E. Form E1R-29" H x 12 1/2" D	\$125.00

CRYSTAL DIODES

IN21	\$1.19	IN37	\$1.79	IN41	\$11.25
IN21A	1.69	IN31	8.10	IN42	18.75
IN21B	3.50	IN34A	.66	IN43	1.55
IN22	1.09	IN34A	.95	IN45	.94
IN23	1.95	IN38	1.70	IN52	1.05
IN25A	3.25	IN39	6.25	IN55	3.15
IN25B	4.25	IN40	10.60	IN60	.55

TYPE "J" POTENTIOMETERS

Resis.	Shaft	Resis.	Shaft	Resis.	Shaft
60	SS	5K	1/4"	50K	3/8"
160	19/16"	5K	3/8"	50K	1/2"
100	SS	5K	1/2"	100K	SS
200	SS	10K	SS	150K	1/2"
250	1/8"	10K	3/8"	200K	3/8"
500	SS	10K	1/2"	250K	SS
500	5/16"	15K	SS	250K	3/4"
500	1/2"	15K	1/2"	250K	3/8"
500	5/8"	20K	SS	500K	SS
500	1/2"	25K	SS	500K	1/4"
1K	SS	25K	1/4"	500K	7/16"
2K	3/8"	30K	1/8"	1 Meg	SS
2500	SS	40K	SS	2.5 Meg	SS
4K	SS	50K	SS	5 Meg	SS
5K	SS	50K	1/4"		

\$1.25 each

SOUND POWERED TELEPHONES

U. S. NAVY TYPE M HEAD AND CHEST SETS	
U.S.I. A-260	W.E. D-17301
A.E. GL832BA0	
ANY TYPE	\$14.88 EACH
TS-10 Type Handsets	\$9.25

GENERATORS AND INVERTERS

Eclipse-Pioneer type 716-3A (Navy Model NEA-3A)	
Output-AC 115V 10.4A 800 to 1400cy. 1ϕ; DC 30	
Volts 60 Amps. Brand new	\$38.50
Eclipse-Pioneer type 1235-1A. Output-30 Volts DC	
15 Amps. Brand New-Original Packing	\$15.50
PE-218 Inverters-28 VDC to 115 VAC 400 cy 1500	
VA. (New)	\$49.50
G. E. 5D21N3A Inverter-24 VDC to 115 VAC 400	
cy 485 VA (New)	\$32.50
Pioneer Type 800-1B Inverter-28VDC to 120V 800	
cy 7 amp AC (used)	\$22.65
G. E. Inverter-28 VDC to 120 VAC 800 cy 750 VA	
1ϕ	\$39.50
ATR Inverter 6VDC to 110 VAC 60 cy 75W	\$22.95
PU-7/AP Inverter-28 VDC to 115 VAC 400 cy 2500	
(used)	\$75.00
Eclipse-Pioneer type 12121A Inverter-Voltage and	
frequency regulated-24VDC 18 Amp Input-AC	
output 115V 3ϕ 400 cy 250VA 0.7 PF	
(New)	\$225.00

TEST EQUIPMENT

Gen. Radio 475B Frequency Monitor	\$200.00
Gen. Radio 681A Freq. Deviation Meter	.90
I-72K Signal Generator	\$48.50
C-D Quietone Filter Type IF-16 110/220V AC/DC	
20 Amps.	\$9.00
TS-143/CPN Oscilloscope	\$95.00
Dumont 175A Oscilloscope	\$225.00
Gen. Radio 757-P1 Power Supply	\$27.00
I-130A Signal Generator	\$85.00
A.W. Barber Labs. VM-25 VTVM	\$86.00
TS-10A/APN Delay Line Test Set	\$45.00
TS-19/APQ-5 Calibrator	\$75.00
CW1-60AAG Range Calibrator for ASB, ASE, ASV	
and ASV-VC Radars	\$39.95
CRV-14AAS Phantom Antenna for Transmitters up	
to 400 MC.	\$11.75
3 CM Pickup Horn Antenna AT-48/UP	\$9.95
I-138A Signal Generator-10 cm.	\$185.00
BC-221 Frequency meter	\$125.00
BC-221 Freq. Meter (late models)	\$125.00
CW-60ABM Frequency Meter-10 CM.	\$97.50
Weston Model 1 D.C. Milliammeter 50/1500 MA	
with leather case.	\$75.00

All items New Except Where noted * (Exc. Used Condition.)

MISCELLANEOUS EQUIPMENT

I-82F Selsyn Indicator	\$6.95
SCR-515 control motor, w/dynamotor, control box	69.50
Amperex IB98 Gamma Counter	9.87
Powerstat 1226-115/230V Input-0-270V out.	
@ 9 amp.	37.00
EIMAC 35T Ionization Gauge	5.95
R-7/APS-2 Receiver	49.50
R-7/APS-15 Receiver	49.50
FL-8 1020 cycle filter	2.95
RM-29 remote control unit	8.95
RM-14 remote control unit	8.95
RTA-1B 12/24 V dynamotor	40.00
BC-1206-CM2 Receiver	12.95
AS-4 Radar equip. Complete	69.75
RCA AVR-15 Beacon Recvr	18.50
Navy DP-14 Direction Finder complete	385.00
CU-24/ART-13 Antenna Loading Cond.	4.95
T-85/APT-5 300-1600 MC Transmitter	175.00
BC-1016 Tape Recorder	350.00
AN/APA-30	375.00
BC-910A Oscilloscope	147.50
BC-1068 Receiver	57.50
ATJ and ATK TV Block Equip.	Quote

PULSE TRANSFORMERS

UTAH	UTAH
9262	9318
9278	9340
9280	9350
G.E. 68G-627	Westinghouse 232-AW2
G.E. 68G828	Westinghouse 232-BW-2
G.E. 68G929G1	AN/APN-4 Block Osc.
G.E. 60C13	Philco 352-744
G.E. K-2469A	Philco 352-7150
G.E. K-2744B	Philco 352-7071
AN/APN-9 (901756-501)	Philco 352-7178
AN/APN-9 (901756-502)	Raytheon UX-7350
AN/APN-9 (352-7250)	W.E. D-161310
AN/APN-9 (352-7251)	W.E. D-163247
Westinghouse 132-AW	W.E. D-163255
Westinghouse 139DWF	W.E. D-164661
Westinghouse 187AW2F	W.E. KS-9563

AN/APA-23 RECORDER

Sweeps any receiver through its tuning range and permanently records frequency and time of received signals on paper chart. Power input—(motor) 27V DC 1.5A, and (reorder) 80/115V AC 60-2600 cy 135W.
Originally designed to record pulse or sinewave modulated signals received by AN/APR-1, AN/APR-2, AN/APR-4, AN/APR-5, BC-348, S-27, SX-28, BRAND NEW \$14

ELECTRONIC RESEARCH TUBE SPECIALS

GUARANTEED BRAND NEW

STANDARD BRANDS ONLY

Receiving Tubes	6AG7	1.59	6SK7	.89	14A7	.97	3FP7	4.95	885	1.90	4B24	5.75	WE-257A	3.77	807	1.70
6AH6	1.39	6SK7GT	.89	14B6	.93	3FP7A	6.95	1865	1.80	4B25	1.80	WE-274A	5.50	808	2.65	
6AJ5	2.50	6SL7GT	.96	14B8	1.09	3GF1	4.95	1904	14.80	EL-6CF	8.95	274B	2.85	809	2.40	
6AK5	1.35	6SN7GT	.89	14C5	1.29	3HP7	4.91	2050	1.80	4E27	17.25	WE-275A	6.95	810	10.95	
WE-6AK5	2.85	6SN7WGT	2.30	14C7	1.15	4AP10	4.75	2051	1.15	4J36	150.00	WE-283A	4.25	811	3.60	
6AK5W	3.05	6SQ7	.75	14E6	1.09	5AP1	5.95	5545	32.50	4J38	120.00	WE-285A	5.87	813	9.50	
6AK6	.99	6SQ7GT	.75	14E7	1.29	5AP4	4.75	5BP1	5.75	4J52	375.00	WE-286A	7.90	814	3.95	
6AL5	.69	6SR7	.81	14F7	.93	5BP4	5.75	5BP4	5.75	5D21	26.50	WE-294A	5.75	815	2.75	
6AL5W	2.90	6SR7	.99	14H7	.99	5CP1	4.95	Purpose Tubes		5J23	24.50	304TH	9.75	816	1.45	
6AO5	.89	6ST7	1.25	14J7	.93	5CP1	4.95	OA2	\$1.30	5J29	18.50	304TL	9.75	826	1.45	
6AO6	.79	6T7G	1.09	14N7	.93	5CP7	9.50	OA3	1.51	6-8B	.85	307A	5.50	828	13.45	
6AR5	.79	6T8	1.11	14R7	.93	5FP7	4.95	OB2	1.50	6AN5	5.95	WE-309A	6.45	829	9.95	
6AS5	.99	6U5	1.19	14W7	.93	5HP1	5.75	OB3	1.29	6AR6	3.35	WE-310A	7.50	829A	14.50	
6AS6	3.30	6U7G	.88	14X7	.93	5HP4	5.75	OC2	1.29	6C21	29.50	WE-313C	4.25	832	3.95	
6AS7G	4.53	6V6	1.60	19T8	1.16	5JP2	26.50	OD3	1.15	6C24	52.50	316A	.89	830B	3.95	
6AT6	.63	6V6G	.79	22	1.16	5JP4	26.50	IB21A	2.85	6J4	7.95	WE-331A	4.25	832	9.95	
6AU5GT	1.21	6V6GT	.79	22	1.16	5LP1	19.75	IB22	3.25	7-7-11	1.19	WE-343A	185.00	832A	9.95	
6AU6	.69	6W4GT	.72	24A	.79	5LP5	19.75	IB24	9.95	10T1	.88	WE-346A	2.75	837	1.85	
6AV6	.63	6W6GT	.99	25A6	1.16	5M1	10.65	IB24 (West)	12.95	13-4	.80	WE-350A	6.95	838	3.25	
6B4G	1.60	6X4	.59	25L6GT	.89	7BP1	8.75	1B24		15E	2.35	350B	4.95	841	.49	
6B5	1.20	6X5GT	.59	25Z5	.99	7BP7	7.95	(Sylv)	18.95	15R	.95	WE-356B	5.45	844	.59	
6B7	.97	6Y6G	.99	26	.79	7BP12	14.95	1B26	3.73	REL-21	2.25	361A	4.75	845	5.75	
6B8	.85	6ZY5G	.89	27	.27	7BP14	14.95	1B27	19.50	2AC	1.85	371A	6.95	845W	6.75	
6B8G	.85	7A4	.79	28D7	1.75	7CP1	14.95	1B29	2.90	HK-24	3.95	371B	.95	851	67.00	
6BA6	.72	7A5	.88	30	.30	9CP7	12.85	1B41	47.50	HK-25	3.82	388A	2.95	852	22.60	
6BA7	1.20	7A6	.83	30 Spec.	.48	9FP7	9.95	1B42	9.80	FG-32		WE-399A	4.70	860	4.95	
6BA8	.83	7A7	.83	32	.32	10BP4	18.50	1B44	47.50	5558	6.75	417A	16.95	861	24.50	
6BC7	1.10	7A8	.83	32L7GT	.89	10FP4	24.50	1B44	47.50	REK-34	.49	434A	17.50	864	1.28	
6BD5GT	1.60	7AD7	1.44	32L7GT	.89	10FP4	24.50	1B44	47.50	35T Ion	4.95	446A	1.95	865A	1.48	
6BD6	1.01	7AH7	1.08	33	.33	12DP7	16.50	1B42	9.80	35T Ion	4.95	446A	1.95	865B	45.00	
6BE6	.72	7B4	.83	34	.34	12DP7	16.50	1B42	9.80	gauge	5.95	446B	2.25	869B	45.00	
6BF5	1.10	7B5	.83	35/51	.89	12DP7	16.50	1B42	9.80	450TH	42.50	450TH	42.50	872A	3.95	
6BF6	.83	7B6	.83	35A5	.89	902P1	9.95	1B24	9.95	450TH	42.50	450TH	42.50	874	1.45	
6BG6G	1.92	7B7	.83	35B5	.89	902P1	9.95	1B24	9.95	450TH	42.50	450TH	42.50	876	1.60	
6BH6	.99	7B8	.89	35L6GT	.81	12Z	3.75	1B22	2.22	REK-36	.78	475A	1.39	878	1.85	
6BJ6	.99	7C4	.69	35W4	.55	1B23	\$4.10	1B22	2.22	REK-37	4.92	475A	1.39	881	3.50	
6BK7	1.60	7C5	.83	35Y4	.81	1B23	\$4.10	1B22	2.22	EF-50	1.65	511	2.75	886	3.95	
6BL7GT	1.59	7C5GT	.83	35Z4GT	.81	1B24	1.75	1B22	2.22	VT-52	.75	511	2.75	886	3.95	
6BN6	1.59	7E5	1.20	35Z5GT	.81	1B24	1.75	1B22	2.22	53A	5.60	SS-501	12.50	886	3.95	
6BO6GT	1.26	7E6	.58	36	.36	1B24	1.75	1B22	2.22	53A	5.60	503AX	1.65	886	3.95	
6C4	.82	7E7	.83	37	.37	1B24	1.75	1B22	2.22	53A	5.60	506AX	1.47	886	3.95	
6C5	.75	7F7	.99	38	.38	1B24	1.75	1B22	2.22	53A	5.60	506AX	1.47	886	3.95	
6CB6	.89	7F8	1.59	39/44	.59	1B24	1.75	1B22	2.22	53A	5.60	506AX	1.47	886	3.95	
6C6	.97	7F9	1.32	41	.41	1B24	1.75	1B22	2.22	53A	5.60	506AX	1.47	886	3.95	
6C8G	.96	7H7	.83	42	.42	1B24	1.75	1B22	2.22	53A	5.60	506AX	1.47	886	3.95	
6CD6G	2.40	7J7	1.32	43	.43	1B24	1.75	1B22	2.22	53A	5.60	506AX	1.47	886	3.95	
6D6	.88	7K7	1.32	45	.45	1B24	1.75	1B22	2.22	53A	5.60	506AX	1.47	886	3.95	
6D8G	.83	7L7	.97	45Z5GT	.79	1B24	1.75	1B22	2.22	53A	5.60	506AX	1.47	886	3.95	
6E5	1.10	7N7	.97	46	.46	1B24	1.75	1B22	2.22	53A	5.60	506AX	1.47	886	3.95	
6F5GT	.83	7P7	.83	47	.47	1B24	1.75	1B22	2.22	53A	5.60	506AX	1.47	886	3.95	
6F6	.99	7R7	.94	48	.48	1B24	1.75	1B22	2.22	53A	5.60	506AX	1.47	886	3.95	
6F6G	.99	7S7	1.11	49	.49	1B24	1.75	1B22	2.22	53A	5.60	506AX	1.47	886	3.95	
6G7	.85	7V7	1.11	50	.50	1B24	1.75	1B22	2.22	53A	5.60	506AX	1.47	886	3.95	
6H6G	1.06	7X4	.73	50A5	.88	1B24	1.75	1B22	2.22	53A	5.60	506AX	1.47	886	3.95	
6H6GT	.83	7Y4	.73	50B5	.88	1B24	1.75	1B22	2.22	53A	5.60	506AX	1.47	886	3.95	
6I6	.89	7Z4	.83	50C5	.88	1B24	1.75	1B22	2.22	53A	5.60	506AX	1.47	886	3.95	
6J6GT	.83	7Z4	.83	50L6GT	.79	1B24	1.75	1B22	2.22	53A	5.60	506AX	1.47	886	3.95	
6J5	.79	7J5	.75	50Y6GT	.92	1B24	1.75	1B22	2.22	53A	5.60	506AX	1.47	886	3.95	
6J5G	.64	7J5G	.64	51	.51	1B24	1.75	1B22	2.22	53A	5.60	506AX	1.47	886	3.95	
6J5GT	.64	7J5GT	.64	51A6GT	.69	1B24	1.75	1B22	2.22	53A	5.60	506AX	1.47	886	3.95	
6K6	1.10	7K6	1.16	51B5B	.40	1B24	1.75	1B22	2.22	53A	5.60	506AX	1.47	886	3.95	
6K6GT	.89	7K6GT	.89	51B5B	.40	1B24	1.75	1B22	2.22	53A	5.60	506AX	1.47	886	3.95	
6L7	.89	7L7	1.32	51B5B	.40	1B24	1.75	1B22	2.22	53A	5.60	506AX	1.47	886	3.95	
6L7GT	.79	7L7GT	1.32	51B5B	.40	1B24	1.75	1B22	2.22	53A	5.60	506AX	1.47	886	3.95	
6L8G	1.28	7L8G	.89	51B5B	.40	1B24	1.75	1B22	2.22	53A	5.60	506AX	1.47	886	3.95	
6L8GT	.99	7L8GT	.89	51B5B	.40	1B24	1.75	1B22	2.22	53A	5.60	506AX	1.47	886	3.95	
6M6	.89	7M6	.89	51B5B	.40	1B24	1.75	1B22	2.22	53A	5.60	506AX	1.47	886	3.95	
6M6GT	.89	7M6GT	.89	51B5B	.40	1B24	1.75	1B22	2.22	53A	5.60	506AX	1.47	886	3.95	
6N6	.89	7N6	.89	51B5B	.40	1B24	1.75	1B22	2.22	53A	5.60	506AX	1.47	886	3.95	
6N6GT	.89	7N6GT	.89	51B5B	.40	1B24	1.75	1B22	2.22	53A	5.60	506AX	1.47	886	3.95	
6O6	.89	7O6	.89	51B5B	.40	1B24	1.75	1B22	2.22	53A	5.60	506AX	1.47	886	3.95	
6O6GT	.89	7O6GT	.89	51B5B	.40	1B24	1.75	1B22	2.22	53A	5.60	506AX	1.47	886	3.95	
6P6	.89	7P6	.89	51B5B	.40	1B24	1.75	1B22	2.22	53A	5.60	506AX	1.47	886	3.95	
6P6GT	.89	7P6GT	.89	51B5B	.40	1B24	1.75	1B22	2.22	53A	5.60	506AX	1.47	886	3.95	
6Q6	.89	7Q6	.89	51B5B	.40	1B24	1.75	1B22	2.22	53A	5.60	506AX	1.47	886	3.95	
6Q6GT	.89	7Q6GT	.89	51B5B	.40	1B24	1.75	1B22	2.22	53A	5.60	506AX	1.47	886	3.95	
6R6	.89	7R6	.89													

NEW YORK'S RADIO TUBE EXCHANGE

TYPE	PRICE	TYPE	PRICE	TYPE	PRICE	TYPE	PRICE	TYPE	PRICE	TYPE	PRICE	TYPE	PRICE
OA2	51.40	2C34	.35	3C24	1.95	2950	29.50	304TL	14.50	705A	3.95	815	3.50
OA3	1.75	2C40	29.00	3C21	8.95	C8A	8.95	307A	4.95	707A	17.95	818	1.45
OB2	1.75	2C43	27.00	3D1A	10.95	C8A	10.95	310A	7.95	707B	27.00	820	12.95
OC3	1.25	2C44	.90	3DPIA	12.00	7BP7	7.95	311A	7.95	714AY	17.95	820A	13.95
OD3	1.25	2D21	1.75	3E20	15.50	7DP4	10.00	312A	3.95	715A	7.95	820B	15.95
OA	4.95	2E22	3.75	3GP1	5.50	12A4	55.00	320A	25.00	715B	15.00	830B	3.50
C1A	6.95	2E30	2.75	SN4	1.75	15E	1.95	327A	3.95	715C	25.00	832	7.95
C1B	2.75	2J21	17.95	4A1	2.75	NE16	.68	350A	7.95	718AY/EY	45.50	832A	9.95
1B21A	3.95	2J22	17.95	4A21	10.95	FG17	6.95	350B	5.95	719A	29.50	834	7.95
1B22	9.95	2J26	27.75	4B26	25.00	RX21	3.95	357A	20.00	721A	3.95	830	4.95
1B24	17.95	2J27	29.95	4C28	35.00	FG32	12.95	368AS	6.95	722A	3.95	837	2.95
1B28	2.95	2J31	29.95	4E27	17.50	35T	4.95	371B	2.95	723A/B	17.95	838	6.95
1B27	19.50	2J32	69.95	4J28	199.00	45 Special	.35	385A	4.95	724A	4.95	840	5.95
1B32	4.10	2J36	105.00	4J25	199.00	RK30	2.95	388A	2.95	724B	6.95	849	52.50
1B38	33.00	2J38	17.95	4J26	199.00	HF60	1.75	394A	7.95	725A	3.95	851	80.50
1B42	19.95	2J40	35.00	4J27	199.00	YT52	.25	MX408U	7.95	726A	6.95	860	4.95
1B41	9.95	2J49	109.00	4J31	199.00	RK72	1.95	417A	27.95	728B	56.00	861	39.50
1B58	49.95	2J50	69.50	4J32	199.00	RK73	1.95	434A	29.95	728C	69.00	860A	4.95
1B60	69.95	2J55	95.00	4J33	199.00	100TH	9.00	440A	1.95	728AY	27.00	869B	37.50
1N1	1.35	2J61	75.00	4J37	199.00	FG105	18.00	450A	5.40	801A	1.00	869BX	35.00
1N21A	1.75	2J62	75.00	4J38	199.00	F123A	8.95	450TH	45.00	802	4.25	872A	3.95
1N21B	4.25	2K25	37.50	4J39	199.00	203A	8.95	450TL	45.00	803	7.95	878	1.95
1N22	1.75	2K28	37.50	4J41	199.00	211	18.00	464A	9.95	804	12.50	884	1.95
1N23	2.00	2K29	37.50	C5B	6.95	217C	10.00	471A	3.50	805	2.75	885	5.95
1N23A	2.00	2K41	150.00	5BP1	6.95	242C	10.00	475A	15.00	806	25.00	889R	199.50
1N23B	3.75	2K45	149.50	5BP4	6.95	244A	12.95	W530	3.50	807	1.65	914	75.00
1N23C	6.00	2V3G	2.10	6CP1	27.50	249C	4.95	W531	22.50	808	3.50	931A	6.95
1N27	5.00	3BP1	5.50	6D21	27.50	250TL	19.95	W533	17.50	810	11.00	954	.35
1N43	5.00	3B4	5.50	5JF1	19.50	274A	3.00	700A/D	25.00	811A	2.15	955	1.75
1B21	6.95	3B24W	7.50	5JF2	27.50	274B	3.00	701A	7.50	813	8.95	956	.69
2B22	1.95	EL3C	5.95	5JF4	27.50	274C	3.00	708A	6.95	814	3.95	967	.29
3B26	3.75	3C22	120.00	W66AK5	2.50	304TH	15.00						

Minimum Order \$25.00

ATTENTION OIL COMPANY ENGINEERS SHIP SUPPLIERS USERS OF SHORAN WE HAVE FOR IMMEDIATE DELIVERY TESTED AND GUARANTEED PERFECT, NEW

4C28 SPECIAL PRICE \$35.00

MICROWAVE TEST EQUIPMENT

TS148U/P SPECTRUM ANALYZER

147 also available

Field type X Band Spectrum Analyzer, Band 8430-9580 Megacycles

Will check Frequency and Operation of various X Band equipment such as Radar Magnetrons, Klystrons, TR Boxes. It will also measure pulse width, c-w spectrum width and Q of resonant cavities. Will also check frequency of signal generators in the X band. Can also be used as frequency modulated Signal Generator etc. Available new complete with all accessories.

Also available of new production TS239A Synchroscope.

Other test equipment, used checked out, surplus.

- TSK1/SE K Band Spectrum Analyzer
- TS3A/AP Frequency and power meter S Band
- RF4A/AP Phantom Target S Band
- TS10/APN Altimeter Test Set
- TS12/AP VSWR Test Set for X Band
- TS13/AP X Band Signal Generator
- TS15/AP Flux Meter
- TS16/AP Altimeter Test Set
- TS33/AP X Band Power and Frequency Meter
- TS34/AP Western El. Synchroscope
- TS34A/AP Western El. Synchroscope

- TS35/AP X Band Signal Generator
- TS36/AP X Band Power Meter
- TS45/AP X Band Power Source
- TS47/APR 40-400 MC Signal Generator
- TS69/AP Frequency Meter 400-1000 MC
- TS100 Scope
- TS102A/AP Range Calibrator
- TS110/AP S Band Echo Box
- TS125/AP X Band Power Meter
- TS126/AP Synchroscope
- TS174/AP Signal Generator

- TS175 Signal Generator
- TS226 Power Meter
- TS251 Range Calibrator APN9
- TS270 S Band Echo Box

SURPLUS EQUIPMENT

- APA10 Oscilloscope and panoramic receiver
- APA38 Panoramic Receiver
- APS 3 and APS 4 Radar
- APR5A Microwave Receiver
- APT2 Radar Jamming Transmitter
- APT5 Radar Jamming Transmitter

SPECIAL

Wide Band S Band Signal Generator 2700/3400MC Using 2K41 or PD 8365 Klystron, Internal Cavity Attenuator, Precision individually calibrated Frequency measuring Cavity, CW or Pulse Modulated, externally or internally.

Large quantities of quartz crystals mounted and unmounted.
Crystal Holders: FT243, FT171B others.
Quartz Crystal Comparators.
North American Phillips Fluoroscopes Type 80
Large quantity of Polystyrene beaded coaxial Cable

YOU CAN REACH US ON TWX NY1-3235

MINIMUM ORDER 25 Dollars



Cables: TELSERSUP

PHONE WORTH 4-8262

135 LIBERTY ST., NEW YORK 6, N.Y.

A LEADING SUPPLIER OF ELECTRONIC & AIRCRAFT EQUIPMENT

**IMMEDIATE
DELIVERY -- FULLY
GUARANTEED**

A C MOTORS

TELECHRON SYNCHRONOUS MOTOR, Type B3, 110 V., Cy., 4 W., 2 RPM. PRICE \$5.00 EA.
TELECHRON SYNCHRONOUS MOTOR Type BC, 110 V., 60 Cy., 6 W., 60 RPM. PRICE \$4.00 EA.

HAYDON TIMING MOTORS 110 V., 60 CY.

Type 1600, 2.2 W., 4/5 RPM. PRICE \$3.00 EA.
TYPE 1600, 2.2 W., 1/240 RPM. PRICE \$3.00 EA.
TYPE 1600, 2.3 W., 1 RPM. PRICE \$3.00 EA.
TYPE 1600, 2.2 W., 1-1/5 RPM. PRICE \$3.00 EA.
TYPE 1600, 2.2 W., 1/60 RPM. PRICE \$3.00 EA.

SERVO MOTORS

CK1, PIONEER, 2 ϕ 400 Cy. PRICE \$10.00 EA.
CK2, PIONEER, 2 ϕ , 400 Cy. PRICE \$14.00 EA.
CK2, PIONEER, 2 ϕ , 400 Cy., with 40:1 reduction gear. PRICE \$15.50 EA.
10047-2-A, PIONEER, 2 ϕ , 400 Cy., with 40:1 reduction gear. PRICE \$10.00 EA.
MINNEAPOLIS HONEYWELL Amplifier Type G403, 115 V., 400 Cy., Used with above motor. PRICE \$10.00 EA. WITH TUBES

REMOTE INDICATING COMPASSES 26 V., 400 CY.

PIONEER TYPE AN5730-2 Indicator and AN5730-3 Transmitter. PRICE \$40.00 PER SET
KOLLSMAN TYPE 680K-03 Indicator and 679-01 Transmitter. PRICE \$15.00 PER SET

D C MOTORS

BODINE NFHG-12 MOTOR 27 V. DC Governor Controlled, 1/30 HP, Constant Speed. PRICE \$16.50
DELCO MOTOR, TYPE 5068750, 27 V., D.C., 160 R.P.M., with Brake. Price \$22.50 EA.
JAEGER WATCH CO. TYPE 44K-2 Contacter Motor, 3 to 4.5 V. Makes one contact per second. PRICE \$3.50 EA.
BARBER-COLMAN CONTROL MOTOR, Type AYLK 5091, 27 V., 0.7 Amps., 1 RPM. Contains 2 ad. limit switches. 500 in. lbs. torque. PRICE \$9.50 EA.
WHITE ROGERS ELECTRIC CO., Type 6905 No. 3, 12 V., 1.3 Amps., 1 1/2 RPM, torque 75 in. lbs. PRICE \$10.50 EA.

ENGINE HOUR METER

John W. Hobbs Model MI-277. Records running time up 1000 hours. 20 to 30 volts D.C. PRICE \$15.50 EA.

INVERTERS

WINCHARGER CORP. PU 16/AP, MG570. Input 24 V. D.C., 60 Amps. Output 115 V., 400 Cy., 1 ϕ , 6.5 Amps. PRICE \$100.00 EA.

HOLTZER CABOT TYPE 149F, Input 24 V. D.C. at 36 Amps., Output 26 V. at 250 V.A., 400 Cy., and 115 V., 400 Cy., at 500 V.A., 1 ϕ . PRICE \$100.00 EA.

PIONEER TYPE 12117. Input 12 V. D.C., Output 26 V., 400 Cy. at 6 V.A. PRICE \$30.00 EA.

PIONEER TYPE 12117. Input 24 V. D.C., Output 26 V., 400 Cy. at 6 V.A. PRICE \$30.00 EA.

WINCHARGER INVERTER TYPE MG-2500, PU-7 Input 24 V. D.C. 160 Amps., Output 115 V., 400 Cy., 1 ϕ 216 Amps. PRICE \$75.00 EA.

GENERAL ELECTRIC TYPE 5D21NJ3A. Input 24 V. D.C. at 35 Amps. Output 115V., 400 Cy., 485 V.A., 1 ϕ . PRICE \$50.00 EA.

LELAND PE 218. Input 24 V. D.C. at 90 Amps. Output 115 V., 400 Cy., 1 ϕ at 1.5 K.V.A. PRICE \$47.50 EA.

PIONEER AUTOSYNS

TYPE AY1, 26 V., 400 Cy. PRICE \$8.50 EA.
TYPE AY5, 26 V., 400 Cy. PRICE \$8.50 EA.
TYPE AY14G, 26 V., 400 Cy. PRICE \$15.00 EA.
TYPE AY14D, 26 V., 400 Cy. PRICE \$15.00 EA.
TYPE AY54D, 26 V., 400 Cy. PRICE \$10.00 EA.
TYPE AY131D Precision Autosyn. PRICE \$35.00 EA.

PIONEER AUTOSYN POSITION INDICATORS & TRANSMITTERS

TYPE 5907-17. Dial graduated 0 to 360°, 26 V., 400 Cy. PRICE \$30.00 EA.
TYPE 6007-39. Dual Dial graduated 0 to 360°, 26 V., 400 Cy. PRICE \$50.00 EA.
TYPE 4550-2-A Transmitter, 26 V., 400 Cy., 2:1 gear ratio. PRICE \$20.00 EA.

VOLTAGE REGULATORS

LELAND ELECTRIC CO. TYPE B, Carbon Pile type. Input 21 to 30 V. D.C. Regulated output 18.25 at 5 Amps. PRICE \$6.50 EA.

WESTERN ELECTRIC TRANSTAT VOLTAGE REGULATOR Spec. No. V-122855, Load K.V.A. 0.5. Input 115 V., 400 Cy. Output adjustable from 92 to 115 V. PRICE \$10.50 EA.

RATE OR TACHOMETER GENERATORS

GENERAL ELECTRIC TACHOMETER GENERATOR TYPE AN5531-1. Variable frequency, 3 ϕ output. PRICE \$30.00 EA.

GENERAL ELECTRIC TACHOMETER GENERATOR TYPE AN5531-2. Variable frequency, 3 ϕ output. PRICE \$30.00 EA.

ALL PRICES
F. O. B.
GREAT NECK
N. Y.

SYNCHROS

IF SPECIAL REPEATER, 115 V., 400 Cy. PRICE \$20.00 EA.
2J1F3 GENERATOR, 115 V., 400 Cy. PRICE \$10.00 EA.
2J1G1 CONTROL TRANSFORMER, 57.5/57.5 V., 400 Cy. PRICE \$10.00 EA.
2J1F1 GENERATOR, 115 V., 400 Cy. PRICE \$10.00 EA.
2J1H1 DIFFERENTIAL GENERATOR 57.5/57.5 V., 400 Cy. PRICE \$10.00 EA.
5SDG DIFFERENTIAL GENERATOR, 90/90 V., 400 Cy. PRICE \$20.00 EA.
5G GENERATOR, 115 V., 60 Cy. PRICE \$50.00 EA.
W. E. KS-5950-L2 Size 5G, 115V, 400 Cy. PRICE \$10.00 EA.

D C ALNICO FIELD MOTORS

DIEHL TYPE S.S. FD6-23, 27 V., 10,000 RPM. PRICE \$10.00 EA.
DELCO TYPE 5069370, 27 V., 10,000 RPM. PRICE \$15.00 EA.
DELCO TYPE 5072400, 27 V., 10,000 RPM. PRICE \$15.00 EA.

BLOWER ASSEMBLIES

JOHN OSTER TYPE MX215/APG, 28 V. D.C., 7,000 RPM, 1/100 H.P. PRICE \$10.00
WESTINGHOUSE TYPE FL, 115 V., 400 Cy., 6,700 RPM, Airflow 17 C.F.M. PRICE \$10.00 EA.
DELCO TYPE 5608571 Motor and Blower Assembly, P.M. Motor, 27 V., 10,000 RPM. PRICE \$15.00 EA.

GENERAL ELECTRIC D C SELSYNS

8TJ9-PAB, TRANSMITTER, 24 V. PRICE \$4.50 EA.
8DJ11-PCY, INDICATOR, 24 V. Dial marked -10° to +65°. PRICE \$6.00 EA.
8DJ11-PCY, INDICATOR, 24 V. Dial marked 0 to 360°. PRICE \$7.50 EA.

RECTIFIER POWER SUPPLY

Hammett Electric Mfg. Co., Model SPS-130, Input Voltage AC 208 or 230, 60 cycle, 3 phase, 21 amps. Output 28 Volts, 130 amps, continuous duty. 37" high, 22 1/2" wide, 21" deep. Contains DC Volt meter, DC amp meter and 8 point tap switch for variable output voltage. Brand new. Price \$350.00.

MISCELLANEOUS

PIONEER MAGNETIC AMPLIFIER ASSEMBLY Saturable reactor type output transformer. Designed to supply 1 phase to a 400 cycle motor such as the Pioneer CK-5 or CK-2 from the plate of a 6SN7 tube. PRICE \$15.00 EA.
SPERRY A5 CONTROL NIT, Part No. 644836. PRICE \$7.50 EA.
SPERRY A5 AZIMUTH FOLLOW-UP AMPLIFIER, Part No. 656030, with tubes. PRICE \$5.50 EA.
SPERRY A5 DIRECTIONAL GYRO, Part No. 656029, 115 V., 400 Cy., 3 ϕ . PRICE \$25.00 EA.
PIONEER TYPE 12800-1 GYRO SERVO UNIT. 115 V., 400 Cy., 3 ϕ . PRICE \$20.00 EA.
ALLEN CALCULATOR TYPE C1 TURN & BANK INDICATOR, Part No. 21500, 28 V. D.C. PRICE \$15.00 EA.
TYPE C1 AUTO-PILOT FORMATION STICK, Part No. G1080A3. PRICE \$15.00 EA.
PIONEER GYRO FLUX GATE AMPLIFIER Type 12076-1-A, 115 V., 400 Cy. PRICE \$40.00 EA.

**INSTRUMENT
ASSOCIATES**

Write for Catalog NE100

363 GREAT NECK ROAD, GREAT NECK, N. Y.
Telephone GReat Neck 4-1147

Reliance Specials

GEAR ASSORTMENT

100 small assorted gears. Most are stainless steel or brass. Experimenters' dream! Only \$6.50

VERNIER DIAL or DRUM (From BC-221)
Dial—2 1/2" dia. 0-100 in 360°. Black with silver marks. Has thumb-clip. DRUM—0-50 in 180°. Black with silver marks either 85¢

SOUND POWER HANDSET BRAND NEW

Includes 6 ft. cord.—No batteries or external power source—used. \$18.50 pr

AC LINE CORDS 6 ft. long with molded rubber plug 18¢

BALL BEARINGS

Mfg. No.	ID	OD	Thick.	Price
MRC5028-1	5 1/2	6 1/2	1	\$3.75
MRC7026-1	4 1/4	5 1/4	1	3.50
MRC7021-200	4 3/8	5 3/8	23/64	2.95
MRC106M2	1 17/64	2 7/16	25/64	1.75
MRC106M1	1 13/64	2 7/16	25/64	1.60
Federal LS11	1 1/8	2 1/2	5/8	1.75
Norma S11R	1 1/8	2 1/8	5/8	1.70
Federal A941	1 1/16	1 1/2	9/32	1.50
Schatz	3/4	1 3/4	9/16	1.00
Norma 203S	5/8	1 9/16	7/16	.90
ND5202-C13M	1/2	1 3/8	1 3/8	1.00
ND 3200	25/64	15/32	11/32	.60
ND R6	3/8	7/8	7/32	.40
MRC39R1	1 1/32	1 1/32	5/16	.45
MRC38R3	8/16	55/64	13/32	.45
FAFNIR 33Kdd	1/8	5/8	3/16	.35

NEEDLE BEARINGS

TORRINGTON B108 1/8" wide 1/2" 13/16" 30¢

Brand New Meters—Guaranteed 2.50
0-10 ma. D.C. 3 1/4" ... 3.95 0-80 Amp. D.C. 2 1/2" ... \$2.25
0-1 ma. D.C. 3 1/4" DeJur. ... Scale Reads 0-4 KV. ... \$5.75

SELENIUM RECTIFIERS

Full Wave 200 MA 115V. \$1.79
Half Wave 100 MA 115V.91

TIMING MOTOR

8 RPM 115V 60 cyc  **\$1.79**
E. Ingraham Co.

400 CYCLE INVERTERS

Leeland Electric Co.
#10890 in: 20-28 V.D.C. 82 A. 3000 R.P.M. Out: 115V.
400 Cyc. 1 phase. 1500 V.A. 90 PF. \$24.95

3 AG FUSES

Amp.	Per 100	Amp.	Per 100	Amp.	Per 100
1/8	\$4.00	3/4	\$4.00	8	\$3.00
3/8	4.00	4	3.00	10	3.00
1/2	4.00	5	3.00	15	3.00

3 AG FUSE HOLDERS (Finger) 25¢

DELAY NETWORK—ALL 1400Ω

T 114—Approx. 2.2 micro sec. delay. 1.95¢
T 115 Similar to T 114 with tap brought out. 1 each

Sound Powered Chest Set RCA—With 24 Ft. Cord



Per Pair **USED \$17.60**
NEW \$26.40

POSTAGE STAMP MICAS

mmf	mmf	mmf	mmf	mmf	mmf	mmf	mfd	mfd
7	25	56	110	250	500	800	.001825	.0044
7.5	26	60	120	270	510	820	.002	.006
8.2	33	82	125	300	560	910	.0027	.0062
10	39	98	150	330	580	.001	.0033	.0065
15	40	30	180	600	.0012	.0035	.0066	
18	43	75	175	370	620	.0013	.0036	.0082
20	47	80	180	390	650	.00136	.004	.01
22	50	82	200	400	680	.0015		
23	51	90	220	430	750			
24		100	240	470				

Price Schedule

7 mmf to 820 mmf.	5¢
.001 mmf to .001825 mfd.	8¢
.002 mfd to .0082 mfd.	15¢
.01 mfd.	26¢

SILVER MICAS

mmf	mmf	mmf	mmf	mmf	mmf	mfd	mfd	mfd
8	40	82	155	270	470	800	.0024	.0039
10	50	100	170	325	500	.0011	.0025	.004
18	51	110	180	350	510	.0013	.0027	.005
22	58	115	208	360	525	.0015	.00282	.0051
23	60	120	225	370	560	.0016	.002828	.0056
24	62	125	240	390	570	.001625	.003	.006
27	68	130	250	400	680	.0018	.0033	.0068
30	73	135	255	410	700	.0019	.0033	.0082
39	75	150	260	430		.0023		.01

Price Schedule

8 mmf to 800 mfd.	10¢
.001 mfd to .002 mfd.	20¢
.002 mfd to .0082 mfd.	50¢
.01 mfd.	\$1.00

PULSE TRANSFORMERS

UTAH—9262 9278 9280
WESTERN ELECTRIC—D168173 D161310
KS8096, KS9585, KS9800, KS9862, KS13161
GENERAL ELECTRIC—K2731 K2729A 80-G-5
JEFFERSON ELECTRIC—C-12A-1318
DINION COIL—TR 1048 TR1049
also 352-7250-2A; 352-7251-2A; T-1229621-60

COAXIAL CABLE CONNECTORS



15¢	\$1.30	30¢	80¢	40¢	12¢
UG 175/U	83-1F	83-1AP	83-1J	SO-239	HOOD
83-1AC	\$.42	UG-22/U	\$1.30	UG-104/U	\$1.40
83-1AP	.30	UG-22A/U	1.65	UG-106/U	.12
83-1F	1.20	UG-22B/U	1.65	UG-167/U	5.70
83-1H	.12	UG-23/U	1.20	UG-175/U	.15
83-1HP	.25	UG-23B/U	1.90	UG-176/U	.15
83-1J	.80	UG-23C/U	1.90	UG-185/U	1.35
83-1R	.40	UG-24/U	1.30	UG-224/U	1.20
83-1RTY	.65	UG-25/U	1.35	UG-255/U	2.45
83-1SP	.50	UG-27/U	1.30	UG-260/U	1.20
83-1SPN	.60	UG-27B/U	3.45	UG-290/U	1.20
83-1T	1.30	UG-30/U	2.30	UG-306/U	2.95
83-2AP	1.95	UG-37/U	2.30	UG-499/U	1.25
83-2T	2.10	UG-37B/U	2.30	UG-625/U	1.35
83-2R	1.70	UG-58/U	.80	CW-123A/U	.50
83-22AP	1.40	UG-58A/U	1.15	M-358	1.30
83-22R	.68	UG-59A/U	2.25	M-359	.30
83-22SP	.90	UG-85/U	1.75	PL-258	.80
83-185	.15	UG-87/U	1.60	PL-259	.50
83-185	.15	UG-88/U	1.10	PL-259A	.60
UG-13/U	1.70	UG-89/U	1.35	PL-274	1.20
UG-21/U	.95	UG-102/U	.90	SO-239	.40
UG-21B/U	1.35	UG-103/U	.68		

NEW COAXIAL CABLES

	Price per 1000 Ft.		Price per 1000 Ft.
RG 5/U*	\$140.00	RG 22A/U	\$285.00
RG 6	180.00	RG 24	675.00
RG 7*	85.00	RG 26	475.00
RG 8*	100.00	RG 28	50.00
RG 9*	250.00	RG 30	300.00
RG 9A/U	275.00	RG 35	900.00
RG 10	240.00	RG 41*	295.00
RG 11*	100.00	RG 54A/U	97.00
RG 12*	240.00	RG 55*	110.00
RG 13*	216.00	RG 57*	62.00
RG 17	650.00	RG 58*	35.00
RG 18*	900.00	RG 58A/U*	65.00
RG 19	1250.00	RG 59*	55.00
RG 20	1450.00	RG 62*	75.00
RG 21	220.00	RG 77*	100.00
RG 22/U*	150.00		

Add 25% for orders less than 500 feet.
* No minimum order—others 250' minimum.

UNIVERSAL JOINT ALUMINUM



1/4" hole x 1/2" O.D.
1 1/8" long 85¢

SPAGHETTI SLEEVING—assortment—90 feet. \$1.00

TYPE "J" POTENTIOMETERS

100 S.S.*	1,500 1/4S.S.	15K 1/4	200K S.S.*
150 S.S.*	2,000 1/4	25K S.S.	250K 5/8
300 S.S.*	2,500 S.S.	70A S.S.	250K S.S.*
400 S.S.*	3,000 3/8	80K S.S.	500K S.S.*
500 S.S.*	4,000 3/8	100K 7/16	1Meg S.S.*
1,000 3/8	5,000 3/4	100K S.S.*	
1,000 S.S.	10K 5/8	100K 5/8	

*Split Locking Bushing \$1.50 EACH

TYPE "JJ" POTENTIOMETERS

Ohms	Shaft	Ohms	Shaft	Ohms	Shaft
1000	S.S.	30K-10K	3/8"†	1 Meg.	1/2"
10K	5/16"	3K-90K	1/4"	1 Meg.	S.S.
15K	S.S.				

SD—Screw Driver *Split Locking Bushing—† With Switch

PRICE—\$2.00 EACH

JONES BARRIER STRIPS

2-140Y	\$17	3-141W	.27	9-141Y	.71
3-140W	.21	4-141W	.33	12-141	.64
6-140	.28	5-141	.29	3-142	.24
10-140W	.59	5-141 1/2 W	.41	2-150	.43
10-140 1/2 W	.59	7-141 1/2 W	.56	3-150	.60
3-141 1/2 W	.27	8-141 1/2 W	.64		

TIME DELAY RELAY

Raytheon CPX 24166
1 Min. Delay. 115 V., 60 Cycle
2 1/2 second recycling time spring return • Micro-switch contact. 10A. Holds ON as long as power is applied • Fully Cased • ONLY \$6.50

AN CONNECTORS IMMEDIATE SERVICE
PHONE! WIRE! WRITE! YOUR NEEDS

MFD	V.D.C.	Price	MFD	V.D.C.	Price
.25	20,000	\$19.95	8	1,000	\$3.25
.075-.075	8,000	1.95	4	1,000	2.75
.15-.15	8,000	2.95	3	1,000	1.25
2 x .02	7,000	1.60	2	1,000	.95
.03-.03	6,000	1.45	1	1,000	.75
.1	7,500	2.25	1	800	.60
.03	7,500	1.95	10	800	2.95
.1-.1	7,000	2.25	8-8	600	1.75
.1	7,000	1.95	8	600	2.05
.02-.03	7,000	1.65	4	600	1.63
.1	7,000	1.75	2 x 2	600	1.35
3 1/2 x 2	4,000	6.95	2	600	.79
.06	4,000	1.40	4 x 3	600	1.95
.25	4,000	2.25	8	500	1.50
8	2,000	3.75	4	500	.98
3	2,000	2.95			
.5-.1	2,000	1.95			
.5	2,000	1.95			
.3	2,000	1.75			
.1-.1	2,000	1.65			
.02	2,000	.89			
4	1,500	2.50			
1	1,500	1.50			



8 MFD 2000 V.D.C. \$7.95

PRECISION RESISTORS—1/4 WATT—30¢

2	10.48	12.32	14.98	62.54	147.5	\$705
2.5	10.84	13.02	15.8	79.81	220.4	2,193
3.5	11.25	13.52	16.37	105.8	301.8	3,500
6.68	11.74	13.89		125.8	386.6	
				125	414.3	59,148

PRECISION RESISTORS

Buy TOP Radio-Electronic Values!

AIR TRIMMER CONDENSERS

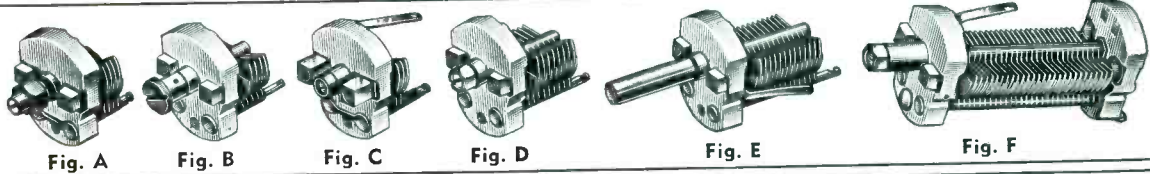

STOCK NO.	CAPACITY Min. Max.	MANUFACTURER'S NUMBER	FIGURE	SHAFT LENGTH	POST LENGTH	GROUND LUG	PRICE EACH
2937	2.5 - 7	Hamm 250034	D	5/16	3/32	Right	18¢
5716	3 - 8	ASP 17A224	A	9/16	3/32	Top	25¢
5717	3 - 10	ASP 22G195	A	9/16	3/32	To Post	18¢
4090	2 - 15	ASP 482212	C	1 x 1/4" D	3/32	Left	25¢
2939	3 - 15	ASP 217-2	D	5/16	1/4	Top	20¢
5718	3 - 15	Telrad 682070-30	E	5/16	3/32	Right	20¢
5719	3 - 15	Hamm 682070-30	D	5/16	3/32	Right	20¢
231	3 - 25	CAIM 481881	D	9/16	3/32	Left	25¢
5720	3 - 27	Hamm 11725-1	D	5/16	3/32	Right	25¢
5721	2.5 - 28	Comar M420864-6	D	5/16	3/32	Top	25¢
5723	3 - 29	ASP 22G190	D	9/16	3/32	To Post	25¢
2940	2 - 30	ASP A8H-501	D	5/16	5/16	To Post	30¢
5724	4.5 - 30	OB7751E-25	B	5/16	5/16	Right	30¢
5086	5 - 30	Hamm SBL-72265-3	B	1/2	3/32	Bottom	30¢
2941	4.5 - 35	Hamm ESA682070-37	D	5/16	3/32	Left	30¢
232	5 - 54	Hamm ESA582070-35	D	5/16	3/32	Left	40¢
5087	5 - 54	Hamm BL72265-4	B	1/2	3/32	Right	40¢
236**	8 - 140	ASP 19A34504	D	5/16	3/32	To Post	55¢
5675	6 - 150	Hamm APQEI150	E	1 1/16 x 1/4" D	3/32	Right	75¢
5726	9 - 204	OAK 114M510	F	9/16	3/32	Top	95¢

* Double spaced plates.
 ** Adjusts both ends, some available w/dust cover.
 Fig. A Round Shaft Screwdriver adj. w/locknut.
 Fig. B Bakelite Knob Ins. Screwdriver adj.
 Fig. C Round shaft Screwdriver adj.
 Fig. D Hexnut Screwdriver adj.
 Fig. E 1/4 Round Shaft.
 Fig. F Double End Plate.

SIGNAL CORPS TRANSFORMERS— CHOKES & FILTERS

2C6191/K1	2Z9618-42	2Z9636.16	3C106B
2C6191/T3	2Z9619.42	2Z9638.16	3C307-1
2C6191A/3	2Z9619.63	2Z9638.44	3C307-46
2C619F T2	2Z9619-99	2Z9643.42	3C317.33
2C6230/123	2Z9620.1	2Z9655	3C317-43
2C6230.3/124	2Z9621.43	2Z9662	3C317-44
2C6307/AK1	2Z9621-112	2Z9702-2	3C323-6C
2C6386A/T14	2Z9625-1	2Z9760	3C323-14A
2C6494A/C11	2Z9625-8	2Z9805	3C323-54B
2C6530-653A/C10	2Z9625-24	2Z9808	3C323-122B
2C653-653A/T5	2Z9626	2Z9828	3C323-145B
2Z3625-66	2Z9627-35	2Z9851	3C324-4
2Z5731-337	2Z9628-2	2Z9853	3C324-40
2Z9600.3	2Z9631.187	2Z9854	3C335-11
2Z9604.16	2Z9632.8	2Z9855	3C343-2
2Z9608.36	2Z9632.14	2Z9876-2	3C344
2Z9611.115	2Z9632.39	2Z9878-1	3C344-9
2Z9611-289	2Z9632.170	2Z9878-11	3C362-8
2Z9612	2Z9632.171	2Z9878-13	3C375-15
2Z9612.52	2Z9632.197	2Z9878-14	3C549
2Z9612.83	2Z9632.248	2Z9879	3C573
2Z9613.14	2Z9632.362	2Z9879-2	3C575G-1
2Z9613.64	2Z9632.365	2Z9879-3	3C362-23
2Z9613.304	2Z9632.366	2Z9900-5	3C362-24
2Z9614-94	2Z9634.4	2Z9931B	3C1987-29
2Z9617-22	2Z9634.39	2Z9944	3C4075
2Z9618-9	2Z9634.46	2Z9984	3F4061B/C1
			6C8/F1

MORE INFORMATION AND PRICES UPON REQUEST

TRANSMITTING MICAS

Stock No.	Cap.	Test Volts	Type No.	Price Each
5493A*	.01	1000	1445	.35¢
5494A	.02	1000	1447	.40¢
5495A	.06	1200	A2	.40¢
5496A	.01	1500	BE 15	.20¢
5493A	.004	2500	4	.30¢
5499A	.001	5000	F	.60¢
5600A	.0036	5000	A2	\$1.00
5601A	.15	1000V	XS	1.90
5602A	.00007	2500V	3	.90¢
5603A	.00005	3000V	15L	1.00
5604A	.0001	5000V	F2L	1.00
5605A	.0008	5000V	F2L	1.00
5606A	.000025	10,000	PL-34L	1.95
5607A**	.00015	10,000	PL-315	7.95

* Supplied with Meter Bracket

** D.C. Working Voltage

OTHER TYPES AND SIZES AVAILABLE

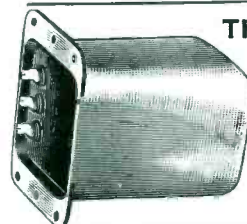

THORDARSON AUDIO PASS FILTERS

Band pass
800 to 1200
cycles input
10000 ohms—
Output 25000
ohms Level
10DB

Stock No. T48500 Price to: \$5.50 ea.

SPECIAL TRANSFORMER BUYS!

HIGH CURRENT FILAMENT TRANSFORMER

Primary 115 VAC 60 Cycle. Secondary 1.25 VAC at 100 AMP.

Stock No. 5783 Price Each **\$5.00**

POWER TRANSFORMER

Horizontal Double Half Shell Type. 117 Volt 60 Cycle Primary. H.V. 380-0-380 Volts at 225 Mils. Filaments: 5V at 3A.; 6.3V at 8A.; 6.3V at 4A. Core Size 1/2" x 3/4"

Stock No. 5785 Price Each **\$4.25**

HIGH FIDELITY TRANSFORMER

P.P. 10,000 ohm to 250 ohm Line. Frequency Response 30 to 20,000 C.P.S. plus or minus 1 DB. Grey Rectangular Case 3" x 2 1/2" x 3 3/8" high. Bottom Solder Lug Terminals. 4 Stud Mtg. Bolts.

Stock No. 5792 Price Each **\$5.50**

6.3 VOLT FILAMENT TRANSFORMERS

Primary 115 Volt 60 Cycle 1600 Insulation Three 6.4 Volt Secondaries

6.3 Volts @ 4.9 Amps.
6.3 Volts @ 4.5 Amps.
6.3 Volts @ 1.1 Amps.

Stock No. 5254A

Horizontal Half Shell Mounting. 2 1/4" x 2 13/16" Mounting Centers. 2 13/16" x 3 3/8" Core Size. 2 1/2" above Chassis. Solder Lug Terminals—All Terminals Marked.



Price EACH **\$2.65**

HAND MICROPHONE

Replacement for T-17 Mike. English make. Single Button. Removable element. Press-to-talk switch. Stock No. 5883A. Unshielded cable.

Price Ea. \$3.25

TERMS:

Open Account to rated or acceptable reference accounts. Others Pre-payment of 25% deposit with order, balance C.O.D. Price F.O.B. Chicago and subject to change without notice. Merchandise subject to prior sale.

ORDER TODAY!

Radio Surplus Corp.

732 South Sherman Street
Chicago 5, Illinois
Phone: HARRISON 7-5923

COMMUNICATIONS EQUIPMENT CO.

PULSE EQUIPMENT

MIT. MOD. 3 HARD TUBE PULSER. Output Pulse Power 144 KW (12 KV at 12 Amp.) Duty Ratio. .001 max. Pulse duration: 5, 1.0, 2.0 microsec. Input voltage: 115V 400 to 2400 cps. Uses: 1-715B, 4-829-B, 3-72's, 1-73. New. \$110.00

APQ-13 PULSE MODULATOR. Pulse Width .5 to 1.1 Micro Sec. Rep. rate 624 to 1348 Pps. Pk Pwr. out 35 KW Energy 0.018 Joules. \$49.00

TPS-3 PULSE MODULATOR. Pk. power 50 amp. 24 KW (1200 KW pk); pulse rate 200 PPS, 1.5 microsec, pulse line impedance 50 ohms. Circuit series charging version of DC Resonance type. Uses two 705-A's as rectifiers. 115 v. 400 cycle input. New with all tubes. \$49.50

APS-1C MODULATOR DECK. Complete, less tubes. \$75.00

PULSE NETWORKS

15A-1-400-50: 15 KV. "A" CKT. 1 microsec 400 PPS, 50 ohms imp. \$37.50

G.E. #8E3-5-2000-50P2T. 6KV "E" circuit, 3 sections .5 microsecond, 2000 PPS. 50 ohms impedance. \$6.50

G.E. #3E (3-84-810) (8-224-405) 50P4T; 3KV "E" CKT Dual Unit: Unit 1, 3-sections, 84 microsec. 810 PPS, 50 ohms imp.; Unit 2, 8 Sections, 2.24 microsec. 405 PPS, 50 ohms imp. \$6.50

7.5E3-1-200-67P. 7.5 KV. "E" Circuit, 1 microsec 200 PPS, 67 ohms impedance. 3 sections. \$7.50

7.5E4-16-60, 67P. 7.5 KV. "E" Circuit, 4 sections 16 microsec, 60 PPS, 67 ohms impedance. \$15.00

7.5E3-3-200-67P. 7.5 KV. "E" Circuit, 3 microsec, 200 PPS, 67 ohms imp. 3 sections. \$12.50

DELAY LINES

D-168184: .5 microsec. up to 2000 PPS 1800 ohm term. \$4.00

D-170499: .25/.50/.75 microsec 8 KV 50 ohms imp. \$16.50

D-165997: 1/4 microsec. \$7.50

RCA 255686-502, 2.2u sec, 1400 ohms. \$2.03

RADAR SETS

- AN/APS-3 Airborne 3CM Radar
- AN/APS-4 30CM Airborne Radar
- SQ 10CM Portable Radar 115V, 60 Cy.
- AN/APN-4 Loran Set, Airborne
- AN/APN-3 Shoran, Xmrtr. only
- SE 10 cm Surface Search Radar
- SO-1 10CM SEA Radar, 115VDC
- SN 10CM Portable Radar, 115V, 60CY
- PP-4/APQ-2 DC Power Supply from 400 Cy. \$65.00
- MK10 10CM Gun Laying Radar
- MKIV 800MC Gun Laying Radar
- SO-8 10CM Radar, 115VDC
- CPN-8 10CM NAV, Beacon, Ground Station
- SG 10CM Heavy Duty Ship Radar

TEST SETS

- Signal Gen. RCA 710A, 370-560 MC. \$350.00
- Signal Gen. Type 605 CS, 9.5KC-50 MC. \$385.00
- Signal Gen. TS 10A
- TS 16/AP Altimeter Test Set. \$2.50
- TS 36 Power Meter, 3 CM Test Osc. 50-3000 MC. \$325.00
- TS 47/AP Slotted Line, 500 MC. \$325.00
- TS 56/AP Wavemeter 300-700 MC. \$72.50
- TS 127/UP Wavemeter 340-1000 MC. \$72.50
- TS 69/AP Crystal Test Set. \$50.00
- TS 268/UP H.V.P. Power Supply
- RA/38

PULSE TRANSFORMERS

U-10198. PRI: 4.5KV, 97A PK. SEC. 18KV 26A. PRR—350-500 Cycles. DURATION 1.3 usec. \$42.50

G.E.K.-2745 \$39.50

G.E.K.-2744-A. 11.5 KV High Voltage, 3.2 KV Low Voltage @ 200 KW oper. (270 KW max. 1 microsec. or 1/microsec. @ 600 PPS.) \$39.50

W.E. #K3 9900 Input transformer. Winding ratio between terminals 3-5 and 1-2 is 1:1.1, and between terminals 6-7 and 1-2 is 2:1. Frequency range: 350-520 c.p.s., Permalloy core. \$6.00

W.E. #D169271 Hi Volt Input pulse Transformer. \$27.50

G.E. K2450A. Will receive 13KV. 4 micro-second pulse on pri. secondary delivers 14KV. Peak power out 100KW G. E. \$34.50

G.E. K2748A. Pulse Input line to magnetron. \$36.00

Ray UX 7896—Pulse Output Pri. 5v. sec. 41v. \$7.50

Ray UX 8442—Pulse inversion—40v + 40v. \$7.50

Ray UX 7361 5 microsec. 60-400 cy. \$7.50

PHILCO #352-7250, 352-7251, 352-7287

UTAH #9262, 9332, 9278, 9341.

RAYTHEON: UX8693, UX7428, UX7350.

WEST. ELECT. D-161310, D-166638, D-166173, D-169114, D-161929, KS9948.

U-11716 PRI: 13.2 KV @ 20A. SEC: 3.6 KV @ 72A use pulse. PRR—500 PPS **\$65.00**

140-600 mc Directional Antenna

140-310 mc cone and 300-600 mc cone, each consisting of 2 end fed half wave conical sections with enclosed matching stub for reactance changes with changing frequency. New: complete with mast, guys, cables, carrying chest. \$49.50

MAGNETRONS

Tube	J262
J272	J331
J231	J530
J2J1 A	718DY
J2J2	720BY
J2J6	725-A
J2J2	730-A
J2J38 Pkg.	QK 62
J2J39 Pkg.	QK 61
J2J48	QK 60
J2J61	

700 A, B, C, D
705 AY, BY, DY, EY, FY, GY

MICROWAVE PLUMBING—ACCESSORIES

X BAND — 1" x 1/2" WAVEGUIDE

1" x 1/2" waveguide in 5' lengths, UG 39 flange to UG40 cover per length, \$7.50

Rotating Joints supplied either with or without deck mounting. With UG40 flanges and covers, each, \$17.50

2142 Magnetron Pulse Modulator. 14kw max. rating 7kw min. Pulse voltage pulsed 5.5kv 6.5 Amp. .001 duty cycles. 2.5 usec pulse length max. filament 6.3V .5 Amp. Includes magnetron mtg. and blower. Requires 3C45 and 2-3124. New. \$75.00

TS 268 Crystal Checker. \$50.00

Bulkhead Feed-Thru Assembly. \$15.00

Pressure Gauge Section 15 lb. gauge and press nipple. \$10.00

Pressure Gauge, 15 lbs. \$2.50

Dual Oscillator-Beacon Mount. 1/0 APS 10 Radar for mounting two 723A/B klystron with crystal mts. matching slugs, shields \$42.50

Dual Oscillator, Mount. (Back to back) with crystal mount, tunable termination attenuating slugs. \$18.50

Directional Coupler, UG-40/U Take off 20 db. \$47.50

2K25/723 AB Receiver local oscillator Klystron Mount, complete with crystal mount. Iris coupling and choke coupling to TR. \$22.50

TR-ATR Duplexer section for above. \$8.50

CU 105/APS 31 Direction Coupler 25 db. \$25.00

723AB Mixer—Beacon dual Osc. Mt. w/xtal holder. \$12.00

Waveguide Section 12" long choke to cover 45 deg. twist & 2 1/2" radius, 90 deg. bend. \$4.50

Twist 90 deg. 5" choke to cover w/press nipple. \$6.50

Waveguide Sections 2 1/2 ft. long silver plated with choke flange 55.75

Rotary joint choke to choke with deck mounting. \$17.50

3 cm. mitered elbow "E" plane. \$12.00

90 degree elbows, "E" or "H" plane 2 1/2 radius. \$12.50

90 degree twist 6" long. \$8.00

45 degree twist. \$8.00

40KW X BAND Radar, complete as described and illustrated in July 1951 PROC TR.

APS-4 Under Belly Assembly, less tubes. \$375.00



S BAND — 3" x 1 1/2" WAVEGUIDE

REACTION WAVEMETER 3000-3700 MC. Mfg. Head. Comp. with Cal. Chart \$125.00

LHTR. LIGHTHOUSE ASSEMBLY. Part of RT39 APG 5 & APG 15. Receiver and Trans. Cavities w/assoc. Tr. Cavity and Type N CPTG. To Recvr. Uses 2C40, 2C43, 11327, Tunable APX 2400-2700 MCS. Silver Plated. \$49.50

BEACON LIGHTHOUSE cavity 10 cm. Mfg. Bernard Rice each \$47.50

MAGNETRON TO WAVEGUIDE Coupler with 721A Duplexer Cavity gold plate. \$45.00

REGULATED POWER SUPPLY for GL 446 type lighthouse tubes (2C40, etc.) 115 vac. 60 cycles. Panel Mounting. Less tubes. \$32.50

RT-39/APG-5 10 cm. lighthouse RF head 60 Xmrtr-Recvr-TR cavity. compl. recvr. & 30 MC IF strip using 6AK5 (2C40, 2C43, 11327 lineup) w/tubes \$12.50

721A TR BOX complete with tube and tuning plungers. \$4.00

MENALLY KLYSTRON CAVITIES for 707B or 2K28. \$5.00

TS 268 CRYSTAL CHECKER. \$50.00

F 29/SPR-2 FILTERS, type "N" input and output. \$12.50

WAVEGUIDE TO 3/8" RIGID COAX "DOORKNOB" ADAPTER CHOKE FLANGE, SILVER PLATED BROAD BAND. \$32.50

AI/APRS A 10 cm antenna equipment consisting of two 10 cm waveguide sections, each polarized, 45 degrees. \$75.00

AS14A/AP-10 CM Pick up Dipole with "N" Cables. \$4.50

S BAND SIGNAL GENERATOR, complete with calibrated attenuator, W. E. coax. wavemeter, McNally Klystron Cavity. Regulated power supply operates from 115 V.A.C. 50-1200 Cycles. Manufactured by W. E. \$650.00

OA1 ECHO BOX, 10 CM. TUNABLE. \$22.50

"E" or "H" Plane Bends, 90 Deg. less flanges. \$7.50

3/8" RIGID COAX—3/8" I. C.

RIGHT ANGLE BEND, with flexible coax output pickup loop \$8.00

SHORT RIGHT ANGLE BEND, with pressurizing nipple. \$3.00

RIGID COAX to flex coax connector. \$3.50

STUB-SUPPORTED RIGID COAX gold plated 5' lengths. Per length. \$5.00

RT. ANGLES for above. \$2.50

RT. ANGLE BEND IS L. OA. Male to female. \$3.50

FLEXIBLE SECTION, 15" L. Male to female. \$4.25

FLEX COAX SECT. Approx. 30' \$16.50

3/8" RIGID COAX, BULKHEAD FEED-THRU \$14.00

Homedell-to-Type "N" Male Adapters, W. E. #D167284 \$2.75

1 f. Amp. Strip: 30 MC, 120 db. gain, 2 CM Bandwidth, uses 6AC7's—with video detector. Less tubes. \$24.50

Polyrod Antenna, AS31/APN-7 in Lucite Ball. Type "N" feed \$22.50

Antenna, AT49A/APR: Broadband Conical, 300-3300 MC Type "N" Feed \$12.50



1 1/4" x 5/8" WAVEGUIDE

Mitred Elbow H Plane UG51-UG52. \$12.00

CG 98B/APQ 13 12" Flex. Sect. 1 1/4" x 5/8" OD. \$10.00

X Band Wave GD, 1 1/4" x 5/8" O.D. 1/16" wall aluminum per ft. 75c

Slug Tuner Attenuator W.E. guide. Gold plated. \$6.50

BI-Directional Coupler, Type "N", Takeoff 25 db. coupling. \$27.95

BI-Directional Coupler, UG-52, Takeoff 25 db. coupling. \$24.95

Waveguide-to-Type "N" Adaptor, Broadband. \$22.50

THERMISTORS

D167018.	\$1.50
D167332.	1.50
D167613.	1.50
D166228.	1.50
D164699.	2.50

VARISTORS

D171812.	\$1.50
D172155.	1.50
D167176.	1.50
D168687.	1.50
D167208E, D171858	1.50
308A, 3A, 27-B.	1.50

K BAND — 1/2" x 1/4" WAVEGUIDE

AFS-34 Rotating Joint. \$49.50

Right Angle Bend E or H Plane, specify combination of couplings desired. \$12.00

45° Bend E or H Plane choke to cover. \$12.00

Mitered Elbow, cover to cover. \$4.00

TR-ATR-Section, Choke to cover. \$4.00

Flexible Section "I" choke to choke. \$5.00

"S" Curve Choke to cover. \$4.50

Adaptor, round to square cover. \$5.00

Feedback to Parabola Horn with pressurized window. \$27.50

90° Twist. \$10.00

MICROWAVE ANTENNAS

Relay System Parabolic reflectors approx. range 2000 to 6000 Mc. Dimensions 4 1/2" x 3". New. \$75.00

AS-31/APN-7: 10 cm. Polyrod in Lucite Ball. Type "N" Firing. Coax Feed. \$22.50

TDY "JAM" Radar rotating antenna 10 cm. 30 deg. beam, 115 V AC drive. New. \$195.00

Parabolic Peel. Radiation pattern approx. 25 deg. in horizontal, 33 deg. in vertical planes \$35.00

Cone Antenna, AS 125 APR. 1000-3200 mc. Stub supported, with type "N" connector. \$14.50

MAIL ORDERS PROMPTLY FILLED. ALL PRICES F.O.B. NEW YORK CITY. SEND M.O. OR CHECK. ONLY SHIPPING SENT C.O.D. RATED CONCERNS SEND P.O. ALL MDSE. SUBJECT TO PRIOR SALE, AND PRICES SUBJECT TO CHANGE WITHOUT NOTICE. PARCELS IN EXCESS OF 20 POUNDS WILL BE SHIPPED VIA CHEAPEST TRUCK & RAILEX.

COMMUNICATIONS EQUIPMENT CO.

131 Liberty St., New York 7, N. Y. Dept E-7 Chas. Rosen Phone: Digby 9-4124

COMMUNICATIONS EQUIPMENT CO.

MFRS! MFRS! MFRS!
NEW, FINISHED
JAN MATERIAL
FOR YOUR WAR
CONTRACTS
Write! Phone! Wire!

932 PHOTO TUBE



Gas Phototube having SI Response, particularly sensitive to Red and Near Infrared Radiation. Can be used with Incandescent light source. Send for data. Price **75¢**

IN-24 AR-N
Dual 0-200 Micro-amp. Movement in 3" Case. ILS Equipment \$9.95

ARC-5 XMTR. COILS MASTER OSCILLATOR

#6029	3-4 MC	\$1.85
#6030	4-5.3 MC	1.75
#6031	5.3-7 MC	1.65
#6032	7-9 MC	2.35

POWER AMPLIFIER

#7247	3-4 MC	2.19
#7250	7-9 MC	2.98

ANTENNA LOADING

#6933	3-4 MC	1.39
#6934	4-5.3 MC	1.25
#6135	5.3-7 MC	1.65
	AND 7-9.1 MC	

ELECTROLYTIC CAPACITORS



TWIST PRONG

Cap. Mfd	WVDC	Price
2	450	\$0.16
30	300	.18
40	400	.38
50	400	.36
60	300	.21
80	150	.29
80	500	.43
8-8	450	.24
30-20	150	.23
80-80	300	.21
90-10	350	.21
80-10	450	.49
150-50-25	150	.49
80-10-10-10	300	.21
40-40-20-2	150	.28
30-15-15-15	300	.28
80-10-10-10	350	.32
40/10	450/350	.55
40/20	150/25	.21
40/50	400/300	.61
80/50	450/50	.65
250/1000	10/6	.30
8-8-10	450/25	.26
10-10/10	150/25	.23
10-10/20	450/25	.26
10-15/20	350/25	.18
15-15/10	450/350	.23
16-16/25	450/50	.23
80-40/150	400/50	.45
120-60/20	150/25	.45
30-30-15/30	300/50	.39
40-40-20/20	350/15	.28
60-40-20/50	300/25	.28
60-40-20/200	150/10	.39
80-40-30/20	150/25	.36
80-40-30/100	150/25	.36
4/8	475/100/100	.23
10/50/100	350/100/50	.23
10/50/100	450/100/50	.27
20/20/10/20	350/300/300/25	.35

UPRIGHT OIL CAP.

MFD	Each
220VAC/600VDC	\$1.29
6.2	1.29
15	3.49
330VAC/1000VDC	
15	3.79
15	1000VDC
	.69
	1.19
	1.49
	2.19
	1.39
	1.59
	1.59
	1.79
	2000 WVDC
	1.79
	2500 WVDC
	2.98
	4000 WVDC
	6.95
	4800 WVDC
	4.79
	6000 WVDC
	3.69
	15-15
	3.89
	10.98
	7000 WVDC
	3.79
	10K VDC
	8.95
	15K VDC
	7.95
	16K VDC
	9.50
	20K VDC
	17.50
	25K VDC
	85.00
	65.00

POWER TRANSFORMERS

Comb. Transformers—115V/50-60 cps input

CTJ5-2 600VCT .2A, 5V/6A	\$5.95
CT-15A 550VCT .085A	6.3V/6A, 6.3V/1.8A 2.85
CT-164 4200V.002A/22KV Test	5VCT/3A/12KV 12.95
CT-341 1050 10 MA.—625V @ 5 MA, 26V @ 4.5A	16.95
CR-825 360VCT .340A	6.3VCT/3.6 3.95
CT-626 1500V .160A	2.5/12, 30/100 9.95
CT-071 110V .200A	33,200, 5V/10, 2.5/10 4.95
CT-367 580VCT .050 A	5VCT/3A 2.25
CT-99A 2x110VCT .010 A	6.3/1A, 2.5VCT/7A 3.25
CT-403 350VCT .076 A	5V/3A, 6.3V/6A 4.25
CT-931 585VCT .086 A	5V/3A, 6.3V/6A 4.25
CT-610 125V .002 A	2.5V/2.1A, 2.5V/1.75A 4.95
CT-866 330V .065 A	6.3V/1.2, 6.3V/600 MA 1.75
CT-459 390VCT 30 MA	6.3V/1.3A, 5V/3A 3.45
CT-168 800VCT 100 MA	5V/1.2A, 5V/3A 4.95
CT-431 285VCT 86 MA	5V/3A, 6.3V/6A 4.95
CT-442 525VCT 75 MA	5V/2A, 10VCT/2A, 50V/200 MA 3.85
CT-720 550-0-550V/250 MA, 6.3V/1.8A	8.95
CT-43A 600-0-600V/.08A, 2.5VCT/6A, 6.3VCT/1A	6.49
CT-7-501 650VCT/200 MA, 6.3V/8A, 6.3V/5A	6.49
CT-444 230-0-230V/.085A, 5V/3A, 6V/2.5A	3.49

Filament Transformers—115V/50-60 cps input

Item	Rating	Each
FT-674	8.1V/1.5A	\$1.10
FT-157	4V/16A, 2.5V/1.75A	2.95
FT-101	6V/.25A	.79
FT-924	5.25V/21A, 2x7.75V/6.5A	14.95
FT-82A	2x5V/1A, 7V/1A, 7.2V/7A, 6.4V/10A, 6.4V/2A	8.95
FT-463	6.3VCT/1A, 5VCT/3A, 5VCT/3A	5.49
FT-55-2	7.2V/21.5A, 6.5V/6.85A, 5V/6A, 5V/3A	8.95
FT-986	16V @ 4.5A or 12V @ 4.5A	3.75
FT-38A	6.3V/2.5A, 7V/7A	4.19
FT-A27	2.5V/2.5A, 7V/7A, TAP 2.5V/2.5A, 16KV TEST	18.95
FT-608	6.3V/3A/750V Test	1.79
FT-873	4.5V/.5A, 7V/7A	2.19
FT-899	2x5V @ 5A, 29KV Test	24.50

Plate Trans.—115V, 60 cps

Item	Rating	Price
PT-446	185V3.5A	\$4.59
PT-699	300/150V/.05A, 300/150V/.05A	2.79
PT-302	120-0-120V/350 MA	4.69
PT-109	17.600V/144 MA	2.30
PT-671	62V/3.5A	7.95

Special Fil. Transformers—60 cps

Item	Volts	Price
STF-370	220/440	3x2.5V/5A, 3KV Test 2.5V/15A \$6.95
STF-11A	220V	2x40V/.05A, 2x5V/6A 12.6V/1A 4.49
STF-608	220V	24V/0.6A, 5V/3A, 6.3V/1A 3.45
STF-968	230V	2.5V/6.5A 3.50
STF-631	230V	2x5V/27A, 2x5V/9A 17.59

Step Down Transformers

Wattage	Price
250	\$5.95
300	7.49
500	10.95
1000	19.95
1500	24.95

STEP DOWN TRANSFORMERS

ALL PRIMARIES 220V, 60 Cy., 1 ph.
SECONDARIES 110V, 60 Cy., 1 ph.

NEW STANDARD BRANDS, COMPLETE WITH LINE CORD AND OUTLET

POWER INVERTERS

INPUT—115 VDC OUT: 115 VAC 60 Cy.
50 W. INT. OR 350 W CONTIN.
NEW. ORIGINAL PACKING \$75.00

FILTER CHOKES

Stock	Description	Price
CH-317	10H/450 MA—10KV	\$12.95
CH-366	20H/.3A	6.95
CH-322	35H/350 MA—10 Ohms DCR	2.75
CH-141	Dual 7H/75 MA, 11H/60 MA 5KV DCR Test	4.69
CH-119	8.5H/225 MA	2.79
CH-69-1	Dual: 120H/17 MA	2.35
CH-8-28	2 x .5H/380 MA/25 Ohms	1.79
CH-8-19	SWING .006H/5A—.035H/.5A, .032 ohms	2.95
CH-776	DCR: 1KV TEST	2.25
CH-344	1.28H/130 MA/75 ohms	2.35
CH-43A	1.5H/15MA—850 ohms DCR	1.75
CH-917	10H, 450MA, 10KV TEST	12.95
CH-366	20H/300MA	6.95
CH-999	15HY/15MA—400 ohms DCR	1.95
CH-511	6H/80MA—310 ohms DCR	2.45
CH-2-501	2x5H/400MA	2.79
CH-188M	5HY 200MA	1.79
CH-488	10HY .030A	1.19
CH-791	Dual 1.75-.125 HY 100 MA	1.27
CH-991	15 HY 110A	1.59
CH-22-1	1 HY 100A	1.17
CH-779	.6 HY 490A	1.25
CH-25A	SW .09/.018 HY 3/3A	8.95
CH-922	10000 HY 0 MA	2.75
CH-043	2.2 HY 80 MA	.98
CH 89A	2 x 1.52H @ .167A	1.39
CH 69A	Mult. Choke	
SECT. 1.	Swing 3-12H/.52-.05A	
SECT. 2.	Smooth 5H/.52A	
SECT. 3.	Swing 3.25-18H/.138-014A	
SECT. 4.	Smooth 3.4H/.138A	14.95

1 PER CENT PRECISION RESISTORS

ALL VALUES IN OHMS	7,500	10,000	12,000	17,000	20,000
5	82	150	800	7,500	20,000
5.05	120	250	920	10,000	30,000
10.1	125	430	1100	12,000	35,000
18	128	468	4300	17,000	84,000

30c EACH 120K 150K 10 FOR \$2.50
100K 220K 10 FOR \$3.50
40c EACH 1 MEGOHM EACH 75c

400 CYCLE TRANSFORMERS

(All Primaries 115V, 400 Cycles)

Stock	Rating	Price
702724	640VCT @ 250MA, 6.3V/.9A, 6.3V/6A, 5V/6A	\$5.49
12033	9800/8600V @ 32MA	8.95
K9584	4540V/250MA	17.50
521652	5000V/290MA, 5V/10A	22.50
K9567	13,500V/3.5MA	14.65
352-7273	734VCT/177A, 1710VCT/.377A	6.79
	700VCT/350MA, 6.3V/0.9A, 6.3V/2.5A, 6.3V/.05A, 5V/6A	
352-7070	2x2.5V/2.5A (2KV TEST) 6.3V/2.25A, 1200/1000/750V @ .005A	6.95
352-7196	1140V/1.25MA, 2.5V/1.75A, 2.5V/1.75A—5KV Test	7.45

POWER RESISTORS

Res.-Ohms	Price	Res.-Ohms	Price
2.5"	198*	55c	35c
25*	35c	225	30c
30	45c	250	40c
32.5	35c	300*	65c
40	30c	450	40c
70*	45c	500*	55c
100	70c	4,500	50c
125	35c	8,000	90c
125*	45c	160,000	55c

* Tapped to give 10 equal sections with 9 tabs.

SCOPE TRANSFORMER

PRI: 115V, 60 Cy., Sec. 3000V/5 MA, 6.4V/8.7A, 6.4V/.6A 5V/3A, 360-0-360V/200 MA, 1.25V/.3A **\$3.95**

SILVER MICA BUTTON COND.

MMF	MMF	PRICE
50	180	\$7.00/100
175	185	15.00/100
	500	

CERAMICON TYPE CAPACITORS

MMF	MMF	MMF
14	50	125
15	51	180
20	60	200
27	62	240
30	65	345
47	82	

PRICE **\$5.00/100**

SPECIALS

CIRCUIT BREAKERS

24V, 7A—AMIS10N-7 \$1.95
40V, 10A, 1 POLE 1.95

AIR TRIMMERS

3-15 uuf, 8-85 uuf, 3-35 uuf, 5-50 uuf, 3-10 uuf, 3-7 uuf32 each

SHOCK MOUNT RACKS

MT-5/ARR-2/FT-338/FT-156/FT-487/FT-185/FT-265A/MT-62/ARC-5FT-225/FT-162/MT-170A/FT-449/MT-171A/MT-167/U

Write for Prices

T-30 Carbon Mikes. New \$9
Tel. Tane. 3/8" x 8 1/2" Rolls 23 ea. 5/1/00
Tel. Tape. 4" Rolls 12 ea. 10/51/00
BC366 Interphone Jack Box \$ 79 ea.
AN/109-A Antenna 1.98 ea.
C-30/ARC-5 Control Box 2.35 ea.
EE-89A Telephone Repeater 12.50 ea.
EE-65A Telephone Test Set 50.00 ea.
ID24/ARM-9 Cross Point Indicator 6.95 ea.
TU-8 Tuning Unit 6.2-7.7mc 4.95 ea.
BC496-A Dual Revr. Control box, 3-6 & 6-9.1mc 1.75 ea.
AN/104-A Antenna, 150mc 1.49 ea.
BC704 Indicator, CR Tube, New 22.50 ea.
BC929 Indicator, 3BPI, all tubes, New 29.50 ea.
Noise Filters, 100 AMP, G.E. 1.39 ea.
MC211 Right Angle Drives19 ea.
IF Transformers, 112 KC Double Slug Tune69 ea.
BC704 Indicator, CR Tube, New 22.50 ea.
MD-7 Modulator for ARC/5, All tubes 7.95 ea.
ARC-5 Xmtr. Tuning Cond. #5032 1.49 ea.
ARC-5 Xmtr. M.O. Trimmer #4990 1.29 ea.

BIRTHEM TUBE CLAMPS

926B-16 926C-15 926C-19
926B-18 926K-2 @ 2¢ ea.

COILS FOR BC 230 XMTRTS.

C-293 1250-1500 kc \$.97 ea.
C-382 3200-4000 kc97 ea.
C-184 4-5mc (with 4495kc Xtal.) 1.95 ea.
C-484 5-6.2mc9

IMMEDIATE DELIVERY

Servo-Tek

FULLY GUARANTEED

BLOWER ASSEMBLY



Lear frame CO10, 5500 rpm motor with 3" Sirroco impeller. Motor 28 v. DC @ 12 Amps. Output 16 watts. Cont. duty. Stock #SA-347 Price \$9.75 each.

SERVO MOTOR (DC)



Sperry 8001058 6 terminal-armature and dual field control motor, 2" diam.-3 1/4" lg. Front flange mounting. Shaft ext. 1/4", 5/32" diam. Stock #SA-289 Price \$9.75 each.

AIRCRAFT MOTOR

G. E. Type 5BA25AJ32A



24 volts at 2.9 amps. 75 in/lb. torque. 3 lead shunt with brake. 1 minute rating. Double worm gear reduction. 4 rpm reversible.

Stock #SA-298

Price \$39.50 each.

27.5 VOLT DC MOTOR



John Oster Type E-7-5 4 lead shunt. 1/20th hp. Internal fan cooled 3/4" lg. 3/4" diam. 3/8" shaft extension. 5/16" diam. 3650 rpm Stock #SA-311. Price \$19.50 each.

G. E. 1/10 HP DC Motor



G.E. Type 5BN58LA5 125 volts DC at 1.2 amps. 4000 rpm. Int. duty Internal fan cooled. 3 1/2" sq. front mounting flange.

Stock #SA-312

Price \$19.50 each.

60 CYCLE AMPLIDYNES

G.E. Types 5AM45DB15 and 5AM73AB95. Type 45DB15 input 115 v. 60 cy. at 5 amps. Output 250 volts DC at 0.6 amps. Stock #SA-147.

Type 73AB95 input 115 volts 60 cy. at 9 amps. Output 250 volts DC at 1.5 amps. Stock #SA-257.

PRICES ON REQUEST

DELCO CONSTANT SPEED MOTOR A-7155

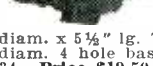

1/30 hp. 27.5v d-c 3600 rpm. Cont. duty. 2 1/2" diam. x 5 1/2" lg. 3/8" shaft extension. 5/32" diam. 4 hole base mounting. Stock #SA-34. Price \$19.50 each.

BLOWER ASSEMBLY



Delco 27 v. DC motor, 5400 rpm. 3" Sirroco impeller. Shunt motor, 4 in/oz. torque. Base Mtg. Stock #SA-352. Price \$9.75 each.

INSTRUMENT INVERTER



Pioneer Type 12128-1B Post War Model. Input 27.5 volts DC at 1 amp. Output 26 volts 400 cy. Single phase. P.F. 0.4. 6.0 VA. Stock #SA-295. Price \$39.50 each.

SYNCHRO CAPACITORS

Production quantity requirements of the following Synchro "Exciter" Capacitors are available for immediate delivery.

Type 6C—connected 20-20-20 mfd. Type 1C—Mk. 12—connected .6x.6x.6 mfd. Type 3C—Mk. 1—connected 10x10x10 mfd. Type 4C—Mk. 14—connected 3x3x3 mfd.

Quantity Quotations on Request

— SERVO SPECIAL —

Low Inertia Servo Motor 400 Watts Output

115 volt 2 ph. 2 pole. 60 cy. Mfd. by Pioneer-Bendix.

Uses built in Fan Motor.

Navy Type CM-211518A W.E. KS-151182L1 Small Qty. only

AUTOSYN POWER SUPPLY (CONVERTER)

PIONEER Dwg. 12108-2B. Designed to supply 26 v. 400 cycle excitation to from 20-50 Pioneer Autosyn units. Input voltage 24 v. DC at 3.0 Amps. 4000 rpm. Stock #SA-504. Price \$59.50 each.

MOTOR GENERATOR SET

Navy Type CM-21989. For OBE-3 Underwater sound equipment. Mfd. by Holtzer Cabot. Motor—115 volts DC at 8.3 Amps. 0.75 hp. Generator—115 volts 60 cycles single phase. 4.0 Amps. 0.88 P.F. Self-excited. Cont. Duty. Stock #SA-505. Price \$195.00 each.

1 H.P. VARIABLE SPEED DRIVE

Louis Allis Adusto-Spede

Squirrel Cage A-C motor and an electromagnetic clutch and pilot governor. Speed range 0-1050 rpm. Three phase. 208 v. operation. 60 cycles. DC excitation 0-10 volts. Small quantity available.

Aircraft Turret Motor—G.E. 5BA501LJ22. 1/2 hp. Amplidyne controlled motor. Armature voltage 60 max. Field 27 v. Max. Arm. current 8.3 amps. Field 2.9 amps. 10 minute rating. Stock #SA-345. Quantity prices on request.

BODINE GEARHEAD DC MOTORS



Type NSH-11R. 200:1 reduction. Output shaft 10 rpm. 1/150 hp. Int. duty. 75 volts @ 0.28 Amps. Large Qty. Stock #SA-1001. Quotations upon request.

Type NSE-11R. 1/400 hp. 630:1 gear reduction. 250 volts DC or AC. Output shaft 10 rpm. Current 0.15 Amps. Int. duty. Large Qty. Stock #SA-1002. Quotations upon request.

Bodine NSH-12R—1/400 hp. 630:1 gear reduction. Output speed 3.5 rpm. Torque 3.5 in/lbs. 115 v. DC. Cont. Duty. Stock #SA-1003. Large Quantity. Prices on request.

400 CYCLE INVERTERS

Pioneer—12130-4B; 12108-2B; 12121-2; 12116-2; 12117-5; 12123-1A.

Holtzer Cabot—MG-149; MG-149F; MG-149H; MG-153; MG-153F.

Leland—10339; 10285; PE-218; 10486-846.

Elec—AN-3187-1.

Wincharger—PU-7/AP; PU-16.

General Electric—5AS131NJ3; 5D21NJ3A; PE-118; PE-218.

DRAG CUP GENERATOR



Kollman Type 977-01630 115 volt 60 cycle input. 60 cycle output voltage proportional to shaft speed rotation. Stock #SA-307. Price \$29.50 each.

DC MOTOR



John Oster Type A-16A-2B. 28 v. DC Shunt wound. 8000 rpm. 0.09 oz./in. torque. Large Qty. Prices on request.

PIONEER AUTOSYNs



Pioneer Bendix Types AY-1; AY-54; AY-14D; AY-14G and others.

Prices on request.

KOLLSMAN TELETORQUE



Kollman Type 403 self synchronous units. (Synchro) 115 volt 60 cycle excitation. Use as either generator or repeater. Stock #SA-79. Prices on request.

115 VOLT D-C MOTOR



G.E. Type SD. 1/20 hp. 4 lead shunt. Reversible. Double shaft extensions. Speed 1725 rpm. Large Quantity.

Special \$19.50 each.

LEAR POSITIONING MOTOR



Model 156A. 115 watt 24 v. DC motor. 10,000 rpm. Int. duty. Reversible. Dual rt. angle output shaft. Release clutch. 7:1 reduction to output. 250:1 reduction to limit switches. Stock #SA-343. Prices on request

MAGNETIC AMPLIFIER

Pioneer Type 12077

115 V. 400 cy. One Tube Servo Amplifier using saturable reactor type outlet transformer. Limited Quantity

SYNCHROS AND SELSYNS



Navy Types

A; M; 1SF; 5G; 5F; 5SDG; 5SG; 5SF; 5HSF 6DG; 7G; etc.

Army Types

II; IV; V; VII; IX; XXI; XV; etc.

G.E. Types

2J6F2; 2JD5J2; 2J5A2; 2J5HA1; 2J1H1; 2J1F1; 2J1G1; 2J1F3; 2JD5HB1; 2J5LA1; 2JD5C2, etc.

SERIES MOTOR

John Oster Type A-21D-7A



24 v. DC. 0.005 hp. .8 Amps. 11,000 rpm. Cont. duty. 1-1/2" diam. x 2-1/2" lg. Front flange mtg. Shaft 3/16 dia. x 3/8" ext. Stock #SA-353. Price \$8.75 each.

WRITE FOR LISTING

Prices F.O.B. Paterson
Phone ARmory 4-3366

Servo-Tek products co.
4 Godwin Ave. Paterson, N. J.

SPECIALISTS IN FRACTIONAL HORSE POWER MOTOR SPEED CONTROL

SURPLUS EQUIPMENT

PE 218 Leland Electric

Output: 115 VAC; Single Phase; PF 90; 380/500 cycle 1500 VA. Input: 25-28 VDC; 92 amps; 8000 RPM; Exc. Volts 27.5. **BRAND NEW . . . \$39.95 ea.**

16486 Leland Electric

Output: 115 VAC; 400 Cycle; 3-Phase; 175 VA; 80 PF. Input: 27.5 DC 12.5 amp; Cont. Duty **\$90.00 ea.**

INVERTERS



10563 LELAND ELECTRIC

Output: 115 VAC; 400 cycle; 3-phase; 115 VA; 75 PF. Input: 28.5 VDC; 12 amp. **\$80.00 ea.**

12116-2-A PIONEER

Output: 115 VAC; 400 cyc; single phase; 45 amp. Input: 24 VDC 5 amp. . . . **\$90.00 ea.**

MG 153 HOLTZER-CABOT

Input: 24 V, DC, 52 amps; Output: 115 volts—400 cycles, 3-phase, 750 VA, and 26 Volt—400 cycle, 250 VA. Voltage and frequency regulated **\$95.00 ea.**

94-32270-A LELAND ELECTRIC

OUTPUT: 115 Volts, 190 V.A., Single Phase; 400 cyc.; .90 PF, and 26 Volts, 60 V.A., 400 cyc., .40 PF. INPUT: 27.5 Volts DC, 18 amps; Cont. Duty, Voltage and frequency regulated **\$95.00**

5 RPM GEAR HEAD MOTOR



Mfg. RAE., Type 7519, 115 Volts AD, DC. Fractional HP, Overall dimension: 5 1/4" **\$12.95 ea.**
Lots of 10. **\$11.95 ea.**

METERS

AMMETER: DC; 2" 100-0-100, complete with external shunt. **\$5.95 ea.**
AC Volt, Westinghouse, Type NA-35—3-inch round. F.S.-10 MA. **\$6.95 ea.**

MICROPOSITIONER

Barber Colman AYLZ 2133-1 Polarized D.C. Relay: Double Coil Differential sensitive; Alnico P.M. Polarized field. 24V contacts; .5 amps; 28 V. Used for remote positioning, synchronizing, control, etc. **\$12.50 ea.**

VEEDER ROOT COUNTER MODEL S-1



5-figure (0-99,999) non-reset type. Adds ten for each complete revolution of shaft in one direction. Subtracts ten for each revolution in opposite direction. Black figures on metal background. Size: 3/4" high x 3/4" wide x 1-5/16" long. Dovetail mounting — Lever arm removable **\$1.95 ea.**
10 for **\$17.50**

6 RPM GEAR BOX MOTOR

110 Volt, 60 cyc., Single Phase; Ratio—544:1; Mfg. by Merkle-Korff Gear Co. Overall dimensions approx. 3 1/2" x 3 1/4". **\$9.95 ea.**
Lots of 10. **\$9.50 ea.**



WESTINGHOUSE HYDRAULIC TRANSMISSION



BRAND NEW
Ideal as hydraulic torque converters. Contains hydraulic pump and hydraulic motor; 10 ball bearings; has reversible controls. High quality precision workmanship . . . made to exacting specifications for use on 2-ton 40 mm anti-aircraft guns. Overall dimensions: 12" long x 5 1/4" wide x 6 1/4" high. Shipping weight: 20 lbs. Government cost more than \$300. **BRAND NEW \$29.95 ea.**

AC CONTROL MOTOR

Diehl Mfg. Co., FPE-25-7, 20 Volts, 2 phase, 1600 RPM, .85 amps **\$15.00 ea.**

ALL EQUIPMENT FULLY GUARANTEED

Please enclose full amount with order
All prices net FOB Pasadena, Calif.
Prices subject to change without notice

G. E. ALTERNATOR

208 Volts, 400 Cycle, 3 Phase Mod. 2CM97B1
55.5 Amps, PF .75, Speed 8000 KW 15, Cont. Duty, Limited Quantity. **\$320.00**

SERVO MOTOR 10047-2-A: 2 Phase; 400 Cycle; with 40-1 Reduction Gear \$10.00 ea.

PIONEER TORQUE UNITS

TYPE 12604-3-A: Contain CK5 Motor coupled to output shaft through 125:1 gear reduction train. Output shaft coupled to auto-syn follow-up (AY43). Ratio of output shaft to follow-up Autosyn is 15:1 **\$70.00 ea.**
TYPE 12606-1-A: Same as 12604-3-A except it has a 30:1 ratio between output shaft and follow-up Autosyn. **\$70.00 ea.**
TYPE 12602-1-A: Same as 12606-1-A except it has base mounting type cover for motor and gear train. **\$70.00 ea.**

BLOWER ASSEMBLY

115 Volt, 400 Cycle. Westinghouse Type FL 17CFM, complete with capacitor. New **\$12.50 ea.**



ALNICO FIELD MOTORS

(Approx. size overall . . . 3 3/4" x 1 1/4" diameter)
Delco-Type 5069230: 27.5 volts; DC; 145RPM **\$19.95 ea.**

PIONEER AUTOSYNS

AY-1. 26 Volt—400 Cycle. **\$6.95**
AY-5. 26 Volt—400 Cycle. **\$7.95**
AY27D **\$25.50**
AY6—26 Volt—400 cyc. **\$4.95 ea.**
AY30D—26 Volt—400 cyc. **\$25.00 ea.**
AY14D **\$14.00**
AY34 **\$20.00**
AY20—26 Volt—400 cyc. **\$12.50 ea.**

400 CYCLE MOTORS

AIRESEARCH: 115V; 40 CPS; Single phase; 6500 RPM; 1.4 amp; Torque 4.6 in. oz.; HP .03. **\$10.00 ea.**
EASTERN AIR DEVICES TYPE JM6B: 200 VAC; 1 amp; 3 phase; 400 cycles; 6000 RPM **\$12.50 ea.**
EASTERN AIR DEVICES, TYPE 3J1B: 115 V, 400-1200 Cycle, Single Phase. **\$12.50 ea.**

PIONEER, CK-2, 400 cycle 2-phase \$20.00 ea.

AIRESEARCH: AC Induction, 200 V; 3 Phase, 400 Cycle, 2 H.P.; 11,000 RPM; 8 amps. \$79.50 ea.

AIRESEARCH: AC Induction, 200 V; 3 Phase, 400 Cycle; .12 H.P., 6500 RPM; 1.5 amps. \$25.00

SYNCHROS

IF Special Repeater (115V-400 Cycle) \$15.00 ea.
2JIF3 Generator (115V-400 cyc) . . . \$10.00 ea.
5CT Control Transformer; 90-50 Volt; 60 Cyc. \$50.00 ea.
5F Motor (115/90 volt—60 cyc.) . . . \$60.00 ea.
5G Generator (115/90 volt—60 cyc.) . . \$50.00 ea.
5SDG Differential Generator (90/90 volts —400 cyc.) \$30.00 ea.
5DG Differential Generator (90/90 volts 60 cycle) \$50.00 ea.
TRANSMITTER, BENDIX C-78248: 115 Volt, 60 Cycle. \$25.00 ea.

POWER RHEOSTATS



Standard Brands: 5 Ohms; 100 Watt; 4.48 amps 100 Ohms; 100 Watt; 1.0 amp

Boxed, Brand New with Knob \$2.50 each — or — \$25.00 per Doz.

SMALL DC MOTORS

(Approx. size . . . 4" long x 1 1/4" dia.)
General Electric-Type 5AB10AJ37: 27 volts, DC; 5 amps, 8 oz inches torque; 250 RPM; shunt wound; 4 leads; reversible. **\$12.50 ea.**
G. E. Type 5BA10FJ215, 24 volts DC, .77 amp, 30 lbs. in. torque, 4 RPM. . . . \$15.00 ea.
General Electric-Type 5BA10AJ32C: 27 volts; DC; 5 amps, 8 oz. inches torque; 145 RPM; shunt wound; 4 leads; reversible **\$12.50 ea.**

SENSITIVE ALTIMETERS



Pioneer Sensitive altimeters, 0-35,000 ft. range . . . calibrated in 100's of feet. Barometric setting adjustment. No hook-up required. **\$12.95 ea.**

PIONEER GYRO FLUX GATE AMPLIFIER
Type 12076-1-A, complete with tubes **\$27.50 ea.**

MOTOR GENERATORS

G.E. Model 5LY77AB1, Input: 115 volts D.C.; 1 1/2 H.P. motor; 13 amp; 3600 RPM; shunt contact regulated. Output: 115 Volts A.C. 60 cycles; KVA .06; shunt self excited. **\$129.00 ea.**
MG-183, Input: 70 Volts DC, 5.4 amps, 1/3 H.P., 3500 RPM, Output: 50 Volts AC, 2.6 amps, 175 cycles, 3 phase, .225 KVA. **\$79.00 ea.**

SYNCHRONOUS SELSYNS

110 volt, 60 cycle, brass cased, approx. 4" dia. x 6" long. Mfg. by Deihl and Bendix.



Quantities Available
REPEATERS \$15.00 ea.
TRANSMITTERS \$15.00 ea.

SINE-COSINE GENERATORS (Resolvers)

Diehl Type FJE-43-9 (Single Phase Rotor). Two outputs equal to the sine and cosine of the angular rotor displacement. Input voltage 115 volts, 400 cycle. **\$25.00 ea.**
Diehl Type FPE-43-1 same as FJE-43-9 except it supplies maximum stator voltage of 220 volts with 115 volts applied to rotor **\$25.00 ea.**

C and H Sales Company

BOX 356-X EAST PASADENA STATION • PASADENA 8, CALIFORNIA

— THE BEST IN ELECTRONIC SURPLUS —

TRANSMITTERS

3 KW GE FM BROADCAST STATION (Formerly WGVN), COMPLETE. 88-108 mc. Includes FM Exciter-Drive in one cabinet, 3 KW Amplifier with Power Supply in second cabinet, 2 RCA type 70-C1 Transcription turntables 3 3/4 and 7 8 rpm include Gray Recorder arms and heads, 1—RCA M1-11301A Power Supply, 1 RCA Type 76-B2 Studio Console, plus Freq. & Mod. Monitor, Station Monitor, Monitor Amplifier, etc., and all tubes for all equipment. All in good operating condition.

PRICE (not crated) \$5,000.00
2 KW Radio Ranging or Homing Transmitter, 125 to 525 KC; A1, A2 & A3 emission. Consists of Wilcox 96-200A with VFO or Crystal-Controlled Oscillator in one cabinet, Wilcox 36A Rectifier in 2nd cabinet, and Wilcox 50A Modulator in 3rd cabinet. All NEW, unused equipment, export packed. Operation from 220 V. 50-60 cycles, 3-phase A.C. **Write for Price.**

LINK FM TRANSMITTER-RECEIVER, 70-100 mc, 50 watts output, Model 1498 DC. Wall style cabinet containing transmitter, receiver and 14 V. D.C. or 110V. A.C. power supply, hand-set. Dim.: 34" x 21" x 11". NEW condition. Complete with tubes, crystals, special telescopic antenna, instruction book. **PRICE \$500.00**

MODEL A1D AIRCRAFT RADIO TRANSMITTER EQUIPMENT. This is a Navy Model 4-channel (motor driven band switching), covering the range of 540 KC to 9500 KC. Output 50 watts phone, but operates A-1, A-2 as well as A-3. Operates from 24-28 volt DC Dynamotor. Each set includes: Dynamotor, Remote Control, Channel Selector Control, Plug Connectors, Operating Tubes, Spare Chest with Spare Tubes and Parts, and Instruction Books. All BRAND NEW, in Original Cases; each with 4 Tuning Units to cover the aforementioned range of frequency.

PRICE EACH \$160.00
T1Q TRANSMITTERS, VHF, 45 watts output AM, 110 to 156 mc; 115/230 V. AC, 60 cycles, with tubes, cables, EXCELLENT condition. **PRICE EACH \$650.00**
BC-797-A TRANSMITTERS, 110-126 mc, 50 watts output phone, AM for 110 V. 60 cycle operation. **PRICE EACH \$600.00**
SCR-522 VHF AIRBORNE TRANSMITTER RECEIVERS, With Tubes, LIKE NEW condition.

PRICE, EACH, less accessories, \$75.00
MODEL GP-7 AIRCRAFT TRANSMITTING EQPT., 40 watts output A1, A2, and A3. Range 350 to 9050 Kcs covered by 6 plug-in tuning coil units. Eqpt. includes: External Loading (Ant.) Coil, Operator's Control Box, Pilot's Control Box, Cable Connectors. All NEW material, export packed. **Price, Per Set, \$75.00**

NEW GE 1 KW, 3 KW, and 10 KW-RF AMPLIFIERS!!

G.E. Transmitting Equipment of recent design. NOT WAR SURPLUS, all NEW and export cased—at tremendous reduction from original price! Available IN QUANTITY. Type BF-1-A, 1 KW Power Amplifier and Power Supply; BF-2-A, 3 KW Power Amplifier with separate matching Rectifier-Power Supply; BF-3-A, 10 KW Power Amplifier with separate matching Rectifier-Power Supply. This equipment is designed for 88-108 MC FM broadcasting application, beautifully engineered and constructed. (250 Watt FM Exciter or Driver NOT INCLUDED). Conversion to lower frequencies (2 to 24 mc, or other frequencies) can be accomplished at very low cost. Our factory will be glad to quote on conversion to specified frequencies. All units designed for 208/230 volts, 50/60 cycles operation; 3 KW and 10 KW units require 3-phase. All incorporate internal blower systems for forced air-cooling, and use latest G.E. hi-efficiency tubes. Quantities sufficient to interest manufacturers—to convert for other applications. Ideal for FM Broadcasters, communication companies, Schools, Labs! Available as separate units, or complete. Write for more complete specifications and prices.

TRANS-RECEIVERS

TCS COLLINS SHIP TRANSMITTER-RECEIVERS. Each with cables, remote control box and loading coil, radio-telephone and radio-telegraph at 20 and 40 Watts, 1.5 to 12.0 mc. Following power supplies available. 12 V. DC, 24 V. DC, 230 V. DC, 110 V. AC. Complete with all accessories EXCELLENT, like NEW condition. **WRITE FOR PRICE.**

SCR-624 VHF (100-156 mc) TRANSMITTING - RECEIVING EQPT. Same as SCR-522, but with 110V. AC Power Sup-

ply, all contained in Chests CH-172-A and CH-173-A, with Antenna Masts MA-7-A for each set. 4-channels, crystal control both X'mtr. and receiver. 6 watts output Amp. modulated. NEW material. **WRITE FOR PRICE.**

SCR-284 EQUIPMENT, consisting of BC-654 Transmitter-Receiver, PE-103 Generator Power Supply, GN-45 Hand Generator with cranks and legs, and PE-104 Receiver-Vibrator Power Supply, plus other minor accessories. All equipment in EXCELLENT Condition, with complete tubes. **WRITE FOR PRICE.**

SCR-511 POGO STICK WALKIE-TALKIE. This is a low-powered portable AM Radio Telephone Transmitter-Receiver, covering a frequency range of from 3 to 6 mc. Pre-Tuned Plug-in Tuning Units (BC-746) which contain appropriate Transmitter and Receiver. Crystals and matching coils are employed to provide quick changeover to any frequency in the 3 to 6 mc. band. The Transmitter-Receiver (BC-745) is mounted on a 30" metal stake, which can be driven into the ground to support the unit. A telescopic antenna is provided at the top, along with a convenient "press to transmit" switch. Each set consists of: BC-745 Transmitter-Receiver, complete with Tubes; 13 Plug-in Tuning Units BC-746, with crystals and coils to provide coverage over the 3 to 6 mc. range; PE-157 Vibrator Power Supply, which incorporates the dynamic Loud-speaker (for reception). Vibrator, Dry Disc Rectifier, and space for a 2 volt non-spillable acid type storage battery (not supplied). Equipment is NEW and UNUSED. A T-17 Microphone and 2-Volt Storage Battery (Plastic case type readily available) are all that are required for each set to put into operation. **PRICE, EACH, \$125.00**

AUDIO SOUND

Beachmaster 250 W.; Western Elec. Model 11LAS—500W.; RCA 25W.

RECEIVERS

RBM, RBS, BC-1068 VHF, SCR-206 Direction Finders, (BC-224, BC-969-T1 & 974-T2, CRV-46136, 100 to 1500 KC, part of DP-13 Radio Eqpt.
RT-3/ARN-1 Radio Receivers, New, Model ZB-3, Aircraft Homing Adapters, with plugs and accessories. New Eqpt.

MISCELLANEOUS

GENERAL ELECTRIC VOLTAGE REGULATOR (POWER SUPPLY), Model 3GVD-14B-3, delivers up to 750 volts at 100 MA, with voltage divider network to provide lower voltages all regulated. Incorporates switch for "regulating", "non-regulating", and "stand-by". Uses following tubes (not supplied): 1—807, 1—6SR7, 1—6H6, 1—VR-105, 1—VR-150, 1—6AG7, and 1—5R4GY. Chassis dimensions 11" x 16" x 3" with chassis cover 9" high. Ideal for laboratories, Frequency Shift Equipment, Stable Oscillator construction, etc. All NEW Units. **PRICE, EACH \$24.50**

RADIOSONDE AN/AMQ-1. Meteorological Balloon transmitter with self-contained instruments. New Units, with slide-rule temperature evaluators and spare (sealed) humidity elements. Large quantity available. Receiving and Recording supplementary eqpt. also available. Type AN/FMQ-1. **WRITE FOR PRICE.**
"SNOOPERSCOPE" TUBES, British Infra-Red Image Converter Tubes, with matching Bausch & Lomb front-end Lens. **TUBE \$5.00 ea. LENS \$10.00.**

20-40 MC RADIO BEACON EQUIPMENT

For SCR-508, 526, 608, 628, 509, 510, 609, 610, etc.

MODEL RC-163 is designed for ready connection to RADIO SET SCR-508, 528, etc., and 608, 628, etc.—or similar transmitting and receiving equipment. It permits directional transmission and reception for beacon, homing, etc., applications. Eqpt. consists essentially of a rotating directional antenna (Adcock type) synchronized to an automatic code keyer (which can be removed). Four sets of plug-in inductors are supplied to cover the 20 to 40 mc range. Designed to operate from a 12-volt storage battery, power consumed approximately 54 watts (4.5 amps). Supplied with antenna array, antenna mount with rotating motor, code discs, audio oscillator, phase load box, mast sight, tuning indicator-receiver which checks field strength as well as frequency, valuable compass and tripod, control panel, all necessary cables and complete technical manuals for installation, theory and service. Equipment is NEW and export packed, two cases per complete set. **PRICE EACH SET \$169.50**

Westinghouse
ELAPSED
TIME
METERS



\$15.50

ALL BRAND NEW

General
Electric
Round Case
Smaller
Numerals

\$14.50

Genuine TELECHRON Motors



- 2 RPM\$2.90
 - 3 RPM 3.90
 - 3.6 RPM 3.15
 - 1 RPM 3.95
 - 60 RPM 4.30
- One of each \$15.00

ZENITH 1951 TV Remote Control Motor Units

Reversing control switch at end of 17 foot cable. Powerful 4 RPM clutch motor.

Will drive anything

Can be used for door opener, window raiser, model RR turntable. Complete with transformer. **\$10.95**
10 for \$95.00



MARKTIME
5 HOUR SWITCH

A 10 amp. timing device. Pointer moves back to zero after time elapses. Ideal for shutting off radios and TV sets when you go to bed. Limited supply at this special PRICE. **\$4.90**

Also available in 15 min., 30 min., 1 hr. at \$5.90

A similar timer to the above but less calibration and knob. 10 sec. to 24 min. for Photographic, Electric Mixer, Cookers, Time Delay, etc. Biggest BARGAIN We Ever Had\$1.00

Veeder-Root Counter, Rotary \$.90
 Veeder-Root Counter, Ratchet 2.25
 Guardian, No. 4, 115 v. A.C. Solenoid 3.50
 Price Bros. No. 1A, 115 v. A.C. Solenoid 1.50

ISOLATION TRANSFORMER \$1.95
 Nat. known Mfgs. 50 watt 2 windings, 115 V. to 115 V. 60 cy. Ideal to prevent shocks from small radios and medical and electronic devices.

ALNICO **LUCKY** **17% COBALT**
 PURCHASE ENABLES US TO OFFER YOU THESE *Actual Size*
MAGNETS!
39¢ EACH 3 FOR \$1.00

ANTENNA ROTATOR or DOOR OPENER **\$7.50**

Geared down 24v. universal motor with transformer \$7.50
 GE Argon Glow Lamps 4 for \$1.00
 100 for \$20.00



Mossman Lever Switch **\$1.50**

10 Amp. Heavy Duty Silver Contacts. Contacts can easily be restacked. Now momentary OFF CENTER but can be changed by user to STAY either side. Removed from unused Government Surplus Equipment.

ALL PRICES F.O.B. N. Y.

EST. 1923 **BLAN** EST. 1923
 64 Dey St. New York 7, N. Y.

Portable Instruments

Molded Bakelite case 7" x 4 1/2" x 3"

- D.C. MICROAMMETERS 5 . 10 . 50 microamperes
- THERMOCOUPLE MILLIAMMETERS 1, 5 . 5 . 10 milliamperes
- THERMOCOUPLE VOLTMETERS 5 to 500 volts

Available in multiple range combinations

Precision Electrical Instrument Co.
 146 Grand Street New York 13, N. Y.

TELEMARINE COMMUNICATIONS COMPANY

CABLE ADDRESS: Phone— 540 W. 27th St., N. Y. 1, N. Y.
 TELEMARINE, N. Y. LOngacre 4-4490



COMPASS

COMMUNICATIONS COMPANY

393 GREENWICH STREET
NEW YORK 13, N. Y.

CABLE ADDRESS: COMPRADIO, N. Y.

ALL PHONES: BEEKMAN 3-6509

**WE MAINTAIN
OUR OWN FULLY
EQUIPPED TESTING
LABORATORY TO
TEST AND GUARANTEE
ANYTHING WE SELL**

Suppliers of

MARINE, GROUND & AIRBORNE
TRANSMITTERS

FROM 25 WATTS TO 5 KILOWATTS

RADAR

SONAR

TEST SETS

TELEPHONE EQP'T.

CONVERSION EQP'T.

- MOTOR GENERATORS
- CONVERTORS
- DYNAMOTORS
- INVERTERS
- POWER SUPPLIES
- RECTIFIERS

AND

TUBES—

SPECIAL PURPOSE and TRANSMITTING TYPES

THIS IS A SAMPLE LISTING • WRITE FOR OTHER ITEMS & UNLISTED PRICES

Tube#	Selling Price	Tube#	Selling Price	Tube#	Selling Price	Tube#	Selling Price	Tube#	Selling Price
O1A.....	write	2J32.....	65.00	3B28.....	9.00	250TH.....	30.00	725A.....	write
OC3.....	\$1.60	2J33.....	100.00	3C31.....	5.75	250TL.....	30.00	730A.....	45.00
OD3.....	1.50	2J34.....	write	3E29.....	15.00	304TH.....	9.75	803.....	7.00
C1A.....	6.00	2J36.....	100.00	4C27.....	25.00	304TL.....	9.75	807.....	1.65
C1B.....	7.00	2J38.....	49.50	4C28.....	35.00	307A.....	5.00	813.....	9.00
C6A.....	write	2J39.....	49.50	4E27.....	17.50	339A.....	35.00	829A.....	12.00
C6F.....	12.50	2J42.....	150.00	4J25.....	175.00	371B.....	2.50	832A.....	10.00
C6J.....	write	2J49.....	100.00	4J26.....	175.00	388A.....	2.75	833A.....	42.50
1B22.....	3.95	2J50.....	75.00	4J28.....	175.00	446A.....	2.00	836.....	4.75
1B23.....	10.00	2J61.....	75.00	4J29.....	175.00	446B.....	3.75	837.....	2.75
1B24.....	write	2J62.....	75.00	4J30.....	write	450TH.....	45.00	843.....	write
2B22.....	4.95	2K22.....	write	4J31.....	175.00	450TL.....	45.00	849.....	50.00
2B26.....	3.75	2K25.....	35.00	4J33.....	190.00	464A.....	9.50	851.....	45.00
2C40.....	18.00	2K26.....	150.00	4J52.....	350.00	705A.....	3.25	860.....	5.00
2C43.....	25.00	2K29.....	35.00	5J23.....	write	706AGY..	45.00	861.....	write
2D21.....	1.70	2K36.....	write	5J26.....	350.00	707B.....	12.50	865.....	1.40
2E22.....	3.75	2K41.....	150.00	5J29.....	write	714AY....	17.50	872A.....	3.85
2J21.....	17.50	2K45.....	100.00	6C21.....	29.50	715B.....	17.50	874.....	1.50
2J22.....	17.50	2K54.....	150.00	10Y.....	1.25	720.....	write	889R.....	195.00
2J26.....	27.50	2K55.....	100.00	100TH....	9.00	721A.....	3.75	891R.....	250.00
2J27.....	27.50	3B24.....	5.40	204A.....	60.00	723A/B...	25.00	892.....	150.00
2J31.....	27.50	3B27.....	10.00	211.....	1.00	724B.....	6.50	892R.....	250.00

ALL TUBES GUARANTEED. ALL PRICES ARE F.O.B. OUR WAREHOUSE, AND ARE SUBJECT TO CHANGE WITHOUT NOTICE

WIRE-CABLE TUBES PARTS

CORDAGE

CO-122 3 conductor each #22 AWG neoprene jacket 550' length
 CO-127 single #14 AWG braided and tinned copper braid shield

MULTI-CONDUCTOR

2 conductor AWG 12 7 conductor AWG 16
 7 conductor AWG 14 19 conductor AWG 16
 14 conductor AWG 18 6 conductor AWG 20
 11 conductor shielded 10 conductor AWG 16
 AWG 20 22 conductor AWG 16
 2 conductor AWG 18 22 conductor AWG 16
 2 conductor shielded AWG 10

ARMOUR

DR1A-23 DHFA-100 FRIA-4

SINGLE CONDUCTOR AWG 10

shielded cable with terminal lug each end 100' and 150' lengths

WIRE

AWG 18 copperweld
 AWG 29 tinned copper
 Resistance wire AWG 32
 AWG 22 with nylon core plastic insulation

LINEAR WIRE WOUND POTENTIOMETERS

10 Ohm	25 Watt	\$3.90	15000 Ohm	25 Watt	\$1.70
15	25	.95	20000	25	2.00
20	25	.95	6	50	1.60
25	25	.95	150 w/switch	50	2.15
50	25	.95	200 w/switch	50	2.15
100	25	.95	10000	50	2.95
200	25	1.20	15	75	2.95
350	25	1.20	.5 Meg 1" shaft AB "J"	1.45	
500	25	1.20	200,000 1/8 SD AB "J"	1.40	
1000	25	1.30	200 1/8 SD AB "J"	1.40	

SPECIALS

80-86 Crystal in Holder \$2.50
 Balloon with Hydrogen Generator \$2.50
 300 Feet Aerial Wire \$2.00
 Box Kite 17" x 17" x 36" \$2.25

SWITCHES - BATHTUB - OIL FILLED - MICA CONDENSERS - POTENTIOMETERS. SEND FOR CATALOG

MICROWAVE TEST EQUIPMENT

10 CM echo box CABV 14ABA-1 of OBU-3, frequency range 2890 MC — 3170 MCS. Direct reading micrometer head. Ring prediction scale plus 9% to minus 9% Type "N" input. Resonance indicator meter. With accessories, spares and 10 CM directional coupler. Brand New

TUBES

2C34	.50	803	\$3.75	CEQ-72	\$1.15
2X2/879	.50	826	.95	CK-70	4.25
3B24	5.00	864	.40	CRP-72	1.15
3C24	1.75	931A	4.45	E1148	.35
7C4/1203A	.75	955	.40	HY-615	.20
10Y	.45	957	.40	RKR 72	1.15
15L	.70	CK1005	.50	RK-73	.60
30 Special	.45	CK1007	.30	SBP4	4.95
39/44	.30	1626	.40	SFP7	1.95
45 Special	.35	1629	.35	IJ6G	.70
WE 203A	8.00	2051	1.15	1B3GT	.89
316A	.65	7193	.50	BA4	.65
WL-531	5.50	8011	1.50	5U4G	.57
713A	.95	9005	.40	6K6GT	.65
801A	.40	C3B	8.50	12A6	.65

HI VOLTAGE FILTER CHOKES

.4 HY 4.5 Amp DC 3 ohms 1230 RMS to ground GE69G351. New.
 .25 HY 4 Amp .5 ohm 20,000 Test. New.
 1 HY 3.2 Amp DC 3.5 ohm GE69G459. New.
 1.7-3 HY 2 Amp DC 34,000 VDC GE Y346A. New.

SPECIAL

Bodine NSHG-12 Motor. Constant Speed. 27 VDC governor controlled 3600 RPM 1/30 HP 5 Amp. Brand New, \$13.95.

10 CM ROTATING ANTENNA

24" Parabola in turret 360° span at 12 RPM DC, motor control and reversing switch New

TIME DELAY SWITCHES

1 Minute 115 VAC 60 cycle Enc. in Waterproof Metal Case New \$5.25
 3 Micro Switches Contact at 40-41-42 Second Time Delay 110 VAC Motor New \$4.50
 Thermo Switch 50° to 300° F 115 VAC @ 6A 230 VAC @ 5A
 Breaks Contact with Increase of Temperature New \$1.35

CONTACTORS

DPST 115 VAC 60 cycle 15 Amp De-Ion Line Starter Westinghouse \$6.95
 DPST 115 VAC "AB" #700 \$5.95

RELAYS

12 VDC DPST Allied Control Box 32 \$1.25
 24 VDC DPST Allied Control BJ6D36 \$1.45
 24 VDC 3PDT 8 Amp \$1.50
 110 VAC DPST 1 Amp Contacts Struthers Dunn CKA 1970 \$3.65
 115 VAC DPST Struthers Dunn CXA 2997 \$3.65
 220 VDC DPST Struthers Dunn CK 2122 \$4.50
 230 V 50 cycle DPST G.E. 12HG11A2 \$4.00

TRANSMITTING MICAS

MFD	VDC		MFD	VDC	
.000075	3000	51.30	.005	3500	\$1.70
.0005	3000	1.10	.008	3500	2.20
.0001	3000	1.30	.00075	5000	2.45
.004	3000	1.50	.000375	5000	2.65
.003	3000	1.50	.0003	5000	2.65

METERS

Portable 0-25 Amps AC Weston #433 Brand New \$37.50
 Switch Board Panel 0-100 Amps DC Weston #269 with 100 Amp Shunt Brand New \$24.95

EQUIPMENT

Walkie-Talkies 2.3-4.6 MC
 MN-26Y Bendix Compass Receiver
 BC-733 Glide Path Receiver
 DAB-3—Direction Finder
 RDF Receiver Equipment 200-550 KC Fixed Tuned

TERMS: Minimum order \$5.00 — Mail orders promptly filled—All prices F.O.B. Boston, Mass. Send M.O. or check. Shipping charges sent C.O.D. 25% deposit required with all C.O.D. orders.

COMET ELECTRONIC SALES CO.

22 Washington St. Tel. Beacon 2-7863 Brighton 35, Mass.

UG CONNECTORS ALL JAN APPROVED

UG 9/U	UG 28A/U	UG 89/U	UG 115/U	UG 203/U	UG 252/U	UG 333/U
UG 10/U	UG 29/U	UG 90/U	UG 119A/P	UG 204A/U	UG 253/U	UG 334/U
UG 11/U	UG 29A/U	UG 91/U	CW 123A/U	UG 206/U	UG 254A/U	UG 335/U
UG 12/U	UG 29B/U	UG 91A/U	UG 131/U	UG 207/U	UG 255/U	UG 336/U
UG 13/U	UG 30/U	UG 92/U	UG 146/U	UG 208/U	UG 256/U	UG 344/U
UG 14/U	UG 32/U	UG 92A/U	UG 148A/U	UG 212A/U	UG 257/U	UG 349/U
UG 15/U	UG 32/U	UG 93/U	UG 149A/U	UG 213A/U	PL 258	UG 352/U
UG 16/U	UG 34/U	UG 94/U	UG 154/U	UG 215/U	PL 259	M 358
UG 17/U	UG 35A/U	UG 94A/U	UG 155/U	UG 216/U	PL 259A	M 359A
UG 18/U	UG 36/U	UG 94A/U	UG 155/U	UG 217/U	UG 259/U	MT 412
UG 18A/U	UG 37/U	UG 95/U	UG 156/U	UG 218/U	UG 260/U	UG 414/U
UG 18B/U	UG 37A/U	UG 95A/U	UG 157/U	UG 219/U	UG 261/U	UG 421/U
UG 19/U	UG 38A/U	UG 96/U	UG 158/U	UG 220/U	UG 262/U	UG 422/U
UG 19A/U	UG 39/U	UG 96A/U	UG 159A/U	UG 222/U	UG 266/U	UG 423/U
UG 19B/U	UG 40/U	UG 97/U	UG 160A/U	UG 223/U	UG 269/U	UG 428/U
UG 20/U	UG 45/Y	UG 97A/U	UG 160B/U	UG 224/U	UG 270/U	UG 479/U

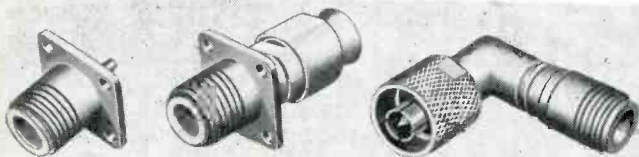

UG 20A/U	UG 46/U	UG 98/U	UG 166/U	UG 231/U	UG 271/U
UG 20B/U	UG 57/U	UG 98A/U	UG 167/U	UG 233/U	UG 272/U
UG 21/U	UG 57B/U	UG 100/U	UG 167A/U	UG 234/U	UG 273/U
UG 21A/U	UG 58/U	UG 100A/U	UG 173/U	UG 235/U	UG 274/U
UG 21B/U	UG 58A/U	UG 101/U	UG 174/U	UG 236/U	PL 274
UG 21C/U	UG 59/U	UG 101A/U	UG 175/U	UG 237/U	UG 275/U
UG 22/U	UG 59A/U	UG 102/U	UG 176/U	SO 239	UG 276/U
UG 22A/U	UG 60/U	UG 106/U	UG 180A/U	UG 241/U	UG 279/U
UG 22B/U	UG 60A/U	UG 107A/U	UG 181A/U	UG 242/U	UG 286/U
UG 23/U	UG 61/U	UG 107B/U	UG 182A/U	UG 243/U	UG 287/U
UG 23A/U	UG 61A/U	UG 108/U	UG 185/U	UG 244/U	UG 290/U
UG 23B/U	UG 83/U	UG 108A/U	UG 188/U	UG 245/U	UG 291/U
UG 23C/U	UG 85/U	UG 109/U	MX 195/U	UG 246/U	UG 294/U
UG 27A/U	UG 86/U	UG 109A/U	UG 197/U	UG 249/U	UG 299/U
UG 27B/U	UG 87/U	UG 110/U	UG 201/U	UG 250/U	UG 306/U
UG 28/U	UG 88/U	UG 114/U	UG 202/U	UG 251/U	UG 309/U

Available for immediate delivery from stock.
 Write, wire, phone your requirements.
 Complete stock of "AN" Connectors. Send for our bulletins and listings of all components.



ACORN ELECTRONICS CORP.

76-E Vesey St. WOrth 4-3270 New York 7, N. Y.

ATTENTION BUYERS OF ELECTRONIC EQUIPMENT

Here is Your One Complete Dependable Source for All of Your Electronics Needs

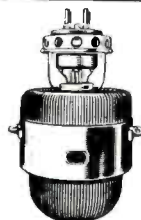

RECEIVING TUBES				
OZ4	6AU6	6SC7	7F7	12SK7GT
1U4	6BA6	6SN7GT	7Y4	12SQ7GT
3S4	6BE6	6T8	12AT7	25L6GT
5V4G	6CB6	6W4GT	12AV7	35W4
6AB4	6BK7	7A4/XXL	12BA7	35Z5GT
6AC7	6F6	7A6	12BF6	50B5
6AH6	6J6	7B6	12H6	50L6GT
6AS7G	6L6G	7C6	12SH7	75L6

TRANSMITTING AND SPECIAL PURPOSE TUBES			
3C45	304TH	832A	2051
5R4GY	723A/B	845	5829
6AN5	807	954	8020
100TH	813	957	9002
211	829B	658	9003

BRAND NEW COAXIAL CABLE

Meeting Jan-C-17A Specifications
 RG-8/U \$110.00 per M Feet
 RG-11/U 107.90 per M Feet
 RG-59/U 59.60 per M Feet

300 OHM Lead Wire 70 Mil Webbing \$19.00 per M Feet

JK26 Jacks—39¢ ea. 500 MMFD Volt DCW
 TV High Voltage Condensers—36¢ ea.
 Centralab TV1-501—One end threaded, other end plain stud. . . . 32¢
 Centralab TV3-501—One end threaded, other end screw terminal. . . . 32¢

LET US KNOW ALL YOUR ELECTRONIC NEEDS
 Write - Wire - Phone For Prices

Electronic Expeditors

Dept. EE, 225 N. Wabash Avenue
 Chicago 1, Illinois
 Cable Address "ELEXPEDITE" • TWX CG1510



RELAYS... WORLD'S LARGEST STOCK!



Your requirements of large or small quantities of relays can be quickly supplied from our huge stock. Wide variety of types, all made by leading manufacturers. Each relay is brand new, inspected and fully guaranteed by Relay Sales.

- ✓ STANDARD TELEPHONE RELAYS
- ✓ SHORT TELEPHONE RELAYS
- ✓ DUAL TELEPHONE RELAYS
- ✓ SLOW ACTING RELAYS
- ✓ SEALED RELAYS
- ✓ ROTARY RELAYS
- ✓ MIDGET RELAYS
- ✓ KEYING RELAYS
- ✓ DIFFERENTIAL RELAYS
- ✓ PLATE CURRENT RELAYS
- ✓ ANTENNA SWITCHING RELAYS
- ✓ "BK" SERIES
- ✓ STEPPERS & RATCHET RELAYS
- ✓ LATCHING & INTERLOCKING RELAYS
- ✓ MECHANICAL ACTION RELAYS
- ✓ VOLTAGE REGULATORS
- ✓ OVERLOAD & CIRCUIT BREAKERS
- ✓ REVERSE CURRENT RELAYS
- ✓ AIRCRAFT CONTACTORS
- ✓ MOTOR & CONTROL DEVICES
- ✓ TIMERS
- ✓ SOLENOIDS
- ✓ RELAY ASSEMBLIES



New
RELAY SALES CATALOG NOW READY

WRITE FOR YOUR COPY TODAY



833 W. CHICAGO AVE.
DEPT. 4, CHICAGO 22, ILL.

OVER 300,000 RELAYS IN OUR STOCK

OVER 1000 DIFFERENT TYPES

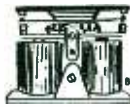

DIFFERENTIALS

Dual 8000 ohm coils, Armature pivoted between poles, all contacts normally open. High-speed. Suitable for P.P. bridge or balanced circuits where differential action is required.
COOK 11710/618 DPDT, 6 ma., #R605 \$5.95
ALLIED 803476 SPDT, 2.5 ma., #418 4.95

ALLIED DSX3 9500 ohm, 4 ma, 2A, 2B, #R941 \$5.95

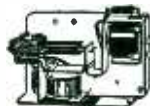

A.C. RELAYS

GUARDIAN: 24 VAC, 25 ohms, Interlocking Relay Breaks 3 Makes 2—Electrical reset #R 806 \$2.49



GUARDIAN 110AC: 800 ohm; 2A, 1C; #R946 \$1.95

GUARDIAN: 24 VAC, 48 ohm relay, Makes 2 Breaks 2 #R 808 \$1.49

Sigma 41FZS7	110VAC 1C	R909	\$2.95
Ward Leonard 105	200VAC 1C†	R911	3.25
G. E. HGA	110VAC 2C†	R912	5.95
Guardian 200	24VAC 1A†	R274A	.98
Guardian 200	24VAC 1A, 1C†	R273A	1.10
Clare B19553†	24VAC 2C, 1A	R582	3.49
Leach 1154	50VAC 2A†	R431	2.49
	12VAC 2A	R275	.98
Potter Brumfield KR11A	12-24VAC† DPDT or 6VDC	R812	1.95



STEPPING RELAYS GUARDIAN SERIES R

Three basic types for 24V AC operation:

1. Continuous rotation: In this type the contact finger advances one step each time the circuit is made and broken.
 2. Electrical reset. Resets when a second coil is energized.
 3. Add and subtract. Steps back one or more contacts at a time instead of resetting completely.
- 10 Pulses per second. Contacts are rated at 1 ampere at 110 volts, 60 cycles, non-inductive AC. The electrical reset type has up to 36 active contacts while the continuous rotation types each have 40 contacts. SEND US YOUR REQUIREMENTS.

* A=Normally Open; B=Normally Closed; C=Double Throw.

† Octal Type Plug Base.

‡ Heavy Duty 10 Amp Contacts.

TERMS:—

All Prices F.O.B. Our Plant. **R a t e d Firms** Net 10 Days; All Others Remittance with Order. Orders Under \$5.00 Remittance With Order, Plus Approximate Shipping Charges (coverage will be returned.)

WE ALSO HAVE PRODUCTION QUANTITIES IN STOCK OF

- | | | | |
|------------------|-------------------|--------------------|------------------------------------|
| APC Air Trimmers | Coils | Knobs | Spaghetti |
| Binding Posts | Controls | Sine-Cosine | Micro Switches |
| Cable | Crystals | Potentiometers | Toggle Switches |
| Capacitors | Filters | Pulse Transformers | Transformers |
| Ceramicons | Fuses | Relays | Tubes |
| Ceramics | Kovar Glass Seals | Resistors | And Other Radio & Electronic Parts |
| Adel & Tinnerman | Rubber Grommets | Servo Transformers | |
| Clamps | Hardware | Shockmounts | |
| Chokes | Iron Core Slugs | Sockets | |



SOLENOIDS

GUARDIAN No. 1: 24 VAC, 6 ohms 1/2 to 1/2 stroke, 6 oz.-in. #R 804\$1.95
GUARDIAN No. 4: 115 VAC, 133 ohms 1/2 to 1 1/4" stroke, 14 oz.-in. #R 805 \$3.50

GUARDIAN No. 4: 115 VAC, Intermittent Duty, 49 ohms 1/2" to 1 1/4" Stroke, 2 lb.-in.\$3.50

ALLEN BRADLEY BULLETIN 860, 110VAC, 1/2 to 1" stroke, 2 lb-in pull; #R942.....\$3.50
WARD LEONARD N83 CONTACTOR: 110VAC, Heavy Duty 5 double make contacts, 3 at 50 Amp, 2 at 30 Amp; 8 lb-in stroke; #R233.....\$10.95



DELAY RELAYS

PARAGON Model 815; 115V, 60 cyc; Adjustable 0 to 100 sec; 2 1/2 sec Recycling time; SPDT, 10 Amp contacts; #R944\$13.95
PARAGON Model 810B; 115V, 60 cyc; 60 sec Delay, 2 1/2 sec Recycling time; SPST, n.o., 10 Amp contacts; #R945\$7.95

EDISON 501, 115VAC, 5 sec Delay, SPST, n.o., 10 Amp contacts, #R943.....\$2.25

AMPERITE 26NO2, 24VAC, 2 sec Delay, SPST, n.o., can be used on 110V with 1250 ohms, #R316\$2.25

31V STEPDOWN TRANSFORMER

STURGES ELEC; 1.7KVA; Tapped Pri 115VAC; Heavy Cast Shield; Net Wt. 55 lb; Shipping Wt. 85 lb., #T311.....\$37.50

STEPPING SWITCHES

AUTOMATIC ELECTRIC TYPE 13 25



Position: Non-Bridging; Interlocking Wipers; Self Interrupter Springs; Norm. Oper Volts: 24VDC; Max 30VDC; 0.6 Amps; 30 Ohm. Two Levels; #R905\$15.95
Three Levels with two wipers; #R906

Four Levels with two wipers; #R907 16.95
Six Levels with two wipers; #R908. 17.75

324 CANAL ST., N.Y.C., 13, N.Y. WALKER 5-9642

Universal general corp.

WE SELOOM "WE AIN'T GOT IT" SAY:

BECAUSE OUR STOCK OF JAN-C-25 CAPACITORS IS JUST ABOUT THE MOST COMPLETE IN THE COUNTRY CHANNELS—BATHTUBS—UPRIGHT TYPES MOST VOLTAGES, Circuits & Terminal layouts ENGINEERING & PRODUCTION ORDERS WELCOMED. A trial order will convince you.

MICA TRANSMITTING CONDENSERS

TYPES	CM-45	CM-50	CM-55	CM-56	CM-70 ETC.
600VDCW	.0005	.001	.0025	.005	\$25
600VDCW	.002	.003	.0035	.004	\$30
600VDCW	.005	.006	.008	\$35	.01 .02 .03 \$40
1200VDCW	.0015	.003	.004	\$35	.01 \$50

FOR FAST • INTELLIGENT • FRIENDLY SERVICE • CALL ON

ESSCO . . . Electronic Specialty Supply Co.
56 LISPENARD STREET Barclay 7-2684 NYC 13, N. Y.

A NEW ESSCO SERVICE

GUARANTEED 24 HOUR SHIPMENTS ON NEW "AN" CONNECTORS—BLACK OR MELLOWINE INSERTS 3100 — 3101 — 3102 — 3106 — 3108 A&B TYPES AT HARD TO BELIEVE DISCOUNTS INVESTIGATE

Special Noise Suppression Capacitors

CA-442, CA-445, CA-481, CA-209, CA-275 & others BRAND NEW OUTPUT TRANSFORMER, ES-691027. Used in SCR-274 & other equipment. \$1.45

• • SPECIAL THIS MONTH • •
A. E. STEPPER 8-12 VDC, 3 deck 20 pos. 360' \$8.95

TEST EQUIPMENT

- Dummy Load, X Band, 1/4"x5/8" guide, choke or plain flange, dissipates 300 watts average power continuously in still air, VSWR less than 1.15 between 7 and 10 KMC, weight 5 1/4 pounds.
- Dummy Load, X Band, 1/2"x1" guide, choke flange, dissipates 100 watts average power continuously in still air, VSWR less than 1.15 between 8.2x12.4 KMC, weight 14 oz.
- Dummy Load, X Band, 1/4"x5/8" guide, plain flange, dissipates 250 watts average power continuously in still air VSWR less than 1.15 between 7-10 KMC, weight 3 1/4 pounds.
- Dummy Load, X Band, 1/4"x5/8" guide, plain flange, dissipates 200 watts average power continuously in still air, weight 2 pounds 4 ounces.
- Dummy Load, S Band, 1 1/2"x3" guide dissipates 1000 watts average power in still air, VSWR less than 1.15 between 2.5 to 3.7 KMC, choke flange, weight 13 pounds.
- TS-36, X Band Power Meter measures 1 milliwatt to 1 watt of X Band average power for 5/8"x1 1/4" wave guide.—\$200.00.
- X Band Power and Frequency Meter for 8,500 to 9,600 megacycles measures 1 to 1,000 milliwatts average power. The frequency meter is direct reading within 25 megacycles and within 4 megacycles with correction chart; commercial equivalent of TS-230 B/AP.
- X Band Spectrum Analyzer 8500-9600 Mc., calibrated linear below cut-off attenuator, calibrated frequency meter, tuned mixer, 4 i.f. stages, 3 video stages over-all gain 125 db., req. power supply. Can be used as signal generator with internal or external modulation.
- S Band Spectrum Analyzer 2700-3400 Mc., similar to above.
- Amplifier Strip AM-CCA/SPR-2, contains I. F. amplifier, detector, video amplifier, pulse stretcher and audio amplifier and Rectifier Power Unit PP-155A/SPR-2, band width 10 megacycles, center frequency 30 megacycles, sensitivity 50 microvolts for 10 milliwatts output. Power supply 80/115 V ac, 60-2600 cps, 1.3 amps. Send for schematic.
- Tuning Units for APR-4 Receiver—TN 16 30-80 megacycles, TN 17 80-300 megacycles, TN 18 300-1,000 megacycles, TN 19 1,000-2,200 megacycles, TN 54 2,200-4,000 megacycles.
- T-85/APT-5, 300-1,600 megacycles Noise Modulated Transmitter, 40 watts C. W. Microline MK SX-12 Klystron Supply and Panel.
- Spectrum Analyzer R. R. L. Model D 1203 100-490 Mc. Made by Hewlett-Packard.
- Spectrum Analyzer, made by G. E. for NDRC, RP-347 100-1500 Mc.
- Standard Signal Generator, Measurements Model 75, 124-510 MC.
- Ferris Model 18B Microvolter
- Ferris Model 10B Microvolter
- TS-226, TS 184, TS 100, TS-12AP, TS 89, P-4E Synchroscope.
- Power Supply, input 220V 3 ph 60 cycles
- | | |
|------------------------------|-------------|
| output: 3500 volts 2 amps DC | 11v 31a ac |
| 1750 volts 0.4 amps DC | 10v 6.5a ac |
| 600 volts 0.3 amps DC | 10v 6.5a ac |
| | 7.5 6.0a ac |
- Waveguide Below Cut-Off Attenuator L101-A, U. H. F. Connectors at each end, calibration 30-100db.—\$25.00.

ELECTRO IMPULSE LABORATORY

62 White Street Red Bank 6-0404 Red Bank, N. J.

AIRCRAFT ELECTRONICS

ARC—1's, ART—13's, RTA 1B's, BC348's
AND COMPONENT PARTS FOR ABOVE

WRITE OR CALL FOR BULLETIN

MERRICK ELECTRONICS

166-08 DOUGLAS AVE. JAMAICA, N. Y.
RE 9-5960

TUBE REBUILDING

Large Transmitting and Power types

Economical • Guaranteed
FREELAND PRODUCTS CO.
700 DRYADES ST., N. O., LA.

GLASS TUBING

PYREX - NONEX - URANIUM
BULBS & CYLINDERS
WRITE FOR FREE MONTHLY LIST
HOUE SUPPLY COMPANY
PHONE KEYPORT 7-1286
M. R. #1 Box 86X Keyport, N. J.

SAVE With New Surplus!

LARGEST VARIETIES AT
GREAT SAVINGS

• OIL CAPACITORS

LARGE RECTANGULARS
SMALL RECTANGULARS
BATHTUBS; TUBULAR

• MICA SILVER TRANSM. 61-2-3-4

• ELECTROLYTIC FP CANS

• AMPHENOL-CANNON

• AN-UG-UHF CONNECTORS

• LORD SHOCK MOUNTS

• BIRTCHEr Tube CLAMPS

• JONES PLUGS—SOCKETS BARRIER STRIPS

• POWER RHEOSTATS

• SWITCHES TOGGLE, ROTARY MICRO, PUSH-MOM.

• POTENTIOMETERS J. JJ. JJJ.

• OTHER CARBON WIRE-BOUND POTS

• MOSSMAN LEVER SWITCHES

• AIRCRAFT NOISE FILTERS

• RESISTORS GLASS FERRULE PRECISION

• FUSEHOLDERS-MOUNTS

• INSTRUMENT KNOBS

• MANY OTHER ITEMS

Write-Wire-Phone Your Specs.

ALEXANDER MOGULL COMPANY

50 W. Broadway N. Y. 7, N. Y.

WORTH 4-0865

SURPLUS NEW GUARANTEED

METERS

D.C. AMMETERS

0-1 Westinghouse NX-35, 3 1/2" rd. AWS type # MR34W001DCAA @ \$6.00

30-0-30 Gen. Elec. DW-51, 2 1/2" rd. metal case @ 4.50

0-50 Gen. Elec. DW-61, 2 1/2" rd. hermetically sealed, 50 M.V., comp. ext. shunt, MR25W050DCAA, S.C. Stock # 3F1050-41 @ 6.50

0-100 Simpson 25, 3 1/2" rd., 50 MV. comp. ext. shunt @ 10.50

0-200 Weston 506, 2 1/2" rd., 50 M.V., ext. shunt, AWS type MR24W200DCAA @ 7.50

A.C. AMMETERS

100 MAAC, WESTON 476, 3 1/2" rd. @ \$7.50

100 MAAC, HICKOK 57 M, 3 1/2" rd. @ 4.95

10 AMPS, BURLINGTON 142, 4" sq. surf. mounted case @ 4.95

120 WESTINGHOUSE NA-35, 3 1/2" rd, 3 Amp mvt., use with 200.5 C.T. @ 6.00

150 WESTINGHOUSE NA-35, 3 1/2" rd., 5 Amp mvt., use with 150.5 C.T. @ 6.00

CURRENT TRANSFORMERS, Donut type, for use with above meters 150:5 or 200:5 @ 7.50

R.F. AMMETERS

1.5 GEN. ELEC. DW-52, 2 1/2" rd. metal case, black scale @ \$3.50

2 WESTON 425, 3 1/2" rd. @ 8.50

2.5 McCLINTOCK MD3001, 3 1/2" rd., S.C. Stock # 3F311 @ 6.50

2.5 WESTON 425, 3 1/2" rd. @ 6.50

3 GEN. ELEC. DO-44, 3 1/2" rd. @ 6.50

5 GEN. ELEC. DO-44, 3 1/2" rd. @ 7.50

8 WESTON 425, 3" sq. @ 10.50

10 WESTON 425, 3 1/2" rd. @ 10.50

A.C. VOLTMETERS

8 WESTON 517, 2 1/2" rd. @ \$4.50

10 SIMPSON 59, 4" x 4 1/2" case @ 9.75

15 WESTINGHOUSE NA-35, 3 1/2" rd. AWS type MR34W015ACVY @ 5.50

50 SIMPSON 59, 4" x 4 1/2" case @ 9.75

300 BURLINGTON 22A, 2 1/2" rd. metal case @ 6.00

D.C. MICROAMMETERS

0-100 WESTON 643, 3 1/2" rd., 1600 ohms @ \$21.00

0-500 SIMPSON, 2 1/2" rd., 15/600 volt scale @ 4.50

0-500 WESTINGHOUSE RX-35, 3" sq. scale 0-25 watts @ 6.00

D.C. MILLIAMMETERS

0-1 DEJUR 310, 3 1/2" rd., 4 KV scale @ \$4.95

0-3 GRUEN GW-587, 2 1/2" rd., spec. volt. M.A. scale @ 3.50

0-5 GRUEN, GW-124, 2 1/2" rd. MR25-W005DCMA @ 4.50

0-5 SIMPSON, 2" sq. @ 3.50

0-15 SIMPSON 26, 3" rd., AWS type @ 6.00

0-50 MR35W015DCMA @ 6.00

0-50 GRUEN, GW-124, 2 1/2" rd. @ 4.50

0-50 GEN. ELEC. DO-58, 4" x 4 1/2" @ 6.00

0-150 GEN. ELECTRIC DO-41, 3 1/2" rd. @ 5.50

0-150 GRUEN 508, 2 1/2" rd. @ 3.95

0-200 MARION, 3 1/2" rd., knife edge pointer @ 4.00

0-200 SIMPSON 26, 3 1/2" rd., AWS type @ 5.95

0-500 MR35W200DCMA @ 4.50

0-500 GEN. ELEC. DW-51, 2 1/2" rd. @ 5.00

0-500 DEJUR 312, 3" sq. @ 5.00

0-800 DEJUR 312, 3 1/2" rd., S.C. Stock # 3F980 @ 4.50

D.C. VOLTMETERS

0-30 WESTON 301, 3 1/2" rd., 62 ohms per volt @ \$9.50

0-50 WESTINGHOUSE NX-35, 3 1/2" rd., 200 ohms per volt @ 6.95

0-50 GRUEN, GW-515, 2 1/2" rd. # MR25W050DCVY @ 4.50

0-50 NORTON, 4" rd. surf. mt. metal case @ 12.00

0-150 HOYT 17-L, 3 1/2" rd. metal case @ 4.50

0-300 SUN 2AU346, 2 1/2" rd., 1000 ohms per volt @ 6.00

0-500 WESTON 506, 2 1/2" rd., 1 MA. with ext. type 8 res. box, AWS type MR25W500DCVY @ 9.50

0-50/500 WESTON 506, 2 1/2" rd., black scale, 1000 ohms per volt @ 6.00

0-600 TRIPLETT 222-T, 2" sq., ext. @ 6.95

MISCELLANEOUS

PORTABLE D.C. VOLTMETER, MULTIPLE RANGE, Weston 430, mvt. range of 3/75/15/3/75/18/30/75/150 Volts, at 1000 ohms per volt, 1/2% of 1% accuracy. ONLY \$79.50

STROBOTAC, General Radio type 631-B for 115 volt 60 cycle. ONLY \$95.00

PORTABLE TACHOMETER, MULTIPLE RANGE, JONAS MOTOROLA, 200-1200, 1000-4000, and 3000 to 12,000 RPM and PPM. Complete in case with accessories. Meets Navy specs. 18-T-22, type B, Class A. List Price \$75.00. ONLY \$37.50

D.C. KILOVOLTMETERS

All meters listed below are 1 MA movement, and are supplied complete with appropriate external precision, wire wound, hermetically sealed ferrule type tubular multiplier and mounting clips.

0-1 Weston 301, 3 1/2" rd., w Weston mult. @ \$18.00

0-1 Weston 301, 3 1/2" rd., w Sprague mult. @ 11.00

0-1.5 Weston 301, 3 1/2" rd., w Weston mult. @ 19.50

0-1.5 Weston 301, 3 1/2" rd., w Sprague mult. @ 12.00

0-2.5 Weston 301, 3 1/2" rd., w Weston mult. @ 24.00

0-2.5 Weston 301, 3 1/2" rd., w Sprague mult. @ 15.00

0-3 Weston 301, 3 1/2" rd., w Weston mult. @ 28.00

0-4 Weston 301, 3 1/2" rd., w Weston mult. @ 29.50

0-4 Weston 301, 3 1/2" rd., w Sprague mult. @ 17.00

0-4 Gen. Elec. DO-41, 3 1/2" rd., w Sprague Mult. @ 13.50

0-5 Weston 301, 3 1/2" rd., w 2 Weston 2.5 Meg Mult. @ 32.00

0-5 Weston 301, 3 1/2" rd., w 2 Sprague 2.5 Meg. Mult. @ 18.00

0-10 Weston 301, 3 1/2" rd., w Weston mult. @ 48.00

0-10 Weston 301, 3 1/2" rd., w Sprague mult. @ 25.00

0-12.5 Weston 301, 3 1/2" rd., w Weston mult. @ 54.00

0-12.5 Weston 301, 3 1/2" rd., w Sprague mult. @ 26.60

0-15 Weston 301, 3 1/2" rd., w Weston mult. @ 61.00

0-20 Weston 301, 3 1/2" rd., w Weston mult. @ 69.50

0-20 Weston 301, 3 1/2" rd., w Sprague mult. @ 31.00

SPECIAL METERS

Replacement movement for Weston 665 Volt Ohm Milliammeter, 0-400 uad, 3" meter, with 665 scale @ \$7.50

Replacement movement for Output Meter, Triplett, 3" square, scale cal. 0-1.5 and 6 Volts A.C., constant impedance 4000 ohms @ \$6.00

Voltage Relay, 140 volts, 200 MADC max. Roller Switch type CMR-2 adjustable from minus 20 to plus 20%, complete with external resistor box @ \$7.50

0-1.5 Volt, Rectifier type A.C. Voltmeter, Western 301, 3 1/2" round, 2000 ohms per volt @ \$8.95

0-300 Volt, Rectifier type A.C. Voltmeter, Weston 732, 3" square @ \$11.00

0-500 Volt, Rectifier type A.C. Voltmeter, Weston 732, 3" square 1000 ohms per volt @ \$14.00

0-10 Milliampers A.C. Rectifier type, General Electric DO-55, 3" square @ \$5.50

Only a partial listing. Space does not permit us to list our complete stock of Surplus New meters. We also carry a wide assortment of Simpson panel meters. Send for our free listing.

MARITIME SWITCHBOARD INSTRUMENTS—ACCESSORIES
338 Canal Street, New York 13, N. Y.
Worth 4-8217

All items are Surplus-New-Guaranteed. We have a large variety of meter multipliers, shunts, current transformers, etc., in stock. We also modify quantity lots of meters to order. Let us know your requirements.

QUARTZ CRYSTALS
NEW LISTING

Made from the finest Brazilian Quartz. Will provide a high degree of activity and frequency stability. All tested and marked by the manufacturer to a very close tolerance. In the frequencies outlined below the crystals itemized under the heading "From & To" are mostly in progressive frequencies between the limits shown (as for example: "From 3300 to 3377," are as follows: 3300KC, 3301KC, 3302KC—, 3377KC.) are of limited quantities in each frequency. Those listed singly are in quantities of 50 or more.

FT243				CR 1A/AR or FT241				XL5 Dual		FT241A	
Prong centers 1/2", Prong dia. 3/32"				Prong spacing 1/2", Prong dia 1/8"				3 prongs 1/2" X 1 19/32" prong dia.		SPECIAL TYPE WE. Prong spacing 1" CTS. Prong Size 3/32" dia.	
Price \$1.15 ea. (25 for \$25.00)				Price 79¢ ea. 12 for \$9.00				Price \$1.95 ea.		These are in successive steps of 1 MC variation from 20.0 MC to 38MC.	
FROM	TO	FROM	TO	FROM	TO	FROM	TO	2520 & 2698	2731 & 2891	2438 & 2276	3128 & 3153
1915	1995	6100	6173.3	2853	7650	8002	8010	2605 & 3153			
2030	2065	6200		3988	7738	8007	8092				
2125	2155	6250		4188	7740	8007	8092				
2300		6275		4285	7750	8007	8092				
2320	2390	6206	6292	4300	7760	8007	8092				
2420	2490	6300	6375	4640	7770	8007	8092				
2604	6400	6300	6498	4785	7775	8007	8092				
2605	6500	6300	6675	5020	7778	8007	8092				
2750	6500	6300	6775	5100	7780	8007	8092				
2880	6700	6300	6875	5120	7780	8007	8092				
2940	6800	6300	6875	5200	7780	8007	8092				
3110	6815	6300	6875	5225	7780	8007	8092				
3215	6830	6300	6875	5300	7780	8007	8092				
3652	6900	6300	6875	5410	7780	8007	8092				
3729	6900	6300	6875	5470	7780	8007	8092				
3805	6978.75	6300	6875	5470	7780	8007	8092				
4014	7228	6300	6875	5740	7790	8007	8092				
4104	7228	6300	6875	5740	7790	8007	8092				
4104	7325	6300	6875	5810	7790	8007	8092				
4244	7458.75	6300	6875	5810	7790	8007	8092				
4300	7475	6300	6875	5810	7790	8007	8092				
4305	7500	6300	6875	5810	7790	8007	8092				
4400	7500	6300	6875	5810	7790	8007	8092				
4500	7500	6300	6875	5810	7790	8007	8092				
4735	7675	6300	6875	5810	7790	8007	8092				
4800	7700	6300	6875	5810	7790	8007	8092				
4915	7725	6300	6875	5810	7790	8007	8092				
5065	7725.8	6300	6875	5810	7790	8007	8092				
5100	7750	6300	6875	5810	7790	8007	8092				
5200	7750.25	6300	6875	5810	7790	8007	8092				
5300	7775.75	6300	6875	5810	7790	8007	8092				
5320	7775.5	6300	6875	5810	7790	8007	8092				
5630		6300	6875	5810	7790	8007	8092				
5633.3		6300	6875	5810	7790	8007	8092				
5655.5		6300	6875	5810	7790	8007	8092				
5677.7		6300	6875	5810	7790	8007	8092				
5700		6300	6875	5810	7790	8007	8092				
5706.6	5775	6300	6875	5810	7790	8007	8092				
5800	5852	6300	6875	5810	7790	8007	8092				
5900	5975	6300	6875	5810	7790	8007	8092				
6000	5925	6300	6875	5810	7790	8007	8092				
6150	7906	6300	6875	5810	7790	8007	8092				
6175	8000	6300	6875	5810	7790	8007	8092				

EDLIE ELECTRONICS, Inc.
154 Greenwich Street, New York, N. Y. Telephone Dlgby 9-3143

SAVE ON	TUBES	BRAND NEW	TUBES	GUARANTEED	TUBES
0A2.....	51.25	2D21.....	1.49	3Q4.....	.59
0B2.....	1.39	2D21W.....	2.49	3Q5GT.....	1.00
0B3/VR90.....	1.10	2E25A.....	4.50	4B24.....	6.95
0C3/VR105.....	.98	2E30.....	2.95	4C22/HF100.....	25.00
0D3/VR150.....	.69	2J21.....	1.98	4C35.....	24.50
0A1.....	8.50	2J22.....	8.95	4E27.....	12.50
VS-2.....	.98	2J23.....	14.95	4J21.....	129.50
1A3.....	2.28	2J27.....	14.95	4J22.....	129.50
1B22.....	7.95	2J31.....	27.50	4J23.....	129.50
1B23.....	8.50	2J32.....	27.50	4J26.....	129.50
1B24.....	1.95	2J33.....	27.50	4J27.....	129.50
1B26.....	12.95	2J34.....	27.50	4J28.....	129.50
1B27.....	3.10	2J40.....	27.50	4J29.....	149.50
1B35.....	12.95	2J48.....	32.95	4J30.....	249.50
1B37.....	14.50	2E58.....	149.50	4J31.....	99.50
1B38.....	29.95	2J61.....	39.50	4J35.....	99.50
1B42.....	12.50	2J62.....	32.95	4J41.....	99.50
1N21B.....	2.25	2K23.....	75.00	4X150A.....	35.00
1N21C.....	22.50	2K25/723A/B.....	29.50	5BP1.....	4.50
1N22.....	.98	2K28.....	33.95	5BP4.....	4.50
1N23.....	1.25	2K39.....	99.50	5D21.....	19.95
1N23A.....	2.25	2K55.....	120.00	5GP1.....	4.50
1N23B.....	3.65	2X2A.....	1.75	5JP1.....	17.50
1N26.....	7.50	3A5.....	1.39	5JP2.....	17.50
1N36.....	.69	3A8GT.....	1.39	5JP5.....	17.50
1N40.....	7.95	3AP1.....	10.95	5J23.....	59.50
1N43/400A.....	1.25	3B2.....	4.95	5J26.....	149.50
1N54.....	.89	3B26.....	3.50	5J29.....	11.95
1N55.....	2.75	3B28.....	6.50	5J30.....	39.50
1N56.....	.89	3B29.....	7.50	5R4GY.....	1.50
1N60.....	.60	3BP1.....	6.95	5T4.....	1.98
1N63.....	2.39	3BP1.....	3.95	6AK6.....	1.10
2AP1.....	9.95	3DP.....	3.95	6AN5.....	3.30
2C21/1642.....	.69	3C22.....	99.50	6AS6.....	4.50
2C22/7193.....	.29	3C24/24G.....	1.50	6AS7G.....	4.50
2C26A.....	.39	3C27.....	1.75	6BL7GT.....	.95
2C39.....	24.50	3C33.....	9.95	6C21.....	19.50
2C40.....	24.50	3C39.....	13.95	6F8G.....	.98
2C43.....	24.50	3FP7.....	1.39	6G8G.....	1.39
2C44.....	1.19	3GP1.....	3.95	6L6GA.....	1.39
2C52.....	3.95	3NP7.....	3.25	6SN7GT.....	.98
6SN7WGT.....	1.98	217C.....	4.95	700A/B/C/D.....	16.50
6V6GT.....	.79	221A.....	1.95	702A.....	2.75
7BP7.....	6.95	RX233A.....	3.50	703A.....	4.95
7C23.....	59.50	250R.....	8.95	705A.....	1.50
12A47GT.....	1.29	250TH.....	20.00	706Y.....	49.50
12DP7.....	16.95	274B.....	3.25	706Y.....	49.50
12GP7.....	25.00	VT98-BR.....	9.95	706Y.....	49.50
15E.....	1.98	279A.....	Q	707A.....	7.95
15R.....	.69	304TH.....	8.95	707B.....	14.95
ES-17.....	3.95	304TL.....	8.95	708A.....	3.95
T-20/1623.....	3.75	307A/RK75.....	4.50	714AY.....	4.50
24G/3C24.....	1.50	327A.....	4.50	715B.....	24.50
FG-27A.....	6.95	331A.....	12.50	715C.....	1.10
FG-32.....	12.95	349A.....	8.50	717A.....	99.50
FG-235A.....	49.50	350A.....	6.95	720BY.....	1.95
350B.....	4.95	350B.....	4.95	721A.....	1.95
350B.....	4.95	350B.....	4.95	722A.....	1.95
350B.....	4.95	350B.....	4.95	723A/B.....	16.95
350B.....	4.95	350B.....	4.95	724A.....	4.50
350B.....	4.95	350B.....	4.95	724B.....	2.75
350B.....	4.95	350B.....	4.95	725A.....	6.95
350B.....	4.95	350B.....	4.95	726A.....	6.95
350B.....	4.95	350B.....	4.95	726B.....	59.50
350B.....	4.95	350B.....	4.95	730A.....	25.00
350B.....	4.95	350B.....	4.95	802.....	3.95
350B.....	4.95	350B.....	4.95	803.....	3.75
350B.....	4.95	350B.....	4.95	804.....	12.50
350B.....	4.95	350B.....	4.95	805.....	3.95
350B.....	4.95	350B.....	4.95	807.....	1.99
350B.....	4.95	350B.....	4.95	808.....	2.95
350B.....	4.95	350B.....	4.95	809.....	2.95
350B.....	4.95	350B.....	4.95	810.....	10.95
350B.....	4.95	350B.....	4.95	812.....	2.95
350B.....	4.95	350B.....	4.95	813.....	8.50
350B.....	4.95	350B.....	4.95	814.....	2.95
350B.....	4.95	350B.....	4.95	815.....	2.95
350B.....	4.95	350B.....	4.95	828.....	12.95
350B.....	4.95	350B.....	4.95	829B.....	11.95
350B.....	4.95	350B.....	4.95	830B.....	3.75
350B.....	4.95	350B.....	4.95	832.....	7.95
350B.....	4.95	350B.....	4.95	832A.....	9.95
350B.....	4.95	350B.....	4.95	833A.....	34.95
350B.....	4.95	350B.....	4.95	833A.....	1.50

YOUR SURPLUS WANTED
We Pay Highest Prices!

Special: VACUUM CAPACITORS
12 mmfd., 20,000 V. \$7.50

Special: VACUUM CAPACITORS
50 mmfd., 32,000 V. \$12.50

J. S. H. SALES CO.
Dept. E-13, 7552 Melrose Ave.
Los Angeles 46, California

All Prices F.O.B. Los Angeles, subject to change without notice. Minimum order \$3.00

1000's of other types in stock. Send us your requirements.

PHOTOCON SALES
417 N. Foothill Blvd. SYcamore 2-4131
Pasadena 8, Calif. RY an 1-6751

FREE 24 PAGE
SUMMER SURPLUS SALES CATALOG

WANTED new or clean used electronic surplus. Please state exact description of the condition and details of modification. Include lowest price in first letter.

Audio Oscillator Hewlett-Packard 200BR 20-20,000 cps.Exc. \$110.00
Leeds & Northrop Wheatstone Bridge Test Set No. 5430A, Varley Loop Test.Exc. 125.00
4286 Kelvina Bridge Ohmmeter, Leeds & Northrup, .0001-11 ohms.Exc. 100.00
804CS UHF Signal Generator 8-330 mc., Federal.Exc. 400.00
804LX-1 Signal Generator UHF 8-330 mc.Exc. 400.00
LM & BC-221 Frequency Meter with cal. book, crystal, and tubes.Exc. 99.50
Frequency Standard 1-10-100 KC. James Knight FS34A.New 60.00
TS-352/U Weston Test Set.Exc. 89.50
TS-251/UP Test Set, less crystals.New 89.50
TS-174/U Frequency Meter 20-280 mc. with cal. book, and crystal.Exc. 450.00
TS-173/UR Frequency Meter 90-450 mc. - Complete with crystal, cal. book, & 115 VAC. Power Supply.Like New PUR* 600.00
TS-146/UP X-Band Signal Generator.Exc. Measurements Corp. Signal Generator Model 84 300-1000 mc.Exc. PUR* 350.00
TS-13/AP X-Band Signal Generator.Exc. 350.00
TS-34/AP Portable Oscilloscope.Exc. Industrial Circuit Tester Weston Model 785 Like New 125.00
Electronic Analyzer Weston 769.Like New 225.00
APR-4 Search Receiver.PUR* 150.00
Tuning Units for APR-4 Receiver.PUR* 150.00
BC-348, BC-312, BC-342 Receivers.PUR* 79.50
Communication Receivers—made by Hallicrafters, Nationals, & Hammett. Many models.Prices start 79.50
T-17 Hand Microphone with cord and PL-68.Exc. 4.50
HS-23 8000 ohm. Used 2.95 New 5.95
HS-18 8000 ohm. Used 1.75 New 2.25
HS-33 600 ohm. Used 3.50 New 6.95
HS-38 600 ohm. Used 1.75 New 2.25

* PUR—Price upon request.

NOTE: One of the largest and most complete electronic surplus stocks in the country. We have thousands of tubes, capacitors, plugs, accessories, transmitters-receivers, test equipment, etc. Send us your requirements.

TERMS: Prices F.O.B. Pasadena, California. 25% on all C.O.D. orders. Californians, add 3% Sales Tax. Prices subject to change without notice.

TELEPHONE RELAYS

Large Stock of
CLARE, TYPES C, D & E
COOKE, AUTOMATIC—ELECTRIC

ALL TYPES OF COILS and PILE-UPS
Send Us Your Specs. for Our Quote

Clare Type C Standard Size Sensitive Telephone Relays

Coil	Contacts	Will Close At	Price
1) 6500 ohms 1C	1C	1.5 MA	\$2.75 ea.
2) 6500 ohms 1B-1C	1B-1C	3.2 MA	2.75 ea.
3) 6500 ohms 3A	3A	4.0 MA	3.00 ea.
4) 6500 ohms 3A-1B	3A-1B	4.0 MA	3.00 ea.
5) 6500 ohms 1C	1C	1.5 MA	3.25 ea.

Clare Type G Half Size Sensitive Telephone Relays

Coil	Contacts	Will Close At	Price
1) 6500 ohms 2A	2A	5 MA	\$2.50 ea.
2) 5800 ohms 3A	3A	5 MA	2.50 ea.
3) 5800 ohms 2B-1C	2B-1C	5 MA	2.50 ea.
4) 4850 ohms 1C	1C	4 MA	2.50 ea.
5) 3600 ohms 1C	1C	6 MA	2.00 ea.
6) 4850 ohms 1A	1A	5 MA	2.00 ea.

All above Relays may be used for continuous duty operation on 110V. D.C.

Other Type G Telephone Relays

Coil	Contacts	Will Close At	Price
1) 1300 ohms 1A-1C	1A-1C	24 or 48V.	2.50 ea.
2) 700 ohms 2A-1C	2A-1C	24V.	2.50 ea.

Legend (A) Normally open set of contacts.
(B) Normally closed set of contacts.
(C) Single pole double throw set of contacts.
MA = Milliamps.

SIGMA HERMETICALLY SEALED RELAYS
Operates at six volts A.C. 60 cycles or 400 cycles.
Contacts—SPDT Price—\$5.50 ea.

Chase Electronic Supply Co.
222 Fulton St.
New York 7, N. Y.
Dlgbly 4-3088
HOllis 4-5033

FOR SALE
PLATE TRANSFORMERS

Several hundred new 10 K.W. Amertran oil cooled plate transformers 115 v. 60 cy., 1 phase primary, 17,600 volts, 5 amp secondary. Can be furnished center tapped or two wire 8800 volts, 1.0 amps. Priced \$75.00 each f.o.b. Los Angeles. Special Quantity discounts available.

SCR 545-A Radar
New RA-38 15 KV Power Supplies and components.

EPCO
1527 E. 7th St., Los Angeles 21, Calif.

TIME DELAY

RELAY 115v 60cy adjustable 6 sec. to 2 minutes
Cramer TD-2 1203. Also TD608 6 to 60 sec. \$12.95
RELAY SPDT 24 vdc 250 ohm Clare Type K \$1.95
BLOWER MOTOR 400-1800cy 115v EAD J31C \$9.95
SYNCHRO MOTOR 1F Special 115/00V400cy. \$11.95
FIL XFRMR 6.3 @ 1.3A (other sizes avail.) \$1.25
250 WATT OUTPUT XFRMRPP-Bohm KS 9496 \$12.95
CHOKE 4H 70ma. 110 ohm.Exc. 5.48
BIRTCHEK CLAMPS 928A, 928B, 928C.Exc. 3-15MMF variab. No. EF. \$4.95; MC-100-S. \$3.99
MICRO & microswitch pin pl. spst. spdt (others) \$3.99
ISOLATION XFRMR 85 watts prim. 115v sec.
115 or 135v & 6.3 tap 2 1/2x2 1/2x3"\$2.48
SUBMINATURE subsocket 3 pin 100\$10.00
POWER XFRMR 760VCT @ 170ma 3 @ 1.3 @ 4.5-9.5
SILVER CER. TRMR T29A 7-45 @ 32c; 1.5-7.5 @ 24
AN306-105-25 PL-68. PL-259A. 83-1H. 88
JK 88A. CONDENSERS: BATHUB, MICA, AIR,
OIL, HV, CER. JPOTS. RELAYS, MIKES,
SAG&MDL fuses, SWITCHES SPARES for: AN/
TRC-1, MK11 Radar, AN/TPN-2 2% .002 Silver
Mica CM30; many other items.

EMPIRE ELECTRONICS COMPANY
409 Avenue L Brooklynn 30, N. Y.
CLeverdale 2-2411 BRyant 9-1220

YOU GET 2

Absolutely the greatest cabinet buy in years

101 uses for this sturdy handsome black plastic cabinet. Can be used for TV boosters, remote control units, etc. In compact size (5 3/4" x 5" x 3 1/4") A genuine bargain you can't afford to miss.

2 For \$3

Postpaid Anywhere in the United States

No C.O.D. Send check or money order.

MANUEL KLEIN CO.
94E Chamber St. New York 7, N. Y.

FOR SALE
MAGNET WIRE
Nos. 29, 30, & 31 SCE, 31 DCC & 44 HE
At Close-Out Prices
CORD SETS 17,000 22" G.E. Plastic, 7¢
STRECKLAND ELECTRIC CO.
1427 E. 18th Ave., Columbus, Ohio

WHOLESALE ONLY
ELECTRONIC COMPONENTS
AIRCRAFT EQUIPMENT
HYDRAULICS
RADIO & ELECTRONIC SURPLUS
13933-9 Brush St. Detroit 3, Mich.
Phone Townsend 9-3403

R.C.A. Model MI-8167 TRANSMITTERS

Point-to-point communications

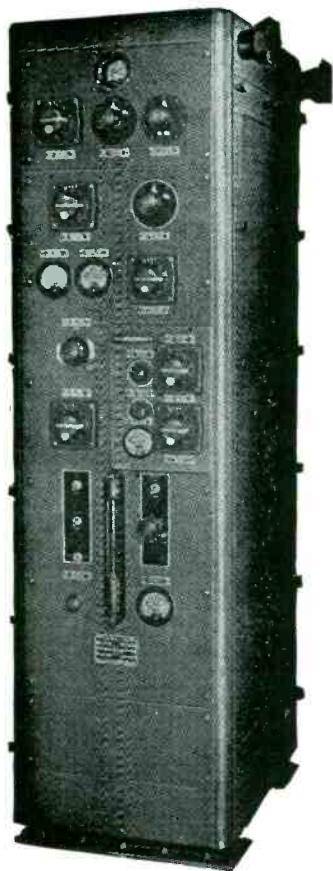

Freq. Range: 2000 to 20,000 Kcs.
Output: 350 Watts C.W. 250 Watts Radio telephone
Input: 190 to 250 Volts AC 50/60 cps.
Size: 60" high, 17" wide, 27" deep.
Tubes: 807s, 813s, 805s, 866s.
Crystal Oscillator unit built-in, fully shielded and stable. All self contained including antenna network. Master Oscillator unit (available) fits in place of Xtal unit. Speech amplifier is only external unit and has 110/220 v. AC input, four stages, high gain. Total net weight, 625 lbs.

Complete! New! From Stock! Quantities!
Prices on Request.

COMMUNICATION DEVICES CO.
INCORPORATED
2331 Twelfth Ave. N. Y. 27, N. Y.

Headquarters for Microwave Test Equipment

ANNOUNCING THE AVAILABILITY OF NEW TS-125 S BAND POWER METERS

This precision instrument, now being produced by Weston Laboratories, provides for quick visual measurement of CW, modulated or pulsed average power output from 0.2 MW to more than four watts. Calibrated in two scales (MW of power and DB above and below one milliwatt). Temperature compensated thermistor construction with 1/4 wave matching stub RF element. Supplied with complete accessories and instruction book available now.

A partial list of other test equipment available follows:

TS-1ARR	TS-61/AP	TS-173/UR	TS-324/U	I-167-A	BC-1236/A
TS-3A/AP	TS-62/AP	TS-174/U	TS-328	I-177	BC-1255/A
TS-8A/U	TS-69/AP	TS-175/U	TS-359A/U	I-178	BC-1287/A
TS-10A/APN-1	TS-76/APM-3	TS-184/AP	TS-363/U	I-196A	BC-1277
TS-11/AP	TS-87/AP	TS-192/CPM-4	TS-375	I-198A	BE-67
*TS-12	TS-89/AP	TS-194/CPM-4	TS-377/U	I-208/A	LAD
*TS-13	TS-92/AP	TS-197/CPM-4	TS-389/U	I-212	LAF
TS-14	TS-96/TPS-1	TS-198/CPM-4	TS-421/U	I-222/A	LAG
TS-15B/AP	TS-98/AP	TS-203/AP	TS-437/U	I-223A	LM13
TS-16/APN	TS-100/AP	TS-204/AP	I-56	I-225	LU2
TS-18	TS101/AP	TS-205/AP	I-61B	I-233	LU3
TS-19	TS-102/AP	TS-210/MPM	I-83A	IE-21/A	LZ
TS-23/AP	TS-108/AP	TS-218/UP	I-95/A	IE-36	OAA-2
TS-26/TSM	TS-110/AP	TS-220/TSM	I-98A	IF-12/C	OAW
TS-27/TS	TS-111/CP	TS-226A	I-106/A	IS-185	P4E
TS-32A/TRC-1	*TS-117/GP	TS-233/TPN-2	I-114	IS-189	SG/8U
TS-33/AP	TS-118/AP	TS-239A	I-115	AN-PNS-1	TA-16EA
TS-34/AP	*TS-125/AP	TS-251	I-122	BC-221 (*)	TSS4SE
TS-34A/AP	TS-127/U	TS-263	I-122-B	BC-376	TSX35E
TS-35/AP	TS-131/AP	TS-268	I-126	BC-438	TSX45E
TS-36/AP	TS-142/APG	TS-270A/UP	I-130A	BC-439	TTS-4BR
TS-24/APM-3	TS-144/TRC-6	TS-281/TRC-7	I-134B	BC-838	TTX-10RH
TS-46/AP	TS-146	TS-285/GP	I-137A	BC-308/D	TUN-9HU
TS-47/APR	*TS-147/UP	TS-294/U	I-139A	BC-943/A	
TS-48	*TS-143	TS-297/U	I-145	BC-1090/A	
TS-51/APG-4	TS-153	TS-301/U	I-147	BC-1066/A	
TS-56/AP	*TS-155A/AF	TS-314/FSM-1	I-148	BC-1201/A	
TS-60/U	TS-170/APN-5	TS-323	I-153A	BC-1203	

* Of new manufacture.

Before selling your idle test equipment, please get our offer
Cable: WESLAB Tel: Boston: WE 5-4500

Weston Laboratories
Weston 93, Mass.

ATTENTION: PURCHASING AGENTS

If the type of tube you are looking for is listed, you have a buy!! All brand new, guaranteed tubes at the lowest prices in the industry. We have them in stock. Immediate delivery.

OA2 .89	2C43 16.95	4J42/700A 17.50	REL5 45.00	331A 6.95	707A 7.95	899B 14.50	1608 3.95
OA3/VR75 1.19	2C44 .75	5AP1 3.49	FG81A 3.49	350B 3.95	708A 3.75	830B 2.95	1616 .6
OB2 1.05	2J22 7.50	5C30/C5b 3.75	VT90 .75	353A 3.95	710A/8011 .92	838 2.95	1619 .3
OB3/VR90 1.05	2J26 9.95	5FP7 3.95	VT98 75.00	357A 14.95	713A .92	841 .39	1625 .4
OC3/VR105 1.10	2J27 9.95	5B7 3.75	HY114B 75	371B .89	714AY 5.75	843 .33	1626 .4
OD3/VR150 .85	2J39 19.50	C6A 5.75	VT127 1.75	388A 1.29	715A 4.95	846 49.95	1629 .30
1B22 2.19	2J40 29.50	6AK5 85	205B 1.49	394A 4.75	715B 6.95	851 39.50	1636 2.95
1B26 2.49	2J61 39.50	6K7G .45	211 .75	417A 14.95	717A 1.19	860 6.50	1642 .59
1B27 14.50	2J62 29.95	7BP5 14.95	211 GE 1.75	450TH 37.50	721A 1.75	861 21.50	1651 1.69
1B29 4.75	2V3G .75	7C4 .35	217C 6.95	530 5.31	722A 1.89	864 .75	2051 1.95
1B36 7.50	2X2 .49	7E5 .39	245B 3.25	531 6.75	723AB 17.95	865 1.25	7193 .30
1B56 24.50	3B7/1291 .30	10Y .39	250TH 18.95	533 45.00	724B 2.49	866A 1.45	8011 .75
EL1C 2.49	3B22 2.49	12A6 .49	250TL 16.95	559 2.25	725A 6.75	872A GE 3.95	8012 2.75
1D8G .59	3C24 1.49	24G 1.49	957B 4.95	HY615 .92	800A 1.75	874 .69	8013A 3.95
1L4 .59	3C28 4.95	RK34 .39	986A 4.95	700A 17.50	801A .44	876 .59	8021 1.95
1R4/1294 .79	3CP1/S1 1.49	45 Special .29	986A 6.95	701A 4.95	803 3.25	879 .49	8025A 6.95
1T4 .59	3DP1 3.95	FG17 4.50	304TH 7.50	702A 2.49	805 3.69	931A 5.95	9001 1.50
2C21/1642 .59	3D6/1299 .35	CRP72 1.00	304TL 8.75	703A 4.75	807 1.59	954 .35	9002 1.25
2C22/7193 .30	3D23 4.75	RP72 1.00	307A 3.50	704A .89	808 1.75	955 .45	9003 1.75
2C26A .29	3FP7 1.75	CRP73 1.00	316A .49	705A 1.95	812 3.25	957 .45	9004 .49
2C34/RK34 .39	3Q4 .59	RK73 1.00	328A 7.95	706AY-DY 39.50	813 8.50	E1148 .29	9005 1.50
2C40 9.95	4B28 2.95	RK75 3.95	329A 7.95	706EY-GY 29.95	814 3.40	CK1005 .65	9006 .29

6 Amp Westinghouse Tungar \$2.95

MARITIME INTERNATIONAL COMPANY

11 State Street, New York 4, N. Y.

Cable Address "Foxcroft"

Phones: Dlgbly 4-3192-3



FOR ELECTRONIC COMPONENTS

We offer immediate delivery from our vast stock of more than 25,000 items—all standard make, carefully inspected and fully guaranteed. Our prices are below market.

Always Check Wells' Stock First!

Quotations and quantities available will be given immediately upon request.

**ADEL CLAMPS
ANTENNAS**

Insulators, Mast Sections

**BINDING POSTS
BLOWERS
CABLE ASSEMBLIES
CHOKES
COILS**

CONDENSERS

Oil Filled, Bathub, Hearing Aid, Transmitting Micas, Silver Micas, Ceramic, Variable, Trimmer

CRYSTALS

DYNAMOTORS & BRUSHES

FILTERS

FUSES & MOUNTINGS

GENERATORS

GROUND RODS

HEADSETS

IF COILS

JACKS

JACK BOXES

KEYS, Telegraph

KNOBES

LAMPS

LORD MOUNTS

LUGS

MOTORS & BRUSHES

PLUGS

RECTIFIERS

Selenium, Copper Oxide, Meter, Diode

RESISTORS—All Types

SELSYNS

SOCKETS

SWITCHES

Aircraft, Micro, Switchettes, Toggle

TIMERS

TUBING—Flexible

TUNING SHAFTS

TRANSFORMERS—All Types

VIBRATORS

WALKIE TALKIES

Available Now!

A complete signal corps stock number listing of items in our stock. Write for listing No. SG-200. (For government agencies and contractors only.)

Manufacturers and distributors—write for Radio-Electronics Catalog No. H 501.

Write, Wire, Phone Your Requirements
all phones: **SEeley 8-4143**



833 W. CHICAGO AVE., DEPT. SL, CHICAGO 22, ILL.



Formerly
COLUMBIA ELECTRONICS LTD.
of N. Hollywood and
ARROW SALES, INC.
of Chicago

NEW HEADSETS & HANDSETS

HS-23	HS-38	TS-18-C
HS-33	RS-83	

RADAR

APS-4	Complete Radar	RC-1841FF
APS-6 Complete	Mark J6	RC-214
APT-1	MD4/APS2	RC-224
APT-2	MD5/APS3	RC-266
APT-3	MD22/UPN2	RT34/APS13
APT-4	MD38/APQ13	T-86/APT-5

**TEST EQUIPMENT
Complete Line!**

DuMont 224-A Oscilloscope
1-77 Hickok Tube Checker
1-208 FM Signal Generator
RFC Model 644 Multimeter
Ferris Microvoltage Mod. 18-C
Hewlett Packard #200-C
1-83G TS12/AP TS159
1-86A TS16/APN TS170 ARN
1-114 TS19/APQ TS175/UP
1-183 TS24A/ARQ-2 TS182/UP
1-185 TS27/TSM TS184A/AP
1-187 TS34/AP TS204/AP
1-198 TS36/AP TS251
BC-1255 TS61/AP TS311A/UP
IE-36 TS62/AP TS323/UP
I-122 TS89 SLI Slotted
I-139 TS92 Line Test Set
I-145 TS100/AP Range Calibrator
I-212 TS111/CP I-146
I-222 TS126 UPM-1
TS3/AP TS127/U
TS10A/APN TS131

VHF FREQUENCY METER

Complete, crystal controlled, with 110/220 VAC 60 cycle power supply. 5 channels. Freq. range: 100-156 MC. Mounts in standard rack. With diagram, less crystals. NEW . . . Price on Request.

AN/ART-13 PARTS

Part #	Item
564916	Barometric Switch
565027	4-Pile Ceramic, Variable Cap.
K7890443	6-Pile Ceramic, Variable Cap.
564605	4 Centralab-Type 843-003 Cap. Assembly

RA-38 RECTIFIER

High voltage power supply. Used with ground radar set. New. Price on request.

FLUX METER

For measuring flux density between magnet poles. Has two meters in series with a potentiometer and battery for power supply. Range: 500-4000 Gauss in 3 scales. Requires 1 battery which mounts in case. NEW. Price On Request.

DIRECTION FINDER KIT

Complete kit to make any receiver (freq. range: 200-1750 Kc.) a complete Direction Finder Set. This kit consists of: MN-20 Loop, Loop-To-Receiver Transmission Line, MN-52 Loop Control with 360° azimuth dial and shaft. New. \$17.50

RECEIVERS—TRANSMITTERS

APR-4	ID-6/APN-4	R89
APR-5)	MP-10G	RCA/1B
ARC-1	PE-125AX	SCR-522
ARC-3	R-9/APN-4	TA2J-24
R-4/ARR-2	340-580 MC. New complete	733-D

RA-52 RECTIFIER

Transtat controlled to produce high voltage DC from 110 VAC 60 cycle source. Up to 11,500 VDC @ 50 W. Metered high voltage (0-15 KV) and current (0-20 MA). NEW. \$74.50

MISCELLANEOUS

MINE DETECTOR: SCR-625 for prospecting, mining, etc. NEW. \$59.50
LP-21 LOOPS: Mod. LM, AM, A. Excel. cond.
● NOTE: WE HAVE ONE OF THE LARGEST.
● MOST COMPLETE INVENTORIES OF MILI-
● TARY ELECTRONICS IN THE U. S. CALL
● OR WRITE TODAY. SEND FOR FREE
● CATALOGUE.

ARROW SALES, INC.

7460 VARNA AVE.
N. HOLLYWOOD, CALIF.
SUnset 3-7319 STAnley 7-6005
Cable address: ARROWSALES
(See Arrow Sales Inc. ad Page 364)

**SWEET DEALS
FROM A SWEET OUTFIT**

Looking for
Hard-to-Find Equipment?

Here is just a partial list of
What we have to offer:

- BC-348's ● BC-342's ● ART-13's
- ARC-1's ● ARC-3's ● LM's
- DYNAMOTORS ● SCR-522's
- APN-9's ● APN-4's
- VARIOUS TEST EQUIPMENT

We'll Pay
SWEET PRICES
for your
**RADIO & AIRCRAFT
EQUIPMENT**

We want to buy parts or equipment—and we'll pay top dollar to get it. Just send us the complete dope on what you have, the type and condition of your equipment—and your asking price. You'll get fast, profitable action. It's just like taking "Candee" from a baby! Write today!

CANDEE-AIRCO

Dept. E-3, 3306 Burbank Blvd.
Burbank, California
CHARLESTON 0-1486 ROCKWELL 9-1070

**WESTINGHOUSE
HIPERSIL CORES**

Quantity	Gauge	Strip Build		Window Window	
		Width	Up	Width	Height
11,365	.003	1 1/8	1/2	7/16	3
3,741	.003	7/8	3/8	7/16	3

Available for immediate delivery

RAYTHEON MFG. CO.

Surplus Sales Dept. Waltham, Mass.
Tel. Waltham 5-5860—Ext. 2

SHEET METAL MACHINERY

NEW & USED—COMPLETE LINE OF

Box Brakes, Press Brakes, Notchers, Shears, Punches, Rolls, Spot Welders—Di-Acro, Pexio, Whitney Equipment, etc.

B. D. BROOKS, INC. 310 Atlantic Ave.
Boston, Mass. Tel. HANcock 6-5200

**TUBES
FOR SALE**

2C40

RCA, JAN, individ. boxed and in Hermetic Sealed Bags at \$12.00 each.

2K25 at \$29.50

2K29 at \$25.00 each

Emeltone Electronics Co.
1975 Walton Ave., Bronx, New York
LUdlow 3-8775

● New, Selenium Rectifier Transformers
 PRI: 115 V., 60 cycles in. } 4 Amps ... \$ 8.75
 Sec: 9, 12, 18, 24, and 30 } 12 Amps ... 16.75
 } 21 Amps ... 35.75
 volts
 Made to our specs. for continuous, heavy duty use
 ● 115V. PRI.—36V. 50 amp second XFMR. \$39.95
 ● 115V. PRI.—5V. @ 190 AMP. SEC. \$59.95
 ● 115/230 V. 60 cy. PRI. SEC.: 1.5, 30.5, 33.5, and
 36.5 V @ 4 AMPS. Herm. Sealed. \$6.50

PROBLEMS ON TRANSFORMERS AND
 CHOKES? LET US QUOTE YOU ON
 YOUR SHORT RUN NEEDS. YOU WILL
 LIKE OUR PRICES, PRODUCTS, AND
 FAST ACTION!

**SELENIUM RECTIFIERS
 FULL-WAVE BRIDGE TYPES**

Current Con- tinuities	18/14 Volts	36/28 Volts	54/42 Volts	130/100 Volts
1 Amp.	\$2.20	\$2.10	\$6.50	\$8.95
2 1/2 Amps.	3.75	3.60	13.00	10.50
4 Amps.	5.00	6.75	8.75	32.00
5 Amps.	5.95	9.95	16.50	36.50
6 Amps.	6.75	12.00	20.00	45.00
12 Amps.	8.50	16.00	25.50	52.50
20 Amps.	13.25	24.00	36.00	90.00
24 Amps.	16.00	31.00	39.50	98.00
30 Amps.	18.50	36.00		
36 Amps.	25.50	45.00		

We manufacture standard as well as special types of selenium rectifiers, rect. supplies and XFMRs. Low prices... Write. You will like our quick service, low prices, and good workmanship.

TUBES SEE BACK ISSUES FOR REAL VALUES. WRITE ON TYPES NOT LISTED

OA2.....95	4D32.....22.40	805.....2.00
OB2.....1.00	6C4......50	807/807-A...1.55
2C43.....16.95	6AJ5.....1.25	872-A (GE)...3.25
(GE Box)	6AK5......75	5516.....5.50
2E24.....2.50	7C30.....110.00	
304-TH.....7.95	7C30 FIL.....	
304-TL.....8.25	XFMR.....	

Terms: FOB-NYC—25% Deposit with order—order send full remittance to save COD charges—Rated Firms (D.&B.) Net 10 days—All merchandise guaranteed.

BARRY
 ELECTRONICS CORP.

136 LIBERTY STREET • NEW YORK 6, N. Y.
 Phone: REctor 2-2663

**JULY SPECIAL SALE
 Jan 814 TUBES \$2.25 Each**
 Plus many other equal values

Query us on any type Crystal Diodes and Jan type Tubes.

ALLIED ELECTRONIC SALES

136 Liberty Street, New York 6, N. Y.
 Tel. COrtlandt 7-4320

**CONTRACT
 WORK**



**DO YOU NEED
 PRECISION ROLLED
 OR ULTRA-THIN
 METAL STRIP?**

- WE ROLL •** Beryllium-Copper-Invar
 • Phosphor Bronze • Copper • Brass
 • Nickel-Silver • Stainless Steels
 • Low Carbon Steels • Nickel • Monel
 • Haynes Stellite Alloys • Magnetic Alloys
 • Chrome Iron Alloys • and Many Others

WE REGULARLY PRODUCE metal strip up to 8" in width and down to .0005" thin—to tolerances as close as ±.0001"

OUR MODERN EQUIPMENT INCLUDES Sendzimir, 2-High, and 4-High precision rolling mills, precision gage slitters, and continuous atmosphere annealers.

WE CARRY A WORKING INVENTORY of some metals for prompt service. Send us your order for one pound or a thousand—or write for catalog of products and services.

AMERICAN SILVER CO., Inc.
 INDUSTRIAL DIVISION
 38-03 PRINCE ST. • FLUSHING 54, N. Y.



**INDUCTION VOLTAGE
 REGULATOR**

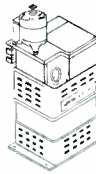

General Electric. Spec. #3263300. Single phase 60 cycle. Primary voltages (0-460 V) applied to regulator can be varied smoothly and infinitely 78.6% above and below their values by remote control. Operated by 115 V type KCP control motor. Continuous ratings for typical inputs are: 120 VOLT-output 26 to 214 V at 1.85 amp., 240 VOLT-output 52 to 428 V at 1.63 amp., 460 VOLT-output 98 to 822 V at 1.40 amp. Size 8 1/2"x12 1/2". Wt. 122 lbs. List over \$300.00. Price NEW...\$29.50



RADIO RECEIVER

BC-AR-429. Western Electric. Uses four—39/44's, one—37, and one—88 tubes. Comes complete with six new tubes and tuning cable. Size 6x7x15". Wt. 1 1/2 lbs. Price brand new...\$7.95

3.750 WATT RECTIFIER TUBE

Continental Electric Co. Type CE202. Half-wave mercury vapor. Rated up to 250 VDC at 15 amp. Filament 2.5 volt—20 amps. Mogul base. Price NEW...\$9.95

2.28 KVA PLATE TRANSFORMER

United Transformer Co.—117 VAC-60 cy primary. Secondary 4800 volts CT at 0.475 amp DC. HIPOUT: Pri-1500 VRMS, Sec-7000 VRMS. Hermetically sealed. Size 10 x 10 x 11". Wt. 94 lbs. Finish has a few scratches but otherwise perfect. Price brand NEW...\$29.50



**ELAPSED
 TIME
 METERS**



GENERAL ELECTRIC. (Left fig.) Sym. M305. Indicates 1-99,999 hours. 115 VAC 60 cycles. 3" round bakelite case. Square flush face. Price NEW...\$11.00
 AERO INSTRUMENT CO. (Right fig.) Model 1001. Indicates 0.1 to 9,999.9 hours by tenths. Totally enclosed in heavy bakelite case. Front measures 3 1/2" in diameter and has glass covered face. 120 VAC 60 cycle. Price NEW...\$8.50

SPECIALS

AMPLIDYNE MOTOR GENERATOR. Emerson Electric. #5AM31N13A. Input 27 VDC 44 amp. Output 60 VDC—3.8 amps. 530 watts. 8300 RPM. 6X8X12". Wt. 34 lbs. Price NEW...\$7.95
 WHITE-ROGER SERVO MOTORS—24 VDC. Torque 150 in. lbs. Reversible. Control box on top has limit switches, relays, and selenium rectifiers (to block AC out of motor). 5x5x4". Can be supplied in Models 6904—5 RPM, 6904—3 1/2 RPM or 6905—2 1/2 RPM. Price each NEW...\$8.95

SEE APRIL AD ON PAGE 380 FOR OTHER GEAR HEAD MOTORS. OUR CUSTOMERS HAVE USED THESE TO MAKE COIL WINDERS, MIXERS, HOISTS, WINCHES, DUMB WALTERS, GARAGE DOOR-OPENERS, RETRACTABLE STAIRS, BUFFERS, AND FOR MANY OTHER APPLICATIONS. LIMITED STOCK ON SOME TYPES.

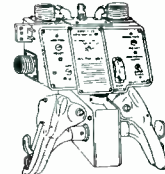

HAND CONTROL

Emerson Electric. #250 CE15. For Martin Power Gun Turret which this unit completely controls. Handle assembly moves in two planes, operating built-in elevation and azimuth rheostats. Six switches built into molded plastic handles, control signals and firing of guns. Unit is filled with other switches, circuit breakers, resistors, gears, AN connectors and cables, etc. Size 12x11 1/2x6 1/2". Wt. 10 lbs. Acquisition Cost over \$200.00. Price NEW in original boxes...\$8.00

NOTE: OTHER GUN TURRET EQUIPMENT IN STOCK INCLUDING JUNCTION BOXES, COUNTER FOLLOWERS, ELEVATION-AZIMUTH AMPLIDYNE UNITS, SWITCH BOXES, AND INTERRUPTERS.



**OPEN TYPE
 TRANSFORMERS—60 CY.**

#0692. Input 115/230 V. Output 18 V at 100 amps. Secondary leads 18" long. 7 1/2"x5x6". Wt. 40 lbs. Price NEW...\$16.00
 #4320. Input 115 V. Output 25 V at 9 amp. 3 1/2"x4 1/2". Wt. 6 1/2 lbs. Price NEW...\$3.75
 #306. Input 115 V. Output 11 V at 5 amp. 2 1/2"x3 1/2"x2 1/2". Wt. 3 lbs. Price NEW...\$2.95

PROMPT DELIVERY ON ALL ORDERS
 ALL MERCHANDISE FULLY GUARANTEED

Terms: Prices FOB St. Louis. Cash or 25% with orders. Balance COD. Rated Concerns (D&B) Net 10 days cash. Prices subject to change without notice.

**McNEAL ELECTRIC &
 EQUIPMENT CO.**
 4736 Olive St. St. Louis 8, Mo.



Write for Your Free "TABOGRAM"

Money Back Guarantee (Cost of Midge Only) on Order FOB N. Y. C. Add Shpg. Charges & Postage. Prices Subject to Change Without Notice.

Phone: WOrth 2-7230

2 1/2 MILLION PRECISION RESISTORS IN STOCK

"TAB"—Specialists in Precision Resistors No Mfrs Choice—We ship Types in Stock

0.136	150	600	1830	3333	10500	36000	200000
0.42	358	620	1850	3384	10600	37000	201000
0.425	165	620	1865	3500	10900	38140	205000
0.607	170	623	1882	3599	11300	38500	210000
0.7	127	633	1894	3600	11000	39000	215000
1.03	179	640	1895	3700	11400	39500	220000
1.35	180	644	1897	3760	11690	41400	229000
1.75	182	645	1898	3900	12000	42000	230000
2.5	182.4	649	1898	3900	12000	42000	230000
3.83	200	657	1900	4000	12500	43000	235000
4	210	665	1901	4200	13100	47000	240000
4.35	216	670	1902	4280	13500	48000	250000
5.2	220	673	1903	4300	13550	48600	260000
5.025	220.4	675	1904	4314	13600	49000	265000
6.25	225	681	1905	4440	14000	50000	270000
7	230	684	1907	4440	14250	51000	275000
7.8	240	690	1908	4500	14500	52000	280000
7.8	245	697	1909	4720	14550	52000	280000
8	245.4	699	1910	4720	14550	52000	280000
10.38	250	705	1911	4750	14600	52500	285000
10.38	250	711	1912	4850	15000	58333	314000
12.75	270	733	1913	4885	16000	60000	316000
13.52	274	734	1914	4900	16000	60000	316000
14.2	275	750	1915	5000	16800	62000	330000
14.5	280	800	1916	5100	17000	64000	330000
14.5	286	806	1917	5100	17000	64000	330000
15	289	820	1918	5235	17777	66600	353000
16	299	850	1919	5270	18000	66666	370000
17	300	856	1922	5300	18300	67500	380000
19.5	310	899	1924	5500	18300	68000	390000
19.5	311.5	900	1926	5600	18500	70000	40000
19.5	320	910	1927	5700	18600	70000	42000
22	325	917	1980	5770	19000	73500	42000
22	330	946	2000	5910	19500	75000	42000
24	340	970	2000	6100	20000	78000	42500
25	350	1000	2000	6100	20441	82000	43000
27	360	1030	2095	6125	20500	84000	43000
28	366.6	1056	2141	6150	20500	84000	43000
30	370	1059	2142	6200	21500	85750	47000
31.5	375	1067	2145	6300	22000	88000	47000
35	380	1100	2150	6300	22500	91000	47000
46	389	1110	2160	6500	22990	91000	50000
50	390	1150	2180	6800	23000	93000	50000
50	400	1155	2187	6800	23150	95000	50000
51.78	410	1162	2195	6990	23235	95000	521000
55	414.3	1200	2200	7000	23400	100000	57000
55	418.8	1215	2200	7100	23500	100000	57000
60	425	1250	2300	7500	24000	115000	58000
63	426.9	1260	2400	7700	24600	118667	59000
66	427	1275	2410	7700	24800	120000	70000
74	430	1350	2463	7900	25200	130000	57500
75	440	1335	2485	7930	25400	135000	60000
80	450	1440	2490	8100	26000	140000	62000
81.4	452	1488	2500	8000	26000	141000	69000
88	460	1495	2525	8094	26500	145000	65000
88	465	1500	2560	8100	26600	145000	66000
95	475	1510	2625	8250	27000	150000	68000
100	478	1518	2635	8500	27500	155000	70000
101	480	1510	2700	8700	28000	160000	761000
103.2	487	1640	2750	8770	28430	165000	75000
105	500	1646	2850	9000	28500	166750	80000
105.7	500	1608	2860	9100	28600	167000	82000
107	520	1670	2870	9445	29500	169200	813000
110	525	1680	2900	9500	29990	175000	85000
120	540	1710	3000	9700	30000	180000	85000
122.5	550	1712	3100	9800	31000	180600	86000
125	560	1740	3163	9800	31500	186000	90000
137	570	1770	3250	9800	32000	188500	91000
135	580	1800	3290	10000	33000	190000	93000
147.5	588	1818	3300	10430	33000	198000	95000

Any Size Above, Each 35¢ Ten for \$3.29

		MEG OHMS		Ten for \$3.29	
1.	1.4	1.9	2.5	5.1	7.5
1.1	1.5	2.1	2.8	5.5	7.62
1.2	1.57	2.11	2.855	5.6	7.74
1.25	1.679	2.25	3.23	6.5	8.12
1.3	1.65	2.25	3.3	6.6	8.02
1.35	1.75	2.5	3.5	7.5	13.85
1.39	1.8	2.6	3.673	7.	9.05



AN/APR-4 LABORATORY RECEIVERS

Complete with all five Tuning Units, covering the range 38 to 4,000 Mc.; wideband discone and other antennas, wavetraps, mobile accessories, 100 page technical manual, etc. Versatile, accurate, compact—the aristocrat of lab receivers in this range. Write for data sheet and quotations.

For the limited budget, we can supply AN/APR-1 Receivers (a predecessor to the APR-4), or even the earlier SCR-587; or individual Tuning Units covering the desired frequencies, for use as a converter feeding your own 30Mc. L. F. strip or receiver tuned to 30 Mc.

SOME SPECIAL ITEMS IN OUR STOCK: 723A/B Tubes, \$12.00 postpaid . . . GL-446A Tubes (interchangeable with 2C40), \$1.00 each in lots of ten, postpaid . . . APR-5A Receivers (1,000-6,230Mc.) . . . APA-10 Panadapters . . . G-R 804, Ferris 16C, Measurements 78B, etc. Signal Generators . . . BC-433 ADF Receivers, new . . . ARR-5, ARR-7, BC-348 etc. Receivers . . . BC-221, TS-323, etc. Frequency Meters . . . BC-1016 Code Recorders . . . BC-303B A-N Beacon Transmitters . . . RBL-3 Receivers (16-630Kc.) . . . TS-13, TS-14, etc. Microwave Units . . . APS-2 R-F-Heads (new) . . . Northern Radio Oscillator-RF Bridge-Detector Equipment . . . Sonar Generator & 60-cycle Power Supply (17-27Kc, 600 Watts) . . . G-R 815 50 Cycle Standard Fork set . . . ARN-7, APN-1, ARR-1 Spares . . . ARC-1, ARC-3, ART-13, etc. . . .

Buy from us with confidence—Army-Navy Standards are rigidly maintained. When any irregularities exist, you will be advised in detail. Write for quotations and data on your needs; place your name on our mailing list. We also have production line items—Power Supplies to 800 Amps at 12 to 28 volts DC, and 0-15.000 VDC 500MA, from 60 cycle line, etc.

We will buy any Electronic Material at top prices.

SCHOOLS—We will obtain anything you can use and exchange for your useless surplus.

ENGINEERING ASSOCIATES

434 E. Patterson Road

Dayton 9, Ohio



THREE CONDUCTOR WIRE

Three twisted conductors of 18 gauge. Each conductor has 3 strands copper for conductivity; 1 strand steel for strength. Ideal for intercoms, telephone or any communication work. Tough, durable covering for outdoor or indoor use. Government surplus = WT-1/U.

525 foot roll \$4.75 per roll, f.o.b. Cincinnati—rated concerns net ten days, others please mail check or M. O.

LAPIROW BROS.

1649-1657 HOFFNER STREET
CINCINNATI 23, OHIO

WANT TO BUY SYNCHROS SELSYNS

Size 5—60 or 400 cycles
Any Electronic Material

Give full details—Cash waiting

AMBER COMPANY

393 Greenwich St., N. Y. 13, N. Y.
BEekman 3-6509

WANTED

SYNCHROS

Autosyns—Selsyns

Any Type—Any Quantity

W-3976, Electronics
330 W. 42nd St., New York 36, N. Y.

WANTED

- AN/TRC-1 Equipments.
- T14 Transmitters.
- R19 Receivers.
- TS32 Test Oscillators.

Any condition or quantity

W-3858, Electronics
330 W. 42nd St., New York 36, N. Y.

WANTED

SURPLUS STOCKS OF EVERY DESCRIPTION

★ MUST BE NEW CONDITION

Electrical, Radio, Telephone, Etc. Etc.

Please Airmail Written F.O.B. Offers to:

DOMINION SALES (LONDON)

6 Finsbury Square, LONDON, E.C.2

Look What We'll Pay for This Equipment:
If Needed We'll Pay Up to:
ATC or T-47 type ART-13 . . . \$250.00
BC-312 & BC-348 . . . 70.00
BC-221 & R5/ARN-7 . . . 45.00
IS-251 . . . 175.00
FL-30 or F-21/ARA-9 Audio Filters . . . \$6.00 ea.
Plus TS-147, TS-148, RTA-1B, MG-149 or parts.
What have you?
V & H RADIO & ELECTRONICS SUPPLY CO.
2033 W. Venice Blvd., Los Angeles 6, Calif.
Telephone: REpublic 3-1127

ELECTRONIC EQUIPMENT WANTED!

Sell to



We want to buy all types of new and used surplus electronics equipment. Use coupon to tell us what you have. We are the largest purchasers of such equipment. **WRITE TODAY!**

Use following numbers to indicate conditions: N-1, brand new; N-2, used, like new; N-3, used.

ITEM	CONDITION	PRICE WANTED

To: ARROW SALES, INC., 7460 Varna Ave., N. Hollywood, Calif.

Name

Address

SEE ARROW SALES, INC. AD ON PAGE 362

WANTED

BD110 Telephone Switchboards, BD100 Telegraph Switchboards, BD90 Power Boards, EE101 V-F Ringers, BE72 Cabinets, FM19 Frames, RA43, REC30, KS5988, RA87, RA37, RA91 Rectifiers, BD101 Test Boards, SB6 Switchboards, Type CF1A, CF3A, CF2B Carrier Equipments. Any condition and quantity.

W-4212, Electronics
330 W. 42 St., New York 36, N. Y.

FOR PROMPT ANSWERS
to your business problems
use

The SEARCHLIGHT SECTIONS

(Classified Advertising)

- | | |
|--------------------------|------------------------|
| American Machinist | Engineering and Mining |
| Aviation Week | Journal |
| Business Week | Engineering |
| Bus Transportation | News-Record |
| Chemical Engineering | E. & M. J. Markets |
| Chemical Week | Factory Management |
| Coal Age | and Maintenance |
| Construction Methods | Fleet Owner |
| & Equipment | Food Engineering |
| Electrical Construction | Nucleonics |
| and Maintenance | Power |
| Electrical Merchandising | Product Engineering |
| Electrical World | Textile World |
| Electronics | Welding Engineer |

For advertising rates or other information address

Classified Advertising Division

McGRAW-HILL PUBLISHING CO., INC.

New York 36, N. Y.

FOR SALE!

39 UNITS BC957A RADAR INDICATOR UNUSED

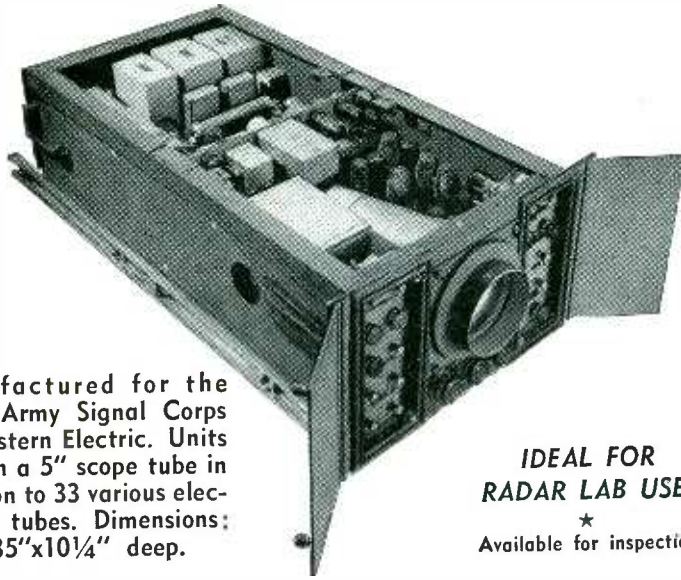

Manufactured for the U. S. Army Signal Corps by Western Electric. Units contain a 5" scope tube in addition to 33 various electronics tubes. Dimensions: 17 $\frac{1}{4}$ x35"x10 $\frac{1}{4}$ " deep.

IDEAL FOR
RADAR LAB USE!

★
Available for inspection

WRITE—WIRE—PHONE

COMMERCIAL SURPLUS SALES CO.

4101 Curtis Avenue, Baltimore 26, Maryland
Telephone Curtis 3300

DEPENDABILITY IN ELECTRONICS

Attn: Industrial Purchasing Agents . . .

Our new Radio Master Catalogue is available to you at no charge upon receipt of your request on your letterhead. We are National Distributors of General Electric, Sylvania, Ohmite, Amphenol, Sprague, Aerovox, Sangamo, Stancor, Merit, A. H. & H. Simpson and many others. All telegrams, cablegrams, and inquiries acknowledged and promptly answered.

NORMAN RADIO DISTRIBUTORS INC.
94-29 MERRICK BOULEVARD JAMAICA, N.Y. REpublic 9-4651

RELAY SPECIALISTS

100,000 RELAYS
50 TYPES

E
X
A
M
P
L
E

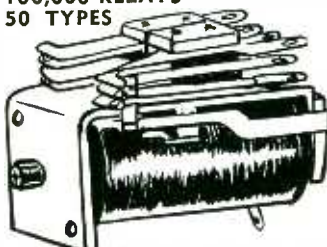

MINIATURE AIRCRAFT TYPE—4 Pole D.T. contacts. 1 $\frac{1}{2}$ " overall. 280 ohm coil. 24 V.D.C.—\$2.95
SIX-POLE DOUBLE THROW ALLIED #BN-18D—39 lbs 10 AMPERE CONTACTS 2800 ohm coil operates on 30 mills DC.....\$6.95
ADVANCE 115V A.C. Relays $\frac{1}{4}$ " D.P.D.T. contacts. Ceramic insulation.....\$3.95

AUTHORIZED FACTORY DISTRIBUTORS
STRUTHERS-DUNN; POTTER & BRUMFIELD
Write for Catalog #532
FOR YOUR RELAYS & SOLENOIDS
WRITE, WIRE, OR CALL

RADIO DEVELOPMENT & SALES CO.
323 Atlantic Ave. Brooklyn 2, N. Y. ULster 5-0488

CERAMICON CONDENSERS

All sizes and types

below

manufacturers price.
Large quantities in stock.
Immediate delivery.

Cap Electronics, Inc.

136 Liberty St.
New York City, N. Y.
DIgby 9-2797



AIRCRAFT EQUIPMENT

ARN-7 RADIO COMPASS. Complete.....\$150.00
MN-26C RADIO COMPASS. Complete..... 89.50
ARB RADIO COMPASS RECEIVER. Complete..... 89.50
SCR-522 VHF TRANSMITTER-RECEIVER. 24 V. Complete..... 150.00
SCR-274N or ACR-5 (Medium or VHF frequency) Complete installation available P.U.R.
LORAN APN-4 Complete..... 150.00
APN ALTIMETER. Complete..... 49.50

SCR-625 MINE DETECTOR

NEW cond.\$59.50 USED cond.\$39.50

TUBES

2J22..... \$6.95	717A..... \$9.95	WE-700C \$24.95
2J26..... 10.95	829B..... 9.95	VR75..... 1.25
2I62..... 34.50	832A..... 9.95	VR90..... 1.25
304TL..... 9.95	C5B..... 8.45	VR105..... 1.25
715C..... 22.95	IN21B..... 3.50	VR150..... 1.25

MARINE EQUIPMENT—Complete Line

5—100 W. Transmitters: voltage input 6, 12, 24, 32, 48, 110 VDC and 110 VAC. 60-day warranty with each set. Here are some samples:
100 W. TRANSMITTER. New, complete.....\$349.00
85 W. TRANSMITTER. New, complete.....\$299.50
50 W. TRANSMITTER-RECEIVER. Good cond.\$199.50
25 W. TRANSMITTER, surplus, like new.....\$99.50
5 W. TRANSCIEVER. New.....\$89.95

TEST EQUIPMENT

BC-221	TS-10	TS-124
I-38	TS-16	TS-127
I-130A	TS-34A	TS-170
I-222	TS-46AP	TS-215/AP
LM	TS-47APR	

MN-24C LOOP CAA approved.....\$34.50
BC-375 TRANSMITTER: 100 W. Complete with tuning and dynamotor, plugs and cables \$47.50
BC-312 RECEIVER
HS-33 HEADSETS: New with CD-307 cord to match.

WHAT DO YOU NEED?

Halioafter BC-610 Transmitter. 400 W.
BC-640 & BC-639. Complete.
BC-460 Collins Auto-Tune Xmtr. 200 W.
BD-71 & BD-72 Switchboard. SCR-193.

WE WILL NOT BE UNDERSOLD ON ANY ITEM!

REMEMBER: WE ALSO BUY NEW AND USED RADIO GEAR. WE PAY TOP DOLLAR AND WILL BEAT ANY COMPETITIVE PRICE! WRITE US TO SELL ANYTHING IN ELECTRONICS.

WE HAVE TREMENDOUS STOCK.

WRITE FOR PRICES AND INFORMATION
ON ANYTHING IN ELECTRONICS!

COLUMBIA ELECTRONICS SALES

522 South San Pedro St.
Los Angeles 13, Calif.

WANTED

WE NEED YOUR SURPLUS
ELECTRONIC COMPONENTS
OR EQUIPMENT

WE PAY TOP \$\$\$\$\$\$ FOR:

Radio Components	Wire & Cable
Instruments	Selsyns or
Relays	Synchros
Tubes	Autosyns
Signal Corps	Motors or
Equipment	Generators
Receivers	Transformers
Transmitters	Air Cooled
Television	Components
Components	Test Equipment

Kindly send us your listing of materials available with lowest price and condition or place our name on your mailing list to receive any listings you may issue.

**TECHNICAL MATERIALS
COMPANY**

104 Pearl Street Boston 10, Mass.

JULY SPECIALS OIL CONDENSERS

10 mfd.—600 V. . . . \$.89
Three term, bot. mntg. channel type. Dims. 3 3/4"x3 1/2"x2". Two 5 mfd. sections rated 400 V at 72 deg. "C". 1800 V test. Meets commercial specs. for 600 V operation up to 40 degs. "C". Ideal for filter or power factor application where ruggedness and quality are paramount. Carton or 24 weight 42 lbs. \$.79 ea.

16 mfd.—600 V. . . . \$1.75
Dual 8 mfd oil filled cond. hermetically sealed and packed. Tube type PT-SC-11 measuring 3 3/4"x2 1/2"x2 1/2". Stud mntg. centers 2". Plugs into standard four prong socket. QUANTITY DISCOUNT.

8 mfd.—1000 V. . . . \$2.10
Dual 4 mfd. oil cond. herm. sealed and packed. Cass. of 10. . . . \$1.85

6 mfd.—150 V. . . . \$.29
Three term. dual 3 mfd. oil cond. complete with brackets, measuring 4 1/4"x1 3/4"x1". Ideal for audio crossover networks.

JAN APPROVED

10mfd—1000V 4.55 8mfd—600V 2.25
8mfd—1500V 4.25 6mfd—600V 1.55
8mfd—1000V 3.25 4mfd—600V 1.75

Mfd	Volts	Price	Mfd	Volts	Price	
.005-.01	10KV	3.75	2	2500V	3.39	
.012	25KV	19.50	2	3000V	4.69	
.02	20KV	15.90	2	4000V	5.69	
.075			2	5000V	10.95	
.075	7.5KV	3.95	2-2	13.5KV	39.50	
.08	12.5KV	15.95	3	600V	1.25	
.1	1500V	.59	3	600V	1.59	
.1	2000V	.49	3	4000V	6.95	
.1	2500V	1.20	3-3-3	400V	.75	
.1	3000V	1.75	3.75	1000V	1.59	
.1	7500V	1.95	4	400V	.85	
.1	7500V	4.25	4	600V	1.25	
.1-1	10KV	8.95	4	600V	1.35	
.1	15KV	15.95	4	1000V	1.95	
.1	25KV	25.95	4	1500V	2.79	
.15-.15	8000V	1.95	4	2000V	4.25	
.2	10KV	10.95	4	3000V	7.95	
.25	2000V	1.25	4-4	4000V	10.95	
.25	3000V	2.15	5	1000V	1.85	
.25	6000V	1.75	5	VAC	1.75	
.25	18KV	15.95	5	600	1.35	
.25	20KV	19.95	5	606V	2.49	
.25	10KV	12.95	5-1	400V	.89	
.5	1500V	1.02	6	600V	1.45	
.5	2000V	1.39	6	330	VAC	2.49
.5	3000V	2.69	6	VAC	2.49	
.5-1	2000V	.89	6	1000V	2.49	
.5-.5	600V	.69	6	1500V	3.25	
1	400V	.45	6	2000V	3.95	
1	500V	.59	7	600V	1.45	
1	1000V	.69	7	800V	1.90	
1	1500V	1.35	8	1000V	2.49	
1	2000V	1.95	8	500V	1.35	
1	2500V	2.25	8	600V	1.75-2.15	
1	3000V	3.50	8	660	VAC	4.25
1	5000V	4.99	8	1000V	4.25	
1	15KV	Quote	8	2000V	3.95	
1	16KV	Quote	8	600V	1.75	
1	20KV	Quote	8-8	600V	2.50	
1	25KV	Quote	10	1000V	4.55	
1-1	7500V	19.50	10	1000V	4.55	
2	600V	.59-.79	10	6000V	Quote	
2	TLAD	600V	.80	12	1000V	4.95
2		1000V	.85	14	1000V	5.25
2	TLA	1500V	1.29	15	1000V	5.25
2		2000V	2.80	17	25V	.89
2				24	1500V	8.50

POWER SUPPLY: 800 cycle 115V input. 2.5/56.5/880/2000V output. Complete with controllers, tubes, resistors and male connectors. New. SPECIALLY PRICED.

SEE MAY ISSUE

For many other listings of condensers, switches, connectors and instruments. Inquiries solicited.

WANTED

Condensers of all types in any quantity, also other standard components. Top prices.

Write:—ART HANKINS, Owner

MONMOUTH RADIO LABS.

BOX 159 OAKHURST, N. J.



TUBES!! BRAND NEW! STANDARD BRANDS! TUBES!!

We are clearing our tremendous tube stock at the lowest prices ever. Take advantage of this opportunity to stock up. Transmitting—Cathode Ray—Magnetrans—Photo Electric—Klystrons—Special Purpose—Receiving.

0A3/VR75	\$1.04	5JP4	\$24.45	809	\$1.69	FG105	\$17.95	5Y4G	\$0.67	7K7	\$1.10
0B3/VR90	1.19	5J23	12.25	810	9.95	FG146	8.95	5Z3	.85	7L7	.85
0C3/VR105	1.19	5J29	12.25	811	2.85	FG172	33.50	5Z4	.85	7N7	.85
0D3/VR150	.95	5J30	49.50	812	2.75	FG451	2.95	5Z5	.85	7Q7	.85
1B22	2.15	5J32	99.50	813	7.75	FG562	97.50	6A4LA	.95	7R7	.85
1B23	9.75	5J31	22.50	814	2.69	GL434A	29.95	6A6	.82	7S7	.89
1B24	9.75	5NP1	5.50	815	2.69	GL502A	1.79	6AT	.82	7W7	.95
1B26	2.35	6AN5	3.75	816	1.05	HF100	8.95	6ASGT	.85	7W7	.95
1B27	14.95	6AS6	2.75	825	9.95	HF300	22.45	6AB7	.98	7X7	.99
1B29	2.45	6AS7	4.45	826	1.69	HY14B	2.59	6AC5GT	1.05	7Y4	.99
1B32	3.75	6C21	22.25	828	10.95	HY115	.69	6AG6	1.29	7Z4	.95
1B36	19.95	6C4	6.25	829B	12.95	HY615	.19	6AD7GT	1.29	12A	.59
1B38	28.75	6G4	7.55	830	2.75	KC4	37.50	6AE6G	.79	12A6	.59
1B42	4.75	7BP7	6.55	832	8.95	KU610	.75	6AG5	.82	12A8GT	.69
1N21 xtal	7DP4	14.50	832A	9.45	REL1	1.95	6AG7	1.45	12AH7GT	1.19	
1N21A	1.59	9P7	13.75	836A	3.49	RK421A	2.89	6AJ5	1.95	12AT6	.55
1N21B	3.25	9P1P	14.95	837	1.45	RK59	1.35	6AK5	1.30	12AT7	1.10
1N22	1.25	9P7	23.95	838	2.75	RK80/1641	2.25	6AK6	1.09	12AUG	.75
1N23	1.25	9P7	17.45	841	.45	RK72	.48	6AL5	.59	12AU7	.68
1N23A	2.39	10BP4	14.39	843	.27	RK73	.48	6AQ5	.57	12AV6	.68
1N23B	3.69	10Y	14.39	849	27.50	RL21A	2.89	6AQ6	.62	12BA8	.69
1N24	1.59	12GP7	14.75	851	47.50	RL120	12.95	6AR5	1.25	12CB8	.69
1N27	1.59	12HP7	14.75	851	47.50	TZ40	3.75	6AT6	1.65	12CB8	.69
1N34A	.97	12P7	1.35	860	3.95	VR10	6.95	6AU6	1.65	12CF6GT	.69
1P23	37.25	15E	.69	861	22.50	VR78	.48	6AV6	.55	12EGT	.59
1P24	1.79	15D	.45	865	.98	VR91	.95	6B4G	1.55	12F5GT	.65
1P25	2.59	25D4	.45	865	.98	VR92	.95	6B7	.75	12K7GT	.75
1S21	6.85	25D4	.45	865	.98	VT127A	2.45	6BR8	.75	12K8	.72
2AP1	10.95	28D7	2.25	866A	1.35	VT158	13.95	6BA8	.95	12Q7	.65
2C21/RK33	1.30	30 special	3.25	866JR	1.25	VT158	13.95	6BA9	.95	12R7GT	.79
2C22/7193	.29	35TG	3.25	867	3.00	VU111	1.19	6BE6	.65	12S7GT	.85
2C26A	.18	45 special	5.32	872A	2.95	VX33	3.95	6BE6	.65	12S7GT	.85
2C26B	.18	55A	5.32	874	1.19	WL468	19.95	6BF6G	1.75	12SF5	.75
2C39	32.50	55TL	6.25	874	1.19	WL530	12.75	6BF6G	1.75	12SG7	.85
2C40	8.49	100R	.89	878	1.59	WL531	5.95	6BH0	.95	12SH7GT	.68
2C43	1.95	100TH	7.95	884	1.75	WL532	5.95	6BQ6	1.90	12SK7GT	.80
2C44	1.19	100T	7.95	884	1.75	WL578	1.29	6C4	.55	12SL7GT	.75
2C46	7.95	203A	8.45	902A	9.95	WL618	34.50	6C5	.60	12SN7GT	.85
2D11	6.95	204A	69.50	905	3.25	WL619	18.95	6C8G	.85	12SR7	.72
2D21	1.95	211B	9.95	906	9.95	WL697	27.50	6C8G	.85	12SR7	.72
2E22	1.92	212E	49.50	918	1.45	ZB3200	145.00	6C8G	.85	12SR7	.72
2E28	4.65	215A	.15	919	2.79	0A4G	1.15	6D8	.85	12Z3	.75
2E30	2.15	227A/5C27	4.59	923	1.25	0A4G	1.15	6E5	.79	14A7	.85
2J21A	8.95	249C	3.69	927	1.10	01A	.65	6F7	.85	14B6	.85
2J26	24.50	250TH	21.95	931A	4.50	01A	.65	6F8G	.87	14F8	.85
2J27	24.50	250TL	17.95	954	.25	1A3	9.55	6G6	.87	14H7	.85
2J30	24.50	262B	2.95	955	.35	1A4P	.79	6H6	.85	14N7	.85
2J31	27.50	274A	5.50	955	.35	1A5GT	.58	6H6	.85	14N7	.85
2J32	27.50	274B	2.95	957	.35	1A6T	.65	6H6	.85	14Q7	.85
2J33	27.50	274C	2.95	958	.35	1A7	.65	6H6	.85	14Q7	.85
2J34	27.50	293A	2.69	958	.35	1A8	.65	6H6	.85	14Q7	.85
2J36	110.00	294A	3.95	959	3.95	1A8	.65	6H6	.85	14Q7	.85
2J37	11.95	301A	9.95	961/NE16	.35	1A8	.65	6H6	.85	14Q7	.85
2J38	11.95	304TH	8.95	1803	4.95	1B3/R016	.82	6J6	.95	19BG6G	1.85
2J39	44.50	304TL	8.95	1814	2.49	1B5/25S	.82	6J7G	.60	25L6GT	.65
2J40	44.50	304TL	8.95	1814	2.49	1B7GT	.85	6K6GT	.55	25Z6GT	.68
2J46	39.50	307A/RK75	4.45	1816	.69	1C8	.85	6K8	.95	26	.47
2J48	24.50	310A	5.95	1822	2.45	1C8	.85	6K8	.95	26	.47
2J49	24.50	310A	5.95	1824	1.45	1C7G	.69	6L5G	.75	30	.25
2J50	21.50	323A/B	23.95	1824	1.45	1D7P	.65	6L6G	1.25	31	.85
2J54B	32.50	327A/5C37	4.75	1826	.35	1D7G	.65	6L6G	1.25	31	.85
2J55	32.50	328A	4.75	1829	.25	1D8GT	.65	6L6G	1.25	31	.85
2J61	44.50	331A	11.95	1830	.25	1E5GT	.65	6L7G	.85	32L7GT	.77
2J62	47.50	350A	6.45	1831	1.75	1E7G	.65	6L7G	.85	32L7GT	.77
2K25/		350B	3.95	1832	.72	1F4	.65	6N7GT	.85	35/51	.60
723AB	28.75	358AS	3.95	1834	.69	1F5G	.65	6O7GT	.85	35A5	.68
2K28	32.50	371A	.95	1834	.69	1G4	.65	6O7GT	.85	35A5	.68
2K29	32.50	371A	.95	1836	2.75	1G6GT	.65	6S7G	.85	35C5	.67
2K33A	310.00	371A	1.45	1836	2.75	1G6GT	.65	6S7G	.85	35C5	.67
3AP1	9.95	393A	7.95	1841/RK60	2.25	1G6GT	.65	6S7G	.85	35C5	.67
3B22/ELIC	9.95	394A	3.95	1844	.89	1H6GT	.72	6S7G	.85	35L6GT	.65
3B23/RK22	4.69	434A	27.50	1855	1.50	1I6	.77	6S7G	.85	35W4	.65
3B24	5.25	446A	1.15	1865	1.25	1I4	.65	6S7G	.85	35Z3	.69
3B34W	4.39	446B	3.75	1865	1.25	1I4A	.85	6SF5GT	.77	3Z2A	.60
3B25	4.39	450TH	38.75	1960	.65	1I4	.65	6SF5GT	.77	3Z2A	.60
3B26	3.59	450TH	43.95	1961	4.95	1I5	.65	6SH7	.65	3Z2A	.60
3B27	3.75	450TL	43.95	2031	1.18	1I5	.65	6SH7	.65	3Z2A	.60
3B28	8.39										

WANTED WANTED

Test Sets TS-12, 13, 14, 33, 35, 146, 147, 174, etc. Radio Radar Equip. ARC-1, 3, ART-13, ATC, APS-10, 15, 33, 34, TPQ-2, BC-348, 342, BC-1016 Recorders, etc.
 WRITE! WIRE! CALL!



RADAR—COMMUNICATIONS AND TEST EQUIPMENT

FLUXMETER

Portable Gauss Meter with range of 500-4000 Gauss. Used to test Magnatron and other magnets. Probe has a gap of 1/4". Complete. Brand New \$32.50

TS-34/AP SYNCROSCOPE AND OSCILLOSCOPE. Used to test and service airborne and ground radars. Complete in portable carrying case with all probes, cables and accessories. Input 110v 60-2600 cyc. Excellent.

TS-16 Altimeter Test Set. Used to check various altimeters or as an accurate wavemeter. New \$29.95

TS-61/AP S-band Echo Box. Using meter provided, it is possible to maximize the XMTR adjustment and determine relative power output. Complete with probe and cable. Very good condition. \$140.00

TS-13/AP Xa band signal generator, wave meter, wattmeter. Precision lab microwave. Test set will provide either pulsed or CW output in Xa band. Input 115v 60-800 cyc.

TS-226/AP used to measure peak power output of any xmtr in the range of 200-1000 mcs. Has provision for oscilloscopic signal observation and built in calibration. Part of AN/APM-29.

TS-69/AP freq. meter covering range of 400-1000 mcs. complete with calibration charts, antenna & crank. In metal carrying case. Excellent \$72.50

TS-170/ARN-5 XTAL controlled test osc. with the following freq. ranges: 332.6, 333.8, 335.0 depending on XTAL in use. This set is used to align glide path receivers. Batteries and antenna are self contained. Excellent condition.

TS-89/AP Voltage Divider. 1:10 and 1:100 ratios. Wide band for true pulse shape. Output to scope.

TS-10/APN Altimeter Test Set. Good condition. Complete with cables and dummy antenna \$35.00

TS-12/AP V.S.W.R. Test Set for X-band. Complete with amplifier, slotted line, termination, adaptors, etc. In 2 carrying cases. Excellent.

TS-45/APM-3 X-band signal generator. 8400-9600 mcs. pulsed & CW output. Used to check APS4 and similar sets.

TS-36/AP X-band Power Meter. Consists of power measuring circuit. Horn antenna, co-ax to wave guide adaptor, connecting cable and probe. Will measure either absolute or relative power. Nominal band of usefulness is approx. 8.5-9.7 KMC.

TS-3/AP S-band Frequency and Power Meter. Portable. Battery operated. Complete with all cables.

TS-33/AP X-band Frequency Meter. 8500-9600 mcs. Contains crystal detector and indicating meter. Output to scope will indicate pulse wave shape.

TS-62/AP X-band Echo Box. 8400-9600 mcs. tuned and untuned input. Will indicate resonance on meter. Complete with pick up antenna and cable.

IE-19 TEST SET. V.H.F. portable equipment covering 100-156 mcs. Used to test SCR-522, ARC-1, ARC-3, etc. Complete with signal generator, field strength meter and accessories. In carrying case. Excellent.

BC-221 PRECISION FREQ. METER. Covers 150kc-20,000kc. Can be supplied with or without modulation. Portable. Complete with calibration book and crystal. Excellent.

S-BAND SIGNAL GENERATOR. Laboratory test set using 707 Klystron in McNally Cavity. Has precision attenuator and wave meter. Complete with cables. Mfg'r. Western Electric. Input 110v 60-2600 cyc. \$400.00

OTHER TEST SETS

- | | | |
|-----------|-------------|-------------------|
| TS-278/AP | TS-189/U | LM |
| TS-102/AP | TS-110/AP | IE-36 |
| TS-47/APR | TS-164/AR | TS-59/APN |
| TS-184/AP | TS-19/APQ-5 | TS-23/APN |
| TS-268/UP | TS-98/AP | TS-18/AP |
| 1-130 | TBN-3EV | Thermister Bridge |

AN/TPS-3 PORTABLE RADAR

Lightweight Portable Search Radar for detection of aircraft in the frequency range of 600 MCS. Power input: 115v 400 cyc. 1330 watts, 28V DC 400W. Complete installation.

PE-104 VIBRAPACK for SCR-284. Overseas packed in original cartons with spare vibrator. Large quantity available. New.

SO-13 S-BAND MARINE RADAR

Compact Sea Search Radar for small vessels. P.P.I. indication is provided. Complete in original cases with complete sets of spares. Excellent condition.

We maintain a completely equipped reconditioning shop and development laboratory. All equipment is reconditioned and checked out to original specs. Our laboratory facilities, technical and production know-how and thirty thousand feet of space is available for electronic subcontractors.

AN/APS-15A RADAR

High resolution X-band Navigation and Blind Bombing Radar. Can be used for high or low altitude blind bombing, precision navigation and to home on X-band ground beacons. Can also be used for ground installations. Available with or without the flux gate gyro stabilizing system. Presentation is a 5" P.P.I. a 3" A scope and a 5" remote P.P.I. Power input is 28v and 110v 400 cyc. The following units are supplied: transceiver RP-15A, indicator R-78A, antenna AS-18, control C-35, amplifier AM-19/APA-14, range unit CP-11, computer CP-10, remote P.P.I. 1D-30/APS-2, junction box J-15 and J-14, all plugs and connectors. With the flux gate system AM-21 and CN-4 are supplied in addition. Weight is approx. 375 lbs. installed. Electrical characteristics are as follows: freq. X-band, power output approx. 40 KW, range 5, 30, 50 and 100 mile search and beacon. Precision ranging and bombing on 5 to 30 miles. Antenna beam width 4°. Precision expanded beacon range from 10-200 miles. Supplied from stock, reconditioned and checked out.

SCR-555 DIRECTION FINDER

Freq. range 18-65 mcs. Complete installations available including the quonset hut. Bearing indication is aural-null or left-right bearing on a meter type indicator. Power input is 12v. Weight of complete installation, approx. 2500 lbs.

AN/UPN 1 & 2 PORTABLE RADAR BEACONS

S-band beacons that can be interrogated by any S-band radar in a 45 mile range and will answer with a coded reply which can be changed as desired. The UPN-1 is battery operated. The UPN-2 is 110v 60-2600 cyc. Weight is approx. 65 lbs. complete.

APR-1 MICROWAVE RECEIVER

We can supply from stock AN/APR-1 receivers and 3 tuning units to cover the freq. range of 38-1000 mcs. These receivers are almost identical to the APR-4 equipment and the tuning units are directly interchangeable. These sets have outputs for a panadapter and pulse analyzer which can be supplied on request.

AN/TPS-1 SEARCH RADAR. This is a pack portable ground search radar for the detection of aircraft up to 100 miles. Range and azimuth data is displayed on a 7" P.P.I. and a 5" "A" scope. This set was called the G.I.'s radar because of its ruggedness, dependability and ease of servicing. Complete tech data is as follows:

Range	Max. 100 Mi.	P.R.R. 200 Per Sec.
	Min. .25	
Azimuth Mech.	300° Automatic 360°	Pulse Width 2 Micro Sec.
Scanning Manual	Accuracy ±3° Automatic	Beam Width 3° Horiz. 13° Vert.
Presentation	7" P.P.I. 5" A Scope	
I.F.F. not provided but has provision for.	Frequency 1074-1086 Mcs	Power Input 1100 W at 115V 400 Cyc. and 180 W at 27V DC
Power output 150 K.W.		Weight: 1,518 Lbs.

AN/APS-3 Airborne X-band Search and Homing radar. Complete. Contains RF head, modulator, synchronizer, control boxes, plugs, antenna, etc. 115v 400 cyc.

SQ 10 CM PORTABLE RADAR. This set is a very compact search radar. Complete installation available. New in carrying cases. Tech. data as follows:

power input: 90-130v cy cyc.; pulse rate: 800 cyc.; range: 3, 15, 45 miles; pulse width: 1 microsec.; 300 yds. min. range, all ranges; I.F.F. synch. output available; accuracy ±5°; power output 1 KW; beam width: 8° horiz. 15° vert.; presentation: A, B, P, F, I.

PANEL METERS

- 2" SQUARE WESTON—SANGAMO**
- 0-20 Volts D.C. \$2.95
 - 0-5 Ma. \$2.95
 - 0-40 Volts D.C. 2.95
 - 0-500 Microamp. 4.95
 - 0-.5 Amp R.F. 2.95
 - 0-100 Ma (0-300 scale) 2.95

AN/ARC-1 TRANS/REC.

Provides Radio-Telephone Communication between Aircraft or Aircraft and Ground. Complete with Shock Mount and Control Box. Input: 28V DC. Excellent condition. Available in either 10 or 20 Crystal Controlled Channels 100-156 MCS. checked out.

SCR-269/G Automatic Radio Compass. Freq. range 200-1750KC. Complete with BC-433-G receiver, BC-434, A, B, C, 21, 1-81, 1-82, BK22, etc. Very good condition \$129.95

TCS Marine Radio Telephone and Telegraph Xmitting and Receiving Equipment. Freq. range 1500 12000KC. Consists of xmtr, receiver, antenna loading coil, remote control box, power unit, cables, etc. Power input is 12 or 32v DC. We can supply an 110v AC power supply for station-ary use at additional cost. Excellent condition.

SCR-536 Xmitter-Receiver (handy talkie). Freq. range 3885-5500KC. Complete with coils, tubes, crystals. Very good condition. Pair. \$185.00

AN/APA-10 Panoramic Adaptor for use with any receiver with following IF's: 455KC, 5 mcs, 30 mcs. Unit will give panoramic presentation (1 mc wide for 455KC input) (100KC for 5MC input) (20 KC for 30 mc input). Power input 115v 400 cyc. but can be changed with the addition of a proper power transformer. Excellent condition \$175.00

10 CM R.F. package, 2700 mcs. Consists of BC-1007 modulator and BC-1091 RF head. Power output approx. 40 KW. Complete with tubes \$125.00

AN/CRT-1 Victory Girl. Dual frequency emergency lifeboat xmtr. Complete with xmtr, kite hydrogen generator, etc. New in knapsack. C.A.A. approved.

AN/APR-5 Radar Search Receiver. Freq. range 1000-3100 mcs. Will detect signals up to 10,000 mcs. with reduced sensitivity. Contains oscillator and mixer cavity, IF strip, power supply. Input 60-2600 cyc. 115v. Excellent condition.

T-50 Radiotelegraph Transmitter complete with power supply and all accessories with spares. Portable. New in cases. \$275.00

AN/APT-5 300-1500 mcs. xmtr cavity oscillator using 3C22 lighthouse tube. Power output 30 watts. Noise modulated. Excellent condition. Complete with all tubes. \$169.50

SK-1M Radar Receiver Indicators. Freq. 195 mcs. 2 R.F. stages, 3 IF stages. 1 video, etc. New condition \$97.50

SCR-522 VHF Airborne Command Equipment. Freq. range 100-156 mcs. in 4 channels receiver and transmitter. Crystal controlled. Complete equipment. Consists of trans/rec. control box BC-602, dynamotor PE-94, AN104A antenna, plugs, etc. Power input with PE-94 in 28v. We can supply PE-98 dynamotor for 12v input at additional cost.

AN/ARR-2X RECEIVER

Secret Transmission Receiver for reception of double modulated carrier. Will receive 235-258 mcs signals that have been modulated by a 600-750 KC signal. When carrier is heard on a standard receiver no modulation is heard on the carrier when actually speech is being transmitted. 12V DC input.

MISCELLANEOUS

- Sound powered chest and headsets MI-2454-B type O, mfg. RCA. Brand new. Pair. \$ 29.95
 - R-57/ARN-5 Receiver 29.50
 - AS-32/APX-1 antenna 3.95
 - HS-33 headset, Good 24.95
 - RA-62 power supply for SCR-522. 165.00
 - RA-34 power supply for BC-375. 250.00
 - BC-1206 beacon rec. 300-400KC 28v in. exc. 14.95
 - MN/26-y compass receiver. Excellent. 24.95
 - HS-33 headsets. Good 4.95
 - BC-1016 tape recorder. Complete. New. 29.95
 - BC-733D receiver w/tubes 29.95
 - C-3 Navy sniperscope in carrying case. Uses flashlight batteries 425.00
 - BC-1284 lighthouse tube preamplifier. 69.95
 - AN/ARC-4 2 meter trans/rec. 22.50
 - AN/APA-17 radar direction finding antenna, back to back parabola; freq. range 300-1000 mcs. horizontally and vertically polarized. 59.00
 - BC-986 interphone amplifier 9.95
 - RL-42 motor antenna reel 6.95
 - 30 MC I.F. strips using 6AK5 135.00
 - RD-7/APA-22 recorder for APR 4.95
 - AS-27/ARN-5 antenna. Excellent 24.95
 - ARA-500-1500 KC receiver 129.95
 - ID-80/APA-17 indicator. Excellent. 34.95
 - R-28/ARC-5 100-156 mc. receiver. 17.95
 - BC-639 receiver. New 13.95
 - RF-29 remote control. New. 14.95
 - BC-455 6-y mc receiver. 39.95
 - BC-454 3-y mc receiver. 49.50
 - BC-800 xmtr/receiver. 32.50
 - BC-950 100-156 mc xmtr. 3.95
 - RA-300 FM exciter (mfg. Tempco). New. 2.65
 - FL-5 filter. Less cables. Fair. 19.95
 - SC-16-D GSAP gun camera computers with all in carrying case. Excellent. 32.50
 - AT-2A/APN-2 antenna. Fair 4.95
- We have a large stock of TS-34A/AP spares.

SEE OUR TUBE AD OPPOSITE PAGE

PHONE: DIGBY 9-0347-8-9

TELETYPE: NY1-771

CABLE: HAMSHACK NEWYORK

WRITE FOR QUANTITY PRICES

Prices subject to change without notice. F.O.B., NYC minimum order \$10.00. 20% deposit required. All merchandise guaranteed.

RAD OHAM SHACK INC
 189 GREENWICH STREET NEW YORK, N. Y.

INDEX TO ADVERTISERS

A/G'A Division of Elastic Stop Nut Corporation of America.....	299
Ace Engineering & Machine Co., Inc.....	192
Acme Electric Corporation.....	311
Acme Electronics, Inc.....	295
Advertising Council.....	253
Aeronautical Communications Equipment, Inc.....	178
Aerovox Corporation.....	207
Aircraft Radio Corporation.....	246
Airpax Products Company.....	331
Alco Electronics Mfg. Co.....	317
Alden Products Company.....	55
Allen-Bradley Co.....	65
Allen Co., Inc., L. B.....	332
Allied Control Company, Inc.....	245
Allied Industries, Inc.....	297
Allmetal Screw Products Company, Inc.....	70
American Electric Motors Co.....	287
American Enterprises.....	332
American Lava Corporation.....	53
American Phenolic Corporation.....	158
American Relay & Controls, Inc.....	182
American Smelting & Refining Co., Federated Metals Div.....	78
American Television & Radio Co.....	274
American Time Products, Inc.....	52
Amperite Co., Inc.....	160
Amplex Electric Corporation.....	169
Andrew Corporation.....	180
Arma Corporation.....	197
Arnold Engineering Company.....	32
Arrow Electronics, Inc.....	263
Art Wire & Stamping Co.....	263
Astron Corporation.....	31
Audio Devices, Inc.....	261
Avery Adhesive Label Corp.....	273
Ballantine Laboratories, Inc.....	176
Baltic Metal Products Co.....	199
Bardwell & McAllister.....	174
Barker & Williamson, Inc.....	206
Barry Corporation.....	15
Beaver Gear Works, Inc.....	250
Belden Manufacturing Co.....	41
Bell Telephone Laboratories.....	227
Bendix Aviation Corporation, Eclipse-Pioneer Division.....	214
Pacific Division.....	217
Bentley, Harris Manufacturing Co.....	187
Berkeley Scientific Corporation.....	286
Bird Electronic Corp.....	330
Birnback Radio Co., Inc.....	325
Birther Corporation.....	252
Biwax Corporation.....	329
Bodnar Industries, Inc.....	186
Boeing Airplane Company.....	186
Boonton Radio Corp.....	153
Borg Corporation, George W.....	324, 325
Breeze Corporations, Inc.....	191
Bridgeport Brass Company.....	30
Brown Electro-Measurement Corp.....	250
Brush Development Company.....	200, 285
Burlington Instrument Company.....	268
Burnell & Company.....	61
Bussmann Mfg. Co.....	81
Cambridge Thermionic Corporation.....	247
Cannon Electric Co.....	220
Carboloy Dept., General Electric Company.....	26, 27
Carborundum Company.....	94
Cargo Packers, Inc.....	301
Centralab, Div. Globe-Union, Inc.....	11, 12, 13
Century Geophysical Corporation.....	166
Chase Brass & Copper, Sub. of Kennecott Copper Corp.....	60
Chicago Telephone Supply Corporation.....	72, 73
Chicago Transformer, Div. of Essex Wire Corporation.....	244
Cinch Manufacturing Corp.....	149
Clarostat Mfg. Co., Inc.....	215
Cleveland Container Co.....	59
Chppard Instrument Laboratory, Inc.....	218
Cohn Mfg. Co., Inc., Sigmund.....	254
Communication Products Company, Inc.....	56, 57, 311
Computer Research Corp.....	284

Condenser Products Company.....	83
Constantin & Co., L. L.....	324
Continental Connectors, Div. of DeJur Amsco Corp.....	85
Continental-Diamond Fibre Company.....	171
Cornell-Dublier Electric Corp.....	38
Coto-Coll Company.....	326
Crescent Company, Inc.....	246
Crest Laboratories, Inc.....	307
Cross Co., H.....	325
Crucible Steel Company of America.....	237
Dage Electric Company, Inc.....	325
Dale Products, Inc.....	297
Daniels, Inc., C. R.....	272
Dano Electric Co.....	323
Daven Co.....	Third Cover
DeJur Amsco Corporation.....	322
Delco Radio, Div. of General Motors.....	51
Dial Light Company of America.....	166
Distillation Products Industries.....	163
Donham Craft, Inc.....	172
Dow Corning Corp.....	174
Driver-Harris Company.....	195
DuMont Laboratories, Inc., Allen B.....	37
DX Radio Products Co.....	268
Eastern Air Devices, Inc.....	280
Eastman Kodak Company, Industrial Optical Sales Div.....	155
Edin Company.....	320
Edison, Inc., Thomas A.....	290
Edo Corporation.....	66
Eicor, Inc.....	234
Eisler Engineering Co.....	190, 332
Eitel-McCullough, Inc.....	33
Electrical Industries, Inc.....	23
El-Tronics, Inc.....	332
Electro Products Laboratories.....	263
Electro-Tec Corporation.....	226
Electro-Tech Equipment Co.....	182
Electronic Associates, Inc.....	316
Electronic Tube Corporation.....	295
Electrons Incorporated.....	188
Engineering Research Associates, Inc.....	307, 323
Eric Resistor Corp.....	76
Eveready Plating Co.....	332
Fairehild Camera & Instrument Corporation.....	235
Federal Telephone & Radio Corp.....	257
Federated Purchaser, Inc.....	301
Fidelity Chemical Products Co.....	270
Filtron Co., Inc.....	39
Five Star Co.....	332
Foote Mineral Company.....	309
Frequency Standards.....	186
Fugle-Miller Laboratories.....	287
Furst Electronics.....	370
Gamewell Company.....	272
General Electric Company, Apparatus Dept.....	62, 63, 177, 293
Electronics Dept.....	249
General Precision Laboratory, Inc.....	205
General Radio Company.....	17
Giannini & Co., Inc., G. M.....	328
GM Laboratories, Inc.....	309
Graphite Metallizing Corporation.....	166
Gray Research & Development Co., Inc.....	291
Green Instrument Co., Inc.....	276
Gries Reproducer Corp.....	332
Guthman & Co., Inc., Edwin I.....	252
Hallcrafters.....	84
Hammarlund Manufacturing Co., Inc.....	58
Harper Company, H. M.....	271
Hathaway Instrument Company.....	232
Haydon Company, A. W.....	319
Heath Company.....	178
Heiland Research Corp.....	369
Heinemann Electric Company.....	278
Heidor Manufacturing Company.....	168

dependable instruments

Heiland
DENVER

oscilloscope
recorders

FOR AIRCRAFT
LABORATORY AND INDUSTRIAL
APPLICATIONS



A-500
Compact... Lightweight
12 channels

The A-500 Portable Recorder is being widely used in many diversified fields as it is designed for applications where space is at a premium. Although extremely compact, 6 $\frac{3}{4}$ " x 9 $\frac{7}{8}$ " x 12 $\frac{3}{4}$ ", and lightweight, 33 lbs., the Heiland A-500 retains the versatility and embodies many of the features usually found only in much larger instruments. The features of the A-500 include four quick change paper speeds; precision time lines; trace identification; direct monitoring of galvanometer light spots. Paper width, 4"-100' long. Available for either 12 volt or 24 volt D.C. operation.

Write today for catalog of Heiland oscilloscope recorders, galvanometers and associate equipment.



HEILAND RESEARCH CORP.
130 E. FIFTH AVE. • DENVER, COLORADO

1500 VOLT Regulated POWER SUPPLY

For Photo-Multiplier Tubes



Front View of Model 710-PR Power Supply

Continuously Adjustable from
600 to 1500 V.D.C. at 0-1 Milliampere

POSITIVE TERMINAL GROUNDED

Regulation: Output voltage varies less than .01% per volt change of line voltage. Output voltage varies less than 1 volt with variations of output current between 0-1 milliamperes. (Internal impedance less than 1000 ohms.)

Also available with 2 or 3 independently regulated and independently adjustable outputs.

Write for Descriptive Bulletin

MODEL 710-P
Cabinet Mounted
\$190.00*

MODEL 710-PR
Standard Rack
Mounting
\$195.00*

Models Available With Negative Terminal Grounded (Substitute letter "N" for "P" in model designation)

*Prices net F.O.B. Chicago



FURST ELECTRONICS

3324 W. Lawrence Ave., Chicago 25, Illinois

Material Control THROUGH

**RIGID
LABORATORY
TESTS** means

**PRECISION
COIL BOBBINS**

- have
- GREATER INSULATION
 - INCREASED MOISTURE-RESISTANCE
 - BETTER HEAT DISSIPATION

Also, conscientious testing of all materials with modern laboratory methods makes Precision Coil Bobbins 15 to 20% stronger—yet lighter—in weight. Still another important feature is the greatly increased coil winding space of Precision Bobbins.

Flanges with leads, slots, holes or plain—all types furnished flat, recessed or embossed to fit any mounting. Tube ends swaged to lock flanges. Any size, any shape available—round, square, rectangular—in dielectric Kraft, Fish Paper, Cellulose Acetate or combinations.

Send specs. for sample and request New Mandrel List of over 1000 sizes.



PRECISION PAPER TUBE CO.

2041 W. Charleston St.,
Chicago 47, Ill.

Plant No. Two, 79 Chapel St., Hartford, Conn.

Also Mfrs. of **PRECISION PAPER TUBES**

Helipot Corporation	180A, 180B
Hermetic Seal Products Co.	91
Hewlett-Packard Company	89
Hexacon Electric Co.	323
Hudson Tool & Die Company, Inc.	35
Hughes Research & Development Laboratories	310, 330
Hytron Radio & Electronics Co.	71

Improved Seamless Wire Company	315
Industrial Condenser Corporation	213
Instrument Resistors Co.	289
Instrument Wire Company	323
International Nickel Company, Inc.	86
International Rectifier Corporation	19
Ippolito & Co., Inc., James	285
Irvington Varnish & Insulator Co.	193
I-T-E Circuit Breaker Company	251

Jeffers Electronics Division, Speer Carbon Company	90
Jelliff Manufacturing Corp., C. O.	160
Jennings Radio Manufacturing Co.	198
Johnson Co., E. F.	236
Jones Div., Howard B. Cinch Mfg. Corp.	317

Kahle Engineering Co.	321
Karp Metal Products Co., Inc.	43
Kartron	332
Kay Electric Company	305
Kellogg Company, M. W.	74
Kenyon Transformer Co., Inc.	175
Kester Solder Company	229
Keystone Products Company	255
Kirk & Blum Mfg. Co.	224
Knights Company, James	243
Kollsman Instrument Corp.	40

Laboratory for Electronics, Inc.	79
Lambda Electronics Corp.	323
Lampkin Laboratories, Inc.	332
LaPointe-Plascomold Corp. (Vee-D-X)	160
Lapp Insulator Co., Inc.	29
Leeds & Northrup Co.	34
Lenkurt Electric Sales Company	240
Lenz Electric Manufacturing Co.	303
Lewis Engineering Co.	321
Lewis Spring & Manufacturing Co.	314
Little, Inc., Arthur D.	279
Lord Manufacturing Company	256

Mallory & Co., Inc., P. R.	96, 151
Manson Laboratories	278
Marconi's Wireless Telegraph Company, Ltd.	210
Marion Electrical Instrument Co.	2
Markem Machine Company	254
McGraw-Hill Book Co.	190
Melpar Inc.	318
Mepeo, Inc.	46
Metal Textile Corporation	311
Metals & Controls Corp., General Plate Div.	64
Mica Insulator Company	185
Michel Manufacturing Co.	332
Mico Instrument Co.	315
Micro Switch, Div. of Minneapolis-Honeywell Regulator Co.	68
Microwave Associates Inc.	173
Miles Reproducer Co., Inc.	332
Millford Rivet & Machine Co.	242
Millen Mfg. Co., Inc., James	159
Minneapolis-Honeywell Regulator Co.	24, 25, 289
Mitchell-Rand Insulation Company, Inc.	233
Monowatt Department, General Electric Company	209
Mosinee Paper Mills Company	306
Motorola, Inc.	75
Muirhead & Co., Ltd.	3
Mycalex Corporation of America	36

National Company, Inc.	264, 265
National Moldite Company	277
Neo-Sil Corporation	203
New Hampshire Ball Bearings, Inc.	170
New Hermes Inc.	329

New York Transformer Co., Inc.	216
Ney Company, J. M.	274
North American Aviatlon, Inc.	170
Northrop Aircraft, Inc.	270
Nothelfer Winding Laboratories	293

Ohmite Manufacturing Company	32A, 32B
Olympic Metal Products Company, Inc.	301
Oregon Electronics Mfg. Co.	170

PCA Electronics, Incorporated	291
Panoramic Radio Products, Inc.	182
Phalo Plastics Corporation	272
Phaostron Co.	222
Pix Manufacturing Co., Inc.	278
Plastoid Corporation	223
Polarad Electronics Corporation	239
Potter Instrument Company, Inc.	294
Power Equipment Company	204
Precision Apparatus Co., Inc.	372
Precision Paper Tube Co.	370
Premax Products, Div. Chisholm-Ryder Co., Inc.	311
Production Engineering Corp.	507
Pyroferic Co.	238

Radio Cores, Inc.	283
Radio Corporation of America	157, Fourth Cover
Radio Materials Corporation	221
Radio Receptor Company, Inc.	42
Railway Express Agency, Air Express Div.	80
Raytheon Manufacturing Company	259, 296
Remler Company, Ltd.	326
Republic Foil & Metal Mills Incorporated	269
Resistance Products Company	174
Revere Copper & Brass Inc.	165
Rex Corporation	293
Rhode Island Insulated Wire Co., Inc.	54
Richardson Company	50
Robinson Aviation, Inc.	272
Rome Cable Corporation	281
Runzel Cord & Wire Co.	329

Sanborn Company	202
Sarkes Tarzian, Inc., Tuner Division	288
Scientific Electric Div. of "S" Corrugated Quenched Gap Co.	297
Scintilla Magneto Div. of Bendix Aviation Corp.	44
Secon Metals Corporation	329
Servo Corporation of America	186
Sessions Clock Company, Timer Div.	212
Shakeproof, Inc.	189
Shalleross Manufacturing Company	312
Sigma Instruments, Inc.	262
Signal Engineering & Mfg. Co.	285
Simpson Electric Company	167
Skyway Precision Tool Co.	321
Southwestern Industrial Electronics Co.	162
Specialty Battery Company	190
Sprague Electric Company	9, 231
Stackpole Carbon Company	87
Standard Piezo Company	278
Standard Transformer Corporation	282
Stoddart Aircraft Radio Co.	292
Streeter-Amet Company	325
Struthers-Dunn Inc.	275
Stupakoff Ceramic & Mfg. Co.	161
Sturtevant Company, P. A.	315
Superior Electric Co.	45
Superior Tube Company	28
Supreme Inc.	312
Sylvania Electric Products, Inc.	7, 241
Synthane Corporation	47
Syntron Co.	276

Taylor Fibre Co.	21
Taylor Tubes, Inc.	184
Tech Laboratories	276
Technical Service Corporation	274
Technology Instrument Corp.	300
Tektronix, Inc.	208
Tel-Instrument Co., Inc.	308
Teledron Department, General Electric Company	201
Teletronics Laboratory Inc.	317, 332
Televiso Corporation	299

CHEMELEC

MADE OF TEFLON[®]

ELECTRONIC PARTS



Chemelec Teflon*-insulated electronic components include a complete line of 7 and 9 pin miniature tube sockets, crystal sockets, feed-through insulators and terminals.

All provide the same high performance which this superior insulating material assures. Surface resistivity 3.5×10^{13} ohms. Loss factor less than 0.0005. Dielectric constant 2.0 (60 cycles to 30,000 megacycles). Serviceable at -110°F . to 500°F . Won't carbonize under arcing. Zero water absorption by ASTM Test. Unaffected by extreme humidity. Won't DC plate. Chemically inert, non-gassing, immune to corrosive atmospheres, fungus, oil, solvents. Non-flammable, tough, resilient, withstands and absorbs mechanical shock and vibration.

TEFLON and KEL-F STOCK and Custom-Fabricated Parts

Fabricating "Know-how", the result of years of specialized experience—and the most modern facilities for rapid, low-cost, close-tolerance production are at your command when you specify Teflon or Kel-F†, fabricated by the United States Gasket Company. Ours is the most complete line in the country—sheets, tape, rods, cylinders, tubing, bars, and custom-machined or molded parts to manufacturers' specifications.

*duPont's trademark for its tetrafluoroethylene resin.

†Trademark M. W. Kellogg Co.

UNITED STATES GASKET COMPANY

FLUOROCARBON PRODUCTS DIVISION
 FABRICATORS OF "TEFLON", "KEL-F" AND OTHER FLUOROCARBON PLASTICS
 CAMDEN 1, NEW JERSEY



-PRECISION-
SERIES ES-500A
High Sensitivity—Wide Range
5" OSCILLOSCOPE
with PUSH-PULL
VERTICAL and HORIZONTAL
AMPLIFIERS

20 mv. per inch "V" Sensitivity
150 mv. per inch "H" Sensitivity



IMPORTANT FEATURES

- ★ High Sensitivity, Extended Range, Push-Pull, Voltage Regulated Vertical Amplifier — 10 cycles to 1 MC response. Input 2 meg. 22 mmfd.
- ★ Frequency Compensated "V" Input Step Attenuator.
- ★ Vertical Phase-Reversing Switch.
- ★ Extended Range, High Sensitivity, Push-Pull Horizontal Amplifier — 10 cycles to 1 MC response at full gain. Input 1/2 meg. and 20 mmfd.
- ★ Linear Multi-Vibrator Sweep Circuit — 10 cycles to 30 KC plus line and external sweep.
- ★ 4-Way Synch. Selection — Internal Positive, Internal Negative, External and Line.
- ★ "Z" Axis Modulation terminal for blanking, etc.
- ★ Internal, Phasable, 60 cycle Beam Blanking.
- ★ Sweep Phasing Control. Wide-angle bridge circuit.
- ★ Direct H and V Plate Connections; all 4 plates.
- ★ Audio Monitoring Phone Jacks.
- ★ High Intensity CR Patterns through use of adequate high voltage power supply with 2X2 rectifier.
- ★ Tube Complement and Circuit — 6C4 "V" cathode follower, 6CB6 "V" amplifier. 6C4 "V" phase inverter. Push-Pull 6AU6's "V" CR driver. 7N7 "H" amplifier and phase inverter. Push-Pull 6AU6's "H" CR driver. 7N7 sweep oscillator. 5Y3 and 2X2 rectifiers. VR-150 voltage regulator. 5CP1/A CR Tube.
- ★ 7 Four-Way Lab. Type Input Terminals — Take banana plugs, phone tips, bare wire or spade lugs.
- ★ Light Shield and Mask removable and rotatable.
- ★ Extra Heavy-Duty Construction and components to assure "Precision" performance.
- ★ Heavy Gauge, Anodized, No-Glare, Aluminum Panel. Fully Licensed under W.E. Co. patents.
- ★ In louvered, black ripple, heavy gauge steel case. Size 3 1/4" x 14 1/2" x 18". Complete with light shield, calibrating mask and instruction manual. **NET PRICE \$169.50**

See this new "PRECISION" 5" Oscilloscope on display and available at leading radio equipment distributors.

Precision Apparatus Co., Inc.
 92-27 HORACE HARDING BLVD.
 ELMHURST 10, N. Y.

Export: 458 B'way, N.Y.C., U.S.A. Cables: MORHANEX
 In Canada: Atlas Radio Corp. Ltd., Toronto, Ontario

Telewave Laboratories Inc.	270	Blan	354
Terpening Company, L. H.	298	Boonton Radio Corp.	335
Thermador Electrical Manufacturing Co. ..	309	Brooks Inc B D.	362
Thompson Products Inc.	211	Candee-Airco	362
Tinnerman Products Inc.	95	Cap Electronics Inc.	365
Titeflex, Inc.	69	Capehart-Farnsworth Corp.	343
Tobe Deuschmann Corporation.	266, 267	C & H Sales Co.	353
Transradio, Ltd.	295	Chase Electronic Supply Co.	360
Trans-Wind Co.	332	Chatham Electronics.	343
Trimount Plastic Co., Inc.	317	Collins Radio Co.	340, 342
Triplett Electrical Instrument Co.	181	Columbia Electronics Sales.	365
Tru-Ohm Products Division of Model Engineering Mfg. Co., Inc.	225	Comet Electronic Sales Co.	356
Tung-Sol Electric Co.	64A, 64B	Commercial Surplus Sales Co.	365
Ucinite Company	88	Communications Devices Co.	361
Ulanet Company, George.	315	Communications Equipment Co.	350, 351
United Manufacturing & Service Co.	287	Compass Communications Co.	355
United States Gasket Company.	371	Convair	339, 342
United States Radium Corporation.	164	Cornell-Aeronautical Laboratory Inc.	338
United Transformer Co.	Second Cover	Curtiss-Wright Corp.	335
Universal Winding Company	179	Daystrom Inc Instrument Division.	341
Varflex Corporation	77	Davies Laboratories The.	341
Varian Associates	219	Dominion Sales (London).	364
Veeder-Root Inc.	82	Edlis Electronics Inc.	359
Victoreen Instrument Company.	299	Electro Impulse Laboratory.	358
Victory Engineering Corporation.	268	Electronic Engineering Co of Calif.	336
Waldes Kohinoor Inc.	67	Electronic Expeditors	356
Ward Leonard Electric Co.	92, 93	Electronic Specialty Supply Co.	357
Warren Wire Company.	276	Emeltone Electronics Co.	362
Waterbury Brass Goods Branch of The American Brass Co.	194	Empire Electronics Co.	360
Waterman Products Co., Inc.	319	Engineering Associates.	364
Western Gold & Platinum Works.	178	E P C O.	360
Westinghouse Electric Corporation 48, 49, 183, 328		Freeland Products Co.	358
Wheeler Insulated Wire Co.	321	General Electric Co.	338
White Dental Mfg. Co., S. S.	248, 319	General Motors Corp, AC Spark Plug Div.	341
Whitehead Stamping Company.	274	Goodyear Aircraft Corp.	336
Williams & Co., C. K.	196	Houde Supply Co.	358
Winchester Electronics, Inc.	327	Instruments Associates	347
Xcelite Incorporated	289	J S H Sales Co.	360
Zophar Mills, Inc.	291	Kaman Aircraft Corp.	343
		Klein, Manuel.	360
		Land-Air Inc.	340
		Laperow Brothers.	364
		Lectronic Research Laboratories.	344, 345
		Liberty Electronics Inc.	346
		Maritime International Co.	361
		Maritime Switchboard.	359
		Maxson W L.	336
		McDonnell Aircraft Corp.	337, 339
		McNeal Electric Equipment Co.	363
		Merrick Electronics.	358
		Michener & Holland.	335
		Michigan, University of.	342
		Minnesota, University of.	340
		Mogull Co Inc Alexander.	358
		Monmouth Radio Laboratories.	366
		National Cash Register Co.	338
		Norman Radio Distributors Inc.	365
		Phillips Petroleum Co.	338
		Photocon Sales	360
		Precision Electrical Instrument Co.	354
		Radio Development & Sales Co.	365
		Radio & Electronic Surplus.	360
		Radio Ham Shack Inc.	366, 367
		Radio Surplus Corp.	349
		Raytheon Mfg Co.	362
		Reeves Instrument Corp.	341
		Relay Sales	357
		Reliance Merchandizing Co.	348
		Sandia Corp.	337
		Servo-Tek Products Inc.	352
		State Labs.	334
		Stavid Engineering Inc.	339
		Strickland Electric Co.	360
		Sylvania Electric Products Inc.	336
		Tab	363, 368
		Technical Materials Co.	365
		Telemarine Communications Co.	354
		Tracerlab Inc.	342
		Universal General Corp.	357
		V & H Radio & Electrical Supply Co.	364
		Wells Sales Inc.	362
		Weston Laboratories.	361
		Wilcox Electric Co.	340

PROFESSIONAL SERVICES..... 333

SEARCHLIGHT SECTION
(Classified Advertising)

H. E. Hilty, Mgr.

EMPLOYMENT

Positions Vacant.	335-343
Selling Opportunities Offered.	340
Positions Wanted.	335
Selling Opportunities Wanted.	335
Employment Agencies.	335

SPECIAL SERVICES

Contract Work.	363
Rebuilding	358

BUSINESS OPPORTUNITIES

Offered	335
---------------	-----

EQUIPMENT

(Used or Surplus New)	
For Sale.	334, 344-368

WANTED

Equipment	364
-----------------	-----

ADVERTISERS INDEX

Acorn Electronics Corp.	356
Allied Electronic Sales.	363
Amber Company.	364
American Meter Co.	343
American Silver Co.	363
American Technion Society.	342
Arrow Sales Inc.	362, 364
Barry Electronics Corp.	363
Bendix Aviation Corp.	340

This index is published as a convenience to the readers. Every care is taken to make it accurate, but ELECTRONICS assumes no responsibility for errors or omissions.

More Video Drive at less cost



CHARACTERISTICS, CLASS A₁ AMPLIFIER

Plate Voltage	300 volts
Plate Current	30 ma
Plate Resistance (Approx.)	0.15 megohm
Transconductance	11000 μ mhos
Grid No. 2 Voltage	150 volts
Grid No. 1 Voltage	-3 volts
Interelectrode Capacitances (Without external shield):	
Grid No. 1-to-plate	0.120 μ mf
Input	11 μ mf
Output	5.5 μ mf
Performance, 4-Mc Video Amplifier	
Input Volts (peak-to-peak)	3 volts
Output Volts (peak-to-peak)	132 volts

... with the new RCA-6CL6 miniature power pentode

Another RCA First... the new RCA-6CL6 miniature power pentode was specifically designed to fill the need for a low-cost, high-output video amplifier tube.

Improved in performance over the RCA-developed 6AG7, this new 9-pin miniature has decreased microphonic response and is capable of driving high-voltage picture tubes with low amplitude distortion.

Having a voltage gain of approximately 44, the RCA-6CL6 can be driven directly by the video detector. It will pro-

vide an output of 132 volts peak-to-peak with an input of only 3 volts peak-to-peak from the video detector in a 4-Mc video amplifier.

RCA Application Engineers are ready to assist you in the application of the RCA-6CL6 to your television receiver designs. For further information write RCA, Commercial Engineering, Section GR-42, Harrison, N. J., or contact your nearest RCA field office:

FIELD OFFICES: (East) Humboldt 5-3900, 415 S. 5th St., Harrison, N. J. (Midwest) Whitehall 4-2900, 589 E. Illinois St., Chicago, Ill. (West) Madison 9-3671, 420 S. San Pedro St., Los Angeles, Calif. Tmks. ®

Another new RCA tube

RCA-6AF4 Miniature UHF Triode, for use as the local oscillator in UHF television receivers covering the range of 470 to 890 Mc. Features silver-plated base pins and short mount structure.



THE FOUNTAINHEAD OF MODERN TUBE DEVELOPMENT IS RCA



RADIO CORPORATION of AMERICA
ELECTRON TUBES

HARRISON, N. J.