

JULY · 1949

electronics

A M c G R A W - H I L L P U B L I C A T I O N

SUBMINIATURE
COUNTER

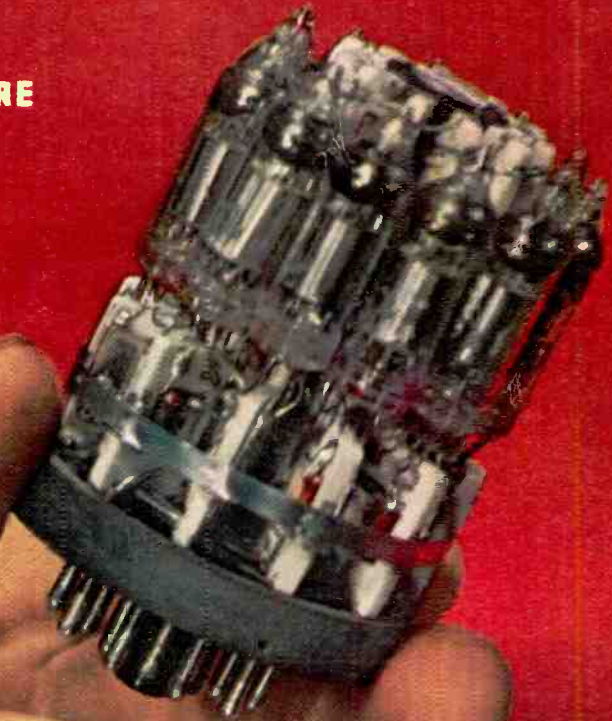



Linear Standard Units...

THE ULTIMATE IN QUALITY...

UTC Linear Standard Audio Transformers represent the closest approach to the ideal component from the standpoint of uniform frequency response, low wave form distortion, high efficiency, thorough shielding and utmost dependability.

UTC Linear Standard Transformers feature...

- **True Hum Balancing Coil Structure**... maximum neutralization of stray fields.
- **Balanced Variable Impedance Line**... permits highest fidelity on every tap of a universal unit... no line reflections or transverse coupling.
- **Reversible Mounting**... permits above chassis or sub-chassis wiring.
- **Alloy Shields**... maximum shielding from inductive pickup.
- **Hiper-Alloy**... a stable, high permeability nickel-iron core material.
- **Semi-Toroidal Multiple Coil Structure**... minimum distributed capacity and leakage reactance.
- **Precision Winding**... accuracy of winding .1%, perfect balance of inductance and capacity; exact impedance reflection.
- **High Fidelity**... UTC Linear Standard Transformers are the only audio units with a guaranteed uniform response of ± 1 DB from 20-20,000 cycles.

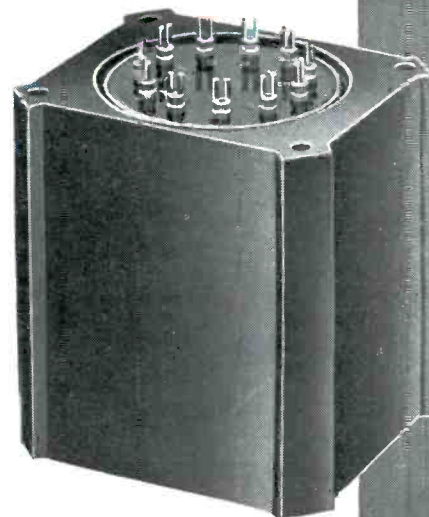

TYPICAL LS LOW LEVEL TRANSFORMERS

| Type No. | Application | Primary Impedance | Secondary Impedance | ± 1 db from | Max. Level | Relative hum-pickup reduction | Max. Unbalanced DC in prim'y | List Price |
|----------|---|--------------------------------------|---------------------------------------|------------------|------------|-------------------------------|------------------------------|------------|
| LS-10 | Low impedance mike, pickup, or multiple line to grid | 50, 125, 200, 250, 333, 500/600 ohms | 60,000 ohms in two sections | 20-20,000 | +15 DB | -74 DB | 5 MA | \$25.00 |
| LS-10X | As Above | As above | 50,000 ohms | 20-20,000 | +14 DB | -72 DB | 5 MA | 32.00 |
| LS-12 | Low impedance mike, pickup, or multiple line to push pull grids | 50, 125, 200, 250, 333, 500/600 ohms | 120,000 ohms overall, in two sections | 20-20,000 | +15 DB | -74 DB | 5 MA | 28.00 |
| LS-12X | As above | As above | 80,000 ohms overall, in two sections | 20-20,000 | +14 DB | -92 DB | 5 MA | 35.00 |
| LS-26 | Bridging line to single or push pull grids | 5,000 ohms | 60,000 ohms in two sections | 15-20,000 | +20 DB | -74 DB | 0 MA | 25.00 |
| LS-19 | Single plate to push pull grids like 2A3, 6L6, 300A. Split secondary | 15,000 ohms | 95,000 ohms; 1.25:1 each side | 20-20,000 | +17 DB | -50 DB | 0 MA | 24.00 |
| LS-21 | Single plate to push pull grids. Split primary and secondary | 15,000 ohms | 135,000 ohms; turn ratio 3:1 overall | 20-20,000 | +14 DB | -74 DB | 0 MA | 24.00 |
| LS-22 | Push pull plates to push pull grids. Split primary and secondary | 30,000 ohms plate to plate | 80,000 ohms; turn ratio 1.6:1 overall | 20-20,000 | +26 DB | -50 DB | .25 MA | 31.00 |
| LS-30 | Mixing, low impedance mike, pickup, or multiple line to multiple line | 50, 125, 200, 250, 333, 500/600 ohms | 50, 125, 200, 250, 333, 500/600 ohms | 20-20,000 | +17 DB | -74 DB | 5 MA | 25.00 |
| LS-30X | As above | As above | As above | 20-20,000 | +15 DB | -92 DB | 3 MA | 32.00 |
| LS-27 | Single plate to multiple line | 15,000 ohms | 50, 125, 200, 250, 333, 500/600 ohms | 30-12,000 cycles | +20 DB | -74 DB | 8 MA | 24.00 |
| LS-50 | Single plate to multiple line | 15,000 ohms | 50, 125, 200, 250, 333, 500/600 ohms | 20-20,000 | +17 DB | -74 DB | 0 MA | 24.00 |
| LS-51 | Push pull low level plates to multiple line | 30,000 ohms plate to plate | 50, 125, 200, 250, 333, 500/600 ohms | 20-20,000 | +20 DB | -74 DB | 1 MA | 24.00 |
| LS-141 | Three sets of balanced windings for hybrid service, centertapped | 500/600 ohms | 500/600 ohms | 30-12,000 | +10 DB | -74 DB | 0 MA | 28.00 |

TYPICAL LS OUTPUT TRANSFORMERS

| Type No. | Primary will match following typical tubes | Primary Impedance | Secondary Impedance | ± 1 db from | Max. Level | List Price |
|----------|---|---|---|-----------------|------------|------------|
| LS-52 | Push pull 2A5, 250, 6V6, 42 or 2A5 A prime | 8,000 ohms | 500, 333, 250, 200, 125, 50, 30, 20, 15, 10, 7.5, 5, 2.5, 1.2 | 25-20,000 | 15 watts | \$28.30 |
| LS-55 | Push pull 2A3's, 6A5G's, 300A's, 275A's, 6A3's, 6L6's | 5,000 ohms plate to plate and 3,000 ohms plate to plate | 500, 333, 250, 200, 125, 50, 30, 20, 15, 10, 7.5, 5, 2.5, 1.2 | 25-20,000 | 20 watts | 28.30 |
| LS-57 | Same as above | 5,000 ohms plate to plate and 3,000 ohms plate to plate | 30, 20, 15, 10, 7.5, 5, 2.5, 1.2 | 25-20,000 | 20 watts | 20.30 |
| LS-58 | Push pull parallel 2A3's, 6A5G's, 300A's, 6A3's | 2,500 ohms plate to plate and 1,500 ohms plate to plate | 500, 333, 250, 200, 125, 50, 30, 20, 15, 10, 7.5, 5, 2.5, 1.2 | 25-20,000 | 40 watts | 50.30 |
| LS-6L1 | Push pull 6L6's self bias | 9,000 ohms plate to plate | 500, 333, 250, 200, 125, 50, 30, 20, 15, 10, 7.5, 5, 2.5, 1.2 | 25-20,000 | 30 watts | 42.00 |

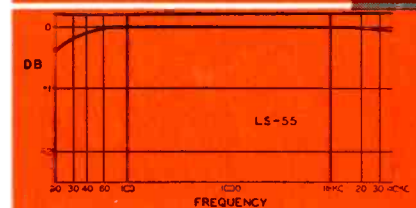
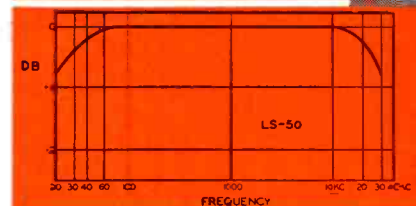
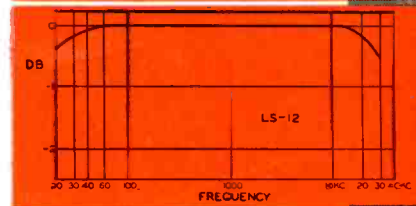
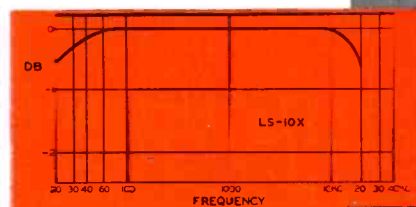

Write for our Catalog PS-409

United Transformer Co.

150 VARICK STREET NEW YORK 13, N. Y.
EXPORT DIVISION: 13 EAST 30th STREET, NEW YORK 16, N. Y., CABLES: "ARLAB"

electronics

A McGRAW-HILL
PUBLICATION



JULY • 1949

| | |
|---|-------|
| SUBMINIATURE COUNTER | Cover |
| Printed circuitry developed by Sylvania in cooperation with U. S. Army permits mounting eleven subminiature thyatrons of decade ring counter in 6L6-size plug-in unit | |
| NEEDED: BETTER PARTS FOR INDUSTRIAL CONTROLS , by Roland Russo | 66 |
| The need for specialized rather than radio-type components is still great | |
| CONTINUOUSLY TUNED CONVERTER FOR UHF TELEVISION , by Robert P. Wakeman | 68 |
| Construction and operation of 475 to 890-mc continuously-tuned unit | |
| DUPLICATING TAPE RECORDINGS , by Reynolds Marchant | 72 |
| Pilot-model duplicator dubs eight reels of two-track tape simultaneously for home entertainment | |
| TUNABLE A-F AMPLIFIER , by Oswald G. Villard, Jr. | 77 |
| Novel variable-frequency circuit functions as oscillator, filter, or selective amplifier | |
| METAL DETECTOR FOR CONVEYORS , by Kenneth Urbach | 80 |
| Detects nonmagnetic as well as ferro-magnetic materials | |
| PICTURE STORAGE TUBE , by L. Pensak | 84 |
| Single glass bulb contains combination kinescope and iconoscope | |
| A-M AND F-M BROADCAST STATION MEASUREMENTS , by Torrance Downey | 89 |
| Summary of legal requirements, including new provisions for measuring audio response and noise at a-m stations | |
| INCREMENTAL PHASE SPLITTER , by Edward Kasner | 94 |
| Radar range simulator also serves as laboratory phase standard | |
| IMPROVED ULTRASONIC DELAY LINES , by Frank A. Metz, Jr. and Walther M. A. Andersen | 96 |
| Forged magnesium alloys have reasonable attenuation, wide bandwidth and useful delays when used as memory devices | |
| MODERN BREADBOARD CHASSIS , by B. L. Snavely, J. Brown and J. V. Atanasoff | 101 |
| Permits mounting and wiring experimental circuits in half the usual time | |
| CATHODE-COMPENSATED VIDEO AMPLIFICATION—Part II , by Alexander B. Bereskin | 104 |
| Input admittance design equations and comparison of performance with other types of video amplifiers | |
| PORTABLE HIGH-VOLTAGE POWER SUPPLY , by Victor Wouk | 108 |
| Provides reversible 0 to 30 kv from 60-cycle voltage-doubler circuit | |
| ATTENUATION BETWEEN PARABOLOID ANTENNAS , by E. Dyke | 114 |
| A simple table of decibels derived from physical quantities to show space-wave losses | |

| | | | |
|------------------------------|-----|-----------------------------------|-----|
| BUSINESS BRIEFS | 66 | ELECTRON ART | 120 |
| CROSTALK | 71 | NEW PRODUCTS | 124 |
| TUBES AT WORK | 116 | NEWS OF THE INDUSTRY | 128 |

**NEW BOOKS
BACKTALK
INDEX TO ADVERTISERS**

DONALD G. FINK, Editor; **W. W. MacDONALD**, Managing Editor; John Markus, Vin Zeluff, A. A. McKenzie, Associate Editors; William P. O'Brien, James D. Fahnestock, Assistant Editors; Hal Adams Burleson, Ann Mastropolo, Sophie D. Feeney, Editorial Assistants; Gladys T. Montgomery, Washington Editor; Harry Phillips, Art Director; Eleanor Luke, Art Assistant; R. S. Quint, Directory Manager; Russell F. Anderson, Editor, World News; Dexter Keezer, Director Economics Department

KEITH HENNEY, Consulting Editor

H. W. MATEER, Publisher; **WALLACE B. BLOOD**, Manager; D. H. Miller, H. R. Denmead, Jr., New York; Wm. S. Hodgkinson, New England; Warren W. Shew, Philadelphia; C. D. Wardner, Chicago; J. L. Phillips, Cleveland; J. W. Otterson, San Francisco; Carl W. Dysinger, Los Angeles; Ralph C. Maultsby, Atlanta; Bernard H. Butler, London, England; J. E. Blackburn, Jr., Director of Circulation

Contents Copyright 1949, by McGraw-Hill Publishing Company, Inc. All Rights Reserved. McGRAW-HILL PUBLISHING COMPANY, INCORPORATED, JAMES H. McGRAW (1860-1948), Founder • PUBLICATION OFFICE 99-129 North Broadway, Albany 1, N. Y., U. S. A. EDITORIAL AND EXECUTIVE OFFICES, 330 West 42nd St., New York 18, N. Y., U. S. A.—Member A. B. P. Member A. B. C.

James H. McGraw, Jr., President; Curtis W. McGraw, Vice-President and Treasurer; Eugene Duffield, Senior Vice-President, Publications Division; Nelson Bond, Director of Advertising; James A. Gerardi, Secretary; and J. E. Blackburn, Jr., Director of Circulation.
ELECTRONICS, July, 1949, Vol. 22, No. 7. Published monthly, with an additional issue in June, price 75c a copy for U. S. and possessions, and Canada; \$1.50 for Latin America; \$2.00 for all other foreign countries. Directory issue \$2.00. Allow at least ten days for change of address. All communications about subscriptions should be addressed to the Director of Circulation. Subscription rates—United States and possessions, \$6.00 a year, \$9.00 two years, \$12.00 for three years. Canada (Canadian funds accepted), \$7.00 a year, \$11.00 for two years, \$14.00 for three years. Latin American countries \$15.00 for one year, \$25.00 for two years, \$30.00 for three years. All other countries \$20.00 for one year, \$30.00 for two years, \$40.00 for three years. Please indicate position and company connections on all subscription orders. Entered as Second Class matter August 29, 1936, at Post Office, Albany, New York, under the Act of March 3, 1879. **BRANCH OFFICES**: 520 North Michigan Avenue, Chicago 11, Ill.; 68 Post Street, San Francisco 4; Aldwych House, Aldwych, London, W.C. 2; Washington, D. C. 4; Philadelphia 3; Cleveland 15; Detroit 26; St. Louis 8; Boston 16; Atlanta 3, Ga.; 621 So. Hope St., Los Angeles 14; 738-9 Oliver Building, Pittsburgh 22. **ELECTRONICS** is indexed regularly in The Engineering Index.

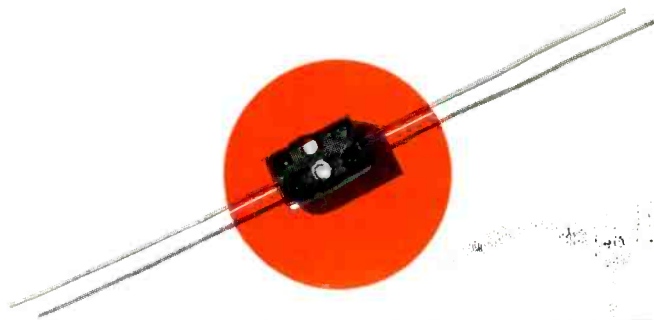

EL-MENCO'S PLACE

in

YOUR PRODUCT

Wherever fixed mica dielectric capacitors are used, the first choice with men of experience is always El-Menco

Precision-made under rigid conditions, tested seven ways to meet strict Army-Navy standards, thoroughly impregnated and provided in water-sealed low-loss bakelite; these tiny capacitors protect and maintain your reputation for quality equipment. To insure performance-excellence, place *El-Menco* capacitors in *your* product. Results will prove El-Menco to be a wise choice.

THE ELECTRO MOTIVE MFG. CO., Inc.
WILLIMANTIC CONNECTICUT

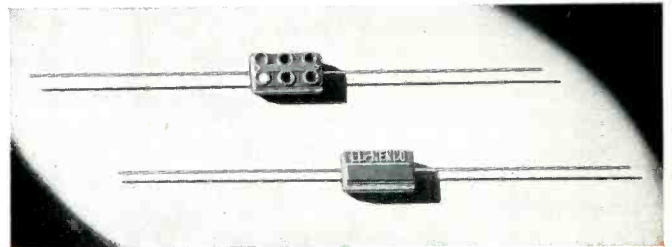

CM 15 MINIATURE CAPACITOR

Actual Size $\frac{3}{8}$ " x $\frac{1}{2}$ " x $\frac{3}{16}$ "
For Radio, Television and Other
Electronic Applications
2 to 420 mmf. capacity at 500v DC w
2 to 525 mmf. capacity at 300v DC w
Temp. Co-efficient ± 50 parts per
million per degree C for most
capacity values
6-dot standard color coded

Write on your firm letterhead for
Catalog and Samples



MOLDED MICA **El-Menco** **MICA TRIMMER**
CAPACITORS

FOREIGN RADIO AND ELECTRONIC MANUFACTURERS COMMUNICATE DIRECT WITH OUR EXPORT DEPT. AT WILLIMANTIC, CONN.
ARCO ELECTRONICS, INC. 135 Liberty St., New York, N. Y.—Sole Agent for Jobbers and Distributors in U.S. and Canada

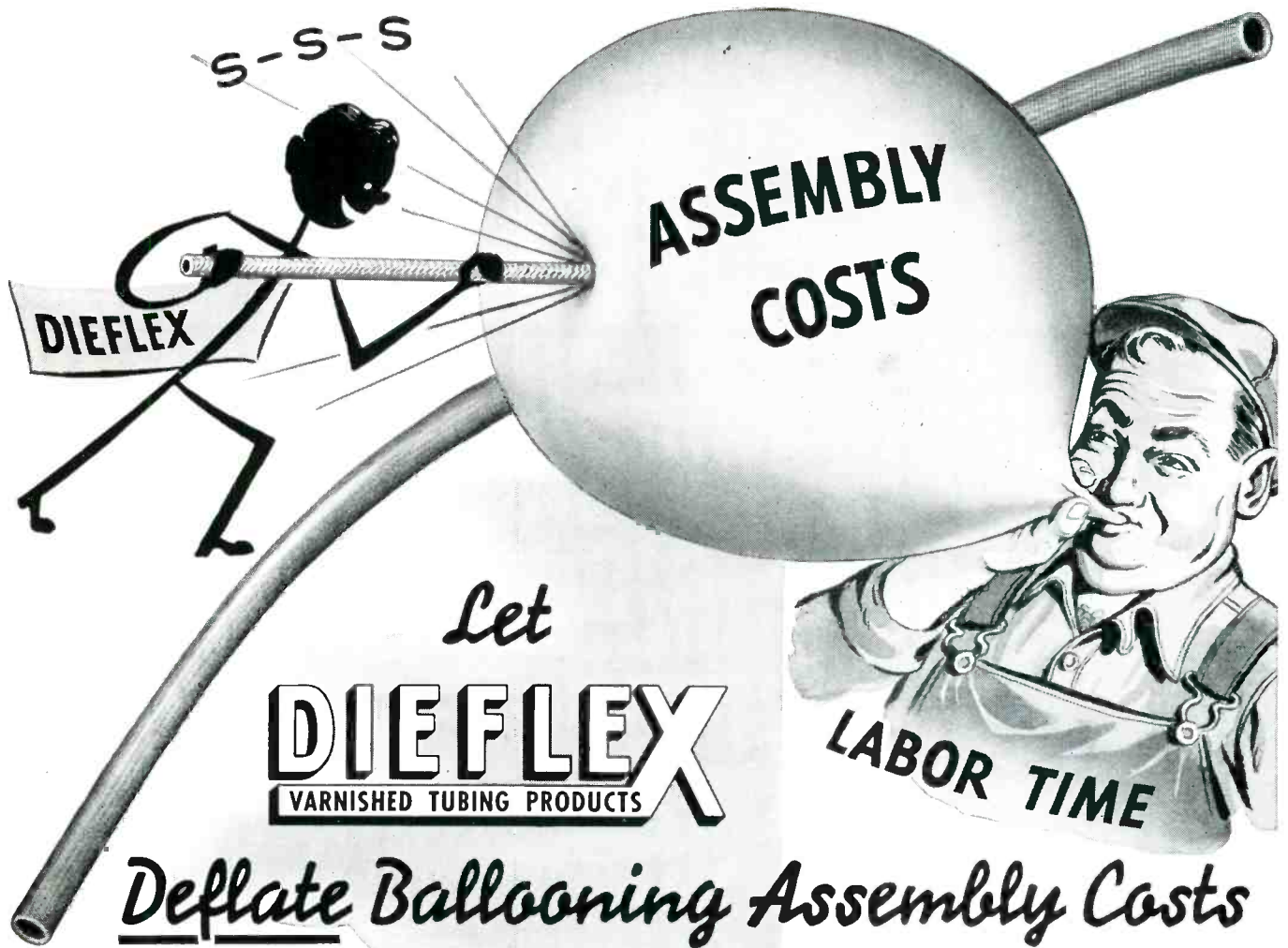

Let
DIEFLEX
 VARNISHED TUBING PRODUCTS

Deflate Ballooning Assembly Costs

You'll be amazed how labor costs shrink when you use Dieflex Varnished Tubing products to save assembly time. Test the flexibility and stretch of Dieflex... see how quickly it slides over rough joints and around sharp bends... see how its smooth bore prevents snagging... how it cuts cleanly without fraying. All these features add up to easier handling and rock bottom assembly costs.

Now, beyond assembly—you can expect fewer breakdowns, reduced repair costs, minimum lost production, because Dieflex gives top mechanical and dielectric protection. Write or phone the sales office nearest you, and start deflating assembly costs today. A folder giving technical information on Dieflex products will be sent upon request.

Braided glass base varnished tubings and saturated sleeveings are as inexpensive as corresponding grades of cotton base varnished tubings and saturated sleeveings.

DIEFLEX PRODUCTS LIST

MADE WITH BRAIDED COTTON SLEEVEING BASE

- Grade A-1 Magneto Grade Varnished Tubings
- Grade B-1 Standard Grade Varnished Tubings
- Grades C-1 and C-2 Heavily Coated Saturated Sleeveings
- Grade C-3 Lightly Coated Saturated Sleeveings
- Heavy Wall Varnished Tubings and Saturated Sleeveings

MADE WITH BRAIDED GLASS SLEEVEING BASE

- Grade A-1 Magneto Grade Varnished Glass Tubings
- Grade C-1 Extra Heavily Saturated Glass Sleeveings
- Grade C-2 Heavily Saturated Glass Sleeveings
- Grade C-3 Lightly Saturated Glass Sleeveings
- Silicone-Treated Glass Varnished Tubings and Sleeveings

**INSULATION
 MANUFACTURERS CORPORATION**

Chicago 6 • 565 W. Washington Blvd.

MILWAUKEE 2
 312 E. Wisconsin Ave.

DETROIT 2
 15 Lawrence Ave.

CLEVELAND 14
 1231 Superior Ave., N. E.

DAYTON 2
 120 W. Second St.

IMC Representatives
 W. C. JOHNSON—PEORIA 5—101 Heinz Court
 H. A. HOLDEN—MINNEAPOLIS 3—1208 Harmon Place
 H. R. BRETHEN—DETROIT 2—15 Lawrence Ave.

Authorized Distributors
 INSULATION and WIRES INCORPORATED
 St. Louis 3, Mo. • Atlanta, Ga. • Boston 20, Mass.
 Detroit 2, Mich. • Houston 2, Tex. • Hillside, N. J.
 and other cities.

TRI-STATE SUPPLY CORPORATIONS
 Los Angeles 13, Cal. • San Francisco 7, Cal. • Seattle 4, Wash.

SUFLEX CORPORATION
 33-11—57th St., Woodside, N. Y.



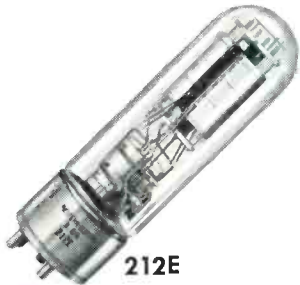

212E



343A

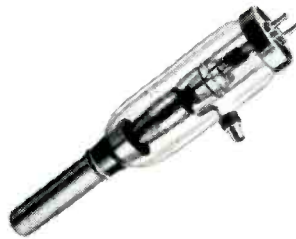

232B



357B

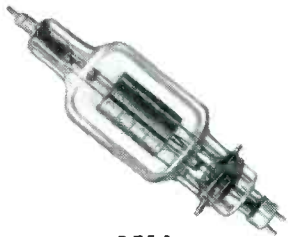

251A



233A



343AA



5541



220C



5530

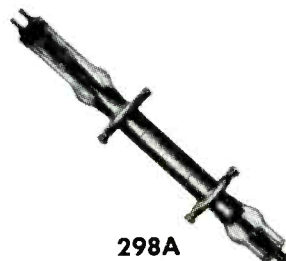

298A



342A

Stay on the air... with Western Electric tubes

SINCE the early days of the broadcast industry, Western Electric electron tubes designed by Bell Telephone Laboratories have set the pace for quality performance and long operating life.

Western Electric's line of power tubes and rectifiers for AM and FM includes many codes that have proved their dependability in stations from coast to coast.

For full information on Western Electric power tubes—now being made for Western Electric by Machlett Laboratories—call your local Graybar representative. Or write to Graybar Electric Co., 420 Lexington Ave., New York 17, N.Y.

— QUALITY COUNTS —

Western Electric



DISTRIBUTORS: IN THE U. S. A. — Graybar Electric Co. IN CANADA — Northern Electric Co., Ltd.

Western Electric's line of high power transmitting tubes includes:

- | | | | |
|-------|--|----------|---|
| 212E | Air cooled triode, 275 watts | 270A | Air cooled triode, 350 watts |
| 220C | Water cooled triode, 10 kilowatts | 279A | Air cooled triode, 1200 watts |
| 220CA | Forced-air cooled triode, 5 kilowatts | 298A & B | Water cooled triode, 100 kilowatts |
| 222A | Water cooled high vacuum rectifier, 25 kv. inverse voltage | 308B | Air cooled triode, 250 watts |
| 228A | Water cooled triode, 5 kilowatts | 340A | Water cooled triode, 25 kilowatts |
| 232B | Water cooled triode, 25 kilowatts | 341AA | Forced-air cooled triode, 5 kilowatts |
| 232BA | Forced-air cooled triode | 342A | Water cooled triode, 25 kilowatts |
| 233A | Water cooled high vacuum rectifier, 50 kv. inverse voltage | 343A | Water cooled triode, 10 kilowatts |
| 236A | Water cooled triode, 20 kilowatts | 343AA | Forced-air cooled triode, 5 kilowatts |
| 240B | Water cooled triode, 10 kilowatts | 357B | Air cooled triode, vhf, 400 watts |
| 241B | Air cooled triode, 275 watts | 363A | Air cooled pentode, vhf, 350 watts |
| 251A | Air cooled triode, 1000 watts | 379A | Air cooled triode, 1200 watts |
| 255B | Mercury vapor rectifier, 20 kv. inverse voltage | 5530 | Forced-air cooled triode, vhf, 3 kilowatts |
| | | 5541 | Forced-air cooled triode, vhf, 10 kilowatts |

**Fansteel
will
fabricate**

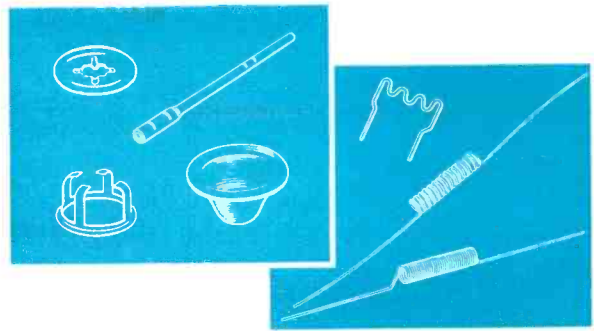

Tungsten and Molybdenum

to your specifications or you can fabricate in your own plant.

SOME OF THE USES OF TUNGSTEN AND MOLYBDENUM

ELECTRONIC TUBES

—tungsten for cathodes, lead-in wires and anodes—molybdenum for grids, anodes, supports.

ELECTRICAL CONTACTS

—automotive, ignition, vibrators, telegraph relays, other contacting parts in continuous service.

HEATING ELEMENTS

in electric furnaces of temperatures 1600° to 2000° C, above range of other metals.

HEATING ELEMENTS

in vacuum equipment where metals are deposited by vaporization. Do not contaminate other metals used in process.

TUNGSTEN

is chief ingredient of Fansteel "77" metal for small rotors, flywheels, balance weights, other devices where maximum weight or inertia is required in small space.

TUNGSTEN TARGETS

for all types of X-ray tubes.

INERT GAS WELDING

—tungsten electrodes sustain the arc, giving longer service.

Fabrication processes now available from Fansteel include stamping, forming, machining and assembling.

Thirty-six years of Fansteel's specialized engineering, and every laboratory facility have greatly extended the uses of these high refractory metals for unequaled services with economy, in electrical, electronic and mechanical industries.

Fansteel production assures the utmost in purity. Fansteel metallurgy also integrates the characteristics of tungsten and molybdenum—high melting points, low vapor pressure, resistance to arc erosion

and mechanical strength—with the electrical conductivity of silver and copper. Performance and durability for the severest requirements are effected.

Parts, units and complete assemblies can be fabricated by you or will be made complete to your specifications by Fansteel. You are invited to consult us on the possibilities of these metals for your applications. Fansteel Metallurgical Corporation, North Chicago, Illinois.

PURE METALS

Tantalum, Tungsten, Molybdenum, and Columbium in sheet, rod, wire, special shapes and parts.

POWDER METALLURGY PRODUCTS

Finished or semi-finished shapes and parts of special analysis to achieve high strength, density, electrical conductivity, resistance to wear, impact, heat erosion, or combinations of these and other properties.

COPPER BASE ALLOYS

Copper alloyed with other elements, to combine high conductivity with strength, elasticity, resistance to heat, impact, or wear. Available in bars, rod, sheet, strip, castings, forgings, finished or semi-finished parts, for current-carrying springs and other parts, soldering tips, resistance welding electrodes, dies and fixtures.

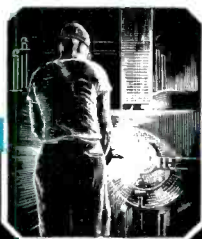

Fansteel

11602

SPECIAL PRODUCTS
In Controlled Metallurgy

YOU CAN BE **SURE**.. IF IT'S
Westinghouse

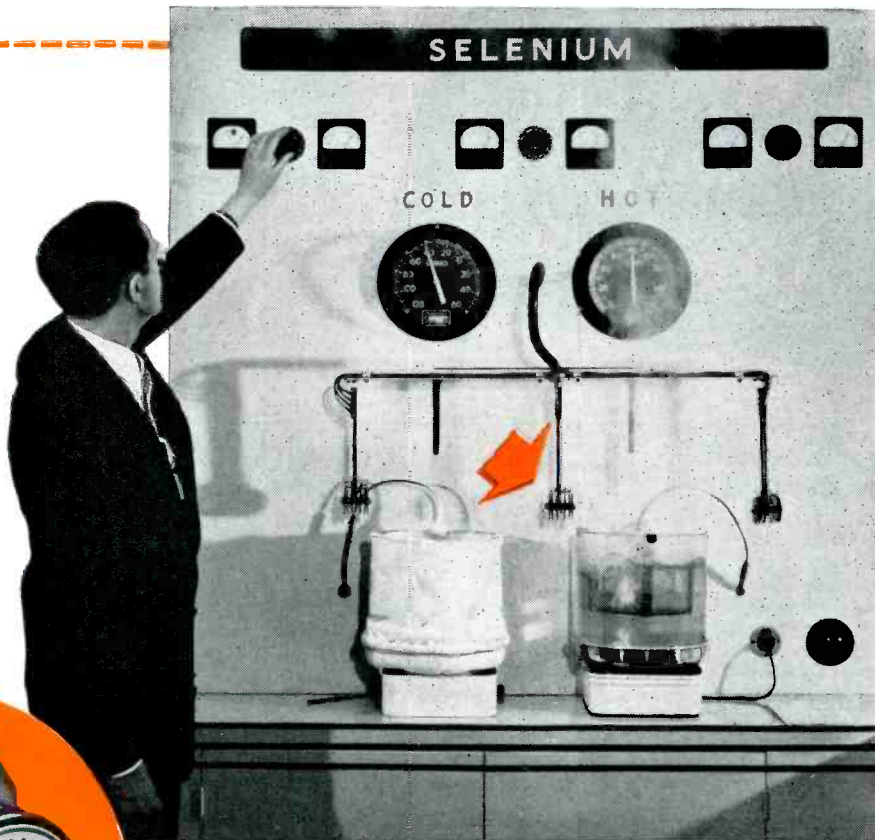

New Selenium Licks **HIGH TEMPERATURE** **...HIGH VOLTAGE**

Here's good news. Westinghouse offers you these important plus features in selenium rectifiers.

Visitors at the IRE Exposition, held recently in New York City, saw this demonstrated by a unique hot-cold shock cycle test. Every 5 minutes during the 4 days, shock changes in temperature from 40° C below zero to boiling water were applied to a Rectox 24-Volt DC/33 RMS Plate Rectifier. Variation in output was extremely small. Extensive laboratory tests at stack temperatures up to 125° C further prove ability to meet unusual requirements.

Since each plate will stand more voltage, fewer plates are needed . . . smaller stacks may be used.

The exclusive Westinghouse process of manufacture also assures lowest rate of

forward aging and constant, uniform cell performance.

TRY A SAMPLE.

Test it under your own conditions. Call your local Westinghouse office for details. Westinghouse Electric Corporation, P. O. Box 868, Pittsburgh 30, Penna. J-21532

Westinghouse

Rectox

SELENIUM RECTIFIERS



MODERN COMMUNICATIONS *Require* **ABSOLUTE DEPENDABILITY**

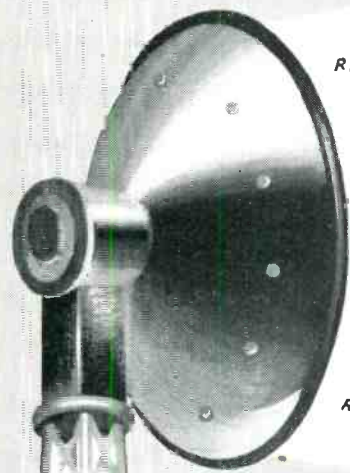

MODEL 707

MODEL 752

MODEL 755

MODEL 751

MODEL 757

You can **RELY on**

RELIABLE RELAYS BY

REL

MODEL 707 HIGH FIDELITY STUDIO TO TRANSMITTER (STL) LINK:

Carrier Frequency Range...890 to 960 megacycles
Power Output.....5 watts (nominal minimum)
Modulation Range.....50 to 15,000 cycles

MODEL 751 RADIO RELAY SET:

Carrier Frequency Range...450 to 500 megacycles
Power Output.....40 watts
Modulation Range.....250 to 120,000 cycles

MODEL 752 RADIO RELAY SET:

Carrier Frequency Range...450 to 500 megacycles
Power Output.....40 watts
Modulation Range.....50 to 60,000 cycles

MODEL 755 RADIO RELAY SET:

Carrier Frequency Range...146 to 174 megacycles
Power Output.....10 or 100 watts
Modulation Range.....250 to 60,000 cycles

MODEL 757 RADIO RELAY SET:

Carrier Frequency Range...890 to 960 megacycles
Power Output.....5 watts (nominal minimum)
Modulation Range.....250 to 60,000 cycles

TO THOSE WHO WANT the maximum degree of dependability in point to point equipment, REL offers the five groups listed above. These types cover practically every present day requirement including high-fidelity studio-to-transmitter links, point to point communication and multi-channel telephone and telegraph service. In each instance, the performance characteristics equal or exceed the standard requirements of the service for which the equipment was designed. Throughout all five groups, the electrical, radio and mechanical engineering exceed the exacting standards that have made REL the leader in FM since 1935. All incorporate important exclusive features found only in REL designs:

- (a) All direct crystal controlled transmitters and receivers.
- (b) Continuous wave for most efficient spectrum use.
- (c) All sets are characterized by the low noise and distortion of FM signalling.
- (d) All tubes used are conventional triode and pentode tubes and are operated conservatively enough to insure exceptionally long life.
- (e) Suitable antennas for each equipment and path are available.

From any standpoint, the complete line of REL FM point to point equipment is the finest, most economical, easiest to operate and most reliable equipment of its kind available today. Write today for details, including specifications and complete descriptions of equipment to meet your needs.

**RADIO
ENGINEERING
LABS · INC.**

35-54 38th STREET
LONG ISLAND CITY 1, NEW YORK

VARIATIONS ON THESE STANDARD DESIGNS ARE PRACTICAL
AND REL INVITES YOUR INQUIRY IN SUCH SPECIAL CASES

Crowded chassis are



on resistors too!

The smaller you make your electrical or electronic instruments and equipment, the bigger your problems grow. But when you specify miniature IRC resistors you conserve space without sacrificing efficiency, and miniaturization creates no bottlenecks.

Because of our years of experience in the manufacture of resistors, IRC long ago foresaw the trend to miniaturization—and prepared for it. With the widest line of resistor types in the industry, we are able now to supply miniature components for most resistor applications.

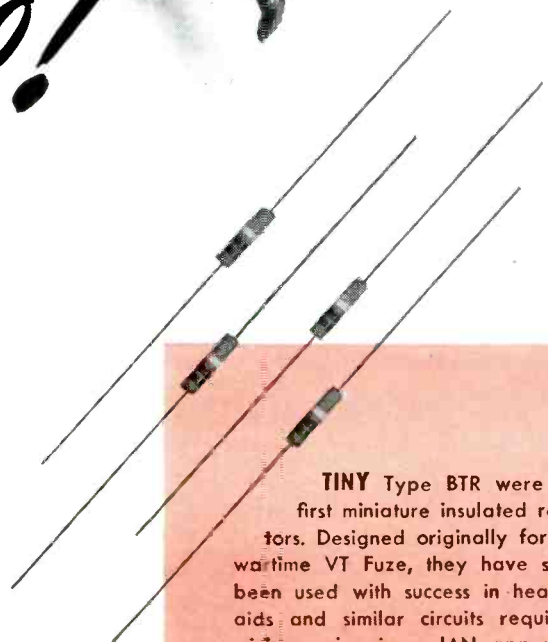

TINY Type BTR were the first miniature insulated resistors. Designed originally for the wartime VT Fuze, they have since been used with success in hearing aids and similar circuits requiring minimum size in a JAN approved resistor. $\frac{1}{3}$ watt rating in RMA ranges up to 22 megohms. The convenient coupon brings you full details.

tough



THIN AS A WAFER and no bigger than a nickel, IRC Type HB Fingertip Control features a quiet element, simplified construction and a unique rotating cover and contactor which permit ready resistance adjustment. It entirely eliminates the shaft, bushing and bulky knob of conventional-type controls. Four point switch of similar design is also available. Fully described in IRC Catalog Bulletin A-1.

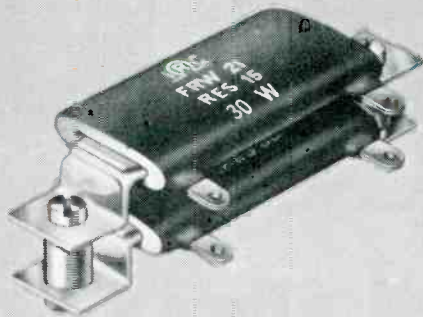

FLAT POWER WIRE WOUND RESISTORS

provide a higher space-power ratio than tubular types. Designed to satisfy requirements of high wattage dissipation in limited space applications, they can be mounted vertically or horizontally, singly or in stacks. The lightweight construction of these flat units includes non-magnetic mounting brackets which permit easy installation and transfer of heat to chassis. Flat FRW's are manufactured in fixed and adjustable types. Bulletin C-1 gives characteristics and specifications.

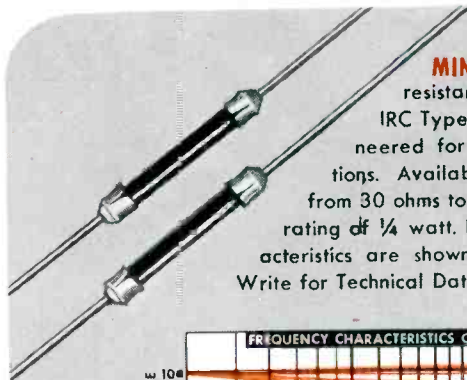

MINIATURE UNITS with active resistance section only $\frac{3}{8}$ " long, IRC Type MPM Resistors are engineered for VHF and UHF applications. Available in resistance values from 30 ohms to 1.0 megohm, at a power rating of $\frac{1}{4}$ watt. Excellent frequency characteristics are shown in the adjacent chart. Write for Technical Data Bulletin F-1.

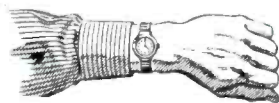
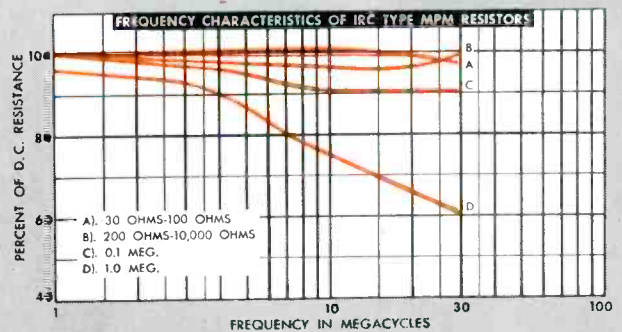

When you are cramped for standard resistors in a hurry, IRC's Industrial Service Plan gives you the speedy service you need. For small orders of standard resistors for experimental work, pilot runs, maintenance, simply call your local IRC Distributor. We'll gladly send you his name and address.



Wherever the Circuit Says

Power Resistors • Precisions
Insulated Composition Resistors
Low Wattage Wire Wounds
Rheostats • Voltage Dividers
Controls • Voltmeter Multipliers
Deposited Carbon Precistors
HF and High Voltage Resistors
Insulated Choices

**INTERNATIONAL
RESISTANCE COMPANY**

401 N. Broad Street, Philadelphia 8, Pa.

In Canada: International Resistance Co., Ltd., Toronto, Licensee

INTERNATIONAL RESISTANCE COMPANY
403 N. BROAD ST., PHILA. 8, PA.

Send me additional data on the items checked below:

- BTR Resistors Fingertip Controls
 Flat FRW Resistors MPM Resistors
 Name and address of local IRC Distributor

NAME.....

TITLE.....

COMPANY.....

ADDRESS.....

Simple Jobs...
Intricate Jobs...

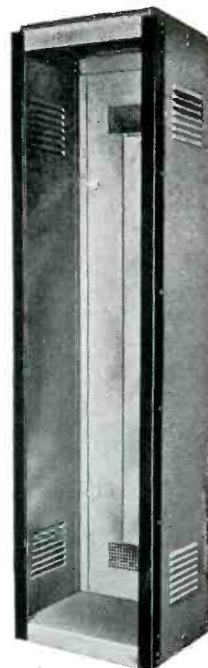
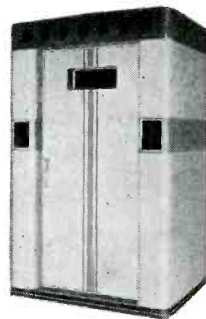
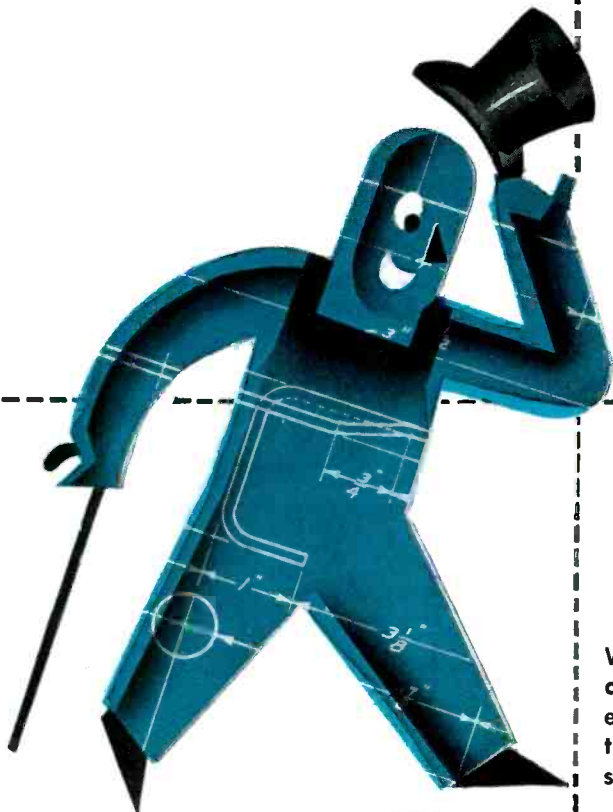

**We Give Them All
 "High Hat" Quality**

Whether you come to us for simple stamped-out chassis, ordinary metal boxes or the most intricate electronic apparatus housing, your job will receive the same Karp quality treatment, plus every possible economy.

The same long-experienced principals of our staff will give you intimate, personalized service, from planning and design to delivery. Your work will be done by highly skilled specialists, in a plant which is without an equal in its field for up-to-date machinery and modern facilities. Welding, when needed, will be done under precise timing controls . . . painting and finishing with the most modern equipment and conditions.

In most cases, our vast variety of dies will save you the cost of special dies and jigs. We will give your work accuracy and uniformity that will make your final assembly easy, time-saving and hence economical.

Try us for the plain or the precise . . . the everyday or the elaborate and de luxe . . . in modest or substantial quantity. Whatever your needs in sheet metal fabrication, it pays to get our estimate.

WRITE FOR NEW CATALOG

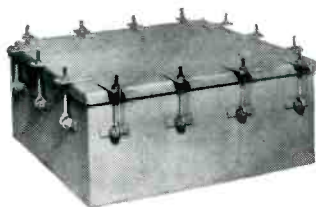
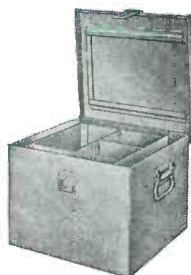

KARP METAL PRODUCTS CO., INC.

215 - 63rd STREET, BROOKLYN 20, NEW YORK

Custom Craftsmen in Sheet Metal

ADVENTURES IN ELECTRONIC DESIGN

HOW FRAZER CUT COSTS 60%!



This is the success story of the Frazer Company, Auckland, New Zealand. Recently, using Centralab's amazing P. E. C.* *Ampec* — a tiny audio-amplifier — in the hearing aids it manufactures. Frazer quickly found that with *Ampec's* help, it could produce more and finer hearing aids than ever before. What's more, Frazer found it could cut the costs of its hearing aid production nearly 3/5ths. Now — less than one year since Ampec, seven out of every ten deaf patients applying for hearing aids, under New Zealand's Social Security System, ask for . . . and get Frazers. Is there any doubt that is proud of being FIRST in the British Empire to use *Ampec* in hearing aids?

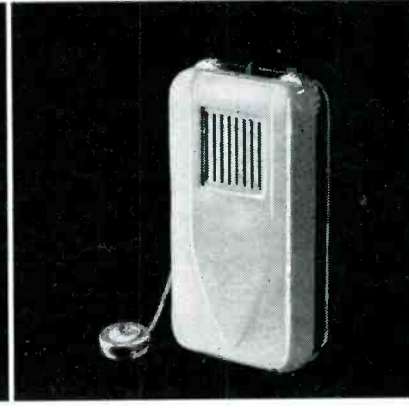
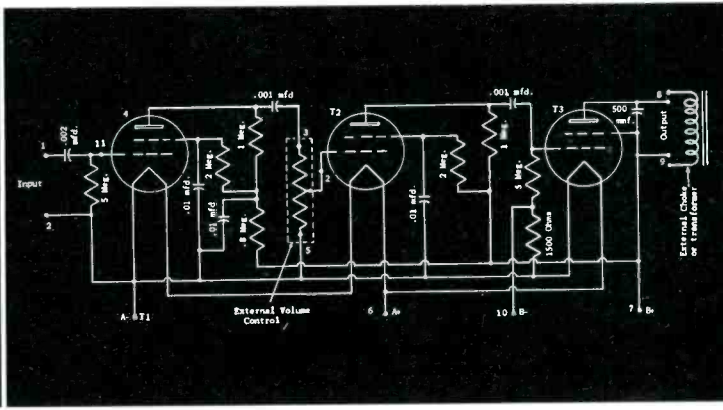
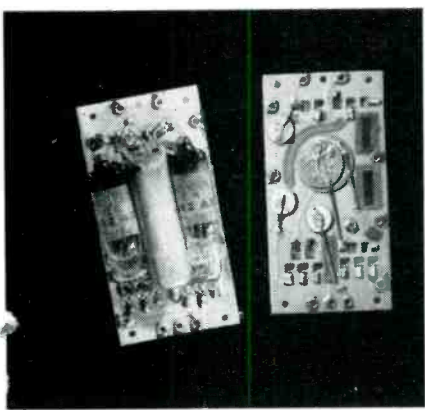

*Each P. E. C. unit—including *Ampec*, above — is an integral assembly of *Hi-Kap* capacitors and resistors, closely bonded to a ceramic plate and connected by "printed" silver paths.

This is a schematic diagram of *Ampec*, Centralab's amazing P. E. C. unit that combines all components of an audio-amplifier — tube sockets, capacitors, resistors and wiring — on one compact, ceramic chassis.

Here's the Frazer Hearing Aid. Because it uses *Ampec*, the Frazer is smaller, lighter. What's more, *Ampec* helps Frazer produce more dependable hearing aids, faster.

Centralab — DEVELOPMENTS THAT CAN HELP YOU

Division of GLOBE-UNION INC. • Milwaukee

Centralab reports to

JULY, 1949

How Admiral Uses
CRL's Printed
Electronic Circuit
to build
more and finer
TV sets!

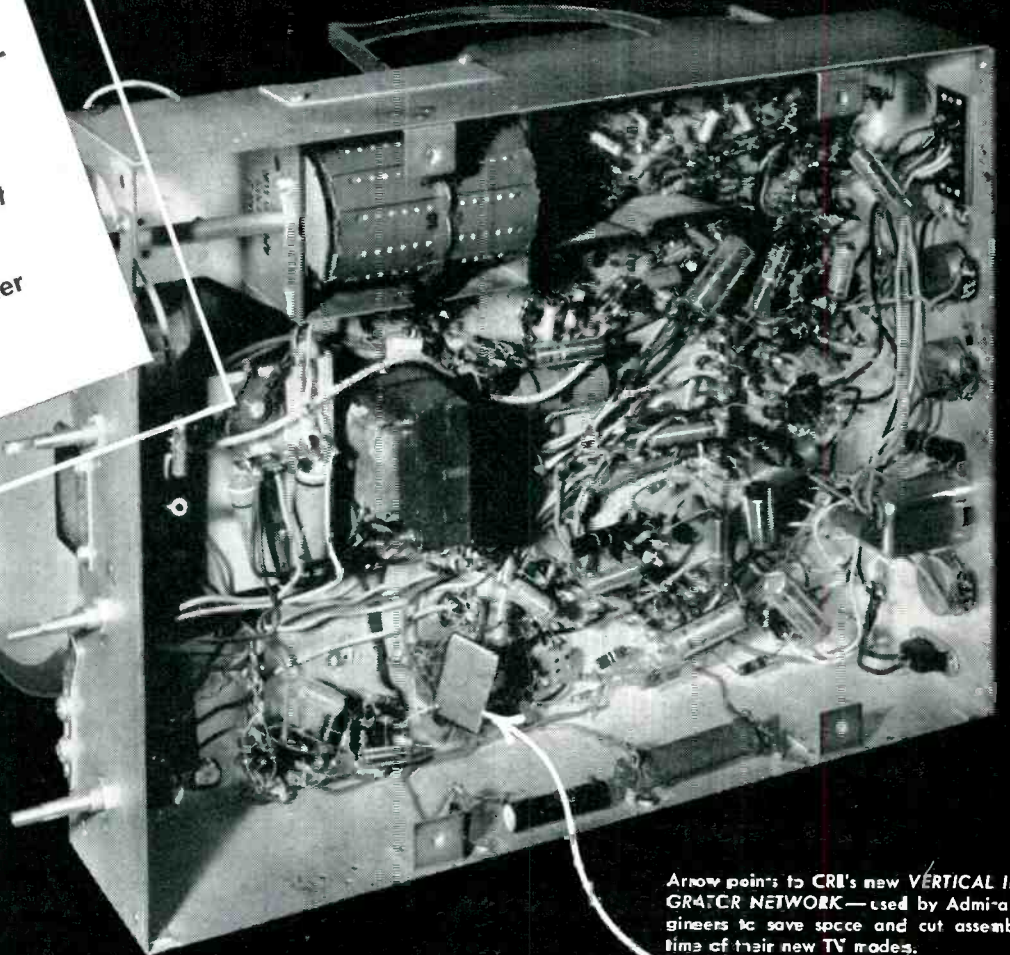

Arrow points to CRL's new VERTICAL INTEGRATOR NETWORK—used by Admiral engineers to save space and cut assembling time of their new TV models.

Chassis courtesy of Admiral Corp.

1 Wherever Centralab's revolutionary P. E. C. is used, you are sure to find speeded production . . . quality products. Just look at Admiral Corporation's fine new television receivers. A series of Admiral's video sets makes use of CRL's *Vertical Integrator Net-*

work—a tiny, compact plate containing both capacitors and resistors. It saves production time . . . reduces 16 soldered connections to 3. Simplifies wiring operations for faster assembly. What's more, the *Network* helps produce better TV receivers.

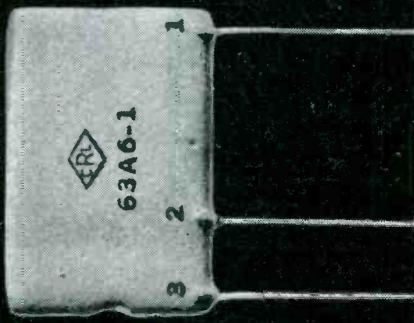

Resistor

Capacitor

Capacitor

Actual size

2 This is the new CRL *Vertical Integrator Network* used by Admiral. Variations of this Centralab *Network* are available on special order.

3 Centralab's *Filpec* is designed for use as a balanced diode load filter, combines up to three major components into one tiny unit, lighter and smaller than one ordinary capacitor. What's more, *Filpec's* Ceramic-X construction assures long life. Capacitor values from 50 to 200 mmf. Resistor values from 5 ohms to 5 megohms.

Electronic Industry



4 *Hi-Vo-Kaps* are filter and by-pass capacitors combining high voltage, small size and a variety of terminal connections to fit most TV needs.

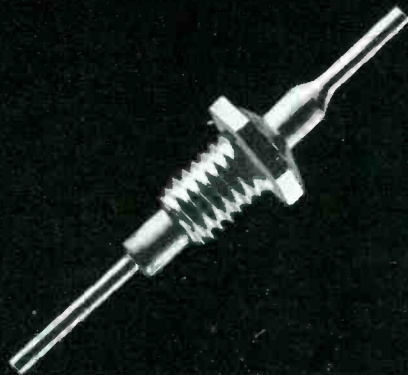

5 *FT Hi-Kaps* Centralab's new feed-thru or bushing mounted capacitors eliminate structural and electrical damage during installation.

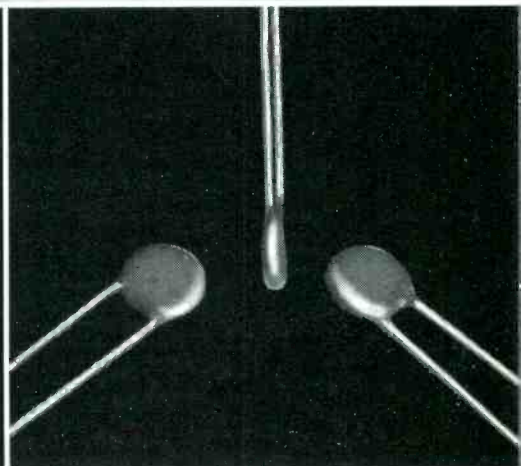

6 For by-pass or coupling applications, check CRL's original line of ceramic disc and tubular *Hi-Kaps*. *Disc Hi-Kaps* are smaller than a dime!

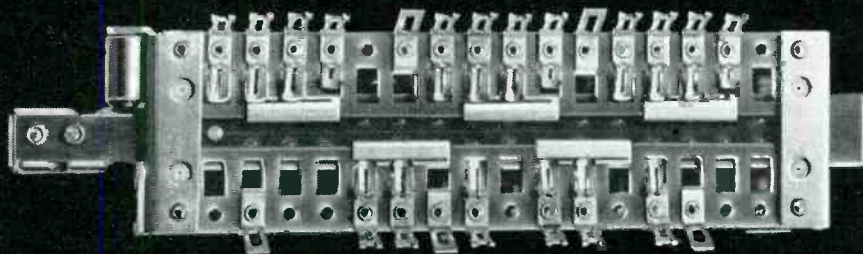

7 Centralab's development of a revolutionary, new *Slide Switch* promises improved AM and FM performance! Flat, horizontal design saves valuable space, allows short leads, convenient location to coils, reduced lead inductances for increased efficiency in low and high frequencies. CRL *Slide Switches* are rugged and efficient, too.

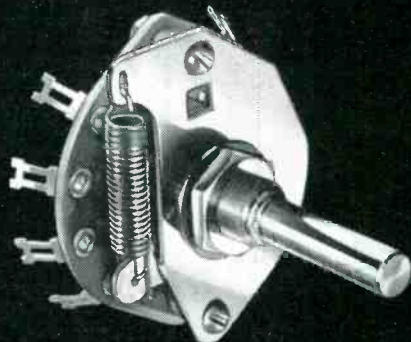

8 Great step forward in switching is CRL's New *Rotary Coil and Cam Index Switch*. Its coil spring gives you smoother action, longer life.

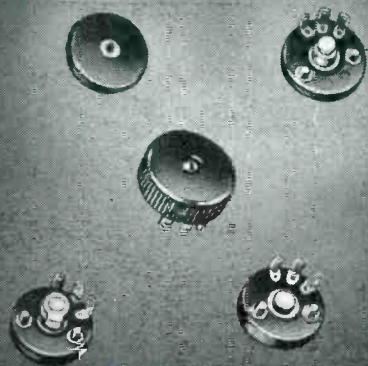

9 Model "1" *Radiobm* control is no larger than a dime. Especially designed for hearing aids, pocket radio receivers, miniature amplifiers.

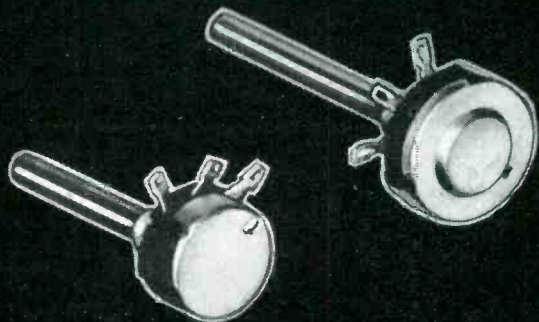
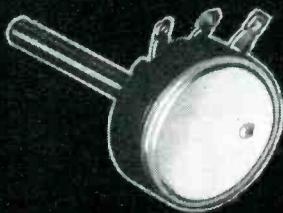

10 Let Centralab's complete *Radiobm* line take care of your special needs. Wide range of variations: *Model "R"* — wire wound, 3 watts; or composition type, 1 watt. *Model "E"* — composition type, 1/4 watt. Direct contact, 6 resistance tapers. *Model "M"* — composition type, 1/2 watt.

IMPORTANT BULLETINS FOR YOUR TECHNICAL LIBRARY!

They're factual!



THEY'RE FREE!

Choose From This List!

Centralab Printed Electronic Circuits

- 973 — AMPEC — three-tube P. E. C. amplifier.
- 42-6 — COUPLATE — P. E. C. interstage coupling plate.
- 999 — PENTODE COUPLATE — specialized P. E. C. coupling plate.
- 42-9 — FILPEC — Printed Electronic Circuit filter.

Centralab Capacitors

- 42-3 — BC TUBULAR HI-KAPS — capacitors for use where temperature compensation is unimportant.
- 42-4 — BC DISC HI-KAPS — miniature ceramic BC capacitors.
- 42-10 — HI-VO-KAPS — high voltage capacitors for TV application.
- 695 — CERAMIC TRIMMERS — CRL trimmer catalog.
- 991 — HI-VO-KAPS — capacitors for TV application. For jobbers.
- 42-18 — TC CAPACITORS — temperature compensating capacitors.
- 814 — CAPACITORS — high-voltage capacitors.
- 975 — FT HI-KAPS — feed-thru capacitors.

Centralab Switches

- 953 — SLIDE SWITCH — applies to AM and FM switching circuits.
- 970 — LEVER SWITCH — shows indexing combinations.
- 995 — ROTARY SWITCH — schematic application diagrams.
- 722 — SWITCH CATALOG — facts on CRL's complete line of switches.

Centralab Controls

- 42-7 — MODEL "J" RADIOHM — world's smallest commercially produced control.
- 697 — VARIABLE RESISTORS — full facts on CRL Variable Resistors.

Centralab Ceramics

- 720 — CERAMIC CATALOG — CRL's steatite and ceramic products.

General

- 26 — GENERAL CATALOG — Combines Centralab's line of products for jobber, ham, experimenter, serviceman or industrial user.

Look to CENTRALAB in 1949! First in component research that means lower costs for the electronic industry. If you're planning new equipment, let Centralab's sales and engineering service work with you. For complete information on all CRL products, get in touch with your Centralab Distributor. Or write direct.

CENTRALAB
Division of Globe-Union Inc.
900 East Keefe Avenue, Milwaukee, Wisconsin

Yes—I would like to have the CRL bulletins, checked below, for my technical library!

- | | | | | | | |
|-------------------------------|-------------------------------|--------------------------------|------------------------------|------------------------------|-------------------------------|------------------------------|
| <input type="checkbox"/> 973 | <input type="checkbox"/> 42-9 | <input type="checkbox"/> 42-18 | <input type="checkbox"/> 953 | <input type="checkbox"/> 953 | <input type="checkbox"/> 722 | <input type="checkbox"/> 720 |
| <input type="checkbox"/> 42-6 | <input type="checkbox"/> 42-3 | <input type="checkbox"/> 695 | <input type="checkbox"/> 814 | <input type="checkbox"/> 970 | <input type="checkbox"/> 42-7 | <input type="checkbox"/> 26 |
| <input type="checkbox"/> 999 | <input type="checkbox"/> 42-4 | <input type="checkbox"/> 991 | <input type="checkbox"/> 975 | <input type="checkbox"/> 995 | <input type="checkbox"/> 697 | |

Name.....

Address.....

City..... State.....

TEAR OUT COUPON

← for the Bulletins you want →

Centralab

Division of GLOBE-UNION INC. • Milwaukee

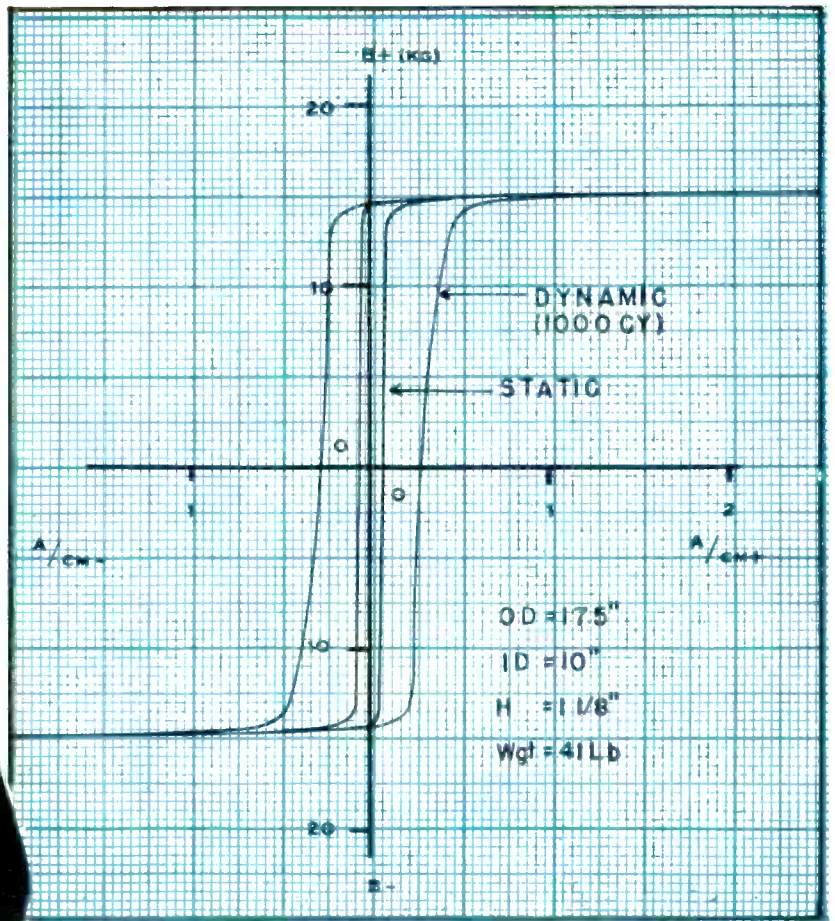

Take another look at Permeron*

... I-T-E'S NEW MAGNETIC CORE MATERIAL

Get the full significance of the static and dynamic (1000 cycle) magnetization characteristics of this new alloy. Examine the dynamic curve particularly—as this indicates how the material acts under actual operating conditions.

Note these facts:

1. Magnetic saturation is achieved with only the slightest change in magnetizing current.
2. The extremely low magnetizing current makes it possible to build smaller magnetic amplifiers of extreme reliability.
3. The knees of the saturation curve are sharp, even at higher frequencies.
4. The most important fact: all Permeron cores have identical magnetization characteristics.

The dynamic characteristic of each core is checked by a "Vectormeter," specially developed for this purpose. This consistency allows designers to predict amplifier performance accurately and positively.

Permeron Cores are available now

in widths of 20 mm. and 30 mm., in any specified inside and outside diameters. Cores are delivered heat treated and insulated. They are always furnished in housings designed to protect the magnetic material against deformation.

Take Another Look at Permeron — and continue to look to I-T-E to bring you better equipment and better designs . . . first!

* Formerly known as "Permanite"

For Additional Information write — I-T-E Rectifier Division or consult your local I-T-E Representative

I-T-E PERMERON

I-T-E CIRCUIT BREAKER COMPANY

19th AND HAMILTON STREETS, PHILADELPHIA 30, PA.

SWITCHGEAR • UNIT SUBSTATIONS • ISOLATED PHASE BUS STRUCTURES • RESISTORS • SPECIAL PRODUCTS • MECHANICAL RECTIFIERS

FIXED RESISTORS



In all standard R.M.A. values as follows— $\frac{1}{2}$ watt from 10 ohms to 22 megohms; 1 watt from 2.7 ohms to 22 megohms; 2 watt from 10 ohms to 22 megohms. Small in size; tops in quality.

ADJUSTABLE RESISTORS

Type J Bradleyometers can produce any resistance-rotation curve. Resistor element is solid-molded as a one-piece ring that is unaffected by age, wear, heat, or moisture. Can be supplied in single-, dual-, or triple-unit construction for rheostat or potentiometer applications. Built-in line switch is optional on single or dual types.



SMALL CONTACTORS

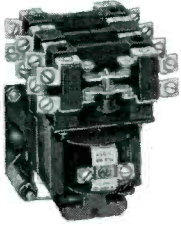

Bulletin 700 Universal Relays are available in 10-amp rating with 2, 4, 6, and 8 poles. Two contact banks permit quick changes from normally open to normally closed contacts. The double-break, silver-alloy contacts require no maintenance. There are no pins, pivots, bearings, or hinges to bind, stick, or corrode.

LARGE CONTACTORS

Bulletin 702 Solenoid Contactors are available for ratings up to 300 amperes. Arranged for 2- or 3-wire control with push buttons or automatic pilot devices. Enclosing cabinets furnished for all service conditions. The double-break, silver-alloy contacts need no maintenance. For complete description and dimensions, please send for Bulletin 702.

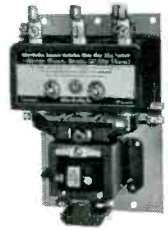

TIMING RELAYS

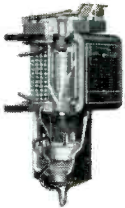

Bulletin 848 Timing Relays are ideal for any service requiring an adjustable, delayed-action relay. They have normally open or normally closed contacts. The magnetic core is restrained from rising by the piston in fluid dashpot. Ideal for transmitter plate voltage control. Time delay period of these relays is adjustable.

LIMIT SWITCHES



Essential for safety interlocks on transmitter cabinets. Also used for sequence switching, restricting machine motions, and starting, stopping, and reversing motors. Let us send you Bulletin 701-2.



RESISTORS • RELAYS • CONTACTORS

for Quality Electronic Equipment

When you design an electronic device that must meet rigid performance specifications... your component parts must be "tops" in quality. For such applications, the leading electronic engineers use Allen-Bradley fixed and adjustable resistors; Allen-Bradley relays and contactors; Allen-Bradley standard and precision

limit switches. Let us send you data on all items listed above. In war service and in peacetime applications, Allen-Bradley components are the choice of electronic engineers for television and radar circuits.

Allen-Bradley Co.

110 W. Greenfield Ave., Milwaukee 4, Wis.

Sold exclusively to manufacturers



of radio and electronic equipment

ALLEN-BRADLEY

RESISTORS RELAYS

QUALITY

Plastics where plastics belong

for dimensional stability

... wear resistance

... and strength

Synthane pump bearings used in this Allis-Chalmers vertical mixed flow pump illustrate an interesting application of Synthane requiring stability of dimensions within close tolerances under conditions of severe exposure to wear and water.

Other interesting applications for Synthane result from its many additional properties in combination—a few of which are high dielectric strength, good structural strength, light weight, low moisture absorption, and corrosion resistance.

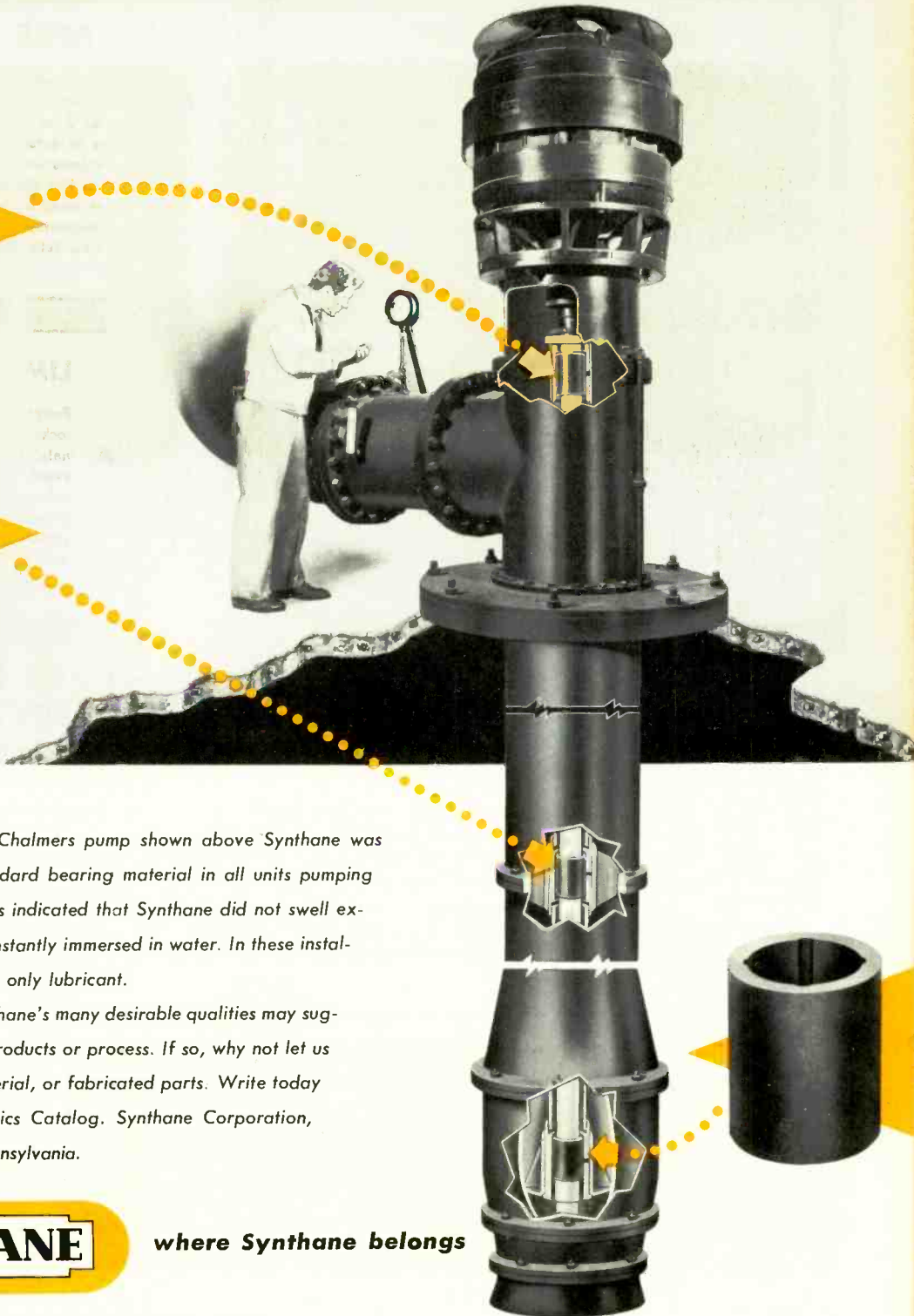
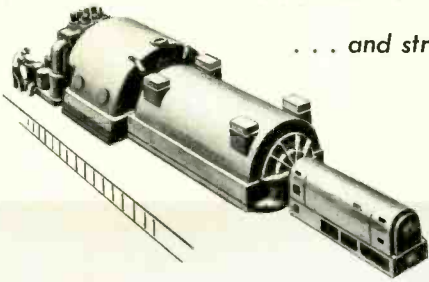

In the Allis-Chalmers pump shown above Synthane was selected as standard bearing material in all units pumping clear water. Tests indicated that Synthane did not swell excessively when constantly immersed in water. In these installations water is the only lubricant.

These few of Synthane's many desirable qualities may suggest its use in your products or process. If so, why not let us help with design, material, or fabricated parts. Write today for the Synthane Plastics Catalog. Synthane Corporation, 6 River Road, Oaks, Pennsylvania.

SYNTHANE
S

where Synthane belongs

DESIGN • MATERIALS • FABRICATION • SHEETS • RODS • TUBES
FABRICATED PARTS • MOLDED-MACERATED • MOLDED-LAMINATED

Question:
What 3 points
have these
7 JOBS
in common?

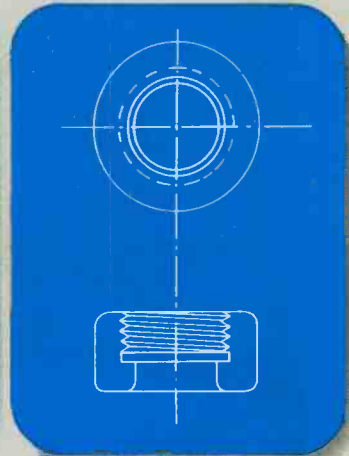
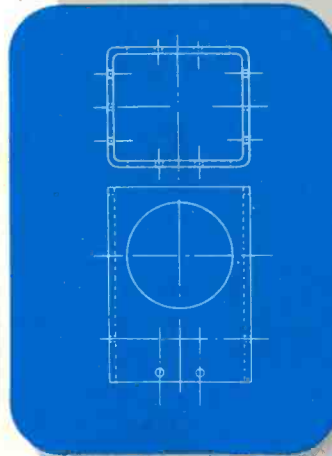
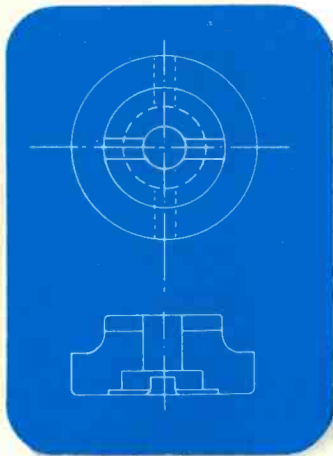
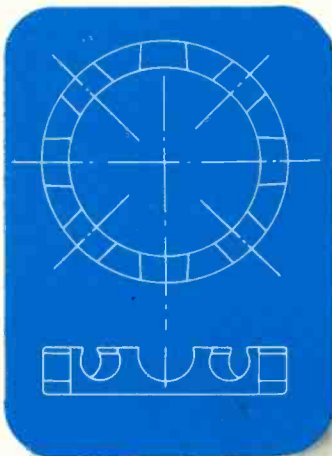
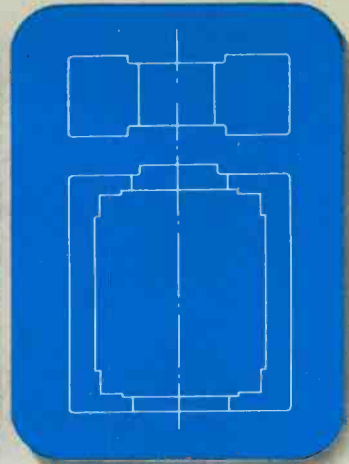
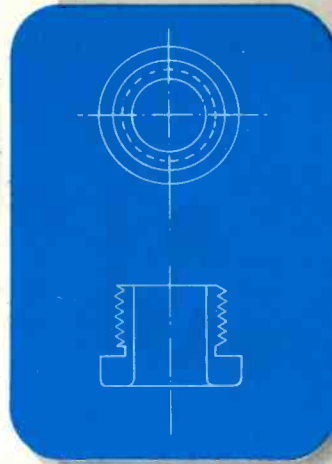
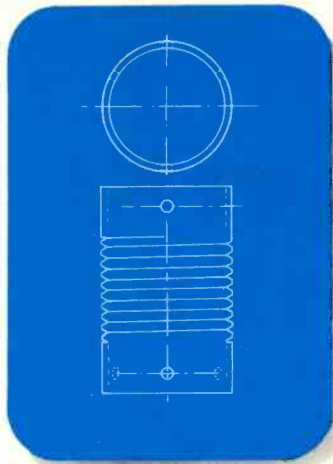

ANSWER:

1. All of them have an unusual combination of requirements.
2. All of them are made from Synthane laminated plastics.
3. All of them are machined from Synthane tubes or rods.

QUESTION: *What properties in combination?*

ANSWER:

Properties such as structural strength; light weight; toughness; moisture and corrosion resistance; dimensional stability; hardness; abrasion resistance; low coefficient of expansion; and desirable characteristics for electrical applications, as low power factor, high dielectric strength, low dielectric constant.

QUESTION: *Is Synthane easy to machine?*

ANSWER:

Synthane tubes and rods are easily and quickly machined by standard shop equipment, including saws, drills, lathes, millers, punch presses, and automatic screw machines.

QUESTION: *Does Synthane produce finished parts?*

ANSWER:

Synthane produces rods and tubes, helps you design for use of plastics, and delivers top quality finished parts. Send for the Tubing Folder today.

Synthane produces a wide variety of shapes. For example: a—round tubes or rods, b—square or irregular tubes or rods, c—oval tubes or rods, d—angles or channels, e—irregular bore or insert.

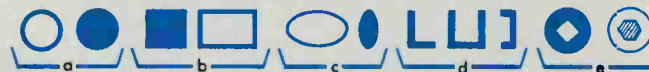

Standard round tubing is always a little more economical to use, but if your needs call for an irregular shaped section, it will pay you to inquire about Synthane's diversified line of rods and tubes.

Specifications:

- Diameters:** Rod— $\frac{1}{8}$ " to 4" O.D.
 Tubing— $\frac{1}{8}$ " to 22" I.D., O.D. to specifications.
 (Molded tubing to 4" O.D. only.)
- Lengths:** 18" to 36", longer on order
- Colors:** Natural (Tan) or black
- Finishes:** Ground, buffed or varnished

For diameter or wall thickness tolerances, standards of quality for tensile and compressive strength, dielectric strength, density, percent of moisture absorption, power factor, and dielectric constant, write for descriptive Tubing Folder.

SYNTHANE CORPORATION, 6 RIVER ROAD

Oaks, Pennsylvania

Please send me the Synthane Tubing Folder by return mail

Name _____

Company _____

Title _____

Address _____

City _____ Zone _____ State _____



SYNTHANE CORPORATION **S** OAKS • PENNSYLVANIA

Representatives in ALL Principal Cities

**LOW CURRENT
PAYS OFF...**

with the
GENERAL ELECTRIC PM-EM* FOCUS COIL!

PERFORMANCE-ENGINEERED at Electronics Park, the General Electric Focus Coil is now being used by many leading television manufacturers. The reason for this widespread adoption of the G-E Focus Coil by design engineers is best explained by the following equation:

$$\begin{aligned} \text{PEM} &= I^2R = .109^2 \times 247 = 2.93 \text{ watts} \\ \text{PEM-PM} &= I^2R = .029^2 \times 960 = 0.81 \text{ watts} \\ \text{Power Saving} &= 2.12 \text{ watts} \end{aligned}$$

In addition to its low current requirements (which permit the use of lower-priced power supplies) the G-E focus coil is small, compact and light in weight. These features provide additional space which TV set designers can use to advantage.

For complete information on the G-E Focus Coil and other television components, write: *General Electric Company, Electronics Park, Syracuse, New York.*

**Permanent Magnet—Electro-Magnet.*

You can put your confidence in—

GENERAL  ELECTRIC

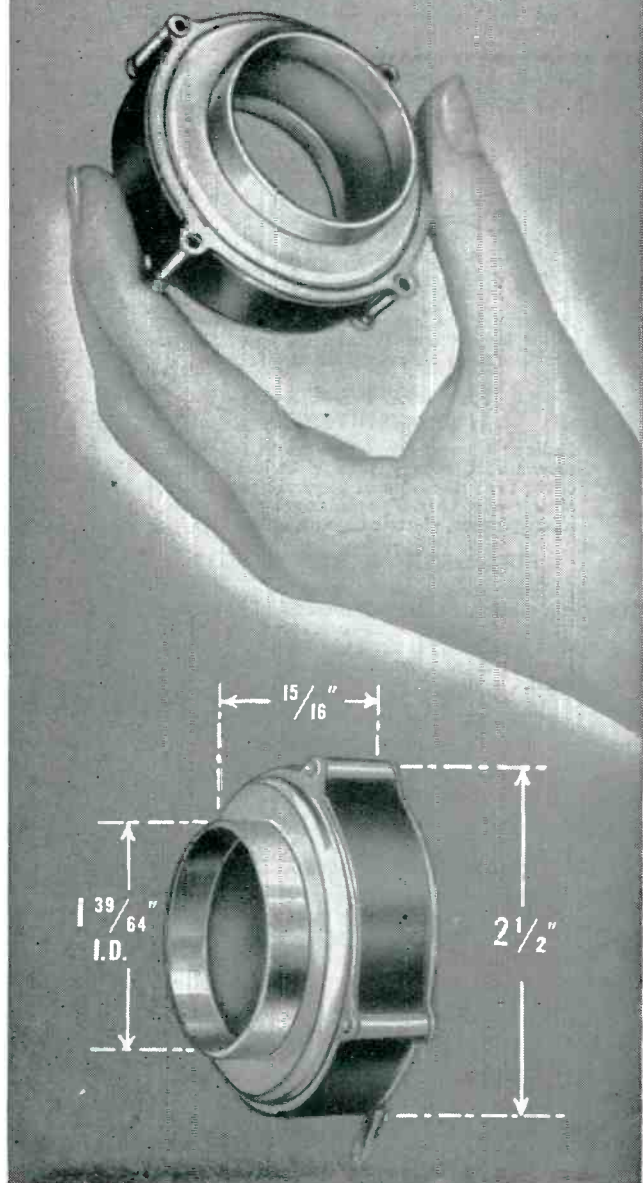

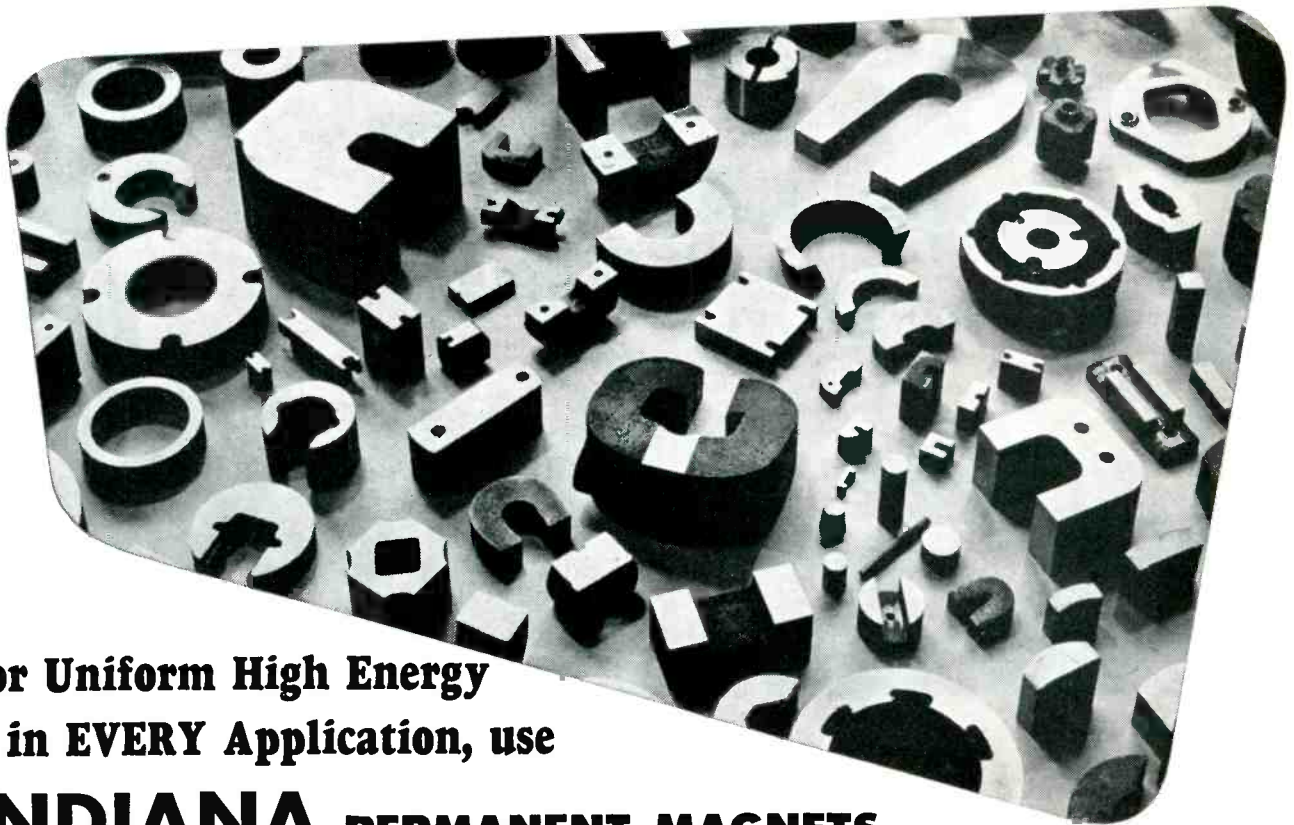

**For Uniform High Energy
in EVERY Application, use
INDIANA PERMANENT MAGNETS**



THIN-WALL ALNICO RINGS

All sizes of thin-wall, ring-type permanent magnets for television focus coils. Indiana quality assures a strong magnetic field.

"ION-TRAP" PERMANENT MAGNETS

Permanent magnets to deflect electrons out of the ion-electron stream. Made of Alnico and Cunife in all diameters and forms.

**PERMANENT MAGNETS FOR
PHONOGRAPH PICK-UPS**

Indiana permanent magnets for transforming mechanical energy into electrical energy cover the full range of physical properties, sizes, and shapes. For phonograph pick-ups, microphones, electric organs, etc.

PERMANENT MAGNETS FOR SPEAKERS

Indiana permanent magnets for transforming electrical energy into mechanical energy in loud speakers, telephone receivers, polarized vibrators, electric clocks, etc. Indiana has the right permanent magnet for each need.

**PERMANENT MAGNETS FOR INSTRUMENTS,
RELAYS, AND CONTROLS**

A complete variety for ammeters, galvanometers, light meters, voltage regulators, switches, polarized relays, etc. Indiana brings you the latest methods and techniques.

PERMANENT MAGNET SUB-ASSEMBLIES

Assemblies, of which the permanent magnet is a part, designed to meet your specifications. Furnished for all requirements.

● Look to INDIANA for *quality* permanent magnets—for skill in manufacture—for cost-cutting engineering aid. Strict supervision in every step of production is your assurance of exact magnetic and mechanical characteristics.

ALL MATERIALS • ALL SIZES • ALL SHAPES

INDIANA—the world's largest exclusive producer of permanent magnets, and the only manufacturer furnishing *all commercial grades* of permanent magnet alloys—has the know-how and facilities to develop and produce the permanent magnets you require. More than 30,000 different needs have been met successfully by INDIANA "packaged energy." Write today.

Sales Offices Coast to Coast

- Boston 16, Mass., 258 Park Square Building.
- Cleveland 14, O., 508 Hippodrome Building.
- Detroit 2, Mich., 908 Fisher Building.
- Los Angeles 15, Calif., 1151 S. Broadway.
- New York 17, N. Y., 51 East 42nd Street.
- Philadelphia 7, Pa., Real Estate Trust Bldg.
- Rochester 4, N. Y., 519 Sibley Tower Bldg.
- Washington 7, D. C., 1011 New Hampshire Ave.

Ask for Book No. 4E-8

INDIANA'S wide variety of magnet alloys permits precise selection.

- CAST**
- Alnico I, II, III, IV, V, VI, XII
- Cobalt
- Cunico
- Indalloy
- SINTERED**
- Alnico II, IV, V
- Indalloy
- Vectalite
- DUCTILE**
- Cunico
- Cunife I, II
- Silmanal
- FORMED**
- Chrome
- Cobalt
- Tungsten

**INDIANA
PERMANENT
MAGNETS**

THE INDIANA STEEL PRODUCTS COMPANY

6 NORTH MICHIGAN AVENUE • CHICAGO 2, ILLINOIS

SPECIALISTS IN "PACKAGED ENERGY" SINCE 1908

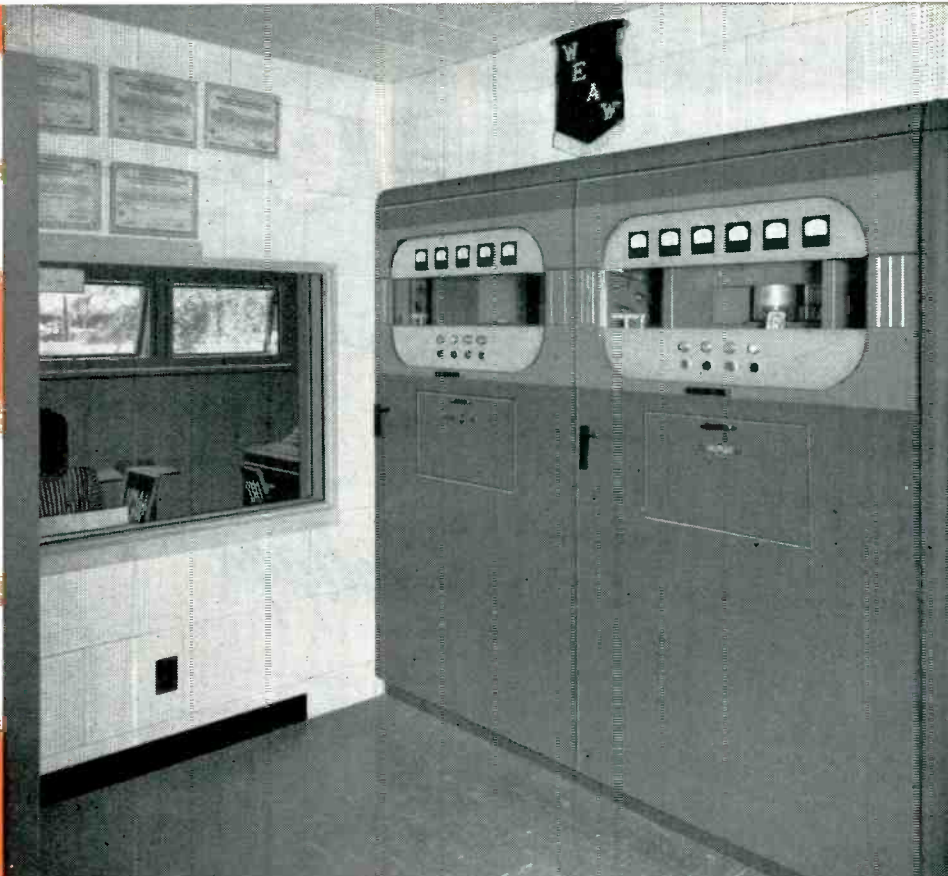
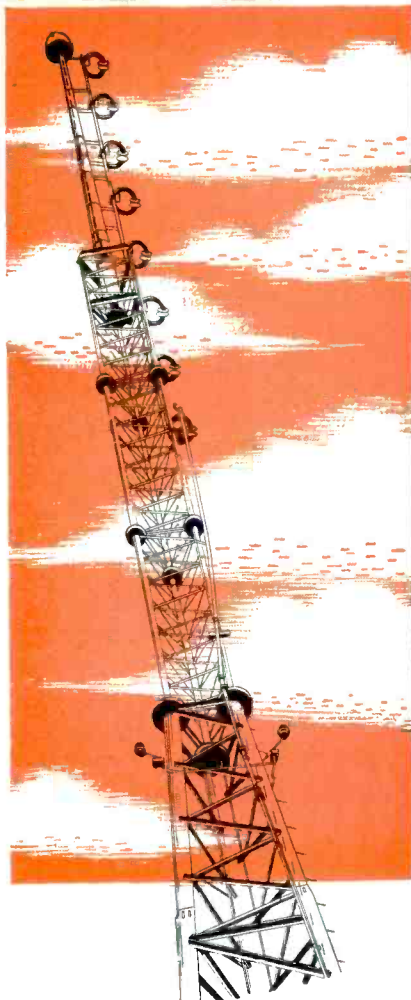

WEAW-FM's 37M-8 eight-bay antenna

WEAW-FM's 737A "5 kw" transmitter

Nominal power rating: 5 kw FM ... actually a 6½ kw transmitter

WEAW-FM, Evanston, Illinois, has been radiating 36 kilowatts with the Collins 737A "5 kw" transmitter and the Collins 37M-8 eight-bay antenna shown on this page.

Recently the station's management applied to FCC for permission to increase its effective radiated power from 36 to 45 kilowatts.

This increase can be made without buying a more powerful transmitter . . . without even using all the power of which the present transmitter is capable.

Although it is nominally rated in the 5 kw classification, the Collins 737A is

actually a 6½ kilowatt FM transmitter.

Operated conservatively, with a 37M-8 Collins antenna having a gain of 8.3, this transmitter presents plenty of power to the transmission line to cover line loss and furnish the 45 kw of radiated power for which WEAW-FM has applied.

The Collins 737A transmitter with a 4-to-8-bay Collins 37M antenna is your best and most economical equipment with which to radiate FM power in the range of 20 to 45 kilowatts. Write us for literature which will give you more complete information.

FOR THE BEST IN FM, IT'S . . .



COLLINS RADIO COMPANY, Cedar Rapids, Iowa

11 West 42nd Street, New York 18, N. Y.

458 South Spring Street, Los Angeles 13, California

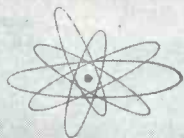

Designers

Now..higher voltage
 from
GENERAL ELECTRIC
SELENIUM STACKS

using new 18-volt (D-C) cells

New process for depositing selenium gives rectifier stacks greater uniformity, higher efficiency and longer useful life.

Here's real news for rectifier users. G.E.'s new 18-volt selenium cells, made by a special evaporation process which deposits selenium on the aluminum base with greater uniformity than otherwise possible, give you these advantages:

GREATER OUTPUT—With 50% more output than the standard 12-volt cells, the new design can be used for any application except those few which demand 24-hour, year-around service.

HIGHER EFFICIENCY—Not only is the initial efficiency higher, but more uniform coating keeps it high during the life of the stack.

SAVING IN SPACE—About one-quarter less space is required for the same output.

LOWER COST—Depending on the voltage across the stack, the 18-volt cells can save 25% in cost compared to standard 12-volt cells.

Selenium stacks are available in several standard sizes. Output in d-c voltage ranges from 18 to 126; applied a-c voltage, from 26 to 161. Bulletin GEA-5258 will give you detailed information. Send for it today!



**STYLED FOR READABILITY
 BUILT FOR RELIABILITY**

This brand-new line of 2½-inch thin panel instruments has streamlined features which will give your panels a "new look." Arc lines have been eliminated,

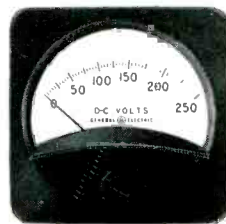

GENERAL  **ELECTRIC**

Digest

TIMELY HIGHLIGHTS ON G-E COMPONENTS

leaving only the upright scale divisions. New tapered pointer helps eye focus only on the reading. All but essential markings are masked by attractive case.

Internal mechanism is designed for extra reliability. High coercive Alnico magnet assures proper alignment, even under severe operating conditions. Large air gap reduces danger of stickiness caused by foreign particles. A variety of types and ratings in round or square cases are available for use in radio, television or testing equipment. Get complete details from Bulletin GEC-368.

DESIGNED FOR YOUR REQUIREMENTS

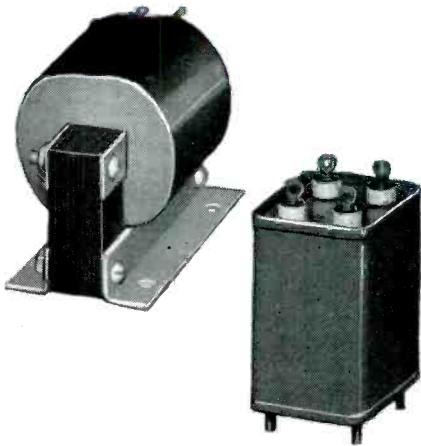

General Electric pulse transformers for radar and associated applications are designed to perform dependably in extremes of operating conditions. Many ratings in current production are of a special nature—designed to keep pace with rapidly changing requirements of the industry. However, for certain applications, they can be built to the specifications of electronic equipment manufacturers. Types available include interstage transformers, blocking oscillator transformers, charging chokes, current transformers, and pulse thyatron grid transformers. For a listing of available designs and ratings, send for bulletin GEC-481.

THEY'RE SMALL BUT THEY CAN TAKE IT

Cast-glass bushings with sealed-in nickel-steel hardware can be readily welded, soldered, or brazed directly to the apparatus, thus eliminating gaskets and providing a better seal. Small, compact structure often makes possible reduction of over-all size and weight of equipment. Practically unaffected by weathering, micro-organisms, and thermal shock, they're particularly well suited for use in electronic equipment and in installations where operating conditions are severe. Available in ratings up to 8.6 kv and for currents to 1200 amperes. Check Bul. GEA-5093.



RELY ON THESE FOR STABILITY

Fixed paper-dielectric capacitors are manufactured in accordance with joint Army-Navy specification JAN-C-25. They're constructed with thin Kraft paper, oil or Pyranol* impregnated, for stable characteristics and high dielectric strength. Plates are aluminum foil; special bushing construction provides for short internal leads, prevents possible grounds and short circuits. Cases have permanent hermetic seal.

DOES A BIG JOB IN CLOSE QUARTERS

G.E.'s midget soldering iron can do a big job with only one-fourth the wattage usually used. This handy 6-volt, 25-watt iron is only 8 inches long with $\frac{1}{8}$ " or $\frac{1}{4}$ " tips and weighs but $1\frac{1}{4}$ ounces. Designed for close-quarter, pin-point precision soldering, the "midget" offers you all these advantages: low cost soldering; "finger-tip" operation; quick, continuous heat; easy renewal; long life; low maintenance. A real aid in designing radios, instruments, meters, electric appliances, and many other products requiring precision soldering. Available from stock. Check bulletin GEA-4519.

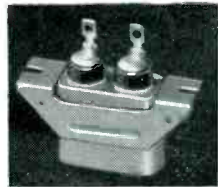
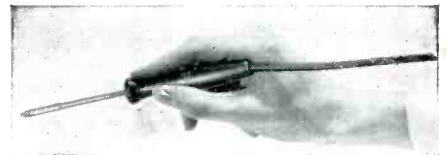

Case style CP 63 (shown above) is rated 0.1–0.1 muf and 1000 volts. Other ratings range from .01 muf to 15 muf and from 100 to 12,500 volts. Write for detailed description and operating data in bulletin GEA-4357A. *Reg. U.S. Pat. Off.

General Electric Company, Section A667-2
Apparatus Department, Schenectady, N. Y.

Please send me the following bulletins:

- | | |
|---|---|
| <input type="checkbox"/> GEA-4357A D-C Capacitors | <input type="checkbox"/> GEC-481 Pulse Transformers |
| <input type="checkbox"/> GEA-4519 Midget Soldering Iron | |
| <input type="checkbox"/> GEA-5093 Glass Bushings | |
| <input type="checkbox"/> GEA-5258 Selenium Stacks | |
| <input type="checkbox"/> GEC-368 Panel Instruments | |

NAME

COMPANY

ADDRESS

CITY STATE

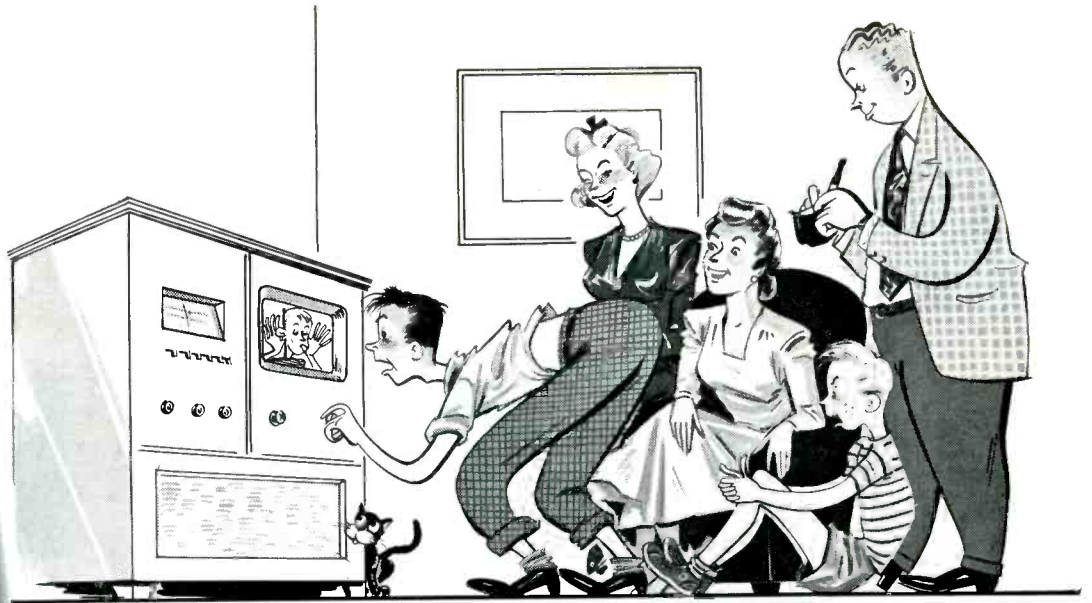

FOR A SHARPER IMAGE OF
**TOP PROFITS IN TELEVISION
 PRODUCTION and SALES**

... set-builders use

AMERICAN PHILLIPS SCREWS

SEE NEW PRODUCTION PROFITS: Assembly of costly television sets puts a prohibition on spoilage. That's why American Phillips Screws are used, to help keep sets rolling out to an eager market, and to keep rejections down. No delays or losses, then, and output hits the main channel with highest return per man-hour, *which means time-savings up to 50%!*

SEE NEW SALES-STIMULATION: Smoothly finished, unmarred cabinet work is the basis of television-set sales. And that's the way sets come from an assembly department using *American Phillips Screws*.

Does YOUR product have this double-feature of production-economy and sales promotion? Then write:

AMERICAN SCREW COMPANY, PROVIDENCE 1, RHODE ISLAND

Chicago 11: 589 E. Illinois St.

Detroit 2: 502 Stephenson Building

4-WINGED DRIVER CAN'T SLIP OUT
 OF PHILLIPS TAPERED RECESS



**AMERICAN
 PHILLIPS**

Screws



ALL TYPES
 ALL METALS: Steel,
 Brass, Bronze, Stain-
 less Steel, Aluminum,
 Monel, Everdur (sili-
 con bronze)

a Revolutionary method of drilling microscopic holes

that depends on

NICHROME*

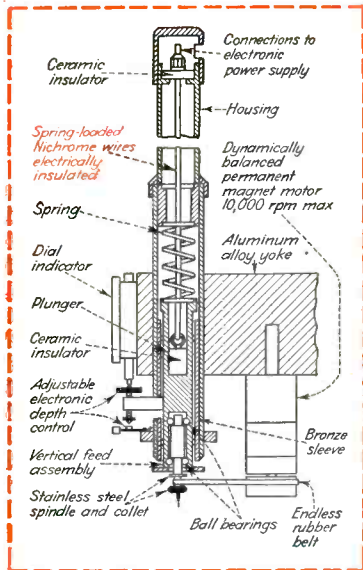

High coefficient of linear expansion of Nichrome V permits maximum vertical movement of spindle with shortest possible length of wire.

High tensile strength of Nichrome V permits use of a spring large enough to furnish sufficient force to drive spindle down.

High heat-resistance of Nichrome V permits heating wire to 1700°F. without permanent elongation—affording substantial drill feed range.

High specific resistance of Nichrome V minimizes heating current required.

Until now, precision drilling of extremely small diameter holes (such as .0016" dia.) has been manually controlled. Even with highly skilled operators, however, drill breakage has been frequent—resulting in waste of time and effort, and damage to work and equipment.

But now comes the revolutionary Microdrill. Relying on sensitive electronic circuits, instead of the human senses of feeling and sight, it operates infallibly and precisely by means of remote electric controls.

Heart of the drill press is a spring-loaded Nichrome V wire which, when heated electrically, expands, thereby lowering the drill spindle. Conversely, when heating current is decreased, it contracts and raises the spindle. Electronic control of the heating current effects extremely smooth vertical travel, the drill being raised or lowered at a precisely adjustable rate.

Holes as small as .0016" in diameter are drilled with utmost ease—drill breakage reduced to a negligible minimum. Time is saved. Costs are cut.

Says the manufacturer, Teletronics Laboratory, Inc., Westbury, N.Y.: "The wire used in the Microdrill must have a high coefficient of linear expansion, high tensile strength, high specific resistance—and must be able to retain its physical and electrical properties at high temperatures. We know of no other wire as suitable for our purpose as Nichrome V."

If you, too, have a product-performance problem, why not consult with us. In addition to Nichrome and Nichrome V, we make over 80 alloys for the electronic and electrical industries. One or more of these may be what you are looking for.

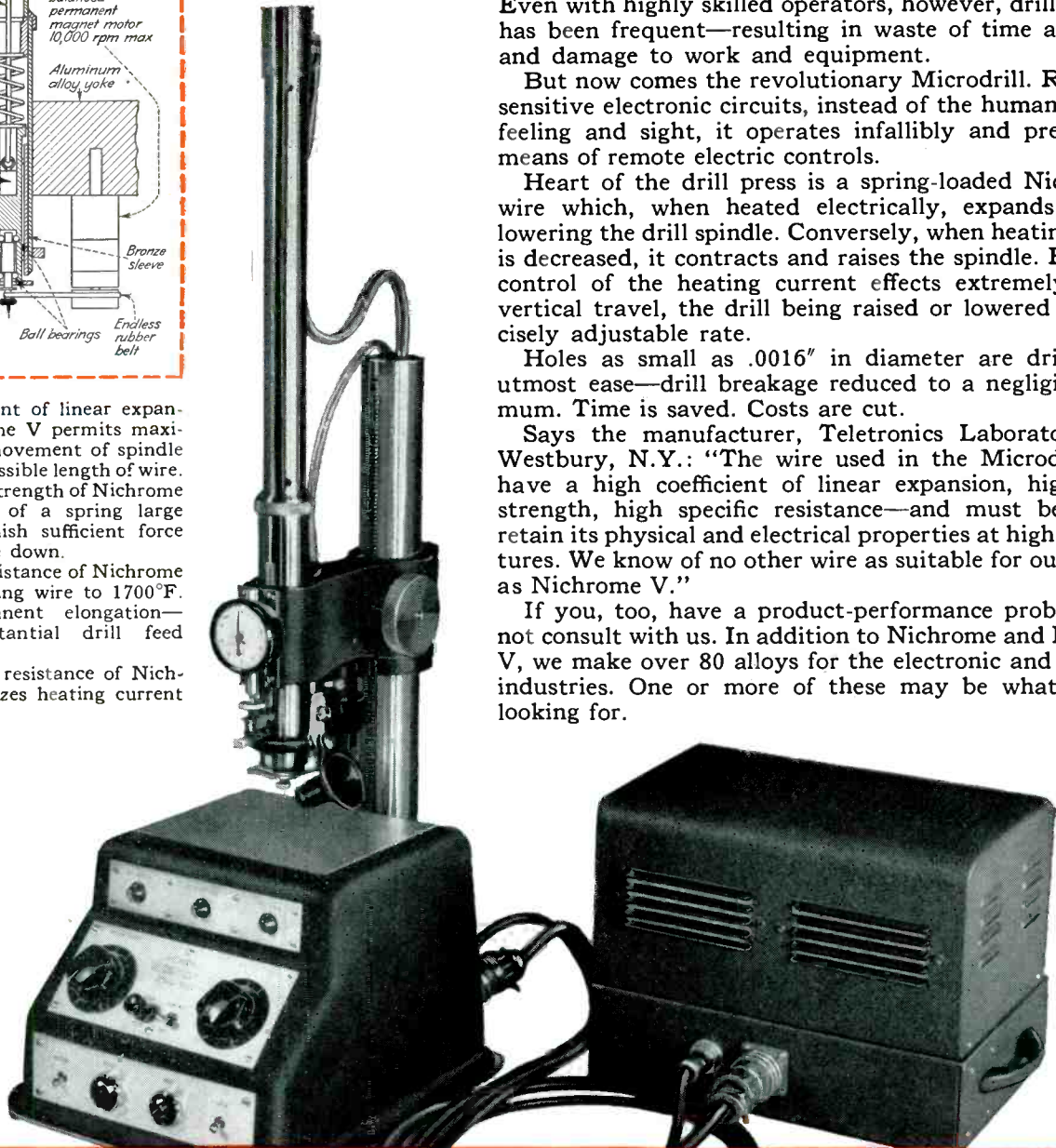

*Nichrome is manufactured only by

Driver-Harris Company

HARRISON, NEW JERSEY

BRANCHES: Chicago, Detroit, Cleveland, Los Angeles, San Francisco, Seattle

Manufactured and sold in Canada by

The B. GREENING WIRE COMPANY, LTD., Hamilton, Ontario, Canada

*T.M. Reg. U. S. Pat. Off.

ONCE AGAIN, MYCALEX 410 GETS THE CALL . . .

Leading Automobile firm specifies MYCALEX 410 molded insulation for new dashboard lightswitch . . .

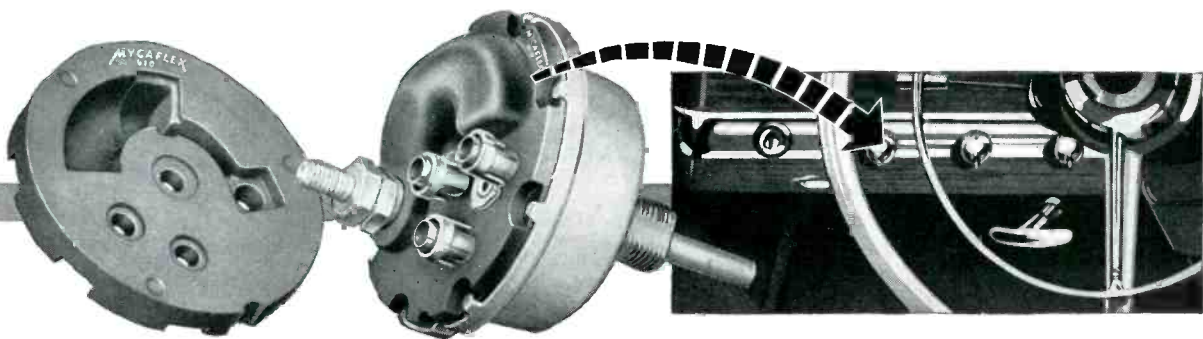

Sorry, we can't mention names, but this is the insulator body for a new type of dash-board light-switch being manufactured of MYCALEX 410 molded insulation for one of the leading lines of cars* . . . *names on request.

It's no great secret that automotive firms buy wisely and well . . . and it's justly proud we are that after making exhaustive tests and comparisons, this large maker of cars specified MYCALEX 410 molded insulation as ideal for the new type dash-board light-switch being introduced in their 1949 line.

Again, it was proved that on long run, round the clock production, MYCALEX 410 insulation parts, molded with or without metal inserts, are low-cost and competitive with less-effective molded insulation materials.

Again, MYCALEX 410 molded insulation demonstrated its absolute dimensional and electrical stability; low dielectric loss; high dielectric strength; high arc resistance; stability over wide

humidity and temperature changes; resistance to high temperatures, moisture and oils; and great mechanical precision and strength. Inserts of common or precious metals may be injected in the MYCALEX 410 molding process.

Yes, MYCALEX 410 molded insulation meets the most exacting requirements of high frequency applications.

REMEMBER . . .

MYCALEX 410 MOLDED INSULATION IS THE EXCLUSIVE FORMULATION OF MYCALEX CORPORATION OF AMERICA.

We stock these

MYCALEX 410

Tiny Tie-In Terminals

for . . .

Sub-miniature

Transmitting Equipment

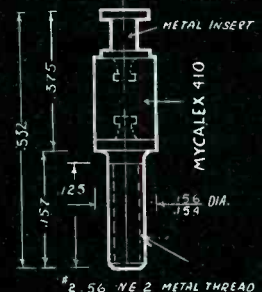

MYCALEX CORP. OF AMERICA

"Owners of 'MYCALEX' Patents"

Plant and General Offices, CLIFTON, N. J.

Executive Offices, 30 ROCKEFELLER PLAZA, NEW YORK 20, N. Y.

SIE

Custom-Built

TRANSFORMERS



At Standard Stock Prices

SIE, one of the leading designers and manufacturers of transformers and reactors for the petroleum geophysical industry, is a recognized specialist in the low frequency field of transformers and sub-sonic hermetically sealed transformers and reactors.

As a result of recently expanded plant capacity and the latest innovations in manufacturing techniques, SIE is now in a position to produce highest quality custom-built transformers and reactors to any desired specifications at standard stock prices.

SOUTHWESTERN INDUSTRIAL ELECTRONIC CO.

2831 POST OAK ROAD • HOUSTON, TEXAS

Distributed by
HARRISON EQUIPMENT COMPANY
 HOUSTON • DALLAS • TULSA



Send today for your FREE COPY of the SIE Transformer Catalog.

NAME _____
 TITLE _____
 COMPANY _____
 ADDRESS _____

The "EXTRA SOMETHING" that spells **TOP** **PERFORMANCE**

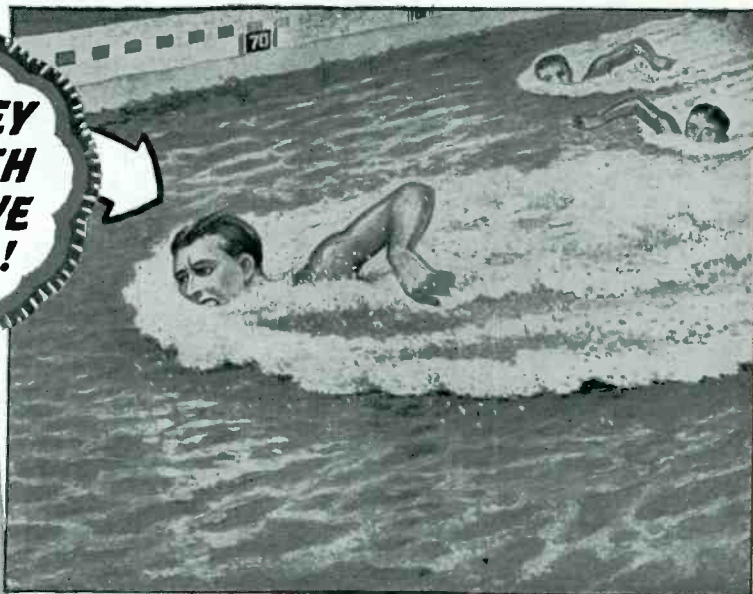
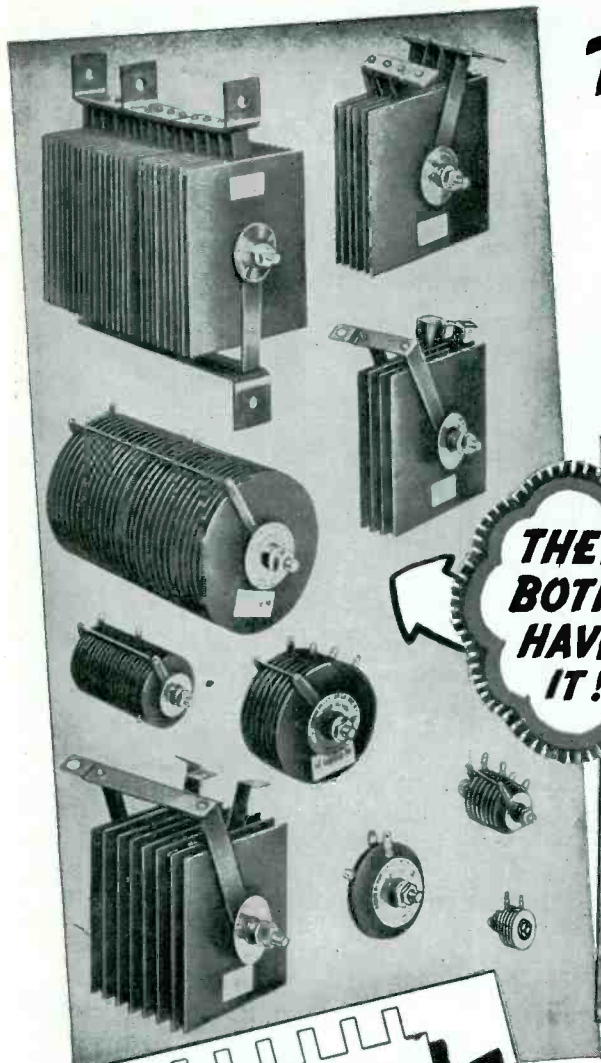

Seleton
SELENIUM RECTIFIERS

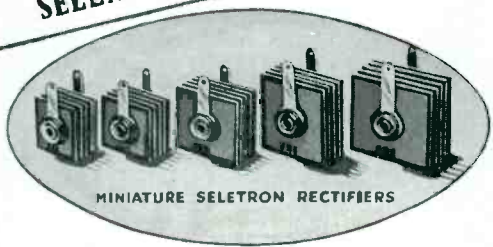

FOR ALL ELECTRONIC AND
RADIO APPLICATIONS

SPECIFY "SELETRON MINIATURES"

They insure dependable service.

| | | | | | | |
|----------------|--------|---------|---------|---------|---------|---------|
| Code Number | 5M4 | 5M1 | 5P1 | 5R1 | 5Q1 | 5S1 |
| Current Rating | 75 ma. | 100 ma. | 150 ma. | 200 ma. | 250 ma. | 500 ma. |
| Plate Height | 1" | 1" | 1 3/16" | 1 1/2" | 1 1/2" | 2" |
| Plate Width | 1" | 1" | 1 3/16" | 1 1/4" | 1 1/2" | 2" |

SLASHING his way to victory by powerful, telling strokes the swimming champion is first at the finish line by a safe margin—a winner because he has the "extra something" in skill and endurance that spells **TOP PERFORMANCE**.

Top performance in every rectifier application is assured to users of Seleton Selenium Rectifiers by reason of the "Extra Something" we put into them.

All chemicals of high purity to meet rigid special specifications.

Precision methods in all mechanical and chemical processes plus scrupulous care in assembling give them "Extra Something No. 2."

And to clinch all, every Seleton Selenium Rectifier must pass through an uncompromising series of tests and inspections, before we give it our OK for shipment to you.

Fabricated under such rigid rules, it is easy to understand why Seleton Rectifiers have won a nation-wide reputation for long dependable service in AC to DC applications of every type.

Furnished in a variety of assemblies to cover a wide range of currents and voltages.

Write today for Catalog
Address Dept. ES-19



SELETRON DIVISION
RR RADIO RECEPTOR COMPANY, Inc. RR

Since 1922 in Radio and Electronics

251 WEST 19TH STREET, NEW YORK 11, N. Y.

MEASURE TOTAL DISTORTION
Between 20 cps and 20 kc



330B DISTORTION ANALYZER

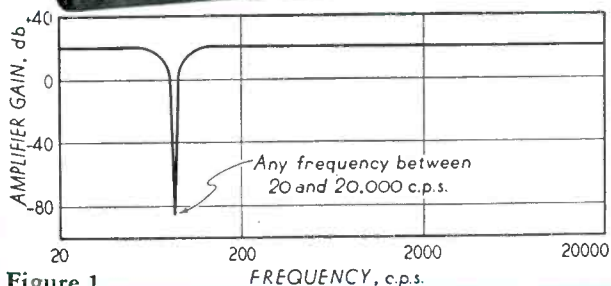

CHECK THESE SEVEN IMPORTANT FUNCTIONS:

1. Measures total audio distortion.
2. Checks distortion of modulated r-f carrier.
3. Determines voltage level, power output.
4. Measures amplifier gain and response.
5. Directly measures audio noise and hum.
6. Determines unknown audio frequencies.
7. Serves as high-gain, wide-band stabilized amplifier.

This fast, versatile *-hp-* 330B Analyzer measures distortion at *any* frequency from 20 cps to 20 kc. Measurements are made by eliminating the fundamental and comparing the ratio of the original wave with the total of remaining harmonic components. This comparison is made with a built-in vacuum tube voltmeter.

The unique *-hp-* resistance-tuned circuit used in this instrument is adapted from the famous *-hp-* 200 series oscillators. It provides almost infinite attenuation at one chosen frequency. All other frequencies are passed at the normal 20 db gain of the amplifier. Figure 1 shows how attenuation of approximately 80 db is achieved at any pre-selected point between 20 cps and 20 kc. Rejection is so sharp that second and higher harmonics are attenuated less than 10%.

Full-Fledged Voltmeter

As a high-impedance, wide-range, high-sensitivity vacuum tube voltmeter, this *-hp-* 330B gives precision response flat at any frequency from 10 cps to 100 kc. Nine full-scale

ranges are provided: .03, .1, .3, 1.0, 3.0, 10, 30, 100 and 300. Calibration from +2 to -12 db is provided, and ranges are related in 10 db steps.

The amplifier of the instrument can be used in cascade with the vacuum tube voltmeter to increase its sensitivity 100 times for noise and hum measurements.

Accuracy throughout is approximately $\pm 3\%$ and is unaffected by changing of tubes or line voltage variations. Output of the voltmeter has terminals for connection to an oscilloscope, to permit visual presentation of wave under measurement.

Measures Direct From R-F Carrier

The *-hp-* 330B incorporates a linear r-f detector to rectify the transmitted carrier, and input circuits are continuously variable from 500 kc to 60 mc in 6 bands.

Ease of operation, universal applicability, great stability and light weight of this unique *-hp-* 330B Analyzer make it ideal for almost any audio measurement in laboratory, broadcast or production line work. Full details are immediately available. Write or wire for them—today Hewlett-Packard Company, 1437A Page Mill Road, Palo Alto, Calif.

hp laboratory instruments
FOR SPEED AND ACCURACY

| | | |
|--------------------------------|-------------------------|------------------------|
| Noise and Distortion Analyzers | Wave Analyzers | Frequency Meters |
| Audio Frequency Oscillators | Audio Signal Generators | Vacuum Tube Voltmeters |
| Amplifiers | Power Supplies | UHF Signal Generators |
| Square Wave Generators | Frequency Standards | Attenuators |
| | | Electronic Tachometers |

How

GLOBAR

TRADE MARK

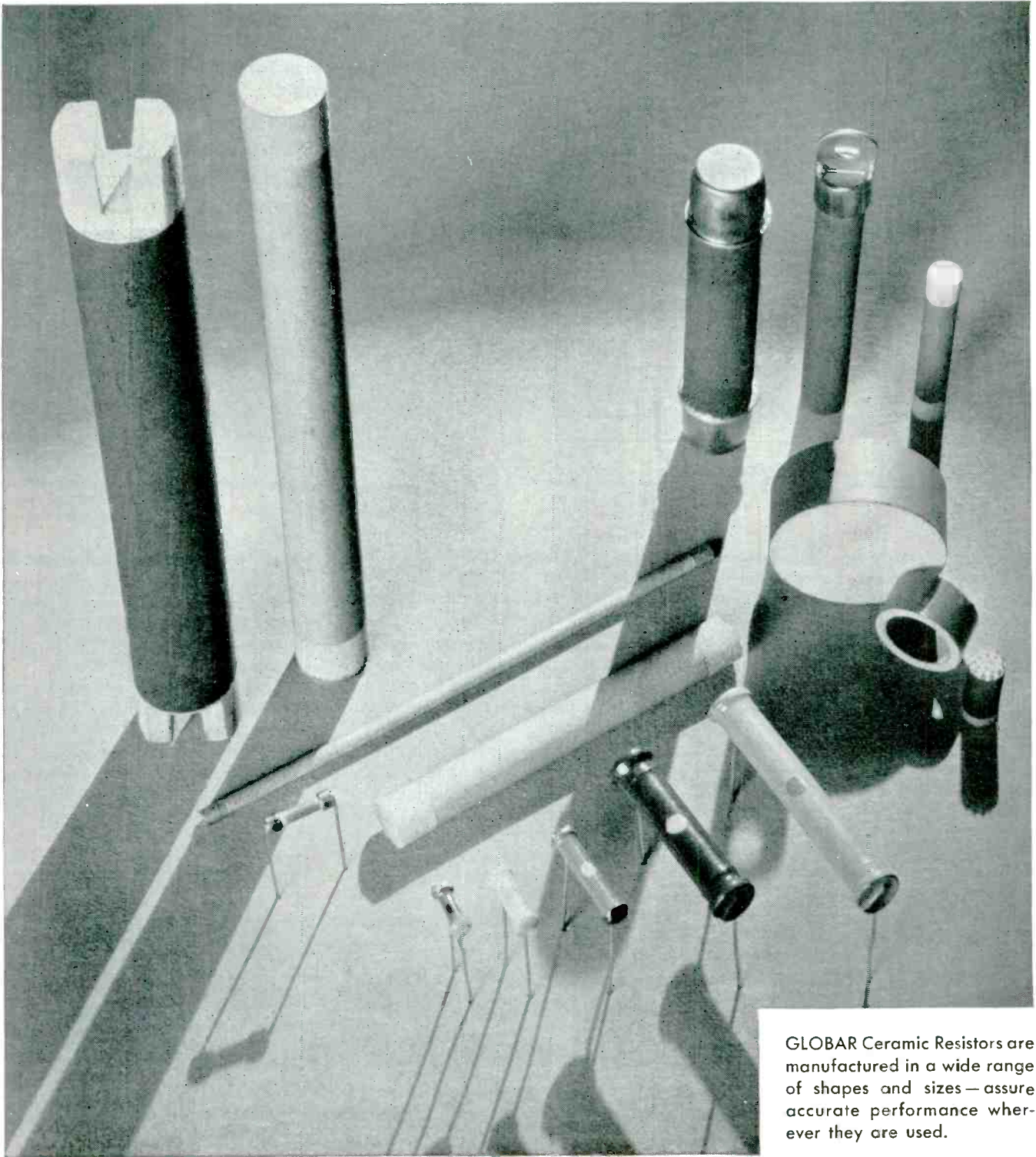

GLOBAR Ceramic Resistors are manufactured in a wide range of shapes and sizes — assure accurate performance wherever they are used.

Resistors Improve Product Performance

THE performance of electronic circuits in radio, television and industrial applications is improved through the use of GLOBAR Brand Ceramic Resistors. That's because GLOBAR resistors are made to meet the exact needs of your circuit. Through careful attention to design and composition, characteristics are imparted which insure accurate operation under the most difficult conditions. In many instances, they provide the most economical way of supplying resistor requirements.

The accompanying table lists a few of the general characteristics and typical applications of GLOBAR resistors. Where required, working samples of each of these types can be supplied for engineering tests. When requesting samples, complete information on your circuit should be furnished.

Bulletin R contains useful engineering data on GLOBAR Ceramic Resistors. Copies will be supplied immediately upon request.

There is no obligation. Write Dept. V-79, The Carborundum Company, GLOBAR Division, Niagara Falls, N. Y.



| TYPE | CHARACTERISTICS | TYPICAL APPLICATIONS |
|------|--|---|
| A | Low negative voltage and temperature sensitivity. | General purpose resistor for radio receivers and transmitters. |
| B | Medium negative voltage and temperature sensitivity. | Instrument compensation. X-Ray Equipment. |
| BNR | High negative voltage sensitivity. | Magnetic valves. Motor governors. |
| CX | Low negative voltage and low positive temperature sensitivity. | Radio transmitters for dummy antenna and parasitic suppressors. |
| F | High negative temperature sensitivity. | AC-DC radio receivers to prevent surge currents when starting tube filaments. |



GLOBAR Ceramic Resistors
BY CARBORUNDUM
TRADE MARK

"Carborundum" and "Globar" are registered trademarks which indicate manufacture by The Carborundum Company

MITCHELL RAND

M-R



friction and sealing tapes

M-R FASTHOLD FRICTION TAPE

Double Coated With Rubbery Compounds . . . Tensile Strength more than 44 lbs.—Adhesive Strength more than 50 lbs.

In the manufacture of FASTHOLD FRICTION TAPE the best procurable cotton sheeting (long staple 56/60) is first dried to eliminate moisture . . . then the fabric is thoroughly impregnated with a filler coat of insulating, waterproofing and preserving compound . . . after several days of drying a second coat, exceptionally heavy in rubber content, is forced through the fabric by means of enormous rollers . . . then follows another period of drying out before cutting and wrapping in tin foil for protection. The materials used and the precision and control exercised in the manufacture of FASTHOLD FRICTION TAPE enables it to meet all known electrical tests and requirements . . . and to Guarantee it against Unraveling or Drying Out. FASTHOLD FRICTION TAPE is New York warehouse stocked in widths of $\frac{3}{8}$ — $\frac{1}{2}$ — $\frac{3}{4}$ —1— $1\frac{1}{2}$ and 2 inches.

M-R ANHYDROUS SEALING TAPE

IMPROVES WITH AGE AND SERVICE

25.58% Cotton Sheeting • 74.42% M-R Insulating Compounds
Weatherproof . . . Waterproof . . . Acid, Alkali, Oilproof . . .
Permanently Flexible . . . Will not Vulcanize or Dry Out . . .
Tensile Strength 30 Pounds . . . Dielectric 1,000 volts

ANHYDROUS SEALING TAPE contains nothing which will injure fabrics or metals. It is made of the best procurable cotton sheeting and special M-R Bituminous Compounds. A wrapping of ANHYDROUS TAPE gradually becomes one solid mass (glass hard on the outside and soft inside) that excludes air, moisture, vapors, etc. It can be used to great advantage under conditions which disintegrate ordinary tapes; inside work where acids or alkali fumes or spray prevail; outside for cable joint insulation in conduits transformer connections, extreme high or low temperatures, etc., mines and damp places where atmospheric conditions and constant friction demand maximum wearing qualities. A joint, properly taped with ANHYDROUS, is absolutely waterproof even after complete submergence for many weeks. ANHYDROUS SEALING TAPES are New York warehouse stocked in widths of $\frac{3}{4}$ and $1\frac{1}{2}$ inches . . . other sizes are available, as ordered.

free
FOR THE ASKING...

Write today for samples of M-R Friction and Sealing Tapes . . . also your Free Card of Varnished Tubing with samples ranging from size 0 to 20 to fit wires from .032 to .325 inches . . . other valuable aids, are the M-R Guide Book of Electrical Insulation . . . the Wall Chart with reference tables, electrical symbols, allowable capacities of conductors, dielectric averages, thicknesses of insulating materials and tap drill sizes . . . and the M-R Wax and Compound Guide Book . . . they are full of valuable information . . . write for them on your letterhead.

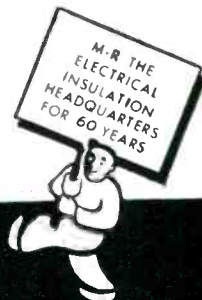

MITCHELL-RAND INSULATION CO. Inc.

51 MURRAY STREET • COrtlandt 7-9264 • NEW YORK 7, N. Y.

A PARTIAL LIST OF M-R PRODUCTS: FIBERGLAS VARNISHED TUBING, TAPE AND CLOTH • INSULATING PAPERS AND TWINES • CABLE FILLING AND POTHEAD COMPOUNDS • FRICTION TAPE AND SPLICE • TRANSFORMER COMPOUNDS • FIBERGLAS SATURATED SLEEVING • ASBESTOS SLEEVING AND TAPE • VARNISHED CAMBRIC CLOTH AND TAPE • MICA PLATE, TAPE, PAPER, CLOTH, TUBING • FIBERGLAS BRAIDED SLEEVING • COTTON TAPES, WEBBINGS AND SLEEVINGS • IMPREGNATED VARNISH TUBING • INSULATED VARNISHES OF ALL TYPES • EXTRUDED PLASTIC TUBING

"Give us the tools..."

YOUR ONLY CHANCE of Getting Ahead

Where is the "brave new world" so glowingly promised us by the politicians during and after the war? We were told then that postwar America would live 50% better than it had before. Why has that promise faded out? Why are men today discouraged and frustrated?

We have not yet made good 1944's promises because the *American worker turns out no more in an hour now than he did in 1941*. We are getting more total production in our country — but only because we have more people working. Not because each one of us is producing more. American industry's ability to turn out more and more goods — with less of each worker's time and effort — has been stymied for eight long years.

Progress has been blocked because in some cases workers have not been willing to work as hard as they did before the war. In other cases unions restrict the use of labor-saving machines and methods. In some places obsolete building codes and ordinances prevent advances. In still other cases progress has been blocked by collusive practices between unions and manufacturers or operators.

But the biggest block to progress is the fact that our industry in the United States has been unable to provide our workers with all the new tools and equipment that they need.

Increasing productivity — that is, each one of us turning out more in each hour of work — is the key to higher living standards. Productivity depends directly upon the kind of tools workers use.

His tools, more than anything else, determine how much a worker can turn out; and what his paycheck will buy depends in large part on what he turns out—not on how long or how hard he works.

Look what happened in our country in the forty years from 1900 to 1940. Productivity of the United States *more than doubled*. It doubled because:

Business investment in capital equipment gave workers new tools—tools that had three and one-half times as much power—

So—Americans' living standard rose almost 50% while the average work week was dropping from 61 to 43 hours.

Industry did continue to raise its output per man hour, even in the depressed 1930's. But it did it because, with unemployment widespread, companies used only their most efficient equipment. *Actually the great depression saw industry fall far behind in the job of providing workers with new tools.*

Then came World War II. Few new tools for peacetime industry were produced. *As a result of depression and war, the U.S. fell behind in needed investment in new industrial facilities by more than \$100 billion.*

Since the war business has spent almost \$60 billion for new plants and equipment —

But the greater part of that money went to *expand* production to take care of the needs of our bigger population, and to *replace* plants and equipment that were worn out and ready to be junked at the end of the war.

Only a small fraction of the \$60 billion went to *modernize equipment* — the equipment that increases efficiency and improves productivity of the individual worker.

Right now industry is desperately trying to do the job of increasing efficiency of machines so that each worker can turn out more.

McGraw-Hill's national survey of Business' Needs for New Plants and Equipment shows that manufacturers plan right now to spend in the 5 years ahead three-quarters of their capital funds to replace and modernize facilities. The biggest part of the more than \$55 billion industry plans to spend on its plants and equipment will go directly to improve efficiency of the individual.

If industry can carry through its plans — and expand them as it would like to and as it must do — the U. S. can catch up on its depression-war-time lag in progress within a few short years.

If American industry is allowed to earn the money to buy the equipment, it can raise the American standard of living 50% in our generation — in the next 25 years. No other nation can promise its people that much — and deliver on the promise.

But the promise can only be fulfilled by American industry. Wherever you turn, industry has dramatic new ways of doing things. Using oxygen by the ton, steel makers are increasing production from blast furnaces by 20%. New high-speed machine tools are doing three times the work of 1940 tools. A new coal-mining machine will multiply a miner's daily output 10 times. Diesel locomotives do the work of three steam locomotives on many jobs.

New products — and larger production of standard products — are already making their impact on American life. Two million Americans will get new television sets this year. Automatic washing machines, electric dishwashers, and home freezers are easing the daily tasks of thousands of housewives. Millions of homes that did not have them before the war now have telephones, automatic heat and refrigerators. Frozen foods, nylon clothing — these and many other things

coming along now — will shape the *real* new world for Americans.

But industry can provide them only if it can keep on investing at least \$15 billion a year now — and more in future years — in new plants and equipment.

Today Washington is taking a course which, if pursued, will make that investment by industry impossible. Government spending now strains our resources to the limit, and more multi-billion dollar spending proposals are being piled on. *But government spending cannot improve American living standards.* It never has, and it never will. Increasing government spending *now* will only block progress, because the government proposes to pay for its plans by taxing away the profits industry is using, and must continue to use, to improve and expand its plants and equipment — our only hope for greater worker productivity and higher living standards.

Better living can only be paid for with more production. And we can only get more production by increasing productivity — by each one of us producing more for each hour of work.

The first thing is to get the production — in peace and in war — for better living — for security. Industry is planning to provide it — and is using \$13 billion of its profits this year to improve and expand its facilities.

The only sensible, the only safe national policy is to make it possible for American industry to do its job — not to terrorize private industry with proposals of ruinous taxation and paralyzing controls and threats of nationalization. For American industry is not a thing apart from the American people any more than is government. American industry is the lifeblood of the American people and whatever makes industry do its work better contributes more to the common welfare than a bureaucratic government can ever hope to do.

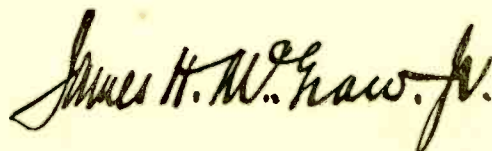

President, McGraw-Hill Publishing Company, Inc.

VALUABLE FIRST EDITION

FREE
ON
REQUEST*

JAN-C-25
specifications

CATALOG
No. 400

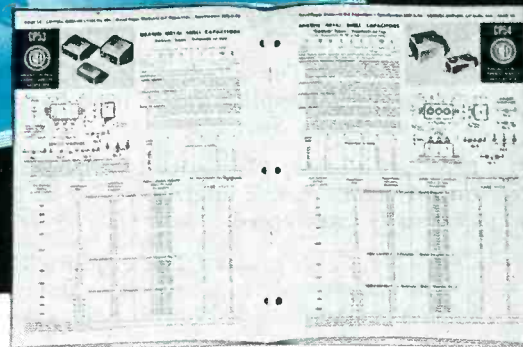
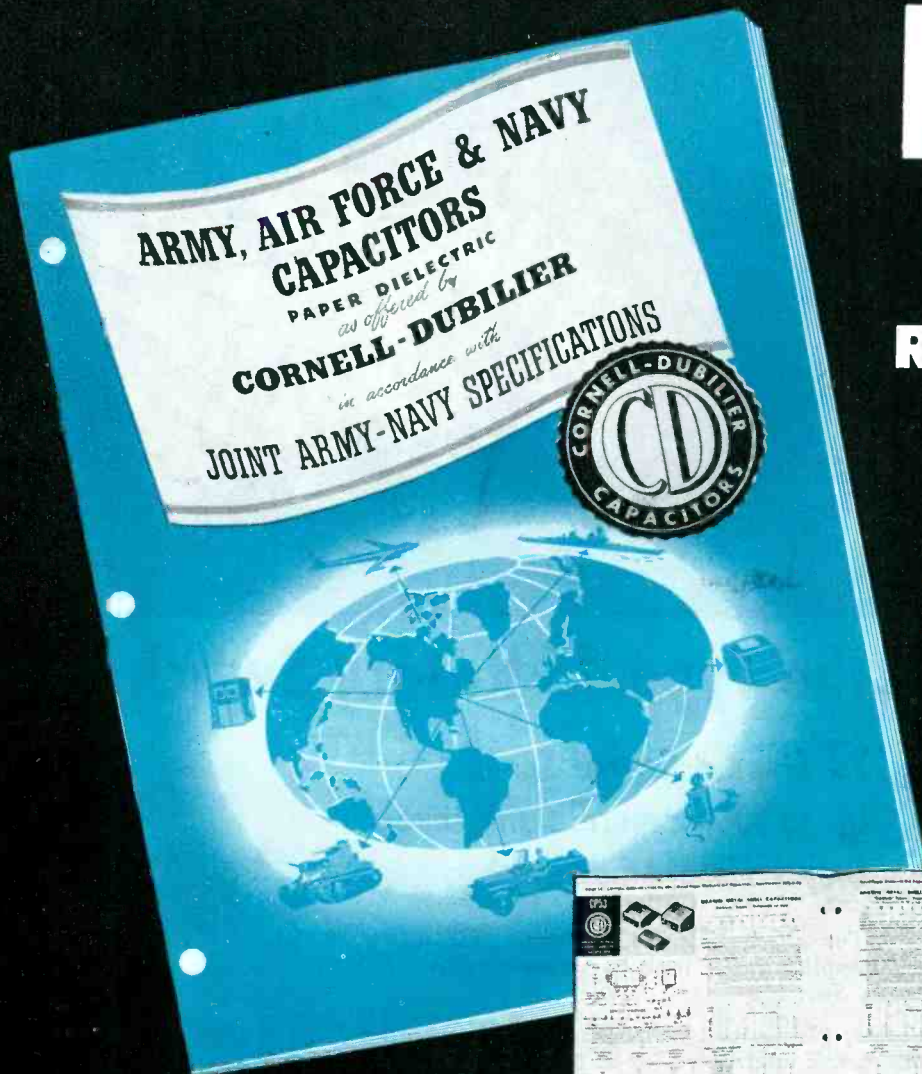

This conveniently arranged catalog illustrates and describes completely every capacitor in every case style listed in Specification JAN-C-25. All information for any given type is visible at a glance, without the annoyance of page turning or cross reference hunting. Prompt action is suggested before this first edition is exhausted.

Cornell-Dubilier Electric Corporation, Dept. K79, South Plainfield, New Jersey. Other plants in New Bedford, Worcester and Brookline, Mass.; Providence, R. I., Indianapolis, Ind., and subsidiary, The Radiart Corp., Cleveland, Ohio.

*Please use your business letterhead when requesting this JAN-C-25 Catalog Number 400

CORNELL-DUBILIER
Consistently Dependable
capacitors • vibrators
antennas • converters

1910



1949

Reg. U.S. Pat. Off.

C-D CAPACITORS—BEST BY FIELD TEST

new!

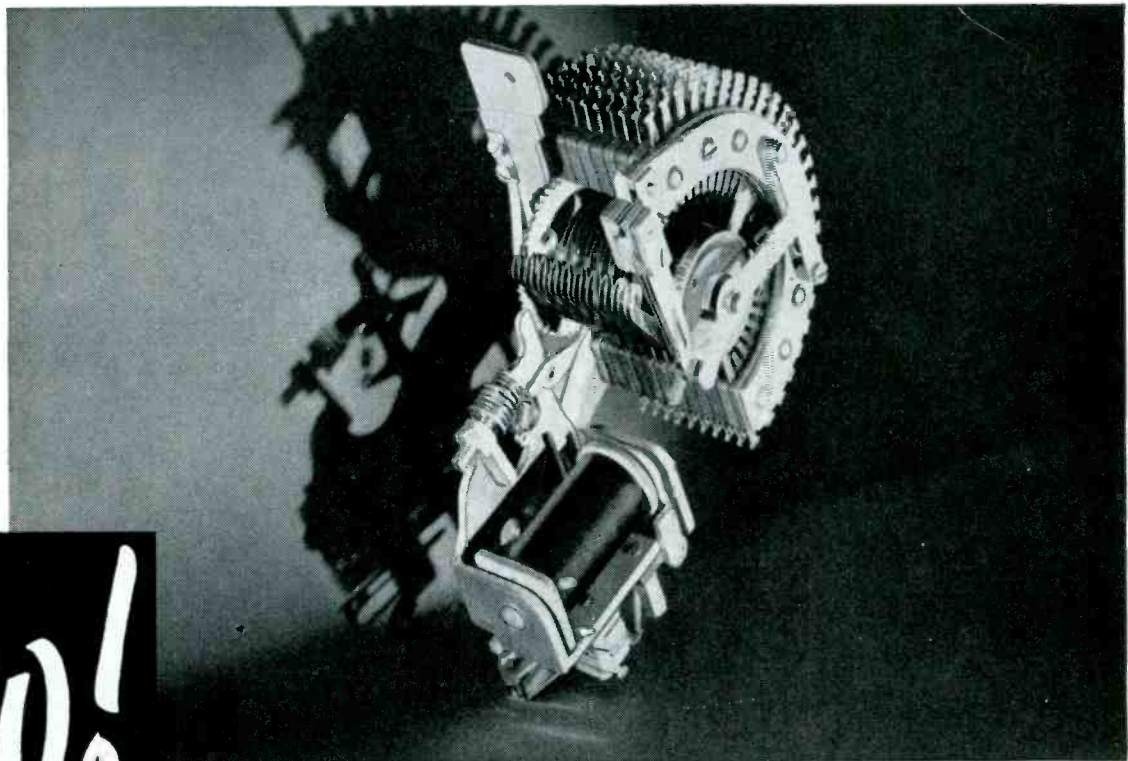

the Type 45 Rotary Switch

70 Steps a Second Speed
Up to 10 (or more) Bank Levels
Only 1 Field Adjustment

For *all* the features you want . . . in *any* remote-control application . . . look to Automatic Electric's Type 45 Rotary Switch!

SPEED . . . it's faster! It carries 10 wipers at 70 steps a second on 46 volts d.c. self-interrupted, or at 35 steps a second, externally interrupted.

CAPACITY . . . it's greater! Ten or more 25-point bank levels can be accommodated on the same frame, and single ended wipers can be provided for 50-point operation.

ADJUSTMENT . . . it's simpler! A rare readjustment of the interrupter springs is all that's normally required.

OPERATION . . . it's smoother! With an even load on *all* contacts, the Type 45 runs without galloping; there's no chatter or bounce.

ADAPTABILITY . . . it's more useful! With more levels, faster speed and 25- or 50-point operation, it's suitable for a wider variety of control applications.

For complete information on this switch that's new and better, write for our new circular.



the Class "B" Relay

Here's a new relay, too, that can be used for ordinary relay service—opening, closing or switching circuits—and for extremely high-speed operation. Independently operating twin contacts assure perfect contact operation. Contact points are dome-shaped to maintain uniformly low contact resistance. They may be arranged in one or two pile-ups with a maximum of 16 contacts on 13 springs in each pile.



Distributors in U. S. and Possessions:
Automatic Electric Sales Corporation
1033 West Van Buren Street, Chicago 7, Illinois
In Canada: Automatic Electric (Canada) Limited, Toronto

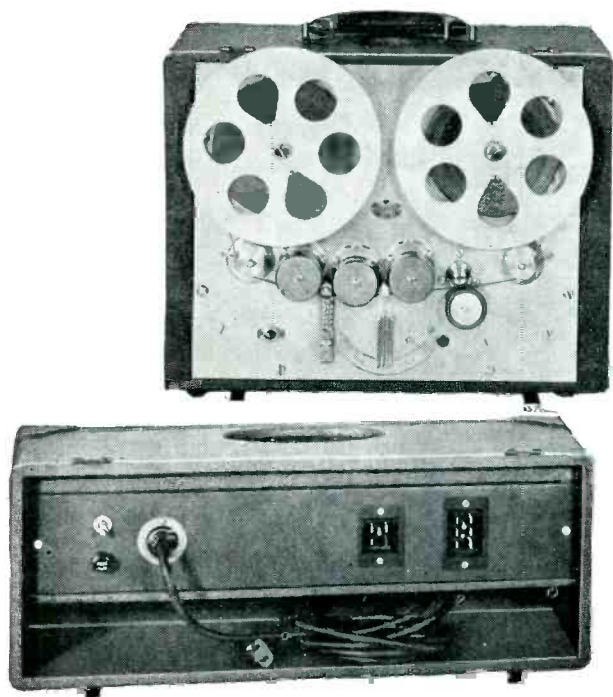

Comparisons

indicate this is the world's
finest recorder of its type

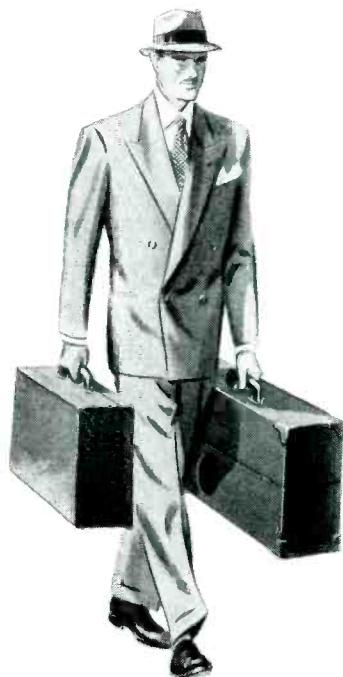

Complete in two easily portable cases—
one containing the recorder, the other
the amplifying equipment.

NEW PRESTO

Portable Tape Recorder 900-P

MANY OUTSTANDING FEATURES:

- Three separate heads for superior performance (and for monitoring direct from tape). One head each to erase, record and play back.
- 3 microphone channels with master gain control in recording amplifier.
- Weston type 30 V.U. meter with illuminated dial to indicate recording level, playback output level, bias current and erase current.
- 2-speed, single motor drive system. Toggle switch to change tape speeds from 7½" to 15" per second.

Don't choose your tape recorder until you see the *new* Presto Portable Tape Recorder. Write for complete details today.

Write today to be put on our mailing list for "The Presto Recorder," new house organ of practical ideas for anyone in the recording and broadcasting field.

Mailing Address: P. O. Box 500, Hackensack, N. J.
In Canada: WALTER P. DOWNS, Ltd., Dominion Square Building, Montreal



RECORDING CORPORATION
Paramus, New Jersey

WORLD'S LARGEST MANUFACTURER OF INSTANTANEOUS SOUND RECORDING EQUIPMENT AND DISCS

INSUROK

by RICHARDSON

Dependable names in plastics

UNDIVIDED RESPONSIBILITY

Many users of plastics enjoy Richardson's VARIETY of products and services. They like the convenience of handing all of their plastics problems to one organization. More important, they like for Richardson to assume complete responsibility for their plastics requirements.

Such an arrangement is possible with Richardson because here, from one company, you can get (1) Laminated INSUROK in a wide variety of grades suitable for virtually every plastic laminate requirement (2) complete punching facilities (3) complete fabricating facilities (4)

complete molding facilities (5) experienced engineering (6) complete laboratory facilities if your job calls for laboratory research (7) mold and die design and facilities to produce molds and dies and (8) conscientious, personal attention to your particular needs.

Why not see what this variety of products and services can do for you? Send a set of specifications today and learn, without obligation, how Richardson would approach your job . . . find out for yourself how Richardson's "undivided responsibility" can work to your advantage.

*INSUROK is a registered
trade-mark of
The Richardson Company*

The RICHARDSON COMPANY

GENERAL OFFICES: LOCKLAND, OHIO FOUNDED IN 1858

Sales Headquarters: MELROSE PARK, ILLINOIS

CLEVELAND - DETROIT - INDIANAPOLIS - MILWAUKEE - NEW BRUNSWICK, (N. J.) - NEW YORK - PHILADELPHIA - ROCHESTER - ST. LOUIS

Follow the Leaders to

Eimac
TUBES
The Power for R-F

Circuit Research

HELPS BUILD BETTER VACUUM TUBES

With the increasing demand for higher powers at higher frequencies the importance of close relationship between tube and circuit design has become paramount.

A large segment of the laboratory facilities at Eitel-McCullough is concerned with the development of basic new circuits closely correlated with vacuum tube development. The efforts of this group are receiving wide recognition for their outstanding accomplishments. These new circuits are being made available, as developed, to the industry enabling greater realization of a vacuum tube's potential abilities.

Evidence of these efforts is illustrated above . . . A 14-tube annular r-f generator. This compact equipment can provide 500 watts of CW power at 1000-Mc, and has operating possibilities as high as 2500-Mc. This is but one application of the basic annular circuit design developed by Eimac. The power-output in such a generator is directly proportional to the number of tubes used, and single tube efficiency is maintained.

EITEL-McCULLOUGH INC.

728 SAN MATEO AVE., SAN BRUNO, CALIFORNIA

Export Agents: Frazer & Hansen, 301 Clay St., San Francisco, California

These Three ALLIED POWER RELAYS

FROM SINGLE-POLE TO FOUR-POLE

TYPIFY ALLIED VERSATILITY

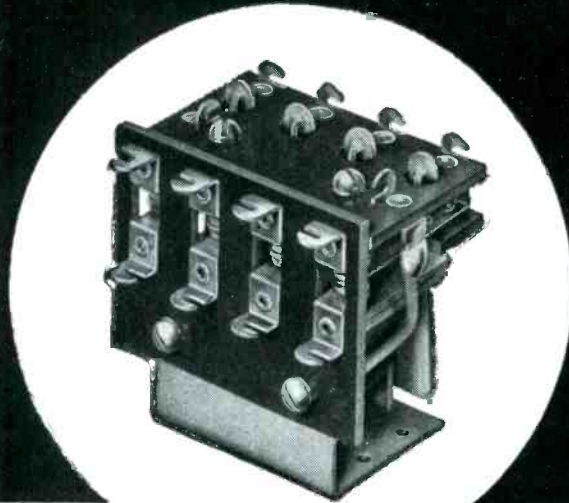

3-POLE & 4-POLE "PO" TYPE RELAY

This medium power relay is supplied with contact arrangements up to 4-pole double-throw. Standard silver contacts rated at 15 amperes for 24 volts DC or 110 volts AC non-inductive. Coil rating 2.5 watts up to 112 volts DC and 10.5 volt-amperes up to 230 volts AC. Dimensions: 3-pole 2-1/4" x 1-7/8" x 1-5/8". 4-pole 2-1/4" x 1-7/8" x 2-3/16".

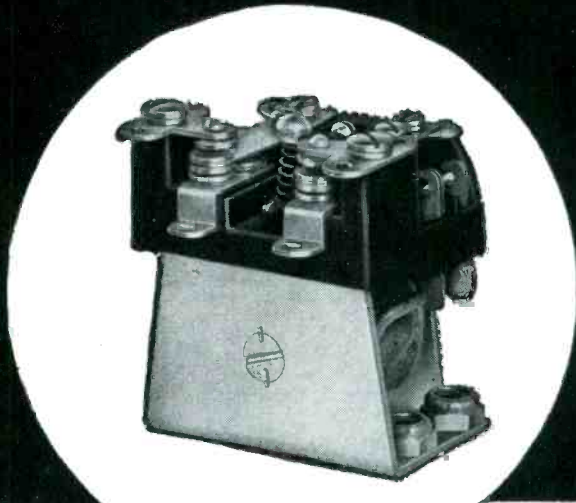

DOUBLE-POLE "BO" TYPE RELAY

This all-purpose power relay is supplied with single or double-throw contacts. Molded insulation throughout. Standard silver contacts rated at 15 amperes for 24 volts DC or 110 volts AC non-inductive. Coil rating of 2.5 watts up to 112 volts DC and 4.5 volt-amperes up to 250 volts AC. Dimensions: 1-7/8" x 1-13/32" x 1-5/8".

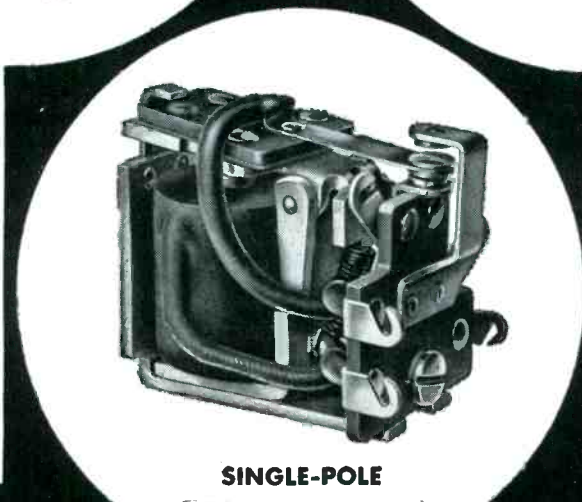

SINGLE-POLE "AS" TYPE RELAY

This small, light-weight power relay is supplied with single or double-throw contacts. Standard silver contacts rated at 5 amperes for 24 volts DC or 110 volts AC non-inductive. Coil rating 1 watt up to 95 volts DC and 3.5 volt-amperes up to 230 volts AC. Dimensions: 1-3/8" x 1-5/8" x 15/16".

Like all Allied Relays, types "AS," "BO" and "PO" may be had hermetically sealed, with choice of standard octal plug-in base or solder-type terminals.

For complete information on these and other Allied Relays, write for latest Bulletin.

NEW RELAY GUIDE

This new folder shows 24 small, compact Allied Relays with a carefully detailed table of characteristics and specifications. Write for YOUR free copy today.



ALLIED CONTROL COMPANY, INC.

2 EAST END AVENUE, NEW YORK 21, NEW YORK

New...
for positive identification...

**ERIE Radial Lead
 Insulated CERAMICONS[®]
 now have distinctive
*red bodies***

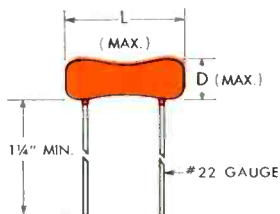
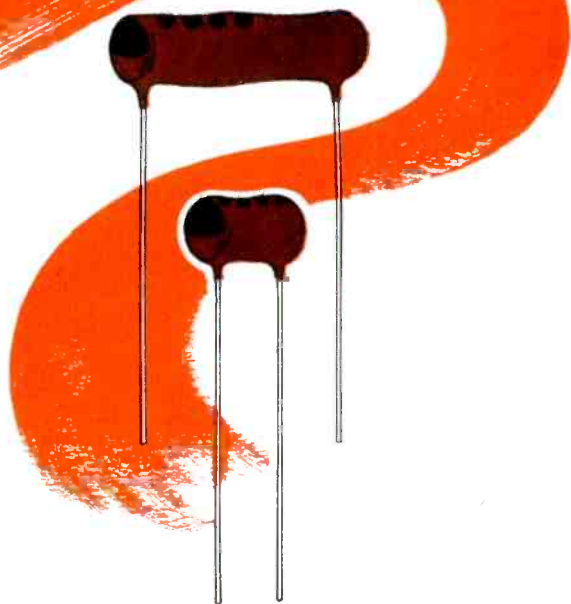

DIPPED PHENOLIC INSULATED

| Style | Dia. "D" | Length "L" | Max. Cap. |
|-------|----------|------------|-----------|
| 331 | .240 | .460 | 715 MMF |
| 332 | .240 | .710 | 1500 MMF |
| 338 | .312 | .550 | 2000 MMF |
| 337 | .312 | .937 | 4100 MMF |
| 333 | .315 | 1.250 | 5100 MMF |
| 344 | .415 | 1.213 | 8000 MMF |
| 335 | .415 | 1.650 | .012 MFD |
| 336 | .415 | 2.025 | .016 MFD |

ERIE brings order out of confusion . . . by the simple expedient of giving ERIE radial lead, dipped phenolic coated Ceramicons distinctive red bodies.

In the past manufacturers have found it almost impossible to differentiate between the various makes of such condensers. The common brown body color has sometimes caused confusion in incoming inspection departments and in the final assembly lines. In addition, it has been difficult to fix responsibility for any service reports.

Now, ERIE Radial Lead Insulated Ceramicons are positively and unmistakably identified . . . and the red body also makes it easier to read all RMA color code dots. ERIE axial lead ceramicons will continue to have molded low-loss phenolic insulation.

When you see ceramic condensers with the red body color, you can be sure you have high-quality, dependable ERIE radial lead insulated Ceramicons which will "stay put" in your chassis for the life of the set.



Electronics Division
ERIE RESISTOR CORP., ERIE, PA.
 LONDON, ENGLAND TORONTO, CANADA.



New washing machine cuts TV tube costs... with the help of Inco Alloys

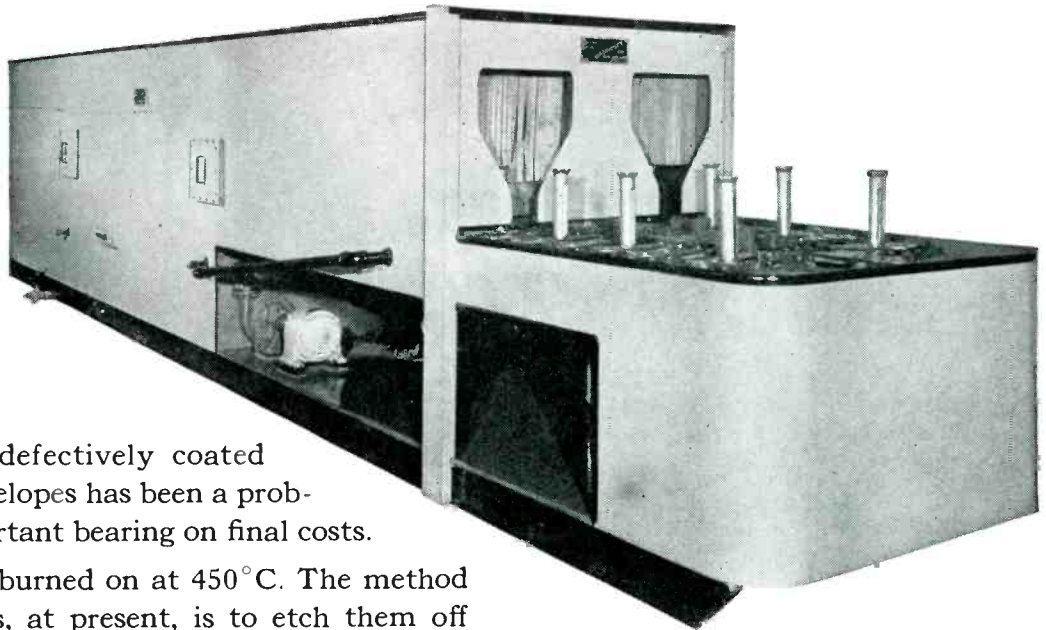

THE SALVAGING of defectively coated television tube envelopes has been a problem . . . with an important bearing on final costs.

Tube coatings are burned on at 450°C. The method of removing coatings, at present, is to etch them off with ammonium bifluoride or hydrofluoric acid.

Attempts to mechanize the "washing" or etching process ran into this difficulty . . . most metals suitable for machine construction were unable to withstand the corrosive attacks of the etchant solutions.

Inco's Corrosion Engineering Section helps

Now the Better Built Machinery Co. of New York City has designed a production machine to clean out new tube envelopes and also salvage defective ones. The problem of a material to resist action of the violently corrosive etching fluids was referred to International Nickel, where corrosion problems have been analyzed for over 40 years. Inco's Corrosion Engineering Section recommended: *Monel** for spray chamber liners and tube holders; *Ni-Resist** #2 castings for conveyors.

Result? The new Better Built tube washing machine . . . first of its kind . . . is now at work in the Allan B. Dumont Laboratories. And with tube envelope cleaning and reclaiming on a production basis, tube costs are expected to be significantly lowered.

If you have metal problems, talk them over with Inco. One of the versatile Inco Nickel Alloys may be the solution you are seeking.

THE INTERNATIONAL NICKEL COMPANY, INC.

67 Wall Street, New York 5, N. Y.

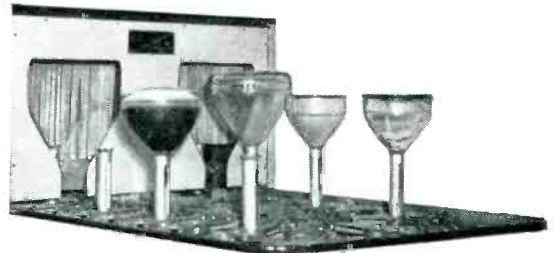

How the Better Built Tube Washer Operates

New tube envelopes and those with defective coatings are loaded onto the Monel tube holders. A conveyor, made of Ni-Resist #2 castings, carries the tubes through a Monel-lined spray chamber where etchant solutions "wash" away the unwanted coatings.

Final cleaning of the tubes is accomplished with a hot caustic wash, followed by several pre-rinses and a final rinse in distilled water.

The washing machine is 30 ft. long, 4½ ft. wide, and 6 ft. high. It follows the general design of standard Better Built machines used for washing glass containers and laboratory ware.

For further information about Better Built machines, write directly to:

BETTER BUILT MACHINE COMPANY
73 East 130th St., New York, N. Y.

EMBLEM OF SERVICE
NICKEL  **ALLOYS**

MONEL* • "K"* MONEL • "R"* MONEL • "KR"* MONEL
NICKEL • "D"* NICKEL • "Z"* NICKEL • INCONEL*
*Reg. U. S. Pat. Off.

You've a record year ahead...



LIVING ROOM



RECREATION ROOM



PLAY ROOM

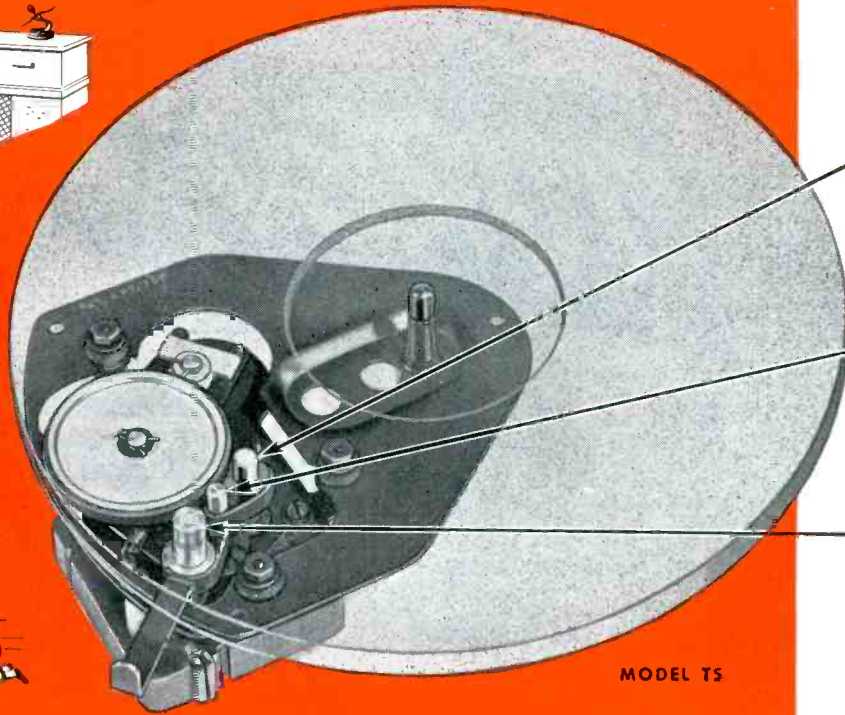

33½
RPM

78
RPM

45
RPM

MODEL TS

...WITH THIS **G** *3-Speed* PHONOMOTOR

Here's the motor that plays all three types of records without fuss or bother . . . the *one* motor designed, engineered and built to enable radio and phonograph manufacturers to offer their customers dependable, *complete* record entertainment. It's GENERAL INDUSTRIES' new Model TS three-speed phonomotor.

External speed change lever affords positive, accurate shifting to any of the three speeds without removing the turntable. Ingenious, yet simple, shift mechanism is both trouble-free and fool-proof. Compact size of motor makes it ideally suited for portables as well as console models. Cost is surprisingly low.

For complete information—blueprints, performance specifications and quotations—write, wire or phone *today*.



The GENERAL INDUSTRIES Co.

DEPARTMENT B • ELYRIA, OHIO

INSULATION COSTS GO

DOWN WITH

TURBO SATURATED SLEEVING*

*EXCLUSIVELY PROCESSED FOR

HIGHER TENSILE STRENGTH

GREATER FLEXIBILITY

ABSOLUTE CONCENTRICITY

SLOW BURNING COMPOSITION

LOW MOISTURE ABSORPTION

FREEDOM FROM PEELING

CHECK THESE **TURBO** PRODUCTS FOR ALL YOUR INSULATION NEEDS

- TURBO VARNISHED TUBING FOR HIGH VOLTAGE
- TURBO EXTRUDED TUBING FOR EXTREME TEMPERATURE
- TURBO GLASS TUBING FOR HIGH HEAT RESISTANCE
- TURBO REL-16-A TUBING FOR SUPER-FLEXIBILITY
- MICA PLATE, BLOCK FILMS AND SEGMENTS
- TURBO WIRE MARKERS FOR LASTING IDENTIFICATION
- VARNISHED CAMBRIC AND PAPER TAPE

Write today for your free sample board of TURBO Tubing—no obligation.



SPECIFICATIONS

| | |
|----------------|---|
| SIZES | 41 sizes from .022" to 1.5" inside dia. |
| LENGTHS | Standard bundles of 42" strands. Sizes 13 to 24 inclusive can be supplied in any length on spools. |
| COLORS | Black, yellow, red, green, brown, blue. Standard up to Size No. 12. Black and yellow on larger sizes. Other colors special. |

A low cost insulation tubing impregnated for maximum serviceability and extra long life!

TURBO Saturated Sleeving is made from select cotton braid sleeving, saturated with a special TURBO varnish that seals every pore without impairing flexibility. While relatively low in cost, this tubing offers excellent advantages in general wiring applications—becoming all-purpose when only moderate temper-

ature extremes are encountered, and where electrical stress does not exceed 1200 volts. The impregnation applied to TURBO Saturated Sleeving insures negligible moisture absorption and imparts a high resistance to acid and oil. TURBO Saturated Sleeving is slow burning.

Full particulars on request — please address inquiries on company letterhead



WILLIAM BRAND & COMPANY

276 FOURTH AVE., NEW YORK 10, N. Y. • 325 W. HURON ST., CHICAGO 10, ILL.

To Top Flight Development, Design and Instrumentation Engineers:



TYPE 1A-60

This table gives the characteristics of Arma Two-Phase Induction Motors. The information may suggest applications of these components to your designs.

| Type | Field Voltages | | No Load Speed R.P.M. (Min.) | Max. Watts Output @ R.P.M. | Stalled Torque Oz. In. (Min.) | Rotor Inertia Oz. In. ² | Weight (Lbs.) |
|--------|----------------|---------|--------------------------------|----------------------------------|-------------------------------------|--|------------------|
| | Main | Control | | | | | |
| 1A60 | 40 | 40 | 3200 | 1.5 @ 1500 | 1.7 | 0.03 | 0.8 |
| 1B60 | 115 | 115 | 3000 | 2.4 @ 2000 | 3.0 | 0.25 | 1.4 |
| 1D60 | 115 | 115 | 3000 | 6.4 @ 2150 | 8.0 | 0.25 | 1.4 |
| 1E60 | 115 | 110 | 3000 | 6.0 @ 2000 | 7.5 | 0.04 | 1.5 |
| *1A400 | 115 | 115 | 9800 | 1.6 @ 5300 | 0.9 | 0.03 | 0.8 |
| 5A | 75 | 90 | 3000 | 6.3 @ 1800 | 8.0 | 0.32 | 4.0 |
| †5C | 90 | 75 | 3000 | 7.5 @ 2000 | 8.0 | 5.51 | 4.3 |
| 6 | 115 | 90 | 3000 | 18.0 @ 2000 | 17.0 | 1.38 | 9.8 |

Operating Ambient Temperature Range 0°C to 55°C.
Reversible Rotation. 2 Phase. 60 Cycle.
*400 Cycle Unit. †High-Inertia Rotor.

These Two-Phase Induction Motors Extend the Possibilities of Precision Instrumentation

Arma Corporation designed and built them for use in some of the highest-precision control systems, electromechanical computing systems and servo mechanisms ever devised. Long unpublicized because of security restrictions, many engineers are yet to have their first opportunity to consider new applications of these motors.

Response of Arma Induction Motors is Phenomenally Rapid

Full-Speed reversing in as little as three one-hundredth second characterizes the unusual acceleration and deceleration of Arma Induction Motors. This derives from the high torque-to-inertia ratio reflected in the table of characteristics. Such rapid response might well set new standards of automatic operation for industrial processes too complex to be trusted to manual operation.

Other Advantages of Arma Induction Motors

No Preferred Positions. Symmetrical rotor design eliminates all "clogging" or slot effects.

High Mechanical Accuracy. Extremely close tolerances make possible precise assembly and complete interchangeability.

Minimum Inductive Interference. Stray fields are low, larger types are shielded.

Arma Induction Motors are designed to minimize the possibility of damage by shock or corrosion. They are nearly noiseless in operation. All types have double shaft extensions.

Use These Other Arma Components, Too

Investigate possible applications of these other Arma components released for private industry: Tachometer-type Induction Generators for high-performance servo systems; Electrical Resolvers* for solving problems involving triangles, coordinates and vectors; Synchro Units for remote control and indicating purposes; high-precision Mechanical Differentials for computing applications.

How Ideas Become Realities

For over 30 years Arma Corporation has been quietly taking on (under wraps) one complex development and design problem after another for the U. S. military establishments—problems concerned with instrumentation. In the initial stage these problems may be little more than a gleam in someone's eye, a vague hope, a "dream"! That's where Arma starts. When Arma finishes, the problem is not only solved but the actual equipment to do the job, built—whether it be a complicated gun director, a gyro compass or a complex remote control system. Arma follows through to practical realities.

You are invited to request whatever information you may need to explore the possibilities of making use of any Arma product which has been released from security restrictions.

A R M A C O R P O R A T I O N

254 361st STREET, BROOKLYN 32, N. Y.

SUBSIDIARY OF AMERICAN BOSCH CORPORATION

ARMA
PRODUCTS
RELEASED
FOR
PRIVATE
INDUSTRY

ARMA ELECTRICAL RESOLVERS • ARMA SYNCHROS • ARMA INDUCTION MOTORS • ARMA INDUCTION GENERATORS • ARMA MECHANICAL DIFFERENTIALS • ARMA ALTERNATING VOLTAGE COMPARATOR • COMPUTING MECHANISMS • INDUSTRIAL CONTROLS • STABILIZATION DEVICES • NAVIGATIONAL EQUIPMENT • LIMITRON AUTOMATIC INSPECTION SYSTEM

* Licensed for use under Arma patents Nos. 2,465,624 and 2,467,646. License information available.

QUALITY



PRECISION

When the Heat's on!

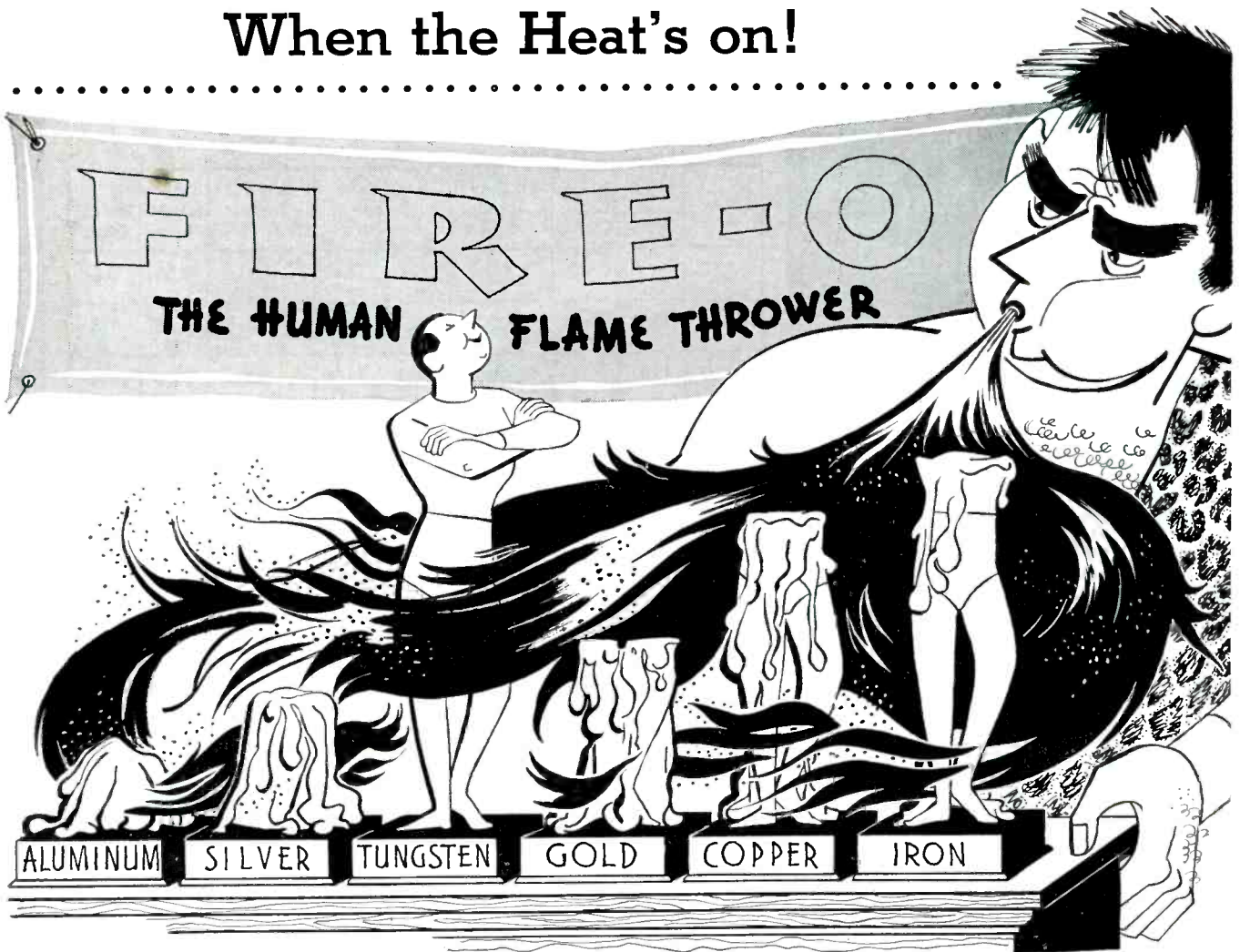

BECAUSE the *melting point* of tungsten is higher than the *boiling point* of iron, copper, aluminum, silver, gold, and nickel, it is the perfect material for the application of heat in processes which involve a physical change in these metals. More and more, manufacturers are adapting improved techniques made possible by tungsten's exceptional qualities as a substitute for conventional methods.

ELMET Tungsten offers unique possibilities to manufacturers with production problems calling for a metal which combines the features of strength, hardness, ductility, and resistance to unusually high temperatures. North American Philips can supply tungsten in powder, rod, or wire form to your precise specifications. We will be glad to show you how ELMET Tungsten can fit your particular requirements.

★ ★ ★

North American Philips also specializes in drawing, enameling, and plating extremely fine wires in practically all metals and alloys.

So when you have a problem on Fine Wire, Tungsten, or Molybdenum, why not call on Fine Wire Headquarters—phone, wire, or write to North American Philips, makers of NORELCO Fine Wires and ELMET Tungsten and Molybdenum products.

NORTH AMERICAN PHILIPS COMPANY, INC.

Dept. FA-7, 100 East 42nd Street, New York 17, N. Y.



THESE NEW LONG-LIVED THYRATRONS LEAD FOR MOTOR-CONTROL APPLICATIONS

With oversize gas charge to offset absorption from inductive loads

- high anode voltage
- high peak-to-average current ratio
- stable control characteristics
- short heating time
- “climate-proof” ambient temperature range

GL-5544



GL-5545



SPECIFY General Electric's 3.2-amp GL-5544 or 6.4-amp GL-5545 for the motor-control unit now on your drawing-boards. Your equipment will benefit (no snubber circuit is needed with these tubes), while users will have the advantage and economy of full-measure tube life.

Both thyratrons have a charge of inert gas twice that of former types—sufficient to offset anode gas absorption caused by the inductive load in field and armature-control circuits.

Though of paramount value, this is but one of many improvements that put the GL-5544 and GL-5545 far ahead of other gas-filled thyratrons. Study the list of features above. Then add *strength of construction*. Key tube parts are internally braced; the grid-anode structure is solidly supported both at top and bottom. Add *electrical stability* . . . a special shielded-grid design cushions any grid effect from voltage surges. Here are dependable tubes you can count on to do a job where men are pushing machines hard for high production!

Help in applying the GL-5544 or GL-5545 to new motor-control circuits gladly will be given you by experienced G-E tube engineers. Phone your nearby G-E electronics office. Or wire or write *General Electric Company, Electronics Department, Schenectady 5, New York.*



“THEY OUTLAST AND
OUT-PERFORM GAS-FILLED
TUBES OF EARLIER DESIGN”

| | GL-5544 | GL-5545 |
|---|--------------|--------------|
| Filament voltage | 2.5 v | 2.5 v |
| Filament current | 12 amp | 21 amp |
| Peak anode voltage, forward and inverse | 1,500 v | 1,500 v |
| Peak cathode current | 40 amp | 80 amp |
| Avg cathode current | 3.2 amp | 6.4 amp |
| Current averaging time | 15 sec | 15 sec |
| Ambient temp range | -55 to +70 c | -55 to +70 c |

GENERAL ELECTRIC

180-H28

FIRST AND GREATEST NAME IN ELECTRONICS

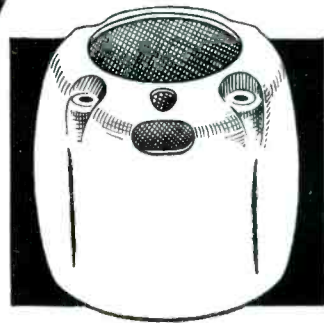

Line sketch shows unusual contour of barrel shaped metal stamping.

AN ACCOMPLISHMENT IN METAL FORMING . . .

An ordinary cylindrical shape presents no particular metal stamping problem. However, to maintain the precise specifications of this barrel shaped body in perfect concentricity presented an unusual and difficult manufacturing problem.

Ribs were provided in the body for strength and to overcome the need for appurtenant reinforcements. Another feature . . . to aid economy in assembling, the bolt head seats were struck flat, eliminating the need for costly machining.

Again Presteel engineering, toolmaking and metal forming techniques made a routine job out of the unusual.

ALLOY STEELS AND OTHER
METALS COLD FASHIONED
SINCE 1883



Representatives in ALEXANDRIA, VA. • BUFFALO • CANTON, OHIO • CHICAGO
DENVER • DETROIT • FORT WORTH • INDIANAPOLIS • LOS ANGELES • NEW YORK
PHILADELPHIA • SYRACUSE • TORONTO, CANADA

WORCESTER PRESSED STEEL CO.

307 BARBER AVENUE
WORCESTER 6, MASS.

FONO-FITTED



CARTRIDGES

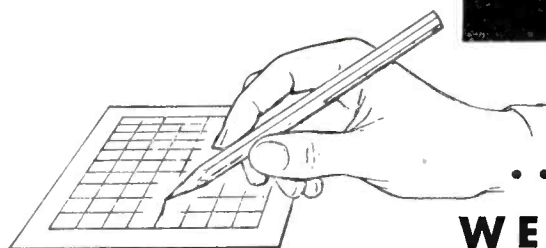

... you draw the curve
WE'LL BUILD THE CARTRIDGE

Your specifications . . . your special requirements in phono pickup cartridges . . . are ideally "custom-solved" through E-V creative engineering . . . unusual manufacturing facilities . . . and inherent advantages of exclusive TORQUE DRIVE.*

CUSTOM RESPONSE

Smooth upper response with roll off frequency to your specifications or wide range, peak-free response to 10 kc. You draw the curve, we'll build the cartridge.

VOLTAGE

E-V TORQUE DRIVE cartridges provide the highest compliance per volt output. For example, the E-V 14 cartridge tracks at 5 grams with excellent wave form down through 50 c.p.s. on the RCA 12-5-31V record at 1 volt at 1,000 c.p.s.

TRACKING FORCE

With the high compliance and low mass of the driving system, needle forces at 5 grams for both one and three mil records are used in everyday production by leading manufacturers. Cartridges with even lower needle force with slight reduction in voltage are thoroughly practical. 3 gram tracking pressures are definitely in sight.

**COMBINATION
One and Three Mil**

E-V TORQUE DRIVE again leads in twin needle cartridge design. Tracking force of 5 grams on both one and three mil records precludes weight changing. Straight line needle position assures accurate set down when used with changers. Approximately the same output is obtained on both styli. The E-V Twin-Tilt cartridge mounts in any arm with 1/2" mounting holes with no modification except adjustment for correct needle force.

MOISTURE PROOFING

The cartridge is *entirely filled* with DC4 Silicone jelly—the material that is used for inhibiting moisture on aircraft wiring. Tests indicate that it increases the life of an ordinary crystal *some 20 times*. This is a *plus* feature, found in all E-V crystal cartridges.

Our engineering staff and full facilities are at your service. Contact us today.



Modern One-Acre Plant with Complete Internal Facilities for Quality-Controlled Volume Production

From original conception to final product, you get full benefit of the unusual E-V processes. Here are E-V laboratories, where constant research keeps making new contributions to the Art. Here we make tools and dies . . . die cast, plate, screw machine, stamp, mold plastics, and assemble. Here we use specially designed test equipment for quality control. With all these facilities, we produce high standard acoustical products in quantity, with utmost economy. Come—see this plant in action.

NO FINER CHOICE THAN

Electro-Voice

*E-V Pat. Pending
Licensed under Brush patents

Export: 13 East 40th St., New York 16, U.S.A.
Cables: Arlab

ELECTRO-VOICE, INC. • BUCHANAN, MICHIGAN

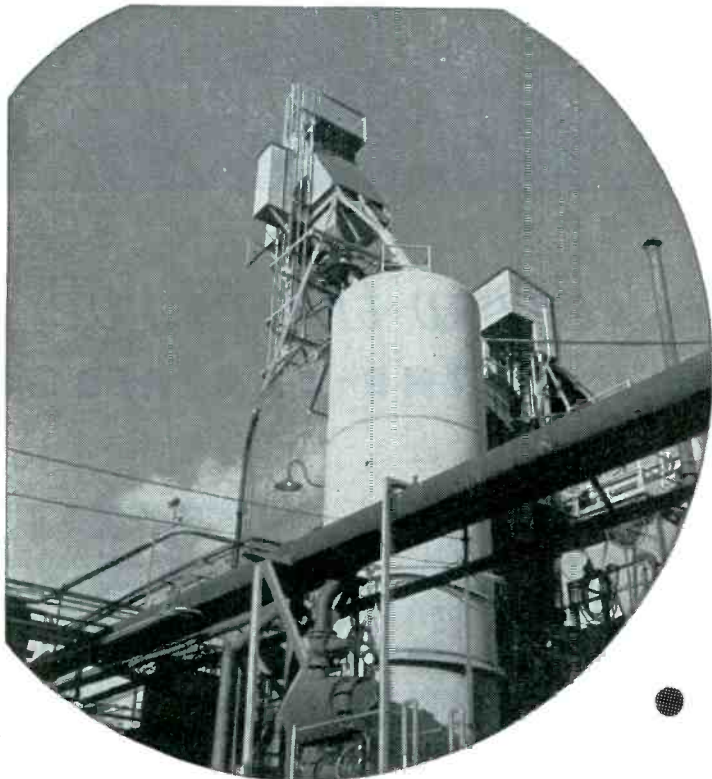

Chemically Processed—Highly specialized chemical equipment, such as illustrated here, reacts carbon monoxide with iron-containing ores to form liquid iron pentacarbonyl. Further processing decomposes the liquid into the spheres which are Carbonyl Iron Powder. The closest attention to detail assures products of constantly uniform properties.

carbonyl iron

Plant Facilities—The Grasselli N. J. plant, right, was the sole producer of Carbonyl Iron Powders until this month. Now, increased production will be forthcoming from the new plant at Huntsville, Ala. The demand for all grades of Carbonyl Iron Powder has made this production increase necessary.

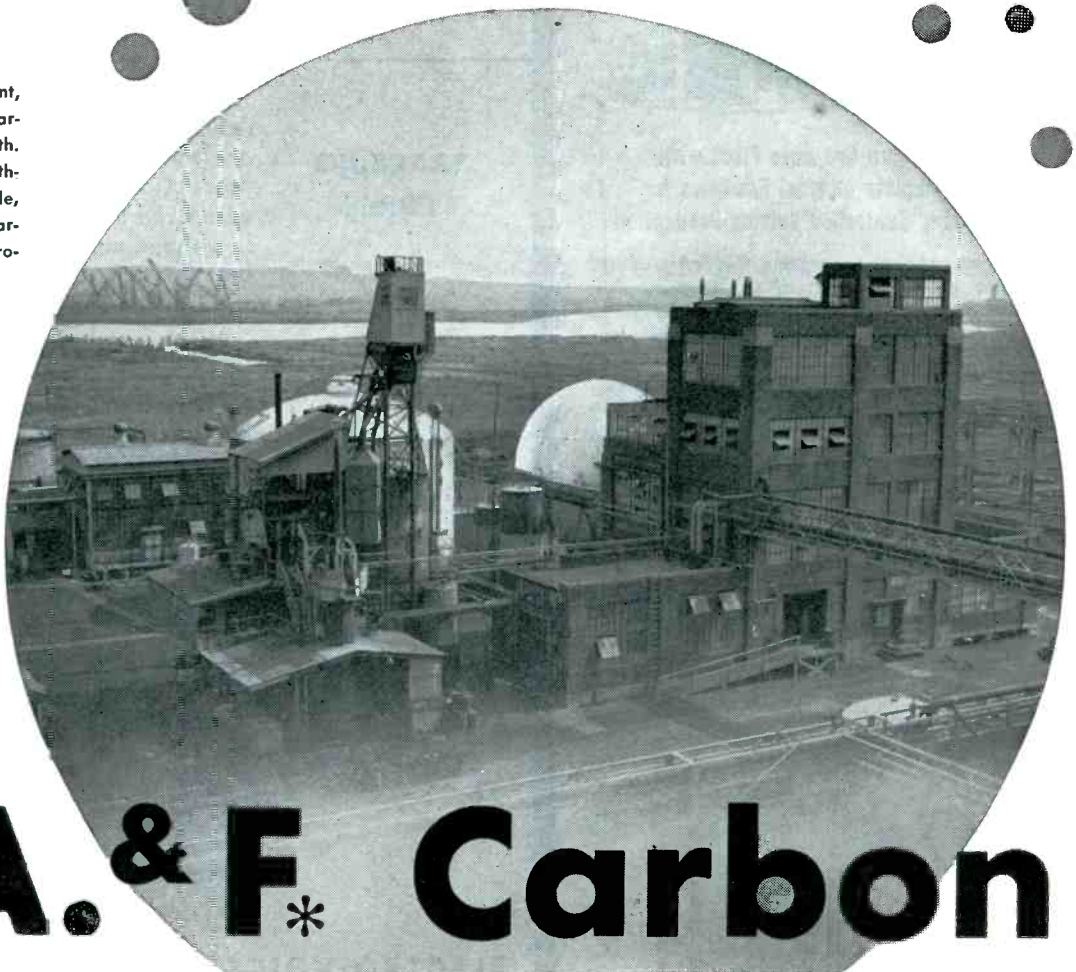

G. A. & F. Carbon

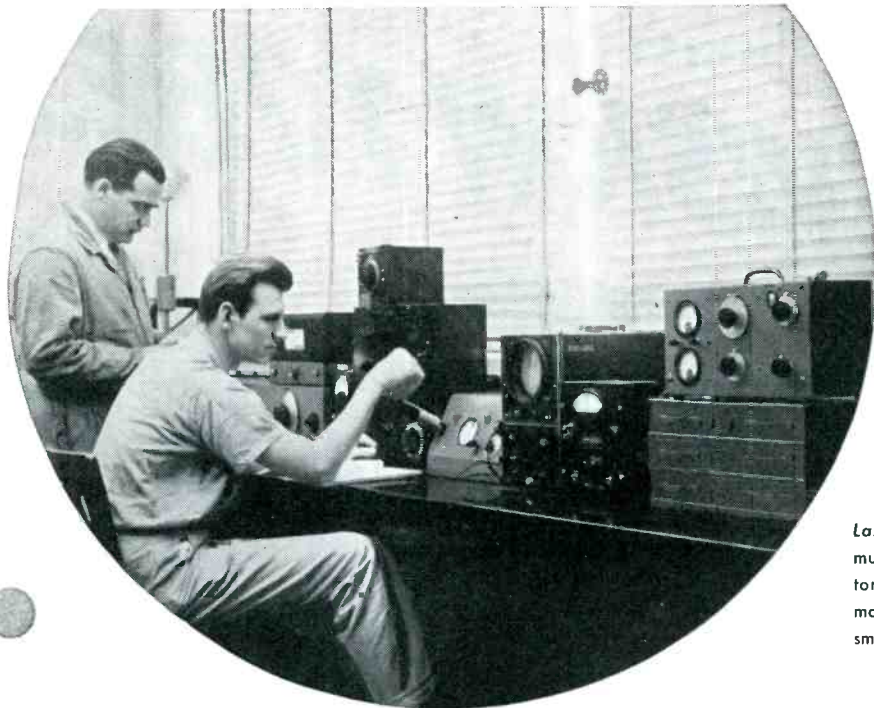

Laboratory Controlled—Every batch of CIP must be put through very extensive laboratory tests to keep quality high. Test cores are made from every batch at the lab. Above, a small section of the test equipment.

powders are superior

Carbonyl Iron Powders are high quality products with low loss characteristics—superior in every way because this quality is achieved by strict control in processing. These high “Q” materials work best because they are manufactured and tested for quality under the most careful conditions.

Chemically, Carbonyl Iron Powders are high in iron with an absence of non-ferrous materials. Structurally, the particles are spherical, built up of concentric cells. Particle distributions range from 0.5 to 15 microns diameter. Some grades are mechanically hard and quite incompressible. Hysteresis loss is low, insulation is easy thus keeping eddy currents low. Particle size distribution is controlled.

The illustrations on these pages show to some extent the manufacture, the tests for quality, and the checks on control made by GA&F. For more detailed information on any problem involving Carbonyl Iron Powders write . . .

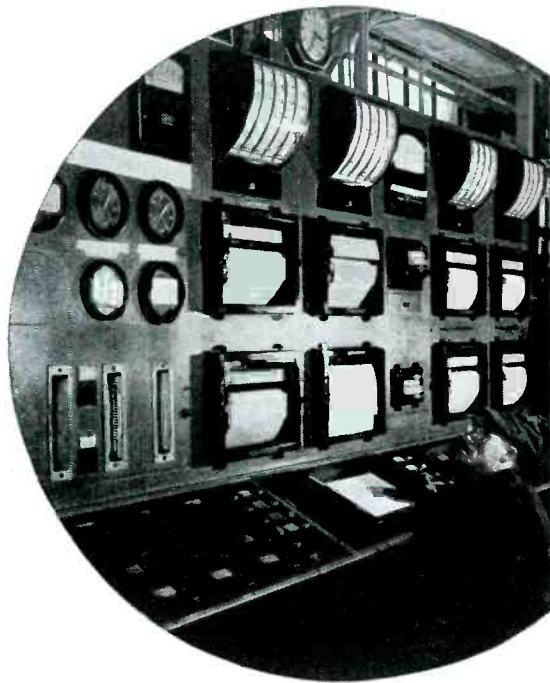

Production Controlled—Instruments, such as these, control the processes which make Carbonyl Iron Powders. Such control makes possible the constant uniformity of CIP. The panel above is one of many instrument boards used for controlling the processing of GA&F Carbonyl Iron Powders.



ANTARA* PRODUCTS
GENERAL ANILINE & FILM CORPORATION

444 Madison Ave.
New York 22, N. Y.

*®

yl Iron Powders

First with the Finest in TELEVISION TUBES!

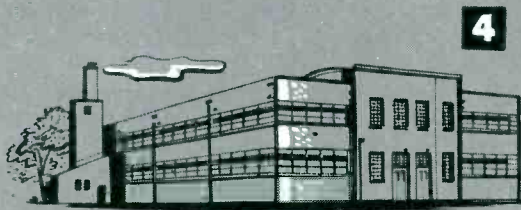
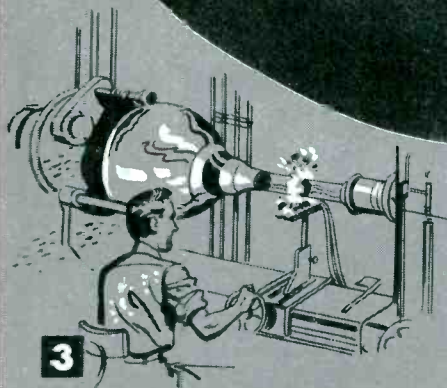
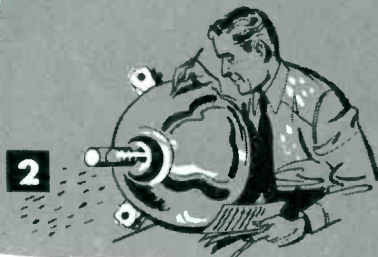
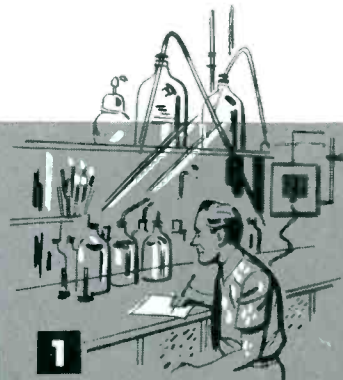

Allen B. Du Mont gave us the commercialized cathode-ray tube. Starting with a scientific curiosity in 1931, he pioneered the practical television picture tube of today. And Du Mont pioneering has never ceased. Examples? **1** Du Mont chemical research has led to tube screens of various persistencies and intensities precisely matched to any television requirements. **2** Du Mont research and development engineers have always led in large television tubes—those 12½", 15" and 20" Teletrons*—because Dr. Du Mont has insisted on "comfortable" viewing. **3** Du Mont craftsmen, provided with the finest glass-working equipment known, can translate advanced tube designs into greater tube values at lesser prices. **4** And to keep pace with the huge and still growing demands, Du Mont quantity-quality production has steadily stepped up, climaxed by the new Allwood plant. Yes, it's Du Mont Teletrons for the "First with the Finest in Television Tubes."

*Trade-mark

© ALLEN B. DU MONT LABORATORIES, INC.

FIRST WITH THE FINEST
IN TELEVISION TUBES

DU MONT Teletrons

ALLEN B. DU MONT LABORATORIES, INC., TUBE DIVISION, PASSAIC, N. J.

SPRAGUE KOOLOHM RESISTORS

T.M. Reg. U.S. Pat. Off.

**Tops for TV and other
difficult applications!**

Available in 5, 10, 25,
50 and 120 watt
ratings.



WIRE-WOUND RESISTORS WITH LOW S.Q.!

S.Q.? That means "Service Quotient." With dependable, tropicalized Koolohm resistors, it's practically nil!

That's why major television manufacturers specify Sprague Koolohms and avoid unnecessary and expensive service calls due to resistor failures.

Koolohms far outperform and outlast ordinary wire-wound resistors, yet are smaller in size than ordinary units of the same wattage rating. Koolohms are wound with larger diameter wire for the same rating yet are available in far higher resistance values (for example, 70,000 vs 25,000 ohms at a full 10 watts). Koolohms are available in *truly non-inductive* windings when needed. Koolohms have exceptional resistance stability.

Koolohms have all these advantages because they are the *only* resistors wound with ceramic-insulated wire (an exclusive Sprague development) and are enclosed in glazed moisture-resistant ceramic outer shells. Mounted on a metal chassis, Koolohms will withstand a 10,000 volt breakdown test from winding to ground.

Koolohm resistors are ideal for television sets and other tough applications—and are equally good for all ordinary electronic and industrial control uses.

Best of all, premium-quality Koolohm resistors are *competitively priced*.

Sprague Catalog 100E tells The Complete Koolohm Story. Write for your copy today.

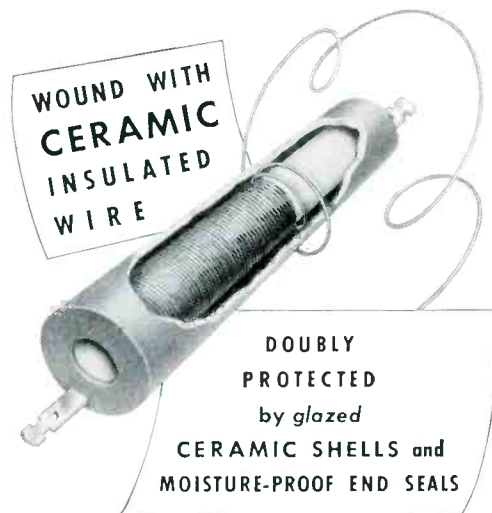

SPRAGUE ELECTRIC COMPANY
NORTH ADAMS, MASS.
PIONEERS IN ELECTRIC AND ELECTRONIC PROGRESS

Magnetic Materials

The Arnold Engineering Company
offers to the trade a complete line of
Magnetic Materials



PERMANENT MAGNET MATERIALS

- Cast Magnets, Alnico I, II, III, IV, V, VI, XII, X-900
 - Sintered Magnets, Alnico II, IV, V, VI, X-900, Remalloy*
 - Vicalloy* • Remalloy* (Comol)
 - Cunico • Cunife • Cast Cobalt Magnet Steel

HIGH PERMEABILITY MATERIALS

- Deltamax Toroidal Cores • Supermalloy* Toroidal Cores
 - Powdered Molybdenum Permalloy* Toroidal Cores • Permendur*

*Manufactured under licensing arrangements with WESTERN ELECTRIC COMPANY

Write for information relating to any of these Magnetic Materials



THE ARNOLD ENGINEERING COMPANY

SUBSIDIARY OF ALLEGHENY LUDLUM STEEL CORPORATION

147 EAST ONTARIO STREET, CHICAGO 11, ILLINOIS

Specify **Hi-Q** COMPONENTS for **PRINTED CIRCUITS**

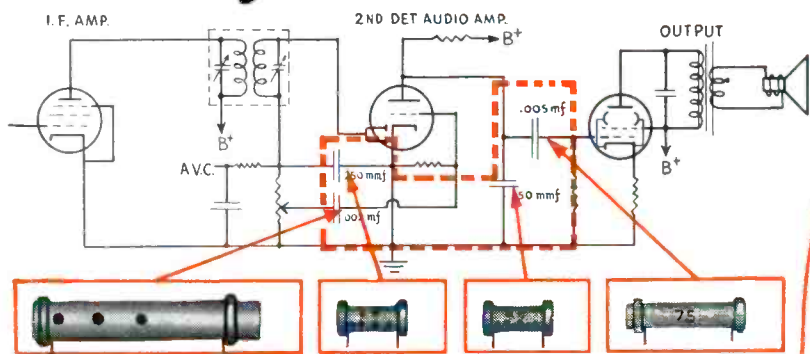

...THE PROBLEM

Hi-Q engineers were recently asked to design a component which would replace the 4 standard components called for in the schematic drawing illustrated at left. The problem was one of space saving without affecting the operation of the circuit.

HERE IS HOW Hi-Q SOLVED THE PROBLEM OF SPACE SAVING AND REDUCED COST

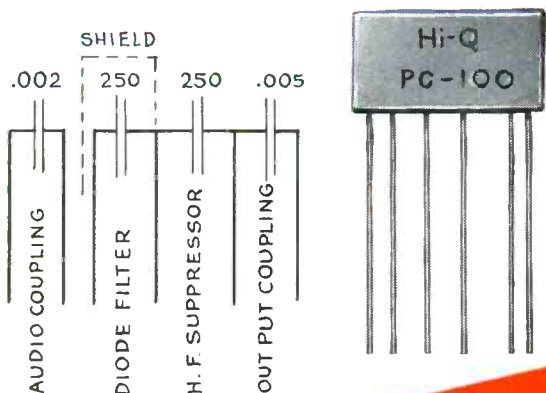

THE SOLUTION

Hi-Q engineers designed a printed circuit known as the Hi-Q P. C. 100. This component replaced all 4 of the standard sized units formerly used, thus reducing the physical proportions of the space formerly required. In addition, this new component eliminated 25% of soldering time as well as eliminating 75% of the unit handling cost. The result of this customer's foresight in placing his problem before Hi-Q engineers is that a new component was designed which saved our customer space, labor and time.

Hi-Q COMPONENTS BETTER 4 WAYS

PRECISION Tested step by step from raw material to finished product. Accuracy guaranteed to your specified tolerance.

UNIFORMITY Constancy of quality is maintained over entire production through continuous manufacturing controls.

DEPENDABILITY Interpret this factor in terms of your customers' satisfaction . . . Year after year of trouble-free performance. Our Hi-Q makes your product better.

MINIATURIZATION The smallest BIG VALUE components in the business make possible space saving factors which reduce your production costs . . . increase your profits.

WHAT'S YOUR PROBLEM?

Our engineering department will gladly work with you on any problems you might have. Consult with us and ask for our suggestions regarding your specifications before your design has gone too far. Perhaps we can work out savings in space, time and labor for you.

WRITE FOR FREE CATALOG

Hi-Q

Electrical Reactance Corp.

FRANKLINVILLE, N. Y.

Plants: FRANKLINVILLE, N. Y.—JESSUP, PA.

Sales Offices: NEW YORK, PHILADELPHIA, DETROIT, CHICAGO, LOS ANGELES

Watch  *Master*

Frequency Standards



**GUARANTEED
ACCURACY**
1 part in 100,000
(.001%)

Uses

Time bases, rate indicators, clock systems, chronographs, geo-physical prospecting, control devices and for running small synchronous motors.

Features

1. Bimetallic, temperature-compensated fork, no heating or heat-up time is required.
2. Fork is hermetically sealed, no barometric effects on frequency.
3. Precision type, non-ageing, low coefficient resistors used where advantageous.
4. Non-linear negative feedback for constant amplitude control.
5. No multi-vibrators used.
6. Synchronous clock simplifies checking with time signal.

Specifications

Accuracy—1 part in 100,000 (.001%).

Temperature coefficient—1 part in 1,000,000 per degree centigrade (or better).

Outputs—

1. 60 cycles, sine wave, 0-110 volts at 0 to 10 watts (adjustable).
2. 120 cycle pulses, 30 volts negative.
3. 240 cycle pulses, 30 volts positive and negative. Pulse duration, 100 micro-seconds.

product of

**AMERICAN TIME PRODUCTS
INC.** New York 19, N. Y.
Operating under patents of the Western Electric Company

Type 212

TERMINATION

Front and Rear

CONSTRUCTION

Standard 8¾" x 19" Panel

HOUSING

8¾" x 19" x 8" Metal Cabinet

WEIGHT

25 pounds

American Time Products, Inc.,
580 Fifth Ave., New York 19, N. Y.

Gentlemen:

Please send descriptive folder, No. 212

Name.....

Company.....

Address.....

City..... State.....

Check YOUR NETWORK PROBLEM WITH LOGIC

In any technical business the specialist has a unique value in his specific field. It is logical that a manufacturer of a specialty product should be of greater value in his particular field.

Three Channel Substitution Filter
Yonkers 3 cm. inches

Telemetering Filters in sets up to 20 channels.

Crystal filters for telemetering and commercial radio.

Audio discriminators for FM multi-channel applications.

Extremely sharp side band suppression filter.
Size: 2 1/2 x 4 x 2 1/2

Tone channel filter for extremely high cross over attenuation requirement.
Size: 2 1/2 x 2 1/2 x 5

Frequency Cycles

Frequency Cycles

Frequency

170 Cycle Spacing Pass Band

Center Frequency

Cycles Deviations

As one of the largest producers of toroidal coils and filters Burnell & Co's facilities and production experience have been of immeasurable technical and economical value to our customers. Many engineers have benefitted by our prompt technical service. Why not bring your network problem to us for the most practical and economical solution?

EXCLUSIVE MANUFACTURERS OF COMMUNICATIONS NETWORK COMPONENTS

WRITE FOR TECHNICAL INFORMATION
ALL INQUIRIES WILL BE PROMPTLY HANDLED

Burnell & Company

YONKERS 2, NEW YORK

CABLE ADDRESS "BURNELL"





YOUR telephone receiver should treat each tone in the voice alike; that is important to you, because proper balance makes pleasant listening and easy understanding. Naturalness in receiver performance is pictured in a matter of seconds by the apparatus shown at left.

The receiver is clamped in place and an oscillator feeds into it frequencies representing all talking tones. Then a bright spot darts across an oscilloscope screen leav-

**It listens so
YOU
can hear better**

ing behind it a luminous line which shows instantly the receiver's response at each frequency. It is precise; and it is many times faster than the old method of measuring receiver performance point-by-point and then plotting a curve.

At Bell Laboratories, development of techniques to save *time* parallels the search for better *methods*. For each time an operation is made faster, men are freed to turn to other phases of the Laboratories' continuing job—making your telephone system better and easier for you to use each year.



BELL TELEPHONE LABORATORIES

EXPLORING AND INVENTING, DEVISING AND PERFECTING, FOR CONTINUED IMPROVEMENTS AND ECONOMIES IN TELEPHONE SERVICE.

MOLONEY ELECTRIC'S NEW *HiperCore* TRANSFORMER HAS LEADS INSULATED AND PROTECTED

with

NATVAR 400

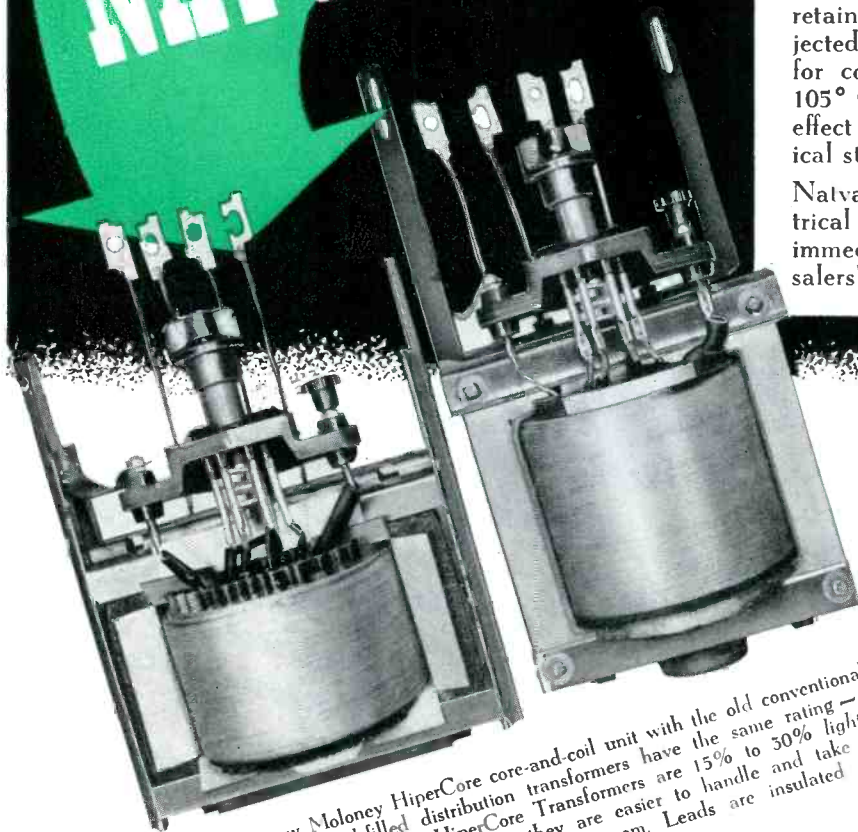

Compare the new Moloney HiperCore core-and-coil unit with the old conventional type. Both of these oil-filled distribution transformers have the same rating — 3 Kva, 7200-120/240 volts. Yet HiperCore Transformers are 15% to 30% lighter and up to 30% smaller, which means they are easier to handle and take up less space on the line truck and in the storeroom. Leads are insulated and protected with Natvar 400.

THE new HiperCore Transformers manufactured by Moloney Electric Company, St. Louis, are lighter and smaller than their predecessors, and yet have improved performance characteristics. They provide better voltage regulation and permit greater short-time overloads.

Cores are wound of high permeability, oriented silicon steel having 50% to 50% greater flux carrying capacity than hot rolled core steel, making it possible to decrease the amount of steel, copper and other materials, and at the same time improve operating characteristics.

Natvar 400 Extruded Vinyl Tubing is used to insulate and protect leads because it retains its original properties when subjected to both heat and oil. It is approved for continuous operating temperatures of 105° C, and immersion in oil has no adverse effect on its flexibility, dielectric, or mechanical strength.

Natvar 400 and other Natvar flexible electrical insulating materials are available for immediate delivery, either from your wholesalers' stocks, or direct from our own.



Natvar Products

- Varnished cambric—straight cut and bias
- Varnished cable tape
- Varnished canvas
- Varnished duck
- Varnished silk
- Varnished special rayon
- Varnished Fiberglas cloth
- Silicone coated Fiberglas
- Varnished papers
- Slot insulation
- Varnished tubings and sleeveings
- Varnished identification markers
- Lacquered tubings and sleeveings
- Extruded vinyl tubing and tape
- Extruded vinyl identification markers

Ask for Catalog No. 21

THE NATIONAL VARNISHED PRODUCTS

Corporation

TELEPHONE
RAHWAY 7-2171

CABLE ADDRESS,
NATVAR: RAHWAY, N. J.

201 RANDOLPH AVENUE ★ WOODBRIDGE, NEW JERSEY

There's no hot air about this ...

3J/221S
10 KW TRIODE
H.F. POWER AMP.
 Max. Ht. (Inc. Pins) 506 mm.
 Max. Dia. 172 mm.

3J/192E
4½ KW
H.F. TRIODE
 Max. Ht. (Inc. Pins) 230 mm.
 Max. Dia. 158 mm.

5J/180E
3½ KW
H.F. PENTODE
 Max. Ht. (Inc. Pins) 230 mm.
 Max. Dia. 158 mm.

3J/170E
3½ KW
VHF TRIODE
 Max. Ht. (Inc. Pins) 223 mm.
 Max. Dia. 158 mm.

3J/160E
1 KW
UHF TRIODE
 Max. Ht. (Inc. Pins) 133 mm.
 Max. Dia. 65 mm.

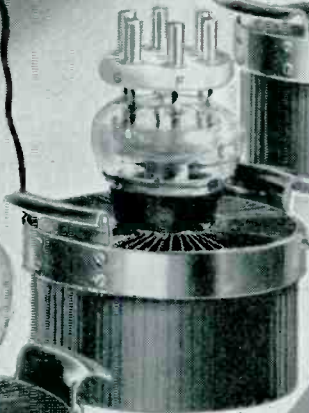

Cold Facts:-
 Our experience & development work over a period of 15 years have produced air blast cooled valves of outstanding performance, reliability & long life.
 Save space & labour by installing air blast cooled valves & eliminate complicated water cooling systems.
MEMO Write for more details

Standard Telephones and Cables Limited Radio Division

An I. T. & T. associate

OAKLEIGH ROAD, NEW SOUTHGATE, LONDON, N.11, ENGLAND

R.D.12

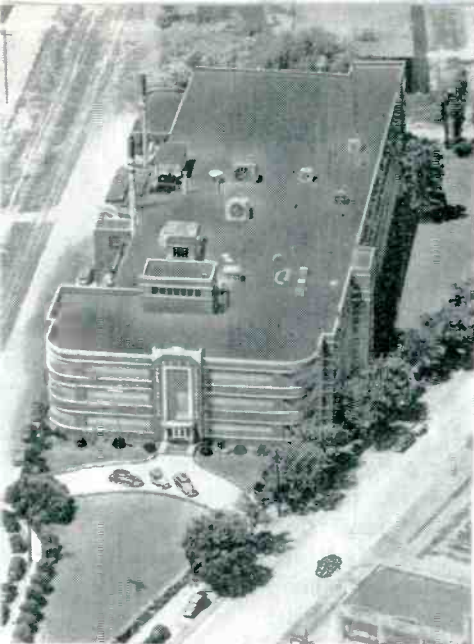

extrusion

Carefully controlled compositions extruded through precision made dies . . . a fast, economical production method for many shapes in Custom Made Technical Ceramics

Basic shapes which have been extruded can be cut, machined, threaded, drilled in the unfired state. This combination of processes . . . all available under one roof . . . can produce seemingly complex parts at prices favorable to your production budget. Send us your blueprint for recommendations.

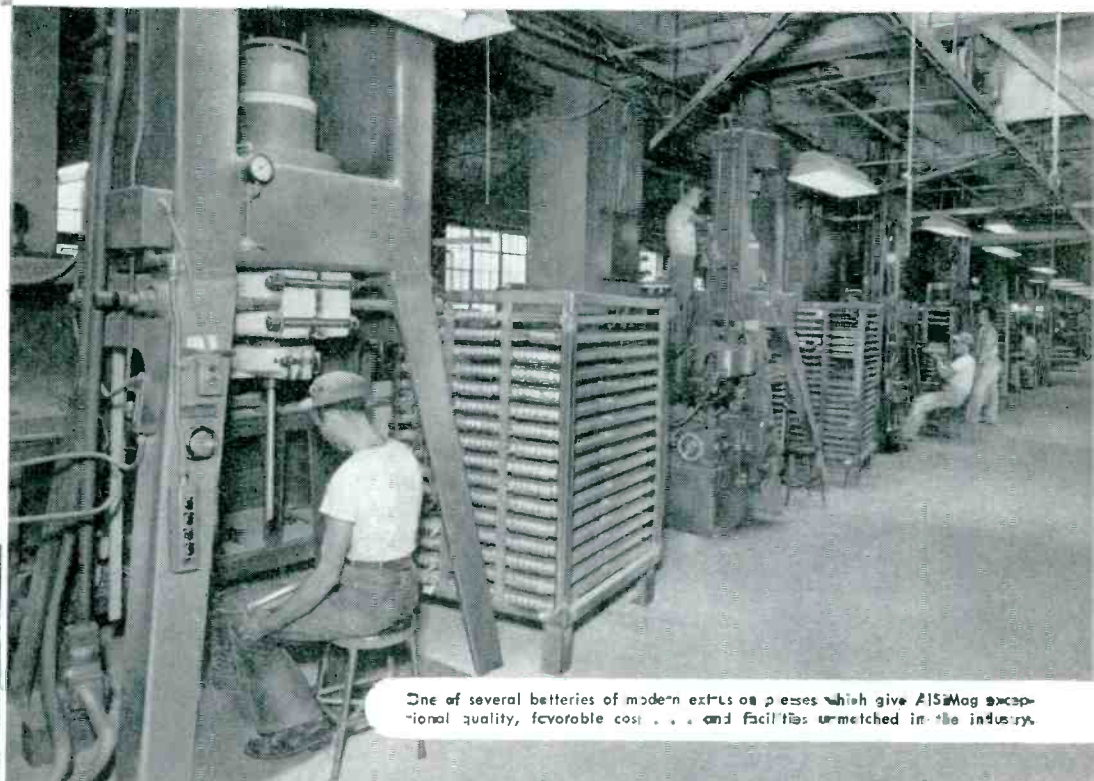

One of several batteries of modern extrusion presses which give ALSIMAG exceptional quality, favorable cost . . . and facilities unmatched in the industry.

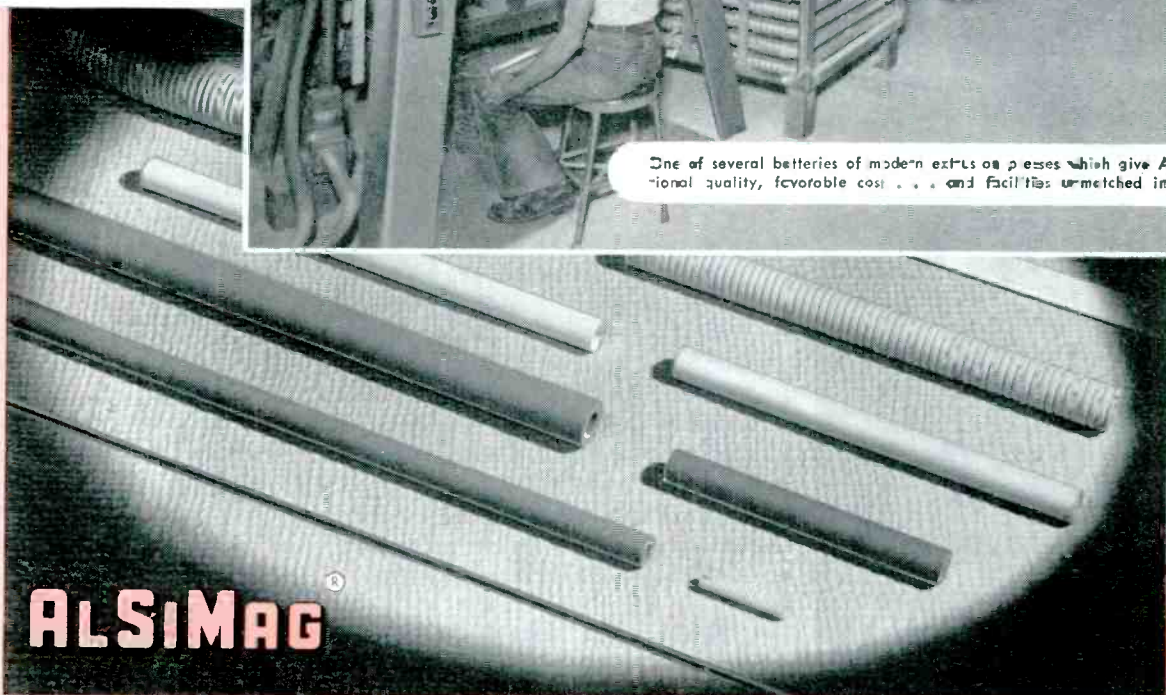

ALSIMAG[®]

A M E R I C A N L A V A C O R P O R A T I O N
A B T H Y E A R O F C E R A M I C L E A D E R S H I P
C H A T T A N O O G A 5, T E N N E S S E E

OFFICES: METROPOLITAN AREA: 671 Broad St., Newark, N. J., Mitchell 2-8159 • CHICAGO, 9 South Clinton St., Central 1721
PHILADELPHIA, 1649 North Broad St., Stevenson 4-2823 • LOS ANGELES, 232 South Hill St., Mutual 9076
NEW ENGLAND, 38-B Brattle St., Cambridge, Mass., Kirkland 4498 • ST. LOUIS, 1123 Washington Ave., Garfield 4959

BUSINESS BRIEFS

By W. W. MacDONALD

Choose
PYRAMID
ELECTROLYTICS
for
Top performance
at **85c**



Pyramid Type 85TM Capacitors are now in volume production for leading TV-receiver manufacturers throughout the U.S.A. and Canada.

PYRAMID
CAPACITORS

PYRAMID ELECTRIC COMPANY

155 Oxford Street
Paterson, N. J., U.S.A.

TELEGRAMS: WUX Paterson, N. J.
CABLE ADDRESS: Pyramidusa

Prices Are Dropping. This will be news to nobody. But you may not sit at a vantage point like ours, so you may not realize that while prices are dropping they have not yet dropped much.

Will prices drop farther? We think so, but we do not think they are going into the cellar. Just as soon as they are low enough to bring people who have money to spend but do not think it buys enough at present back into the market the drops will stop.

This may be in late 1949. Or it may be later.

Comparison Shopping is just around the corner in the television receiver market, unless we miss our guess. Already there are signs that initial enthusiasm has worn off to the point where buyers are becoming interested in more than just the size of the picture. They are beginning to check up on brightness, sharpness and steadiness. And the eye is more critical than the ear, so this tendency may play a much more important part in the television business than it ever did in radio.

Little differences in television receiver design may in the near future make a sale or lose it to a competitive make. Several manufacturers are aware of this and are improving picture quality rather than just shooting at price. One, for example, is building voltage-regulating transformers into his sets, with another on the verge of following suit. The trick transformer is considerably more expensive than a conventional type but we understand that the differential was held to a mere 68 cents by taking advantage of better regulation to effect economies in other parts.

Nearly All established tube manufacturers are now turning out cathode-ray tubes for television. so the bottleneck is pretty well broken. There are, as a matter of fact, a lot of new companies in the field so the competition for business is apt to be keen in the months immediately

ahead. Already, we hear, set manufacturers have been offered price concessions in return for long-term contracts.

Beating Popular Magazines and newspapers to a possible low punch, we have it on good technical authority that picture tubes in television receivers radiate no measurable quantity of x-rays when operated below 10,000 volts (where most of the sets at present on the market *do* operate) and not enough even at double this voltage to be injurious unless one does a Rip Van Winkle in their presence.

We understand, furthermore, that where large-screen direct-view or projection models use very high voltages manufacturers have already quietly taken design steps to eliminate any radiation that might occur, playing it safe for their own workers as well as the ultimate consumer.

An NAB Study indicates that with only 57 stations on the air television already employs about 10 percent as many full-time workers as the entire a-m/f-m broadcasting industry. The average station at present employs 46 full-time workers. About 50 percent of these people are technicians, 22 percent program personnel, 16 percent general administration, 8 percent film department and 4 percent sales.

Record-Player Makers have pulled out all the stops in their effort to give the consumer machines that handle 33 $\frac{1}{3}$, 45 and 78-rpm platters. Out at the Parts Show in Chicago we saw a new one that not only plays all three but plays them automatically on both sides. About the only thing it will not play is a manhole cover.

Speaking Of Chicago, trouble seems to be brewing for the Parts Show policy makers. Many exhibiting manufacturers were unhappy about the comparatively light distributor attendance, didn't know



Let's Put the Chill on a Hot Subject . . .

As you read this message engineers the country over are hard at work planning, experimenting on fused hermetic sealing for their company's electrical product.

When the subject of a so-called glass terminal comes up (and it's bound to) they're apt to talk in terms of thermal shock. That's where Fusite Hermetic Terminals come in.

Take the interfusion of steel and inorganic glass that is a Fusite terminal. Apply the sizzling heat of a soldering or welding operation. And if you want to be ornery, shove it right out on the shipping dock on a zero day.

What happens?

Absolutely nothing. Your seal remains as tight as your production skill made it. All Terminals remain as smooth, as rugged, and uniform as only Fusite makes them.

Would you like to know more, or see samples? Write to Dept. E.

TERMINAL ILLUSTRATED 908HTO—For plug-in to standard "Octal" sockets. Available with two to eight hollow tube electrodes.



THE FUSITE CORPORATION

CARTHAGE AT HANNAFORD, NORWOOD, CINCINNATI 12, OHIO

PRECISION RESISTORS!



**Shallcross
makes
them
all!**

- ... Wire wound with any alloy to meet JAN-R-93 styles
- ... Hermetically sealed
- ... With low temperature coefficient
- ... With predetermined time constants
- ... For high resistance in small space
- ... With definite positive or negative temperature coefficient
- ... With special low-tolerance
- ... With highest stability of resistance values
- ... For high voltage applications
- ... Potted (for RC, bridge and fixed pad networks)
- ... Mounting styles for any need

**Latest Data on
SHALLCROSS
AKRA-OHM RESISTORS
to meet JAN Specifications**

The new Shallcross Engineering Bulletin R-3 brings you complete mechanical and electrical data on close tolerance resistors that meet joint Army, Navy and Air Force Specifications—also suitable for practically any industrial application. A copy will gladly be sent on request.

SHALLCROSS MANUFACTURING COMPANY Dept. E-79 Collingdale, Penna.

**Shallcross—the only complete
precision resistor line!**

**Write for
your copy
today!**

how much to attribute to a general slackening of business and how much to the fact that admission was limited to members of NEDA during certain hours.

Military Business for the electronics industry has so far this year been disappointingly less than expected, according to RMA's Max Balcom. He expects it to pick up, however, in the near future.

Potted Circuits have moved out of the experimental into the early commercial stage. Subassemblies cast in plastic are now in use in a number of military items and we know of several examples of use in connection with apparatus offered for general sale.

Suppliers of plastics privately admit that they still have much to learn and point out that a potting material suitable for one application may not be suitable for another. They are making progress, however, and one of the things they have learned is that in addition to protecting parts against shock, vibration, humidity, temperature and tampering some assemblies can actually be made cheaper because no chassis and no anchoring accessories are needed.

The technique may not grow fast, but it is certain to grow.

Back In March (p 66) we pointed out that static electricity could be used to attract liquids or powders to paper or cloth.

Huebner Laboratories of New York has developed a method of printing without pressure, based on this principle. In connection with his process W. C. Huebner uses the words *electro-migratetics* (for liquids, wet particles, solvents, vapors, dyes and lacquers), *electronographics* (for inks, semi-wet particles, pigments and pastes), *depositronics* (for powders, semi-dry particles, deflocculated materials), *magnetetics* (for metallic dry particles) and *combustion-precipitronics* (for smoke particles, chemical colors and gases).

A Friend Of Ours out in Detroit has an idea that should interest people who use tubes in equipment requiring extremely uniform char-

acteristics and long life. He is set up to study the operation of various tubes in newly designed apparatus, duplicate required operating conditions in a test setup, and then to build or supply instructions for building test racks in which a supply of tubes can be aged and checked.

Sounds to us like a natural for certain measurement, control and computer applications.

Test Equipment is big business. A whale of a lot of instruments go into manufacturing plants of all kinds. Take the Electronics Section of The Glenn L. Martin Company, down in Baltimore, for example. It owns:

- 47 a-f signal generators
- 41 ammeters
- 16 amplifiers
- 4 analyzers
- 10 bridges
- 51 capacitor decades
- 8 field-strength meters
- 12 frequency meters
- 37 miscellaneous items
- 64 oscilloscopes
- 3 potentiometers
- 95 power supplies
- 31 pulse generators
- 20 Q-meters
- 5 receivers
- 5 recording meters
- 65 resistor decades
- 14 r-f meters
- 43 r-f signal generators
- 9 special-purpose testers
- 20 special r-f items
- 8 square-wave generators
- 23 synchrosopes
- 2 tube testers
- 80 vacuum-tube voltmeters
- 51 variable-power controls
- 30 voltage regulators
- 56 voltmeters
- 105 volt-ohm-milliammeters
- 4 wattmeters
- 8 wavemeters

One will get you three that the average reader of **ELECTRONICS** doesn't even know that Martin, well known for its airplanes, is even casually active in our field.

On The Odd Chance that you are as interested in our problems as we are in yours, one of the crosses an editor has to bear is the fact that he continually runs across engineers who have a good technical story in their system but "no time to write." This phrase is indelibly engraved upon the mind of every staff man.

Usually, there is some mutually advantageous solution. We have developed a number of effective shortcuts. Try us and see.

He studied electrons with vigor;
An oscilloscope's use was de rigeur.
But his poor mind was maimed;
Saw a girl and exclaimed,
"What a beautiful Lissajous figure."

—Sam H. Seeleman
McLaughlin Research Corp.
New York

VOLTAGE RELAYS

TEMPERATURE COMPENSATED for Constant Voltage Operation, or Battery Charge Control.

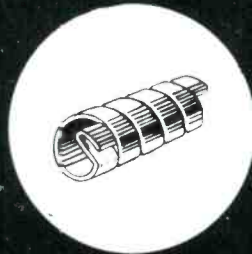

BIMETAL SPRING

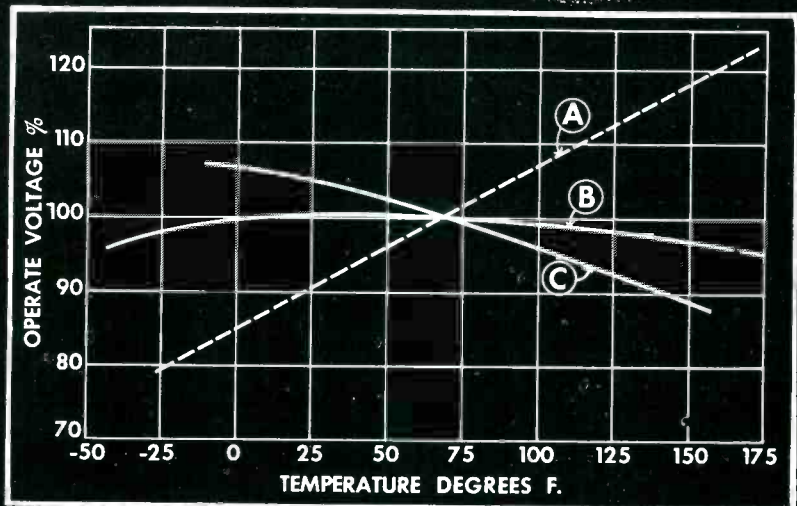
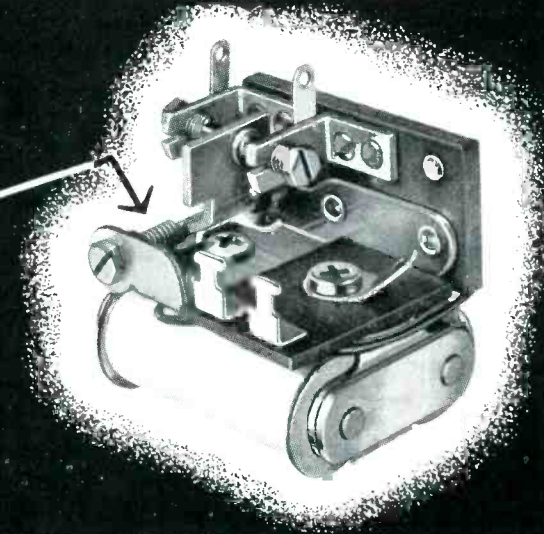

- A Resistance, hence operating voltage, of uncompensated relays rises with temperature.
- B Compensation from Spring's Thermal Characteristic gives constant operating voltage.
- C Overcompensation, giving negative characteristic used in Battery Charge Control.

ALL SIGMA SERIES 5 RELAYS are available with either characteristic. Write for "Application Notes #3" giving detailed description and listings.



Sigma Instruments, Inc.
Sensitive RELAYS

62 CEYLON ST., BOSTON 21, MASS.

NOW!

The MALLORY MIDGETROL DUAL

... to help you make
MORE CONVENIENT,
MORE EFFICIENT,
BETTER LOOKING
Television Receivers

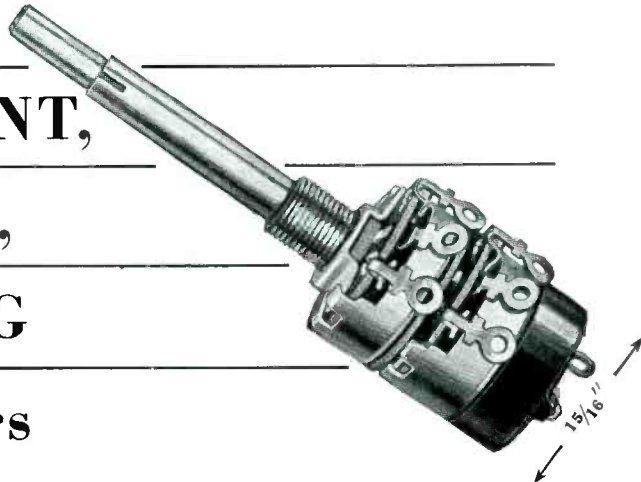

Highlights of the MALLORY MIDGETROL DUAL

1. Combines two quiet, compact controls on concentric shafts.
2. Insulated for the higher voltages encountered in television.
3. Special low-drift resistance element meets temperature-humidity drift problem.
4. Only dual control with two-point shaft suspension, which means—shorter bushing may be used, more stable resistance values are obtained, less danger of damage in assembly, longer life, longer shafts may be safely specified.
5. Available now for prompt delivery and competitively priced!

Now Mallory has produced a *Dual* Mallory Midgetrol with concentric shafts.

Mallory precision manufacturing PLUS small size ($\frac{15}{16}$ " diameter) provide a method to move several key television adjustments from the rear of the chassis to the front. Eight single controls now required to make adjustments can be changed to only four Dual Mallory Midgetrols, permitting ready adjustment at the front of the chassis.

You get a cleaner-looking set, an easier set to produce—and the Mallory Midgetrol provides the ruggedness and dependability television parts must have.

Read the highlights of the Mallory Midgetrol *Dual*... and see why those who have seen what it can do to improve quality and cut costs are so enthusiastic about its future.

P. S. The unique qualities of the Mallory Midgetrol *Dual* make it perfect for many applications in other fields as well. Mallory engineers will be glad to tell you more about it. Write Mallory today.

Precision Electronic Parts—Switches, Controls, Resistors

P. R. MALLORY & CO., Inc.
MALLORY

P. R. MALLORY & CO., Inc., INDIANAPOLIS 6, INDIANA

SERVING INDUSTRY WITH

Capacitors Rectifiers
Contacts Switches
Controls Vibrators
Power Supplies
Resistance Welding Materials



CROSS TALK

► **INVENTION** . . . It is fashionable in our industry to say that patents have become unimportant, that they represent only a license to sue. But the electronics business operates on the basis of patent pools operated, and for the most part wisely administered, by a few large corporations. The question of what constitutes an invention is, therefore, of prime importance to the electronic engineer, whether he be inventor or licensee.

The basic argument seems to be between the Patent Office and the Courts, notably the Supreme Court. Unless the patent discloses a transport of pure inventive genius, the chances are it will be ruled invalid by the high courts. The process of assembling prior art into a system or process which fills a long-felt need is considered by the Bench to be praiseworthy but not patentable.

We think a recent dissenting opinion of Mr. Justice Jackson reveals the fallacy of this argument with telling effect. The case involved the "lost-wax" process of casting intricate metal shapes, and it was shown that Benvenuto Cellini had used a similar process centuries ago. But it was also shown that the casting industry had not known how to apply the Cellini technique and hence needed, and had been eager to obtain licenses under, the patent in question. Said Mr. Justice Jackson: "And if Benvenuto Cellini's age-old writings are so revealing to us laymen of the Appellate Bench, it is hard to see why this practical-minded industry, which the Court says was following Cellini, failed through all the years to get his message." We hope the other members of the Bench get Mr. Jackson's message. Otherwise inventive progress may slow to a walk.

► **OBIT** . . . We regret to record the passing of Edwin H. Colpitts, whose name is known to tens of thousands of radio amateurs and engineers for his development of the Colpitts oscillator. Like his colleagues

Hartley and Heising at the Bell Laboratories, Colpitts entered the ken of many a young man when the momentous decision of what kind of an oscillator to build, and how to modulate it, was made. Like these men, also, he is best known for a minute part of the work of a busy lifetime. Dr. Colpitts worked with the great G. A. Campbell on telephone line loading, he designed toroidal repeating and retarding coils, cross talk and transposition systems, and as early as 1911 was in charge of the staff working on application of electron tubes to long-distance telephony by wire and radio. In 1937, then vice-president of the Laboratories, he retired, but remained active in engineering affairs until his death at the age of 77. His was a vigorous life, well spent in a demanding profession, a challenging example for those that follow.

► **MISCELLANY** . . . Viennese violinists can dial a number and get standard musical pitch from the Vienna Bureau of Weights. Bell System please copy. . . . The CIO's Political Action Committee has tipped off local leaders that they can get a citizens radio permit by return mail from the FCC, suggest using handie-talkies to operate picket lines and to get out the vote. Being neutral in politics but partisan for citizens radio, we urge the NAM and the U. S. Chamber of Commerce to rally around with some uses of their own, including getting out the vote. . . . A cyclotron in Chicago has been caught interfering with flight communications at LaGuardia Field in New York. The professors have been busy plugging up the chinks in the shielding and at last report they had left the field to old man static, who remains supreme. . . . By a very roundabout method, National Bureau of Standards men have come up with two new digits in the charge-to-mass ratio of the electron. Paste it in your hats, boys, it's 1.7588×10^7 emu per gram.

NEEDED: Better Parts for Industrial Controls

An equipment designer serving the industrial field tells what new components are needed and makes suggestions for improvement of existing lines. Demand for industrial rather than radio-type parts is still great

SINCE the end of the war the designer of industrial electronic devices has seen the development of a variety of components more suitable for his specialized requirements than radio-type parts.

Many rugged and conservatively rated components designed to meet the needs of industry have appeared on the market. However, the need for other parts, and improvement of existing types, is still great.

Connectors and Terminal Boards

Servicing of industrial devices is simplified by a minimum number of soldered connections. Screw connections are preferred in many cases since a screwdriver is the most common tool around any plant. Furthermore, use of this technique often decreases production costs. Design has advanced to the point where solderless connectors, properly applied, result in connections as good as any well-soldered joint.

Terminal boards and strips are available in a large variety of designs. A compact feedthrough-type board with screw terminals on both sides would, however, be a welcome addition. It is further suggested that there be included in such a line resistor and capacitor mounting boards with screw terminals. The design should be such as to permit making connections to the mounting board without disturbing resistor or capacitor leads. More generous electrical barriers should be placed between adjacent terminals. Tie points should be stronger and

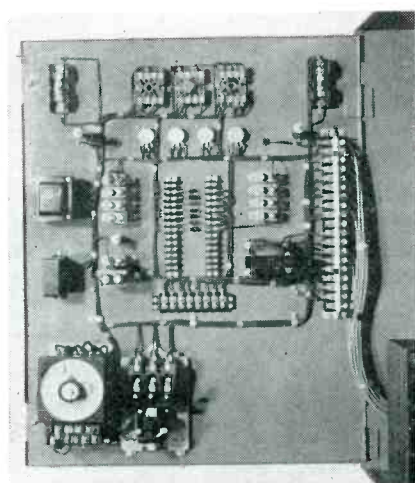

Electronic regulator using a hinged panel, generous spacing of parts and screw-type terminal strips to simplify maintenance

have better electrical clearances to ground than they do at present.

Tubes and Sockets

A few phototubes, regulator tubes, amplifier tubes and high-vacuum rectifier tubes are already available in industrial versions. Conventional radio amplifier tubes such as the 6SN7, 6SJ7 and 6SL7

are also available in ruggedized design, providing excellent uniformity, stability and long life. In line with this trend, there should also be a more extensive line of high-vacuum rectifiers, regulator tubes, and phototubes designed specifically for industrial use.

Some noteworthy strides have been made in tube sockets. Screw terminals have been provided. Good insulating materials give high dielectric strength, satisfactory shock factors and low moisture absorption. Barriers providing electrical clearances are more than adequate. Metal parts are well protected against corrosive atmospheres and tube pin contacts are designed to maintain good spring tension under conditions of high temperature. Contact resistance has been reduced to a minimum through increased pin contact area.

While the socket line is fairly complete in its coverage, some weaknesses have shown up which may be worthy of consideration by manufacturers. In some industrial octal sockets the center hole has been found to be slightly undersize, making it difficult to insert or remove tubes. The metal screw terminals permit utilization of only a very short threaded section, restricting the number of connections that can be made to any one terminal. It might be desirable to use a speednut style which would accommodate a standard machine-screw size, thereby making effective use of the full threaded length of

TIPOFF

Parts manufacturers may find here just the idea they need to open up new accounts or increase sales to those already served

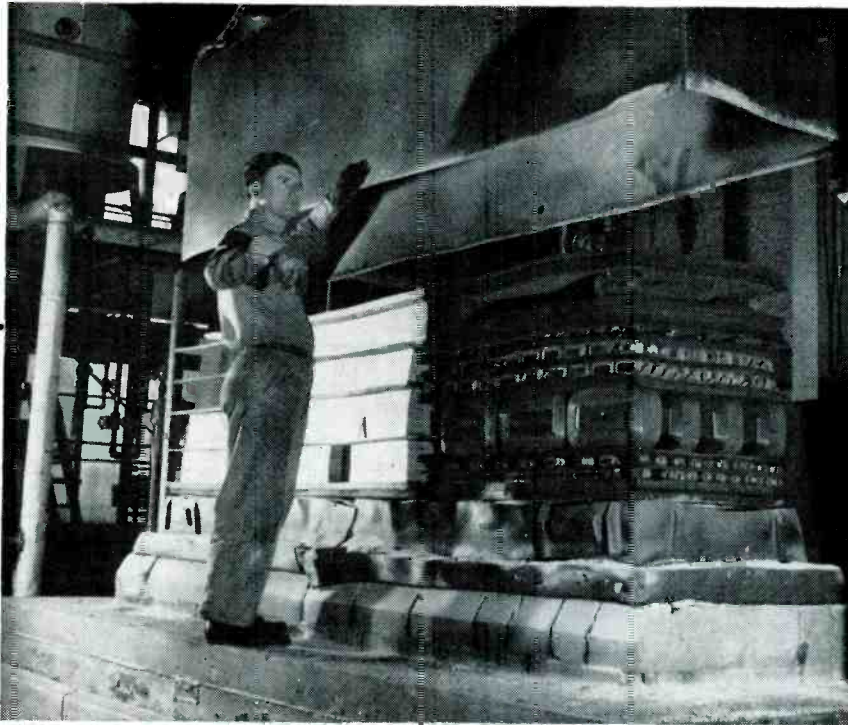

Heavy industry needs controls that are rugged and stand up under the extreme conditions encountered in a variety of plants

By **ROLAND RUSSO**

*The Clark Controller Company
Cleveland, Ohio*

tion, provision should be made for easy correction of secondary voltage.

A standard line of universal power transformers for supplying control-amplifier d-c voltages would also be desirable. At the present time the radio-type universal replacement power transformer is generally used. This type of transformer is not ideally suitable for industrial work since the rating is generally too liberal and construction is not rugged enough.

the terminal screw. Binding-head terminal screws might be indicated.

On most angle-type sockets for medium-base four-pin tubes, the terminal screws are definitely too small; wires that have to carry heavy filament current cannot be readily accommodated. The insulating barriers which separate the terminals of such sockets are often located so that wiring of the socket is quite difficult. The terminal design of the super-jumbo angle socket is good and the same scheme should be worked out for the medium-base socket.

Resistors and Capacitors

Little need be said about the composition resistor situation inasmuch as fixed resistors of this type to satisfy almost any requirement are available.

In the wire-wound styles the selection is also satisfactory. The situation, however, in the variable-resistor types is not as good, especially in the lower ratings from less than one watt up to about 25 watts. Such types do not always have adequate clearances between terminals or from terminals to case. Screw-type terminals and heavier construction in mechanical details would be desirable, with insulation

designed to withstand at least 2,500 volts to ground.

Capacitors generally present little or no problem in procurement. Some of the needs in the industrial field are being presently fulfilled, with one of the more recent innovations being a line of molded tubular paper capacitors, small in size and able to operate in high temperatures and withstand high humidity.

Metal-can capacitors with good electrical properties are widely available but a lack of screw-type terminals prevails. The most common terminals seem to be the threaded-stud type on the larger capacitors and the solder terminal on the smaller types. Capacitors with screw-type terminals, insulating barriers between terminals and means of restricting solderless connections from turning and touching together are needed.

Transformers used in industrial electronic circuits are varied in design and type. The majority are necessarily pretty specialized. However, a standard line of filament transformers could be offered industrial equipment designers for use with the more commonly used rectifier tubes. Since tube filament voltage must be maintained within close limits for proper tube opera-

Other Needs

There is a need for rugged and inexpensive time-delay relays for filament pre-heating, preferably of the adjustable type. Those presently available in the low-priced field are often susceptible to faulty operation under shock and vibration conditions. Most types instantly release when there are momentary power failures, resulting in unnecessary delay while the relay recloses.

While fuses generally are used in the anode circuit of the power rectifier for tube protection, it is extremely desirable to use circuit breakers so that controlled protection is available and immediate resetting may be provided. However, no circuit breaker with tripping characteristics that match tube current ratings is at present known to the writer.

A new connector for the medium C1-5 tube cap is also needed, one which has no exposed metal, is molded of high-temperature insulating material and to which leads may be attached with a screwdriver. Riveted or soldered connectors are undesirable from the standpoint of the heat encountered at tube caps as well as the amount of time expended in wiring the leads to the cap connectors.

CONTINUOUSLY

Designed to cover the band from 475 to 890 mc, this unit will feed the antenna input or i-f amplifier of an existing receiver to extend range to proposed uhf channels. Modification of Karplus coaxial tuner used in antenna and oscillator circuits

By **ROBERT P. WAKEMAN**

Research Division, *Allen B. DuMont Laboratories, Inc.*
Passaic, N. J.

THE growth of television during the past year, its remarkable acceptance by the public, and the increasing interference as new stations come on the air have combined to prove the inadequacy of the twelve channels now assigned to commercial broadcasting. It appears quite probable, therefore, that ultrahigh frequency allocations will be made by the FCC in the near future. When uhf service starts, the receiver manufacturers will have uhf receivers available. But, there are approximately one and a half million television receivers in use today and there will probably be another million in use before uhf television becomes a reality. It is certainly in the manufacturer's interest as well as his responsibility to protect the investment of the pioneer viewers. The protection may take the form of a converter located near the receiver. In some cases it may be possible to place a small unit inside the television cabi-

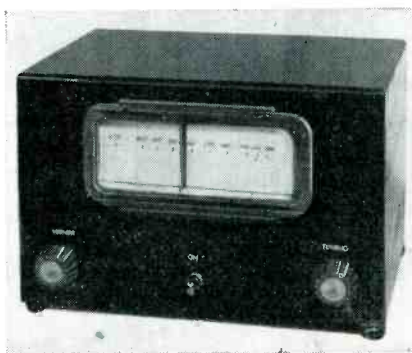

FIG. 1—External view of converter. Dial scale shows compression of tuning at high-frequency end of band

net and bring out additional controls on the front panel.

The receivers to be sold during the next few months present more of a problem. Protection can work two ways. The customer must be protected against obsolescence, but he must also be protected against being forced to buy a gadget which he can never use. Since many homes may never be within range of a

uhf station, it is equally wrong to build in a uhf tuner as an integral part of every television receiver or to ignore the problem entirely. Probably the best solution is to design future receivers so that a uhf converter section can be readily installed and made an integral part of the set, when and if a uhf station becomes available to the purchaser.

The portion of the uhf band to be made available for commercial television, the number of channels and their spacing have not yet been decided. Consequently, the tuner, either in the converter form or as an additional unit to be installed in the receiver, must be capable of covering the entire uhf television band. In the interest of minimizing expense to the set owner when he moves from one area to another, a continuous tuner is desirable. Such a tuner has certain other advantages. The initial allocations may be on a temporary basis subject to change. The continuous tuner ob-

UHF TELEVISION NOW IN THE WORKS

On May 26, 1949, the FCC announced a plan for allocating approximately 35 channels for 6-mc black-and-white television, in the lower half of the uhf band from 475-890 mc. While this plan must go through the formal rule-making procedure, including a hearing to be held this fall, it is expected that the final allocation will follow closely the present proposal, and that applications for uhf television broadcasting may be acted upon early in 1950. The equipment described in Mr. Wakeman's paper is, therefore, of particular significance.

The Editors

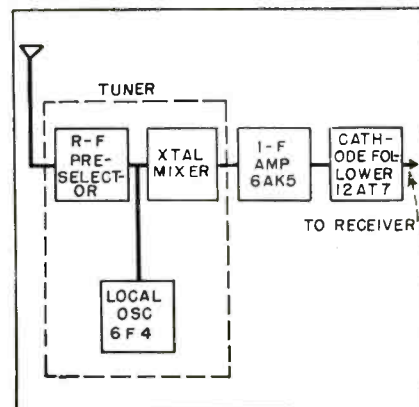

FIG. 2—Block diagram. Adjustment of oscillator permits choice of output frequency on vhf channel or i-f of receiver

TUNED CONVERTER for UHF Television

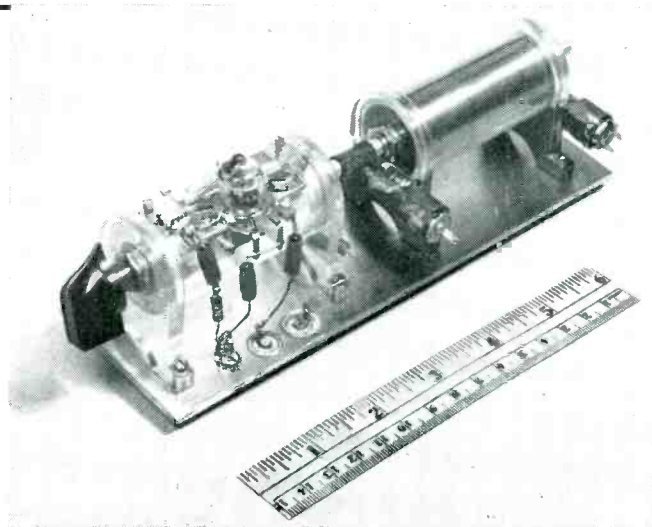

FIG. 3—Tuning assembly. Oscillator at left uses 6F4 acorn tube. Compression screws at ends of assembly adjust tracking

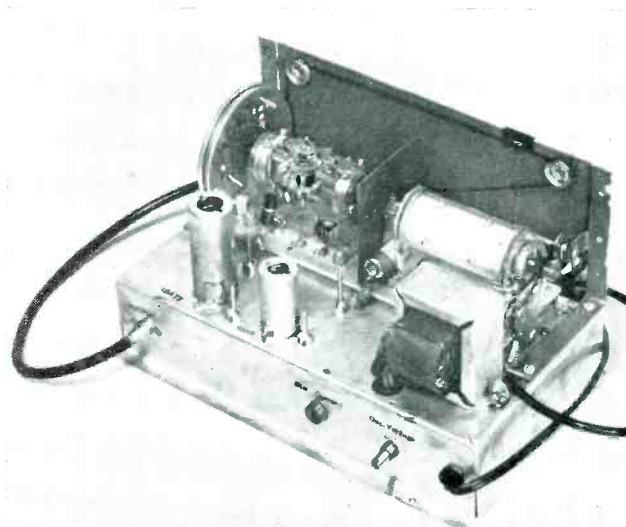

FIG. 5—Rear view of converter assembly. Dial cord at right permits vernier adjustment of tuning

viates the necessity of readjusting a large number of receivers in the field. Furthermore, initial installations will be simplified since the receiver will not have to be set up on specific channels.

Converter Design

These considerations have been taken into account in the converter illustrated in Fig. 1, designed to be used with present day receivers. In a slightly different form it may fit into a specially prepared niche in future receivers.

Figure 2 is a block diagram of the converter. The preselector and local oscillator are ganged and tune from 475 mc to 900 mc. The uhf signal is mixed with the local oscillator signal in a crystal mixer, the difference frequency is selected and amplified in a broad-band i-f stage, and a cathode follower transforms the output to a low impedance. The local oscillator is tuned below the carrier so that the normal position of sound carrier, higher in frequency than picture carrier, is maintained. This is

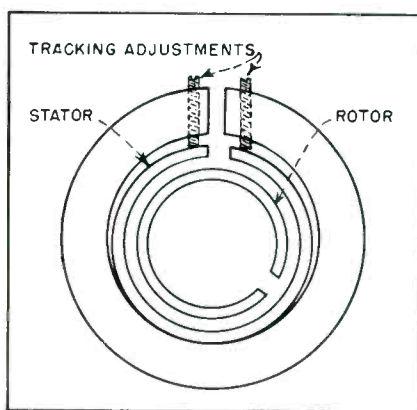

FIG. 4—Cross-section view of coaxial tuner elements

necessary since the signal is being fed to the antenna input of the receiver. The i-f amplifier can be tuned to Channels 1, 2 or 3, depending upon which of these is unoccupied in the area where the converter is to be used.

Both uhf and vhf antennas are brought into the converter. A switch permits connecting either the vhf antenna or the converter output to the receiver antenna terminals. This switch disables the

uhf local oscillator, by removing its plate voltage, when vhf is being used. This precaution helps to reduce spurious "birdies".

When the converter is used as an integral part of a receiver, the output frequency is made equal to the receiver intermediate frequency and the switch connects either the vhf or uhf tuner to the i-f amplifier. In this case the switch also serves to disable whichever local oscillator is unused. This system has been found to operate satisfactorily with present receivers and it will probably work even better with the higher intermediate frequency now being considered as an industry standard.

Tuner Construction

The heart of the converter, the tuner, is shown in Fig. 3. The oscillator tuner and tube are at the left and the preselector is at the right. The antenna input is at the far right and the crystal mixer is in the center.

Figure 4 shows a cross section of one of the tuning elements. This

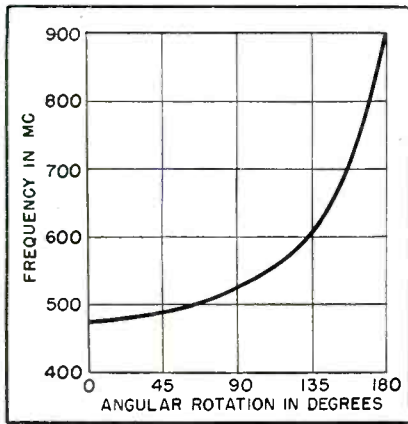

FIG. 6—Tuning characteristic. Compression of frequency scale at high end can be corrected by shaping tuner cylinders

tuner was first described by Edward Karplus and a complete discussion of the theory and construction may be found in his paper¹. It consists of two slotted coaxial cylinders, the inner one free to rotate, a housing and means of adjustment.

In the oscillator tuner, the plate and grid of the 6F4 tube are connected across the center of the slot in the outer cylinder with appropriate bypass condensers, and the cathode is returned to an intermediate point on this cylinder. When the two slots are aligned the *L* and *C* are minimum and the highest frequency is obtained. This frequency is determined primarily by the dimensions of the outer cylinder and the tube capacity. When the inner cylinder is rotated 180 deg. minimum frequency is obtained. This frequency, and consequently the range of the tuner, is largely determined by the spacing of the two cylinders. A greater frequency range requires closer spacing with the attendant problems in mechanical precision. Several adjusting screws are provided which permit slight deformation of the external cylinder to obtain the desired minimum frequency.

The preselector tuner is similar to the oscillator tuner except that there is no cutout for the tube. Similar adjusting screws are provided to permit tracking of this unit with the oscillator.

A primary advantage of this type of tuner is the complete absence of any sliding metallic contacts, thus eliminating this source of noise,

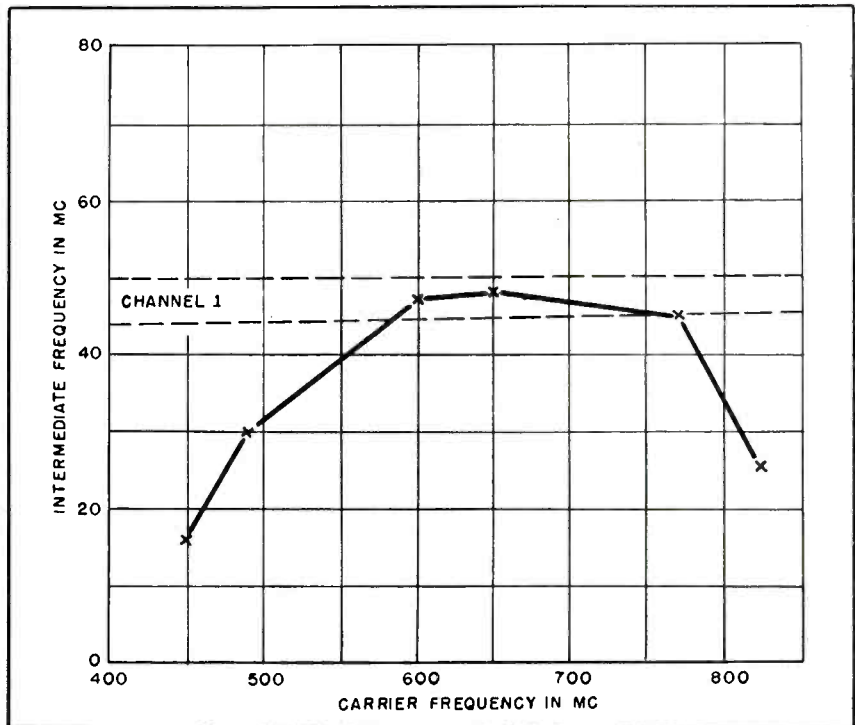

FIG. 7—Tracking characteristic, for feeding on channel 1 to existing receiver. Range from 580 to 780 mc is covered adequately, but end regions require correction

attenuation and service problems.

The complete converter assembly is shown in Fig. 5. The two tuning elements are ganged with a flexible coupling and driven by the pulley arrangement shown. In addition, the preselector tuner contains a second inner cylinder about one-fourth inch long which is driven from the right hand end. This permits a front panel tracking adjustment. The chassis also contains a selenium rectifier power supply and

the i-f tubes. A jack in the rear permits measurement or monitoring of the crystal current.

Tuner Characteristics

Significant characteristics of the tuner are shown in Fig. 6 through 10. Like every engineering problem, this one is never completed and these curves represent more or less transitory samples of the converter characteristics. Figure 6 shows the curve of frequency versus angular

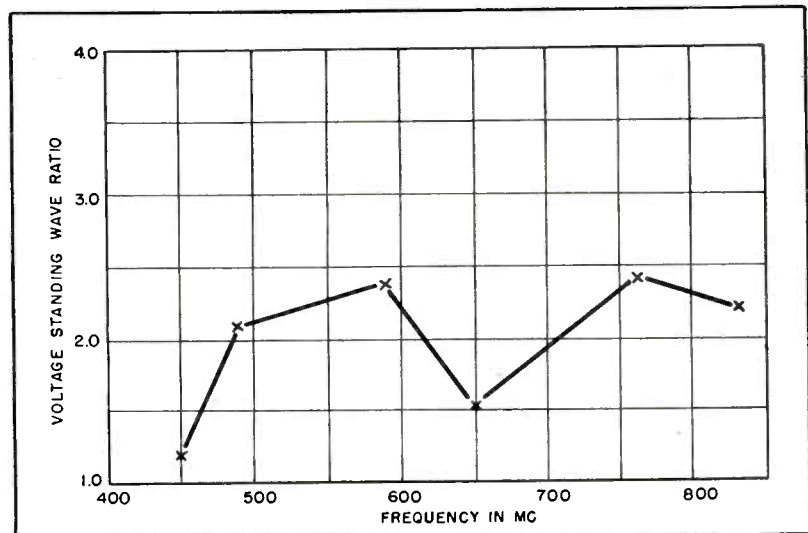

FIG. 8—The match to the 50-ohm input transmission line is excellent over the entire band

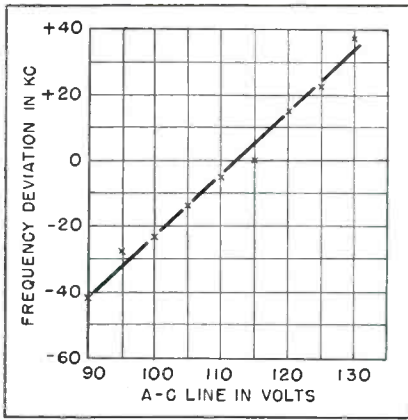

FIG. 9—Stability of oscillator frequency against line voltage changes. Deviation is less than 10 kc over 110-120 volt range

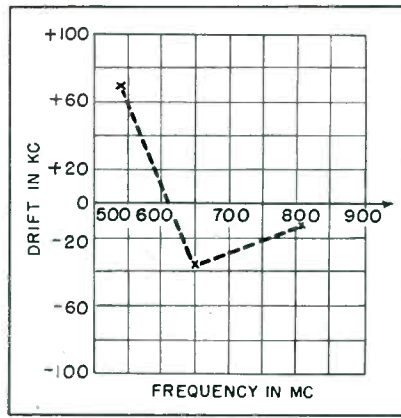

FIG. 10—Drift characteristic during warm-up period at various frequencies. Continuous tuning makes drift permissible

rotation of the rotor. As can be seen, the entire band is covered, but the compression at the high-frequency end is rather severe. Shaping of the rotors can alleviate this condition and work is now going forward toward producing a more nearly linear characteristic throughout the tuning range.

In Fig. 7, tracking is illustrated by plotting the beat frequency versus the incoming signal frequency. This characteristic was taken on a pre-production unit and shows good tracking between the limits of 580 mc and 780 mc. Again the low-frequency tracking can be improved by shaping the preselector rotor.

The standing wave ratio versus frequency at the converter input

measured with fifty-ohm coaxial line for one particular unit is shown on Fig. 8. The mismatch ratio does not exceed 2.5 at any point within the band.

Figure 9 shows the oscillator frequency variation as a function of line voltage. Over the range from 100 to 130 volts, the oscillator variation is only ± 40 kc. Abrupt changes of this magnitude are rare, so this variation is not considered serious.

Drift Characteristic

The oscillator drift problem is one of the most serious. Figure 10 shows the drift after a warmup period, as a function of frequency. A large amount of work has been done on this problem and a measure of success has been achieved. A

positive coefficient applies over part of the band and a negative coefficient over another part. This particular characteristic was taken using silvered brass cylinders, but no frequency compensating device was employed. Experiments are continuing with other materials in the interest of minimizing this drift.

Finally, Fig. 11 illustrates comparative reception on vhf and uhf. The two test patterns shown here were taken at the same time at a location, within line-of-sight, about 14 airline miles from New York. The two transmitters were located at the same point atop the 515 Madison Avenue building. The picture at the right was received from WABD operating on channel 5 with an effective radiated power of 14,000 watts while that on the left was received from the uhf transmitter operating at 612 mc with an effective radiated power of about 40 watts. The vhf signal measured at the receiver terminals was 47,000 μ v and the uhf signal was 450 μ v. These pictures are not exceptional but were selected because neither showed an appreciable ghost. At approximately fifty random spot checks, the ghost problem was found to be less severe on the uhf band than on the vhf band.

REFERENCE

(1) Edward Karplus, Wide-Range Tuned Circuits and Oscillators for High Frequencies, *Proc. IRE* 33, p 426, July 1945.

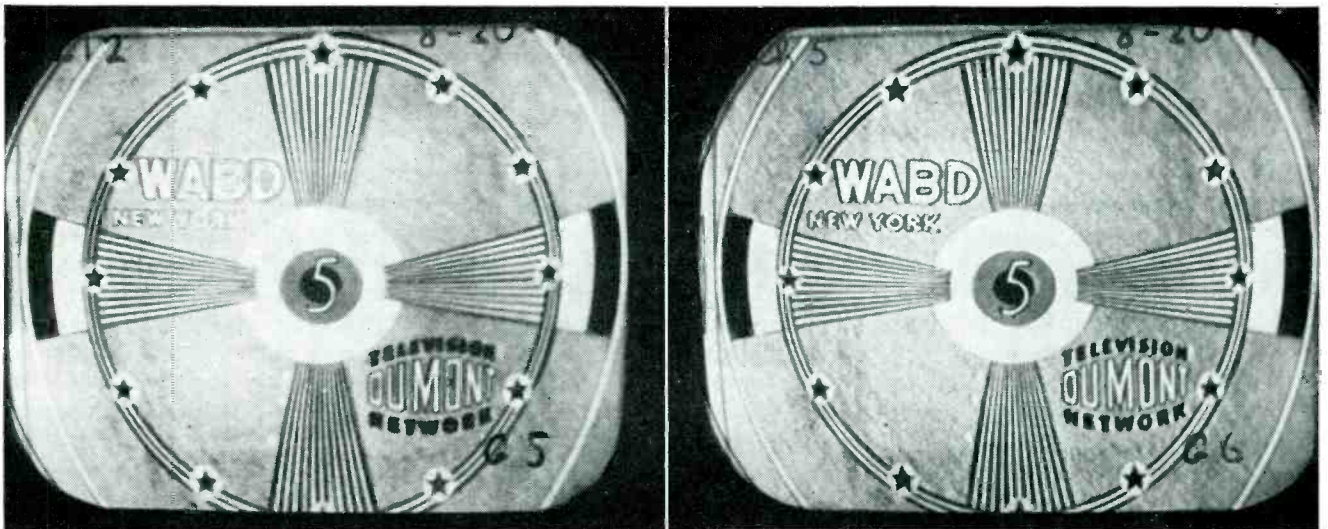
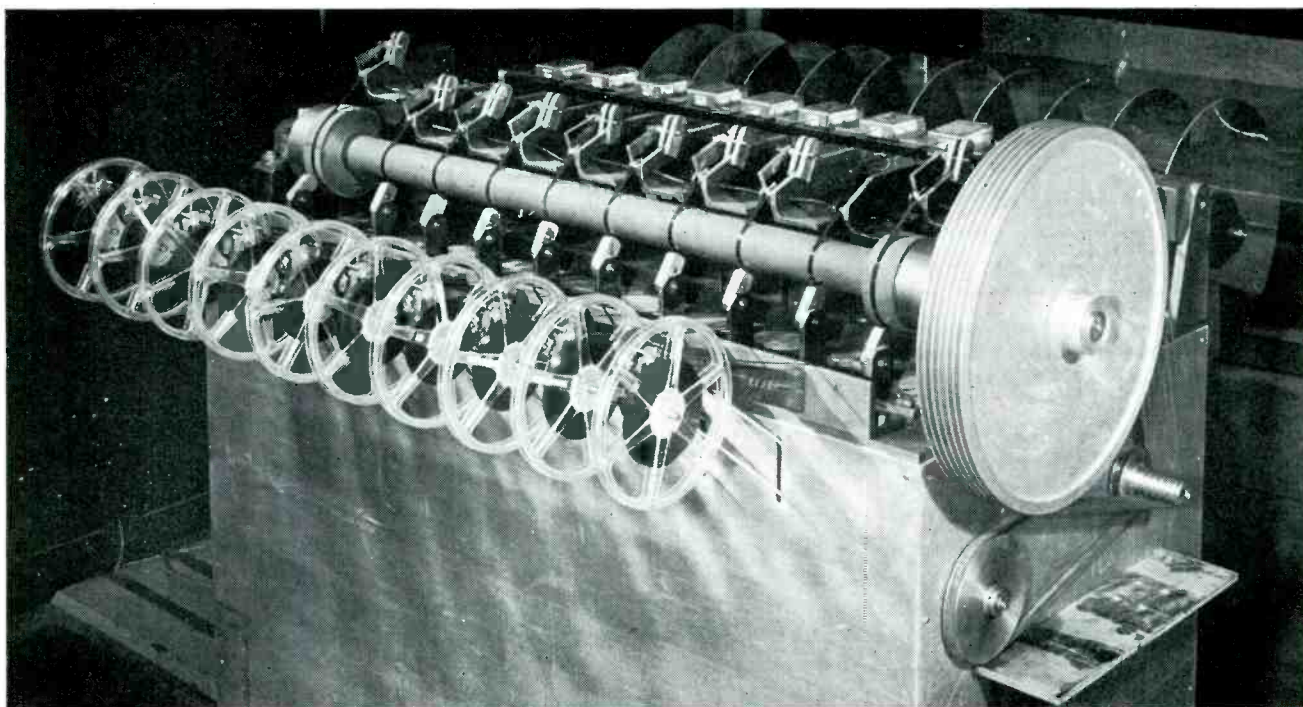

FIG. 11—Images photographed at 14 miles airline from DuMont transmitters. At left, 612 mc, 40 watts radiated power. At right, 77.25 mc at 14 kw radiated power

DUPLICATING



General view of multiple magnetic tape duplicating machine, with takeup reels for recorded tapes in foreground. Recording heads are on highest bar. Large pulley at right is on common capstan shaft

By REYNOLDS MARCHANT

*Division Engineer
Minnesota Mining and Manufacturing Co.
St. Paul, Minn.*

SINCE practically all magnetic tape recorders are also playback machines, the question has very naturally arisen about the possibility of supplying pre-recorded program material on tape. While the practicability of duplicating magnetic tape records in quantity was generally accepted, little was known about the economics involved. It was felt that a proper analysis could be made only through the construction and operation of a multiple duplicating machine which would be a production prototype and would permit a detailed study of the operations involved.

The main problem was found to be that of mass handling of tape, which has to be unwound from a stock roll, passed through the recorder and rewound onto a hub or reel for subsequent distribution. Direct labor accounts for most of the recording cost, even though little labor is required for the act-

ual recording operation. Most of the operator's time is consumed in changing reels and threading the machines.

It was decided to drive a number of tapes side by side on a common capstan. Recording on these tapes is by individual recording heads, the recorded signal being supplied from a master tape driven by the same capstan. Elements of the machine are arranged to permit easy threading of the tape and quick exchange of reels on the windup spindles.

Over-All Design Details

The recording section of the capstan has basic operating speeds of $7\frac{1}{2}$, 15 and 30 inches per second. The playback section of the capstan, which accommodates master tapes, is run at twice the speed of the recording section, because better dubbings are obtained from masters run at higher speeds than copies.

The tentative RMA standard for two-track recording provides that the two tracks shall be played in opposite directions. This is to permit playing a tape completely to one end on one track and playing

back on the second track to the starting point, to avoid the necessity of rewinding and to permit essentially uninterrupted playing of the entire tape. Each tape recording channel of the duplicator is therefore provided with two heads which simultaneously record the two tracks, one being put on in reverse. Program material is provided from a special two-track master tape which is passed over playback heads displaced to either side of the tape center line.

The duplicator is designed so that satisfactory dubbings can be made from a master tape played either in the forward or reverse direction. Recording of the tape copies from reversed masters eliminates the necessity for rewinding, the copy tapes being ready for playing as they are removed from the machine. In simultaneous two-track dubbing, recording is started from the reverse end of the tape, so that the number-one recording track is made in the reverse direction and the tape is ready for immediate playback when removed from the machine.

TAPE RECORDINGS

Pilot-model duplicator places program material on eight reels of two-track tape simultaneously as prelude to mass duplication of tape records for home entertainment. Doubling supersonic-bias frequency permits recording at twice playback speed, lowering cost

The recording and playback amplifiers were designed to have a total harmonic distortion no greater than 1 percent at their maximum operating loads. The basic frequency response of these amplifiers was to be such as to provide essentially flat output from 30 to 15,000 cycles.

A common bias supply is used for all recording channels. Bias frequency is adjustable from 20,000 to 100,000 cycles and the output of the bias system is terminated in an adjustable-impedance network to match the characteristics of different recording heads.

The pilot machine has 8 duplicating channels and 2 playback channels for master tapes. This arrangement provides adequate accessibility to all parts of the machine and space for experimental machine modifications. The use of two master channels permits alternate use of separate master tapes so that either master can be rewound while the other is used for recording.

Capstan Design Details

The capstan is essentially a slow-speed element having an outside diameter of approximately 2 inches. The capstan surface is covered with a $\frac{1}{8}$ -inch thick layer of rubber which is vulcanized in place. This rubber surface is ground to a concentricity of better than 0.0002 inch with the

capstan bearings. Bearing surfaces are one-inch diameter sections turned on the ends of the capstan shaft. The bearing blocks are made of bronze and are relieved over most of their circumference so that bearing pressure is applied to the shaft at three narrow points spaced equally around the shaft. This prevents the capstan shaft from wandering, and spring loading of the bearing caps eliminates the possibility of binding of the shaft.

The playback capstans are rubber-coated sections fastened to each end of the recording capstan. Their surfaces are ground to concentricity with the recording capstan. A flywheel is mounted on one end of the capstan shaft to provide mechanical filtering. The fly wheel is rim-driven from the motor pulley by six round plastic belts which are made of special material having high elasticity and high internal friction. The belts are essentially endless and the belt diameter and number of belts was selected so that the internal belt friction provided approximately critical damping for the system.

The motor pulley size is selected to give a proper speed reduction to the capstan. From a basic motor speed of 900 rpm, the capstan speed must be reduced to approximately 75 rpm to provide a $7\frac{1}{2}$ -inch-per-second basic recording capstan speed.

The size of the motor pulley is changed to provide other basic capstan speeds.

Tape Traction and Tension

Positive tape traction at the capstan surface is obtained by use of individual pressure rollers which increase the friction pressure of the tape against the capstan. These rollers are mounted on a common lever which can be moved to disengage them from the capstan.

Uniform and adequate contact of the tape surface with the recording head must be maintained in order to produce uniform results. Since most record heads are cylindrical in shape, radial pressure of the tape against the head can usually be produced by maintaining the tape under tension. This tension must be maintained at a relatively uniform value and instantaneous variations should be particularly avoided to prevent frequency modulation of the recorded signal.

Proper tape tension is provided, in this case, by stationary pressure pads through which the tape moves. These pads are provided with felt faces to equalize the friction pressure and to provide a uniform friction surface. Weights are provided for use with these pads to change the tape tension.

A small amount of tape tension is supplied by a friction brake ap-

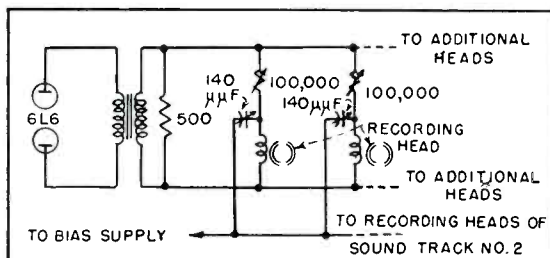

FIG. 1—Method of feeding signal and bias currents to each recording head

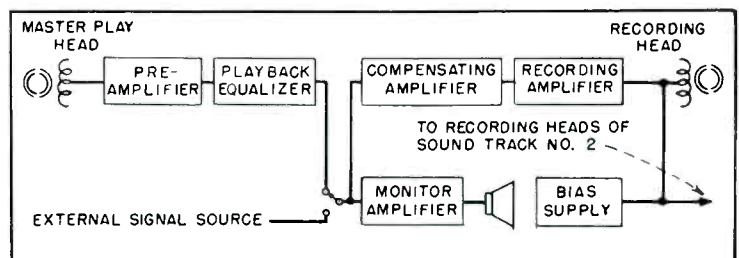
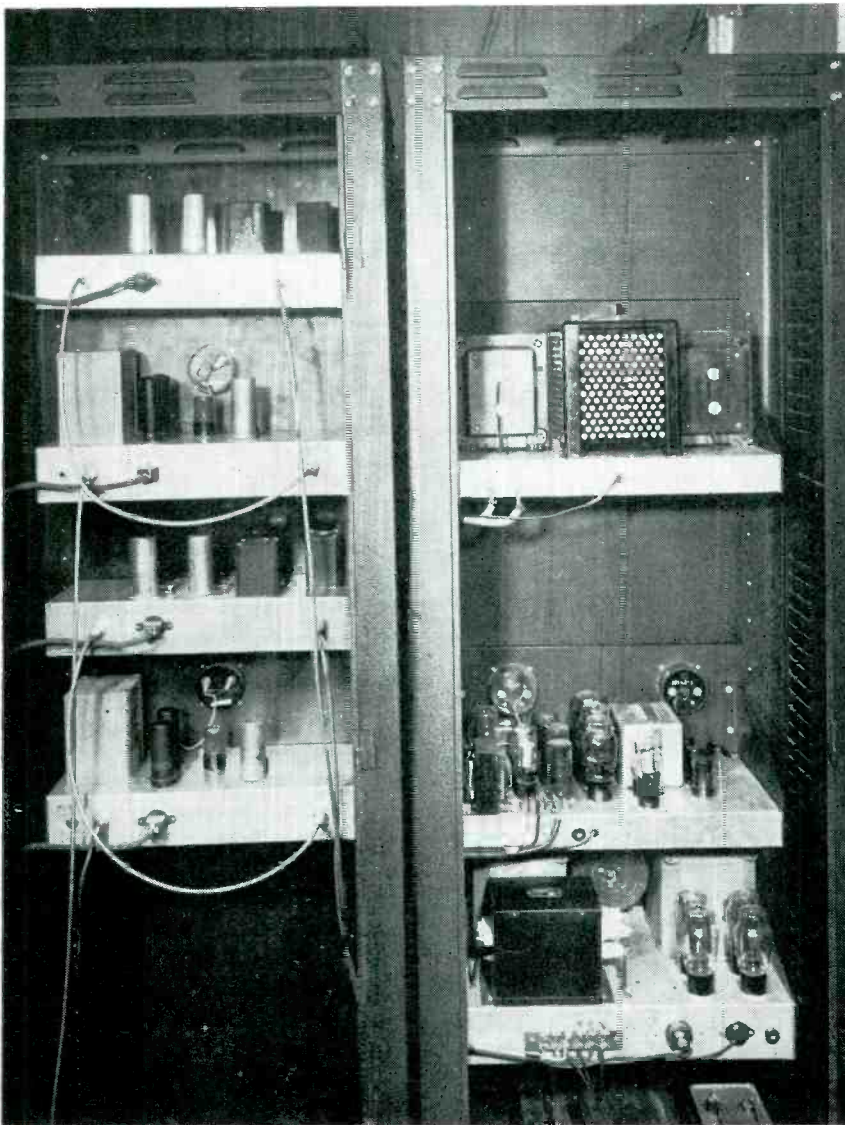
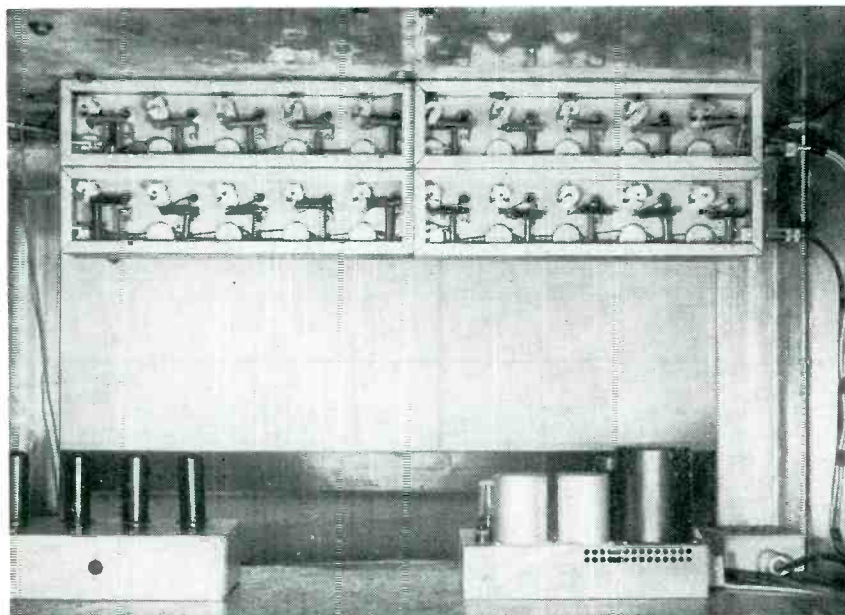

FIG. 2—Block diagram of playback and recording amplifiers, showing equalizer and compensating amplifier locations in system



Recording amplifiers and equalizers for tape duplicator are in left-hand rack, and regulated power supply is in rack at right



Interior of base of multiple recorder, showing high-frequency bias supply and individual networks for supplying bias and signal to recording heads

plied to the tape stock reel shaft. Since this friction is constant, the tape tension varies from the outside to the inside of a stock reel, but because this tension is a small portion of the total tape tension, its effect is negligible.

The stock roll shafts are designed to accommodate reels of tape up to 20 inches in diameter. Such reels would hold enough tape for a large number of recorded programs, thus eliminating the necessity for frequent threading of tape through the machine.

The windup spindles are designed to accommodate reels up to 15 inches in diameter. They are provided with automatic friction drives which can be preset to wind the tape at either constant torque or constant tension, or a compromise between the two. Constant torque winding is usually considered most desirable where the ratio of reel diameter to hub diameter is not excessive.

Recording Head Mounting

The recording heads are mounted on plates which are pivoted on the head assembly bracket. Adjusting screws permit the head gap position to be set so that the recorded signal on the tape is oriented exactly at right angles to the direction of tape travel. Proper orientation of the recorded signal on the tape is very necessary to the achievement of uniform playback characteristics on other magnetic recording equipment. Exact orientation of the record head is determined by comparison of a tape made on this head with a specially prepared head alignment tape when both are played on the same reproducing system.

Bias and Audio Feed

Previous experience with several individual recording machines operating in close proximity to each other indicated that troubles were often encountered from beat notes in the audio-frequency range. These beat notes resulted from small differences in frequency of the high-frequency oscillators. To avoid this problem, a common source of high-frequency bias was used for all recording channels on the duplicating machine.

The waveform of the bias current should be sinusoidal and should be relatively free from harmonics. The presence of even-order harmonics is particularly objectionable. This type of wave distortion tends to greatly increase the background noise of the tape and thus reduce the useful dynamic recording range. Adjustment of the bias frequency can be made over a frequency range of from 20,000 to 100,000 cycles and impedance-matching networks are provided to permit use of record heads having a wide range of impedances. Proper bias current is supplied to each recording head individually through an adjustable coupling capacitor. This permits adjustment of the bias to suit individual head characteristics.

Two amplifiers are provided for simultaneous two-track recording. Each amplifier feeds a group of recording heads to supply the proper signal to the separate tape tracks. Individual heads are connected to the source of audio signal through a constant-current network so that the current in the recording head is independent of frequency.

Figure 1 shows the network used to feed the bias current and the audio signal to a recording head, and Fig. 2 shows the amplifier and equalizer system. For simultaneous two-track recording, an identical amplifier and equalizer system is used to supply the audio signal to all of the heads in the No. 2 track position. A common bias oscillator provides the bias current for all record heads.

Preamplifier and Equalizer

The signal from a playback head on the master tape is fed to a special pre-amplifier having flat frequency response. The cathode heating current for the tubes in this amplifier is supplied from a d-c source. The plates are fed from an electronically regulated and filtered power supply having a ripple component less than 0.00001 percent. Tubes are selected for low microphonic and emission noise. The entire amplifier is mounted inside a heavy malleable-iron box which provides shielding.

When the value of audio signal

current supplied to a recording head is kept constant regardless of the signal frequency, the recorded signal on the tape does not produce a uniform output when the tape is played on a standard playback head. Part of the reason for this is that the voltage developed by the playback head is proportional to the rate of change of the magnetic flux supplied by the tape. For a given remanent tape flux the output voltage from the head is, therefore, directly proportional to the frequency of the recorded signal. This relation would hold true throughout the entire audio-frequency range, were it not for the effect of other factors relating to the head gap length and to the wavelength of the recorded signal. These factors tend to reduce the output at higher frequencies. It is therefore necessary to equalize the signal from a recorded tape in order to produce a flat frequency output. To accomplish this, the signal from the tape is passed from the preamplifier through a special playback equalizer in which amplification is incorporated to compensate for the equalizer loss. A switch is provided to permit the characteristics of the equalizer to be changed as required by differing tape speeds.

Figure 3A shows the relative voltage output from a playback head at different tape speeds, when the signal on the tape has been recorded

at these same speeds with constant current. Figure 3B shows the characteristics of the equalizer settings which are required to produce the uniform signal output of Fig. 3C at the different tape speeds.

Response Curves

The equalizer output signal should be a faithful replica of the signal originally impressed on the tape, and would normally pass directly to the recording amplifier for re-recording. It is often desirable, however, to alter the character of the original signal in order to compensate for some deficiencies in the original recording. It may also be desirable to pre-emphasize either the high or low frequencies as recorded on the tape in order to improve the signal-to-noise ratio or to match the playback characteristics of some special commercial recording equipment. For this reason, the signal from the playback equalizer is passed through a compensating equalizer before it enters the recording amplifier. This compensating equalizer is provided with controls which may be set to pass the signal without alteration, or which may permit boost or attenuation of the signal at either low or high frequencies. The frequency transmission characteristics of this equalizer are shown in Fig. 3D.

The recording amplifier is de-

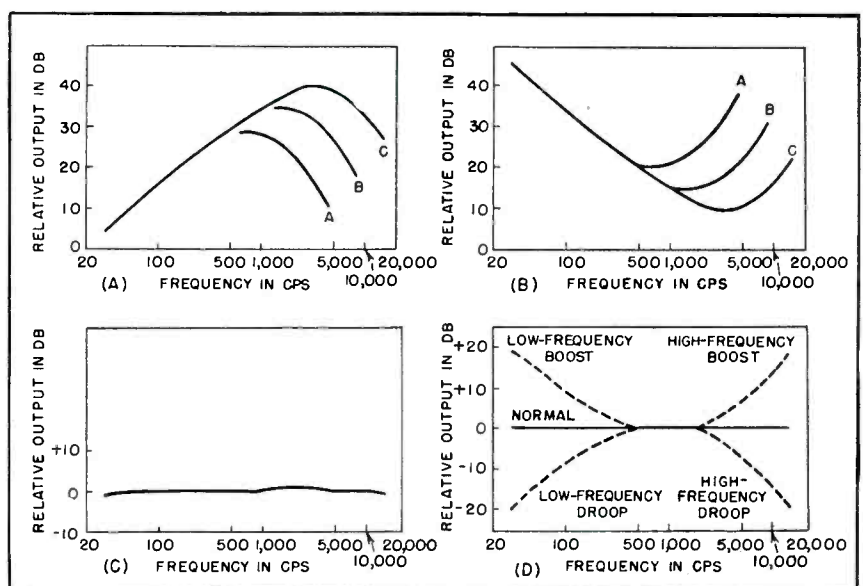

FIG. 3—Response curves of duplicator. (A) Playback characteristic with constant recording current and various tape speeds; (B) Equalizer amplifier frequency characteristics required for various tape speeds; (C) Equalized playback output for 15 feet per second; (D) Frequency characteristics of compensating amplifier

signed to supply adequate signal to eight heads in parallel. The current fed to each head is individually adjustable to accommodate individual variations in impedance and efficiency. Sufficient latitude is provided in this adjustment to permit use of heads having considerable differences in impedance.

The recorder section may also be fed from an external signal source so that master tapes, to supply a number of duplicating machines, can be made simultaneously on one machine. For two-track recording an identical system is used to supply the recording heads for the number-two tracks.

A monitor amplifier and loudspeaker are provided for listening as required. Since the installation of monitor heads in the recording channels would complicate the machine design considerably, it was felt that all monitoring of the dubbed copies should be done on separate playback equipment. A quality-control procedure based on selective sampling of the tapes from different recording channels would permit adequate inspection of the finished product.

The high-voltage supply for the amplifier tubes is obtained from a rectifier whose output is controlled by a combination of voltage and current-regulator tubes which limit the output voltage fluctuations from any source to less than 0.0001 percent. Regulation of the power supply to this unusual extent permitted an appreciable gain in signal-to-noise on the recorded tapes by eliminating random background noise resulting from rapid line-voltage fluctuations.

The high-voltage power supply, the equalizing networks and the recording amplifier are mounted in standard relay racks. The bias supply and the playback preamplifiers are mounted in the base of the recorder in order to keep the connections to the heads as short as possible. The lead wires to the heads are made of low-capacitance shielded cable to minimize attenuation of the high-frequency bias to the recording heads and to reduce the possibility of changing the resonant frequency of the playback heads.

A further gain in production effi-

ciency can be achieved by operating the tapes at higher than normal playback speed during the recording process. This time multiplication can be successfully employed within a restricted range of speeds. For example, tapes to be played at a standard operating speed of 7.5 inches per second can be recorded without difficulty at 15 inches per second. In order to do this the master tape and the copy tapes must all be run at twice their normal speeds.

When the signal frequencies from the master tape are doubled by



Individual mounting bracket for pair of recording heads that act simultaneously on two sides of a single tape to produce two tracks

speed-up, the frequency of the supersonic bias current must also be doubled in order to maintain satisfactory frequency relationships. In the case of tapes normally played at 7.5 inches per second, a bias frequency of 35 kc may normally be used for a top audio-frequency range of 7,500 cycles. When the recording process is accelerated to twice normal speed, the top limit of audio frequency becomes 15,000 cycles and this requires a 70-kc bias frequency.

Recording Speed Limitations

If the recording speed is increased by a factor of 3, the maximum audio frequency becomes 21.5 kc and the bias frequency must be 105 kc. Since most recording heads in use today lose efficiency at a rapid rate with bias frequencies greater than 70 kc, the practical limitation to increasing the recording speed is one of recording-head design.

If suitable heads can be made, it appears perfectly practical to speed up the recording process by a factor of four or five from a basic playing speed of 7.5 inches per second. Since the maximum recording speed is limited by a fixed maximum frequency response, the amount of speed increase is a function of the maximum audio frequency resulting from such increase. For example, tape masters made at 15 inches per second and having a maximum frequency response of 15,000 cycles would require a bias frequency of 60 to 70 kc. Copies of this tape for playing at 15 inches per second would be made at normal playing speed.

As contrasted with this, tapes made for a playing speed of 3.75 inches per second would have a maximum frequency response in the neighborhood of 4,500 cycles. Increasing the recording speed by a factor of 3 or 4 would result in a maximum audio frequency of 15 to 20 kc, and a bias frequency of 70 to 80 kc would permit satisfactory recording. From an economic standpoint, time multiplication is more advantageous for the lower tape speeds because the reduction in cost provided by the increased speed would parallel the cost reduction achieved by lowered tape cost.

Economic Aspects

There is a very practical economic limit to the speedup process in recording. Since the speedup process has very little effect on the cost of direct labor required by the recording process, the net effect of the speedup is to permit greater production from the machine, but not from the operator. Much greater gains can be made by reducing the direct labor involved in the recording operation. Such reduction can be accomplished through the use of automatic threading and reel changing devices which will minimize the machine shutdown time. The design of such a mechanism has been completed.

Production experience has indicated that the cost of recording can be held to a small proportion of the total tape record cost so that mass production of tape recordings is commercially practical.

Tunable A-F Amplifier

Variable-frequency circuit used as an oscillator from 200 to 10,000 cycles also serves as a selective amplifier in the same range. For code reception through interference, the device is switched to provide better rejection than a crystal filter

RECENT DISCLOSURE of a simple phase-inverter connection for driving a half-lattice R-C filter of the all-pass type¹ greatly simplifies a variable-frequency circuit useful both as an audio oscillator and as a selective amplifier for rejecting or emphasizing a particular frequency.

This circuit has certain interesting advantages in comparison with the conventional bridged-T, parallel-T, and Wien-bridge methods of accomplishing an equivalent result. It makes practical, for example, an easily-constructed wide-range oscillator in which the magnitude of the feedback voltage is substantially independent of the operating frequency. Thus, it is possible to dispense with special limiting or variable-impedance devices for automatic amplitude control.

When the circuit is used as a rejection network, only one knob need be turned in order to find the null. Inexpensive ganged resistances may be used to change frequency, and frequency ratios of the order of 100 to 1 may readily be obtained without range switching. Finally, the circuit as an oscillator inherently provides a source of quadrature voltage suitable for obtaining a circular sweep on a cathode-ray tube.

Method of Operation

A block diagram of one useful form of this circuit is shown in Fig. 1.

The all-pass-type filter delivers an output voltage whose magnitude is independent of frequency, but whose phase is determined by frequency. The variation of this phase with frequency (that is, the time constant of the network) is adjustable, and this adjustment also has no effect on the magnitude of the

By **OSWALD G. VILLARD, Jr.**

*Department of Electrical Engineering
Stanford University
Stanford, Calif.*

output voltage. In Fig. 1A a null will occur when the transmission through each of the parallel circuit branches is equal, and the phase shift through the network is 180 degrees. In Fig. 1B, oscillation occurs when the phase shift of the voltage fed back around the single-stage amplifier is 180 degrees. Consequently oscillations and the null will occur at the same frequency for a given setting of the network time constant.

It is convenient to do the phase shifting in this network in two sections. In Fig. 2 will be found the essential details of one section. Each may be viewed either as an R-C phase shifter of the familiar variety shown in many textbooks, (see Fig. 2A), or as one half of an

R-C lattice filter of the all-pass phase-correcting type, as in Fig. 2B. The vector diagram of one section, which shows why the output voltage remains constant as either R , C , or frequency f is varied, is given in Fig. 2C. The phase shift of the output with respect to the input is $2 \arctan 2fCR$. The network may be driven equally well by a vacuum-tube phase inverter, or by a transformer.

The special advantage of this particular half-lattice, when used as part of a null bridge or oscillator, is the fact that changing the phase shift by varying R cannot alter the phase-shifter output voltage and consequently affect the completeness of bridge balance or the magnitude of the oscillator feedback. If the corresponding full lattice were used (see the dashed lines in Figure 2B), both resistances would have to be varied in exact synchronism if changes in the magnitude of

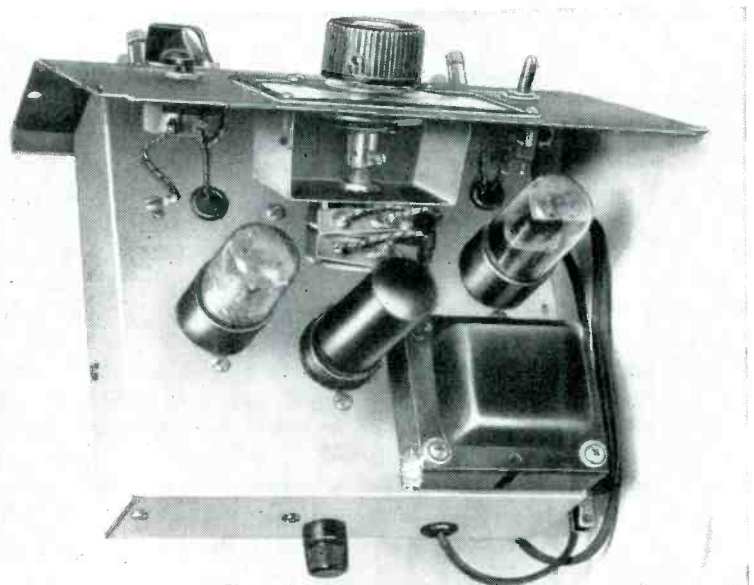

Top chassis view showing parts layout. Ganged variable-resistor frequency control at center

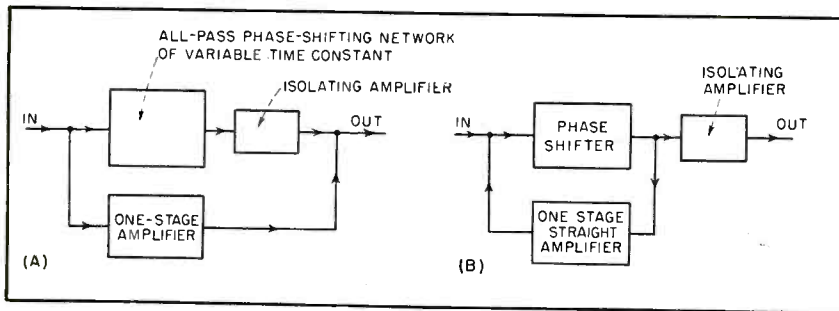

FIG. 1—Block diagram of basic rejection circuit (A) and basic oscillator circuit (B)

the output voltage were to be avoided.

Lattice-Filter Method

Another method of obtaining feedback voltage whose magnitude is independent of frequency or frequency-control setting, and also using an all-pass lattice filter, has been disclosed² but is considerably more complicated than the present arrangement because no loss in the all-pass network was permitted. In the present case, greater constructional simplicity is obtained at the expense of a certain amount of amplification.

With the conventional Wien-bridge circuit, two accurately-ganged capacitors or resistors must be varied to change frequency. If these elements are not in perfect track, the depth of the null will be proportionately reduced, and the feedback voltage will not be constant when the circuit is used as part of an oscillator. Similarly, parallel-T networks which must be varied over a wide frequency range require the accurate ganging of three circuit elements. It is usually necessary, with these circuits, to provide a fine balance control in addition to the coarse frequency control.

Constructional Details

A complete schematic of a typical oscillator-rejection filter device is found in Fig. 3, together with a vector diagram illustrating its operation in rejecting a particular signal. With two phase-shifter stages (V_1 and V_2) it is seen that the null is found when the phase shift through each stage is 90 degrees—that is, when the frequency is such that X_c equals R in Fig. 2C. It follows that the null frequency is

inversely proportional to resistance. The same is true of the oscillation frequency.

The gain control P in the grid of V_1 allows adjustment of the depth of the null when the switch S is at the 2, or null, position. Once set for best rejection at one frequency, it is ordinarily not necessary to readjust this control when frequency is changed. When S is set in the 1, or oscillator position, this same gain control P adjusts the amount of feedback. When the feedback is set somewhat below the threshold of oscillation, the unit becomes a variable-frequency selective amplifier.

The sharpness of the passband may be controlled by adjusting the amount of feedback. When oscillations are desired, the gain control is set slightly above the threshold of oscillation. Under these conditions waveform will be good and output will not vary appreciably as frequency is changed. Too much feedback causes distortion; too little will make the oscillations unstable and likely to drop out with small residual changes in feedback as frequency is varied.

The only critical circuit components in Fig. 3 are the plate and cathode resistors of the phase inverters. These must be matched very accurately in pairs. The absolute magnitude, of course, is not important. Similarly, the two-to-one ratio between the corresponding resistors of the two tubes need only be approximate. Thus the matching may readily be done on an ohmmeter. For best long-time stability, precision resistors should be used.

It is desirable that the power supply be well-filtered and have a very low output impedance, in order

to avoid coupling between the phase inverter stages. Where stability of operation must be maintained in spite of large line-voltage fluctuations, voltage regulation is desirable.

Dial Calibration

In a great many so-called resistance-tuned oscillators, capacitance is varied in order to change frequency. Owing to the effect of the minimum capacitance inherent in variable capacitors, the tuning

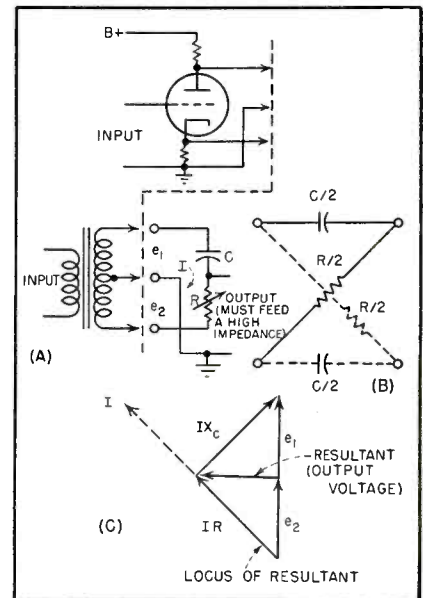

FIG. 2—Phase-shift circuit (A) that can be driven by transformer or vacuum tube; (B) all-pass lattice from which the simple phase-shifter is derived; (C) vector diagram

range obtainable is generally of the order of 10 to 1. By varying resistance in the present circuit, a wide tuning range may be covered in one rotation of the dial. If a straight line frequency-versus-resistance characteristic is desired, the phase-shifting capacitor in Fig. 2A can be replaced by an inductance. However an inverse frequency-versus-resistance calibration is quite practical in many applications. The dual-ganged resistance used in the unit of Fig. 3 is a readily-available Centralab type C-104 which has what is termed a standard audio taper. By taking advantage of this taper, the range from 200 to 10,000 cycles can be spread out reasonably well on a standard 180-degree vernier dial.

The chief limitation on the upper frequency limit which may be achieved by progressively reducing resistance, in addition to amplifier frequency response, is the loading effect of each R-C phase-shifting network on its associated phase inverter. This upsets the equality of the plate-to-ground and cathode-to-ground a-c voltages, and causes their relative phase to depart from exact phase opposition.

Sharpness of Rejection Band

It is desirable that a frequency-rejection device have as sharp a rejection notch as possible. The circuit described has a performance in this respect which is slightly superior to that of both a Wien and a parallel-T R-C bridge.

A curve of percent response versus frequency is shown in Fig. 4. The parallel-T response curve shown is that of a commonly used and relatively simple type² in which two of the resistors and two of the capacitors are identical and the other two elements are half or twice as large. A sharper rejection curve can be obtained by using a more complex relationship between these elements, but even when this is done the best of several typical cases³ does not equal the performance of the phase shift bridge.

Discrimination of the phase-shift bridge may be improved by adding

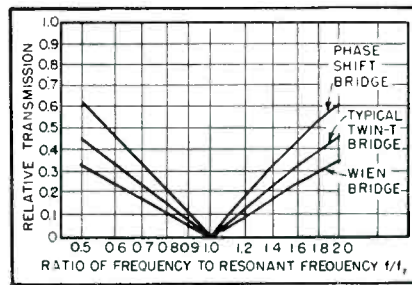

FIG. 4—Relative transmission as a function of frequency rejection

additional phase-shifting sections. With three instead of two, a second null, rather than a maximum of transmission, will occur as frequency approaches either zero or infinity, depending on circuit polarity. With the oscillator connection, there would accordingly be a tendency for simultaneous oscillation at two frequencies. However it is possible that the second oscillation might not prove too troublesome in view of the falling-off in amplifier response at the frequency involved.

Applications

The ease with which this device may be constructed, recommends it for application wherever a simple general-purpose audio signal source, variable-frequency selective amplifier, and frequency-rejection filter would be useful.

By providing an output connection shown in Fig. 3 which samples

a portion of the voltage at the junction between the two phase shifters, a quadrature voltage is available by means of which a variable-frequency circular sweep on an oscilloscope may be obtained. In this case, the accuracy of the 90-degree phase shift is a function of the accuracy with which the two variable resistors remain in step as the common shaft is rotated, and accordingly will not be very good unless precision resistors are used.

This unit is particularly suitable as an accessory for a communications receiver. In phone reception, the frequency-rejection feature may be used to eliminate interfering heterodyne whistles. The sharpness of the rejection slot is, if anything, superior to that of a good crystal filter. For code work, the operator has a choice: he may use the device to reject an interfering code station, leaving the desired signal little affected, or by throwing a switch he may use it as a variable-frequency selective amplifier to amplify one signal more than the others. The selectivity is continuously variable and may be adjusted to suit.

It is interesting, as this control is advanced, to hear a signal of one particular pitch rise up out of the others simultaneously present. Since the null frequency and frequency of regeneration are the same, it is possible to select and amplify a particular signal, and then by throwing the switch to make it disappear leaving all the others behind.

Acknowledgment

The author is indebted to his colleague, F. W. Clelland, for the suggestion that this oscillator may be used as a source of quadrature voltages. This work is an outgrowth of research for the Watson Laboratories, Air Materiel Command, under Contract W28-099-Ac-131.

REFERENCES

- (1) E. W. Rosentreter, Single-Sideband Adapter, *ELECTRONICS*, p. 124, July 1948.
- (2) Valley and Wallman, "Vacuum Tube Amplifiers", Radiation Laboratory Series, 18, 384, McGraw-Hill Book Co., New York, 1948.
- (3) Leonard Stanton, Theory and Application of Parallel-T Resistance-Capacitance Frequency-Selective Networks, *Proc. IRE*, 34, No. 7, p. 447, July 1946.
- (4) G. Willoner, and F. Tihelka, A Phase-Shift Oscillator with Wide Range Tuning, *Proc. IRE*, 36, No. 9, p. 1096, September, 1948.

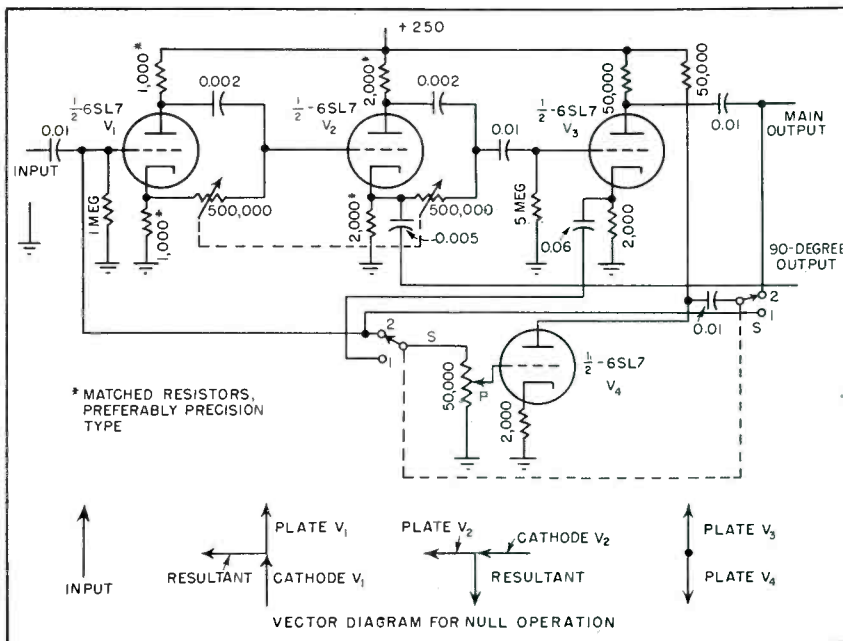
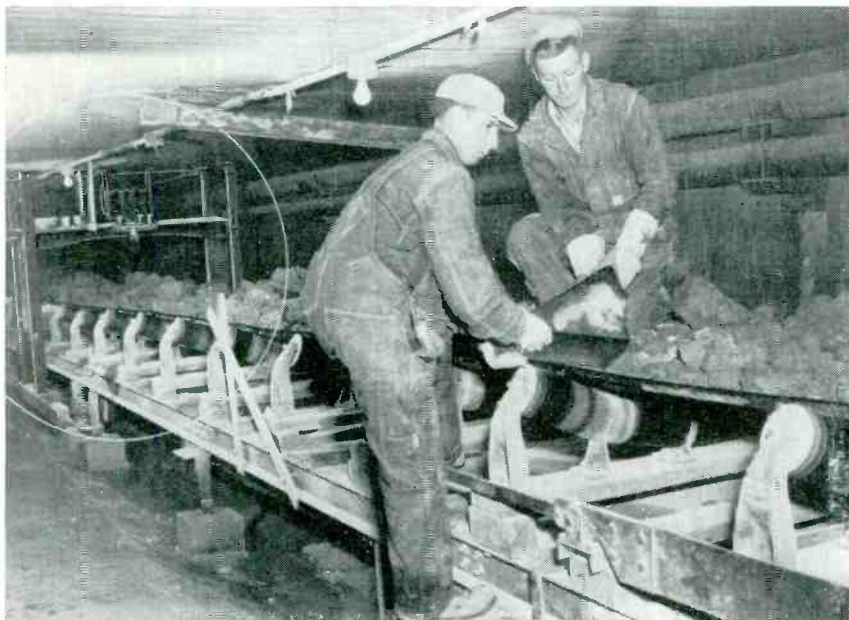

FIG. 3—Schematic circuit diagram and vector diagram for null operation

METAL DETECTOR



Operator runs bolt of rubber through metal detector coil, shown over conveyor belt housed in wood baffle for protection. Metal detector unit may be seen on shelf at upper right corner of picture



Workmen remove a manganese steel (nonmagnetic) shovel tooth from a conveyor belt loaded with limestone. Inspection coil and marker device are encircled in background. Marker dumps cup of white chalk on conveyor when metal is detected

By **KENNETH URBACH**

*Electronic Engineer
Radio Frequency Laboratories, Inc.
Boonton, N. J.*

INDUSTRY is continually confronted with the problem of finding metal (nonmagnetic as well as ferromagnetic) in process media before serious damage is done to machinery, plant, product, or—in the case of foods and drugs—before it reaches the consumer. The metal detector described in this paper should find extensive application in the textile, rubber, plastics, lumbering, paper, mining, milling, sugar, grain and drug industries.

Metal detectors generally work on the distortion of a radio-frequency or audio-frequency field. The Army Engineers have mine detectors utilizing these principles that do the job for which they were designed very well, but in general they are not sufficiently sensitive, stable or versatile to find many industrial applications. The metal detector described is the result of an independent development specifically for industrial application to a wide variety of problems.

Principles of Operation

The operation of the instrument is based on the momentary distortion of the r-f field when a metallic particle passes through or near the tank coil of a stable oscillator. This distortion may result in an increase or a decrease in the efficiency or Q of the tank and will, therefore, be reflected back into the plate circuit as a change in the resistive component, giving rise to a change in voltage magnitude. If this change is in the negative direction, and of sufficient steepness and amplitude, an alarm signal results.

Most common materials cause a decrease in the Q due to the increased losses. These losses are apparently of three characters: eddy

for CONVEYORS

Metallic particles passing through or near the tank coil of a stable oscillator cause a change in the output of the oscillator due to eddy current, hysteresis and dielectric-loss changes. Change in output is detected, amplified and used to actuate alarm and marker circuits

current, hysteresis and dielectric. The magnitudes of the losses depend, in general, on the surface, shape, mass, resistivity, and permeability of the material and the frequency and concentration of the electromagnetic field. Since two classes of material, the product to be inspected and the tramp metal to be detected, are involved in the metal detector problem and since the designer has no control over the physical characteristics of either, his aim is to choose an operating frequency and coil design that will emphasize the losses due to the tramp metal and minimize those due to the product.

The depth of the penetration δ of an electromagnetic field in a conductor, limited by skin effect, is given by:

$$\delta \text{ (cm)} = \sqrt{\frac{\rho \times 10^2}{\mu \mu_0 \pi f}} \text{ or } \delta' \text{ (mils)} = 1.99 \sqrt{\frac{\rho}{\mu f}} \quad (1)$$

where δ is the depth at which the current is reduced to 37 percent of the surface value, ρ is the resistivity in ohms per cm cube, $\mu_0 = 4 \pi \times 10^{-7}$, μ is the permeability, and f the frequency in cycles. For copper δ' is 6, 12 and 26 mils at frequencies of 200, 50, and 10 kc respectively. For iron of assumed permeability 200, δ' at 50 kc is only 2 mils. Thus it is the surface area of a conducting sheet or particle that usually influences or is influenced by the r-f field.

Eddy-current losses in an object of volume V cubic meters are, neglecting skin effect¹:

$$W_e' = \frac{\pi^2 f^2 t^2 B_{\max}^2 V}{6 \rho} \quad (2)$$

where W_e' is in watts, t is the thickness of the object in meters, B

is in webers per square meter, and ρ is in ohms per cm cube. Since B may be written as $\mu \mu_0 H$, it is seen that the eddy-current losses are proportional to the square of the frequency and permeability, and inversely proportional to the resistivity. If we take into account the redistribution of induced current due to skin effect, the equation for the eddy-current loss becomes:

$$W_e = \frac{f B_{\max}^2 V}{12 \mu} \left(\frac{t}{2 \times 10^{-2} \delta} \right)^2 \left[1 - \frac{6}{945} \left(\frac{t}{2 \times 10^{-2} \delta} \right)^4 \dots \right] \quad (3)$$

or

$$W_e = W_e' \left[1 - \frac{6}{945} \left(\frac{t}{2 \times 10^{-2} \delta} \right)^4 \dots \right] \quad (4)$$

If we assume a sheet of copper 1 millimeter thick and a frequency of 50 kc, the term in the brackets amounts to 5 percent. Considering the material characteristics and field as fixed, we may write Eq. 3 in terms of frequency.

$$W_e = K_1 f^2 (1 - K_2 f^2) \quad (5)$$

and

$$f_c = \frac{1}{\sqrt{2 K_2}} \quad (6)$$

Equation 5 shows that at or beyond a critical frequency f_c there will be

no appreciable eddy-current losses. Since K_2 is a function of the material, calculations based on the above formulas are useful in selecting a frequency that will give maximum discrimination between two media.

Hysteresis losses, appreciable only for ferromagnetic materials, are due to a tendency to oppose a change in magnetic state. These losses may be expressed in the form:

$$W_h' = \alpha f B_{\max}^n V \quad (7)$$

where the values of α and n depend on the material. Note the hysteresis losses vary linearly with frequency if we neglect the skin effect. Actually with magnetic materials the skin effect is far from negligible. Qualitatively, the depth of penetration may be considered as limiting the value of B_{\max}^n over a portion of the volume, and thus reducing the loss W_h' to some value W_h . The quantitative expression is somewhat difficult to handle and experimental comparison of the amount of signal (loss) produced by steel and copper spheres of equal diameters at various frequencies seem to substantiate the equations,

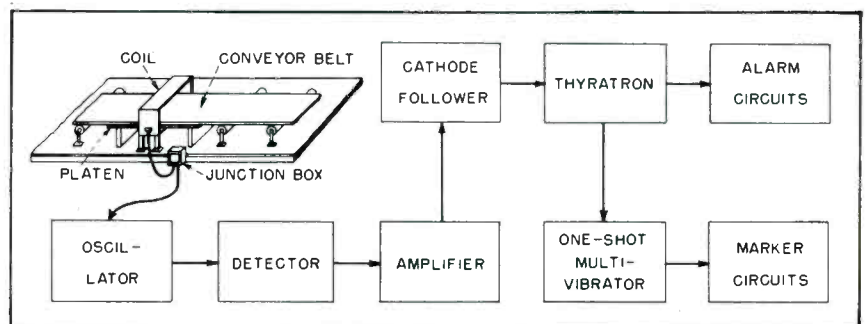

FIG. 1—Block diagram of metal detector. Lines up to 40 feet long have been used successfully between inspection coil and oscillator

and are a great deal simpler to handle.

The third type of loss mentioned is that found in dielectric materials as contrasted to conductors. The loss in a dielectric is generally expressed in terms of frequency, capacitance and power factor of an ideal capacitor whose only losses are in the dielectric. This type of loss is noticed in metal detector applications where the product being inspected momentarily occupies a large portion of the volume of the coil, and the resistivity is high. The losses are directly proportional to frequency, since there is no radical change in power factor over the range of frequencies utilized. This must also be considered in selecting the inspection frequency.

Circuits

Figure 1 is a block diagram of the Eriez metal detector, the circuitry of which is shown in Fig. 2. The material to be inspected is passed through or near the coil which, together with a fixed capacitor, forms the tank circuit of the 6J5 oscillator. The operating frequency, between 10 and 200 kc, is selected as previously outlined, and the tank circuit is designed to match the plate impedance of the tube at this frequency. A decrease in tank efficiency or Q, such as might be caused by a piece of tramp metal, causes a momentary decrease in the magnitude of the generated voltage.

Half of V_2 is used as a rectifier, conducting on the negative portion

of the oscillator cycle and charging C_1 and C_2 negatively to approximately the peak oscillator voltage. Under steady-state conditions no signal will be applied to the first amplifier grid unless the magnitude of the generated voltage is suddenly changed. A decrease in oscillator voltage will allow C_2 to discharge to a new and less negative value, thus applying a positive signal to the amplifier grid.

The two-stage amplifier is capacitance coupled, having an overall voltage gain of approximately 60 db, with the half-power points at $\frac{1}{4}$ cycle and 40 cycles. The upper frequency could easily be raised, but is kept low to reduce the noise level. The low-frequency response is more difficult to improve, and imposes some limitations on the application of the device. Inspection must be accomplished at sufficiently high speed so that the fundamental frequency of a pulse generated by a small metal object will be amplified at near maximum gain to secure the utmost in sensitivity. The long time constants necessary to attain the low-frequency response also result in a long recovery time after a large signal. With the present circuit values a large signal may upset the circuit for as long as 8 seconds, during which time a small signal might be lost. This time must be considered in certain types of installations.

The output of the amplifier, in the form of a positive pulse, is capacitively coupled to the grid of a biased cathode follower. The bias

voltage is obtained by a voltage-doubler circuit across the filament supply. The output of the cathode follower is directly coupled to the control grid of a type 2050 thyatron, and the grid level established by adjusting the cathode-follower bias. A positive pulse applied to the cathode follower will lower the thyatron grid and allow it to fire. When the thyatron fires, relay RE_1 is energized. Holding contacts keep RE_1 energized until the circuit is broken by pressing a reset button, while V_5 is extinguished very quickly when its plate voltage drops almost to zero as current is supplied through the one-megohm resistor, R_1 . The alarm relay, RE_2 , may be used to actuate controls for shutting down a conveyor, blowing a horn, or turning on any type of alarm.

When the thyatron fires, a negative pulse is applied to the grid of the conducting side of a one-shot multivibrator. This flips the circuit, de-energizing the marker relay, RE_2 , for the duration of a delay time determined by R_2 and C_3 . This delay time, variable from about 0.1 to 2 seconds is intended to facilitate adjustment of control and marking devices. When the marker circuits are used for controlling automatic reject mechanisms, an external time-delay relay may often be necessary. Since both the thyatron and the multivibrator are quickly restored to normal after an alarm signal, a subsequent signal or signals will actuate the marker relay even though the alarm relay has not

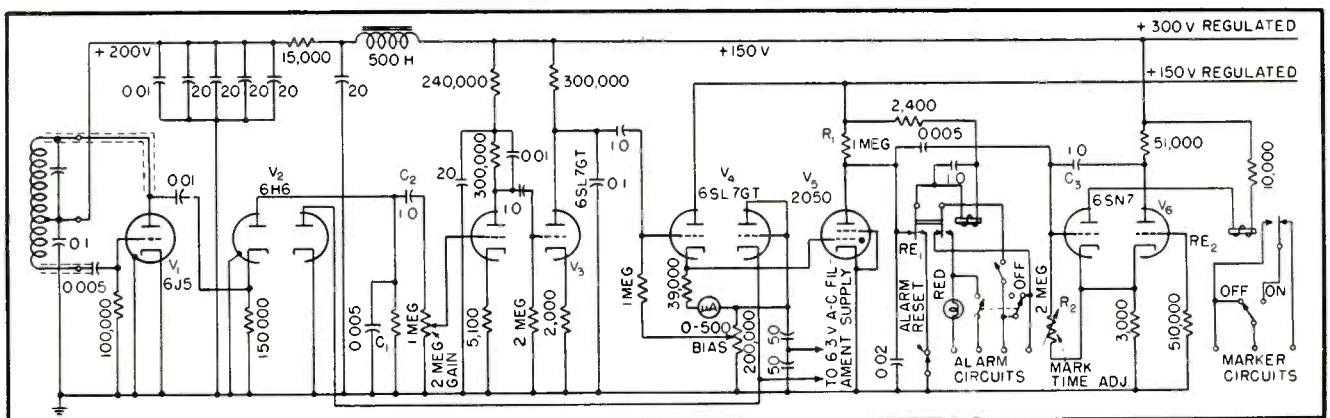

FIG. 2—Schematic diagram of metal detector minus power supply. Extremely well-regulated d-c voltages are necessary because of the high degree of circuit stability required

been reset. The installation shown in one of the photographs makes use of this feature. The first signal shuts down the conveyor and trips the first marker (the device above the coil). Should a second or third or fourth alarm signal be received while the belt is coasting to a stop the respective markers would be operated indicating the locations on the belt of the additional contamination.

The power-supply circuits are fairly conventional. Input power is applied through a constant-voltage transformer of $\frac{1}{2}$ -percent regulation and about 0.1-second response time. The output of the full-wave rectifier is applied through a capacitor-input filter to a degenerative voltage regulator. Two sets of VR tubes act as voltage dividers (and decoupling networks) to split the regulated voltage into four channels. The response of the overall regulated power supply is sufficient to nullify the effect of normal line variations, but is still not capable of entirely eliminating the transients caused by such inductive loads as small motors, relays and fluorescent lights. A power source (125 watts) free from these transients is therefore required if the unit is to be operated at maximum sensitivity and without false alarms.

Installation and Maintenance

Coils are designed for each specific application, and may range in size from 1 in. by 1 in. to 4 ft by 6 ft, with maximum sensitivities of $\frac{1}{2}$ to 2-inch diameter steel balls, respectively. An intermediate coil, such as pictured in the rubber bolt inspector, has an optimum sensitivity of 0.187 inch, while the large coil over the limestone conveyor has a maximum sensitivity of 1 inch. Because of an orientation effect (the most unfavorable condition for a long thin object is perpendicular to the axis of the coil) sensitivities are conservatively referred to in terms of diameters of steel, brass or aluminum spheres. How near to the maximum sensitivity a given installation may be operated is usually governed by the mechanical details of the installation and the product to be inspected.

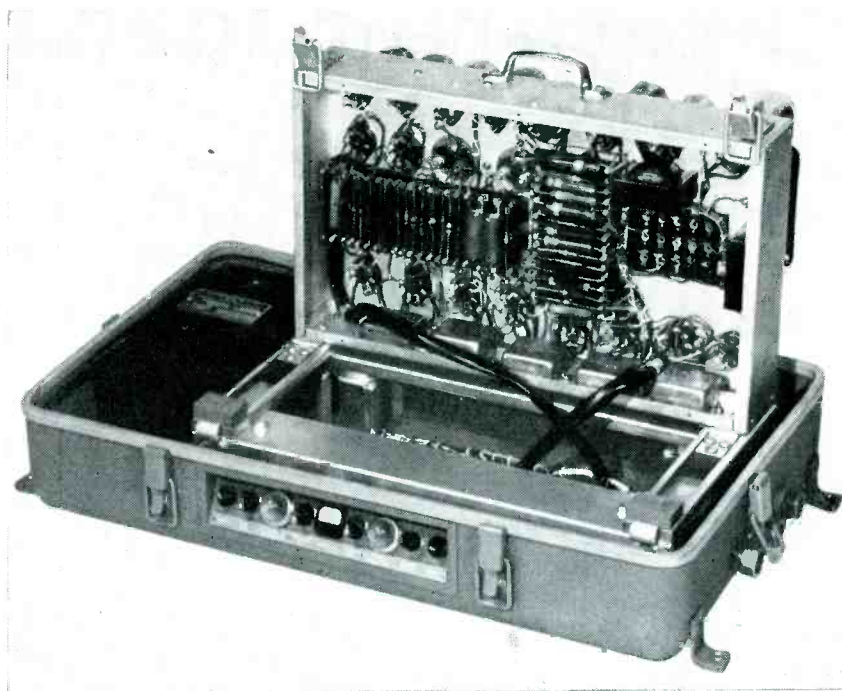

FIG. 3—Metal detector chassis shown in position for servicing

The frequency response characteristic of the amplifier requires an alarm pulse having a fundamental frequency greater than $\frac{1}{4}$ cycle for maximum sensitivity. To obtain such a pulse from a small object requires a minimum inspection speed of approximately 20 feet per minute for a 2-inch aperture and 120 feet per minute for a 12-inch aperture. For most applications this is no problem, as it is within the normal operating range of conveyors and chutes.

Stationary metal objects near the coil reduce the overall efficiency but do not cause an alarm. Moving metal must be shielded or kept two to six times the coil dimensions away from the coil, depending on the size and symmetry of the object. A moving loop circuit or an intermittent shorted turn if oriented so as to loop a portion of the electromagnetic field is capable of causing false alarms. These factors must be considered in selecting an installation area and in designing or altering materials-handling equipment for use in conjunction with the Eriez metal detector.

The metal detector chassis is shock-mounted in a gasket-sealed aluminum case, permitting installation in exposed locations. The in-

spection coil is connected to the detector by up to forty feet of conduit, coaxial cable being used for the plate and grid circuits. This makes the installation very flexible in that a minimum of space is required in the inspection zone, and the control equipment can be located in any convenient place.

The tilting-chassis type construction makes the components and tube sockets readily accessible for voltage checking and servicing. Actual installations are made simply by connections to terminal blocks.

The only maintenance required is an occasional sensitivity check with a standard test specimen, and the normal periodic check of the tubes.

Acknowledgment

The author wishes to acknowledge with thanks the assistance and contributions of E. A. Gilbert and B. F. Snively, both of the Radio Frequency Laboratories, Inc., to the success of this development. The cooperation of the Eriez Manufacturing Company, which markets the Metal Detector, in supplying photographs is greatly appreciated.

REFERENCE

- (1) E. E. Staff, MIT, "Magnetic Circuits and Transformers," John Wiley and Sons, Inc., Ch. V, 1943.

Picture Storage Tube

Combination kinescope and iconoscope in one glass envelope consists of two cathode-ray guns bombarding a special target plate. One gun writes the pattern on the target and the other scans it to generate signals and erase the picture

By **L. PENSAK**

*RCA Laboratories Division
Radio Corporation of America
Princeton, New Jersey*

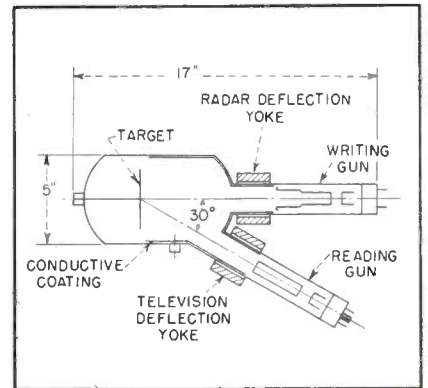
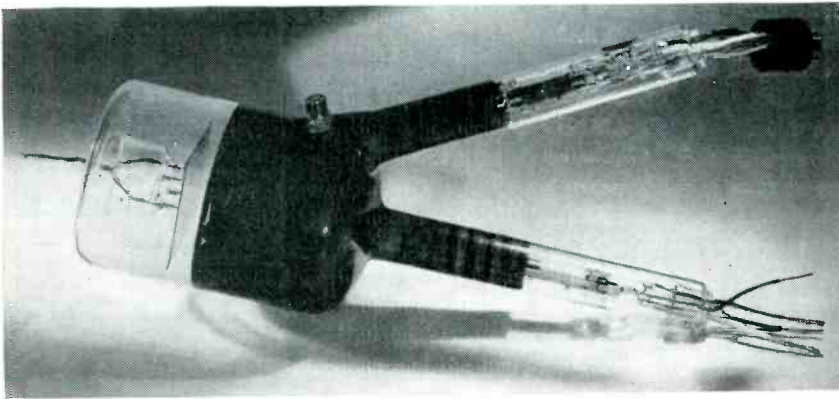

FIG. 1—Magnetic-deflection type of graphechon

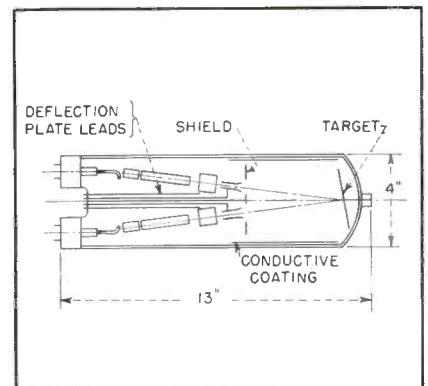
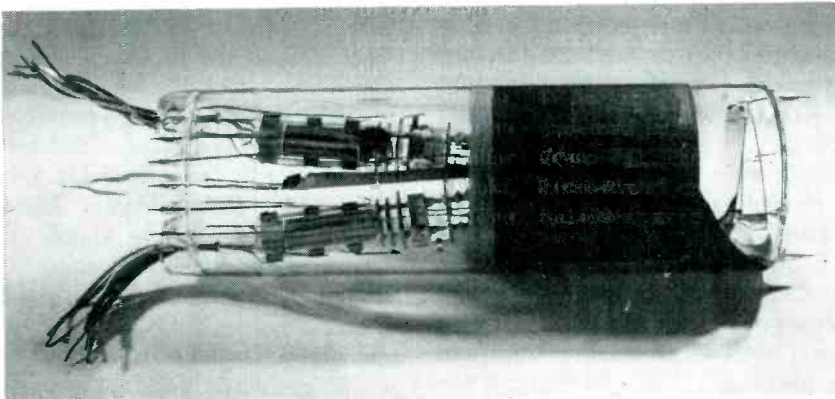

FIG. 2—Electrostatic type of graphechon

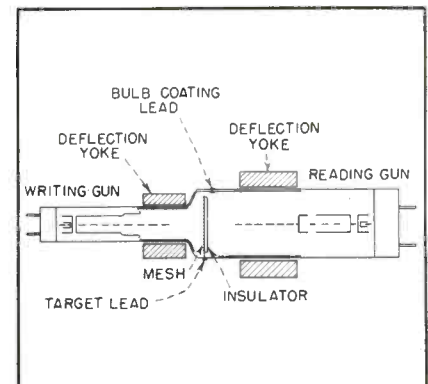
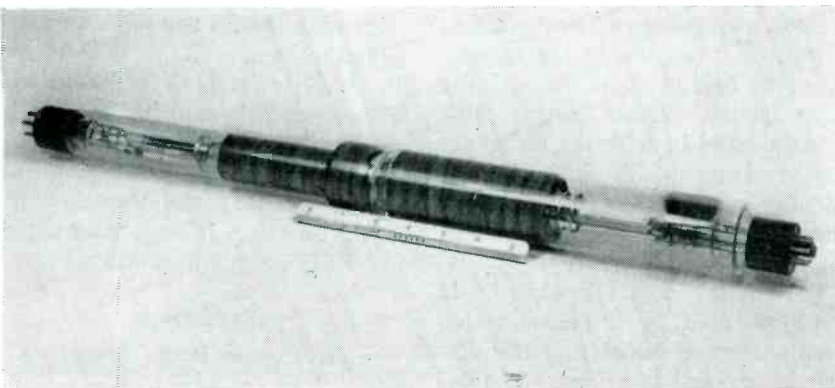

FIG. 3—Double-ended type of construction

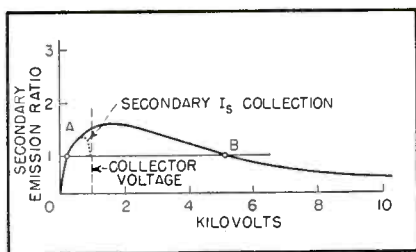

FIG. 4—Typical curve for secondary emission from silica

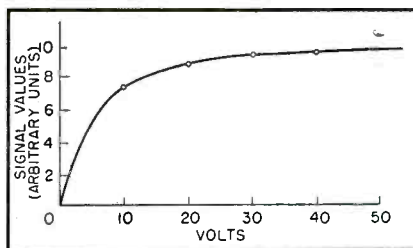

FIG. 5—Surface potential in volts below collector potential

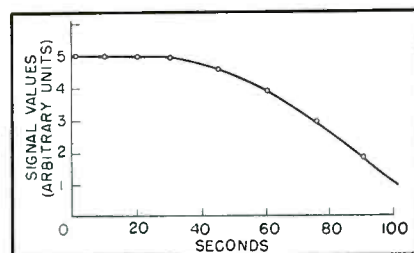

FIG. 6—Typical signal output against viewing time

THE PROBLEM of providing a means for electrically storing complete radar ppi-type patterns and generating from them signals which could provide television pictures of the radar patterns arose in the Teleran system¹ for airborne navigation.

It was highly desirable to be able to broadcast a composite television picture of a radar pattern, its associated ground map and other information. The tube that was developed to meet this need proved to have several other interesting applications.

A means of converting radar signals to television signals without loss of the pattern geometry was needed. This implies storage of the radar signals for at least several seconds because it can take this long to complete one ppi pattern. Also, because television pictures are generated at the rate of thirty per second, it may be necessary to generate several hundred television copies of a radar pattern before it fades out. Such conversion of signals has been obtained with a special high-capacity orthicon² picking up the initial flash of a cathode-ray tube without any afterglow, the picture being retained in the capacity of the orthicon photocathode.

To obtain an all-electronic converting scheme, a new type of tube called a graphechon was built. This name is derived from the Greek words graphe (to write) and echo (to keep or to hold). The tube can be regarded as a kinescope and iconoscope in one bulb with the mosaic and kinescope screen replaced by a charge-sensitive high-capacity storage target. The kinescope gun will be referred to as the writing gun

which takes the radar signal and writes it on the target. The other gun will be called a reading gun. Its function is to generate the television signal and gradually remove the stored signals.

Construction of Tube

The design of the bulb is determined by the requirements of the cathode-ray guns. Figure 1 shows a sketch and photograph of one type of tube using magnetic deflection. To simplify the circuit requirements, the writing gun is mounted perpendicular to the target, which avoids keystone correction for a radial deflection pattern. This correction has been solved very simply for the iconoscope, and so the reading gun is mounted off the axis at the same angle as is used for the standard iconoscope.

When preferable, a tube can be built with all-electrostatic focus and deflection. It is more suitable for oscilloscope operation or, where weight and size are critical, it permits eliminating the deflection yokes. Figure 2 shows such a tube which can be made smaller and more compact than the magnetic deflection type, but is necessarily subject to the lower resolution limits imposed by the electrostatic deflection system.

Figure 3 illustrates the most recent form of the tube. This modification was built to make possible mounting the guns on a common axis and thereby avoid the need for keystone correction. The target construction was modified to permit the writing beam to penetrate through the target.

For the magnetic deflection writing gun it is possible to use a stand-

ard kinescope gun with either magnetic focus (type 12DP7) or electrostatic focus (type 12AP4). Both types have been used for radar purposes and have adequate resolution at the rated voltages of 6,000 to 10,000 volts, which is also the range of voltage used in the graphechon. The reading gun can be a standard iconoscope gun and runs at standard iconoscope voltages, 800 to 1,000 volts.

The target consists of a plate of metal upon which is deposited a film of insulating material of the order of 6,000 Angstroms thick (approximately half a micron). Where the two guns are on the same side, any of a number of metals thick enough to be self supporting can be used for the target. The insulator like silica or magnesium fluoride, applied by any suitable means, such as evaporation.

In tubes where the guns are on opposite sides of the target, it is necessary to make the metal backing transparent to electrons and yet strong enough to support the insulating layer. This can be done by using very fine mesh with a high transmission factor to provide the mechanical support. Then an organic film is spread over the mesh to act as a base upon which to evaporate a thin layer of aluminum. The insulating layer is evaporated onto the aluminum to complete the target. The high-voltage writing gun is located on the mesh side of the target. The mesh is made fine enough so that it does not limit the resolving power of the tube. Sample targets have employed approximately 500-per-inch mesh.

The reading beam, operating at

1,000 volts, has a secondary emission ratio greater than unity. It scans uniformly over the insulator surface and therefore brings it approximately to the potential of the collector, which is the conductive wall coating. This is true regardless of the potential of the underlying metal. It is therefore possible to adjust the potential drop across the thickness of the insulating film to approximately the difference in potential between the target metal and the wall coating.

It is possible to regard the insulator as the dielectric in a capacitor, one of whose plates is the target metal and the other is the surface scanned by the electron beam. As a starting equilibrium condition, the capacitor is charged uniformly over its area. Because the one plate is the insulating surface of the dielectric and does not conduct transversely, it is possible to discharge any part of the capacitor without affecting the rest of it. Such discharging can occur in any arbitrary pattern.

The mechanism for discharging the dielectric is a newly discovered phenomenon⁸ which can be observed in films thin enough to be completely penetrated by an electron beam. It can be shown that currents can flow through the film which are many times larger than the bombarding beam, that the currents flow in the direction of the gradient, and that the insulation recovers on removal of the beam.

Since the penetration of an electron beam increases with the square of the voltage, a film may be chosen of such thickness that, though fully penetrated by a 10,000-volt beam, it is scarcely penetrated at all by a 1,000-volt beam. If the latter low-velocity beam is employed to charge up the dielectric, the 10,000-volt beam may be used to discharge it.

The mechanism for signal generation is a simple form of that in the iconoscope⁴. The target surface is brought to equilibrium potential with the target metal at approximately 50 volts negative. Where the writing beam has struck and driven the surface negative, the secondary emission collection is greater than unity and some charge is removed every time the reading beam scans those areas. This re-

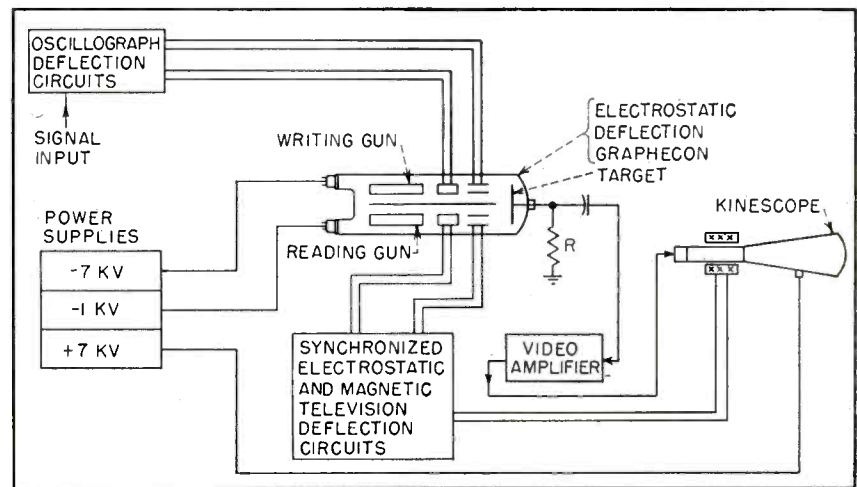

FIG. 7—Block diagram of circuits for using the graphecon as an oscilloscope

moval of charge produces the signal which is amplified to operate the viewing kinescope. As is true for all capacitors, removal of charge from one electrode causes an equal charge to flow onto the other, which, in this case is the signal plate. This current produces an IR drop across the load resistor *R* (see Fig. 7) and thereby produces the signal.

Figure 4 shows the relationship between the secondary emission ratio and the secondary emission collection (dotted line). When the surface is at collector potential, the secondary emission collection is equal to the beam current and the ratio is unity. However, if the surface goes below equilibrium the collection tends quickly to go to the true secondary emission ratio which is characteristic of the particular material. Because the collection is the charge removed, the signal output increases with decreasing surface potential to the limit of saturated secondary emission.

Output Signal

The actual variation of the output signal is shown in Fig. 5. The curve levels off at the higher voltages because the secondary emission collection tends to saturate at relatively weak fields, and the signal current therefore remains almost constant at the higher fields.

The saturation of secondary emission provides a means of obtaining many television pictures of the writing pattern. The saturated secondary emission is proportional to the beam current so that it is only necessary to reduce the beam

current to reduce the amount of charge removed on each scan. However, this also reduces the signal output and the lower limit in this direction is the noise inherent in the video amplifier.

Approximate calculations were made on the time for which a signal would be seen, assuming a television type scan for the reading beam and that one spot of the target was discharged completely by the writing beam. The amount of charge removed on each scan is assumed to be a constant. The formula is

$$T = 0.0885 \times 10^{-12} \frac{kAV}{d} (r - 1) I \text{ seconds}$$

where *T* = viewing time, *d* = film thickness, *A* = target area, *V* = target voltage, *r* = secondary *I*, ratio and *I* = beam current.

An experimental value for *T* of 5 minutes was obtained with *V* = 100 volts, *d* = 5 × 10⁻⁵ cm and *r* = 1.3. One to two minutes of continuous viewing is more usual. Several thousand scans at television standards are therefore quite feasible. Value *T* can be called the viewing or charging time, or the period during which the element will produce a detectable signal in the reading amplifier. The storage time when the reading beam is turned off is much greater and is determined only by the leakage resistance of the insulator. A value of ten days was obtained in one test.

It should be noted that the equation for *T* does not involve the number of elements in the picture, nor does it require scanning, but is exactly that which would be obtained

by calculating the charging time, if it is assumed that current I is spread out uniformly over the whole area of the target.

Because the charging time is proportional to the total area of the target, a reduction in tube size will result in a proportional reduction in the maximum viewing time. However, in applications where it is not necessary to keep the reading beam scanning constantly, the combination of storage time and viewing time can make the picture available for periods of time greater than T as given by the equations.

Target Factors

The factor of insulator thickness, however, does not necessarily vary the maximum charging time even though it varies target capacitance. If it is assumed that the dielectric strength of the insulator is constant, then varying the thickness also permits varying the voltage across it in proportion. As the capacitance per element goes down, the voltage can go up, and the charge per element remains constant. Therefore, the charging time remains constant and the maximum viewing time is independent of the insulator thickness.

The film thickness is subject to a basic limitation arising from the requirements of the conduction effect which depends on the penetration of the film by the writing beam. The efficiency of the effect, that is, the number of conduction electrons per primary, depends on the absorption of the energy of the beam. There is, therefore, an optimum writing beam voltage for each film thickness such that the maximum amount of beam energy is absorbed in the insulator. This voltage is somewhat greater than that required for complete penetration alone. Fortunately, this value is not very critical. Another factor affecting the efficiency is the gradient through the film, which should be as high as possible if it is desired to obtain the greatest sensitivity to the writing beam.

Varying the film thickness also varies the degree of half-tone reproduction. Half-tones are obtained in the voltage range where the output signal varies with the surface potential (the sloping part of the curve in Fig. 5). Beyond this slope,

the signal is independent of surface potential and produces a black and white picture, so the signal is either at its maximum value or is not present. If the film is thin or the total film voltage is less than ten volts for any other reason, the reproduction will be all half-tone and the viewed picture will decay continuously.

On the other hand, a thick layer can take a large voltage and the signal will be black and white for most of the charging time. The picture will stay at constant level for a while and then decay. The choice of film thickness will, therefore, be determined by the desired ratio of half-tone to black and white viewing times and by the penetration limitations.

A typical curve of signal output versus time is shown in Fig. 6. The actual duration of the signal can be made to vary by varying the reading beam, but the ratio of the times in the two modes of operation stays constant for any given voltage change on the film. Reducing this voltage from the maximum possible reduces the viewing time as well as the ratio of black and white to half-tone time.

One of the applications of the tube is as a d-c or single-trace oscilloscope which can provide a bright picture of the complete trace for adjustable periods of time. The circuits for such a function are relatively complex compared to an oscilloscope with an afterglow type phosphor, but there are several advantages that may justify the extra equipment.

The problem of large-screen oscillography for viewing by large numbers of people can be met by using a commercial television projection set and operating the graphechon as an oscilloscope-iconoscope combination. The problem of photography of very short duration transients can be met by recording the trace in the graphechon and photographing the picture on a standard kinescope. If the interval between transients is long, the reading beam and kinescope need only be turned on when desired for photographing. In either case, the tube can be made sensitive to the writing beam and thereby reduce the need for a high-voltage type of oscilloscope which

ordinarily might be required for high writing speeds.

Oscillograph

For such applications, where the writing beam is not modulated in intensity, the circuit requirements are shown in block form in Fig. 7. The components are all of a type that can be found described in television and oscillography literature.

The requirement that the writing beam be not modulated in intensity arises from the fact that it will produce a video signal in the target of the same form as the modulation and of an intensity that could be many times that of the signal produced by the reading beam. This occurs because, as was shown above, any removal or addition of charge to the target produces a signal and the writing beam, being above the second crossover point, tends to put down charge which will vary in amount with the intensity of the beam. As long as the writing beam intensity is constant, it produces only a d-c type of signal which is blocked by the input capacitor of the video amplifier.

For many applications, such as for radar conversion, it becomes necessary to modulate the writing beam at frequencies in the same range as that of the video output signal and it is therefore not possible to separate the two signals on the basis of signal frequency. However it is possible to create a frequency difference between the reading and writing signals by modulating the reading beam at some frequency well above the maximum contained in the writing signal. The output signal will now be an amplitude-modulated high-frequency carrier, which can be amplified by conventional means and rectified to provide the desired video signal free of the writing modulation.

A typical circuit is shown in block diagram form in Fig. 8, giving the components required to operate the tube as a radar converter. The operation of the tube in this manner is quite satisfactory provided suitable precautions are maintained.

The original objective and main application of this tube is to provide means of viewing radar ppi patterns. A number of advantages can be attained over conventional

practice with systems using tubes made with the P7 type phosphor. A few of these will be mentioned without description:

The decay curve of the brightness of a signal is very much improved over the exponential decay of phosphors (see Fig. 6).

The brightness level is limited only by what the best cathode-ray tubes can do, so that ambient light level is not important.

The size of the picture can be made as large as desired by television projection techniques.

The viewing time is continuously adjustable over the range of a few seconds to several minutes.

A means is provided for obtaining television type signals and this means can be used to reduce the bandwidth requirements for relaying purposes.

Improvements in signal-to-noise ratio are possible by the integration effects of superposing successive radar patterns.

A block diagram of a system is shown in Fig. 8. In the tests performed, the radar system was adjusted to a rotation period of approximately 6 seconds and the sweep times were operated at both 800 microseconds (80-mile range) and 100 microseconds (10-mile range) with adequate performance at both ranges. This showed that the writing speed was adequate to record the short-range radar which required much higher sweep speeds and peak currents in the writing beam than the long-range radar equipment.

Single-Frame Television

The high writing speed makes possible operation of the writing gun with television-type scan in which the modulating signal is applied for a thirtieth of a second (one frame time) during which time the whole target can be covered. The writing beam can then be turned off for one or more seconds before another picture is flashed on, but the reading beam, operating continuously, produces a signal for a steady picture on the kinescope. This type of operation provides a means of viewing continuously a television type picture that is generated at a rate too slow for normal viewing due to excessive flicker. Such operation has been tested and

found satisfactory both in terms of storage time and resolution.

The resolution of the stored picture is best discussed in terms of television practice. Because the picture is formed by the action of a moving cathode-ray beam, the smallest picture element possible is the size of the focused spot. Therefore, the maximum picture content possible is the number of elements or adjacent spot areas that can cover the total area of the target.

A television-type scan is the most efficient because it arranges the elements as close together as possible

ratio of 4:3 or its height is three-fourths of its width, and it therefore contains over 300,000 elements. This is the order of magnitude of the picture content available in the graphechon with present standard guns and techniques.

Writing speed is customarily measured in oscillographic practice in feet or meters per second. So measured, the writing speed of the graphechon is considerably better than 4,000 feet per second. Expressed in more meaningful terms, this is equivalent to better than nine million elements per second. This speed has been demonstrated by the test of television operation in which a picture containing 300,000 elements was written onto the target in one thirtieth of a second. Still higher writing speeds can be obtained, though only at the expense of resolution, because they require higher beam currents and this causes the spot size to increase, when all else is constant.

General Comments

It should be noted that the effect of the writing beam is not necessarily the complete discharge of the target potential but, for small beams, the target is only partially discharged. Therefore, small writing signals will disappear faster than large ones. This effect can be useful in looking at noisy radar ppi pictures. The noise disappears quickly, leaving only the stronger radar pips. Also, when the tube is adjusted to store for several radar frames, which are superimposed, the signal input to any point is additive. Therefore a repeated signal will give a strong output signal, whereas random noise of the same level will not repeat to the same point to the same extent, and so produce a weaker output signal.

The author wishes to acknowledge the invaluable advice and assistance of L. E. Flory, A. Rose, H. B. Law, and many others at the RCA Laboratories.

REFERENCES

- (1) D. H. Ewing and R. W. K. Smith, *Teleran*, *RCA Rev.* 7, p 601, Dec. 1946.
- (2) Stanley Fargue, *The Storage Orthicon*, *RCA Rev.* p 633, Dec. 1947.
- (3) L. Pensak, *Conductivity Induced by Electron Bombardment in Thin Insulating Film*, *Phys. Rev.*, Jan. 30, 1949.
- (4) Zworykin, Morton and Flory, *Theory and Performance of the Iconoscope*, *Proc. IRE*, p 1,071, Aug. 1937.

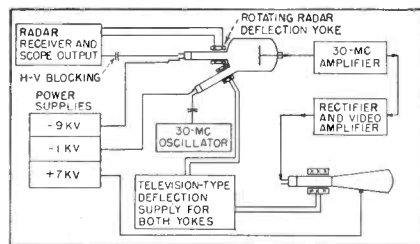
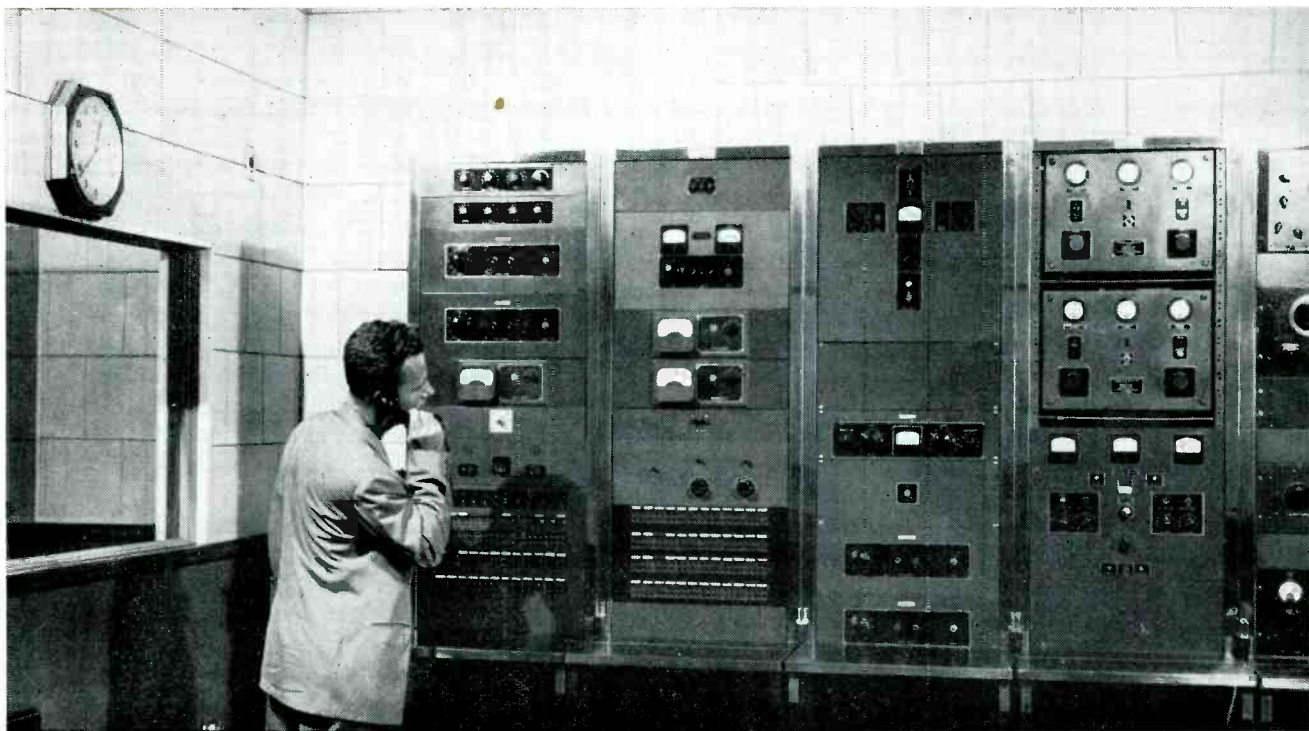

FIG. 8—Circuits required for using the graphechon to view ppi-type radar

without producing any overlapping. The ppi-type scan has considerable overlapping near the center of the picture, but this does not appreciably affect the resolution. Its only effect is to increase the bandwidth of the signal required to send its pictures over that required for the same picture rate with television type scan.

It can be shown, too, that the number of picture elements possible does not vary with the target size. A larger target must be moved further away from the electron lens of the gun if it is to be covered by the same deflecting angle of the beam. The increased gun-to-target distance causes the spot area to increase in direct proportion to the increase in target area, and so the number of elements stays constant. This property, inherent in the electron optics of cathode-ray tubes, applies when all other factors stay constant.

In view of the above, it is customary to refer to the number of elements contained in a picture by the number of parallel lines in which they can be arranged, which is the number of scanning lines used to build up the picture. A standard television picture has approximately 500 lines and an aspect



Audio facilities (left) transmitter monitoring equipment (right) at modern a-m station includes phase monitor for directional antenna array

A-M and F-M Broadcast Station Measurements

Routine operating checks required by law and proof-of-performance measurements necessary before a station can be authorized for regular operation. New audio-frequency and noise measurements mandatory for a-m transmitters after August 1949 are summarized

BEFORE granting a broadcast station license the Federal Communications Commission requires that certain measurements be made (during the equipment test). After the station goes into regular service other continuous measurements are mandatory. In addition, there are periodic measurements necessary in order to conform to legal requirements.

These requirements and the equipment necessary for satisfying them are described below. Functional descriptions of the manner in which the measurements are made are not included, because most engineers have their own particular methods which depend upon the

By TORRANCE DOWNEY

*Consultant
New York, N. Y.*

exact equipment used.

When the station has been completed in accordance with the terms of the construction permit, equipment tests are conducted. During this time the proof-of-performance of the station and antenna resistance measurements are made. Until the latter measurement has been made and approved by the Commission the station must measure its power by the indirect method. This entails finding the product of the three parameters, the plate voltage, plate current and an efficiency factor laid down by the

Commission for the class of station. The resultant figure is then used as the output power until the antenna measurements have been approved and authority given to operate, measuring power by the direct method. As its name implies, the direct method involves the actual antenna current and the antenna resistance only. The product of $(I_{ant})^2 \times R_{ant}$ gives the actual power in the antenna.

Although it may not be recognized as a separate indicating or measuring instrument, the antenna meter is one of the most essential pieces of equipment the broadcast operator uses. Whenever any measurements involving this instrument

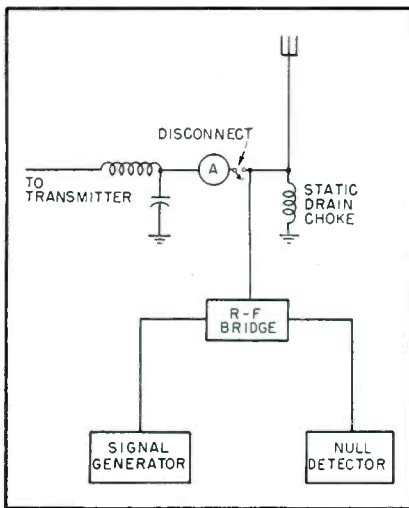

FIG. 1—Apparatus setup for antenna resistance measurements

are filed they must be accompanied by a statement giving the maker's name, name of instrument, manufacturer's rated accuracy, and the date, the determined accuracy and name of person by whom it was last calibrated. During the time that the station is on equipment test the antenna resistance measurements will be made. After these have been approved and authority given to measure output power using the direct method the antenna ammeter comes into its own, and is the indicator of power output.

In addition to determining antenna resistance when a new station is put on the air, this parameter must also be measured at other times. For example: if any characteristics of the antenna are changed, or the directional pattern is changed or any damage to the antenna itself occurs, the resistance must be remeasured and authority to indicate output power by the direct method requested.

To measure antenna resistance, the following equipment is required: A signal generator that will cover at least 60 kc each side of the assigned frequency, an r-f bridge and some form of balance detector, such as a sensitive receiver.

The equipment is connected as shown in the block diagram in Fig. 1, and a series of resistance measurements is made on the antenna at frequency intervals of 10 kc. A curve is drawn through these points and the resistance at the operating frequency taken from this graph.

The antenna is disconnected from the transmitter during the measurements. For a directional array, the resistance at the common junction point is measured, not at the individual towers. Figure 2 illustrates this method of measurement.

Field Intensity

For the proof-of-performance measurements, a field intensity measuring set like that illustrated is used. For ease of operation the set is frequently built into a semi-permanent installation in a car or station-wagon as shown. In the

latter case the whole unit, including the car, has to be calibrated by a responsible organization (such as the National Bureau of Standards) to satisfy the FCC that the measuring equipment is accurate and reliable. This check on reliability also applies to the engineer. When presenting his data he must include proof of his qualifications as an engineer to show that he is able to do an accurate job. Of course, if his qualifications are already on file with the Commission, a statement to that effect is sufficient. Measurements are made along a number of

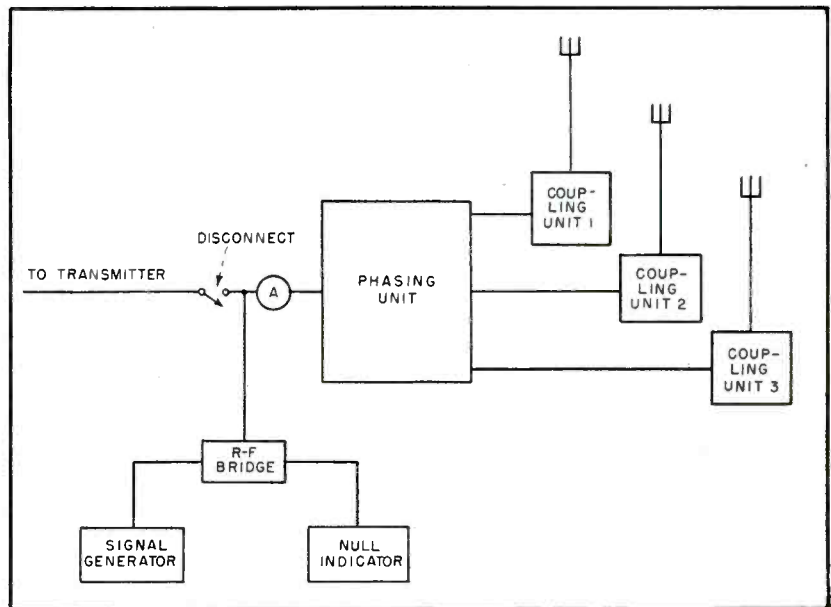

FIG. 2—Resistance measurements on a three-tower array are made at the phasing unit using the same type of testing equipment as for the simple antenna

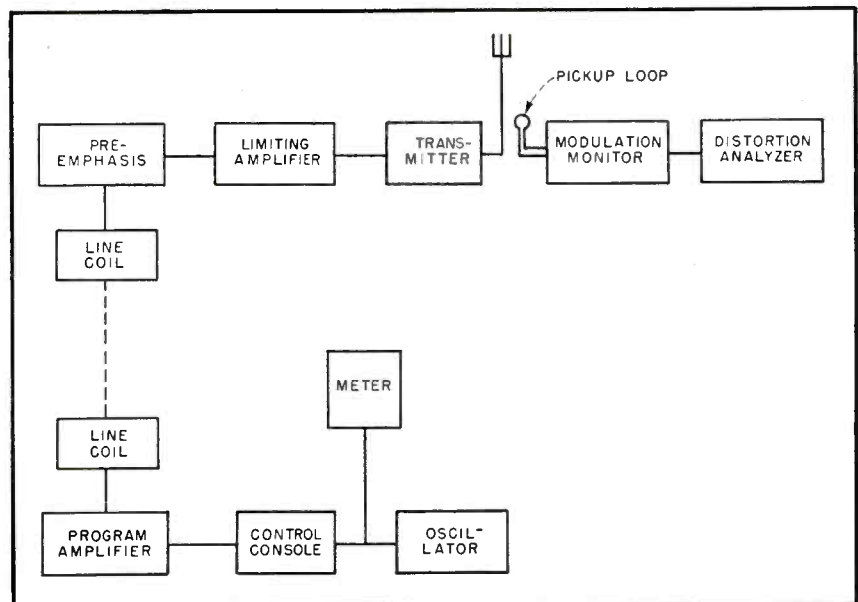

FIG. 3—Arrangement of apparatus for audio measurements on f-m transmitter

radials running out from the transmitter site. A minimum of eight radials is usual. The field strengths are plotted against distance and from these curves the distance to the various contours can be found and the contours themselves outlined on a chart.

In the case of a directional antenna the proof is more involved in that it is necessary to determine the pattern of the antenna system,¹ and prove that it is operating the way the application said it would. It often takes days and sometimes weeks to get the radiation in the

critical directions down to the values specified in the construction permit.

In the adjustment of the directional antenna, as well as in the normal operation of the transmitter, a very important part is played by the phase monitor. This may be a commercial model or composite (homemade) type.² Because the commercially manufactured equipment has already been type-approved by the FCC, and since full details must be submitted by applicants using unapproved equipment, and requirements are rigid,

it is usual to employ the commercial apparatus.

Frequency and Modulation Monitors

Frequency and modulation monitors are often grouped together, because their functions are sometimes combined in a single unit of equipment. Even when the modulation monitor is not so combined, this ancillary equipment is customarily designed for rack mounting, and quite often placed next to the frequency monitor for convenience. In operation, the modulation monitor can be set to indicate peaks of modulation of any value up to 100 percent. Some models will show as high as a calibrated 120 percent.

The frequency monitors used for a-m are a little different from those for f-m in their operating characteristics, as well as their method of operation. The frequency tolerance for a-m on the standard broadcast band is plus or minus 20 cycles, so that the range of the meter is not required to be very great, whereas in f-m (because of the nature of the modulation) the allowable deviation is plus or minus 2,000 cycles, and a different type of meter is used to accommodate greater range.

External Frequency Checks

The accuracy of the frequency monitor is a matter of great importance. Although the FCC does not require that it be checked regularly, most radio stations obtain a monthly frequency check of the transmitter from one of the commercial frequency checking services. The frequency monitor is thereby checked at the same time (since its indicated frequency can be compared with the external reading). By this means, any tendency of the monitor to drift off frequency and give inaccurate readings will be stopped before interference is caused.

Less attention is required by the modulation monitor. The level of the r-f signal fed into it must be adjusted to ensure accurate readings, and routine checks of the various voltages made. There are no oscillatory circuits to get out of tune.

A heterodyne-type frequency monitor is used in most cases. The signal from a local, very stable os-

Table I—Measurements and Equipment for Broadcast Stations

| Measurements | Mod. | Equip. Required | Location | | Conditions | | |
|----------------------------------|------------|---|--|-------------|------------|--|--------------|
| | | | Portable | Fixed | Essential | Optional | |
| Antenna resistance and reactance | a-m | Signal generator, r-f bridge null detector, receiver | Base of antenna, or common point for directional antenna | | | For license (and after change in any antenna parameters) | |
| Antenna power | a-m | Remote reading r-f ammeter | | Transmitter | | Regular use | |
| Antenna power | f-m | Power output meter (calibrated with dummy antenna when transmitter installed) | | Transmitter | | Regular use | |
| Antenna phase | a-m | Phase monitor for checking currents in each tower of directional antenna | | Transmitter | | Regular use | |
| Field intensity | f-m | Field intensity measuring set, auto recording milliammeter | Field, service area | | | For license | When desired |
| Field intensity | a-m | Same as above | Field service area | | | For license (after change in directional antenna) | When desired |
| Audio response | f-m | Audio-freq. oscillator, distortion analyzer, vtvm | Studios and transmitter | | | For license | When desired |
| Audio response | a-m | Same as above plus frequency-shift indicator (freq. monitor) | Studios and transmitter | | | For license renewal | When desired |
| Transmitter efficiency | a-m f-m | Plate current and voltage meters, antenna current meter | | Transmitter | | License and renewal | When desired |
| Frequency and modulation | f-m | Freq. and modulation monitors | | Transmitter | | Regular use | |
| Frequency and modulation | a-m | Freq. and modulation monitors | | Transmitter | | Regular use | |

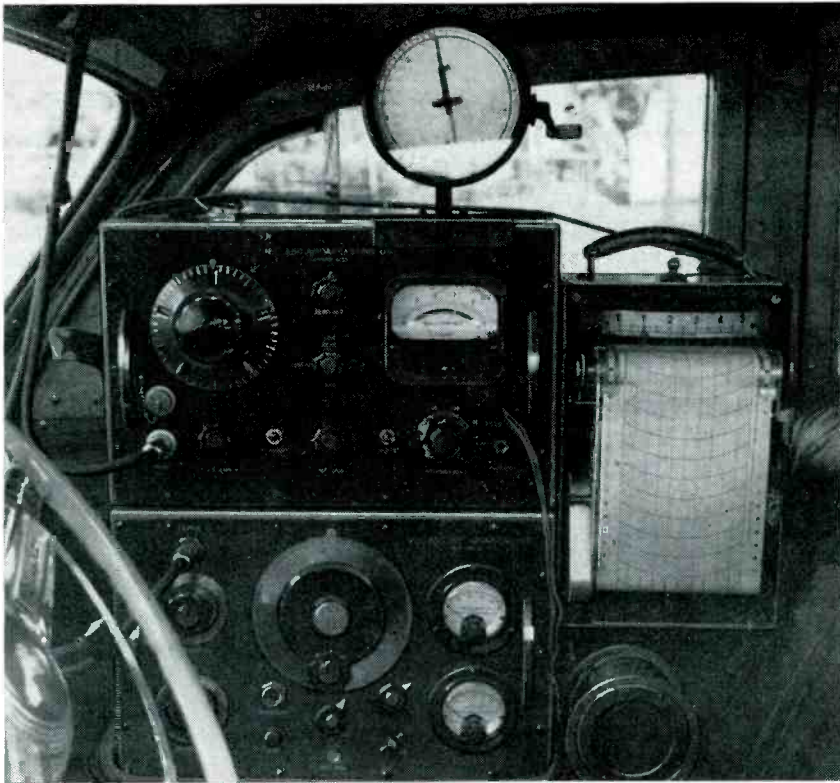

Field strength measuring equipment mounted in station wagon. Loop is oriented by turning crank and direction is indicated on dial

cillator, crystal-controlled with temperature correction, is mixed with the sample signal from the transmitter. The resulting beat at some low audio frequency is amplified and used to drive a zero-center type of meter. When the transmitter is on frequency and the monitor is operating correctly zero deviation will be indicated. As the frequency varies one way or the other the resulting positive or negative difference will be read on the meter directly in cycles.

New Audio and Noise Measurements

The modulation monitors of various manufacture also work on a more or less common principle although no two designs are alike. Generally speaking, the signal to be measured is applied to a diode circuit and rectified; this provides a means of calibrating the equipment. The audio component of the rectified r-f is then rectified and applied to a vacuum-tube voltmeter circuit with suitable circuit constants so that the a-f peaks are indicated. The visual flasher for indicating overmodulation is operated from a relay which is driven by the a-f signal and adjusted to close on varying modulation peaks accord-

ing to the setting of the sensitivity control.

Until quite recently, audio measurements for a-m stations were not required by the FCC. Although they do not now have to be supplied with the license application they are required to be made annually, and must be made within the four months preceding the license renewal application.³ Since these measurements are very similar in nature to those required for an f-m license application the description of the equipment involved will be combined with that for f-m below. The equipment is only employed once a year and therefore can be borrowed or hired for the occasion.

The audio measurement requirements of the FCC for a-m stations are detailed in paragraphs 3.45 and 3.46 of the Rules and Regulations, and are abstracted in the accompanying box.

Frequency-Modulation Requirements

The license application for an f-m station calls for a field intensity survey to be made of the area purported to be served by the station, and the submission of maps showing the area, routes followed (radials) and the 1 millivolt-per-meter

and 50 microvolt-per-meter contours (class B station).

The field intensity measurements are made in a similar manner to those for a-m except for the fact that continuous recordings are required along the radials from the transmitter.⁴ Equipment for this service is generally self-powered from a six-volt storage battery and vibrator power supply in a separate case. The antenna supplied with it is a dipole adjustable to length for any of the f-m frequencies and mounted on a collapsible tripod. For full field survey work the set is often mounted in a station wagon with a circular loop antenna above the roof and a calibration curve made for the whole unit.

The requirement of continuous recordings makes a nondirectional loop almost mandatory, but at the same time cuts down the sensitivity of the equipment. An Esterline-Angus recording milliammeter is driven from the output of the field set. The paper feed is turned by a flexible drive from the speedometer shaft drive. In this way the distance and field intensity can be correlated, provided the car follows a reasonably straight route. As an aid to this, prominent landmarks and position fixes are marked on the chart to help in identifying locations.

Audio Standards for F-M

The Commission requires that the audio measurements be made in accordance with the following, abstracted from Sections 8 and 13 of the Standards of Good Engineering Practice. All measurements shall be made with the equipment adjusted for normal program operation and include all circuits between the main studio microphone terminals and the antenna output, including telephone lines, pre-emphasis circuits and any equalizers employed (except for microphones) and without compression if a compression amplifier is installed.

The usual setup for making these measurements is shown in block diagram form in Fig. 3. The general arrangement is the same whether the main studio or local input to the transmitter is being used. A good audio oscillator is essential, and a distortion analyzer is needed.

The same equipment is also required for making the a-m audio measurements referred to above. For measuring the a-m carrier noise on f-m transmitters a separate diode circuit is needed for a-m rectification. A number of the distortion analyzers on the market make provision for this by including a diode in the circuit.

Measurements of audio-frequency response are made with 25, 50 and 100 percent modulation on the following minimum number of frequencies: 50, 100, 500, 1,000, 5,000, 10,000 and 15,000 cycles. These measurements are normally made without using de-emphasis, but if the accuracy of the de-emphasis circuits is good enough to ensure that the measured response is within the required limits, it can be used.

Harmonic distortion for the same modulation percentages is also required to be measured at the following frequencies: 50, 100, 400, 1,000 and 5,000 cycles; also harmonics for 100-percent modulation with fundamental frequencies of 10,000 and 15,000 cycles. Harmonics to 30,000 cycles shall normally be included. The standard (75 microsecond) de-emphasis is used in the system or measuring equipment.

Measurement is also required of the output noise level (f-m) between 50 and 15,000 cycles in decibels below the audio-frequency level representing a frequency swing of 75 kc. The 75-microsecond de-emphasis shall also be used here. The a-m noise level in the same frequency band below the level representing 100-percent modulation is also required. In this case, too, standard

Broadcast Audio Tests Required After Aug. 1, 1949

The licensee of each standard broadcast station shall make the following equipment performance measurements at yearly intervals. One such set shall be made during the four-month period preceding the date of filing application for renewal of station license. Since renewals are to be filed two months before expiration date, that means any station which files on or after February 1, 1950 for renewal will be required to state on the application that measurements have been made.

Data and curves showing overall audio-frequency response from 30 to 7500 cycles for approximately 25, 50, 85 and 100 (if obtainable) percent modulation. Family of curves should be plotted (one for each percentage above) with db above and below a reference frequency of 1,000 cycles as ordinate, and audio frequency as abscissa.

Data and curves showing audio-frequency harmonic content for 25, 50, 85 and 100-percent modulation for fundamental frequencies of 50, 100, 400, 1000, 5000 and 7500 cycles (either arithmetical or root sum square values up to the tenth harmonic or 16,000 cycles). Plot family of curves (one for each percentage above) with percent distortion as ordinate and audio frequency as abscissa.

Data showing percentage carrier shift for 25, 50, 85 and 100-percent modulation with 400-cycle tone.

Carrier hum and extraneous noise generated within the equipment and measured as the level below 100-percent modulation throughout the audio spectrum or by bands.

Measurements or evidence showing that spurious radiations including radio-frequency harmonics are suppressed or are not present to a degree capable of causing objectionable interference to other radio services. Field intensity measurements are preferred but observations made with a communications type receiver may be accepted. However, in particular cases involving interference or controversy, the Commission may require actual measurements.

Measurements shall be made with the equipment adjusted for normal program operation and shall include all circuits between main studio amplifier input and antenna output including equalizer or correction circuits normally employed, but without compression if such amplifier is employed.

The above data together with a description of instruments and procedure signed by the engineer making the measurements, shall be kept on file at the transmitter and shall be made available upon request to any duly authorized representative of the FCC

de-emphasis is used.

Frequency and modulation monitors are just as essential in f-m stations as in a-m. The two functions of monitoring are combined in these instruments, making for more compact station layouts. These instruments come under the classification of essential instruments, and waiver of the appropriate sections of the Rules and Regulations must be requested to cover operation without them. When the application for license is submitted, full data on the frequency calibration checks of both the transmitter and frequency monitor must be sup-

plied to show the comparative readings of the two instruments.

Although the instruments themselves are part of the transmitter proper, and thus could be excluded on the grounds that they are not separate instruments in the general sense of the word, the indications of the plate current and voltage meters in the final stage (both a-m and f-m) are extremely important. No specific external readings are made on them, but the regular current and voltage readings entered in the operating log are measurements which are essential to the broadcaster in maintaining legal power output.

Table I is appended showing the various types of equipment, operation, and location for various measurements required by the FCC either for initial installation, regular operation or in special contingencies.

REFERENCES

- (1) J. H. Battison, Directional Antennas for A-M Broadcasting, *ELECTRONICS*, p 101, April 1949.
- (2) Bernard C. O'Brien and Francis L. Sherwood, Phase Monitor for Broadcast Arrays, *ELECTRONICS*, p 109, Dec. 1947.
- (3) Royden R. Freeland, Distortion and Noise Meter for Testing Broadcast Equipment, *ELECTRONICS*, p 86, January 1949.
- (4) J. B. Epperson, Television Field Intensity Measurements, *ELECTRONICS*, p 73, March 1949.



Typical field-measurement car showing loop antenna on roof

Incremental

By EDWARD KASNER

Communication Measurements Lab., Inc.
New York, N. Y.

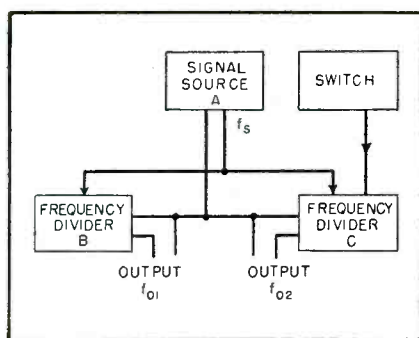

FIG. 1—Block diagram of a basic phase splitter

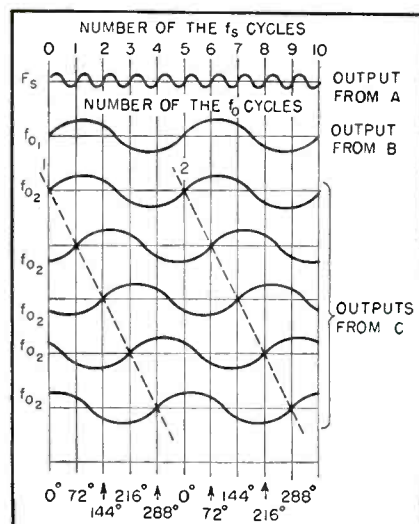

FIG. 2—Phase relations in the incremental phase splitter

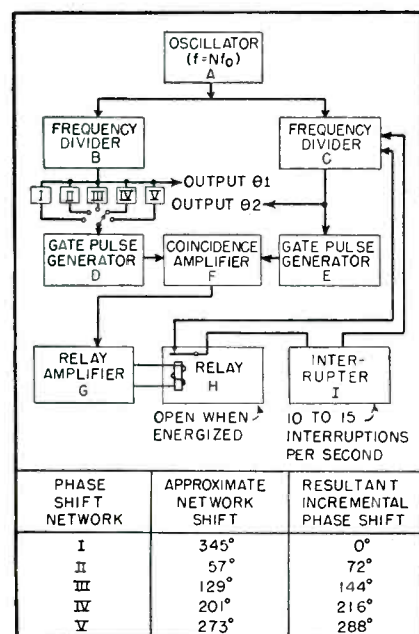

FIG. 3—Phase splitter allowing predetermined selection

THE incremental phase splitter and range simulator to be described is a circuit productive of two signals of the same frequency and differing in phase by a series of discrete increments of equality.

The incremental phase splitter is ideally suited to applications requiring precise time or phase relationships between two signals of the same or harmonically related frequencies. A few of its possible applications are the simulation of radar and loran data, generation of accurate synchronizing signals for the production of delay gates and timing pulses, and use as a laboratory phase standard.

Range Simulator

The circuit was developed as a target range simulator to facilitate the development of radio ranging equipment.

An 81.94-kc sine wave, corresponding to 2,000 radar yards per cycle, is employed as the ranging system's time base. The phase displacement between the transmitted and received timing signals is determined by their transmission time through space and is directly proportional to target range. In order to function as a calibrating range simulator, the circuit must provide two 81.94-kc sinusoidal signals, one fixed in time and the other variable through a series of angular displacements corresponding accurately to the required range test points. The ranging system's test points are: 0, 400, 800, 1,200, and 1,600 yards. The corresponding phase displacements between the transmitted and received signals are: 0, 72, 144, 216, and 288 degrees.

The basic circuit of the incremental phase splitter is shown in block form in Fig. 1 wherein f_s is the source frequency, f_o is the out-

put frequency, N is required number of phase increments, and $f_o = Nf_s$. The circuit consists of signal source, A, of frequency f_s ; a constantly operating frequency divider, B, synchronized by A and dividing its output frequency by N ; and another frequency divider, C, identical to B but provided with means whereby its operation may be momentarily interrupted. The circuit operates as follows. Divider B provides the fixed, or reference phase. Divider C provides the incrementally variable phase. A momentary contact switch is wired into C in such a manner as to render it inoperative when the switch is closed. Upon releasing the switch, divider C again becomes operative, synchronizing with A in one of N phase relationships. This is graphically illustrated by Fig. 2 in which $N = 5$.

The generalized values of the N phase relationships the $\theta + 0$, $\theta + [360/N]$, $\theta + [2(360)/N]$, $\dots \theta + [(N-1) 360/N]$ degrees, where θ represents the residual phase displacements between the outputs of B and C when the incremental displacement equals zero. The value of θ reduces to zero when B and C are synchronized at identical points in time on the signal from A. The phase selection sequence cannot be predetermined in this basic circuit because of the random nature of the synchronization of C to any one of five cycles of A.

Figure 3 illustrates a method whereby any one of a predetermined series of angular increments can be selected at will. Blocks A, B and C comprise the oscillator-divider combination previously described. Here, again, $N = 5$. Divider B feeds five networks that shift the phase of its output to a few degrees less than the required in-

Improved Ultrasonic Delay Lines

Forged magnesium-alloy delay lines developed as memory devices have bandwidths as great as 4 mc at a carrier frequency of 10 mc. The attenuation is the least so far available in practical lines. Special clamping of S-cut ADP crystal transducers is described

THE ULTRASONIC DELAY LINE is a device developed during World War II to store intelligence for periods of several milliseconds and is now used in high-speed digital computers and other devices.

The construction and operation of a typical delay line is shown in Fig. 1. The crystals have a resonant frequency in the range of 10 to 30 mc. The intelligence to be stored modulates the carrier frequency. The first delay lines used employed

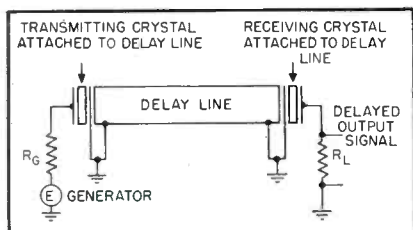

FIG. 1—Elementary delay line, showing how signal is transmitted by input transducer and delayed output having same waveform is received

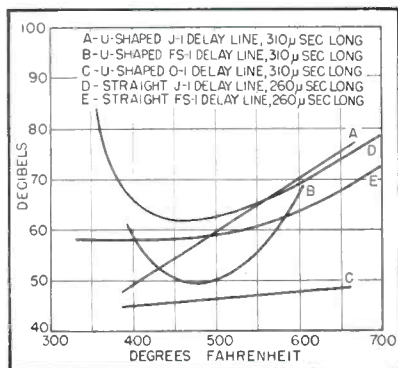

FIG. 2—Successive annealings at increasing temperatures change the attenuation

liquids as transmitting media, but the many disadvantages of liquids caused a search to be made for a suitable solid.

During the war much effort was spent in finding solids with low ultrasonic absorption for use in constructing ultrasonic delay lines. An account of this work, and the solid delay lines constructed, are to be found in the report of D. L. Arenberg¹. A complete bibliography of previous work is also given in his report.

At the end of the war, Arenberg's conclusions were that fused quartz offered the best transmission qualities of any known substance, but that the length of delay was limited by the size of the blanks available. It was also difficult to machine properly, and great angular accuracy of the reflecting faces was necessary to prevent the generation of spurious signals resulting from inaccuracies.

Single crystals showed good ultrasonic transmission, but when polycrystalline media such as steel, tungsten, fine-grained aluminum and magnesium were tried, their absorption was too high for delay-line purposes. Magnesium alloys were not considered at that time.

The Delay Medium

The objective of our investigations was to find a medium from which lines having 3 milliseconds or more delay could be constructed, operating at a carrier frequency of 10 mc or higher, and having a bandwidth greater than 2 mc. At the time these studies were initiated, there was no solid that would give this performance. Fused quartz was acceptable, except that 2,000 μsec was the longest delay obtainable without strong spurious signals.

Many materials were tested to de-

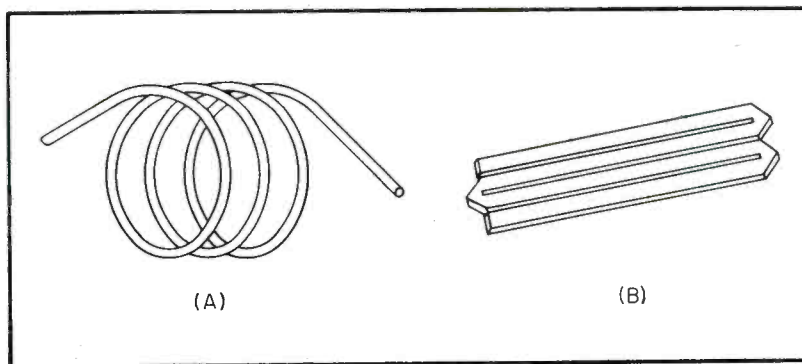
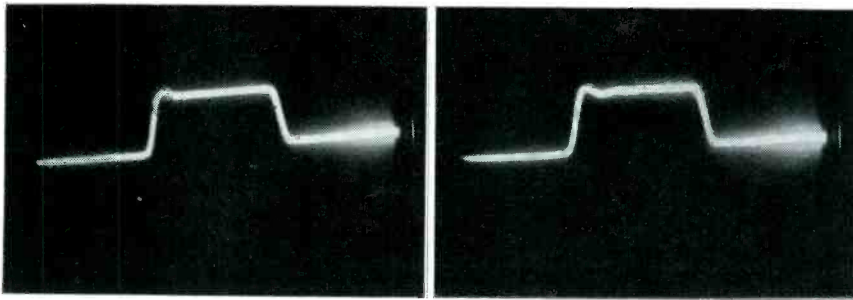

FIG. 3—Two of the experimental folded forms of delay lines used. Various conformations were tried in developing compact units



A 2.4-microsecond pulse (left) is received (right) with little distortion

By FRANK A. METZ, Jr. and WALTHER M. A. ANDERSEN

*Electronic Engineer
Air Materiel Command
Cambridge, Mass.*

*Vice-President in Charge of Engineering
Crystal Research Laboratories, Inc.
Hartford, Conn.*

termine their suitability. Some results are shown in Table I. The velocity measurements were taken with a Sperry Reflectoscope at a frequency of 10 mc.

To determine whether the attenuation was low enough in the metal, test lines having about 500- μ sec delay were constructed and the losses in the crystals and medium measured. In all measurements taken, mismatch and cement losses were of the order of 30 db.

This attenuation was sufficient to reject all materials listed in Table I except fused quartz and the magnesium alloys O-1, J-1 and FS-1. These materials were far superior to any of the others, the transmission being best in the order named. For example, a J-1 delay line, delay 397 μ sec, at carrier of 10 mc had an attenuation of 40 db; and an FS-1 delay line, 970 μ sec, at 10 mc, had an attenuation of 50 db. These measurements were made with 1,500-ohm resistors and a resonant coil shunting the crystals. The shear mode was used in both cases, with the crystals cemented to the magnesium alloy. No end cells were used. Other examples include a straight rod of O-1 alloy, delay 329 μ sec, with attenuation of 35 db when untreated. After heat treatment at 450 F, the attenuation was 30 db, and the pulse shape improved. A straight rod of FS-1 alloy, with a delay of 330 μ sec, had an attenuation untreated of 38 db;

upon treatment at 450 F attenuation dropped to 32 db, with improved pulse shape.

The next series of tests was made using rods bent into the shape of a U. Three rods of J-1, FS-1, and O-1 were heated to 400 F and bent. Before heat treatment the attenuations at 10 mc were FS-1, 67 db; O-1, 47 db; and J-1, 75 db.

The rods were then heat treated and tested after the temperature was raised in steps. The results are shown in Fig. 2. If plots had been made at lower temperatures minima could have been found for O-1 (C) and J-1 (A) also.

To determine these minima, readings were taken on two other samples of J-1 (D) and FS-1 (E). These curves are also plotted in Fig. 2. There is little agreement in these curves. It seems that 500 F is a good annealing temperature, but the results vary too much in the two samples to arrive at any general conclusion. The composition of commercial alloys is not constant enough to determine the best heat treatment. Laboratory samples of these alloys will probably give consistent results.

As an illustration of the great variation in transmission properties, one long rod tested showed a signal internally reflected several times that was delayed 4,950 μ sec, with an attenuation 47 db below the input pulse. But in the compact, folded configurations used in these

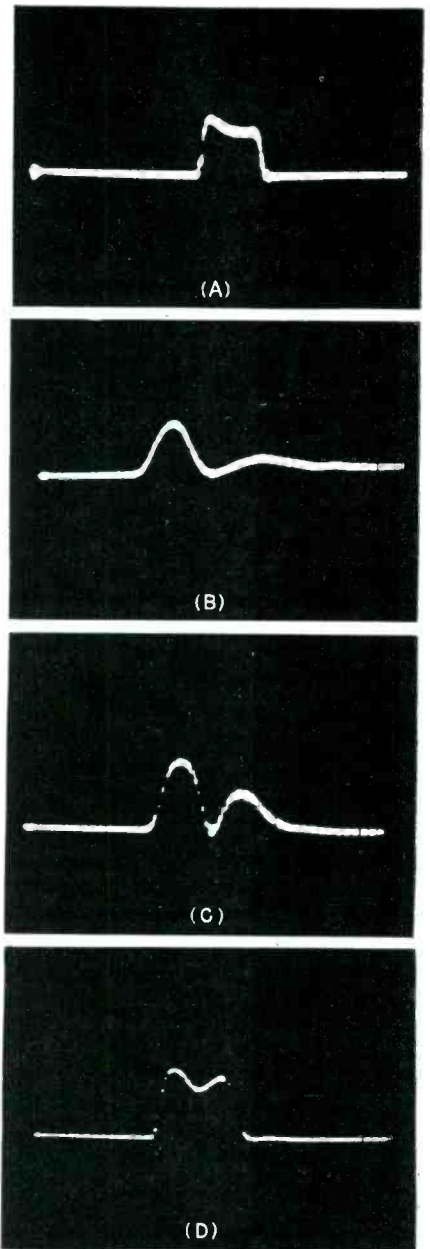

FIG. 4—Change in transmission characteristics after successive forgings. The transmitted pulse is shown at (A). See text for explanation of (B), (C) and (D)

experiments, 1,600 μ sec is the upper limit that can be relied upon using commercial alloys. Two of the configurations used are shown in Fig. 3.

Another type of treatment to improve transmission in magnesium and the alloys mentioned above was hot forging with a drop hammer forge. The pressure used was approximately 5 tons per square inch.

The first sample treated by forging was a billet of pure magnesium 10 centimeters long. The results

obtained are illustrated in Fig. 4, the transmitted pulse being shown at 4A. Before forging, the signal could not be seen, placing the attenuation above 90 db. After the first forging at 550 F, and heat treatment, the attenuation was 61 db, with a change in wave shape as shown at 4B. After the second forging the received pulse was down 68 db as at 4C. The third forging, not illustrated, showed an increase in attenuation but a somewhat better pulse response. The fourth forging, at 500 F, showed marked improvement in pulse response with attenuation at 61 db, as indicated in 4D.

Before treatment the grain size of the magnesium was small and very jumbled. After the final forging, the grain size was larger, and more orderly in arrangement. The amount of inclusion was not changed.

A sample of J-1 alloy was also forged that had good transmission, but poor pulse reproduction. After passing through the same treatment as the pure magnesium, the pulse reproduction was much improved.

Upon microscopic examination, the grain size proved to be unchanged after forging, being smaller than the pure forged magnesium. The compound was more evenly distributed between grains after forging. The sample had an attenuation of 38 db, and was 10 centimeters long.

In addition to the transmission

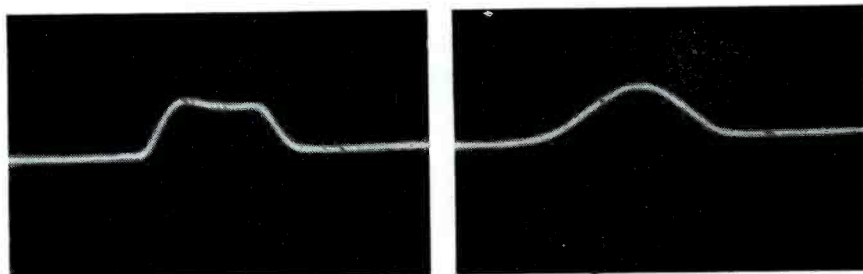

FIG. 5—A 1-microsecond 10-mc pulse, at left, and the corresponding received pulse through a magnesium delay line using cemented-quartz AC-cut transducers

and pulse fidelity of the medium, the change of delay time of the signal with temperature is of importance in using these devices. This condition was measured by mounting a delay line made of FS-1 alloy 10 inches long inside an oven and the change in delay time measured. The change in delay time with temperature proved to be linear, and the total delay time for a sample of length L is given by

$$D_{Mg} = L (8.34 + 0.0021T)$$

T being the temperature in degrees centigrade, and 8.34 being the delay per inch at 0 C.

In Report 745, Radiation Lab., MIT, Jacobson obtained for a mercury delay line.

$$D_{Hg} = L (17.42 + 0.0052T)$$

where the symbols have the same meaning as before. From these relations the temperature coefficient of delay of mercury is 2.99×10^{-4} sec per sec per deg C while for FS-1 alloy it is 2.52×10^{-4} sec per sec per deg C. The coefficient for mercury is 18.7 percent greater

than that of FS-1 alloy.

The shear mode of vibration was found to be the best type for solid delay-line application. Since the bars used were many wavelengths wide, there was no velocity dispersion present in the bar. The use of the shear mode has the advantages of less spreading of the sound beam in the medium, decreased velocity of propagation, and a noticeable improvement in signal-to-noise ratio of the delay line.

Shear Crystals

Since the shear mode gives a polarized wave, only a portion of the noise originating in the medium affects the receiving crystal. The computed gain in signal-to-noise ratio over the compressional mode is 4.97 db.

These advantages have been realized in practice, and use of the longitudinal mode has been discontinued in solid delay lines.

The first delay lines constructed using magnesium alloys used AC-

Table I—Characteristics of Delay-Line Materials

| Material | ρ (grams per cu cm) | V_L (cm per sec $\times 10^5$) | V_T (cm per sec $\times 10^5$) | V_R (cm per sec $\times 10^5$) | σ | E (dynes per sq cm $\times 10^{11}$) |
|----------------------------|--------------------------------|---|---|---|---------------|---|
| FS-1 Extruded Magnesium... | 1.690 ± 0.020 | 5.473 ± 0.012 | 3.030 ± 0.013 | 2.800 | 0.279 ± 0.004 | 3.07 ± 0.19 |
| J-1 Extruded Magnesium... | 1.700 ± 0.030 | 5.673 ± 0.013 | 3.010 ± 0.013 | 2.793 | 0.304 ± 0.004 | 4.02 ± 0.19 |
| AM3S Magnesium..... | 1.735 ± 0.002 | 5.787 ± 0.029 | 3.095 ± 0.015 | 2.870 | 0.300 ± 0.006 | 4.32 ± 0.07 |
| M-Extruded Magnesium... | 1.750 ± 0.010 | 5.758 ± 0.011 | 3.092 ± 0.010 | 2.866 | 0.297 ± 0.002 | 4.34 ± 0.05 |
| 0-1 Extruded Magnesium... | 1.817 ± 0.002 | 5.800 ± 0.029 | 3.041 ± 0.015 | 2.825 | 0.310 ± 0.005 | 4.40 ± 0.06 |
| Fused Quartz..... | 2.198 ± 0.004 | 5.926 ± 0.030 | 3.751 ± 0.019 | 3.395 | 0.166 ± 0.006 | 7.30 ± 0.12 |
| Pyrex..... | 2.226 ± 0.001 | 5.574 ± 0.028 | 3.436 ± 0.017 | 3.127 | 0.194 ± 0.010 | 6.27 ± 0.12 |
| Plate Glass..... | 2.510 ± 0.010 | 5.769 ± 0.029 | 3.426 ± 0.017 | 3.137 | 0.227 ± 0.008 | 7.32 ± 0.11 |
| 2SO Aluminum..... | 2.713 ± 0.005 | 6.349 ± 0.032 | 3.105 ± 0.016 | 2.900 | 0.343 ± 0.004 | 7.02 ± 0.10 |
| Molybdenum..... | 10.09 ± 0.03 | 6.286 ± 0.031 | 3.348 ± 0.016 | 3.106 | 0.302 ± 0.004 | 29.4 ± 0.5 |
| Tungsten..... | 19.25 ± 0.01 | 5.183 ± 0.026 | 2.873 ± 0.014 | 2.654 | 0.278 ± 0.006 | 40.6 ± 0.6 |

ρ = density

V_L = longitudinal velocity

V_T = transverse velocity

V_L and V_T correspond to those computed using the bulk modulus of elasticity

V_R = Rayleigh wave velocity (computed from V_L and V_T in this table)

σ = Poisson's ratio

E = Young's modulus

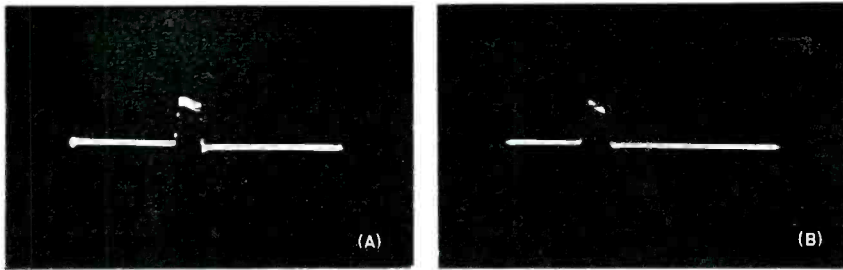

FIG. 6—A 1.5-microsecond 10-mc pulse, at left, and the pulse received after a delay of 225 microseconds, using S-cut ADP crystal transducers

cut quartz crystals as transducers. The crystal capacitance was tuned out with an inductance, and the resulting resonant circuit loaded with a 1,500-ohm resistor to improve the response. The crystals were cemented to the magnesium alloy with a thin film of phenyl benzoate, which is applied melted and cools to form an adherent layer.

Bandwidth of Lines

Although the attenuation in these delay lines was low, a measurement of the response showed the bandwidth to be 0.8 mc at a carrier frequency of 10 mc. This is entirely inadequate for many applications of the device.

Since the typical pulse response of the delay line, shown in Fig. 5, was not satisfactory, it appeared that this might be improved by a different choice of crystal. According to the current theory used in delay line design,^{2,3,4} for optimum bandwidth the ratio of the acoustic impedances of the magnesium to the crystal should be equal to the square root of 2. The crystal should have a high dielectric constant and a high piezoelectric constant for good coupling of energy into the medium.

The crystal chosen was S-Cut ADP (Ammonium Dihydrogen Phosphate, $\text{NH}_4\text{H}_2\text{PO}_4$) which is nearly ideal from these considerations. Its constants are: piezoelectric constant, 24×10^{-10} cm per volt; sound velocity in crystal, 2.02×10^5 cm per sec; acoustic impedance, 3.6×10^5 acoustic ohms; dielectric con-

stant, $K_x = 55$; $K_z = 14.5$.

This cut is derived from Z-cut by rotation about the X axis, 45 deg off the Y axis, and vibrates in thickness shear.

The thickness constant for this crystal is fairly small, and blanks were available at a resonant frequency of 1 mc. To operate at 10 mc, the 1-mc blank was cemented to the magnesium, as in the case of the quartz crystal, and then lapped down in a special jig to the required frequency. There was considerable improvement over quartz, but the results were still inadequate.

The results are shown in Fig. 6. From the rise time of the delayed pulse, the estimated response is seen to be somewhat greater than 1.2 mc. This is not considered adequate except for fairly wide pulses.

It was apparent that the bandwidth obtained was much less than that predictable using existing theories—both in the case of quartz and ADP crystals. While there is good reason to question the ade-

quacy of the existing theories describing the bandwidth of loaded piezoelectric crystals when the loading is as heavy as occurs in delay lines,* it was also felt that the effectiveness of the cement bond might be a limiting factor in the obtainable bandwidth.

Mason and McSkimin⁶ show that slippage due to poor bonding between the crystal and delay line can be considered as a shunt capacitance across the delay line. In the equivalent circuit they use for illustration it is obvious how improper bonding limits the bandwidth of a delay line. Since a wide bandwidth is required in the storage of narrow pulses it became evident that radical changes would have to be made in order to remove the limitations of solid delay lines using cemented crystals. Efforts made in this direction resulted in the development of a pressure mounted crystal with which control of the bonding between the crystal and the delay line is secured by varying the pressure applied to the crystal through a pressure block. This pressure block has the additional function of absorbing spurious reflections. A further result of the development of pressure-mounted crystals was extreme ruggedness and resistance to changes due to elevated temperatures.

Figure 7 shows the possible design of a pressure-mounted crystal which, while mechanically simpler than designs actually used, indi-

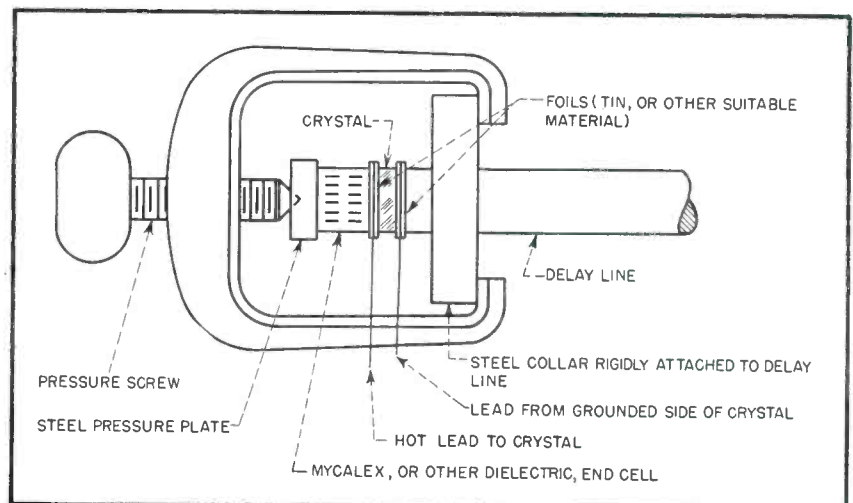

FIG. 7—Improved method of pressure-mounting a quartz crystal to a solid delay line

* Swann⁵ shows that the acoustic output is theoretically a nonlinear function of applied emf, and that the relative prominence of harmonics increases with acoustic loading.

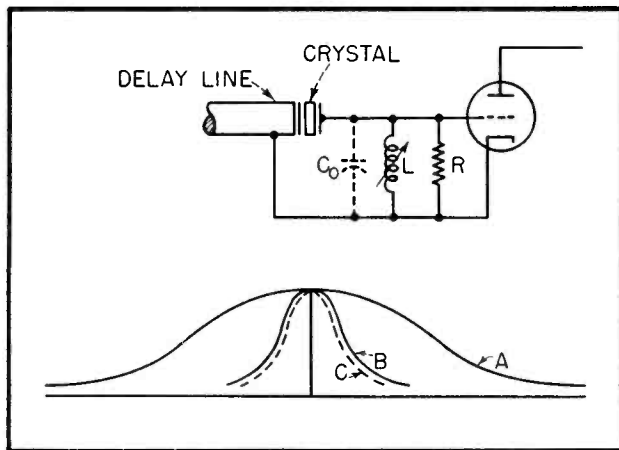

FIG. 8—Output circuit and characteristic curves for a delay line using conventional electrodes

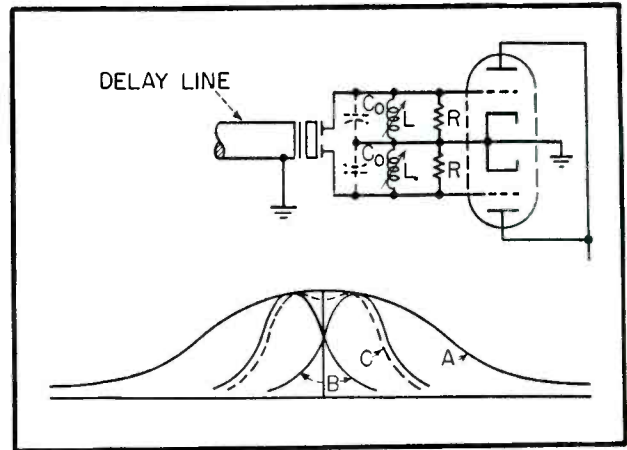

FIG. 9 — Divided-electrode output circuit and delay-line characteristics

icates clearly the function of the various parts. Using pressure-mounting methods similar to that illustrated, it was found that the acoustic response of the delay line was as great as 62.5 percent. This measurement was made using r-f modulated by 400 cycles and tuning out the shunt crystal capacitance as the r-f frequency was varied. This bandwidth was considerably greater than could be obtained in practice due to limitations imposed by the purely electrical characteristics of the delay line.

The receiving end of a delay line with the necessary attached circuit elements is shown in Fig. 8. Shunt capacitance of the crystal and any necessary stray capacitance is denoted by C_0 . A tuning coil L is used to tune out C_0 at the carrier frequency used. The resistance R is used to broaden the frequency response of L and C_0 in parallel. In practice, R cannot usually be made much smaller than 500 ohms.

In Fig. 8, curve A typifies the acoustic response of the delay line-crystal combination, B the frequency response of the parallel C_0 , L , and R combination and curve C typifies the overall frequency response of the delay line in conjunction with the necessary electrical circuit elements. Although these curves are not drawn to scale, they show that with clamped crystals the overall bandwidth is now limited by the electrical circuits that must be used at the terminations of the line.

An arrangement used to broaden the overall frequency response of a

delay line is indicated in Fig. 9. It will be noted that the hot electrode of the crystal is now divided and that each division is separately tuned and damped. In the illustration the signals applied to the two grids of the tube are mixed electronically and the amplified resultant appears at the plates of the tube. This output is depicted by curve C in Fig. 9. Curve A is the same as that in Fig. 8 and the two curves B are the responses appearing at the two grids of the mixer. In practice, as many as four subdivisions of the hot electrode of the crystal have been used. Overall responses corresponding to curve C of Fig. 9 and as wide as 4 mc have been attained working at a carrier frequency of 10 mc, using two subdivisions of the hot electrode. Circuit arrangements similar to those in Fig. 8 and 9 are used at the input of delay lines. By careful use of this method the overall bandwidth of the delay line may be made to approach its acoustical response.

Acknowledgement

The authors wish to acknowledge their indebtedness to Lawrence Mansur of Cambridge Field Station, Air Materiel Command, for his cooperation and many helpful suggestions in this work. Acknowledgement for their contributions at various times to this work is also due Eric B. Hansell, Leo F. Epstein and Gilbert W. Bett.

REFERENCES

- (1) D. L. Arenberg, Solid Supersonic Delay Lines, Rad. Lab. MIT Report 932,

November 30, 1945.

- (2) W. P. Mason, "Electromechanical Transducers and Wave Filters," D. Van Nostrand, 1942.
- (3) W. G. Cady, "Piezoelectricity," McGraw-Hill Book Co., 1946.
- (4) H. B. Huntington, A. G. Emslie and V. W. Hughes, Ultrasonic Delay Lines I, *J. Frank. Inst.*, 245, No. 1, Jan. 1948.
- (5) W. F. G. Swann, General Dynamical Considerations Applied to Piezoelectric Oscillations of a Crystal in an Electric Circuit, *J. Frank. Inst.*, 242, Sept. 1946.
- (6) W. P. Mason and H. J. McSkimin, Attenuation and Scattering of High Frequency Sound Waves in Metals and Glasses, *J. Acous. Soc. Am.*, 19, No. 3, May 1947.

BIBLIOGRAPHY

- C. Zener and R. H. Randall, Variation of Internal Friction with Grain Size, *Am. Inst. of Mining and Metallurgical Engineers*, Technical Pub. No. 1113.
- H. Jeffreys, Reflexion and Refraction of Elastic Waves, *Roy. Astron. Mon. Nat. Geophys. Suppl.* No. 7, p 331, Jan. 1926.
- Jeffries and Archer, "Science of Metals," McGraw-Hill Book Co., 1927.
- N. F. Budgen, "Heat Treatment and Annealing of Aluminum and Its Alloys," Sherwood Press, Cleveland, Ohio, 1933.
- R. L. Wegel and H. Walther, Internal Dissipation in Solids for Small Cyclic Strains, *Physics*, 6, p 141, 1935.
- Alfred von Zeerleder, "The Technology of Magnesium and Its Light Alloys," 2nd ed., Gustav Fock, New York, 1936.
- C. Zener, Internal Friction in Solids, *Proc. Phys. Soc.*, London, 52, 1940.
- A. Beck, "Technology of Magnesium and Its Alloys," F. A. Hughes & Co. Ltd., London, 1943.
- A. Gemant, Frictional Phenomena XIII, *J. Appl. Phys.*, 14, p 204, 1943.
- F. Seitz, "Physics of Metals," McGraw-Hill Book Co., 1943.
- L. Bergmann, "Der Ultraschall," 3rd ed., Edwards Brothers, Ann Arbor, Michigan, 1944.
- R. I. Jacobson, A Measurement of Supersonic Velocity in Mercury at 15 Megacycles per Second as a Function of Temperature, *Rad. Lab. MIT Report 745*, 20 Sept. 1945.
- W. G. Cady, Piezoelectric and Ultrasonic Phenomena in the Ultrasonic Trainer. Final Report to MIT, OSRD contract OEMsr-262, Sept. 30, 1945.
- American Magnesium Corporation, Properties of Magnesium Products, 1946.
- Macelwane and Sokon, "Introduction to Theoretical Seismology," John Wiley & Sons, 1946.
- Ultrasonic Delay Lines, *J. Acous. Soc. Am.*, 20, No. 1, Jan. 1948.
- A. G. Emslie, H. B. Huntington, H. Shapiro and A. E. Benfield, Ultrasonic Delay Lines II, *J. Frank. Inst.*, 245, No. 2, Feb. 1948.
- W. Roth, Scattering of Ultrasonic Radiation in Polycrystalline Metals, *J. Appl. Phys.*, 19, No. 10, Oct. 1948.
- Crystal Research Laboratories, Interim Engineering Reports, Contract W28-099 ac110, July 1946 to Dec. 1948.

Modern Breadboard Chassis

Components and tubes for experimental circuits are mounted and wired in less than half the usual time by employing a novel arrangement of socket holes, bus bars, special spring contacts and flexible leads

By **B. L. SNAVELY**

*Chief of Facilities Subcommittee
Acoustics Division of Research Department*

J. BROWN

*Acoustics Division
Electronics Engineer
Naval Ordnance Laboratory
White Oak, Maryland*

J. V. ATANASOFF

*Chief
Acoustics Division*

TESTED in more than a dozen laboratories, the chassis system to be described has proved highly successful. Its convenience and versatility will appeal to the electronic engineer as well as the technician, teacher, or researcher whose work involves the temporary or experimental assembly of electrical circuits.

The design of the chassis combines the best features of older breadboard designs with several important innovations that contribute materially to the convenience and ease of assembly of experimental circuits. Tube sockets are mounted so that the terminals are accessible for easy wiring. Bus bars, tie-points, the shelf-like base of the chassis, and a vertical panel with holes of several sizes provide means for mounting various types of electronic components, while the general shape of the chassis permits simple, compact wiring.

Pins on the ends of the bus bars and on some of the tie points fit the sockets on flexible leads so that the leads can be used for connecting circuits on the chassis to external equipment. Although the chassis and leads have been designed to be used together, they may also be used independently. The leads are particularly useful for making the temporary hookups frequently required around the laboratory.

The leads are flexible, insulated conductors of assorted lengths, with socket-like terminals at both ends which can engage pins $\frac{3}{32}$ inch in diameter—similar to those used on

some types of vacuum-tube bases. Such pins form an integral part of various kinds of terminal fittings such as lugs, clips, and probes, which can be plugged into the ends of the leads. This system eliminates both the waste of material associated with the use of new wire for every temporary hookup, and the waste of time entailed in trying to re-use old hookup wire from the tangled pile in which it invariably collects.

A typical lead is shown in Fig. 1. The sockets at the ends of the leads are covered with insulating plastic sleeves to reduce the possibility of accidental contact with metallic parts of the sockets and lead. A lead socket with its insulating sleeve is only slightly larger in

diameter than the rubber covered wire used for the leads; yet, despite its small size, it gives a firm electrical connection between the lead and an inserted pin. The connections will carry more than two amperes without overheating.

Special Connectors

Some frequently used types of terminal fittings and connectors are shown in Fig. 2. The fittings include banana plugs, pin plugs, alligator clips, battery clips, test probes, spade lugs, grid cap clips, Fahnestock clips and snap connectors. Short lengths of $\frac{3}{32}$ -inch-diameter brass rod with slightly rounded ends make very versatile connectors. A $\frac{5}{8}$ -inch length of such rod is useful for joining the end of one

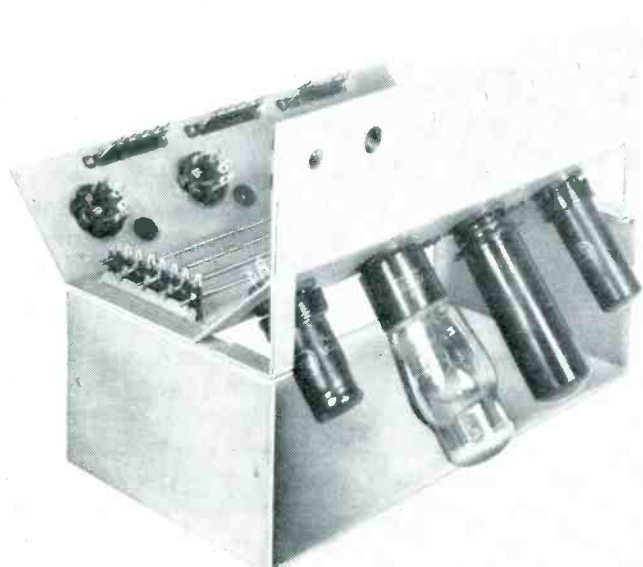

Chassis for assembly of experimental and temporary electronic circuits

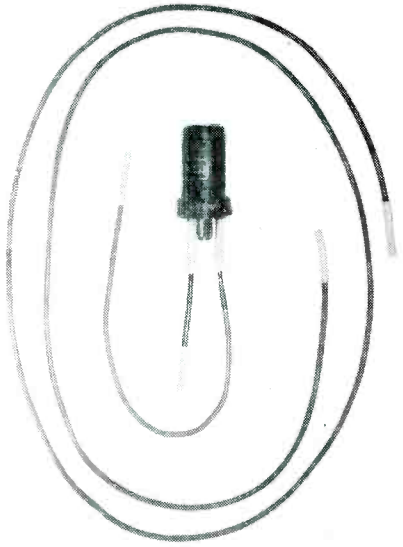

FIG. 1—Wire leads are terminated in spring sockets which grip tube pins

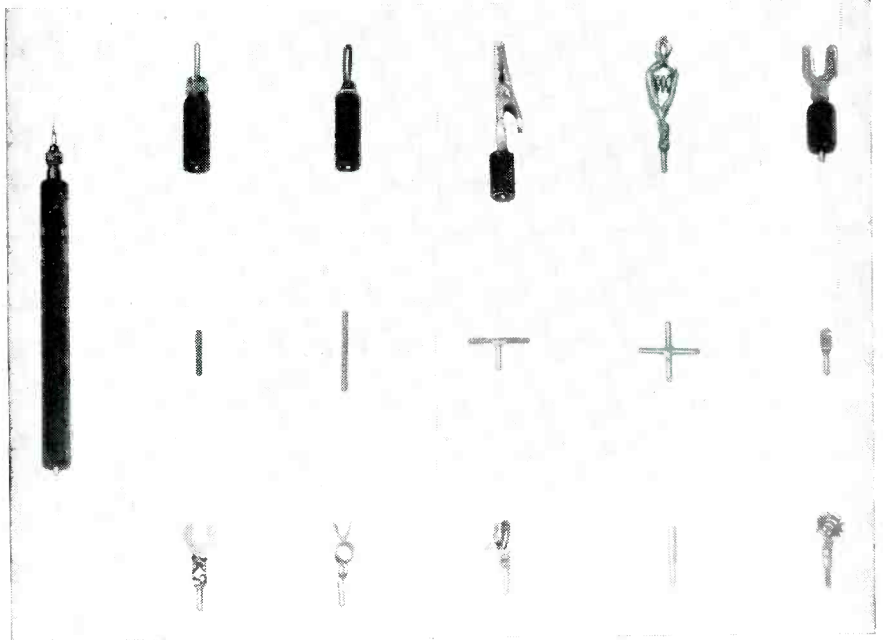

FIG. 2—All fittings and connectors have pins that fit the sockets on wire leads. The lug at right of the cross connector is slotted to fit a wire

lead to another. A similar rod slightly more than an inch long may be used either straight or appropriately bent to make connections to many types of terminal strips or binding screw terminals. Such a rod, in conjunction with one type of commonly used binding post having a hole in the stud, permits the connection of leads on both sides.

Three or more leads can be connected together by use of tees or crosses, both of which are shown in Fig. 2. One very useful stub connector shown has a pin at one end and is flattened and tinned at its other end so that it may be soldered to any point of a circuit where it is desired to connect a lead. A slot in the flattened part facilitates soldering of the stub to wires and to irregular surfaces. These stubs are particularly useful where other types of terminal fittings are either too bulky or too insecure.

Chassis Details

The breadboard chassis is shown in Fig. 3. Space is provided for eight tube sockets. Although it is not usually convenient to mount as many as eight vacuum tubes within the space of a single chassis, it is desirable to have extra sockets available for mounting components of the plug-in type. The growing list of components which mount in the ordinary octal sockets includes

capacitors, crystals, transformers, relays and vibrators.

The breadboard design anticipates that most circuits assembled on it will have soldered connections. However, connections between the breadboard and external equipment, such as batteries and meters, are most conveniently made by means of the flexible leads which can be plugged onto the pins provided on the chassis for this purpose.

When a breadboard is not in use the leads are easily pulled off so that there are no dangling wires. This feature is especially appreciated when the chassis is used for circuits of a semipermanent nature, and has to be kept on a shelf for extended periods.

The vertical panel of the chassis has $\frac{3}{8}$ -inch and $\frac{1}{2}$ -inch holes for mounting components such as switches, rheostats, potentiometers, jacks and variable capacitors. The knobs and dials associated with these components appear near the top of the chassis where they are easy to adjust and read.

Mounting the vacuum tubes at an angle, instead of vertically, has important advantages. The chassis height required to accommodate tubes of a given size is reduced, and almost the whole base of the chassis is made available as a shelf for mounting heavy or bulky components such as batteries or trans-

formers. Furthermore, the angular arrangement of the panels makes wiring more compact and easier to install. Connections to components placed on the base of the chassis or connections to grid cap terminals on the tubes may be carried through rubber-grommetted holes.

Small components usually need no support on a breadboard other than that provided by their leads, and they can generally be bridged directly between terminals of the larger components, or bridged between terminals and bus bars. When this is impractical, the six terminal strips along each side of the chassis may be used to support these small components. There are twenty-four additional tie-points on the strips supporting the bus bars; eight of these have pins for connection with the leads and twelve connect to the bus bars.

Grooved Bus Bars

The bus bars are generally used for those parts of a circuit which represent the juncture of many elements, like ground or B leads. By insuring that the wires connected to them will all be at nearly the same potential, bus bars reduce unwanted interactions between different parts of a circuit. Poor grounds, a constant source of trouble for the experimenter, are almost completely eliminated.

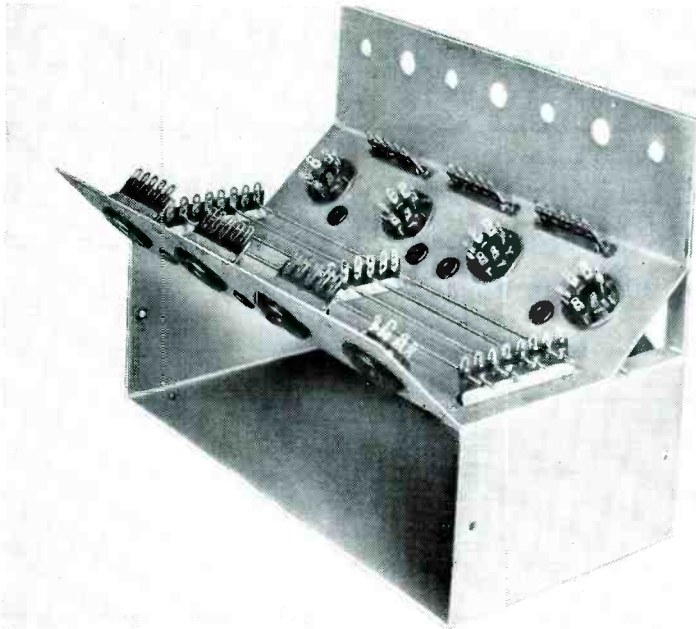

FIG. 2—This layout of wiring points, tube sockets and slotted bus bars permits ready access when circuit changes are contemplated

The bus bars have pins at their ends to which the leads may be plugged. Another important innovation is a shallow groove along the top of each bar. The grooves run nearly the full length of the bars, stopping just short of the pins formed by the ends. The bars are tinned and the grooves are partly filled with solder so that wires to be attached to the bars need only be tinned, laid in the groove, and touched with a soldering iron. Removal of wires from the bars is just as easy as their attachment.

The four bus bars on the chassis are supported about one-quarter inch above it by three insulating strips. Two of these strips, one at each end of the chassis, also support four short pins which can be used with the leads for making external connections to circuits on the chassis. Connections between the pins and equipment on the chassis are made by means of metal lugs which also serve to secure the pins to the insulating strips. These pins, together with the pins on the ends of the bus bars, provide for connection of twelve different external leads. Additional pins for plugging on external leads may be provided, if necessary, by inserting stub connectors at appropriate points on the chassis.

Two or more chassis may be bolted end to end when required for

circuits that have more tubes or components than can be mounted on a single chassis. This gives a rigid combination which is effectively the same as a single large chassis. Short jumpers may be used to join the bus bars into conductors running the whole length of the combination.

In building up models of complex circuits, it is frequently advantageous to use a separate chassis for each block or major subdivision of the system. When the chassis are used in this way it is desirable to use the flexible leads for interconnecting them, since the different parts of the circuit can then be easily disconnected and isolated for individual testing.

The chassis has electrical characteristics superior to most breadboards. It provides electrical shielding which is usually sufficient to permit operation of circuits at moderately low levels without appreciable pickup from external fields. With suitable precautions as to arrangement of wiring, the chassis can usually be used at any frequency handled by ordinary receiving tubes.

The chassis is well adapted to instructional uses. Some types of shallow wafer sockets permit the pins of octal tubes to protrude far enough so that the flexible leads can be plugged directly to them. Using

sockets of this type, and stub connectors soldered to the terminals of other components mounted on the chassis, it is possible to hook up even complex circuits entirely by means of the flexible leads, without the use of a soldering iron.

In most laboratories, it is frequently necessary to build up amplifiers, oscillators, or test equipment of various types for extended but not permanent use. The chassis described is ideally suited to this type of service. The compact arrangement of the chassis permits it to be handled and stored conveniently, and the plugin system of leads permits the chassis to be easily connected to, or disconnected from, associated apparatus.

The flexible leads should be used for all external connections to the chassis; that is, the leads should be used for all connections between the chassis and equipment which can not be mounted directly on it. It is also advantageous to use the leads for making minor temporary or experimental changes in a circuit already on the breadboard. Between twenty and fifty leads in an assortment of lengths ranging from three inches to three feet will be adequate for the needs of the average worker.

Experience has indicated that a circuit can be assembled on the chassis in from one-quarter to one-half of the time required to assemble the same circuit without the use of the chassis.

Breadboard chassis of this type have been in use at the Laboratory for nearly two years. They have proved themselves in many types of applications ranging from relatively simple circuits having one or two tubes, to fairly complex circuits involving more than fifty tubes. Those accustomed to using the chassis regard them as indispensable.

The chassis includes the ideas of many members of the Naval Ordnance Laboratory staff. Particularly significant contributions were made by C. E. Kelly, L. M. Robertson, G. White, R. J. Wylde and T. F. Johnston. Many valuable suggestions regarding applications and methods of using the equipment have been made by Stanley F. Reed of Uni-Products, Inc., who also aided in preparation of this article.

Cathode-Compensated

In this concluding installment, the input admittance of the compensated amplifier is derived theoretically and the experimental verification described. The performance characteristics of this and other video amplifiers are compared

Part II

By

ALEXANDER B. BERESKIN

Associate Professor of
Electrical Engineering
University of Cincinnati
Cincinnati, Ohio

AN investigation of the factors affecting the input admittance in amplifiers is very important since the input admittance determines to a large extent the loading on the preceding stage. In order to make this investigation, a fictitious test voltage \bar{E}_T is applied in the input circuit of an amplifier such as shown in Fig. 1B (Part I). The resulting flow of current from \bar{E}_T determines the input admittance of the amplifier. As shown in Fig. 11 this current flows through three distinct paths, indicated at I_1 , I_2 and I_3 .

The current I_1 includes all of the currents except those specifically flowing through C_{gp} and C_{gk} . The conductance G_i , the intrinsic input conductance, would effectively be that which would be obtained with a cold tube in the socket. The capacitance C_i , which will be called the intrinsic input capacitance, is not as easily defined or measured but includes the input lead to ground capacitance, the grid to screen capacitance, and the grid to suppressor capacitance. Of course, the intrinsic input conductance and capacitance are modified by the fact that they include distributed as well as lumped effects. The distributed parameters must be taken into account in the analysis.

The magnitude and phase of the current \bar{I}_2 will depend on the amplification and phase shift of the amplifier and the magnitude of C_{gp} . This is the ordinary Miller effect

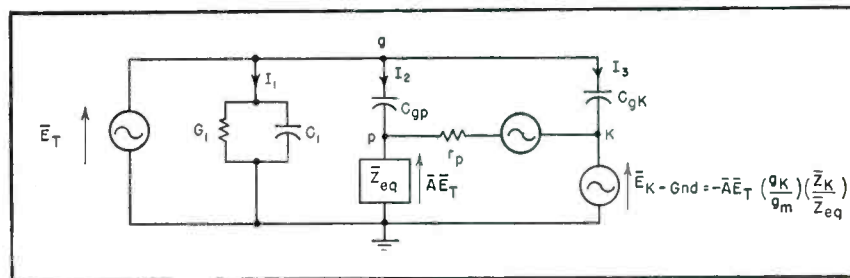

FIG. 11—Equivalent amplifier input circuit for admittance calculations

which is described in most texts on communications under the heading of input admittance. The input conductance and input capacitance due to the grid-plate capacitance are

$$G_{i_{gp}} = \omega C_{gp} A \sin \theta \quad (32)$$

and

$$C_{i_{gp}} = C_{gp} (1 - A \cos \theta) \quad (33)$$

In this case A represents the magnitude of the voltage amplification and θ the phase shift of the plate to ground voltage with respect to the grid to ground voltage. For an uncompensated amplifier with infinite cathode bypass, θ will range from 90 to 180 degrees for capacitive loads and from 180 to 270 degrees for inductive loads. Thus it is seen that capacitive loads tend to produce positive input conductances while inductive loads tend to produce negative input conductances. In the case of the amplifier using cathode compensation, the angle θ can fall outside the limits specified above, but otherwise the two equations apply.

The magnitude and phase of the current \bar{I}_3 will depend on the magnitude of C_{gk} and on the vector cathode to ground voltage \bar{E}_{K-Gnd} . If the values of \bar{A}_2 , \bar{Z}_K , and \bar{Z}_{eq} from Eq. 25, 16 and 24 respectively are substituted in the expression for \bar{E}_{K-Gnd} , the following expression results:

$$\begin{aligned} \bar{E}_{K-Gnd} &= -A \left(\frac{g_K}{g_m} \right) \left(\frac{\bar{Z}_K}{\bar{Z}_{eq}} \right) \bar{E}_T \\ &= - \left[\frac{-gm(1 + g_K R_K) R_{eq1}}{(1 + g_K R_K) + ja \frac{\omega}{\omega_0}} \right] \\ &\quad \times \left[\frac{1 + ja \frac{\omega}{\omega_0}}{1 + j(1 + g_K R_K) \frac{\omega}{\omega_0}} \right] \frac{g_K}{g_m} \\ &\quad \times \left[\frac{R_K}{1 + ja \frac{\omega}{\omega_0}} \right] \bar{E}_T \\ &\quad \times \left[\frac{(1 + g_K R_K) R_{eq1}}{1 + j(1 + g_K R_K) \frac{\omega}{\omega_0}} \right] \\ &= \frac{+g_K R_K \bar{E}_T}{(1 + g_K R_K) + ja \frac{\omega}{\omega_0}} \quad (34) \end{aligned}$$

If the cathode compensation circuit of Fig. 1C is used then the same equation holds with the exception that a_{eq} from Eq. 31 (Part I) should be used in place of a . Then

$$\bar{E}_{K-Gnd} = \frac{g_K R_K \bar{E}_T}{(1 + g_K R_K) + j a_{eq} \frac{\omega}{\omega_0}} \quad (35)$$

A loop equation can now be written for the outside loop so that

$$\bar{E}_T - \frac{g_K R_K \bar{E}_T}{(1 + g_K R_K) + j a_{eq} \frac{\omega}{\omega_0}} = \bar{I}_3 \left(-j \frac{1}{\omega C_{gk}} \right) \quad (36)$$

and

$$\bar{Y}_{i_{gk}} = \frac{\bar{I}_3}{\bar{E}_T} = \frac{\omega C_{gk} (1 + j a_{eq} \frac{\omega}{\omega_0})}{a_{eq} \frac{\omega}{\omega_0} - j(1 + g_K R_K)} \quad (37)$$

Video Amplification

Rationalizing,

$$\bar{Y}_{i_{gK}} = \frac{-\omega C_{gK} a_{eq} \frac{\omega}{\omega_0} g_K R_K + j\omega C_{gK} \left[\left(a_{eq} \frac{\omega}{\omega_0} \right)^2 + (1 + g_K R_K) \right]}{\left(a_{eq} \frac{\omega}{\omega_0} \right)^2 + (1 + g_K R_K)^2} \quad (38)$$

Therefore

$$G_{i_{gK}} = \frac{-\omega C_{gK} \left(a_{eq} \frac{\omega}{\omega_0} \right) g_K R_K}{\left(a_{eq} \frac{\omega}{\omega_0} \right)^2 + (1 + g_K R_K)^2} \quad (39)$$

and

$$C_{i_{gK}} = \frac{C_{gK} \left[a_{eq} \left(\frac{\omega}{\omega_0} \right)^2 + (1 + g_K R_K) \right]}{\left(a_{eq} \frac{\omega}{\omega_0} \right)^2 + (1 + g_K R_K)^2} \quad (40)$$

As long as \bar{Z}_K is capacitive in nature a_{eq} will be positive and the input conductance due to the grid-cathode capacitance will be negative. For values of frequency at which \bar{Z}_K is inductive in nature a_{eq} becomes negative and therefore this particular input conductance will be positive.

All terms in the expression for the input capacitance due to the grid-cathode capacitance are essentially positive so that this input capacitance will always be positive but will be variable in magnitude.

The total input conductance will be the sum of the input conductances seen by the three currents and may be either positive, zero or negative depending upon the relative values involved. In order to avoid the possibility of high negative values of input conductance, which might result in oscillations, it is desirable to keep the grid-cathode capacitance as low as possible.

In a like manner the total input capacitance will be the sum of the input capacitances seen by the three currents. The input capacitance due to C_{gp} will tend to decrease with increasing frequencies. The input capacitance due to C_{gK} will be $C_{gK}/(1 + g_K R_K)$ at low frequencies, attaining a maximum of C_{gK} at f_R (when $a_{eq} = \infty$) and again decreasing

to $C_{gK}/(1 + g_K R_K)$ at very high frequencies. There is a net tendency towards cancellation of the changes in these two capacitances at frequencies below f_R , although the change will be in the same direction at frequencies above f_R .

Experimental Verification

Proper experimental verification of the input admittance relations would require that the effects due to the various paths be measured individually and then combined to produce the proper total value. The only quantity that can be determined directly with any degree of accuracy is the intrinsic input conductance of the circuit. This is measured with a cold tube in the socket since in this case the C_{gp} and C_{gK} paths introduce practically pure capacitance as far as the input admittance is concerned.

A separation of C_{gp} and C_{gK} from all the other capacitances in the circuit by direct measurement would be quite difficult due to the possibility of multiple paths between the various points. It will be noticed, however, that at the frequency f_R the input conductance due to C_{gK} is equal to zero because at this frequency $a_{eq} = \infty$. The re-

maining input conductance must therefore be the sum of the intrinsic conductance and the conductance due to C_{gp} . Since the intrinsic conductance can be measured directly, the difference between the total input conductance and the intrinsic conductance, at this frequency, will be due solely to the C_{gp} path and therefore we can solve for C_{gp} in Eq. 32. Of course, values of A and θ in this equation must be determined in the manner shown in Table I, part I.

The input conductance due to C_{gp} can now be computed for any other suitable frequency, such as $f_R/2$, at which the input conductance due to C_{gK} is relatively prominent. If the total input conductance for this frequency is measured and the measured intrinsic and computed grid-plate input conductances are subtracted from it, the difference must be the input conductance due to C_{gK} . Using this difference and Eq. 39 the capacitance C_{gK} can be determined.

Experimental data for only two frequencies were required to determine C_{gp} and C_{gK} , but with these values and the experimental intrinsic input conductance the total input conductance can be computed

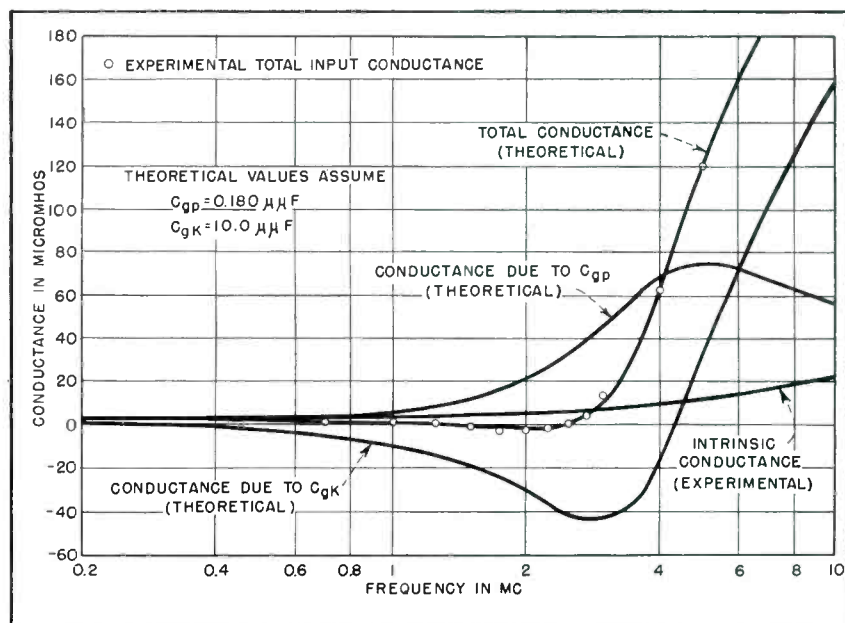

FIG. 12—Input circuit conductance for cathode-compensated amplifier

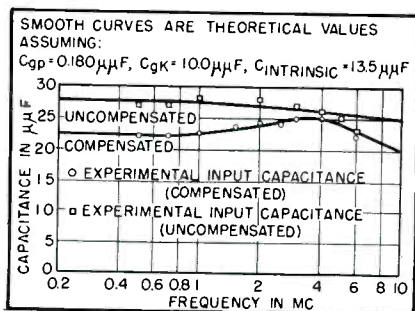

FIG. 13—Theoretical and experimental values of input capacitance

for any frequency. A measure of the accuracy of the method will be the correlation between measured and computed input conductance at frequencies other than the two used to determine C_{gp} and C_{gk} .

The curve for the intrinsic input conductance, shown in Fig. 12, was obtained experimentally. It was found to be the same for both the compensated and uncompensated amplifiers. At low values of frequency it approaches 2 micromhos which is the value of the 0.5-megohm grid leak resistor used. This conductance increases gradually with frequency, reaching approximately 24 micromhos at 10 megacycles.

By the methods described previously for the compensated amplifier, C_{gp} was found to be 0.180 $\mu\mu\text{f}$ and C_{gk} was found to be 10.0 $\mu\mu\text{f}$. The two smooth curves for input conductances due to C_{gp} and C_{gk} were computed using Eq. 32 and 39 respectively, and were then combined to obtain the theoretical total input conductance curve. Experimental values of total input conductance were also determined and they are shown by the circled points on this diagram. The correlation obtained is very satisfactory and it is believed that the values determined for C_{gp} and C_{gk} are quite accurate.

The intrinsic input capacitance can be determined by measuring the total input capacitance, at any convenient frequency, and subtracting from it the sum of the input capacitances due to C_{gp} and C_{gk} . The total input capacitance can then be determined for any frequency by adding to the intrinsic input capacitance the effective input capacitances due to C_{gp} and C_{gk} at that frequency.

The smooth curves in Fig. 13 are

the theoretical input capacitances expected for the amplifier, both compensated and uncompensated, and the circled and squared points are the corresponding experimental values obtained. The correlation appears to be quite satisfactory.

The value determined for the intrinsic input capacitance of the compensated amplifier was 13.5 $\mu\mu\text{f}$. The various values of capacitance determined are not believed to be typical of normal practice since the amplifier used was set up on a standard breadboard used for classroom demonstration. Resistors and capacitors were connected to Fahnestock clips and while reasonable care had been exercised in separating the grid and plate leads no attempt had been made to isolate the grid, cathode, and ground return leads. In normal practice it is doubtful that C_{gp} could be reduced appreciably but it would probably be reasonable to expect a reduction of 2 to 3 $\mu\mu\text{f}$ in C_{gk} and about 4 to 5 $\mu\mu\text{f}$ in the intrinsic input capacitance. The total input capacitance

and conductance would also be modified correspondingly.

In Fig. 14, the theoretical input conductance computed for the uncompensated amplifier using $C_{gp} = 0.180 \mu\mu\text{f}$ is slightly lower than the experimental values shown by the circled points. This discrepancy would have been eliminated if 0.10 $\mu\mu\text{f}$ had been added to C_{gp} in computing the theoretical input conductance. It is entirely possible that a minor circuit rearrangement could have actually caused this change in capacitance.

The input capacitance and input conductance of the compensated amplifier do not become undesirably excessive in any region of the frequency range considered. Sample computations for some of the points in Fig. 12 and 13 are carried out in Table II.

Comparison With Other Circuits

A basis of comparison among different types of video amplifier circuits can be established on many points, the most important of which

Table II—Sample Calculations for Input Admittance of Compensated Amplifier (Data Plotted in Fig. 12 and Fig. 13)

| Working Equations: | | | | | |
|---|---------|---------|---------|---------|---|
| $C_{i_{gp}} = C_{gp} (1 - A \cos \theta)$ | | | | | $G_{i_{gp}} = \omega C_{gp} A \sin \theta$ |
| $C_{i_{gk}} = \frac{C_{gk} [(a_{eq} \omega / \omega_0)^2 + (1 + g_k R_k)^2]}{(a_{eq} \omega / \omega_0)^2 + (1 + g_k R_k)^2}$ | | | | | $G_{i_{gk}} = \frac{-\omega C_{gk} (a_{eq} \omega / \omega_0) g_k R_k}{(a_{eq} \omega / \omega_0)^2 + (1 + g_k R_k)^2}$ |
| $C_i = C_{intrinsic} + C_{i_{gp}} + C_{i_{gk}}$ | | | | | |
| $G_i = G_{intrinsic} + G_{i_{gp}} + G_{i_{gk}}$ | | | | | |
| Circuit Constants in Addition to Those in Table I: | | | | | |
| $C_{gp} = 0.180 \mu\mu\text{f}$, $C_{gk} = 10.0 \mu\mu\text{f}$, $C_{intrinsic} = 13.5 \mu\mu\text{f}$ | | | | | |
| $A_m = 20.8/180^\circ$ | | | | | |
| Quantity | 0.03 | 0.1 | 0.3 | 1.0 | 3.0 |
| ω / ω_0 | 0.106 | 0.354 | 1.06 | 3.54 | 10.6 |
| f (mc) | 2.00 | 3.00 | 5.10 | 9.70 | 27.0 |
| $G_{intrinsic}$ (micromhos) | 20.8 | 20.8 | 20.55 | 18.2 | 4.41 |
| A | 178.41° | 174.71° | 164.46° | 124.46° | 77.80° |
| θ | -20.8 | -20.6 | -19.8 | -10.3 | +9.3 |
| $A \cos \theta$ | 3.92 | 3.89 | 3.74 | 2.04 | .013 |
| $C_{i_{gp}}$ ($\mu\mu\text{f}$) | 0.0681 | 0.2280 | 0.7230 | 6.600 | -1.384 |
| $(a_{eq} \omega / \omega_0)$ | 0.0046 | 0.052 | 0.524 | 43.6 | 1.92 |
| $(a_{eq} \omega / \omega_0)^2$ | 2.135 | 2.182 | 2.654 | 45.73 | 4.05 |
| $(a_{eq} \omega / \omega_0)^2 + (1 + g_k R_k)$ | 4.545 | 4.592 | 5.064 | 48.14 | 6.46 |
| $(a_{eq} \omega / \omega_0)^2 + (1 + g_k R_k)^2$ | 4.70 | 4.75 | 5.25 | 9.50 | 6.27 |
| $C_{i_{gk}}$ ($\mu\mu\text{f}$) | 22.12 | 22.14 | 22.49 | 25.04 | 19.78 |
| C_i ($\mu\mu\text{f}$) | 0.576 | 1.92 | 5.51 | 15.00 | 4.31 |
| $A \sin \theta$ | 0.069 | 0.769 | 6.59 | 60.1 | 51.7 |
| $G_{i_{gp}}$ (micromhos) | -0.112 | -1.245 | -10.70 | -34.4 | +161.2 |
| $G_{i_{gk}}$ (micromhos) | 1.957 | 2.524 | 0.99 | 35.4 | 239.9 |
| G_i (micromhos) | | | | | |

are probably: (a) cost, (b) simplicity, (c) disturbance of normal circuit relations, (d) gain, (e) frequency response, (f) time delay, (g) linearity of the output voltage-vs-input voltage characteristic and (h) input admittance relations. Cathode compensation as developed in this paper is superior to other circuits in most of these aspects and is comparable in the rest.

On a cost basis, the circuit with cathode compensation is not only less expensive than any other compensated circuit but is even less expensive than the ordinary uncompensated video amplifier. In an ordinary video amplifier a large electrolytic capacitor is used in parallel with the cathode resistor. Very often this is bypassed by a small paper or mica capacitor which takes over at the higher frequencies at which the electrolytic capacitor becomes very poor. With cathode compensation the large electrolytic capacitor is discarded, the small capacitor is made the proper size, and an inductor consisting of about ten turns of enameled wire on a quarter-inch Bakelite spool is inserted in series with the small capacitor. A counterbalancing effect might be the necessity of increasing the wattage rating of the load resistor but even this will not overcome the cost advantage of eliminating the electrolytic capacitor.

As far as simplicity is concerned, the ordinary shunt-peaking type of circuit is the only one that compares with cathode compensation. All other circuits require additional elements. In the series peaking circuits a certain division of the stray capacitance is required. If this is not available, then the theoretical curves are not reproduced. Sometimes it is necessary to insert additional capacitance in the circuit in order to obtain this proper distribution. This of course will tend to impair the available frequency response. Adding elements in the plate circuit will also tend to increase the stray capacitance present. This effect was noticed to a slight extent in the experimental case discussed but need not have been present at all if the proper value of resistance had been available.

In all other compensating circuits

the impedance of the compensating elements is of the same order of magnitude as the load impedance. In the case of the inductances this results in difficulties due to self-resonance effects which are normally not taken into account. One instance in which this effect is taken into account is in the improved shunt-peaking¹ circuit. In the case of cathode compensation there is never any reason for concern over the stray capacitance of the inductors or the series inductance of the capacitors.

On the basis of gain from a certain tube for a given frequency response, cathode compensation is as good as ordinary shunt peaking

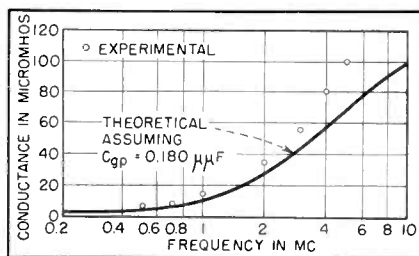

FIG. 14—Input conductance versus frequency of uncompensated amplifier

and improved shunt peaking but not quite as good as the series peaking circuits which make use of filter circuit characteristics. This however is further modified by considerations as to whether frequency response is limited by amplitude or time delay considerations. On an amplitude consideration basis the series peaking circuits probably have a slight advantage over cathode compensation but this advantage disappears if time delay is used as the criterion of frequency response.

As a matter of fact, video amplifiers intended for television applications continue to have useful output as long as the time delay variations do not become excessive. In the amplifier of Fig. 8 (part I) the variation in time delay between the valley and the peak of the curve is of the order of magnitude of 0.004 microsecond. This represents a horizontal distance which corresponds to approximately one-twentieth of the distance between line centers in a television picture. This is certainly a negligible variation in time delay. The only other circuit

that even approaches this constant a time delay over such a large frequency range is the shunt peaking compensation in which the inductive reactance at f_0 is equal to 35 percent of the load resistance.

On the basis of linearity of output voltage for a given frequency response, cathode compensation is superior to all other circuits in the middle-frequency region and probably as good as any of them at the high-frequency end of the characteristic.

A thorough comparison of the input admittances of the various circuits is not possible because of the lack of data on the other circuits. With cathode compensation the input capacitance is slightly lower than in the corresponding uncompensated amplifier. The input conductance has some elements that tend to make it negative and others that tend to make it positive. A judicious combination of these elements will produce practically zero input conductance over most of the operating range.

All other video amplifiers are limited in their low-frequency response to some extent by the cathode bypass capacitance used. In the case of cathode compensation, the circuit behaves as though the original uncompensated amplifier had infinite cathode bypass capacitance. Of course the screen bypass and coupling capacitors still have the same effect as they have in any circuit.

There is a possibility that the introduction of additional elements in the plate circuit might make the linearity in the high-frequency region comparable to that obtained at middle frequencies. This possibility has not been investigated up to the present time.

The author wishes to acknowledge the opportunity that he has had for discussing the problems involved in this development with his colleagues and especially with Professor W. C. Osterbrock. He would also like to thank the electrical engineering class of '48 of the University of Cincinnati, for the time they devoted to calculations in his behalf in the early stages of the project.

REFERENCE

- (1) A. B. Bereskin, Improved High Frequency Compensation for Wide Band Amplifiers, *Proc. IRE*, p 608, Oct. 1944.

Portable High-Voltage POWER SUPPLY

Weighing less than 35 pounds, this rectified-60-cycle unit provides continuously adjustable voltage from 0 to 30 kv at currents as high as 500 μ a, with reversible polarity and approximately 5-percent ripple at full load. Protective circuits insure long life of components and operating personnel

A GROWING NEED has been felt in many fields of research and engineering for a compact, portable, low-current high-voltage d-c power supply, continuously adjustable from 0 to 30,000 volts.

In home television receivers, voltages up to 30 kv are required for the accelerating potential of the cathode-ray tube. In nuclear physics, dust precipitation, some fields of medical testing, the new field of xerography¹, experimentation on electrostatic-charge dissipation and electrostatic painting high voltages at low currents are needed. In most of these applications, the maximum current drain required from the power supply is 1 ma. Usual maximum current requirements are of the order of 500 microamperes.

By **VICTOR WOUK**

*Chief Engineer
Beta Electric Corp.
New York, N. Y.*

sign and construction of such a power supply.

Desirable Properties

Desirable features in a general-purpose high-voltage power supply include the following: (1) Continuous adjustability, (2) compactness and light weight, (3) reversible high-voltage polarity (In television work, positive high voltage with respect to ground is required, while in dust precipitation work the opposite is often the case. In many nuclear physics studies, both polarities are often required during the course of a series of tests), (4) moderately accurate output-voltage indication, (5) safety to operating personnel whether skilled or unskilled, (6) reliability (wide margins against component failure), (7) minimum corona compatible with general low cost and compactness and (8) low ripple (less than 5 percent being desirable for television and nuclear physics work).

Available Circuits

In general, high-voltage power supplies fall into four common categories: r-f², fly-back, pulsed³, and rectified 60-cycle. The fly-back type, when considered as an independent supply, becomes a pulsed power supply.

In planning the design of a supply incorporating the features listed above, r-f and pulsed types were discarded for several reasons. If the supply is to be continuously adjustable, the filaments of the rectifiers cannot be energized from the

Where it is desired to test puncture strength on flashover ratings of insulating materials or circuit components, considerably smaller currents are normally satisfactory.

A portable, reversible-polarity power supply capable of providing these voltages and currents, employing rectified 60-cycle power, has been made feasible by the development of new insulating materials, new rectifiers for television applications and new compact circuit components with high-voltage ratings. This article describes the de-

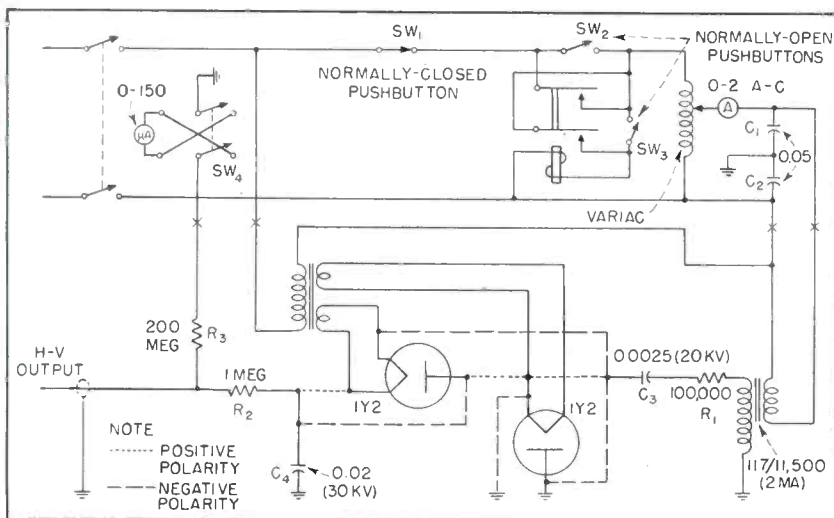
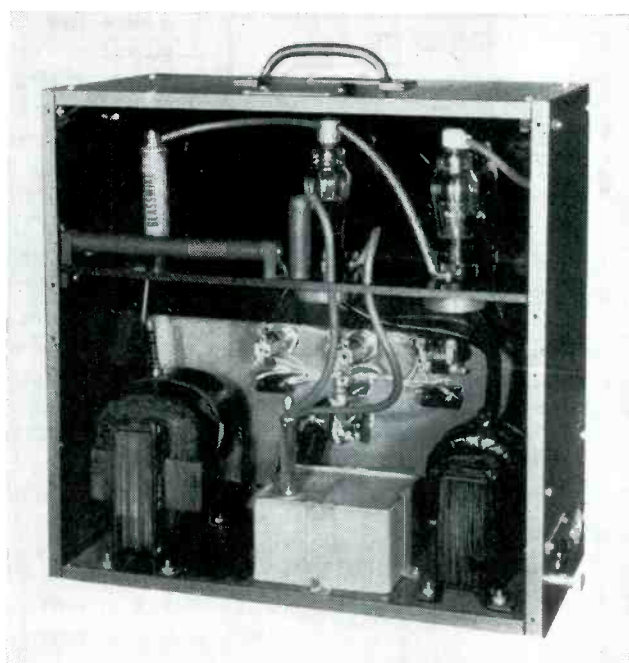

FIG. 1—Circuit diagram of portable high-voltage power supply. Switches 1, 2 and 3 are momentary switches. Control panel may be removed from power supply and cabled at points marked with x's



Front view of 30-kv portable power supply. Control panel may be removed and cabled to power supply for remote operation



Cover-removed rear view of power supply, showing physical placement of components

same source that supplies the high-voltage power, as in usual r-f and pulsed types. When filaments are so energized, the filament voltage decreases with lowered output voltage, reducing the cathode's emissivity; when the cathodes are cold the output voltage varies greatly with small changes in heater voltage.

Further disadvantages of this type of operation are the long time lags between successive equilibrium states when the output voltage is changed slightly at low output voltage and shortened rectifier life due to high forward tube drops when filament voltage is low and normally-rated currents are being drawn. Separate filament-energizing transformers must be of the low-capacitance type in these types of supplies, otherwise excessive capacitance loading of the high-voltage generator will occur. A low-capacitance transformer of suitable voltage rating is bulky, and if two filaments are at high r-f voltage the capacitance between filament windings must be low as well as the capacitance to ground. Such a transformer would be bulky and expensive.

A straightforward 60-cps rectifier is less complicated, and hence more reliable, since it eliminates the

two stages of low-voltage rectification and high-frequency generation found in r-f and pulsed types of supplies. It was also in the interest of reliability through less complication that separate r-f or pulsed-filament energizing was not considered for use with an r-f or pulsed power supply.

Finally, and oddly enough, a 0 to 30-kv rectified 60-cps supply is lighter and less bulky than an r-f or pulsed type of similar rating. This is so because of the weight of filter chokes and plate and filament transformers. True, the high-voltage r-f coil or pulsing coil is considerably lighter than the high-voltage 60-cps transformer, and the high-voltage filter capacitors are of much lower capacitance, and hence less weight, in the r-f or pulsed units. However, these weight savings are considerably overbalanced by the plate B+ supply requirements.

It must be remembered that the r-f and pulsed power supplies are inherently low-efficiency devices; a 30-percent efficiency in conversion of B+ to high voltage is excellent. Thus, for 30 kv at 500 μ a, an r-f or pulsed supply operating at 350 volts B+ will require at least 150 ma, well filtered. Such a B+ supply, with associated filament transformers, is heavier than the combined

weights of a 60-cps 12-kv transformer, and a 0.02 μ f, 30-kv polyethylene-dielectric capacitor.

As to bulk, an r-f or pulsed power supply for 30 kv requires more stages of voltage multiplication than a rectified 60-cps system. An 11-kv rms transformer yields a peak voltage greater than 15 kv, producing 30 kv after doubling. However, r-f and pulsed supplies using ordinarily available tubes and circuit components can produce not much more than 10 kv peak at the high-voltage generator, requiring three stages of multiplication.

The 10-kv value is the limiting factor on r-f power supplies because of corona on the high-voltage coil. Since a high-Q r-f coil is required in an r-f power supply, thin wire is used in winding the high-voltage pies. The thin wires are sources of heavy corona above 10 kv.

In pulsed supplies, the 10-kv figure is determined by the peak plate voltage rating of the driver tube³. A 6BG6G can handle no more than 6 kv reliably. By means of autotransformer action of the peaking coil, this can be stepped up, but analysis³ shows that a step-up much more than 50 percent is inefficient.

Because of the above-mentioned factors, 60-cycle power was chosen

the output is set for high voltage, and there is a short circuit or flash-over in the external load.

Resistor R_3 is rated at 40 kv by the manufacturer. It has been found that these are linear up to about 30 kv, permitting an initial full-scale meter indication accuracy of about 3 percent. The resistor warms up perceptibly, introducing an error as large as 2 percent above 30 kv. This is compensated for by calibrating each meter to read slightly low when cold. The reading is then slightly high when warm. (The resistors have negative temperature and voltage coefficients.)

Resistor R_1 is included to lengthen tube life by limiting capacitor-charging current surges when the output control is set for high voltage, and power is suddenly turned on.

Corona

To minimize corona, sharp points at high voltage are avoided. Where sharp points are unavoidable, these regions are surrounded by anti-corona shields. This is particularly the case around the rectifiers' cathodes.

Where other connections are made at high voltage, rounded brass caps are used. These are employed on the two capacitors, and can be seen in Fig. 3G. All 30-kv points are kept at least one inch from the nearest ground through air, or two inches if flashover can occur across a surface.

Resistors R_2 and R_3 are wax-dipped to minimize corona from the sharp edges of the conducting material. This wax coating also prevents minor knocks from chipping the thin conducting deposit on the ceramic form and developing an open circuit in the resistor.

Regulation

Although good regulation is usually desirable in any power supply, it is not attained readily in this type of high-voltage-generating circuit without increasing the weight, size and circuit complexity considerably. Since in many general laboratory and test applications of the power supply, such as voltage-breakdown testing, cathode-ray-tube life testing, and dust precipitation, good regulation is not

necessary, no automatic regulation was incorporated into the unit.

The regulation of the power supply is indicated in Fig. 4. The load lines for various fixed Variac positions are shown. It can be seen from line A, the curve for maximum Variac setting with a 1 to 1 Variac ratio, that at no load slightly over 30 kv are available. If the Variac is set to give 135 volts output, then the load line is B, and over 500 μ a are available at 30 kv, or 1 ma at about 27 kv. Due to the fact that the output capacitor C_2 is rated closely at 30 kv, the curve B is not extended above the 30-kv line; curve B indicates use of the power supply to yield relatively heavy currents in the 20 to 30-kv range, and not use to provide more than 30 kv.

From Fig. 4 it is further seen that the output voltage drops off linearly with load current for fixed Variac settings. The rate of terminal-voltage drop-off is, as theoretical considerations indicate, independent of the input voltage—that is, the load lines are all parallel, meaning that the internal resistance of the power supply is independent of the input voltage and load resistance. From the slope of the lines, it can readily be calculated that the internal resistance is approximately 8 megohms.

Extrapolation of the load line A indicates that the steady-state short-circuit current should be 4 ma. Measurements reveal this to be the case. As previously discussed, this value is well below the let-go value of current.

Actual ripple measurements, made under typical operating conditions, show close adherence to the ripple values as calculated by standard methods for the type of filter used.

The minimum ripple percentage is about 0.4 percent, due to the constant presence of the voltmeter load represented by R_3 in Fig. 1.

As typical values, the ripple present when the power supply is used on a projection television tube requiring 300 μ a at 25 kv, or a load of 83 megohms, is 1.2 percent. This is satisfactory for all normal projection television applications. For a direct-viewing tube of 7 kv and 400 μ a, or a load of 17.5 megohms, the ripple is approximately 5 percent; this is just about the limit of

acceptability for high-quality picture appearance. It is very good for routine test purposes.

Additional Features

In order to make the power supply quite flexible and useful for many applications, several features are included in the control circuits that are not ordinarily associated with a high-voltage power supply.

In many applications, it is desired to control the high voltage remotely. Therefore, the control panel has been made removable by means of a cable connector set. The points in the wires where the various breaks occur are indicated by X's in the diagram. The fuse, switches, pilot lights, pushbuttons, relay, Variac and meters are located on the control panel. All other components are located either in or on the cabinet that houses the high-voltage components.

Since some corona is present in the secondary side of the high-voltage transformer, a small amount of r-f noise is fed back into the mains. To minimize the r-f effects, two capacitors, C_1 and C_2 (Fig. 1) are employed as a high-frequency filter. At maximum output voltage, the r-f radiated away and fed back into the mains does not affect reception on a radio plugged into a utility socket on the control panel.

The entire unit is 16 inches wide x 16 inches high x 8 inches deep and is provided with a suitable carrying handle. Total weight is 35 pounds.

Because of the wide variation of types of connector used for different applications at high voltage, no special attempt has been made to provide a high-voltage connector of particular design. Instead, a large-size battery clip with rubber shield is provided. This proves satisfactory for all applications except those in which corona must be reduced to a minimum.

REFERENCES

- (1) Xerography, a Dry Printing Process, *Electrical Engineering*, 68, p 46, Jan. 1949.
- (2) O. H. Schade, Radio-frequency Operated High-Voltage Supplies for Cathode-Ray Tubes, *PROC. IRE*, 31, p 158, April 1943.
- (3) G. J. Sieszen and F. Kerkhof, Pulse-Type High-Voltage Supply, *PROC. IRE*, 36, p 401, Mar. 1948.
- (4) D. L. Waidelich and C. H. Gleason, The Half-Wave Voltage-Doubling Circuit, *PROC. IRE*, 30, p 535, Dec. 1942.
- (5) C. F. Dalziel, Effects of Electric Currents in Man, *Electrical Engineering*, 60, p 63, Feb. 1941.

CINCH-ERIE "Plexicon"

Miniature Tube Socket



**A joint development of ERIE RESISTOR CORP.
and CINCH MANUFACTURING CORPORATION**

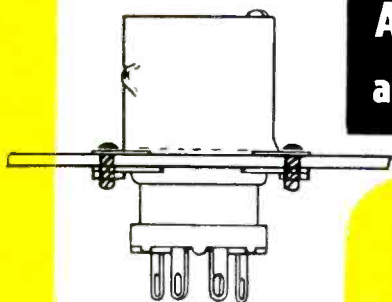

Bayonet shield base when shielding of tube is necessary.



Three lengths of shield cans are available:
No. 8660, height 1 3/8"
No. 8661, height 1 3/4"
No. 16G12564, height, 2 1/4"

With built-in Ceramic Condensers, Plexicon Tube Sockets provide the most effective method of by-passing . . . with condenser close to tube element providing shortest path to ground. Capacity up to 1,000 MMF — any tube element may be coupled or by-passed as desired.

Any or all terminals of this socket may be by-passed to ground or coupled.

Also available in Octal, Loktal and Noval type sockets.

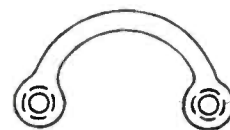

Mounting Strap, EXP 8556



Erie Ceramic Condensers

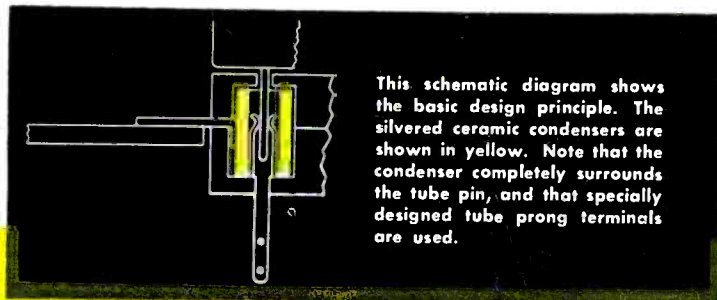

This schematic diagram shows the basic design principle. The silvered ceramic condensers are shown in yellow. Note that the condenser completely surrounds the tube pin, and that specially designed tube prong terminals are used.

Write for detailed information, and in ordering specify capacities required and position of condensers.

AVAILABLE AT LEADING ELECTRONIC JOBBERS . . . everywhere

CINCH MANUFACTURING CORPORATION

1026 SOUTH HOMAN AVENUE

CHICAGO 24, ILLINOIS

Subsidiary of United-Carr Fastener Corporation - Cambridge 42, Massachusetts



ATTENUATION

Between Paraboloid Antennas

Antenna diameters, distance and wavelength figures are simply converted to gain and loss in db with the table. Algebraic addition shows attenuation

THE TABLE provides a convenient means of calculating line-of-sight space attenuation between two paraboloid antennas, but can be used for other shapes and designs if the effective diameter is utilized.

The left-hand column represents the physical quantities shown in the figure and listed below. The corresponding right-hand numerals are equivalent decibel values. The table can be extended since the right column is $20 \log_{10}$ of the left column. Equation 1 shows the algebraic signs to be applied to the db values. The 93-db constant is a value representative of good design practice.

$$\text{Space attenuation, } P_r/P_t = -93 - S - \lambda + D_r + D_t \text{ decibels (1)}$$

- When D is antenna diameter in inches
- S is separation between antennas in miles
- λ is wavelength in centimeters
- P_r is power received
- P_t is power transmitted

By E. DYKE
Communication and Electronics Div.
Motorola Inc.
Chicago, Ill.

| Physical Quantities | Gain or Loss in Db | 48 | 33.6 |
|---------------------|--------------------|-----|------|
| | | 50 | 34 |
| | | 60 | 35.6 |
| | | 70 | 36.9 |
| | | 72 | 37.2 |
| | | 80 | 38.1 |
| | | 90 | 39.1 |
| | | 100 | 40 |
| 0.1 | -20.0 | 120 | 41.6 |
| 0.5 | - 6.0 | 140 | 42.9 |
| 1.0 | 0.0 | 160 | 44.1 |
| 2 | + 6.0 | 180 | 45.1 |
| 3 | + 9.5 | 200 | 46.0 |
| 4 | 12.0 | 250 | 48.0 |
| 5 | 14.0 | 300 | 49.5 |
| 6 | 15.6 | 400 | 52.0 |
| 7 | 16.9 | 500 | 54.0 |
| 8 | 18.0 | | |
| 9 | 19.1 | | |
| 10 | 20.0 | | |
| 12 | 21.6 | | |
| 14 | 22.9 | | |
| 16 | 24.0 | | |
| 18 | 25.1 | | |
| 20 | 26.0 | | |
| 22 | 26.8 | | |
| 24 | 27.6 | | |
| 26 | 28.3 | | |
| 30 | 29.5 | | |
| 35 | 30.9 | | |
| 40 | 32.0 | | |
| 45 | 33.1 | | |

Example:

| Factor | Dimension | Db |
|--------------------------|-----------|-----|
| Constant | | -93 |
| Distance (S) | 50 miles | -34 |
| Wavelength (λ) | 4.5 cm | +13 |
| Rec ant. (D_r) | 40 in. | +32 |
| Trans ant. (D_t) | 40 in. | +32 |
| Attenuation | | -76 |

Received power P_r can be obtained in dbm by adding the value of transmitted power P_t in dbm to the db value of the attenuation.

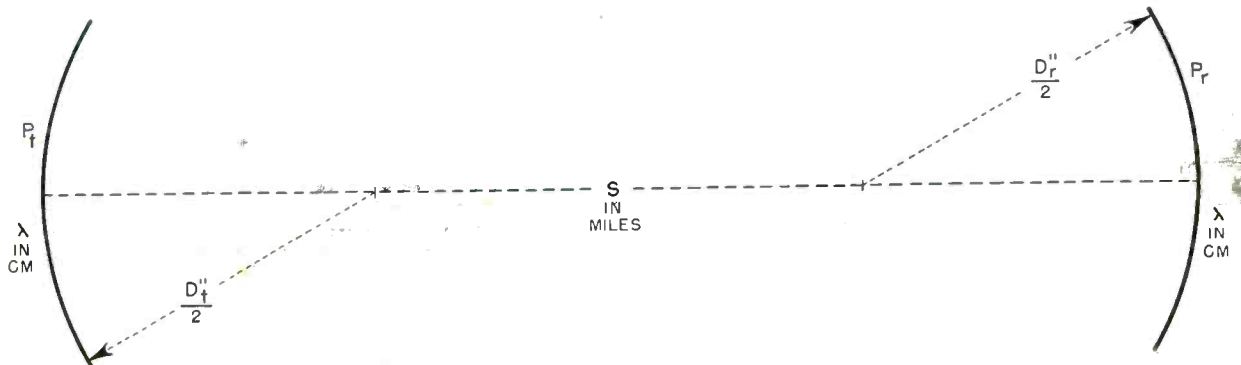

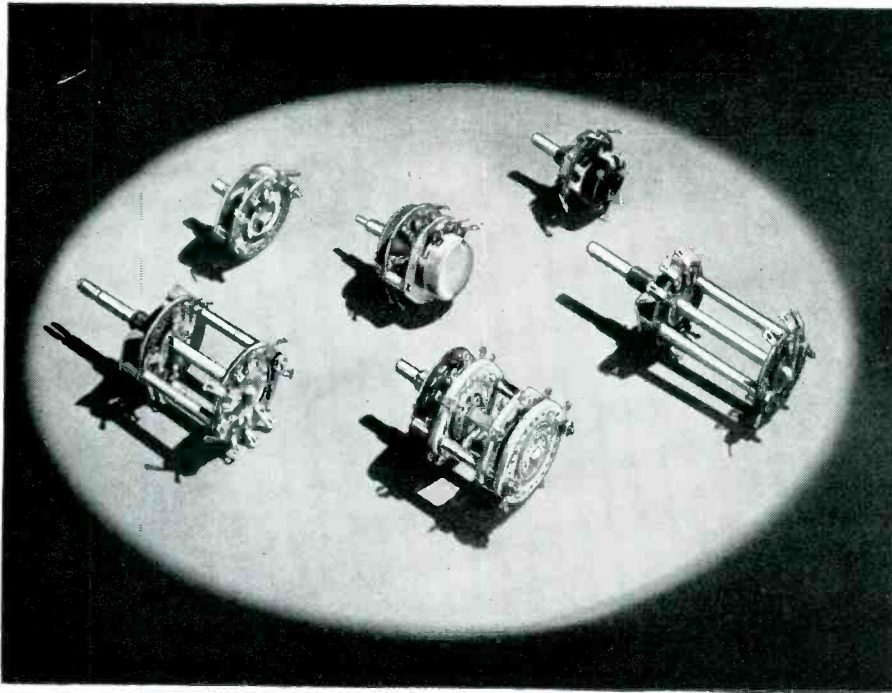

Use a Switch
Worthy of
Your Design

*There is no
substitute for*
MALLORY
Quality
Switches !

Mallory RS switches are designed to give you everything you want—maximum efficient service, substantial construction, precision manufacture. Mallory switches are constructed with cam and ball type index assembly, or with positive indexing hill-and-valley double roller type index assembly. Note these many features of the Mallory RS series which make their dependability and quality known wherever switches are used. These advantages are of extreme importance in television and high-frequency applications where stability is essential.

- Insulation of high-grade, low-loss laminated phenolic.
- Terminals and contacts of special Mallory spring alloy, heavily silver-plated to insure long life at low contact resistance.
- Terminals held securely by exclusive Mallory two-point fastening—heavy staples prevent loosening or twisting.
- Double wiping action on contacts with an inherent flexing feature—insures good electrical contact with the rotor shoes throughout rotation.
- Six rotor supports on the stator—insure accurate alignment.
- Brass rotor shoes, heavily silver-plated—insure low contact resistance.
- All shoes held flat and securely to phenolic rotor by rivets—prevents stubbing—insures smooth rotation—*minimum of noise in critical circuits.*

The Mallory RS series consists of RS-30, RS-40, RS-50, RSA-50, and RSA-60.

ENGINEERING DATA SHEETS

Send for the Mallory Engineering Data Sheets on the RS series. They contain complete specifications for available circuit combinations with respective terminal locations, dimensional drawings — everything the engineer needs.

SPECIFICATION SHEETS

Specification sheets for all RS switches have also been prepared. These sheets are printed on thin paper to permit blueprinting. The sectional drawings indicate standard and optional dimensions—make it easy for you to order production samples built to your requirements.

Precision Electronic Parts—Switches, Controls, Resistors

P. R. MALLORY & CO., Inc.
MALLORY

P. R. MALLORY & CO., Inc., INDIANAPOLIS 6, INDIANA

SERVING INDUSTRY WITH

| | |
|----------------|------------|
| Capacitors | Rectifiers |
| Contacts | Switches |
| Controls | Vibrators |
| Power Supplies | |

Resistance Welding Materials

TUBES AT WORK

Including INDUSTRIAL CONTROL

Edited by VIN ZELUFF

| | |
|---|-----|
| Electronic Instruments in Large Aircraft..... | 116 |
| Reduced Ignition Interference..... | 118 |
| Making Oil from Coal..... | 134 |
| Compact Microwave Signal Generator..... | 144 |
| Generator Regulation by Saturable Reactors..... | 150 |

Electronic Instruments In Large Aircraft

By JOSEPH ALBIN
New York, N. Y.

IN THE DAYS when the still-popular DC-3 was the ruler of the commercial airways, and later, when its big brother, the DC-4 took over on some of the longer runs, the instrument maintenance problem was one chiefly of mechanics, pneumatics and hydraulics. Lately, however, the popularity of the DC-6 with its preponderance of electronic instruments has caused a noticeable change in the maintenance scene.

The American Airlines maintenance depot at Tulsa, Oklahoma, which had been fully equipped, both in equipment and personnel, for servicing DC-3's and DC-4's, found itself lacking in the ability to repair and maintain the numerous electronic instruments in the DC-6's. A completely new air-conditioned electronic laboratory has been installed and manned, chiefly by former radio personnel.

The accompanying photographs show several examples of the resulting gear for testing the highly complex DC-6 instruments. The large photograph shows a test bench setup which allows rapid and dependable checking of the A-12 automatic pilot. It includes a complete operating system of all the units of the A-12 comparable to the system which is installed in the DC-6's. Through the use of this test analyzer and the substitution of questionable components in the mockup, defective units may be detected and isolated. Ship wiring systems are duplicated in the cabinet beneath the shelf.

The horizon test stand is used principally for aligning the horizon-rotor axis to the true vertical position. The microscope is so designed that a deviation of 15 minutes is easily discernible and a

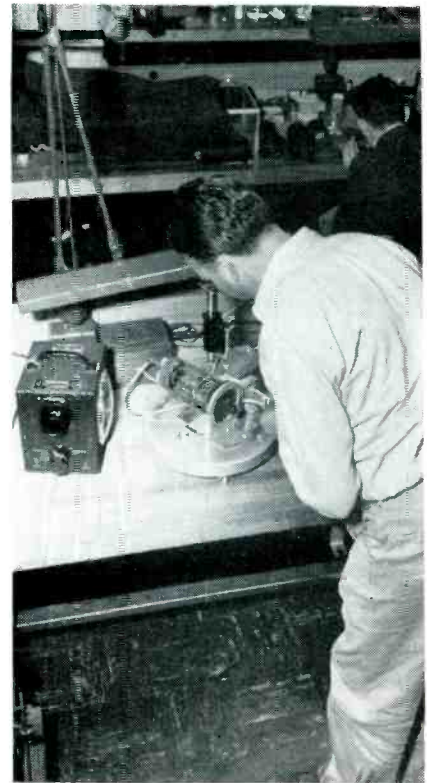

Strobotac and microscope allow visual alignment of horizon rotor for angular accuracies of 15 minutes

difference of as little as 1 degree exceeds the field of view of the microscope; that is, no image of the roto shaft is seen in the microscope when the deviation exceeds 1 degree.

The third photograph shows the cabin pressurization instrument test panel which is complete with pressure lines, vibrators and electrical connectors so that any malfunctioning unit can be detected immediately upon test. Through the manipulation of the various

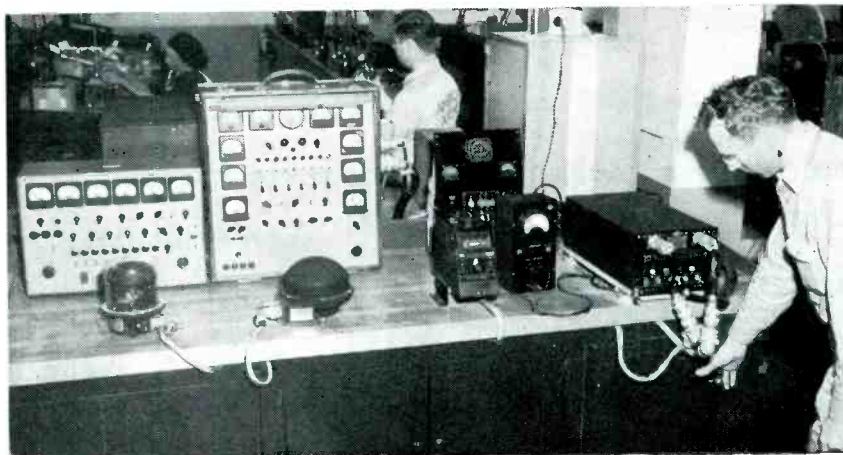

Test setup for checking the A-12 automatic pilot. Questionable components are plugged into this complete test-bench version, and malfunctioning units can be isolated



Test setup for checking operation of cabin pressurization instruments and gages

SOLDERING TIPS

Previous to the late war, many of the largest users of solder maintained schools to teach their employees the art of soldering. Due to the great need of materials during the war and the great rush to be first on the market in the post-war years, much of this educational work has been pushed into the background. As a result, on many production soldering lines, many different techniques have been developed. The lack of a thorough understanding of making an efficient soldered joint has resulted in the waste of high-priced time and valuable materials. Most solder users understand the correct method of making a solder joint, but perhaps a brief resume of the essential points may bring to mind some forgotten technique and further the cause of a well-made, efficient soldering operation.

1. A SOLDERING IRON OF SUFFICIENT HEAT CAPACITY to rapidly heat the metal being soldered to a temperature sufficient to melt the solder.
2. A CLEAN IRON TIP, WELL TINNED. Keep a rag handy to the soldering operation so that the iron may frequently be wiped clean of the burnt particles of the soldering flux.
3. USE THE FULL FACE OF THE IRON TIP, not just the point. This will assist in transmitting the heat more rapidly.
4. ROTATE THE IRON TIP. Soldering irons have many sides. Use them. This will increase the life of your tip between dressings.
5. USE THE PROPER AMOUNT OF FLUX FOR YOUR OPERATION. Too much flux results in spreading solder and flux over the adjacent area and makes a bad-looking joint. Too little flux will result in an inefficient, poorly-soldered joint.
6. FLUX-CORE SOLDER should always be applied to the exact junction of the metal and the soldering iron. Flux-core solder applied high up on the iron will result in the dissipation of all or part of the flux before it reaches the metal to be soldered.

Finally, an efficient solder operation requires **CLEANLINESS—HEAT—THE PROPER SOLDER—THE PROPER FLUX.**

QUESTION: What is the smallest diameter flux-core solder made?

ANSWER: Kester Solder Company makes a flux-core solder that is .0085" (eight and one-half thousandths) in diameter. However, generally speaking, the smallest made for practical use is .011" (eleven thousandths), produced by Kester Solder Company as a regular item.

"Soldering Tips" will be pleased to answer all inquiries pertaining to solder, soldering fluxes, and soldering technique. Merely address "Soldering Tips", Kester Solder Co., 4204 Wrightwood Ave., Chicago 39, Ill.

... NOW AVAILABLE ... The New Manual—"SOLDER and Soldering Technique"!

Send for this complete analysis of the properties of soft solder alloys and soldering fluxes . . . a comprehensive reference book that you will want to retain. It's yours for the asking . . . request it NOW!

(ADVERTISEMENT)

ELECTRONICS — July, 1949

Standard in the RADIO AND TV FIELD



Kester is constantly developing new and better flux-core solders. At present there are over 100,000 types and sizes, each designed to do a certain job in the most efficient manner.

Take advantage of Kester's highly specialized Technical Service. Call in a Kester technical engineer today and let him specify the solder that will enable you to do your soldering faster and better.

Free—Technical Manual

Send for Kester's new 28-page manual, "SOLDER and Soldering Technique" . . . a complete analysis of the application and properties of soft solder alloys and soldering fluxes.



KESTER SOLDER COMPANY

4204 Wrightwood Avenue, Chicago 39, Illinois

Factories Also At
Newark, New Jersey • Brantford, Canada

**KESTER
SOLDER**

THE FRONT COVER

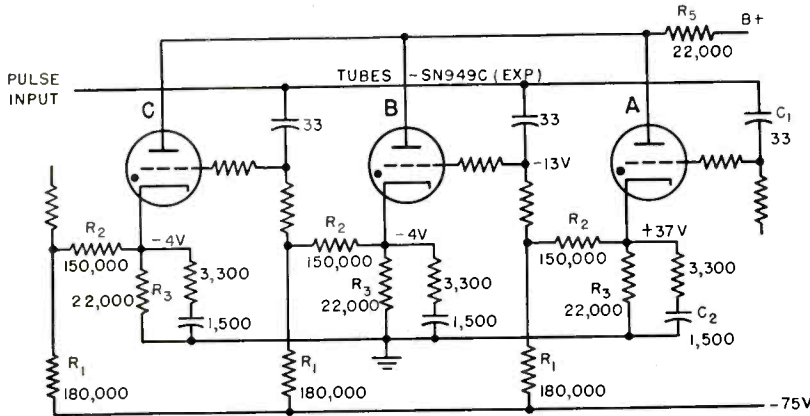

CONTAINING 11 tubes, 80 resistors and 23 capacitors, the decade ring counter counts pulses at a random rate or in a continuous train of rates from 0 to 5,000 per second and holds the count indefinitely or until the power is turned off or a tube fails.

The basic operation of three typical counting tubes is illustrated in the accompanying diagram. The resistor network composed of R_1 , R_2 and R_3 is a voltage divider which places the cathode voltage to tubes B and C at about -4 volts and puts the grid voltage of tube C at about -38 volts. Assume that tube A is conducting and the current through the tube and the resistor R_3 are such that the cathode of tube A is at about positive 37 volts. Voltage divider R_1, R_2 in the circuit of tube A then places the grid of tube B at -13 volts. The bias becomes -34 volts for tube C , but is only -9 volts for tube B . Since the pulse input line is connected to all the grids, each tube grid will receive the same pulse, but tube B will be fired by a much lower pulse than tube C , say a pulse of 15 volts positive. This still leaves a considerable margin of safety so that tube C is still biased to about $-34 + 15 = -19$ volts.

After tube A has been conducting for a few microseconds, capacitor C_2 is charged to the cathode potential or -37 volts. When tube B fires, an additional current flows through the common plate resistor R_5 and this causes a sudden drop in anode voltage, but the capacitor tends to hold the cathode at -37 volts. This allows the anode voltage to drop below the critical value long enough so that conduction stops, thus permitting the grid to regain control. The count has now advanced from tube A to tube B and continues through the tubes until tube 9 is conducting. The circuit for this tube is shown in the small diagram.

When tube 9 is conducting, it sets up the bias or primes both the 0 tube and the transfer tube in exactly the same fashion as before. When the next or 10th pulse comes along the 0 tube and the transfer tube will both conduct for a few microseconds and then go out because $R_6 + R_8$ is quite high. A pulse is thus sent through the output to the next decade.

When the equipment is turned on and before any pulses are applied the voltage is removed momentarily from the line marked II. This removes the bias from the 0 tube and puts zero bias on the tube, and thus the tube fires.

The pulse height may be between 15 and 25 volts. The rise time of the pulse can be rather slow compared to many other modern counters.

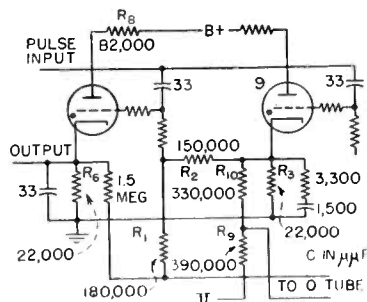

controls, actual atmospheric conditions at various altitudes can be applied to the pressure instruments for checking.

Other electronic test gear includes a unit which introduces an artificial signal into the C-2 gyro-syn compass system amplifier for the purpose of checking the resulting output. Another setup is provided for checking the operation of fuel quantity gages used on DC-6's and Convairs.

Reduced Ignition Interference

RELIEF for communications services that suffer from ignition interference is promised by the future use of resistor-type spark plugs on automobiles.

Until recently, the opinion has prevailed that resistor-type plugs required increased voltage over that used by non-resistor plugs of identical design when set at the same gap settings, and the opinion has been expressed that resistor plugs would adversely affect starting and road load fuel economy. Investigations have shown that resistor plugs with values up to 20,000 ohms have no practical effect upon starting and require no increase in secondary voltage over those of non-resistor plugs of identical design when used with the same gap setting.

An investigation was undertaken by engineers of the Electric Auto-Lite Co. to analyze the possibilities of wider initial gap settings.

It has been found that wider gap settings, when used in conjunction with resistors and an ignition coil having improved wave front characteristics can bring about increased effectiveness of the spark discharge and initiate combustion through a wider band of complex and variable factors.

A spark or a spark followed by an arc is the process whereby an electrical circuit in a highly unstable condition returns to a more stable state by passing a current through the intervening gas between two electrodes. This return to stability or lower electrical stress occurs in a very short period of time and an

(continued on p 132)

A MAGNET WIRE

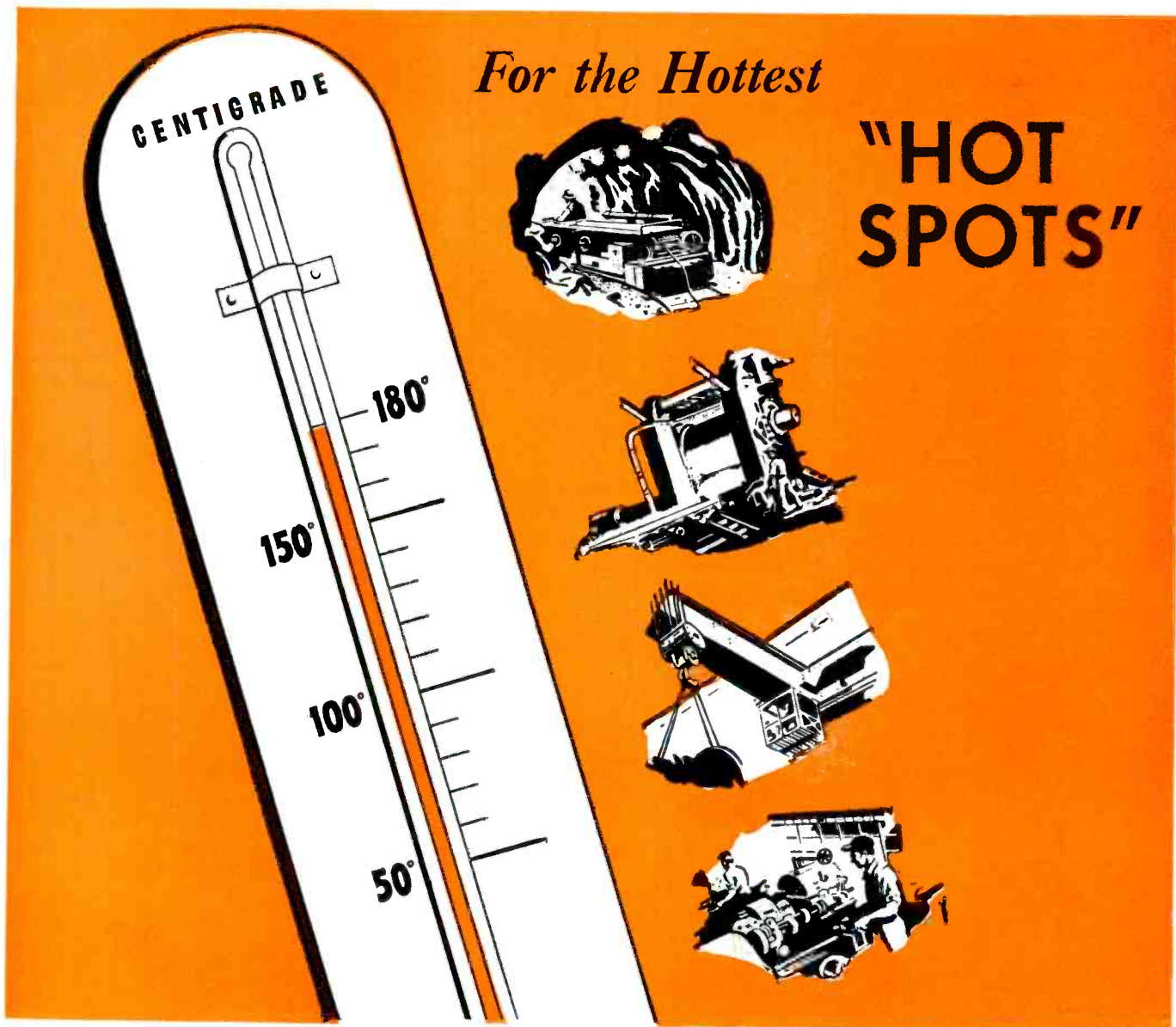

HOW CAN MAGNET WIRE, even *Silotex**, withstand continuous operation at extreme high temperatures?

The answer is in war-developed *silicones*, now brought to the magnet wire field by Anaconda in amazing glass insulated *Silotex*—bonded with *silicone varnish*. Such insulation qualifies for the new A.I.E.E. high-temperature rating of "Class H"... 180°... a 140° rise

in temperature over an ambient 40° C!

Even at operating temperatures around 180° C, here's what *Silotex* offers: Greater life expectancy, greater over-load protection, immunity to ambient temperature, greater moisture resistance, reduction in fire hazard. For complete information on the properties of *Silotex*, write to Anaconda Wire and Cable Company, 20 N. Wacker Drive, Chicago 6, Ill.

48444



Anaconda
SILICONE BONDED

SILOTEX

*
Magnet Wire

•Reg. U. S. Pat. Off.

THE ELECTRON ART

Edited by JOHN MARKUS

| | |
|--|-----|
| Underground Prospecting Tests with Radio Waves | 120 |
| Superconductivity Research Program | 122 |
| Bombardment of Semi-Conductors with Neutrons | 156 |
| Study of Vanishing Gases | 160 |
| Double-Ended D-C Restorer | 162 |
| A New Moisture-Sealing Compound | 165 |
| Determining Form Factors of I-F Transformers | 168 |

Underground Prospecting Tests with Radio Waves

GEOLOGISTS, geophysicists and radio engineers in an abandoned tunnel of a deep salt mine at Grand Saline, Texas, recently witnessed a demonstration of radio reception from a transmitter located some 1,200 feet away on the surface. The test, made by engineers of William M. Barret, Inc., consulting geophysicists in Shreveport, La., was conceived to provide proof that the specially transmitted waves actually traveled through the earth. In actual prospecting both receiver

and transmitter would be on the surface, and waves would be reflected from the subsurface deposit being explored.

Mineral Radiolocation Problems

To indicate clearly the existence and size of a mineral deposit deep underground, it is essential that the radio waves be directed along selected paths. However, if the frequency is made high enough to permit use of convenient sizes of antenna arrays, then the waves are

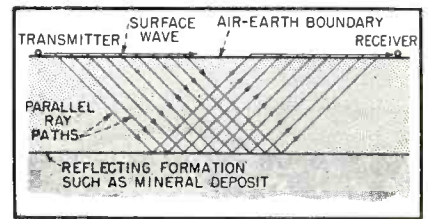

Special antennas on surface produce parallel underground ray paths that reinforce each other at receiver after refractions

absorbed after traveling only a relatively short distance into the earth. Furthermore, only a small percentage of the energy actually enters the earth, most being reflected at the surface. Conversely, if the frequency is made low enough to prevent excessive absorption, surface reflection increases still more and the antenna system required approaches an office building in size.

Studies indicate that geologic strata selectively absorb and transmit electromagnetic waves, with certain frequencies undergoing far less absorption than others. These critical frequencies are not necessarily adapted to transmission through the air-earth boundary by conventional means, however. This problem is believed to have been solved by use of a unique type of radiating device, technical details of which have not yet been revealed. As indicated in the diagram, this antenna system directs a surface wave along the air-earth boundary. Rays progressively peel off the wave by refraction and enter the earth along a multitude of parallel-ray paths. When these parallel rays encounter a reflecting formation or mineral deposit, they are partially refracted downward and partially reflected back to the earth's surface for final refraction to the receiving antenna. All of the reflected rays reach the receiver in space phase and time phase and therefore reinforce each other to give the required signal input strength.

Through differences between reflecting properties of mineral deposits and sedimentary media, the character of the received waves may disclose the presence of underground deposits. The surface wave picked up directly by the receiver acts as a reference wave for inter-



W. M. Barret (right) explains operation of his radio system for geophysical prospecting during demonstration at Grand Saline, Texas. Note insulated antenna wires running along ground in opposite directions from transmitter



Listening to code messages picked up by receiver deep underground in salt mine. Receiver is perched on dynamite box, with antenna wires running in opposite directions from it along floor of tunnel 1,800 feet from shaft of mine

For the MEASUREMENT of Q, INDUCTANCE and CAPACITANCE

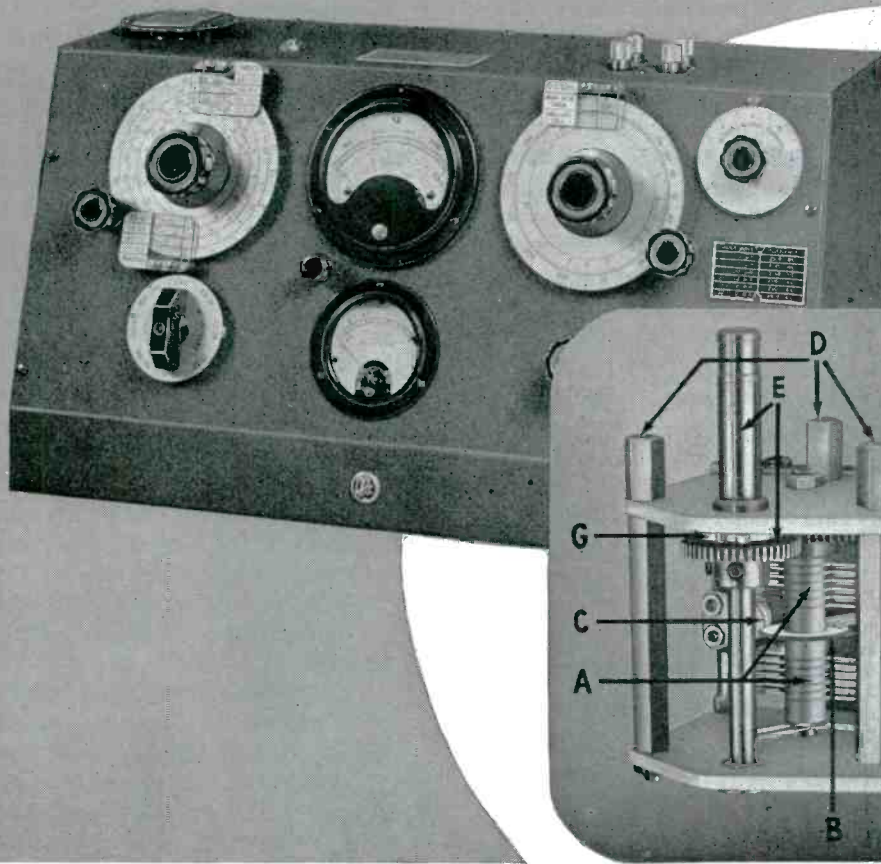

The
160-A Q-METER
50 KC. to 75 MC.

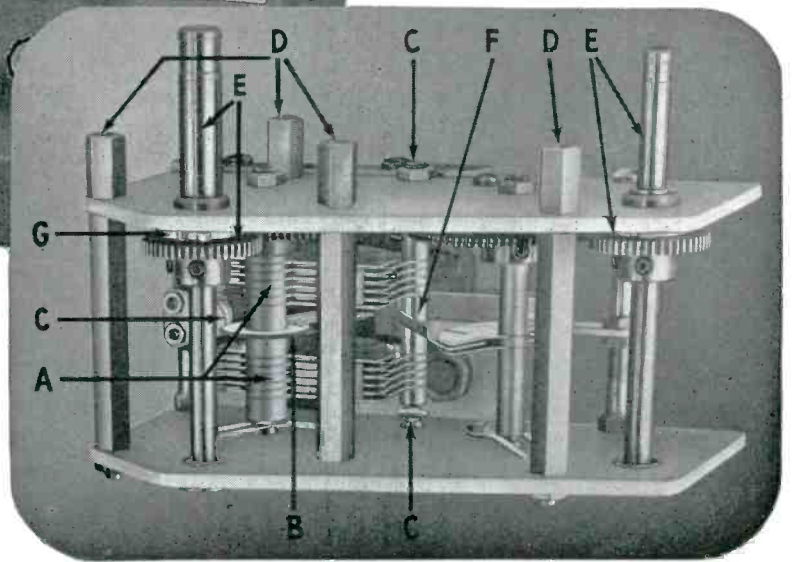

Radio frequency circuit design often requires the accurate measurement of Q, inductance, and capacitance values. For this application, the 160-A Q-Meter has become the universal choice of radio and electronic engineers throughout the country.

Each component part and assembly used in the manufacture of this instrument is designed with the utmost care and exactness. Circuit tolerances are held to values attainable only in custom built instruments.

Consider, for example, the Q tuning capacitor assembly of the 160-A Q-Meter, specially manufactured for maximum range, low loss, and minimum residual inductance. The ultimate design of this unit was reached only after months of intensive engineering research to produce the finest in performance, quality, and workmanship.

This is but one of the many desirable features of the 160-A Q-Meter which contribute to its outstanding accuracy and dependability.

Be sure to include the 160-A Q-Meter in your new equipment plans.

Write for Catalog "F"

BOONTON RADIO
BOONTON · N · J · U · S · A · *Corporation*



Shown above is the Q tuning capacitor assembly of the 160-A Q-Meter. Note the following design features of this unit—features which insure reliable, trouble-free operation.

- A. Parallel connection of dual rotor and stator assemblies minimizes internal inductance and resistance.
- B. Spring silver fingers contact both sides of silver disc to provide low series resistance.
- C. Three point pyrex ball stator suspension reduces losses and permits accurate stator alignment.
- D. Four point panel mounting designed to produce maximum structural rigidity and capacitance stability.
- E. Precision-cut brass spur gears and stainless steel shafts, mounted in oversize bearings, assure long, trouble-free service.
- F. Common stator mounting for main and vernier stator plates reduces loss and internal series resistance of vernier capacitor section.
- G. Positive shaft stop protects main rotor assembly and gears against mechanical overload.

SPECIFICATIONS

Oscillator Frequency Range: 50 kc. to 75 mc. in 8 ranges.

Oscillator Frequency Accuracy: $\pm 1\%$, 50 kc.—50 mc.
 $\pm 3\%$, 50 mc.—75 mc.

Q Measurement Range: Directly calibrated in Q, 20-250. "Multiply—Q—By" Meter calibrated at intervals from x1 to x2, and also at x2.5, extending Q range to 625.

Q Measurement Accuracy: Approximately 5% for direct reading measurement, for frequencies up to 30 mc. Accuracy less at higher frequencies.

Capacitance Calibration Range: Main capacitor section 30-450 mmf, accuracy 1% or 1 mmf whichever is greater. Vernier capacitor section +3 mmf, zero, -3 mmf, calibrated in 0.1 mmf steps. Accuracy ± 0.1 mmf.

DESIGNERS AND MANUFACTURERS OF THE Q METER · QX CHECKER
FREQUENCY MODULATED SIGNAL GENERATOR · BEAT FREQUENCY
GENERATOR AND OTHER DIRECT READING INSTRUMENTS

preting reflected waves returning from underground geologic strata.

In practice, the subsurface may be explored by simultaneously moving transmitter and receiver or by varying the separation between them. The depth to a reflecting formation may be measured by determining the separation when the first reflected energy is received, by determining the transit time of the underground rays or by varying the frequency and analyzing the resulting interference patterns between surface and reflected rays.

Details of Test

The radio transmission demonstration at Grand Saline was conceived to provide proof that the transmitted waves actually traveled through the earth. The receiver was set up in an abandoned part of the mine that was free of metal and separated from the shaft by 1,800

feet of circuitous tunnels, with the two long wires of its special antenna extending in opposite directions along the mine tunnel much like a conventional dipole for the 1,602-kc carrier frequency employed.

Elaborate precautions were taken to prevent signals from reaching the receiver through air or metal in the shaft. Electric and phone lines were cut and grounded at both top and bottom. The water line and pneumatic-signaling tube were likewise grounded. The hoist cable was grounded at the hoist, at the sheaves and at the bottom of the mine. Vertical and interconnected reinforcing rods within the concrete shaft were naturally grounded by a heavy seepage of salt brine at the 200-foot level. The diameter of the shaft was 14.5 feet, considered far too small to act as a waveguide for the 614-foot wavelength used.

Superconductivity Research Program

As a part of a comprehensive research program on superconductivity at the National Bureau of Standards, an experimental investi-

gation was recently made of the restoration of the resistance of superconducting wires with increase in current. Straight lengths of pure

indium wires of three different diameters were immersed in a bath of liquid helium and cooled until they became superconducting.

It was found that there was a sudden rise of resistance when the current reached a critical value, followed by a slower rise of resistance as the current was further increased. Moreover, the amount of resistance that appeared suddenly was independent of the temperature of the specimen, even though the current required to restore this resistance was temperature-dependent. To this extent the results described are in agreement with the theory. However, the magnitude of the sudden rise of resistance was 77 to 85 percent of the normal resistance, instead of one-half as predicted. Also, the larger the diameter of the wire, the smaller was the fraction of the normal resistance that reappeared when the current reached the critical value, although the theory shows no dependence on specimen diameter.

This disagreement with theory adds interest to the experimental results. Recent theoretical investigations on the nature of the intermediate state of superconductors have pointed out in a qualitative way some of the shortcomings of the earlier theory, but as yet no quantitative theoretical treatment has explained the results obtained experimentally.

Microwaves and Superconductivity

Another phase of superconductivity research at the Bureau concerns the behavior of superconductors at microwave frequencies. In experiments using low-frequency or direct currents, superconductors show a complete loss of resistance below the transition temperature, whereas at optical and infrared frequencies the superconducting state does not occur. The microwave region remains as a kind of twilight zone; here the metals exhibit an intermediate type of behavior, losing only a portion of their resistance at low temperatures.

Second Sound

At 2.19K, ordinary liquid helium (HeI) undergoes a transition to HeII with a radical alteration of

(continued on p 156)

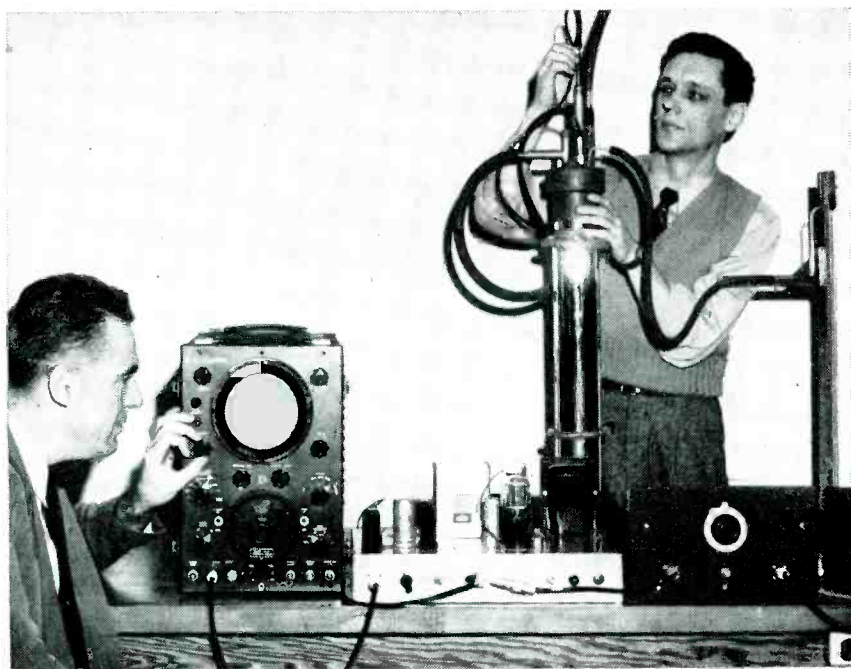

Apparatus being used at the National Bureau of Standards for the study of the velocity and attenuation of second sound in helium II near absolute zero. Oscilloscope at left triggers multivibrator (center) and at same instant begins its horizontal time sweep. Electrical pulses from the multivibrator then travel through coaxial lines to a Dewar flask of liquid helium II which is mounted in the Dewar of liquid air in the background. The heat pulses thus generated travel through the helium II as second sound and are detected by a temperature-sensitive element. The resultant faint voltage signals are amplified by an audio amplifier (right) and impressed upon the vertical plates of the oscilloscope to give an easily detected visual signal



This New
VARGLAS Tubing
 is better 5 ways!

Impregnated with
 General Electric's
PERMAFIL
 for superior insulation...

Varglas Permafil Tubing excels oleoresinous and other synthetic coated tubing in several important performance characteristics. Outstanding among these are:

1 TOUGHNESS

Remains pliable even after severe flexing. This new tubing can be twisted, bent or tied in knots with no loss in its dielectric value (7,000 volts).

3 HEAT AGING

Withstands more than 2,000 hours at 105° to 110° C., 1,000 hours at 125° C. and extensive periods at 150° C.

2 SOLVENT RESISTANCE

Is relatively immune to alcohol. Petroleum and aromatic hydrocarbons have only slight effect after long exposure.

4 BAKING

Can be after-treated in baking and varnishing operations—reacts better than most oleoresinous materials.

5 AVAILABLE IN COILS

—In standard colors and wide range of sizes. Meets or exceeds all requirements of A.S.T.M. specifications.

Send for **FREE SAMPLE** and complete data.



VARFLEX Corporation, 308 Jay St., Rome, N. Y.

Please send me full information as well as a free sample of your new Varglas Tubing Impregnated with G.E. Permafil. I am particularly interested in samples suitable for.....

Name.....

Company.....

Street.....

City..... Zone..... State.....

NEW PRODUCTS

Edited by A. A. McKENZIE

Tele Remote Control

TRANSVISION, INC., New Rochelle, N. Y., announces a new remote control unit designed to operate and control any television set from a distance up to 50 feet. It features



continuous tuning on all channels. The tuner unit has a high-gain with about 50- μ v sensitivity, factory-wired and tuned.

Tiny Ballast Tube

AMPERITE Co., INC., 561 Broadway, New York 12, N. Y. The new sub-miniature ballast tube requires no base; leads can be soldered directly to the leads coming from the tube. It can be supplied to dissipate any wattage up to 3 watts. Maximum



current is 0.9 ampere. A 100-percent increase in voltage across the tube will produce a current change of less than 5 percent. An ambient change of -50 to $+70$ C will produce a current change through the ballast of less than 2 percent.

Projection Oscilloscope

BETA ELECTRIC CORP., 1762 Third Ave., New York 29, N. Y. Model 701 portable projection oscilloscope

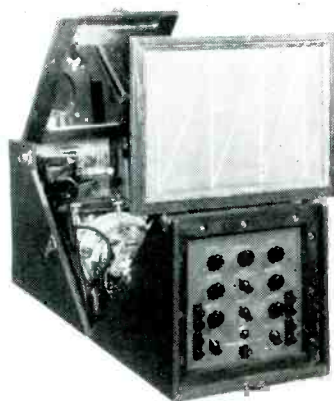

designed for use in educational institutions gives an oscillogram approximately 16 inches wide by 12 inches high. Vertical deflection sensitivity is approximately 60 millivolts rms per inch, or 0.6 volt for full-scale deflection. Horizontal deflection sensitivity is approximately 0.65 volt rms per inch or 1.0 volt full scale. Vertical amplifier response is good to 50 kc and usable to 100 kc. Horizontal sawtooth sweeps are good to 2 kc and usable to 5 kc.

Resistor Spark Plug

THE ELECTRIC AUTO-LITE Co., Toledo 1, Ohio, has developed a new resistor spark plug designed to prevent interference with television re-



ception caused by the ignition system of automobiles. The heart of the unit is a 10,000 ohm built-in and concealed resistor which dampens the high-voltage peaks in the capacitance phase of the spark so its effect on the radio signal is kept below an acceptable minimum (within 35 μ v per meter from 540 kc to 150 mc at 50 ft).

Instrument Kit

ELECTRONIC INSTRUMENT Co., INC., 276 Newport St., Brooklyn 12, N. Y., is now supplying most of its test instruments in a kit form de-



signed for quick and economical assembly. Model 221K vacuum-tube voltmeter illustrated is a sample of the line of equipment being put together by students, experimenters and servicemen.

Sound Measuring Device

MASSA LABORATORIES, INC., 3868 Carnegie Ave., Cleveland 15, Ohio. Model GA-1002A sound pressure measurement equipment has a specially isolated socket tip which effectively separates the microphone clamping structure from the pre-

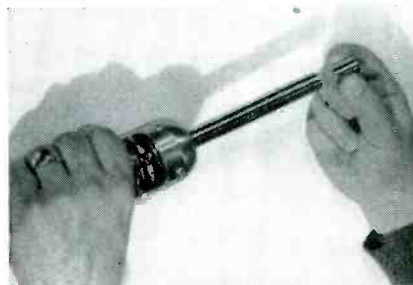

THIS SPACE
RESERVED FOR
18
RAYTHEON
SUBMINIATURE
TUBES

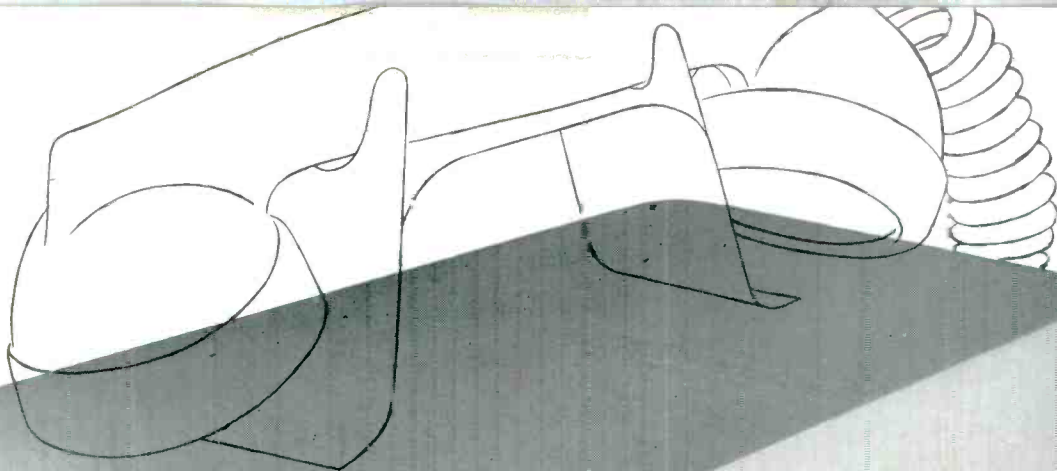

Here is the actual size of a portable FM Radiotelephone Transmitter and Receiver that provides up to five mile, 2-way communication on the 25-50 mc. band or, with a different electrical design, on the 152-162 mc. band.

It employs 17 or 18 Raytheon Flat Subminiatures with plenty of room left over for dozens of other components. The uses for these small, light (not over 9 lbs.) "Handie-Talkie" units are growing by leaps and bounds. Contractors, Farmers, Fire Fighters, Foresters, Game Wardens, Geophysicists, Lumbermen, Miners, Movie Directors, Gilmen, Police, Ranchers, Railroad Men, Reporters and Surveyors find them invaluable — and thoroughly dependable, thanks in large measure to the reliability as well as the compactness of Raytheon Subminiatures.

Why leading makers of electronic equipment such as MOTOROLA's "Handie-Talkie" and DOOLITTLE's "littlephone" use RAYTHEON Subminiature Tubes:

1. **Increased Product Salability** — Raytheon Filamentary Subminiatures are flat. Filament drain is extremely low. Product size is reduced, convenience increased.
2. **Plug Into Standard Sockets.** All Raytheon Subminiatures can be soldered in, or plugged into readily available sockets.
3. **Raytheon Reliability** — the result of unique precision methods and ten years continuous production of long-life Subminiature Tubes.
4. **Readily Available From Stock** — over half a million on top at all times. Over 40 types. Standard throughout the world. Over 300 Raytheon Special Purpose Tube Distributors are ready to serve you.

Write for Data Sheets

SUBMINIATURE TUBES • SPECIAL PURPOSE TUBES • MICROWAVE TUBES
CATHODE RAY TUBES • RECEIVING TUBES

THIS SPACE RESERVED FOR BATTERIES

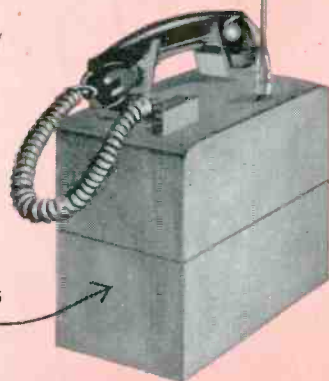

RAYTHEON

Excellence in Electronics
**RAYTHEON
MANUFACTURING
COMPANY**
SPECIAL TUBE SECTION
Newton 53, Massachusetts

amplifier extension tube. Dynamic range is such that sound pressures from less than 1 and up to 20,000 dynes per sq cm (160 db level) may be directly measured. A multiplier is available for extending the range up to 200,000 dynes per sq cm (180 db). A built-in calibrating circuit is provided.

Photoelectric Cells

INTERNATIONAL RECTIFIER CORP., 6809S. Victoria Ave., Los Angeles 43, Calif. The new line of unmounted selenium self-generating photoelectric cells find use in such

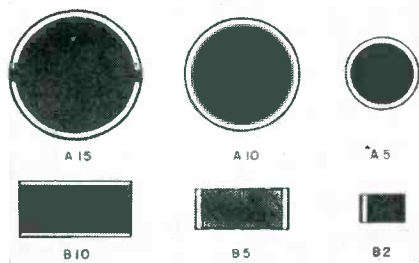

applications as photographic exposure meters and illumination meters. Sizes vary from the rectangular 23/32 in. by 7/16 in. to the round type 1 3/4 in. in diameter. Sensitivity is of the order of 600 μ a per lumen.

Tele Slide Projector

GRAY RESEARCH & DEVELOPMENT Co., INC., 16 Arbor St., Hartford 1, Conn. Type T-101 Telop is a television optical projector for use with television film cameras. Cards and slides measuring 3 1/4 x 4 in. as well as small physical objects may be dually projected, with one image fading to another instantly or by superimposing, with exact density



control of each object. The unit has four slide openings with individual brightness controls for each. Light intensity through the lens is 12 to 15 foot candles.

Regulated Power Supply

KEPCO LABORATORIES INC., 149-14 41st Ave., Flushing, N. Y. Model 245 power supply has a d-c output of 200 to 450 volts at currents from 0 to 200 ma, regulated; and an a-c output of 6.3 volts at 6 amperes,



unregulated. Regulation is 0.5 percent for both load and input variations. Power required is 300 watts, and output impedance is less than 2 ohms.

Twin Line Connector

GRAYHILL, 1 North Pulaski Road, Chicago 24, Ill., has announced a twin line connector for television receivers and accessories. Such ac-

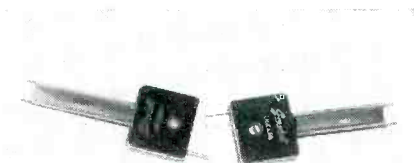

cessories as inside and outside antennas, boosters, matching stubs and matching devices can be connected. Added lengths of line can be inserted for standing wave correction. Impedance within the connector is matched to that of the 300-ohm twin line wire.

Photoelectric Control

PHOTOSWITCH INC., 77 Broadway, Cambridge 42, Mass. Type 20DA4 delayed action photoelectric control is designed to indicate the

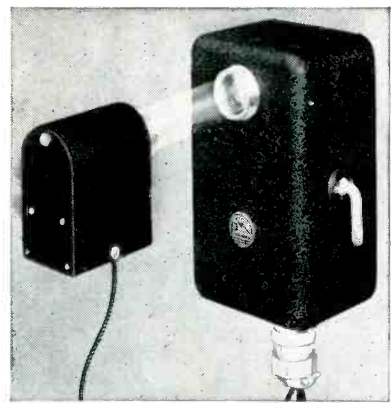

presence of a jam and to introduce stop motion or other correction on a conveyor line. The dpdt relay is operated in 0.05 second. Delayed action is adjustable from 0.05 to 5 seconds. The control operates on 115 and 230 volts, 50-60 cycles a-c. Bulletin PA494 is descriptive of the unit.

Photo-Flash Lamp

KEMLITE LABORATORIES, 1819 W. Grand Ave., Chicago 22, Ill. The Sunflash is an electronic photoflash lamp for use in photography or any application requiring intense, instantaneous light values. In use as a photographic illuminator, 100,000 brilliant white flashes of metered

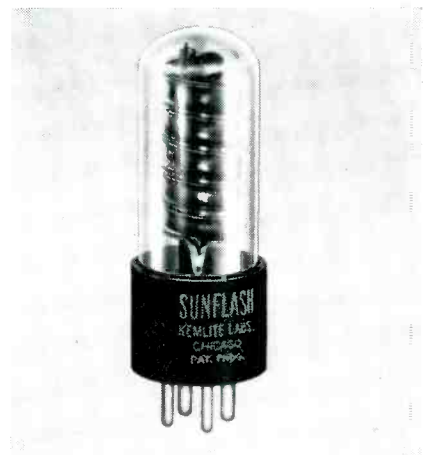

consistency are commonly realized. It is self-ionizing and requires no auxiliary triggering circuit for its operation.

Wideband Oscilloscope

FEDERAL TELECOMMUNICATION LABORATORIES INC., 500 Washington Ave., Nutley 10, N. J. Model FTL-

(continued on p 170)

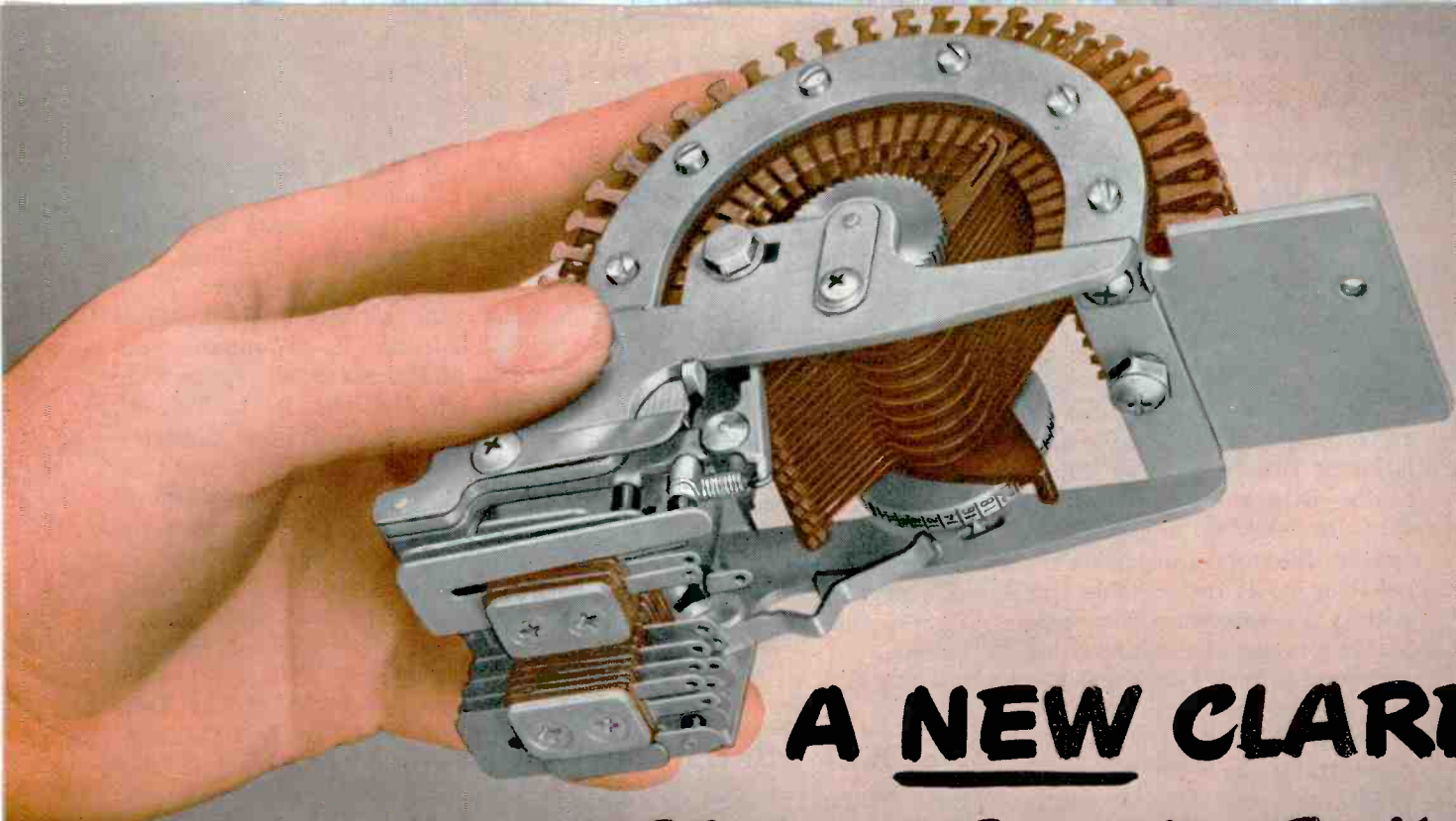

A NEW CLARE

26-Point Stepping Switch

STANDARD SPECIFICATIONS

OPERATION:

Automatic (self-interrupting) or remote controlled.

WIPERS:

One to ten, traversing individual contact levels.

INTERRUPTER SPRINGS:

Form 1B (to open the operating circuit at the end of each step). Contacts are single platinum-iridium.

OPERATE SPEED:

Remote controlled operation: maximum 30 steps per second. Self cycling operation: average 60 steps per second, with 48-volt power supply.

FINISH:

Framework and armature: cadmium; Bank contacts and wipers: phosphor bronze.

MOUNTING:

Frame drilled and tapped at each end to accommodate No. 8-32 mounting screw.

DIMENSIONS:

Overall length: 6-9/16 in.; width: 2-3/8 in.; height: 4-5/8 in.

NET WEIGHT:

27 oz., approximately.

SHIPPING WEIGHT:

4 lbs., approximately.

Write for Clare Bulletin 101
on complete details.

For Selection - Sequence Control - Counting - Totalizing

Selection of any channel or circuit path from a total of 26 or 52 circuits is provided by this new CLARE Stepping Switch.

This selection may be at the rate of 30 steps per second on remote control—up to 60 steps per second on self-cycling operations. Operating at these speeds, the switch gives a minimum life of 5 million half-revolutions or 130 million stepping operations.

Each of the ten levels possible for the Type 26 Switch, or the five levels of the Type 52 Switch, is unit-molded in Bakelite. Hand positioning of individual contacts is thus eliminated, and each bank level is easily replaced if a contact becomes damaged in service.

In operation, a pair of double-ended wiper springs is stepped over each bank level of 180 degrees. One end of the wipers is engaged with the bank contact at all times, one end is always free of the bank. The stepping magnet may be remotely controlled or wipers may be stepped automatically by interrupting the magnet circuit through a pair of interrupter springs. As many as eight auxiliary interrupter springs may be provided for other control or signal functions.

Like many other CLARE developments, this new stepping switch was designed to meet a specific requirement . . . has provided an answer to others. Whatever your relay problem, it will pay you to submit it to CLARE. Sales engineers are located in principal cities for your convenience. Look in your classified telephone directory . . . or write to C. P. Clare & Co., 4719 West Sunnyside Ave., Chicago 30, Illinois. In Canada: Canadian Line Materials Ltd., Toronto 13. Cable address: CLARELAY.

CLARE RELAYS

First in the Industrial Field

NEWS OF THE INDUSTRY

Edited by WILLIAM P. O'BRIEN

Radomes Aid All-Weather Microwave Television Reception

THE NATIONAL BROADCASTING COMPANY recently completed the installation of two radomes on the roof of the RCA Building, New York City, to provide a reliable all-weather microwave television relay receiving point for portable transmitters at remote pickup points within a radius of about 30 miles.

Housed in each Lucite and Plexiglas radome is the receiving antenna, a six-foot parabola which concentrates the short radio waves (7,000 mc, approximately equivalent to $1\frac{1}{8}$ inches) toward a waveguide element at the parabola's focus. The parabola is mounted on a fixture which permits directing it both horizontally and vertically toward the transmitting point.

The output of the primary receiving element in the parabola is connected with coax cable to the main receiving equipment on the 67th floor of the RCA Building and thence to the tv master control board.

The radomes are heated and ventilated for both winter and summer and may be operated under all weather conditions without interfering with broadcast reception. They have been installed on each side of the building and between them cover the entire 360-degree horizon.

New RMA Officers

AT A MEETING of the board during the Radio Manufacturers Association Silver Anniversary Convention at Chicago, May 16 to 20, officers were elected for the coming year. The 1949-50 RMA officers are as follows:

President, Raymond C. Cosgrove, executive vice-president of Avco Mfg. Co.; treasurer, Leslie F. Muter, president of The Muter Co., Chicago; executive vice-president and secretary, Bond Geddes of Washington, D. C. John W. Van

Allen of Buffalo was reappointed general counsel.

Nine directors were re-elected. Five new ones are J. B. Elliott, vice-president of RCA Victor; W. J. Halligan, president of Hallicrafters Co.; Richard A. O'Connor, president of Magnavox, all representing the set division; R. L. Triplett, president of the Triplett Electrical Instrument Co., in the parts division; A. Liberman, president of Talk-A-Phone, in the amplifier and sound equipment division.

New vice-presidents, in addition to two holdover ones, include R. E. Carlson, vice-president of Tung-Sol Lamp Works; W. J. Barkley, executive vice-president of Collins Radio Co.; and A. Liberman of Talk-A-Phone. Max Balcom, former RMA president, was chosen chairman of the tube division. Other division chairmen are: Transmitter, T. A. Smith of RCA Victor; amplifier and sound equipment, A. G. Schifino of Stromberg-Carlson.

ASTM Annual Meeting

THE 52nd annual meeting of the American Society for Testing Materials will be held at the Chalfonte-Haddon Hall, Atlantic City, N. J., during the week of June 27. In the diversified technical program scheduled, the sessions of particular interest to electronic engineers will be those on radiography and ultrasonic testing.

Two series of papers on these topics have been arranged by Committee E-7 on Nondestructive Testing. Six papers on radiography will cover such subjects as x-ray moving pictures and the radium exposure calculator. Five others will deal with the basic principles of practical ultrasonic testing, its uses in the forging industry, railroad field, nonferrous metals field and the consumer's plant.

Analog Computation Course

DESIGNED particularly to meet the needs of users of industrial types of computing machines, a special course in analog computation is being given at the Massachusetts Institute of Technology for the

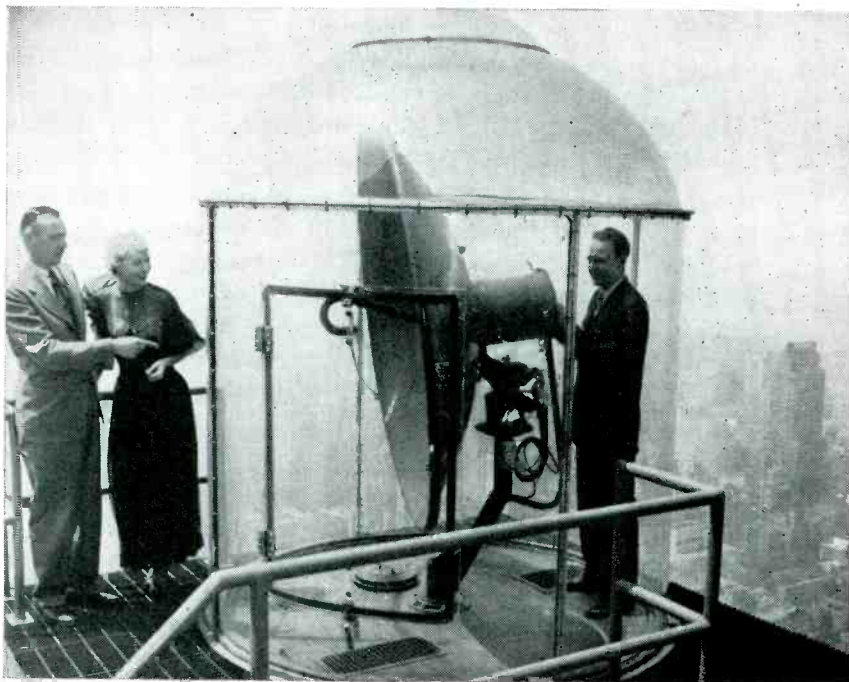

Radome housing 7,000-mc receiving parabola for remote television pickups, recently installed atop RCA Building, Radio City, New York. Left to right: Chester Rackey, NBC engineer; Kyle MacDonnell, television actress; Robert Barnaby, NBC engineer

PREDICT Crystal Oscillator Operation with the LAVOIE CRYSTAL IMPEDANCE METER

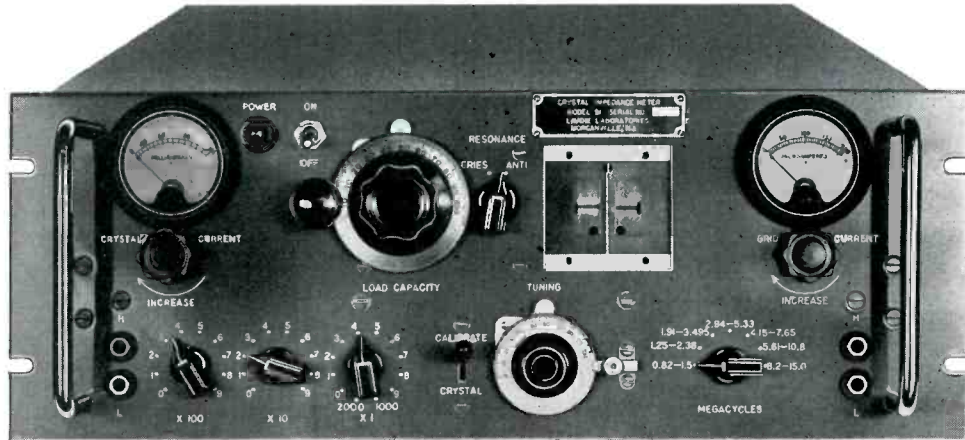

*Model 50 . . . Frequency range, 76 kc to 1100 kc with provision for plug in coils.
Maximum resistance, 29,900 ohms (3 place setting).*

*Model 51 . . . Frequency range, 820 kc to 15 mc.
Maximum resistance, 2,990 ohms (3 place setting).*

POWER . . . 115 V 60 CPS SIZE . . . 7"x19"x7 $\frac{7}{8}$ " WEIGHT . . . 21 LBS., 12 OZS.

CONTROLS AND INDICATIONS

CRYSTAL ACTIVITY RESISTANCE ADJUSTMENT
CRYSTAL VOLTAGE MEASURING POINTS
SERIES RESONANCE—PARALLEL RESONANCE
CRYSTAL CURRENT (MODEL 51 ONLY)

FREQUENCY ADJUSTMENT (COARSE AND FINE)
LOAD CAPACITANCE
GRID CURRENT
CRYSTAL-RESISTOR SELECTION SWITCH

Measures parameters of piezoelectric crystals sufficient to predict quality and operation properties of oscillators in which they will be used.

Measurements of a crystal resistance can be made at either the series or anti resonant frequency of the crystal. An indication of the equivalent resistance of a crystal is an indication of the quality of the crystal. The CI meter yields a measurement of crystal activity in terms of ohmic resistance. This is in contrast to previous measurements of crystal quality in terms of arbitrary activity in a standard oscillator. At present, Government specifications on crystal units specify a maximum allowable series resonant resistance.

The Crystal Impedance Meter consists of a tuned oscillator with the crystal unit connected in the feedback path. A switching arrangement is provided whereby a condenser may or may not be used in series with the crystal. This condenser is calibrated and is used to simulate load capacity when the crystal resistance is to be measured at the anti resonant frequency of the crystal. The condenser is shorted when the series resonant resistance of

the crystal is measured. In addition, a switching arrangement is provided to substitute three banks of calibrated decade resistors into the feedback path replacing the crystal. A grid current meter is provided as an indication of oscillator activity with either crystal or resistance in the feedback path of the oscillator.

In addition to the crystal switching circuit, the calibrated decade switches, frequency controls, the variable capacitor in the crystal circuit, and the oscillator grid current meter, a control which varies oscillator activity, and thereby crystal current, is provided in both models 50 and 51. A crystal current meter is provided in model 51 only.

The series and anti resonant frequencies of crystals can be measured with conventional frequency measuring equipment. With frequency measuring equipment and a VTVM, simple measurements and calculations can be made to yield crystal voltage at either series or anti resonant operation, the series inductance of the crystal, the series capacitance of the crystal, and the Performance Index of the crystal.



Lavoie Laboratories

RADIO ENGINEERS AND MANUFACTURERS
MORGANVILLE, N. J.

Specialists in the Development and Manufacture of UHF Equipment

three weeks beginning June 20, 1949. Chief subject will be the treatment of engineering problems by machines designed for the solution of differential equations.

The course meets for one and one-half hours of lectures and demonstrations each week-day from June 20 through July 9. It is under the direction of S. H. Caldwell, professor of electrical engineering and director of the Institute's Center of Analysis.

Demonstrations have been planned which will make use of the MIT differential analyzer as well as vari-

ous types of electronic analyzers available or under development at the Institute.

Proposed Low-Power Rules

TO PROVIDE for operation of low-power radio devices without interference to established radio services, and to learn more of the nature of the devices now operating, the FCC has proposed amendments to its present rules.

The Commission contemplates recognizing two categories of radiation devices: incidental and re-

NEW FCC EMISSION AND MODULATION SYMBOLS

| Type of modulation or emission | Type of transmission | Symbol | |
|--|---|--|----|
| 1. Amplitude | Absence of any modulation | A0 | |
| | Telegraphy without the use of modulating audio frequency (on-off keying) | A1 | |
| | Telegraphy by the keying of a modulating audio frequency or audio frequencies or by the keying of the modulated emission (special case: an unkeyed modulated emission). | A2 | |
| | Telephony | | |
| | Double sideband, full carrier | A3 | |
| | Single sideband, reduced carrier | A3a | |
| | Two independent sidebands, reduced carriers. | A3b | |
| | Facsimile | A4 | |
| | Television | A5 | |
| | Composite transmissions and cases not covered by the above. | A9 | |
| | Composite transmissions, reduced carrier | A9c | |
| | 2. Frequency (or phase) modulated | Absence of any modulation | F0 |
| | | Telegraphy without the use of modulating audio frequency (frequency shift keying). | F1 |
| Telegraphy by the keying of a modulating audio frequency or audio frequencies or by the keying of the modulated emission (special case: an unkeyed emission modulated by audio frequency). | | F2 | |
| Telephony | | F3 | |
| Facsimile | | F4 | |
| Television | | F5 | |
| Composite transmissions and cases not covered by the above. | | F9 | |
| 3. Pulsed emissions | | Absence of any modulation intended to carry information. | P0 |
| | Telegraphy without the use of modulating audio frequency. | P1 | |
| | Telegraphy by the keying of a modulating audio frequency or audio frequencies, or by the keying of the modulated pulse (special case: an unkeyed modulated pulse). | | |
| | Audio frequency or audio frequencies modulating their pulse in amplitude. | P2d | |
| | Audio frequency or audio frequencies modulating the width of the pulse. | P2e | |
| | Audio frequency or audio frequencies modulating the phase(or position)of the pulse. | P2f | |
| | Telephony | | |
| | Amplitude-modulated pulse | P3d | |
| | Width-modulated pulse | P3e | |
| | Phase-(or position)- modulated pulse | P3f | |
| Composite transmissions and cases not covered by the above. | P9 | | |

MEETINGS

JUNE 27-29: Conference on Ionospheric Research, The Pennsylvania State College, State College, Pa.

JUNE 27-JULY 1: 1949 Annual Meeting of the American Society for Testing Materials, Chalfonte-Haddon Hall, Atlantic City, N. J.

AUG. 29-SEPT. 1: National Conference of Associated Police Communications Officers, Hotel New Yorker, New York City.

AUG. 30-SEPT. 1: Fifth Annual Pacific Electronic Exhibit sponsored by the WCEMA and the 1949 IRE western regional convention, Civic Center, San Francisco, Calif.

SEPT. 12-16: Instrument Society of America National Conference and Exhibit, Municipal Auditorium, St. Louis, Mo.

SEPT. 26-28: National Electronics Conference, Edgewater Beach Hotel, Chicago, Ill.

OCT. 10-14: ASTM 1949 West Coast Meeting, Fairmont Hotel, San Francisco, Calif.

Nov. 14-18: 23rd NEMA Annual Meeting, Haddon Hall Hotel, Atlantic City, N. J.

stricted. Incidental devices would include laboratory signal generators, beat-frequency audio oscillators and radio receiver oscillators. The restricted group would cover wireless record players, carrier current communication systems and remote-control devices using radio.

It also proposed that no low-power broadcasting be permitted on any frequency other than in the 535 to 1,605-kc band, and then only in accordance with FCC broadcast service rules, as appropriately amended. Use of the radio spectrum by restricted radiation devices will be subject to certain provisions.

Comment by interested parties received up to and including June 1 is being considered before final action is taken.

OTS Lists Infrared Reports

THE Office of Technical Services has compiled a bibliography of 165 reports on infrared, designated as SB-6. Listed therein are PB num-

(Continued on page 202)



Finger tip facts on Germanium Diodes

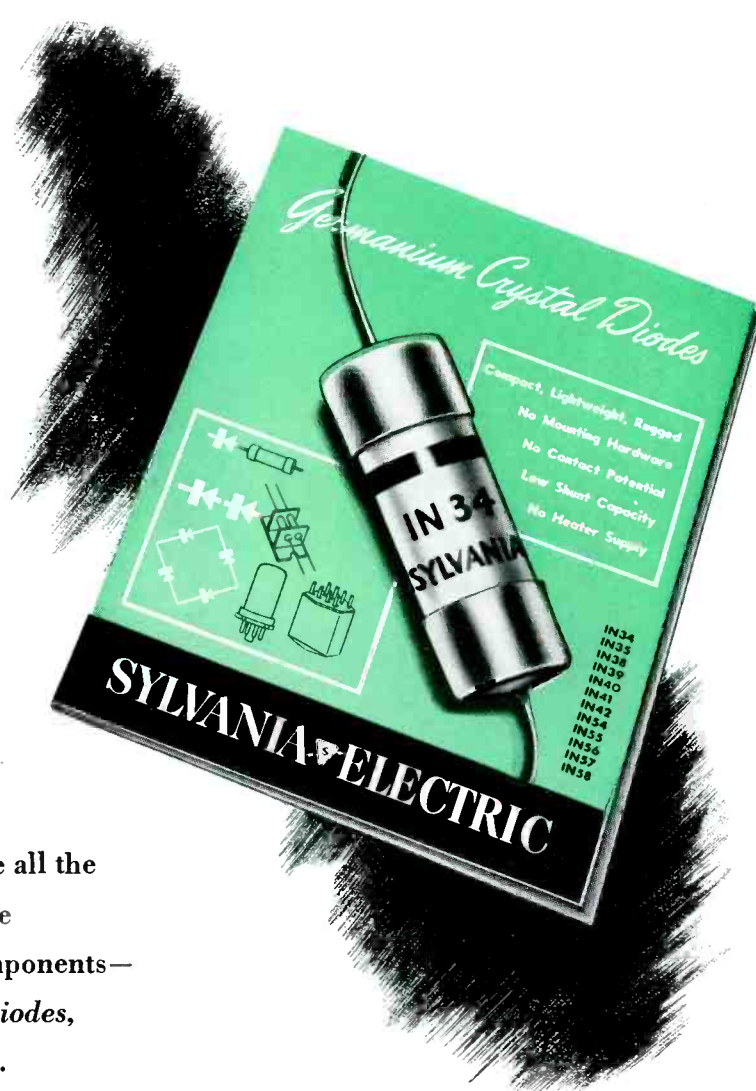

Here, combined in a single booklet, are all the essential facts you want on the entire line of 12 Sylvania Germanium Crystal Components—the most extensive line of Germanium Diodes, Duo-Diodes and Varistors on the market.

This new booklet contains complete electrical and mechanical specifications and includes typical static characteristic curves on all diode types.

You'll find this booklet helpful in making most effective use of these compact, long-life, rugged diodes that require no heater supply.

SYLVANIA ELECTRIC

Electronics Division

500 Fifth Avenue, New York 18, N. Y.

ELECTRONIC DEVICES; RADIO TUBES; CATHODE RAY TUBES; PHOTOLAMPS; FLUORESCENT LAMPS, FIXTURES, WIRING DEVICES, SIGN TUBING; LIGHT BULBS

Mail coupon for your copy of this new booklet

Sylvania Electric Products Inc.
Electronics Division, Dept. E-2907
500 Fifth Avenue, New York 18, N. Y.

Gentlemen:

Please send me your new booklet on Germanium Crystal Components. I am also interested in receiving literature on your other products in the fields of:

- Communications, Television and Industrial Electronics
- Radioactivity Radar and Microwaves

Name.....

Home Address.....

City.....State.....

Company.....

Position.....

• Stupakoff HERMETIC SEALS

TUBES AT WORK

(continued)

enormous amount of power is precipitated into the space between two electrodes. In an automotive ignition system with secondary capacitance of $50 \mu\mu\text{f}$ discharging at 10 kv, peak amperages of the order of 30 amperes for 2.5×10^{-8} second have been measured. This amounts to a power output of 300,000 watts or 400 hp for 2.5×10^{-8} second. No comparable mechanism with which we are acquainted can precipitate such great amounts of energy as can the spark discharge.

Increased spark plug gap settings are conducive toward ignition of lean mixtures, as are electrodes of small mass and high temperature, located as remotely as possible from any surfaces which might detract

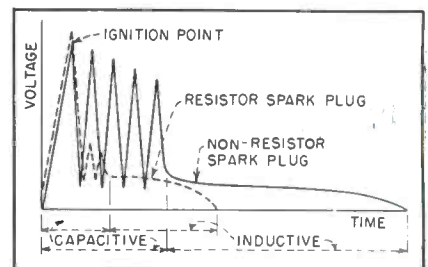

Discharge chart for both types of spark plugs shows that ignition point is practically the same

from the heat content of the initiating sphere of burned mixture.

By incorporating a 10,000-ohm resistor in the spark plug, as is done in the Autolite resistor plug, a very substantial reduction in electrode erosion can be obtained. With resistor plugs set initially at 0.035 inch as against non-resistor plugs set initially at 0.025, after 10,000 miles both types of plugs will have eroded to 0.040.

Resistor plugs do not have a practical detrimental effect upon starting because of the reduced gap erosion and the fact that after use, their required voltage is usually less than that of non-resistor plugs.

By improvements in the magnetic circuit of the average automotive coil, increased voltage can be obtained without increasing primary current. Also, some very high frequency secondary oscillations can be obtained in the portion of the spark discharge immediately following ignition. It is believed that these oscillations, well up in the megacycle range, can and do contribute

• TYPES AND SIZES TO MEET YOUR NEEDS

Listed below are typical standard sizes of Stupakoff KOVAR-GLASS Terminals. We are equipped to handle orders of any size.

| FIGURE | TERMINAL NO. | FLANGE DIAMETER (Inches) | OVERALL LENGTH (Inches) | MAXIMUM AMPERES | MAXIMUM LEAKAGE PATH (Inches) |
|--------|--------------|--------------------------|-------------------------|-----------------|-------------------------------|
| A | 960044 | .625 | 2.500 | 30.0 | .188 |
| B | 954004 | 1.250 | .750 | 15.5 | .125 |
| C | 952065 | .380 | .875 | 12.0 | .400 |
| D | 952056 | .200 | .220 | 4.0 | .060 |
| E | 950053 | .200 | .484 | 5.5 | .035 |
| F | 955007 | .340 | .250 | 4.0 | .035 |
| G | 952013 | .875 | .937 | 75.0 | .200 |
| H | 952006 | .375 | .843 | 12.0 | .080 |
| J | 951049 | .280 | .531 | 10.0 | .050 |
| K | 951027 | .380 | 1.250 | 15.5 | .400 |
| L | 951015 | .375 | .800 | 15.5 | .090 |
| M | 951007 | .212 | .781 | 5.5 | .312 |
| N | 952053 | .220 | .531 | 4.0 | .060 |
| O | 950049 | .500 | .687 | 15.5 | .080 |
| P | 950048 | .718 | 1.000 | 21.5 | .150 |
| Q | 950044 | .672 | 1.500 | 15.5 | .550 |
| R | 950041 | .340 | 1.125 | 10.0 | .425 |
| S | 950022 | .500 | 1.375 | 15.5 | .295 |
| T | 950001 | .212 | .875 | 5.5 | .070 |

Write for detailed specifications and prices.

STUPAKOFF
CERAMIC & MANUFACTURING CO.
LATROBE, PENNA.





Type 1301-A Low-Distortion Oscillator

Here's Your "PROOF-OF-PERFORMANCE"

AS ANNOUNCED by the Federal Communications Commission,* effective August 1, 1949 all a-m and f-m broadcast stations will be required to make proof-of-performance checks of over-all noise and distortion of the complete station at least once a year.

Many stations already make these measurements at frequent intervals as routine operating maintenance to insure the continuous high-quality service the modern transmitter system is capable of supplying.

General Radio instruments for these measurements have been available for some time, and are in regular use by the leading stations where this equipment has given accurate, convenient-to-use and trouble-free service.

The G-R Type 1932-A Distortion and Noise Meter meets all of the F.C.C.'s requirements for measurements of this type for both a-m and f-m services; the Type 1301-A Low-Distortion Oscillator is the ideal companion unit for use with the Type 1932-A. Both of these instruments are relay-rack mounted and can be supplied in panel finishes to match most existing installations.

TYPE 1932-A DISTORTION & NOISE METER

For measurements of sine-wave voltages, distortion and noise throughout the audio range. Over-all pass-band of the voltmeter circuit extends to 45,000 cycles, thus including all

*F.C.C. Rules and Regulations, Sections 3.254 and 3.46, as amended



GENERAL RADIO COMPANY

Cambridge 39, Massachusetts

90 West St., New York 6 920 S. Michigan Ave., Chicago 5 1000 N. Seward St., Los Angeles 38

noise and distortion products contained in this range; particularly the 3rd harmonic of a 15,000-cycle test is included.

This instrument is continuously adjustable and can be set to any frequency quickly since it has only one main tuning control plus a small trimmer. With it measurements can be made on a-f distortion in radio transmitters, line amplifiers, speech amplifiers, speech input equipment to lines; noise and hum levels of a-f amplifiers, wire lines to the transmitter, remote pick-up lines and other station equipment.

Full-scale deflections on the large meter read distortions of 0.3, 1, 3, 10 or 30 per cent; range for carrier noise measurements extends to 80 db below 100% modulation, or 80 db below an a-f signal of zero dbm level. The a-f range is 50 to 15,000 cycles, fundamental, for distortion measurements and 30 to 45,000 cycles for noise and hum.

Type 1932-A Distortion and Noise Meter: **\$575.00**

TYPE 1301-A LOW-DISTORTION OSCILLATOR

Especially designed for rapid measurements, this highly-stable oscillator has exceptionally low distortion. By means of push buttons, 27 fixed frequencies between 20 and 15,000 cycles may be selected in logarithmic steps. Any frequency between steps can be obtained by plugging in external resistors. The distortion over the entire range will not exceed the following percentages: with 5,000-ohm output, 0.1% from 40 to 7,500 cycles; 0.15% at other frequencies. With 600-ohm output 0.1% from 40 to 7,500 cycles; 0.25% from 20 to 40 cycles and 0.15% above 7,500 cycles.

The oscillator is calibrated to within $\pm(1\frac{1}{2}\% + 0.1 \text{ cycle})$; the calibration is not affected by changes in load or plate supply voltage; drift is less than 0.02% per hour after a few minutes operation. The operation of the oscillator is unaffected by ordinary climatic changes.

Type 1301-A Low Distortion Oscillator: **\$395.00**

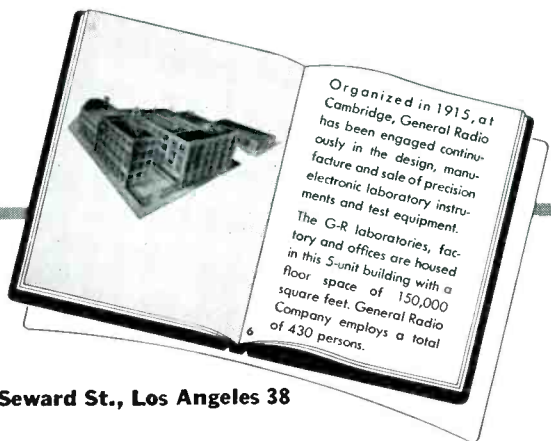

Organized in 1915, at Cambridge, General Radio has been engaged continuously in the design, manufacture and sale of precision electronic laboratory instruments and test equipment. The G-R laboratories, factory and offices are housed in this 5-unit building with a floor space of 150,000 square feet. General Radio Company employs a total of 430 persons.

to the flame propagation process under part-throttle conditions either through the creation of nascent oxygen or mechanically by accelerating the expansion of the initiating sphere of burning gases.

Making Oil from Coal

MEASUREMENT and control of all the major process variables in the high-pressure coal hydrogenation process demonstrated recently at Louisiana, Missouri, presented many new problems to the instrumentation engineers of Bechtel Corporation and the Bureau of Mines.

All temperatures in the high-pressure area are measured by means of thermocouples connected to panel-mounted ElectroniK potentiometers which are either indicators, recorders, or recorder-controllers. For control of temperatures, separate Brown ElectroniK circular chart potentiometers equipped with Air O-Line pneumatic control are used. This type of control provides a throttling action of the pneumatic-operated control valves, such that the temperature is maintained close to the desired value in spite of varying requirements for heat in the process.

All pressure recorders, controls, and recorder-controllers in the high-pressure area utilize Bourdon tube elements for measurements. Fisher nonindicating pressure controls are locally mounted on the process equipment, but the Brown recorders and recorder-controllers are located in the control house and connected to locally mounted indicating pneumatic transmitters containing the Bourdon tube elements.

The large majority of gas, liquid, and vapor flows in the hydrogenation process are measured on the differential pressure principle whereby an orifice placed in the flow line creates a pressure drop which is a measure of the rate of fluid flow.

For the measurement of high-pressure flows two different types of nonindicating differential pressure transmitters are utilized, namely: Statham elements for flows to be recorded only, and special Brown electric meter bodies of the mercury manometer type for flows

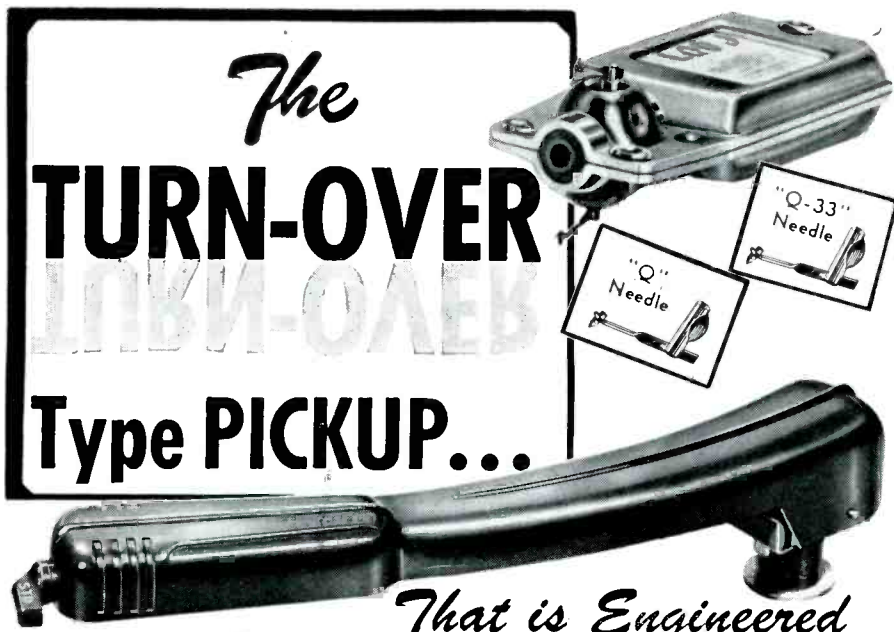

The TURN-OVER Type PICKUP...

That is Engineered

TO PLAY 33-1/3, 45 AND 78 RPM RECORDS AT THE . . .

SAME LOW NEEDLE PRESSURE

**THE
ASTATIC
CLD**

NO concealed mechanism raises or lowers needle pressure as the knob is turned on Astatic's new CLD Turn-over Type Pickup, in switching of play from one type record to another. Thanks to Astatic engineering accomplishments, the CLD plays 33-1/3 or 45 RPM recordings and standard 78 RPM at the same feather-light, eight-gram pressure . . . tracking perfectly, providing first quality reproduction free of needle talk. Elimination of a needle pressure adjusting mechanism abolishes a potential source of trouble and varying reproduction characteristics. The CLD Pickup employs the LQD-1 Crystal Cartridge, with two separate "Q" Needles (sapphire or precious metal) which snap in or out independently by gentle pry or pressure with the tip of a penknife and without removing cartridge from arm. The excellence of frequency response is particularly notable at low frequencies. A die-cast curved arm finished in dark brown Hammerlin, mounts seven inches from turntable center. Available for prompt delivery.



| MODEL | FINISH | CARTRIDGE USED | OUTPUT 1 kc. | NEEDLE PRESSURE |
|-------|----------------------|------------------|-----------------------------------|-----------------|
| CLD | Dark Brown Hammerlin | LQD-1J or LQD-1M | LP.—0.9 Volts† Std.—1.2 Volts* | 8 Grams |

†Columbia #281 Test Record, 33-1/3 RPM

*Audio-tone Test Record, 78 RPM

And which Metallic Rectifier Is Best?

No one type is "best." Each type of rectifier has characteristics which made it a "natural" for a particular application. For every application there is usually one best type. The correct choice depends upon the application. Here are general recommendations!

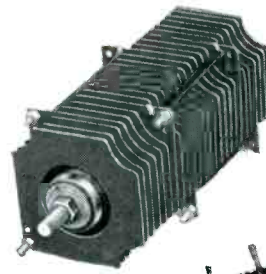

copper-oxide

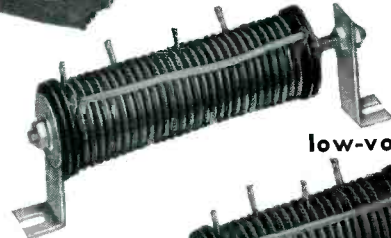

low-voltage selenium

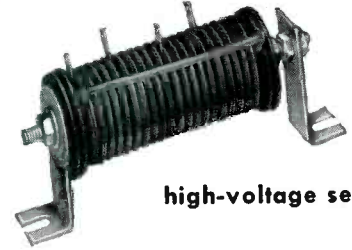

high-voltage selenium

GENERAL RECOMMENDATIONS

| Where you want | Use | Because |
|------------------------------------|-------------------------|---|
| Small size | High-Voltage Selenium | Except for 12 volts and below, fewer high-voltage selenium cells are needed. |
| Light Weight | High-Voltage Selenium | Selenium-on-aluminum cells are much lighter than copper-oxide. |
| High Power for a few seconds | Copper-Oxide | Both types will withstand high short-time current overloads but only copper-oxide will withstand the higher a-c voltage necessary to deliver short-time high power output. |
| High current with Low Voltage | Fan Cooled Copper-Oxide | While with fan cooling, selenium can operate at higher current densities than copper-oxide, efficiency will be lower. Copper-oxide aging remains stable. |
| High Voltage | High-Voltage Selenium | Fewer selenium cells are required. |
| Low Current at 6 volts or less | Copper-Oxide | Cell for cell, copper-oxide costs less than selenium. Where the minimum number of cells of either type is required, copper-oxide will be cheaper. |
| Long life with unchanged output | Copper-Oxide | While both types appear to have unlimited life. Characteristics of copper-oxide do not change after the first 6 to 12 months of continuous operation. Selenium continues to age—to build up internal resistance with time and particularly with high current densities. |
| Blocking in D-C Circuits | Copper-Oxide | Selenium tends to "unform" when used as a check valve in d-c circuits or when idle for a period of time (though it reforms quickly when reverse voltage is impressed). |
| Resistance to Corrosive Atmosphere | Oil-Filled Selenium | Stacks are hermetically sealed in oil, protected against fumes, dirt and dust. |

Low-voltage selenium is generally recommended as a compromise between copper-oxide and high-voltage selenium. Where some of the features of both high-voltage selenium and long life copper-oxide are desired, low-voltage selenium would be a logical choice.

To fully meet your needs General Electric makes all three types. If you have a rectifier problem, bring it to us. As we make all three types, we play no "favorites." You can expect

an impartial recommendation. Contact your G-E Apparatus Agent or write *Apparatus Dept., General Electric Company, Schenectady 5, New York.*

GENERAL  **ELECTRIC**

466-14

to be recorded and controlled. Both types employ separate panel-mounted Electronic circular chart potentiometers for recording or control.

The Statham element operates on the principle that stretching or compressing wire causes changes in electrical resistance and that such a change can be a measure of the force acting on the wire. For flow measurement the differential pressure across the orifice plate is connected to the element in such a way that a force in one direction is created on four wires in the element. The wires are arranged so that two tend to be stretched by the force while the other two are compressed. Thus an appreciable resistance change, measured by the potentiometer, is created as an indication of the flow.

In the low-pressure vessels several designs of nonindicating level controls or alarms as well as level indicators are employed. These are: Fisher displacement type with pneumatic control, Varec float type remote indicator, Bin-Dicator diaphragm type electric alarm, and Taylor diaphragm type with pneumatic transmission of level readings.

As a check on the composition of the gas streams in both the liquid and vapor phases, several Bailey hydrogen analyzers and recorders, together with Ranarex specific gravity recorders, are used. The gas samples are let down from 700 atmospheres to 10 inches of water

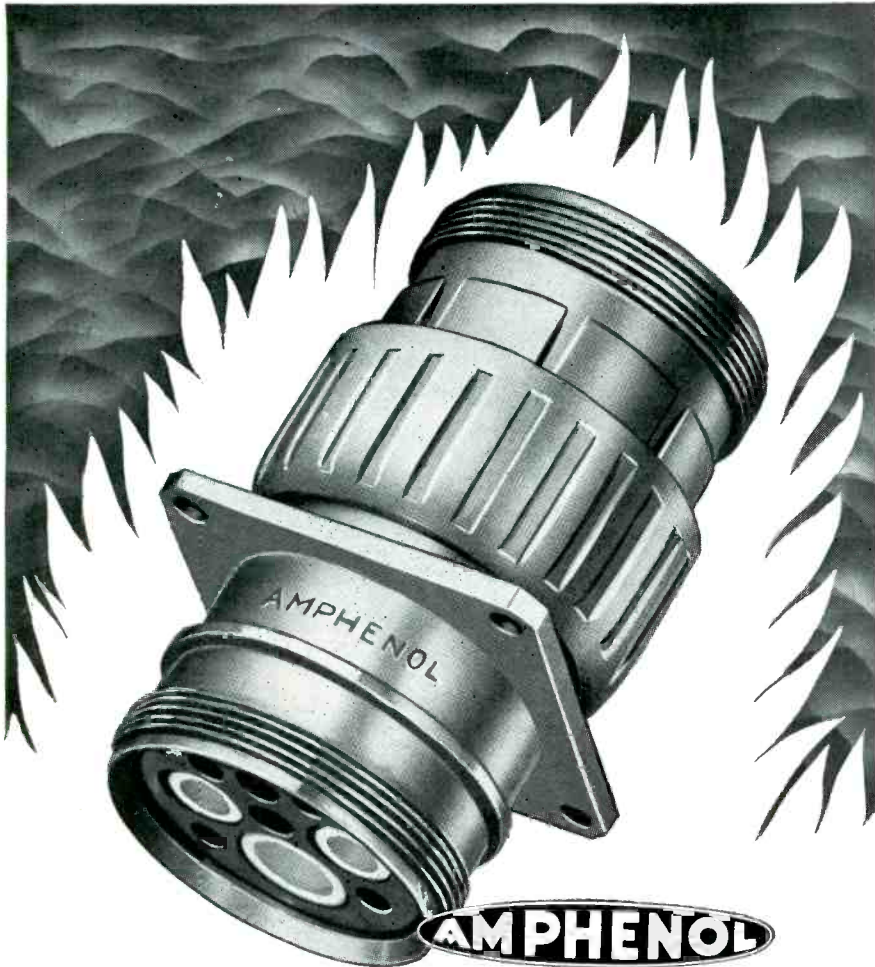

AMPHENOL

FIREWALL CONNECTORS

Operate Continuously at Destructive Temperatures

For aircraft firewall, jet engine, thermocouple and other high temperature installations, Amphenol offers the best heat-resistant and vibration and shockproof electrical connectors. Connectors are of a unique one-piece design manufactured of steel protected by cadmium plating. Ceramic dielectric inserts, shock mounted, protect the contacts at abnormally high temperatures.

With silver plated contacts, circuit continuity is not impaired, and selected alloys retain spring tension and function with lowest millivolt drop.

Amphenol Firewall Connectors have been subjected to the full C.A.A. requirements and have continued to operate efficiently long beyond the test time limit. Amphenol, again, has given the aircraft industry a new contribution to safety in the air. Amphenol's Firewall Connectors are also an indispensable new tool for high temperature industrial applications.

AMPHENOL

Write to Department J on Company letterhead for Amphenol Catalog A-1 and the supplement A-1-B, a comprehensive listing of firewall connectors.

AMERICAN PHENOLIC CORPORATION
1830 SO. 54TH AVENUE
CHICAGO 50, ILLINOIS

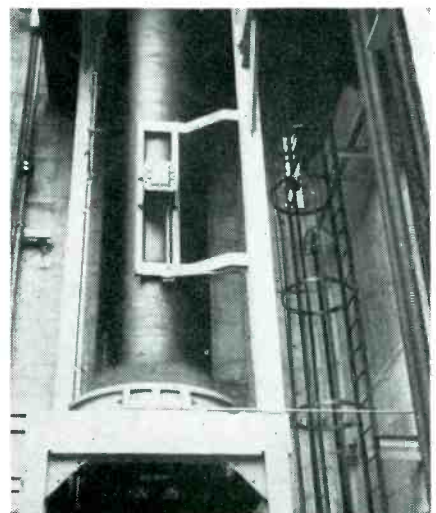

Sensing element of gamma-ray level indicator is square box mounted on side of this hot catchpot

Hook-up wire jacketed with HEAT-RESISTANT DU PONT NYLON PLASTIC approved for temperatures to 90°C.

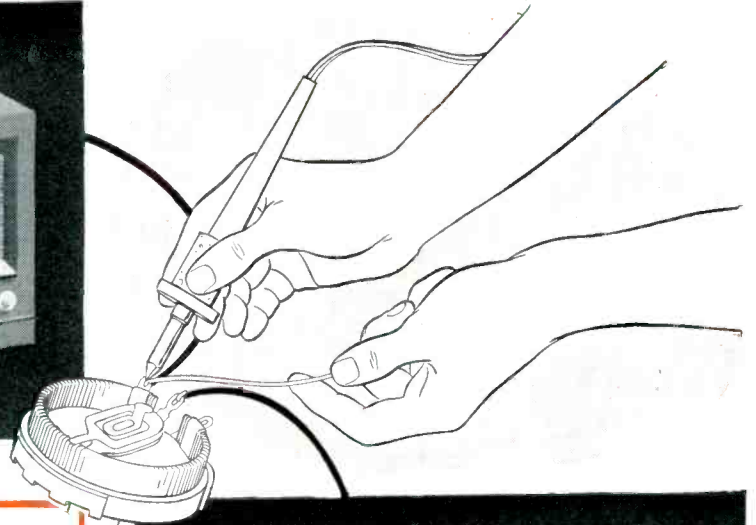
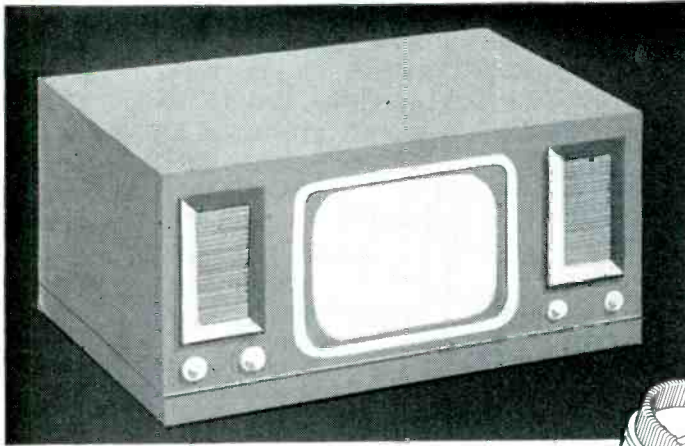

NEW NYLON-JACKETED WIRE for Radio, Electrical and Electronic Devices



HEAT-RESISTANT nylon-jacketed wire, made by Gavitt Manufacturing Co., Brookfield, Mass., in two types: 1/64" wall thickness with 300-volt rating, and 1/32" wall thickness with 600-volt rating—both with 5-mil extruded nylon jackets.

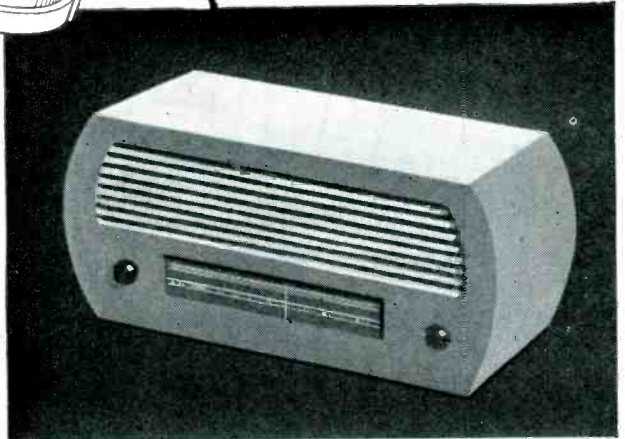

Small diameter, light weight, and flexibility among the many extra advantages of nylon heat-resistant jackets

The first thermoplastic-insulated wire to receive Underwriters' approval for use in electrical appliances at temperatures to 90°C. is now being made by covering the wire with a jacket of Du Pont nylon plastic.

Only a thin coating of lightweight nylon is needed to provide this added heat-resistance, instead of the heavy asbestos jacket formerly used. Thus this wire has the advantages of *light weight, small diameter, and flexibility.*

And in addition to raising the heat-resistance of the primary insulation, nylon provides improved resistance to

oils, chemicals, and abrasion . . . plus *extra smoothness* for easier pulling.

To help you make better products

Today, manufacturers of electrical wire are finding that a jacket of nylon reduces deformation under load at elevated temperatures, and they are using this property to help meet the increasing demand for heat-resistant wiring. Nylon can help you make many electrical products better. This Du Pont plastic can be extruded over bare wire or over primary insulation. It can be molded into thin sections and intricate shapes, and around metal inserts.

How can you take advantage of its unusual properties? To see how other manufacturers are using nylon profitably, and for valuable information on molding and extrusion of nylon, write for free booklets.

E. I. du Pont de Nemours & Co. (Inc.),
Plastics Department.

MAIN SALES OFFICES: 350 Fifth Avenue,
New York 1, N. Y.; 7 So. Dearborn Street,
Chicago 3, Illinois; 845 E. 60th Street,
Los Angeles 1, California.



Leach RELAYS

ARE PERFORMANCE PROVED!

INDUSTRIAL RELAYS

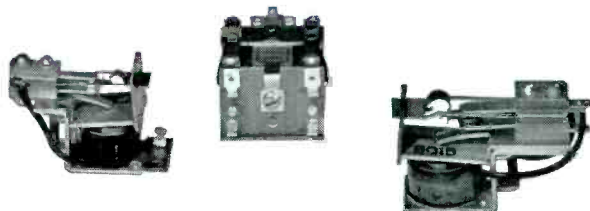

AIRCRAFT RELAYS

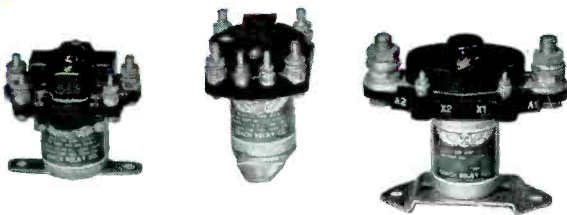

SPECIAL RELAYS



You get better service from LEACH RELAYS because thousands of types of relays for thousands of applications have been proved-in-use for over 30 years.

LEACH RELAYS are designed with an exceptionally high factor of safety for *extra* dependability. Simplicity of designs makes installation quick, easy and inexpensive. Get *all* the facts and make your own comparisons. LEACH RELAYS' outstanding performance, reliability, sturdiness and economy have been *proved-in-use*.

Highest standards of engineering, materials and workmanship assure long, safe, efficient, trouble-free service.

FOR BETTER CONTROLS THROUGH BETTER RELAYS—CONTACT LEACH



LEACH RELAY CO.

5915 AVALON BOULEVARD, ★ LOS ANGELES 3, CALIF.

Representatives in Principal Cities of U. S. and Canada

TUBES AT WORK

(continued)

through capillary tubing, which also tends to reduce the time lag of measurement. The hydrogen analyzer operates on the thermal conductivity principle, measuring the hydrogen content of the sample by its cooling effect on an electrically heated wire as compared to that of a standard.

The specific gravity recorder operates on the principle that the turning force imparted by the gas sample on an impeller-type fan wheel is directly related to the specific gravity of the gas. The turning force of air on a similar fan wheel is opposed to the sample wheel as a basis for comparison, and the difference in the two forces is mechanically connected to the instrument indicating pointer and the recording pen.

Combustion Check

To insure safe combustion of the fuel gas in the paste and vapor phase preheaters and in several other portions of the process, Protectoglo combustion safeguard controls detect the presence or absence of a flame by electrodes inserted at the burners. In the event of flame failure, they function to shut off the fuel supply as well as to energize alarm signal lights and horns in the control room.

The major phase of the coal hydrogenation process from the instrument viewpoint is the high-pressure area. Industrial instruments used for automatic control of coal preparation in this operation are panel-mounted on the ground floor of the coal preparation building and include (1) a Foxboro temperature controller on the furnace which supplies hot gases used to dry the pulverized coal in the ball mill; (2) a Wheelco combustion safeguard system on the fuel supply of the gas furnace; and (3) a Bailey oxygen analyzer and recorder for the gases out of the furnace.

Of particular interest is the special Kennedy Van Saun device for controlling the level of pulverized coal in the ball mill by operation of a Bailey disc feeder on the crushed coal inlet line. The control comprises a panel-mounted unit which contains a small glass U-

YOU CAN BE **SURE**.. IF IT'S
Westinghouse

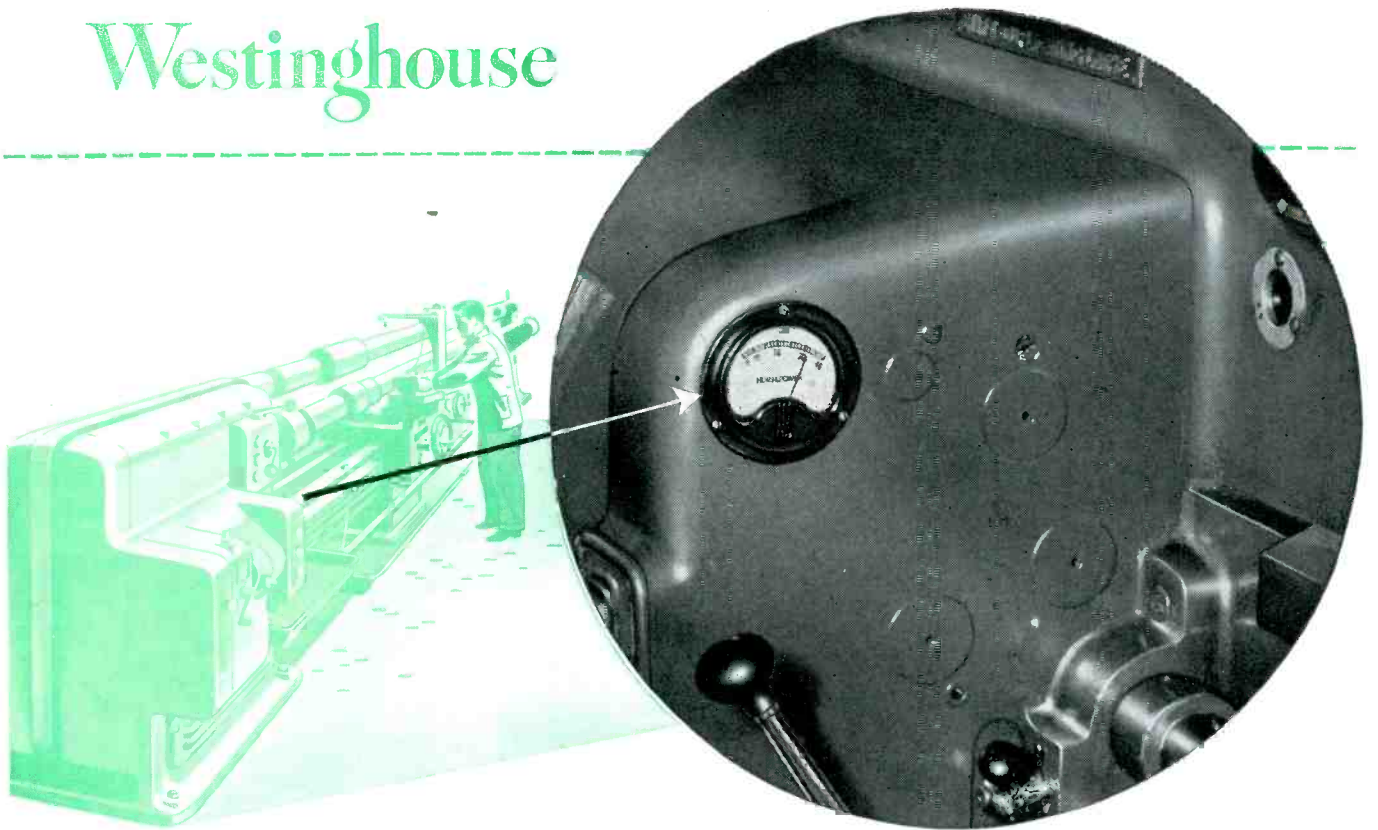

This Westinghouse Instrument helps set *New Production Records*

Savings in machine time up to 75% are common among the users of the American Tool Works Company's new hydraulic duplicating lathes!

A standard feature of these lathes is the Westinghouse horsepower instrument. It shows, at a glance, the horsepower being consumed by the cut. This enables the operator to take full advantage of the capabilities of the machine and to make maximum cuts without overloading. Machines can be easily operated at peak loads, without the dangers of overtaxed motors and damaged cutting tools.

This is another example of the application of Westinghouse instruments to *specific* problems. Westinghouse instruments are *engineered* and built to give you reliable performance in *every* application. The completeness of the line means electrical measuring instruments to fill *your* needs exactly in every field of industry.

Westinghouse instrument specialists are available in the field for consultation. Call your nearest Westinghouse office or write Westinghouse Electric Corporation, P. O. Box 868, Pittsburgh 30, Pennsylvania. J-40373



Westinghouse
ELECTRICAL
MEASURING INSTRUMENTS
FOR ANY JOB



WARD LEONARD RESISTORS

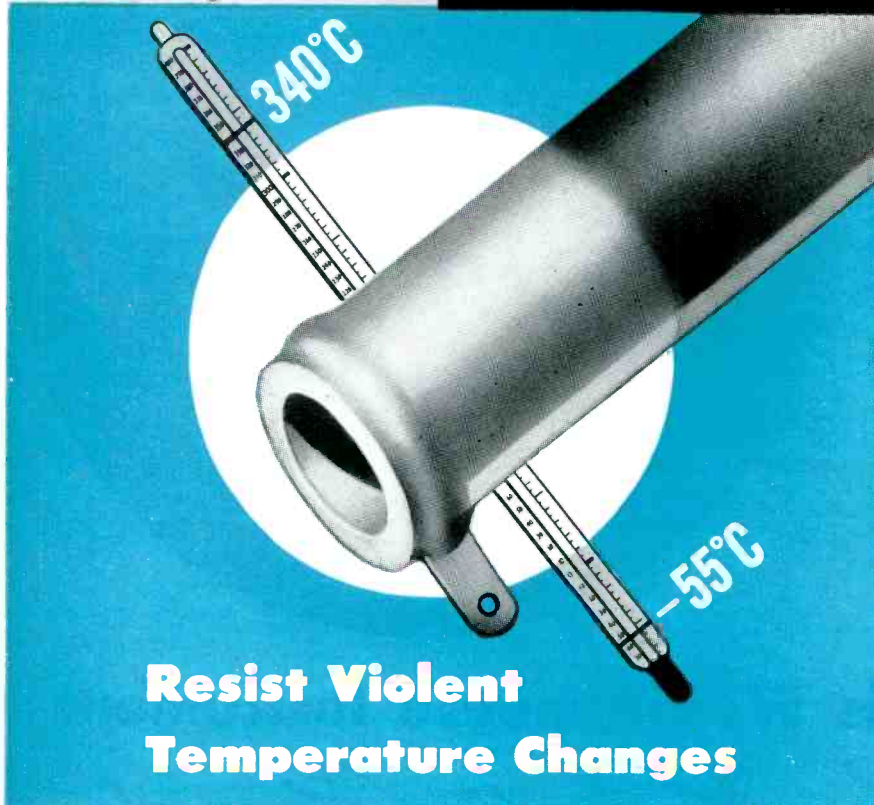

**Resist Violent
Temperature Changes**

**because all parts are
MATCHED
for thermal characteristics**

Switch the temperature back and forth from 340 to -55°C , over and over, and still you won't affect the stability of Ward Leonard Vitrohm Resistors.

Reason is: Ward Leonard, making all components*, can control thermal characteristics so as to survive the greatest temperature variations.

Write for Vitrohm Resistor Catalog, Ward Leonard Electric Co., 31 South Street, Mount Vernon, N. Y. Offices in principal cities of U. S. and Canada.

**Vitreous enamel coating and ceramic cores formulated and made by Ward Leonard . . . wire drawn to Ward Leonard's specifications.*

**WARD LEONARD
ELECTRIC COMPANY**
Result-Engineered Controls

RESISTORS • RHEOSTATS • RELAYS • CONTROL DEVICES



TUBES AT WORK

(continued)

tube, one side of which is connected to a vertical tube installed in the ball mill to the level control point. This tube is normally subjected to the draft pressure in the mill when the level is below its bottom end and results in a certain level of liquid in the U-tube. When the level reaches the bottom of this tube, the change in pressure causes the U-tube liquid level to change and intercept a photoelectric cell which electrically actuates the coal feeder.

Primary instruments used in paste preparation include: (1) three Taylor indicating level gages connected to diaphragm-type transmitters installed on the bottom of

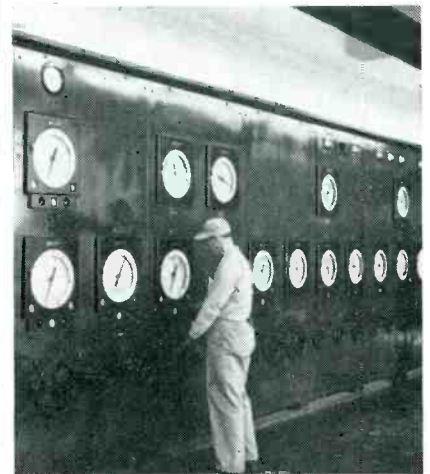

Some electronic gear of the recorder-controllers for liquid level, flow and temperature used in coal to oil conversion

the paste feed and other storage tanks, (2) three Jeffrey Waytrol control units for the automatic weighing scales which proportion the amounts of pulverized coal and dry catalysts to the paste mixer, and (3) a Brown recording paste oil flow controller which regulates the amount of oil to solids in the paste mixer.

In this stage of the process a number of auxiliary control devices are used for high limit and supplementary control functions. For example, high and low level Bin-Dicator alarms are installed on the pulverized coal storage bin. Also, Taylor self-operated thermometer-actuated control valves are used on such service as regulating glow-pressure steam to the jacket of the coal paste mixer and to the paste feed storage tank, as a means of temperature control. Fisher displacement type level controls are

operate
in safety

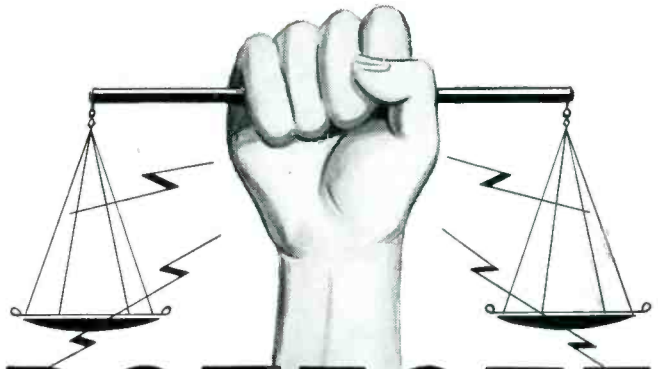

WITH FULLY

PROTECTED

LINE AND LOAD STABILIZATION

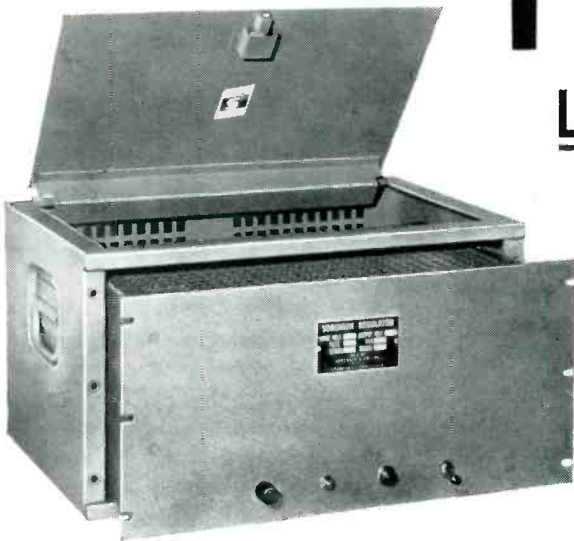

Sorensen Electronic Voltage Regulators

alone give you all these extra safety features:—

- Full protection against both line and load changes from one instrument.
- Overvoltage protection using the special Safety Diode, developed by Sorensen for hair line precision.
- Additional protection against overvoltage by use of a Heinemann Circuit Breaker.
- Protection against overload through a Klixon Overload Protector.

The Sorensen Voltage Regulator is simple and compact, easy to install. It has only four tubes — all standard except the special Sorensen Diode*. It is designed to fit in a small space — ideal for either relay rack mounting or cabinet mounting.

Don't take chances! There is one sure, safe protection for delicate instruments and complex equipment — Sorensen Voltage Regulators.

SPECIFICATIONS for the 1000S Model

| | |
|----------------------|--|
| Input Voltage Range | 95—125 V. |
| Output Voltage Range | adjustable between 110—120 V. |
| Output Load Range | 0—1 KVA |
| Regulation Accuracy | ± 0.1% against line ± 0.2% against load |
| Harmonic Distortion | less than 2% |
| Power Factor Range | down to 0.7 P. F. |
| Recovery Time | 3 to 6 cycles |
| Line Frequency Range | 50 to 60 cycles |

Other Models from 150 VA to 15 KVA single phase and 45 KVA three phase.

NOBATRON and B-NOBATRON

Send for information on these highly stabilized D. C. Regulators.

Literature Available! Send for your Saturable Core Reactor Data Booklet — It's FREE.

NEW 400 CYCLE REGULATORS



Two 400 cycle regulators of higher capacity than previously advertised are now available in the Sorensen 400 cycle line.

These units, primarily designed for aircraft, are compact and lightweight. Working from a 115 VAC, 400 cycle source, the regulators will hold the output at 115 VAC at an accuracy of 0.5% over a wide input frequency and voltage range. The capacities of the regulators are 1200 and 2000 VA.

TECHNICAL SPECIFICATIONS

| | |
|------------------------------|--------------------|
| Input Voltage Range | 95 to 125 volts |
| Output Voltage Range | 110 to 120 volts |
| Regulation Accuracy | 0.5% |
| Inductive Power Factor Range | Down to 0.7 P. F. |
| Ambient Temperature Range | —55 °C to +70 °C |
| Input Frequency Range | 400 to 2400 cycles |

Sorensen and Company, Inc.

375 Fairfield Ave., Stamford, Connecticut

An EASY and ACCURATE Way to Measure Audio Frequency Voltages



Ballantine Model 300
SENSITIVE
ELECTRONIC
VOLTMETER
 Featuring a Logarithmic
 Voltage Scale and
 Uniform Decibel Scale

- Designed for the measurement of AC Voltages from .001 Volt to 100 Volts over a frequency range of 10 to 150,000 cycles. ● Accuracy of readings is $\pm 2\%$ at any point on the scale. ● Very stable calibration—unaffected by changes in line voltage, tubes or circuit constants.
- Range switching in decade steps—easy to use—only ONE scale to read. ● Output jack and output control provided so that Voltmeter can be used as a high-gain (70 DB) high-fidelity amplifier. ● Accessories available to extend readings up to 10,000 Volts and down to 10 microvolts. ● Precision Shunt Resistors convert Model 300 Voltmeter to very sensitive direct-reading milliammeter. ● Write for complete data.

PRICE \$200.00

BALLANTINE
LABORATORIES, INC.
 BOONTON N. J. - U. S. A.

In addition to the Model 300 Voltmeter, Ballantine Laboratories also manufacture Battery Operated Electronic Voltmeters, R. F. Electronic Voltmeters, Peak to Peak Electronic Voltmeters, and the following accessories—Decade Amplifiers, Multipliers, Precision Shunt Resistors, etc.

also used on vessels in this portion of the process.

One unusual instrument application is the Brown area meter which measures the flow of viscous paste from storage to the preheaters. This unit operates on the inductance bridge principle and utilizes changes in area through a variable orifice with a fixed differential pressure as the basis for flow measurement.

Two Level Indicators

Measurement and control of the heavy oil level was probably the most difficult instrumentation problem to solve in connection with the hot catchpot. Should the level in this vessel go too low, all pressure in the system would be lost; should the level rise too high, failure to make separation of the lighter hydro-carbons and hydrogen from the heavy oil could occur. Two methods of measurement are employed and arranged so that either can be used to control the level.

In one arrangement, a Brown high-pressure mercury manometer measures the differential pressure between two hydrogen purge lines. One line is connected to the upper vapor space of the catchpot; while the outlet of the other line, which passes vertically down through the liquid, is located slightly less than two feet above the bottom of the vessel. It is desired to maintain the level about five feet above the bottom of the vessel.

Equal flows are maintained in both purge lines so that the pressure difference is due only to the liquid head in the hot catchpot. Hydrogen flows through these tubes must also be sufficient to prevent asphalt from creeping back onto the lines.

Level readings are transmitted electrically to an electronic recorder and pneumatic controller on the main instrument control panel. This latter instrument automatically controls the heavy oil level by throttling the flow of heavy oil through a diaphragm motor valve located on the heavy oil outlet line.

The second method of checking and alternately controlling the above level is accomplished by a Geiger-Muller detector, known as the Gagetron, which is installed on

IT'S **STACKPOLE** FOR **IRON CORES!**

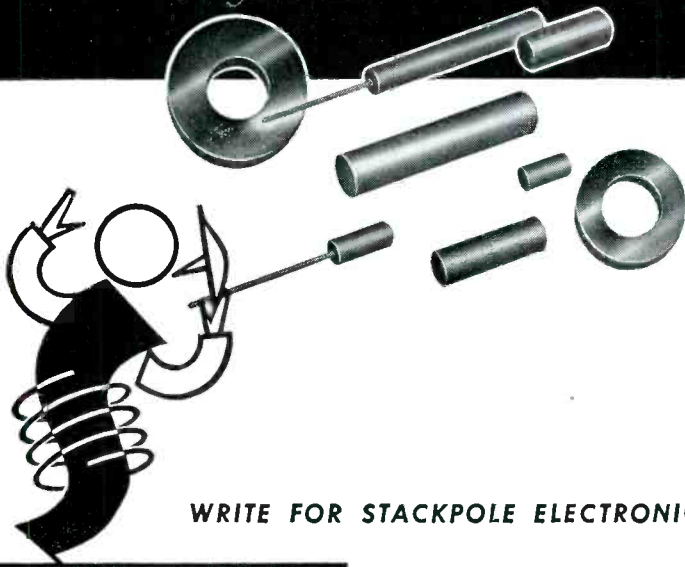

The rapid increase in the use of molded iron cores throughout electronic engineering has resulted in large part from Stackpole engineering that has made new and improved types available at attractive prices. In addition to dozens of standard broadcast, permeability tuning and high frequency types, Stackpole offers numerous others, a few of which are illustrated below.

WRITE FOR **STACKPOLE ELECTRONIC COMPONENTS CATALOG RC-7**

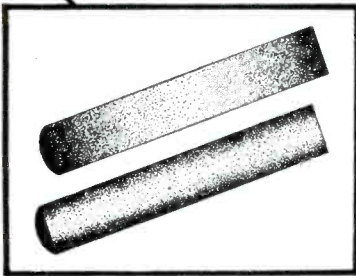

◀ **SIDE MOLDED**

Extra density of pressure extends evenly the entire length of the core. Resulting uniform permeability makes Stackpole Side-Molded Cores outstandingly superior for tuning applications. Broadcast band and short-wave types available.

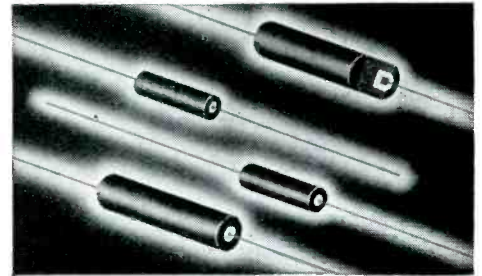

CHOKES COIL CORES ▲

Ideal for audio, "hash," r-f chokes and others. Reduce coil dimensions and increase "Q." Insulated leads connect to coil and permit point-to-point wiring. Frequency ranges from 100 cycles to 175 megacycles.

TRANSFORMER CORES ▶

for filter coils in carrier frequency equipment. Assure constant inductance over a given frequency range. Widely used where constant inductance, limited only by predetermined saturation point of core, is needed for various currents.

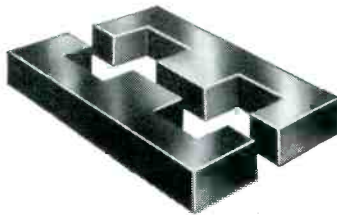

HIGH-RESISTIVITY CORES

Made of a special material showing resistance of practically infinity. Reduce leakage currents and noise troubles, minimize voltage breakdown possibilities between coils and core; and, where cup cores are used, eliminate heavily insulated lead-in wires.



◀ **SLEEVE CORES**

By permitting use of smaller cans of less critical and less costly materials, these cores assure a high order of tuning efficiency in greatly reduced size. In some instances, it may not even be necessary to use cans.



◀ **TELEVISION CORES**

From horizontal deflection and flyback transformer cores to I.F. and other types, Stackpole offers a complete line. The types illustrated here assure remarkably uniform results, save on assembly costs.

CUP CORES ▶

These unique, self-shielding units are available in a wide range of shapes and sizes and are finding steadily increasing use throughout modern electronics. Can be mounted close to chassis or other metal parts.

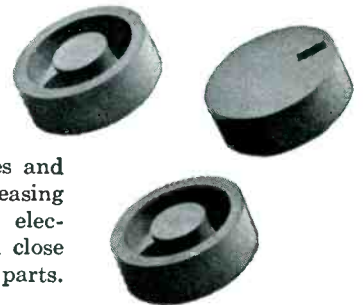

ELECTRONIC COMPONENTS DIVISION

STACKPOLE CARBON COMPANY, St. Marys, Pa.

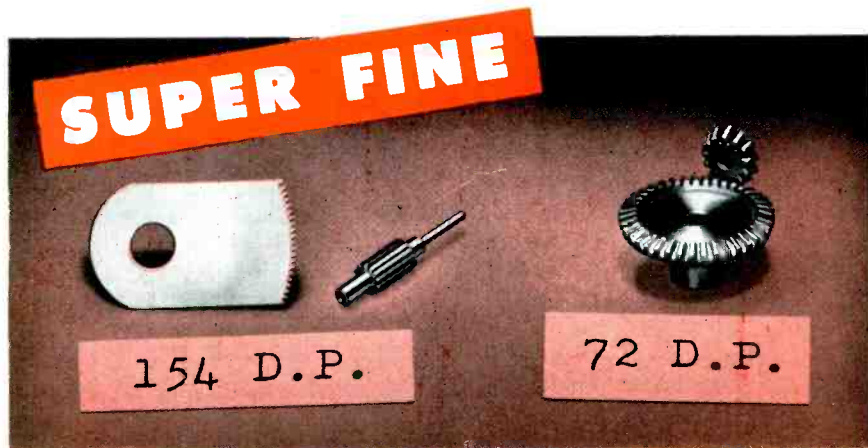

● If your requirements are for extra fine-pitch gears and pinions with precision tolerances, send us your prints for quotation. Beaver Gear engineers are trained to assist you in the design and application of this type gear. Our workmen are specialists in manufacturing small and medium size, fine and extra fine-pitch gears to your most exacting specifications.

MEMBER OF



SEND FOR BULLETIN

Beaver Gear Works Inc.

1021 PARMELE STREET, ROCKFORD, ILLINOIS

Save Space and Weight
With New, Plate-to-Plate

TRANSICOIL

Control Motors



**Low Inertia Motors,
Precision Gear Trains
And Combinations
for 400 cycle or
60 cycle operation.**

Direct plate-to-plate winding eliminates the output transformer in the servo amplifier. Wherever weight and compactness are important in a military or industrial control system, this new Transicoil design development is your logical solution.

- Varied housing designs suitable for all standard mountings.
- Motor stall torque .25 in. oz. to 4.25 in. oz.

TRANSICOIL CORPORATION
114 WORTH ST., NEW YORK 13, N. Y.

Complete Technical Data Available.
Request on Company Letterhead

the outside of the vessel. This unit detects gamma rays which are emitted by a radium salt contained in an iridium-platinum needle mounted on the pyrometer tube located inside the vessel. The gamma-ray absorption properties of the heavy oil differ sufficiently from the vapors and gases in the vessel so that this device serves well to detect the heavy oil level. This type of measurement is not influenced by changes in temperature, pressure, or chemical composition of the fluids in the vessel.

Impulses received by the Gage-tron are amplified and transmitted to a Brown electronic recording controller located on the main instrument control panel. Hand valves in the control air lines from the two level controllers are provided so that either can be used to operate the control valve.

Compact Microwave Signal Generator

BY WILLIAM EISNER

Leru Laboratories
New York, N. Y.

THE KLYSTRON SIGNAL GENERATOR to be described provides a handy source of microwave energy for use in studying uhf phenomena, as a demonstration unit to illustrate microwave beacon systems, or as a piece of test equipment for making sensitivity and signal-to-noise measurements on microwave receivers. The unit employs a 2K25 klystron operating at approximately 10,000 mc, and either modulated or continuous-wave output is available.

The unit consists of three main sections: the rather unique circuits used for modulating the klystron output, the scope and its associated circuits to give a visual indication of the modulating pulses, and the power supply section.

The klystron signal generator utilizes a system of modulation which was developed by Robert Rudin, formerly associated with the Leru Laboratories. The system is based on the intermittent generation of a carrier of constant amplitude with the ratio of on to off periods being varied.

To illustrate this principle, let us

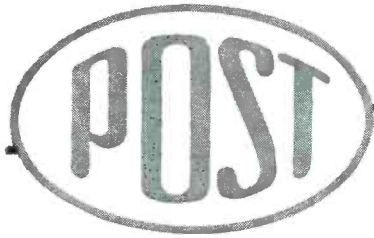

**P.T.M.
173**

**EXCELALL
179H**

TRACING PAPERS

**IVORY
167**

**BLUTEX
175H**

**ONE FORTY
140**

MADE TO MEET YOUR REQUIREMENTS

Fitting the exact needs of draftsmen and engineers for over half a century, POST has sought to produce the finest product for each problem, purpose or need.

In tracing mediums, POST has perfected a specialized group of 5 papers which they believe exhibit a marked superiority over all competitive products—a superiority so obvious that a single trial is sufficient to establish their use as standard practice in your organization.

THE FREDERICK **POST** COMPANY

3650 AVONDALE AVENUE • CHICAGO 18, ILLINOIS • • Houston • Detroit • Chicago • Los Angeles • Milwaukee

Distributors in all Principal Cities

FOR EVERY PLAN YOU MAKE — — — THERE'S A PAPER BY



Exactly!

TRY

these 5 POST Tracing Papers under your operating conditions. Write for your free samples today — care of P.O. Box 1091, Chicago 90, Ill.



investigate ...

PHENOLITE

Reg. U.S. Pat. Off.

FIBERGLAS LAMINATES

Three versatile grades ...

- 1. SILICONE FIBERGLAS**—Grade G-7-830—Combines high heat, flame and arc resistance. It is recommended for exacting low-loss electrical applications and for insulation in transformers, motors and other applications subjected to elevated temperatures.
- 2. MELAMINE FIBERGLAS**—Grade MGB-811—Extremely high tensile, flexural, compressive and impact strength values. High heat resistance and good arc resisting properties. Dielectric strength and dielectric loss characteristics excellent under high humidity conditions and elevated temperatures.
- 3. PHENOLIC FIBERGLAS**—Grade GB-801—A staple type that has high impact strength, good electrical properties and resistance to heat. Low dimensional change under moist conditions. Especially suitable for Class B insulation and other electrical applications requiring heat resistance.

For full details on Phenolite Fiberglass Laminates call or write

NATIONAL VULCANIZED FIBRE CO.

WILMINGTON
Offices in



DELAWARE
Principal Cities

Since 1873

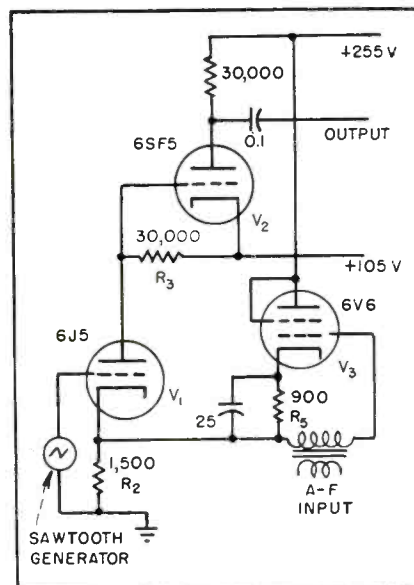

FIG. 1—Circuit diagram of unique modulator used in microwave signal generator

suppose that the emission of an r-f wave is being interrupted at a certain rate and that the on periods are as long as the off periods; the envelope will then be a square wave. If this signal is then detected at the receiver by a diode rectifier, the diode current will follow the envelope and the resulting square wave, if averaged over a period of time, will assume a steady value. If now the ratio of on to off periods is changed so that the emission is on longer than off, the average diode current at the receiver will increase. Lengthening the off periods and shortening the on periods will result in a reduction of diode current.

It is convenient to keep the repetition rate (25,000 pps) of the pulses constant and vary the length of the on periods. Also instead of completely cutting off the emission of the carrier wave during the off periods, its amplitude can be reduced to a constant predetermined fraction of the amplitude during the on periods. It is seen that the relative variations of diode current depend only on the ratio of on to off periods and are independent of the actual amplitude. It is therefore possible to pass the received signals thru amplitude-limiting devices before detecting them and in this way practically eliminate the influences of variations in transmission.

To accomplish the cutting on and

HERE'S PACKAGED POWER ON TAP!

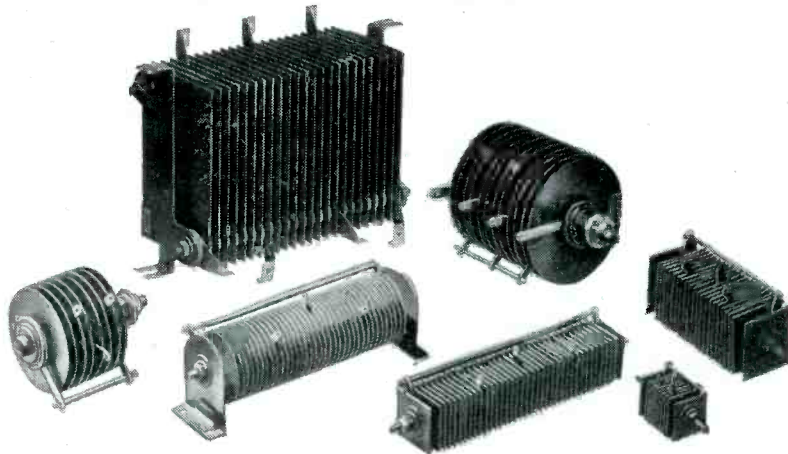

Your Check-List of FEDERAL'S Selenium Rectifier Stacks . . .

SELECT THE TYPE YOU NEED . . .

Get immediate delivery from Dealer or Distributor

Now you can engineer your own AC to DC power conversion. Just check your requirements against Federal's list of Packaged Power and order what you need. Dealers and distributors stock these popular standard sizes, and can fill your order promptly and accurately.

This list includes but a fraction of Federal Stacks—many more types have been developed for special applications. Our engineers always stand ready to cooperate in the design of any new stack you may require. Send for handy "Packaged Power" check list. Write Department F-513.

Federal, America's oldest and largest manufacturer of Selenium Rectifiers, also has a complete line of Miniature Selenium Rectifiers, ranging in size from 65 Ma. to 500 Ma.

| D.C. OUTPUT VOLTS | RECTIFIER STACK CODE NUMBER | APPROX. A.C. INPUT VOLTS | | CIRCUIT AND STACK CONN. DIAGRAM | RECTIFIER STACK DIMENSIONS | | | CATALOG NUMBER |
|-------------------|-----------------------------|--------------------------|------|---------------------------------|----------------------------|-----------|------|----------------|
| | | NEW | MAX. | | A | B = 1/16" | FIG. | |
| 6 | 2 6C1ABX1 | 8 | 9 | 'B' | 3 3/8" | 1 7/16" | 1 | 2001 |
| | 4 7C1ABX1 | 8.2 | 9 | | 4 3/8" | 1 7/16" | 1 | 2002 |
| | 6 233C1ABX1 | 8.5 | 11 | | 4 3/8" | 1 3/4" | 1 | 2003 |
| | 8 28C1ALX1 | 8.2 | 9 | | 6 1/8" x 4 1/2" | 1 1/2" | 2 | 2004 |
| | 12 234C1ALX1 | 8.5 | 11 | | 6 5/8" x 4 1/2" | 1 1/16" | 2 | 2005 |
| 6 | 2 6B1ABX1 | 9 | 18 | 'A' | 3 3/8" | 2 1/16" | 1 | 2006 |
| | 4 7B1ABX1 | 9.4 | 18 | | 4 3/8" | 2 1/16" | 1 | 2007 |
| | 6 33B1ABX1 | 10 | 18 | | 4 3/8" | 2 1/16" | 1 | 2008 |
| | 8 28B1ALX1 | 9.4 | 18 | | 6 5/8" x 4 1/2" | 2 1/16" | 2 | 2009 |
| | 12 34B1ALX1 | 10 | 18 | | 6 5/8" x 4 1/2" | 2 1/16" | 2 | 2010 |
| 12 | 2 6B1ABX1 | 16 | 18 | 'A' | 3 3/8" | 2 1/16" | 1 | 2011 |
| | 4 7B1ABX1 | 16.3 | 18 | | 4 3/8" | 2 1/16" | 1 | 2012 |
| | 6 233B1ABX1 | 16.8 | 22 | | 4 3/8" | 2 1/16" | 1 | 2013 |
| | 8 28B1ALX1 | 16.3 | 18 | | 6 5/8" x 4 1/2" | 2 1/16" | 2 | 2014 |
| | 12 234B1ALX1 | 16.8 | 22 | | 6 5/8" x 4 1/2" | 2 1/16" | 2 | 2015 |
| 24 | 2 6B2ALX1 | 32 | 36 | 'A' | 3 3/8" | 3 1/16" | 3 | 2016 |
| | 4 7B2ALX1 | 32.6 | 36 | | 4 3/8" | 3 1/16" | 3 | 2017 |
| | 6 233B2ALX1 | 33.6 | 44 | | 4 3/8" | 5" | 3 | 2018 |
| | 8 28B2ALX1 | 32.6 | 36 | | 6 5/8" x 4 1/2" | 3 3/8" | 4 | 2019 |
| | 12 234B2ALX1 | 33.6 | 44 | | 6 5/8" x 4 1/2" | 5" | 4 | 2020 |
| 32 | 2 206B2ALX1 | 41 | 44 | 'A' | 3 3/8" | 3 1/16" | 3 | 2021 |
| | 4 207B2ALX1 | 41.5 | 44 | | 4 3/8" | 3 1/16" | 3 | 2022 |
| | 6 133B2ALX1 | 42.5 | 52 | | 4 3/8" | 5" | 3 | 2023 |
| | 8 228B2ALX1 | 41.5 | 44 | | 6 5/8" x 4 1/2" | 3 3/8" | 4 | 2024 |
| | 12 134B2ALX1 | 42.5 | 52 | | 6 5/8" x 4 1/2" | 5" | 4 | 2025 |
| 36 | 2 106B2ALX1 | 45 | 52 | 'A' | 3 3/8" | 3 1/16" | 3 | 2026 |
| | 4 107B2ALX1 | 45.5 | 52 | | 4 3/8" | 3 1/16" | 3 | 2027 |
| | 6 133B2ALX1 | 46.7 | 52 | | 4 3/8" | 5" | 3 | 2028 |
| | 8 128B2ALX1 | 45.5 | 52 | | 6 5/8" x 4 1/2" | 3 3/8" | 4 | 2029 |
| | 12 134B2ALX1 | 46.7 | 52 | | 6 5/8" x 4 1/2" | 5" | 4 | 2030 |
| 48 | 2 206B3ALX1 | 61.5 | 66 | 'A' | 3 3/8" | 4 1/2" | 3 | 2031 |
| | 4 207B3ALX1 | 62 | 66 | | 4 3/8" | 4 1/2" | 3 | 2032 |
| | 6 133B3ALX1 | 63.5 | 78 | | 4 3/8" | 6 3/4" | 3 | 2033 |
| | 8 228B3ALX1 | 62 | 66 | | 6 5/8" x 4 1/2" | 4 1/2" | 4 | 2034 |
| | 12 134B3ALX1 | 63.5 | 78 | | 6 5/8" x 4 1/2" | 7 1/16" | 4 | 2035 |
| 120 | .5 104B6SALX1 | 148 | 156 | 'A' | 1 17/32" sq. | 4 7/8" | 5 | 2036 |
| | 1. 105B6ALX1 | 148 | 156 | | 2 3/8" | 7 3/8" | 3 | 2037 |
| | 2. 106B6ALX1 | 149 | 156 | | 3 3/8" | 7 3/8" | 3 | 2038 |
| | 4. 107B6ALX1 | 151 | 156 | | 4 3/8" | 7 3/8" | 3 | 2039 |
| | 6 133B7ALX1 | 157 | 182 | | 4 3/8" | 14 1/8" | 3 | 2040 |

Federal Telephone and Radio Corporation



An IT&T Associate

ELECTRONICS — July, 1949

SELENIUM and INTELIN DIVISION, 900 Passaic Ave., East Newark, New Jersey

In Canada: Federal Electric Manufacturing Company, Ltd., Montreal, P. Q.
Export Distributors: International Standard Electric Corp., 67 Broad St., N. Y.



FEDERAL TELECOMMUNICATION LABORATORIES, Nutley, N. J. . . . a unit of I T & T's world-wide research and engineering organization.

LOCKSEAM* NICKEL CATHODES

right for
TELEVISION

Lockseam* Cathodes, a patented product of the Superior Tube Company's Electronic Division, has "earned its spurs" by producing quality cathodes for the expanding field of television. By this unique method, special machinery turns out cathodes directly from thin strip stock.

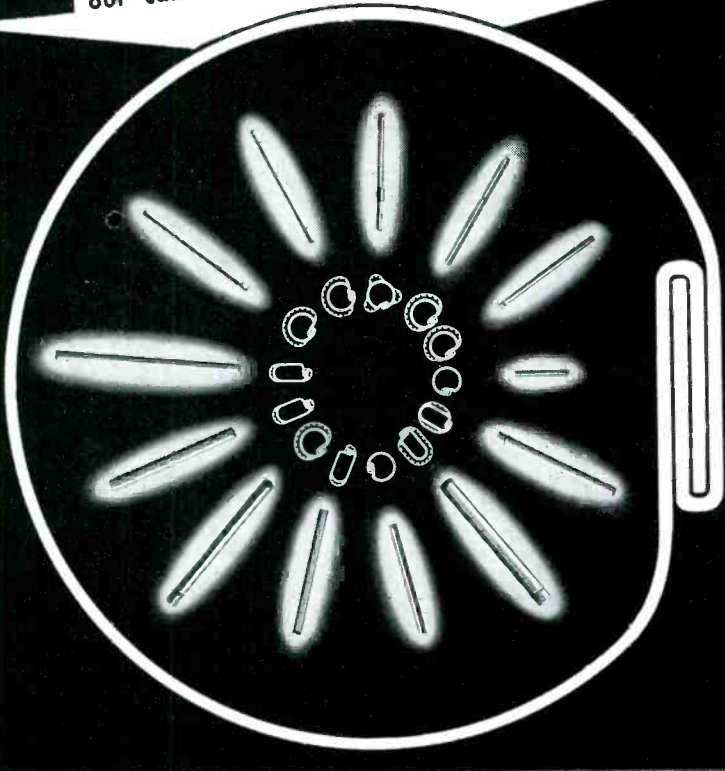

Correct performance characteristics are assured by a combination of exacting production procedures, constant metallurgical and chemical laboratory control and continuous testing both in our Electronics Laboratory and in actual service.

Superior Lockseam* cathodes are available in round, oval and rectangular shapes, plain or beaded as required.

Write for full information on types of materials, dimensional range and tolerances of these revolutionary Lockseam* cathodes.

For Electronic products for export, contact Driver-Harris Company, Harrison, New Jersey. Harrison 6-4800.

*Superior Tube Company Patents

Superior

THE BIG NAME IN SMALL TUBING (.010" TO 5/8" O.D. MAX.)

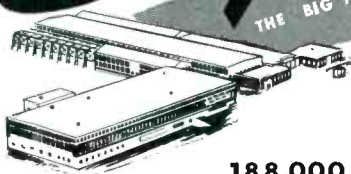

SUPERIOR TUBE COMPANY
2500 Germantown Ave., Norristown, Pa.
ELECTRONICS DIVISION
188,000 SQ. FT. PRODUCING METAL TUBING

TUBES AT WORK

(continued)

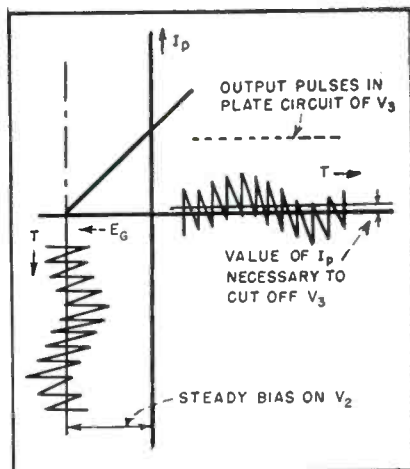
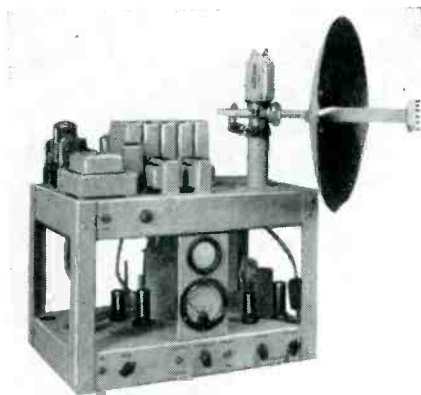

FIG. 2—Curve of E_G vs I_p showing how length of output pulses is changed by modulator shown in Fig. 1

off of the 2K25 klystron output in a practical way, the circuit of Fig. 1 is used. A sawtooth voltage is applied to V_1 . The cathode of V_1 is biased by the voltage output of the cathode-follower triode V_3 , which in turn is modulated by the a-f input. The steady cathode bias of V_1 is determined by R_5 , which also determines the grid bias of V_3 . The drop in the cathode resistor R_2 determines the bias of V_1 , and determines the ratio of on to off of V_1 . The plate current of V_1 is carried thru R_3 and the voltage drop of the plate current thru R_3 is applied to the control grid of V_3 . The length of the plate current pulses in V_3 are the on and off periods desired (see Fig. 2). These pulses are amplified and used to turn the Klystron plate voltage on and off.

The front panel controls provide a means for varying the klystron repeller voltage and thereby vary the r-f frequency within narrow



Compact microwave signal generator capable of producing modulated or unmodulated r-f at approximately 10,000 mc. Scope monitors modulating pulses, and meter reads average klystron cathode current

For new simplicity, wide range, and high accuracy in the control of modern electronic circuits...

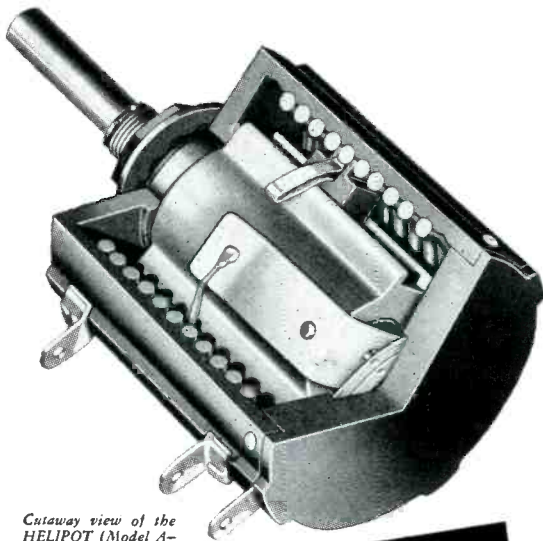

Cutaway view of the HELIPOT (Model A-10 Turn-1 3/4" Diameter)

THE BECKMAN Helipot

(Trademark of the HELICAL POTentiometer)

Provides many times greater resistance control in same panel space as conventional potentiometers!

IF YOU are designing or manufacturing any type of precision electronic equipment be sure to investigate the greater convenience, utility, range and compactness that can be incorporated into your equipment by using the revolutionary HELIPOT for rheostat-potentiometer control applications...and by using the new DUODIAL turns-indicating knob described at right.

Briefly, here is the HELIPOT principle...whereas a conventional potentiometer consists of a single coil of resistance winding, the HELIPOT has a resistance element many times longer coiled helically into a case which requires no more panel space than the conventional unit. A simple, foolproof guide controls the slider contact so that it follows the helical path of the resistance winding from end to end as a single knob is rotated. Result...with no increase in panel space requirements, the HELIPOT gives you as much as 12 times* the control surface. You get far greater accuracy, finer settings, increased range—with maximum compactness and operating simplicity!

COMPLETE RANGE OF TYPES AND SIZES

The HELIPOT is available in a complete range of types and sizes to meet a wide variety of control applications...

MODEL A: 5 watts, 10 turns, 46" slide wire length, 1 3/4" case dia., resistances 10 to 50,000 ohms, 3600° rotation.

MODEL B: 10 watts, 15 turns, 140" slide wire length, 3 1/2" case dia., resistances 50 to 200,000 ohms, 5400° rotation.

MODEL C: 3 watts, 3 turns, 13 1/2" slide wire length, 1 3/4" case dia., resistances 5 to 15,000 ohms, 1080° rotation.

MODEL D: 15 watts, 25 turns, 234" slide wire length, 3/4" case dia., resistances 100 to 300,000 ohms, 9000° rotation.

MODEL E: 20 watts, 40 turns, 373" slide wire length, 3/4" case dia., resistances 150 to 500,000 ohms, 14,400° rotation.

Also, the HELIPOT is available in various special designs...with double shaft extensions, in multiple assemblies, integral dual units, etc.

Let us study your potentiometer problems and suggest how the HELIPOT can be used—possibly is already being used by others in your industry—to increase the accuracy, convenience and simplicity of modern electronic equipment. No obligation, of course. Write today outlining your problem.

*Data for Model A, 1 3/4" dia. Helipot. Other models give even greater control range in 3" case diameters.

THE BECKMAN Duodial

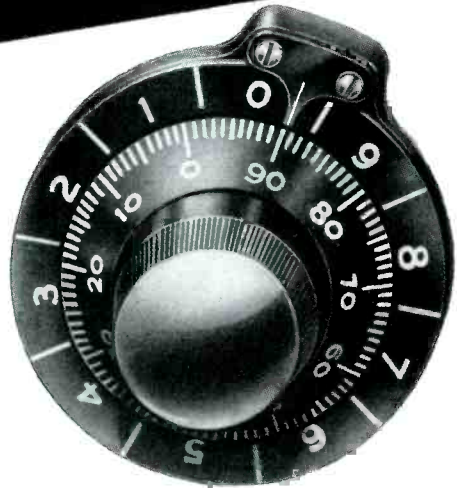

The inner, or Primary dial of the DUODIAL shows exact angular position of shaft during each revolution. The outer, or Secondary dial shows number of complete revolutions made by the Primary dial.

A multi-turn rotational-indicating knob dial for use with the HELIPOT and other multiple turn devices.

THE DUODIAL is a unique advancement in knob dial design. It consists essentially of a primary knob dial geared to a concentric turns-indicating secondary dial—and the entire unit is so compact it requires only a 2" diameter panel space!

The DUODIAL is so designed that—as the primary dial rotates through each complete revolution—the secondary dial moves one division on its scale. Thus, the secondary dial counts the number of complete revolutions made by the primary dial. When used with the HELIPOT, the DUODIAL registers both the angular position of the slider contact on any given helix as well as the particular helix on which the slider is positioned.

Besides its use on the HELIPOT, the DUODIAL is readily adaptable to other helically wound devices as well as to many conventional gear-driven controls where extra dial length is desired without wasting panel space. It is compact, simple and rugged. It contains only two moving parts, both made entirely of metal. It cannot be damaged through jamming of the driven unit, or by forcing beyond any mechanical stop. It is not subject to error from backlash of internal gears.

TWO SIZES—MANY RATIOS

The DUODIAL is now available in two types—the Model "R" (illustrated above) which is 2" in diameter, and the new Model "W" which is 4 3/4" in diameter and is ideal for main control applications. Standard turns-ratios include 10:1, 15:1, 25:1 and 40:1 (ratio between primary and secondary dials). Other ratios can be provided on special order. The 10:1 ratio DUODIAL can be readily employed with devices operating fewer than 10 revolutions and is recommended for the 3-turn HELIPOT. In all types, the primary dial and shaft operate with a 1:1 ratio, and all types mount directly on a 1/4" round shaft.



Send for this HELIPOT AND DUODIAL CATALOG!

Contains complete data, construction details, etc., on the many sizes and types of HELIPOTS...and on the many unique features of the DUODIAL. Send for your free copy today!

THE Helipot CORPORATION, SOUTH PASADENA 2, CALIFORNIA

**AIRCRAFT
RADIO
CORPORATION**

Announces

THE TYPE H-12

SIGNAL GENERATOR



900-2100 Megacycles

... for research and for
production testing

- 900-2100 megacycles, single band
- Continuous coverage with single-dial control directly calibrated
- Directly calibrated attenuator, 0 to -120 dbm
- CW or AM pulse modulation
- Extensive pulse circuitry

Write for details

Aircraft Radio Corporation

BOONTON, New Jersey



Dependable Electronic Equipment Since 1928

TUBES AT WORK

(continued)

limits. The klystron can also be operated continuous wave. If the klystron is to be evenly pulsed (no modulation), the centering control is used to vary the length of the pulse, and this modulating pulse can be seen on the scope. The meter on the front panel gives the average klystron cathode current.

The output of the microwave generator may be radiated by the antenna system, shown in the photograph, which is mounted on a swivel arrangement so that the r-f can be radiated in any desired direction. Or the parabolic reflector and end piece may be removed and a 3-cm waveguide clamped in place and used to pipe the microwave signal to the desired location.

Generator Regulation by Saturable Reactors

BY T. A. BENHAM

*Assistant Professor in Physics
Haverford College
Haverford, Pennsylvania*

AN EXISTING 24-volt d-c generator had a rather poor regulation characteristic. It was desired to design a simple compensating system without the use of vacuum tubes as that method would entail relatively expensive tubes, and the control would be as costly as the generator itself. Since the author had had some experience with the use of saturable reactors for both controls and amplifiers, efforts were directed along

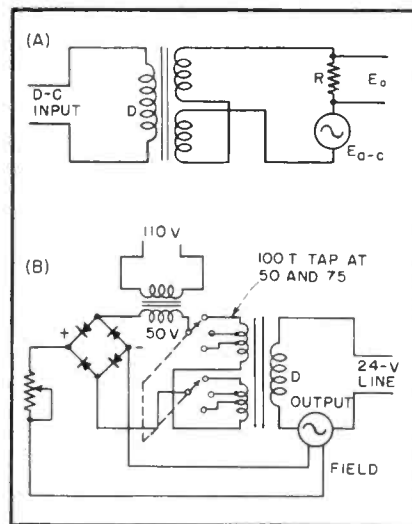

FIG. 1—Schematic diagrams of (A) basic saturable reactor circuit, and (B) the actual circuit for using a saturable reactor to control the voltage output of a generator

PREFERRED

by these outstanding television set makers..

Admiral



*Andrea
Automatic
Radio*

*Bendix
Radio*

CROSLLEY

DEWALD

*Emerson
Radio*

**FADA
Radio**

Farnsworth
GAROD RADIO

GLOBE
hallicrafters

Hoffman

Magnavox



Motorola
NATIONAL

Olympic
Radio and Television

Packard Bell
PHILCO



Regal

Sentinel Radio

Silvertone

Spartan

STROMBERG
CARLSON

Tele-tone



TRAV-LER

Westinghouse

ZENITH
RADIO

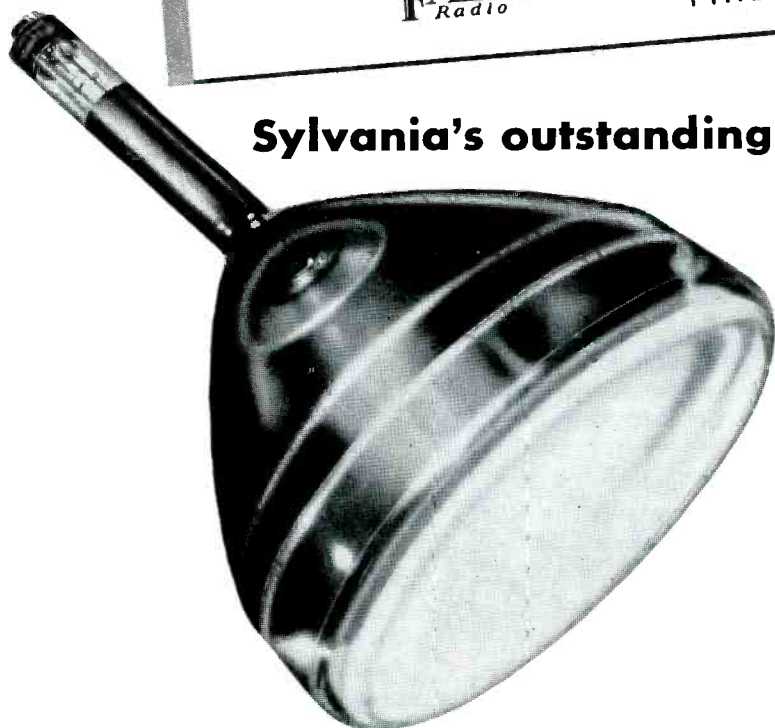

Sylvania's outstanding television picture tubes

When 32 nationally known television set makers specify Sylvania television tubes for their sets, you have a sure indication of their excellent quality.

If you wish full information about the entire line of Sylvania Cathode Ray Tubes, made by the manufacturers of highest quality radio tubes for many years, write Sylvania Electric Products Inc., Cathode Ray Division, Emporium, Pa.

SYLVANIA ELECTRIC

CATHODE RAY TUBES; RADIO TUBES; ELECTRONIC DEVICES; FLUORESCENT LAMPS, FIXTURES, WIRING DEVICES; ELECTRIC LIGHT BULBS; PHOTOLAMPS

Easy on the Ears...

TELEX MONOSET*—Under Chin Headset

Stethoscope design of the Telex *Monoset* eliminates tiresome pressure—instrument swings lightly *under* the chin. Wear it for hours without fatigue!

Telex *Monoset* sends signal directly into both ears, blocking out background noise. Built of durable Tenite, the *Monoset* is excellent for communications, office dictation equipment, aircraft radio, wired sound installations, dental offices and beauty shops. Choice of five-foot cords: standard, or with built-in volume control.



TELEX TWINSET*—Nothing Need Touch Ears!

Here's the lightest twin-receiver headset made—Telex *Twinset* weighs only 1.6 oz! In-phase receivers assure excellent sensitivity and full-range high fidelity, non-resonating sound reproduction . . . eliminate listening fatigue. Adjustable, self-locking sound arm may fit into the ear, or may be moved a fraction of an inch away, so that *nothing* touches the ear.

Telex *Twinset* adjusts simply to any shape head, without pinching or pressure. So flexible it may be coiled up and slipped into the pocket! Perfect for any headset need—amateur, experimental, commercial.

Special cord with built-in volume control available.



TELEX Earset*—Slips onto the Ear

Unlimited earphone applications are possible with the new Telex *Earset*. Weighing only 1/2 oz., this entirely new conception in earphone design finds a ready welcome among stenographers, technicians—all who use single-phone headsets.

Earset's flat plastic frame slips onto the ear, holds the sensitive receiver securely in place. User's other ear is always free for phone calls or conversation. Telex *Earset* won't fall or slide off—fits either right or left ear, may be worn by anyone without special adaptation.



TELEX PILLOW SPEAKER— For private radio listening

Solves the problem of radio listening without disturbing others—in hospitals, hotels, trains, buses, institutions. Telex Pillow Speaker tucks away beneath pillow, headrest or cushion—makes possible perfect individual reception!

Palm-sized, weighs only 1.1 ounces, yet virtually unbreakable. Easily sterilized in alcohol. Entire assembly completely shock-proof. Detachable flexible cord.

*Trademark



For further information write

TELEX

DEPT. B-14-7 • TELEX PARK
MINNEAPOLIS 1, MINNESOTA
In Canada, Atlas Radio Corp., Toronto

STANDARD OF THE WORLD FOR QUALITY HEADSETS

these lines experimentally.

The theory and function of such reactors are fairly common knowledge, therefore only a brief explanation will be given here. If a three-leg laminated core of the E-I type is arranged with windings on each leg and with the outside pair connected in series-aiding, then there will be no transformer action between this pair of windings and the center coil.^{1,2,3} This is because the flux from one outside coil goes directly from one outside leg to the other without going through the center leg. However, flux due to a current in the center leg passes through the outside legs. The inductance, and hence the reactance, of the outside coils is a function of the permeability of the core material. If direct current is passed through the center coil, the resulting steady flux causes the permeability of the outside legs to become smaller thus reducing the reactance of these coils. Figure 1A shows how this principle may be used to vary the voltage appearing across R as the direct current through D is changed.

Now suppose R is replaced by a dry-disc rectifier while the d-c output of the rectifier is connected to the field winding of the generator to be regulated. Further, suppose the output current of the generator is caused to flow through the center winding D in Fig. 1B. With no load current being drawn from the generator, the field rheostat is varied to obtain the proper generator output voltage.

Of course, the rectifier must be capable of delivering the rated field current, and the a-c source must supply a voltage which is larger than the desired field voltage by an amount equal to the drop across the outside coils of the reactor plus the losses in the rectifier.

When the initial adjustments have been made, a load may be connected to the generator. The current flows through coil D thus reducing the reactance of the coils in series with the field supply. This results in an increase in field excitation and an increase in the generated voltage.

Not much forethought is required to realize that if the amount of compensation is too great, the system

NOW YOU CAN—

SPECIFY Components Precisely,
Accurately—

MEASURE the Basic Quality of
Components—

with this **NEW**



Radio Frequency Ohmmeter

HERE'S a stable, low impedance instrument for direct measurement of the radio frequency characteristics of:

- Coils • Transmission Lines • Antennas
- Capacitors • Resistors • Dielectrics

Resistance at radio frequencies between 50 kc and 85 mc may be read directly on the meter. Capacitive or Inductive Reactance may be determined readily. For information write Specialty Division, General Electric Company, Electronics Park, Syracuse, New York.



TYPE YKS-1

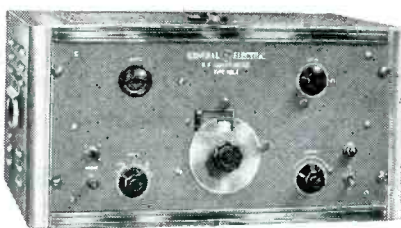

CAPACITOMETER TYPE YCL-1

A convenient, self-contained unit for rapid and extremely accurate measurement of inductance and capacitance.

- Capacity: 0-20,000 micromicrofarads.
- Inductance: 0-10,000 microhenries.



SQUARE WAVE GENERATOR TYPE YGL-1

- Wide frequency range: 5-125,000 cycles.
- Output voltage 0-75 volts.
- Low output impedance.
- Rise time .3 microsecond.



Send for this

FREE CATALOG!

Complete specifications and descriptions of G-E Test Equipment will be sent to you on request. Specialty Division, General Electric Company, Electronics Park, Syracuse, New York.

You can put your confidence in—

GENERAL  **ELECTRIC**

How SPEED helped catch "bugs" in the lacquer



Final finish on pianos mysteriously going "sour." Production halted. Lab needed X-ray diffraction camera to identify impurity. At 9 A.M., 10-lb. camera Air Expressed from 1100 miles away, delivered by 4 P.M. same day. Cost, only \$3.58. Company uses Air Express as routine method to get supplies fast, keep inventory low.

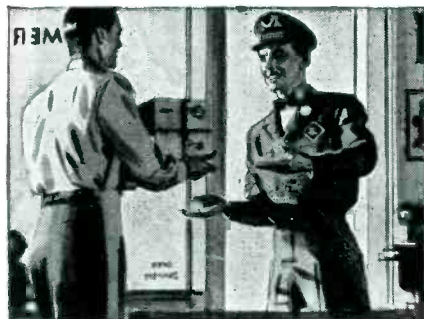

That low \$3.58 figure was total cost for Air Express and included door-to-door service. That makes the world's fastest shipping method exceptionally convenient, complete, and easy to use.

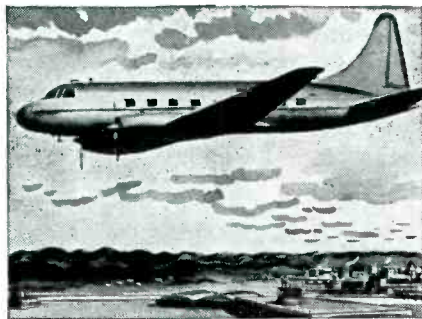

Scheduled Airlines carry Air Express on every flight. Speeds up to 5 miles a minute! Direct by air to 1300 cities; air-rail for 22,000 off-airline offices. Serves many foreign countries, too.

FACTS on low Air Express rates

Package of blueprints (4 lbs.) goes 800 miles for \$1.54.
Special tools (21 lbs.) go 600 miles for \$3.87.
(Every kind of business finds Air Express pays.)

Only Air Express gives you all these advantages: Special pick-up and delivery at no extra cost. You get a receipt for every shipment and delivery is proved by signature of consignee. One-carrier responsibility. Assured protection, too—valuation coverage up to \$50 without extra charge. Practically no limitation on size or weight. For fast shipping action, phone Air Express Division, Railway Express Agency. And specify "Air Express delivery" on orders.

SPECIFY AIR EXPRESS
AIR EXPRESS
GETS THERE FIRST

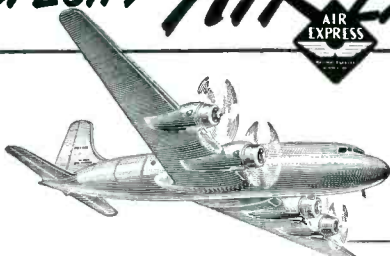

Rates include pick-up and delivery door to door in all principal towns and cities



AIR EXPRESS, A SERVICE OF RAILWAY EXPRESS AGENCY AND THE
SCHEDULED AIRLINES OF THE U.S.

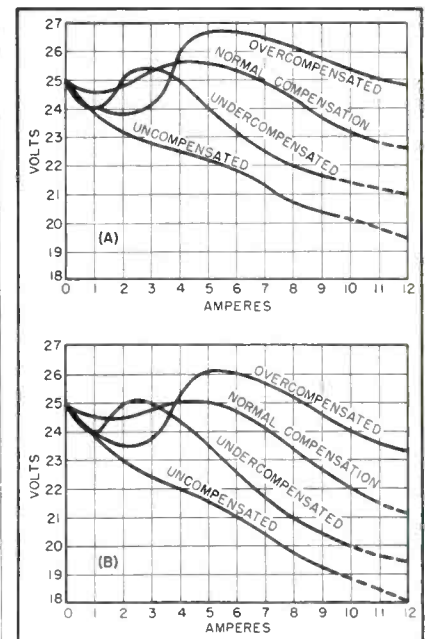

FIG. 2—Response curves for saturable reactor-controlled generator. Curves in (A) are taken at generator output terminals, while those in (B) are from the end of a 0.12-ohm line

will run away, and the generator might be permanently damaged. Proper fusing, therefore, is indicated. However, in the model under discussion, the amount of compensation could be adjusted by selecting the proper taps on the series coils as shown in Fig. 1B. It was found that 75 turns on each coil gave satisfactory compensation while 100 turns on each resulted in slight over-compensation (Fig. 2A). Still more turns would over-compensate sufficiently to permit the use of a long line.

For the purpose at hand, the system is entirely satisfactory. However, there is one serious disadvantage for certain applications where rapid response is required. Because of the lag in the magnetic effects in the core, the voltage regulation is poor for sudden changes in load. For example, when full load is removed suddenly, the voltage momentarily jumps up by an amount of approximately 10 percent and then settles back to the original value.

REFERENCES

- (1) Alan S. FitzGerald, Magnetic Amplifier Characteristics — Neutral Type, *J. Frank. Inst.*, p 249, Oct. 1947; and p 415, Dec. 1947.
- (2) Alan S. FitzGerald, Some Notes on the Design of Magnetic Amplifiers, *J. Frank. Inst.*, p 323, Nov. 1947.
- (3) Frank G. Logan, Saturable Reactors and Magnetic Amplifiers, *ELECTRONICS*, p 104, Oct. 1948.

NO BIGGER THAN A DIME!

A FIT COMPANION FOR SUB-MINIATURE TUBES...

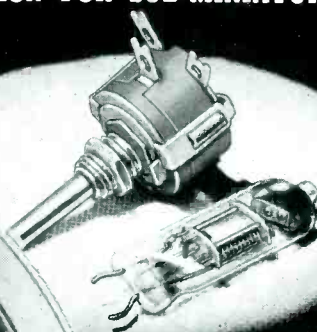
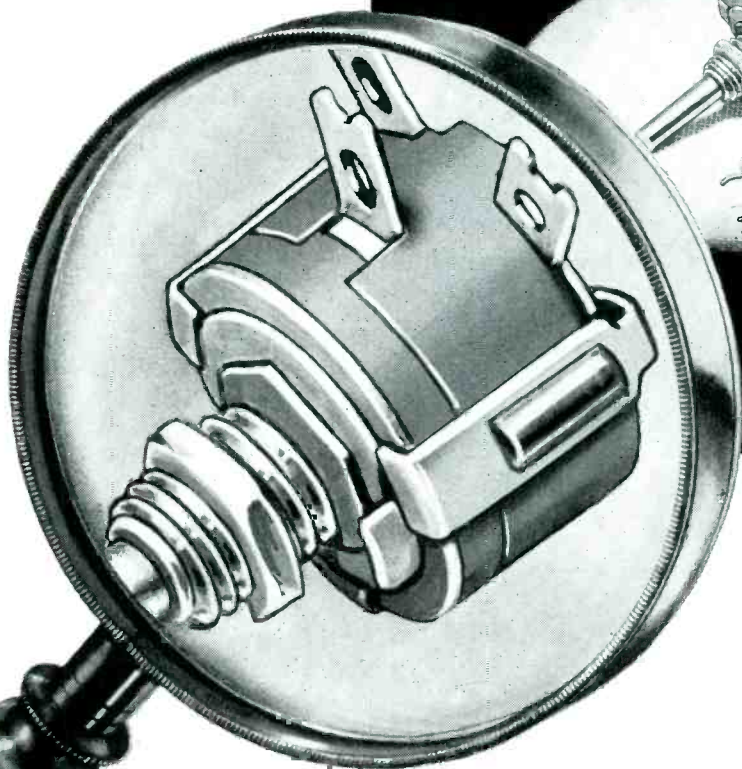

**ACTUAL
SIZE**

**CLAROSTAT
SERIES 48
COMPOSITION ELEMENT**

SUB-MINIATURE
Controls

DETAILS ON REQUEST

CLAROSTAT



Controls and Resistors

CLAROSTAT MFG. CO., INC. • DOVER, NEW HAMPSHIRE • In Canada:

CANADIAN MARCONI CO., LTD.
Montreal, P. Q., and branches

Microphones **BY TURNER**



PRACTICAL FOR ALL SOUND APPLICATIONS

If you need a microphone for studio or recording work, call system, public address, or amateur communications—you want a Turner Model 25X—25D. It's an all around unit for all around performance. You'll praise its smooth, wide range response and high output level. And you'll like the full 90 degree tilting head and convenient removable cable set. Finished in two tone umber gray with chrome plated grill or bright chrome at slight additional cost. Turner Engineers went all out in designing the 25X—25D. See it at your dealer.

Write for Complete Microphone Literature

THE TURNER COMPANY

905 17th Street N. E. Cedar Rapids, Iowa

IN CANADA

Canadian Marconi Co., Ltd.
Montreal, P. Q., and branches

EXPORT

Ad. Auriema, Inc.
89 Broad St., New York 4, N. Y.

Licensed under U. S. patents of the American Telephone and Telegraph Company, and Western Electric Company, Incorporated. Crystals licensed under patents of the Brush Development Company.



THE ELECTRON ART (continued from p 122)

many of its properties. In some ways HeII acts as though it has no viscosity, flowing through virtually vacuum-tight openings and up the side of a containing vessel in apparent defiance of gravity. At the transition temperature the thermal conductivity of HeI increases very abruptly to an apparent value for HeII much greater than that of any other substance. This is because heat is propagated in HeII as a kind of wave motion analogous to sound and known as "second sound," whereas in other materials heat flow is purely a diffusion phenomenon. All of these effects may be explained by the presence in HeII of a superfluid. The atoms of the superfluid have had their energies reduced by cooling to the point where thermal motion has almost ceased, yet the intermolecular forces are not great enough to produce a rigid solid. As a result, viscosity practically disappears, and other remarkable properties are observed.

Second sound has recently been obtained at the National Bureau of Standards through use of liquid helium produced in a new Simon-type liquefier. Unlike ordinary sound, second sound is generated thermally and can be detected only by temperature-sensitive devices, rather than by microphones. The present investigation employs a recently developed pulse method so that signals that would otherwise be quite difficult to detect are presented on an oscilloscope screen for visual observation. Pulses of heat generated electrically within liquid HeII travel through the helium and are detected upon arrival at a temperature-sensitive element; meanwhile, their transit time is measured accurately by electronic timing circuits.

Bombardment of Semi-Conductors with Neutrons

BY ADDING carefully controlled amounts of impurity atoms to pure silicon and germanium, it is possible to produce at will semi-conductors which owe their conductivity at room temperature primarily to carriers released by ionization of the impurity centers. Any of the ele-

How to CUT YOUR DISC DOLLAR



SOUNDCRAFT discs are made in 25 types and sizes. You don't wear your Sunday go-to-meeting clothes to work in the garden. Why use unnecessarily expensive disc grades for everything?

Unlike some brands, Soundcraft discs are all coated with the same high-fidelity lacquer. The grading differences are based on the nearness to microscopic physical perfection.

Three grades in five sizes plus single or double face, and oversize masters, are tailored to every budget.

STANDARD NET PRICES TO RADIO STATIONS AND RECORDING STUDIOS (In Standard Packages)

THE 'BROADCASTER'

A MASTER selection in instantaneous sizes for vitally important recordings.

| | | |
|-----------------|-------|--------|
| 10" Double Face | | \$.84 |
| 12" " " | | 1.32 |
| 16" " " | | 2.37 |
| 10" Single Face | | .54 |
| 12" " " | | .90 |
| 16" " " | | 1.63 |



THESE ARE STRICTLY LONG HAIR... SUPER FANCY

THE 'PLAYBACK'

A standard broadcasting-quality blank record for all professional uses in radio stations, recording and motion picture studios.

| | |
|-----------------|----------|
| 10" Double Face | ..\$.69 |
| 12" " " | 1.14 |
| 16" " " | 2.07 |
| 10" Single Face | ..48 |
| 12" " " | ..84 |
| 16" " " | 1.44 |



THESE ARE THE WORK A-DAY KIND THE NETS LIKE. EQUAL TO THE BEST GRADES OF OTHER BRANDS

THE 'AUDITION'

A selection from the runs of "BROADCASTERS" and "PLAYBACKS" having minor physical defects outside of the recording areas.

| | |
|--------------------|------------|
| 6 1/2" Double Face |\$.27 |
| 8" " " | ..42 |
| 10" " " | ..60 |
| 12" " " | ..93 |
| 16" " " | 1.59 |



THESE ARE SUCH A BARGAIN! TALK IN A WHISPER!

Standard Soundcraft economy packages of only 20 discs permit stocking wide variety of grades and sizes while simultaneously holding inventory value down.

ELECTRONIC ELECTRONICS CO.



301 252 foremostradio parts distributors in principal cities and towns deliver Soundcraft discs from local stocks.

REEVES Soundcraft CORP.
10 EAST 52nd STREET • NEW YORK 22, N. Y.

MARGIN CONTROL RECORDING BOOSTS MICROGROOVE RANGE

By A. C. Travis, Jr.*

For some time now Mercury Records have carried a little notation on their record envelopes explaining that the recording was done by a special process called, "Margin Control". That many recordists are not familiar with the meaning of these words is evidenced by the fact that we have so many times been asked for an explanation. Credit for the technique goes, according to all indications, to Bob Fine of Reeves Sound Studios. An interpretation of "Margin Control" follows in the form of a quotation from the external house organ of a famous manufacturer of blank records for both master and instantaneous recording.

"It seems that one of the major tactical problems in the ten inch versus seven inch microgroove war is the problem of the crescendo (evidently an old Mexican word meaning a noise that grows so loud it wakes up the customers). Now, when one of these crescendo passages comes along in microgroove recording, naturally the cutting stylus starts beating from side to side with such ferocity, that, while it cuts, it also displaces land material sufficiently to distort the adjoining groove. The resulting echo, even with the best discs, has relegated many master recordings to the reject pile. The obvious remedy of reducing volume cuts dynamic range, but, of course, when an irresistible force meets an immovable object, something has to give. Bob Fine gave—with an idea. He runs through the original recording or live number and "scores" it by plotting VU meter readings against time. Then, using new Fairchild equipment wherein lines-per-inch are infinitely variable from approximately ninety to five hundred, he makes the master fine-line recording by monitoring the lines-per-inch so that spacing is finest on lowest passages, coarsest on loudest ones. Appearancewise this procedure makes, from a light pattern standpoint, a funny looking record. For our money a disc recording, however, was always something to be more listened to than looked at. So, Mercury Records seem downright pleased with the resulting 62 db dynamic range."

"Margin Control", according to Mr. Fine, because of the inherent low noise level of the material is particularly effective with Soundcraft 'Maestro' discs. Soundcraft's triple-filtering to remove foreign matter, and Soundcraft's uniform consistency establish wide-dynamic-range microgroove recording on a predictable basis. Incidentally, Soundcraft ads, like Soundcraft discs are equally effective either way up.

Advertisement

*Vice Pres., Reeves Soundcraft Corp.

REEVES Soundcraft CORP. 10 EAST 52nd STREET - NEW YORK 22, N. Y.

PROF. SOUNDY SAYS..

Not just the usual lacquer ingredients, but also new in lacquer ingredients, gradient "X".

Not just the usual big-piece-removing filters to remove high pressure stone filters for remove microscopic matter small as .000012".

But also batteries of paper filter press.

Not just the usual dirt-removing filters for drying air. But also batteries of fine electrostatic precipitators that even remove dust-stop air. Not just conventional dust-stop air. But also batteries of fine electrostatic precipitators that even remove dust-stop air.

THE ANALYSIS:

EQUALS NEW IMPROVED QUIETNESS IN CUTTING

MINUS } FOREIGN MATTER IN LACQUER. MICROSCOPIC DUST IN DRYING AIR. PROPERLY COMPOUNDED RECORDING LACQUER

THE FORMULA:

WITH Soundcraft CLEAN CUT LINES REDUCE EXTRANEOUS NOISE!

Advertisement

GRID-CONTROL RECTIFIER TUBE
EL C6J/A

Tantalum Anode and Xenon Gas Filling

| | |
|--|-----------------|
| D-c. Amperes Output (Max. Rated) | 6.4 |
| D-c. Meter Value-Continuous | 12.8 |
| D-c. Meter Value Overload less than 3 sec. | 77 |
| Oscillograph Peak-Continuously recurring | 1000 |
| Peak Forward Volts (Max. Instantaneous) | 1250 |
| Peak Inverse Volts (Max. Instantaneous) | 9 |
| Average Arc Drop Volts | 12 |
| Average Tube | |
| Highest Tube at end of life | 2.5 |
| Filament | |
| Volts | 21-2A |
| Amperes | Approx. 60 sec. |
| Heating Time | |

Grid Characteristics

| | | |
|--|--------------|-------------|
| Critical Grid Volts @ 1,000 p.f.v. | 4.8 | 1.6 |
| Critical Grid Current | Less than 10 | Microamps |
| Maximum Negative Grid Volts | 40 | 75 |
| Starting Volts Instantaneous @ +4 grid volts | 40 | 75 |
| Average Tube | Approx. 1 | millisecond |
| Highest Tube | Approx. 4 | microsec |
| Maximum De-ionization Time | Approx. 21 | microsec |
| Grid-anode Capacitance | 0.66 | |
| Grid filament Capacitance | 770A | |
| Rectification Factor % $I_{d-c} \times A_{used}$ | 2 x 9 = 18 | 7 gas. |
| Max. a-c. Short-circuit Current (0.1 sec.) | | |

Overall Dimensions

Weight

Connections

Filament & Grid

Temperature Limits

The filament must be lit before drawing d-c. load current.

Filament prong #1 is connected to heat shield.

All of the above values are for returns to the filament transformer center tap.

The anode is designed to operate at full red heat when used in order to take full advantage of the gettering properties of tantalum.

ELECTRONS,
127 SUSSEX
NEWARK

9/1/48

ELECTRONS INCORPORATED
127 SUSSEX AVENUE
NEWARK, N. J.

*A higher voltage quick-heating
gas thyatron.*

ments from the fifth column in the periodic table will produce n-type material conducting by electrons. Any of the elements added from the third periodic group will produce p-type conducting by defect electrons or holes that react as solid charges. Each of the impurity atoms is supposed to release one carrier only.

With the number of electrons or positive holes and their temperature dependency as determined from Hall effect, it is possible to develop a general theory of resistivity and thermoelectric power which accounts completely for the

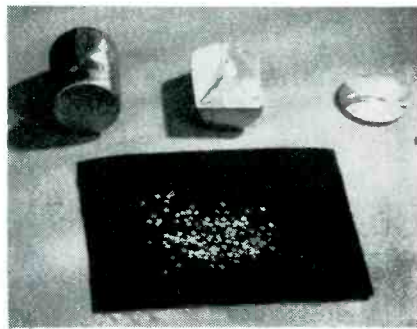

Bell Labs photo showing purified germanium ingot, first saw cut, slab and finished pellets ready for use in semi-conductors

electrical behavior of these semi-conductors from very low temperatures up to the melting point.

By adding a large enough number of impurity centers it is possible to produce a semi-conductor which follows quantum statistics. By measuring the conductivity to low temperatures it is possible to go continuously from classical to quantum statistics, for the first time producing an experimental proof for this behavior of the electron gas.

Recently it has been possible to develop a new type of semi-conductor by displacing the atom in the semi-conductor due to nuclear bombardment by either neutrons or alpha particles or deuterons from the cyclotron. Polonium alpha particles have also been used with success. In this way it is possible to change an N-type semi-conductor into a P-type semi-conductor and study in detail the changes in rectifying action by bombarding, for instance, germanium-point contact rectifiers with nuclear particles.

If silicon containing both p and



TEST CHAMBERS

TO SIMULATE

TEMPERATURE • ALTITUDE • HUMIDITY

Designed by Bowser, Inc., to meet the most rigid requirements for testing electronic components or equipment in relation to temperature, humidity or altitude. Used widely by government and industry in laboratories for research and development work and on the production line.

BOWSER LABORATORY UNITS—L-Series

These Units are designed so that industry may perform its testing and processing simply, accurately, and in a minimum of time. Electronic equipment or components which are to be subjected to severe weather conditions can be proved in a Bowser Laboratory Unit. The temperature ranges (+180°F. to -100°F) cover every conceivable application from Tropic heat to Arctic cold and from sea level to 75,000 ft. above the earth. These temperatures are controlled to within $\pm 2^\circ$ F. within the range. The range of Relative Humidity simulation (from 20% to 95%, see table) is equivalent to practically any condition, and the Vacuum simulation easily meets all present day needs for this type of equipment.

| MODEL NO. | SIZE | | | LOW TEMP. POINT F. | PULL DOWN FROM AMB. MIN. | DISSIPATION AT LOW OPERATING POINT AT SEA LEVEL | MASS LOAD OF STEEL | 8 POST. 4 THERMOCOUPLE TERMINAL PAD | CUT OUT AND REMOVABLE INSULATION BATT |
|--------------------------------------|------|-----|---------------------|-----------------------------|--------------------------|---|----------------------|---|--|
| | H | W | D | | | | | | |
| L1-50 VH L1-76 VH L1-100 VH | 12" | 12" | 12" (1 cu. ft.) | -50°F. -76°F. -100°F. | 70 105 170 | 100 watts 100 watts 50 watts | 25# 25# 25# | Available in all 3 L1 Units installed on left side wall, only if "cut out" not required | Available in all 3 L1 Units, installed on left side wall, only if Terminal Pad is not required |
| L5-50 VH L5-76 VH L5-100 VH | 18" | 30" | 15½" (5 cu. ft.) | -50°F. -76°F. -100°F. | 70 110 200 | 200 watts 200 watts 100 watts | 50# 50# 50# | Installed in left side wall | Installed in left side wall |
| L8-50 VH L8-76 VH L8-100 VH | 24" | 24" | 24" (8 cu. ft.) | -50°F. -76°F. -100°F. | 70 110 200 | 200 watts 200 watts 100 watts | 50# 50# 50# | Installed in left side wall | Installed in left side wall |
| L18-50 VH L18-76 VH L18-100 VH | 30" | 30" | 36" (18 cu. ft.) | -50°F. -76°F. -100°F. | 70 110 210 | 200 watts 200 watts 100 watts | 25# 25# 25# | Installed in left side wall | Installed in left side wall |
| L27-50 VH L27-76 VH L27-100 VH | 36" | 36" | 36" (27 cu. ft.) | -50°F. -76°F. -100°F. | 75 110 210 | 200 watts 200 watts 100 watts | 100# 100# 100# | Installed in left side wall | Installed in left side wall |

THE FOLLOWING SPECIFICATIONS ARE STANDARD FOR ALL MODELS:

- Reheat time from ambient to +180°F. is 70 minutes.
- Thermocouple Type Indicating Controller; installed in instrument panel to right of free-working space. Range: -150°F. to +200°F.
- Altitude Simulation Equipment: Laboratory Type, Oil Sealed Vacuum Pump and Hand Operated Climb-Neutral-Dive Valve.
- Current (for control): 110 volt, 60 cycle, single phase. (for power): 220 volt, 60 cycle, three phase.
- Average Climb Rate: 3,000 feet per minute to 50,000 feet.
- Maximum Vacuum: 1" mercury absolute.
- Vacuum Gauge: 4½" Dial Type, 0' to 80,000'.
- ¾" I.D. Low Pressure Pipe: 50 psi. installed in left side wall.
- Special instrumentation can be supplied at customer's request.

CONSTRUCTION

Cabinet mounted on rigid steel base of welded channel irons to prevent warpage or distortion. Refrigeration equipment and vacuum pump, etc., mounted on separate inner frame to minimize vibration. Work being tested checked during processing through inspection window mounted in door of chamber. Interior illuminated by means of a light mounted on door outside the chamber. Instrument panel is also supplied with a light mounted over it.

OTHER BOWSER UNITS

Some of the many Bowser units are shown and briefly described on this page. They have a wide scope of application throughout industry. Complete details regarding any of them are available upon request.

INDUSTRIAL

For the user whose requirements do not call for conditions of high altitude or relative humidity, the Industrial "low temperature" Unit is available. A typical application might be the expansion fitting of bushings.

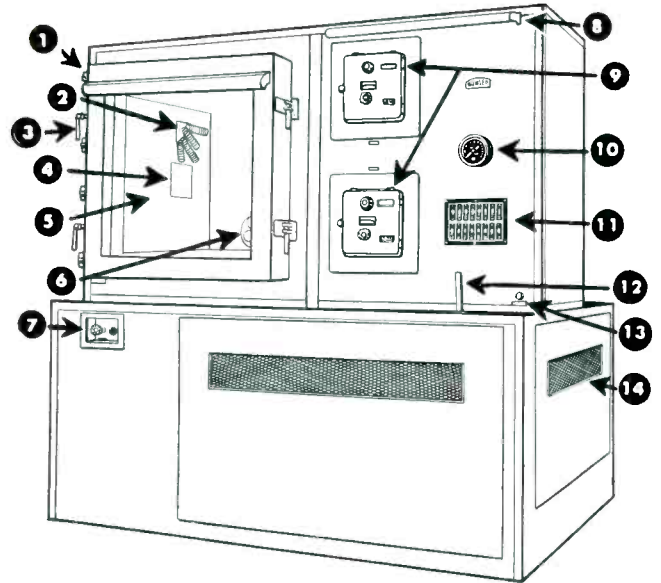
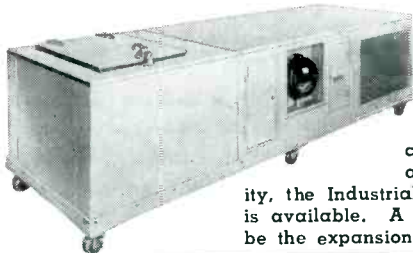

- Door Light
- Internal Terminal Pad
- Cam Latch
- Access Port
- Inspection Window
- Air Mover
- Hand Regulating Water Valves
- Instrument Panel Light
- Indicating Potentiometer, Controller (Wet and Dry Bulb)
- Altitude Gauge
- Control Panel
- Climb-Dive Valve
- Manometer Connection
- Condensing Unit Compartment

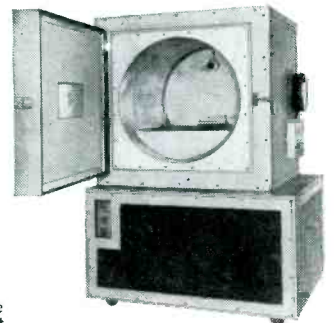

UTILITY UNITS

Designed for rapid, dependable production testing and processing. It is also capable of being used for limited amounts of research and development work. Adaptable to a wide range of applications from production processing of radio crystals to testing of cameras and camera lenses. Provided with temperature control from +158°F. to -80°F., with a tolerance of control of $\pm 3^\circ$ F. over the range.

BOWSER, INC. REFRIGERATION DIVISION — 420 LEXINGTON AVE., N. Y. C.

IN CANADA, S. F. BOWSER CO., LTD., 344 SHERMAN AVE., HAMILTON, ONTARIO

Anti-Corrosive STAINLESS STEEL FASTENINGS DO THE JOB *Better*

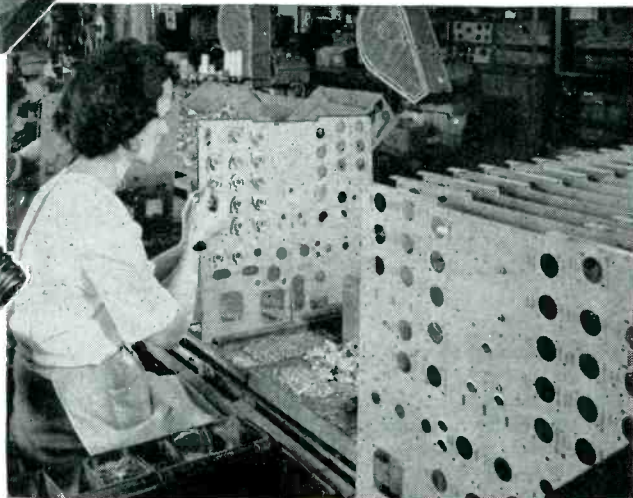
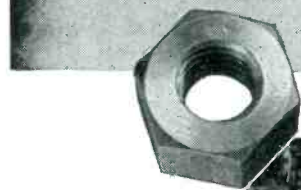

Discover Why Stainless Fastenings Are a Must in Electrical Manufacturing!

Every day stainless plays a more important part in electrical equipment manufacturing. Chosen for non-magnetic qualities, resistance to corrosion and vibration, permanence and fine appearance, or any one of a dozen other properties, stainless fastenings provide greater efficiency and a longer life, plus a sizable saving in maintenance and re-use quality. Specify stainless fastenings today, since you're sure to use them tomorrow!

7,000 Varieties of Stainless Fastenings On Hand—Plus Speed in Special Orders!

Anti-Corrosive, America's oldest and largest supplier dealing *exclusively* in stainless fastenings, carries this tremendous stock for your convenience . . . plus a special order service available for occasional odd sizes. Try A-C first for the most efficient answer to fastening problems in electrical manufacturing!

Ask Your Secretary to Write for Folder C-49 for the Latest Information on Stainless Fastenings . . . **TODAY!**

Anti-Corrosive
Metal Products Co., Inc.
Manufacturers of STAINLESS STEEL FASTENINGS
CASTLETON-ON-HUDSON, NEW YORK

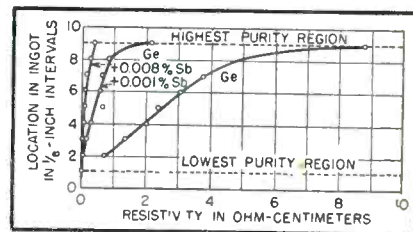

Effect of antimony additions on resistivity of germanium

n-type impurities is caused to solidify slowly the first frozen region is p type and the last frozen region n type. The boundary between the two regions is the seat of an interesting rectification and photovoltaic effect. This boundary may be resolved microscopically. Also the segregation and compensation effects may be employed to reduce the variation in resistivity in an ingot.

The germanium used for high-back-voltage rectifiers or for transistors may be converted reversibly from n to p type by heat treatment. This is interpreted as being due to the simultaneous presence of both p and n type impurities. Normally the n-type impurities are in excess.

The study of alloys of germanium with radioactive antimony has permitted the accurate determination of the distribution of antimony in an ingot even for concentrations as low as 4×10^{-6} percent. The concentrations determined by analysis agree with those computed from measurements of electrical properties. By this means it has been shown experimentally that each antimony atom present contributes one conduction electron to the germanium.

These applications of nucleonics to semi-conductors were reported in separate papers by J. H. Scaff of Bell Laboratories and K. Lark-Horovitz of Purdue University at the 1949 IRE National Convention.

Study of Vanishing Gases

THE LIFE of gas-filled tubes is limited by a gradual reduction in gas pressure with use. This tendency of filler gases to disappear from the tube volume is known as clean-up and is generally thought to result from the bombardment of negatively charged electrodes by high-velocity positive gas ions that penetrate the metal surfaces and

become permanently trapped.

A study of clean-up phenomena is now underway at the Electron Tube Laboratory of the National Bureau of Standards. A specially-designed discharge tube with a replaceable tantalum probe wire to collect the positive ions is being used. During operation, the rate of gas clean-up is measured for various negative d-c potentials on the probe in the presence of an arc discharge.

Since self clean-up cannot be avoided completely, its value is determined experimentally by operating the discharge tube with a positive probe voltage so that electrons rather than positive ions are drawn to the probe. Each test run is preceded by a self clean-up run, yielding a correction factor for the net clean-up into the probe. To avoid overheating the probe wire, negative voltage is applied in pulses of several milliseconds duration repeated several times a second.

Further problems under study include the complete recovery of trapped gas, a determination of the amount of gas which can be absorbed by the probe before satur-

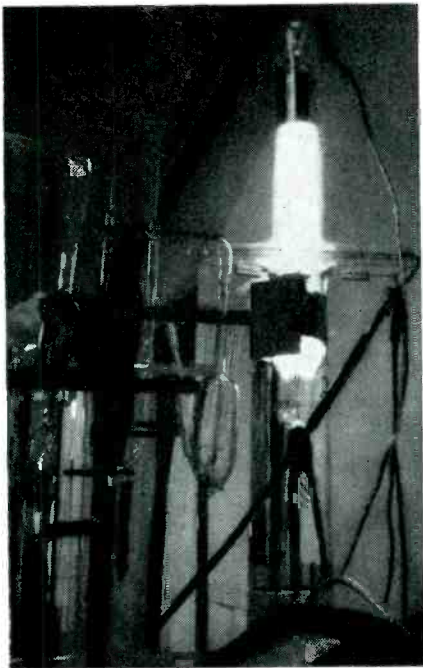

Special helium-filled arc discharge tube in operation in the Electron Tube Laboratory of the National Bureau of Standards. The ionized helium in the discharge column gives off enough rose-colored light to illuminate the other apparatus clearly. The tube contains a nickel anode at the top, a tantalum probe wire at the center, and an oxide-coated cathode at the bottom

Instantaneous recordings from D. C. to 100 cps of voltages, pressures, strains, vibrations, and countless other phenomena are accurate and permanent with Brush Oscillographs. A. C. or D. C. signals can be measured. Whenever desired, recordings may be stopped for notations on chart-paper! Investigate Brush measuring devices before you buy... they offer more for your money. Why not have a Brush field engineer call? At no obligation, of course. Just call or write, today, you will find it worth a few seconds' time!

THE **Brush** DEVELOPMENT COMPANY

3405 Perkins Avenue • Cleveland 13, Ohio, U.S.A.
 MAGNETIC RECORDING DIV. • ACOUSTIC PRODUCTS DIV.
 INDUSTRIAL INSTRUMENTS DIV. • CRYSTAL DIVISION

Canadian Representative: A. C. Wickman, (Canada) Ltd., P. O. Box 9, Station N, Toronto 14

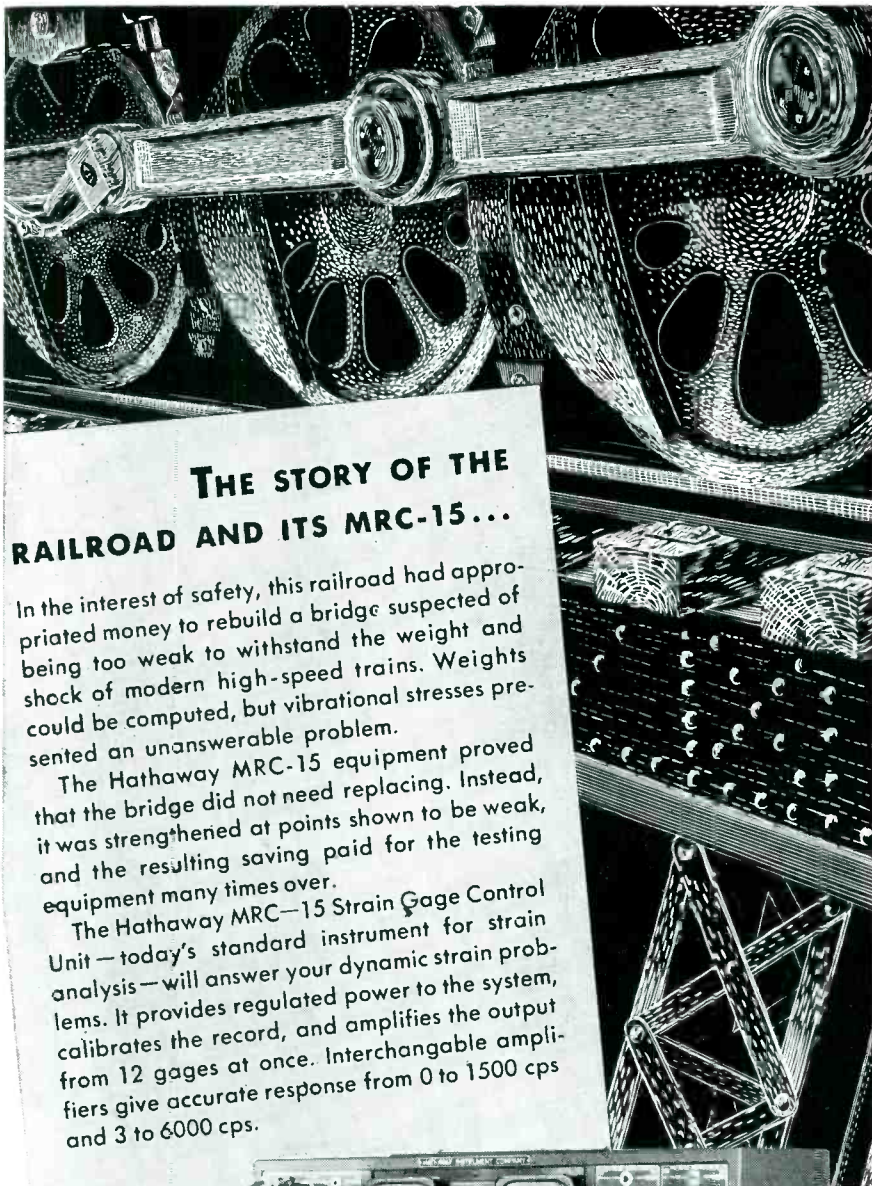

THE STORY OF THE RAILROAD AND ITS MRC-15...

In the interest of safety, this railroad had appropriated money to rebuild a bridge suspected of being too weak to withstand the weight and shock of modern high-speed trains. Weights could be computed, but vibrational stresses presented an unanswerable problem.

The Hathaway MRC-15 equipment proved that the bridge did not need replacing. Instead, it was strengthened at points shown to be weak, and the resulting saving paid for the testing equipment many times over.

The Hathaway MRC-15 Strain Gage Control Unit—today's standard instrument for strain analysis—will answer your dynamic strain problems. It provides regulated power to the system, calibrates the record, and amplifies the output from 12 gages at once. Interchangeable amplifiers give accurate response from 0 to 1500 cps and 3 to 6000 cps.

The Hathaway Type MRC-15 Strain Gage Control Unit

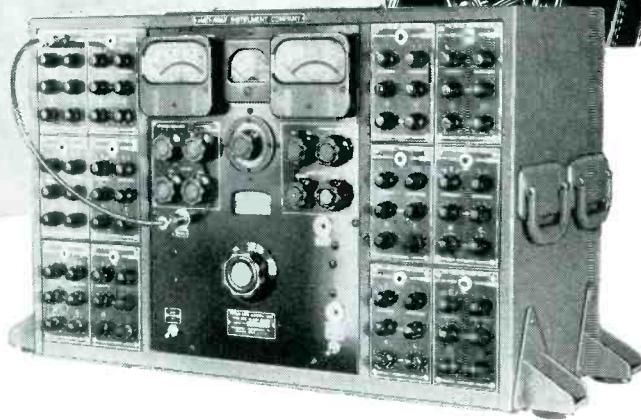

WRITE FOR TECHNICAL BULLETIN SP-195R

Hathaway
INSTRUMENT COMPANY
 1315 SO. CLARKSON STREET • DENVER 10, COLORADO

ation occurs, and a correction of the probe current for electron emission. Now that satisfactory techniques have been developed for a particular probe material and filler gas, these methods can be extended to other solids and noble gases of interest to tube designers.

Double-Ended D-C Restorer

By D. A. BELL

*Taplow, Maidenhead
 England*

DIRECT-COUPLED AMPLIFIERS are apt to be inconvenient for a number of reasons. Not the least of these is the risk of drift in the first stage causing serious unbalance or even overloading when amplified and applied to the last stage. There is therefore a motive for using an a-c coupling whenever possible.

When the signal has periodic excursions to a fixed limit but contains a d-c component because of varying amounts of signal on either side of the center line, a-c coupling can be used with a d-c restorer or clamping diode which fixes the mean position of the wave by reference to the excursions to the fixed limit. The name clamping diode does not seem to have come into general use, but

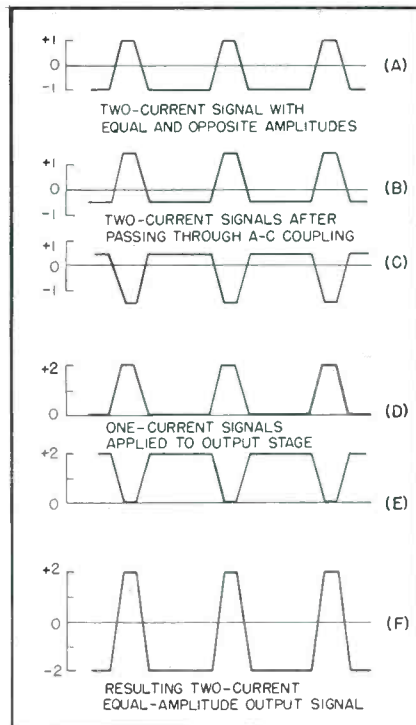

FIG. 1—Waveforms of 3-to-1-ratio of off-to-on telegraph signal, and effects of a-c coupling networks and d-c restoration circuits

is very expressive of the function of the diode in clamping one limit of the waveform to a fixed voltage level.

Probably the most familiar example of the d-c-restoring technique is to television video amplifiers, where the line sync pulses provide a repeated excursion to a fixed limit. There are cases, however, where the requirement is rather to keep the signal symmetrically balanced (in amplitude) on either side of the datum line, in spite of differences in proportion of time spent with either polarity.

The best example of this is a telegraph signal working on a mark and space basis represented by signals of opposite polarity. Figure 1A represents a hypothetical signal having the times spent on space and mark in the ratio 3 to 1 but with equal and opposite amplitudes of +1 and -1. Figure 1B shows the result of passing a repeated signal of this form through an a-c coupling (capacitor and leak). The datum line has shifted so as to produce equal areas on either side of zero, instead of equal amplitudes.

Now the problem is to get the datum line back into the center of the waveform, so that a relay or other device will operate exactly in the center of the transition from mark to space. This would not be important if the waveform were square, but in practice the reversals take a finite time and any departure from a symmetrical datum line will change the ratio of mark-to-space times. A distortion of mark-to-space time ratio of this kind is called bias distortion by telegraph engineers.

The desired result can be achieved by the circuit shown in Fig. 2, which includes a double-ended d-c restorer and operates as follows. The first tube is simply a phase-splitter, so that in addition to the waveform shown in Fig. 1B we have the inverted waveform of Fig. 1C. Each of the waveforms is applied to a d-c restorer consisting of the coupling capacitor between the phase-splitter output and the grid of one of the push-pull tubes in conjunction with a diode (half a 6H6 for each side). The diode is inverted, with anode grounded, so that signals on the

CHIEF ENGINEER FLEXY SAYS:-

**"HERE ARE TWO PLACES WHERE
S.S. WHITE FLEXIBLE SHAFTS
CAN HELP YOU"**

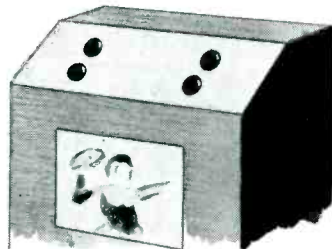

CABINET DESIGN

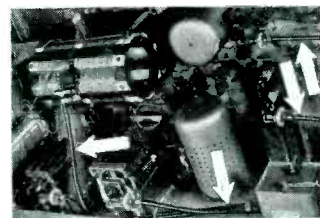

CIRCUIT DESIGN

"Many of the problems met in designing circuits and cabinets can be greatly simplified by using S.S. White flexible shafts to connect variable elements to their control knobs.

"Here's why. Irrespective of where you locate an element or its control, you need only a single, easily applied flexible shaft to connect the two. This gives you almost unlimited freedom in the placement of coupled parts and permits you to develop cabinet and circuit designs to get top electrical efficiency, better appearance, more convenient operation, and to meet space, assembly and wiring requirements.

"S.S. White flexible shafts have proved to be a successful answer to these problems in many electronic and radio devices including broadcast transmitters, diathermy units, AM and TV receivers and radar equipment. It will pay you to consider their use in your equipment."

FREE — FLEXIBLE SHAFT HANDBOOK

This informative 260-page handbook contains many helpful ideas on how to select and apply flexible shafts. A free copy will be sent if you write for it on your business letterhead.



S.S. WHITE

THE S. S. WHITE DENTAL MFG. CO.

INDUSTRIAL

DIVISION

DEPT. E 10 EAST 40th ST., NEW YORK 16, N. Y.



FLEXIBLE SHAFTS AND ACCESSORIES
MOLDED PLASTICS PRODUCTS—MOLDED RESISTORS

One of America's AAAA Industrial Enterprises

WHAT DO YOU NEED IN TELEVISION COILS?



If you use choke coils, band-tuning coils, channel coils, contact coils and others for television assembly, and if you want them coated with plastic, cotton, nylon, enamel, lenzak, formvar, etc., you can depend on Lewis for your needs. *Coils are stripped and tinned, ready for assembly!*

Lewis has the facilities and experience for mass production of all types of television coils—and our efficient methods permit economical prices.

Whatever your requirements, have a Lewis Engineer call and check them, quote delivery and prices. No obligation.

LEWIS SPRING & MANUFACTURING COMPANY
2656 West North Avenue, Chicago 47, Illinois

Lewis PRECISION **SPRINGS**
THE FINEST LIGHT SPRINGS AND WIREFORMS OF EVERY TYPE AND MATERIAL

grids of the pushpull tubes are positive-going only. (This polarity was chosen so that the output stage could be fairly heavily biased and run cool in the absence of a signal.)

Since the signals shown in Fig. 1D and Fig. 1E are applied to the output stage in pushpull, their combined effect in the common anode circuit is proportional to their difference as shown in Fig. 1F, which is a true copy of Fig. 1A. This waveform may be viewed by connecting the points Y_1 and Y_2 directly to the plates of a cathode-ray tube. It will not be seen if the points are connected to the input terminals of an oscilloscope having capacitor-coupled input, since the introduction of this a-c coupling destroys

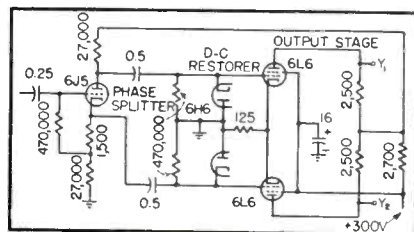

FIG. 2—Circuit diagram of double-ended d-c restoration amplifier

the d-c-restored condition which has been achieved in the amplifier. A striking demonstration of the efficacy of the system is given by having a changeover switch to give either direct or capacitive coupling from the points Y_1 and Y_2 to the plates of the cathode-ray tube.

For more practical use the loads in the anode circuit of the output stage may consist of the two halves of the windings of a telegraph relay or recorder.

Besides allowing a telegraph signal to be amplified in a-c-coupled stages and d-c-restored in the final stage, this circuit might be used for converting single-current (Fig. 1D) to double-current (Fig. 1F) signals. As mentioned above, a telegraph relay must change over at a signal amplitude exactly half way between the mark and space levels in order to avoid bias distortion of the signals, and with double-current working the changeover should occur at the neutral point of zero current. But in single-current working, where space is indicated by zero current, the changeover must occur at half the

mark amplitude to avoid distortion.

This is normally achieved by biasing the operating point of the relay to half the signal amplitude, and therefore requires adjustment for any change of signal amplitude. By using the phase-splitter and double-ended d-c restorer, either with or without preceding a-c amplification, a symmetrical two-current output is obtained. This has the advantage of operating a relay at neutral bias, so that it changes over at zero current and its operation does not require adjustment for signal amplitude.

A New Moisture-Sealing Compound

By W. B. RITCHIE AGNEW

*Consulting Engineer
Bellflower, California*

MOISTURE will leak into holders for quartz crystals and other components through gasket or pin leaks and may also transfer through phenolic housing material by moisture vapor transmission. To combat this action in small phenolic holders for crystals intended for tropical use, a special moisture sealing compound was developed in the Aircraft Radio Laboratory at Wright Field.

Several types of holders were involved in the initial research problem. The top loader type is sealed with a phenolic or metal cover and a neoprene gasket. One type of side loader has a round screw in cover and gasket. The inverted type seals with a gasket near the pin end. Such holders have two pins molded into the plastics container, one-half inch apart for contact through a suitable socket to the radio circuit.

The day to night cycling of temperature or the change in pressure from ground to high elevation brought on by airplane flight or a sunshine to shade cycling of temperature will cause breathing. This breathing sucks in moist air. When this air is exhaled at the other end of the cycle moisture will remain within the holder. It has been reported that some holders which were subjected to high humidity for long periods of time were actually

T PRECISION Transformers

**FOR TODAY'S
MORE EXACTING
REQUIREMENTS**

**POWER - - AUDIO
CHOKES - - FILTERS**

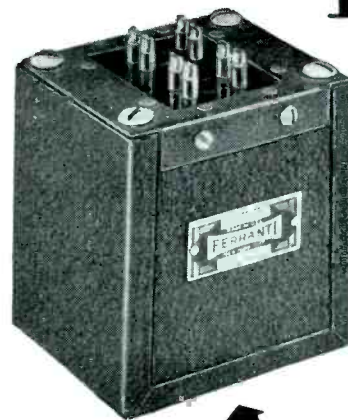

ENCLOSED CASE, compound filled, for high moisture resistance. Standard cases up to 500 VA. Wide range of standard audio transformer units.

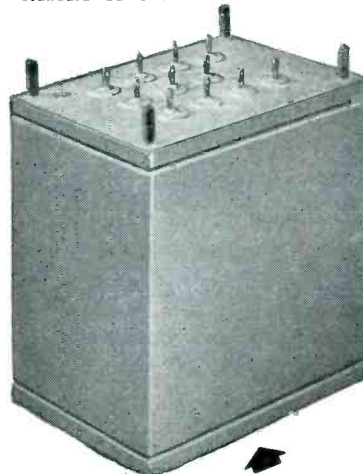

HERMETICALLY SEALED and compound filled cases. Glass or ceramic sealed terminals. Designed to meet JAN salt water immersion tests.

For Television and all other applications where specifications are precise and the emphasis is on quality and performance, famous FERRANTI transformers offer superior value.

Into each unit goes long years of specialized experience, plus up-to-the-minute knowledge of today's improved practices and latest materials. Our large and varied stock of patterns, tools, and dies often permits us to supply "custom" requirements from standard parts, effecting worthwhile savings. We invite your inquiries.

FERRANTI

**FERRANTI
ELECTRIC, INC.
30 ROCKEFELLER PLAZA
New York 20, N. Y.**

OPEN FRAME TYPE for mass production, minimum cost and weight for enclosed equipment.

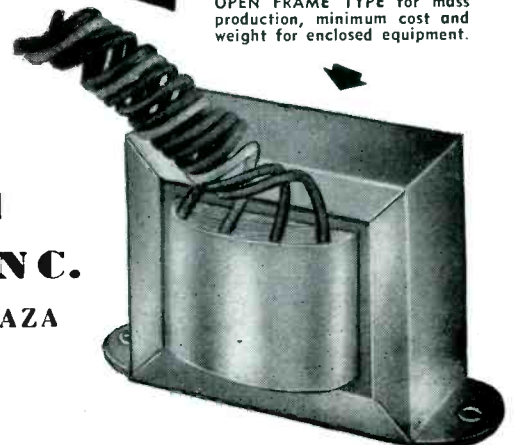

TAPE OR DISK

YOU CHOOSE FAIRCHILD FOR TOP PERFORMANCE



UNIT 100

★ The Fairchild "Synchroll" Drive System combines advantages of the transfer of power through soft rubber idlers with those of direct gear control of the capstan. This unique development of Fairchild results in a *no-slip synchronous* tape drive.

★ High Frequency Flutter causes roughness in a reproduced sine wave tone. *Smooth motion* in the Fairchild Tape Recorder is apparent in the *cleanliness* of simple musical tones.

★ Hum problems are generally recognized as inherent in magnetic recorders. The high efficiency of Fairchild Playback Head design and amplifier construction results in a hum measurement at least *68 db down*. (ref. 2% distortion).

THE FAIRCHILD PROFESSIONAL TAPE RECORDER easily outperforms requirements set by NAB Standards. Features include: "plug-in" type construction, both mechanical and electrical, for uninterrupted service; interlock system to prevent accidental erasing; volume indicator and circuit metering; adjustment of playback head during operation for optimum performance with all tapes; simultaneous monitoring from the tape during actual recording. Major network and recording studios are using Fairchild Tape Recorders. Write for complete information.

FAIRCHILD SYNCHRONOUS DISK RECORDERS

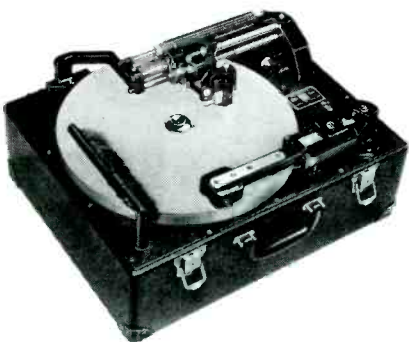

ACCURATE PROGRAM TIMING—Synchronous direct to the center gear drive for shows "on the nose".

FREEDOM FROM WOW—No slippage. No musical pitch change to make listeners aware the show is transcribed.

SOUND ON FILM DUBBING—Many of the motion picture sound tracks you hear and enjoy are first recorded on Fairchild Synchronous Disk Recorders.

Above are some of the features that have gained FAIRCHILD the reputation for the finest in recording equipment. Fairchild Synchronous Disk Recorders are manufactured in 3 models; Unit 523 for the finest fixed studio installation; Unit 539K for the small budget studio; Unit 539G (shown above) for console performance in a portable unit. Maintain your reputation for making the finest transcriptions and masters with Fairchild equipment. Write for illustrations and complete specifications.

 *Fairchild*

RECORDING EQUIPMENT CORPORATION

154TH STREET AND 7TH AVENUE, WHITESTONE, L. I., N. Y.

partially filled with water when opened for inspection.

Development Procedure

Over one hundred different materials were tested, including plastics, resins, waxes, paints and varnishes. A commercial asphaltum paint showed virtues of having the best sealing properties. This material had several disadvantages, such as being too brittle at -55 C and too soft at $+90\text{ C}$. These two temperatures are the extremes that a crystal unit must withstand in the using organizations of the Services.

Upon investigation, it was found that the asphaltum paint contained some rosin, which was eliminated so that the material would not be brittle at -55 C . This new material was still too soft at $+90\text{ C}$. Gilsonite was added to Hydrolene in various quantities until a formula was found that had enough plasticity at -55 C and still remained in a suitable state at $+90\text{ C}$. The percentages finally used were 60 percent Gilsonite and 40 percent Hydrolene.

Gilsonite is a natural asphaltum and is mined in Utah, while Hydrolene is a trade name of a material procured from Standard Oil Company and is a brand of petroleum asphaltum.

Several mixes of the above-mentioned proportions of asphaltum were tried in different mineral spirits and aromatic thinners. Xylene was decided upon as the vehicle due to its ease of coating and its drying behavior.

Another series of mixtures was tested, one containing 40 percent nonvolatile matter, another 50 percent and still another 60 percent. The 60 percent mixture, when heated in a water bath to 100 F , gave a coating material of the right viscosity for a dip-coating thickness of approximately 0.004 inch . Tests had shown this thickness was necessary to exclude a reasonable amount of moisture in a one-coat dip. The dip-coating compound was composed of 6 parts Gilsonite and 4 parts Hydrolene to make up 60 percent of the mixture, and Xylene to make up the remaining 40 percent.

A small amount of commercial grade aluminum paste as a filler

aided moisture imperviousness, and 12 ounces per gallon were added to the above formula. Materials were mixed in the above order.

Results of Tests

All moisture imperviousness and moisture vapor transmission tests were accomplished by coating a given holder which had previously had a chemically-treated blank installed in place of the crystal blank. The moisture transferred to within the holder was then detected by an electrolytic reaction and indicated with the aid of a specially-constructed moisture indicating meter.

All tests were run in humidity cabinets at one of the following temperatures with a 95-percent relative humidity: cycling 25 to 50 deg C, cycling 25 to 65 deg C, and static at 50 deg C.

It was also noted that resistance between pins remained nearer to the original resistance of 50,000 megohms or better after being coated. Some uncoated holders dropped to less than 100 megohms in a few days. This was due to water absorption of the phenolic material. The moisture sealing compound was found to have high dielectric characteristics and would resist fungus growth more readily than some of the phenolics of the uncoated holders.

Dipping Technique

Dipping is best done automatically at a slow speed, probably not more than $1\frac{1}{2}$ inches a minute withdrawal speed. This is intended to eliminate any drip or bead on the edge of the holder.

After some production by a West Coast contractor, it was found that spraying under pressure with special spraying equipment designed by Alemite Corporation was superior to the dipping process. Tears and heavy drainage areas were entirely eliminated.

After the crystal units were coated with the moisture sealing compound and allowed to dry for approximately 18 hours, a second coat was applied, this time using a special aluminum paint which would not wrinkle in humid atmospheres. This special aluminum paint differed from the commercial alumi-

YOU CAN BE SURE.. IF IT'S Westinghouse

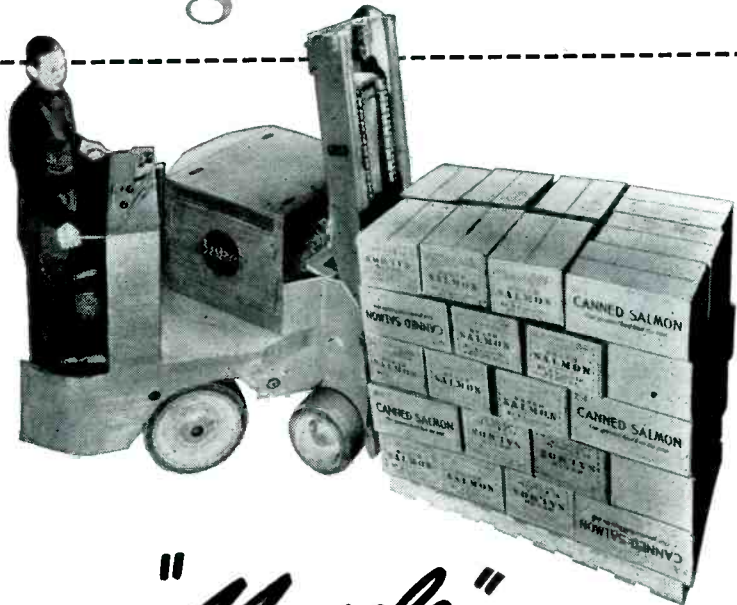

MORE "Muscle"
FOR ELECTRICAL APPARATUS
... at no extra cost

Your apparatus can have higher electrical stamina . . . longer operating life . . . if insulated with Westinghouse "Tuffernell" Insulating Varnishes.

Outstanding among these new varnishes are Tuffernell B-161, B-163, and B-165. All are thermosetting; and each has specific properties of high resistance to heat . . . moisture . . . centrifugal force . . . and to other enemies that break down ordinary varnishes.

It is because of these properties that Baker-Raulang, of Cleveland, chose Tuffernell B-163 for their well-known line of industrial trucks, tractors, and cranes. They like B-163's deep penetration of windings, giving better heat transfer and cooler-running motors. They have found, too, that B-163 is economical and faster to use, and stands up in rugged service.

The complete Tuffernell line includes Insulating Varnishes and Compounds for *your* application. All are described in Bulletin 65-120, available on request.

Investigate Tuffernell today for your needs. Call your nearby Westinghouse office, or write Westinghouse Electric Corporation, Dept. 37, P.O. Box 868, Pittsburgh 30, Pennsylvania.

J-06418

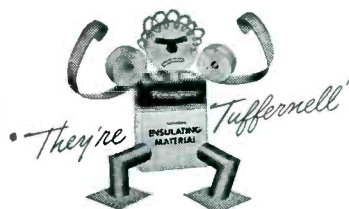

Westinghouse
TUFFERNELL INSULATING VARNISHES
— for every electrical need

Another OUTSTANDING ACHIEVEMENT *by*

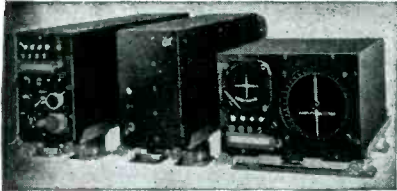

AIRBORNE RECEIVING EQUIPMENT



**AN/FRN-8 LOW
FREQUENCY
OMNIDIRECTIONAL
RADIO RANGE SYSTEM
DESIGNED AND
DEVELOPED BY RADIO
RECEPTOR FOR U.S.
AIR FORCE**

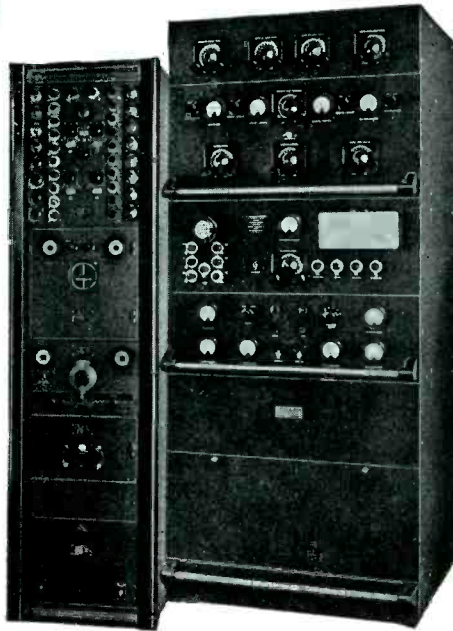

MONITOR UNIT

GROUND TRANSMITTER

Enables aircraft to navigate safely along any radial track to a ground station from distances up to 500 miles. The ground equipment is completely air transportable, permitting the expeditious setting up of a complete medium range navigation system when required.

A novel FM-AM system confines the navigational signal to a total r-f bandwidth of 60 c.p.s. permitting simultaneous voice broadcast on the same carrier. The airborne receiver employs push-button selected crystal control and has a navigational i-f bandwidth of only 150 c.p.s.

This entire project, from its original theoretical conception to final delivery to the U.S. Air Force, was undertaken by Radio Receptor. This includes preliminary research, development of the component equipments, production of a complete packaged station including transmitter, monitors, test equipment, antennas, and tuning units, production of airborne receivers and finally actual installation of the complete working system at a U. S. A. F. base.

Communications Division



RADIO RECEPTOR COMPANY, INC.



Since 1922 in Radio and Electronics

251 WEST 19th STREET

NEW YORK 11, N. Y.

num paint inasmuch as it contained a resin vehicle designated BR254 resin. The application of this aluminum paint overcame all stickiness at elevated temperatures.

Some of the specifications of the moisture sealing compound are as follows: Solids content, 60 percent by weight; specific gravity at 25 deg C, 0.984; weight per gallon, 8.2 pounds; viscosity at 25 deg C, 115 to 120 Kreh units; drying time at 25 deg C, 16 to 18 hours; flash point, 93.

The material should be heated in a water bath at 100 deg F. This gives a consistent coating of approximately 0.004 inch in both winter and summer months.

Determining Form Factors of I-F Transformers

By WILLIAM C. VERGARA

*Communication and Navigation Section
Bendix Radio Div., Bendix Aviation Corp.
Baltimore, Md.*

THE DEGREE OF COUPLING of a conventional i-f transformer can be determined readily by measuring the bandwidths at two levels of attenuation and computing the ratio of these bandwidths. This ratio is directly related to the coupling factor of the transformer and is plotted in the accompanying graph to facilitate the determination.

Development of Method

The selectivity characteristic of the circuit shown on the graph is given by the well known (see for example J. E. Maynard's treatment in *ELECTRONICS*, p 15, Feb. 1937) relation given at the top of the graph with the terms as defined. The assumptions on which this relation was derived limit its validity to the practical case where only frequencies close to resonance are of interest; that is (1) the Q's are constant for all frequencies close to resonance, (2) the Q's are sufficiently high so that the inductive and capacitive reactances are equal and parallel and series resonances occur at substantially the same frequency, (3) there is no feedback in the associated vacuum tube circuit and (4) the tuned circuits are coupled by pure reactance.

This relation (at the top of the

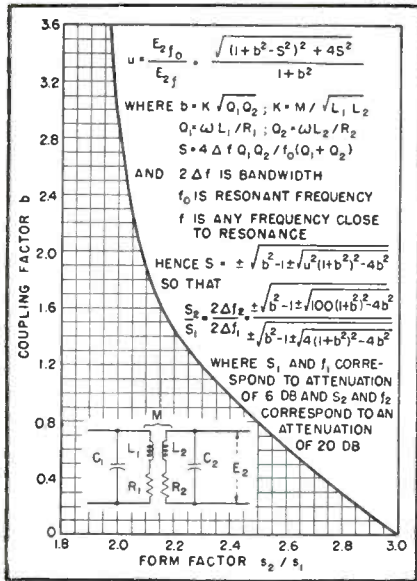

Transformer coupling can be determined simply from this chart and measurements at bandwidth at two levels of attenuation from the response at resonance

graph) can be solved for s giving the result shown on the graph. This expression relates the departure from resonance s to the coupling factor b and the attenuation factor u .

The factor s and therefore the bandwidth can be computed for any level of attenuation by substituting the appropriate value of u . Let s_1 be defined as the bandwidth factor corresponding to an attenuation of 6 db below the response at the resonant frequency; u is then equal to 2. Similarly, s_2 corresponds to an attenuation of 20 db for which u is 10.

Substituting these values of u and writing the ratio s_2/s_1 gives the final equation presented on the graph. This equation is plotted as the curve of the graph and is used in determining the coupling factor of a transformer.

Using the Graph

The ratio s_2/s_1 equals the ratio of the bandwidths at 20 and at 6-db attenuation. The coupling factor b can be determined for a particular transformer by measuring s_2/s_1 and then reading the corresponding value of b from the graph.

The choice of 6 and 20-db levels for the bandwidth measurements was made arbitrarily for ease and accuracy of performing the measurements.

NEW

JELLIFF RESISTANCE WIRE

ALLOY 1000
ALLOY 1000
ALLOY 1000
ALLOY 1000
ALLOY 1000
ALLOY 1000
ALLOY 1000
ALLOY 1000
ALLOY 1000
ALLOY 1000
ALLOY 1000
ALLOY 1000
ALLOY 1000
ALLOY 1000
ALLOY 1000

ALLOY 1000



RESISTIVITY—1000 Ohms per Circular Mil-Foot.
TENSILE STRENGTH—165,000 pounds per square in.
THERMAL EMF vs COPPER— +7 microvolts per ° C.
COEFFICIENT of LINEAR EXPANSION 20° to 100°
—0.0000139 per ° C.

SURFACE-CORROSION RESISTANCE—equal to that of the best nickel-chromium alloys.
TEMPERATURE COEFFICIENT OF RESISTANCE
20° C to 100° C— ±0.000025.

SIZES—all standard diameters from 0.0100" to 0.0009"; also in small sizes of ribbon.

FINISHES—Bright or Oxidized; insulated with enamel, silk or Nylon.

APPLICATIONS—wherever you can use more compact precision resistors at lower cost per ohm.

AVAILABILITY—Immediate.

Thus, in the continuing effort to provide the electronic and electrical industries with ever-better materials, Jelliff scores again —with the latest advance in Resistance Wires.

Full Information on Request—Address Depart. 17.

THE C. O. JELLIFF MFG. CORP.

DIPPING BASKETS
LEKTROMESH
RESISTANCE WIRE

SOUTHPORT

WIRE MESH PARTS
WIRE CLOTH
STRAINERS • FILTERS

CONNECTICUT

KINNEY

**HIGH VACUUM
FOR
HIGH PRODUCTION**

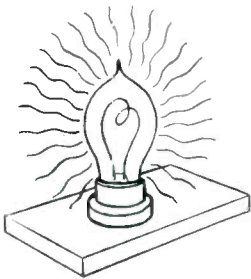
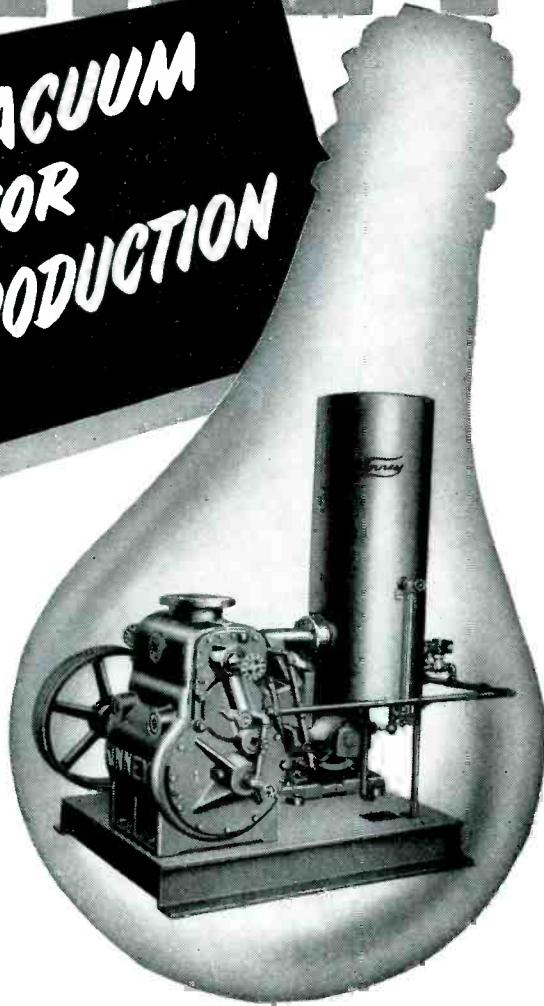

It's a far cry from the original incandescent lamp to the long-lived, efficient lamp coming off today's production line. Kinney High Vacuum Pumps are making available, at low cost, many vital products that only yesterday were laboratory discoveries.

Processing with Kinney High Vacuum Pumps has unlimited possibilities — the large scale production of electronic tubes, coated lenses, the miracle drugs, sintered metals, dehydrated foods, and scores of other products.

For any range of vacuum, high or low, their rapid pump down, long life, and dependability make Kinney Pumps the first choice in Industry. Single Stage Pumps test to low absolute pressures of 10 microns; Compound Pumps to 0.5 micron. Low pressure processing can improve your product and reduce production costs! Write for Bulletin V45 — the complete story on Kinney high vacuum producers.

KINNEY MANUFACTURING COMPANY

3565 WASHINGTON ST., BOSTON 30, MASS.

NEW YORK • CHICAGO • CLEVELAND • PHILADELPHIA • LOS ANGELES • SAN FRANCISCO

FOREIGN REPRESENTATIVES

GENERAL ENGINEERING CO. (RADCLIFFE) LTD.

Station Works, Bury Road,

Radcliffe, Lancashire, England

Melbourne, C. I. Australia

HORROCKS, ROXBURGH PTY., LTD.

W. S. THOMAS & TAYLOR PTY., LTD.

Johannesburg, Union of South Africa

NOVELECTRIC, LTD.

Zurich, Switzerland

WE ALSO MANUFACTURE LIQUID PUMPS, CLUTCHES AND BITUMINOUS DISTRIBUTORS

NEW PRODUCTS (continued from p 126)

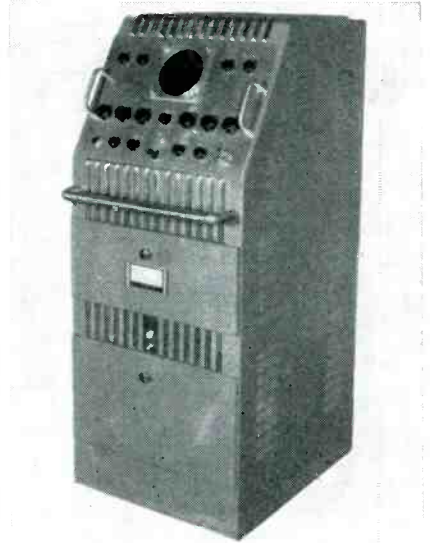

32A video oscilloscope enables the observation of waveforms having frequency components as high as 50 mc and as low as 10 cps. This wideband frequency response is obtained with sufficient amplification to provide deflection sensitivity of 0.1 peak-to-peak volt per inch. The horizontal amplifier has a bandwidth of 10 cps to 10 mc.

Survey Meter

RADIATION COUNTER LABORATORIES, INC., 1844 W. 21st St., Chicago 8, Ill. The Atomic Blinker is a portable survey meter containing a low-voltage thin-wall Geiger counter for radiation detection. Amount of radia-

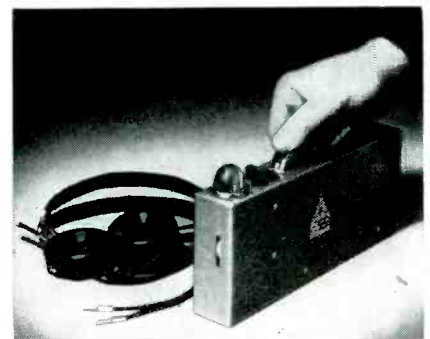

tion is indicated instantaneously by the rate of flashing of a lamp. Ear-phone tip-jacks are also provided. Battery life is from three to six months with normal usage.

F-M/A-M Isolation Unit

RADIO CORP. OF AMERICA, Camden, N. J. Type BAF-14A f-m/a-m isolation unit weighing less than 30

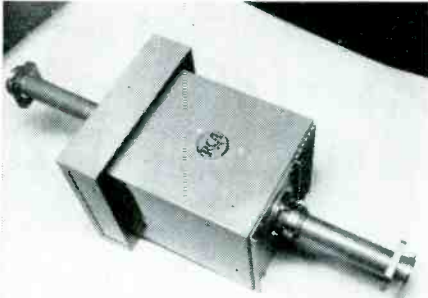

pounds was recently announced. The device is used to transfer f-m power across the insulating zone of an a-m antenna tower to feed an f-m antenna mounted atop the tower. It provides isolation of f-m and a-m signals and efficient operation over the entire f-m frequency range. The unit features swivel flanges at input and output which connect to standard 1½-in. 51.5-ohm flanged line.

Crystal Phono Cartridges

SHURE BROTHERS, INC., Chicago, Ill., has announced the Vertical Drive series of crystal phonograph cartridges. Tracking force is 5 grams on fine-groove records, 7 grams on 78-rpm recordings. The cartridge uses Muted Stylus needles which

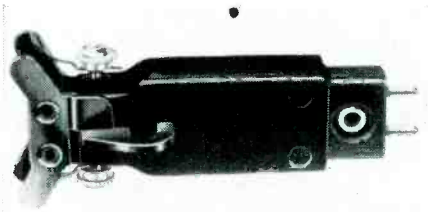

rotate on a vertical axis. It is available in three models: one for standard records, another for fine-groove, and a third, which is an all-purpose turnover model with replaceable needles for playing both standard and fine-groove records with the same pickup head.

Industrial Counters

AIRLECTRON INC., P. O. Box 151, Caldwell, N. J., has announced a new series of presettable high-speed electronic counters for industrial applications. Having a counting speed of 10,000 per minute, the devices operate from photoelectric or magnetic pickup sources. Output circuits may be connected so as to

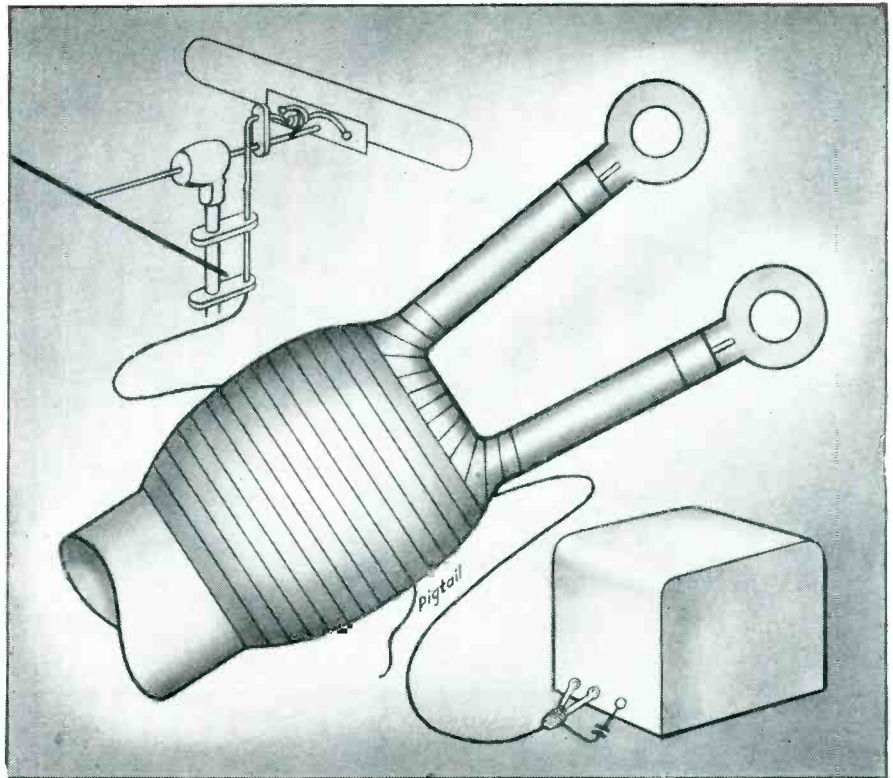

FEDERAL TELEPHONE AND RADIO CORPORATION'S shielded balanced 300-OHM Lead-in, lap-wrapped with "SCOTCH"

No. 33 Plastic backed Electrical Insulating Tape to prevent moisture from condensing under cable jacket.

Protect TV lead-ins with this new plastic tape

Happier customers, more customers, fewer trouble-calls when you protect TV lead-ins with "Scotch" No. 33 Electrical Tape. This tough, weather-proof plastic-backed tape helps protect against snow and ghosts, improves the signal-to-noise ratio.

Try "Scotch" No. 33 Electrical Tape on your next installation. Find how this amazing tape can simplify your television and radio work. A letter to us will bring complete information and a trial roll—with no obligation. Write Dept. ES-7.

Quick facts about "SCOTCH" No. 33 Electrical Tape

- **TOUGH**—plastic backing is abrasion resistant, unaffected by water or weather.
- **STRETCHY**—conforms snugly to uneven surfaces, odd shapes.
- **HIGH DIELECTRIC**—insulates against charges of over 7,000 volts.
- **THIN CALIPER**—only .007 of an inch thick, takes less room, gives neater jobs in all insulation work.
- **QUICK**—pressure-sensitive adhesive holds at a touch. Only *one tape* and *one operation* needed for all common electrical jobs.



ANOTHER 3M COMPANY PRODUCT

Made in U. S. A. by

MINNESOTA MINING & MFG. CO. SAINT PAUL 6, MINN.

also makers of other "SCOTCH" pressure-sensitive tapes, "Underseal", "Scotchlite", "3M" Abrasives, "3M" Adhesives.

GENERAL EXPORT: DUREX ABRASIVES CORP., 240 NORTH AVE., NEW ROCHELLE, N. Y.
IN CANADA: CANADIAN DUREX ABRASIVES LTD., BRANTFORD, ONTARIO



MOSINEE

"More than Paper"

If you have a fabricating or processing problem involving paper . . . if you require definite technical characteristics and, above all, *dependable uniformity*, it may be worthwhile for you and MOSINEE technicians to get together. MOSINEE is not interested so much in terms of volume production as in our ability to render helpful service to manufacturers in the field of electronics and in the electrical goods industry. Our "paperologists" are at your service for consultation. Please write Dept. E,



MOSINEE PAPER MILLS COMPANY • MOSINEE, WIS.
Essential Paper Manufacturers



NEW PRODUCTS

(continued)

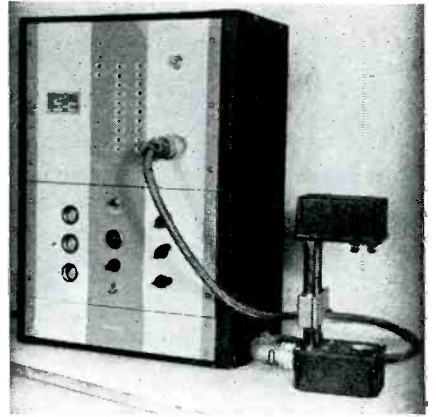

start and stop machine operation or perform any function associated with counting. Further information is contained in bulletin C-140.1.

Portable Recording Oscillograph

CENTURY GEOPHYSICAL CORP., 1333 North Utica, Tulsa, Oklahoma. The portable recording oscillograph is applicable for laboratory or field work. It is equipped with mirror-

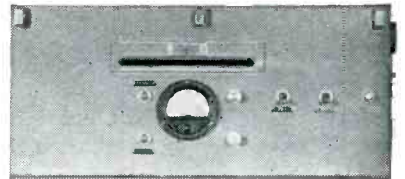

type galvanometers, fork-controlled synchronous timing system and variable paper widths up to 6 inches maximum. The unit may be battery or a-c operated and is available for multiple channel recording up to 25 traces.

Insulated Leads

AIRCRAFT-MARINE PRODUCTS INC., 1611 N. Fourth St., Harrisburg, Pa., has added to its line of solderless wiring devices new plug-in leads with a special flexible plastic insulation. They feature precision positioning of the jack-pin and will withstand temperatures up to 170 F.

Hermetic Relays

STRUTHERS-DUNN, INC., 150 N. 13th St., Philadelphia, Pa. Type CX3554 is a hermetically-sealed d-c miniature relay of special aviation design. It has shock resistance up to 50 g; vibration resistance better

than 10 g; high-speed opening and closing without contact bounce; and reliable operation over an ambient temperature range from minus 75 to plus 200 C. The hermetic sealing makes the unit insensitive to humidity changes and capable of rated operation at altitudes as high as 70,000 feet.

Communications Measurement

WESTON ELECTRICAL INSTRUMENT CORP., 617 Frelinghuysen Ave., Newark 5, N. J. Model 779, type 5, analyzer, was designed for communication system maintenance. It measures low-level speech circuits



with a minimum of circuit disturbance. The a-c response is essentially flat to 50 kc within 1 db over the range -20 to +22 dbm, and is usable for comparative db readings on all common carrier current frequencies above 50 kc.

Pickup Cartridge

ELECTRO-VOICE, INC., Buchanan, Mich., has announced the Twilt, a new torque-drive twin-tilt phono pickup cartridge. The cartridge with a single twin-tip replaceable needle plays 78, 45 and 33 $\frac{1}{3}$ -rpm

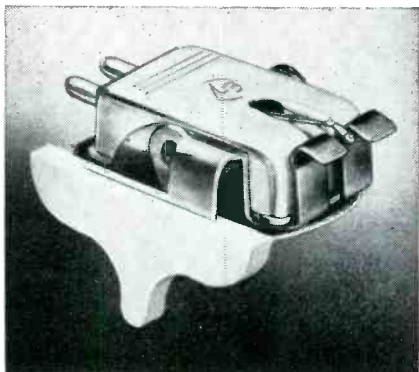

TRANSFORMERS

New York Transformer Company builds hermetically sealed transformers to meet your most exacting requirements. Specifications are translated by NYT experience and skill into the components you require.

Enlarged facilities for the development and manufacture of fine equipment assure the production of hermetically sealed units in accordance with your schedules. Ten or ten thousand—every transformer is built with the same specialized care. Shop procedures for testing insure the perfection of the seal on every unit. Hermetically sealed transformers from NYT meet all civilian and government specifications — including current JAN T-27, U. S. Navy 16-T-30, and Signal Corps 71-4942. Other sealed type transformers include specially treated, uncased, lightweight units for airborne use, built to government specification.

Engineering and design facilities, as well as production know-how, are always at your service. Write or phone your requirements.

Radio and television power transformers and reactors . . . audio transformers, filters and chokes . . . control and operating transformers . . . calibrators and special equipment for electronics.

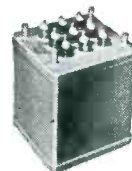
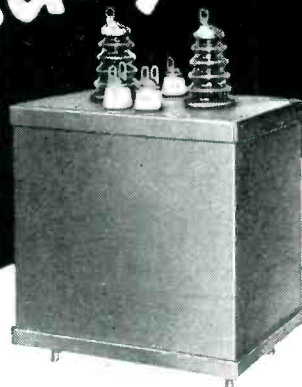

**NEW YORK
TRANSFORMER CO. INC.**

Alpha, New Jersey

NOTICE OF IMPORTANCE TO THE ELECTRICAL INDUSTRY

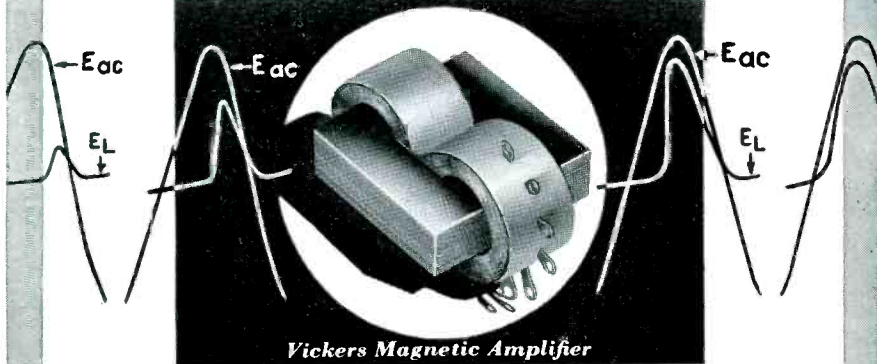

Vickers Magnetic Amplifier

VICKERS ELECTRIC DIVISION, Vickers Inc.,
Announces a complete Research and Development Section
available for your technical problems in relation to the
following —

**MAGNETIC AMPLIFIERS
MAGNETIC AUDIO AMPLIFIERS
STATIC VOLTAGE REGULATORS
STATIC MOTOR SPEED CONTROLS
POWER SATURABLE REACTORS
RECTIFIERS
PHOTOELECTRIC CELLS
SERVOMECHANISMS
MAGNETIC FLUID CLUTCHES
SPECIAL MOTORS AND GENERATORS
TRANSFORMERS • ARC-WELDERS
CONTROLLED POWER RECTIFIERS FOR
ELECTRO-CHEMICAL PROCESSES**

*The fundamental schemes employed in many of the above involve
general use of tubeless amplifier circuits—Magnetic Amplifiers.*

*For information regarding application of the above relative to your
requirements, you are cordially invited to consult our Engineering
Department.*

VICKERS  **ELECTRIC**
DIVISION

1815 LOCUST ST.

ST. LOUIS 3, MISSOURI

A UNIT OF THE SPERRY CORPORATION

E-7

NEW PRODUCTS

(continued)

records without weight change and with a tracking pressure of only 6 grams on either needle tip. Tilting the Twilt selects the one-mil or three-mil needle tip as desired.

Stylus Force Gage

GRAY RESEARCH & DEVELOPMENT Co., INC., 16 Arbor St., Hartford 1, Conn. The instrument illustrated, which is accurate to grams, is designed to check stylus force to obtain maximum quality reproduction

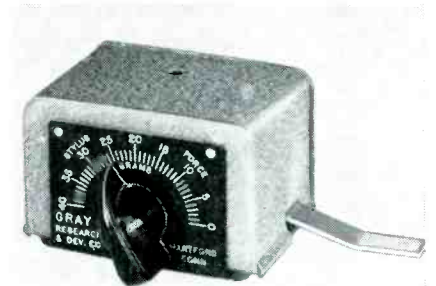

from records. Correct stylus pressure preserves high quality, prolongs record use and reduces replacement costs.

VHF Airborne Receiver

FEDERAL TELEPHONE AND RADIO CORP., Clifton, N. J. Type 139-BY vhf radio receiver for single-channel aircraft reception is the successor to the 139-B. Discrimination against undesired pulsed carriers and against spurious responses is good. Technical details of the equipment performance can be obtained from the manufacturer.

R-F Power Supply

EMBASSY ENGINEERING Co., 224 E. 204th St., New York 58, N. Y., has developed a new high-voltage r-f power supply for a wide variety of uses including television, c-r oscillography and general experimental

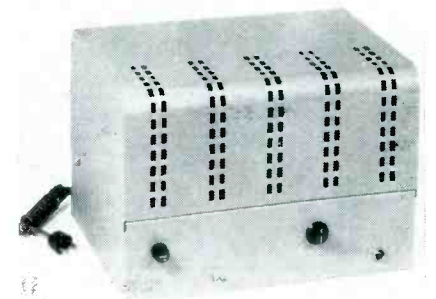

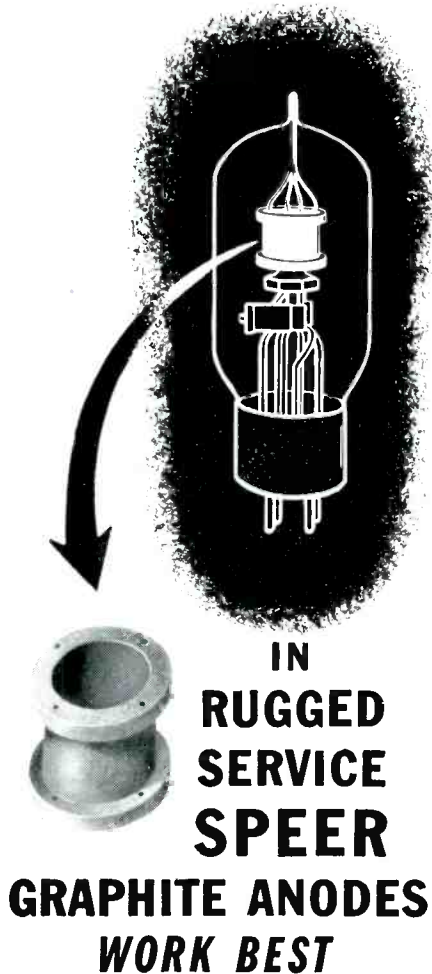

**IN
RUGGED
SERVICE
SPEER
GRAPHITE ANODES
WORK BEST**

You don't have to run the risk of tube failure in applications where operating conditions may be tough. Graphite — and *only* graphite — anodes work best when the going's roughest.

Here's why:

- Graphite anodes are capable of 200-300 % higher power rating over most metallic anodes.
- They provide stability — keep their original characteristics — won't warp even over the 200 megacycle range.
- Graphite *lasts* because it operates at lower temperatures, even when usage is severe and continual.

More and more, equipment manufacturers are *demanding* graphite anodes tubes for such applications as diathermy, vhf, short wave and FM transmitters, motor control, electrostatic precipitation, resistance welding, electronic heating, counting and sorting. Follow their lead, and you'll get better tube performance!



5464

Speer

**CARBON COMPANY
ST. MARYS, PENNA.**

Standard TIMERS

**WORLD'S MOST ACCURATE AND RUGGED
TIME MEASURING INSTRUMENT.
CAN BE MANUALLY OR ELECTRICALLY
OPERATED. FURNISHED IN PORTABLE
CASES OR FOR PANEL MOUNTING**

T-1E

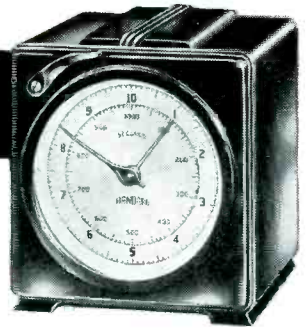

| Model | Reads | Totalizes | Accuracy |
|---------|-------------|-----------|-------------|
| S-100 | 1/5 sec. | 6000 sec. | ±.1 sec. |
| S-60 | 1/5 sec. | 60 min. | ±.1 sec. |
| SM-60 | 1/100 min. | 60 min. | ±.002 min. |
| S-10 | 1/10 sec. | 1000 sec. | ±.02 sec. |
| S-6 | 1/1000 min. | 10 min. | ±.0002 min. |
| S-1 | 1/100 sec. | 60 sec. | ±.01 sec. |
| MST | 1/1000 sec. | .360 sec. | ±.001 sec. |
| MST-500 | 1/1000 sec. | 30 sec. | ±.002 sec. |

WRITE FOR BULLETIN 153

also Standard Chrono-Tachometers •

Standard Custom-built Laboratory Test and Distribution panels

THE Standard Electric Time Co.

97 Logan Street

STANDARD
FOUNDED 1884

Springfield, Mass.

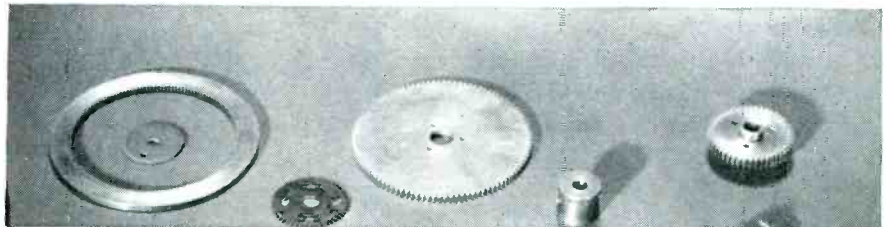

SPECIALISTS IN ELECTRONIC GEARS

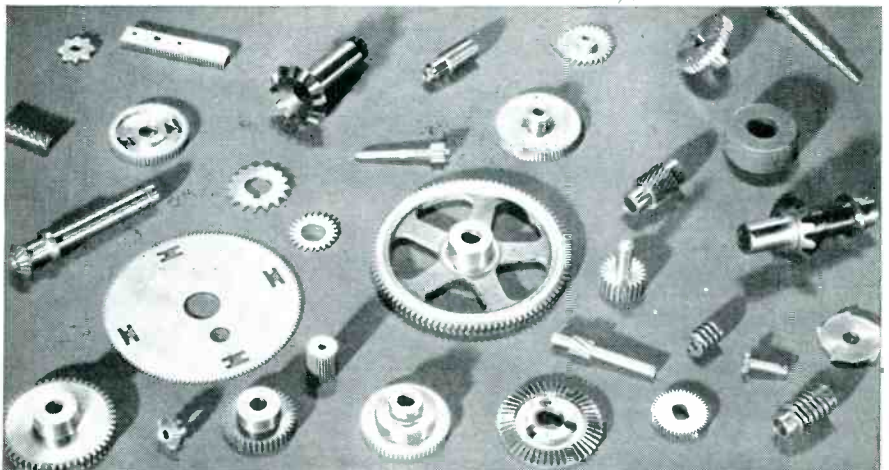

QUAKER CITY GEAR WORKS 1908-32 N. FRONT ST. PHILADELPHIA 22, PA.

LEDEX ROTARY SOLENOID



... solves remote control problems

The many production uses of Ledex Rotary Solenoids vary from actuating bomb releases in military aircraft to controlling hydraulic valves in heavy duty industrial material handling equipment.

Five Ledex Rotary Solenoid models are manufactured. Diameters range from 1 1/8 to 3 3/8 inches. Predetermined rotation up to 95°, either right or left, can be engineered to suit your production requirements. Starting torques for 45° of rotation range from 1/4 to 50 pound-inches.

Precision manufacture to exacting specifications and individual operating tests are your assurance of dependable, long-life service under severe operating conditions.

Magnetic action moves the armature along the solenoid axis. This action is converted into a rotary motion by means of ball bearings on inclined races.

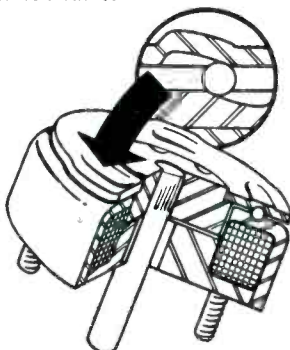

G. H. Leland INC.
DAYTON 2, OHIO

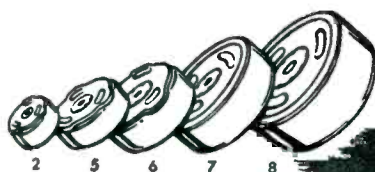

| MODEL No. | 2 | 5 | 6 | 7 | 8 |
|----------------------|--------|--------|--------|--------|--------|
| Diameter | 1 1/8" | 1 7/8" | 2 1/4" | 2 3/4" | 3 3/8" |
| Torque lb.-inches | 1/4 | 5 | 10 | 25 | 50 |
| Weight lbs. | 1/8 | 1/2 | 1 | 2 1/4 | 4 1/4 |

G. H. LELAND, INC.
118 Webster Street, Dayton 2, Ohio

Send descriptive literature on the Ledex Rotary Solenoid. The Ledex Rotary Solenoid may be applicable to our . . .

Product _____

Name _____
(Please Print)

Company _____

Street Address _____

City _____ State _____

FILL IN
AND MAIL
COUPON FOR
ILLUSTRATED
FOLDER GIVING
COMPLETE
INFORMATION

work. Input voltage is 110 v, 60 cycle a-c, with output voltage factory preset at 30 kv. Output current is 200 μ a normal at 30 kv; regulation is 3.3 percent at 30 kv with a load of 50 to 200 μ a. Power consumption is 75 watts.

Automatic Locking Plugs

RUSSELL & STOLL Co., INC., 125 Barclay St., New York 7, N. Y., announces a new line of midget Ever-Lok automatic locking plugs, receptacles and cord connectors, adaptable as components for all

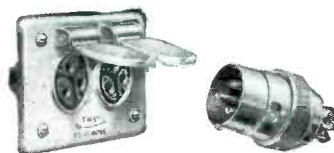

types of portable electrical equipment. A 12-page catalog EL49-64 describes and illustrates the unit's many features.

D-C/A-C Chopper

STEVENS-ARNOLD INC., 22 Elkins St., South Boston 27, Mass. Type 242 chopper is a single-pole, double-throw electromechanical chopper, rectifier, demodulator or square-wave generator which will operate

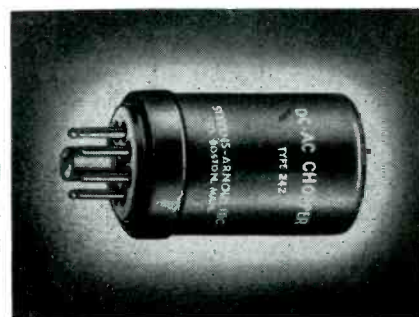

at any frequency over the 45 to 65-cps range. The unit features liquid filling, special shielding and make-before-break contacts. Complete details are given in catalog 246.

Electrical Tape

BAUER & BLACK, Dept. F., 222 West Adams St., Chicago, Ill. Polyken 822 is a plastic-backed electrical adhesive tape with a dielectric strength of over 10,000 volts. It has the insulation and electrical

Are You
in this
GROUP?



- MANUFACTURERS
- DISTRIBUTORS
- WHOLESALEERS
- RETAILERS
- INDIVIDUAL USERS

Then you'll want to know today's facts about RAILWAY EXPRESS high-quality rail or air service, designed to meet your shipping needs—and why this complete service for one, all-inclusive charge offers the most value for your shipping dollar.

Write FOR YOUR COPY

of booklet "Complete Service for A Single Charge", please address: Railway Express Agency, Inc., Dept. 230 Park Avenue, New York 17, N. Y.



NATION-WIDE RAIL-AIR SERVICE
ELECTRONICS — July, 1949



air-spaced articulated
R.F. CABLES

Patents Regd. Trade Mark

**THE LOWEST EVER
CAPACITANCE OR
ATTENUATION**

We are specially organised to handle direct enquiries from overseas and can give

IMMEDIATE DELIVERIES FOR U.S.A.

*Billed in Dollars Settlement by your check.
Transaction as simple as any local buy.*

TRANSRADIO LTD

CONTRACTORS TO H.M. GOVERNMENT
138A CROMWELL ROAD LONDON SW7 ENGLAND
CABLES: TRANSRAD. LONDON.

| LOW ATTEN TYPES | IMPED OHMS | ATTEN db/100ft of 100 Mcs. | LOADING Kw | O.D." |
|-----------------|------------|----------------------------|------------|-------|
| A 1 | 74 | 1.7 | 0.11 | 0.36 |
| A 2 | 74 | 1.3 | 0.24 | 0.44 |
| A 34 | 73 | 0.6 | 1.5 | 0.88 |

HIGH POWER FLEXIBLE

| LOW CAPAC TYPES | CAPAC mmf/ft | IMPED OHMS | ATTEN db/100ft 100Mcs. | O.D." |
|-----------------|--------------|------------|------------------------|-------|
| C 1 | 7.3 | 150 | 2.5 | 0.36 |
| PC 1 | 10.2 | 132 | 3.1 | 0.36 |
| C 11 | 6.3 | 173 | 3.2 | 0.36 |
| C 2 | 6.3 | 171 | 2.15 | 0.44 |
| C 22 | 5.5 | 184 | 2.8 | 0.44 |
| C 3 | 5.4 | 197 | 1.9 | 0.64 |
| C 33 | 4.8 | 220 | 2.4 | 0.64 |
| C 44 | 4.1 | 252 | 2.1 | 1.03 |

PHOTOCELL CABLE

V.L.C. ★

★ Very Low Capacitance cable.

IN · RES · CO
Wire Wound
RESISTORS
meet all instrumentation needs

- TOLERANCE TO ± 0.1%
- .01 OHM TO 1.0 MEGOHM
- HIGH OR LOW WATTAGE
- HERMETIC SEALED TYPES
- ALL TYPES OF MOUNTING



INRESCO Resistors are a product of high-speed winding techniques that introduce a new measure of economy in precision wire wound resistors.

They are available for IMMEDIATE DELIVERY, in diversified types that meet practically every circuit requirement of load, ohmic value, size, shape, and operating condition.

When planning a new circuit design, investigate the advantage of INRESCO resistors for economy, dependability and permanently fixed characteristics. For complete details, call or write today for your copy of the INRESCO catalog.

Manufacturers and designers of wire wound resistors—exclusively. Estimates on custom built—resistors—furnished.



INSTRUMENT RESISTORS COMPANY

1036 COMMERCE AVENUE, UNION, NEW JERSEY

B&W TEST INSTRUMENTS

Inexpensive . . . Accurate . . . Reliable

Built to Match Broadcast Station Requirements

Although relatively low in cost, these B & W instruments meet the exacting demands of modern research and engineering laboratories, as well as the full indorsement of many well-known broadcast stations. They combine a high degree of accuracy with outstanding durability and ease of use.

B & W AUDIO OSCILLATOR

Provides an extremely low distortion source of frequencies between 30 and 30,000 cycles. Self-contained power supply. Calibration accuracy of $\pm 3\%$ scale reading. Stability 1% or better. Frequency characteristics: output flat within ± 1 DB, 30 to 15,000 C.P.S. Size $13\frac{3}{4}$ " x $7\frac{1}{4}$ " x $9\frac{1}{2}$ " Fully portable.

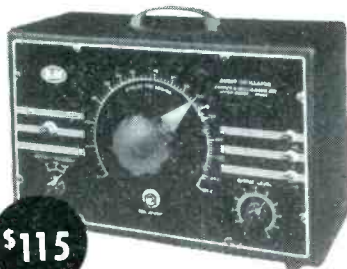

\$115

MODEL 200

B & W DISTORTION METER

An ideal instrument for either laboratory or field use. Measures total harmonic distortion for the range of 50 to 15,000 cycles, and measures harmonics to 45,000 cycles. Also measures residual hum and noise up to 60 DB below any reference level. Voltmeter and DB meter range is from 30 to 30,000 cycles. Highly sensitive and accurate. Size $13\frac{3}{4}$ " x $7\frac{1}{4}$ " x $9\frac{1}{2}$ ".



\$140

MODEL 400

B & W FREQUENCY METER

An accurate and convenient means of making direct measurements of unknown frequencies up to 30,000 cycles. Useful in measuring beat frequency between two R.F. signals. Integral power supply. Handy for routine checking of audio oscillators or tone generators. Highly sensitive, this unit will operate on any wave form with peak ratios under 8 to 1. Size $13\frac{3}{4}$ " x $7\frac{1}{4}$ " x $9\frac{1}{2}$ ".



\$105

MODEL 300

WRITE FOR B & W CATALOG SUPPLEMENT NO. 1...containing full details on these and other B & W instruments and electronic specialties.

BARKER & WILLIAMSON, Inc.

Dept. EL-79, 237 Fairfield Ave.

Upper Darby, Pa.



characteristics of polyethylene. Thickness is 0.009 inch and tensile strength is 22 pounds per inch of width.

Projection Lens

ALLEN B. DUMONT LABORATORIES, INC., 1000 Main Ave., Clifton, N. J. Type 2542 projection lens is a two-element, symmetrical objective lens having a relative aperture of f 3.3 and a focal length of 7.7 inches. It projects an oscillographic pattern

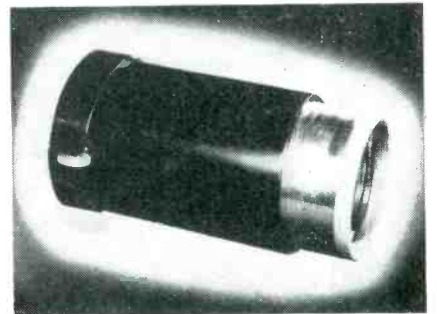

of an area up to 3 inches square to distances from 8 to 30 ft from the screen of the c-r tube, resulting in a picture size that may be as large as 12 sq ft. Axial light transmission of the lens system is approximately 85 percent.

Slotted Line

FEDERAL TELECOMMUNICATION LABORATORIES, INC., 500 Washington Ave., Nutley 10, N. J., have developed the FTL-30A slotted line, a precision device for measuring impedance and wavelength in the 60 to 1,000-mc range. Measurements can also be made with slightly less

EAD **NEW!**

Variable Frequency Induction Motors and Blowers

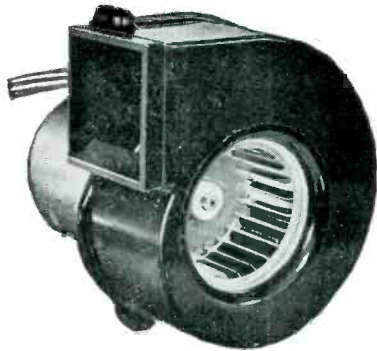

115 volts:
400-800 Cycles—140 C.F.M.
400-1600 Cycles—15-20 C.F.M.
NOW IN PRODUCTION

Other frequency ranges available
**GEAR MOTORS, AXIAL FLOW FANS
AND MOTORS ALSO FURNISHED**

These Induction Motors and Blowers are designed for use with engine driven alternators supplying variable frequency power throughout a wide range. They are very suitable for use in cooling tubes and amplifier boxes, band switching or driving mechanisms on military and electronic equipment.

**ALSO NEW
PERMANENT MAGNET**



ALTERNATORS
For critical Instrument and Equipment Applications.

PURE WAVE FORM
1, 2, or 3 Phase
2, 4, 6, 8, or 12 poles

All Frequencies

*Special Types for customer needs
Standard Types Available.
Continuous Duty*

- N2A 115V, 3 Phase, 45VA, 400 cycle at 6000RPM
- N2B 115V, 2 Phase, 15VA, 60 cycle at 3600RPM
- N3C 15V, 1 Phase, 1.1VA 180 cycle at 3600RPM
- N4A 70V, 1 Phase, 10 VA, 60 cycle at 3600RPM
- N6A 45V, 1 Phase, 25 VA, 1000 cycle at 5000RPM

EASTERN AIR DEVICES, INC.
585 DEAN ST., BROOKLYN 17, N.Y.

**DESIGNERS AND BUILDERS OF STANDARD
AND SPECIAL ROTATING EQUIPMENT**

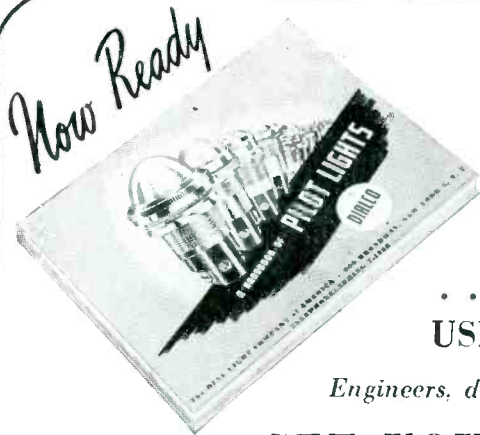

The **NEW DIALCO**
HANDBOOK

... 192 PAGES of
USEFUL INFORMATION

Engineers, designers, purchasing agents —

GET YOUR COPY

You will find complete data on the lamps used in pilot lights.
And illustrations - all full size - of hundreds of items you will use.
There is a table of resistors for operation of lamps on all voltages.
Complete dimensional data on each unit.
More than 2,000 Underwriters' Listed Assemblies.

The DIAL LIGHT COMPANY of AMERICA
Foremost Manufacturer of Pilot Lights.

900 BROADWAY, NEW YORK 3, N. Y. TELEPHONE SPRING 7-1300

Write for Handbook D-149

WHEN DESIGNING A COIL TO MEET
RIGID PERFORMANCE SPECIFICATIONS —

COIL QUALITY

begins at the
CORE!

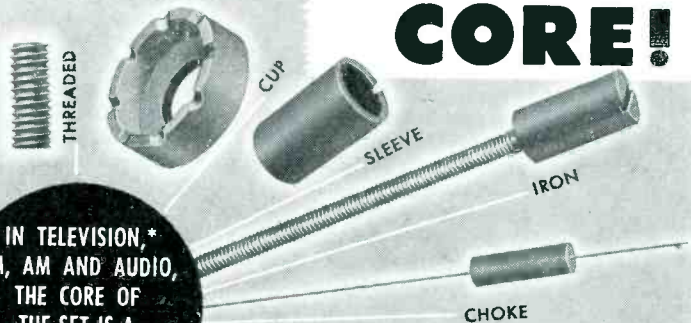

IN TELEVISION,*
FM, AM AND AUDIO,
THE CORE OF
THE SET IS A
**MOLDITE
PRODUCT!**

All MOLDITE CORES are made to exact specifications. An exclusive MOLDITE powder mix is used for best results in each specific requirement. New MOLDITE methods in processing and volume manufacture results in higher quality at lower cost. Uniformity of quality is maintained over entire production through continuous manufacturing controls. Call or write for MOLDITE Catalog 104.

*MOLDITE High Resistivity Cores, made with a special material, assure you of infinite resistance. Specify Mixes 13, 14 and 17 for guaranteed performance (TV applications).

NATIONAL MOLDITE COMPANY
Specialists in Iron Cores • HILLSIDE, NEW JERSEY

MID-WESTERN REP.
Irv Rose
314 No. Michigan Ave.
Chicago, Illinois

WESTERN REP.
Perlmuth-Colman & Assoc.
1335 So. Flower St.
Los Angeles, Calif.

SO. AMERICAN REP.
Jose Luis Pontet
Cordoba 1472
Buenos Aires, Argentina

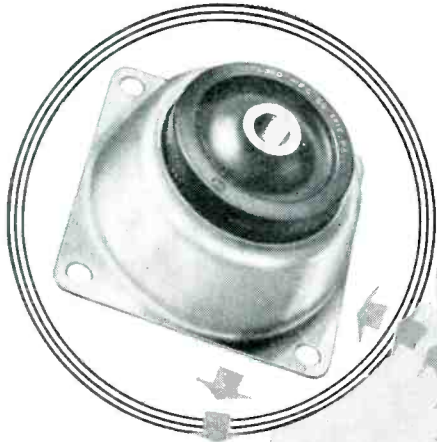

how LORD helps "TOCCO" stand the gaff

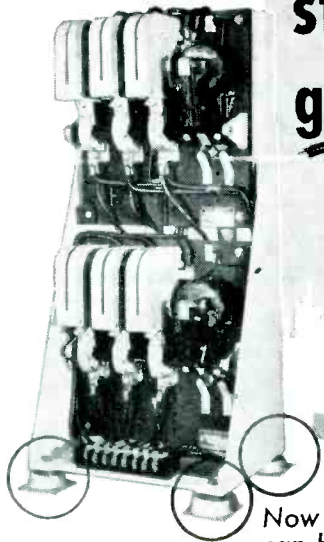

Now electronic induction heaters
can be used in the shop.

Electronic tube induction heating long was confined to the laboratory because the electronic equipment just "couldn't stand the gaff" of shop usage.

After four years of intensive research and testing, The Ohio Crankshaft Company found the answer. The Tocotron 20 has proved a dependable shop tool for uniform, low cost production in numerous applications.

Four Lord Plate Form Mountings effectively isolate the Power Contactor Panel Assembly and protect the Tocotron from vibratory disturbances in the shop, regardless of their direction. Tube assemblies also are protected by Lord Mountings.

Whether you make electronic equipment or massive machinery—if your product is exposed to external vibration or if it has moving parts, a Lord Vibration Control System will increase its efficiency, durability and customer appeal. Consult a Lord engineer.

See our Bulletin in Sweet's 1949 File for Product Designers or write for Bulletin 900 today. It describes the complete line of Lord products and services.

LORD MANUFACTURING COMPANY, ERIE, PA.

Canadian Representative: Railway & Power Engineering Corp. Ltd.

LORD Vibration Control Systems

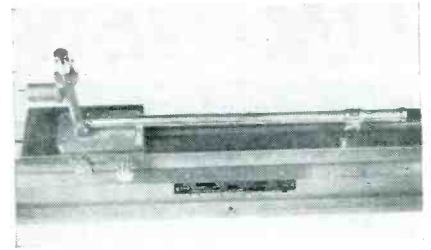

accuracy in the 1,000 to 2,000-mc range. The unit is a coaxial line 250 cm long having a surge impedance of $51.0 \text{ ohms} \pm 0.5 \text{ ohm}$.

Switch Adaptor

UNIMAX SWITCH DIVISION OF THE W. L. MAXSON CORP., 460 W. 34th St., New York 1, N. Y. Style "P" Adaptaplate provides single-button, maintained-contact control with a-c, a-c/d-c, or metal-cased snap acting

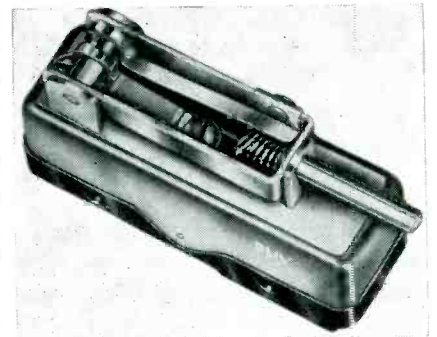

switches. It comprises a ratchet-driven rotary detent cam which alternately presses and releases the operating button of the switch when the drive plunger is pushed.

Vibration Measurement

HERMON HOSMER SCOTT, INC., 385 Putnam Ave., Cambridge 39, Mass. Type 410-X5 vibration integrator and type 410-X6 calibrated vibration pickup enable measurement of vibration displacement, velocity and acceleration in the audio-frequency



3½ KW
VACUUM TUBE
BOMBARDER
or
INDUCTION
HEATING UNIT



Only \$975

Never before a value like this 3½ KW bombarder or high frequency induction heater . . . for saving time and money in surface hardening, brazing, soldering, annealing and many other heat treating operations. Is

Portable . . . mounted on four rubber coasters. Width 14½"; depth 27"; height 42½"; weight 300#.

Operates from 220 volt line. Complete with foot switch and one heating coil made to customer's requirements. Send samples of work wanted. We will advise time cycle required for your particular job. Cost, complete, only \$975. Immediate delivery.

Scientific Electric Electronic Heaters are made in the following ranges of power: 1-2-3-5-7½-10-12½-15-18-25-40-60-80-100-250. KW.

*Scientific
Electric*

Division of
"S" CORRUGATED QUENCHED GAP CO.
105-119 Monroe St., Garfield, N. J.

ANNOUNCING Roanwell's NEW
MOBILE MIKE

THIS NEW MOBILE MICROPHONE PROVIDES CONSISTENTLY HIGHER MODULATION PERFORMANCE

Weighs a mere 7 oz. Button is riveted on face of mic; allows easy change-over from speaking to hang-up position with turn of wrist. Tough, shock-proof aluminum alloy case; dustproof and moistureproof. Switch and all other internal elements completely enclosed. Mic element cushioned in rubber makes unit shock-and-vibration proof. Suitable for replacement on all existing equipment.

COMPACT!
RELIABLE!
HANDLES
EASILY!

STYLE No. 737



Write for full particulars.



ROANWELL CORPORATION
662 Pacific St. • Brooklyn 17, N. Y.

If the Specific Dry Battery You Need
Is NOT Listed in This Free Manual...

**BURGESS ENGINEERS WILL
DESIGN A NEW BATTERY TO
MEET YOUR SPECIFICATIONS**



It's all part of the Burgess Service! This complete Engineering Manual lists *hundreds* of battery types developed by Burgess Engineers to meet new requirements. If the specific battery you need is not among them, the complete Burgess facilities, design, production, and engineering will be placed at your disposal to build the battery you need in any quantity—large or small!

Write for **ENGINEERING MANUAL** and **CHECK SHEET**

No obligation. By return mail you will receive the FREE Engineering Manual listing the complete line of Burgess Batteries together with specifications; also the Burgess "Check Sheet" on which you may outline your requirements in the event that the battery you need has not already been developed. Address:

BURGESS

BATTERY CO., (DEPT. E1) FREEPORT, ILLINOIS

Pioneered

the Electric Connector on the DC-1

Developed

the new Firewall Connectors now used on Douglas, Boeing, Convair, Lockheed and other airline ships

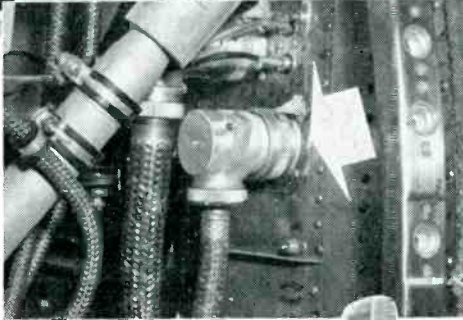

Firewall 90° Plug on DC-6

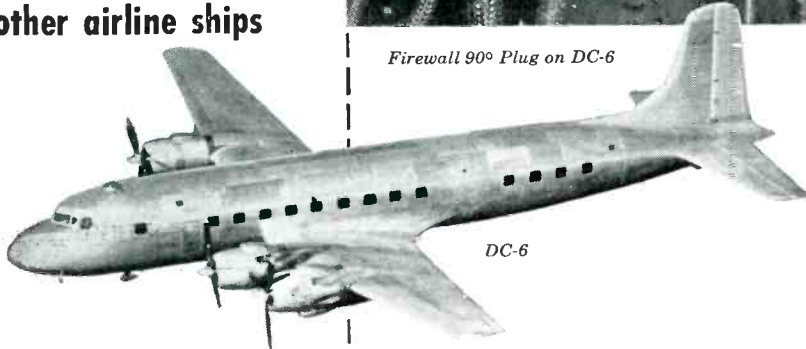

DC-6

CANNON ELECTRIC was first with Firewall Connectors — maintaining engineering leadership in connector design for the aircraft industry.

A requirement for all airline craft operating under CAA, Firewall Connectors are specified for operational safety. This is protection against further damage from engine fires—if they break out—by preventing fire from traveling through the firewall to other parts of ship or weakening frame. Special asbestos compound inserts and end bell packing provide the ultimate in safety, and protect such circuits as prop feathering, etc.

Not only are "AN" types available in Firewall construction, but Cannon Electric "K", "AF" and "FM".

Shown in the new AN7-1248 Bulletin and KS-1 Supplement to the K Bulletin. Address Department G-120.



FW00 (AN3100)
Receptacle
Steel Shell



FW08 (AN3108)
Steel Shell



FW06 (AN3106)
partially exploded
showing special

alloy crimp-type contacts,
steel barrel and end-bell

NEW PRODUCTS

(continued)

range. Displacement can be measured from 0.14 microinch to 0.028 in.; velocity, from 51.3 microinches per second to 10.3 inches per second; and acceleration, from 0.15 in. per second per second to 3,900 in. per second per second over a 25 to 3,000-cycle range. Response is flat from 60 to 1,000 cycles.

High-Fidelity Transformer

ACRO PRODUCTS Co., 5328 Baltimore Ave., Philadelphia 43, Pa. The TI-100 is a transformer unit for pre-amplifying and equalizing the output of reluctance-type pickup cartridges. It provides full undistorted high-frequency response, plus a rising bass characteristic for low-frequency equalization necessary for quality reproduction. The unit's output provides sufficient voltage to energize the tuner, phonograph, or other medium-level high-impedance input channels.

Deflection Amplifiers

HYTRON RADIO & ELECTRONICS CORP., Salem, Mass. Types 6BQ6GT (illustrated) and 25BQ6GT beam pentodes were designed specifically for use as horizontal deflection amplifiers in television receivers using magnetic deflection tubes. The 6BQ6GT with its 6.3-volt heater

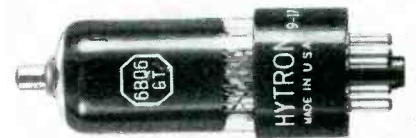

is for use in transformer-operated sets, while the 25BQ6GT with its 25-volt heater is used in sets with series heater connections. Complete mechanical and electrical data are found in bulletin 140.

H-V Selenium Rectifiers

WESTINGHOUSE ELECTRIC CORP., P. O. Box 868, Pittsburgh 30, Pa., has announced new high-voltage selenium rectifier cells designed for 24 volts per cell d-c, with an rms a-c voltage of 33 volts per cell for single-phase bridge circuits. They are available in six round sizes

SINCE 1915

CANNON ELECTRIC

Development Company 3209 HUMBOLDT ST., LOS ANGELES 31, CALIF.

World Export: Frazar & Hansen, San Francisco. Canadian plant: Cannon Electric Co., Ltd., Toronto

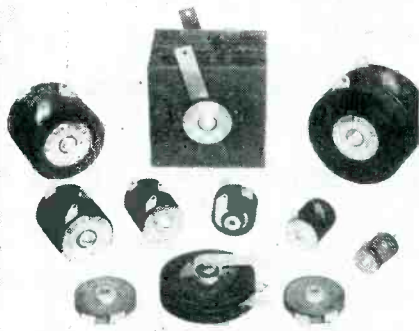

from 1 to $4\frac{3}{8}$ in. in diameter, and in five-inch-square and $4\frac{1}{4} \times 6$ -in. sizes.

Pulse Amplitude Analyzers

CANADIAN MARCONI Co., P. O. Box 1690, Montreal, P. Q., Canada. Illustrated are two 6-channel pulse amplitude analyzers for research into the energy spectrum of a radioactive sample. Analysis is possible up

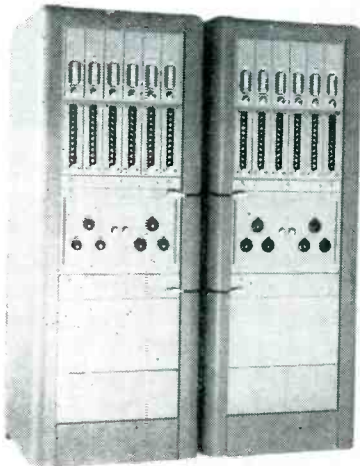

to 48 energy ranges. Six channel assemblies use the standard decade, numerator, discriminator and power supply units with the addition of driving amplifier, reset unit, discriminator bias controls and associated power supply units.

Precision Pliers

TRANSVISION, INC., New Rochelle, N. Y. Model P-1 Hook-Cut pliers has both a sharp, tempered cutting edge and a long nose for probing

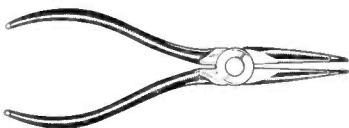

Radiation instrumentation at its finest

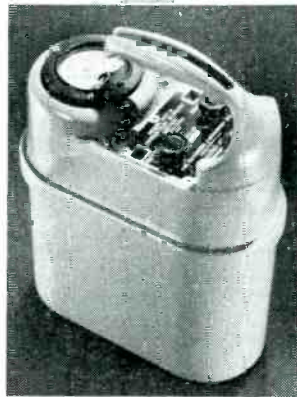

Gamma Radiation Survey Meter Model 247A

A compact portable instrument designed to cover four ranges of gamma radiation intensities, 2.5—25—2500 milliroentgens (1/1000 r) per hour. The most sensitive range approximates that of a Geiger instrument and is inherently more stable. The ionization chamber and meter are hermetically sealed, and the case is watertight. Die castings have been used wherever possible for unusual rugged construction.

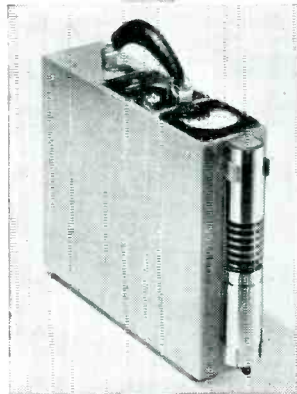

Beta and Gamma Survey Meter Model 263B

A portable Geiger-Mueller Counter for extreme sensitivity, capable of detecting individual ionizing particles. The instrument has three full scale ranges of 20.0—2.0—0.2 milliroentgens per hour measured with gamma radiation from radium.

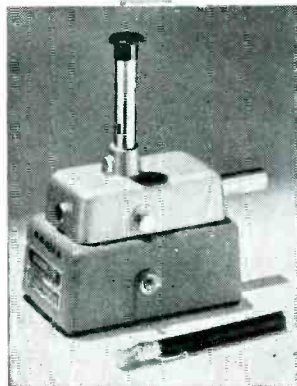

Victoreen Minometer Model 287

The Minometer provides a prescription for computing daily, the amount of radiation exposure. It consists of a small compact string electrometer and an ionization chamber designed in the shape of a fountain pen to be carried conveniently in a coat pocket. The chamber value is 0.2 r full scale when checked against the calibrated scale in the electrometer.

For twenty years our exclusive business has been the development and design of instruments and components used in the measurement of gamma and x-radiation. We welcome your inquiries on any phase of radiation measurement.

Dept. A.

THE VICTOREEN INSTRUMENT CO.
5806 HOUGH AVENUE
CLEVELAND 3, OHIO

MODERN BREADBOARD CHASSIS

UniChassis

PAYS FOR ITSELF IN TWO DAYS

Components and tubes for experimental circuits are mounted and wired in less than half the usual time by employing a novel arrangement of socket holes, bus bars, special spring contacts and flexible leads.

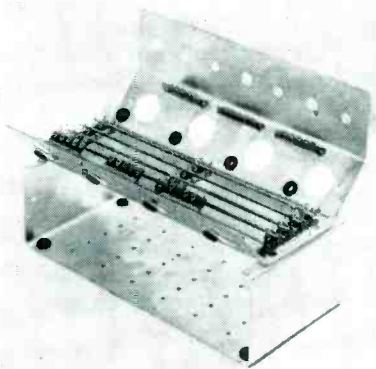

Tube sockets are mounted so that the terminals are accessible for easy wiring. Bus bars, tie-points, the shelf-like base of the chassis, and a vertical panel with holes of several sizes provide means for mounting various types of electronic components, while the general shape of the chassis permits simple, compact wiring. Pins on the ends of the bus bars and on some of the tie points fit the sockets on the flexible leads so that the leads can be used for connecting circuits on the chassis to external equipment.

The bus bars are tinned and the grooves are partly filled with solder so that wires to be attached to the bars need only be tinned, laid in the groove, and touched with a soldering iron. Removal of wires from the bars is just as easy as their attachment.

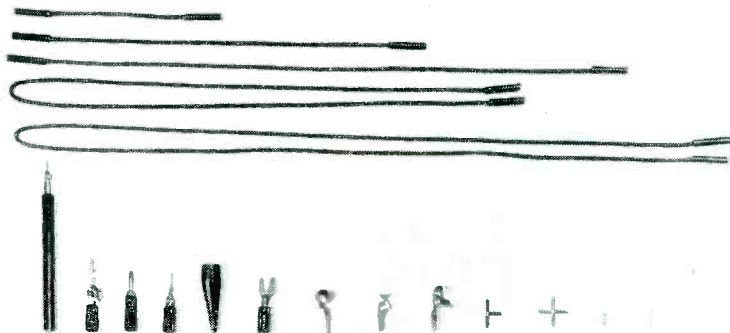

UniLeads

The UniLeads are flexible, insulated conductors of assorted lengths with socket-like terminals at both ends which can engage pins 3/32" in diam., similar to those used on some types of vacuum tube bases. Such pins form an integral part of various kinds of terminal fittings, such as lugs, clips, plugs, and probes, which can be plugged into the ends of the leads.

- Complete kit contains 22 UniLeads and 96 UniLead Attachments
- | | | |
|--|--------------------|-------------------------|
| 1 UniChassis (as shown above) | 2 Phone tip plugs | 22 1" connectors |
| 22 UniLeads 4-6", 6-12", 6-18", 4-30", 2-42" | 2 PeeWee Clips | 22 1/2" connectors |
| 2 test Probes | 2 Spade lugs | 24 soldering stub conn. |
| 2 Alligator Clips | 2 Grid caps large | 4 Tee Connectors |
| 2 Banana Plugs | 2 Grid caps small | 4 X connectors |
| | 4 Fahenstock clips | |

Price \$22.50 FOB Washington, D. C.

Mail orders promptly filled. Send money order or check and we pay the postage.

Showing some of the possibilities of the UniChassis and UniLead combinations. Everything plugs in and out quickly and surely, insuring positive, shortproof connections. Circuit building and circuit testing time is cut in half and best of all, at last a breadboard that can be put on the shelf and used again and again.

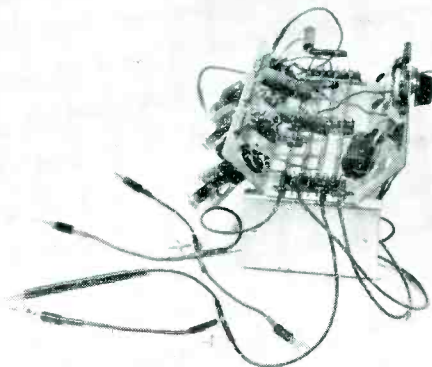

IT PAYS FOR ITSELF IN TWO DAYS

UNI-PRODUCTS INC.

1048 Potomac Street, N.W.
Washington 7, D. C.

NEW PRODUCTS

(continued)

into small places such as miniature sockets. Overall length is 6 1/2 inches; width tapers from 2 inches on the handle to 1/8 inch on the extreme tip.

Smaller Tubular

AEROVOX CORP., New Bedford, Mass. Stud terminals in place of conventional rivet-type terminals make possible a reduction in the bulk of new PRS midget-can dual-section capacitors with dual leads.

Microwave Meter

KAY ELECTRIC Co., Pine Brook, N. J. The Microwave Mega-Match operates between 8,500 and 9,700 mc. It includes a delay waveguide approximately 75 feet long formed



into a space of 8 ft by 1 ft, a calibrated X-band wave meter, and a box housing power supply and control devices. Reflection coefficient changes down to 0.02 are indicated. Frequency sweep on the display up to 30 mc anywhere in the X-band is available.

Thermal Switch

MANNING, MAXWELL & MOORE, INC., Bridgeport 2, Conn. The Microsen thermal switch operates from a



IMMEDIATE DELIVERY*

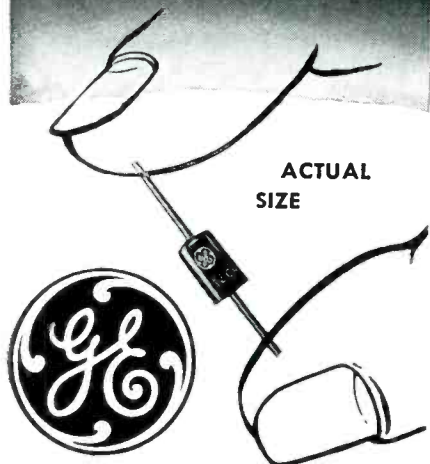

ACTUAL SIZE

Welded GERMANIUM DIODES

NOW AVAILABLE AT NEW LOW PRICES!

Compare the Cost!

| Type | Quantity 100-10,000 | Quantity 10,000-50,000 |
|------|---------------------|------------------------|
| 1N51 | was \$.65—now \$.58 | was \$.58—now \$.53 |
| 1N48 | was .75—now .64 | was .65—now .60 |

GENERAL ELECTRIC'S four types of Germanium Diode Rectifiers are available to meet electronic requirements where problems of space or AC hum exist, or where heat produced by a vacuum tube would be objectionable.

LOOK AT THESE FEATURES—

- ★ **Welded Contact Construction**—For stability, shock resistance, high ambients, long life.
- ★ **Insulating Case**—For low lead-to-lead capacitance, high moisture resistance, mechanical strength.
- ★ **Small Size**—For "no room" applications.

Call the G-E office near you, or write for specifications and price list: *General Electric Company, Specialty Division, Electronics Park, Syracuse, New York.*

*Subject to prior orders.



Volume users
of
Special Fasteners
and allied devices
turn first to
UNITED-CARR
for cost-cutting
design engineering
service

Send us your specifications or requirements. Address Dept. 14

UNITED-CARR FASTENER CORP.
Cambridge 42, Mass.

MAKERS OF **DOT** FASTENERS

KENYON Fits Your Production To A "T"

KENYON "T's"—high quality, uniform transformers, are your best bet for development, production and experimental work. For over 20 years, the KENYON "K" has been a sign of skillful engineering, progressive design and sound construction.

Now — reduce inventory problems, improve deliveries, maintain your quality — specify KENYON "T's," the finest transformer line for all high quality equipment applications.

New Catalog Edition! Write Today!
KENYON new modified edition tells the complete story about specific ratings on all transformers. Our standard line saves you time and expense. Send for your copy of our latest catalog edition now!

KENYON TRANSFORMER CO., Inc.

840 BARRY STREET · NEW YORK 59, N. Y.



THE

Advanced VOLTOHMYST*

- ✓ For AC Voltage Measurements at Frequencies to 250 Mc
- ✓ For Peak-to-Peak Voltage Measurements of Recurrent Pulses

THE RCA WV-75A VOLTOHMYST is a versatile electronic volt-ohmmeter, particularly useful for HF and VHF measurements in the laboratory or at test positions in the factory. The full-wave diode probe, which contains a fitting for direct connection to coaxial lines, reads peak-to-peak rf voltages of sine waves or recurrent complex waves or pulses, up to a frequency of 250 Mc. The WV-75A also reads RMS ac and dc voltages up to 1000 volts and dc resistances to 1000 megohms.

The input resistance for all dc ranges is 11 megohms, resulting in negligible circuit loading and greater accuracy. A 1-megohm isolating resistor is incorporated in the dc voltage probe for dynamic checking.

For dc voltage measurements up to 30,000 volts, ask for the new RCA

*Reg. Trade Mark, U. S. Pat. Off.

WG-284 High-Voltage probe, available at a small additional cost.

For further details, ask your RCA Distributor for Bulletin 2F718 or write RCA, Commercial Engineering, Section 42GY, Harrison, N. J.

SPECIFICATIONS

| | |
|---|-----------------------------------|
| DC Voltage Range (6 scales) | 0.3 to 1000 volts |
| AC Voltage Range (6 scales) | |
| Direct to Probe | 0.3 to 100 RMS volts |
| Through Multiplier to Probe | 3 to 1000 RMS volts |
| Resistance Range (6 scales) | 0.1 ohm to 1000 megohms |
| Frequency Response: | |
| Direct to Probe (lower scales) | 30 cycles to 250 Mc. |
| Through Multiplier to Probe | 30 cycles to 15 kc. |
| Input Resistance and Capacitance: | |
| DC Probe (Resistance only) | 11 megohms |
| AC Probe (at 1 Mc) | 625,000 ohms shunted by 15.6 mmf. |
| Scale Indication: | |
| With Sine Waveform | RMS volts |
| With Complex Recurrent Waveform | 0.354 of peak-to-peak volts |
| Dimensions | w. 6-5/16"; h. 9-5/8"; d. 6-3/4" |

Available from your RCA Test and Measuring Equipment Distributor



RADIO CORPORATION of AMERICA
TEST AND MEASURING EQUIPMENT HARRISON, N. J.

thermocouple input to signal temperature variations in heating processes. Signal output is given by electrical relay action. On and off switching of 10 amperes at 115 volts a-c or 32 volts d-c directly is possible for any temperature setting from 100 to 2,000 F. A single 6SN7 vacuum tube operates in conjunction with the Microsen balance and a precision relay.

Glass Picture Tube

ZETKA TELEVISION TUBES, INC., 131-137 Getty Ave., Clifton, N. J., is now producing a 16-in. glass television tube which features a flat face for greater picture area. The tube also has an ion trap which

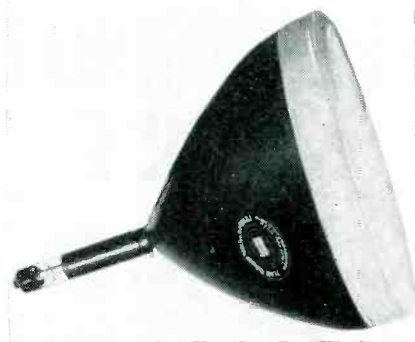

eliminates the brown stain sometimes found in the center of the picture. It is one inch shorter than the 15-in. glass tube and two inches shorter than the 16-in. glass-to-metal tube.

Smoke Control

GENERAL ELECTRIC Co., Schenectady 5, N. Y. A new smoke density indicator and control comprises a light source, phototube holder and an enclosure containing the required control and indicating meter calibrated in Ringlemann units. In

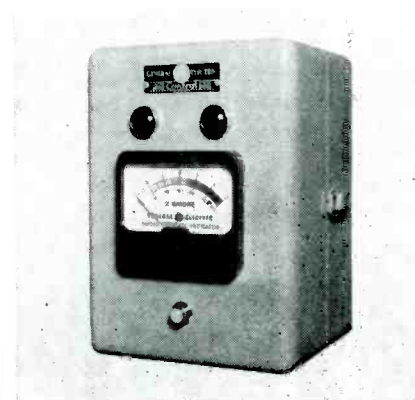

NEW PRODUCTS

(continued)

operation, a relay is set to operate when smoke density reaches some predetermined level such as 35 percent at which time a blower forces air to the firebox until smoke density drops to approximately 15 percent.

Continuous Loop Recorder

AMPLIFIER CORP. OF AMERICA, 398-7 Broadway, New York 13, N. Y. Models CL-3 and CL-10 continuous loop drive mechanisms make possible continual repetition of any recorded message from 4 seconds to 3 minutes and 4 seconds to 10 minutes in duration respectively.



Both systems are designed in detachable form for easy installation on Twin-Trax tape recorders, and either can be adapted for automatic recycling if desired.

Marine Radar

WESTINGHOUSE ELECTRIC CORP., Box 868, Pittsburgh 30, Pa. Type MU-1 marine radar detects targets at ranges between 80 yards and 40 miles. A newly developed 12½-inch flat-face scope provides a usable

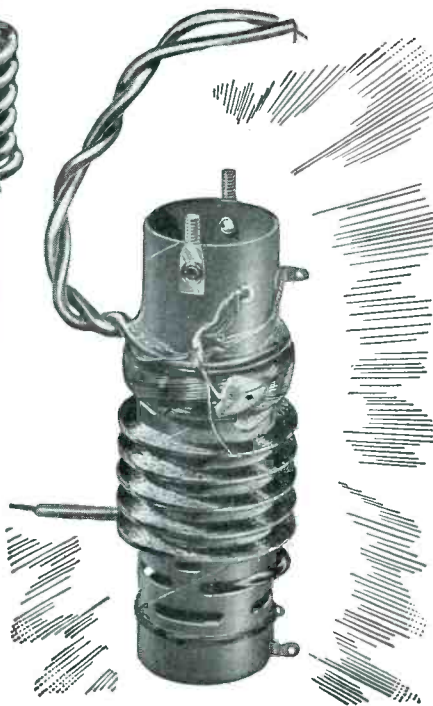

☆
2 new stars in the field

☆
For TELEVISION RECEIVERS

☆ ☆

Specify COSMALITE*

Cosmalite Coil Forms give exceptional performance at a definite saving in cost to you.

Punched, threaded, notched and grooved to meet your individual specifications.

COSMALITE
Low cost, spirally wound paper base phenolic tubing, suitable for all coil forms in Radio and Television Receivers.

Ask us about the many various punching dies we have available.

Inquiries given quick action and specialized attention.

*Reg. U. S. Pat. Off.

The **CLEVELAND CONTAINER Co.**
6201 BARBERTON AVE. CLEVELAND 2, OHIO

PLANTS AND SALES OFFICES at Plymouth, Wisc., Chicago, Detroit, Ogdensburg, N.Y., Jamesburg, N.J.
ABRASIVE DIVISION at Cleveland, Ohio
CANADIAN PLANT: The Cleveland Container, Canada, Ltd., Prescott, Ontario

REPRESENTATIVES

CANADA } WM. T. BARRON, EIGHTH LINE, RR #1, OAKVILLE, ONTARIO
METROPOLITAN } R. T. MURRAY, 614 CENTRAL AVE., EAST ORANGE, N.J.
NEW YORK }
NEW ENGLAND } E. P. PACK AND ASSOCIATES, 968 FARMINGTON AVE. WEST HARTFORD, CONN.





SPECIFICATION:

TYPE T/2

| | |
|---|--------------------|
| Overall Diameter | 12.5/16" |
| Overall Depth | 6 3/8" |
| Fundamental Resonance..... | .75 c.p.s. |
| Voice Coil Impedance... 15 ohms at 400 c.p.s. | |
| Maximum Power Capacity.. | 12 watts Peak A.C. |
| Total Flux..... | 145000 Lines |
| Net Weight..... | 12 lbs. 4 ozs. |

A speaker of unique versatility. Designed and built with Goodmans' tradition of excellence. Its performance and ideal frequency response have placed this unit in the forefront of medium heavy-duty loudspeakers.



GOODMANS
World-Famous
T2 12" P.M. LOUDSPEAKER
Fully Dustproof

GOODMANS INDUSTRIES LTD., Lancelot Road, WEMBLEY, Middlesex, ENGLAND

area of 95 sq in. for the ppi display. The unit's design includes a new sea suppressor control which gives constant target intensity above sea return.

VTVM

SYLVANIA ELECTRIC PRODUCTS INC., 500 Fifth Ave., New York 18, N. Y. Type 221 Polymeter is a vacuum tube voltmeter providing an essentially flat response from 20 cycles to 300 mc; and useful measurement between 300 and 500 mc. The r-f probe contains a special subminia-



ture tube which provides a combination of high input impedance and very low input capacitance. By means of switching design, four leads permit rapid measurement on all ranges of a-c, d-c, r-f, milliamperes and resistance without interchanging the panel connectors.

Heat Radiating Connectors

BUD RADIO, INC., 2118 E. 55th St., Cleveland 3, Ohio. Nine sizes of heat radiating connectors are available to fit all grid and plate leads for tubes operating in the range from 50 to 2,000 watts. Machined from special aluminum rod stock, the edges of these connectors are rounded to prevent corona loss.

Cycle Timers

THE R. W. CRAMER Co., INC., Centerbrook, Conn. The type CF3 single or multi-contact cycle timers control automatically a one, two, three or four-circuit operation in a predetermined timing sequence. The unit is designed for built-in applications

TWO NEW CTC TERMINALS PROMISE IMPROVED WIRING

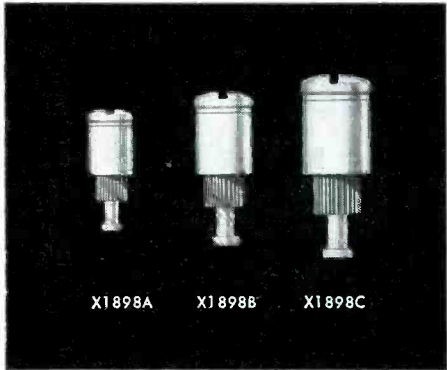

X1898A

X1898B

X1898C

1.

New Combination Terminal In 3 Sizes Has Variety of Uses

With a screw on top and a terminal lug on the bottom, this combination simplifies top and bottom wiring. Remove the screw and you can mount components directly to the screw end. Or, you can adapt this terminal to provide removable link connections at the screw end. Terminal is plated with bright alloy for corrosion resistance and ease of soldering. Mounting shank is heavily knurled for secure mounting into terminal boards.

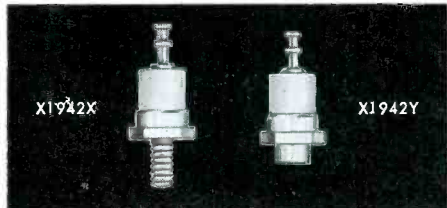

X1942X

X1942Y

2.

New Ceramic Stand-Off

The body of this stand-off is made of JAN-1-10-grade L-5 ceramic, silicone impregnated. This gives you a component with highly improved resistance to moisture and fungi, as well as higher dielectric properties. X Type has a 6-32 thread screw stud; Y Type has a rivet stud.

These and other *Guaranteed Components* are described at length in the new CTC #300 Catalog. Write for it today.

**Custom or Standard
The Guaranteed
Components**

CAMBRIDGE THERMIONIC CORP.
437 Concord Ave., Cambridge 38, Mass.

TWO NEW TWIN POWER SUPPLIES



MODEL 610-F

MODEL 1210

- Precise Electronic Regulation.
- 2 Independent Sources of Power.
- 0-335 V.D.C. at 0-60 Milliamperes. Continuously Adjustable.
- 0-325 V.D.C. at 0-120 Mills if the 2 Sources are Combined.
- Both D.C. Outputs Metered for Voltage or Current.
- 6.3 and 12.6 V.A.C. Outputs Provided.
- A.C. Ripple Less than 10 Millivolts.

- Precise Electronic Regulation.
- 2 Independent Sources of Power.
- 0-500 V.D.C. at 0-150 Milliamperes. Continuously Adjustable.
- 0-500 V.D.C. at 0-300 Mills if the 2 Sources are Combined.
- Both D.C. Outputs Metered for Voltage or Current.
- 6.3 or 12.6 V.A.C. Outputs Provided.
- A.C. Ripple Less Than 10 Millivolts.

Furst *Twin Power Supplies* double the usefulness of a single unit at considerable saving in space and cost. Write for complete specifications on these and other Furst *Twin Power Supply* Models.



FURST ELECTRONICS

10 S. Jefferson St., Chicago 6, Ill.

Large or Small

SQUARE, ROUND OR RECTANGULAR PAPER TUBES

FOR COIL WINDING

**SEND FOR ARBOR LIST
OF OVER 1000 SIZES**

Inside Perimeters from .592" to 19"

With specialized experience and automatic equipment, PARAMOUNT produces a wide range of spiral wound paper tubes to meet every need . . . from 1/2" to 30" long, from .592" to 19" inside perimeter, including many odd sizes of square and rectangular tubes. Used by leading manufacturers. *Hi-Dielectric, Hi-Strength.* Kraft, Fish Paper, Red Rope, or any combination, wound on automatic machines. Tolerances plus or minus .002". Made to your specifications or engineered for YOU.

Paramount PAPER TUBE CORP.

616 LAFAYETTE ST., FORT WAYNE 2, IND.

Manufacturers of Paper Tubing for the Electrical Industry

Designed for

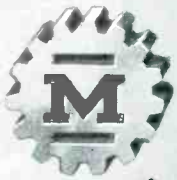

Application

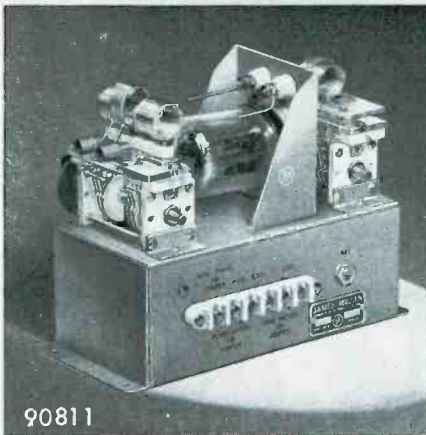

90811

**90811 HIGH FREQUENCY
RF AMPLIFIER**

The No. 90811 RF Amplifier is the same unit as used in the No. 90810 complete 2-6-10-20 meter Ham Band crystal controlled transmitter. Can be panel or base mounted. Uses 829B or 3E29 tube with normal 75 watt output. (Higher output may be obtained by the use of forced cooling.) Provisions are made for quick band shift by means of the new 48000 series high frequency plug-in coils. Extremely compact. Chassis 4" x 7 3/4" exclusive of flanges. Over-all height 6 3/4".

**JAMES MILLEN
MFG. CO., INC.**

MAIN OFFICE AND FACTORY
**MALDEN
MASSACHUSETTS**



NEW PRODUCTS

(continued)

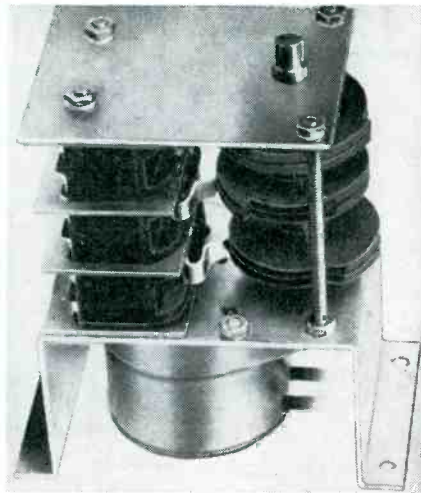

to control a series of machine operations, to reverse motors, or to operate motors, valves, signals or combinations of these in sequence. Twenty-seven different time ranges are available from one revolution in 10 seconds to one revolution in 24 hours. For detailed information request bulletin 1520.

Mike Desk Stand

ELECTRO-VOICE, INC., Buchanan, Mich. The Break-In touch-to-talk stand has a specially-designed lever-type switch for relay operation or microphone ON-OFF. The switch closes on pressing the lever and opens when pressure is re-



leased. The unit may be kept in the TALK position by pressing a locking button. Four models, either with or without a dpdt switch, are available.

Vertical Power Resistor

CLAROSTAT MFG. Co., INC., Dover, N. H. The Standee vertical power resistor for above-chassis mounting

**Crystal
Manufacturers**

PLEASE NOTE

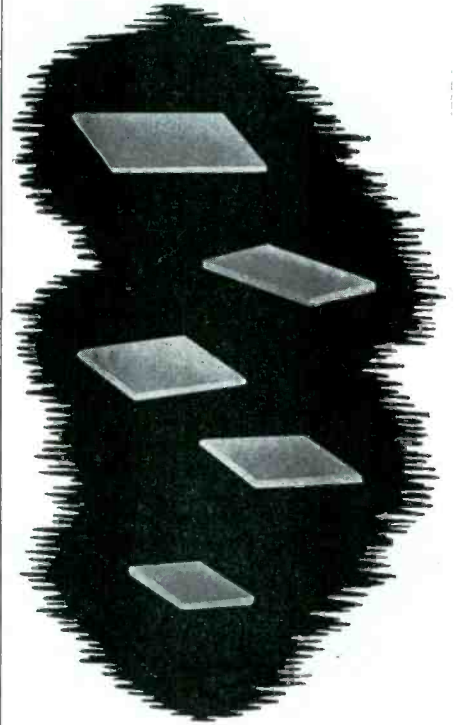

Instead of importing raw quartz or buying it from importers, you can save time and money by using our Quartz Crystal Blanks.

Our blanks are cut by the most modern and precise technique, under X-ray orientation, from the purest Quartz Crystal.

We can supply you blanks at reasonable prices, cut to your specification or from our large stock, in the usual cuts AT, BT, CT, DT, GT, etc., delivered promptly to all parts of the world, guaranteed against all defects or mis-cuttings. We accept both small and large orders.

We also accept orders for lapped and dimensioned crystals, to be calibrated by the customer, as well as completely finished crystals, calibrated to exact frequencies and mounted in holders for all classes of radio services. Ask for our Bulletin A-47, or for a quotation based specifically on your needs. Inquiries invited. Some agencies open.



Radio Cristais do Brasil Ltda.

PO BOX 1965 Cable Address: CRISTALBAR
RIO DE JANEIRO — BRAZIL

comprises a wire-winding on fiber-glass core, bent in hairpin form with mica separator between the legs, placed in a ceramic tube filled with cold-setting inorganic cement and provided with bottom terminals and mounting bracket. Available in heights of 1½, 2, 2½ and 3 inches, the resistors have respective power ratings of 10, 15, 20 and 25 watts. Maximum resistance values are 6,000, 9,000, 12,000 and 15,000 ohms, respectively.

Miniature Tube

GENERAL ELECTRIC Co., Schenectady, N. Y. Type GL-5670 miniature tube is a high-frequency twin triode designed for such applications as mobile communication and aircraft radio equipment. Heater voltage is 6.3 volts, a-c or d-c, with a heater current of 0.350 ampere.

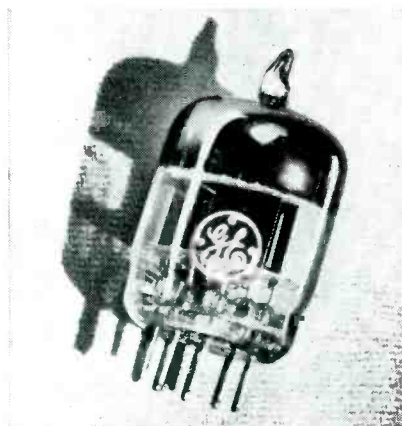
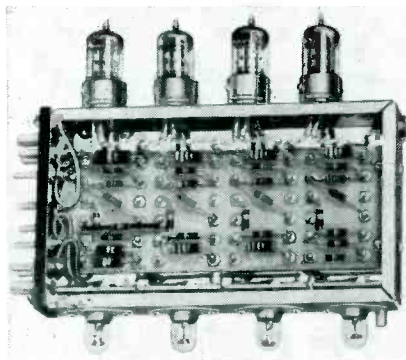

Plate voltage is 300 volts, maximum. The tube has a maximum height of 1½ in. and a maximum diameter of 7/8 in.

Counter Decades

POTTER INSTRUMENT CO., INC., 136-56 Roosevelt Ave., Flushing, N. Y. The plug-in decade illustrated uses



MICROSEN D. C. AMPLIFIER

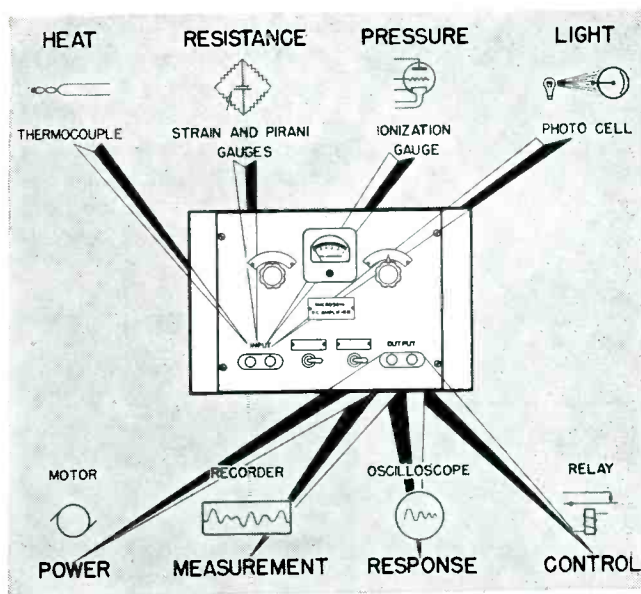

Performance plus Versatility

THE Microsen D. C. Amplifier provides stable and accurate amplification that is simple in operation, compact in design, moderate in cost. Particularly adaptable to laboratory and field work, the Microsen Balance principle assures the advantages of high gain with stability and fast response. The versatility and scope of this electronic instrument opens new fields in engineering research and process development work.

Line voltage variations of 15 per cent cause output changes of less than .5 per cent. There are no mechanical rectifiers or choppers. Tubes are standard. Time constant from .001 to .2 seconds. Drift less than 5 microvolts per day.

Models available include Voltage, Current and Potentiometer Type Amplifiers, Direct Current Converters, Direct Current Transformers and engineered designs to meet special requirements.

For complete data including operation, applications, advantages and specifications—write for the Microsen D.C. Amplifier Bulletin.



**MICROSEN
D. C. AMPLIFIER**

A Product of
MANNING, MAXWELL & MOORE, INC.
BRIDGEPORT 2, CONNECTICUT

Makers of 'American' Industrial Instruments, Hancock Valves, Ashcroft Gauges, Consolidated Safety and Relief Valves. Builders of 'Shaw-Box' Cranes, 'Budgit' and 'Load Lifter' Hoists and other lifting specialties.

Crystals for the Critical

WHAT ARE YOUR CRYSTAL NEEDS?

No matter how specialized—or standardized—they may be, JAMES KNIGHTS CO. is fully equipped to satisfy them quickly and economically.

To effect greater savings for you on short runs, a special production system has been established.

We are also equipped to quickly build "Stabilized" crystals to meet every ordinary need—precision built by the most modern methods and equipment.

For quality—speed—economy, contact the JAMES KNIGHTS CO. You'll be glad you did!

"STABILIZED" CRYSTALS

To Meet Every Need



A WATCH TIMER MANUFACTURER wanted a crystal for use in timing standards. The JAMES KNIGHTS COMPANY designed a special unit and has delivered thousands of satisfactory crystals.

New James Knights Co. Catalog
On Request.

The JAMES KNIGHTS Co.

SANDWICH, ILLINOIS



NEW PRODUCTS

(continued)

four type 12AU7 tubes and can be used at counting rates up to 130,000 per second accurately. The unit features a wide bias range. Direct decimal readout (0 to 9) on four neon-glow lamps provides a simple means of locating a defective tube since the lamps directly indicate the on-off condition of each tube.

Lab Amplifier

GAWLER-KNOOP, INC., 1060 Broad St., Newark 2, N. J. Type 106 d-c amplifier for general laboratory use is particularly suitable for increasing the sensitivity of d-c oscillographs. Maximum voltage gain is 150 times. Response is flat within 0.5 percent from 0 to 20 kc, and is down less than 25 percent at 100 kc. Standard input impedance is 20,000 ohms resistance. At reduced gain settings it can handle signals as large as 100 volts and transient peaks as high as 600 volts.

Voltage Regulator

THE SUPERIOR ELECTRIC Co., 77 Hannon Ave., Bristol, Conn. Stabilized type EM4102 automatic voltage regulator consists of a variable transformer controlled by a specially-designed electronic detector.

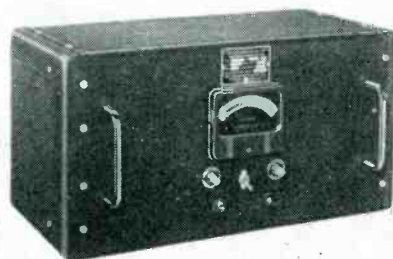

Ratings are as follows: input range, 95 to 135 volts; output, adjustable between 110 and 120 volts; output current, 20 amp; output kva, 0 to 2; input frequency range, 50 to 60 cycles; waveform distortion, zero; recovery time, 0.075 second per volt.

Grid Bias Cell

P. R. MALLORY & Co., INC., Indianapolis 6, Ind. The new miniature-type grid bias cell provides a constant potential for bias of electronic tubes and circuits where no current is required of the cell. It is avail-

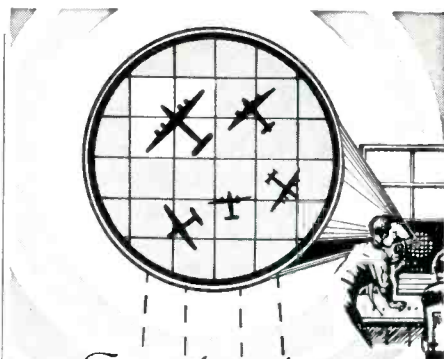

For extraordinary
electrical performance

Use SILVER GRAPHALLOY*



THE SUPREME CONTACT MATERIAL



BRUSHES

CONTACTS

in BRUSHES

for high current density minimum wear low contact drop low electrical noise self-lubrication

in CONTACTS

for low resistance non-welding character

GRAPHALLOY works where others won't! Specify GRAPHALLOY with confidence.

*A special silver-impregnated graphite

GRAPHITE METALLIZING CORPORATION

1055 NEPPERHAN AVENUE, YONKERS 3, NEW YORK

MICO ENGRAVER

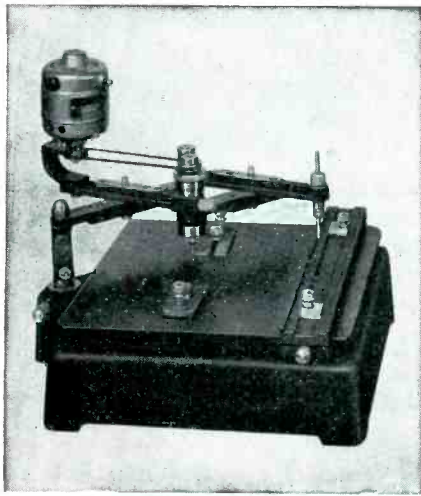

FEATURES

1. Ball Bearing Micrometer spindle for absolute control of depth of cutter in all four ratios.
2. Accuracy of reproduction in four ratios due to excellent precision machining of pantograph arms.
3. Absolute accuracy in three-dimensional duplicating.
4. Many attachments available to increase versatility, such as extension arm, rapid self-centering vise, extension post for pantograph and copy carrier, hand engraving spindle and many more.
5. Copy and work right-side up and in view of operator.

Catalog on Request

MICO INSTRUMENT CO.
76E Trowbridge St. Cambridge 38, Mass.



BLUE PRINT

**IF IT'S
SPECIAL
SEE
PROGRESSIVE**





ENLARGED VIEW

KEEP YOUR COSTS DOWN

Progressive specializes in manufacturing special heads, threads and finishes on any metal or alloy adapted to cold upset. Please write for catalog showing many Progressive specials. Catalog includes purchasing and engineering helps.

The **PROGRESSIVE MANUFACTURING CO.**

50 NORWOOD ST.
TORRINGTON, CONNECTICUT

Working with Inert Gases?

Linde HELIUM · NEON
ARGON · KRYPTON · XENON
are spectroscopically pure

Consult LINDE for your rare gas requirements . . . We can meet your individual needs of purity . . . volume . . . mixtures . . . containers . . .

THE LINDE AIR PRODUCTS COMPANY
Unit of Union Carbide and Carbon Corporation
30 East 42nd Street  New York 17, N. Y.
In Canada: Dominion Oxygen Company, Limited, Toronto

The term "Linde" is a registered trade-mark of The Linde Air Products Company.

NEW... Improved Wiring Eliminates Leakage

TYPE 12A^T & TYPE 12ATK (KIT)

TRANSMISSION MEASURING SET

Range: 111 db. in 0.2 steps.
Frequency resp.: 0.1 db. from 0 to 20 kc.
Accuracy: 0.1 db.
Impedance, load section: 4, 8, 16, 50, 150, 200, 500, & 600 ohms.
Impedance, trans. set.: 50, 150, 200, 500 & 600 ohms.
Reference level: 1mw. into 600 ohms.
Circuit: "T", unbalanced.
Attenuators: 10x10, 10x1 & 5x0.2 db.
Load carr. cap.: Transm. sect. 1 w. Load section 10 w.



A precision Gain Set with specially developed wiring that permits no troublesome leakage and provides improved frequency characteristics. Available completely assembled, or in kit form—which permits the sale of a high accuracy instrument at a low price.

WRITE FOR DESCRIPTIVE BULLETIN



Manufacturers of Precision Electrical Resistance Instruments
PALISADES PARK, NEW JERSEY

NEW!
High Speed

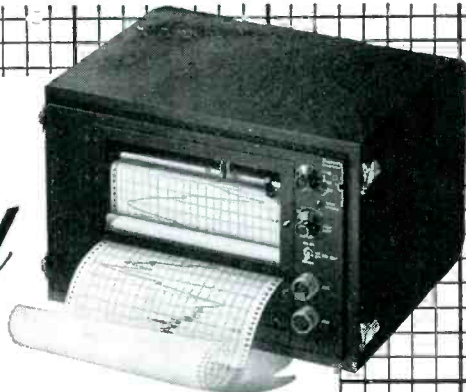

RECTANGULAR COORDINATE RECORDER

AIL's Type 373 Recording System plots voltage—or the logarithm of voltage—as a function of time or of the displacement angle of a measured element. The System increases accuracy, delivers inked charts, saves time, eliminates point-by-point plotting.

Custom-built, versatile. Portable or rack-mounting construction. Voltage range: 10,000 to 1, 80 db. Max. pen speed: 40 inches, 320 db, per second.

ANTENNA PATTERNS
LIGHT INTENSITIES
SOUND PRESSURES
HEAT LEVELS
COUNTING RATES



SEND FOR FULL INFORMATION

**REDUCE ASSEMBLY
REJECTS WITH...**

**TINNED STEATITE
HERMETICALLY SEALED
TERMINALS**

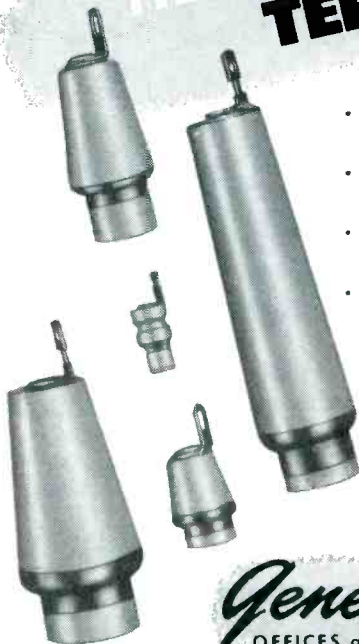

- ... THAT WITHSTAND HIGH SOLDERING TEMPERATURES
- ... ARE IMMUNE TO ROUGH SHOP HANDLING
- ... HAVE TINNED SHOULDER FOR RAPID ASSEMBLY
- ... FOR 200°C SERVICE ON SPECIAL ORDER

A tinned surface, permanently bonded to the glazed body of these terminals permits rapid soldering to any metal enclosure. Exceptional strength of the steatite body practically eliminates assembly rejects that frequently result when other types of terminals are subjected to soldering temperatures or rough handling. Leads are brought out through an axial hole in the center of the bushing and terminated on the tinned lug. A drop of solder on the hole effects a complete hermetic seal. For complete information concerning tinned steatite terminals, call or write today.

General CERAMICS and STEATITE CORP.
OFFICES and PLANT: CROW'S MILL ROAD, KEASBEY, N. J.

MAKERS OF STEATITE, TITANATES, ZIRCON PORCELAIN, ALUMINA, LIGHT-DUTY REFRACTORIES, CHEMICAL STONEWARE

NEW PRODUCTS

(continued)

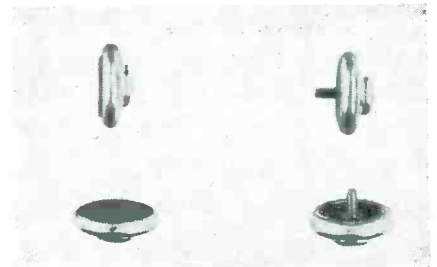

able in 1.5 and 1.75 volts. At audio frequencies the cells have a nonreactive impedance between 250 and 1,500 ohms. Satisfactory operation can be had from -60 to +60 C.

Literature

G-M Counter Instructions. Tracerlab Inc., 55 Oliver St., Boston, Mass. A recent six-page folder gives operating instructions for types TGC-1/1B83 and TGC-2/1B-84 Geiger-Muller counters. The tubes described are self-quenching counters suitable for the measurement of gamma and x-ray photons and most beta particles.

Electronic Control. Sargrove Electronics Ltd., Effingham, Surrey, England. A recent folder contains seven leaflets on photoelectric cell or electronic eye applications for counting, protection, inspection and control. Technical information and illustrations of several units are included.

Tele and Radio Noise Filters. Cornell-Dubilier Electric Corp., South Plainfield, N. J. Bulletin NB-132 describes four new television and radio noise filters developed for use on motors, generators and r-f heating equipment. Ratings, dimensions, attenuation and outstanding features are listed.

Narrow Beam Antenna. Andrew Corp., 363 E. 75th St., Chicago 19, Ill. Type 3605 Corner Reflector antenna for use in the 152 to 162-mc band is described and illustrated in bulletin 84. Included on a single sheet are electrical and mechanical features, specifications and accessories.

Parts Catalog. Standard Transformer Corp., 3580 Elston Ave., Chicago 18, Ill., has announced

Etched TUNGSTEN WIRE

• From .0004" to
.00015" diameter
and even smaller

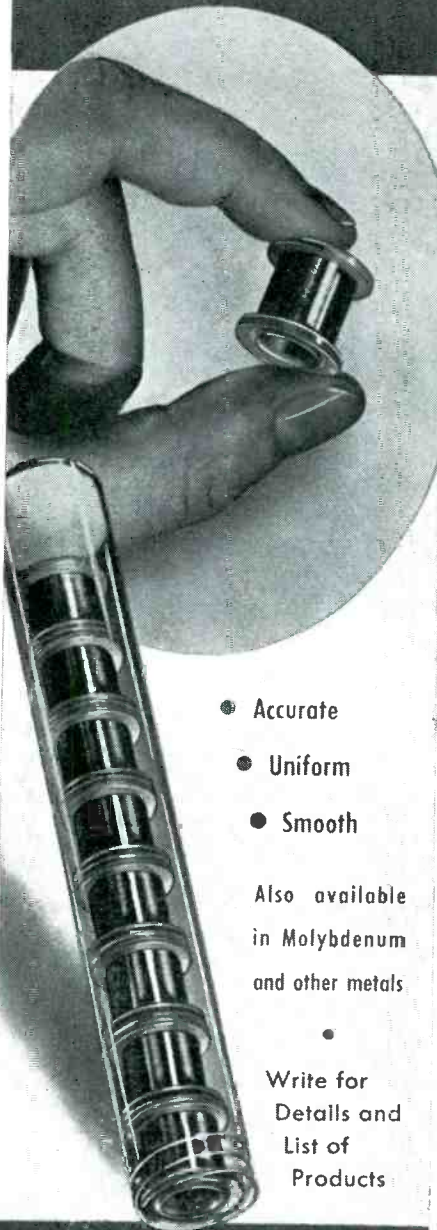

- Accurate
- Uniform
- Smooth

Also available
in Molybdenum
and other metals

Write for
Details and
List of
Products

SIGMUND COHN CORP.
44 GOLD ST. NEW YORK

SINCE  1901

NEW PRODUCTS

(continued)

publication of the 1949 edition of its catalog giving detailed electrical and physical specifications, including list prices, of more than 400 items. Audio and power transformers, chokes and related components for radio, television and other electronic applications are included.

Relay Guide. Struthers-Dunn Inc., 150 N. 13th St., Philadelphia, Pa., has available a booklet comprising a list of relays classified according to function. Types listed include power relays, small relays, sensitive relays, latch relays with electric reset, special-purpose relays and timers. Comprehensive data and adaptations are given.

Resistor Bulletin. International Resistance Co., 401 N. Broad St., Philadelphia 8, Pa. Bulletin B-5 is a catalog sheet giving technical data on the type BW $\frac{1}{2}$, 1 and 2-watt insulated wire-wound resistors. The units covered feature small size, light weight, full insulation and stability.

Recording Counter. Streeter-Amet Co., 4101 N. Ravenswood Ave., Chicago 13, Ill. A four-page illustrated circular deals with the scientific and industrial counter which can be used in conjunction with an arc welder, drill press or other power device, as well as Geiger counters and scaling circuits. Well-labeled drawings and samples of printed tape are included.

Tube Application Notes. Radio Corp. of America, Harrison, N. J., recently issued two new sets of electron tube application notes, AN-138 and AN-139. The former describes the application of the 6J6 or the 19J6 in an a-m/f-m circuit in which one section of the tube is used as a mixer and the other section as a local oscillator; the latter covers characteristics of pentodes and triodes in mixer service.

Motor-Control Unit. Servo-Tek Products Co., 4 Godwin Ave., Paterson 1, N. J. A 4-page brochure describes the new stepless variable-speed motor control unit. The catalog complete with illustrations of the unit and details of

TEKTRONIX PLEDGES...

To serve our customers with products and policies unexcelled in the electronics industry and limited only by the current state of the art.

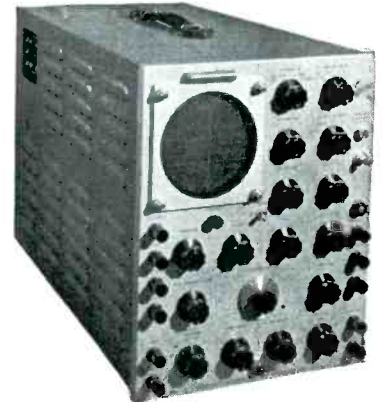

Tektronix Type 511-AD Oscilloscope
\$845 f.o.b. Portland

Wide Band, Fast Sweeps

The Type 511-AD, with its 10 mc. amplifier, 0.25 microsecond video delay line and sweeps as fast as .1 microsec./cm. is excellent for the observation of pulses and high speed transient phenomena. Sweeps as slow as .01 sec./cm. enable the 511-AD to perform superlatively as a conventional oscilloscope.

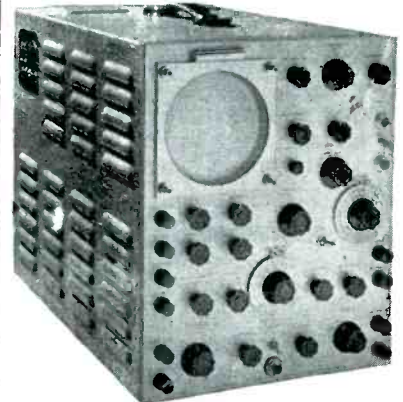

Tektronix Type 512 Oscilloscope
\$950 f.o.b. Portland

Direct Coupled, Slow Sweeps

The Type 512 with a sensitivity of 5 mv./cm. DC and sweeps as slow as .3 sec./cm. solves many problems confronting workers in the fields where comparatively slow phenomena must be observed. Vertical amplifier bandwidth of 2 mc. and sweeps as fast as 3 microsec./cm. make it an excellent general purpose oscilloscope as well.

Both Instruments Feature:

- Direct reading sweep speed dials.
- Single, triggered or recurrent sweeps.
- Amplitude calibration facilities.
- All DC voltages electronically regulated.
- Any 20% of normal sweep may be expanded 5 times.

The Tektronix Field Engineering Representative in your area will be pleased to demonstrate our instruments upon request.



Cables, Tektronix
712 S.E. Hawthorne Blvd. Portland 14, Ore.

FOR EVERY NEED



QUARTZ CRYSTALS

FROM Electronics Park, General Electric offers a complete line of Quartz Crystal Units, including:

- ★ *The G-E Metal Shell (Hermetically Sealed) Series*—for use where long life, under severe atmospheric conditions, is essential.
- ★ *G-E Plastic Cases*—to withstand atmospheric conditions less severe than those encountered by metal tube types.
- ★ *G-E Thermocell*Units for Precise Frequency Control*—Exclusively G-E, Thermocell units are of metal vacuum-tube type construction—truly hermetically sealed.

A MESSAGE TO LARGE CONTRACT USERS OF CRYSTALS

General Electric devotes the greater part of its crystal manufacturing facilities to large runs where mass production economies can be effected for the buyer.

We will be happy to quote on your quantity requirements.

Write for complete information and brochure "G-E Quartz Crystals":
General Electric Company, Specialty Division, Electronics Park, Syracuse, New York.

* Reg. U. S. Pat. Off.

You can put your confidence in—
GENERAL ELECTRIC

NEW PRODUCTS

(continued)

the operation and uses will be mailed on request.

Catalog Inserts. Eitel McCullough, Inc., San Bruno, Calif. Three recent 4-page pamphlets for insertion in a loose-leaf catalog cover types VVC60-20, VVC2-60-20 and VVC4-60-20 variable vacuum capacitors; the 100TH high-mu triode; and the 100TL low-mu triode. Characteristics and dimensional drawings of each are given.

Remote Antenna Control. Eclipse-Pioneer Division, Bendix Aviation Corp., Teterboro, N. J. A remote microwave antenna position control device featuring pushbutton selection is illustrated and described in a recent 8-page folder. Dimensional drawings are included.

Twin Power Supply. Furst Electronics, 12 S. Jefferson St., Chicago 6, Ill. Model 610-F electronically regulated twin power supply is described on two sides of a recently issued catalog sheet. Complete technical data are given.

Sealed Relays. Automatic Electric Sales Corp., 1033 W. Van Beuren St., Chicago 7, Ill. The illustrated circular 1700 describes a line of relays hermetically sealed in a metal container enclosing an atmosphere of dry, inert gas; sealing offers complete protection from the harmful effects of moisture, ice, fungi, acid, salt and varying air pressure. Outlined in the circular are the advantages of such sealing, a description of the process, and a list of some of the applications.

Electronic Alloys. The International Nickel Co., Inc., 67 Wall St., New York 5, N. Y. A 26-page booklet describes the electrical and electronic properties of 18 high-nickel alloys. Designed primarily for electrical engineers, it cites typical uses, mechanical and other properties, and the various forms in which the materials are available.

General Price List. Andrew Corp., 363 E. 75th St., Chicago 19, Ill. Bulletin 10B is a 28-page general price list of a wide line of coaxial



PLUG-IN COMPONENTS

GIVE NEW VERSATILITY TO

Bendix-Pacific

*Telemetry
Systems*

In the Bendix-Pacific Telemetry Systems each sub-carrier oscillator unit now is readily plugged into or removed from a unitized telemetering case of standard dimensions. This exclusive feature, which combines even smaller components than heretofore used, provides extreme flexibility in the selection of functions and greatly facilitates field maintenance of the system. These plug-in connectors entirely eliminate all need for use of schematics or soldering leads, yet they will withstand the extremes of acceleration and vibration.

Bendix-Pacific units operate on telemetering bands of 80-84 mc and 210-220 mc, or intelligence can be transmitted by the use of a single land line circuit. They are for use in guided missiles, experimental aircraft and for industrial applications where conventional methods of measurement are impractical. In addition to the manufacture of precision components for the remote instrumentation field, Bendix-Pacific facilities include installation and application engineering, field operation, data reduction and engineering consultation.

Details gladly furnished to qualified companies.



TO MEASURE - TO INDICATE - TO WARN - AT A DISTANCE
East Coast Office—475 Fifth Ave., N. Y. 17

MICROMETER FREQUENCY METER

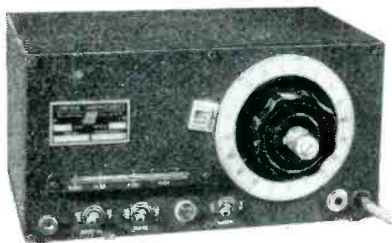

... an accurate, AC-operated, heterodyne meter; ONE instrument will check several transmitters, 0.1 to 175 mc., within 0.005%.

- **RATIO-COUPLED OSCILLATOR:** stability 5 to 10 times that of usual circuits; temperature coefficient less than 2 cycles/10%/°C.; line voltage effect 1 cycle per million for 1% change.
- **MICROMETER CONDENSER:** rugged cylinder-and-tube construction on regular micrometer head—no flimsy plates.
- **PRECISION DIAL:** rotates micrometer head, has 40-turn range and Veeder counter, readable to 0.0017%.
- **PER CENT DEVIATION CURVES:** results readily compared with FCC tolerances.

—Write today for data—

 **LAMPKIN**
LABORATORIES, INC.
BRADENTON . . . FLORIDA

HOW DO YOU KNOW YOU'RE FIRING ON TOP DEAD CENTER?

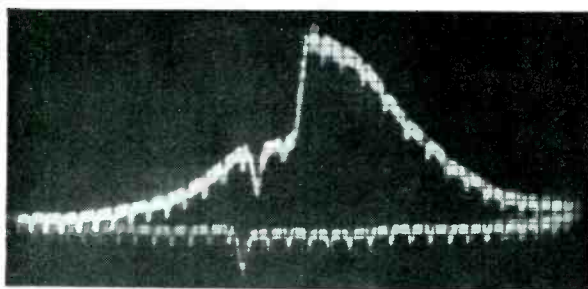

**CAN YOU SHOW THIS
—A PERFECT PRESSURE-TIME CURVE?
FIND OUT INSTANTLY
WITH**

THE SYNCRO-MARKER PRESSUREGRAPH

Close is never close enough. If your firing is off it means trouble—broken piston rings, crankshafts, other damage. The Pressuregraph can tell you why, give you a complete picture of the firing, pressure variations, both regular and instantaneous. It accurately, precisely measures pressure rise with time from vacuum to 14,000 p.s.i.

The Pressuregraph provides oscillograph pictures showing relation of pressures to engine shaft rotation (top dead center) or indications in degrees of rotation or relates pressures to time (milliseconds). Can also be applied to hydraulic, gas, steam or pressure line measurement of static, dynamic or instantaneous pressures.

Above illustration shows ideal Diesel engine performance. Ignition was about 8 degrees after top dead center. The peak pressure occurred 13 degrees after top dead center; therefore, the angular position of the crank is more favorable for efficiently converting pressure thrust into mechanical rotation. The small markers on the curve are 5 degree indications while the larger markers are top dead center.

**WRITE TODAY FOR COPY OF "ELECTRONIC METHODS
FOR MEASUREMENT OF PRESSURE AND DISPLACEMENTS."**

ELECTRO PRODUCTS LABORATORIES, INC.

549 W. Randolph St.

Chicago 6, Ill.

Phone STate 2-7443

AIRBORNE RADIO

FOR ALL CLASSES OF AIRCRAFT



Equipment for:

- TWO-WAY VHF
- STANDARD LF RANGES (with homing loop)
- VHF OMNI RANGES
- LOCALIZERS
- GCA VOICE
- ISOLATION AMPLIFIERS (10 inputs — 2 outputs)

Name of nearest sales and installation agency on request



Aircraft Radio Corporation
BOONTON, NEW JERSEY

For Precision Washers... For Precision Stampings...

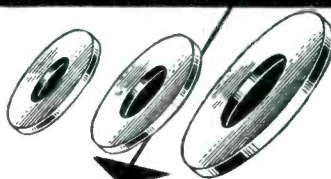

WHITEHEAD STAMPING CO.

A preferred source of precision-made WASHERS and STAMPINGS. 46 years of experience and up-to-the-minute facilities, assure highest quality and service.



EST. 1903

WHITEHEAD STAMPING CO.

1691 W. Lafayette Blvd.

Detroit 16, Michigan

Pioneer in Radio Engineering Instruction Since 1927

CAPITOL RADIO ENGINEERING INSTITUTE

An Accredited Technical Institute

ADVANCED HOME STUDY AND RESIDENCE COURSES IN PRACTICAL RADIO-ELECTRONICS AND TELEVISION ENGINEERING

Request your free home study or residence school catalog by writing to:

REGISTRAR
16TH AND PARK ROAD, N.W.
WASHINGTON 10, D. C.

Approved for Veteran Training



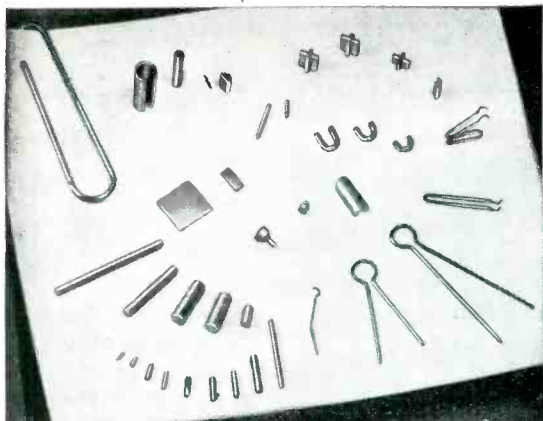

NEY PRECIOUS METALS

FOR

**ELECTRICAL CONTACTS
ON POTENTIOMETERS,
SLIP RINGS, RELAYS
AND SWITCHES**

PALINEY #7

SLIDING CONTACTS FOR POTENTIOMETERS

PALINEY #7 is being used for a contact material on potentiometers wound with a nickel-chrome alloy resistance wire. This combination is consistently producing units with life of better than one million cycles and maintained accuracy of 0.1% or better throughout the life of the unit.

Write or telephone (HARTFORD 2-4271) our Research Department

THE J. M. NEY COMPANY 179 ELM STREET • HARTFORD 1, CONN.
SPECIALISTS IN PRECIOUS METAL METALLURGY SINCE 1812

NEY-ORO #28

SLIP RING BRUSHES

NEY-ORO #28 is a special alloy developed as a contact brush material for uses against coin silver slip rings. Laboratory tests and reports from users indicate life of better than 10 million revolutions with no electrical noise.

NEW PRODUCTS

(continued)

cables and fittings, miscellaneous line accessories, tower lighting equipment, antennas, antenna equipment and components.

Phase Meter. Technology Instrument Corp., 1058 Main St., Waltham 54, Mass. A cardboard-covered bulletin gives an illustrated description of the type 320-A phase meter. The instrument described makes possible the measurement of phase difference between two voltages at audio and ultrasonic frequencies essentially independent of voltage amplitude, frequency and wave shape.

Timing Motors and Devices. Haydon Mfg. Co., Inc., Torrington, Conn. Catalog 321 gives a twenty-page detailed treatment of a line of synchronous timing motors, chart drives, timing devices and clock movements. A separate page is devoted to each item for ease of reference.

Recording Equalizers. Fairchild Recording Equipment Corp., 154th St. & 7th Ave., Whitestone, N. Y. The 626-A1 and B1 NAB equalizers for modifying frequency characteristics of a recording system are described and illustrated in a new bulletin. Specifications and catalog listings are included on the single sheet.

Capacitance Checking. Aerovox Corp., New Bedford, Mass., has issued an illustrated folder on the capacitance and resistance bridge for quick checking of capacitance, resistance, power factor, shorts, and opens, and leakage.

X-Ray Protection. National Bureau of Standards, U. S. Dept. of Commerce, Washington 25, D.C., has published a handbook, Medical X-Ray Protection up to Two Million Volts, giving recommended standards of safety for the installation and use of high-voltage x-ray equipment. The 49-page handbook No. 41 is obtainable for 15 cents from the Superintendent of Documents, U. S. Govt. Printing Office, Washington 25, D. C.

European Technology. Office of Technical Services, Dept. of Commerce, Washington 25, D. C. A new 270-page subject index and abstract collection of more than

FILTER VERSATILITY

Check your filter problems at Lenkurt. Lenkurt combines filter know-how—gained from years of carrier engineering—with the most modern facilities for molding precision

magnetic parts, winding toroids in a wide range of sizes and sealing assemblies for maximum life.

A few standard items illustrated... others to your most stringent specifications. Write.

LENKURT
knows how



LENKURT ELECTRIC CO.
SAN CARLOS • CALIFORNIA

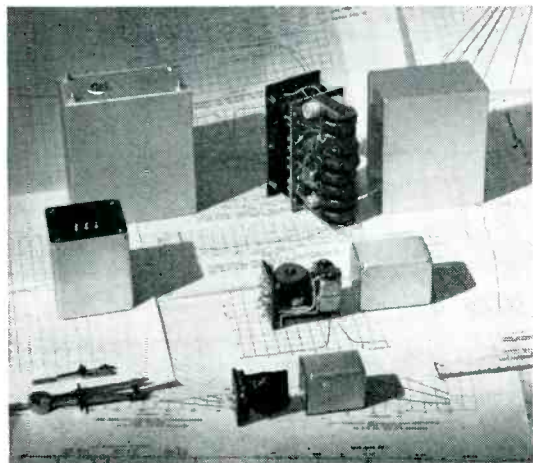

FM SIGNAL GENERATORS



MODEL 78-FM 86 Mc.—108 Mc.

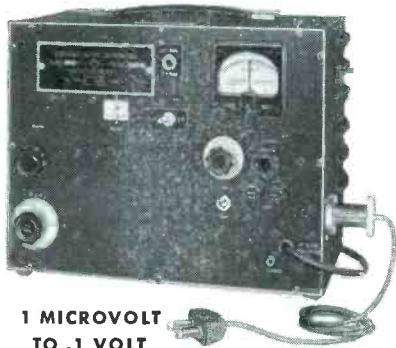

1 MICROVOLT
TO .1 VOLT

DEVIATION: Directly calibrated dial. Two ranges, 0 to 30 kc., 0 to 300 kc. Internal 400 cycle oscillator. Can also be modulated from external source.

DIMENSIONS: 10"x13"x7". Weight 20 lbs.

POWER SUPPLY: 117 volts, 50-60 cycles, 36 watts.

• SPECIAL GENERATORS

One-band Model 78-FM generators, with a tuning ratio of approximately 1.2 to 1, are available for use within the limits of 30 to 165 megacycles.

MODEL M-275 I. F. CONVERTER

For Use With Model 78-FM.



CARRIER FREQUENCIES: 4.5 Mc., 10.7 Mc., 21.7 Mc. (Provision for one extra frequency).

OUTPUT: When used with Model 78-FM the output voltage is variable from 10 microvolts to 1 volt.

POWER SUPPLY: 117 volts, 50-60 cycles, 45 watts.

MEASUREMENTS CORPORATION
BOONTON NEW JERSEY

NEW PRODUCTS

(continued)

1,000 unclassified scientific and technical reports on European technology has been prepared by the Combined Intelligence Objectives Subcommittee. Designated as PB96941, the volume sells for \$3.00 per copy.

Selenium Rectifiers. Vickers Electric Division, Vickers Inc., 1815 Locust St., St. Louis 3, Mo. A 24-page catalog illustrating selenium rectifier characteristics, applications, design factors and listing prices is now available on request. Ask for catalog VC-3000.

Capacitor Assembly. The Compton Co., Bethesda, Md. A short bulletin on one side of a sheet covers the type 6MA Capaci-Ring, a capacitor assembly designed to simplify the problem of socket terminal r-f by-passing. The unit described is designed for application to the standard 7-pin miniature tube socket.

D-C Motor Control. Westinghouse Electric Corp., P. O. Box 868, Pittsburgh, Pa. Booklet B-4112 is a 23-page treatment of Mot-O-Trol, a packaged electronic, adjustable speed drive for precise control of d-c motors operated from a-c sources. Technical and application data are included.

House Organ. International Rectifier Corp., 6809 So. Victoria Ave., Los Angeles 43, Calif., has announced publication of the first issue of Rectifier News. The four-page periodical will feature technical articles on new developments in the field of dry-plate rectifiers for converting a-c to d-c. Regular subscription is available to all qualified engineers without charge if requested on company stationery.

Photoelectric Cells. Vickers Electric Division, Vickers Inc., 1815 Locust St., St. Louis 3, Mo., has made available catalog VC-4000, describing and illustrating a line of self-generating photoelectric cells. Applications and design specifications are given.

Tele Camera Chain. Television Equipment Corp., 238 William St., New York 7, N. Y. Model 1200A portable television camera chain, designed for image orthicon pick-

Outstanding—

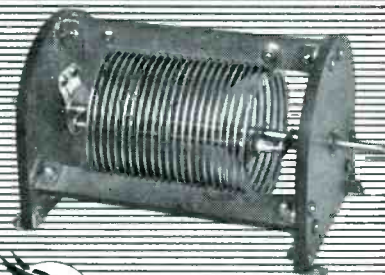

JOHNSON

**FIXED AND VARIABLE
INDUCTORS**

For Every Application . . .

Outstanding in every respect, JOHNSON Variable and Fixed Inductors are available in a wide variety of types to meet every electronic application. JOHNSON has available a wide range of standard models — or can build special types, in production quantities, on short notice.

Among the different types are:

222 SERIES (Illustrated above)

For low power electronic heating and medium power transmitting. Internal sliding contact type. Mycalex insulation, conductor 1/2" copper strip nickel plated. Inductors of this standard type are wound to specific requirements.

224 SERIES

For high power application. Roller contact type. Approximate maximum inductance 75 uh with 3/8" tubing, 50 uh with 1/2" tubing. Cast aluminum end frames.

226 SERIES

For high frequencies. Rotating coil type. Optional variable pitch winding for wide frequency band coverage. Edgewise copper strip, silver plated. Wound to customer specifications.

227 SERIES

A high current Inductor especially adapted to Electronic Heating Equipment. Rotating coil type. Available in single or dual models, with or without coupling links. End frames and support bars, Mycalex. Conductor 3/4" flat wound silver plated copper.

229 SERIES

For low power transmitters. Rotating coil type. Smooth tuning! Available with 27 to 63 turns with inductance of 37 uh to 150 uh in standard models. Steatite or phenolic insulation. Wire sizes 12 and 16 gauge.

TYPE M

Inductance: built to any specified inductance from 10 uh up. Basic M design permits any length and diameter.

TYPE VM

Same as M except supplied with variable coupling rotors, flippers, or as variometers. Faraday screens may be incorporated to reduce electrostatic coupling.

TYPE N

Fixed Inductors wound with either copper strip, ribbon, tubing or wire. Inductance: built to any specified inductance from 10 uh up. May be supplied with either internal or external coupling winding.

TYPE VN

Same as N except variable. Main winding stationary with rotating winding connected as variometer or coupling inductor.

E. F. JOHNSON CO.
WASECA, MINNESOTA

COPPER ARMORED SISALKRAFT



Photo courtesy of Sentinel Radio Corp., Evanston, Ill. This Central Control Room in a modern Television and Radio manufacturing plant is lined with Copper Armored Sisalkraft that eliminates stray signals and electrostatic interference.

A Practical Method for Shielding of TELEVISION AND RADIO STUDIOS, TESTING ROOMS, INDUSTRIAL LABORATORIES, AND DIATHERMY, RADAR, AND ELECTRONIC EQUIPMENT

The success of COPPER ARMORED SISALKRAFT for shielding during the past decade, proves that this reinforced "electro-sheet-copper" is practical for large or small enclosures and equipment requiring electrostatic shielding. COPPER ARMORED SISALKRAFT is low in cost (as low as \$9.75 per 100 sq. ft.), is flexible and easy to apply.

Installations include the following: Steinmetz Hall, New York • Hollywood Television Studio of Don Lee • WBKB Television, Chicago • Corn Products Company's Argo Laboratory • Delco Radio Sets • CBS Radio Testing Laboratories

SISALKRAFT engineers will be glad to furnish data on the merits of COPPER ARMORED SISALKRAFT in these and allied fields.

COPPER ARMORED SISALKRAFT

A Product of The SISALKRAFT Co., Chicago 6 New York 17 • San Francisco 5

The SISALKRAFT Co., Dept. EL, 205 W. Wacker Drive, Chicago 6, Ill.

Please send samples of COPPER ARMORED SISALKRAFT. The use I contemplate involves (describe briefly)

.....

Name.....

Address.....

City, Zone and State.....

NEW PRODUCTS (continued)

up tubes, is discussed in a four-page brochure. Description, features and summary specifications are included.

Technical Data Sheets. Radio Corp. of America, Harrison, N. J. Four recent data sheets give technical information on the 3RP1, a 3-in. oscillograph tube; the 12S8-GT, a triple diode, high-mu triode; the 5794, a fixed-tuned oscillator triode for radiosonde service at 1680 mc; and the 408S3, an 8-in. permanent magnet speaker.

Multipurpose Carrier. Lenkurt Electric Co., Inc., 1113 County Road, San Carlos, Calif. Radio and wire-line applications are both covered by the Type 44 carrier equipment described in a new folder, Form 44P4. The pamphlet shows how the units can be used for voice, telegraph, telemetering and control installations as well as a wide variety of combinations of the four uses.

Signal Generator. J. & A. Television & Manufacturing Co., 5066 Broadway, Chicago 40, Ill. A four-page bulletin describes and illustrates model 30G1 composite video generator designed for use on the television receiver production line, in the laboratory, television transmitter or by the serviceman. The unit described supplies video synchronizing and blanking pulses plus a video dot pattern for alignment purposes.

Tube Data. Radio Corp. of America, Harrison, N. J. Bulletins are now available giving technical data on the following new tubes: the 4-65A a vhf power tetrode; the 16AP4, a 16-inch metal picture tube; the 5763, a vhf beam power amplifier (9-pin miniature type); the 715-C, a pulse amplifier tetrode; and the 5825, a half-wave rectifier tube for r-f operated, high-voltage, low-current power supplies.

Mobile-Service Antenna. Andrew Corp., 363 E. 75th St., Chicago 19, Ill. Tentative Bulletin 102 is a one-page description of the Cardiod antenna, a vertically polarized, directional, ground plane antenna for transmitting and receiving in the 152 to 162-mc band. Accessories are also listed.

INKLESS RECTILINEAR Direct Writing RECORDERS

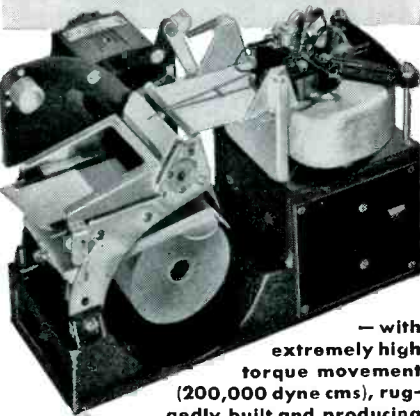

— with extremely high torque movement (200,000 dyne cms), ruggedly built and producing clear, permanent records.

Sanborn Direct Writing Recorders offer these advantages, plus performance characteristics (see table below) that make them outstandingly useful in a wide variety of industrial recording applications.

Whenever a phenomenon or action lends itself to transformation to an electrical quantity, and whether the variation is steady or of a pulse type, these Recorders (with associated amplifiers) can be used for immediate, direct, continuous registration.

Typical applications, actual and potential, include: temperature changes, automotive noise and vibration, varied output of strain gages and bridges, lightning and earthquake recording, pressure variations, audio frequency response, and many others.

Recording paper (Sanborn Permapaper) is heat sensitive — eliminating ink — yet clear and permanent. Trace is rectilinear — no curvature, no negative time intervals — yet with totally negligible tangent error.

Sanborn Recorders are available in self-contained, portable recording outfits, complete with cases and controls, or in component form for integration with existing equipment. Associated amplifiers are also available.

TABLE OF CONSTANTS

| | |
|---|--|
| Sensitivity | 10 ma/l cm. |
| Coil resistance | 3,000 ohms, center tapped for push-pull operation. |
| Critical damping resistance | 500 ohms. |
| Undamped fundamental frequency | 45 cycles/sec. |
| Stylus heater requires from external source | 1.25 volts, 3.5 amps, AC or DC. |
| Maximum undistorted deflection | 2.5 cm. each way from center. |
| Marker requires from external source | 1.25 volts, at 1.5 amps, AC or DC. |
| Paper speed | 25 mm/sec. |
| Chart ruling | 1 mm intervals. |

— additional constants, sizes and weights, general description and photographs are contained in this catalog.

Send today for copy (briefly stating proposed applications) to

INDUSTRIAL DIVISION
Sanborn Company
CAMBRIDGE 39, MASSACHUSETTS

Specify... 

D'ARSONVAL PORTABLE GALVANOMETERS AND MOVEMENTS...

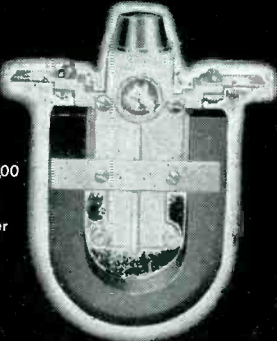

Series 570-500
Mirror-Type
D-C
Galvanometer

Ideal as a built-in component of other instruments—with the sensitivity and ruggedness that is especially desirable for Colorimetry, Densitometry, and various other measurements. Unit includes mirror movement, magnet and zero correction knob. Choice of 4 standard models.

Write us about your application and requirements



LABORATORIES, INC.

4314 N. Knox Ave. Chicago 41, Ill.



STOP



Are Your ELECTRICAL CONNECTORS Jerk Resistant?

Jerked disconnects cause many apparently excellent connectors to open or short-out quickly.

Not MINES Portable Plugs, however... they're designed for rough treatment! Integrally molded of Neoprene rubber and joined to their cables by tapered-neck vulcanization, they outwear and outperform molded phenolic, plastic or porcelain types. In addition, MINES Connectors can't crack or shatter, and are impervious to the ill effects of moisture, oil, acids and dust.

Write for DESCRIPTIVE BULLETIN TODAY

It will pay you to investigate the complete MINES Connector line before placing your next electrical connector order.



MANUFACTURED BY

MINES EQUIPMENT COMPANY

4265 CLAYTON AVE.  ST. LOUIS 10, MO.

Lavite

STEATITE CERAMIC



Design engineers and manufacturers in the radio, electrical and electronic fields are finding in LAVITE the precise qualities called for in their specifications... high compressive and dielectric strength, low moisture absorption and resistance to rot, fumes, acids, and high heat. The exceedingly low loss-factor of LAVITE plus its excellent workability makes it ideal for all high frequency applications.

Complete details on request

D. M. STEWARD MFG. COMPANY

Main Office & Works: Chattanooga, Tenn.
Needham, Mass. • Chicago • Los Angeles
New York • Philadelphia

Manufacturer now offers

RA-62 VG RECTIFIER

Power Supplies for Ground Station
Operation of SCR 522 VHF Radio

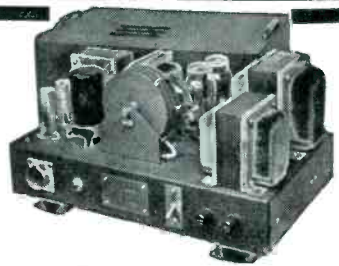

SPECIFICATIONS: INPUT: 110/120/220/240 volts A.C. 50-70 cps, 225 watts. OUTPUT: 300 volts D.C. at 300 ma 150 volts D.C. at 30 ma. 13 volts D.C. at 4.4 amp. **\$138** fob factory

ALL RATINGS ARE FOR 24-HR. CONTINUOUS DUTY SERVICE (Now in CAA Service)

| | |
|--|--|
| SPECIAL ELECTRONICS equipment manufactured to customer's specifications. | AIRCRAFT TEST EQUIPMENT in production TS-67C, TS-170, TS-173, MB-2 (BC376), I-100, An/ARN-1, IE-19A, TS-16, TS-10. |
| MODIFICATIONS ARC 3 RADIO FOR 32 CHANNEL CRYSTAL CONTROL. | MFG. OF AM-FM WALKIE-TALKIES 35-45 mc and 116 mc. |
| ARC 1 RADIO for 20 channel crystal control. | MFG. OF HF and VHF AIRPORT GROUND STATIONS. |

THE AMERICAN ELECTRONIC CO. 2112 S. LA BREA, LOS ANGELES 16, CALIF.

Dano has made a reputation for handling even very difficult—or the simplest coil problems with equal efficiency. Send us your specifications for quotation whether you require an untreated coil or one that is vacuum preganated with wax or varnish.

- Form Wound
 - Paper Section
 - Acetate Bobbin
 - Acetate Section
 - Bakelite Bobbin
 - Cotton Interweave
- COILS FOR HIGH TEMPERATURE APPLICATIONS
MADE TO EXACT SPECIFICATIONS
ALSO TRANSFORMERS MADE TO ORDER

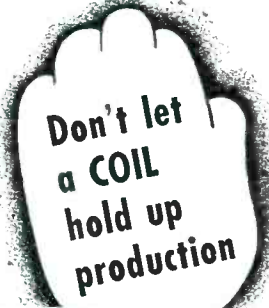

Don't let a COIL hold up production



THE DANO ELECTRIC CO.
MAIN ST., WINSTED, CONN.

for Results



Mc GRAW-HILL
DIRECT MAIL LIST SERVICE

MAILING LISTS THAT WORK...

McGraw-Hill Industrial Mailing Lists are a direct route to today's purchase-controlling executives and technicians in practically every major industry.

These names are of particular value now when most manufacturers are experiencing constantly increasing difficulty in maintaining their own lists.

Probably no other organization is as well equipped as McGraw-Hill to solve the complicated problem of list maintenance during this period of unparalleled changes in industrial personnel. These lists are compiled from exclusive sources, based on hundreds of thousands of mail questionnaires and the reports of a nation-wide field staff, and are maintained on a twenty-four hour basis.

Investigate their tremendous possibilities in relation to your own product or service. Your specifications are our guide in recommending the particular McGraw-Hill lists that best cover your market. When planning your industrial advertising and sales promotional activities, ask for more facts or, better still, write today. No obligation, of course.

McGraw-Hill Publishing Co., Inc.

DIRECT MAIL DIVISION

330 West 42nd Street

New York, 18, N. Y.

NEWS OF THE INDUSTRY (continued from p 130)

ber, author, title, date, paging and prices. Volume and page numbers given in parentheses at the end of citations refer to the Bibliography of Scientific and Industrial Reports where abstracts may be found.

The 16-page infrared bibliography is available from the Office of Technical Services, U. S. Department of Commerce, Washington 25, D. C.

Television Information Committee

TO PRESENT full, factual information on television to the public, the government and other interests, an industry committee was recently appointed by Max F. Balcom of the RMA. Outstanding engineers and technical television experts of the industry will assist in the public relations project which will include information on present tv service and receivers in the vhf channels, and also in prospective future uhf channels.

The committee is headed as chairman by Paul V. Galvin of Motorola Inc., Chicago. Other members are as follows: Benjamin Abrams of Emerson Radio & Phonograph Corp.; W. R. G. Baker of GE; H. C. Bonfig of Zenith Radio Corp., James H. Carmine of Philco Corp.; James W. Craig of Crosley Division, Avco Mfg. Corp.; Allen B. DuMont of Allen B. DuMont Laboratories, Inc.; Joseph B. Elliott of RCA Victor; and William J. Halligan of the Hallicrafters Co.

BUSINESS NEWS

MICROTONE Co., Minneapolis, Minn., hearing-aid manufacturer, has purchased the Audiometer Division of the Audio Development Co., Minneapolis, to consolidate production of medical and portable speech-testing audiometers.

WALTER E. PEEK, INC., Indianapolis, Ind., is a newly formed company engaged in the manufacture of television antennas.

AIRBORNE INSTRUMENTS LABORATORY, Mineola, N. Y., recently organized a new research group designated as the Applied Physics Section. The new unit is presently

engaged in the development of a neutron velocity selector for Brookhaven National Laboratories.

COLUMBIA WIRE & SUPPLY CO., assemblers of cord sets, wire and wire products, recently moved into a new



Columbia Wire's new building

and larger building at 2850 Irving Park Road, Chicago 18, Ill.

GENERAL ELECTRIC Co., Syracuse, N. Y., will spend over a million dollars to provide for picture tube manufacturing and engineering facilities at Electronics Park. Production is expected to start in August. The first size to go into mass production will be the new 8½-inch metal-cone tube.

STATION WOR-TV has purchased the entire square block bounded by 67th and 68th Streets, Broadway and Columbus Ave., New York City, as a site for the future construction of buildings for offices and studios.

PERSONNEL

ARTHUR V. LOUGHREN, formerly director of engineering, has been elected vice-president in charge of research at Hazeltine Electronics Corp.

ORVILLE M. DUNNING, for the past several years engaged in administrative and technical supervision of engineering work under military contracts for Hazeltine Electronics Corp., was recently elected its vice-president in charge of engineering.

WAYNE S. WAMSLEY, formerly electronics project engineer in the Research and Development Laboratories at Ft. Belvoir, Va., has joined the staff of the National Bureau of Standards where he will conduct radar, radio and electronics research in the Ordnance Engineering Laboratory of the Electronics Division.

HARRY JACOBS, with the KGO engineering staff since 1937, was re-

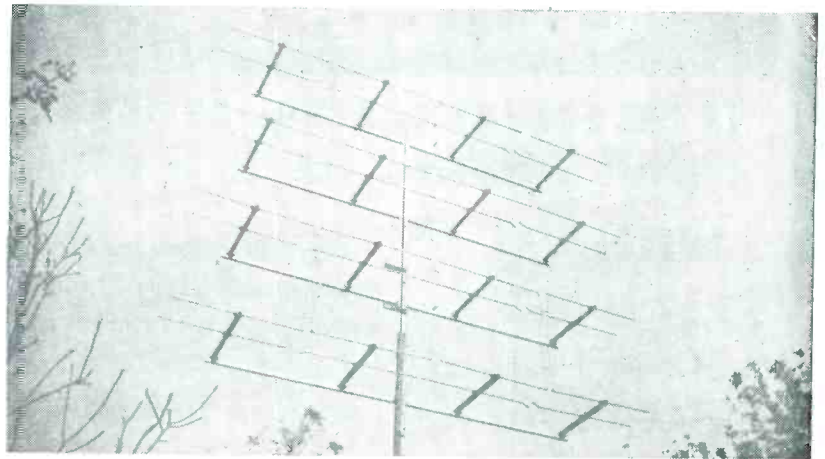

32 Element TV Beam

POWER GAIN 127 OVER DIPOLE

TV, FM, and special, multi-element beams, 8 to 32 elements, peaked on channel, or on your frequency.

Folder with all prices, weights, etc. on request.

W. F. HOISINGTON

U. H. F. RESONATOR CO.
GUION ROAD RYE, N. Y.

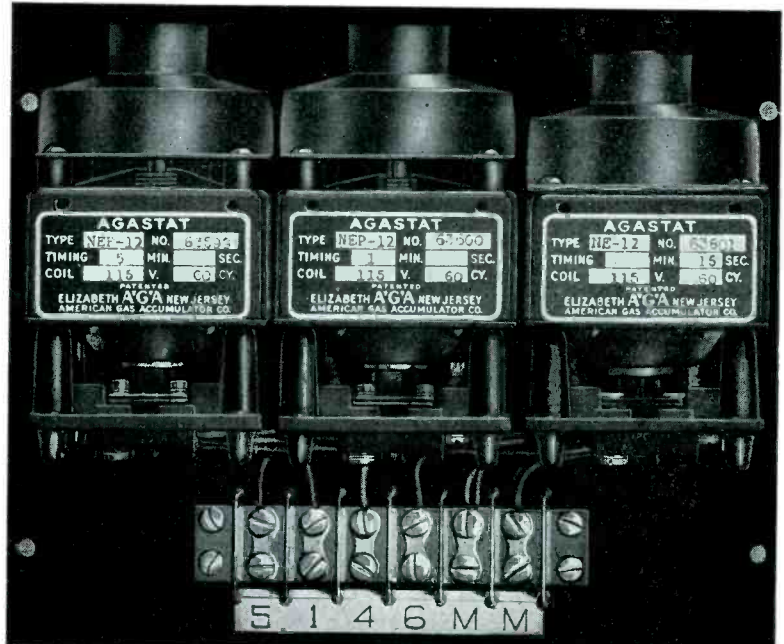

Proportional Unit—Two proportional and one standard AGASTAT combination.

PROPORTIONAL AGASTAT—Provides time delay *proportional* to any power failure time up to 15 minutes. Custom built to specification.

Complete data on request.

A'G'A
AMERICAN GAS ACCUMULATOR COMPANY
1029 Newark Avenue • Elizabeth 3, New Jersey

CUT COSTS

IN FREQUENCY CONTROL DESIGN . . .
ELIMINATE TEMPERATURE CONTROL OF CRYSTALS

WITH

$\pm .0025\%$
 -55°C to $+90^{\circ}\text{C}$

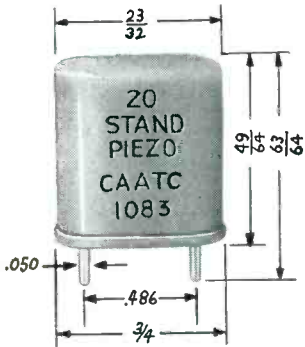

Improved processing of our hermetically sealed Type 20 unit has made it possible to eliminate the cost of temperature control.

Lower power requirements, reduced weight, compactness, ruggedness, and dependability in our improved Type 20 is your answer for reducing costs and increasing sales.

For complete details, write for free catalog.

Standard Piezo Company

CARLISLE, PA.



Kahle

specialists in custom-built, ultra-precision

ELECTRON TUBE MACHINERY

KAHLE CUSTOM-BUILDS machines to make the exact tubes you require—from big 20-inchers to tiny sub-miniatures—from laboratory types to those for high-speed production. Kahle puts each unit through exhaustive trial runs in our plant to assure trouble-free operation in yours.

#1414 BUTTON STEM MACHINE
for Cathode Ray Tube Stems

24 heads, with 4 upper moulds.
Dual motor drive—one for indexing, one for heads.

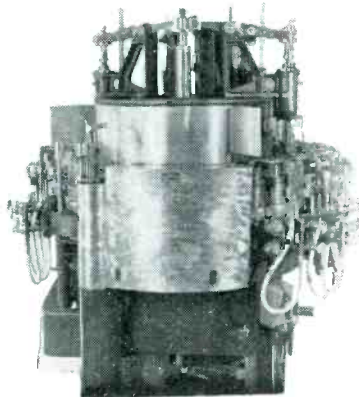

We specialize in cost-cutting, production-boosting, labor-saving equipment for complete manufacture of cathode ray tubes, standard, miniature and sub-miniature radio tubes, sub-miniature tubes, fluorescent lamps, photocells, x-ray tubes, glass products.

Consultations invited
Send for our new catalog

Kahle ENGINEERING CO.

1309 Seventh Street, North Bergen, New Jersey

cently appointed station engineer in charge of the KGO-TV and KGO-FM transmitters in San Francisco, Calif.

HARVEY J. FINISON, former application engineer for the General Electric Co., has been named assistant chairman of the electrical engineering department of Armour Research Foundation, Illinois Institute of Technology.

ROGER E. ROBERTSON, previously associated with Bell Aircraft Corp. as an electronics engineer, has been appointed to the staff of the National Bureau of Standards to conduct engineering research for the guided missile projects of the Electronics Division.

JOHN F. DREYER, JR., formerly consulting engineer for Dreyer Surveys, Inc., has joined the staff of Crosby Laboratories, Mineola, N. Y.

RAYMOND F. GUY, manager of radio and allocations engineering for the NBC, was recently appointed chairman of the engineering committee of the Television Broadcasters Association Inc.

FRANK R. NORTON has been promoted from principal research engineer to chief engineer of the radio-television and broadcast division of Bendix Aviation Corp., Baltimore, Md.



F. R. Norton



R. J. Slutz

RALPH J. SLUTZ, formerly with the Institute for Advanced Study, has joined the electronics division of the National Bureau of Standards to work on basic research, design and development of electronic computers.

LESLIE J. WOODS, with Philco since 1925 in various engineering and management capacities, has been

SOLVED...

SPECIAL PROBLEMS REQUIRING HIGH VOLTAGE POWER SUPPLIES!

TYPICAL PROBLEM:
A group of research physicists associated with a major photographic equipment supply manufacturing company required a 0-40 KV DC reversible polarity power supply. Low ripple was essential.

SOLUTION: →

BETA BUILT IT!
MAJOR SPECIFICATIONS

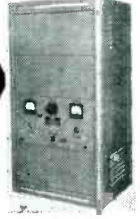

Input: 115 volts, 50/60 cycles; 200 volt-amperes.
Output: 0-40 KV DC; Variac controlled. Either positive or negative polarity as desired.
Output Current: More than 200 μ a at 40 KV. Less than 1% ripple. Size: 21" x 16" x 48"
Insulation: Air insulation throughout.

Power Supplies up to 200,000 volts DC, regulated or unregulated, built to specifications. Compactness, low cost and rapid delivery featured. Submit your high-voltage power supply requirements to us for a prompt bid on price and delivery.

Other BETA products include:
KILOVOLTMETERS up to 50 KV.
PORTABLE 0-30 KV DC POWER SUPPLIES.
ELECTRONIC MICROAMMETERS — 0.01 μ a full-scale.

Send for descriptive literature
Field engineers throughout the country are at your service to discuss our products more thoroughly with you.

BETA ELECTRONICS CO.
1762 Third Ave., New York 29

HERE'S HELP

for technical and business men

NEW 1949 Catalogue of McGRAW-HILL BOOKS



DESCRIBES OVER 2,000 BOOKS

Here is a guide to practical, expert information on many business and technical subjects. This catalogue contains clear, concise descriptions of more than 2,000 books written by leaders of business, industry and research. Get your copy now. In it you will find an up-to-date listing of books that give you the facts—experience—data—you need in solving your particular problems.

McGraw-Hill books bring you the experience of experts in your field

MAIL THIS COUPON FOR YOUR FREE COPY

Readers Service Department
McGraw-Hill Book Co., Inc.
330 W. 42nd St., N. Y.

Send me a free copy of the New 1949 Catalogue of McGraw-Hill Books. I want to know more about: (Name subjects of most interest to you.)

.....

.....

Name

Address

City.....State.....L-7-49

OVENS

for

CATHODE RAY TUBES
SCREEN BAKING
ANNEALING
EXHAUSTING

STEINER-IVES CO.

16 AVE. L, NEWARK 5, N. J.

DESIGNERS AND BUILDERS OF INDUSTRIAL OVENS

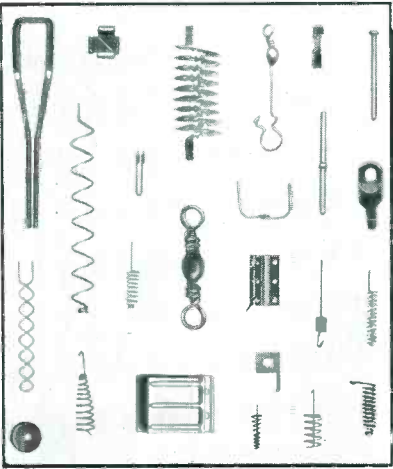

SMALL PARTS

Filaments, anodes, supports, springs, etc. for electronic tubes. Small wire and flat metal formed parts to your prints for your assemblies. Double pointed pins. Wire straightened and cut diameter up to 1/8-inch. Any length up to 12 feet. LUXON fishing tackle accessories. Inquiries will receive prompt attention.

ART WIRE AND STAMPING CO.

227 High St. Newark 2, N. J.

Be **FIRST!** with the **16" GLASS TUBE** by **ZETKA**

famous for Quality and Dependability

- ★ Long life
- ★ Flat face
- ★ Ion trap

★ *15" and 16" tubes available NOW!*

write: **ZETKA TELEVISION TUBES, INC.**
131 Getty Ave. Clifton, N. J.
or phone: PAssaic 2-9095

appointed vice-president and director of research and engineering at Philco Corp., Philadelphia, Pa.

PAUL F. WALKER, formerly with the Andrew Corp., Chicago, has joined the engineering staff of Cleveland Container Co., manufacturers of tubes for television deflection yokes.

DAVID R. HULL, formerly assistant chief of the Bureau of Ships for electronics in the Navy and more recently assistant technical director of the International Telephone and Telegraph Corp., has been named executive vice-president of Capehart-Farnsworth Corp., subsidiary of IT&T.

CLEDO BRUNETTI, associate director of Stanford Research Institute, has been appointed to the Research and Development Board of the National Military Establishment, to head the board's subpanel on miniature components and packaged subassemblies.

ROGER M. WISE, presently engaged in tube research and development for Philco Corp., has been awarded the Certificate of Merit by President Truman for his war work on subminiature tubes for proximity fuzes.

COAX CABLE INVENTORS



Twentieth anniversary of the invention of the coaxial cable system (May 23, 1949) found the two Bell Telephone Laboratories engineers who invented it comparing their first experimental model with the newest type of cable. Lloyd Espenschied, left, holds a section of the early, experimental cable which was installed at Phoenixville, Pa., late in 1929. His colleague, Herman A. Affel, holds a section of the modern, eight-tube cable now being installed in the Bell System's expanding coaxial cable network. Today's cable can carry 600 simultaneous telephone conversations or two television programs on each pair of the eight tubes

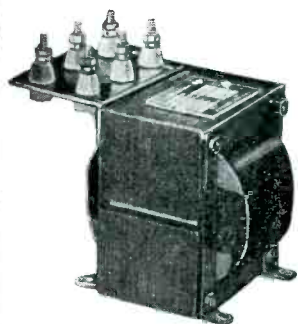

Check With NOTHELPER For Custom Built TRANSFORMERS



Over 25 years' experience in the manufacture of specials at cost that compares favorably with standard types. Built-in quality proved by years of actual use.

From 10VA to 300 KVA Dry-Type Only. Both Open and Encased. 1, 2, & 3 Phase 15 to 400 Cycles.



NOTHELPER

WINDING LABORATORIES

9 ALBERMARLE AVE., TRENTON 3, N. J.

WHEN IT'S A PRECISION BOBBIN

YOU
DON'T
NEED
INSULATION
STRIPS

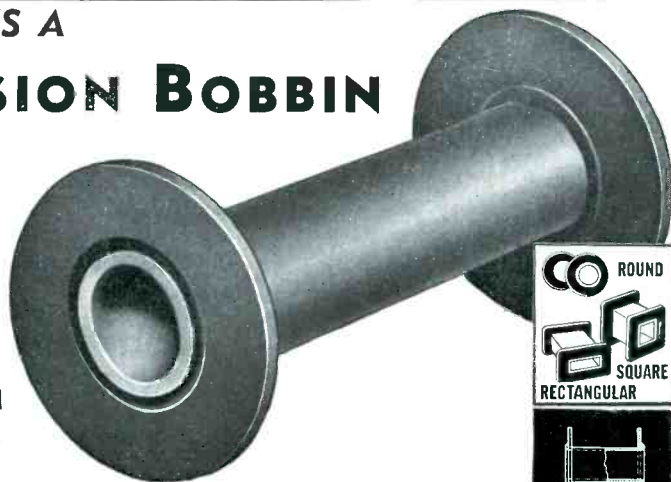

Precision gives you built-in insulation—other direct advantages: stronger magnetic fields, closer windings, more room for larger gauge, or more wire of the same gauge on the same size coil base.

Precision Bobbins are heat treated for greater strength and less weight—have swaged tube ends—and entire Bobbin impregnated for better electrical characteristics. Impregnation also permits attachment of terminal lugs to flanges for acceptance with underwriters requirements.

Precision Bobbins make a lighter, stronger coil—at a definite economy and are available in any shape, any size, round, square, rectangular; in dielectric Kraft, Fish Paper, Cellulose Acetate or combinations.

WRITE FOR SAMPLE TODAY

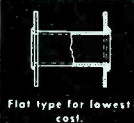

PRECISION PAPER TUBE CO.

2041 W. Charleston St.

Plant No. 2, 79 Chapel St., Hartford, Conn.

Chicago 47, Ill.

BRADLEY RECTIFIERS

HIGH CURRENT SELENIUM RECTIFIERS

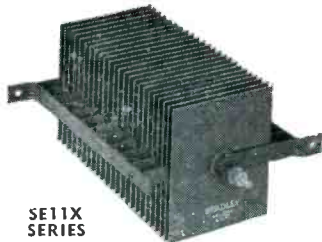

SE11X
SERIES

Bradley's exclusive Vacuum-Processed Selenium Rectifiers provide good efficiency and stability. Square plates afford a maximum ratio of rating to space factor. Forced cooling gives higher current per plate. Plate size up to 5" x 6". Rated up to thousands of amperes. Consult Bradley engineers for best rectifier for your need.

PHOTO CELLS

Simplify Photo Cell Control



Luxtron* photo cells convert light into electrical energy. No external voltage is required to operate meters and meter relays directly from Bradley photo cells, improving control over your processes, reducing your costs. Housed model shown. Many different sizes and shapes, mounted and unmounted.

* T. M. REG. U. S. PAT. OFF.

Our engineers will select or develop Selenium or Copper Oxide Rectifiers or photo cells to meet your needs exactly. Write for BRADLEY LINE showing basic models.

**BRADLEY
LABORATORIES, INC.**
82 Meadow St. New Haven 10, Conn.

NEW BOOKS

Radio Wave Propagation

Report of the N. D. R. C. Committee on Propagation, C. R. BURROWS, Chairman, STEPHEN S. ATTWOOD, Editor. Academic Press Inc., New York, 1949, 548 pages, \$8.80.

THIS book has been long awaited by the many workers who are familiar with the program of study of wave propagation conducted during the war by the NDRC Committee on Propagation as an aid to siting and predicting the performance of radar equipment. The only other book to cover this ground is Volume 13 of the Radiation Laboratory Series, which recounts the work of the MIT group on microwave frequencies. The present volume generally covers the frequency from 100 to 100,000 megacycles.

The book is divided into three sections. The first is a technical survey, including theoretical and practical studies of standard and nonstandard propagation. The second records a number of propagation experiments made under military and NDRC auspices, while the third treats transmission problems in the standard atmosphere in detail.

The book is as authoritative and exhaustive in its treatment of the vhf and uhf propagation problems as one could wish. The treatment is mathematical, but a number of useful nomograms are included for those not inclined to lengthy computations. The book should prove most useful in bringing a wider circle of readers into the mysteries of propagation above 100 mc, on which the future development of radar, television and microwave communications so largely depends.—D. G. F.

Nuclear Radiation Physics

By R. E. LAPP AND H. L. ANDREWS. Prentice-Hall, New York, N. Y., 1948, 487 pages, \$6.00.

WRITTEN as an introductory textbook to the suddenly important field of nuclear physics, this book presents well-rounded descriptions of various radiation phenomena in nuclear physics. The sequence of subject matter of the chapters and the developments within chapters are from simpler concepts and phenom-

For CONTROL and ELIMINATION of SHOCK AND VIBRATION BARRYMOUNTS

AIRCRAFT MOUNTING BASES

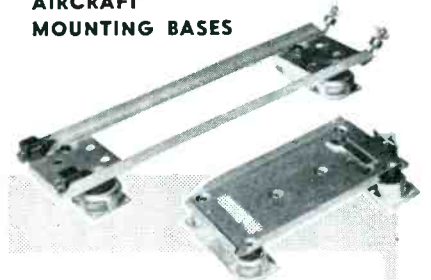

Standard bases with dimensions to government specifications. Special bases to customers' exact requirements.



AIRCRAFT VIBRATION ISOLATORS

Unit isolators designed to meet Army, Navy, and CAA requirements. Stock mountings — 1/4 pound to 45 pound load range. Others on order.

SHOCK MOUNTINGS



For mobile, railroad, and shipboard electronic and electrical equipment. Also for isolation above 2000 c.p.m., and for general sound isolation.

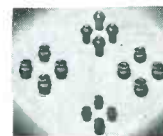

INSTRUMENT MOUNTINGS

For electronic components, tiny fractional H.P. motors, record changers, dictating machines, and other light-weight apparatus.

INDUSTRIAL MOUNTINGS

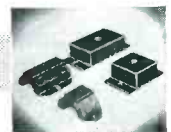

For fans, motor generator sets, transformers, punch presses, and other heavy industrial equipment.

Mountings designed and built for special applications. Consulting Engineering Service for research, product design, and laboratory testing.

THE BARRY CORP

MAIN OFFICE
177 SIDNEY ST.,

CAMBRIDGE 39,
MASSACHUSETTS

New York Rochester Philadelphia Washington
Cleveland Dayton Chicago Minneapolis
St. Louis Los Angeles

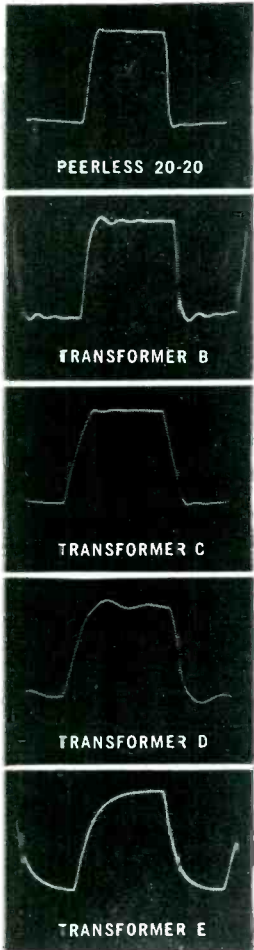

ENGINEERS AT I.R.E. CONVENTION AND JOBBERS AT RADIO PARTS SHOW SEE PEERLESS 20-20 TRANSFORMERS PROVEN BEST BY SQUARE WAVE TEST

*Photos show square wave response with
11,000 cycle fundamental frequency*

Square waves provide the most rigorous test of an audio system and give indisputable evidence on transformer performance. These square wave tests were made under conditions simulating actual transformer operation, that is, square waves were fed from a balanced generator through resistors equivalent to the plate load of the tubes. A non-inductive resistance load was used on the secondary. All transformers were demonstrated under identical conditions. No compensation of any kind was used. A switching mechanism was arranged to give an A-B comparison between any of the transformers. All competitive transformers (as well as the Peerless transformer used) were selected from jobber stock items of leading transformer manufacturers. Only the highest priced "high quality" transformer of each manufacturer was chosen. Equally decisive comparative results were obtained at all other frequencies from 20,000 down to 20 cycles. Let Peerless figure on all of YOUR transformer requirements.

PEERLESS ELECTRICAL PRODUCTS DIVISION

1161 N. Vine St., Hollywood 38, Cal.
161 Sixth Avenue, New York 13, N. Y.

Frazar & Hansen Ltd., 301 Clay St., San Francisco 11, Cal.
Exclusive Export Agent



NEW BOOKS

(continued)

ena to the more complex, following the historical growth where it fits this pattern. The treatment is predominantly descriptive, interspersed with illustrative calculations and problems.

Whereas most of the recent books on this subject follow a pattern of more or less rigorous mathematical development of theory, this text describes the phenomena and the theory of its mechanism with a minimum of mathematical derivation. It might well be termed an engineering treatment as distinguished from a scientific treatment. Thus, although the academician may criticize the book for lack of rigor at some points, the practicing engineer will find it an illuminating introduction to nuclear phenomena and means for dealing with it, as well as a compact, readable presentation. For those wishing to pursue certain topics further, well-chosen references at the end of each chapter provide a key to the literature. —FRANK H. ROCKETT, *Airborne Instruments Laboratory, Mineola, N. Y.*

Theory of Oscillations

BY A. A. ANDRONOW & C. E. CHAIKIN.
Edited under the direction of Solomon Lefschetz. Princeton University Press, 1949, 358 pages, \$6.00.

IT IS not easy to find books written on theoretical subjects of interest to electrical engineers where the difficult problem of combining advanced mathematics and circuit practice is solved as satisfactorily as in this work on theory of oscillations.

The authors of this book are Russian and from reading the text one can presume that they are a mathematician and engineer respectively. The book however has been translated, condensed and edited by a group of Princeton University personnel under the direction of Professor Lefschetz; it is not easy therefore to share the credit properly between the Russian authors and the American editors and translators.

The field of the theory of oscillations has been studied for more than a century and the mass of theoretical material available on the

**Convenient
Decimal Scale
Registration!**

For Radioactivity Measurements!



THE NEW POTTER DECADE SCALER Model 2092—\$495.00

- ★ Direct Decimal Scale Registration
- ★ Scaling Factors of 10, 100 and 1000
- ★ Low Resolution Time — 5 Microseconds
- ★ Self-Contained Mechanical Register
- ★ Regulated High Voltage Power Supply
- ★ Provision for Clock Timer
- ★ High Sensitivity — 0.25 Volt
- ★ Stable, No Adjustments
- ★ High Quality Construction

FOR COMPLETE LITERATURE OR CONSULTATION ON HIGH SPEED COUNTING, TIMING AND CONTROL PROBLEMS CALL OR WRITE DEPARTMENT 6E, TODAY.

POTTER INSTRUMENT COMPANY
INCORPORATED

136-56 ROOSEVELT AVENUE • FLUSHING, NEW YORK



BIRTCHEr

STAINLESS STEEL - LOCKING TYPE

TUBE CLAMPS

Stainless Steel

Corrosion Proof



83 VARIATIONS

Where vibration is a problem, Birtcher Locking TUBE CLAMPS offer a foolproof, practical solution. Recommended for all types of tubes and similar plug-in components.

More than three million of these clamps in use.

FREE CATALOG

Send for samples of Birtcher stainless steel tube clamps and our standard catalog listing tube base types, recommended clamp designs, and price list.

THE BIRTCHEr CORPORATION
5087 HUNTINGTON DR. LOS ANGELES 32

S.S. White MOLDED RESISTORS

The "All-Weather" Resistors



ARE USED IN THIS ULTRA SENSITIVE ELECTRONIC PHOTOMETER

In this instrument—designed for measurement of very low light values—S.S. White Resistors serve as the grid resistance in the all-important high-gain D.C. amplifier circuit. The manufacturer, Photovolt Corp., New York, N. Y., reports that the resistors "work very satisfactorily"—which checks with the experience of the many other electronic equipment manufacturers who use S.S. White resistors.

WRITE FOR BULLETIN 4505

It gives essential data about S.S. White Resistors, including construction, characteristics, dimensions, etc. Copy with price list on request.

Photo courtesy of Photovolt Corp., New York, N. Y.



S.S. WHITE RESISTORS are of particular interest to all who need resistors with inherent low noise level and good stability in all climates.

HIGH VALUE RANGE
10 to 10,000,000 MEGOHMS

STANDARD RANGE
1000 OHMS to 9 MEGOHMS

S.S. WHITE INDUSTRIAL DIVISION

THE S. S. WHITE DENTAL MFG. CO. DEPT. R. 10 EAST 40th ST., NEW YORK 16, N. Y.



FLEXIBLE SHAFTS AND ACCESSORIES
MOLDED PLASTICS PRODUCTS—MOLDED RESISTORS

One of America's AAAA Industrial Enterprises

Check TERMINAL FOR EVERYTHING IN

PHONE

Biggest stock of Radio Parts & Equipment in New York—speedy and courteous attention to your orders—alert salesmen who talk your language.

WIRE

Highest quality, sensibly priced sound equipment for all requirements. Ask for our big free Sound Catalog!

WRITE

Radio amateurs' headquarters for all well-known lines of ham equipment.

DROP IN

Television components, test equipment, tubes, antennas, accessories.

ELECTRONICS
SOUND
HAM GEAR
TELEVISION

TERMINAL RADIO CORPORATION

85 CORTLANDT ST., NEW YORK 7, N. Y.
Phone: WOrth 4-3311 Cable: TERMRADIO

WIDE BAND 5" OSCILLOSCOPE HIGH GAIN

2 MEGACYCLES

- BANDWIDTH 10 cycles to 2 MC (3 DB Down)
- SENSITIVITY .06 RMS Volts/inch
- Hor. Amp. 2 cycles to 500 kc
- Hor. Amp. Sensitivity .15 RMS Volts/inch
- Decade Attenuators (Frequency Compensated)
- Direct Connection to Deflection Plates
- Z Axis Input
- Calibration Test Signal

IDEAL FOR TV WORK—CUTS EQUIPMENT COSTS
A QUALITY INSTRUMENT—AN AMAZING LOW PRICE

Vert. Amp. 1-6SN7, 1-6AC7, 2-6AG7, Hor. Amp. 2-6SN7, 5CPI CR tube 5Y3 and 2x2. Cased in ham-mertone grey cabinet, complete with instructions.
GUARANTEEDMODEL 50

\$149.50
F.O.B. N. Y.

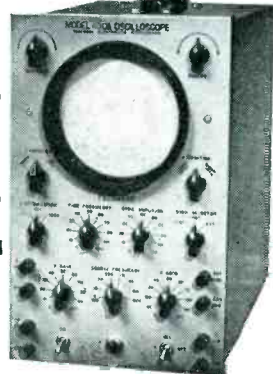

Phone: SL ocum 6-7000

TELEMARK ELECTRONICS CORP. 325 TROY AVE. BROOKLYN 13, N.Y.

for Results



McGraw-Hill
DIRECT MAIL LIST SERVICE

If You Are Having Difficulty Maintaining Your Mailing Lists...

Probably no other organization is as well equipped as McGraw-Hill to solve the complicated problem of list maintenance during this period of unparalleled change in industrial personnel.

McGraw-Hill Mailing Lists cover most major industries. They are compiled from exclusive sources, and are based on hundreds of thousands of mail questionnaires and the reports of a nation-wide field staff. All names are guaranteed accurate within 2%.

When planning your direct mail advertising and sales promotion, consider this unique and economical service in relation to your product. Details on request.

McGraw-Hill Publishing Co., Inc.
DIRECT MAIL DIVISION
330 West 42nd Street New York, 18, New York

subject is unquestionably staggering. Some of the abstractions and generalizations which were formerly of no practical interest have been realized by means of vacuum tubes. Thus the theoretical mathematician finds his love for abstractions once more vindicated when the engineer has to use basic theories written many decades ago to fully explain the characteristics of flip-flop circuits or discontinuous oscillators. On the other hand the authors were faced with the difficult task of choosing the important contributions in a century of scientific work, coordinating the different sections and illustrating each step with practical considerations. In this task the authors succeeded beyond expectations. The book is such that engineers, who remember their college mathematics and are not afraid of the apparent complication of some of the terminology, can read without difficulty. The reader will be amply rewarded by a clearer understanding of devices he uses every day, an understanding that will help him in many development problems.

The book begins with an explanation of the familiar L, C, R tuned circuits from a point of view that will be new to many engineers. Full use is made of the representation in the phase space where the coordinates are displacement and velocity, or charge and current or voltage and current. Such concepts as singular points and phase portraits are thus introduced with reference to extremely well-known physical examples. Naturally the importance of these concepts in nonlinear oscillators derives from the fact that it is often much easier to determine the trajectories of the point representing an oscillator in the voltage-current coordinate plane than to determine the functional relation between these magnitudes and time.

Nonlinear systems are then considered and the concepts introduced in the first chapter are expanded to cover first nonlinear systems without friction or externally supplied energy, and then nonlinear systems where energy is either expended or supplied (non-conservative); systems which produce periodic motions whose amplitudes do not vary much when the systems are changed

DUMONT GLASSITE

THE WORLD'S FINEST TUBULAR

CAPACITORS

NEW TYPE P6M

FINEST MOULDED OIL CAPACITOR

HIGHLY MOISTUREPROOF

NO HEAT • NO HIGH PRESSURES • LONG LIFE ASSURED

COST NO MORE THAN WAX SEALED CONDENSERS

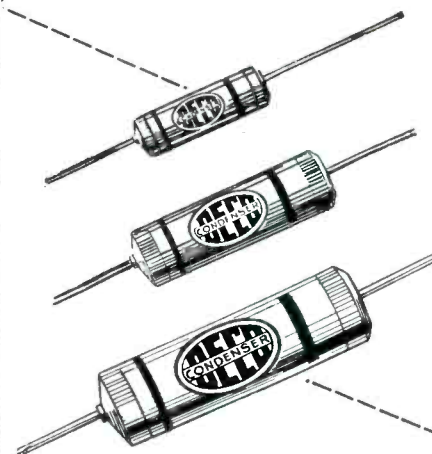

FULL RANGE FROM .0001 TO 1.0 MFD

FROM 100 VOLTS TO 15000 VOLTS

Send For Literature And Samples

DUMONT

ELECTRIC CORP.

MFR'S OF CAPACITORS FOR EVERY REQUIREMENT

108 DYCKMAN ST., NEW YORK, N. Y.



STANDARD AND HEAVY DUTY INVERTERS



For Inverting D. C. to A. C.

Specially Designed for operating A. C. Radios, Television Sets, Amplifiers, Address Systems, and Radio Test Equipment from D. C. Voltages in Vehicles, Ships, Trains, Planes and in D. C. Districts.



AUTO RADIO VIBRATORS

A Complete Line of Vibrators . . .

Designed for Use in Standard Vibrator-Operated Auto Radio Receivers. Built with Precision Construction, featuring Ceramic Stack Spacers for Longer Lasting Life.

NEW MODELS NEW DESIGNS
NEW LITERATURE
"A" Battery Eliminator. DC-AC Inverters, Auto Radio Vibrators
See your jobber or write factory

AMERICAN TELEVISION & RADIO CO.
Quality Products Since 1931
SAINT PAUL 1, MINNESOTA-U. S. A.

a great deal are considered in particular detail. In this chapter the clock and feedback (tuned grid) oscillator are considered together.

The general family of systems of which the gas tube sweep generator is a typical member is then discussed, followed by a theoretical chapter on the large family of systems that need for their definition two first-order differential equations. The flip-flop circuit is a typical representative of this family and this reviewer found here one of the most satisfactory explanations of this familiar device. Discontinuous oscillators, of which the capacitance-coupled multivibrator is a typical example, are then fully discussed.

After a short chapter on cylindrical phase fronts of very little interest for electronics engineers, the book ends with a chapter on the Van der Pol and the Poincaré's method for the quantitative study of wave shapes in nonlinear systems that do not differ too much from linearity. Here the difference between self-starting (soft) and non-self-starting (hard) oscillations is discussed. Mixed cases are also considered. This chapter is the only one where detailed analysis of wave shapes is actually made. A tribute to the power of the mathematical methods employed in the previous chapters is represented by the fact that almost all information necessary for the development of nonlinear oscillators had been given before employing only the representation in the phase space.—E. G. FUBINI, *Supervising Engineer, Airborne Instruments Laboratory, Mineola, L. I., N. Y.*

Books Received for Review

DICTIONARY OF GUIDED MISSILE TERMS. By Committee on Guided Missiles, RDB. Public Affairs Press, Washington, D. C., 57 pages, \$1 paperbound, \$2 clothbound. Outgrowth of smaller classified monograph compiled in 1947 by Lt. Col. J. A. White, defining new words coined for guided missile art, conventional words that have been given different meanings, and certain general technical terms.

PERSONNEL MANAGEMENT. By W. D. Scott, R. C. Clothier and W. R. Spiegel. McGraw-Hill Book Co., Fourth Edition, 1949, 648 pages, \$4.50. Principles, practices and point of view. Completely revised to emphasize wartime and reconversion changes in union-management relations and the increasing importance of psychology in initial selection, transfer, promotion, training, morale measurement and boosting productive efficiency.

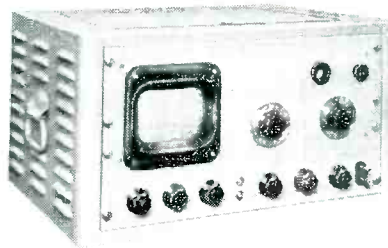

USES

- Ultrasonic Vibration Measurements
- Harmonic Analysis
- Cross Modulation Studies
- Noise Investigations
- Determining Transmission Characteristics of Lines and Filters
- Monitoring Communications Carrier Systems
- Checking Interference, Spurious Modulation, Parasitics, Effects of load changes, shock, humidity, component variations, etc. upon frequency stability
- Telemetry

SPECIFICATIONS

Frequency Range: 2KC—300KC, stabilized linear scale

Scanning Width: Continuously variable from 200KC to zero

Four Input Voltage Ranges: 0.05V. to 50V. Full scale readings from 1 millivolt to 50 volts

Amplitude Scale: Linear and two decade log

Amplitude Accuracy: Within 1db. Residual harmonics suppressed by at least 50db.

Resolution: Continuously variable. 2KC at maximum scanning width, 500c.p.s. for scanning widths below 8KC.

WRITE NOW For Complete Information, Price and Delivery

Available Now!

Easy, Fast Ultrasonic Spectrum Analysis

WITH

MODEL SB-7

PANORAMIC ULTRASONIC ANALYZER

An invaluable new direct reading instrument for simplifying ultrasonic investigations, the SB-7 provides continuous high speed panoramic displays of the frequency, amplitude and characteristics of signals between 2KC and 300KC. The SB-7 allows simultaneous observation of many signals within a band up to 200KC wide. Special control features enable selection and highly detailed examination of narrower bands which may contain signals separated by less than 500c.p.s. The instrument is unique in that it provides rapid indications of random changes in energy distribution.



New! Burlington

ILLUMINATED

INSTRUMENTS

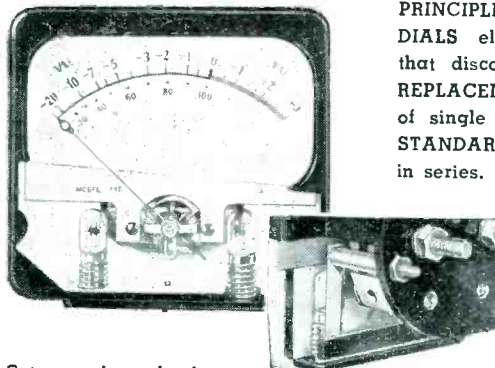

Cutaway views showing positions and connections of lamp assembly.

EXCELLENT LIGHT DISTRIBUTION affords EASE in READING. GLARE REDUCED to a minimum by retaining COMPACT DESIGN of front case extension. REFLECTED LIGHT PRINCIPLE permits use of standard METAL DIALS eliminating translucent materials that discolor with age and use. BULB REPLACEMENT FACILITATED by removal of single lamp assembly. Two 3.8 volt STANDARD BULBS are used and connected in series.

Available in all ranges 3½" and 4¼" rectangular semi-flush models. Write Dept. F-79 for complete details.

BURLINGTON INSTRUMENT COMPANY
BURLINGTON, IOWA

TITONE

**FIRST
BASIC
PICKUP
ADVANCE
in 10 years!**

LIST PRICE \$7.50

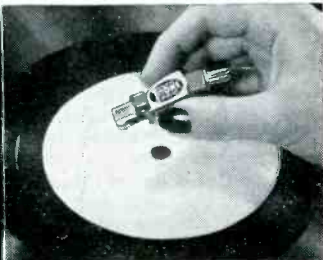

**NEW
TITONE
PICKUP
helps every
record player!**

This original ceramic pickup does wonders for tone and stability in every kind of climate. Wider frequency range gives unequalled reproduction. Designed to fit all tone arms. Made by SONOTONE, famous makers of hearing aids and miniature tubes.

- **TRANSCRIPTION TONE QUALITY!** Full frequency to 10,000 cycles! Real high fidelity! Bell-like supertone makes even old players thrilling!
- **SURE-FIRE IN HUMID CLIMATES!** Unaffected by climate, moisture, fungus! Booms sales, wins back customers.
- **DOUBLES RECORD LIFE AND PLEASURE!** Gives "ordinary" records sparkling quality—revives worn favorites. Will play down to 1/2 normal pressure. NO "needle talk"!
- **RUGGED! PERMANENT!** No crystals, magnets, filaments to fail! No pre-amplifiers. Ceramic TITONE performs perfectly for years!

**NO TONE LIKE
TITONE
INQUIRIES INVITED!**
write now to
SONOTONE, Box T-4, Elmsford, N.Y.

**Wins
new
friends**

Backtalk

This department is operated as an open forum in which our readers may discuss problems of the electronics industry or comment upon articles that ELECTRONICS has published.

Shocking Business

DEAR SIRs:

ON SEEING MY LETTER to Steven Pantages in print (April *Backtalk*), it looked rather sarcastic, so I'd like to do a little apologizing.

His suggestion brings up some interesting points on the electric shock hazard. The idea of wearing a short circuit between hands would look a little less risky in high-power circuit applications if insulated jumpers and contacts were applied. However, one would still get his fingers or hands burned off.

Still another angle lies in the matter of migration currents. Since body skin resistance is relatively high, the presence of a metallic jumper making contact with the fingers, hands or arms, might not shunt enough current to prevent electrocution. Only about 0.1 ampere will kill, regardless of the voltage applied.

Another problem is that an electrical shock presents other hazards besides strangulation, heart stoppage, tissue burns and so on. One might fall off a high tower, drive a screw-driver through an eye, smash one's skull on a steel beam, burn one's eyes out with a blast of molten metal, damage the retinas with an intense short-circuit arc flash, cause one to shove his arm into moving machinery, and so forth.

However, the jumper idea has some interesting possibilities. A large insulated conduction band around both arms might shunt enough current around the vital heart, lung and brain areas to prevent death, even though hands might be charred or severed by high-power circuits.

While working on power transmission systems, some electricians and technicians safeguard themselves by pulling all fuses and switches, tying switches and break-



NATIONAL

- **P**roven
- **D**ependable
- **Q**uality

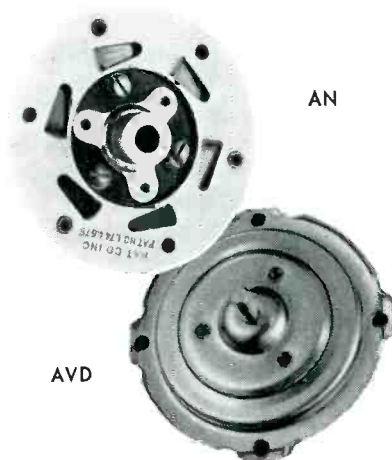

NATIONAL'S POPULAR VERNIER MECHANISMS

Standard AN has an insulated coupling for connecting to 1/4" shaft. Drive shaft fits 1/4" knob. Ratio 5-1. Price \$1.80 net.

AVD same as AN except coupling is not insulated. Price \$1.65 net.

Many variations available for commercial applications. Write for particulars.



WANTED

SPECIAL TOROIDAL WINDING JOBS



Vickers Electric Division—

is equipped to custom wind toroidal cores. Core material furnished if necessary.

SIZE LIMITS: Max. O. D. 4½"
Min. I. D. ½"
Max. Stack Height 2"

WIRE SIZES: #40 to #12

Send your specifications for quotation today.

VICKERS ELECTRIC DIVISION
1815 LOCUST ST., ST. LOUIS, MO.

Faster Evacuation to Low Pressures with Top Efficiency

Beach-Russ Type RP Single Stage Vacuum Pump. Capacity —17 to 845 c. f. m.

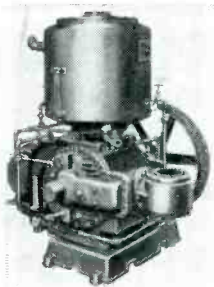

For vacuum exhausting and processing at low pressures in electronic or electrical operations, these pumps offer the advantages of positive rotary, automatically lubricated, noiseless operation. They are "tops" for producing high vacuum or for backing diffusion pumps. Test to absolute pressures as low as 4 microns.

BEACH-RUSS
high vacuum
PUMPS

Write for
Catalog
No. 84

BEACH-RUSS COMPANY
52 CHURCH ST. NEW YORK 7, N. Y.

POLARAD LABORATORY Equipment

for studio • laboratory • manufacturer

20 MC VIDEO AMPLIFIER Model V

- Flat frequency response from 100 cps to 20 mc \pm 1.5db.
- Uniform time delay of .02 micro-seconds.
- Gain of 50 db.
- Frequency compensated high impedance attenuator calibrated in 10 db steps from 0-50.
- Fine attenuator covers a 10 db range.
- Phase Linear with frequency over entire band.

This unit is designed for use as an oscilloscope deflection amplifier for the measurement and viewing of pulses of extremely short duration and rise time, and contains the Video Amplifier Unit, Power Unit and a low Capacity Probe.

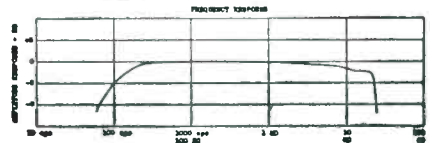

Specifications

Input Impedance: Probe—12 mmf + 470,000 ohms; Jack—30mmf + 470,000 ohms; Output Impedance 18mmf + 470,000 ohms each side push pull;
Max. input Volts 500 peak to peak with probe; Max. Output Volts 120 volts peak to peak (push pull);
Power: 115 volts 50/60 cps AC Line;
Size 19¼"x22"x14¾".

Polarad
Electronics Company

9 FERRY STREET NEW YORK 7, N. Y.

TELEVISION ENGINEERS and CONSULTANTS to the Nation's Leading Television Stations

COMPOUNDS

Scientifically compounded for specific applications from waxes, resins, asphalt, pitches, oils, and minerals. Available in wide range of melting points and hardnesses. Special potting compounds are heat conducting and crack resistant at extremely low temperatures. Recommendations, specific data, and samples will be furnished on request.

for

- | | |
|---|--|
| IMPREGNATING radio coils transformer coils ignition coils wire coverings paper tubes and forms porous ceramics | SEALING condensers batteries switch base terminals socket terminals light fixtures |
| DIPPING Coils Transformers Condensers | POTTING Radio Transformers Light Units Loading Coils Condensers |



BIWAX CORPORATION

3445 HOWARD STREET
SKOKIE, ILLINOIS

Little thought-of facts about capacitors . . .

The short time breakdown voltage of a well-made D.C. capacitor is not less than 5 to 6 times the actual working voltage at 20°—

$$E = 5 \times e \text{ min}$$

$$E = \text{Breakdown voltage}$$

$$e = \text{Rated d.c. working voltage}$$

INDUSTRIAL CAPACITORS are unvaryingly held to this formula.

Designed for maximum safety factor and the smallest possible volume, INDUSTRIAL CAPACITORS are the most widely used capacitor in industrial applications.

WRITE TODAY FOR DETAILED CATALOG

INDUSTRIAL CONDENSER CORP.

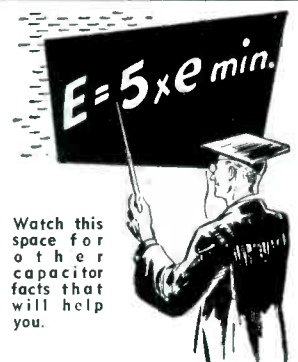

Watch this space for other capacitor facts that will help you.

Sales Offices in
All Principal Cities
3243 N. California Ave.
Chicago 18, Illinois

YOU CAN BE **SURE** IF IT'S A

GRACOIL
"One Good Turn or a Million"

Transformer

because you **TRY** before you buy . . .
with a **PRODUCTION SAMPLE!**

★ For many years, The Gramer Company has engaged in the successful design and quantity production of Gracoil Transformers and Windings, making countless thousands for big name manufacturers in American industry. Such success is due in part to Gracoil's "production sample" method of testing in advance for physical and electrical correctness. No guesswork. Try it.

THE PRODUCTION SAMPLE IS YOUR
GUARANTEE OF DEPENDABLE PERFORMANCE!

Write today!

THE GRAMER COMPANY

Electrical Coils and Transformers

2734 N. PULASKI ROAD

CHICAGO 39, ILL., U.S.A.

ESTABLISHED IN 1935

OPEN TYPE—STRAP MOUNTING

"Gracoil" Transformers include:
Open Types—Step-Down-Up—Fully Enclosed—Line Voltage Regulating—Filament—Audio—Filter Reactors—Isolation—to specifications.

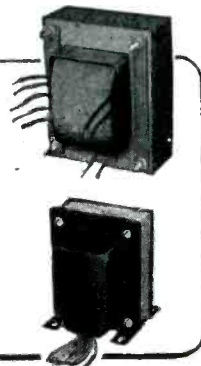

FULLY ENCLOSED

BACKTALK

(continued)

ers in the open position, and by coupling massive jumpers across the feeders at the point where the work is being done so that breakers or fuses will blow if some irresponsible worker throws them without checking up first.

Another difficulty with applying safety devices lies in attempting to get personnel to wear them, particularly in hot weather. The resistance to regulations, to something new, and the addiction to the gambling urge, seem to be all too universal human traits.

TED POWELL
Maspeth, N. Y.

Valves

DEAR SIRs:

IN THE ARTICLE entitled, "European Receiving Tubes" by H. A. S. Gibas in February, 1949 *ELECTRONICS*, the names of the principal British valve manufacturers are given, and the statement made that, "All these make similar tubes as the Continental standard types, some with different designations."

We wish to put on record the fact that Standard Telephones and Cables Limited do not make equivalents of the so-called Continental types, and do not contemplate doing so.

Our policy has been consistently directed to cover all overseas markets, and with that point in view a comprehensive range of the more popular American types are manufactured and listed by this Company under the "Brimar" trade mark.

B. J. AXTEN
Publicity Manager
Standard Telephones and Cables Ltd.
London, England

SLICE
Rising Time Costs
with
Solder Pre-Forms

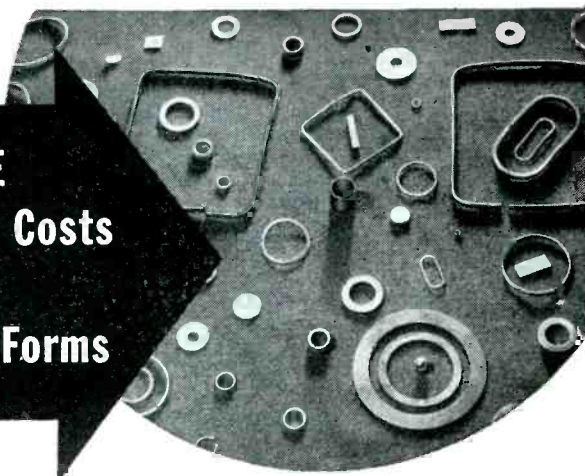

Eliminate time-consuming manual solder operations in your assembly processes. Pre-formed rings, washers, discs, pellets, squares, etc., complete with flux, save time, trim labor costs, insure cleaner, more uniform, sturdier bonds. We meet your specifications in the widest variety of solder alloys. Consult with us on any solder or brazing problem.

(Literature on Request).

Soldering Specialties

Dept. C, Summit, N. J.

How About Gates?

DEAR SIRs:

ALL THIS TALK, talk, and more talk about where are the frequencies to come from for the utility companies, the taxicab companies, the nurses' call, doctors' exchange, and miscellaneous other utilities (including police and fire) seems to me a bit superfluous.

While it may be true that in New

York, Chicago, Los Angeles, and other cities whose population exceeds 1 million, a problem may arise, the solution for the major part of the USA seems simple.

Under the present setup, only one taxicab can logically have a station on the share-the-same-frequency setup. No other taxicab company will get radio for their competitor to "listen in" on a share-time basis. This has been the main objection of the second and third "sharers" to get radio, after one company already has it.

Apparently a very important development of the war has been forgotten in planning utility radio. That is the idea of pulse time modulation.

It seems to me that a band of frequencies similar to the television channels could be set up for pulse time stations in the public interest. Owned and operated by a separate company or a corporation whose stock is controlled by the individual subscriber companies, the pulse time station would operate at all times, transmitting those messages it receives from the individual dispatchers in the member company offices.

The cabs of company A would receive only the signals meant for them, as their receivers would be gated that way (to borrow the term from radar). Likewise, company B's mobile units would not receive any of company A's or anyone else's messages except his own.

A system for New Orleans, as an example, would not need more than ten or twelve gates. This would take care of the police department (1), fire department (2), utility companies (3 and 4), three taxicab companies (5, 6 and 7), doctors, nurses and emergencies (8), city emergency services (9), and for twelve channels, the remaining channels would be available for other services.

The system is one in which the transmission (c-w) is cut up into twelve equal pulses, or gates, and a thirteenth trigger pulse. In each section of time, the voice frequencies are modulated on the carrier only during the gate applying to one particular subscriber's time. In other words, gate number one might carry only the information



AEROCOM'S NEW ARTIFICIAL ANTENNA, SIMULATING ACTUAL OPERATING CONDITIONS, SAVES TIME ON TRANSMITTER AND RECEIVER TUNING

It is no longer necessary to final tune transmitters or receivers aboard aircraft. With the new Artificial Antenna (Model DA200) you can precisely simulate, electrically, any normal aircraft antenna. All this without leaving the test bench. This equipment will accept any transmitter power up to 200 watts -- coaxial fitting provides direct 52 ohm metered load. Sturdily constructed for hard usage, can be mounted in standard rack cabinet or used on bench top.

A letter or wire from you will bring descriptive literature

CONSULTANTS, DESIGNERS AND MANUFACTURERS OF STANDARD OR SPECIAL ELECTRONIC, METEOROLOGICAL AND COMMUNICATIONS EQUIPMENT.

AER - O - COM
Reg. U. S. Pat. Off.

AERONAUTICAL COMMUNICATIONS EQUIPMENT, INC.
3090 Douglas Road, Miami 33, Florida

DEALERS: Equipelero Ltda, Caixa Postal 1923, Rio de Janeiro, Brasil * Henry Newman Jr., Apartado Aereo 138, Barranquilla, Colombia * Radelec, Reconquista 46, Buenos Aires, Argentina

HEAT RESISTANT WIRES FOR EVERY APPLICATION . . .

DESIGN ENGINEERS . . .

Do those new circuit designs present new wire problems?

Then check with Lewis Engineering for an economic solution and fast delivery. For twenty years we've successfully been solving the heat and age resistance wire problems of industry. We don't stock wire—we make it to your specs—for an experimental run or for the production line. If you're designing in the electronic, electrical or appliance field . . .

- HEATING UNITS
- HEATING ELEMENTS
- RESISTANCE LINE CORD
- THERMOCOUPLE WIRE
- ASBESTOS LEAD & FIXTURE WIRE
- INSULATED RESISTANCE WIRE
- FIBERGLAS INSULATED WIRE
- WIRE TO ANY SPECIFICATIONS

Let Lewis Build The Wire For You

Send your electronic control, communications or appliance wiring specifications for a recommended solution by our engineers. FOR A TRIAL ORDER OR A CARLOAD consult



THE LEWIS ENGINEERING CO.

Wire Division
NAUGATUCK CONNECTICUT



Reg. U. S. Pat. Off.

SELF-LOCKING SET SCREWS



Pat'd and Pats. Pend.

"... they won't shake loose!"

Machine failure from any cause is expensive—in downtime, repair costs, lowered production, poor deliveries and loss of customer goodwill. Frequently such failure is caused by the loosening of set screws holding vital machine parts together.

UNBRAKO Self-Locking Set Screws won't shake loose! Their exclusive knurling makes them exceptionally vibration-resistant, prevents "creep" and subsequent loosening of the screws. They "stay put," even under the most chattering vibration.

UNBRAKO Self-Locking Set Screws can be real "Vibration Insurance" for your production machinery. And remember, they make an impressive selling point when you use them on your finished products.

Our folder 658-1 gives you further details. Write for yours today!

SPS

STANDARD PRESSED STEEL CO.

BOX 596 JENKINTOWN, PENNSYLVANIA

"Serving Industry continuously since 1903 through Industrial Distributors"

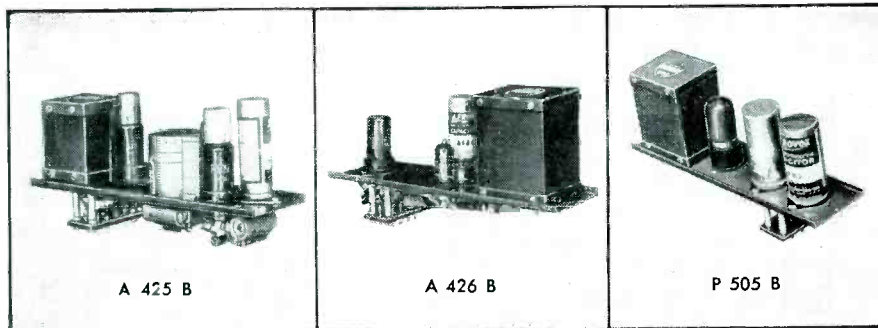

ANNOUNCING A NEW LINE OF PRE-AMPLIFIERS TO MEET THE NEED FOR GREATER FLEXIBILITY IN PUBLIC ADDRESS & RADIO BROADCAST SYSTEMS

The new Altec Lansing line of input amplifiers meets a demand for units of small size with excellent characteristics. Dimensions of the A-425B Pre-Amplifier with mixer control, the A-426B Line Amplifier and the P-505B Power Supply are 2½ inches wide by 10 inches long.

The 10675 Mounting Base permits mounting 6 units of any type in a standard rack or in a mixer console. Thus, complete facilities for 4 microphone inputs with line amplifier and power sup-

ply will occupy the space 19 inches wide by 10½ inches high.

All amplifiers have a flat frequency response from 20 to 20,000 cycles.

☆☆☆☆☆☆

Full technical description upon request.

1161 North Vine St.
Hollywood 38, Calif.

161 Sixth Avenue
New York 13, N.Y.



IN THE PROFESSION, AN HONORED NAME

of dispatcher A, and so on.

Each receiver would have an oscillator which is synchronized by the trigger pulse, then phased to the proper gate time, and applied to the i-f's to turn them on only during the proper gate.

I believe the whole system could be placed in one channel about the size of one present television channel. Answer back would require a separate frequency for each subscriber, but if the answer back is allocated in the vhf band (about 200 or 300 mc) and suitable receivers placed at selected spots in the city, sufficient room could be found. Several noncompetitive subscribers could even use the same answer back frequency, as most answers are short messages.

In cities other than the crowded few, it would be highly possible to utilize one or more of the unused television channels for this purpose. Look at all the unused frequencies all over the country being held open for no justifiable reason except that they are being used in New York, and will maybe be used 1 or 2 hundred years from now in another city.

Another item that needs rectification is the present ship-to-ship and ship-to-shore frequency setup. There is no earthly reason, from the low frequencies and short distances involved, to continue to use the crowded short wave (2 to 5-mc) range. In New Orleans, some fisherman cannot tell his wife that he will be late for dinner because a 100-watt tug is carrying on a long-winded orders conversation with his office. Again on 2,670 or 2,638 it is next to impossible to find time to talk. It seems that everyone is there. Why not give the geophysics floating laboratories their own frequency and forbid them the use of the fisherman's channel; give the tugs their own frequency to use and forbid them to use the geophysicist channel and so on.

The only ones that seem to have logical reasoning in assignment are the present vhf aircraft channels.

Yours for better utility of the radio spectrum,

C. R. MADUELL, JR.
Delta Electronic Equipment Company,
New Orleans, Louisiana.

PROFESSIONAL SERVICES

Consulting—Patents—Design—Development—Measurement

in

Radio, Audio, Industrial Electronic Appliances

THE BARRY CORPORATION

Specialists in the Control of
VIBRATION IMPACT NOISE

*Engineering Development
Manufacturing*

185 Sidney Street Cambridge, Mass.
Telephone: ELIot 0861-0140

The Trend Toward Economy—

The service of the consulting engineer is a real economy. With his knowledge of organization and production problems and his wide and varied experience, he can usually reveal the points of waste and inefficiency that are costing you money and suggest inexpensive means for their elimination.

NIAGARA ELECTRON LABORATORIES

CONSULTATION - DESIGN - CONSTRUCTION
MFG. - THE THERMOCAP RELAY

Specializing in solution of problems of electronic and electro-physical instrumentation for the research or analytical laboratory. Industrial plant problems also invited.

Andover, New York Cable Address: NIATRONLAB

S. BERTRAND BARNARD, LL.B., M.E.,

REGISTERED PATENT ATTORNEY

Mechanical, Electronic,
Automotive and Aircraft Patents.

PATENT ANALYSES and INVESTIGATION

29-28 41st Avenue STILLwell 4-5428
Long Island City 1, N. Y.

ERCO RADIO LABORATORIES, INC.

Radio Communications Equipment

Engineering - Design - Development - Production
Pioneers in Frequency Shift Telegraph

Garden City • Long Island • New York

PICKARD AND BURNS, INC.

Consulting Electronic Engineers

Analysis and Evaluation
of Radio Systems
Research, Development & Design
of Special Electronic Equipment

240 Highland Ave., Needham 94, Mass.

CROSBY LABORATORIES

MURRAY G. CROSBY & STAFF

*Specializing in FM,
Communications & TV*

Offices, Laboratory & Model Shop at:

128 Old Country Rd., Mineola, N. Y.
Garden City 7-0284

PAUL GODLEY CO.

Consulting Radio Engineers

GREAT NOTCH, N. J.

Est. 1926 Little Falls 4-1000

ALBERT PREISMAN

Consulting Engineer

Television, Pulse Techniques, Video
Amplifiers, Phasing Networks,
Industrial Appliances

Affiliated with
MANAGEMENT-TRAINING ASSOCIATES
3308-14th St., N.W. Washington 10, D.C.

EDGERTON, GERMESHAUSEN & GRIER, Inc.

Consulting Engineers

Research, Development and Manufacture
of Electronic and Stroboscopic Equipment
Specialists in High-Speed Photography

160 Brookline Avenue, Boston 15, Mass.

HANSON-GORRILL-BRIAN INC.

Product & Mfg. Development

ELECTRICAL - ELECTRONIC
HYDRAULIC - MECHANICAL

One Continental Hill Glen Cove, N. Y.
Glen Cove 1922

PAUL ROSENBERG ASSOCIATES

Consulting Physicists

Main office: Woolworth Building, New York 7, N. Y.

Cable Address Telephone
PHYSICIST WOrth 2-1939

Laboratory: 21 Park Place, New York 7, N. Y.

ELECTRO IMPULSE LABORATORY

Consulting Physicists

Radio Interference and Noise Meters; Interference
Suppression Methods for Ignition Systems and
Electrical Devices.

P. O. Box 250 Red Bank, New Jersey
Red Bank 6-4247

MEASUREMENT ENGINEERING LIMITED

Consultants on Special Equipment for measurements
and production tests, communications and audio
systems.

Head Office and Plant
Amprior Canada Montreal
60 Front Street West Canada
Toronto, Canada

A. F. SMUCKLER & CO., INC.

Electronic and Communication

Engineers and Manufacturers

202-208 Tillary Street Brooklyn 1, N. Y.

ULster 5-5141

ELECTRO-MECHANICAL RESEARCH INC.

Specialized Research and Manufacture

High and Low Frequency Circuit Development
Electronic Measuring and Test Equipment
Optical and Infra-Red Studies
Special Geophysical Equipment
Automatic Inspection Devices

Ridgefield, Conn.

Eugene Mittelmann, E.E., Ph.D.

Consulting Engineer & Physicist

High Frequency Heating — Industrial Electronics
Applied Physics and Mathematics

549 W. Washington Blvd. Chicago 6, Ill.
State 2-8021

TECHNICAL MATERIEL CORPORATION

Communications Consultants

RADIOTELETYPE • FREQUENCY SHIFT
INK SLIP RECORDING
TELETYPE NETWORKS

453 West 47th Street New York 19, N. Y.

ELECTRONIC ENGINEERING CO. of CALIFORNIA

Radio and Electronic Consulting and
Designing.

2008 W. Seventh St.
DRexel 8323

Los Angeles
California

NEWTON ENGINEERING SERVICE

Transformers for Electronics

Designs, prototypes and production quantities to
individual requirements. We offer a highly personal
service and fast delivery on "Breadboard
models".

84 Linden Park Street Highlands 2-1310
Boston 20, Mass. Nights—Holidays LA Salle 7-4959

YARDENY LABORATORIES, INC.

Research and Development

Remote Controls and Electro Chemical
Generators of Energy

105 Chambers Street WO 2-3534, 35
New York, N. Y.

THE
REAL
VALUE

of placing your unusual problem in the hands of a competent consultant is that it eliminates the elements of chance and uncertainty from the problem and provides real facts upon which to base decisions.

CONTACTS

FOR THE FIELD OF ELECTRONICS

EISLER

SPECIALIZES IN EQUIPMENT FOR THE COMPLETE MANUFACTURE OF

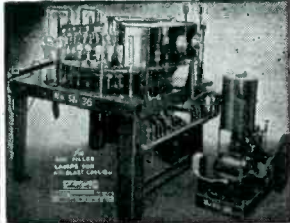

36-Head Radio Tube Exhausting Machine.

Incandescent and Fluorescent Lamps, Luminous Neon Signs, Radio, Cathode Ray, Television and Electronic Tubes of All Sizes

Transformers of All Types
IN SIZES FROM 1/4 TO 300 KVA

For Lighting Power Welding Phase Changing Auto Testing

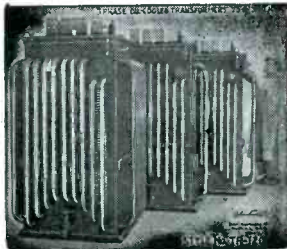

Special Transformers For Electronic Devices

EISLER ENGINEERING CO. Inc.
751 So. 13th St. Newark 3, N. J.

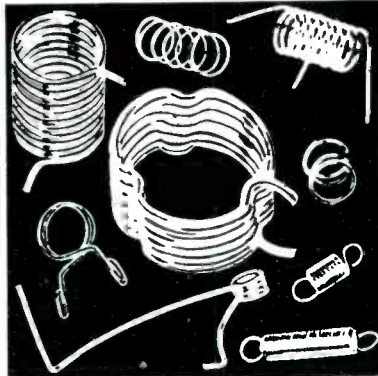

Antenna Coils, Grid Clips, Dial Cord Springs and Precision Springs of all types pertaining to Radio and Television.

Your Inquiries Invited

WEBSTER SPRING CORPORATION

176 Johnson St., U.L. ster 5-3196-7-8, Brooklyn 1, N. Y.

PRINTED CELLOPHANE

Colorful - Self Adhesive - Cellophane, processed in Rolls. Easy to buy - Easy to apply - used for Packaging - Point of Sale advertising - Parts marking and Aircraft Wire terminal identification.

TOPFLIGHT TAPE - YORK, PA.

FINE RIBBONS OF TUNGSTEN and MOLYBDENUM

Quality and accuracy in our fabrication of Tungsten & Molybdenum Ribbons have characterized our service to the Electronic industry.

A development of
H. CROSS Co.
15 Beekman St., New York 7, N. Y.

EL-TRONICS, INC.

Research, development, and manufacture of electronic equipment—a single model to large quantities.

Specialists in Geiger-Muller equipment

2647-67 N. Howard St., Phila. 33, Pa.
Garfield 5-2026

FLUXES
SODERING
BRAZING & WELDING
L. B. ALLEN CO. INC. Chicago 31, Ill.

6751 Bryn Mawr Ave.

EISLER—Manufactures Complete Equipment for:

SPOT WELDERS, Electric, for 1/4 to 250 KVA.
A.C. ARC WELDERS from 100 to 400 Amps.
TRANSFORMERS, Special and Standard Types.
INCANDESCENT LAMP Manufacturing Equipment.
FLUORESCENT TUBE Manufacturing Equipment.
NEON SIGN MAKERS EQUIPMENT.
ELECTRONIC EQUIPMENT, Vacuum Pumps, etc.
WET GLASS SLICING and Cutting machines for Laboratory use.
EISLER ENGINEERING CO., INC. 751 So. 13th St., Newark 3, N. J.



McGraw-Hill
DIRECT MAIL LIST SERVICE

MAILING LISTS THAT WORK...

McGraw-Hill Industrial Mailing Lists are a direct route to today's purchase-controlling executives and technicians in practically every major industry.

These names are of particular value now when most manufacturers are experiencing constantly increasing difficulty in maintaining their own lists.

Probably no other organization is as well equipped as McGraw-Hill to solve the complicated problem of list maintenance during this period of unparalleled changes in industrial personnel. These lists are compiled from exclusive sources, based on hundreds of thousands of mail questionnaires and the reports of a nation-wide field staff, and are maintained on a twenty-four hour basis.

Investigate their tremendous possibilities in relation to your own product or service. Your specifications are our guide in recommending the particular McGraw-Hill lists that best cover your market. When planning your industrial advertising and sales promotional activities, ask for more facts or, better still, write today. No obligation, of course.

McGraw-Hill
Publishing Co., Inc.

DIRECT
MAIL
DIVISION

630 WEST 42nd STREET
NEW YORK, 18, N. Y.

SEARCHLIGHT SECTION

EMPLOYMENT • BUSINESS • OPPORTUNITIES • EQUIPMENT—USED or RESALE

UNDISPLAYED RATE:

\$1.20 a line, minimum 4 lines to figure advance payment count 5 average words as a line.

INDIVIDUAL EMPLOYMENT WANTED undisplayed advertising rate is one-half of above rate, payable in advance.

PROPOSALS \$1.20 a line an insertion.

INFORMATION:

BOX NUMBERS in care of any of our New York, Chicago or San Francisco offices count 1 line additional in undisplayed ads.

DISCOUNT of 10% if full payment is made in advance for four consecutive insertions of undisplayed ads (not including proposals).

DISPLAYED—RATE PER INCH

The advertising rate is \$10.25 per inch for all advertising appearing on other than a contract basis. Contract rates quoted on request.

AN ADVERTISING INCH is measured $\frac{7}{8}$ inch vertically on one column, 3 columns—30 inches—to a page.

NEW ADVERTISEMENTS received by June 30th will appear in the August issue, subject to limitation of space available.

SERVICE MANAGER

Experienced Service Manager to head nationally distributed radio and television line. Must be able to supervise national service organization. Write in detail, stating experience.

P-9133, Electronics
330 W. 42nd St., New York 18, N. Y.

ELECTRONIC ENGINEERS PHYSICISTS

"A leading Electronics Company in Los Angeles, California offers permanent employment to persons experienced in advanced research and development. State qualifications fully."

P 6606 Electronics
68 Post St., San Francisco 4, Calif.

REPRESENTATIVES WANTED

Manufacturer of Electronic Heating Equipment desires representation on commission basis in several open territories. Experience in electronic heating desirable. Write full details.

RW-9157, Electronics
330 W. 42nd St., New York 18, N. Y.

GRADUATE ELECTRICAL ENGINEER OR PHYSICIST

Experienced on micro-waves and servo-mechanism for design and layout of electronic circuits. Write

CHANCE VOUGHT AIRCRAFT
DIVISION UNITED AIRCRAFT CORP.
BOX 5907 — DALLAS, TEXAS

SCIENTISTS AND ENGINEERS

Wanted for interesting and professionally challenging research and advanced development in the fields of microwaves, radar, gyroscopes, servomechanisms, instrumentation, computers and general electronics. Scientific or engineering degrees or extensive technical experience required. Salary commensurate with experience and ability. Direct inquiries to Mr., Engineering Personnel, Bell Aircraft Corporation, P. O. Box 1, Buffalo 5, N. Y.

Electronic Engineers

BENDIX RADIO DIVISION

Baltimore, Maryland

manufacturer of

RADIO AND RADAR EQUIPMENT

requires:

PROJECT ENGINEERS

Five or more years experience in the design and development, for production, of major components in radio and radar equipment.

ASSISTANT PROJECT ENGINEERS

Two or more years experience in the development, for production, of components in radio and radar equipment. Capable of designing components under supervision of project engineer.

Well equipped laboratories in modern radio plant . . . Excellent opportunity . . . advancement on individual merit.

Baltimore Has Adequate Housing

Arrangements will be made to contact personally all applicants who submit satisfactory resumes. Send resume to Mr. John Siena:

BENDIX RADIO DIVISION

BENDIX AVIATION CORPORATION

Baltimore 4, Maryland

CONTRACT

ENGINEERING—MANUFACTURING

electronic and electro-mechanical devices

• developed to meet your specifications

• manufactured per sample or drawings

TELETRONICS LABORATORY, Inc.

Westbury, L. I., N. Y.—Westbury 7-1028

WANTED PATENTABLE IDEAS

A reliable transformer company is looking for patentable ideas on transformers to manufacture.

1122 W. Catalpa Avenue
Chicago 40, Illinois

Time is money. Save it by referring to our

ACCUMULATIVE INDEX FOR
ELECTRONICS BIBLIOGRAPHY

Simple and dependable

Write for descriptive literature

TECHNICAL INDEX SERVICE

Box 632

Asbury Park, New Jersey

REPLIES (Box No.): Address to office nearest you
NEW YORK: 330 W. 42nd St. (18)
CHICAGO: 520 N. Michigan Ave. (11)
SAN FRANCISCO: 68 Post St. (1)

POSITIONS VACANT

DESIGN DRAFTSMAN to prepare full detail mechanical drawings from layouts involving largely portable instruments. Detail will involve sheet metal screw machine parts, castings, plastics, radio components, electric wiring, etc. Experience with military IFF. Design desirable. Location. Southeast local area, housing available. P-9129, Electronics.

PROMINENT ELECTRONIC Manufacturer requires senior radio engineer with minimum of 3 yrs. design experience in UHF or TV. Salary open. P-9119, Electronics.

EMPLOYMENT SERVICES

SALARIED POSITIONS \$3,500-\$35,000. If you are considering a new connection communicate with the undersigned. We offer the original personal employment service (39 years recognized standing and reputation). The procedure, of highest ethical standards, is individualized to your personal requirements and develops overtures without initiative on your part. Your identity covered and present position protected. Send only name and address for details. R. W. Bixby Inc., 278 Dun Bldg., Buffalo 2, N. Y.

EXECUTIVES \$3,000-\$25,000. This reliable service, established 1927, is geared to needs of high grade men who seek a change of connection under conditions assuring, if employed, full protection to present position. Send name and address only for details. Personal consultation invited. Jira Thayer Jennings, Dept. E, 241 Orange St., New Haven, Conn.

POSITIONS WANTED

ELECTRICAL ENGINEER and Biologist, designer of AMA accepted equipment, seeks association with research institution, hospital or manufacturer. Seven years experience in biological, chemical, nuclear and electronic instrument design, power generation and distribution. Five years director of medical electrical equipment corporation. B.S. Mass. Inst. of Tech. 1936. Married. PW-8733, Electronics.

Production Foreman

Wide experience in manufacturing and production of vacuum tubes. For the past several years engaged in manufacture of cathode ray tubes. Desire connection with A-I organization engaged in manufacture of cathode ray tubes.

PW-8999, Electronics
330 West 42nd Street, New York 18, N. Y.

POSITIONS WANTED

TEACHING OR Research position wanted, experience in both industries and teaching, advanced degree, widely published. PW-8535, Electronics.

ELECTRONIC ENGINEER desires position with company making electronic equipment. Consider development, laboratory, service or sales. Ten yrs. experience, prefer midwest. PW-9127, Electronics.

GRADUATE ELECTRICAL Engineer, 23. 2 years experience design and development transformers, control panels. Interested in design and development of servomechanisms and electro mechanical equipment. Graduate course servo mechanisms. Navy electronic technician. Conscientious, resourceful. PW-9126, Electronics.

EXPERIENCED ENGINEER, advanced degree, excellent background development and production, especially electron-tube circuits, radio, FM, television. PW-9065, Electronics.

ENGINEER-PHYSICIST. Available for directing and conducting original analysis, research, and development in applied electronics. Advanced educational background; comprehensive experience. PW-9116, Electronics.

COMMUNICATION ENGINEER, first phone license, 12 years experience short wave, telephone, carrier current communication, load control, and telemetering. Last 6 years to present in Supervisory position. PW-8962, Electronics.

ENGINEERING ASSISTANT. Business Administration plus engineering training. MBA, BSEE, BS (Math). MEMBER HKN, Age 26, single. 2 yrs. ASC technician. 1 yr research, production quality control. Desires job in medium size concern. Resume on request. PW-9057, Electronics.

TECHNICAL EXPORT Sales Executive, solid engineering background; broadcast, communications, etc. leading companies. Travelled, resided abroad, knows foreign languages. Desires change, position more responsibility with reliable concern. Energetic, competent, pleasant personality, will relocate if proposition attractive. PW-9173, Electronics.

SERVOMECHANISMS ENGINEER desires position as supervisor of servo systems development lab. 10 yrs. design and development including servo control, stabilization and auto pilots. PW-8890, Electronics.

Additional Positions Vacant Ads on page 220

The continued expansion of the
NATIONAL UNION RESEARCH DIVISION
 has created many fine positions for men interested in
VACUUM TUBE RESEARCH

Our laboratories are devoted entirely to research and development work on vacuum tubes. These include cathode ray, microwave, receiving, radial beam, subminiatures, and various special tube types. We are in a position to offer an interesting job, a stable future, and ideal working conditions to men who are qualified. Men with vacuum tube or similar experience and with degrees in Physics or Engineering are needed at the present time. Recent graduates without experience but with degrees in Physics or Electrical Engineering, as well as tube or circuit technicians, are invited to apply.

Before you decide on your future connection, be sure to look into the opportunities National Union has to offer.

Send Resume To: **Divisional Personnel Manager,
 National Union Research Division
 350 Scotland Road, Orange N. J.**

**RESEARCH OPPORTUNITIES
 AT WESTINGHOUSE
 IN TELEVISION**

Physicists and electronic engineers needed for an extensive project at the Westinghouse Research Laboratories in Pittsburgh. Excellent opportunities for specialists in electron-optical devices, optics, systems and circuits.

For application write **Manager, Technical Employment**
 Westinghouse Electric Corp., 306 Fourth Ave., Pittsburgh, Pa.

Positions Open For:

- PHYSICISTS
- SENIOR ELECTRONIC ENGINEERS
- ADVANCED CIRCUIT DEVELOPMENT ENGINEERS
- SENIOR MECHANICAL ENGINEER
- VACUUM TUBE ENGINEERS

Experienced in the development of radar, servomechanisms, computers and guided missiles to fulfill the requirements of expanding airborne projects—Experienced Tube and Circuit Engineers for increased research and advanced development programs.

Salary commensurate with experience and ability—insurance plan—paid vacations—excellent opportunity for suitably qualified personnel. Please furnish complete resume of education, experience and salary required to:

**Industrial Relations & Personnel Department,
 CAPEHART-FARNSWORTH CORPORATION
 FORT WAYNE 1, INDIANA**

**RADAR, COMMUNICATIONS
 AND
 SONAR TECHNICIANS
 W-A-N-T-E-D
 For Overseas Assignments**

Technical Qualifications:

1. At least 3 years practical experience in installation and maintenance
2. Navy veterans ETM 1/c or higher.
3. Army veterans TECH/SGT or higher.

Personal Qualifications:

1. Age, over 22—must pass physical examination.
2. Ability to assume responsibility.
3. Must stand thorough character investigation.
4. Willing to go overseas for 1 year.

Base pay, Bonus, Living Allowance, Vacation add-up to \$7,000.00 per year. Permanent connection with company possible,

Apply by Writing to
**A-1, P. O. Box 3414,
 Philadelphia 22, Pa.**

Men qualified in RADAR, COMMUNICATIONS or SONAR give complete history. Interview will be arranged for successful applicants.

**PROJECT
 ENGINEERS**

Real opportunities exist for Graduate Engineers with design and development experience in any of the following: Servomechanisms, radar, microwave techniques, microwave antenna design, communications equipment, electron optics, pulse transformers, fractional h.p. motors.

Send complete resume to employment office.

**SPERRY
 GYROSCOPE CO.**
Division of the Sperry Corp.
 GREAT NECK, LONG ISLAND

SEARCHLIGHT SECTION

Write for your FREE Tabogram

TUBES . . . New Standard & JAN Types

| | | | | | | | |
|------------|-------|-----------|-------|-----------|-------|-----------|-------|
| 0A4G | \$.15 | 6AL5 | .80 | 12SO7 | .59 | 876 | .36 |
| OZ4 | .87 | 6A05 | .49 | 12SO7GT | .54 | 878 | 2.29 |
| 1A4 | .49 | 6AS7G | 4.95 | 12SR7GT | .45 | 884 60S6 | 1.27 |
| 1A5GT | .70 | 6B4 | .69 | 14B6 | .81 | 885 | .85 |
| 1A6 | 1.26 | 6B6A | .96 | 19R7 | .85 | 902 | 5.49 |
| 1A7GT | .69 | 6B8 | 1.49 | 19T8 | .98 | 905 | 4.89 |
| 1B3 8016 | .81 | 6B8B | 1.19 | 24G 3C24 | .69 | 923 | 1.19 |
| 1B21 471A | 2.95 | 6B8G | 1.05 | 25B6 | 1.49 | 927/CE25 | 1.49 |
| 1B23 | 4.89 | 6BA | .59 | 25B6GT | .59 | 930 | 3.89 |
| 1B24 | 4.89 | 6B6 | .59 | 28D7 | .56 | 931A | 3.49 |
| 1B27 | 29.95 | 6BF6 | .59 | 30 | .36 | 954 | .16 |
| 1C6 | 1.26 | 6BG6G | 1.49 | 31 | .36 | 955 | .18 |
| 1C7G | 1.27 | 6BH6 | .79 | 32 | 1.17 | 956 | .33 |
| 1D5GP | 1.25 | 6BJ6 | .59 | 32L7GT | 1.08 | 957 | .45 |
| 1E4G | .89 | 6C4 | .25 | 35A5 | .69 | 958A | .45 |
| 1E5 | 1.38 | 6C6 | .71 | 35C5 | .69 | 1000UHF | 59.95 |
| 1E7G | 1.17 | 6C6G | .71 | 35G6T | .63 | 1603 | 3.98 |
| 1F4G | 1.05 | 6C8G | 1.05 | 35W4 | .45 | 1609 | 5.98 |
| 1F7GV | 1.55 | 6C2J | 29.95 | 35Z5GT | .49 | 1613/6F6X | .55 |
| 1G4GT | 1.05 | 6D4 | 1.25 | 37 | .78 | 1614 | 1.50 |
| 1G6GT | .98 | 6E5 | .71 | 38 | .39 | 1616 | 1.36 |
| 1H4G | .87 | 6E6 | 1.05 | 39 44 | .39 | 1619 | .75 |
| 1H5G | .65 | 6E7 | .65 | 40 | .58 | 1620 | 4.95 |
| 1H6G | 1.27 | 6F6G | .59 | 43 | .66 | 1622 | 1.75 |
| 1L6G | 1.27 | 6F8G | 1.04 | 45S/VT52 | .30 | 1625 | .35 |
| 1L4 | .69 | 6G6G | 1.05 | 50 | 1.49 | 1626 | .45 |
| 1LA4GT | 1.05 | 6H6 | .49 | 50B5 | .54 | 1629 | .25 |
| 1L4B | 1.85 | 6H6GT | .38 | 50L6 | .63 | 1633 | 1.19 |
| 1L4C | 1.85 | 6H7 | 6.45 | 70L7GT | 1.67 | 1641/RK60 | 1.19 |
| 1LE3GT | .96 | 6J5 | .56 | 73 | 1.20 | 2050 | .67 |
| 1LH4 | 1.05 | 6J6 | .81 | 75 | .56 | 2051 | .45 |
| 1LN5 | .75 | 6J7 | .75 | 77 | .45 | 7193 | .18 |
| 1N5GT | .69 | 6K5GT | .86 | 78 | .45 | 8012A | 1.49 |
| 1P24 | .69 | 6K6GT | .69 | 80 | .45 | 8013A | 3.95 |
| 1P5GT | .69 | 6K7G | .69 | 81 | 1.49 | 8020 | 3.49 |
| 1Q5GT | .69 | 6K8 | .86 | 82 | .39 | 9001 | .75 |
| 1R4 1294 | .98 | 6L5 | 1.05 | 83 | .98 | 9002 | .37 |
| 1R5 | .54 | 6L6 | .89 | 83V | 1.05 | 9003 | .29 |
| 1T4 | .54 | 6L7 | .75 | 84 6Z4 | .72 | 9004 | .27 |
| 1T5GT | 1.05 | 6N7 1635 | .85 | 2051/VT2 | 1.98 | 9006 | .25 |
| 1U4 | .87 | 6N7GT | .90 | 211 VTA4 | .89 | 9007 | 9.95 |
| 1V | .87 | 6P5GT | .94 | 250TH | 1.49 | 9008A | 12.95 |
| 2A3 | 1.25 | 6O5G | 1.27 | 750T1 | 14.95 | 9009 | 4.95 |
| 2A4G | 1.08 | 6O7 | .75 | 304TH | 5.95 | CK1005 | .25 |
| 2A5 | .86 | 6S7 | 1.19 | 304T1 | 1.98 | CRD72 | 1.85 |
| 2A6 | 1.05 | 6S8GT | .79 | 307A/RK75 | 3.95 | CRP72 | 1.37 |
| 2A7 | 1.05 | 6A7GT | .49 | 327A | 2.90 | EP50 | .72 |
| 2B7 | 1.05 | 6B7G | .69 | 327A | 1.89 | FI27A | 16.95 |
| 2B22 GL559 | .73 | 6S7GT | .45 | 371B | .85 | FG17 | 9.90 |
| 2C21 1642 | .81 | 6SF5 | .63 | 380A | .79 | FG27A | 9.90 |
| 2C34/RK34 | .55 | 6SF7 | .78 | 388A | .49 | FG104 | 14.95 |
| 2G40 446A | 1.49 | 6SG7 | .79 | 393A | 5.95 | FG105 | 11.95 |
| 2C43 464A | 1.69 | 6SH7 | .72 | 446R | 1.89 | FG166 | 49.00 |
| 2C44 | 1.69 | 6S7 | .72 | 450TH | 24.50 | GL434 | 3.90 |
| 2D21 | 1.49 | 6SK7 | .45 | 460TH | 11.98 | GL34 | 1.95 |
| 2E22 | 1.34 | 6SK7GT | .45 | HF200 | 11.98 | IS21 | 1.95 |
| 2E25/HY65 | 2.98 | 6SL7GT | .81 | 468 | 8.98 | HY115/145 | .89 |
| 2J21 725 | 11.98 | 6SN7GT | .69 | 527 | 4.75 | HY615 | .98 |
| 2J21A | 11.98 | 6S07 | .57 | 527C1M | 11.95 | KU627 | 7.49 |
| 2J25 | 39.95 | 6T7 | .70 | 530 | 4.90 | O1A | 1.80 |
| 2J26 | 8.89 | 6S7 | .63 | 531 | 1.21 | O1A | 4.95 |
| 2J31 | 9.95 | 6T7G | 1.19 | 550P1 | 19.95 | P123/868 | 1.85 |
| 2J33 | 14.50 | 6T8 | 1.29 | 575A 975 | 14.25 | REL36/6J4 | .98 |
| 2J34 | 23.98 | 6U5 6G5 | .81 | 601B | .19 | RK665 | 22.98 |
| 2J38 | 13.89 | 6U6GT | .69 | 701A | 3.95 | RX 215 | 9.95 |
| 2J42/700A | .89 | 6V6G | .79 | 702A/702B | 3.95 | RX885 | .98 |
| 2J47 | 39.95 | 6V6 | 1.17 | 703A | 2.79 | VR75 | .98 |
| 2J48 | 45.00 | 6V6GT | .69 | 705 | 1.65 | VR90 | .74 |
| 2J50 | 45.00 | 6X4 | .54 | 705A 8021 | 1.65 | VR92 | .23 |
| 2J61 | 39.95 | 6X5GT | .58 | 707B | 8.95 | VR105 | .90 |
| 2J62 | 39.95 | 6Y6G | .87 | 710A/8011 | 7.95 | VR150 | .65 |
| 2K25 | 29.95 | 6Z7G | 1.23 | 713A | 1.59 | WE215A | 6.98 |
| 2K28 | 24.89 | 7A4 | .70 | 715B | 9.89 | WL468 | 6.98 |
| 2K29 | 24.95 | 7A6 | .69 | 717A | .96 | WL531 | 1.95 |
| 2V3G | 1.05 | 7A8 | .69 | 721A | 1.95 | WL619 | 20.00 |
| 2X2 | .49 | 7A7G | .87 | 722A/287A | 9.95 | WL632A | 8.98 |
| 3A4 | .38 | 7B5 | .70 | 723A | 7.95 | | |
| 3A5 | 1.20 | 7B7 | .69 | 723AB | 14.95 | | |
| 3B7 1291 | .95 | 7C7 1203A | .38 | 725A | 7.95 | | |
| 3B24 | 1.85 | 7C6 | .69 | 725A | 7.95 | | |
| 3B25 | 4.95 | 7E5 1201 | .89 | 726A | 14.98 | | |
| 3C23 | 1.48 | 7E6 | .69 | 802 | 3.75 | | |
| 3C31 | 2.47 | 7E7 | .85 | 803 | 7.95 | | |
| 3D6 1299 | .85 | 7G7 | 1.03 | 804 | 11.98 | | |
| 3Q4 | .79 | 7H7 | .67 | 807 | .86 | | |
| 3S4 | .79 | 7N7 | .85 | 807 | 1.15 | | |
| 3V4 | .69 | 7O7 | .86 | 808 | 1.50 | | |
| 4C35 | 22.95 | 7V7 | 1.04 | 809 | 2.90 | | |
| 4H27/201 | 2.49 | 7Y4 | .69 | 810 | 6.95 | | |
| 4J47 | 4.90 | 807 | .67 | 811 | 2.20 | | |
| 4T4 | 2.95 | 10Y | .60 | 812 | 2.35 | | |
| 5C30/C5B | 9.95 | 12A6 | .23 | 813 | 12.80 | | |
| 5D21 | 24.95 | 12AH7GT | .87 | 814 | 2.61 | | |
| 5J29 | 17.98 | 12AT6 | .45 | 815 | 2.45 | | |
| 5R4GY | 1.05 | 12AU7 | .69 | 816 | 1.10 | | |
| 5T4 | .96 | 12B6 | .89 | 826 | 3.98 | | |
| 5U4G | .46 | 12BA7 | .89 | 828 | 6.49 | | |
| 5V4 | .95 | 12BE6 | .45 | 829B | 5.95 | | |
| 5W4 | .87 | 12C8 | .65 | 832 | 2.45 | | |
| 5X4G | .71 | 12H6 | .36 | 834 | 1.12 | | |
| 5Y3GT | .81 | 12J5GT | .45 | 837 | 2.35 | | |
| 5Z3 | .81 | 12K8 | .85 | 838 | 3.98 | | |
| 6A4 | 1.29 | 12K8Y | .98 | 842 | 2.75 | | |
| 6A6 | 1.02 | 12O7GT | .69 | 845 | 4.75 | | |
| 6AB7/1853 | .84 | 12SA7 | .59 | 849 | 1.97 | | |
| 6AC7 | .85 | 12SA7GT | .50 | 861 | 11.90 | | |
| 6AF6G | .87 | 12S7 | .69 | 865 | 1.00 | | |
| 6AG5 | .81 | 12SK7 | .63 | 866A | .99 | | |
| 6AG7 | 1.27 | 12SK7 | .63 | 866Jr. | 1.00 | | |
| 6AH5 | .98 | 12SK7GT | .58 | 868 PJ23 | 1.90 | | |
| 6AJ5 | .85 | 12SL7GT | .85 | 872A | 2.45 | | |
| 6AK5 | .85 | 12SN7GT | .54 | 874 | 1.49 | | |

TAB THAT'S A BUY!

2J1G1 Selsyns Buy!
with DATA 24V or 110V
60 cyc AC Used
Tested, TWO for \$1.49

HEAVY DUTY MICA
Cndsr ComDub FT14 .012mf/25000 \$4.98

VIBRAPACKS
6VD Cdn. 425V/110ma. \$10.95
PE157Sprk/Bat&Chgr p/o SCR-
593 & Sprk. 8.95
12VD Cdn. 190V/85ma Out 3.49
17P18AR 12-13 Vin24VDC \$6.95

DYNAMOTORS
6In/240v/Out 100ma (125ma Int) or 12x21vIn/
500v Out 50ma NEW HIF P-Max Grid. \$3.49
28In Out 55V/160ma Cont (510/250ma Int)
p/o SCR121 Grid Used. \$1.49
120V24vIn 275/110ma 812x3a PM. \$1.95
PE-91A BENDIX MG-1A New Complete
V-Reg in/out ftrs & RelaysForSCR522. \$9.95

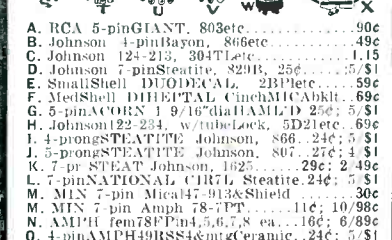

A. RCA 5-pin GIANT, 803etc. .90c
B. Johnson 4-pin Bayon. 806etc. .45c
C. Johnson 4-pin Bayon. Steatite. Chng. 9c. 1.15
D. Johnson 7-pin Steatite. 820R, 25c. 5/51
E. Small Shell D10UDICAL. 231P etc. .59c
F. Med Shell D10UDICAL Chng MIC Abklt. 69c
G. 5-pin ACORN 1 9/16" dia HAML D 25c. 5/1
H. Johnson 12-234 w tube Lock. 5D21 etc. 69c
I. 4-prong SPEAKING Johnson. 866. 24c. 5/1
J. 5-prong SPEAKING Johnson. sur. 27c. 4/1
K. 7-pin ST-AT Johnson. 1625. 29c. 2/4c
L. 7-pin NATIONAL CH7L Steatite. 24c. 5/1
M. MLN 7-pin Mical 47-913A Shield. 30c
N. M/N 7-pin Amp H 78-7TP. 11c. 10/98c
O. AMP H fem 78P Pin 5.6, 7.8 ea. 16c. 6/89c
P. OCTAL 8-pin Pin Steatite Ceramic. 24c. 5/1
Q. 8-pin Pin Steatite Ceramic. Chng. 9c. 1.15
R. LOCKAL 8-pin Lock plate Chng. 11c. 10/51
S. KLYSTRON Socket Chng. ea. 35c. 10/33
T. LOCKAL AMP 498SL Steatite. 24c. 5/1
U. OCTAL Amp 788Mica Bklt. 8c. 25/149
X. U. OCTAL Amp 788Mica Bklt. 15c. 7/51
Y. OCTAL Amp 498SL Steatite. 15c. 12/149
Z. 8-pin Pin Steatite Ceramic. Chng. 4/1. 81
A. MAGNAL 498SL ceramic. 54c. 2/98c
BANTAM Jr. 78-511 Ampholn. 7c
SOCKET FOR 872 211. .49c
SOCKET Ceramic 4 prong 511 Pin SIMPSONSON
122-241 for 8008, C6J, 5C22, 575. .98c
MAGIC EYE ASSY Ampholn. .59c

TRANSFORMERS—115V 60 cyc Input
1000VCT/200ma. 6V/5A. 5V/8A. Fully Encl
w/90V bias/24V/18V/55Awdg. \$6.95
850VCT/125ma. 6.3VCT/3A. 5VCT/3A. 6.3VCT
/2A H'Sid HVins Divrs 250ma USN. \$3.98
700VCT/120ma. 115V/100ma. 2x6.3V/1A. 5V
/2A. Csd HVins. \$2.98
650VCT/175ma. 5V/3A. 6.3V/2.1A. \$3.29
500VCT/60ma. 6.3V/4A USN H'Sid. \$1.29
2x330VCT/10ma (or 60VCT/10ma) Csd \$1.49
1200VCT/300ma & 18V/1Awdg/250HVins \$6.95
1300V/4ma USN Csd. 18V/1Awdg. \$3.29
2100V/10ma STANCO H'Vins Csd HVins. \$3.98
3000V/10ma WE Chn Trans Csd HVins. 4.50
500V/4ma (for 2X20Csd) 7.95
7500V/15000V Dblr 35ma. 17.95
10800VCT/20r210V Dblr @ 95ma Csd. \$19.95
2.5V 1.75A, 4V/16A 20KVins Csd. 4.95
2.5V 2A/for 2X20 HVins 69c. 10. 7.95
5VCT/4A KENOV HVins Chng. 9c. 1.15
5VCT/15A KENOV HVins. 12.95
6.3V/17A USN Csd HVins. 1.39
6.3VCT/4A (4wdg. 5A) Csd HV USN. 1.69
12.6VCT/2A H'Sid HVins \$1.49; 2 for 2.79

FILTER CHOKES
13.5H/1amp/420mf/17KVins. \$54.00
15-29H/150ma Swinging Cased. 2.95
12H/300ma. 83.95; 3H/40ma. 3 for 1.00
15H/400ma or 20H/300ma 12KVins. 7.95
8H/150ma New 17V Coked 18H/100mf 2/ 2.25
50H/125ma Csd. \$1.95; 8H/100ma 1.10
12H/275ma. Csd. \$3.29; 15H/80ma GE. .79
3H/975ma & 2x17H/125ma H'Sid. 3.49

BATTERIES—Storage & Dry
A. BR206U 2V/11AH \$1.89
A. N76 BR214U 6V/6AH
Willard S' Bat. \$1.75
B. BR54 2V/27AH \$1.89
C. Willard 4V/40AH \$5.95
D. Willard ER25 6V/25AH S' Bat. \$3.98
E. Willard ER10 6V/10AH S' Bat. \$1.98
F. BR18/1H52 26Vmins H' Bat. 98c; 12 for \$1
G. Burgess V 21P 47date. ea. 2/10
H. Eveready HlyDv Minimax BA43, 90,
45. 1 1/2 v w/ectal skt 2 3/4x3 3/4x6 1/4"/Crd.
47date. 98c; 2/\$1.89
USN Hydrometer Kit & Box. .98
Bat Acid (Std Exp) unit. 59c; 2 pts. 98c
WESTON T'Cell unmttd 1.0194 Av. \$5.98

BARGAINS—New Dry Batt's
SigCops SPECIFICATIONS
Outdated Tested—Grd Plenty Life!
SigC Volts sim Burgess Each
BA34 -7-, -6-, -4- 5540p 0772 39¢
-3-, -1- Weston Nitr 39¢
BA35 15, 22 530 PFI 1.25
BA36 45, 22 530 PFI 1.25
BA37 1 1/2 HvyDty Walky Talky 2.98
BA38 103 1/2 Walky Talky \$1.49
BA40 90, 1 1/2 4GB60 \$1.19
BA40 90, 1 1/2 4GB60 \$1.69
BA41 60, 2 1/2, 4 1/2 3 1/2x2 1/2x2 89¢
BA51 67 1/2 MiniMax 89¢
BA70 90, 60, 4 1/2 6x10 1x4 1/2 \$2.50

XTAL DIODES

| No. | Each | 2 for | 10 for |
|-------|--------|--------|--------|
| IN1 | \$1.00 | \$1.79 | \$8.30 |
| IN21A | 1.00 | 1.79 | 8.30 |
| IN21B | 1.75 | 3.35 | 15.00 |
| IN22 | 1.50 | 2.79 | 14.00 |
| IN23 | 1.50 | 2.79 | 14.00 |
| IN23A | 1.50 | 2.79 | 14.00 |
| IN23B | 3.00 | 5.90 | |

SAVE

**BRAND NEW
GUARANTEED**

INVERTERS

Wincharger Corp. Dynamotor Unit. PE-101-C. Input 13, V.D.C. or 26 V.D.C. AT. 12.6 or 6.3 Amps. Output 400 V.D.C. AT. .135 Amps., 800 V.D.C. AT. .02 Amps., 9 V.A.C. 80 Cycle at 1.12 Amps. Price \$10.00 each net

153F, Holtzer Cabot. Input, 24 volts D. C. Output 115 volts, 400 cycle 3 phase, 750 V. A. and 26



volts 400 cycle, 1 phase, 250 V. A., Voltage and frequency regulated also built in radio filter. Price \$115.00 each net.

149H, Holtzer Cabot. Input 28 volts at 44 amps. Output 26 volts at 250 V. A. 400 cycle and 115 volts at 500 V. A. 400 cycle. Price \$39.00 each net.

149F, Holtzer Cabot. Input 28 volts at 36 amps. Output 26 volts at 250 V. A. 400 cycle and 115 volts at 500 V. A. 400 cycle. Price \$35.00 each net.

12117, Pioneer. Input 12 volts D. C. Output 26 volts, 400 cycles, 6 V. A. Price \$22.50 each net.

12117-2, Pioneer. Input 24 volts D. C. Output 26 volts, 400 cycle, 6 V. A. Price \$20.00 each net.

5D21NJ3A General Electric. Input 24 volts D. C. Output 115 volts 400 cycle at 485 V. A. Price \$12.00 each net.

WESTON FREQUENCY METER

Model 637, 350-450 cycle, 115 volts. Price \$10.00 each net.

WESTON VOLTMETER

Model 833, 0 to 130 volts. 400 cycle. Price \$4.00 each net.

VIBRATOR

Rauland Corp. vibrator non-synchros type. Stock No. 3H6694-11; 6, 12 or 24 volt D.C. input, frequency 200 cycle. Price \$3.25 ea. net

ALL PRICES, F.O.B. FLUSHING, N. Y.

PIONEER AUTOSYNS

AY1, 26 volts, 400 cycle. Price \$5.50 each net.
Ay 14D, 26 volts, 400 cycle, new with calibration curve. Price \$15.00 each net.
AY20, 26 volts, 400 cycle. Price \$7.50 each net.



AY31, 26 volts, 400 cycle. Shaft extends from both ends. Price \$10.00 each net.

AY38, 26 volts, 400 cycle. Shaft extends from both ends. Price \$10.00 each net.

PIONEER PRECISION AUTOSYNS

AY101D, new with calibration curve.



PRICE—WRITE OR CALL FOR SPECIAL QUANTITY PRICES

AY131D, new with calibration curve. Price \$35.00 each net.
AY130D new Price \$3.50 ea. net.

PIONEER TORQUE UNITS

Type 12602-1-A. Price \$30.00 each net.



Type 12604-3-A. Price \$30.00 each net.

Type 12606-1-A. Price \$40.00 each net.

Type 12627-1-A. Price \$80.00 each net.

MAGNETIC AMPLIFIER ASSEMBLY

Pioneer Magnetic Amplifier Assembly Saturable Reactor type output transformer. Designed to supply one phase of 400 cycle servo motor. Price \$8.50 each net.

PIONEER TORQUE UNIT AMPLIFIER

Type 12073-1-A, 5 tube amplifier, Magnesyn input, 115 volts, 400 cycle. Price \$17.50 each net with tubes.
Type 12077-1-A, single tube Amplifier, Autosyn input, 115 volts, 400 cycle. Price \$49.50 each net with tube.

BLOWER ASSEMBLY MX-215/APG

John Oster, 8 volt D. C. 7000 R. P. M. 1/100HP. Price \$2.90 each net.
Westinghouse Type, FL Blower, 115 volts, 400 cycle, 67000 R. P. M., Air-flow 17 C. F. M. Price \$4.50 ea. net.

RATE GENERATORS



PM2, Electric Indicator Company, .0175 V. per R. P. M. Price \$8.25 ea. net.
F16, Electric Indicator Company, two-phase, 22 V. per phase at 1800 R. P. M. Price \$12.00 each net.
J36A, Eastern Air Devices, .02 V. per R. P. M. Price \$9.00 each net.
B-68 Electric Indicator Co., Rotation Indicator, 110 volts, 60 cycle, 1 phase. Price \$14.00 each net.
Weston Tachometer Generator (aircraft type) model 752-J4 single phase A.C. output. Price \$17.50 ea. net

SINE-COSINE GENERATORS (Resolvers)

FPE 43-1, Diehl, 115 volts, 400 cycle. Price \$20.00 each net.
FJE 43-9, Diehl, 115 volts, 400 cycle. Price \$20.00 each net.

SYNCHROS

If Special Repeater, 115 volts, 400 cycle. Will operate on 60 cycle at reduced voltage. Price \$15.00 each net.



7G Generator, 115 volts, 60 cycle. Price \$30.00 each net.

6DG Differential Generator, 90-90 volts, 60 cycle. Price \$15.00 each net.

2J1M1 Control Transformer 105/63 Volts, 60 cycle. Price \$20.00 each net.

2J1G1 Control Transformer, 57.5/57.5 volts, 400 cycle. Price \$1.90 ea. net.

2J1H1 Selsyn Differential Generator, 57.5/57.5 volts, 400 cycle. Price \$3.25 each net.

2J5S1 Selsyn Differential Generator, 105-105 volts, 60 cycle. Price \$15.50 each net.

W. E. KS-5950-L2, Size 5 Generator, 115 volts, 400 cycle. Price \$3.50 ea. net.

5G Special, Generator 115/90 volts, 400 cycle. Price \$15.50 each net.

5SF Repeater, 115/90 volts, 400 cycle. Price \$19.00 each net.

2J1F1 Selsyn Generator, 115 volts, 400 cycle. Price \$3.50 each net.

1CT Control Transformer, 90/55 volts, 60 cycle. Price \$25.00 ea. net

INSTRUMENT ASSOCIATES

Write for complete listings

Western Union Address: WUX Flushing, N. Y.

147-57 41st AVENUE FLUSHING, N. Y.
Telephone INdependence 3-1919

SAVE

BRAND NEW GUARANTEED

A. C. MOTORS

5071930, Delco, 115 volts, 60 cycle, 7000 R. P. M.

Price \$4.50 each net.

36938-2, Haydon Timing Motor, 110 Volts, 60 Cycle, 2.2 Watts, 4/5 R. P. M.



Price \$3.00 each net.

Haydon Timing Motor—110 V. 60 cycle 3.2 Watts, 4 R. P. M., with brake.

Price \$4.00 each net.

45629R Haydon Timing Motor, 110 volts, 60 cycle, 2.2 watts, 1/240 R. P. M.

Price \$3.15 each net.

36938-3, Haydon Timing Motor, 110 volts, 60 cycle, 2.2. Watts, 1 1/5 R. P. M.

Price \$3.15 ea. net

Eastern Air Devices Type J33 Synchronous Motor 115 V., 400 cycle, 3 phase, 8,000 R. P. M. Price \$8.50 each net.

Telechron Synchronous Motor, Type B3, 115 volts, 60 cycle, 2 R. P. M., 4 watts. Price \$5.00 each net.

SERVO MOTORS

CK1, Pioneer, 2 phase, 400 cycle.

Price \$10.00 each net.

CK2, Pioneer, 2 phase, 400 cycle.

Price \$4.50 each net.

FPE-25-11, Diehl, Low-Inertia, 75 to 115 V., 60 cycle, 2 phase.

Price \$16.00 each net.

FPE-49-7 Diehl, Low-Inertia, 115 volts, 60 cycle, 2 phase, 3.0 amps., 10 watts output.

Price \$34.50 ea. net

FP-25-2, Diehl, Low-Inertia, 20 volts, 60 cycle, 2 phase. Price \$9.00 each net.

FP-25-3, Diehl, Low-Inertia, 20 volts, 60 cycle, 2 phase. Price \$9.00 each net.

CK2, Pioneer, 2 phase, 400 cycle, with 40:1 reduction gear.

Price \$6.70 ea. net

MINNEAPOLIS HONEYWELL TYPE B Part No. G303AY, 115 volts, 400 cycle, 2 phase, built-in gear reduction, 50 in lbs. torque. Price \$7.50 each net.

REMOTE INDICATING MAGNESYN COMPASS SET

Pioneer Type AN5730-2 Indicator and AN5730-3 Transmitter 26 volts, 400 cycle.

Price \$40.00 per set new sealed boxes



Kollsman Remote Indicating Compass Set Transmitter part No. 679-01, indicator part No. 680k-03, 26 volts, 400 cycle. Price \$12.50 ea. net

GYROS

Schwein Free & Rate Gyro type 45600. Consists of two 28 volt D. C. constant speed gyros. Size 8" x 4.25" x 4.25".

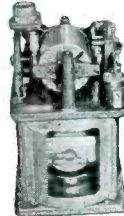

Price \$10.00 each net.

Schwein Free & Rate Gyro, type 46800. Same as above except later design.

Price \$11.00 each net.

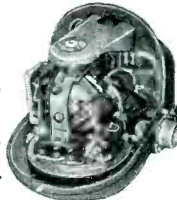

Sperry A5 Directional Gyro Part No. 656029, 115 volts, 400 cycle, 3 phase. Price \$17.50 each net.

Sperry A5 Vertical Gyro. Part No. 644841, 115 volts, 400 cycle, 3 phase. Price \$20.00 each net.

Sperry A5 Amplifier Rack Part No. 644890. Contains Weston Frequency Meter. 350 to 450 cycle and 400 cycle, 0 to 130 voltmeter. Price \$10.00 each net.

Sperry A5 Control Unit Part No. 644836. Price \$7.50 each net.

Sperry A5 Azimuth Follow-Up Amplifier Part No. 656030. With tube. Price \$5.50 each net.

Pioneer Type 12800-1-D Gyro Servo Unit. 115 volts, 400 cycle, 3 phase. Price \$8.00 each net.

Norden Type M7 Vertical Gyro. 26 volts D. C. Price \$19.00 each net.

Norden Type M7 Servo Motor. 26 volts D. C. Price \$20.00 each net.

Allen Calculator, Type C1. Bank and Turn Indicator, Part No. 21500, 28 Volts, D.C. Contains 28V. D.C. constant speed gyro. Price \$10.00 ea. net

D.C. MOTORS

Jaeger Watch Co. Type 44-K-2 Contact Motor, Operates on 3 to 4.5 volts D.C. Makes one contact per second. Price \$2.00 ea. net

General Electric Type 5BA10AJ52C, 27 volts D.C., 0.65 amps., 14 oz. in torque, 145 R. P. M. Shunt Wound, 4 lead reversible. Price \$4.70 ea. net

D. C. MOTORS



5069625, Delco Constant Speed, 27 volts, 120 R. P. M. Built-in reduction gears and governor. Price \$3.90 each net. A-7155, Delco Constant Speed Shunt Motor, 27 volts, 2.4 amps., 3600 R. P. M., 1/30 H. P. Built-in governor. Price \$6.25 each net.

C-28P-1A, John Oster Shunt Motor, 27 volts, 0.7 amps., 7000 R. P. M., 1/100 H. P. Price \$3.75 each net.

D.C. ALNICO FIELD MOTORS

5069456, Delco, 27.5 V., 10,000 RPM. Price \$4.70 each net.

5069600, Delco, 27 V., 250 R. P. M. Price \$4.70 each net.

5069466, Delco, 27 V., 10,000 R. P. M. Price \$3.00 each net.



5069370, Delco, 27 V., 10,000 R. P. M. Price \$4.70 each net.

S. S. FD6-16, Diehl, 27 V., 10,000 R. P. M. Price \$3.75 each net.

S. S. FD6-18, Diehl, 27 V., 10,000 R. P. M. Price \$3.75 each net.

S. S. FD-6-21, Diehl, 27 V., 10,000 R. P. M. Price \$3.75

Sampsel Time Control Inc. Alnico Field Motor, 27 Volts D.C. Overall length 3-5/16" by 1-3/8". Shaft 5/8" long by 3/16", 10,000 RPM. Price \$4.50 each net.

GENERAL ELECTRIC D.C. SELSYNS



8TJ9-PDN Transmitter, 24 volts. Price \$3.75 each net.

8DJ11-PCY Indicator, 24 volts. Dial marked -10° to +65°. Price \$4.50 each net

8DJ11-PCY Indicator, 24 volts. Dial marked 0 to 360°. Price \$7.50 each net.

AMPLIFIER

Pioneer Gyro Flux Gate Amplifier, Type 12076-1-A. Price \$17.50 ea. net, with tubes

COMPLETE LINE OF AIRCRAFT THERMOCOUPLES

INSTRUMENT ASSOCIATES

Write for complete listings

U. S. Export License-2140

147-57 41st AVENUE FLUSHING, N. Y.
Telephone INdependence 3-1919

PULSE EQUIPMENT

PULSE TRANSFORMERS

- G.E.K.-2745 \$39.50
 G.E.K.-2744-A. 11.5 KV High Voltage. 3.2 KV Low Voltage @ 200 KW over. (270 KW max.) 1 microsec. or 1/4 microsec. @ 600 PPS. \$39.50
 W.E. #D166173 Hi Volt input transformer. W.E. Impedance ratio 50 ohms to 900 ohms. Freq. range: 10 kc to 2 mc. 2 sections parallel connected. potted in oil. \$36.00
 W.E. KS 9800 Input transformer. Winding ratio between terminals 3-5 and 1-2 is 1:1.1, and between terminals 6-7 and 1-2 is 2:1. Frequency range: 380-520 cps. Repetition Rate: 635 PPS. Pri. Imp: 50 Ohms. Sec. Imp: 450 Ohms. Pulse Width: 1 Microsec. Pri. Input: 9.5 KV PK. Sec. Output: 28 KV PK. Peak Output: 800 KV. Rfltr: 2.75 Amp. \$64.50
 W.E. #D169271 Hi Volt input pulse Transformer. \$27.50
 G.E. K2450A. Will receive 13KV. 4 micro-second pulse on pri., secondary delivers 14KV. Peak power out 160KW G.E. \$4.50
 G.E. #K2748A. Pulse Input, line to magnetron. \$36.00
 #9280 Utah Pulse or Blocking Oscillator XPMR Fre. limits 790-810 cy-3 windings turns ratio 1:1:1 Dimensions 1 1/16 x 3 1/4" 19/32. \$1.50
 G.E. 9318 Pulse Trans. 1:1:1 \$1.50
 Raytheon UX 8693 3 x 32 Turns T.V. 1000 RNS. \$4.95
 UX-7350 \$5.95

PULSE NETWORKS

- 15A-1-400-50. 15 KV. "A" CKT. 1 microsec. 400 PPS. 50 ohms imp. \$12.50
 G.E. #6E3-5-2000-50P2T. 6KV. "E" circuit. 3 sections. 5 microsecond. 2000 PPS. 50 ohms impedance \$6.50
 G.E. #3E (3-84-810; 8-224-405) 50P4T. 3KV. "E" CKT Dual Unit: Unit 1, 3 Sections. .84 Microsec. 810 PPS. 50 ohms imp.; Unit 2, 8 Sections. 2.24 microsec. 405 PPS. 50 ohms imp. \$6.50
 7.5E3-1-200-67P. 7.5 KV. "E" Circuit. 1 microsec. 200 PPS. 67 ohms impedance. 3 sections. \$7.50
 7.5E4-16-60-67P. 7.5 KV. "E" circuit. 4 sections. 16 microsec. 60 PPS. 67 ohms impedance. \$15.00
 7.5E3-3-200-6PT 7.5 KV. "E" Circuit. 3 microsec. 200 PPS. 67 ohms imp., 3 sections. \$12.50

DELAY LINES

- D-168184: .5 microsec. up to 2000 PPS. 1800 ohm term. \$4.00
 D-170499: .25/.50/.75. microsec. 8 KV. 50 ohms imp. \$16.50
 D-165997: 1/4 microsec. \$7.50



RELAYS

| Type | Con-tacts | Rating | Res. Coil | Mfg | Price |
|----------|-----------|----------|--------------|--------|-------|
| H DPDT | 24-28V | 170 ohms | GEGR2791B | \$1.75 | |
| (8A) vdc | | | 10013 | | |
| H SPDT | 28 vdc | 175 ohms | GEGR2791B | 1.25 | |
| H 3PDT | 24-28 vdc | 175 ohms | GEGR2791B | 1.75 | |
| H 4PST | 24 vdc | 180 ohms | GEGR2791G | 1.75 | |
| G DPDT | 12 vdc | 44 ohms | Leach 1067- | 1.45 | |
| SPST | | | | | |
| G DPDT | 22-28 vdc | 160 ohms | Leach | 1.25 | |
| D SPST | 28 vdc | 250 ohms | Allied BO48 | 1.39 | |
| I DPST | 14 vdc | 85 ohms | Price X20-A | 1.50 | |
| D 3PDT | 24-28 vdc | 280 ohms | Allied DDX-3 | 2.50 | |
| H SPST | 24-28 vdc | 2400 | GAM 12917-1 | 2.00 | |
| D DPDT | 24 vdc | 280 | Allied BO935 | 1.00 | |
| D 3PDT | 26 vdc | 280 | Allied KS | 1.10 | |
| D DPDT | 28 vdc | 280 | Allied BS | 1.10 | |
| D SPST | 75MA | 60 | Allied KO | 2.10 | |
| (NC) | | | 5862 | | |
| H DPDT | 20-30 vdc | | Onnce 50XB | 2.00 | |
| H DPDT | 10-14 vdc | | Onnce 100AB | 2.00 | |
| H DPDT | 24-28 vdc | | PB21C057-A | 1.75 | |
| H 3PDT | 24-28 vdc | | GEGR2791 | 2.60 | |
| H SPDT | 24-28 vdc | | GEGR2791 | 1.75 | |
| A DPDT | 12 vdc | | Onnce | 2.40 | |
| (6A) | | | CX8190 | | |
| A SPDT | 10-12v | 125 | Onnce | 2.40 | |
| | 60 cy | | CX2120 | | |
| H DPDT | 27.5 vdc | 400 | Allied | 1.10 | |
| D DPDT | 9-14 vdc | | Allied | 1.10 | |
| H DPDT | 24v60cy | 50 | Allied | 1.40 | |

RADAR SONAR

- SE 10CM Shipboard Radar (Magnetron)
- SF 10CM Shipboard Radar
- SG 10CM Shipboard Radar
- SM 10CM Shipboard Radar (Light-house)
- SO1 10CM Shipboard Radar (Magnetron)
- SO13 10CM Shipboard Radar (Magnetron)
- SQ 10CM Shipboard Radar (Light-house)
- CPN6 3CM Beacon Gnd Installation
- APS3 3CM Airborne Radar
- APS4 3CM Airborne Radar
- APS5 3CM Airborne Radar
- QBG Underwater Sound Unit (Sonar)
- TBM Navy Transmitters
- DE Navy Transmitters
- TBK Navy Transmitters
- RAK7 Navy Receivers
- DAB HF-Direction Finder
- DP12 LF-Direction Finder
- RC148 200 Mc. IFF
- RC148 200 Mc. IFF
- SCR518 Pulse Altimeter
- APS2 10CM Airborne Radar

WRITE FOR INFORMATION AND PRICE

COMMUNICATIONS EQUIPMENT for your needs COMPANY

J.A.N. APPROVED

UG TYPE CONNECTORS

Deduct 10% from prices shown on orders of 100 or more per type

| AN # | Price ea. | AN # | Price ea. |
|-----------|-----------|-----------|-----------|
| UG-9/U | \$1.18 | UG-114/U | 1.88 |
| UG-10/U | 1.95 | UG-115/U | 1.69 |
| UG-11/U | 1.82 | CW-123/U | .56 |
| UG-12/U | 1.18 | UG-131/U | 7.50 |
| UG-13/U | 1.95 | UG-146/U | 2.81 |
| UG-14/U | 1.82 | UG-153/U | 6.64 |
| UG-15/U | 1.18 | CW-155/U | .50 |
| UG-16/U | 1.95 | UG-155/U | 6.69 |
| UG-17/U | 1.82 | UG-156/U | 5.31 |
| UG-18/U | 1.25 | UG-157/U | 5.31 |
| UG-18A/U | 1.31 | UG-160/U | 2.38 |
| UG-18B/U | 1.95 | UG-161A/U | 1.94 |
| UG-19/U | 1.57 | UG-167/U | 3.775 |
| UG-19A/U | 1.72 | UG-167A/U | 5.31 |
| UG-19B/U | 1.82 | UG-173/U | .38 |
| UG-20/U | 1.46 | UG-174/U | 20.00 |
| UG-20A/U | 1.57 | UG-175/U | .19 |
| UG-20B/U | 1.76 | UG-176/U | .19 |
| UG-21/U | 1.57 | UG-188/U | 1.18 |
| UG-21A/U | 1.31 | MX-195/U | .94 |
| UG-21BU | 1.36 | UG-197/U | 6.25 |
| UG-22/U | 1.35 | UG-201/U | 2.89 |
| UG-22A/U | 1.72 | UG-202/U | 3.44 |
| UG-22B/U | 1.68 | UG-203/U | .76 |
| UG-23/U | 1.25 | UG-213/U | 2.81 |
| UG-23A/U | 1.57 | UG-201A/U | 2.81 |
| UG-23B/U | 1.62 | UG-206/U | 1.28 |
| UG-27A/U | 3.44 | UG-207/U | 22.50 |
| UG-28/U | 2.93 | UG-208/U | 22.50 |
| UG-29/U | 1.53 | UG-212/U | 5.63 |
| UG-29A/U | 1.95 | UG-213/U | 5.63 |
| UG-30/U | 2.19 | UG-215/U | 4.19 |
| UG-32/U | 25.00 | UG-216/U | 10.87 |
| UG-33/U | 25.00 | UG-217/U | 3.88 |
| UG-34/U | 21.88 | UG-218/U | 8.13 |
| UG-35A/U | 20.00 | UG-222/U | 43.75 |
| UG-36/U | 20.00 | UG-223/U | 2.50 |
| UG-37/U | 20.00 | UG-235/U | 35.63 |
| UG-37A/U | 20.00 | UG-236/U | 14.69 |
| UG-37/U | 2.81 | UG-239/U | .64 |
| UG-38/U | 3.44 | UG-241/U | 2.75 |
| UG-39A/U | 2.81 | UG-242/U | 3.13 |
| UG-40/U | 2.81 | UG-243/U | 3.44 |
| UG-60A/U | 1.63 | UG-244/U | 3.13 |
| UG-61/U | 2.56 | UG-245/U | 1.56 |
| UG-61A/U | 2.25 | UG-246/U | 1.85 |
| UG-62/U | 35.00 | UG-252/U | 5.63 |
| UG-63/U | 1.88 | UG-254/U | 2.28 |
| UG-65/U | 2.06 | UG-254A/U | 2.81 |
| UG-65/U | 2.06 | UG-255/U | 2.31 |
| UG-66/U | 2.16 | UG-256/U | 13.75 |
| UG-67/U | 1.75 | UG-257/U | 13.75 |
| UG-68/U | 1.46 | PI-258 | 1.22 |
| UG-69/U | 1.19 | PL-259 | .70 |
| UG-70/U | 1.31 | UG-261/U | 7.50 |
| UG-81/U | 1.56 | UG-259/U | 5.13 |
| UG-91A/U | 1.31 | UG-260/U | 1.24 |
| UG-92/U | 1.38 | UG-261/U | 1.19 |
| UG-92A/U | 1.59 | UG-262/U | 1.31 |
| UG-93/U | 1.56 | UG-269/U | 3.25 |
| UG-94A/U | 1.81 | UG-270/U | 8.13 |
| UG-94/U | 1.56 | UG-271/U | 8.13 |
| UG-94A/U | 1.31 | UG-273/U | 1.88 |
| UG-95/U | 1.38 | UG-274/U | 2.48 |
| UG-95A/U | 1.69 | PI-274 | 1.40 |
| UG-96/U | 1.55 | UG-275/U | 5.63 |
| UG-96A/U | 2.06 | UG-276/U | 5.63 |
| UG-97/U | 4.38 | UG-279/U | 3.00 |
| UG-98/U | 1.94 | UG-287/U | 6.56 |
| UG-100/U | 2.93 | UG-290/U | 1.06 |
| UG-101/U | 3.69 | UG-291/U | 1.31 |
| UG-102/U | .90 | UG-306/U | 2.54 |
| UG-106/U | .56 | UG-333/U | 5.88 |
| UG-107/U | 2.56 | UG-334/U | 7.19 |
| UG-107A/U | 2.88 | UG-335/U | 13.75 |
| UG-108/U | 2.19 | UG-352/U | 7.50 |
| UG-109/U | 2.19 | M-358 | 1.32 |
| | | M359 | 1.32 |

If you don't see it write for it

CERAMICON CONDENSERS \$7.50 per 100

| | | | |
|---------|----------|----------|------|
| 3 mmf | ±5% | 60 mmf | ±3% |
| 5 mmf | ±5% | 67 mmf | ±20% |
| 4 mmf | ±5 mmf | 115 mmf | ±2% |
| 8.5 mmf | ±5 mmf | 120 mmf | ±5% |
| 11 mmf | ±5% | 240 mmf | ±3% |
| 15 mmf | ±2.5 mmf | 330 mmf | ±5% |
| 50 mmf | ±20% | 1000 mmf | ±5% |

THERMISTORS

- D-167332 (tube) .95
- D-170396 (bead) .95
- D-167613 (button) .95
- D-166228 (button) .95
- D-164699 for MTG, in CG band, Guide \$2.50
- D-167018 (tube) .95

VARISTORS

- D-170225 \$1.25
- D-167176 .95
- D-168687 .95
- D-171812 .95
- D-171528 .95
- D-168519 .95
- D-162482 \$3.00
- D-163298 \$1.25
- D-99428 \$2.00
- D-161871A \$2.85
- D-171121 .95
- 3A (12-43) \$1.50
- D-167020 \$3.00

WRITE FOR C.E.C. CATALOG NOW AVAILABLE FREE

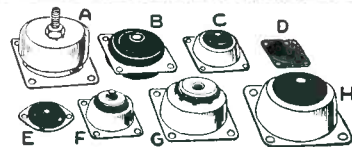

SHOCK MOUNTS

| | | |
|-----------------|------------------------|-----|
| D Lord #1 | 1 1/4x1 1/4x3/8H | 10¢ |
| D Lord #6 | 1 1/4x1 1/4x3/8H | 10¢ |
| D Lord #15 | 1 1/4x1 1/4x3/8H | 10¢ |
| B Lord #15 | 3/4x1 3/4x5/8H | 15¢ |
| B Lord #12 | 3/4x1 3/4x5/8H | 15¢ |
| B Lord #35 | 2 1/4x2 1/4x1 1/4H | 18¢ |
| G U. S. #5150-C | 2 3/8x2 3/8x1 1/8H | 18¢ |
| F Lord #4 | 1 23/32x1 23/32x1 1/4H | 35¢ |
| C Lord #1 | 1 11/16x1 11/16x3/4H | 14¢ |
| C Lord #10 | 2 3/8x2 3/8x1 1/16H | 25¢ |
| C Lord #16 | 2 3/8x2 3/8x1 1/16H | 20¢ |
| H Lord #35 | 3x3x1 1/2H | 45¢ |
| H Lord #20 | 3x3x1 5/8H | 45¢ |
| H Lord #25 | 3x3x1 5/8H | 45¢ |
| H Henrite #55 | 3x3x1 5/8H | 49¢ |
| H Lord #15 | 3x3x1 1/2H | 35¢ |
| H Lord #45 | 3x3x1 1/2H | 49¢ |
| A Barry #C2070 | 3x3x1 1/2H | 55¢ |
| A Barry #C2069 | 3x3x1 1/2H | 55¢ |
| A Barry #C2090H | 3x3x1 1/2H | 55¢ |

Shaft 6 1/8" Lx3/8" Dia Thread both sides with nut, washer, and two woven leads. ea. 35¢

WRITE FOR TYPES NEEDED

30' U. S. ARMY SIGNAL CORPS RADIO MASTS

Complete set for the erection of a full flat top antenna. Of rugged plywood construction telescoping into 3 ten-foot sections for easy storage and transportation. Supplied complete: 2 complete masts, hardware, shipping crate, shipping wt. approx. 300 lbs. Sig Corps #2A289-223-A New \$35.00 per set of 2

400 CYCLE TRANSFORMERS

- 352-7273: Pri: 115 v. 400 cy. Sec: 6.3 v. 2.5 amp; 6.3 v. .06 amp; 6.3 v. 9 amp; 5 v. 6 amp; 700 vct \$4.75
 352-7176: For APS-15, T201. Sec: 6.3 v. 2.25 amp; 6.3 v. .5 amp; 6.3 v. 3 amp; 320 v (2-6X3's). For APS-15, T202 \$5.25
 352-7278: Pri: 115 v. 400 cy. Sec: 2.5 v. 1.75 amp; 3500 v (2X2). For APS-15, T203, (Anode #2 5F17) \$5.85
 352-7070: Pri: 118 v. 440 cy. Sec: 2.5 v. 2.5 amp; 2.5 v. 2 amp; 4200 v (ins.); 6.3 v. 2.25 amp; 1200 v. tapped at 1000 and 750 v. p/o AN/AP8-15 \$4.95
 #7469105: Pri: 115 v. 400 cy. Sec: Tapped to give 742.5 v. 50 ma; 709 v. .0477 amp; 671 v. .045 amp \$2.95
 M-7474319: Pri: 115 v. 400 cy. Sec: 6.3 v. 2.7 amp; 6.3 v. .66 amp; 6.3 v. 21 amp \$2.95
 3232: Pri: 115 v. 400-2400 cy. Sec: 400 vct. 35 ma; 6.4 v. 2.5 amp; 6.4 v. 15 amp \$2.25
 332-7138M: Pri: 115 v. 400-2400 cy. Sec: 640 v. 5 ma; 2.5 v. 1.75 amp. \$3.85
 352-7179: Pri: 115 v. 400-2400 cy. Sec: 6.5 v. 12 amp; 6.5 v. 2 amp; 100 ma; 5 v. 2 amp. \$3.50
 #9069: Pri: 115/80 v. 400-2600 cy. Sec: 650 vct. 50 ma; 6.3 v. 2 amp; 5 v. 2 amp \$2.15
 352-7096: Pri: 115/80 v. 400-2400 cy. Sec: 2.5 v. 1.75 amp; 3 KV ins; 5 v. 3 amp; 6.5 v. 6.5 amp; 1.2 amp \$3.95
 KS 9607: Pri: 115 v. 400-2400 cy. Sec: 734 vct. 177 ma. 1710 vct. 177 ma. \$5.95
 D-166333: Pri: 115 v. 400-2400 cy. Sec: 6.3 v. 0.9 amp; 6.3 v. 365 amp \$2.79
 GE #7471957: Pri: 100/110/120/130 v. 400-2400 cy. Sec: 2.5 v. 20 amp. 11V ins. \$4.85
 D-163254: Pri: 115 v. 400 cy. Sec: 6.3 v. 12 amp; 6.3 v. 2 amp; 6.3 v. 1 amp. P/O AN/AP8-15 \$5.85
 KS-9685: Pri: 115 v. 400-2400 cy. Sec: 6.4 vct. 7.5 amp; 6.4 v. 3.8 amp; 6.4 v. 2.5 amp \$4.35
 PLATE XMR: Pri: 115 v. 400 cy. Sec: 9800 v. or 8000 v. @ 32 ma dc. \$12.50
 #12033: Plate Xfnr. Pri: 115 v. 800 cy. Sec: 4550 vct. 250 ma \$7.95

WRITE TO C.E.C. FOR YOUR 400 CYCLE NEEDS

TELEPHONE EQUIPMENT

- Pike Pole. Telephone, MC123, for Wire Laying 2 sections. 4 1/2 ft. ea. section w/M100 Lock. New Unused \$9.95
 Telephone Handset Shell. For TS10 Sound Power W.E. Light weight. \$6.9¢
 Tape Bridge TG815. McElroy used for standard %" White Paper for Sight Reading and Typewriter transcription. SPECIAL PRICE \$5.50

W.E. Teletype Switchboard #5. Complete Installation. 6-20 ft. bays. NEW EXPORT PACKED. AVAILABLE FOR INSPECTION.

BC 686 LINE AMPLIFIER

With magnet ringer, 3-tube 25L6 amplifier. For local point-to-point telephone operation, remote operation of Phone Xntr, remote reception of receiver output, monitoring facility. Requires only 24 vdc for tube "B" plus supply for full operation.
 New, less tubes, in wooden chest. \$18.50
 Per pair for 2 way pt-to-pt operation. \$35.00

Silver-Mica Button Capacitors (Standard Brand) \$9.50 per 100

| | |
|---------|----------|
| 185 mmf | ±2.5 mmf |
| 175 mmf | ±2.5 mmf |
| 500 mmf | ±10% |

COMMUNICATIONS EQUIPMENT COMPANY

CABLE ADDRESS: COMSUPO
 PHONE DIGBY 9, 4124
131 LIBERTY ST. DEPT. E
NEW YORK 7, N.Y.

C. E. C. MONEY BACK GUARANTEE, 43 MIN. ORDER.
 F.O.B. N.Y.C. SEND MONEY ORDER OR CHECK, ONLY SHIPPING CHARGES SENT C.O.D.

SEARCHLIGHT SECTION

YOU'LL SAVE FREE FREE
MANY DOLLARS
WRITE FOR OUR CATALOG TODAY AND SAVE
FREE CATALOG

FILTER CHOKES

| | | | |
|-----------------------------------|--------|------------------|--------|
| 15-29NY/150MA | \$3.25 | 8.5HY/125MA | \$1.50 |
| 25HY/65MA | 1.00 | 6HY/150MA | 1.50 |
| Dual 7HY/75MA, 11HY/65MA | 1.65 | | |
| 7HY/40MA | 1.60 | Dual 2HY/100MA | .75 |
| Dual 2.5HY/130MA | 1.25 | 116HY/150MA | 4.25 |
| .01HY 2.5A | 1.45 | 35HY/350MA | 7.25 |
| Dual 5HY/380MA | 1.00 | 5HY/40MA | .55 |
| 2HY/200MA | .75 | Dual 120HY/17MA | 2.45 |
| 30HY/20MA | .85 | 5HY/200MA | 1.45 |
| 2.1HY/200MA | 1.20 | 2 x 2.2HY/.55A | 9.95 |
| 25HY/75MA | 1.10 | 20HY/300MA | 12.95 |
| Dual 22HY/600MA, 44HY/400MA | 1.95 | | |
| Swing 1-3HY/225.02A, 1.75HY/225MA | 2.25 | | |
| Tapped Choke 2 x 1.52HY/167MA | 2.25 | | |
| .0331HY 7A | 9.50 | Dual 10HY/150MA | 3.50 |
| Dual 1.52HY/167MA | 2.49 | Dual 2.2HY/550MA | 5.95 |
| 5HY/200MA | 1.49 | 1.35HY/11A | 4.95 |
| 12HY/100MA | 1.75 | 11HY/100MA | 1.60 |
| 2x2.5HY/700MA | 6.95 | | |
| 3.5HY/400MA | 5.95 | | |

POWER EQUIPMENT

- Fil. Trans. 110v 60 cy in., 5vct/30A out. \$9.95
- In 110v 60 cy out 6.3vct/20A, 6.3v/1.8A, 6.3v/600, MA \$4.95
- In 110v 60 cy out 2x5vct/6.75A, 5vct/13.5A, 3500 Test \$6.95
- In 110v 60 cy out 10vct/13A, 10vct/6.5A, 6.3vct/2A \$7.95
- In 115v 60 cy out 760vct/500MA, 800vct/40MA \$10.95
- In 110v 60 cy out 690vct/400MA \$6.95
- Tapped in. 107 to 127v out 160v to 200v/700MA 12 Taps \$12.95
- In 110v 60 cy out 4v/16A, 2.5v/1.75A \$4.75
- In 110v 60 cy out 1700v/144MA, w/choke 26 x 29 x 3" oil immersed \$65.00
- In 115v 60 cy out 2x5v/5.5A 29kv ins. \$24.50
- In 115v 60 cy out Tapped to give 2750/2470/2240/@ 750 MA 7000v ins. \$34.50

SPECIAL TRANSFORMERS

- In 440/220/110v 60 cy 3kva out 115v 25kv ins. 12"x12"x7" \$40.00
- In 220v 60 cy .05kva out 5vct 34kv Test. \$24.50
- In 115v/230v 50-60 cy out 21000v 100MA. \$120.00
- In 220v 60 cy out 220v/360MA, 3x2.5v/5A, 2.5v/15A \$6.75
- In 220v 60 cy out 10vct/13A, 7.5vct/2.5A \$5.50
- In 220v/440v 60 cy out 123vct/2.85A \$7.50
- In 240v 60 cy 7000vct/900MA, 4700vct/750 MA \$135.00
- In 210/15/20/25/30/35/240v 60 cy out 11vct/35A, 10vct/35A, 7.5vct/35A, 5vct/35A \$37.50
- In 220/440 60 cy 1 ph out 123vct 2.85 amp Test 1780 \$6.95
- In 230/460 out 7320vct/6.55A, 660vct/2A \$29.95

TRANSAT AMERTRAN



Input: 0.115 v. 50-60 cycle. Max. output: 115 v. 100 amp.
 All units are new, guaranteed \$95
 2 KVA: 90-130v input 50-60 cycles, output 115v 2kva type RH Amertran \$29.95 each

KITS POWER SUPPLY

Basic TV 5" & 7" Pwr Supply
 Consists of xfrmr 2300v/4MA, 2.5v/2A, 1 condenser, .1 mfd, 7500v Pwr., 2x2 tube, socket 100K ohm resistor. Price \$9.95
5BP1. \$1.95 5BP4. \$4.95
5CP1. \$3.75

Basic TV 3" & 5" Pwr Supply
 Consists of xfrmr 1080v/55MA, 2x6.3v/1.2A, 1 Cond., .1 mfd 7500v Pwr., 2x2 tube, socket 100 K ohm resistor. Price \$7.95
3BP1. \$2.25 3DP1. \$2.25
3EP1. \$2.95

3" Oscilloscope Kit
 BC929 uses 9 tubes 3BP1, 6SN7, 6H6, 6RB6, 6X5 2X2 (now 400 cy) easily converted to 115v 60 cy New Complete w tubes & conn. inst \$22.50

5" Oscilloscope Kit
 BC 704 Less Pwr Supply Kit includes 8 tubes, 5BP1, 6AC7, 6116 w/wooden Case & Diag. \$29.50

COMMUNICATIONS EQUIPMENT COMPANY



932 PHOTOTUBE

This tube is a gas phototube having 5-1 response, particularly sensitive to red and near infrared radiation. Can be used with incandescent light source. Send for data. PRICE \$1.00

GREAT TUBE VALUES

| | | | | | |
|---------|-------|-----------------|--------|---------|--------|
| 01-A | \$.45 | 12SR7 | \$.72 | 804 | \$9.95 |
| 11B26 | 4.85 | 15P | 1.40 | 815 | 2.50 |
| 2C22 | .69 | 28D7 | .75 | 836 | 1.15 |
| 2C24 | 25.00 | 30 (Spec) | .70 | 837 | 1.95 |
| 2J21-A | 25.00 | 35 (Spec) | .59 | 843 | .59 |
| 2J22 | 25.00 | 39/4B | .49 | 860 | 15.00 |
| 2J26 | 25.00 | 35/51 | .72 | 861 | 40.00 |
| 2J27 | 25.00 | 227A | 3.85 | 874 | 1.95 |
| 2J31 | 25.00 | 225 | 8.80 | 876 | 4.95 |
| 2J32 | 25.00 | 268-A | 20.00 | 1005 | .35 |
| 2J38 | 35.00 | 355-A | 19.50 | 1619 | .21 |
| 2J39 | 35.00 | 41A | 15.00 | 1624 | .85 |
| 2J34 | 55.00 | 530 | 90.00 | 1629 | .35 |
| 2J40 | 65.00 | 531 | 45.00 | 1961 | 5.00 |
| 2J49 | 85.00 | 532 | 3.95 | 9002 | .65 |
| 3J31 | 55.00 | 569 | 4.00 | 9004 | .47 |
| 2K41 | 65.00 | 552 | 90.00 | CEQ 72 | 1.95 |
| 2X2/879 | 69.99 | DY | 50.00 | EP 50 | 7.99 |
| 3BP1 | 2.25 | 700A,B,C,D50.00 | F-127 | PC 258A | 165.00 |
| 2C24 | .60 | 703-A | 7.00 | FC 532 | 7.50 |
| 3C30 | .70 | 704-A | .75 | GC 271 | 40.00 |
| 3D6 | .79 | 705-A | 2.85 | GL 562 | 75.00 |
| 3CP1 | 3.50 | 706A,B,C | 50.00 | GL 623 | 75.00 |
| 3D21-A | 1.50 | 706B,C,FY | 50.00 | GL 687 | 75.00 |
| 3DP1 | 2.25 | 706E,FY | 50.00 | GL 697 | 75.00 |
| 3EP1 | 2.95 | GY | 50.00 | NIL 100 | 60.00 |
| 3FP7 | 1.20 | 1707-B | 20.00 | OK 59 | 65.00 |
| 3Q5 | .79 | 711A | 25.00 | OK 60 | 65.00 |
| 3B11 | 1.95 | 715A | 12.00 | OK 61 | 65.00 |
| 5BP4 | 4.95 | 720B | 50.00 | OK 62 | 65.00 |
| 5CP1 | 3.75 | 720C | 50.00 | VR 91 | 1.00 |
| 5FP7 | 3.50 | 721-A | 3.60 | VR 130 | 1.25 |
| 5J30 | 39.50 | 723-A/B | 12.50 | VR 135 | 1.25 |
| 6G | 2.00 | 724B | 1.75 | VR 137 | 1.25 |
| 6SC7 | 1.00 | 725-A | 25.00 | VU 120 | 1.00 |
| 7C1 | 1.00 | 726-A | 15.00 | VU 134 | 1.00 |
| 7E5 | 1.00 | 728A,B,C | WL 532 | 4.75 | |
| 7E6 | .72 | CY,DY,EY | WN 150 | 3.00 | |
| 10Y | .60 | FY,GY | 50.00 | WT 260 | 5.00 |
| 12A6 | .35 | 730A | 25.00 | | |
| 12BK7 | .65 | 800A | 2.25 | | |
| 12SF7 | .49 | 801-A | 1.10 | | |

Socket 115B, 705A \$1.00
 Socket Klipspring 723A,B \$2.00
 Time Delay Relay Vacuum, Time Delay 30 sec. 117 \$2.25
 60 cy Metal Tube, 4 Prong, Edison, \$2.25
 Grid Cap H.V. Bakelite 3/4" w/air lead 10 for \$1.00
 Tube Clamps. Bircher 926-A-B-15-C-A2-R1 etc. 10 for \$1.10
 Thermostatic Switch N.C. 3 amp contacts opens 75° 7 For \$1.00
 Fuses 250v indicators amps 1, 2, 3, 4, 5, 6 @ \$2.49
 Fuses 1000v .amps 1/4, 3/4, 1, 1 1/2, 2 @ \$1.00
 Fuses 2500-3000v 1/4, 3/4, 1, 1 1/2, 2 @ \$1.00
 RF Indicator contains neon bulb. 20¢ for 90¢

TRANSFORMERS

115V 60cy. 1N1UT Equip. Conservatively Rated

FILAMENT TRANSFORMERS

5 Volts/6 Amp

| | |
|-------------------------------------|--------|
| F083: 6.3VCT/6A, 5V/2A | \$2.25 |
| 2.5VCT/6.5A | 1.85 |
| F- 6.3VCT/2A, 6.3VCT/2A | 2.45 |
| F087: 6.3VCT/1A, 6.3VCT/7A | 2.75 |
| F103: 6.3V 1A, 6.3V/1A | 1.95 |
| F123: 6.3VCT/5A, 6.3V/1A | 2.25 |
| F127: 6.3VCT/3.2A, 6.3VCT/1A | 2.25 |
| F674: 8V 1.5A | 2.75 |
| F- 2.5 1.75A, 6.5 8A, 5V 3A, 6.5 6A | 3.95 |
| F414: 2 x 2.5VCT/6.5A | 3.25 |
| F161: 6.3VCT/7A, 6.3VCT/5A, 5VCT/6A | 3.95 |
| 2 x 6.3V 6A, 6.3V/3A | 1.75 |
| F829: 6V 2.5A | 3.25 |
| F38A: 6.3V 2.5A, 2 x 2.5V/7A | 4.25 |
| F12: 2 x 2.5VCT/6.5A, 2.5V/6.5A | 1.95 |
| F14A: 6.3 6A | |

PLATE TRANSFORMERS

| | |
|-----------------------------------|-------|
| P410: 800VCT/40MA, 760VCT/500MA | 6.50 |
| P415: 600V 450MA | 4.95 |
| P699: 2 x 300VCT/150MA | 2.25 |
| P403: 70V/1A | 2.25 |
| P413: 510VCT/150MA, 650VCT/15MA | 4.95 |
| P42: 600VCT/0166A, 250VCT/077A | 2.95 |
| P883: 1620VCT/400MA 11V 1A8 | 11.95 |
| P894: 2 x 200V 350MA, 2 x 20V/01A | 1.95 |
| P450: 2 x 150V/910MA | 4.50 |
| P371: 246VCT/830MA | 3.95 |
| P345: 1470VCT/1.2A, 3500T | 24.00 |

COMBINATION TRANSFORMERS

| | |
|--|--------|
| C965: 78V/600MA, 6.3V/2A | \$3.95 |
| C111: 2 x 300V 42MA, 55V/125MA | |
| 45V/3.5 Amp | 3.95 |
| C608: 880VCT/150MA, 5V 3A, 6.3V/0.25A | 5.00 |
| C931: 585VCT/80MA, 5V 3A, 6.3V/6A | 3.95 |
| C055: 525VCT/75MA, 5V/2A, 6.3V/1.8A | |
| 10V 2A | 4.45 |
| T102: 1080VCT/55MA, 2 x 6.3V/2A | 5.95 |
| C848: 600VCT/155MA, 6.3VCT/5A | |
| 5VCT/3A HV Ins | 3.95 |
| C899: 2 x 10VCT/01A, 6.3V/1A | 4.50 |
| 2.5VCT/7A | |
| C760: 6.3VCT/10A, 65V/1A, 100VCT/1A | |
| 40V/1A, 18VCT/1A, 18V-6V/1A, 6.3V/1A | 5.50 |
| C354: 825VCT/190MA, 5VCT/3A | 3.95 |
| C367: 1120VCT/3A, 380VCT/040 | 2.95 |
| T160: 1120VCT/770MA, 590VCT/082A | |
| HV Ins | 12.75 |
| C579: 24V/900MA, 770V/0025, 2.5V/3A | 4.25 |
| HV Ins | 8.95 |
| T378: 2300V/001A, 2.5V/2A HV Ins | 8.95 |
| C375: 1120VCT/600MA, 2 x 5VCT/6-2A | |
| 6.3VCT/3A, 6.3V/300MA | 14.95 |
| C364: 6.3VCT/3A, 5VCT/6A, 610VCT/330MA | |
| C434: 40V 01A, 6.3V/1.25A | 4.75 |
| C383: 215VCT/300MA, 5VCT/6A | 1.95 |
| C360: 640VCT/080A, 5VCT/3A, 6.3VCT/3.2A | 2.29 |
| C821: 1500V/4A, 6.3V/6A, 2.5V/1.75A, 3500T | 3.95 |
| | 8.95 |

CONDENSERS

MICA

| Mfd | Voltage | Price |
|---------|-----------|--------------|
| .01 | 1200V VDC | 2 for 95¢ |
| .00025 | 2500V VDC | 2 for 55¢ |
| .00004 | 2500V VDC | 2 for 75¢ |
| .01 | 500V VDC | 4 for 95¢ |
| .002 | 3000V VDC | 2 for \$2.00 |
| .01 | 2000V VDC | 2 for 2.90 |
| .00003 | 2000V VDC | 2 for 95¢ |
| .00009 | 3000V VDC | 2 for 1.85 |
| .00082 | 3000V VDC | 2 for 1.95 |
| .002 | 3000V VDC | 2 for 1.95 |
| .005 | 5000V VDC | 2 for 3.25 |
| .0004 | 6000V VDC | 2 for 2.95 |
| .0006 | 3000V VDC | 2 for 1.95 |
| .0008 | 3000V VDC | 2 for 1.85 |
| .0016 | 3000V VDC | 2 for 1.25 |
| .000090 | 3000V VDC | 2 for 75¢ |
| .03 | 1500V VDC | 2 for 19.50 |
| .03 | 2000V VDC | 2 for 23.50 |
| .045 | 2000V VDC | 2 for 23.50 |
| .00015 | 20KVDC | 2 for 47.50 |
| .0001 | 20KVDC | 2 for 47.50 |
| .002 | 15KVDC | 2 for 37.50 |
| .006 | 2500V VDC | 2 for 2.85 |
| .00027 | 2500V VDC | 2 for 65¢ |

UPRIGHT OILS

| Mfd | Voltage | Terminals | Price |
|--------|---------|-----------|--------------|
| .01 | 600V DC | 2 | 3 for \$1.00 |
| .25 | 400V DC | 2 | 3 for 1.10 |
| .5 | 600V DC | 2 | 3 for 1.00 |
| .1 | 600V DC | 3 | 3 for 1.10 |
| 2 x .5 | 600V DC | 3 | 3 for 1.45 |
| 3 x .1 | 600V DC | 3 | 2 for 1.05 |
| .25 | 400V DC | 2 | 3 for 1.10 |
| .5 | 600V DC | 2 | 3 for 1.00 |
| .1 | 600V DC | 3 | 3 for 1.00 |
| .5 | 600V DC | 2 | 3 for 1.00 |
| .1 | 400V DC | 2 | 2 for 1.00 |
| .4 | 400V DC | 2 | 2 for 75¢ |
| .4 | 600V DC | 2 | 3 for 1.10 |
| .1 | 600V DC | 2 | 2 for 83¢ |
| 2 x .1 | 600V DC | 2 | 2 for 95¢ |
| 1.75 | 400V DC | 2 | 2 for 1.00 |
| 3 x .1 | 600V DC | 2 | 2 for 1.05 |
| 2 x .5 | 600V DC | 3 | 2 for 95¢ |
| .1 | 600V DC | 2 | 2 for 85¢ |
| .1 | 600V DC | 2 | 2 for 85¢ |
| .1 | 600V DC | 2 | 2 for 85¢ |
| .1 | 600V DC | 2 | 2 for 85¢ |

OIL CONDENSERS

| | | |
|-------------------|-----------|--------|
| .0016 MFD | 15000 VDC | \$8.00 |
| .015 MFD | 16000 VDC | 7.00 |
| .01-.005-.005 MFD | 10000 VDC | 4.75 |
| 1 MFD | 2500 VDC | 1.25 |
| 1-1 MFD | 7000 VDC | 3.49 |
| 1 MFD | 6000 VDC | 2.97 |
| 1 MFD | 7500 VDC | 3.00 |
| 2 x 1 MFD | 4800 VDC | 3.90 |
| .15 MFD | 4000 VDC | 3.09 |
| .15-.15 MFD | 6000 VDC | 4.00 |
| 2 x .15 MFD | 8000 VDC | 5.00 |
| .25 MFD | 1500 VDC | 1.05 |
| .4 MFD | 5000 VDC | 3.00 |
| .5 MFD | 1000 VDC | 1.05 |
| | | |



SPECIAL SURPLUS BROADCAST OF OUR SUPER SPECIALS!!!

I. F. F. TRANSMITTER ASB-7A



Uses 2 transmitting UHF tubes, 15E and contains 400 cycle blower unit, etc. Freq. range 500 MCS. 18x8x7 1/2 New\$12.95

SPERRY A-5 VERTICAL GYRO UNIT



#644841. 115 V. 400 CY 3 phase. Contains gyro assembly, erection motor, erection relay assembly, pick-off assembly, elevator and alleron limit switches, and roll axes. 15 x 12 x 9. New.\$27.50

G. E. MOTOR CONTROLLED VOLTAGE REGULATOR



Cat. #837625, Type 'Airs', Form M, .568 KVA, cont. duty, 60 cy., primary volts 115, Load Amps 16.2. Indoor service. Voltage controlled by mtr. 120/160-1/40 HP. \$39.50

Outdoor Distribution Transformers OIL FILLED—BRAND NEW



General Electric 3 KVA; Type HS: 3000/3200Y - 115/230 volts. Style 3266596-01.

In original Factory Cases \$36
Westinghouse Type S. 2400/4160 Y—120/240 volts. \$50.00
3 KVA\$37.50
1 1/2 KVA

G. E. Motor Starting Reactors Type 1TK2840G2



Rated at 440 Volts, 3 Ph., 60 Cy., 16.8 Amp. 15-20 HP. Waterproof steel case. 17" x 15" x 10". New in orig. cases.
Special of the month \$7.75

DICTOGRAPH INTER-COMMUNICATION SETS



800 ft. off flashlight batteries. New Pair.\$9.95

SPERRY A-5 AMPLIFIER RACK

#644890, contains Weston Model 833 Voltmeter 0-130 and Weston Model 637 Frequency Meter 350-450 cycles. Several 24 VDC relays, transformers and condensers. New\$12.95

Blower Assembly MX-215/APG

John Oster C-2P-1L 28 v. DC 7000 RPM 1/100 hp. #2. L-R Blower. 25 C.F.M.Price \$2.75

John Oster, 6 Volt, DC Motor

1.8 Amps—5000 R.P.M. #1 1/2 L-R Blower 5.0 C.F.M.Price \$4.50

Westinghouse Type FL Blower

115 V. 400 Cy. 6700 RPM. 2" Sirrocco Impeller 17 C.F.M.Price \$4.50

F. A. Smith AC Blower

115 V. 60 Cy. 0.38 A 3250 RPM. Outlet 1 1/2" Diameter Motor fan cooled. 25 C.F.M.Price \$7.95



D. C. 604 F. M. TRANSMITTER

Wide or narrow band FM. 30 watt power output. Excellent possibility for ten or eleven meter exciter. Freq. 20-27.9 MC. Working space permits modification. W/ tubes but less power supply and xtls. LN \$11.50. Complete with Crystals \$27.50

New Submarine Signal QBE-1 Underwater Sound Equipment



CBM 52265 Driver Rectifier

Emission A1. Freq. 18-25 KC. 30W output. 110V. 60 Cy. 1 ph supply 19x13x10 inch. Price \$32.50



Type CBM 46169. Receiver amplifier. Freq. 18-25KC., input 115/1/60. 75 lbs. 19 x 13 x 10 1/2.\$26.50



Type CBM 55081 Indicator Unit — Ranges 0-1000 yds. and 0-5000 yds. Visual & Audio Indication Synchronous motor driven, input 115/1/60. 20 x 16 x 8 1/2.\$25.00



DELCO CONSTANT SPEED MOTOR

Type A-7155, 27 VDC, 2.4 A, 1/30 HP, 3600 RPM, 2 1/2" Diam. x 5 1/2" L. 7/8" Sh. Ext. Cont. Duty. Base mounted.\$4.25 ea.



SELECTOR SWITCHES

Heavy duty, U. S. N. Control any type of multi-circuit devices. Removable contacts enabling any comb. of closed and open circuit. The following available: 5 section-10 pole or 10 section-20 pole, \$1.50 ea. Case lots of (8) \$8.00 or (5) cases, special.\$32.50



INDUCTION VOLTAGE REGULATOR

Type IRT, form M, 1.64 KVA, 3 phase, 60 cycles, cont. duty. Outdoor service. Primary: 208 V., 10.5 load amps. Oil-filled. Wgt. 365 lbs. 35 x 17" x 14".\$53.50



FITCH CRYSTAL DUPLICATOR

Calibrates crystal plate of unknown freq. against standard plate of desired freq. Consists of standard and test oscillators whose outputs are mixed to produce an amplified beat note; the freq. is shown on 500, 5000, 50,000 cycle meter. Metal cabinet w/hinged cover. 9" L. x 13" W. x 19" L. Comp. w/4" sq. activity and freq. meter.\$22.50



DYNAMOTOR GENERATOR

Model 3975-1. Electro Spray Co. p/of "Gibson Girl". Input 28 VDC @ 175 amps. Output 300 VDC @ .040 amps. 5" L. 3 1/2" D.\$1.00 ea.

RCA TRACK LIGHTING & CONTROL PANEL. Model 713-AS, comp. wire ready for immed. oper. Controls the filament volt. on vacuum tubes in the process of being exhausted on rotary turn table equip. 7" H. 15" D. 32" W. Units complete with meters, variac dist. transformers, switches, rheostats, etc.\$275.00

RETARD CHOKE COILS



Amertran, Disc Type. Line voltage 15,000; ripple freq. 120. Oil-filled. 020A DC @ 900H @ 48% ripple. 52A DC @ 25H @ 48% ripple. 17"x17"x22" w/term. 10" above case. 40°C temp. rise.\$34.00



MILLIAMMETERS

150-0-150 MA DC. Accuracy 1/2 of 1%. Scale length 4 1/2". Wt. 3 1/2 lbs. 6" x 2 1/2" x 4 1/2". L. N. \$2.50



MINE DETECTOR SCR 625

Detects metallic objects (ferrous or non-ferrous) to a depth of approx. 6 ft. Find outboard motors on the bottom of lakes, locate underground piping, treasure, metallic fragments in lumber, etc. New, complete with inst. book, \$65.00. Used but like new.\$45.00

SPECIAL of MONTH

W.E. Motor KS-5603-L02, 28 v. DC. 0.6 amps. 1/100 hp. 4 lead shunt.

Price \$1.50 ea.

TRANSTAT VOLTAGE REGULATOR



Amertran type RH. Input: 115 V. 400 cy. 0.5 KVA, 5.5 max. amps. Output: 92-115 V. 5 1/2 x 4 1/2 x 3 1/2. \$1.95

25 KVA Fixed winding 115/1/60. Commutator range 103-126 V. 2.17 Max Amps.\$9.45

W. E. HIGH VOLTAGE POWER SUPPLY

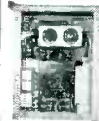

RA50-A, used with SCR 296A. Secondary of hi voltage trans. supplies 20,000 volts @ 45 MILS to two 705A'S; the filaments are heated from 5 V. 10 A. trans. Also 0.05 mfd 12,500 V. cond. 2 1/2 x 17 x 1 1/2.\$49.95



AMERTRAN HEAVY DUTY TRANSFORMERS

Pri.: 115/230 VAC 60 cy. Sec.: 4730/2365 V. 1.66KVA. RMS. 12 KV. Wgt. 150#. 11"x11"x9". 700 MA. New\$27.50



Standard Brand RHEOSTATS

High shock rheostats, four 13" plates, 100 ohms 8-2A, 175-345 V connected in series. Assembled for back of board mtg. or by reversing the supporting brackets for floor or table oper. New\$19.75

DECK ENTRANCE INSULATORS

(Bowl and Flange Type)



Mfd. by Ohio Brass Co. heavy galv. metal flange 10 1/2" D. porc. bowl set in rubber gaskets. Top bell 7 1/2" D. brass feed thru rod 10 1/2" L. Insul. dist. between top bell and flange 6 1/2". \$2.50



DAVEN SOUND ATTENUATORS

Type 350-A. Network, ladder, linear, imped. 30/30 ohms. 2DB attenuation. 19 W dissipation. Brand new.\$3.95



DC SERVO MOTORS

White Rodgers Elec. Co. (6905X-46). 24 VDC @ .65 Amps. Torque 50 in/lb. 1/2 RPM reversible, comp. w/limit switch, relays and selenium rectifiers on top of motor, to keep AC out of motor. 5x5x4. \$7.95 6904X-27, 24 VDC @ 1 Amp., 150 in/lb. torque, 2 1/2" RPM reversible. Complete w/limit switch, relays and selenium rectifiers same as above.\$7.95

TUBE SPECIALS THIS MONTH ONLY

| | | | |
|-----------|--------|-----------|--------|
| C1B/3C31 | \$2.00 | 12SK7GT | \$.58 |
| 1R4/1294 | .80 | 12SR7 | .45 |
| 2A3 | .92 | 28D7 | .30 |
| 2C22 | .20 | 39/44 | .20 |
| 2E22 | 1.10 | 53 | 1.00 |
| 2X2/879 | .60 | 0B3/VB90 | .65 |
| 3B24 | 1.75 | 0D3/VB150 | .65 |
| 4B24 | 3.75 | 250R | 5.00 |
| 4B26 | 4.50 | 274B | 1.20 |
| 5A1P | 3.95 | 304TH | 5.75 |
| 5B1P | 2.50 | 304TL | 1.50 |
| 5CP1 | 3.50 | 371A | 1.25 |
| 5P1P7 | 1.00 | WL417A | 9.00 |
| 6AG5 | .90 | WL481 | 2.00 |
| 6AK5 | 1.00 | WL531 | 1.75 |
| 6AK6 | .90 | 705A | 1.85 |
| 6B4G | 1.20 | 708A | 2.00 |
| 6B6G | .85 | 714AY | 5.00 |
| 6I16 | .50 | 721A | 2.00 |
| 6J5GT | .50 | 725A/B | 9.50 |
| 6L6 | 1.10 | 72A | 4.00 |
| 6L75 | 1.00 | 801A | .49 |
| 6SA7GT | .50 | 874 | 1.50 |
| 6SCT/1655 | .70 | 1616 | 1.20 |
| 6SG7 | .75 | 1622 | 1.70 |
| 6SN17 | .40 | 1625 | .39 |
| 6SJ7Y | .62 | 1626 | .45 |
| 6SN7GT | .85 | 1629 | .20 |
| 10Y | .50 | 2050 | .95 |
| 12SC7 | .65 | GLS#20 | 3.50 |
| 12SH7 | .39 | | |



Finest of Surplus PEAK ELECTRONICS CO. Fraction of Cost

H.V.-H. CURRENT PLATE TRANS.

1500-0-1500 volts at 1.5 amps. Tapped at 1350 and 1250. Pri. 110/220 volts 50/60 cycles in 2 Separate windings. Built to rigid Navy specs by Amertran. Suitable for broadcast transmitters, induction heating, etc. Continuous duty. 10 x 10 x 7. swt 125 lbs.



New only39.50

BARGAIN OF THE MONTH

As illustrated above, 1500-8-1500 volts at 600 ma. Pri. 110/220 v. 50/60 cycles. 8 x 8 1/2 x 7 s.w.t. 78 lbs. Made by Amertran. Only.....19.95

HIGH CURRENT TRANSF. 820 Volts CT at 775 Ma. Pri. 110/220 Volts 60 cycles. Fully Cased6.95

MALLORY VIBROPACK

6.3 Volt input—output 300 Volt @ 100 ma. Complete onlyeach \$8.95

MALLORY TRANSFORMER & 534C Vibrator as used in above. Both for.....\$5.95

UTC type PA 5000 ohm plate to 500 ohm line and 6 ohm voice coil. 10 watts. 60 to 10,000 cps ±1 DB. GREAT VALUE.....ea. \$2.75

THORDARSON PLATE TRANSF. 2370 volts CT at 250 MA tapped at 300-0-300 volts, plus 215 volts 55 MA bias winding. 110 volt 60 cy. pri. Fully shieldedea. \$11.95

GENERAL PURPOSE TRANSFORMERS

Ideal for Bias, Filament, Isolation, Stepdown, etc. 2 isolated 110v pr. sec. 110v at 900 ma plus 6.3 @ 2 amps. Fully cased.....Now \$1.49 ea.

SCOPE TRANSFORMERS

Pri 110V 60Cy — Hermetically Sealed

2500V @ 12Ma\$3.95
2300 @ 4Ma, 2.5 Volts @ 2 Amp4.95
1050V @ 20Ma, 20V 4.5A, 2.5V 5A4.75
4500V @ 4 Ma8.50

SOLA CONSTANT VOLTAGE TRANS.

Pri. 95-125 Volts 60 Cy See 115V, 120VA.....17.95

PLATE AND FIL TRANSF PRI 110v 60 cy. sec. 1120 volts CT @ 600 ma. 6.3v CT # 3A, 2x5VCT @ 6A Hermetically sealed.....\$9.95 ea.

1500, 5000 Ohm 100 Watt Ferrule Resistors. 20,000 Ohm 50 Watt Ferrule Resistors. Any Types only .10 ea. Min. order 50.



HS 30 HEADPHONES

250 ohms imp. Can be used for sound power Telephones.

Brand new69 ea.

LARGE QUANTITY AVAILABLE

STEPDOWN TRANSFORMER

220/110 volts, 100 watts. Fully encased, 5 1/2 x 4 1/2 x 5 1/2. 110V 60 cycle.....\$2.49 each

PHASE SHIFT CAPACITOR



4 Stator Single Rotor. 0-360 Degrees RotationOnly \$2.95 each

ODDS AND ENDS BARGAINS

.004 4000 VDC Micas9 for .99
.01 600 VDC Mica Cond.9 for .99
GE 24V DC Relays5 for .99
.02 400 V DC Tubulars15 for .99
1000 MFD 25 Volt Electrolytic.2 for .99
25 MFD 25 Volt Elect. Tubular.6 for .99
JAN 6CX Tubes, New, Boxed.4 for .99
3:1 PP Input, Hermetic Seal.2 for .99
.05 600 VDC Oil Tubular.10 for .99
10 MMF Midget Variable Cond4 for .99
Heineman 5 Amp 110 VAC CKT Breaker.99
Heineman 25 Amp 110 VAC CKT Breaker.1.49
2 MFD 250 VAC Oil Cond.5 for .99
Solar .02 600 VDC Dominoes.9 for .99
Erie .0005 N750D Ceramicons.15 for .99
.1x.1 2 KV DC Oil-Condenser.79
H&H SPST P.B. Switch N.O.5 for .99
Weston 507 RF Meters, Less Thermo.99
1/40 Amp (25 Ma) Littlefuses.15 for .99
.25 MFD 600 V. Tubulars.6 for .99
C-D 1 MFD 400 V Oil Tubulars.9 for .99
Butterfly Cond 2-11 MMF Ball Bearings.2 for .99
50 MFD 50 Volt Etect. Tubulars5 for .99
.0015 5% Silver Micas.9 for .99
Midget Closed CKT Jacks.7 for .99
CD Type 4 .001 600 VDC Micas.50 for 4.99



SELSYN MOTORS

115 volts 60 cycles. Large size, high torque. Made by Diehl and Bendix. Ideal for rotating TV beam, etc. Great value at \$6.75 per pair.

PANEL METERS—BRAND NEW

2" WESTON .0-1 Ma Dc 26 ohms res.\$3.50
2" GE 0-1 Ma Dc (volt scale)2.95
2" GE 0-5 Ma Dc (amp scale)1.95
2" WESTINGHOUSE 0-10 Ma Dc2.45
2" GE 0-500 Ma Dc1.95
2" GE 0-10 Volts AC2.50
2" GE 0-30 Volts Dc 1000Q/v2.50
2" WESTON 150-0-150 Microamps Dc3.95
2" GE 0-30 Amps Dc2.45
2" GE 0-1 Amp Rf (Internal Thermo)2.45
2" WESTON 0-1 Amps Rf (Internal Thermo)2.50
3" McCLINTOCK 0-1 Ma Dc. (MA Scale)3.95
3" WESTINGHOUSE 0-2 Ma Dc.3.95
3" GE 0-15 Ma Dc (Square Case)3.95
3" WESTERN ELECTRIC 0-80 Ma Dc.2.95
3" DEJUR 0-100 Ma Dc.2.95
3" GE 0-200 Ma Dc.3.95
3" WESTINGHOUSE 0-50 Amps AC3.95
3" WESTON 0-50 Amps AC4.95
3" TRIPLETT 0.75 Amps AC2.95
3" WESTINGHOUSE 0-20 Ma Dc.3.95
3" WESTINGHOUSE 0-150 Volts AC3.95

2" GE 0-200 MICROAMPS
Model DW51\$4.50 ea.

FILAMENT TRANSFORMERS

110V 60Cy Pri. Fully Cased.
5 Volt 15 Amp\$2.75
2.5 Volt 10 Amp3.49
2.5 Volt CT 21 Amp4.75
6.3 Volt 10 Amp1.89

MULTIPLE SECONDARIES

5 1/4V CT 21A, 7.5V 6A, 7.5V 6A.....\$4.95
6.3V 21 Amp, 6.3V 2A, 2.5V 2A3.95
5 Volt 4A, 6.3V, 3A2.45
2.5V CT 20A, 2.5V CT 20A6.95
2.5V CT 10A, 10V 3A, 5V 3A, 5V 3A3.95

CHOKE BARGAINS

6 Henry 50 ma 300 ohms3 for \$0.99
6 Henry 80 ma 220 ohms2 for .99
8 Henry 160 ma 140 ohms99
1.5 Henry 250 ma 72 ohms59
6 Henry 300 ma 65 ohms3.75
4.3 Henry 620 ma 42 ohms6.95
Swing, Choke 1.6/12 Henry 1 Amp/100 ma 15 ohm19.95

U. H. F. COAX. CONNECTORS

831AP-UG12U—UG21U-UG-14U-831 R-831/SP .39 ea.



FEDERAL ANTI-CAPACITY SWITCH. Double Pole. Double Throw85¢ each; 10 for \$7.50

MEG OHM METER

Industrial Instruments model L2AU 110/220 volts 60 cycle input. Direct reading from 0-100000 megohms on 4" meter can be extended to 500000 megohms with external supply. Sloping hardwood Cabinet 15"x8"x10". Brand new with tubes plus running spare parts including extra tubes. Great value Only \$69.50

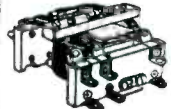

ADVANCE D.P.D.T. ANTENNA RELAY
110 V. 60 cycle coil Steatite insulation. Only \$1.95 each.

DUNCO RELAY 6 volt 60 cycle coil DPST....\$1.39

WIRE WOUND RESISTORS

5 Watt type AA, 20-25-50-200-470-2500-4000 ohms09 ea.
10 watt type AB, 25-40-84-400-470-1325-1900-2000-4000 ohms15 ea.
20 watt type DG, 50-70-100-150-300-750-1000-1500-2500-2700-5000-7500-10000-16000-20000-30000 ohms20 ea.

30 WATT WIRE WOUND RESISTORS

Ohms: 100-150-1590-2500-3k-4k-4500-5k-5300-10k-15k-18k-40k15 ea. 8 for .99

ADJUSTABLE RESISTORS

20 Watt: 1, 5, 50 Ohms......25
50 Watt: 80, 100, 500 Ohms......35
75 Watt: 40, 80, 100, 150, 200 Ohms......39
100 Watt: 20, 50, 75, 120, 180 Ohms......49
150 Watt: 50, 100 Ohms......59

1% PRECISION RESISTORS

2000-2500-5000-8500-10,000 ohmsea. 25
50000-95000 ohmsea. 29
10000-750000-1 megea. 69

Precision 15 Meg. 1% Accuracy Resistor. Non-inductive, 1 watt, hermetically sealed in glass. .29 ea 10 for\$2.50



50 megohm 35 watt Resistor with mount...\$1.95 each; 10 for \$15.00

W. W. POWER RHEOSTATS

25 Ohms 25 Watt49
150 Ohms 50 Watt59
250 Ohms 50 Watt59
300 Ohms 50 Watt59
Dual 200 Ohms 50 Watt79
8 Ohms 150 Watts1.79

HIGH VOLTAGE—CURRENT MICAS



| MMF | VDC | Price | MMF | VDC | Price |
|---------|------|--------|---------|-------|--------|
| D .001 | 600 | \$1.18 | C .0005 | 5 KV | \$.85 |
| E .01 | 600 | .24 | C .0015 | 5 KV | 1.60 |
| E .02 | 600 | .26 | C .003 | 5 KV | 1.90 |
| E .027 | 600 | .26 | B .001 | 8 KV | 2.50 |
| D .039 | 600 | .39 | B .002 | 8 KV | 3.50 |
| C .01 | 1 KV | .45 | B .003 | 6 KV | 3.75 |
| C .056 | 1 KV | .50 | A .004 | 6 KV | 4.95 |
| C .07 | 1 KV | .55 | B .006 | 6 KV | 4.25 |
| D .02 | 1200 | .35 | B .0085 | 8 KV | 2.90 |
| C .024 | 1500 | .65 | B .001 | 8 KV | 3.25 |
| C .033 | 1500 | .75 | B .002 | 8 KV | 4.00 |
| C .015 | 2 KV | .80 | B .003 | 8 KV | 4.75 |
| C .02 | 2 KV | .90 | B .004 | 8 KV | 5.50 |
| D .002 | 2500 | .45 | B .005 | 8 KV | 5.75 |
| E .005 | 2500 | .55 | A .006 | 15 KV | 26.50 |
| C .025 | 2500 | 1.25 | A .0098 | 15 KV | 32.50 |
| C .001 | 3 KV | .90 | A .0059 | 18 KV | 28.50 |
| C .002 | 3 KV | .95 | A .0013 | 30 KV | 36.50 |
| D .005 | 3 KV | .70 | A .0025 | 35 KV | 26.50 |
| C .006 | 3 KV | 1.24 | A .0001 | 10 KV | 4.95 |
| D .002 | 3 KV | 1.50 | | | |
| C .0001 | 5 KV | .76 | | | |

OIL CONDENSERS

20 mfd 330 vac—1.85
5 mfd 150 vac—49
1 mfd 600 vdc—29
2 mfd 600 vdc—39
4 mfd 600 vdc—59
6 mfd 600 vdc—79
3/3 mfd 600 vdc—79
10 mfd 600 vdc—89
2 mfd 1000 vdc—79
4 mfd 1000 vdc—95
15 mfd 1000 vdc—2.95
2 mfd 1500 vdc—1.25
6 mfd 1500 vdc—2.95
1 mfd 2000 vdc—1.45
2 mfd 2000 vdc—2.25
6 mfd 2000 vdc—3.95
2 mfd 4000 vdc—4.95
1 mfd 5000 vdc—4.50
1/1 mfd 7000 vdc—2.25
1 mfd 7500 vdc—1.95
1 mfd 7500 vdc—9.25
.01/.01 mfd 12 kv dc—5.75
.005/.01 mfd 12 kv dc—5.50
1/16 mfd 16 kv dc—5.50
.05 mfd 12,500 vdc—12.95
.75/35 mfd 8/16 kv—7.95
2 mfd 18 kv dc—59.50

WESTINGHOUSE

Type MN Overcurrent Relay, Adjustable from 250 ma. to 1 amp. External Push Button Reset. Enclosed in glass case. Hand calibrated adjustments, only \$6.75

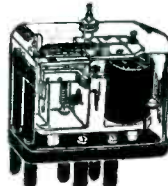

Tremendous stocks on hand. Please send requests for quotes. Special quantity discounts. Price f.o.b. N. Y. 20% with order unless rated, balance C. O. D. Minimum order \$5.00.

PEAK ELECTRONICS CO.
188 Washington St., New York 7, N. Y.

PHONE CO-7-6443
DEPARTMENT EA
SEND FOR BULLETIN



SPECIAL METERS

WATTMETER, 0-10 Watts Full Scale, Weston 498, 5 1/2" Square surface mt. case, Single phase A.C. or D.C. 115 Volt Normal, 140 volt Maximum, 80 M.A. Normal, 150 M.A. Maximum, Current coil 35 ohms. (These units have been used but have been completed, checked and tested and are fully guaranteed).....\$27.50

FREQUENCY METER, 58 to 62 cycles, Westinghouse type IIA, complete with external reactor, 5 1/2" Square flush or surface mtd. (State which you require).....\$35.00

FREQUENCY METER, 55 to 65 cycles, James Bid- die Co. type MF-11, Trahm vibrating reed type, 11 reeds, 100 to 150 volt operation, 3 1/2" round flush bakelite case.....\$7.50

FREQUENCY METER, Dual range, 48 to 52 & 58 to 62 cycles, J.B.T. type 30-F, dual element, vibrating reed, 115 volt, 3 1/2" rd fl metal case.....\$5.95

FREQUENCY METER, 350-450 cycles, Weston 637, 3 1/2" Aircraft type, black scale, iron core dynamometer type, 5 cycles per sec division.....\$4.95

D.C. MILLIAMMETER, Weston 271, Pan type, 1-0-1 MA (60-0-60 M.V.) movement, Se. cal. 600-0-600 R.P.M.....\$12.50

RECTIFIER TYPE MILLIAMMETER, Weston 545 type 81, Aircraft type, full scale equals 1.1 MA AC, 940 UA DC mvt, 70 ohms resistance, black scale cal 0-270.....\$6.50

DECIBEL METER, Weston 201 type 61, minus 10 to plus 6 DB, 3 1/2" rd fl bak case, 6 MW 600 ohms, High speed type, with 3 external wire wound multipliers to extend range. List Price \$37.50.....\$11.50

D.C. MILLIAMMETER, —1-0-1.25 miniature MA, black sc, Aircraft style G-1, 1 1/4" sq bak case, Hulova Watch Co.....\$3.95

D.C. MILLIAMMETER, 0-2 miniature meter, Hollar Smith 0-2 MA 0-20 MV movement, 1 1/4" square.....\$2.50

D.C. MILLIAMMETER, 0-12.5 miniature meter, Hollar Smith 12.5 MA 0-50 MV movement 1 1/4" square.....\$4.50

PORTABLE TACHOMETERS

0-20,000 RPM Range, Jaeger #43 A-6 Chronomet- ric type.....\$24.50

300-1200, 1000-4000, 3000-12000 RPM, Jones Mo- torola Co., Multiple Range, Continuous Indicating.....\$24.50

300-1500, 1000-5000, 3000-15000 RPM, Jones Mo- torola Co., Multiple Range, Continuous Indicating.....\$25.50

TACHOMETER GENERATOR, Weston 752 type J4, 2 terminals.....\$22.50

SALINITY INDICATOR, McNab Model M.....\$95.00

CELLS for above panel.....\$60.00

BC 1161-A RADIO RECEIVER 150-210 Mega- cycles, operates off 115 volt 60 cycle, with 14 tubes.....\$34.50

BC 1160-A TRANSMITTER, 157 to 187 Mega- cycles, operates off 117 volt 60 cycle, with blower, variac, 10 tubes, 3" 0-1 MA meter, etc.....\$29.50

GASOLINE HEATER, Motorola GN-3-24, 15,000 B.T.U., 1 gal. gasoline lasts 6 hours, 24-28 volt D.C. supply, can be adapted to 115 volt 60 cycle by use of transformer & rectifier.....\$22.50

BOWL INSULATOR, Clear Glass, all brass fittings, S. C. Stock #3G-1830-67076.1 Corning Glass Works #87076 type C, comprises flanged bowl 4 3/4" x 6 15/16" O. D. at base, Center lead-in pin 3/8" Dia x 1 1/2" long, mounts by means of 6 studs through mtg. flange, Overall dia 8 3/4".....\$6.00

COMBINATION OFFERS

**30 AMP A.C. METER
150 VOLT A.C. METER**

Triplett 331-JP 3" round flush bakelite case

Both Meters for \$7.95

Both above meters plus an external resis- tor to extend the range of the Voltmeter to 300 volts

Complete for \$8.95

**30 AMP A.C. METER
150 VOLT A.C. METER**

Triplett 332-JP 3" round flush metal case

Both Meters for \$6.95

All meters are in round flush bake- lite case with white scale and are standard in every respect unless otherwise specified. All items are Surplus — New — Guaranteed unless specified otherwise.

PORTABLE METERS

A.C. AMMETER, 0-3 & 0-15, Weston 528 with case & leads.....\$12.50

D.C. VOLTMETER, 3-0-3, W.H. PX-4, 100 ohms per volt.....\$9.50

D.C. VOLTMETER, 0-3 & 0-150, W.H. PX-4, 200 ohms per volt.....\$17.50

D.C. VOLTMETER, 0-15 & 0-150, Roller Smith "Steel Six", 100 ohms per volt.....\$21.00

CURRENT TRANSFORMER, Weston 461 type 4, 5 Amp Secondary, 50, 100, 250, 500 & 1000 Amp Primary, 15 V.A. capacity, 1/4% acc.....\$35.00

POTENTIAL TRANSFORMER, Weston 311, for use with 150 volt instruments, Max potential ratio of 1500 & 750 volts to 150 volts, 15 V.A., 1/5% acc.....\$90.00

INSULATION TESTER, Vibrotest Model 201, Range 0-200 Megohms & 0-2000 ohms & 0-150/300/600 Volts A.C. & D.C. (Slightly used—excellent condition—guaranteed).....\$38.00

INDUSTRIAL ANALYZER, Weston 639 type 2, measures Volts, Amps, Power Factor & Kilo- watts, single & polyphase. (Used—excellent condition—guaranteed).....\$245.00

DUAL RANGE MILLIAMMETER, Weston 264, 0-25 & 250 milliammeter, mtd on vertical stand with test cord.....\$9.00

AC VOLTMETERS

0-15 G.E., AW-41, 2" R-B bl sc, 800 cyc.....\$2.50

0-15 G.E., AV-41, 2" R-B bl sc, Signal Corps JS-122.....\$2.50

0-15 G.E., AO-22, 3" R-B bl sc.....\$3.00

0-15 Weston, 476, 3" R-B.....\$4.50

0-15 W.H., NA-35, 3" R-B.....\$3.95

0-40 Weston, 517, 2" R-M 400 cyc.....\$3.50

0-40 W.H., NA-33, 2" R-B 400 cyc.....\$3.50

0-75 Weston, 517, 2" R-M ring mtd.....\$2.95

0-150 G.E., AO-22, 3" R-B 400 cyc.....\$4.00

0-150 Triplett, 332-JP, 3" R-M.....\$4.00

0-150 Triplett, 331-JP, 3" R-B.....\$4.50

0-150 Triplett, 331-JP, 3" R-B w/Resistor for 300 volts.....\$5.50

0-500 G.E., AO-22, 3" R-B.....\$12.00

AC AMMETERS

0-30 Triplett, 331-JP, 3" R-B.....\$4.00

0-30 Triplett, 332-JP, 3" R-M.....\$3.50

0-50 G.E., AO-22, 3" R-B.....\$4.50

0-50 W.H., NA-35, 3" R-B.....\$4.50

0-60/120 Burl, 32XC, 3" R-B w/Ext Trans- former.....\$7.50

0-60/120 Burl, 32XC, 3" R-B without Ext Trans.....\$4.50

0-150 G.E., AO-22, 3" R-B 5 Amp mvt, with ext. Trans.....\$7.50

RF AMMETERS

0-120 MA Simpson, 25, 3" R-B.....\$7.50

0-1 G.E., DW-44, 2" R-B bl sc.....\$2.95

0-1 G.E., DW-44, 2" R-B.....\$3.50

0-1 G.E., DW-52, 2" R-M.....\$3.00

0-1.5 G.E., DW-52, 2" R-M bl sc.....\$2.95

0-1.5 Weston, 507, 2" R-M bl sc.....\$2.50

0-1.5 Weston, 425, 3" R-B.....\$8.25

0-2 Simpson, 135, 2" R-B.....\$3.50

0-2 Weston, 425, 3" R-B.....\$8.50

0-2.5 Weston, 507, 2" R-B.....\$3.95

0-2.5 McClintock, 3" R-B S.C. #IS-111.....\$4.50

0-2.5 Simpson, 35, 3" R-B.....\$4.95

0-2.5 Weston, 425, 3" R-B.....\$8.50

0-2.5 W.H., NT-35, 3" R-B.....\$5.50

0-3 W.H., NT-35, 3" R-B.....\$5.50

0-3 Weston, 425, 3" R-B.....\$8.50

0-3 Weston, 425 3" R-B w/Ext couple.....\$9.50

0-4 G.E., DW-44, 2" R-B bl sc.....\$2.95

0-5 Weston, 425, 3" R-B.....\$8.50

0-6 G.E., DW-44, 2" R-B bl sc.....\$2.50

0-20 Weston, 507, 2" R-B.....\$3.50

0-20 G.E., DO-44, 3" R-B.....\$4.95

0-30 Triplett, 0347-A, 3" S-B w/Ext leads & couple.....\$8.00

DC MICROAMMETERS

0-200 Superior, 4"x4 5/8" F.B.....\$7.50

0-200 W.H., NX-35, 3" R-B MR 35 W 200 DC UA.....\$8.50

0-400 Triumph, 4"x4 5/8" F.B.....\$5.50

0-500 De Jur Amseo, 2" R-B.....\$3.00

0-500 Gruen, 221-T, 2" R-B.....\$3.95

0-500 Simpson, 6103, 2" R-B.....\$3.50

0-500 Triplett, 0221-T, 2" R-B.....\$3.50

DC MILLIAMMETERS

0-1 G.E., DW-41, 2" R-B Spec Scale.....\$3.00

0-1 G.E., DW-51, 2" R-B Spec Scale.....\$3.50

0-1 W.H., NX-33, 2" R-B Black Spec Scale.....\$3.00

0-1 G.E., DO-41, 3" R-B.....\$5.50

0-1 G.E., DO-41, 3" R-B Spec Scale.....\$4.50

0-1 McClintock S-1811, 3" S-B Spec Scale.....\$3.50

0-1 McClintock, 3" R-B Spec Scale.....\$3.50

0-1 W.H., NX-35, 3" R-B MR 35 W 00 1 DC MA.....\$7.50

0-1.5 Hickok, 56-R, 2" R-M.....\$2.00

0-3 Gruen, GW-580, 2" R-B.....\$3.50

5-0-5 W.E., 3" R-B Concentric style.....\$3.00

0-15 Simpson, 26, 3" R-B.....\$4.50

0-20 G.E., DW-55, 2" R-B Black Scale.....\$3.00

0-20 G.E., DO-53, 3" S-B.....\$3.75

0-30 G.E., DO-41, 3" R-B.....\$3.50

0-80 G.E., DO-41, 3" R-B.....\$3.75

0-150 Gruen, 508, 2" R-B.....\$3.00

0-200 Marion, 511, 2" R-B.....\$3.00

0-200 Marion, 3" R-B.....\$4.00

0-200 Simpson, 25, 3" R-B.....\$4.50

0-200 G.E., DO-41, 3" R-B.....\$4.50

0-200 W.H., NX-35, 3" R-B.....\$4.50

0-500 W.H., NX-33, 2" R-B.....\$3.95

DC AMMETERS

0-2 Simpson, 25, 3" R-B.....\$4.00

0-5 Gruen, 531, 2" R-B.....\$3.50

0-15 Sun, AP-381, 3" R-B.....\$3.50

0-15 Triplett, 0321-T, 3" R-B.....\$4.00

0-30 Hoyt, 123, 2" R-M.....\$2.50

30-0-30 Beede, 2" R-M.....\$2.95

30-0-30 G.E., DW-51, 2" R-M.....\$3.50

30-0-30 U. S. Gauge, 2" R-M.....\$1.50

0-150 Simpson, 125, 2" R-M with shunt.....\$5.50

0-200 Weston, 506, 2" R-B with shunt.....\$7.50

0-200 G.E., DO-41, 3" R-B with shunt.....\$9.50

0-300 G.E., DW-51, 2" R-B with shunt.....\$7.50

0-500 G.E., DW-51, 2" R-B less shunt.....\$3.50

DC VOLTMETERS

0-3 Simpson, 125, 2" R-M ring mtd.....\$2.00

0-5 W.H., NX-33, 2" R-B 200 r/v.....\$3.50

0-10 Sun, 2AP458, 2" R-B 100 r/v.....\$2.50

0-15 Gruen, GW 505, 2" R-B.....\$3.50

0-15 McClintock, D-100-R-1, 2" R-B Black scale, 1000 r/v.....\$3.00

0-30 DeJur Amseo, 210, 2" R-B.....\$2.50

0-30 G.E., DW-41, 2" R-B 250 r/v.....\$2.95

0-50 Weston, 301, 3" R-B 200 r/v.....\$5.50

0-50 Readrite, 2" R-M.....\$1.00

0-150 Weston, 301, 3" R-B Surf mtd 200 r/v.....\$4.50

0-150 G.E., DW-51, 2" R-B Special scale.....\$3.95

0-500 Sun, 3" R-B MR35W50DCVV.....\$7.00

0-5 KV W.H., NX-35, 3" R-B 1 MA mvt, less resistor.....\$4.95

0-1.5 KV W.H., NX-35, 3" R-B 1 MA mvt, with resistor.....\$7.50

0-15 KV G.E., DO-53, 3" S-B 500 ua mvt, less resistor.....\$4.95

0-15 KV W.H., NX-35, 3" R-B 1 MA mvt, less resistor.....\$4.50

0-20 KV G.E., DO-41, 3" R-B 500 UA mvt, less resistor.....\$4.95

0-20 KV G.E., ON-33, 2" R-B Black sc 1 MA mvt, less resistor.....\$3.50

0-20 KV G.E., DO-41, 3" R-B 1 MA mvt, less resistor.....\$4.50

0-35 KV W.H., NX-35, 3" R-B FS 1 Ma mvt, less resistor.....\$4.95

MARITIME SWITCHBOARD

338 CANAL STREET
NEW YORK 13, N. Y.
Worth 4-8217

Orders accepted from rated concerns, public institutions & agencies on open account, others please send 25% deposit, balance C. O. D. or check with order. All prices FOB our warehouse, N.Y.C.



NEW LOW PRICES!

ALL BRAND NEW
STANDARD BRAND
WATCH THIS LISTING EACH MONTH FOR LATEST CHANGES

MINIMUM ORDER \$5.00
QUANTITY PRICES ON REQUEST

| Type | Price | Type | Price | Type | Price | Type | Price | Type | Price | Type | Price | | |
|--------|---------|---------|---------|-------|--------|-------------|----------|-----------|---------|------------|--------|-----------|--------|
| 1B22 | \$ 4.95 | 12LP4 | \$55.00 | 838 | \$3.95 | ML101 | \$150.00 | 3A5 | \$ 1.49 | 6SA7GT | \$.66 | 12SN7GT | \$.80 |
| 1B23 | 9.50 | 15E | 1.50 | 841 | .69 | REL36 | .98 | 3A8GT | 1.98 | 6SB7Y | .88 | 12SO7 | .60 |
| 1B24 | 4.95 | 15R | .49 | 843 | .69 | RK22 | 4.95 | 3B7 | .36 | 6SC7 | .72 | 12SO7GT | .60 |
| 1B25A | 4.95 | 33D4 | 3.00 | 845/W | 4.95 | RK23 | 4.95 | 3D6 | .36 | 6SD7GT | .49 | 12SR7 | .39 |
| 1B27 | 4.95 | 24G | .98 | 851 | 75.00 | RK25 | 2.95 | 3F4 | 1.28 | 6SE5GT | .66 | 12SR7GT | .39 |
| 1B29 | .89 | 35T | 4.95 | 860 | 3.00 | RK33 | .98 | 3Q4 | .38 | 6SE7GT | .72 | 12X3 | .98 |
| 1B32 | 4.95 | 45SPEC. | .49 | 861 | 49.95 | RK34 | .59 | 3Q5GT | .96 | 6SE7 | .80 | 12X3 | .98 |
| 1B36 | 4.95 | 75TL | 3.95 | 864 | .69 | RK39 | 1.75 | 3S4 | .80 | 6SG7 | .72 | 14A7 12B7 | .88 |
| 1B38 | 49.50 | 100TH | 12.95 | 865 | 2.98 | RK50 | 5.95 | 3V4 | .80 | 6SH7 | .39 | 14AF7/XXD | .88 |
| 1B40 | 4.95 | 100TS | 3.00 | 866/A | .99 | RK65 | .79 | 5A4 | .50 | 6SJ7 | .66 | 14B6 | .88 |
| 1B60 | 4.95 | 114A | 6.95 | 866JR | 1.19 | RK72 | 24.95 | 5A4Z | .50 | 6SJ7GT | .66 | 14B8 | .88 |
| 1P23 | 1.95 | 114B | 1.25 | 869B | 75.00 | RK73 | 1.95 | 3R4GY | 1.15 | 6SK7GT | .66 | 14C5 | .88 |
| 1S21 | 1.96 | 120 | 5.95 | 872A | 2.49 | RK75 | 3.95 | 5U4G | .60 | 6SK7GT | .66 | 14C7 | .88 |
| 2B4 | .98 | 121A | 2.65 | 874 | 2.49 | RX120 | 10.00 | 5V4G | .96 | 6SL7GT | .66 | 14E7 | .88 |
| 2AP1 | 3.95 | 203A | 16.95 | 885 | 1.49 | SD809 | 4.95 | 5W4 | 1.06 | 6SN7GT | .88 | 14E6 | .72 |
| 2C4 | 1.18 | 205B | 4.50 | 891 | 110.00 | T20 | 1.50 | 5W4GT | .66 | 6SO7 | .60 | 14F7 | .88 |
| 2C21 | .98 | 211 | 98.50 | 902PI | 7.95 | T200 | 3.95 | 5X4G | .72 | 6SQ7GT | .60 | 14F8 | 1.06 |
| 2C22 | .39 | 215A | 3.00 | 904 | 9.95 | T220 | 10.95 | 5Y3GT | .42 | 6SR7 | .72 | 14H7 | .88 |
| 2C26A | .28 | 217C | 7.30 | 905 | 11.95 | T240 | 1.50 | 5Y4G | .72 | 6SR7GT | .72 | 14H7 | 1.06 |
| 2C34 | .59 | 218 | 49.50 | 907 | 9.95 | UH50 | 5.95 | 5Z4 | 1.06 | 6ST7 | .88 | 14I7 | 1.06 |
| 2C40 | 1.98 | 221A | 2.95 | 904 | 9.95 | V70D | 6.95 | 6A3 | 1.28 | 6SV7 | .88 | 14O7 | .88 |
| 2C43 | 7.50 | 231D | 1.49 | 905 | 11.95 | VR75 | .98 | 6A6 | 1.06 | 6T7G | 1.24 | 14S7 | 1.06 |
| 2C44 | 1.75 | 242C | 6.95 | 923 | 3.49 | VR90 | 1.40 | 6A7 | .80 | 6U5G5 | .72 | 14W7 | 1.06 |
| 2C46 | 7.50 | 249C | 3.49 | 925 | 1.40 | VR91 | 4.95 | 6A8 | .80 | 6U6GT | .72 | 14X7 | 1.06 |
| 2D21 | 1.18 | 250R | 7.95 | 925 | 1.40 | VR91 | 1.49 | 6A8GT | .83 | 6U7G | .72 | 14X4 | .88 |
| 2E22 | 1.50 | 250TH | 19.50 | 931A | 4.95 | VR105 | .98 | 6AB5/6N5 | .88 | 6V6 | 1.28 | 19T8 | 1.56 |
| 2E24 | 4.95 | 250TL | 19.50 | 931A | 4.95 | VR115 | .75 | 6AB7 1853 | 1.06 | 6V6GT | .80 | 19T8 | 1.56 |
| 2E25 | 4.25 | 252A | 4.95 | 958A | 7.95 | VL127A | 3.00 | 6AC5GT | 1.16 | 6W7G | .88 | 22 | 1.28 |
| 2E26 | 3.95 | 254 | 4.95 | 957 | .75 | VL127A | 1.19 | 6AC7 1852 | .88 | 6X4 | .60 | 24A | .88 |
| 2E30 | 2.39 | 259A | 4.95 | 957 | .75 | WL460 | 14.95 | 6AC7GT | 1.16 | 6X5GT | .60 | 25A6 | 1.06 |
| 2J21A | 12.95 | 262A/B | 3.50 | 957 | .75 | WL468 | 14.95 | 6AD7G | .88 | 6Y6G | .88 | 25AC5GT | 1.16 |
| 2J26 | 8.95 | 274A/B | 1.25 | 957 | .75 | WL532A | 4.95 | 6AF6 | 1.25 | 6Z7G | 1.28 | 25AC5GT | .66 |
| 2J31 | 10.95 | 282A/B | 9.95 | 957 | .75 | WL562 | 150.00 | 6AG5 | 1.06 | 6Z7G | 1.28 | 25Y5 | 1.16 |
| 2J32 | 13.95 | 290A | 4.95 | 957 | .75 | WL616 | 105.00 | 6AG7 | 1.28 | 6ZY5G | .88 | 25Z5 | .60 |
| 2J33 | 24.95 | 291A | 4.95 | 957 | .75 | Z225 | 1.95 | 6AH6 | 1.56 | 7A5 | .72 | 25Z6GT | .60 |
| 2J34 | 24.95 | 294A | 4.95 | 957 | .75 | ZB120 | 6.95 | 6AJ5 | .96 | 7A5 | .72 | 25Z6GT | .60 |
| 2J37 | 17.95 | 304B | 4.95 | 957 | .75 | ZP477/12DP8 | 14.95 | 7AK5 | 1.56 | 7A6 | .72 | 26 | .60 |
| 2J38 | 13.95 | 304TH | 6.95 | 957 | .75 | 0A2 | 1.69 | 6AK6 | .96 | 7A7 | .72 | 27 | .60 |
| 2J49 | 24.95 | 304TL | 1.49 | 957 | .75 | 0A3 VR75 | .98 | 6AL5 | 1.06 | 7A8 | .72 | 28D7 | .39 |
| 2J5B1 | 4.95 | 307A | 4.95 | 957 | .75 | 044 | 1.06 | 6AL7GT | .80 | 7AD7 | 1.06 | 30 | .39 |
| 2J54 | 17.95 | 316A | .69 | 957 | .75 | 0B2 | 2.05 | 6AQ5 | .80 | 7AF7 | .72 | 31 | .39 |
| 2K23 | 24.95 | 327A | 4.95 | 957 | .75 | 0B3 VR90 | .75 | 6AQ6 | .72 | 7AG7 | .88 | 32 | 1.28 |
| 2K25 | 24.95 | 338A | 4.93 | 957 | .75 | 0C3 VR105 | .98 | 6APGT | .88 | 7AH7 | .88 | 32L7GT | 1.28 |
| 2K28 | 24.95 | 339A | 24.95 | 957 | .75 | 0D3 VR150 | .75 | 6AR5 | .66 | 7B4 | .72 | 33 | .39 |
| 2K41 | 24.95 | 350A/B | 2.95 | 957 | .75 | 0V4 | .88 | 6AS7G | 4.95 | 7B5 | .72 | 34 | .38 |
| 3AP1 | 4.95 | 354C/D | 19.95 | 957 | .75 | 0Z4 | .88 | 6AT6 | .60 | 7B6 | .72 | 35/51 | .80 |
| 3B22 | 4.95 | 368AS | 4.93 | 957 | .75 | PZ4G | .88 | 6AU6 | .80 | 7B7 | .72 | 35A5 | .72 |
| 3B23 | 4.95 | 371A/B | 4.93 | 957 | .75 | QA1A | .50 | 6AV6 | .60 | 7B8 | .72 | 35B5 | .80 |
| 3B24 | 3.95 | 393A | 7.95 | 957 | .75 | IA3 | 1.28 | 6B4G | 1.28 | 7C4/12303A | .39 | 35L6GT | .66 |
| 3B26 | 1.89 | 394A | 7.50 | 957 | .75 | IA4 | 1.28 | 6B7 | 1.28 | 7C5 | .72 | 35W4 | .46 |
| 3B27 | 3.95 | 399A | 2.50 | 957 | .75 | IA4P | 1.56 | 6P/G | 1.28 | 7C6 | .72 | 35Y4 | .72 |
| 3B28 | 5.95 | 400A | 3.25 | 957 | .75 | IA5GT | .72 | 6B7 | 1.28 | 7C7 | .72 | 35Z3 | .46 |
| 3BP1 | 3.95 | 401A | 1.95 | 957 | .75 | IA6 | 1.28 | 6B8 | 1.28 | 7E5/1201 | 1.66 | 35Z4GT | .60 |
| 3C22 | 18.95 | 403A/B | 1.75 | 957 | .75 | IA7GT | 1.28 | 6B8G | 1.28 | 7E6 | .72 | 35Z5GT | .50 |
| 3C23 | 4.95 | 408A | 1.75 | 957 | .75 | IB3GT | 1.49 | 6BA6 | .80 | 7E7 | .88 | 36 | .39 |
| 3C24 | .69 | 417A | 24.95 | 957 | .75 | IB4 | 1.56 | 6BE6 | .72 | 7E7 | .88 | 37 | .39 |
| 3C30 | 1.50 | 444A | 7.95 | 957 | .75 | IB5 258 | 1.28 | 6BG6G | 1.02 | 7F8 | .98 | 38 | .39 |
| 3CP1 | 3.00 | 446A/B | 1.95 | 957 | .75 | IB7GT | 1.06 | 6BH6 | .80 | 7G7/1232 | 1.06 | 39/44 | .39 |
| 3D21A | 1.50 | 450TH | 24.95 | 957 | .75 | IC5GT | .88 | 6BJ6 | .80 | 7H7 | .80 | 41 | .66 |
| 3DP1 | 3.95 | 527 | 12.95 | 957 | .75 | IC6 | 1.28 | 6C4 | .39 | 7J7 | 1.06 | 42 | .66 |
| 3EP1 | 3.95 | 531 | 24.50 | 957 | .75 | IC7G | 1.28 | 6C5 | .66 | 7K7 | 1.06 | 43 | .66 |
| 3E29 | 4.95 | 532A | 4.95 | 957 | .75 | IC8GT | 1.28 | 6C5GT | .72 | 7L7 | .88 | 45 | .66 |
| 3FP7 | 3.95 | 575A | 14.95 | 957 | .75 | ID7G | 1.28 | 6C6 | .80 | 7M7 | .88 | 45Z3 | .66 |
| 3J31 | 49.50 | 701A | 4.95 | 957 | .75 | ID8GT | 1.56 | 6C7 | 1.28 | 7O7 | .72 | 45Z5GT | .60 |
| 4-65A | 14.50 | 703A | 4.95 | 957 | .75 | IE5GT | 1.38 | 6C8G | 1.28 | 7R7 | .88 | 46 | 1.06 |
| 4-125A | 27.50 | 705A | 2.95 | 957 | .75 | IE7G | 1.56 | 6D6 | .66 | 7S7 | 1.06 | 47 | .96 |
| 4-250A | 37.50 | 706CY | 2.95 | 957 | .75 | IF4 | 1.06 | 6D8G | 1.28 | 7V7 | 1.06 | 49 | .88 |
| 4A1 | 1.98 | 707A/B | 24.95 | 957 | .75 | IF5G | 1.56 | 6E6 | 1.06 | 7X7/XXFM | 1.50 | 50A5 | 1.56 |
| 4AP10 | 6.95 | 708A | 5.95 | 957 | .75 | IF6 | 1.56 | 6F5 | .66 | 7Y4 | .72 | 51B5 | .66 |
| 4B24 | 4.95 | 710A | 2.95 | 957 | .75 | IF7G | 1.06 | 6F5GT | .66 | 7Z4 | .72 | 51L6GT | .66 |
| 4C35 | 19.95 | 713A | 1.65 | 957 | .75 | IG4GT | 1.06 | 6F6 | .66 | 80 | .69 | 6Y6GT | .72 |
| 4E27 | 12.95 | 714AY | 6.95 | 957 | .75 | IG6GT | 1.06 | 6F6GT | .80 | 12A | .66 | 53 | 1.06 |
| 4J26 | 110.00 | 715A/B | 9.95 | 957 | .75 | IH4G | .66 | 6F7GT | 1.06 | 12A6 | .39 | 56 | .72 |
| 5AP1 | 4.95 | 715C | 24.95 | 957 | .75 | IH6G | 1.28 | 6F8G | 1.28 | 12A6GT | .29 | 57/3 | .80 |
| 5AP4 | 5.95 | 717A | .99 | 957 | .75 | IH6GT | 1.28 | 6G6G | 1.06 | 12A7 | 1.28 | 58 | .80 |
| 5BP1 | 2.95 | 720DY | 34.95 | 957 | .75 | IJ6GT | 1.28 | 6H6 | .60 | 12A8GT | .80 | 59 | 1.06 |
| 5BP4 | 4.95 | 721A/B | 4.35 | 957 | .75 | IL4 | 1.06 | 6H6GT | .60 | 12AH7GT | .88 | 70L7GT | 1.56 |
| 5CP1 | 3.95 | 723AB | 7.95 | 957 | .75 | IL4A | 1.06 | 6J5 | .54 | 12AL5 | .80 | 71A | .80 |
| 5CP7 | 13.95 | 724A/B | 4.95 | 957 | .75 | ILB4 | 1.06 | 6J5GT | .54 | 12AS7 | .60 | 75 | .66 |
| 5D21 | 29.95 | 725A | 9.95 | 957 | .75 | ILC5 | 1.06 | 6J6 | 1.16 | 12AT7 | 1.16 | 76 | .66 |
| 5FP7 | 3.95 | 726A | 23.50 | 957 | .75 | ILC6 | 1.06 | 6J7 | .80 | 12AU6 | .80 | 77 | .66 |
| 5GP1 | 9.95 | 750TL | 49.50 | 957 | .75 | ILD5 | 150.00 | 6J7GT | .80 | 12AU7 | .96 | 78 | .66 |
| 5HP4 | 9.95 | 800 | 2.25 | 957 | .75 | ILE3 | 3.25 | 6K8G | 1.28 | 12BA6 | .72 | 79 | .88 |
| 5JP2 | 11.95 | 801A | 3.75 | 957 | .75 | ILG5 | 9.95 | 6K5GT | .96 | 12BE6 | .72 | 80 | .46 |
| 5LP1 | 11.95 | 802 | 3.75 | 957 | .75 | ILH4 | 8.95 | 6K6GT | .66 | 12C8 | .60 | 81 | 1.06 |
| 5LP5 | 14.95 | 803 | 8.95 | 957 | .75 | ILN5 | 1.06 | 6K7 | .66 | 12F5GT | .72 | 82 | 1.56 |
| 5NP1 | 2.95 | 804 | 12.95 | 957 | .75 | IN5GT | .80 | 6K7GT | .66 | 12H6 | .39 | 83 | .66 |
| 6AF6G | | | | | | | | | | | | | |

IMMEDIATE DELIVERY

LOW PRICES

FULLY GUARANTEED

D. C. MOTORS



**Blower Assembly
MX-215/AGP**

John Oster C-2P-1L
28 v. DC 7000 RPM
1/100 hp. #2 L-R
Blower.
Stock #SA-202.
Price \$2.95 each



Universal Electric DC
W.E. KS-5603-L02. 28 v. DC
0.6 amps. 1/100 hp. 4 lead
shunt. Stock #SA-233.
Price \$1.95 ea. plus 15c p.p.



Delco 5069466 Motor
Alnico PM field, 27.5 v.
DC. 1" x 1" x 2" lg. Pin-
ion gear on shaft. Stock
#SA-65. Price \$3.75 each plus 15c p.p.



**DELCO CONSTANT SPEED MOTOR
A-7155**
1/30 hp. 3600 rpm. Cont.
duty. 2 1/2" diam. x 5 1/2"
lg. 3/8" shaft extension, 5/32" diam. 4 hole
base mounting. Stock #SA-94. Price \$4.75
each.



**Delco 5069625 Constant
Speed DC Motor, 27 v.**
DC. 120 rpm. Governor
controlled. Stock #SA-
249. Price \$3.95 each. Qty. prices on
request.

Fractional Motors M-100. 3/16 HP.
Compound wound. Cont. duty. 115 v. DC.
5" diam. 8" lg. 1 1/2" shaft ext. x 1/4"
diam. Stock #SA-171. Price \$6.75 each.
(230 volt models also available.)

DC SERVO MOTORS

**C-1 Autopilot Servo Unit—28 v. DC Shunt
motor.** 2250 rpm. 2 magnetic clutches,
reduction gear, differential and 2 magnetic
brakes. Output shaft 15 rpm. Torque 225
in/lbs.
Stock #SA-180 Price \$19.50 each

**Elineco B-64 DC Servo Unit—80 v. DC max.
armature voltage, 27.5 v. field.** 1/165 h.p.
3100 rpm. Field current 200 ma. Armature
current 200 ma. at normal torque.
Stock #SA-211 Price \$12.50 each



MAGNESYNS

Pioneer CL-3
Use as transmitter or in-
dicator on 26 v. 400 cy.
or 52 v. 800 cy. May be
used as indicator with
360° potentiometer on DC.
Stock #SA-6 Price \$1.95 each



DYNAMOTOR

**D-101 27 v. DC in @
1.5 amps. DC out. 285
v. @ 0.60 amps. Stock
#SA-187.
Price \$1.50 each**

AMPLIFIER SPECIAL

Pioneer 5 tube amplifier converted for
Autosyn input. 115 volts, 400 cycles.
Stock #SA-45A. Price \$29.50 each net
with tubes.

ALSO

**COMPLETE 400 CYCLE SERVO SYSTEMS
PIONEER TORQUE UNITS (400 CYCLES)
400 CYCLE BLOWERS
PRECISION AUTOSYNS
MAGNETIC AMPLIFIER ASSEMBLIES
ETC.**

AC-SERVO MOTORS

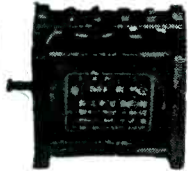

Pioneer—CK-2 and 10047-2A for 400 cy.
Kollsman—776-01 for 400 cycles.
Diehl—FP-25-3. PFE-25-11 (CDA-211052)
and ZP-105-14 for 400 cycles.

Prices on Request



Remote Position
Indicating System

6-12 v. 60 cycles 5 inch indicator with 0 to
360° dial. Heavy duty transmitter. Stock
#SA-115. Price \$9.95 per system

LP-21-LM Compass Loops



New

QUANTITY
PRICES
ON REQUEST

MERCURY CONTACT RELAY



W.E. D-168479
Millisecond switch-
ing at up to 60 c.p.s.
Technical data on
request. Stock #SA-
259. Price \$4.75 ea.
Special qty.
prices.

INVERTERS



400 Cycles
Three Phase

**Holtzer Cabot MG-153—Input 28 volts DC
at 52 amps. Output three phase 115 volts
400 cycles at 750 va. 0.90 P.F. Also sec-
ond output of 26 volts 400 cycles at 250
V.A. Voltage and frequency regulated.
New—Perfect \$99.50 ea.
New—Surface Damages 59.50 ea.**

**Leland SD-93—(10285)—Input 28 volts DC
at 60 amps. Output 115 volts three phase
400 cycles at 750 va. 0.90 P.F. Second
output voltage of 26 volts 400 cycles at
50 V.A. Voltage and frequency regulated.
Designed for use with various autoplots.
Stock #SA-209. Price \$79.50 each**

**Holtzer Cabot MG-149H—Similar to MG-
149F but draws 44 amps DC at 28 v. Out-
put ratings are at 0.90 P.F. Equipped with
high altitude brushes. Stock #SA-4.
Price \$34.50 each**

**General Electric 5D21NJ3A — Input 28
volts DC at 35 amps. Output 110 volts 400
cycles. 485 V.A. at 0.90 P.F. Weight 15
lbs. Stock #SA-41. Price \$12.50 each**

GYROS

**Sperry A5 Vertical Gyro. Part No. 644841,
115 volts 400 cycle 3 phase, \$19.50 ea.**
**Sperry A5 Directional Gyro. Part No.
656029, 115 volts 400 cycle, 3 phase.**
Schweins Free & Rate Gyro, Type 46800.

**Schweins Free & Rate Gyro—45600—Stock
#SA-148. Special Price \$8.75 each.**



**Bodine NYC-13 AC
Motor**

115 v. 60 cycles, 1/40
hp. 1800 rpm. Cont.
duty. .55 amps. Stock
#SA-245.
Price \$9.50 each.

SYNCHROS

Navy Types

1G, 1F, 1CT, 5C, 5F, 5CT,
5DG, 5HCT, 5SF, 5HSF,
5SDG, 6DG, 6G, 6DG, 7G,
etc.

Prices on Request



All prices F.O.B., Paterson.
Teletype PAT. 199
Phone ARMORY 4-3366
Write for Listing.



THERMOSTATIC TIME DELAY RELAYS

Amperite type 115 No-45.

Heater voltage 115V. Normally open SPST contacts. 45 sec. delay. Contact rating 115V-3A., A.C. (or 440V., A.C. 2A.) max. voltage on contacts—1000. max voltage bet. contacts and heater—1500. Size 3 9/32 x 1 1/4" oversall. Made for U. S. Navy.



New surplus \$1.10

LINEAR SAWTOOTH POTENTIOMETER

W.E. No. KS 15138

Input 24 volts D.C. Output varies in accordance with linear sawtooth wave.

Brand New \$5.75

STEPDOWN TRANSFORMERS

Input: 115V. 60 cycles.
Output: 20 V., at 10 amps.
Also tapped at 8V., for pilot light. Ideal for Selenium Rectifier Applications, etc.

Brand New \$2.45



RELAY

Clare octal base Relay No. 30FMX 115V. 60 cy. 8.140 amp. Res. 75 ohms. Makes two breaks one.

Brand new \$2.45

SELENIUM RECTIFIER

Bridge Type

Input: 36 V. AC.
Output: 28 V. DC., 1.1 Amps.

Brand New \$2.75



MOTOR GENERATORS

Allis Chalmers 115V. D.C. to 120V. 60 cy. 1 Ph. 1.25 K.V.A., P.F. .80 Centrifugal starter. Fully enclosed.

New \$97.50

Same as above but for 230V. D.C. **\$125.00** input

Diehl 120V. D.C. to 120V. A.C., 60 cy., 1 Ph., 2.5 K.V.A., P.F. 4. Complete with magnetic controller, 2 field rheostats and full set of spare parts including spare armatures for generator and motor.

New \$185.00

O'Keefe and Merritt, 115V. D.C. to 120V. A.C. 50 cycles, 2 K.V.A., P.F. .9 Idles as a 3 phase synchronous motor on 208V. 50 cy.

New \$165.00

Electrolux Dynamotor 105/130V. D.C. at 6 amps. to 26 or 13V. D.C. at 20 amps. or 40 amps. respectively. Fully filtered for radio use and complete with Square "D" lineswitch. Navy type CAJO 211444.

New \$74.50

PEAK-TO-PEAK V.T.V.M.

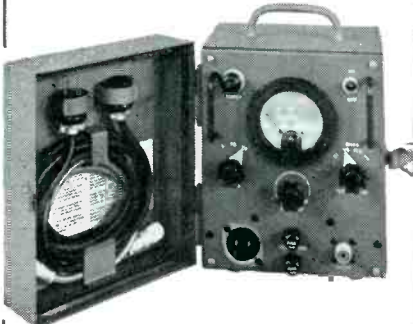

A small, lightweight, portable instrument designed to measure peak-to-peak voltages of recurrent waves, particularly of the type normally found in radar video circuits. It is especially intended for use in setting the levels of video and synchronizing voltages in radar equipment where the relationships between these voltages are important to the operation of associated equipment.

Designed by Radiation Labs. M.I.T. for the U. S. Navy.
Type TS-487U **Price \$49.50 each**



10 CM WAVEGUIDE

90 degree elbow —
Bronze—Brand New
Price \$9.75

RADAR COMPONENTS

CRP-23AGC Load Dividers for use with S.G. Modernization Kits. New.

CBM-50AFO Navy type Radar Repeater Adapters. New and complete with 14 tubes, coax fittings, installation plans and wiring diagrams.

SO Series Radar P.P.I. Units and accessory Control Panels. New.

Synchro Amplifiers. New

Type CARD 23AEK Bearing Control Units. New.

Type T.D.Y., SO-1, SO-13, SO-3 Radar. Antenna Assemblies. New.

T.D.Y. Antenna Control Units.

Radar Tubes, types 4C35, 7BP7, 3B24, 3C45, 721A, 2J62, 9LP7, 3B22, 1B24, IN21B Crystals, etc.

Radar Crystals Raytheon 98.35 KC.

Type SO-11 Radar Modulator.

Type SO-1 and SO-3 Transmitter Receivers

MODEL AN/APA 10 PANORAMIC ADAPTER

Provides 4 Types of Presentation:

(1) Panoramic (2) Aural

(3) Oscillographic (4) Oscilloscopic

Designed for use with receiving equipment AN/ARR-7, AN/ARR-5, AN/APR-4, SCR-587 or any receiver with I.F. of 455kc, 5.2mc, or 30mc. With 21 tubes including 3" scope tube. Converted for operation on 115 V. 60 cycle source

Includes 80 page T. M. **\$195.00**

8,000-Volt TRANSFORMERS

Primary: 115 V., 60 cycles.
Secondary: 8000' V., C.T., 800 V.A.

Brand new in sealed cans. . \$27.50

SHOCK MOUNTS

| | |
|--|-----|
| Lord #20, 3" x 3" x 1 1/2" | .40 |
| U. S. Ruther #5150 C, 2 1/2" x 2 1/2" x 1 1/2" | .30 |
| Lord 15, 2 1/2" x 2 1/2" x 1 1/2" | .25 |
| Lord #10, 1 1/2" x 1 1/2" x 1" | .10 |
| Lord #3, 1 1/2" x 1 1/2" x 3/4" | .10 |

PARABOLOIDS

1 7/8" diameter, spun magnesium dishes, 4 inches deep. Reinforced perimeter. Two sets of mounting brackets on rear. Opening at apex for waveguide dipole assembly 1 1/2" x 1 1/2".

Brand new, per pair, \$8.75

WESTERN ELECTRIC

MERCURY CONTACT RELAYS



TYPE D-168479

These relays are glass sealed, mercury-wetted contact switches surrounded by operating coils and enclosed in metal housings, mounted on an octal tube base.

TYPICAL APPLICATIONS

- High speed keying
- Tabulating, sorting and computing machines
- Relay Amplifiers
- Vibrator Power Supplies
- Servo-mechanisms

CHARACTERISTICS

- High speed of operation
- Constant operating characteristics
- Freedom from chatter
- High current capacity
- Long, trouble-free service

Single Pole, Double Throw Contacts. Two coils of 700 ohms and 3300 ohms. Operating current with coils connected in series 6.6 ma. Release current 5.2 ma.

When operated under specified conditions this relay has a life expectancy of 1000 hours at 60 operations per second.

Overall length—3-3/8". Overall dia.—1-5/16"

**Brand new
Priced at a fraction
of Government cost**

\$4.75

Send for 4 page Technical data.

SOUND POWERED TEL. FIELD SETS

Type TP3

For two-way signaling for voice communication. No batteries needed. May be used on metallic or grounded circuits, open-wire lines, cables or circuits using local-battery telephones, switchboards; two-way-ring-down trunk circuits of common battery switchboards, etc. Contained in treated waterproof fabric cases with adjustable carrying straps.

Brand new \$29.50

Per Pair \$55.00

25,000 VOLT CAPACITORS STANDARD BRANDS

Inerteen Type FP 25,000 volts .5 MFD. Size 1 1/2" x 1 1/2" x 1 1/2" with mounting brackets.

Brand new \$23.50

15,000 Volts 1MFD. Cat. No. 1463. Size 1 1/2" x 1 1/2" x 1 1/2". With mounting flange.

Brand new \$14.50

All prices indicated are F O B Tuckahoe, New York. Shipments will be made via Railway Express unless other instructions issued.

ELECTRONICRAFT

INC.

5 WAVERLY PLACE TUCKAHOE 7, N. Y.
PHONE: TUCKAHOE 3-0044

All merchandise guaranteed. Immediate delivery, subject to prior sale.

**All Prices Subject to
Change Without Notice**

RELIANCE SPECIALS

COAXIAL CABLE

RG 8/U 52 OHM—Per 1,000 ft. \$50
 RG 22/U 95 OHM (2 cond.)
 per 1000 ft. \$120.00
 RG 62/U 93 OHM per 1000 ft. \$ 50.00

COAXIAL FITTINGS

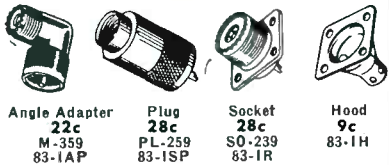

Angle Adapter 22c
 M-359 83-1AP
 Plug 28c
 PL-259 83-1SP
 Socket 9c
 SO-239 83-1R
 Hood 83-1H
 83-1H

PL-259-A, 83SPN 28c; 83-1F 75c; 83-1J 65c
 83-2R; 83-2AP, UG 13/U; UG 21/U; UG 22/U; UG 24/U; UG 27/U; UG 59/U; UG 87/U; UG 281/U with short length of coax attached. Each ONLY.....50c

COAXIAL RELAY. Struthers Dunn—coil 12 V.D.C., 90Ω Equipped with three UG 87/U BN receptacles for small size RF cable.....\$8.95

STEEL JUNCTION BOX

Water-tight, 14 ga. steel, 17"x25"x6 1/2". Screw type brass hinge on lid. 50 lb. Reduced to \$2.95.

ALLEN SET SCREWS

4-40 x 1/8 6-32 x 1/8 8-32 x 3/16
 4-40 x 3/16 8-32 x 1/8 8-32 x 5/16
 ALL SIZES\$1.50 per 100

Wrapped—BALL BEARINGS—New

| Mfg. | ID | OD | Width | Price |
|---------------|----------|----------|--------|-------|
| Fafnir 33K5 | 3/16" | 1/2" | 5/32" | \$.25 |
| N.D. 38 | 5/16" | 7/8" | 9/32" | .45 |
| Fafnir K8A | 1/2" | 1 1/8" | 5/16" | .60 |
| N.D. 3201 | 15/32" | 1 1/4" | 3/8" | .60 |
| N.D. 5202C13M | 1 1/2" | 1 3/8" | 1 3/8" | 1.00 |
| Fafnir 7308W | 1 37/64" | 3 9/16" | 15/16" | 2.00 |
| SKF 466430 | 6" | 7 1/8" | 7 1/8" | 5.00 |
| SKF 170645 | 3 11/32" | 4 1 7/8" | 1 1/2" | 1.50 |
| Fafnir K37B | 2 5/16" | 3 1/16" | 1 1/2" | 1.00 |
| Fafnir 545 | 2 1/16" | 2 5/8" | 15/32" | 1.00 |

NEEDLE BEARINGS

| | | | |
|-----------------|-------|---------|-----|
| B88 1/2" wide | 1/2" | 1 1/16" | 25c |
| B108 1/2" wide | 5/8" | 13/16" | 30c |
| GB34X 1/4" wide | 3/16" | 1 1/32" | 25c |

POWER RHEOSTATS

| Resist. | Mfg. | Shaft | Pr. | 90Ω | 123 IRC | 1000 Ohmite | 1500 Ohmite | 2,000 Ward Leonard |
|---------|-------------|------------------|-----|-------|--------------|-------------|-------------|--------------------|
| 100Ω | Claro | 1/8" | .79 | 123 | IRC | 1000 | Ohmite | 1 1/8" |
| 15 | Ohmite | 1/8" | .95 | 500 | Ohmite | 1500 | Ohmite | 1 1/8" |
| 25 | IRC | S.D. | .79 | 1,000 | Ohmite | 1500 | Ohmite | 1 1/8" |
| 35 | Ohmite | 1/8" | .95 | 1,250 | Ohmite | 1500 | Ohmite | 1 1/8" |
| 50 | Claro | 1/8" | .79 | 2,000 | Ward Leonard | | | |
| 145 | Grimes Mfg. | 1/2" with switch | .95 | 3,500 | Ohmite | 1 1/8" | | |
| 200 | IRC | 1/8" | .79 | | | | | |
| 250 | Ohmite | 1/8" | .95 | | | | | |
| 350 | Ohmite | 1/8" | .95 | | | | | |
| 370 | IRC | 1/8" | .79 | | | | | |
| 1,500 | Claro | 1/2" | .79 | | | | | |
| 2,000 | Ohmite | 1/8" | .95 | | | | | |
| 2,500 | Ohmite | S.D. | .95 | | | | | |
| 3,500 | Ohmite | 1/8" | .95 | | | | | |
| 5,000 | Ohmite | S.D. | .95 | | | | | |

50 WATT

| | | | |
|----|--------|------|------|
| 2Ω | Ohmite | 1/8" | 1.11 |
| 6 | Ohmite | 1/8" | 1.11 |
| 8 | Ohmite | S.D. | 1.11 |
| 10 | Ohmite | 1/8" | 1.11 |
| 12 | Ohmite | 1/8" | 1.11 |
| 20 | Ohmite | 1/8" | 1.11 |
| 50 | Ohmite | 1/8" | 1.11 |

* S.D. = Screwdriver

PRECISION POTENTIOMETERS

| 6 WATT | | 4 WATT | |
|---------|------------|--------|-----------------------|
| 20,000Ω | Muter 314A | \$1.70 | 500Ω Centralab 48-501 |
| 20,000 | GR 314A | 2.50 | 50 De jur 292 |
| 6,000 | GR 314A | 2.50 | 50 GR 301 |
| 6,000 | De jur 290 | 1.70 | 25 GR 301 |
| 6,000 | Muter 314A | 1.70 | 20 De jur 292 |
| 5,000 | Muter 314A | 2.50 | 20 GR 301 |
| 5,000 | GR 314A | 2.50 | 12 GR 301 |
| 5,000 | GR 214A | 1.40 | |
| 2,000 | De jur 290 | 1.70 | 10,000Ω GR 471-AS15 |
| 600 | GR 314A | 2.25 | 10,000 GR 371T |
| 400 | GR 214A | 1.40 | 10,000 Muter 371T |
| 200 | GR 214A | 1.40 | 10,000 De jur 271T |
| 40 | GR 214A | 1.40 | 5,000 De jur 271T |

PHASE SHIFT CAPACITOR

4 Stators—single rotor—90° quadrants—
 4 taps—360° rotation.
ONLY \$2.79—Lots of 10.....\$25.00



CAPACITORS

POSTAGE STAMP MICAS

| 8.2mmf | 56mmf | 200mmf | 560mmf | .0015mfd |
|--------|-------|--------|---------|----------|
| 10 | 60 | 250 | 600 | .002 |
| 18 | 70 | 250 | 650 | .0026 |
| 20 | 90 | 270 | 680 | .0027 |
| 22 | 100 | 350 | 800 | .003 |
| 25 | 140 | 370 | .001mfd | .0039 |
| 40 | 150 | 400 | .0012 | .007 |
| 47 | 160 | 470 | .0013 | .008 |
| 50 | 180 | 500 | .00135 | .01 |

Price Schedule
 8.2mmf to .001mfd 5c .003mfd to .008mfd 12c
 .0012mfd to .002mfd 7c .01mfd 18c

SILVER MICAS

| 10mmf | 125mmf | 390mmf | 680mmf | .0025mfd |
|-------|--------|--------|----------|----------|
| 22 | 150 | 400 | 700 | .0027 |
| 39 | 180 | 430 | 750 | .003 |
| 50 | 200 | 466 | 820 | .0033 |
| 62 | 240 | 470 | 1.001mfd | .0039 |
| 66 | 250 | 488 | .0012 | .004 |
| 68 | 300 | 510 | .0013 | .005 |
| 100 | 330 | 525 | .0015 | .0051 |
| 110 | 360 | 560 | .002 | .0068 |
| 120 | 370 | 665 | .0024 | .01 |

Price Schedule
 10mmf to .001mfd 10c .003mfd to .0068mfd 50c
 .0012mfd to .0027mfd 20c .01mfd 65c

CERAMICS

| 3mmf | 12mmf | 22mmf | 56mmf | 110mmf | 220mmf |
|------|-------|-------|-------|--------|--------|
| 3.44 | 13 | 27 | 62 | 115 | 1000 |
| 1.7 | 15 | 33 | 68 | 140 | 1090 |
| 6.8 | 16 | 40 | 75 | 150 | |
| 8 | 18 | 47 | 82 | 180 | |
| 10 | 20 | 50 | 91 | 200 | |

\$6 per 100

OIL FILLED

| MFD | V.D.C. | Price | MFD | V.D.C. | Price |
|-------------------|--------|---------|---------|----------------|--------|
| .1 | 25,000 | \$14.95 | 1-1 | 7,000 | \$1.75 |
| .012 | 25,000 | 6.20 | 1 | 7,000 | 1.95 |
| .03 | 16,000 | 4.50 | .02-.02 | 7,000 | 1.65 |
| (.375@ 16,000 and | | | 1 | 6,000 | 8.50 |
| .75@ 8,000(dual) | | 8.95 | 1 | 6,000 | 1.75 |
| 15-15 | 8,000 | 2.85 | .03-.03 | 6,000 | 1.65 |
| 5-5 | 7,500 | 23.95 | 1 | 4,000 | 4.50 |
| .1 | 7,500 | 1.85 | .25 | 3,000 | 1.75 |
| | | | 2 | 750 V.A.C. | .39 |
| | | | 2 | (2,200 V.D.C.) | .95 |
| | | | 4 | 2,000 | .90 |
| | | | 4 | 1,000 | .90 |
| | | | 3 | 1,000 | .80 |
| | | | 2 | 1,000 | .65 |
| | | | 1 | 800 | .40 |
| | | | 10 | 600 | 1.00 |
| | | | 2 | 600 | .69 |
| | | | 2 | 600 | .39 |



2 mfd.

4,000 (2,200 V.D.C.)

V. D. C.

≡23F47

SPECIAL!

\$4.50

BATH TUBS

| | | | | |
|-------------------|------|-------|----------|------|
| 4 mfd 50 VDC | .21e | .25 | 600 VDC | .23e |
| 2 mfd 200 VDC | .14e | .5 | 600 VDC | .25e |
| 2 mfd 400 VDC | .15e | 1 | 600 VDC | .30e |
| .25 mfd 400 VDC | .15e | 2 x 1 | 600 VDC | .36e |
| .05 mfd 600 VDC | .15e | 2 | 600 VDC | .36e |
| 1 mfd 600 VDC | .20e | .06 | 1000 VDC | .17e |
| 2 x 1 mfd 600 VDC | .27e | 1 | 1000 VDC | .25e |
| 3 x 1 600 VDC | .30e | 1 | 1000 VDC | .36e |
| .176 600 VDC | .21e | | | |

SPAGHETTI SLEEVING—Asst. sizes and colors, 3 ft. lengths.....99 feet—Only \$1.00

Gear Asst.—Mostly stainless steel and brass. Over 100 pcs.—Experimenter's Dream—Only \$6.50.

WW PRECISION RESISTORS 1%

| 1/4 WATT—25c | | | |
|--------------|--------|--------|--------|
| 6.68Ω | 12.32Ω | 16.37Ω | 123.8Ω |
| 10.48 | 13.02 | 20 | 147.5 |
| 10.84 | 13.52 | 62.54 | 220.4 |
| 11.25 | 13.89 | 79.81 | 301.8 |
| 11.74 | 14.98 | 105.8 | 366.6 |

| 1/2 WATT—25c | | | |
|--------------|-------|-------|--------|
| 250Ω | 11.1Ω | 235Ω | 4,451Ω |
| 334 | 13.15 | 280 | 5,000 |
| 502 | 46 | 270 | 5,900 |
| 557 | 52 | 295.3 | 6,500 |
| 627 | 55 | 400 | 7,500 |
| 76 | 75 | 723.1 | 7,500 |
| 1.01 | 97.8 | 2,500 | 8,000 |
| 1.53 | 125 | 2,850 | 8,500 |
| 2.04 | 180 | 3,427 | 10,000 |
| | 210 | 4,000 | 14,825 |

| 1 WATT—30c | | | |
|------------|-------|--------|--------|
| 1.01Ω | 5.21Ω | 1,250Ω | 9,000Ω |
| 2.58 | 10.1 | 3,300 | 18,000 |
| 3.39 | 10.9 | 7,000 | 50,000 |
| 5.05 | 270 | | 75,000 |

| 1 WATT—40c | | | |
|------------|----------|----------|----------|
| 100,000Ω | 128,000Ω | 150,000Ω | 522,000Ω |
| 150,000 | 180,000 | 320,000 | 525,000 |
| 125,000 | 160,000 | 470,000 | 650,000 |

1 Megohm, 1 Watt, 1%—65c.; 5%—40c
 Orders for 100 pieces—10% off;
 Orders for 1,000 pieces—20% off.

UNIVERSAL JOINT
 ALUMINUM
 1 1/2" long x 1/2" O. D. 1/4" ID
ONLY 40c

JONES BARRIER STRIPS

| Type | Price | Type | Price | Type | Price |
|-------------|-------|-------------|-------|-------------|-------|
| 3-140Y | 5.05 | 5-141Y | .25 | 5-142 | .21 |
| 3-140 3/4W | .12 | 7-141 | .26 | 8-142 | .25 |
| 3-140 | .10 | 8-141 | .27 | 8-142Y | .38 |
| 4-140 | .13 | 8-141 3/4W | .38 | 8-142Y | .52 |
| 5-140Y | .19 | 9-141Y | .42 | 10-142 3/4W | .58 |
| 8-140 | .23 | 10-141 3/4W | .47 | 11-142 | .48 |
| 10-140 3/4W | .41 | 12-141 | .43 | 12-142Y | .68 |
| 13-140 | .36 | 14-141 | .51 | 17-142Y | .97 |
| 15-140 | .42 | 17-141 | .60 | 18-240 | .35 |
| 2-141 | .09 | 17-141Y | .78 | 22-240 | .45 |

Any order for 100 pieces—10% off;

PULSE TRANSFORMERS

X 124 T2, UTAH, marked 9262 or 9280, small gray case 1 1/2" high x 1 1/2" x 3/4" with two 6-32 mtg. studs. Ratio 1:1:1, hypersil core... \$1.50
352-7178—Spec. 10, 111 Chicago Trans., equivalent to 9262 (above)..... \$1.50
D161310, 50 Kc to 4 Mc, 1 1/4" dia. x 1 1/4" high, 120 to 2350 ohms..... \$2.00
TR 1048, Dinion Coil Co..... \$1.25
TR 1049, Dinion Coil Co..... \$1.25
352-7250-2A, cased 15/16" dia. x 1 1/2" high, DC 10 ohm, 3 1/2 ohm, 140 cv. to 175 KC..... \$1.25
352-7251-2A, similar—shorter pulses..... \$1.25
300 KVA GE 7557296, 50 ohm pulse cable connection; 3,850 V. in., 17,300 V. out. (250 KVA @ 1/2 microsecond)..... \$15.00
800 KVA G.E. K2731, 28,000 Volt pk. output. Bifilar, pulse width; one-microsecond..... \$19.50
D166173, W. E. Freq. response 10KC to 2 MC..... \$12.00
KS9800, Ratio, 1:1:1, 2:1, Freq. range 380 to 520 C.P.S..... \$4.00

TIME DELAY RELAY

Raytheon CPX 24166
 KS 10193-60 Sec.
 • 115 V., 60 Cycle
 • Adj. 50-70 Seconds
 • 2 1/2 seconds recycling time, spring return
 • Micro Switch Contact, 10A
 • Holds On as long as power is applied
 • Fully Cased.
ONLY \$6.50

DC AMMETER

O-15A BASIC MOVE.
 12 Ma
 5" x 4"
METAL CASE MIRROR SCALE
 Lots of 10—\$35 \$3.85 ea.

400 MA CHOKE
 12 H.
 90 Ω
 6,000 V. D. C.
 TEST \$3.85

DYNAMOTOR RIOT! NEW and GUARANTEED



Whether you require large quantities of relays for production runs or single units for laboratory or amateur work, Wells can make immediate delivery and save you a substantial part of the cost.

Our capable engineering staff is prepared to offer assistance in the selection of correct types to suit your exact requirements.

Each relay is brand new, standard make, inspected, individually boxed and fully guaranteed.

The following list represents only a tiny portion of our relay stock. Write or wire us for information on types not shown.

RELAYS FOR EVERY PURPOSE Over a Million in Stock!

STANDARD DC TELEPHONE RELAYS

| Stock No. | Operating Voltage | Coil Resistance | Contacts | Manufacturer | Net Each |
|-----------|-------------------|-----------------|----------------|--------------|----------|
| R-101 | 24V | 1500. | DPST (NO) | Auto. Elec. | \$1.35 |
| R-102 | 24V | 400. | SPDT | Auto. Elec. | 1.10 |
| R-103 | 24V | DUAL-1000 | 3PST (NO) | Auto. Elec. | 1.35 |
| R-105 | 24V | 600. | 3PST (NO) | Clare | 1.20 |
| R-106 | 24V | 1300. | 3PST (NC) | Clare | 1.25 |
| R-152 | 12V | 50. | DPDT-SPST (NO) | Guardian | 1.10 |
| R-153 | 12V | 200. | SPDT-SPST (NO) | Stromberg | 1.25 |
| R-154 | 12V | 200. | SPST (NO) | Clare | 1.20 |
| R-155 | 12V | 100. | SPST (NO) | Clare | 1.15 |
| R-158 | 6V | 50 | 4PST (NO) | Stromberg | 1.10 |
| R-159 | 6V | 50 | DPST (NO) | Stromberg | 1.10 |
| R-160 | 6V | 12 | 3PDT-3PST (NO) | Auto. Elec. | 1.05 |
| R-161 | 6V | 10 | 3PST (2NC-1NO) | Auto. Elec. | .90 |
| R-121 | 150V | 5000. | 2PST (NO) SPDT | Clare | 1.65 |
| R-123 | 150V | 6300 | SPST (NO) | Clare | 1.75 |
| R-602 | 150V | 6500 | 3PST (NO) | Clare | 1.75 |
| R-515 | 24V | 750 | SPST (NO) | Clare | 1.25 |
| R-517 | 12V | 250 | DPST (NO) | Clare | 1.20 |
| R-519 | 250V | 14000 | SPDT | Auto. Elec. | 1.95 |
| R-520 | 250V | 14000 | DPDT | R. B. M. | 2.10 |
| R-521 | 32V | 1000. | DPDT | Kellogg | 1.20 |
| R-166 | 24V | DUAL-200. | DPDT-SPST (NO) | Stromberg | 1.75 |
| R-168 | 24V | DUAL-200. | 4PST (NO) | Auto. Elec. | 1.20 |
| H-240 | 24V-350V | 40000 | DPST (NO) | Auto. Elec. | 2.95 |
| H-241 | 48V | 660 | SPDT-SPST (NO) | Clare | 1.25 |

TYPE 18 DC TELEPHONE RELAYS

| Stock No. | Operating Voltage | Coil Resistance | Contacts | Manufacturer | Net Each |
|-----------|-------------------|-----------------|----------------|--------------|----------|
| R-109 | 24-48V | 4000. | SPDT | Auto. Elec. | \$1.50 |
| R-110 | 24-32V | 3500 | SPDT | Auto. Elec. | 1.50 |
| R-112 | 90-120V | 6500 | SPST (NC) | Auto. Elec. | 1.75 |
| R-114 | 24V | 500 | 4PST (NO) | Auto. Elec. | 1.30 |
| R-603 | 24V | 400 | DPST (NO) | Auto. Elec. | 1.25 |
| H-238 | 24V | 150 | DPDT-SPST (NC) | R. B. M. | 1.25 |
| H-239 | 24V | 180 | DPST (NO) | Auto. Elec. | 1.25 |



SEALED DC TELEPHONE RELAYS

| Stock No. | Operating Voltage | Coil Resistance | Contacts | Manufacturer | Net Each |
|-----------|-------------------|-----------------|----------|--------------|----------|
| R-125 | 24V | 300. | DPDT | Clare | \$2.75 |
| R-126 | 90-120V | 2000 | DPDT | Clare | 3.00 |
| R-504 | 24-70V | 2800 | SPDT | GE-C103C25 | 3.00 |

V TYPE DC TELEPHONE RELAYS

| Stock No. | Operating Voltage | Coil Resistance | Contacts | Manufacturer | Net Each |
|-----------|-------------------|-----------------|---------------------|--------------|----------|
| R-164 | 24-32V | 1000. | SPST (NO) | W. E. | \$1.20 |
| R-512 | 24-48V | 3500 | DPDT | W. E. | 1.30 |
| R-513 | 12-24V | 300 | DPDT-SPST (NC) | W. E. | 1.20 |
| R-514 | 4-6V | 60 | SPDT | W. E. | 1.05 |
| R-526 | 6V | 35 | DPDT-SPST (INC-1NO) | W. E. | 1.05 |

AC-STANDARD TELEPHONE RELAYS

| Stock No. | Operating Voltage | Coil Resistance | Contacts | Manufacturer | Net Each |
|-----------|-------------------|-----------------|----------------|--------------|----------|
| R-212 | 90-135V | — | NONE | Clare | \$0.95 |
| R-213 | 5-8V | — | DPST (NO) | Clare | 1.15 |
| R-605 | 24V | — | 3PST (NO) | Auto. Elec. | .95 |
| R-606 | 24V | — | DPST (1NO-1NC) | Auto. Elec. | .95 |
| R-607 | 24V | — | SPST (NO) | Auto. Elec. | .95 |



DIRECT CURRENT MIDGET RELAYS

| Stock No. | Operating Voltage | Coil Resistance | Contacts | Manufacturer | Net Each |
|-----------|-------------------|-----------------|------------------|--------------|----------|
| R-132 | 24V | 300 | DPDT | Clare | \$1.20 |
| R-133 | 24V | 300 | NONE | Clare | .60 |
| R-134 | 24V | 250 | 4PDT | Clare | 1.20 |
| R-135 | 24V | 300 | SPST (NC) | Clare | 1.15 |
| R-137 | 24V | 300 | SPDT | Clare | 1.15 |
| R-138 | 24V | 300 | 4PST (NO) | Clare | 1.15 |
| R-139 | 24V | 200 | 4PDT | Clare | 1.15 |
| R-140 | 24V | 280 | SPDT | R. B. M. | 1.15 |
| R-141 | 24V | 280 | SPST (NO) | R. B. M. | 1.15 |
| R-142 | 24V | 400 | DPDT | Allied Cont. | 1.20 |
| R-143 | 24V | 280 | SPST (NO) | R. B. M. | 1.15 |
| R-144 | 24V | 250 | SPST (NO) | Allied Cont. | 1.15 |
| R-145 | 24V | 300 | QPST (NO) | Allied Cont. | 1.15 |
| R-146 | 12V | 126 | DPST (1NO) (1NC) | Clare | 1.10 |
| R-147 | 9-14V | 75 | SPDT | Guardian | 1.05 |
| R-148 | 12V | 100 | DPDT-SPST (NC) | Price Bros. | 1.10 |
| R-149 | 6-8V | 45 | SPST (NC) | Clare | 1.00 |
| R-150 | 6V | 30 | SPST (NO) | E-Z Elec. | .95 |
| R-522 | 2-6V | 2. | SPST (NO) | R. B. M. | .65 |
| R-523 | 90-125V | 6500 | DPDT | Clare | 1.90 |
| R-222 | 12V | 100 | DPST (NO) | P & B | .95 |
| H-242 | 24-32V | 300 | DPDT | R. B. M. | 1.20 |
| H-243 | 24-32V | 300 | 4PDT | R. B. M. | 1.20 |

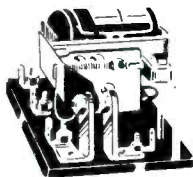

SENSITIVE DC RELAYS

| Stock No. | Operating Voltage | Coil Resistance | Contacts | Manufacturer | Net Each |
|-----------|-------------------|-----------------|----------------|--------------|----------|
| R-218 | 4-6V | 1800. | SPDT | Kurman 220C | \$1.95 |
| R-220 | 75V | 5000 | SPDT | Allied Cont. | 1.20 |
| R-221 | 18-24V | 5000 | SPST (NO) | Allied Cont. | 1.15 |
| R-174 | 250V | 14000 | SPST (NO) | G. M. | 1.85 |
| R-175 | 350V | 11000 | DPDT-SPST (NO) | G. M. | 2.95 |
| R-176 | 24V | 250 | DPST (NO) | G. M. | 1.50 |
| R-177 | 24V | 300 | 4PDT | G. M. | 1.65 |
| R-600 | 8-12V | 5000 | SPDT | S-Dunn-KS | 2.10 |
| R-507 | 24-48V | 1000 | SPDT-SPST (NC) | Guardian | 1.15 |

TYPE B0 DC RELAYS

| Stock No. | Operating Voltage | Coil Resistance | Contacts | Manufacturer | Net Each |
|-----------|-------------------|-----------------|----------------|--------------|----------|
| R-169 | 24V | 250 | SPST (NO) | Allied Cont. | \$1.95 |
| R-171 | 24V | 230 | DPDT | Allied Cont. | 2.15 |
| R-172 | 5-8V | 30 | DPDT-SPST (NO) | Allied Cont. | 1.70 |
| R-529 | 24-48V | 1000 | SPST (NO) | Allied Cont. | 1.25 |
| H-237 | 24V | 230 | DPDT | Allied Cont. | 2.50 |

TYPE BJ DC RELAYS

| Stock No. | Operating Voltage | Coil Resistance | Contacts | Manufacturer | Net Each |
|-----------|-------------------|-----------------|-----------|--------------|----------|
| R-204 | 32V | 65 | DPST (NO) | Allied Cont. | \$1.15 |
| R-205 | 24V | 260 | DPDT | Allied Cont. | 1.25 |
| R-224 | 32V | 75 | SPST (NO) | Allied Cont. | 1.15 |
| H-237 | 24V | 230 | DPDT | Allied Cont. | 1.25 |

HEAVY DUTY KEYING RELAYS

| Stock No. | Operating Voltage | Coil Resistance | Contacts | Manufacturer | Net Each |
|-----------|-------------------|-----------------|---------------|----------------|----------|
| R-248 | 28V DC | 150 | SPST (NO) 10A | Guard. 36471 | \$1.05 |
| R-244 | 25V AC | 265 | SPST (NO) 20A | Leach 1327 | 1.75 |
| R-206 | 24V DC | 150 | SPDT-3 AMP | P & B-KL | 1.20 |
| R-207 | 24V DC | 210 | 4PDT-3 AMP | P & B-KL | 1.10 |
| R-219 | 50V DC | 1500 | DPST (NO) 15A | P & B-S | 1.25 |
| R-217 | 115 AC | 600 | SPDT-10 AMP | St. Dunn IAX22 | 2.25 |
| R-525 | 24V DC | 200 | DPDT-10 AMP | Guard. 34464 | 1.25 |
| R-508 | 110 AC | 600 | SPDT-5 AMP | Guard. 37189 | 1.95 |
| R-506 | 24 V DC | 300 | DPST (NO) 6A | — | .95 |
| R-510 | 24 V DC | 200 | 3PDT-10 AMP | Guard 516983 | 1.05 |
| R-604 | 24 V DC | 200 | SPST (NO) 30A | St. Dunn B2A | 1.25 |
| H-608 | 115 AC | 400 | SPST (NO) 20A | St. Dunn IHX22 | 2.25 |
| R-620 | 12V DC | 35 | 3PST (NO) 10A | Guard-BK2 | 1.05 |
| R-223 | 28V DC | 150 | SPST (NO) 40A | Price Bros. | 1.35 |
| H-230 | 12-24V DC | 80. | DPST (NO) 10A | — | 1.15 |
| H-231 | 24V | 230. | DPST (NO) 5A | R. B. M. | 1.20 |

DC-TYPE 76 ROTARY RELAYS

| Stock No. | Operating Voltage | Coil Resistance | Contacts | Manufacturer | Net Each |
|-----------|-------------------|-----------------|-------------------------------|--------------|----------|
| R-197 | 9-16V | 70 | DPDT | Guardian | \$1.65 |
| R-198 | 9-16V | 125 | 6PST (3NO) | Price Bros. | 1.65 |
| R-199 | 24-32V | 250 | (3NC) SPDT | Price Bros. | 1.65 |
| R-200 | 24-32V | 275 | SPDT-SPST (NC) | Price Bros. | 1.65 |
| R-201 | 24-32V | 250 | 3PDT-SPST (NC) | Price Bros. | 1.65 |
| R-601 | 9-14V | 60. | DPST (NO) SPDT (NC) DPST (NO) | Price Bros. | 1.65 |



DIRECT CURRENT KEYING RELAYS

| Stock No. | Operating Voltage | Coil Resistance | Contacts | Manufacturer | Net Each |
|-----------|-------------------|-----------------|------------------|---------------|----------|
| R-190 | 12V | 65 | DPDT 10 AMP | Advance Elec. | \$1.15 |
| R-191 | 28V | 125 | DPDT 10 AMP | Type 2000-A | 1.20 |
| R-192 | 12V | 44 | 3PDT 10 AMP | Allied Cont. | 1.35 |
| R-193 | 5-8V | 11 | DPDT 10 AMP | Type NB5 | 1.35 |
| R-194 | 24V | 265 | SPST (NO) | Leach | 1.05 |
| R-195 | 6V | 32 | DPST (NO) 10 AMP | Type 1027 | 1.05 |
| R-196 | 12V | .50 | DPDT 3 AMP | Type 1054SNW | .25 |
| R-242 | 24V | 170 | DPDT 10 AMP | G.E. Co. | 1.15 |
| H-236 | 5-8V | 18.5 | DPDT 2 AMP | Guardian | 1.15 |
| | | | SPDT 2 AMP | Leach | 1.05 |
| | | | SPDT 10 AMP | Type 1253DEW | 1.25 |
| | | | | Leach-BFM | 1.05 |

CUTLER HAMMER HEAVY DUTY CONTACTORS



| Stock No. | Operating Voltage | Coil Resistance | Contacts | Manufacturer | Net Each |
|-----------|-------------------|-----------------|----------------|--------------|----------|
| R-178 | 24V DC | 100 | SPST (NO) 100A | 6141H34A | \$3.85 |
| R-179 | 6V DC | 6.5 | SPST (NO) 50A | 6041H83A | 3.00 |
| R-180 | 12V DC | 25. | SPST (NO) 50A | 6041H83B | 3.25 |
| R-181 | 24V DC | 65 | SPST (NO) 100A | 6041H8B | 3.85 |
| H-232 | 24V | 55. | SPST (NO) 50A | Metal Cased | 3.25 |
| H-233 | 6V | 15 | SPST (NO) 50A | Metal Cased | 3.15 |
| H-235 | 24V | 70. | SPST (NO) 100A | Type B6 | 3.85 |

DIRECT CURRENT AIRCRAFT CONTACTORS

| Stock No. | Operating Voltage | Coil Resistance | Contacts | Manufacturer | Net Each |
|-----------|-------------------|-----------------|----------------|------------------|----------|
| R-182 | 28V | 80 | SPST (NO) 25 A | Guardian | \$1.85 |
| R-183 | 24V | 60 | SPST (NO) 50 A | Allen Bradley | 2.75 |
| R-184 | 28V | 50 | SPST (NO) 100A | Type B6A | 2.95 |
| R-185 | 24V | 100 | SPST (NO) 50 A | Leach 5055ECR | 2.75 |
| R-186 | 24V | 132 | SPST (NO) 50 A | Leach 7220-3-243 | 50 |
| R-187 | 24V | 100 | SPST (NO) 50 A | Allen Bradley | 2.95 |
| R-188 | 24V | 200 | SPST (NO) 75 A | Allied Cont. | 2.95 |
| H-234 | 14V | 45 | SPST (NO) 30 A | — | 1.65 |

ANTENNA CHANGEOVER RELAYS

| Stock No. | Operating Voltage | Coil Resistance | Contacts | Manufacturer | Net Each |
|-----------|-------------------|-----------------|----------------|--------------|----------|
| R-192 | 6-12V DC | 44 | 2PDT 10 AMP | Allied-NB5 | \$1.35 |
| R-231 | 12V DC | 100. | DPDT 6 AMP | G. E. | 1.95 |
| R-256 | 24-32V DC | — | SPDT-SPST (NC) | Guardian | 1.45 |
| R-501 | 110 AC | 4 | DPDT (1KW) | G. E. | 2.45 |
| R-503 | 12-32V DC | 100 | SPDT-5PST | G. E.-500 W. | 1.95 |

COMBINATION PUSH BUTTON AND REMOTE RELAY

| Stock No. | Operating Voltage | Coil Resistance | Contacts | Manufacturer | Net Each |
|-----------|-------------------|-----------------|----------|---------------|----------|
| H-244 | 12-24 V DC | Dual-60 | SPDT | CR2791-R106C8 | \$1.65 |

ADJUSTABLE TIME DELAY RELAY

| Stock No. | Operating Voltage | Coil Resistance | Contacts | Manufacturer | Net Each |
|-----------|-------------------|-----------------|---------------------------|--------------|----------|
| R-246 | 115 AC | — | SPST (NO) or (NC) 10 AMPS | R. W. Cramer | \$8.95 |

DC MECHANICAL ACTION RELAYS

| Stock No. | Operating Voltage | Coil Resistance | Contacts | Manufacturer | Net Each |
|-----------|-------------------|-----------------|----------|--------------|----------|
| R-245 | 12V | 25. | 4' Lever | G. M. | \$0.95 |
| R-527 | 6-12V | 200. | 2' Lever | — | .95 |

TYPE C.M.S. RELAY

| Stock No. | Operating Voltage | Coil Resistance | Contacts | Manufacturer | Net Each |
|-----------|-------------------|-----------------|---------------------|--------------|----------|
| R-511 | 24V DC | 200 | MICRO-SW. SPST (NO) | Clare | \$2.45 |

DC CURRENT REGULATOR

| Stock No. | Operating Voltage | Coil Resistance | Contacts | Manufacturer | Net Each |
|-----------|-------------------|-----------------|-----------|--------------|----------|
| R-509 | 6-12V DC | 40 | SPST (NC) | G. E. | \$0.85 |

LATCH AND RESET RELAY

| Stock No. | Operating Voltage | Coil Resistance | Contacts | Manufacturer | Net Each |
|-----------|-------------------|-----------------|----------|--------------|----------|
| R-500 | 12V DC | 10. | DPDT- | | |

PERMALLOY SHIELDS
for CATHODE RAY TUBES

| | |
|-----------|-------------|
| 3" Shield |\$1.47 |
| 6" Shield |1.97 |



NOW AVAILABLE

| | |
|-----------------|-------------|
| 1000 KC Crystal |\$2.97 |
| Socket |07 |

SELENIUM RECTIFIERS

Full Wave Bridge Type

| INPUT | OUTPUT | | |
|---------------|---------------|----------|--------|
| up to 18v AC | up to 12v DC | 1/2 Amp. | \$1.47 |
| up to 18v AC | up to 12v DC | 1 Amp. | 1.97 |
| up to 18v AC | up to 12v DC | 5 Amp. | 5.27 |
| up to 18v AC | up to 12v DC | 10 Amp. | 8.97 |
| up to 18v AC | up to 12v DC | 15 Amp. | 11.57 |
| up to 18v AC | up to 12v DC | 30 Amp. | 22.57 |
| up to 36v AC | up to 28v DC | 1 Amp. | 3.47 |
| up to 36v AC | up to 28v DC | 5 Amp. | 8.57 |
| up to 36v AC | up to 28v DC | 10 Amp. | 14.57 |
| up to 36v AC | up to 28v DC | 15 Amp. | 22.27 |
| up to 115v AC | up to 100v DC | .25 Amp. | 2.57 |
| up to 115v AC | up to 100v DC | .6 Amp. | 5.27 |
| up to 115v AC | up to 100v DC | 5 Amp. | 22.57 |
| up to 115v AC | up to 100v DC | 3 Amp. | 17.97 |

RADIO TUBES

NEW! STANDARD BRANDS!

| | | |
|-------------------|------------------|-----------------|
| 1 24.....\$4.87 | 802.....\$2.97 | OZ4.....\$.67 |
| 1B28.....3.97 | 803.....4.87 | 1A5GT......47 |
| 1B29.....3.97 | 804.....6.57 | 1A7GT......67 |
| 1B32.....1.97 | 805.....3.87 | 1H6GT......57 |
| 1N21......67 | 807.....1.07 | 1L4......67 |
| 1N23......77 | 808.....1.57 | 1LC6......87 |
| 1N34.....1.37 | 809.....2.47 | 1LD5......77 |
| 1P24.....2.87 | 810.....5.97 | 1LE3......97 |
| 2A1P1.....3.87 | 811.....1.97 | 1M4......77 |
| 2C21......17 | 812.....2.47 | 1N5......57 |
| 2C22......17 | 813.....6.47 | 1N5GT......57 |
| 2C26A......27 | 814.....2.67 | 1R5......67 |
| 2C34......27 | 815.....1.87 | 1R4......67 |
| 2C40.....6.57 | 816.....1.07 | 1R5......57 |
| 2C44......27 | 822......47 | 1T4......57 |
| 2C46.....6.87 | 829B.....5.97 | 2A3......97 |
| 2D21.....1.27 | 830B.....3.57 | 3A5.....1.37 |
| 2J21.....11.47 | 832A.....4.57 | 3B4......67 |
| 2J22.....13.97 | 833A.....32.57 | 3C4......67 |
| 2J26.....12.47 | 836A......97 | 3C5......67 |
| 2J48.....9.97 | 837.....1.27 | 3T4......97 |
| 2J54A.....39.97 | 838.....2.87 | 3U4G......47 |
| 2K25.....32.97 | 841......37 | 5V4......87 |
| 2K28.....32.97 | 843......37 | 5W4......67 |
| 2V3G......97 | 845.....4.17 | 5X4......57 |
| 2X2......37 | 851.....24.97 | 5Y3......37 |
| 3A2.....3.97 | 860.....1.87 | 5Y4......47 |
| 3B22.....2.97 | 861.....10.47 | 6AG5......87 |
| 3B24.....1.87 | 862A.....497.47 | 6A7......77 |
| 3B26.....1.47 | 864......47 | 6A8GT......67 |
| 3BP1.....1.37 | 865......97 | 6AB7......77 |
| 3CP1.....2.67 | 866A.....1.17 | 6AC7......77 |
| 3DP1.....3.97 | 866JR.....1.17 | 6AL5......67 |
| 3C23.....2.47 | 868B.....27.57 | 6AG5......87 |
| 3C24/24G.....5.57 | 872A.....1.47 | 6AG7.....1.17 |
| 3C30......37 | 874......57 | 6AJ5......87 |
| 3C31.....1.47 | 876......67 | 6AK5......87 |
| 3D21A.....1.47 | 878.....1.27 | 6AK6......87 |
| 3DP1.....1.97 | 884.....1.27 | 6AL5......67 |
| 3E29.....8.97 | 885......67 | 6AL6......67 |
| 3GP1.....4.97 | 902P1.....4.97 | 6AQ6......67 |
| 4AP10.....2.97 | 905.....1.87 | 6AT8......47 |
| 4B24.....2.27 | 923......87 | 6AU6......77 |
| 4E27.....12.97 | 954......27 | 6BA6......97 |
| 4FA4.....3.97 | 955......37 | 6BG6G.....1.97 |
| 5BP1.....1.87 | 966B.....3.97 | 6B5......67 |
| 5BP4.....2.97 | 957......27 | 6B8......87 |
| 5CP1.....1.97 | 958A......27 | 6C4......27 |
| 5CP1A.....8.97 | 1613......57 | 6C5......47 |
| 5D21.....34.97 | 1616......57 | 6C6......57 |
| 5F27.....1.27 | 1619......27 | 6D6......47 |
| 5FP2.....39.97 | 1624......77 | 6E3......57 |
| 5LP1.....13.97 | 1625......37 | 6F7......97 |
| 5NP1.....8.97 | 1626......37 | 6G6......77 |
| 5R4GY.....1.17 | 1629......27 | 6H6......47 |
| 6C21.....24.97 | 1630.....1.87 | 6J5......47 |
| 6J4.....6.87 | 1636.....3.97 | 6J6......87 |
| 9GP1.....3.97 | 1638.....1.47 | 6K5......67 |
| 9JP1.....3.57 | 1641......57 | 6K6......47 |
| 9LP7.....3.57 | 1654.....1.97 | 6K7......57 |
| 10Y......37 | 1851......97 | 6L6.....1.17 |
| 12DP7.....12.97 | 1960.....2.97 | 6L8G......97 |
| 12CP7.....12.97 | 2030......67 | 6L7......87 |
| 15E.....1.97 | 2031......77 | 6N7......77 |
| 15R......77 | 8011.....1.27 | 6Q7......67 |
| 28D7......37 | 8012A.....1.47 | 6SA7......47 |
| 30 Spec......27 | 8013A.....1.27 | 6SC7......67 |
| 45 Spec......37 | 8016.....1.37 | 6SF5......57 |
| 75TL.....2.87 | 8020.....1.47 | 6SG7......67 |
| 100R.....1.97 | 8025.....3.57 | 6SH7......47 |
| 100TH.....9.97 | 9001......37 | 6SJ7......47 |
| 211......47 | 9002......37 | 6SK7......47 |
| 227A.....2.97 | 9003......37 | 6SL7......57 |
| 249C.....2.57 | 9004......37 | 6SN7......57 |
| 250R.....6.97 | 9006......37 | 6SQ7......47 |
| 250TH.....19.47 | C6J.....3.97 | 6V6GT......67 |
| 250TL.....19.47 | CK507AX.....1.47 | 6X5GT......57 |
| 294A.....4.97 | CK1005.....2.47 | 6ZY5G......87 |
| 304TH.....3.47 | CK1090.....1.27 | 12A6......17 |
| 304TL.....1.47 | B1148......67 | 12AT8......57 |
| 305A.....12.47 | BF50......47 | 12AV6GT......57 |
| 307A.....3.97 | F128A.....14.97 | 12C8......37 |
| 316A......67 | F127A.....17.97 | 12J5GT......37 |
| 327A.....2.97 | F128A.....39.47 | 12SA7GT......57 |
| 350B.....1.47 | F660.....39.47 | 12SK7GT......57 |
| 368AS.....3.27 | F862A.....497.47 | 12SG7GT......57 |
| 371B.....1.97 | FG17.....2.87 | 12SH7GT......57 |
| 378A.....1.97 | FG81A.....3.97 | 12SL7GT......67 |
| 434A.....3.27 | FG95.....8.97 | 12SQ7GT......57 |
| 446A......67 | FG105.....9.97 | 12SR7GT......57 |
| 450TH.....18.47 | GL697.....29.47 | 14A7......87 |
| 451.....1.47 | HY69.....3.97 | 14Q7......57 |
| 530.....22.57 | HY615......37 | 2A......67 |
| 531.....4.97 | ML100.....19.97 | 2BL6GT......57 |
| 532.....2.87 | ML101.....49.47 | 2Z5......47 |
| 559......87 | ML502.....69.47 | 27......47 |
| 575A.....12.97 | RK59.....1.97 | 36/51......57 |
| 703A.....3.27 | RK60......57 | 35L6GT......57 |
| 705A.....1.97 | RK72......67 | 35Z3......57 |
| 706CY.....18.97 | RK73......97 | 3Z5......47 |
| 707B.....8.47 | RK75.....3.97 | 45......57 |
| 708A.....1.97 | RK705.....1.97 | 50B5......67 |
| 713A.....1.27 | RX21.....3.27 | 50L6GT......57 |
| 715B.....7.57 | RX120.....9.97 | 56......47 |
| 715C.....34.97 | SS56.....2.97 | 78......47 |
| 717A......67 | VR75......97 | 78......47 |
| 721A.....2.97 | VR78......37 | 78......47 |
| 723AB.....12.97 | VR90......67 | 80......47 |
| 725A.....12.87 | VR105......67 | 83......77 |
| 726A.....7.57 | VR150......57 | 84/8Z4......67 |
| 750TL.....44.97 | VT127A.....2.37 | 117Z3......57 |
| 800.....1.87 | VU111......37 | 117Z6GT......87 |
| 801A......27 | | |

TRANSFORMER—115 V. 60 Cy.

HI-VOLTAGE INSULATION

| | |
|---|------------------|
| 2500v @ 15 ma |\$4.97 |
| 2150v @ 15 ma |3.97 |
| 2100v @ 10 ma |4.87 |
| 1800v @ 10 ma; 6.3v @ 2A; 2.5v @ 2A |4.97 |
| 1750v @ 4 ma; 6.3v @ 3A |4.27 |
| 1600v @ 4 Ma.; 700v CT @ 150 ma; 6.3v @ 9A |6.47 |
| 525-0-525v @ 60 ma.; 925v @ 10 ma.; 2x5v @ 3A; 6.3v @ 3.6A; 6.3v @ 2A; 6.3v @ 1A |6.97 |
| 500-0-500v @ 25 ma.; 262-0-262v @ 55 ma.; 6.3v @ 1A; 2x5v @ 2A |4.47 |
| 335-0-335v @ 70 ma.; 2.5v @ 10A; 5v @ 6A; 5v @ 3A |4.97 |
| 450-0-450v @ 300 ma.; 140-0-140v @ 100 ma.; 36v @ 1A, 6.3v @ 5A, 5v @ 3A, 110/220 Dua, Pri. |7.97 |
| 400-315-0-100-315v @ 200 ma.; 2.5v @ 2A; 5v @ 3A; 6.3v @ 9A; 6.3v; 9A |5.97 |
| 385-0-385-550v @ 200 ma.; 2 1/2v @ 2A; 5v @ 3A; 3x6.3v @ 6A—PRI. |6.27 |
| 110/220 |6.27 |
| 340-0-340v @ 300 ma.; 1540v @ 5 ma. |4.97 |
| 300-0-300v @ 65 ma.; 2x5v @ 2A; 6.3v @ 2 1/2A; 6.3v @ 1A |3.47 |
| 150-0-150v @ 80 ma.; 150v @ 40 ma.; 6.3v @ 3.5A; 6.3v @ 1A |1.97 |
| 120-0-120v @ 50 ma. |97 |
| 80-0-80v @ 225 ma.; 5v @ 2A; 5v @ 4A |3.97 |
| 24v @ 6A |3.47 |
| 13v @ 15A |9.97 |
| 13.5v CT @ 3.25A |2.97 |
| 3x10.3v @ 7A; CT |7.97 |
| 6.3v @ 12A; 6.3v @ 2A; 115v @ 1A |3.47 |
| 6.3v @ 10A; 6.3v @ 6 |2.97 |
| 6.3v CT @ 3.5A; 2.5v CT @ 3A; 2.5v CT @ 3A |2.97 |
| 6.3v @ 1A; 2 1/2v @ 2A |2.47 |
| 6.3v @ 2 1/2A; 6.3v @ 2A; 2 1/2v @ 2A |4.97 |
| 6.3v @ 1A.....\$0.97 | 8v CT 1A......97 |
| 2.5v @ 20A |3.47 |
| 5v @ 3A; 2.5v @ 2A |2.97 |
| 5v @ 20A, Dual 110v Pri. |3.47 |

FILTER CHOKES

HI-VOLTAGE INSULATION

| | | | |
|------------------|-------------|--------------------|--------------|
| 8 hy @ 300 ma |\$3.97 | 1 hy @ 800 ma |\$14.97 |
| 25 hy @ 160 ma |3.47 | 10 hy @ 250 ma |2.47 |
| 12 hy @ 150 ma |3.27 | 10 hy @ 200 ma |1.97 |
| 25 hy @ 65 ma |1.37 | 10/20 @ 85 ma |1.57 |
| .05 hy @ 15 amps |7.97 | 15 hy @ 125 ma |1.47 |
| 1 hy @ 5 amps |6.97 | 15 hy @ 100 ma |1.37 |
| 4 hy @ 600 ma |5.97 | 30 hy @ 50 ma |27 |
| 200 hy @ 10 ma |3.47 | 30 hy Dual @ 20 ma |1.47 |
| 600 hy @ 3 ma |3.47 | 8/30 hy @ 250 ma |3.47 |
| 325 hy @ 3 ma |3.47 | | |

UHF 83 SERIES CONNECTORS

UHF—Small—Coaxial

| Amphenol No. | Army or PL-259 | Description | |
|--------------|----------------|--|------|
| 83-15P | UG-176/U | Reducing Adapter. Use with 83-ISP or 83-ISPN | 37¢ |
| 83-168 | | Receptacle. | 17¢ |
| 83-1R | SO-239 | T Connector. | 117¢ |
| 83-1T | M-358 | Angle Plug Adapter. | 27¢ |
| 83-IAP | M-359 | Junction. | 77¢ |
| 83-1J | PL-258 | Feed-thru Pressurized. | 87¢ |
| 83-1F | PL-274 | | |

All Tubes guaranteed, except for open filaments, shorts and broken glass, for which we check before shipment. Please specify how to ship.

All Prices Subject to Change Without Notice

All merchandise guaranteed. Mail orders promptly filled. All prices F.O.B. New York City. Send money order or check. Shipping charges sent C.O.D. Minimum order \$5.00. 20% Deposit required with all orders.

OIL CONDENSERS
NATIONALLY ADVERTISED BRANDS

All Ratings D. C.

| | | | |
|----------------|--------|----------------|--------|
| 2x.1mfd. 600v | \$0.37 | 1mfd. 2000v | \$0.97 |
| .25mfd. 600v | .37 | 2mfd. 2000v | 1.77 |
| .5mfd. 600v | .37 | 4mfd. 2000v | 3.77 |
| 1mfd. 600v | .37 | 15mfd. 2000v | 4.97 |
| 2mfd. 600v | .37 | 4mfd. 2500v | 3.97 |
| 4mfd. 600v | .57 | 2mfd. 2500v | 2.47 |
| 8mfd. 600v | 1.07 | 1mfd. 2500v | 1.27 |
| 10mfd. 600v | 1.17 | 25mfd. 2500v | 1.47 |
| 3x.1mfd. 1000v | .47 | .5mfd. 2500v | 1.77 |
| .25mfd. 1000v | .47 | .05mfd. 3000v | 1.97 |
| 1mfd. 1000v | .57 | 1mfd. 3000v | 2.27 |
| 2mfd. 1000v | .67 | .25mfd. 3000v | 2.67 |
| 4mfd. 1000v | .87 | 1mfd. 3000v | 3.47 |
| 8mfd. 1000v | 1.97 | 12mfd. 3000v | 6.97 |
| 10mfd. 1000v | 2.07 | 2mfd. 4000v | 5.97 |
| 15mfd. 1000v | 2.27 | 1mfd. 5000v | 4.97 |
| 20mfd. 1000v | 2.97 | 1mfd. 7000v | 2.97 |
| 24mfd. 1500v | 6.97 | 3mfd. 4000v | 6.97 |
| .1mfd. 1750v | .87 | 2mfd. 3000v | 3.47 |
| .1mfd. 2000v | .97 | 2x.1mfd. 7000v | 3.27 |
| .25mfd. 2000v | 1.07 | .02mfd. 12000v | 8.97 |
| .5mfd. 2000v | 1.17 | .02mfd. 20000v | 11.97 |

HIGH CAPACITY CONDENSERS

| | |
|---------------------|-------------|
| 10,000 mfd.—25 WVDC |\$6.97 |
| 2x3500 mfd.—25 WVDC |3.47 |
| 2500 mfd.—3 VDC |37 |
| 3000 mfd.—25 WVDC |2.47 |
| 2x1250 mfd.—10 VDC |1.27 |
| 1000 mfd.—15 WVDC |97 |
| 200 mfd.—35 VDC |57 |
| 100 mfd.—50 WVDC |47 |
| 4x10 mfd.—400 VDC |87 |
| 4000 mfd.—18 WVDC |1.97 |
| 4000 mfd.—25 WVDC |2.97 |
| 4000 mfd.—30 WVDC |3.27 |

TWO-SPEED PLANETARY DRIVE

Auxiliary Speed Reducer fits on Condenser Shaft back of panel or on dial knob shafts. Ratios 5 to 1 and 1 to 1. Fits any 1/4 inch round shaft.

57c Each—Two for.....97c

GUARANTEED GOVT SURPLUS

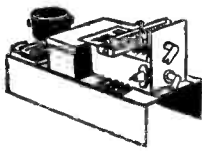

420-750 MC OSCILLATOR.

Compact, beautifully built line oscillator employing two W.E. 368AS (703A) "door-knob" tubes in push-pull. Exceptionally stable. 5W output at 420mc, 2W at 700mc. Independent grid and plate tuning. Adjustable output coupling and tuning assembly. Coaxial output connection. Built-in blower may be operated from 110VAC. Power requirements: 300VDC/150ma, 1.2V/4A, 1.2V/4A, 5 1/2"x6 1/2"x1 1/2". 7 lb. Supplied complete with tubes. Ideal for 420mc amateur operation or for use in the 460-470mc citizens radio band. Stock No. APO-66...\$6.95 Spare 368AS/703A tubes.....\$1.69 ea.



UHF 50 OHM COAXIAL POWER MEASURING ASSEMBLY.

Panel mounting, silver-plated assembly with integrally coupled crystal mount. Type "N" UG-58U female receptacle (easily replaced by SO-239). Originally designed for power measurement at frequencies up to 700mc. Stock No. APM-89.....\$3.95

MATING TYPE MAE PLUG.

For use with above. Stock No. PCM-17.....\$0.49

SPERRY MODEL 12 KLYSTRON TUNER

for use with 2K39, 2K42, 2K43, 2K44, 417A. Stock No. VKT-27.....\$1.95

MAGNETRON MAGNET 1900 GAUSS.

Pole dia. 1-3/4". Gap 1 1/2". Stock No. UMM-21.....\$5.75

MAGNETRON MAGNET 4800 GAUSS.

Pole tip dia. 3/4". Gap 0.635". Stock No. UMM-48.....\$7.00

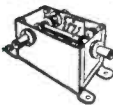

50 OHM COAXIAL RELAY.

Double coil actuating relay operates from either 12VDC/120ma or 24VDC/60ma. May be operated in plate return circuits to provide automatic transmitter-receiver antenna changeover. Supplied with British type connectors which are easily replaced by standard SO-239 (83-1R) receptacles or soldered to directly. Completely enclosed in compact housing. 2-3/4" x 3" x 4-3/4". An outstanding buy at \$2.49. Stock No. KDC-723.

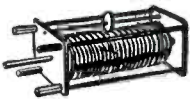

VARIABLE INDUCTOR.

67 microhenries max. Minimum near zero. Wheel type sliding short. Ceramic insulation. Quality construction. Barker-Williamson #1565. Originally used as transmitter plate tank coil to tune from 1 1/2 to 20mc. Ideal for pin-networks, antenna tuners and plate tanks. Stock No. LRF-32.....\$1.95

APC AIR TRIMMER.

35 mmf max. Screw slot adjustment. STOCK NO. CAV-105. 10 for \$1.00

APC AIR TRIMMER.

Two separate trimmers on ceramic base. Shield between sections. Each section 25 mmf max. Stock No. CAV-104. 10 for \$1.00

AIR CAPACITOR 100 MMF MAX.

1/4" dia. shaft. Receiving type. Ceramic insulation. Standard Brand. Similar to MC-100-M. Straight-line capacity. Stock No. CAV-15. \$0.72

SUPER-FLEXIBLE PIGTAIL WIRE.

Sperry Special. Part No. P55357. Consists of 350 strands of 0.002" diameter soft copper wire. Total diameter: 1/32". Useful in applications where electrical connection is to be made to moving parts, e.g., variometers, variable capacitors, motor-brushes, etc. Stock No. WFP-350. 10 foot rolls. \$0.69 per roll.



750 CPS BANDPASS TRANSFORMER.

Center frequency adjustable over a small range. Input 23,000 ohms. Output 225,000 ohms. Triple alloy shielded. 1 1/2" x 1 1/2" x 2". Stock No. ZBP-750. \$2.49

BLOCKING OSCILLATOR TRANSFORMER.

Two winding 1.35:1. Ideal for television sweep oscillators. Compact. Stock No. TFF-64.....\$0.95

NON-INDUCTIVE CERAMIC RESISTOR.

350 ohms/24 watt. Standard Brand. Stock No. RCF-52.....8 for \$1.00

Tube Specials

| | | |
|---------------|---------------|---------------|
| 1A7GT \$0.72 | 6Q7 .72 | 215A .95 |
| 1G6GT .49 | 6SA7GT .60 | 304TH 7.75 |
| 1V .49 | 6SC7 .69 | 304TL 1.95 |
| 2A3 .98 | 6SF7 .72 | 316A .89 |
| 2C4 .95 | 6SH7GT .39 | 350A 2.95 |
| 2C21/1642 .29 | 6SS7 .59 | 417A 14.95 |
| 2C34/RK34 .29 | 6S7GT .49 | 650 1.19 |
| 2C40 1.98 | 6SK7 .72 | 705A 2.95 |
| 2C44 .75 | 6SL7GT .69 | 723A/B 9.95 |
| 2D21 1.49 | 6SN7GT .79 | 725A 14.95 |
| 2J26 14.95 | 6SR7 .67 | 730A 12.50 |
| 2J38 14.95 | 6SU7GT/Y 1.29 | 801 .79 |
| 2I48 15.95 | 6V6GT .79 | 803 8.95 |
| 2J55 39.75 | 6Y6 1.09 | 805 3.95 |
| 2K28 12.95 | 6X4 .69 | 807 1.19 |
| 2X2 .69 | 6X5GT .63 | 811 1.95 |
| 3B7/1291 .39 | 6Y8G .88 | 813 7.95 |
| 3C23 2.95 | 6Z5Y5G .81 | 814 3.95 |
| 3D21A 1.95 | 7C7 .81 | 815 1.95 |
| 3E29 3.45 | 7E6 .72 | 838 .89 |
| 3FP7 1.95 | 7G7 1.06 | 837 1.49 |
| 3Q4 .69 | 7H7 .72 | 861 15.00 |
| 4A1 .49 | 7Q7 .72 | 866A .95 |
| 5BP1 1.95 | 7V7 .72 | 872A 1.69 |
| 6CP1 1.95 | 7Y4 .72 | 874 .39 |
| 6E4GY 1.09 | 7Z4 .72 | 902A 3.95 |
| 6U4G .65 | 12SF7 .59 | 931A 3.95 |
| 6V4G 1.09 | 12SG7 .59 | 954 .39 |
| 6Y3GT/G .49 | 12SH7 .59 | 955 .39 |
| 6AC7 .79 | 12SJ7 .59 | 956 .49 |
| 6AE5GT .79 | 12SL7GT .79 | 957 .39 |
| 6AG7 1.29 | 12SQ7 .65 | 958A .39 |
| 6AK5 1.29 | 12SR7 .72 | 959 .39 |
| 6AU6 .95 | 14F7 .72 | 991/NE-16 .29 |
| 6C4 .49 | 14H7 .79 | 1625 .49 |
| 6C8G .72 | 14N7 .72 | 1626 .39 |
| 6F6 .89 | 16K21 .95 | 1629 .29 |
| 6F8G .89 | 12SQ7 .65 | 958A .39 |
| 6G6G .49 | 25Z6GT .59 | 1050/RK60 .95 |
| 6H6 .49 | 35W4 .49 | 8013 1.49 |
| 6H6GT/G .29 | 46 .46 | 9001 .39 |
| 6J5 .65 | EF50 .49 | 9002 .39 |
| 6K7 1.17 | RFK69 1.49 | 9003 .39 |
| 6L7 .69 | RFK72 1.49 | 9004 .39 |
| 6K8GT/G .65 | RFK73 .39 | 9005 .79 |
| 6K8 .88 | 80 .80 | 95 9006 .39 |
| 6L6 1.28 | 85 .72 | VR90 .69 |
| 6L6GA .89 | 89Y .54 | VR105 .69 |
| 6L7 .98 | 117Z6GT/G .88 | VR150 .59 |
| 6N7 .95 | PG178 1.95 | |
| 6N7GT .79 | 211 .69 | |

Wide Range Butterfly Wavemeter & Oscillator Elements



Precision wide range butterfly circuit elements. Sturdily constructed. Mounted in ball bearings. Suitable for motor drive. Ideal for use as wavemeters and oscillators (see description below).

| Stock No. | Freq. (mc.) | Notes* | Unit Price |
|-----------|-------------|--------|------------|
| TN-20 | 105-330 | 1, 3 | \$2.95 |
| TN2A | 75-330 | 1, 4 | 2.95 |
| TN-30 | 135-485 | 2, 3 | 3.95 |
| TN3A | 300-1000 | 2, 5 | 4.95 |

Brand new, in original packing.

- *NOTES: 1) Aluminum construction
2) Silver-plated brass
3) Designed as oscillator element (955 acorn triode)
4) Has diode socket mounted on unit (955 as diode)
5) Has crystal diode mount for 1N21 crystal

BLILEY SMC-100 100 AND 1000KO CRYSTAL.

Regularly sells for \$8.75. Stock No. QCM-19.....\$5.95

HAMMARLUND CERAMIC ACORN SOCKETS.

5 contact. Silver-Plated. Stock No. XRT-25.....20 for \$1.00

CINCH MICA FILLED OCTAL SOCKETS.

1" dia. 1-5/16" mtg ctrs. Stock No. XRT-20. 20 for \$1.00
1-1/2" dia. 1 1/2" mtg. ctrs. Stock No. XRT-40. 20 for \$1.00

DELAY LINE.

2 microsecond (one direction). 1500 ohms. Bandwidth 1mc. 8 section tapped. Stock No. ZAL-22.....\$1.69

DELAY LINE.

1 1/2 microsecond (one direction). 1500 ohms. Bandwidth 1mc. 6 section tapped. Stock No. ZAL-13 \$1.49

DELAY LINE.

5 microsecond (one direction). 1500 ohms. Bandwidth 1/2mc. Stock No. ZAL-14.....\$0.89

4200 VOLT TELEVISION OR SCOPE TRANSFORMER.

Primary: 115V/60c. Secondary: 3000VRMS (4200 Volts Peak) 10ma. Hermetically sealed. 4 1/2"x4-3/4"x5 1/2". Stock No. TFF-83.....\$5.95

HV TFMR.

10,000-0-10,000 VOLTS @42 MA. Oil-filled, hermetically sealed. 11"x13"x6". Pri. 115V/50-60cy. Stock No. TFF-451 \$29.95

FILTER CHOKES

| Stock No. | Description | Price |
|-----------|--------------------------|--------|
| LFF-45 | 10H/120ma/600 ohms | \$0.95 |
| LFF-21 | 20H/300ma/125 ohms/5000V | 9.95 |
| LFF-144 | 2H/700ma/16 ohms/1500V | 4.95 |

MULTIPLIER PHOTOTUBE HOUSING.

Cast aluminum cylindrical housing containing a submagnal 11 pin socket (for 931A, 1P21, 1P22) and a dynode voltage divider network. Moisture proof construction. An integral 6 volt pilot lamp provides light source when used as a noise generator. A window may be drilled in the housing for use with an external light source. Operates with approximately 700 volts at 3-4ma. 2" dia. x 4" long. Supplied less phototube. Stock No. AMP-65.....\$3.95

PRECISION HIGH TORQUE TYPE 5 SELSYNS.

Bronze housing 4 1/2" dia. x 6" long. 115V/60c operation. Brand new in original packing. Stock No. SEL-44.....\$4.85 each

110/60CPS/0.38A BLOWER.

Exceptionally quiet. 50 cu. ft. min. Stock No. BLR-344..\$3.95

3" SCOPE INDICATOR.

3BP1 cathode ray tube mounted in a mu-metal housing with an adjustable light shield. May be mounted on a panel, table-top or clamped to a bar. When mounted on a table top or wall, the scope housing may be tilted at any angle up to 45° from the mount for comfortable viewing. Ideal for remote scope indicators. An outstanding buy at \$5.95. Stock No. ASI-85.

OIL-FILLED CAPACITORS

| Mfd | Rating | Price | Mfd | Rating | Price |
|------|----------|--------|------|----------|--------|
| 2-2 | 600 VDC | \$0.75 | 0.1 | 5000 VDC | \$1.95 |
| 4 | 600 VDC | .84 | 2 | 5000 VDC | 7.30 |
| 7 | 600 VDC | 1.15 | 1 | 6000 VDC | 6.95 |
| 10 | 600 VDC | 1.37 | -1-1 | 7000 VDC | 1.95 |
| 50 | 350 VAC | 4.95 | .05 | 7500 VDC | 1.75 |
| 2 | 1000 VDC | .95 | 24 | 7500 VDC | 11.95 |
| 2 | 1000 VDC | 1.19 | .02 | 10 KV DC | 2.95 |
| 8 | 1000 VDC | 1.71 | 1 | 15 KV DC | 19.95 |
| 0.25 | 2500 VDC | 1.06 | 0.25 | 20 KV DC | 15.95 |
| 2 | 4000 VDC | 4.95 | 15 | 440 VAC | 2.95 |
| 3 | 4000 VDC | 5.95 | | 1500 VDC | |

Note: 10 or more capacitors of a type 10% dis.

RF and DC PANEL METERS

| Stock | Description | Price |
|---------|--------------------------------------|--------|
| MAD-251 | 0-2 ma DC Westinghouse 3 1/2" round | \$3.95 |
| MAD-262 | 0-20 ma DC Westinghouse 3 1/2" round | 3.95 |
| MAD-285 | 0-80 ma DC W.E. 3 1/2" round | 3.49 |
| MAD-503 | 0-1000 ma DC DeJur 3 1/2" round | 3.95 |
| MAD-276 | 0-30 ADC GE 2 1/2" round | 2.95 |
| MRT-355 | 0-100 ma RF Weston 425 3 1/2" round | 11.95 |
| MRT-372 | 0-120 ma RF Weston 507 2 1/2" round | 8.95 |
| MRT-367 | 0-1A RF GE 2" round | 2.95 |
| MRT-394 | 0-20A RF GE 3 1/2" round | 6.95 |



INVERTER PE 21SD.

Output 115V/400 cps/1500VA/1ph. Input 24-28 VDC. Made by Win-charger. Complete with starting relays, hash filters, voltage and speed regulators. 5 1/2"x11"x16". Brand new in original packing. Stock No. GAC-10..\$27.50

Delivery: Immed. from stock (sub) to prior sale. Minimum Order: \$5.00. Terms: Rated organizations (U. S. and Canada). Open account. Others: Cash with order, or 20% with order, balance C. O. D. Foreign: Payment in U. S. funds with order or irrevocable letter of credit payable against documents in U. S. funds at New York. Condition of material: The major portion of the material listed above is brand new. Some of the items have been removed from new equipments. We guarantee material to be clean and in perfect operating condition. All prices above are quoted domestic packed f.a.b. our warehouse, Corona, New York.

DUBIN

Tel. Hickory 6-3066-7-8

Cable: "Dublectron, New York". We will be pleased to send our bulletins to you regularly. Write or phone Dept. E-7 for our latest catalog.

ELECTRONICS CO. INC.,

103-02 NORTHERN BLVD., CORONA, N. Y.

ELECTRONIC-INDUSTRIAL-RADIO-SUPPLIES

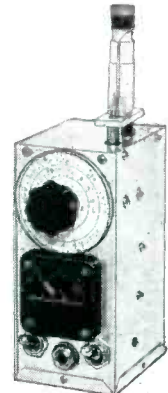
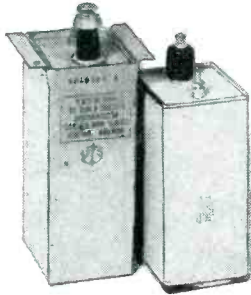
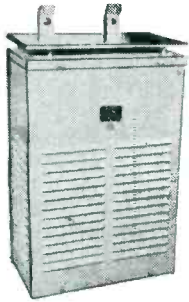

VOLTAGE REGULATOR

Raytheon CRP-301407. Prim. 92-138v, 57/63 cps. Sec. 115v .82 kva 1% reg., .96 PF. Regulating trans., chokes, capacitors, power correct. In navy gray cabinet, 36" x 20" x 12", net wt. 250 lbs. PRICE \$97.50

"LAVOIE" VHF FREQUENCY METER

375-725 mc. and above, 0.1% Model 105SM. Features precision cavity and vernier, absorption type with amplifier. Ideal for alignment, production test and lab work. Complete with spares and individual calibration. ONLY \$59.50

"TELRAD" FREQUENCY STANDARD

Complete self contained, dual 100/1000 kc xtl, multivibrator, and harmonic amplifier. Calibrates with WWV or broadcast for high accuracy, 100 to 45,000 kc. check points every 1000-100-10 kc. Complete at \$29.50

OIL CAPACITORS

| | |
|-------------------------------|--------|
| 2 mf 5500 vdc "Inerteen"..... | \$5.80 |
| 2 mf 6000 vdc..... | 6.50 |
| 1 mf 7500 vdc..... | 5.50 |
| 1 mf 5000 vdc 5009..... | 3.95 |

GDA GRID DIP OSCILLATOR

An all-around laboratory instrument for measurement of resonant circuits, Q, rf voltages, antennas and many other purposes—3 mc to 250 mc or other extended ranges. Compact and complete in kit form at \$21.50 with instruction and application booklet.

TRANSFORMERS

115V 50/60 CPS

| | |
|---|---------|
| 3700-0-3700v @ 500 ma..... | \$59.00 |
| 2500-0-2500v @ 500 ma..... | 39.50 |
| 1800-0-1800v @ 350 ma..... | 17.50 |
| 740-0-740v @ 1.2 amp..... | 17.50 |
| 230/460 to 115v @ 6 kva..... | 65.00 |
| 230/460 to 115v @ 2 kva..... | 28.00 |
| 440v to 115v @ 50 kva..... | 150.00 |
| 36v @ 10 amp..... | 5.95 |
| 11.5v @ 11.5-20 amp..... | 3.50 |
| 10v @ 6 amp..... | 2.75 |
| 2.5v @ 10A 10 kv..... | 3.75 |
| 4500v @ 4.5 ma; 5v @ 3A..... | 6.75 |
| 3750v @ 2 ma..... | 4.50 |
| 1200v @ 2 ma, 6.3v @ 4A, 5v @ 3A..... | 3.95 |
| 1300v @ 160-200 ma, 5v @ 2-3A, 2-2.5v @ 2A..... | 5.50 |
| 1100v @ 200 ma, 6.3 @ 4A, 6.3 @ 4A, 5 @ 3A..... | 7.50 |
| 830v @ 125 ma, 6.3 @ 6A, 5 @ 3A..... | 3.95 |
| 850v @ 150 ma..... | 2.50 |
| 750v @ 300 ma..... | 3.50 |
| 78v @ 1.34 amp..... | 2.50 |

230V 50/60 CPS

| | |
|--------------------------|-------|
| 3000v @ 800 ma 3 ph..... | 32.50 |
| 700-0-700 @ 350 ma..... | 5.70 |
| 5.0v @ 30 amp..... | 6.50 |
| 6.3v @ 2.7 amp..... | 1.50 |

OIL CAPACITORS

| | |
|-------------------------------|--------|
| 2 mf 600 vdc..... | \$0.35 |
| 4 mf 600 vdc 609 etc..... | 0.60 |
| 6 mf 600 vdc..... | 0.75 |
| 7 mf 600 vdc rect..... | 0.75 |
| 10 mf 600 vdc A1000..... | 1.15 |
| 2 mf 1000 vdc 1009..... | .70 |
| 4 mf 1000 vdc 23F252..... | .95 |
| 10 mf 1000 vdc 22F47..... | 1.95 |
| 4 mf 1500 vdc TJU..... | 1.85 |
| 2 mf 2000 vdc 23F161..... | 1.95 |
| 1 mf 3600 vdc 8412..... | 3.10 |
| 0.15 mf 4000 vdc 26F386..... | 2.10 |
| .25 mf 4000 vdc 26F767..... | 2.85 |
| .1 mf 7000 vdc B8B1170..... | 1.95 |
| .005-.01 mf 12 kv 25F646..... | 4.75 |
| .02 mf 20 kv BT-15G..... | 5.95 |

VARIABLE CAPACITORS

| | |
|---|--------|
| 10 mmf midget Card. ZR10AS..... | \$.50 |
| 15 mmf midget BTD MC-1850..... | .45 |
| 15 mmf midget Card. ZR15AS..... | .50 |
| 25 mmf midget double sp..... | .55 |
| 3-18 mmf micro-dual, dbl sp..... | 1.15 |
| 2-28 mmf dual neut. Card..... | .40 |
| 250 mmf Trans. Jr Bud. JCI528..... | .85 |
| 240 mmf dual 1 gap Card. NE240XD..... | 4.35 |
| 190 mmf dual .05 gap Card. MO180BD..... | 1.95 |
| 260 mmf dual .03 gap Card. MR260BD..... | 1.35 |

MICAS AT 90% DISCOUNT

| Capacity | Types Fil. XR, etc. | | Price |
|----------|---------------------|--|--------|
| | Wkg Volts | | |
| 750 | 3,000 | | \$.75 |
| 500 | 5,000 | | .75 |
| 375 | 5,000 | | .75 |
| .001 | 4,500 | | 1.10 |
| .002 | 3,500 | | .95 |
| .003 | 3,000 | | .95 |
| .004 | 3,000 | | .60 |
| .005 | 3,000 | | .70 |
| .006 | 3,000 | | .70 |
| .007 | 3,000 | | .55 |
| .008 | 3,000 | | .70 |
| .009 | 3,000 | | .55 |
| .010 | 3,000 | | .50 |
| .015 | 3,000 | | .50 |
| .025 | 2,500 | | 1.10 |
| .030 | 2,500 | | .70 |
| .035 | 2,000 | | .45 |
| .045 | 1,500 | | .75 |
| .12 | 500 | | 1.15 |

| Type H. A2, #4, 9 | | |
|-------------------|---------|--------|
| 3500 #9 | | \$.60 |
| 2500 #4 | | .45 |
| 400 | 2500 #9 | .30 |
| 350 | 2500 #9 | .35 |
| .002 | 1000 #4 | .25 |

| Ceramicons | |
|-----------------------|--------|
| 50 mmf Feedthru..... | \$.06 |
| 50 mmf 7,500 vdc..... | .30 |

WIRE

| | |
|--------------------------------|----------|
| #20 HV str. white plastic..... | \$4.95/M |
| #20 str. white lacquer..... | 3.50/M |
| #20 str. red lacquer..... | 3.50/M |
| #20 str. green lacquer..... | 3.50/M |
| 3/16" magnet, DCC, rect..... | .35/lb |
| #30 SSE magnet..... | .60/lb |
| 1/4" tin shield braid..... | .30/lb |

FILTER CHOKES

| | |
|-------------------------------------|--------|
| 10H/75ma/260 ohm, herm..... | \$.70 |
| 4-20H/100ma, 120 ohm, herm..... | .95 |
| 10H/100ma, 280 ohm, herm..... | .90 |
| 5H/130ma/100 ohm, herm..... | 1.20 |
| 10-14H/145-200ma/100 ohm..... | 1.95 |
| 5H/200ma/70 ohm..... | 1.95 |
| 3-3H/200ma/60 ohm, herm..... | 4.50 |
| 6H/350ma, 82 ohm, herm..... | 2.50 |
| 16H/450ma, 112 ohm, herm..... | 9.50 |
| 8H/500ma, 80 ohm..... | 8.50 |
| 5-20H/500ma, 80 ohm..... | 8.25 |
| 8H/700ma/60 ohm..... | 12.75 |
| 5-20H/700ma, 60 ohm..... | 12.50 |
| 3H/275ma, 17H/175ma, 17H/125ma..... | 3.75 |
| 4H/85ma, 6H/90ma, 12H/65ma..... | 2.10 |

RELAYS — CONTACTORS

| Type | Coil | Contacts | Price |
|------------------------|---------------------|-----------|--------|
| CH Contactor | 115vac | 4PST, 30A | \$7.95 |
| West. MC gl. encl. | 115vac | 4PST, 20A | 7.50 |
| Allied BO | 6vdc | DPDT, 10A | .75 |
| Advance min. | 450 ohm 12vdc | SPST, 5A | .60 |
| G.E. PJC adj. overload | 4-12A ac/dc..... | | 12.50 |
| G.E. PJC adj. overload | 2-8A ac/dc..... | | 12.50 |
| G.E. PJC adj. overload | 0.5-1.5A ac/dc..... | | 7.95 |

ALL MATERIAL NEW AND GUARANTEED
 10% DISCOUNT ON ORDERS OVER \$100.00
 15% DISCOUNT OVER \$500.00
 LARGE QUANTITIES AVAILABLE — QUOTES ON REQUEST

CABLE

| | |
|---|-----------|
| 9 cond. #20 str. plas. 2 vinyl jack, shield, 1/2" dia. G.E..... | \$.08/ft |
| 10 cond. #20 sol. plas., vinyl jack, 1/2" dia..... | .07/ft |
| 28 cond. #20 str. plas., vinyl jack, 1/2" dia..... | .20/ft |
| 4 cond. 1/8" scr. plas., vinyl jack, 1" dia..... | .26/ft |
| 3 cond. #18 str. shield, jack..... | .04/ft |
| 2 cond. #20 str. shield, jack..... | .03/ft |
| RC8/U Amphecol, Federal..... | .07/ft |
| RC77/U Federal..... | .06/ft |

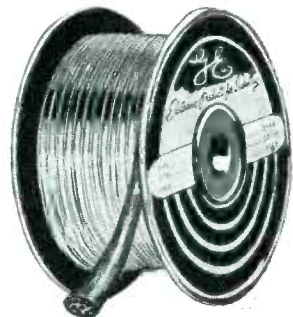

ELDICO OF NEW YORK, INC.

44-31 DOUGLSTON PKWAY., DOUGLSTON, L.I., N.Y., U.S.A. Cable Address. ELDICOINC

BAYSIDE 9-8686



SELENIUM RECTIFIERS

— and —
ELECTRONIC COMPONENTS

THREE PHASE BRIDGE RECTIFIERS

| Input 0-126VAC | Current | Output 0-130*VDC | Price |
|-------------------|---------|---------------------|---------|
| Type # 3B7-4 | 4 AMP. | | \$32.95 |
| 3B7-6 | 6 AMP. | | 48.90 |
| 3B7-15 | 15 AMP. | | 70.00 |
| Input 0-234VAC | Current | Output 0-250*VDC | Price |
| Type # 3B13-4 | 4 AMP. | | \$56.00 |
| 3B13-6 | 6 AMP. | | 81.50 |
| 3B13-15 | 15 AMP. | | 120.00 |

CENTER TAPPED RECTIFIERS

| Input 12-0-12VAC | Current | Output 0-8*VDC | Price |
|---------------------|----------|-------------------|--------|
| Type # C1-10 | 10 AMP. | | \$6.95 |
| C1-20 | 20 AMP. | | 10.95 |
| C1-30 | 30 AMP. | | 14.95 |
| C1-40 | 40 AMP. | | 17.95 |
| C1-50 | 50 AMP. | | 20.95 |
| C1-80 | 80 AMP. | | 26.95 |
| C1-120 | 120 AMP. | | 34.95 |

CUSTOM DC POWER SUPPLIES
Built to your specifications.
For:

- INDUSTRY LABORATORIES
- UNIVERSITIES
- GOVERNMENT AGENCIES

We will be pleased to quote on your requirements.

* Select Proper Capacitor to Obtain Higher VDC Than Indicated.

VACUUM CAPACITORS



| Standard Brands | | | |
|-----------------|--------|--|--------|
| 12 Mmfd | 20 Kv. | | \$4.95 |
| 50 Mmfd | 20 Kv. | | 4.95 |
| 50 Mmfd | 32 Kv. | | 5.95 |

SILVER CERAMIC TRIMMERS

| Type | Value | Temp. | Price |
|--------|-------------|------------|-------|
| 820-Z | 5-20 Mmfd | Zero Temp. | 24¢ |
| 822-N | 5-20 Mmfd | Neg. 300 | 24¢ |
| 822-AZ | 4.5-25 Mmfd | Zero Temp. | 24¢ |
| 823-AN | 20-125 Mmfd | Neg. 650 | 33¢ |

VARIABLE AIR TRIMMERS

| Standard Brands—Screw Driver Adj. | | | |
|-----------------------------------|------------|-------------|--|
| | Lots of 10 | Lots of 100 | |
| 7.5 MIMF | \$2.90 | \$27.00 | |
| 25 MIMF | 3.10 | 29.00 | |
| 50 MIMF | 3.30 | 31.00 | |
| 100 MIMF | 4.10 | 39.00 | |
| 140 MIMF | 4.90 | 47.00 | |

ATTENTION!!!
INDUSTRIALS, EXPORTERS, SCHOOLS,
GOV'T AGENCIES, LABORATORIES

Our engineering staff is at your service to facilitate the application of rectifiers to your specific requirements.
Write for quantity discount on company letterhead.

FULL WAVE BRIDGE RECTIFIERS

| Input 0-18VAC | Current | Output 0-13*VDC | Price |
|------------------|----------|--------------------|--------|
| Type # B1-250 | 250 MA. | | \$8.98 |
| B1-500 | 500 MA. | | 1.95 |
| B1-1 | 1 AMP. | | 2.49 |
| B1-1X5 | 1.5 AMP. | | 2.95 |
| B1-3X5 | 3.5 AMP. | | 3.95 |
| B1-5 | 5 AMP. | | 5.95 |
| B1-10 | 10 AMP. | | 9.95 |
| B1-15 | 15 AMP. | | 13.95 |
| B1-20 | 20 AMP. | | 15.95 |
| B1-30 | 30 AMP. | | 24.95 |
| B1-40 | 40 AMP. | | 27.95 |
| B1-50 | 50 AMP. | | 32.95 |
| B1-60 | 60 AMP. | | 36.95 |
| B1-80 | 80 AMP. | | 44.95 |

| Input 0-36VAC | Current | Output 0-26*VDC | Price |
|------------------|----------|--------------------|--------|
| Type # B2-150 | 150 MA. | | \$8.98 |
| B2-250 | 250 MA. | | 1.25 |
| B2-300 | 300 MA. | | 1.50 |
| B2-450 | 450 MA. | | 1.95 |
| B2-1 | 1 AMP. | | 3.95 |
| B2-2 | 2 AMP. | | 4.95 |
| B2-3x5 | 3.5 AMP. | | 6.95 |
| B2-5 | 5 AMP. | | 9.95 |
| B2-10 | 10 AMP. | | 15.95 |
| B2-15 | 15 AMP. | | 24.95 |
| B2-20 | 20 AMP. | | 27.95 |
| B2-30 | 30 AMP. | | 36.95 |
| B2-40 | 40 AMP. | | 44.95 |

| Input 0-54VAC | Current | Output 0-40*VDC | Price |
|------------------|---------|--------------------|--------|
| Type # B3-150 | 150 MA. | | \$1.25 |
| B3-250 | 250 MA. | | 1.95 |
| B3-600 | 600 MA. | | 3.25 |
| B3-5 | 5 AMP. | | 13.95 |
| B3-10 | 10 AMP. | | 24.95 |

| Input 0-72VAC | Current | Output 0-54*VDC | Price |
|------------------|---------|--------------------|--------|
| Type # B4-600 | 600 MA. | | \$3.95 |
| B4-3 | 3 AMP. | | 14.95 |
| B4-5 | 5 AMP. | | 17.95 |
| B4-10 | 10 AMP. | | 32.95 |

| Input 0-115VAC | Current | Output 0-110*VDC | Price |
|-------------------|----------|---------------------|--------|
| Type # B6-150 | 150 MA. | | \$1.95 |
| B6-250 | 250 MA. | | 2.95 |
| B6-1 | 1 AMP. | | 7.95 |
| B6-3X5 | 3.5 AMP. | | 18.95 |
| B6-5 | 5 AMP. | | 24.95 |
| B6-10 | 10 AMP. | | 36.95 |

| Input 0-234VAC | Current | Output 0-180*VDC | Price |
|-------------------|---------|---------------------|---------|
| Type # B13-600 | 600 MA. | | \$12.95 |
| B13-1 | 1 AMP. | | 16.95 |
| B13-3 | 3 AMP. | | 35.95 |
| B13-5 | 5 AMP. | | 54.95 |
| B13-10 | 10 AMP. | | 69.95 |

OIL CONDENSERS

| | |
|-----------------------------------|-------|
| 2 Mfd 200VDC Bathtub | \$.20 |
| 5 Mfd 400VDC | .20 |
| 2 Mfd 400VDC Bathtub | .30 |
| 2X.1 Mfd 600VDC | .39 |
| 6 Mfd 600VDC w/mtg. Clamp | .79 |
| 10 Mfd 440VAC/1500VDC | 1.55 |
| 8 Mfd 660VAC/2000VDC | 3.50 |
| 15-15 Mfd 8000VDC Voltage Doubler | 3.95 |

ELECTROLYTIC CONDENSERS

| Cap | WV DC | Each | Lots of 10 | Lots of 100 |
|------------|---------|--------|------------|-------------|
| 100 Mfd | 50 | \$0.27 | \$2.20 | \$19.00 |
| 40 Mfd | 150 | .23 | .80 | 17.50 |
| 8-8-20 Mfd | 350/150 | .40 | 3.50 | 30.00 |
| 20-20 Mfd | 400/250 | .35 | 3.00 | 25.00 |
| 10 Mfd | 450 | .30 | 2.50 | 20.00 |
| 15 Mfd | 450 | .30 | 2.50 | 20.00 |
| 40 Mfd | 450 | .50 | 4.20 | 36.00 |

Minimum order \$3.00. No C.O.D.'s under \$25.00. 25% deposit on C.O.D. Add 10% for Prepaid Parcel Post and Handling. Terms: Net 10 days in the presence of approved credit.

All prices subject to change without notice.

Orders Promptly Filled from Our Stocks
All Prices F.O.B. our NYC Warehouse

RECTIFIER CAPACITORS

| Type | Value | VDC | Price |
|-------|------------|--------|--------|
| CF-13 | 6000 MFD | 10VDC | \$2.49 |
| CF-14 | 3000 MFD | 12VDC | 1.69 |
| CF-15 | 6000 MFD | 12VDC | 2.95 |
| CF-1 | 1000 MFD | 15VDC | .98 |
| CF-2 | 2000 MFD | 15VDC | 1.69 |
| CF-20 | 2500 MFD | 15VDC | 1.95 |
| CF-3 | 1000 MFD | 25VDC | 1.25 |
| CF-4 | 2X3500 MFD | 25VDC | 3.45 |
| CF-5 | 1500 MFD | 30VDC | 2.49 |
| CF-6 | 4000 MFD | 30VDC | 3.25 |
| CF-7 | 3000 MFD | 35VDC | 3.25 |
| CF-8 | 100 MFD | 50VDC | .98 |
| CF-19 | 500 MFD | 50VDC | 1.95 |
| CF-16 | 2000 MFD | 50VDC | 3.25 |
| CF-9 | 200 MFD | 150VDC | 1.69 |
| CF-10 | 500 MFD | 200VDC | 3.25 |
| CF-12 | 125 MFD | 350VDC | 2.49 |

RECTIFIER TRANSFORMERS

All Primaries 115VAC 50/60 Cycles

| Type # | Volts | Amps. | Price |
|----------|-------|-------|--------|
| XF15-12 | 15 | 12 | \$3.95 |
| TXF36-2 | 36 | 2 | 3.95 |
| TXF36-5 | 36 | 5 | 4.95 |
| TXF36-10 | 36 | 10 | 7.95 |
| TXF36-15 | 36 | 15 | 11.95 |
| TXF36-20 | 36 | 20 | 17.95 |
| XF1710 | 17 | 10 | 4.95 |

All TXF Types are Tapped to Deliver 32, 34, 36 Volts. XPC type is tapped to deliver 15, 16, 17 Volts Center-Tapped.

RECTIFIER CHOKES

| Type # | Value | Amps. | Price |
|---|---------|-------|--------|
| HY6 | .02 Hy | 5 | \$3.25 |
| Dimensions 3 3/4" H x 3" D x 3 1/2" W Wt. 5 Lbs. Hermetically Sealed | | | |
| HY8X5 | .02 Hy | 8.5 | 7.95 |
| HY10 | .02 Hy | 10 | 9.95 |
| HY12 | .02 Hy | 12 | 12.95 |
| HY15 | .015 Hy | 15 | 13.95 |

RECTIFIER MOUNTING BRACKETS

For Types B1 through B6, and Type C1 \$.35 per set
For Types B1370 per set
For Types B3 1.05 per set

RECTIFIER KIT

6 and 12 VDC at 10 Amps.

This unit will deliver unfiltered direct current for operation of motors, dynamos, solenoids, electroplating, battery charging and similar equipment.

- The following components are supplied:
- 1 ea. Full Wave Bridge Rectifier
 - 1 pr. Rectifier Mounting Brackets
 - 1 ea. Transformer 115 VAC 50/60 CPS.
 - 3 ea. Silver-Plated Binding Posts
 - 1 ea. 4-Position Tap-Switch
 - 1 ea. Fuse and Fuse Holder
 - 1 ea. Line Cord and Plug

The primary of the transformer is multi-tapped permitting adjustment of the DC output voltages.

Complete with schematic diagram \$15.95
Filter Kit for above \$3.50

SYNCHRO MOTORS

Type 1F Special—KS-5949, L1 Western Electric 115/90 VAC—400 Cycles
Price Each \$8.00

WRITE FOR CATALOG #619

ON COMPANY LETTERHEAD

OPAD-GREEN COMPANY

71 Warren St.
New York 7, N. Y.

Phone: BEekman 3-7385-6

INDUSTRIAL
POWER SUPPLY
EQUIPMENT

for worthwhile savings to you

7.5 KW 0-15 KV OUTPUT
RECTIFIER POWER SUPPLY

NEW RA-38 HIGH VOLTAGE POWER SUPPLIES: 0-15,000 volts d-c @ 500 ma. Ripple 1/2% @ 100 ma; 3% @ 500 ma. Regulation 15,800 volts @ 100 ma, 15,000 volts @ 500 ma; 6,800 volts @ 100 ma, 5,000 volts @ 500 ma. Input 115 volts 60 cycle single phase. Full wave bridge rectifier using 4 371B tubes is utilized. Units are designed for continuous duty operation. Units have a full complement of controls, meters and safety devices. A remote control and spare set of tubes are included with each unit. Units are assembled in steel cabinets 62-1/2" long by 53-3/4" wide by 56-1/2" high. The cabinets are rubber shock mounted on skids. Weight 2040 lbs. Priced at less than 25% Government acquisition cost. Complete detailed information on request.

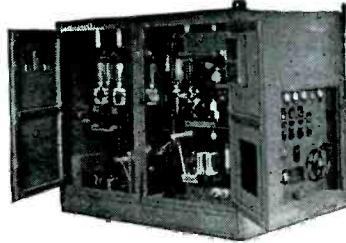

ASD RADAR
TRANSMITTER

3 centimeter, complete w/725A magnetron, cavity, two 723A/B klystrons, IKR 73, four 72's, 715B, 829B, two 724B's, two 6AC7's, IN23 crystal diode, high voltage supply, cooling blowers, etc. Input: 115 v 400 c. N-2 condition. \$110.00

PARTS FROM
ABOVE EQUIPMENT

Pre. Amp. Assembly: Includes plumbing, two 723A/B Klystrons, two 6AC7's, two 724B's, IN23 crystal diode etc. \$37.50
Power transformer: D9178, two 2.5 volt windings, 6.3 volt winding and high voltage winding, 115 v, 400 cy. Pri. \$11.50
725A Magnetron \$12.50
Magnet for 725A. Pole dia. 3/4", spacing 5/8" 4850 Gauss. 7.50
Tubes, filaments guaranteed: CRP 72. \$1.10; RKR73. \$1.30; 715B \$3.25; 829B. \$2.50.
Capacitor: Vitamin Q, 30 mfd @ 2,000 v d-c. .85
Capacitor: Vitamin Q, 2 x .15 mfd @ 8,000 v or .075 mfd. @ 16,000 volts. 2.90
Telephone Type Relays: #1 DPST normally open; #2 same as #1 plus a SPDT contact; 1,000 ohm coils both mounted in metal case 3/4 x 3/4 x 1/2. 2.50
Motor blowers: 28 v a-c/d-c. 2.95

NEW CAPACITORS
STANDARD BRANDS
OIL

2 mfd 600 v d-c tubular: \$3.30 each 10 for \$2.50
3.5/5 mfd 1000 v d-c. .90 each 4 for 3.00
3 x 1.0 mfd 3 kv d-c test, 1.2 kv d-c wk. Isolated sections. 1.20
1.25/1.25 mfd 7.5 kv d-c or .625 mfd 15 kv d-c Pyranol. 12.50
25/25 mfd 6 kv d-c or .125 mfd 12 kv d-c. 3.75
1.0 mfd 25 kv d-c; 65 lbs net; Pyranol. 36.00

ELECTROLYTIC

500 mfd 200 mv d-c, insulated terminals. .95

MICA

.001 mfd 25 kv d-c; 25 a @ 3,000 kv, 18 a @ 1,000 kv, 11 a @ 300 kv. 25.00

VACUUM

50 mmfd 32 kv d-c; tubular 4.95

T-102-Filament Transformer, American Transformer Co. Spec. 29106, Type WS .050 KVA, 50/60 cyc. Single phase, 35 KVA test, 12 KV D.C. operating. Primary 115 V., secondary 5 V., 10 amps with integral standoff insulator and socket for 250 T, 371, 872 and 5563, etc. rectifier tubes \$12.50
Net Wt. 15 1/2 lbs. Dim 6 1/2" W x 6" D x 12" H.O.A

WIRE

660 volt Simplex Type S (19) conductor #18 AWG \$170.00 per M*
3000 volt Simplex underground single conductor #8 AWG \$140.90 per M*
No. 18 AWG single conductor, solid, annunciator wire 7-lb spool. \$2.90 10 spools. \$27.00
*Above cable in full spools only, i.e. 1000 to 1200 feet.

SPECIALS

WESTINGHOUSE METER MULTIPLIER: 1 meg; 1/2% accuracy; wire wound; noninductive. \$1.25
RUNNING TIME METER: R. W. Cramer Type RT3H; 220 v 60 c; 3" square face; 5 figure indicator. (new) \$6.95
FILAMENT TRANSFORMER: Constant current type, pri. 110/220 v 50/60 c, sec. 21.5 v 40.5 amps. 17.50
TUBE WL 386/ML-3W; 125 kv X-ray rectifier; oil immersion type; filament; 10 v # 11.6 amps. 32.00
CRAMER TIME DELAY RELAY type TD2 120S; 0-120 seconds 115 v 60 c; synchronous motor driven; contact rating 10 amps 115 v; single pole normally open. 4.95

VOLTAGE
REGULATORS

TRANSTAT: 115 v 50/60 cycle input; 0-115 v 100 amps 11.5 KVA output \$95.00
TRANSTAT: 115/230 v 50/60 c input; 0-260 v output @ 2.5 amps. \$21.50
TRANSTAT: 115 v 50/60 c input; 0 to 130 v output @ 10 amps. \$24.50

METERS

Weston or Westinghouse
3" 0-120 a-c amps, w/current transf \$ 8.50
3" 0-20 kv d-c w/precision multiplier. 18.00
3" 0-4 kv d-c w/precision multiplier. 9.50
3"-10 to +6db, 6 mw 600 ohms 6.50

CONSTANT VOLTAGE
TRANSFORMERS
SOLA

95 to 125 volt 50 cycle single phase input; 115 volt output:
60 va ... \$ 8.40 380 va ... \$27.00
120 va ... 13.20 500 va ... 34.00
180 to 250 volt input; 220 volt output:
60 va ... 8.40 250 va ... 18.00

RAYTHEON

198 to 242 volts 50/60 cycle single phase input; 220 volt 500 watt output \$38.00

POWER FACTOR Correction
9:12 mfd 1265 v a-c, 80 c, 1 ph, 5 kilovolt amps reactance. New G. E. Pyranol \$17.50

TUBES

All Tubes are New, of Standard Mfg. in original boxes

| Type | Price |
|-----------|--------|
| 1B22 | \$5.75 |
| 1B23 | 9.75 |
| 1B24 | 4.75 |
| 2D21 | 1.25 |
| 2162 | 47.50 |
| 3B22 | 2.75 |
| 3B24 | 2.75 |
| 3C23 | 3.75 |
| 4B28 | 2.75 |
| 15E | 1.25 |
| 250R | 7.50 |
| 250TH | 19.50 |
| 250TL | 19.50 |
| *304TL | 7.50 |
| 307A/RK75 | 4.50 |
| 316A | .75 |
| 371B | 2.75 |
| 388A | 2.75 |
| 458TH | 22.50 |
| 700A | 37.50 |
| 701A | 4.75 |
| 702A | 3.75 |
| 703A | 4.75 |
| 704A | 2.25 |
| 705A | 2.25 |
| 706BY | 17.50 |
| 706Y | 9.50 |
| 707A | 7.75 |
| 707B | 16.50 |
| 708A | 4.75 |
| 713A | 1.25 |
| 714AY | 5.75 |
| 715A | 9.50 |
| 717A | 7.75 |
| 719A | 11.75 |
| 721A | 2.75 |
| 722A | 13.75 |
| 725A | 17.50 |
| 730A | 19.50 |
| 750TL | 47.50 |
| 814 | 4.75 |
| 830B | 4.75 |
| 872A | 2.25 |
| 921 | 1.25 |
| 931A | 2.75 |
| C5B | 8.50 |
| C6A | 8.50 |
| C61 | 9.50 |
| FG81A | 4.75 |
| WE-203A | 4.75 |
| WL-531 | 17.50 |
| WL-533 | 17.50 |

*Includes 115 v 60 c H.V. fl. trans & socket.

UNITED'S
SUMMER VALUES
TOP QUALITY
COMPONENTS

PRECISION MICA CONDENSERS
(Silver-Cap. 1%)

Size 1 1/2" x 1" 400 Mmfd., 1000 Mmfd., 1500 Mmfd., 2000 Mmfd. 15c. each 100 assorted for \$15.00

PRECISION RESISTORS

WW-3 150,000 Ohms 1/4" x 1 1/4" .25¢, 100 for \$21.00
W-1 10,000 Ohms 1/8" 9/16" x 9/16" .25¢, 100 for \$21.00

GLASS, VACUUM SEALED

Within 1/2 of 1% minus tolerance. Each unit marked with exact value to the 6th place. With pigtail leads. 4.0 Megohms at 85¢, each. 10 for \$7.50

FERRULE TYPE RESISTORS

Supplied with clips for mounting. Well-known makes

GLASS TYPES

15 Watts 19¢ ea. 30 Watts 35¢ ea. 90 Watts 59¢
1800 Ohms 400 Ohms 4 Ohms
2000 Ohms 630 Ohms 4000 Ohms
3000 Ohms 5000 Ohms 7500 Ohms
5150 Ohms 10,000 Ohms 15,000 Ohms
120 Watts79¢ ea.

63 Ohms
750 Ohms
INSTRUMENT MULTIPLIER, 3 Megohms 3 Watts 3000 V. 1.0 Ma Ea.98¢

VITREOUS TYPES

25 W. 8 Ohms.15¢ 100 W. 800 Ohms. 65¢
25 W. 20 Ohms.15¢ 100 W. 3000 Ohms. 65¢
30 W. 2800 Ohms. 29¢ 100 W. 6500 Ohms. 65¢
90 W. 800 Ohms.59¢ 200 W. 10,000 Ohms 85¢

OIL FILLED TUBULAR CONDENSERS

Phenolic shell over metal case. Size 1/2" x 3/4". 8-32 screw terminals. 1 Mfd. 1250 V.D.C. Each 23¢. 10 for \$2.00

ROUND METAL CAN UPRIGHT
FILTER CONDENSERS

40 + 40 Mfd. 250 V.D.C. 1 1/2" D. x 1" L. 55¢ Ea. 10 for \$5.00; 500 Mfd. 200 V.D.C.W. 2" D. x 4 1/2" L. With mtg. bracket. Ea. \$1.19. 10 for \$11.00

AMMETER SHUNT

Leece-Neville #S-24602. .005 Ohms mounted on asbestos base with aluminum mounting plate. Perforated metal shield for personnel protection and air cooling. Capable of handling at least 200 Amps. New-\$1.39.

CURRENT TRANSFORMER

Model 880-Ratio 75:1. Freq: 50 to 133 Cycles. With mounting bracket. Shpg. Wt. Approx. 1 Lb. New-\$2.75

D. C. AMMETER RELAY

Well known brand. 6 1/2" Diameter 3 1/4" Deep. Industrial. Stand-off type. 0-50 Amps. for 250 Mw. drop. Relay adjustable over full scale. Relay operates when current drops to preset minimum. *Approx. Shpg. Wt. 10 Lbs. New-\$10.50.

COAXIAL CABLE

RG-21/u 53 Ohms. New-\$3.49 per 100 Ft. *Approx. Shpg. Wt.-12 1/2 Lbs.

COAXIAL FITTINGS

Female SO-239. 3 for 55¢. Right Angle-Male and Female M-359-A. 3 for 55¢.

NAVY TYPE DYNAMOTORS

High efficiency PM. field units. May be used on 6 V.D.C. with 1/2 output voltage ratings. MODEL #516 BPC-Output: 275 V. @ 110 Ma. Input: 12 to 24 V.D.C. Approx. Shpg. Wt.-10 1/2 Lbs. \$2.50. MODEL #515 TRANS-Output: 500 V. @ 50 Ma. Approx. Shpg. Wt. 10 1/2 Lbs. \$3.50. New in cartons.

OUNCER TRANSFORMER W-226262-4

AF OUTPUT. Pri. Impedance: 10,000 Ohms. Sec. Impedance: 4000 Ohms, tapped at 250 Ohms. Metal can; 1 1/2" Lg. x 1" O. D. Overall. 10% at 75 Mw. @ 400 Cyc. 20% at 75 Mw. @ 250 Cyc. Response: 250 to 2500 Cyc. ± 3 DB. Glass sealed. New-95¢ each.

OUNCER TRANSFORMER #7254502

Pri. Impedance: 5000 Ohms. Sec. Impedance: 250 Ohms. Size: 1 1/2" Lg. x 1" Overall. Diagram on case. Hermetically sealed. New-89¢ each.

STEPPER RELAY

Type H-706. 4 circuits 25 positions, continuous. Position indicator on drum. D.C. Coil resistance 12 Ohms. Like New condition-\$4.75.

WAVE GUIDES

5' long with flange at both ends. Approx. 3 CM. Completely silver plated. Outside finished in Battle-shield Gray. Flange ends are sealed. New with Flange Hdwe.-\$3.39. *Approx. Shpg. Wt.-4 Lbs. *Shipped Railway Express only

WRITE FOR QUANTITY PRICES

Stocks are limited! Order now! C.O.D. orders require 25% deposit. All prices F.O.B. Chicago. Minimum order-\$2.00.

UNITED SURPLUS MATERIALS

312 South Halsted St.,
Chicago 6, Illinois

Telephone

CE ntral 6-4899

All merchandise in "as new" condition. Add approx. 20% to net weights for estimated shipping weights. Terms are 30% with order, balance C. O. D. All prices f.o.b. Los Angeles Warehouse. Write for additional detail information on any of the above items and for special quantity discounts. Telephone MADison 8-5381

1527 E. SEVENTH ST.

EPCO

LOS ANGELES 21, CALIF.

See Dick ERECO
Send me
your free list.

Yes Sir! the HOTTEST LIST
in the LAND. brim full of
electronics, hydraulics, air-
craft parts, gadgets
Rush me your name TODAY

AC/DC SELSYN SYSTEM

Here's the perfect remote position indicating system—very accurate—operates from 6-12 volts d.c. or 110 a.c. with 75 ma. half wave rectifier and or resistor. Diag. furnished.



Per set **\$4.95**

MIDGET SELSYNS



AY type operates from 6-12 V. 60 cycle. (28 V 400 cycle) use for either transmitter or receiver **ea. 98c**

500 CYCLE GENERATOR



4 KVA 110 Volt single phase p/f 1 3400 RPM. Just the thing to hook up to a 60 cycle motor as a power source to operate surplus 400-500 cycle equipment. Has 1 1/2" keyed drive shaft. Built in exciter and separate DC output of 14 volts @ 40 amps. OD 2 1/2" x 12" dia. Wt. approx. 200 lbs. Brand New. FOB EVERETT OR MID WEST. **ea. \$79.95**

AMPLIDYNE



GE #5AM31N39A 28 VDC input 68-0 60 VDC output at 8.8 Amps. 1 watt field power controls 530 watts output power. The ideal DC motor speed control & AC generator

voltage control. Brand New **ea. \$2.95**

CONTROL CABLE

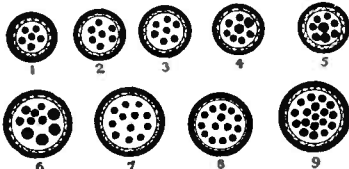

- 6 cond. #18 stranded, shielded, rubber covered .440 OD ft. **8c**
- 7 cond. #20 stranded, shielded, rubber covered. .440 OD ft. **8c**
- 7 cond. #16 stranded, plastic covered ft. **9 1/2c**
- 8 cond. (2 #14, 6 #20) stranded, shielded, plastic covered ft. **9 1/2c**
- 8 cond. (2 #16, 6 #20) stranded, shielded, plastic covered, ft. **10 1/2c**
- 10 cond. (4 #12, 2 #16, 4 #18) stranded, shielded, plastic covered. .730 OD, ft. **14c**
- 12 cond. #18 stranded, shielded, plastic covered, ft. **15c**
- 16 cond. #18 stranded, shielded, plastic covered, ft. **16c**
- 18 cond. (2 #16, 16 #20) stranded, shielded, plastic covered, ft. **16c**

All conductors color coded. Write for other sizes and types of control cable.

Include return address. Satisfaction Guaranteed or your money back. Hundreds of bargains in our free illustrated list.

DICK ROSE ERECO
2912 Hewitt Ave. Everett 20, Wash.

TS-155B/UP SIGNAL GENERATOR. pulsed, calibrated output, 110 v. 60 cy. NEW.

TS-34/AP SYNCHROSCOPE.

S BAND STANDARD REFERENCE CAVITY, Type N input connector, crystal holder **\$15.00**

ECHO BOX CUO-14AAAY FOR OBU-2 RADAR.

APR-1 RADAR SEARCH RECEIVER, complete with tuning units for range of 38-4000 mc, 30 mc I.F., 2 mc wide.

TUNING UNITS for APR-1 or APR-4 RECEIVERS (can be used with any 30 mc amplifier):

- TN-16, range 30-90 mc
- TN-17, range 80-300 mc
- TN-19, range 1000-2000 mc
- TN-54, range 2000-4000 mc

A LOW COST SUBSTITUTE FOR APR-4 RECEIVER, consisting of an APR-4 power supply and 30 mc I.F. with video amplifier chassis of BC8000AH, complete with tubes and necessary schematic. Equipment is new, but requires minor changes in wiring. **\$60.00**

ANOTHER POSSIBLE SUBSTITUTE consists of 30 mc I.F. and video amplifier chassis, plus power supply, 115 V 60-800 cps, of APR-5 Radar Receiver. Bandwidth is 10 mc. Complete with tubes, NEW. **\$90.00**

X BAND VSWR TEST SET TS-12/AP, complete with linear amplifier, direct reading VSWR meter, slotted wave guide with gear driven traveling probe, matched termination and various adapters, with carrying case, new.

X BAND POWER METER TS-36/AP, 8700-9500 mc, 1 to 1000 milliwatts.

X BAND PICK-UP HORN AT-48/UP, with coaxial fittings. **\$5.00**

S BAND SIGNAL GENERATOR CAVITY with cut-off attenuator, 2700-2950 mc. 2C40 tube, with modulator chassis **\$30.00**

TEST SET TS-278/AP, for AN/APS-13, synchronized, delayed pulse signal generator, 400-430 mc, calibrated waveguide below cut-off attenuator, synchronized marker generator, 115 V 60 cps, new, complete.

HIGH PASS FILTER, cut-off at 1000 mc, coaxial, 50 ohms. **\$12.00**

BROAD BAND TEST LOAD, 50 ohms, 1 watt, V.S.W.R. less than 1.1 to 2500 mc **\$7.50**

S BAND TEST LOAD, TPS-55PB/T, 50 ohms **\$8.00**

X BAND TEST LOAD, TS-108/AP, 150 watts, accessories **\$35.00**

COAXIAL WAVEMETER, Mico Instrument, from 1250 Mc to 4000 Mc. **\$60.00**

NOISE FIGURE METER 10-400 mc, measures N. to 30, for 50 ohm impedance. 75 and 270 impedance also supplied.

MUTUAL INDUCTANCE ATTENUATOR, Calibrated: frequency range 1 to 1000 mc by means of plug-in coils, attenuation range 120 db. **\$100.00**

MUTUAL INDUCTANCE OR PISTON TYPE ATTENUATOR, type N connectors, rack and pinion drive, attenuation variable 120 decibels, calibrated 20-120 db, frequency range 300-2000 mc. **\$32.00**

LOSSY LINE ATTENUATOR, consisting of RG-21/U cable rolled in metal box with UG-10/U connectors, furnished in any attenuation up to 20 db at 3000 mc **\$15.00**

S BAND MIXER, type N signal input, oscillator input, and I.F. output connectors, variable oscillator injection. **\$17.50**

SHIPBOARD RADAR—SQ, SN, SD-3 and SA-1

GENERAL RADIO PRECISION WAVE-METER, type 724A, range 16 kc to 50 mc, 0.25% accuracy, V.T.V.M. resonance indicator, complete with accessories and carrying case, new. **\$175.00**

RDF EQUIPMENT DP-15, 100-1500 kc, for ship use, complete with pedestals, azimuth scale, loop assembly, used 110 V 60 cps **\$250.00**

TUBES: W.E. 703, 704A Miniature Diode, and 705A H.V. Rectifier. **\$2.00 each**

DM-43 DYNAMOTOR, G.E., 24 V. 615/1030/2/5 volts at 250/280 ma, new, export packed **\$5.00**

LOOP MN-20 E for MN-26, D.F., new **\$7.00**

TRANSFORMERS, 115 volts, 60 cps primaries:

- 6250, 3250 and 2000 volts, tapped primary, voltage doubler, 12.5 kv ins **\$14.00**
- 6250 volts 80 ma, ungrounded, G.E. voltage doubler, 12.5 kv ins. **\$12.00**
- 2 secondaries at 500 volts 5 amps each, wt 210 pounds. **\$50.00**

PULSE INPUT TRANSFORMER, permalloy core, 50 to 4000 kc impedance ratio 120 to 2350 ohms. **\$3.00**

PULSE TRANSFORMER, UTAH 9280 **\$1.50**

PULSE TRANSFORMER 132-AWP. **\$6.00**

PULSE TRANSFORMER, GE 68G, 828G-1 **\$5.00**

PULSE TRANSFORMER, Westinghouse 145-EWP **\$10.00**

W.E. EQUALIZER D162118 **\$5.00**

HYPERSIL CORE CHOKE, 1 Henry, Westinghouse L-422031 or L-422032 **\$3.00**

PULSE FORMING NETWORK, 20 kv. .02 microsecond, 50 ohms, 800 p.p.s. **\$40.00**

Clough Brengle Resistance Capacity Bridge, model 230A, new. **\$50.00**

Audie Signal Generator, Hickok 198, RC tuned 20-20,000 cps. **\$15.00**

CONNECTORS:

| | | | |
|-----------------|------|-------------------|------|
| UG-10/U | .80 | UG-190/U | 1.00 |
| UG-12/U | .80 | UG-201/U | 2.00 |
| UG-21/U | .80 | UG-245/U | .50 |
| UG-22/U | .80 | SO-235/U | .28 |
| UG-24/U | .80 | PL-259 | .28 |
| UG-25/U | .80 | (for small cable) | |
| UG-27/U | .50 | M-359 | .28 |
| UG-29/U | 1.00 | UG-266 | 1.00 |
| UG-30/U | 1.00 | | |
| UG-30/U special | 1.00 | | |
| UG-58/U | .50 | PL 54 | .10 |
| UG-59/U | 1.00 | PL 81 | .50 |
| UG-83/U | 1.00 | AN-3102-14S-5P | .25 |
| UG-86/U | 1.00 | AN-3102-14S-2P | .25 |
| UG-167/U | 2.00 | RC-10066-20-1P | .50 |

METERS:

- 0-350 VOLTS, WESTINGHOUSE NX-35 METER, 1000 ohms per volt, 3 1/2" **\$4.50**
- 0-8 AMPS R.F. SIMPSON IS-89, 2% to 10 mc **\$4.50**
- 0-10 AMPERES, TRIPLETT 327-A, 3" square **\$4.00**

CAPACITORS:

- Feed thru, ceramic, 55 mmfd, 1000 VDC, threaded **.10 each**
- Feed thru, silver mica, disc type, 300 mmfd, 500 v. **.20 each**
- Ceramic double cap. 55 mmfd, 10,000 v **.50 each**
- Mica .005, 2500 V.V. DC. **10 for 5.00**

TRANSMITTING OIL-FILLED CAPACITORS:

- 2 MFD 600 WVDC ROUND CAN 10 for \$2.100 for **\$10.00**
- 2 Mfd 1000 WV **1.00**
- 1 mfd 2500 WV **1.50**
- .15 mfd 4000 WV **1.00**
- 2 mfd 4000 WV **5.00**
- .1 — .1 mfd 7000 WV **2.00**
- .075 — .075 mfd 8000 WV **2.00**
- 1 mfd 15000 WV **25.00**
- 2 mfd 10000 WV **5.00**

AB26CR MAST EQUIPMENT COMPONENTS such as Anchor screws, coupling units, base plates and guy cables, designed for 72 ft transportable mast, New Equipment.

INVERTER PE 206, INPUT: 28 VDC, 38 Amps. **OUTPUT:** 80 V, 300 Cy. 500 VOLT-AMPS **\$12.50**

ELECTRO IMPULSE LABORATORY

P. O. Box 250 Eatontown 3-0768 Red Bank, N. J.

LLECTRONIC SURPLUS SPECIALS

ASB YAGI ANTENNA

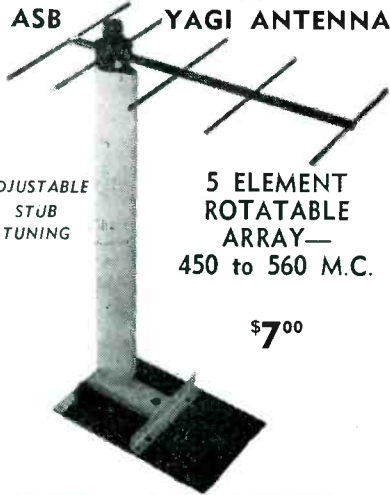

ADJUSTABLE STUB TUNING

5 ELEMENT ROTATABLE ARRAY—450 to 560 M.C.

\$7⁰⁰

GENERAL ELECTRIC FG-172 THYRATRONS \$14⁵⁰ EA.

\$10⁰⁰ EA.

IN LOTS OF 10 BRAND NEW ORIGINAL CARTONS FULLY GUARANTEED

RCA HI-VOLTAGE TRANSFORMER

Pri—115/230V 60Cy
Sec—6000V—80 MA

\$11.80

TRANSFORMERS

Pri. 115/230 V 60cy 2 KVA, Sec. 500/500 V @ 4A, 400/400-300/300 V @ 5A\$67.50
 Pri. 210/230/250 V 60cy, Sec. 1450, 2050, 2900 V—3.77 KVA\$49.00
 Pri. 115/230 V 60cy, Sec. 11 V @ 15A—25 KV insulation\$48.00

GERMANIUM CRYSTALS

IN34 - 1.19 IN44 - 1.22
 IN43 - 1.40 IN45 - 1.22

HIGH VOLTAGE MICA CAPACITORS

Type G-1 .004 mfd. 6KV \$6.35
 " G-3 .00015 mfd. 20KV \$12.70
 " G-4 .004 mfd. 20KV \$18.77
 " UC-3260 .0005 mfd. 20KV \$6.90
 " UC-2317K .0035 mfd. 4KV \$3.15
 " UC-2938K .002 mfd. 5KV \$3.15
 " UC-3135A .00005 mfd 35KV \$11.90

SOUND POWERED PHONES

RCA or Western Electric Navy Head and Chest Sets—Brand New.....\$14.88
 Western Electric Chest Mike with 20 ft. cable \$3.88

OIL-FILLED CONDENSERS

50 mfd. 220 V AC \$1.56
 7 mfd. 660 V AC \$2.95
 .045 mfd. 16 KV \$4.70
 32 mfd. 2500 V DC \$10.80

Kollsman 2 Phase Low Inertia motors Type 937-0240\$8.22
 Model ASB-4 Radar Equipment—Complete \$69.75
 CW1-60 AAG Range Calibrator for ASB \$39.95
 Navy Model LD-3 Het. Freq. Meter and Crystal Controlled Calibrator Equip. manufactured by General Radio.....\$370.00
 G. E. Type JP-1 Portable Instrument Current Transformer\$32.50

WESTINGHOUSE HYPERSIL TRANSFORMER



PRI-115V. 60CY ¾ KVA
 SEC #1 - 240V - 1.56A
 SEC #2 - 240V - 1.56A
 WT. 30 LBS.

\$1150 EACH

\$10⁰⁰ ea. Lots of 10



200 W. WIRE WOUND FERRULE RESISTORS
 Fixed taps at each 10% of full resistance value.
 25 ohms 200 ohms 500 ohms 2000 ohms
 50 ohms 300 ohms 1500 ohms

77c Each 10 for \$6.10

YAGI ANTENNA

DOUBLE STACKED 6 ELEMENT

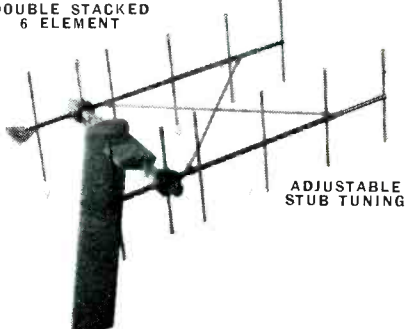

ADJUSTABLE STUB TUNING

LLECTRONIC RESEARCH LABORATORIES

1021-23 Callowhill St. —New Location— Phila. 23, Pa.
 Telephones: Market 7-6590 and 6591

UNIVERSAL SAVES U 50%



PULSE INPUT TRANSFORMER
 Imp. ratio 50 to 1000 to 1000 (3 wdgds.) Hypersil core. Working voltage: 15kV A.V.E. type KS 9798. Shipping wt. 3½ lbs. \$4.95 ea. No. T94

CONNECTORS
 SO 239 (83-1R) "UHF" COAX Sample 2nc ea. \$25/C \$220/Al
 AN-3106-40-9S69c ea.
 AN-3108-36-15S69c ea.
 AN-3108-18-11"39c ea.

SERVO OUTPUT TRANSFORMERS
 PP 6L6 to Servo mechanism with 10% feedback winding. MU metal core..... \$3.25 ea.

Dual unit PP 6V6 to Servo mechanism with 10% feedback winding and 6SN7 to Servo mechanism. Both in 1 can. **\$3.95 ea.**

400 CYCLE POWER TRANSFORMER
 Hermetically sealed—400 to 2400 cycle units. Type TX37—2000 v. 4ma; 315-0-315v, 100ma. 115v pri with 80 v tap Type 96-1578..... \$3.95 ea.
 Type TX36-Filament Transformer 2.5v 1.25a; 5v, 3a; 6.3v, 2a; 6.3v, 4a\$3.95 ea.

TELEVISION HORIZONTAL OSCILLATOR STABILITY COIL
 11-38ma. Powdered iron core and shield. 39c ea. \$25/C
 Min. Order \$2.50. Prices Net FOB Our Plant

Universal/general corp
 365 CANAL ST. N. Y. 13, Walker 5-9642

PRECISION resistor WIRE

| Size | Advance * Copper-nickel alloy—low temp. | Coppic * Ohms per ft. | Cupron * Ft. co-ef. .00004 | Price/lb. |
|----------|--|--------------------------|-------------------------------|-----------|
| #22 dec | .459 (180 alloy) | 515 | 515 | \$1.29 |
| #24 dec | .728 | 820 | 820 | 1.35 |
| #25 dec | .917 | 1,029 | 1,029 | 1.50 |
| #26 dec | 1.163 | 1,305 | 1,305 | 1.58 |
| #27 dec | 1.458 | 1,536 | 1,536 | 1.70 |
| #28 dec | 1.852 | 2,078 | 2,078 | 1.92 |
| #29 dec | 2.302 | 2,584 | 2,584 | 2.00 |
| #30 dec | 2.940 | 3,300 | 3,300 | 2.20 |
| #33 dec | 5.833 | 6,546 | 6,546 | 2.35 |
| #35 dec | 9.375 | 10,522 | 10,522 | 3.90 |
| #34 S.E. | 7.408 | 8,314 | 8,314 | \$3.25 |
| #35 S.E. | 9.375 | 10,522 | 10,522 | 3.90 |
| #36 S.E. | 11.76 | 13,200 | 13,200 | 4.60 |
| #39 S.E. | 24.00 | 26,930 | 26,930 | 8.50 |
| #40 S.E. | 30.59 | 34,330 | 34,330 | 10.50 |

ORDERING INSTRUCTIONS Unless specified we will ship any of the types advertised above.
MINIMUM ORDERS D.C.C. #22 to 35, 1 lb. +30% —15%, respoold from original 3 lb. av. spools.
ENAMELED #34-35-36, min. order 1 lb. ±30%; sizes 39 & 40, ½ lb. ±30% min. Enameled wire is spooled on mfr's precision spools. All guar'd.

ATLANTIC INDUSTRIAL CO.
 101-38 91st St. Ozone Park, New York

EXCEPTIONAL VALUES

Surplus and Standard lines. Test Equipment, Meters, Rheostats, Oil Filled Condensers, Switches, Co-ax connectors, Resistors, Shielded Cables, Multi Conductor Cables, Fuses and Holders, Sockets, Crystals, Variable Condensers and many quality items too numerous to mention. Send for our latest 12 page flyer "E" Special get acquainted offer!! 250MM Precision Vernier Caliper in fitted case. \$50 Value; our price \$13.95.

STANDARD RADIO—ELECTRICAL PRODUCTS
 2260 WASHINGTON AVENUE
 NEW YORK 57, NEW YORK

ELECTRONIC TUBE-MAKING MACHINERY

For manufacturing radio tubes, electronic tubes, cathode-ray tubes, lamps. New and used. Reasonably priced, satisfaction guaranteed.

AMERICAN ELECTRICAL SALES CO.
 67 E. 8th St. New York, N. Y.

D. C. MICROAMMETERS

0-100 ua 4" sq. G.E. DO 58.....\$12.00
 0-100 ua 4½" round Weston 643..... 14.00
 0-50 ua 4½" round Weston 643..... 15.00
 0-200 ua 3" sq. G.E. DO 50..... 8.00
 0-50 ua 3" sq. G.E. DO 50..... 12.00

R. F. MILLIAMMETERS

0-100 Ma 3¼" r. Weston 425\$11.00
 0-120 Ma 3¼" r. Weston 507 7.00
 0-10 Ma 4¼" r. Weston (vacuum) 22.00
 0-2 Ma 4¼" r. Weston (vacuum) 26.00

A. C. VOLTMETERS

0-300 v 3½" r. Weston 476.....\$8.00

Precision Electrical Instrument Co.
 146 Grand Street New York 13, N. Y.

CLARE STEPPING SWITCHES

Guaranteed As Advertised or Money Back. Ideal for laboratory work, counters. At this price they are worth stocking a few till needed.

Type SD-14 20 steps, 6 levels. Coil 12V, D.C. Lists at \$40.26; our low price \$13.07. All brand new in original boxes, not war surplus.

NEOMATIC, INC.
 938 W. Wash. Blvd., Los Angeles 15, Calif.
 Phones RI-9363 or AR-34897

SURPLUS BARGAINS - - NOW !!

L & N MICROMAX

—D. C. POTENTIOMETER

Model S INDICATING & RECORDING CONTROLLER

Rebuilt, Reconditioned, Adjusted Electrically and Mechanically.

Single Point, Curve-Drawing, Continuous Line, Set H-C-L Contacts. 115 V 60 cy. Motor.

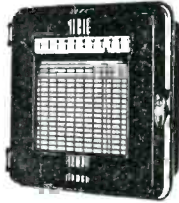

\$210.00

Ranges:

- 0—1200° F C/A
- 0—1500° F C/A
- 0—1800° F C/A
- 200—2000° F C/A
- 1000—2000° F C/A
- 1000—3000° F Plat.
- 10% R

STEP DOWN TRANSFORMERS SPECIAL

Made by GE, heavy duty, considerable over-design, open frame, ideal for rectifier application, size: 3 1/2" x 3 1/2" x 4".
PRI—115 Volts 60 Cycles
SEC—16 V at 12 Amps

\$3.75

HIGH VOLTAGE CAPACITORS

| | |
|---|-----------------------|
| 1 MFD 20 KV DC 18" x 13 1/4" x 5" | \$25.00 |
| 1 MFD 25 KV DC 13" x 7" x 4" | 9.85 |
| .001 MFD 50 KV DC 5 1/4" x 7 1/4" x 1-1/16" | 12.50 |
| 4" dia. x 7" high | |
| Cap. Volts | Price |
| Mfd. D.C. | Height Width Length |
| 4 1000 | 6-7/8 x 1-3/4 x 3-7/8 |
| 1 1000 | 6-7/8 x 2-3/4 x 1-1/4 |
| 1 1000 | 3-5/7 x 2 x 1-1/16 |
| 1 500 | 2" x 1-1/4" x 1-1/16" |
| .25 1000 | 1-1/2 x 1" x 3/4" |

RACK PANEL CABINET

42" H x 22" W x 16 1/2" D

Heavy Gauge Metal, Black Wrinkle Finish, shipped knocked down, ready to assemble with rear door and hardware. Front Panel not included. Panel size 19 1/4" x 36 3/4". Shipping weight 99 lbs.
NEW! A REAL BUY \$17.50

POWERTRON

117 LAFAYETTE STREET

PANEL METERS

Code—R-Round, S-Square, B-Bakelite, M-Metal, F-Flush, SF-Surface, FS-Full Scale

A. C. VOLTS

| | | | | |
|--------|-------|---------------------------------|--------|------|
| Weston | 517 | 0-10 | 2" R-M | 2.95 |
| Weston | 517 | 0-15 | 2" R-B | 2.95 |
| Weston | 517 | 0-150 | 2" R-B | 3.50 |
| Whse | RA35 | 0-7.5 | 3" R-B | 3.95 |
| Weston | 476 | 0-8 | 3" R-B | 3.95 |
| Trpltt | 331JP | 0-150 | 3" R-B | 4.50 |
| Whse | RA37 | 0-300/600 | 4" S-B | 9.75 |
| | | w/2 to 1 Potential Transformers | | |

AC AMPS

| | | | | |
|--------|-------|---------------------------------|----------------|------|
| Trpltt | 332JP | 0-30 | 3" R-M | 4.95 |
| Weston | 642 | 0-75 | 4" R-M SF or F | 7.50 |
| Whse | RA37 | 0-75/150 | 4" S-B | 9.75 |
| | | w/external Current Transformers | | |

DC MICROAMPS

| | | | | |
|--------|-----|-------|--------|-------|
| Weston | 301 | 0-100 | 3" R-B | 12.50 |
|--------|-----|-------|--------|-------|

DC MILLIAMPS

| | | | | |
|---------|------|-------|-------------------------|------|
| McClntk | 2001 | 0-1 | 2" R-B | 3.95 |
| GE | DW41 | 0-25 | 2" R-B Wide Flange | 3.50 |
| Simpson | 25 | 0-1 | 3" R-B Spec Scale | 4.50 |
| GE | DO41 | 0-1 | 3" R-B Black Spec Scale | 4.50 |
| Weston | 301 | 0-1 | 3" R-B Spec Scale | 7.50 |
| Weston | 301 | 0-25 | 3" R-M | 5.95 |
| Weston | 301 | 0-200 | 3" R-B | 6.50 |
| Weston | 301 | 0-300 | 3" R-B | 6.50 |
| Weston | 301 | 0-500 | 3" R-B | 6.50 |

DC AMPS

| | | | | |
|--------|------|-----------|-------------------|------|
| Weston | 506 | 50-0-50MV | 2" S-B Spec Scale | 3.95 |
| GE | DO50 | 50MV | 3" S-B Spec Scale | 2.95 |
| Weston | 301 | 0-1 | 3" R-M | 6.50 |

DC VOLTS

| | | | | |
|---------|-----|-------|------------------|------|
| Sun | 378 | 0-3 | 2" R-B | 2.50 |
| Simpson | 125 | 0-35 | 2" R-M | 2.50 |
| Weston | 301 | 0-150 | 3" R-M Blk Scale | 5.95 |

ALL PRICES FOB OUR WAREHOUSE NYC.
INCLUDE SUFFICIENT FOR POSTAGE

CIRCUIT ANALYZER

WESTON Model 772, Type 6 with lever to extend DC range to 5000 V.

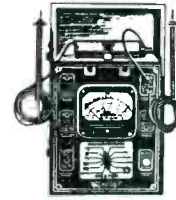

NEW! \$57.50

SENSITIVITY—
20,000Ω/V-DC
1,000Ω/V-AC
RANGES: (All self contained) AC & DC Volts—
5/10/50/250/1000
DC Amps—1/10 A
DC MA—1/10/50/250
MA MICRO A—100
MICS
RESISTANCE—3000/30
K/3 Meg/30 Meg Db—6
Ranges from —14 to +54
In handsome wood case

WHSE PORTABLE GALVANOMETER



Type PX-12, Movement 7 MA, special scale, solid connecting terminals, contains a 1 Volt internal cell which can be easily removed for conversion to DC AMMETERS & VOLTMETERS, with leather case and canvas carrying strap.

A BUY at \$4.95

DUMONT Model 164-E 'SCOPE



Used! Guaranteed

3" CRT operates at accelerating potential of 1100 V—brilliant well-defined trace Vert amp voltage gain approx 43, horiz amp voltage gain approx 55, Freq. range vert. & hor. amp both uniform ±3 DB from 5-100,000 CPS Input impedance 1 megohm vert., 8 megohm hor. Operates 115 V, 40-60 cycle.

**Price New \$115.00
Your Cost \$77.50**

SAVE WITH GUARANTEED SURPLUS

POWER RHEOSTATS
(nationally known mfrs)

| ohms | watt | ea. | ohms | watt | ea. |
|------|------|--------|-------|------|--------|
| 5 | 50 | \$1.24 | 378 | 150 | \$2.74 |
| 5 | 150 | 2.74 | 400 | 25 | .98 |
| 6 | 25 | .98 | 500 | 25 | .98 |
| 6 | 50 | 1.24 | 500 | 75 | 1.97 |
| 7 | 25 | .98 | 585 | 150 | 2.74 |
| 7.5 | 100 | 2.25 | 750 | 25 | .98 |
| 8 | 50 | 1.24 | 750 | 150 | 2.74 |
| 10 | 25 | .98 | 1000 | 25 | .98 |
| 12 | 25 | .98 | 1200 | 225 | 3.25 |
| 15 | 25 | .98 | 1250 | 50 | 1.24 |
| 16 | 50 | 1.24 | 1250 | 150 | 2.74 |
| 22 | 50 | 1.24 | 1500 | 50 | 1.24 |
| 25 | 25 | .98 | 2000 | 25 | .98 |
| 50 | 25 | .98 | 2000 | 50 | 1.24 |
| 50 | 50 | 1.24 | 2500 | 100 | 2.25 |
| 60 | 25 | .98 | 3000 | 25 | .98 |
| 75 | 150 | 2.74 | 3000 | 100 | 2.25 |
| 80 | 50 | 1.24 | 3500 | 50 | 1.24 |
| 80 | 500 | 4.95 | 5000 | 25 | .98 |
| 100 | 50 | 1.24 | 5000 | 50 | 1.24 |
| 125 | 25 | .98 | 7500 | 50 | 1.24 |
| 150 | 50 | 1.24 | 7500 | 100 | 2.25 |
| 200 | 25 | .98 | 10000 | 50 | 1.24 |
| 250 | 25 | .98 | 10000 | 100 | 2.25 |
| 350 | 25 | .98 | 20000 | 150 | 2.74 |

(Discounts to Quantity Users)

ALLEN-BRADLEY

potentiometers



| Type "J" | | | |
|----------|------|-------|---------|
| 60 | 1200 | 10000 | 75000 |
| 100 | 1500 | 12000 | 80000 |
| 150 | 2000 | 15000 | 100000 |
| 200 | 2100 | 16000 | 200000 |
| 400 | 2200 | 20000 | 250000 |
| 500 | 4000 | 25000 | 300000 |
| 600 | 4700 | 30000 | 1.0 meg |
| 1000 | 5000 | 50000 | 5.0 meg |

Type "JJ" and Type "JJJ"
2 x 500 2 x 150K 3 x 750K
2 x 600 2 x 200K 3 x 800K
2 x 2K 2 x 250K 3 x 1.0 meg
2 x 10K 2 x 1.0 meg 2 x 5.0 meg
Prices Quoted Upon Request



OIL CONDENSERS

FAMOUS MAKES
most with ceramic pillar insulators.

| | |
|---|--------|
| .1 Mfd—3000 vdcw | \$9.75 |
| .25 Mfd—3500 vdcw | 1.15 |
| 1.0 Mfd—500 vdcw | .28 |
| 1.0 Mfd—600 vdcw | .35 |
| 2.0 Mfd—400 vdcw | .35 |
| 2.0 Mfd—600 vdcw | .39 |
| 4.0 Mfd—500 vdcw | .59 |
| 4.0 Mfd—600 vdcw | .69 |
| 6.0 Mfd—400 vdcw | .75 |
| 6.0 Mfd—600 vdcw | .79 |
| 10.0 Mfd—600 vdcw | .98 |
| 14.0 Mfd—600 vdcw | 1.75 |
| 15.0 Mfd—600 vdcw | 1.98 |
| 15.0 Mfd—1000 vdcw | 2.25 |
| 4-4 Mfd 400 vdcw 3 sec. 4 prong plugs in can 4; 7" high x 3" Dia. | \$1.49 |



BATHTUB CAPACITORS

FAMOUS MAKES

| | | | |
|-----------|-----|-------------|-----|
| .033/400V | 17¢ | 1.0/200V | 29¢ |
| .05/200V | 13¢ | 1.0/600V | 35¢ |
| .05/400V | 19¢ | 2.0/600V | 45¢ |
| .05/600V | 21¢ | 2x.05/1500V | 33¢ |
| .1/200V | 17¢ | 2x.1/600V | 29¢ |
| .1/400V | 20¢ | 2x.1/1000V | 31¢ |
| .1/600V | 22¢ | 2x.16/600V | 28¢ |
| .15/600V | 23¢ | 2x.25/600V | 29¢ |
| .25/200V | 19¢ | 2x.5/600V | 34¢ |
| .25/400V | 21¢ | 3x.05/600V | 30¢ |
| .25/600V | 23¢ | 3x.1/600V | 33¢ |
| .5/200V | 20¢ | 3x.25/600V | 30¢ |
| .5/400V | 23¢ | 3x1.0/100V | 35¢ |
| .5/600V | 25¢ | | |
| 4.0/50V | 35¢ | 200/12V | 25¢ |
| 25/25V | 27¢ | 300/6V | 35¢ |
| 25/50V | 28¢ | 2x10/25V | 25¢ |
| 25/75V | 30¢ | 2x200/9V | 49¢ |
| 50/25V | 28¢ | | |

PRECISION RESISTORS

Standard Brand

| | | | | |
|--------|------|------|-------|-------|
| 6 | 248 | 1155 | 5294 | 29500 |
| 24 | 280 | 1250 | 5470 | 29870 |
| 28 | 286 | 1260 | 5500 | 30000 |
| 34.6 | 300 | 1280 | 5910 | 32000 |
| 35.7 | 370 | 1400 | 8000 | 33800 |
| 38.6 | 490 | 1477 | 6207 | 37500 |
| 40 | 450 | 1485 | 6550 | 38140 |
| 47.7 | 500 | 1607 | 6800 | 39000 |
| 75 | 636 | 2000 | 7000 | 40500 |
| 78.8 | 650 | 2142 | 7500 | 47710 |
| 80 | 680 | 2500 | 15000 | 60000 |
| 88 | 700 | 3460 | 17000 | 61000 |
| 100 | 733 | 3500 | 18380 | 61400 |
| 107.85 | 743 | 3760 | 19500 | 70000 |
| 110 | 750 | 3900 | 20000 | 72000 |
| 125 | 900 | 4000 | 20500 | 75000 |
| 125 | 946 | 4280 | 21000 | 76100 |
| 215 | 100 | 4500 | 22000 | 83700 |
| 225 | 5000 | | | 90000 |

Any Above Each 30¢; 10 for \$2.50

1000000 125000 145000 347000
110000 130000 220000 390000
115000 135000 235000 500000
120000 140000 260000 750000
800000

Any Above Each 40¢; 10 for \$3.50

1.0 meg 4.0 meg 10.0 meg
Any Above each 75¢; 10 for \$6.50

Many Other Types in Stock

DYNAMOTORS

brand new in sealed cartons

Type B-19 Pack, Mark II

Mfd. by Delco, Pioneer, Winco.

Input: 12 volts @ 9.4 amps

Output: 275 volts @ .110 amps

500 volts @ .050 amps

Price \$8.49

Open Accounts to Rated Concerns
Prices net FOB our whse NYC

ALEXANDER MOGULL CO., INC.

161 Washington St., N. Y. 6, N. Y.

Worth 4-0865

HANDY TALKIES - WALKIE TALKIES
Popular Army & Navy models in NEW and NEAR-NEW condition, complete, checked and guaranteed.

RADAR

Western Electric and General Electric models in "S" and "VHP" bands with ranges to 80 miles. All NEW in original packing and complete. Prices of our models on request.

SCR-528—F.M. Radiotelephone, complete in every detail. For two-way voice communication in mobile, fixed location, or relay installations. Western Electric designed. NEW, export packed, ready for IMMEDIATE delivery. Weight 227 lbs. A terrific buy! Write for its comprehensive description in our catalogue.

RADIO DIRECTION FINDERS

Models DF-1011, Range 280-580 Kcs. Binnacle type with long shaft & loop, nine tubes & manual, Mfg. Bludworth. Price\$325.00
Model DF-1016, like above, and also receives A1, A2, A3 signals, but with short shaft and loop and nine tubes. Price\$275.00

TRANSMITTERS

Selected units in all power outputs and voltages. All complete and guaranteed. A wide variety for all purposes to choose from. See our catalogue.

TDE—U.S. Navy, Mfg. Westinghouse 300 to 18,100 Kcs. two transmitting sections in one steel cabinet; phone, CW., ICW., most voltages, in NEW and NEAR-NEW condition. COMPLETE, CHECKED & GUARANTEED.

RECEIVERS

AVR-20A, Mfg. by R.C.A., 2300-6700 Kcs., receives phone, CW & ICW. Runs on 6 volts AC or DC and low "B" supply. Use batteries, small AC pack or our AVA-126A. Manual & two xtal positions. Ideal for mobile, aircraft or fixed station monitoring of Time Signals, etc. Size 5 1/2" x 6 1/2". Wt. 6 lbs. NEW & NEAR NEW. Price \$15.50

TOWERS

Dural construction in 10' to 100' heights. Shipped knocked down with all accessories. Prices for various sizes on request.

SPECIAL DEVICES

VIBRAPACKS—For all purpose usage—mobile, aircraft, boats. Model AVA-126A MFG by RCA, with BOTH 6 & 12 Volt vibrators, OZ4GT rectifier, 3 built-in relays for rcvr. and trans. Delivers 320 V. DC at 110 Ma. Contained in grey steel box 7"x7"x7", wt. 10 lbs. NEW\$14.95

WHIP ANTENNAS, AN-131A, famous "Throw Out" (p/o SCR-300) folds into 8 interconnected lengths 17" long. When thrown out measures 10'6". Threaded base for mtg. NEW.....\$1.65

TEST UNIT I-135, a must for servicing Handy Talkie SCR-536. Contained in black crackle steel cabinet. NEAR-NEW\$45.00

INFRA RED IMAGE CONVERTER TUBES—NEW, individually boxed, each tested before shipment, with data sheet, and FREE filter.....\$9.00

HIGH VOLTAGE OIL-FILLED PYRANOL Condensers—25 mfd x 20,000 Volts in better brands. Brand NEW in cartons. Bargained priced at\$12.95

Our NEW Catalogue mailed on request.

Call: Communidiv
Tel: AD-4-9277

COMMUNICATION DEVICES CO.

2331 TWELFTH AVENUE

Subject to prior sale.
FOB: WHSE
NEW YORK 27, N. Y.

FP CONDENSERS STANDARD BRANDS

| SINGLE SECTION | | |
|----------------|-------|--------|
| Cap. | Volt. | Each |
| 2,000 | 15 | \$.79 |
| 1,000 | 25 | .74 |
| 10 | 450 | .34 |
| 20 | 450 | .39 |
| 30 | 475 | .47 |
| 30 | 450 | .49 |

| DUAL SECTION | | |
|--------------|--------|-------|
| Cap. | Volt. | Each |
| 40-20 | 25 | \$.39 |
| 80-80 | 25 | .49 |
| 20-20 | 25 | .54 |
| 40-40 | 250 | .79 |
| 10-40 | 300-25 | .49 |
| 90-10 | 350 | .69 |
| 40-20 | 450 | .79 |
| 40-40 | 450 | 1.09 |
| 20-20 | 450 | .49 |
| 50-50 | 450 | 1.19 |

| TRIPLE SECTION | | |
|----------------|-------------|-------|
| Cap. | Volt. | Each |
| 90-90-20 | 200-200-50 | \$.89 |
| 30-15-10 | 350-300-25 | .59 |
| 10-10-20 | 350-350-25 | .51 |
| 30-15-10 | 350-300-300 | .69 |
| 15-10-10 | 400-400-350 | .62 |
| 15-10-10 | 350-350-250 | .64 |
| 40-40-20 | 400-300-250 | .89 |
| 10-10-20 | 450-450-25 | .69 |
| 15-15-10 | 450-400-350 | .73 |
| 30-10-10 | 450-450-350 | .79 |
| 30-30-10 | 450-450-25 | .89 |
| 60-20-20 | 450-450-400 | 1.19 |

| QUADRUPLE SECTION | | |
|-------------------|-----------------|-------|
| Cap. | Volt. | Each |
| 60-30-100-40 | 150-150-25-25 | \$.79 |
| 40-40-20-200 | 150-150-50-10 | .79 |
| 40-50-20-20 | 300-250-250-25 | .79 |
| 10-30-20-20 | 350-300-25-25 | .69 |
| 40-20-10-40 | 300-300-300-250 | .89 |
| 20-20-20-20 | 450-450-450-450 | 1.29 |
| 20-20-20-20 | 475-475-475-450 | 1.34 |

ACORN

SERVES SCHOOLS, LABS, INDUSTRIALS! SAME DAY SERVICE!



"UHF" COAXIAL CONNECTORS

| No. | AN # | Type | Each | Per 100 |
|---------|---------|------------|------|---------|
| 83-1H | UG-106U | Hood | .12 | .10 |
| 83-1R | SO-239 | Rec. | .35 | .28 |
| 83-1AP | M-359 | Ang. Adap. | .28 | .22 |
| 83-1T | M-358 | Conn. | 1.20 | 1.19 |
| 83-1J | PL-258 | Junction | .80 | .70 |
| 83-22P | UG-103U | Rec. | .45 | .40 |
| 83-22B | UG-102U | Plug | .45 | .40 |
| 83-1SP | PL-259 | Plug | .27 | .22 |
| 83-1SPN | PL-259A | Plug | .27 | .22 |
| 83-168 | UG-176U | Red. Adap. | .15 | .12 |

U.G. TYPE CONNECTORS

In Orders of 50 or More—Deduct 10%

| | | | | | |
|----------|--------|-----------|--------|-----------|--------|
| UG 10/U— | \$1.56 | UG 26/U— | \$1.25 | UG 88/U— | \$1.17 |
| UG 11/U— | 1.45 | UG 27/U— | 1.75 | UG 89/U— | .95 |
| UG 12/U— | 1.14 | UG 27/AU— | 2.25 | UG 90/U— | 1.05 |
| UG 13/U— | 1.56 | UG 29/U— | 1.22 | UG 115/U— | 1.35 |
| UG 18/U— | 1.25 | UG 30/U— | 1.25 | UG 171/U— | .90 |
| UG 19/U— | 1.28 | UG 34/U— | 34.90 | UG 176/U— | .15 |
| UG 21/U— | .99 | UG 58/U— | .63 | UG 178/U— | .15 |
| UG 22/U— | 1.08 | UG 85/U— | 1.65 | UG 206/U— | 1.02 |
| UG 23/U— | .99 | UG 86/U— | 1.69 | UG 245/U— | 1.25 |
| UG 24/U— | 1.15 | UG 87/U— | 1.40 | UG 255/U— | 1.85 |
| | | | | UG 273/U— | 1.50 |

BARGAINS IN SPEAKERS

8" Magnavox PM 22 oz. Alnico III Magnet, 8 watts output. **\$2.99**
A Terrific Value.....
10" PM Jensen, "Standard Series" P10T St. 119. An excellent speaker for good quality radio sets or PA systems. Output undistorted 8 watts. Voice coil imp. 6-8 ohms. **\$4.49**
Wt. 7 lbs.
12" high fidelity extended range 50-10,000 Cx. Jensen PM 12SH. Alnico V Magnet. 6-8 ohm voice coil, 9 watts output. Wt. 12 **\$8.45**
lbs. List \$18.00.....
12" Coaxial JRP-40 Jensen high fidelity, tweeter woofer. Built-in network. Frequency range 50-12,000 C.P.S. Voice coil imp. 6-8 ohms. 12 watt undistorted output. Shipping wt. 15 lbs. List **\$16.50**
\$30.00.....

WIRE WOUND RESISTORS

| | | | | | | | |
|-----------------------|----------------------|-----------------|------|------|------|-------|--|
| 5 WATT—Price Ea. 12¢ | | Per 100 \$9.00 | | | | | |
| Ohms | 14 25 84 230 | 1K | 2K | 5K | 30K | | |
| 4 | 6.3 15 36 100 | 250 | 1.2K | 2.2K | 6K | 40K | |
| 5 | 9.3 20 51 140 | 450 | 1.5K | 2.5K | 20K | | |
| 6 | 10 24 60 150 | 500 | 1.8K | 3K | 25K | | |
| 10 WATT—Price Ea. 18¢ | | Per 100 \$15.00 | | | | | |
| Ohms | 15 32 65 93 470 800 | 1.25K | 5K | 12K | | | |
| 1.5 | 10.5 20 40 70 100 | 500 | 850 | 1.5K | 6K | 12.5K | |
| 3 | 11 21 42 75 133 | 550 | 1K | 2.2K | 7.5K | 13.5K | |
| 4 | 12 22 50 80 135 | 700 | 1.1K | 2.5K | 10K | 15K | |
| 7 | 14 25 60 85 175 | 750 | 1.2K | 3K | 11K | 25K | |
| 20 WATT—Price Ea. 25¢ | | Per 100 \$21.00 | | | | | |
| Ohms | 12 25 50 150 | 600 | 2500 | 5K | 25K | | |
| 3.5 | 15 33 75 250 | 1075 | 2700 | 5.5K | 35K | | |
| 8 | 20 35 80 320 | 1380 | 3500 | 10K | 40K | | |
| 10 | 22 40 100 | 350 | 2250 | 4900 | 20K | | |
| 50 WATT—Price Ea. 65¢ | | Per 100 \$50.00 | | | | | |
| Ohms | 1 10 50 1K 3K 5K 10K | | | | | | |

GRAIN of WHEAT LAMPS

Used for illuminating meters, compass dials, airplane instruments, etc. Soldering iron removes lamp from base to use in models, doll houses, miniature trains, Xmas trees, etc.



Mazda G.E. 323 Mazda G.E. 328
3V. .19 A 6V. .2 A
Photo, actual size. Glass Bulb 1/2"x3/8"

Either type doz. **\$1.50** 75.00 Per M.



MARKTIME 5 HOUR SWITCH

A 10 amp timing device. Pointer moves back to zero after time elapses. Ideal for shutting off radios and TV sets when you go to bed. Limited supply at this special PRICE **\$3.90**

Also available in 15 mi.-30 mi.-1 hr. at \$6.55

D.P.S.T. LEACH RELAY
Split coil 12 or 24 V.D.C.
10 amp. 45c each, 3 for \$1.00, 7 for \$2.00, 15 for \$4.00. Min. shipment \$1.00

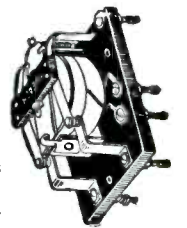

ISOLATION TRANSFORMER
Nat. known Mfrs. 50 watt 2 windings, 115 V. to 115 V. 60 cy. Ideal to prevent shocks from small radios and medical and electronic devices **\$1.95**
Shipping Weight 5 lbs. s. Other sizes and 220-110 in stock.

A newly Written (1948) Book on Photoelectric (Electric Eye) Circuits..... **\$1.00**
10 for \$7.50

Kilowatt Demand Meter Totalizer containing heavy-duty telechron B-7, 1 RPM motor and hundreds of watch size gears, clutches, springs, etc. Shipping weight 2 lbs. 5 for \$10.00. **\$2.50**

We are Authorized Wholesalers for Micro Switch Corp. and carry the largest stock of Allen-Bradley Solenoids, Potter & Broomfield Relays, Guardian Electric Co. Solenoids and Relays and Haydon Clock Motors in all speeds.

EST. 1923 **BLAN** EST. 1923

Experimenters and Inventors Supplies

64 Dey St., New York 7, N. Y.

PHONE: WORTH 4-3270

ACORN ELECTRONICS CORP.

76 Vesey St., Dept. E-7, New York 7, N. Y.

TERMS: 20% cash with order. Balance C.O.D. unless rated. All prices F.O.B. our warehouse in New York City. No orders under \$2.50.

WAR SURPLUS BARGAINS

GIGANTIC MAIL SALE!

- ELECTRONIC • RADIO
- ELECTRICAL APPARATUS

Sale ends midnight July 31st

Amazing values. Opportunity for home experimenters, laboratories, schools, etc., to get fine new, or new condition guaranteed equipment at fraction of original cost. We pay freight or postage. Typical items are listed below.

- | | |
|---|-----------------|
| • 3000-watt, 115-volt, 60c Power Plants | \$299.50 |
| • Wheatstone Bridges (0 to 11, 110 ohms.) | 59.50 |
| • Weston Air Port Photo-Light Control Units | 29.90 |
| • Weston Model 689-1F Industrial Ohmmeter and case | 12.90 |
| • W.E. Desk or Wall C.B. Telephones and ringer (complete) | 4.99 |
| • RCA (5", 3" and 2") Cathode Ray Tubes | 3.55 |
| • RCA Light, burglar alarm kit. Consists of rectifier, photo cell, thyatron, relay, sockets, etc. | 4.49 |
| • Drill press 31" polishing/grinding shaft and stone | 1.29 |
| • Burglar Alarm Units—Protect home and business | 6.99 |
| • High Pressure Steel Bottles (1800 lb.) Heating Elements (24"—800-W) | 5.69 |
| • Chromolux Heating Elements (24"—800-W) | 2.19 |
| • Selsyn Motors—Cost Gov't \$90.—110 V.—60-C. Pair | 4.99 |
| • DeLuxe, Outstanding Electrical Radio Home Lab kit 80 pieces | 6.77 |
| • Carbon Pile Regulator. Dozens of uses | .99 |
| • Miniature Multi-Station Telephone. Fine for office-residence, intercomm. Secret Line. A four star value. Pair | 7.89 |

Order from ad or send card for bargain laboratory, experimenter and amateur catalog. Satisfaction guaranteed. Our reference—National Bank of Commerce.

LECO ENGINEERING CO.

BOX 908 E-7 LINCOLN, NEBRASKA

MARINE and AVIATION

• TRANSMITTERS—Navy types: TBK, TBL, TBM, TDE, TAJ, TCS, TBS, et al. Commercial types: RMCA and Mackay.

• DIRECTION FINDERS—DAE, DAK, RMCA and Blutworth.

• RADAR—We have in stock a quantity of SN radar sets in excellent condition; also, some complete and some partial sets of SA, SD, SF, SG, SK, SO, SQ and YJ responder.

• SONAR—QBE, QCB, QBF, QJA, QCO and NAA.

• TUBES—A variety of Magnetrans, klystrons, special purpose and transmitting tubes, new, individually boxed only; very few receiving tubes.

• ROTARY CONVERTORS — MOTOR GENERATORS—12, 24, 28, 32, 115, 230 volts dc input, various outputs 25 watts to 7.5 kw.

We supply governments, laboratories, airlines and institutional users—and invite inquiries on your letterhead. All equipment and components guaranteed as represented.

Compass Communications Co.

37 Montgomery St. Jersey City 2, N. J.

DE laware 2-4656

LIFE Offers Savings in "Hard to Get" Items.

COAXIAL CABLE AND CONNECTORS

UG TYPE CONNECTORS

| | | | | |
|---|---------|-----------|----------|-----------|
|  | AN No. | Price Ea. | AN No. | Price Ea. |
| | UG9/U | \$.95 | UG96A/U | 1.45 |
| | UG10/U | 1.56 | UG97/U | 3.50 |
| | UG11/U | 1.45 | UG98/U | 1.55 |
| | UG12/U | .95 | UG100/U | 2.34 |
| | UG13/U | 1.56 | UG101/U | 2.95 |
| | UG14/U | 1.45 | UG107/U | 2.25 |
| | UG15/U | .95 | UG108/U | 1.75 |
| | UG16/U | 1.56 | UG109/U | 1.75 |
| | UG17/C | 1.45 | UG114/U | 1.50 |
| | UG18/U | .99 | UG115/U | 1.33 |
| | UG18A/U | 1.05 | CW123/U | .45 |
| | UG18B/U | 1.09 | UG131/U | 6.00 |
| | UG19/U | 1.28 | UG146/U | 2.25 |
| | UG19A/U | 1.38 | CW155/U | .40 |
| | UG19B/U | 1.45 | UG154/U | 5.35 |
| | UG20/U | 1.17 | UG156/U | 4.25 |
| | UG20A/U | 1.26 | UG157/U | 4.25 |
| | UG20B/U | 1.41 | UG160/U | 1.90 |
| | UG21/U | .99 | UG160A/U | 1.55 |
| | UG21A/U | 1.05 | UG167/U | 3.00 |
| | UG21B/U | 1.09 | UG173/U | .30 |
| | UG22/U | 1.08 | UG174/U | 16.00 |
| | UG22A/U | 1.38 | UG188/U | .95 |
| | UG22B/U | 1.34 | MX195/U | .75 |
| | UG23/U | .99 | UG197/U | 5.00 |
| | UG23A/U | 1.26 | UG201/U | 1.83 |
| | UG23B/U | 1.29 | UG202/U | 2.75 |
| | UG27A/U | 2.25 | UG204/U | 2.25 |
| | UG28/U | 2.34 | UG206/U | 1.02 |
| | UG29/U | 1.22 | UG208/U | 28.50 |
| | UG29A/U | 1.56 | UG212/M | 4.50 |
| | UG30/U | 1.75 | UG213/U | 4.50 |
| | UG32/U | 20.00 | UG215/U | 3.35 |
| | UG33/U | 20.00 | UG216/U | 8.70 |
| | UG34/U | 17.50 | UG217/U | 3.10 |
| | UG35A/U | 16.00 | UG218/U | 6.50 |
| | UG36/U | 16.00 | UG222/U | 35.00 |
| | UG37/U | 16.00 | UG231/U | 2.00 |
| | UG37A/U | 16.00 | UG235/U | 28.50 |
| | UG57/U | .99 | UG236/U | 11.75 |
| | UG58/U | .65 | UG241/U | 2.20 |
| | UG59/U | 2.75 | UG242/U | 2.50 |
| | UG59A/U | 1.70 | UG243/U | 2.75 |
| | UG60/U | 1.90 | UG244/U | 2.50 |
| | UG60A/U | 1.30 | UG245/U | 1.25 |
| | UG61/U | 2.05 | UG246/U | 1.45 |
| | UG61A/U | 1.80 | UG252/U | 4.50 |
| | UG62/U | 28.00 | UG254/U | 1.82 |
| | UG83/U | 1.50 | UG255/U | 1.85 |
| | UG85/U | 1.65 | UG259/U | 4.10 |
| | UG86/U | 1.69 | UG260/U | .99 |
| | UG87/U | 1.40 | UG261/U | .95 |
| | UG88/U | 1.17 | UG262/U | 1.05 |
| | UG89/U | .95 | UG269/U | 2.60 |
| | UG90/U | 1.05 | UG270/U | 6.50 |
| | UG91/U | 1.25 | UG273/U | 1.50 |
| | UG91A/U | 1.05 | UG274/U | 1.98 |
| | UG92/U | 1.10 | UG279/U | 2.40 |
| | UG92A/U | 1.35 | UG287/U | 5.25 |
| | UG93/U | 1.25 | UG290/U | .85 |
| | UG93A/U | 1.45 | UG291/U | 1.05 |
| | UG94/U | 1.25 | UG306/U | 2.03 |
| | UG94A/U | 1.05 | UG333/U | 4.70 |
| | UG95/U | 1.10 | UG334/U | 5.75 |
| | UG95A/U | 1.35 | UG352/U | 6.00 |
| | UG96/U | 1.25 | | |



"UNF" COAXIAL CABLE CONNECTORS

83 SERIES



83-1SPN

83-1T

| No. | AN No. | Description | Each | Price Per C |
|---------|----------|--------------|------|-------------|
| 83-1SP | (PL259) | Plug | .35 | .28 |
| 83-168 | (UG176U) | Adapter | .15 | .12 |
| 83-185 | (UG175U) | Adapter | .15 | .13 |
| 83-1SPN | (PL259A) | Plug | .35 | .28 |
| 83-776 | (UG203U) | Plug | .61 | .55 |
| 83-1R | (SO239) | Recept. | .35 | .28 |
| 83-1RTY | | Recept. | .66 | .60 |
| 83-1H | (UG106U) | Hood | .12 | .10 |
| 83-765 | (UG177U) | Hood | .31 | .25 |
| 83-1AC | | Cap & Chain | .61 | .50 |
| 83-1BC | | Cap & Chain | .38 | .34 |
| 83-1T | (M358) | T Connect | 1.12 | .98 |
| 83-1AP | (M359A) | Angle Adapt. | .35 | .28 |
| 83-1J | (PL258) | Junction | .85 | .70 |
| 83-1F | (PL274) | Feed-Thru | 1.12 | .98 |
| 83-22SP | (UG102U) | Twin Plug | .50 | .40 |
| 83-22R | (UG103U) | Twin Recept. | .50 | .40 |
| 83-22AP | (UG104U) | Twin Adapt. | .98 | .80 |
| 83-22J | (UG105U) | Twin Junct. | 1.25 | 1.12 |
| 83-22T | (UG196U) | Twin Tee | 1.65 | 1.50 |

COAXIAL CABLE



| No. | Impedance | Price per M ft. |
|-------|------------|-----------------|
| RG5U | 52.5 ohms | \$70.00 |
| RG6U | 76.0 ohms | 120.00 |
| RG7U | 97.5 ohms | 70.00 |
| RG8U | 52.0 ohms | 55.00 |
| RG9U | 51.0 ohms | 125.00 |
| RG9AU | 51.0 ohms | 135.00 |
| RG10U | 52.5 ohms | 125.00 |
| RG11U | 75.0 ohms | 100.00 |
| RG12U | 75.0 ohms | 190.00 |
| RG13U | 75.0 ohms | 125.00 |
| RG18U | 52.0 ohms | 450.00 |
| RG19U | 52.0 ohms | 350.00 |
| RG20U | 52.0 ohms | 450.00 |
| RG22U | 95.0 ohms | 120.00 |
| RG24U | 125.0 ohms | 240.00 |
| RG25U | 48.0 ohms | 575.00 |
| RG27U | 48.0 ohms | 290.00 |
| RG29U | 53.5 ohms | 50.00 |
| RG34U | 71.0 ohms | 175.00 |
| RG39U | 72.5 ohms | 180.00 |
| RG41U | 67.5 ohms | 575.00 |
| RG44U | 58.0 ohms | 65.00 |
| RG44A | 58.0 ohms | 75.00 |
| RG37U | 95.0 ohms | 100.00 |
| RG58U | 53.5 ohms | 55.00 |
| RG59U | 73.0 ohms | 45.00 |
| RG62U | 93.0 ohms | 50.00 |
| RG71U | 93.0 ohms | 175.00 |
| RG74U | 52.0 ohms | 225.00 |

Minimum quantity 500 ft. per type. For cut lengths add 50% to prices shown.

FREE! LIFE ELECTRONIC SALES

Send for our bulletin L-500

91 GOLD STREET N.Y. 7 N. Y. DIGBY 9-4154-5

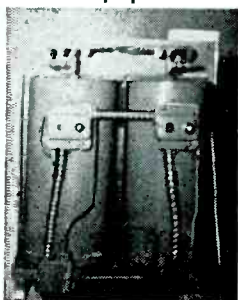

The "KELLOGG DEHYDRATOR"

An all purpose self-reactivating dehydrating unit. To be used for removing moisture from gases. Numerous applications in the fields of Physics, Electronics and Chemistry. Dual insulated tanks with thermostatically controlled heating elements. Complete with 20 lbs. of Silica gel, heating elements, shut-off and safety valves.

\$62.50

F.O.B. N. Y.



INTERSTATE Appliance Co., Inc.

Dept. KD, 600 Broadway, NEW YORK 12, N. Y.



BUDGET STRETCHERS

COAXIAL FITTINGS

SO 239 sockets 35¢  PL 259 plugs 35¢ 
 Hoods 10¢ M559 angles 20¢
 UG 87U, UG 21U40¢
 UG 167U\$1.50

RELAYS

PRICE fast acting solenoid type 110, has 115 vac coil marked Z30 (70 ohm dc). The long fast travel (5/16") and the use of two contacts in series on each circuit insures reliable service while breaking DC. Cont. duty.
 #110—3P N.O., 1/2 inch dia. cont. on two, 3/8" on other contact ONLY \$3.25 ea.
 Allied DOX, 115 v.a.c. coil, 3 P.D.T., 6 ampere contacts \$2.50
 Either type ONLY \$3.25 ea.
 Plate Circuit, Leach 1024, 10,000 ohm, 12.5ma coil, DPST NO 3/16" contacts \$1.10
 SIGMA tiny 1200 ohm 10ma coil, SPDT, 3/8"x3/8"x1-7/16" 55¢

CORD-O-MATIC

50 foot two conductor #18 rubber covered cord on a spring return reel. Features dual silver plated contacts and slip rings. Pays for itself in the time saved from untangling ordinary drop cords. Install one in your closet at home for the vacuum cleaner. Regular price \$26.50
 Sale Price \$9.95 

26 CONDUCTOR CABLE made up by Western Electric in 50 foot lengths with S324CT connectors on each end. Each conductor is #22 stranded and rubber covered. Although the O.D. is only 9/16 inches there is a heavy live rubber jacket. Complete with two mating P324AB connectors ONLY \$7.50



IN21 crystal diode up to 3000 Mc., 8.5db conversion loss, 4.0 output noise ratio, burn out test 0.3erg
 SPECIAL49¢

LEVER SWITCHES

3/16" CONTACTS

Mossman SPDT center open \$1.45
 CDM 24536—make 6, make 3, center open95
 CDM 24543—DPDT & SPST65

TOGGLE SWITCHES

H&H DPST bat handle 6 amp125v29
 H&H SPDT ball handle 6 amp125v35
 H&H DPDT bat handle 6 amp125v60
 CH DPDT center off 20 amp125v \$1.85

MICRO SWITCHES

1K7-R5 SPDT35
 Switchette GE make-break35

VOLTAGE REGULATOR

Do you have a fluctuating line voltage? Here is the answer for making those precise measurements. It is a ruggedly built Amertran 250va Transtat. Variable from 103 to 126 volts, it features easy adjustment approx. six volts spread out over a whole revolution of the knob. Cat No. 29144 \$9.75

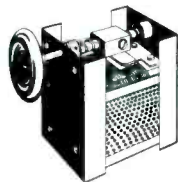

GEAR DIFFERENTIAL

GE ASM 8640201 GI IBM—A beautifully made geared unit from the B29 computer, inputs and outputs on the same axis. 1 11/16" OD by 2 1/2" overall length of shaft \$3.85

The above merchandise is all brand new. Satisfaction is positively guaranteed, or your money returned. FOH Philadelphia, Pa. Write for a more complete listing.

HAROLD H. POWELL

632 Arch St. Philadelphia, Pa.

Good Values—Large Stocks—Prompt Service

POWER SUPPLIES:

0-15,000 v.—5 amp. d.c. output—110 v. a.c. input \$395.00
 0-15,000 v.—.035 amp. d.c. output 110 v. a.c. input \$215.00
 1000 v.—350 ma. d.c.—14 v. a.c.-d.c. output 110-220 \$95.00

SWITCHES—S.P.D.T.—motor operated 110 v. a.c.—will handle 15 kv. @ 1.5 amp.—oil filled—small size—ideal for switching any h.v. output \$47.50

LABORATORY POTENTIOMETERS—20 k. ohms.—10 v. a.c. reversible motor 5G Selsyn—accuracy better than 1%—oil filled \$55.00

TELEVISION TUBES—We are in the center of the C.R. tube industry and can supply 7-10-12-15-16-20 inch tubes at low prices. Also tuners, chassis and complete sets.

RADAR—See us for test sets. Plumbing—Co-ax—T.R. units—antennas, magnetrons, Klystrons. Special 10 cm. test dipole \$4.75

TRANSFORMERS—From 1v to 100 kv.—5 w. to 75kw. all sizes and types of power, filament, audio, modulation, pulse, supersonic, etc.

MOTOR GENERATORS—115 v. d.c. to 120 v. a.c., 1000 watts, continuous duty, ball bearings, fully inclosed \$97.50

LET US KNOW YOUR NEEDS—WE CAN FILL THEM NOW

VETSALCO Inc.

FOR ELECTRONICS

78—21ST. AVE.

PATERSON, N. J.

ARMORY 4-4435

CONNECTORS - CABLE

Canon DP and AN Types: large quantities of several types available. Also large stock of multi-conductor cable, transformers, capacitors, panel meters and other electronic components. Write for list or send us your requirements.

RAILWAY RADIOTELEPHONE INC.
 1307 Central Ave., KANSAS CITY 2, KANS.

WANTED

WANTED, AIRCRAFT RADIOS

AN/ART-13, BC-348, RTA-1B, AN/APN-9, R5A/AN-7, AN/ARC-1, AN/ARC-3, BC-788-C, I-152, MN-26, Test Sets with TS- or J- prefix, Dynamotors, Control Boxes, Transmitters, Receivers, Power Supplies, etc. State quantity, condition and best price first letter.

HI-MU ELECTRONICS
 Box 105, New Haven, Conn.

| | | |
|--------|------|-----------------|
| 5CPI | 9LP7 | 304TH .. \$1.95 |
| 5API | 3DP1 | 371B70 |
| 5AP4 | 1630 | 2N225 |
| 4AP10 | 8013 | 87898 |
| \$1.95 | 95¢ | 80065 |
| | | 55940 |
| | | 12CP7 .. 7.75 |

Gould Green

252 GREENWICH ST., NEW YORK, N. Y.

TS-8A/U OSCILLOSCOPE VOLTAGE CALIBRATOR

Brand new, reads continuously from .005 through 1200. Net price \$17.50 f.o.b. Boston.

WESTON LABORATORIES
 Weston 93, Massachusetts

WANTED

Teletypewriters complete, components or parts. Any quantity and condition.

W-6654, Electronics
 330 West 42nd Street, New York 18, N. Y.

EXHAUST MACHINE

For the manufacture of electronic tubes, 16 heads; automatic production. Made by G.E. Can be adapted for television tubes. Cost \$22,500. Will sacrifice for \$4,500.

GAYLIN PRODUCTS CO.
 40 East 21 St. New York 10, N. Y.

WANTED WESTERN ELECTRIC VACUUM TUBES

Types 101F, 102F, 272A, 274A or B, 310A or B, 311A, 313C, 323A, 328A, 329A, 348A, 349A, 352A, 373A, 374A, 393A, 394A, 121A Ballast Lamps.

WV-6641, Electronics
 330 West 42nd St., New York 18, N. Y.

MICA CAPACITORS

| | |
|---------------------------|---------------------------|
| 1000 MMFD .. 10,000 volts | YOUR CHOICE \$3.00 ea. |
| 120 MMFD .. 10,000 volts | |
| 100 MMFD .. 10,000 volts | |
| 20 MMFD .. 10,000 volts | |
| 3000 MMFD .. 7,000 volts | |

DRILLICK SALES CO.
 5453 Virginia Avenue Los Angeles, Calif.

WILL BUY ALL

BC348's with Dynamotor

All letters except "C" \$60.00 ea., modified types \$50.00 ea. Also ART-13 Transmitters type 47—\$80. ea. Type 47A—\$95.00 ea. Ship via Express C.O.D. subject to inspection to:

H. FINNEGAN
 49 Washington Ave., Little Ferry, N. J.



TELEPHONE HANDSET HANGER

NEW LOW PRICE \$1.49 POST PAID

Fits most types on market. Made of heavy duty aluminum casting. Excellent for desk, mobile or marine use. BRAND NEW.

American Surplus Co., Dept. E-3
 4274 S. B'way, Los Angeles 37, Calif.

WANTED—NEW TEN SCR 694

Radio Receiver-Transmitters

Govt Surplus
 Crescent International Corp.
 16 Liberty St., New York 5, N. Y.

SAVE NOW! ON SURPLUS ELECTRONICS LOW PRICES

TBS XMITTER-RCVR

Will xmit or rcve messages by means of voice or telegraphically key tone—mod signals in freq range 60-80 Mc. Rev: Xtal cont, output 2W. RF imp 70 ohm, sensitivity 5 microvolt, input 110vac 60 cy. Xmitter: Freq stability ±.025%, output 50W, mod capability 100%, external pwr required. All accessories available. Less tubes & xtals w/inst book. Brand new\$175.00

TBY-8 TRANSCEIVER

28-80 Mc in 4 bands voice or MCW. Xtal calibrated in 130 channels. Comes in original trunk complete w/vibropack, headset, mic, ant, spare tubes & inst book. Like new\$39.50

ARC-5 VHF SET

R-28 RCVR: Superhet operating on 4 xtal channels, 100-156 Mc, remote control to actuate turret-tuning mechanism, 12 tubes—4-717A, 1-12A6, 3-12SH17 & 2-12SL7CP, w/dm.

T-23 Xmitter: MCW & phone on 4 channels, 100-156 MC, automatic turret tuning, tank circuits remote controlled, 4 tubes—2-1625, 2-832A.

MD-7 MODULATOR: Contains all necessary circuits & components for plate mod of T-23 xmitter, w/dyn which supplies plate & screen voltages for mod. xmitter, revr, mod, plugs, xtals, tubes & diagram. Used\$49.50

BC-1161 RCVR

150-210 MC. input 115VAC 60 cy. Inductance tuning for RF, ant, detector & OSC. Has tuning ind. with few conversions. Makes good 2 meter or FM receiver. w/14 tubes & diagram used.....\$24.50

BC-1160 XMITTER

157-187 MC. Input 117VAC 60 cy. Has parallel rod OSC using 2-826 PP, contains pwr supply, general radio variac 1.5A. 3 1/2" 0-5 kilovoltmeter, 10 tubes and loads of other parts too numerous to mention. W/circuit. Diagram & tubes, used.....\$22.00

ARR-5 RCVR

27.8-143 MC in 3 bands FM or AM. New...\$125.00

APR-1 RCVR

Comes w/tuning units TN-1B 38-95 MC & TN-3B 300-1000 MC. W/manual. New.....\$275.00

Send 30% with order or full price and save COD charge. All shipments will be made via railway express unless other instructions given. All prices subject to change without notice and all merchandise subject to prior sale. Quantity price available.

APR-2 RCVR

90-1000 MC. Has automatic scanning & recording device. Includes ANT filter P-3/APR-2. mounting rack & inst book brand new.....\$175.00

APR-5 RCVR

1000-3000 MC & 3000-6000 MC continuously by use of interchangeable tuners. IF freq. 30 Mc. NEW\$195.00 USED\$125.00

APS-13 TAIL WARNING RADAR

Contains 9-6AG5, 5-6J6, 2-2D21 & 1-VR-150/30. 420-460 MC. Brand new.....\$14.50
W/ANT, warning bell, plug & handbook New.\$18.50

BC-800 RADAR XMITTER RCVR

5 stages RF at 30 MC, 2 stages RF 160-186 MC, uses 2-2C26, 19 tubes total, has blower. BRAND NEW\$29.50 USED..... \$12.95

PP-104/APT-5

Power supply for APT-5 jammer brand. New...\$14.95

T9/APQ-2 JAMMER

210-500 MC, 8 tubes: 2-388, 1-931, 2-6AC7, 1-6AG7, 2-807, 11 watt. Brand new.....\$14.00

T-28/APT-1 JAMMER

93-212 MC, 14 tubes: 1-931A, 3-6AC7, 1-6V6, 1-6x5, 2-5R4GY, 2-6C4, 2-832. Has 2 blowers. Used.\$22.50

RECORDER RD-7/APA-23

Drive motor 28V DC. Pwr supply 110VAC 60 cy for tubes. 2-2050, 1-6SN7, 1-5Y3 & 1-6AC7. Used.....\$45.00

T-43/ART-3 JAMMER

Covers 27-34 & 34-45 MC. Uses PP 304TL. Complete with 400cy pwr supply & 2 tuning units. Brand new\$75.00

T-36/ART-9 JAMMER

37-44 MC. Uses PP 35TG. Complete w/shock mount & book. Brand new.....\$25.00

BC-1334 IF AMP.

36 MC, band width 1.4 MC, built in AVC, 7 tubes. New.....\$25.00

RADAR XMITTER RCVR

CW-43AAF-1. Used W/SJ, SE, SH & Mark 16 Radar. Uses 706 Magnetron and 707A Clystron. Complete with tubes & wave guide fitting. Used excellent.....\$72.00

MARK 16 RADAR TEST SCOPE

CW-60ABP-1, type LZ. Used. Excellent.....\$49.50

MARK 16 RADAR FREQ METER & SIG GEN

CW-60ABQ-1, type LZ, 2700-3333 MC. Used. Excellent\$59.00

SIGNAL GENERATOR MOD-78B

Made by measurements corp. Calibrated from 1-100,000 microvolts. 2 bands 25-50 MC & 190-230 Mc. 400cy or 82cy modulation. Has built in vacuum tube voltmeter for calibration. 110VAC 60 cy input. Used\$42.00

PHANTOM TARGET RF-4A/AP

Used for checking operation & alignment of SCR-717A, 717B, 720A, 720B radar. Brand new w/inst. book\$14.50

725A MAGNETRON

W/magnet & shield\$7.95

2J22 MAGNETRON

W/magnet, connector, shield & wave guide fittings & plumbing assy for connection to mixer, local OSC & ant.\$9.95

2J21 MAGNETRON

W/magnet & shield\$8.95

2K28 CLYSTRON

W/cavity socket & fittings\$8.95

WL-417A CLYSTRON

W-cavity, mounting bracket, socket & fittings.\$12.95

3 CENTIMETER DUPLEXER, MIXER, DETECTOR & OSC ASSY

Includes 2-723A/B LOC, OSC, 2-724B duplexers, IN23 mixer with connector to IF strip. Has ANT & magnetron flanges\$18.95

3 CENTIMETER DUPLEXER, MIXER, DETECTOR & OSC ASSY

Includes 2-723 clystrons, 2-724B duplexers, IN23 mixer & 2-6AC7.\$16.95
Above magnetrons, clystrons & assy's have been removed from spare equipment. All are in excellent cond. & filaments checked.

RADIO V & H ELECTRONICS

2033 WEST VENICE BLVD.

Write for New Catalog

LOS ANGELES 6, CALIF.

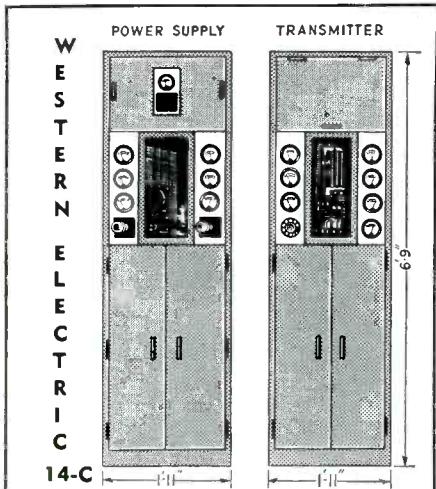

- Freq range 2 to 18 MC.
- Power Output: 800 w. A1, 400 w. A2 A3.
- Telephone dial 10-channel selector.
- Input: 220/3/60.

This equipment is packed in 8 cases and includes 2 cases of spares. Export crated, F.O.B. N.Y.C. subject to prior sale.

AIRCRAFT RADIO INDUSTRIES, INC.
101 Dixwell Ave., New Haven, Conn.

SPECIAL OFFERING RG 18/U COAXIAL CABLE

Braided armor overall, otherwise same as RG 17/U. 52 ohms OD .920 efficient solid dielectric cable. A REAL BARGAIN 40¢ per foot. Other coaxial cables. Write for price information and availability.

MARLAN CORPORATION Dept. E.
162 N. Clinton St. Chicago, Illinois

UNUSUAL PRICES

PERFECT JAN. & STANDARD MAKE TUBES

| | | | | | | | | | | |
|-----------|-----------|---------|-----------|-------|-------|-------|-------|-------------|--------|------|
| Magnetron | 701A | 6.00 | 394A | 3.95 | 705A | 1.25 | 446A | 1.80 | 1624 | .69 |
| 2J26 | 715A | 6.00 | 885 | 1.45 | 719A | 14.95 | 450TH | 19.95 | 1625 | .25 |
| 2J27 | 715B | 9.00 | Rectifier | 2X2 | 866A | 1.50 | WL468 | 8.95 | 8012A | 1.95 |
| 2J31 | 8D21 | 29.95 | 2X2 | 872A | 2.50 | 703A | 1.80 | 8025 | 3.95 | |
| 2J32 | Thyratron | | 2X2A | 869B | 29.95 | 802 | 4.25 | Acorn | | |
| 2J40 | CI1B | \$3.95 | 371B | 1616 | 1.95 | 803 | 5.25 | 1A3 | \$2.29 | |
| 2J49 | 3C23 | 3.95 | 5R4GY | 8020 | 2.95 | 807 | 1.35 | 954 | .45 | |
| 2J50 | 3C31 | 3.95 | RK72 | Power | | 813 | 6.95 | 955 | .45 | |
| 2J61 | 393A | 3.95 | RK73 | 2C40 | 1.80 | 814 | 2.95 | 956 | .45 | |
| 2J62 | | | | 2C44 | .75 | 832A | 3.95 | 957 | .35 | |
| 714AY | | 4.00 | | 350B | 2.40 | 845 | 3.25 | 958A | .45 | |
| 725A | | 15.00 | | 368AS | 1.80 | 849 | 29.95 | 959 | .55 | |
| 730A | | 12.00 | | 388A | 1.80 | 851 | 19.95 | 9001 | .55 | |
| Klystron | | | | | | | | 9002 | .35 | |
| 2K25 | | \$24.95 | | | | | | 9003 | .45 | |
| 2K28 | | 19.95 | | | | | | 9004 | .45 | |
| 707A | | 9.95 | | | | | | 9006 | .35 | |
| 707B | | 9.95 | | | | | | C. R. Tubes | | |
| Pulse | | | | | | | | 5BP1 | 2.75 | |
| 527 | | 8.95 | | | | | | 5BP4 | 4.75 | |



135 LIBERTY STREET NEW YORK 6, N. Y.
PHONE WORTH 4-8262
ASK FOR FREE CATALOG

Minimum order \$10.00.
Add postage or tubes will be sent by Express Collect.

SHEET METAL MACHINERY

NEW and Used — Brakes — Shears
Forming Rolls — Folders — Punches —
Di-Acro, Pexto, Niagara & Whitney Equip-
ment.

R. D. BROOKS CO., INC.
Han. 5226
361 Atlantic Ave., Boston, Mass.

| | |
|--|--------|
| Reactor, Filter: 10 H, 0.7 ADC; 45 ohms | \$1.00 |
| Trans; 10,000 eye; Pri 100; Sec 600 & 1.25 | 1.00 |
| Variometer, ceramic; 1500-1800 KC; split sta- tor & Rotor | 1.75 |
| Drop Lines, WE; Standard relay & Drop for Tele Sw Bds. | .38 |
| Dee Rings; Steel, joint-weld; for 1" belting; per 1000 | 1.75 |
| Vibrator; 19 cyc; 12 V. 4-prong plug-in; tele work | .09 |
| Vibrator; Non-syn; 24 V. Sp. plug-in socket req. #VB-11A | .10 |
| Vibrator; Syn; 12 V. Stand. 7-prong, 1 1/2" dia; Oak V-6485 | .11 |
| Bell ringers, MC-131; NEW, for field tele EE-8, 9A, etc. | .35 |

GOULD GREEN

252 Greenwich St. New York, N. Y.

SEARCHLIGHT

IS

Opportunity Advertising

—to help you get what you want.
—to help you sell what you no longer need.

Take Advantage Of It

For Every Business Want

"Think Searchlight First"

SEARCHLIGHT SECTION

MICROWAVE PLUMBING & ACCESSORIES



1.25 CENTIMETER
 "K" BAND DIRECTIONAL COUPLER CU104/AP8-34 20 DB. \$49.50 ea.
 "K" BAND FEEDBACK TO PARABOLA HORN with pressurized cavity. \$30.00
 MITRED ELBOW cover to cover. \$4.00
 TR/ATR SECTION choke to cover. \$4.00
 FLEXIBLE SECTION 1" choke to choke. \$5.00
 ADAPTER, rd. cover to sq. cover. \$5.00
 MITRED ELBOW and S sections choke to cover. \$4.50
 WAVE GUIDE 1/2 x 1/2 per ft. \$1.00
 K BAND CIRCULAR FLANGES. \$50c

10 CENTIMETER
 WAVEGUIDE TO 7/8" RIGID COAX "DOOR-KNOB" ADAPTER, CHOKE FLANGE, SILVER PLATED, BROAD BAND. \$49.50 EACH
 WAVEGUIDE DIRECTIONAL COUPLER, 27 db. Navy type CABV-47AAN, with 4 in. slotted section. \$42.50
 SQ. FLANGE to rd. choke adapter, 18 in. long OA 1 1/2 in. x 3 in. guide, type "N" output and sampling probe. \$32.00
 "S" BAND CRYSTAL MOUNT, gold plated, with 2 type "N" connectors. \$12.50
 PICKUP LOOP, Type "N" Output. \$2.75
 TR BOX Pickup Loop. \$1.25
 POWER SPLITTER: 726 Klystron input, dual "N" output. \$5.00

MAGNETRON TO WAVEGUIDE coupler, with 721-A duplex mixer, gold plated. \$27.50
 10 CM WAVEGUIDE SWITCHING UNIT, switches 1 input to any of 3 outputs. Standard 1 1/2" x 3" guide with square flanges. Complete with 115 vac or dc arranged switching motor. Mfg. Raytheon. CR1-24AAS. New and complete. \$150.00
 10 CM END-FIRE ARRAY POLYRODS. \$1.75 ea.
 "S" BAND Mixer Assembly, with crystal mount, pick-up loop, tunable output. \$3.00
 721-A TR CAVITY WITH TUBE. Complete with tuning plungers. \$12.50
 10 CM. McNALLY CAVITY Type SG. \$3.50
 WAVEGUIDE SECTION, MC 445A, rt. angle bend, 5 1/2" H. OA. 8" slotted section. \$21.00
 10 CM OSC. PICKUP LOOP, with male Homedell output. \$2.00
 10 CM DIPOLE WITH REFLECTOR in lucite ball, with type "N" or Sperry fitting. \$4.50
 10 CM FEEDBACK DIPOLE ANTENNA, in lucite ball, for use with parabola 7/8" Rigid Coax Input. \$8.00
 PHASE SHIFTER, 10 CM WAVEGUIDE, TYPE ES-68381E. E PLANE TO H PLANE. MATCHING SLUGS. \$95.00
 721A TR cavities. Heavy silver plated. \$2.00 ea.
 10 cm. horn and rotating joint assembly, gold plated. \$65.00 ea.
 10 cm. right angle bend "E" or "H" plane, less flanges. \$17.50 ea.

7/8" RIGID COAX—1/2" I.C.
 SHORT RIGHT ANGLE BEND. \$2.50
 Rotating joint, with deck mounting. \$15.00
 RIGID COAX, slotted section CU-60/AP. \$5.00
 "S" BAND "Y" JUNCTION, SQ. FLANGES. \$65.00

10 cm. waveguide to 7/8" rigid coax doorknob transition, 21" high with 8" slotted section. \$52.50
 10 cm. flexible section 4 feet long. \$42.50
 10 CM. FLANGES, UG65/U. \$8.50
 UG65/U 10 CM. FLANGE. \$8.50
 ADAPTER 1 1/2 x 3 TO 1 1/2 x 2. SQ. 10 CM FLANGE TO SQ. 5 CM CHOKE. \$57.50
 KLYSTRON MOUNT W/TUNABLE MATCHING SLUGS TO TYPE "N" CONNECTOR. SOCKET & TUBE CLAMP INCLUDED. \$12.50

7/8" RIGID COAX—3/4" I.C.
 RIGID COAX ROTARY JOINT, PRESSURIZED. SPERRY #810813. GOLD PLATED. \$27.50
 Dipole assembly. Part of SCR 584. \$25.00 ea.
 Rotary joint. Part of SCR-584. \$35.00 ea.
 RIGHT ANGLE BEND, with flexible coax output. \$8.00
 SHORT RIGHT ANGLE bend, with pressurizing nipple. \$3.00
 RIGID COAX to flex coax connector. \$3.50
 STUB-SUPPORTED RIGID COAX, gold plated 5" lengths. Per length. \$5.00
 RT. ANGLES for above. \$2.50
 RT. ANGLE BEND 1 1/2" L. OA. \$3.50
 FLEXIBLE SECTION. 15" L. Male to female. \$4.25
 MAGNETRON COUPLING TO 7/8" rigid coax, with TR pickup loop, gold plated. \$7.50
 FLEX COAX SECT. Approx. 30 ft. \$16.50

MISCELLANEOUS
 Type "N" patching cord UG11/U female to UG9/U using RG5/U cable 12" long. \$2.25 ea.
 AN/TPS-1B flanged nipple and insert assembly for rotary coupling. \$3.75 ea.
 Pulse connector Navy type 49579. \$1.50 ea.
 Transmission line pressure gauge, 2" 15 lbs \$1.85 ea.
 Pulse cable assembly Western Electric type D163262. 10 feet long. \$4.50 ea.
 Hotmelled Jack Western Electric #BO-12962-1 D.B. #J-102X. \$3.75 ea.
 Adapter type "N" RG8/U to RG17/U or 18/U cable. \$4.50 ea.
 ADAPTER TYPE "N" TO RG-17/U CONNECTOR. \$5.50
 F-29/SPR-2 HIGH PASS FILTER P/O AN/APR-5A.X. TYPE "N" CONNECTORS. \$12.50
 Magnetron coupling to 7/8" rigid coax. \$5.00 ea.
 Hand pumps for pressurizing transmission line with humidity indicator. \$12.50 ea.

MARINE RADAR
 SO-1 AND SO-8 RADAR SETS. Complete, in Used but Excellent Condition. 10 CM Surface Search using 2J26 or 2J27 Magnetron, 707B Mixer, PPI Indicator, Input 115VDC. Used on Merchant Ships throughout the world. FCC Approved. Guaranteed. \$1250.00.

TEST EQUIPMENT

TS-L17/GP 10 CM WAVEMETER TEST SET. Mfg. Sperry. 2400-3400 MC. Micrometer Adj. Coaxial Cavity. Freq. Meter. Modulation. Transmission method. Mounts Crystal Current Meter & Calib. Chart. \$145.00
 VSWR AMPLIFIER TS-12/AP. Unit 1 3 stages of Amplif. and Diode Rectifier w/direct VSWR reading on meter. 115 volts 60 cyc. AC operation. Inst. BK and CPT diag. New. \$235.00
 SLOTTED LINE PRB and/or Matched Termination Includ'g Accessories TS-12/AP Unit 2 incl. UG81/U, CG92/U, CG91/U, CG89/U, UG79/U, CG87/U, MX158/U, CG-88/U, CG90/U, UG80/U plus Tools. New. \$135.00
 COMPLETE TS-12/AP UNITS 1 AND 2. \$350.00
 10 CM ECHO BOX GABV 14ABA-1 of OBU-3. 2800 MC to 3270 MCS. direct reading meter. head. Ring prediction scale plus 9% to minus 9%. Type "N" input. Resonance indicator meter. New and Comp. w/access. Box and 10 CM Directional Coupler. \$350.00
 3 CM RECEIVER. SO-3. Complete with W.G. Mixer Assy (723 A/B) Reg. Fil. Power Supply, 6 Stages IF (6A7) etc. \$127.50
 10 cm. echo line PRB. Part of SF-1 Radar with 115 volt DC tuning motor Sub SJ 1118A. \$47.50 ea.
 TS33AP WAVEMETER, MICROMETER ADJ. TYPE "N" FITTINGS. \$125.00
 "X" Band test set TS45A. APM-3 using 723 AP Oscillator. Input 115 volts single phase 60 to 800 cycles. 0 to 35 DB attenuator in used, fair condition. \$110.00 ea.
 TS-268/U crystal test set for checking IN21, IN21A, IN21B, IN23, IN23A, IN23B crystals. New. \$39.50 ea.
 THERMISTOR BRIDGE: Power meter I-203-A. 10 cm. mfg. W.E. Complete with meter, interpolation chart, portable carrying case. \$72.50
 W. E. I 138 generator of SF-1 Radar with 115 volt range. Lighthouse tube oscillator with attenuator & output meter. 115 VAC input, reg. Pwr. supply. With circuit diagram. \$50.00
 3 cm. Wavemeter: 9200 to 11,000 mc. transmission type with square flanges. \$15.00
 3 cm. stabilizer cavity, transmission type. \$20.00

MAGNETRONS

| Tube | Freq. Range | Pk. Pwr. Out | Price |
|--|-----------------------------|--------------|---------|
| 2J31 | 2820-2880 mc. | 265 KW. | \$25.00 |
| 2J21-A | 9345-9405 mc. | 50 KW. | \$25.00 |
| 2J22 | 3267-3333 mc. | 265 KW. | \$25.00 |
| 2J26 | 2992-3019 mc. | 275 KW. | \$25.00 |
| 2J27 | 2965-2992 mc. | 275 KW. | \$25.00 |
| 2J32 | 2780-2820 mc. | 285 KW. | \$25.00 |
| 2J37 | | | \$45.00 |
| 2J38 Pkg. | 3240-3263 mc. | 5 KW. | \$35.00 |
| 2J39 Pkg. | 3267-3333 mc. | 87 KW. | \$35.00 |
| 2J40 | 9305-9325 mc. | 10 KW. | \$65.00 |
| 2J49 | 9000-9160 mc. | 58 KW. | \$85.00 |
| 2J34 | | | \$55.00 |
| 2J61 | 3000-3100 mc. | 35 KW. | \$65.00 |
| 2J62 | 2913-3010 mc. | 25 KW. | \$55.00 |
| 3J31 | 21,000 mc. | 50 KW. | \$55.00 |
| 5J30 | | | \$39.50 |
| 7J44Y | | | \$25.00 |
| 7J8DY | | | \$25.00 |
| 7Z0BY | 2800 mc. | 1000 KW. | \$50.00 |
| 7Z0CY | | | \$35.00 |
| 7Z5-A | 9345-9405 mc. | 50 KW. | \$25.00 |
| 7Z5-A | 9345-9405 mc. | 50 KW. | \$25.00 |
| 7Z8 | A.Y. BY. CY. DY. EY. FY. GY | | \$50.00 |
| 760 | A. B. C. D | | \$50.00 |
| 706 | A.Y. BY. DY. EY. FY. GY | | \$50.00 |
| Klystrons. 723/U. \$12.50; 707B. \$20.00 | | | |
| | 417A \$25.00 | 2K41 | \$65.00 |

MAGNETRON MAGNETS

| Gauss | Pole Diam. | Spacing | Price |
|-------|------------|-----------|---------|
| 4550 | | 1/2 in. | \$12.50 |
| 5200 | 2 1/2 in. | 1/2 in. | \$17.50 |
| 1300 | 1 1/2 in. | 1 1/2 in. | \$12.50 |
| 1860 | 1 1/2 in. | 1 1/2 in. | \$14.50 |

Electromagnets for magnetrons. \$24.50 ea.

MICROWAVE ANTENNAS

SO-3 RADAR 3 CM. SURFACE SEARCH ANTENNA. Complete with 24 VDC Drive Motor, Selsyn, Gear Mechanisms. "X" Band Slotted "Peel" Reflector. Less Plumbing. \$135.00
 As Shown
 APS-15 Antennas. New. \$99.50
 AN MPG-1 Antenna. Rotary feed type high speed scanner antenna assembly, including horn parabolic reflector. Less internal mechanisms. 10 deg. sector scan. Approx. 12 1/2 x 4 1/2 x 9 1/2. Un-used. (Gov't Cost. \$4500.00). \$250.00
 APS-3 3 cm. antenna. Complete. 1 1/2 dish. Cut-ter feed dipole directional coupler, all standard 1" x 1/2" waveguide. Drive motor and gear mechanisms for horizontal and vertical scan. New, complete. \$85.00
 AN/TPS3. Parabolic dish type reflector approx. 10' diam. Extremely lightweight construction. New in 3 carrying cases. \$89.50
 RELAY SYSTEM PARABOLIC REFLECTORS: approx. range: 2000 to 6000 mc. Dimensions: 4 1/2 x 3" rectangle, now \$65.00
 TR "X" BAND ROTATING ANTENNA 10 cm. 30 deg. beam. 115 v.a.c. drive. New. \$100.00



R. F. EQUIPMENT

LHTR. LIGHTHOUSE ASSEMBLY. Part of RT-39/AP8 & AP7-15 Receiver and Transmitter Lighthouse Cavities with Type N Cavity and Type N CPLG. To Revr. Uses 2C40, 2C43, 112T. Tuneable APX 2400-2700 MCS. Silver plated. \$49.50
 Receiver transmitter Rt-39A/APG-5 10 cm. gun laying RF package using 2C40 and 2C43, new. \$150.00 ea.
 APS-2 10CM RF HEAD COMPLETE WITH HARD TUBE (715B) Pulsar, 714 Magnetron 417A Mixer all 7/8" rigid coax. incl. revr. front end. \$210.00
 Beacon Lighthouse cavity 10 cm with miniature 28 volt DC FM motor, Mfg. Bernard Rice. \$47.50 ea.
 T-128/APN-19 10 cm. radar Beacon transmitter package, used, less tubes. \$59.50 ea.
 SO-3 "X" band 3 cm RF package, new complete, including receiver unit as illustrated on Page 337, Volume 23 RAD LAB Series. \$375.00 ea.
 Pro-amplifier cavities type "M" 7410590GL to use 448A lighthouse tube. Completely tunable, Heavy silver plated construction. \$37.50 ea.
 RT32/APS 6A RF HEAD. Compl. with 725A Magnetron magnet pulse rfmtr. TRA-A/B local osc. and beacon mount, pre amplifier. Used but exc. cond. \$97.50
 AN/APS-15A "X" Band compl. RF head and modulator, incl. 725-A magnetron and magnet, two 723A/B klystrons (local osc. & beacon), 1B24, TR, revr-ampl. duplexer, H.V. supply, blower, pulse rfmtr. Peak Pwr. Out: 45 KW ea. Input: 115, 400 cy. Modulator pulse duration .5 to 2 micro-sec. apx. 13 KV Pk Pulse. Compl with all tubes incl. 715-B, 829B, RKR 73, two 72's. Compl. pkg. new. \$210.00
 APS-15B. Complete pkg. as above, less modulator. \$150.00
 "S" BAND AN/APS-2. Complete RF head and modulator, including magnetron and magnet, 417-A mixer, TR, receiver, duplexer, blower, etc., and complete pulsar. With tubes, used, fair condition. \$75.00
 10 CM, RF Package. Consists of: SO Mixer-receiver using 2J27 magnetron oscillator, 250 KW peak input. 707-B receiver-mixer. \$150.00

3 CM RECEIVER

SO-3. Complete With W.G. Mixer Assy (723 A/B) Reg. Fil. Power Supply, 6 Stages IF (6AC7) \$99.50

3 CENTIMETER UNLESS OTHERWISE SPECIFIED

3 cm. 180° bend with pressurizing nipple. \$4.00 ea.
 3 cm. 90° bend. 1 1/2" long 90° twist with pressurizing nipple. \$4.00 ea.
 3 cm. "S" curve 18" long. \$5.50 ea.
 3 cm. "S" curve 6" long. \$3.50 ea.
 3 cm. right angle bends. "E" plane 18" long cover to cover. \$6.50 ea.
 3 cm. Cutler feed dipole, 11" from parabola mount to feed back. \$8.50 ea.
 3 cm. directional coupler. One way waveguide output. \$15.00 ea.
 TR ATR section for mounting 1B24 with 721A ATR cavity. Iris coupling flange. Choke to choke. \$12.50 ea.
 APS-31 mixer section for mounting two 2K25's Beacon reference cavity 1B24 TR tube. New and complete with attenuating slugs. \$42.50 ea.
 DUPLEXER SECTION for 1B24. \$10.00
 CIRCULAR CHOKE FLANGES, solid brass. .55
 SQ. FLANGES, FLAT BRASS. .55
 APS-10 TR/ATR DUPLEXER section with additional iris flange. \$10.00
 FLEX WAVEGUIDE. \$4.00/ft.
 TRANSITION 1 x 1/2 to 1 1/2 x 1/2. 14 in. L. \$8.00
 "X" BAND PREAMPLIFIER, consisting of 2-723 A/B local oscillator-beacon feeding waveguide and TR/ATR Duplexer sect. incl. 60 mc. RF amp. \$67.50
 Random Lengths wavegd, 6" to 18" LG. \$1.10 Ft.
 WAVEGUIDE RUN, 1 1/4" x 1/2" guide, consisting of 4 ft. section with Rt. angle bend on one end 2" 45 deg. bend other end. \$8.00
 WAVEGUIDE RUN, 1 1/4" x 1/2" guide, consisting of 4 ft. long. \$10.00
 "X" BAND PRESSURIZING gauge section with 1/2 lbs. gauge & Pressurizing Nipple. \$18.50
 45 DEG TWIST 8" Long. \$10.00
 12" SECTION 45 deg twist 90 deg. bend. \$6.00
 11" STRAIGHT WAVEGUIDE section choke to cover. Special heavy Construction, silver plated. \$4.50
 15 DEG BEND 10" choke to cover. \$4.50
 5 FT SECTIONS choke to cover. Silver Plated. \$14.50
 18" FLEXIBLE SECTION. \$17.50
 "E" and "H" PLANE BENDS. \$12.50
 BULKHEAD FEED THRU. \$15.00
 "X" BAND WAVEGUIDE 1 1/4" x 1/2" OD 1/16" wall. Aluminum. Per Foot. \$5.00
 WAVEGUIDE 1" x 1/2" I.D. Per Foot. \$1.50
 TR CAVITY FOR 724-A TR Tube. \$3.50
 3" FLEX SECT. sq. flange to Circ Flange Adapt. \$7.50
 724 TR TUBE (41-TR-1). \$25.00
 SWR MEAS. SECTION, 4" L with 2 type "N" output probes MTD full wave apart. Bell size guide. Silver plated. \$10.00

ALL MERCHANDISE GUARANTEED. MAIL ORDERS PROMPTLY FILLED. ALL PRICES F.O.B. NEW YORK CITY. SEND MONEY ORDER OR CHECK ONLY. SHIPPING CHARGES SENT C.O.D. RATED CONCERNS SEND P. O. MERCHANDISE SUBJECT TO PRIOR SALE

COMMUNICATIONS EQUIPMENT CO.

131 E Liberty St., New York, N. Y. Cable "Comsup" Ph. Digby 9-4124

INDEX TO ADVERTISERS

| | | | |
|--|-------------------|--|-----------------------|
| Aeronautical Communications Equipment, Inc. | 215 | Electrons, Inc. | 158 |
| Airborne Instruments Laboratory | 194 | El-Tronics, Inc. | 218 |
| Aircraft Radio Corp. | 150, 197 | Erle Resistor Corp. | 39 |
| Allen-Bradley Co. | 16 | | |
| Allen Co., Inc., L. B. | 218 | Fairchild Recording Equipment Corp. | 166 |
| Allied Control Co., Inc. | 38 | Fansteel Metallurgical Corp. | 5 |
| Altec Lansing Corp. | 216 | Federal Telephone & Radio Corp. | 147 |
| American Electroneering Co. | 201 | Ferranti Electric, Inc. | 165 |
| American Gas Accumulator Co. | 203 | Furst Electronics | 189 |
| American Lava Corp. | 59 | Fusite Corporation | 61 |
| American Phenolic Corp. | 136 | | |
| American Screw Company | 22 | General Aniline & Film Corp. | 48, 49 |
| American Television & Radio Co. | 210 | General Ceramics & Steatite Corp. | 194 |
| American Time Products, Inc. | 54 | General Electric Company | |
| Anaconda Wire & Cable Co. | 119 | Apparatus Dept. | 26, 21, 135 |
| Anti-Corrosive Metal Products Co., Inc. | 160 | Electronics Dept. | 17, 43, 153, 185, 196 |
| Arma Corporation | 43 | General Industries Co. | 41 |
| Arnold Engineering Co. | 52 | General Radio Co. | 133 |
| Art Wire & Stamping Co. | 205 | GM Laboratories Inc. | 201 |
| Astatic Corporation | 134 | Goodmans Industries, Ltd. | 188 |
| Audak Company | 248 | Gramer Company | 214 |
| Automatic Electric Sales Corp. | 34 | Graphite Metallizing Corp. | 192 |
| | | | |
| Ballantine Laboratories, Inc. | 142 | Hathaway Instrument Co. | 162 |
| Barker & Williamson, Inc. | 178 | Helipot Corporation | 149 |
| Barry Corporation | 207 | Hewlett-Packard Co. | 29 |
| Beach-Russ Company | 213 | | |
| Beaver Gear Works, Inc. | 144 | Indiana Steel Products Co. | 18 |
| Bell Telephone Laboratories | 56 | Industrial Condenser Corp. | 213 |
| Bendix Aviation Corporation | | Instrument Resistors Co. | 177 |
| Pacific Division | 196 | Insulation Manufacturers Corp. | 3 |
| Beta Electronics Co. | 205 | International Nickel Co., Inc. | 40 |
| Birther Corporation | 209 | International Resistance Co. | 8, 9 |
| Biwax Corporation | 213 | I-T-E Circuit Breaker Co. | 15 |
| Boonton Radio Corp. | 121 | | |
| Bowser, Inc. | 159 | Jelliff Mfg. Corp., C. O. | 169 |
| Bradley Laboratories, Inc. | 207 | Johnson Company, E. F. | 199 |
| Brand & Co., Wm. | 42 | Jones Div., Howard B., Cinch Mfg. Corp. | 247 |
| Brush Development Co. | 161 | | |
| Burgess Battery Co. | 181 | Kable Engineering Co. | 204 |
| Burlington Instrument Co. | 211 | Karp Metal Products Co., Inc. | 10 |
| Burnell & Company | 55 | Kenyon Transformer Co., Inc. | 185 |
| | | Kester Solder Company | 117 |
| Cambridge Thermionic Corp. | 189 | Kinney Manufacturing Co. | 170 |
| Cannon Electric Development Co. | 182 | Knights Co., James | 192 |
| Capitol Radio Engineering Institute | 197 | | |
| Carborundum Company | 30, 31 | Lampkin Laboratories, Inc. | 197 |
| Centralab, Div. Globe-Union, Inc. | 11, 12 | Lavole Laboratories | 129 |
| | 13, 14 | Leach Relay Company | 138 |
| Cinch Manufacturing Corp. | 113 | Leland, Inc., G. H. | 176 |
| Clare & Co., C. P. | 127 | Lenkurt Electric Co. | 198 |
| Clarostat Mfg. Co., Inc. | 155 | Lewis Engineering Co. | 215 |
| Cleveland Container Co. | 187 | Lewis Spring & Mfg. Co. | 164 |
| Cohn Corporation, Sigmund. | 195 | Linde Air Products Co. | 193 |
| Collins Radio Company | 19 | Lord Mfg. Company | 180 |
| Cornell-Dubiller Electric Corp. | 33 | | |
| Cross Company, H. | 218 | Mallory & Co., Inc., P. R. | 64, 115 |
| | | Manning, Maxwell & Moore, Inc. | 101 |
| Dano Electric Co. | 201 | McGraw-Hill Book Co. | 205 |
| Daven Company | Inside Back Cover | | |
| Dial Light Company of America. | 179 | | |
| Driver-Harris Co. | 23 | | |
| Dumont Electric Corp. | 210 | | |
| Du Mont Laboratories, Inc., Allen B. | 50 | | |
| du Pont de Nemours & Co., E. I. | 137 | | |
| | | | |
| Eastern Air Devices, Inc. | 179 | | |
| Eisler Engineering Co., Inc. | 218 | | |
| Eitel-McCullough, Inc. | 37 | | |
| Electrical Reactance Corp. | 53 | | |
| Electro-Motive Mfg. Co. | 2 | | |
| Electro Products Laboratories. | 197 | | |
| Electro-Voice, Inc. | 47 | | |
| Electronic Instrument Co., Inc. | 218 | | |

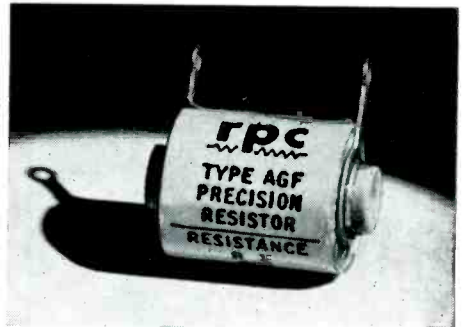

rpc

WIRE WOUND PRECISION RESISTORS

RPC Resistors are designed to meet stringent requirements of manufacturers of test instruments, meters and scientific equipment. Made of finest materials, they are carefully wound with controlled wire tension. Impregnation in insulating varnish and baking at high temperature insures stability and long life. Plastic labels provide improved protection. RPC Resistors are widely used by the Armed Forces, research laboratories, instrument makers and universities. Quick delivery is a feature of RPC service. Write today for catalog.

Also manufacturers of High Voltage and High Frequency Resistors.

RESISTANCE PRODUCTS CO.

714 RACE STREET

HARRISBURG • PENNSYLVANIA

HERE'S BIG HELP IN TERMINAL WIRING!

The New JONES FANNING STRIP

The correct wire to correct terminal every time!

Connections are made through Fanning Strip, on bench or anywhere apart from barrier strip, and quickly slipped into assembly.

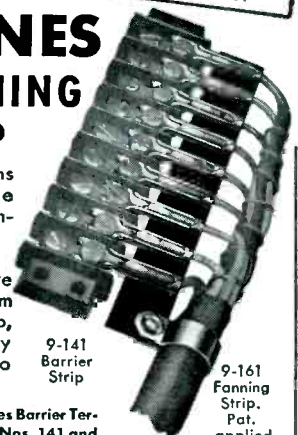

Use with Jones Barrier Terminal Strips, Nos. 141 and 142, for 1 to 20 terminals.

Simplifies soldering. Insures correct connections. Saves time. Ideal for harness or cable assembly. Brass terminals, cadmium plated. Bakelite mounting. Send for complete data.

HOWARD B. JONES DIVISION

Cinch Mfg. Corp.
2460 W. GEORGE ST. CHICAGO 18, ILL.

... FOR THOSE TOUGH "Switching" PROBLEMS TRY DAVEN!

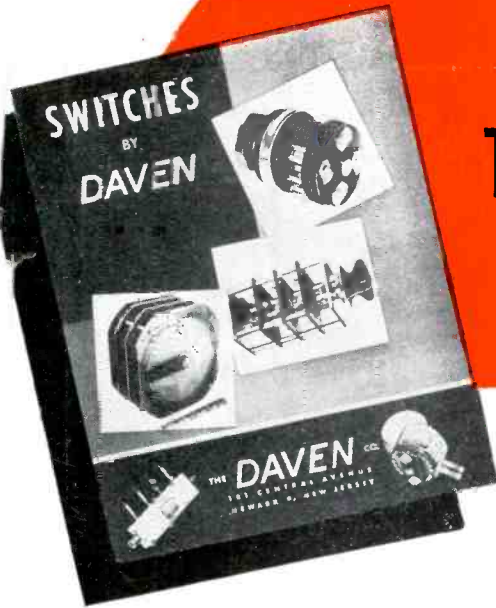

Write for your copy of
our new Switch Bulletin

Whether you use switches for industrial applications, communications or laboratory work, a Daven-constructed unit will give maximum performance. Many years of engineering experience and skilled workmanship have been combined to make a truly superior switch.

Daven switches are the rotary selector type—outstanding in design and capable of withstanding the most critical tests. They are preferred by engineers who want the best.

Some outstanding features are —

- Low and uniform contact resistance.
- Minimum thermal noise.
- High resistance to leakage.
- Trouble-free operation and long life.
- Roller-type positive detent action.
- Depth of unit not increased by addition of detent.

A full line of standard switches are available. Listed below are a few of the popular types.

| Type | Operation | Maximum No. of Positions (per pole) | Maximum Poles per Deck | Deck Diameter |
|------------|-------------------------|-------------------------------------|------------------------|---------------|
| C1A | Make before break | 31 | 1 | 1 3/4" |
| C2B | Break before make | 15 | 1 | 1 3/4" |
| C7A | Make before break | 11 | 2 | 1 3/4" |
| C8A | Break before make | 5 | 2 | 1 3/4" |
| D1A | Make before break | 47 | 1 | 2 1/4" |
| D7A | Make before break | 14 | 4 | 2 1/4" |
| D9A | Make before break | 9 | 5 | 2 1/4" |
| D10B | Break before make | 5 | 5 | 2 1/4" |
| E3A | Make before break | 47 | 2 | 2 3/4" |
| E4B | Break before make | 23 | 2 | 2 3/4" |
| E7A | Make before break | 23 | 4 | 2 3/4" |
| E8B | Break before make | 12 | 4 | 2 3/4" |
| F1A | Make before break | 60 | 1 | 3" |

Daven has a standard switch for your special requirements.
Our engineers will be glad to offer suggestions on your problems.

Send your detailed information to Dept. E-1

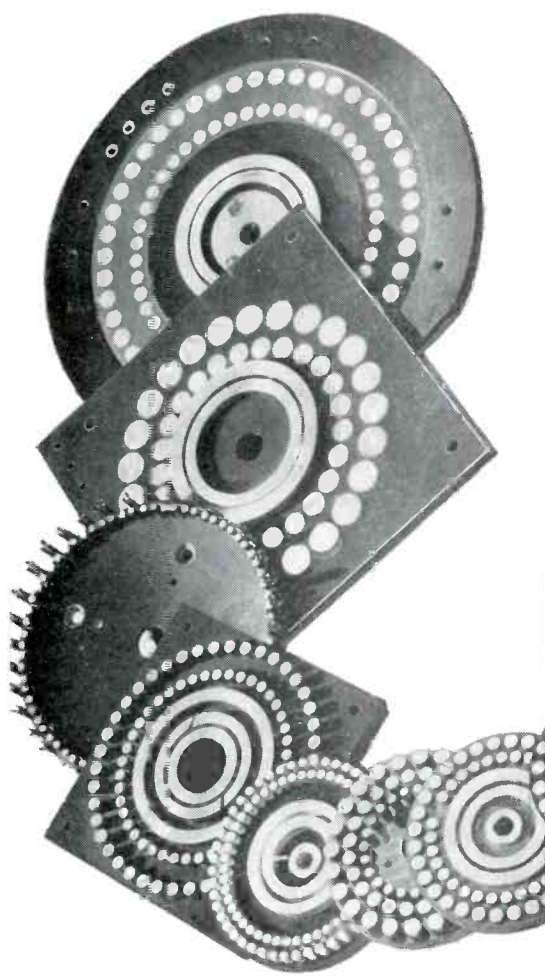

Another RCA First...



THE FOUNTAINHEAD OF MODERN TUBE DEVELOPMENT IS RCA

A new milestone in television progress

... the RCA 16-inch metal-cone television kinescope

● The RCA-16AP4—a 16-inch, directly viewed metal-cone kinescope—is RCA's newest contribution to the television industry. It is the outgrowth of a perfected process of sealing glass to large areas of metal.

Use of the metal cone reduces weight substantially below that of a similar all-glass tube and provides greatly increased strength.

Other features of the 16AP4 include high picture brightness, good contrast even under high ambient light conditions, a high-quality face plate, and large useful screen area in relation to face area.

The RCA-16AP4 meets the growing demand for a picture size midway between that of the popular directly viewed RCA-10BP4 and the larger, projected picture provided by the RCA-5TP4.

The 16AP4 is currently being produced in quantity at the RCA Lancaster plant. Ground has been broken for a new large plant in Marion, Indiana, the entire production of which will be centered on the 16-inch metal tube.

RCA Application Engineers are ready to cooperate with you in applying the 16AP4 and associated components to your specific designs. For further information write RCA, Commercial Engineering, Section 42GR, Harrison, New Jersey.



The world's most modern tube plant . . .

RCA, LANCASTER, PA.



RADIO CORPORATION of AMERICA
ELECTRON TUBES

HARRISON, N. J.