

OCTOBER • 1945

A MCGRAW-HILL PUBLICATION

# electronics



RADAR AT SEA

# THE AMPEREXTRA FACTOR IN DIELECTRIC HEATING

Dielectric heating has revolutionized the processing of plastics, textiles, rubber, drugs, foods, wood, paper and many other products. For dielectric heating equipment AmpereX has originated a number of electronic tube types especially suited for use as oscillators at high frequencies. Dependable operation and reserve capacity are the **Amperextra Factor** in this group of tubes — a Factor which will increase in importance in the highly competitive postwar years when goods must be delivered better, cheaper—and on time.

"WON'T GO CUCKOO"

... that is how one electronic heat generator manufacturer describes AmpereX tubes. If your equipment is right, AmpereX Special Application Engineering will help you make it better. Dependable operation is assured, replacements minimized, and greater value per dollar expended may be anticipated.



## THE AMPEREX SPECIAL APPLICATION ENGINEERING DEPARTMENT

... AmpereX Special Application Engineers have nothing to sell. Their job is to work with you on the development of new equipment or the improvement of present products. Their time and knowledge is yours for the asking, without charge or obligation.



## RESERVE CAPACITY

... the measure of tube life is in the reserve capacity of the tube. Because of novel design, AmpereX high frequency tubes may be used at plate voltages and plate power inputs sufficiently high to allow power outputs at maximum rated watts per tube.



*AmpereX Type 235-R Transmitting Tube. Filament voltage, 14.5-15.0 volts. Filament current, 39.0 amperes. Amplification factor, 14.0. Grid to plate transconductance at 500 ma., 6500 micromhos. Direct interelectrode capacitance: grid to plate, 9.0  $\mu\text{f}$ ; grid to filament, 10.0  $\mu\text{f}$ ; plate to filament, 1.5  $\mu\text{f}$ . List price, \$125.00.*



*AmpereX Type 889 Transmitting Tube. Filament voltage, 11 volts. Filament current, 125 amperes. Amplification factor, 21. Direct interelectrode capacitance: grid to plate, 17.8  $\mu\text{f}$ ; grid to filament, 19.5  $\mu\text{f}$ ; plate to filament, 2.5  $\mu\text{f}$ . List price, \$175.00.*



*AmpereX Type 889-R Transmitting Tube. Filament voltage, 11 volts. Filament current, 125 amperes. Amplification factor, 21. Direct interelectrode capacitance: grid to plate, 20.7  $\mu\text{f}$ ; grid to filament, 19.5  $\mu\text{f}$ ; plate to filament, 2.5  $\mu\text{f}$ . List price, \$325.00.*

## AMPEREX

... the high performance tube

Many standard types of AmpereX tubes are now available through leading radio equipment distributors

# AMPEREX ELECTRONIC CORPORATION

25 Washington St., Brooklyn 1, N.Y., Export Division: 13 E. 40th St., New York 16, N.Y., Cables: "Arlab"  
Canadian Distributor: Rogers Majestic Ltd. • 622 Fleet Street West, Toronto

HOLD ON TO THE WAR BONDS YOU HAVE — AND KEEP BUYING MORE



# electronics

A MCGRAW-HILL PUBLICATION



OCTOBER • 1945

RADAR AT SEA.....		Cover
Radio detecting and ranging antennas are shown atop the "island" of the aircraft carrier U. S. S. Bennington (Navy photo)		
RADAR WARFARE.....		92
The technical factors behind the uses of the electronic device contributing most to victory		
FINGERTIP CONTROL FOR FORMATION FLYING, by D. G. Taylor and G. Volkenant.....		98
Newest accessory for C-1 electronic autopilot permits effortless maneuvering of largest bombers		
VHF MULTIPLE-RELAY TELEVISION NETWORK, by F. J. Bingley.....		102
Description of a chain through which video programs originating in Washington are telecast in Philadelphia		
THE TECHNICAL BASIS OF ATOMIC EXPLOSIVES.....		109
Production and use of uranium-235 and plutonium		
CRACK DETECTOR FOR PRODUCTION TESTING, by John H. Jupe.....		114
The instrument makes use of skin effect to determine the presence and depth of cracks in metals		
DESIGN OF STABLE HETERODYNE OSCILLATORS, by John B. Moore.....		116
Proper design of the variable capacitor minimizes effect of temperature changes on frequency		
AUTOMATIC FADER, by Dan Hunter.....		119
Complete or partial fading of a program is accomplished without the use of motors		
MICROWAVE TECHNIQUES, by Frederic A. Jenks.....		120
Transmitter and receiver designs insuring adequate stability are discussed		
BRIDGE NULL INDICATOR, by E. W. Herold.....		128
New circuit provides sensitivity with overload protection and visual indication of output		
COAXIAL CABLE TESTS, by Perry H. Ware.....		130
Production testing by substitution in bridge or resonant circuits		
INDUSTRIAL TEST EQUIPMENT DESIGN, by Ted Powell.....		135
Why circuit analyzers used for heavy field-duty fail, and how to avoid it		
CRYSTAL-TUNED F-M RECEIVERS, by William Maron.....		138
Advantages of quartz crystals in oscillator stage include high stability, easy alignment, and precise tuning		
GRAPHICAL ANALYSIS OF COMPLEX WAVES, by Larry S. Cole.....		142
Arithmetic combined with 6, 8, or 12 measurements gives equation and amplitudes of harmonics up to the sixth		
REACTOR MEASUREMENTS, by Howard L. Daniels.....		146
Circuit for measuring electrical parameters of iron-core inductors		
TRANSMISSION LINES AS TUNING ELEMENTS, by H. E. Newell, Jr.....		150
Graphical determination of line length and shunting capacitance for resonance		
CROSSTALK.....	91	
REFERENCE SHEET.....	150	
INDUSTRIAL CONTROL.....	154	
TUBES AT WORK.....	216	
ELECTRON ART.....	254	
NEWS OF THE INDUSTRY.....	316	
NEW PRODUCTS.....	380	
NEW BOOKS.....		418
BACKTALK.....		432
INDEX TO ADVERTISERS.....		443

**KEITH HENNEY, Editor; DONALD G. FINK, Executive Editor; W. W. MacDonald, Managing Editor; John Markus, Associate Editor; Vin Zeluff, Associate Editor; Assistant Editors—Frank Haylock, Frank Rockett, J. M. Heron, M. L. Matthey, and J. E. Grolimund; G. T. Montgomery, Washington Editor; Harry Phillips, Art Director**

**H. W. MATEER, Publisher; J. E. Blackburn, Jr., Director of Circulation, Electronics; Wallace B. Blood, Manager**

**DISTRICT MANAGERS, D. H. Miller, H. R. Denmead, Jr., New York; R. H. Flynn, New England; F. P. Coyle, R. E. Miller, Philadelphia; C. D. Wardner, A. F. Tischer, R. A. Werth, Chicago; E. J. Smith, J. L. Phillips, Cleveland**

Contents Copyright, 1945, by McGraw-Hill Publishing Company, Inc.

All Rights Reserved

**MCGRAW-HILL PUBLISHING COMPANY, INCORPORATED**

JAMES H. MCGRAW, Founder and Honorary Chairman

PUBLICATION OFFICE 99-129 North Broadway, Albany, N. Y., U. S. A.

EDITORIAL AND EXECUTIVE OFFICES 330 West 42nd St., New York 18, N. Y., U. S. A.

James H. McGraw, Jr., President; Curtis W. McGraw, Senior Vice-President and Treasurer; Howard Ehrlich, Vice-President (for business operations); Willard Chevallier, Vice-President (for editorial operations); Joseph A. Gerardi, Secretary; and J. E. Blackburn, Jr., Director of Circulation.

**ELECTRONICS**, October, 1945, Vol. 18; No. 10. Published monthly, price 30¢ a copy. June Directory Issue \$1.00. Allow at least 10 days for change of address. All communications about subscriptions should be addressed to the Director of Circulation, 330 W. 42nd St., New York 18, N. Y.

Subscription rates—United States and possessions, Mexico, Central and South American countries, \$5.00 a

year, \$8.00 for two years, \$10 for three years. Canada (Canadian funds accepted) \$5.50 a year, \$9.00 for two years, \$11.00 for three years. Great Britain and British Possessions, 42 shillings for one year, 84 shillings for three years. All other countries \$7.00 for one year, \$14.00 for three years. Please indicate position and company connection on all subscription orders. Entered as Second Class matter August 26, 1936, at Post Office, Albany, New York, under the Act of March 3, 1879. **BRANCH OFFICES:** 620 North Michigan Avenue, Chicago 11, Ill.; 68 Post Street, San Francisco 4; Aldwych House, Aldwych, London, W.C. 2; Washington, D. C. 4; Philadelphia 2; Cleveland 15; Detroit 26; St. Louis 8; Boston 16; Atlanta 3, Ga.; 821 So. Hope St., Los Angeles 14; 38-9 Oliver Building, Pittsburgh 22.

## CHANGE OF ADDRESS

Director of Circulation,  
**ELECTRONICS**,  
330 West 42nd Street  
New York 18, N. Y.

Please change the address of my **Electronics** subscription.

Name .....

Old Address .....

New Address .....

New Company Connection .....

New Title or Position .....

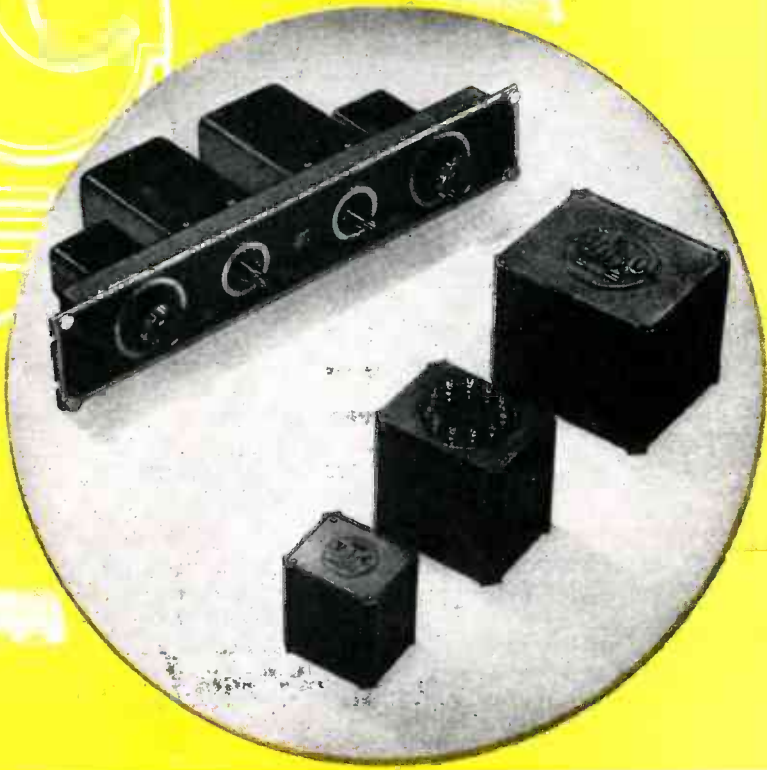

# BROADCAST STATION COMPONENTS

*United Transformer Corp.*

180 VARICK STREET NEW YORK 13, N. Y.  
EXPORT DIVISION: 13 EAST 40th STREET, NEW YORK 16, N. Y. CABLES: "ARLAB"



ALL PLANTS



So clearly and unmistakably are draftsmen able to express their ideas on paper that their drawings have re-shaped the world. Through line, figure and symbol, draftsmen define the work to be done by the labor and machines of a nation. Assisting them to attain precision and clarity are drafting instruments that act almost as living extensions of their own hands...instruments that function figuratively as their partners in creating.

For 78 years Keuffel & Esser Co. drafting equipment and materials have been partners, in this sense, in shaping America, in making possible its swift-moving highway traffic, its speed in conducting business, its victorious might in war ... So universally is K & E equipment used, it is self-evident that every engineering project of any magnitude has materialized with the help of K & E. Could you wish any surer guidance than this in the selection of your own "drafting partners"?

You will find special advantages, for example, in PHOENIX\* Tracing Cloth, which K & E has made almost "ghost-proof." Here is a cloth from which you can erase either pencil or ink lines without risking untidy "ghosts" on the prints, a cloth practically immune to stains from perspiration and water. You can even soak it in water for ten minutes at a time without harm! For further details about PHOENIX\* Tracing Cloth, write on your letterhead to Keuffel & Esser Co., Hoboken, N. J.

# partners in creating

\*REG. U. S. PAT. OFF.

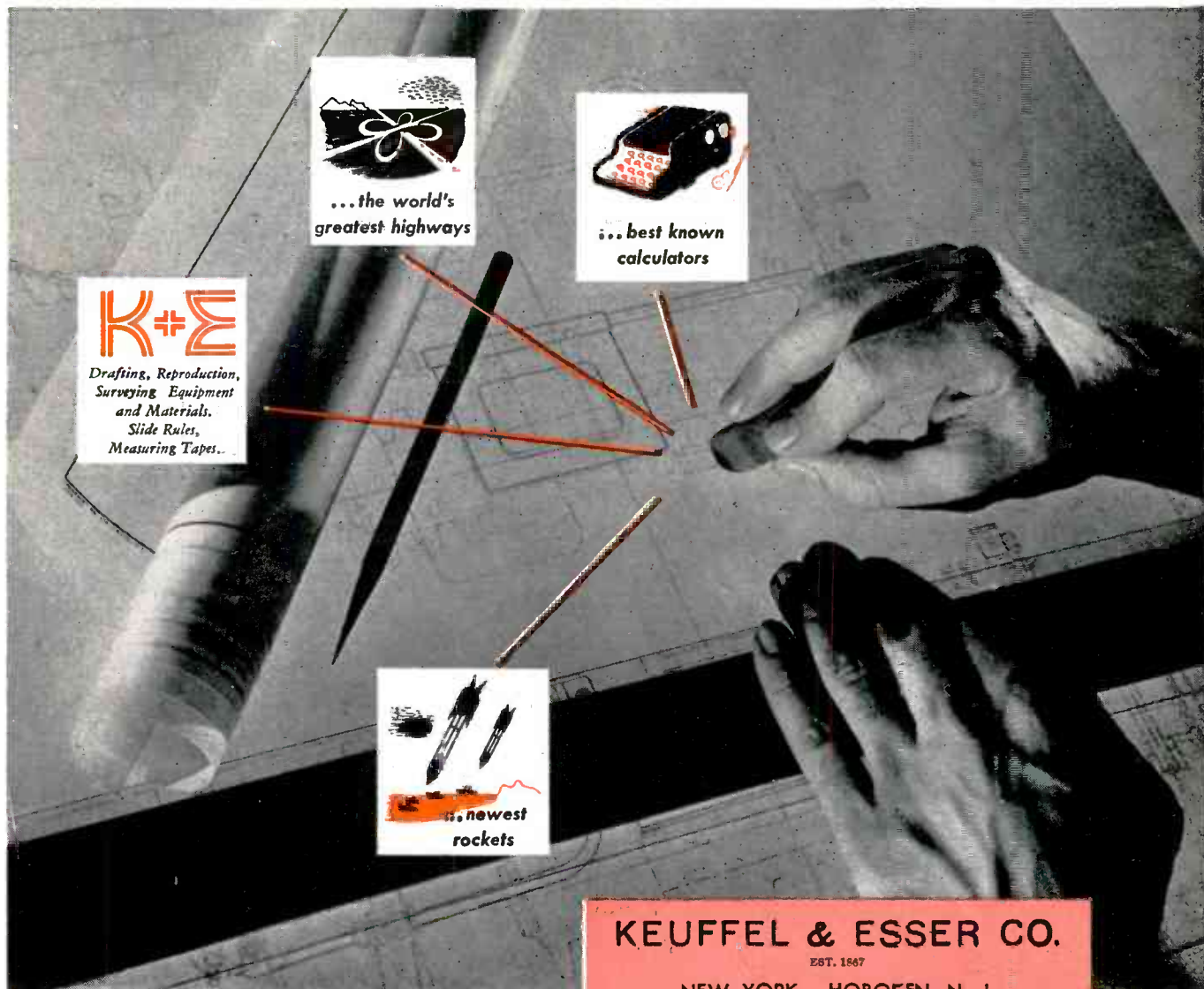

... the world's  
greatest highways



... best known  
calculators

**K+E**  
Drafting, Reproduction,  
Surveying Equipment  
and Materials.  
Slide Rules,  
Measuring Tapes.



... newest  
rockets

**KEUFFEL & ESSER CO.**  
EST. 1867  
NEW YORK • HOBOKEN, N. J.  
CHICAGO • ST. LOUIS • DETROIT • SAN FRANCISCO  
LOS ANGELES • MONTREAL

All of the big guns on Navy ships and a majority of their smaller guns are directed by radars designed by Bell Telephone Laboratories and made by Western Electric.



# What **TEAMWORK**

Bell Telephone Laboratories and Western Electric were "naturals" for the leading part they played in the radar program. For years they've worked as a team in developing and producing complex electronic equipment.

Here are some unadorned facts about what their teamwork made possible.

Up to the end of the war, Western Electric had furnished the Army, Navy and Air Forces with more than 56,000 radars of 64 different types, valued at almost \$900,000,000.

In 1944 alone, Bell Laboratories worked on 81 different types of radar systems and Western Electric produced 22,000 radars of 44 different types — of which 20 were new in production that year.

Western Electric was the largest producer of the cavity magnetron and other essential vacuum tubes for radar. Number of tubes required for Western Electric radar systems varied from less than 100 to nearly 400 per system.

Complexity of radar manufacture is indicated by the fact that even a simple type may require 4,000 labor hours to manufacture and the larger types as much as 40,000 labor hours.



Bomb-directing radars used on B-29s were designed by the Laboratories and made by Western Electric.



This team developed and produced low altitude radar bombsights widely used against the enemy's merchant shipping.



From the very beginning, ground radars made by Western Electric played an important role in all theatres of war.

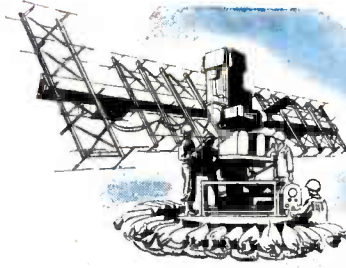

# *did for* **RADAR**

Bell Laboratories developed more than 100 different radar test sets. In 1944, Western produced over 40,000 test sets of 68 types.



*The same team is working for YOU!*

The unique combination of brain power and manufacturing facilities that made Bell Laboratories and Western Electric the nation's largest source of radar, is now devoted to bringing you the best in communications equipment for a world at peace. In peacetime off-shoots of radar—and in FM, AM and television broadcasting—in radio telephone equipment for every type of mobile service—this team can be counted on to lead the way.

A school to train military personnel to operate and maintain radar was established by the Laboratories. Over 100 courses were given to some 4,000 officers and men.



Western Electric built up a Field Engineering Force of more than 500 specialists. They served with all branches of the Armed Forces on all fighting fronts.



**BELL TELEPHONE LABORATORIES**  
*World's largest organization devoted exclusively to research and development in all phases of electrical communication.*



**Western Electric**  
*Manufacturing unit of the Bell System and nation's largest producer of communications and electronic equipment.*

HERE'S THE FORMULA FOR CAPACITOR SATISFACTION

$P_c + CQC = DP$



Productive capacity ( $P_c$ ) plus continuous quality control ( $CQC$ ) equals the dependable Tobe Type DP Oil-impregnated Molded Paper Capacitor, relied upon for performance in electronic and industrial apparatus.

This hermetically-sealed unit supersedes paper tubular capacitors where long life is essential. And where high capacitance must be provided in small space, it replaces mica capacitors.

From every standpoint — convenience, cost, and performance — Tobe DP capacitors merit your consideration in all your post-war designs.

Available in  
CN35 and CN20  
case sizes

*Check these Features!*

- Capacitances: 1,000 to 50,000 mmfd.
- Working voltages: 120 to 800 d-c
- Power Factor = 0.004 to 0.006 at 1,000 cycles
- Operating Frequencies: up to 40 megacycles
- Shunt Resistance: 50,000 megohms at 250° C.
- Moisture Seal: meets all thermal cycle, immersion, and humidity requirements
- Working Temperatures: -55 to +105° C.

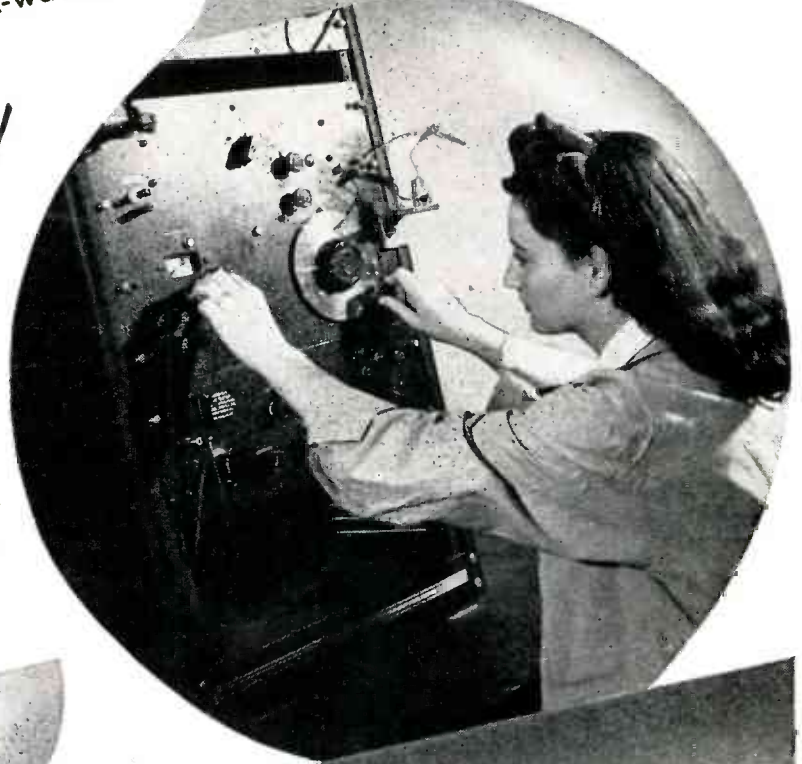

FIELD OFFICES IN NEW YORK CITY · CHICAGO · DETROIT · GLENDALE, CALIFORNIA



# NEED SOLUTIONS TO PROBLEMS LIKE THESE?

- Aircraft Instrument Lubrication
- Electrostatic Shielding
- Electrodes for Light Sensitive Cells
- Undesired Thermionic Emissions
- Wire Drawing Lubricant (Tungsten, Molybdenum, etc.)

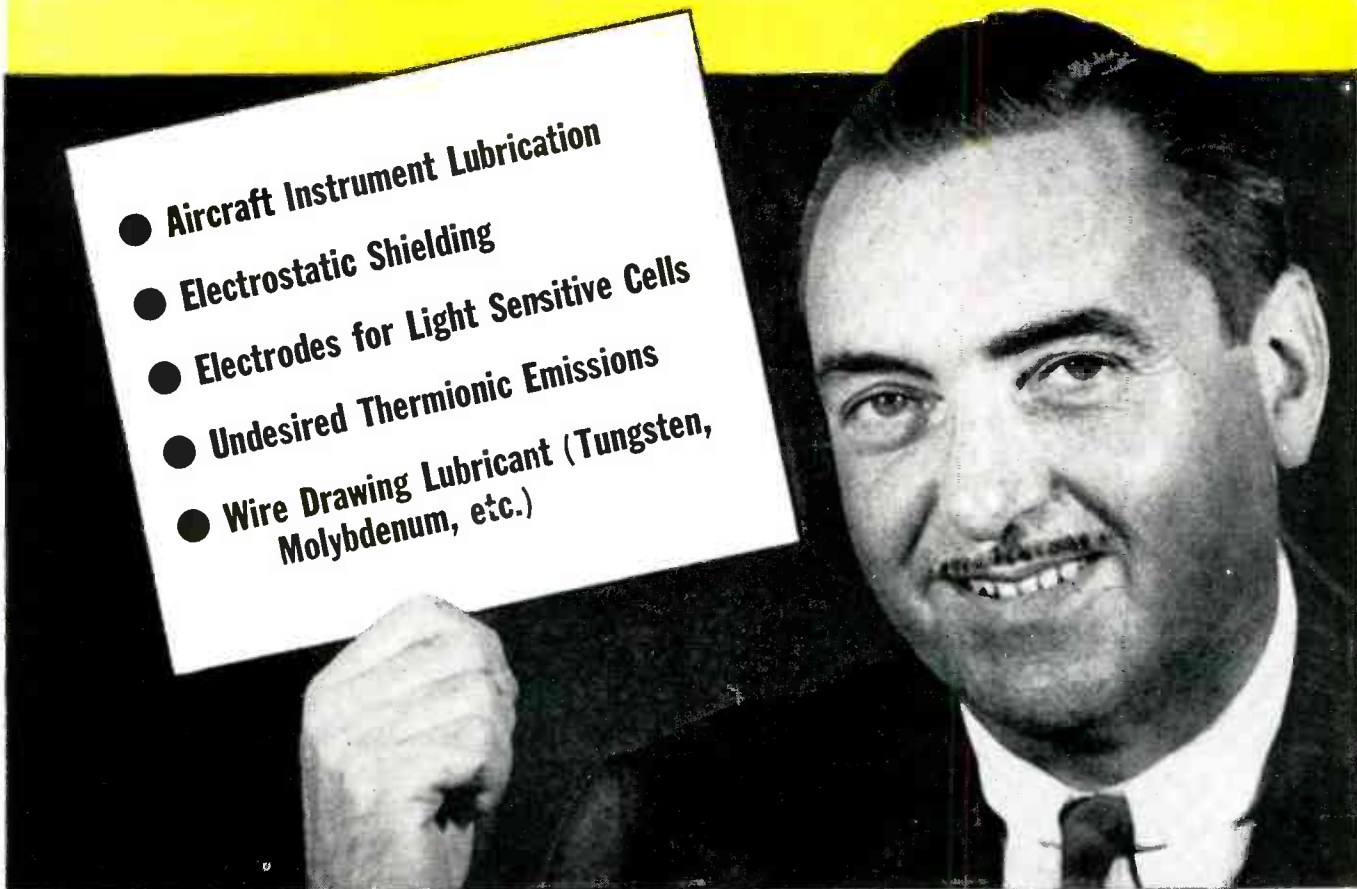

Problems like those in the box above have beset many in your industry...But that was before the recent developments of "dag" colloidal graphite—developments made to successfully meet war production emergencies. The end result is that you may now obtain remarkable assist-

ance with your problems from the amazing versatility of "dag" colloidal graphite dispersions.

A 3¢ stamp will mail the convenient coupon below. Fill in your name and check the list for free copies of booklets which fit your specific needs.



## colloidal graphite

ACHESON COLLOIDS CORPORATION,  
Port Huron, Michigan



### TO GET THESE . . . MAIL THIS

This new literature on "dag" colloidal graphite is yours for the asking:

- 430** A general booklet on the story of "dag" colloidal graphite. 12 pages profusely illustrated.
- 440** A complete list of "dag" colloidal graphite dispersions with applications.
- 422** "dag" colloidal graphite as a PARTING COMPOUND.
- 423** "dag" colloidal graphite as a HIGH TEMPERATURE LUBRICANT.
- 431** "dag" colloidal graphite for IMPREGNATION AND SURFACE COATINGS.
- 432** "dag" colloidal graphite in the FIELD OF ELECTRONICS.

JML Co. A-K1

ACHESON COLLOIDS CORPORATION  
PORT HURON, MICHIGAN DEPT. K-5

Please send me, without obligation, a copy of each of the bulletins checked:

- No. 430  NAME \_\_\_\_\_
- No. 440  POSITION \_\_\_\_\_
- No. 422  ADDRESS \_\_\_\_\_
- No. 423  ZONE No. \_\_\_\_\_ STATE \_\_\_\_\_
- No. 431  OUR PRESENT OIL SUPPLIER IS \_\_\_\_\_
- No. 432  (Lubricants containing "dag" colloidal graphite are available from major oil companies.)

# Allis-Chalmers Electronic

## NEW KIND OF

➡ *Compare Engineering: A-C's years of industrial electronic experience give you superior operating features.*

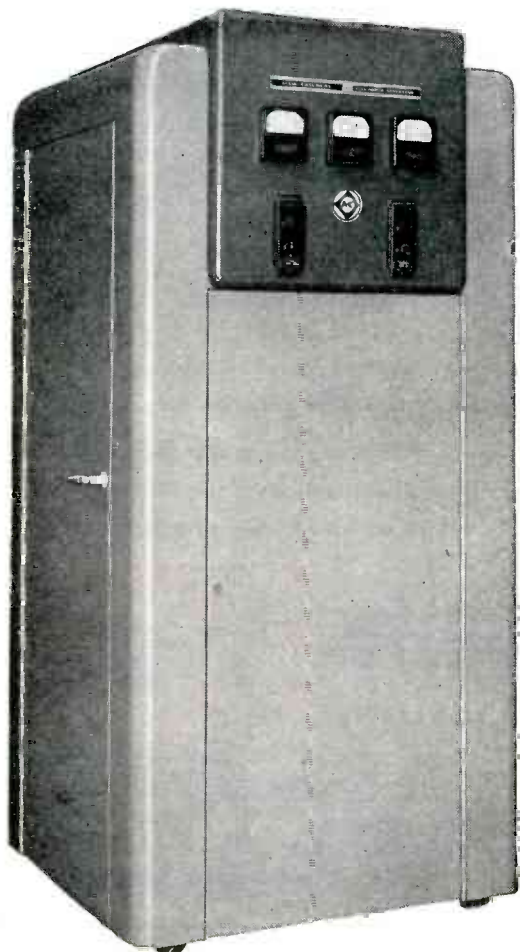

**C**ONVENIENCE, economy, low cost — the magic of induction heating at its finest — that's what Allis-Chalmers new Electronic Heater now offers you!

➡ **Completely Automatic:** Pre-set timer controls heat sequence from 2/10 seconds to 2 minutes — so that even unskilled operators can harden and braze metal parts in volume — uniformly — at simple touch of starter button. All controls are located on one panel for easy change in applications. Job settings are protected from tampering by door and lock.

➡ **High Efficiency:** 3-phase rectifying system guarantees maximum power from Electronic Heater, prevents unbalanced load on power lines. All tubes carry manufacturer's guarantee (minimum: 1000 hours), often have useful life in excess of 5000 hours. New coupling system keeps losses low, permits adaptation to most applications without use of radio frequency transformers.

➡ **Safety Features:** Operator and equipment are fully protected by heavy-duty control, fuses, high water-temperature relay, interlocking switches on door, choke coil, water filters and pressure switches.

Maybe your manufacturing operation can be performed better, faster, cheaper with this great new production tool. Write for further information, or send samples for free laboratory test. No obligation. ALLIS-CHALMERS, ELECTRONIC DEVICES SECTION, MILWAUKEE 1, WISCONSIN.

A 1914

*Pioneer Builders of Electronic Equipment for Industry.*

**Allis**





# Heater Now Offers You A

# METAL MAGIC

➔ *Compare Results: High frequencies, accurate control of A-C's new unit give you finer products at lower costs.*

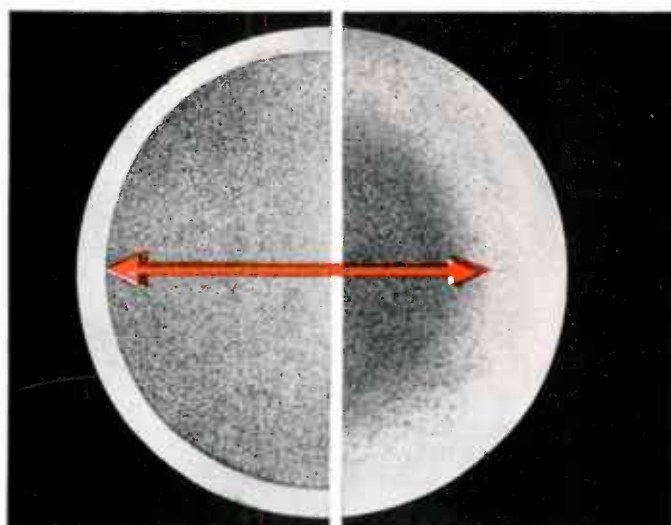

## INCREASES PRODUCTION

Joining parts by brazing is ideal for induction heating — an application of this new magic process which can slash product costs by doubling and redoubling production rates! Here's how A-C's Electronic Heater solved the problems of one lubricator manufacturer who formed sub-assemblies by torch-brazing. His rejects were high, his production was slow (15-20 units per hour), and slow heat affected cadmium plating on parts so that it peeled off in a short time. A-C's Electronic Heater was able to step production up to 200 units per hour! Rejects became negligible, and plating was not affected. Maybe Allis-Chalmers Electronic Heater can show you the same spectacular results!

## MORE EFFICIENT HARDENING

Allis-Chalmers Electronic Heater gives you surface hardening to controlled depths — faster, cleaner, without heat, fumes, space-waste of conventional methods. Tendency of high-frequency currents (400,000 cycles and up) is to hug surface of conductor. Result: thin, hardened surface with healthy, ductile core — as shown above, left, in unretouched micro-photograph section of  $\frac{3}{4}$  inch bar of SAE 1045 steel — hardened by Electronic Heater. Compare this with micro-photograph section of  $\frac{3}{4}$  inch SAE 1045 steel bar hardened by conventional methods — above, right! Here, uncontrolled hardening has penetrated deep into the core, making the bar brittle and weak.

# Chalmers

**MILWAUKEE  
WISCONSIN**

# NEW!

# HQ-129-A

\$129<sup>00</sup> AMATEUR  
NET  
LESS SPEAKER



PRICES SUBJECT TO CHANGE  
WITHOUT NOTICE

**WRITE TODAY**

A postcard will bring description  
of this outstanding new receiver.

## FINEST LOW COST RECEIVER

By all measurement this is unquestionably one of the  
greatest values ever offered to amateurs . . . Here is "ham" communication  
at its best, streamlined for highest performance at a modest cost . . .

WRITE TODAY. Send card for descriptive folder.

# HAMMARLUND

THE HAMMARLUND MFG. CO., INC., 460 W. 34<sup>TH</sup> ST., NEW YORK 1, N. Y.  
MANUFACTURERS OF PRECISION COMMUNICATIONS EQUIPMENT





# GREAT GENERAL-PURPOSE TRANSMITTING TUBE

**TYPE GL-805**

**\$10**



**H**ere is a leader in General Electric's highly developed, *complete* line of transmitting tubes! Type GL-805 not only gives you high power output at relatively low plate voltages (see ratings below), but the tube's grid-bias requirements are unusually low (zero for many Class B operating conditions). These features mean economy in use.

Type GL-805 does a wide variety of jobs efficiently. It is used in the low-power stages of large transmitters, and also as a power amplifier in smaller

stations. An excellent amateur tube, as well as standard for other communications, the GL-805 is one of the more versatile transmitting types.

High amplification factor, and a frequency range above most power-tubes in its class (30 megacycles at maximum plate output; 80 at reduced ratings)—these are still other advantages. See your nearest G-E office or distributor for further information, or write *Electronics Department, General Electric Company, Schenectady 5, N. Y.*

*Check these ratings*

*New Booklet ETX-5 gives ratings and prices on General Electric's complete line of transmitting tubes. Ask for your free copy.*

Continuous ratings	Class B A-F service (two tubes)	Class C R-F service, plate-modulated	Class C R-F service, without modulation
Filament voltage	10 v	10 v	10 v
Filament current	3.25 amp	3.25 amp	3.25 amp
Max plate voltage	1,500 v	1,250 v	1,500 v
Max plate current	210 ma (per tube)	175 ma	210 ma
Max plate input	315 w (per tube)	220 w	315 w
Max plate dissipation	125 w (per tube)	85 w	125 w
Driving power (approx.), typical operation	7 w	16 w	8.5 w
Plate power output, typical operation	370 w	140 w	215 w

**GENERAL  ELECTRIC**

161-D10-8880

TRANSMITTING, RECEIVING, INDUSTRIAL, SPECIAL PURPOSE  
TUBES • VACUUM SWITCHES AND CAPACITORS



# FM

## does it—

### THROUGH STORM AND NOISE

with clear reception that will build  
and hold greater audiences

Over a period of a year, more radio receivers are turned off during programs because of man-made and natural electrical disturbances than for any other cause. If your station serves areas where electrical devices produce high noise-levels, if you are geographically located where static is a problem, consider FM. Frequency Modulation will give your listeners vastly improved reception, virtually free from noise—and do it with less transmitter power and reductions in operating costs. Or, with the same power and the same cost, it will enlarge your primary service area.

In order to provide radio reception with low background noise level, the signal strength of an AM broadcast station should be about 100 times stronger than that of the interfering noise or signal. By comparison, an FM broadcast station can provide reception with the same low background noise level but with a signal strength only about twice that of the noise level itself.

# AM

Natural and man-made electrical disturbances can "cut holes" in an AM broadcast program because waveforms of such disturbances have similar modulation characteristics.

Consider, for example, the case of the 1-kw AM station on 1200 kc. With a 400-ft half-wave antenna overlooking flat country and where conditions of ground conductivity are average ( $3 \times 10^{-14}$  EMU) this station can generally provide its radio audience with satisfactory noise-free service over the following approximate effective areas:

AM Service	Range	Coverage
Day	22 miles	1520 square miles
Night	10.5 miles	346 square miles

Compare this performance with the virtually interference-free reception that a 1-kw FM station can provide over the same terrain, using a 2-bay circular antenna 400 feet high:

FM Service	Range	Coverage
Day and Night	43 miles	5800 square miles

Performance like this provides better service. Service like this builds larger audience and greater advertiser interest.

STUDIO AND STATION EQUIPMENT • TRANSMITTERS

# GENERAL ELECTRIC

169-D1-6914



The G-E pre-war  
3-kw FM Transmitter

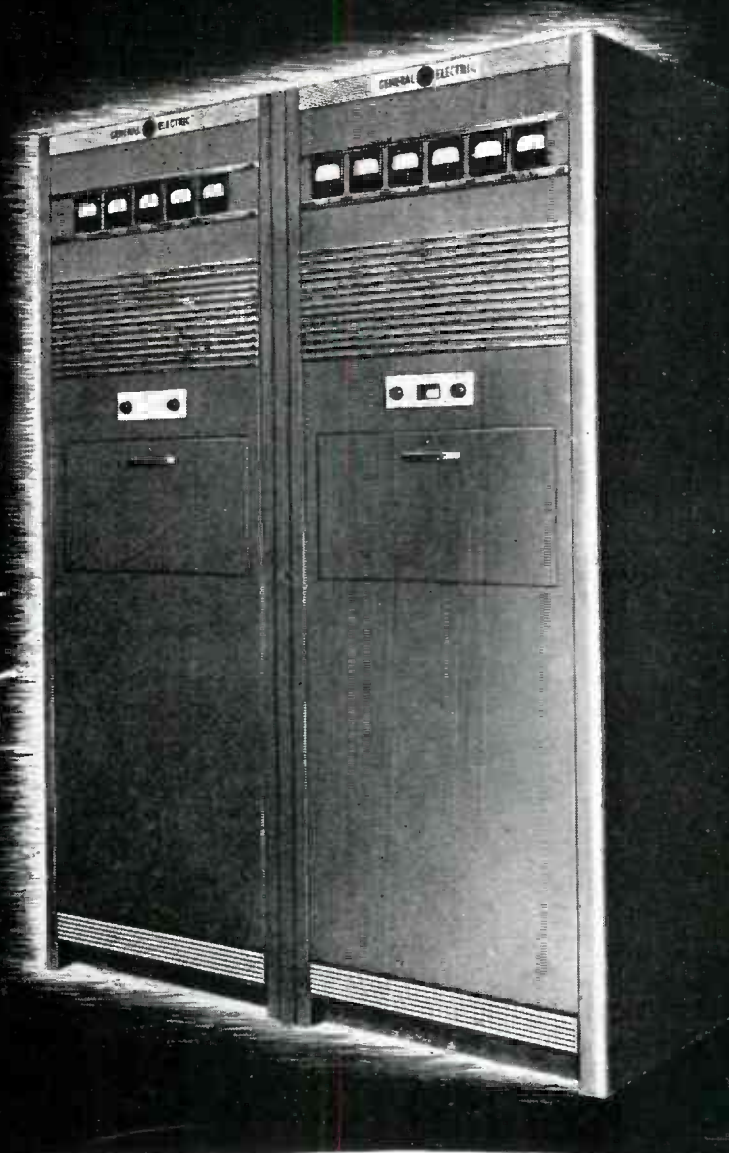

**FM**

FM broadcasting is unaffected by natural and man-made electrical disturbances because the waveform of frequency modulation is unlike that of noise.

Look to General Electric when you plan your FM station. G.E. is the one radio manufacturer with experience in designing and building complete FM systems—from transmitters to receivers. G.E. has designed and built more FM broadcast transmitters than any other manufacturer. G.E. built the first FM home receivers and has furnished a large percentage of today's half-million now in use. Today, the six studio-transmitter FM relay links now operating in the 340-megacycle band are all G.E.—with thousands of hours of regular operation to their record. G.E. operates its own FM proving-ground, station WGFM, at Schenectady. For information on General Electric FM broadcast equipment, write: *Electronics Department, General Electric Company, Schenectady 5, N. Y.*

**50 FM BROADCAST STATIONS ON THE AIR  
OVER 400 APPLICATIONS PENDING**

**FM DOES IT—**

- FM multiplies your effective coverage day and night.
- FM gives your audience programs with lower background noise.
- FM minimizes station interference on your frequency.
- FM contributes to the economy of your broadcasting system.

General Electric's FM equipment will include revolutionary circuit developments, new component designs, and improved layout features that will contribute directly to the quality and economy of your broadcasting system.

*Tune in General Electric's "The World Today" and hear the news from the men who see it happen, every evening except Sunday over CBS network. On Sunday evening listen to the G-E "All-Girl Orchestra" over NBC.*

**FOR EARLIEST POSSIBLE DELIVERY OF YOUR  
BROADCAST EQUIPMENT, PLACE YOUR ORDER NOW**

**ANTENNAS • ELECTRONIC TUBES • HOME RECEIVERS**

**FM • TELEVISION • AM**

*See G.E. for all three!*

# These tubes team up to produce high frequencies for electronic heating



At left, above: Type GL-889-A high-frequency oscillator tube—price \$160. Right: Type GL-869-B mercury-vapor rectifier tube—price \$100.

**T**O produce the high-frequency current needed for electronic heating—the fast, precise method used widely in industrial processes—specify a G-E oscillator tube like the one shown on the left.

To change standard a-c power to the d-c used by the oscillator tubes, specify a G-E rectifier tube like the one shown on the right.

Whether your electronic heating design calls for induction heating (used for metals) or dielectric (for bonding plywood and treating other non-metallic materials) these two types of tubes are the heart of the equipment.

General Electric has engineered a wide variety of tubes for electronic

heating applications. All are backed by extensive research and broad field experience. All have been proved in service over substantial periods—give the solid performance so essential to meeting high production schedules.

Consult G-E tube engineers on all of your tube requirements. Also ask for your copy of the booklet "How Electronic Tubes Work." Your nearest G-E office or distributor will be glad to serve you, or you may write to *Electronics Department, General Electric, Schenectady 5, New York.*

*Hear the G-E radio programs: "The World Today" news, Monday through Friday, 6:45 p. m., EWT, CBS. "The G-E All-Girl Orchestra," Sunday 10 p. m., EWT, NBC. "The G-E House Party," Monday through Friday, 4 p. m., EWT, CBS.*

## Characteristics of Type GL-889-A

Three-electrode vacuum oscillator tube. Its water-cooled anode suits Type GL-889-A for induction heating, where water-cooling generally is employed. Filament voltage and current are 11 v and 125 amp. Maximum anode ratings are: voltage 8,500 v, current 2 amp; input 16 kw, dissipation 5 kw. For dielectric heating, Type GL-889R-A is available with copper-fin radiator for forced-air cooling. Price \$280. Ratings are the same as those given for Type GL-889-A.

## Characteristics of Type GL-869-B

Two-electrode mercury-vapor rectifier tube. Special filament design allows either in-phase or quadrature excitation. Filament voltage and current are 5 v and 18 amp. Anode ratings for in-phase operation are: peak voltage with natural ventilation 10,000 v, with forced ventilation 20,000 v, peak current 10 amp, avg current 2.5 amp. For quadrature operation: peak voltage (forced ventilation) 15,000 volts, peak current 15 amperes, avg current 5 amperes.

G. E. HAS MADE MORE BASIC ELECTRONIC-TUBE DEVELOPMENTS THAN ANY OTHER MANUFACTURER

# GENERAL ELECTRIC

102-510-6000



**A**  
**HARVEY**  
 Regulated Power Supply  
**106 PA . . .**

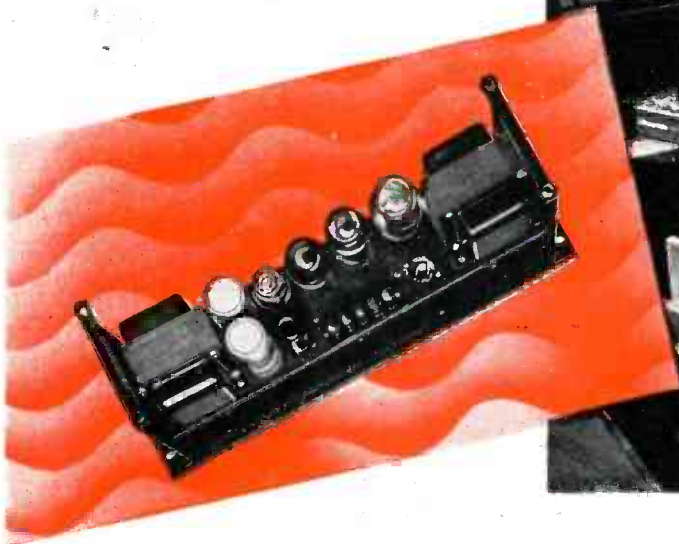

**Helps RECORD A SUBTERRANEAN RESERVOIR'S REACTIONS**

This Petroleum Reservoir Behavior Analyzer, developed by a major oil company, is used to analyze the behavior of petroleum reservoirs and predict the future performance of these reservoirs under arbitrarily assumed conditions of reservoir control. It makes automatic computations in a matter of minutes that would take a dozen mathematicians several months.

A HARVEY Regulated Power Supply 106 PA like the one pictured plays an important role in the operation of this amazing device. To perform efficiently, the Analyzer must have a constant source of

static-free regulated power. The HARVEY 106 PA has proven a dependable, controllable source of this power.

The HARVEY Regulated Power Supply 106 PA provides laboratory D.C. power between 200-300 volts. Operates from 115 volts A.C. . . . output remains constant even though line voltage varies between 95 and 115 volts. Ripple content is better than 10 MV . . . two separate filament voltages available, 6.3 volts, 5 amps. each . . . parallel operation possible making 6.3 volts at 10 amps. available.

*If you operate equipment requiring a constant source of laboratory D.C. power—pulse generators, amplifiers, measurement equipment, constant frequency oscillators and the like—you should have complete information on the HARVEY 106 PA on hand. Write for HARVEY Regulated Power Supply Bulletin H-25 today.*

**HARVEY RADIO LABORATORIES, INC.**

439 CONCORD AVENUE • CAMBRIDGE 38, MASSACHUSETTS



And now . . .

# MYCALEX

## 410

### PRECISION-MOLDED

**Newest and Greatest Advancement  
in Low Loss Insulation**

Just as sound advanced motion pictures and as television is advancing radio, so the new improved MOLDED MYCALEX will advance the cause of electronic engineers who seek ever-higher standards in insulating materials.

New and exclusive methods of MYCALEX CORPORATION now enable us to mold MYCALEX to far more exacting specifications . . . closer tolerances, with metal inserts molded in and other refinements.

Our technique affords a virtually endless variety of irregular shapes that compare with molded plastics for smoothness and precision. Yet MYCALEX offers so much more in electrical and physical advantages.

For example: greater strength and dimensional stability, freedom from cold flow, freedom from carbonization, imperviousness to moisture and gases . . . ability to withstand temperatures beyond 400 C.

Investigate the new uses and applications of this remarkable new advancement in MYCALEX. Get the facts about MYCALEX 410.



## MYCALEX CORPORATION OF AMERICA

*"Owners of 'MYCALEX' Patents"*

Plant and General Offices, CLIFTON, N. J.

Executive Offices, 30 ROCKEFELLER PLAZA, NEW YORK 20, N. Y.



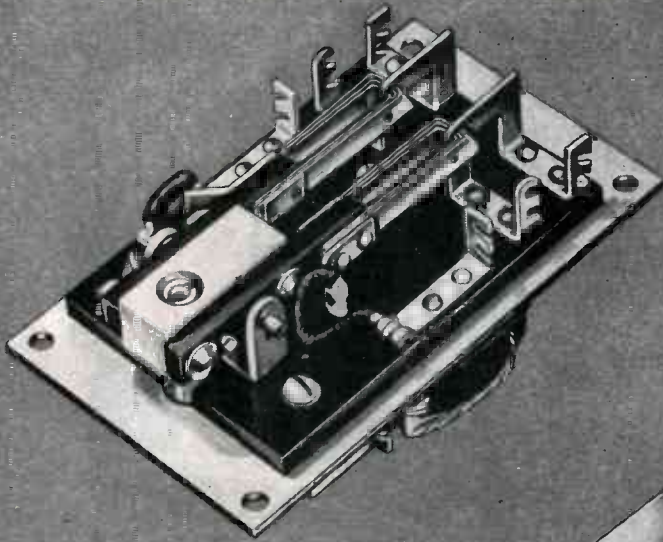

✓ **MAKE-BEFORE-BREAK CONTACT**  
Action.. eliminates transfer "click" interferences or circuit interruptions.

✓ **UNIQUE LAMINATED BRUSH TYPE CONTACTS**  
... Low and constant contact resistance.

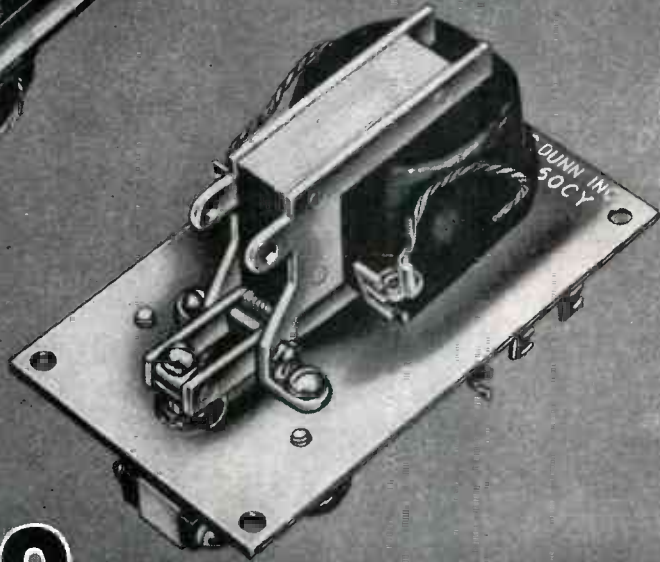

# 91XBX100 . . . . . DESIGNED FOR MICROPHONE AND THERMO-COUPLE SWITCHING CIRCUITS . . . *and other extremely low power control applications*

The Struthers-Dunn a-c operated Type 91XBX100 Relay has double-pole double-throw, make-before-break contacts that are especially designed for handling milli-volt, milli-ampere, and milli-watt loads. Each moving contact consists of six laminations. The long sliding motion of the six contact surfaces results in extremely low and constant contact resistance, thus assuring electrically smooth performance—a "must" in audio frequency or recording instrument switching circuits.

The metal mounting plate acts as a shield, isolating the magnetic structure from the contacts, minimizing the possibility of induced a-c hum in the contact circuits.

Operating coils are available for use on standard voltages up to 230 volts a-c, 60 cycles.

**DISTRICT ENGINEERING OFFICES  
IN THESE CITIES TO SERVE YOU:**

ATLANTA • BALTIMORE • BOSTON •  
BUFFALO • CHICAGO • CINCINNATI •  
CLEVELAND • DALLAS • DENVER •  
DETROIT • HARTFORD • INDIANAPOLIS •  
LOS ANGELES • MINNEAPOLIS • MON-  
TREAL • NEW YCRK • PITTSBURGH •  
ST. LOUIS • SAN FRANCISCO • SEATTLE  
SYRACUSE • TORONTO



**STRUTHERS-DUNN, Inc., 1321 Arch Street, Philadelphia 7, Pa.**

# STRUTHERS-DUNN

## 5,312 RELAY TYPES

Where **SPACE** and  
**PERFORMANCE** are Vital  
DUMONT OFFERS . . . .

The  
**TINYMITE**

**SMALLEST PAPER  
CAPACITOR . . . .**  
yet 100%  
**MOISTUREPROOF**

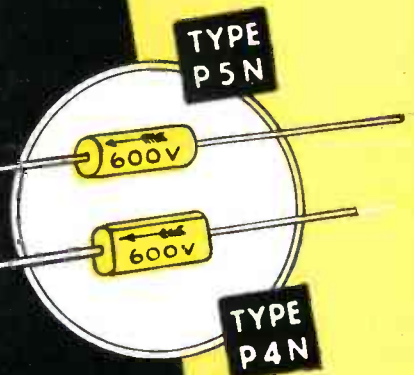

CLOCK  
RADIO



AUTO RADIOS

**FEATURES**

1. Bakelite Resinoid Ends. Lead wire cannot pull out, even under hot conditions.
2. Non-Inductive.
3. Excellent Temperature Coefficient.
4. Very high leakage Resistance.
5. Fine Power-Factor.
6. Range from 20 MMFD to .25 MFD. From 150 volts to 600 volts.
7. Types P4N, P5N for 100% humidity operation.
8. Types P4, P5 for 85% humidity operation.

*Samples and price list on request*

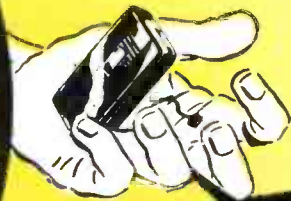

HEARING  
AIDS

PAT.  
PEND.



CARRYING  
RADIOS

**DUMONT  
ELECTRIC CO.**  
MFRS OF  
CAPACITORS FOR EVERY REQUIREMENT  
34 HUBERT STREET NEW YORK, N. Y.

KEEP ON BUYING VICTORY BONDS



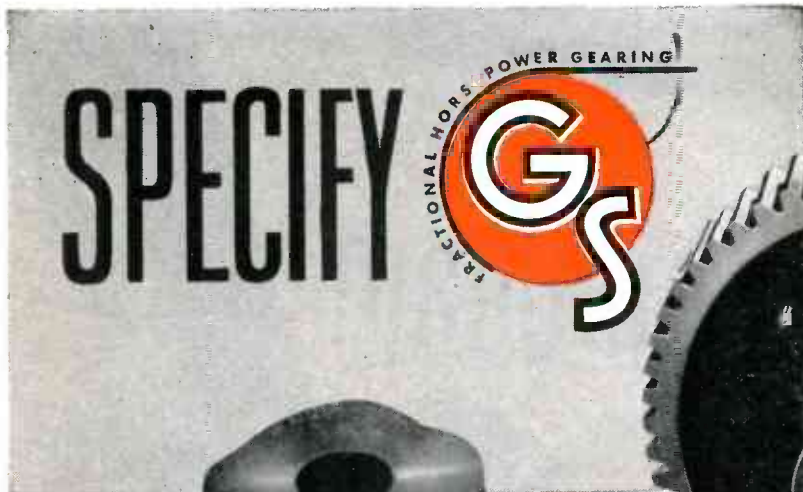

**GUARANTEE THE UNIFORMITY OF YOUR SMALL GEARS**

Our day in year out job is the manufacture of small gears so unvaryingly precise that rejections are an almost unbelievable fraction. Hypercritical inspection—manufacturing processes—design—expert craftsmen—know-how gained from 25 years experience specializing in small gear manufacture . . . *all* add their share to a reputation justly gained for superlative workmanship. If you would reduce your post war small gear rejections to the smallest known degree—specify G-S when you need fractional horsepower gearing.

**GEAR Specialties**  
 Spurs • Spirals • Helicals • Bevels • Internals • Worm Gearing • Racks • Thread Grinding  
 2635 WEST MEDILL AVENUE • CHICAGO 47, ILLINOIS

WORLD'S LARGEST EXCLUSIVE MANUFACTURERS OF FRACTIONAL HORSEPOWER GEARS

# KEEPS KILOWATTS "on the beam"

A major improvement in the operation of aircraft electrical systems came with the adoption of the differential-voltage type relay, which acts as a one-way gate to permit the flow of power whenever the potential in the generators is higher than that of the batteries or load bus.

This type of operation frees the relays from dependence on fixed potentials and eliminates the chattering found in common relays, so the contacts last far longer. Now, the generator is never connected to the system under conditions whereby reverse current would tend to drive it as a motor.

Further improvement in operation came with the complete sealing of the differential relay in a case, so that it is unaffected by dust and moisture.

For further information on differential relays, as well as on other Westinghouse aircraft products, write to Westinghouse Electric Corporation, Lima, O.

J-03231

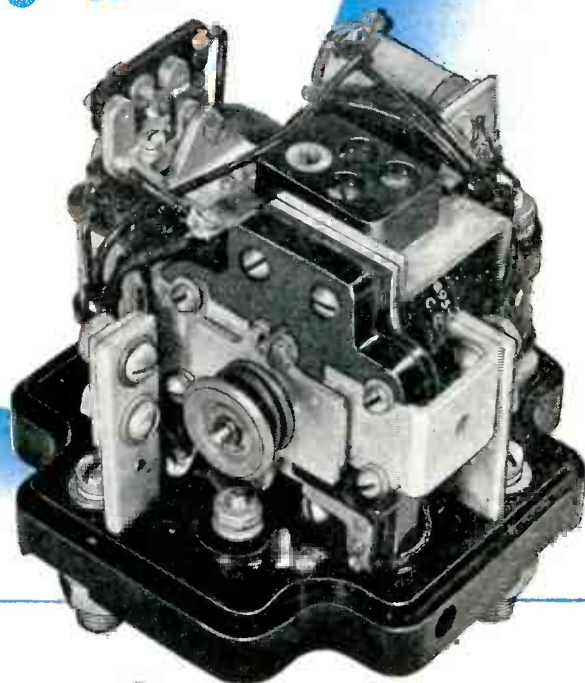

The Westinghouse differential relay illustrated, operates with any d-c generator having a normal regulated voltage of 28 volts and a current rating up to 300 amperes.



## Westinghouse

### AVIATION PRODUCTS

#### OTHER WESTINGHOUSE AIRCRAFT PRODUCTS

Generator develops 5.7 kw at 28.5 v at 2500/4500 rpm. Weight 44.5 lbs. Has special high-altitude brushes.

Voltage Regulator for 28.5-volt circuits over full range of engine speeds and loads for 50, 100, 200 and 300-ampere generators. Weight: 2.5 lbs.

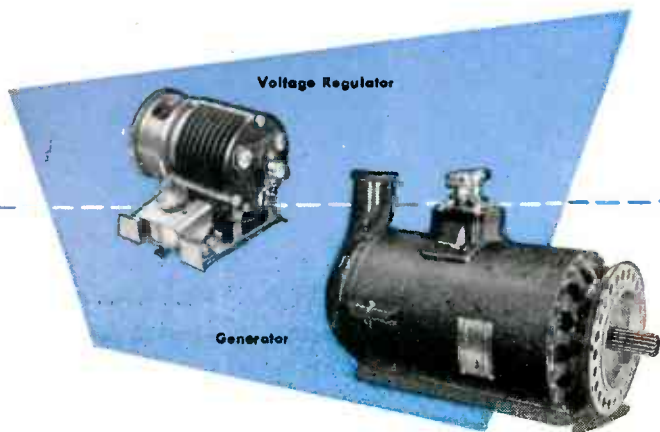



ANOTHER WILCO DEVELOPMENT

# SILVER JACKETED WIRE

**WILCO Silver Jacketed Copper Wire now widely used for coils in Short Wave Radio Communications Systems.**

**PROPERTIES AND CHARACTERISTICS**—WILCO Silver Jacketed Copper Wire—an economical non-corrosive wire with solid-silver characteristics—is used successfully in many *electronic* applications, where high frequency currents are a problem. Another WILCO jacketed type combines great physical strength with high conductivity. A third unites stamina with highly desirable electrical characteristics. In fact there is almost no limit to WILCO facilities for combining metals of widely differing physical and electrical properties to meet individual engineering needs.

Gold, silver, copper, brass, bronze, iron, steel, nickel, monel and invar, are all utilized in producing WILCO'S uniform, non-porous, securely bonded jacketed wire and rolled strip.

**CONSULT OUR ENGINEERING DEPARTMENT**—Write our Engineering Department for help in developing the proper application of WILCO materials to your products.

**SEND FOR WILCO BLUE BOOK**—The Blue Book contains charts, formulae and full descriptions of *all* Jacketed Materials and other WILCO products. Send for **FREE** copy today.



## WILCO PRODUCTS INCLUDE:

- |   |   |
|---|---|
| <b>Contacts—</b><br>Silver<br>Platinum<br>Tungsten<br>Alloys<br>Sintered Powder Metal               | <b>Precious Metal Collector Rings—</b><br>For rotating controls   |
| <b>Thermostatic Bimetal—</b><br>High and Low Temperature with new high temperature deflection rates | <b>Silver Clad Steel Jacketed Wire—</b><br>Silver on Steel, Copper, Invar or other combinations requested |
|   | <b>Rolled Gold Plate</b>  |
|   | <b>Special Materials</b>  |



## THE H. A. WILSON COMPANY

105 Chestnut Street, Newark 5, N. J.  
Branch Offices: Chicago • Detroit • Los Angeles

**SPECIALISTS FOR 30 YEARS IN THE MANUFACTURE OF • THERMOMETALS  
ELECTRICAL CONTACTS • PRECIOUS METAL BIMETALLIC PRODUCTS**

# WHEN THE INSULATION

# GOES -



**BH SPECIAL TREATED  
FIBERGLAS SLEEVING  
Tops In Electric Irons!**

- Won't Fray When Cut
- Flexible and Strong
- Non-Burning to 1200°F!



## YOUR TROUBLE STARTS!

**W**HAT does it mean to you when Mrs. Smith's electric iron goes *phht*? If electrical insulation is a part of *your* product, whether it's appliance, radio or electrical equipment, you, like the iron manufacturer, run this *risk*. The risk of insulation failure—of inconveniencing customers, jeopardizing good will, and possibly losing sales.

Since your product's performance may depend on a few cents worth of insulation, be sure to use the best. Assure trouble-free service with BH Fiber-glas Sleevings, the *original* non-fraying, non-stiffening, non-burning Fiber-glas sleevings.

An exclusive BH process combines *permanent* freedom from hardening, cracking or rotting with the many advantages of Fiber-glas — including high dielectric and tensile strength, resistance to moisture, oil, grease and most chemicals.

Severest wartime uses prove beyond question the superior qualities of all three BH Fiber-glas Sleevings in electrical applications for home and industry. One of them may fit your needs to a "T"—*plus!* Write for free BH samples today and put them to the toughest tests your product can dish out!

### 3 GREAT BH FIBERGLAS SLEEVINGS—EACH 3 WAYS BETTER!



**NON-STIFFENING\***



**NON-FRAYING\***



**NON-BURNING\***



**BH EXTRA FLEXIBLE FIBERGLAS SLEEVING • BH SPECIAL TREATED FIBERGLAS SLEEVING  
BEN-HAR COATED FIBERGLAS SLEEVING**

\*Ask for sample folder giving degree above characteristics are combined in these three sleevings. All standard sizes and colors—available in standard 36-in. lengths and 500-ft. coils.

ALSO SLOW-BURNING IMPREGNATED MAGNETO TUBING • SLOW-BURNING FLEXIBLE  
VARNISHED TUBING • SATURATED SLEEVING • A. S. T. M. SPECIFICATIONS

**BENTLEY, HARRIS MANUFACTURING CO.**

**Dept. E Conshohocken, Penna.**





# Reduce YOUR CONTROL SIZE WITH ALLIED'S "CR" RELAY

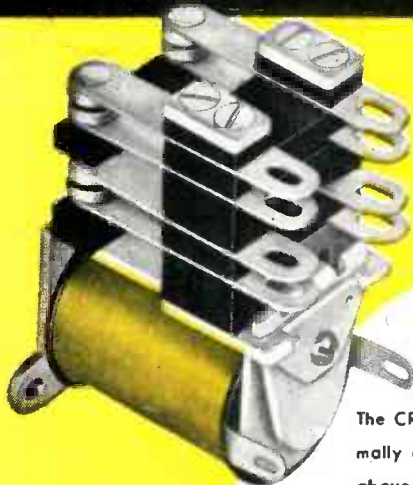

The CR relay shown below is a single pole normally open double break arrangement. Shown above is the four pole single throw, normally open combination. The CR uses molded bakelite throughout. Standard contacts are silver; alloy contacts can be supplied. Contact rating with  $\frac{1}{4}$ " silver contacts is 15 amperes at 24 volts DC or 110 volts AC non-inductive. The single pole weighs 3 ounces and is  $1\frac{33}{64}$ " high;  $1\frac{3}{32}$ " wide and  $1\frac{25}{32}$ " long. The four pole weighs  $3\frac{1}{4}$  ounces and is  $1\frac{29}{32}$ " high,  $1\frac{3}{32}$ " wide and  $1\frac{25}{32}$ " long.

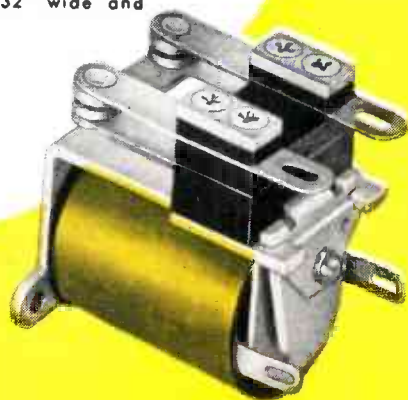

The CR type relay is amazingly small compared to previous power relays. It was developed by Allied to allow greater compactness and less weight in your electronic controls.

More efficient than larger power relays the CR is designed with a minimum number of parts, which simplify accurate adjustment, and assure positive action. Large contacts, up to  $\frac{1}{4}$ " in diameter, and heavy gram pressure permit power switching heretofore only possible with much larger relays. Versatile too, the CR can be supplied in two, three and four pole combinations. If you prefer it can be hermetically sealed with a plug-in arrangement for easy replacement in the

field. Solder type terminals are also available.

Allied is ready to supply your requirements for all types of relays; power, sensitive, telephone, differential and others, as well as solenoids and electro-magnetic devices. Several strategically located plants are ready to supply your immediate requirements. Allied relays and controls will live up to the standard of quality of your post war products—check us today for more information.



## ALLIED CONTROL COMPANY, INC.

GENERAL OFFICES: 2 East End Ave. (at 79th St.) New York 21, N. Y. Factories: New York City (2 East End Ave.)—Plantville, Conn. Chicago—4321 N. Knox Avenue, Chicago 41, Illinois. In California: Allied Control Co. of California, Inc. 1633 South Hope St., Los Angeles 15, Calif.



# 50 YEARS OF X-RAYS

# 48 YEARS OF

# MACHLETT ELECTRON TUBES

# X-RAY HISTORY IS

IT WAS 50 YEARS AGO, on November 8, 1895, that scientific investigation led Roentgen to the discovery of X-rays. In this semi-centennial year we honor his work, and the work of the pioneers who, sometimes at the sacrifice of their own lives, developed the theory and practice of a science that today means so much to all mankind.

Very soon after Roentgen publicly announced his discovery in 1896, Robert H. Machlett made the first practical American X-ray tube. Quickly he improved his techniques, creating a whole series of "firsts" such as the first ray-proof tube, the first cooled by water, the first for contact therapy. The organization he founded carries on his principle of constant research, improvement and initiative, and has many other firsts to its credit, culminating in the amazing and unique 2,000,000-volt, direct current, sealed-off, precision X-ray tube.

To a large extent, X-ray history is Machlett history, a history of service to mankind. Today, Machlett tubes are in use by doctors, hospitals, laboratories and factories in many parts of the world, saving lives, inspecting products, performing delicate analyses, expanding man's knowledge, serving with unmatched exactitude and economy. For the future, Machlett's talents will create other and still more valuable applications, for Machlett never stands still, is always creative, improving its tubes, developing new ones for old and new services.

In addition to X-ray tubes for all purposes, we also make oscillators, amplifiers and rectifiers for radio and industrial uses, all to the same high (and unmatched) standards to which our X-ray tubes are held. It will pay you to buy Machlett tubes. For information as to the available types, write Machlett Laboratories, Inc., Springdale, Connecticut.



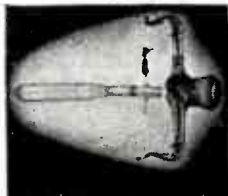

Cornell contact therapy tube



Transformer tube



Pyrex heavy anode bulb tube, type MR



Compact ray-proof tube, type CVR



Small shockproof tube, type CYS



Silver bearing long-life rotating target tube, type DX

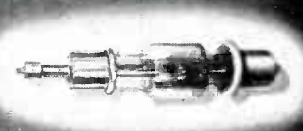

Tube with beryllium window and hooded anode, 250 k. v., type IR



Tube with vacuum-tight beryllium window in envelope—the Diffraction Tube

2,000,000 volt direct current precision radiographic tube, type VM

first

# MACHLETT HISTORY!

## From the Beginning

"When in 1895 Professor Roentgen announced his discovery, Machlett was immediately interested and began experiments to reproduce the results of Roentgen. He was ideally equipped for such work, for just at that time he had perfected a mercury pump capable of producing a very high vacuum. He attacked the difficult task and before many days had passed, succeeded in producing the first X-ray tube in this country." —I. S. Hirsch, *Radiology* 8:254, 1927.



APPLIES TO RADIO AND INDUSTRIAL USES  
ITS **40** YEARS OF ELECTRON-TUBE EXPERIENCE



**"Singers always have  
a favorite critic**

**...mine is a**

**PRESTO RECORDING!"**

"I know of no better check on my work than hearing it with my own ears," says Morton Downey of the famed voice. "That's why I have each of my Coca-Cola programs transcribed. I feel that a Presto Recording—with its fine, clear reproduction and fidelity to musical tones—give me a reliable basis for improvement."

Presto sound recording and transcription equipment is used by major broadcasting stations from coast to coast. Schools, colleges and business organizations, too, depend on Presto to help train students and personnel. A Presto Recorder is easy to operate. It stands up under hard usage. In short, it's a precision instrument designed to produce consistently superior results. Write for complete information.



**PRESTO**

**RECORDING CORPORATION**  
242 West 55th Street, New York 19, N. Y.  
Walter P. Downs, Ltd., in Canada



**WORLD'S LARGEST MANUFACTURER OF INSTANTANEOUS SOUND RECORDING EQUIPMENT AND DISCS**



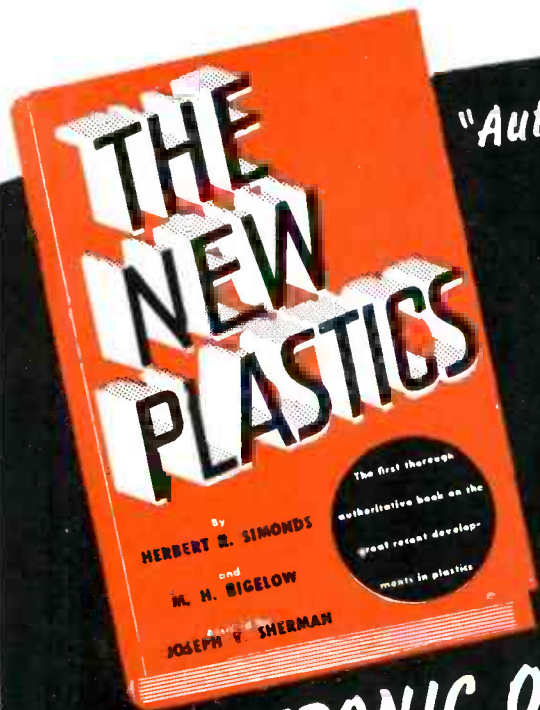

"Authorities in plastics are agreed that

**THE  
MOST REVOLUTIONARY  
NEW PROCESS IN THE  
INDUSTRY IS  
ELECTRONIC OR HEATRONIC HEATING.**

"High frequency or electronic heating is a method of converting electricity into a form that will cause the molecules in a substance to distort and rub together, thus setting up friction that results in internal heat."

From *THE NEW PLASTICS* by Herbert R. Simonds and M. H. Bigelow, published 1945 by D Van Nostrand Company, Inc.

## **Thermatron**

### **INDUSTRIAL ELECTRONIC HEAT GENERATORS**

The THERMATRON line comprises a wide range of standard sizes from 1 KW to 30 KW, which are engineered and built to deliver consistent operation under exacting production requirements. The smaller units possess great versatility and are ideally suited for experimental or pilot plants. Models specially designed for sealing of thermoplastics, heating of preforms or general purposes.

### **THREE OUTSTANDING UNITS**

For most purposes the 1 KW, 2.5 KW or 5 KW output units will be suitable, according to power requirements. Available in frequencies from 5 megacycles to 30 megacycles, according to application desired.

Send for our new circulars

"ELECTRONIC HEATING WITH THE THERMATRON"

"ELECTRONIC HEAT-SEALING OF THERMOPLASTICS"

## **Thermatron Division**

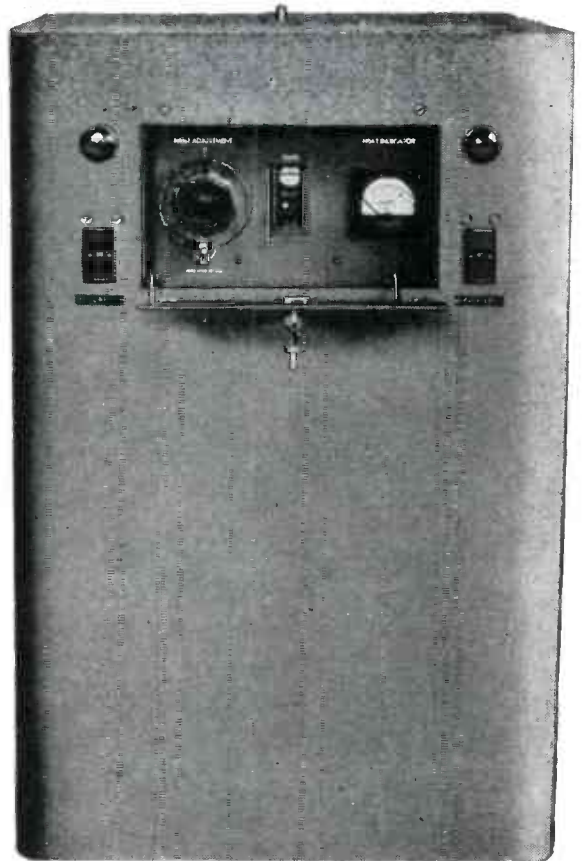

**RADIO RECEPTOR COMPANY, Inc.**  
251 WEST 19th STREET  
NEW YORK 11, N. Y.

Engineers and Manufacturers of Airway and Airport Radio Equipment  
SINCE 1922 IN RADIO AND ELECTRONICS





In center: Type GC-25 with new one piece center terminal and collector ring.

## *One way to assure* **TOP PERFORMANCE**

Chicago Telephone Supply Company's test and research laboratory is continually making performance tests on every electrical and mechanical characteristic of CTS variable resistors.

In addition, production resistors are carefully checked, not only against customers' specifications,

but against the recognized CTS standards of quality.

This control of quality and thorough inspection assures the fine performance to which CTS customers all over the world have always been accustomed.

CTS engineers are ready to help solve your variable resistor problems.

#### REPRESENTATIVES

R. W. Farris Co.  
406 West Thirty-fourth Street  
Kansas City 2, Missouri  
Phone: Logan 7495

Frank A. Emmet Co.  
2837 West Pico Boulevard  
Los Angeles 6, California  
Phone: Rochester 9111

#### BRANCH OFFICES

S. J. Hutchinson, Jr.  
401 North Broad Street  
Philadelphia 8, Pennsylvania  
Phone: Walnut 5389

#### IN ENGLAND

Chicago Telephone Supply Co.  
St. John's Woods  
103 Grove End Gardens  
London, N. W. 8, England

VARIABLE RESISTORS  
PLUGS AND JACKS



SWITCHES • RINGERS  
TELEPHONE GENERATORS

**CHICAGO TELEPHONE SUPPLY**  
*Company*

ELKHART • INDIANA

#### IN CANADA

C. C. Meredith & Co.  
Streetsville, Ontario

#### IN SOUTH AMERICA

Jose Luis Pontet  
Cordoba 1472  
Buenos Aires, Argentina  
South America

Masculina 2624  
Montevideo, Uruguay  
South America

Avda. Conselheiro Rodrigues  
Alves 1057  
Villa Mariano  
Sao Paulo, Brazil  
South America

*Manufacturers of Quality Electro-Mechanical Components Since 1896*



**SPECIALISTS IN DESIGN  
AND MANUFACTURE OF  
FINE ACOUSTIC EQUIPMENT**

**NEW Jensen  
PRODUCTS—  
WATCH FOR COMING  
ANNOUNCEMENT**

FREE to the Armed  
Forces, Colleges,  
Technical Schools,  
Libraries.



PRODUCT NO. 1  
PRODUCT NO. 2  
PRODUCT NO. 3  
PRODUCT NO. 4  
PRODUCT NO. 5

THROUGHOUT the war JENSEN re-  
mained true to a more than fifteen-year-old tra-  
dition of specialization in the design and manufacture of  
fine acoustic equipment. Very shortly now this persistent adherence  
to specialization will again bring forth new and improved  
JENSEN Loud Speakers and related products. Their quality and per-  
formance ability, in the JENSEN tradition, will suggest  
their use by all who want the best. Watch for further announcements.

**5 MONOGRAPHS AVAILABLE**

1. Loud Speaker Frequency-Response Measurements.
2. Impedance Matching and Power Distribution.
3. Frequency Range in Music Reproduction.
4. Effective Reproduction of Speech.
5. Horn Type Loud Speakers.

**25c** Each



**Jensen**  
SPEAKERS WITH

**ALNICO 5**

JENSEN RADIO MANUFACTURING COMPANY • 6607 SOUTH LARAMIE AVENUE, CHICAGO 38, ILLINOIS  
IN CANADA—COPPER WIRE PRODUCTS, LTD., 137 RONCESVALLES AVENUE, TORONTO

# HOW EXCELLENCE IS BUILT INTO



Checking mica capacitors for current carrying ability on high frequency.



The above operator is shown checking a capacitor on a precision bridge.



A view of the "merry-go-round" automatic checking equipment used for dielectric strength test.



The above picture shows an operator color coding capacitors on special equipment used for this purpose.

## SANGAMO ELECTRIC

ESTABLISHED 1898 • • • MICA CAPACITORS • • •



# Sangamo

## MICA CAPACITORS

### *Final Testing*

The final measure of the quality of a mica capacitor is its performance in actual service. In order to insure that each and every capacitor shipped by Sangamo will perform accurately and faithfully the functions expected of it, numerous tests are made. Each capacitor is tested to make sure that it is within the capacity limits requested by the customer. Insulation resistance is carefully measured, as is dielectric strength. In those cases where special characteristics are required, careful and accurate measurements are made for temperature coefficient and capacitance drift. These measurements are made on precision equipment which has, in most cases, been designed and built by Sangamo for the particular measurement for which it is used.

These measurements, together with the careful selection of the materials from which capacitors are manufactured, insure an excellence of quality which is reflected in the performance of the capacitors under the most severe operating conditions.



**COMPANY** SPRINGFIELD  
ILLINOIS

• • • WATT HOUR METERS • • • TIME SWITCHES • • •

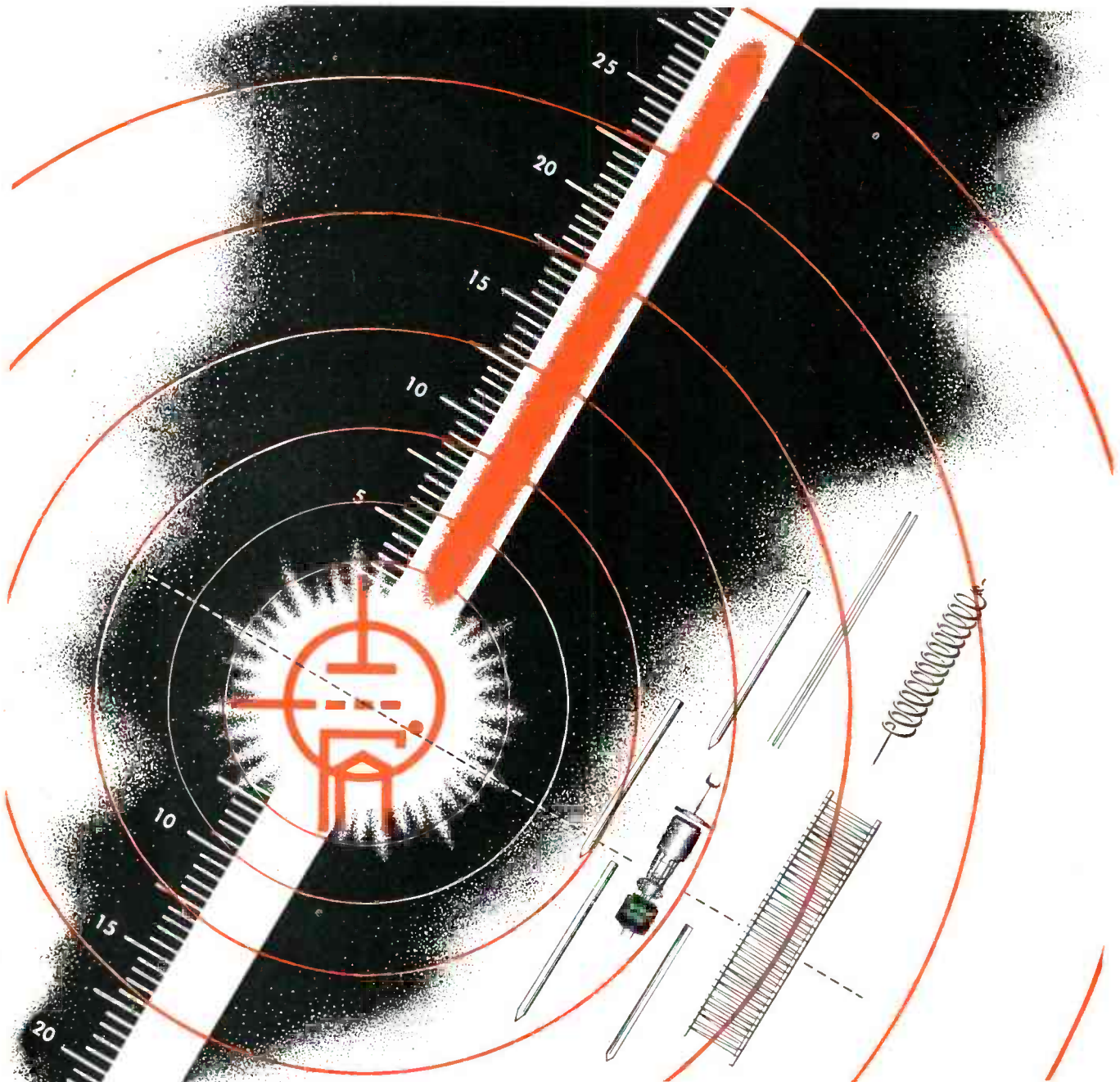

## built to stand **shock!** with Callite filaments and grids

The Cetron 305 is a quick-heating, gas-filled thyratron tube in the medium current field that will stand higher-than-usual voltage. It is especially suited to applications where large temperature changes are involved, such as resistance welder control, motor control, and controlled rectifiers.

Callite supplies the Continental Electric Company with thoriated tungsten filament wire and molyb-

denum grid bars for this highly efficient, heavy-duty tube.

Callite processes tungsten and molybdenum alloys for supports, hooks and grids in electron tubes. It will pay you to investigate our complete range of metallurgical components—our specialty for over a quarter-century. Callite Tungsten Corporation, 544 Thirty-ninth Street, Union City, N. J. Branch Offices: Chicago, Cleveland.



# Callite

*Tube components*

Hard glass leads, welds, tungsten and molybdenum wire, rod and sheet, formed parts and other components for electron tubes and incandescent lamps.



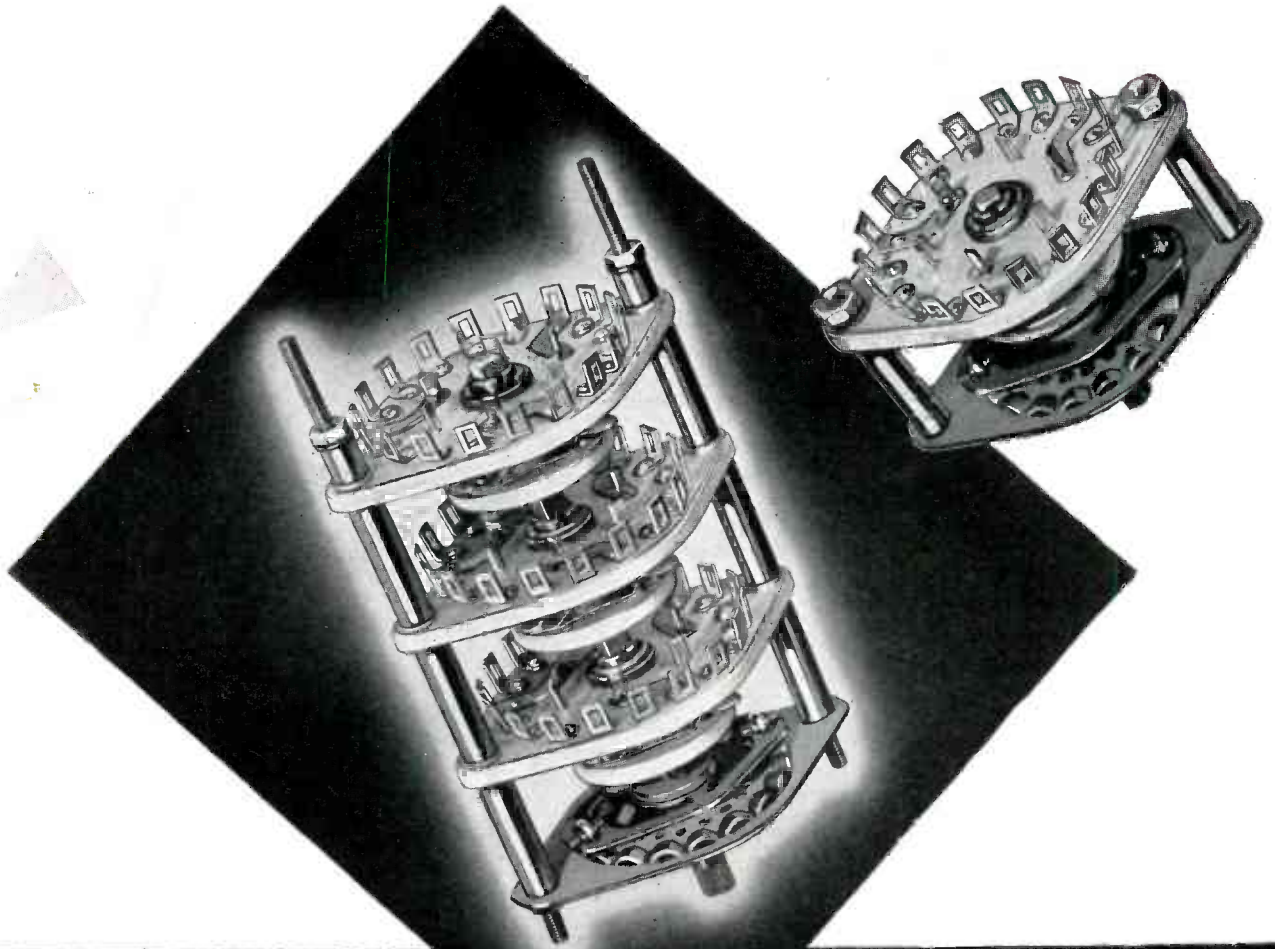

# Centralab

## MEDIUM DUTY POWER SWITCHES

*Producers of:*

- Variable Resistors •
- Selector Switches •
- Ceramic Capacitors,
- Fixed and Variable
- Steatite Insulators
- and Silver Mica But-
- ton-type Capacitors.

... available for transmitters, power supply converters and many special industrial and electronic uses.

The units are assembled in multiple gangs with a choice of shorting or non-shorting contacts.

The switching combinations manufactured for stock delivery are in single or multiple sections . . . 3 pole, 5 positions and 1 pole, 17 positions. (17 positions can be furnished with 18 positions continuous rotation.) Special combinations available.

Rated at 7½ amperes at 60 cycles, 115 volts, voltage breakdown 2500 volts D.C. to ground.



Write for Bulletin 815.

# Centralab

Division of GLOBE-UNION INC., Milwaukee

# Again, Revere is ready



Revere metals are impartial. They don't care whether they are used for battleships or baby carriages, for rockets or refrigerators, for primers or piping. That is why there are no difficult reconversion problems at Revere to slow down production of copper, brass, bronze, aluminum, magnesium, steel.

We are ready *now* to fill industry's peacetime needs.

Revere hopes that, in the conflict just ended, what we won was the gigantic opening battle for better living. To fight *this* war our nation needs materials and the products of industry on a scale even greater than that which won military victory.

One inevitable result of Revere's war effort is that not only our ability to produce, but our ability to give service, have been expanded many times. Revere research has probed further and further. Revere Technical Advisors are armed with greater knowledge and experience. New methods and new machines may save precious time or cut all-important cost.

With all these enhanced resources we are ready now to serve man's creative spirit and, by supplying industry in abundance, to help make of life the rich, joyous thing it can be.



... **NOW!**



The full Revere facilities, including the Revere Technical Advisory Service, are made available to you through the Offices listed here.

In addition Revere Distributors in all parts of the country are eager to serve you.

# REVERE

## COPPER AND BRASS INCORPORATED

*Founded by Paul Revere in 1801*

*Executive Offices: 230 Park Ave., New York 17, N. Y.*

*Listen to The Human Adventure on the Mutual Network every Wednesday Evening; 10 to 10:30 p. m., EWT.*

### DIVISION OFFICES AND MILLS

#### BALTIMORE DIVISION

P. O. Box 2075  
1301 Wicomico Street  
Baltimore 3, Md.  
Phone: Gilmore 0222  
Teletype: BA 164

#### MICHIGAN DIVISION

5851 West Jefferson Avenue  
Detroit 9, Mich.  
Phone: Vinewood 1-7350  
Teletype: DE 237

#### ROME DIVISION

Rome, New York  
Phone: Rome 2000  
Teletype: ROME NY 447

#### MAGNESIUM-ALUMINUM DIVISION

P. O. Box 2075  
1301 Wicomico Street  
Baltimore 3, Md.  
Phone: Gilmore 0222  
Teletype: BA 164

#### DALLAS DIVISION

2200 No. Natchez Avenue  
Chicago 35, Ill.  
Phone: Merrimac 2600  
Teletype: CG 957

#### NEW BEDFORD DIVISION

24 North Front Street  
New Bedford, Mass.  
Phone: New Bedford 8-5601  
Teletype: NB 87

#### CHICAGO MANUFACTURING DIVISION

2200 No. Natchez Avenue  
Chicago 35, Ill.  
Phone: Merrimac 2600  
Teletype: CG 957

#### ROME MANUFACTURING COMPANY DIVISION

Rome, New York  
Phone: Rome 2800  
Teletype: ROME NY 449

### DISTRICT SALES OFFICES

*At above Mill Points and in the following cities*

#### ATLANTA 3, GA.

Rhodes-Haverty Bldg.  
Phone: Main 2142  
Teletype: AT 96

#### BOSTON 10, MASS.

140 Federal Street  
Phone: Hubbard 7190

#### BUFFALO 7, N. Y.

1807 Elmwood Avenue  
Phone: Delaware 7616

#### CINCINNATI 2, OHIO

Carew Tower  
Phone: Main 0130  
Teletype: CI 171

#### CLEVELAND 15, OHIO

Midland Bldg.  
Phone: Cherry 3930  
Teletype: CV 572

#### DALLAS 1, TEXAS

Tower Petroleum Bldg.  
Phone: Central 8681  
Teletype: DL 88

#### DAYTON 2, OHIO

Mutual Home Bldg.  
Phone: Hemlock 3271

#### GRAND RAPIDS 2, MICH.

Keeler Building  
Phone: Grand Rapids 8-0511  
& 6-1314  
Teletype: GR 376

#### HARTFORD 3, CONN.

410 Asylum Street  
Phone: Hartford 2-3828  
Teletype: HF 87

#### HOUSTON 2, TEXAS

Mellie Esperson Bldg.  
Phone: Fairfax 7932

#### INDIANAPOLIS 4, IND.

Circle Tower  
Phone: Market 1908

#### LOS ANGELES 15, CALIF.

714 W. Olympic Blvd.  
Phone: Richmond 9314

#### MILWAUKEE 2, WIS.

626 E. Wisconsin Avenue  
Phone: Marquette 1440  
Teletype: MI 292

#### MINNEAPOLIS 2, MINN.

Metropolitan Bldg.  
Phone: Atlantic 3285

#### NEW YORK 17, N. Y.

New York Central Bldg.  
75 East 45th Street  
Phone: MURray Hill 9-6800  
Teletype: NY 1-1222

#### PHILADELPHIA 3, PA.

Sixteen Sixteen Walnut St. Bldg.  
Phones: Bell—Pennypacker 6133  
Keystone—Race 1847  
Teletype: PH 206

#### PITTSBURGH 19, PA.

Gulf Bldg.  
Phone: Court 4342  
Teletype: PG 572

#### PROVIDENCE 3, R. I.

Industrial Trust Bldg.  
Phone: Gaspee 8110

#### ST. LOUIS 1, MO.

Telephone Bldg.  
1010 Pine Street  
Phone: Garfield 4416  
Teletype: SL 191

#### SAN FRANCISCO 4, CALIF.

Russ Bldg.  
Phone: Sutter 0282

#### SEATTLE 1, WASH.

1331 Third Avenue  
Phone: Main 8372



Aerovox high-frequency capacitance bridge test of mica capacitors in heat chamber at right.

Block mica check for power factor. Every piece is checked before splitting and sorting according to thickness.

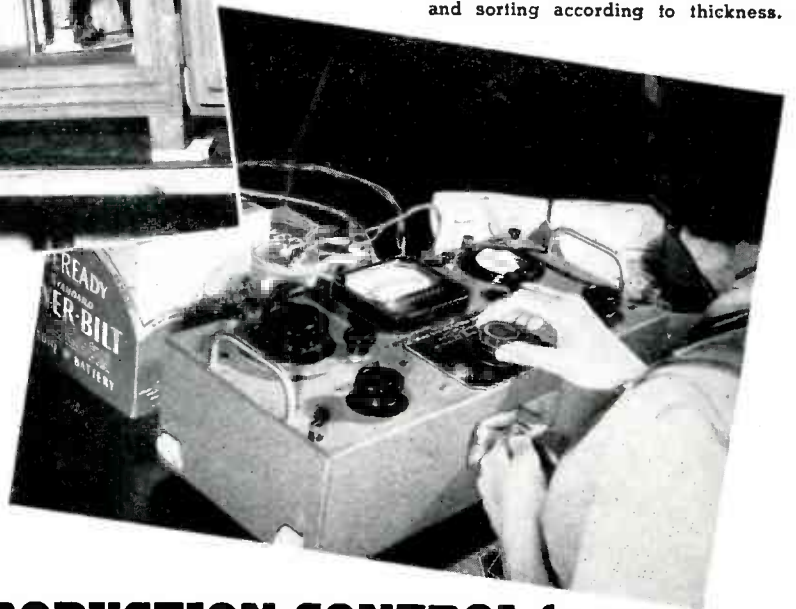

**QUALITY PRODUCTION CONTROL from Alpha to Omega... step by step... with nothing taken for granted or left to chance... spells AEROVOX MICA CAPACITOR**

*Craftsmanship*

● Mica capacitors are usually precision units. Capacitance tolerances may be tight. But even more important, critical characteristics such as power factor and "Q" must be met.

AEROVOX QUALITY CONTROL is exercised at every step in production. Incoming block mica is checked piece by piece for power factor and "Q." This proved invaluable

during the wartime mica shortage when new sources of supply had to be used. A spot check simply would not do.

Split micas are checked—electrically, visually, micrometrically. Mica assemblies are checked. Completed mica units are checked on the Q-meter. And since operating characteristics may change with operating temperatures, such units

are checked at given temperatures, by means of precision instruments of recognized accuracy, including Aerovox-designed and -built instruments.

It is this kind of production inspection, along with skilled craftsmanship and engineering "know-how," that accounts for the enviable reputation enjoyed by Aerovox mica capacitors.



*Capacitors*

**INDIVIDUALLY TESTED**

AEROVOX CORPORATION, NEW BEDFORD, MASS., U. S. A.

SALES OFFICES IN ALL PRINCIPAL CITIES

Export: 13 E. 40 ST., NEW YORK 16, N. Y. • Cable: 'ARLAB' • In Canada: AEROVOX CANADA LTD., HAMILTON, ONT.



# THESE *Gammatron* TUBE TYPES ARE NOW AVAILABLE!

Gammatron tubes, famed for the past 18 years for their ability to stand up under heavy overloads, and for their efficiency even at very high frequencies, are again available for civilian use! Look for the "HK" before the type number — your assurance of the best in tantalum-element tubes.

## STANDARDIZED *Gammatron* TYPES

Electrical and physical characteristics guaranteed to meet currently high standards. These tube types will always be readily available.

### 14 TRIODES

TUBE TYPES	PLATE DISSIPATION	TUBE TYPES	PLATE DISSIPATION
HK-24	25 watts (Grid lead to base)	HK-454L	250 watts (Low Mu)
HK-24G	25 watts (Grid lead through envelope)	HK-454H	250 watts (High Mu)
HK-54	50 watts	HK-654	300 watts
HK-254	100 watts	HK-854L	450 watts (Low Mu)
HK-354C	150 watts (Low Mu)	HK-854H	450 watts (High Mu)
HK-354E	150 watts (High Mu)	HK-1054L	750 watts
		HK-1554	1000 watts
		HK-3054	1500 watts

### 1 PENTODE

HK-257B Plate Dissipation, 75 watts (Beam pentode)

### 4 RECTIFIERS

HK-253	Inverse Peak Volts, 15,000	HK-953D	Inverse Peak Volts, 75,000
HK-953B	Inverse Peak Volts, 30,000	HK-953E	Inverse Peak Volts, 150,000

### 3 IONIZATION GAUGES

VG-2	VG-24G	VG-54
------	--------	-------

## REPLACEMENT *Gammatron* TYPES

The following Gammatrons are being made available primarily for replacement use. Designers of new equipment are asked to consider recommended standardized types.

REPLACEMENT TUBE TYPE	DESCRIPTION	RECOMMENDED STANDARDIZED TUBE TYPE
HK-354	Triode, grid lead to base pin, ratings same as HK-354C	HK-354C HK-454L HK-454H
HK-354D	Triode, Medium Mu	HK-354C or E HK-454L or H
HK-354F	Triode, High Mu	HK-354E
HK-257A	Beam Pentode	HK-257B
HK-153	High Vacuum Rectifier, inverse peak volts, 5000	HK-253
HK-54S	Triode. Same as HK-54 except fil. current is 3.35 instead of 5 amps.	HK-54
HK-2054A	Triode	
HK-2054B	Triode	



AWARDED  
FOUR TIMES

## HEINTZ AND KAUFMAN LTD.

SOUTH SAN FRANCISCO • CALIFORNIA

*Gammatron Tubes*

Export Agents: M. SIMON & SON CO., INC., 25 WARREN STREET, NEW YORK CITY, N. Y.

# STANDARD CRYSTALS

*Announcing*

STANDARD'S MIDGET crystal unit, now on a production basis.

STANDARD brings you, as an answer to your frequency control problem, the MIDGET. A precision crystal to your specifications in a holder that's radically different\* — designed to fit *minimum* space requirements. Furthermore, the cost is attractive.

The MIDGET is a real triumph of that skill and knowledge gained through our years of research, development and production experience. We have furnished the armed forces millions of crystal units—NOW we welcome the opportunity to supply *your* requirements.

STANDARD'S engineering staff is at your command. *Write, wire or phone* us your frequency control problems.

For general AIRLINE, POLICE, BROADCAST, AIRCRAFT, AMATEUR and COMMERCIAL uses we make a complete line of crystals in standard or special holders. *Send for new catalog just coming off the press.* We take this opportunity to greet our old customers in these fields and to solicit their continued business.

\* Refers to designs of holders.

→  
In the inset (opposite page) the new STANDARD MIDGET is reproduced in actual size. The background pictures popular types in the STANDARD line.



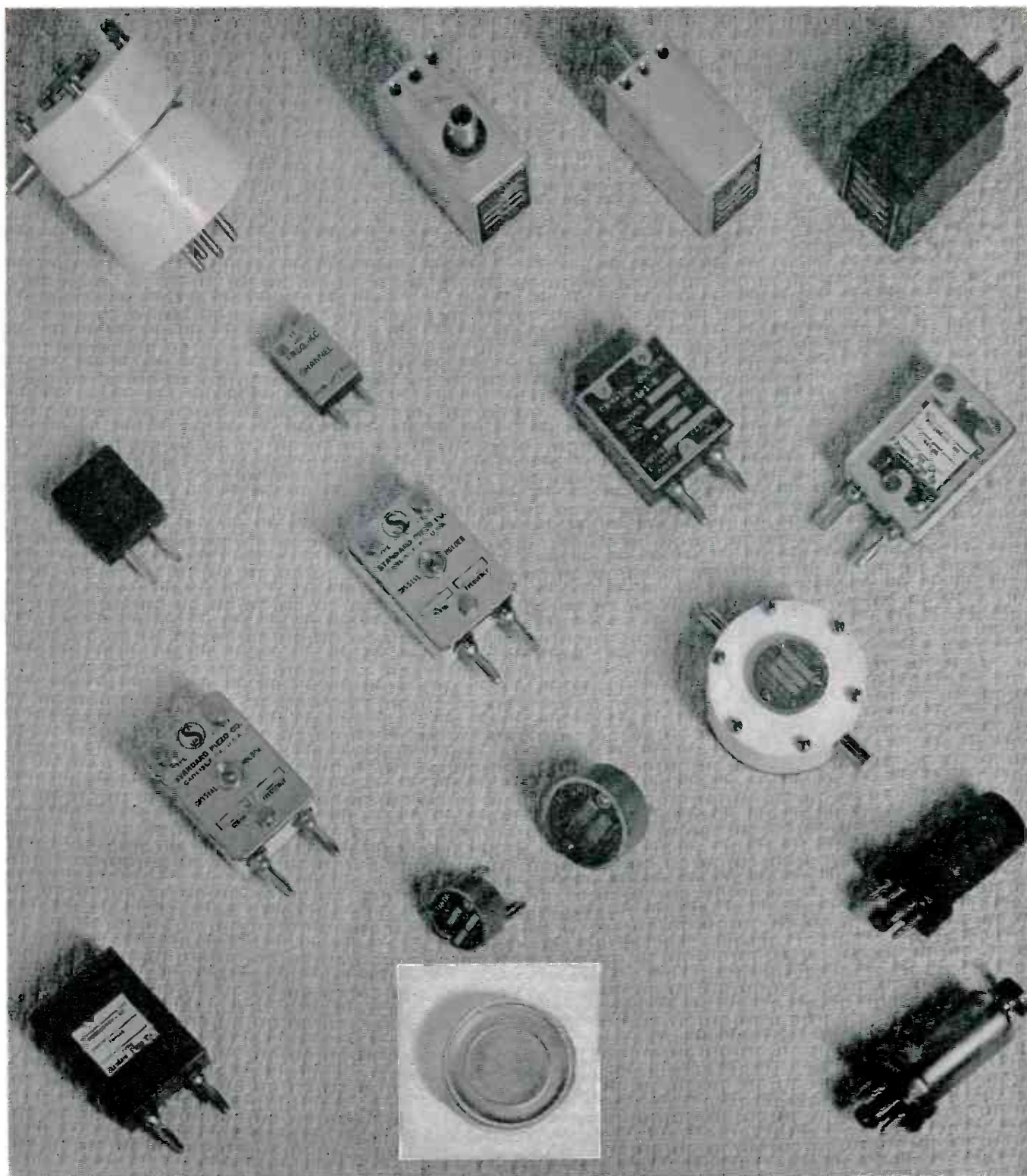

# ***STANDARD PIEZO COMPANY***

Established 1936

Quartz Crystals and Frequency Control Equipment  
*Office and Development Laboratory*

CARLISLE, PA., P. O. Box 164

SCRANTON, PA.

CARLISLE, PA.

Does your oscillograph have single or recurrent sweep frequencies as low as 0.2 cycles per second? **IT CAN...**

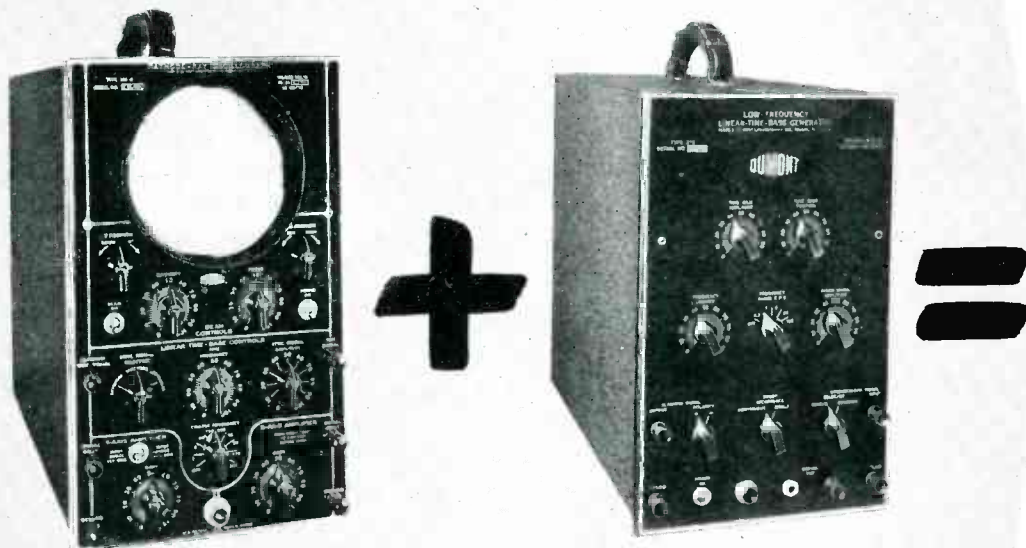

with the **DuMONT Type 215**  
**LOW-FREQUENCY LINEAR-**  
**TIME-BASE GENERATOR**

Here's the means for vastly increasing the usefulness of your already useful oscillograph.

This accessory instrument provides a 450 v. d.c. or peak-to-peak undistorted linear-time-base signal voltage of a frequency variable from 0.2 to 125 cycles per second! Special compensating circuit assures linearity.

The single sweep can be initiated either manually or by observed signal. The oscillograph-screen pattern can usually be spread out to three times' full

scale deflection. Return trace blanking signal of either positive or negative phase.

For single sweep, and for low-frequency recurrent-sweep studies, the DuMont Type 215 Low-Frequency Linear-Time-Base Generator used in combination with the DuMont Type 208-B general purpose oscillograph, or equivalent, provides excellent results. Note the typical studies herewith. Definitely "must" equipment.

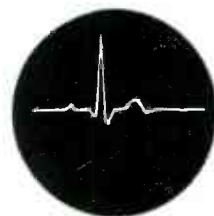

ELECTROCARDIOGRAPHY

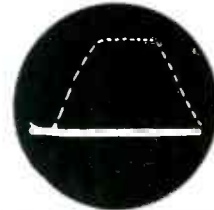

FLASH BULB CHARACTERISTICS

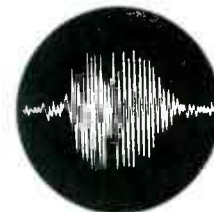

MACHINERY VIBRATION STUDY

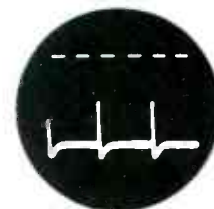

ELECTROENCEPHALOGRAPHY

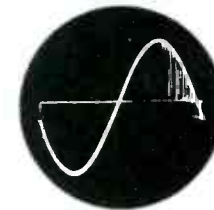

RELAY REBOUNCE STUDY

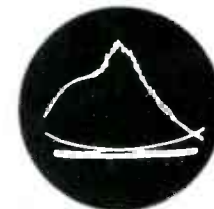

DIESEL ENGINE CYLINDER PRESSURE



**Descriptive literature on request.**

© ALLEN B. DUMONT LABORATORIES, INC.

**DUMONT** Precision Electronics & Television  
 ALLEN B. DUMONT LABORATORIES, INC., PASSAIC, NEW JERSEY



# TOUGH



Shuttles slamming back and forth at high rates of speed in textile looms must be able to "take" it. The toughness and resiliency of National Vulcanized Fibre provide long service.

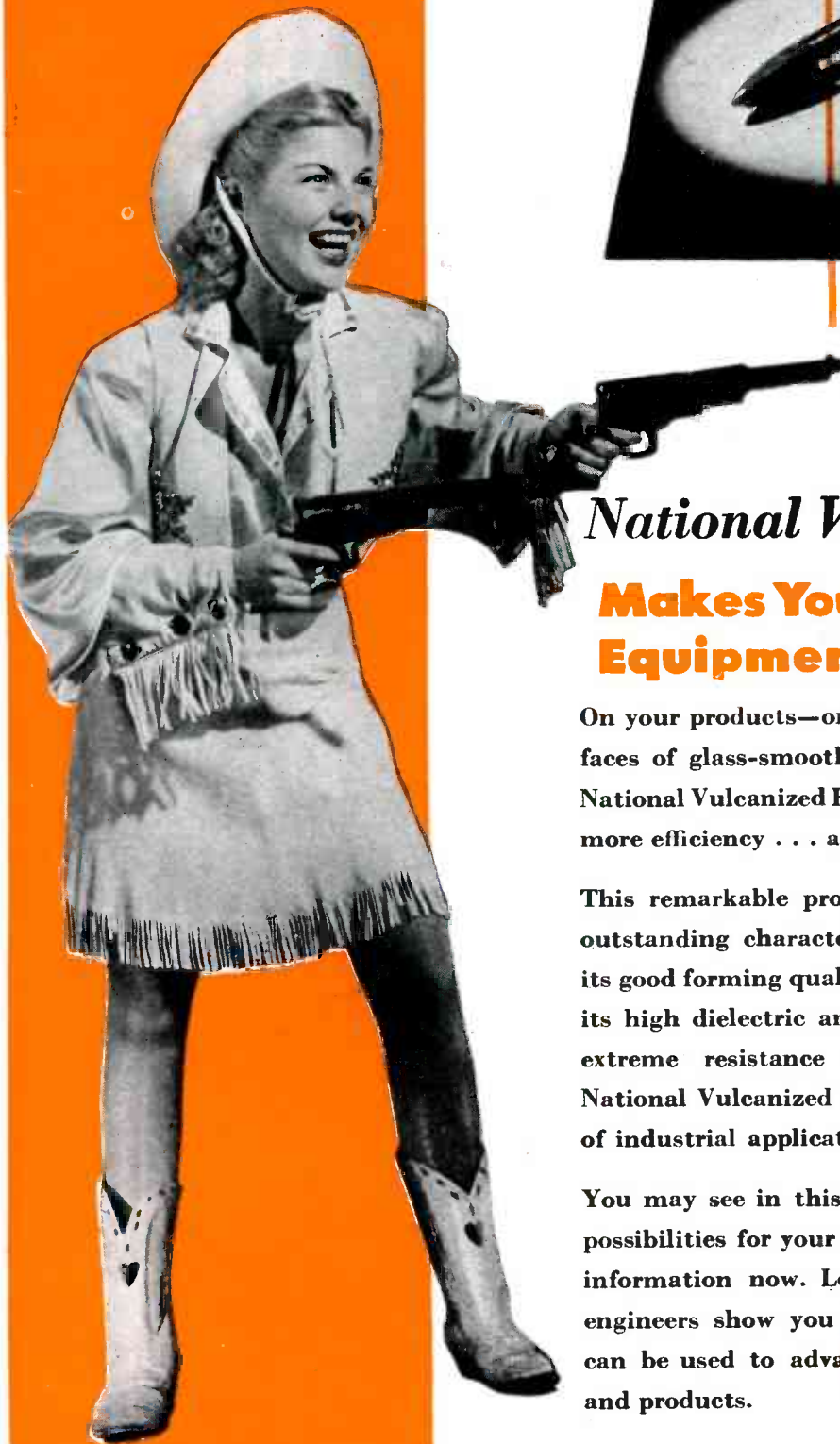

## *National Vulcanized Fibre*

### **Makes Your Products and Equipment Last Longer**

On your products—or on your plant equipment—surfaces of glass-smooth, naturally tough and resilient National Vulcanized Fibre give longer performance and more efficiency . . . at greater economy to you.

This remarkable property, combined with its other outstanding characteristics—its lightness in weight, its good forming qualities, its excellent machinability, its high dielectric and mechanical strength, and its extreme resistance to wear and abrasion—make National Vulcanized Fibre adaptable to a wide range of industrial applications.

You may see in this tough, versatile material many possibilities for your post-war projects. Write for full information now. Let one of our trained technical engineers show you how National Vulcanized Fibre can be used to advantage in your plant equipment and products.



**NATIONAL VULCANIZED FIBRE CO.** WILMINGTON, DELAWARE  
Offices in Principal Cities

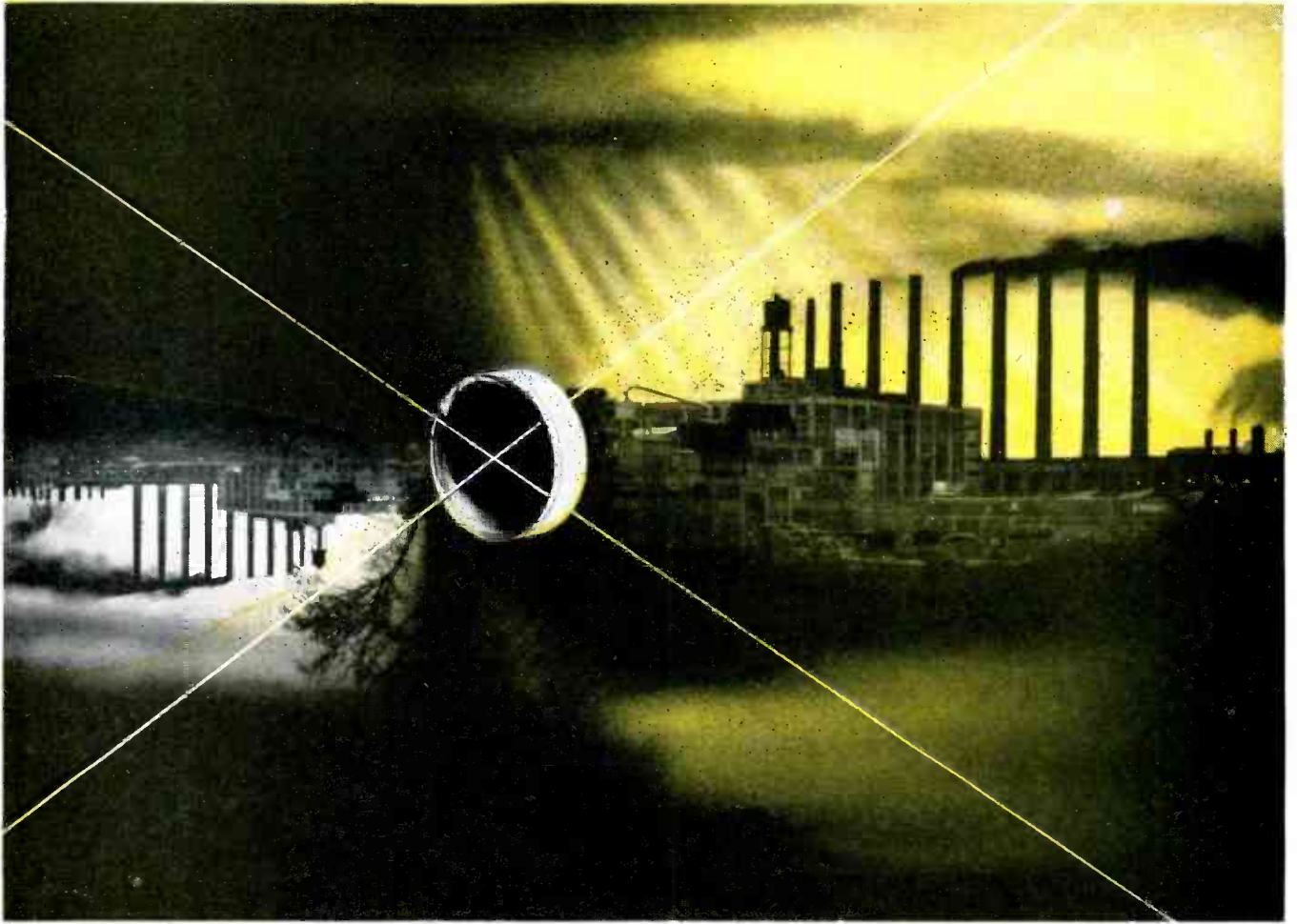

## LET'S GO!!

American industry turned its plants upside down to help in the war effort. Now many manufacturers are up to their chins in reconversion. American Lens is ready to help those manufacturers needing optics for peace—just as they helped our Government with optics for war.

Our new machine techniques, accelerated by urgent wartime demands, have brought precision manufacturing up to new highs in volume. This means better optics at lower prices. The Army, the Navy, and war contract manufacturers have kept our compact group busy since Pearl Harbor.

Now our force is ready, with sharpened skills, finer equipment and widely varied experience to go to work for you.

Our plant makes only optical components for other manufacturers—no finished products of our own. Every order here has priority and the careful attention of specialists who have been carefully trained to get the outside viewpoint.

If you are planning to use optics in your postwar products, it would be a good idea to contact us early. For every job we do is "custom-made" to suit exact requirements.

for precision OPTICS come to

**AMERICAN LENS COMPANY, INC.**

45 Lispenard Street, New York 13, N. Y.



LENSES . . . PRISMS . . . FLATS . . . REFLECTORS



# turbo INSULATIONS

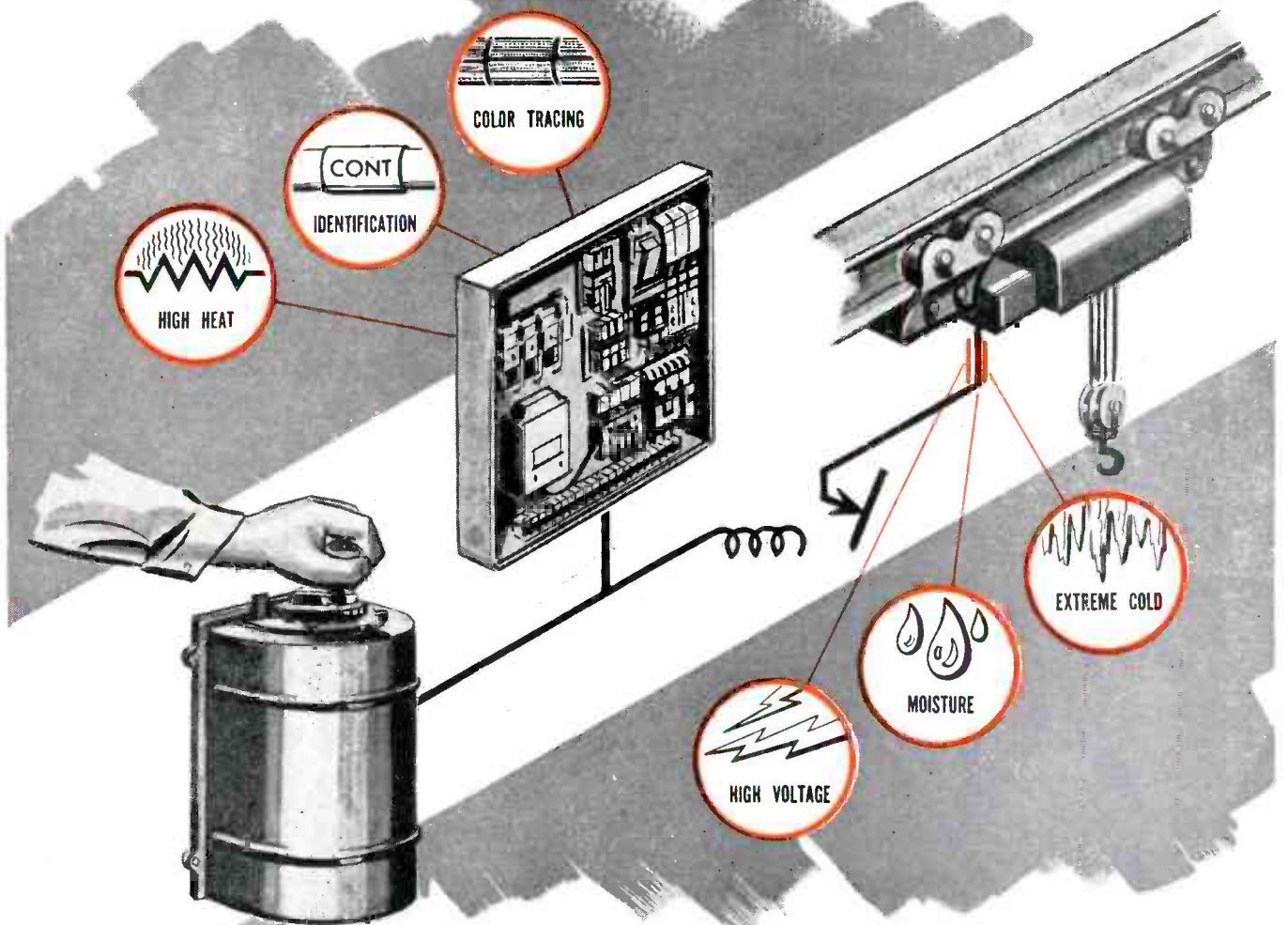

**..provide simple solutions to intricate problems!**

Control circuits—the nerve centers of modern industrial equipment—are critical in demands on dependability. TURBO insulations—diversified in characteristics—meet these exacting requirements. In both protected or exposed locations they provide a type of insulation—safety factor engineered—to preclude operating impairment resulting from insulation breakdown. To further economy, they are supplied in a full range of vivid colors that simplify maintenance and speed repair.

**FLEXIBLE VARNISHED OIL TUBING:** offers immunity to corrosive fumes, acid, alkalis and most solvents. It is impervious to moisture and non-hygroscopic.

**VARNISHED GLASS TUBING:** capable of functioning in high ambient temperatures—enclosed motors, unventilated areas, and general heavy duty installations.

**EXTRUDED TUBINGS:** smooth wall, withstand extreme low temperature without embrittlement. Provide dependable insulation in sub-zero cold. Retains flexibility at all times.

**WIRE IDENTIFICATION MARKERS:** two types—sleeve type that slips directly over pipes, tubes, conductors; and tab type with flexible flag attached to sleeve. Both available in any marking.

Write today for free Specimen Board with samples and sizes of each.

# TURBO



## WILLIAM BRAND & CO.

276 Fourth Ave., New York 10, N. Y. • 325 W. Huron St., Chicago 10, Ill.

TUBING • PAPER AND TAPE

SATURATED SLEEVING • VARNISHED CAMBRIC • MICA AND MICA PRODUCTS

For **TOUGH** outdoor applications...

## 4B32 RECTIFIER

PEAK INVERSE VOLTAGE: 10,000 VOLTS  
AVERAGE ANODE CURRENT: 1.25 AMPS.  
CONSTANT VOLTAGE DROP: 10 VOLTS  
AMBIENT TEMP. RANGE:  $-75^{\circ}\text{C.}$  to  $+90^{\circ}\text{C.}$   
FILAMENT VOLTS: 50 V AC  
FILAMENT CURRENT: 7.5 AMPS.  
RUGGED, SHOCKPROOF CONSTRUCTION.

The 4B32 is the latest addition to the CHATHAM family of application-designed power rectifiers. It meets the growing need for a rectifier tube having low voltage drop, high current capacity and ability to function in exposed locations without auxiliary heaters and controls.

This tube—Xenon gas filled—performs perfectly in ambient temperatures from  $-75^{\circ}\text{C.}$  to  $+90^{\circ}\text{C.}$  There is no trouble from arc back throughout this temperature range provided the ratings are not exceeded.

Mechanical construction is especially rugged and well adapted to all mobile, airborne and similar applications where immunity to severe shock and vibration are essential. All ratings are conservative and ample overload capacity is provided to prevent failure under accidental overload.

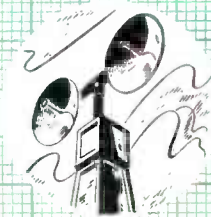
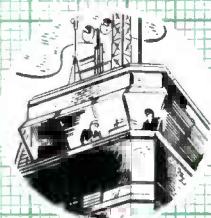
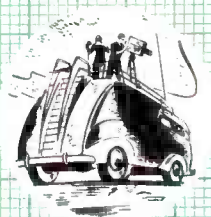

**MOBILE INSTALLATIONS  
REMOTE RELAY STATIONS  
AIRCRAFT COMMUNICATION  
BEAM & BEACON TRANSMITTERS**



**CHATHAM ELECTRONICS**

475 WASHINGTON STREET, NEWARK 2, NEW JERSEY



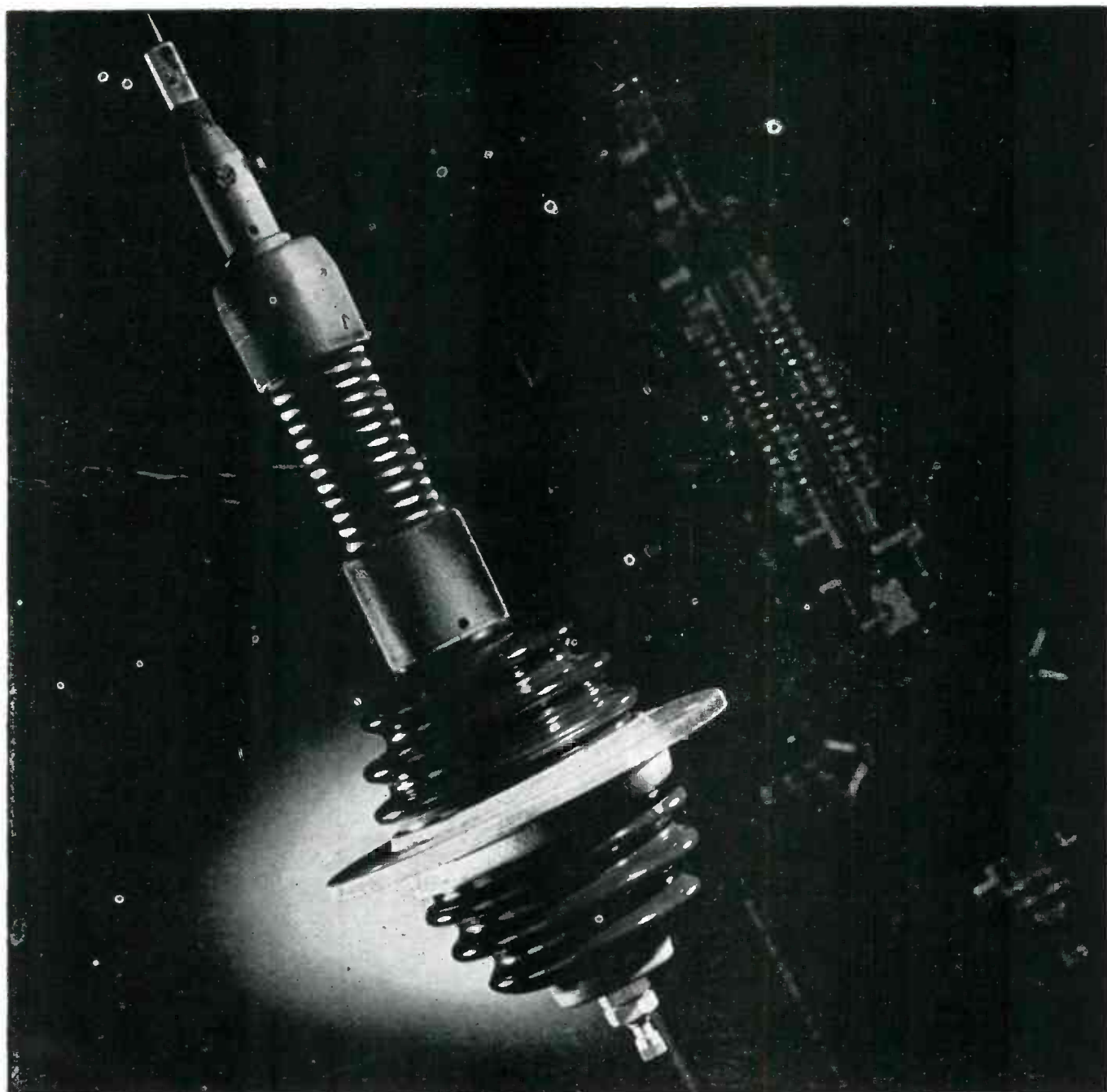

## LAPP-DESIGNED, LAPP-BUILT— TO DO A SPECIFIC JOB

This is an antenna base insulator for use on a communications center transmitter. It is one of several Lapp designs for transmitter and receiver mast bases for military vehicular radio—on jeeps, halftracks, tanks and other rolling equipment.

Whether or not this special-purpose gadget has application to anything you build or propose to build, there's a moral in it for you. In this case, as in hundreds of others, an original and impractical design was modified by Lapp engineers—to provide a part that meets all electrical and mechanical requirements, and that Lapp can build economically and efficiently.

Lapp engineering talent and Lapp production methods are such that we can say, "If it's an assembly that can be made of porcelain or steatite and metal parts, tell us what

the requirements are and how you think it might be made; Lapp will tell you how it can best be made—and will make it." Our right to that claim has been proved over and over in military electronic production; it's going to be a competitive advantage to smart post-war electronic producers. *Lapp Insulator Co., Inc., LeRoy, N. Y.*

# Lapp

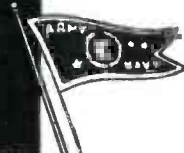

# JOHNSON

## NOW IN PRODUCTION ON PHASING EQUIPMENT

You no longer have to be satisfied with mere planning for better market coverage! Johnson engineers are now ready to tackle your directional antenna problem and to get the Phasing Equipment you need into production.

Phasing equipment by Johnson can be found successfully operating in more than 50 broadcast stations and is backed by over 20 years experience in the manufacture of radio transmitting equipment. All major components used in Johnson Phasing and Antenna coupling equipment are designed and manufactured by Johnson, assuring the best material and workmanship. The quality of the equipment is under control of Johnson engineers at all times.

Shown at right is one of the Johnson installations designed to match existing equipment.

A Johnson Phasing Unit can be made to exactly match your present equipment and thus become an integral part of your station.

Orders for Phasing and Coupling equipment will enter production in the order received. Contact us without delay, directly or through your consulting engineer.



Write for Brochure-

"Some considerations in Directional Antenna Design"

-By Johnson

E. F. JOHNSON COMPANY, Waseca, Minn



# JOHNSON

*a famous name in Radio*

E. F. JOHNSON COMPANY • WASECA • MINNESOTA



# A New and Better High Speed Counting Method...

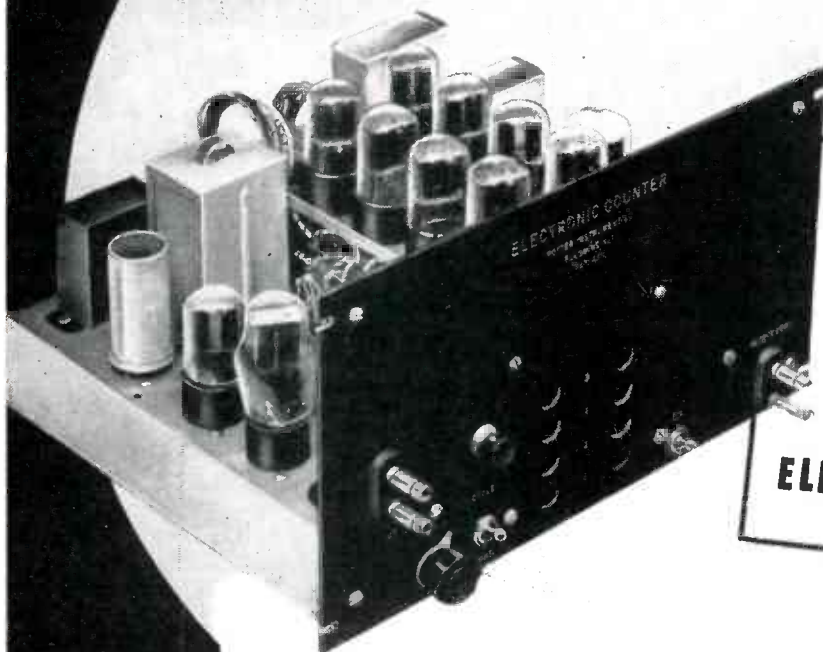

## Potter TWO DECADE ELECTRONIC COUNTER

*A versatile, efficient instrument for use as a counter, timer, interval controller, radiation counter, and many other applications*

- The Potter Two-Decade Electronic Counter is especially well suited for counting rates exceeding 10 cycles a second, a speed generally too fast for conventional counters.
- For continuous high speed operation, it will readily replace those mechanical counters that cannot stand up under such conditions.
- Another use for this versatile and efficient instrument is counting and calibration of cycles in resistance welding operations.
- It may also be used as an interval timer by connecting it through a switch to a known external frequency; readings are observed in terms of the number of cycles of the known input frequency.
- We can install dial switches on this unit to make it predetermining. It then becomes useful in a number of control applications.

The Potter Two-Decade Electronic Counter operates from a 60 cycle, 105 to 125 volt line, at speeds up to 1000 cycles a second. Each decade divides by 10, giving a scaling factor of 100. A telephone-type relay, whose contacts close once for each 100 input cycles, is connected to output terminals. An electro-magnetic counter may be added to this output to extend the count to as many places as desired. It uses 11 tubes. Delivery now in 60 days. Additional details will be forwarded promptly.

Other counter products are — RADIATION COUNTERS which resolve repetition rates of well over 2.5 microseconds; PREDETERMINED COUNTERS using several decades for control of industrial processes requiring a rapidly repeated operation to occur after a predetermined number of counts; COUNTER CHRONOGRAPHS for measuring projectile velocities to accuracies of one part in 10,000; INTERVAL GENERATORS that generate a predetermined time interval from 10 microseconds to 10 seconds in 999,999 steps of 10 microseconds.

INSTRUMENT  
**Potter**  
COMPANY

**ELECTRONIC COUNTER PRODUCTS...**

136-56 ROOSEVELT AVENUE

FLUSHING, NEW YORK

# Here's Rugged Locking Power!

FOR POSITIVE PROTECTION AGAINST THE  
LOOSENING ACTION OF VIBRATION, SPECIFY

## SHAKEPROOF

TRIPLE-ACTION LOCK WASHERS

Strong, tapered-twisted teeth bite into both surfaces. The greater the vibration, the tighter they lock... that is how Shakeproof Lock Washers efficiently protect every connection.

The combination of strut-action, spring tension and line bite produces a powerful triple-action lock. This assures locking at initial contact, prevents any backing-up movement of nut or screw and forces teeth to bite deeper as vibration increases.

Let our engineers help you incorporate Shakeproof Lock Washers into your product. Ask for this helpful service today!

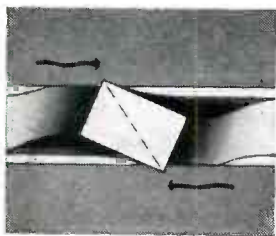

### SPECIAL APPLICATION SUGGESTIONS BULLETIN

Ask for Bulletin No. 61. It illustrates and explains various applications of Shakeproof Lock Washers. Informative and interesting. Write for it today!

### THE LOCK THAT NEVER LETS GO!



External Tooth  
Lock Washers



Internal Tooth  
Lock Washers



Extra-Heavy Internal  
Tooth Lock Washers



Countersunk Tooth  
Lock Washers



External-Internal Tooth  
Lock Washers



Dome  
Lock Washers

**SHAKEPROOF inc.**  
*fastening Headquarters*



Distributor of Shakeproof Products Manufactured by ILLINOIS TOOL WORKS  
2501 North Keeler Avenue, Chicago 39, Illinois  
Plants at Chicago and Elgin, Illinois • In Canada: Canada Illinois Tools, Ltd., Toronto, Ontario  
Los Angeles Office: 5679 Wilshire Blvd., Los Angeles, 36, Calif. • Detroit Office: 2895 E. Grand Blvd., Detroit 2, Mich.



# NEW INSTANT-HEATING BEAM TETRODE

## Ruggedized 2E25

### FOR MOBILE OPERATION



Developed for Signal Corps portable, mobile, or emergency communications equipment, the 2E25 r.f. beam tetrode is easy on the battery. The thoriated tungsten filament permits simultaneous application of filament and plate potentials. Precious battery power is conserved during standby periods.

Completely shielded for r.f., the 2E25 requires no neutralization even at its maximum frequency of 100 megacycles. Other features are: low-loss octal base, plate connection to top cap, filament potential centered at 6.0 volts, and extremely rugged construction.

Consider the advantages of the 2E25 as an instant-heating replacement for the 6V6GT or 6L6G in older equipment, or for use in modern equipment such as the new Kaar mobile FM set illustrated. Remember, the versatility of the 2E25 beam tetrode simplifies the spares problem; this one type can power a whole transmitter—R.F. and A.F. Order your engineering samples today.

### HYTRON 2E25

Instant-Heating 15-Watt R.F. Beam Tetrode  
TENTATIVE ELECTRICAL DATA

Filament Potential	6.0 ± 5% ac or dc volts
Filament Current	0.80 amp.
Plate Potential	450 max. dc volts
Screen Potential	250 max. dc volts
Grid Potential	-125 max. dc volts
Plate Current	75 max. dc ma.
Plate Dissipation	15 max. watts
Screen Dissipation	4 max. watts
Grid Driving Power (Class C)	0.5 watt approx.
Power Output (Class C)	20 watts

#### AVERAGE DIRECT INTERELECTRODE CAPACITANCES

Grid to Plate (with external shielding)	0.18 max. mmfd
Input	8.5 mmfd
Output	6.0 mmfd

#### MECHANICAL DATA

Maximum Overall Length	4 <sup>3</sup> / <sub>16</sub> inches
Maximum Diameter	1 <sup>7</sup> / <sub>16</sub> inches
Bulb	T-11
Cap	Small metal
Base	7-pin med. short shell low-loss octal

The New 2E25 Supersedes and Replaces the HY65



New instant-heating mobile FM transmitter developed by Kaar Engineering Co. uses 7 Hytron 2E25 and 2 Hytron HY69 or HY1269.

WRITE TODAY to Dept. 12 for these:  
New Hytron transmitting and special purpose tube catalog; 21 x 17 inch sheet illustrating Step-by-Step Assembly of Typical Hytron Tube.

OLDEST MANUFACTURER SPECIALIZING IN RADIO RECEIVING TUBES

# HYTRON

RADIO AND ELECTRONICS CORP.



MAIN OFFICE: SALEM, MASSACHUSETTS

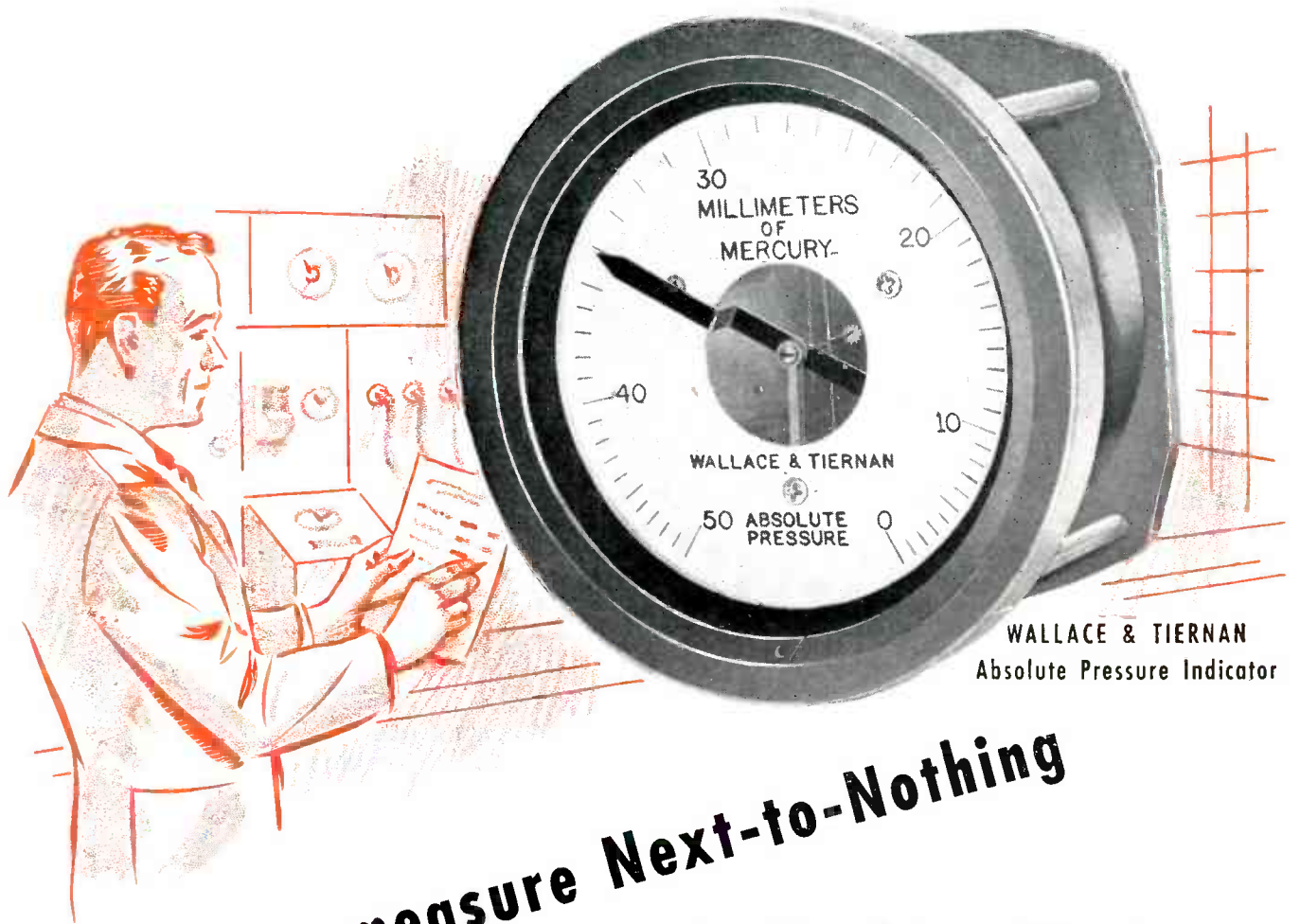

WALLACE & TIERNAN  
Absolute Pressure Indicator

## How to measure Next-to-Nothing ...in Nothing Flat!

Measurement of high vacuum need no longer be complicated by time-consuming and error-producing barometric corrections. The W&T Absolute Pressure Indicator shows true vacuum *directly*, as pressure above absolute zero, without computation or adjustment.

In such diverse fields as radio tube and lamp manufacturing, and high vacuum distillation, the greater speed and accuracy thus obtained means increased production, lower costs and closer control of the finished product.

### SPECIFICATIONS — TYPE FA-160

**RANGE** — 0 to 20 mm. Mercury absolute pressure  
0 to 50 mm.  
0 to 100 mm.

**GRADUATIONS** — 50      **SCALE LENGTH** — 7 inches

**SCALE DIAMETER** — 2½ inches

**SENSITIVITY** — one part in 500      **ACCURACY** — one part in 300

*Write for Technical Publication 256*



# WALLACE & TIERNAN PRODUCTS, INC.

BELLEVILLE 9 • NEW JERSEY



A 52



# distinguished cabinet member on a secret mission...

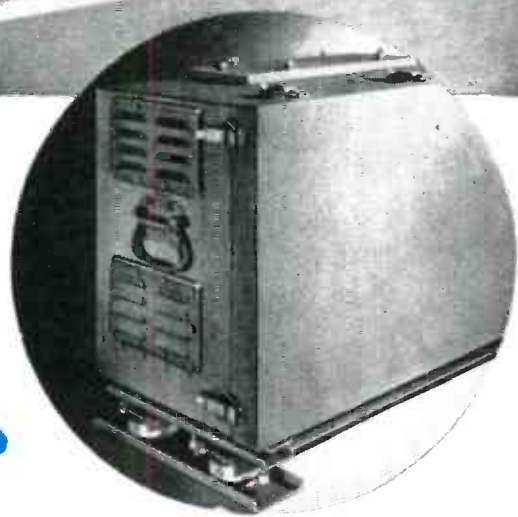
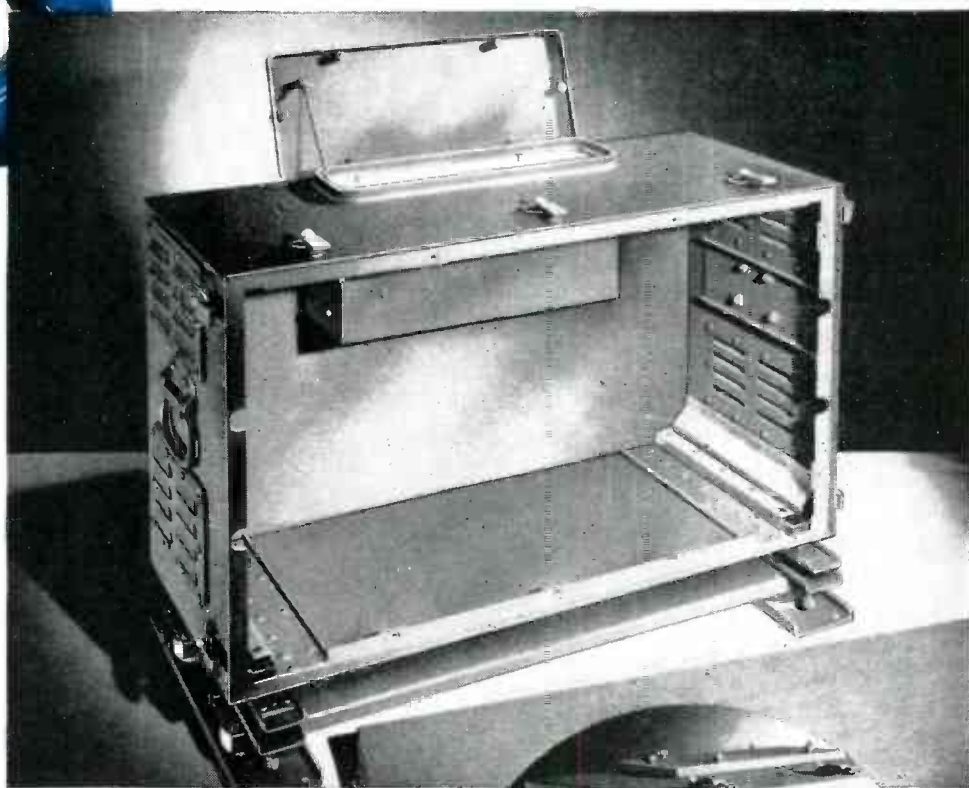

**T**he actual use of this Karp-constructed cabinet assembly for electronic apparatus is a military secret.

We can, however, reveal the superior details of the all-welded aluminum construction. It is splash-proof, insect-proof—and at the same time ventilated. The assembly also includes a shock mount. Suspension slides permit the electronic apparatus to move in and out like a drawer.

If you require special-built housings, racks, panels, chassis or enclosures for electrical equipment, get the benefit of our 20 years of specialized experience in this field. Our hundreds of skilled craftsmen will save your time. Our complete facilities and numerous stock dies will save you money.

**ANY METAL • ANY GAUGE • ANY SIZE • ANY FINISH**

# KARP

**METAL PRODUCTS CO., INC.**

*Custom Craftsmen in Sheet Metal*

124-30th Street, Brooklyn 32, N. Y.









# The most honored instrument of the war

This is not our own appraisal of the Simpson 260. We knew, before the war, that it was a fine instrument but, frankly, we didn't know *how* good it was until war wrote the record. Now the story of the 260 is written into the records of such wartime industrial developments as that of synthetic rubber, and into the vast and secret research and servicing of radar.

Originally designed as a radio serviceman's test unit, the Simpson 260, because of its sensitivity and wide range was found adaptable to general service duties in the entire electronics and electrical fields. Not a warborn instrument, the 260 was given thousands of essential war jobs in the production and servicing of communications equipment. It made a vital contribution to the success of tactical operations.

Over 300 government agencies and university laboratories of the United States and Canada procured every one of these test instruments Simpson could deliver on an expanded war production schedule. They were turned out by the thousands. Every

branch of the armed services—Army, Navy, Marines, Coast Guard—carried them to the far ends of the earth. They were compelled to perform under conditions often so arduous that testimonials of amazement at their ability to function at all became commonplace as the record grew.

Chosen on its merits, the Simpson 260 became uniquely *the* test instrument of the war.

## AVAILABLE NOW TO YOU

Now the Model 260, always the preferred instrument of radio servicemen, is available again to a widened field of peacetime services. We ask you to remember its record as an example of the quality and advanced engineering that goes into all Simpson instruments, as evidence that other new Simpson developments are well worth waiting for. They will be released as soon as Simpson standards for their manufacture are satisfied. They will continue the leadership that has given Simpson a world-wide reputation for "instruments that *stay* accurate" with ideas that *stay* ahead.

SIMPSON ELECTRIC COMPANY  
5200-5218 W. KINZIE ST., CHICAGO 44, ILL.

# Simpson

## SIMPSON 260, HIGH SENSITIVITY SET TESTER FOR TELEVISION AND RADIO SERVICING

Ranges to 5000 Volts—Both A.C. and D.C. At 20,000 ohms per volt, this instrument is far more sensitive than any other instrument even approaching its price and quality. The practically negligible current consumption assures remarkably accurate full scale voltage readings. Current readings as low as 1 microampere and up to 500 milliamperes are available.

Resistance readings are equally dependable. Tests up to 10 megohms and as low as 1/2 ohm can be made. With this super sensitive instrument you can measure automatic frequency control diode balanc-

ing circuits, grid currents of oscillator tubes and power tube, bias of power detectors, automatic volume control diode currents, rectified radio frequency current, high- $\mu$  triode plate voltage and a wide range of unusual conditions which cannot be checked by ordinary servicing instruments. Ranges of Model 260 are shown below.

Price, complete with test leads.....\$33.25  
Carrying case ..... 4.25

### ASK YOUR JOBBER

Volts D.C. (At 20,000 ohms per volt)	Volts A.C. (At 1,000 ohms per volt)	Output	Milliamperes	Microamperes	Ohms
2.5	2.5	2.5 V.	D.C.	100	0-1000 (12 ohms center)
10	10	10 V.	100		0-100,000 (1200 ohms center)
50	50	50 V.	500		0-10 Megohms (120,000 ohms center)
250	250	250 V.			
1000	1000	1000 V.			
5000	5000	5000 V.			

(5 Decibel ranges: -10 to +52 DB)

**WATCH FOR NEW SIMPSON DEVELOPMENTS. THEY WILL BE WORTH WAITING FOR!**

# SILENT SAFEGUARD

## Against CORROSION

This Federal Cathodic Protection unit was installed near Elizabeth, New Jersey, for the Public Service Electric and Gas Company, to protect 132KV underground lead sheathed power cables.

Operating silently . . . without moving parts, the dependable Federal Selenium Rectifier in this compact unit provides a small, steady direct current which counteracts the corrosive forces in the surrounding soil, and guards against interruption of vital power supply to industrial plants in the area.

For sure protection against galvanic or electrolytic damage to any underground power or other metal installation . . . a Federal Cathodic Protection unit is the logical choice . . . silent safeguard against corrosion.

Write us today for booklet "Cathodic Protection and Applications of Selenium Rectifiers" . . . get the full story of this effective means of protection.



STEEL RAIL  
GROUND BED

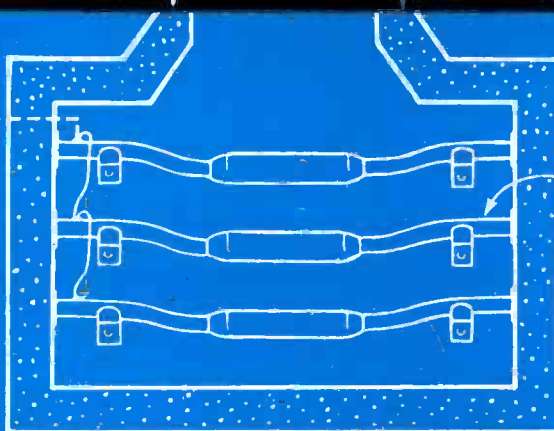

LEAD SHEATHED  
POWER CABLES



*Federal Telephone and Radio Corporation*



Newark 1, N. J.





*Quiet*



Efficient—reliable—above all, *QUIET*—  
that's the Ballentine Phonograph Drive.

Basic refinements in design, *precision*  
*dynamic balance*, the most advanced  
manufacturing technique and equipment make  
the Ballentine Phonograph Motor unequalled  
for low background noise or rumble.

Send for descriptive bulletin.

**RUSSELL ELECTRIC COMPANY**

364 WEST HURON ST., CHICAGO 10, ILL.

*Manufacturers of*

**BALLENTINE PHONOGRAPH DRIVE**

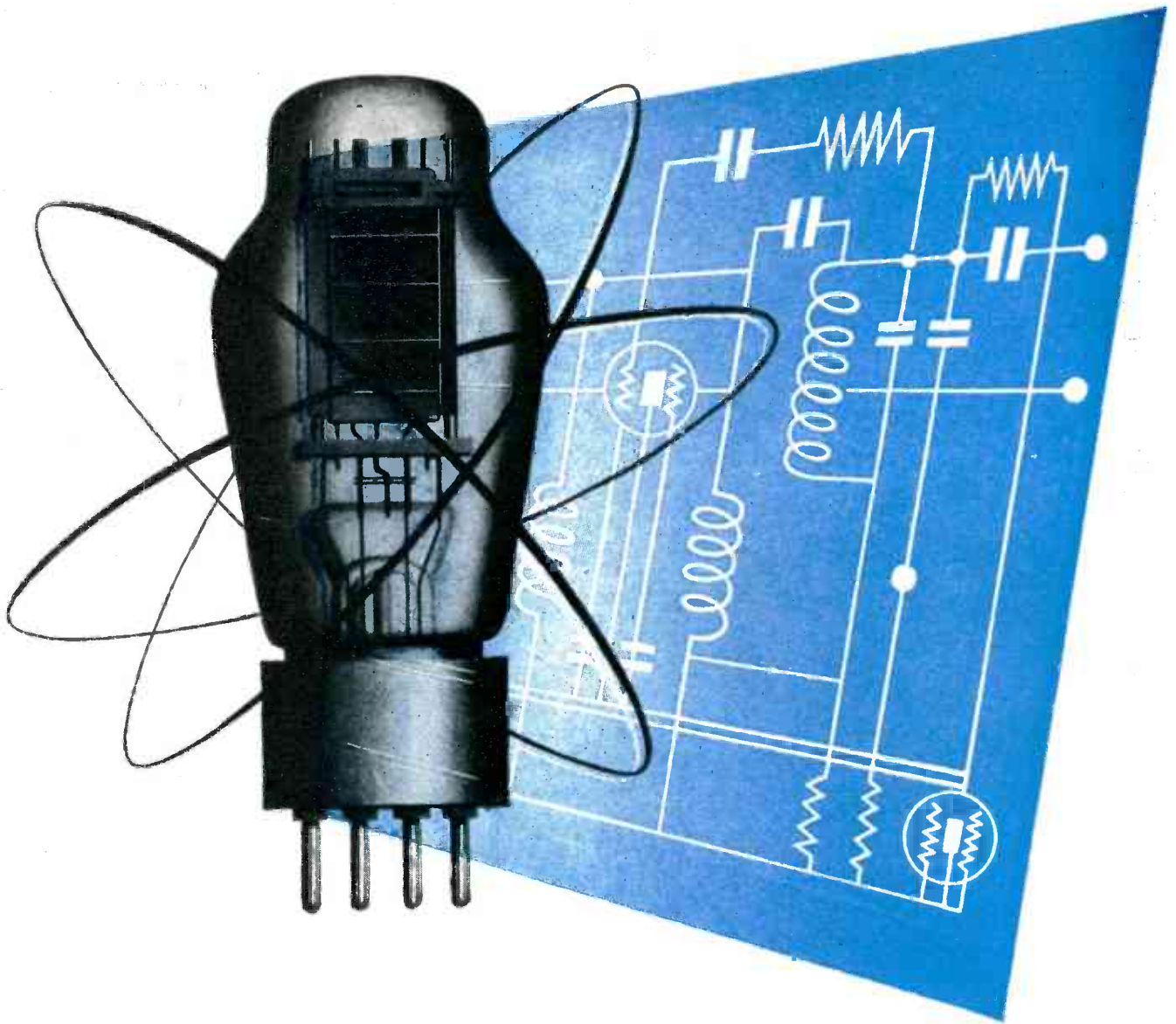

## ● Decide AT THIS POINT to use TAYLOR FIBRE

WHETHER YOUR POST-WAR PRODUCT will be in the field of electronics or aviation, automotive or home appliance, or any field in which light weight, ease of machineability, high insulating qualities or structural strength are important, decide now—in the blueprint stage—to give thorough consideration to the advantages of using Taylor Laminated Plastics. New, war-born developments in Phenol Fibre and Vulcanized Fibre may change your whole conception about the possible applications of Laminated Plastics. Our engineering department is ready to consult with you on this subject, without obligation, either in our plant or yours. Start the ball rolling, by writing us today.

# TAYLOR FIBRE COMPANY

**LAMINATED PLASTICS: PHENOL FIBRE • VULCANIZED FIBRE • Sheets, Rods, Tubes, and Fabricated Parts**  
NORRISTOWN, PENNSYLVANIA • OFFICES IN PRINCIPAL CITIES • PACIFIC COAST HEADQUARTERS: 844 S. SAN PEDRO ST., LOS ANGELES





LABORATORY INSTRUMENTS FOR SPEED AND ACCURACY

## What Happens Inside an -hp- Model 500A Frequency Meter

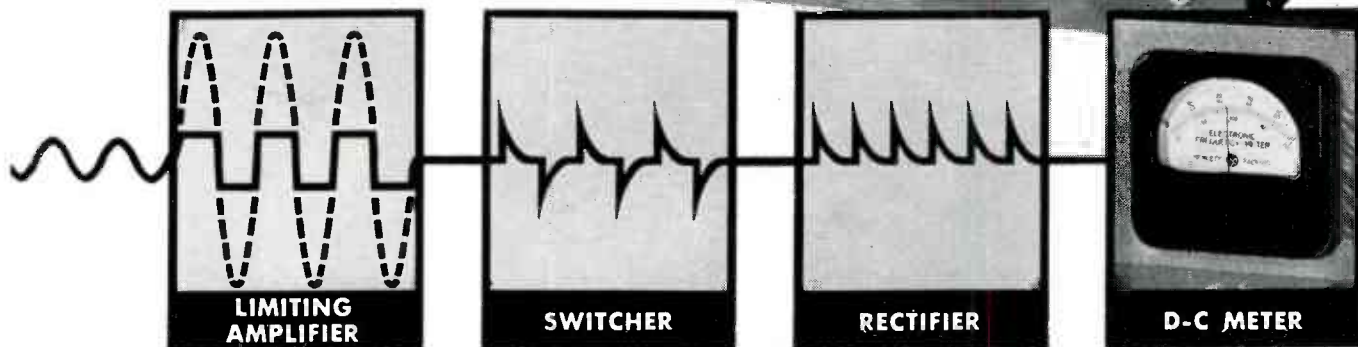

### This Instrument Counts Cycles of an Unknown Frequency

The above diagram shows how the -hp- 500A analyzes an unknown frequency so that cycles per second will accurately register on the specially calibrated d-c meter.

The unknown frequency is introduced to a limiting amplifier which generates a square wave output. The square wave voltages are applied to two switching tubes which become alternately conducting on opposite half cycles. From a constant current supply, the two switching tubes deliver a current to load resistors. Each load resistor causes the charge on a pair of capacitors to vary in accordance with the switched current pulses. Thus a current flows from the combination to the rectifier. The rectified pulses are delivered to the d-c meter. Each pulse is of the same size and independent of other factors. The meter integrates these pulses and gives a deflection which is proportional to the number of

pulses per second. Thus the meter reading is directly related to the unknown frequency.

The instrument is easy to use and requires but a small amount of power. It has good sensitivity and a wide range of usable voltages. The input range is from 0.5 to 200 volts—input impedance is 50,000 ohms. A switch on the panel selects one of ten ranges which are read directly on the meter.

Accuracy of the instrument is  $\pm 2\%$ —independent of line voltages, vacuum tube characteristics and magnitude and wave form of applied voltage—because the meter reading is dependent only upon the constant current supply and the RC combination.

The uses for this meter become readily apparent. Of special interest is its use as a high speed tachometer. (See column at right.) Write for more detailed information today. -hp- engineers are at your service,

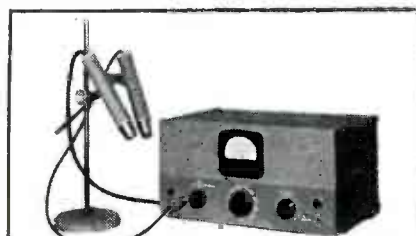

You can measure  
**3,000,000 r.p.m. with this  
-hp- Electronic Tachometer**

Using a photo electric cell pickup in conjunction with an -hp- Model 500A Frequency Meter provides an Electronic Tachometer capable of accurately measuring incredible speeds. This method places no load on the device being clocked.

Two special models of -hp- frequency meters, complete with light source and pickup, are available for this purpose. One model (505A) is calibrated in r.p.m. from 600 to 3,000,000 r.p.m.; the other model (505B) is calibrated in r.p.s. from 50 to 50,000 r.p.s. Speeds as slow as 600 r.p.m. (10 r.p.s.) are conveniently measured directly, while still slower speeds can be measured by a simple expedient. Ask for special technical bulletin on -hp- Models 505A and 505B.

1073

## HEWLETT-PACKARD COMPANY

BOX 1073A · STATION A · PALO ALTO, CALIFORNIA

Audio Frequency Oscillators	Signal Generators	Vacuum Tube Voltmeters
Noise and Distortion Analyzers	Wave Analyzers	Frequency Meters
Square Wave Generators	Frequency Standards	Attenuators
		Electronic Tachometers

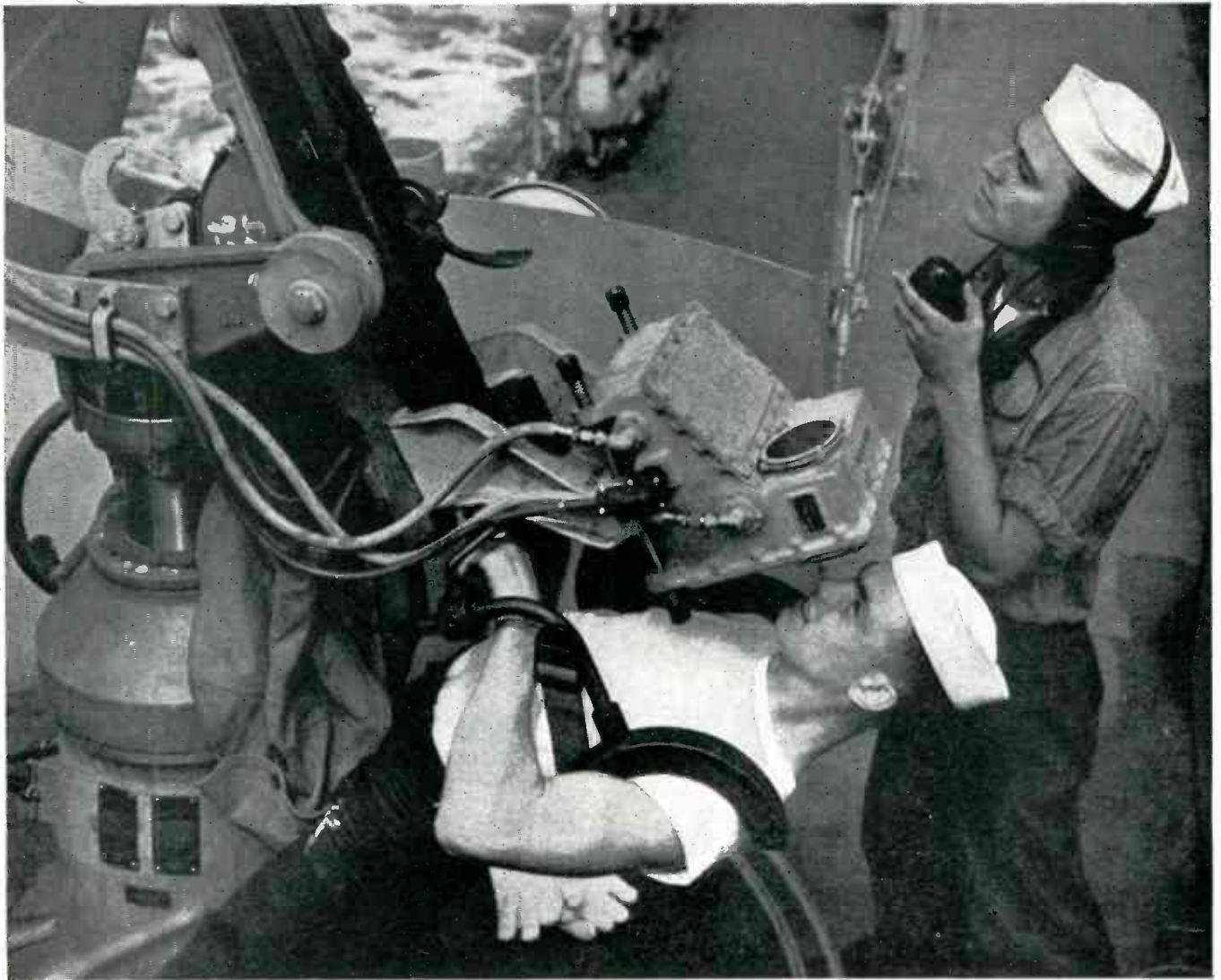

*Official photograph, United States Navy*

## COMMUNICATION FOR PRECISION

demands precision in communication. To hit the target with your electronic product in the present peacetime market, you must regard precision as your first essential in design and manufacture. DICO is the word for unmatched precision in both. There are no working standards or specifications so exacting that DICO cannot fulfill them, thus assuring the utmost in quality and control. Furthermore, there will not be enough facilities like DICO's available for a long time to supply the needs of the rapidly expanding electronics industry. Therefore it would be foresighted to consider your possible immediate and future needs from DICO now. Our representative will call for consultation, without any obligation.



PRODUCT ENGINEERING, DESIGNING, DEVELOPMENT;  
GOLD AND SILVER PLATING; SOLDERING, WELDING,  
CASTING, ASSEMBLING, FINISHING



# Announcing...

## The NEW Temco Line

100 W-10 KW • 500 Kc-500 Mc

A. M. and F. M.

### Broadcast and Communication

# TRANSMITTERS

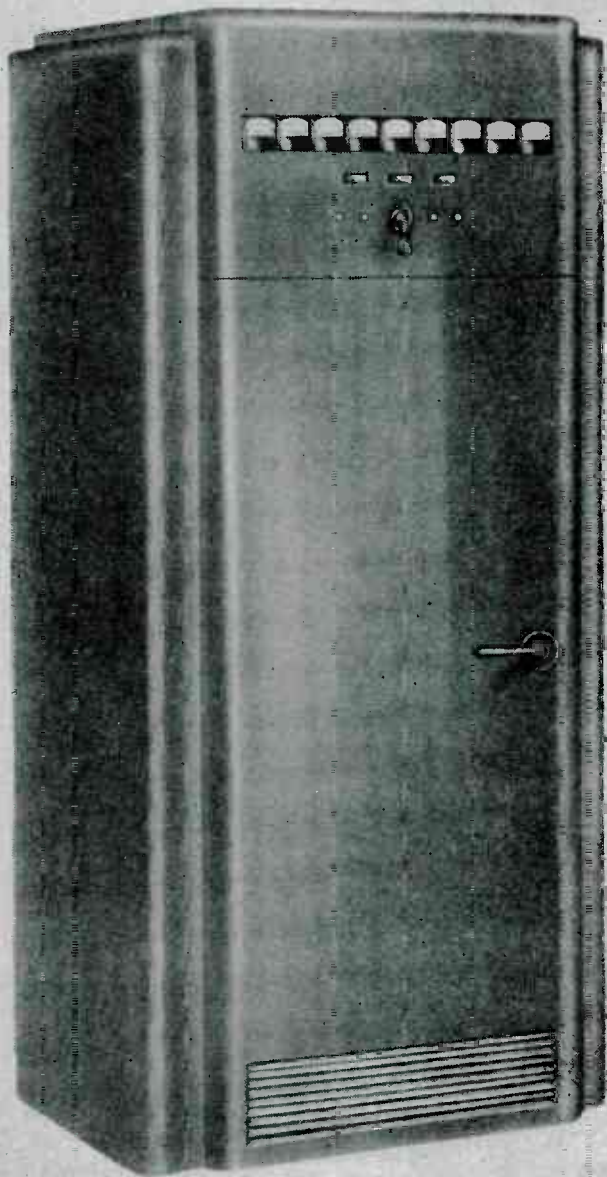

500 watt to 1000 watt output ratings or multiple cabinets for ratings up to 10KW.

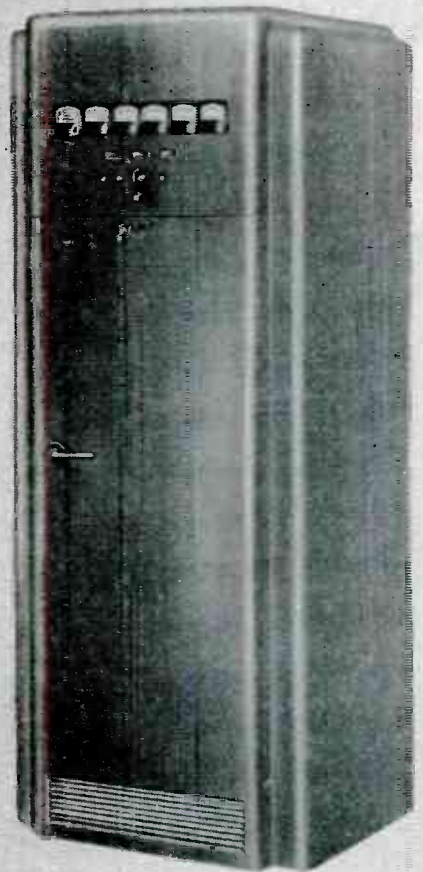

### Featuring-

100 watt to 350 watt output ratings.

1. Single Control-Tracked Tuning Exciter Unit eliminating independent tuning of all low powered R. F. stages.
2. Motorized Tuning Controls permitting placement of components in chassis positions best suited for maximum circuit efficiency.
3. Eye-Zone Meters and Hand-Level Controls introducing a highly desirable innovation for ease of operation.
4. Temco Power-Flex Multiple Unit Design for expanding power output without making obsolete lower power units and retaining uniform over-all appearance.
5. Dust and Tamper Proof Cabinets.
6. Forced Draft - Filtered Ventilation.
7. Handsome, dignified styling throughout.

Designed and built by Temco Radar specialists, these Transmitters represent a complete embodiment of technically advanced concepts of radio engineering and design, combined with Temco's distinguished high standard craftsmanship. Write for specifications stating your power and service requirements. Orders will be filled in rotation as received.

# TEMCO

RADIO COMMUNICATION EQUIPMENT

TRANSMITTER EQUIPMENT MFG. CO., INC.  
345 Hudson Street, New York 14, N. Y.



# RESEARCH.

These moisture absorption tests in continuous operation since 1930, are augmented by samples of each new standard insulation which comes into the picture.

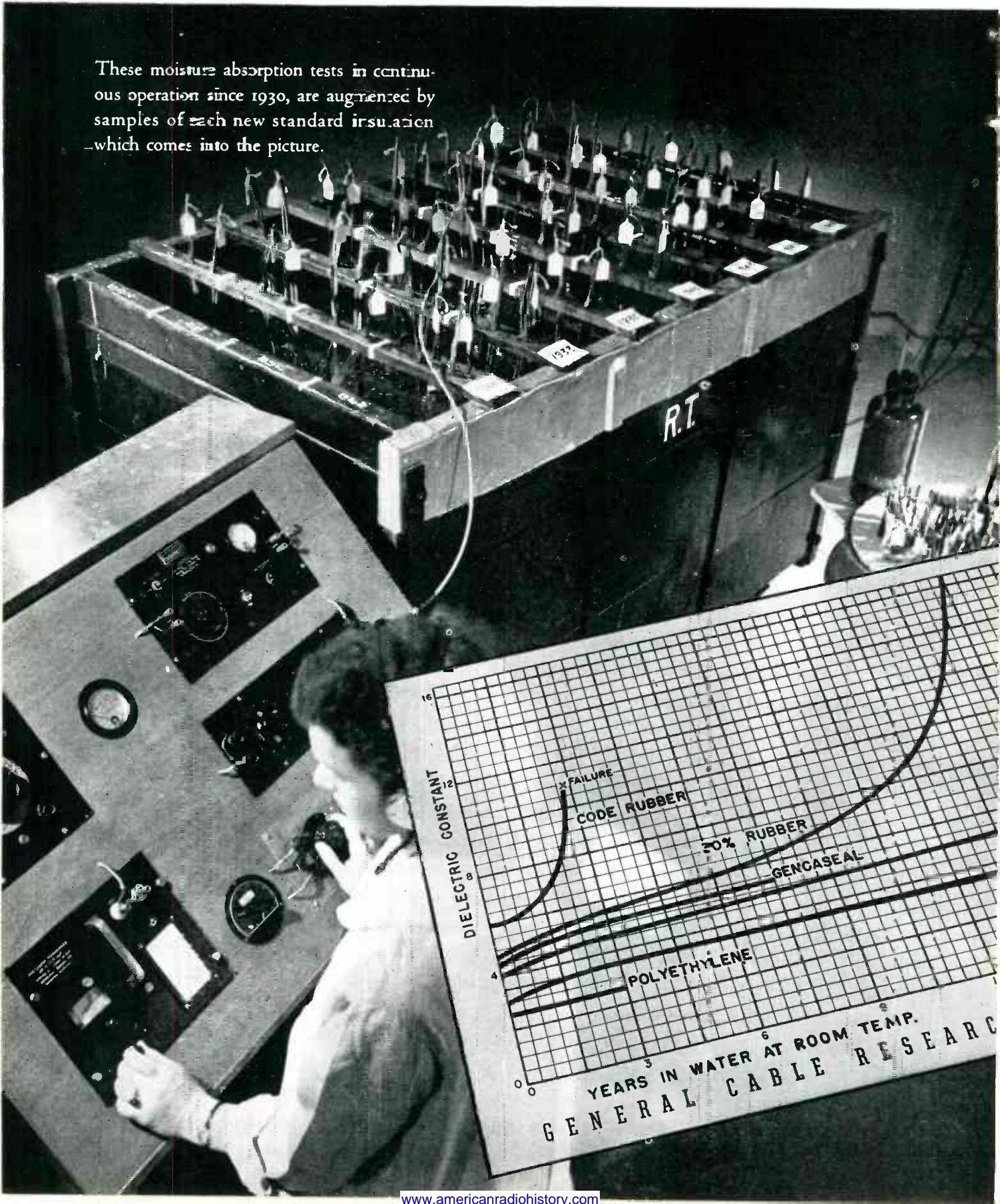

DIELECTRIC CONSTANT

YEARS IN WATER AT ROOM TEMP.  
GENERAL CABLE RESEARCH



# .. BY DECADES

Preparedness for Post-War  
Industry Developments  
based on cumulative data  
long in preparation

In the comparison of rubber insulating compounds and the new synthetics, it is easy and hazardous to jump at conclusions. Through the years, General Cable has been broadening its base of data by which to predict with some assurance the performance to be expected of the new materials. And out of practical experience, it recognizes, too, that there is no substitute for time in the determination of the industry's final answers.

These and other tests, extending over years of simulated service conditions, prepare General Cable to furnish synthetic insulations for all operating conditions.

## GENERAL CABLE CORPORATION

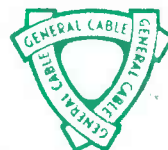

*General Cable Corporation Sales Offices are located at Atlanta, Boston, Buffalo, Chicago, Cincinnati, Cleveland, Dallas, Detroit, Houston, Kansas City (Mo.), Los Angeles, New York, Philadelphia, Pittsburgh, Rome (N.Y.), St. Louis, San Francisco, Seattle, Washington (D. C.)*

# Who sets the *Quality Standard* FOR TRANSMITTING TUBES



WERE it possible, within the limits of this page, to show you all the numerous operations required to construct United Tubes, you would realize why the name United means Quality Standard for transmitting tubes. For the sterling quality of United Electronic tubes is born of a series of unique manufacturing processes vigilantly guarded by Quality Standard Tests. Many are standard procedure; many more are exclusively United features. Those illustrated represent a few of the extra operations which help maintain leadership for United.

Since 1934 United has won recognition by specializing exclusively in the engineering, designing and building of transmitting tubes which are unchallenged for excellence. That is why, with each succeeding year United tubes are used more and more in important places.

Write for a copy of our latest catalog.

**QST-1**—No machine can rival the skill of human hands in fitting the precise parts of Electronic Power Tubes. These are the hands of craftsmanship building the quality into United Tubes.



**QST-1**—In this United Comparator grids are carefully checked. The slightest variations in grid wire spacings would affect tube characteristics and performance. Critical tolerances are strictly adhered to, and any deviation from precision standards is severed at the greatly enlarged grid stage.



**QST-2**—Every thoriated tungsten filament is carburized in a controlled atmosphere chamber to enhance its emitting qualities. It is an added step that assures accurate filament current and maximum emission. This is but one of many procedures that contribute to the dependable performance of United tubes.



**QST-3**—The tell-tale colors of glass strains are detected in time by this United Polariscope that all possibility of glass fatigue is obviated.

\*Quality Standard Test

*Masterpiece of Skilled Hands*

# UNITED

ELECTRONICS COMPANY

NEWARK, 2



NEW JERSEY

Transmitting Tubes EXCLUSIVELY Since 1934

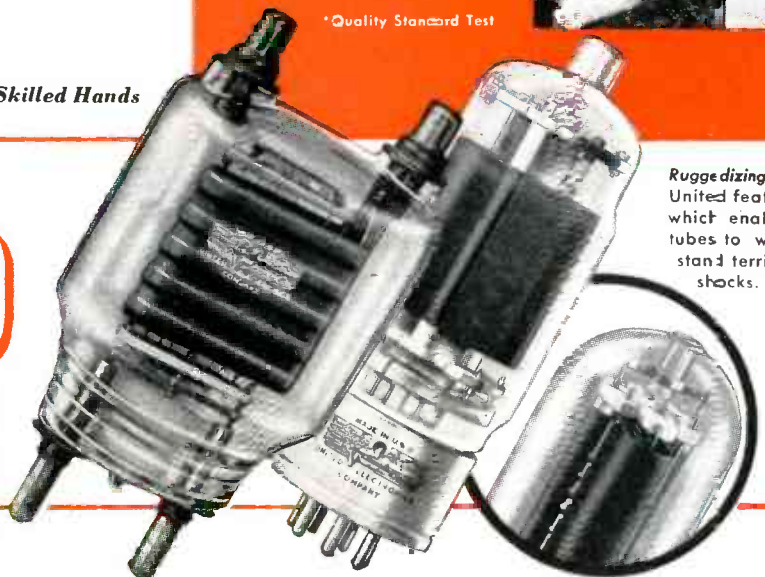

**Ruggedizing:** A United feature which enables tubes to withstand terrific shocks.



# SPECIFY THE RIGHT TAPE FOR THE JOB!

Doplex Asbestos  
Type AB

Doplex Asbestos  
Type CL

Doplex Rope Paper  
Type PJT

Doplex Cambric  
Type AC  
Bias cut

Straight cut

Doplex Acetate  
Type AA

**DOPLEX ASBESTOS TYPE AB**—Meets Class B insulation requirements at less cost. For use under high temperatures. High-grade nonferrous asbestos paper, .007" thick, laminated one side with .0016" cellulose acetate-butyrate film for mechanical strength. Noncorrosive, alkali and acid resistant.

**DOPLEX ASBESTOS TYPE CL**—Another less expensive Class B insulation. High-grade nonferrous asbestos paper, .007" thick, laminated one side with cotton cloth for mechanical strength and abrasion resistance. Flame-inhibiting coating on cloth side. Noncorrosive, low organic content.

**DOPLEX ROPE PAPER TYPE PJT**—Conserves space, only .0035" thick. High-quality thin rope paper laminated on one side with special flame-resistant cellulose film. For use as separator or barrier in cables. Prevents sulphur in rubber compounds from attacking untinned copper conductors.

**DOPLEX CAMBRIC TYPE AC**—Exceptionally high dielectric for Class A insulation under high temperature and humidity. Purified cotton cloth saturated with aceto-butyrate resins and laminated one or both sides with aceto-butyrate film. Available in straight or bias cut tapes and in pads for automatic coil-winding machines.

**DOPLEX ACETATE TYPE AA**—Recommended for all uses requiring thin, high dielectric insulation. 4-ply tape, only .004" thick with dielectric equivalent to .007" of varnished cambric under normal conditions, with marked improvement in humid atmosphere up to 250°F. Not affected by dipping and baking in varnish.

- The versatility of DOPLEX insulating tapes to meet different requirements may be seen in the accompanying descriptions. You can have high dielectric and mechanical strength, resistance to such factors as heat, flame, acids and abrasion—in combinations to meet your specific needs.

These qualities have already been proved in a variety of successful cable and coil applications for leading manufacturers, resulting in substantial savings and product improvements. Widths from one-eighth inch up with a variety of put-ups on universal cops and pads, for mechanical or manual application. Ask for data and samples, and names of leading manufacturers making DOPLEX wire.



CLEVELAND PLANT



**THE DOBECKMUN COMPANY**  
Industrial Products Division, Cleveland 1, Ohio

Makers of "LEXEL" insulating tape and  
"DOBAR" laminated paper insulation

FINE POINTS MAKE FINE



PRODUCTS

# Immersion Vacuum Test OF AMERTRAN HERMETICALLY SEALED TRANSFORMERS



AMERICAN TRANSFORMER COMPANY  
178 EMMET STREET • NEWARK 9, NEW JERSEY

**EVERY UNIT GETS A BATH.** The photographs above and to the left show one of the tests to which AmerTran Hermetically Sealed Transformers are subjected. All receive this test—not just random units.

**NOT A BUBBLE SHOWING!** Continuous inspection during and between manufacturing steps insures optimum performance and long life. The high dependability of AmerTran Hermetically Sealed Transformers is due to exceptionally rigid standards of manufacture and inspection.

**NEW—OIL IMPREGNATION** with bellows style case to permit complete sealing with provision for expansion.

**OTHER FINE POINTS.** Uniform characteristics correct terminations—vacuum impregnation with varnish or wax—vacuum filling with oil or wax—high mechanical strength—induction soldering—infra-red pre-heating—continuous inspection—42 years transformer manufacturing experience.

# AMERTRAN

MANUFACTURING SINCE 1901 AT NEWARK, N. J.

Pioneer Manufacturers of Transformers, Reactors and Rectifiers for Electronics and Power Transmission



October 1945 — ELECTRONICS



# Television's Great Problem *Solved at last!*

## TELICON "INTRA-VIDEO" SYSTEM INSURES TROUBLE-FREE RECEPTION IN LARGE CITIES

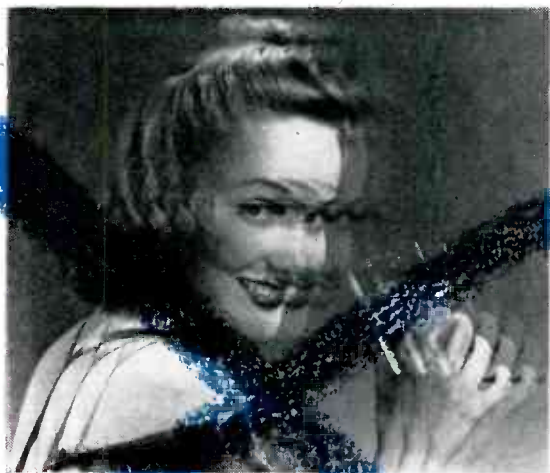

### **Television Ghosts Hushed!**

Easily three-quarters of potential purchasers of television sets dwell in urban areas. The majority of them are tenants in multi-family apartment houses. Echo or ghost images due to waves reflected from steel frame buildings, bridges or other elevated structures cause havoc in the television picture on the screen. A number of television receiving antennas operating *independently* in close proximity to each other—as would be the case on a roof of an apartment house—are bound to mar still further the ultimate result on the viewing screen.

This problem, which has been vexing television engineers for some time, has found its solution in the Telicon "Intra-Video" System. It is the result of time, thought and effort on the part of Telicon, members of whose organization comprise some prominent pioneers in the field of pre-war television development. Telicon "Intra-Video" has removed the final obstacle in the path of successful commercial television.

The Telicon "Intra-Video" System (patents pending) makes possible, for residents in multi-apartment houses, satisfactory trouble-free reception from *all* television transmitters in their area. *All signals—from each transmitter—picked up by a special antenna arrangement, then individually amplified and "cleaned up," will be fed through a single co-axial cable and distributed (without inter-action) to as many outlets as desired.* Pickup of the FM band is included for good measure.

Telicon "Intra-Video" installations require but little space in the building. They require no more attention than the electric lights on the staircase. Cost to landlords—and tenants—will be more than reasonable in light of the service to be performed.

A written inquiry will place you on our mailing list for further details. • TELICON CORPORATION  
851 Madison Avenue, New York 21, N. Y.

# TELICON

*Television Designed with Vision*

AM & FM CRYSTAL CONTROLLED RADIO • PERFECT VISION RECEIVERS • CRYSTALS

# WHAT WILL YOU NEED TO PRODUCE BETTER POST-WAR PRODUCTS ?

**CORNING  
GLASS  
GIVES YOU**

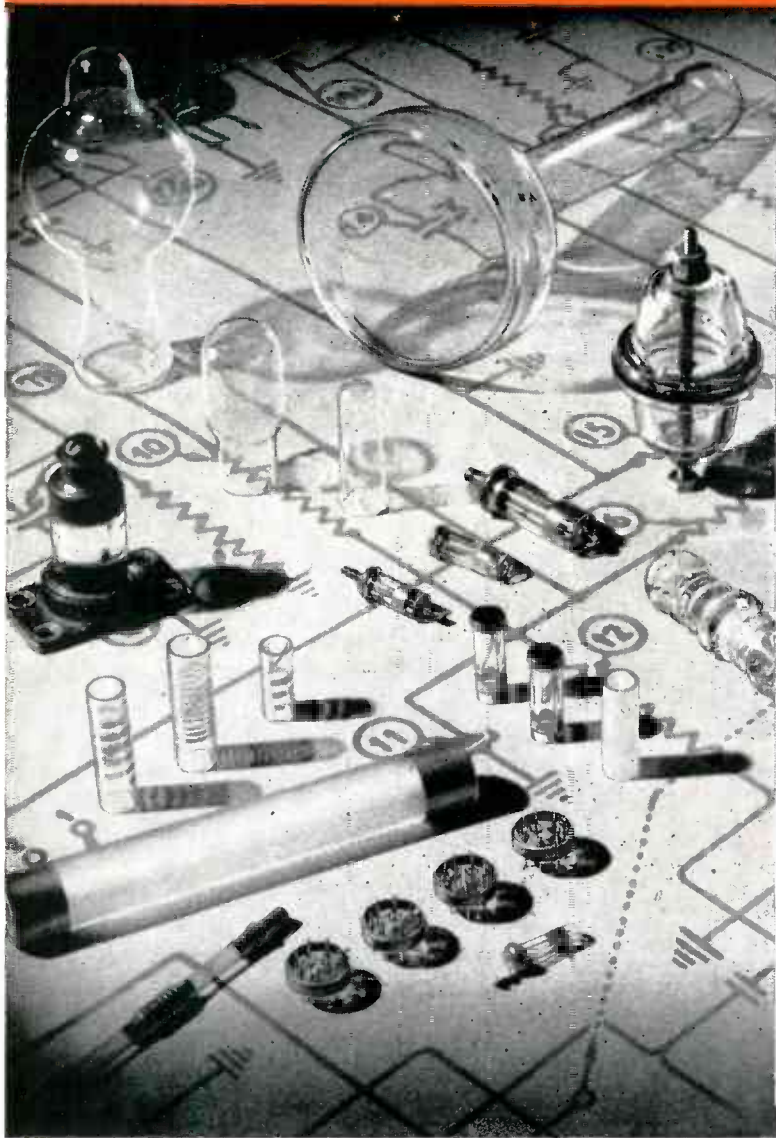

## Special Electrical Qualities

**Thermal Endurance**

**Hermetic Sealing**

**Mechanical Strength**

**Corrosion Resistance**

**Precision**

**Permanence**

**Metallizing**

**Dimensional Stability**

High dielectric strength—high resistivity—low power factor—wide range of dielectric constants—low losses at all frequencies.

Permanent hermetic seals against gas, oil and water readily made between glass and metal or glass and glass.

Commercial fabrication to the fine tolerances of precision metal working.

Corning's metallizing process produces metal areas of fixed and exact specification, permanently bonded to glass.

**A**S YOU plan post-war electronic products, give a thought to versatile glass. We really mean glasses, for Corning has, at its fingertips, 25,000 different glass formulae from which to select those especially suited to your electronic applications. Let us show what glass can do for you. We may already have a solution — or Corning Research can find the answer for you. Address Electronic Sales Dept., E-10, Bulb and Tubing Division, Corning Glass Works, Corning, New York.

**CORNING**  
— means —  
Research in Glass

**Electronic Glassware**



“PYREX”, “VYCOR” and “CORNING” are registered trade-marks and indicate manufacture by Corning Glass Works, Corning, N. Y.



# Search Warrant for Spring Trouble



Spring coiling can, and often does, become a very complicated and vexing problem where both machine and material must yield peak performance in order to meet critical dimensional and test specifications.

Then ordinary methods of analyzing the product deviations and its many possible causes are out. Only unusual technical skill supported by advancing instrumentation can succeed in obtaining the desired solution. All of the many special electronic devices used in regular production and for special investigations are designed and constructed by Hunter's Special Apparatus Division. If you agree we go to more trouble to make springs right than you expected of leading springmakers, we can only say—you haven't seen anything yet.

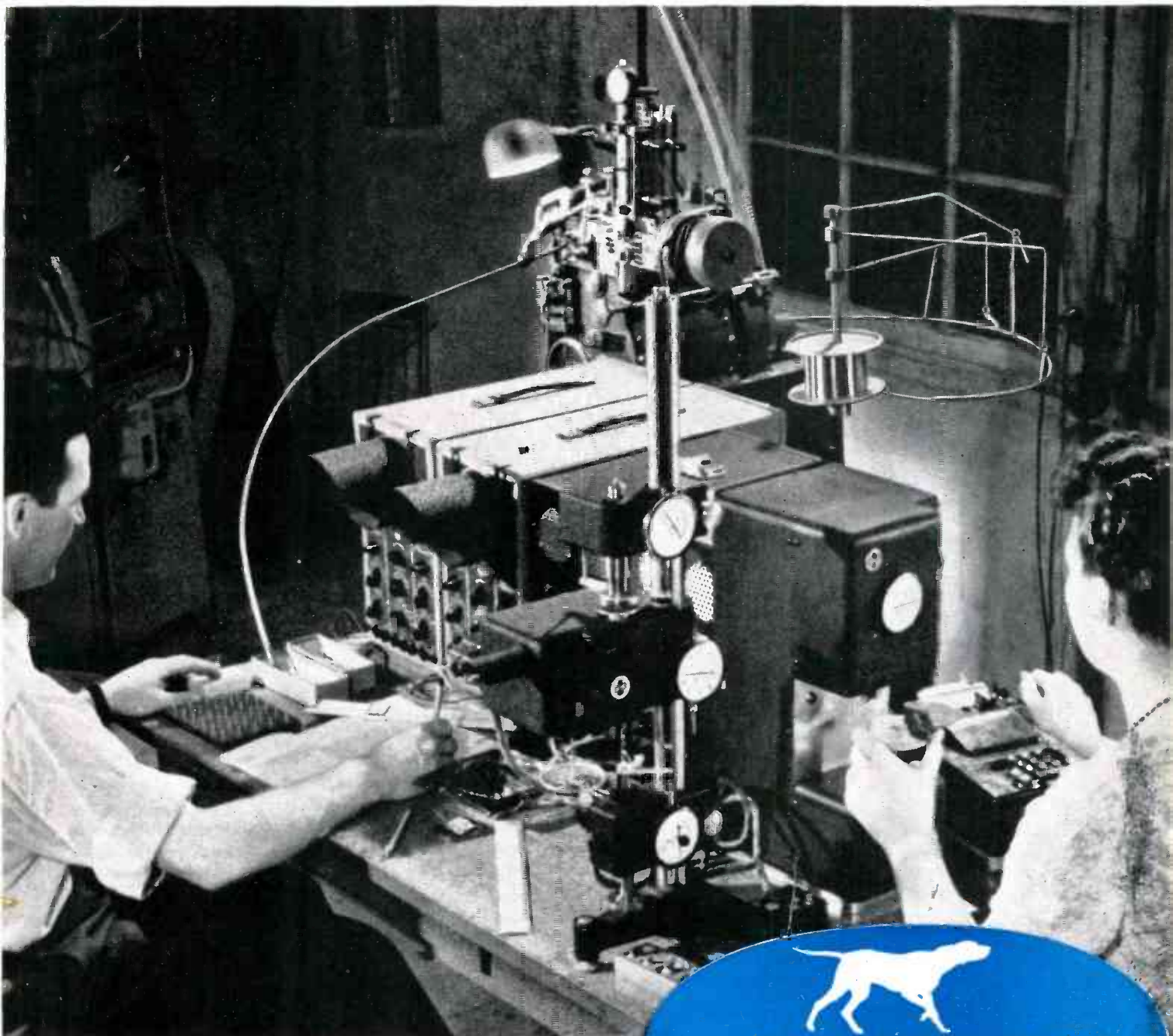

HUNTER PRESSED STEEL COMPANY, LANSDALE, PENNA.

Springs, Metal Stampings, Wire Forms, Mechanical and Electrical Assemblies.

GENERAL  ELECTRIC

*Announces*

# A 12-PART TALKING SLIDEFILM COURSE in INDUSTRIAL ELECTRONICS

THESE 5 ILLUSTRATIONS AND (RECORDED) CAPTIONS are typical of the simple, interesting sequences—100 in each slidefilm.

When the lamp is lighted and the filament glows, current flows through the extra wire, even though it is not connected with the filament itself. This phenomenon (Edison Effect) demonstrates the underlying principle of electronic tubes.

Electrons, being negatively charged particles, repel each other and hinder the flow of other electrons from cathode to anode. This repelling action is called "space-charge"—a factor of very great importance in electronic-tube design.

In some types of electronic tubes, we "boil" the electrons out of the cathode with heat, much as boiling water produces steam.

A gas-filled tube (phanotron) can be damaged if forced to operate before its cathode has been heated sufficiently to emit the required amount of electrons. To prevent such abuses, most electronic equipments have automatic timers built in to protect rectifier tubes.

In our electric circuit, we use a second voltage supply called the control, or grid, voltage. It performs much the same function as the control handle on the valve in a hydraulic circuit.

.. **visualized** for easy understanding, even by non-technical people

.. **packaged** for easy instruction, using your own "home-talent" leaders

.. **practical** up-to-the-minute subject matter, technically authentic

Now, an understanding of electronics as applied in industry can be built up, right within your organization, using the ingenious techniques of *visual instruction* that have proved so successful for wartime training. Every sequence of this 12-part course has been put to test on groups of widely different education levels. Educators have joined practical plant executives in praising its combination of *easy understanding and technical accuracy*.

As you follow the instruction manual, the sessions almost "conduct themselves," so that no great experience in organizing or instructing people is necessary. Everything essential is furnished except a sound slidefilm projector (35 mm, 33½ rpm), screen, and a meeting place. Upon completion of the course, your people will have a well-rounded acquaintance with electronic devices, tubes, circuits, and applications.

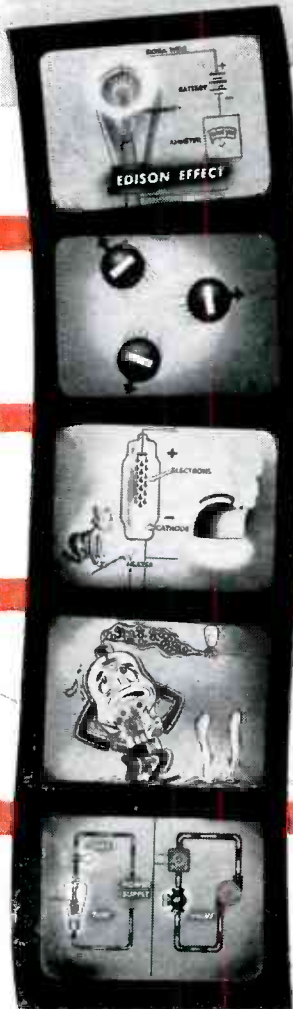





## ALL THESE WILL BENEFIT

As electronic apparatus is applied more and more widely to industrial plants and processes, more and more of your people—from managers to maintenance men—will find their work depending upon electronics in a very practical way. Some of them must learn to service this equipment. Others will be better equipped to get the most out of electronic equipment when it is no longer "all a mystery" to them.

**PLANT ELECTRICIANS** and maintenance men will find the course understandable, even if their knowledge of electrical theory is limited. In learning about electronics and its application, they'll get a background of fundamentals of electricity, too.

**PLANT AND DESIGNING ENGINEERS** will find the course stimulating in suggesting practical electronic applications to improve processes or products.

**PRODUCTION MANAGERS** and foremen will get a clearer concept of the workings of equipment for which they are responsible. New process control ideas may also be suggested.

**EXECUTIVE MANAGEMENT** and purchasing agents can get a clearer concept of practical electronic possibilities. They will be in a better position to consider and approve recommendations.

**SALESMEN** selling electronic products will be better equipped to talk to their customers.

Note: **ELECTRICAL UTILITY COMPANIES** and electrical associations in many communities are organizing inter-company groups for this course of instruction. You may want to check with your local utility on this point.

### THESE ARE THE 12 SUBJECTS OF INDIVIDUAL FILMS AND LESSON BOOKS

1. Harnessing the Electron
2. Electronic Tubes as Rectifiers
3. Grid Control of Electronic Tubes
4. Fundamentals of Electricity, Part I
5. Fundamentals of Electricity, Part II
6. Electronic Relay Systems
7. Electronic Rectifier Equipment
8. Thy-mo-trol (Thyratron Motor Control)
9. Electronic Control of A-c Power
10. Electronic Frequency Changing
11. Photoelectric Systems
12. Electronics, Today and Tomorrow

**GENERAL  ELECTRIC**

BUY ALL THE BONDS YOU CAN—AND KEEP ALL YOU BUY

## Here's what you get

**12 SLIDEFILMS AND RECORDED TALKS**—each about 1/2 hour long

**300 REVIEW BOOKLETS**—25 sets of 12 individual lessons, keyed to the slidefilms

**1 INSTRUCTOR'S MANUAL**—a 140-page book with hundreds of illustrations and detailed steps for conducting the course

**1 CARRYING CASE**—attractive and strongly built, it holds records, films, and manuals

**THE PRICE**—for the complete "package" as above, \$100; extra manuals, \$3; extra sets of 12 review booklets, \$2

**ORDERS**—can be placed through any local G-E office, or use the coupon below.

General Electric Company  
Apparatus Dept., Section E685-13  
Schenectady 5, N. Y.

—Enclosed is our order for ..... complete INDUSTRIAL ELECTRONICS courses at \$100 each (May be returned without charge if you are not fully satisfied.)

—When could someone in our organization see a showing of one of these lessons and examine the complete kit?

Name .....

Company .....

Address .....

# Enclosed CLARE "Custom-Built" RELAYS

Assure Long Life, Trouble-Free Operation  
for WELTRONIC WELDING TIMERS

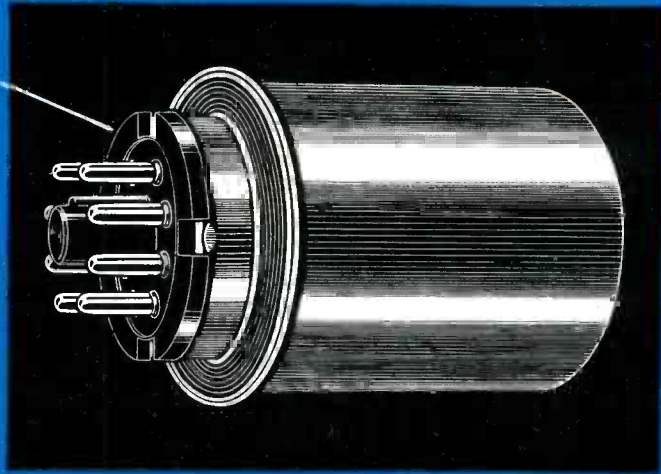
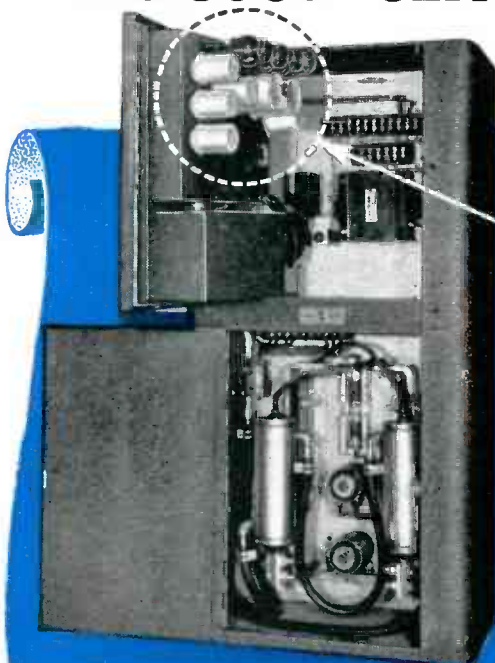

**TYPE "K" SEALED-IN RELAY**

Clare Type "K" Sealed-in Relay  
(2 11/32" long x 1 21/32" wide)



Strong, hard, long wearing Bakelite bushing insulators resist vibration and heavy contact pressures.



Hinge of "fatigueless" beryllium copper insures long life under vibration.



Contacts are welded to nickel silver springs by special process.

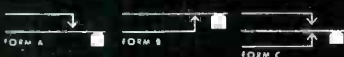

Spring assemblies may include any combination of these basic forms.

● Welding timers have to stand the gaff. They are an important part of the production line which cannot lag from failure of individual units.

That's why the Weltronic Company of Detroit, Michigan, chose Clare Enclosed "Custom-Built" Relays as important components of their automatic weld and sequence timers. These trouble-free units are sealed against dirt and dust. The plug-in feature makes them as easy to service and replace as an electronic tube.

Five Clare Type "K" Sealed Relays, in individual protective housings, are located on the hinged control panel of the Weltronic Weld Timer illustrated above. These small, compact, fast-operating relays provide accurate timing for each operation in the welding cycle.

Clare "Custom-Built" Relays give maximum reliability in such special functions because of the flexibility of Clare design which offers a relay that will give exceptional service, long life, and absolute dependability for the specific requirement.

Exceptional performance is being provided by Clare "Custom-Built" Relays for sequence control of machine tools, counting equipment, electric eye controls, in radio, radar, and many other electronic devices. Designers and engineers should know about Clare Relays. Send for the Clare catalog and data book. Address: C. P. Clare & Co., 4719 West Sunnyside Avenue, Chicago 11, Illinois. Sales engineers in all principal cities. Cable address: CLARELAY.



# CLARE RELAYS

"Custom-Built" Multiple Contact Relays for Electrical, Electronic and Industrial Use



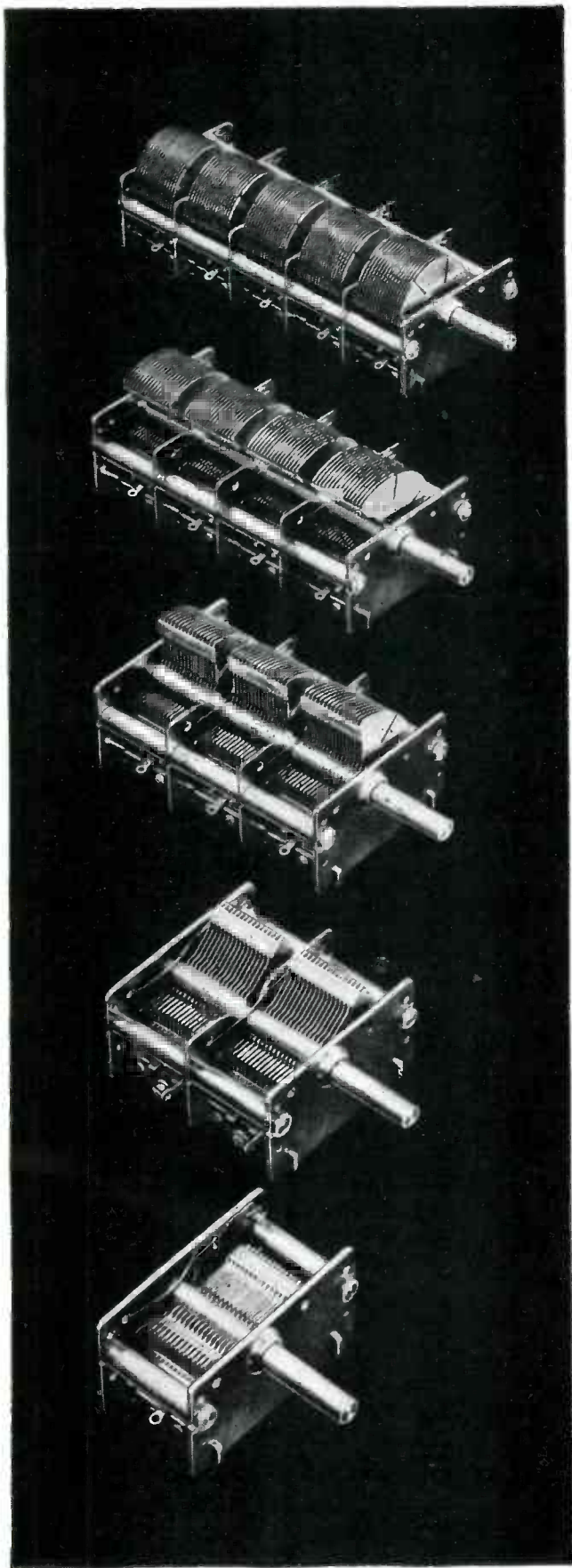

an **R/C**  
*Favorite*



ONE of the most popular of all Radio Condenser Company's variable capacitor designs, the Series 17, is so designed that additional plates may be added to increase the capacity per section. In spite of the high capacity thus achieved a lower minimum capacity is possible than on any other R/C model of equal size. Split stator construction may be incorporated to operate on the new F.M. bands. New types of lower loss insulation permit improved performance at all frequencies.

Series 17 units are ruggedly constructed and are available in from one to five sections as illustrated. Where space is not a critical factor, these models can be heartily recommended for hard continuous service.

Should you have a variable capacitor problem, R/C engineers, backed with exceptionally broad experience in variable capacitor design and engineering will be glad to suggest other standard types or inexpensive adaptations designed to meet your specific needs.

**RADIO CONDENSER COMPANY**  
 CAMDEN, N. J.  
 RADIO CONDENSER CO., Ltd., Toronto, Canada

**RADIO CONDENSER COMPANY**

**SUPPLIERS TO SET MANUFACTURERS**

# SELECTOR MECHANISMS

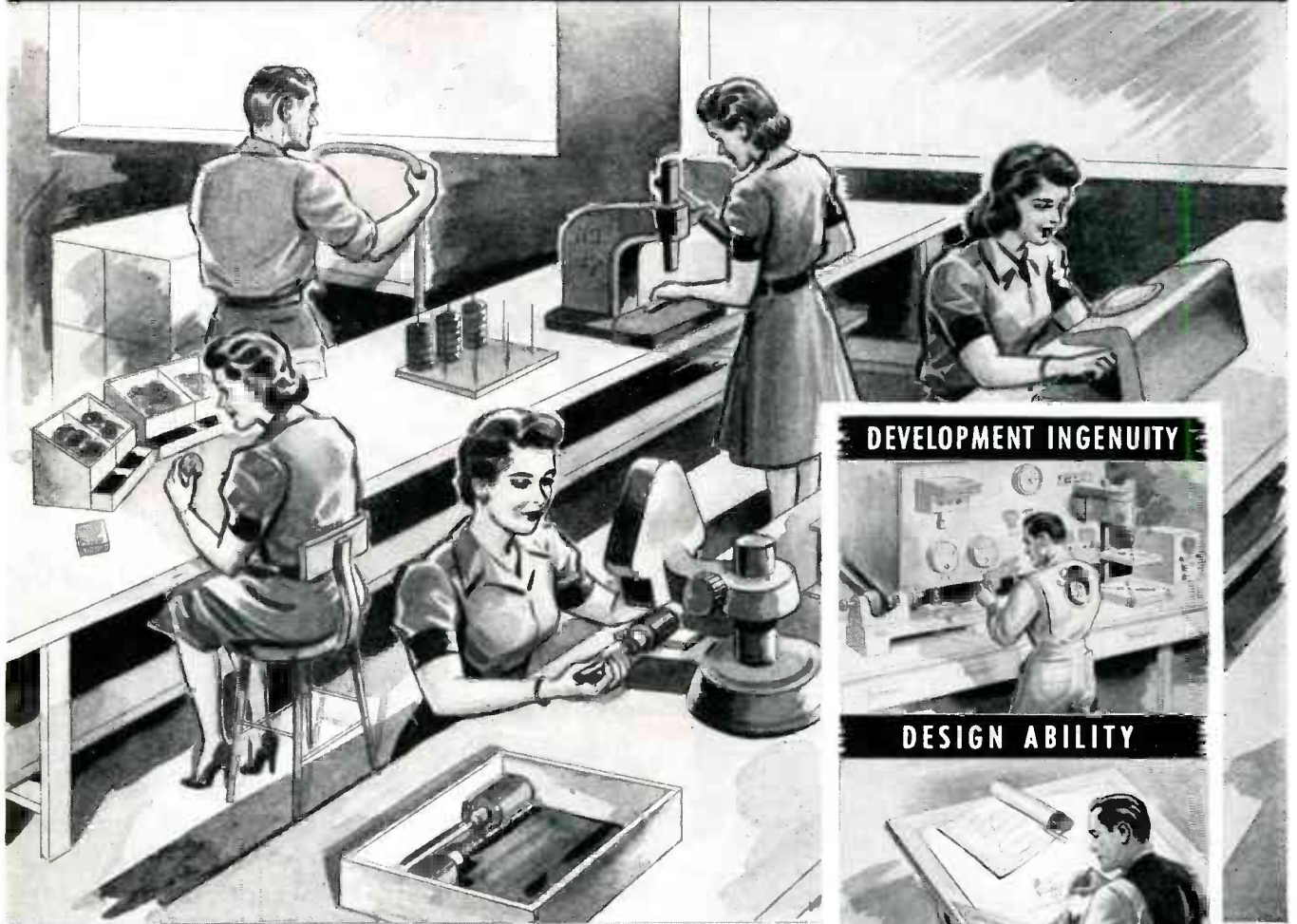

## MANUFACTURING FACILITIES

Santay has the manufacturing facilities to produce *Selector Mechanisms* for you.

In addition to the necessary machines needed to perform assembly operations, Santay has (1) the engineers to design and the tool makers to build the special jigs and fixtures, so often needed, and (2) the production engineers and methods to assure accurate work and prompt delivery.

When you are considering a Selector Mechanism, of your own design or a combination of your design and ours, consult Santay.



INJECTION MOLDING AND METAL STAMPING • ELECTRO-MECHANICAL ASSEMBLIES



**SANTAY CORPORATION, 353 NORTH CRAWFORD AVE., CHICAGO 24, ILLINOIS**

REPRESENTATIVES: POTTER & DUGAN, INC., 29 WILKESON STREET, BUFFALO 2, NEW YORK • PAUL SEILER, 7779 CORTLAND AVENUE, DETROIT 4, MICHIGAN • QUEISSER BROS., 110 E. NINTH STREET, INDIANAPOLIS 2, INDIANA





## Pull up a chair!

Get a ringside seat at the ideal ham shack of tomorrow. The above picture was made at Hallicrafters Ham Shack on the Boulevard, in Chicago. But no picture can represent, no artist can paint what Hallicrafters has in store for the amateurs when the demands of war production are relaxed. Rugged, dependable, sensitive high frequency transmitters and receivers—like the HT-4 which went to war as the famous mobile radio station SCR-299 and the SX-28A, the great communications receiver—belong in the postwar picture of your ideal ham shack. Hallicrafters

equipment has been constantly refined and developed under the fire of war. In peace it will come closer than ever to meeting the exacting requirements of the radio amateur who has played such a prominent part in the progress of all radio and who assumed such a valuable role in war communications.

Even now you can "pull up a chair" in your ideal ham shack by sending for Hallicrafters 1945 Catalog . . . a fascinating piece of ham literature . . . detailed specifications on more than 20 models that are helping to win the radio war. Specify Catalog S-36A.

COPYRIGHT 1945 THE HALLICRAFTERS CO.

BUY A WAR BOND TODAY!



# hallicrafters RADIO

THE HALLICRAFTERS CO., WORLD'S LARGEST EXCLUSIVE MANUFACTURERS OF SHORT WAVE RADIO COMMUNICATIONS EQUIPMENT, CHICAGO 16, U.S.A

**USE STANDARD PARTS—SAVE TIME AND MONEY**

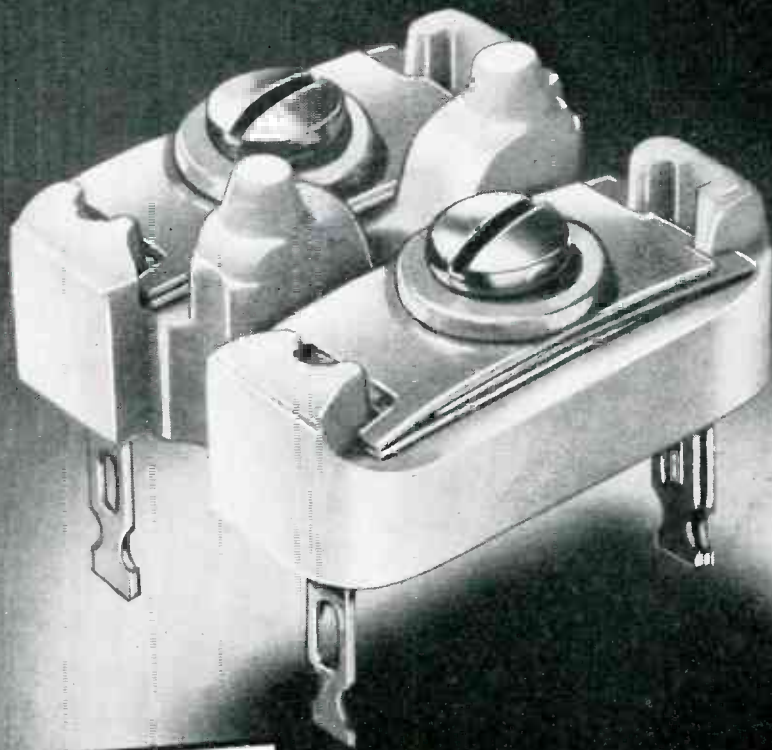

**HELP!**

*Automatic is delivering  
Mass Production Coils and Trimmers  
We Need Help*

*To integrate many war-borne developments  
into civilian mass production.*

*We have permanent openings for men  
who want to work hard and have imagination  
Radio Engineers - Mechanical Designers - Draftsmen  
Write - Wire - Phone - Call in Person*



***AUTOMATIC***  
**MANUFACTURING**  
CORPORATION

Harrison 6-6630

**MASS PRODUCTION COILS & MICA TRIMMER CONDENSERS**

900 PASSAIC AVE.

EAST NEWARK, N. J.



## REMEMBER THE NAME



Remember the name ALSIMAG.

It represents the highest quality Steatite Ceramics for electrical and other technical uses.

Assembled in your design *you can forget the insulators.*

For they will give trouble-free, worry-free service from now on.

Whatever you are planning in the electronic or electrical field, we believe our specialized knowledge will be helpful.

Let's work together.

### AMERICAN LAVA CORPORATION

CHATTANOOGA 5, TENNESSEE

43RD YEAR OF CERAMIC LEADERSHIP



*ALCO has been awarded for the fifth time the Army-Navy "E" Award for continued excellence in quantity and quality of essential war production.*

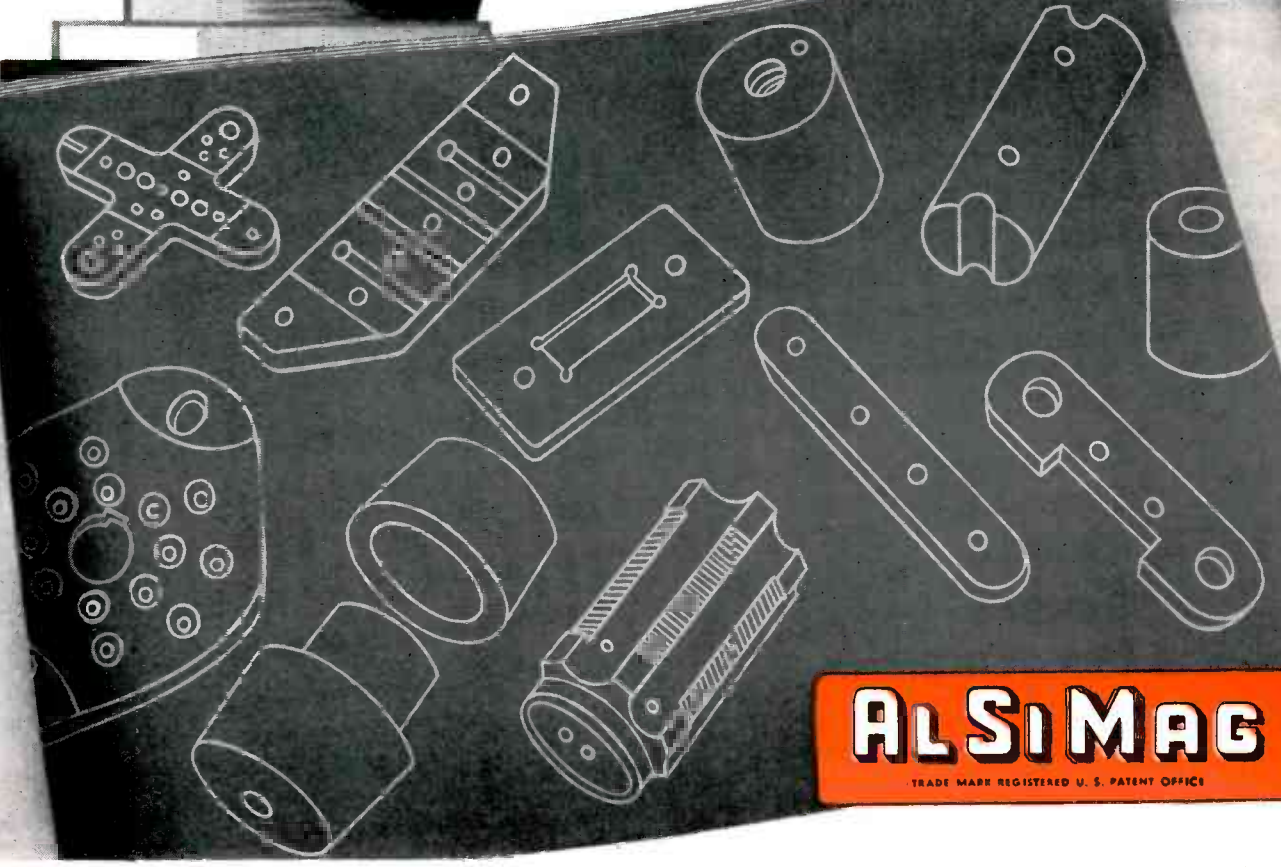

**ALSiMAG**  
TRADE MARK REGISTERED U. S. PATENT OFFICE

**What  
you may  
expect from  
LITTON**

**Vacuum Tube Baking Oven**

- *Double wall stainless steel cylinder*
- *High temperature sheathed Calrod heaters*
- *Slide guide mounting brackets*
- *Lightweight*
- *Continuous operation at 500° C. with long life*
- *Short heating time*
- *Adaptable to nearly every design of power tube exhaust station*

These ovens are normally supplied with stainless steel bottoms and open tops. Tops are closed with asbestos mill board discs made simply by the user to fit his manifold requirements.

Send for Litton catalog on Molube Vapor Pump Media, High Vacuum Pumps and auxiliaries—Glass Working Fires, Machines and accessories—Spot Welder, Metal to Glass Seals and other special production items.

*"For Twelve Years the  
Standard of the Industry"*

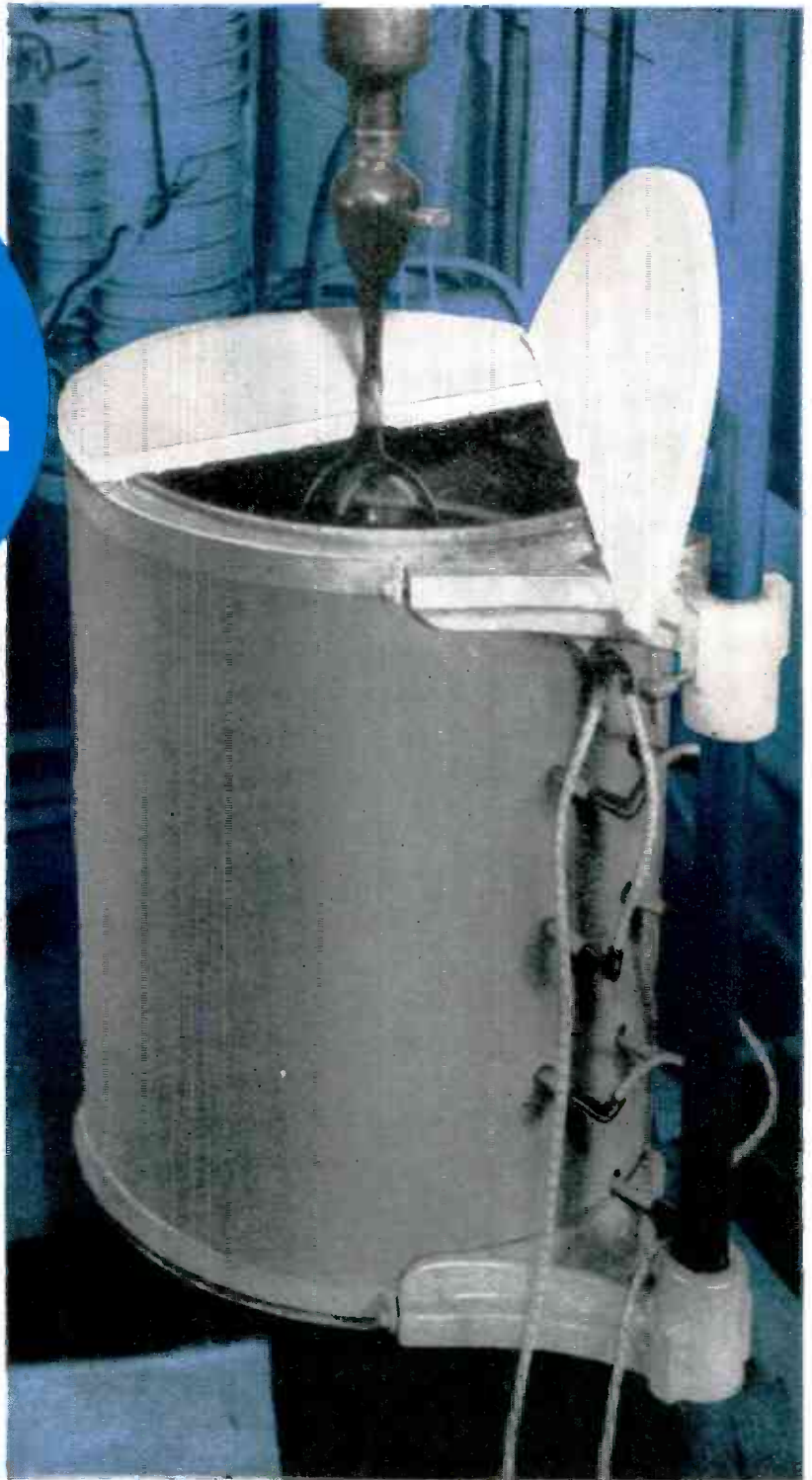

**Litton**



**ENGINEERING LABORATORIES**

**REDWOOD CITY, CALIFORNIA, U. S. A.**



**From Ventilation to Alarm Signals...**

# **ELECTRONICS Does it better for the MINING INDUSTRY**



Alert, gas-testing, automatic... electronics has a vital role to play in establishing the safeguards so persistently sought after by the mining industry. No other means is so surely calculated to checkmate the hazards and dangers of mining. For control and detection are commonplace accomplishments of the extraordinary power we know as electronics. Not only can electronics do a better job, but it can do it more economically in terms of manpower, more dependably in terms of safety... As an engineering and manufacturing organization, we are serving some of America's foremost companies in the design, development and manufacture of custom-built electronic equipment. Write to learn how Sherron Electronics can help you.

## **How Electronics Can Serve The Mining Industry**

- ELECTRONIC HEAT TREATING — for tools and tool faces.
- ELECTRONIC CONTROLS — for motion initiating, ventilating fans, motor speed, timing controls and others.
- ELECTRONIC REGULATION — for generator voltage output.
- ELECTRONIC COUNTERS, flaw detectors, foreign matter detectors and other inspection devices.
- ELECTRONIC MOLECULAR vibrating systems for roof inspection.
- ELECTRONIC meters for measurement of pH and associated control devices.
- ELECTRONIC measurement and control of air flow throughout mine ventilating system.
- ELECTRONIC CURVE TRACER adapted for geophysical surveys.
- ELECTRONICALLY controlled alarms and signals.

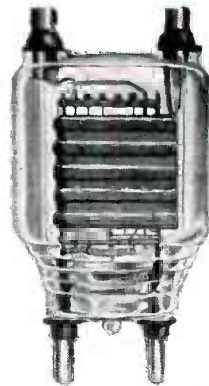

**Sherron  
Electronics**

## **SHERRON ELECTRONICS COMPANY**

*Division of Sherron Metallic Corporation*

1201 Flushing Avenue

Brooklyn 6, N. Y.

**"WHERE THE IDEAL IS THE STANDARD, SHERRON UNITS ARE STANDARD EQUIPMENT"**

# FERRANTI

*is NOW in the*

## POSTWAR SPOTLIGHT!

Just as Ferranti led the prewar field, Ferranti is again the focal point of attention!

Before the war the Ferranti name was synonymous with QUALITY . . .

Now thru' experience gained in mass war-time production Ferranti gives you

*Quality!*  
**AT LOW COST •**



ACTUAL  
SIZE

Ferranti has a large stock of standard items for immediate shipment without priority.

Special items to your specification on short notice!

Send us your specifications or write your requirement NOW!

**TRANSFORMERS • CHOKES • FILTERS • WIRING and ASSEMBLIES**

**FERRANTI ELECTRIC, Incorporated**  
RCA BUILDING • New York 20 • NEW YORK



# The Secret of Nichrome\* Superiority

## Metallurgical Control from Furnace to Spool

To produce genuine Nichrome takes more than the combining of the two metals Nickel and Chromium. It requires highly specialized techniques to make this superior heat and oxidation resisting alloy.

Step-by-step through every stage of manufacture, from the first melting of the metals to the final spooling of the finished wire, precise metallurgical checks and controls operate to assure the peerless quality of Nichrome.

These exclusive Driver-Harris quality controls represent 45 years of continuous alloy research. No wonder, therefore, that Nichrome is the time-tested standard by which other electrical resistance alloys are measured. Although there are many excellent nickel chromium combinations there is *only one Nichrome* . . . and it is made *only* by Driver-Harris.

For full technical information regarding D-H Nichrome write for Data Book R-42.

NICHROME is made only  
by



\*Trade Mark Reg.  
U. S. Pat. Off.

**Driver-Harris**  
COMPANY  
HARRISON, N. J.

Branches: Chicago • Detroit • Cleveland  
Los Angeles • San Francisco • Seattle



# ERIE

## Button Silver Mica Condensers

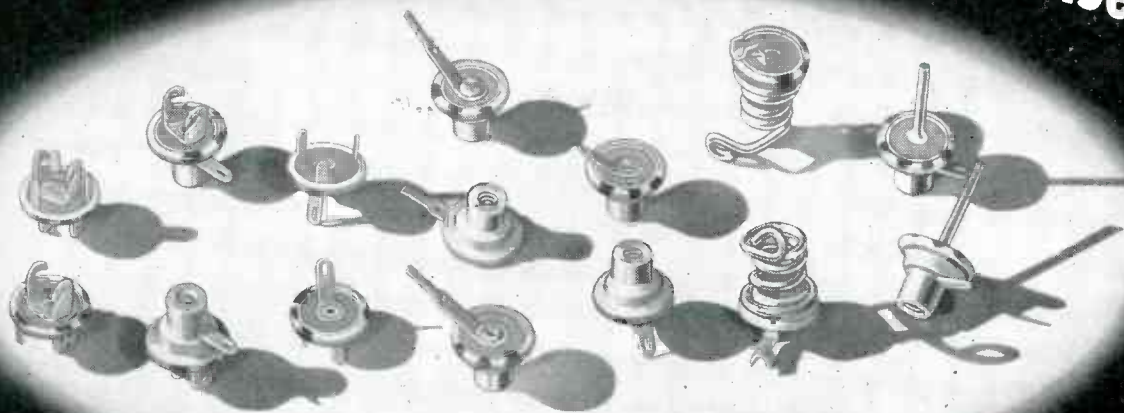

Now available up to 1000 MMF

**T**HE compact Erie Type 370 Button Silver Mica Condensers are now available with uniform nominal diameter of .447" in all capacities up to and including 1,000MMF. This higher capacity range greatly broadens the field of application for these popular units.

These condensers have proven to be ideal components for V.H.F. and U.H.F. applications where short ribbon-type leads, low series inductance, and compactness are requisite factors. Their efficiency and quality have been thoroughly established through practical service, in large quantities since 1941.

Illustrated above are several special and standard styles of type 370 Button Micas. In the interest of economical production 18 styles have been selected as standard units. The chart at the right gives the corresponding letter designations for the case and terminal styles of these standard units.

When ordering, case style should be specified first, by its corresponding letter, followed by terminal letter.

Complete technical information on Erie Type 370 Button Micas will be sent to interested engineers on request.

CASE STYLE		B	C	D	E	F	G
TERMINAL STYLE							
A	SINGLE L	370BA	370CA		370EA	370FA	
B	FEED-THRU L	370BB	370CB				
C	SINGLE U	370BC	370CC	370DC			
D	FEED-THRU U	370BD	370CD			370FC	
E	PILLAR				370EE	370FE	
F	LONG L				370EF	370FF	
G	WIRE LEAD						370GG
H	EYELET		370CH				



Electronics Division

**ERIE RESISTOR CORP., ERIE, PA.**

LONDON, ENGLAND • • TORONTO, CANADA





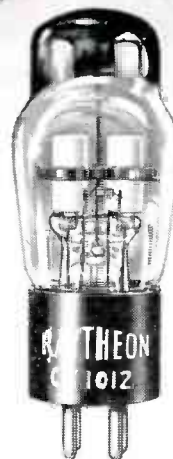

1/2 ACTUAL SIZE

**RAYTHEON**

**TYPE CK1012**

**A High Current, Medium Voltage Gas Rectifier**

The Raytheon type CK1012 full wave gas rectifier was developed to supply the requirements at high rectification efficiency for those applications which require more power than is obtainable with conventional receiving tubes and yet cannot justify the size and expense of transmitting type tubes. In this category are the larger fm and television receivers and small fixed or mobile transmitters.

The CK1012 is contained in an ST-14 bulb, which is the size of a type 80. The emitter can be directly heated — or, under the proper conditions noted below, ionically heated for greater efficiency and elimination of heater windings.

The very rugged construction is ideal for mobile equipment, and the use of an inert gas allows it to operate over a wide range of ambient temperature. No preheating time is required, and consequently full output is obtainable almost instantly. Any tendency to generate noise in radio frequency applications can be minimized by proper filtering and shielding of the tube and associated wiring.

Whether or not CK1012 fits your requirements, it is an example of the advanced engineering and painstaking manufacture found in the entire Raytheon tube line. For best results, specify Raytheon High-Fidelity Tubes for your postwar products.

**TYPE CK1012 RATINGS — FULL WAVE RECTIFIER SERVICE**

	IONICALLY HEATED*	DIRECTLY HEATED	
Filament Voltage	0	1.75	volts
Filament Current	0	2.00	amp
Maximum Peak Inverse Voltage	1200	1200	volts
Average D.C. Voltage Drop	25	20	volts
Maximum D.C. Output Current	300	300	ma
Minimum D.C. Output Current	70	0	ma
Minimum Starting Peak Voltage	400	300	volts
Maximum Steady State Peak Anode current per anode	900	900	ma

\*This condition is not recommended for rapid intermittent operation



All Four Divisions Have Been Awarded Army-Navy "E" with Stars



*Radio Receiving Tube Division*

NEWTON, MASSACHUSETTS • LOS ANGELES  
NEW YORK • CHICAGO • ATLANTA

DEVOTED TO RESEARCH AND THE MANUFACTURE OF TUBES AND EQUIPMENT FOR THE NEW ERA OF ELECTRONICS

**a new idea**

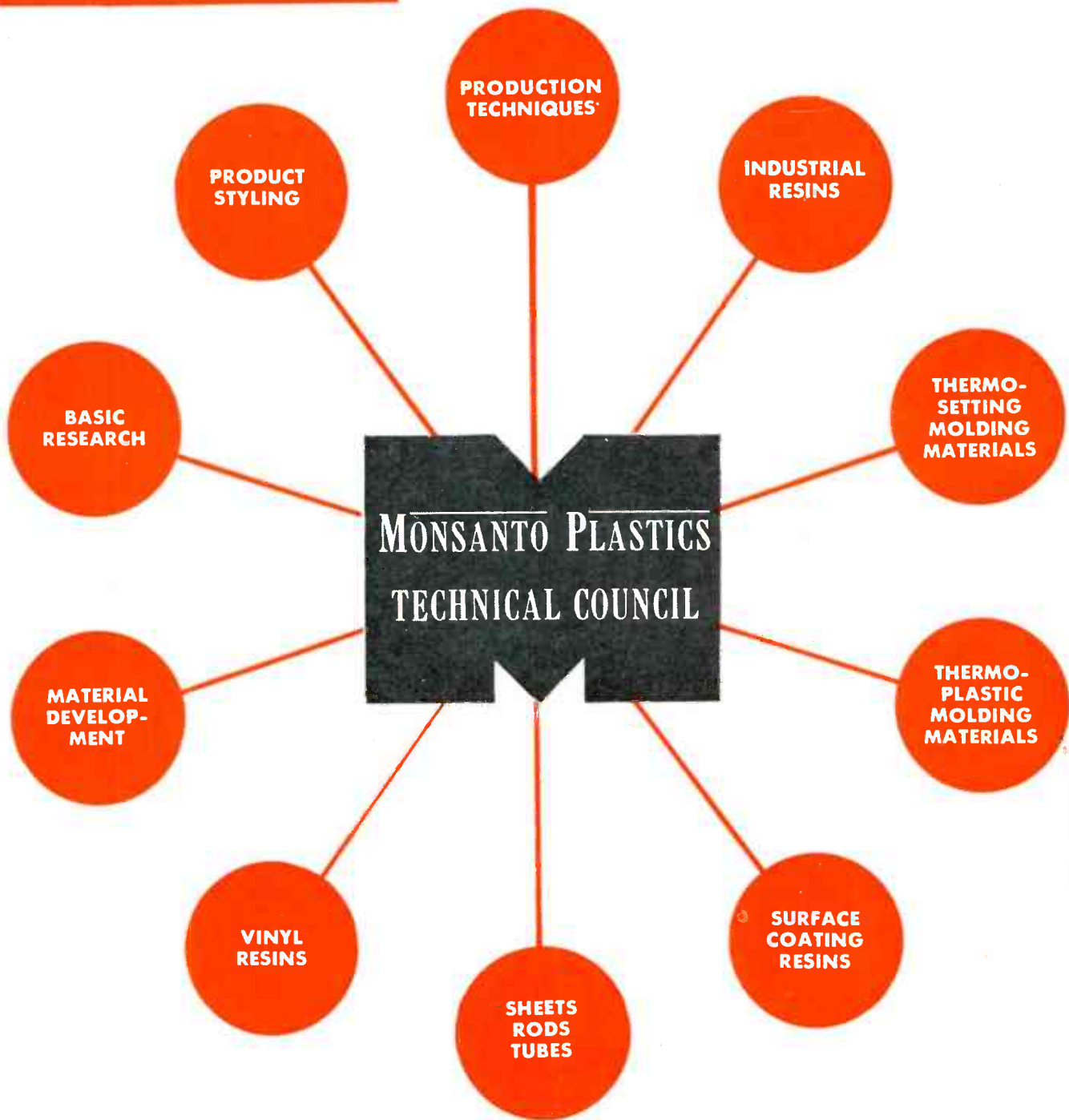



# get the answer to your plastics problem from group of experts

## Ten heads are better than one.

That's why we invite you to put your plastics problem up to this group of ten picked plastics experts...each one a highly qualified representative of a different major phase of plastics practice.

Your problem, whether it concerns plastics materials, methods, designs or costs, will undergo the thorough analysis of this entire group, representing a combined experience of more than a hundred years in this young industry.

You will receive a written recommendation, practical and comprehensive, bearing the seal of Monsanto Plastics Technical Council . . . your assurance of sound unbiased advice.

## How to Get Your Problem before the Council.

Manufacturers, molders or fabricators—anyone who would like to receive this free consultative service need only write describing in full his particular problem. The information needed by the Council is outlined in a bulletin describing the Council and its functions.

The Council meets regularly in Monsanto's Springfield, Massachusetts conference room. Address all requests for the bulletin or information to: MONSANTO PLASTICS TECHNICAL COUNCIL, MONSANTO CHEMICAL COMPANY, Plastics Division, Springfield 2, Massachusetts.

The broad and versatile family of Monsanto Plastics includes: Lustron\* polystyrene • Cerex\* heat resistant thermoplastics • Vinyl acetals • Nitron\* cellulose nitrates • Fibestos\* cellulose acetates Resinox\* phenolics • Thalid\* for impression molding • Resimene\* melamines • Forms in which they are supplied include: Sheets • Rods • Tubes • Molding Compounds • Industrial Resins • Coating Compounds • Vuepak\* rigid, transparent packaging materials.  
\*Reg. U. S. Pat. Off.



# Proven Dependability

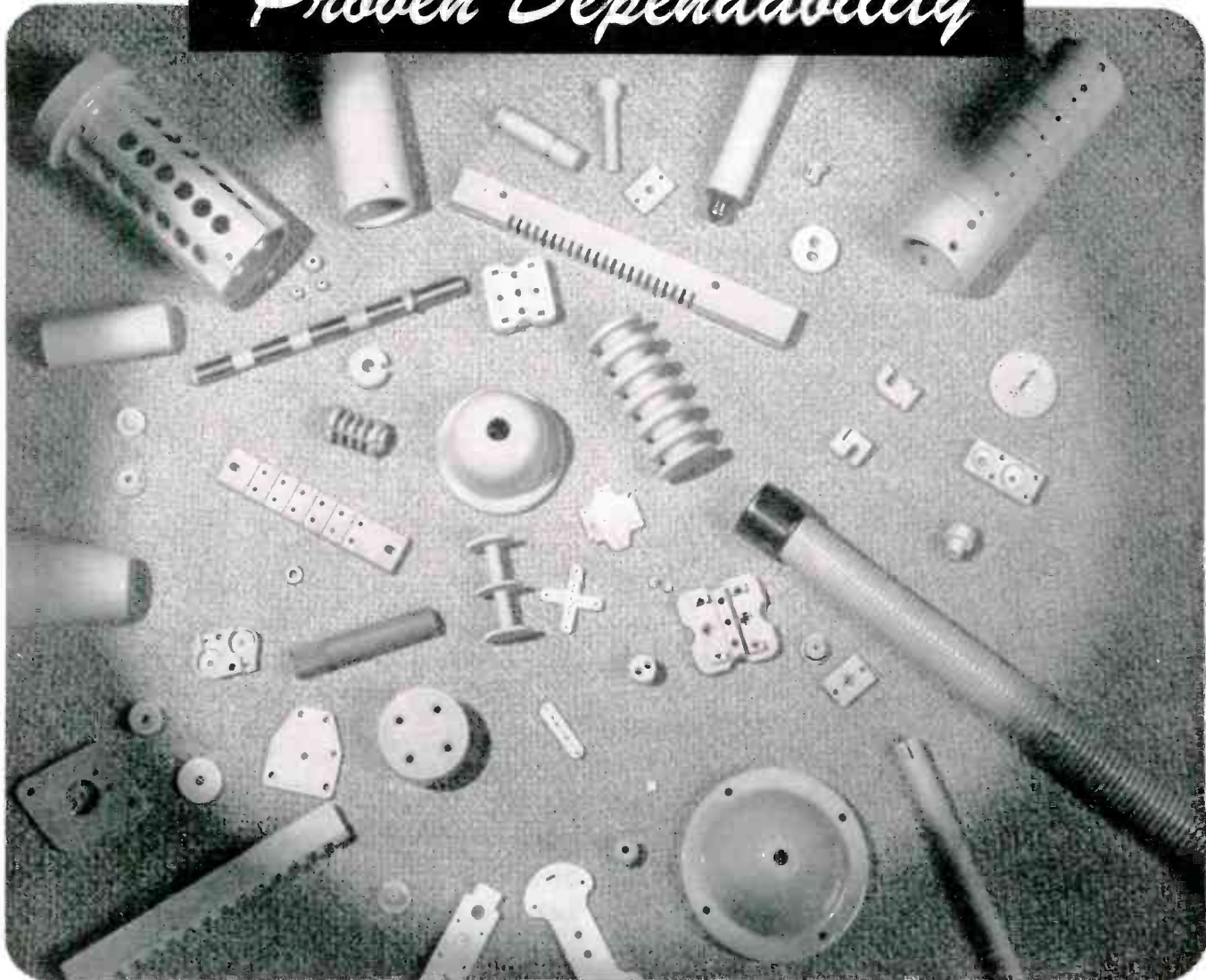

## PRECISION CERAMICS by **STUPAKOFF**

**D**URING two generations of research and experience, Stupakoff solved many unprecedented insulation problems and thus added much to its rich store of knowledge of ceramic insulation.

While the United States and her allies were at war, Stupakoff devoted its whole energy to the production of engineered ceramic insulators for military applications—insulators built to withstand the severe and infinitely varied conditions found in scattered fields of operation.

Now that the war is over, STUPAKOFF again offers its PRODUCTS unhesitatingly to the manufacturer of electronic equipment, electrical apparatus and appliances, as THE VERY FINEST CERAMIC

**INSULATORS OBTAINABLE**—insulators that materially contribute to the perfection of any finished product and satisfaction of its users.

Qualities incorporated in Stupakoff insulators represent the applied knowledge of two generations of experience plus additional skill acquired during intensified wartime activity. The result—mass production of ceramic insulators with a new high in electrical and mechanical values.

With production and development facilities unsurpassed in the industry, Stupakoff is anxious to work with you on your insulation problems. Write, wire or phone your requirements. **DELIVERY—NOW.**

BUY VICTORY BONDS



STUPAKOFF CERAMIC AND MANUFACTURING CO., LATROBE, PA.

*Products for the World of Electronics*





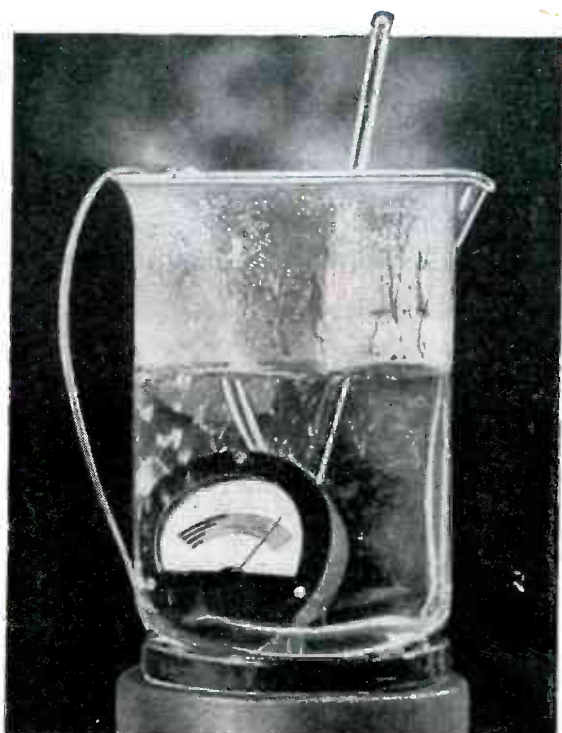

We weren't satisfied to test our hermetically sealed instruments for temperature, humidity and salt spray individually — we went whole hog and combined the three conditions in a beaker of boiling brine. This test, which really exacts more from an instrument than is normally necessary, was conducted for two weeks without failure or permanent error in excess of 1%. The maximum zero shift was .75%, the current sensitivity plus .5% — and the instrument showed no moisture penetration and no leaks as was evidenced by further production vacuum checking.



What may be "unfair" in a test of Marion hermetically sealed instruments is only fair to their users. Whether you're a manufacturer or a consumer, our tests serve to prove the quality and dependability of our instruments. They are an assurance that when these "hermetics" are installed in any equipment, and used in any part of the world, their trouble-free performance will be sustained. Remember — Marion glass — to — metal hermetically sealed instruments are positively interchangeable, and cost no more than standard conventional types. Write for our 12-page brochure.

## **Marion Glass-to-Metal Truly Hermetically Sealed 2½" and 3½" Electrical Indicating Instruments**



MARION ELECTRICAL INSTRUMENT CO.  
MANCHESTER, NEW HAMPSHIRE

WHAT CAN MARION "HERMETICS" DO FOR ME? WRITE—WE'LL SUPPLY THE ANSWER

# M-R FIBERGLAS TYING CORDS

3 to 5 times stronger than ordinary electrical twines  
 AVAILABLE, TREATED OR UNTREATED, IN SIZES RANGING FROM 1/64" TO 1/8" IN 1/64" INCREMENTS.

*Resist Heat,  
 Moisture, Acids,  
 Alkalies, etc.*

*Have Exceptional  
 High Tensile Strength*

•  
 minimum breaking strength  
 1/32", cord No. ECS-1 . . . 66 pounds  
 1/8", cord No. ECS-8-T . . . 274 pounds



Write for the new Fibreglas cata og EL447 in which is included performance and application cata of interest to all concerned with electrical insulation—also it contains data covering Fibreglas Tapes, Fibreglas-Mica Combinations and many other Fibreglas Insulation materials.

Write today to Mitchell-Rand for this valuable aid.

Mitchell-Rand Fibreglas Tying Cords provide all the insulation advantages inherent in Fibreglas: heat, moisture, acid resistance and exceptionally high tensile strength. They are being widely used throughout the electrical industry for all kinds of tying purposes—banding field coils, wrapping string bands on armatures, protecting commutator V-rings from flash-overs, banding on V-ring extensions on dc equipment, filing in winding coils, reset strings and for tying slot insulation in place. They are also used to lash ends of coils in large motors and generators and to hold spacer blocks in place . . . and for so many other tying purposes.

Treated cord is used primarily for its exceptional knot strength and resistance to abrasion and is preferred for construction and repair of electrical equipment. Untreated cord is frequently used where space is to be filled, regardless of strength requirements.

**MITCHELL-RAND**  
 for 56 YEARS  
 THE ELECTRICAL  
 INSULATION  
 HEADQUARTERS

EST. 1889

**MITCHELL-RAND INSULATION COMPANY, INC.**  
 51 MURRAY STREET      COrtlandt 7-9264      NEW YORK 7, N.Y.

Fibreglas Varnished Tape and Cloth  
 Insulating Papers and Twines  
 Cable Filling and Pothead Compounds  
 Friction Tape and Splice  
 Transformer Compounds

A PARTIAL LIST OF M-R PRODUCTS  
 Fibreglas Saturated Sleeving, Varnished Tubing  
 Asbestos Sleeving and Tape  
 Varnished Cambric Cloth and Tape  
 Mica Plate, Tape, Paper, Cloth, Tubing

Fibreglas Braided Sleeving  
 Cotton Tapes, Webbing and Sleevings  
 Impregnated Varnish Tubing  
 Insulating Varnishes of all types  
 Extruded Plastic Tubing



# INSIST ON PROOF BY TRIAL

before you buy an  
Electronic Heater

This is how Scientific Electric proved the value of electronic heating to the Progressive Welding Company of Norwalk, Connecticut . . .

**G**REAT improvements in product quality and remarkable savings in time and money are being achieved by means of electronic heating. Industrialists everywhere are now acclaiming its many advantages. But don't let your enthusiasm lead you to invest in an electronic heater before you have seen it perform the work you expect of it.

Another important point is this . . . in order to work at maximum efficiency and live up to its reputation for doing things better, faster and cheaper . . . electronic heating must be "tailored" to the job. That is why we never sell a Scientific Electric unit until it has been satisfactorily demonstrated. Regardless of the amount of time and effort required, our engineers will not release a single machine for sale until it has fulfilled every claim we make for it.

So here is a word of counsel . . . get plenty of advice before you buy. Consult with our recognized engineers who have pioneered in electronic heating since 1921 and, without obligation, they will demonstrate what electronic heating can do for you.

## Scientific Electric

Division of

"S" CORRUGATED QUENCHED GAP COMPANY

119 MONROE ST.  GARFIELD, N. J.

Manufacturers of

Vacuum Tube and Spark Gap Converters Since 1921

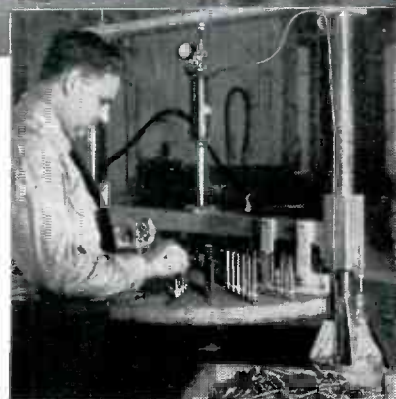

Above: This practical, automatic brazing turntable powered by a 40 KW. Scientific Electric heater speeded up production 700%—cut costs 87% and reduced rejects by 90%.

Left: Close-up of the finished two-piece tube assembly after being brazed by induction heating. Three complete brazing installations have been built for Progressive.



Write for a free copy of our handbook . . . The ABC of Electronic Heating which contains an easily understood explanation of this new heating method.

40 KW INDUCTION HEATER

Scientific Electric Electronic Heaters are made in these power sizes... and a range of frequencies up to 300 Megacycles depending upon power requirements.

3 KW	18 KW
5 KW	25 KW
7½ KW	40 KW
8 KW	60 KW
10 KW	80 KW
12½ KW	100 KW
15 KW	250 KW

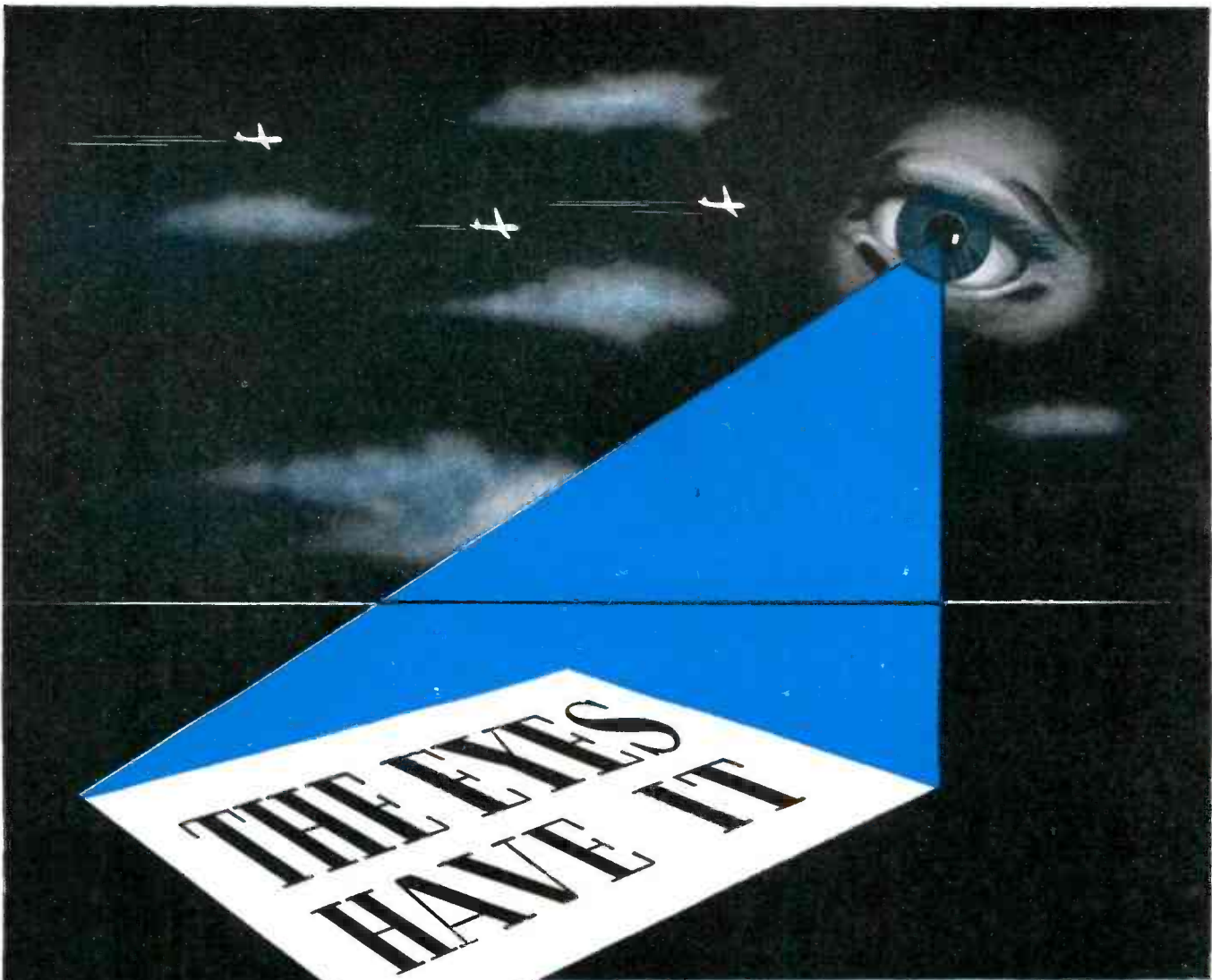

Quick as a wink the Fairchild Night Owl Camera records enemy movements intended to be hidden by darkness. Quick as a flash the radio of the photo-reconnaissance plane keeps touch with its base — and clearly — for Solar Elim-O-Stats are part of the electronic equipment of these highly perfected cameras. This is but one of many instances where Solar Elim-O-Stats are being used to absorb local interference and keep speech channels free. Let Solar advise you on radio-noise suppression.



WEST N. Y. BAYONNE  
PLANT PLANT  
A TOTAL OF NINE  
ARMY-NAVY EXCELLENCE AWARDS

**SOLAR MANUFACTURING CORP.**  
285 Madison Avenue • New York 17, N. Y.

8013



# LABOR *and* MANAGEMENT MEET — *for* PEACE *or* CIVIL WAR?

**T**HE prospect of a knock-down and drag-out fight in the automobile industry does not augur well for the reconversion outlook, which upon every other score is bright. Any widespread outbreak of the type of industrial warfare which now threatens will disrupt, more thoroughly than anything else on the horizon, an orderly transition to a peacetime economy.

It is doubly unfortunate that there should be a general tightening of union and company battle lines upon the eve of the Labor-Management Conference, which on November 5th will convene at President Truman's direction for the purpose of "working out by agreement means to minimize labor disputes." If the current work stoppages occasioned by industrial conflicts should increase rather than diminish between now and November first, the Conference atmosphere hardly promises to be favorable to a dispassionate examination of basic issues.

Yet the shadow of the threatened industrial storm that hangs over the Conference only serves to emphasize the importance of reaching satisfactory agreement upon two problems with which such a Conference might deal. The first is that of determining what machinery shall be used for settling disputes upon which employers and workers have reached an impasse. The second, and more far-reaching, is that of arriving at some common understanding upon the major issues which commonly lead to irreconcilable disputes.

## Settlement of Wartime Disputes by the War Labor Board

During the war the first problem was handled largely by machinery centered in the National War Labor Board. Supported by general adherence to patriotic pledges by labor leaders and employers not to resort to the use of economic force against each other during wartime, and backed up on rare occasion by use of the President's power to seize plants for war purposes when its orders were not obeyed, the Board managed, by what amounted to compulsory arbitration, to settle the nation's wartime labor disputes with relatively little economic loss.

But it can scarcely be claimed that the War Labor Board did much to resolve the issues from which disputes grow. Indeed, the fact that it was available to issue orders in cases which the Secretary of Labor certified as likely to "lead to substantial interference with the war

effort", resulted in the conversion into full fledged disputes of many disagreements which would otherwise have been settled at a local level in the course of collective bargaining. Meanwhile, local collective bargaining machinery which should have been doing most of this work was neglected, and will need thorough reconditioning even to be brought back to its prewar level of effectiveness.

With V-J Day came an abrupt change in the status of the War Labor Board. One of its main props, labor's "no strike pledge", was promptly withdrawn. It could no longer rely on the President to use his power to seize plants for war purposes to force obedience to its orders. Consequently the Board agreed that it would accept new cases only if both parties to the dispute stipulated in advance that they would abide by the Board's findings, that it would clear its dockets of old cases as rapidly as possible, and that it would then go out of business, leaving to the Labor-Management Conference the question of what should take its place in the postwar period.

## What Shall Take the War Labor Board's Place?

The immediate and pressing task of the Labor-Management Conference is to agree upon machinery for settling industrial disputes in the peacetime economy.

Neither management nor labor wants the continuation of compulsory arbitration to which they submitted as a necessary war measure. But it must be clear to everyone that if any substantial proportion of the disputes that inevitably arise are settled by resort to strikes and lock-outs, economic anarchy will result. Not only will it be impossible to achieve the high levels of output and employment that have been set as postwar goals, but it is questionable whether our economy could survive. The only alternative to compulsory arbitration under government auspices is for management and labor to demonstrate their ability to effect a peaceable resolution of their differences without it.

The most obvious need is to set up local machinery at the grass roots where disputes originate. That is where most of them should be settled by local negotiation and, when that fails, through voluntary submission to mediation or arbitration under terms of reference to which the parties agree. Many issues, which at plant level are relatively simple in character, are blown up to formidable dimension and complexity when they are passed along

the line for decision in Washington. The centralizing process is one that frightens everyone connected with it because it focuses attention upon the possible importance of precedents established by a decision, rather than upon resolving satisfactorily the particular dispute at hand.

Unquestionably, some Federal machinery must be provided which may be called upon in cases where the size or implications of a threatened dispute clearly run beyond local jurisdiction. That will mean the thorough revamping of conciliation and mediation machinery which exists, but which has grown rusty through disuse while compulsory arbitration was the order of the day.

At least, this involves a complete overhauling of the United States Conciliation Service with a noteworthy strengthening of its personnel. There may be wisdom also in recently advanced suggestions for the creation of a board of arbitration to act in cases voluntarily submitted by the parties concerned, and for boards of inquiry to make reports upon the merits of disputes in which the public interest is concerned. But there is valid ground for questioning what appears to be the common assumption that such machinery should be located in the Department of Labor. It belongs neither there nor in the Department of Commerce. For the work which such agencies are called upon to perform, both the appearance and fact of complete impartiality are essential to effective performance. Assurance of impartiality will not be fostered by placing them in a department specifically charged by Congress with the task of advancing the interests of wage workers.

### Resolving the Issues Over Which Disputes Arise

It may be, as many think, that the forthcoming Labor-Management Conference cannot effectively handle any problems beyond the procedural ones suggested above. If that is true, its agenda probably should be restricted to planning the reconstitution of collective-bargaining and dispute-settlement machinery, in view of the urgent need for putting it in working order.

But either in this Conference, or in subsequent ones, there will have to be an attempt to reach a reasonable measure of labor-management accord upon certain basic issues over which most industrial disputes originate. The best of machinery can be swamped if disputes are generated in ever-increasing number.

Most important of such issues is that of the fair determination of wages. There is clear need for reaching agreements at least upon the major factors on which such determination should rest. It seems evident that if we are ever to hope to reach the high levels set and generally accepted as postwar goals, we must harness economic incentives to promote production efficiency. That means that workers, as well as management, must be given a genuine stake in increased productivity. No universal formula is possible, but we should be able to agree upon general principles for dividing returns derived from improved performance in output between workers and investors, and consumers in the form of lowered prices.

Again, since unionism is here to stay, general accept-

ance by management of the principle of collective bargaining would save innumerable disputes which are concerned more with the method of negotiation than with the concession sought. Few in management still question the validity of the collective bargaining process as such, but there are many matters to be resolved of which the question of the open shop, the union shop, or the closed shop is merely a conspicuous example, upon which there is wide divergence of conviction between and within labor and management groups.

On the management side, there is sincere concern about the intent or ability of union leaders to exercise responsible control that assures compliance with contractual obligations. Wild-cat strikes are of sufficiently frequent occurrence to give substance to this distrust, and union discipline seldom has been administered in a decisive or effective fashion. The prospective rivalry of three competing labor organizations of national scope gives management little confidence that a bargain made and kept in good faith with any one of them provides assurance against work stoppages.

All of these matters, and many others, need thrashing out between management and labor, with the view of arriving at as large a measure of specific and detailed agreement as can be achieved. The greater the area of such agreement, the smaller will be the area for disputes that must be handled by settlement machinery, or put to the final test of force.

### Peace or Civil War in Industry

The Labor-Management Conference is of major importance to national welfare. It is important even if it restricts its objectives to the procedural problem of how industrial disputes are to be handled.

It can make an even larger contribution if it lays the groundwork for an attempt to reach working agreements upon such policy issues as have been cited above.

Neither management nor labor can afford to lend anything less than their best intelligence and effort to an attempt to arrive at common understanding. Success will mean that we have a genuine chance of reaching new levels of economic well-being. Failure will mean industrial civil war, in which the casualties will be high. One almost certain casualty of such a war will be the principle of collective bargaining, since the Government can scarcely refrain from establishing compulsory arbitration if sufficient breakdown occurs.

It is to the vital interest of both management and labor to demonstrate that they can responsibly control themselves.



President McGraw-Hill Publishing Co., Inc.





THE COUNTERSIGN OF DEPENDABILITY IN ANY ELECTRONIC EQUIPMENT

# Tests Prove Eimac Vacuum Condensers Far Superior in Operating Efficiency

Ability to handle high current at high frequencies is the true measure of the performance of a capacitor. A high peak voltage rating based on low frequency measurements does not tell the whole story.

The chart on this page shows the results of tests at 50 Mc. conducted on a standard Eimac VC50-32 Vacuum Capacitor and three other 50 mmfd. vacuum capacitors, designated on the chart by "A," "B" and "C." At just over 17 amps. (approximately 1525 peak volts across the capacitor) Unit "A" (rated at many times the applied voltage) became sufficiently heated to melt the solder on the end caps. Under this same test, the Eimac VC50-32 operates at less than 70°.

Eimac introduced the vacuum capacitor in 1938. It is interesting to note that the original Eimac capacitor design is still outperforming all comers. Such outstanding performance is typical of all Eimac products, which is one of the reasons why they are first choice of leading electronic engineers throughout the world.

Follow the leaders to



1113

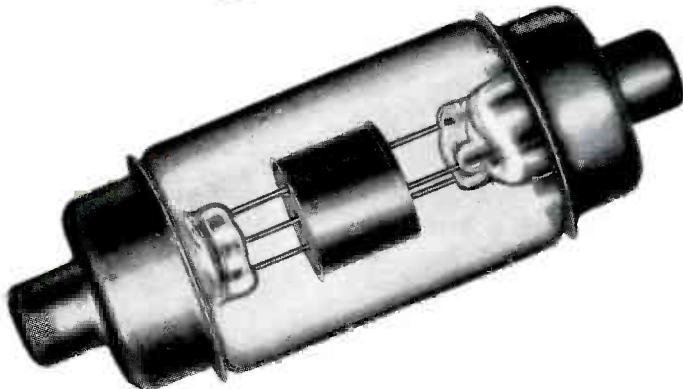

### EIMAC VACUUM CAPACITOR TYPE VC50-32 General Characteristics

#### Mechanical:

Maximum Overall Dimensions  
Length . . . . . 6.531 inches  
Diameter . . . . . 2.281 inches

#### Electrical:

Maximum Peak Voltage . . . . . 32,000 volts  
Maximum RMS Current . . . . . 28 amps.

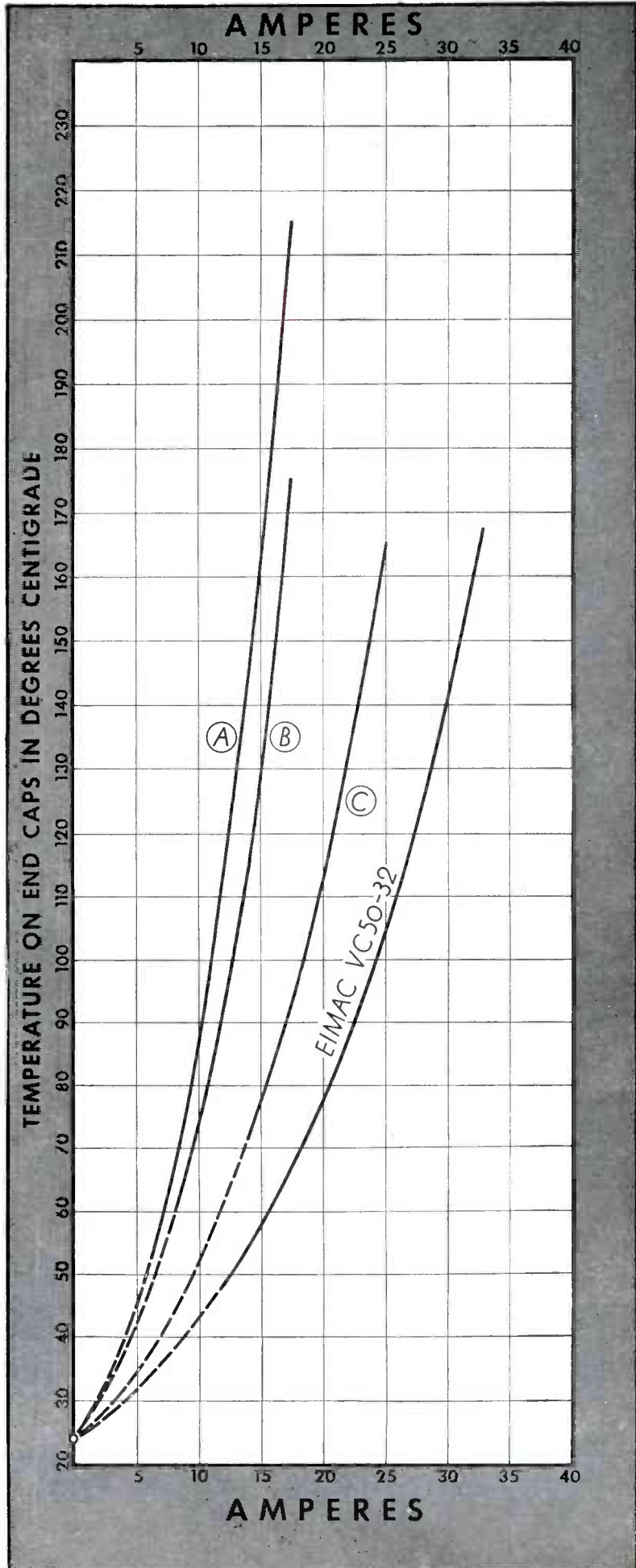

EITEL-McCULLOUGH, INC., 1113 San Mateo Avenue, San Bruno, Calif.

Plants located at: San Bruno, California and Salt Lake City, Utah

Export Agents: Frazer & Hansen, 301 Clay St., San Francisco 11, Calif., U. S. A.



Operating this electrocardiograph is sure and simple with the Mallory Circuit Selector Switch indicated by the large dial at upper left. Mallory also provides the Sanborn Company with other switches, jacks and electronic parts for other heart testing instruments and electronic equipment.

# Heart of This Heart Recorder is a **MALLORY** Precision Switch

**C**OMPACT, weighing only 23 pounds, the Cardiette is a modern portable electrocardiograph made by the Sanborn Company, Cambridge, Mass. Operation of this precise heart recorder is swift and simple with its "Instomatic" switch—a standard Mallory Circuit Selector Switch.

Standard Mallory precision switches have a number of *special* features, including: low-resistance, self-cleaning contacts; "hill-and-valley" index for smooth, positive switching action; heavy insulating sections; notched shafts for easy cutting to desired lengths.

Multi-gang, single gang and push button switches, variable and fixed resistors, volume controls, condensers, plugs and jacks—these and other Mallory Approved Precision Products meet the most exacting design requirements of electronic engineers building for industry and the professions, for assembly line and laboratory.

Write Mallory precision parts into *your* circuit diagrams and blueprints. It's a great convenience to specify *standard* electronic parts built for precision. They are available from your nearest Mallory Distributor or if you have a special design problem, consult our engineers.

**P. R. MALLORY & CO., Inc., INDIANAPOLIS 6, INDIANA**



Time-saving information on electronic products is contained in this Mallory catalog. Ask your distributor for a free copy.



**P. R. MALLORY & CO. Inc.**  
**MALLORY**



## Industrial and Electronic Switches





# CROSS TALK

► **DGF** . . . As of September 1, Mr. Donald G. Fink, a member of the editorial Staff of *ELECTRONICS* since 1934, but on leave of absence for the last four years, returns to the staff as Executive Editor. A graduate of MIT, Mr. Fink spent a year in graduate study before joining *ELECTRONICS*. While Managing Editor, he was "loaned" in May 1941 to the Radiation Laboratory shortly after its formation and was assigned to a group working under Melville Eastham (General Radio Company) which developed the Loran system of long-range navigation which now covers most of the globe with electronic lines of position for the navigation of ships and aircraft. The Loran transmitters now in world-wide use are based on his designs.

During his work at the Radiation Laboratory he wrote the first radar textbook, "Microwave Radar", for use of the laboratory staff and military personnel. Early in 1943 he was appointed head of the Loran division of the Laboratory and later went to England and to Africa to initiate the installation of Loran equipment for the guidance of bombers over Germany. After the conclusion of this work he transferred to the office of Dr. E. L. Bowles in Washington where, as Expert Consultant in the Office of the Secretary of War, he advised the Army Air Forces concerning the use of Loran and related navigational devices. In the winter of 1943-44 he traveled the Pacific as far as Western Australia exploring for sites for the Loran stations in that part of the world. In his air travels from Darwin to Cairo he has covered some 75,000 miles.

With Loran well under way, Mr. Fink was assigned by Dr. Bowles to the headquarters of the Ground Forces to advise on the use of radar for ground force application, particularly gunfire control and the detection of ground targets by radar. At the same time he was appointed a member of the Committee on Air Navigation and Traffic Control, a group of civilian consultants who have been advising General Arnold on the long-term uses of radar and communication to the Army Air Forces.

Mr. Fink will retain his membership on this impor-

tant committee. As Executive Editor he will share with Keith Henney the responsibility for the editorial direction of *ELECTRONICS* and, of course, will maintain and extend his acquaintance with the industry. At the same time he will continue to serve the Government in ways which his four years "on leave" have so particularly fitted him.

► **PATENTS** . . . An agenda listing the topics under study by President Truman's committee on the patent system has been made public by William H. Davis, Director of Economic Stabilization, and chairman of the committee. The committee set up by Secretary Wallace is made up of Mr. Davis, Tom C. Clark, Attorney General, Dr. Vannevar Bush of OSRD and C. F. Kettering, Chairman of the National Patent Planning Commission.

The subjects for consideration by the committee fall into four groups:

1. What action should be taken to prevent the issue of patents that are not for true inventions.
2. What action should be taken to make patent protection for true inventions more simple and effective.
3. What action should be taken to prevent abuse of patent rights.
4. A re-examination of the scope of the patent system in the light of the constitutional objective to promote the progress of science and useful arts.

In making public the agenda, the Committee hopes that interested persons will express their views on the subjects to be examined and that these persons will communicate their views to the Secretary of Commerce.

► **RATS** . . . The story of the pied piper of Hamelin, who got rid of rats by tootling on a flute, seems to have a modern counterpart in a Spokane electronics engineer. He is about to rid the county courthouse of pigeons by use of a supersonic whistle which, though "four times too high to be detected by human ears is extremely irritating to pigeons."

# RADAR



FIG. 1—The radiator of this British CH early warning station is of the mattress-type, supported on 360-foot steel towers. Since 1938 these ponderous stations have guarded the English coast against invading aircraft

IT IS BY NOW no secret to the readers of *ELECTRONICS* that radar contributed more toward winning the war than any other technical device of recent advent, save only the atomic bomb. The head of our largest radar laboratory has drawn a nice comparison in saying: "The atomic bomb finished the war. Radar fought it."

Nor are the uses of radar in warfare any longer a mystery; the popular press has seen to it that everyone who can read knows about radar blind bombing, radar gunfire control, radar warning of approaching aircraft. To this great story there is little, in broad outline, that the editors can add.

But much remains to be added in filling in the essential technical background. With the lifting of censorship a steady stream of such technical material will now be forthcoming in these pages, including discussion of basic factors underlying operation and design, descriptions of radar gear, and analysis of circuits and components in the light of future applications.

Meanwhile this report on the uses of radar in war is presented.

Radar got its start, both here and abroad, as a device to detect the approach of enemy aircraft. The first radars used operationally were the CH (chain home) stations along the English channel coast (see Fig. 1), which went into regular operation in 1938. These low-frequency (about 25 mc) units were successful in detecting enemy bombers forming over airfields in France and in tracking them in over the coast. Meanwhile, fighters and fighter-control radar stations

were alerted to meet them. Similarly, one of the first American radars was the SCR-270, operating on approximately 110 mc, which detected unidentified aircraft approaching Pearl Harbor on December 7, 1941 at a distance of 132 miles.

As the war progressed the need for early warning continued unabated and newer equipments, working on higher frequencies, were produced. The size was reduced so that the entire gear could be carried by men storming a beachhead (Fig. 2). As a result of wide-

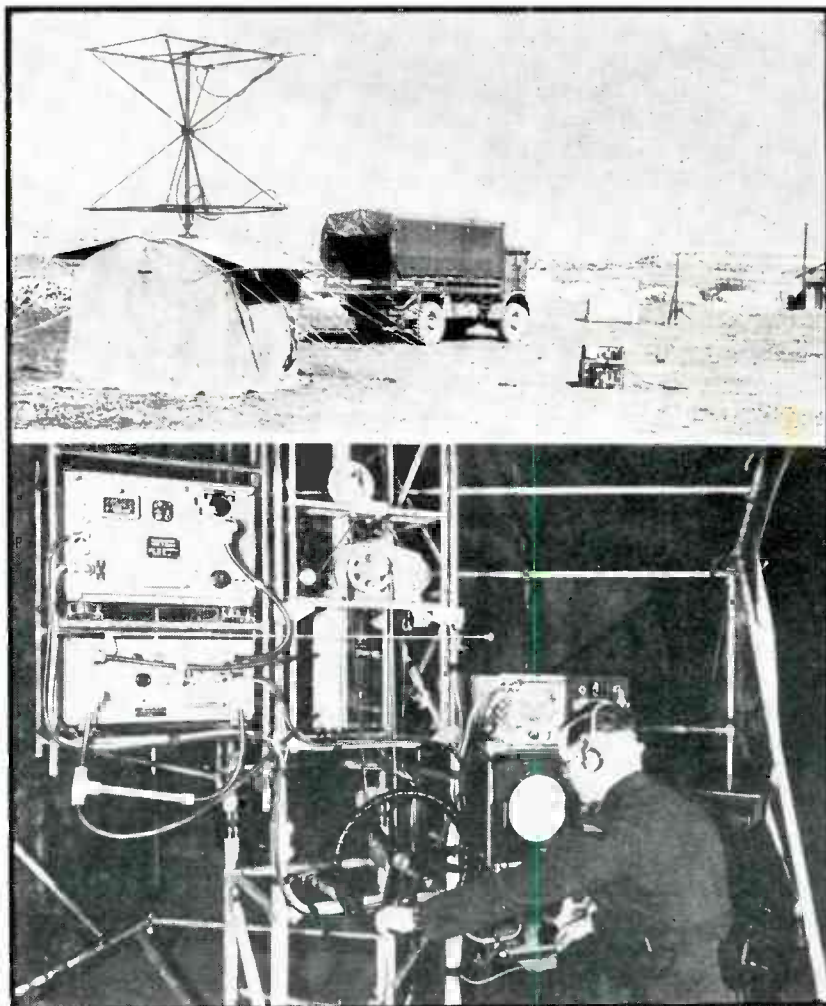

FIG. 2—British LW (light warning) radar, similar to the American SCR-602. It serves the same purpose as the CH station but is man-portable. Four Yagi antennas are used, each consisting of a reflector, a folded dipole, and four directors. It can be set up and operating two hours after arrival at the site



# WARFARE

The technical factors behind the uses of radar for warning and surveillance of enemy activity; to control guns, searchlights and bombs; for navigation of ships and aircraft

spread installation of this warning gear, virtually all ships and aircraft which approached the shores of Great Britain, Africa and the Continent, America and the outposts of the Pacific war, were tracked by radar.

Technically, the problem of early warning by radar resolves itself into certain definite requirements. First, since it is necessary to detect the oncoming aircraft at the greatest possible distance, the power of the transmitters and the sensitivity of the receivers must be the highest obtainable. By high power is meant not only high peak power in the transmitted pulses, but also high energy in each pulse. This is achieved by using pulses of considerable length, as long as 20 or 30 microseconds in some cases. Such long pulses have the disadvantage of blocking the receiving system for a correspondingly long time, so that very nearby targets, within a few miles, are not detectable. But since the purpose was long-range detection this was not considered an objection.

A second requirement for early warning by radar is widespread coverage of the area from which airplanes might come. Such coverage is obtained either by use of a wide beam, moved slowly over the suspected area, or a narrow beam moved correspondingly faster. Beams as wide as 30 degrees were used at first. But in the interest of increasing the power density within the beam, narrower beams, involving higher frequency radiation, were introduced.

Finally, and most important, is the requirement of complete coverage, without gaps through which the enemy can sneak undetected. The cause of such gaps is the presence of reflections from the ground

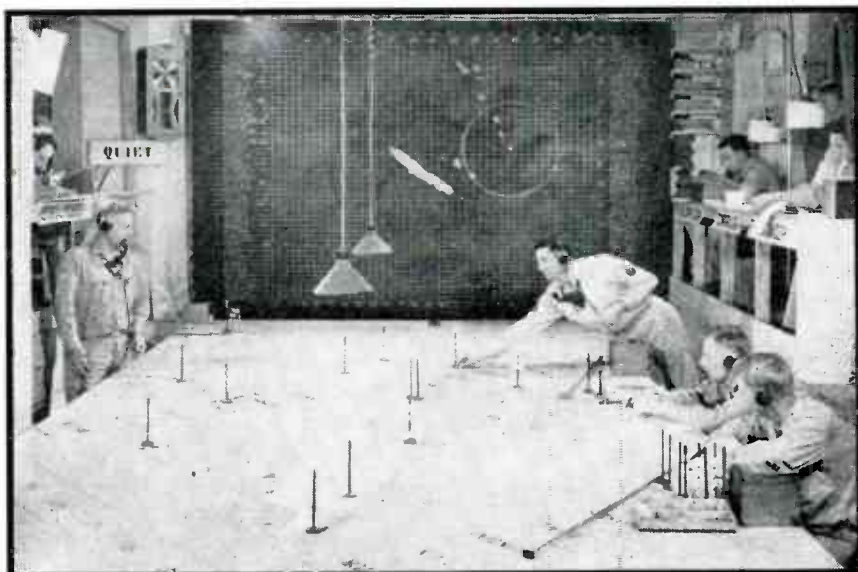

FIG. 3—The plotting board of the 1st Island Command in Noumea. Here position reports of aircraft detected by many scattered radars are coordinated and the progress of unidentified units followed by moving the rod-like structures, each one of which represents an aircraft



FIG. 4—A microwave search and warning radar on a PT boat. The dome structure houses the revolving parabolic reflector, or dish. Such radars were useful not only to warn of nearby air and surface units, but permitted accurate navigation among blacked-out ships and inside enemy harbors

or the surface of the sea. The reflected rays, combining with the direct rays, produce a many-lobed coverage diagram, the gaps in which constituted a serious short-coming of the early equipment. The most serious gap was that existing close to the ground; to take advantage of this, both Germans and Japanese soon learned to approach less than 100 feet above the terrain. The solution was, again, in the use of higher frequencies and narrower beams. The high frequency increases the number of lobes and so narrows the gaps between them. Moreover, the narrower beams of the high frequency gear reduce the amount of signal transmitted toward the ground, so the effect of reflections was cut down or eliminated entirely.

The detection of the enemy is of little value unless something can be done about it. The first step is to collect target information from a number of radar stations which report into a central plotting room (Fig. 3), where tracks of all targets are kept. The telephonic communication required for

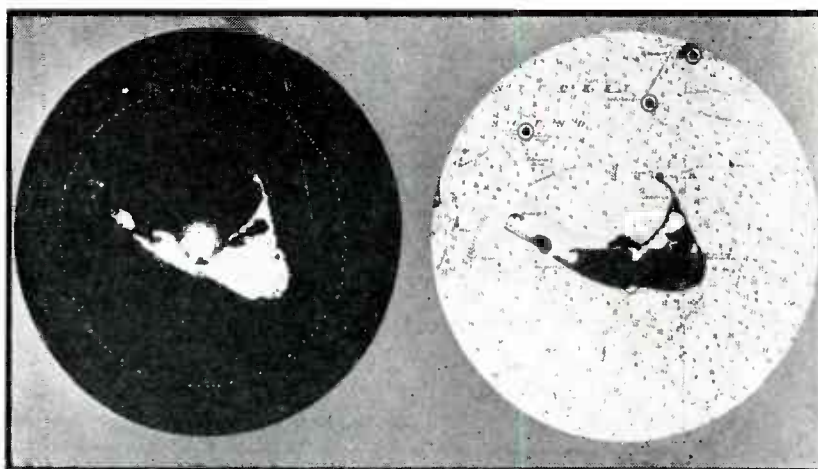

FIG. 6—Radar map (left), of Nantucket Island photographed from the PPI indicator of an airborne radar. The bright spot at the center indicates the position of the aircraft. The circle is a distance calibration, produced by the range circuit of the radar to indicate the distance scale. At the right, for comparison, is a map of the island

such activities is complex, and it must be surefire. The same function is carried out aboard ship, in the Combat Information Center, a plotting room which receives target data from all radars aboard and even from radars of nearby fleet units. Even PT boats (Fig. 4), carried warning radar.

Since the best way to attack an airplane is to go after it in another

airplane, it was natural that the next extension of early warning radar should be control of fighters and fighter-bombers. The technique, developed in England in 1940-41, is known as GCI (Ground Control of Interception) and AI (Airborne Interception). In GCI, the radar operator on the ground observes echoes from the enemy aircraft and the opposing fighter, on the same indicator screen. Instructions are radioed to the fighter pilot to indicate the height and direction of the enemy aircraft. As the fighter closes in, he is controlled until he reports visual contact and begins the attack.

#### GCI and AI—Partners of Early Warning

This technique was outstandingly successful during the German daylight attacks; in one day 185 bombers out of 500 attacking were destroyed, largely through radar detection of enemy planes and guidance of our pilots.

Success in this technique requires fairly accurate knowledge of the height of both defending and attacking aircraft, information not supplied by the early-warning radars. Several height-finding methods were developed, the most elementary depending simply on the strength of the radar echo observed at a given range (that is, by a calibration of the contour of the beam). A more elaborate method used a narrow beam radiator which could be swung upward and thus measured the elevation angle, as well as the range, of the target. A

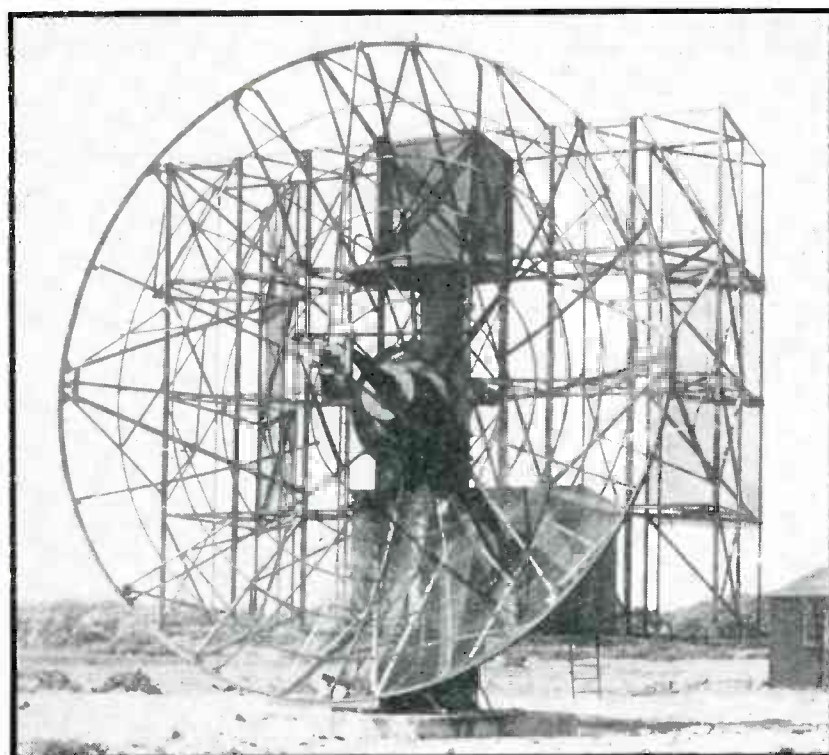

FIG. 5—British Type 16 GCI radar, used for the control of aircraft in offensive operations. The parabolic reflector is composed of a wire mesh, the holes in which are considerably smaller than a wavelength and hence essentially opaque to the radiated signal



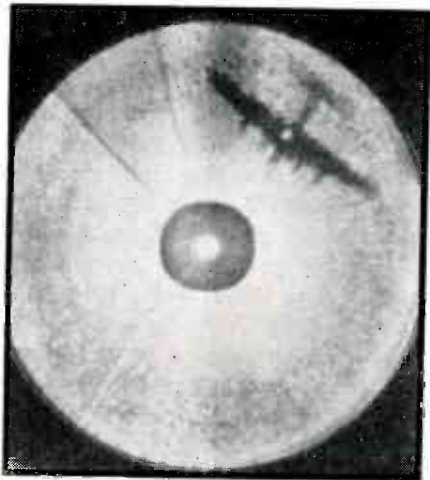

FIG. 7—Radar shadow picture. As a friendly bomber flew underneath an airborne radar, it intercepted the radar signal and thereby cast its shadow on the ground

typical GCI station (of a type used largely for offensive operations late in the war) is shown in Fig. 5.

When the Germans, balked during daylight, switched to night operations, visual contact was less easy to achieve. So GCI was supplemented by airborne radar which would permit the fighter to see the enemy aircraft regardless of visibility conditions. Here the technical obstacles were formidable. Total equipment weight had to be reduced to a few hundred pounds at most, and the radiator size was so limited that a narrow beam (necessary for precise determination of the enemy aircraft's position) could hardly be achieved with the low frequencies feasible for ground applications.

The need for better AI gear gave powerful impetus to the development of microwave radar. In 1940, a practical source of high-power pulses at frequencies of the order of 3000 mc was developed at the University of Birmingham. This was the cavity magnetron, the details of which are still under wraps at the time of writing. But it can be said that this device is one of the basic inventions of the radio art, an improvement in principle as well as in degree over all previous forms of magnetron. The magnetron was brought to America in August of that year and copies hastily produced by the Bell Telephone Laboratories.

On this basic item was founded the research program of the Radia-

tion Laboratory at M.I.T., which has since been the principal source of microwave radar development. This Laboratory, now so well-known to the electronics industry, started with less than 50 people and grew to over 3800 by the end of the war. Radiation Laboratory solved the AI problem and went on to other, even more important applications of microwaves.

The microwave technique, devel-

vention made its appearance. This is the Plan Position Indicator (PPI) which makes it possible to view many targets simultaneously. In the PPI, the cathode ray spot starts its motion from the center of the screen, and moves outward at constant speed in the radial direction. The direction of the radial deflection is tied in with the direction of the radiated beam, and the distance from the center of the

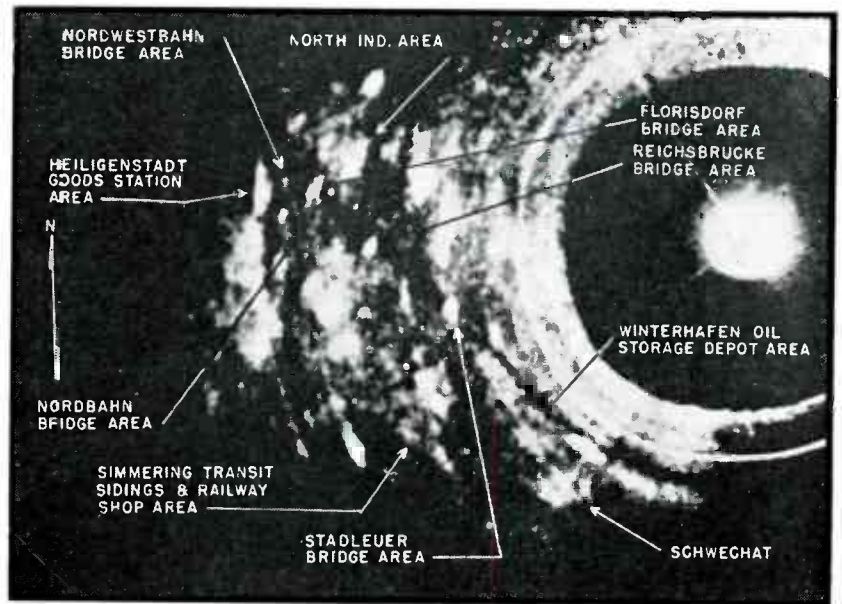

FIG. 8—The area around Vienna, as it appears on the scope of a radar bomb-sight. Extensive training, including comparison with reconnaissance photographs, is necessary before such PPI pictures can be interpreted with sufficient accuracy to permit blind bombing of the targets indicated

oped to solve the AI problem, brought with it the need for all manner of r-f components, particularly r-f mixers, duplex switching gear (t-r box), r-f plumbing of every possible description, rotating joints in waveguides and coaxial lines, new forms of radiators and reflectors, in fact a whole new art. The success of the effort is well known. Basic designs of microwave radar for the Allies originated at Rad Lab and were put into production by the electronics industry of America to the value of well over two billion dollars. As of July 1st, 1945, the U. S. Army and Navy alone, not counting supplies to the British, had accepted delivery of 2.7 billion dollars worth of radar, most of it microwave, and nearly half of it for airborne use.

During the development of the GCI technique, another basic in-

tube is proportional to the time interval between transmission of each pulse and the reception of the echo. As the beam rotates the phosphor retains the image for as long as several minutes. The PPI thus paints a picture on the cathode-ray screen which is a plan view of the territory surrounding the radar. The bias of the cathode-ray tube is normally set so that the beam is dark. When an echo is received from a target, the spot is brightened momentarily. This light represents the distance and direction of the target relative to the radar.

#### PPI—Navigation and Bombing by Terrain Echoes

At first PPI was used simply to indicate aircraft targets. But it soon became evident that echoes from the features of the surrounding terrain would give rise to a

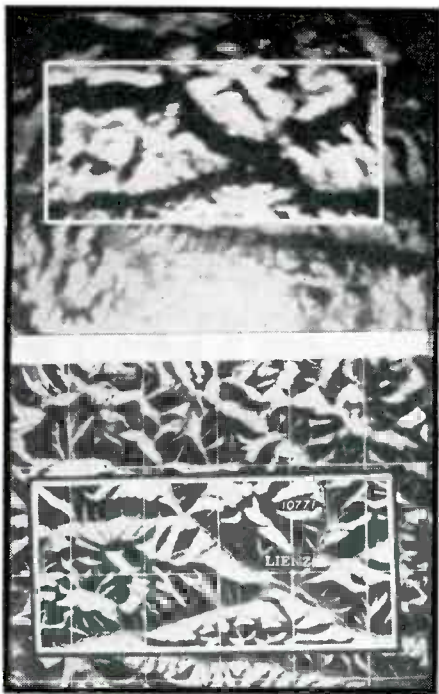

FIG. 9—Radar relief map, obtained over mountainous territory in the Austrian Alps. This PPI picture (top) shows bright surfaces on the near side of the mountains, dark shadows beyond. The relief map below provides a comparison

radar map, which could serve as a navigational aid.

Behind the PPI picture are a number of interesting technical factors. First it must be realized that the map is a true representation of the earth's surface only when the radar is situated on the ground or aboard ship. When the radar is airborne, the distance represented on the c-r tube is the so-called slant-range, or the distance from aircraft to target, and not the distance along the surface of the earth. This distortion can be compensated, of course, by adjusting the rate of radial deflection in accordance with the height of the aircraft. The detail visible in a PPI map is determined by the size of the radar beam relative to the terrain features. In Fig. 6, the radar beam was narrow enough to resolve clearly many of the smaller features (note the lake at the right-hand edge of the island).

The echoes which go to make up a PPI picture are in themselves worthy of attention. Radar echoes arise through the r-f current induced in the target as the outgoing radar signal passes over it. But the reflection of signals is by no means limited to metallic targets. When

the target is non-conducting a displacement current, similar to that in the dielectric of a capacitor, is induced and gives rise to a re-radiated wave. In general, the echo is produced by the discontinuity in the electrical properties between the target and its surroundings, and this discontinuity may be either in the electrical conductivity or the dielectric constant. In fact, a discontinuity in magnetic permeability is equally effective, but the magnetic property is usually overshadowed by the conductivity effect.

It is clear, then, how non-conducting sands can give rise to echoes. But it is not so clear why echoes from land should be stronger (as their relative brightness testifies)

constant of the material in it.

In line with this reasoning the PPI picture shown in Fig. 7 is of particular interest. This picture was widely misinterpreted in the daily press as a radar picture of a four-motored bomber. Actually it is the radar picture of the shadow of the bomber on the ground beneath. The direct echo from the aircraft itself shows up as a bright spot near the center of the wing span. The aircraft was so close to the radar that it intercepted a large part of the signal and thus cast a shadow of itself on the ground. Outside the shadow, echoes from the ground formed the outline shown. Such pictures are freaks, of course; this one was not

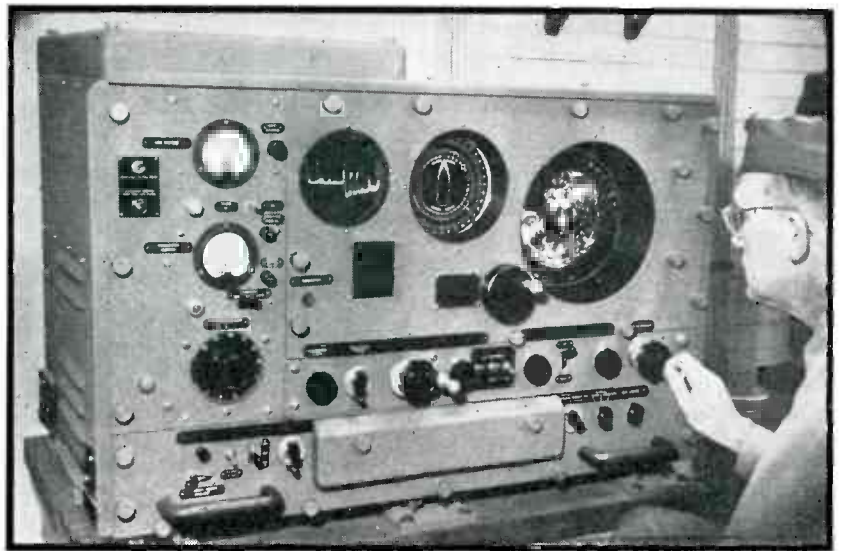

FIG. 10—The Navy's type SG radar, showing (left to right) A-scope, relative azimuth indicator, and PPI-scope. The A-scope resembles an ordinary test oscilloscope, indicating the relative timing of the transmitted pulse and the succeeding echoes. It is used for tuning to peak efficiency and to measure accurately the range of particular targets, selected from the PPI at the right

than the echoes from surrounding sea water, which is a better conductor. The answer is found in the fact that the surface of the sea is much smoother, electrically, than the surface of the land, and hence the land reflections are scattered backwards to the radar. The sea reflections are stronger, but in form they closely approximate the specular reflection from a mirror and hence glance off at an angle, away from the radar. The contrast displayed by terrain echoes depends primarily on such differences in the scattering properties of the reflecting surface, and only secondarily on the relative conductivity or dielectric

understood for several days after it was first photographed.

Not all PPI pictures are easy to interpret. An important application, radar bombing, requires extensive experience on the part of the operator. An example of the picture presented by a radar bomb-sight is shown in Fig. 8. The individual targets are discernible, but only when you know what to look for. The radar contrast is not great between a manufacturing plant as a target on the one hand and the nearby buildings and countryside on the other. To aid in identifying targets, reconnaissance runs were often made and the PPI pictures



photographed for comparison with aerial photographs of the target area. The most effective use of the radar bombsight was in close partnership with the optical (Norden) bombsight. The bombardier operated the Norden sight in the conventional manner, setting in his corrections for drift, etc in accordance with readings given by the radar operator. Both continued to track on the target, and the final bomb release was controlled visually if a break in the clouds permitted. Otherwise the bombs were dropped on the basis of radar indications fed into the Norden computer.

Still another type of PPI picture is the radar relief map, an example of which is shown in Fig. 9. This is a shadow picture, the nearby sides of the terrain features (in this case a mountain range) showing brightly against the shadows on the far side.

The PPI picture is evidently an excellent device for navigation when sharp contrasts are available. Since such contrast is generally available along coastlines, the PPI is especially useful for the navigation of surface craft. One of the most widely used shipboard radars is shown in Fig. 10. Three indicators are shown. At the left is the type-A indicator, a c-r tube which displays the transmitted echo and the echo reflections along the di-

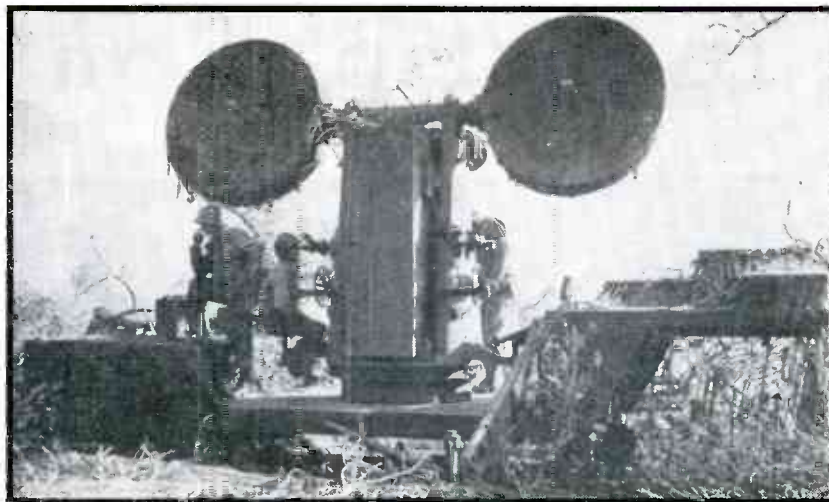

FIG. 12—Mickey Mouse, or SCR-547, a unit made to replace the visual range finder in AA gunfire. This 10-cm radar can measure the distance to aircraft at a distance of 20 miles and with an accuracy of 25 yards

rection occupied by the radiated beam at any instant during its rotation. Next is the relative azimuth indicator which shows the axis of the ship (note figure at center of dial) with respect to true north or some other reference direction. At the right is the PPI indicator which shows the plan view of all radar echoes within range, oriented against the axis of the ship.

#### Gunfire Control

To determine the position of an airplane or ship accurately enough to control gunfire is a problem which requires for solution more

than the use of high frequencies and narrow beams. In addition, it is necessary to refine the accuracy of the angular indications by using lobe switching (see "The SCR-268 Radar," *ELECTRONICS*, September 1945) or its close relative, conical scanning. Pending release of details on this equipment, it may only be stated that such methods permit spotting the position of an aircraft accurately to a few hundredths of a degree in elevation and azimuth. Precise timing circuits determine the range to an accuracy of a few tens of yards in range.

Since gunfire at high speed targets must be computed to lead the target, the radar data is fed into a gun-control computer which controls the action of guns automatically. Figure 11 shows a 90-mm anti-aircraft battery controlled by the SCR-584 radar, one of the outstanding radar sets of the war. Another gunfire control radar on which technical details are available is the SCR-547, shown in Fig. 12. This device possesses separate antennas for transmitting and receiving and indicates only the range to the target. The frequency used is in the microwave region, roughly 2800 mc (wavelength 10.7 centimeters). The radar is put on the target optically and indicates the distance to the target within 25 yards, which is equivalent to timing the echo to an accuracy of 0.15 microsecond. Details of the circuits which accomplish this remarkable result will be published in an early issue.—D.G.F.



FIG. 11—A 90-mm AA battery protecting the invasion coast in Southern France. The fire-control radar, barely visible at the right (radiator painted out for security reasons), aims the guns automatically with the aid of a computer which introduces the necessary lead. This combination stopped the buzz-bomb attacks on England

# Fingertip Control FOR



Installation of formation stick in B-17G bomber. Autopilot release switch is clamped on a spoke of the control wheel, 1½ inches in from the rim, and is pressed in case of autopilot damage by enemy fire, to restore all manual controls

**P**ILOT fatigue is one of the big problems of long-range bombing missions. Maneuvering a 70-ton airplane full of bombs and gasoline for long hours, holding a tight formation through flak and fighter opposition, and still being alert for every move of the flight leader through the bombing run and all the way home again . . . all this often left pilots with barely enough strength to crawl out of their seats at the end of a mission. The Minneapolis-Honeywell electronic automatic pilot was used for straight-and-level flight, but for maneuvers the human pilot had to operate the controls manually. Usually the combined efforts of both pilot and copilot were required to keep a plane in formation when rough weather made control difficult.

The answer to this problem has been found in the formation stick, an adjunct to the automatic pilot. It provides a means for rapidly maneuvering the largest bomber with very little pilot effort. Operated in a similar manner to the joy-stick on small aircraft, this

control allows the pilot (or copilot) to bank, climb, or dive his plane by merely moving the formation stick away from its neutral center position. The degree of bank and turn and the rate of climb or glide are proportional to the displacement of the stick in its two axes of movement. Since it automatically provides coordinated turns, it transforms the airplane into a two-control ship which won't spin.

#### Pilot Tries Discarded Model

The first fingertip control was built in 1943. Since our planes were not yet flying wing-tip to wing-tip as they were later forced to by enemy fighter tactics and since other more pressing problems needed solving, the project was shelved until a strange trick of fate brought it into the light again. It happened this way. A young army pilot, visiting Minneapolis, picked up the discarded first model from a corner of the flight research hangar and secretly installed it on his B-17. He later flew the airplane into combat over Germany, where it attracted the attention of

a senior officer. Army Air Force technicians pressed for immediate production. A short time later (in the fall of 1944) a redesigned stick came off the production lines. Since then it has been installed on Flying Fortresses, Liberators, and B-29 Super Fortresses.

#### Relation to Autopilot

The principle of the stick's operation is quite simple. As explained in *Electronic Autopilot Circuits*, p. 110, *ELECTRONICS*, Oct. 1944, the autopilot electrical bridge system is made up of three channels—one each for aileron, rudder, and elevator control. Without the formation stick each of these channels functions to maintain the airplane in a predetermined attitude by operating its corresponding control surface. The only way for the pilot to change course is by means of the turn control knob, which is not convenient for rapid course changes, and in addition does not allow control of the elevator surfaces.

The formation stick is essentially two potentiometers mounted at right angles to each other, with provision for the pickup wiper on each potentiometer to be driven by movement of the stick in a corresponding direction. These potentiometers introduce electrical signals into the autopilot bridge circuits calling for control surface movement. When the stick is moved backward or forward, a signal in the elevator channel causes the elevator to be driven so that the airplane will either climb or glide. A side movement of the stick, on the other hand, produces a coordinated turn by introducing signals into both the aileron and rudder channels, plus a measured up-elevator response to hold the ship's nose up. Therefore, if the electrical system is properly adjusted beforehand, it would be impossible for the operator to accidentally make the plane slip or



# FORMATION FLYING

Pistol-grip formation stick, newest accessory for C-1 electronic autopilot, permits effortless maneuvering of largest bombers during wing-tip to wing-tip flying in any weather, and provides servo boost for rapid changes in course or altitude during combat action

By **D. G. TAYLOR** and **GORDON VOLKENANT**

*Chief Mechanical Engineer*      *Coordinator, New Products Research*  
*Minneapolis-Honeywell Regulator Co., Minneapolis, Minn.*

skid when using the stick. Of course, climbing or gliding turns can be obtained with diagonal movements of the stick.

## Function Selector Switch

Two formation sticks (one each for pilot and copilot) are installed in the airplane. A special switch called the function selector has four positions which control the authority of the stick as follows: (1) ON SERVO BOOST (gyros off), (2) OFF (autopilot knobs now maneuver the plane), (3) ON (gyros continue to stabilize the plane), and (4) ON ELEV. ONLY. The switch assembly is made up of five cam-operated switches, with the cams mounted on a central shaft. These switches activate relays which are used to make the actual load circuit changes.

In the operational procedure, the autopilot master switch is first turned on, and a few minutes allowed for the gyros to warm up. The two basic sensing units for the autopilot, the vertical flight gyro providing stability in pitch and roll, and the directional stabilizer gyro performing the function its name implies, also serve the formation sticks.

The next step is to engage the servos, which mechanically drive the airplane's control surfaces in response to power signals from the autopilot amplifier. Assuming that all flight adjustments are correct, the airplane is then being flown by the autopilot. During this setting-up procedure the function selector has been at OFF, indicating that

the formation sticks were inoperative.

## Circuit for OFF Position

A schematic circuit for the autopilot with formation sticks is shown in Fig. 1. In the lower center the internal switches of the function selector are shown at OFF position. Note that the center switch grounds the aileron and rudder channels through the turn control, thus giving normal autopilot operation. The elevator channel is grounded through a resistor and the center tap on the formation stick elevator potentiometer. Since this potentiometer is not energized in this position of the selector, an accidental movement of the stick

will not affect autopilot operation. (Because the current flow of any signal is extremely low, resistances of this order to ground have a negligible effect on the electrical characteristics of the autopilot without formation stick. The 600-ohm resistor is used to reduce elevator signals when the formation sticks are energized.)

## Circuit for ON Position

When the function selector knob is moved to ON (position 3), the first switch energizes the stick potentiometers, the second makes the ECO and DAL delay switch circuits operative (see a following paragraph for explanation), and the third switch removes the direct ground of the turn control so that formation stick signals affect the aileron and rudder channels. The fourth and fifth switches have no effect in this position.

## Effect of Stick Movements

With the formation stick circuit thus energized, note that the pilot's stick is the effective one. However, a transfer switch is located on top of each stick which, when pressed, transfers control away from the opposite stick. If the copilot's transfer switch is pressed, the transfer relay solenoid is grounded, pulling in the contacts necessary to give the copilot control and providing a hold-in ground to keep the solenoid energized. As can be seen in the diagram, the pilot's switch will return control to him even if the copilot's switch is depressed, since it effectively grounds the circuit ahead of the transfer solenoid.



Automatic units controlled by the formation stick in the C-1 electronic autopilot

When the pilot's stick (or co-pilot's if control has been transferred) is moved sideways, a voltage signal from the banking potentiometer is introduced into the turn control bridge, unbalancing both the aileron and rudder channels. A voltage above ground is produced at the grid of the first tube of the amplifier in each of these channels, and servo movement is immediately started through the amplifier-controlled relays (not shown). Sufficient servo movement will be produced to rebalance the aileron and rudder bridges by movement of the balance potentiometers on the servos (shown as part of the autopilot bridges). Then, as the airplane responds, the vertical flight gyro will measure the angle of bank and put in its own rebalancing signal, causing the servo to drive the ailerons back to streamline position.

When the stick is allowed to return to neutral position, the opposite action takes place until the airplane is again leveled and all circuits balanced.

#### Action of Delay Switch

Whenever the stick is moved off center, a locking switch (shown near the lower center of the diagram) is closed, energizing the delay switch and heating a piece of resistance wire within it. As this wire is heated, it expands and allows the spring to close the grounding contact for the locking relay. (This action occurs in a fraction of a second, and serves no function until the stick is again centered). The locking relay energizes the directional arm lock (DAL) and erecting cut-out (ECO) circuits. The DAL locks the directional panel of the autopilot to prevent a corrective signal being introduced as the airplane moves off its established heading, while the ECO acts in the vertical flight gyro to prevent the gyro from erecting perpendicular to the floor of the airplane during the bank.

#### Elevator Action

After the stick is back in center position the delay switch described above momentarily maintains a ground for the locking relay until the airplane has had time to recover straight-and-level flight.

The preceding action takes place when the stick is moved to one side or the other. The only elevator action is a small amount of up-elevator provided by the up-elevator potentiometer of the vertical flight gyro to maintain the airplane's altitude during turns. However, if the stick is moved forward or backward, either without side movement or while a turn is being made, the down or up elevator called for will be provided by servo

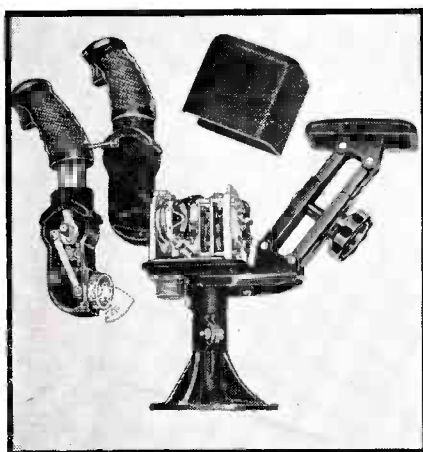

Construction of formation stick

movement. The signal is produced by the elevator potentiometer of the formation stick and is sent up through the elevator input channel to the amplifier, where it causes the amplifier to produce servo action. Balancing and return to level flight take place in a manner similar to the action in the aileron channel. With elevator signals, however, there is no accompanying action of the locking relay.

#### Circuit for ON Servo Boost

Two additional positions are provided for special flight conditions. During tight formation flying, for example, it is often necessary for the pilot to make rapid changes in course or altitude in order to maintain his proper position in the formation. There might also be emergencies when banks greater than those allowed by the gyros would be necessary. When flying manually this would mean extreme and rapid movement of the controls. The formation stick performs this job when the selector switch is turned to ON SERVO BOOST (po-

sition 1). The stick then controls the individual servo units directly, without any stabilization or balancing out by the gyros, and under this condition the airplane must be flown as if it had no autopilot and the sticks were mechanically connected to the control cables.

Looking at the action of the function selector switches for this type of operation (bottom to top), the formation stick potentiometers are still energized. The ECO is not needed and therefore not energized since no gyro balancing is used, and the DAL circuit is controlled by a different switch in this type of operation. Aileron and rudder signals reach the autopilot channels only through a 500-ohm resistor which serves to reduce them slightly. Elevator signals reach the autopilot channel through a 600-ohm resistor (the same as in normal stick control) and the fifth switch performs its function of energizing the servo relay and also the DAL so that it is constantly locked during ON SERVO BOOST operation.

Direct control of the servos without one of the gyros balancing out the formation stick signals is obtained by operation of the servo relay, which shorts out a portion of the rudder bridge and transfers the aileron and elevator bridges to semi-fixed trimming potentiometers. Note that the only balancing of formation stick signals is performed by the servo potentiometers, and that the signals are then sent directly to the amplifier tubes through trimming or centering potentiometers on two of the channels, and simply shorted around the autopilot rudder potentiometer in the rudder channel. These adjusting potentiometers (plus a number of others) are semipermanent settings, and are located in the junction box serving all three channels.

#### Circuit for Elevator Only

Switch position 4, ELEVATOR ONLY, is for use in bombing. In a high-altitude bomb run it is essential that a constant altitude be held until the bombs are released. If altitude varies during the run, the mechanical calculations of the bombsight will be in error and the bombs will miss their target. With



the standard autopilot in use it was necessary for the pilot to adjust a small knob or to electrically disconnect the elevator control and manually maintain altitude. In addition, stabilization of flight in the pitch axis of the airplane (up and down) was removed.

With the stick in use, ELEVATOR ONLY position allows control of this channel only, without interfering with the work of the bombardier who is constantly introducing corrections into the aileron and rudder channels by means of his bombsight. Also, every stick movement is automatically stabilized by the gyro of the autopilot so as to maintain accurate flight. Small deviations due to air conditions are corrected before the pilot may be aware of them.

In the ELEVATOR ONLY position the potentiometers are still energized, the DAL and ECO circuits are again dead, the turn control is grounded to eliminate any aileron

or rudder signals from the formation stick, and the fifth switch is inoperative. The fourth switch is now active, grounding the elevator circuit through a 300-ohm resistor so that only a limited amount of elevator control is available. This gives a more cautious reaction to stick movement at a time when altitude must be carefully held.

#### General Considerations

As a safety precaution for the whole system, emergency disconnect switches are installed on each control wheel. In case of an autopilot malfunction, such as might occur if part of the system were destroyed by enemy fire, pushing either button will immediately disengage the entire autopilot including the formation sticks.

Several auxiliary functions are designed into the stick. To prevent abrupt and violent attitude changes and to give the pilot a control feel, a mechanical brake and centering

mechanism are installed in each axis of movement. In addition, a trigger switch on each stick operates the microphone, replacing a switch used on the control wheel when the plane is being flown manually. The addition of an arm rest on the complete assembly makes it more convenient and less tiresome to use.

The use of formation sticks solves the control problem of designers who are planning huge postwar transports and passenger planes, since a one-pound pull on the stick takes the place of a hundred-pound pull that might be necessary on the control wheel. Enthusiastic reports on its wartime use received by Air Technical Service Command presage a successful peacetime future. When installed on postwar aircraft where automatic flight control is a necessity, this device will substantially contribute to the simplification of control problems.

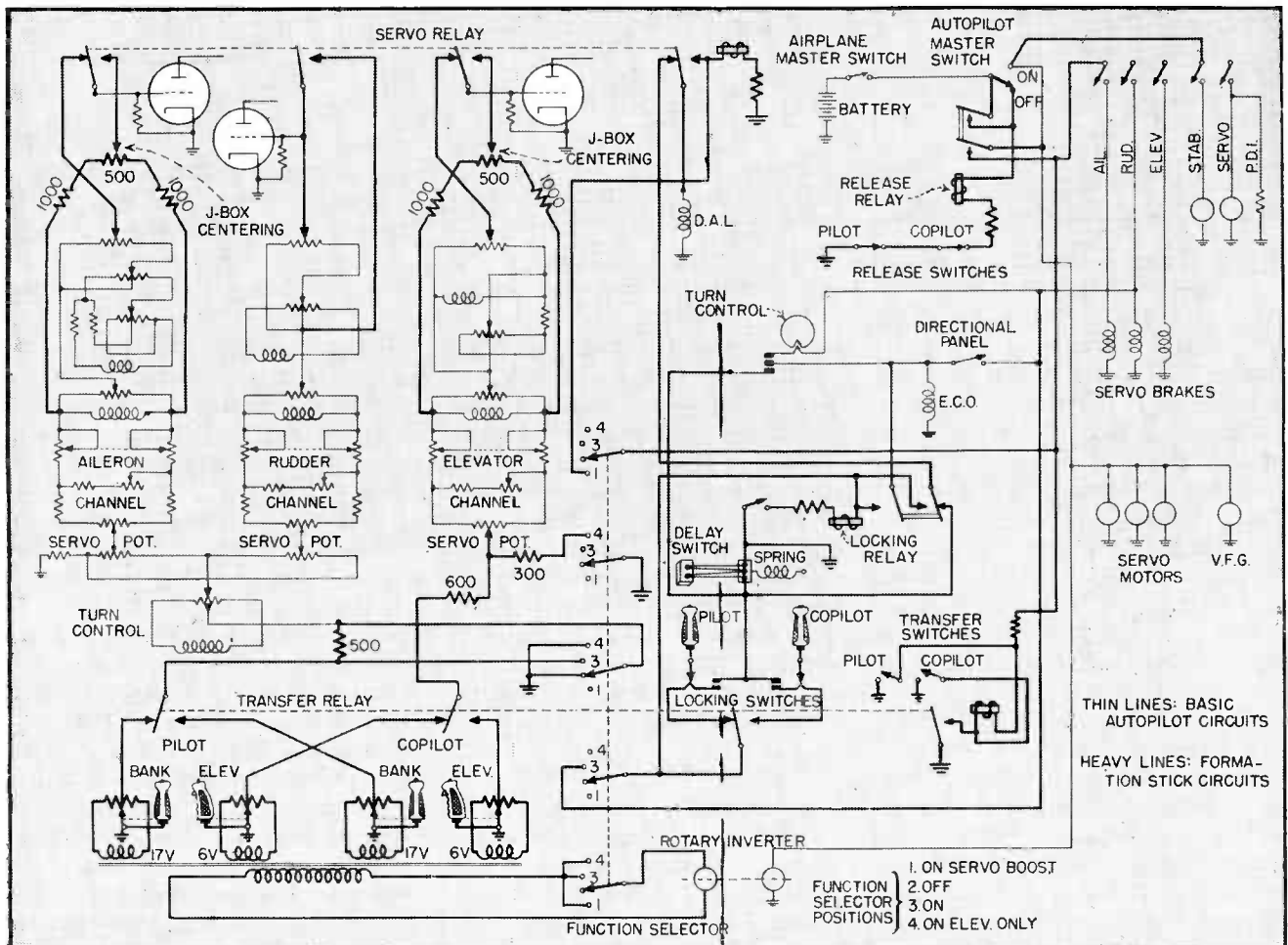

FIG. 1—Schematic circuit diagram of Minneapolis-Honeywell C-1 electronic autopilot with formation stick

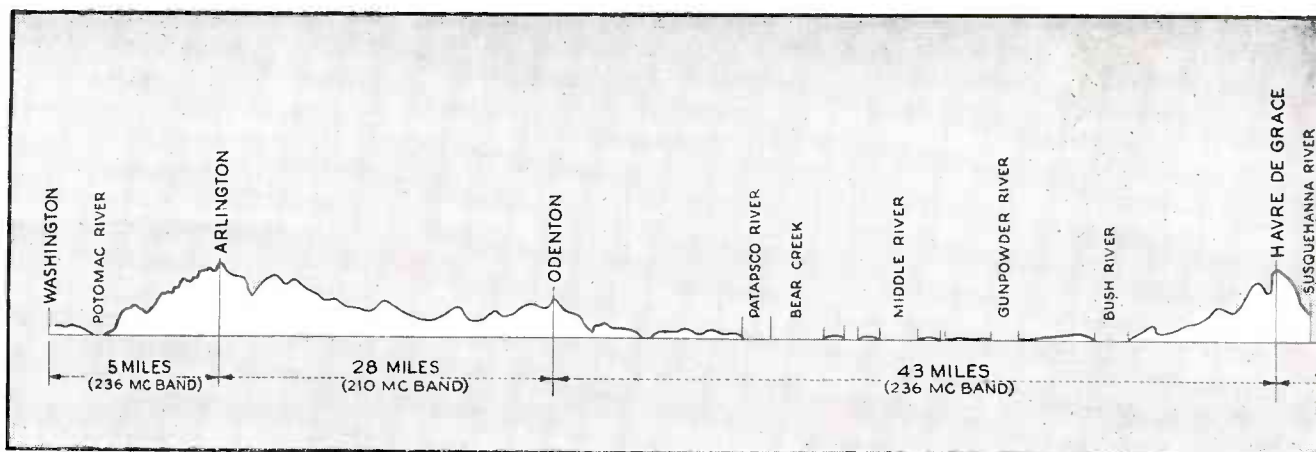

FIG. 1—Profile of the vhf multiple-relay television network route between Washington and Philadelphia, showing the relative heights of the two terminal stations and the four hilltop relay

# VHF Multiple-Relay

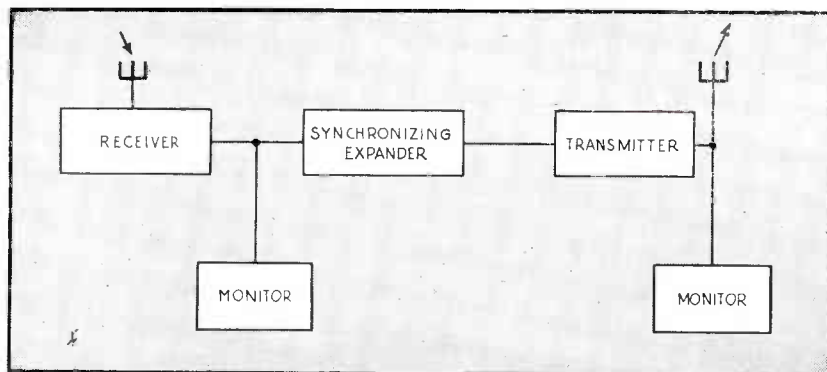

FIG. 2—Block diagram of a typical hilltop relay station, showing the principal elements of equipment, illustrated in detail elsewhere in these pages

By F. J. BINGLEY

Chief Television Engineer  
Philco Radio and Television Corp.  
Philadelphia, Pa.

ON THE EVENING of April 17, 1945, a television program originating in a Washington, D. C. studio was relayed through a chain of four vhf stations located on hilltops at Arlington, Va., Odenton, Md., Havre de Grace, Md., and Honeybrook, Pa., to WPTZ at Wyndmoor, Pa., and from there broadcast to residents of the Philadelphia area. Multiple relaying tests have continued since that time.

The four hilltop sites were selected to insure 100-foot clearance over all intervening terrain, with an eye to possible future use of uhf or shf equipment. This necessitated some staggering of the sites, with the result that the transmission path length totals 156 miles whereas the airline distance between Washington and Philadelphia is 143 miles. A profile of the

network route between the two terminal cities is shown in Fig. 1.

In the following paragraphs some of the problems encountered in setting up and operating the relay stations will be discussed, and hitherto unpublished details concerning the equipment employed therein will be given. The block diagram of Fig. 2 shows the principal elements of a typical relay station. The physical appearance of one such station, at Arlington, is shown in Fig. 3.

## Antennas and Frequencies

Antennas for receiving and retransmitting the video signals are similar in design, but are mounted on separate 100-foot towers. The arrays consist of 24 elements, 12 driven dipoles and 12 reflectors.

The driven elements, shown in Fig. 4, are half-wave dipoles. Two

master elements in the center of the array are connected through a matching box to the receiver or transmitter by means of a 3-inch coaxial cable. Inside the matching box is an inverter section that provides a balanced transformation from the single-ended line to the antennas. The remaining 10 driven elements are end-fed, by means of suitable high-impedance transmission lines, from the two master dipoles.

One difficulty arose because the receiving antenna, which must pick up a signal of a few millivolts, is at the same site and only about 75 feet from the transmitting antenna, which sends out a 40-watt signal. Obviously, the transmitted signal might be expected to interfere with reception. This problem of intra-station interference was solved by a combination of two expedients. The first was the physical arrangement of the antennas. At each relay site, the receiving antenna is mounted end on with respect to the transmitting antenna tower. The transmitting tower is at a null point for the receiving antenna's



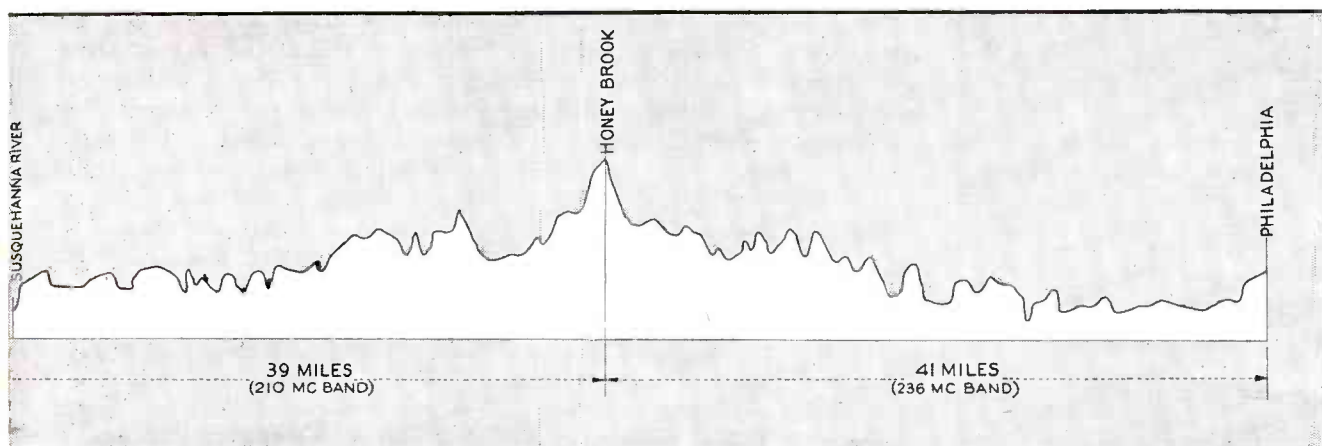

stations involved. Line-of-sight clearances of at least 100 feet were desired. This involved staggering of the relay stations but added only 13 miles to the transmission path

# Television Network

Detailed description of a six-station chain through which video programs originating in Washington are telecast in the Philadelphia area. Staggered frequencies within the 210 and 236-mc bands are used, but uhf or shf equipment should ultimately prove feasible

pattern, which is shown in Fig. 5. Thus, the transmitting antenna itself may be placed in any position on its tower, since this tower is at the point of lowest sensitivity for the receiving antenna.

To further reduce local interference, the receiver and transmitter at each relay station operate in two separate frequency bands. This is possible because the transmitters in the network are operated on staggered frequencies. Washington, Odenton and Honeybrook, transmitters 1, 3 and 5, transmit in the 236-mc band (230-242 mc). Arlington and Havre de Grace, transmitters 2 and 4, transmit in the 210-mc band (204-216 mc). The result is that at the first relay point at Arlington, for example, the receiving antenna is picking up a 236-mc signal, while the transmitting antenna is sending out video intelligence on 210 mc.

A third device for reducing interference became necessary because it was found that the forward wave received at one relay station was obscured somewhat by the back wave from the next relay



FIG. 3—Relay station at Arlington. The two 100-foot towers supporting receiving and transmitting antennas, the trailer in which equipment is housed, and the small metal building in which tools, spare parts and an emergency gasoline-engine driven generator are kept may be seen

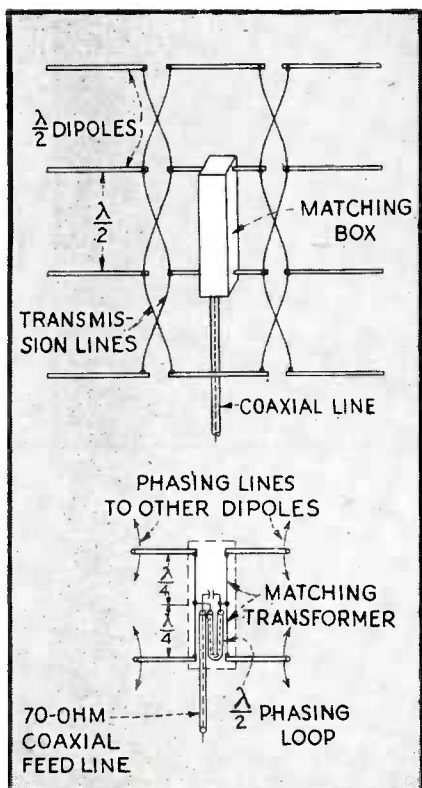

FIG. 4—Driven elements of a typical transmitting or receiving antenna array as used in the multiple-relay television network. Reflectors are omitted from the drawing for simplicity

station. For example, at the Odenton station, it was found that the signal received from Arlington was being interfered with by the back wave from Havre de Grace. The effect, viewed on the receiver picture monitor at Odenton, was similar to stray beat patterns caused by a diathermy machine near a home television receiver. To eliminate this inter-station interference, transmitter frequencies were staggered again within the two available 12-mc wide bands. Arlington and Havre de Grace transmit on different frequencies within the 210-mc band. These frequencies are far enough apart so that the beat pattern is of a frequency above the video acceptance band of the system. Similarly, Havre de Grace is protected against inter-station interference because Odenton and Honeybrook transmit at different frequencies within the 236-mc band.

Washington transmits on 236 mc. Arlington receives on 236 mc and transmits on 208 mc. Odenton receives on 208 mc and transmits on 234 mc. Havre de Grace receives on

234 mc and transmits on 212 mc. Honeybrook receives on 212 mc and transmits on 238 mc. WPTZ in Wyndmoor receives on 238 mc and telecasts on 67.25 mc.

#### Relay Receiver Design

The relay receiver, receiver monitor, synchronizing expander, relay transmitter, transmitter monitor, and the associated power supplies, together with duplicate standby equipment, are all mounted in racks in an automobile trailer. A typical trailer floor plan is shown in Fig. 6. Two views of equipment in a trailer are shown in Fig. 7 and Fig. 8.

In the relay receiver a grounded-grid cathode-driven r-f amplifier,  $R_1$  in Fig. 9, is used to step up the received signal and feed it into a push-pull mixer,  $R_2$ , which also receives a signal from a line-con-

tuned bandpass stages. The response of this section is essentially flat from 37 to 41 mc, with 39 mc as the center of the response curve. The carrier is placed on this characteristic in such a manner that it is 50 percent down from the peak of the characteristic, in the familiar single-sideband method of reception. The i-f stages are so staggered that the first and succeeding odd-numbered stages are tuned to 41.5 mc, while all even-numbered stages are tuned to 36.5 mc. Each i-f coil is damped suitably by a load resistor. Typical response curves are shown in the lower right-hand section of the circuit diagram.

After amplification, the 39-mc i-f signal goes to a conventional diode detector,  $R_{12}$ , and the resultant video signal is sent through a cathode follower,  $R_{15}$ , acting as a buffer stage, to the synchronizing expander.

The video signal is also fed to a 10-inch picture tube for monitoring received picture quality, and to a 5-inch oscilloscope used to check the wave form of the received signal. The choke in the plate lead from the detector to the cathode follower acts as an i-f filter.

A typical relay receiver, such as the one shown schematically in Fig. 9, is illustrated in Fig. 10.

#### Synchronizing Expander

The video signal from the receiver enters the sync expander with the white positive and the sync pulses down. Note the wave forms of Fig. 11. The purpose of the sync expander is to amplify the synchronizing voltage content of the composite signal more than the video voltage. This is necessary because of the non-linear amplitude characteristics of the relay transmitters in the synchronizing region; that is, the sync content of the video signal tends to be compressed in transmission, and the sync expander compensates by amplifying the sync.

In the sync expander, the video signal first passes through three amplifier stages. At the second stage, a degenerating variable resistor in the cathode circuit serves as a video gain control.

When the signal leaves the third amplifier,  $S_3$ , the sync pulses are up,

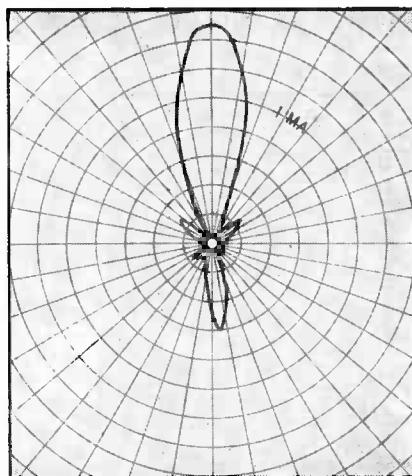

FIG. 5—Pattern of 24-element array

trolled push-pull oscillator,  $R_8$ . The oscillator may be tuned to operate at either 171 or 275 mc. In the 210-mc band receivers the oscillator is tuned to 171 mc, 39 mc below the received signal's carrier frequency. In the 236-mc band receivers, the oscillator is tuned to 275 mc, or 39 mc above the received carrier. This staggering of oscillator frequencies is necessary in order to reduce interference from harmonic beats produced between the local transmitting carrier and the local receiver oscillator.

From the mixer, the i-f signal goes to the i-f amplifier section, tubes  $R_3$  through  $R_{11}$ , consisting of eight frequency-staggered, single-



as the waveform indicates. The circuit of d-c restorer  $S_5$  acts to maintain the sync pulse tip level at a constant d-c potential in the plate circuit of amplifier  $S_4$ , regardless of changes in picture content. In the plate circuit of  $S_4$ , the sync pulses are amplified and inverted. Here is where the sync expansion takes place. Note that the plate load of  $S_4$  consists of two parts: (1) a fixed resistive load,  $R_1$ , connected to a 380-volt regulated supply, and (2) a variable resistive load, separately connected to a 230-volt regulated supply. The variable load,  $S_6$ , comprises a diode circuit such that its resistance, which is in parallel with the fixed load, is practically infinite during the synchronizing pulse, when the diode is not conducting. However, this resistance becomes finite when the video level is reached, since at that time the diode will conduct current. Thus the total plate load, and hence the amplification, is greater during the sync pulse. Correspondingly, the two resistive loads in parallel produce a lower total plate load, and thus lower voltage amplification from  $S_4$ , for the video intelligence.

Next comes a cathode follower circuit, with  $S_7$  and  $S_8$  in parallel.

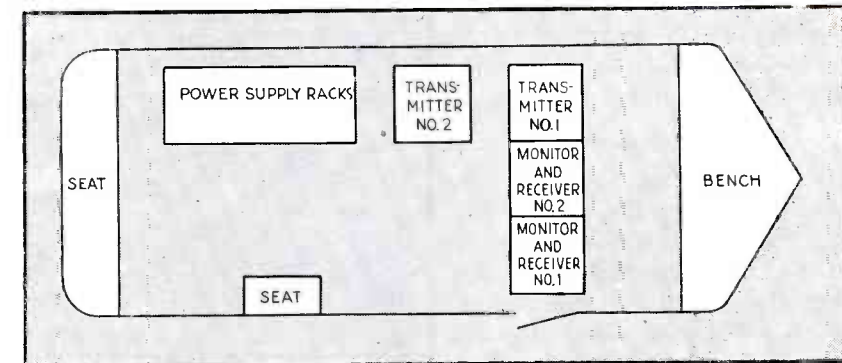

FIG. 6—Layout in a relay station trailer. Power is obtained from 110-volt supply lines, except in cases of emergency, when externally housed gasoline-engine driven generators are pressed into service. Note that standby transmitters and receivers are provided

Small resistors are placed in the control grid leads to act as suppressors of parasitic oscillation. A larger resistance is added in the cathode circuit ahead of the output to the 70-ohm line. This degenerating cathode resistor acts to improve the linearity of the cathode follower. It also cuts down the gain of the stage from about 60 percent to 20 percent. However, as the video voltage applied at the grids of  $S_7$  and  $S_8$  is about 20 volts, a signal of 4 volts remains and is carried to the relay transmitter by the 70-ohm line.

Tube  $S_6$ , in the grid circuit of the cathode follower stage, merely acts

as a d-c restorer. A potentiometer is used to set its bias at such a point that the sync pulse tip level is at the desired voltage regardless of changes in picture content.

The effect of sync expander action may be seen in Fig. 12. This graph shows output voltages at the plate of  $S_4$  as ordinates and input voltages at the control grid of  $S_4$  as abscissae. The knee of the curve appears at the point where the variable load assumes a finite value and, in parallel with the fixed results in a reduced plate load for  $S_4$  and hence a lower voltage amplification. As the waveform shows, this knee appears at the base of the sync



FIG. 7—Interior of a trailer, showing the operator talking to men at other points of the network via farmer's phone line



FIG. 8—Another view inside a trailer, showing one of the transmitters and the two rack-mounted monitor units

pulses, so that the latter are amplified to a greater degree than the remainder of the signal.

### Relay Transmitter

At each relay station in the network two transmitters are provided, one for regular operation and the other as a standby. Philco originally used 10-watt relay transmitters for remote pickup telecasts in the Philadelphia area. Similar transmitters were originally planned for each of the four relay stations in the Washington-to-Philadelphia network. Soon, however, it was found that this power did not give adequate signal strength for satisfactory definition and clarity of the received picture. The signal-to-noise ratio was too low. Hence the transmitters were redesigned to include a power amplifier having an output of 40 watts. The problem of adding this power stage was simplified by "packaging" the power amplifier and connecting it to the 10-watt transmitter unit through a matching device. A close-up of the r-f portion of a typical transmitter is shown in Fig. 13.

Starting at the lower left corner of the transmitter circuit diagram shown in Fig. 14, note that the video signal from the synchronizing expander enters a modulator unit. The first stage of amplification

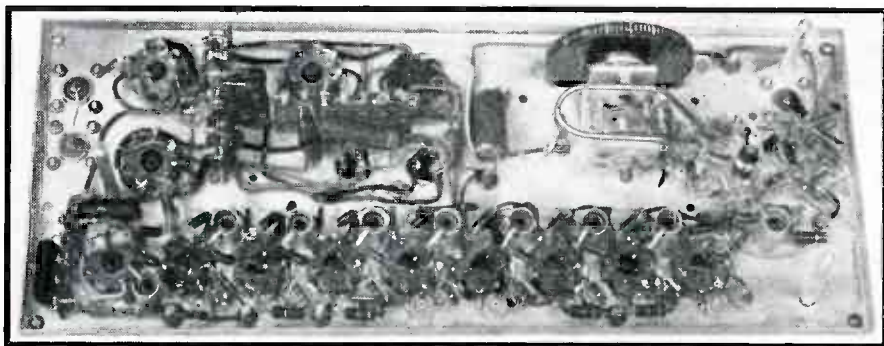

FIG. 10—Physical layout of a typical video receiver

finds the video (white up) applied both on the grid and cathode of  $T_1$ . The signal on the grid is varied by means of a 500-ohm potentiometer. The output is then amplified by the two stages  $T_2$  and  $T_3$ , and we again have a positive video signal (white up) appearing on the grid of  $T_4$ . Diode  $T_5$  acts as a d-c restorer to maintain the sync tip voltage level on the grid of  $T_4$ , at the voltage set by the 30,000-ohm rheostat connected to the plate of  $T_5$ . From the plate of  $T_4$ , the amplified video signal goes into the grid of the modulated stage of the transmitter through  $T_6$ , a voltage regulator. An r-f choke in this lead serves as a series video peaking coil. Capacitors are used to pass the high-frequency components of the video signal. Tube  $T_7$  acts as a 150-volt battery and maintains the d-c component in r-f output.

The amplified video signal from the modulator is imposed on the r-f carrier, which is generated by a line-controlled oscillator  $T_8$  and  $T_9$ , coupled to the modulated amplifier  $T_{10}$  through buffer stage  $T_1$ . Oscillator tuning range covers the two channels used in relaying, namely 204-216 mc and 230-242 mc.

In the original 10-watt transmitter design the output of the modulated amplifier  $T_{10}$  was coupled to the antenna by means of a coaxial line. When the 40-watt amplifier was added it was considered simplest from the standpoint of existing gear modifications to utilize half-wave inverter sections of coaxial line in the modulated amplifier section and in the power amplifier section to couple these two stages.

It will be noted that a lead from the r-f output of the modulated

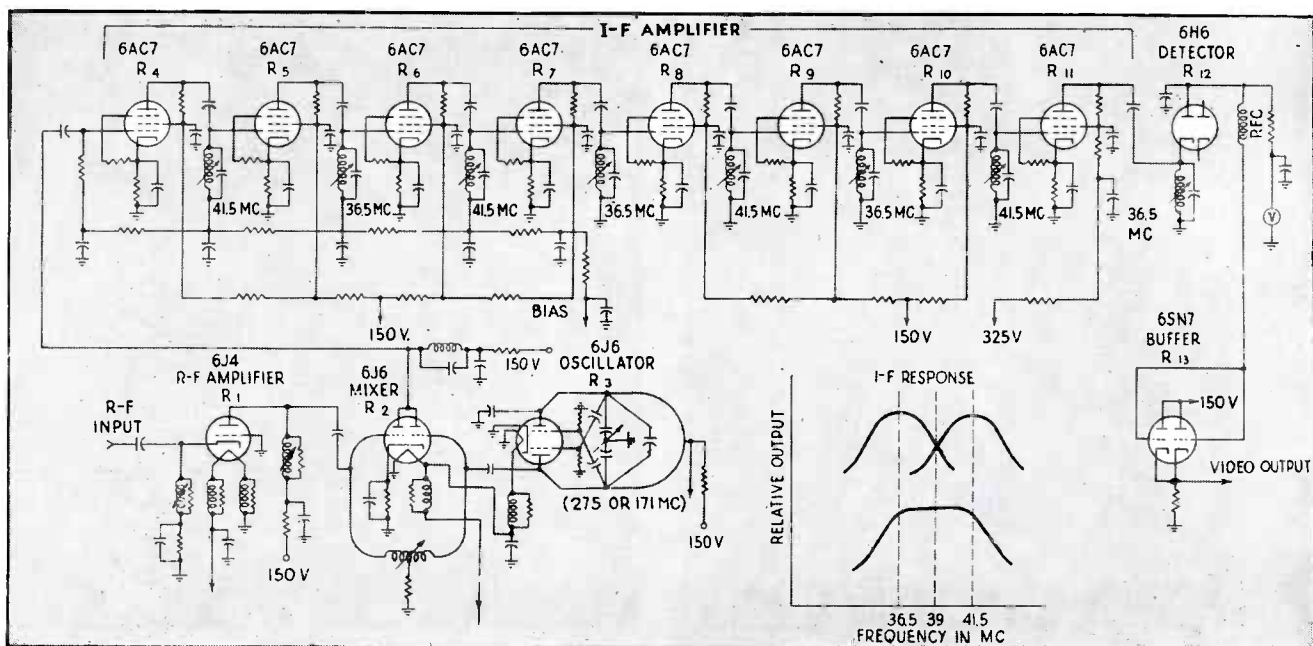

FIG. 9—One of the multiple-relay television network's video receivers, tunable to either of the two bands utilized by the system



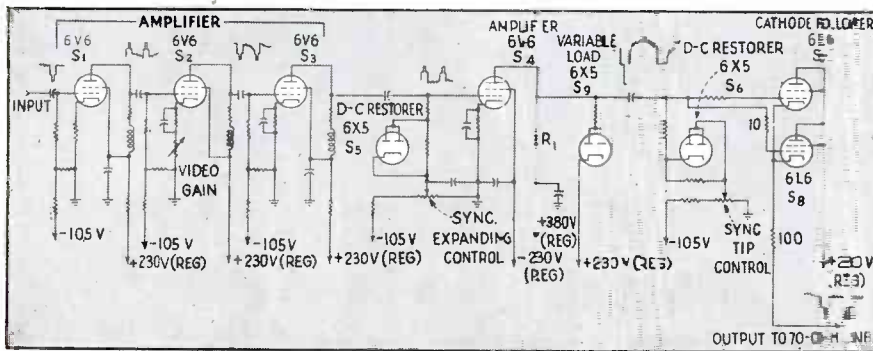

FIG. 11—Simplified schematic of the sync expander unit

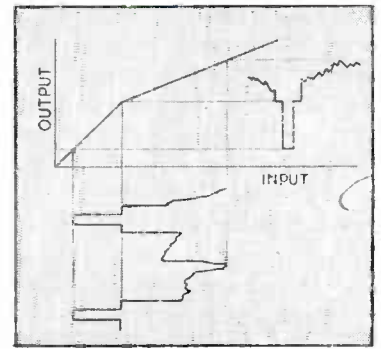

FIG. 12—Sync expander load characteristic

amplifier goes to the cathode of diode  $T_{11}$ . In the plate circuit of this diode is a load resistor which feeds a video signal to cathode follower  $T_{12}$ . This arrangement distributes the signal to a picture monitor and an oscilloscope through the test points shown.

The 40-watt power amplifier tubes  $T_{13}$  and  $T_{14}$  are operated as a grounded-grid cathode-driven stage. Because of the low plate-to-cathode capacitance when operated in this circuit, no neutralization is necessary.

A half-wave section of coaxial line is used in a manner similar to that employed for coupling between modulated amplifier and power amplifier to couple the latter to a coaxial line feeding the antenna.

#### Trailers and Other Equipment

Early in the design of the network, it was decided to mount all receiving, monitoring and transmitting equipment for each relay station, including a complete standby system and power supplies, in a suitable automobile trailer.

It was possible to obtain electrical power from the local lines near each of the four relay points. This meant that we needed to install, in addition to the antenna towers and trailer at each hilltop relay site, only a simple galvanized steel building to house spare parts, tools and an auxiliary gasoline-driven generator for standby power.

In the building a monoscope video signal generator has also been installed. It is pictured in Fig. 15. Arlington is the only relay station so equipped. Usually, the generator is used to televise a test chart and transmit the chart image along the

network to simplify operational checks at all relay points and at the home station.

We use farmer's telephone lines to connect the television studios in Washington and Philadelphia with the four relay stations. In addition to these six phone installations, we have a seventh at the laboratories in North Philadelphia. Each point

has a specified number of rings, and we can hold a seven-man roundtable conversation when checking operation along the route.

#### Location of Sites

A study of 100-odd profiles of possible paths enabled us to select tentatively four hilltop sites for relay stations. After choosing the

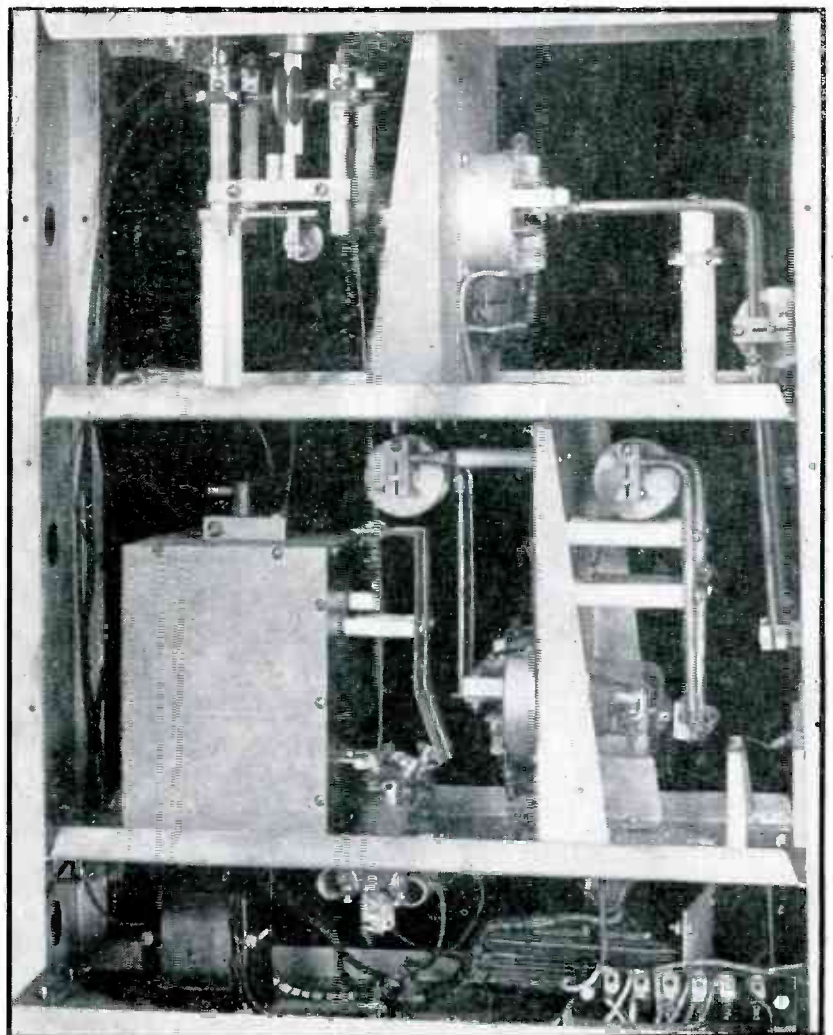

FIG. 13—Close-up of the r-f portion of a typical television relay station video transmitter

four sites and obtaining permission from the owners to proceed with testing, we took a portable television receiver to Honeybrook, the site nearest our home base. At Honeybrook we received a satisfactory picture from WPTZ so we next tried transmitting to WPTZ with a portable transmitter unit that included a portable monoscope video signal generator.

By the time that this two-way test had been completed satisfactorily, our first trailer installation was available. We pulled it to Havre de Grace, the second site to be checked. Here we went through a one-way test, sending out a television picture from the portable monoscope in Havre de Grace to Honeybrook and then relaying it to WPTZ. At Odenton, procedure was the same except that the check included three relay points, Odenton, Havre de Grace and Honeybrook, as well as WPTZ.

At the fourth and last relay site, at Arlington, the permanent monoscope installation was used instead of the portable video signal generator. The same sequence was followed, however, in checking the picture transmitted along the entire network.

The final step was to establish a studio in Washington. The site

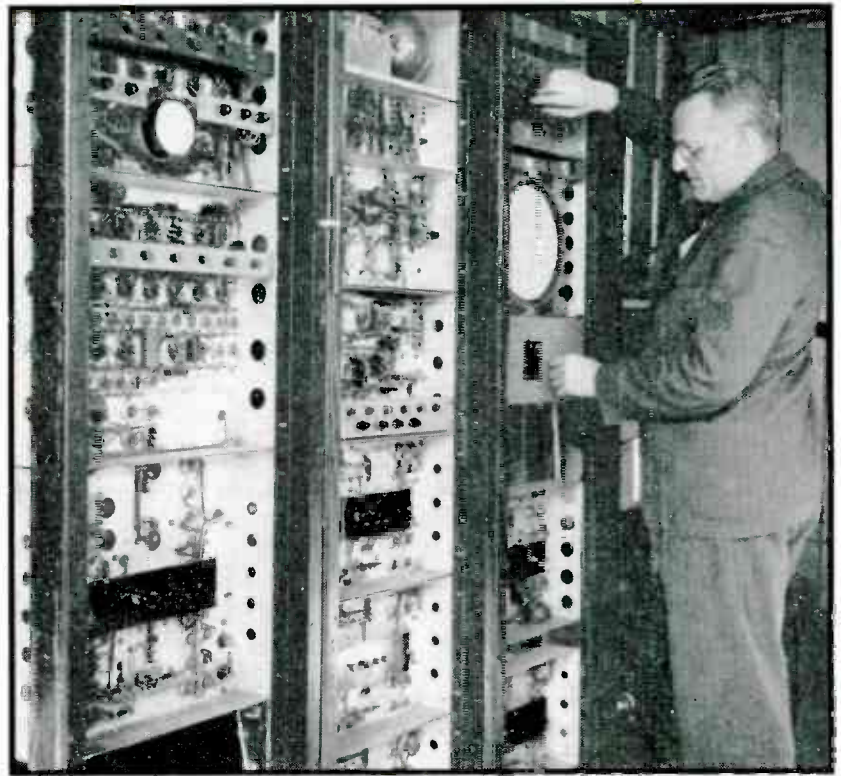

FIG. 15—Television engineer operating monoscope video signal generator in the steel shed at Arlington

eventually chosen was a corner suite on the top (14th) floor of the Hotel Statler. Cameras, lights, transmitters, monitoring and receiving equipment, and test apparatus are installed in this three-room suite. A large room on the corner

is the actual studio, and two smaller flanking rooms are used for transmitting and control (monitoring) respectively. The antenna is a simple 3-element dipole on the roof, since the hop from Washington to Arlington is only about 5 miles.

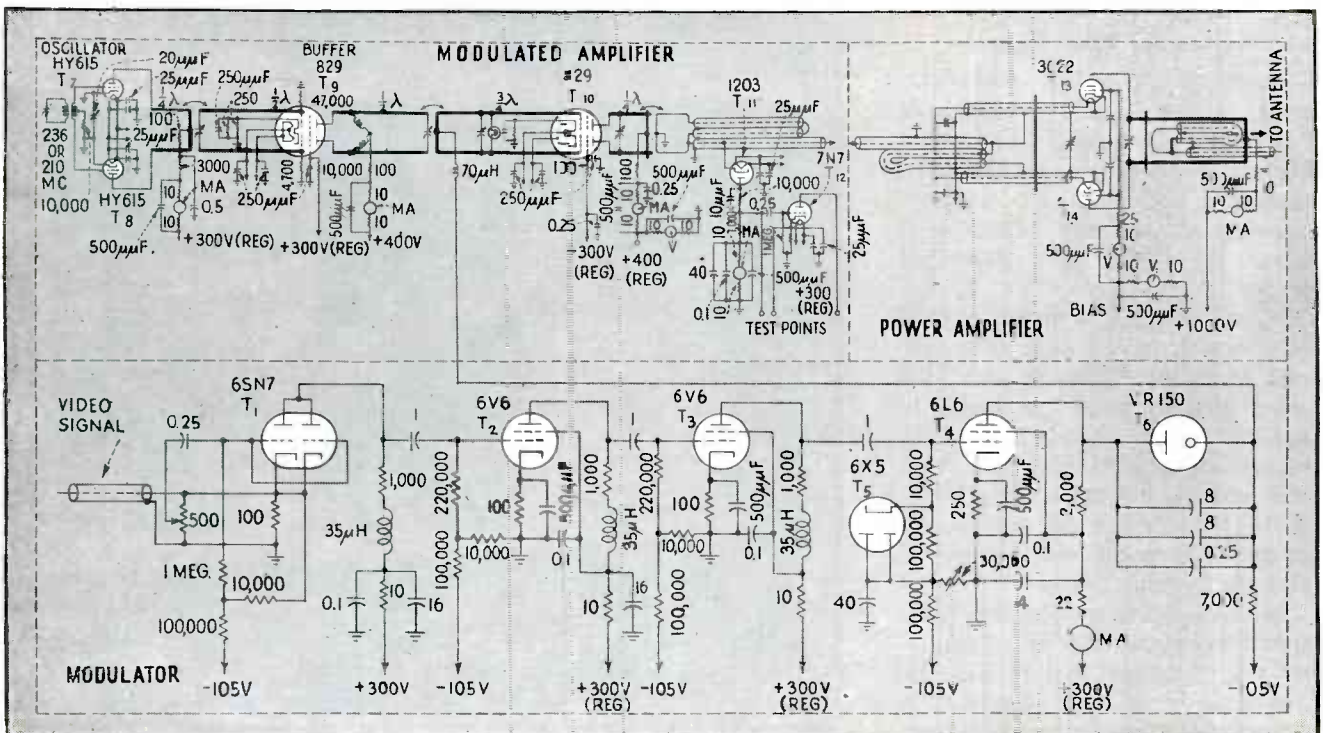

FIG. 14—Circuit of a complete 40-watt video transmitter. Originally 10 watts was fed to an antenna from the output of the modulated amplifier stage. The power amplifier was added later



# The Technical Basis of ATOMIC EXPLOSIVES

**S**EVERAL DAYS after the first-atomic bomb attacks on Japan, to the surprise and gratification of the technical press, the War Department issued a 175-page report on the technical background of the atomic bomb project. The report was written by Prof. H. D. Smyth, head of the Physics Department of Princeton University and consultant to the U. S. Corps of Engineers, to supply as much information as national security would permit.

The document is a masterpiece of technical exposition and is recommended to every reader of *ELECTRONICS* who can secure a copy. Unfortunately, the report received but scant attention in the daily press and its distribution is not widespread. To rectify this situation, the editors have prepared from the report the following summary of the production and use of the atomic explosives.

## Fission—The Fundamental Action

As is now well known, the production of atomic energy is accounted for by the energy-mass equivalence theorem first stated by Einstein in 1905. The equation states that a mass of  $m$  grams may be viewed as being equivalent to an energy of  $mc^2$  ergs, where  $c$  is the velocity of light. This theoretical postulate was later proved through the study of radioactive materials. It was found that when a heavy radioactive substance undergoes a spontaneous transmutation, it breaks up into one or more elements of less total mass. The difference in mass appears in the form of radiant or kinetic energy, as evidenced by

Based on information recently released by the War Department, this article describes the production and use of the two principal atomic explosives, uranium-235 and the new element plutonium

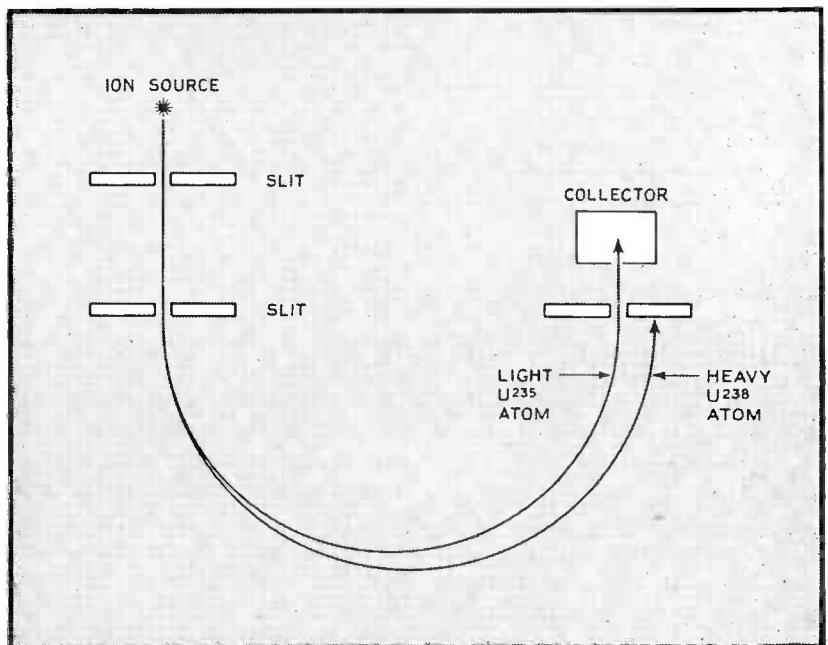

An electronic method of separating desired  $U^{235}$  atoms from the  $U^{238}$  atoms which constitute the bulk of uranium metal. Here, utilizing a principle similar to that employed in a mass spectrograph, light  $U^{235}$  atoms are caused to move along a curved path to a collector, while heavier  $U^{238}$  atoms move along a path having a different radius and are blocked

the radiations and particle emissions which accompany the transmutation.

The striking aspect of this process is the size of the quantity  $c^2$  which relates the energy produced to the loss of mass. This quantity is  $9 \times 10^{20}$  ergs per gram. Thus 2.2 pounds of a substance (1 kilogram)

completely transmuted into energy is equivalent to 25 billion kilowatt hours of energy, which is equal to the electrical energy generated by all the U.S.A. utilities over a period of two months. It is evident that if even a small portion of a gram of matter could be so transformed, an explosion of epic proportions might

be made to occur. But the transmutations occurring in natural radioactive substances involve so small a percentage of the material present, and the mass change itself is so small, that no substantial concentration of energy occurs.

The search for practical amounts of atomic power was directed along two avenues: to find natural or artificial radioactive substances whose transmutations involved a large change in the atomic mass, and to develop means of concentrating these substances so that a large portion of the material present would undergo transmutation at once. Both of these avenues have been explored with almost superhuman intensity over the past five years, with the result which the world now recognizes as perhaps the greatest achievement of organized science.

#### Uranium and Plutonium

Two radioactive substances having the necessary large mass change have thus far been isolated on the scale necessary for atomic bombing: a natural isotope of uranium, known as uranium-235 ( $U^{235}$ ), and a new artificially-created element, tentatively named plutonium ( $Pu^{239}$ ). These substances have the property of undergoing a particular form of radioactive transmutation known as *fission* (a cleaving or breaking into parts) when irradiated with low-speed neutrons.

When an atom of either of these elements breaks up, the products formed are elements much lighter than the original, and the sum of the masses of the lighter elements is substantially less than the mass of the original atom of  $U^{235}$  or  $Pu^{239}$ . Hence the energy released by the fission is very great. Moreover, and most important, the fission is accompanied by the production of additional neutrons. Thus if but one neutron is originally present and only one atom is transmuted at the start, additional neutrons are produced which irradiate the nearby atoms, producing new fissions. The process builds up cumulatively and the disintegration of the whole mass of material is self-sustaining. This is the so-called chain reaction which is essential to the action of the atomic explosive.

For the chain reaction to proceed

it is necessary that the number of neutrons produced in a given time exceed the number absorbed or lost by the system in the same time. This condition is expressed by an equation which is basic to the whole science of atomic power. A chain reaction occurs if

$$N\epsilon pf\eta \geq N \quad (1)$$

where  $N$  is the number of free neutrons originally present and the factors  $\epsilon pf\eta$  represent the regeneration and loss of neutrons in the course of the atomic disintegration. Specifically  $\epsilon$  is a factor greater than 1 representing the production of fast (high velocity) neutrons,  $p$  a factor less than one representing the loss of neutrons by resonance capture without succeeding disruption of the atoms,  $f$  is a probability factor representing the chance that the low speed (thermal) neutrons will be absorbed in the uranium or plutonium atoms and thus produce fission, and  $\eta$  is the number, between 1 and 3 of neutrons produced by the fission of each atom. If the product of these factors  $\epsilon pf\eta$  (called the multiplication constant,  $k\infty$ ) is greater than unity, the reaction occurs; otherwise it does not.

One of the basic problems of atomic research was to find a suitable arrangement of uranium or plutonium, mixed with other substances, to insure that  $k\infty$  exceeds unity. The first such successful arrangement was produced in 1942 at the University of Chicago, and the chain reaction was first observed on December 2 of that year. The reaction was stabilized or controlled so that  $k\infty = 1$  and a steady flow of power produced. The power produced was minute, only  $\frac{1}{2}$  watt. But the principle was established, proving not only the feasibility of the atomic bomb itself, but indicating the process whereby plutonium could be manufactured on a continuous basis from uranium metal. This process was embodied in the Hanford, Washington, plant which began operation in September 1944 and has since served as one of the principal sources of atomic explosives.

#### Basic Requirements of an Atomic Bomb

There are several requirements which must be met in the design of

an atomic bomb. First, the bomb must be stable and safe to handle prior to its release from the bombing aircraft. Second, it must be efficient in the use of the atomic explosive, which is a very precious material. The first requirement is satisfied by making use of the fortunate fact that the atomic explosive does not explode so long as the amount of material initially present is smaller than a certain critical size. By bringing several such small pieces together quickly, so that the sum of their masses exceeds the critical size, the explosion can be made to occur at any desired time.

The second requirement, efficiency, is met by confining the explosion in a strong and massive container or tamper, so that the disintegration of the desired amount of explosive occurs before the bomb flies apart. If no such container were provided the initial force would separate the explosive material into small pieces which, by themselves, would not disintegrate further. Even with such a container, the time available for completion of the chain reaction in the bomb is very short, of the order of milliseconds, so means must be taken for insuring complete migration of the neutrons through all parts of the explosive before the container releases its contents. This implies the use of fast neutrons as the detonating agent.

The reason that pieces of atomic explosive smaller than a certain critical size will not explode is readily seen from the following: In a small piece of material, the surface area of the piece is large compared with its volume, and the number of neutrons lost through the surface is so great, relative to the number produced, that sufficient multiplication of the neutrons to cause a chain reaction does not occur and the material remains stable. As the size is increased, however the volume increases faster than the surface area and the ratio of neutrons produced to those lost through the surface increases proportionately. The critical size is reached when the number of neutrons lost through the surface, and through the other losses indicated in Eq. (1), just equals those produced. In pieces larger than this,



the chain reaction becomes self-sustaining and the explosion occurs.

For reasons of security the exact value of the critical size is not given in the report, but it is stated to be between the limits of 2 kilograms and 100 kilograms (between 4.4 and 220 pounds). The press has stated that a piece weighing 25 pounds is sufficient for the atomic bomb, but there is no official confirmation of this figure.

No other details regarding the bomb itself are available except the method of bringing the pieces of explosive together. The reaction will start when the pieces are brought in close proximity and the speed of the reaction is so great that the pieces might be blasted apart before they reach firm contact, with consequent lowering of efficiency. To avoid this, the pieces must be brought together in a few microseconds, and this is accomplished by shooting, with a gun mechanism, one piece at another with such force and at such high velocity that they merge into a solid mass before the explosion takes place.

Even though these precautions have been taken the full force of the atomic explosion has not yet been realized. Although the present efficiency is not reported, a report on the subject written in 1941 indicated that from 1 to 5 percent of the potential fission energy might be released before the material becomes so far separated as to cause the reaction to cease. On the basis of these figures it was stated that 1 kilogram of  $U^{235}$  would equal the effect of 300 tons of TNT. Figures released to the press regarding the first bomb dropped on Japan indicated an explosive effect equal to that of 20,000 tons of TNT, which would indicate a weight of  $U^{235}$  of about 67 kilograms (150 pounds), based on the above figures. If the efficiency realized is higher than that predicted in 1941 (as it may well be), the weight required to produce this effect is proportionately less. The weight is evidently not a deterrent from the standpoint of carrying the bomb in an aircraft, even considering the auxiliary detonating and containing structures. Nor is the size excessive, since 25 pounds of

## Equations Behind the Atomic Bomb

### Mass-energy equivalence theorem

$$E = 9 \times 10^{20} m$$

where E = energy in ergs

m = grams of matter

### Chemical reaction producing plutonium

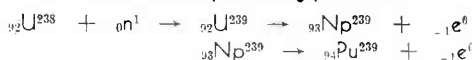

where U = uranium

n = neutron

Np = neptunium

e = electron

Pu = plutonium

Subscripts indicate atomic number, or positive charges on nucleus

Superscripts give mass number, that is: the number of massive particles in the nucleus

### Fission reaction (atomic explosion)

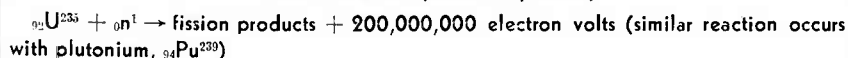

uranium occupy a cube only 3.3 inches on a side. But obtaining such amounts of the uranium or plutonium from natural sources, was a staggering problem.

### Availability of Materials

Estimates place the percentage of natural uranium in the earth's crust at about 4 parts per million. Substantial deposits are known to exist in Colorado, northern Canada, Czechoslovakia, and in the Belgian Congo. By the end of 1941 only a few grams of purified metal had been produced. But by June 1942 deliveries of the brown dioxide of uranium, the basic raw material, had reached 30 tons per month. By Nov. 1942, 6000 pounds of pure uranium metal had been accumulated, and by 1943 upwards of 500 pounds of the metal were being produced each day. The cost at that time was 22 dollars per pound. Thereafter, improved processes were introduced and no further metal shortages have since occurred.

Uranium metal consists of two isotopes, one of atomic mass 238 ( $U^{238}$ ) and the other of atomic mass 235 ( $U^{235}$ ). The active portion,  $U^{235}$ , is present only to the extent of 1 part in 140 (0.7 percent). The remaining 99.3 percent of  $U^{238}$  so dilutes the  $U^{235}$  that in the natural state uranium does not react chainwise except when assembled in masses so great as

to be completely impractical for purposes of bombing. The alternative was to remove the  $U^{235}$  from the  $U^{238}$  to permit its use in concentrated form. The compactness thus achieved permits easy transportation by aircraft and also permits achieving high efficiency in the bomb.

Separation of the  $U^{235}$  from  $U^{238}$  is far from simple. The two isotopes have similar chemical properties and hence cannot be separated by chemical processes. The only basis on which they can be separated is a slight difference in mass, amounting to about 1.3 percent. Thus the separation must be based on some physical process, involving a difference in the speed of the atoms as they move under thermal, mechanical or electric forces. Unfortunately, the difference in speed depends only on the square root of the mass ratio, and in a large group of atoms the speeds have statistical distributions which overlap. Hence the separation is only partial and must be repeated many times to produce even partially pure  $U^{235}$ . Of over a dozen methods of isotope separation known, four were considered capable of large scale operation in 1942, provided that truly heroic measures were taken in setting up the separation equipment on a large scale.

Since this approach would take time, and since there was great

fear that the Germans might be well ahead in the same problem, another approach was sought, found and pursued independently. This second approach was the production and separation from uranium metal of a new element, plutonium.

During the study of the effect of neutrons on uranium, it was found that two new elements might be produced artificially. These two new elements have different chemical properties and hence are separable from the parent uranium by chemical means of much higher efficiency than the physical methods necessary to separate  $U^{235}$ . The production of plutonium starts when a neutron of proper speed enters the nucleus of  $U^{238}$  (the more plentiful part of uranium metal) and is absorbed there, giving rise to a new isotope of uranium,  $U^{239}$ . This isotope transmutes spontaneously, one half the atoms present changing in 23 minutes, into an intermediate element, neptunium, accompanied by the emission of a high speed electron. The neptunium thereupon transmutes (half-life 2.3 days) into plutonium, again with the emission of a high speed electron.

The plutonium has a half-life of over 1000 years, that is, it decays so slowly that in effect it can be considered a stable element. When its properties were first investigated, theoretical predictions were made that plutonium, like  $U^{235}$ , would undergo fission when bombarded with slow neutrons. This was later proved to be in case. Thus for all practical purposes, pure  $U^{235}$  and plutonium are equivalent as atomic explosives, whereas plutonium is considerably easier to produce and extract because large scale chemical processes may be employed. Moreover, the raw material from which plutonium is extracted is  $U^{238}$ , which constitutes 99.3 percent of natural uranium, and hence the plutonium obtainable from a given store of metal is potentially much greater than the amount of  $U^{235}$  (0.7 percent) present.

All these factors made plutonium production very attractive and plans to produce it on a large scale were drawn up. The scale of this effort can be estimated from the

fact that at one time some 60,000 people were at work on the site of the Hanford, Washington, plutonium plant, and the total area under government control is nearly 1000 square miles. The temperature of the Columbia River has been raised an appreciable number of degrees by the cooling water discharged from the plant, which consists of three huge producing units and associated chemical separation plants.

#### Methods Used to Separate U-235

To insure a source of separated  $U^{235}$ , three plants were also set up in the Clinton Engineering District in Tennessee, each plant designed for a different method of isotope separation. The three methods used are gaseous diffusion, thermal diffusion, and electromagnetic separation utilizing the principle of the mass spectrograph. The thermal diffusion process was not used to produce the end-product, but rather to provide an enriched form of  $U^{235}$  to feed into the electromagnetic process.

The gaseous diffusion plant was planned in the winter of 1942-43 and a few sections went into operation in 1944. The completed plant was in full operation before the summer of 1945. Separation by gaseous diffusion is based on the fact that the light molecules of a gas mixture diffuse more readily through a thin sheet of metal than do the heavy molecules. For diffusion to take place, the sheet (known as a barrier) must have billions of tiny holes in it, none of which is larger in diameter than 0.0000004 inch.

One form of barrier, since improved upon greatly, is a thin sheet of silver-zinc alloy etched with hydrochloric acid. A gas containing uranium (uranium hexafluoride was used in the early work and other gases have been investigated) is placed on one side of such a barrier, at atmospheric pressure, and the space on the other side is evacuated. As the gas diffuses, the lighter molecules made up of the  $U^{235}$  isotope pass through the holes somewhat more readily so the mixture of gas which accumulates on the evacuated side contains a higher percentage of  $U^{235}$  than that

on the other side. The enrichment in one such stage of diffusion is very slight, amounting to about 0.3 percent for  $UF_6$ , and not all this is realized due to reverse diffusion. To secure substantially pure hexafluoride of  $U^{235}$  the process must be repeated over and over again, roughly 4000 separate stages of diffusion being required to achieve 99 percent purity. The  $U^{235}$  metal can then be recovered from the gas by conventional chemical processes.

To secure large amounts of  $U^{235}$  by this process literally acres of barrier sheets, and thousands of pumps to evacuate the low-pressure side of each stage, were required. The steam power plant built to supply the power for this purpose is one of the largest ever built.

Thermal diffusion, the second method of separation, accomplishes separation of molecules of different weight by the effects of a temperature gradient. The method had been applied to gases prior to 1920 and had been used successfully to separate isotopes in Germany in 1938. The process adopted at Clinton makes use of the liquid, rather than gaseous, phase of uranium hexafluoride. The plant structure is much simpler than that required for gaseous diffusion and construction was completed in the summer of 1944.

The electromagnetic separating plant, the first large-scale producer of purified  $U^{235}$ , began operation in 1943 in a small number of units which were subsequently enlarged. The plant began large-scale operation at the end of 1944 and produced  $U^{235}$  of sufficient purity for use in atomic bombs. The principle of operation is basically that of the mass spectrograph, in which positive ions of uranium are accelerated electrically to a very high speed and then passed through a transverse magnetic field which causes the ions to move in circular paths, the radii of which are proportional to the atomic mass.

A diagram in these pages shows the basic action of such a separator. The lighter ions, containing the  $U^{235}$ , move through an arc of shorter radius, at the end of which is a slit through which the atoms pass to the collector. The heavy atoms of  $U^{238}$ , moving along another



arc, are intercepted. This electronic method of purifying  $U^{235}$  is attractive in its simplicity, but prior to 1941 it was not considered suitable for large scale operations. The limitations were the difficulty of producing a large quantity of gaseous uranium ions, the wastage incident to forming the ion beam, and space charge effects in a dense beam of ions, all of which limited the yield of purified  $U^{235}$ .

The final form of mass separator, called a calutron (after California University, where it was developed), overcomes these limitations in several respects. The space charge is neutralized by ionization of the residual gas in the chamber through which the ion beam passes. A more copious source of ions was obtained by widening the slit of the ion gun, and controlling the divergence of the beam through space-variations in the applied magnetic field. In this way the current in the ionic beam, and hence the rate of collecting separated  $U^{235}$ , were vastly increased. The process was applied experimentally on a large scale by the use of a great many calutron separators within the field of a single magnet, the largest in existence, with circular pole faces 15 feet across, and with an air gap of 6 feet. This magnet had been built for the giant cyclotron at Berkeley but was converted and used in the development of the calutron. In the final production system a number of magnets, each containing many separators in its air gap were set up at the Clinton works and fed with power from the TVA system.

Although the report makes no mention of the fact, newspaper reports indicate that 28 million pounds of silver were borrowed from the U. S. Treasury to wind the coils for these magnets, because copper was not available. The silver also had lower losses, and would be recoverable at the end of the project.

Another electronic device for separation is the isotron. This tube employs the principle of the klystron, bunching ions by velocity modulation of the ionic beam. A source of positive ions (an area larger than the slit of the calutron, and hence carrying more material) is accelerated to high velocity by application of a steady high-voltage

electric field. Since the ionic velocity is inversely proportional to the square root of the mass, the  $U^{235}$  ions reach higher velocities than the  $U^{238}$  atom. Superimposed on the steady accelerating voltage is a sawtooth wave of voltage which causes the ionic velocity to be modulated, and the stream of ions is thus bunched in the same manner as the electron beam in a klystron. Since the two forms of ions are traveling at different speeds, the  $U^{235}$  and  $U^{238}$  bunches occur at different positions along the axis of the tube. Hence separation of the ions is achieved along the ion beam.

To collect the  $U^{235}$  ions, it is necessary to transmit them to a collector plate without at the same time collecting the  $U^{238}$  bunches. The separation is carried out by a transverse electric field, synchronized with the sawtooth bunching field, and timed so as to deflect the  $U^{235}$  bunches as they arrive. The field is cut off as the  $U^{235}$  bunches pass, hence this component of the ion beam passes undeflected to a collector plate. While this device produced partially separated samples of  $U^{235}$ , it was not deemed as useful as the other separation methods and its large-scale applicability to large scale processes was not investigated.

Another electronic means of separation, based on the principle of the magnetron, was investigated but not developed to the point of large scale use. This device, known as the ionic centrifuge, operates on the principle of whirling an ionic beam in a transverse magnetic field.

#### Production of Plutonium

The reaction producing plutonium has already been described. In the production of plutonium the problem was to achieve a controllable chain reaction such that plutonium could be produced at a continuous rate from uranium metal without danger of an atomic explosion. The solution to this problem is a structure known as a chain-reacting pile, consisting of rods of uranium sealed in aluminum jackets and inserted in a large block of graphite. The heat produced in the reaction is removed by passing water through the pile, between the uranium rods and the

graphite. Control rods of inert material are inserted in the graphite and moved in or out of the pile by remote control so that the neutron production may be speeded up or slowed down as the reaction proceeds. The positions of the control rods are adjusted automatically so that the neutron multiplication factor remains at unity. The chain reaction is thereby stabilized and proceeds at a constant rate, and the  $U^{238}$  in the uranium metal is continuously transformed into plutonium.

Two processes occur simultaneously in the pile: the  $U^{235}$  present undergoes fission in a chain reaction (the amount of uranium present is large enough in the presence of the graphite to support such a reaction) and the fission of the  $U^{235}$  provides a continuous supply of fast neutrons. These are slowed down in the graphite. Some of these slow neutrons enter the remaining  $U^{235}$  to maintain the chain reaction, while others, of suitable speed, are absorbed by the  $U^{238}$  present, thereby initiating the plutonium reaction previously described. As the reaction proceeds, the  $U^{238}$  is transmuted to a number of fission products, the  $U^{238}$  yields an increasing amount of plutonium, and a great deal of heat is liberated. When the reaction has proceeded to a safe limit, the control rods are manipulated to stop the reaction and the aluminum jackets, now containing  $U^{235}$ ,  $U^{238}$ , plutonium and fission products, are removed from the pile and transported to the chemical separation plant.

The separation is accomplished in huge concrete troughs or canyons. The contents of the aluminum jackets are dissolved and the plutonium precipitated from the solution in the form of an oxide salt. By successive precipitations of different oxides, the plutonium is removed from the uranium as well as from the fission products, which comprise some 20 elements, all violently radioactive. The separated plutonium oxide is then reduced to produce the pure metal. Three piles, operating at a power level in the hundreds of thousands of kilowatts (a measure of the heat produced by the reaction) were in operation during the summer of 1945 at the Hanford plant.—D. G. F.

# CRACK DETECTOR FOR

Cracks in metal wire, bars, and tubing, passed through the field of the inductor of one of two oscillators, change the beat frequency. Beat voltages are rectified to operate a meter, a neon tube and a relay. Cracks are marked by paint sprayer when relay closes

By JOHN H. JUPE

Enfield, England

**D**ETERMINATION of the quality of a metal product has frequently been a laborious process where it has been necessary to rely on fatigue tests and the study of microsections of samples. Such procedure is slow and costly and conducive to waste in production. A solution to the problem of production testing, at high speed, for cracks in metal wire, tubing and bars is based on the electrical characteristics of the metal under test. A compact electronic instrument has been designed for this purpose

by Salford Electrical Instruments, Ltd., a subsidiary of General Electric Company, Ltd., of England.

### Basic Principle

It is well known that the depth of penetration of r-f current in a conductor is related to frequency, permeability and conductivity. The decay of current toward the center of the conductor is exponential and can be compared to a transmission line, where the attenuation constant gives a measure of the decay in current at the end. In practice, where

depth is concerned, it is sufficiently accurate to take the depth of current as being the point where attenuation occurs to the extent of one neper (8.686 db).

Depth of current, in thousandths of an inch, for one neper loss, is given by the formula

$$D = 1.98 \sqrt{\frac{1}{f\mu\sigma}}$$

where  $f$  = frequency

$\mu$  = permeability

$\sigma$  = resistivity in microhms per cu cm

Figure 1 shows a graph which has been calculated for copper at 60 F, steel at 60 F and steel at the Curie point. Of course, the depth of current will vary with  $\mu$  and  $\sigma$  but in general, variations in magnetic materials are sufficiently narrow to assume a uniform depth of current at one frequency for low values of magnetic field strength. Slight variations of conductivity (the only variable in the case of non-magnetic materials) cause little difference in the depth of current, which is proportional to the square root of the conductivity.

### Simulates Transformer

The above theory is applied in the new instrument by first arranging a coil to induce eddy currents in the sample at right angles to the axis. Then, if the frequency is such that the current penetration is deeper than the deepest crack, the effect will be to provide a short-circuited turn and an effective variable resistance in the coil, which will act like the secondary of a transformer transferring its load to the primary. If the oscillator frequency is now measured, using a

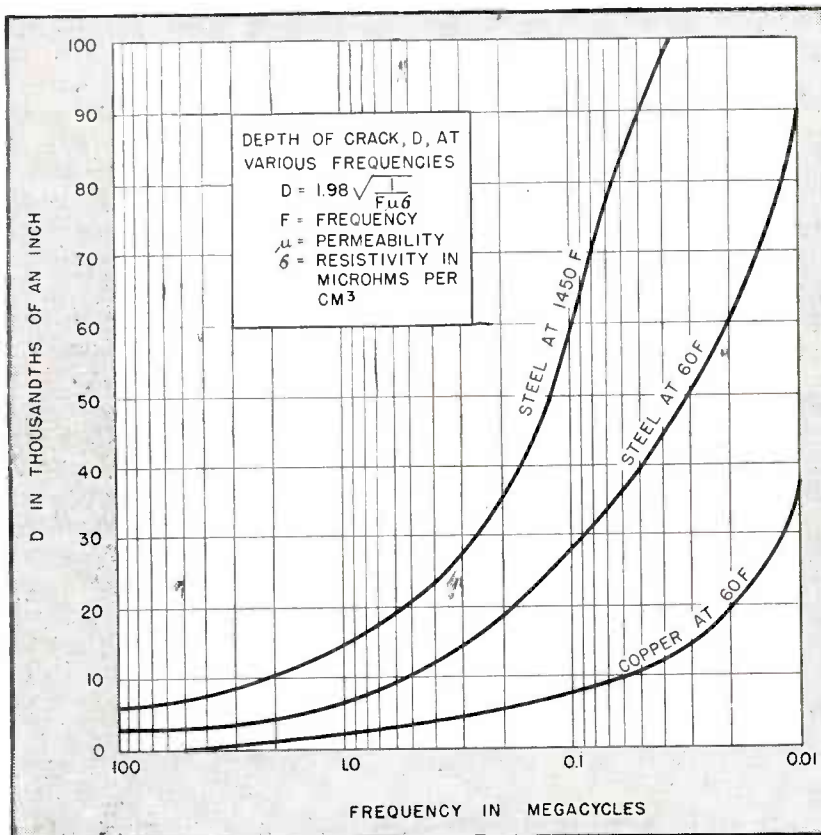

FIG. 1—Depth D of crack is graphically represented as a function of frequency



# PRODUCTION TESTING

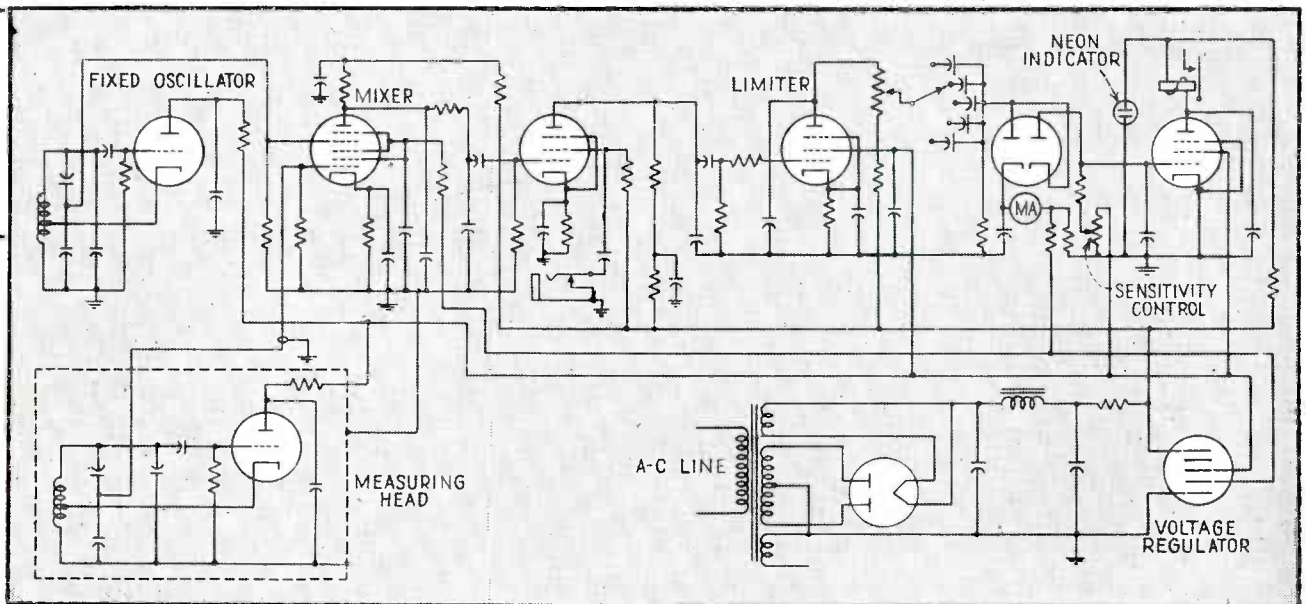

FIG. 2—Complete circuit of the radio-frequency crack detector. Materials to be tested are introduced into the field of the inductor in the measuring head. Cracks in the material act like shorted turns, changing the inductance and hence the beat frequency produced in the mixer

crack-free sample to act like a short-circuited turn, the frequency will be found to change because of the change in the oscillator inductance when a crack enters the field of the coil.

A portion of the oscillator voltage is taken and passed through filter circuits and an indicating instrument so that a variation in frequency, caused by a crack, has the effect of causing a large variation in output voltage as shown on a meter. To avoid worker fatigue and to insure against missing short flicks of the meter pointer a neon lamp flashes at the same time.

The fact that cracks are rarely uniform in depth for more than a fraction of an inch, or may be full of oxide, has not been found to be serious in operation of the instrument but should be borne in mind when attempting to take a micro-section on a sample.

The crack detector is capable of giving indications of cracks from 0.0005 to 0.25 inch deep. The lower limit is set, not by the apparatus but by the surface condition of the sample. Material from 0.125 to 0.5 inch and from 0.5 to 6.0 inches in diameter can be tested in two standard instruments.

Figure 2 shows a schematic of the equipment. The method of operation is as follows: The sample to be tested passes through the inductance of an oscillator in the measuring head, which is beating against a fixed frequency oscillator. The resultant output is mixed in the pentagrid tube. Audio output is amplified by the first stage and passed into a limiter, which feeds a square-wave output to the diode frequency-measuring circuit. Another diode takes the rectified d-c and operates a neon tube and relay in the anode circuit of the final

pentode. The function of the neon tube is to provide a quick indication of a crack when material is being tested at a high speed.

The neon tube can be made to fire at any predetermined depth of crack by adjustment of the potentiometer in the grid circuit of the pentode. To make the operation entirely automatic, the relay in the anode circuit of the last pentode operates a small compressed-air paint sprayer, which marks the faulty material over the crack. The relay is adjusted to close when the neon tube fires.

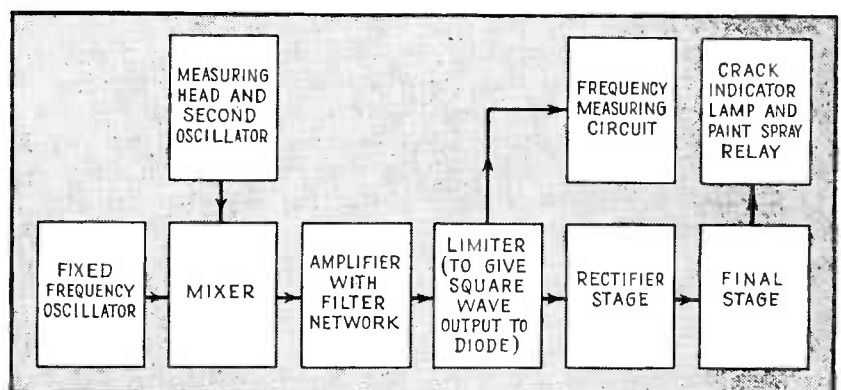

FIG. 3—Inter-relation of circuit functions is illustrated by this block diagram of the crack detector

# Design of STABLE

By JOHN B. MOORE

RCA Communications, Inc.  
New York, N. Y.

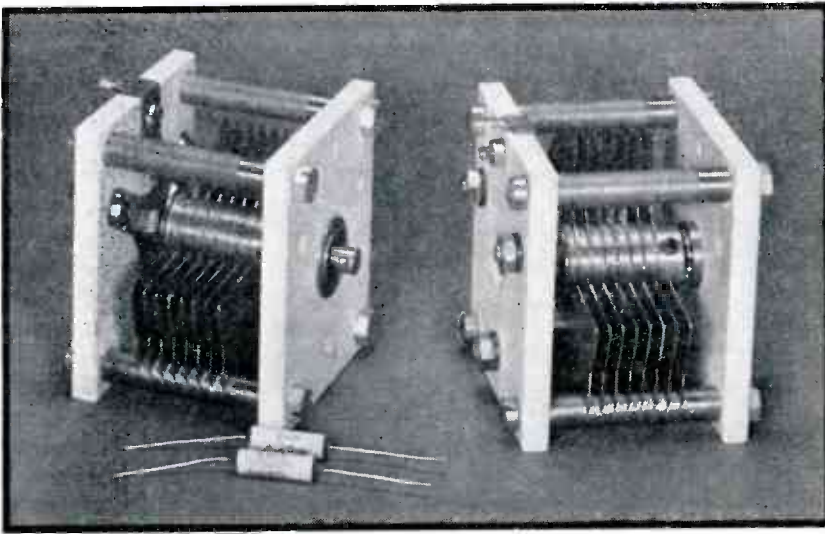

FIG. 1—Examples of variable capacitors designed to compensate the temperature coefficient of coils in heterodyne oscillators, and midget ceramic capacitors used to compensate small fixed values of capacitance in the tuning capacitors

THE PRINCIPLES, factors, and methods discussed herein have been successfully applied in the design of heterodyne oscillators for certain commercial equipment. Variation of frequency with temperature can be brought down to a consistently low value of less than  $10/10^6/^{\circ}\text{C}$  (ten parts per million per degree centigrade) over the normal tuning range of something more than 2 to 1 in oscillator frequency, without resort to special treatment of individual oscillator assemblies, by employing a carefully designed variable capacitor like those shown in Fig. 1.

The electrical circuit of the heterodyne oscillator under consideration employed a conventional Hartley oscillator arrangement, as shown in Fig. 2. The frequency-determining elements that are affected by temperature are (1) the inductance coil  $L$ , (2) the variable capacitor  $C$ , (3) the interelectrode capacitances in the tube, its base, and its socket, and (4) resistance values, stray capacitances from wiring to grounded chassis, etc. The main elements will be treated separately.

## Inductance Coil

For high-frequency oscillators to cover a receiver range of from about 4 mc to 25 mc, the coil nor-

mally will be of bare copper wire wound on a form made of insulating material. Except where special means are employed to wind the wire under tension and to anchor both ends in such a manner as to retain this tension, the wire normally will be sufficiently loose on the form so that its expansion and contraction is essentially independent of that of the insulating form. The diameter of the copper-wire coil therefore has a temperature coefficient of expansion of plus  $14/10^6/^{\circ}\text{C}$ . The resultant variation of inductance is plus  $28/10^6/^{\circ}\text{C}$  and that of frequency is minus  $14/10^6/^{\circ}\text{C}$ . Lengthwise expansion and contraction of the insulating form has a much lesser effect, and ordinarily may be disregarded.

While it is possible to reduce or compensate the temperature coefficient of inductance of the coil assembly, such methods generally are not practical for quantity production. They are apt to be fussy, expensive, and none too reliable over a long period of time and under usual conditions or procedures of maintenance and repair. It therefore seems preferable to make a good substantial and low-loss coil, preferably on a ceramic form, having a reliably uniform and constant temperature coefficient of induc-

tance. As stated above, that should be about  $28/10^6/^{\circ}\text{C}$ , giving a frequency variation of minus  $14/10^6/^{\circ}\text{C}$ .

## Variable Capacitor

The variable capacitor is the element that can be expected to give most of the trouble. Various types tested have given overall frequency variations vs temperature that vary widely in magnitude. In some cases the variations are plus and in some cases they are minus. The major problem, therefore, is to obtain a design of variable capacitor that can be produced under factory conditions and yet will have a uniform temperature coefficient of capacitance of the desired sign and magnitude.

Instead of attempting to analyze any specific type of commercially available capacitor of conventional construction, let us point out the basic factors and solutions. Their practical application will depend upon the specific design problem or equipment.

In Table I are listed approximate values of the linear coefficients of thermal expansion, expressed in parts per million per degree centigrade, for various materials that enter into the construction of variable capacitors.

## Plate Area Problem

The most obvious fact is that the area of the interleaved metal plates of the variable capacitor will increase with increasing temperatures, and vice versa. For aluminum plates, the increase in area, and therefore in capacitance, would be approximately  $48/10^6/^{\circ}\text{C}$ . This would add to the change in oscillator frequency produced by the coefficient of inductance of the coil. Obviously this is not what is needed. We should have a capacitor that will provide a negative rather than



# HETERODYNE OSCILLATORS

Methods of eliminating, minimizing, or compensating the temperature-produced changes that affect frequency. Overall oscillator stability of better than 10 parts per million per degree C over a 2-to-1 tuning range at 24 mc can be obtained in production

a positive temperature coefficient of capacitance. This then will compensate for the inductance variation.

Further inspection of the tabulated figures will show that Invar—a special 36 percent Ni nickel-steel—has an almost negligible coefficient of thermal expansion. Invar, copper-plated to provide good electrical conductivity, would seem to be the metal to use for the plates of the variable capacitor. This is a satisfactory partial answer, provided such copper-plated Invar plates are supported at essentially one point—as in the rotor assembly. If supported at two or more points in a framework composed of other metals or of insulating materials, the difference in coefficients of thermal expansion will cause such plates to buckle and thereby change the spacing between, say, stator and rotor plates. This buckling is very slight, but we are dealing in terms of parts in a million. That means, in this case, millionths of an inch.

If we make the rotor plates of Invar, and so arrange the stator plates that their expansion toward the central shaft is compensated by their being bodily shifted away from the central shaft because of expansion of the supporting end

plates, we find that the area of dielectric (air) included between the interleaved rotor and stator plates then remains constant. The method of accomplishing this will depend on the general mechanical design of the variable capacitor. Reference to Table I will show that one possible combination is to have supporting end-plates of Isolantite and stator plates of 42 percent Ni nickel-steel, because these two materials have nearly identical coefficients of thermal expansion.

## Plate Spacing Problem

We now have an area of active air dielectric which, instead of varying with temperature, remains constant. This is a step in the right direction. But how about the thickness of the dielectric—the spacing between rotor and stator plates? If that varies in either an undesirable or an unpredictable manner with variations in temperature, the overall temperature coefficient of capacitance still will not be what is required.

In order to compensate for the plus temperature coefficient of inductance of the coil, the coefficient of capacitance of the variable tuning capacitor should be negative. This can be attained by mounting

rotor plates and stator plates on, let us say, brass supporting and spacing members. A built-up pile of plates and spacing washers is undesirable, because of the various uncertainties introduced by such a construction. A preferable design, from the viewpoint of reliability and reproduceability, is one in which the plates—Invar for rotor and possibly 42 percent Ni nickel-steel for stator—are soldered into annular grooves machined into the surface of the brass sleeve (rotor) or pillar (stator) used as a supporting and spacing member. This insures that the linear expansion of the rotor assembly and of the stator assembly, in the direction of the axis of the main shaft, will be identical. Spacing between the rotor and stator plates thus is maintained uniform, regardless of temperature variations, throughout the length of the rotor and stator assembly. These brass supporting members produce a uniform linear expansion of approximately  $18/10^6$  /°C. This uniformly increases the air spacing between rotor and stator plates by a coefficient greater than that of the brass itself, because of the lesser coefficient of expansion of the sheet stock of which the rotor and stator plates are made. The net coefficient obviously depends upon the coefficients of the several metals used, and also upon the ratio of metal plate thickness to air gap.

## Example of Capacitor Design

A numerical illustration will aid in understanding the foregoing. Assume a rotor plate of Invar having a thickness of 30 mils (0.030 inch), a stator plate of 42 percent Ni

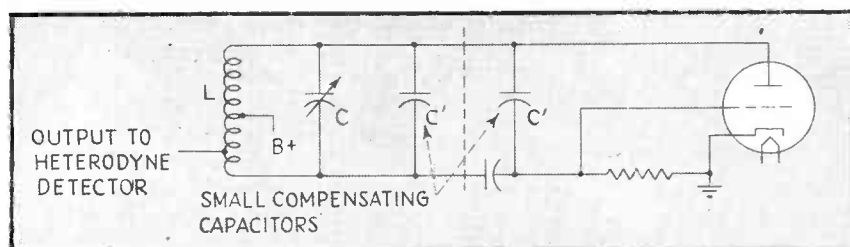

FIG. 2—Hartley oscillator arrangement employed in the heterodyne oscillator under consideration

nickel steel having a thickness of 30 mils, and an air gap of 40 mils. This gives a total spacing between centers, of either rotor or stator plates, of 140 mils (15 plus 40 plus 30 plus 40 plus 15). Expansion of the brass is  $0.140 \times 18 \times 10^{-6}$  inch per degree C. Expansion in thickness of a single rotor plate is approximately  $0.030 \times 1 \times 10^{-6}$ . That of a single stator plate is approximately  $0.030 \times 7 \times 10^{-6}$  inch per degree C. The increase for two air gaps totalling 40 mils is, therefore,  $2.52 - (0.03 + 0.21)$  or  $2.28 \times 10^{-6}$  inches per degree C. This gives a resultant coefficient of  $28.5/10^6/^\circ\text{C}$  instead of only  $18/10^6/^\circ\text{C}$  which might erroneously have been expected.

The resulting thermal coefficient of capacitance is  $-28.5/10^6/^\circ\text{C}$ . Note that this is almost numerically equal to the thermal coefficient of inductance of the coil, but is opposite in sign. The two therefore will compensate each other.

In order to insure the above action, it is essential that the uniform linear expansion of rotor sleeve and stator pillar start from a common reference point or plane. If the brass pillars supporting the stator plates start from a common end frame or insulating plate, but the brass sleeve carrying the rotor plates is fastened to a steel main shaft by means of a setscrew located about  $\frac{1}{4}$  inch from the end frame or insulating plate, the differential in expansion between  $\frac{1}{4}$  inch of brass (stator support) and  $\frac{1}{4}$  inch of steel (rotor shaft) upsets matters. The trouble must be remedied by the insertion of  $\frac{1}{4}$  inch of steel in the brass pillars that support the stator.

That takes care of the variable portion of the tuning capacitor. In addition, though, there generally are small fixed values of capacitance having both air and solid dielectric. Published data show that the dielectric constants of porcelain, Isolantite, etc, have extremely high thermal coefficients. These may run as high as  $500/10^6/^\circ\text{C}$  or more. A very few micro-microfarads of stray capacitance through such a solid dielectric can, therefore, introduce a serious variation at the lower values of total capacitance used at the high-frequency end of the tuning range.

TABLE I. LINEAR COEFFICIENTS OF THERMAL EXPANSION

Material	Coefficient
Aluminum	$24/10^6/^\circ\text{C}$
Brass	$18/10^6/^\circ\text{C}$
Copper	$14/10^6/^\circ\text{C}$
Invar (36% Ni Steel)	$0.9/10^6/^\circ\text{C}$
Isolantite	$7/10^6/^\circ\text{C}$
Nickel-steel (42% Ni)	$7/10^6/^\circ\text{C}$
Steel	$10/10^6/^\circ\text{C}$

This is most satisfactorily taken care of by the addition of a small fixed capacitor, such as a Ceramicon, which will give the required micromicrofarads compensation—say  $1000 \times 10^{-12}$ —per degree Centigrade.

It is only by such separate treatment of the variable and fixed portions of the main tuning capacitor that the desired result can be most closely approximated in a consistent and reliable manner. It will be apparent that a combination of proportional compensation and fixed compensation—for the variable and the fixed portions of the total tuning capacitance—can not provide perfect compensation of the variation of inductance of the coil. The amount of fixed capacitance compensation to be used, therefore, is somewhat of a compromise. Actually, however, the frequency of the complete oscillator can be compensated to within a few parts per million per degree C over a frequency range of two to one.

#### Tube and Miscellaneous Capacitances

Inter-electrode capacitances in the oscillator tube, capacitances in tube base and socket, and other miscellaneous stray capacitances in the oscillator circuit and to ground generally have an overall temperature coefficient of capacitance that is plus in sign. They therefore are compensated by use of a small compensating capacitance that provides capacitance compensation of perhaps  $-1000 \times 10^{-12} \mu\mu\text{f}$  per degree C. The value required must be determined experimentally for any particular design.

#### General Considerations

General mechanical construction of all components and of the mountings and wiring must be of good design and rigidity. Clearance between high-potential r-f points in

the circuit and ground should be reasonably large.

In special experimental assemblies it has been possible to obtain a temperature coefficient of frequency of some  $2/10^6/^\circ\text{C}$  or less, over a frequency range of approximately two to one in the high-frequency region up to 24 mc.

Production units employing the oscillator design described can be expected to have temperature coefficients of frequency that will be consistently less than  $10/10^6/^\circ\text{C}$ .

#### Applications

In radio receiving equipment intended for commercial use, such as in transoceanic radiotelegraph services, the problem of frequency stability is becoming of greater and greater importance as channel widths and spacings are reduced in an attempt to provide the large number of separate communication channels desired. In some cases, crystal oscillators have been employed. These are, however, of use only for reception on a few fixed frequencies. Where it is necessary to be able to tune in any one of a large number of signals quickly, over a wide range of frequencies, the simplest solution appears to be the use of a highly stable oscillator of the continuously variable type. It is then that design considerations aimed at reducing the temperature coefficient of frequency of the r-f heterodyne oscillator become questions of major importance.

As an example, consider the case of operation at an r-f carrier frequency of 10,000 kc and with an i-f pass band of 1 kc total or plus and minus 0.5 kc. If the frequency of the local heterodyne oscillator drifts 0.5 kc, which at 10,000 kc is only 50 parts per million, the signal will be at the edge of the pass band of the receiver. An uncompensated oscillator may easily drift this much with a change in ambient (room) temperature of only one degree C or approximately two degrees F. A well-constructed oscillator having a low temperature coefficient of frequency will, however, permit of five to ten times as great a change in the ambient temperature. It therefore will take care of the temperature variations normally expected in any installation at which operating personnel are in attendance.



# AUTOMATIC FADER

By DAN HUNTER *Chief Engineer, Station WMAL, Washington, D. C.*

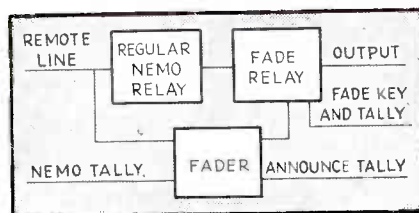

FIG. 2—Essential elements of the automatic fader system

**T**HE device to be described automatically fades a program either completely or partially in or out, at predetermined rates, without the use of motors. The only moving parts consist of three relays, and individual fade-in and fade-out timing is easily adjusted.

The automatic fader is used to fade the nemo, a remote or network program for a local broadcast, or to join a remote or network program already under way. In the studio, it is also convenient for announcing a remote program. These operations involve strict cooperation between the master-control operator and the announcer unless the program is routed through a studio having a studio operator. This close cooperation demands the type of attention very difficult to achieve in any master control.

## Circuit

The automatic fader was designed to operate from the nemo and announce tally lights plus an installed fade key and tally. As shown in Fig. 1, the fader is essentially an amplifier adjusted for zero gain, with time-delayed bias for control.

The amplifier tube is biased to cut-off for complete fade-out, at an intermediate point for partial fade-out or in, and normal for complete fade-in. The bias is obtained from the two potentiometers in the bleeder circuit.

Two variable timing controls are included (slotted shaft for screwdriver adjustment), one for complete fadeout and one for complete fade-in. Timing of a complete fade is adjustable from 1 to fifteen seconds. The timing for the background level or partial fade is fixed at approximately two seconds.

The 6C5 is operated at a plate current of 0.5 to 0.6 ma to obtain a smooth fade. This quiescent point places the operation of the tube slightly above the point where the amplification begins to vary. This imposes a definite limitation on the maximum permissible input level at which the fader may be operated without distortion. The input is 10,000 ohms bridging, while the output is 500 ohms. The fader and its power supply were mounted on 3.5-in. rack-mounting panels.

At WMAL, the fader is in the nemo circuit, as shown in the block

diagram of Fig. 2. The input of the fader is bridged across the nemo line and the fade relay switches either the nemo or the fader to feed the equipment. This switching can be done any time during a program provided a relay with grounding resistors is used. At WMAL an Automatic Electric relay is used, with 50,000-ohm resistors from all contacts to ground.

The relay  $L_2$  which gives complete fades obtains its battery from the nemo tally light. This was done so that the fader would always be ready to perform. If the nemo is down, the fader is ready to fade in and vice versa.

The partial fade or background-level relay  $L_1$  connects to the battery supplying the announce tally through a contact on relay  $L_2$ . This allows a background level only when both announce and nemo are set up. Since the tally lights and set-up buttons are on the announcers switching console, (delite), the fade key and tally were also placed on the delite. This enables the announcer to completely fade in or out a program or announce over a background level without an operator.

## Operation

If a fade is desired, the fade key is turned on; the fade tally gives indication. When nemo is released, the program is faded out, or if nemo is set up, the program is faded in. If announce is set up at the same time, then the program is either faded in or out but to a background level.

It was found that a partial fade of 10 db of tone (500 cycles) gave a good background level. The level is adjustable to -58 db when using the circuit shown in Fig. 1.

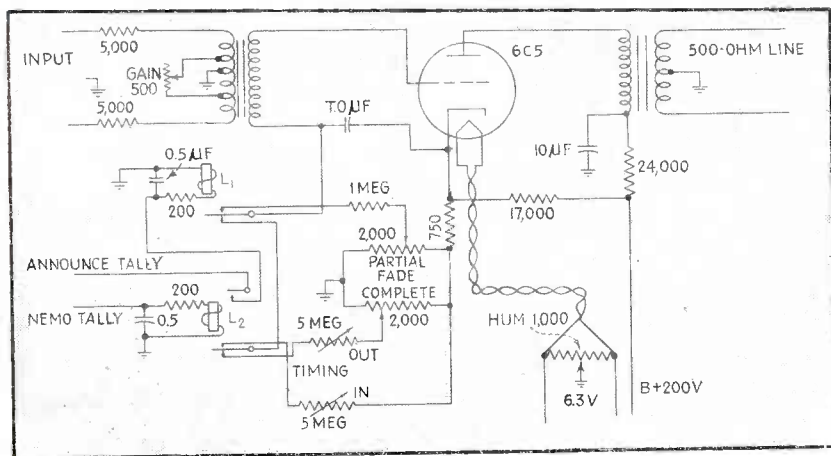

FIG. 1—Vacuum-tube circuit for complete or partial automatic fading of programs

# MICROWAVE

Propagation characteristics of the super high frequencies are ideally suitable for short-range communications services. Systems can effectively use highly directional antennas and low power. Stability may be as good as in any other part of the radio spectrum. Transmitter and receiver design is discussed

**T**HE WAR stimulated radio progress to such an extent that many new communications services are on the verge of becoming a commercial reality. A large number of applications will involve short-haul or line-of-sight distances. It is conceivable that there might be thousands of microwave links within a small area, such as a county. To prevent interference with each other, as well as with other services, the correct use of frequencies is as important as the proper design of circuits used in the new equipment.

Recent electronic developments in the ultra high frequency (uhf) and super high frequency (shf) regions have provided sufficient technical progress to open up these bands for practical use. In the past, most equipment which operated at such high frequencies was considered experimental and was often crudely built and difficult to adjust. Modern equipment designed for the microwaves is ruggedly con-

By **FREDERIC A. JENKS**

*Research Laboratories  
Sperry Gyroscope Co., Inc.  
Garden City, N. Y.*

structed, easy to adjust, and utilizes circuits which perform favorably by comparison with those used in lower frequency apparatus.

When studying channel space available for the new services it is interesting to examine Fig. 1A. This chart of the radio frequency spectrum was drawn on a logarithmic basis. Plotting in this manner provides a convenient way of visualizing all channels with equal clarity, but it does not present an adequate picture of the tremendous portion of the spectrum which has been made available by recent microwave developments. In Fig. 1B the same amount of spectrum has been replotted on a linear basis and it is immediately apparent that the new high frequency regions represent the major portion of the spectrum.

At first glance it might appear

that such an expanse of new frequencies will provide sufficient space for all the channels which might be required for many years to come, especially for line-of-sight transmissions. This may be true if the new bands are properly utilized. It must be remembered, however, that many of the services to be operating in the uhf and shf bands will require wide bandwidths, possibly in the order of 20 megacycles or more. It only takes 50 of these 20-megacycle channels to fill a 1000-megacycle block of frequencies, and there are not too many of these blocks available.

Fortunately, such short wavelengths allow the use of mechanically practical antenna structures that provide sharply directional beams for point-to-point communications and relay links, and minimize interference with other services outside the coverage area of the beamed radiation. This directivity together with freedom from atmospheric interference allows the

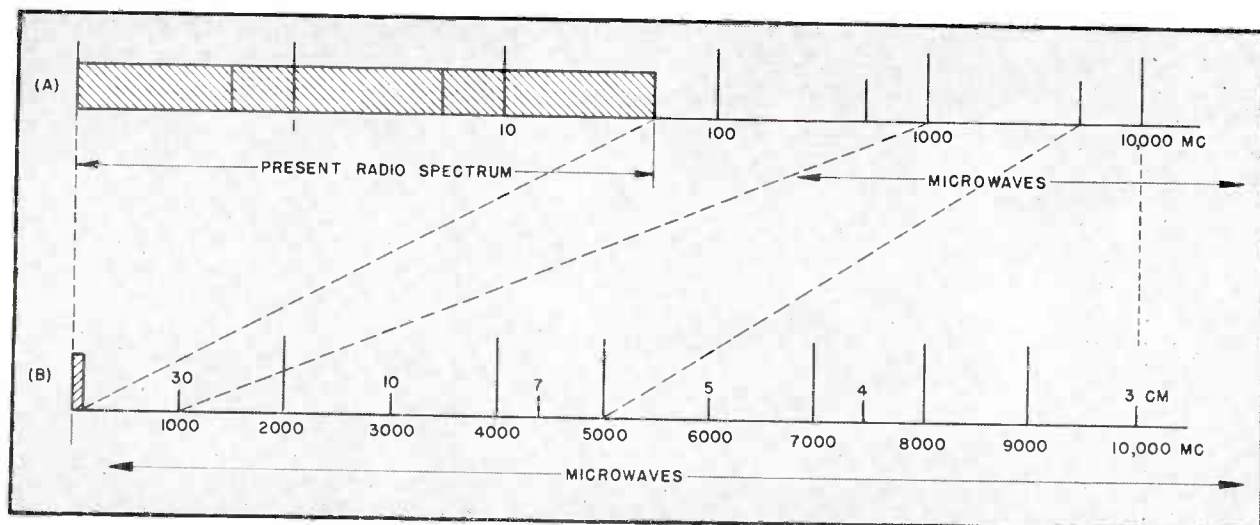

FIG. 1—(A) The radio spectrum, plotted on a logarithmic basis, presents an inadequate picture of the space available in the microwave region for postwar development. (B) When the spectrum is plotted linearly the importance of the super high frequencies becomes at once apparent



# TECHNIQUES

use of surprisingly low transmitter powers to accomplish reliable communication.

Services which can take advantage of this type of communication might include the following: program relay links, pickup-to-studio circuits, railroad communications, emergency short range services, aircraft aids to navigation, and domestic airport traffic control, just to mention a few.

## General Considerations

Adjacent fixed station microwave systems can use the same frequency bands in many instances by taking advantage of the fact that even radiation having a low vertical angle is eventually lost in space, passing through the ionosphere region rather than being reflected back to earth. This condition is illustrated in Fig. 2A. Notice that the beams of adjacent stations in the two separate systems A and B, pass over each other, and that the systems therefore do not interfere. If directivity is used in the horizontal plane, as shown in Fig. 2B, many systems such as those represented at C, D and E may be located in the same area without causing interference to each other. For simplicity of illustration one-way systems are shown. Two-way systems are obviously equally practical.

While ground stations cannot receive radiation passing over them, aircraft in the vicinity will be subject to interference. If many ground installations are in operation, aircraft will be in a beam from some station nearly all the time. Consequently, the frequencies used for aviation services should be removed from those used by point-to-point ground systems. Airplane-to-ground communications will require special consideration. With a large number of airports in the same vicinity it is quite necessary, unlike point-to-point ground services, that they operate on different channels. Aircraft flying at high altitudes will be exposed to

radiation from airports, other aircraft, weather stations, aids to navigation, and possibly other ground services. To be certain that microwave equipment carried in the airplane is receiving the desired signals, and not unwanted radiations, many frequency channels will have to be provided. From 50 to 100 closely spaced aircraft channels may be the common thing a few years hence, especially on airplanes flying the international routes.

Realizing these facts, it becomes apparent that the tremendous frequency band occupied by the new wavelengths will not provide an unlimited number of channels even if many communication systems are sharply beamed. However, by employing frequency stability tolerances which are comparable to those used on the lower frequency bands, channels can be placed close enough together so that none of the spectrum is wasted. Techniques are now available whereby stability on the microwave bands can be as good as that in any other part of the radio spectrum.

## Transmitter Power

Electromagnetic energy radiating from a point source in space produces a power per unit solid angle of

$$p'_{d\omega} = \frac{P}{4\pi} \text{ watts} \quad (1)$$

where  $P$  is the total power radiated from the point source. However, since dipoles are generally used as the standard of comparison, the radiated power from a dipole in the direction of a receiver which lies in a plane perpendicular to and centered upon the dipole is given by

$$p_{d\omega} = \frac{3P}{8\pi} \text{ watts per unit solid angle} \quad (2)$$

where the increase of  $3/2$  is due to the directional characteristics of the dipole.

Since the equivalent area of a dipole<sup>1</sup> is given by

$$A_d = \frac{3\lambda^2}{8\pi} \quad (3)$$

it is capable of absorbing an

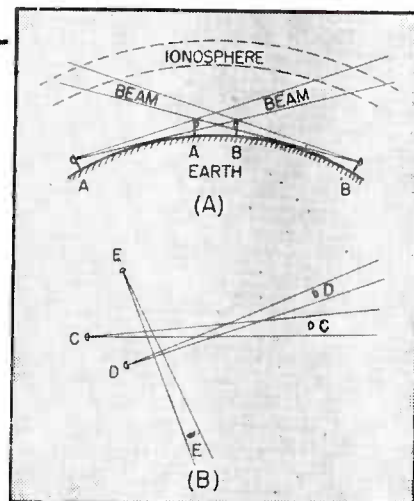

FIG. 2—(A) Because the microwaves normally penetrate the ionosphere and are lost beyond it, and are not reflected back to earth, transmissions between the two stations in system A and the two stations in system B will not ordinarily cause mutual interference. (B) Transmissions sharply beamed in the horizontal plane permit the operation of a plurality of adjacent stations such as those constituting systems C, D and E, without mutual interference

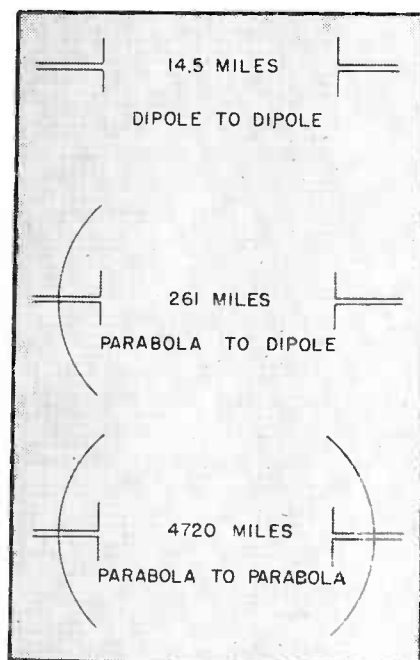

FIG. 3—Theoretical distances which may be covered by point-to-point microwave systems using various transmitting and receiving antenna combinations are shown in miles. In all three cases illustrated transmitter power is 0.1 watt, wavelength is 10 cm, transmitted bandwidth is 200 kc, and the receiver noise figure is 15 db or 31.6-to-1 on a power basis. Parabola area is 6000 square centimeters, giving an effective power gain of 325

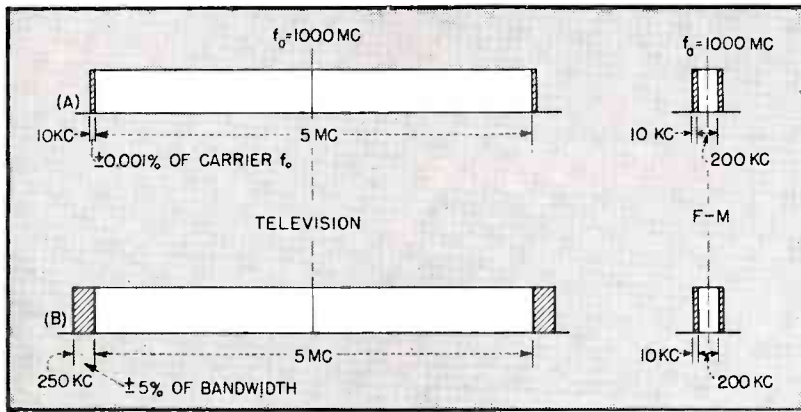

FIG. 4—(A) Stability expressed as a percentage of carrier frequency, showing how 10-kc latitude which might represent a standard for an f-m system operating on 1000 mc would be difficult if not impossible to achieve in connection with a television transmitter operating on the same frequency but requiring greater bandwidth. (B) Stability expressed as a percentage of bandwidth, illustrating the practicability of standards based upon such a scheme

amount  $p_r$  of the radiated power per unit solid angle at a distance  $r$ , and is given by

$$p_r = \frac{3P}{8\pi} \times \frac{3\lambda^2}{8\pi} \times \frac{1}{r^2} = \left[ \frac{3}{8\pi} \right]^2 \frac{P\lambda^2}{r^2} \text{ watts (4)}$$

where both  $\lambda$  and  $r$  are given in centimeters. This equation gives the energy at a distant receiver for a system using dipoles for transmitting and receiving.

If a directional antenna such as a parabola is used at one end, the energy at the receiver is increased directly by the effective power gain of the directional antenna used. The power gain of a parabolic antenna is the ratio of the effective absorbing area of the parabola to that of a dipole, and is given by

$$G = 0.65A / (3\lambda^2 / 8\pi) = \frac{8\pi}{3} \frac{A}{\lambda^2} \times 0.65 \quad (5)$$

where  $A$  is the mouth area in square centimeters,  $\lambda$  is the wavelength in centimeters, and 0.65 is an empirical factor related to non-uniform illumination of the parabolic surface by the dipole. The energy at the receiver is now increased by this gain figure and is

$$p_r = \left[ \frac{3}{8\pi} \right]^2 \frac{P\lambda^2}{r^2} \times \left[ \frac{8\pi}{3} \frac{A}{\lambda^2} \times 0.65 \right] = 0.0775 \frac{PA}{r^2} \text{ watts} \quad (6)$$

With a parabola at each end of the system, the ability to concentrate the energy in the desired direction is further enhanced, and the receiver power then becomes

$$p_r = \left[ 0.0775 \frac{PA}{r^2} \right] \times \left[ \frac{8\pi}{3} \frac{A}{\lambda^2} \times 0.65 \right] = 0.423 \frac{PA^2}{r^2 \lambda^2} \text{ watts} \quad (7)$$

In all of the above cases the transmission was assumed to be through free space, without any nearby objects to disturb the path of the radiated energy. In applications such as point-to-point fixed systems this ideal condition will not be realized. A scattering effect caused by the energy passing over the ground at grazing incidence will reduce the signal at the receiver. Scattering caused by trees, houses, and other objects may be appreciable, and should be taken into account when determining transmitter powers for such propagation conditions.

For a receiver signal-to-noise ratio equal to unity, the available signal power at the receiver should be equal to the theoretical noise power of the receiver times its noise figure. The noise figure is defined<sup>2</sup> as the ratio of the available signal-to-noise ratio at the signal source terminals to the available signal-to-noise ratio at the receiver output terminals.

$$F = (S_i / KTB) / (S_o / N_o) = (S_i / KTB) / (N_o / S_o)$$

where  $K = 1.38 \times 10^{-23}$  joules per degree Kelvin

$T = 300$  degrees Kelvin

$B =$  effective bandwidth in cycles per second

$F =$  noise figure of the receiver

$S_i =$  available signal power at signal source terminals (antenna matched)

$S_o =$  available signal power at receiver output

$N_o =$  available noise power at receiver output

Solving for the available signal power at the signal source (antenna) terminals, gives

$$S_i = \frac{S_o}{N_o} F KTB \text{ watts} \quad (9)$$

To make the signal-to-noise ratio at the output equal to unity, the available signal power delivered by the receiving antenna circuit must be equal to

$$S_i = F KTB \text{ watts for } \frac{S_o}{N_o} = 1 \quad (10)$$

Now let us compare the range of several systems in which the antenna power, transmitted bandwidth, and noise figure are the same but the antennas used are different, as illustrated in Fig. 3. It will be assumed that the transmission is over a line-of-sight path without grazing incidence. The following conditions will be alike in each case:

- $P = 0.1$  watt transmitter power
- $B = 200$  kilocycles transmitted bandwidth
- $F = 15$  db = 31.6 to 1 (on power basis)
- $\lambda = 10$  centimeter wavelength = 3000 mc
- $A = 6000$  square centimeters, parabola area to give an effective power gain of about 325

For a system using a dipole at each end, Eq. (4) equals Eq. (10) for maximum range.

$$p_{min} = \left[ \frac{3}{8\pi} \right]^2 \frac{P\lambda^2}{r^2} = F KTB = 2.61 \times 10^{-14}$$

$$r^2 = \left[ \frac{3}{8\pi} \right]^2 \frac{P\lambda^2}{F KTB} = (0.0142) \frac{(0.1)(100)}{2.61 \times 10^{-14}}$$

$$r^2 = 5.44 \times 10^{12}$$

$$r = 2.33 \times 10^6 \text{ cm} = 14.5 \text{ miles range}$$

For a system using a parabola at one end and a dipole at the other, Eq. (6) equals Eq. (10) for maximum range.

$$p_{min} = 0.0775 \frac{PA}{r^2} = F KTB = 2.61 \times 10^{-14}$$

$$r^2 = 0.0775 \frac{PA}{F KTB} = 0.0775 \frac{(0.1)(6000)}{2.61 \times 10^{-14}}$$

$$r^2 = 17.85 \times 10^{14}$$

$$r = 4.20 \times 10^7 \text{ cm} = 261 \text{ miles range}$$

For a system using a parabola at each end, Eq. (7) equals Eq. (10) for maximum range.

$$p_{min} = 0.423 \frac{PA^2}{r^2 \lambda^2} = F KTB = 2.61 \times 10^{-14}$$

$$r^2 = 0.423 \frac{PA^2}{\lambda^2 F KTB} = \frac{(0.423)(0.1)(6000)^2}{(10^2) 2.61 \times 10^{-14}}$$

$$r^2 = 0.582 \times 10^{16}$$

$$r = 0.761 \times 10^8 \text{ cm} = 4720 \text{ miles range}$$

The use of parabolas increases the system range by the square root of the product of the effective antenna gains at each end. The 4720 mile range of the last calculation is used for illustration purposes only, and is obviously not realizable on the surface of the earth.

Frequency stability can be de-



defined as the amount of random frequency variation in an unmodulated carrier, compared to the carrier frequency on a percentage basis. Since the various radio services such as television, f-m and a-m broadcasting, and telegraph, require widely different bandwidths for the transmission of their intelligence, it seems reasonable that they should require different carrier frequency stabilities also.

Consider a television channel five megacycles wide and an f-m channel 200 kilocycles wide. If both of these services had the same stability, it would probably be the narrower of the two which would determine what the stability should be. Suppose the allowable carrier drift of the f-m channel was  $\pm 10$  kilocycles. It would be folly to expect the television people to keep their transmitter carrier to within

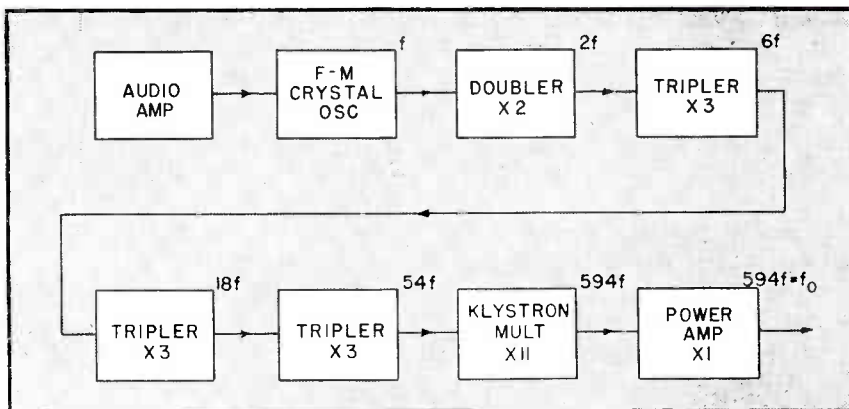

FIG. 6—Block diagram of a microwave transmitter employing a crystal oscillator for frequency control, a conventional doubler and triplers, a klystron providing a multiplication factor of 11 in one tube, and a power amplifier. If the oscillator operated at 5 mc the final output of the transmitter would be 2970 mc

$\pm 10$  kilocycles, as indicated in Fig. 4A, when their receiver bandwidths vary more than that in production. A more logical way of assigning a stability figure to a

given service would be to base the allowable random carrier variation upon a certain percentage of the transmitted bandwidth. For example, if the stability figure in the above illustration was  $\pm 5$  percent of the bandwidth, then the f-m carrier would have to be maintained within  $\pm 10$  kilocycles, as before, but the television carrier would be allowed a  $\pm 250$  kilocycle drift, as shown in Fig. 4B.

Equipment operating in the microwave bands can have a frequency stability as good as that obtainable on the lower frequency bands, with 0.001 percent not too difficult. Crystal control is commonly used, with the oscillator operating at a frequency of several megacycles, followed by a series of frequency multiplier stages. The stability of the carrier is that of the crystal oscillator multiplied by the factor required to increase the crystal frequency up to the microwaves. The nomograph in Fig. 5 provides a convenient means of determining microwave frequency shifts caused by small frequency changes in the low frequency oscillator.

Commercial AT-cut crystals in temperature-controlled ovens have been used in many oscillators to furnish a stable driving source for the multiplier chain. Usually the multiplying stages are doublers and triplers, although quintupling has been used successfully. As the stages approach the ultra high frequencies the tank circuits change from coils and capacitors to resonant lines in various forms. These give way to resonant enclosures or

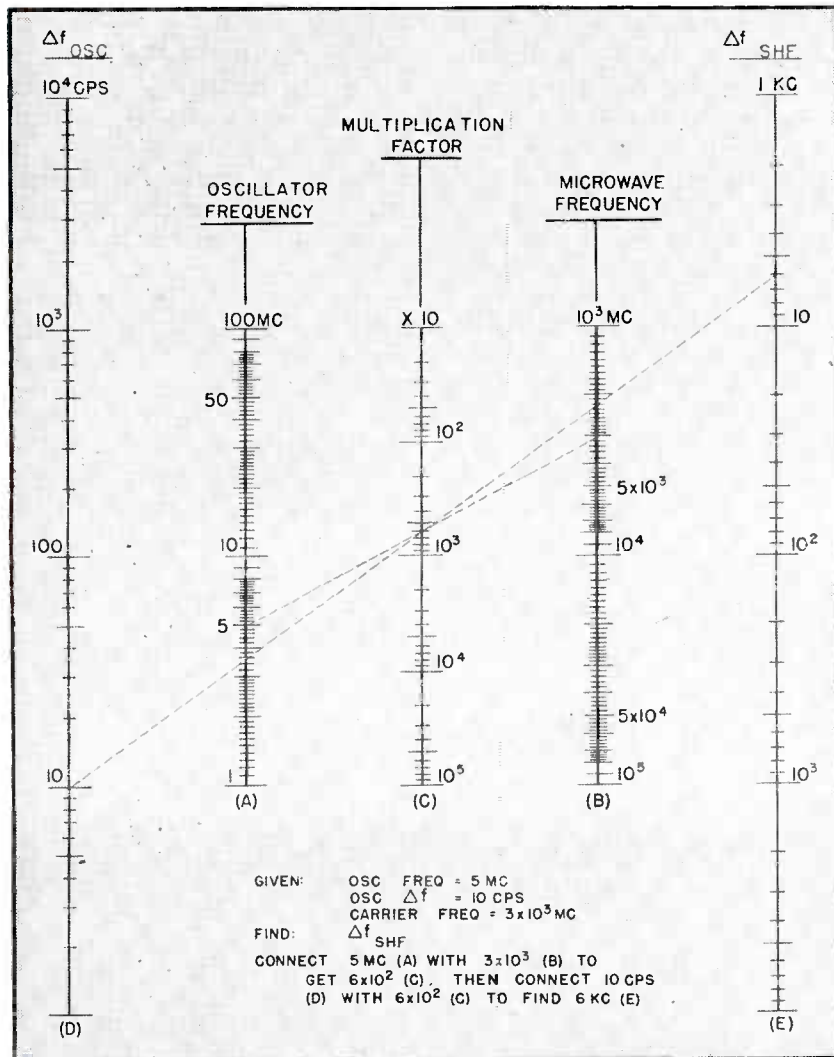

FIG. 5—Chart useful in determining the amount of carrier shift caused by a shift in the frequency of an oscillator, where the microwave transmitter employs a frequency multiplier chain. An example is given

cavities at the super-high frequencies. If the signal is of too low power at the carrier frequency it is frequently amplified to usable levels with tubes, such as klystrons, employing the velocity modulation principle.

Although crystal control has been considered the best means of obtaining a stable carrier at conventional frequencies it is having considerable competition from various automatic frequency control (afc) systems used for stabilizing microwave oscillators. Stabilities comparable to that obtained from a crystal-controlled multiplier chain can be had from a correctly designed afc unit.

At conventional frequencies it is possible, by comparing the phase of the amplitude modulated output from a resonant circuit with the original frequency modulating signal, to obtain a correction voltage which can be used to adjust the system so that the carrier and the resonant-circuit frequencies coincide. A similar afc scheme can be used on the microwaves, employing a resonant cavity as the tuned circuit. By making the resonator tunable, the microwave oscillator can be automatically stabilized on any frequency within this tunable band. This is advantageous because of the fact that in crystal control systems the complete multiplier chain must be retuned if the carrier frequency shift is large compared to the bandwidth of the resonant circuits.

Other low-frequency afc techniques can also be applied to microwave apparatus. For example, the variable-magnitude reversible-polarity voltage from a receiver discriminator can be used to keep a microwave local oscillator in track with an incoming signal. This is similar to the system used in some broadcast receivers.

#### Transmitter Design Considerations

To illustrate what is possible in modern microwave transmitter designs it is worthwhile to consider a general example, and to show how crystal control and afc compare for the job. Suppose it is desired to build a single channel f-m transmitter capable of a frequency deviation of  $\pm 75$  kilocycles and a frequency stability of 0.001 percent, with a carrier power of a few watts in the 10-cm microwave region. In this discussion it will be assumed that any detuning effects in the resonator and line circuits due to ambient temperature changes have been corrected by proper temperature-controlling means.

In Fig. 6 is shown a block diagram of a crystal controlled multiplier chain, in which conventional high-frequency doublers and triplers driven by a 5-megacycle crystal oscillator supply power to the input resonator of a velocity-modulation frequency multiplier. The output resonator of the multiplier is tuned to the eleventh harmonic of the tube's input frequency, thus providing a convenient means of

obtaining an eleven-to-one frequency multiplication in one tube. Other multiplying values could be obtained by changing the ratio of the resonant frequencies of the output to input cavities. A two-stage cascade power-amplifier klystron is then used to raise the level from a few milliwatts to several watts output. The amplifier has a power gain of about 1000.

To maintain a microwave carrier frequency stability of  $\pm 0.001$  percent the crystal oscillator frequency must not deviate more than  $\pm 0.001$  percent. To accomplish this the plate and screen voltages on the crystal oscillator are kept low and are maintained at a constant potential by means of a gas tube or an electronic regulator. With modern crystal ovens capable of holding their temperature constant to better than one degree Centigrade throughout the ambient temperature ranges encountered in practice, it is possible to limit an AT-cut crystal to only a few cycles drift. To keep a well designed crystal oscillator operating in the five-megacycle range on frequency to better than  $\pm 50$  cycles (0.001 percent) is not difficult as this is only one part in  $10^6$ .

Modulation of the transmitter unit can be accomplished in a number of ways. For example, phase modulation of any of the multiplier stages is possible, as well as phase modulation of the amplifier. Frequency modulation of the crystal oscillator can also be used with

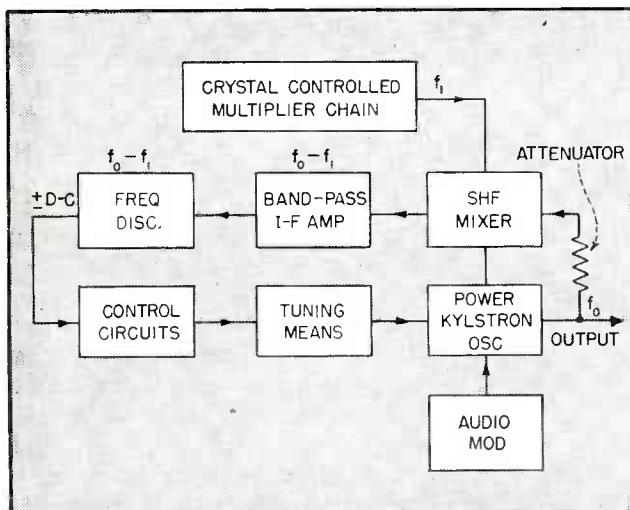

FIG. 7—Transmitter employing automatic frequency control of a modulated oscillator to achieve stability. Here a low-power crystal-controlled multiplier chain is used as the standard

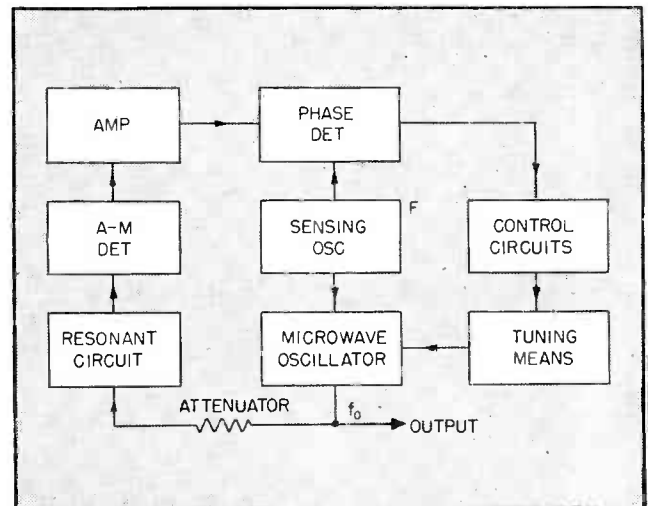

FIG. 8—Modulated oscillator employing a temperature-compensated cavity resonator as a resonant-circuit standard for the automatic frequency control system



success, even though the frequency deviations available from such an arrangement are quite small. The high multiplication factor between the crystal and carrier frequencies (594 for the above example) increases any oscillator deviations into carrier swings of considerable amounts. This is also the reason that good carrier stability is required in systems using relatively narrow band transmission.

### AFC System

With automatic frequency control it is possible to stabilize a powerful velocity modulation type of oscillator tube operating in the desired microwave band or to control a low-power microwave oscillator and then follow it with a cascade power amplifier. In either case it is necessary to have a source of frequency reference to use as the standard of comparison. This frequency standard can be either a compact crystal-controlled source such as the multiplier chain described earlier or a temperature-stabilized resonant cavity tuned to the transmitter frequency. The basic principle involved in applying automatic frequency control is the same regardless of the type of standard used. The frequency of the transmitter is compared to the known standard frequency. Any random carrier shift is detected in the comparison circuit, and the resulting signal is used to apply a tuning correction to bring the carrier back into step with the standard. The loop gain and the bandwidth of the feedback control circuit determine how closely the carrier will be held to the standard.

Figure 7 shows a block diagram of an automatic frequency control system using a low-power crystal-controlled frequency multiplier chain as the standard. The purpose of such an arrangement is to provide a stable high-power transmitter in the absence of a suitable microwave power amplifier to follow the multiplier chain. In the diagram it will be noticed that the frequency of the standard is different from the transmitter frequency by an amount required to produce a convenient intermediate frequency signal, which is generated in a suitable mixer. The if

amplifier has sufficient gain to operate a frequency discriminator of conventional design, similar to those used in current f-m practice. The bandwidth of the amplifier should be sufficient to allow the system to lock-in without too much searching. If the bandwidth is too wide, tightness of frequency control will be sacrificed, and if it is too narrow, fast deviations will not be corrected, so a compromise solution is needed which depends upon the requirements imposed upon the transmitter itself. Schemes can be devised to provide a wide pull-in range and a tight hold-in range simultaneously. The signal from the discriminator is a d-c potential whose magnitude and polarity depend upon how far the transmitter frequency has drifted, and in which direction. This variable-magnitude reversible-polarity voltage can then be used to control either a two-phase tuning motor, or the electrical power in any other electro-mechanical device, or can be applied through suitable amplifiers directly to an electrode in the transmitting tube which is frequency sensitive to voltage. The various tuning means can be used alone or in combination with one another.

Another method of obtaining automatic frequency control is to use a temperature-compensated cavity resonator rather than a crystal as the standard resonant circuit for frequency reference, as illustrated in the block diagram of Fig. 8. This circuit is used to obtain correction signals in a manner similar to the low frequency technique mentioned earlier. The standard resonant circuit for frequency reference, as illustrated in the block diagram of Fig. 8. This circuit is used to obtain correction signals in a manner similar to the low frequency technique mentioned earlier. The standard resonant circuit for frequency reference, as illustrated in the block diagram of Fig. 8. This circuit is used to obtain correction signals in a manner similar to the low frequency technique mentioned earlier.

For purposes of illustration, assume that the transmitting microwave oscillator is frequency modulated with frequency  $F$ . If the transmitter is exactly in tune with the resonant cavity, the frequency modulation will be converted into amplitude modulation of frequency  $2F$ , as shown in Fig. 9A. This is true since a half-cycle carrier swing allows the signal amplitude to increase and then decrease again to

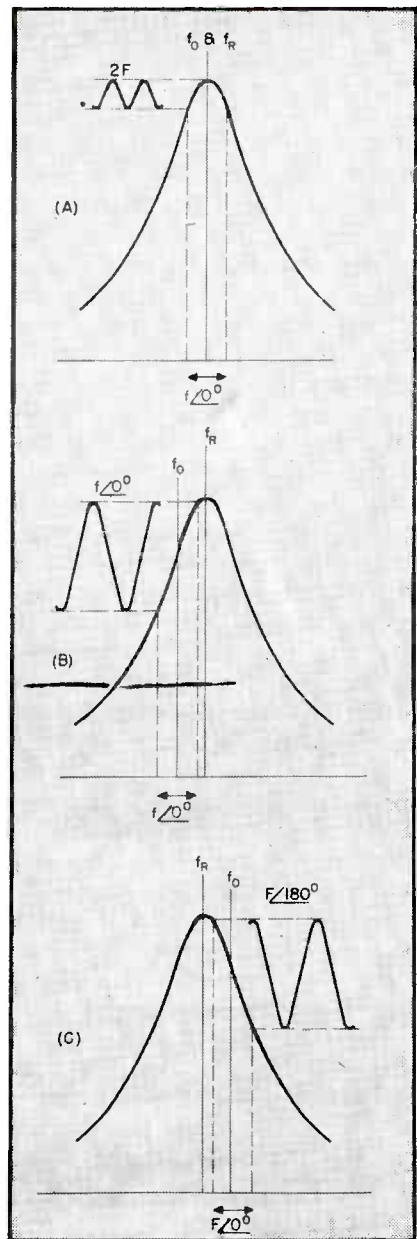

FIG. 9—Curves illustrating the operating principle of the afc system diagrammed in Fig. 8 and discussed in the text. (A) Microwave oscillator in tune with the resonant circuit used as a frequency standard, (B) with the carrier shifted to one side and (C) with the carrier shifted to the other side

its original value, hence one a-m cycle is produced during each half cycle of f-m caused by the modulating frequency  $F$ . Should the transmitter be slightly out of tune with the resonant circuit, the amplitude modulation output will be predominantly of fundamental frequency  $F$ , and in phase with the modulating signal  $F$  when the carrier has shifted to one side as shown in Fig. 9B. The amplitude modulation output will be 180 degrees out of phase, Fig. 9C, when the carrier

shift is in the other direction. It is this 180-degree phase shift which, when compared to the phase of the original modulating signal, provides the sensing for the control circuit in this type of afc system. The phase detector produces a voltage whose magnitude and polarity depends upon how far and in which direction the carrier has drifted. This control voltage is then used to tune the transmitter.

Perhaps the simplest type of afc transmitter would use an oscillator-buffer type klystron capable of the required power output and equipped with electro-mechanical tuning. The tube might be frequency modulated with small deviation at a super-audible rate to provide a control signal which could be used to alter the power in the electro-mechanical tuning device to keep the oscillator on frequency. Sufficient loop gain would be provided to hold the frequency to the required tolerance, taking into account the possibility of resonator drift. Audio modulation of the carrier might be produced by applying the signal in series with the plate voltage, the maximum amplitude of

this audio voltage being adjusted to allow a  $\pm 75$  kilocycle carrier swing, the same as in the crystal controlled example. The afc system should be made insensitive to frequency shifts occurring in the audio passband.

#### Receiver Design Considerations

The basic receiver circuit used at microwave frequencies is still the superheterodyne. The i-f amplifier is usually operated at a considerably higher frequency than in similar lower frequency receivers. New and improved tubes have been developed to keep pace with the steady increase in frequency of the i-f amplifiers. Unfortunately, the local oscillator for microwave communication receivers presents a rather special problem. It is important that it be stable in frequency and yet compact, so that the receiver is not excessively large. Several local oscillator arrangements are possible, using crystal control or afc techniques.

The present difficulty with crystal control for this particular application is the amount of space and power required for the multi-

plier chain, which may consist of several tubes and their tuned circuits, and a klystron multiplier. Another problem with this type of local oscillator is the lack of a simple channeling means, unless the i-f amplifier is made tunable to accomplish the channeling. The tunable i-f amplifier arrangement is a perfectly practical method of obtaining the channeling feature.

Figure 10A shows a block diagram of a crystal controlled receiver, using a tunable i-f amplifier. Notice that in this case the whole i-f amplifier is gang tuned, including the discriminator, a condition which makes it difficult to maintain a constant bandwidth over the complete tuning range of the amplifier. To avoid this difficulty, the double superheterodyne or triple detection method can be used, as shown in Fig. 10B. The first local signal is fixed in frequency, and may be generated by a crystal-controlled unit. The second local oscillator has automatic frequency control similar to that used in some broadcast receivers. Only the second mixer and the second local oscillator need to be tuned (unless a first i-f stage, shown dotted, is used before the second mixer), and the bandwidth problem does not arise since the second i-f amplifier operates at a fixed frequency. A system of this type is the same as using a crystal-controlled microwave converter feeding directly into a standard f-m superheterodyne receiver with afc applied to its local oscillator.

Another method of obtaining a satisfactory microwave local oscillator is to use a compact microwave generator of the reflex type, and to apply automatic control to this local oscillator from the discriminator of the receiver, as shown in Fig. 11, in much the same way as afc is used in standard broadcast receivers.

#### Experimental Systems

One early microwave experimental system was set up over a combination land and water path, slightly beyond line-of-sight range. The equipment used free-running klystron oscillators as the transmitters. Frequency modulation was produced by applying an audio signal in series with the plate voltage

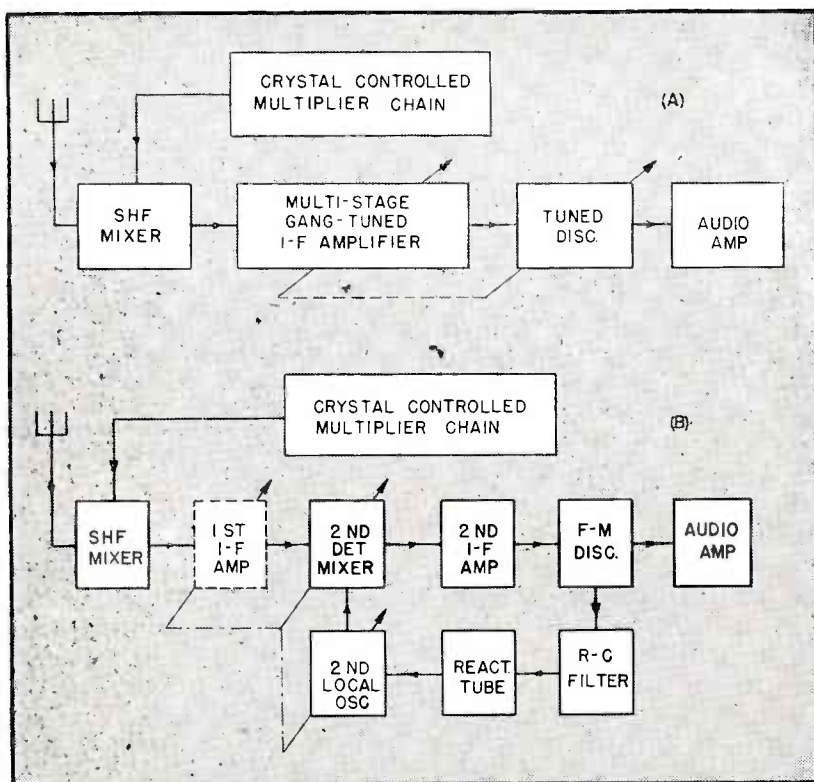

FIG. 10—Two methods of tuning a crystal-controlled superheterodyne receiver. (A) Tuning the i-f amplifier and the discriminator circuit. (B) Double superheterodyne with afc. If the first i-f amplifier stage, shown within dashed lines, is omitted only the second detector-mixer and the second local oscillator need be tuned



of the oscillators. Only a small amount of modulation voltage was required, since the 10-cm carrier deviation used in the system was purposely limited to  $\pm 75$  kilocycles.

One receiver consisted of a standard f-m broadcast unit, fed by a microwave converter which used a tunable reflex klystron as the local oscillator and a silicon crystal as the mixer. Automatic frequency control was employed to keep the receiver in tune with the free-running transmitter. The voltages obtained from the discriminator were passed through an R-C network of

A later system was installed over a five-mile link, using crystal control in both the transmitters and the receivers. The frequency multiplier chain used to increase the crystal frequency to the microwave region was identical in circuit design for the transmitters and receivers. The basic circuit of the frequency modulated crystal oscillator used is shown in Fig. 12. A modified Pierce parallel oscillator was used, with capacitive reactance in series with one grid and the crystal, and inductive reactance in series with the other grid

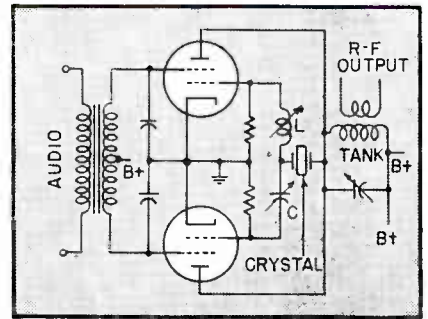

FIG. 12—Basic method of screen-grid modulating a crystal-controlled oscillator. Useful as a low-power f-m signal source, the circuit is a modified Pierce design with the two tubes in parallel

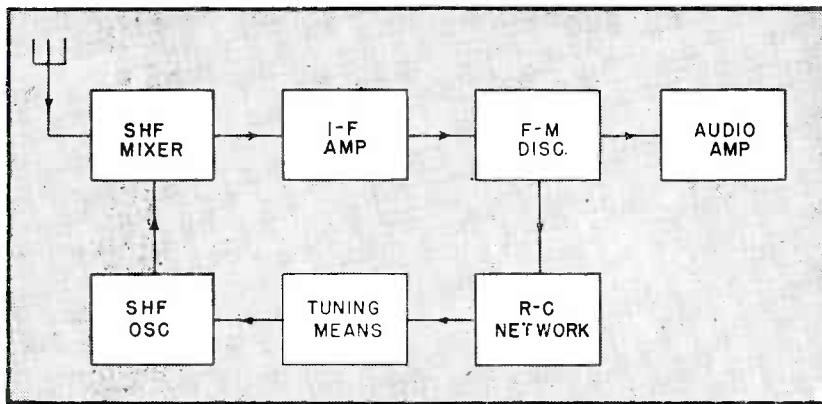

FIG. 11—Block diagram of a microwave receiver employing automatic frequency control alone to achieve the desired stability

long time constant to filter out the audio signals present, and were then used to control a tuning motor. The other receiver in this two-way communications system used a somewhat different scheme for obtaining automatic frequency control. The voltage from the discriminator was brought out through a low-pass filter, but was applied to an electro-mechanical tuning unit connected to the local oscillator. The discriminator control voltage was also used to provide electrical tuning for correcting transient deviations which the electro-mechanical device could not follow.

The transmission path covered a distance of 21 miles. With a power of several watts and parabolic antennas at each end, each with an effective gain of about 450, the signal output from the mixer of each receiver was well above the 50-microvolt level required by the f-m units. The system maintained normal communications when lower frequency channels failed due to interference conditions.

and the crystal. If the tube with the capacitive reactance in its grid circuit oscillated alone, it would operate at a frequency slightly higher than that of the crystal, due to the leading phase shift at its grid. The other tube, oscillating alone, would operate at a frequency slightly lower than that of the crystal, due to lagging phase shift in its grid circuit. The two tubes are thus arranged to oscillate an equal amount above and below the crystal frequency, and their common tank circuit is tuned to the crystal frequency. It will be seen that it is possible to swing the frequency of the oscillator unit about the crystal frequency by several hundred cycles per second when audio modulation is applied in push-pull to the screen grids of the two tubes.

The frequency swing that such an oscillator is capable of producing is somewhat less than the initial oscillating frequency separation of the two tubes. The factor which determines the maximum separation possible with stable operation is the Q of the crystal

feedback loop. No amplitude modulation is present in the unit, because as one tube begins to take over frequency control it also increases its power output, while the other tube, in losing control, reduces its output. This keeps the net power output of the oscillator constant over the entire frequency swing.

Other crystal-controlled microwave systems have been built, using phase modulation in one of the frequency multiplier stages, with good results. Even though the phase swing is rather limited in such an arrangement, the large multiplication factor again brings it up to values which are quite usable on the microwaves.

#### REFERENCES

- (1) Slater, J. C., "Microwave Transmission," McGraw-Hill Book Company, New York, N. Y., p. 224, Eq. 33.29.
- (2) Friis, H. T., Noise Figures in Radio Receivers, *Proc. I.R.E.*, 32, p. 419-422, July 1944.

#### BIBLIOGRAPHY

- (1) Barrow, W. L., Transmission of Electromagnetic Waves in Hollow Tubes of Metal, *Proc. I.R.E.*, 24, p. 1298, October 1936.
- (2) Barrow, W. L., and Chu, L. J., Theory of Electromagnetic Horn, *Proc. I.R.E.*, 27, p. 51-64, January 1939.
- (3) Ramo, S., Electrical Concepts at Ultra High Frequencies, *ELECTRONICS*, 15, p. 34, September 1942.
- (4) Barrow, W. L., and Melner, W. W., Natural Oscillations of Electrical Cavity Resonance, *Proc. I.R.E.*, 28, p. 184, April 1940.
- (5) Webster, D. L., Theory of Klystron Oscillators, *Jour. App. Phys.*, 10, p. 804, December 1939.
- (6) Varian, R. H., and Varian, S. F., A High Frequency Oscillator and Amplifier, *Jour. App. Phys.*, 10, p. 321, May 1939.
- (7) Harrison, A. E., "Klystron Technical Manual," Sperry Gyroscope Co., Inc., New York, N. Y.
- (8) Everitt, W. L., "A Report in Progress of F-M," A.I.E.E. Technical Paper Number 40-116, May 1940.
- (9) Skilling, H. H., "Fundamentals of Electric Waves," John Wiley and Sons, New York, N. Y.
- (10) Sarbacher, R., and Edson, W., "Hyper and Ultra High Frequency Engineering," John Wiley and Sons, New York, N. Y.
- (11) Terman, F. E., "Radio Engineers Handbook," McGraw-Hill Book Company, New York, N. Y.
- (12) "Trail Blazers to Radionics and Reference Guide to Ultra High Frequencies," Zenith Radio Corp., Chicago, Ill.

# BRIDGE NULL-

**A**N essential element of an a-c bridge, such as those used for vacuum-tube measurements, is a detector or null-indicator. The day in which a pair of earphones sufficed has long since passed. The present paper describes a tuned null-indicator, for a 1000-cycle bridge, which possesses many advantages, including delayed automatic-gain-control and both cathode-ray and meter-indication of output.

## Requirements

Experience has shown that the chief requirements of a good null indicator are high-sensitivity near balance, adequate discrimination against harmonics, ability to distinguish phase in the off-balance position, a visual output indicator to minimize operator fatigue, and overload protection when the

Delayed automatic-gain-control permits utilization of high sensitivity in this a-c bridge null-indicator with visual indication of phase and amplitude relations

By **E. W. HEROLD**

*RCA Laboratories  
Princeton, New Jersey*

bridge is far off balance. The high sensitivity is easily met by a two-stage pentode amplifier. At the same time, a delayed automatic-gain-control may be used as overload protection for conditions far off balance without destroying the sensitivity at balance. Harmonic discrimination is accomplished by using tuned choke or transformer coupling while phase is shown by a cathode-ray type of indicator.<sup>2</sup> In addition, a sensitive output meter

is a useful supplementary unit.

## The Circuit

A circuit diagram is shown in Fig. 1. Input is to be connected directly to the bridge through a tuned transformer which is a part of the bridge itself, as in the General Radio type 561-D. A manual gain control permits reduction of large inputs to below the value which operates the automatic-gain-control circuit. The two-stage

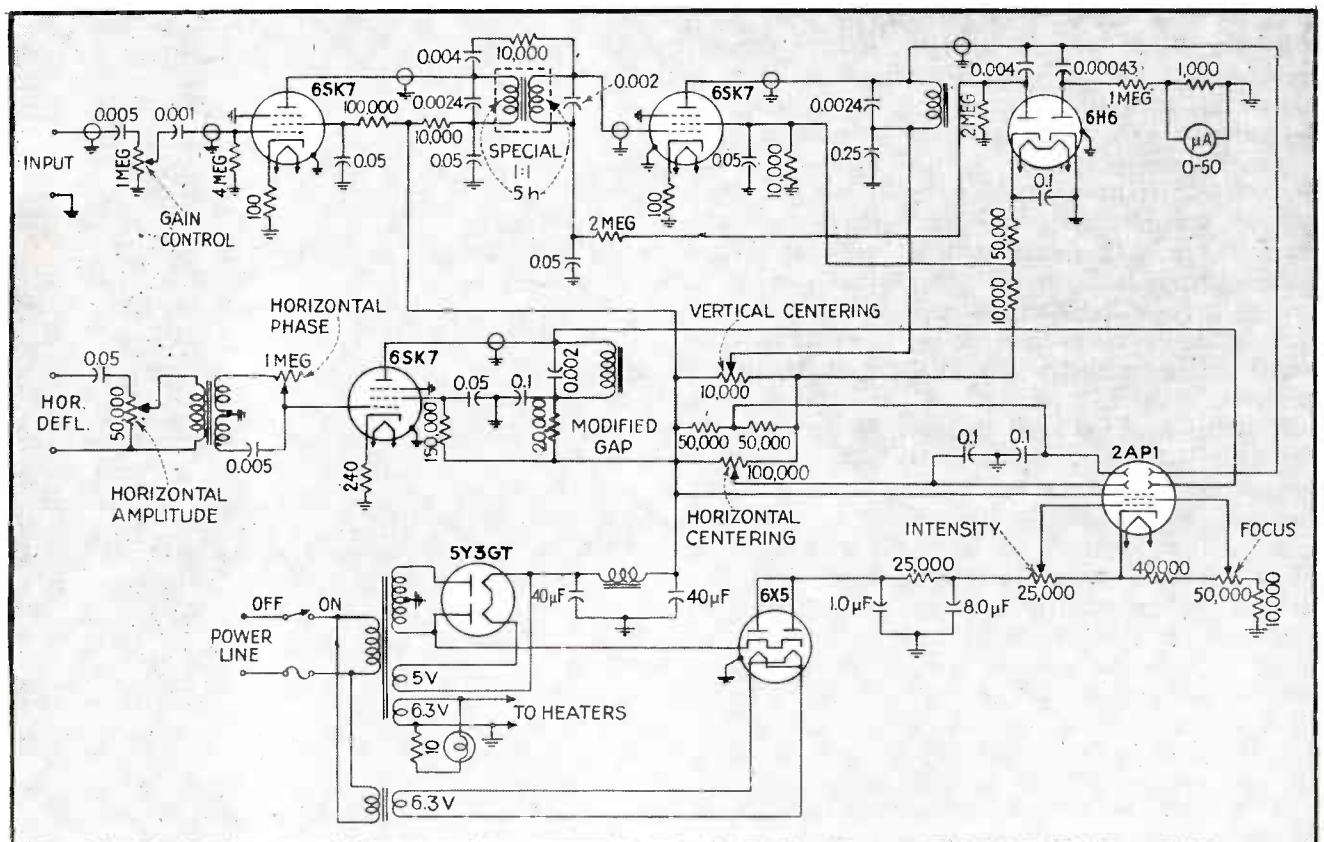
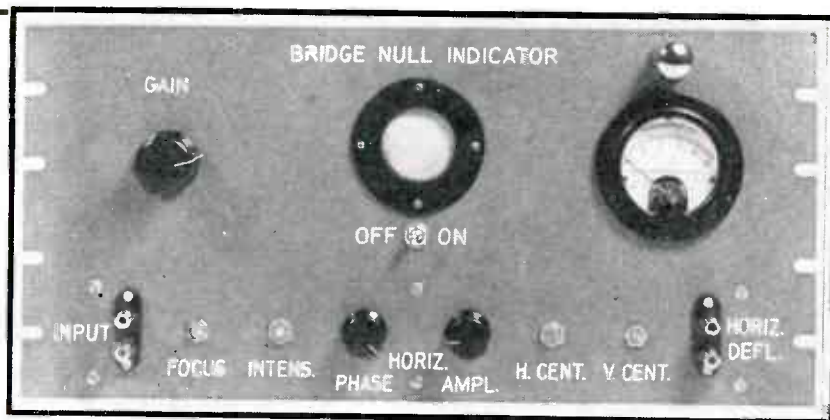

FIG. 1—Complete schematic of null-indicator. This circuit offers high sensitivity, discrimination against harmonics, ability to distinguish phase, visual output indication and overload protection



# INDICATOR



All controls are plainly marked and are easily accessible in this rack version of the bridge null-indicator

6SK7 amplifier has a special inter-stage transformer, designed by Mr. Otto Schade of RCA Victor and made by the American Transformer Company, mounted in a mu-metal shield can. For highest Q, about 13 at 1000 cycles, the inter-stage transformer tuning capacitance is split between primary and secondary as shown. A first-stage gain of over 500 is obtained. The R-C series combination, joining the high side of primary and secondary, eliminates high-frequency resonance (around 7000 cycles) due to the second resonance peak of a double-tuned circuit. The transformer must be correctly poled for this connection to be effective.

The second 6SK7 with a tuned-choke plate load, which has a 1000-cycle Q of about 5, is coupled, directly to one vertical deflection plate of a 2AP1 cathode-ray tube, which serves as an output amplitude and phase indicator. A second indication is obtained by reading the rectified current of one of the 6H6 diodes on the output meter. The other 6H6 diode, used for automatic gain control, has a positive delay bias of about 100 volts applied to its cathode. The automatic-gain-control voltage is applied to the grid of the second 6SK7 and gives adequate limiting action by a combination of bias variation and plate-circuit overload as shown in Fig. 2. The meter shunt is adjusted to give full-scale indication with maximum input.

Horizontal deflection voltage for

the cathode-ray tube is obtained through a separate input from the bridge source, and is amplified by a single 6SK7 tube operated with a tuned-choke plate-load (a 6SJ7 is now being used here). The power supply, centering circuits, etc., are straightforward. The cathode-ray tube is operated with its cathode 300 volts below ground through the 6X5 rectifier, thus providing a second anode voltage of 600 volts from an ordinary 300-volt power supply transformer.

## Performance

An input of 10 microvolts is sufficient to give an observable indication on either the meter or the cathode-ray vertical deflection. Figure 2 shows the input vs. output curve of the instrument at full gain. As the input is increased, the indication increases linearly up to about half scale on the meter, at which point the automatic gain control begins to operate. Thus, full sensitivity is realized over about half the meter range and yet the meter can never go off scale.

Phase indication on the cathode-ray tube is made by the method devised by Lamson.<sup>2</sup> With this method, a resistive unbalance of the bridge is caused to give a tilted line on the cathode-ray tube by adjustment of the horizontal phase control. An unbalance in the opposite direction is shown by a reversal of slope of the line, and perfect balance by a horizontal line. Reactive unbalance of the

bridge causes the cathode-ray pattern to become an ellipse. The output indicating meter may be used as a simple null instrument and also as a quantitative indicator of the relative amount of input voltage to the instrument.

The selectivity of the null indicator, without an input transformer, is shown in Fig. 3. It is seen that second-harmonic discrimination is about 35 db and higher harmonics are attenuated even more. When the selectivity of a tuned input transformer (the bridge output transformer) is added to this, the harmonic reduction meets the most severe requirements.

## REFERENCES

- (1) Hague, B., A-C Bridge Methods, 5th Edition, Pitman & Sons, London.
- (2) Lamson, H. W., An Electronic Null Indicator for Impedance Bridges, *Rev. Sci. Instr.*, 9, p. 272-275, 1938.

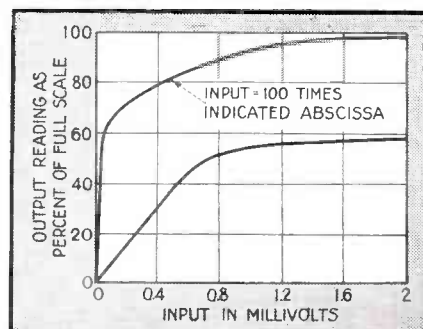

FIG. 2—Sensitivity curve, showing effect of delayed automatic-gain-control at high input levels

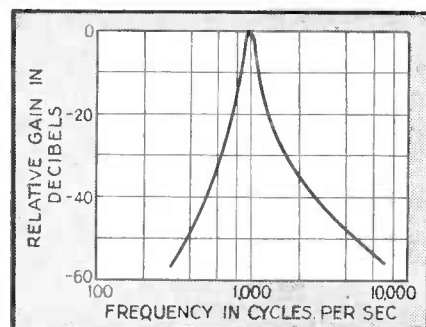

FIG. 3—A high degree of selectivity is obtained by the coupling methods used in the null-indicator

# Coaxial Cable Tests

Production testing methods suitable for coaxial cable depend upon ease of testing and reducing data to cable parameters. Open and shorted cable lengths are substituted into either bridge or resonant circuits using variable air capacitors for balance.

By PERRY H. WARE

Laboratory Engineer  
Simplex Wire and Cable Co.  
Cambridge, Massachusetts

$\alpha$	—attenuation of cable in nepers per unit length; $\alpha l$ : Eq. (19)
$\beta$	—phase shift of cable in radians per unit length; $\beta l$ : Eq. (20), (25)
$B$	—input susceptance of cable; $B_{oc}$ : Eq. (4)
$C$	—capacitance at critical condition with unknown in circuit, measured; $C'$ , without unknown in circuit, measured; $C_{oc}$ , input of cable: Eq. (3); $C_m$ , mica capacitor, measured: Fig. 1(C); $C_s$ , mica capacitor and cable in series, measured: Fig. 1(C); $C_t$ , total of cable in farads, measured
$\gamma$	—propagation constant per unit length: Eq. (2), (18), (18a), (21)
$D$	—dissipation factor ( $D = R \omega C$ ), measured; $D_{oc}$ input of cable: Eq. (7), (15); $D_m$ , see $C_m$ ; $D_s$ , see $C_s$
$\delta$	—phase angle of impedance
$E$	—potential, measured; $E_r$ , at resonance
$f$	—resonant frequency of test cable length, measured
$G$	—conductance, measured
$\theta$	—phase angle; $\theta_{oc}$ , admittance: Eq. (5), (7); $\theta_{sc}$ , impedance: Eq. (9)
$I$	—current, measured; $I_r$ , at resonance
$l$	—length of cable sample
$n$	—number of quarter wavelengths of cable sample
$oc$	—subscript indicating cable output is open circuit
$R$	—resistance, measured, see $C$ ; $R'$ , sec $C'$ ; $R_m$ , sec $C_m$ ; $R_s$ , sec $C_s$ ; $R_{sc}$ : Eq. (16)
$\phi$	—phase angle of admittance
$sc$	—subscript indicating cable output is short circuit
$X_{sc}$	—reactance at cable input with cable output a short circuit: Eq. (8), (11)
$Y_{oc}$	—admittance at cable input with cable output an open circuit: Eq. (6)
$\psi$	—phase angle of $\tanh \gamma l$
$Z$	—complex impedance; $Z_0$ , characteristic: Eq. (1), (17), (17a) (30); $Z_{oc}$ , see $Y_{oc}$ ; $Z_{sc}$ , see $X_{sc}$ : Eq. (10)

**I**N TESTING radio-frequency coaxial cables we must decide what cable properties it is desirable to know. Parameters of prime interest to the user of cable are the working parameters, that is: characteristic impedance and propagation function. With a knowledge of these parameters the designer of radio-frequency equipment can calculate the performance of the installed cable. The cable design engineer is, of course, vitally interested in these same factors, but he also must know the basic parameters of the cable, that is: resistance, inductance, conductance, and capacitance.

We are therefore interested in measuring all the parameters of the cable, both basic and working. The method will be chosen principally for ease and accuracy of measurement and computation.

## Test Frequency

It has been found expedient in laboratory cable testing to standardize the test frequencies, for several reasons.

Many specifications are written giving limits for cable parameters at specified frequencies. Using a few predetermined frequencies it is possible, with a minimum of testing to make comparisons with other cables and from previous experience to estimate probable behavior at other frequencies. Cor-

rections depending on frequency, which must necessarily be made at high frequencies, can be systematized by graphs and tables thereby cutting the time of computation and reducing the probability of computation error. In a test where actual manipulation of instruments may take ten minutes or less and computations may occupy three-quarters of an hour, the time factor becomes important.

Measurements will, therefore, be made at fixed frequencies. This consideration almost entirely eliminates methods of test which require specific electrical lengths; in fact it is impractical to vary the length of a cable until an exact resonant length is obtained. Further, at frequencies below one megacycle, a quarter wavelength of cable becomes too long physically for convenient laboratory testing.

The principal method left is measurement of impedance of the cable with the far end successively short-circuited and open-circuited. Characteristic impedance and propagation constant may be determined from these measurements by the relationships

$$Z_0 = \sqrt{Z_{sc} Z_{oc}} \quad (1)$$

$$\gamma = (\tanh^{-1} \sqrt{Z_{sc}/Z_{oc}})/l = \alpha + j\beta \quad (2)$$

The symbols used in equations are defined in Table I.

Regardless of the instrument or circuit used for measurement, open-

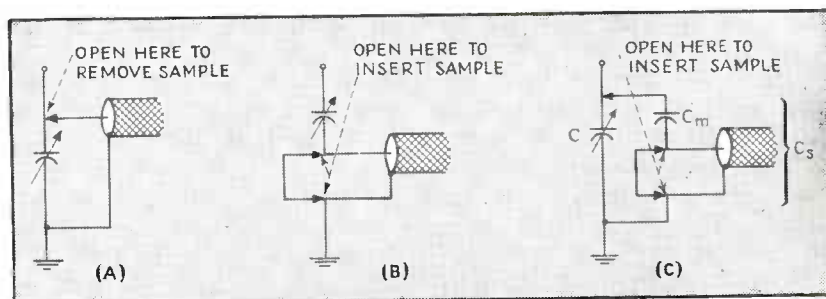
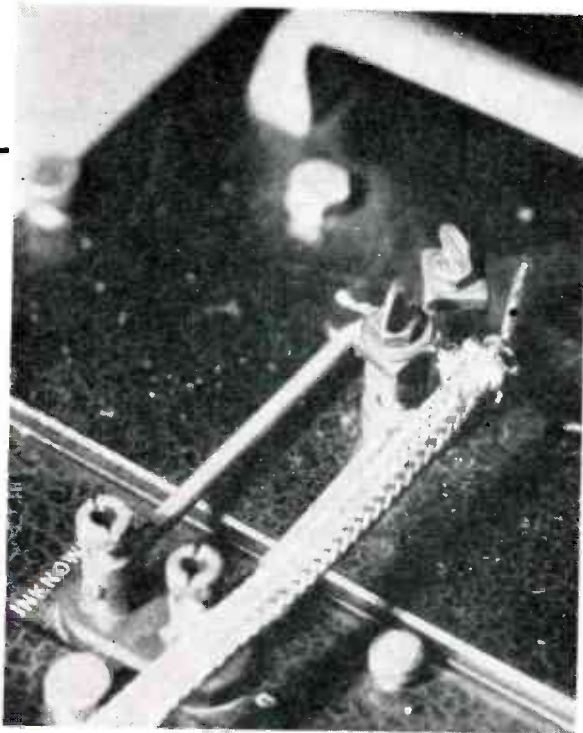

FIG. 1—Coaxial cable can be connected into measuring circuit by (A) parallel substitution, (B) series substitution, or (C) series-parallel substitution

TABLE I—Symbols for coaxial cable measurements discussed in the text





Coaxial cable in position for parallel substitution measurements has its outer conductor connected to the variable air capacitor. The parallel combination of cable and capacitor is connected across the unknown terminals of a bridge

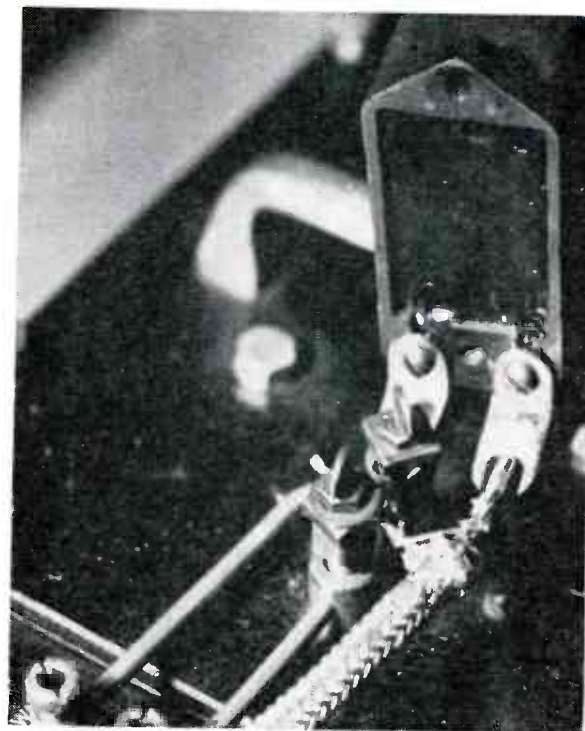

For series-parallel substitution a short wire is soldered between the outer coaxial braid and the inner conductor thereby shorting the cable. Cutting wire places cable and mica capacitor in series across the capacitor

circuit and short-circuit impedances may be determined with the least probability of unaccounted-for errors by some form of substitution measurement.

#### Substitution Measurements

Circuit components, which at audio frequencies may be considered as pure elements such as resistances and inductances, will in general show at radio frequencies distributed capacitance, inductance, and resistance, which alter their behavior. At high frequencies the stray component becomes appreciable, and introduces into any circuit containing it an impedance which may be neither readily calculated nor measured.

In general, the most satisfactory standards at radio frequency are fixed resistors and variable capacitors. Fortunately the residual resistance and inductance of an air capacitor can readily be measured, and from these measurements its behavior may be accurately predicted.

A substitution method will reduce to a minimum the necessary corrections to be made in either bridge or resonance methods. If all impedance is defined in terms of fixed

resistance and variable capacitance, with reasonable precautions such as correct shielding and correction for residual parameters, impedance can be measured up to sixty megacycles.

#### Parallel Substitution

The parallel substitution method illustrated in Fig. 1(A) is commonly used for measurement of relatively high impedances such as short lengths of cable under open-circuit conditions. Results are most conveniently expressed as admittance (the reciprocal of impedance) or as capacitance, which is measured directly.

Bridge balance or resonance is established with a variable air ca-

pacitor alone in the circuit. The unknown is then connected in parallel with the air capacitor, and the latter is varied until either the bridge is rebalanced or the circuit is returned to resonance. The capacitance of an open-circuited sample is then given by

$$C_{oc} = (C' - C) \quad (3)$$

and susceptance by

$$B_{oc} = \omega C_{oc} \quad (4)$$

If, for example, the initial setting of the capacitor at a frequency of 100 kilocycles is 1000  $\mu\mu\text{f}$ , and the second setting is 200  $\mu\mu\text{f}$ ,  $C_{oc} = 800 \mu\mu\text{f}$ , and  $B_{oc} = 2\pi (10^6) (800) (10^{-12}) = (503) (10^{-6})$  mho. Assuming a capacitor having a range

TABLE II—Reactance limits of series or series-parallel substitution

Freq in Mc	$C'$ in $\mu\text{f}$	Inductance Range	Capacitance Range in $\mu\text{f}$
0.01	0.10	— 0.25 — 25 $\mu\text{h}$	10.0 — 1000
	0.01	— 0.025 — 2.2 mh	0.1 — 10
	0.001	— 2.5 — 130 mh	0.001 — 0.1
0.10	0.01	— 0.25 — 22 $\mu\text{h}$	0.1 — 10
	0.001	— 0.025 — 1.3 mh	0.001 — 0.1
1.0	0.0009	— 0.32 — 2.5 $\mu\text{h}$	0.08 — 0.001
	0.0005	— 1.0 — 25 $\mu\text{h}$	0.025 — 0.001
	0.0001	— 25.0 — 220 $\mu\text{h}$	<0.001
10.0	0.0006	— 0.007 — 2.0 $\mu\text{h}$	0.0013 — 0.037

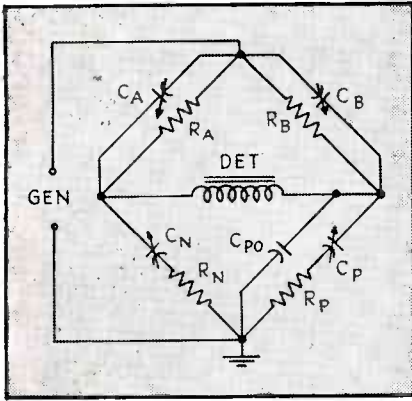

FIG. 2—For measurements from one kilocycle to five megacycles the Schering bridge is the most usable

of 100 to 1100  $\mu\mu\text{f}$ , the range of values which may be measured with reasonable accuracy is given in Table II.

The conductive component of the unknown admittance is the difference between the conductance of the parallel combination and that of the air capacitor alone, as determined by the particular measuring circuit used. A bridge will often be designed to yield results in the form of dissipation factor (tangent of the defect or loss angle); if so the complex admittance may easily be determined both in phase angle and magnitude from the relationships

$$\cot \theta_{oc} = D_{oc} \quad (5)$$

$$Y_{oc} = B_{oc}/\sin \theta_{oc} \quad (6)$$

If  $G_{oc}$  is measured directly, we can also apply the following

$$\cot \theta_{oc} = G_{oc}/B_{oc} = D_{oc} \quad (7)$$

In all these measurements, to reduce the determined cable parameters to unit length the results given above should be divided by the length of the measured cable.

#### Series Substitution

For measurement of low impedances such as short-circuited samples of short length, a series substitution method illustrated in Fig. 1(B) is used. The initial balance is made as before on a variable air capacitor or, particularly at frequencies below one megacycle, on a mica capacitor of suitable capacitance using a variable air capacitor in parallel as a means of measuring increments of capacitance.

The unknown impedance is inserted in series with the capacitor, often by removing a short-circuiting lead from its terminals, and initial conditions are re-established by

resetting the air capacitor. The reactance of the short-circuited sample is given by

$$X_{sc} = (C - C')/\omega CC' \quad (8)$$

The resistive component of the unknown impedance is the difference between the resistance of the series combination and the effective series resistance of the capacitor alone, as determined by the particular measuring circuit used:  $R_{sc} = R - R'$ .

The complex impedance, in magnitude and phase, is computed from the expressions

$$\cot \theta_{sc} = R_{sc}/X_{sc} \quad (9)$$

$$Z_{sc} = X_{sc}/\sin \theta_{sc} \quad (10)$$

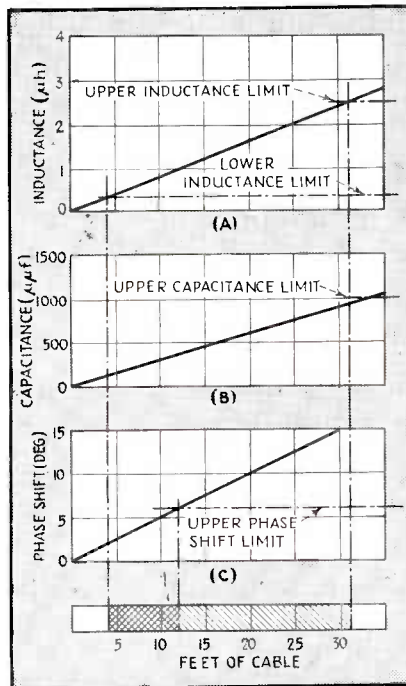

FIG. 3—To determine the sample length to be used in cable testing, a chart of this type is made

As an example, at 100 kilocycles  $C'$  is 0.01  $\mu\mu\text{f}$ ,  $C$  is approximately 0.01  $\mu\mu\text{f}$  and the difference, measured with the air capacitor is 25  $\mu\mu\text{f}$ . The reactance given by Eq. 8 is  $X_{sc} = (25) (10^{-12})/2\pi (10)^5 (0.01) (0.01) (10^{-12}) = 0.398$  ohm.

#### Series-Parallel Substitution

For measurement at frequencies of one megacycle and higher it is more convenient to use a modification of the series substitution method. In this case the substitution is made in series with a mica capacitor, with the initial and final impedances measured by a parallel-substitution method across a variable air capacitor; the method is

called series-parallel substitution and connections are shown in Fig. 1(C). Reactance is given by

$$X_{sc} = (C_s - C_m)/\omega C_s C_m \quad (11)$$

If, for example, measurement by parallel substitution yields 1000  $\mu\mu\text{f}$  for  $C_m$  and 1010  $\mu\mu\text{f}$  for  $C_s$  at a frequency of one megacycle, then by Eq. (11)  $X_{sc} = (10) (10^{-12})/2\pi (1000) (1010) (10^{-21}) = 1.578$  ohms.

#### Resistance Measurement

The resistive component of impedance is equal to the difference between the measured equivalent resistances of the series combination and of the mica capacitor alone. If the parallel-substitution measurement yielded dissipation factor for the two measurements ( $D_m$  and  $D_s$ , respectively) the resistances are given to a close approximation by

$$R_m = D_m/\omega C_m \quad (12)$$

$$R_s = D_s/\omega C_s \quad (13)$$

and the resistance of the sample is  $R_{sc} = R_s - R_m$ . The complex impedance is computed as for the regular series substitution measurement. For either type of substitution, the useful range of measurement is shown in Table III.

Precautions should be taken in connecting and disconnecting the cable during measurements not to change stray lead impedances. Place equipment so that leads are moved but short distances, and stray capacitances are measured as part of the initial capacitance and do not appear as an error in the impedance of the sample.

#### Frequency Range

Until now only general methods of measurement have been discussed. The actual instrument or circuit used for these measurements is principally dependent upon the test frequency. Up to three megacycles, bridge measurements are entirely satisfactory. A Schering bridge designed for radio-frequency use has been used by the author with consistent results from one kilocycle to three megacycles; with proper design and correction for residual parameters, a bridge may be used as high as fifty megacycles.

#### Schering Bridge

In the Schering circuit of Fig. 2 the only variable elements are ca-



capacitive. If a substitution method is used, the reactance balance is obtained with an air capacitor used in the unknown  $P$  arm of the bridge; phase balance is obtained with a variable air capacitor in the diametrically opposite  $A$  arm. For an equal-arm bridge (i.e.,  $R_A = R_B$ ) the total capacitance in the  $P$ -arm remains constant and the change in dissipation factor of the  $P$ -arm is given by

$$D_P - D_{P'} = (C_A - C_A') \omega R_A = \Delta D \quad (14)$$

If the bridge is originally balanced with the standard capacitor alone in the  $P$ -arm, using  $C_P$  and  $C_B$  to attain balance, introduction of the sample will necessitate a change in the standard capacitor and in  $C_A$  to rebalance the bridge. The change in dissipation factor of the entire  $P$  arm depends, not on an absolute value of  $C_A$ , but merely on an increment which can be accurately determined. If  $R_A$  is known, capacitor  $C_A$  may be calibrated directly in dissipation factor at a given frequency. This value is then proportional to frequency as shown by Eq. 14 and calibrated values may be multiplied by the ratio of test frequency to frequency of calibration to obtain values at other frequencies. Stray capacitance of the  $P$  arm are lumped into  $C_{P0}$ .

With the Schering circuit, dissipation factor of a capacitive sample measured by parallel substitution is given by

$$D_{oc} = \frac{[\Delta D(C_P' + C_{P0}) / (C_P' - C_P)] + R_c \omega (C_P' + C_P)}{R_c \omega (C_P' + C_P)} \quad (15)$$

For series substitution, the re-



Fewest possible alterations should be made in changing connections. For series substitution, connection is arranged so that removing plug jumper at right inserts the mica capacitor in series with cable and at the same time removes the short on the cable

sistance is given by

$$R_{oc} = \Delta D(C_P' + C_{P0}) / \omega C_P'^2 \quad (16)$$

The variable capacitor  $C_A$  can be calibrated in terms of resistance instead of  $\Delta D$  by measuring an accurately known resistor as a standard. By this means, the absolute value of  $C_P'$  need not be accurately known, and correction for stray capacitance is automatically made. Correction should also be made for the residual inductance of leads in the  $P$  arm.

#### Resonance Method

It has been found expedient to use resonance methods at frequencies of five megacycles and higher. Ordinarily, the resistive or conductive component of the unknown impedance or admittance is determined from the width of the resonance curve, when current or voltage is plotted against capacitance setting of a variable air capacitor used as a standard.

The following means of interpreting resonance data, suggested by Sinclair, is less subject to the error which might occur in a single measurement. If the ordinate is made  $\sqrt{(E_R/E)^2 - 1}$ , and the abscissa capacitance, for parallel resonance, or if for series resonance  $\sqrt{(I_R/I)^2 - 1}$  is plotted vs the elastance (reciprocal of capacitance), the real component of impedance may be determined from the slopes, and the reactive component from the intercepts on the axis. The limits of resistance which can be measured are determined by ability to distinguish between two very nearly equal slopes at one end, and by inability to obtain a wide enough portion of the resonance curve at the other.

#### Calculation of Results

As mentioned earlier, characteristic impedance and propagation function may be computed from the complex values of short-circuit and open-circuit impedances. If both have been measured as impedance, the following equations apply

$$Z_0/\delta = \sqrt{Z_{sc} Z_{oc}} / 0.5 (\theta_{sc} + \theta_{oc}) \quad (17)$$

$$\tanh \gamma l / \psi = \sqrt{Z_{sc} / Z_{oc}} / 0.5 (\theta_{sc} - \theta_{oc}) \quad (18)$$

If, as is customary for short samples, the open-circuit measurement has been made in terms of admittance, the following modifications are used

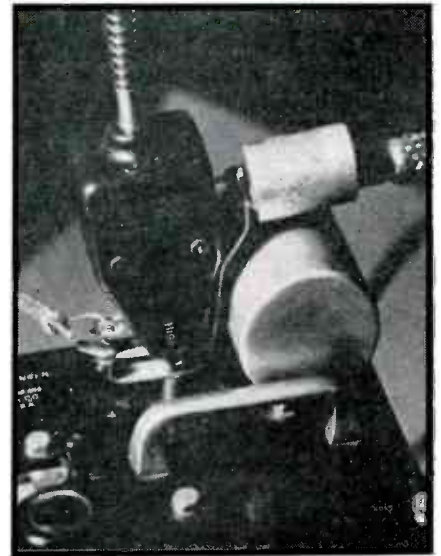

Measurements by resonance method use resonant circuit in large lower shield. Vacuum-tube voltmeter, test cable (left), variable capacitor, and input circuit (right) are connected by rigid straps

$$Z_0/\delta = \sqrt{Z_{sc} Y_{oc}} / 0.5 (\theta_{sc} - \theta_{oc}) \quad (17a)$$

$$\tanh \gamma l / \psi = \sqrt{Z_{sc} Y_{oc}} / 0.5 (\theta_{sc} + \theta_{oc}) \quad (18a)$$

The value of  $\gamma l$  is determined from its hyperbolic tangent. For short lengths of sample, this is most readily accomplished by using

$$\tanh 2\alpha l = (2 |\tanh \gamma l| \cos \psi) / (1 + |\tanh \gamma l|^2) \quad (19)$$

$$\tan 2\beta l = (2 |\tanh \gamma l| \sin \psi) / (1 - |\tanh \gamma l|^2) \quad (20)$$

where  $\tanh \gamma l$  is determined from Eq. 18 or Eq. 18a. Table IV gives approximations for characteristic impedance and phase shift which are valid under the specific conditions.

For lengths over  $\lambda/4$  wavelength the above expressions still apply, but work may be sometimes simplified by using a hyperbolic tangent table. Another method of determining  $\gamma l$  from the tanh is

$$\gamma l = 0.5 \log_e [(1 + \tanh \gamma l) / (1 - \tanh \gamma l)] \quad (21)$$

where, in general,  $\log_e (r/\theta) = \log_e r + j\theta$ . Having determined  $\gamma l = \alpha l + j\beta l$ , the propagation function per unit is easily obtained, since it varies directly with length. That is

$$\alpha = \alpha l \text{ (1000/l) nepers/1000 ft.}$$

$$\beta = \beta l \text{ (1000/l) radians/1000 ft.}$$

The primary constants may be found as follows

$$Z/\theta = \gamma Z_0 = R + j\omega L \quad (22)$$

$$Y/\varphi = \gamma/Z_0 = G + j\omega C \quad (23)$$

Resistance:  $R = Z \cos \theta$  ohms/1000 ft

**TABLE III—Reactance limits of parallel substitution**

Freq in Mc	Inductance Range	Capacitance Range in $\mu\mu\text{f}$
0.01	250 mh—25 h	10—1000
0.10	2.5 mh—250 mh	10—1000
1.0	25 $\mu\text{h}$ —2.5 mh	10—1000
10.0	0.5 $\mu\text{h}$ —25 $\mu\text{h}$	10—500

Inductance:  $L = (Z \sin \theta) / \omega$  henrys/1000 ft

Conductance:  $G = Y \cos \phi$  mhos/1000 ft

Capacitance:  $C = Y \sin \phi / \omega$  farads/1000 ft

where  $\gamma$  and  $Z_0$  are both considered as vector quantities, having magnitude and phase angle. If the length of sample is electrically short (i.e., less than 1/60 wavelength, or 6 degrees)  $\tanh \gamma l$  does not differ by more than one percent from  $\gamma l$  in either real or imaginary parts, and the primary constants may be computed from the measured values of short-circuit and open-circuit impedance as follows

$$R = R_{sc}(1000/l) \text{ ohms/1000 ft}$$

$$L = (X_{sc}/\omega) (1000/l) \text{ henrys/1000 ft}$$

$$G = G_{oc} (1000/l) \text{ mhos/1000 ft}$$

$$C = C_{oc} (1000/l) \text{ farads/1000 ft}$$

#### Ultrahigh-Frequency Measurements

At ultrahigh frequencies neither bridge nor resonance methods may be used satisfactorily. The usual method of test consists of an attenuation measurement, generally of the insertion-loss type.

Insertion-loss methods depend upon measurements of power, voltage, or current at each end of a cable loosely coupled to an oscillator at one end and terminated in its characteristic impedance at the other. The attenuation constant can then be computed by whichever of the following relationships is applicable

$$\text{Attenuation (db)} = 10 \log_{10} (P_{in}/P_{out})$$

$$\text{Attenuation (db)} = 20 \log_{10} (E_{in}/E_{out})$$

$$\text{Attenuation (db)} = 20 \log_{10} (I_{in}/I_{out})$$

Characteristic impedance can be measured by determining the frequency at which a length of cable becomes resonant (i.e., the frequency at which it is an odd

**TABLE IV—Approximate formulas for computing cable parameters**

Condition	Formula
$\alpha l < 0.02$	$\alpha l = (\tanh \gamma l \cos \theta) / (1 + \tanh^2 \gamma l)$
$X_{sc}/R_{sc} > 5$	$\left\{ \begin{aligned} \alpha l &= (R_{sc} / Z_0 + G_{oc} Z_0) / 2 (1 + Z_{sc} B_{oc}) \\ \beta l &= (Z_{sc} B_{oc})^{1/2} / (1 - Z_{sc} B_{oc}) \\ Z_0 &= (Z_{sc} / B_{oc})^{1/2} \end{aligned} \right.$
$B_{oc}/G_{oc} > 22$	

quarter-wavelength electrically). From this frequency, and the capacitance of the whole length, which may be determined for non-polar dielectrics at a lower frequency, the characteristic impedance is given by

$$Z_0 = 4nC_0 f \quad (24)$$

Phase shift is determined from the same measurements by

$$\beta = 500\pi n/l \text{ radians/1000 ft} \quad (25)$$

Relative velocity of propagation, expressed in percent of velocity in free space, is

$$\%V = 1.28 f l / \pi n \quad (38)$$

#### Choice of Sample Length

If approximate values of the cable parameters are known in advance, it is possible to select a length of sample which will place the short-circuit and open-circuit impedance measurements in the middle of the testing range for the available equipment. In the first place, it is desirable to keep the length below approximately fifty feet from the standpoint of convenience. A typical example will show how sample length may be determined.

Cable parameters at one megacycle are

Resistance: 0.02 ohms per ft

Inductance: 0.80 microhenrys per ft

Conductance: 0.60 micromhos per ft

Capacitance: 30. micromicrofarads per ft

Phase shift: 0.5 degrees per ft

Figure 3 shows inductance, capacitance and phase shift as a function of sample length. Limiting values for inductance range

**TABLE V—Optimum length of cable sample**

Freq in Mc	Length in Ft
0.01	25—30
0.10	15—30
1.0	8—25
100.0	(100±25)

using 900  $\mu\mu\text{f}$  in a series or series-parallel substitution are shown in Fig. 3(A). The limits for capacitance range in a parallel substitution measurement across a capacitor having a range of 1000  $\mu\mu\text{f}$  are shown in Fig. 3(B). The maximum limit for short-line calculations is shown in Fig. 3(C).

It may be seen that for ease in computation a 10-foot length of sample is satisfactory. If a longer sample, possibly more representative of the cable as a whole, is desired, and if time for calculation is not a deciding factor, a 20-ft to 30-ft length of sample may be used, and parameters computed from the long-line equations. Similar plots may be drawn for other frequencies and types of measurement.

For direct attenuation measurements it becomes necessary, in spite of considerations of convenience, to use a longer length. Too short a length would not yield inputs and outputs sufficiently different from each other to give precise computed values of attenuation. Table V shows test lengths which have been found convenient over the frequency range.

#### BIBLIOGRAPHY

- (1) Brown, H. A., "Radio Frequency Electrical Measurements," McGraw-Hill Book Co., Inc.
- (2) Field, R. F., "An Improved Measuring Circuit for the Susceptance-Variation Method," *General Radio Experimenter*, Sept.-Oct. 1940.
- (3) Field, R. F. and Sinclair, D. B., "A Method for Determining the Residual Inductance and Resistance of a Variable Air Condenser at Radio Frequencies," *Proc. I. R. E.*, 24, Feb. 1936, p. 255.
- (4) Hartshorn, L., "Radio-Frequency Measurements by Bridge and Resonance Methods," John Wiley & Sons, Inc.
- (5) Hund, A., "High Frequency Measurements," McGraw-Hill Book Co., Inc.
- (6) McIlwain, K. and Brainerd, J. G., "High-Frequency Alternating Currents," John Wiley & Sons, Inc.
- (7) Race and Larrick, "High-Frequency Coaxial-Line Calculations," *Trans. A.I.E.E.*, 61, July 1942, p. 526.
- (8) Sinclair, D. B., "A Radio Frequency Bridge for Impedance Measurements from 400 Kilocycles to 60 Megacycles," *Proc. I. R. E.*, 28, Nov. 1940, p. 497; "Parallel-Resonance Methods for Precise Measurements of High Impedance at Radio Frequencies," *Proc. I. R. E.*, 26, Dec. 1938, p. 1466; "Impedance Measurements at High Frequencies with Standard Parts," *General Radio Experimenter*, Sept. 1939.
- (9) Sterba and Feldman, "Transmission Lines for Short-Wave Radio Systems," *Bell System Tech. Jour.*, 11, July 1932, p. 411.



# Industrial Test Equipment Design

Circuit analyzers suitable for bench work frequently fail when subjected to necessarily rough treatment in the field and in shops handling heavy work. This article tells why they fail, and suggests design improvements

**T**HIS PAPER is based upon notes made during the training and supervision of a crew of repair-force men in a large east coast shipyard. It is slanted directly at postwar manufacturers of test equipment and is intended to bring out the fact that most circuit analyzers designed for shop work are inadequate for field duty since the conditions encountered are entirely different, especially where heavy construction work is in progress.

The shortcomings of the ordinary commercial analyzer can be summed up in a few words—inadequate provision for mechanical and electrical damage-protection, inadequate shock-proofing, and insufficient water and dust-proofing. The large damaged test equipment backlog in industrial plants doing essential war work is eloquent testimony to this fact.

## Mechanical Damage-Proofing

Out in the field, tools may be dropped upon the analyzer, or it may be struck against ladder rungs, scaffolding, switchboards, etc. This common trouble points out the need for white-metal, brass or aluminum alloy knobs, or at very least more rugged plastic knobs. Welding and burner-torch sparks burn most plastic knobs.

Analyzer panels should be made of heavier-gage metal. If such

By **TED POWELL**

*New York, N. Y.*

equipment is leaned against accidentally, or a fairly heavy weight is rested on it, the ordinary lightweight panel warps or collapses entirely. Furthermore, selector switches inside the analyzer case may be cocked and their wiring may strain against them. This often warps thin pancake switch sections enough to cause the contacts to open up.

The panel instrument or meter glass window is probably the biggest headache for field service technicians. If the palm of the hand is accidentally pressed against the meter, or if the meter is struck against an obstruction, or if some-

thing is dropped on the analyzer, a collapsed or smashed glass is the usual result. If, instead of fitting the meter window in an inside recess, it could be set in an outside recess, it would at least not cave in on the dial and indicator or pointer at the slightest pretext. The meter could be further protected by a plate of Plexiglass or Lucite or some other non-brittle plastic.

Meter cases are too fragile as a rule. If an analyzer is accidentally dropped a few inches the weight of the meter parts often tears the meter case apart. A heavier case and base, and more anchoring screws between them, would greatly reduce trouble.

Flush-mounted meters are advisable, since protruding meter cases are struck against obstructions while the analyzer is carried about on a construction job. A protective cover cannot be perpetually opened and closed without wasting too much time on rush jobs.

Resistor assemblies should not be secured to small sub-assembly panels which, in turn, are secured to meter terminals. If the analyzer is accidentally dropped, the weight of the resistors in conjunction with the weight of the meter parts frequently tears the plastic meter case open or tears the case anchoring screws out of the meter base.

Industrial analyzer potentiome-

## TYPICAL TROUBLES

Control knobs break or burn  
Panels bend or collapse  
Meter glass moves or shatters  
Meter pointers stick  
Meter pointers bend  
Meter hair-springs buckle  
Meter cases smash  
Test-lead insulation wears  
Jacks and binding-posts weaken  
Switch contacts corrode  
Sub-assemblies shift  
Wiring tears loose  
Insulation resistance declines  
Ohmmeters burn out

ters should be at least 1-watt units. They must be considered from the mechanical as well as the electrical angle for reasonable wear.

Jacks and binding posts should be more massive. The usual light-weight posts quickly wear out or develop loose contacts, and their insulation often breaks apart and falls through the panel. They should preferably be of a flush-panel design, to avoid breakage.

More rugged test leads are needed. Conductors often break at the plug-in jacks and at the plastic tubing end of the test prods. Edges, where the test-lead wire enters prods and jacks, should be chamfered off and cushioned with some sort of a flexible plastic sheath in order to prevent flex-point copper embrittlement and breakage.

#### Electrical Damage-Proofing

A serious and perpetual headache is the ohmmeter-burn-out-on-energized-circuit problem. One test crew is frequently unaware of what another is doing elsewhere on a job, and throws switches. The other crew, taking cold-circuit readings, sees its analyzer meter indicator or pointer do a rumba, sees smoke curl up from behind the panel and says goodbye to the meter or multipliers or both.

Low-current fuse protection is rarely adequate protection because of the relatively high resistance and time-constant of fuses in the milliampere ranges. Some sort of midget relay protection is needed.

A switch or pushbutton-controlled neon indicator lamp would be useful in a copper-oxide meter type analyzer, to act as a voltage indicator. When both lamp electrodes glowed, the voltage under test would be a-c. When only one electrode glowed, the voltage supply would be d-c. This would reduce damage to sensitive copper-oxide rectifiers.

When an analyzer is accidentally connected across the wrong terminals excessive meter current may be drawn and the meter-movement-coil restraining hair-springs may buckle up or cone up. This spring-buckling action necessitates opening the meter case and flicking the buckled hairsprings back into shape again. Some sort

of light-weight disks or cross-bars might be mounted on the coil-shaft close to the hair-springs to prevent them from buckling up.

A common design fault is the use of a single meter-indicator stop near the pivot end. When analyzer test prods are accidentally placed across the wrong terminals and the meter indicator slams across the dial it strikes the single stop, bends around it and either breaks off or is warped out of shape. If two stops were used, one near the pivot end as usual and one out near the indicator end, the indicator would not so often be damaged. Stops should be soft-spring cushioned to further reduce damage.

#### Shock-Proofing

Meter-pivot conical thrust-bearing points exert a pressure of from one-quarter to two tons per square inch upon their jewel bearings. If an analyzer is jarred sharply, pivot points are sometimes flattened and jewel bearings are gouged or fractured. Meter action becomes sticky and erratic and meter readings are worthless. For this reason, field-duty analyzers should be shock-proofed by floating them in sponge rubber or on springs. This would also reduce shock-demagnetization of meter permanent magnets.

Small jewel bearings might be spring-cushioned against collars, so that the springs would absorb shock. At the same time, the bearing clearance might be made adjustable.

Meter hair-springs can buckle up from severe vertical shock as well as from overload current. Not only will hair-springs buckle up under such a condition but they may also jam up in the fine turns of wire on the crossbar counterweights. Again, this points out the need for some sort of light-weight disks or crossbars next to the pivot hair-springs to prevent buckling action.

Analyzer wiring should be arranged and secured with an eye to shock and vibration conditions. Constant shock-flexing of wiring will result in crystallization at connection points, and breakage and opens. Similarly, if resistors are allowed to hang loosely, or have wiring or other components

hanging from them, the internal connections may work loose.

#### Water and Dust-Proofing

Field service conditions often require the use of an analyzer under rain, snow, dust or fume conditions. Protective covers cannot be kept closed while tests are being conducted, especially on an emergency job. For this reason, industrial analyzers should be water and dust-proofed.

The meter panel can be recessed in a rubber-gasketed groove in the analyzer case. Test-lead jacks and binding posts, and the meter itself, can be set in rubber-washer mountings. The individual components can themselves be water-proofed.

Analyzer case covers could be rubber gasketed and could contain a water-tight plastic window, so that under severe conditions the cover could be closed down and readings taken through the window.

Wiring should employ one of the new synthetic-resin plastic-insulated wires now available. Such insulation is practically moisture, chemical, fungus and corrosion-proof. The 40 and 50- $\mu$ a meters are highly sensitive and some older insulations, tightly laced, often develop too much leakage error, especially in the case of outdoor field-duty analyzers.

Soldered connections should be cleaned off with carbon tetrachloride during analyzer production, since most fluxes are hygroscopic. The consequent moisture absorption results in chemical and electrolytic corrosion at connections. It is advisable to paint over soldered joints with Glyptal, Dolph's Oil or asphalt paint such as Rubberoid. This is especially important where chemical fumes may later be present. Corrosion is especially troublesome at selector-switch connections.

Where severe moisture conditions are apt to be encountered, it is advisable to provide for an easily and externally replaceable cartridge of silica gel or some similar hygroscopic desiccant chemical in order to keep the analyzer interior dry.

Water-proofing the analyzer automatically keeps it dust-proof.



This is of great advantage where testing must be carried out on, say, a steel construction job. Metallic dust and fragments work their way into the usual commercial analyzer and into the meter coil or magnetic air gap. This results in a sticky or jamming instrument, and the trouble cannot usually be corrected by blowing out or jarring.

Ordinary dust will also cause some trouble. It coats internal analyzer wiring and circuit components and insulation surfaces, moisture is absorbed by this dust film and leakage paths and corrosion are set up.

#### Design Suggestions

Batteries replaceable from the outside of an analyzer through water-tight covers would be a time-saving convenience and would stop unnecessary punishment of the analyzer wiring and components during the replacement routine.

Wider-scale meters are needed in analyzers. They save eye and nerve-strain, especially in poor-visibility field conditions.

Shoulder-straps are useful for analyzer cases used out in the field. Ladders and scaffolding can be more easily and safely climbed with the analyzer slung from a shoulder.

Spring clips for securing test leads would be a convenience where the open-faced type analyzer is involved. This would prevent loss of the test leads and would also increase the portability of the analyzer.

Some sort of an air-gap shield might be advisable for field-type analyzer-meters. It would tend to "keep" the permanent magnet and would also discourage the migration of metallic dust into the air-gap by reducing the magnet's stray magnetic field.

#### Analyzer Range Needs

Many commercial analyzers have a low-range ohmmeter scale with a center-scale reading of 30 to 50 ohms, which is too high for most practical work. The center-scale reading should not be more than 10 or 15 ohms, so that resistances of one-tenth or one-eighth-ohm could be easily read. Resist-

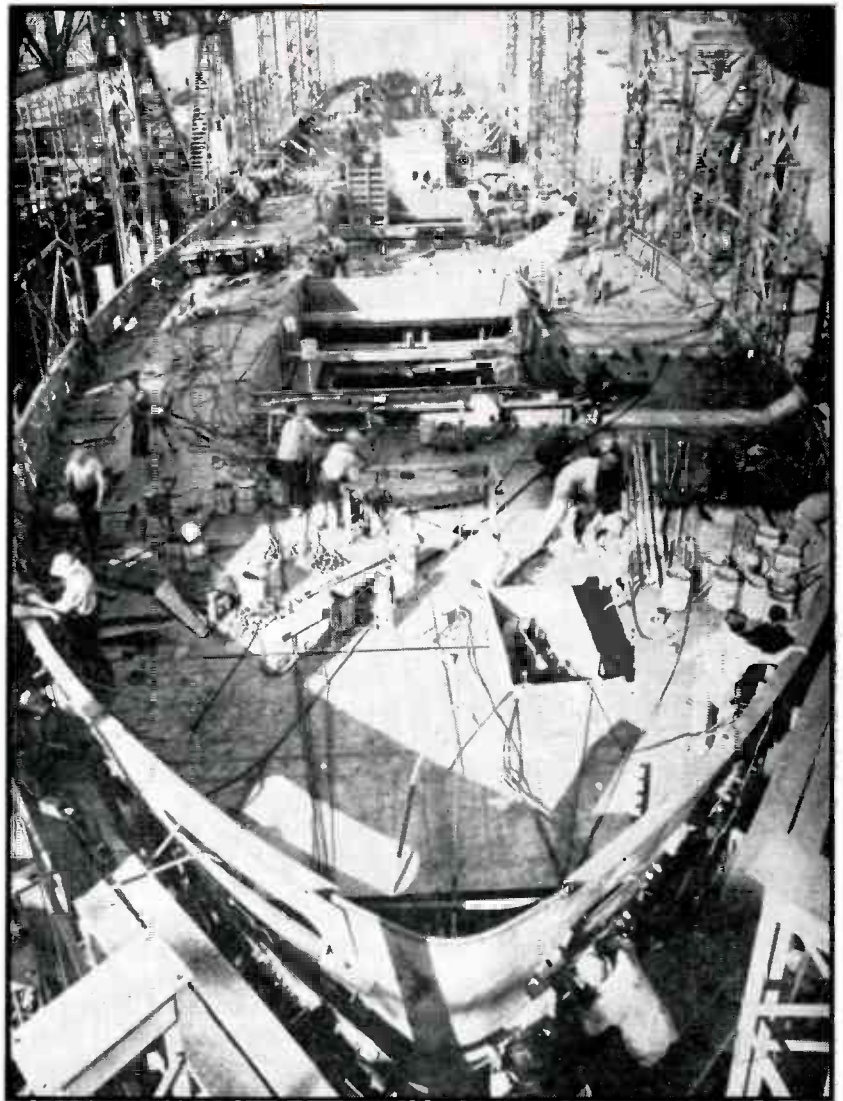

A typical ship yard, in which test equipment used during the repair of damaged electronic and electrical gear is subjected to necessarily rough usage. Test equipment used in many industrial plants encounters similar conditions

ance readings lower than this are not usually required. Terminal-lug, plug, switch and cable-copper series-resistance total up to one or two ohms for frequently encountered cable runs. Where very low resistances must be read in special instances, a Kelvin bridge or Wheatstone bridge should preferably be used.

The usual ohmmeter does not have a high enough ohmmeter scale. It should be readable to about five megohms, since some cable specifications call for insulation readings of about five megohms for normal cable lengths and operating temperatures. Such a high-range scale is a convenience and a time-saver, since sectional preliminary ground checks can be

made before a final over-all Megger or electronic megohmmeter insulation test is made. The average battery-powered high-range ohmmeter will usually read about one-third to one-fifth too high as compared to the high-voltage insulation testers but will generally show up all low and medium-resistance grounds and leaks.

Most analyzers lack a 500-volt range. There is usually a 750-volt jump from the 250 to the 1,000-volt range. A great deal of the postwar radio and electronic follow-up equipment will probably use amplifier-circuit voltages in the 250 to 500-volt range. The more common use of a 500-volt scale would save many man-hours of test work in the field.

# CRYSTAL-TUNED

**F**REQUENCY-modulation broadcasting has been proposed as a greatly improved medium for providing a high-quality transmission of programs, unmarred by background noise, static and man-made electrical interference. While a number of radio engineers take a controversial point of view, f-m is here to stay and has already received promising commercial acceptance.

To fully secure the benefits of f-m it is necessary, among other things, that accurate tuning means be provided in the receiver. The heart of receiver stability lies in the local oscillator and i-f system. Only with proper stability will the noise-free and distortionless capabilities of f-m reception be attained.

The purpose of this paper is to take up engineering and commercial considerations that will show the benefits to be derived from the use of quartz crystals as the means of obtaining stability hitherto unrealized, in a manner practical from design and cost viewpoints and attractive from sales and advertising angles.

When the receiver to be described was designed and built the final f-m allocations were far from settled, consequently it was made for

By **WILLIAM MARON**

*Senior Radio Engineer  
North American Philips Company  
Dobbs Ferry, New York*

the 42-50 mc f-m band. Some of the necessary changes for operation at the new frequencies will be discussed.

## Oscillator and I-F Design

Desirable stability has been expressed as  $\pm 0.01$  percent of carrier or  $\pm 5$  kc at 50 mc. This stability, neglecting variations in transmitter carrier center frequency, may be expressed as the permissible frequency drift in the local oscillator over temperature ranges from 40 to 120 F and over humidity conditions between 5 and 100 percent for relatively long periods of time.

The transmitter channel accuracy is held to within 0.002 percent ( $\pm 1000$  cycles). The receiver design engineer is, therefore, faced with a problem of maintaining design and production tolerances in his oscillator and i-f system to within  $\pm 4$  kc for the lower-frequency f-m band. At the new higher frequencies, holding the local oscillator to required stability will be even more difficult. To approach this, using a self-excited oscillator, the entire system must

make use of closely calibrated capacitors and trimmers having negative temperature coefficient, and low-thermal-expansion materials for coil forms, switch wafers, sockets, etc. Low-expansion metals (Invar or similar) for powdered iron inductance trimmer mountings and/or variable capacitor components are all considerations that, in addition to posing major design difficulties, certainly fall in the category of expensive.

The burden on the design engineer will be considerably reduced if he has readily available an economical and simple means of holding one major section within very close limits. This would apply either to the local oscillator or the i-f channel. Whichever one is easily held within close tolerances obviously allows more leeway in the other.

## Advantages of Quartz Crystals

From the above considerations and others which will be explained in detail, it was decided to approach the local oscillator problem by applying quartz crystals in such a manner as to realize their inherent frequency stability.

Quartz wafers may be processed to provide almost inconceivable ac-

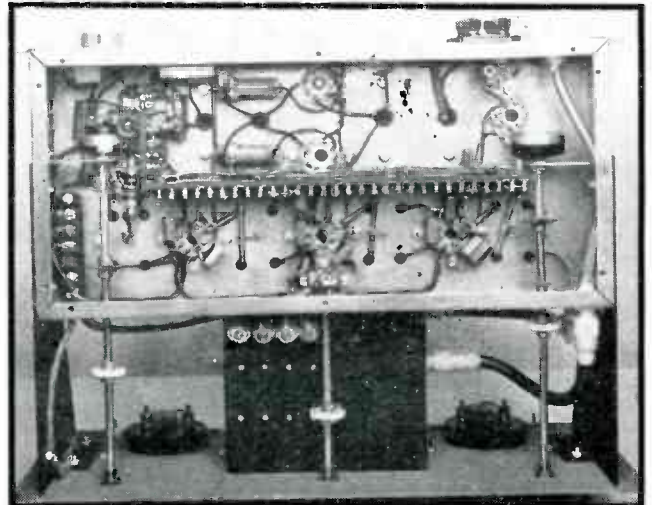
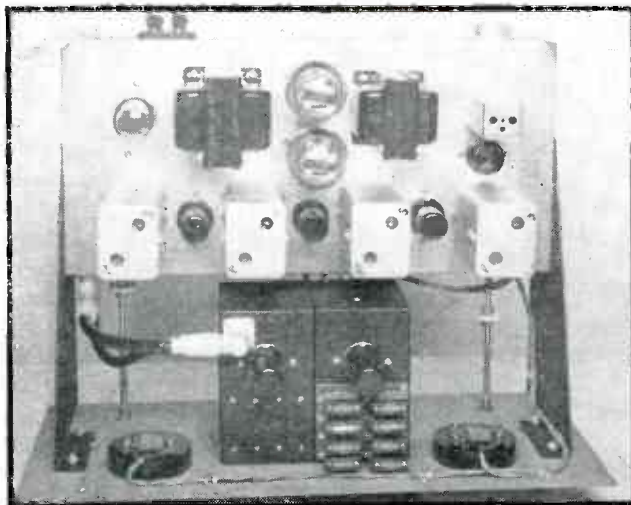

Top and bottom views of chassis of laboratory model, 8-station crystal-tuned f-m receiver. Highest-quality parts were used throughout since production engineering was not required



# F-M RECEIVERS

Quartz crystals in the oscillator stage of a superheterodyne f-m receiver provide hitherto unrealized stability, make tuning independent of listener skill, and offer other advantages

**TABLE I. FREQUENCY VALUES FOR NINE-STATION F-M RECEIVER**

Station	Freq. in mc	Osc. Freq. in mc	Crystal Freq. in mc
W2XMN	42.8	27.8	5.56
WNYC-FM	43.9	28.9	5.78
WGYN	44.7	29.7	5.94
WEAF-FM	45.1	30.1	6.02
WQXQ	45.9	30.9	6.18
WHNF	46.3	31.3	6.26
WABC-FM	46.7	31.7	6.34
WBAM	47.1	32.1	6.42
WABF	47.5	32.5	6.50

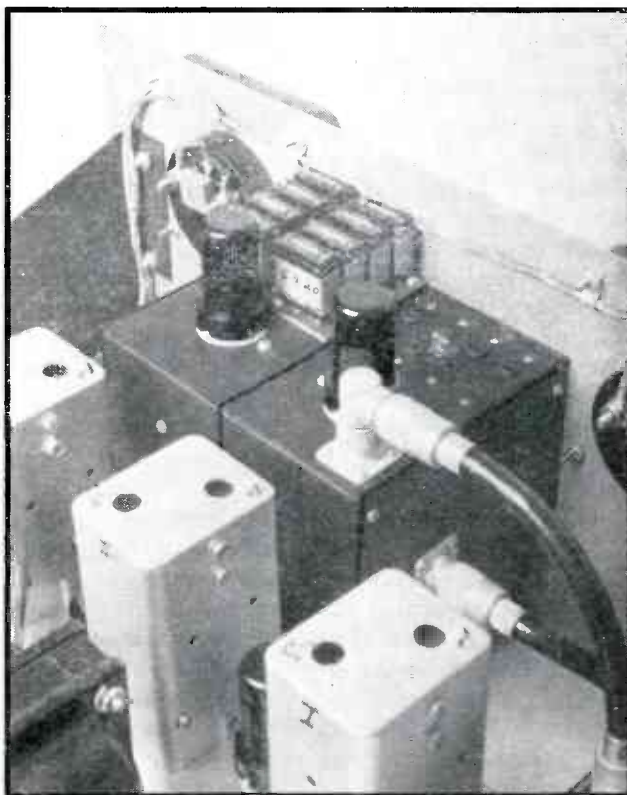

Closeup of oscillator and mixer stages, in black metal boxes. The plug-in quartz crystals are readily changed. Since two trimmers are associated with each crystal, only two adjustments need be made after a new crystal is inserted

curacy of frequency control. On a laboratory basis, one part in 5 million (0.0002 percent) is common. On a production basis, economical performance can be realized within 0.001 percent, which is 300 cycles at 30 mc. Variations, due to temperature and humidity conditions, result in an additional 0.004 percent—a total deviation of 0.005 percent or roughly 1500 cycles. This allows a margin of  $\pm 3$  kc overall, a readily obtainable result with standard components.

Other advantages to be realized from the use of quartz crystals in the local oscillator of an f-m circuits are

(1) Most existing f-m receivers are subject to wide drift which during the first half-hour of operation necessitates retuning until temperature stability has been established, and still requires occasional retuning thereafter. The use of quartz control eliminates this

undesirable condition, if design considerations outlined above are followed.

(2) Crystal control circuits lend themselves to practical applications of pushbutton or fixed station tuning. This is particularly important in view of the fact that conventional LC pushbutton circuits above 20 mc are a major design and manufacturing problem. Furthermore, manual tuning devices for f-m require repeated attention and skill on the part of the user if optimum performance is to be realized. In fact, conventional tuning is impractical unless combined with a suitable (and expensive) tuning indicator device.

(3) From an economic standpoint, the comparative cost of a properly designed 8 or 10-position crystal tuner is not unfavorable when measured against the cost of one manual tuner with proper indicator or pushbutton tuner of con-

ventional design, or a combination of the two. This is particularly true if the advantages and better performance of crystal-controlled circuits are taken into account. In other words, it is possible to justify and even capitalize through sales and advertising on the benefits of crystal operation.

(4) Fixed crystal tuning has sales and service advantages unrealized in conventional types of fixed station tuning.

(5) Factory and service alignment is simplified by using crystals.

## Design Data

To illustrate the principle of crystal control, a model receiver operating in the lower-frequency f-m band (42 to 50 mc) was designed and built. For a tuning range of 40 to 50 mc, the i-f band width was  $\pm 100$  kc, and crystal oscillator stability at the 5th harmonic was better than  $\pm 1.5$  kc. The overall sta-





The crystal oscillator and mixer are built into a separate 6 x 5 x 4-inch metal box, filament and plate power being supplied through ceramic feed-through insulators. Cables and fittings are used for antenna input and for feeding from the mixer plate to the i-f input.

The i-f and audio stages are on a 8 x 17 x 3-inch chassis, with i-f stages built in line along the front, and audio stages occupying the rear of the chassis. Power is supplied from an external source.

The i-f limiter, discriminator and audio stages are conventional and require little explanation.

The unusually large number of mica bypass capacitors is due to the fact that the receiver was designed as a laboratory model, no expense being spared in its construction and no production engineering being done. However, if the power supply is combined on the same chassis, the 0.01- $\mu$ f filament and power supply bypass capacitors will not be needed. For i-f bypass capacitors, paper may be substituted for mica. However, if oscillations should occur due to the increased inductance of the paper capacitors, mica will have to be used. The use of any paper capacitors in the r-f unit is contraindicated.

#### Alignment Procedure

During alignment, the 0-200  $\mu$ a carrier level meter is connected in series with the limiter grid and is used for aligning the i-f amplifier and checking carrier levels of stations. The 50-0-50  $\mu$ a deviation

meter is connected across the discriminator and is used for balancing the discriminator and for observing crystal drift. Alignment of the i-f amplifier is effected by sweep generator methods.

Insert the complement of station crystals. Make sure stations are on the air, rotate the selector switch to the proper channel, and carefully adjust the oscillator trimmer and mixer trimmer for maximum limiter grid current. This is done for each station.

Unless each crystal is on the exact required frequency the discriminator meter will not read zero. The reading for each station will vary plus or minus from zero depending on how far off the crystal happens to be. Movement of this meter reading over a period of time will show crystal drift; station carrier shift will also be indicated, but this may be neglected.

#### Conclusions

At the time of this writing the above receiver has been in operation every day for over two months. From the time it was initially aligned it has not been touched.

The maximum drift observed has been about 3 kc. This drift is an accumulation of several factors, such as aging, heat, humidity, line voltage fluctuations, and station center frequency deviation.

In order to check drift the reading of the deviation meter must be correctly evaluated.

From a serviceman's point of view, alignment is swift and sure.

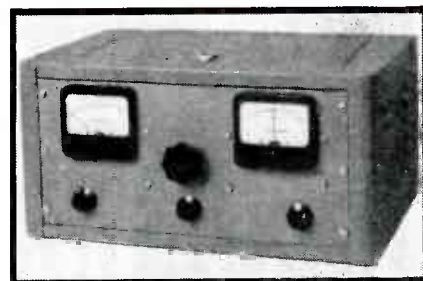

Front view of crystal-tuned receiver. Large knob at center controls 8-position rotary selector switch providing instant choice of eight preselected f-m stations

Listeners will have a receiver that will always give them f-m at its best without the need of careful tuning, as there is no tuning. Should the listener move to another area, different crystals can be plugged in to cover stations in the new locality and the r-f trimmers quickly realigned.

Whereas the above analysis has dealt chiefly with the receiver design for the present f-m band (42-50 mc), the considerations shown become of even greater importance in the new band (88-106 mc).

For operation in the higher-frequency band the i-f and audio systems remain the same. The r-f unit will have to be modified. All components comprising the unit should be arranged to result in the shortest possible leads. Heavy wire, such as No. 6 or 8 or small diameter copper tubing, preferably silver plated, will make ideal inductances. Undoubtedly, some of the new high-frequency miniature tubes will give superior performance, especially in the mixer stage.

#### Summary

Optimum f-m reception requires a high degree of tuning accuracy and stability. The use of quartz crystals in the local oscillator of an f-m receiver is the most economical means of obtaining the desired result while permitting the balance of the receiver to follow conventional lines of design and manufacture. In addition, crystal-tuned f-m receivers provide instant, exact, and stable tuning that insures optimum performance independently of the user's skill. Finally, crystal-tuned f-m receivers will be much easier to service and maintain and will minimize the equipment and skill of the serviceman.

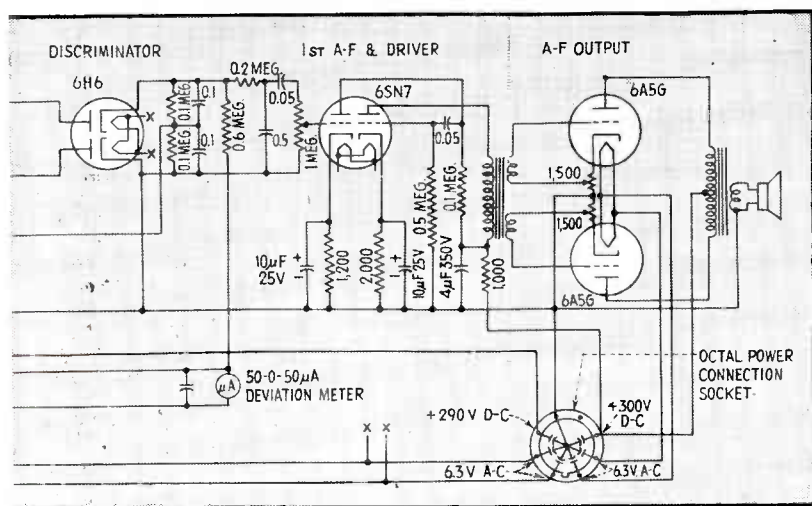

selector switch that makes tuning independent of listener skill

# GRAPHICAL

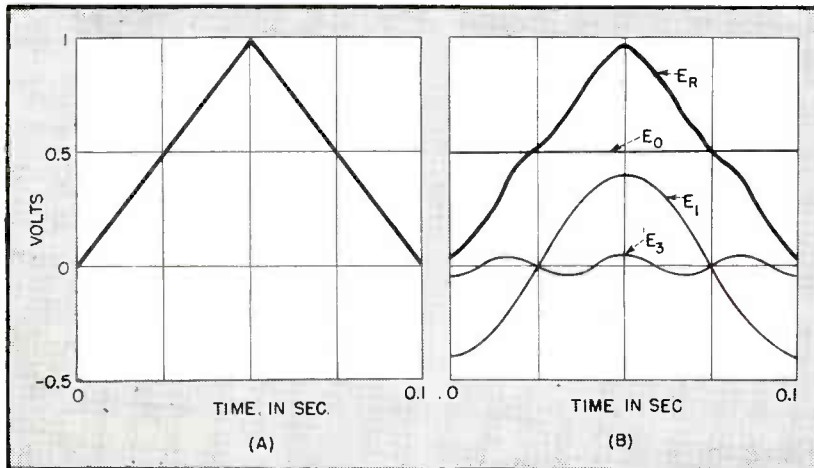

FIG. 1—Example showing how addition of first three principal components  $E_0$ ,  $E_1$ , and  $E_3$  gives a reasonably close approximation  $E_R$  to a pure triangular wave

Simple procedure for determining equation of wave and harmonic amplitudes up to the sixth by measuring ordinates on a cathode-ray oscilloscope screen or elsewhere, then substituting measured values in 6, 8, or 12-point schedules requiring only use of arithmetic

By **LARRY S. COLE**

*Department of Radio  
Utah State Agricultural College  
Logan, Utah*

**T**HE determination of the d-c and various a-c components of a complex or distorted wave (such as might be seen on an oscilloscope screen) is frequently of considerable importance and value to both the student and the engineer. The graphical method presented here will yield this information with sufficient detail and accuracy for all ordinary needs, is purely arithmetical, and requires no long or involved calculations.

### Principles of Method

Any sine-wave voltage making a specified angle with the time base can be represented by a sine-wave voltage (in phase with the time base) and a cosine-wave voltage (a sine wave  $90^\circ$  out of phase with the time base), each having the proper magnitude. The reason for the utilization of this principle is that often one of the sine-wave components of a complex wave is out of

phase with the time base of the complex wave. In the analysis to follow, such a component will appear as a sine and a cosine term, and to obtain the magnitude of the actual component (and its phase angle if desired), these two terms are simply added vectorially.

Any continuous and periodic complex wave of voltage (or current) can be duplicated by adding together a number of separate voltages (or currents), each of which is a simple sine or cosine wave form of proper magnitude and frequency plus, in some cases, a d-c voltage (or current). Further, the frequencies of these a-c voltages will be integral multiples (harmonics) of the frequency of the complex wave.

As an example, consider the triangular wave shown in Fig. 1A having a peak value of 1 volt and a period of 1/10 sec (frequency 10 cycles). The Fourier analysis of

this particular wave shows its principal components to be a d-c voltage of 0.5 volt, an a-c voltage of 0.405 volt at 10 cycles with a phase angle of  $-90^\circ$ , and an a-c voltage of 0.045 volt at 30 cycles with a phase angle of  $-90^\circ$ .

Figure 1B shows the results of adding together these first three principal components, which gives a reasonably good approximation of the original triangular wave. Of course the wave contains an infinite number of higher-order components other than those named, but they are of rapidly decreasing magnitude. (The next two, the 5th and 7th, have magnitudes of 0.0162 and 0.00827 respectively).

We may summarize these principles by stating that the equation of the general complex wave may be written in the form

$$E_R = E_0 + (e_1 \sin 2\pi ft + E_1 \cos 2\pi ft) + (e_2 \sin 2\pi 2ft + E_2 \cos 2\pi 2ft) + (e_3 \sin 2\pi 3ft + E_3 \cos 2\pi 3ft) + \dots + (e_n \sin 2\pi nft + E_n \cos 2\pi nft)$$



# ANALYSIS OF COMPLEX WAVES

where  $E_0$  is the d-c component,  $e_1 + jE_1$  is the fundamental a-c component (having the same period as that of the complex wave),  $e_2 + jE_2$  is the second harmonic a-c component (having a period one-half that of the complex wave), etc. In a large number of practical cases, we are only interested in the first two or three a-c components of a complex wave because the magnitudes of the higher-order components are small.

Utilizing the above formula and the principles just discussed, let us analyze one cycle of the general complex wave of period  $1/f$  sec (frequency  $f$ ), shown in Fig. 2, for the d-c and first three a-c components.

### Analysis of General Complex Wave

First, we divide the period of one cycle of the complex wave ( $1/f$  sec) into six equal intervals of  $1/6f$  sec each. From the graph, we measure

the instantaneous values of the complex wave at these time intervals, noting the respective values as  $Y_1, Y_2, Y_3$ , etc., and tabulate as follows:

Time (sec)	$\frac{1}{6f}$	$\frac{2}{6f}$	$\frac{3}{6f}$	$\frac{4}{6f}$	$\frac{5}{6f}$	$\frac{1}{f}$
Inst. values	$Y_1$	$Y_2$	$Y_3$	$Y_4$	$Y_5$	$Y_6$

Since the value of the complex wave at any instant must be equal to the algebraic sum of its components at that instant, we may write the following equations

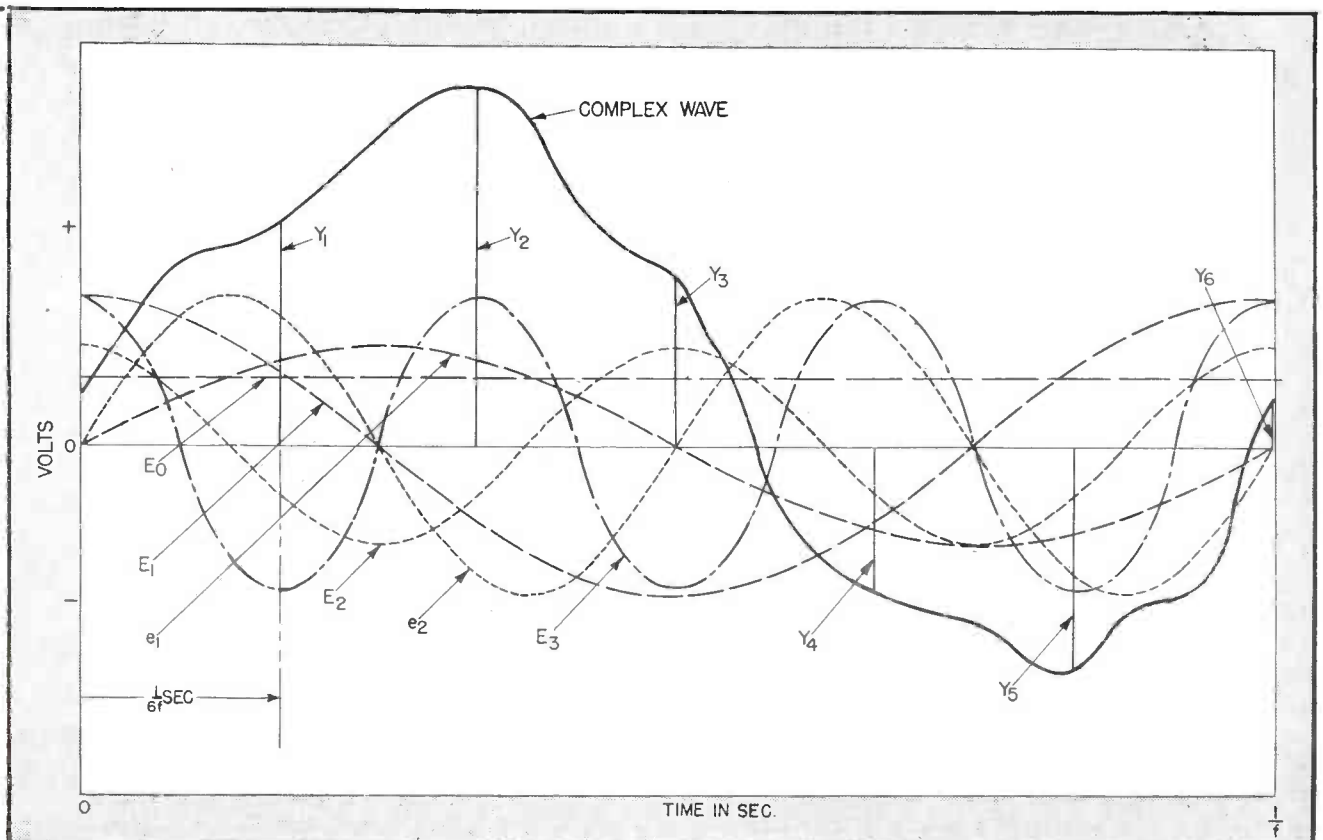

FIG. 2—Complex wave, showing method of measuring ordinates for a six-point analysis. The d-c component and the five sine-wave components are drawn in here only for illustrative purposes without any attempt to show correct amplitudes, and are not needed in the graphical analysis described

At  $t = 1/6f$  sec:

$$E_R = Y_1 = E_0 + e_1 \sin 2\pi f \times 1/6f + E_1 \cos 2\pi f \times 1/6f + e_2 \sin 2\pi \times 2f \times 1/6f + E_2 \cos 2\pi \times 2f \times 1/6f + E_3 \cos 2\pi \times 3f \times 1/6f$$

At  $t = 2/6f$  sec:

$$E_R = Y_2 = E_0 + e_1 \sin 2\pi f \times 2/6f + E_1 \cos 2\pi f \times 2/6f + e_2 \sin 2\pi \times 2f \times 2/6f + E_2 \cos 2\pi \times 2f \times 2/6f + E_3 \cos 2\pi \times 3f \times 2/6f$$

At  $t = 3/6f$  sec:

$$E_R = Y_3 = E_0 + e_1 \sin 2\pi f \times 3/6f + E_1 \cos 2\pi f \times 3/6f + e_2 \sin 2\pi \times 2f \times 3/6f + E_2 \cos 2\pi \times 2f \times 3/6f + E_3 \cos 2\pi \times 3f \times 3/6f$$

At  $t = 4/6f$  sec:

$$E_R = Y_4 = E_0 + e_1 \sin 2\pi f \times 4/6f + E_1 \cos 2\pi f \times 4/6f + e_2 \sin 2\pi \times 2f \times 4/6f + E_2 \cos 2\pi \times 2f \times 4/6f + E_3 \cos 2\pi \times 3f \times 4/6f$$

At  $t = 5/6f$  sec:

$$E_R = Y_5 = E_0 + e_1 \sin 2\pi f \times 5/6f + E_1 \cos 2\pi f \times 5/6f + e_2 \sin 2\pi \times 2f \times 5/6f + E_2 \cos 2\pi \times 2f \times 5/6f + E_3 \cos 2\pi \times 3f \times 5/6f$$

At  $t = 1/f$  sec:

$$E_R = Y_6 = E_0 + e_1 \sin 2\pi f \times 1/f + E_1 \cos 2\pi f \times 1/f + e_2 \sin 2\pi \times 2f \times 1/f + E_2 \cos 2\pi \times 2f \times 1/f + E_3 \cos 2\pi \times 3f \times 1/f$$

These six equations become, after simplification and substitution of trigonometric values

$$Y_1 = E_0 + (1/2)E_1 + (\sqrt{3}/2)e_1 - (1/2)E_2 + (\sqrt{3}/2)e_2 - E_3$$

$$Y_2 = E_0 - (1/2)E_1 + (\sqrt{3}/2)e_1 - (1/2)E_2 - (\sqrt{3}/2)e_2 + E_3$$

$$Y_3 = E_0 - E_1 + E_2 - E_3$$

$$Y_4 = E_0 - (1/2)E_1 - (\sqrt{3}/2)e_1 - (1/2)E_2 + (\sqrt{3}/2)e_2 + E_3$$

$$Y_5 = E_0 + (1/2)E_1 - (\sqrt{3}/2)e_1 - (1/2)E_2 - (\sqrt{3}/2)e_2 - E_3$$

$$Y_6 = E_0 + E_1 + E_2 + E_3$$

We now have six linear simultaneous equations containing six unknowns  $E_0$ ,  $E_1$ ,  $e_1$ ,  $E_2$ ,  $e_2$ , and  $E_3$ . (The  $Y$  values are known, having been measured from the graph.) When solved, these equations give the values set forth in Table I for a six-point analysis. Corresponding formulas for the eight and twelve-point methods, also given in Table I, are derived in the same manner and are used when it is necessary to take a greater number of points in order to secure more detailed and accurate results. The d-c, fundamental, and harmonic components are obtained from these values in the manner indicated at the bottom of the table.

The phase angles of the various a-c components with the time base

**TABLE I. SCHEDULES FOR GRAPHICAL ANALYSIS OF COMPLEX WAVES**

SIX-POINT SCHEDULE—for d-c, 1st, 2nd, and 3rd harmonics

$$E_0 = (1/6) (Y_1 + Y_2 + Y_3 + Y_4 + Y_5 + Y_6)$$

$$E_1 = (1/6) (Y_1 - Y_2 - Y_4 + Y_5) + (1/3) (-Y_3 + Y_6)$$

$$e_1 = (\sqrt{3}/6) (Y_1 + Y_2 - Y_4 - Y_5)$$

$$E_2 = (1/6) (-Y_1 - Y_2 - Y_4 - Y_5) + (1/3) (Y_3 + Y_6)$$

$$e_2 = (\sqrt{3}/6) (Y_1 - Y_2 + Y_4 - Y_5)$$

$$E_3 = (1/6) (-Y_1 + Y_2 - Y_3 + Y_4 - Y_5 + Y_6)$$

EIGHT-POINT SCHEDULE—for d-c, 1st, 2nd, 3rd, and 4th harmonics

$$E_0 = (1/8) (Y_1 + Y_2 + Y_3 + Y_4 + Y_5 + Y_6 + Y_7 + Y_8)$$

$$E_1 = (\sqrt{2}/8) (Y_1 - Y_3 - Y_5 + Y_7) + (1/4) (-Y_4 + Y_8)$$

$$e_1 = (\sqrt{2}/8) (Y_1 + Y_3 - Y_5 - Y_7) + (1/4) (Y_2 - Y_6)$$

$$E_2 = (1/4) (-Y_2 + Y_4 - Y_6 + Y_8)$$

$$e_2 = (1/4) (Y_1 - Y_3 + Y_5 - Y_7)$$

$$E_3 = (\sqrt{2}/8) (-Y_1 + Y_3 + Y_5 - Y_7) + (1/4) (-Y_4 + Y_8)$$

$$e_3 = (\sqrt{2}/8) (-Y_1 + Y_3 - Y_5 - Y_7) + (1/4) (-Y_2 + Y_6)$$

$$E_4 = (1/8) (-Y_1 + Y_2 - Y_3 + Y_4 - Y_5 + Y_6 - Y_7 + Y_8)$$

TWELVE-POINT SCHEDULE—for d-c, 1st, 2nd, 3rd, 4th, 5th, and 6th harmonics

$$E_0 = (1/12) (Y_1 + Y_2 + Y_3 + Y_4 + Y_5 + Y_6 + Y_7 + Y_8 + Y_9 + Y_{10} + Y_{11} + Y_{12})$$

$$E_1 = (\sqrt{3}/12) (Y_1 - Y_3 - Y_7 + Y_{11}) + (1/12) (Y_2 - Y_4 - Y_8 + Y_{10}) + (1/6) (-Y_6 + Y_{12})$$

$$e_1 = (1/12) (Y_1 + Y_3 - Y_7 - Y_{11}) + (\sqrt{3}/12) (Y_2 + Y_4 - Y_8 - Y_{10}) + (1/6) (Y_3 - Y_9)$$

$$E_2 = (1/12) (Y_1 - Y_2 - Y_4 + Y_5 + Y_7 - Y_8 - Y_{10} + Y_{11}) + (1/6) (-Y_3 + Y_6 - Y_9 + Y_{12})$$

$$e_2 = (\sqrt{3}/12) (Y_1 + Y_2 - Y_4 - Y_5 + Y_7 + Y_8 - Y_{10} - Y_{11})$$

$$E_3 = (1/6) (-Y_2 + Y_4 - Y_6 + Y_8 - Y_{10} + Y_{12})$$

$$e_3 = (1/6) (Y_1 - Y_3 + Y_5 - Y_7 + Y_9 - Y_{11})$$

$$E_4 = (1/12) (-Y_1 - Y_2 - Y_4 - Y_6 - Y_7 - Y_8 - Y_{10} - Y_{11}) + (1/6) (Y_3 + Y_6 + Y_9 + Y_{12})$$

$$e_4 = (\sqrt{3}/12) (Y_1 - Y_2 + Y_4 - Y_5 + Y_7 - Y_8 + Y_{10} - Y_{11})$$

$$E_5 = (\sqrt{3}/12) (-Y_1 + Y_3 + Y_7 - Y_{11}) + (1/12) (Y_2 - Y_4 - Y_8 + Y_{10}) + (1/6) (-Y_6 + Y_{12})$$

$$e_5 = (1/12) (Y_1 + Y_3 - Y_7 - Y_{11}) + (\sqrt{3}/12) (-Y_2 - Y_4 + Y_8 + Y_{10}) + (1/6) (Y_3 - Y_9)$$

$$E_6 = (1/12) (-Y_1 + Y_2 - Y_3 + Y_4 - Y_5 + Y_6 - Y_7 + Y_8 - Y_9 + Y_{10} - Y_{11} + Y_{12})$$

SIGNIFICANCE OF NOTATIONS

D-c component =  $E_0$

Fundamental a-c component =  $e_1 + jE_1$ ; peak value =  $\sqrt{e_1^2 + E_1^2}$

Second harmonic a-c component =  $e_2 + jE_2$ ; peak value =  $\sqrt{e_2^2 + E_2^2}$

Third harmonic a-c component =  $e_3 + jE_3$ ; peak value =  $\sqrt{e_3^2 + E_3^2}$

Fourth harmonic a-c component =  $e_4 + jE_4$ ; peak value =  $\sqrt{e_4^2 + E_4^2}$

Fifth harmonic a-c component =  $e_5 + jE_5$ ; peak value =  $\sqrt{e_5^2 + E_5^2}$

Sixth harmonic a-c component =  $E_6$  (peak value)

of the complex wave are generally of no interest, but may be obtained from the complex notations if desired.

**Example 1**

To illustrate the application of the formulas just developed for a six-point analysis, let us analyze the complex wave of Fig. 3, whose

period is 1/10 sec (frequency 10 cycles).

First, divide the time period of one cycle into six equal intervals, and measure the instantaneous values of the complex wave at these times, tabulating as follows:

Points	Y <sub>1</sub>	Y <sub>2</sub>	Y <sub>3</sub>	Y <sub>4</sub>	Y <sub>5</sub>	Y <sub>6</sub>
Values	2	4	1	-1	-2	1

Substituting these values in the six-



point formulas in Table I, we obtain

$$E_0 = (1/6)(2 + 4 + 1 - 1 - 2 + 1) = 0.833$$

$$E_1 = (1/6)(2 - 4 + 1 - 2) + (1/3)(-1 + 1) = -0.5$$

$$e_1 = (\sqrt{3}/6)(2 + 4 + 1 + 2) = 2.6$$

$$E_2 = (1/6)(-2 - 4 + 1 + 2) + (1/3)(1 + 1) = 0.167$$

$$e_2 = (\sqrt{3}/6)(2 - 4 - 1 + 2) = -0.289$$

$$E_3 = (1/6)(-2 + 4 - 1 - 1 + 2 + 1) = 0.5$$

The results of the analysis are

D-c component =  $E_0 = 0.833$  volt  
 Fundamental a-c component (10 cycles) =  $2.6 - j 0.5 = 2.65$  volts (peak)  
 Second harmonic a-c component (20 cycles) =  $-0.289 + j 0.167 = 0.333$  volt (peak)  
 Third harmonic a-c component (30 cycles) =  $E_3 = 0.5$  volt (peak)

### Example 2

As a further illustration of the method, let us apply the twelve-point analysis to the output waveform of a 60-cycle half-wave rectifier output having a peak value of 100 volts. The graph of this waveform is shown in Fig. 4.

Note that the period of a complete cycle of this particular wave extends along the time base from  $t = 0$  to  $t = 1/60$  sec. Divide this time of one complete cycle into twelve equal intervals ( $1/720$  sec), measure the instantaneous values of the wave at these times, and tabulate as follows (in this case the values may be calculated inasmuch as the wave is exactly half a sine wave whose equation is known)

Points	$Y_1$	$Y_2$	$Y_3$	$Y_4$	$Y_5$	$Y_6$	$Y_7$	$Y_8$	$Y_9$	$Y_{10}$	$Y_{11}$	$Y_{12}$
Values	50	86.6	100	86.6	50	0						

Substituting these values into the twelve-point formulas of Table I gives

$$E_0 = (1/12)(50 + 86.6 + 100 + 86.6 + 50) = 31.1$$

$$E_1 = (\sqrt{3}/12)(50 - 50) + (1/12) \times (86.6 - 86.6) = 0$$

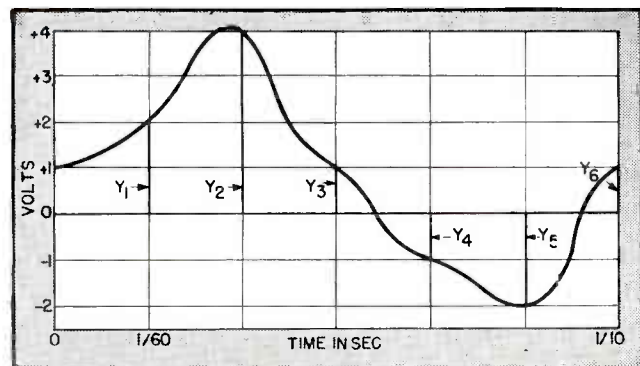

FIG. 3—Complex wave analyzed in Example 1 by means of the six-point schedule in Table I

$$e_1 = (1/12)(50 + 50) + (\sqrt{3}/12) \times (86.6 + 86.6) + (1/6)(100) = 50.0$$

$$E_2 = (1/12)(50 - 86.6 - 86.6 + 50) + (1/6)(-100) = -22.8$$

$$e_2 = (\sqrt{3}/12)(50 + 86.6 - 86.6 - 50) = 0$$

$$E_3 = (1/6)(-86.6 + 86.6) = 0$$

$$e_3 = (1/6)(50 - 100 + 50) = 0$$

$$E_4 = (1/12)(-50 - 86.6 - 86.6 - 50) + (1/6)(100) = -6.09$$

$$e_4 = (\sqrt{3}/12)(50 - 86.6 + 86.6 - 50) = 0$$

$$E_5 = (\sqrt{3}/12)(-50 + 50) + (1/12) \times (86.6 - 86.6) = 0$$

$$e_5 = (1/12)(50 + 50) + (\sqrt{3}/12) \times (-86.6 - 86.6) + (1/6)(100) = 0$$

$$E_6 = (1/12)(-50 + 86.6 - 100 + 86.6 - 50) = -2.23$$

As in the previous example, these results simplify to

D-c component =  $E_0 = 31.1$  volts  
 Fundamental a-c component = 50.0 volts (60 cycles)  
 Second harmonic component = 22.8 volts  
 Third harmonic component = 0  
 Fourth harmonic component = 6.1 volts  
 Fifth harmonic component = 0  
 Sixth harmonic component = 2.23 volts

The Fourier analysis for this same wave shows the respective values of the components to be 31.8, 50.0, 21.2, 4.24 and 1.82 volts. A comparison with the values obtained with the graphical method above shows good correlation. It should be noted here that the Fourier analysis can only be applied when the equation of the wave is known or can be pieced together, while the graphical method may be applied in all cases.

The following rules and suggestions will prove of value in applying the graphical analysis.

1. Be certain to take a full cycle of the complex wave to apply the analysis. The choice of the starting and end points is not important so long as they cover the interval of an entire cycle.

2. All values of a-c components in the analysis are peak values.

3. In certain cases, where a sort of symmetry exists in the wave, the d-c and/or certain of the a-c components may be zero.

4. Frequently, we are not interested in absolute values of the components, but relative ones with respect to the complex wave. In these cases, any arbitrary scale of values may be assigned to the complex wave and the values of the components expressed as percentages.

5. The values of the components of a given wave obtained by the 6, 8 or 12-point method may differ somewhat, becoming more accurate as a greater number of points are taken. In a sense, we may look on the Fourier analysis as one taking an infinite number of points.

6. Should the phase angle of any of the a-c components be desired, it will be given as  $\arctan e/E$ . Further, it should be noted that one cycle of the complex wave represents  $360^\circ$  at the fundamental frequency,  $720^\circ$  at the second harmonic, etc.

7. The usual care in the observation of algebraic signs should be taken when measuring the Y values and substituting them into the formulas.

### BIBLIOGRAPHY

- (1) Hutcheson, J. A., Graphical Harmonic Analysis, ELECTRONICS, Jan., 1936, p. 16. Description of method applicable to waves of the type where there are sine components of odd harmonics and cosine components of even harmonics, as in amplifiers or modulators.
- (2) Denman, R. P. G., 36 and 72 Ordinate Schedules for General Harmonic Analysis, ELECTRONICS, Sept., 1942, p. 44. Systematization of procedure facilitates the tedious calculations required in harmonic analysis of complex waves. The schedules, with equations for checking results, are applicable to use with odd and even harmonics.

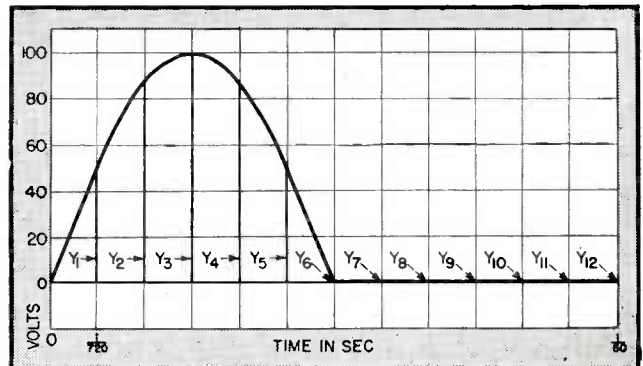

FIG. 4—Output wave form of half-wave rectifier, analyzed in Example 2 by means of the twelve-point schedule

# Reactor Measurements

Current feedback creates high-impedance source from which resonant circuit containing saturable core inductor can be fed both a-c and d-c for measurement of inductor's electrical parameters. Circuit provides coupling for test oscillator and vacuum-tube voltmeter

By **HOWARD L. DANIELS**

*Naval Ordnance Laboratory  
Washington, D. C.*

**A**N INDUCTANCE used in a vacuum-tube circuit is often required to carry a direct current. If the magnetic circuit includes iron, permalloy, or any of the other saturable core materials, the presence of the direct current may profoundly modify the  $L$  and  $Q$  of the coil to the superimposed a-c signal. These properties are also functions of signal level and frequency, and are adequately described only when their dependence on all three of these variables has been investigated.

### Possible Measurement Methods

Measurement of the properties of the inductance under such con-

ditions can sometimes be made by paralleling the coil with a capacitor, feeding the direct current and the a-c signal to the parallel circuit through a series resistor, and investigating the shape of the parallel impedance curve as a function of either frequency or parallel capacitance. However, if the shape of the curve is not to be seriously affected by the driving circuit, the resistance must be large compared to the parallel circuit impedance at resonance; and if the  $L$  and  $Q$  of the coil are even moderately high by present standards, the voltage and power consumed by the series resistor may be prohibitive.

A method applicable in some

cases is to supply the signal and saturating current through the plate of a pentode, but even the relatively high pentode plate impedance is often inadequate for the purpose. A simple triode may be given a high apparent output impedance by inserting an unbypassed resistor in its cathode circuit, but the usefulness of this method is similarly limited.

### Feedback Circuit

A vacuum tube circuit which is well suited for nearly all measurements of this type in the frequency range 20—100,000 cps is shown in Fig. 1. This circuit provides a direct coil current which is contin-

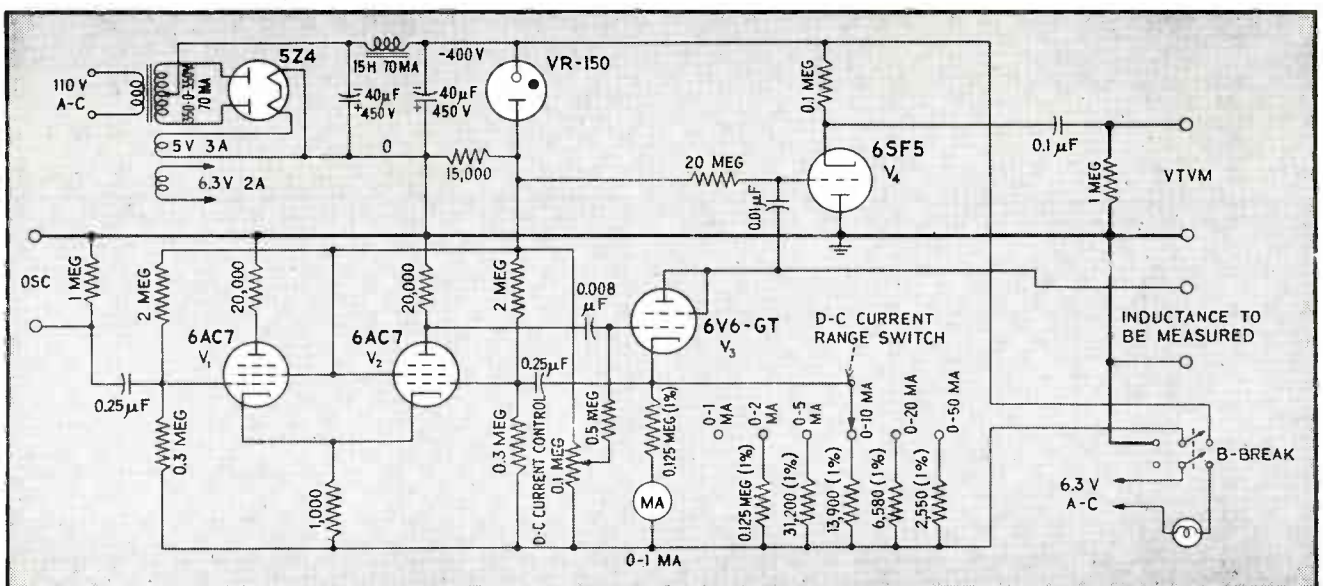
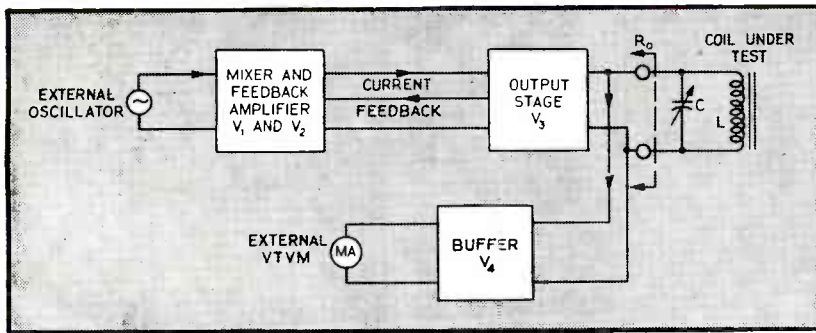

FIG. 1—Circuit for supplying a-c and d-c to reactors for measurement of their characteristics





Test set for reactor measurements consists of an oscillator injector, a high-impedance output stage, and a vtmv buffer

uously adjustable from 0.3 ma to 50 ma, with an a-c output impedance between 2.5 megohms and 90 megohms, depending on the selected current range. High a-c output impedance is achieved by application of a large amount of current feedback, with dissipation of only a small fraction of the power and voltage that would be required to obtain similar results by any of the means mentioned above.

The output stage  $V_3$ , through which both saturating current and test signal are applied to the inductance, is a triode-connected 6V6-GT. The direct current is controlled by a range selector switch, which inserts various fixed resistors in series with the cathode, and a potentiometer, which permits the d-c voltage between the grid and B- to be varied continuously from 0 to 150 volts. A milliammeter is provided in the cathode circuit of  $V_3$  to indicate the direct current.

If a signal were applied directly to the grid of the output stage, the apparent output impedance  $R_o$  would be the sum of plate resistance  $r_p$  and the a-c cathode circuit resistance  $R_c$ , plus a current feedback component equal to  $\mu R_c$ , the latter being by far the largest part of the total. In this circuit, however, and signal developed across  $R_o$  is amplified by the gain  $N$  of  $V_2$  and applied in opposite phase to the grid of the output tube. This effectively increases the current feedback component of the output impedance by a factor  $(N-1)$ . Thus the output impedance  $R_o = r_p + R_c + \mu(N-1)R_c = \mu NR_o$  approximately.

#### Injection and Buffer Stages

The test signal is injected into the circuit through the cathode of

$V_2$ , which is coupled directly to, and driven by, the cathode of  $V_1$ . This system reduces the gain of  $V_2$  by a factor of two, but is superior to other possible methods from the standpoints of simplicity and stability. To the extent that the gain between the grid of  $V_2$  and the cathode of  $V_3$  is large, the voltage across  $R_o$  is constrained to follow the oscillator voltage, and  $V_3$  acts as a constant-current source, giving a signal current  $i_o = e_{osc}/R_o$  approximately.

The effect of the impedance of the parallel circuit under test is to diminish this gain, and hence to reduce  $i_o$ ; which is simply another way of stating that the output of  $V_3$  may be taken as a constant current source only when  $R_o$  is large compared to the impedance of the circuit under test. In any case, the equivalent circuit of Fig. 2(A) applies. The above expression for  $i_o$  is not entirely accurate, since  $e_{osc}$  suffers a slight loss between the grid of  $V_1$  and the cathode of  $V_2$ . Values of  $i_o$  which take this loss into account are listed in Table I. They were checked experimentally

and found to be within five percent of the measured values. They are of occasional use for direct calculation of resonant circuit impedances.

It may be pointed out that a double triode might be substituted for  $V_1$  and  $V_2$  with appropriate circuit redesign but only at a sacrifice in output impedance or high-frequency response, or both.

The buffer stage is simply a cathode follower which prevents the input impedance of the external vacuum-tube voltmeter or oscilloscope used in tracing the parallel-circuit impedance curve from loading the parallel circuit, and hence affecting the results of the measurement. The total stray capacitance from the plate of  $V_3$  to ground is limited to about 15  $\mu\mu\text{f}$  by this means, and the added shunt resistance is about 500 megohms.

The grounding of B+ rather than B- provides some protection against shock while manipulating the coil under test. As an additional safeguard, a switch is provided which breaks B-, and also operates a pilot light to indicate its position at all times. Whenever the d-c coil circuit is to be broken, this switch is first operated to protect the operator from the negative supply voltage.

#### Method of Measurement

Characteristics of the inductance are most conveniently determined by studying the impedance curve of the inductance under test in parallel with a known capacitance, either as a function of variable frequency or of variable capacitance as indicated in Fig. 2(B). Inductance is readily calculated from  $L = 1/(2\pi f_r)^2 C_r$ .

The value of  $Q$  may be evaluated

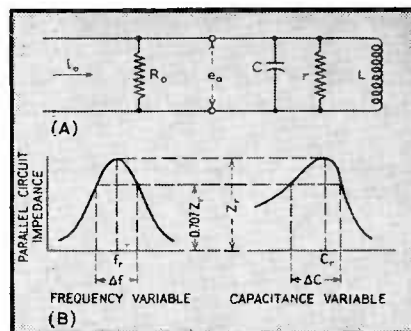
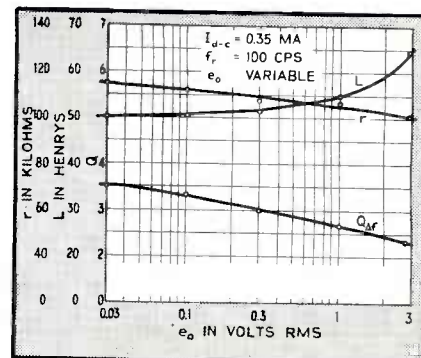
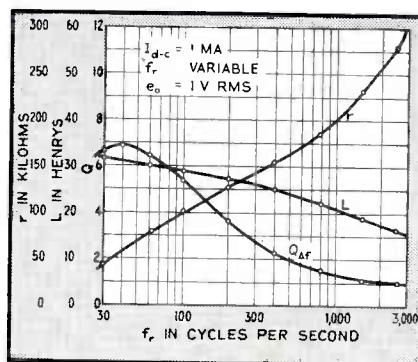
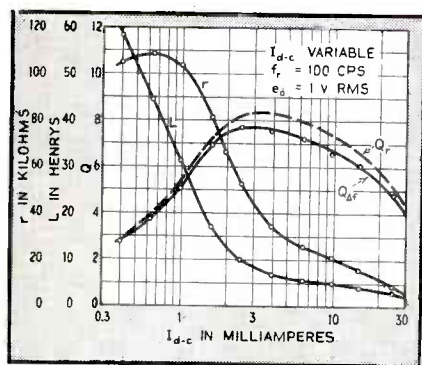

FIG. 2—(A) Equivalent circuit of driver and test circuit, and (B) the significant dimensions of the resonance curves from which inductance, resistance and quality of the inductor can be computed



from the width of the impedance curve between the points of 70.7 percent of the peak impedance. For frequency detuning,  $Q_{\Delta f} = f_r/\Delta f$ ; for capacitance detuning,  $Q_{\Delta c} = 2C_r/\Delta C$ .

The resonant impedance  $r$  of the parallel circuit can be calculated directly from  $e_o/i_o$  evaluated at resonance, where  $e_o$  is measured by the external vtvm, and  $i_o$  is found from  $e_{osc}$  and the value of  $i_o/e_{osc}$  given in Table I.

The error which can result from the shunting effect of  $R_o$  on the parallel circuit is readily evaluated as follows. The value of  $Q$  for the parallel circuit is defined as  $Q_r = r/X$  where  $X = 2\pi f_r L = 1/(2\pi f_r)C$ . The value actually measured by either of the above procedures is  $Q = [rR_o/(r + R_o)]/X$ . Combining these two equations gives  $Q_r = Q/(1 - QX/R_o)$ . Normally, this circuit provides a value of  $R_o$  sufficiently high as compared with the parallel circuit resonant impedance  $QX$  to make the correction negligible.

The above discussion assumes that the losses in the capacitor are small compared to those in the coil, and care must be taken to insure that this is the case; that is, the capacitance power factor must be small as compared to  $1/Q$ .

#### Inductor Measurements

Examples of data obtainable from the circuit and calculations outlined above are presented graphically in Fig. 3, 4, and 5. The independent variables for these curves are respectively the direct coil current  $I_{d-c}$ , the resonance frequency  $f_r$  of the parallel circuit,

and the rms signal voltage  $e_o$  developed across the coil. The test specimen for these curves was an audio-frequency choke having a core of closely interleaved laminations of a high-permeability nickel-iron alloy.

The saturating effect of a direct coil current is shown by Fig. 3 to be roughly equivalent to the introduction of an air-gap in the magnetic circuit. As the direct current increases, the value of the inductance decreases. Increasing saturation also reduces the core losses, in this case at such a rate relative to the drop in inductance that the value of  $Q$  has a peak in the region of  $I_{d-c} = 3$  ma. The resonant circuit impedance also has a peak value, but at a lower value of direct current.

The curves representing  $Q$  in Fig. 3 are derived from the relations  $Q_r = r/2\pi f_r L$ , and  $Q_{\Delta f} = f_r/\Delta f$ . That slight discrepancies exist between corresponding points on the two curves is not surprising because the equivalent circuit of Fig. 2(A) is only a simplifying approximation, even though it yields results which are sufficiently accurate for most purposes. Moreover, both  $r$  and  $L$  are variable with changes in frequency and in signal

level; and the frequency-increment measurement of  $Q$ , which involves changes of both kinds, cannot be expected to agree exactly with the definitive relation  $Q = r/2\pi f_r L$ . Sharpness of the resonance curve with respect to frequency is usually of primary interest, however, and the results of the frequency-increment determination therefore provide the best description of performance.

The value of  $Q$  also has a maximum with respect to frequency, as shown in Fig. 4. At low frequencies, losses are relatively large because of the flow of a heavy magnetizing current through the coil resistance; at high frequencies, the losses again become large because of the rapid increase of core losses. The gradual reduction in  $L$  throughout the represented range of frequencies is attributable to an effective reduction in the cross-sectional area of the core by the eddy currents. The resonance impedance  $r$  rises throughout this frequency range, but might be expected to drop at frequencies for which the charging currents required by the distributed coil capacitance again causes the copper loss to predominate.

The increase in inductance with signal level shown in Fig. 5, which is typical of ferromagnetic core materials, results from the initial upward curvature of the B-H characteristic. The application of a sufficiently high signal voltage to work the core above the saturation knee of the magnetization curve will, of course, reverse this trend and cause the inductance to drop sharply.

TABLE I—Relative values of  $i_o$ , taking into account test circuit losses

D-C range in ma	$R_o$ in megohms	$i_o/e_{osc}$ in ma/v
1	90	0.010
2	50	0.017
5	23	0.038
10	12	0.075
20	6	0.14
50	2.5	0.35



# CINCH

# MANUFACTURING CORPORATION



# Octal Chassis-Clinch

# Sockets

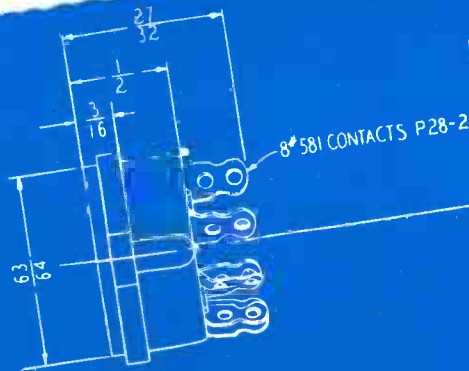
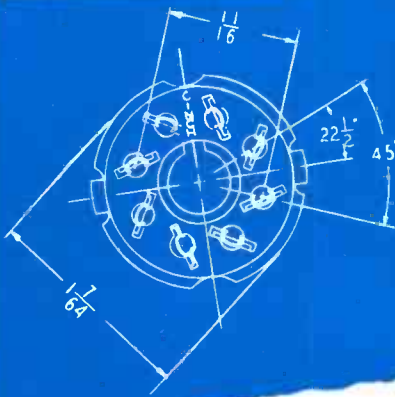

9914

MATERIAL-GENERAL PURPOSE BLACK

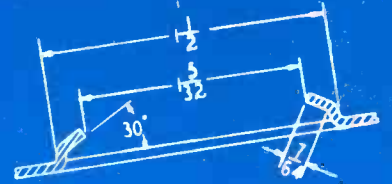
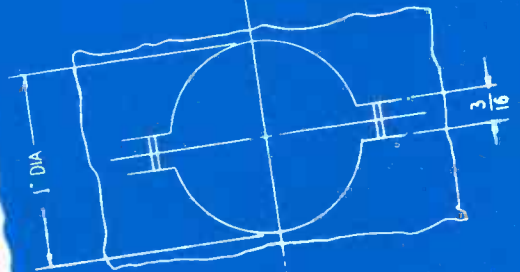
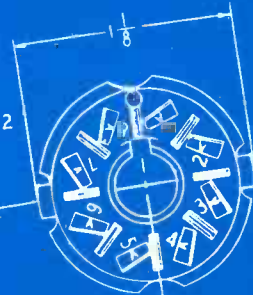

USE PUNCH NUMBER PD-202 TO PERFORME SHEAR AND FORM EARS IN CHASSIS. USE CLINCHING TOOL NUMBER PD-203 FOR THIS SOCKET.

## it's "know how"

Sockets are our business and Cinch development, engineering, quality and quantity production have made our tube socket leadership an important part of the radio industry. An additional reason is because we give your socket problems our close personal attention backed by years of experience. For example, we illustrate complete engineering data on the Cinch Octal Chassis Clinch Socket. Samples, tools and a visit by our field engineers are at your service on request.

# CINCH MANUFACTURING CORPORATION

2335 W. Van Buren Street, Chicago 12, Illinois  
Subsidiary of United-Carr Fastener Corp., Cambridge, Mass.



• The NEW CINCH catalog, 140 pages describing metal parts and metal plastic assemblies.

# Transmission Lines as TUNING ELEMENTS

Graph for designing tuning element consisting of a section of transmission line shunted by a capacitor. Values of one or two unknown circuit parameters may be found when values of two or three others are known

By H. E. NEWELL, JR.

Naval Research Laboratory  
Washington, D. C.

SEGMENTS of transmission lines used as circuit elements in present day high frequency work have made desirable a simple, rapid method for solving the equation

$$1/\omega C = Z_0 \tan 2\pi l/\lambda, l \approx \lambda/4 \quad (1)$$

The equation gives the wave length  $\lambda$  of the resonant frequency  $\omega/2\pi$  of a parallel combination of a capacitance  $C$  and a short circuited length  $l$  of transmission line of characteristic impedance  $Z_0$ , shown in Fig. 1.

The graph on the next page shows two sets of contours, the plots of which are superimposed upon each other in such a manner as to afford a convenient means for solving Eq. 1 graphically. The discussion below contains a brief outline of the construction of the graph, followed by its application to the solution of two typical problems.

### Construction of the Graph

Rewrite Eq. 1, by using the relations  $\omega = 2\pi f$  and  $\lambda = v_0/f$ , where  $f$  is frequency in cycles per second, and  $v_0 = 3 \times 10^8$  meters per second, the propagation constant.

$$1/Z_0 C = 2\pi f \tan(2\pi f l/v_0) \quad (2)$$

Equation 2 may be applied to the circuit of Fig. 1 by expressing  $Z_0$  in ohms,  $C$  in farads,  $f$  in cycles per second, and  $l$  in meters.

But if  $Z_0$  is in ohms,  $C$  in  $\mu\mu\text{f}$ ,  $f$  in mc, and  $l$  in cm, Eq. 2 becomes

$$\frac{1}{Z_0 \times 10^{-12} C} = 2\pi 10^6 f \tan \frac{2\pi 10^6 f \left(\frac{l}{100}\right)}{3 \times 10^8}$$

$$\frac{10^3}{Z_0 C} = \frac{2\pi f}{10^3} \tan \frac{2\pi f l}{3 \times 10^4} \quad (3)$$

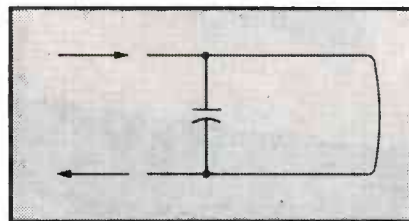

FIG. 1—Short-circuited transmission line of length  $l$ , and characteristic impedance  $Z$ , tuned by shunt capacitance

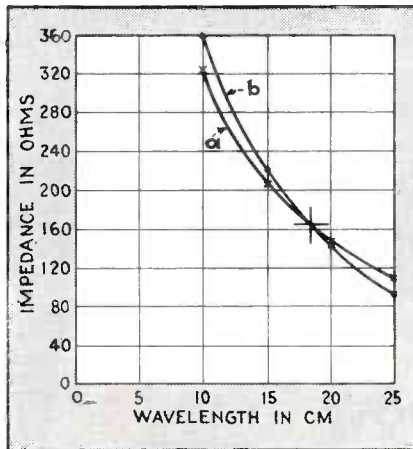

FIG. 2—Graphical solution for Eq. 1, where two quantities are unknown

or

$$F_2(Z_0, C) = F_1(l, f)$$

where

$$F_1(l, f) \equiv (2\pi f/10^3) \tan(2\pi f l/3 \times 10^4)$$

and

$$F_2(Z_0, C) \equiv 10^3/Z_0 C$$

On logarithmic graph paper, plot  $F_1(l, f)$  against  $l$  for the various values of  $f$ . Upon these contours

superimpose those of  $F_2(Z_0, C)$  plotted versus  $C$  with  $Z_0$  as a parameter, so that the  $F_1$  and  $F_2$  scales coincide. The  $C$  and  $l$  scales coincide as do the  $F_1$  and  $F_2$  scales. This, however, is not necessary, and in this case is due merely to the choice of range for the values of  $C$ . It is essential that the  $F_1$  and  $F_2$  scales be identical.

### Use of the Chart

The construction of the chart makes evident the general principles involved in its use. A solution is obtained for Eq. 3, by making  $F_1(l, f) = F_2(Z_0, C)$ . Suppose that a 10 cm line of 50 ohms characteristic impedance is to be tuned to resonance at 400 mc by shunting a lumped capacitance  $C$  across the input and short circuiting the other end.

To find  $C$ , the solution is as follows: from the 10 cm point on the  $l$  scale of the graph move vertically to the  $F_1(l, f)$  contour marked 400 mc. Then move horizontally to the  $F_2(Z_0, C)$  contour labelled 50 ohms. From this point move vertically again to the  $C$  scale and read off the capacitance,  $7.3 \mu\mu\text{f}$ .

If any three of the quantities  $l$ ,  $Z_0$ ,  $C$ ,  $f$  in Eq. 3 be given, the fourth is obtained by a procedure similar to that used above. If two of quantities be given, the remaining two can assume infinitely many pairs of values satisfying Eq. 3.

Consider now the problem of a shorted open wire line to be used as



# MALLORY is Headquarters for Contacts and Contact Assemblies ... Large or Small

FOR electrical contacts and contact assemblies from large assemblies surfaced with Elkonite\* for circuit breakers and heavy duty controls, to tiny fine silver, platinum or Elkonium\* contacts for small relays or thermostats... Mallory has become the recognized headquarters.

Mallory provides the widest range of materials for contacts and supporting members. Mallory engineers have created more than 5000 designs for contact assemblies and contacts. Mallory manufacturing facilities are the most complete in the industry, supplying contact assemblies, individual contacts, or efficient attachment of contacts to studs, arms, springs or brackets furnished by the customer.

Consult Mallory while your electrical or electronic equipment designs are being blueprinted. Often you can save engineering time and production costs by obtaining a complete contact assembly. Write today for your copy of the Mallory contact catalog. The New Mallory Contact



Data Book will be sent gratis to engineers when requested on company letterhead. Available to students, libraries and schools at \$2.50 per copy, postage paid.

P. R. MALLORY & CO., Inc., INDIANAPOLIS 6, INDIANA

## Some Contact Applications

### Mallory Tungsten Contacts and Contact Assemblies for:

Automotive Ignition  
Voltage Regulators  
Vibrators  
Business Machines  
Aviation & Marine Magnetos  
Aircraft Equipment  
Diesel Starting Equipment  
Electric Fence Chargers  
Electric Clocks  
Electric Shavers

### Mallory Silver, Elkonium and Platinum Contacts and Assemblies for:

Industrial Relays  
Domestic Appliances  
Low Voltage Relays  
Telephone Jacks & Relays  
Thermostat Equipment  
Low Voltage Meters and Gauges  
Voltage Regulators  
Automotive Light Switches  
Motor Starting Relays

### Mallory Elkonite Contacts and Contact Assemblies for:

Oil Circuit Breakers  
Air Circuit Breakers  
Industrial Controls  
Heavy Duty Relays  
Starting Switches  
Voltage Tap Changers  
Aircraft Relays  
Heavy Arcing Equipment



\*Reg. U. S. Pat. Off. for electric contacting elements.

P. R. MALLORY & CO. Inc

# MALLORY

## ELECTRICAL CONTACTS AND CONTACT ASSEMBLIES

a circuit element in a high frequency amplifier. A variable capacitance, ranging from  $5 \mu\mu\text{f}$  to  $10 \mu\mu\text{f}$ , is shunted across the open end of the line and used for tuning. If the frequency range to be tuned is from 150 mc to 200 mc, what should the physical length and characteristic impedance of the line be?

Mathematically this problem is that of solving simultaneously two equations in two unknowns

$$F_1(l, 150 \text{ mc}) = F_2(Z_0, 10 \mu\mu\text{f.}) \quad (4a)$$

$$F_1(l, 200 \text{ mc}) = F_2(Z_0, 5 \mu\mu\text{f.}) \quad (4b)$$

Using the graph, make a table of solutions of Eq. 4a, alone, and an-

other of solutions of Eq. 4b, alone.

$l$ in cm	$Z_0$ in ohms from Eq. 4a	$Z_0$ in ohms from Eq. 4b
10	325	360
15	207	220
20	147	143
25	108	94

Draw the curves corresponding to both tables on the same graph, using identical scales for both as in Fig. 2. The intersection of the two curves gives the solution; in the present case:  $Z_0 = 164$  ohms,  $l = 18.4$  cm.

As a purely mathematical prob-

lem, the contours of the graph may be used over the entire ranges of  $f$  and  $Z_0$  for the solution of Eq. 3, but the application of such solutions to actual physical circuits is of doubtful validity in the upper ranges of frequency and impedance. At high frequencies a shorting bar on a very high impedance line of less than a quarter wave length must itself form a considerable part of the line. Moreover, the assumption that the total capacitance involved can be lumped into a single element is undoubtedly invalid under these conditions.

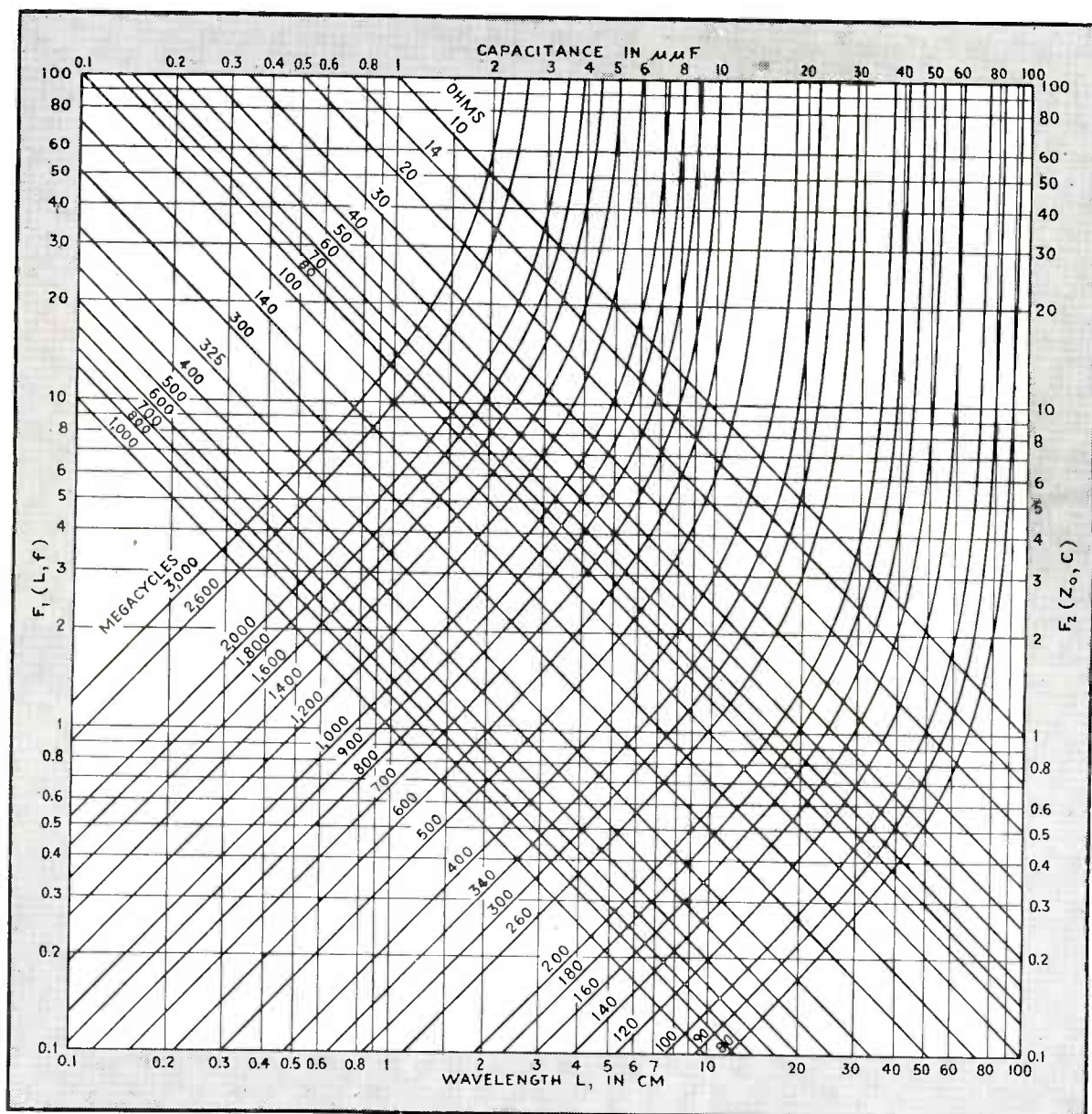

Graphical solution of Eq. 1 for obtaining the value of one quantity when values of three are known or values of two quantities when the other two are known



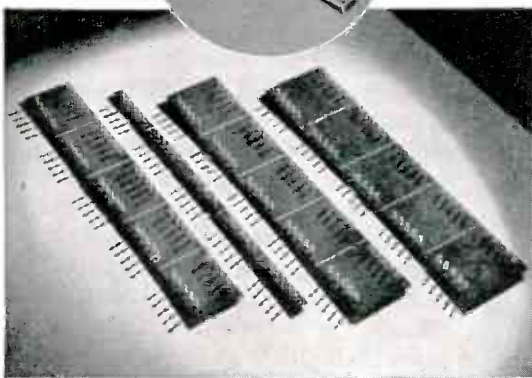
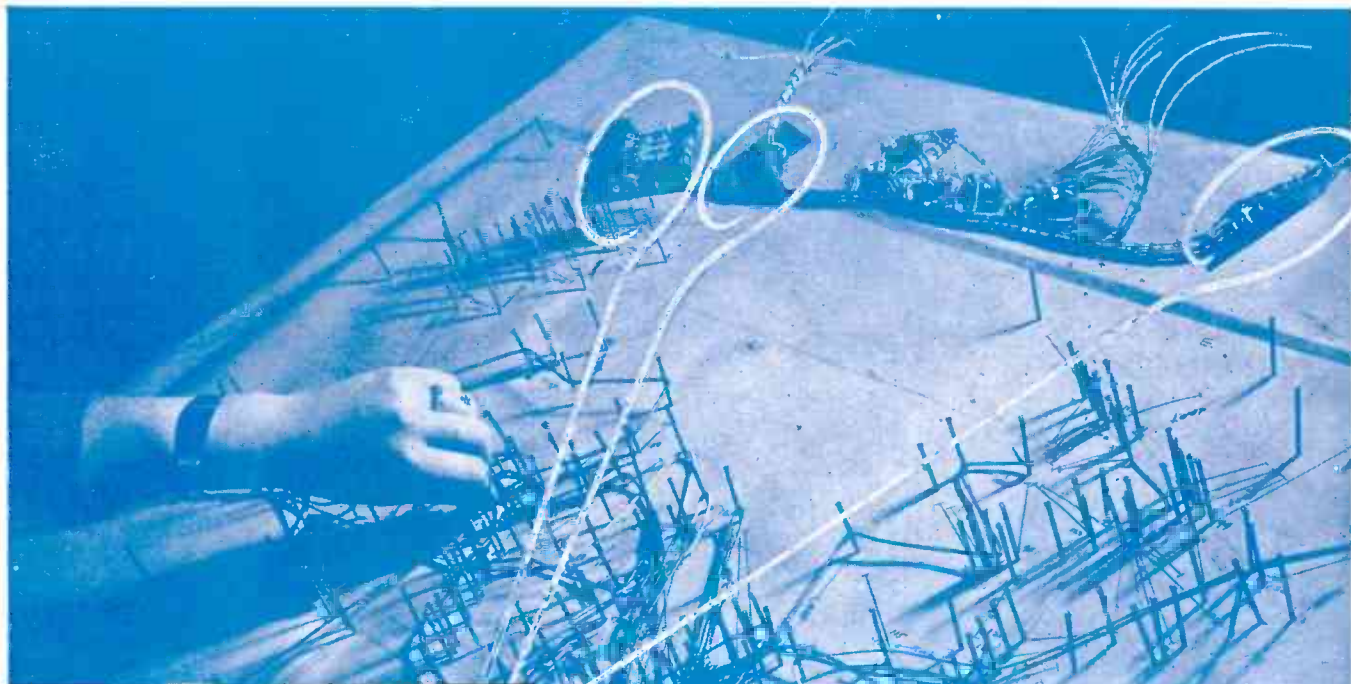

## STEP UP PRODUCTION

*In the Laboratory—On the Assembly Line*  
with

### C.T.C. *All-Set* TERMINAL BOARDS

No more time-wasting board cutting, drilling and lug mounting when you have C.T.C. All-Set Terminal Boards on hand. They're furnished completely assembled with any size C.T.C. Turret Terminal Lug in four widths,  $\frac{1}{2}$ " (lug row spacing  $1\frac{1}{2}$ ");  $2\frac{1}{2}$ " (lug row spacing 2"); 3" (lug row spacing  $2\frac{1}{2}$ ") to fit all standard resistors and condensers. Select proper width board and go to work.

C.T.C. All-Set Terminal Boards are made of  $\frac{3}{32}$ ",  $\frac{1}{8}$ " and  $\frac{3}{16}$ " linen bakelite only and come in five-section boards which can be broken into fifths by bending on a scribed line. They may be ordered in sets of the four widths, or in lots of six or multiples of six in any single width. Extra lugs and stand-offs are supplied.

*For complete information on these new, money-saving All-Set Terminal Boards, write for C.T.C. Catalog Number 100.*

**CAMBRIDGE THERMIONIC CORPORATION**  
439 CONCORD AVENUE • CAMBRIDGE 38, MASSACHUSETTS

# INDUSTRIAL CONTROL

Radar Navigator for Commercial Shipping.....	154
Balancing Operation Speeded by Motor Control.....	154
Precision Gaging by Blind Workers.....	156
Measuring Temperature of Molten Steel.....	164
A Phototube Amplifier.....	168
Timing Action of the Blocking Oscillator.....	184
Improved Socket-Punch Wrenches.....	204
New Photocell for Ultraviolet.....	212

## Radar Navigator for Commercial Shipping

FIRST REPORTED SALE of radar equipment for peacetime industry has been made by General Electric Company who will supply five radar units ordered by the U. S. Maritime Commission for installation in merchant ships now being built. For navigation through fog and darkness, it enables the navigator to

respect to the course and position of the ship.

A control console in the wheelhouse contains a cathode-ray tube indicator of the PPI type. Concentric rings indicate the range with the ship's position being in the center of the scope. A range switch permits changing the scale



In the wheelhouse of the American Mariner, Captain Joseph Masse studies the screen of the cathode-ray tube in the General Electric radar navigator for commercial shipping. On the Great Lakes alone, more than 4,000,000 gross tons of cargo space were lost in 1943 because of the hazards of navigation through fog

locate shore lines, land masses, other ships, buoys and other obstacles from 200 yards away up to 30 miles distant.

One installation of the electronic navigator has been operating on the U. S. Maritime Service training ship American Mariner and used in navigating the waters of Long Island Sound. A few minutes of instruction have been found sufficient for beginners to grasp the fundamentals of operation and with a few hours of practice they learn safe recognition of various types of objects as well as their bearing with

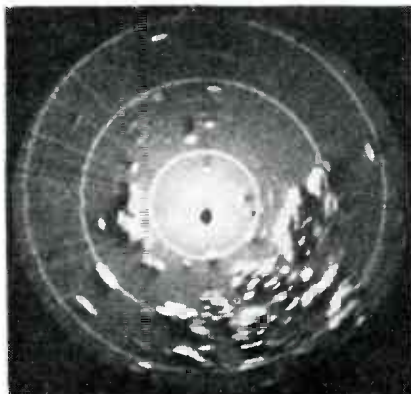

View of the radar screen, showing other ships, islands, and other obstacles to navigation

of the field to cover a 2, 6, or 30-mile radius. This permits the navigator to use the 30-mile range until the ship approaches to within six miles of the obstacle, then switching to the chart whose radius is six miles. Further localizing can be made with the 2-mile range and objects can be observed down to about 200 yards on this scale. High shore lines are discernible at 30 miles distance, low shore lines at 10 to 15 miles, ships at 3 to 8 miles, and buoys at 1 to 3 miles.

A parabolic antenna is located on the top deck of the ship to transmit and receive the radar pulses. This rotates at a speed of 110 rpm and weighs 250 pounds. As in military radar, reflected waves from obstacles in the surrounding waters return to the rotating antenna during the time intervals between the outgoing pulses.

## Balancing Operation Speeded by Motor Control

REDUCTION OF TIME in balancing submarine electric motor armatures from twenty man-hours to five man-hours is accomplished by use of General Electric Thy-mo-trol in controlling the speed of a balancing machine at Mare Island, Cal.

The illustration on the next page shows the control cabinet which contains two electronic rectifiers that supply voltage to the field and armature of the balancing machine drive motor. The control tubes in the cabinet regulate the output of thyratrons and permit throttling down to almost zero speed or smooth adjustment up to maximum speed.

Preselection of speeds is made by means of a potentiometer which is manually set. Through electronic circuits, it causes the thyatron tubes to increase or decrease their voltage output to the drive motor armature or field.

The cycle time is that elapsed from the time the stop button is pushed, weights adjusted, and the motor started again to the point where critical speed is attained. The Thy-mo-trol cycle is only thirty-seven seconds, compared to the two to four minutes required for a free-wheeling stop.

Such electronic control equipment is today practically a package



84



*Presenting*

**No. 150,003,414!**

With a war record of more than one hundred and fifty million successful "missions" to their credit, IRC's

**BTS INSULATED METALLIZED RESISTORS**

have given unquestioned evidence of their complete dependability.

The exact counterparts of these efficient and precision-engineered "veterans" are now available in quantities for your own essential requirements.

Their construction features, resistance-temperature characteristics and specifications are described fully and charred graphically in Bulletin #3 which will be sent to you upon request directed to Dept. 1-J.



**INTERNATIONAL RESISTANCE CO.**

401 N. BROAD STREET • PHILADELPHIA 8, PA.

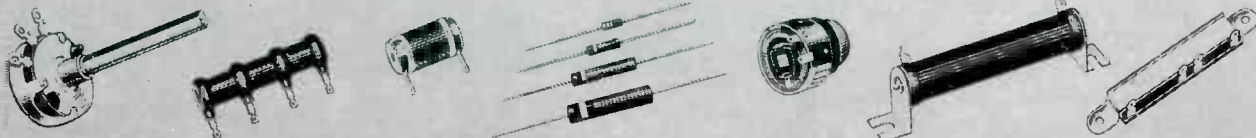

*IRC makes more types of resistance units, in more shapes, for more applications than any other manufacturer in the world.*

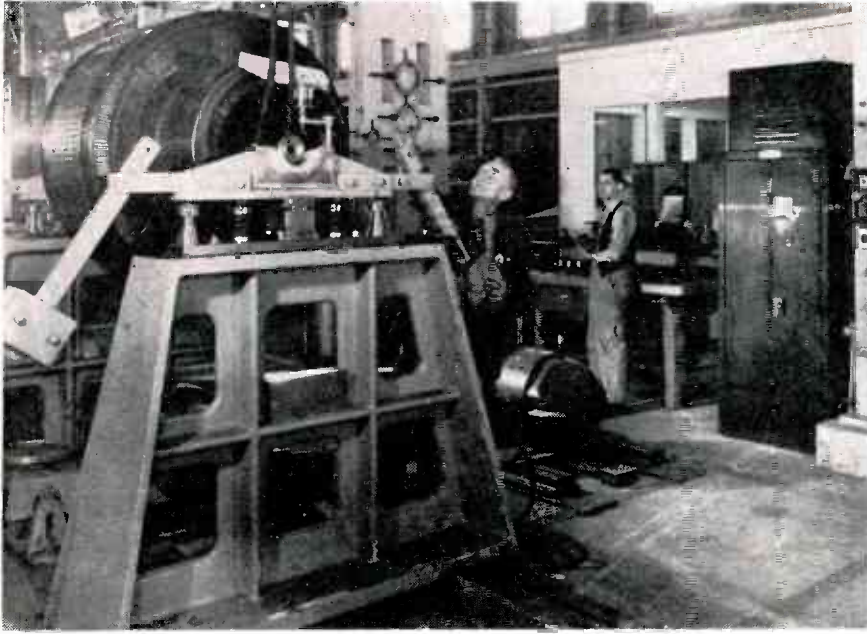

Complete setup of equipment for balancing submarine electric motor armatures. Free to revolve in the frame, the armature is rotated by the drive motor on the floor. Controlled acceleration and deceleration is accomplished by a General Electric Thy-mo-trol unit in the cabinet at the right.

unit. It includes the d-c motor, the control panel, control station and the transformer. It is easy to install and has been applied to many

other machinery applications such as, lathes, drill presses, millers, and similar equipment, and in the operation of many testing machines.

### Precision Gaging by Blind Workers

THOUSANDS OF BLIND PERSONS who seek jobs in industry were given new hope by a recent demonstration of a precision production gage in the Canton factory of Timken Roller Bearing Company. A blind operator using the instrument checked the outer races of bearings in an outside diameter gage at a rate that compares favorably with that of an operator having normal sight. Indication of oversize, undersize, and normal readings are provided by an a-f oscillator that produces three different tones from a loudspeaker mounted on the back of the workman's chair.

The diameters of the components of Timken bearings are ground within very close limits of their specified sizes and checked on precision gages with electrical or mechanical dial-type indicators. These show amplified readings of variations in the diameter of the work piece under test.

For blind operators, the a-f oscillator provides audible signals. An article that is within the size limit produces a tone of one frequency and the article is passed as meeting

the standard. If the speaker produces a tone of a higher frequency, the article under test is oversize,

while a lower tone an undersize part. A tones causes the operat. the unit.

#### Oscillator Circuit

The three audio frequencies a. produced by the circuit shown in Fig. 1. This electronic oscillator is controlled by relays connected

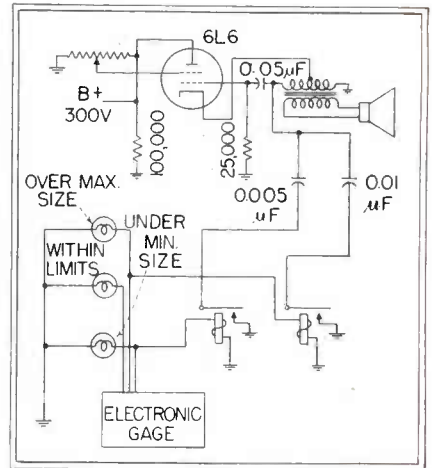
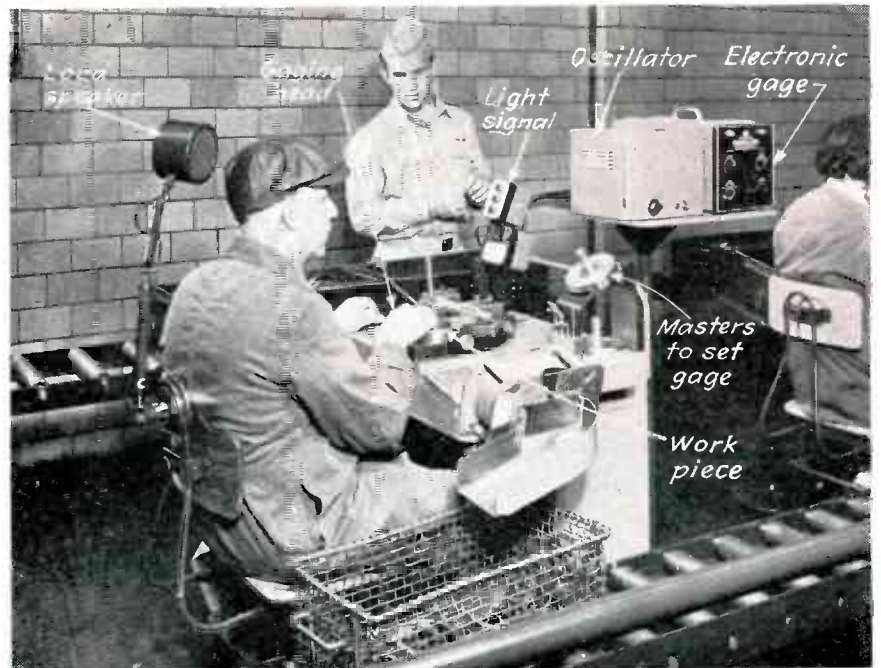

Fig. 1—Circuit of the audio oscillator used by Timken to provide audible gage indications to blind workers

to the three indicator lights of an electronic gaging system. The red, green and orange panel lamps correspond to the three frequencies of the oscillator. The red lamp



The outside diameter of roller bearing cups are gaged by Sylvester Pfendler, blind Timken employee. Audible indication of over, under, and normal size is provided him by an a-f oscillator that feeds the loudspeaker. Manufacturing details of the device will be released without charge to any interested manufacturer



*. . . this is the single unit\* construction of*  
**SHURE Super-Cardioid**  
*Dynamic Microphones*

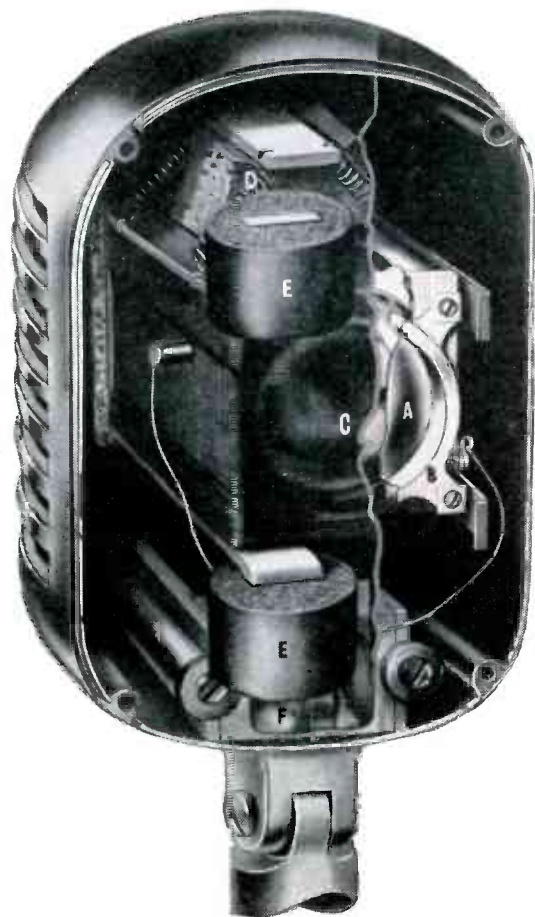

- (A) Single moving coil diaphragm.
- (B) Rugged 4 point moving coil suspension.
- (C) First wind and dust screen.
- (D) Spring mounted mechanism.
- (E) Shock absorbers.
- (F) High fidelity transformer.

\* Using the "Uniphase" principle, an exclusive patented Shure development, this single unit construction is possible in a unidirectional Microphone. This eliminates the problems of matching two dissimilar units and results in compactness and ruggedness. Because only one unit is employed, all these advantages are available at less cost to you.



List Prices . . . Shure Super-Cardioid  
Dynamic Microphones

*Models "556" Broadcast . . . . \$75*

*Models "55" Unidyne . . . . . \$47 to \$49.50*

# SHURE BROTHERS

*Designers and Manufacturers of Microphones and Acoustic Devices*

**225 West Huron Street, Chicago 10, Illinois • Cable Address: SHUREMICRO**



# FOR THOSE WHO SEEK

*The Finest  
Cored Solder in the World*



**WE** look forward, in the near future, to sending once more supplies of Ersin Multicore Solder to our friends in the U.S.A. and elsewhere overseas. Ersin Multicore contains 3 cores of non-corrosive Ersin Flux and provides just that extra rapidity of fluxing action which ensures a precision standard of consistently reliable solder joints. Only a solder wire having 3 independent cores of flux, evenly distributed across the cross-section of the solder wire, can give this extra efficiency. If you make high quality electronic equipment you will wish to learn more about Ersin—the flux contained in the 3 cores. It possesses all the non-corrosive properties of best grade Rosin but is specially activated to remove surface oxides and prevent them forming during soldering processes. It operates with a speed and certainty which previously has never been thought possible with a non-corrosive flux. Whether you buy solder by the 1-lb. or 10,000-lbs. it would give us much pleasure to send you technical literature and samples of Ersin Multicore 3 Core Solder. *Just send us your name and address.*



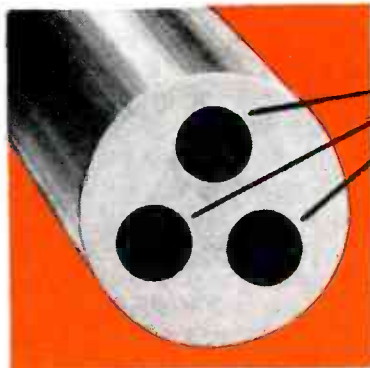

**3 CORES OF FLUX** provide just the correct proportion of flux to solder. NO extra flux is required. The flux does not tend to run out of the cores: so there is always a supply available for the next joint. The utmost economy of flux and solder is achieved.

Five standard antimony free alloys are available. Ersin Multicore Solder is supplied in bulk quantities in any other tin-lead alloy to special order. Recently 45 tin and 55 lead alloy has been in most demand for electronic equipment. Colour coding of reels and packages makes different alloys instantly recognisable.

ALLOYS—Table of Melting Points.

Tin Lead	Multicore Colour Code	Solidus	Liquidus
60/40	Red	183°C	190°C
45/55	Crimson/Buf	183°C	227°C
40/60	Green	183°C	238°C
30/70	White	183°C	257°C
20/80	Purple	183°C	276°C

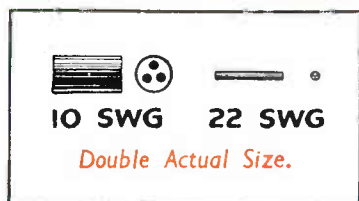

### GAUGES

Ersin Multicore Solder is made in a wide range of gauges. Standard gauges supplied are from 10 S.W.G. - 22 S.W.G. (.128" - .028") (3.251 - .7109m/ms). 13 S.W.G. (.092", 2.336m/ms) and 16 S.W.G. (.064", 1.625m/ms) are the most widely used sizes for the production of electronic equipment.

### ERSIN—THE ACTIVE NON-CORROSIVE FLUX.

Ersin which is contained in the 3 cores of Multicore Solder is a pure high grade rosin which has been subjected to a complex chemical process to increase its fluxing action to the highest possible degree without impairing in any way the well-known non-corrosive and protective properties of the original rosin. In effect, rosin as a flux suffices only as an agent to avoid oxidation during soldering, whereas Ersin will not only remove surface oxides, but also prevent their formation during the soldering operation.

**ERSIN  
ACTIVE  
NON-CORROSIVE  
FLUX**

# ERSIN MULTICORE

THE SOLDER WIRE CONTAINING  
*3 cores* OF NON-CORROSIVE ERSIN FLUX

## MULTICORE SOLDERS LTD.

SUITE 5, COMMONWEALTH HOUSE, NEW OXFORD STREET, LONDON, W.C.1, ENGLAND  
Telephone: CHANCERY 5171/2. Cables: DUSTICKON, WESTCENT, LONDON.

U.S.A. DISTRIBUTORS:  
BRITISH INDUSTRIES SALES CORPORATION  
401 BROADWAY, NEW YORK, N.Y.13

CANADIAN DISTRIBUTORS:  
SNI-DOR RADIOELECTRIC LTD.,  
455 CRAIG ST. WEST, MONTREAL

# HICKOK

## Water Proof, Moisture Proof and Steam Proof METERS

Built in accordance with  
the War Standards Drawings



AVAILABLE IN  
2½" — 3½" — 4¼"  
ROUND STYLES  
INTERNAL PIVOT  
CONSTRUCTION

**VOLTMETERS... AMMETERS... MILLIAMMETERS...  
MICROAMMETERS... WATTMETERS... BOTH AC AND DC**

Now, you can get HICKOK precision and dependability in a new line of hermetically sealed meters. Available in 2½", 3½" and 4¼" round styles. Dimensions of American War Standards Assn. Drawings C39.2-1 and C39.2-2. The 4¼" size is built especially for use in radio service equipment where several scale arcs are required.

All instruments are hermetically sealed and both vacuum and pressure tested under water. Case fabricated of pressed steel and made corrosion resistant to meet specifications. Terminals are a special glass soldered-in type.

All meters are fully shielded, permitting use on either magnetic or non-magnetic panels. Operation is accurate and dependable even up to 85° centigrade. Internal pivot construction in D.C. types assures longer life and greater resistance to shock and vibration. Write for further information today.

**THE HICKOK ELECTRICAL INSTRUMENT CO.**  
10527 DUPONT AVENUE • CLEVELAND 8, OHIO

PRECISION CALIBRATED . . . LASTING ACCURACY

indicates high, the green low, and the orange middle.

The lamps give the setup technician a quick visual check on the efficiency of the gage. When originally set, the gage is adjusted to a master gage and gives both a visual and audible indication as close as 0.000002 inch over or under a specified diameter tolerance.

In developing the present model, almost two years of experimental work with various gages was spent before Timken engineers were satisfied. They first developed a Braille gage in which the article to be gaged was pushed between two points (representing the proper diameter) in a horizontal plane electrically connected to a

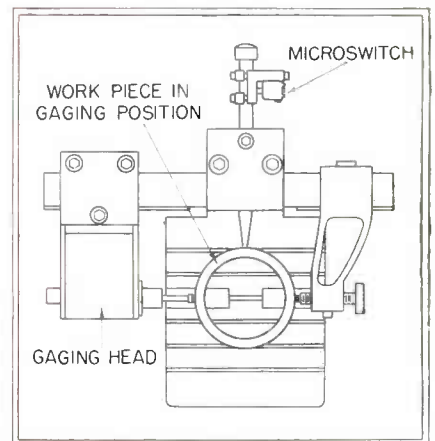

Fig. 2—Mechanical diagram of the work table and gage head on which bearing races and other parts are gaged by blind workers

finger block. The contact of the article raised the first, second, or third of three points on a vertical plane. This was considered too cumbersome for wide application.

### Radio Range Signals

An electronic gage was suggested by a Timken official whose flying experience had made him familiar with the A and N on-course signals. An earphone reproduced the letter A if the article was too small and if too large, the letter N. If the article was acceptable, the signals joined to produce a continuous tone. Minute high and low spots in the surface of the article interfered with the transmission of the signals and this



# Check THE ADVANTAGES OF THIS LIGHTWEIGHT STRUCTURE IN ALUMINUM OR STEEL...

and what they mean when applied  
to YOUR product or its housing



FOR CABINETS



FOR EQUIPMENT HOUSINGS



FOR DRYERS AND OVENS



FOR REFRIGERATORS



FOR INSTRUMENT AND CONTROL PANELS



FOR BUILDINGS AND PARTITIONS

FOR TRUCK  
AND  
TRAILER BODIES

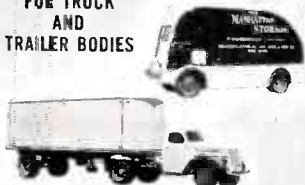

#### Ls simplifies production:

Proves ideal for both single-unit and production line assembly.  
Eliminates waste—parts are die-rolled, die-drawn, die-cut to exact specifications, with no trimming or fitting necessary.  
Needs no welding or riveting.  
Requires no special tools, machines, or equipment for its assembly.  
Hastens delivery by speeding production.

#### Ls simplifies changes:

Disassembles and reassembles with no loss of strength.  
Permits variations from standard models without delay or undue expense.  
Permits overnight design changes.  
Makes possible immediate reconversion to civilian production.

#### Ls simplifies repairs:

Speeds repairs, reduces maintenance costs.  
Requires replacement of damaged sections only.  
Uses interchangeable parts, available from the nearest Ls warehouse.

#### Ls offers structural advantages:

Utilizes *all* the strength in light sheet metal through uniform tensioning, with a resulting high strength-weight ratio.  
Remains unaffected by stress and vibration.  
Provides ample support for heavy equipment and control panels.  
Offers ready access to all parts of the interior with removal of the nearest panel.  
Is easily insulated, since wracking will not break air seals. Ls construction permits use of phenolic spacers which eliminate through-metal contact between double walls of units.  
Ships k. d., or partially assembled, in minimum space.

For information, send drawings, data, or blue prints to Lindsay and Lindsay, 222-D W. Adams St., Chicago 6, Ill.; to 60 E. 42nd St., New York 17, N. Y.; or to Lindsay Structure (Canada) Ltd., Dominion Square Bldg., Montreal.

Easy to Assemble



# LINDSAY

**Ls**  
REG. U. S. PAT. OFF.

# STRUCTURE

U. S. Patents 2017629, 2263510, 2263511—U. S. and Foreign Patents and Patents Pending

THE MODERN METHOD OF LIGHT METAL CONSTRUCTION

# SYLVANIA NEWS

ELECTRONIC EQUIPMENT EDITION

OCT.

Published by SYLVANIA ELECTRIC PRODUCTS INC., Emporium, Pa.

1945

## SYLVANIA CATHODE RAY TUBES NOW AVAILABLE

*Ready for New Television Sets To Be Produced*

Sylvania Electric announces the welcome news that cathode ray tubes are once more available for the manufacturers of television sets.

Constant research in this field, combined with wide experience in large-



*Sylvania Electric precision-built cathode ray tube now available to television set manufacturers.*

scale production to meet war requirements, has placed Sylvania in a position to manufacture these tubes to a much higher standard than ever before.

This is an important factor to manufacturers of television receivers whose "plans" are rapidly becoming realities.

Check today with Sylvania Electric Products Inc., Emporium, Pa.

## MANY MANUFACTURERS TO USE ELECTRICALLY SUPERIOR TUBE

*Sylvania Lock-In Radio Tube  
Ideal For FM, Television, Radar*

With the increasing trend toward higher frequencies—as shown by recent FCC decision assigning FM the band between 88 and 106 megacycles—set manufacturers will tend, more than ever, to use a tube ideally suited to the adoption of these very high frequencies.

The Sylvania Lock-In is known to be electrically and mechanically superior to any tube made.

Electrically, it is more efficient because the element leads are brought directly down through the low-loss glass header to become sturdy socket

pins—reducing lead inductance—and interelement capacity.

Mechanically, it is more rugged because support rods are stronger and thicker—there are fewer welded joints and no soldered joints—the lock-in lug is metal, not molded plastic—the elements are prevented from warping and weaving.

Today, set manufacturers considering the many developments in the field of communications, are looking to the Sylvania Lock-In Tube as a perfect electronic unit—the tube built to handle ultra-high frequencies.

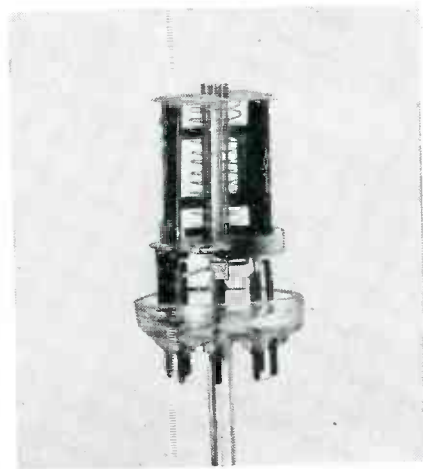

*The Sylvania Lock-In Tube showing construction—electrical and mechanical—that makes it superior to any tube made.*

# SYLVANIA ELECTRIC

Emporium, Pa.

MAKERS OF RADIO TUBES; CATHODE RAY TUBES; ELECTRONIC DEVICES; FLUORESCENT LAMPS, FIXTURES, WIRING DEVICES; ELECTRIC LIGHT BULBS



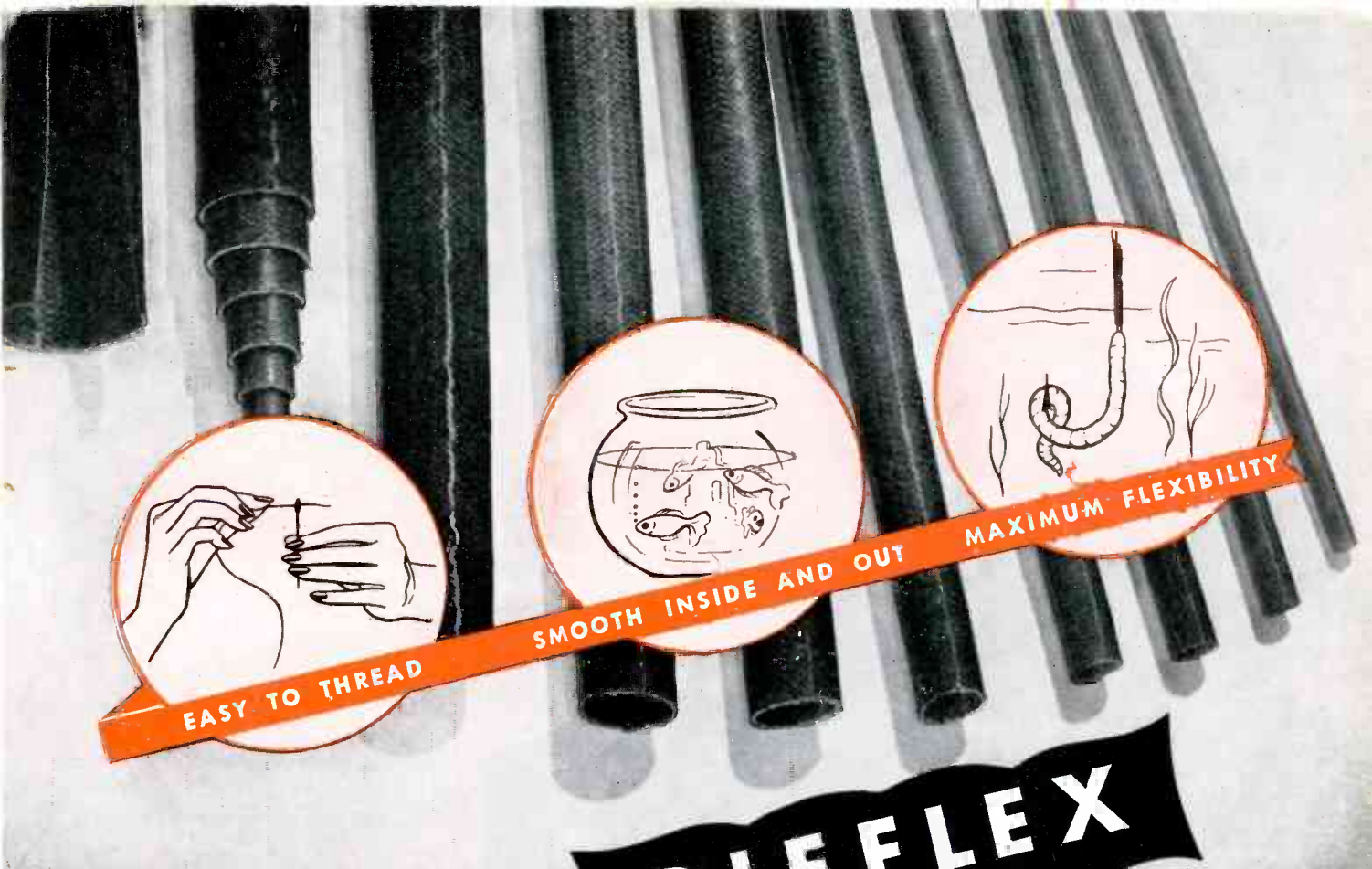

### OTHER IMC PRODUCTS

Vartex Varnished Cloth and Tapes  
 —Varslot Combination Slot Insulation—Varnished Silk and Paper  
 —Fiberglas Electrical Insulation—Manning Insulating Papers and Press Boards—Dow Corning Silicones—Pedigree Varnishes—Dieflex Varnished Tubings and Saturated Sleeveings of Cotton and Fiberglas—National Hard Fibre and Fishpaper—Phenolite Bakelite—Adhesive Tapes—Asbestos Woven Tapes and Sleeveings—Cotton Tapes, Webbing, and Sleeveings, and other insulating materials.

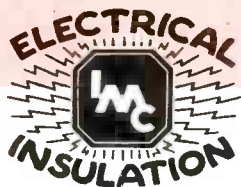

## FLEXIBLE VARNISHED TUBING PRODUCTS INCLUDING FIBERGLAS

Ease of handling in the shop and permanence in the finished assembly are features of Dieflex varnished tubings and sleeveings which designers and production men appreciate.

Dieflex Products are a decided aid in manufacturing—the smooth inside treated bore is easy to thread—prevents snagging—facilitates telescoping. The roundness and non-flattening qualities—extreme flexibility and non-fraying qualities, give maximum workability and protection. The Fiberglas grades give permanence. Its complete varnish impregnation gives excellent protection against moisture, oils, and chemicals and provides maximum electrical insulating qualities.

Obtain the finest varnished tubing products by specifying Dieflex. They meet or surpass V. T. A. and A. S. T. M. standards.

WHEN IN NEED CALL FOR THE IMC ENGINEER

## INSULATION MANUFACTURERS CORPORATION

★ CHICAGO 6 • 565 West Washington Blvd.  
 ★ CLEVELAND 14 • 1005 Leader Building

Representatives in

MILWAUKEE: 312 East Wisconsin Avenue  
 DETROIT: 11341 Woodward Avenue  
 MINNEAPOLIS: 316 Fourth Ave., South  
 PEORIA: 101 Heinz Court

**WRITE FOR YOUR  
COPY TODAY!**



**Akra-Ohm  
Resistors**  
Accurate Fixed  
Wire Wound  
Types

*This New Bulletin  
tells you what you  
want to know about*  
**ACCURATE FIXED  
WIRE WOUND  
RESISTORS**

**DIMENSIONAL SPECIFICATIONS • MOUNTING AND TERMINAL DESIGNS • POWER DISSIPATION • TEMPERATURE COEFFICIENT OF RESISTANCE • MAXIMUM RESISTANCE CHARTS • RESISTANCE ALLOYS • MOISTURE AND FUNGUS PROOFING • HERMETIC SEALING**

*Shallcross Types Designed to Meet JAN-R 93 Specifications*

**SHALLCROSS MFG. CO.**

DEPT. E-105 COLLINGDALE, PA.

ENGINEERING • DESIGNING • MANUFACTURING

indicating gage was abandoned.

Another electronic unit was tried that produced a high, low, and normal audio tone in the earphones. To overcome fatigue due to the constant sound, a photoelectric unit was installed. This used a beam of light across the gage block so that when no work was in the gage the sound ceased. This was discarded after the operator objected because the earphones deprived him of any outside sound, making him feel closed-in and helpless.

This led to the use of a loud-speaker fixed on the back of the operator's chair. Then the lineman, who sets up the gage with a master and checks it for accuracy, objected to the new model because it required two masters to set up and check, one for the high limit and one for the low limit.

*Simplified Gage*

A visual gage was then added to the sound one, eliminating the need for two masters. Since the device was becoming complicated, the phototube was eliminated by adding a switch to the back-stop of the gage to shut off the tone when the gage was not in operation. This final model proved satisfactory to the operator and the lineman and is the one now in operation.

Helen Keller, flanked by Polly Thomson, her constant companion for more than thirty years, attended the demonstration with high-ranking leaders of the blind, of industry, the American Legion, and officers of the company.

• • •

**Measuring Temperature  
of Molten Steel**

THE TEMPERATURE of molten steel covered with slag is measured within 45 seconds by a new platinum thermocouple when used in conjunction with an electronic recorder. Use of the device is expected to improve the quality and uniformity of stainless steel.

The thermocouple has an immersion head comprising a platinum and platinum-rhodium thermocouple encased in a fused silica tube



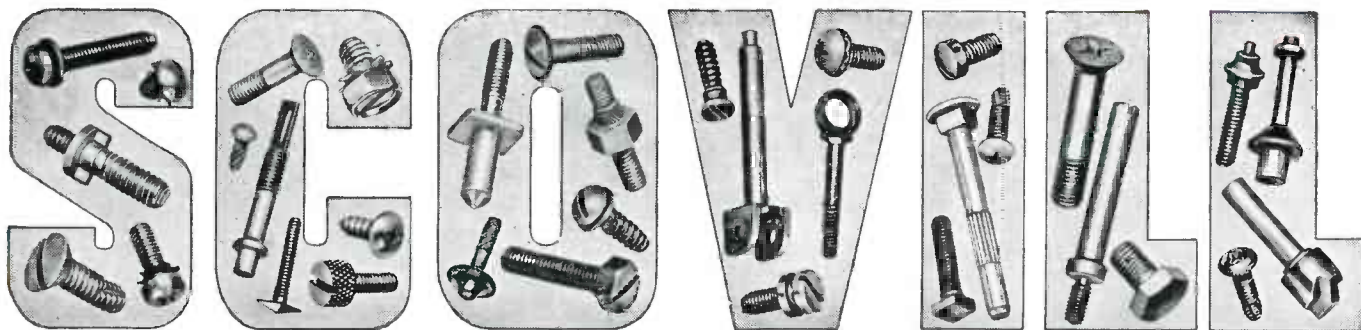

# SPEED UP ASSEMBLY JOBS PLAN FASTENINGS NOW



"Cold-forging"—proof #34... more each month

## It Pays To Plan Early:

...because the right fastening planned in the product design stage can well be the one remaining factor essential to the speed and success of that vital assembly job—no assembled product can be better than its fastenings.

...because early action allows time for an exacting choice—your choice must be either a standard fastening or a part specially designed to meet your specific need.

## It Pays To Choose Scovill:

...because we can help you—our broad experience in fastenings qualifies us as specialists to aid you in that selection. Our demonstrated ability in special design\* makes Scovill your logical choice.

...because our skill in special design, our special processing plus our ingenuity in cold-forging means a substantial saving in *money—materials—motions*.

## Call A Scovill Fastenings Expert Today

\*Above is illustrated one of many special-purpose items—proof of Scovill ingenuity in cold-forging and ability in special design.

## 3 Standard Fastenings for Production Efficiency



**1 Phillips Recessed Head Screws**—The modern, effective, time-saving fastening device proven in tens of thousands of assembly lines. Other standard head styles are also available.



**2 Self-Tapping Machine Screws**—Eliminate separate tapping operations for fastenings to castings, heavy gauge sheet metal, and plastics. Also available with Phillips Recessed Head.



**3 Washer-Screw Assemblies**—When use of lock washers is indicated, the time-saving of pre-assemblies is obvious. Also available in standard slotted head styles.

# SCOVILL MANUFACTURING COMPANY

## WATERVILLE SCREW PRODUCTS DIVISION

WATERVILLE 48, CONN.



TEL. WATERBURY 3-3151

NEW YORK, Chrysler Building • DETROIT, 6460 Kercheval Avenue • CHICAGO, 135 South LaSalle Street • PHILADELPHIA, 18 W. Chelton Avenue Building  
PITTSBURGH, 2882 W. Liberty Ave. • SYRACUSE, Syracuse • Kemper Insurance Bldg. • LOS ANGELES, 2627 S. Soto St. • SAN FRANCISCO, 434 Brannan St.

# WILCO

## NOW EQUIPPED

for large scale production of

# JACKETED WIRE



WILCO wire, tubing and other products are used in various electronic applications for the Army and Navy. In response to the wartime demand for these various products, the H. A. Wilson Company has enlarged its plant, increased its manufacturing facilities, added essential new equipment and developed new products and techniques. Both present and future customers will find these new WILCO developments of great advantage.

The H. A. Wilson Company manufactures and is interested in receiving inquiries regarding the following typical products—

#### WILCO JACKETED WIRE

Silver (Fine, Sterling or Coin)  
 Silver Jacketed Copper  
 Silver Jacketed Invar  
 Silver Jacketed Brass  
 Silver Jacketed Steel  
 Gold Jacketed Silver (Fine, Sterling, Coin)  
 Gold Jacketed Brass or Bronze  
 Copper Jacketed Monel  
 Nickel Jacketed Copper

#### WILCO JACKETED TUBING

Silver Tubing (Fine, Sterling or Coin)  
 Gold Tubing (any Color or Karat)  
 Silver Jacketed Brass or Bronze (one or both sides)  
 Gold Jacketed Silver (one or both sides)  
 Gold Jacketed Brass or Bronze (one or both sides)

#### WILCO STRIP MATERIAL

Silver (Fine, Sterling or Coin) on Brass or Bronze (Inlay or Overlay)  
 Gold on Silver (any Karat on Fine, Sterling or Coin)  
 Gold on Brass or Bronze

#### Other WILCO products include Electrical Contacts—

Silver, Platinum, Tungsten, Alloys, Powder Metal. *Thermostatic Bimetal* (High and Low Temperature with new high temperature deflection rates.) *Precious Metal Collector Rings*—For Rotating controls. *Silver Clad Steel*. *Rolled Gold Plate*. *Special Materials*.

*Let us analyze your problems.*

## THE H. A. WILSON COMPANY

105 Chestnut Street, Newark 5, N. J.

Branches: Detroit • Chicago





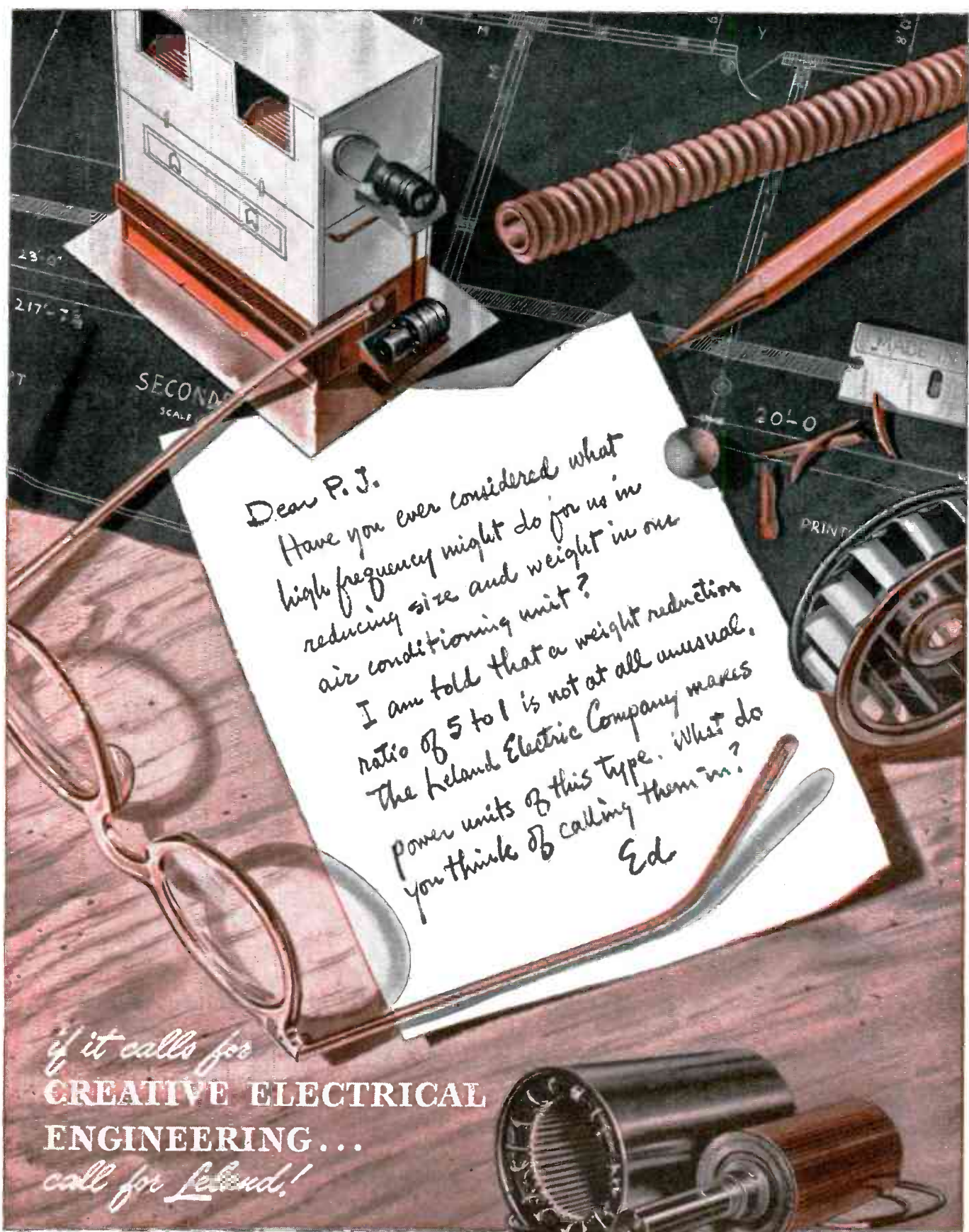

Dear P. J.  
 Have you ever considered what  
 high frequency might do for us in  
 reducing size and weight in our  
 air conditioning unit?  
 I am told that a weight reduction  
 ratio of 5 to 1 is not at all unusual.  
 The Leland Electric Company makes  
 power units of this type. What do  
 you think of calling them in?  
 Ed

*if it calls for*  
**CREATIVE ELECTRICAL  
 ENGINEERING...**  
*call for Leland!*



Motors, Generators, Motor Gen-  
 erators and Voltage Regulators

# THE Leland ELECTRIC COMPANY

DAYTON, OHIO • IN CANADA, LELAND ELECTRIC CANADA, LTD. ... GUELPH, ONTARIO



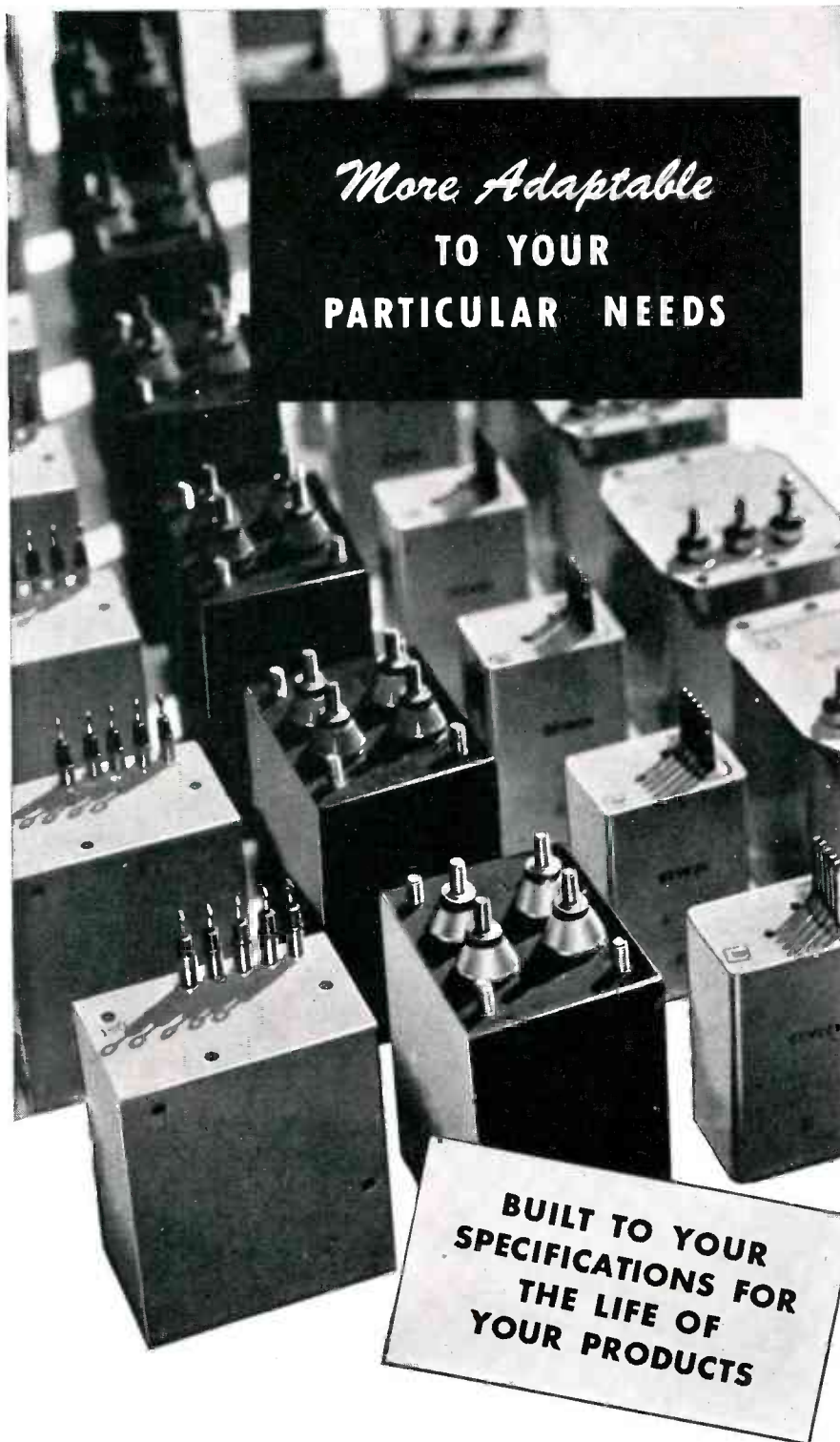

*More Adaptable*  
**TO YOUR  
 PARTICULAR NEEDS**

**BUILT TO YOUR  
 SPECIFICATIONS FOR  
 THE LIFE OF  
 YOUR PRODUCTS**

**T**HE know-how gained in engineering transformers to war's exacting specifications is now available to solve your peacetime transformer needs. Stancor engineers are ready to study and master the toughest problems you can set them. Production men trained to exacting standards, with modern equipment and precision winding machinery, assure that highest specifications will be met in the finished product.

When you have a transformer problem, think first of Stancor. Competent sales engineers are ready to satisfy your most exacting transformer requirements.



**STANCOR**  
 STANDARD TRANSFORMER CORPORATION  
 1500 NORTH HALSTED STREET CHICAGO 22, ILLINOIS

mounted in a block of graphite at the end of a 12-foot insulated pipe.

As shown in the drawing, the immersion head is manipulated through the furnace door and dipped into the steel bath. The exposed tip of the silica tube, containing platinum thermocouple wires, is immersed in the steel itself. A

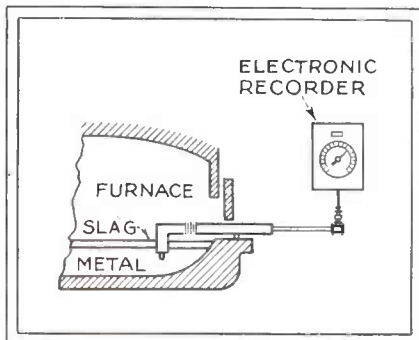

Arrangement of thermocouple and Brown electronic recorder for measuring temperature of steel in furnace

graphite block protects the sensitive silica tube against deterioration by slag or mechanical shock.

Temperature is recorded automatically on a Brown ElectronicK recorder designed expressly for this application. The chart rotates at the rate of one revolution in four minutes and only during reading.

Patent rights to the platinum thermocouple have been acquired by Brown Instrument Company from Rustless Iron and Steel Corporation, whose engineers developed the unit.



### A Phototube Amplifier

By LT. JOHN F. SCULLY  
*Point Lookout, New York*

AN AMPLIFIER is often desired which, when used with a phototube, can be used as a switch to control a variety of industrial equipment. A number of such devices have been described in the literature, some of them more complex than might be desirable.

The amplifier to be described contains no coupling capacitors between stages and therefore only the inertia of the relay limits the speed of operation. In addition, it is positive in its action, being unaffected by normal power supply changes



# CONTACT

## Lumarith\* Plastics

*for items of  
personal use*

LOW THERMAL CONDUCTIVITY is just a laboratory way of saying that Lumarith plastics are inviting to the touch in all temperatures. It explains one of the many reasons why these jade-like thermoplastics are used so frequently in applications involving personal contact and handling: electric shaver housings, hardware, tool handles, telephone handsets . . .

Lumarith molded and fabricated items have a uniform surface texture and smoothness that actually improves with handling. They are odorless, tasteless and non-toxic, and can be produced in a limitless range of colors, color densities and transparencies.

Would you like to know more about these modern plastics? Write for Product Designer's Booklet, or refer to Sweet's Catalog. Celanese Plastic Corporation, a division of Celanese Corporation of America, 180 Madison Avenue, New York 16, N. Y.

*A Celanese\**  
*Plastic*

\*Reg. U. S. Pat. Off.

### Information for Product Designers

Toughness is characteristic of all Lumarith plastics. They have excellent colorability, water resistance, dielectric strength, lightness, uniformity and stability—are interchangeable in many applications. The different Lumarith types and formulations accent particular physical properties in the following manner:

#### LUMARITH C.A.

Cellulose acetate. The most versatile of the cellulose . . . ideal in applications requiring balanced physical properties . . . superb color.

#### LUMARITH X

High acetyl cellulose acetate. Provides added dimensional stability and moisture resistance, with superb color.

#### LUMARITH E.C.

Ethyl cellulose. Superior toughness at temperature extremes, plus lightness and form retention.

#### CELLULOID

Cellulose nitrate. Color, economy and all around toughness maintain the popularity of this "first plastic" . . . used in volume for fabricated items.

Success with plastics depends on the proper selection of plastic type and formulation. Our technical staff is at your service.

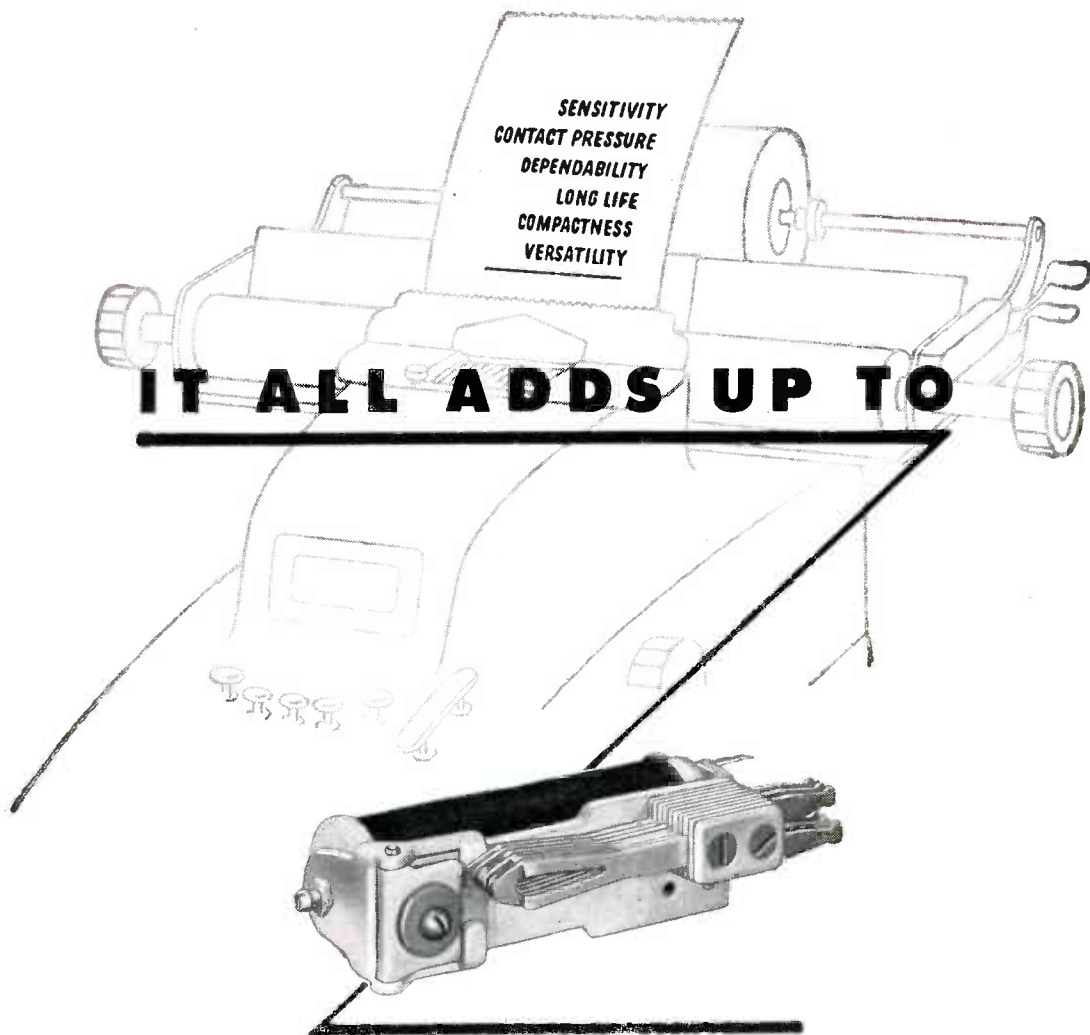

## **AUTOMATIC ELECTRIC'S CLASS "B" RELAY**

All six of the features you want—perfectly combined in one unit—that's what you get in this new relay. It meets all purposes, in widely varied applications, without compromising with the most exacting requirements. For in the Class "B" relay, Automatic Electric has combined the features you need—*all* of them, and each in greatest measure.

*Independent twin contacts for dependable contact closure... efficient magnetic circuit for sensitivity and high contact pressure... unique armature bearing for long wear under severe conditions... compact*

*design for important savings in space and weight. Now available for coil voltages to 300 volts DC and 230 volts AC, with capacities up to 28 springs; also with magnetic shielding cover, when specified.*

The Class "B" relay, and many others, are shown in Catalog 4071. Write today for your copy.

*Relays by*

**AUTOMATIC  ELECTRIC**

**AUTOMATIC ELECTRIC SALES CORPORATION**  
 1033 WEST VAN BUREN STREET • [CHICAGO 7, ILLINOIS  
*In Canada: AUTOMATIC ELECTRIC (CANADA LIMITED, TORONTO*

**PARTS AND ASSEMBLIES FOR EVERY ELECTRICAL CONTROL NEED**



# MR. EQUIPMENT MANUFACTURER:

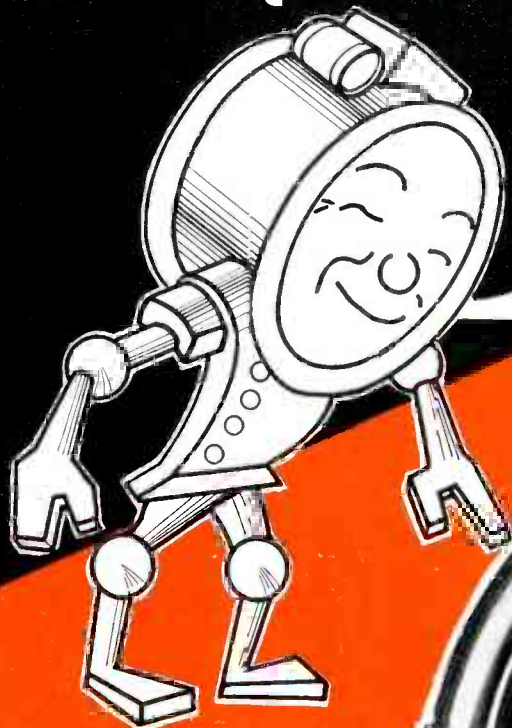

*If you need air movement  
in your equipment,  
investigate our*

**H. P. AXIAL FLOW  
BLOWERS!**



## TYPICAL SMALL UNIT

#4581-A  
Delivers 180 CFM @ 1" S.P.,  
7500 RPM.  
Length, 6-7/16"; Diameter, 5-3/4".  
Weight, 4 lbs., 2 oz., H.P., 1/12.

With high pressure axial flow  
blowers you get more air  
against high pressures with—

- *less weight . . .*
- *less space . . .*
- *less power input*

ENTIRELY new conceptions of equipment design are made possible by Axial Flow Blowers as developed by our engineers. Dynamic Air *High Pressure* Axial Flow Blowers deliver volume and pressure with fractions of space, weight and power necessary with ordinary blowers. Investigate these adaptations.

Many Dynamic models are available in single and two-stage ratings from 25 c.f.m. at .25" S.P. to 10,000 c.f.m. at 10" S.P.

Aircraft, electronic and Marine units available with motors as follows:

24/28-V D.C.	1/500 to 4 h.p.
115-V D.C.	1/100 to 4 h.p.
115-VA.C.	1/100 to 1/2 h.p.
400-cycle A.C.	1/500 to 1 h.p.

All units available for shaft or belt drive. Adaptations can be made to precise requirements. Prototypes for postwar development projects are available. *Consult us about your Blower needs.*

**DYNAMIC AIR ENGINEERING**  
LOS ANGELES, U. S. A. *me.*  
DESIGNERS and BUILDERS of HIGH EFFICIENCY AXIAL FLOW EQUIPMENT

and parameter changes over a wide range. The circuit, shown in the diagram, contains a 927 phototube for the input excitation, a 6SN7 as a cathode follower working into a control amplifier, and a 6V6 power amplifier feeding the relay.

*Circuit Operation*

The unit operates as follows: First, assume the phototube to be removed from the circuit. Under this condition, the grid of the first 6SN7 section (the cathode follower) is at ground potential. Plate current of both sections of the 6SN7 flows through the 2200-ohm cathode resistor, so that the cathode follower is biased almost to cutoff.

The second section (control am-

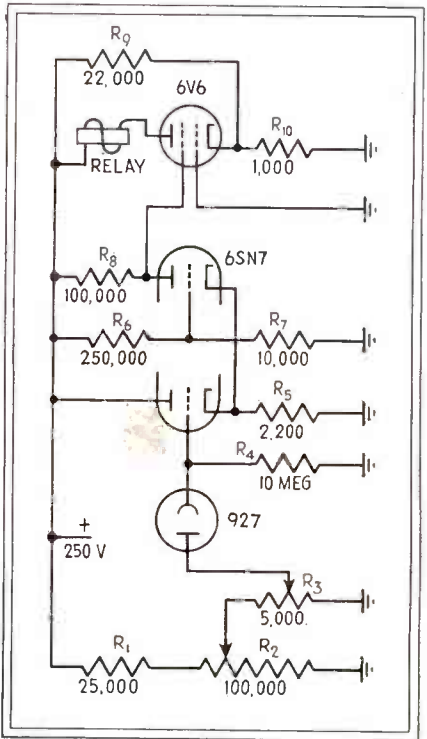

Circuit of novel phototube amplifier which eliminates the time constant of coupling capacitors by driving the grid of the output tube

plifier) of the 6SN7 has a positive 9 volts on the control grid, so that it conducts sufficiently for the plate voltage to drop to about 50 volts. The combined plate currents furnish a positive voltage of about 10 volts on the two cathodes. The plate of the control amplifier is connected to the power-amplifier screen which then has a potential of 50 volts. The grid of the 6V6 is grounded, and



# B & W

## SPECIAL ELECTRONIC EQUIPMENT

... from design engineering to the finished product

In addition to its complete, well-known lines of Air Inductor Coils and Heavy Duty Variable Condensers, B & W offers a wealth of specialized facilities for the engineering, design and production of custom-built electronic equipment. Among units recently produced are special transmitters, test equipment, tuning units, high- and ultra-high frequency assemblies, high-voltage equipment and many more. What do you need—designed and constructed throughout to match your application *exactly*?

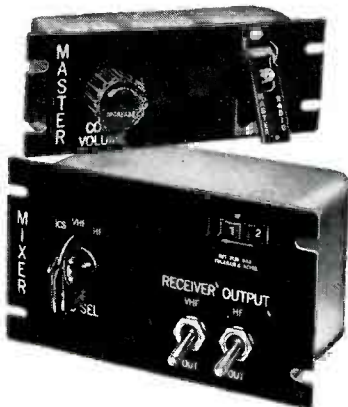

**TYPICAL!**—These three units comprising mixer and master output switching assemblies for a critical application are typical of B & W facilities for handling custom-built engineering and production assignments.



# BARKER & WILLIAMSON

AIR INDUCTORS • VARIABLE CONDENSERS • ELECTRONIC EQUIPMENT ASSEMBLIES

DEPT. E-105 235 FAIRFIELD AVENUE • UPPER DARBY, PA.

Export: LINDETEVES, INC., 10 Rockefeller Plaza, New York, N. Y., U. S. A.



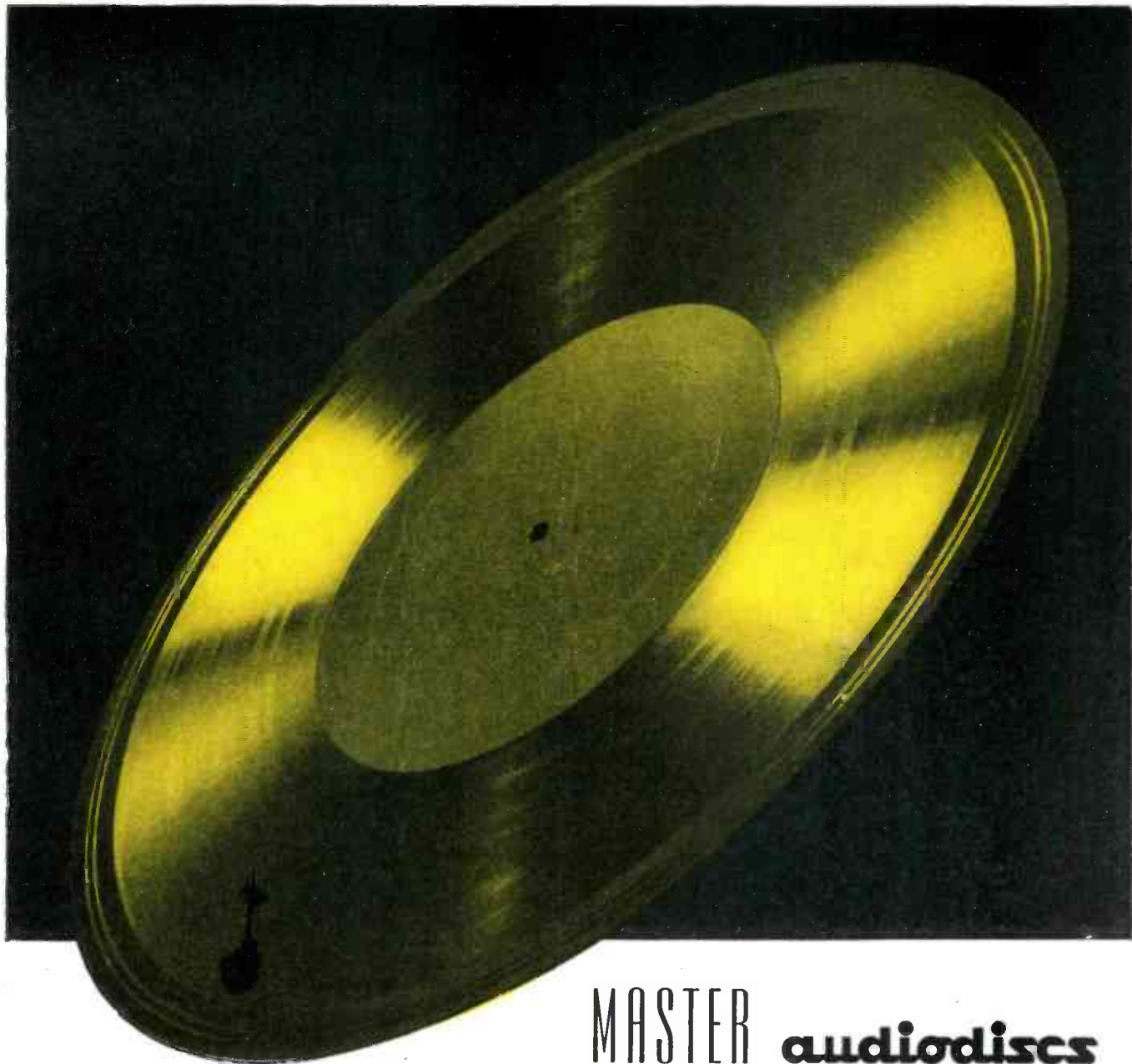

## MASTER **audiorecords**

The excellence and consistent quality of Master Audiorecords gained wide acceptance for them prior to the war. Now, the demand for these recording blanks, from which pressings are made, has increased more than fourfold. And here are a few of the reasons:

1. They give fine results with either the gold sputtering or silvering process.
2. Like regular Audiorecords, the thread throws well, and there is no annoying static.
3. Cut under good recording conditions there is no audible "background scratch".
4. It is easy to ship them safely from recording studio to processor.
5. Especially important—there is no increase in surface noise from recording time to processing—be it a few minutes or many months.



Master AUDIORECORDS are manufactured in three sizes on stretcher leveled No. 2 aluminum recording sheet—12", 13¼" and 17¼" for 10", 12" and 16" pressings.

### AUDIO DEVICES, INC.

444 MADISON AVENUE

NEW YORK 22, N. Y.



*they speak for themselves* **audiorecords**



*Now . . . Leakage  
Resistance Measurements  
at Low Potentials!*

Because of its compactness and extreme high sensitivity, this direct reading instrument fills an important measurement gap in the production and servicing of a wide variety of components and electrical devices. Minute faults can be detected in advance . . . tests can be made without destructive breakdown. Test potential less than 50 Volts.

Here's what a few typical users say about Model 799:

"We use it for testing the leakage between windings in transformers, or from windings to core or case."

"We can test the leakage of low voltage paper and mica condensers with the 799, and without danger of damaging the dielectric."

"We test leakage resistance between individual wires in cable harnesses."

"Model 799 is also ideal for checking leakage due to moisture in fiber terminal strip."

For complete data on Model 799 Insulation Tester, communicate with the WESTON representative in your locality, or write... Weston Electrical Instrument Corporation, 618 Frelinghuysen Ave., Newark 5, N.J.



# Weston

## MODEL 799

### INSULATION TESTER

• 10 BILLION Ohms •

*will measure:*

- ✓ Insulation Properties
- ✓ Resistance Leakage
- ✓ Conductivity of Insulating Materials
- ✓ Leakage due to Moisture Absorption
- ✓ Readings — .1 to 10,000 megohms

# Weston Instruments

ALBANY • ATLANTA • BOSTON • BUFFALO • CHICAGO • CINCINNATI • CLEVELAND • DALLAS • DENVER • DETROIT • JACKSONVILLE • KNOXVILLE • LOS ANGELES • MERIDEN  
MINNEAPOLIS • NEWARK • NEW ORLEANS • NEW YORK • PHILADELPHIA • PHOENIX • PITTSBURGH • ROCHESTER • SAN FRANCISCO • SEATTLE • ST. LOUIS • SYRACUSE

In Canada, Northern Electric Co., Ltd., Powerlite Devices, Ltd.



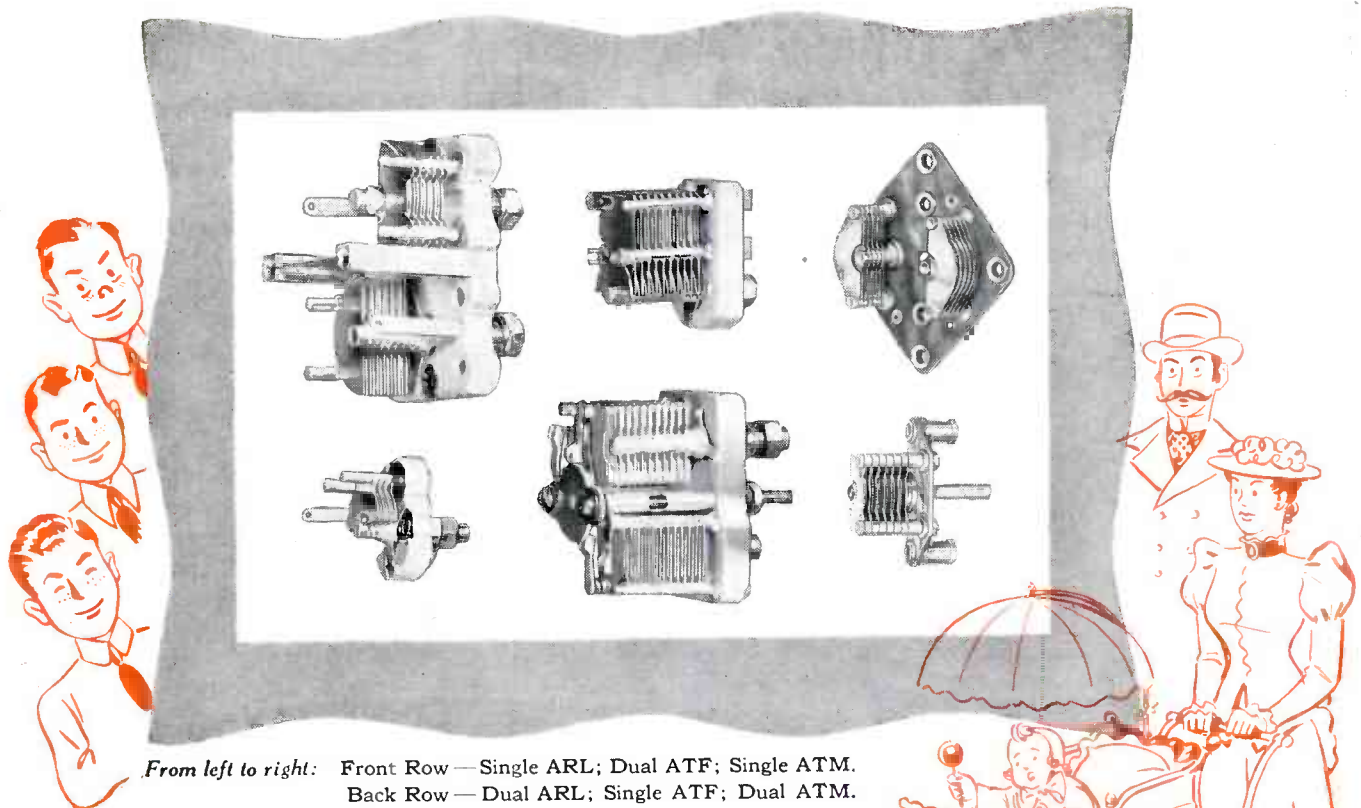

From left to right: Front Row — Single ARL; Dual ATF; Single ATM.  
Back Row — Dual ARL; Single ATF; Dual ATM.

Now There Are Six . . .

## The SICKLES' Air Dielectric Trimmer Condenser Family

From one Condenser, The Sickles' Air Dielectric Trimmer Condenser Family has grown until today there are six. All of them have the Sickles' Family Characteristics of quality production backed by top engineering skill.

First on the list of the Trimmer Condenser Family is Type ARL which, equipped with a slightly larger plate than the others and with a close spacing, has a wide effective capacity range. This Condenser has no fixed capacity plates.

Type ATF is particularly suited for I.F. Trans-

former Tuning. Fixed plates in parallel with its rotor produce a high minimum, low range, stable condenser. It is available, also, without fixed section to give a standard version smaller than the ARL. This is known as Type ATR.

Type ATM is the baby of the family. One of the smallest condensers made, it has a wide variety of applications; as, for instance, in a double-tuned transformer with a  $1\frac{3}{8}$ " square shield.

The complete story on any of these Sickles' quality products is available on request.

THE F. W. SICKLES COMPANY, CHICOPEE, MASSACHUSETTS

# SICKLES



*Radio and Electronic Specialties for Today and Tomorrow*

# Faster Mounting

## OF VARIABLE RESISTORS AND BAND SWITCHES

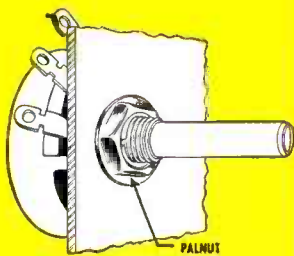

### 3/8"-32 THREAD TYPE WT PALNUTS

#### SPEED—SECURITY—SAVINGS!

Type WT PALNUTS greatly simplify and speed up the mounting of variable resistors and band switches to the chassis. These one-piece, self-locking nuts replace a regular nut and lockwasher. Assembly is much faster because one part is handled instead of two and assembly can be made with power tools.

Type WT PALNUTS are single thread nuts made of resilient, tempered spring steel, accurately formed to fit  $\frac{3}{8}$ "—32-

thread bushings. They run onto work easily, without damage to parts. Smooth, flat base fits snugly against chassis. Double locking spring action holds tight under vibration. Costs less than regular nut and lockwasher—requires no more space.

**WRITE** on business stationery for samples of Type WT PALNUTS and engineering data.

#### The Palnut Company

77 Cordier St. Irvington 11, N. J.

#### TO MANUFACTURERS OF VARIABLE RESISTORS AND BAND SWITCHES

Type WT Palnuts are ideal for replacement part. Include them in shipments to service trade.



## Self-Locking PALNUTS

bias for the stage is furnished by the voltage divider consisting of  $R_6$  and  $R_{10}$ , plus whatever voltage is developed across  $R_{10}$  by plate current. With 50 volts on the screen grid, 250 on the plate, and about 10 volts on the cathode, the tube is very nearly cut off, and the relay in the plate circuit remains unenergized.

#### Conditions With Phototube

When the phototube is inserted in the circuit and illuminated by an outside source, current through the phototube makes the grid of the cathode follower more positive. The increase of cathode-follower current results in a higher cathode voltage of 22 volts for the stage. This rise also is applied to the cathode of the control amplifier. Since the grid voltage of the control amplifier is held constant by divider  $R_6$  and  $R_7$  at 9 volts, the result is that close to cutoff bias is applied to this section. Actually, the tube would be cut off with the exact values given. However, the meter used in making the measurements was not sensitive, hence the voltages given are not exactly those which would be read with a vacuum-tube voltmeter.

#### Screen Control

The result of the drop in plate current is to raise the plate voltage, and hence the screen voltage of the power amplifier, to 170 volts. This increased screen voltage permits the 6V6 to conduct heavily enough to close the relay in the plate circuit. This relay then serves to control whatever device may be used with the amplifier.

The actual voltages for the non-operative condition are between those given in the two cases above, since under normal conditions the phototube conducts to some extent, although not enough to operate the relay.

If desired, the device can be kept normally energized by a light source on the phototube, in which case any interruption of the beam would deenergize the relay and operate the controlled device.

Resistors  $R_2$  and  $R_2$  are the coarse and fine sensitivity controls, respectively. One control may be



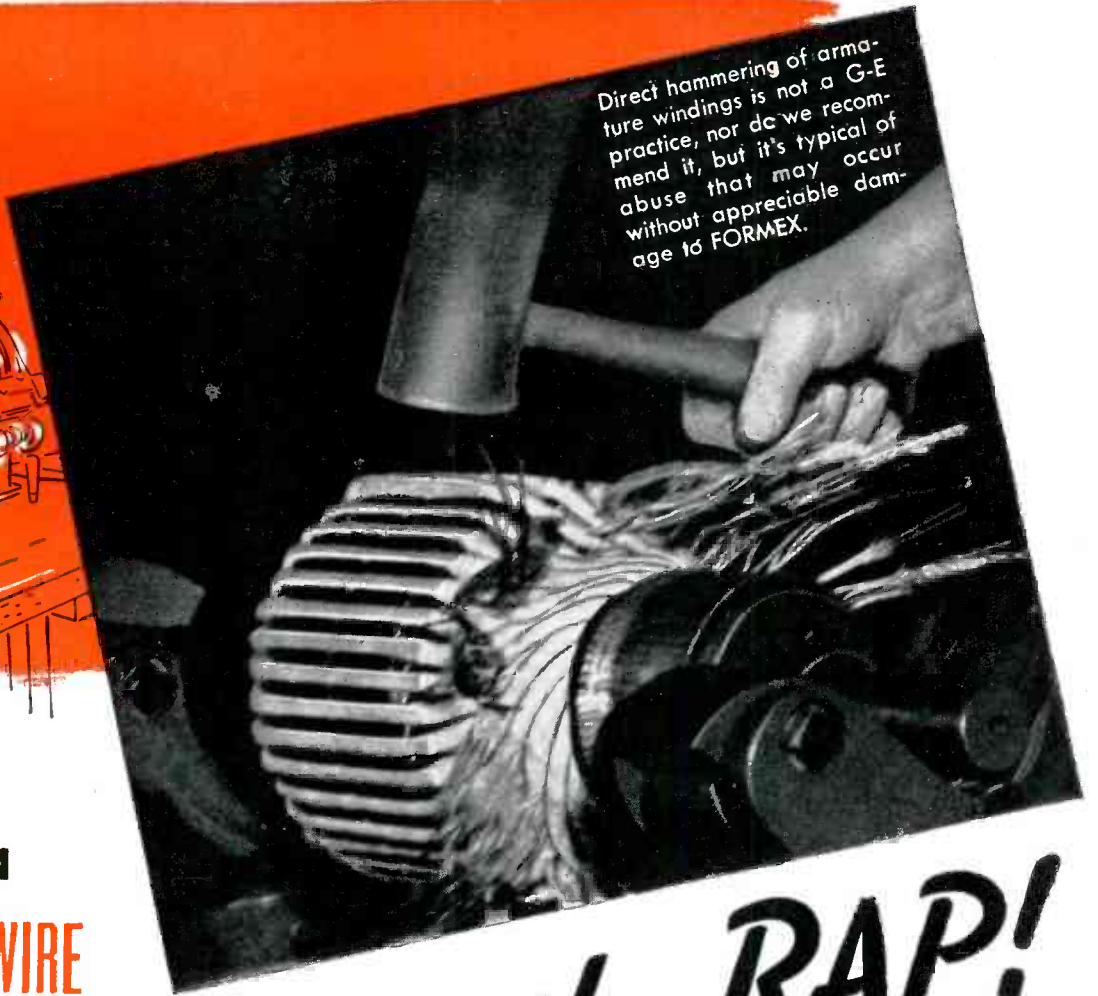
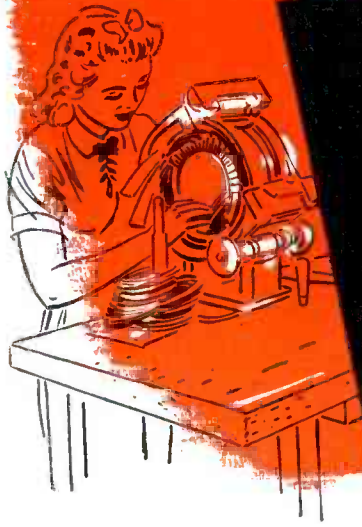

Direct hammering of armature windings is not a G-E practice, nor do we recommend it, but it's typical of abuse that may occur without appreciable damage to FORMEX.

**WHEN  
MAGNET WIRE**

# Must take the **RAP!**

**FORMEX\* helps keep down rejects—lowers cost of completed windings.**

Few operations put magnet wire to a tougher test than bench assembly of armatures and stators. And rough treatment is intensified by today's push for high production despite high labor turnover.

Because of its exceptionally tough and flexible insulating film, FORMEX magnet wire can take a lot more such abuse than conventional enameled wire. When coils are being wound, bonded, baked, formed, or handled, this extra toughness (and extra resistance to heat-shock and solvents) helps to reduce rejects without requiring "babying" techniques.

As the world's largest user of magnet wire, General Electric makes the same sort of comparisons of installed costs as you might make. These comparisons show that, even in those few cases where the cost of Formex may be slightly higher than the cost of conventional magnet wire which it replaced, the higher first cost is definitely offset

by lower costs of manufacturing the completed coil or installed winding. In addition, the choice of Formex for new designs permits more compact windings, which, in turn, save space, copper, and frame materials.

Why not, right now, ask your G-E representative for complete information and samples of Formex wire. General Electric Company, Schenectady 5, N. Y.

Round wire sizes: No. 8 Awg to .001 in.  
Rectangular wire: Full range of sizes

Buy all the BONDS you can—and keep all you buy



\*Trade-mark  
Reg. U.S. Pat. Off.

**GENERAL ELECTRIC**

503-22-1200

# 3 D 23

$E_F = 6.3$  VOLTS.

$E_{c_2} = 250$  VOLTS.

$I_p$

250

200

150

100

50

0

$E_{c_1} = +40V$

$E_{c_1} = +30V$

$E_{c_1} = +20V$

$+0V$

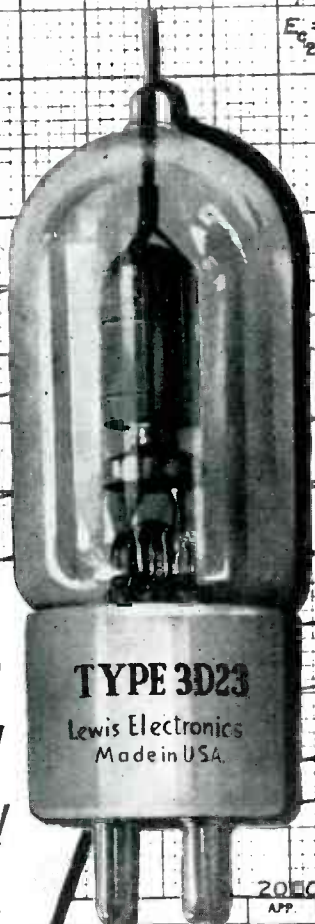

ACTUAL SIZE

2000	DATE	PRINT	OF

A remarkable new  
**TETRODE** for fixed  
or mobile operation!

- FILAMENT VOLTAGE, 6.3 AC or DC VOLTS
- FILAMENT CURRENT . . . . . 3.0 AMPERES
- AMPLIFICATION FACTOR . . . . . 65
- MUTUAL CONDUCTANCE . . . . . 2,750
- PLATE DISSIPATION . . . . . 35 WATTS
- MEDIUM 4 PIN CERAMIC BASE
- MAXIMUM POWER OUTPUT, 130 WATTS
- APPROX. DRIVING POWER . . . 4.5 WATTS

*Inter-Electrode Capacities*

- INPUT TO PLATE . . . . . .2 MMFD
- INPUT, 6.5 MMFD — OUTPUT, 1.8 MMFD

Licensed under R. C. A. Patents

Catalog Sheet and Tubes  
Now Ready for  
Distribution

*Lewis at Los Gatos*

A manufacturing organization . . . the pride of an entire community . . . with an electronic engineering background of 20 years experience! Plus a war-born performance record of meeting huge production demands and exacting technical requirements — on time and economically!

EQUIPPED and READY  
to produce YOUR TUBES  
under YOUR BRAND name!

*Lewis*

**ELECTRONICS**  
LOS GATOS · CALIFORNIA



# Invisible to the Naked Eye—

but you'll want these\* in your Plastic Parts

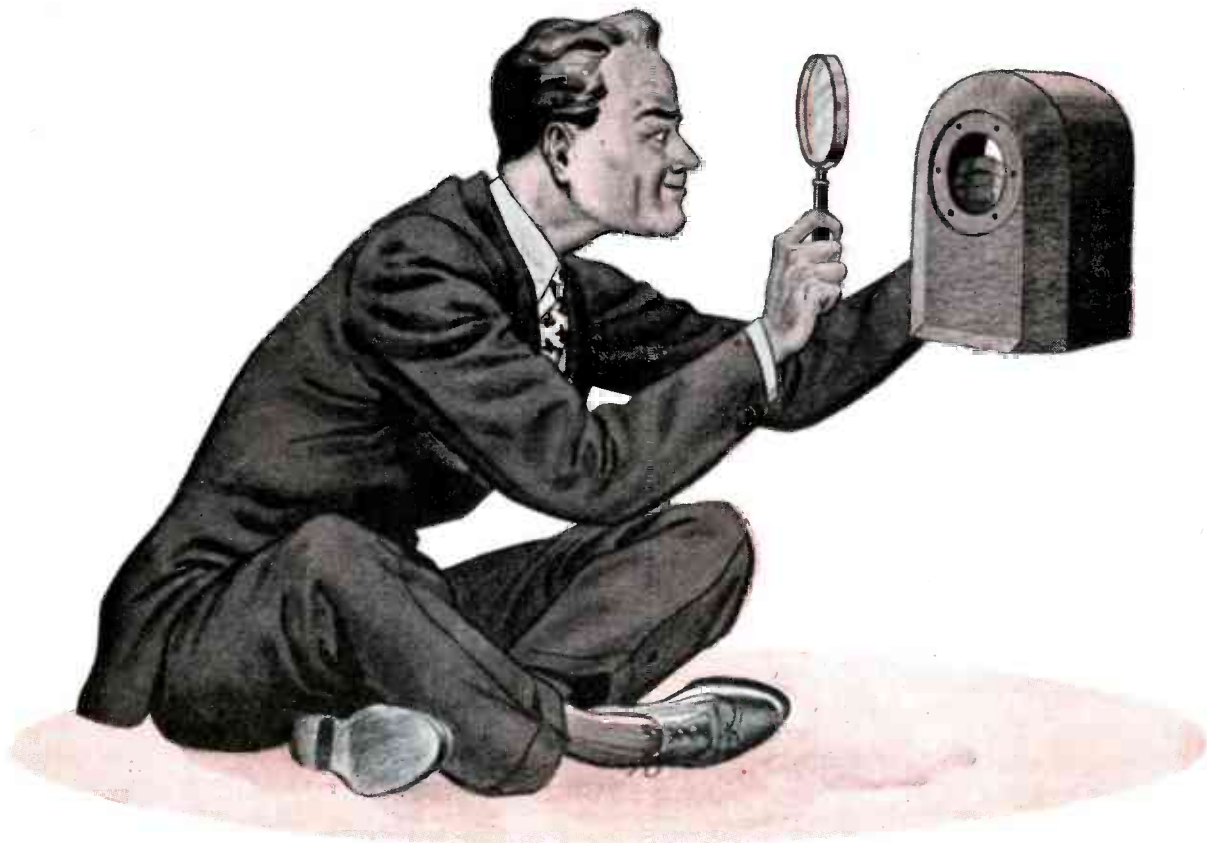

WHETHER you're interested in food machine housings or any other larger parts, the same thing applies—these hidden qualities *add value* to your product:

- 1. Minimized internal stress
- 2. Uniform density
- 3. Most thorough cure possible
- 4. Better finish
- 5. No "weld" lines
- 6. Generally improved properties
- 7. Less or no washing of inserts (fewer rejects)

These are seven of the by-products of incorporating Heatronics (radio fre-

quency pre-heating) into standard molding techniques. And they're qualities you'll probably want in your next molding job.

We've been developing Heatronic molding standards since one of the first units in the industry was delivered to our plant—today we can show you a large and still-growing Heatronic installation, as well as many outstanding molding jobs accomplished through its use. We do the whole job, of course—designing, mold-making, molding and finishing—and we can talk business.

If you're interested in these plus-values in plastics, ask for a Kurz-Kasch engineer.

### "A Businessman's Guide to the Molding of Plastics"

Send for your free copy of this illustrated brochure. Just write to Dept. 7 on your letterhead and we'll send it with our compliments.



**THE WAR BONDS YOU KEEP ARE THE BONDS THAT COUNT**

# Kurz-Kasch

For over 28 years Planners and Molders in Plastics

Kurz-Kasch, Inc., 1425 South Broadway, Dayton 1, Ohio. Branch Sales Offices: New York • Chicago • Detroit • Indianapolis • Los Angeles • Dallas • St. Louis • Toronto, Canada. Export Offices: 89 Broad Street, New York City

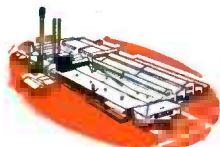

# PLUGS *and* JACKS

## for every known application!

Built in accordance with latest Signal Corps and Navy specifications, Amalgamated Plugs and Jacks are tropicalized to make them fungus resistant, waterproof and moistureproof when called for. Insulators of these components are designed to withstand extremes of temperatures for  $-67^{\circ}\text{F}$  to  $+167^{\circ}\text{F}$ , at humidities up to 100%. We also specialize in producing Plugs which will bear up under the high heat met in rubber molding cord sets.



### PLUG PL-55 and N.A.F. 1136-1

Long sleeve, two-conductor plug, mate to Jack JK-34-A. Withstands minimum of 500 cycles AC, potential of 500 volts effective, applied between any two terminals for not less than two seconds. Meets minimum insulation value of 2000 megohms between conductors at  $68^{\circ}\text{F}$  at humidities up to 100%.



### PLUG, STYLE "A"

Two-conductor, special type plug for use with Neoprene or Buna S molded cords. Same specifications as PL-55.



### PLUG, STYLE "D"

Two-Conductor, special type plug for use with Neoprene or Buna S molded cords. Same specifications as PL-55.



### PLUG PL-204

Hand set. A special plug wherein both a modified plug, PL-55 and PL-68, are held in place by a phenolic case. Same specifications as PL-55 and PL-68.



**NOTE:** Amalgamated Engineers will gladly consult with you on the design and development of Plugs and Jacks for special applications—present or postwar.

### JACK JK-26, N.A.F. 215284-2

Two-conductor Jack, mate to PL-54. Tropicalized. Withstands 60 cycle AC potential of 500 volts effective, applied between any two terminals for not less than two seconds. Meets minimum insulation value of 2000 megohms between conductors at  $68^{\circ}\text{F}$ , at humidities up to 100%.



### JACK JK-48

Light duty, two-conductor Jack, mate to Plug PL-291 and Plug 291-A.



### PLUG PL-54, PL-540, PL-354, N.A.F. 215285-2

Short sleeve, two-conductor plug, mate to Jack JK-26. Same specifications as PL-55.



AMALGAMATED RADIO TELEVISION CORP.

476 BROADWAY • NEW YORK 13, N. Y.

used, but if both are used adjustment of the amplifier is simplified. If the plate of the phototube is connected to the arm of  $R_2$  and  $R_3$  is not used,  $R_1$  should be replaced by a 750,000-ohm resistor.

### Adjustments

Maintain moderate tension on the relay spring, with as small a travel distance as necessary to prevent sparking being maintained when the contacts are opened. A suppressor capacitor should be used across the relay contacts. Adjust  $R_3$  to the maximum sensitivity position (all 5,000 ohms in the circuit). Adjust  $R_2$  to the maximum sensitivity position. If the relay is properly adjusted, it will now operate regardless of the light on the phototube. If it does not, change the spring adjustment or the contact gap.

With the phototube under excitation from the light source with which it will be used, back off  $R_2$  until the relay is deenergized. Rotate  $R_2$  about one-eighth of a turn in the reverse direction. The relay will again be energized. Rotate  $R_1$  until the relay is deenergized, and reverse the adjustment just past the point at which the relay energizes again. This last step completes the adjustment. Cutting off the light

• • •

### GURKHAS HANDIE-TALKIE



Gurkhas of an Indian division in Italy used British radio equipment. Above, Havildar Birbahadur Limbu, Gurkha wireless operator on patrol is clad in white to blend with the snow. Gurkhas were members of an Indian division that held a section of the Italian front



# New Pilotless Plane?



## **B**ACK IN 1939 PACIFIC DIVISION HAD ALREADY FLOWN THIS RADIO CONTROLLED AIRPLANE

Six years ago we did it the hard way. Month after month at an isolated camp in the Mojave Desert Pacific Division radio engineers collaborated with Lockheed engineers to perfect electronic controls and the aerodynamic characteristics of one of the first airplanes to fly by radio direction alone. The operations were part of a special Army project and, in all, six airplanes of Lockheed design were successfully flown. In light of the tremendous strides Pacific Division radio engineers have made since those early days, it is interesting to know that this first radio control receiver had to provide simultaneous operations of *thirteen* controls—for the elevator, rudder, 5-position throttle, altitude, airspeed, counter, camera and parachute release. The success of these early, complicated experiments have given Pacific Division a six-year lead in the development of numerous types of VHF control and communication equipment. We would like the opportunity to demonstrate how these modern controls may solve your problems, too.

© 1945, Bendix Aviation Corp.

**Pacific Division**  
Bendix Aviation Corporation  
11618 Sherwood Way, North Hollywood, Calif.  
LINCOLN BLDG. NEW YORK 17      CONTINENTAL BLDG. ST. LOUIS 8  
**COMMUNICATION SYSTEMS**

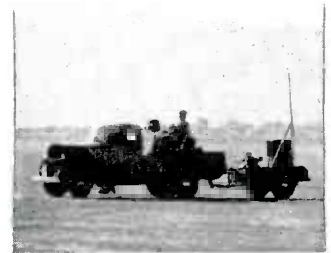

This portable 100 watt transmitter was used to control the plane. "Ground Pilot" sat in the truck body.



Taken from movie film, this shows an actual take off. Note perfect flight attitude for this critical operation.



Trailing smoke made observation easier. The 80 h.p. plane, comparable to a single-seater, had speed of 105 m. p. h.

**OPERATING SIX VHF EXPERIMENTAL STATIONS**

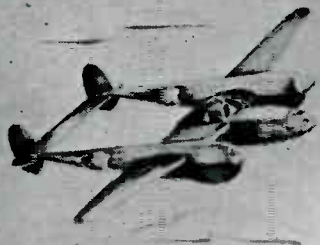

HEILAND

### FOR PICTURES OF VIBRATION...

Heiland's compact Oscillograph Recorders give an accurate record of vibration and strain. Developed for use where space is at a premium, their high sensitivity galvanometers make it possible to record most dynamic strains and vibrations without intervening amplifiers. Write for catalog and complete specifications.



© HEILAND RESEARCH CORPORATION



# MILITARY or COMMERCIAL

—they're ***BOTH*** Breeze Shielded

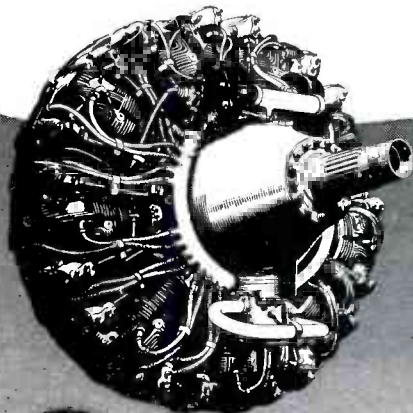

BREEZE  
MARK



Four Breeze-Shielded Wright Cyclone 18's rated at 2200 HP power the Boeing B-29 Superfortress in its smashing attacks against the Japanese homeland.

The 55-passenger Lockheed Constellation, whose trans-continental record of 6 hours, 58 minutes was powered by four Breeze-Shielded Wright Cyclone 18's.

● For many years Breeze has been recognized as the General Headquarters for Radio Ignition Shielding. The reputation which the products bearing the Breeze Mark of Quality built up on national and international airlines before the war has now been augmented by the service record of thousands of Breeze Shielding Assemblies for America's famous fighting aircraft, tank, marine and commercial engines. When final victory has been won, Breeze will once again be able to return to production of Shielding for commercial applications without delay for reconversion. And the reservoir of Breeze Shielding experience so materially increased in maintaining dependable communication in war, will be available to help pace progress in peace.

# BREEZE

*Corporations Inc.*

NEWARK 7  NEW JERSEY

*Other Breeze Products* ● SHIELDING FOR AIRCRAFT ● MARINE ● ELECTRONIC APPLICATIONS OF ALL TYPES

# WHAT MAKES UP AN 'Iron Constitution' IS REVEALED WITH THE HELP OF Cannon Plugs

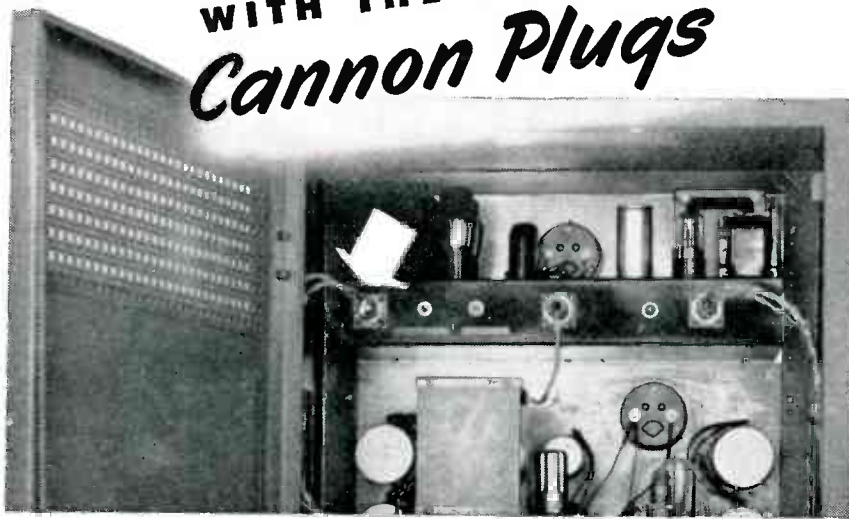

This is the Waugh Metal Analyzer (above and below). It gives an instantaneous indication of the hardness, grain structure and other properties of ferrous materials on which it is used. It performs this scientific feat by means of magnetic analysis and employs many precise electric circuits in its hook-up. These circuits are connected and test units are plugged in through various Cannon Connectors—indicated in the rear view of the open cabinet. Both plug and receptacle types are shown.

Wherever you need a quick, positive and secure connection in the electric

circuits of the instruments you use or the products you manufacture, use Cannon Connectors. There are thousands of stock styles and sizes to choose from and a staff of experienced engineers to develop special Cannon Connectors for your use if need be.



A Type "K" Cannon Connector with integral clamp is pictured at left. Write for a Type "K" Cannon Catalog to get a general introduction to this Cannon line. Address Department A-120, Cannon Electric Development Co., 3209 Humboldt St., Los Angeles 31, Calif.



## CANNON ELECTRIC

Cannon Electric Development Co., Los Angeles 31, Calif.

Canadian Factory and Engineering Office:  
Cannon Electric Company, Limited, Toronto

REPRESENTATIVES IN PRINCIPAL CITIES—CONSULT YOUR LOCAL TELEPHONE BOOK

source will deenergize the relay, applying it will give positive closing of the relay.

### Precautions

It is recommended that the leads to the phototube be shielded, as the cathode follower acts as a rectifier in the presence of 60-cycle pickup, changing the voltage levels in the amplifier. With proper placement of the leads, however, this causes no trouble even without the shielding.

No bypass capacitor can be used at the input grid because the 10-megohm resistor in conjunction with a sufficiently large capacitor to bypass 60 cycles would cause intolerable delay in circuit reaction time.



## Timing Action of the Blocking Oscillator

BY EMANUEL LAST  
Development Engineer  
Munston Mfg. and Service Co.

TIMING AND TRIGGER circuits are becoming increasingly important with each new application of electronic circuits in industry, television, and allied radio fields. All types of multivibrators, start-stop circuits, and relaxation oscillators have made their appearance as timing devices. One of the lesser known but very useful timing methods is the blocking oscillator.

### Operation of Circuit

A typical blocking oscillator circuit is shown in Fig. 1. The transformer shown has a one-to-one turns ratio. Since there is no external or fixed biasing arrangement in this circuit, the tube will conduct

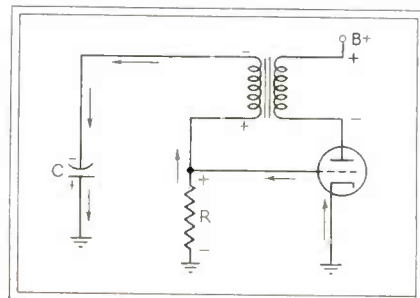
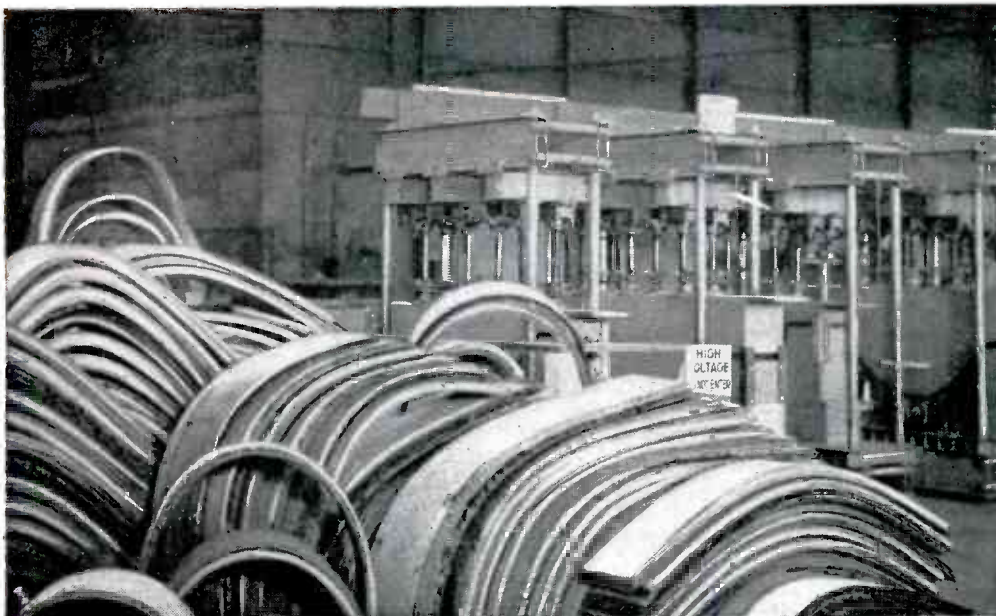

FIG. 1—Circuit of typical blocking oscillator and polarities established when switch is first closed



# PRODUCTION TIME ON LAMINATED RIBS CUT 90% WITH "R.F."



The Higgins Boat in action.



Up to 50,000 BTU of heat per hour can be delivered to the work through electronic platens from this RCA 15-kw generator. Operating cost (total) is only 35¢ per hour. Higgins uses this type of unit.

## Higgins Plastics Builds Air-borne Rescue Boat with Electronic Heat

THE air-borne rescue boat designed and made by Higgins Plastics Corp. grew out of the need for large, rigid boats that could be dropped to flyers lost at sea. Fully equipped, these boats weigh more than 1½ tons—and they are dropped into the sea by parachute from 800 feet altitude. Each boat will comfortably accommodate twelve men, and when dropped is completely equipped with food, medicines, radio equipment, gasoline engine, and fuel . . . and 20-foot mast and sails. Its cruising range is at least 1500 miles.

**CONSTRUCTION:** Over-all, the boat is 27 feet long, 8 feet wide. The 8-ply hull is only 0.6 inches thick—molded in one piece. Birch faces and backs give high impact resistance. Keel, bulkheads and ribs are all laminated for superstrength. Resin-gluing throughout provides permanent waterproof bonds.

**MOLDING TECHNIQUE:** Originally a rubber-bag molding technique was employed for the lamination of the ribs and framing

Plywood ribs and keels molded in presses, at right; electronic heat reduced rejects to 2%! Higgins Plastics Corporation saves 350 man-hours per day by this method of manufacturing.

members. This rubber-bag method was replaced by bonding in presses heated with electronic heat using an RCA 15-kw generator. The results were nothing short of spectacular!

**WHAT ELECTRONIC HEAT DID:** By utilizing electronic heat, Higgins engineers were able to develop the following advantages:

1. Achieve a brighter, less brittle product because of the application on only low bonding temperatures.
2. Reduce rejects from a large proportion to only 2%.
3. Save 5% on materials, in addition to the saving on rejects.
4. Eliminate the use of rubber bags, which were costly, and cumbersome.
5. Save 350 man-hours per day.
6. Relieve the bottleneck on this operation by providing ample supplies of laminated parts.
7. Cut direct labor costs 90%.

The over-all cost of electronic heat from an RCA 15-kw generator, like that used by Higgins Plastics, is just 35¢ per hour—including power, depreciation, maintenance, and tube replacement!

### ELECTRONIC MOLDING CAN HELP YOU!

If you are gluing or bonding laminar wood structures—either flat or curved—you cannot afford to pass up electronic heat. You can obtain free consultation on your problem if you will write, giving details, to our application engineers. We will gladly arrange for an engineer to call at your plant. Address your inquiry to: Radio Corporation of America, Electronic Apparatus Section, Box 70-206H, Camden, N. J.

RCA  
ELECTRONIC  
HEAT



RADIO CORPORATION  
OF AMERICA

RCA VICTOR DIVISION • CAMDEN, N. J.

BUY WAR BONDS

### FILL IN AND MAIL TODAY

RCA, Electronic Apparatus Section, Box 70-206H, Camden, N. J.

We are interested in the application of electronic heat to the following process. Please have an RCA application engineer get in touch with me. I understand this places me under no obligation.

Process.....

Name.....

Position.....

Company.....

Address.....

City..... Zone..... State.....

70-6236-208

**LOW FREQUENCIES**  
**ACCURACY TO 1/1,000th of 1%**

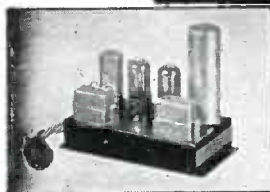

**TOP**  
**FREQUENCY STANDARD**  
*(60 cycle) for use with external power supply*

**CENTER**  
**CHRONOGRAPH**  
*Records time intervals with resolution to .001 second*

**BOTTOM**  
**FREQUENCY STANDARD**  
*(120 cycles) with self-contained power supply*

These tuning forks which include new engineering principles, provide frequencies from 120 to 1,000 cycles directly with an unqualified guarantee of accuracy to 1 part in 100,000 over a wide temperature range. (Better than 1 second in 24 hours). Closer tolerances are obtainable on special order.

These tuning fork assemblies are available only in single or multi-frequency instruments of our own manufacture which are de-

signed to test, measure or control other precision equipment by mechanical, electrical, acoustical or optical means.

The dependability of these frequency standards is being demonstrated for myriad purposes in all climates and under all working conditions.

If you have need for low frequency standards of exceptional accuracy, your inquiries are invited.

**American Time Products, Inc.**

**580 Fifth Ave.**

**New York, N. Y.**

*Dist. of Western Electric &*



*Watch-rate Recorders*



# "HEATRONIC MOLDING

## MADE THIS JOB

## PRACTICAL"

THESE HEAVY-DUTY electrical connecting plugs, molded from BAKELITE plastics, are used on every type of U. S. combat vessel. They are unusual because of their exceptional wall thicknesses and density—conclusive evidence that pre-war limitations on the size, shape, and design of BAKELITE plastic insulating parts no longer exist. They were produced by Heatronic molding—announced by Bakelite Corporation in 1943—which has vastly increased the moldability of all types of phenolic molding plastic, including those with a high bulk factor.

In Heatronic molding, the heat is uniformly generated *within* the molding material charge by high-frequency current. By the addition of high-frequency preheating units to standard compression- and transfer-molding equipment, parts are now readily molded that formerly involved long and expensive molding cycles. Heatronic molding shortens curing time by one-tenth to one-half, often reduces molding pressures by 30 to 40 per cent, and permits larger moldings on present presses. It also causes less wear on molds, minimizes shearing and displacement of inserts, and permits greater production per mold cavity.

The extremely valuable Heatronic molding experience gained during the war is now available to engineers and designers through the facilities of the Bakelite Engineering Staff. Write Department 67 for detailed information about the advantages of this outstanding development. Also, write for Booklet G-8, "A Simplified Guide to BAKELITE and VINYLITE Plastics."



# BAKELITE MOLDING PLASTICS

TRADE-MARK



BAKELITE CORPORATION

Unit of

Union Carbide and Carbon Corporation



30 EAST 42ND ST., NEW YORK 17, N.Y.

Draw a picture here...rough or detailed...of  
the type of rectifier you have in mind...\*

\* We'll build it . . . Rectifier engineering  
is our business



**W. GREEN ELECTRIC COMPANY, INC.**

GREEN EXCHANGE BUILDING • 130 CEDAR ST., NEW YORK 6, N. Y.

with the closing of the switch. When the tube current begins to build up through the plate coil of the transformer, there will be a back emf across the coil, of polarity as shown in Fig. 1, which results in a dropping of plate voltage.

The changing primary current will induce a voltage into the secondary or grid coil of opposite polarity to the voltage in the plate coil. This induced voltage will cause an electron flow in the grid circuit producing a voltage across resistor  $R$  of such polarity as to make the grid positive with respect to the cathode. At the same time, this grid current will be charging capacitor  $C$  through resistor  $R$  until the grid goes positive, when the charging current will flow mainly through the tube from cathode to grid. This charging path being through the cathode-to-grid resistance, which is

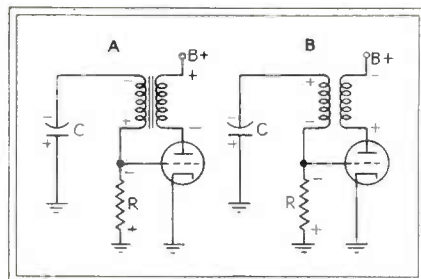

FIG. 2—Changes in polarities that lead to cutoff of plate current

relatively small, the capacitor will tend to charge quickly to the voltage induced into the grid coil.

The grid of the tube having been driven in a positive direction, the tube will draw more plate current. The increased plate current will produce a further drop in plate voltage and a greater induced voltage into the grid circuit, tending to drive the grid further positive. If this action continues we soon arrive at a point where the increase in grid voltage will not result in an increase in plate current as great as previously. Since the rate of change of plate current thus decreases, the voltage induced into the grid coil decreases.

*Effect on Capacitor*

The voltage across capacitor  $C$  has been closely following the voltage induced into the grid circuit. Therefore, a reduction in the in-



# ROSÁN INSERTS AND STUDS

revolutionize fastening in  
**SOFT METALS • PLASTICS • WOOD**



ROSÁN INSERT MOLDED IN



INSTALLATION OF INSERT WITH LOCKING RING



1. Drill, counter-bore and top



2. Screw insert flush with surface



3. Drive in locking ring



ROSÁN STUD

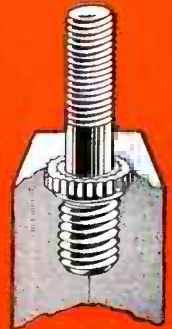

Permanent because locked in the material.

May be molded in, or installed later for repair or replacement purposes.

Removable by drilling without disturbing the parent material.

The heart of the Rosán Locking System is the locking ring. Its serrations are broached into the parent material and prevent turning or loosening under vibration or torque.

Rosán Inserts and Studs are easily installed, can be easily removed. They do away with the need for oversize replacements, and so effect great savings in parts inventory, in addition to the savings in parts salvaged.

Leading aircraft companies have adopted the Rosán Locking System. The automotive industry and others are also recognizing the advantages of this revolutionary method of fastening.

Write or wire for full information.



*National*  
HEADED AND THREADED  
PRODUCTS

THE NATIONAL SCREW & MFG. CO., CLEVELAND 4, O.

# "AEROTROLS"



## *The Small Relays with the Big Performance*

- Engineered and manufactured for the necessities of military aircraft operation, Cook "Aerotrols" have opened new fields in electrical and electronic remote control applications in radio-radar, wire communications, mining, manufacturing, testing and innumerable other fields where greater dependability and accuracy must be provided.

- Here are some of the general specifications of the "Aerotrol" "400" Series relays. The size of the "Aerotrol" without springs (the frame, coil and armature) is  $1\frac{5}{16}$ " wide,  $1\frac{1}{16}$ " long and 1" high. Spring assemblies add to overall height, up to 1" for 6 springs. Average weight for two spring pile-ups is  $1\frac{3}{4}$  oz. The coil spool is one piece, moulded bakelite. Heel piece is arranged for two mounting screws with solder terminal for coil located at the armature end, at which end also, spring solder terminals are located. Coil winding capacity can be provided up to 10,000 ohms and for positive operation on current values as low as 2 milliamperes. Coil treatment normally includes impregnation

with fungus lacquer and Insulex covering, and where required, the coil is treated for high humidity and other tropical conditions.

- "Aerotrols" are small, compact, yet rigidly constructed relays that have proven their dependability, not only in laboratory tests, but in actual operation under the most severe wartime conditions all over the world.

- "Aerotrols" are "application engineered" to provide specific performance suitable to circuit and control conditions. There are many selective features that can be incorporated into these relays. Bushings and insulators can be provided made of Cook patented "Cecotite" ceramics, to provide freedom from carbonization and wear, and to provide permanent stability of original adjustment and rapid frequency of operation. Mounting arrangements can be provided to meet installation conditions, including the plug-in types.

- "Aerotrols" of various types, such as time delay, latching, A.C. or D.C., both single and double pile-ups, can be supplied.



Illustrated above is an "Aerotrol" heavy current relay, with two Form "A" contacts operating on a double armature.

SEND FOR BOOKLET AR-145 FOR INFORMATION ON THE COMPLETE LINE OF "AEROTROL" RELAYS.

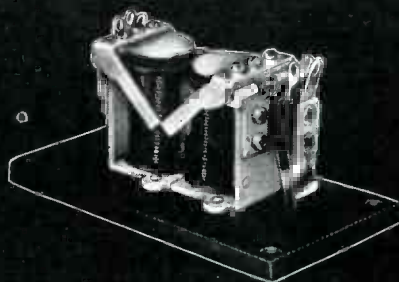

Illustrated above is a latching type "Aerotrol" combining two type "401" "Aerotrols." Any combination of the "400" series relays can be combined into a latching "Aerotrol."

**COOK ELECTRIC**  
Company



CHICAGO 14, ILLINOIS



To measure temperatures <sup>BELOW</sup>

# 3000° F.

## THE NEW ROLLER - SMITH PORTABLE PYROMETER



For Use In Tool Rooms, Foundries, Metal Working Plants, Chemical Plants, Melting Furnaces, Heat Treating Furnaces, Brazing Furnaces, Annealing Furnaces, Salt Baths, Process Cookers, Pouring Ladles

- LIGHT WEIGHT** Weighs less than 3 lbs.
- ACCURATE CALIBRATION** Guaranteed 2% of full scale; 1% accuracy for critical points.
- STURDY CONSTRUCTION** Designed specially for portable use.
- REPLACEABLE THERMOCOUPLE** Uniformity permits replacement without changing calibration.
- VARIOUS TEMP. RANGES** Designed to suit the application.

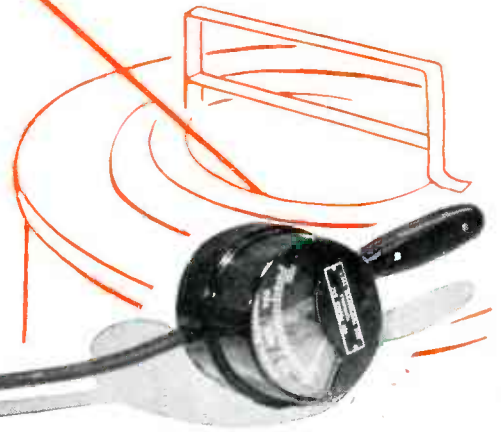

● Where you have the problem of measuring elevated temperatures, the new Roller-Smith Portable Pyrometer provides a convenient economical answer. Originally designed for Navy use on aircraft carriers, it combines ruggedness with portability and accuracy.

The portable pyrometer can be used where permanently installed temperature measuring equipment is not justified. It can be used to advantage on jobs where temperature is estimated or guessed in heat treatment or metal-working processes.

Temperature ranges of the Portable Pyrometer can be designed to suit the application. For help in measuring temperatures, write us the details. Address Department E.



# ROLLER SMITH

## Testing Instruments

BETHLEHEM • PENNSYLVANIA

In Canada: Roller-Smith Marsland, Ltd., Kitchener, Ontario

STANDARD AND PRECISION ELECTRICAL INSTRUMENTS • AIRCRAFT INSTRUMENTS • SWITCHGEAR  
AIR AND OIL CIRCUIT BREAKERS • ROTARY SWITCHES • RELAYS • PRECISION BALANCES

Sales Representatives  
in all Principal Cities



# NEW!

A complete,  
24 page  
Illustrated  
Manual

on *Permanent Magnets*

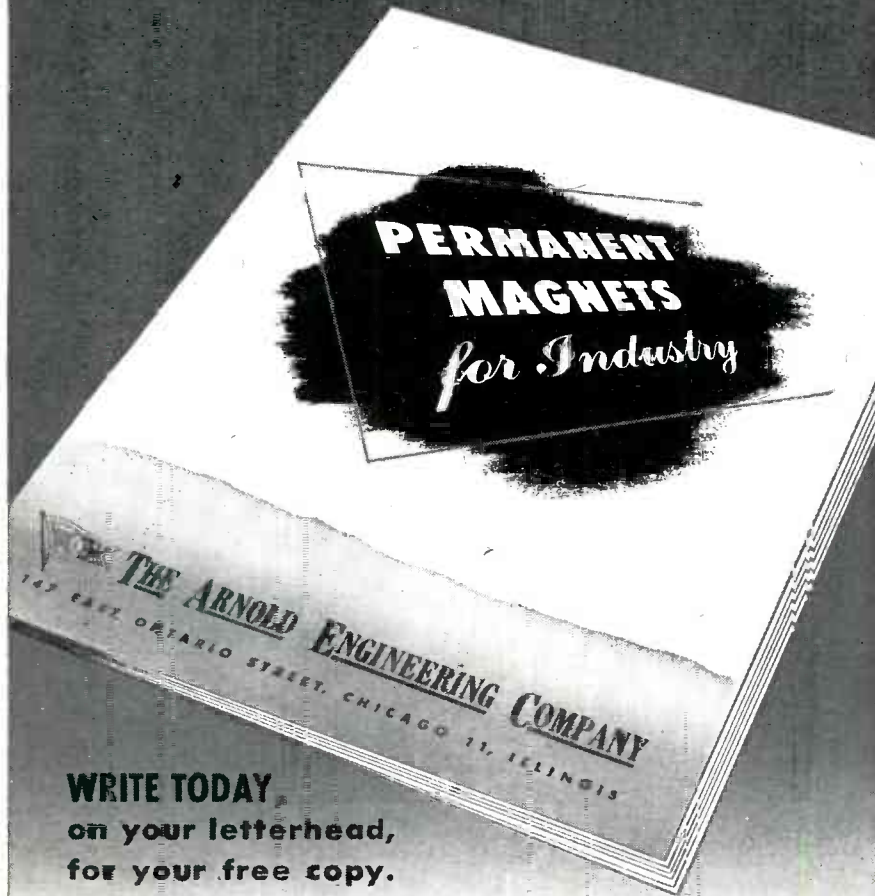

**WRITE TODAY**  
on your letterhead,  
for your free copy.

This unusual Arnold manual on permanent magnets is the product of many months of careful research and planning.

It is devoted entirely to the consideration of the factors affecting the design, fabrication and application of Alnico permanent magnets. Written entirely by Arnold engineers, its purpose is to help engineers in industry to better utilize the magnetic and physical characteristics of the Alnico alloys in arriving at efficient design.

Write today, on your letterhead, for your free copy.



## THE ARNOLD ENGINEERING COMPANY

147 EAST ONTARIO STREET, CHICAGO 11, ILLINOIS

Specialists in the Manufacture of ALNICO PERMANENT MAGNETS

duced voltage due to the reduced rate of increase of plate current will result in the voltage across the capacitor being slightly larger than the induced voltage. The resultant reversal of current flow in the grid circuit gives us a slight negative voltage on the grid (voltage across the capacitor less the induced voltage as shown in Fig. 2A).

#### *Condition for Cutoff*

The grid voltage going slightly negative would tend to make the tube draw less current. Since there is a coil in the plate circuit, the coil will build up a counter emf to oppose this change in current. The grid coil will have a voltage induced into it 180 degrees out of phase with the plate-coil voltage. Now the voltage across the capacitor and the induced voltage are additive, causing a current flow that gives a large voltage across resistor  $R$ . (See Fig. 2B.) This voltage makes the grid negative with respect to the cathode by a more than sufficient amount to cut off the tube.

The cutting off of plate current will cause the plate voltage to rise to  $B +$  and then rise above this value due to the back emf of the plate coil resulting in a slight oscillation whose extent will depend on circuit constants.

The induced voltage in the grid circuit will be negligible after the fast positive rise in plate voltage. The voltage on the grid will now be due only to the capacitor  $C$  discharging through resistor  $R$ . This discharge will give an exponential decay of grid voltage continuing to fall till the grid voltage reaches the cutoff potential of the tube. As soon as the grid voltage rises above cutoff, the tube will conduct and thus the cycle will repeat itself. Figure 3 shows the plate voltage  $E_p$ , the grid voltage  $E_g$ , and the voltage across the capacitor  $E_c$  for a period of three cycles.

#### *Output at Plate*

The output of this circuit is usually the platevoltage variation. The negative pips or pulses occur each time the tube operates. Thus the frequency of the pulse repetition depends on the amount of time the tube is cut off or the time of dis-



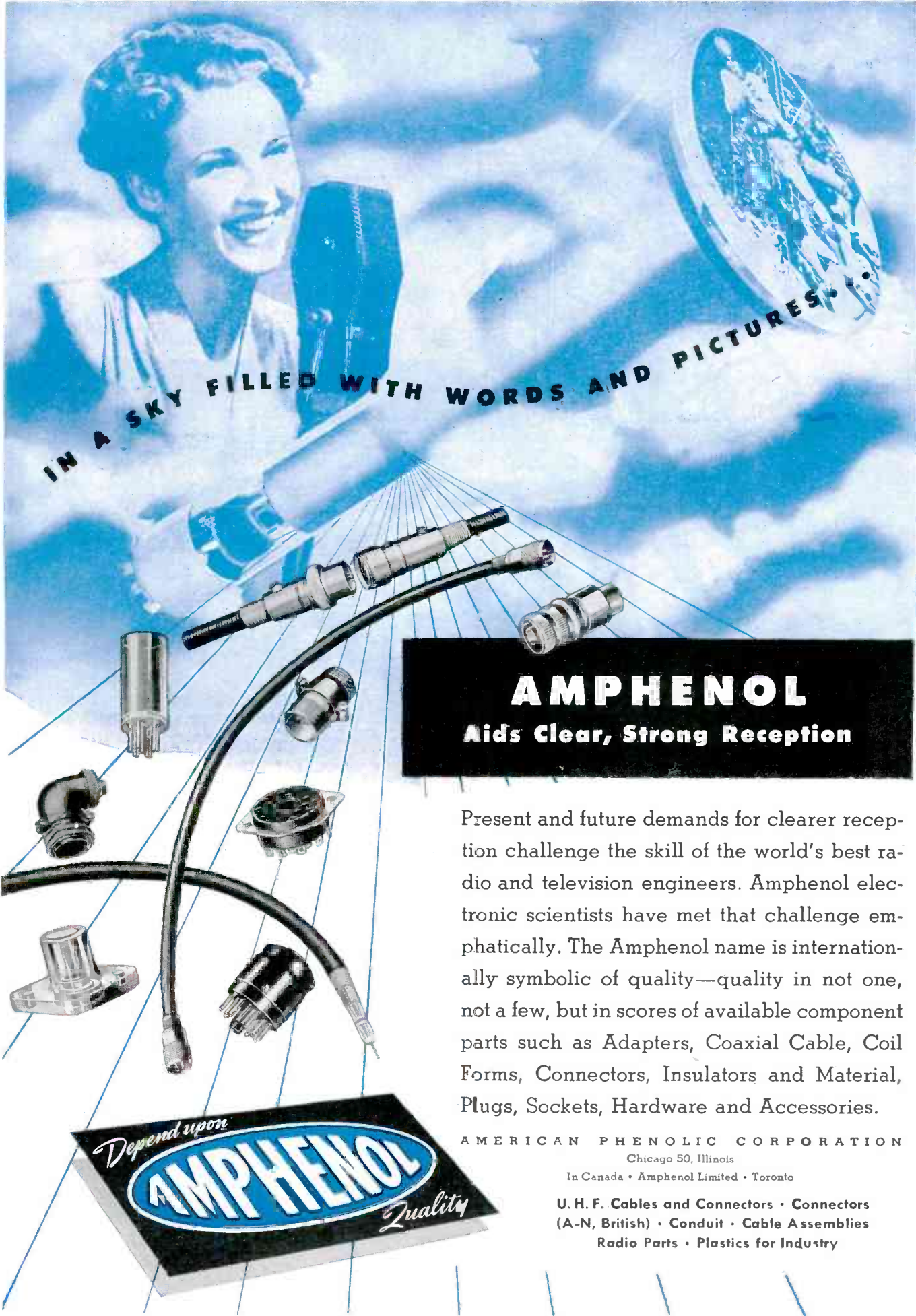

IN A SKY FILLED WITH WORDS AND PICTURES

# AMPHENOL

**Aids Clear, Strong Reception**

Present and future demands for clearer reception challenge the skill of the world's best radio and television engineers. Amphenol electronic scientists have met that challenge emphatically. The Amphenol name is internationally symbolic of quality—quality in not one, not a few, but in scores of available component parts such as Adapters, Coaxial Cable, Coil Forms, Connectors, Insulators and Material, Plugs, Sockets, Hardware and Accessories.

AMERICAN PHENOLIC CORPORATION  
Chicago 50, Illinois

In Canada • Amphenol Limited • Toronto

U. H. F. Cables and Connectors • Connectors  
(A-N, British) • Conduit • Cable Assemblies  
Radio Parts • Plastics for Industry



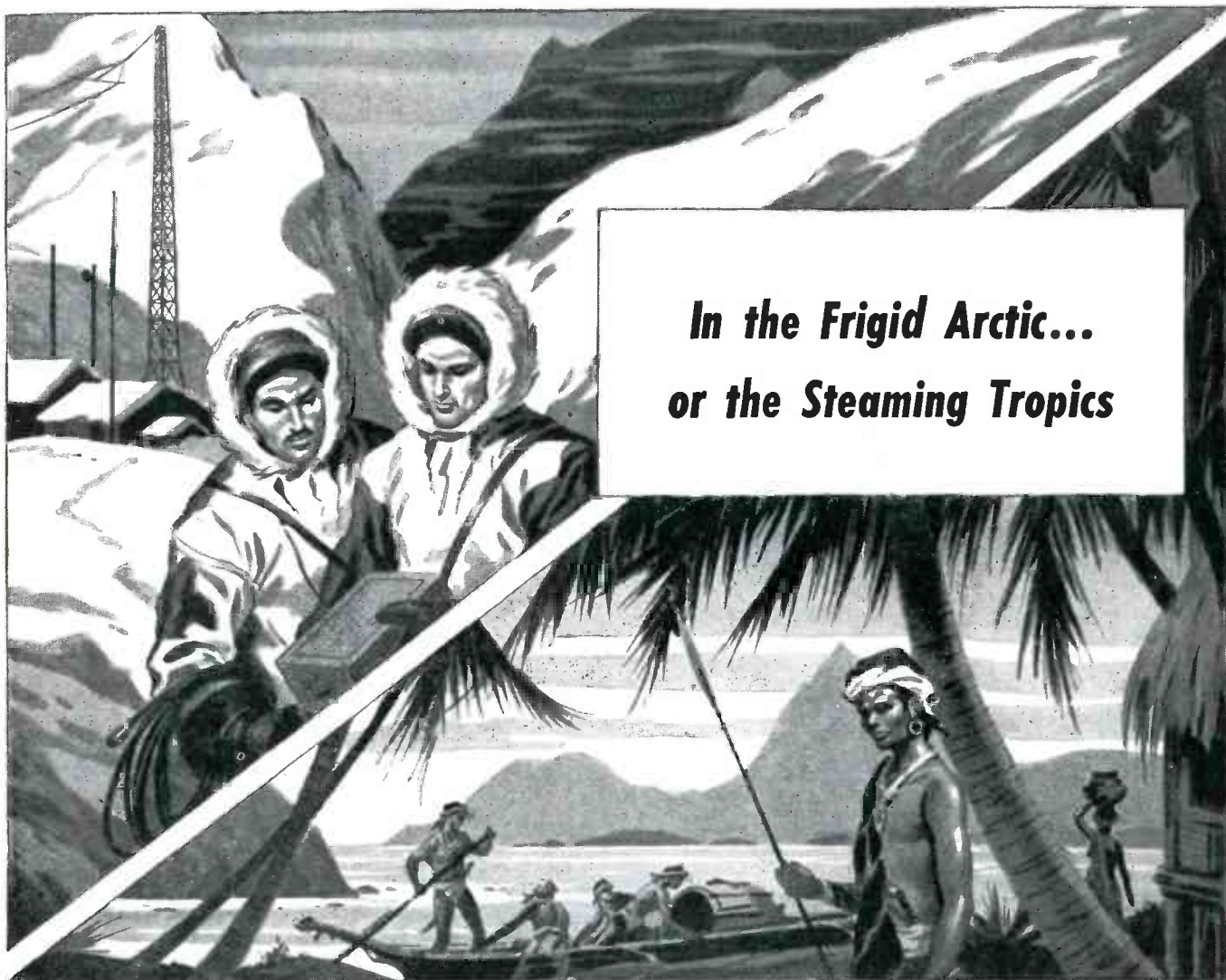

***In the Frigid Arctic...  
or the Steaming Tropics***

**T**HROUGHOUT our service to the Armed Forces, Eastern has always delivered every piece of equipment to the highest Government standards. Now Eastern's wartime "proving ground" is converted to simulate normal *peacetime conditions* in our laboratories, assuring you of

precision, quality and performance.

Every product bearing the Eastern trade mark will conform to the most exacting requirements. The Eastern Amplifier line will include standard items and many exceptional innovations. For complete details, write our Sales Manager, Department 10-F.

*Buy War Bonds*

***EASTERN AMPLIFIERS***

U. S. Reg'n. Applied For

**EASTERN AMPLIFIER CORPORATION  
794 EAST 140th STREET • NEW YORK 54, N. Y.**



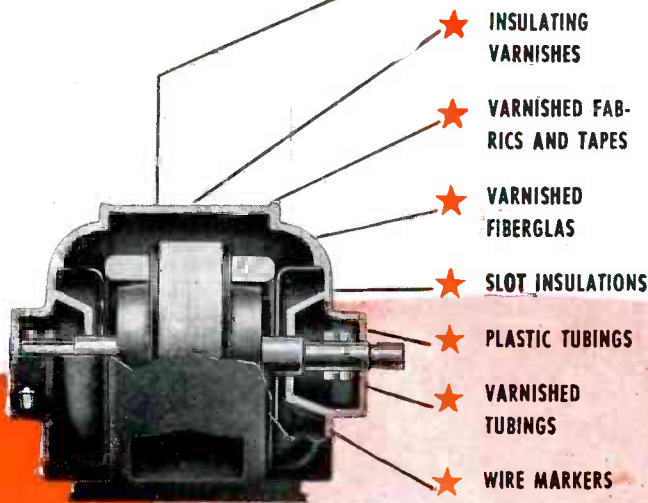

# Completely INSULATED

by the Leader in Insulation!

Motor manufacturers have come to the realization that the specification "Completely Insulated by Irvington" means longer motor life with less chances of electrical failures. Basic to this is the fact that every Irvington insulation has been formulated to produce definite and outstanding characteristics — resistances to the agents of motor destruction — heat, corrosive fumes, excessive moisture etc. Insulations have been designed for regular and unusual motor needs — matched to work with each other for blended, smooth acting motor performance — to produce long-lasting and dependable motors. From this one source, *Irvington*, you can obtain insulations not only for motors but for all other electrical equipment as well. Each and every product is kept to Irvington's high standards by strict laboratory and production control. We offer our cooperation and invite your inquiries. Write Department 106

**IRVINGTON PRODUCTS include:**  
 Core Plate, Finishing and Sticking Varnishes • Varnished Canvas and Duck • Varnished Nylon, Rayon and Silk • Varnished Papers • Insulating Punchings • Fibron Plastic Tapes • Cardolite Compounds

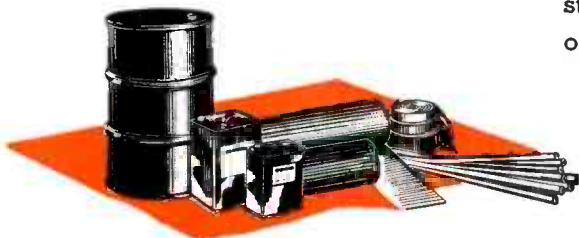

**IRVINGTON**  
 VARNISH & INSULATOR COMPANY  
 Irvington 11, New Jersey, U. S. A.



OUR metallurgical and chemical experts, working in close collaboration with Electronic Engineers, have proven an important factor in the solution of many difficult soldering problems.

The achievements of the Glaser Staff in bringing soldering media under advanced scientific control constitute a noteworthy contribution to the Electronic Industry.

Glaser Solders form a permanent bond because, first and foremost, they are made of Grade A virgin metals. Perfect performance is further assured by the correct proportioning of the flux core to meet specific uses.

Glaser Plastic Rosin Core Solders are widely used in the manufacture of fine electronic and radio equipment for the Signal Corps and other branches of the military service. Glaser Plastic Rosin Flux is non-conducting, non-corrosive and non-hygroscopic.

Glaser Solders are your guarantee of continuous satisfactory performance under the most exacting service conditions. And remember, Glaser Solders go further, enabling you to cut soldering costs. Furnished in every gauge and alloy.

Glaser Rosin Core Solders exceed government specifications in purity, and are guaranteed to meet A.S.T.M. Class A specifications for solder.

Consult our Engineering Department on your soldering and flux problems, without obligation.

**GLASER LEAD CO., INC.**

31 Wyckoff Avenue,

Brooklyn 27, N. Y.



**OTHER GLASER PRODUCTS**

Silver Brazing Solder and Flux

Fluxes for every purpose.

Glaser 2-in-1 Hot Tinning Compound.

Glaser Cold Tinning Compound.

Glaser Galvanizing Compound for resurfacing or touching up damaged galvanized surfaces

Lead Products of every description.

Lead Lining of acid or plating tanks.

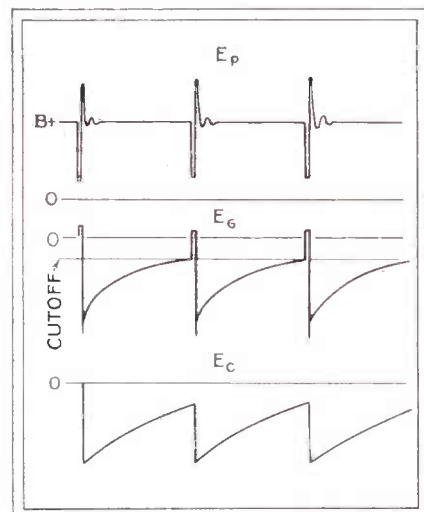

FIG. 3—Voltages produced at the plate, grid, and capacitor by the blocking action

charge of the capacitor in the grid circuit from its charged voltage to the cut-off voltage. This time will depend on three items; first, the voltage to which the capacitor is charged; second, the cut-off value of the tube; and third, the  $RC$  of the discharge circuit. The first two items will be determined by the applied voltage, the tube, and the transformer. Once these factors have been determined, the  $RC$  will be the main frequency controlling factor. Thus by varying the resistor and capacitor, we can considerably vary the frequency of the output pulses.

*Shape of Pulse*

In addition to controlling the frequency of the output voltage, we may also be interested in the output waveshape. The output waveshape can be considered under two aspects; first, the sharpness and time duration of the negative pulses; and second, the oscillation following the negative pulse.

The sharpness and time duration of the pulses will depend largely on the transformer used. For a sharp, short-duration pulse, we must have a transformer that will pass this pulse. This involves the transformer's ability to pass some fairly high frequencies of which the pulse is composed. With an iron-core transformer, this is practically impossible due to eddy current and hysteresis losses at high frequencies. However, with the advent of



# Projection Tubes for Home Television

Pioneering experience in the development of large screen television projection has given *Rauland* physicists and engineers the "know-how" necessary to produce projection tubes for home television receivers.

The *VISITRON R-6016* Front Surface Projection Tube with refractive optic . . . fluorescent screen of 4 inches . . . concave target to simplify lens . . . easy change of magnification . . . gives at least twice the light of a conventional projection tube of the same screen diameter . . . both tube and optic small enough to fit into a table cabinet . . . voltage requirement approximately 30 kilovolts.

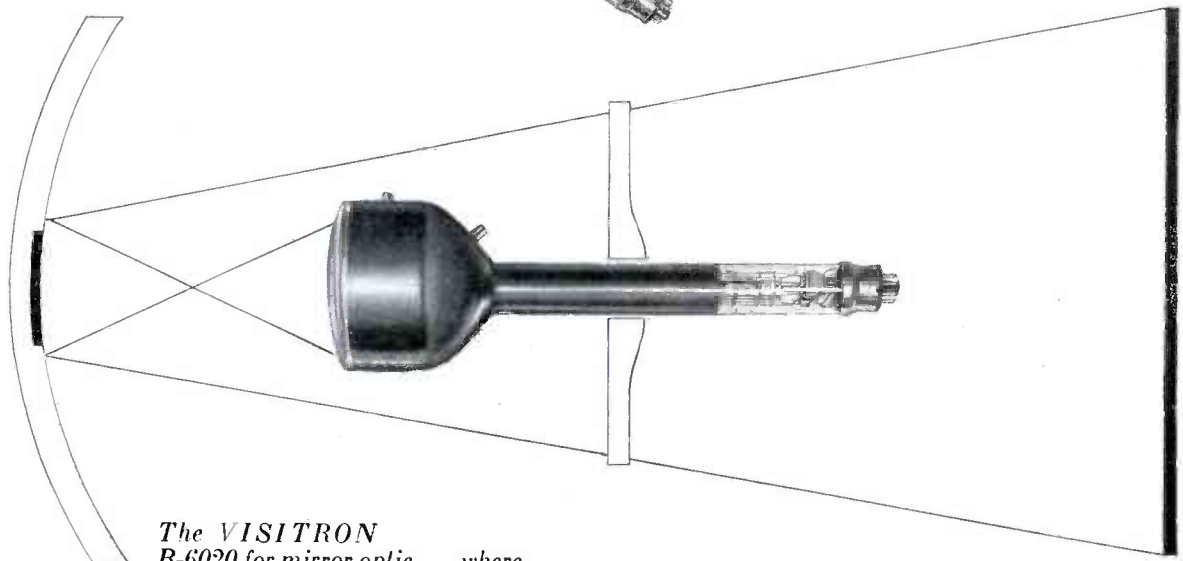
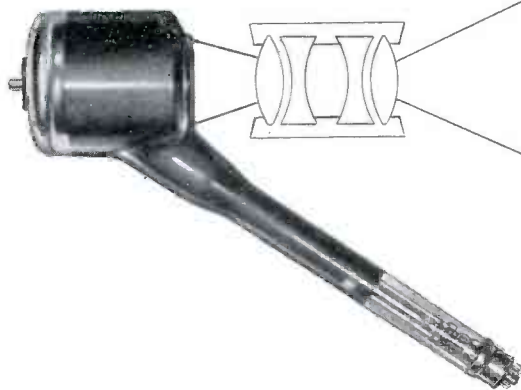

The *VISITRON R-6020* for mirror optic . . . where maximum light at lower anode voltage is desired . . . 5 inch diameter fluorescent screen.



Consult with *Rauland* about your television tube problems. We have the facilities to build projection tubes to special requirements.

RADIO • RADAR • SOUND

## *Rauland*

COMMUNICATIONS • TELEVISION

*Electroneering is our business*

THE RAULAND CORPORATION • CHICAGO 41, ILLINOIS

# DULAC FUNGUS RESISTANT LACQUERS, VARNISHES AND COATINGS

*containing*

## FLUORESCENT COMPOUNDS

**ARE NOW MANUFACTURED  
FOR PROTECTING VITAL  
ELECTRONIC and ELECTRICAL  
EQUIPMENT**

For use on Signal Corps contracts, it is no longer necessary for the manufacturer or user of communication equipment to undertake the job of mixing fluorescent solutions with the fungus resistant coatings he is using. For M & W's complete line of tropicalization coatings is now available with fluorescent compounds already incorporated in them.

These fluorescent compounds, used to facilitate inspection under black light, are not destroyed when the coating is dried or baked in accordance with M & W recommendations. The use of these factory-mixed lacquers, varnishes and coatings will result in a marked speed-up of the Tropicalization Program in your plant.

For information on any phases of tropicalization of electronic and electrical equipment, write today to:



### MAAS & WALDSTEIN COMPANY, NEWARK, N. J.

PRODUCERS OF LACQUERS, ENAMELS, SYNTHETICS AND SPECIALTY FINISHES FOR ALL PURPOSES  
BRANCH OFFICES & WAREHOUSES: 1658 CARROLL AVE., CHICAGO, ILL. • 1228 W. PICO BLVD., LOS ANGELES, CALIF.



WE REPEAT...

*Solving Problems  
is a Franklin Forte!*

and this is an example of  
how it is done at FRANKLIN...

Manufacturers of radio receivers, dissatisfied with the frailties of available coil clips and with their slowness of assembly, asked Franklin to design and fabricate an inexpensive and easy to assemble coil clip which would hold an iron core and coil assembly so that smooth side pressure is applied to the screw threads of the iron core and to the coil. This pressure must be maintained in a rigidly fixed position over the coil and entire screw length. Also that the clip must not have cutting edges which might strip off the plating on the screw threads.



*Franklin's Solution  
to this problem is  
the M-1 COIL CLIP*

Specifically developed to solve the problem . . . and now available to all of the radio and electronic industry.

The exploded view and photograph of the M-1 Coil Clip each illustrate the simplicity of its design and its method of use and assembly. Four sharp teeth or points engage the coil and maintain a fixed position for the coil and iron core under excessive vibration and drop tests. With M-1 Coil Clips even inexperienced operators are able to speed up the assembly and production of tuning coils.

**BRING YOUR PROBLEMS TO FRANKLIN... IF  
THERE IS A SOLUTION FRANKLIN WILL DEVELOP IT**



**A.W. FRANKLIN**

**MANUFACTURING CORP.**

175 VARICK ST., NEW YORK 14, N. Y.

SOCKETS • TERMINAL STRIPS • PLUGS • SWITCHES • PLASTIC FABRICATION • METAL STAMPINGS • ASSEMBLIES



*This Kind of WAVE GUIDE Is Not Our Business . . .*

**DE MORNAY  
BUDD *inc.***

EQUIPMENT  
FOR  
97% OF ALL  
RADAR SETS

but we are recognized as experts on wave guides and all micro-wave equipment.

Our specialized skills in research, development, design and production offer advantages to the radio and television industries, and to the electronic field in general, which are worth exploring.

DE MORNAY-BUDD, INC., 475 GRAND CONCOURSE, NEW YORK, N. Y.

WAVE GUIDES • DIRECTIONAL COUPLERS • MIXERS  
CO-AXIAL STUB SUPPORTED LINES • ROTATING JOINTS  
R. F. BENCH AND FIELD TESTING EQUIPMENT • AMPLIFIERS  
MODULATORS • I. F. STRIPS • ANTENNAE



powdered permalloy cores, the frequency range of these transformers has been considerably increased. With this type of transformer, short-duration pulses can be obtained.

Our second waveshape problem, that of oscillation, can be counteracted in a few ways. One possible way is to load down the plate coil with a shunt resistor which will tend to reduce oscillation. An example of this effect is shown in Fig. 4A.

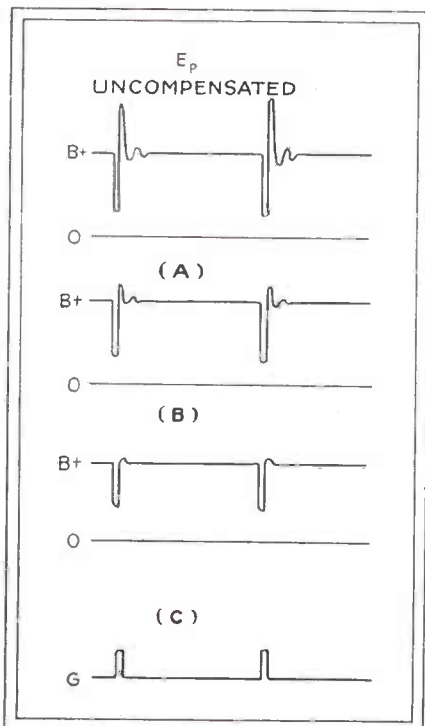

FIG. 4—Uncompensated output from plate compared with output from other points in circuit

Another method of reducing the oscillation in the output signal is to place a load resistor between the plate coil of the transformer and B+. The output is then taken off at the point between the plate coil and the load resistor. This results in eliminating most of the oscillation in the output. The value of the load resistor must be large enough to produce a sufficiently large pulse voltage across it, yet it must not be so large as to excessively limit tube current. Figure 4B shows the output with the plate load resistor in the circuit.

A third possible method can be used where a low-impedance output

# *There's no substitute for* **ACCURACY**

B.R.C. instruments are designed and manufactured to give accurate and precise direct reading measurements with simplicity of operation.

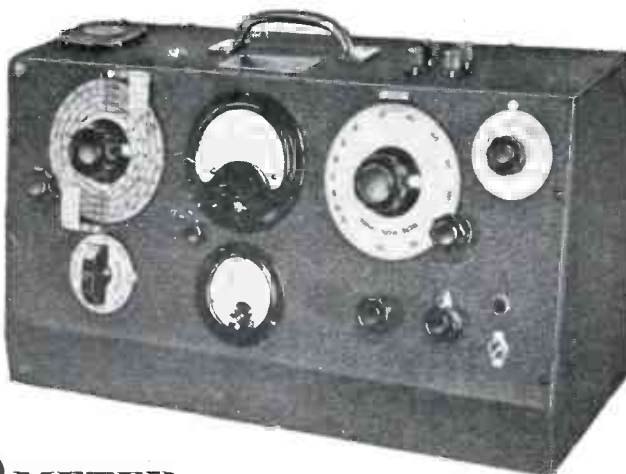

## **Q**METER TYPE 160-A

A Standard for "Q" Measurements with a reputation for accurate and dependable service. Has a Frequency Range of 50 kc to 75 mc which may be extended with external oscillator down to 1 kc.

## **F.M.** SIGNAL GENERATOR

TYPE 150 series



Type 150 A—Frequency 41-50 mc. and 1-10 mc.  
Type 151 A—Frequency 30-40 mc. and 1-9 mc.  
Type 152 A—Frequency 20-28 mc. and 0.05-5 mc.  
Type 154 A—Frequency 27-39 mc. and 1-7 mc.  
Developed specifically for use in design of F.M. equipment. Frequency and Amplitude Modulation available separately or simultaneously.



**BOONTON RADIO**

BOONTON, N. J.

*Corporation*



DESIGNERS AND MANUFACTURERS OF THE "Q" METER . . . QX-CHECKER . . . FREQUENCY MODULATED SIGNAL GENERATOR . . . BEAT FREQUENCY GENERATOR . . . AND OTHER DIRECT READING TEST INSTRUMENTS

# **EASTERN AIR DEVICES · INC ·**

*proud of the part their products have played  
in bringing about **TOTAL VICTORY**  
pledge themselves to continue  
the same high degree of*

**ENGINEERING & MANUFACTURING  
INTEGRITY**  
*in products for **PEACE***

*Specialists in the development and manufacture of*  
*fractional HP*  
*and miniature motors,*  
*generators*  
*and blowers.*

*Tachometers,*  
*solenoids,*  
*control apparatus*  
*and special devices.*

*We solicit engineering and production problems*



**EASTERN AIR DEVICES · INC ·**

585 DEAN ST. · BROOKLYN 17, N. Y.





## Versatile Plastic Effects Manufacturing Economy

Probably no other field uses more plastics than electrical manufacturing. The myriad of electrical products on the market today call for thousands of versatile-property plastic parts. The majority of these parts are molded from phenolic compounds because the phenolics are the most versatile of all plastics.

Since its inception the plastics industry has been prone to stress volume when it comes to molded plastics applications. At times, applications where plastics fit the job better than any other material have been passed up because the number of parts required was so limited. However, there are many instances where the inherent physical properties of plastics so far outweigh higher costs due to small volume that the end result warrants the use of these materials. Such was the case with Budd Induction Heating, Inc., who use the heavy molded Durez parts illustrated in their induction heating machines, and who found that the molding of plastics was more practical and economical than machining.

### Electrical Resistance Required

Induction heating machines employ high-power, high-frequency currents and naturally require a plastic material with excellent electrical properties for many of their vital parts. In addition, they require a material of high impact strength. In short—and like so many instances in electrical manufacturing—they require a material that is versatile. Therefore, the choice of a Durez phenolic compound for this purpose was a most logical one.

### Molding Ingenuity

As molders of the large, heavy plastic terminal assembly illustrated, Michigan Molded Plastics, Inc., in collaboration with engineers of Budd Induction Heating, Inc., accomplished a feat which typifies the ingenuity of America's custom molders. They took a versatile, high-impact Durez phenolic molding compound with unusually excellent electrical properties and molded a 3-piece terminal assembly for an induc-

tion heating machine which not only replaced an original assembly consisting of five pieces but did it with tremendous savings in time and costly machining.

### Versatile Phenolics

Too much can't be said about the versatility of phenolic plastics. Such properties as dielectric strength, diversity of finishes, excellent moldability, impact strength and highest dimensional stability at temperature extremes, as well as resistance to moisture, heat, mild acids and alkalis, are inherent characteristics in all of the more than 300 Durez phenolic molding compounds.

Perhaps you are looking for the plastic that fits your job. If so, you should make Durez your starting point. The services of experienced Durez technicians are available at all times for your benefit. Durez Plastics & Chemicals, Inc., 3210 Walck Road, North Tonawanda, New York.



INDUSTRIAL  
RESINS

MOLDING COMPOUNDS

INDUSTRIAL RESINS

OIL SOLUBLE RESINS

**PLASTICS THAT FIT THE JOB**

# Service Approved DYNAMOTORS

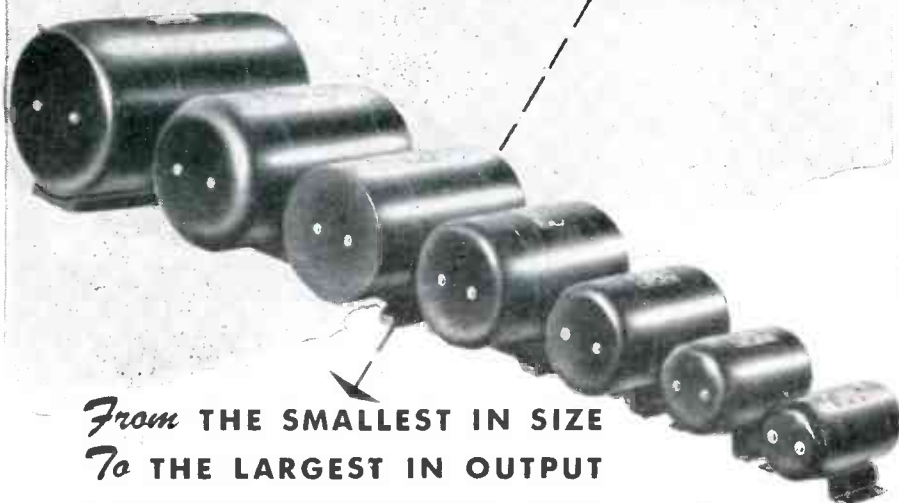

*From* **THE SMALLEST IN SIZE**  
*To* **THE LARGEST IN OUTPUT**

Engineered and built by specialists, EICOR DYNAMOTORS have earned their fine reputation through years of exacting service. These dependable units furnish the necessary high voltage power for communications, direction finding, radio compass and other controls.

Our complete line of frame sizes makes possible the widest available range of dynamotor output ratings in the most compact sizes and weights. This assures the *most economical size and weight for every need!*

The experience and skill of Eicor Engineers are instantly available to help you on any problem involving Dynamotors, Motors, or Inverters.



### Send for Helpful DATA FOLDER

*This handy folder gives useful data and information on EICOR Dynamotors, D. C. Motors, and other Rotary Electrical Equipment. Write for it!*

SERIES NO.	MAX. OUTPUT WATTS	DIAMETER	LENGTH	WEIGHT
2300	10	2 $\frac{5}{16}$ in.	4 $\frac{7}{8}$ in.	2 $\frac{1}{8}$ lbs.
2700	15	2 $\frac{3}{4}$ in.	4 $\frac{3}{4}$ in.	2 $\frac{3}{4}$ lbs.
3400	125	3 $\frac{1}{16}$ in.	5 $\frac{5}{8}$ to 8 $\frac{1}{2}$ in.	4 $\frac{1}{2}$ to 7 $\frac{1}{2}$ lbs.
4100	200	4 $\frac{1}{16}$ in.	6 $\frac{1}{2}$ to 7 $\frac{3}{8}$ in.	6 $\frac{3}{4}$ to 9 lbs.
4500	250	4 $\frac{1}{2}$ in.	6 $\frac{1}{2}$ to 8 in.	11 $\frac{1}{2}$ to 13 $\frac{1}{4}$ lbs.
5100	350	5 $\frac{1}{8}$ in.	8 $\frac{1}{2}$ to 10 in.	17 to 21 $\frac{1}{2}$ lbs.
6100	500	6 $\frac{3}{16}$ in.	9 $\frac{5}{8}$ to 12 in.	28 to 36 lbs.

**EICOR, INC.** 1501 W. Congress St., Chicago, U. S. A.

DYNAMOTORS • D. C. MOTORS • POWER PLANTS • CONVERTERS

Export: Ad Aurema, 89 Broad St., New York, U. S. A. Cable: Aurema, New York

is acceptable and where too large a voltage is not required. This method is to insert an unbypassed cathode resistor and take the output across the cathode resistor. Using this method we obtain positive pulses which have no oscillating component. (See Fig. 4C.) A fourth possibility would be to take the original output and feed it into a limiter circuit that would respond only to the negative pulse.

• • •

## Improved Socket-Punch Wrenches

By RONALD L. IVES

*Dugway Proving Ground  
Tooele, Utah*

IN MODIFYING FINISHED chassis units of complicated electronic equipment, new socket holes were required. The requirement that the instruments be out of service for a minimum length of time imposed a number of tooling problems that are not ordinarily encountered.

Greenlee screw-type socket hole punches were chosen for the job and it was found that the traditional method of tightening the pressure screw on these punches was with a pair of pliers. This led

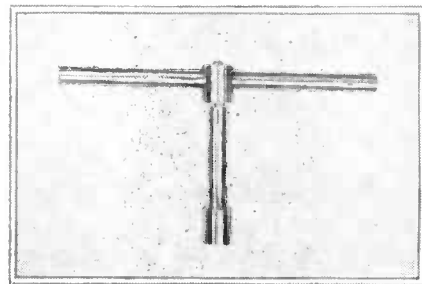

Fig. 1—Tool A consists of a T handle and a socket extension

to short tool life, considerable damage to adjacent equipment due to the pliers slipping off the screw head, and numerous hand injuries to personnel.

Use of a wrench greatly increased the life of the socket-punch screw head, but did not greatly decrease damage to equipment and hands due to wrench slippage.

### *New Tools*

Use of a  $\frac{1}{2}$ -in. square ratchet box wrench, in locations where there was adequate hand clearance, led to a satisfactory reduction in the



# TREFZ

## DEPENDABLE WIRE-WOUND PRODUCTS

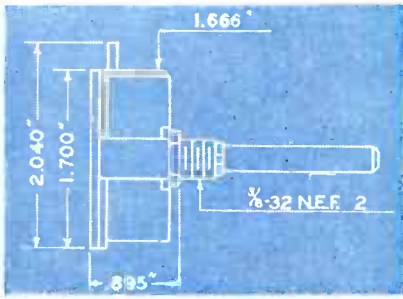

**MODEL PWW-5:** A ruggedly built precision unit designed to meet Navy Spec. RE-13A-492C and Spec. JAN-R-19. Rated at 8 watts this model incorporates features which demonstrate "there is none finer." Dual units are also available (Model DPWW-5).

**MODEL PWW-4:** Rated at 4 watts. A competitively priced counterpart of the PWW-5 yet retaining many of the outstanding features. Its black phenolic case distinguishes it from the PWW-5. Unique one piece contact arm assembly adds stability and life to this new Potentiometer. Dual units can be furnished (Model DPWW-4).

All models can be furnished in a range 1 ohm to 150,000 ohms. Duals require 1.780" of space behind mtg. surface. Other space requirements shown above. Switches and tapered windings can be supplied.

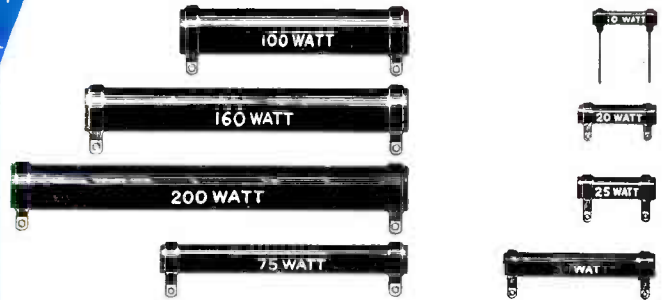

Wartime quality wire-wound power Resistors now available in peacetime quantity to meet your immediate needs. Units ranging from 5 to 200 watts can be furnished to your specifications in either fixed or semi-variable versions.

"Hitempcote" serves as an ideal protecting cover and because of its special inorganic structure, Trefz Resistors can absorb sudden and severe overloads for a prolonged time without damage to the coating. All winding terminations are soldered to the tabs and the best of materials are used throughout.

Extreme care is used in all steps of the manufacturing cycle to avoid the possible entrance of extraneous matter which might later cause electrolytic action and final failure of the Resistor.

EXCLUSIVE SALES AGENTS

Amalgamated  Electronics  
ASSOCIATED

60 EAST 42nd STREET : : VANDERBILT 6-3506 : : NEW YORK 17, N. Y.

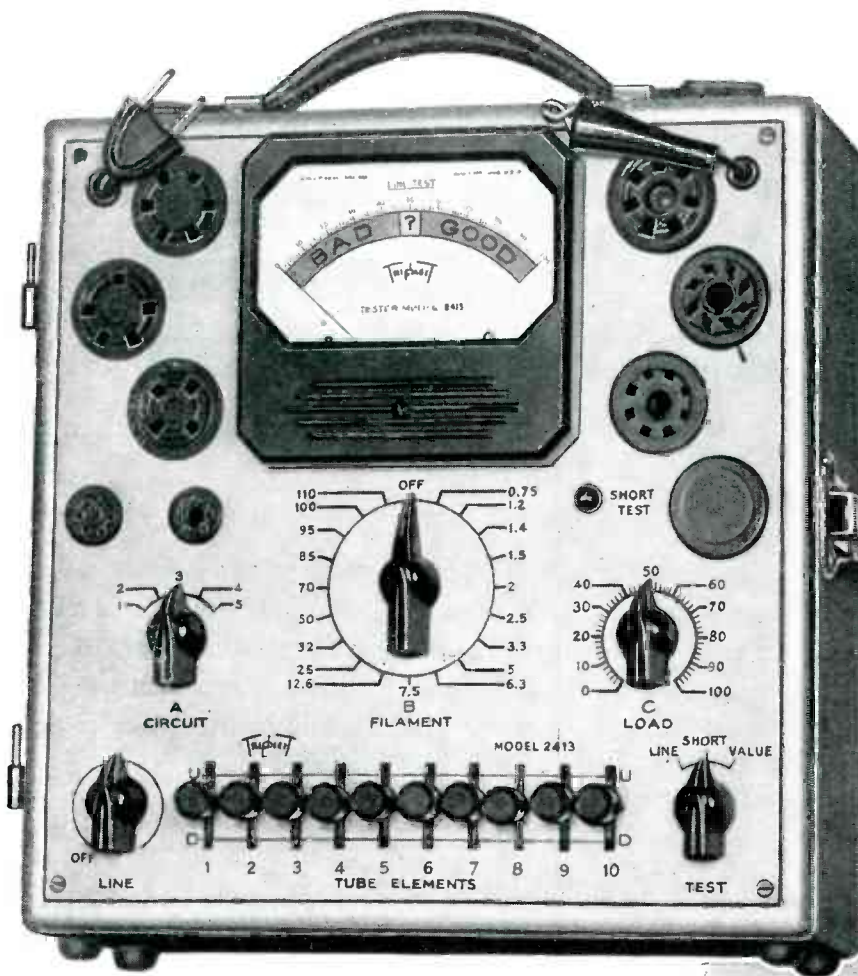

## MODEL 2413

is another  
member of the  
**NEW TRIPLET**  
Square Line

# The New Speed-Chek Tube Tester

### MORE FLEXIBLE • FAR FASTER • MORE ACCURATE

Three-position lever switching makes this sensational new model one of the most flexible and speediest of all tube testers. Its multi-purpose test circuit provides for standardized VALUE test; SHORT AND OPEN element test and TRANSCONDUCTANCE comparison test. Large 4" square RED•DOT life-time guaranteed meter.

Simplicity of operation provides for the fastest settings ever developed for practical tube testing. Gives individual control of each tube element.

New SQUARE LINE series metal case 10" x 10" x 5½", striking two-tone hammered baked-on enamel finish. Detachable cover. Tube chart 8" x 9" with the simple settings marked in large easy to read type. Attractively priced. Write for details.

### Additional Features

- Authoritative tests for tube value; shorts, open elements, and transconductance (mutual conductance) comparison for matching tubes.
- Flexible lever-switching gives individual control for each tube element; provides for roaming elements, dual cathode structures, multi-purpose tubes, etc.
- Line voltage adjustment control.
- Filament Voltages, 0.75 to 110 volts, through 19 steps.
- Sockets: One only each kind required socket plus one spare.
- Distinctive appearance with 4" meter makes impressive counter tester—also suitable for portable use.



# Triplet

ELECTRICAL INSTRUMENT CO. BLUFFTON, OHIO

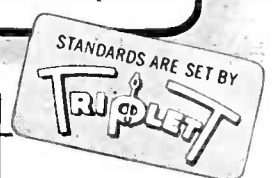



# New! L-A-R-G-E-R Size Sheets of



Make Possible Many  
Additional Uses for this  
Superior Insulation

## Now You Can Use MYKROY For:

- Large Terminal Boards
- Switch Board Panels
- Large Inductance Bars and Strain Insulators up to 29 inches long
- Switch Connecting Rods
- Transformer Covers
- Large Meter Panels
- Bases for Radio Frequency and Electrical Equipment assemblies requiring large one-piece sheets

HERETOFORE the largest sheet of glass-bonded mica insulation available measured  $14\frac{1}{2}'' \times 19\frac{1}{4}''$ . By doubling the size, Electronic Mechanics, exclusive manufacturers of Mykroy, now afford Design and Production Engineers many important, new application and fabricating advantages.

Lower Cost per square inch affects savings as high as 33% depending upon work piece size, greatly reducing the cost per fabricated part. Better Cutting efficiency lowers cost still further extending the use of Mykroy to a longer list of electronic applications where formerly cost prohibited its use.

Get the full facts about this versatile dielectric now. Ask for a copy of the new MYKROY BULLETIN 102 which describes the new, larger  $19\frac{1}{4}'' \times 29\frac{3}{4}''$  sheets.



$19\frac{1}{4}$   
x  
 $29\frac{3}{4}$

10th  
Anniversary  
1935-1945

Supplied in thicknesses ranging from  $\frac{1}{8}''$ — $1\frac{1}{4}''$

### MECHANICAL PROPERTIES\*

MODULUS OF RUPTURE.....	18000-21000psi
HARDNESS	
Mohs Scale 3-4 BHN. BHN 500 K9 Load. 63-74	
IMPACT STRENGTH.....ASTM Charpy .34-.41 ft. lbs.	
COMPRESSION STRENGTH.....	42000 psi
SPECIFIC GRAVITY.....	2.75-3.8
THERMAL EXPANSION.....	.000006 per Degree Fahr.
APPEARANCE.....	Brownish Grey to Light Tan

### ELECTRICAL PROPERTIES\*

DIELECTRIC CONSTANT.....	6.5-7
DIELECTRIC STRENGTH ( $\frac{1}{16}''$ ).....	630 Volts per Mil
POWER FACTOR.....	.001-.002 (Meets AWS L-4)

### \*THESE VALUES COVER THE VARIOUS GRADES OF MYKROY

- GRADE 8 Best for low loss requirements.
- GRADE 38. Best for low loss combined with high mechanical strength.
- GRADE 51 Best for molding applications.

Special formulas compounded for special requirements.

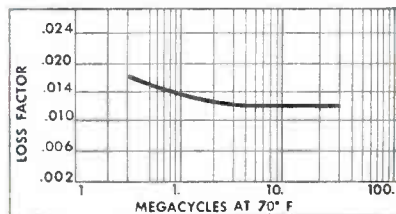

Based on Power Factor Measurements made by Boonton Radio Corp. on standard Mykroy stock.

MADE EXCLUSIVELY BY

**ELECTRONIC MECHANICS INC.**

70 CLIFTON BLVD., CLIFTON, N. J.  
CHICAGO 47; 1917 N. Springfield Ave., Tel. Albany 4310  
EXPORT OFFICE: 89 Broad Street, New York 4, New York

MYKROY IS SUPPLIED IN SHEETS AND RODS — MACHINED OR MOLDED TO SPECIFICATIONS

# Specialists in Special Crystals



**200 - 500 K. C.**

**EXTREMELY STABLE CRYSTALS FOR HIGH OUTPUT AND KEYING**

Clamped low frequency plated crystal units with permanent frequency precision,  $\pm 0.1\%$  from  $-30^{\circ}\text{C}$  to  $+60^{\circ}\text{C}$ ! None of the instability typical of old-style spaced units. A crystal that can take it, designed for use in such places as the 30-ton Coast Guard buoy transmitter, lighthouse transmitters, aircraft landing, etc. Each unit subjected to rigid Government specification keying tests. Mounted in aluminum hermetically-sealed holder.

- \* 3 point edge suspension. Top 2 points are spring adjusted, tamper-proof sealed for permanent frequency stability.
- \* Electrical contacts soldered to silver plate at nodal points — no mechanical strain.
- \* Hermetically sealed holder accomplished by spinning aluminum can over gasket under high pressure.
- \* Another Crystalab-engineered development.

Write Dept. E.L. for comprehensive catalogue "Selectronic Crystals" and facilities booklet "Crystalab Solves a Problem".



*Yankee Ingenuity makes us*

SPECIALISTS IN SPECIAL CRYSTALS



**CRYSTAL RESEARCH LABORATORIES**

INCORPORATED

LABORATORIES AND MAIN OFFICE: 29 ALLYN STREET, HARTFORD 3, CONN

New York Office: 15 E. 26th Street, New York 10, N. Y. Phone M.H. 5-2952

number of tool replacements, breakages, and injuries.

Where the location of the new socket hole was in the center of a chassis so that adequate hand clearance was not provided, the punch was first turned with a  $\frac{1}{2}$ -in. square socket extension fitted with a tap wrench. From this, tool A (Fig. 1) was developed. This tool consists of a  $\frac{1}{2}$ -in. square socket extension brazed into a hole in a T handle.

By turning the square extension with a  $\frac{1}{2}$ -in. square ratchet box

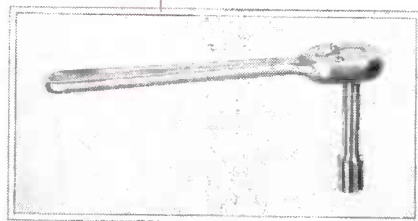

Fig. 2—Tool B, a ratchet wrench that fits a socket punch

wrench, a ratchet wrench for tightening punch screws in difficult locations developed. The final form of this is tool B (Fig. 2), consisting of a square extension fitted and brazed into a ratchet handle.

### Speed Tool

On the basis of experience with the two tools described, tool C (Fig. 3), consisting of a square exten-

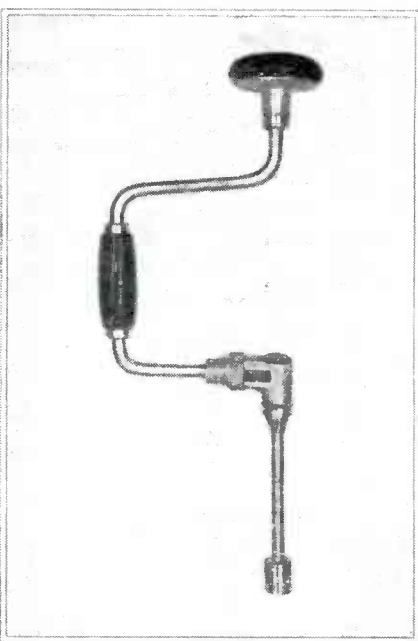

Fig. 3—Tool C uses a carpenter's brace for rapid production work

**QUALITY CONTROL of MICA**

The illustration shows the use of the metallurgical microscope, with filar micrometer attachment, which gives the greatest known accuracy in measuring the diameter of fabricated mica holes. (This is typical of the Quality Control of production of Ford Mica).

**FOR EVERY ELECTRICAL, RADIO AND ELECTRONIC USE**



**FORD RADIO & MICA CORP.**

Joseph J. Long, President

538 63rd Street, Brooklyn 20, N. Y.

Established 1917 • Telephone: Windsor 9-8300



# A COMPLETE LINE OF TRANSMITTER EQUIPMENT FOR AIRLINE GROUND STATIONS

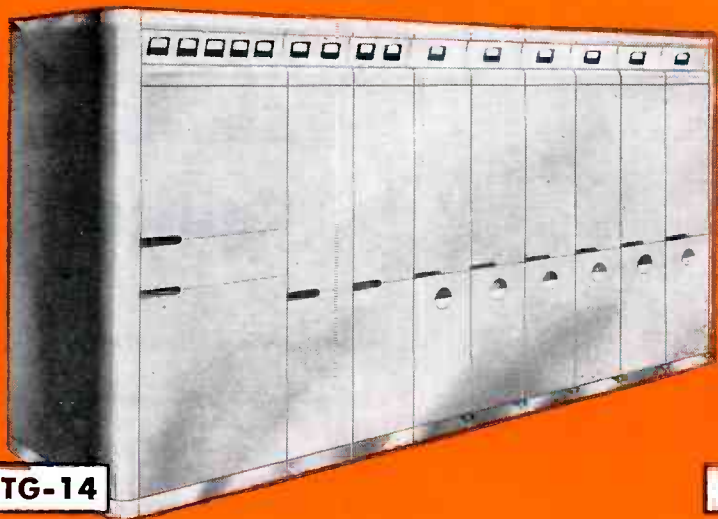

**TG-14**



**TG-15**

**FEATURING  
TRADITIONAL BENDIX RELIABILITY**

Bendix Radio, for years the leading manufacturer of aircraft radio equipment, now offers a complete and flexible line of transmitter equipment to fit the power and frequency requirements of any airline ground station.

Engineered for reliability in operation, these transmitters are designed specifically for aeronautical services in this country and in foreign operations.

Airline ground stations are now assured long, trouble-free, unattended transmitter service—with a minimum of maintenance —by the sound design and sturdy construction that has for years made the products of Bendix the Standard of the Aviation Industry.

For information as to dimensions, weight, construction, electrical characteristics and easy-service features, write



**TG-16**

# *Bendix* Radio **DIVISION**

BALTIMORE 4  MARYLAND

STANDARD FOR THE AVIATION INDUSTRY



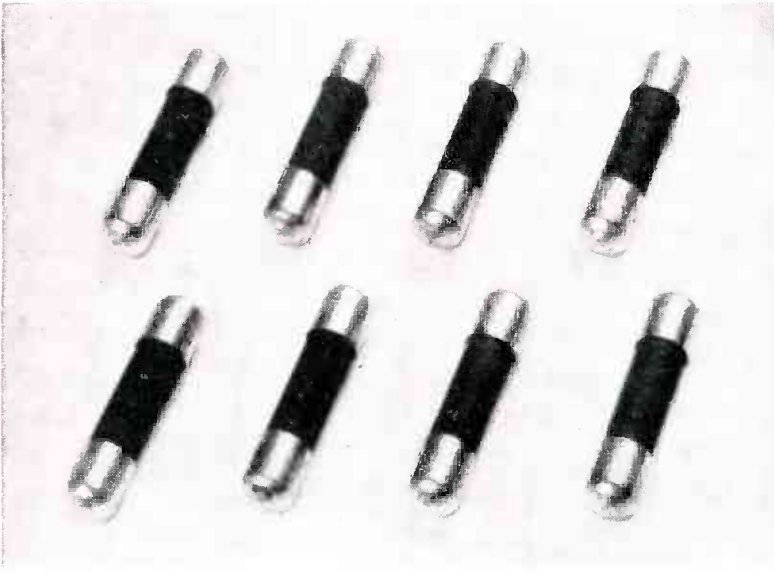

# Let "GLOBAL" Temperature- Sensitive Resistors . . .

- 1 Reduce your manufacturing cost
- 2 Simplify your product
- 3 Provide exceptional accuracy
- 4 Give you top performance

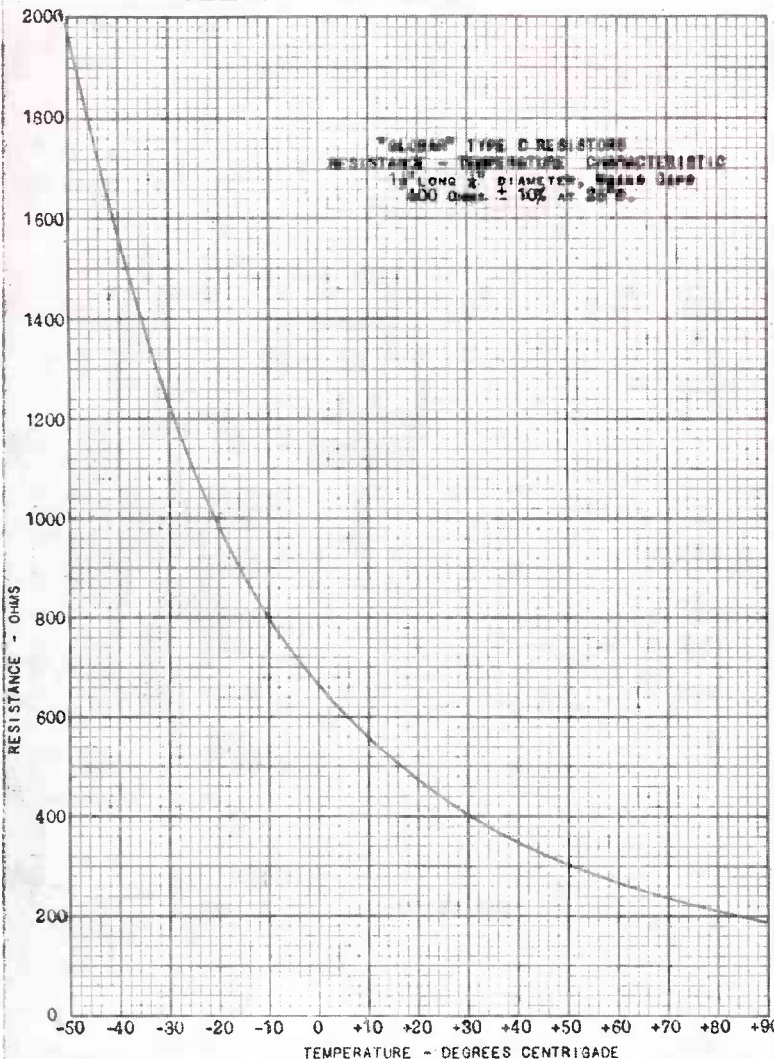

"GLOBAL" Type D Resistors have an extreme negative Resistance-Temperature characteristic which means that they will do a wide variety of jobs, accurately and economically. For example, one manufacturer uses them as Resistance Thermometers while another uses them as Temperature Compensators. They also perform a wide variety of useful functions in many electronic devices.

Light-weight—compact—efficient—reliable—"GLOBAL" Type D Resistors never get out of adjustment, because their function is purely electrical instead of mechanical. They may be used on A. C. or D. C. circuits.

These resistors are manufactured to meet the specific needs of each application, so be sure to include full information about your circuit when writing. We will be glad to provide working samples on request.

By the way, if your engineers haven't yet investigated "GLOBAL" Ceramic Resistors we invite them to do so without obligation. Write to The Carborundum Company, Global Division, Niagara Falls, New York.

*"Global" Ceramic Resistors*  
**by CARBORUNDUM**  
TRADE MARK

("CARBORUNDUM" and "GLOBAL" are registered trade marks of and indicate manufacture by The Carborundum Company)





*another proof*

**that Truarc Retaining Rings hold moving parts together better!**

"The simplicity of the Walides Retaining Ring assembly enabled us to conceive a design for our spindle that assured us of all the physical qualities required in a high-speed machine of this type."

(Signed)

AMERICAN SEPARATOR CO., Inc.

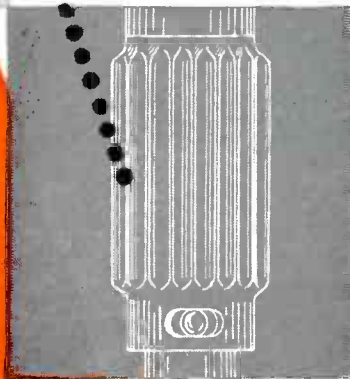

**BEFORE TRUARC**

The American Separator Company found no solution to the problem of excessive noise and vibration set up by the spur gear train action of this separator bowl revolving at 8500.



**AFTER TRUARC**

Truarc Retaining Rings eliminated vibration and noise while actually simplifying the assembly, achieving a rigid bearing of greater strength with no loss of speed!

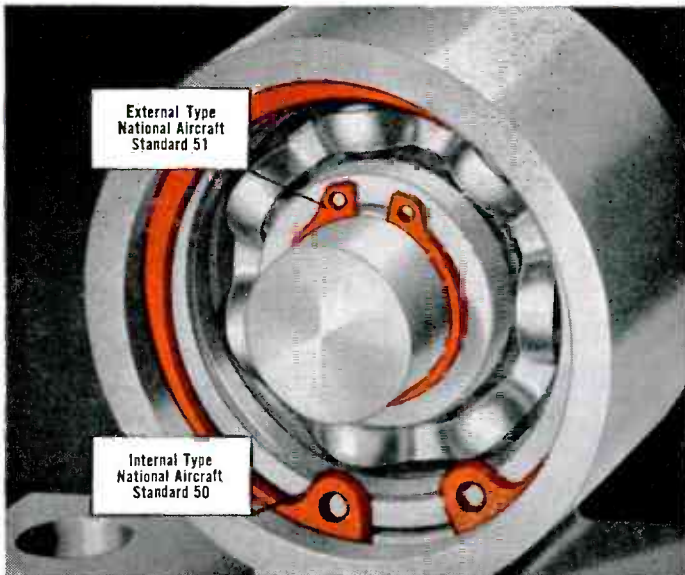

If your problem is holding together or positioning moving parts, you should know Truarc Retaining Rings. They offer important advantages over nuts, shoulders, collars and pins. They save space. They make assembly and disassembly easier, simpler, quicker. They keep their bulldog grip, hold their true circularity indefinitely under severe working conditions. Test Walides Truarc in your products, in the machines that make them. Write for samples and complete data. Dept. H-10.

**WALDES**

**TRUARC**



**RETAINING RING**

WALDES KOHINOOR, INC., LONG ISLAND CITY 1, NEW YORK

CANADIAN REPRESENTATIVES: PRENCO PROGRESS CORP., LTD., 72-74 STAFFORD STREET, TORONTO  
U. S. PAT. RE-18,144



The urgent demand, in peacetime days, by the aircraft and radio industries for a compact, efficient D.C. motor was the challenge that led Pioneer to develop the Pincor BX series. Today Pincor BX motors flow from our plant in a steady stream to the producers of aircraft and radio equipment for the armed services.

Pincor BX motors, in their classification, meet the varied requirements of aircraft and radio manufacturers that demand light weight, compact motors for efficient and dependable application. Pincor BX motors are direct drive, ball bearing, high speed units wound for continuous or intermittent duty. Shunt, series or split series windings are for operation on 12 to 24 volt battery systems currently used and may be easily modified to meet your product demand.

Depend on these rugged Pincor quality-proven motors in the BX series. Send your problem to Pioneer engineers and let them put their years of experience to work for you. Consultation with these men will not obligate you in the least.

DYNAMOTORS • CONVERTERS  
GENERATORS  
POWER PLANTS • GEN-E-MOTORS



**PIONEER GEN-E-MOTOR CORPORATION**

5841-49 DICKENS AVENUE CHICAGO 39, ILLINOIS

**BUY MORE BONDS!**

Export Office, 25 Warren Street, New York 7, U.S.A.  
Cable Address: Simonrice, N. Y.

sion fitted and brazed to the chuck core of a ratchet carpenter's brace, was developed. This was found quite satisfactory for rapid production work.

By coupling various 1/2-in. square fittings to any of these tools, a socket hole can be made in almost any location where it is possible to drill a pilot hole for the punch screw.

Use of these tools led to an estimated 25-percent increase in production, with an accompanying decrease of equipment damage, and a virtual elimination of hand injuries.

### New Photocell for Ultraviolet

THE BRITISH COMPANY Cinema-Television Ltd has produced a new photocell for ultraviolet light which is an improvement on the older sodium cell with a quartz window.

The envelope of the new tube is made entirely of fused quartz since the cathode is antimony caesium and there does not seem to be any cement known which can be used to make a vacuum-tight quartz window in a glass cell and yet which does not combine chemically with the caesium vapor used during the sensitising process.

The antimony-caesium cathode responds to wavelengths between 6,500 and 2,000 Angstroms with a peak between 4,000 and 4,600. In the ultraviolet region, the new cell is far superior to the older sodium type and produces from 100 to 500 times the output, size for size and operating in a vacuum.

What is equally or more important, is the fact that the antimony-caesium cathode has good response in the visible region, where the sodium cell is bad. This last defect often required two cells (of differing color response) when continuous measurements had to be made from the ultra violet to the red end of the spectrum.

Radio Relay Services. The latest figure for radio relay service subscribers in England is 551,703 and it is interesting to note that during the last three months of 1944, when we had flying bombs, rockets, and what you will, the total increased by 24,000.



We, the "decadent democracies," the "softies and amateurs," went in and tackled the "professionals"—showed them how to wage and win a war.



Now, Let's Show Them  
How To Win The Peace!

Shortages of materials? Pricing problems? Production flow problems? G. I. is not alone with these problems. They are just hurdles in the race to attain peak production and the greatest possible employment. The war ended so suddenly, Glory be, that some hitches are inevitable. But like the rest of industry, we are taking a realistic view. Every day breaks another bottleneck and output surges ahead.

We are putting into practical operation the advanced techniques, the ingenuity and know-how which were the natural outgrowth of five years of intensive war effort, in the manufacture on an extensive scale of

*VARIABLE CONDENSERS • TUNING MECHANISMS • SPEAKERS  
RECORD CHANGERS • AND OTHER RADIO COMPONENTS*

**G**ENERAL **I**NSTRUMENT  
CORPORATION •

829 NEWARK AVENUE, ELIZABETH 3, N. J.





FOR  
CRITICAL WIRING APPLICATIONS

# AMP

The only solderless terminal with the insulation sleeving permanently bonded to the terminal.

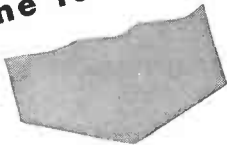

1/32" Minimum Insulation Beyond Metal Protects Against Flash-over

Insulation Color Identifies Size

1/64" Insulation Withstands Abrasion High Voltage . . . High-Pressure Crimping

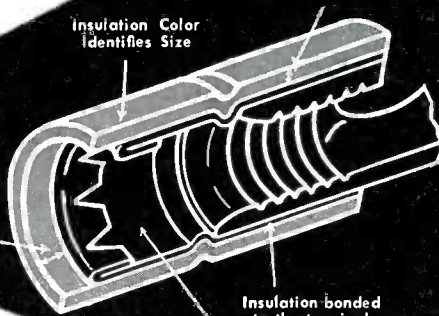

Insulation bonded to the terminal  
Positive pure copper insulation support

Write today for AMP  
Catalog Section 10

THESE 3  
STEPS



1 SLIDE TUBING OVER WIRE



2 CRIMP TERMINAL TO WIRE



3 SLIDE TUBING OVER TERMINAL

REDUCED  
TO 1  
QUICK  
OPERATION



1 CRIMP "PRE-INSULATED" TERMINAL TO WIRE

# The AMP PRE-INSULATED TERMINAL

Providing Revolutionary speed and accuracy in mass production wiring with superlative electrical properties.

## PERFORMANCE CHARACTERISTICS

1. Terminals withstand a temperature of 350 degrees for 10 hours without physical damage to insulation or any deleterious effects on insulation.
2. Minimum breakdown voltage is 2500 volts D.C. in air at sea level; 800 volts D.C. at altitude of 30,000 feet.
3. Insulation does not support combustion when tested in accordance with ASTM D350-40T.

4. Insulating qualities are unaffected by long immersion of terminals in 10 per cent salt solution.
5. Water absorption of insulation is less than 1 1/2 per cent.
6. The pre-insulation takes the exact contour of the crimp without distortion or cracking. It will not dry out or come loose.
7. Maximum electrical and mechanical properties of the AMP "Diamond Grip" Insulation Support Crimp assure vibration-proof connections. All three crimps made in one operation by AMP hand tools or press dies.

## PRODUCTION ECONOMIES

THE INSULATION IS PERMANENTLY BONDED TO THE BARREL OF THE TERMINAL. The AMP Pre-Insulated Terminal is delivered to you ready to install with AMP precision hand, foot or power installation tools — thereby eliminating all stocking and handling of separate sleeving, and eliminating costly human errors in its application. The cost of applying separate tubing to the terminal is approximately the same as the cost of applying the terminal itself to the wire.

Color identification of wire sizes clearly marked on terminals and tools.

FOR SUPER PERFORMANCE USE THE SUPER AMP PRE-INSULATED TERMINAL

# AMP

## AIRCRAFT-MARINE PRODUCTS Inc.

1521-53 NORTH FOURTH STREET, HARRISBURG, PA.

In Canada: DAVID C. ORROCK, 1405 BISHOP STREET, MONTREAL, QUEBEC  
F. N. ADAMS, 726 HOMER STREET, VANCOUVER, BRITISH COLUMBIA





# **MOISTURE** the enemy of radio insulators **CAN'T PENETRATE STEATITE**

Moisture in hot steaming jungles and in cold foggy climates is a life-shortening enemy of radio equipment.

Steatite is absolutely impervious to moisture. The American Society of Testing Materials porosity test (Steatite placed in a chamber with fuch sine dye under five tons of pressure for six hours) has proved that General Ceramics and Steatite insulators are not porous and therefore do not absorb moisture.

The low loss factor, the high physical strength, the stability of shape of Steatite is not affected by age or climatic changes. For a long trouble-free life of your equipment specify Steatite Insulators made by General Ceramics & Steatite Corporation.



*General Ceramics*  
**AND STEATITE CORP.**  
KEASBEY  
NEW JERSEY

639

# TUBES AT WORK

Power Measurements at Very High Frequencies.....	216
Recorded Sound Waves Locate Bomb Hits.....	218
Stabilized Pulse Circuit.....	230
Post War Receivers.....	234

## Power Measurements at Very High Frequencies

By WILLIAM MARON  
*Senior Radio Engineer  
 North American Philips Co.  
 Dobbs Ferry, New York*

THIS PAPER DESCRIBES a means for measuring r-f power between 20 and 40 watts at 100 megacycles.

Figure 1 shows a single-ended class C amplifier stage, using long lines. The antenna coupling circuit, consisting of  $L_1$  and  $C$ , is designed to match a 70-ohm coaxial line to feed the antenna. The load should, therefore, be in the vicinity of about 70 ohms. A 60-watt, 110-volt lamp operated below full watt-

possible to find the amount of r-f power produced by the amplifier.

### Construction Details

As some photoelectric cells are damaged if subject to temperatures above 120 F, it is advisable to separate the cell from the lamp by at least twelve inches. This is particularly important if measurements are to be made over an extended length of time.

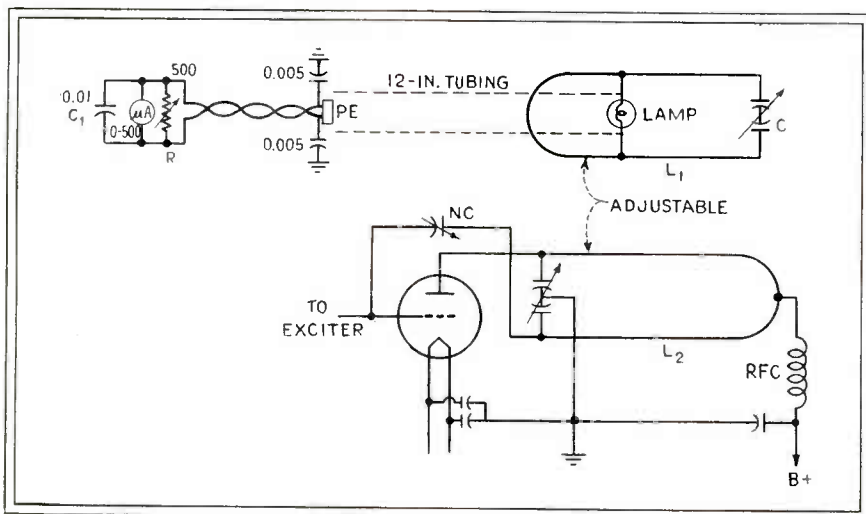

Fig. 1—Photoelectric method of measuring r-f power at 100 megacycles

age has a resistance of about 70 ohms; any slight discrepancy is compensated by the point of attachment to the coupling circuit.

If a photoelectric cell  $PE$  is placed in the path of light from the lamp, a direct current will be generated by the photocell which can be measured by a microammeter. The amount of current given by  $PE$  is dependent on the quantity of light produced by the lamp, which in turn is a function of the magnitude of r-f flowing through it. By calibrating the microammeter it is

A piece of Bakelite tubing with an inside diameter sufficient to accommodate the lamp is cut to proper length. A series of small holes is drilled in the tubing to provide ventilation. A hood over the holes prevents entrance of extraneous light. The photocell is mounted at the other end of the tubing and bypassed for r-f as shown in Fig. 1. The length of leads going to the microammeter is of no relative importance; the leads, preferably, should be shielded. Bypassing the meter is also desirable

to prevent burn-out due to stray r-f current. The meter shunt  $R$  may or may not be necessary, although it is a precaution to include it.

The bulb is debased to cut down capacitance and the cement and insulation removed between the center contact and outside contact.

### Calibration

Figure 2 illustrates a calibration circuit for lighting the lamp from the a-c line. The meters are used for computing the power input to the bulb; a wattmeter may be used if available.

To calibrate, remove one leg of the bulb from  $L_1$  and, without dis-

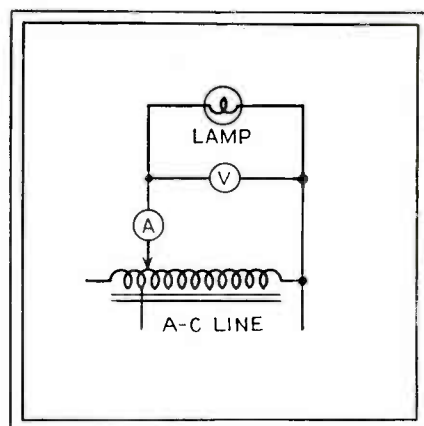

Fig. 2—Circuit for calibrating the lamp from an a-c line. If the lamp is replaced, recalibration is necessary

turbing the position of it in regard to the photocell, connect the low-frequency a-c. Adjust the voltage with the autotransformer and read the microammeter. Plot the wattage input to the lamp versus meter reading. Should the pointer go off

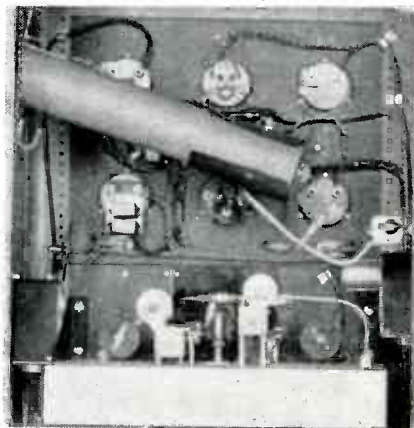
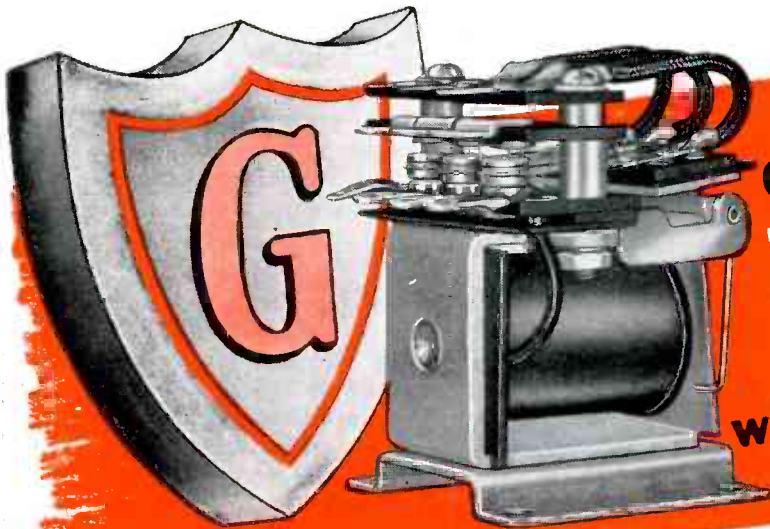

Fig. 3—A 100-mc transmitter with photoelectric equipment built in for measuring the power output





# GUARDIAN Series 345 RELAY

a "Basic Design"  
with many variations

*meets special applications*  
saves time . . . saves tooling . . . speeds delivery!

If your application requires a specially designed relay Guardian engineers can be of great help to you. But, as a result of their wide experience in designing "specials" they have evolved a standard design so flexible that it is now specified in numerous applications that would ordinarily require a specially designed unit. Perhaps you can use it in your "special" application . . . with a saving in money and delivery time. This unusually flexible relay is the SERIES 345. Its chief features are the large coil winding area, numerous contact combinations, the non-binding pin type armature hinge pin, its resistance to shock and vibration, and an ability to operate in extremes of temperature. It is now being used in aircraft, radio, and other exact-

ing applications to insure dependable performance.  
**STANDARD SERIES 345**—The ample coil winding area of the SERIES 345 gives you a wide range of windings for various voltages and currents. Coil winding area is approximately .75 cubic inches. Average power required is 3.56 watts with three pole, double throw contacts of 12½ amp. capacity. Coils are available for either A.C. or D.C. operation.  
The maximum switch capacity of the Standard Series 345 is three pole, double throw. Contacts are rated at 12½ amperes at 110 volts, 60 cycles, non-inductive A.C. Moving contacts are attached to but insulated from the armature by a bakelite plate. Terminals are solder lugs. Weight is 6½ ounces.

## VARIATIONS OF THE SERIES 345 RELAY



**TIME DELAY**

**WINDING**—Multi-wound coils are available for operation on two or more circuits. Or coil may be wound to operate on the discharge of a 3 mfd. condenser.

**CONTACTS**—Normal switch capacity is three pole, double throw; maximum switch capacity may be up to six pole double throw with 12½ amp. contacts, or any vari-

ation of contact combinations within this range, including the operation of contacts in sequence. The flexibility of the contact springs may be increased through the use of coil spring rivets.

**TIME DELAY**—On D.C. coils a time delay of 0.25 seconds on release or 0.06 second on attract may be achieved through the use of copper slugs which require these time intervals for saturation or de-energizing depending on whether they are used on the heel or head of the coil.

**DUST COVER**—For applications where this relay may be subject to injury or in atmosphere where dust may be present in sufficient quantity to impede operation, the SERIES 345 may be equipped with a metal dustproof cover.

**SCREW TERMINALS**—Screw type terminals are optional for applications where terminals must be disconnected occa-

sionally or where solder lug terminals are not otherwise practical.

**INTERLOCKING:** Here the series 340 a-c relay is coupled with the d-c coil of a series 405 short telephone type relay in an overload application. Under normal conditions the series 340 contacts are mechanically held in a closed position. Normal



**DUST COVER**

current flows through the series 405 coil and then through the series 340 contacts to the circuit for which overload protection is desired. Excessive current, however, energizes the series 405 coil, releasing the locking arrangement and breaking the series 340 contacts. Push button control resets to normal but is ineffective if current is still excessive.

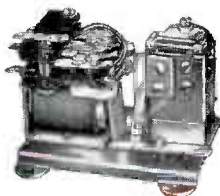

**INTERLOCKING UNIT**

### SERIES 345 RELAY DATA

Normal Volts	Minimum Volts	Normal M.A.	Minimum M.A.	Coil Resist.	Normal Wattage
6	4.8	600	480	10	3.56
12	9.8	300	245	40	3.56
24	18	148	111	162	3.56
32	25.6	112	89	287	3.56
115	92	31	25	3720	3.56

Minimum operating wattage . . . . . 2.3

*If you will write us about your relay problems our engineers will be glad to make recommendations which may save you time and money. Should you desire a quotation, please mention quantity.*

**GUARDIAN**  **ELECTRIC**  
1625-L W. WALNUT STREET CHICAGO 12, ILLINOIS  
A COMPLETE LINE OF RELAYS SERVING AMERICAN WAR INDUSTRY



FIRST AWARD . . . JUNE 23, 1944

FIRST RENEWAL WITH STAR . . . DEC. 16, 1944

SECOND RENEWAL WITH STAR . . . MAY 26, 1945

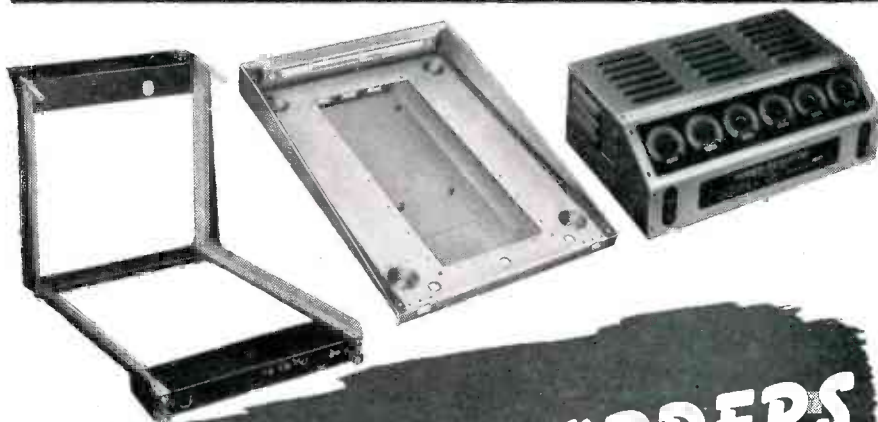

**UNLIMITED ORDERS ACCEPTED NOW**  
FOR METAL CHASSIS, CABINETS, TERMINAL BOARDS, AND STAMPINGS  
**TO YOUR SPECIFICATION**

Insuline is equipped to make anything from a lug to a huge transmitting cabinet according to your specifications. All materials—steel, aluminum, brass, copper, etc.—are on hand; and the following facilities for producing the complete job, from beginning to end, are available:

A complete tool and die shop; automatic and hand-screw machines; engraving, coil-winding, milling, and grinding machines; power shears; power brakes; punch presses; automatic welding machines; spray booths; baking ovens; plating tanks, etc., plus an entire floor devoted to machine and hand assembly.

In addition, our competent engineering staff and a modern experimental laboratory are always available to help you with your production problems.

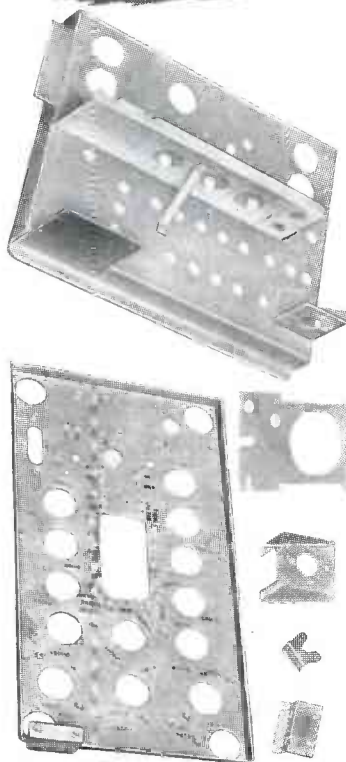

**insuline**  
CORPORATION OF AMERICA

INSULINE BUILDING • LONG ISLAND CITY, N. Y.

QUALITY PRODUCTS SINCE 1921

scale before the maximum wattage range is reached, then  $R$  is adjusted to keep the meter on scale.

The calibration obtained holds only for each individual lamp and distance between the lamp and the photocell. Any change makes re-calibration necessary. Figure 4 is a typical calibration chart obtained with the unit in the transmitter illustrated in Fig. 3.

After calibration has been completed, reconnect the lamp to  $L_1$ . The transmitter is turned on and  $L_1$  coupled to  $L_2$  so as to make the

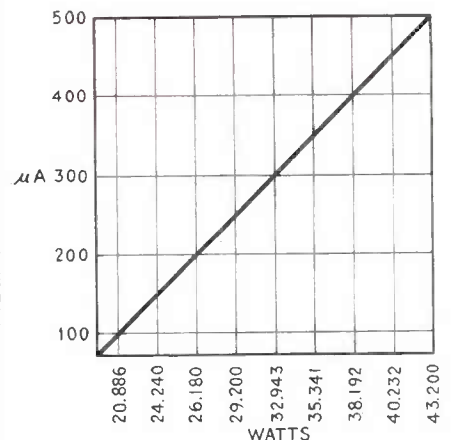

Fig. 4—Typical calibration chart obtained by use of the circuit shown in Fig. 2

tube draw normal plate current. The plate tank is repeatedly retuned for minimum plate current while  $C$  is being adjusted for maximum plate current. The connections from the lamp to  $L_1$  should be tried in several places for correct impedance match. The proper place is where the meter indicates maximum for the required input to the tube.

Once the proper connections of the lamp to  $L_1$  and the correct relationship between  $L_1$  and  $L_2$  has been established,  $L_1$  should be fixed in position. To determine the r-f power, observe the meter reading and refer to the calibration chart.

• • •

### Recorded Sound Waves Locate Bomb Hits

A SONIC METHOD of scoring practice bomb hits has been used at Midland Army Air Field in Texas, the AAF central school for bombing. The system involves recording the sound





**WHEN IT  
COMES TO  
TOLERANCE**

**We are very narrow**

... so narrow, in fact, that we consider a tolerance of + or - 10% the limit of possible variation on our .00025" gauge insulating paper. That's one of the reasons why we're the preferred source for Thin Gauge paper for capacitors, coils, transformers and other insulating purposes. Grades range in thickness from .00025" through .004".

**SCHWEITZER PAPER CO.**

142 MILLER STREET, NEWARK, N. J.  
Plants: Newark, Jersey City, Mt. Holly  
Springs, Pa. Research Laboratories:  
Chrysler Bldg. New York, N. Y.

SPECIALISTS IN THIN GAUGE INSULATING PAPERS

*don herold*

# Cut Assembly Time

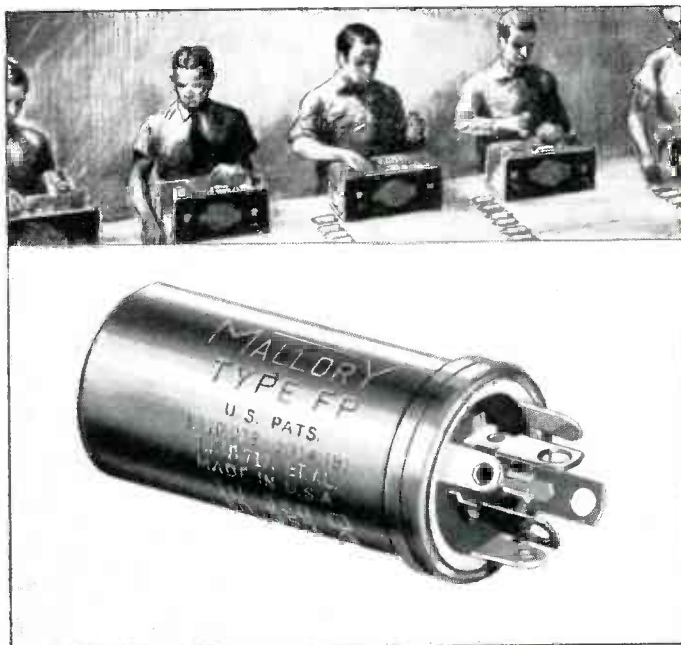

## *with* MALLORY "FP" CAPACITORS

**T**OP chassis mounting for Mallory "FP" Capacitors . . . plus the "twisted-ear" feature that eliminates other hardware . . . can save plenty of man-minutes on your assembly lines.

Mallory "FP's" make designing easier, too, if you want to save chassis space, for they are the smallest capacitors available for a given electrical rating. Capacities range from 3,000 mfd. at 10 volts to 80 mfd. at 450 volts.

Long life and uniformly high quality are

built into every "FP" capacitor by Mallory precision workmanship. You'll eliminate many engineering and production problems if you specify Mallory "FP" Capacitors for any electronic equipment you plan to produce in volume.

Ask your nearest Mallory Distributor for a copy of the latest Mallory catalog—containing complete specifications on "FP" capacitors and many other approved precision products. Or write us today.



P. R. MALLORY & CO., Inc., INDIANAPOLIS 6, INDIANA

P. R. MALLORY & CO. Inc.

# MALLORY

Electrolytic,  
Film and Paper  
CAPACITORS



# VICTORY

## OVER VIBRATION

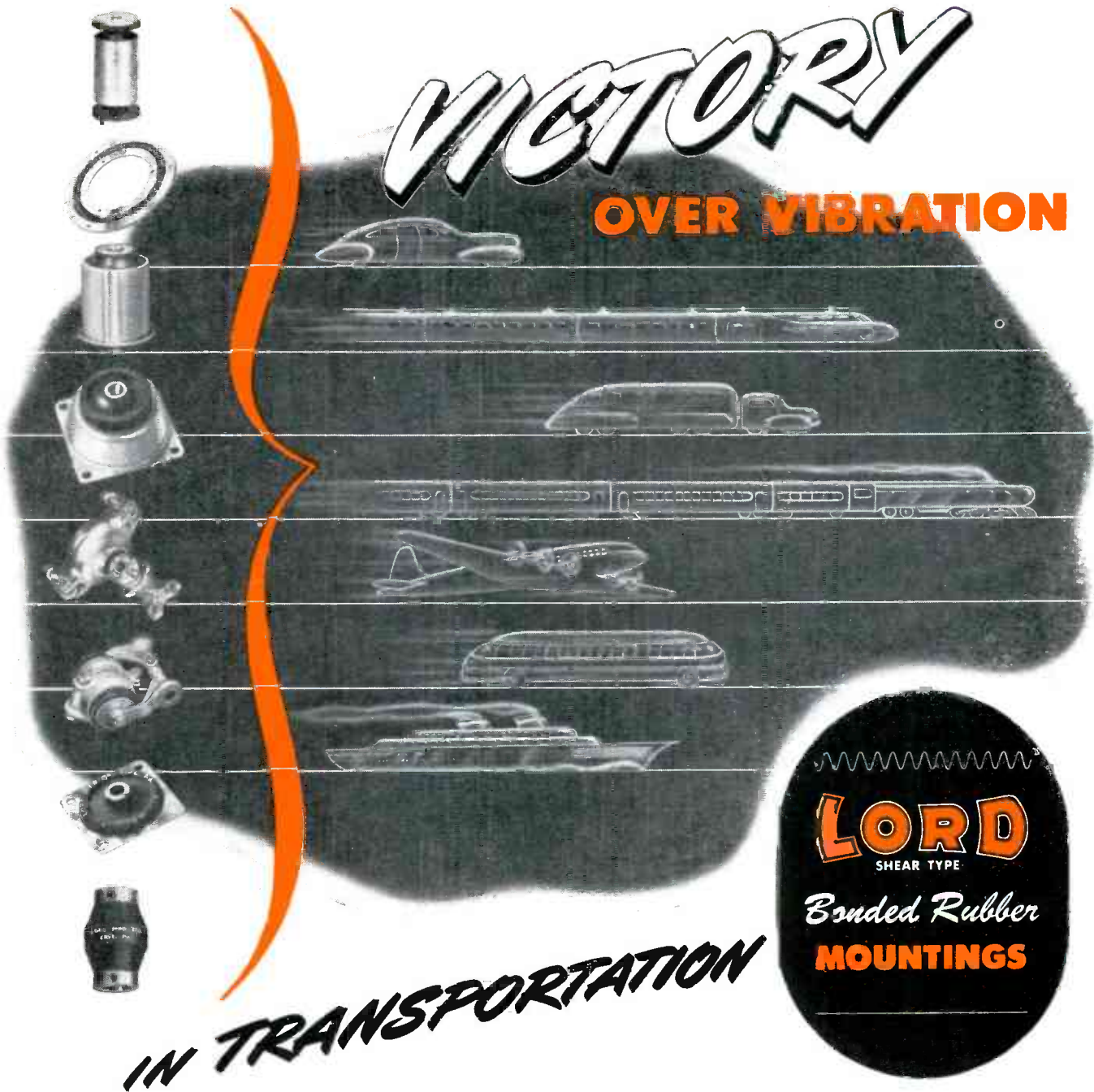

# IN TRANSPORTATION

**LORD**  
SHEAR TYPE

*Bonded Rubber*  
**MOUNTINGS**

The science of vibration control has not been behind other sciences in the advances it has made under the spur of urgency to win the war. Lord Bonded Rubber Mountings solved vibration problems on practically every vehicle of war that sailed the skies, traveled on land or water, or bored the dark caves of the ocean.

All that Lord has learned in a generation of pioneering the field of vibration control, through peace and war, is at the disposal of manufacturers, design engineers, and operation managers, in this new age of faster transport in a travel-minded world.

Lord Vibration Control increases effective power through improved transmission; it prolongs the life of engines and auxiliary equipment. It safeguards delicate instruments upon whose functioning safety depends. It promotes the comfort and efficiency of operators, the relaxation and enjoyment of passengers.

We have a Lord Mounting to solve your vibration problem, or we'll make one. Lord engineers are at your service. Keep up to date on vibration control; let us add your name to our mailing list.

*Lord Mountings for Faster-Smoother-Quieter Travel*

IT TAKES BONDED RUBBER *In Shear* TO ABSORB VIBRATION

**LORD MANUFACTURING COMPANY**  
ERIE, PENNSYLVANIA

SALES REPRESENTATIVES  
NEW YORK • 280 MADISON AVE.  
CHICAGO • 520 N. MICHIGAN AVE.  
DETROIT • 7310 WOODWARD AVE.  
BERBANK, CAL. • 245 E. OLIVE AVE.  
CANADIAN REPRESENTATIVES  
RAILWAY & POWER ENGINEERING CORP., LTD.  
TORONTO, CANADA

*Originator's of Shear Type Bonded Rubber Mountings*

An  
*Outstanding New Line*  
 of  
**A.C. and D.C. RELAYS**

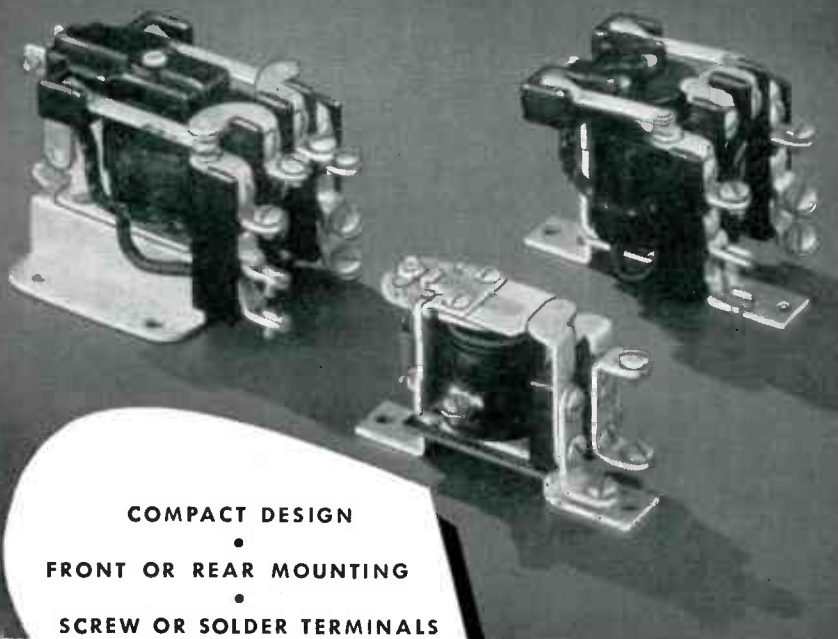

COMPACT DESIGN  
 •  
 FRONT OR REAR MOUNTING  
 •  
 SCREW OR SOLDER TERMINALS

● R-B-M announces a new and improved design of magnetic relays rated 10 amperes at 24 volts D. C. and 110 volts A. C. and 5 amperes at 220 A. C. Relays rated at one horse power single phase 110 and 220 volts A. C. Silver to silver contacts. Self-aligning armature. All wiring terminals accessible from front. Contact arrangement—single and double pole; normally open, normally closed and double throw. Steel mounting with A. C. and D. C. relay mounting dimensions interchangeable. Available in open type or with sheet steel general purpose enclosure. Bulletin 510 on D. C. relays and Bulletin 560 on A. C. relays available upon request. Write Department A-10 . . .

**R-B-M MANUFACTURING COMPANY**

*Division of*  
**ESSEX WIRE CORPORATION**  
**LOGANSPORT, INDIANA**



MANUAL AND MAGNETIC ELECTRIC CONTROLS—FOR  
 AUTOMOTIVE, INDUSTRIAL, COMMUNICATION AND ELECTRONIC USE

waves picked up by microphones in the target area.

Four low-frequency microphones are placed about the target in a square pattern, each 600 feet from the target center. Each microphone is connected to a reflecting galvanometer in an oscillograph recording unit 1600 feet away. When a bomb explodes, the time of arrival of the sound wave is measured and recorded on a photographic paper tape as four individual traces in the oscillograph. The low-frequency microphones pick up only the bomb noise and are not actuated by engine noise or other extraneous sounds.

Geophones are used to turn on the recorder when it is needed to receive the sound waves. Because a ground tremor travels faster than a sound wave through air, the geophone can signal the recorder a fraction of a second before the signal from the microphone. The sig-



**FIG. 1—View of target area as seen from the air by the bombardier**

nal from the geophone trips the recorder so that it can operate for one to one and a half seconds and then shut itself off by means of an electronic control. Eight geophones are used; one between each microphone and one adjacent to each microphone.

Figure 1 shows a view of the target as seen by the bombardier. The puff of black smoke comes from a bomb planted in the lower left quadrant of the target circle. Figure 2 shows the sound waves registered on the sonic scoring tape. The top trace in the illustration



**NEW!**

## *Sweep-Balance Recorder*



✓ PLOTS CURVES OR SETS OF CURVES OF TWO FUNCTIONAL VARIABLES.

✓ PRODUCES A PERMANENT RECORD.

Now you can record many types of relationship with new speed and accuracy. Obtain permanent inkless records of such functions as *viscosity vs. temperature . . . speed vs. torque . . . angle vs. light emission . . . volts vs. amperes.*

A complete picture of the required information is automatically and quickly produced without chance of error due to human element. As many as 1000 related points visually recorded in three minutes' time. Up to six variables can be traced simultaneously as a function of a common seventh, making multiple testing simple.

For example, three samples of oil can be tested at one time, for *viscosity vs. temperature,* with each test permanently recorded.

The Sweep-Balance X-Y Recorder is readily adapted for recording any magnitude which can be transformed into an electrical signal. Adaptation to a multitude of recording problems is simple. Often, only the pick-ups (for temperature, pressure, humidity, etc.) may have to be changed to meet specific applications.

Outline your production or laboratory testing requirements by letter. They will have the prompt attention of our engineers. Great American Industries, Inc., Connecticut Telephone & Electric Division, 400 Britannia Street, Meriden, Connecticut.

**Connecticut**  
ELECTRICAL  EQUIPMENT

# When the time for Action Comes



Oiljak production facilities, engineers, designers, and shopmen are at your service when you have a question, or a problem having to do with the design, fabrication, assembly, or manufacture of a product in light metals—to solve it satisfactorily, economically, and within the allotted time.

Our experience in manufacturing new, unusual and intricate parts and products, in a minimum of operations, with great precision, and at reasonable cost is available for planning and carrying out a wide variety of projects.

That service may be helpful to you. We invite your inquiries.

**MACHINING • STAMPING • WELDING • PLATING • FINISHING • ASSEMBLING**

**The OILJAK MANUFACTURING CO., Inc.**  
MONTCLAIR, N. J.

The Job Complete—from blueprint to finished product





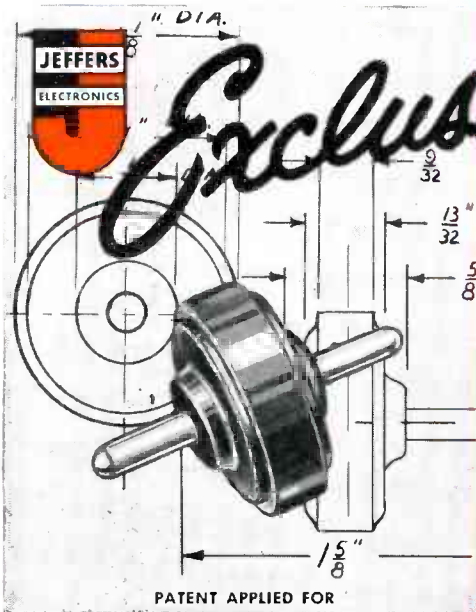

PATENT APPLIED FOR

**FOR HI-VOLTAGE TELEVISION**  
**SUPER KILOVOLT CAPACITOR** TYPE SKC-19  
**MADE ONLY BY JEFFERS**

Again Jeffers leads the field with its introduction of the Super Kilovolt Capacitor. Developed in cooperation with one of the nation's leading television manufacturers, the Jeffers Super Kilovolt Capacitor provides a dependable solution to the need for compact, ceramic capacitors for installation in television circuits. The Jeffers Super Kilovolt Capacitor is tested at 16,000 volts DC and is designed to operate up to 8000 volts DC. Available in capacities from 10 to 1500 mmf. Contacts secured by metal to ceramic bond, insulated with Melmac. Write today on your company letterhead outlining your problems or requirements. A Jeffers representative will call to discuss them with you.

The standard line of Jeffers capacitors, resistors and chokes is shown in the center "J" panel.

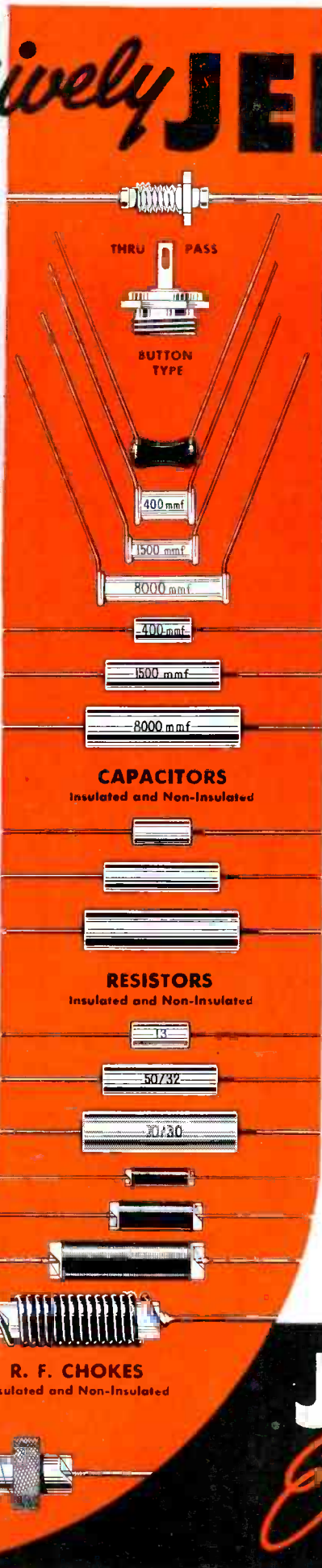

**R. F. CHOKES**  
 Insulated and Non-Insulated

**SPECIAL WINDINGS**

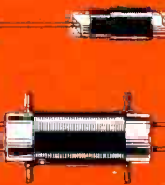

**WHERE SPACE IS A PROBLEM**  
**THE SMALLEST INSULATED CERAMIC CAPACITOR** TYPE JC1-A1  
**MADE ONLY BY JEFFERS**

Another and interesting Jeffers innovation is the ceramic capacitor Type JC1-A1. This is the smallest insulated capacitor unit to be found in the entire industry and provides a dependable answer where space limitations are a problem. The Jeffers ceramic JC1-A1 is made in a range of capacities from 1 to 25 mmf when our material N750 is utilized and up to 400 mmf where high dielectric constant material is employed. Like all units in the Jeffers line, it is produced to high accuracy standards. Write on your letterhead today stating your problems or requirements and a Jeffers representative will call to discuss them with you.

Send for FREE Jeffers catalog covering the full line of capacitors, resistors and chokes and including information on special windings for resistor units.

**JEFFERS**  
*Electronics*  
 DU BOIS, PENNSYLVANIA

# POSTWAR PRODUCT



**E**lectrical manufacturers with an eye to sales leadership know the value of proper insulation. That's why on post-war products most likely to succeed, specifications call for INSL-X coatings. INSL-X Research Leadership is your guarantee of *Quality, Service and Dependability.*



*Informative Literature Upon Request*

**INSL-X**  
MEANS MODERN  
INSULATION

**THE INSL-X COMPANY INC.**

857 MEEKER AVE., BROOKLYN 22, N. Y.  
CHICAGO      DETROIT      LOS ANGELES      PHILADELPHIA  
CLEVELAND      ST. LOUIS

shows the sound waves were first picked up by the microphone in the lower left quadrant. The other traces show that the sound waves next hit the microphone at upper left, then lower right, and upper right respectively. Measurement of the space between peaks on the tape permits the scorers to determine

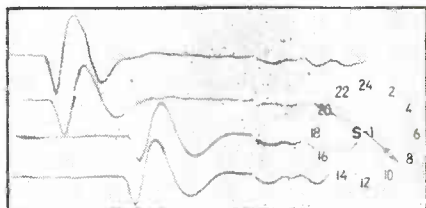

FIG. 2—The pertinent portions of the recording tape are the traces recorded from the four microphones, at left, and the clock face showing the time of impact

how accurately each practice bomb was dropped. A direct hit on the target center would show four peaks that coincided vertically on the tape.

Individual bomb hits are identified by a clock face which is automatically photographed at the time of recording. This is compared to the bombardier's record of the time of bomb impact to the nearest second to distinguish his release from that of other bombardiers. The circular area accurately recorded has a radius of about 1000 feet. Bombs are seldom dropped outside that area.

At Midland, the system was de-



## VETS BUILD RADIOS



At the Army Air Forces Convalescent Hospital, at Fort Logan, Colorado, veterans build and repair commercial receivers and the 90 standard military sets. A course in theory is also given at the hospital



# WHY SPEED NUTS ARE FIRST WITH

## *Purchasing Agents*

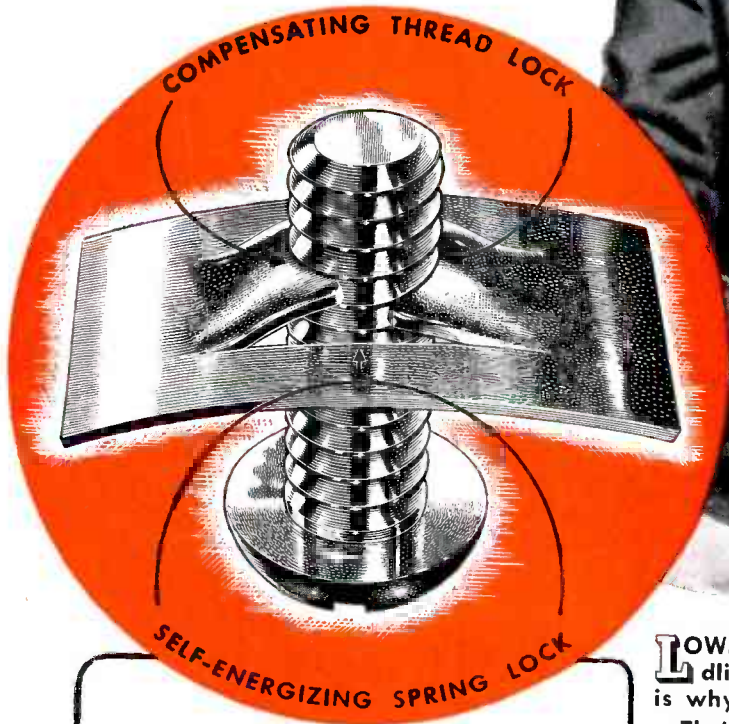

### NOTHING LOCKS LIKE A SPEED NUT

Only **SPEED NUTS** provide a **COMPENSATING** thread lock and a **SELF-ENERGIZING** spring lock. As the screw is tightened the two arched prongs move inward to lock against the root of the screw thread. These free-acting prongs **COMPENSATE** for tolerance variations. Compression of the arch in prongs and base creates a **SELF-ENERGIZING** spring lock. These two forces combine to definitely prevent vibration loosening.

**L**OWER COSTS . . . reduced inventories . . . fewer handling problems . . . availability . . . in a few words, here is why Purchasing Agents prefer **SPEED NUT** fasteners.

Their initial cost, in many cases, is less than ordinary fasteners. Then, when you add in the savings in assembly time and reduction in number of parts brought about through the use of **SPEED NUTS**, total net assembly costs really take a tumble.

**SPEED NUTS** keep inventories down, too, because they completely do away with washers, and often eliminate many other assembly parts as well. This, of course, means quick inventory turnover and savings in the handling and dispersing of parts in stock.

Finally, Purchasing Agents have learned that Tinnerman service is dependable. Unlimited production and service facilities assure the utmost cooperation in getting **SPEED NUTS** on their way to you . . . on time. Investigation will prove that **SPEED NUTS** should be **YOUR** first choice, too. Write for information today.

**TINNERMAN PRODUCTS, INC., 2106 Fulton Road, Cleveland 13, Ohio**

In Canada: Wallace Barnes Co., Ltd., Hamilton, Ontario  
In France: Aerocessoires Simmonds, S. A., Paris

In England: Simmonds Aerocessories, Ltd., London  
In Australia: Simmonds Aerocessories, Pty. Ltd., Melbourne

# *Speed Nuts*

PATENTED

\*Trade Mark Reg. U. S. Pat. Off.

**FASTEST THING IN FASTENINGS . . . OVER 3000 SHAPES AND SIZES**

# WHISTLER PERFORATING—NOTCHING SLOTING—ROUNDING DIES

## MAKE TOUGH JOBS EASY

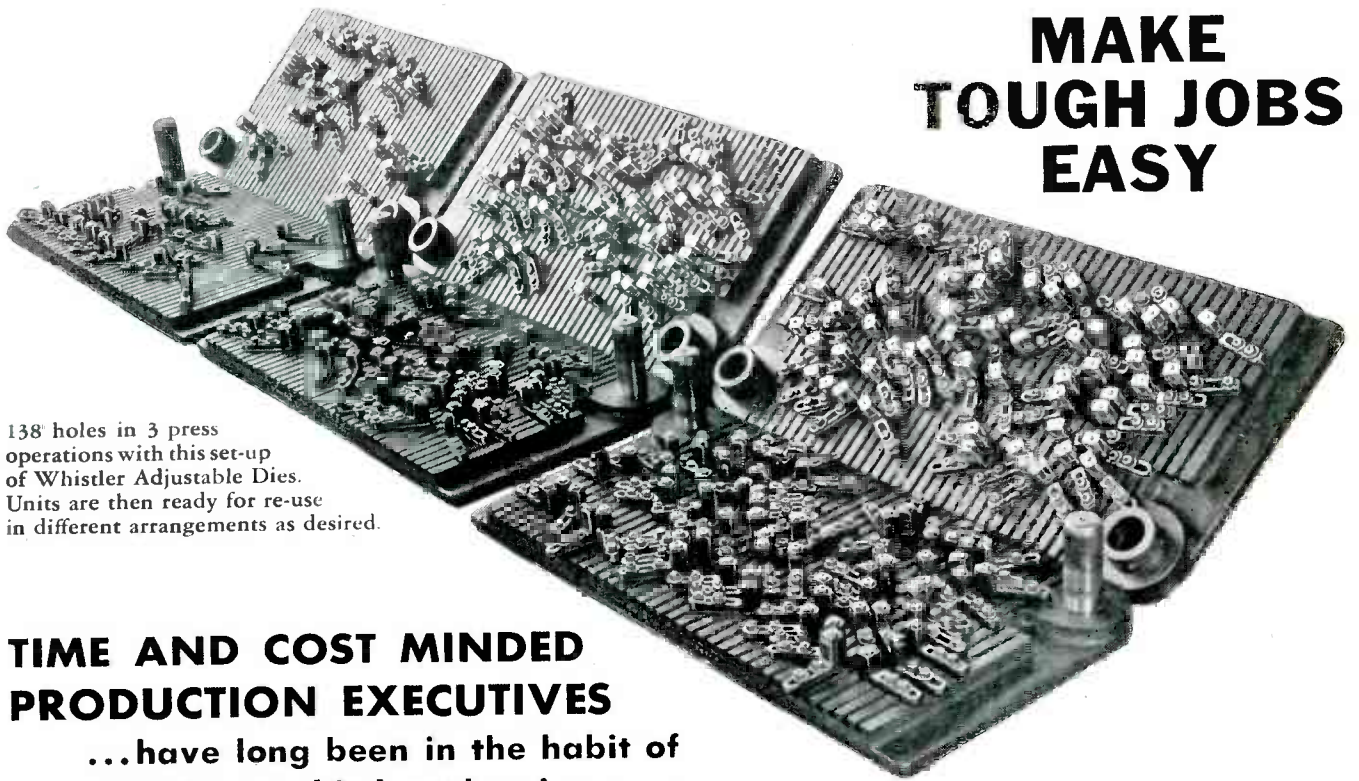

138 holes in 3 press operations with this set-up of Whistler Adjustable Dies. Units are then ready for re-use in different arrangements as desired.

### TIME AND COST MINDED PRODUCTION EXECUTIVES

...have long been in the habit of consulting Whistler when it comes to dies for work on sheet metals.

A leading Whistler achievement in reducing die-making and production costs is the multi-use Adjustable Perforating Dies which enable most set-ups to be made from stock units. The Single Hole Perforator, another Whistler development, presents new advantages in quick changes and a wide range of hole sizes. In fact Whistler adjustable dies, group dies, and single purpose dies have contributed greatly to the production achievements of the nation's leaders in practically every line of manufacture. Write for the Whistler catalogs and get the entire story of how to reduce manufacturing costs and get into production faster.

**S. B. WHISTLER & SON, INC.**  
752-756 MILITARY ROAD, BUFFALO 17, NEW YORK

Illustrated below, ready for production, is the Whistler Single Hole Perforator set with punch and die adaptor rings for perforating  $\frac{1}{32}$ " to  $1\frac{1}{2}$ " in mild steel to and including  $\frac{1}{4}$ " thickness when used with Whistler Punches, dies and strippers.

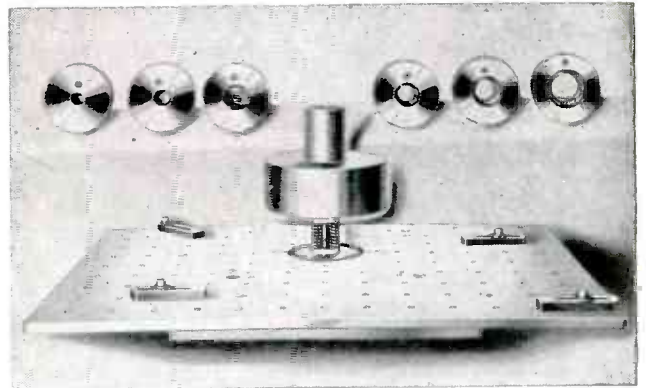

Group dies and special shapes to order. Often used on the press in combination set-ups with Whistler Adjustable Dies.

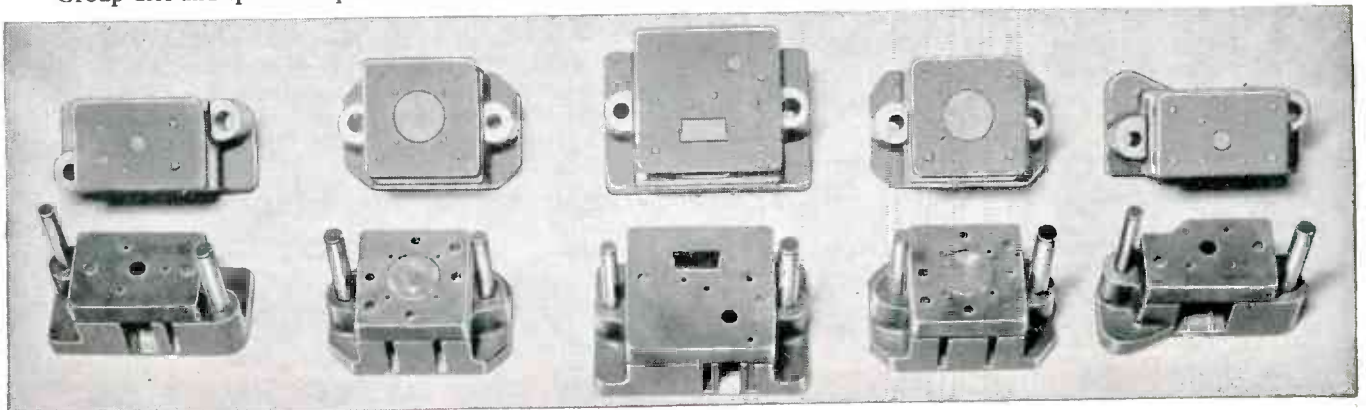



# TRANSMITTERS

by

# PRESS WIRELESS



**RADIO TRANSMITTER PW-981-A**

This compact 2500 watt, remote-control, air-cooled, radio transmitter is engineered to the same precision standards that characterize all Press Wireless communication equipment. Operating frequencies from 2.5 to 23 megacycles are available for radio-telegraph, radio-teleprinter, radio-photos and facsimile.

Amplitude ON-OFF keying speeds to 150 w.p.m. may be employed. A Frequency Shift Unit built into the transmitter permits the important advantages of high-speed frequency shift keying.

Radio transmitter PW-981-A combines simplicity of operation with carefully integrated design to occupy a floor space less than one square yard. The unit operates from a 3-phase, 220/230 volt, 50/60 cycle, 8-kilowatt power source.

Write for free engineering bulletin.

## PRESS WIRELESS, INC.

Executive and Sales Office, 1475 BROADWAY, NEW YORK 18



Awarded to our Hicksville, L. I. plant for outstanding achievement in war production.

PARIS · BUENOS AIRES · RIO DE JANEIRO · MONTEVIDEO · MANILA · BERNE · SANTIAGO DE CHILE · NEW YORK · CHICAGO · LOS ANGELES · LONDON · HAVANA

THE COMCO LINE IS

*Customized*

Engineered for Long Years  
of Dependable Performance

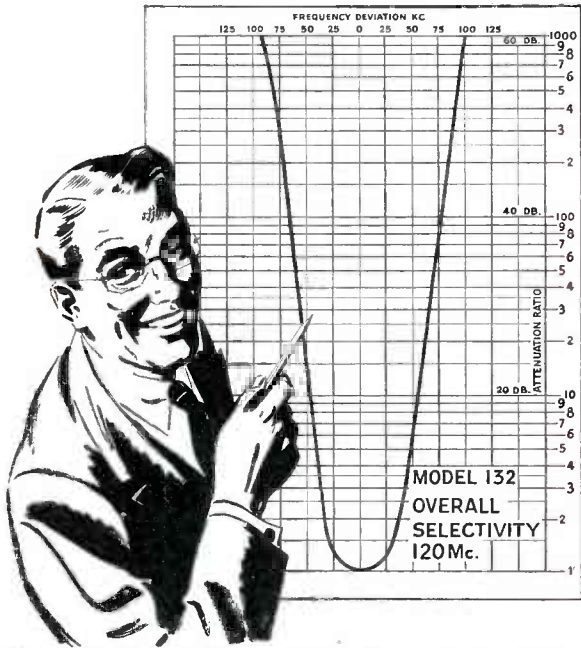

Painstakingly designed and built by seasoned engineers and skilled craftsmen in *limited* volume, COMCO Electronic Equipment, in every way, measures up to highest *custom* standards. Easy to service, COMCO guarantees you long years of dependable performance under all climatic and working conditions.

**COMCO TRANSMITTER Model 170**

Reliable VHF, 50 watts output. Frequency range 100 to 165 Mc. Cabinet size: Width 23"; depth 18"; height 48"; COMCO Model 127AA Transmitter also available for operation on a frequency range of 200 to 550 kc.



**COMCO RECEIVER Model 132**

Compact VHF crystal controlled, fixed frequency, superheterodyne. Single channel reception; 5 1/4-inch relay rack panel mounting, 12 tubes. Frequency range 100 to 165 Mc. Medium and low frequency receivers also available.



WRITE! Just a note on your company letterhead outlining your exact requirements. We'll give you the benefit of our specialized experience. We can supply a wide variety of customized equipment on priority NOW. We are accepting non-priority orders for post-war delivery.

MANUFACTURERS OF RADIO & ELECTRONIC EQUIPMENT



COMMUNICATIONS COMPANY, Inc.  
CORAL GABLES 34, FLORIDA

SONIC LOCATOR

(continued)

veloped under the direction of Major Edward McKaba of the special projects section. At first, experiments were made with the seismographic equipment borrowed from a nearby oil company. Recording bomb hits with these geophones was found impractical. For one thing, different types of soil and different amounts of moisture in the soil caused variations in the velocity of the ground tremors. Another obstacle with the geophones was that the recorder had to run constantly during the entire bombing period.

• • •

**Stabilized Pulse Circuit**

A SIMPLE AND USEFUL pulse circuit which it is claimed produces stable output pulses that are independent of tube or anode voltage changes is shown in the diagram.

Tube VT-2 is made to conduct by pulses applied between points A and B and generates its output pulse across the impedance Z. The cathode resistor  $R_5$  introduces negative feedback and stabilizes the anode current of tube VT-2 for any applied grid voltage, rendering the amplitude of the output pulses less sensitive to changes of tube or

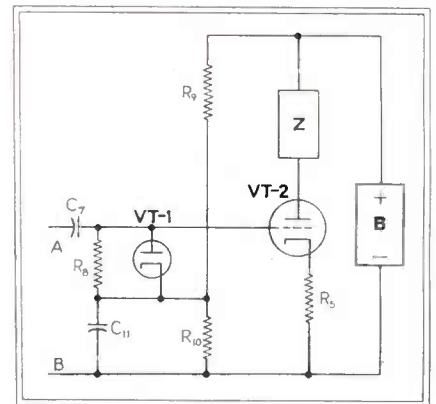

Pulses of constant amplitude are produced by this circuit

anode voltage. As negative feedback is used in the setup, the pulses applied between A and B will need to be larger than usual.

Tube VT-1 acts in conjunction with capacitor  $C_7$  and resistor  $R_6$  to form a peak wave rectifier and operates to adjust the bias on tube VT-2 so that the peaks of the incoming pulses always reach the same voltage and cause VT-2 to



# Now VIBRASHOCK\*

SERVES  
THE  
AIRLINES

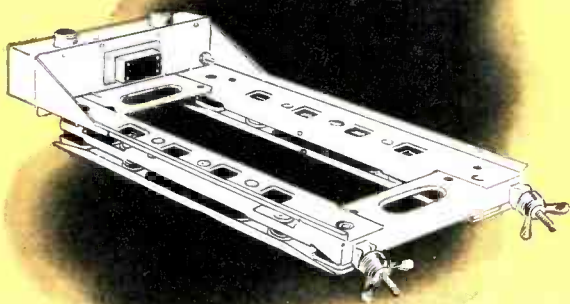

This Robinson Vibrashock suspension (Model W-386) supports all the ARC-1 radio transmitter-receivers. Originally designed for the Bell Telephone Laboratories, these Vibrashock suspensions are being supplied to both Western Electric Company and Westinghouse Electric and Manufacturing Company, the manufacturers of the ARC-1 transmitter-receiver.



These 14 airlines, through Aeronautical Radio, Inc., recently ordered a large quantity of the famous Navy ARC-1 radio transmitter-receivers, equipped with Robinson Vibrashock suspensions, which have helped to make this unit an outstanding success.

The significance of this order is that these airlines, alert to equip their airplanes with the most advanced airborne equipment available, are the first commercial companies to use the combat-proven Robinson Vibrashock suspension to support important radio communication equipment.

Vibrashock suspensions are the only complete, fully engineered suspensions guaranteed to absorb over 90% of all vibration within the operating range of aircraft. This is an efficiency rating far beyond previous shock mount standards.

Robinson engineers are available to aircraft radio and electronic manufacturers and users to help solve any vibration problem in connection with mechanical or electronic units requiring protection against vibration and shock.

\*Trade Mark

## ROBINSON AVIATION, INC.

730 FIFTH AVENUE, NEW YORK 19, N. Y.  
3757 WILSHIRE BLVD., LOS ANGELES 5, CALIF.



## MOVING AIR...

15 CUBIC FEET A MINUTE  
ONLY 2 1/2" OF SPACE NEEDED

The blower illustrated, No. 1 1/2\*, is one of many blower models manufactured by the L-R Mfg. Div. with C.F.M.'s at 8000 R.P.M. ranging from 15 to 270. These blowers will outperform many larger and heavier types formerly in use and where size and weight are factors, they are the answer to cooling problems presented by electronic tubes or circuit components in airborne communication units as well as in many industrial applications.

\*WEIGHT: 2 oz.; CAPACITY: 15 C. F. M. at 8000 R. P. M.;  
CONSTRUCTION: Housing of high impact phenolic plastic.  
Wheel is turbo-type cadmium-plated steel; SIZE: 2 5/8" long  
x 61/64" wide x 2 1/2" high.

L-R MANUFACTURING DIVISION OF

*The* **RIPLY** *Company*

13 NEW LITCHFIELD STREET

TORRINGTON, CONNECTICUT



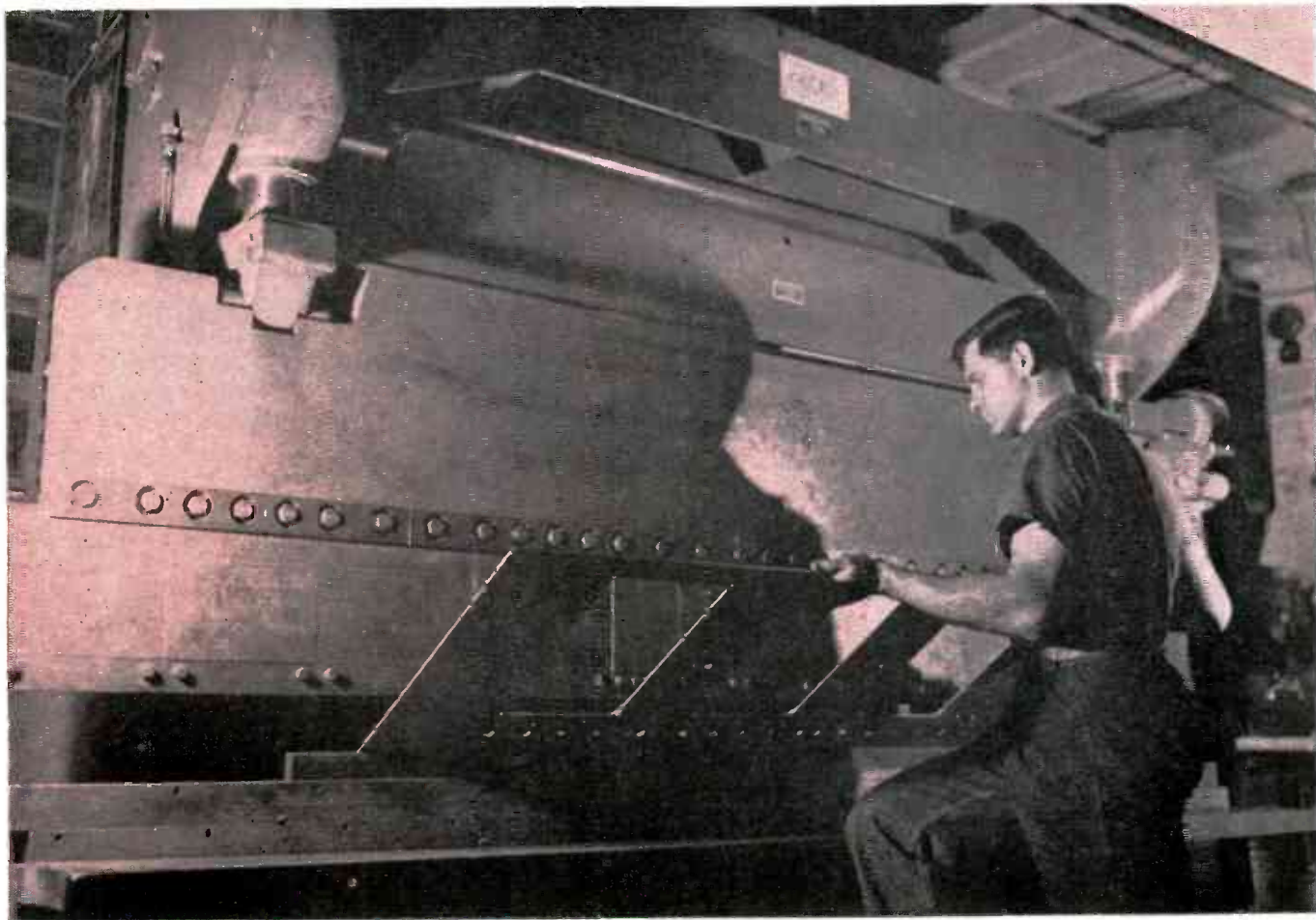

## No "Margin for Error" in PORTER operations

When you require sheet metal work — in any metal — and PRECISION to close tolerances is a must . . . Porter has the experience and equipment to meet your needs to your complete satisfaction.

The skilled technicians and engineers of our thoroughly modern factory stand ready to help you work out money-saving and time-saving changes in design. Also, our large stock of available dies often helps speed up production while reducing manufacturing costs.

**METAL BOXES \* CASES \* CABINETS \*  
CHASSIS \* ODD-SHAPED FLAT PIECES  
\* STRIPS \* PANELS \* HOUSINGS \* ETC.**

**PORTER**

**METAL  
PRODUCTS  
COMPANY**

121 INGRAHAM ST.

BROOKLYN, N. Y.

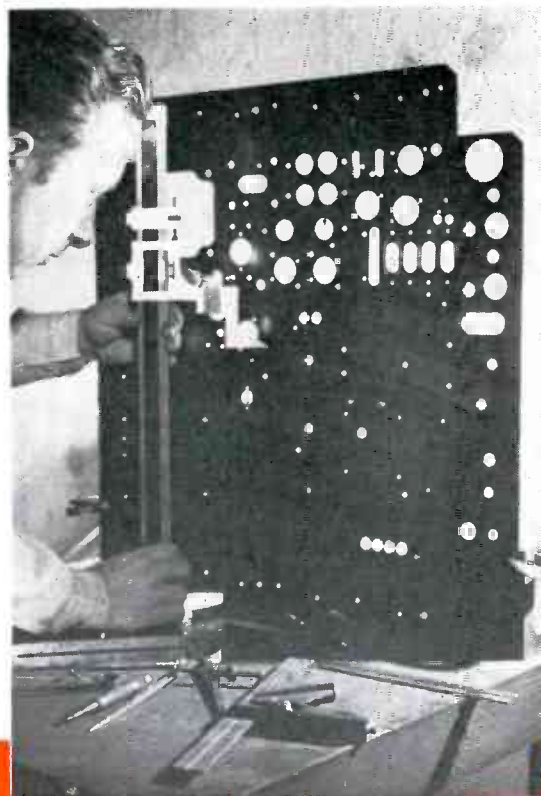

pass the same anode current. The voltage at which the peaks of the applied pulses are stabilized can be controlled by varying the values of resistors  $R_0$  and  $R_{10}$ . These determine the bias on the cathode of VT-1. Capacitor  $C_{11}$  is merely a bypass across resistor  $R_{10}$ .

A variation of the circuit is to replace the cathode resistor  $R_0$  with a constant resistance in the form of a delay network terminated with a matched resistance so that further pulses can be developed from the cathode.

In the schematic, tube VT-2 is shown as a triode but if the anode load presents a high impedance it may be advantageous to use a pentode. The circuit was developed in the E.M.I. Laboratories, England.

• • •

### Post War Receivers

By JOHN H. JUPE,  
London Correspondent

THE DESIGN of postwar domestic radio receivers is giving our manufacturers headaches, as none of them are sure of what the public wants. In the industry there is fair support for the abandoning of frills, e.g. magic eyes, and to reduce the number of knobs to a minimum. Personally, I have never seen the slightest justification for tuning indicators except as catch-eye advertising stunts. Most people listen to comparatively near and powerful transmitters and the sideband swish enables one to tune quite well without fancy devices. Even the persistent mistuners of superhets, chiefly women, seldom bother to use a magic eye if one is present.

Pushbutton tuning seems to be an answer to both the mistuning and simplified control problems and I think it may be used in all except the cheapest sets. My main hope in this field is that the pushbutton mechanisms will be better mechanical jobs.

At a recent I.E.E. discussion an important speaker pointed out that more attention ought to be paid to the low-frequency end of the audio response band and not so much to the high end. This, sadly enough, has a bitter taste attached to it, since any British radio dealer will

**WE MAKE MILLIONS**  
*Every day!*

• This isn't an unusual statement at all—not when you're talking about punched parts made of Laminated INSUROK! For in the electrical insulation field Richardson *precision* plastics have long been favorite materials . . . used by the millions in all shapes, sizes and thicknesses.

This outstanding preference is easy to understand, for Laminated INSUROK is an easy-to-handle product whose physical characteristics remain commercially uniform. It can be drilled, punched, sawed, turned, planed or milled in your own shop—without special tools—or Richardson Plastics will do it for you. Write today for the full story about INSUROK . . . laminated and molded.

**INSUROK** *Precision Plastics*

**The RICHARDSON COMPANY**

MELROSE PARK, ILL. NEW BRUNSWICK, N. J. FOUNDED 1869 INDIANAPOLIS 1, IND. LOCKLAND, CINCINNATI 15, OHIO  
DETROIT OFFICE: 8-252 G. M. BUILDING, DETROIT 2, MICHIGAN NEW YORK OFFICE: 75 WEST STREET, NEW YORK 6, N. Y.  
CLEVELAND OFFICE: 328-7 PLYMOUTH BLDG., CLEVELAND 15 OHIO



# UNEXCELLED FOR HIGH TEMPERATURE APPLICATIONS...



## CAN TYPES 25P

Two standard types, one for 105° C. and one for 95° C. continuous operation. Other ratings available.

## HERMETICALLY SEALED IN GLASS TUBES

Famous Sprague glass-to-metal end seals. Extended construction gives maximum flash-over distance between terminals.

## ...ideal for higher ratings in smaller sizes at lower temperatures

Sprague Capacitors impregnated with the exclusive VITAMIN Q impregnant make possible the use of much smaller units—with a substantial safety margin—on numerous high-voltage, high temperature applications ranging from transmitting to television. Where high temperature is not a factor, their unique characteristics assure materially higher capacity ratings for a given size.

Type 25 P VITAMIN Q Capacitors operate satisfactorily at thousands of volts at ambient

temperature as high as 115° C. Insulation resistance at room temperature is *more than 20,000 megohms per microfarad*. Throughout the temperature range of +115° C. to -40° C. they retain all virtues of conventional oil-impregnated capacitors.

### WRITE FOR NEW CATALOG

Sprague Catalog 20—just off press—brings you details on VITAMIN Q Capacitors in both can and glass tube types as well as dozens of other paper dielectric types for today's exacting uses.



**SPRAGUE ELECTRIC COMPANY • North Adams, Mass.**

# SPRAGUE

# VITAMIN "Q" CAPACITORS

TRADE MARK REG. U. S. PAT. OFF.



# HOLD THAT LINE

## WITH A SECO VOLTAGE REGULATOR

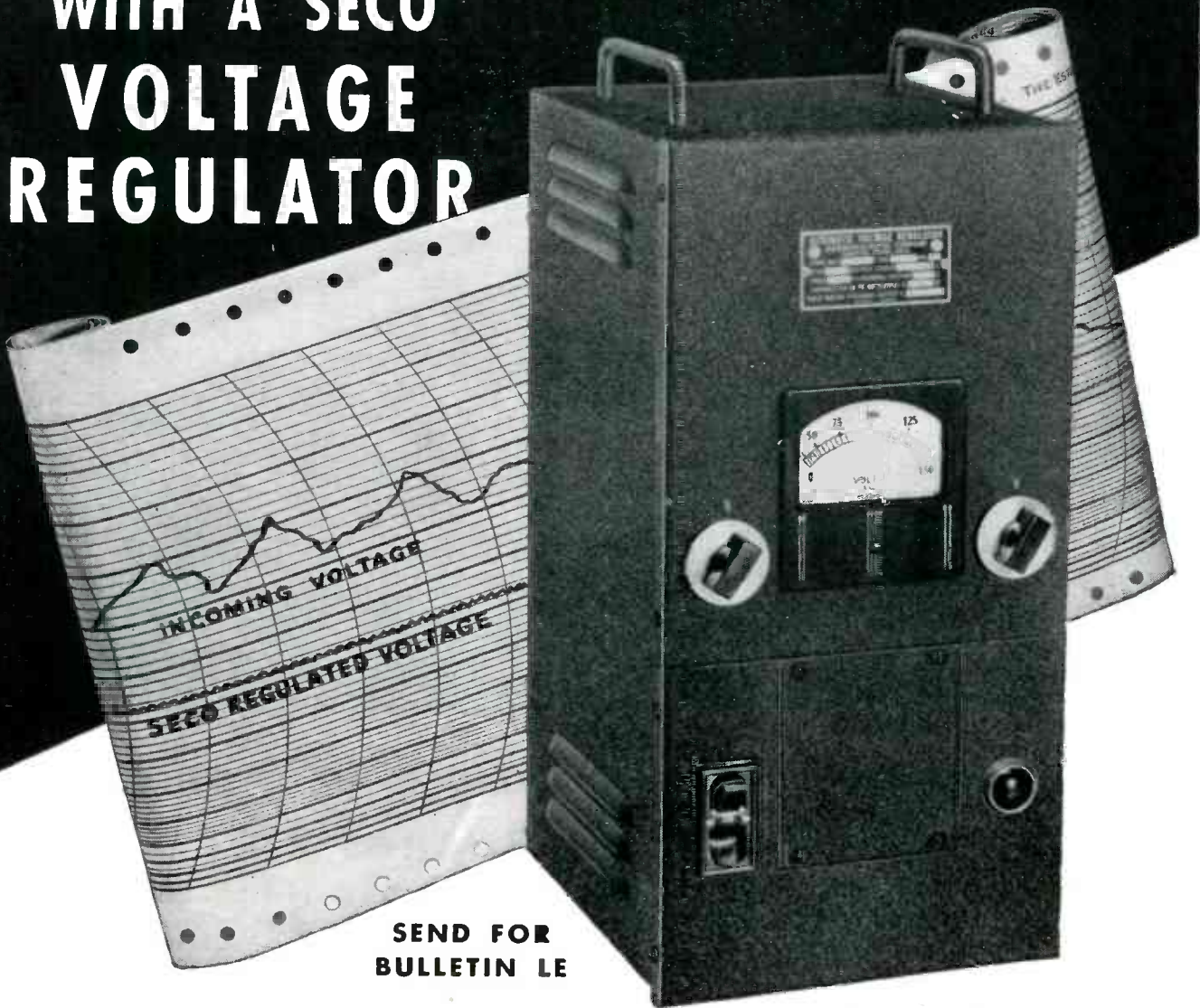

SEND FOR  
BULLETIN LE

**N**O matter what capacity a particular voltage control application requires, there is a SECO automatic voltage regulator to hold the incoming line voltage to a specified value. In contrast to other types of voltage stabilizers, these electronically-controlled regulators are not restricted to controlling small loads or certain types of equipment. Upon investigation, the potential user learns that SECO regulators offer trouble-free performance in supplying a constant voltage to any type of load up to 100 KVA. An example of the adaptability of SECO regulators to any requirement is model SVR 4101-H illustrated. Although the incoming line voltage might fluctuate from 95 to 135 volts, it will maintain a constant 115 volts to a 1 KVA load regardless of changes in the power factor or load current of the system. After installation there are no critical mechanical adjustments. Other decided advantages are zero wave-form distortion, adjustable output voltage and high efficiency. Type SVR 4101-H is designed for table or wall mounting, but is available on a standard relay rack panel for incorporation as a component part of existing equipment. To those interested, the SECO engineers will be pleased to offer suggestions and recommendations on any voltage control problem.

### SUPERIOR ELECTRIC COMPANY

408 LAUREL STREET

BRISTOL, CONNECTICUT





# Save Time . . . Cut Costs!

**If your product requires  
electrical wiring—**

## *Whitaker Can Wire It*

A lower cost of manufacturing is one of many advantages Whitaker offers you through our engineered wiring service. We are wiring *specialists*, and if your production needs include WIRING HARNESSSES . . . BONDING JUMPERS . . . CABLE ASSEMBLIES . . . CABLE or TERMINALS — you'll find Whitaker is a dependable source of supply . . . In addition to an engineered wiring service, Whitaker also offers a quality line of standard cable products. We invite you to write and advise us of your needs.

### **WHITAKER CABLE CORPORATION**

General Offices: 1307 Burlington Avenue Kansas City 16, Missouri  
Factories: Kansas City, Mo. • St. Joseph, Mo. • Philadelphia • Oakland

# Flexibility of Design



and  
compactness  
with **ACRO Switches**

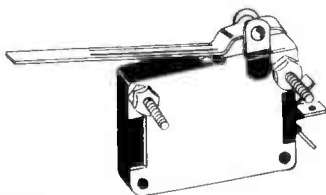

• Mechanism of the patented Acro Rolling Spring switch lends itself to adaptation in various shapes to fit the design of your units. Multiple mountings—flat or vertical—end to end, or side by side. Small case shapes—rectangular or curved. Various types of brackets for flexibility of mounting. Actuation pressure as low as two grams (using leaf bracket) or as high as 1 ¼ lbs. Surely one of the many ACRO Model "M" designs should fit your needs. Send your design details showing space dimensions and operating features for quicker reply.

**ACRO ELECTRIC COMPANY**

1316 Superior Avenue

Cleveland 14, Ohio

tell you that it is easier to sell a set on good low-note response rather than on good overall response or at the high end. One told me that a set with a heavy, thumping bass and no high notes was an ideal one from the sales point of view, although he admitted that there has been a slight improvement in public taste, poisoned in the earlier days of radio by sets made to sell at a maximum profit and hang the quality of reproduction.

Miniature components I cannot see as particularly desirable in ordinary domestic sets. In airborne, car or lightweight portables they may have something in their favor but the irrational craze to do things in miniature has always afflicted human beings and radio engineers must be on their guard against it. The Lord's Prayer has been written on a grain of rice but the technique has little to commend it in everyday life and anyway, as L. H. Bedford of Cossors has pointed out, the greatest obstacle in the way of miniature components is that nobody has yet invented a miniature watt.

**Narrow-Band Relay System.** A simple but useful idea for using limited-frequency-response transmitters for the relaying of high quality broadcast programs is brought forward in the June 1945 issue of *Wireless World* by W. Stockman, editor of *Popular Radio*, Stockholm.

He proposes to record the program on disks or tape and to use this canned version, running at sub-normal speed, to modulate the transmitter. The audio frequencies would decrease in the same ratio as the speed but would retain the same relative strengths.

Since high audio frequencies would be absent the receiver could have limited bandwidth (actually it could be reduced in the same ratio as the speed) and the overall noise level would be lower. There would also be a reduction in selective fading.

At the receiving end the program would have to be recorded and then reproduced at normal speed. Since many broadcasting stations have recording gear the cost of us-



**TESTIMONIAL TO PERFORMANCE!**



## ... THORDARSON TRANSFORMERS

The quality of a product and its performance over the years can best be judged by the repeat orders received. Repeat orders mean one thing above everything else . . . *customer satisfaction!*

For over 50 years, *Thordarson* has supplied transformers and other electronic products constantly to many of the most prominent manufacturers in industry. Yes, *Thordarson* has always enjoyed a large repeat order business.

At *Thordarson* . . . continuous research, progressive design and engineering are responsible for the development of the excellent transformers that have earned for *Thordarson* this reputation for fine performance.

Try *Thordarson* for your transformer requirements. Then you, too, will know why the many long-time users of *Thordarson* show their approval by repeat orders. New sales and distribution policies make *Thordarson* products available to everyone, everywhere.

500 WEST HURON ST., CHICAGO, ILL.

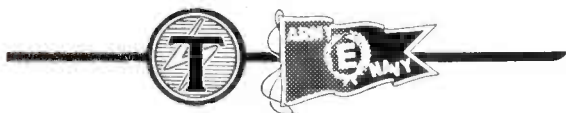

ORIGINATORS OF TRU-FIDELITY AMPLIFIERS

**THORDARSON**  
ELECTRIC MANUFACTURING DIVISION  
MAGUIRE INDUSTRIES, INCORPORATED

# NATVAR INSULATED

## Redmond DYNAMOTORS

### Meet Flight Conditions



Natvar VC is furnished in two shapes, punched to Redmond's dimensions and angular specifications. The window-like piece insulates end turns between high voltage coils; the rectangular piece insulates high voltage from ground and from low voltage winding.



- Type 8 Dynamotors built by the Redmond Company, Inc., Owosso, Michigan, deliver high voltage for electronic equipment in fighter planes. They must be extremely durable, light to the last fraction of an ounce, and able to withstand changes in ambient temperatures ranging more than 160°F

**B**EFORE Redmond Dynamotors fly, they are put through temperature, humidity and corrosion tests exceeding anything found either in the Tropics or in the Arctic. Electrical tests are equally rigid. Ground tests are made at 1750 volts.

Insulation must be top-quality — light in weight, but high in dielectric strength; extremely uniform, and accurately punched. Natvar Special Thin Varnished Cambric is consistently meeting these requirements.

We are interested in your requirements. Write, wire or phone us for deliveries, either from nearby wholesalers' stock or from our own.



- Varnished cambric — straight cut and bias
- Varnished cable tape
- Varnished canvas
- Varnished duck
- Varnished cellulose acetate
- Varnished special rayon
- Varnished Fiberglas cloth
- Varnished papers
- Varnished tubings and sleeving
- Varnished identification markers
- Lacquered tubings and sleeveings
- Extruded vinyl tubing
- Extruded vinyl identification markers

Write for Catalog No. 20

**THE NATIONAL VARNISHED PRODUCTS Corporation**

TELEPHONE  
RAHWAY 7-2171

CABLE ADDRESS  
NATVAR: RAHWAY, N. J.

201 RANDOLPH AVENUE

★ WOODBRIDGE NEW JERSEY



## GOOD NEWS FOR BROADCASTERS!

### REL 88-108 Megacycle Band FM BROADCASTING TRANSMITTERS in ASSEMBLY PLACE YOUR ORDER NOW!

These REL broadcasting transmitters can now be ordered . . . to meet or exceed present FCC requirements.\* Entirely new . . . with important design advancements in the Armstrong Modulator . . . providing simple, stable . . . even more efficient performance than ever before!

Power Output	Cat. No.
250 watt	549 ADL
1000 watt	518 ADL
3000 watt	519 ADL

Note: Future REL advertisements will give you information regarding transmitters of higher power. Watch for them!

Wire or write today for technical data, prices and delivery . . . or better yet . . . do as other broadcasters have already done—send your order, subject to later confirmation, thus assuring early delivery.

\*REL FM Transmitters are guaranteed to meet or better the FCC standards of good engineering practice for FM Broadcast stations.



#### SALES REPRESENTATIVES

Michigan  
M. N. Duffy & Co., Inc.  
2040 Grand River Ave., W.  
Detroit, Mich.

Midwest  
REL Equipment Sales, Inc.  
612 N. Michigan Blvd.  
Chicago, Ill.

Pacific Coast  
Norman B. Neely Enterprises  
7422 Melrose Avenue  
Hollywood 46, Cal.

PIONEER MANUFACTURERS OF FM TRANSMITTERS EMPLOYING ARMSTRONG PHASE-SHIFT MODULATION

## RADIO ENGINEERING LABS., INC.

*Long Island City, N.Y.*

# ELECTRONIC AC VOLTMETER

## with Logarithmic Scale

Percentage Accuracy  
of reading is uniform  
over entire scale!



MODEL 300  
ELECTRONIC  
VOLTMETER

### ACCESSORIES

MODEL 220 DECADE AMPLIFIER  
MODEL 402 MULTIPLIER

*Since its development in 1935 the Ballantine Electronic AC Voltmeter is the only instrument of its kind with a Simplified Logarithmic Scale.*

The important feature of logarithmic scale indication in the Ballantine Voltmeter provides the same degree of accuracy at 1 as at 10. Also the simplicity of this scale reduces errors in visual observation, common with most multi-range instruments. Finally, the care taken in overall calibration combined with the inherent stability of the circuits used permits reliable readings within the 2% specified tolerance over the complete range of operation.

Write for descriptive  Technical Bulletin 8

## BALLANTINE LABORATORIES, INC.

BOONTON, NEW JERSEY, U. S. A.

ing this new system would be only the cost of increased transmission time.

A 5:1 ratio has been proposed; that is, a program which would normally be handled by a transmitter of 100-5000 cps response could be handled by one of 20-1000.

**Television Talk.** If a dozen radio men meet over here nowadays you can be pretty sure that there will be at least twelve theories presented as to how television should be restarted in Britain. Good engineers say that the old 400-line system should be revamped. Other and equally good engineers say that we should go up to 1000 lines and 100 Mc carrier frequencies. And how are we going to distribute the programs from central points? Wave guides—u-h-f links—coaxial cables; nobody seems to have any compelling ideas on the point.

On the other side of the fence sits the man who is going to buy a set and install it at his fireside. He has been told a lot about what electronics has done during the war and if something really good cannot be produced fairly quickly after hostilities cease he will just sit back and say, "I'll wait for a few years until sets get cheap and the results are worth seeing". In fact a lot are saying that already and if anything is going to kill television stone-dead it is that kind of outlook.

**Sensory Electronics.** Two groups who could well benefit from the more intensive researches of electronicists are the deaf and the blind. Deaf aids certainly exist but it is high time that steps were taken to redesign them and to reduce the exorbitant prices which are charged. Similarly, we could do much more to make talking books accessible to the blind. The Central Library of the National Institute for the Blind in Great Britain has only 464 books recorded. The average number of disks for each book is 10. They are doublesided 12 inch, with 200 grooves to the inch and playing at 24 rpm.

**Transparent Ultraviolet Barrier.** One of our war-time chemical discoveries which has proved very useful to the engineer is a paint which



Radio  
Masterpieces are  
yours to keep  
on

*"The Wise  
that Remembers"*



Designed  
and Made in Grand Rapids

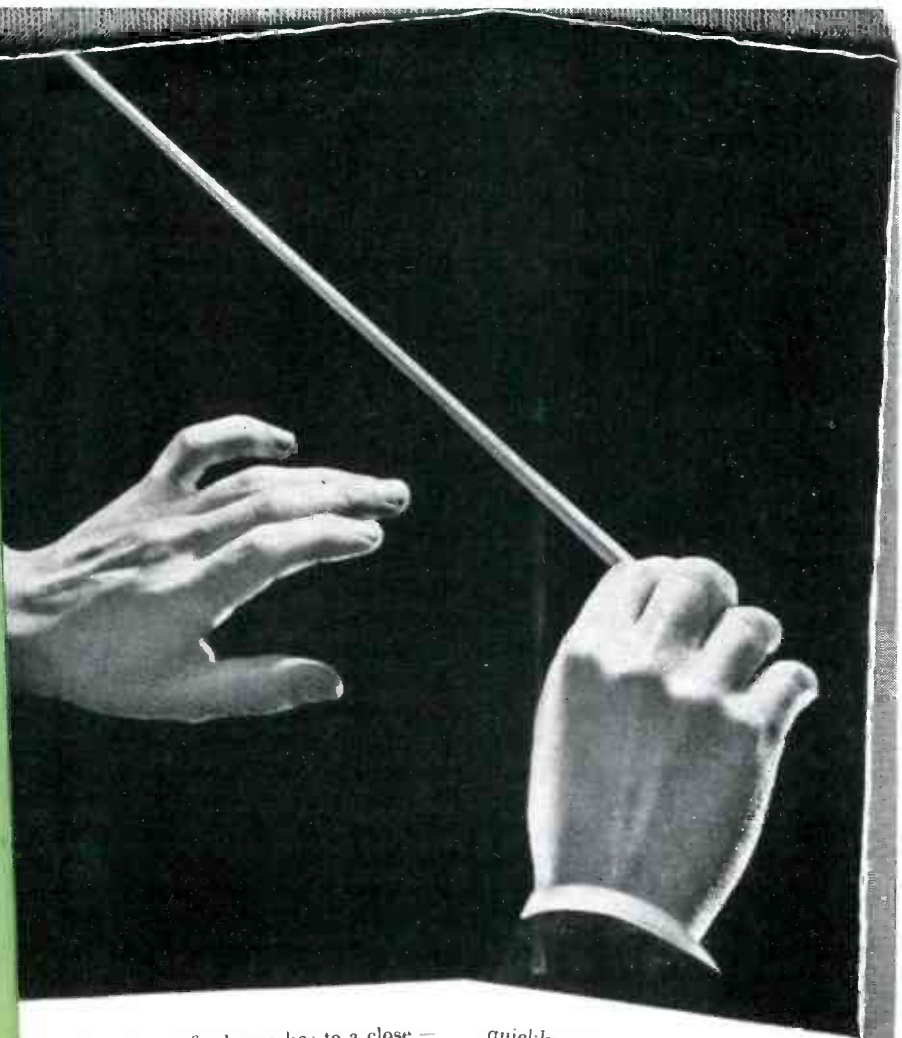

The stirring finale crashes to a close — the work of the master conductor is over — the broadcast has ended. It was a spectacular outstanding interpretation. But it's gone.

How wonderful to have this music — this particular performance — to hear over and over — as often as you wish — with all its superior qualities preserved for years.

This is not farfetched. Today it is a reality. Simply! Easily! With as little effort as snapping a switch.

How? With a development of Lear — a new way of recording — the wire that remembers.

As this slim wire speeds across the poles of a magnet, it gathers these masterpieces of music, the dramas, your favorite broadcasts from the air. Or it records your own voice, the songs of children, the fun of your friends.

It gives you all this to keep forever if you want to. What you don't want is

quickly erased — simply by recording something else over it.

You've never seen anything like the Lear wire that remembers. In fact you've never seen a radio like Lear's — a master radio creation which brings you the finest achievements in FM, television, easily tuned, world-wide short wave, and phonograph-combination automatic record-changing. It is the only kind of radio that will satisfy you. Make it a point to see and hear the Lear Radios just as soon as war work permits Lear to produce them.



Listen to Orson Welles every  
Sunday afternoon 1:15 EWT  
on your local station of the  
American Broadcasting System

# LEAR RADIO

LEAR, Incorporated

Home Radio Sales: 230 E. Ohio St. Chicago 11, Illinois • Radio Division: Grand Rapids 2, Michigan

# Continental-Diamond *Engineered Dielectric Materials*



The part illustrated is a machined Dilecto XX Insulation Terminal Block. It is used in circuit controllers in railway signal equipment. It mounts current carrying parts and must be strong as well as being a Dielectric.

KP-45

On the modern Railroad, with its high speed comfort and safety, signal systems must function without fail. The role which C-D Dielectric materials play in insulating Railroad Signal Systems demonstrates their remarkable combination of properties. Resiliency . . . toughness . . .

long life . . . adaptability to fabrication . . . electrical insulating properties . . . combine in C-D Dielectrics to provide engineers and designers with NON-metallic materials that will answer many "What Material?" problems.

## C-D PRODUCTS

### The Plastics

**DILECTO**—A Laminated Phenolic.

**CELORON**—A Molded Phenolic.

**DILECTENE**—A Pure Resin Plastic Especially Suited to U-H-F Insulation.

**HAVEG**—Plastic Chemical Equipment, Pipe, Valves and Fittings.

### The NON-Metallics

**DIAMOND** Vulcanized FIBRE

**VULCOID**—Resin Impregnated Vulcanized Fibre.

**MICABOND**—Built-Up Mica Electrical Insulation.

**Standard and Special Forms**  
Available in Standard Sheets, Rods and Tubes; and Parts Fabricated, Formed or Molded to Specifications.

### Descriptive Literature

Bulletin GF gives Comprehensive Data on all C-D Products. Individual Catalogs are also Available.

### DISTRICT OFFICES

NEW YORK 17 • CLEVELAND 14 • CHICAGO 11  
SPARTANBURG, S. C. • SALES OFFICES IN PRINCIPAL CITIES

WEST COAST REPRESENTATIVES  
MARWOOD LTD., SAN FRANCISCO 3

IN CANADA:  
DIAMOND STATE FIBRE CO. OF CANADA, LTD., TORONTO 8

# Continental - Diamond FIBRE COMPANY

Established 1895.. Manufacturers of Laminated Plastics since 1911—NEWARK 16 • DELAWARE



Belden Connect-A-CORD



**A new and effective sales feature**  
*for* **your newly designed appliances**

**what is the Belden  
CONNECT-A-CORD?**

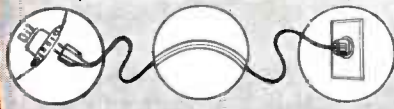

CONNECTOR + CONDUCTOR + PLUG

**Appliance users  
want this new advantage**

The Belden Connect-A-cord is a new idea—but already surveys show that considerable percentages of electrical appliance users want its advantages. No mere postwar dream, the Belden Connect-A-cord is already engineered. It is offered now only after a thorough check establishing a customer demand for it on better electrical equipment.

Detachable at *both* appliance end and plug end, Belden Connect-A-cords are something new in electrical cords. They greatly simplify line assembly, packing, and product display, and they add still another effective sales feature to your newly designed electrical appliances. Available in matching colors and in almost any length, Connect-A-cords are completely interchangeable—ending the nuisances of too-short-to-reach cords and tangled coils of extra lengths.

Connect-A-cords eliminate dealer cord repair service and, like all other Belden electrical cords, offer complete freedom from Corditis. Also, consistent national advertising pre-sells Connect-A-cords to your customers. Write for information today.

Belden Manufacturing Company  
4625 W. Van Buren St., Chicago 44, Ill.

**Belden**

*Corditis-free* **CORDS**



# Why **MEPCO** "Tru Tolerance" **RESISTORS** are "Tops" with Manufacturers of Instruments, Radio, Electronic Equipment

## They're Triple Improved!

### ACETATE LABEL

Tougher, cleaner, more durable covering. Protects winding from mechanical handling. Prevents lugs from piercing label. Affords fungus protection to winding.

### ADDED INTERNAL INSULATION

Cross-over wires are insulated from rest of winding with acetate cloth. An exclusive Mepco feature (patent pending).

### DOUBLE SEAL IMPREGNATION

Prevents breakdowns and shorted turns. Withstands humidity and salt spray tests better. Is fungus resistant.

### Non-Hygroscopic Ceramic Forms:

High insulating value, low expansion coefficient, high mechanical strength.

### Highest Grade Alloy Wire:

Especially enameled to meet most rigid tests.

### Extra Terminal Protection:

Lug type winding leads and lug embedded and molded into one unit. Lead wire type securely anchored in grooves with winding wire protected so as to prevent possible breaking in handling.

### True Tolerance Precision Resistors:

Standard tolerance 1%. Special tolerances down to 0.10% on special orders.

### Severe Breakdown Test

for every unit. Rejections minimized by special winding technique which prevents chafing of wire.

### Careful Calibration

and precision winding keep all units well within specified tolerances.

Send us your requirements on special resistors for quotation.



## MADISON ELECTRICAL PRODUCTS CORPORATION

MADISON, NEW JERSEY

Precision Resistors · Thermocouples  
Voltmeter Multipliers  
Electronic Specialties

GET THE MEPCO RESISTOR GUIDE. IT'S FREE! Shows all Mepco standard sizes and gives complete data as to electrical and mechanical characteristics.

Madison Electric Products Corp.  
 Madison New Jersey  
 NAME.....  
 POSITION.....  
 ADDRESS.....  
 CITY.....STATE.....

is opaque to ultraviolet light but transparent to visible light.

The problem arose in connection with instruments on the control panels of aircraft, where u-v light is sometimes used to render scale markings clearly visible to the pilot.

A snag arose, however, when certain equipment involved the presence of a cathode-ray tube on the panel, since u-v light caused the whole of the phosphor to glow and so the trace was effectively obliterated.

Research showed that the solution lay in spraying the end glass of the c-r tube with a colorless nitro-cellulose laquer containing a little picric acid. This effectively blocked the u-v but did not decrease the visibility of the tube trace.

**Shipyard Strain Gages.** I notice in *Shipbuilding* that resistance strain gages have been used in marine boiler investigations. Wire 0.001 in. in diameter was wound on a flat form and bonded in the usual manner with resin-impregnated paper. A particular research involved the strains on boiler plates, the experimental method being to work on a test box having panels representative of those in the combustion chamber of a boiler.

**Random Radiations.** "The power which has to be measured (cross talk between carrier channels) may be less than a hundredth of a millionth of a microwatt. As heat energy, this is roughly equal to that from a 60 watt lamp falling on a collector one foot square at a distance of 4000 miles."—W. G. Radley. (G.P.O. Research Station).

**Radioplanets To Order.** An official of the British Interplanetary Society has brought forward an interesting, and apparently quite sound proposal based on the tremendous speed of the Nazi V-2 weapon. He points out that if a rocket could be given a velocity of about 8 kilometers per second (about 3 times that of V-2) it could be sent up to the stratosphere and would circle the earth forever, as an artificial satellite.

The value of the device would lie in the fact that it could carry meteorological instruments and radio the readings back to earth at regu-



# THESE MODERN RIVETS IMPROVE MODERN ELECTRICAL FASTENING

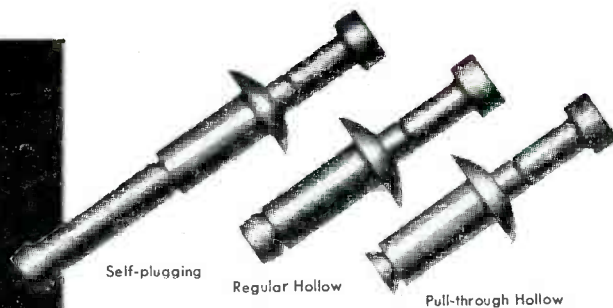

CHERRY BLIND RIVETS are designed to meet the installation requirements of modern electrical fastening, as well as to simplify and speed up blind and hard-to-get-at rivet applications.

They are upset in a modern way—with a pull exerted by small, easy-to-handle Cherry Rivet pneumatic or hand guns. Installation can be made by one operator from one side of any location, blind or not, without bucking.

Cherry Rivets conform to modern contours; hold securely on curved surfaces, in tubes, bends and ducts; fasten double surface structures from one side.

Modern materials such as plastics, rubber, leather, fabrics, plywood, as well as all sheet metals can be fastened quickly, easily, and with complete success.

Cherry Rivets meet the stress and strain requirements of modern uses. They aid in simplifying and speeding up modern production and repair methods. Because of their wide range of applications, they allow greater flexibility in modern designing.



Arrows indicate Cherry Rivet installations.

The installed appearance of Cherry Rivets is up-to-date, modern—enhances the appearance-value of the finished product. And their installed cost is low.

For more information, contact your nearest jobber or write now for illustrated Manual D-45, Dept. A-120, Cherry Rivet Company, 231 Winston Street, Los Angeles 13, California.



CHERRY RIVETS. THEIR MANUFACTURE & APPLICATION ARE COVERED BY U. S. PATENTS ISSUED & PENDING



Hollow Cherry Rivets are best adapted for radio installations. They exert an exceptionally strong clinch—hold securely—can be easily removed for further servicing.



Small, one-hand G-25 gun shown below has head at right angles to gun axis to provide easy access to tight, crowded locations typical of radio installations.



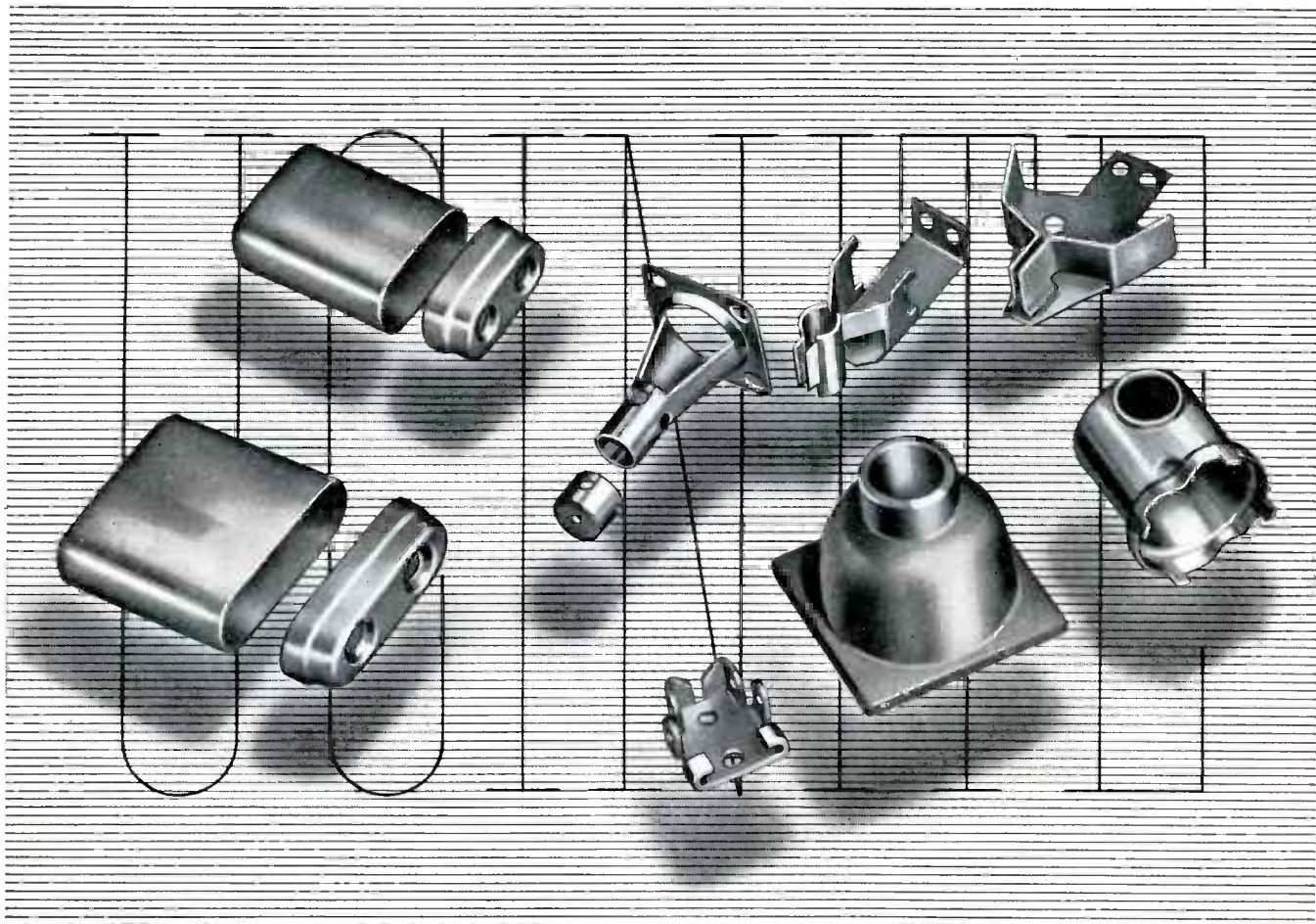

**HAVE YOU HEARD ABOUT UCINITE'S**

## *one operation?*

Every one of these was made in a single operation at Ucinite. They were all blanked and drawn on eyelet machines. But even on close examination some experts have doubted that they could be produced complete without any extra processes or finishing.

It takes more than the right kind of equipment to turn out such intricate metal parts in one operation. At Ucinite we are fortunate in having the highly skilled people who can do it.

From the service angle, of course, we would just as soon handle this kind of work in complete assemblies wherever possible.

**The UCINITE CO.**

*Newtonville 60, Mass.*

Division of United-Carr Fastener Corp.

*Specialists in* **RADIO & ELECTRONICS**

**LAMINATED BAKELITE ASSEMBLIES**

**CERAMIC SOCKETS • BANANA PINS &**

**JACKS • PLUGS • CONNECTORS • ETC.**



# Now, as before, expect quality leadership in Collins broadcast equipment

THE NEW COLLINS AM transmitters and remote amplifiers, now ready, reflect characteristically advanced Collins engineering.

Notable transmitter refinements include extremely high fidelity, and increased safety factors through the use of oversize components throughout.

The Collins 21A is a superb 5,000 watt transmitter, with reduced power operation at 1,000 watts also available. Its response curve is flat, within  $\pm \frac{1}{2}$  db, from 30 to 10,000 cycles.

The Collins 20T is a 1,000 watt transmitter, of similar characteristics, equipped for reduced power operation at 500 watts if desired.

The Collins 300G is a 250 watt transmitter of equal fidelity, with reduced power operation at 100 watts available.

The Collins 12Y one channel remote amplifier is light, handy, simple and efficient. It is for unattended operation from a 115 volt a.c. power source.

The Collins 12Z four channel remote amplifier is a.c.-d.c. powered, the d.c. source being self-contained batteries which take the load automatically in case of a.c. line failure.

A complete line of Collins high-quality studio equipment is available for either AM or FM application.

An outstanding broadcasting station begins with outstanding equipment. We will be glad to know about your plans and submit complete recommendations. For additional detailed information, write the Collins Radio Company, Cedar Rapids, Iowa; 11 West 42nd Street, New York 18, N. Y. Collins equipment is sold in Canada by Collins-Fisher, Ltd., Montreal.

... FOR BROADCAST QUALITY, IT'S ...



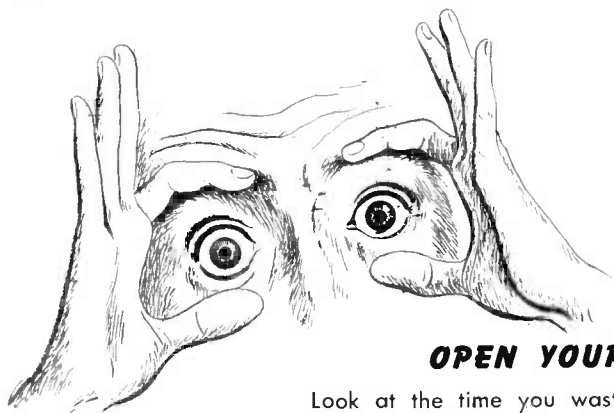

### OPEN YOUR EYES

Look at the time you waste making smudges and trying to unmake them . . . on tracing paper. Look at the foggy reproduction. Then look at Arkwright Tracing Cloths.

### A CHOICE THAT'S WISE

Arkwright Tracing Cloths have the surface for clean erasing and easy, clear re-inking . . . and the transparency to give sharp reproduction.

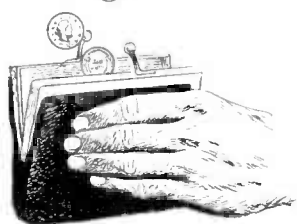

### A WAY TO ECONOMIZE

It's what you get for what you pay that determines cost. In Arkwright Tracing Cloths you get time saving, quality saving and a plus . . . durable transparency. Prove it by writing today for free samples. Arkwright Finishing Company, Providence, Rhode Island.



Sold by leading drawing material dealers everywhere

# Arkwright

## TRACING CLOTHS

AMERICA'S STANDARD FOR OVER 20 YEARS

lar intervals. Revolving once in 24 hours it would be within optical range of half the earth's surface and three receiving stations 120 degrees apart would be sufficient for receiving the data. Batteries would, of course, only have a limited life but it is suggested that photocells and thermo-couples could be used to switch off the electrical gear for much of the time and so increase the period over which we could get results.

**Photo-Mechanical Oscillators.** For medical and other biological research, it is sometimes required to produce oscillations at a frequency below 10 cps and two interesting pieces of equipment for producing these were described in *Electronic Engineering* recently.

The first was simply a sectored disk revolving in front of a circular aperture through which light passed on to a photocell. With a 1-watt bulb and a rectifier-type cell the output was 5 mv at frequencies between 1 and 100 cps with only about 5 percent odd harmonics in the waveform.

A rather more complicated arrangement of this principle enables waves to be synthesized, with the phase and amplitude of harmonics up to the tenth, controllable with respect to the fundamental.

Two disks are used, each drilled with five rings of holes, one disk giving the fundamental, 3rd, 5th, 7th and 9th harmonics while the other has spacings to give the 2nd, 4th, 6th, 8th and 10th. A small photocell is mounted opposite each ring and each cell is mounted on a lever, so that it can be rotated about an axis in line with the disk spindle. This allows phase adjustment. Potentiometers connected across the cells give amplitude adjustment.

A variable-speed phonograph motor is used for driving purposes and a carefully prepared stroboscopic disk, used in conjunction with a neon lamp, allows accurate frequency determination. The output of the apparatus is 0.5 mv in the range  $\frac{1}{2}$ -4 cps and owing to the low output it was found necessary to screen the driving motor with Mumetal.



THE HIGH SPEED LATCH

# HEINEMANN MAGNETIC CIRCUIT BREAKERS *Have THREE Great Advantages*

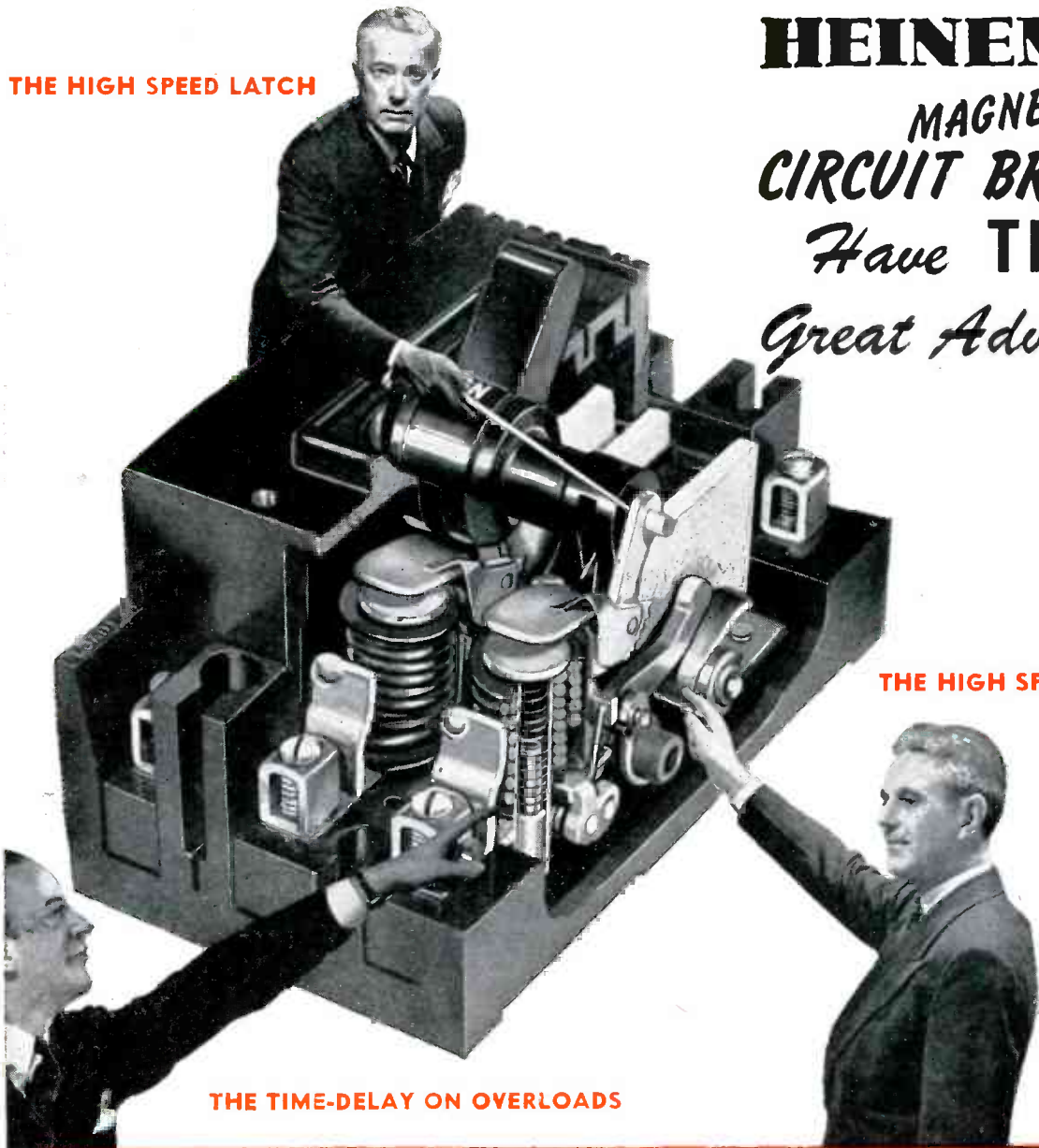

THE HIGH SPEED BLOWOUT

THE TIME-DELAY ON OVERLOADS



Above sketch shows the action of the Time Delay Tube, which prevents the breaker from opening on sudden inrush current, but allows it to open on sustained overloads. This is done by means of the plunger action in the liquid-filled tube. The speed with which the plunger is drawn toward the magnetized pole piece depends on the viscosity of the liquid. (At left—plunger in normal position. At right—after overload has attracted plunger to pole piece, opening contacts).



The Latch Mechanism performs two functions: (1) It opens the breaker with the least mechanical delay, and (2) It opens the breaker independent of handle operation. Of all known latches, this mechanism operates with the least amount of friction and with the greatest speed. The Latch collapses only under overload or short circuit conditions—and it does that even if the handle is held in the "on" position.

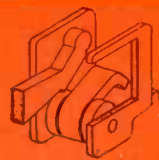

Speed is added to the arc interruption by means of the High Speed Blowout shown above. Magnetic blowout contacts are mounted in individual arcing chambers, carefully insulated from each other. These add speed to the arc interruptions. As the value of the current to be interrupted increases, the quenching effect becomes greater, due to the intensified magnetic blowout field.

## HEINEMANN CIRCUIT BREAKER CO.

Subsidiary of Heinemann Electric Co.—Est. 1888

97 PLUM STREET

TRENTON, N. J.

# WHAT DO YOU WANT IN A CABLE?



**ANSONIA**  
and  
**ANKOSEAL**  
can supply the  
combination of  
Qualities You Need!

To do your job and do it right, you need cable with certain characteristics. Three or four or more factors—heat resistance, dielectric strength, flexibility and durability, for instance—must be satisfied in the *one* cable. You *can* settle for less—but when a cable fails, it's *your reputation* that suffers.

At Ansonia, electrical cable is engineered to meet *all* necessary requirements as far as that is possible. And,

thanks to ANKOSEAL, a remarkable thermoplastic insulation, our engineers are usually able to combine in one cable all the qualities you need.

Simply tell us what you *want* in a cable—we'll design and produce it. It won't be the cheapest cable—but *it will be right!* The difference will result in longer life and better performance.

We'll be glad to describe in detail what Ansonia can offer you in the form of *job-engineered* cable. Write now for fuller information.

## Why ANKOSEAL solves cable problems

Ankoseal, a thermoplastic insulation, can help solve many electrical engineering problems, now and in the future. *Polyvinyl* Ankoseal possesses notable flame-retarding and oil resisting characteristics; is highly resistant to acids, alkalies, sunlight, moisture, and most solvents. Polyethylene Ankoseal is outstanding for its low dielectric loss in high-frequency transmission. Both have many uses, particularly in the radio and audio fields. Ankoseal cables are the result of extensive laboratory research at Ansonia—the same laboratories apply engineering technique in the solution of cable problems of all types.

## THE ANSONIA ELECTRICAL COMPANY



Specializing in "Ankoseal" a Thermoplastic Insulation  
ANSONIA • CONNECTICUT



A Wholly-Owned Subsidiary of

## NOMA ELECTRIC CORPORATION

GENERAL OFFICES • NEW YORK, N. Y.

Makers of the famous Noma Lights—the greatest name in decorative lighting. Manufacturers of fixed mica dielectric capacitors and other radio, radar and electronic equipment.





# RESISTANCE WELDING

SIMPLIFIES SMALL PART ASSEMBLY

## SWIFTLY, ACCURATELY, WITH THIS NEW ELECTRONIC TIMER

Aluminum and copper welding gain new accuracy with this Westinghouse electronic SP-18  $\frac{1}{2}$ -cycle welder control. Heat control is precise and swift over a stepless range of 4 to 400% of normal heat available with full cycle timers. This unit is admirably suited to the resistance welding of radio tube parts and sockets, pig-tailed resistors to terminal lugs, watch and instrument parts, electrical relay contact tips, toys and similar small parts.

Welding current starts at exactly the same point on the voltage wave on every operation. *Damaging transients are eliminated.* Rejects are reduced. Welds are exact duplicates. The calibrated heat-adjustment dial is quickly set for operation and no time is lost setting controls for welding precision parts.

Available for either wall or bench-mounting, the one-shot operations of the Westinghouse SP-18 require no sequence timer. You can learn more about this improved electronic welder control from your nearest Westinghouse office. Or write Westinghouse Electric Corporation, P. O. Box 868, Pittsburgh 30, Pa. J-21319

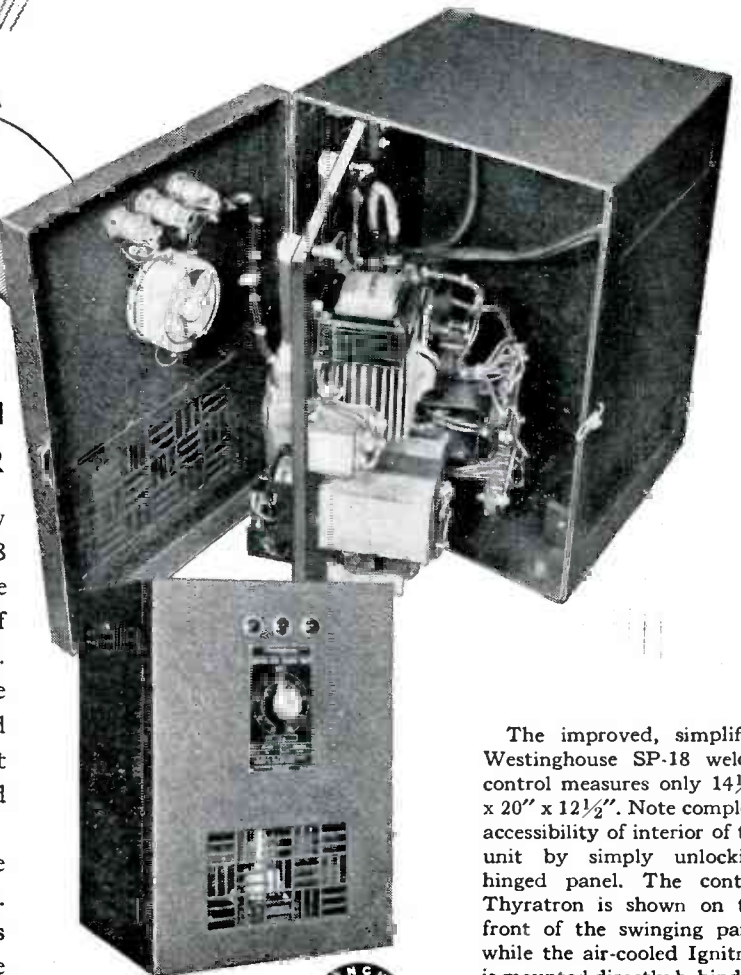

The improved, simplified Westinghouse SP-18 welder control measures only  $14\frac{1}{2}$ " x 20" x  $12\frac{1}{2}$ ". Note complete accessibility of interior of the unit by simply unlocking hinged panel. The control Thyratron is shown on the front of the swinging panel while the air-cooled Ignitron is mounted directly behind it.



**Westinghouse**  
PLANTS IN 25 CITIES . . . OFFICES EVERYWHERE

*Electronics at Work*

# THE ELECTRON ART

Conversion from Series to Parallel Impedance.....	254
Two-Voltage Regulated Power Supply.....	254
Square-Wave Modulator for Signal Generator.....	260
Permeability of Iron at Radio Frequencies.....	268
Universal Electronic Indicator for Aircraft.....	280
Aviation's Electronic Requirements.....	288
Medical Probe.....	300

## Conversion from Series to Parallel Impedance

By GERSHON J. WHEELER

IMPEDANCE MEASUREMENTS made on r-f bridges are usually determined in series form  $R \pm jX$ , but in many applications, it is desirable to know the equivalent parallel impedance; that is, that value of resistance and reactance in parallel which will have an impedance equivalent to that measured on the bridge. The accompanying graph presents a quick method for determining the equivalent parallel resistance  $R_p$  and reactance  $X_p$  when the series resistance  $R$ , and reactance  $X$ , are known.

To determine the value of *parallel resistance*, enter the value of

series resistance on the horizontal axis and the value of series reactance on the vertical axis. The number at the right-hand end of the arc at which these coordinates intersect is the value of the parallel resistance.

To determine the value of *parallel reactance*, enter the value of series reactance on the horizontal axis and the value of series resistance on the vertical axis. The arc now indicates parallel reactance.

The arc indicates the parallel value of whichever series component was entered on the horizontal axis. The units may be ohms, tens

of ohms, megohms, or anything else, but must remain the same throughout.

If the value of the series resistance is more than ten times or less than one-tenth the series reactance, the graph should not be used. Instead, the following relationships which hold within one percent produce the required result more quickly. With small  $R$ ,  $R_p = X_s^2/R$ , and  $X_p = X_s$ . With large  $R$ ,  $R_p = R$ , and  $X_p = R_s^2/X_s$ .

### Illustrations

EXAMPLE I:  $R_s$  is 42 ohms,  $X_s$  is 58 ohms. Find  $R_p$  and  $X_p$ . The numbers on the graph will be used to indicate tens of ohms. Enter with 4.2 on the horizontal axis and 5.8 on the vertical. These coordinates intersect just above the arc numbered 12. The value of  $R_p$  is about 122 ohms. Next enter with 5.8 on the horizontal axis and 4.2 on the vertical. The intersection is just below the arc numbered 9. The value of  $X_p$  is about 89 ohms.

EXAMPLE II:  $R_s$  is 400 ohms,  $X_s$  is 70 ohms. Find  $R_p$  and  $X_p$ . Here, the numbers on the graph must indicate hundreds of ohms. Enter with 4 on the horizontal axis and 0.7 on the vertical. The intersection indicates that  $R_p$  is about 410 ohms. Enter with 0.7 on the horizontal axis and 4 on the vertical. The intersection is on arc 23, thus,  $X_p$  is 2300 ohms.

The graph may be used for either capacitive or inductive reactance. The parallel reactance, of course, has the same sign as the series reactance.

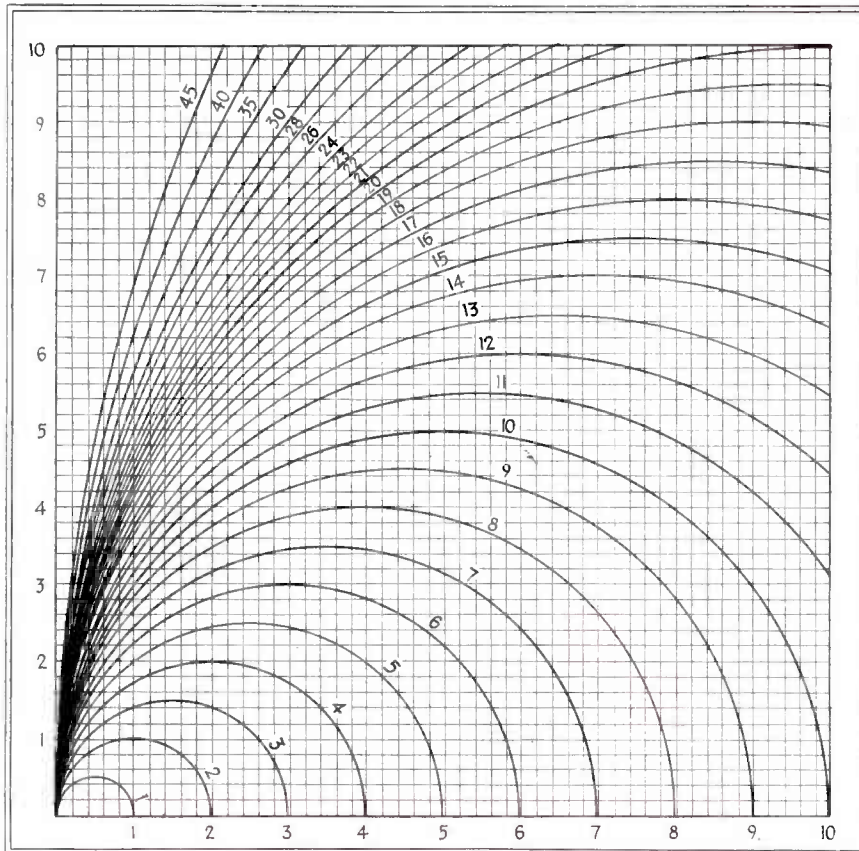

Graph for converting resistive and reactive series-impedance components into equivalent parallel-impedance elements is constructed from circles the locus of whose centers are on the horizontal axis of a rectangular coordinate system

## Two-Voltage Regulated Power Supply

A METHOD of obtaining both positive and negative regulated power from a common source is described in *Electronic Engineering*, (43-44 Shoe Lane, London, E.C. 4) for June 1945.

A simple arrangement utilizing a conventional regulator circuit is shown in Fig. 1. This is useful where the current demand on both polarities is similar. Regulated power is fed to terminals A and B and the circuit operates as a voltage divider. When terminal E is grounded positive voltage appears



*Enduring Accuracy  
in Vital R.F. Applications*



# OHMITE RESISTORS & CHOKES

The unique characteristics of these Ohmite units have made them especially suitable for many r.f. applications. Proved by use before war came . . . they are performing vital functions today in the production and operation of critical equipment. Tomorrow—they will be more popular than ever!

**GLASS-SEALED NON-INDUCTIVE DUMMY ANTENNA RESISTORS**—for testing and measuring power output accurately. 100-watt and 250-watt sizes in variety of resistances.

**R. F. PLATE CHOKES**—single-layer wound on low power factor steatite cores, with moisture-proof coating. Built to carry 1000 M.A. 5 stock sizes from 2½ meters to 160 meters.

**PARASITIC SUPPRESSOR**—small, light, compact non-inductive resistor and choke, designed to prevent u.h.f. parasitic oscillations.

**NON-INDUCTIVE VITREOUS ENAMELED POWER-SIZE RESISTORS**—Useful in wide variety of radio frequency applications. 50-watt, 100-watt and 160-watt stock sizes in many resistances.

*Ohmite Engineers are glad to assist you on any resistance-control problem.*

**OHMITE MANUFACTURING CO.**  
4816 FLOURNOY STREET • CHICAGO 44, U. S. A.

*Be Right with*

# OHMITE

**RHEOSTATS • RESISTORS • TAP SWITCHES**

SEND FOR CATALOG No. 40  
Write on company letterhead for helpful Catalog and Engineering Manual No. 40. Address Ohmite Mfg. Co., 4816 Flournoy Street, Chicago 44, Illinois.



Here's a soldering iron with . . .

**HEAVY  
POWER**  
(225 WATTS)







**LIGHT  
WEIGHT**  
(14 OUNCES)

made possible by  
**KWIKHEAT'S  
BUILT-IN  
THERMOSTAT**

- ★ HEATS IN ONLY 90 SECONDS
- ★ MAINTAINS PROPER HEAT
- ★ CAN'T OVERHEAT
- ★ LESS RETINNING NEEDED
- ★ TIPS LAST LONGER
- ★ COOL, SAFE HANDLE
- ★ LIGHT WEIGHT

The Kwikheat Soldering Iron has ample reserve power for your soldering jobs—225 watts held in check by a thermostat built right into the iron\*—maintaining ideal temperature for perfect soldering—preventing overheating (which causes deterioration in other irons)—prolonging life of tips and eliminating the need for constant retinning. Besides these big advantages, the Kwikheat Iron is hot, ready to use only 90 seconds after plugging in. It is extremely light (14 ounces), well-balanced, and has a safe, cool handle. No wonder Kwikheat is a sensation wherever it is used. Ask your jobber. With choice of #0, 1, 2, or 3 tips. \$11.00

**6 INTERCHANGEABLE TIP STYLES**

- |   |        |   |        |   |        |   |        |   |        |   |        |
|---|--------|---|--------|---|--------|---|--------|---|--------|---|--------|
|  | #0     |  | #1     |  | #2     |  | #3     |  | #4     |  | #5     |
|   | \$1.25 |   | \$1.25 |   | \$1.25 |   | \$1.25 |   | \$1.75 |   | \$1.25 |

VANATTA

*kwikheat*  
**THERMOSTATIC SOLDERING IRON**  
A Division of  
Sound Equipment Corp. of Calif. • 3903 San Fernando Rd., Glendale 4, Calif.

across terminals *D* and *E* and negative voltage across terminals *E* and *F*. Tubes  $V_1$  and  $V_2$  are so connected that the potential difference between the cathode of  $V_2$  and terminal *B* will remain constant at a value determined by the bias applied between terminals *B* and *C*. By a suitable choice of bias, the output voltage between terminals *E* and *F* may be made half or any other desired fraction of the supply voltage.

This arrangement has certain limitations in that, if the load across terminals *D* and *E* is increased substantially, the voltage

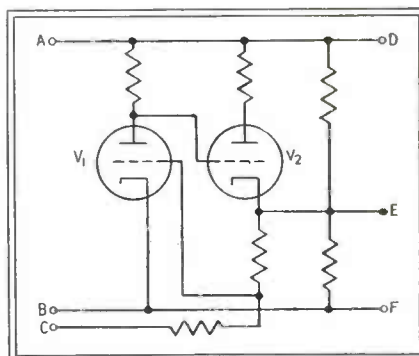

FIG. 1—Simplified circuit suitable for applications where loads are balanced and essentially constant

at *E* will tend to rise; this action is resisted by an increase in the plate to cathode resistance of  $V_2$ . Compensation can continue only to the cut-off point of  $V_2$ . On the other hand, if the load across terminals *E* and *F* increases, the voltage at *E* can be maintained only up to the point at which  $V_2$  begins to saturate.

If large variations of load current are likely to be encountered,

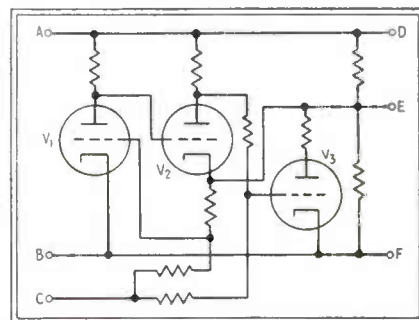

FIG. 2—The addition of  $V_3$  provides for constant voltage division with fluctuating loads





## LABORATORY VOLTAGES accompany your equipment into the field with built-in **CONSTANT VOLTAGE**

On the drafting boards of hundreds of sales-minded design engineers, product insurance is being written into the specifications of new electronic and electrically operated equipment.

A critical analysis of sales department records of past performance usually discloses that the most frequent cause of equipment failure or sub-standard performance is the one most often overlooked—field voltages that do not correspond to the rated voltage at which the

equipment is designed to operate.

Today sales-minded design engineers make certain that carefully controlled laboratory voltages, on which the operation of their equipment is predicated, go with it into the field, by writing "SOLA Constant Voltage Transformers" into their design specifications. In many cases the inclusion of the "CV" transformer is accomplished at an actual saving in cost over standard equipment design.

Thus rated voltage is available at

all times because SOLA Constant Voltage Transformers instantly correct fluctuations as great as 30% to less than  $\pm 1\%$  of rated requirements. These sturdy, automatic transformers require no pampering or supervision. They protect both themselves and the equipment against line surges and short circuits.

Standard units are available in capacities from 10VA to 15 KVA or special units can be built to your specifications.

# Constant Voltage Transformers

# SOLA

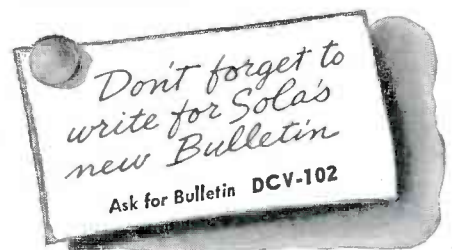

Transformers for: Constant Voltage • Cold Cathode Lighting • Mercury Lamps • Series Lighting • Fluorescent Lighting • X-Ray Equipment • Luminous Tube Signs  
Oil Burner Ignition • Radio • Power • Controls • Signal Systems • Door Bells and Chimes • etc. SOLA ELECTRIC CO., 2525 Clybourn Ave., Chicago 14, Ill.

*Here's where the egg came first*

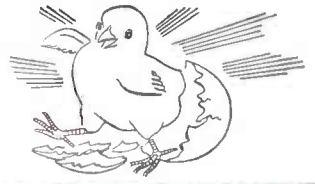

# MICRO SWITCH

## SNAP-ACTION

Helps bring the chick

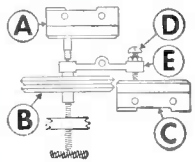

### Here is how it works

Switch "A" is held in an open position by the pressure of liquid filled bellows "B" against the spring plunger. If temperature falls, the bellows contracts and releases the pressure on switch "A" which causes current to be switched on.

Switch "C" is an auxiliary pin plunger type switch, also operated by bellows "B". It is actuated by adjusting screw "D" on lever arm "E" and is operated only in case expansion of the bellows fails to operate switch "A".

Incubators for hatching poultry eggs depend on constant, precise regulation of temperature. Deviation of as little as half a degree, if long sustained, means loss of an entire setting.

That is the reason the Reliable Incubator and Brooder Company of Quincy, Illinois, selected Micro Switch snap-action switches as the monitors to insure the even temperature on which the success of their products depends.

Reliable Incubator and Brooder Company provides two switches as an additional safety check. Should lightning strike the line and cause the switch points to fuse together, a second standby switch will take over. The over-travel plunger on the main switch permits further expansion of the bellows to operate the standby switch and at the same time operate an alarm bell.

This application makes excellent use of the small, com-

pact size of Micro Switch products and their ability to handle up to 10 amperes of current at line voltage without the use of relays.

Because of their long life and rugged dependability, designers and engineers in almost every branch of industry are using Micro Switch snap-action switches for limits, safeties and interlocks. A full line of housings and actuators make them applicable under all conditions where a tiny, precise, completely accurate switch is required to handle substantial amounts of power at line voltage.



Your engineers should know all about Micro Switch controls. Send for as many copies of Handbook-Catalog No. 60 as you need. If you are designing for aircraft, send for Handbook-Catalog No. 71 also. Write today.



© 1945 First Industrial Corporation

**MICRO** MARK **MS** **SWITCH**

TRADE

A DIVISION OF FIRST INDUSTRIAL CORPORATION

Freeport, Illinois, U. S. A., Sales Offices in Principal Cities



Buy More War Bonds



To Finish the Job!

The basic switch is a thumb-size, feather-light, plastic enclosed, precision, snap-action switch, Underwriters' listed and rated at 1200 V. A., at 125 to 460 volts a. c. Capacity on d. c. depends on load characteristics. Accurate reproducibility of performance is maintained over millions of operations. Basic switches of different characteristics are combined with various actuators and metal housings to meet a wide range of requirements.



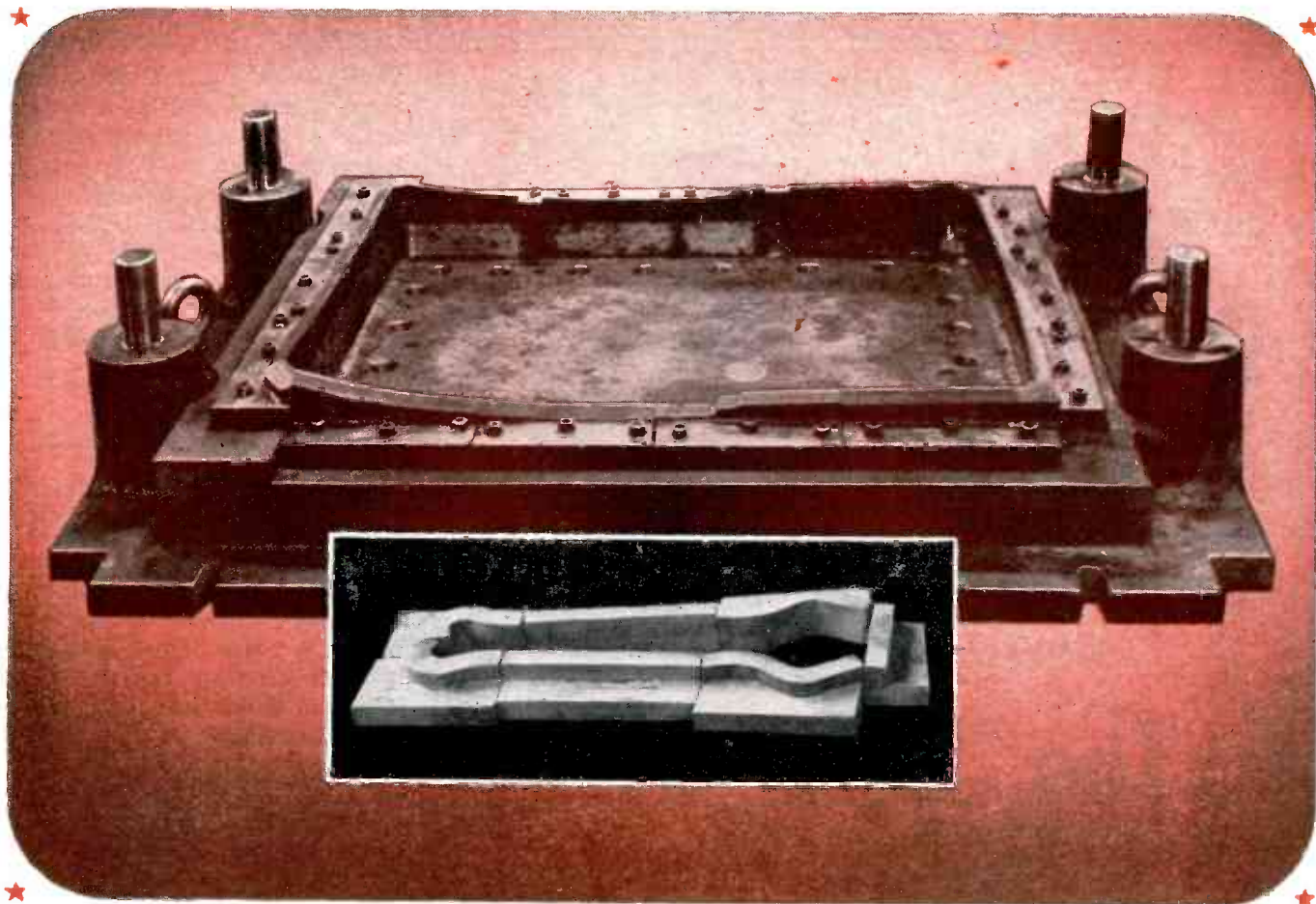

*When time is precious —*  
**SPEED YOUR DIE MAKING**

**SAVE MONEY TOO**

**WRITE FOR  
 ENGINEERING  
 DATA FOLDER**

It contains a blue-print showing thirty-five standard sections available for quick shipment, from combinations of which thousands of die shapes can be made. It also contains prices, weight tables and shows rib-reinforced extra high sections with full instructions for ordering. Get your copy. Write for it today.

Address Dept. E-35

**F**CC Composite Die Sections are quickly available to your order. Shipment to your specifications can usually be made in five to ten days.

On large dies or small for blanking, beading or trimming, these prefabricated die parts save steel, and a vast amount of time and trouble in the die shop.

They are made of fine tool steel cutting edges in a selection of grades, electrically butt welded by a special process to non-hardenable mild steel bases. Accurate temperature control assures uniformity of behavior in heat treatment.

Further information is available from any Allegheny Ludlum field representative, or write us direct for engineering data (see details at left).



**Allegheny Ludlum**  
**STEEL CORPORATION**  
 Forging and Casting Division  
 DETROIT 20, MICHIGAN

W&D 9759-B



# The "Lid's" Off

With government restrictions lifted and essential materials again available, The Astatic Corporation is back on peacetime production . . . better located, better equipped and better manned than ever before, to do a grand job. The lid is off! Astatic Microphones, Phonograph Pick-ups and Crystal Cartridges, long restricted to military requirements, are now going to manufacturers of radio, phonograph and sound equipment, as well as parts jobber outlets, for civilian use. The tempo of production is being stepped up daily. Orders, long held in abeyance, are being filled as rapidly as possible in the order in which they were received.

"You'll HEAR MORE from Astatic"

**THE**  
**Astatic**  
**ASTATIC CORPORATION**  
 CONNEAUT, OHIO  
 IN CANADA: CANADIAN ASTATIC LTD., TORONTO, ONTARIO

the circuit of Fig. 2 is to be preferred. The plate-to-cathode resistance of  $V_3$  appears across terminals  $E$  and  $F$ . With the grid of  $V_3$ , coupled to the plate of  $V_2$ , the plate-to-cathode resistance of  $V_3$  will be varied in the opposite sense to that of the plate-to-cathode resistance of  $V_2$ , permitting greater variations in loads before the characteristics of  $V_3$  begin to limit regulation.

• • •

## Square-Wave Modulator for Signal Generator

DESIGN DETAILS and construction hints on apparatus for pulse-modulating the output of a high-frequency standard signal generator are described in an article by W. R. Piggott in *Wireless Engineer* (Dorset House, Stamford St. London S. E. 1) for March 1945.

The equipment consists of a neutralized, push-pull, cathode-follower, electronic switch used as a modulator, and a simple pulse generator which may be driven by power from the a-c line or by the output of an audio oscillator. The modulator, shown in Fig. 1, and the pulse gen-

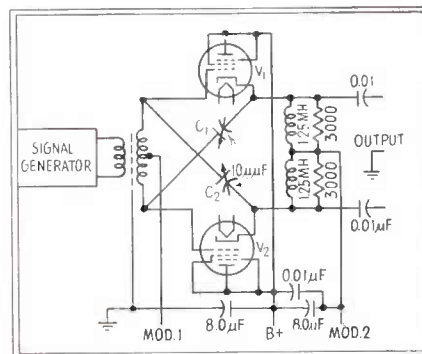

FIG. 1—Push-pull cathode-follower circuit used to impress pulse modulation on output of high-frequency signal generator

erator, shown in Fig. 2, are designed to operate as a unit from a common power supply.

Application of the push-pull cathode-follower offers several distinct advantages as a modulator; low-output impedance, approximately unity stage gain, and independence of changes in tube operating conditions. High-frequency current is fed to the grids of the high mu tubes through the input transformer. The tubes are biased to



a new and still better polystyrene



# STYRON 411

**Finer Products**—durable plastic products that are efficient, long lived and better appearing—these are the direct results of Styron 411C. Here is important news to every user of plastics. For this new member of a new polystyrene series produces improved finished products. Now, beautiful surfaces are obtained—free from flow marks. High clarity and gloss are assured. And, of course, you still have all the familiar Styron advantages: sparkling colors, acid resistance, low moisture absorption, and outstanding dielectric qualities.

**Faster Production**—another advantage of Styron 411C. In actual use, this new Dow plastic speeds handling and improves molding. Reduced rejects and simple finishing operations produce greater yield per pound—greater economy for you.

**Low Cost**—a Styron advantage that continues unchanged—for Styron 411C is offered at the same low price. Write to the Plastics Sales Division or any sales office for complete details.



*Let's work it out together*

Success in plastics is not a one-man nor even a one-industry job. It calls for the cooperation and combined skill of manufacturer or designer plus fabricator plus raw materials producer. Working together, this team saves time and money and puts plastics to work successfully. Call us—we'll do our part.

**PRESENT AND POTENTIAL USES:** Lighting fixtures; insulators; battery cases; hydrometers; funnels; closures, food handling equipment; pharmaceutical, cosmetic and jewelry containers; costume jewelry; novelties; refrigeration parts; pens; pencils; liquor dispensers; escutcheons; chemical apparatus; lenses; decorative objects, trim.

**PROPERTIES:** Clear, translucent or opaque; broad color range; excellent high frequency electrical insulator; can "pipe" light through rod at angles, and around corners; resistant to acids and many alkalies; low water absorption; light weight; stable at low temperatures.

**THE DOW CHEMICAL COMPANY, MIDLAND, MICHIGAN**

New York • Boston • Philadelphia • Washington • Cleveland • Detroit • Chicago • St. Louis  
Houston • San Francisco • Los Angeles • Seattle

**DOW**  
**PLASTICS**

STYRON • STYRALOY • ETHOCEL  
ETHOCEL SHEETING • SARAN • SARAN FILM

# PERMANENT MAGNETS MAY DO IT BETTER

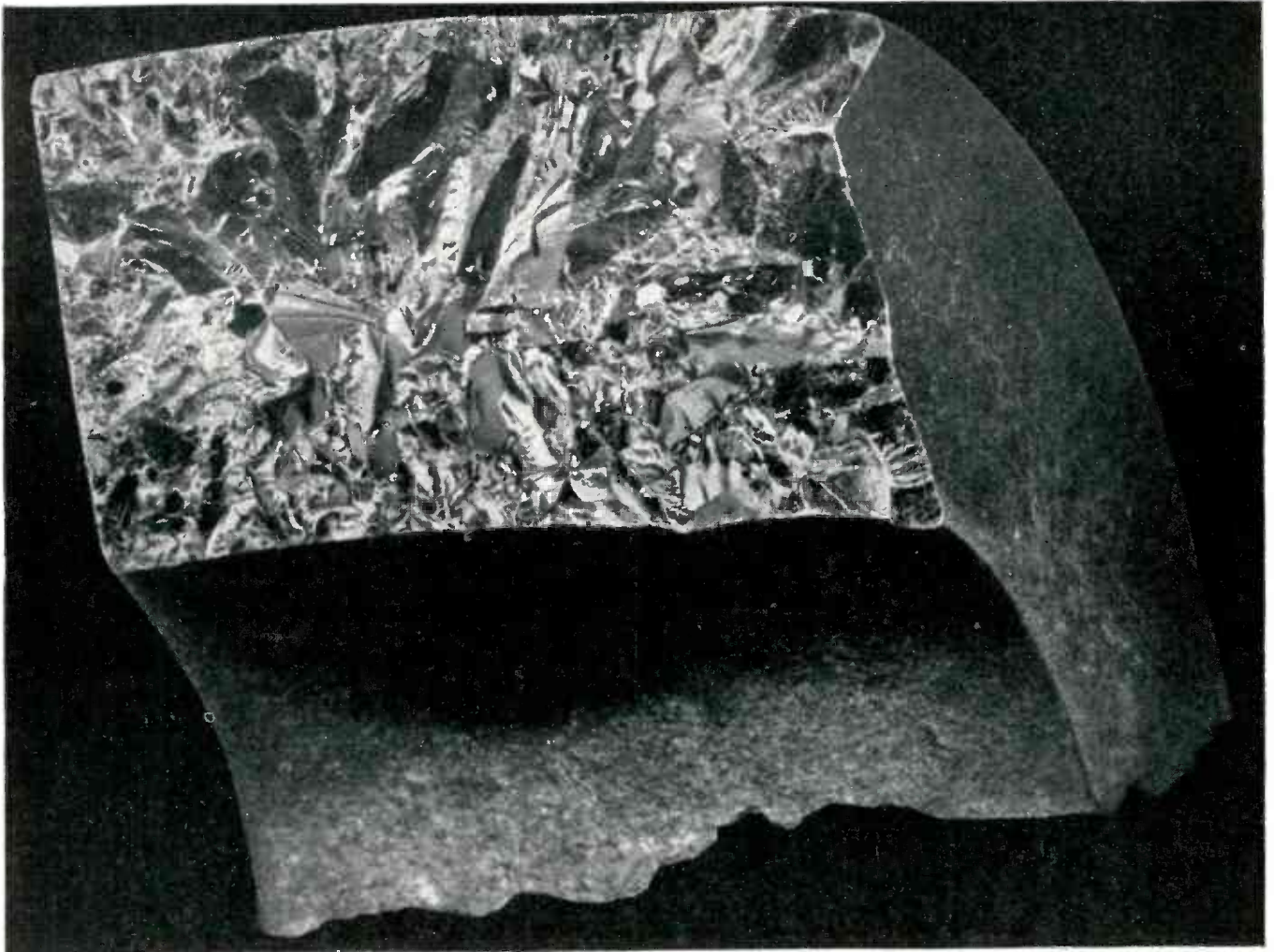

Photograph of a fragment of Alnico V

(This is the third of three advertisements regarding permanent magnet materials)

*What is your magnet made of?*

## ALNICO V

If your product requires a permanent magnet that develops the maximum magnetic energy in limited space and weight, Alnico V is the solution. It is the newest and "strongest" of the Alnicos, the aluminum-nickel-cobalt-iron permanent magnet alloys. Its store of magnetic energy is about five times that of cobalt magnet steel and three times that of the other grades of Alnico. Of the permanent magnet materials commercially available, it is highest in residual induction as well as available energy. Like the other Alnicos, No. V is hard, brittle, non-forgable and non-machinable and is formed by casting.

The improved permanent magnet characteristics of Alnico V are obtained by using

a higher percentage of cobalt and lower percentages of the other elements and a new heat treatment. The treatment consists of normalizing at a much higher temperature than with the other grades, cooling in a magnetic field parallel to the field in the finished magnet and annealing for several hours.

Utilization of the maximum available energy requires that both magnet and magnetic circuit be designed with expert consideration of the magnetic characteristics of Alnico V. For over 35 years, this company has specialized in permanent magnet engineering and production. We invite the consultation of manufacturers who have problems in the use or application of permanent magnets. Write for free technical handbook: *Permanent Magnet Manual*.

\*\*\* **THE INDIANA STEEL**

6 NORTH MICHIGAN AVENUE, CHICAGO 2, ILLINOIS



**PRODUCTS COMPANY** \*\*\*

Corpr. 1946, The Indiana Steel Products Co.

SPECIALISTS IN PERMANENT MAGNETS SINCE 1910





*deserves* **PH.D.**

## FOR THESE MARKS IN CHEMISTRY AND PHYSICS

**T**his recent graduate of the Formica war-expanded laboratories has passed the following tests and is qualified for employment in many old and new applications.

**I**t is made with melamine resins and glass fibre base and conforms to Navy Grade GMG.

**I**t withstands 440 degrees F for a short period, and 390 degrees continuously.

**I**ts arc resistance reaches a new level—by ASTM test D 495-42 it is rated at 185 seconds.

**I**t is so strong it can take structural stresses when desirable. Test figures: Tensile strength 25,000 P.S.I.; Compressive strength (flatwise) 90,000 P.S.I.; Modulus of Elasticity in bending 3,000,000 P.S.I.; Izod impact, 12 ft. lbs. per inch of notch.



*Here is a new combination of desirable properties not previously available in one material. Unlike various materials which possess some of these characteristics, FF-55 can be easily punched and machined. It is superior for rapid fabrication by production methods.*

THE FORMICA INSULATION COMPANY, 4661 SPRING GROVE AVENUE, CINCINNATI 32, OHIO

## Speed Your Production With This Money-Saving Automatic Inspector

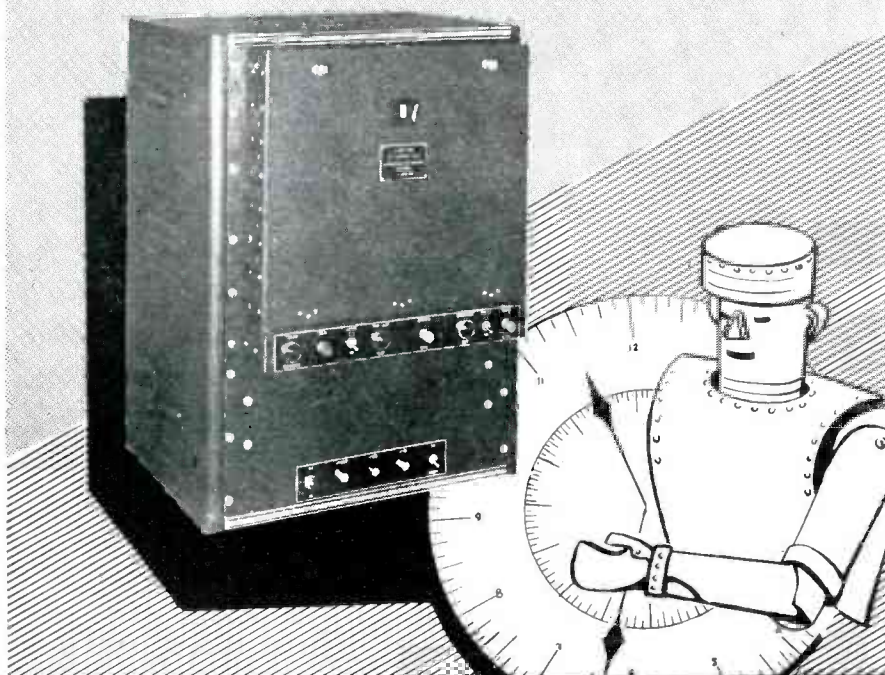

# ROTOBRIDGE

## Checks a Circuit a Second!

Instantaneous and accurate, the Rotobridge functions with robot-like fidelity in checking wiring errors, resistance and reactance values.

Designed for continuous 24-hour duty, the Rotobridge does your bidding exactly. Do you wish a 10% resistance tolerance at one point? A 25% capacity tolerance at another spot? The Rotobridge gives it to you—automatically and accurately.

An error detected? The Rotobridge stops cold, flashes on a red blinking signal, which winks insistently until the defect is attended to.

The Rotobridge can be put to work on several small sub-assemblies or on a complete set, involving as many as 120 circuits. Want to inspect a 30 or 40 tube set-up? Two or three of these robots, working simultaneously, will do the trick . . . in five minutes flat!

*Write for complete details.*

## Communication Measurements Laboratory

120 Greenwich Street

New York 6, N. Y.

cutoff, and any signal appearing at the output terminals is due to leakage through the grid-to-cathode capacitances of the tubes. This leakage is balanced out by feeding back small out-of-phase voltages from the cathodes through capacitors  $C_1$  and  $C_2$ . Inductive cathode loads are used to prevent low-frequency modulation of the output, and the resistive shunts prevent shock excitation of the inductors.

Feeding a square-wave, positive pulse from the pulse generator to the grids of the modulator tubes reduces the effective grid bias on these tubes, permitting amplifica-

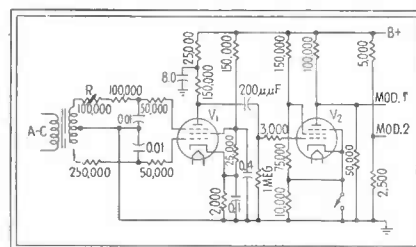

FIG. 2—Pulse-generator circuit develops square wave of variable width from audio-frequency sine wave

tion of the r-f signal to take place.

Square-wave, positive pulses are obtained from the circuit of Fig. 2, when sine-wave a-c is fed, from the a-c line or an audio-frequency oscillator, to the input transformer and through the phase-shifting network to the control grid and suppressor grid of  $V_1$ . The pulse repetition rate is determined by the frequency of the applied a-c, and the pulse length by the phase-difference in the voltages applied to the two grids. When the voltages fed

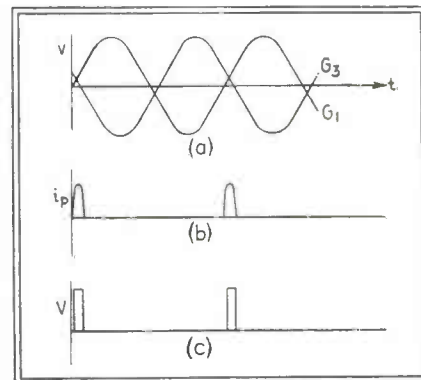

FIG. 3—Graphic representation showing development of square wave from vector sum of voltages applied to tube grids



# MODERNIZE YOUR PRODUCT

## *at Low Cost*



### WITH THESE INEXPENSIVE, HIGHLY ADAPTABLE SWITCHES

#### OTHER STACKPOLE PRODUCTS

Brushes and Contacts  
Carbon Regulator Discs  
Bearings—Pipe  
Anodes and Electrodes  
Packing, Piston and  
Seal Rings  
Welding Carbons, etc.

Up-to-the-minute switches add efficiency to the electrical product, that means greater sales appeal to the ultimate consumer. Stackpole line, slide, and rotary-action switches are highly adaptable to the individual needs of a wide variety of electrical equipment and cost but

little. Eighteen standard units include 3-position types and 1-, 2-, 3-, and 4-pole switches with or without spring return, detent, covers and other optional features. Each can be adapted mechanically or electrically to meet a wide variety of specific requirements.

#### WRITE FOR ELECTRONIC COMPONENTS CATALOG

... for complete details on Stackpole Switches, also Fixed and Variable Resistors, and molded iron cores.

**STACKPOLE CARBON COMPANY, St. Marys, Pa.**

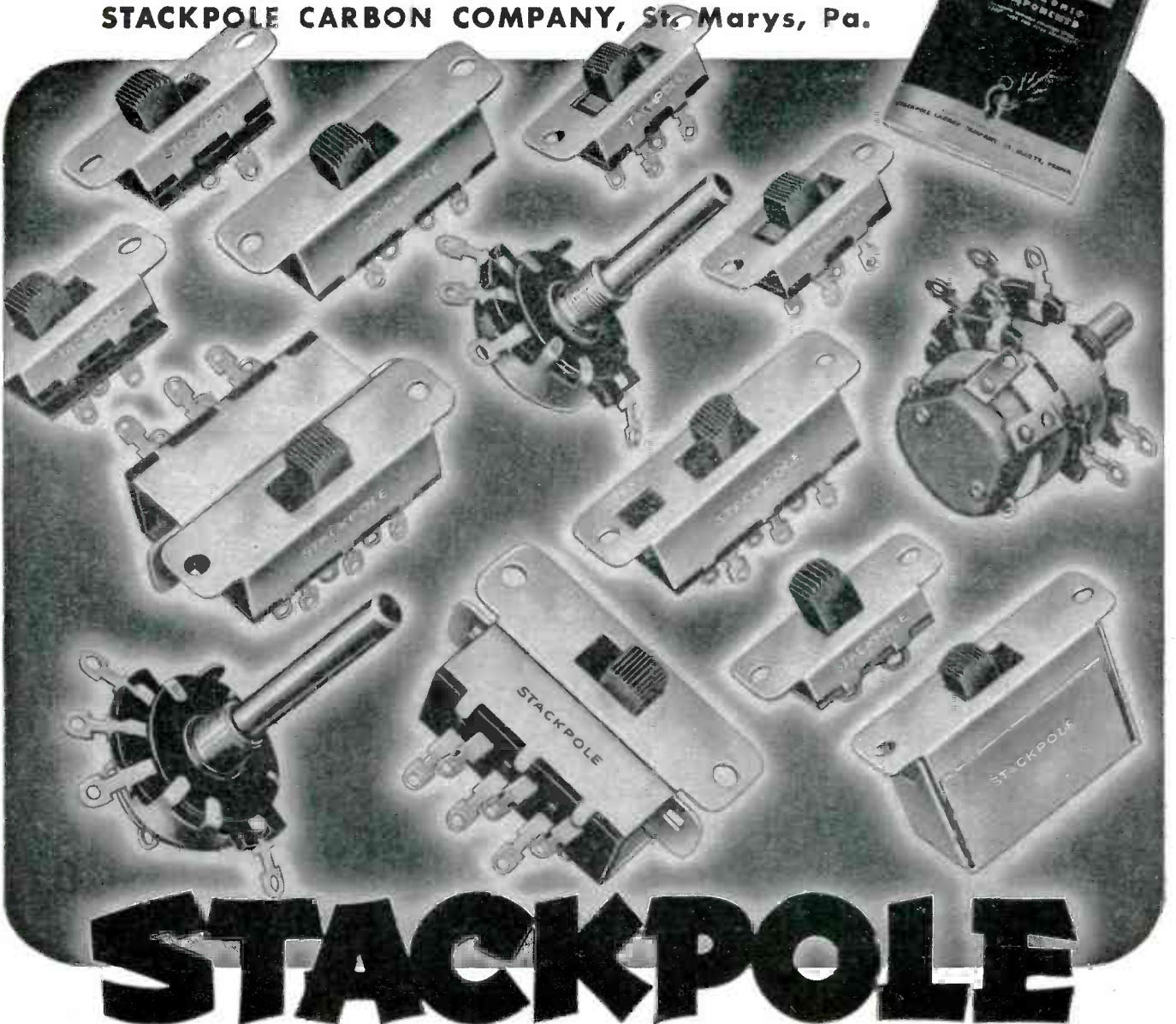

# STACKPOLE



**HERE'S NEW HELP  
FOR THE  
"IN-BETWEEN"  
PRINT USER**

**NEW BRUNING MODEL 41 BW  
PRINTER-DEVELOPER**

Here's a new, medium-priced Printer-Developer—especially designed for those who want fast, efficient production of black and white prints without investing in high-volume equipment. The new Bruning Model 41 BW Printer-Developer is a complete departure from conventional design. The printer and developer are combined in a single, compact, easily movable unit, making it possible to produce BW Prints in your own drafting room, office or plant. In addition, the Model 41 is unusually easy to operate—simple in design and built for long service.

With an actual printing and developing width of 46 inches, the Model 41 exposes and develops black and white prints from roll stock or cut sheets up to 6 feet per minute and has a mechanical speed of 7½ feet per minute.

Find out about the new Bruning Model 41 BW Printer-Developer and about other Bruning printing and developing equipment for every need... Mail the coupon!



**NEW ADVANTAGES . . .  
HIGHLIGHTS OF THE MODEL 41**

**Efficient Printing**—2,000 watt glass mercury vapor lamp gives uniform light distribution over entire printing area of cylinder.

**Easy Control**—Assured by single, hand-operated knob for controlling printing speed and by easily-read dial. Foot pedal instantly releases tension on contact bands.

**Better Cooling**—Entirely new method (pat. applied for) draws cool air through cylinder and contact bands, assuring minimum machine temperature and uniformity of exposure.

**Simple Operation**—Feeding of original and sensitized paper into printer is simple and direct. Developer delivers flat, dry BW Prints ready for use.

**No Plumbing**—This simple, compact printer-developer requires no plumbing and no provision for exhaust fumes (there are none).

CHARLES BRUNING COMPANY, INC.,  
4712-22 Montrose Avenue, Chicago 41, Illinois

Please send me complete information about the new Bruning Model 41 Printer-Developer and about other Bruning printing and developing equipment.

Name .....

Address .....

City ..... State .....

**CHARLES BRUNING COMPANY, INC.**

Since 1897

**NEW YORK**

Atlanta  
Kansas City  
St. Louis

**CHICAGO**

Boston  
Milwaukee  
San Francisco

**LOS ANGELES**

Detroit  
Newark  
Seattle  
Houston  
Pittsburgh



# The "chance" factor...

**eliminated in  
transformer production  
by N.Y.T. engineers**

NYT Engineering, through long experience and specialization in problems of transformer design, assures units of dependability.

All required characteristics are incorporated to an exacting degree, with mechanical and electrical problems effectively surmounted at the blueprint stage.

Equally important is the fact that every NYT design is checked for mass production.

*Address inquires to Dept. E*

**NEW YORK  
TRANSFORMER  
COMPANY**

26 WAVERLY PL NEW YORK 3, N. Y.

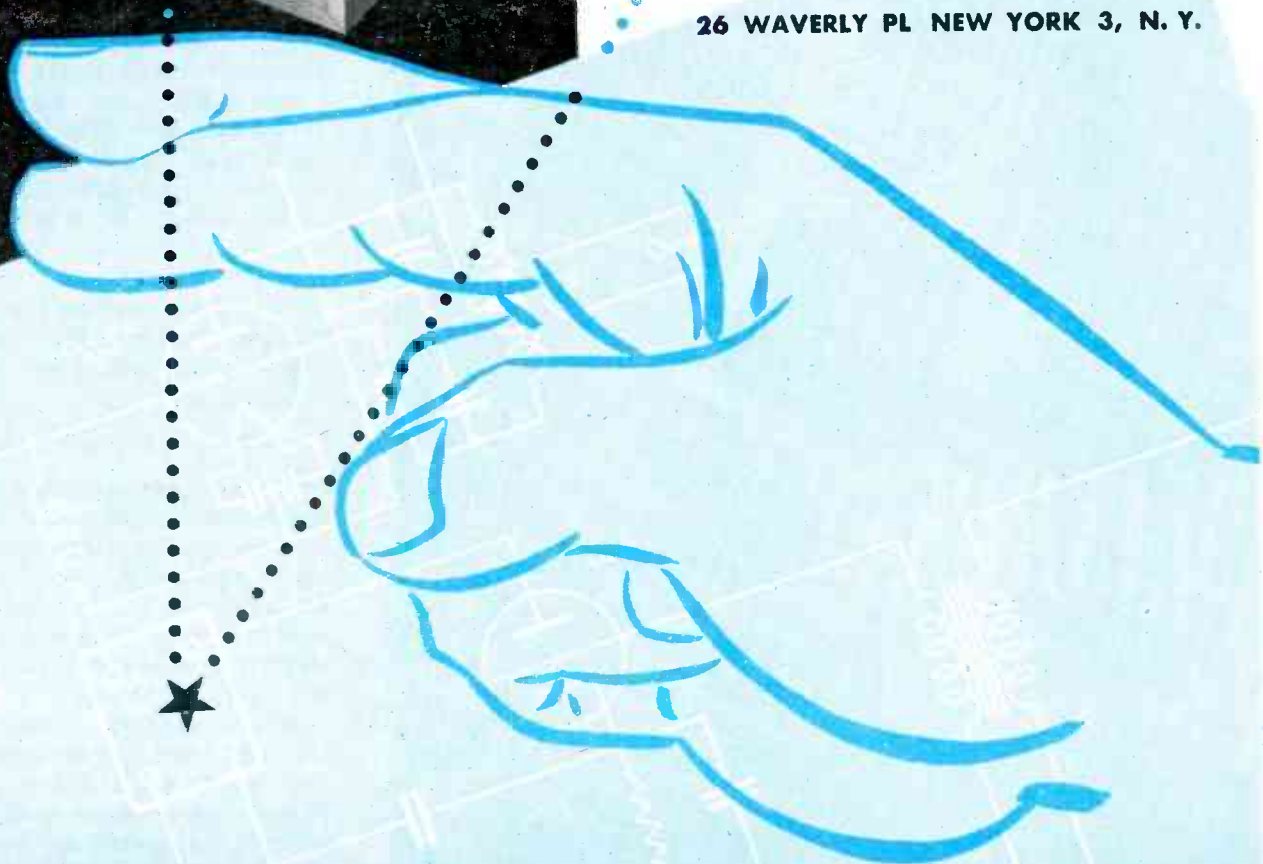
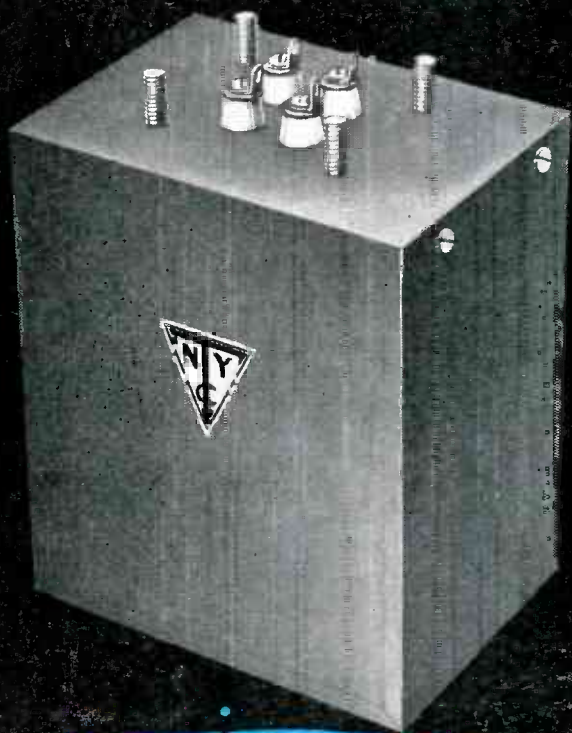

# the HEART OF AN INSTRUMENT

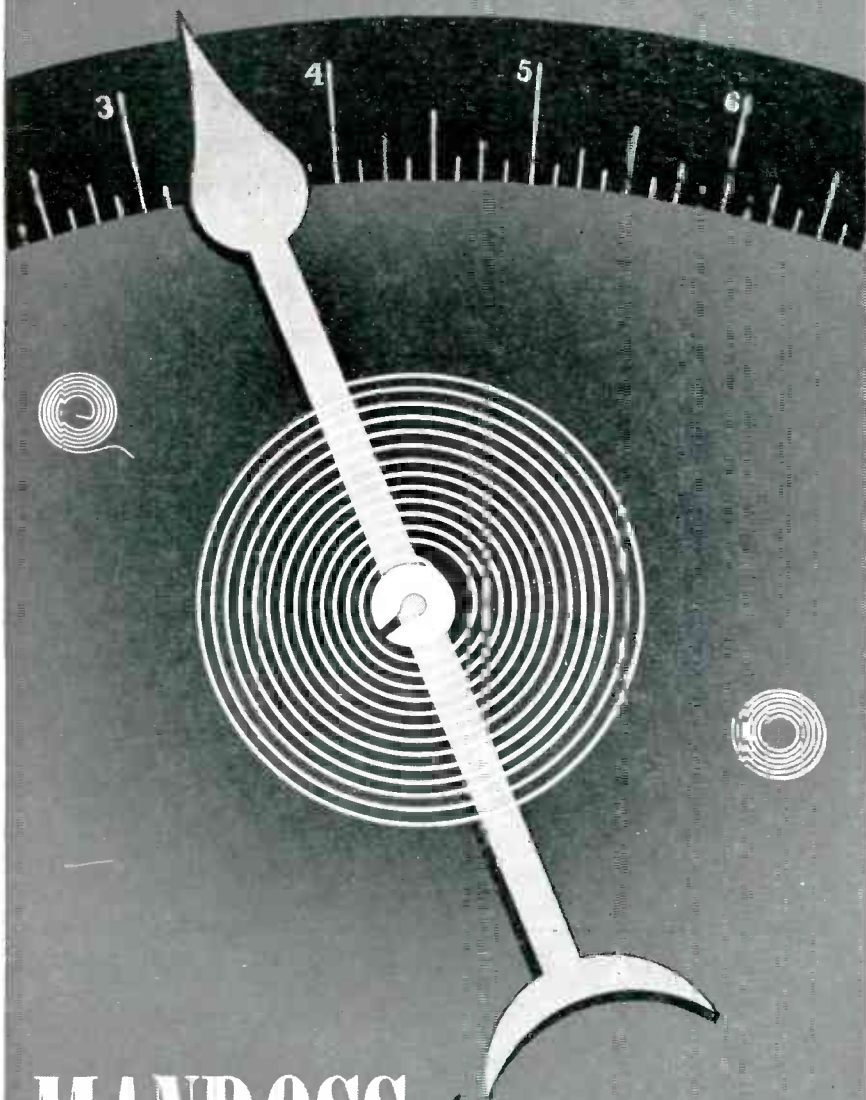

**MANROSS** *hair springs*

**F. N. MANROSS & SONS**  
DIVISION OF ASSOCIATED SPRING CORPORATION  
BRISTOL, CONNECTICUT

to the grids are exactly opposite in phase, no plate current is drawn by  $V_1$ . Adjustment of resistor  $R$  will produce a phase shift in the voltage applied to the suppressor grid, and plate current can flow during a part of the cycle as shown graphically in Fig. 3. The pulse developed in the plate circuit of  $V_1$  is amplified and squared by  $V_2$ , appearing at the output terminals of the pulse generator in the form shown in Fig. 3(c). The minimum pulse width available from any given input voltage is inversely proportional to frequency, that is, a circuit producing a 10  $\mu\text{sec}$  pulse from 50 cps, will produce a 0.1  $\mu\text{sec}$  pulse from 5000 cps.

Careful attention to shielding of components and units, and grounding and orientation of components is necessary to obtain efficient, stable and consistent operation.

The device has many applications in pulse field-strength measurements, and measurements of the transient behavior of transmission lines, antenna systems and the like.

• • •

## Permeability of Iron at Radio Frequencies

MAGNETIC PERMEABILITY of small diameter iron wires was measured at low field intensities in alternating fields of from 54 to 1150 meters wavelength by Alva W. Smith, F. P. Dickey, and S. W. Foor while at Ohio State University. The results, reported in the *Jour. App. Phys.* for Jan. 1945, indicate that apparent permeability decreases with decrease in wavelength and increase in wire size.

### *Permeability Measurements*

The measurements were made to obtain data for design of iron-cored coils and to enlarge our understanding of magnetism. For experimental measurement, iron wires are used because of their simple geometry from which eddy current effects can be evaluated.

Several methods of magnetization have been used for such measurements, as well as different means of inductance measurement. Longitudinal magnetization has been used in connection with measure-



DESIGNED AND ENGINEERED AT NO. 1 PLASTICS AVENUE

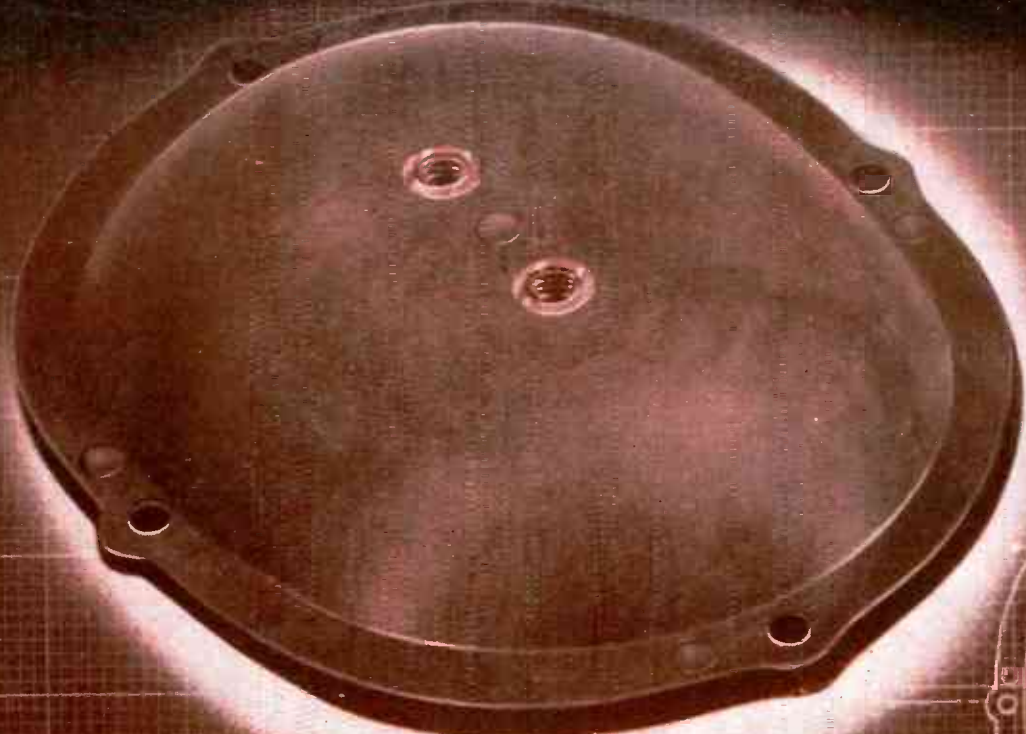

PROBLEM: MOLD ANTENNA "FEED-THROUGH" PLATE---  
PRECISION CONTOUR WITH METAL INSERTS

## NO HIGH-FREQUENCY CREEPAGE HERE, WITH G-E MYCALEX

● Shaped like a turtle's shell, this "Feed-Through" plate supports antenna leads at the point of entrance to a powerful radio transmitter.

This component is molded for the Collins Radio Company by G.E.'s complete plastics service from G-E mycalex . . . compound of glass and powdered mica with a unique combination of properties.

G-E mycalex could be molded to exacting contour specifications . . . to control creepage of high frequency current . . . to give the required mechanical strength.

Maybe G-E mycalex and new G-E molding techniques can solve your high frequency insulation problem.

G-E mycalex is available to all manufacturers . . . in standard sheets or rods or molded to your design. For information, write to Section S-3, Plastics Divisions, General Electric Company, 1 Plastics Avenue, Pittsfield, Massachusetts.

Hear the General Electric radio programs: "The G-E All-Girl Orchestra" Sunday 10 P.M. EWT, NBC. "The World Today" news every weekday 6:45 P.M. EWT, CBS. "G-E House Party" every weekday 4:00 P.M. EWT, CBS.



### G-E MYCALEX

#### A Unique Combination of Properties

1. High dielectric strength
2. Low power factor
3. Prolonged resistance to electrical arcs
4. Chemical stability—no deterioration with age
5. Dimensional stability—freedom from warpage and shrinkage
6. Imperviousness to water, oil, and gas
7. Resistance to sudden temperature changes
8. Low coefficient of thermal expansion
9. High heat resistance

Samples Supplied on Request

GENERAL  ELECTRIC  
GD45-M8

BUY VICTORY BONDS AND HOLD THEM

# Microphones Engineered by

## *Electro-Voice*

### Answer Everyday Sound Problems

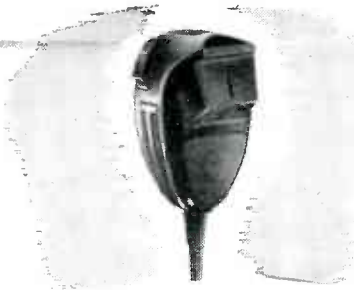

#### Maximum Intelligibility Under Extreme Noise

Hand-Held, close-talking single button carbon \*DIFFERENTIAL microphone for all speech transmission in any noisy, windy, wet or extremely hot or cold locations. Cancels out background noise. Articulation is at least 97% under quiet conditions, and 88% under a 115 db noise field.

Model 205-S. List Price . . . . . \$25  
\*Patent No. 2,350,010



#### Higher Articulation with Less Fatigue

Moving coil, hand-held Dynamic microphone for high fidelity speech transmission. Uniform response, free from peaks, in the useful frequencies gives higher articulation, provides more usable power level, and is less fatiguing to the listener. For outdoor or indoor use.

Model 600-D. Dynamic. List. \$27.50  
Model 210-S. Carbon. List. \$17.50

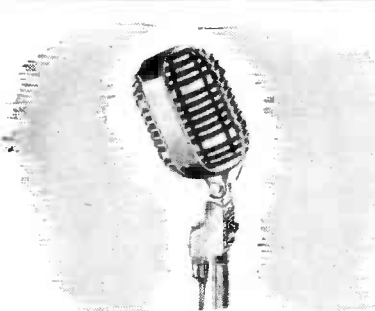

#### Poly-Directional with Adjustable Polar Pattern

The versatile high fidelity Cardak is readily adjustable to reduce any combination of reflected sound. Cuts reverberation or random noise pick-up . . . minimizes acoustic feedback. For broadcasting, recording, public address, communications.

Model 725—Cardak I. List. . . . . \$55  
Model 730—Cardak II. List. . . . . \$75



#### General-Purpose Dynamic for Voice and Music

Widely used because of its dependable all-around performance. Excellent frequency response for both indoor and outdoor speech and music pick-up. Rugged, small size, light weight. High output. Suitable for public address, dispatching, paging, recording and remote broadcast.

Model 630-C. List Price . . . . . \$30

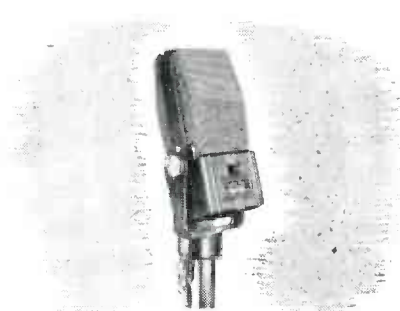

#### Velocity High Fidelity Bi-Directional Sound Pick-Up

Wide, flat frequency response, bi-directional polar pattern, high fidelity characteristics, wide-angle front pick-up, and pick-up range make it ideal for solo, orchestra, or chorus, for single speaker or groups. For indoor P.A., broadcasting, recording.

Model V-1-C. List Price . . . . . \$30  
Model V-2. List Price . . . . . \$37.50  
Model V-3. List Price . . . . . \$50

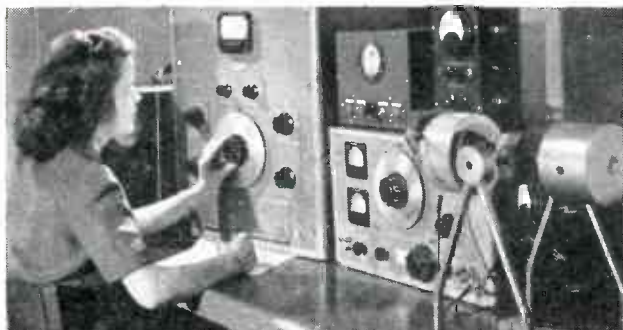

#### Corner of E-V "Lab"

One of our Quality-Control units used in testing close-talking microphones. Harmonic distortion, frequency response, positional response (for carbons) level, etc., are carefully analyzed. Calibration is effected by Bell Laboratory standards and our own reciprocity checks.



#### SEND FOR COMPLETE CATALOG

Gives valuable data on Electro-Voice Microphones for communications, public address, broadcasting and recording. Includes helpful Reference Level Conversion Chart.

Authorized Distributors Everywhere



No finer choice than

# Electro-Voice

## M I C R O P H O N E S

#### GUARANTEE

The E-V models shown here are guaranteed forever against defects in workmanship and material.



# ENGINEERING RESEARCH . . .



Thermoplastic insulation specialists . . . producing a complete line from fine wires to heavy power cables . . . serving: Public Utilities, Radio, Electronic, Appliance and Instrument Manufacturers, Telephone Companies and Contractors.

There is no substitute for engineering. Nationally recognized engineering talent . . . PLUS exclusive equipment, careful materials control, and exacting inspection . . . explain PLASTIC'S amazing achievements in the design and production of thermoplastic insulated wire and cable. This engineering "know how" is at your command . . . for today's planning or tomorrow's production. Write for complete information and samples engineered to fit your particular requirements. Remember . . . when you're thinking of PLASTIC you're thinking of US!

# PLASTIC



W I R E & C A B L E  
C O R P O R A T I O N NORWICH CONN

# OHIO

## MOTORS for ELECTRONIC APPLICATIONS



$\frac{1}{8}$  HP—115 Volt D. C. Shunt Wound 1725 R. P. M.—  
Reversible, Ball Bearing, Ventilated

Cut shows one of many types and sizes of Ohio Motors designed for driving Electronic Devices.

### RANGE

1/100 to 2 HP.—A.C.

1/100 to 1 HP.—D.C.

1/100 to  $\frac{1}{4}$  HP.—A.C. Synchronous.

1 to 100 oz. ft. A.C. Torque.

Shell type motors for built-in applications to  
4 H.P.—D.C. and to  $7\frac{1}{2}$  HP.—A.C.

All usual voltages and cycles.

*What is your problem?*

## THE OHIO ELECTRIC MANUFACTURING CO.

5908 Maurice Avenue Cleveland 4, Ohio

ments of the change in inductance of the magnetizing coil resulting from introduction of the specimen. Circular magnetization has been used with wavelength measurements of the electro-magnetic waves on Lecher wires made from the sample, or with measurements of the change in radio-frequency resistance of the specimen as determined from bridge or resonance observations—depending upon the frequency range to be covered.

There are three high-frequency permeabilities recognized in the literature. From the change-in-resistance method there comes  $\mu_R$  calculated by skin-effect formulas. For circular and longitudinal magnetization there is  $\mu_L$  calculated from inner self-inductance formulas. In both cases it is necessary to correct for the non-uniformity of radial flux distribution within the specimen.

By correcting for eddy-current effects in the  $\mu_L$  permeability, the apparent permeability  $\mu$  is obtained. The permeabilities presented in this paper are apparent.

#### *Measurement Circuit*

Permeability was determined from change in inductance of a specimen coil in an oscillating circuit. Inductance changes were calculated from changes in capacitance necessary to restore the oscillating frequency to its initial condition after the specimen was inserted in the coil. Frequency was measured by double heterodyning, first by a fixed radio-frequency oscillator to an audio frequency, and then by a fixed audio-frequency oscillator to a second-order audio beat. When the two radio-frequency oscillators were at the same frequency, there was no second-order beat.

Figure 1 shows the essential features of the apparatus. A General Radio wavemeter was used to determine the operating frequency. The two tank coils  $L_1$  and  $L_2$  in the specimen oscillator were magnetically and electrostatically shielded, and the specimen coil  $L_2$  was electrostatically shielded from the specimen which was inserted axially.  $L_2$  was wound to form a coil about



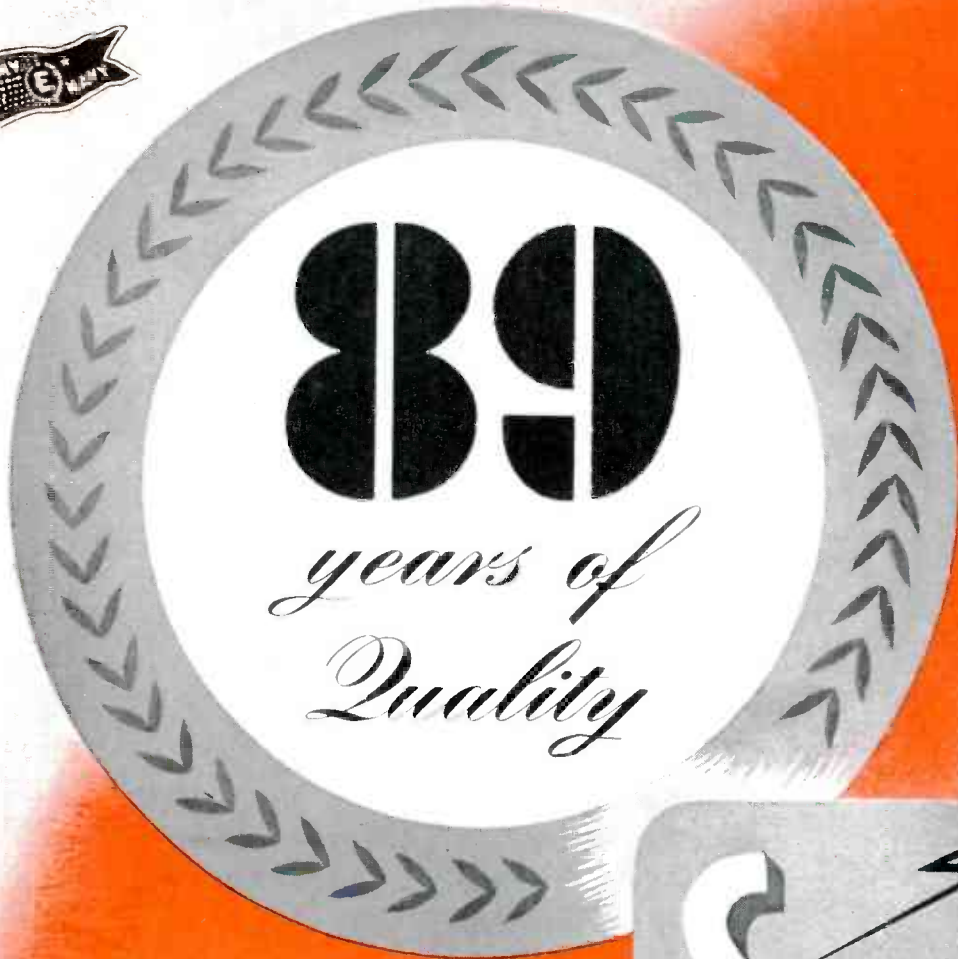

THIS TRADE MARK IS  
YOUR GUIDE TO SUPERB  
QUALITY IN PERFECTLY

*Designed*

# TRANSFORMERS

*Limited Quantities  
are Available NOW!*

**SWAIN NELSON**  
*Company*  
GLENVIEW, ILLINOIS

# POSSIBILITIES IN PLASTICS

PLASTIC MANUFACTURERS  
INCORPORATED  
**PM** STAMFORD, CONN.

PLAN TODAY FOR THE PLASTIC USES OF TOMORROW—

**T**ODAY is the time to plan; the way to plan is with the help of your experienced custom molder. The experience of Plastic Manufacturers in designing, engineering and molding can help you to secure the best results from plastics for your peacetime products and product parts.

Each of the many plastic materials has its own group of properties to recommend it for specific applications and conditions of service. The material and the method of molding must be determined with an understanding of plastics performance and requirements of your product.

To get the fullest benefit from plastics, consult with us during your early planning. Perhaps product design should be changed to permit savings in cost of dies, or to provide closer tolerances or greater strength. Perhaps plastics combined with metals may solve a problem for you. We have developed special techniques in this work that may result to your profit.

For information on our services, in convenient reference form, write for Folder File E-10



REG. U.S. PAT. OFF.

COMPLETE SERVICES FROM  
DESIGN TO ASSEMBLY

MOLD MAKING

INJECTION MOLDING

TRANSFER MOLDING

COMPRESSION MOLDING

## PLASTIC MANUFACTURERS INCORPORATED

STAMFORD, CONNECTICUT

Representatives: DETROIT 2-805-06 New Center Bldg. • LOS ANGELES 35-1440 So. Robertson Blvd.

CANADA—A. & M. Accessories Ltd., 19 Melinda Street, Toronto; 1405 Bishop Street, Montreal



# HERE'S THE FULL STORY

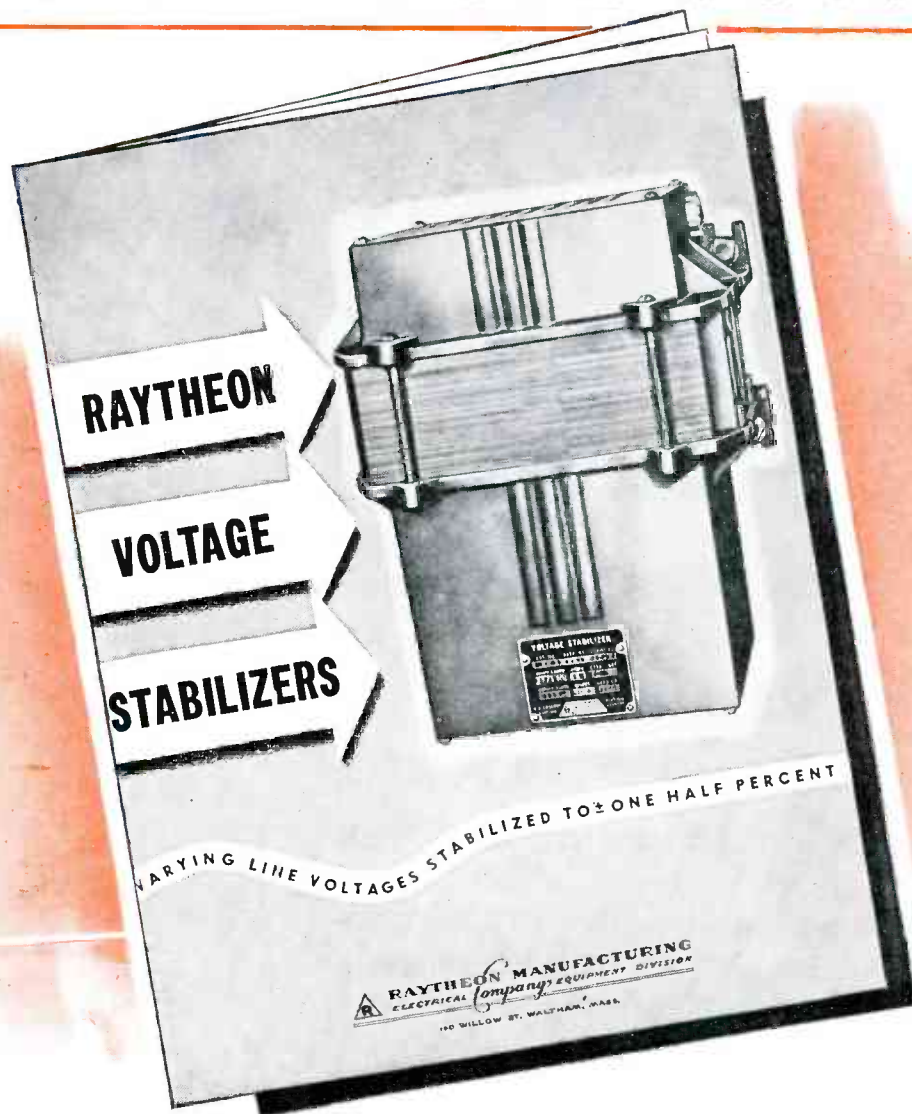

## SEND FOR IT TODAY...

IN A DETAILED, 8-page bulletin now available, Raytheon Manufacturing Company tells the complete story about the dependable Raytheon Voltage Stabilizers. These trouble-free magnetic-type units . . . with no moving parts to get out of order . . . stabilize AC from ordinary voltage sources to within plus or minus a half percent, throughout their full rating.

The bulletin includes such useful information as electronic applications, performance features, principles of operation, operating characteristics, graphs, specifications of the three immediately available designs, cased, uncased, and endbell, and a price list.

We urge you to send for your copy promptly. Ask for Bulletin DL48-537, and address your request to Raytheon Manufacturing Company, Electrical Equipment Division, Waltham 54, Mass.



# Industrial Condenser Corporation's NEW HOME



## THE WORLD'S MOST MODERN CONDENSER PLANT with these outstanding features

- ★ 1,000,000 VOLT RESEARCH LABORATORY
- ★ VERY LATEST PRODUCTION EQUIPMENT
- ★ SPECIALIZED WAR-LEARNED TECHNIQUES

From this NEW ultra-modern factory come capacitors carefully engineered and accurately produced. Staffed by skilled engineers and backed by 16 years of technical progress, Industrial Condenser Corp. is supplying capacitors for every application. If your specifications call for Electrolytic, Paper, Oil, or Motor capacitors, look to Industrial Condenser Corporation.

## INDUSTRIAL CONDENSER CORPORATION

3243-65 NORTH CALIFORNIA AVENUE, CHICAGO 18, U. S. A.  
District Offices in Principal Cities

PAPER, OIL AND ELECTROLYTIC MOTOR CAPACITORS

16 cm long to assure a uniform field into which the specimen was inserted.  $L_1$  was a plug-in coil, interchangeable for changes of frequency bands.

The series-parallel arrangement of the tank capacitors increased the accuracy of measurements by requiring a large change in  $C_{s1}$  or  $C_{s2}$ .

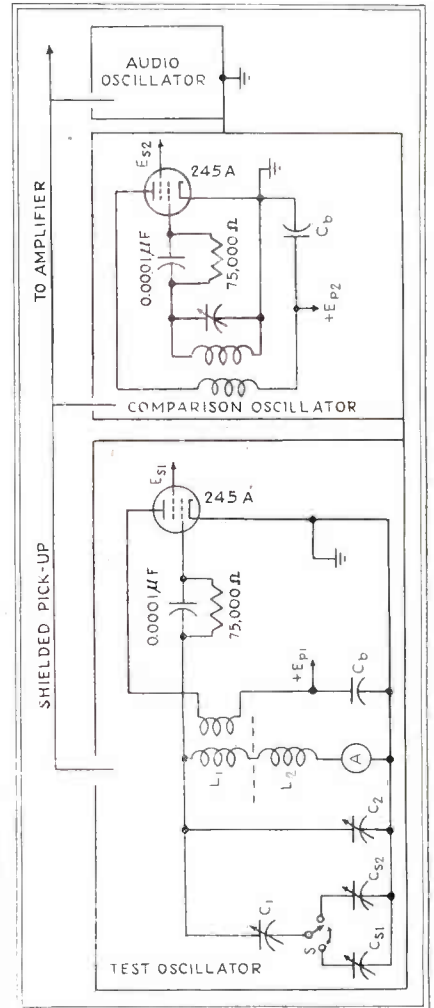

Fig. 1—Test circuit for measurement of permeability of iron wire at high frequencies

to produce a small change in effective tank capacitance. The two capacitors  $C_{s1}$  and  $C_{s2}$  were General Radio precision capacitors against which the other capacitors were calibrated. Mercury switch  $S$  operated by the same pulley system that moved the specimen in and out of  $L_2$ , switched one or the other precision capacitor into the circuit. The difference in capacitance between  $C_{s1}$  and  $C_{s2}$ , when operation of the specimen-switch system produces no frequency change, is indicative



# To Our Friends and Customers

**T**he Langevin Company Inc. believes its customers are entitled to a statement of the company's future plans. The entire life of the company has been spent in the audio frequency field. *It intends to remain in that field.*

Due to its war effort, its facilities, experience and personnel have been increased. It will continue to develop, design and manufacture—to better than FM standards—sound and broadcast speech input equipment.

Its products will continue to include quality transformers and quality amplifiers, ranging from the smallest unit to especially-engineered speech input sys-

tems for the large broadcast stations. Much of this equipment is now in production; some in development—some between development and production.

To our old customers, the above is sufficient. To those who may be interested in becoming customers—we are 23 years old, all our equipment carries the Union Label and is fully licensed under A.T.&T. patents.

*Paul C. Langevin*  
PRESIDENT

## The Langevin Company

INCORPORATED

SOUND REINFORCEMENT AND REPRODUCTION ENGINEERING

NEW YORK  
37 W. 65 St., 23

SAN FRANCISCO  
1050 Howard St., 3

LOS ANGELES  
1000 N. Seward St., 38



They Used to Call Him  
**"SUICIDE  
SAM"**

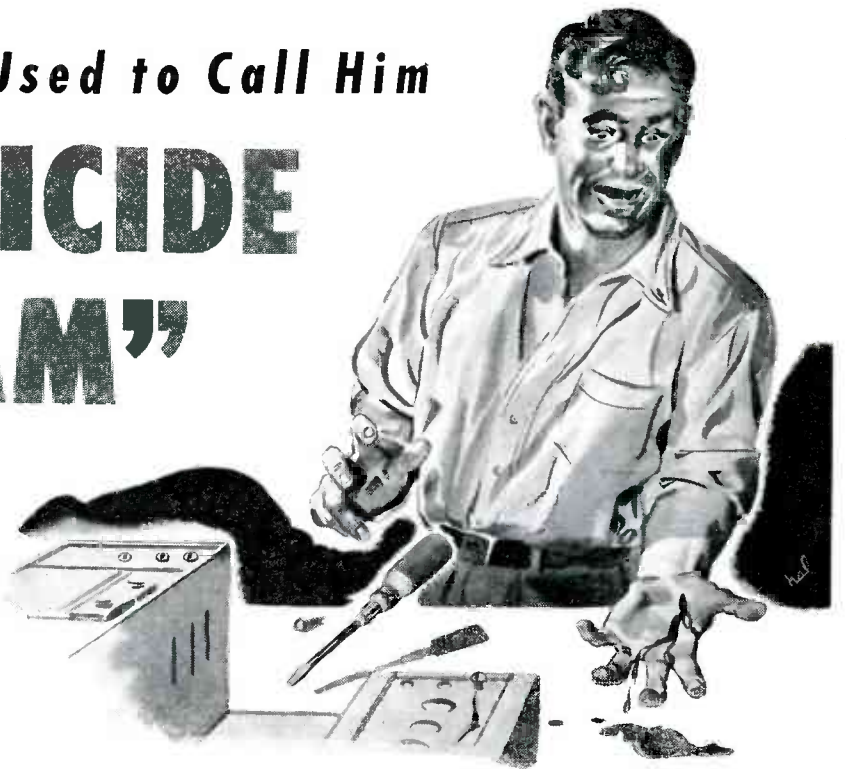

... because that slotted-screw driver used to slip all the time, and carve him up — ruining his work, and laying him off for a day or so — in spite of the best he could do. And Sam wasn't weak either in body or brain!

---

**.. but he hasn't stabbed himself once ... since they gave him AMERICAN PHILLIPS SCREWS**

A slotted-screw driver is a dangerous weapon ... because there's no sure way of keeping it in the slot. There are two *open ends* of this slot through which the driver can skid out into trouble ... slashing work-surfaces or human flesh *or both*.

But there are no open roads to trouble in the recessed heads of American Phillips Screws. The 4-winged Phillips Driver can't skid ... out of this tapered recess, no matter what the driving stress. American Phillips Screws and Drivers fit together firm and straight, and stay that way until the screw is turned up tight. This means safe driving, all the time.

This firm fit means easier driving. For all the worker does is put the American Phillips head onto the bit of his power driver, aim it at the work, and pull the trigger. No straining, no wobbling, *no driving any way but straight*.

**NET RETURN TO YOU: TOTAL TIME SAVINGS AS HIGH AS 50%.**

**AMERICAN SCREW COMPANY, PROVIDENCE 1, RHODE ISLAND**

Chicago 11: 589 E. Illinois Street

Detroit 2: 502 Stephenson Building



**AMERICAN  
PHILLIPS** *Screws*



# A NEW POST WAR **WEBSTER** RECORD CHANGER

## OF PROVED PERFORMANCE



Designed for post war use in the finest radio-phono combinations. Most outstanding development in a long list of Webster achievements—the new Webster Record Changer has more than passed rigid operating tests in the laboratory and field. In addition—it has been adapted to the needs of the armed services where it is now giving brilliant performance under the most exacting conditions. This, of course, is important to you—but equally important to you and your dealers are the many new features it possesses.

**THESE FEATURES WILL WIN DEALER AND PUBLIC ACCLAIM**



- ✓ Changes all standard 10 or 12 inch records; no chipping of record edge.
- ✓ Positive and fast change cycle—less time between records; automatic stop at end of play of last record.
- ✓ Light needle pressure. Freedom from noise and rumble—improved motor and drive—velocity trip.
- ✓ Highly styled; clean, beautiful lines.
- ✓ Compact—uses minimum space; ingenious mounting means.
- ✓ Many other important advantages.
- ✓ New post war design.

**WHIP THE NIP**  
BUY EXTRA  
V/AR BONDS TODAY



**WRITE FOR  
INFORMATION**

**WEBSTER**



**CHICAGO**

3825 W. ARMITAGE AVENUE

CHICAGO 47, ILLINOIS

**31 YEARS OF CONTINUOUS SUCCESSFUL MANUFACTURING**

# HANOVIA

## HERMETICALLY SEALED

# R. F. CHOKES

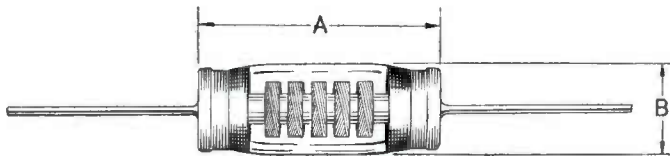

MILLI-HENRIES	A	B
1.0	1-3/4"	5/8"
2.0	1-3/4"	5/8"
2.5	2"	5/8"
5.0	2"	11/16"
10.0	3"	11/16"

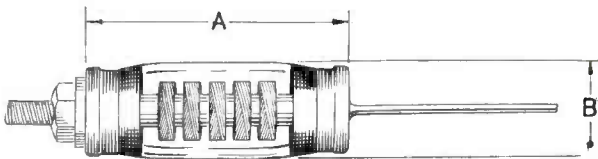

AVAILABLE IN ABOVE TWO FORMS  
RATED AT 125 M.A. FOR ALL SIZES

*Complete information on these and  
other Hanovia Chokes on request.*

# HANOVIA

## CHEMICAL & MANUFACTURING CO.

Industrial Division

Dept. E-16

Newark 5, N. J.

of the reflected inductance of the sample.

A Western Electric vacuum thermocouple and galvanometer were used to observe that the current in the specimen coil remained constant at a known value. Current was controlled by the screen-grid voltage. The d-c component of the grid current produced negligible magnetic effect.

The chemically pure iron-wire specimens were enclosed in individual sealed glass capillary tubes. Groups of from one to twenty wires enclosed in a larger tube constituted a test sample. The test samples were carried to the same position in the coil at each insertion.

### Results and Conclusions

Logarithmic plots of permeability against wire diameters indicate that permeability  $\mu$  varies inversely as the 0.9 power of the diameter. Although measurements were made

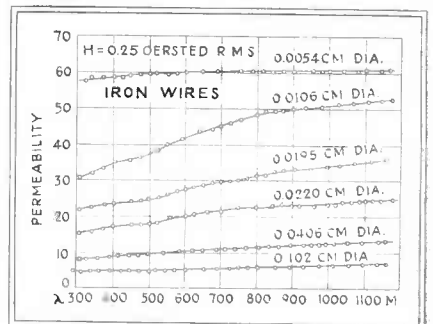

Fig. 2—Permeability as a function of wavelength for several sizes of iron wire

at low flux densities where permeability is assumed to be constant, the data seemed to indicate an increase in  $\mu$  with increasing  $H$ .

The decrease in permeability with decrease in wavelength and increase in wire diameter indicated in Fig. 2 is caused by the reduction in flux produced by eddy currents flowing in the cross section of the wire. These eddy currents produce a counter mmf that increases with wire diameter and conductivity and decreases with wavelength.

• • •

### Universal Electronic Indicator for Aircraft

WITH THE LARGE-SCALE development of commercial aviation just around the corner, consideration is being



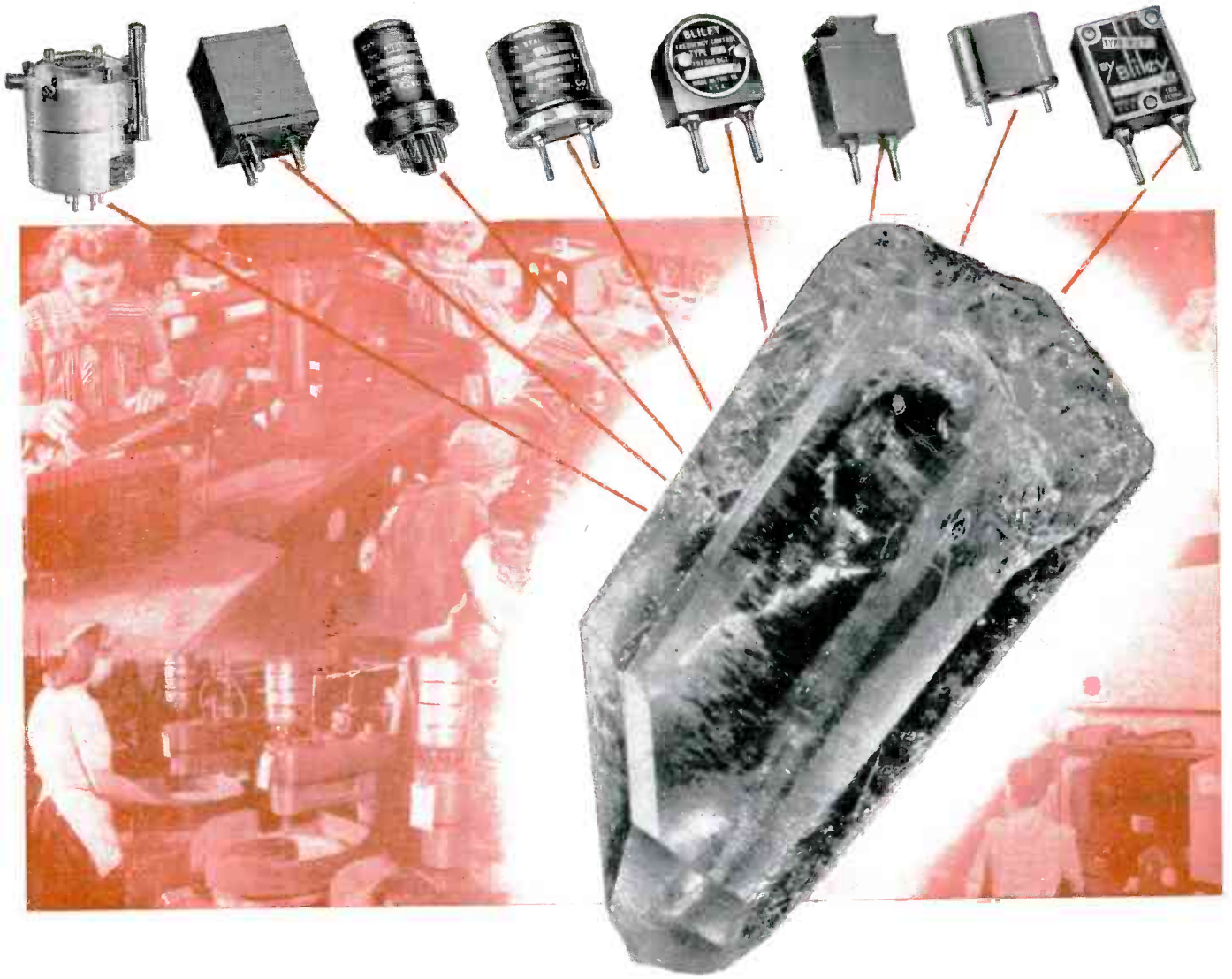

*You name the application . . .*

## **BLILEY** has the crystals

Post VJ Day production of Bliley acid etched\* crystals for FM receivers, Aircraft and Marine radios, Railroad communications equipment and many other applications is proceeding with the same skill and efficiency that marked our wartime operations.

Substantial quantities of these crystals are in the hands of foresighted manufacturers who planned in advance with Bliley engineers for frequency stabilization in their post-war models.

Now, more than ever before, you

need the versatile experience of Bliley engineers and craftsmen gained through more than 15 years of quartz crystal engineering exclusively. Whether your requirements are one crystal or a million, you can be sure of top quality—top design—and top performance—in Bliley crystals.



*Another star has been added. Our 5th citation for outstanding achievement in producing materials essential to the war effort.*

# **Bliley** CRYSTALS

\*Acid etching quartz crystals to frequency is a patented Bliley process.

Radio Engineers —  
write for temporary  
Bulletin E-26

**BLILEY ELECTRIC COMPANY • UNION STATION BUILDING, ERIE, PENNSYLVANIA**

If your post-war product needs the design and operating

advantages of **constant speed . . .** investigate the possibilities of this **governor-controlled**

# Oster Motor

MADE IN U. S. A.

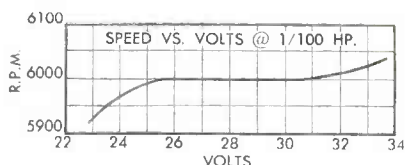
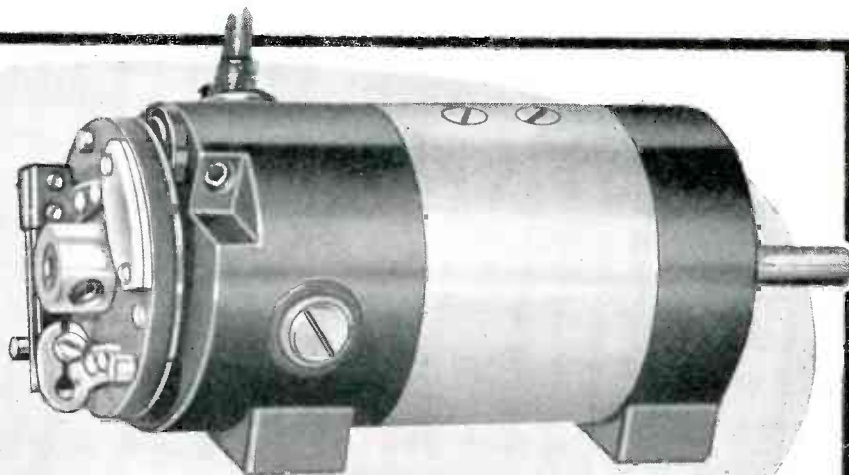

## Rating of Motor Type BSTG-1A-2

Horsepower — 1/100 continuous duty

Speed — 6000 R.P.M.  $\pm 1\%$

Voltage — 25-30 volts D.C.

Amps. input — .95

Starting Torque—300% of full load torque

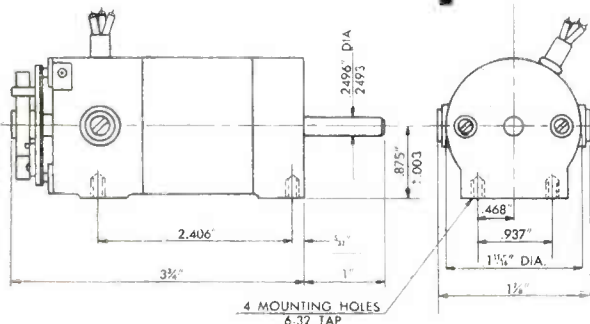

Here is a new Oster development in a constant speed, governor-controlled motor that backs up your good judgment when you specify it for applications where constant speed is a necessity. This motor is now in production and deliveries can be made in the very near future. Here are the features that assure you of satisfaction:

**Housing:** Die cast aluminum end brackets. Mild steel field housing. Totally enclosed.

**Finish:** Black anodized end brackets. Cadmium plated field housing.

**Weight:** 15 oz.

**Bearings:** Single shielded ball bearings, lubricated with a grease suitable for any specific application. Bearing housings fitted with steel inserts.

**Wirings & Insulation:** Field coils and armature wound with a select grade of insulated copper wire and impregnated with a high quality heat and moisture resisting insulating varnish.

**Brushes:** Equipped with high grade metal graphite brushes. Beryllium copper brush springs.

**Governor:** Furnished with a centrifugal governor to maintain constant speed over a voltage range of 25 to 30 volts.

**Temperature Rise:** Maximum frame temperature rise at rated output will not exceed 55° C.

**Modifications:** Motors can be furnished with special shaft extensions, mounting arrangements, finishes, leads, etc. All modified units are considered special.

M-27

Let us help you fit this and other Oster Motors to your requirements.

**John Oster Manufacturing Co.**  
DEPARTMENT L-27 • RACINE, WISCONSIN





## **PATHWAY TO EARTH... *Everywhere***

*All over the world...* from the mud-caked European fields to sun-baked air-strips in southern Burma . . . Federal Instrument Landing Systems are "bringing 'em in". . . *on the beam.*

Bombers, pursuit ships, night-fighters, transports . . . American, Canadian, British, Russian . . . ships wearing all the colors of the Allies . . . coming in on this "pathway

to earth", day and night, through the toughest kinds of flying weather.

This is the instrument landing equipment that Federal developed over more than ten years of intensive research . . . and which has set the standard for aerial navigation equipment in all parts of the world.

For the coming "age of the air" . . . see Federal first for the finest in aerial-navigation and communications equipment.



*Federal Telephone and Radio Corporation*



Newark 1, N. J.

# Webster Electric Pickups are Precision-Built for Flawless Tone Reproduction

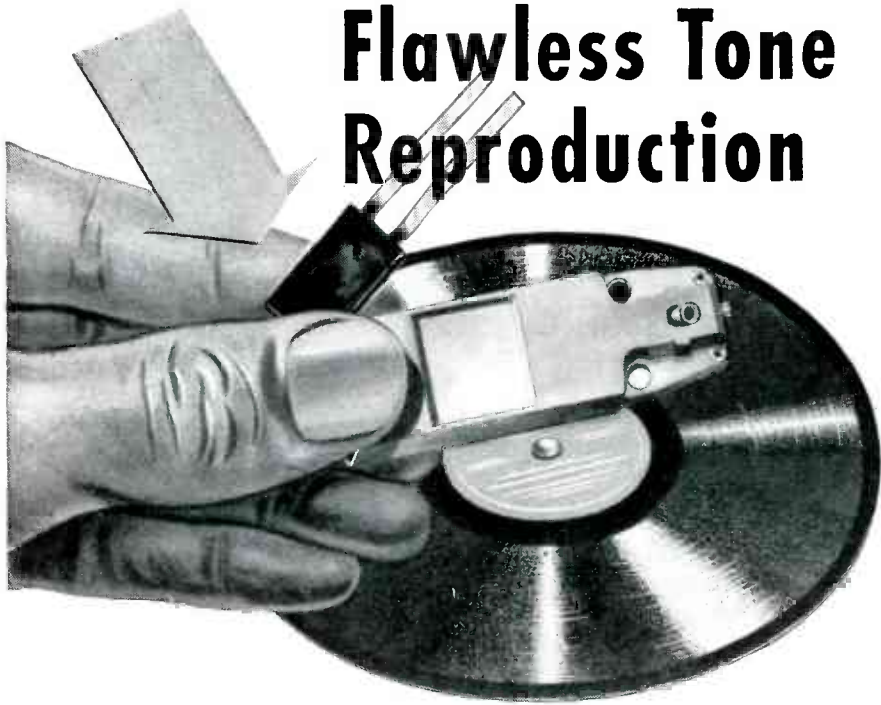

No radio-phonograph combination is better than its pickup—and no pickup ever built is better than the modern Webster Electric Pickup. That simple fact has led more and more manufacturers of fine quality instruments to standardize on crystal pickups and cartridges bearing the authentic Webster Electric name.

Webster Electric Pickups . . . delicate, sensitive, responsive to every tone shading and color range . . . are designed and built by an organization possessing vast experience in sound engineering and the manufacture of sound equipment. We are making every effort to supply the ever-increasing demand for Webster Electric Pickups and Cartridges as rapidly as possible.

We suggest that you permit us to consult with you with a view to determine the best application of our products as integral parts of your present or planned models. Write us direct—today.

Let's All Back the Attack  
Buy Extra War Bonds



(Licensed under patents of the Brush  
Development Company)

## WEBSTER ELECTRIC

Racine, Wisconsin, U.S.A. • Established 1909 • Export Dept.: 13 E. 40th Street, New York (16), N. Y.: Cable Address "ARLAB" New York City

"Where Quality is a Responsibility and Fair Dealing an Obligation"

given to more simplified instrumentation in aircraft. Proposals for a single indicator for presenting instrument readings to a pilot is described by P. Postlethwaite in *Electronic Engineering* (43-44 Shoe Lane, London, E.C. 4) for November, 1944.

The author takes as his starting point, the screening of an outline of the plane on a cathode-ray tube. Below the tube is a gyro mechanism and an artificial horizon bar which is arranged to move between the cover glass of the instrument and the screen of the tube. That much is mechanical.

Surrounding the c-r screen is a compass scale, while in front are a horizontal scale of speed and two vertical scales; one for height and the other for rate of climb or descent. Presentation of the various conditions of flight is made in the following ways:

**Air Speed.** The measuring mechanism is made to vary the gain of the c-r tube amplifiers and so vary the size of the outline. The wing tip acts as a pointer to read against the horizontal scale of speed.

**Ground Speed.** This is presented in a similar way, using a radio beam in conjunction with the Doppler effect.

**Climb or Descent.** The indications are presented by a vertical displacement of the outline, i.e., the rate of climb conditions are changed into electrical quantities and applied as bias to the vertical deflector plates of the tube.

**Bank and Turn.** Rheostats are connected to the usual instruments to obtain conversion to electrical quantities. Deliberate distortion of the outline could be used to indicate over or under banking. One way would be to alter the bias of a pentode tube and so cause the wings of the outline to become of unequal length.

**Landing.** The position of the outline relative to the screen could be equal to the position of the real plane relative to a Lorenz-type beam.

**Height.** A radio altimeter, working on the reflection principle, would enable a spot to be exhibited at the correct point of the height scale.

**Compass Bearing.** This is shown



M A S T E R S O F P R E C I S I O N



**1/4 inch = 9 miles up**

Just imagine trying to measure 47,520 feet with a ruler only a quarter of an inch long! That in effect is what the diaphragm of the altimeter in the picture does.

Each time the 'plane climbs 20 feet, the lessening air pressure expands the diaphragm nine one-hundred-thousandths of an inch—equivalent to approximately 1/13th the diameter of a human hair—but when the 'plane is nine miles high the total of the device's expansion is *only a fourth of an inch.*

C. G. Conn, Ltd., of Elkhart, Ind., manufacturers of the altimeter, were able to reduce rejections of diaphragms from 30% to just 5% when they switched to Western Super-X phosphor bronze. Thus, keeping 'planes flying just where they ought to be is another of the many war jobs being performed efficiently by a Western "tailor-made" copper-base alloy.

You, too, might find it beneficial to investigate Western metals. Our mills at East Alton, Ill., and New Haven, Conn., deliver alloy metals as *specified* . . . in sheet, strip, long coils or stamped parts. Your inquiry will be welcomed.

**WESTERN BRASS MILLS**

DIVISION OF OLIN INDUSTRIES, INC.

*East Alton, Illinois*



BRASS • BRONZE • PHOSPHOR BRONZE • NICKEL SILVER • COPPER



**GRAPHITE . . . .0000027 per °C—or lower**

**MATERIAL A . . . .00000545 per °C**

**MATERIAL B . . . .0000065 per °C**

## **. . . COMPARE GRAPHITE'S COEFFICIENT OF EXPANSION!**

The coefficient of expansion of "National" High Purity Graphite is approximately one half that of the next best electronic-tube anode materials. This coefficient is virtually constant up through temperatures far in excess of a tube's peak operating range.

The relatively low coefficient of expansion of "National" graphite anodes assures greater stability of form at maximum tube temperatures.

Furthermore, because graphite anodes carry off heat rapidly, other tube components are far less apt to warp or change

their positional relationship. And the anodes themselves, even when of large area, are safe from local overheating.

The newest grades of "National" Electronic Graphite possess much greater strength, finer grain structure, smoother machined or machinable surfaces, in addition to greatly increased erosion resistance.

We welcome the opportunity to discuss with engineers and manufacturers the many advantages of "National" Electronic Graphite for both small and large tube components.

The word "National" is a registered trade-mark of National Carbon Company, Inc.

### **NATIONAL CARBON COMPANY, INC.**

*Unit of Union Carbide and Carbon Corporation*



*General Offices: 30 East 42nd Street, New York 17, N. Y.*

*Division Sales Offices: Atlanta, Chicago, Dallas, Kansas City, New York, Pittsburgh, San Francisco*



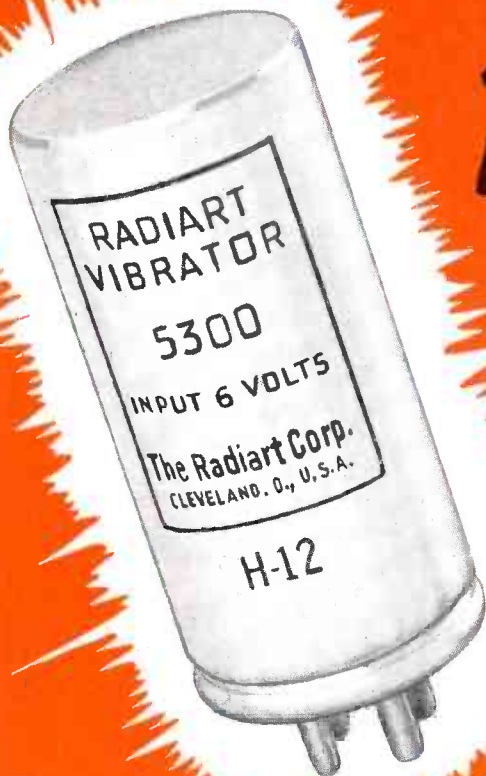

# RADIART VIBRATORS..



*Individually Engineered*

FOR SPECIFIC APPLICATIONS

### High Quality Materials . . .

For the past six months Radiart Vibrators have been equal or superior to pre-war vibrators in quality and performance.

Our engineers will be glad to co-operate with you in the development of the proper Radiart Vibrator for your specific needs.

### Physical Characteristics

Since each RADIART VIBRATOR is individually engineered all additional attachments for electrical grounding or for holding the vibrator in the socket are eliminated.

### Electrical Characteristics

RADIART VIBRATORS are engineered for the individual requirements of each circuit application, taking into consideration every operating essential such as frequency, current carrying capacity, points and reads properly tuned for transformer-buffer circuit requirements.

This individual engineering guarantees much longer life than could possibly be obtained if any of these characteristics were compromised for the sake of vibrator type simplification.

RADIART VIBRATORS assure minimum R. F. interference, low level of mechanical noise and starting under adverse battery conditions.

*Manufactured by makers of famous RADIART Rust Proof Aerials.*

## Radiart Corporation

3571 W. 62nd STREET

CLEVELAND 2, OHIO

*Export Division*  
25 Warren St., New York 7, N.Y.

*Canadian Office*  
455 Craig St. W., Montreal, Canada

## HIGHLY ACCURATE, STABLE VT VOLTMETER



## features WAR RESTRICTED DEVELOPMENTS!

TELEVISO, pioneering in the production of measuring apparatus for the SONIC to UHF SPECTRUM, has specialized in building dependable Vacuum Tube Voltmeters.

A necessity wherever dependable voltage measurements within the range of 7 cps to 500 megacycles are required—the Televiso Series 200A VT Voltmeter is highly accurate and stable. IMPORTANT WAR TIME DEVELOPMENTS ARE AVAILABLE FOR THE FIRST TIME IN THE FOLLOWING FEATURES:—

**SUPERSENSITIVE RANGE**—the lowest readable voltage is .05 volts on a maximum scale range of .5 volt.

**FIVE VOLTAGE RANGES**—5, 2, 15, 50, 150—spread full scale on a 4½" meter dial for easy reading. Accuracy of readings are 2% full scale; middle scale accuracy is 5% or better.

**PROBE CONSTRUCTION**—detachable probe to eliminate cable wear; easily dismantled for tube replacement or for soldering to tube terminals for measurements in the 250-500 MC region; flat ½" wide brass terminals connect to input to make easy soldering to test or work piece; for low frequency work up to 100 MC, removable banana plugs are spaced ¾" center to center for use with standard jacks.

**MECHANICAL CONSTRUCTION**—of aluminum throughout; panel and cabinet are ¼" thick (cabinet is dural.); sub-chassis is ⅛" and spaced off the panel by stubs to simplify servicing; all components are fastened to sub-chassis.

**ELECTRICAL CONSTRUCTION AND CIRCUIT**—Series 200A utilizes the finest components throughout and carries a two year guarantee. The circuit is a stable plate circuit rectifier. No diode input tube is used. The plate circuit rectifier type makes available higher input impedance at all frequencies. No shortening of input probe is required for zero adjustments. All zero adjustments are made once and remain constant. A panel adjuster is available to make the unit usable without heating up time. All filament and plate voltages are transformer and tube regulated.

**BUILT-IN CALIBRATION VOLTAGE**—All units have a jack which produces a constant 6.3 volts for standardizing. This is the regulated filament voltage. The sensitivity can be adjusted without tools in the event tubes are replaced in the field. The Series 200A will operate satisfactorily from any source of voltage from 95 to 130 volts ac. Line voltage surges are not observable during use.

**SIZE**—14" H x 9½" W x 7½" D. Guaranteed 2 years. Price \$170.00 F.O.B. Chicago.

*Televiso Products Inc.*

7466 IRVING PARK ROAD

CHICAGO 34, ILLINOIS

in a similar way to height and is a spot on the outer edge of the screen, positioned to repeat the indication of the compass in the tail of the aircraft.

These last two spots are from the same beam as used to trace the outline, since even under these conditions the c-r tube is not being worked so hard as under television conditions.

**Icing.** Here, a simple device is suggested to increase the brilliancy of the spot when tracing the upper edges of the wings and to decrease it when tracing the lower.

**Gasoline.** To indicate that fuel supplies are running low the designer proposes to modulate the beam so that the outline is dotted instead of solid.

Perhaps the most important part of the whole instrument is the method of obtaining the outline of the plane on the screen. One way would be to use television technique and to scan a cut-out of the machine, but the designer proposes another method, under the claim that the outline would be brighter and more distinct. The method consists essentially of motor-driven cams interposed between a series of photocells and lamps. Six cams are suggested, two each for the outline, the wing flaps and the retractable undercarriage, the last two appearing on the outline at the required times.

The outputs of the photocells are amplified to produce the various voltages necessary for application to the deflector plates of the c-r tube.

• • •

### Aviation's Electronic Requirements

By D. W. RENTZEL, *President*  
Aeronautical Radio, Inc.  
Washington, D. C.

COME OF AGE as a major means of transportation by the impetus of the war, aviation is in a position to dominate the coming age. However, the prominent limitations to safe, on-schedule flights are capable of solution only through electronic means. At present in the aviation industry electronic developments are trailing some of the other elements of air transportation. Solutions to many of these problems are in the offing; all that





## **EVEN FALLING ASHES CAN SET UP ELECTRONIC DISTURBANCES**

The problem of insulating sensitive electronic equipment against vibration is frequently a highly scientific one. Fortunately, research has shown that rubber, properly compounded and engineered, can usually be relied upon to insulate tubes and other parts against vibrations' disturbing effects.

United States Rubber Company scientists have pioneered in the development of such insulators... commonly called "rubber mountings". Individually engineered for specific needs, these

structural rubber parts interrupt and absorb vibrations, slight but harmful to the continuous, uninterrupted service of electronic and electrical devices.

The success of "U. S." Rubber Mountings is due to a thorough knowledge of the physical properties of rubber—reflected in unusual compounding skill—and to exceptional experience in engineering such parts to extreme precision standards.

The counsel of these experts is being widely sought by manufacturers in the electronics field.



**SERVING THROUGH SCIENCE**

# **UNITED STATES RUBBER COMPANY**

1230 SIXTH AVENUE • ROCKEFELLER CENTER • NEW YORK 20, N. Y.

# Outstanding Test Equipment



Range and accuracy to meet your requirements are offered by these and other models of STANDARD INSTRUMENTS for Electronic Testing that are available *now*.

## Incremental Inductance Bridges

### Model 520:

Range 1 MH—1100 H.

A.C. test voltage .01—300 V. R.M.S. 60 cycles.

D.C. Saturation 0—1 ampere.

Fully shielded.

Center pointer meter indicates balance or percentage plus or minus deviation.

Measures inductances of any Q.

Send for bulletin PR 520

### Model 510:

Range 50 MH—1100 H.

A.C. test voltage 3—100V. R.M.S.

D.C. Saturation 0—500 M.A.

Visual null indicator

PRICE COMPLETE \$650. net

## A. C. Bridges

With self contained generator, phase and frequency selective null indicator, center pointer meter and necessary power supplies. *Each Instrument complete in itself.*

### Universal A. C. Bridge, Model 430:

Inductance Range 1  $\mu$ h—100 henrys } Acc.  
Capacity Range 1  $\mu$ fd—100 $\mu$ fd }  $\frac{1}{2}$ %

Center pointer meter indicates balance or percentage plus or minus deviation.

PRICE COMPLETE \$375. net

*Additional information on request.*

## Capacity Bridges

### Model 310:

Range .1  $\mu$ fd—100 $\mu$ fd. Accuracy .1%

PRICE COMPLETE \$475. net

### Model 320:

Range 1  $\mu$ fd—100 $\mu$ fd. Accuracy 1%  
Center pointer meter indicates balance or percentage plus or minus deviation.

PRICE COMPLETE \$275. net

All instruments are equipped with self-contained generator, center pointer meter, indicating balance or percentage plus or

## Inductance Bridges

### Model 410:

Range .1 microhenry—100 henrys  
Accuracy .1%

PRICE COMPLETE \$475. net

### Model 420:

Range 1 microhenry—100 henrys  
Accuracy 1%

PRICE COMPLETE \$275. net

minus deviation. All bridges are suitable for use as limit bridges.



### NULL INDICATOR MODEL 380

The ideal null detector for use with any type of A.C. bridge circuit. The large 4" zero center meter indicates balance or percentage deviation. This instrument makes any bridge a production bridge. A self contained generator with variable output serves as the bridge source.

**Send for  
Bulletin  
PR-380**

We also manufacture a complete line of Vacuum tube voltmeters. Send for bulletin P. R. 500

# STANDARD INSTRUMENTS Corp.

## Electronic Test Equipment

568 Prospect Ave., New York 55, N. Y. Phone MOtt Haven 9-4664





## INCREDIBLE SALVAGE

### *The Case of the Flying Gull . . .*

During the storm season of 1942, *The Flying Gull* ran into heavy seas in the Gulf of Mexico.\* Running before a terrific wind, she all but made port. Then, just as she was putting about near Hunter's Point, she shipped a gigantic wave and foundered. All hands were saved. But *The Flying Gull* rested in eight fathoms of Gulf water.

Salvage operations were started. Later in 1942, when *The Flying Gull* was in the dock and her electrical equipment ripped out, an amazing thing occurred. George Long, of The Harris Salvage and Drydock Company of Galveston, put the Thermador transformer equipment on a shelf in the sunshine—mentally assigning it to the scrap metal drive. Three days later, out of curiosity, he hooked the transformers onto a testing bench and flipped on the current. To his amazement, they still showed signs of life. He then ran standard tests. To his further astonishment, all twelve of the transformers were not only working—they

were working perfectly.

Harvy Stark, owner of the boat, had already ordered a complete new set of transformers from Thermador. He cancelled the re-order. And today *The Flying Gull* sails with her original Thermador transformers. Not designed for the briny deep—but they could take it!

Such stories of plus performance are not accidents, for Thermador transformers are

built to perform beyond normal expectations. They are completely manufactured—not just assembled—under one roof on a vast array of modern precision equipment. They are made *only* from the finest materials, engineered by men of broad experience. The result is not alone quality but *quality in quantity*. If that meets your specifications, better discuss transformers with Thermador.

**THERMADOR  
TRANSFORMERS**  
DEFEAT HEAT • COLD • HUMIDITY



*\*An actual case history from Thermador files; however names, dates, and location have been altered. Buy MORE War Bonds.*

**THERMADOR ELECTRICAL MANUFACTURING COMPANY**  
5119 SOUTH RIVERSIDE DRIVE • LOS ANGELES 22, CALIFORNIA

# it is folly to put the plow in front of the oxen . . .



. . . and it is equally bungling to use a cheap substitute for Macallen Mica. Not many do, but every once in a while somebody has to learn from experience that trifling with insulation can be a disastrous experiment. The fact of dependability in Macallen Mica has been known to experts for more than 50 years.



When you think of MICA think of MACALLEN

**the Macallen Company**

16 MACALLEN STREET - BOSTON 27

CHICAGO: 325 W. Washington Blvd.

CLEVELAND: 1966 Leader Bldg.

remains for some is to be put into commercial form.

### *Obstacle Indicator*

Increased flying speeds require a warning to the pilot of obstructions such as mountains, buildings (This paper was prepared prior to the Empire State Building disaster.—Ed. note) or other aircraft. Such equipment should take advantage of transmitters on the obstacle or other aircraft. A cone of  $\pm 15$  degrees from the plane's center line should be scanned continuously, and it should be possible to explore a wider angle at will. The instrument should give indications of distance, position, elevation relative to the plane, and sight or sound alarm if the aircraft comes within a preset distance of the obstacle.

The obstacle indicator should have a range of approximately twenty miles (at current transport flying speeds this range allows only four minutes for avoiding obstructions). Its weight should be held within 50 pounds, 90 pounds if the instrument also serves as radio altimeter. Ground beacons could be used to reduce the weight and power of aircraft installations.

### *Radio Altimeter*

Preferably operating in conjunction with the obstacle indicator, the radio altimeter should have a vertical range of 40,000 feet, the elevation being indicated on low and high altitude scales. Its accuracy should be within three percent and its stability within 30 feet over a 15 minute period. There should be a button for service test indications. The altimeter indication might well be combined with the indication of a ranging instrument.

One important application of the radio altimeter is in isobar flying. Instead of flying the most direct course, transports fly on long hops with the motion of the air masses thus flying the course giving the shortest flight time.

In addition to weather reports indicating the positions of high pressure areas which rotate clockwise and low pressure masses which rotate counter-clockwise (in the northern hemisphere) from





All of the well known Utah qualities of workmanship and design go into Utah vibrators, yet they cost no more than ordinary vibrators.

- ★ 70 vibrator replacement types.
- ★ 39 different hook-up diagrams.
- ★ Servicing 3651 different auto and farm radio models.
- ★ More than a million radio sets are equipped with Utah vibrators.



*There is a Utah vibrator for every replacement requirement!*

**UTAH RADIO PRODUCTS COMPANY • 820 ORLEANS STREET • CHICAGO 10, ILLINOIS**

Utah Electronics (Canada) Ltd., 300 Chambly Road, Longueuil, Montreal 23 P. Q. • Ucoa Radio S. A., Misiones 48, Buenos Aires



### DAMAGE EXPELLER!

While using slotted screws, work-spoiling driver skids were causing frequent damage to plastic shades in the assembly of desk lamps. Refinishing slowed down production, and spoilage boosted costs... until the manufacturer started using Phillips Recessed Head Screws.



### OUTPUT IMPELLER!

With the change to Phillips Screws, damage and delays were eliminated. And with no more worry about driver skids, power drivers could be used, speeding output further. Costs came tumbling down... production set new records.



### PROBLEM DISPELLER!

Phillips Recessed Head Screws, engineered to take heavier driving pressures, simplify product design, give it more strength, more rigidity... often with the use of fewer screws. Screw-driving is faster, easier, surer... permits design innovations slotted screws just can't touch.



### SALES PROPELLER!

The Phillips Recessed Head radiates quality. It's trimmer... smarter looking... modern as tomorrow. No unsightly burrs and uneven appearance to cool off interested prospects. Put the extra sales push of Phillips Screws behind your product... make good merchandise look better!

# It's Phillips... the engineered recess!

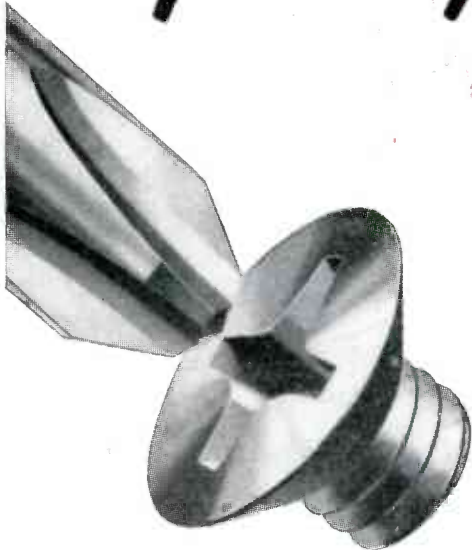

In the Phillips Recess, mechanical principles are so correctly applied that every angle, plane, and dimension contributes fully to screw-driving efficiency.

... It's the exact pitch of the angles that eliminates driver skids.

... It's the engineered design of the 16 planes that makes it easy to apply full turning power - without reaming.

... It's the "just-right" depth of recess that enables Phillips Screw Heads to take heaviest driving pressures.

With such precise engineering, is it any wonder that Phillips Screws speed driving as much as 50% - cut costs correspondingly?

To give workers a chance to do their best, give them faster, easier-driving Phillips Recessed Head Screws. Plan Phillips Screws into your product now.

## PHILLIPS *Recessed Head* SCREWS

WOOD SCREWS • MACHINE SCREWS • SELF-TAPPING SCREWS • STOVE BOLTS

Made in all sizes, types and head styles

**25 SOURCES**

American Screw Co., Providence, R. I.  
Atlantic Screw Works, Hartford, Conn.  
The Bristol Co., Waterbury, Conn.  
Central Screw Co., Chicago, Ill.  
Chandler Products Corp., Cleveland, Ohio  
Continental Screw Co., New Bedford, Mass.  
The Corbin Screw Corp., New Britain, Conn.  
General Screw Mfg. Co., Chicago, Ill.

The H. M. Harper Co., Chicago, Ill.  
International Screw Co., Detroit, Mich.  
The Lamson & Sessions Co., Cleveland, Ohio  
Manufacturers Screw Products, Chicago, Ill.  
Milford Rivet and Machine Co., Milford, Conn.  
The National Screw & Mfg. Co., Cleveland, Ohio  
New England Screw Co., Keene, N. H.  
Parker-Kalon Corp., New York, N. Y.  
Pawtucket Screw Co., Pawtucket, R. I.

Phell Manufacturing Co., Chicago, Ill.  
Reading Screw Co., Norristown, Pa.  
Russell Burdall & Ward Bolt & Nut Co., Port Chester, N. Y.  
Seovill Manufacturing Co., Waterville, Conn.  
Shakeproof Inc., Chicago, Ill.  
The Southington Hardware Mfg. Co., Southington, Conn.  
The Steel Company of Canada Ltd., Hamilton, Canada  
Wolverine Bolt Co., Detroit, Mich.



# YOU CAN TAKE THE SAME GRIP



## BUT CAN YOU PITCH LIKE A CHAMP?

There is more to throwing curves than holding a ball a certain way—

And there is more to producing top-performance transformers than assembling coils, cores, etc. in an enclosing case.

Correct use of engineering—years of experience—control of quality and manufacture in everyday large scale production—and the selection of the appropriate type and design for each particular requirement—are all essential to successful operation.

The hundreds of thousands of trans-

formers regularly produced—are ample proof that leading manufacturers of equipment in electronic, lighting, radio and similar fields prefer Jefferson Electric Transformers. Recommendations concerning transformers made by the Jefferson Electric engineering staff can save time for you—and insure the performance you desire. JEFFERSON ELECTRIC COMPANY, Bellwood (Suburb of Chicago), Illinois. In Canada: Canadian Jefferson Electric Co. Ltd., 384 Pape St., Toronto, Ont.



*ELECTRONIC • RADIO • TELEVISION*  
**TRANSFORMERS**

**SMOOTH**  
PRODUCTION WITH

**Follansbee**

**SILICON STEELS**

Follansbee Electrical Sheets and Strip help minimize production problems with excellent mechanical properties that match their magnetic characteristics.

In standard grades—or special high silicons to meet specific requirements—Follansbee punching and shearing quality reaches the ultimate permitted by the silicon content . . . width and gauge are to the closest tolerances . . . surface finishes and stacking factors meet exacting specifications.

The rigid control necessary in the production of high quality Silicon Steels coincides perfectly with the practices followed by Follansbee through generations of fine steelmaking. When placing your next order for Electrical Sheets or Strip—check with Follansbee.

#### FOLLANSBEE STEEL CORPORATION

GENERAL OFFICES • PITTSBURGH 30, PA.



Sales Offices—New York, Philadelphia, Rochester, Cleveland, Detroit, Milwaukee. Sales Agents—Chicago, Indianapolis, St. Louis, Kansas City, Nashville, Houston, Los Angeles, San Francisco, Seattle; Toronto and Montreal, Canada. Plants—Follansbee, W. Va. and Toronto, Ohio

ALLOY BLOOMS & BILLETS, SHEETS & STRIP • COLD ROLLED CARBON SHEETS & STRIP • POLISHED BLUE SHEETS • ELECTRICAL SHEETS & STRIP SEAMLESS TERNE ROLL ROOFING

which the navigator can choose the course, the navigator can compare the indications of the radio and barometric altimeters and thus observe his position relative to high and low pressure areas.

Experience with radio altimeters as landing instruments has indicated that obstructions on the path of approach to the runway, while not high enough to interfere with the glide path, produce excessive needle flutter in the altimeter.

#### *Automatic Position Reporting*

With increased aircraft traffic it is necessary to have available continuous data on plane positions. There is need for automatic equipment that will identify and give altitude, azimuth and range of all aircraft within the control area and duplicate this information to all interested parties. It would be advantageous if there could be superimposed on the indications of aircraft positions the locations of such navigational hindrances as thunderstorms.

#### *Written Communications to Aircraft*

The volume of information required in airline aircraft necessitates a means of sending written communications to aircraft, either by facsimile or radio teletype. Such an installation would free the plane personnel from the necessity of giving their attention to routine messages as such communications were transmitted.

The aircraft printer should be of the page type rather than of the tape type to eliminate the necessity of scanning for information, and should not weigh in excess of 25 pounds exclusive of the receiver. Paper should feed freely to avoid jamming during unattended periods. There should be several selectable channels, but transmission should be held to a narrow bandwidth. A keyboard and transmitter aboard the plane is not necessary, but such units should be adaptable to the receiver-printer.

#### *Electrical Power on Aircraft*

Equipment should operate from the normal power system of the plane. At the present most airline and private aircraft utilize the 12



**THYRATRON WL-678**  
**Grid Controlled Mercury Vapor Rectifier**

**General Characteristics**

Filament Voltage .....	5.0 Volts
Filament Current .....	7.5 Amperes
Filament Heating Time (Minimum) .....	1 Minute
Typical Control Bias at Rated Voltage .....	-75 Volts

**Maximum Ratings**

Anode Voltage, Peak Forward .....	15000
Anode Voltage, Peak Inverse .....	15000
Anode Current, Average .....	1.6 Amperes
Anode Current, Peak .....	6 Amperes
Temperature Range, Condensed Mercury .....	25 to 50° C

**THIS NEW**

**15,000 VOLT**

**THYRATRON**

**provides split-cycle control of high power  
for R. F. heating units, and radio transmitters**

The WL-678 combines the high voltage characteristics of a Kenotron, the efficiency of a Phanotron, and the controlability of a Thyatron. This latest feat of Westinghouse engineering offers the electronic equipment designer the following outstanding advantages:

- Smooth and instantaneous power control from 0% to 100% load . . .
- Simplified automatic load control . . .
- High speed automatic overload protection . . .
- Low space and weight requirements . . .
- Low control power requirements . . .

For more detailed information—write to your nearest Westinghouse office or to Westinghouse Electric Corporation, Lamp Division, Bloomfield, N. J. Westinghouse Electronic Tube distributors are located in principal cities.

**Westinghouse**  
PLANTS IN 25 CITIES OFFICES EVERYWHERE

*Electronic Tubes at Work*

# Providing precise industrial process control.. E·E GRID CONTROLLED RECTIFIERS

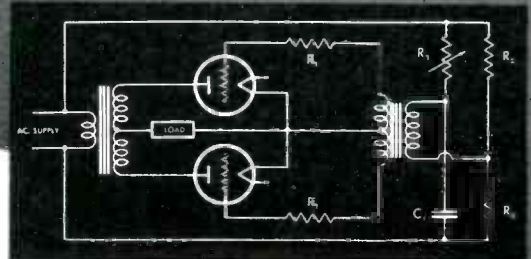

CONTINUOUSLY  
VARIABLE OUTPUT  
CONSERVATIVE  
RATINGS  
PERFECT ON-OFF  
CONTROL

Typical of the complete line of **ELECTRONIC ENTERPRISES** grid-controlled rectifiers, is Type 873 illustrated. It incorporates all important electronic and mechanical features essential for industrial use, and is capable of dependable functioning in severe service.

The grid control characteristic permits usage in the most exacting applications when variable output, or instantaneous on-and-off control is desired. Use is particularly suited for spot welding, induction heating and bombardment equipment. Also, ability to provide precise control offers many advantages over other means of regulation. Elimination of numerous components in circuit design, lowered costs and reduced maintenance are effected. Data Book sent on request.

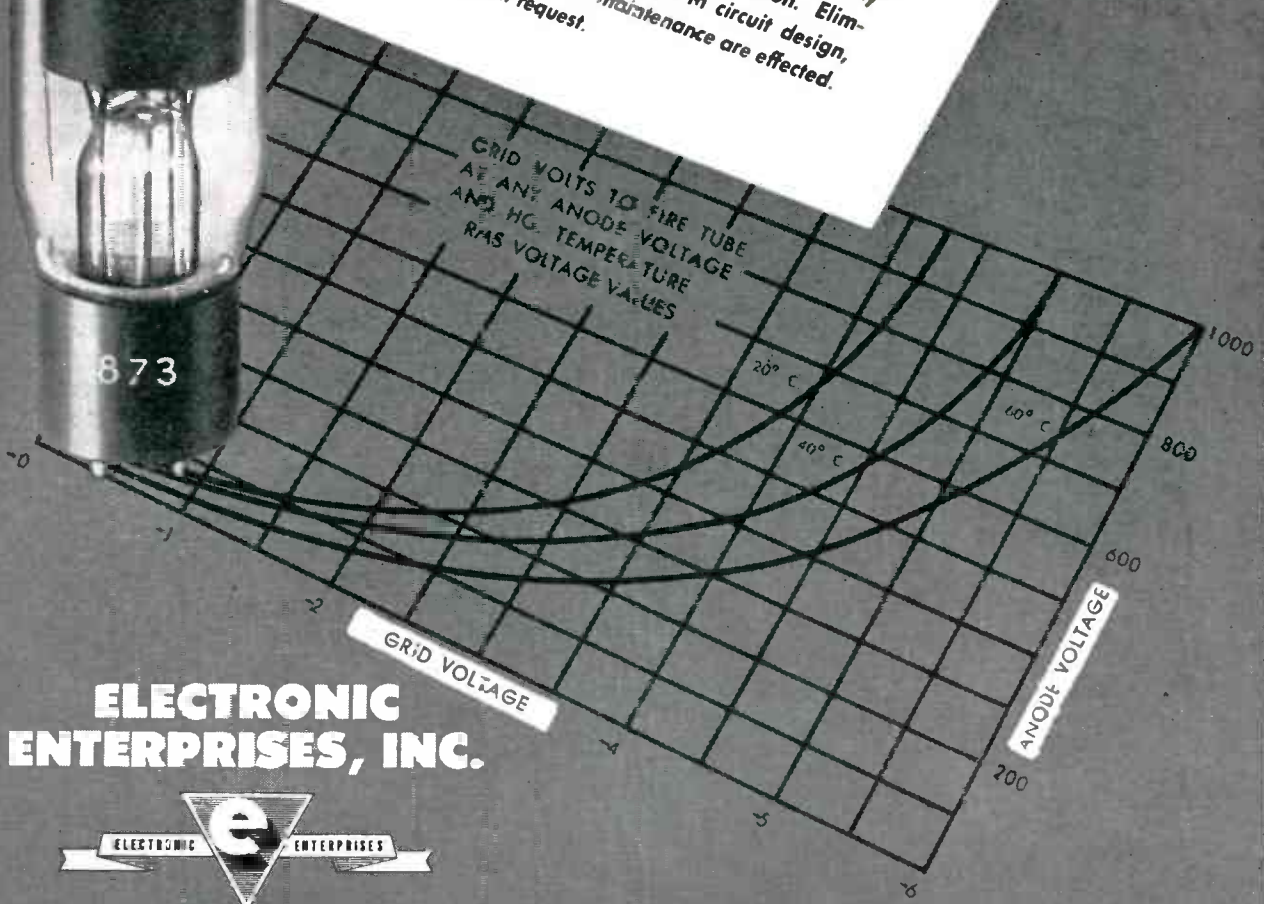

**ELECTRONIC  
ENTERPRISES, INC.**



GENERAL OFFICES: 65-67 SEVENTH AVENUE, NEWARK 4, N. J. EXPORT DEPT. 25 WARREN STREET, NEW YORK CITY, N. Y. CABLE ADDRESS SIMONTRICE, N. Y.



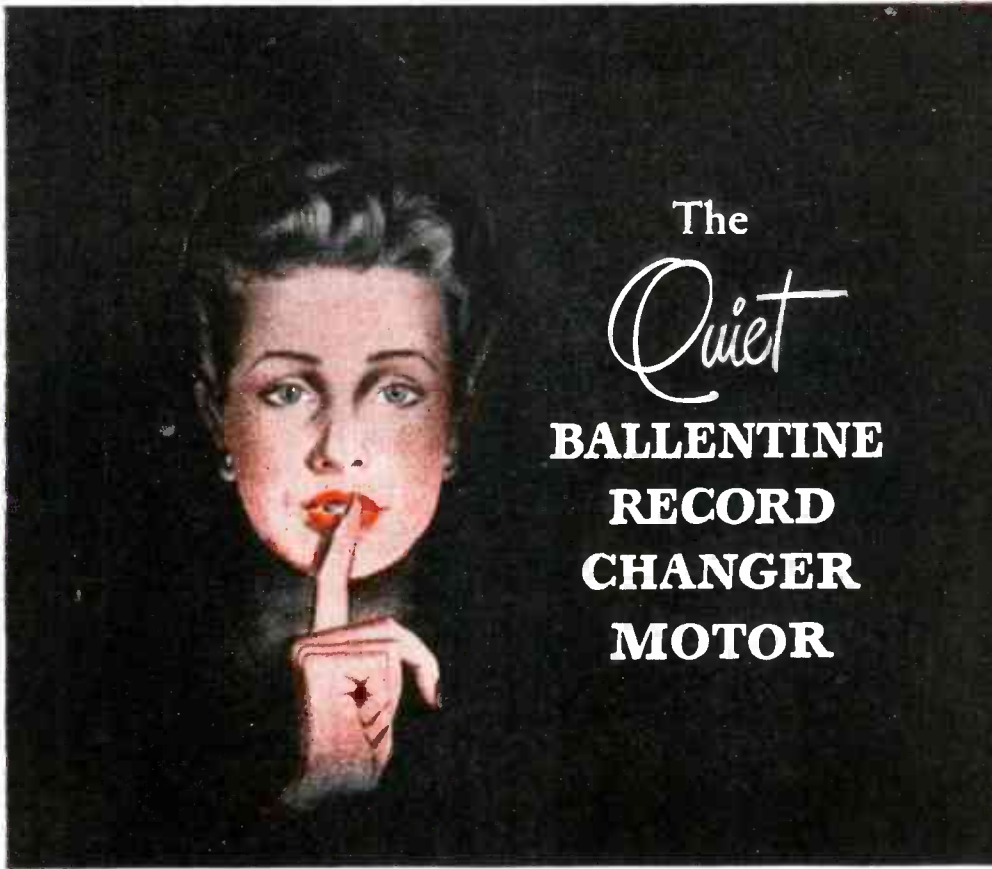

## The *Quiet Ballentine* Changer Motor

has these four characteristics achieved by advanced design, skilled engineering and precision manufacturing

- Lowest Rumble
- Highest Efficiency
- Most Compact Design
- Longest Life

The *Quiet Ballentine* Changer Motor is recommended to record changer manufacturers seeking to provide the ultimate in performance.

**RUSSELL ELECTRIC COMPANY**

364 WEST HURON STREET • CHICAGO 10, ILLINOIS

*Manufacturers of* **BALLENTINE**  
**RECORD CHANGER MOTOR**



**"This  
Remote Control  
works like a  
Direct Connection"**

Operation of remote control flexible shafts must be smooth and easy, free from any tendency to "jump". That's why the greatest care is taken in winding Walker-Turner Remote Control Shafting—to eliminate "back-lash"—to hold torsional deflection to a minimum in either direction of rotation—to keep internal friction low.

Result: in many applications, the same sensitive control is achieved with Walker-Turner Flexible Shafting as with a direct connection. Whether you need flexible shafting for remote control, push-pull or power transmission, you'll find careful design and manufacture, and high performance, characteristic of every type of Walker-Turner Flexible Shafting. Write today for our latest catalog.

**WALKER-TURNER COMPANY, INC.**  
PLAINFIELD NEW JERSEY



volt, d-c system; most military aircraft utilize the 24-30 volt, d-c system. It appears, from a survey made by Aeronautical Radio on behalf of the airlines, that the 24-30 volt d-c system will be predominant after the war, although high voltages at 400 cycles may be common.

#### *Air Borne Equipment*

Equipment carried aloft in the plane must be kept to a weight minimum, 200 pounds seems a reasonable figure for all radio equipment in the ship. Such navigational units as marker receivers which are in use only a minute portion of the flight time should be combined with other services. The grouping of aircraft communication and navigation channels at the same region in the radio spectrum will do a lot toward simplifying receiver design and utilization problems.

For international and overseas operation supplemental equipment will be necessary. The private flier will not be interested in all the available radio services. Manufacturers will do well to develop package units that can be added as the need grows, each building on the circuits present in the previously installed units.

• • •

#### **Medical Probe**

By ROBERT E. RICKETTS  
Auburn, N. Y.

IN THE MEDICAL FIELD of electronics there is a need for several new instruments the development of which need no longer be handicapped by lack of the design of uhf oscillators, transmitters, and receivers. Work was begun on one such instrument prior to the war.

The instrument, designated as the R-K Probe, was originally designed for two purposes: (a) to indicate irregularities of bone and organs under the skin; and (b) to indicate the size and placement of large organs of the body. The utility of such an instrument, which could be highly portable, lies in examining patients whose condition excludes moving them to x-ray or fluoroscope installations.

The instrument consists of a transmitter, receiver, indicator, and a power supply for operation from



**FLEXIBLE SHAFTING**  
FOR REMOTE CONTROL AND POWER TRANSMISSION



# NOW

# AN ACCURATE, MODERN SPEED CONTROL FOR

# *Variable Speed Transmissions!*

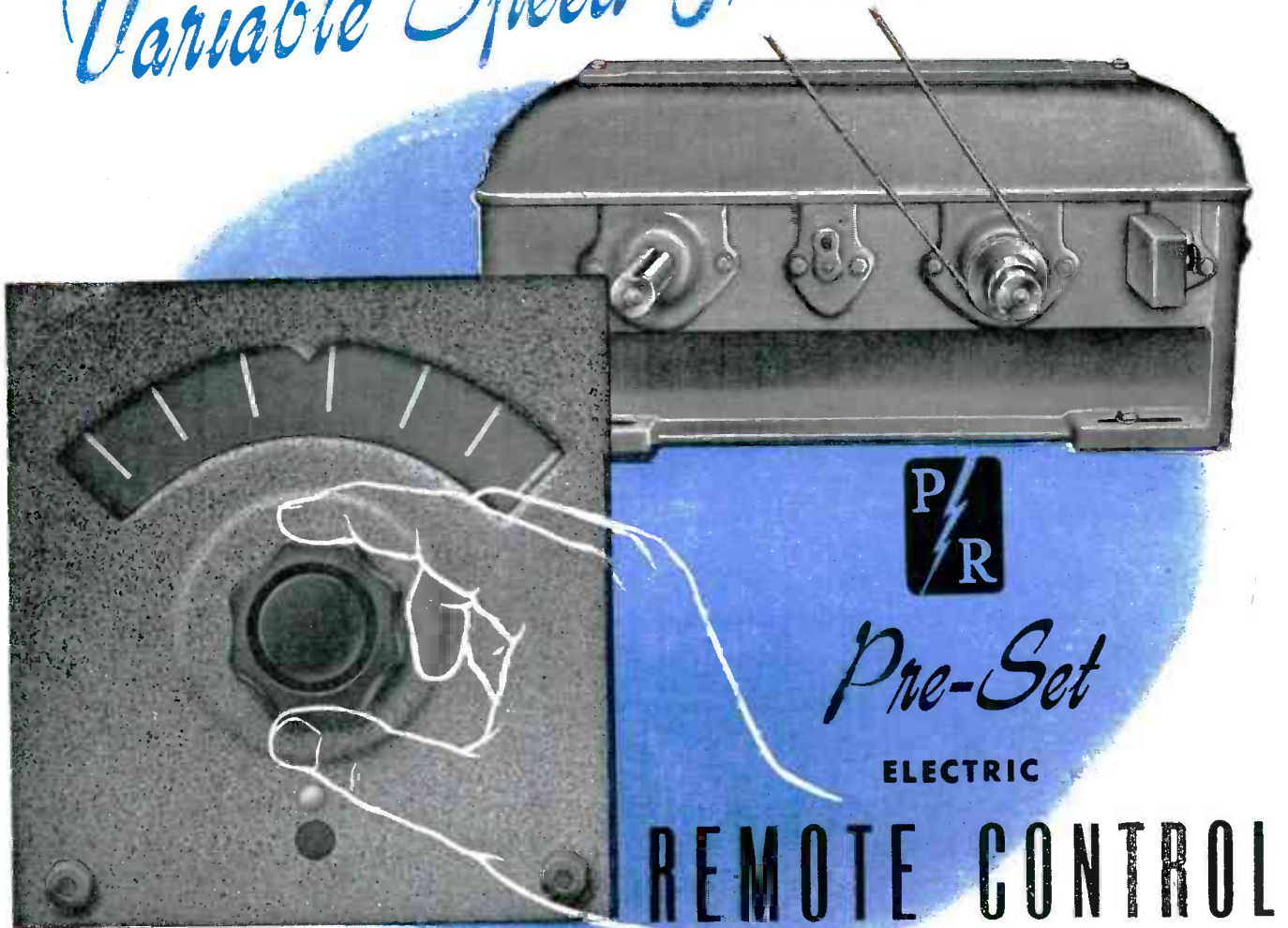

No longer is it necessary to follow instruments or dials in attempting to obtain accurate settings of Variable Speed Transmissions.

With the new P. R. Remote Control, the desired speed is *pre-set*, or *changed*, merely by turning the dial to the desired speed. The transmission then assumes the position to deliver the selected speed. And the setting is *quick*, and *highly accurate*, due to the new but extremely simple all-electric circuit employed.

This compact P. R. Precision Remote Control can quickly be hooked-up to any Variable Speed Transmission of the variable ratio type, either mechanical or hydraulic. It is readily applied to existing equipment, or can be supplied by equipment builders, on request. *For complete information, write . . .*

## REMOTE CONTROL DIVISION

Philharmonic Radio Corporation

528 EAST 72nd STREET

A Subsidiary of American Type Founders, Incorporated

NEW YORK 21, N. Y.



**CONFIDENTIALLY,  
WE'RE JUST A  
BUNCH OF  
HAMS AT  
HEART!**

**F**rankly, the magic of Radio is still a lot of fun to us! We here at GATES—every one of us, right up to the top man—put the enthusiastic imagination of the youngest amateur into our products.

That enthusiasm, supported by a background of continuous experience since 1922—and backed up by engineering ability and real precision workmanship—is what gives GATES Products their dependable quality.

For good Transmitting Equipment—reasonably priced—for your needs today, tomorrow, or whenever—call on GATES! The GATES RADIO CO., Quincy, Ill., U.S.A.

**Write for Details About the GATES Priority System for Prompt Post-War Delivery**



**QUINCY, ILLINOIS**



**GATES ONE KILOWATT  
BROADCAST TRANSMITTER**

This GATES Transmitter embodies the latest in engineering developments—modernized and streamlined to bring efficiency *plus* good looks to the Post-War Broadcasting Station.

All parts are conveniently, accessibly located for simple operation; and the pressure-type cabinet assures dustless, cool performance. A Transmitter of extremely high fidelity.

**Detailed Bulletin on the New GATES 1  
KW Transmitter Will Soon Be Available**

**PROGRESS REPORT**

*Gates is now in full production on civilian equipment and can make prompt delivery on many popular items.*

**EXCLUSIVE MANUFACTURERS OF RADIO TRANSMITTING EQUIPMENT SINCE 1922**



# ONE PURPOSE ... *the improvement of capacitors*

C-D never relaxes in its determination to improve capacitor design and to develop new and better materials and processes of manufacture. The C-D Type TJ series is typical of improved capacitor engineering.

Where a lot of capacitance must be packed into little space, there is no better capacitor for high voltage filter applications than the C-D Type TJ containing the Dykanol impregnant.

Dykanol "G", due to its chemical stability, allows operation at higher temperatures. It also permits the use of maximum paper thickness for a given size container, with a high factor of safety due to low voltage stress. Insulation resistance is five or more times as high as in capacitors using organic oil impregnants. On the larger sizes of the Type TJ series, the sturdy porcelain terminals withstand extremes of heat and cold and are practically unbreakable.

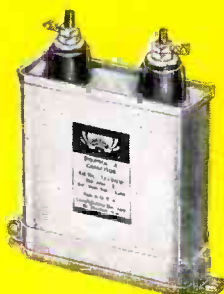

Look to Cornell-Dubilier for the extra quality and dependability that is engineered into every capacitor—the result of C-D's 35 years of capacitor specialization. Cornell-Dubilier Electric Corporation, South Plainfield, N. J. Other plants at New Bedford, Brookline, Worcester, Mass. and Providence, R. I.

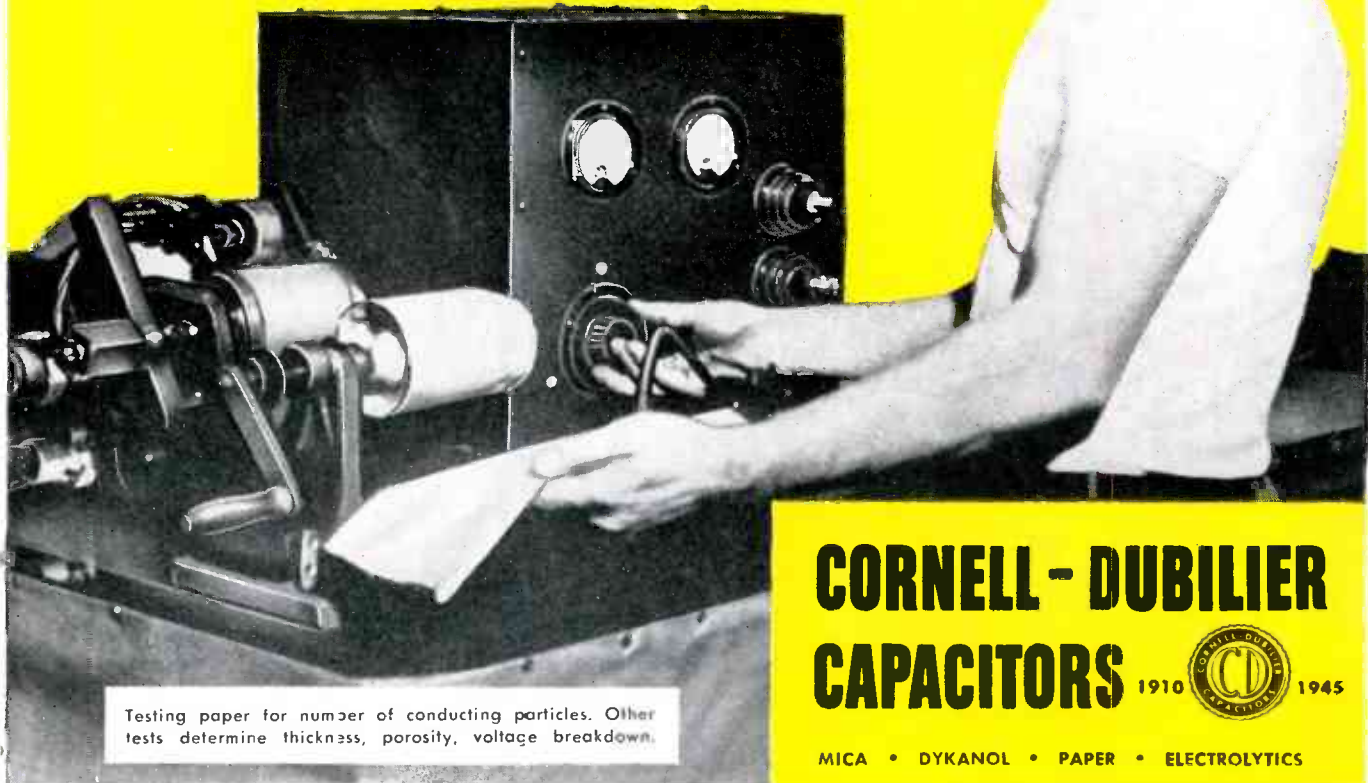
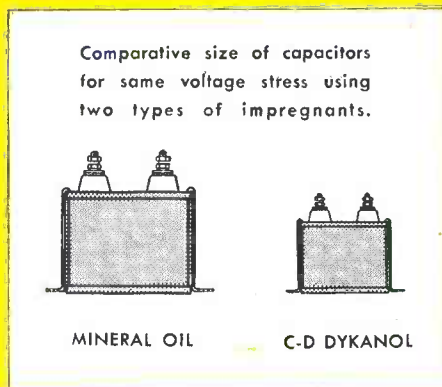

Testing paper for number of conducting particles. Other tests determine thickness, porosity, voltage breakdown.

## CORNELL - DUBILIER CAPACITORS



1910

1945

MICA • DYKANOL • PAPER • ELECTROLYTICS

# Duflex Mounts

## CONTROL VIBRATION ABSORB JOLTS and SHOCKS

### Protect DELICATE INSTRUMENTS

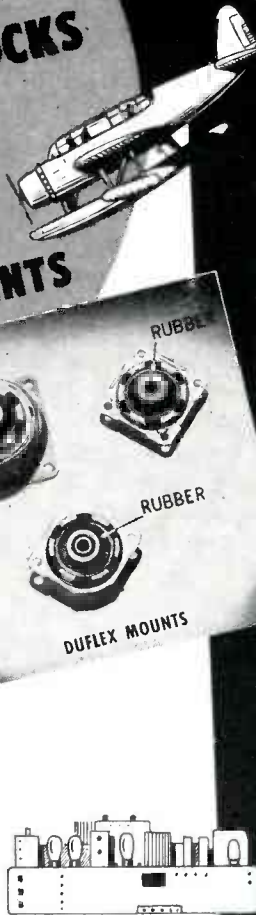

Duflex mounts, through shear-stressed rubber, protect sensitive apparatus from shock and vibration, enabling it to maintain accuracy and prolonging the life of the apparatus.



Duflex mounts are light in weight yet sturdy and in the case of instruments, radios, electrical control equipment, etc., they provide an effective suspension capable of preventing the transmission of vibrations or shocks.

Duflex mounts are made in accordance with the Army-Navy standards to suit any requirements as to weight, frequency, deflection or operating conditions.

If you have a problem send it in; our engineers may already have the answer, if not they will gladly work with your engineers on solving it. Send for our free Bulletin Series 1022 on Duflex mounts today.

**HARRIS PRODUCTS CO.**  
CLEVELAND 4, OHIO

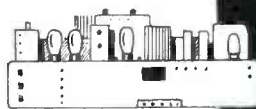
BRANCHES: 44 WHITEHALL STREET, NEW YORK  
GENERAL MOTORS BUILDING, DETROIT

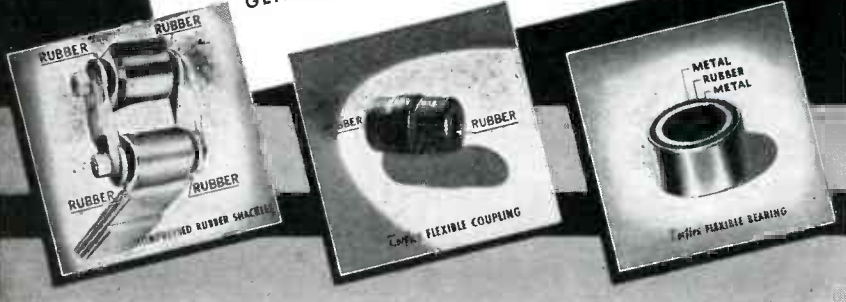
house current. A preliminary model shown in Fig. 1, although itself unsatisfactory, did indicate the direction in which to proceed.

*Basic Principle*

The principle of the device is simple. An electromagnetic field is set up about one inch from the portion of the body to be examined. Assuming the air and outer surface of the medium under examination as a fairly constant dielectric, if the probe were held a fixed distance from the body irregularities would be detected as a change in dielectric.

For example, the probe is held an inch from a reference point on the body—such as the forearm while it rests close to the body—and is adjusted for a set indication. The probe is then moved in the general

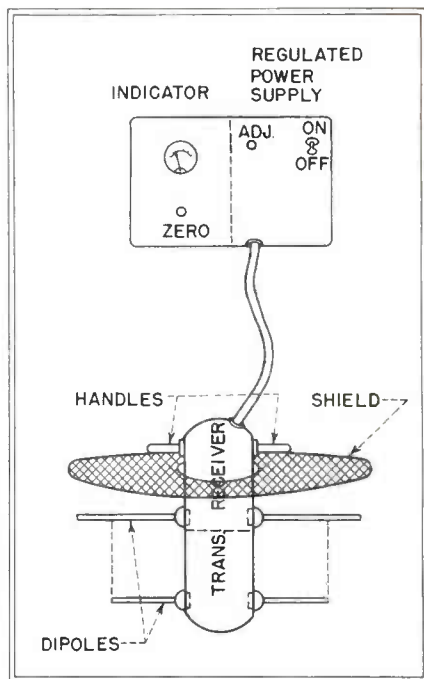
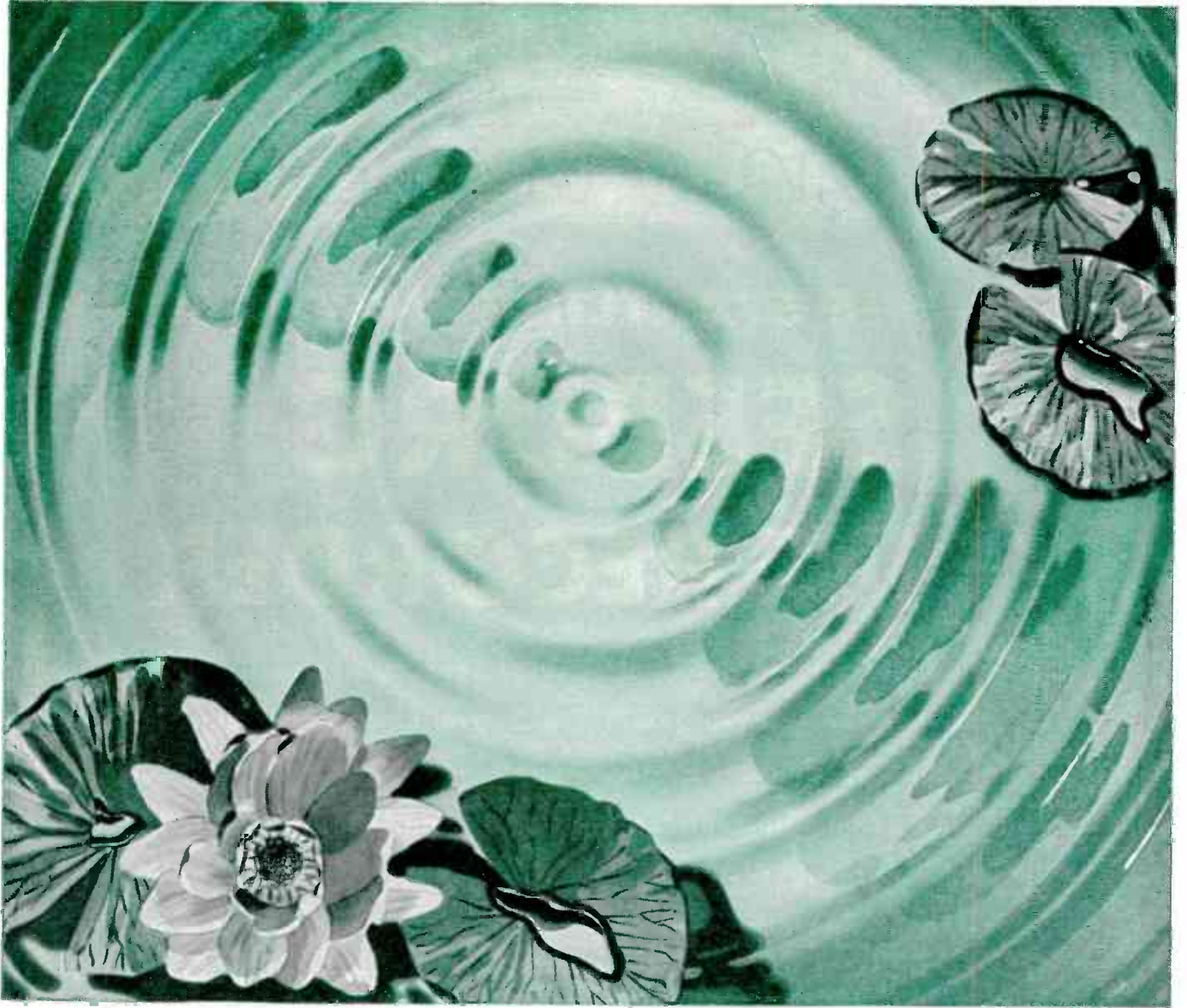

Fig. 1—Experimental model of R-K Probe used to diagnose physical abnormalities. Hand probe used to examine patient contained transmitter and receiver

direction of the heart until a sharp deflection is noted on the indicator. By one's moving the probe in a rough oval, the reading remains about the same, but in one's moving the probe away from the region of the heart the indicator returns to normal. If the operator inserts a





## CONCENTRICITY...

### For Uniform Transmission Characteristics in High Frequency Lines

IN COAXIAL CABLES, more than in any other types, accurate relationship between the component parts is essential.

Concentricity and uniformity of conductors and dielectric join in Anaconda Coaxials to effectively fulfill the objectives of electrical designers.

Each type is specifically designed to serve best in the intended application. All electrical characteristics are held within close limits to uniform standards assuring accurate surge impedances.

In addition to manufacturing standard types of coaxial cables, Anaconda offers research and engineering facilities to meet needs for specialized types.

45308



**ANACONDA COAXIAL CABLES**  
Anaconda coaxial cables are made in a variety of types to Army-Navy specifications.



# ANACONDA WIRE & CABLE COMPANY

GENERAL OFFICES: 25 Broadway, New York City 4

*Subsidiary of Anaconda Copper Mining Company*

CHICAGO OFFICE: 20 North Wacker Drive 6 • Sales Offices in Principal Cities

Announcing

THE STARTLING NEW . . .

# SEEBURG WIRE RECORDER

In addition to the new reliable line of Seeburg Record Changers — after Victory — Seeburg will make available to combination instrument manufacturers — The Seeburg Wire Recorder — truly an amazing accomplishment for home recording. The Seeburg Wire Recorder is being designed to eliminate many of the past disadvantages heretofore associated with home recording — no recording discs to buy — no skilled knowledge necessary to make perfect home recordings and to take favorite programs off the air. Just one simple control knob to operate.

It will be necessary for radio manufacturers to make provision in their circuits to accommodate the Seeburg Wire Recorder and we therefore invite prompt inquiries from interested radio manufacturers.

SEEBURG  
WIRE  
RECORDER

SEEBURG  
RECORD  
CHANGERS

**Seeburg**  
J. P. SEEBURG CORP. ★ CHICAGO  
BUY MORE BONDS!

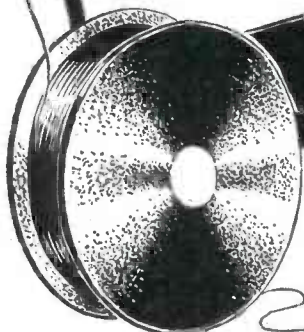

Awarded to the J. P. Seeburg Corporation for outstanding production of war materials in each of its four plants.





*Quality*  
**TRANSFORMERS**

**DESIGNED** **FOR EFFICIENCY**

### **THE "Know-How" OF TRANSFORMERS**

... ITC combines years of experience in the field, with leadership in the scientific design of every type of transformer for every application ... to bring you *better transformers*.

... The trained, skilled engineers who design ITC TRANSFORMERS are ready to aid you with your individual transformer problems.

... For dependable service now ... and in the future, be sure to use and specify ITC TRANSFORMERS.

*... Your inquiries are invited.*



**INDUSTRIAL TRANSFORMER CORP.**  
**2540 BELMONT AVENUE, NEW YORK, N. Y.**

# PORTABLE POWER PROBLEMS

THIS MONTH — WESTINGHOUSE VIBROGRAPH



**THE WESTINGHOUSE VIBROGRAPH**—an accurate instrument for measuring and recording vibrations—is one of many time-saving devices powered by Burgess Industrial Batteries. Where sensitive test and control equipment is regularly employed, engineers specify Burgess for maximum quality and service. The complete Burgess Industrial Battery line is built to meet every standard commercial requirement. Your Burgess distributor can fill your needs today—write for his name and address.

**BURGESS IS FIRST CHOICE OF 2 OUT OF 3** in recent nation-wide survey of manufacturer electronic engineers. If you have a special battery application, Burgess engineers are equipped to develop the type you need. *Burgess Battery Company, Freeport, Ill.*

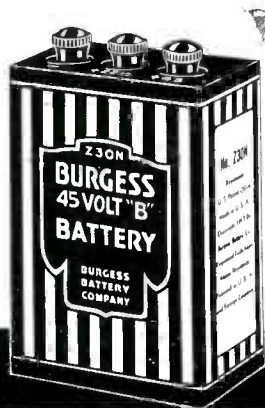
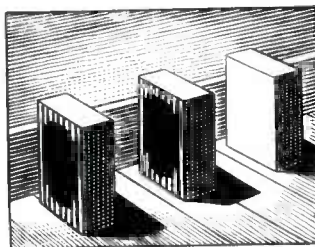

# BURGESS BATTERIES

REMEMBER THE WAR CHEST—GIVE TODAY!

VOTED FIRST BY ELECTRONIC ENGINEERS

MEDICAL PROBE

(continued)

paper between the body and the probe and attaches a black crayon to the probe, a rough sketch of the heart can be quickly drawn.

Similarly the probe can be used to locate bone irregularities or foreign bodies in the patient.

Figure 2 is a wood box with a stone and a piece of metal imbedded between gravel and plaster. The probe is adjusted by using point A for a reference level. At point B the meter shows a sharp deflection, while at point C the indicator reading rises.

### Experimental Models

The preliminary work on the first model indicated that it was extremely sensitive to differences in the medium being examined, providing the surface layer was uniform. Unfortunately, even at 600

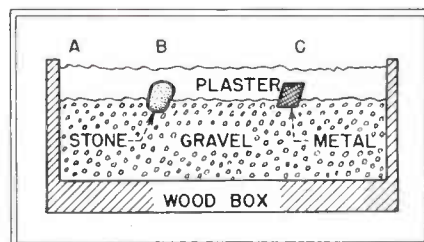

Fig. 2—Laboratory dummy illustrates that probe will indicate irregularities under the surface. Stone and metal simulate foreign particles imbedded in subcutaneous tissue but hidden by the sufferer's skin

mc the electromagnetic field was too sensitive to discontinuities within several feet of the medium under examination. Also the probe housing both transmitter and receiver was heavy and cumbersome. Instabilities indicated a need for tuning of the transmitter and receiver and provision for maintaining a more constant field.

The second model was designed to work at a much higher frequency with a more directive antenna system. A single dipole was used for the transmitter and a single dipole for the receiver. The transmitter and receiver were contained in the indicator housing and connected to the probe by coaxial line. This resulted in a much smaller probe, a major improvement. The housing of the probe was drilled and tapped at many



# First in Circuit Protection

## LITTELFUSE SAFETY SPARKY

A spark gap designed to discharge safely transient high voltage surges appearing on equipment sensitive to over-voltages, such as: condensers, exposed induction coils, delicate vacuum tubes, etc.

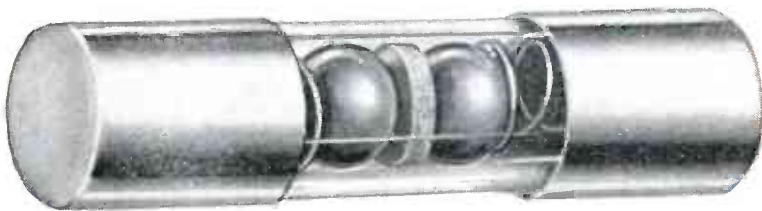

The Littelfuse Safety Sparky has been redesigned for greater accuracy on breakdown voltage tolerance—can be held as close as 50 volts regardless of voltage. It is small in size (9/32" dia. by 1/4" long) and can be mounted in standard Littelfuse Fuse Clips. Sparkies are available in breakdown voltages between 800 and 8000 volts D.C. Power rating approximately 5 to 10 watts. For additional information write to Commercial Engineering Section.

**LITTELFUSE INCORPORATED**  
4757 N. Ravenswood Ave. • Chicago 40, Illinois

### QUALITY IS A CHALLENGE

*Quality is a challenge which the weak must decline but which the strong joyfully accept. The acceptance demands courageous planning and resourceful thinking. It demands patient research and unending vigilance against the temptation of profitable inferiority; it demands an unbending desire to serve well and the will to pursue unwaveringly the desired standards of perfection.*

*The path of quality is the road to victorious accomplishment.*

*W. J. ...*  
President

# LITTELFUSE



# Incorporated

# AT LAST

## PLANES LAND SAFELY THROUGH FOG, STORM, DARKNESS

With the

# Gilfillan RADAR LANDING CONTROL

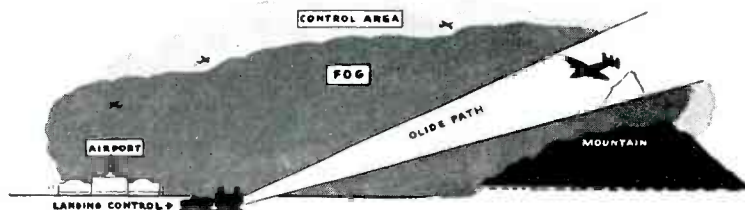

### One of the Greatest Electronic Achievements of the War!

**O**UT of the mountainous fog-bound Aleutian Islands, stormy Iceland, foggy England, and the difficult flying weather of Iwo Jima, comes one of peacetime's greatest benefits—safe airport landings through fog, storm and around invisible hazards, such as mountains, buildings, high tension wires, etc.

Peacetime will see America turned to flying. And just as public demand in the past brought about the adoption of every type of safety device to protect railroad travel, so will public demand insist upon every possible safety device to protect airplane travel.

Fog, storms, unseen mountains, buildings, etc., have been the greatest hazards of airplane travel in the past. These elements have prevented scheduled flights and scheduled landings of planes on air fields; have presented greater dangers, caused greater losses and retarded air progress more than anything else.

Now, they are overcome—through radar and its practical application to peacetime air transportation by Gilfillan Bros., Inc. of Los Angeles, with the Gilfillan Radar Landing Control.

This magic device

1. Brings planes onto any air field safely through fog, storm, darkness and other flying hazards.
2. Guides planes safely around buildings, mountains or other aircraft under all weather conditions.
3. Has been proven beyond question through thousands of landings made under emergency conditions.
4. Will handle any type of aircraft.
5. Controls many planes at one time and keeps them circling in the air if necessary at different elevations to prevent collision.
6. Can land a plane every thirty seconds.
7. Can be installed anywhere.
8. Supplements—does not displace—present airport control equipment.
9. Requires no special equipment in the airplane.

The Gilfillan system, developed in 1942 and put into practical usage in 1943, was especially designed to land airplanes under adverse conditions and is not a modification of some other radar system.

*Gilfillan Bros., Inc. take this opportunity to thank and congratulate Radiation Laboratory, M. I. T.; the Office of Scientific Research and Development; Watson Laboratories, ATSC; the Army Signal Corps and AAF Air Communications Office for the vital parts they took in the development of GCA (Ground Control Approach).*

DEVELOPED BY GILFILLAN BROS. AND RADIATION LABORATORY, M. I. T., FOR ARMY AIR FORCES

Early in 1942 Gilfillan engineers started working with Radiation Laboratory scientists on the development of what was then known as GCA—Ground Control Approach. In 1943, after experimental models had been thoroughly tested and proven by Gilfillan Bros., Inc. and Radiation Laboratory, plans for the device were made available to other manufacturers and their engineers were brought into the Gilfillan factory to learn every practical step in its manufacture.

This equipment was first used in Europe and has since been of incalculable help to our flyers in the Pacific in the adverse weather conditions under which they have operated.

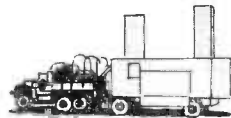

## Available NOW FOR ALL AIRPORTS

*Gilfillan Bros., Inc., LOS ANGELES*



# You're in good company . . .

## in *Southern* *New England*

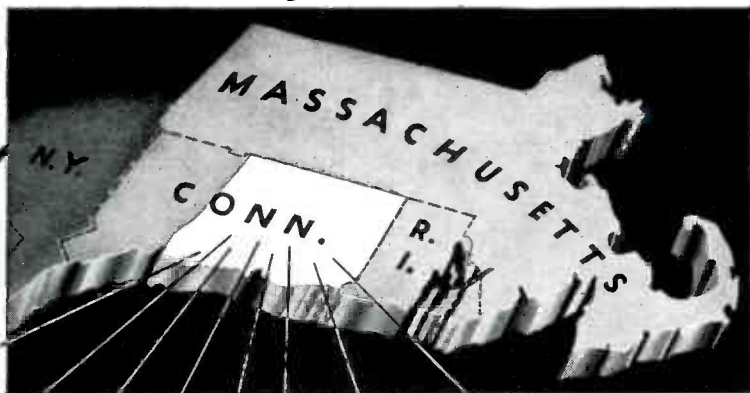

No matter where you go in industrial Southern New England, it won't be long before you come upon the plant of a well-known manufacturer.

For example, in this section of Connecticut, nationally-famous typewriters, locks, firearms, silverware, brushes, tools, safety razors, rugs, vacuum bottles, aviation engines and propellers, rubber goods, shaving cream, soap and skin lotion, as well as many other products, are manufactured.

Every one of these products has a name as familiar as your own. Many of them had their beginnings here. Others have come because of conditions favorable to manufacturing . . . generations of skilled craftsmen; abundant power; fair taxes; industrially-minded banking; State and local government that grew up with industry and understands its problems.

But that is only part of the story.

Southern New England lies in the heart of the world's richest, most-highly concentrated market.

Within a radius of 500 miles live 58,000,000 people to absorb not only Southern New England's consumers' goods but her producers' commodities — the tools and parts that go into other industries.

And because no part of Southern New England is more than 125 miles from tidewater and the

great ports leading to foreign markets, manufacturers locating here will be at the threshold of the huge overseas trade that will develop during the great era of peacetime commerce ahead.

Southern New England offers better personal living, too, for it abounds in charming residential communities with good schools, churches, lakes, hills and sandy beaches — all close by.

In planning your tomorrow, don't overlook Southern New England — perfect for your new or expanding business . . . and for your all-around enjoyment of life.

An industrial booklet in full color, "Southern New England for Tomorrow's Industry", is yours for the asking. Write to P. E. Benjamin, Manager of Industrial Development, The New Haven Railroad, 80 Federal Street, Boston 10, Mass.

*This is one of a series of advertisements presenting the industrial advantages of Southern New England.*

THE **NEW HAVEN** R.R.

Serving SOUTHERN NEW ENGLAND with a network of rail and highway transportation that puts every manufacturer "ON THE MAIN LINE".



# Quality...

## A Success Secret of CAPACITRONS

The Capacitron reputation for progressive design, superior craftsmanship and dependable service is backed by a continuous research program covering every capacitor manufacturing operation. No Capacitron production process is ever given a chance to become "standard procedure"—it is always an engineering project—always open for immediate improvement. Through this system of *method control* has come unquestioned leadership for Capacitron Oil, Wax and Electrolytic Capacitors . . . our customers call it Quality.

Telephone VAN Buren 3322

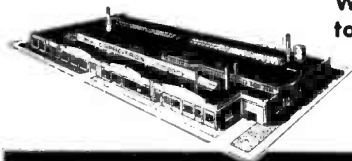

### The CAPACITRON Company

849 North Kedzie Ave., Chicago 51, Illinois

points for reflectors to try forming a beam. These experiments on the second model and its directive array were never completed, however.

#### Results of Experiments

From the work done the following observations can be made.

**SIZE-WEIGHT:** A probe was designed to fit in the palm of the hand and light enough to be handled by one hand. Adjustments were made on the front panel of the instrument proper by the other hand.

**INTERFERENCE:** Two separate problems were encountered here, (a) interference due to organic objects such as the operator, and (b) interference from surrounding objects of which metal caused the greater difficulty. The use of a more directive antenna, lower power, and a sensitivity adjustment on the receiver, would reduce interference.

**SENSITIVITY:** The sensitivity of the receiver, and stability of the transmitter were peculiar problems. An instable transmitter was critical to adjust and made the most sensitive probe useless.

**BALANCED ELECTROMAGNETIC FIELD:** This problem was and still is the major one and has much to do with the phase relationships mentioned previously. A balance is obtained between the portion of the field absorbed by the medium and that reflected to the receiver antenna in the initial adjustment of the probe at its reference point. Variations from the reference adjustment activate the indicator section of the instrument.

#### Further Study

The second model gave a power output of seven watts from the transmitter; considerable of this power was lost in the coaxial line to the probe. The amount of power and the required sensitivity for such an instrument must be determined from further study.

A lower-power probe using a wave guide in duplex as transmitter and receiver may solve some of the interference problems of earlier probes.



• ASK US ABOUT OUR NEW HIGH-TENSILE STRAIGHT BERYLLIUM COPPER WIRE •

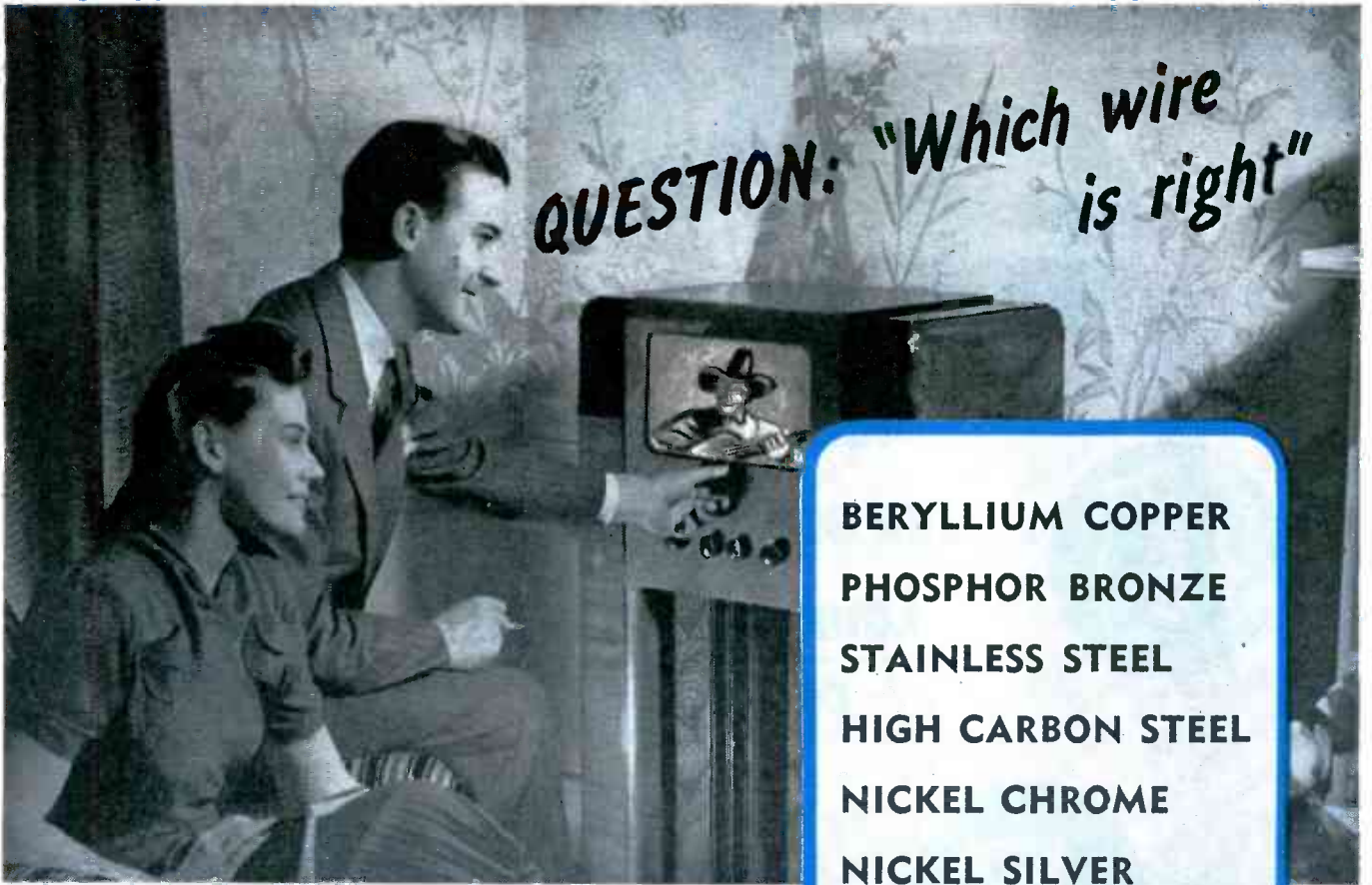

**QUESTION:** "Which wire is right?"

- BERYLLIUM COPPER
- PHOSPHOR BRONZE
- STAINLESS STEEL
- HIGH CARBON STEEL
- NICKEL CHROME
- NICKEL SILVER
- STERLING SILVER

**ANSWER:** "Only the wire that's made for the job!"

In exact sizes with exacting physical characteristics, Spencer wire brings you the right wire to improve your improved product. Write for folder today — Bring your wire problems to . . .

**SPENCER WIRE**

Specify  
**SPENCER**  
for exact specifications

**SPENCER WIRE COMPANY**  
WEST BROOKFIELD PLANT  
WEST BROOKFIELD • MASS.

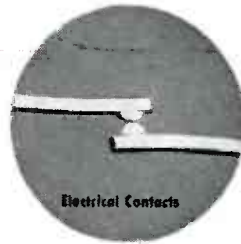
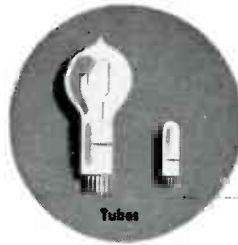

Here's where you  
can use General Plate  
Laminated Metals  
**PROFITABLY**

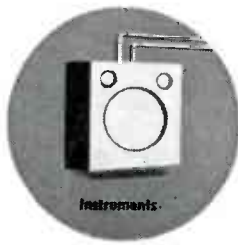

Overlay, precious metals,  
one side or both sides,  
any thickness.

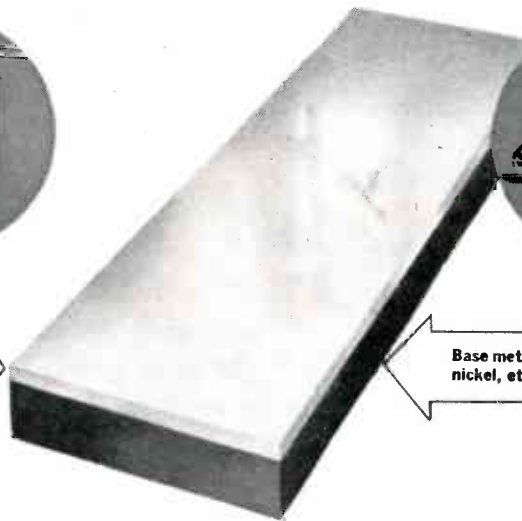

Base metal, steel, copper,  
nickel, etc.

From peanut hearing-aid tubes to huge chemical stills . . . anywhere that out-of-the-ordinary performance and dependability is a must . . . General Plate Laminated Metals not only meet the operating and mechanical requirements, but cut costs, too.

For instance, in electrical equipment permanently bonded silver to base metal gives solid silver performance at a fraction of solid precious metal cost. In chemical apparatus, combinations of silver or other precious metals to base metals provide effective and economical protection against corrosion. The precious metal gives the protection . . . the base metal keeps costs down, adds to workability and rigidity.



While in other applications such as radio, electronics and instruments base to precious metal or base to base metal combinations provide exceptional performance, long life and economy.

Investigate General Plate Laminated metals, today. They give you such advantages as performance, ease of fabrication, ease of soldering, electrical conductivity, and mechanical and structural properties not found in single solid metals. They are available in sheet, wire and tube form . . . inlaid or wholly covered. New metal combinations, developed since the war, are also now available. For engineering assistance or information on General Plate Laminated metals, write:

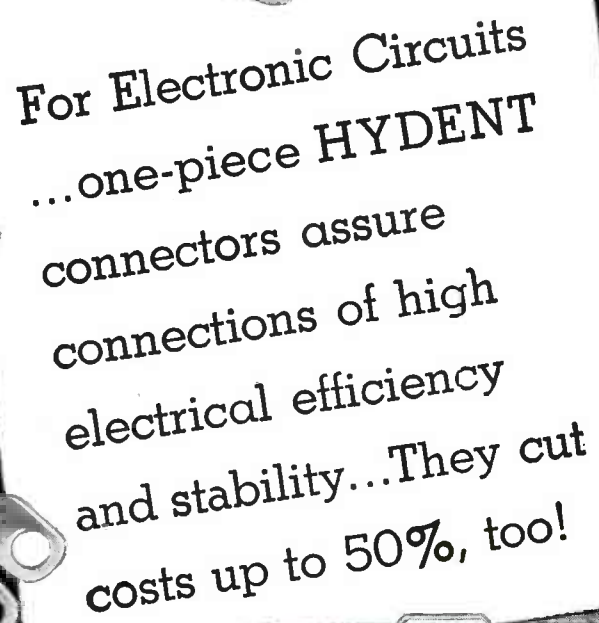

**General Plate Division**  
*of Metals & Controls Corporation*

50 Church St., New York, N. Y.; 205 W. Wacker Drive, Chicago, Ill.; 2635 Page Drive, Altadena, California; Grant Bldg., Pittsburgh, Pa.  
**ATTLEBORO, MASSACHUSETTS**



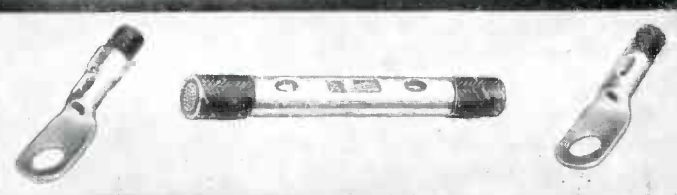

For Electronic Circuits  
...one-piece HYDENT  
connectors assure  
connections of high  
electrical efficiency  
and stability...They cut  
costs up to 50%, too!

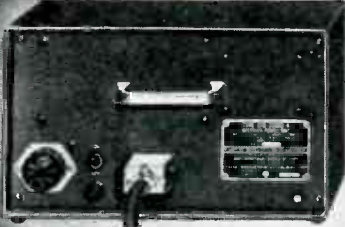

There's never any doubt about either stability or *electrical efficiency* of a HYDENT connection. That's why Federal Manufacturing & Engineering Corp. of Brooklyn, N. Y., selected Burndy HYLUGS for the wiring harness of this signal generator. Built to meet the exacting specifications of military service, the manufacturer could take no chances on faulty connections in this equipment. HYDENT connectors are virtually coined to the conductors by the Burndy HYPRESS, in one quick operation, thus eliminating costly and messy operations involved in soldering. In addition, the finished connections are easy to inspect. Why not investigate this modern, economical connecting method today. Write to . . . Burndy Engineering Co., Inc., 107-L Bruckner Blvd., New York 54, N. Y.

Headquarters for  
CONNECTORS

# Burndy

# NEWS OF THE INDUSTRY

**New RTPB officials; receiver licensees; standards; radar display; meeting schedule; news of Washington; FCC actions; industrial activities; people, and awards**

## Science Search: Man and Material

BECAUSE OF A PREDICTED shortage in scientifically talented people with corresponding training, Dr. Vannevar Bush, director of OSRD (Office of Scientific Research and Development) has recently made some proposals in a report to the President, a report called "Science, the Endless Frontier." In it he suggests that the armed services be culled for people who should continue their scientific education as soon as possible. This would plug up holes in the ranks of science caused by what he describes as the radical way educational activities in science were suspended during the war.

He also points out that higher education has heretofore been available only for those who could afford it and whether they had talent or not. His feeling is that talented individuals in every segment of society should not be wasted by lack of education.

Specifically, he advocates the establishment of a National Research Foundation consisting of nine members to be selected by the President and responsible to him. They would be divided into five sections covering medical research, natural sciences, national defense, scientific personnel and education, and publications and scientific collaboration. He sets the prospective cost at \$33,000,000 at the outset with a possible gradual rise thereafter.

Meanwhile, in Germany, technical specialists are searching through the files of German scientists to be sure we are fully abreast of all types of scientific endeavor. In the communication field, nine specialists were reported by the Foreign Economic Administrator as having been active in investigations. The group included: John A. Parrott, AT&T; Pierre Mertz and John A. Townsend, Bell Labs; Todos M. Odarenko, Federal Telephone & Radio Laboratories; C. W. Hansell,

RCA; Frederick E. Henderson and Roland H. McCarthy, Western Electric Co.; Charles M. Banca, RCA, and C. B. Horsley, Harvey-Wells Electronics.

## Hams in Again

AN ANNOUNCEMENT by FCC permits those amateur radio operators who are in good standing to return to the air at once, operating in the 112-115.5 mc band until November 15. The shift to 144-148 mc will follow.

## Naval Research

BRINGING TOP-FLIGHT technical talent into close contact with fleet operating and maintenance problems is one of the objectives of a recent reorganization of the Naval Research Laboratory. War experience has dictated the changes.

Four new scientific divisions have



Admiral Alex H. Van Keuren



Dr. A. Hoyt Taylor



Dr. Robert M. Page

been set up by Rear Admiral A. H. Van Keuren, director of the Naval Research Laboratory, to cover activities which were formerly contained in a single radio division under Dr. A. Hoyt Taylor of Chicago, Ill. Dr. Taylor now becomes chief consultant and chief coordinator for electronics. Heads for the new divisions are as follows: fire control division—Dr. Robert M. Page,



Electronic controls automatically regulate exposure time in this chest x-ray operation at McNulty Shipyards in Brooklyn, N. Y. Developed by North American Philips Co., this particular unit handles plant workers in rapid-fire order taking x-ray images on 70 mm film. Equipment was provided by the U. S. Public Health Service



# *Specialized Knowledge and Equipment for* **UHF DESIGN**

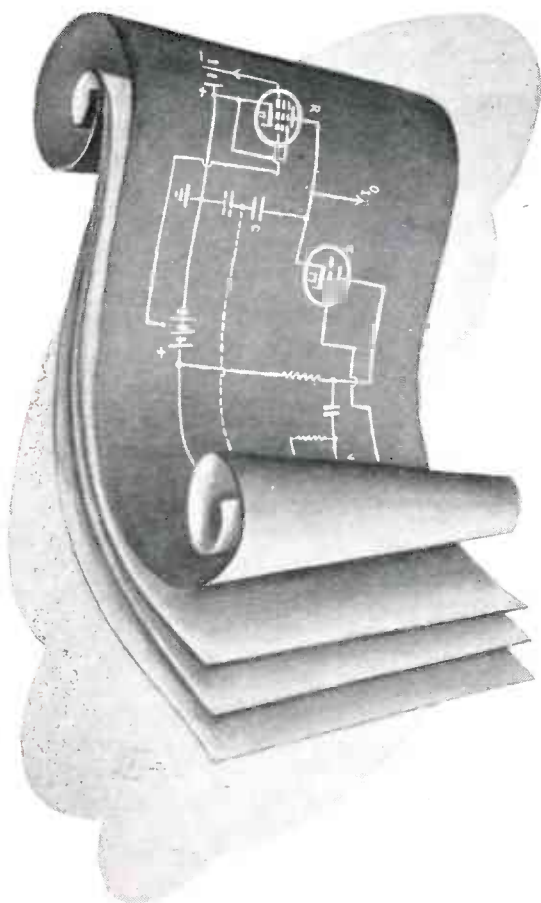

● The phenomena encountered in the UHF field are in many cases so decidedly different from those true of lower frequencies that many manufacturers find themselves in urgent need of specialized UHF knowledge, in order to develop equipment that will handle certain specific conditions.

● Since we are specialists in UHF engineering, we are equipped not only to render technical advice, but also to follow through in the actual production of equipment in our shops.

● Of necessity, during the war period, our efforts have been concentrated largely on Army and Navy work. Now that peace is with us, we have adequate time to devote to civilian requirements. We invite discussion of any problems you may have in the UHF field.



*Larvie Laboratories*

RADIO ENGINEERS AND MANUFACTURERS  
MORGANVILLE, N. J.

**Specialists in The Development of UHF Equipment  
and in The Manufacture of UHF Antennas**

ONE QUICK CENTRAL SOURCE  
for all Leading Makes of  
**TRANSFORMERS**



Thordarson  
Stancor  
Sola  
General Radio  
UTC  
Superior  
Merit Coil  
Knight  
General  
Transformer  
Acme  
Pioneer Electric  
Crest

It's simpler, faster to get your transformer needs from this one central source. Here, under one roof, are *all the leading makes, in all the wanted types:*

Power • Adjustable • Voltage Regulating  
Step-up and Step-down • Plate and Filament  
Audio Input • Interstage and Output • Modulation  
Driver • Microphone, Line and Mixing Transformers  
Filter and Swinging Chokes • Audio Reactors  
Fluorescent Lighting Ballasts

Large and varied stocks are maintained for *rush service*. Close contact with manufacturers expedites procurement. This complete service saves time and work. That's why thousands call ALLIED First!

WRITE, WIRE, OR PHONE HAYMARKET 6800  
for Everything in Radio and Electronics

Helpful  
**BUYING  
GUIDE**  
Available  
on Request  
Write for it!

**ALLIED RADIO**  
CORPORATION

833 W. Jackson Blvd. • Dept. 24-K-5 • Chicago 7, Illinois

SUPPLIERS OF ELECTRONIC PARTS AND EQUIPMENT TO INDUSTRIAL AMERICA  
Electronic Tubes, Rectifiers, Power Supplies, Intercommunicating Systems, Sound Systems, Photo-Cell Equipment, Batteries, Chargers, Converters, Generators, Supplies for Resistance Welders, Fuses, Test Instruments, Meters, Broadcast Station Equipment, Relays, Condensers, Capacitors, Resistors, Rheostats, Transformers, Switches, Coaxial Cable, Wire, Soldering Irons, Microphones, Speakers, Technical Books, etc.

Superintendent, St. Paul, Minn.; special electronics research and development division—John M. Miller Hanover, Pa.; ship-shore radio division—L. A. Gebhard, Buffalo, N. Y.; airborne electronics—R. A. Gordon, Hyattsville, Md.

**RTPB Election**

FOR THE TERM running from Oct. 1, 1945 to Sept. 30, 1946, the administrative committee of RTPB (Radio Technical Planning Board) has elected the following officials: chairman, Haraden Pratt, Mackay Radio



Haraden Pratt

& Telegraph Co., New York; vice chairman, Howard S. Frazier, National Association of Broadcasters, Washington; treasurer, Will Baltin, Television Broadcasters Association, New York; secretary, W. H. Crew, IRE, New York.

**Radio War Museum**

THE ADVERTISING COMMITTEE of RMA headed by John S. Garceau, Fort Wayne, Ind., is proposing the establishment of a national war museum to exhibit radio and radar equipment.

Members of the committee feel that action should be taken shortly. Otherwise electronic equipment may be lost to salvage before an organized movement to preserve it can be made.

As a memorial to the important role of heroic radio and radar operators, gear from historic battles should simultaneously serve as a tribute to the technological achievements of the electronics industry.

**New Receiver Makers**

LICENSES have been issued by RCA to permit receiver manufacturing by a number of new concerns. The present total is 105, a figure which can be compared with the 54 manu-



# **A**ireon rides again

**O**UR spirited steed is not only fast but well-gaited. We curled our lasso around the neck of "Electronics" a long time ago and with our strong personality, and kind treatment, turned it into our pet horse. It took a lot of skull work, a lot of smart engineering, but it worked out. Now our stable has 28 red hot electronic devices that should interest you. How about hitching your chariot to our fast-stepping organization, giving Aireon its head in helping solve your electronic problems?

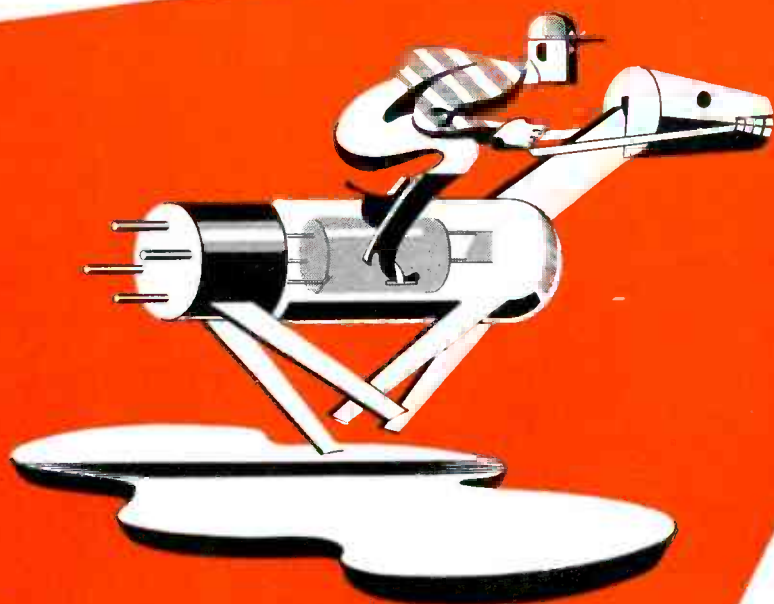

# **Aireon**

**MANUFACTURING CORPORATION**

Radio and Electronics • Engineer Power Controls

NEW YORK • CHICAGO

KANSAS CITY • BURBANK

# SOME RESISTOR



Most resistors are single—but in the Gothard Indicator Light Assembly used with neon lamps, an integral 100,000 ohm resistor is furnished for bright glow and a 200,000 ohm resistor for dimmer glow. Just hook it up. Do you have a Catalog of the complete Gothard Line—write for it!

Model No. 1142 with resistor for neon lamp NE51, also Mazda No. 5 44, 313, and 1815. Lamps available.

**Gothard**  
MANUFACTURING COMPANY  
2114 CLEAR LAKE AVENUE, SPRINGFIELD, ILLINOIS

EXPORT DIVISION: 25 WARREN STREET, NEW YORK 7, N. Y.

# Carter

## FIRST TO POWER 100 WATT MOBILE TRANSMITTER



*It's New!*

*It's Powerful!!*

*It's Carter Equipped!!!*

That's the Kaar Engineering Company's recently developed 100 Watt FM Mobile Transmitter.

CARTER Rotary Products provide unequalled performance and dependability for all types of mobile communication equipment.

Latest catalog and trade bulletin sent upon request.



**Carter Motor Co.**  
*Chicago, Illinois*

1606 Milwaukee Ave. Carter, a well known name in radio for over twenty years. Cable: Genemotor

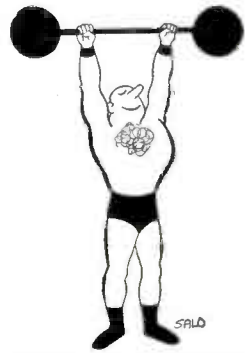

## CAPABILITY ...in the hard-to-do

When you are up against a problem on a special part for your product, call on our consultant service. We'll be glad to help at no obligation to you. Our engineering experience and our specially designed machines are both geared to making the hard-to-make special parts. And usually our cold-forged specialties will save you money.

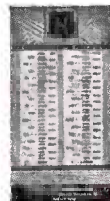

This Decimal Equivalents wall chart is accurate to four places and signalled in three colors. Yours at no cost or obligation. Just send us your name, title and address.

See our Catalog in Sweet's File for Product Designers

**JOHN HASSALL**  
INC.

Specialists in Cold-Forging  
Since 1850

150 Clay Street  
Brooklyn 22, N. Y.





Now—a silicone varnish that cures at 300°F

# DC 996 VARNISH

DOW CORNING  
**SILICONES**

Dow Corning 996 is an electrical impregnating varnish for low temperature baking.

Dow Corning 996 was developed to provide manufacturers of new equipment and rewinders of old equipment with a heat resistant, waterproof silicone varnish which can be cured at temperatures obtainable in ovens now used for curing organic insulating varnishes.

Dow Corning 996 is used as the dipping or impregnating varnish for equipment wound with typical silicone insulation components. These include Fiberglas cloth, tape and sleeving varnished with DC 993; silicone bonded mica-Fiberglas for ground insulation; silicone bonded Fiberglas served magnet wire; silicone-Fiberglas laminated coil separators and slot sticks, and Silastic\* coated lead wire.

Electrical equipment, wound with silicone insulating components and sealed by impregnating with DC 996, will have the high order of thermal stability and retention of waterproofness characteristic of silicone insulation.

Dow Corning 996 thus enables all types of electrical shops to realize the advantages of silicone insulation. It is recommended for use

in equipment which is to be operated at temperatures up to 175°C. (347°F.). For higher operating temperatures, or extremely severe service conditions, DC 993 should be used throughout. The same methods of dipping, spraying, or vacuum-pressure impregnating that are used for applying conventional organic varnishes can be used with DC 996.

**PROPERTIES**—Dow Corning 996 is furnished as a 50 per cent by weight solution in an aromatic solvent and has a viscosity of 2 to 5 poises. In this consistency DC 996 is suitable for impregnating electrical equipment. It can be reduced to any desired viscosity with aromatic naphtha.

Dow Corning 996, when coated on metal, air dries to a slightly tacky, soft film. Baking the coated panel at 150°C. (302°F.) for a period of four hours will cure the coating to a non-flowing, tack-free, flexible film. DC 996 has ample heat stability for continuous use at temperatures as high as 175°C. or for intermittent use at higher temperatures.

**ELECTRICAL PROPERTIES OF DC 996**—(measured on coated panels at 25°C. and 50% relative humidity.)

Dielectric Strength, volts per mil	1500 to 2000
Dielectric Constant, at 1000 cycles	3.0
Power Factor, at 1000 cycles	0.7%

**DOW CORNING CORPORATION**  
MIDLAND, MICHIGAN  
NEW YORK OFFICE: EMPIRE STATE BUILDING

**DISTRIBUTED BY**

Electrical Specialty Co. . . . . San Francisco  
Prehler Electrical Insulation Company . . . . . Chicago  
Insulation Manufacturers Corporation . . . . . Chicago  
Insulation and Wires, Incorporated . . . . . St. Louis  
Mica Insulator Company . . . . . Schenectady  
National Electric Coil Company . . . . . Columbus  
Westinghouse Electric Corporation  
Insulation Section, Micarta Division . . . . . Trafford, Penna.

\* Trade name for Dow Corning Silicone Rubber





Variaten  
Gain Set  
1901-B

## As necessary to perfect Amplifier performance as the fourth leg to a dog!

You can't have perfect performance in amplifying or other speech transmission without knowing the efficiency and performance of each unit in the installation.

With a Variaten Gain Set you can (1) measure the total amplification of an amplifier; (2) measure the gain at all frequencies to determine whether there is discrimination against any part of the frequency spectrum; (3) measure the power output of any amplifier; (4) measure frequency response of transmission lines in absolute quantities; (5) check all control equipment—in fact, quickly make a quantitative analysis of any part of the audio frequency spectrum.

Unvarying accuracy is all-important. Variaten Gain Set, Type 1901-B (shown above) has a flat frequency characteristic of 0 to 20 kilocycles, and leakage is *guaranteed to be less than 1/10th db.* (Measurements have been made at frequencies as high as 100 kilocycles with practically no error.)

Variaten Gain Set 1901-B is equipped with both send and receive impedance matching controls for *both* Straight T and Balanced H circuits. This dependably accurate instrument can be supplied with either one or two meters.

Write today for complete data on Type 1901-B and other Variaten Gain Sets.

Other Variaten products—*Attenuators, Mixers, Resistors, Matching Pads and other precision sound equipment meet the most exacting specifications. Catalog on request.*



**CINEMA ENGINEERING CO.**  
Established 1935 • Burbank • California

factors who were licensed before the war.

The new licensees include: Crystal Products Co., Kansas City Mo.; Electrical Research & Mfg. Co., Los Angeles, Calif.; E. W. McGrade Mfg. Co., Kansas City, Mo.; Megard Corp., Los Angeles, Calif.; National Scientific Products Co., Chicago; Precise Developments Co., Chicago; Premier Tool & Instrument Corp., New York, N. Y.; Radio Process Co., Los Angeles, Calif.; Ray Energy Radio & Television Corp. of America, New York, N. Y.; Scientific Radio Products Co., Council Bluffs, Iowa; Searle Aero Industries, Inc., Orange, Calif.; Signal Electronic & Mfg. Co., New York, N. Y.; Tech-Master Products Co., New York, N. Y.; Electrical Engineering Co., Los Angeles, Calif.; Whiting & Davis Co., Plainville, Mass.

### Radio-Shows Organization

SPONSORSHIP and operation of shows for the radio parts industry will be handled on a non-profit basis by a new corporation called Radio Parts and Electronic Equipment Shows, Inc. The group has been formed as a result of a resolution by the Radio Parts Industry Coordinating Committee.

Merged in the new group will be the Radio Parts Industry National Trade Show and the Electronic In-



Radio officer graduates of the U. S. Maritime Service Radio Training Station, Gallups Island, Boston, Mass., who have lost their lives in the service of their country are memorialized by this dramatic monument. Here it is being inspected by Lt. Comdr. Peter W. Larsen, administrative officer at the station; Commodore Telfair Knight, Commandant of the U. S. Maritime Service; and J. A. Clark, Executive Officer of the station



# No Lubrication needed...

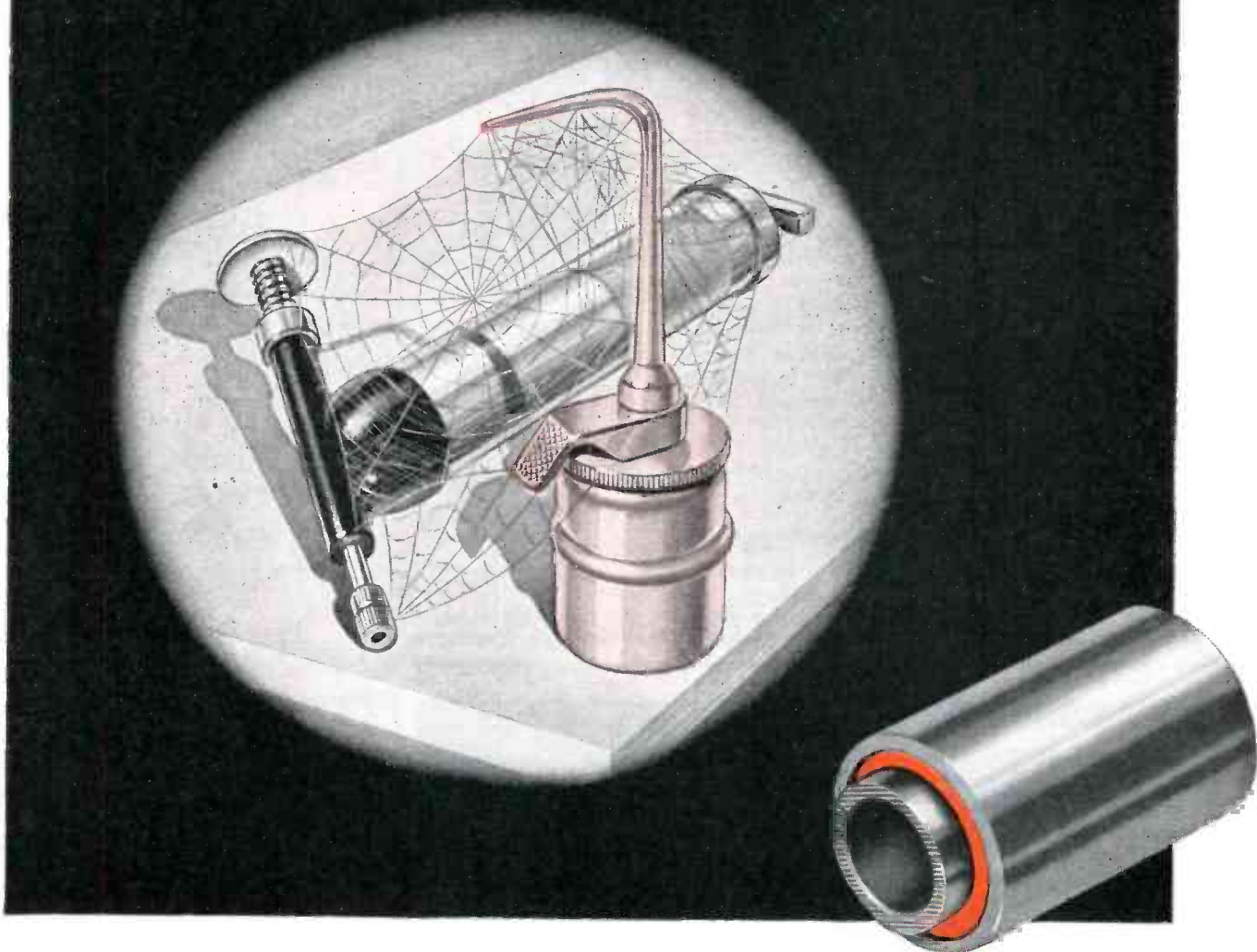

## ... if your product has Silentbloc Torque Bearings

**I**F you are seeking a basic improvement for equipment that works with torque action or oscillation, this is it—*The General Silentbloc Rubber Torque Bearing.*

Check the selling points added to your product by Silentbloc bearings:

*No lubrication; no spoilage from dripping oil. Unaffected by grit, dust, oil, water or gases. Silent operation. Long, trouble-free life.*

No other rubber bearing matches the efficiency of the Silentbloc. The patented construction—elongating rubber at high speed between metal sleeves—gives non-

slipping adhesion and even distribution of compressive stress, vital for long life.

General engineers can help you design a Silentbloc bearing for your specific needs in amplitude and operating conditions. Silentbloc bearings can be made in any size, using any metal and rubber. They are simple to design into your product and easy and economical to install.

For full information, write for booklet on Silentbloc Bearings, Mountings and Bushings; or see Silentbloc Section in Sweet's Product Designers File. The General Tire & Rubber Co., Dept. 193, Wabash, Indiana.

Patented Silentbloc principle of elongating and confining rubber between metal members produces a virtually indestructible adhesion and uniform stress, resulting in precise performance and long life.



*Mechanical Goods Division, Wabash, Ind.*

# THE GENERAL TIRE & RUBBER CO.

*Makers of America's Top-Quality Tire*

# Solder Fast

**TRIGGER CONTROL  
EASY HANDLING**

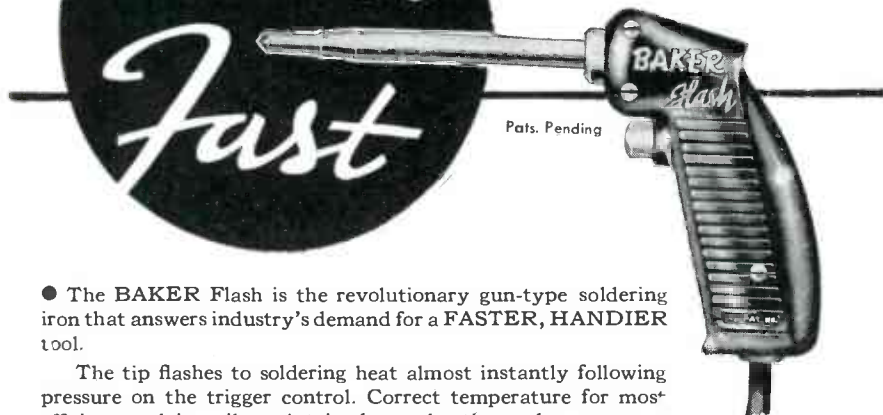

● The BAKER Flash is the revolutionary gun-type soldering iron that answers industry's demand for a **FASTER, HANDIER** tool.

The tip flashes to soldering heat almost instantly following pressure on the trigger control. Correct temperature for most efficient work is easily maintained, over-heating and unnecessary oxydation avoided, cleaning and re-tinning time saved.

Natural gun grip; cool, protected plastic handle; light weight; perfect balance—these are advantages that make the BAKER Flash extremely easy to use, *ideal for work in close places.*

Completely equipped for immediate operation from 110-volt transformer or from standard storage battery.

**Write or Wire for Complete Information**

**ORDER SAMPLE TODAY—Only \$4.75 Postpaid**  
with Transformer \$8.95—Send check or Money Order

**BAKER-PHILLIPS CO.** 3057 LYNDALE AVE. SO.  
MINNEAPOLIS 8, MINNESOTA

**THE YEAR'S  
BIGGEST  
NEWS IN  
SOLDERING**

are **7** heads  
better than **1**?



**VICTORY'S\***  
Engineering Staff  
and 6 Consulting Engineers  
work together... to give you  
**BETTER MOLDED PLASTICS!**

If your post-war product demands injection molding to closest tolerances (like those required in the work we are now doing for the Armed Forces), you'll find VICTORY\* completely equipped to do a better job quickly, and at the lowest possible cost consistent with finest craftsmanship. Now is the

time to plan with our engineers and their consultants, so that your problems can be solved *before* you are ready to market your product.

Member: Society of the  
Plastics Industry

**Automatic  
Injection Molding**  
Small and large parts  
**UP TO 17-OZ. SHOTS**

Lumarith, Tenite,  
Fibestos, Plastacele,  
Crystallite, Lucite,  
Ethyl Cellulose,  
Polystrene, Lustron,  
Styron, Cellulose Acetate  
and others... all molded  
to your exacting  
specifications.

**\*VICTORY  
MANUFACTURING  
COMPANY**

1724 W. Arcade Place, Chicago 12, Ill.  
ESTABLISHED 1930

# Toroids..

by  
**DX**



Doughnut Coils for electronic and telephone purposes. High Permeability Cores are hydrogen annealed and heat treated by a special process developed by DX engineers. Send us your "specs" today—ample production facilities for immediate delivery.

**DX RADIO PRODUCTS CO.**

GENERAL OFFICES 1200 N. CLAREMONT AVE., CHICAGO 22, ILL., U.S.A.

the heart of a good receiver





## IT'S THE **KNOW HOW** THAT MAKES THE DIFFERENCE

From the same basic ingredients can come many different results, some excellent, some, . . . well not so good. Whether it's cakes or regulators, it's the "KNOW HOW" that counts.

The engineering staff of Sorensen and Company, Inc. have developed a new idea in voltage regulators. Models 1K, 2K, and 3K, will meet 90% of all the requirements and applications of voltage regulators.

The 60 cycle models 1K and 2K, cover power requirements from 100 to 2000 watts. The 400 cycle model, 3K handles powers from 50 to 500 watts—(they are not resonant type regulators . . . automatic voltage control is accomplished by electronic means). Voltage control stability is better than plus

or minus  $\frac{3}{4}$  of 1% for input variations of from 90 to 130 volts.

The 60 cycle models are constructed for rack or cabinet. The 400 cycle model, 3K, is in shock mounts. All the regulators are outstanding because frequency variation does not affect the regulation factor.

Sorensen and Company, Inc. likewise offers voltage adjustable transformers in ratings from 500 V.A. to 1500 V.A. These models known as INCRE-VOLT controls are capable of providing voltage in increments as small as ONE TENTH VOLT, in a range of from 0 - 130 volts.

We are the only source for lightweight aircraft transformers which feature the Fosterite and oil filled units.

# SORENSEN & COMPANY, INC.

AIRBORNE ELECTRONICS

STAMFORD, CONN.

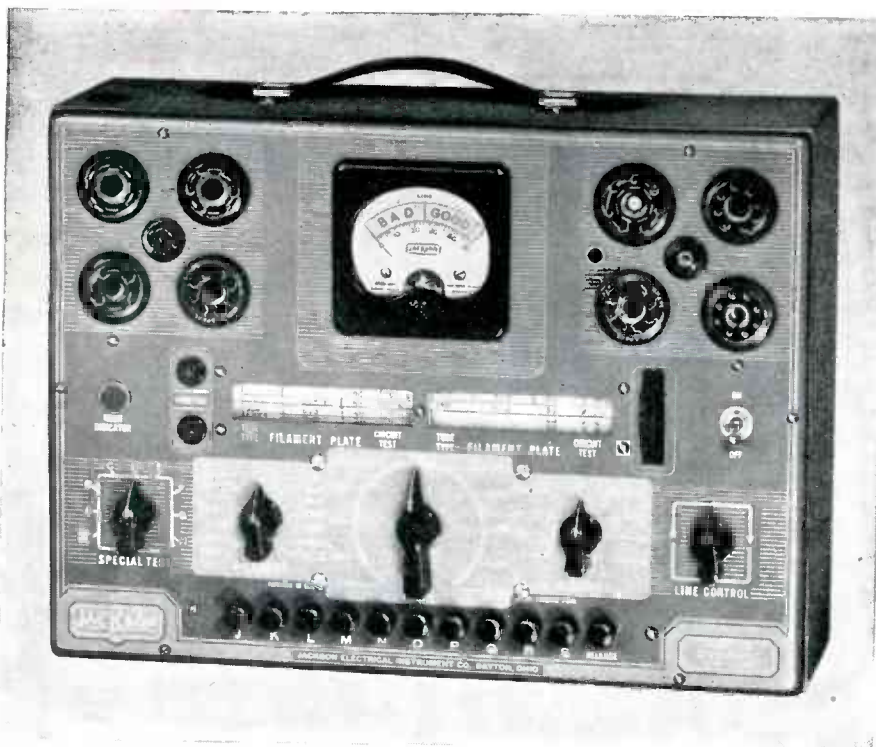

## Model 636 Dynamic\* Tube Tester

With Built In Rotary Tube Chart

**T**ops in design and performance including the latest Jackson patented switching circuits.

**Modern** in every feature of construction, appearance and operation.

**Complete** with every valuable feature. Up to date for all newest tube types.

### SPECIFICATIONS

**"Dynamic" Method of Test**—Makes a better test on every tube. The "Dynamic" method is more accurate, frequently finding "poor" tubes which might pass for "good" in ordinary testers.

**Tests All Tubes**—All of the popular receiving types and television amplifiers, including *Bamtams*—*Loctals*—*Single Ended*—*High Voltage Filament Types and Miniatures*. Provision for many more. The tester

is protected against obsolescence in every possible feature.

**Roll Chart** tube index—simplifies correct settings.

**Full Range Filament Selection**—marked directly in volts.

• • •

**Bench Model 636-B** (illustrated) is installed in welded steel cabinet. This instrument is also furnished (portable model 636) in a French grey leatherette case with removable lid—matched in dimensions and finish to other testing instruments in the Jackson line. It can be assembled with them in the Jackson Service Lab. Buy now with an eye ahead—on a *matched* Jackson testing set.

\*TRADE MARK REG.

BUY WAR BONDS



AND STAMPS TODAY

# JACKSON

*Fine Electrical Testing Instruments*

JACKSON ELECTRICAL INSTRUMENT COMPANY, DAYTON, OHIO

dustry Conference Committee, Inc., mutual interests and treasury balances being pooled.

Eight directors have been appointed, two from each of the four sponsoring groups: RMA parts division, National Electronic Distributors Association, Association of Electronic Parts and Equipment Manufacturers, and Sales Managers Club—Eastern division.

Officers of the new corporation include: H. W. Clough, Belden Mfg. Co., president; Charles Golenpaul, Aerovox Corp., vice-president; Sam Poncher, Newark Electric Co., treasurer; and J. J. Kahn, Standard Transformer, secretary. Plans call for the appointment of a show manager on a full-time basis with the expectation that a convention might materialize by October 1946.

### X-Ray Standard

FOR INDUSTRIAL use of x-rays, a new safety code has been completed by a War Committee of ASA (American Standards Association). It is expected that the code will form the basis for a peacetime standard which will likewise be devoted to the job of protecting industrial users of x-ray against tissue damage. Previous standards, particularly those applicable to the medical field, have been published by the National Bureau of Standards. Increasing use of x-ray equipment in the one- and two-million volt classifications indicates the need for protection beyond that required for medical practice.

### West-Coast Relay

APPLICATIONS have been filed by International Business Machines Corp. for FCC permission to build terminal stations in Los Angeles and San Francisco as part of an experimental radio-relay network.

According to information released by GE, suppliers of the gear, the relay towers are to be triangular in cross-section and about 125 ft high. A covered platform 35 ft wide at the top will be reached by spiral staircase. On each side there will be six antennas, three for reception and three for transmission to provide three channels in each direction.

Located within sight of each other, the towers will be spaced 50



# FLASH! Raytheon Charts Success with ZIRMET\* as Power Tube Getter

\* Foote Ductile Zirconium (Over 99.9% pure).

Through the courtesy of the Raytheon Manufacturing Company, Power Tube Division, we are now able to report on the use of ZIRMET (Foote Ductile Zirconium) in their 371B power tube.



Raytheon RK371B Power Tube. Note the two ductile Zirconium gettering flags  $\frac{1}{4}$ " x  $\frac{3}{8}$ " spot-welded to the dome.

high voltage rectifier. This operation is particularly severe on a thoriated tungsten filament, but when using ductile zirconium it is found that higher inverse voltages are usable."

## BETTER VACUUM

We quote in part from their recent letter: "You will note that the curve makes an upward turn at the start. This is an indication that the vacuum within the tube is better than at the time of seal off, the ductile zirconium taking up some of the seal off gases etc., as well as cleaning up some of the gases the pumps did not remove."

## HIGHER INVERSE VOLTAGES

Again we quote: "One other comment that might be of interest to you is that the RK371B is a very

## BETTER EMISSION, LONGER LIFE, LOWER COST

Actually, Zirmet has many other advantages in manufacture, in pumping, and in operation, such as longer life and better emission with oxide coated cathodes, plus the fact that the price of Zirmet now is 50% of the 1944 level. Write or wire immediately, or telephone (RIT)tenhouse8722 for information on Zirmet.

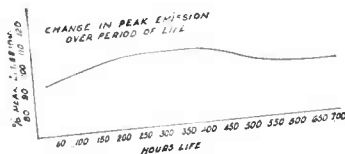

## CAN YOU SEE YOUR FUTURE IN THIS?

Foote researchers not only produce pure ductile zirconium by electrolytic deposition—in tubes like this—but even fabricate the vacuum tubes used in the process. For many an industry there is a foreseeable future with ductile zirconium. For almost all industry Foote chemicals, ores, minerals, alloys and custom grinding have an important mission.

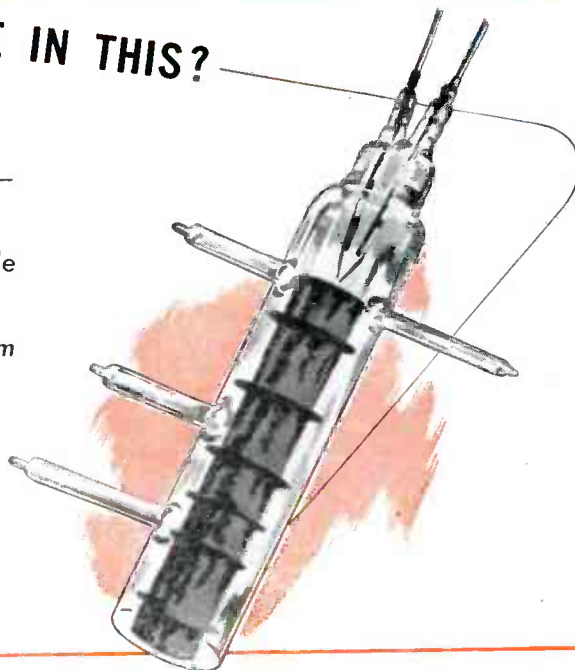

PHILADELPHIA • ASBESTOS • EXTON, PENNSYLVANIA  
Home Office: 1617 SUMMER STREET, PHILADELPHIA 3, PA.  
West Coast Repr.: Griffin Chemical Co., San Francisco, Calif.

# EISLER EQUIPMENT

..complete and diversified for every phase of electronic\* manufacture!



(A) No. 600-KC3P, 50 KVA Press Type Spot Welder, 3 Spots, Air Operated, 18" Throat—a high production unit.

(B) No. 57-81 New Eisler 8 head type Tipless Sealing Machine. Adaptable for all types and sizes of bulbs.

(C) EISLER Special Transformers and Reactors—high or low voltage; air cooled, oil immersed or uncased.

The CHAS. EISLER line of specialized electronic tools, machines and devices is complete and diversified. Included are innumerable types of welders—spot, seam, butt, rocker, arm, pneumatic and special types. Also included are hundreds

of devices for vacuum tube manufacture—glass tube cutters, slicers, stem and sealing machines as well as an all-inclusive line of transformers for every industrial and general need.

\* EISLER serves 99% of American vacuum tube producers today. Write for completely illustrated catalog.

## CHAS. EISLER EISLER ENGINEERING CO.

751 SO. 13th STREET (Near Avon Ave.) NEWARK, NEW JERSEY

# PRINTERS, LAMINATORS, FABRICATORS OF *Plastics*

INJECTION AND  
EXTRUSION  
MOLDERS

PLASTIC PRINTING by special inks and special methods developed in our plant.

LAMINATION of printed sheets on one or both sides, permanently sealing the printed surfaces.

SHEET FABRICATION on even the most complicated jobs.

Write for Free Booklet E.  
"Hopp Plastics Today & Tomorrow"

**THE HOPP PRESS  
INCORPORATED**

460 W. 34th St., New York 1, N.Y.



PAT. APPLIED FOR

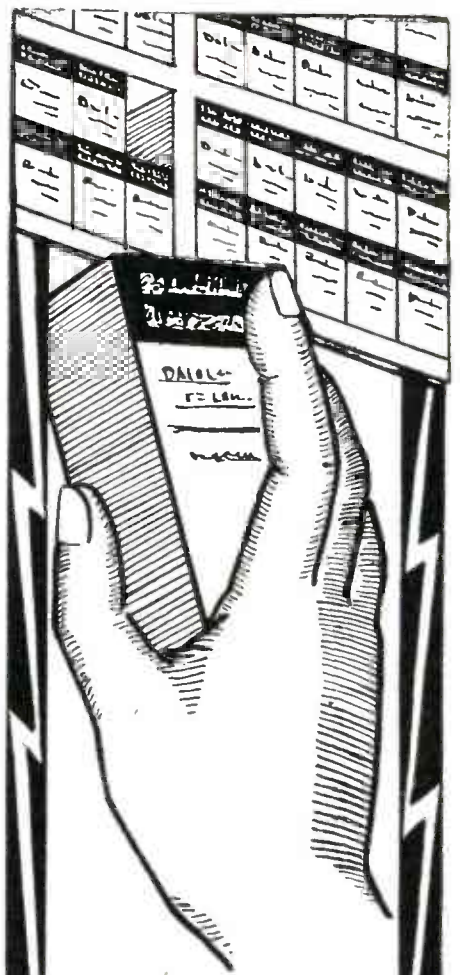

## RIGHT OFF THE SHELF!

Radio-Electronic  
Parts and  
Materials

To fill your priority  
needs . . .

IN A HURRY!



'Phone, wire,  
or write

# H. L. DALIS

Wholesale Distributors  
RADIO-ELECTRONIC SUPPLIES & PARTS  
17 Union Square  
NEW YORK 3, N. Y.

Phones: ALgonquin 4-8112-3-4-5-6-7



# CONVERT WAR AMPLIFIERS TO CIVILIAN USEFULNESS AND MAKE A PROFIT

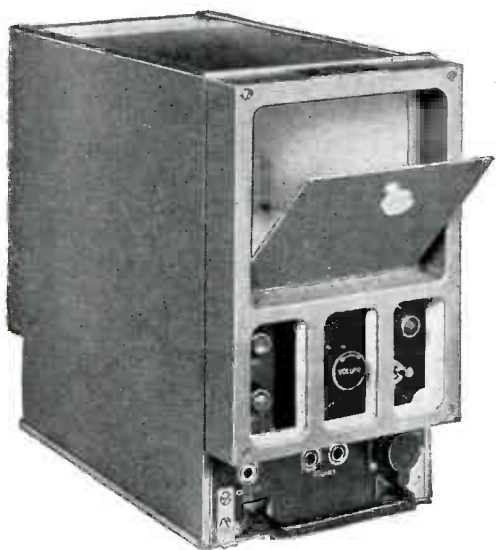

## **R. F. C. Material** **BC-605-D AUDIO AMPLIFIER**

**Specifications:** Two stage cascade amplifier. Chassis and slip-off cover of 18 gauge steel. Cadmium plated. Outside finish olive drab baked enamel. Dimensions: 11½" high, 6⅞" wide, 12½" deep. Total weight 23½ lbs. Access at front to a spares compartment, 5" x 6¼" x 7½" suitable for locating vibrator or small transmitter.

**Input Impedance:** At 400 cycles, 200 ohms; at 1000 cycles, 300 ohms.

**Output Impedance:** Two secondary windings on output transformer with one high for minimum 3,500 ohm load with wired-in "T" pad attenuator. (control on front) and one low for 8 ohm load (no control).

**Output Power:** At 350 volts plate; nominal 4 watts, maximum 5 watts.

**Input Requirements for Maximum Output:** minus 25 db.

**Tube Complement:** Two type RCA 1619.

**Power Requirements:** Low voltage, 12V or 24V DC. High Voltage, up to 350 volts. Filament and bias consumption nominally 2 amps. Plate and screen drain at 350 volts is 75 to 80 milliamperes.

Designed for attachment of a No. DM-34-D 12 volt or a DM-36-D 24 volt dynamotor which may be available from another source. An 18 contact male receptacle at rear for connection to dynamotor.

**Front Panel:** One filament OFF and ON switch; One volume control; One indicator lamp; One fuse; One jack for single button carbon microphone; and one 4 point connector for magnetic microphone; two jacks for high impedance head phones. (Current for carbon microphone is provided as integral part of the amplifier circuit.) A second 30 contact male receptacle is mounted at rear of cabinet for connection to external microphones or other units when used as an inter-com. system.

Suggested microphones to use: WEJ 201 carbon or WEJ202 magnetic. Headphones, any good make, 1000 ohm impedance and up.

All parts and wiring readily accessible for alterations for other use and space for addition of one or two tubes if required.

The large volume of released electronic equipment no longer needed by our armed forces is a challenge to the inventive genius of the electronic industry. Help to prevent waste. Apply your skill and ingenuity to the problem of converting some of this war equipment to meet civilian needs.

Consider the possibilities of this inter-comm amplifier. It was built to lead a rugged life in U.S. Armored Division Tanks. Easily converted for announcing use in motor buses, police or fire department vehicles; yacht, motor boat or fishermen's loud-hailers. It has space in the spares compartment for a micro-wave transmitter. Or perhaps you have a better idea.

Available in large quantities. New — packed in original cartons. Immediate delivery. Send for a sample. Look it over and experiment with it. Price \$10.00, f. o. b. San Francisco. Make checks or money orders payable to Remler Company Ltd.

**REMLER COMPANY Ltd. • 2101 Bryant St. • San Francisco, Calif.**

*Agent for*

**Reconstruction Finance Corporation**

# REMLER

SINCE 1918

*Announcing & Communication Equipment*



# 7 Facts You Should Know About C.M.H. Stainless Steel Bellows

If you plan to use bellows for vacuum equipment, instruments, rotating shaft seals, or for other similar purposes in the electronic field, here are some essential features of C. M. H. Stainless Steel BELLOWS:

1. Corrosion resistant qualities of stainless steel enable wider application of C.M.H. BELLOWS.
2. High and low temperatures do not affect the operating efficiency.
3. Multiple ply construction gives even greater strength factors when needed.
4. Ferrous fittings, attached by Circular Seam Welding, assure permanent, leak-proof joints.
5. Uni-metal assemblies avoid the costly troubles encountered where bi-metal types are used.

6. Long lengths are standard production permitting economical use of C.M.H. Stainless Steel BELLOWS for many unusual types of applications.

7. Better delivery schedules are possible because C.M.H. BELLOWS are standard production products.

For complete information about C.M.H. Stainless Steel BELLOWS and about the many types of Flexible Metal Hose in the complete C.M.H. line, write us today.

Ask for Chicago Metal Hose Form SSB2 on which to submit your bellows requirements. It will save you time—assure more accurate transmittal of essential data.

Flexible Metal Hose for Every Industrial Use



## CHICAGO METAL HOSE CORPORATION

MAYWOOD, ILLINOIS

Plants: Maywood and Elgin, Ill.

to 60 miles apart where mountain tops are available, but in level country the distance will be reduced to about 30 miles. The relay will handle two two-way television programs, four full-fidelity sound channels for f-m broadcasting, two radiophoto or facsimile channels and 120 business-machine channels.

### Industry Predictions

MAKING A STUDY among 1406 individual manufacturers and 158 trade associations with more than 20,000 members, the Marketing Committee of CED (Committee for Economic Development) concludes that American manufacturers plan to produce 41.6 percent more goods in 1947 than they did in 1939. At the 1939 price level, the totals are \$56,843,000,000 against \$80,518,000,000.

Electrical machinery, the classification including durable goods products in the electronic industry, was valued at \$1,727,400,000 in 1939 and is estimated at \$2,698,000,000 for 1947, or an increase of 56.2 percent.

### NAB Engineering

AMONG A NUMBER of new committees appointed by NAB (National Association of Broadcasters) is an engineering executive committee consisting of G. Porter Houston, WCBM, Baltimore, Md. (chairman); J. B. Fuqua, WGAC, Augusta, Ga.; O. B. Hanson, NBC, New York, N. Y.; Karl B. Hoffman, WGR, Buffalo, N. Y.; and William B. Lodge, CBS, New York, N. Y.

### Insulator Standards

REVISED TESTS are included in a current revision of the ASA (American Standards Association) standard on insulators for supporting electrical conductors. The new standard, C29.1-1944, is a revision of AIEE Insulator Tests standard No. 41, of March 1930, also listed as ASA C29a-1930. The work includes pin-type, suspension, switch and bus, guy, spool, wire holder, bushing, and tube insulators.

Test data cover 60-cycle wet and dry flashover, puncture, corona, high-frequency flashover, low-frequency withstand voltage, impulse withstand voltage, impulse flashover voltage, and radio-influence



# NEW TELEVISION LENS OF DU PONT

## "LUCITE"



*Helps bring the new home receiving sets at popular prices... with screen images brighter, clearer... 5 times larger*

THE TELEVISION SET you will have in your home soon—it's ready now—will show on a screen a picture big enough to see... with ease and without distortion.

The new method "does it with mirrors"... adapts a well-known principle of astronomical photography. But while the astronomers need not care too much about the cost, the maker of television sets for millions of average Americans has to care—tremendously. The new method of producing television sets within a popular price range is made possible

by the discovery that a basic part—an aspherical correcting lens possessing excellent light-transmission and low-scattering of light properties—can be mass produced from molded "Lucite" methyl methacrylate resin in a matter of minutes. A glass lens of equivalent quality requires days of skilled grinding and polishing.

"Lucite" has proved its worth helping to win the war. It is now available for peacetime applications. E. I. du Pont de Nemours & Co. (Inc.), Plastics Department, Arlington, New Jersey.

**FOR PLASTICS..CONSULT DU PONT**

SUPPORT THE VICTORY LOAN DRIVE—BUY BONDS

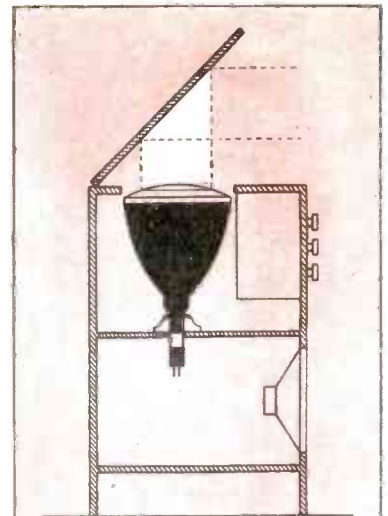

**THE OLD WAY.** Relatively small. With a direct-viewing cathode-ray tube, 12 inches in diameter, the picture you saw in prewar models was about 9 x 7 inches.

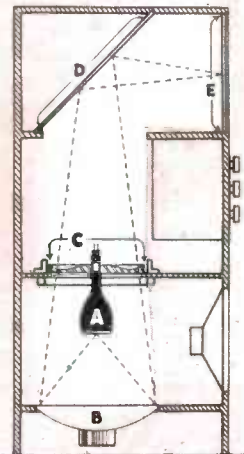

**THE NEW WAY.** Larger, clearer. By reflecting the rays from a spherical mirror (see diagram) and using a correcting lens of "Lucite," a tube only 5 inches in diameter produces an image which fills a screen 21½ x 16 inches, and with greater clarity. The reflective optical system, lens and sets developed by RCA Laboratories, to be produced after the war by RCA Victor Div. of the Radio Corp. of America.

This Lens Projection System utilizes a brilliant image on the face of the cathode-ray tube (A) projected down on the spherical glass mirror (B), then reflected up through the "Lucite" correcting lens (C) on a flat mirror (D) which throws a focused image on the translucent viewing screen (E)

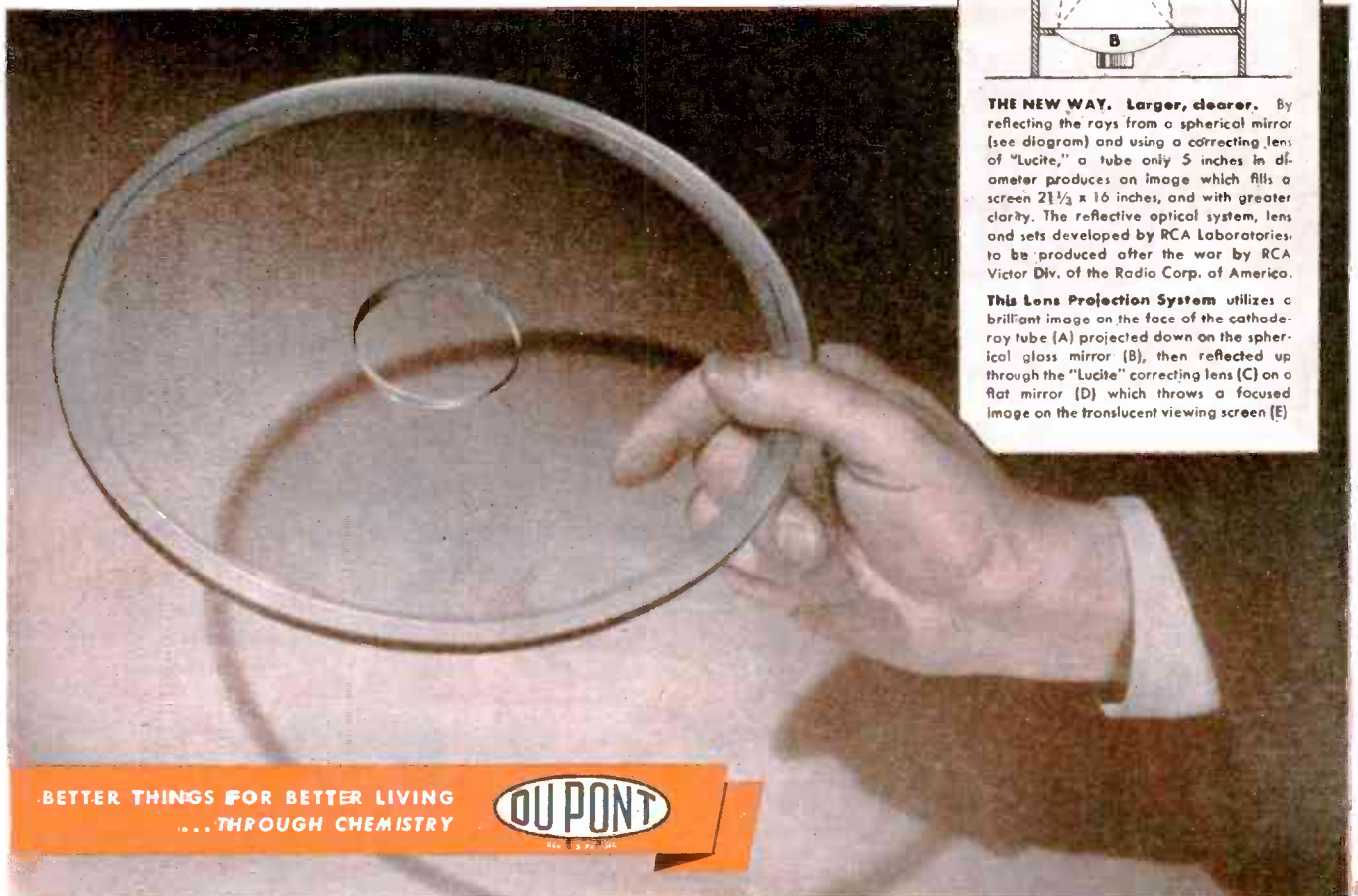

BETTER THINGS FOR BETTER LIVING  
... THROUGH CHEMISTRY





## NEON PILOT LIGHTS

EMBODY THESE IMPORTANT FEATURES:

Penetrating orange-red glow . . . Long life . . . Low current consumption . . . Resistance to vibration and shock . . . Operate direct on high voltage circuits . . . Emit practically no heat—

These advantages of Neon Glow Lamps are enhanced by "SIGNAL" Pilot Light Assemblies. We manufacture a complete line, featuring types fitted with Full-View Plastic Heads. Specialists in supplying completely assembled units, housing G.E. or Westinghouse Lamps. Send specifications for prompt estimates and suggestions . . . Write for Catalog.

# SIGNAL INDICATOR

Corporation

894 BROADWAY . . . NEW YORK 3, N. Y.  
Telephone: ALgonquin 4-4770

WEAR RESISTANT

NON-CORROSIVE

NON-ABRASIVE

NON-MAGNETIC

SUPER-POLISHED

**Yes. Extra Value!**

Long after the ordinary pivot has worn out you'll find PERMOPIVOTS in the prime of life—faithfully keeping precision instruments precise! It's all due to the special PERMOMETAL tip—the ideal osmium alloy. . . . Made to your specifications. Write for information!

**PERMO**  
INCORPORATED

6427 RAVENSWOOD AVE., CHICAGO 26  
MANUFACTURING METALLURGISTS

**ARE  
YOU SURE  
YOU ARE  
USING  
THE MOST  
EFFICIENT**

# Electrical Paper

**FOR YOUR  
JOB?**

We are specialists in Electrical Papers—Let our laboratories analyze your requirements.

**SEND FOR**

Free Booklet  
"Industrial  
Paper.—The  
New Production  
Answer."

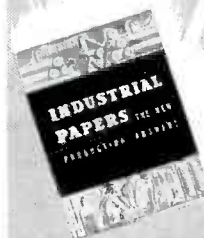

REG. U. S. PAT. OFF.

**CENTRAL PAPER COMPANY**  
INCORPORATED  
2442 LAKESHORE DRIVE, MUSKOGON, MICH.



U. H. F. and other measurements, easily, quickly—at your fingertips

- ★ 25 Millivolts AC Full Scale
- ★ 700 Megacycles Frequency Range
- ★ 7 Micro-Microfarads Input Capacity

with the new Reiner Model 451

## Vacuum Tube Voltmeter and Model 101 Amplifier

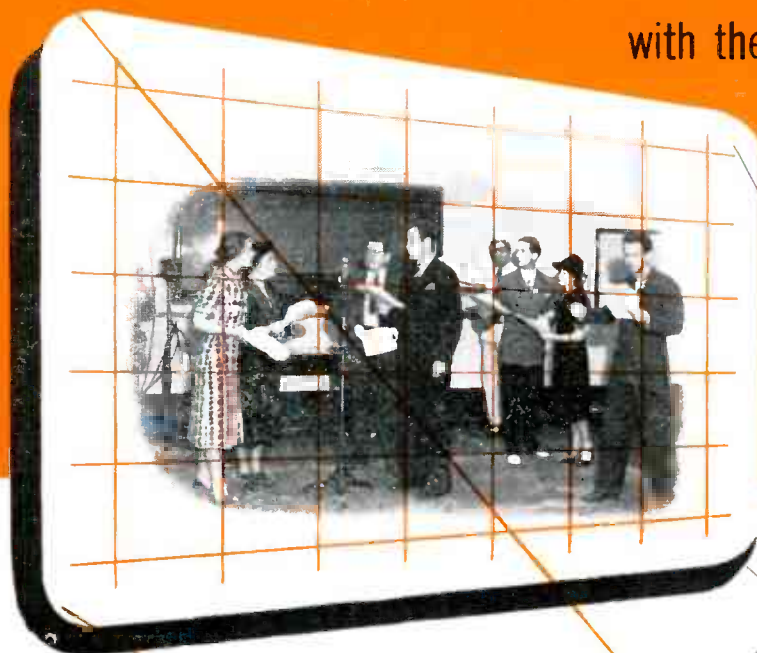

### RANGES:

- A. C. VOLTS: 0 — .025 — 1 — .25 (with amplifier) —  
2.5 — 10 — 25 — 100 — 250 — 1000
- D. C. VOLTS: 0 — 2.5 — 10 — 25 — 100 — 250 — 1000
- D. C. CURRENT: 0 — 2.5 — 10 — 25 — 100 — 250 — 1000 Ma.  
OHMS: 1 ohm to 1000 megohms
- A. C. FREQUENCY RANGE: 10-5000 cps; (with amplifier) — 50 cps.  
to 700 megacycles
- ACCURACY: 2% on full scale — D. C. volt, ohm and current;  
2%, 50 cps to 50 megacycles, A. C. volt; 5%  
accuracy entire A. C. frequency range

### OTHER FEATURES

- Wide Frequency Range • High Input Impedance • One Linear Scale for all Voltage and Current Scales
- Wide Voltage Range • Single Zero Adjust for all A. C. and D. C. ranges • Voltage Regulated Supply — Stable Operation
- Accuracy 2% of full scale values • Large Overvoltage Capacity
- Compartment for Accessories prevents losing or mislaying them;
- Many other time-saving, convenience features

**MODEL 451,** complete with Amplifier Model 101  
weighs 20 lbs.; Size: 10 $\frac{3}{4}$ " x 9" x 8".

For more information on this and other Reiner equipment such as square wave generators, oscilloscopes and signal generators, write Reiner Electronics Co., Inc., 152 W. 25th St., New York 1, N. Y.



**Reiner**  
ELECTRONICS

# HOW CHACE BIMETALS HELPED

*Builders of  
Appliances and  
Controls*

More than twenty years ago Chace developed and introduced thermostatic bimetals made of nickel-chrome steels, which had a longer life at high temperatures than earlier type bimetals made of other alloys.

As a result, the manufacturer of temperature responsive devices was enabled to get a more lasting actuating element and, in consequence, to produce a dependable and more enduring appliance or control. Chace Thermostatic Bimetal thus became "the heart" of many leading temperature indicating and controlling devices whose sales volume steadily increased.

Developed in years of peace, Chace bimetals became vitally important in war, as did the knowledge of our engineering and fabricating divisions, in the application of bimetal to many precision controls.

This knowledge—now fortified by additional hard-won experience—will again be freely offered to manufacturers wishing to refine present designs or to bring out new developments.

**W.M. CHACE Co.**

*Manufacturers of*  
Thermostatic Bimetals and Special Alloys  
1630 BEARD AVE • DETROIT 9, MICH.

**CHACE BIMETALS**

are made in **35** Specific Types  
one of which should precisely fit your needs

**SOLD IN** SHEETS, STRIPS and  
FINISHED FORMS

voltage tests. Data covers physical factors such as mechanical and electrical strengths, thermal characteristics, and dimensions.

American Standards Association is located at 70 East 45th St., New York 17, N. Y.

## Surplus Equipment

SPB (SURPLUS PROPERTY BOARD) estimates that there will eventually be thrown on the market radio equipment and components totalling about \$3,000,000,000. Some types of equipment may have a somewhat nebulous merchandising future such as \$5,000,000 worth of special tubes, currently surplus. Although they have no civilian possibilities at present, they may very well be useful to amateur operators when they are once again on the air.

## Mobile Radio Service

GRANTS ARE BEING offered by FCC for experimentation in two classes of mobile service for which frequencies have been designated. In these two classes, 24 channels were allocated for urban mobile service in the 152-162-mc region and 40 channels were set aside for general highway mobile service in the 30-40 and 42-44-mc regions.

Where the facilities are to be used to obtain factual data relative to needs and requirements of the proposed service and to collect information which might be useful in de-



This scroll of greeting being held by Professor Robert Chambers, president of the Union of American Biological Sciences; Dr. Harlow Shapley, director of the Harvard College Observatory; and Professor Harold C. Urey, Columbia University, was presented to the Academy of Sciences of the U. S. S. R. during that organization's 220th-anniversary ceremonies in Moscow during June. It was prepared under the auspices of the Independent Citizens Committee of the Arts, Sciences, and Professions





# TRUE BEAUTY IS *AGELESS*

● Symbolizing Winged Victory, Nike from Samothrace is a masterpiece of sculpture of 280 B.C., treasured throughout the ages by all peoples for sheer, simple, lasting beauty.

Pride of craftsmanship is represented by idealism in conception and execution of Detrola radio receivers, automatic record changers and other electronic instruments . . . all of unsurpassed beauty and value . . . developed especially for the world's outstanding merchants and their customers.

DETROLA RADIO DIVISION  OF INTERNATIONAL DETROLA CORPORATION, DETROIT 9, MICHIGAN

*Detrola Radio*

ANOTHER  
SPECIAL BY  
PROGRESSIVE

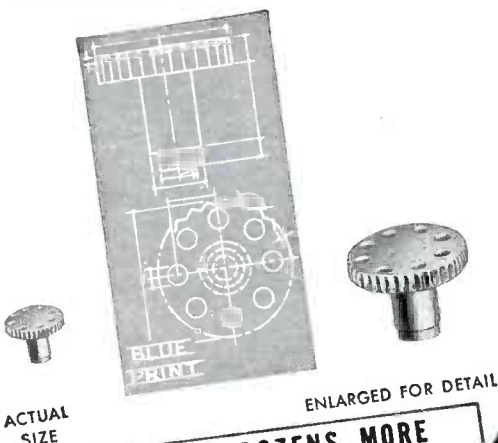

ACTUAL  
SIZE

ENLARGED FOR DETAIL

**CATALOG SHOWS DOZENS MORE**

Special heads, threads and finishes on any metal or alloy adapted to cold upset. Weekly output: 25,000,000 pieces. Many specials, suggesting production savings for you. Illustrated in latest catalog. Includes weights per 1M standard pieces, dec. equivs. of fractions, other purchasing and engineering helps. Write for Catalog 18.

*The* **PROGRESSIVE MFG. CO.**  
50 NORWOOD ST. TORRINGTON, CONN.

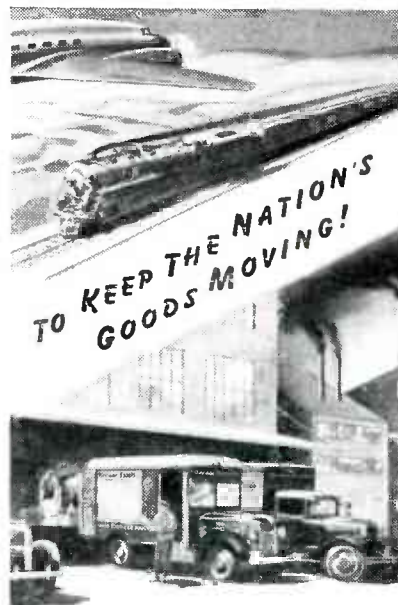

ONE OF THE foremost needs confronting business and industry during the period of readjustment is to keep goods and materials of every kind and for every purpose moving expeditiously.

This is an immediate and vital necessity. Railway Express, realizing the importance of supplying ways and means to meet the demand, is devoting its nationwide facilities and experience to the performance of such a service.

TWO BOOKS EVERY ENGINEER NEEDS

**THE CATHODE-RAY TUBE AT WORK** by John F. Rider



The cathode-ray tube is the most universally used device for research, engineering and maintenance in the radio and electrical fields.

In using this device to its fullest capabilities, it is necessary to understand its theory and functioning. This book presents a complete explanation of the various types and what role each element within the device plays. Different types of cathode-ray oscillographs are discussed.

More than half the book is devoted to the practical applications illustrated with unretouched photographs of actual oscillographs.

338 PAGES . . . 450 ILLUSTRATIONS . . . \$4.00

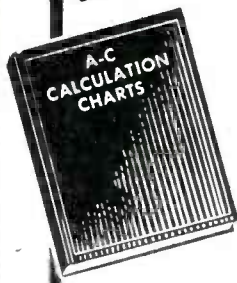

**A-C CALCULATION CHARTS**

This book is a tremendous time saver for engineers and others who work on electrical communication and electrical power problems. Faster than a slide rule. It covers all alternating current calculations in series circuits, parallel circuits, series-parallel and mesh circuits, at frequencies from 10 cycles to 1000 megacycles. 146 Charts—7" x 11"—Two colors—\$7.50.

**JOHN F. RIDER Publisher, Inc.**  
404 Fourth Avenue, New York 16, N. Y.

Export Division:  
Rocke Int. Corp.  
13 E. 40th Street  
New York City  
Cable: ARIAB



NATION-WIDE

RAIL-AIR SERVICE





## SELENIUM COPPER SULPHIDE

*A few B-L Rectifier applications are illustrated below:*



AUTO RADIOS



PIPE ORGANS



CLOCKS

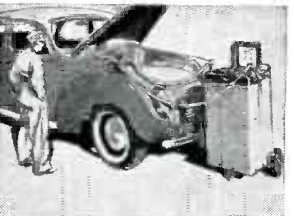

BATTERY CHARGERS



FIRE TRUCKS

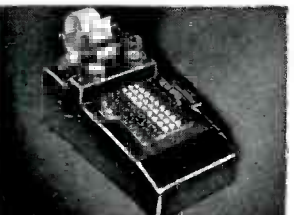

BUSINESS MACHINES

from AC →



→ to DC

# B-L METALLIC ELECTRICAL RECTIFIERS (SELENIUM COPPER SULPHIDE)

### offer you these advantages:

#### They are COMPACT

For a given power output the space required by metallic rectifiers is very small.

#### They are SILENT

B-L Rectifiers are silent in operation and have no moving parts.

#### They are DEPENDABLE

Dependability is assured by their simple and rugged construction, in which no glass bulbs, filaments, or other fragile parts are employed.

#### They are TROUBLE-FREE

Regular maintenance and attention are unnecessary.

#### They are RUGGED

B-L Rectifiers are rugged and will withstand heavy overloads for short periods of time.

#### They are ADAPTABLE

B-L Rectifiers are adaptable for power outputs from Milliwatts to Kilowatts.

Many rectifier applications, heretofore considered impractical, have been devised by B-L Engineers. It is more than likely that they can be of assistance in solving your problems of converting AC current to DC . . . Write for Copper-Sulphide Bulletin R38-A — or for Selenium Bulletin R41-A.

### THE BENWOOD-LINZE COMPANY

1815 Locust Street . . . . . St. Louis 3, Mo.

Long Distance Telephone Central 5830

#### SALES OFFICES:

420 Lexington Ave. ☎ New York 17, N. Y. ☎ MUrray Hill 5-5878  
20 N. Wacker Drive ☎ Chicago 6, Illinois ☎ CENTral 2379

*Designers and Manufacturers of Selenium and Copper Sulphide Rectifiers, Battery Chargers, and DC Power Supplies for practically every requirement.*

# NOW... get an Instrument Rectifier and a Balanced Resistance network in one convenient plug assembly

*it's*



*by* **Conant**

The lid's off! Now, Conant can give you this new development that meets the demands for applications that involve the balanced bridge principle in AC operation.

A striking example of Balac's many uses is the conversion of standard Wheatstone bridge instruments to AC. AC accuracy and performance become equal to DC operation on the same instrument. Null indication is never affected by temperature, frequency, wave form or line voltage changes.

No priorities necessary—no waiting. Write today for information. It's Balac, by Conant.



*Instrument Rectifiers*

**ELECTRICAL LABORATORIES**

6500 O STREET, LINCOLN 5, NEBRASKA, U. S. A.

20 Vesey St., New York 7, New York  
85 E. Gay St., Columbus, Ohio  
600 S. Michigan Ave., Chicago 5, Ill.  
1215 Harmon Pl., Minneapolis 3, Minn.

2017 Grand Ave., Kansas City 8, Mo.  
1212 Camp St., Dallas 2, Texas  
378 Boulevard N. E., Atlanta, Ga.  
4018 Greer Ave., St. Louis, Mo.

1526 Ivy St., Denver, Colo.  
4214 Country Club Dr., Long Beach 7, Cal.  
Export Div., 89 Broad St., N. Y. 4, N. Y.  
50 Yarmouth Rd., Toronto, Canada

cluding the eventual method of operation, a limited number of authorizations will be permitted. However, the Commission will not give any assurance that the licensees will be authorized to operate stations in the new service when it is finally established.

Experimental authorizations have already been introduced in the general mobile radio service to Southwestern Bell Telephone Co., St. Louis, Mo. and Yellow Cab Companies of Cleveland, Ohio and Washington, D. C. Other applications are on file from Bell System Companies, Highway Radio, Southwestern Bell Telephone Co., Raytheon Mfg. Co., Air Associates, Inc., Pacific Freight Lines, U-Drivit Auto Rental Co., Bendix Aviation Corp., Tanner Motor Livery, Ltd. and Federal Telephone & Telegraph Co.

## Theater Loudspeakers

UNDER THE SPONSORSHIP of the Academy of Motion Picture Arts and Sciences a series of tests is being conducted to provide for measuring the efficiency of theater loudspeaker systems.

Because previous power specifications have been based on amplifier characteristics alone, it has been impossible to specify effective acoustical power in a theater auditorium.

Such standards will be useful in



During the Nazi occupation of Holland, patriots of the underground built and operated this tiny clandestine receiver to pick up *verboden* newscasts. Using a selenium rectifier in place of the customary electron type, the circuit was energized from a bicycle generator and formed with components "liberated" at the Philips Radio Works during air raids—the only time Nazi guard control was relaxed sufficiently to make their feasible



# METAL ASSEMBLIES AND COMPONENTS FOR ELECTRONIC AND MECHANICAL DEVICES

●  
**ENGINEERING**

●  
**DEVELOPING**

●  
**FABRICATING**

●  
**ELECTRO-FORMING**

●  
**PLATING**

●  
**FINISHING**  
●

**B**ERNARD **R**ICE'S **S**ONS

I N C O R P O R A T E D

MANUFACTURERS OF QUALITY METAL PRODUCTS SINCE 1867

OFFICE: 325 FIFTH AVENUE, NEW YORK 16, N. Y.

WORKS: 139-145 NORTH TENTH STREET, BROOKLYN 11, N. Y.

A MESSAGE FROM CHIANG KAI-SHEK

SENDING

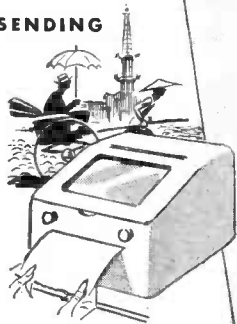

RECEIVING



## INSTANT TRANSMISSION OF "IMPOSSIBLE" MESSAGES

Only by Facsimile can a message like the above be transmitted by wire or radio. Translation-Supporting Democracy and upholding Justice, the world is one family and maintains perpetual Peace.

With Finch Facsimile Equipment (produced under 80 U. S. patents) exact duplicates of any written, printed or drawn messages — including ideographs and photos impossible of wire transmission by ordinary means — can be delivered at high speed, as far as either wire or radio will reach. This is the fastest, most flexible, most accurate communications system known. Now being prepared for business as well as government uses.

FINCH TELECOMMUNICATIONS, INC., PASSAIC, N. J. • N.Y. Office, 10 E. 40th St.

SELF SYNCHRONIZING

 **finch facsimile**

# DINION

**PIONEERS  
IN OIL-FILLED  
TRANSFORMERS  
For RADIO and RADAR**



**DINION COIL COMPANY, Inc.**  
CALEDONIA, N. Y.

# American Beauty

## ELECTRIC SOLDERING IRONS

are sturdily built for the hard usage of industrial service. Have plug type tips and are constructed on the unit system with each vital part, such as heating element, easily removable and replaceable. In 5 sizes, from 50 watts to 550 watts.



### TEMPERATURE REGULATING STAND

This is a thermostatically controlled device for the regulation of the temperature of an electric soldering iron. When placed on and connected to this stand, iron may be maintained at working temperature or through adjustment on bottom of stand at low or warm temperatures.



For further information or descriptive literature, write



107-1

**AMERICAN ELECTRICAL  
HEATER COMPANY**  
DETROIT 2, MICH., U. S. A.





more efficient  
... in miniature



The early camera addict had to be both patient and rugged. He carried a bulky camera in one yellow stained hand and a case containing his plates, tripod and cloth in the other. He would laboriously "set up," struggle with focusing and try to keep subjects still for long time exposures. Compare the size of his equipment, his efforts and the results he obtained with those of the user of the modern camera.

Yet the pocket camera of today is no better example of greater efficiency in miniature than is the modern Electronic Tube. In most high frequency circuits TUNG-SOL miniatures function far better than the larger conventional tubes. Because of

shorter elements they are more rigid and their lesser mass makes them less prone to distortion as the result of vibration.

TUNG-SOL's principal interest in the Electronic industry is to produce tubes that make radio sets and other Electronic Equipment more effective and efficient. Their engineers are at your service to help plan circuits and select tubes. Consultation, of course, is confidential.

**TUNG-SOL**  
*vibration-tested*  
**ELECTRONIC TUBES**



**TUNG-SOL LAMP WORKS INC., NEWARK 4, NEW JERSEY**  
*Also Manufacturers of Miniature Incandescent Lamps, All-Glass Sealed Beam Headlight Lamps and Current Intermittors*

In Vacuum Gauges . . . its the new

# Alphatron

No. 3 in series on new developments in the field of High Vacuum

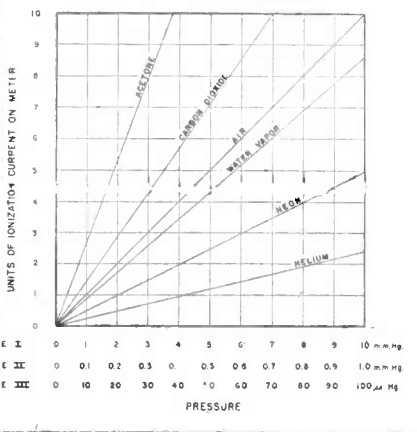

Alphatron Gauge Type 510 Preliminary Calibration Scale

- 1 micron to 10 millimeters** . A single gauge giving continuous linear indication of pressure in three ranges: 1-100 microns; 1-1000 microns and 1-10 millimeters.
- instantaneous response** . . . The Alphatron utilizes the ionization effect of alpha particles. This new principle enables instantaneous response to pressure change and thus avoids lag in readings.
- undamaged by atmospheric pressure** . . . . . The flow of alpha particles is produced from a sealed radium source. There is no filament to burn out, and the gauge is unaffected by exposure to atmospheric pressure.
- simple calibration for different gases** . . . . . The graph above shows that the Alphatron has linear reactions to pressure throughout its entire range. Calibrated for dry air the standard Alphatron may be used directly for other gases by means of calibration factors. Excellent for use with systems containing water vapor and for leak detecting.
- specifications** . . . . . Control box: size 12 $\frac{3}{8}$ " x 9 $\frac{1}{4}$ " x 9 $\frac{3}{8}$ ", weight 20 lbs., finish grey and black crackle with red trim; gauge (including first stage amplifier); size, 12" x 3" O. D., weight 5 lbs., finish natural; cables: 10 feet special 10 conductor; power 110 volts, 60 cycle, A. C., 1 ampere; calibration as shipped: dry air; shipping weight; approximately 27 lbs.

the light of higher efficiency theater loudspeakers which recent tests indicate are becoming available. Also, it is anticipated that higher efficiencies in acoustical levels will be required for proper dramatic presentation of forthcoming pictures wherein improvements in signal-to-noise ratio, an extension of frequency range, and more dramatic effects of sound are expected.

The Research Council Theater Sound Standardization Committee, under whose sponsorship activities have been conducted, has recommended that theaters utilize improved loudspeakers to produce better overall sound results and not as a way to reduce electrical power. Test equipment for these activities is installed in the Fox West Coast Academy Theatre, Inglewood, Calif. where the committee holds meetings.

## Instrument Society Officials

PRO-TEM OFFICERS have been elected by The Instrument Society of America as follows: president, A. F. Sperry, Chicago; vice president, Carl Kayan, professor of mechanical engineering, Columbia University, New York, N. Y.; treasurer, Charles E. Fry, Pittsburgh; and secretary, Richard Rimbach, Pittsburgh.

In addition to these elected individuals, chairman and committee members have been established for the following committees: Constitution, exhibit, finance, membership, nominating, program, publications, and publicity.

## Radar Shown by Radiation Laboratory

A DEMONSTRATION of microwave radar equipment which it had developed during the past four years was made by the Radiation Laboratories at Massachusetts Institute of Technology late in August to members of the technical press.

Occasion for the demonstration was the conclusion of hostilities and recognition of the virtual completion of the developmental work of the Laboratory. A few remaining projects are expected to be completed by the end of 1945. The staff of 3800 has for the most part already returned to the colleges, universities, or industrial concerns



For full particulars send for bulletin G-3.



# ISC Flame Cutting Machine Employs **MOSSMAN** Heavy Duty Switches For Flexible Electronic Control

Seven Series 4101 Mossman Heavy Duty Lever Switches  
in control cabinet of ISC Flame Cutting Machine.



ISC Flame Cutting Machine in operation cutting steel plates. Entire operation is electronically controlled by the operator at the cabinet through Mossman Switches. See article in July issue of "Electronics."

- Seven Mossman Series 4100 Heavy Duty Lever Switches provide flexible control for the operations of this ISC Flame Cutting Machine which is used for oxygen acetylene burning in shipyards and steel works.

These switches operate the electronic controls which start, stop, reverse and jog the 3-phase AC motors which connect and disconnect auxiliary circuits for various automatic and manual operations.

The Flame Cutting Machine is manufactured by the Struthers Wells Corporation of Titusville, Pa., under license of the Industrial Scientific Company of New York City, designers of the machine.

The control panel uses Mossman Series 4101 and 4102 Heavy Duty Lever Switches, including specially engineered switches, for the intricate control of the combined jog and run operation.



This illustration shows manual portable type control cabinet of ISC Flame Cutting Machine equipped with Mossman Switches.

This application is typical of the Mossman specially engineered switches for use in electronic controls. Mossman Heavy Duty Lever Switches are designed to provide unusual flexibility of circuit arrangements. An almost unlimited series of contact assemblies can be built up to meet specific requirements.

Mossman engineers are ready at all times to provide just the switch or electrical component to meet exacting and unusual switching needs. Send for the Mossman catalog for full information on the Mossman line of precision electrical components.

**DONALD P. MOSSMAN, INC., 612 North Michigan Avenue, Chicago 11, Illinois**

# MOSSMAN

## *Electrical Components*

# WARD

BACK AGAIN... SOON WARD AERIALS  
"WORLD'S FINEST FOR CAR & HOME"



## First Choice . . . OF AMERICA'S AUTO MAKERS

Utmost efficiency, finest quality, precision workmanship and vital war-time developments are four important reasons why Ward Antennas are first choice of America's auto makers today, as they were before the war.

For top performance and dependability, together with maximum profits and customer satisfaction, look to Ward for the world's finest antennas for car and home!

**WARD** Antennas BY VICTORY BODDS  
THE WARD PRODUCTS CORPORATION  
1523 EAST 45TH STREET - CLEVELAND 3, OHIO

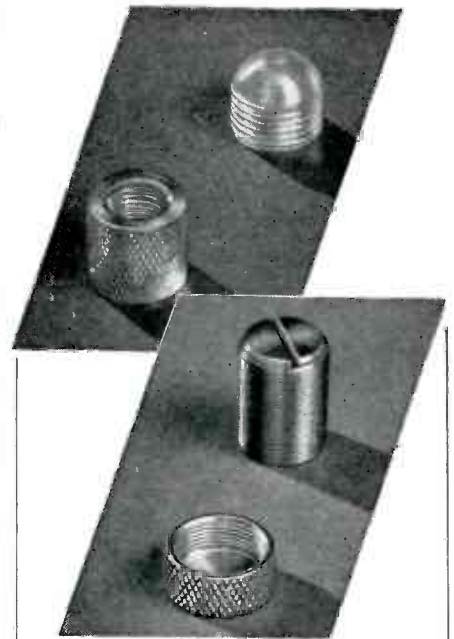

## EITHER IS "O.K."

### AT HARTFORD

Inside threads... outside threads... knurls... in fact, any of the machining jobs you expect of HARTFORD in metal you may also expect of HARTFORD in plastic. The only difference in using either material are those imposed by the characteristics of the material itself. Vast precision secondary operation equipment for producing complete mechanical assemblies, component parts and sub-assemblies.

#### PLASTICS

From Rod & Tubing

Centerless Ground • Machined  
Boring • Slotted • Milled • Knurled  
Drilled • Threaded • Tapped

#### Metal Inserts



## THE HARTFORD MACHINE SCREW COMPANY

Designer of Methods since 1876

#### SCREW MACHINE PRODUCTS

1/64" to 5" Dia. All Metals

HARTFORD, CONNECTICUT



## THERMOSTATIC METAL TYPE DELAY RELAYS PROVIDE DELAYS RANGING FROM 1 TO 120 SECONDS

#### Other important features include:—

1. Compensated for ambient temperature changes from  $-40^{\circ}$  to  $110^{\circ}$ F.
2. Contact ratings up to 115V-10a AC.
3. Hermetically sealed — not affected by altitude, moisture or other climate changes... Explosion-proof.
4. Octal radio base for easy replacement.
5. Compact, light, rugged, inexpensive.
6. Circuits available: SPST Normally Open; SPST Normally Closed.

WHAT'S YOUR PROBLEM? Send for "Special Problem Sheet" and Descriptive Bulletin.

**AMPERITE CO.** 561 BROADWAY  
NEW YORK 12, N. Y.

In Canada: Atlas Radio Corp., Ltd.  
560 King St. W., Toronto

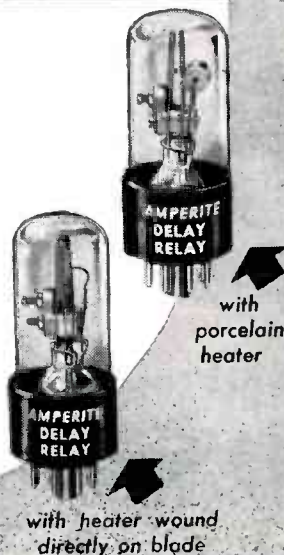



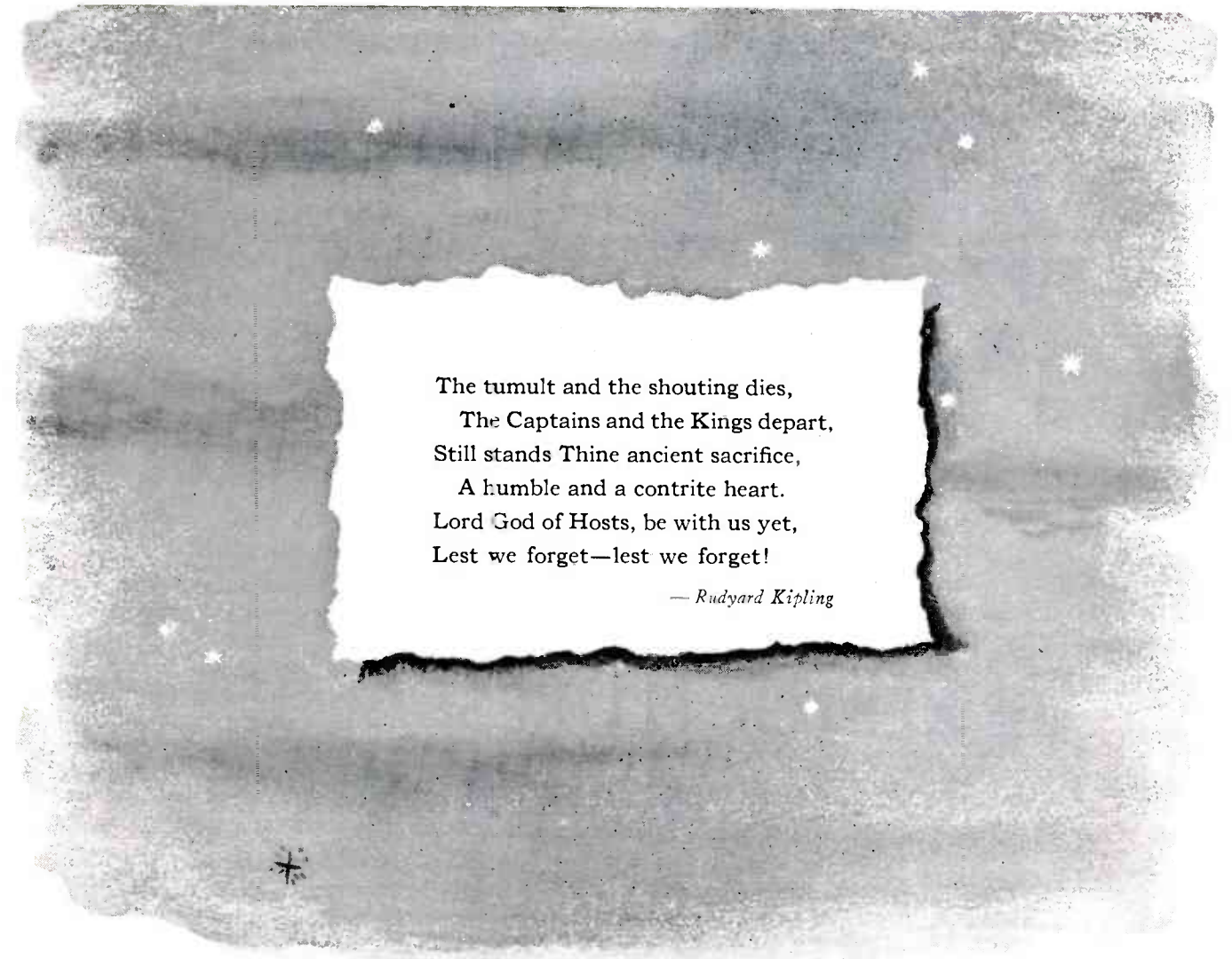

The tumult and the shouting dies,  
The Captains and the Kings depart,  
Still stands Thine ancient sacrifice,  
A humble and a contrite heart.  
Lord God of Hosts, be with us yet,  
Lest we forget—lest we forget!

— *Rudyard Kipling*

### ***To Our Customers and Friends—***

You and we have worked together through four of the world's most tragic years. Our common interest in a common cause has strengthened old business friendships and has made many new ones. For this we are grateful.

This experience of mutual respect and confidence is *one* result of the war that will be carried over to the problems of peace. It is the very stuff that will assure profitable business at home and better relations with our neighbors abroad.

We of the Biddle Company fortunately have no factory problem of reconversion. For the most part, we make the same testing instruments for industry at peace as were required for war. And as more of our products become available for industrial and rehabilitation purposes, we will continue to serve you—in good faith always—and to the best of our ability.

**JAMES G. BIDDLE CO.**

1211-13 Arch Street, Philadelphia 7, Pa.

“MEGGER” INSULATION TESTERS, GROUND TESTERS AND OHMMETERS • “FRAHM” FREQUENCY METERS AND TACHOMETERS • “JAGABI” RHEOSTATS • INDICATING HAND TACHOMETERS • SCIENTIFIC APPARATUS

*Give  
Solder  
STAYING  
Power*



*Photo Courtesy of Stanley Tools*

## USE KESTER FLUXES for Permanence!

- Don't risk service difficulties, mechanical failures, with solder flux that won't hold tight! Chemically correct flux—and different fluxes for different types of operations—are imperative for permanent soldering. That's why Kester fluxes are scientifically compounded to form tight, clean solder-bonds resistant to shock, vibration, bending, contraction and expansion. They insure the lasting quality of your product!
- For over 45 years Kester Fluxes have been tried, tested and proved dependable. There is a wide range of Kester flux formulas to fit every possible solder operation.
- Consult Kester engineers for practical, experienced help in solving any solder problem you may have. They'll gladly suggest the right flux to protect your product—and at no obligation.

BUY VICTORY BONDS

### KESTER SOLDER COMPANY

4204 WRIGHTWOOD AVENUE, CHICAGO 39, ILL.  
Eastern Plant: Newark, N. J., Canadian Plant: Brantford, Ont.



# KESTER

*Solder Fluxes*

STANDARD FOR INDUSTRY

from which they had been recruited. A small staff remains to prepare material for the publication of about 30 volumes of technical information on microwave techniques and electronic developments produced at the Laboratory.

#### MEETINGS TO COME

SEPT. 27-28; SOUTHWARK DIVISION, BALDWIN LOCOMOTIVE WORKS; Strain Gage Conference, Waldorf-Astoria Hotel, New York, N. Y.

OCT. 15-17; SOCIETY OF MOTION PICTURE ENGINEERS, 58th Semi-Annual Fall Conference; Hotel Pennsylvania, New York, N. Y.; Harry Smith Jr., Executive secretary, Hotel Pennsylvania.

OCT. 16-18; CARNEGIE INSTITUTE OF TECHNOLOGY AND INSTRUMENT SOCIETY OF AMERICA, Educational Conference on Instrumentation, Pittsburgh, Pa.; committee chairman, Dr. B. R. Teare Jr., head, Department of Electrical Engineering, Carnegie Institute of Technology, Pittsburgh 13, Pa. Invitation by application only.

OCT. 18-20; OPTICAL SOCIETY OF AMERICA, Thirtieth Annual Meeting, Hotel Pennsylvania, New York N. Y.; Arthur C. Hardy, secretary, MIT, Cambridge 39, Mass.

OCT. 19; INSTITUTE OF RADIO ENGINEERS, Cedar Rapids Section, Polyphase Broadcasting, by Paul Loyet, WHO, and Dehydration by Radio Frequency, by M. R. Himmell, Intratherm Co.; Younkers Tea Room Des Moines, Iowa; J. A. Green, secretary Collins Radio Co., 855 35 St., N. E., Cedar Rapids, Iowa.

NOV. 27; INSTITUTE OF RADIO ENGINEERS, Cedar Rapids Section, Oscillators, by Professor W. L. Caspell, Iowa State College; J. A. Green, secretary, Collins Radio Co., 855 35 St., N. E., Cedar Rapids, Iowa.

JAN. 23-26; INSTITUTE OF RADIO ENGINEERS, Winter Technical Meeting; Astor Hotel, New York, N. Y.; E. J. Content, chairman of meeting committee, WOR, 1440 Broadway, New York 18, N. Y.

#### WASHINGTON NEWS

SURPLUS ELECTRONIC EQUIPMENT. Electronic equipment and communication gear constitutes the fourth largest class of military surplus



# ECCO HIGH FREQUENCY CORP.

7020 HUDSON BOULEVARD  
NORTH BERGEN, N. J.

## ECCO INDUCTION HEATERS FOR TUBE MANUFACTURING

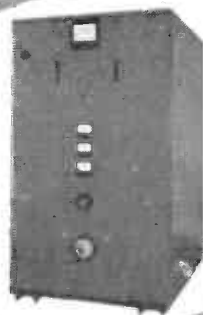

25 KW  
Tube  
Driven  
High  
Frequency  
Oscillator

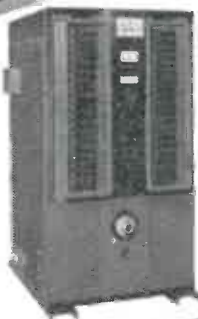

35 KVA  
Water  
Cooled  
Spark  
Gap  
Converter

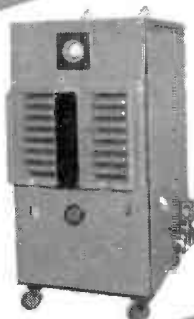

High  
Frequency  
Glass  
Welder



5 KW  
Portable  
Tube  
Oscillator

## ECCO HIGH FREQUENCY AUTOMATIC PROCESSING EQUIPMENT



Conveyor  
Type High  
Frequency  
Soldering  
Machine

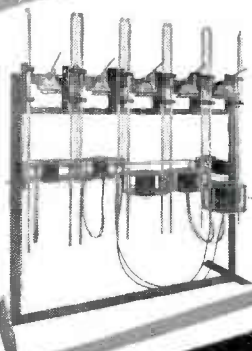

Vacuum  
Heat-treating  
Stand for  
Electronic  
Tube  
Parts



Single  
Position  
High  
Frequency  
Brazing  
Stand



Multiple Position  
Brazing Stand

## ECCO HIGH FREQUENCY ELECTRONIC COMPONENTS AND PARTS



ECCO Tap Selector Switch  
with Auxiliary Interlocked  
Contact



High  
Voltage  
X-Ray and  
Power  
Transformer



Water Jackets  
for All Types  
of Water-cooled  
Oscillator Tubes

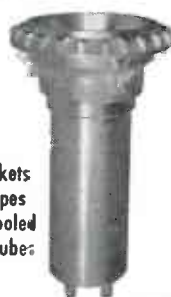

Multiple Section Mica  
Oil Condensers

## ECCO SPECIAL HIGH FREQUENCY SPARK TEST EQUIPMENT

We manufacture all types of high-frequency heating equipment used by the electronic industry. Descriptive literature and engineering recommendations gladly submitted.



Model G-4  
High Frequency  
Spark Glow &  
Vacuum Testers



# FREE!

The famous 64-page, fact-packed book that has stimulated thousands of men!



"Forging Ahead in Business" is a practical, thoughtfully-written book with "punch" and common sense on every page. It carries a message of vital importance to every man who wants to make more money, get a better job and improve his station in life.

#### Partial Contents:

- Law of Success
- Forging a Career
- Organized Knowledge
- Highway of Achievement
- Making Decisions
- Failure and Success

#### Noted Contributors

Among the prominent men who have contributed to the Institute's training plan, which is described in "Forging Ahead in Business," are: Thomas J. Watson, President, International Business Machines Corp.; Clifton Slusser, Vice President, Goodyear Tire & Rubber Co.; Frederick W. Pickard, Vice President and Director, E. I. du Pont de Nemours & Co.

Simply return the coupon below, and your FREE copy of "Forging Ahead in Business" will be mailed to you.

#### MAIL COUPON TODAY

ALEXANDER HAMILTON INSTITUTE  
Dept. 323, 71 W. 23rd St., New York 10, N. Y.  
In Canada:  
54 Wellington Street, West, Toronto 1, Ont.

Please mail me, without cost, a copy of the 64-page book—"FORGING AHEAD IN BUSINESS."

Name.....  
 Firm Name.....  
 Business Address.....  
 Position.....  
 Home Address.....

*Attention please*

## MARINE SALVAGE COMPANIES AND DEEP SEA DIVERS

We are the exclusive suppliers to U. S. Navy of deep sea communicating equipment for divers, designed and manufactured by us.

The U. S. Navy has released this "Restricted" equipment to us for sale to commercial salvage companies and divers.

*Information on request.*

### GUIDED RADIO CORPORATION

161 Sixth Avenue

New York 13, New York



**APPROVED**

*Leakproof*

### ENAMELED MAGNET WIRE

● Much of the success of this Hudson Wire product is due to a new coating method that gives a smooth, permanently-adherent enameling. Mercury-process tests guarantee perfect uniformity; great tensile strength assures perfect laying even at high winding speeds. Especially adaptable for reduction in coil dimensions without sacrificing electrical values.

*Our engineering and design facilities are at your disposal—details and quotations on request.*

**HUDSON WIRE COMPANY**

*Winsted Division*

**WINSTED**

**CONNECTICUT**





- PRECISION WIRE WOUND RESISTORS
- WHEATSTONE BRIDGES
- RADIO & ELECTRONIC TEST EQUIPMENT
- RADAR ASSEMBLIES

## A Message from

R. S. BRUNEAU

Dear Friends:

An introduction to Eastern Electronics at this time is in order.

"Eastern" is an expansion and growth from the Radio Installation Co. which many will recall I started in 1924 in Boston, Mass. We have grown rapidly during the last few years and are busily engaged on war contracts producing many items for the electronics program.

My associates here include Manfred Johnson, well known for his research and design of meters and recording instruments; and Dave Chapman, well recognized for his work in ultra high frequency Radio and Radar. You real old-timers should recall Bob Ringer formerly a partner in the Hixon Electric Co., Boston.

Our engineering and technical staff is well manned. You can be assured our products will meet the most rigid specifications, both for quality and performance.

Sincerely,

*Roland S. Bruneau*

## KORECT-OHM RESISTORS

### General Specifications

To insure stability Korect-ohm resistors are aged and treated to relieve strains due to winding before the final adjustment is made.

Final resistance adjustment to an accuracy of better than .1%.

**TEMPERATURE COEFFICIENT.** Resistors are wound with selected alloy wire having a resistance change vs. temperature of less than .08% between  $-55^{\circ}\text{C}$  and  $+55^{\circ}\text{C}$ . For applications where space is a factor, resistors are wound with an alloy wire having a resistivity of 650 ohms per circular mill ft. the resistance change vs. temperature of this high resistance alloy is  $.5\% \pm$  between  $-50^{\circ}\text{C}$  and  $+50^{\circ}\text{C}$ .

Many years of experience in the making and applying resistors for precision instruments and electronic equipment places us in a position to cooperate with you in supplying the right resistors for your particular need.

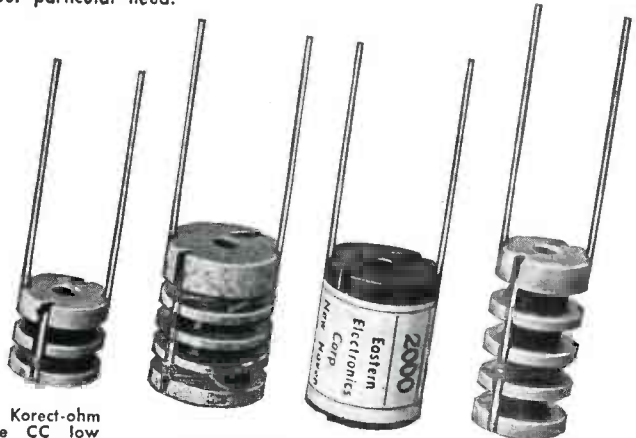

Korect-ohm Type CC low temperature coefficient maximum resistance 250,000 ohms. Type NC maximum resistance 500,000 ohms.

Korect-ohm Type NA maximum resistance 1 million ohms.

Korect-ohm Type CA low temperature coefficient ranges from a few ohms to 500,000 ohms.

Korect-ohm Type CB low temperature coefficient maximum resistance 500,000 ohms. Type NB maximum resistance 1 million ohms.

We will make special resistors to any value and tolerance.

Our regular line of resistors are available for immediate delivery.

Watch our Ads for New Items.

# Eastern Electronics Corp.

41 CHESTNUT STREET, NEW HAVEN, CONN.

Boston Sales Office  
11 Pemberton Square  
Tel. Capitol 2425

Chicago Sales Office  
Bauman & Bluzat 2753 West North Ave.  
Tel. Humboldt 6809



No. 5 of a Series

## MODERN COIL WINDINGS

*Partial View of Assembly Department*

For many months, COTO-COIL facilities have been employed in producing wartime essentials. Now, as we so long hoped, our entire plant can be devoted to peacetime industry.

Our 28 years of experience are at your service to help you with modern coil design and construction.

### COTO-COIL CO., INC.

COIL SPECIALISTS SINCE 1917

65 PAVILION AVE.

PROVIDENCE 5, R. I.

capital and producers' goods held for disposition by Reconstruction Finance Corp. The two major items are electron tubes with an original cost of \$15,989,000 and components and subassemblies at \$14,304,000.

**FCC APPLICATIONS.** On January 25, 1945, FCC issued a public notice outlining the procedure involved in handling standard broadcast applications under their existing policy. It was announced that a 60-day period would be provided for the filing of new applications when manpower and materials again reach the situation where normal licensing practice is to be reestablished. This 60-day period was announced to have commenced running on August 7, 1945. Applicants will not be required to show that they have the necessary equipment on hand. After October 7, FCC will consider applications filed previously and also those filed during the 60-day period. However, f-m and television applications cannot be acted upon until regulations have been adopted.

**WPB CONSOLIDATION.** The radio and transport bureau of WPB has been abolished and its divisions transferred to the equipment bureau, all except the Radio and Radar Division. This organization no longer comes under bureau heading but is now under the office of the operations vice-chairman.

### FCC ACTS

To permit:

To do this:

W9XLA 1  
Denver, Colo.

Operate with changed frequency of 43.5 mc and class of station changed from temporary class 2 experimental high-frequency to developmental broadcast with 1 kw power.

— — — —  
Cincinnati, Ohio

Construct new station to relay to WCFO on frequencies of 31,220, 35,620, 37,020, 39,260 kc with 10 w power.

— — — —  
Gallup, N. M.

Construct new station to operate on 1230 kc at 250 w, unlimited time.

— — — —  
Findlay, Ohio

Construct new relay broadcast station on frequencies of 30,820, 33,740, 35,820 and 37,980 kc with 25 w power.

WSSV  
Petersburg, Va.

Operate newly constructed station on 1240 kc, 250 w, unlimited time.

— — — —  
Grand Island, Neb.

Construct new station to relay to KMMJ on 30,820, 33,740, 35,820 and 37,980 kc with 50 w power.

WHGB  
Harrisburg, Pa.

Operate a newly constructed station on 1400 kc with 250 w unlimited time.





**F**OR 34 years, Magnavox has specialized in speakers and speaker satisfaction.

★★ Magnavox designers and engineers have achieved a breadth of experience and knowledge that enables them to meet your specifications exactly. And Magnavox production men have the know-how to build your speakers at the right price, to a high standard of quality—on time.

★★ Hard-to-satisfy research engineers constantly seek better speaker designs and better production methods. They stand ready to apply their developments to any of your component problems.

★★ When you think of speakers, think of Magnavox. There is no substitute for experience. The Magnavox Company, Components Division, Fort Wayne 4, Indiana.

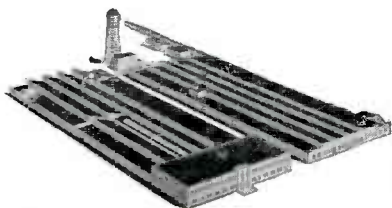

**Magnavox**  
has served the radio industry 34 years

**SPEAKERS · CAPACITORS · SOLENOIDS · ELECTRONIC EQUIPMENT**

# AN 3155 POWER RHEOSTAT

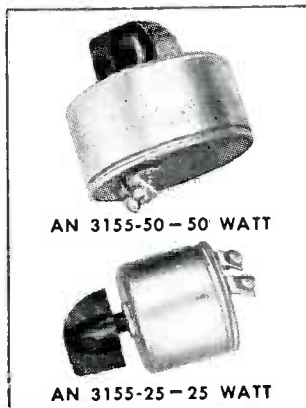

Totally enclosed in accordance with Army-Navy specifications (AN-R-14A).

Permanently sealed in dust-proof, corrosion-proof metal cases.

Smooth control, rugged and thoroughly dependable under the most severe service conditions—shock, vibration, humidity, heat, cold, and altitude.

Hardwick, Hindle is proud of the excellent performance of these power rheostats on thousands of planes flying in every theatre of war under all climatic conditions. And they will prove to be invaluable in innumerable post-war applications.

Let us send you technical data and detailed information on these and many other rheostats and resistors with H-H exclusive features.

*Write today for our new catalogue.*



**HARDWICK, HINDLE, INC.**

RHEOSTATS and RESISTORS

SUBSIDIARY OF

**THE NATIONAL LOCK WASHER COMPANY**

ESTABLISHED 1886

Newark 5, N. J., U. S. A.

## EXPORT INDUSTRIES

53 DOWNING STREET • NEW YORK 14, N. Y.

*Let us clear your shipping room  
and plant for peacetime production!*

Immediate action is necessary to avoid shipping department and production blockades, resulting from terminated inventories. In order to avoid losses from such pile-ups, EXPORT INDUSTRIES offers a complete service. We provide complete handling, storage and shipping facilities; remove terminated inventories, and give proper protective packing; handle all paper work and detail. Final disposal is also effected to your exact specifications. In this way, your floor space, clerical force, shipping and production departments are cleared for new business.

*We specialize in packaging, processing and shipping!*



SHOCK  
RESISTANCE



MOISTURE  
PROOF



IMMUNITY  
TO HEAT



FUNGUS  
PROTECTION

## EXPORT INDUSTRIES

53 DOWNING STREET • NEW YORK 14, N. Y.

*Make Plans Now . . .  
for the coming . . .*

## PLASTIC ERA



*Consult . . .*

## ROGAN

• Here at Rogan, seasoned engineers are ready and willing to assist you in determining your post-war *Plastic* requirements.

Whether your peacetime products are to include electronic equipment, electrical appliances, stoves or what have you, the Rogan Organization will gladly provide cost-free advice on all phases of plastic production.

*Send us  
Your Specifications Today!*

## ROGAN BROTHERS

*Compression Molders and Branders  
of Plastics*

2003 So. Michigan Avenue  
Chicago, Illinois



# FAMOUS KENYON T-LINE TRANSFORMERS



## BORN IN THE EARLY 1930's...

We, at Kenyon, take a good deal of pride in our famous T-LINE TRANSFORMERS. Similar units are now produced and advertised by many of our competitors who long ago realized that the T-LINE Housing was a superior Housing in many respects — outdating by years the unpotted open-type Transformers produced by other Transformer Manufacturers.

### Additional features of the famous KENYON T-LINE are:

- Excellent Appearance
- Universal Mountings

Mounting centers remain exact because they are die-punched all at the same moment in a single operation.

- A Manufacturer's Dream

Because they provide an excellent electrical and mechanical design that can be made cheaply from plentiful materials.

Kenyon is extremely satisfied with its outstanding engineering developments. The KENYON T-LINE case when produced in the early 1930's was years ahead of its time.

Our engineers are indeed proud to be the originators of such a popular design and point to its duplication with pride.

Kenyon engineering intends to maintain its place as a pioneer in the continued development of outstanding Transformer Equipment.

*Inquiries invited. Write for our NEW 1945 Illustrated Catalog*

**TODAY  
THE MOST  
COPIED-OF-ALL  
TRANSFORMER  
HOUSINGS**



THE MARK OF EXCELLENCE

# KENYON TRANSFORMER CO., Inc.

840 BARRY STREET  
NEW YORK, U. S. A.



## LET US HELP YOU WITH YOUR CRYSTAL CONTROLLED CIRCUITS

The public may be very happy just to have a new automobile. But they are conditioned to expect the postwar domestic radio to be different — with the precision and quiet of Crystal Controlled circuits.

Through the war we have learned a lot about the use of Control Crystals, and this knowledge is at the disposal of manufacturers of radio, fm and other electronic devices.

And when you know what crystals you need, our quantity-production methods are ready to supply you with crystals to your exact specifications, on time, clean, and at a price that will be within your production budget.



PAN-Electronics LABORatories, Inc.

500 Spring St., N. W.

Atlanta, Georgia

Pan-El

QUANTITY PRODUCERS OF STANDARD AND SPECIAL

# Control Crystals

To permit:	To do this:
KRMD Shreveport, La.	Change automatic frequency control equipment.
KXOA Sacramento, Calif.	Operate a newly constructed station on 1490 kc, 250 w.
WKAQ San Juan, Puerto Rico	Operate moved transmitter, studio, and auxiliary transmitter at new site.
WHTB Talladega, Ala.	Change antenna in newly constructed station.
Philco Radio & Television Corp. Wyndmoor, Pa.	Construct experimental television broadcast station to develop a television system operating in the 480 to 920 mc region with frequencies to be assigned and A3, A5, Special, and Special emission for f-m, power 1 kw (peak) visual and aural. Also construct three experimental television relay stations on frequencies to be assigned, A0, A1, A3, A5, Special, and Special for f-m emissions.
W2XRA New York, N. Y.	Operate a newly constructed developmental broadcast station.
Allen B. DuMont Labs., Inc. New York, N. Y.	Construct portable-mobile experimental television relay station in the 480 to 920 mc region with frequencies to be assigned. A3, Special, and Special for f-m emissions, 1 kw (peak) visual and aural power.
Emerson Radio & Phonograph Corp. New York, N. Y.	Construct new developmental broadcast station on frequencies to be assigned. A0, A3, and Special emission for f-m.
J. F. Novy Riverside, Ill.	Construct new developmental broadcast station on frequencies to be assigned. A0, A4, Special emission for f-m.
General Railway Signal Co.	Construct and operate ten new experimental Class 2 portable and portable-mobile radio stations in yard and terminal areas and along the roads of principal railroads. Frequencies are to be assigned. Power is 60 w, emission A1, A2, A3, and Special for f-m, and hours of operation unlimited.
KUSC Los Angeles, Calif.	Extend completion date of new non-commercial educational broadcast station to Dec. 21, 1945.
W3XO Washington, D. C.	Operate at new site and with class of station changed from temporary class 2 experimental high-frequency broadcast to developmental broadcast.
KIT Yakima, Wash.	Operate with change in transmitting equipment.
— — — — State College, Pa.	Construct new station to operate on 1450 kc, 250 w, unlimited time.
KLS Oakland, Calif.	Change calls letters to KWBR.
Bendix Aviation Corp.	Construct three identical experimental Class 2 portable and portable-mobile stations and operate for experiment in connection with the development and testing of railroad radio communication systems. Composite transmitters will operate at 10 w, with A1, A2, A3, and Special emissions for f-m, (telephony) on frequencies to be assigned.
Halstead Traffic Communications Corp., Weehawken, N. J.	Construct and operate two new experimental Class 2 radio stations for use to determine relative merits of f-m and a-m for communication between a central office and moving trains or switch engines. Frequencies will be assigned.
Raytheon Mfg. Co.	Construct five experimental radio relay stations to be installed between Boston and New York City. Intermediate locations will be



# FOR SUPERIORITY IN POSTWAR PRODUCTS

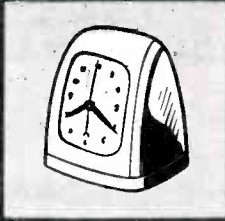

## CHOOSE LOW-VOLTAGE RECTIFIERS

Place your postwar products in a superior class of their own by equipping them with G-E low-voltage rectifiers. There are copper-oxide, selenium or Tungar types and sizes for practically all d-c applications. This makes it possible for manufacturers to design and build their products around the rectifier that is sure to deliver the most efficient, most dependable and most economical performance.

Naturally, all three differ in characteristics, basic materials and construction. Each is better than the other when accomplishing the specific job for which it is designed. Thus the manufacturer of products employing rectifiers must first determine the results to be obtained and the conditions under which the rectifier must function, before making a selection.

Since G-E makes all three — Copper-oxide, Selenium and Tungar — it has no reason to prefer one to the other. It can give you impartial advice on which type is best for your particular requirements. For further information write Section A1056-119, Appliance and Merchandise Department, General Electric Company, Bridgeport, Connecticut.

Hear the General Electric radio programs: "The G-E All Girl Orchestra" Sunday 10 P.M. EWT, NBC. "The World Today" news every weekday 6:45 P.M. EWT, CBS. "The G-E House Party" Monday through Friday 4:00 P.M. EWT, CBS.

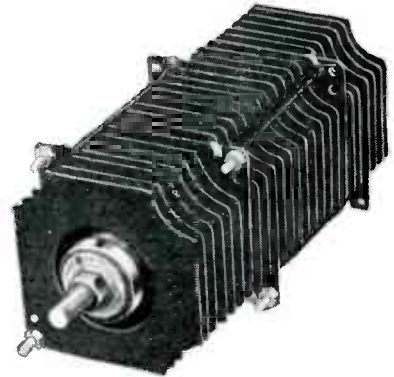

**COPPER-OXIDE**—Rugged in construction, provides virtually unlimited life when operated within rated capacities.



**SELENIUM**—Excellent for continuous operation where space is a factor and weight must be held to a minimum.



**TUNGAR**—Efficient and economical for low-voltage applications where life and price are determining factors.

# GENERAL ELECTRIC

# Piezo

## REMOTE CONTROL HINGED UNIVERSAL LINK JOINT—Type H

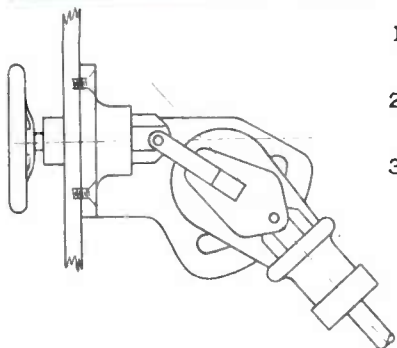

1. It hinges to align with any shaft angle from 0° to 90°
2. With solid shaft controls flexing or backlash is negligible.
3. The output shaft turns in exact angular rotation with the input shaft.



This universal joint is particularly recommended for panel operation of dial and rheostat controls, switches, variable condensers, variable transformers, coils, remote operating rods and other mechanical adjustments. Write for folder 45A giving complete data and specifications.



## PIEZO MANUFACTURING CORPORATION

110 E. 42nd STREET, NEW YORK 17, N. Y.

## THERE'S A DRAKE SOLDERING IRON FOR EVERY TYPE OF ELECTRONIC WORK

From that mighty mite



the Drake No. 400 to the high-speed production "honey"



the Drake No. 600-10 there is a high quality Drake Soldering Iron "just right" for the job.

Drake Heat Controls and the Drake "Magic Cup" Stand are important soldering aids.



SEE  
YOUR RADIO  
PARTS JOBBER

**DRAKE ELECTRIC WORKS, INC.**  
3656 LINCOLN AVE. CHICAGO, ILL.

## OPTICAL MIRRORS and REFLECTORS

FOR ELECTRONIC, OPTICAL  
AND SCIENTIFIC APPARATUS

WE specialize in the production of front or rear surface mirrors, made to your specifications. Closest optical and dimensional tolerances observed.

Because of their proven superiority, ZENITH mirrors are preferred by many leading manufacturers of precision equipment.

- EXCEPTIONAL REFLECTIVITY
- ALUMINUM, SILVER, GOLD, etc.
- OPAQUE OR SEMI-TRANSPARENT
- PERMANENT CHARACTERISTICS
- PROMPT SERVICE

We invite your inquiry. Samples and quotations will be submitted promptly.

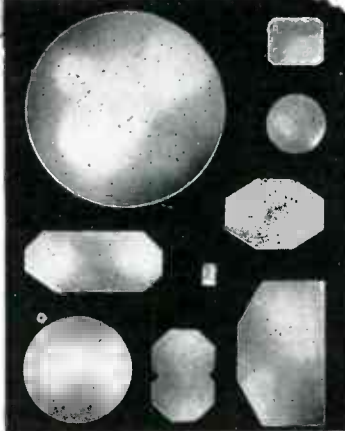

## ZENITH OPTICAL LABORATORY

SPECIALISTS IN  
VACUUM DEPOSITION



123 WEST 64th STREET  
NEW YORK 23, N. Y.

## JOB AHEAD

...and we're equal to it!  
Each day we are shipping  
more for civilian use.



## WIRES

MADE BY  
*Engineers*  
FOR  
*Engineers*

**cornish**  
WIRE COMPANY, INC.

15 Park Row,  
New York City





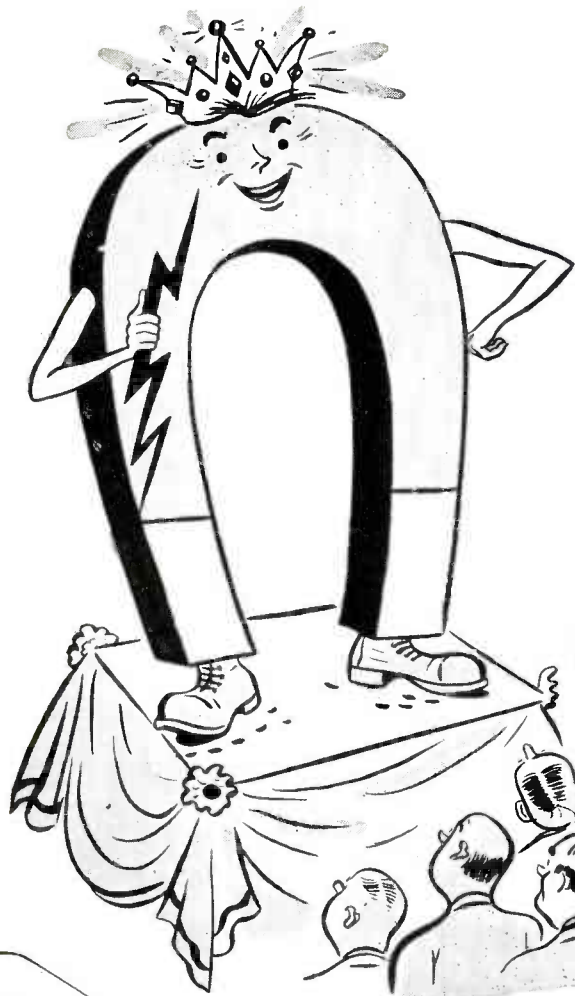

# ***MOUNT HIM RIGHT!***

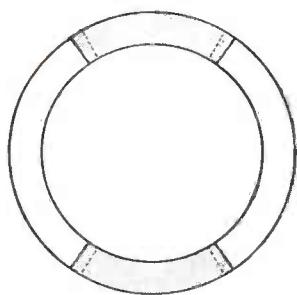
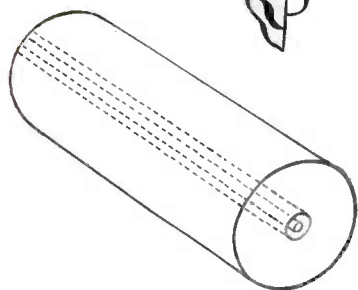

Much as he would like to be, he's no hero, this permanent magnet. However, he should be well mounted. He doesn't need a pedestal so that all the world can admire him, but he does need to be so designed that he can be mounted properly in the instrument or machine he is to serve. Otherwise he may sulk and loaf on the job.

Most permanent magnets are prepared for mounting in one of three ways:

- 1. By casting small holes or slots or shaft holes into the magnets**
- 2. By casting soft iron inserts into the magnet**
- 3. By casting the magnet into a housing wall**

But which method to choose . . . that's the problem!

The selection of the proper mounting for a magnet need not be too troublesome once the advantages and disadvantages of all methods are understood. Our engineers will be glad to advise on this point at any time but perhaps a reading of our pamphlet PERMANENT MAGNET DESIGN will be helpful to those designing their own magnets. Shall we send you a copy?

10-CC-1

## **CINAUDAGRAPH CORPORATION**



**2 SELLECK STREET STAMFORD, CONNECTICUT**

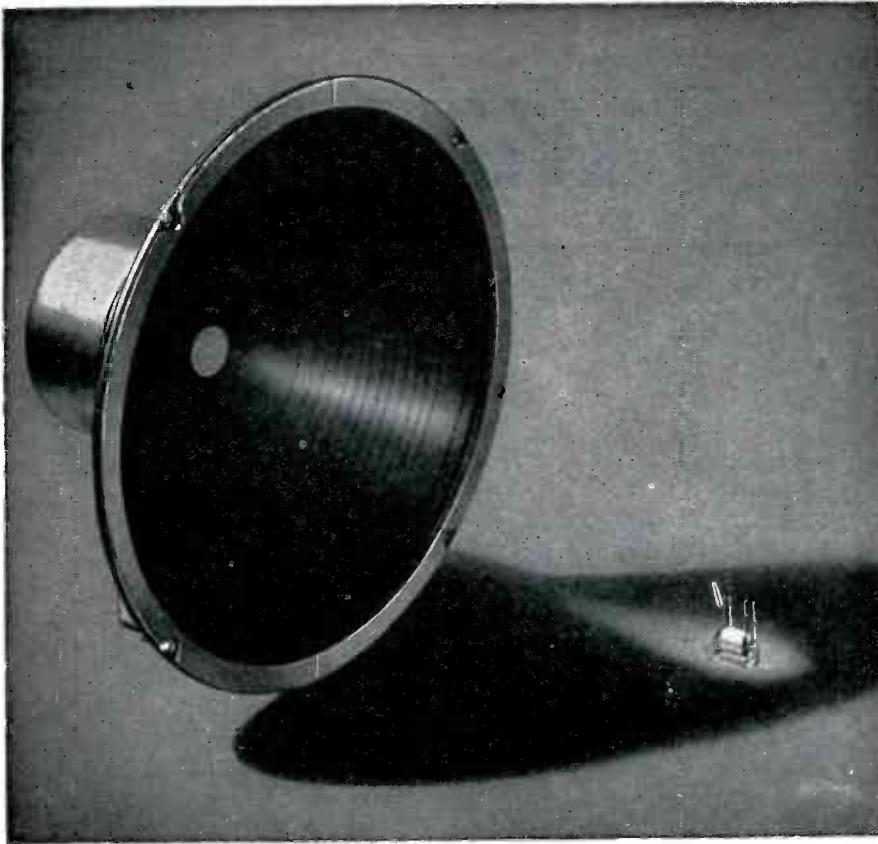

## Permoflux Speakers and Transformers Set New Standards of Comparison!

New Permoflux speakers in a complete range of true-dimensioned sizes from 2" to 15", with power handling capacities from 1 to 20 watts, provide the finest sound reproduction for every application.

Permoflux midget transformers, with their many practical circuit applications, have literally revolutionized efficiency concepts where size and weight are determining factors.

Advanced engineering designs, improved manufacturing methods and new materials have all contributed their share in the development of Permoflux speakers, transformers, microphones and headphones. You can count on Permoflux to provide an acoustical unit to suit your exacting requirements.

**BUY WAR BONDS FOR VICTORY!**

TRADE MARK  
**PERMOFLUX**  
 PERMOFLUX CORPORATION  
 4900 WEST GRAND AVE., CHICAGO 39, ILL.



**PIONEER MANUFACTURERS OF PERMANENT MAGNET DYNAMIC TRANSDUCERS**

To permit

To do this:

- Lexington, Mass., Bristol and Tolland, Conn., and Webster, Mass. Experimentation will involve Class 2 point-to-point radio stations to develop new techniques for the transmission and relaying of high definition and color television programs, high-fidelity f-m and telephone, telegraph and facsimile. Power of 100 w will be used on frequency bands to be assigned.
- WLBZ  
Bangor, Maine Change from directional antenna day and night to directional antenna night only.
- WMAZ  
Macon, Ga. Operate with nighttime directional antenna pattern from 15 min before local sunset to 15 min after local sunrise during those months in which the average hour of local sunset and/or local sunrise occurs on the quarter-hour or three-quarter hour.
- Seaboard Air Line  
Railway Co. Construct four experimental Class 2 portable and portable-mobile stations to investigate possible improvements in public transportation. Frequencies are to be assigned, power is 25 w with Special emission for f-m (telephony).
- Ravtheon Mfg. Co. Construct experimental Class 1 portable radio station for conduct of field strength measurements and determination of propagation characteristics from a series of Western mountain peaks. Frequencies will be assigned, power 250 w with Special emission for f-m.
- Southwestern Tele-  
& Power Co. Construct one experimental Class 2 radio land station and twelve portable mobile stations to be installed in repair trucks and supervisory cars. Frequencies will be assigned. Power 250 w for the land stations and 15 w for the portable-mobile station with Special emission for f-m.

### BUSINESS NEWS

BENDIX AVIATION CORP. anticipates the early installation of radar network systems which will make all-weather flight a reality. Using radar landing techniques, airlines will be able to take off, fly, and land safely under all weather conditions short of a full gale.

OTRONICS COMPANY OF AMERICA, INC. New York, N. Y., is a new company formed to handle a newly developed aid to hearing.

HALSTEAD TRAFFIC COMMUNICATIONS CORP., New York, N. Y., has been acquired by Farnsworth Television and Radio Corp., Fort Wayne, Ind. The Halstead engineering staff as well as the laboratory and manufacturing facilities will be transferred to Fort Wayne.

AUDAR, INC. is the name of a newly formed corporation, an affiliate of John Meck Industries, Inc., Chicago Ill. It will manufacture and sell





Type C-2851 Thermostat. For such use as Roughing Controls on Outer Crystal Ovens.



Type B-3120 Thermostat and Heater, Crystal Dew Point Control.

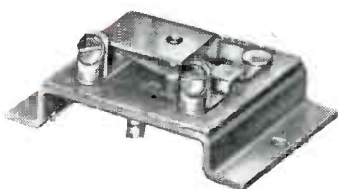

Type C-4351 Thermostat. Used for Tube Warming, Tube Cooling, High Limit Controls, etc.



Type C-7220 Precision Snap Switch 12 amps. 30 Volts D. C., 125 Volts A. C.



Type PM (NAF-1131) Circuit Breaker.



Type ER Series. Ambient Compensated Time Delay Relays.



Type RT Thermostat. Adjustable Temperature Control.



## A Sure Tip on a Winner

USE

### KLIXON Snap-Acting CONTROLS

Klixon Controls go into many things—always providing sure control or protection. In motors and transformers they provide overheat protection. In electrical circuits . . . overload protection. While in still other products . . . it's thermal time delay or temperature control.

No matter what the product . . . if it needs control or protection, take a tip from hundreds of satisfied users . . . use Klixon Snap-Acting Controls. These light-weight, compact, small controls snap open to a quick break or solid make every time they operate. Their accurate performance is unaffected by shock, motion, vibration or altitude. And because Klixon Controls have no magnets, toggles or other complicated mechanisms, they keep on giving reliable control or protection year after year without adjustments or wearing out.

A wide range of standard types and ratings are available to meet most applications. Write for complete information, today.

**SPENCER THERMOSTAT COMPANY, ATTLEBORO, MASS.**





## "Consolidated Wants to See Us at Once"

A TELEPHONE in your postwar car will keep you up-to-the-minute with your home office.

We at Ericsson will keep you up-to-the-minute on engineering changes, service and low-cost mass production of essential parts.

Our organization is geared to

function up-to-the-minute on your postwar products . . . efficiently and economically. You might find it helpful to discuss your problems with us.

(Below) Some of the many thousands of our precision parts that helped "Keep 'em flying and fighting."





# ERICSSON

SCREW MACHINE PRODUCTS CO., INC.  
25 LAFAYETTE STREET, BROOKLYN 1, N. Y.



LET US QUOTE ON YOUR

SMALL STAMPINGS

SPECIAL TERMINALS

SOLDERING LUGS

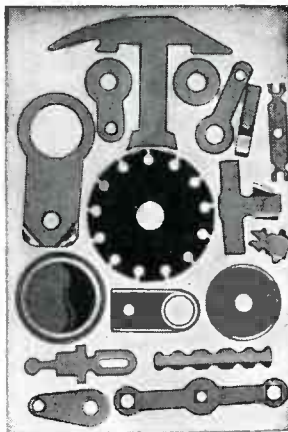

PRECISION WASHERS up to 5/8" O. D.

*Manufactured to Your Specifications*

Large Tool Room Facilities plus 20 Years Experience insure

**HIGH GRADE STAMPINGS  
QUICK DELIVERIES**

on Medium and Large Quantities

*Let Us Quote on Your Requirements*

## DIEBEL DIE & MFG. CO.

3658 N. Lincoln Ave., Chicago 13, Ill. Phone WELLington 4202

## CUT HOLES

3/4" TO 3 1/2"



in radio chassis

Punch cuts through chassis, die supports metal to prevent distortion, cap screw is turned with wrench to cut clean, accurate holes for sockets, plugs, and other receptacles. Saves hours of work — no reaming, filing or drilling! 3/4" to 3 1/2" sizes. Get complete data now from Greenlee Tool Co., 1930 Columbia Ave., Rockford, Illinois.

WRITE FOR FREE FOLDER S-119



Get Ready with Greenlee!  
REGISTERED TOOLS  
**GREENLEE**  
FOR THE CRAFTSMAN

**AIRCO RARE GASES  
AND MIXTURES**

OF TESTED PURITY

STANDARD OF THE INDUSTRY

Airco Rare Gases of highest purity, and Airco Rare Gas Mixtures, blended accurately, meet the most exacting requirements of laboratory and production applications. Their uniformity and purity are definite factors contributing to increased tube operating efficiency...and longer life. Airco Rare Gases are supplied in lead glass or PYREX containers from which they are easily removed with no change in quality. Your nearby Airco Office can supply your needs quickly.

**AIR REDUCTION**

60 EAST 42nd STREET • NEW YORK 17, N. Y.

Offices in Principal Cities

ARGON • NEON • HELIUM • KRYPTON • XENON  
STANDARD AND SPECIAL MIXTURES



That's how they make ONE type of Fiberglas\*-Mica combination



Several processors were quick to realize that mica and Fiberglas each have advantages which, when combined, result in an insulation material with unsurpassed characteristics. That is why the combination of thin glass cloth with mica, for ground insulation, was one of the first applications of Fiberglas in the electrical industry.

#### Types of Fiberglas-Mica Combinations

Fiberglas-Mica combination insulation is available commercially in thicknesses from .004" to .030". The Fiberglas may be applied to one or both facings of the mica, and the thickness of the Fiberglas used may be varied.

For ease in using the material, where minimum space is a factor, Fiberglas may be applied to one surface of the mica, while "fish paper" is applied to the other. In all cases, the strength of the Fiberglas-Mica combination is in excess of any other type of reinforced mica of the same thickness. This is particularly important in the thinnest mica tapes used for conductor or coil insulation. Four mil thick Fiberglas-Mica Tape is nearly three times as strong as the same

thickness of mica tape with silk or paper backing—thus reducing application time.

#### Typical Applications

Fiberglas-Mica combination materials are used wherever there is a need for maximum reliability under high temperatures, either internal or external; where mechanical service is most severe, where a maximum safety factor is required. Its chief use is as ground or slot insulation in motors and generators, as phase insulation in large a-c apparatus, or as coil insulation between high and low voltage sides of dry-type transformers.

#### Complete Information

If you do not have complete information about Fiberglas-Mica combinations, write for the new EL 44-7 catalog, today. It also contains data on Fiberglas Tapes, Sleeving, Cord, etc. The name of the Fiberglas Insulation Materials Supplier located nearest to you will be supplied on request.

Owens-Corning Fiberglas Corporation, 1860 Nicholas Building, Toledo 1, Ohio.

In Canada, Fiberglas Canada Ltd., Oshawa, Ontario.

There is a  
**FIBERGLAS**  
Insulation Material  
for every need



Fiberglas-Mica Sheets or Tapes are available in thicknesses from .004" to .030"—with Fiberglas facings on one or both sides.



One of the chief uses of Fiberglas-Mica combinations is as ground or slot insulation in motors and generators.

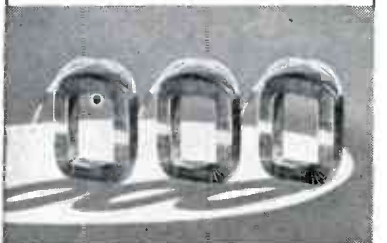

Fiberglas-Mica has exceptional strength, permitting use of thinner tapes for conductor or coil insulation.



Write for catalog EL 44-7, today.

Each distributor of Fiberglas-base Insulation Materials has his own source of supply, since Owens-Corning Fiberglas Corp. does not process these materials.

# FIBERGLAS

\*T. M. Reg. U. S. Pat. Off.

**ELECTRICAL INSULATION MATERIALS**

# another Audio Development

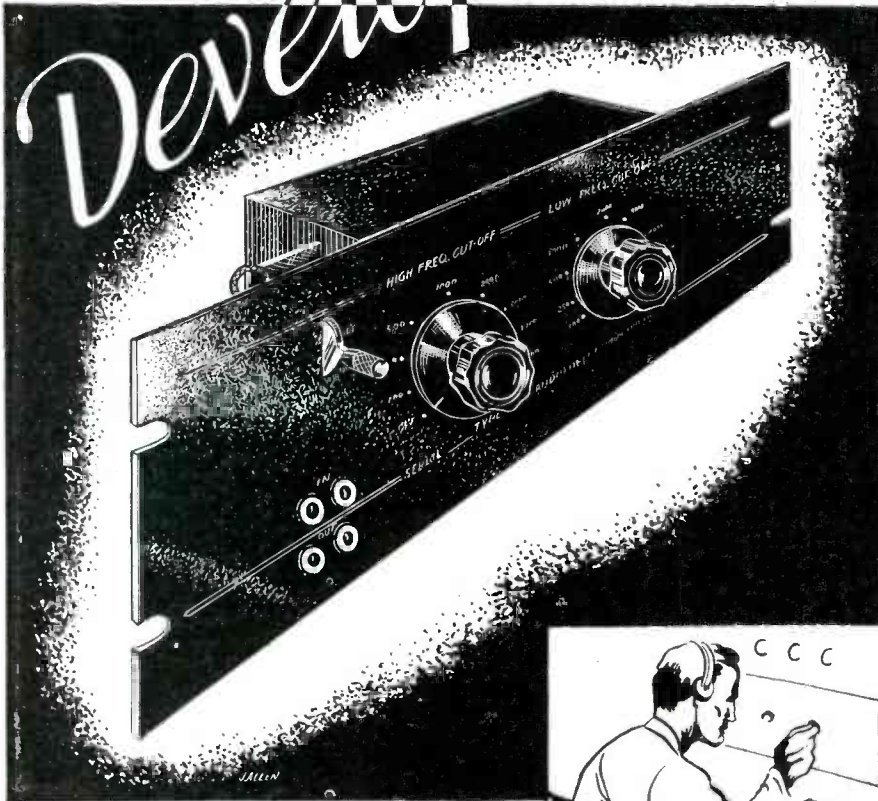

## Our Variable SOUND EFFECTS FILTER

One of hundreds of basically different filter types produced by Audio Development, this unit has been designed principally for the use of broadcasting stations and recording studios. The filter consists of a single prototype low pass and a similar high pass filter section, each with eight different cut off frequencies. This permits the selection of a proper cut off frequency for any application.

Attenuation of at least 18 DB per octave is obtained for both high and low pass sections with the insertion loss in the pass band less than 1 DB. Coils are individually shielded to permit normal operating levels between -40 and +14 VU. Standard impedance is 600 ohms. Mounting facilities are provided within the unit for transformers, thereby permitting operation in systems of any impedance.



sound systems and audio amplifiers.

SYRACUSE UNIVERSITY, Syracuse, N. Y., plans to install a wired television system for use in the conduct of classroom equipment experiments as well as program instruction. General Electric Co. will be the supplier.

RADIO CORP. OF AMERICA adds to its present list of products a complete line of dry batteries. They will be handled by the tube division in conjunction with RCA tubes and parts.

SYLVANIA ELECTRIC PRODUCTS, INC. is leasing an armory building in Scranton, Pa., to serve as a new tube feeder plant for the Williamsport, Pa. electron tube factory.

GENERAL ELECTRIC Co. has an order from Don Lee Television and Don Lee Broadcasting Systems, Hollywood, Calif., for a 40-kw television transmitter. The plan is to install the gear 5,800 ft. above sea level on Mount Wilson and use the present facilities of Station W6-XAO in Los Angeles as a relay station and studio site.

E. I. DU PONT DE NEMOURS & Co. begins production of luminescent chemicals for cathode ray tubes in its new Towanda, Pa. plant. This facility is in the Patterson Screen Division of the photo products department and involves the latest in equipment and techniques for zinc and cadmium phosphors for specific applications.

VULCANIZED RUBBER COMPANY changes its name to Vulcanized Rubber and Plastics Co. Facilities are located in New York City and Morrisville, Pa.

RADIO CORP. OF AMERICA has received from a B-25 bomber crew a Radiotron carton which bears battle autographs including Salerno, Algiers, Avellino, Corsica, Bizerte, Tunisia, Rome, and Naples. One of the crew members is the son of a worker in the Harrison, N. J. tube plant.

INTERNATIONAL DETROLA CORP. proposes to merge Utah Radio Products Co., Chicago, Ill., and Universal Cooler Corp., Marion, Ohio, into its organization. The group and their subsidiaries own and operate a total of nine manufacturing plants in this country and two in Canada.

F. J. STOKES MACHINE Co., Phil-



DO YOU HAVE A FILTER PROBLEM?

**Audio Development Co.**  
2833 13th Ave. S., Minneapolis, Minn.  
*"Audio Develops the Finest"*



# APPLIANCE CONTROL MAKERS

CAN CHOOSE TELECHRON MOTORS NOW

NOTHING LESS than 100% accuracy in an automatic control will satisfy manufacturers now designing post-war washers, ranges, dish washers, refrigerators, automatic roasters, and other electrical home appliances. You can guarantee *absolute accuracy*, together with dependability and long life, if your control has a Telechron synchronous motor.

These self-starting motors are now available at low prices. They are com-

pletely accurate because they operate in perfect synchronism with all commercial AC frequencies. They're light, compact, and powerful. Long, trouble-free life is assured by precision building and Telechron's exclusive lubrication method.

Telechron quality is the result of 25 years' experience. We've built synchronous motors right through the war — *adapting them to an interesting variety of automatic controls.*

This *application engineering* is at the service of appliance control makers who want a better motor. There's no obligation. Address Motor Advisory Service, Dept. C.

*Telechron*

REG. U. S. PAT. OFF.

WARREN TELECHRON COMPANY  
ASHLAND MASSACHUSETTS  
Makers of Telechron Electric Clocks and Synchronous Motors

THE HEART OF

THE INSTALLATION

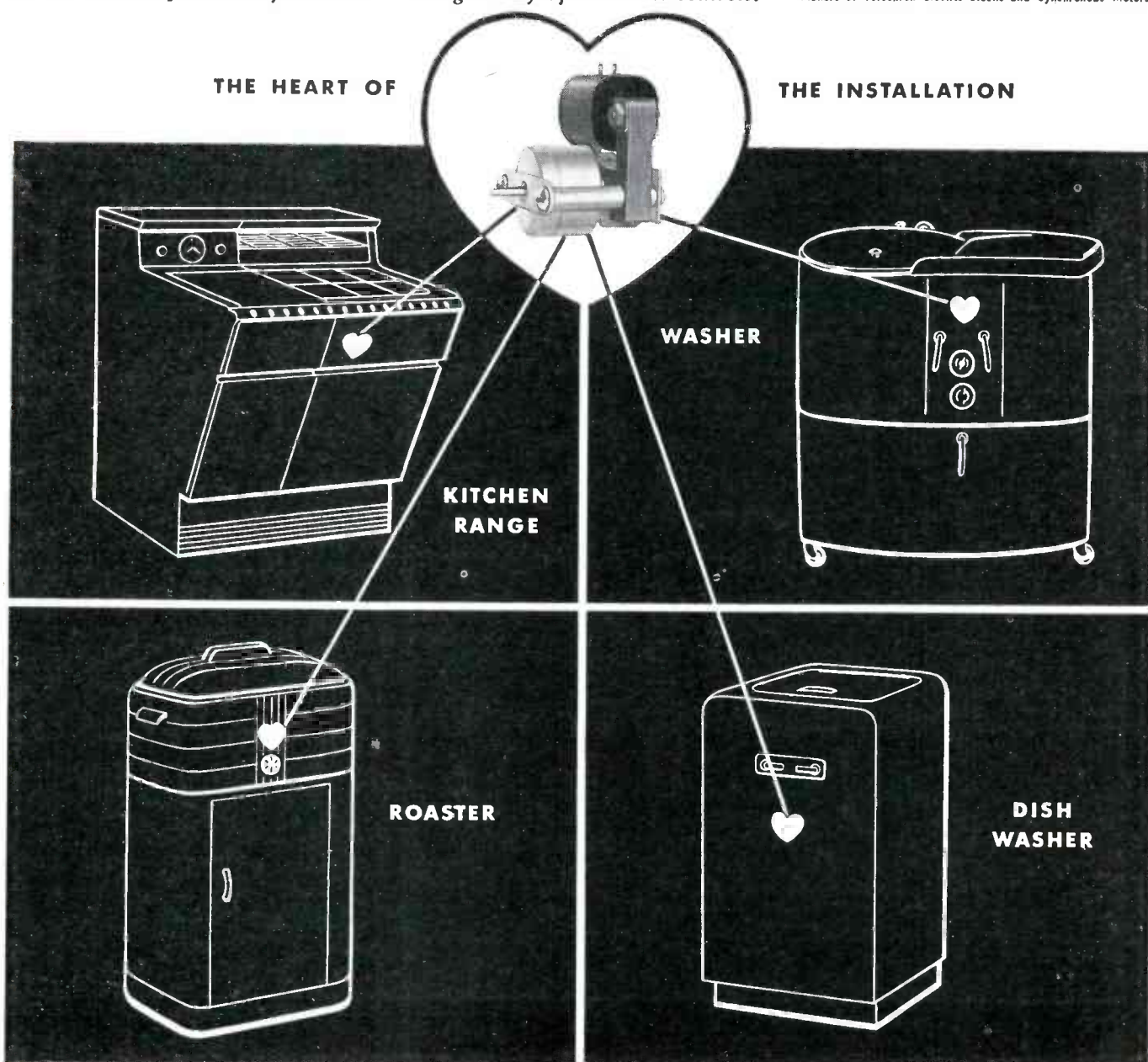

# S.S. White THERMOPLASTIC SCREWS

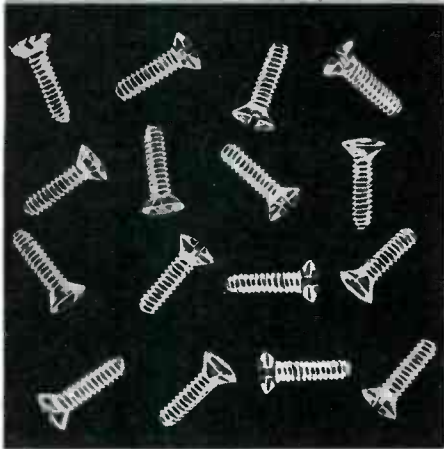

S.S. White offers a new line of small Thermoplastic Screws.

Light Weight  
Electrical Resistance  
Appearance

These screws offer new features for many assembly applications.

Illustration shows #6-32 x 1/2" oval head screws, actual size.

Submit your requirements.

**CONTRACT MOLDING**  
in all standard thermoplastic and thermosetting materials

**S.S. WHITE**

THE S. S. WHITE DENTAL MFG. CO.

**PLASTICS**

DIVISION

DEPT. EP, 10 EAST 40TH ST., NEW YORK 16, N. Y.

FLEXIBLE SHAFTS • FLEXIBLE SHAFT TOOLS • AIRCRAFT ACCESSORIES  
SMALL CUTTING AND GRINDING TOOLS • SPECIAL FORMULA RUBBERS  
MOLDED RESISTORS • PLASTIC SPECIALTIES • CONTRACT PLASTICS MOLDING

One of America's AAAA Industrial Enterprises

**PREMAX**

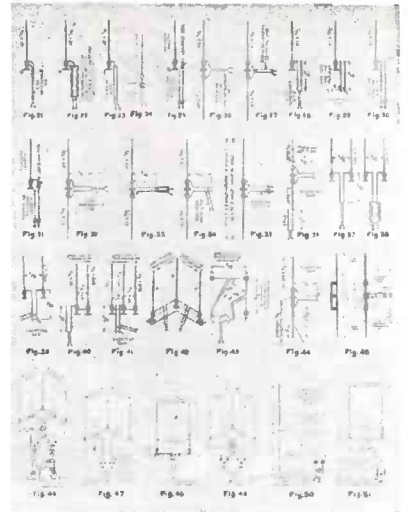

## Premax Antennas Get the Signals

Standard designs, tested in wartime use, are available for commercial and mobile installations. Write for details.

*Premax Products*

Division Chisholm-Ryder Co., Inc.  
4611 Highland Ave., Niagara Falls, N. Y.

## New INLAY PROCESS

### ELIMINATES NAME PLATES ON FRONT PANELS

A proven method for placing durable characters on metal panels, chassis, etc.

- ★ Inlaid baked enamel characters, protected by background finish; resistant to abrasion and salt spray; guaranteed to pass 50 hour salt spray test. NOW available in luminous characters, if desired, either phosphorescent or fluorescent.
- ★ Front panel will match finish of cabinets.
- ★ Recommended and endorsed by scores of manufacturers of electronic, sound and communication equipment.

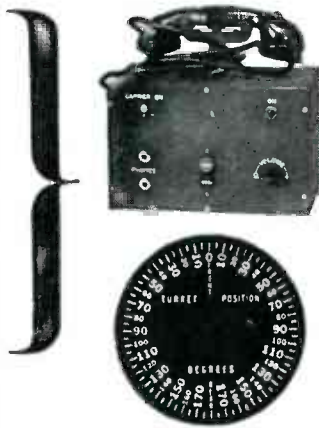

PROMPT DELIVERIES—Send us your bare fabricated steel and within two weeks we will return it finished and marked to your complete satisfaction.

**SCREENMAKERS**

64 FULTON STREET • NEW YORK 7, N. Y.

Tel.: REctor 2-9867

ALSO...  
SILK SCREENING on front panels and chassis, either metal or plastic. Sharp clear characters durably printed on finished or unfinished surfaces.

*For Radio as you want it!*

We're still up to our ears in critical war work but when the war's won we will again be ready

..To DESIGN, DEVELOP and MANUFACTURE..

Radio Receivers and Transmitters  
Industrial Electronic Equipment  
Airport Radio Control Equipment  
Marine Radio Telephone Equipment

Your inquiries will receive immediate action

**ISLIP RADIO MFG. CORPORATION**

ISLIP, L. I., NEW YORK



# LET'S LOOK UNDER THEIR BUSHELS!

 Many and valuable—even spectacular—are the wartime achievements of the electronic industry. On land, at sea and in the air, men and fighting equipment have moved into action with amazing synchronization—victories have been won—many lives and days have been saved—through the direction, guidance and safety of electronic creations. The contributions of electronic devices to all-time war production records here at home are equally amazing. In fact, the needs of war have given such immense impetus to the value of electronics in the communications and industrial fields that it has become one of our Nation's great industries whose peacetime future is full of rich promise.

This war-stimulated progress reflects great credit, indeed, on the genius and resourcefulness of the entire electronic industry—and especially on the tube manufacturers of America. For largely because of their pioneering accomplishments in developing and supplying new kinds of tubes for the many new-found war uses, along with improving existing types, has it been possible to put electronics to work in so many places. Making tubes is *not* our business. Yet we at Speer are keenly aware of the almost incredible wartime record achieved by those who do while taking little or no credit for themselves. For their vital—though still largely censored and unheralded role in gaining Victory, it seems uniquely fitting to say "Well done" to all tube manufacturers, many of whom it has been our privilege to serve.



CHICAGO • CLEVELAND • DETROIT  
MILWAUKEE • NEW YORK • PITTSBURGH

## PRODUCERS OF ELECTRONIC TUBES

Amperex Electronic Products  
de Forest Laboratories, Lee  
Eitel-McCullough, Inc.  
Electronic Enterprises, Inc.  
Federal Telephone and Radio Corp.  
General Electric Co.  
General Electronics Company  
General Electronic Industries  
Heintz & Kaufman, Ltd.  
Hytron Corp.  
Ken-Rad Tube & Lamp Corp.  
Machlett Laboratories  
National Union Radio Corp.  
North American Philips Co.  
Raytheon Mfg. Co.  
Radio Corp. of America  
Sal-Mar Laboratories  
Slater Electric & Mfg. Co., Inc.  
Sperry Gyroscope Co., Inc.  
Sylvania Electric Products, Inc.  
Taylor Tubes, Inc.  
Translite, Inc.  
Tung-Sol Lamp Works, Inc.  
United Electronics Co.  
Western Electric Co., Inc.  
Westinghouse Lamp Div.,  
Westinghouse Electric & Mfg. Co.

# WILEY Books

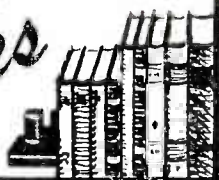

## in COMMUNICATIONS-ELECTRONICS

Scientific progress is entering upon a new productive era. Now is the time to step up your knowledge. Be ready for new ideas . . . profitable opportunities. Look over the important titles listed below. Then, make your selection and order from the coupon today.

### PRINCIPLES OF RADIO—Fifth Edition

By Keith Henney

1945

534 Pages

\$3.50

Designed for those with or without technical training in radio who want a working knowledge of the basic principles of radio communications. Starts with the fundamental principles of electricity, and gradually develops the subject of radio practice. Thoroughly revised to include recent developments and future methods.

### FIELDS AND WAVES IN MODERN RADIO

By Simon Ramo and John R. Whinnery  
1944 503 Pages \$5.00

An authoritative coverage of this field, requiring only a basic knowledge of elementary calculus and physics, which gives a rigorous account of the technique of applying field and wave theory to the solution of modern radio problems.

### HYPER AND ULTRA-HIGH FREQUENCY ENGINEERING

By Robert I. Sarbacher and William A. Edson  
1943 644 Pages \$5.50

A practical treatment of an important new branch of communications engineering, requiring no special advanced knowledge. Of value to the beginner, as well as to those having some familiarity with the subject.

### FUNDAMENTALS OF ELECTRIC WAVES

By Hugh H. Skilling  
1942 186 Pages \$2.75

Discusses the principles of wave action as applied to engineering practice, with particular emphasis on the basic ideas of Maxwell's equations and repeated use in simple examples; also on physical concepts and mathematical rigor.

### APPLIED ELECTRONICS

By the Electrical Engineering Staff, Massachusetts Institute of Technology  
1943 772 Pages \$6.50

Provides a thorough understanding of the characteristics, ratings, and applicability of electronic devices. Gives a working knowledge of the physical phenomena involved in electronic conduction, plus its applications common to various branches of engineering.

### PRINCIPLES OF ELECTRONICS

By Royce G. Kloeffler  
1942 175 Pages \$2.50

Tells clearly and simply the story of electron theory and the operation of the electron tube. Beginning with the discovery of the electron and the forces of attraction and repulsion of charged particles, the entire action taking place in electronic devices is carefully explained.

### HIGH FREQUENCY THERMIONIC TUBES

By A. F. Harvey  
1943 244 Pages \$3.00

Gives the details of these important new tubes and describes the experimental work that has been done with them. Presents a thoroughly comprehensive account of the properties of thermionic tubes at very high frequencies and their relation to those of the associated electric circuits.

### THE TECHNIQUE OF RADIO DESIGN

By E. E. Zepher  
1943 312 Pages \$3.50

Thoroughly practical, this treatment of radio design deals with the day-to-day problems of the radio engineer, both in the development and in the testing of radio receiving apparatus of all types.

### ELECTRON OPTICS AND THE ELECTRON MICROSCOPE

By V. K. Zworykin, G. A. Morton, E. G. Ramberg, J. Hillier, and A. W. Vance  
1945 Approx. Pages 759 Probably \$10.00

A comprehensive coverage of the entire field, presenting a thorough discussion of various types of electron microscopes, and offering a survey of theoretical and practical electron optics.

### TIME BASES—(Scanning Generators)

By O. S. Puckle  
1943 204 Pages \$2.75

Covers the subject from both the design and the development points of view; assembles more time bases circuits than have heretofore been available in one volume.

### HOW TO PASS RADIO LICENSE EXAMINATIONS—Second Edition

By Charles E. Drew  
1944 320 Pages \$3.00

This revised edition of a well-known book offers recent material for amateur radio operators, radiotelephone and telegraph operators, whether in the broadcasting, marine, aeronautical, or any other field of transmission or reception.

Philadelphia, Pa., will manufacture and sell the all-electronic drying system developed by RCA to produce penicillin.

THE ROBINSON-HOUCHIN OPTICAL Co., Columbus, Ohio, has changed the name of its electronic equipment from Radiotone to Rad-O-Recorder.

INDUSTRY INVENTIONS, INC. has been established in Ohio to license the use of electronic vulcanization in the manufacture of rubber and plastic products. Available patents will be those held by B. F. Goodrich Co. and Firestone Tire & Rubber Co.

STROMBERG CARLSON Co., Rochester, N. Y., is building a \$300,000 annex with a capacity of 60,000 sq. ft. Space will be used for making cabinets.

MAJESTIC RADIO & TELEVISION CORP. is building a new factory just north of the Elgin, Ill., city limits. The plant, the company's third, will involve about 160,000 sq ft with plans for expansion to 243,000.

VIEWTONE Co., New York, N. Y. has introduced the low-cost table model



television receiver illustrated herewith. It is designed to retail at approximately \$100.

MEISSNER MFG. Co., Mt. Carmel, Ill., is purchased for cash by Maguire Industries and merged with the latter concern as an independent division. No changes are planned in policy or operation except that there will be an expansion of sales volume made possible by increased capitalization.

RADEL MFG. Co., Cleveland, Ohio, is a new company founded to manufacture a line of automobile radio antennas as well as radio parts and

### ON APPROVAL COUPON

JOHN WILEY & SONS, Inc.  
440 Fourth Ave., New York 16, N. Y.

Please send me on ten days' approval the books I have checked in this advertisement (or I am attaching to this coupon a separate list of the books desired). At the end of that time, if I decide to keep the books, I will remit indicated price plus postage; otherwise I will return the books postpaid.

Name .....

Address .....

City and State .....

Employed by .....

E-9-45





# FAST RADIO NOISE-SUPPRESSION *Capacitors*

FAST radio noise-suppression capacitors are of *approved* design and meet the specifications for these types in every respect.

They are particularly efficient in suppressing noise from dynamotors, generators, motors and other motor driven devices which might otherwise impair radio reception.

The illustrations show the rugged construction of the screw-type terminals to safely carry heavy currents. Units are encased in brass containers with a heavy tin dip—oil impregnated, filled, and hermetically sealed to meet the most severe operating conditions.

These capacitors can be supplied in the following capacities and voltage ratings: .01 MFD; .10 MFD; .25 MFD and .50 MFD—100 V. DC.

or 500 V. AC/DC. Side or end BRACKETS are available with mounting holes in 3 sizes. Side bracket can be placed in either of two positions depending upon mounting requirements, and can be provided with mounting hole at various distances from center of terminal. Below is a partial list of these types.

Write for prints or any additional data on these or other units—we will be happy to serve you.

### Standard or Special Units to Meet Every Need

*FAST Capacitors are produced in many types and sizes in standard or special designs. We can supply paper capacitors—oil or wax impregnated—rectangular or tubular—in sizes from the smallest to the largest.*

**"When You Think of Capacitors . . . Think FAST"**

CAP. MFD.	VOLTS	DIMENSIONAL DATA		
		DIA.	LG.T.	MOUNTING HOLE DIA.
.01	100 D.C.	11/16	13/16	7/32; 9/32 or 11/32
.10	100 D.C.	11/16	1-3/8	7/32; 9/32 or 11/32
.25	100 D.C.	3/4	1-9/16	7/32; 9/32 or 11/32
.50	100 D.C.	1	1-13/16	7/32; 9/32 or 11/32
.01	500 AC/DC	11/16	27/32	7/32; 9/32 or 11/32
.10	500 AC/DC	1	1-1/2	7/32; 9/32 or 11/32
.25	500 AC/DC	1	2-9/16	7/32; 9/32 or 11/32

## JOHN E. FAST & CO.

Capacitor Specialists for Over a Quarter-Century

3101 N. Pulaski Road, Chicago 41

Canadian Representatives: Beupre Engineering Works, Reg'd.  
2101 Bennett Avenue, Montreal, for Power Factor Correction  
J. R. Longstaffe, Ltd., 11 King Street, W., Toronto 1, for Special Applications

# Intricate Fabricating

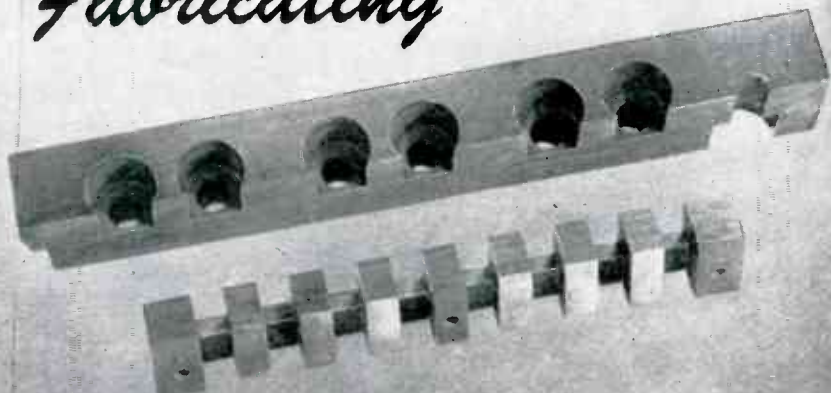

LET OUR TWENTY-ONE YEARS  
OF EXPERIENCE GUIDE YOU

**ELECTRICAL INSULATION CO., INC.**

12 VESTRY ST., NEW YORK 13, N. Y.

**FABRICATED PHENOLIC PARTS . . . SHEETS, RODS, TUBES**

# Janette

## D.C. to A.C. CONVERTERS

The Janette Rotary Converter is a simple, practical method for obtaining Alternating Current when only D.C. power is available.

**.1 to 3.2 K. V. A.**

Janette was one of the first manufacturers to build converters especially for use with A.C. electronic tube devices. Since their inception these machines have established a world wide record for reliable, efficient, quiet, trouble free operation, under the most adverse conditions.

**TWO TYPES** are available; one for commercial applications, the other for marine service. Special filters for suppressing conducted and radiated noise voltage interference can be supplied.

If you want a really dependable converter, guaranteed for one year, we suggest you **TRY A JANETTE!**

**May We Send Literature?**

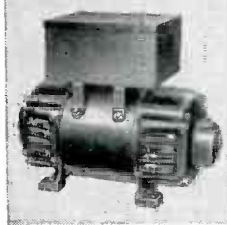
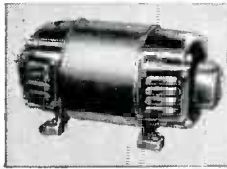

**Janette Manufacturing Company**  
556 W. Monroe St. Chicago 6, Ill.

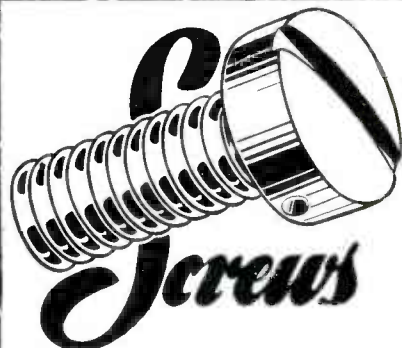

# Screws

Special kinds—difficult kinds  
—tight specifications—close  
precision—special heads or  
threads.

If it is a Screw—we have,  
can or will make it.

Write for easy reference, factual  
catalog.



MACHINE SCREWS	PLASTIC INSETS
SHEET METAL SCREWS	HOLDING PINS
MACHINE SCREW NUTS	SPECIAL RIVETS
ALL TYPES OF HEADS AND THREADS	

# KELNOR

REG. U.S. PAT. OFF.

## electric SOLDERING IRONS

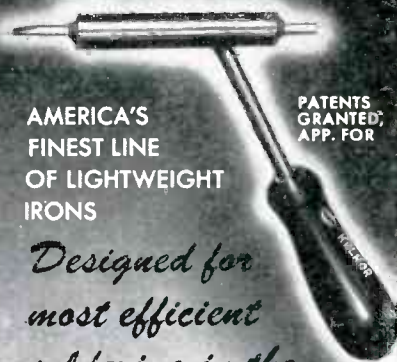

AMERICA'S  
FINEST LINE  
OF LIGHTWEIGHT  
IRONS

PATENTS  
GRANTED;  
APP. FOR

*Designed for  
most efficient  
soldering in the*

**ELECTRONIC,  
RADIO AND  
INSTRUMENT  
manufacturing and  
repairing fields**

Easily solders hard-to-reach connections. Cuts down fatigue, increases accuracy. Illustration above about one-third actual size; weighs 9 ounces. Order from your retailer or jobber.

KELNOR MANUFACTURING COMPANY  
GENERAL OFFICES: CENTRAL TOWER, SAN FRANCISCO 6, CALIF.

"When Ordering Please Mention Electronics"



**IT'S  
NEW**



**SEND FOR THIS  
RESISTOR DATA**

For the convenience of designers of products requiring resistors, Ward Leonard offers this new Resistor Handbook. It describes in detail the full line of wire-wound resistors giving complete information on mountings, enclosures, terminals and resistance values. Write for your copy today.

★ ★  
BUY MORE ★  
WAR BONDS ★



**WARD LEONARD**  
**RELAYS • RESISTORS • RHEOSTATS**

Electric control  devices since 1892.

**WARD LEONARD ELECTRIC COMPANY • 32 SOUTH ST. • MOUNT VERNON, N. Y.**



**GET  
THIS VALUABLE BOOK  
On Temperature Control  
Mailed to you  
without obligation  
immediately**

**TO ELECTRICAL EQUIPMENT  
MANUFACTURERS**

Before deciding on temperature regulating devices for your products, be sure to investigate Fenwal Thermoswitches. They operate on an unusual principle, and offer many advantages not found in other types of switches. The Fenwal Engineering Data Book contains detailed drawings of construction of various models and typical installations.

- Compact construction permits installation in tight places.
- Make and break unaffected by external vibration.
- Readily adjustable for wide range of temperature control.
- Minutely accurate.
- Adaptable for all types of media.
- Inexpensive.
- A 44-page treatise on Thermal Control including installation drawings, photographs, blueprints and descriptive suggestions for future planning with basic principles involved in temperature regulation and control. . . . Just write for your free copy on your business letterhead.

"IF IT'S A FENWAL—IT'S THE BEST OF ALL"

  
**Fenwal, Inc.**  
 FOR COMPLETE TEMPERATURE CONTROL  
 43 Pleasant Street, Ashland, Massachusetts

equipment. It is headed by Sidney Ludwig, former chief engineer of Ward Products.

HOFFMAN RADIO CORP. has under construction a new plant annex, is at the same time leasing three other buildings, and has purchased a new brick 32,000 sq ft structure adjacent to its present quarters in Los Angeles, Calif.

GENERAL ELECTRIC X-RAY CORP. moves its main office from the plant to the Insurance Exchange Bldg., 175 Jackson Blvd., Chicago. The five-story building thus made available will be used for manufacturing purposes.

FEDERATION OF BROADCASTING ASSOCIATIONS is the name of a newly merged organization including Holland's four leading broadcasting associations which before the war shared two stations at Hilversum.

EMERSON RADIO & PHONOGRAPH CORP. has launched its postwar product and policy campaign by revealing the design of specific models of its projected radio receivers.

FERROCART CORP. OF AMERICA and Micro Products Corp., both located in Hasting-on-Hudson, N. Y., have been acquired by Maguire Industries Inc.

**PERSONNEL**

ANTHONY LAMBO becomes vice-president and general manager of Mectron Corp., Lawrence, Mass. In this capacity he heads up electronic and mechanical engineering activities in the company.

MELVIN E. KARNS, RCA Victor Division, RCA, Camden, N. J., is designated director of the Radio and Radar Division of WPB. He succeeds Louis J. Chatten. Mr. Chatten becomes vice president and general commercial manager of North American Philips Co., New York, N. Y. John Creutz becomes assistant director for production to replace Mr. Karns.

FRANCIS X. RETTENMEYER is appointed chief components engineer of Federal Telephone and Radio Corp., Newark, N. J. Mr. Retten-



# KEN-RAD

## METAL TUBES



# Better Than Ever

Ken-Rad for years has aided manufacturers to build and market radio equipment which wins the user's confidence . . . Now, to tube quality already foremost, have been added great new research and manufacturing facilities . . . Ken-Rad Tubes therefore will serve *better than ever* builders of electronic equipment who value top performance and reliability.

Write for your copy of  
"Essential Characteristics"  
the most complete digest of tube  
information available.

78-D9-8660

# KEN-RAD

DIVISION OF GENERAL ELECTRIC COMPANY

OWENSBORO, KENTUCKY

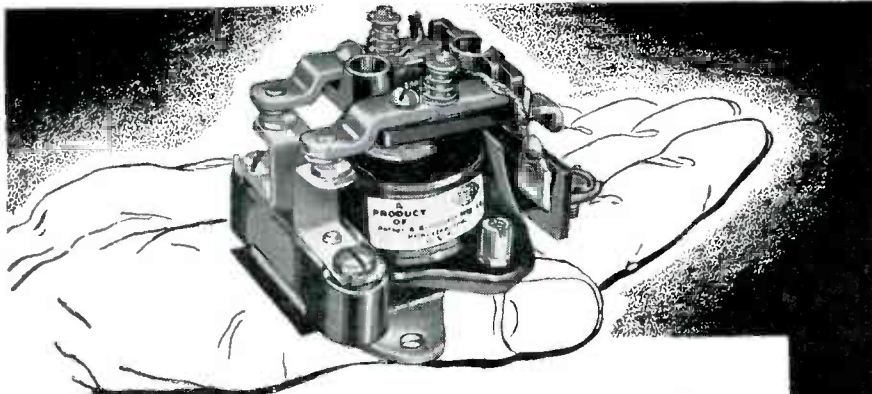

## SO MUCH **DEPENDS** ON A RELAY—

The successful performance of major equipment such as machine tools, refrigerators, communications systems, etc., depends on the operation of a relay mechanism. Any failure of the relay to function properly stops operation of the equipment. The resulting dissatisfaction and loss of good will is far out of proportion to the cost of the relay that failed.

It pays to buy the best relay obtainable. The small extra cost of a high quality relay is justified for any use.

Potter & Brumfield Manufacturing Co. specializes in the building of high grade standard and special relays, and rigid control is maintained over engineering, manufacturing and inspection to produce relays of the highest possible quality. This rigid control assures you of maximum performance over longer periods of service.

Write for catalog giving complete information on Standard and Special Relays. We will also welcome inquiries for special timing devices on large quantity orders.

105 North 10th St.

**Potter & Brumfield**  
Mfg. Co., Inc.

PRINCETON, IND.

## RAWSON SEMI-SUSPENDED METERS



Type .503

### For **ULTRA-HIGH SENSITIVITY**

0.5 Microampere Full-Scale (7000 ohms)  
0.24 Millivolt Full-Scale (10 ohms)  
High Resistance Voltmeters (Megohm per volt). Many other ranges.  
Accurate Portable Meters need no leveling. Will often replace light-beam galvanometers or vacuum tube voltmeters.

Write for bulletin

### WE ALSO SUPPLY

REGULAR DC METERS  
THERMOCOUPLE AC METERS  
MULTIMETERS  
FLUXMETERS  
ELECTROSTATIC VOLTMETERS

Special apparatus built to order

## RAWSON ELECTRICAL INSTRUMENT COMPANY

111 POTTER ST. CAMBRIDGE, MASS.  
CHICAGO Representatives NEW YORK CITY

*PyroFerric*

## IRON CORES



Pyroferric powdered metal cores have kept apace the vital precision instrument development. They are manufactured to specification:

"Q"

HIGH  
as desired FREQUENCY  
LOW

HIGH  
MEDIUM  
LOW

Consult Pyroferric on your Powder Metallurgy requirements

**PYROFERRIC Co.**

175 VARICK STREET NEW YORK, 14, N. Y.

ARGON HELIUM KRYPTON  
NEON XENON MIXTURES

*Linde*

RARE GASES  
AND MIXTURES



... Spectroscopically Pure  
... Easily removed from bulb  
without contamination

Scientific uses for LINDE rare gases include—

1. The study of electrical discharges.
  2. Work with rectifying and stroboscopic devices.
  3. Metallurgical research.
  4. Work with inert atmospheres, where heat conduction must be increased or decreased.
- Many standard mixtures are available. Special mixtures for experimental purposes can be supplied upon request.

The word "Linde" is a trade-mark of

**THE LINDE AIR PRODUCTS COMPANY**

Unit of Union Carbide and Carbon Corporation  
30 E. 42nd St., New York 17 Offices in Principal Cities  
In Canada: Dominion Oxygen Company, Ltd., Toronto





**Make sure wire meets the "specs" for trouble-free performance in every service condition**

You may not be able to anticipate everything that your product will stack up against in service . . . but you should consider all probable trouble factors such as high operating and ambient temperatures, vibration, moisture, fungus, oil, grease, corrosive fumes and fire hazard . . . then wire-plan for dependable performance by selecting wires, cables and cords that meet your requirements and provide an ample safety margin as well.

For performance protection that pays off in satisfied customers by practically eliminating wire-failure breakdowns, rewiring, replacements and service calls, specify Rockbestos *permanently insulated* wires, cables and cords. Every one of the 125 different standard constructions, ranging from 1000 volt No. 22 Radio Hookup Wire to 5000 volt Rockbestos A.V.C. Power Cable, was designed to provide a better wire for a severe or unusual application . . . and Rockbestos Research is always willing to work up a special if you need it.

A phone call or letter will bring complete information or engineering assistance in your wire-planning from the nearest district office or:

**ROCKBESTOS PRODUCTS CORPORATION**  
428 Nicoll Street, New Haven 4, Conn.

New York Buffalo Cleveland Chicago Pittsburgh St Louis  
Los Angeles San Francisco Seattle Portland, Ore.



A few of the 125 different wires, cables and cords developed by Rockbestos to meet severe or unusual operating conditions.



**ROCKBESTOS FIREWALL RADIO HOOKUP WIRE**

The first lightweight, small diameter, flame-resistant hookup wire designed in 1937 and widely used since in airborne and ground communications systems, electronic devices, instruments and apparatus. Operating temperatures range from 125° C. to minus 50° C. Also with tinned copper shielding braid and in twisted pair or tripled construction. Sizes No. 22 to 4 AWG in 1000-volt rating, and No. 12, 14 and 16 AWG in 3000-volt.



**ROCKBESTOS A.V.C. 600 VOLT FLEXIBLE CORD**

This heat-resisting flexible cord is ideal for apparatus leads, etc., where a heavy duty high-dielectric, heat and moisture resistant cord is required. Labeled cord with polarized conductors if desired. Sizes No. 10 to 18 AWG with two or three conductors insulated with impregnated felted asbestos, varnished cambric, felted asbestos and covered with asbestos braid. May be had with polarized conductors if desired.

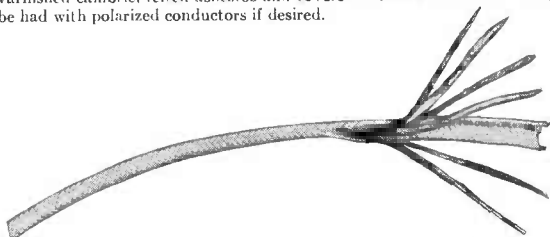

**ROCKBESTOS MULTI-CONDUCTOR FIREWALL INSTRUMENT CABLE**

This unusually small diameter, light weight, high-dielectric No. 26 AWG three conductor cable was designed for an electronic device in which three No. 22 AWG single conductor aircraft circuit wires previously used proved too bulky. It is made to a nominal diameter of .125" (smaller than a No. 14 AWG single conductor 1000-volt Rockbestos Firewall Radio Hookup Wire). Also made in four, five and six conductor construction, and in No. 24, 22 and 20 AWG.

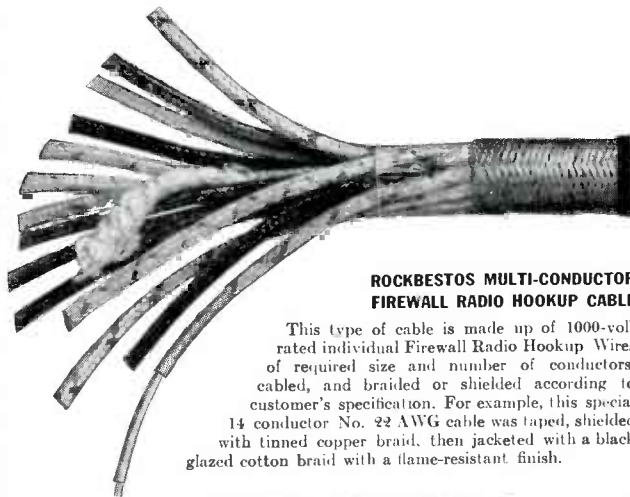

**ROCKBESTOS MULTI-CONDUCTOR FIREWALL RADIO HOOKUP CABLE**

This type of cable is made up of 1000-volt rated individual Firewall Radio Hookup Wires of required size and number of conductors, cabled, and braided or shielded according to customer's specification. For example, this special 14 conductor No. 22 AWG cable was taped, shielded with tinned copper braid, then jacketed with a black glazed cotton braid with a flame-resistant finish.

**Another New Rockbestos Firewall Construction!**

War-developed Rockbestos High-Temperature Wire—with a maximum operating temperature of 400° F.—designed for jet propelled plane applications and circuits to hot-wing de-icers, fire detectors and extinguishers, and air conditioning and heating units where baking temperatures destroy ordinary insulation. Under continuous operation at rated temperature it retains its original dielectric strength and inherent resistance to heat and flame, and progressively improves in its resistance to moisture and abrasion. It is now available for these and other severe applications. Write for complete information and samples.

**ROCKBESTOS RESEARCH**  
**Solves Difficult Wiring Problems**  
**Invest in U. S. Victory Bonds!**

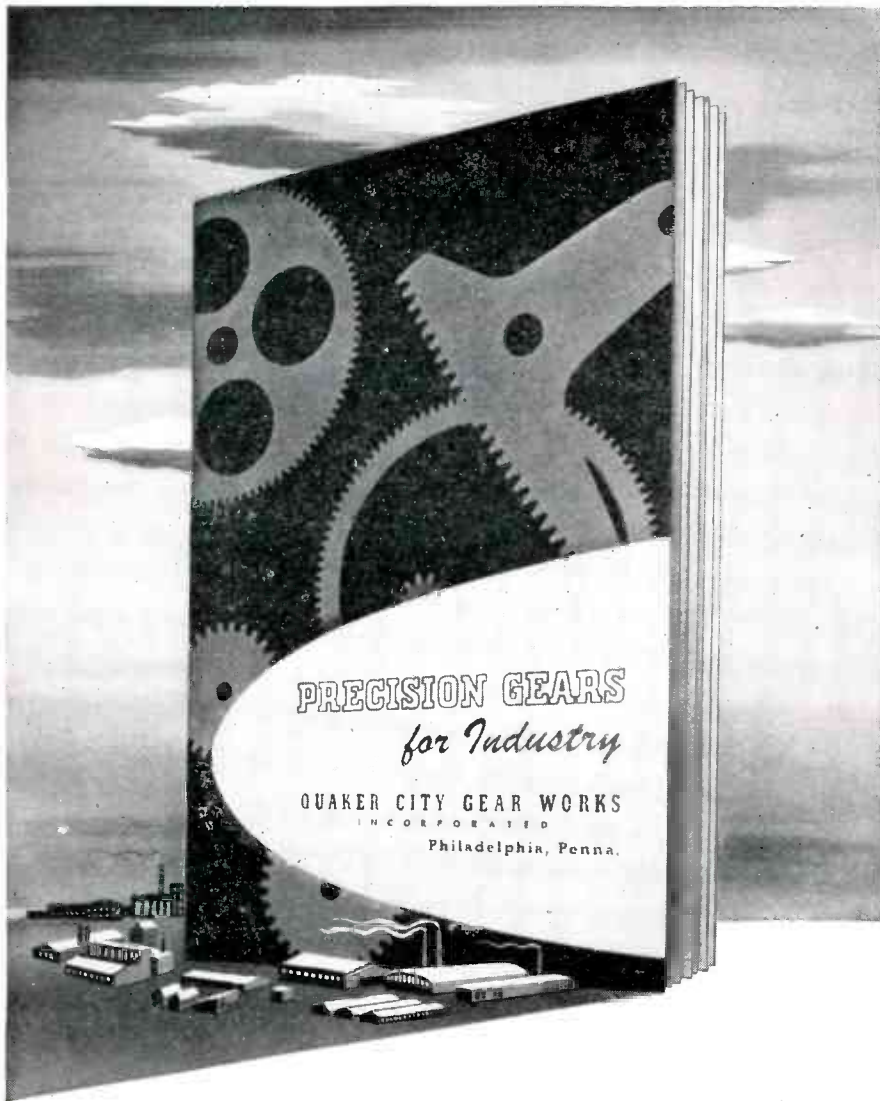

## Yours for the asking

A new informative booklet on gears.

It has illustrated sections  on

practically every known form of gearing,

together with  many reference

tables and formulas. Write for your copy

today on your company stationery. 

 **Quaker City Gear Works**  
INCORPORATED

1910 N. Front Street, Philadelphia 22, Pa.



meyer, who will be in charge of engineering of selenium rectifiers, quartz crystals, transformers and coils, special purpose and transmitting tubes and cables, was formerly chief receiver engineer and staff engineer of RCA Victor Division, RCA.

W. S. WINFIELD, formerly with Colonial Radio, Buffalo, joins Westinghouse Electric Corp. to become chief engineer of the home radio division.

LAWRENCE C. F. HORLE, New York consulting engineer, is appointed chief engineer in the engineering



department of RMA. He will be responsible for management of the department, including the RMA Data Bureau and related activities.

A. D. WILLARD, JR., manager of Radio Station WBT, fills the newly created office of executive vice-president in NAB (National Association of Broadcasters).

ESTERLY CHASE PAGE, until recently a lieutenant colonel, U. S. Army Signal Corps, joins the Mutual network in the newly created post of engineering director. He will head up a new technical planning and engineering department and be responsible for future f-m and television activities as well as improvements on present a-m facilities.

HENRY F. DEVER, vice-president in charge of engineering for Minneapolis Honeywell-Regulator Co.,



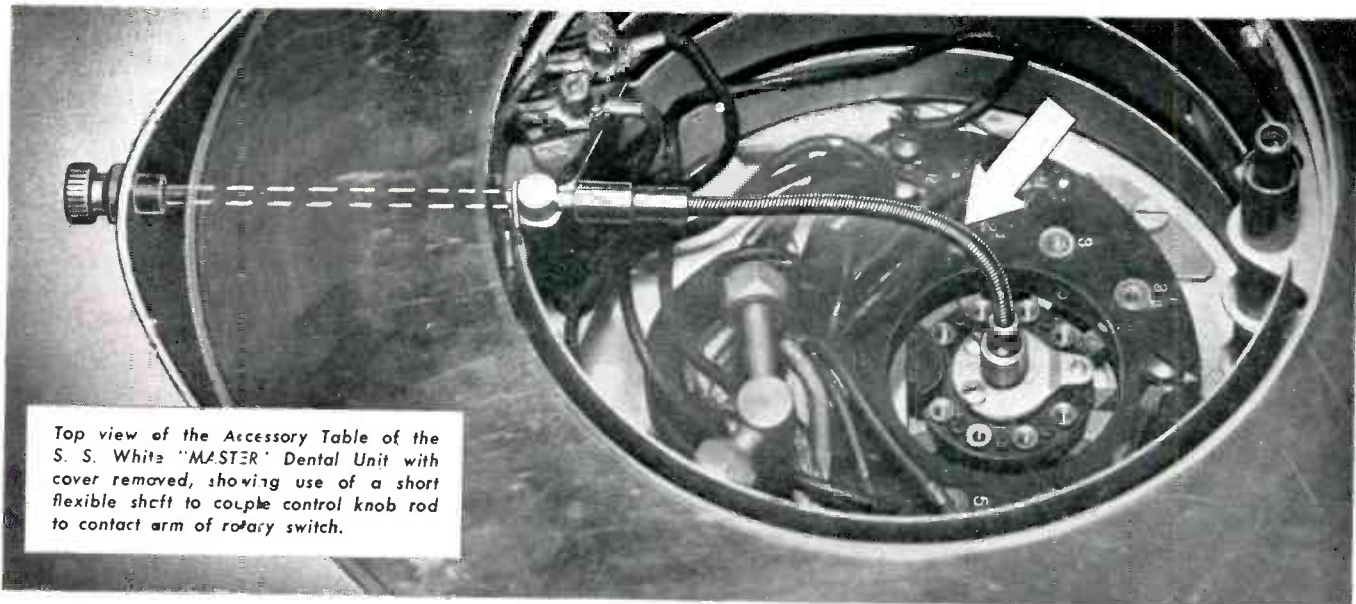

Top view of the Accessory Table of the S. S. White "MASTER" Dental Unit with cover removed, showing use of a short flexible shaft to couple control knob rod to contact arm of rotary switch.



## WHEN DESIGNING ELECTRONIC EQUIPMENT

# Remember this use of . . . S.S. White Flexible Shafts

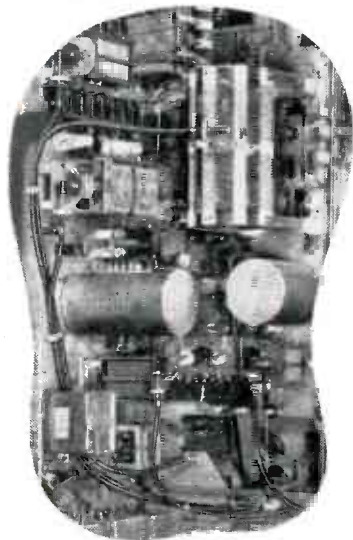

That coupling with S. S. White flexible shafts gives complete freedom in placing variable elements is clear from this interior view of a large broadcast transmitter. Note centralized controls.

Electronic Equipment generally includes elements which require rotational adjustment. In designing the internal arrangement, positioning of these elements is determined by considerations of simplification of assembly and wiring, space saving, convenient servicing. At the same time, control knobs or dials must be placed where they will be in ready reach of the operator.

Coupling of the elements to their control knobs with S. S. White flexible shafts is the simple solution. It gives complete freedom of location—as can be appreciated from a look at the applications illustrated. And nothing is lost in the quality of control, for with correct application, S. S. White remote control shafts provide operation that is as smooth and sensitive as a direct connection.

## GET FULL INFORMATION ABOUT COUPLING IN THIS FLEXIBLE SHAFT HANDBOOK

This 256-page volume completely covers the subject of flexible shafts, coupling included. It gives all technical data and information essential to working out actual applications. A complimentary copy will be mailed to you if you will write for it on your business letterhead and mention your position.

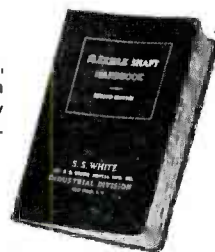

# S.S. WHITE INDUSTRIAL

THE S. S. WHITE DENTAL MFG. CO. DIVISION

DEPT. E, 10 EAST 40th ST., NEW YORK 16, N. Y.

FLEXIBLE SHAFTS      AIRCRAFT ACCESSORIES  
MOLDED PLASTICS  
MOLDED RESISTORS      FLEXIBLE SHAFT TOOLS

*One of America's AAAA Industrial Enterprises*



# *Springs* for **ELECTRONIC USES**



The efficiency of your product—if it requires springs—is highly dependent on the *quality* of those springs. With little or no difference as to cost, the service life and performance of your equipment can be radically improved by proper attention to the design, material, and workmanship on your springs.

Reliable is thoroughly experienced on all varieties of springs, wire forms and light stampings, with special emphasis on precision work requiring close tolerances. Our facilities and personnel are exceptional because our kind of customers very often demand exceptional results.

On all-out war production, Reliable has really done things with springs—attained results which we will certainly later turn to good account on your civilian needs. Remember that for experimental springs or small lots, our small order department is at your service. If you're in a hurry—we have the facilities and the materials for double-quick delivery!

Ask for Reliable Catalog 44.

## THE RELIABLE SPRING & WIRE FORMS CO.

3167 Fulton Rd., Cleveland 9, Ohio

Representatives In Principal Cities

**YOU CAN RELY ON**

# Reliable Springs

ROUND AND FLAT  
WIRE SPRINGS

CLIPS  
LIGHT STAMPINGS

HOOKS

BENDS

Minneapolis, Minn., succeeds Charles B. Sweatt as president of the wholly-owned subsidiary, Brown Instrument Co. He will be replaced by W. J. McGoldrick, vice-president in charge of aeronautical engineering.

PAUL H. FRYE, chief engineer at Electronic Laboratories, Chicago, Ill., has the new title of vice-president.

FRANCES B. SMITH is appointed to the post of chief engineer at the Rola Co., Cleveland, Ohio. He was formerly in charge of audio-frequency and acoustics in Zenith Radio Corp.

E. M. WEBSTER, captain and chief communications officer of the U. S. Coast Guard is promoted to the rank of commodore.

M. L. REDMAN is in charge of the electron microscope field engineering group of RCA Service Co., Camden, N. J. He has been active in the supervision of electron microscope installations.

G. A. BECK becomes manager of the industrial design division in General Electric Co.'s electronics department.

FRANK W. WALTER of the Michigan State Police leaves the presidency of APCO (Associated Police Communications Officers) to become chief communications engineer of Greyhound Corp. He is replaced by Ray Groenier, Madison, Wis.

LOUIS MARTIN is appointed manager of the application engineering section of the RCA tube division.

W. L. EVERITT, chief of the operational research branch in the office of the chief signal officer, has been released from active service to return to his duties as head of the department of electrical engineering at the University of Illinois. He is also president of IRE.

LEROY D. WELD is director of research at the Turner Co., Cedar Rapids, Iowa. Dr. Weld, professor of physics at Coe College, formerly conducted part time research for the company.

ARTHUR C. OMBERG becomes chief research engineer of the Bendix Radio Division, Bendix Aviation



# FARNSWORTH

**EXTENDS COMMUNICATION ACTIVITIES**

**BY ACQUIRING**

## **THE HALSTEAD TRAFFIC COMMUNICATIONS CORPORATION**



WILLIAM S. HALSTEAD, president of the Halstead Company, joins the Farnsworth organization as consultant on radio communications equipment and traffic control, as well as on other phases of Farnsworth's broad electronic developments.



JOHN A. CURTIS, vice president of the Halstead Company and chairman of its management committee, joins the Farnsworth organization as manager of the mobile communications division.

To EXTEND its broad communications activities into the rapidly expanding field of mobile railway and highway communications and control, Farnsworth has acquired the assets of the Halstead Traffic Communications Corporation, including its developments, designs and patents. Key personnel, including William S. Halstead, president, and John A. Curtis, vice president, have joined the Farnsworth staff.

The Halstead organization is a recognized pioneer in this relatively new field of radio communications. It has invented, developed and produced field-tested equipment to provide railroads with modern, unfailing radio communications. It gave the world its first successful highway radio service, including the centralized control of busses, trucks and passenger vehicles.

The Halstead technical staff will establish new headquarters at the Fort Wayne Farnsworth laboratories. The organization will be merged and coordinated with more than two hundred Farnsworth research and development engineering personnel—a staff of scientists and technicians recognized as one of the country's leading technical organizations in the development of television; broadcast transmitters and receivers; radio-phonographs, and the most complicated types of radio and radar equipment for the Armed Forces.

Farnsworth resources, plus its seventeen years of electronic pioneering, its extensive engineering staff, and specialized manufacturing facilities, will strongly augment the outstanding position of the Halstead developments in this field.

### **FARNSWORTH TELEVISION & RADIO CORPORATION** **FORT WAYNE 1, INDIANA**

Farnsworth Radio and Television Receivers and Transmitters • Aircraft Radio Equipment • Farnsworth Television Tubes • Halstead Mobile Communications and Control Systems for Rail and Highway • the Farnsworth Phonograph-Radio • the Capehart • the Capehart-Panamuse

Designed for



Application

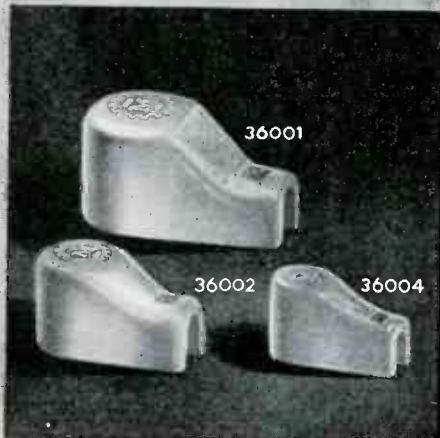

### 36000 SERIES

#### Ceramic Plate or Grid Caps

A new addition to this series of exclusive Millen "Designed for Application" products is the 36004 for use on tubes with 1/4" diameter contacts. Efficient, compact, easy to use and neat appearing. Soldering lug and contact one-piece. Lug ears annealed and solder dipped to facilitate easy combination "mechanical plus soldered" connection of cable. No. 36001 for 9/16" tube terminals. No. 36002 for 3/8". No. 36004 for 1/4".

**JAMES MILLEN  
MFG. CO., INC.**

MAIN OFFICE AND FACTORY  
**MALDEN  
MASSACHUSETTS**



Corp., Baltimore, Md. Formerly assistant chief of operational research in the U. S. Army Signal Corps, he will be responsible for long-term product development and electronic research in radio, radar and television.

HAROLD GOLDBERG becomes research engineer in the Bendix Radio Division of Bendix Aviation Corp., Bal-



timore, Md. He was formerly senior engineer with the Stromberg-Carlson Co.

WILLIAM G. MORAN, superintendent of electronic tube manufacturing at Westinghouse Electric & Mfg. Co., Bloomfield, N. J., is given the company's honorary award—the Order of Merit. His citation is for recognition of pioneering in engineering development and manufacture of radar transmitting tubes.

#### AWARDS

Workers of the following concerns in the electronics field have been awarded Army-Navy burgees for excellence in production:

Federal Telephone & Radio Corp., Newark, N. J.

North American Philips Co.  
Dobbs Ferry, N. Y.  
Mount Vernon, N. Y.

Sylvania Electric Products  
Wakefield, Mass.

**INACCESSIBLE  
WIRING?**

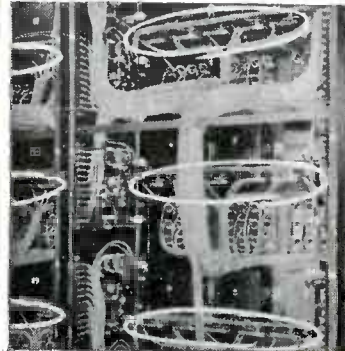

**NOT** FOR MODEL MCL  
AND MODEL MCM  
"Master"  
**LEVER SWITCHES**



with Single Bolt Assembly

**E**VER run into a problem like the wiring shown above? Or worse? Standard Electric Time Co., Springfield, Mass., did and solved it by using General Control Company's Models MCL and MCM Lever Switches! The Models MCL and MCM have single bolt assembly — this means you can attach the switch frame to the panel practically anywhere you like, solder the wiring to the contacts (at a bench, if you wish), then connect the contacts to the frame with a single bolt. This feature saves maintenance time too, because the frame can be removed and repaired, or replaced without disturbing the wiring. Write today for New Handbook and Catalog No. 200.

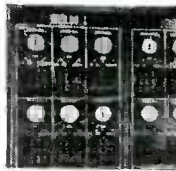

Front view of panel

**General Control Company**

1202 Soldiers Field Road  
Boston 34, Mass.





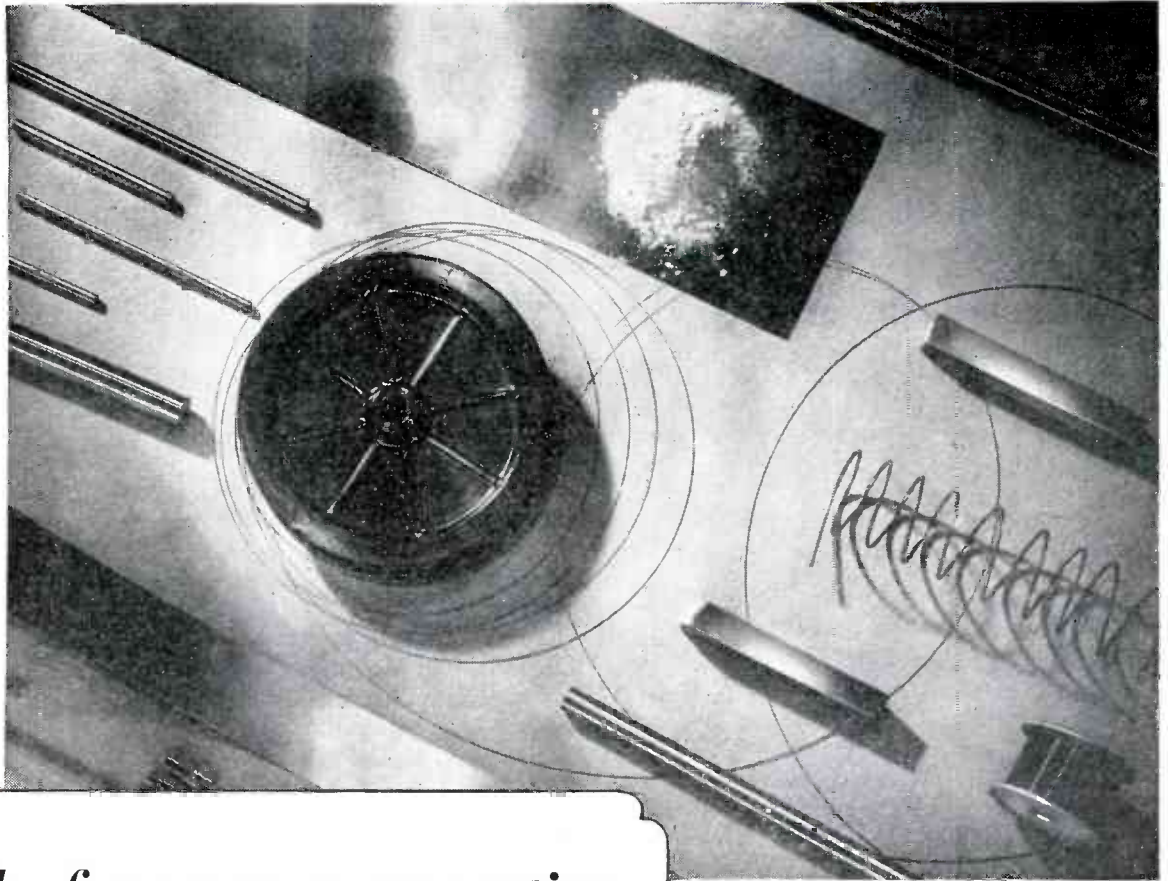

*Thanks for your co-operation*

**... Now we  
can deliver — TUNGSTEN MOLYBDENUM**

**RODS • BARS • WIRE • SHEET • POWDER**

Here's news of interest to you!

As you know, supplies of tungsten and molybdenum products have been limited. During the shortage we tried every means of getting as much of these materials to you as possible. Thanks for understanding the limitations imposed on us and accepting them.

Now we can deliver, *on short order*, most of the tungsten and molybdenum products you need—in rod, bar, wire, sheet or powder form.

Every one of the tungsten or molybdenum products supplied by North American Philips is backed by the

knowledge of processes and techniques developed by an organization with a background of over half a century in the electrical field. Every piece of material is controlled to your most rigid specifications.

North American Philips can supply your needs in a variety of sizes, shapes and thicknesses and deliver on short order.

So, when you want tungsten or molybdenum rod, bar, wire, powder, or sheet stock—write, wire or telephone North American Philips. And remember, the services of our application engineers are also at your disposal.

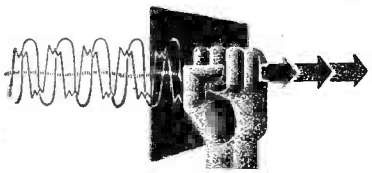
  
**Norelco** *Electronic Products by*  
Reg. U. S. Pat. Off.

OTHER PRODUCTS: Quartz Oscillator Plates; Cathode Ray Tubes; Searchray (Industrial X-ray) Equipment; X-ray Diffraction Apparatus; Medical X-ray Equipment, Tubes and Accessories; Fine Wire; Diamond Dies. • We invite you to visit our office and showroom when in New York City.

**NORTH AMERICAN PHILIPS COMPANY, INC.**

Dept. S-10, 100 East 42nd Street, New York 17, N. Y.

Factories in Dobbs Ferry, N. Y.; Mount Vernon, N. Y. (Metalix Div.); Lewiston, Me. (Elmet Div.)

# NEW PRODUCTS

Month after month, manufacturers develop new materials, new components, new assemblies, new measuring equipment; issue new technical bulletins, and new catalogs

## Heterodyne Frequency Meter

TYPE 720-A HETERODYNE frequency meter is a compact, portable, battery-operated instrument for frequency measurements between 10 and 3000 mc. The internal oscillator covers a frequency range of 100-200 mc. For frequencies below 100 mc harmonics of the unknown frequency are made to produce beats with the internal oscillator. For

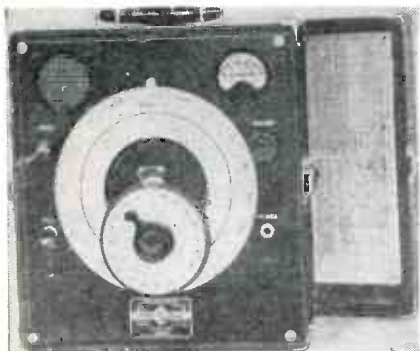

frequencies above 200 mc harmonics of the internal oscillator product beats with the unknown frequency. The internal oscillator uses a butterfly-type circuit in which capacitance and inductance are varied simultaneously. No sliding contacts are used in this circuit and no current is carried by the bearings; consequently, smooth and stable adjustment of the frequency can be made over the frequency range of the instrument.

The detector is a silicon crystal so mounted that it is easily accessible for replacement. A three-stage audio amplifier is included, having a band width of 50 kc. The output of the amplifier operates a panel meter and a built-in loudspeaker. A

jack is provided for head telephones.

The entire assembly is completely self-contained. Sensitivity of the instrument is high and no direct connection to the source under measurement is required. The pickup obtained by the adjustable antenna (mounted on the panel) is usually adequate, but provision is made for connecting an additional pickup wire. Tubes and batteries are supplied with the instrument. Overall dimensions are  $12\frac{1}{2} \times 13\frac{1}{2} \times 10\frac{1}{2}$  in. The unit weighs  $27\frac{1}{4}$  lb, with battery, and is priced at \$250.

General Radio Co., 275 Massachusetts Ave., Cambridge 39, Mass.

## Ground Station Transmitters

TWO TYPES OF GROUND station transmitters are available from Bendix Radio, Baltimore, Md.

The first of these is described in Bulletin No. SE-113 and is designated as Model TG-15. It is a me-

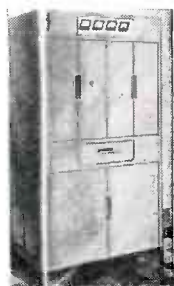

dium-power transmitter for operation in the low-frequency (200-540 kc), high-frequency (2.5-15 mc), and very high-frequency (118-132 mc) bands. It can be operated on four separate channels in any combination of these frequency ranges,

and, as the separate r-f units are mechanically interchangeable, it is easy to modify the transmitter for a different frequency arrangement should requirements change while the unit is in service. The h-f unit is capable of operation on two adjacent channels, the vhf unit on three, making it possible to pretune as many as 12 frequencies on the same transmitter. Either radio telephone or radio telegraph operation may be used with l-f and h-f units while radio telephone only is available on the vhf unit. Power output for continuous commercial service in the low and high-frequency ranges is 500 watts and over 300 watts in the vhf range.

The second type of transmitter is described in Bulletin No. SE-114, and is designated as TG-16. Low-

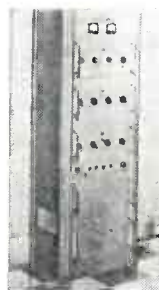

frequency (beacon and control tower), high-frequency (airways communications), as well as very high-frequency (proposed band for all aircraft service) operation are all available in one transmitter with power outputs ranging from 100 watts at vhf to 190 watts at the lower frequencies. Individual and interchangeable r-f sections make possible a high degree of flexibility. Up to four such sections can be operated by a single control unit, and each h-f and vhf section may be pretuned for operation on either of two adjacent channels. If l-f operation is not required, it is possible to operate the transmitter on any one of eight pre-tuned channels using only four r-f sections and one control unit in addition to the power supply and modulator. The equipment is designed for continuous operation at ambient temperatures between  $-40$  and  $+50$  C, and relative humidities between zero and 95 percent.



# DeJUR

**MODEL 120 . . . A New DeJUR Miniature Meter . . . precision instrument for more permanent accuracy in small panel space. Conforms to forthcoming JAN-1-6 specification . . . self-contained up to 1 ampere and 150 volts. D.C. or A.C. (rectifier) . . . external shunts or multipliers . . . in a wide variety of ranges.**

**ALNICO MAGNETS . . . highest grade . . . provide stability and quick response under high torque, with increased protection against magnetic fields.**

**EXTERNAL PIVOTS . . . insure maximum accuracy . . . reduce pointer-rocking, side friction between jewels and pivots, and wear on bearing surfaces.**

**EXTRA-TIGHT SEALING . . . completely waterproof . . . in addition, rubber gasket seals flange to panel. Model 120 is particularly adapted for water-proof equipment.**

*For full information on DeJUR Miniatures and special applications, write*

**DeJUR-AMSCO CORPORATION, Long Island City 1, N.Y.**



**Compact, Trouble-Free Modern Design**

**External Pivot  
(As Used by DeJUR)**

**Internal Pivot  
(Not Used by DeJUR)**

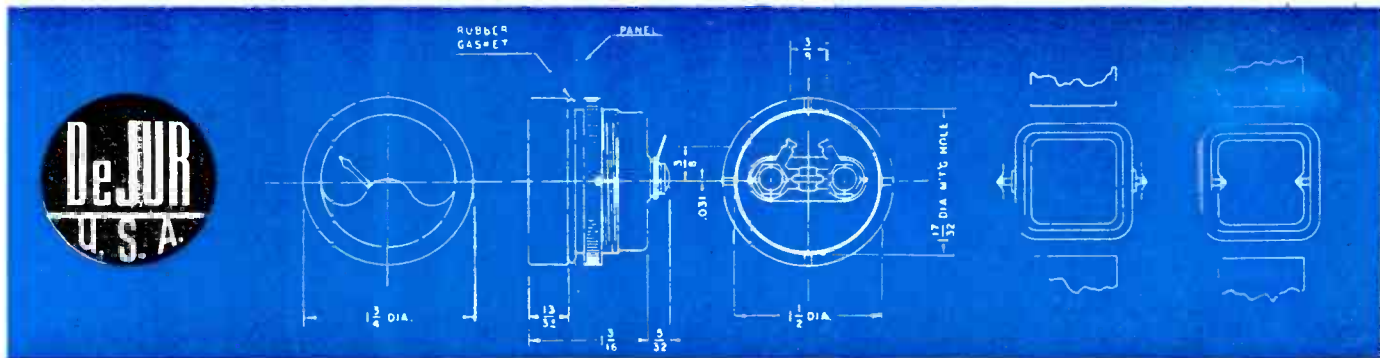

Model 120 . . . Exploded View  
Black Anodized Aluminum  
Case . . . Ring-mounted



**1 1/2 INCH**  
With the accuracy  
resulting from  
external pivot design.

**AMMETERS . . . VOLTMETERS . . . POTENTIOMETERS**

for  
**COMMUNICATION  
LABORATORY  
AND PRODUCTION  
MAINTENANCE**

OVER 10,000 electronic items... one of the largest stocks in the midwest... are available here at W-J for shipment AT ONCE! Maintenance of Industrial Electronic equipment is a highly developed specialty of ours. Users of electronic equipment from coast-to-coast will benefit from W-J Industrial Emergency Service... countless uses may be found such as those in research laboratories, broadcasting stations, railroad communications systems, airport control towers, shipboard radio installations, to name a few! Our trained procurement experts and technical staffs are geared to function with a speed and efficiency unapproached in the history of Electronic Supplies distribution! Save time and trouble. Make us headquarters for ALL your electronics needs.



SEND FOR THIS NEW BUYERS' GUIDE!



Radio and  
*Electronic Supplies*

**WALKER-  
JIMIESON, INC.**

311 SOUTH WESTERN AVE., CHICAGO 12, ILL.

Phone CANal 2525

### Lineman's Bridge

SMALL, RUGGED and compact enough to be carried easily, this bridge (measures 9 x 5 x 4½ in. and weighs 5 lb complete) is built to meet the requirements of the telephone and telegraph lineman. It is used to measure the resistance of wires as well as the unbalance between two wires. It can also be used as a general purpose bridge up to the limit of its capacity. By throwing a switch and changing the position of



the three decade dials the reading on the loop can be changed to the unbalance reading without disturbing the connections. The switching arrangement also designates which wire has the higher resistance. The range of the measurement is up to 111 ohms in steps of 0.1 ohm with an accuracy of one-quarter of 1 percent. The galvanometer (Weston Model No. 375) has a sensitivity of approximately 22  $\mu$ a per division for 30 divisions. Batteries are standard 1½-v flashlight cells arranged so that they can be quickly and easily replaced. Nilsson Electrical Laboratories, Inc., 103 Lafayette St., New York 13, N. Y.

### Brown Instrument Devices

A CHART-DRIVE CONTROL, embodying means for automatically starting and stopping electronic-recorder chart motion by pen position is available from Brown Instrument Co., Philadelphia, Pa. for their circular chart designated as "ElectroniK" recorder. Control contacts are wired in the chart drive circuit. By setting the control point, the chart can be stopped and started as desired, corresponding to any pen position. The new feature is useful in molten-metal thermocou-

## ... INSTALL A PHOTOX

Photographic Silk Screen  
Stencil Department for  
marking and decorating  
your products!

The PHOTOX Process is the only process that *guarantees* exact reproduction of one-color or multi-color jobs in either line work or halftone!

- It is practical on any printing surface - can be successfully used on paper, metal, wood, rubber, glass, plastic, textiles, etc.
- There are few size or contour limitations - makes possible marking in corners and on irregular contours that cannot be marked by machine.
- Preparation and operation are simple - unskilled workers easily taught the preparation and operation of the PHOTOX Process.
- The PHOTOX Process is economical - art work preparation cost is considerably decreased; plate-making cost is eliminated.

Let us show you how a PHOTOX Photographic Silk Screen Stencil Department can mean greater efficiency and greater profits for you. We are prepared to aid you in installing a PHOTOX Marking Department in your plant. Write for further details or personal consultation.



## PHOTOX

SILK SCREEN SUPPLY CO.

Manufacturers of PHOTOX  
Photographic Film and Silk  
Screen Accessories.

30 IRVING PL., NEW YORK 3, N.Y.



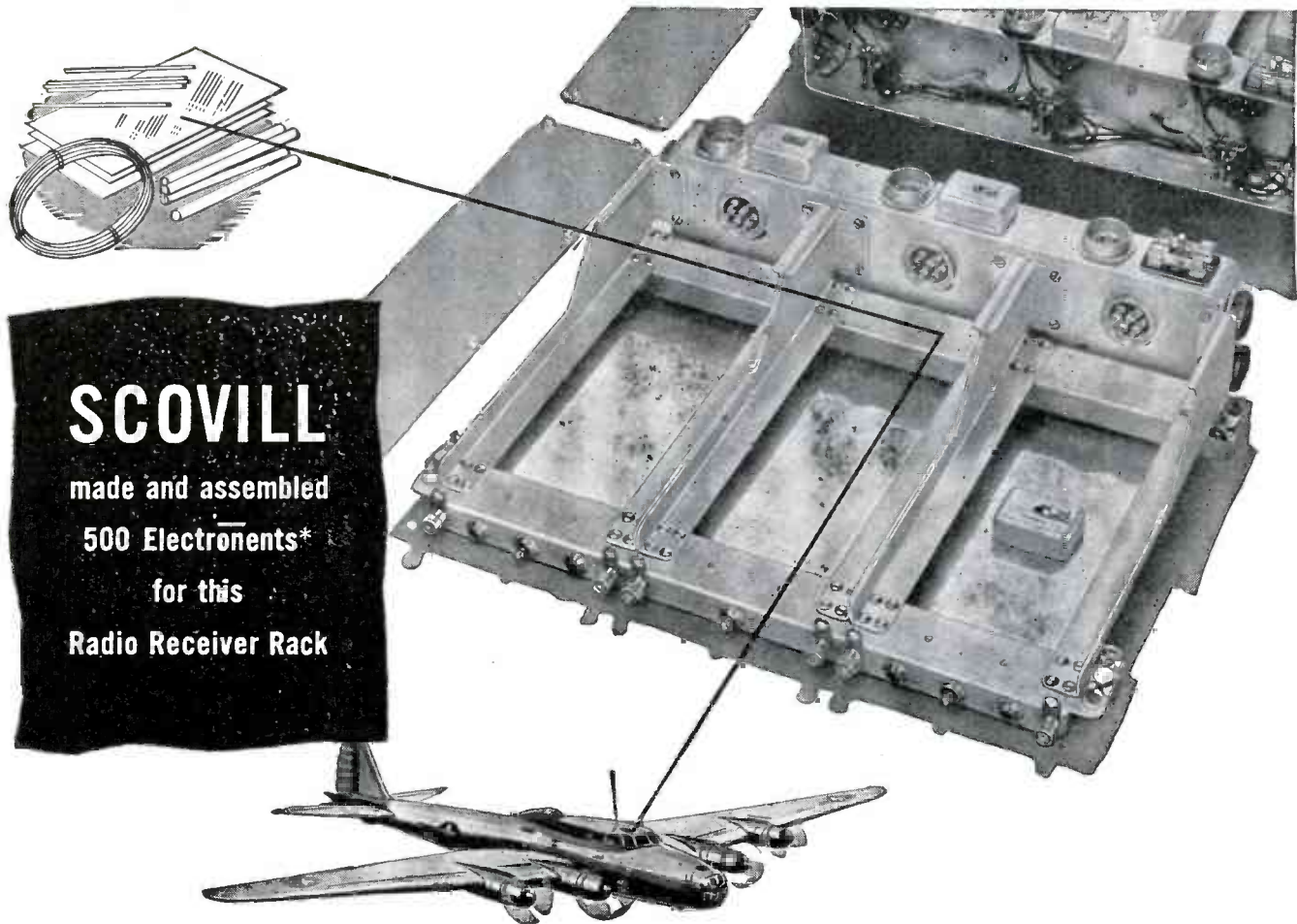

*Demonstrating how Scovill can reduce your overhead  
on small parts or complete assemblies*

Put yourself in the shoes of the prime contractor who needed this three-position, high-frequency radio receiver rack for big bombers in a hurry. He could have undertaken to make in his own plant the more than 500 individual parts required, or . . . made some and purchased the remainder, then assembled the complete unit himself. Instead he turned the complete responsibility over to Scovill . . . and saved time, space, trouble and money.

Here's what Scovill did: made all the metal parts of sheet, rod, wire and tube stock using such metal-working

methods as forging, stamping, drawing, heading, machining and wire forming . . . cut all wires to length, stripped and soldered them into position . . . manufactured, tested and adjusted relays . . . assembled the entire rack as illustrated.

Investigate how Scovill's versatile production setup, as exemplified above, can improve the quality or lower the cost of your small electronic components or complete assemblies. Learn how Scovill's designing and metal-working experience and facilities will make you sure of getting the

one right solution to your metal-parts problems. For proof of Scovill's ability to help you, write for literature. Fill in the coupon below and mail it today.

\*Electrontents = Electronic Components



Please send me a free copy of "Masters of Metal" booklet describing your facilities. I am interested in the ELECTRONENT\* applications checked.

- |  |                                      |  |
|--|--------------------------------------|--|
| <input type="checkbox"/> Batteries       | <input type="checkbox"/> Dials       | <input type="checkbox"/> Panels            |
| <input type="checkbox"/> Record Changers | <input type="checkbox"/> Escutcheons | <input type="checkbox"/> Sockets           |
| <input type="checkbox"/> Clips           | <input type="checkbox"/> Jacks       | <input type="checkbox"/> Stampings (misc.) |
| <input type="checkbox"/> Condensers      | <input type="checkbox"/> Lugs        | <input type="checkbox"/> Tubes             |

Other applications.....

**SCOVILL MANUFACTURING COMPANY**

Electronic Division  
22 Mill Street, Waterbury 91, Connecticut

Name .....

Company .....

Address .....

# Burlington

## PANEL INSTRUMENTS

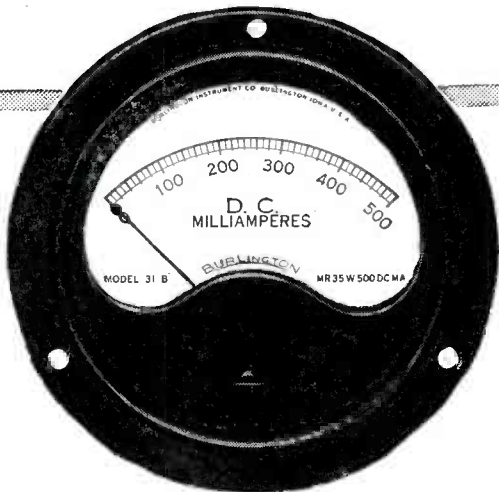

## Guaranteed ACCURACY

Due to design characteristics and close control of manufacturing processes, Burlington instruments embody the following advantages:

**PERMANENCE OF CALIBRATION . . .** All DC instruments employ Alnico magnets which are known to be more highly resistant to shock, heat, vibration, and stray fields than any other magnetic material.

**FREEDOM FROM STICKING . . .** Clearances for all moving parts are such that the results of entrance of small particles as encountered in field service are reduced to a minimum.

**STABILITY OF OPERATION . . .** All instruments are "NORMALIZED" after assembly to eliminate "zero shift" and other calibration errors due to ageing.

Exceptionally high torque to weight ratio of control springs to moving element insures minimum error under conditions of shock, vibration, and other rough usage.

Alignment of jewels and magnet core piece is such that the center lines of these parts coincide within plus or minus .002". The design of the brass movement frame and components is such that mechanical tolerances are reduced to a minimum in assembly. As a result, jewel and pivot wear is uniform which reduces "frictional torque" of the moving coil.

All series resistors and coils are heat treated and impregnated after wrapping to insure stability and long life.

All ranges AC & DC are available in 2½", 3½" and 4½" sizes, both square and round, flush mounting.

Engineering service furnished for specialized applications.  
No obligation. Write today for further information.

### BURLINGTON INSTRUMENT CO.

102 FOURTH STREET  
BURLINGTON, IOWA



PANEL INSTRUMENTS • VOLTAGE REGULATORS  
• AUTOMATIC SYNCHRONIZERS • FREQUENCY REGULATORS

ple and radiation pyrometer applications.

A new safety emergency alarm feature that protects process equipment and materials has been added by Brown Instrument to its line of electronic air-operated controllers. The instrument is designated as ElectroniK contact controller and it provides on-off control in addition to air control to actuate motorized valves, solenoid valves, contactor panels, signal lights, etc.

### Capacitor Mounting Bracket

FASTER, LESS expensive assembly of capacitor motors is facilitated by the use of a new plastic capacitor and mounting bracket developed by P. R. Mallory & Co., Inc., Indianapolis, Ind. The bracket is used with the new Mallory type P



plastic case capacitor and end cap. The bracket requires no special tools since it is fastened to the motor with two screws. The capacitor is snapped into the bracket by hand. Two different lengths of brackets (which will handle four capacitor case sizes) are available. The unit is splash-proof and moisture-proof.

### Variable Isolation Transformer

ISOLATION-TYPE transformers (designated as type W Vari-Formers) are a new development of the Gulow Corp., 26 Waverly Place, New York 3, N. Y. They are double or isolation wound for laboratory and industrial use. The units have a primary wound for 115-v input and a variable secondary wound for an output of 0-130 volts. Separate terminals are provided for both primary and secondary windings. The units can be connected as auto



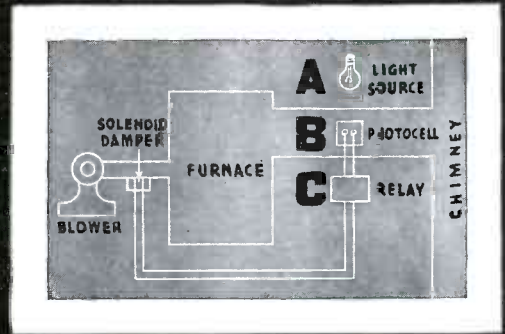
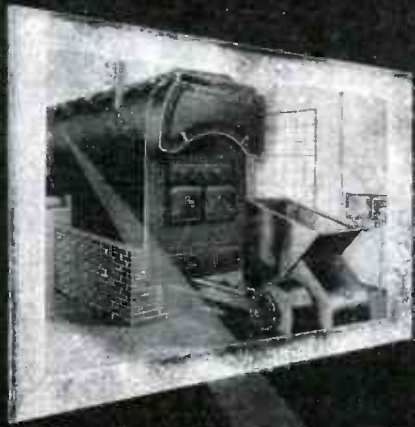

## How to stop smoking with smoke

Typical of the applications possible with a Bradley Luxtron\* photocell is this suggested means of smoke control in a stoker-fired furnace.

Light source "A", beamed through the smoke stack to photocell "B", will cause the cell to generate power sufficient to close relay "C" until smoke diminishes the light. Or the system could be arranged to close the relay when light is reflected by smoke par-

ticles.

In any event, resistance to vibration and temperature changes make the photocell ideal for such an application. As in any photocell application, it is as simple as A, B, C—and the "B" stands for Bradley.

Write Bradley for literature and complete engineering assistance on any photocell application you may have in mind.

### Write for Rectifier Data

Bradley also has available a complete line of unique copper oxide rectifiers, featuring mounting flexibility, pre-soldered terminals for ease and safety in assembly, low forward resistance with high leakage resistance, and gold coating of pellets to provide long life.

Data on five basic models are included in an illustrated Bradley "Coprox" Rectifier bulletin sent on request. Please write for it.

\*TRADE MARK REG U S. PAT. OFF.

PHOTOCELLS—MASTERS OF LIGHT

# BRADLEY

MASTER OF PHOTOCELLS

BRADLEY LABORATORIES, INC., 82 MEADOW STREET, NEW HAVEN 10, CONNECTICUT

ELECTRONICS — October 1945

385

Standard fixed resistors: 10 and 20 watt; 1-50,000 and 1-100,000 ohms.

Standard adjustable resistors: 25 to 200 watt; 1 to 100,000 ohms. Additional sliders available.

Also other types of terminals and mountings.

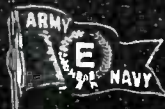

*It's a*  
**GREENOHM!**

★ Yes, it's a Greenohm—not just another power resistor.

And that means a lot to you and the buyers of your products. It means a tougher, longer-lasting, absolutely dependable power resistor.

Greenohms are those green-colored cement-coated power resistors featured in the finest transmitters and receivers; in

power supplies; in electronic, electrical and industrial equipment. Already in service year after year since they were first introduced, Greenohms have proved that "they can take it"—and then some. No tougher resistors are made.

Try a Greenohm! Make your own comparative tests. Then draw your own conclusions once and for all.

★ Greenohms are available in standard sizes and values through local jobbers. For volume requirements or special types, write us direct.

**CLAROSTAT**



*Controls and Resistors*

CLAROSTAT MFG. CO., Inc. · 285-7 N. 6th St., Brooklyn, N. Y.



transformers to obtain several different voltage combinations. Inputs of 115 or 220 volts can be applied and output voltages of 0-65 or 65-130 are obtainable with increments of 0.3 volts. Output ranges of 0-130 or 115-245 volts with increments of 0.6 are obtainable. The separate primary and variable secondary windings are wound on the same core eliminating the need of two transformers to obtain an isolated variable voltage supply. For critical electronic testing and special applications, an electrostatic shield has been imposed between the windings, grounded to the core and brought out to a separate terminal. These units are available with capacities of 500 va to 2000 va.

### Power Supply

MODEL 200-B IS a new and improved power supply for applications in the laboratory and on the production line. Its characteristics are:

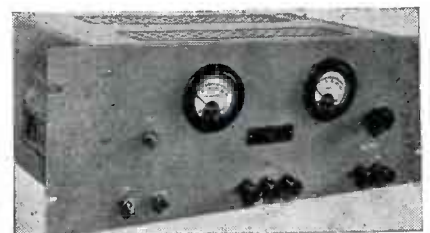

Voltage, from zero to 325-v d-c at 125 ma continuously variable, and 6.3-v a-c at 6 amp, center tapped; Regulation, within 1 percent for voltages between 20-235 volts from no load to full load. Within 2 percent at 10 volts from no load to full load; Hum voltage, less than 10 mv including noise; Metered output, voltmeter and milliammeter included to read output voltage and current. Electronic Measurements Co., 10 West Front St., Red Bank, N. J.



# PLASTIC PARTS

... PRODUCED TO YOUR SPECIFICATIONS

## PRINTING DIE CUTTING CEMENTING

Wide experience by all known processes in the application of printing, engraving, silk screening, die cutting and cementing of all thermoplastics.

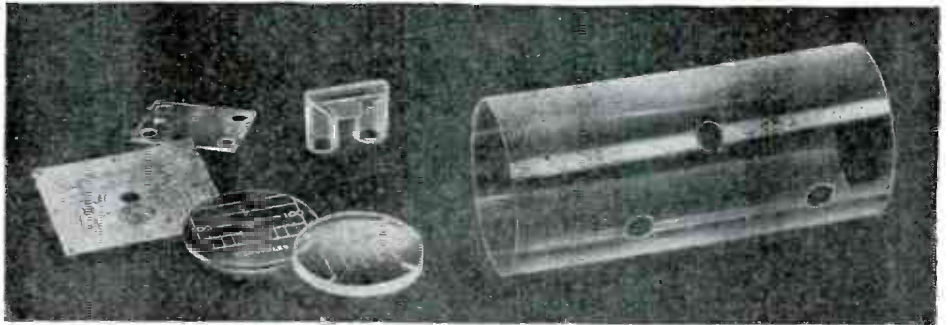

## FORMING

Specialists in deep drawing radio dial windows, embossing, swaging and bending in Acetate, Vinylite and Acrylics.



## MACHINING

Precision threading, screw machine, milling, drilling, turning of Polystyrene, Acrylics, Phenolics, Nylon, Tenite; sheets, tubes and rods; through spindle capacity up to 2½" rod.

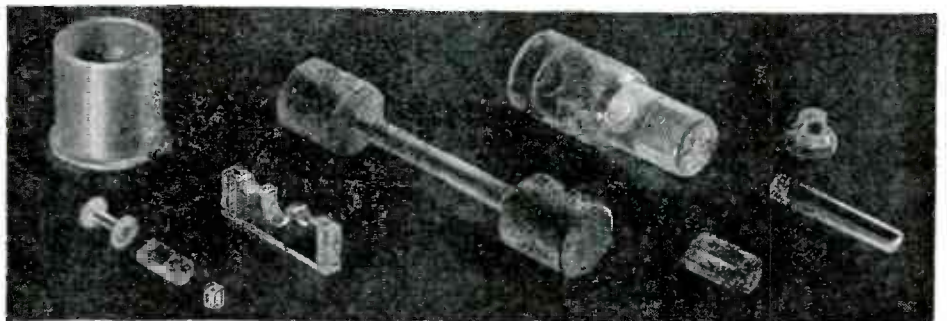

## ASSEMBLY

Our engineers can assist you in problems of design and assembly of your plastic units.

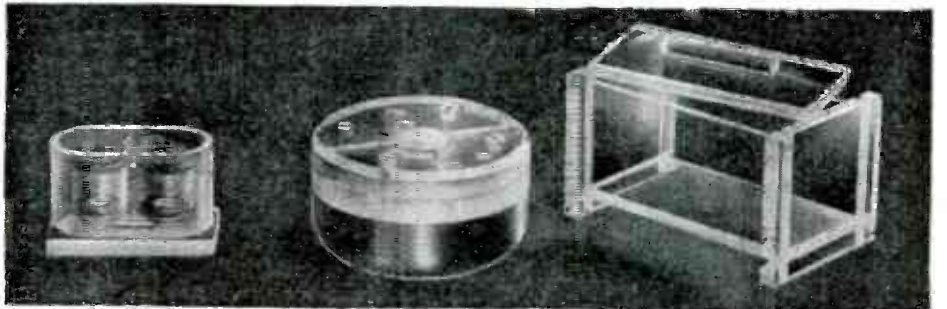

# PRINTLOID, Inc.

93 Mercer Street  
New York 12, N. Y.



in a typical machine control — Sigma sensitivity and *high speed* are applied in this control to safeguard valuable dies in a large press. Continuing press cycles are possible only as each formed piece is ejected and monitored by the control.

**SIGMA RELAYS** have always embodied —

- |           |             |
|-----------|-------------|
| Speed     | Sensitivity |
| Long Life | Compactness |
| Stability | Precision   |

Now is the time to let our Engineering Department know what additional specific features will be required in relays for your product. We intend to design new relays for expressed demands first. Do you need —

- Multicircuit Contacts ?
- Higher Power Handling Capacity ?
- Polarized Relays ?
- Differential Operation ?
- Snap-Action Contacts ?
- A-C-relays ?

Write and let us know the relay features which would be specifically useful to you, *especially those not now obtainable in existing relays.*

**SIGMA**  
**Sigma Instruments, Inc.**  
*Sensitive RELAYS*  
 62 CEYLON ST., BOSTON 21, MASS.

### Oscillator

TYPE 291 IS A portable, battery-operated oscillator especially designed for checking high-frequency aircraft radio receivers. The unit has a frequency range from 49 to 154



mc with modulation frequencies of 70, 90, 400, 1300 and 3000 cycles. It contains an easily extended, collapsible antenna and two coaxial terminals for low and high-level outputs. Andrew Co., 363 East 75th St., Chicago 19, Ill.

### Ionization Gage

THE ALPHATRON is an all-metal ionization gage with continuous linear response to 10-mm total pressure. The ionizing agent is a stream of alpha particles emitted by a radioactive source, which permits operation at any pressure, including atmospheric, without damage to



the gage. The steady emission characteristic of the radioactive element and amplifier design insure stability and reduce needle flicker to a minimum. The model produced at present by the National Research Corp., Vacuum Engineering Div., Boston 15, Mass., covers from zero to 10 mm in three ranges, all reading direct pressure. The ranges are zero to 0.1 mm, zero to 1 mm, and zero to 10 mm. Pressures are read to 1 percent of full-scale reading.



# POSTWAR TRANSFORMERS

BY

## FOSTER

Facilities for peacetime manufacture of transformers are already available at A. P. Foster, and, as war commitments are filled, will be increasingly at your service.

During the war years A. P. Foster has supplied thousands of custom-designed and custom-built transformers to all branches of our armed services, for use in all parts of the world under great extremes of climatic condition.

High production schedules have been maintained by advanced Foster manufacturing techniques. High standards of performance were demanded, achieved and will be maintained—to the benefit of America's peacetime economy.

As your own reconversion plans advance from the conference stage to the blueprint stage, it may well be worth your while to bear in mind that Foster engineers and designers are ready now to consult with you on every transformer problem and to furnish estimated costs and delivery schedules on experimental or quantity production of standard transformers or special jobs custom-built to your own specifications.

⑤ BOB REID, 810 West 57th Street, Indianapolis 5, Ind., Telephone Broadway 2725

⑤ BAUMAN AND BLUZAT, 2753 West North Avenue, Chicago 47, Ill., Telephone Humbolt 6809-10-11-12

⑤ THE A. P. FOSTER COMPANY, BARRITT BORDER, 11 W. 42nd St., New York 18, N. Y., Telephone Pennsylvania 6-9133

SPECIALISTS IN BUILDING TRANSFORMERS SINCE 1938

# A. P. FOSTER COMPANY

TRANSFORMER ENGINEERS & MANUFACTURERS

719 WYOMING AVENUE LOCKLAND 15, OHIO (SUBURB OF CINCINNATI)



*A New Impregnating Service*  
 Which... **PROTECTS STEATITE CERAMIC PARTS AGAINST MOISTURE ABSORPTION AND FUNGUS ATTACK . . . . .**

by the use of  
**DOW-CORNING FLUID #200**

This new method for waterproofing ceramic surfaces results in increased electrical resistance and improved performance of equipment under conditions of high humidity and condensation. Application of Dow-Corning Fluid No. 200 to ceramic bodies coats them with an extremely thin film of silicone. It will adhere effectively even when immersed for days in sea water and does not collect dust or corrode metals; nor will it react with organic materials. It has a power factor of the order of .005% and is effective up to 150°C. It also acts as a neutral flux for soldering, and is not removed by contact with organic solvents. For further applications and engineering data write or phone.

- Other Services:*
- DEHYDRATING
  - DIPPING
  - IMPREGNATING
  - CENTRIFUGING
  - SPRAYING
  - POLISHING

**PRODUCTION ENGINEERING CORP.**  
 666 VAN HOUTEN AVENUE, CLIFTON, N. J. • TEL. PASSAIC 2-5161

The gage is suitable for measuring pressures of gases other than air, such as argon, water vapor, and hydrogen, as the linear response of the gage hold true regardless of the atmosphere.

**Resistors**

EASTERN ELECTRONIC Corporation (41 Chestnut St., New Haven, Conn., manufacturers of precision wire-wound resistors, wheatstone bridges, radio and electronic test equipment and radar assemblies) announce "Korect-Ohm" resistors as follows: Type CC, low-tempera-

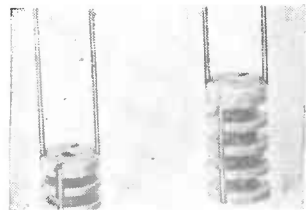

ture coefficient, has a maximum resistance of 250,000 ohms; Type NC has a maximum resistance of 500,000 ohms; Type NA has a maximum resistance of 1 million ohms; Type CA ranges from a few ohms to 500,000 ohms; Type CB has a

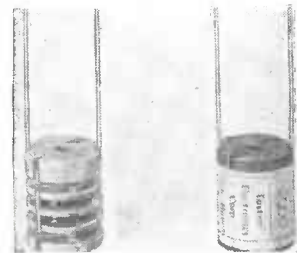

maximum resistance of 500,000 ohms; and finally Type NB which has a maximum resistance of 1 million ohms. All resistors are aged and treated to relieve strains due to winding before the final adjustment is made. Final resistance adjustment accuracy is rated to better than 0.1 percent. The resistors are wound with an alloy wire having a resistance change vs temperature of less than 0.08 percent between -55 and + 55 C. For applications where space is a factor, resistors are wound with an alloy wire having a resistivity of 650 ohms per circular mil ft. The resistance change vs temperature is 0.5 percent plus or minus between -50 and + 50 C.



NATIONAL RECEIVERS ARE THE EARS OF THE FLEET



OFFICIAL U. S. NAVY PHOTOGRAPH

## THE PACIFIC IS A LOT OF OCEAN

It is a big place to get lost in. The ceaseless search by Navy PBM "Mariners" has saved the lives of many downed fliers. Sometimes the plane can make the rescue; often radio sends help on its way.

The Navy knows how important radio equipment is. 3 out of 4 of the Navy's ships — landing craft and larger — use receivers designed by National.



HRO

NC-200

# NATIONAL COMPANY

MALDEN

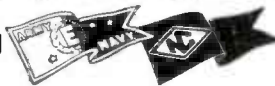

MASS, U. S. A.

NATIONAL RECEIVERS ARE IN SERVICE THROUGHOUT THE WORLD



## For more than 10 years

we have been manufacturing crystals. Not only are we crystal manufacturers, but crystal specialists as well. Consult us on your "crystal problems".



### PETERSEN RADIO CO.

Council Bluffs, Iowa

CRYSTALS EXCLUSIVELY SINCE 1934



THE NO. 527F TYPE



# DRAKE MANUFACTURING CO.

1713 WEST HUBBARD ST., CHICAGO-22, U.S.A.

## Check the Quality Features of the Drake No. 500 Series

- ✓ Time tested — Millions have been used since March 1940!
- ✓ Available in any quantity with any type of bracket.
- ✓ Sturdy Bakelite Molded insulating casting shields socket from outside contact.
- ✓ Center contact lead wire mechanically secured before soldering.
- ✓ Both lead wires withstand over 25 lbs. tension.
- ✓ Rounded eyelet edges prevent cut or frayed lead wire insulation.
- ✓ 1000 volts minimum breakdown voltage between contacts and to ground.
- ✓ Casting mechanically secured to bracket — can't turn.
- ✓ Socket mechanically secured within casting — can't turn or be pulled out.
- ✓ Center contact secured within socket — contact won't protrude when lamp removed.

Consider this better underwriters' approved DRAKE dial light assembly for war or peace-time products. Lead wire 2 3/4 in. to 4 ft. Prompt shipment in any quantity assured. May we send samples or our newest catalog?

### SOCKET AND JEWEL LIGHT ASSEMBLIES

## Wire-Wound Potentiometers

TREFZ MANUFACTURING Co., 38-11 Main Street, Flushing, N. Y. announce Series PWW-5 wire-wound potentiometers which have been produced to Army and Navy specifications for electronic operations. The linearity of both single and dual units makes them readily adaptable to applications using calibrated dials or in circuit arrangements where close series of parallel tracking is a requirement. Wattage rating is high for a standard-size unit (patent pending feature). An electronically-welded instrument spring maintains positive continuity between center terminal and wiping contact. A dust-proof phenolic case houses the units, and

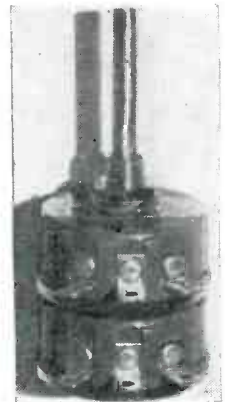

when specified, a sealing washer can be furnished between the case and the heavy cover making a hermetically-sealed potentiometer when used in conjunction with a water tight panel bushing. Resistance range is rated 1 ohm to 150,000 ohms; shafts are made to specification; switches can be supplied in off position and tapered units.

## Magnetic Phonograph Pickups

NEW LOW COST magnetic phonograph pickups, produced by Caltron Company (11746 W. Pico Blvd., Los Angeles 34, Calif.) have a smooth response to 6000 cps and a sharp cutoff beyond top frequency. Units have no bearings, pivots or needle chucks. The manufacturer states that units will track fully modu-



# MORE VARIACS\* NOW!

A portion of our greatly expanded VARIAC production has been released from war orders. VARIAC deliveries are improving daily. We hope that within a comparatively short time *all* models of the VARIAC can be shipped promptly upon receipt of your order.

In the meantime you'll find several weeks required for delivery of some models well worth the waiting . . . VARIACS are still the *original* continuously-adjustable autotransformer first introduced by General Radio . . . redesigned to meet all of the mechanical and electrical requirements for all types of service . . . assuring rugged construction, long life and the same manufacturing care that is given to the finest G-R laboratory instrument.

You may have to wait a little longer for VARIACS, but you'll be satisfied many times longer.

*\*The trade name VARIAC is registered at the U. S. Patent Office. VARIACS are manufactured and sold only by General Radio Company under our U. S. Patent 2,009,013.*



**YOU CAN GET THESE FROM STOCK** At the moment we have a small stock of the popular Types 100-Q and 100-R VARIACS and can ship immediately. These models are rated at 2,000 va. The Type 100-Q supplies continuously adjustable voltages from zero to either 115 or 135 volts from a 115-volt 60-cycle line with a maximum output of 18 amperes; the Type 100-R supplies a maximum of 230 or 270 volts from either a 230- or 115-volt line with a maximum current rating of 9 amperes from a 230-volt input, or 4.5 amperes when used on 115 volts. Price of either model: \$40.00.

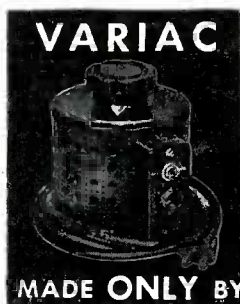

MADE ONLY BY

## GENERAL RADIO COMPANY

Cambridge 39, Mass.  
NEW YORK  
CHICAGO  
LOS ANGELES



*For Planning of*  
**RADIO COMMUNICATIONS**  
*investigate*  
**ERCO'S COMPLETE ENGINEERING SERVICE**

ERCO'S specialized knowledge and technique is reflected in custom-built equipment for such varied users as Pan American Airways, American Airlines, General Motors, Eastman-Kodak, Grumman, Sperry, National Carbon, Westinghouse, and the Hudson's Bay Company.

Whatever your requirements . . . police, airline or industrial; mobile, ground to air, base to branch, office to field . . . ERCO provides complete service in the design, manufacture and installation of equipment that is engineered specifically to meet YOUR needs. We invite your inquiry.

A complete,  
**ERCO-BUILT**  
 Radio Station  
 all in one  
 package.



Erco's  
 Engineering  
 staff is available  
 to fulfill your  
 requirements.

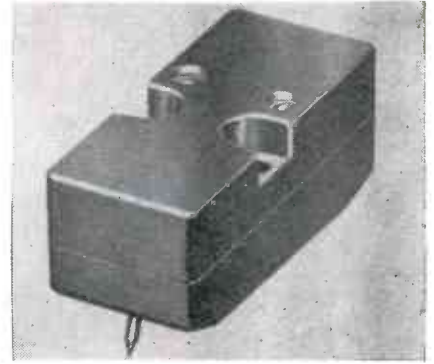

lated pressings with 15 grams needle pressure. The pickups are not affected by temperature or humidity, and no scratch filter is needed in the amplifier.

**Autoflight  
 Instrument**

A MICROTORQUE potentiometer, requiring negligible force to operate, is shown coupled to a pressure gage. It can be used to remotely indicate pressure, to operate alarm signals, cut off switches, and for a variety of other devices. This autoflight in-



strument, now available for commercial uses, was originally developed for the accurate transmission of data on board aircraft by G. M. Giannini & Co., Inc., 161 E. California St., Pasadena, Calif.

**Double-Beam  
 Cathode-Ray Tube**

TYPE 5SP double-beam cathode-ray tube produced by Allen B. DuMont Laboratories, Inc., of Passaic, N. J., provides two complete guns in a single 5-in. glass envelope, both aimed at or converging on the sin-

**ERCO RADIO LABORATORIES** INC.  
 HEMPSTEAD, NEW YORK  
 Manufacturers of CUSTOM BUILT RADIO APPARATUS





**"IT GOT HERE  
PERFECTLY DRY"**

**JAY CEE**

## SILICA GEL

**PROTECTS TELETYPE\* EQUIPMENT  
FROM MOISTURE DAMAGE . . .**

Yes . . . this Teletype printer arrived "perfectly dry" . . . thanks to Jay Cee Silica Gel—which is protecting innumerable over-seas shipments of delicate machines, instruments and weapons from moisture damage.

A few small cotton bags containing this ideal drying agent are enclosed in the box or carton with the equipment. The phenomenal power of Jay Cee Silica Gel to absorb the atmospheric moisture within the container prevents rust or corrosion in transit. Jay Cee Silica Gel is also used in packages of foods, fabrics, chemicals, and other products. Moreover, it has wide application in the air conditioning, refrigeration, and chemical industries. Jay Cee Silica Gel is clear white;

passes a rigid section test, meets exacting Government specifications; is strictly a quality product.

**JOBBERS WANTED**—A few excellent Jay Cee Silica Gel sales territories are still open to jobbers. Write for details.

\* Registered trade-mark

**JOLIET CHEMICALS, LTD.**

INDUSTRY AVENUE  
JOLIET, ILLINOIS

 **40 DEGREE**

*Vertical*



## AREA OF DISTRIBUTION

The new amazing Altec Lansing multi-cellular Duplex Speaker provides up to 800% increased area of quality sound distribution. In the vertical plane, the Duplex delivers a forty degree angle of distribution, or eight times the area distribution at high frequencies as compared to single unit speakers of comparable size. Another reason why the DUPLEX is the SPEAKER that REVOLUTIONIZES the methods of sound REPRODUCTION.

SEND FOR BULLETINS

**ALTEC**  
LANSING CORPORATION

1210 TAFT BLDG., HOLLYWOOD 28, CALIF.  
250 WEST 57 STREET, NEW YORK 19, N. Y.  
IN CANADA: NORTHERN ELECTRIC CO.

gle screen for simultaneous and superimposed traces. There is complete and independent control of the X, Y and Z axis functions for each beam. Adequate shielding between guns and plates minimizes cross talk particularly at high frequencies. Deflection plate leads, brought out through the glass envelope wall, minimize shunt-input deflection-plate capacitance and lead inductance, and also prevent interaction between signals caused by coupling between long leads. Second-anode leads are also brought out through the envelope wall in order to provide better insulation and longer leakage paths. A standard Army-Navy diheptal 12-pin base fits the standard socket. The electrode voltage ratings are similar to those of the Army-Navy preferred type 5CP1. Contact connectors for electrode leads are supplied with the tube.

### F-M Broadcast Transmitters

ILLUSTRATED IS an f-m broadcast transmitter, one of a line of 1, 3, 10 and 50-kw units, recently announced by Federal Telephone & Radio Corp., Newark, N. J. The transmitters are of a multi-unit design. The basic unit is the exciter which generates the initial r-f power, in itself, a complete 250-w transmitter. In this unit are in-

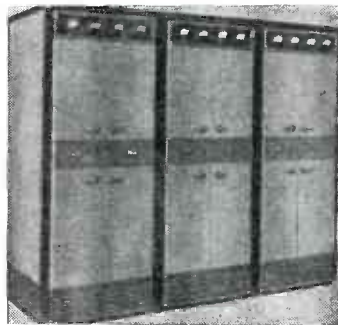

cluded the f-m system, center frequency stabilization system, and the r-f multiplier and output stages. The 250-w output of the exciter unit is stepped up to 1, 3, 10 or 50 kw by a power amplifier unit or series of such units.

Federal's new f-m broadcast antenna arrays are fed by standard coaxial lines and consist of from 1

# QUALITY PLASTIC DIALS

★ **PRECISION - MADE  
TO YOUR  
EXACT SPECIFICATIONS**

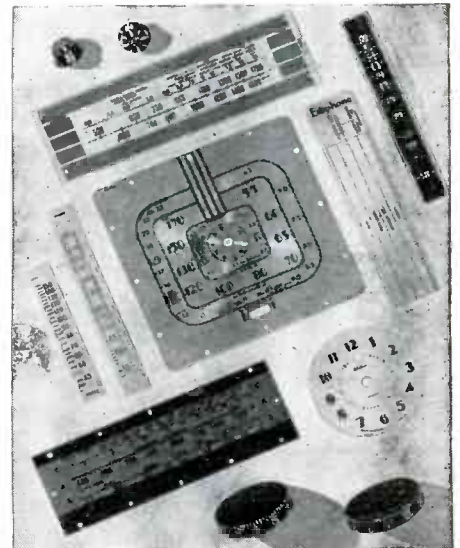

Where your plastic dial requirements demand precision fabrication, it will pay you to call on the experience and skill of Sillcocks - Miller specialists. They can help you in four ways:

1. In working out your own ideas.
2. In developing new ideas for you.
3. In advising you on the most practical and economical methods of fabrication.
4. In selecting the right plastics for your requirements.

Remember, it costs you less to pay a little more for Sillcocks - Miller quality.

**Write for Illustrated Booklet**

**THE SILLCOCKS-MILLER CO.**  
10 West Parker Avenue, Maplewood, N. J.  
Mailing Address: South Orange, N. J.

**Specialists in High Quality, Precision-Made Plastics Fabricated for Commercial, Technical and Industrial Requirements**





# A SHORT-CUT

## TO HAVING THOSE CONSUMER PRODUCTS READY

This little message is addressed to the "Vice-President in Charge of New Consumer Products". For his hairs are probably turning gray . . . trying to get the factory to give him a delivery promise early enough to cash in on the expected demand.

And over his shoulder we want to talk to the "Vice-President in Charge of Production"—for he too has problems, what with Uncle Sam hounding his every waking hour on those remaining war orders—at the same time the sales department and the consumer products division are pushing him for delivery schedules.

### It worked in war—it will work in peace

It is only three years ago that American industry learned a big lesson in the expediting of war production. American industry RE-discovered the principle of sub-contracting.

Instead of waiting until all departments of a plant could be tooled-up for complete production, the bottle-necks were isolated and turned over to a good sub-contractor as grist for his mill.

It worked in converting to war—it will work again in re-converting to peace time products.

Why not isolate those parts and assemblies that are likely to delay the finished job and turn them over to a good sub-contractor.

### Let Lewyt Do It

Here at Lewyt, for over fifty years, we have been pinch-hitting for other manufacturers, dove-tailing our production lines with their assembly schedules. We have worked out short cuts and tricks that enable us to beat the normal time required for tooling-up.

It has worked miracles for many manufacturers . . . it may be just the answer to your problem as you face re-conversion to civilian production. At any rate it won't cost anything to investigate why some of America's leading industries have found it profitable to "let Lewyt do it".

\* \* \*

*Write on your business stationery for 48-page book, "Let Lewyt Do It"—the story of the Lewyt organization in pictures. Lewyt Corporation, 60 Broadway, Brooklyn 11, N.Y.*



# Lewyt

FOR MORE THAN 50 YEARS A CONTRACT MANUFACTURER . . . EXPERTLY STAFFED TO PRODUCE COMPLETE ELECTRONIC AND MECHANICAL ASSEMBLIES, COMPONENT PARTS, SUB-ASSEMBLIES AND METAL PRODUCTS, TO THE MOST EXACTING REQUIREMENTS

BUY VICTORY BONDS

# ELECTRICITY

FOR ANY JOB  
—ANYWHERE

★ ONAN ELECTRIC GENERATING PLANTS supply reliable, economical electric service for electronics applications as well as for scores of general uses.

Driven by Onan-built, 4-cycle gasoline engines, these power units are of single-unit, compact design and sturdy construction. Suitable for mobile, stationary or emergency service.

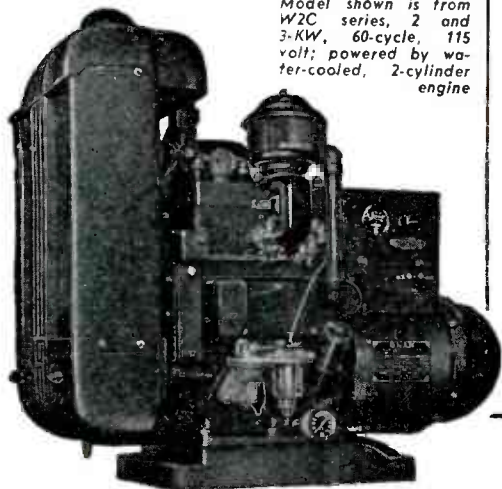

Model shown is from W2C series, 2 and 3-KW, 60-cycle, 115 volt; powered by water-cooled, 2-cylinder engine



"Models range from 350 to 35,000 watts. A.C. types from 115 to 660 volts; 50, 60, 180 cycles, single or three-phase; 400, 500, and 800 cycle, single phase; also special frequencies.

D. C. types range from 6 to 4000 volts.

Dual voltage types available.

Write for engineering assistance or detailed literature".

**D. W. ONAN & SONS** — 3269 Royalston Ave. Minneapolis 5, Minn.

## 6½" HIGH — AND EIGHT MOUNTING ARRANGEMENTS!

*Tens of Thousands Now in Use!*

... for cooling, ventilating purposes by America's most prominent manufacturers of electronic equipment. Available as *Centrifugal Fan and Motor only* or with any one or combination of accessories such as Stand, Inlet Flange and Discharge Flange. Can be practically custom-built to your needs—with all advantages of large-scale production. Extremely compact. Wide pressure range. Capacity 60 cfm at ½" pressure. Low power input. Highly efficient. "One Name-Plate" Guarantee covers both Centrifugal Fan and Motor. Phone nearby ILG Branch Office (consult classified directory) or write us today for engineering data and attractive prices. Special equipment can be furnished for special requirements.

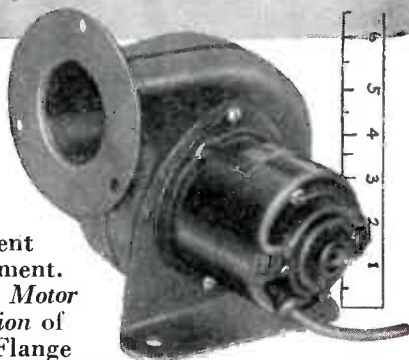

ILG ELECTRIC VENTILATING CO., CHICAGO 41, ILL.  
2882 N. Crawford Ave. • Offices in 40 Principal Cities

**ILG**

**VITALIZED VENTILATION**

AND AIR CONDITIONING

to 12 or more loops, each embodying two or more half-wave elements. The arrays are factory-tuned for easy installation.

## Marine-Radio Telephones

FOUR NEW MODELS of marine-radio telephones for communications requirements in the yachting and coastal harbor services are announced by Hudson American Corp., a subsidiary of Reeves-Ely

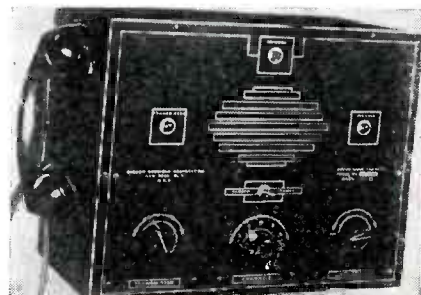

Laboratories, Inc., 25 West 43rd St., New York 18, N. Y. The complete line covers ship-to-ship, ship-to-shore, and ship-to-Coast Guard (emergency) marine radio telephones ranging from 5 watts to 75 watts and operating on frequencies between 2100 kc and 2800 kc. Features of the units include: no variable capacitors are used in the sets; provision for the completely individual adjustment of each channel; and complete crystal control of the transmitter and receiver. An outstanding feature is the development of a new transmitter-output coupling system, designed to give greater efficiency of operation and to minimize both interference with other communications and harmonic radiation.

## Potentiometer

A NEW TYPE of precision, ten-turn helical potentiometer, known as Micropot, is announced by Thomas B. Gibbs & Co., Delavan, Wis. The Micropot is linear within 1/10 of 1 percent (resistance is directly proportional to shaft rotation over the entire range of a 20,000-ohm unit to within plus or minus 20 ohms). Ten full turns on the standard ¼-in. shaft drives a sliding contact



# WHAT DO ALL THESE HAVE IN COMMON?

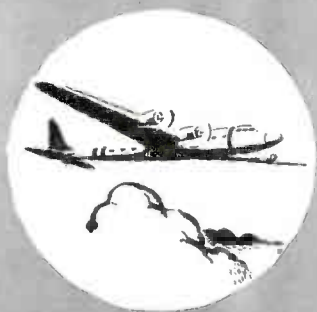
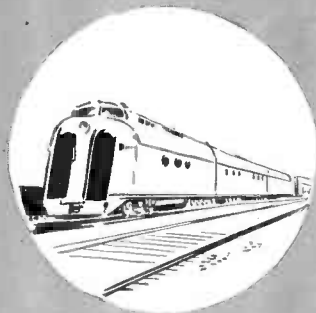
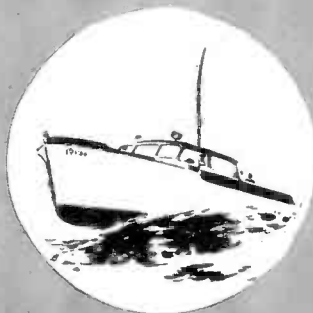

Radio equipment? Right. And one thing more: a common need to make sure the transmitter is on the correct frequency.

This means that, postwar, most transmitter users will also have in common the proud ownership of a very special piece of equipment. For there is only one piece of equipment which, at a modest price, **accurately and quickly** checks the frequency of any transmitter and is especially designed for mobile services. That is the Browning Frequency Meter.

For literature containing complete descriptive data, write for the Frequency Meter Bulletin.



# BROWNING

LABORATORIES, INC.  
WINCHESTER, MASSACHUSETTS

*Back Again!*

NOW AVAILABLE for finer peacetime radio reception are Tru-Sonic Co-axial Speakers. Better than ever as a result of their four years of war experience, these outstanding speakers are ready to offer their superior range and tone to those who demand the best. The Tru-Sonic Co-axial Speaker is a combination of two units; a high frequency reproducer operating into an 8 cell multicellular horn, and a 15" cone low frequency reproducer. This combination speaker, complete in a single unit, gives a horizontal sound distribution of 80 degrees.

## TRU-SONIC CO-AXIAL SPEAKERS

*Licensed under  
Western Electric Patents*

**STEPHENS  
MANUFACTURING CO.**

10416 NATIONAL BLVD  
LOS ANGELES 34, CALIFORNIA

*Tru-Sonic  
Speakers  
are available for  
delivery now.  
Write today for  
complete  
information.*



across more than 40 in. of wire-wound resistance element. The complete potentiometer measures 2½-in. in diameter and extends 2½-in. behind the panel. The running torque is rated less than 1½-in.-oz. at room temperature, and not greater than 3-in.-oz between minus 55 and plus 70 C. The resistance element (with both end terminals soldered in place) is molded as an integral part of the housing to prevent any loosening or shifting of the turns of resistance wire and to insure stability both as to linearity and total resistance. The potentiometers are available in several resistance values from 5000 to 30,000 ohms.

### Aircraft Marker Receiver

MARKER RECEIVER (75 mc) provide stable lamp indicator operation under varying conditions of supply voltage, temperature and humidity. Audio frequency output at the various tone modulations is used to heat the filament of the indicator lamps, thus eliminating the need for saturable reactors, relays and other intermediate operating means. Another feature of these units is the consistent and reliable lamp and audio indications produced at low supply voltage (11 and 22-v d-c). The stabilized superheterodyne receiver with crystal oscillator utilizes i-f transformers which are provided with an easily adjustable coupling control. This coupling control simplifies adjustment procedures and permits variation in the overall selectivity characteristic to provide peak or band pass response as required. The two types of marker receivers available in-

NUMBER FIVE OF A SERIES

**DC**  
*means*  
**SC**

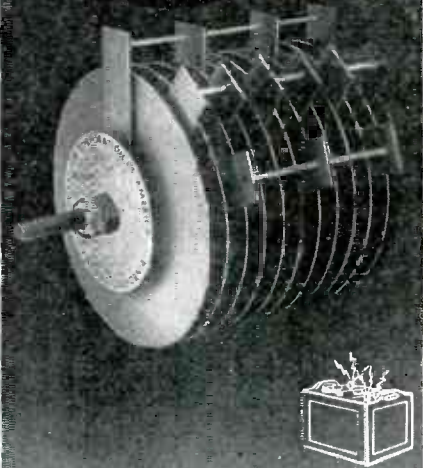

DC means SC...  
Selenium Conversion in battery charging. Fully automatic... absolute dependability over wide temperature range... elimination of maintenance costs... no harmonics in DC wave... power failure protection... small... compact... moisture and fungi proof... immunity to corrosive fumes... these features prove that DC means SC... Selenium Conversion in battery charging. If you use DC... get the facts on SC!

**SEND FOR  
BULLETIN**

**SELENIUM CORPORATION  
of AMERICA**



1719 WEST PICO BOULEVARD  
LOS ANGELES 15, CALIFORNIA

EXPORT DIVISION: FRAZAR & HANSEN  
301 CLAY STREET, SAN FRANCISCO, CALIFORNIA

IN CANADA: BURELCO LTD., TORONTO 13, ONTARIO, CANADA



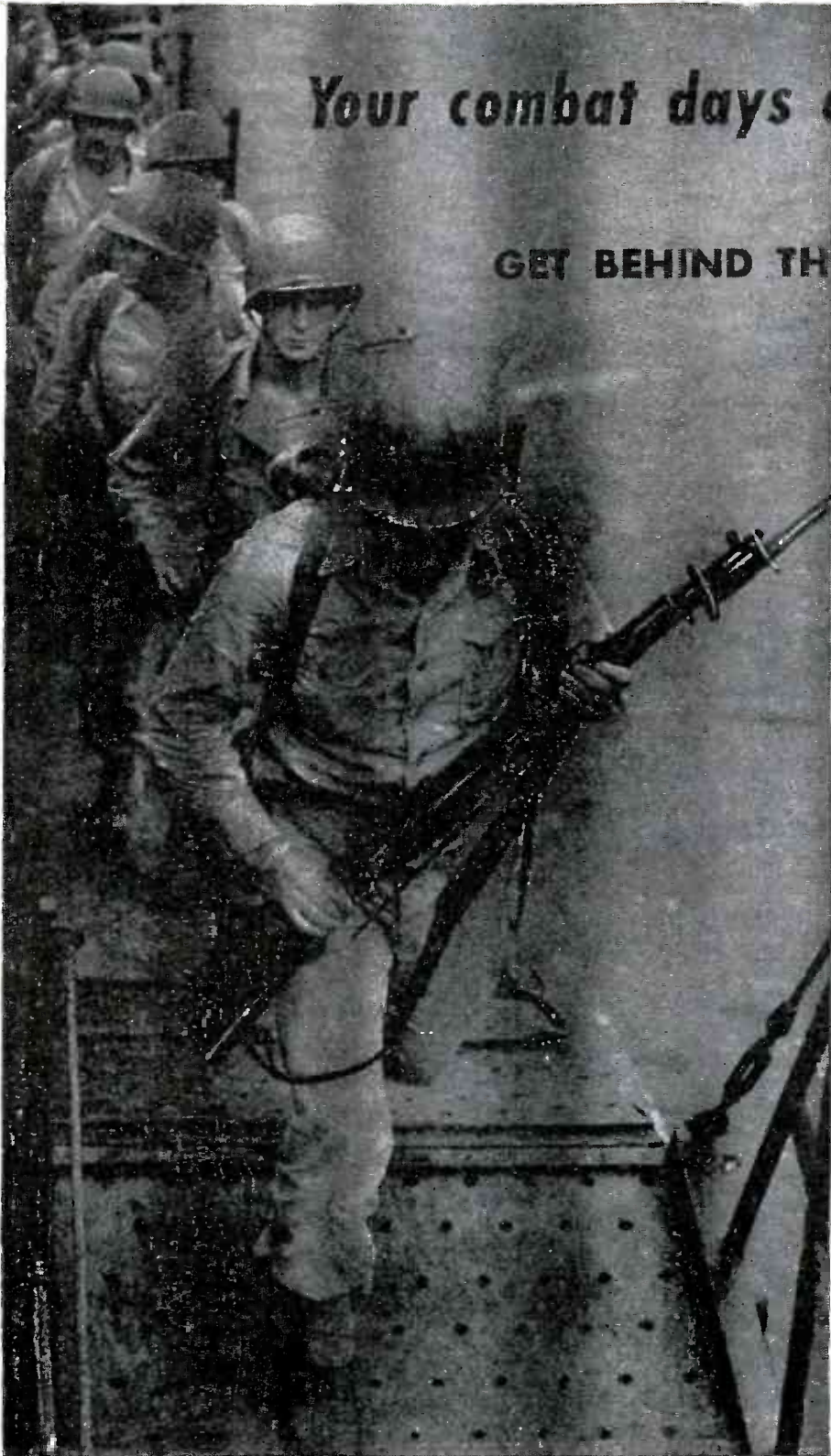

**Your combat days are not over!**

**GET BEHIND THE**

# **VICTORY LOAN!**

There's plenty of action ahead for fast-thinking industrial leaders in putting over the new Victory Loan! Your Victory drive is important because:

**EVERY VICTORY BOND HELPS TO**

- 1** Bring our boys back to the America for which they were willing to give their lives!
- 2** Provide the finest of medical care for our wounded heroes!

**BOOST THE NEW F. D. ROOSEVELT  
MEMORIAL \$200 BOND!**

Urge all your employees to buy this new Franklin Delano Roosevelt Memorial \$200 Bond through your Payroll Savings Plan! At all times better than ready cash, Victory Bonds are industry's "Thanks" to our returning heroes!

**START YOUR VICTORY DRIVE  
TODAY!**

Every Victory Bond aids in assuring peacetime prosperity for our veterans, our nation, your employees—and your own industry!

*The Treasury Department acknowledges with appreciation the publication of this message by*



## **ELECTRONICS**



*This is an official U. S. Treasury advertisement prepared under the auspices of the Treasury Department and War Advertising Council*





# "DIE-LESS" DUPLICATING

SAVES  
MAN  
HOURS  
AND  
DELAYS

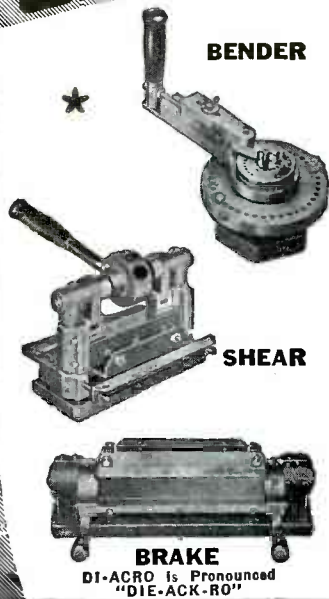

DIE  
ACCURACY  
WITHOUT  
DIES

Send for  
CATALOG

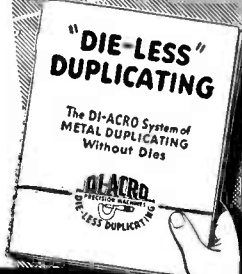

**O'NEIL-IRWIN MFG. CO.**

321 EIGHTH AVENUE SO. • MINNEAPOLIS 15, MINN.

Hook Up Those  
"LOOSE ENDS"  
in Your  
New Products  
By Specifying

**Sherman**  
Terminals  
and Lugs



ONE easy, practical way to speed up development work on your new units, is to turn over your Terminal and Lug problems to Sherman electrical engineers. You'll find that Sherman experience and "know-how" combined with the extensive Sherman production facilities can be extremely helpful to you in getting the right Lug or Terminal for every application.

Sherman can produce practically unlimited quantities of standard or specially designed Lugs and Terminals. Complete facilities are also available for hot tinning, electro-tinning, cad plating, etc. Write today. Let Sherman engineers help you solve your post-war problems NOW.

**H. B. SHERMAN MFG. CO.**  
BATTLE CREEK, MICHIGAN

To test  
over-all  
performance



## SQUARE-WAVE GENERATOR

• This unit, generating its own frequency or synchronized from an external source, will be found invaluable in many fields. FM, AM and Television Broadcasting—Telephone and Telegraph Communications—Manufacture of Transmitting and Receiving Equipment and Parts.

• Many additional functions will recommend it for use in school and college research projects and in scientific laboratories.

For additional information write:  
*Electronics Department,*  
*General Electric Company,*  
*Syracuse, New York.*

Electronic Measuring Instruments

**GENERAL ELECTRIC**

164-D7



Sherman  
Closed Round  
End Solder-  
ing Lugs.

"Uni-Crimp"  
Solderless  
(pressure  
type) Ter-  
minals.

Soldering  
Terminals—  
hundreds of  
sizes and  
styles.



clude Type NM 53-A which is not interchangeable with present equipment, and type MN 55-A which is interchangeable with other manufacturers' receivers. Bendix Radio, Baltimore 4, Md.

### Voltmeter

MODEL 565 vacuum-tube voltmeter utilizes a probe which is designed for measuring r-f voltages and which is small enough that it can be held in the hand as a test lead. The probe contains a high-frequency diode of the miniature type and it can also be used for measurement, with negligible frequency error, over a frequency range of 50 cycles to 100 mc. Shielded leads are used in the d-c voltage measurement circuits. Each shield has installed in it a 20-meg isolating re-



sistor which also acts as part of the multiplier resistors. Input impedance of 80 meg on the 1-v range and 40 meg on the 500-v range makes it possible to make voltage measurements, with negligible error, in circuits having extremely high impedance. A balanced bridge-type circuit (using nearly 100 percent degenerative feedback) eliminates errors due to line-voltage shift and due to grid current in the tube which operates the meter. D-c voltage ranges of 0-1, 0-2.5, 0-10, 1-100, 0-250, and 0-500 and a-c voltage ranges of 0-1, 0-2.5, 1-10, 1-100 and 0-250 are provided by pushbutton selection. Supreme Instruments Corp., Greenwood, Miss.

### Television Connector

ILLUSTRATED IS A television connector designed to utilize a minimum of space behind the prongs of the tube. The connector can be used



## WORLD'S FASTEST PLANE *uses* ANDREW COAXIAL CABLES!

*Lockheed's sensational new jet-propelled super fighter, the P-80 "Shooting Star," is the world's fastest and highest flying plane.*

★ It is highly significant that Andrew coaxial cables were chosen for the vital radio and radar equipment installed in the P-80. They were selected because they are much more resistant than ordinary solid dielectric cables to the high temperature encountered in the tail of the plane.

Andrew Co. is a pioneer manufacturer of antenna tuning and phasing equipment, including a complete line of ceramic insulated coaxial cables and all necessary accessories. Write for catalog.



# ANDREW CO.

363 EAST 75th STREET, CHICAGO 19, ILLINOIS

# Private-brand radios for America's best retailers!

- Retail Chains, Furniture Chains,
- Department Store Buying Combines

**DO YOU PLAN TO SELL FROM 5,000 TO 20,000 RADIOS A YEAR? . . .**

*We will make:*

- ✓ 5- and 6-tube AC-DC table model radios in bakelite, catalin and wood cabinets
- ✓ Table radio-phonograph combinations
- ✓ Portable phonographs

Our policy has consistently been to keep costs at rock-bottom; to accept orders only when we can fill them and live up to agreed-on terms. We welcome inquiry.



First of the pre-war radio manufacturers in the New York Metropolitan area to win the Army-Navy "E."

## ESPEY

MANUFACTURING COMPANY, INC.

33 WEST 46th STREET, NEW YORK 19, N. Y.

BRYANT 9-2300

# Reliable!

- EFFICIENT
- FLEXIBLE
- INSTANTANEOUS RECYCLING
- REASONABLY PRICED
- COMPACT



# AGASTAT

ELECTRO-PNEUMATIC TIME DELAY RELAY

ELIZABETH **AGA** NEW JERSEY  
AMERICAN GAS ACCUMULATOR COMPANY

## Stokes MICROVAC Pumps

HEART OF HIGH VACUUM SYSTEMS

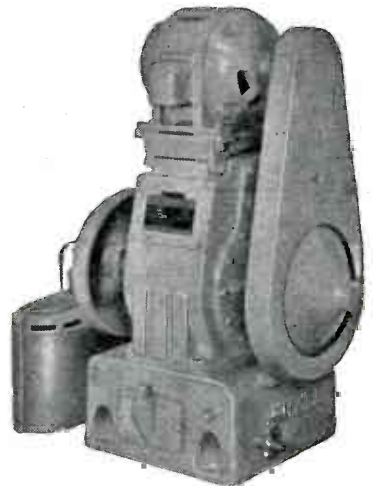

- Higher Vacuum (in the low micron range)
- High volumetric efficiency
- Low power requirement
- Complete discharge of air — no re-expansion
- Continuous dehydration of oil — no moisture to re-evaporate
- Discharges sudden slugs of liquid without injury
- Easily accessible, non-corrosive discharge valve
- Rugged, compact, simple construction
- Long life . . . negligible maintenance.
- Five sizes—from 10 to 235 cu. ft. per min.

## Stokes VACUUM GAUGES

(Patented McLeod Type)

**Are Always Accurate**



- Require no calibration
- Rapid readings
- Simple to operate—just tip and read
- Two models (AA) 0 to 5000 microns—(BB) 0 to 700 microns, with readings to 1/10 microns.

**F. J. STOKES MACHINE CO.**

6046 Tabor Road Philadelphia 20, Pa.

**Stokes High Vacuum PUMPS • GAUGES • EQUIPMENT**



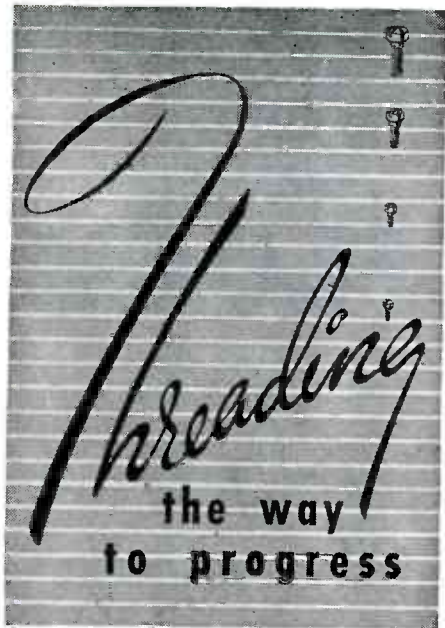

### Screw Machine Products:

- Screw machine products have now entered the field of electronics in volume.
- Experienced Producers of screw machine products are essential to expedite efficient operation.

Your Source—

### Waltham Screw Company because:

- Of sufficient equipment to produce in any quantity screws, tubes, shafts, inserts, nuts and other screw machine products in any thread to meet close tolerance requirements.
- Our experience gained in over half a century of development and production of screw machine products is now available to you in the electronics fields.

Send for our catalog and call upon our Engineering Staff for solutions to your problems in screw machine products.

**WALTHAM SCREW**  
 COMPANY  
 75 Rumford Ave.  
 Waltham, Mass.



in television sets, oscilloscopes and other similar applications. It is designed for the higher voltages and provides longer leakage paths between the contacts protecting the skirt around the prongs of the tube to preclude the possibility of shock. Alden Products Co., 117 N. Main St., Brockton 64, Mass.

### Two-Pole Circuit Breaker

A SMALLER, lighter, more compact, two-pole breaker with a more efficient blow-out action and a faster latch mechanism has been added to the line of circuit breakers made by the Heinemann Circuit Breaker Company of 97 Plum Street, Trenton, N. J.

The unit illustrated here, is fully electro-magnetic, is designed for service on 230-v a-c or 250-v d-c of 50 amp maximum. It may be connected either front or rear. It will carry full load continuously and



Build longer life,  
 better performance, into  
 your products . . . with  
 rugged, dependable

## SPERTI HERMETIC SEALS



Buyers who have waited through the war years will be looking for big improvements in your products. You'll have to meet civilians' expectations . . . just as you have met military specifications.

You can do it by building longer life, better performance, more trouble-free operation into your products. That calls for Sperti Hermetic Seals, the rugged, dependable, war-proved seals that effectively shut out dust, moisture and deteriorating agents.

Sperti Hermetic Seals are durable, one-piece units, easily soldered-in at less expense. Because of Sperti's advanced manufacturing methods, plus exhaustive tests and inspections, you'll get "true" seals that cut down production delays and costly rejects in the inspection line.

*WRITE, TODAY. Get the facts. Find out about the many product applications of Sperti Hermetic Seals and their performance advantages.*

### Here's Why Leading Manufacturers Choose Sperti Hermetic Seals

- Seal out dust, fungus, salt spray, sand atmosphere at high altitudes, etc.
- Will add longer life to a product.
- Will help reduce operational troubles.
- Are one-piece, rugged units. Easily soldered-in at less expense.



**Sperti**

INCORPORATED  
 CINCINNATI 12, O.

RESEARCH • DEVELOPMENT • MANUFACTURING

WIRE SO FINE  
IT MUST BE  
*Magnified*  
TO BE SEEN



**WOLLASTON PROCESS**

Wire as small as

$\frac{1}{100,000}$  } OF AN INCH  
IN DIAMETER

... available in Platinum  
and some other Metals

.00001" is less than 1/30 the  
diameter of the smallest wire  
die commercially available.  
Yet our Wollaston Process  
wire (drawn in a silver jacket)  
closely meets your specifica-  
tions for diameter, resistance  
and other characteristics.

This organization specializes  
in wire and ribbon of smaller  
than commercial sizes and  
closer than commercial toler-  
ances. Write for List of Products.

**SIGMUND COHN & CO.**



44 GOLD STREET NEW YORK 7

Get This New Booklet on

*Cellusuede*  
**FLOCK**



An interesting and colorful book-  
let on their product has been pre-  
pared for your information and  
convenience by the makers of Cel-  
lusuede Cotton and Rayon Flock.  
Brief, clear explanations give all  
the facts you'll want to know about  
this versatile coating material; what

it is made of; how it is applied; how it can be used. In the pages  
of this booklet you may find the answer to one of your manufactur-  
ing problems. You will be  
interested, too, in the col-  
orful and unique applica-  
tion of Cellusuede on the  
booklet cover. Write for  
your copy.



*Need* **TRANSFORMERS FOR  
ELECTRONIC APPLICATIONS ?**

We are completely equipped  
for volume production. Write  
us concerning your require-  
ments.

**DONGAN ELECTRIC MFG. CO.**

2977 Franklin Detroit 7, Mich.



**DONGAN**  
TRANSFORMERS

The Dongan Line  
Since Nineteen-Nine

We Invite  
Inquiries



has instantaneous trip at eight to ten times full load. It also has a selection of three time delays, any one of which may be specified. Overall dimensions are: 5½ in. long by 2-1½ in. high and 2 in. wide.

### Meter for Measuring Maximum Shock

A MEASURING DEVICE, designated as the G Meter, reads the value of the maximum intensity of shock, even though that maximum exists for an extremely short duration. The gravitational unit G is used as the unit of measure. The meter consists of the G meter itself (which is subjected to the shock) and the electronically-operated indicating mechanism. The two are interconnected by a multi-wire cable. The entire device operates from a-c power. Readings are obtained by means of a series of lights which glow at a given impact and which represent graduating degrees of shock.

The meter can be used to determine the shock involved due to



vibration even at relatively high frequencies; shock transmitted to the various components of any moving mechanism; shock administered to a radio, or a carburetor, or any other part of a car or a plane.

Another application of the meter is in packaging materials to determine various means for providing full protection of packaged material. In this application, the meter is securely mounted and incorporated in a mock-up of the article whose packaging is to be tested. The size and weight are adjusted to simulate the article itself. This mock-up is then wrapped, and the completed package dropped a known distance. The reading obtained is a direct indication of



Priorities on all radio parts and electronic equipment have been removed! You can again order long-scarce items, until now available only to producers for war. Concord is ready to fill your needs, from vast stocks.

## RADIO PARTS • ELECTRONIC EQUIPMENT ORDER TODAY FOR SHIPMENT TOMORROW

Our shelves are loaded with standard lines of high quality nationally known parts and equipment until recently reserved for government agencies and war manufacturers. These are now released for you . . . Tubes, Condensers, Transformers, Resistors, Test Equipment, Amplifiers, Intercoms, Repair and Replacement Parts of every description, and hundreds of other essential items. Our two shipping-warehouses—one in CHICAGO and one in ATLANTA—can fill most orders in 24 hours from the day they reach us. No matter what you need in parts and equipment, order from CONCORD for dependable quality, excellent values, and immediate service.

### Mail Coupon for FREE Copy "VICTORY CLEARANCE FLYER"

We have just published an exciting new Flyer offering thousands of standard-line, standard-quality parts and equipment at Victory Clearance prices. It contains exceptional values in many items you have not been able to obtain at any price. Consult this VICTORY CLEARANCE FLYER before you buy. It will save you money. Mail coupon below for your copy—it's FREE.



Aerovox • Amphenol • Amperite • Astatic  
B & W • Cardwell • Centralab • Cornell-Dubilier • Eimac • General Electric • Hallcrafters • Heintz & Kaufman • Hickok • TRC  
Janette • Jensen • Johnson • Mallory  
Meissner • National • Ohmite • Presto • RCA  
Readrite • Shure • Simpson • Sprague  
Stancor • Supreme • Thordarson • Triplett  
UTC • Universal • Utah • Weston • Worner

Order from Former Catalogs  
No. 345 and No. 94

Our former catalogs No. 345 and No. 94 contain many parts now available. Use them to order what you need!

# CONCORD

## RADIO CORPORATION

**CHICAGO**  
801 W. Jackson Blvd.  
CHICAGO 7, ILL.

**ATLANTA**  
265 Peachtree St.  
ATLANTA 3, GA.



Name.....

Address.....

City..... State.....

(Dept. G-105)

# ANTENNAS

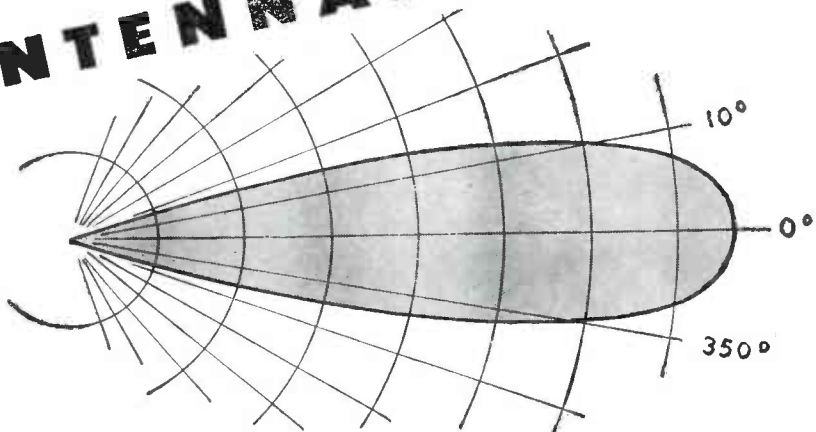

## HIGH GAIN END-FIRE ARRAYS

The pattern of the 18 element, high gain, end-fire array (illustrated above) will convey more than words, the capabilities of the Workshop for manufacturing antennas to fill your requirements. Due to our exceptional electronic test equipment for measuring gain, pattern and impedance match we can readily meet the most exacting specifications for all types of antennas suitable for use in the high frequency spectrum — from 30 mc up.

If you have an antenna problem in the VHF, UHF, or SHF bands we can help you — write or phone the details.

### The WORKSHOP ASSOCIATES

*Antenna Manufacturers* FOR THE ELECTRONIC INDUSTRY  
66 NEEDHAM STREET, NEWTON HIGHLANDS 61, MASSACHUSETTS

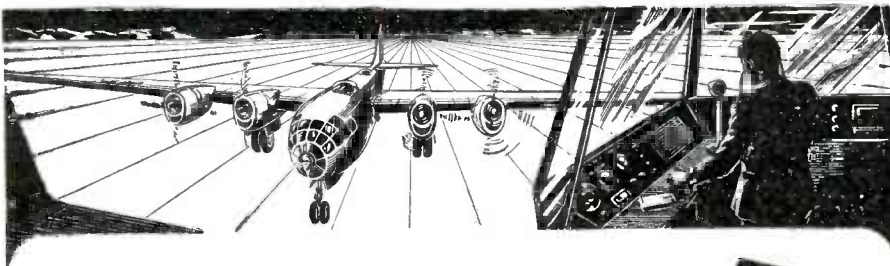

## An Invitation to All Electrical Designers to TRY SILVER GRAPHALLOY

### FOR BRUSHES

High current density, low contact drop, low electrical noise, and self-lubrication are characteristics of this silver-impregnated molded graphite that may be the answer to your electrical brush problems.

### FOR CONTACTS

Low contact resistance and non-welding when breaking surge currents are inherent properties of this unique combination of conductive silver and self-lubricating graphite.

SAMPLES of Silver Graphalloy will be gladly furnished for test on your applications. Silver Graphalloy is usually silver plated to permit easy soldering to leaf springs or holders. Why not WRITE NOW for your test samples?

## GRAPHITE METALLIZING CORPORATION

1055 NEPPERHAN AVE • YONKERS, NEW YORK



SLIP-RING AND COMMUTATOR BRUSHES AND CONTACTS

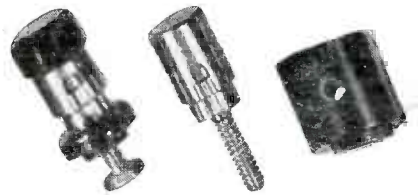

**THERE IS NO SUBSTITUTE FOR EBY SPRING BINDING POSTS**

From the product designer through to final assembly and use in the field, the Eby Spring Binding Post line offers top service based on dependability.

The spring binding post offers unique advantages that can't be duplicated:

1. No screw cap to tighten or come loose with vibration.
2. Constant, even pressure on the wire at all times in all positions.
3. Easy one-hand feeding of wire into the post.
4. Corrosion - resistant, long-life springs.
5. Complete range of sizes, stem lengths, and accessories for every application.

Replace with Eby Spring Binding Posts — Write today.



HUGH H.

**E B Y**

J N CORPORATION  
18 W. CHELTEN AVE.  
PHILADELPHIA, PA.



the shock transmitted through the package to the meter. If desired, the shock transmitted may be correlated to the total shock administered, and the degree of shock insulation of the particular package may be calculated. Different types of packaging may then be investigated and compared.

Literature is available from the manufacturer, Frederic D. Schottland, 82-62 Grenfell Ave., Kew Gardens, N. Y., whose engineering department maintains package design and testing facilities, and is also prepared to analyze any problem and make recommendations as to the range of meter suitable to its application.

## Literature

**Ignitron Tube.** A new 24-page publication (No. ETI-21) on the General Electric Company's ignitron tube is available from the Publicity Section, Electronics Dept., Schenectady, N. Y. The booklet describes the operating characteristics and performance ratings of the GE ignitron types with an explanation of how they are used in welding circuits and for power rectification. Applications of the ignitron in steel mills, mines, plane factories, floating drydocks and other industries are outlined.

**Introduction to Electronics.** This 20-page booklet (No. E6358) was prepared from material used by Dr. Walther Richter for a series of five lectures which he gave to a group of Allis-Chalmers engineers. The booklet is aimed at applica-

## RADIO BOMB



Radio-controlled glider bombs like this were released from German aircraft in attacks on Allied shipping. This bomb was found packed for transport near Paris

# An important statement on CARDWELL deliveries...

Almost all standard Cardwell Capacitors are now being made at our Plainville, Connecticut, plant. The splendid facilities of this newly acquired plant will permit us to produce greater quantities, and to considerably improve delivery schedules.

## Now Ready! CARDWELL CATALOG

NO. 46



... a valuable new edition, just off the press. Filled with descriptions, charts and photographs of standard Cardwell capacitors, accessories and precision instruments.

... a handy reference manual of unusual interest to engineers and purchasing agents working on present and postwar projects. Your copy will be sent immediately.

### MAIL THIS COUPON TODAY

THE ALLEN D. CARDWELL MFG. CORP.  
81 PROSPECT STREET  
BROOKLYN 1, NEW YORK

Please send me a copy of the Cardwell Catalog #46.

NAME .....

FIRM NAME .....

ADDRESS .....

CITY ..... STATE .....

# CARDWELL CONDENSERS

THE ALLEN D. CARDWELL MANUFACTURING CORPORATION  
81 PROSPECT STREET  
BROOKLYN 1, N. Y.



*Streamlined*

... in appearance  
... in assembly

**ELECTRIX  
PLUGS offer**

- ⚡ Superior features of mechanical design
- ⚡ Quick, easy assembly
- ⚡ Lowest cost per finished unit

**ELECTRIX**  
*Corporation*

140-158 MIDDLE STREET  
PAWTUCKET • RHODE ISLAND

UNITED STATES RUBBER COMPANY  
Exclusive Selling Agents



FOR **QUALITY**

## RADELL-BUILT PRODUCTS

• It is easy to recognize the marks of superior craftsmanship in Radell-built electronic products. With a broad basic knowledge and advanced production skill, Radell Corporation is a versatile organization specializing in the assembly and sub-assembly of highest quality electronic products.

**COMPLETE FACILITIES FOR AUDIO WORK**

**RADELL** CORPORATION

6323-37 Guilford Avenue, Indianapolis 5, Indiana

**FLASH!!**

**HARRISON  
HAS RECEIVERS**

**110 KC TO 210 MC!**

FOR IMMEDIATE DELIVERY

Here's the good news we've all been waiting for. Harrison can ship you **WITHIN 24 HOURS** a brand new, latest improved model Communications Receiver.

But hurry! We don't expect even our tremendous stock to be adequate for the pent-up demand. It's first come—first served, so wire or mail your order right now.

**110 KC TO 18 MC**

**HALLICRAFTERS S-22R**



The Skyrider Marine—an efficient marine receiver at a moderate price. Protected against salt air. AC or DC operation. Top performance afloat or ashore.

Eight tubes, nickel plated chassis, built-in speaker. Complete \$74.50.

**550 KC TO 42 MC**

**HALLICRAFTERS SX-28A**



Here's the new Super Skyrider—the receiver that played an outstanding role in War Communications! Improved—up-to-the-minute—ideal for Lab or home.

15 tubes, crystal filter, noise limiter, adjustable band width. . . . . \$223

**27.8 TO 143 MC**

**HALLICRAFTER S-36**

FM-AM-CW, full coverage in three bands, fifteen tubes, 115/230 V. AC operation, audio system flat from 40 to 15,000 cycles, noise limiter. . . . . \$307.50



**130 TO 210 MC**

**HALLICRAFTERS S-37**

Advanced features of design providing peak VHF performance. FM-AM, two RF stages, three I.F. stages, voltage regulated, mechanical bandspread, 14 tubes, noise limiter. . . . . \$591.75

Hallcrafters - Jensen 10 Inch PM dynamic speaker in cabinet to match above receivers. PM-23 . . . . . \$15

**NATIONAL H R O**

Nine tubes, 1.7 to 30 MC Table model, complete with tubes, speaker and pack. \$226.35

Literature describing these Receivers is available upon request.

(Prices subject to change without notice)

Have you our new 800 page **BUYERS GUIDE?** Write today!

**HARRISON**  
RADIO CORPORATION  
12 WEST BROADWAY • NEW YORK CITY 7  
BARCLAY 7-9854  
JAMAICA BRANCH - 172-31 Hillside Ave. - REPUBLIC 9-4102



tion engineers and is designed to provide an understanding of the principles of electronics and to give an idea of the part electronics will play in future industrial developments. A brief discussion on the fundamentals of conversion and control of electric power in a load prefaces the introduction to the subject of electron tubes. The discussion of tubes is divided into two main parts: vacuum and gaseous. Differences between a vacuum tube and the equivalent mechanical device, methods of specifying tube performance, application of tube characteristics for design purposes, and use of the high-speed response of the tube are explained. Principles of tube detector action with applications, and principles of tube oscillators with application to induction and dielectric heating are also given. Line drawings, curves, and sketches add to the comprehensiveness of this booklet. Allis-Chalmers Mfg. Co., Milwaukee 1, Wis.

**RCA Questions and Answers.** A 48-page book entitled "RCA, What It Is, What It Does" was published in response to questions that are often asked of RCA. The booklet covers such subjects as broadcasting, television, manufacturing, communications, marine radio, technical training, research and engineering and other data about RCA. Radio Corporation of America, 30 Rockefeller Plaza, New York 20, N. Y.

**Substitute Tubes for Diathermy.** A substitution list of tubes for diathermy apparatus has been published by Taylor Tubes, Inc., 2312 Wabansia Ave., Chicago, Ill. The leaflet lists the equipment by manufacturer and shows which type tubes are furnished with the unit and the Taylor tube substitute.

**Bushings and Insulators.** Dimensional and electrical data on Tronex 1300 line of solder-seal bushings is contained in an 8-page booklet available from T. C. Wheaton Co., Industrial Div., Millville, N. J. One page of the booklet illustrates types of electronic components available, and two pages of the booklet give background data on Wheaton.

## D.P.I. Vacuum Coating Units



**MEETING** today's rigid requirements of uniform, versatile, high-capacity production.

The units pictured here are part of a large battery of the new D.P.I. Vacuum Coaters—Model LC 1-500-3, designed to deposit metals or metallic salts on glass, other metals, and plastics.

### SIX OUTSTANDING FEATURES

1. Fast evacuation cycle
2. Convenient high-vacuum valve
3. Rugged construction
4. Low maintenance costs
5. Simplicity of operation
6. Completeness—ready for operation with the necessary pumps, gauges, controls, wiring, and service connections

For further information on D.P.I. vacuum coating equipment . . . *Write Vacuum Equipment Division.*



**DISTILLATION PRODUCTS, INC.**

Jointly owned by EASTMAN KODAK COMPANY and GENERAL MILLS, INC.

ROCHESTER 13, N. Y.

**PERFECT YOUR  
POST-WAR  
PRODUCTS  
WITH DIALCO**

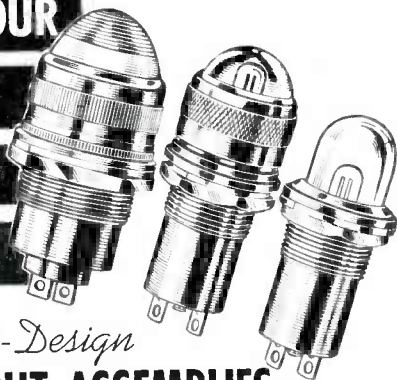

*Functional-Design*  
**PILOT LIGHT ASSEMBLIES**

HOUSING NEON OR MAZDA LAMPS

GREATER emphasis on *functional* design is the trend in post-war engineering of Electrical-Electronic Products. Mindful of this fact, Dialco has produced a line of Pilot Lights calculated to meet readily all post-war requirements. Comprising Warning-and-Signal Pilot Lights, Panel Lights, Jewel Assemblies, and Socket Assemblies, the Dialco line offers unlimited variations in functional design, size, shape, electrical characteristics, color, finish, etc. Special emphasis on applications of NEON Glow Lamps.



Let our Engineering Dept. help you select the *Pilot Light* best suited to the functional design of your post-war product.

**PLUS LAMPS:** To help speed production, we offer Pilot Lights completely assembled with the required General Electric or Westinghouse Lamps.

WRITE FOR NEW  
ILLUSTRATED  
BROCHURE

**DIAL LIGHT CO.** of America, Inc.

900 BROADWAY • NEW YORK 3, N. Y.  
Telephone: ALgonquin 4-5180-1-2-3

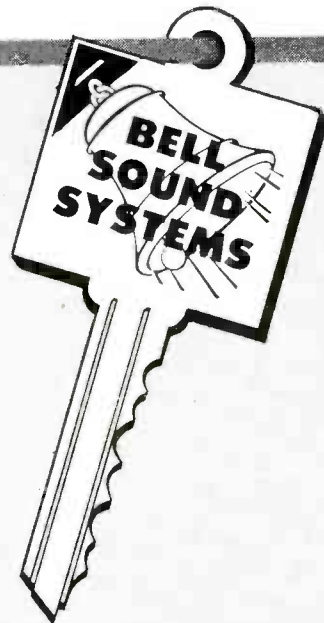

**BELL  
MAY HAVE  
THE "Key"  
TO YOUR  
ELECTRONICS  
NEEDS**



The right use of electronics may unlock new possibilities for your postwar product, or open the way to new efficiency on your production line. Bell engineers may have the key—the electronic answer—to your needs! BELL's wide experience in designing and building electronic assemblies and controls—from the earliest developments right through to the latest types—qualifies them to serve you. Your inquiry will not obligate you in any way.

AMONG PRESENT BELL PRODUCTS ARE—Electronic Sound Devices — Intercommunicating Systems—Industrial Voice-Paging and Broadcasting Equipment — Permanent and Portable Amplifying Systems—Recording and Disc Playing Units — Electronic Controls — Operating Sequence Recorders — Other Special Devices.



**BELL SOUND SYSTEMS, INC.**  
1189 Essex Ave. Columbus 3, Ohio  
Export Off. 4900 Euclid Ave., Cleveland 3, Ohio

**ZOPHAR**

**Fungus-Proofed  
Waxes**

As a vital service to the Armed Forces we now offer Fungus Resistant Materials. These recently developed products are the answer to Communications requirements where the impregnation or coating of radio parts and equipment are concerned.

ZOPHAR waxes and compounds meet every specification of both the Army and Navy for waterproofing and insulating all electrical and radio components. They also have wide application in packaging of every description.

**ZOPHAR MILLS** INC

112-130—26th STREET ESTABLISHED 1846  
BROOKLYN, N.Y.



**Tube Chart.** Amperex Electronic Corp., 25 Washington St., Brooklyn 1, N. Y., have made available a wall-mounting tube interchangeability chart which lists approximately 300 transmitting-tube type numbers and their equivalent designation in Amperex tubes.

**Volt-Ohm-Milliammeter.** Model No. 625-N multi-range, volt-ohm-milliammeter with a 5-in. scale is described and illustrated in a 1-page form (No. 71045-T). The instrument is rated at 20,000 ohms per volt d-c, and 10,000 ohms per volt, a-c. The Triplett Electrical Instrument Co., Bluffton, Ohio.

**Vibrating Reed Frequency Meters.** New uses for vibrating-reed frequency meters are described and illustrated in a 4-page bulletin (No. VF-43-1C) from J-B-T Instruments, Inc., 441 Chapel St., New Haven 8, Conn. Several special purpose meters are included in the bulletin.

**Background Data.** The title of this 20-page booklet is "The Story of Webster Chicago". Besides the data giving the background history of Webster, the booklet contains illustrations and descriptive matter on the products manufactured by Webster Chicago Corp., Chicago, Ill.

**Supplemental Catalog Data.** An 8-page Supplemental Bulletin, No. 3, supersedes all technical data on Types BT (metallized insulated resistors) and BW (insulated wire wound resistors) manufactured by International Resistance Co., 401 N. Broad St., Philadelphia 8, Pa.

**Dry Air Pumps.** Bulletin No. 30 illustrates and describes three different pumps which were originally designed for filling coaxial transmission lines, but which can also be used for electrical, radio and radar equipment. Andrew Co., 363 East 75th St., Chicago 19, Ill.

**Railroad Radio Communications.** This title designates the name of a 20-page brochure designed to tell



# WAVE FILTERS

*Precision Made for Specialized Applications*

Engineering experience and manufacturing know-how combine to make Chicago Transformer unusually well qualified to design and produce all types of audio frequency filters for the most exacting requirements.

**Also makers of . . .**  
Power transformers for radio and other electronic circuits, vibrator power transformers, audio and filter reactors, instrument transformers, auto and control transformers, wave filters, fluorescent ballasts and ignition coils.

## CHICAGO TRANSFORMER

DIVISION OF ESSEX WIRE CORPORATION  
3501 WEST ADDISON STREET  
CHICAGO, ILL.



# HARVEY

delivers  
RADIO AND ELECTRONIC  
EQUIPMENT  
WITHOUT PRIORITY  
anywhere in the  
U. S. A.

With Government regulations eliminated, HARVEY can now fill your needs for radio, electronic, test and laboratory equipment more quickly and efficiently from the finest and largest stocks in our history.

HARVEY carries the lines of leading American radio and electronic manufacturers. Their long-promised postwar products will be on our shelves the very moment they are released.

Our experienced staff is ready to serve you.

**Special Buy!**  
Heavy Duty Desk Panel Cabinets

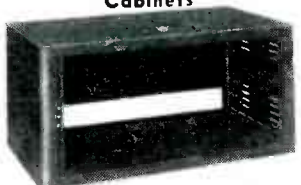

8 3/4" high x 19" long x 1 3/4" deep

Ideal for small transformers, public address amplifiers, oscillators, test equipment, etc.

These cabinets are rigidly constructed of 1/16" cold rolled steel, with all joints electrically welded. Louvres provide ample ventilation through sides and back. Top door is mounted with piano type hinges, and locks with flush mounted snap catches. Two sturdy handles are mounted on each side and semi-recessed. Black ripple finish. Suitable for standard 8 3/4" x 19" relay rack panel or any size chassis up to 13" x 17". Price. \$4.95.

Telephone Orders to LO 3-1800

**HARVEY**  
RADIO COMPANY  
**HARVEY**  
103 WEST 43rd ST., NEW YORK 18, N. Y.

the reader that this company has engineered a comprehensive and integrated communication system which can be adapted to the individual requirements of each railroad. The brochure contains many illustrations relating to different phases of railroad communication. Maguire Industries, Inc., Electronics Div., 1437 Railroad Ave., Bridgeport, Conn.

**Electronic Equipment.** Rectifiers, test equipment, aerial printer, electronic timers, solenoid brakes, 400-cycle timers, junction boxes, oscillators, switches, solenoids, antennas are all illustrated in a 4-page bulletin entitled "Electronic Equipment" which tells the reader that Richardson-Allen Corporation specializes in electronic engineering, development and production. 15 West 20th St., New York 11, N. Y.

**Radio Accessories.** General Cement Manufacturing Co., of Rockford, Ill., have issued a catalog (No. 146) which contains a complete listing of their line of radio cements, chemicals, hardware, cabinet repair kits, repair parts, tools and other service accessories.

**Electrical Instruments.** Types TD and TA, RD and RA, DD and DA, OD and OA, VD special, PD and PA, and VD and VA improved ammeters and voltmeters are illustrated and described in three separate pieces of literature available from the manufacturer, The Norton Electrical Instrument Co., Manchester, Conn.

**Precision Instrument Dials.** A 4-page bulletin (Form No. 1-745-2M) from American Dial Co., Inc., (450 West 45th St., New York 19, N. Y.) contains many illustrations and descriptive data of precision instrument dials which have been produced by means of an optically-recording instrument which utilizes a combination of optical and electro-mechanical principles. Dial graduations are available in any dimension from three microns (0.000120 in.) in width for microscopic dials up to any desired size to meet



## ACCURACY OF LARGER METERS IN MB 1-inch Miniatures

PRECISION DESIGNED and skillfully built, MB meters have the stamina and accuracy to meet the most precise, rigorous tests. Lightweight moving coil mounted on standard size jewel bearings and pivots . . . powerful, retentive magnet . . . hermetically sealed, anodized aluminum case—all combine to give ability to withstand vibration, shock, temperature extremes, moisture.

These 1 1/4 oz. instruments are available in standard DC ranges from 100 microamperes through 10 milliamperes . . . and 0-10 and 0-50 millivolts. Standard external shunts, multipliers, rectifiers available for other ranges. MB also offers a 1 1/2-inch, 1 1/2 oz. model self-contained in all standard DC ranges, and rectifier-type AC voltmeters and milliammeters.

MB miniature meters are adaptable to a hundred and one uses. Our engineers will be glad to aid in your problems. Write Dept. G for catalog and details.

THE  
**MB MANUFACTURING  
COMPANY, INC.**

ELECTRICAL METERS FOR  
AIRCRAFT AND PORTABLE EQUIPMENT

Instrument Division  
250 DODGE AVE., EAST HAVEN 12, CONN.



# ENGINEERED TO THE APPLICATION

## HI-Q

### CERAMIC CAPACITORS

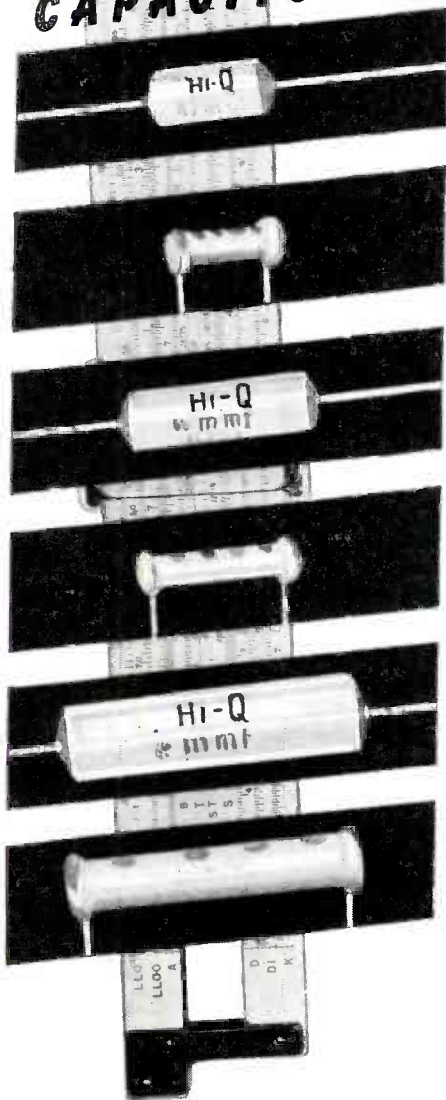

**ELECTRICAL  
REACTANCE  
CORPORATION**  
FRANKLINVILLE, N. Y.



*New* **ATLAS Little GIANT**

**Model DR-12**

Versatile is the word for Atlas Sound's latest creation the DR-12 Little Giant (Bell diameter 7 in. Overall length 7 1/2 in.) Its construction gives equally gratifying service when used for marine application, factory, police and other communications . . . a design that has proven itself more than equal to War's rigorous demands.



*Write for detailed description*

**ATLAS SOUND**  
CORPORATION

1449 39th Street

Brooklyn, New York



**METAL  
STAMPINGS**  
IN SMALL LOTS

Die cut metal stampings in limited quantities can be produced to your special requirements at 15% to 20% of the cost of permanent type tools. No matter how small your quantity requirements or how intricate your work, we can show you a definite saving. During our twenty-three years of specialized experience in this service, there has been no other method of producing metal stampings in small lots that can equal the process originated by Dayton Rogers.

Our new, illustrated booklet #176-17 will give you full particulars.

**DAYTON ROGERS MFG. CO.** 2835 12th Avenue So.  
Minneapolis, Minnesota

# TRANSFORMERS FOR *POSTWAR* ELECTRONIC APPLICATIONS



● Designed to meet your specifications, mechanically and electronically.

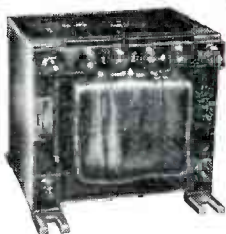

Open type, plastic impregnated transformers provide adequate weatherproofing for certain applications.



This special Radio Power transformer consists of primary winding, high voltage secondary winding and filament winding.

**THE ACME ELECTRIC & MFG. CO.**  
CUBA, N. Y.

**Aeme  Electric**  
TRANSFORMERS

commercial requirements. Any indicated wave forms (sine, square top, or saw-tooth waves) can be recorded to any frequency as close as 1 cycle apart and of any desired amplitude. Dials can be produced on any metal or plastic material, complete and ready for installation.

**Industrial Tube Manual.** A new 412-page technical manual on electronic tubes, prepared by General Electric Company's Tube Division, is available from GE at a cost of \$2.00. The manual is intended to serve as a guide in selecting tubes for industrial applications. Popular applications of ignitrons, phototubes, thyratrons, phanotrons and other tube types are given in the manual, which is illustrated with photographs, outline drawings and performance curves. The manual has an expander-type binder and provision has been made by GE to supply purchasers with new data as prepared for the manual from time to time for a nominal annual charge of \$1.00. Electronics Dept., 267-122 at Schenectady, N. Y.

• • •

## CANCER TREATMENT



Million-volt x-ray provides therapeutic radiation for treatment of cancer, tumors and other malignant diseases responsible for half the deaths in Surgical Service, Army Medical Center, Walter Reed General Hospital. One of four supervolt therapy units installed in the country, its design is based on General Electric industrial x-ray for examining thick metal castings (see *ELECTRONICS*, Dec. '44, p 128; June, '45, p 122)

# GOULD-MOODY *Improved* Professional Quality *"Black Seal"* ALUMINUM INSTANTANEOUS RECORDING BLANKS



Technological advancements brought about by our wartime assignments provide critical engineers with "Black Seal" blanks of improved cutting and reproduction qualities plus more satisfactory play-back life.

### Rapid Deliveries to

Broadcasting Stations  
Recording Studios  
Motion Picture Sound Studios  
Schools and Colleges  
Governmental Agencies

Old Aluminum Blanks Recoated with  
"Black Seal" Formula on Short Notice

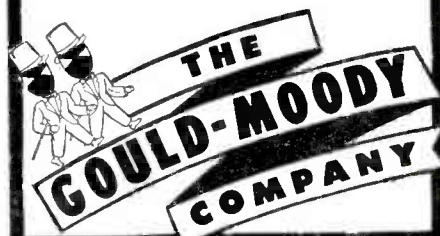

395 BROADWAY, NEW YORK 13, N. Y.  
Cable Address: Recordisc, New York, N. Y.  
Export Dept: Royal National Company, Inc.  
89 Broad Street, New York



**IMMEDIATE DELIVERY FROM STOCK**

**TRIPLETT**  
Volt-Ohm-Milliammeters

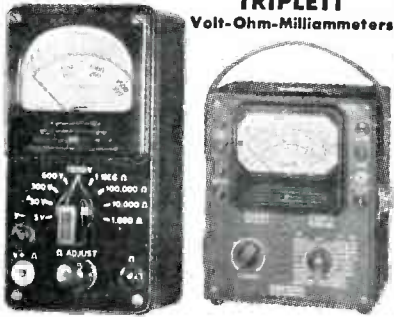

TRIPLETT 666 ..... 15.25  
 TRIPLETT 666-H ..... 16.00  
 TRIPLETT 1200-S ..... 34.67  
 Servicemen's Priority

**MASCO AMPLIFIERS**

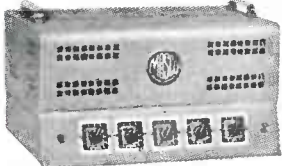

Complete with tubes.

17 Watt ..... 30.30  
 25 Watt ..... 42.60  
 35 Watt ..... 54.60  
 50 Watt ..... 70.50  
 17 Watt with Phono-top ..... 42.30  
 25 Watt with Phono-top ..... 52.20  
 35 Watt with Record-changer ..... 89.10

**TURNER MICROPHONES**

Model	Type	Cord	Level	Each
BX	Crystal	7'	-55	\$5.85
22X	Crystal	7'	-52	10.88
33X	Crystal	20'	-52	13.23
BD	Dynamic	7'	-52	8.53
33D	Dynamic	20'	-54	14.70



**SPEAKER BUYS!**

4" PM square	.....	\$1.35
4" 450 ohm square	.....	2.40
5" PM 2 watt	.....	1.23
5" 450 ohm	.....	1.50
10" PM 11 watt	.....	7.20
12" PM 16 watt	.....	10.14
12" PM 17 watt	.....	14.25



**SPRAGUE - CORNELL DUBILIER AEROVOX CONDENSERS**

8 mfd 450v Upright can	76¢
16 mfd 450v Upright can	1.12
20 mfd 450v Upright can	1.23
8 mfd 450v Tubular	44¢
16 mfd 450v Tubular	65¢
20 mfd 150v Tubular	44¢
20-20 mfd 150v Tubular	76¢
40-20 mfd 150v Tubular	82¢
30-30 mfd 150v Tubular	79¢
50-30 mfd 150v Tubular	94¢



**RADIART VIBRATORS**

Type	Equal	Each
S-1	4-4	\$1.35
5300	294	2.09
5326P	509P	1.76
5334	868	2.09
5341M	001M	1.76
5400	248	3.50
5428	716	3.50

ORDER OTHERS BY MAKE AND SET MODEL

CRYSTALS	.....	M22 2.94	L40 2.35	LP6 4.70
PICKUPS	.....	2.97	3.30	3.90
MOTORS	.....	3.17	3.33	

**PHILCO BEAM OF LIGHT**

Selenium Cell only, no holder ..... 1.80

20% deposit required on all C.O.D. orders. 2% transportation allowance on orders of \$25.00 or more accompanied by payment in full.

Write for FREE CATALOG

**RADIO SUPPLY & ENGINEERING CO., Inc.**  
 127 SELDEN AVE. DETROIT 1, MICH.

Spencer Microscopes bring new precision to the drill press

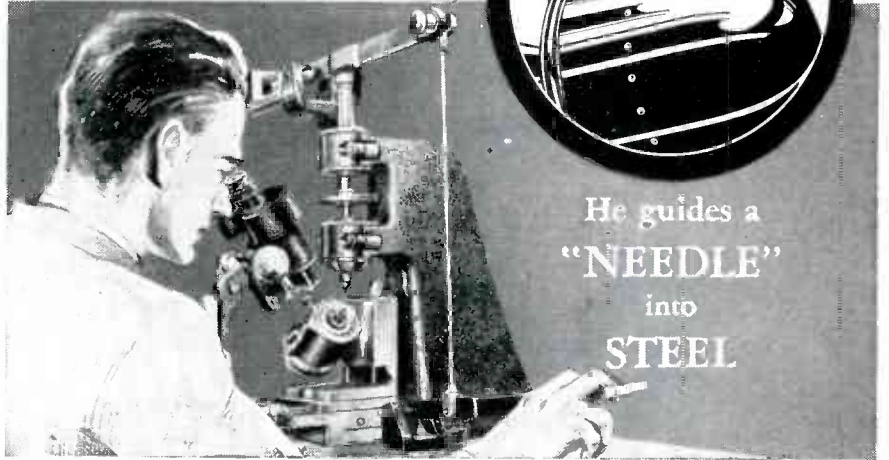

He guides a "NEEDLE" into STEEL

With miniature drills as small as .0040" in diameter, the operator produces Diesel engine injection spray tips with openings barely visible to the naked eye, yet held to remarkably close tolerances. To meet the need for such precise drilling, National Jet Company manufactures these small drills and is now supplying a precision drilling machine equipped with a Spencer Stereoscopic Microscope through which the operation can be observed.

To other manufacturers whose plans call for optical parts or complete instruments, we offer extensive research and manufacturing facilities, plus many years of experience in building fine Spencer scientific instruments.

**American Optical COMPANY**  
 Scientific Instrument Division  
 Buffalo 11, New York

Manufacturers of **SPENCER** Scientific Instruments

**THE CONNECTICUT CABLE CORPORATION**

*Now in Peacetime Production*

OFFERS TO THEIR OLD AND NEW CUSTOMERS

**PROMPT DELIVERY**

OF ALL TYPES OF

*Electric Cord Sets*

Manufactured to commercial specifications or customer's individual requirements.

- EXTENSION CORDS
- HEATER CORDS
- HARNESSES
- LAMP CORDS
- RADIO CORDS
- CUSTOM MOLDED SETS

All wires engineered and manufactured in our own plant. Our prices are truly competitive. We solicit your inquiries regardless of quantity.

**THE CONNECTICUT CABLE CORPORATION**

JEWETT CITY • CONNECTICUT

FOR CAPACITIES UP TO SEVERAL THOUSAND VOLTS AC, GRAYHILL ROTOSWITCHES OFFER A NEW VERSATILITY EQUAL TO PRACTICALLY ANY SPECIAL CIRCUIT COMBINATION. SUBMIT YOUR PROBLEM TO OUR ENGINEERING DEPARTMENT.



**Grayhill**  
5 North Pulaski Road  
Chicago 24, Illinois

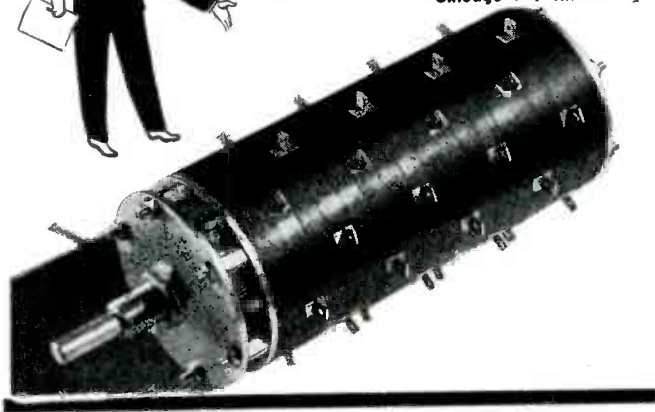

## NEW BOOKS

### Electromagnetic Engineering

By RONOLD W. P. KING, *Cruft Laboratory, Harvard University. McGraw-Hill Book Co., Inc., New York, N. Y. 1945, 580 pages, \$6.00.*

FIRST OF A SERIES of three textbooks written for advanced undergraduate or graduate study, this work lays the foundation for wave propagation problems to be considered in following, as yet unpublished, works. The author should be familiar to technical readers through his papers on wave guides and antennas in engineering society journals.

The approach is highly analytical, beginning with a mathematical description of matter and space, considering field and force equations, reviewing the development of electromagnetic wave analysis in a logical rather than historic order, and concluding with internal impedance (skin effect) and general circuit properties.

To read this work unaided, the engineer needs a firm background of modern physical theory and complex and vector calculus, as well as the usual physics and mathematics of undergraduate level.

This work is indicative of the growth of engineering. Five years ago the material of this book would have been contained in two physics texts which would have been looked upon as scholarly works of but academic interest. Today the material is presented as a single-volume engineering text. The extension from the field of physics to that of engineering is in large measure due to the author's preparation of the analytical approach so that it is available to engineers. The content is what one must know to design uhf equipment.—F.R.

### Electrical Coils and Conductors

HERBERT BRISTOL DWIGHT. *McGraw-Hill Book Co., New York 18, N. Y., 351 pages, \$5.00.*

THE DESIGN OF COILS and conductors as they are used in electrical machinery and power distribution is based on a consideration of many interrelated factors. The evaluation of each factor in itself depends

# IN-RES-CO RESISTORS

For super-performance in critical circuits...

Supplying low-cost wire wound resistors to meet critical circuit requirements is our business. Manufacturers of television, radar, radio or other equipment who require fast delivery on resistors of proven superiority are invited to investigate the low cost and diversified types available from IN-RES-CO. A completely illustrated and informative, it includes inductive, non-inductive, non-inductive types for every application need.

Type BLN: 4 watt, moisture proof, non-inductive resistor. Max. res., 20,000 ohms, dia. 7/16", length 1 1/2" long.



**INSTRUMENT RESISTORS CO.**

25 AMITY STREET, LITTLE FALLS, NEW JERSEY



# Teach yourself MATHEMATICS for big new jobs in radio television radar

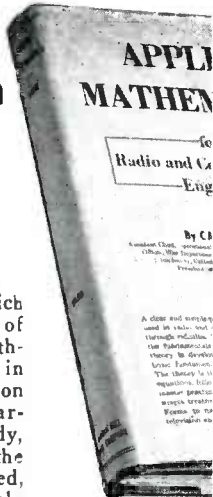

Here's the manual which can make you master of mathematics, from arithmetic to calculus, used in radio and communication engineering. Especially arranged for home study, the book gives all the mathematics you need, from basic fundamentals to more detailed concepts—to help you get ahead in radio, television, frequency modulation, radar development.

**Just Published!**

## APPLIED MATHEMATICS

For Radio and Communication  
Engineers

By **CARL E. SMITH**

Assistant Chief, Operational Research Branch, Office of the Chief Signal Officer, War Department; Development and Research Engineer (on leave), United Broadcasting Co., Cleveland.

**336 pages, 5 1/4 x 8 1/4, \$3.50**

You will find it easy to learn by yourself through this method of presentation. Useful design equations are solved in the text, and 150 exercise problems help you build a sure working knowledge of each subject. There is a simplified treatment of calculus and the last chapter on series and wave forms meets the modern trends to frequency modulation, television and radar development. An unusually full appendix of useful charts and tables contains all necessary reference material.

### CHAPTERS

Arithmetic	Quadratic Equations
Logarithms	Hyperbolic Trigonometry
Algebra	Differential Calculus Treat-
Geometry	ing Algebraic Functions
Trigonometry	Differential Calculus Treat-
Vector Addition	ing Transcendental Func-
Complex Quantities	tions
Curves and Graphs	Integral Calculus
Simultaneous Equations	Series and Wave Forms

Includes 97 figures, 20 tables and charts. The presentation has been streamlined to include only the subject matter most useful in the field of radio and communication engineering.

**See it 10 days—Send coupon**

McGraw-Hill Book Co., 330 W. 42nd St., N.Y.C. 18

Send me Smith's Applied Mathematics for Radio and Communication Engineers for 10 days examination on approval. In 10 days I will send \$3.50, plus few cents postage, or return book postpaid (Postage paid on cash orders.)

Name .....

Address .....

City and State .....

Company .....

Position ..... L 10-45

## NEED SMALL, INTRICATE METAL STAMPINGS TO CLOSE TOLERANCES?

### GOAT *Precise-Formed* METAL STAMPINGS

### HOW GOAT SAVES YOU TIME AND MONEY

Goat specializes in the design and fabrication to close tolerances of small, intricate, drawn, formed, stamped metal and alloy parts. Expert tool design, quality control, and modern manufacturing techniques can save you time and money on parts like those illustrated above.

ENGINEERS  
SEND US  
YOUR  
PROBLEMS



## GOAT

METAL STAMPINGS, INC.

AN AFFILIATE OF THE FRED GOAT CO., INC.  
314 DEAN STREET, BROOKLYN 17, N. Y.



## BLOWERS for Electronic Equipment

Easy-to-install . . . compact . . . quiet-running . . . economical . . . these are the features which make Pilot Blowers ideal for the important job of air circulation and ventilation in Radio Equipment. Available in standard models to move from 15 to 100 C.F.M. Write for Bulletin 507.

## SHADED POLE F. H. P. MOTORS

Tell us what your requirements are and we will send you "fact sheets" giving complete specifications on these dependable, efficient, low-cost Motors. For continuous or intermittent duty with H.P. ratings ranging from 1/15 to 1/500 H.P. and from 1550 to 3400 R.P.M. Plain round or with base or resilient mounting . . . open or enclosed cases.

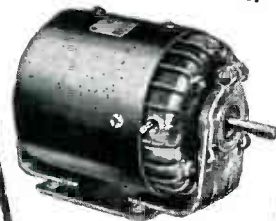

F. A. SMITH MFG. CO., INC.  
801 DAVIS ST., ROCHESTER 2, N. Y.

SHADED POLE  
MOTORS

# Pilot

CENTRIFUGAL  
BLOWERS

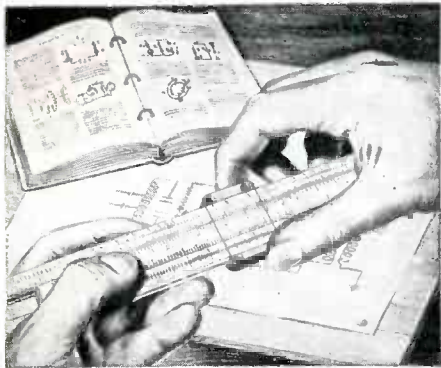

**MR. RADIOMAN: You Can Use These "Tools" To Build a Better Job and a Secure Career in RADIO-ELECTRONICS**

**CREI Home-Study Training in Practical Radio-Electronics Engineering Combined With Your Own Experience Assures You Job Security and an Interesting, Profitable Career**

What's ahead for you in the field of Radio Electronics? One thing is certain. Now that peace is here, Radio-Electronics will surge forth as one of America's foremost industries, offering promising careers for radiomen with modern technical training.

NOW is the time to take the time to prepare yourself for these important, career jobs in radio-electronics engineering. CREI can show you the way by providing you with the "tools" to build a firm foundation of ability based on a planned program of technical training. In our proved home-study course, you learn not only *how* . . . but *why*! Easy-to-read-and-understand lessons are provided you well in advance, and each student has his personal instructor who corrects, criticizes and offers suggestions on each lesson examination. This is the successful CREI method of training for which more than 10,000 professional radiomen have enrolled since 1927.

Your ability to solve tough problems on paper and then follow-up with the necessary mechanical operation, is a true indication that you have the *confidence* born of *knowledge* . . . confidence in your ability to get and *hold* an important job with a secure, promising post-war future. Investigate now the CREI home-study course best suited to your needs, and prepare for security and happiness in the New World of Electronics! *Write for all the facts now.*

• **WRITE FOR NEW, FREE 36-PAGE BOOKLET**

If you have had professional or amateur radio experience and want to make more money—let us prove to you we have something you need to qualify for a better radio job. To help us answer intelligently your inquiry — **PLEASE STATE BRIEFLY YOUR BACKGROUND OF EXPERIENCE, EDUCATION AND PRESENT POSITION.**



## **CAPITOL RADIO ENGINEERING INSTITUTE**

Dept. E-10, 3224 — 16th Street, N. W.  
WASHINGTON 10, D. C.

Contractors to U. S. Navy—U. S. Coast Guard  
—Canadian Broadcasting Corp. Producers of  
Well-trained Technical Radiomen for Industry

Member: National Council of Technical Schools

upon many variables. In this book, the author has isolated the factors and analyzes each one individually. He assumes that the reader is an electrical engineer with a broad and detailed knowledge of the equipment and apparatus used to generate and distribute electrical power.

To comprehend and interpret the subject matter, which consists mostly of formulas complemented with a brief concise statement of their derivation, an electrical engineer should be well versed in the methods of analytical calculus and have some acquaintance with higher mathematical functions.

The formulas presented have many practical applications, but few of the specific applications are discussed in detail. The formulas cover the calculations necessary for evaluating reactance, eddy current loss, skin effect, inductance, and magnetic field strength of coils and conductors that carry electrical current.

One long chapter is devoted to formulas for inverse functions of complex quantities that are used in several branches of electrical engineering, such as in calculations for transmission and communication circuits.

Chapters dealing with trans-

### **MICROSECOND X-RAY**

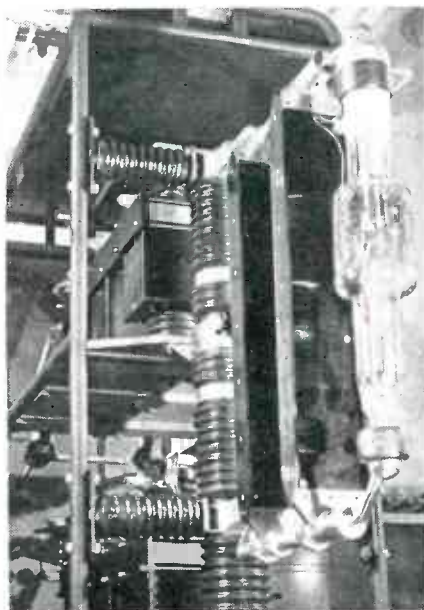

X-ray exposures short enough to catch the action of a bullet traveling down a gun barrel are produced by this Westinghouse tube. The 600 million watts for the exposures are delivered from six capacitors of the surge generator behind the tube

**PARTS?**  
ORDER TODAY FROM . . .

**R. W. T.**  
**WORLD'S LARGEST**  
Radio Supply House • Founded 1922

For Industrial Organizations  
Laboratories • Purchasing Agents  
Radio Dealers & Service Men  
Training Schools • Expeditors  
Amateur Operators and Experimenters

**10,000 PARTS**  
immediately available. (Some no longer  
need priorities.) Selected and shipped  
same day your order is received.

**Radio Wire  
Television Inc.**  
100 SIXTH AVE. (DEPT. E-10) NEW YORK 13  
BOSTON, MASS. NEWARK, N. J.

Originators of the  
*Lafayette Radio*  
soon in production again



# MARTINS INSTRUMENT CO., INC.

is "In the groove and ready to go!"

We have helped Uncle Sam and now  
We would like to help you

**SAVE MANUFACTURING COSTS  
SPEED UP PRODUCTION AND  
YOUR PLANS FOR POST WAR WORK**

These are some of the fields in which we have  
experience and production facilities

- WIRING INSTRUMENTS
- WINDING ARMATURE
- CABLES
- FILTER COILS
- SWITCHBOARDS
- RADIOS

*Machine Shop and Drafting Room Time Available to Create and  
Develop Your Mechanical and Electrical Ideas.*

MARTINS INSTRUMENT CO., INC. 316 37th St., Brooklyn 17, New York

# "SEALOL"

**BALANCED PRESSURE SEAL  
FOR ANY ROTATING SHAFT**

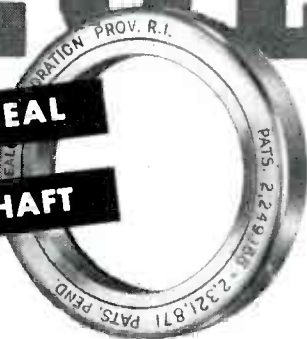

**INVESTIGATE THIS "ENGINEERED" SEAL  
USED IN MANY ELECTRONIC DEVICES  
WRITE AND TELL US YOUR REQUIREMENTS**

"Sealol" is doing a vital job in the Electronic Industry sealing liquids and gases under pressure or vacuum with the utmost dependability. Balanced Pressure feature controls seal face pressure for minimum friction loss. "Sealol" is available in many constructions for efficient sealing under a wide range of conditions. Bulletin on request.

## SEALOL CORPORATION

45 WILLARD AVENUE, PROVIDENCE 5, R. I.

Baltimore • Chicago • Cleveland • Detroit • Los Angeles • New York

# FREE!

NEW 11th. EDITION

# RADIO'S MASTER

*The only official  
Radio and Electronic  
equipment source-book*

## Tells you:

### WHAT

the product does, its specifications, comparable and competing items . . . Thousands of illustrations . . . Data covers 90% of all products in the industry, each item indexed and cross indexed.

### WHO

makes it. Directory of manufacturers alphabetically listed, with page numbers for instant reference.

### HOW MUCH

Prices on thousands of items, all clearly catalogued for easy buying.

### WHERE

you can get it. Your nearest sources that can supply your radio and electronic requirements. Saves time . . . Eliminates bulky files.

**IMPORTANT**

Distributors from coast to coast have just bought quantities of this 800 Page, hard-covered encyclopedia ready for free distribution.

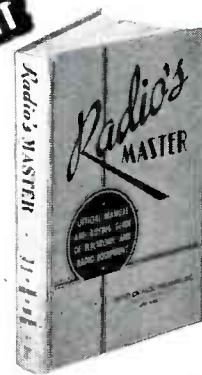

If you are an Engineer or Purchasing Agent WRITE FOR FREE COPY NOW.

★ Write us on your company letterhead and we'll put you in touch with the jobber nearest you who has your FREE Copy. No obligations.

Address Dept. FEP

**UNITED CATALOG  
PUBLISHERS, INC.**  
110 Lafayette St., New York 13, N. Y.

# HEXACON ELECTRIC SOLDERING IRONS

..tagged for  
the big jobs!

TYPE P-150  
(illustrated)



Follow the leaders—and use HEXACON! For rugged, heavy duty work or for light intricate work . . . here's the answer. One reason is "Balanced Heat"—dissipating excessive element-impairing heat—and minimizing element burn-outs and tip replacements. Another is their lightweight. Literature is available describing the complete HEXACON line of screw tip and plug tip irons from 40 to 700 watts, and with tip diameters ranging from 1/4" to 1 1/4"

HEXACON ELECTRIC CO.  
130 W. Clay Ave., Roselle Park, N. J.

## HEXACON

HIGH-QUALITY, LONG-LASTING SOLDERING IRONS



### EXACT Q VALUES:

Precision manufacture assures exact Q values. Resulting uniform tuning and gain helps speed equipment production.

### THREADED ROD AND INSERTS:

These are incorporated where required, and MOLDITE'S exclusive feature for retaining screw concentricity is widely recognized.

### SIZES AND SHAPES:

Screw cores, cup cores, tuning slugs are produced in any desired type, with uniform quality and accuracy.

### FREQUENCIES:

Iron cores manufactured to meet your specifications in high, medium or low frequencies.

### ECONOMY:

New MOLDITE formulae allow the substitution of low cost powders, which usually reproduce the performance of more expensive powders.

MOLDITE iron cores are manufactured to fit any coil requirements. Your inquiries and orders will be given our prompt, efficient attention.

# MOLDITE IRON CORES

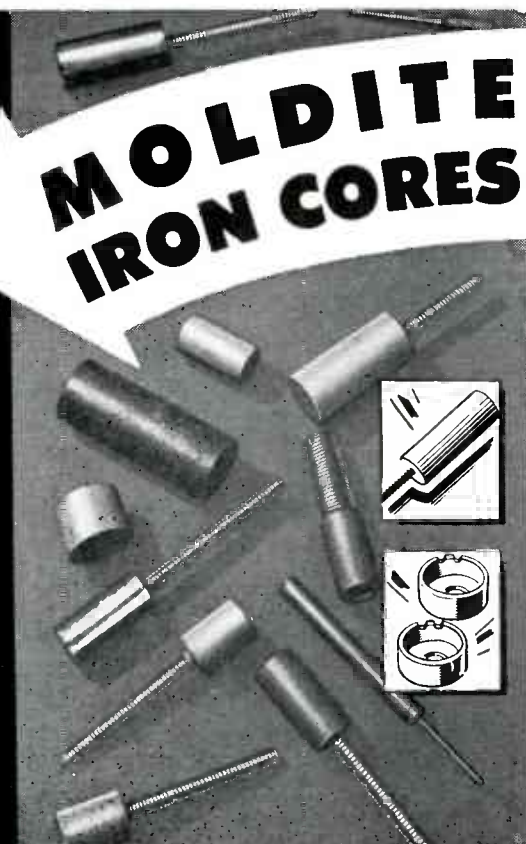

NATIONAL MOLDITE COMPANY  
25 MONTGOMERY STREET, HILLSIDE 5, NEW JERSEY

former design problems include formulas for determining reactance in concentric core-type transformers and those having interleaved components, cross-section of cores, and operation of delta and V banks. Other chapters deal with the reactance of overhead stranded conductors at wide spacing, round tubes, square tubular busbars, and rectangular or strap conductors such as are used to carry heavy alternating currents in busbars on switchboards and in the supply circuits of electric furnaces. Formulas are presented for the calculation of eddy-current loss in transformer windings, armature coils, and in round wire.

The section on heat transfer covers calculations for conduction of heat, thermal resistivity, radiation and convection of heat in transformers and built-up busbars.

Other chapters present methods for determining: The proximity effect in a return circuit of two adjacent strap conductors, in wires, and in thin tubes and sheaths; the mutual inductance of fine wire circles, coaxial solenoids in air, two adjacent thin disk coils in air, and coils with parallel axes; the self-inductance of circular coils without iron; the magnetic field strength near a cylindrical coil in air; the force between coaxial coils without iron, between coils with parallel axes, and between cylindrical transformer coils; the magnetic force on disconnecting switches; the repulsion between strap conductors; the resistance to ground for conductors of different types; and the sag in transmission-line conductors.

Numerous footnotes throughout the text refer the reader to engineering society papers and technical articles that deal with the subject under discussion.—J.K.

## Applied Mathematics for Radio and Communication Engineers

By CARL E. SMITH, *President (on leave to the War Department), Smith Practical Radio Institute, McGraw-Hill Book Co., Inc., New York, 231 pages, \$3.50.*

THE REFRESHER COURSE for home study covered by this text begins with arithmetic and progresses through algebra, geometry, trigonometry into complex quantities



## ATTENTION MANUFACTURERS!

We are distributors to the radio, electronic and electrical trade as well as manufacturers of cord sets, cables and other wire products.

*We are desirous of obtaining additional lines in*

**PLUGS — SOCKETS  
SWITCHES — CAPS  
RADIO and ELECTRICAL  
ACCESSORIES  
and OTHER WIRE PRODUCTS**

*as a distributor or as representatives.*

We prefer to stock the items in Chicago. We have extensive facilities and experience men in the field and can create and handle a large volume of business.

*References Furnished*

**ADVISE AT ONCE**

**COLUMBIA WIRE & SUPPLY CO.**  
4110 N. PULASKI ROAD  
CHICAGO 41, ILLINOIS

# CHASSIS • CABINETS • PANELS • RACKS

*Skill in* **METAL**

PAR-METAL . . . a specialized manufacturing plant employing modern high-speed methods. Nevertheless, Par-Metal products have a definite quality of Craftsmanship—a "handmade" quality born of genuine skill and long experience. *Write for Catalogue.*



Serving the  
Electronics  
Field  
Exclusively

**PAR-METAL PRODUCTS CORPORATION**

32-62—49th STREET . . . LONG ISLAND CITY, N. Y. 100 Varick St., N. Y. C.

Export Dept.



**SCREW  
MACHINE  
PARTS**

**DKE**

*... for exacting needs!*

Facilities for the rapid production of all types of screw machine metal parts—to close tolerance specifications—are available for industry. DKE equipment includes a battery of Brown & Sharpe automatic screw machines, power presses, drill presses, hand turret lathes, and modern machine tools for all other phases of finishing. Quality of work is uniformly high, with particular emphasis on low unit cost.

**INQUIRIES INVITED**

**THE ENGINEERING CO.**  
DANIEL KONDAKJIAN  
27 WRIGHT ST., NEWARK, N. J.

## Draftsmen Wanted

Also

## Designers, Detailers, Tracers and Engineers

We are one of the largest manufacturers of a wide variety of communication and electronic equipment in the world, fully prepared and ready to go ahead with a very ambitious, expansion program as quickly as we are permitted. There will be unlimited possibilities for creative, ambitious men to advance to key positions both in research development and production field. At present, we are producing vital equipment for our fighting forces.

**Good Starting Salaries—Exceptionally fine working conditions**

Apply Personnel Office 8 A. M. to 5 P. M.

**FEDERAL TELEPHONE & RADIO CORP.**

The Mfg. unit of the International Tel. & Tel. Corp.

591 Broad St., Newark, N. J.

W M C Rules Observed

"What goes on!"  
I bellowed,



"I might as well use a  
wooden spoon!"



We know how it is, Tom. Blurs and uneven lines and headaches. What to do? Use Typhonite Eldorado. How that pencil can draw! Crisp, sharp, dense lines—brilliant and true.

No feathering or crumbling in the softer degrees; no grit in the harder degrees. And get this, Tom—Eldorado is dependably uniform in all degrees. A 2H is a 2H today, tomorrow and always!

Eldorado is a sweet pencil. And the best test is to try it. So send for a free Comparison Sample now. Request it on your business or professional stationery, specifying degree.

**DIXON'S  
TYPHONITE  
ELDORADO**

Pencil Sales Dept. 59-J10

JOSEPH DIXON CRUCIBLE CO., Jersey City 3, N. J.

and advanced algebra, and concludes with chapters on differential and integral calculus. The concisely presented material is readily grasped by those reading the book as a review. However, to the readers covering the material for the first time, essential points are not brought out with sufficient force to be readily appreciated. (It is intended that the book be used in connection with a correspondence school.) Answers to the many problems are included.

Illustrative mathematical solutions are well explained. The book has a good index—indexing makes or breaks technical books. Although the contents is solely mathematical, the author makes it clear to readers why particular mathematical knowledge is presented, and why it will be useful to readers. For example: In introducing Chapter 11 on hyperbolic trigonometry the author observes that "Since traveling waves on a transmission line are very conveniently expressed in terms of hyperbolic functions, this chapter will be devoted to the mathematics of these functions."

On pages 87-89 there is developed a slide rule solution for right triangles, unfamiliar to this reviewer,

• • •

### TUBE CHARACTERISTICS



Electron tube characteristics are determined by cathode-ray tube tracing apparatus. Curves are scanned in rapid succession and photographically recorded directly from the cathode-ray tube screen. Developed by Sylvania research engineers to supply design data for radar and high frequency communications, the equipment will be used to assure closer tube production control

FOR **SPEEDY  
ACCURATE  
ALIGNMENT**

**Test  
Oscillator**



### SUPREME MODEL 571

- Simple Operation— all ranges read on two basic scales.
- Dual Tuning Ratio. One for speed—one for vernier adjustments.
- Electron coupled circuit giving greatest stability. Iron core coils.
- Ladder Attenuator.
- Double shielding minimizes leakage.
- Golden Oak carrying case.

### SPECIFICATIONS

#### R.F. RANGES:

65-205 KC, 205-650 KC;  
650-2050 KC, 2050-6500 KC;  
6.5-20.5 MC. Harmonics to  
82 Megacycles.

#### AUDIO FREQUENCY:

400 cycles available for external testing.

#### INTERNAL MODULATION:

R.F. Carrier modulated at approximately 30% and 70% at 400 cycles. Modulation level selected by toggle switch.

#### EXTERNAL MODULATION:

Jack provided for external audio modulation.

#### ACCURACY:

1/2 of 1% on first three bands. 1% on last two bands.

#### SIZE:

9-1/2" x 8-11/16" x 7-3/8"

#### POWER SUPPLY:

115 volts 60 cycles—Special voltage and frequency on request.

**SUPREME**

SUPREME INSTRUMENTS CORP.  
Greenwood, Miss., U. S. A.



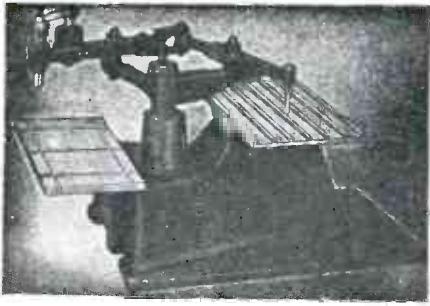

DUPLICATING and PROFILING  
**AUTO ENGRAVER**

Accurate Engraving  
 with Unskilled Operators

Unskilled operators will profile or accurately reproduce in smooth lines any design, number, letter, emblem, signature; on iron, brass, copper, aluminum, soft steels and all plastics. Here are some of its other uses . . .

- Drills a series of holes, or profiles small parts
- Cuts an even channel for wiring on panels. Increases accuracy and production.
- Works from original drawing or templates.
- Etches glass and similar items.
- Will not cause distortion.

For complete information on this and other models and prices write Dept. K.

**AUTO ENGRAVER CO.**  
 1776 BROADWAY, NEW YORK 19

FOR  
**ELECTRONIC USE**

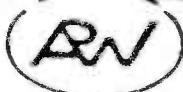

**SILVER**

WIRE · SHEET · TUBING  
 SILVER BRAZING ALLOYS & FLUXES

**PLATINUM**

WIRE · RIBBON · FOIL  
 SEAMLESS TUBING

WE INVITE INQUIRIES REGARDING ALL APPLICATIONS OF PRECIOUS METALS TO ELECTRONIC PRODUCTS.

PRECIOUS METALS



SINCE 1875

**THE AMERICAN PLATINUM WORKS**  
 N. J. R. AVE. AT OLIVER ST.  
 NEWARK 3, N. J.

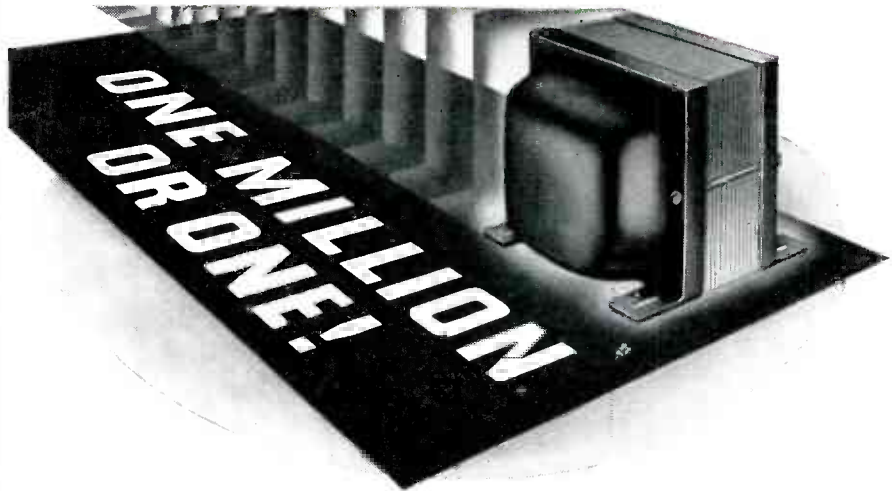

**Electronic Engineering can supply—NOW—transformers in standard or special styles in Any quantity . . .**

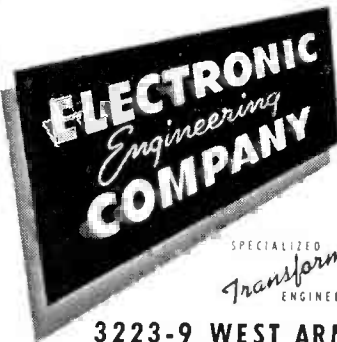

Because there have been no conversion problems at Electronic Engineering, we are now producing and delivering the finest transformers with the same speed and skill as during the war. We are ready to serve your needs . . . with one million or one!

3223-9 WEST ARMITAGE AVE. • CHICAGO 47, ILLINOIS

Now . . .

the basic principles of electric circuits  
 applying to all fields of specialization—  
 electric power—communications  
 —electronics

Use this book to assist you in utilizing latest developments that influence practice in your field—as a basic reference of material for your daily working needs in all branches of electrical engineering over a wide range of frequency. Simple, concise explanations, many diagrams and numerical examples, numerous tables and charts supply quick, dependable reference material on resistance networks, impedance networks, nonsinusoidal waves, polyphase networks and transients.

The book builds up basic electrical principles applicable in all the special fields, taking into account new developments in electricity which tend to overlap from one field of specialization into another.

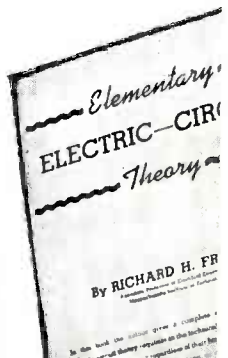

Just Published!

**ELEMENTARY ELECTRIC-CIRCUIT THEORY**

By RICHARD H. FRAZIER

Associate Professor of Electrical Engineering,  
 Massachusetts Institute of Technology

434 pages, 5 1/4 x 8 1/4, \$4.00

Examine this book 10 days on approval, noting diagrams and charts, handy, lucid explanations, practical treatment of electrical principles.

SEE IT 10 DAYS ON TRIAL

McGraw-Hill Book Co., 330 W. 42 St., N.Y.C. 18

Send me Frazier's Elementary Electric-Circuit Theory for 10 days' examination on approval. In 10 days I will send \$4.00 plus few cents postage or return book postpaid. (Postage paid on cash orders.)

Name .....

Address .....

City and State .....

Company .....

Position .....

CONTENTS

- |  |                                  |
|--|----------------------------------|
| 1. Electric-circuit Definitions and Concepts | Appendix: Tables and Charts      |
| 2. Resistance Networks                       | Wire Tables                      |
| 3. Basic Alternating-Current Concepts        | Skin-effect Ratios               |
| 4. Use of Complex Algebra                    | Current Capacities               |
| 5. Impedance Networks                        | Physical Capacities              |
| 6. Nonsinusoidal Waves                       | Trigonometric Functions          |
| 7. Polyphase Networks                        | Natural Logarithms, Exponentials |
| 8. Transients                                |                                  |

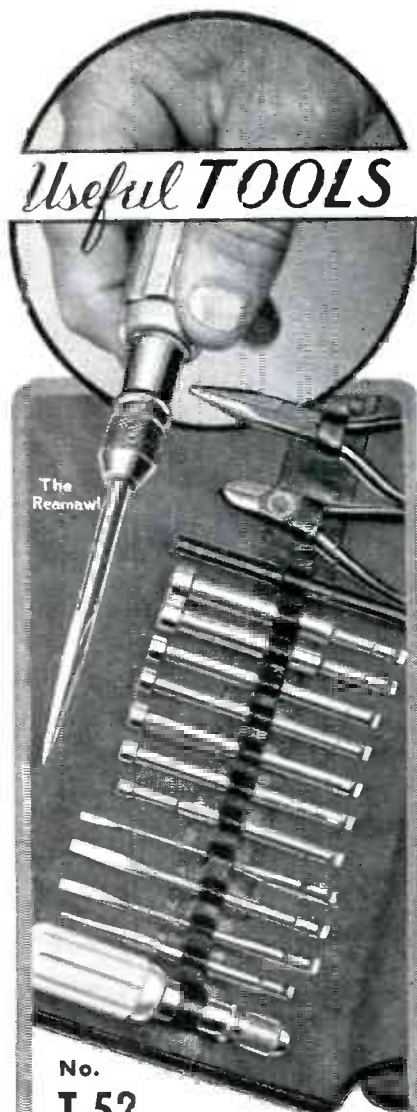

Useful **TOOLS**

No. **T-52**

**SPINTITE SET.**

Chuck Type Handle with Reamawl, 3 Screw Drivers, 7 SPINTITES, Insulated Neutralizing Alignment Wrench, and 2 Pliers, all in a Leatherette Roll. . . .

**A Positive need in every RADIO, HOME and ELECTRICAL SHOP.**

A Fascinating, Fast-Moving Item for thousands of stores. Your good jobber has it. . .

Send for Catalog No. 141 picturing a full line of Automobile, Aircraft and Radio Tools.

**WALDEN WORCESTER WRENCHES**

**STEVENS WALDEN, INC.**  
468 SHREWSBURY STREET  
WORCESTER, MASSACHUSETTS

which reduces the laborious squaring and square-rooting to a surprising minimum.

The symbol used for factorial in this book is not the preferred ! but  $\perp$ , which can be mistaken for the angle sign and on page 176 in Eq. (9) has been printed as an angle sign  $\angle$ .

There is an appendix of some 100 pages which, while useful, duplicates in abbreviated form the contents of the several books of tables and equations that should form a part of every engineer's reference library.—F.R.

. . .

**UHF Radio Simplified**

By MILTON S. KIVER. *D. Van Nostrand Co., Inc. New York, 238 pages, \$3.25.*

WITH RADIO HAVING only one direction in which to expand further—up into the higher frequencies—a knowledge of the logical relations between familiar low-frequency equipment and the new microwave plumbing, uhf tubes, and uhf radiators becomes highly essential today for those who follow the radio field either as a hobby or as their profession. In plain, understandable words without complex theory and math, the author achieves his goal of bringing his readers up to date on the basic principles involved in generating, transmitting, and radiating at frequencies in the range of 300 to 3,000 megacycles and higher. Concurrently the book also gives a real measure of familiarity with the component parts used at these frequencies, making it of particular value for classroom use.

The author makes the initial transition from the low frequencies to the ultrahighs by explaining the use of Lecher wire systems and concentric cables as tuning circuits, then describing the first attempts by Barkhausen and Kurz to put transit time to work in tubes. This introduction paves the way for chapters on the magnetrons and klystrons, followed by a chapter on use of transmission lines as inductances, capacitances, tuned circuits, and matching stubs.

Chapter 5 tells how empty pipes become power conductors and explains how radio waves travel in guides. The nomenclature of waves in guides is clearly presented, with

Engineered and built by

*Doolittle*

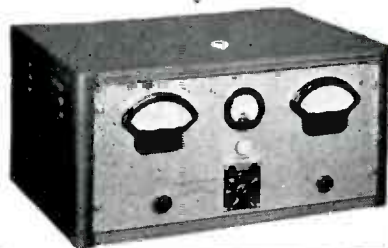

**FM and AM FREQUENCY MONITORS**

*Direct reading. No charts or complicated calculations necessary. Models available for 110 volt A.C. or battery operated portable use. Meet FCC requirements.*



**DISTORTION METER**

*Direct reading device which indicates as a percentage of the fundamental frequency, the square root of the sum of the squares of the harmonic components. It is used for audio frequency measurements in any audio device in the usual range of voice or musical notes from 150 to 15,000 cycles.*

• Utilize the many advantages of these units now. They are sturdily built, self-contained, moderately priced. Remember . . . equipment pioneered by DOOLITTLE years ago, still serves efficiently today!

SEND FOR FULL DETAILS

*Doolittle*

**RADIO, INC.**

7421 SOUTH LOOMIS BOULEVARD  
CHICAGO 36, ILLINOIS

**BUILDERS OF PRECISION RADIO EQUIPMENT**



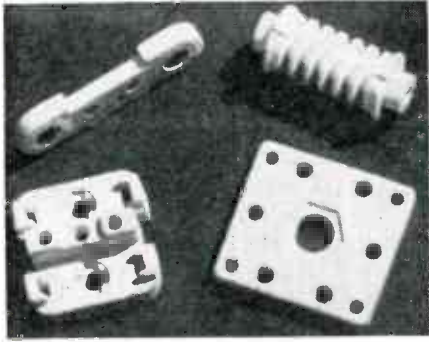

## Lavite STEATITE CERAMIC

### Properties and Characteristics of Our LAVITE S1-5 Steatite Ceramic Body

Compressive Strength	95,000 lbs. per square inch
Tensile Strength	7,200 lbs. per square inch
Flexural Strength	10,500 lbs. per square inch
Modulus of Rupture	20,000 lbs. per square inch
Dielectric Strength	235 volts per mil
Dielectric Constant	6.42
Loss Factor	2.90
Power Factor	.446
Bulk Specific Gravity	2.664%
Density (from above gravity)	0.098 lbs per cubic inch
Hardness (Mohr scale)	7-0
Softening Temperature	2,350°F.
Linear Coefficient of Expansion	8.13x10 <sup>-6</sup>
Moisture Absorption (ASTM D-116-42-A)	0.009%

Makers of electrical and radio apparatus destined for war service are finding in LAVITE the precise qualities called for in their specifications. . . high compressive and dielectric strength, low moisture absorption and resistance to rot, fumes, acids, and high heat. The exceedingly low loss-factor of LAVITE plus its excellent workability makes it ideal for all high frequency applications.

We will gladly supply samples for testing.

**D. M. STEWARD MFG. COMPANY**  
Main Office & Works: Chattanooga, Tenn.  
Needham, Mass. Chicago Los Angeles

## ELECTRONICS

Opportunity offered to manufacturers interested in production of extremely accurate, high-speed dynamic balancing machine for rotating parts involving principally electronic equipment; covered by basic patent and proved in operation with important U.S. manufacturers; to negotiate for manufacturing rights or exclusive license or purchasing U.S. patent from reliable well-known owners. Write:

BO-916, Electronics  
330 W. 42nd St., New York 18, N. Y.

# "ALNICO" PERMANENT MAGNETS

Specializing in the production of highest quality Alnico Magnets in all grades including new triple strength No. 5.

Production material checked to assure highest uniform quality of product.

Castings made to customer's special order on the basis of sketches or blueprints furnished.

Information and suggestions furnished on request.

## GENERAL MAGNETIC

C O R P O R A T I O N

MANUFACTURERS OF HIGH COERCIVE MAGNETIC ALLOYS  
2126 E. Fort Street • Detroit 7, Michigan

# ATTENUATORS

by

## TECH LABS



STANDARD  
TYPE  
700



MIDGET  
TYPE  
600

"Midget" model is especially designed for crowded apparatus or portable equipment.

- Solid silver contacts and stainless silver alloy wiper arms.
- Rotor hub pinned to shaft prevents unauthorized tampering and keeps wiper arms in perfect adjustment.
- Can be furnished in any practical impedance and db. loss per step upon request.
- TECH LABS can furnish a unit for every purpose.
- Write for bulletin No. 431.

TECH  
LABORATORIES

Manufacturers of Precision Electrical Resistance Instruments  
337 CENTRAL AVE. • JERSEY CITY 7, N. J.

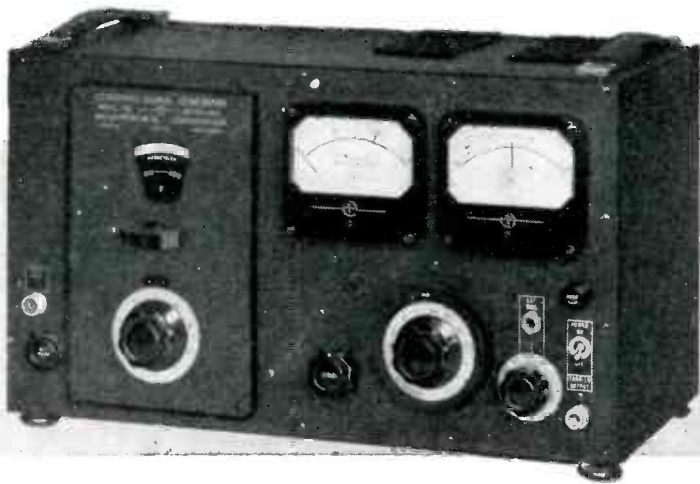

## STANDARD SIGNAL GENERATOR Model 80

### SPECIFICATIONS:

**CARRIER FREQUENCY RANGE** 2 to 400 megacycles.

**OUTPUT:** 0.1 to 100,000 micro-volts. 50 ohms output impedance.

**MODULATION:** A M 0 to 30% at 400 or 1000 cycles internal. Jack for external audio modulation.

Video modulation jack for connection of external pulse generator.

**POWER SUPPLY:** 117 volts, 50-60 cycles.

**DIMENSIONS:** Width 19", Height 10 1/2", Depth 9 1/2".

**WEIGHT:** Approximately 35 lbs.

**PRICE—\$465.00** f.o.b. Boonton.

Suitable connection cables and matching pads can be supplied on order.

**MEASUREMENTS CORPORATION**  
BOONTON NEW JERSEY

## FREE DATA FOLDER! HERMETICALLY-SEALED MULTIPLE HEADERS AND TERMINALS...



*Six pages of complete  
and detailed information!*

A concise, informative piece of literature. Fully illustrated with straightforward data that simplifies proper choice and facilitates ordering to exactly meet your requirements. Covers all standard items as well as custom built sealed leads and multiple headers. Break-down voltages, high voltage, skirted units are included. E-I components can be furnished on short notice—often in quantity direct from stock. Write for your copy of this new folder today. No obligation.

Types . . . sizes . . . standard and custom designs . . . material . . . construction . . . features . . . voltage ratings . . . dimensional data and coding system



**ELECTRICAL INDUSTRIES • INC**  
42 SUMMER AVENUE, NEWARK 4, N. J.

many diagrams to illustrate different types of guides and exciting methods.

The last four chapters cover cavity resonators, uhf antennas and reflectors, uhf measurements, and wave propagation through space, with well-prepared diagrams adding materially to the value of the text in every instance.

All in all, this book is as interesting as it is educational, and its nine chapters lend themselves admirably to a chapter a day of home study. Test questions are grouped at the end of the book for those who wish to check their mastery of the material and for instructors using the book in classes.—J.M.

• • •

## Elementary Electric-Circuit Theory

By RICHARD H. FRAZIER, *Massachusetts Institute of Technology*. McGraw-Hill Book Co., Inc., New York, N. Y., 1945, 414 pages, \$4.00.

A BROAD VIEWPOINT of lumped constant circuits is taken in this text written for a first course in circuits. On page 16 the author concisely states his approach: "Often both

• • •

## KEEPS PIPE OPEN



Before a vacuum pump removes all the air from a tube, the tube's glass exhaust pipe and the larger glass support piece must be joined by heating their tips to a pliable state. At the height of heating, Helen Schmidt of Westinghouse keeps the channel open by blowing air gently through the pipe. Too much air would burst the glass. Later the tube is pumped free of air and sealed



Send for  
Your Copy

of our new  
and latest  
Edition

Many new  
types of  
equipment  
shown and  
described.

Condensed Catalog No. 2  
covering

**Timers  
Relays  
Switches**

by

**Cramer**  
SPECIALISTS ON QUALITY TIMERS



Sent free  
upon request

**R. W. CRAMER COMPANY**  
CENTERTOWN CONNECTICUT

**PURE SILVER  
FOIL**

Available  
Now

**GOLD PLATED  
SILVER FOIL**

.0005" to .003"  
thickness  
± .0005"



TECHNICAL QUALITIES  
UNIFORM THICKNESS  
FREE OF HOLES  
NO POROSITY

Write, Wire, or Telephone

**PEERLESS ROLL LEAF CO., INC.**  
4517-4519 New York Avenue  
UNION CITY • NEW JERSEY  
Union 3-8686

**ALDEN  
CATHODE RAY TUBE  
CONNECTORS**

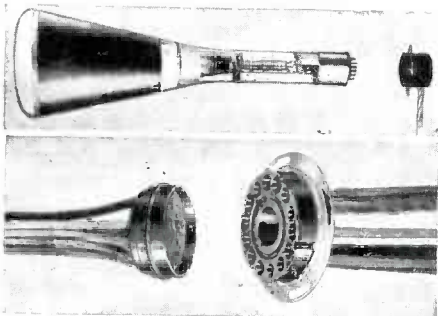

Do not make several problems of Cathode Ray Connectors and Sockets. An experience in supplying the first pioneers for the pilot runs to the latest radar gives you the connectors with leads, compact, individual strain relief, individual insulation with generous safety factors and every type of wire to provide (even in small quantity) a connector with the proper insulation of leads, and to your particular requirements as to length, including shielding of any leads, lacing, overall braiding, intervening connectors or "what have you."

Write for the  
**ALDEN "BLUE-BOOK"**  
of Electrical Components

**ALDEN PRODUCTS COMPANY**  
BROCKTON (64E) MASS.

**SMALL PARTS**

Filaments, anodes, supports, springs, etc. for electronic tubes. Small wire and flat metal formed parts to your prints for your assemblies. LUXON fishing tackle accessories, double pointed pins, fine sizes wire straightened. Inquiries will receive prompt attention.

**ART WIRE AND  
STAMPING CO.**

227 High St. Newark 2, N. J.

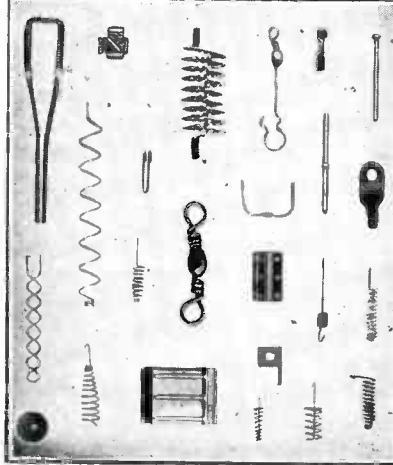

- INSTRUMENT HOUSINGS
- PANELS
- CHASSIS
- METAL AND PLASTIC SPECIALTIES

**SCREW MACHINE PARTS AND STAMPINGS**  
*Manufactured to your Requirements*

Experienced fabrication and dependable service for all types of radio and electronic parts. Send us your drawings and specifications for quotation.

**STAMFORD METAL SPECIALTY CO., 428 BROADWAY, N. Y. 13**  
*Metal Work of Every Description*

## With reconversion in full swing

You will want to use and know more about these new sub-miniature vacuum tubes

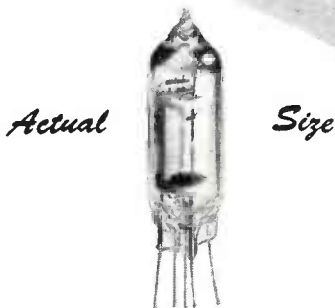

### -Series VW- 15 ma., 1.5 volts

Grid current less than  $10^{-14}$  amperes—grid resistance approximately  $10^{16}$  ohms.

Individually checked for uniformity within the range of the best operating characteristics—each tube is built for exacting circuit requirements.

Available as . . .  
Electrometers  
Pentodes  
Tetrodes  
Triodes  
Diodes

And now in production—new hi-meg vacuum sealed resistors in a range never adequately covered before—values from 1 megohm to 1,000,000 megohms. Write for literature on tubes and resistors or consult us on your tube problems.

1,000,000 Megohms



Actual size



THE VICTOREEN INSTRUMENT CO.  
5806 HOUGH AVENUE  
CLEVELAND 3, OHIO

the power engineer and the communications engineer tend to confine themselves too narrowly to their respective divisions of the field, with the result that interrelated problems may not be adequately handled by either."

The work is self-contained. It begins with definitions and concepts of electric circuits, takes up methods of circuit analysis using resistive networks as examples, introduces a-c concepts and the corresponding complex algebra for handling them, discusses nonsinusoidal waves and polyphase networks, and concludes with transients.

The book is intended as a text for electrical engineers who have completed fundamental physics and mathematics courses. Rather than separating the class into power and communication majors when they begin studying circuits, the instructor can hold it together by the approach of this text. For example, in discussing nonsinusoidal waves, waves encountered both in power and in communication circuits are used as illustrations and problems for Fourier series and graphical analysis.

The author has interspersed the text with non-technical observations which aid in orienting student engineers to their technical studies. As an illustration, on page 2 the author observes that "The engineer should be skilled in leading a double life—one in the concrete world of physical apparatus and one in the abstract world of ideas—and in interpreting each realm in terms of the other."

Brief introductory paragraphs which orient readers at the beginning of each chapter are useful. The quantity of condensed technical information in this book cannot be presented without giving, beforehand, an indication of where the student is being led. Until he sees his goal, he cannot follow. In short, it is a technical book written by a pedagogue, which is unusual!

More books of this sort will be written. It coordinates. The wealth of information and technique that engineers must acquire today cannot be learned without such books. It is indicative of the contemporary trend away from limited specialization, toward broad coordination.

—F.R.

## Get the help of this new aid to industry: PHOTOCOPYING!



With APÉCO PHOTOEXACT quickly make copies of BLUE PRINTS, PENCIL SKETCHES, LETTERS, SPECIFICATIONS, TRACINGS, DIAGRAMS, GRAPHS, CHARTS (over 100 others)

Now, with this handy unit right in your own office or plant, you can always have plenty of copies of *anything*, whether written, typed, printed, drawn, or photographed—even if on both sides! Permanent error-proof photocopies—at amazingly low cost! APÉCO makes them at 1-a-minute speed—saves hours of drafting and typing—expedites *everyone's* work. No darkroom or technical knowledge needed—even a boy or girl can easily operate APÉCO.

Send for your Free copy of this informative book

...tells how APÉCO

Photocopying can serve you

See how you can save time, money, labor, and assure accuracy with this most modern method of copying. APÉCO's 20-page, fully illustrated book gives you the story of Photocopying—shows graphically the "what" and "how" of this amazingly simple procedure. Yours without obligation. Write, today!

AMERICAN PHOTOCOPY EQUIPMENT CO.  
2849 N. Clark St., Dept. AG105 Chicago 14, Ill.  
Representatives in principal cities and Canada

The APÉCO PHOTOEXACT  
*Copies Anything!*

AMERICA'S MOST WIDELY USED PHOTOCOPY EQUIPMENT



R A D E X

# RADEX

CHICAGO

In future peace-time production, Radex will uphold its war-won reputation by the scope and caliber of its service to the radio and electrical industries.

**Radex Corporation**  
93 W. Jackson Blvd., Chicago 4, Ill.

*Have you a High Temperature Capacitor Application?*



## PLASTICONS\* Operate at 256° F.

Plasticon Types AS are silicone impregnated plastic film dielectric capacitors. They will operate from -80° F. to +256° F. with less than 10% capacitance change. Plasticons are small in size as they are not "voltage derated."



**Condenser Products Company**  
1375 NORTH BRANCH STREET • CHICAGO 22, ILLINOIS

## KIRKLAND Pioneer INDICATING LAMPS

FOR USE WHERE QUALITY COUNTS



(1) #650 D/E De-Luxe-Unit of Superior Design & Construction

This Heavy-Duty Unit, extremely shallow in depth, extends but 1 1/4" behind the front of the panel. Single hole mounted in a 1 3/8" diameter hole. Hexagon holding lip 1/8" thickness. Molded bakelite socket for use with S6 Tungsten and T4 1/2 Neon bulbs. Its heavy-walled glass lens is securely held in a screw type lens-cap. The bulb is easily removed from the front without a tool. List Price, \$2.20 (less bulb).



(2) Typical Lamp Annunciator Easily made with Kirkland Bulls-I-Units.

### MAKE UP YOUR OWN LAMP ANNUNCIATORS—EASILY

Kirkland Units provide a simple, practical means of making high quality Lamp Annunciators. Simply provide proper holes in the panel and insert units, locking them in place, connect to the wiring and the Annunciator is in service.

*The Kirkland catalog sent promptly on request, will prove helpful. Write for it.*

**The H. R. KIRKLAND CO., Morristown, N. J.**

## GASES HYDROGEN NITROGEN-OXYGEN

ARGON-NEON  
HELIUM-KRYPTON  
XENON

COMPLETE GAS PRODUCTION PLANTS INSTALLED FOR LOWEST COST OPERATION

FORMING MIXTURES CARBON DIOXIDE ACETYLENE

HIGHEST QUALITIES • ANY QUANTITY DELIVERED ANYWHERE

### AMERICAN GAS & CHEMICAL CO.

HARRISON, NEW JERSEY • Contracted Complete Service on All Gases



C & D

*Precision engineered for electronic requirements*

## QUADRIGA Quality WASHERS



Special, Flat, Tension and Spring, Formed and Drawn, Cupped and Finishing, Wire Terminals, etc. Any quantity. Prompt delivery. Also SMALL STAMPINGS, any design. Send specifications for quotations.

**Ask for Quadriga Catalog**

Photos show samples of Quadriga superiority. Tables, data, valuable information. Wire or write.

### THE QUADRIGA MANUFACTURING CO.

Incorporated 1894. "Half a century"  
221A West Grand Ave., Chicago 10, Ill.



**CONSTANTLY IMPROVED  
TO GIVE YOU BETTER PERFORMANCE !**



BUD Radio and Electronic Products brings you new developments in design and performance. For example, BUD Streamlined Relay Racks are made with

- (1) Additional louvres at the top-front and back—
- (2) More complete louvre construction on all three sides—

to provide maximum ventilation. These added features together with the new reinforced construction illustrated below, make BUD Relay Racks "tops" for performance, utility and beauty.

**NEW — INTEGRAL  
CASTER MOUNTING**

Heavily reinforced bottom construction provides for insertion of casters quickly and easily. Dolly racks are eliminated . . . thus adding to the beauty and serviceability of the cabinet.

**BUD RADIO, INC. CLEVELAND 3, OHIO**

# NORCO

## Electronic Communication Components



**TRANSFORMERS**



**SPECIAL  
COILS**

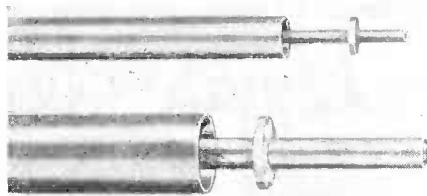

**COAXIAL TRANSMISSION  
LINES AND FITTINGS**

NORCO has been supplying close tolerance electronic communication components, and complete audio frequency amplifiers to discriminating users. The intensive engineering and development work, resulting in the high standard of NORCO products, has been intensified by rigid wartime demands. Whatever your needs, you can depend on NORCO as a dependable source of supply for your present or future requirements.

### NORTHERN COMMUNICATIONS MANUFACTURING CO.

210 EAST 40th STREET NEW YORK 16, N. Y.  
Manufacturers of Transformers • Special Coils • Reactors • Sound Systems  
Recorders • Equalizers • Full Range Phonograph • Coaxial Transmission Lines

# Backtalk

This department is operated as an open forum where our readers may discuss problems of the electronics industry or comment upon articles which **ELECTRONICS** has published.

## Hartley Law

DEAR MR. HENNEY:

YOUR COMMENTS in "Cross Talk" in the June issue of **ELECTRONICS** concerning the band width of frequency necessary for the transmission of intelligence are very timely.

I have reason to believe this concept was well known previously to its formulation by Dr. Hartley in 1927.

I recall hearing a presentation by Dr. Alexanderson of General Electric on the results of his high-frequency alternator at the summer convention of AIEE in Swampscott, Mass. This must have been in 1921 or 1922. In the course of his remarks, Dr. Alexanderson noted that the transmission band width of the transmitter and receiver required to be increased in exact proportion to the increase in keying frequency, and furthermore stated that this requirement necessarily proportionately reduced the total number of available channels in any given portion of the spectrum.

His explanation was so clear that I still remember it vividly, although I was only 14 or 15 years old at the time. Anything which can be explained satisfactorily to a youngster is undoubtedly pretty well understood by the teacher. Therefore, I would like to nominate Dr. Alexanderson as the proponent of the law of the relationship of information, time, and band width.

LOVETT GARCEAU

Director, Electro-Medical Laboratory, Inc.  
Holliston, Mass.

Research indicates that a joint meeting of AIEE and IRE was held in New York City in October 1919 at which Dr. Alexanderson had a paper, Transoceanic Radio Communication, which discussed one application of the Hartley Law. In this paper Dr. Alexanderson pointed out that the higher the speed of sending, the greater must be the separation required between



**STAR** Makes More  
Than Just STEATITE  
Find Out Now About  
**STAR  
CERAMICS**

There are many kinds for special uses, such as applications calling for resistance to electricity, heat, moisture, chemicals or weathering agents. There are more than a score of formulas in actual production at one time in our factory.

Send for "A Brief Survey of Technical Characteristics of Molded Ceramic Products." It is right to the point.



The **STAR**  
**PORCELAIN CO.**  
Electronics Dept.  
Trenton 9, N. J.

*Found!*  
**The MISSING LINK**  
for FM and TELEVISION

It's 'Shur' to complete your merchandising program . . . to complete your sales story . . . to help your franchise family SELL! It's the ONLY versatile Antenna Mount now available whose unique construction enables it to support standard FM and Television Antenna anywhere—anchoring 'SHUR-LY' AT ANY ANGLE ANY PLACE on any house! Available and ready now for a limited number of manufacturers. Complete your aerial kit with a SHUR ANTENNA MOUNT!

NOW! A complete package incorporating the revolutionary new INTERCEPTOR\* Antenna with ALL tunable factors easily adjustable! Ask about it!

\* Pat. Pend.

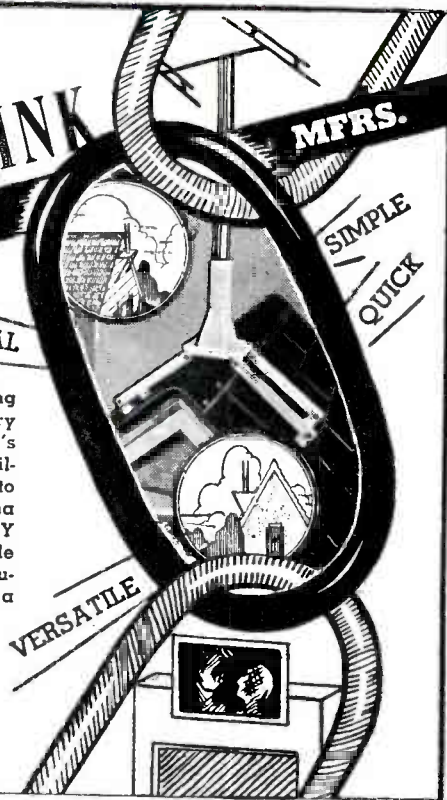

*Shur - Antenna - Mount, Inc.*

NEW YORK CITY  
Cooper-DiBlasi  
259 W. 14th St.  
W Atkins 9-3920

Sea Cliff, Long Island  
New York, U. S. A.

CLEVELAND  
E. J. Wall  
1836 Euclid Ave.  
CHerry 5464

**What Makes a Mailing Click?**

Advertising men agree . . . the list is more than half the story. McGraw-Hill Mailing Lists, used by leading manufacturers and industrial service organizations, direct your advertising and sales promotional efforts to key purchasing power.

In view of present day difficulties in maintaining your own mailing lists, this efficient personalized service is particularly important in securing the comprehensive market coverage you need and want. Investigate today.

*for Results*



McGraw-Hill Publishing Co., Inc.  
DIRECT MAIL DIVISION  
330 West 42nd Street, New York, 18, N. Y.



**COILS**

Hand-wound coils, of any material or construction, delivered promptly. Thousands—small runs—or experimental. Best material—good workmanship. Send prints or specifications for quotation. State delivery requirements.

**BITTERMANN ELECTRIC CO.**  
50 Henry St. Brooklyn, N. Y.  
TRiangle 5-4767  
"If it's a COIL—We'll Make It"

**PERMANENT MAGNETS**

All Shapes—All Sizes—for All Purposes  
**COBALT—CHROME—TUNGSTEN**  
Stamped, formed and cast

**Alnico** (Cast or Sintered)  
(under G. E. License)

Also: Laminations for Radio Transformers  
**TOOLS—DIES—STAMPINGS**  
Heat Treating of Metals and Alloys

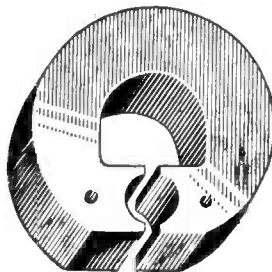

**THOMAS & SKINNER** STEEL PRODUCTS COMPANY  
1116 EAST 23RD STREET • INDIANAPOLIS 5, INDIANA

# UNBRAKO

Reg. U.S. Pat. off.



## MIGHTY SMALL . . . But What a Big Job They Do!

Even though their size is dwarfed, there is no similar shrinkage in the quality of these "Unbrako" Socket Set Screws. The same strength, hardness, and accuracy that are characteristic of "Unbrako" Screw Products will be found in these tiny and efficient counterparts. The "Unbrako" hex socket fits its wrench accurately and securely and so outlasts many times over the old fashioned screw driver slot that wears-out and becomes worse than useless. The "Unbrako" therefore has become a boon to the Electronic and small Electrical manufacturing industries. Sizes from #0 to 1" diameter, all commercial lengths.

More information about the "Unbrako" Socket Screw Products in our Catalog. Send for one today.

OVER 40 YEARS IN BUSINESS

**STANDARD PRESSED STEEL CO.**

JENKINTOWN, PENN. BOX 596

—BRANCHES—

Boston - Chicago - Detroit - Indianapolis - San Francisco - St. Louis



adjacent channels. In 1923 at Swampscott, Dr. Alexanderson, A. E. Reoch and C. H. Taylor delivered a paper before AIEE, The Electrical Plant of Transocean Radio Telegraph, but there is nothing in the formal report of this paper which indicated that the relations between the amount of intelligence to be transmitted and the time or band width were discussed. It is quite possible that this is the convention which Mr. Garceau remembers and that the informal discussion related to the matter at hand.

There is no doubt that numerous pioneers knew and appreciated at a relatively early date, the relationships we have been discussing. As a matter of fact, Mr. Hartley himself knew of the manner in which the factors are tied together. Paul Findley of the Bell Telephone Laboratories has found in the Laboratory files a 14-page memo dated December 9, 1918 in which Mr. Hartley formulates the general relationship he published more formally eight years later.

Perhaps the matter is like the law of gravitation—the effects of which were generally understood for a very great time but which remained rather vague until Newton

### X-RAY TUBE TESTER

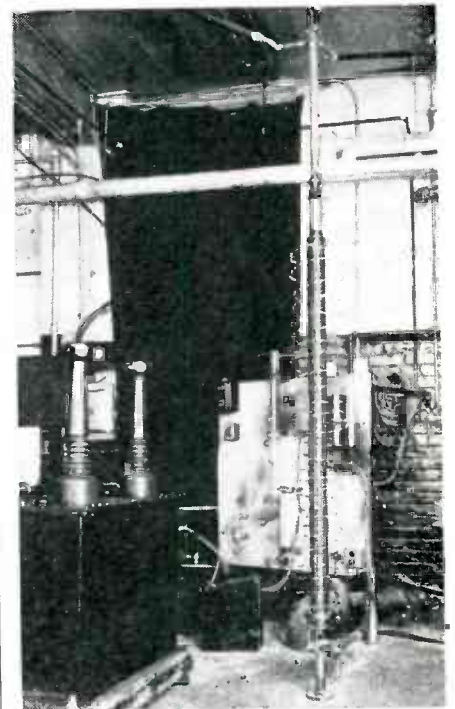

A 2,000,000-volt x-ray tube developed by Machlett Laboratories and some of the equipment used in making high-voltage tests



### INQUIRE

for lab. temperature chart like the one shown below that shows how a Sta-Warm tank varied less than 1°F. during 24 hr. test period.

## INSIST ON ACCURATE CONTROL of compound melting temperatures

The wide distribution of electric heating circuits which blanket sidewall and bottom areas of Sta-Warm compound melting tanks and kettles together with the Sta-Warm thermostat provide accurate control of melting and operating temperature to your specification.

Under average shop conditions, Sta-Warm tanks hold to plus or minus 5°F. max. variation. Under laboratory conditions they hold to 1°F.

Insist on Sta-Warm tanks, kettles or pots for low wattage per sq. in. of tank surface, uninterrupted production, low maintenance and greater daily output.

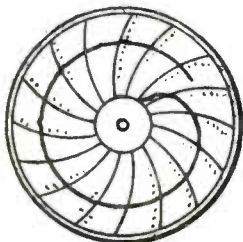

**STA-WARM ELECTRIC CO.**  
1000 N. CHESTNUT ST. • RAVENNA, OHIO



**NOW**

a really high-powered

**RADIO  
ENGINEERING  
LIBRARY**

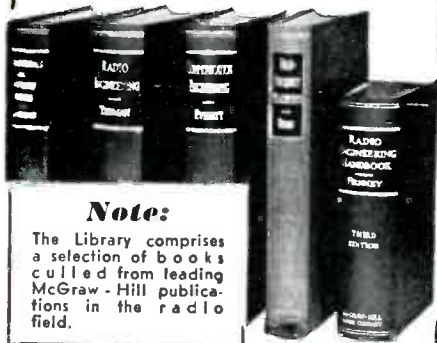

**Note:**

The Library comprises a selection of books culled from leading McGraw-Hill publications in the radio field.

- ↳ especially selected by radio specialists of McGraw-Hill publications
- ↳ to give most complete, dependable coverage of facts needed by all whose fields are grounded on radio fundamentals
- ↳ available at a special price and terms

These books cover circuit phenomena, tube theory, networks, measurements, and other subjects—give specialized treatments of all fields of practical design and application. They are books of recognized position in the literature—books you will refer to and be referred to often. If you are a practical designer, researcher or engineer in any field based on radio, you want these books for the help they give in hundreds of problems throughout the whole field of radio engineering.

5 volumes, 3559 pages, 2558 illustrations

Eastman's FUNDAMENTALS OF VACUUM TUBES, 2nd edition

Terman's RADIO ENGINEERING, 2nd edition

Everitt's COMMUNICATION ENGINEERING, 2nd edition

Hund's HIGH FREQUENCY MEASUREMENTS

Hervey's RADIO ENGINEERING HANDBOOK, 3rd edition

**SPECIAL LOW PRICE • EASY TERMS**

Special price under this offer less than cost of books bought separately. In addition, you have the privilege of paying in easy installments beginning with \$3.00 in 10 days after receipt of books and \$3.00 monthly thereafter. Already these books are recognized as standard works that you are bound to require sooner or later. Take advantage of these convenient terms to add them to your library now.

FOR 10 DAYS' EXAMINATION SEND THIS

ON-APPROVAL COUPON

McGraw-Hill Book Co., 330 W. 42nd St., N.Y.C. 18  
Send me Radio Engineering Library for 10 days' examination on approval. In 10 days I will send \$3.00 plus few cents postage and \$3.00 monthly till \$24 is paid, or return books postpaid. (We pay postage on orders accompanied by remittance of first installment.)

Name .....

Address .....

City and State .....

Company .....

Position ..... F.L. 10-45

**MOLDED  
TERMINAL  
STRIPS**

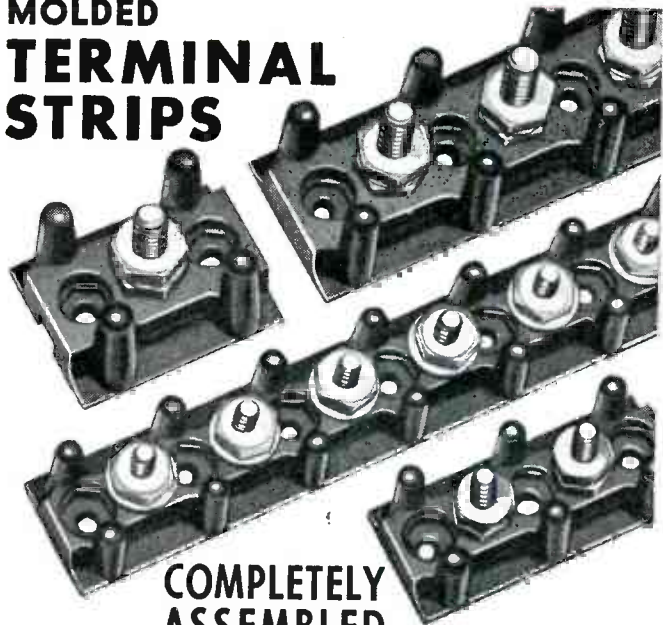

**COMPLETELY  
ASSEMBLED**

WITH HARDWARE

Available in lengths from 1 to 20 terminals.  
2 Types: NAS 17 and NAS 18. Prompt deliveries.

*Northern Industrial  
Chemical Company*

7-11 ELKINS ST., SO. BOSTON 27, MASS.  
36 YEARS OF PLASTIC MOLDING EXPERIENCE



*Preferred*

as a source of precision-made WASHERS and STAMPINGS manufactured to your specifications.

CUP WASHERS  
for Binding Screws

**WHITEHEAD STAMPING CO.**

1691 W. Lafayette Blvd.

Detroit 16, Michigan







**INDICATOR LAMPS**

Indicate and identify circuit operations on radio transmitters and electronic devices. Lock-on caps, available in five different colors, cannot shake loose. Caps and bases of sturdily constructed molded plastic. Easy to mount. With or without "dim-out" feature. For further details write

Electronics Department, General Electric, Schenectady 5, N.Y.

**GENERAL ELECTRIC**

177-DL-1

# CAPACITOR QUESTIONS Answered!

**JUST OUT!**

## "THE ELECTROLYTIC CAPACITOR"

by Alexander M. Georgiev

Probably no Radio-Electronic component is more important than the Electrolytic Capacitor, and this new book by Alexander M. Georgiev who has devoted more than 15 years to Capacitor research and development answers all the many questions engineers, designers, servicemen and others have been asking about this subject. Abundant data is presented as to Electrolytic Capacitor constructional features—where, when and how to use them to best advantage in preference to non-electrolytic types—in short, everything you need to know in order to utilize, buy, specify replace, or service Capacitors intelligently and efficiently. A comprehensive bibliography and list of patents will prove of far-reaching value. Contains over 200 pages and eighty illustrations including graphs, photomicrographs, oscillograms, etc. Just out in limited edition—the first modern book to be written on this vital component! Order today while the supply lasts.

**WHAT TYPE?  
WHY?  
WHERE?**

**\$3.00** \$3.25 foreign

### ALL THE FACTS ON A LITTLE KNOWN SUBJECT

Electrolytic Capacitor Construction Characteristics; Advantages; Applications; Operation at low and high voltages and frequencies; a-c or pulsating d-c; ambient conditions; wet versus dry; electrolytic versus non-electrolytic; behavior of various types; choosing the best type for a given application and operating conditions; servicing; testing; replacement and emergency repairs—and dozens of other subjects of foremost interest to all who design, handle, or service equipment incorporating capacitors.

**ORDER NOW!**

Technical Division, MURRAY HILL BOOKS, Inc. Dept. E-105, 232 Madison Ave., New York 16, N. Y.

Enclosed find \$..... for ..... copies of Alexander M. Georgiev's "THE ELECTROLYTIC CAPACITOR" (Price \$3 each, \$3.25 foreign) or  send C.O.D. (in U.S.A. only) for this amount plus postage.

Name .....  
Address .....  
City & Dist. No. .... State .....

put the facts down into a concise and easily understood law.—(Ed.)

Dear Mr. Henney:

THE PROPOSED Hartley Law, as stated in the "Cross Talk" section of ELECTRONICS for June, 1945, undoubtedly applies to a system wherein scanning methods are employed but does not necessarily apply to a system where the intelligence contained in a large number of elements (such as the individual elementary areas in a video image) are transmitted simultaneously. In the latter system, the band width is entirely dependent on the allowable "crowding" of frequencies consistent with satisfactory frequency differentiation at the receiver.

For example, if frequency is made the "tag" for positioning elementary areas in a video image, and assuming, for the sake of argument, that it is possible by special means to assign frequencies differing from each other by only one-quarter cycle, it then becomes possible to transmit 240,000 elementary areas simultaneously in a band width of only 60 kc.

It is beyond the scope of this letter to discuss whether or not this is possible, but I think you will agree that if such is possible, the so-called Hartley Law does not apply to this system. It is impossible to reduce the band width considerations of the system just described to a law, because they are obviously based on experimental factors, such as the frequency discrimination possible in practical forms in crystal filters. Therefore, for the sake of accuracy, it might be advisable to call attention to this limitation.

PALMER H. CRAIG  
University of Florida  
Gainesville, Fla.

If your background is radio, examine the tail side of the new Canadian nickel with a magnifying lens.

A "crying room" is a glass-enclosed room in a movie theater in Minneapolis. Equipped with loudspeakers, it permits mothers to see and hear the show without their infants' wails being heard by other patrons.

## PROFESSIONAL SERVICES

### ASSOCIATED ELECTRONICS CORPORATION

CONSULTING ENGINEERS  
Complete Engineering Service for all Industries  
RESEARCH DEVELOPMENT DESIGN  
MANAGEMENT PUBLICATIONS  
132 Nassau Street, New York, 7, N. Y.  
251 Kearney Street, San Francisco, 8, Cal.

### MICHAEL BOZOIAN

Consulting Service In Electronics  
Instrumentation & Controls Design—Development—Models Literature & Patent Surveys  
Recommendations For New Laboratories  
Telephone 8521  
702 Fifth Street Ann Arbor, Mich.

### E. STUART DAVIS

Consulting Engineer  
Research—Design—Development  
Radio - Carrier Current - Supersonics - Radiant Energy - Control and Measurement - Methods and Devices, Communication - Transportation & Industrial applications.  
Marine Laboratory facilities aboard the yacht "ELECTRON"  
422 N. E. River Drive Ft. Lauderdale, Florida.

### STANLEY D. EILENBERGER

Consulting Engineer  
INDUSTRIAL ELECTRONICS  
Design—Development—Models  
Complete Laboratory and Shop Facilities  
6309-13—27th Ave.  
Kenosha, Wis. Telephone 2-4213

### ELECTRONIC ENGINEERS

Designers and Consultants  
Design for Manufacture—Radio and Electronic products designed to your specifications  
Engineering models Production drawings  
Consulting—Radio and Electronic Problems  
Complete Development and Research Laboratories  
Branch Office Near Chicago  
611 E. Garfield Ave. Glendale, California

### DON FOSTER

Engineering Consultant  
Electrical Specialists In Mechanical  
Analysis Sound and Electronics Development  
30 Burns Ave., Wyoming 15, Ohio

### PAUL E. GERST & CO.

CONSULTING ENGINEERS  
Specialists in  
Electrical Product Design  
El. Machinery, Apparatus & Applications  
El. Appliances, Hi-Frequency Apparatus  
Electronics, Radio Communication.  
205 W. Wacker Dr. Chicago 6, Ill.

### HODGSON & ASSOCIATES

Physics, Mathematics, Research, Development & Patent Consultants.  
Satisfaction guaranteed. Submit your problem for a preliminary survey without cost.  
Box 874 Sherman Oaks, California

### JOSEPH RAZEK, Ph.D.

Consulting Physicist  
Electrical and Mechanical Engineering Problems  
Instruments and Control Devices Electronics  
Specialists in Colorimetry Spectrophotometry and Industrial Color Control  
Laboratory and Shop Facilities  
202 Darby Road Lianerch, Pa.  
Phone Hilltop 4910



# CONTACTS

FOR THE FIELD OF ELECTRONICS

## SOMETHING NEW!

Sleeveless type

## TUNGSTEN LEADS

PRODUCED FROM CONTINUOUS SPOOLS OF WIRE EITHER STRANDED OR SOLID ASSURING OVERALL UNIFORMITY. EACH TINY WIRE OF THE STRANDED CABLE IS POSITIVELY FUSED TO THE TUNGSTEN

Write for details & Samples

GLENDALE VACUUM PRODUCTS CO.  
8816-77th Ave. Brooklyn 27, N. Y.



FINE RIBBONS OF TUNGSTEN and MOLYBDENUM

Quality and accuracy in our fabrication of Tungsten & Molybdenum Ribbons have characterized our service to the Electronic Industry.

A development of

**H. CROSS CO.**  
Rookman St., New York 7, N. Y.



**REX RHEOSTATS**

REX RHEOSTAT COMPANY, BALDWIN, L. I., N. Y.

PROTECTED & UNPROTECTED RHEOSTATS WITH LUBRICATED CONTACTS

ROTARY DRIVE RHEOSTATS WITHOUT BACK LASH

PROTECTED & UNPROTECTED ADJUSTABLE RESISTORS UP TO 1000 WATT

PROMPT SHIPMENTS

We manufacture a complete line of equipment

SPOT WELDERS, electric from 1/4 to 50KVA  
TRANSFORMERS, special and standard types  
INCANDESCENT LAMP manufacturing equipment  
ELECTRONIC EQUIPMENT, vacuum pumps, etc.  
WET GLASS SLICING and cutting machines for laboratory use  
GENERAL GLASS working machines and burners  
COLLEGE GLASS working units for students and laboratory

AC ARC WELDERS from 100 to 400 Amps

EISLER ENGINEERING CO.  
731 So. 13th St. (near Avon Ave.) Newark, New Jersey

## BRAZILIAN MICA

### and Semi-Precious Stones

Byington and Company own and control deposits of high grade mica and semi-precious stones available for interested buyers. For further information, contact.

BYINGTON AND CO.  
(Rio De Janeiro, Sao Paulo, Brazil)

W. P. BROWN, AGENT  
165 Broadway New York, N. Y.

## Strip Insulated Wires QUICKER... BETTER

with "Speedex" AUTOMATIC WIRE STRIPPER ... Speeds Production

Strips insulation from all types of wire — instantly, easily, perfectly. Just press the handles and the job is done. Cuts wire too. Strips 900 to 1000 wires per hour. Available for all size solid or stranded wires — No. 8 to No. 30. List Price \$6.00. Write Dept. E for Full Particulars



**GENERAL CEMENT MFG. CO.**  
Rockford, Illinois, U.S.A.

## Electron Tube Machinery

of every type,—standard, and special design

Specialists in Equipment for the manufacture of Radio Tubes, Cathode Ray Tubes, Fluorescent Lamps, Incandescent Lamps, Neon Tubes, Photo Cells, X-ray Tubes and other glass or electronic products, on production or laboratory basis.

**Kahle ENGINEERING COMPANY**

1307-1309 Seventh St., North Bergen, N. J.

## MICROMETER FREQUENCY METER

for checking Transmitters from 1.5 to 56 mc., within 0.01 per cent

LAMPKIN LABORATORIES  
Bradenton, Fla., U. S. A.

## Burned Out or Broken Electric Heating Elements



repaired with NICHRO-CITE PASTE. Simply overlap ends, apply paste, turn on current. Used by utility companies, etc. Family size, \$1.00, 4 oz. size \$2.50. Satisfaction guaranteed.

Armstrong Mfg. Co., Box 8616 Minneapolis, Minn.

## BRAZILIAN QUARTZ CRYSTALS

CRYSTAL TRADING COMPANY

importers  
118 Liberty St. New York 6, N. Y.

Make it a HABIT . . . to check this page—EACH ISSUE

THIS WHERE TO BUY SECTION supplements other advertising in this issue with these additional announcements of products and services essential to efficient and economical operation in the field of ELECTRONICS.

## MORE RF KILOWATT HOURS PER DOLLAR WITH F & O TRANSMITTING TUBES

Inquiries Invited—Let us explain how Savings are effected and the F & O greater guarantee.

FREELAND & OLSCHNER PRODUCTS Inc.

611 Baronne St., New Orleans 13, La.  
Raymond 4756

High Power Tube Specialists Exclusively  
(5 KW To 100 KW)



MINIATURE BALL BEARINGS for precision instruments, electronic devices

RADIAL SERIES (see left) 1/8" to 5/16" outside diameter  
PIVOT SERIES 2 to 10 mm. outside diameter

For complete specifications, prices—write for catalog 421-60

**MINIATURE Precision BEARINGS**  
KEENE, NEW HAMPSHIRE, U.S.A.

**FREE TO RADIO MEN**

COLOR CODE and OHMS LAW CALCULATOR

Burstein-Appleebe of Kansas City offers you this great convenience FREE. Easy to work. Solves many problems in a jiffy. FREE to radio men, electronic engineers and others in the business. Attach coupon to your letterhead.

MAIL COUPON NOW

BURSTEIN-APPLEBEE CO.  
1012 MCGEE, KANSAS CITY 6, MO.

Send me FREE Color Code and Ohms Law Calculator along with latest catalog.

I am \_\_\_\_\_  
STATE CONNECTION IN INDUSTRY \_\_\_\_\_

NAME \_\_\_\_\_  
ADDRESS \_\_\_\_\_  
TOWN \_\_\_\_\_ STATE \_\_\_\_\_

**POSITION VACANT**

**WANTED: ENGINEER** familiar with receiving set circuits and component design. Opportunity to design and engineer new lines of product. Established company. Write for interview stating experience and salary expected. P-916, Electronics, 330 W. 42nd St., New York 18, N. Y.

**EMPLOYMENT SERVICE**

**SALARIED POSITIONS \$2,500-\$25,000.** Recon- version is creating lifetime opportunities now. This thoroughly organized confidential service of 35 years' recognized standing and reputation carries on preliminary negotiations for super- visory, technical and executive positions of the calibre indicated, through a procedure individ- ualized to each client's requirements. Retain- ing fee protected by refund provision. Identity cov- ered and present position protected. Send only name and address for details. R. W. Bixby, Inc., 278 Delward Bldg., Buffalo 2, N. Y.

**POSITIONS WANTED**

**PHYSICIST-ELECTRICAL Engineer.** Desires position in charge of research and develop- ment. B.S. in E.E. and Ph.D. (electronic physics), age 39, married, 10 years in charge of research laboratory concerned with design and development of electronic devices; experience in telephone, power and electrical control development. Permanent position only, where initiative, ability and supervising talent required. Nature of undertaking, locale, etc. outweigh remuneration. PW-917, Electronics, 330 W. 42nd St., New York 18, N. Y.

**E.E. COLLEGE graduate,** 14 years of varied engineering experience in the electronic field. Ambitious, initiative, conscientious, and hard working. Wishes position as chief engineer with lively small post war manufacturing firm. PW-918, Electronics, 330 W. 42nd St., New York 18, N. Y.

**ELECTRICAL ENGINEER** desires executive position. Thoroughly familiar with ultra high frequency techniques. Seven years experience in industrial chemistry. Three years with office of scientific research and development engaged in electronic research. Age 30. Available January. PW-919, Electronics, 330 W. 42nd St., New York 18, N. Y.

**SENIOR ELECTRONICS engineer,** four years experience in radio, wishes employment in Florida. PW-920, Electronics, 520 N. Michigan Ave., Chicago 11, Ill.

**E.E. WITH** long American and European experience in electrical eng'g and electronics, presently employed U. S. Navy ship design, seeks position in this country where could make use of his technical, research and business experience and of his thorough knowledge of French, Russian and German. PW-921, Elec- tronics, 330 W. 42nd St., New York 18, N. Y.

**RADIO ENGINEER:** with college education in E.E. Twenty years experience in design of low-priced and deluxe household, auto export, portable receivers and their component parts. War-time experience includes radar technique. Human engineering laboratory says has execu- tive ability and extrovert enough to be sales engineer. Presently employed on FM project. Want engineering position where hard work, ability and results will be rewarded by top- notch salary. PW-922, Electronics, 520 N. Michigan Ave., Chicago 11, Ill.

**ENGINEER EXECUTIVE—**Now employed, government communications, consultant, salary \$9,000. Activities curtailing, excellent education, broad experience: radio radar, elec- tronics, preeminent references. Desire post- war position. Commensurate with ability. West Mississippi. PW-923, Electronics, 520 N. Michigan Ave., Chicago 11, Ill.

(Continued on page 442)

**TECHNICAL WRITER**

Of wide experience, now in electronics, wishes position with progressive manu- facturer, preferably in the Middle West.

**H. H. KETCHAM**

**BOX 221 PIQUA, OHIO**

**Curt E. Patton Personnel Engineers**  
53 W. Jackson Blvd., Chicago 4

offer industry a confidential Personnel Service, selecting and presenting men for positions open— on either a fee or retainer basis.

Outstanding men in electronic and allied fields, with legitimate reasons for seeking a change are invited to file applications at **NO CHARGE**, in confidence, so we may present their qualifications to our clients.

**WANTED**

**MANAGING EDITOR**

For new magazine with one of the lead- ing, well established New York City publishing firms. Excellent opportunity. Thorough knowledge electronics neces- sary.

Salary—HIGH.

All applications in complete confi- dence.

Address all correspondence to Mrs. Pruden.

**PRUDENTIAL PLACEMENTS**

"Publishing Personnel Specialists"  
599 Fifth Ave., New York, N. Y.

**ELECTRONIC ENGINEERS**

**SENIOR AND JUNIOR ENGINEERS WANTED FOR DESIGN AND DEVELOPMENT OF TEST EQUIPMENT, PRECISION WIRE WOUND RESISTORS, AND RF COILS. SHOULD HAVE PROVEN BACK- GROUND IN THESE SUBJECTS.**

**EASTERN ELECTRONICS CORP.**

41 Chestnut St. New Haven, Conn.

**WANTED**

**ELECTRONIC INDUSTRIAL CONTROL ENGINEER**

To assume complete charge of Research & Develop- ment—

Well established electronics con- trol Manufacturer located in Detroit, Michigan — Permanent position for an aggressive individ- ual with the ability to organize the research and further de- velopment of existing products as well as new projects.

P-912, Electronics

520 N. Michigan Ave., Chicago 11, Ill.

**WESTINGHOUSE ELECTRIC CORPORATION**

has a position open for Acoustical Engi- neer with experience in loudspeaker and phonograph record changer development or laboratory measurement. An attrac- tive position for the man with experience. Wire or write for application:

Manager,

**Technical Employment**

306 Fourth Ave., Pittsburgh 30, Pa.

**LOUD SPEAKER ENGINEER**

Large Eastern component parts manufacturer needs graduate engineer with several years de- sign and development experi- ence on loud speakers. Should be capable of handling devel- opment through complete en- gineering design. Excellent post-war opportunity. Salary open. State full particulars, age, education and experience.

P-908, Electronics

330 W. 42nd St., New York 18, N. Y.

**WANTED**

**SENIOR DEVELOPMENT ENGINEER**

Large mid-west manufacturer, now ex- clusively on war radio and radar work, has immediate openings for post-war radio and television development for three senior radio project engineers, two mechanical engineers and one en- gineer on specifications and standards. Confidential inquiries respected. Write

P-813, Electronics

520 North Michigan Ave., Chicago 11, Ill.

**Permanent Employment ELECTRONIC DEVELOP- MENT ENGINEERS**

Well-established Eastern Massachusetts concern desires graduate electronic engineers with flair for research and eye to future. Permanent position concerned at present with important development work for government with increased op- portunities after the war. Unusual open- ings for men with capacity and initiative. Must be U. S. Citizens.

P-670, Electronics

330 West 42nd St., New York 18, N. Y.

**WANTED**

**ELECTRONIC ENGINEER ELECTRICAL ENGINEER**

qualified engineers to assume the re- sponsibility under proper direction of the manufacturer of Electronic Vacuum tubes. Experience and knowledge of radio.

**TUNG-SOL LAMP WORKS, INC.**

WEATHERLY, PENN.



# AVAILABLE ENGINEERING DIRECTOR Plus Electronic Developments for Post War

A man who has been successfully engaged during the past 25 years in the development of electrical apparatus and devices, specializing in the electronic field, is available to responsible people, and with a large group of post war developments in an advanced stage. These developments he owns, and has personally directed with his own finances under his low cost methods of development, learned over many years of spending his own money on projects.

These developments include some 20 issued patents, about 50 pending patent applications, and development records which contain patentable subject matter representing material for probably 100 additional patent applications.

The subject matter of the inventions include, electronic tubes, a radio telegraphic printing system, new oscillators, new amplifiers, electric wave

filters, sound reproducer devices for radio-phonograph combinations, aircraft instruments, industrial control devices, and other related apparatus. These patents, patent applications and additional cases offer an opportunity for a manufacturing organization to acquire a patent situation in the mentioned fields, which may be classed as one chance in a life time, of a company.

This availability is due to the fact that the people who had originally intended to enter the related manufacturing fields with the above, are prevented from doing so because of renegotiation difficulties.

Reliability and not cash is sought. Inquiries are solicited.

**BO-914 Electronics,  
330 W. 42nd St., New York 18, N. Y.**

## Senior Engineer

We are completing the development work on several important new products and require the services of a seasoned

## Electronic Engineer

from the Greater Boston area as a permanent addition to our organization.

**STEVENS ARNOLD CO.**  
22 Elkins St., South Boston, Mass.

## Development Engineers

SENIOR AND JUNIOR

## Design Engineers

Opportunities are available in development, design, or production engineering of products and applications on Industrial and Laboratory Instruments for electrical measurement and control.

Engineering Degree or equivalent and experience on electronics and/or instrumentation required.

Reply, enclosing snapshot, to:

PERSONNEL DEPARTMENT  
**LEEDS & NORTHRUP COMPANY**  
4901 Stenton Ave., Phila. 44, Pa.

## ELECTRICAL ENGINEERS

Post War development Electronic Field. Degree necessary. Familiar with Micro Wave work. Good salary. Finest Lab equipment and working conditions.

P-887, Electronics  
330 West 42nd St., New York 18, N. Y.

## WANTED ASSISTANT CHIEF ENGINEER

Mid-west radio-electronics manufacturer, engaged exclusively on electronic war projects at present, requires experienced engineer to assume complete supervision of post-war development of household and auto radio receivers. Television receiver experience desirable but not essential. All inquiries confidential. Write

P-814, Electronics  
520 North Michigan Ave., Chicago 11, Ill.

## LOUD SPEAKER LABORATORY ASSISTANT

Eastern manufacturer, many years in business, with fine post-war picture can use young engineer, preferably with some speaker experience, to assist in design and development work. Fine opportunity. Salary open. State age, education and experience.

P-907, Electronics  
330 West 42nd St., New York 18, N. Y.

## CHIEF ENGINEER

Thoroughly familiar with the manufacture of capacitors, basically trained in the theory of dielectrics. Should be capable of directing the activities in a well equipped laboratory. Electrical Engineering or Electro-Chemical Engineering degree essential. This is an unusual opportunity for a capable engineer interested in his present and postwar future.

P-855, Electronics  
520 North Michigan Ave., Chicago 11, Ill.

# ENGINEERS

## Post-War Positions Open

A large expansion of our Engineering Division is now under way. We have many openings in many lines of engineering activity for both war and post-war work.

Among the positions open are:

- Senior Radio Engineers
- Electro-Mechanical Engineers
- Physicists
- Acoustic Engineers
- Tube Application Engineers
- Production Engineers
- Specification Engineers
- Aeronautical Radio Engineers

Our fields are Home and Auto Radio Receivers, Television Receivers, Commercial and Aeronautical Radio Receivers and Transmitters, Disc and Wire Recording. We require both design and research engineers in these fields.

Positions are permanent to qualified individuals. Salaries open.

Qualified individuals will be granted appointments for interviews in Buffalo at our expense.

Write stating education, experience and WMC status.

### COLONIAL RADIO CORPORATION

Engineering Division

1280 Main Street

Buffalo 9, New York

#### ENGINEER Wanted

Leading manufacturer of electronics and physiotherapy equipment wants graduate electrical engineer or physicist with business and executive ability as assistant to manager. Excellent opportunity for man with great energy, perseverance and thorough scientific background and experience.

P-911, Electronics

330 W. 42nd St., New York 18, N. Y.

#### TECHNICAL HELP WANTED

ENGINEERS  
Electronic - Mechanical

#### LABORATORY ASSISTANTS

Electronic Experience  
MALE or FEMALE

#### DRAFTSMEN

#### SPECIFICATION WRITERS

CHEMIST  
Fluorescent Experience

#### PATENT ENGINEER

ALLEN B. DU MONT LABORATORIES, INC.  
PASSAIC, N. J.

#### DIRECTOR OF ENGINEERING

Smaller firm with national organization and established post-war business in electronic, audio and electro-acoustic fields has opening for engineer in charge of development and design. Salary \$6,000 to \$8,000. Must have engineering degree and practical experience. Design of audio and electro-acoustic systems.

Replies confidential. State education, experience record, patents, etc. Photograph if available.

P-894, Electronics

520 North Michigan Ave., Chicago 11, Ill.

#### WANTED FOR POST WAR LABORATORY DESIGNING ENGINEER & DRAFTSMAN

With pre-war experience in design of chassis and cabinets for broadcast receivers. Splendid opportunity with growing N. Y. radio manufacturer.

Call or see Mr. C. N. Ehrlich

HAMILTON RADIO CORPORATION  
510 Sixth Avenue, N. Y. C.

#### WANTED

#### RESEARCH ENGINEERS

Prominent radio and electronics manufacturer located in Midwest has immediate openings for three research men preferably with engineering background, on post-war problems in electrical and electronic fields. Confidential inquiries respected.

P-815, Electronics

520 N. Michigan Ave., Chicago 11, Ill.

#### ELECTRONIC ENGINEER

As research and design engineer with vacuum tube hearing aid company. Must be graduate E.E. Some electronic and acoustical experience desired. Unusual opportunity to progress with aggressive company. Compensation secondary to provable ability. Permanent position. Describe education, experience, aptitudes and age. State salary desired. Apply in complete confidence.

P-873, Electronics

330 West 42nd St., New York 18, N. Y.

#### WANTED

#### Production Engineers

One or more electronic production engineers for large British group of companies, splendid opportunity for real producers, minimum contract period two years. Reply to P-890, Electronics, 330 West 42nd St., New York 18, N. Y., giving full details, experience, college education and salary required.



## PIONEERING OIL RESEARCH

Finding and producing oil involve challenging, important research problems—vital in peace and war. Physics, chemistry, mathematics, and chemical, electronic, and mechanical engineering are tools for solving these problems.

This Company's expanding long-range research program—backed by world-wide resources—necessitates enlarging the permanent research staff. Our modern Southwestern laboratory provides complete facilities, pleasant surroundings, stimulating associates. Many projects afford occasional trips to foreign and domestic fields.

If you have imagination, ability, and experience (beyond the bachelor's degree) in academic or industrial research, write now full details of qualifications, and salary expected.

P-910, Electronics  
520 North Michigan Ave., Chicago 11, Ill.

**Progressive  
midwestern  
capacitor  
manufacturer  
has permanent  
key positions  
for top notch  
executive calibre  
men as follows:**

### ELECTROLYTIC DEVELOPMENT ENGINEER

Capable of designing and supervising installation of equipment. To take complete charge of laboratory and supervise production quality control. Must have previous experience with etching and formation processes.

### ELECTRICAL ENGINEER

Should have broad background of theory and practice in small electrical parts or equipment manufacturing. Position at present that of coordinating engineering problems of field sales with laboratory, engineering and manufacturing departments. Will have wide latitude of authority and report directly to management. To the right man, position will lead to that of Chief Electrical Engineer. Experience in capacitor field is advisable.

### ELECTRICAL ENGINEER POWER FACTOR IMPROVEMENT

This key position for a new department requires an electrical engineer with specific experience in power factor improvement problems. Technical writing ability is important. The right man probably would have gained his experience with a public utility or manufacturer of heavy power equipment. He must be qualified to create and supervise an entire department for sales of capacitors used in power factor improvement. He will be given assistance of a competent staff of capacitor engineers but will be required to design and arrange for manufacture of associated power factor equipment. Sales experience will be helpful but not essential.

Applicants are requested to outline experience, education, present and previous earnings and salary requirements. All replies will be held in strictest confidence. Our own engineers know of this advertisement.

ADDRESS P927  
**ELECTRONICS**  
520 North Michigan Avenue  
Chicago 11, Illinois

### WANTED PHYSICISTS— PHYSICAL CHEMISTS

Several unusual opportunities are offered technical men having experience in the Radiation field.

Men working with ultra high frequencies or having training in nuclear physics should find this research attractive.

Important considerations are the present small number in the section, which offers unusual opportunities for advancement and the availability of all the facilities of a large research laboratory which are so necessary to pioneering research.

Radiation Section  
**The Research and Development Laboratories**  
Socony-Vacuum Oil Co., Inc.  
Passaic, N. J.

### WANTED Research Design and Development Engineers

For large capacitor plant located in Southeastern Massachusetts.

Post-War opportunities for qualified engineers.

Write letter giving full details of experience, training, and salary expected.

Applicants will be hired in accordance with the Area Stabilization Plan.

P-892, Electronics  
330 West 42nd St., New York 18, N. Y.

### WANTED Electronic Tube Engineers

We have an opening in our organization with excellent post-war opportunities for capable engineers with experience in development, design or production of radio receiving or transmitting tubes.

Apply  
**Hytron Radio & Electronics Corp.**  
432 Fourth Ave., New York 16, New York

### ENGINEER HIGH QUALITY RADIO RECEIVERS

We need a high grade engineer who is thoroughly familiar with the design and production of radio receivers and has had several years experience. Small company located close to New York.

P. O. Box 430  
Elizabeth, N. J.  
or Elizabeth 2-1735

### OPENINGS FOR TELEVISION ENGINEERS

Design experience in the development of television cameras, terminal equipment or transmitters. State experience and salary desired.

*Apply in person or in writing to:*

Personnel Department  
**RAYTHEON**  
**Manufacturing Co., Inc.**

COMMUNICATIONS DIVISION  
60 E. 42nd St. New York 17, N. Y.



(Continued from page 438)

## REPRESENTATIVES AVAILABLE

**CANADIAN MANUFACTURER:** of record players wishes to make contact with American Manufacturers of phonograph motors and crystal pickups with view to making immediate quantity purchases. Reply RA-925, Electronics, 330 W. 42nd St., New York 18, N. Y.

**ELECTRONIC ENGINEER** wishes to represent large manufacturer of radio, musical instruments, commercial sound, or 16mm motion picture equipment as field sales or service engineer in Southern California area. Exceptional qualifications. RA-926, Electronics, 621 S. Hope St., Los Angeles 14, Calif.

## NATIONAL DISTRIBUTION AVAILABLE

For Manufacturers who make products suitable for sale to radio and electronic jobbers. We have a complete sales staff for national and export distribution. Reply with samples or description of products.

RA-870, Electronics  
330 West 42nd St., New York 18, N. Y.

## SALES IN CHICAGO

Established Sales and Application Engineering organization in Chicago desires to represent and additional manufacturer. If you make products of merit used by Radio, Electronic and other manufacturers as part of their assemblies our efforts can secure substantial and permanent business for you. Write for details.

RA-782, Electronics  
520 N. Michigan Ave., Chicago 11, Ill.

## Manufacturers with Vision

If you manufacture radio and electronic parts, this Chicago sales representative with twenty years industry background and unusual jobber and manufacturer connections wants to add one or two good lines on a commission basis for the lucrative Chicago area. You will be acquiring an exclusive representative of sales-managership calibre and technical experience and nation-wide reputation, calling on your best customers with only one other line considered "tops" in the industry. If your problem is making a change, please be assured that all negotiations will be in the strictest confidence. Available for personal interview anywhere.

RA-915, Electronics  
520 North Michigan Ave., Chicago 11, Ill.

## FOR SALE TRANSFORMER FACTORY

In large eastern market—Wonderful opportunity to buy completely equipped going concern, doing \$350,000. yearly business. \$85,000. cash required.

B0-876, Electronics  
330 W. 42nd St., New York City.

## WANTED

### WANTED

**TYPE 104 UNIVERSAL COIL WINDING MACHINES**

**WILMINGTON COIL CO.**

Brookside Drive Richardson Park, Del.

## Radio Engineering Librarian

We desire to employ an elderly or handicapped, thoroughly experienced, radio engineer as Librarian and General Consultant to our engineering staff. Familiarity with radio patents would be an asset.

Light work, pleasant surroundings on ground floor.

Write, giving full information on experience and education.

## Colonial Radio Corporation

Engineering Division

1280 Main St. Buffalo 9, N. Y.

## REPAIR MEN WANTED

With some knowledge of Radio, Motors or Electro-Medical Equipment, to learn how to service such Apparatus. Oldest est. mfr. Jobs will lead to important sales or service positions in Chicago or other cities. Good starting pay. Thorough instruction.

## McIntosh Electrical Corporation

223-233 N. California Avenue  
Chicago 12, Illinois

### WANTED

## Radio Engineers and Technicians

National Network in New York City  
Knowledge of Television helpful.

Write full details

P-909, Electronics  
330 W. 42nd St., New York 18, N. Y.

## METERS

VOLTIMETERS BRIDGES (Wheatstone)  
AMMETERS MEGOHMMETERS  
MICRO RHEOSTATS  
AMMETERS VARIABLE  
OHMMETERS TRANSFORMERS  
FREQ. METERS RELAYS

Ask for Our Latest Availability List

## ELECTRO-TECH

EQUIPMENT COMPANY

329 Canal St., New York 13, N. Y.

## FM is sweeping the country

We, as pioneer manufacturers of FM broadcast equipment, are prepared . . . and now have openings for sales representatives in the following territories:

NEW ENGLAND • OHIO • SOUTH • SOUTHWEST

### Qualifications:

1. Financially able, with present organization for one in planning.
2. Established, regular contacts with broadcasters in your territory and means of contacting prospective broadcasters in FM
3. Engineering and technical background helpful, but not essential.

Write, stating qualifications, to

SW-913, Electronics  
330 West 42nd Street, New York 18, N. Y.



## Export for Profit

Roburn Agencies, Inc. have represented leading manufacturers of radio and electrical equipment, parts and accessories, in world-wide markets since 1935. Extensive facilities relieve you of all export headaches - correspondence, advertising, sales, finance, packing and shipping. A few additional clients seeking experienced, reliable representation are invited. Write for information on Profits Through Exports.

Roburn Agencies, Inc.  
115E Fulton Street New York 7, N. Y.

### BEST QUALITY, USED

## ELECTRON TUBE MACHINERY

Equipment for the manufacture of all kinds of electron tubes, radio tubes, incandescent lamps, neon tubes, photo electric cells, X-ray tubes, etc.

AMERICAN ELECTRICAL SALES CO., INC.  
65-67 East 8th St. New York, N. Y.

1—High Frequency Induction Furnace, 16 KVA capacity manufactured by Ecco High Frequency Corp., North Bergen, N. J. Purchased June, 1945 for \$2750.00 received but never production operated.

FS-900, Electronics  
520 North Michigan Ave., Chicago 11, Ill.





# POWER

## HIGH VOLTAGE POWER SUPPLY

This is the RA-38 power supply—another of the numerous valuable items in the group of government radio and electronic supplies offered for general distribution through the Hallicrafters Co., agents for RFC under Contract SIA-3-24.

Output voltage continuously variable from 0 to 15,000 volts. Can be easily adapted to deliver up to 6,000 volts at 1 ampere. Excellent power supply for laboratory work or can be used as power source for broadcast stations, induction heating equipment, vacuum tube life tests and many other industrial applications.

### THESE VALUABLE ITEMS

*Available Now*

or very soon. Write, Wire or phone for further information.

- head phones • test equipment • component parts • marine transmitters and receivers • code practice equipment • sound detecting equipment • vehicular operation police and command sets • radio beacons and airborne landing equipment.

### CLIP THIS COUPON NOW

RFC DEPARTMENT 217, HALLCRAFTERS  
5025 West 65th Street • Chicago 38, Illinois

- Send further details and price on RA-38 Power Supply
- Send listings of other available items

Especially interested in.....

NAME.....

ADDRESS.....

CITY.....ZONE.....

STATE.....

# hallicrafters RADIO

HALLCRAFTERS CO., AGENT OF RFC UNDER CONTRACT SIA-3-24  
MANUFACTURERS OF RADIO AND ELECTRONIC EQUIPMENT

COPYRIGHT 1945 THE HALLCRAFTERS CO.

ONE OF A SERIES...

ESSEX

Showing complete manufacturing facilities from raw material to finished product!



## SOLENOID WINDING for HIGH FREQUENCY COILS Space Wound • Close Wound

Whatever your needs in high frequency coils may be, you're sure to find it at ESSEX. Universal and Progressive windings as well as Solenoid windings are produced on the most modern machines that industry can provide . . . and by employees trained to the high quality standards required of all ESSEX'S personnel. For electronic components to meet your own high quality standards, ESSEX is ready to serve you.

Precision manufacturers of all types of I.F. and R.F. coils, chokes and transformers.

**ESSEX  
ELECTRONICS**

1060 Broad St., Newark, N. J.

# INDEX TO ADVERTISERS

	Page		Page
Acheson-Colloids Corporation	7	Celanese Corp. of America	169
Acme Electric & Mfg. Co.	416	Cellusuede Products, Inc.	406
Acro Electric Co.	238	Central Paper Co., Inc.	332
Aerovox Corporation	36	Centralab, Div. of Globe-Union, Inc.	33
Air Reduction	360	Chace Co., W. M.	334
Aircraft-Marine Products, Inc.	214	Chatham Electronics	44
Aireon Manufacturing Corp.	319	Cherry Rivet Company	247
Alden Products Co.	429	Chicago Metal Hose Corporation	330
Allegheny Ludlum Steel Corporation	259	Chicago Telephone Supply Co.	28
Allied Control Co., Inc.	23	Chicago Transformer Corp.	413
Allied Radio Corp.	318	Cinaudagraph Corporation	357
Allis-Chalmers, Electronics Devices Section 8,	9	Cinch Mfg. Corp.	149
Altec Lansing Corporation	396	Cinema Engineering Co.	322
Amalgamated Electronics Associated	205	Clare & Co., C. P.	70
Amalgamated Radio Television Corp.	180	Clarostat Mfg. Co., Inc.	386
American Electrical Heater Co.	340	Cohn & Co., Sigmund	406
American Gas Accumulator Co.	404	Collins Radio Co.	249
American Gas & Chemical Co.	431	Columbia Wire & Supply Co.	423
American Lava Corporation	75	Communication Measurements Laboratory	264
American Lens Co., Inc.	42	Communications Company, Inc.	230
American Optical Co.	417	Conant Electrical Laboratories	338
American Phenolic Corp.	193	Concord Radio Corporation	407
American Photocopy Equipment Co.	430	Condenser Products Company	431
American Platinum Works	425	Connecticut Cable Corp.	417
American Screw Co.	278	Connecticut Telephone & Electric Division of G. A. I.	223
American Time Products, Inc.	186	Continental-Diamond Fibre Co.	244
American Transformer Co.	64	Control Corporation	446
Amperex Electronic Corporation	42	Cook Electric Co.	190
	Inside Front Cover	Cornell-Dubilier Electric Corp.	303
Amperite Co.	344	Corning Glass Works	66
Anaconda Wire & Cable Co.	305	Cornish Wire Company, Inc.	356
Andrew Co.	403	Coto-Coil Co., Inc.	350
Ansonia Electrical Co.	252	Cramer Company, Inc., R. W.	429
Arkwright Finishing Co.	259	Cross, H.	437
Armstrong Mfg. Co.	437	Crystal Research Laboratories, Inc.	208
Arnold Engineering Co.	192	Crystal Trading Co.	437
Art Wire & Stamping Co.	429		
Astatic Corporation	260	Dalis, Inc., H. L.	328
Atlas Sound Corporation	415	Daven Company	Inside Back Cover
Audak Co.	447	Davton Rogers Mfg. Co.	415
Audio Development Co.	362	DeJur Amsco Corporation	381
Audio Devices, Inc.	173	De Mornay Budd, Inc.	200
Auto Engraver Co.	425	Deuschmann Corp., Tobe	6
Automatic Electric Sales Corp.	170	Dial Light Co. of America, Inc.	412
Automatic Mfg. Corporation	74	Diamond Instrument Co.	58
		Diebel Die & Mfg. Co.	360
Bakelite Corporation	187	Dinion Coil Co., Inc.	340
Baker-Phillips Co.	324	Distillation Products, Inc.	411
Ballantine Laboratories, Inc.	242	Dixon's Typhonite ELDORADO Pencils	424
Barker & Williamson	172	Dobeckmun Company, The	63
Belden Manufacturing Company	245	Dongan Electric Mfg. Co.	406
Bell Sound Systems, Inc.	412	Doolittle Radio, Inc.	426
Bell Telephone Laboratories	4, 5	Dow Chemical Company	261
Bendix Aviation Corp., Pacific Div.	181	Dow Corning Corporation	321
Bendix Aviation Corp., Radio Division	209	Drake Electric Works, Inc.	356
Bentley, Harris Mfg. Co.	22	Drake Manufacturing Co.	392
Benwood-Linze Co.	337	Driver-Harris Co.	79
Bidde Co., James G.	345	Dumont Electric Co.	18
Bittermann Electric Co.	433	DuMont Laboratories, Inc., Allen B.	40
Bliley Electric Co.	281	du Pont de Nemours & Co. (Inc.), E. I.	331
Boonton Radio Corp.	201	Durez Plastics & Chemicals, Inc.	203
Bradley Laboratories, Inc.	385	DX Radio Products Co.	324
Brand & Co., William	43	Dynamic Air Engineering, Inc.	171
Breeze Corporations, Inc.	183		
Browning Laboratories, Inc.	399	Eastern Air Devices, Inc.	202
Bruning Company, Inc., Charles	266	Eastern Amplifier Corporation	194
Bud Radio, Inc.	432	Eastern Electronics Corp.	349
Burgess Battery Co.	308	Eby, Inc., Hugh H.	408
Burlington Instrument Co.	384	Ecco High Frequency Corp.	347
Burndy Engineering Co., Inc.	315	Eicor, Inc.	204
Burstein-Applebee Co.	437	Eisler Engineering Co.	328, 437
Byington & Company	437	Eitel-McCullough, Inc.	89
		Electrical Industries, Inc.	428
Callite Tungsten Corp.	32	Electrical Insulation Co., Inc.	368
Cambridge Thermionic Corporation	153	Electrical Reactance Corp.	415
Cannon Electric Development Co.	184	Electrix Corporation	410
Capacitron Company	312	Electronic Engineering Co.	425
Capitol Radio Engineering Institute	420	Electronic Enterprises, Inc.	298
Carborundum Company	210	Electronic Mechanics, Inc.	207
Cardwell Mfg. Corp., Allen D.	409	Electro-Voice, Inc.	270
Carter Motor Co.	320		



	Page
Engineering Company	423
Erco Radio Laboratories, Inc.	394
Ericsson Screw Machine Products Co., Inc.	360
Erie Resistor Corp.	80
Espey Manufacturing Co., Inc.	404
Essex Electronics	444
Export Industries	352
Farnsworth Television & Radio Corporation	377
Fast & Co., John E.	367
Federal Tel. & Radio Corp.	54, 283, 423
Fenwal, Inc.	370
Ferranti Electric, Inc.	78
Finch Telecommunications, Inc.	340
Follansbee Steel Corporation	296
Foote Mineral Company	327
Ford Radio & Mica Corp.	208
Formica Insulation Company	263
Foster Company, A. P.	389
Franklin Mfg. Corp., A. W.	199
Freeland & Olschner Products, Inc.	437
Gates Radio Company	302
Gear Specialties	19
General Cable Corp.	60, 61
General Cement Mfg. Co.	437
General Ceramics and Steatite Corp.	215
General Control Co.	378
General Electric Co.	11, 12, 13, 14, 68, 69, 177, 269, 355, 402, 435
General Instrument Corp.	213
General Magnetic Corp.	427
General Plate Div. of Metals & Controls Corp.	314
General Radio Company	393
General Tire & Rubber Co.	323
Gilfillan Brothers, Inc.	310
Glaser Lead Co.	196
Glendale Vacuum Products Co.	437
Goat Metal Stampings, Inc.	419
Goodrich Chemical Co., B. F.	448
Gothard Manufacturing Company	320
Gould-Moody Co.	416
Graphite Metallizing Corp.	408
Grayhill	418
Green Electric Co., Inc., W.	188
Greenlee Tool Co.	360
Guardian Electric Mfg. Co.	217
Guided Radio Corporation	348
Hallcrafters Co.	73
Hamilton Institute, Alexander	348
Hammarlund Mfg. Co., Inc.	10
Hanovia Chemical & Mfg. Co.	280
Hardwick, Hindle, Inc.	352
Harris Products Co.	304
Harrison Radio Corp.	410
Hartford Machine Screw Co.	344
Harvey Radio Company	414
Harvey Radio Laboratories, Inc.	15
Hassall, Inc., John	320
Heiland Research Corporation	182
Heinemann Circuit Breaker Co.	251
Heintz & Kaufman, Ltd.	37
Hewlett-Packard Company	57
Hexacon Electric Company	422
Hickok Electrical Instrument Co.	160
Hopp Press, Inc.	328
Hudson Wire Company	348
Hunter Pressed Steel Company	67
Hytron Radio & Electronics Corp.	49
Ile Electric Ventilating Co.	398
Indiana Steel Products Co.	262
Industrial Condenser Corp.	276
Industrial Transformer Corp.	307
Inst-X Co., Inc.	226
Instrument Resistors Company	418
Insulation Manufacturers Corp.	163
Insuline Corp. of America	218
International Detrola Corporation	335
International Resistance Co.	155
Irvington Varnish & Insulator Co.	195
Islip Radio Mfg. Corp.	364
Jackson Electrical Instrument Co.	326
Janette Manufacturing Co.	368
Jeffers Electronics	225

# NORMAN H. LAWTON *announces*

the opening of mid-west offices at

635 North Pennsylvania  
INDIANAPOLIS 4, IND.

under the management of

## GEORGE R. BRAND

to better serve mid-west manufacturers  
of radio and electronic equipment.

# NORMAN H. LAWTON

ENGINEERING • SALES • SERVICE

1775 BROADWAY, NEW YORK CITY 19

AND

635 NORTH PENNSYLVANIA, INDIANAPOLIS 4, IND.

A W FRANKLIN MFG CORP—Sockets, Terminal Strips Plugs, Assemblies

FRANKLIN AIRLOOP CORP—"Airloop" Antennas

ELECTRO-MOTIVE MANUFACTURING COMPANY—Molded Mica  
Capacitors, Mica Trimmer Capacitors, etc.

QUAKER CITY GEAR WORKS—Precision Gears for Industry

UNITED TRANSFORMER COMPANY—Transformers

## 2 VITAL AIDS

TO THE MANUFACTURER OF  
*Miniature Tube Radios*

### ★ STAR

DOUBLE-CHECK SYSTEM



#JE-10—Miniature socket wiring plug for accurate alignment of miniature socket contacts during wiring. Precision cast of zinc base alloy—Pins of stainless steel.

#JE-12—(Hardened tool steel insert) or JE-13 (Stainless steel insert) Miniature tube pin straightener to obtain a perfect fit when the tube is placed in the set.



For complete information  
and prices—write

RADIO ACCESSORY DIVISION

STAR EXPANSION PRODUCTS CO.  
147 Cedar St., New York 6, N. Y.

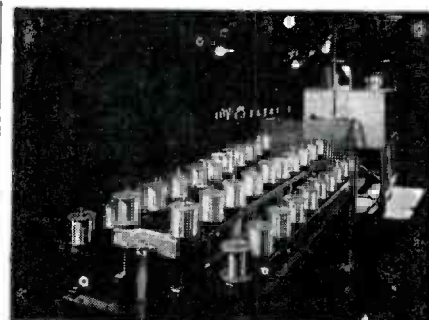

## RESISTANCE WIRE

ALLOYS FOR EVERY PURPOSE

ALLOY "A"—Nickel-chromium non-magnetic; spec. resistance 650 ohms/CMF.

ALLOY "C"—High resistance to oxidation and corrosion; for electronics and industrial equipment.

ALLOY "D"—Nominally 30% nickel 15% chromium, balance iron. Specific resistance 600 ohms/CMF.

ALLOY "45"—Copper-nickel for winding precision resistors. Constant resistance over wide range of temperatures.

KANTHAL—Now available; we will be pleased to supply data for your post-war requirements.

The C. O. JELLIFF MFG. CORP.  
123 Pequot Rd. Southport, Conn.

Valuable **TRANSFORMER**  
Experience at your command

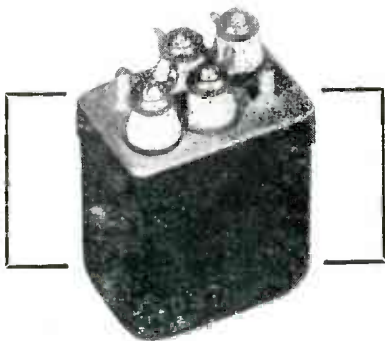

## Control Corporation

... Leaders in the design and production of hermetically-sealed transformers using combinations of the following features:

- Vacuum-pressure impregnated.
- Varnish or wax treatment.
- Oil, wax, or pitch filled.
- Drawn or fabricated cases.
- Gasketed or solder-sealed bushings.
- Cores of punched stock, wound loops, powdered iron.
- Core stock of silicon steel, oriented, or high permeability materials.
- Per Navy, Army, etc. specs.

## CONTROL CORPORATION

718 CENTRAL AVE. (S.E.)

Phone Granville 8897

MINNEAPOLIS 13, MINN.

## JONES 400 SERIES PLUGS and SOCKETS



P-406-CCT

A medium size Plug and Socket that fulfills practically every requirement in the public address, radio and kindred fields. Socket contacts are of phosphor bronze, cadmium plated.



S-406-AB

Plug contacts are of hard brass, silver plated. Insulation is of molded Bakelite. All Plugs and Sockets are Polar-

ized. Made in 2, 4, 6, 8, 10 and 12 contacts. Caps are of steel with baked black crackle enamel. A quality item at popular prices.

Send today for catalog No. 14 listing complete line of Jones Electrical Connecting Devices—Plugs, Sockets and Terminal Strips.

**HOWARD B. JONES COMPANY**  
2460 W. GEORGE ST. CHICAGO 18

# INDEX TO ADVERTISERS

(Continued)

	Page	Page	
Jefferson Electric Co. ....	295	Permo, Inc. ....	332
Jelliff Mfg. Corp., C. O. ....	445	Permoslux Corporation ....	358
Jensen Radio Mfg. Co. ....	29	Petersen Radio Co. ....	392
Johnson Co., E. F. ....	46	Philharmonic Radio Corporation, Sub. of American Type Founders, Inc. ....	301
Joliet Chemicals, Ltd. ....	395	Phillips Screw Manufacturers ....	294
Jones Co., Howard B. ....	446	Photox Silk Screen Supply Co. ....	382
		Piezo Manufacturing Corp. ....	356
Kahle Engineering Co. ....	437	Pioneer Gen-E-Motor Corp. ....	212
Karp Metal Products Co., Inc. ....	51	Plastic Wire & Cable Corp. ....	271
Kelnor Mfg. Company ....	368	Plastics Manufacturers, Inc. ....	274
Ken-Rad Div. of General Electric Co. ....	371	Porter Metal Products Company ....	233
Kenyon Transformer Co., Inc. ....	353	Potter & Brumfield Mfg. Co., Inc. ....	372
Kester Solder Co. ....	346	Potter Instrument Co. ....	47
Keuffel & Esser Co. ....	3	Premax Products ....	364
Kirkland Co., H. R. ....	431	Press Wireless, Inc. ....	229
Kurz-Kasch, Inc. ....	179	Presto Recording Corp. ....	26
		Printloid, Inc. ....	387
Lampkin Laboratories ....	437	Production Engineering Corp. ....	390
Langevin Company, Inc. ....	277	Progressive Mfg. Co. ....	336
Lapp Insulator Co., Inc. ....	45	Pyroferic Co. ....	372
Lavoie Laboratories ....	317		
Lawton, Norman H. ....	445	Quadriga Mfg. Co. ....	431
Lear, Inc. ....	243	Quaker City Gear Works, Inc. ....	374
Leland Electric Company ....	167		
Lewis Electronics ....	178	Radell Corp. ....	410
Lewyt Corporation ....	397	Radex Corporation ....	431
Linde Air Products Co. ....	372	Radiart Corporation ....	287
Lindsay & Lindsay ....	161	Radio Condenser Co. ....	71
Littelfuse, Inc. ....	309	Radio Corp. of America, Victor Div. 185, Back Cover	
Litton Engineering Laboratories ....	76	Radio Engineering Lab's, Inc. ....	241
Lord Manufacturing Co. ....	221	Radio Receptor Co., Inc. ....	27
L-R Manufacturing Co. ....	232	Radio Supply & Engineering Co., Inc. ....	417
		Radio Wire Television, Inc. ....	420
Maas & Waldstein Company ....	198	Railway Express Agency ....	336
Macallen Company ....	292	Rauland Corporation ....	197
Machlett Laboratories, Inc. ....	24, 25	Rawson Electrical Instrument Co. ....	372
Madison Electrical Products Corp. ....	246	Raytheon Mfg. Co. ....	81, 275
Magnavox Company ....	351	R-B-M Manufacturing Company ....	222
Mallory & Co., Inc., P. R. ....	90, 151, 220	Reiner Electronics Co., Inc. ....	333
Manross and Sons, F. N. ....	268	Reliable Spring & Wire Forms Co. ....	376
Marion Electrical Instrument Co. ....	85	Remler Company, Ltd. ....	329
Martins Instrument Co., Inc. ....	421	Revere Copper & Brass, Inc. ....	34, 35
MB Manufacturing Co., Inc. ....	414	Rex Rheostat ....	437
McGraw-Hill Book Co. ....	419, 425, 435	Rice's Sons, Inc., Bernard ....	339
Measurements Corporation ....	428	Richardson Company ....	234
Micro Switch Corp. ....	258	Rider Publisher, Inc., John F. ....	336
Millen Mfg. Co., Inc., James ....	378	Ripley Company, The ....	232
Miniature Precision Bearings ....	437	Robinson Aviation, Inc. ....	231
Mitchell-Rand Insulation Co., Inc. ....	86	Rockbestos Products Corp. ....	373
Monanto Chemical Co., Plastics Div. ....	82, 83	Rogan Brothers ....	352
Mossman, Inc., Donald P. ....	343	Roller-Smith Co. ....	191
Multicore Solders, Ltd. ....	158, 159	Russell Electric Co. ....	55, 299
Murray Hill Books, Inc., Technical Div. ....	436		
Mycalex Corporation of America ....	16	Sangamo Electric Co. ....	30, 31
		Santay Corporation ....	72
National Carbon Co., Inc. ....	286	Schweitzer Paper Co. ....	219
National Company ....	391	Scientific Electric Div. of "S" Corrugated Quenched Cap Co. ....	87
National Moldite Company ....	422	Scovill Mfg. Co., Electronic Div. ....	383
National Research Corp. ....	342	Scovill Mfg. Co., Waterville Screw Pro- ducts Div. ....	165
National Screw & Mfg. Co. ....	189	Screenmakers ....	364
National Varnished Products Corp. ....	240	Sealol Corporation ....	421
National Vulcanized Fibre Co. ....	41	Seeburg Corp., J. P. ....	306
New England Screw Co. ....	368	Selenium Corp. of America ....	400
New Haven Railroad ....	311	Shakeproof, Inc. ....	48
New York Transformer Co. ....	267	Shallcross Mfg. Co. ....	164
North American Philips Co., Inc. ....	379	Sherman Mfg. Co., H. B. ....	402
Northern Communications Mfg. Co. ....	432	Sherron Electronics Co. ....	77
Northern Industrial Chemical Co. ....	435	Shur-Antenna-Mount, Inc. ....	433
		Shure Brothers ....	157
Ohio Electric Manufacturing Co. ....	272	Sickles Company, F. W. ....	175
Ohmite Mfg. Company ....	255	Siema Instruments, Inc. ....	388
Oiljak Manufacturing Co., Inc. ....	224	Signal Indicator Corp. ....	332
Onan & Sons, D. W. ....	398	Sillcocks-Miller Co. ....	396
O'Neil-Irwin Mfg. Co. ....	402	Simpson Electric Co. ....	52, 53
Oster Mfg. Co., John ....	282	Smith Mfg. Co., Inc., F. A. ....	419
Owens Corning Fiberglas Corp. ....	361	Sola Electric Co. ....	257
		Solar Manufacturing Corp. ....	88
Palnut Company ....	176	Soreasen & Company, Inc. ....	325
Pan-Electronics Laboratories, Inc. ....	354		
Par-Metal Products Corporation ....	423		
Peerless Roll Leaf Co., Inc. ....	429		



	Page
Sound Equipment Corp. of Calif.	256
Speer Carbon Company	365
Spencer Thermostat Company	359
Spencer Wire Co.	313
Sperti, Inc.	405
Sprague Electric Co.	235
Stackpole Carbon Co.	265
Stamford Metal Specialty Co.	429
Standard Instruments Corp.	290
Standard Piezo Company	38, 39
Standard Pressed Steel Co.	434
Standard Transformer Corp.	168
Star Expansion Products Co.	445
Star Porcelain Co.	433
Sta-Warm Electric Co.	434
Stephens Manufacturing Co.	400
Stevens Walden, Inc.	426
Steward Mfg. Co., D. M.	427
Stokes Machine Co., F. J.	404
Struthers-Dunn, Inc.	17
Stupakoff Ceramic & Mfg. Co.	84
Superior Electric Co.	236
Supreme Instruments Corp.	424
Swain Nelson Company	273
Sylvania Electric Products, Inc.	162
Taylor Fibre Company	56
Tech Laboratories	427
Television Products, Inc.	288
Telicon Corporation	65
Thermador Electrical Mfg. Co.	291
Thomas & Skinner Steel Products Co.	433
Thordarson Electric Mfg., Div. of Maguire Industries, Inc.	239
Tinnerman Products, Inc.	227
Transmitter Equipment Mfg. Co., Inc.	59
Triplett Electrical Instrument Co.	206
Tung-Sol Lamp Works, Inc.	341
Ucinite Company	248
Union Carbide & Carbon Corp.	187, 286, 372
United Catalog Publishers, Inc.	421
United Electronics Company	62
United States Rubber Co.	289
United Transformer Corp.	2
Utah Radio Products Company	293
Victoreen Instrument Co.	430
Victory Manufacturing Co.	324
Waldes Kohinoor, Inc.	211
Walker-Jimieson, Inc.	382
Walker-Turner Co., Inc.	300
Wallace & Tiernan Products, Inc.	50
Waltham Screw Co.	405
Ward Leonard Electric Co.	369
Ward Products Corporation	344
Warren Telechron Co.	363
Webster-Chicago	279
Webster Electric Co.	284
Western Brass Mills Div. of Olin Industries, Inc.	285
Western Electric Co.	4, 5
Westinghouse Electric Corporation	20, 253, 297
Weston Electrical Instrument Corp.	174
Whistler & Sons, Inc., S. B.	228
Whitaker Cable Corp.	237
White Dental Mfg. Co., S. S.	364, 375
Whitehead Stamping Co.	435
Wiley & Sons, Inc., John	366
Wilson Co., H. A.	21, 166
Workshop Associates, The	408
Zenith Optical Laboratory	356
Zophar Mills, Inc.	412
■	
PROFESSIONAL SERVICES	436
■	
SEARCHLIGHT SECTION (Classified Advertising)	
EMPLOYMENT	423, 438, 442
USED EQUIPMENT	442, 443
American Electric Sales Co., Inc.	442
Electro-Tech Equipment Co.	442
Hallcrafters Co.	443
Wilmington Coil Co.	442

THE IMPORTANCE OF

*Specialization*

IS FORCEFULLY  
DEMONSTRATED BY

**Audax**



Aside from outstanding and long-acknowledged technical skill — our “Specialization Formula” is probably as fully responsible for the world-renowned AUDAX quality as any other single factor.

We proudly concentrate all our energies and resources upon producing the finest pick-ups and cutters. Because we are specialists in this field, much more is expected of us. Because the production of fine instruments like MICRODYNE is a full time job, it stands to reason that we could not afford to jeopardize our reputation — EVER — by making pick-ups a side-line.

Now that Victory is ours you may expect further AUDAX improvements, refinements . . . master-touches to heighten the marvelous facsimile realism of AUDAX reproduction.

## AUDAX COMPANY

500E Fifth Avenue, New York 18

*“Creators of Fine Electronic-Acoustical Apparatus since 1915”*

*“The Standard  
by Which Others  
Are Judged and Valued”*



Send for complimentary copy of our informative  
“PICK-UP FACTS”

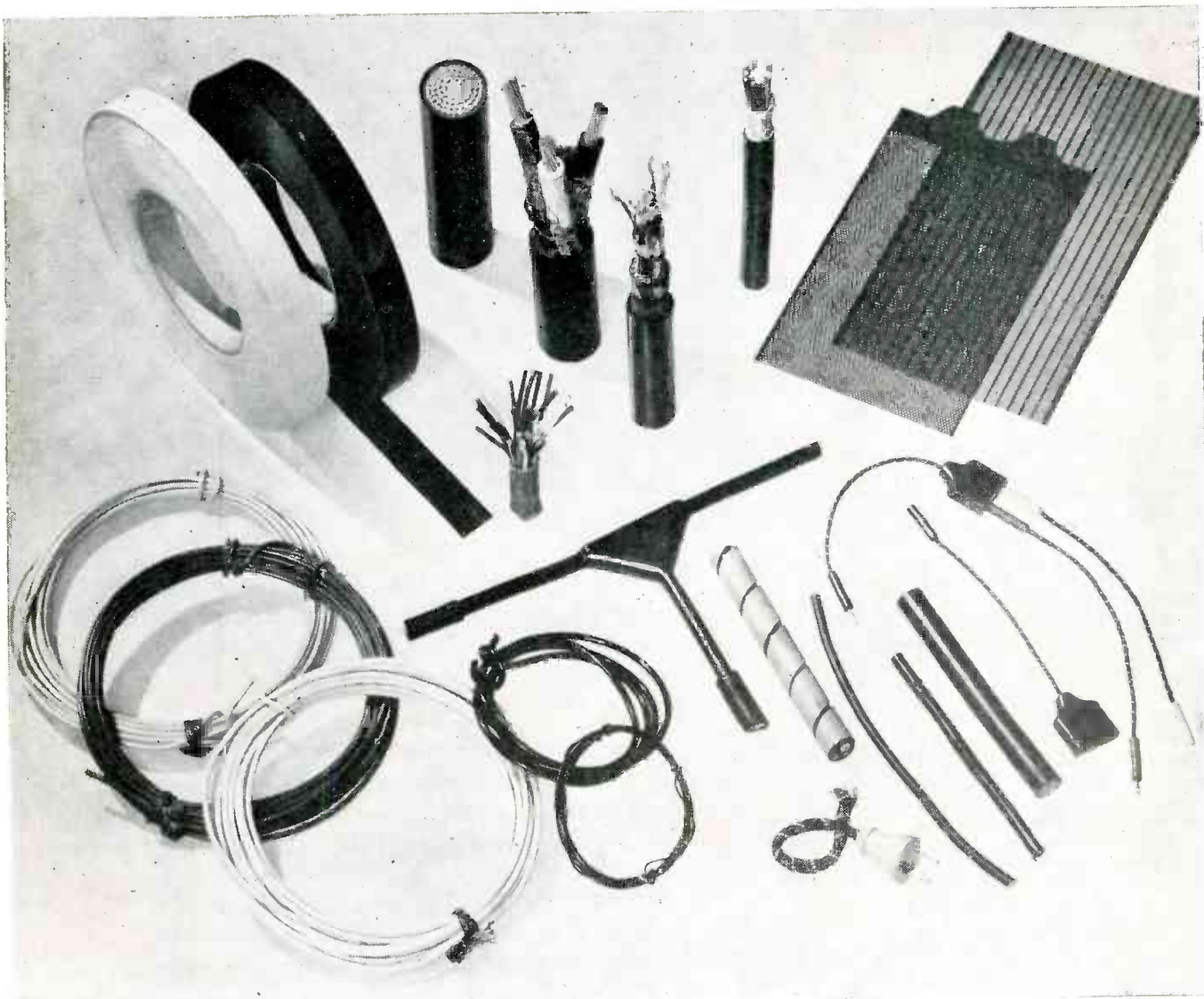

## GEON polyvinyl raw materials have a wide variety of applications in the electrical industry

SHOWN here are some of the important uses—spectacular and prosaic—to which GEON has been put in the electrical field where its outstanding electrical properties have established it as a superior insulating material. Made into wire insulation, GEON's applications range from slip-on "spaghetti" for fine radio wire to large conduit or *sheathless* insulation for buried power cable.

In the form of tape GEON serves as wire insulation, wrappings for plating racks, and in many other ways. Or GEON can be molded into solid forms such as plugs and connectors.

In no one of these services, however, can full advantage be taken of all the properties of GEON. That's because the list of more than 30 separate properties includes, in addition to excellent

electrical properties, resistance to air, ozone, aging, sunlight, heat, cold, flame, acids, alkalis, water, wear and abrasion, and many other normally destructive factors. Products made from GEON may be flexible or rigid, and can be brilliantly colored in the entire NEMA range.

Used as wire insulation GEON's electrical properties permit a thinner-than-usual coating. That means more conductors per conduit as well as reduced weight for easy handling. The smoothness of wire insulation made from GEON simplifies and speeds installation. For more complete information consult your supplier of wire and other electrical materials. Or write Department FF10, B. F. Goodrich Chemical Company, Rose Building, Cleveland 15, Ohio.



# B. F. Goodrich Chemical Company

A DIVISION OF  
THE B. F. GOODRICH COMPANY



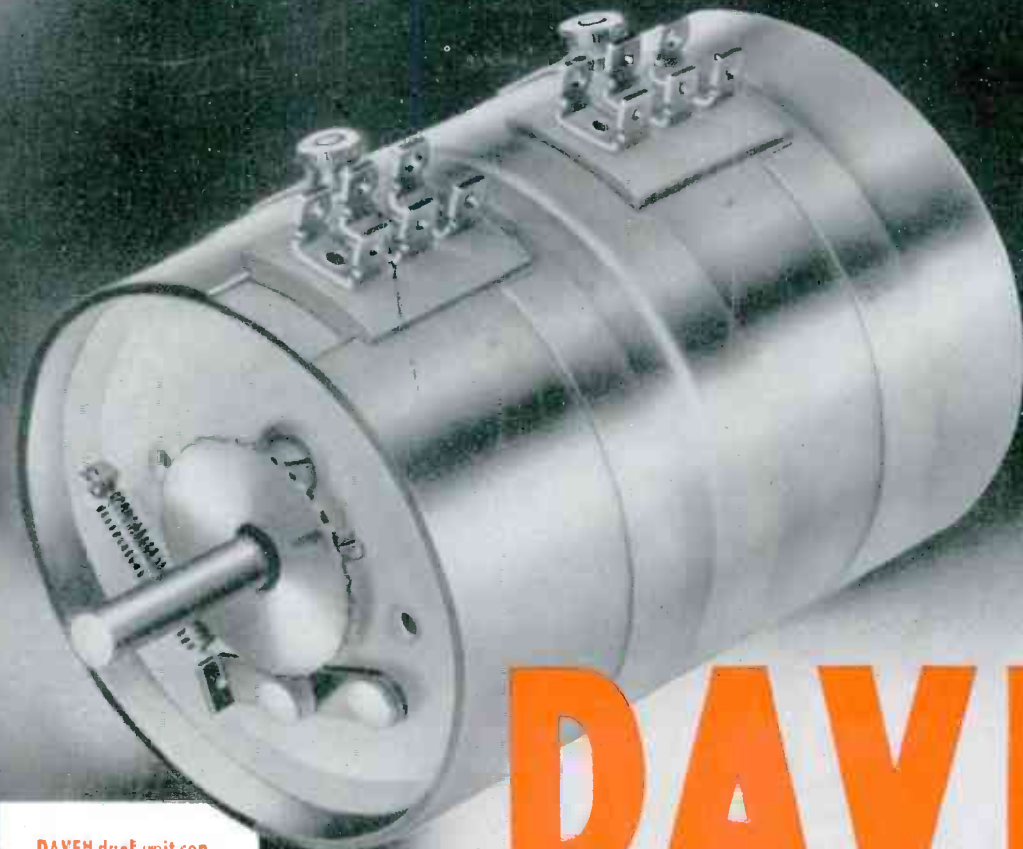

DAVEN dual-unit construction finds most important application in Balanced "H" attenuators, as well as in special multiple-circuit controls of the Potentiometer, "T", Ladder, "L" and Rheostat types.

# DAVEN

## ANNOUNCES A NEWLY-IMPROVED MODEL for DUAL-UNIT\* ATTENUATORS

DAVEN engineers have incorporated into the improved dual-unit all the important new features recently announced for DAVEN standard single-unit attenuators. A noteworthy addition in the dual-unit is the improved method of coupling front and rear attenuators. The respective shafts of each meet in a lap joint within a long, snug collar, providing quick and complete access to either unit. By loosening a knurled nut and releasing a snap-on fitting, the front or rear switch may be reached without dismounting the front unit from the instrument panel.

\*Patent Pending

### Features of DAVEN Dual-Unit Attenuators

**SEPARABLE COUPLING**—Front and rear units now easily separated: gives quick access to either unit. Simple, durable, foolproof construction illustrated at left.

**IMPROVED SHIELDING**—Sturdy, snug fitting, 3 piece steel cover affords superb electrical and dust shielding, as well as greater all around ruggedness.

**NEW DETENT DEVICE**—Large gear and roller mounted in recessed front end of front unit, separate from resistive network, gives accurate indexing. (Illustrated.)

**GREATER COMPACTNESS**—Rear - of - panel depth only 3 7/8"; 9/16" less than former models.

**CERTAIN STOP**—Extrusion of detent gear and steel attenuator cover form sturdy stop to rotation, eliminating rotor-hub strain of previous method.

**CAPTIVE TERMINAL BOARD**—Solder-lugs eye-letted to bakelite boards, which are grooved to fit securely into slots in their respective can sectors.

**ANTI-FUNGUS TREATED**—Bakelite parts and resistive windings treated to resist fungus and mildew.

**SILVER ALLOY**—Contacts, switch arms and returns of tarnish-resisting silver alloy lower internal resistance. Other metals optional.



THE **DAVEN** COMPANY

191 CENTRAL AVENUE  
NEWARK 4, NEW JERSEY

# THE PRICE OF RCA-833A's HAS BEEN REDUCED 26.5% IN LESS THAN 2 YEARS

Now listed at only \$62.50, this sturdily constructed, long-lasting triode has found many applications in industrial, as well as broadcasting, equipment.



**T**HE 833A is RCA's most powerful glass triode. With forced-air cooling, under CCS ratings, it will take a maximum input of 1250 watts in plate-modulated service, and 1800 watts in oscillator service—at frequencies as high as 20 megacycles.

Under CCS ratings, with natural cooling, the RCA-833A will take a maximum input of 1250 watts at frequencies as high as 30 megacycles.

Among the applications of this tube are:

1. Radio transmitters, both fixed and mobile.
2. Electronic generators for dielectric heating.
3. Electronic generators for induction heating of small metal parts, such as gears.
4. High-power sound systems.
5. Variable-frequency measuring equipment.

## DESIGN FEATURES

**100-Watt Thoriated-Tungsten Filament**—provides a tremendous emission reserve, which protects against unexpected overloads and adds greatly to filament life.

**Giant Zirconium Anode**—provides abundant dissipation for high power-output at frequencies up to 30 megacycles. (Maximum of 400 watts CCS rating, with forced-air cooling.)

**Filament End-Shielding**—special plate construction conserves input power by preventing bulb bombardment.

**Post-Terminal Construction**—Electronic heating, used in making metal-to-glass seals in the 833A, made possible a compact tube that packs high power into a minimum of space. Post terminals extend through bulb to provide support for electrodes. Results in a rugged construction that lends itself to heavy-duty industrial applications.

**Write for Data:** For complete technical data on this tube, write to RCA, Commercial Engineering Department, Section 62-35E, Harrison, N. J.

THE FOUNTAINHEAD OF MODERN TUBE  
DEVELOPMENT IS RCA



62-6136-35



RADIO CORPORATION  
OF AMERICA

RCA VICTOR DIVISION • CAMDEN, N. J.