

electronics

radio, communication, industrial applications of electron tubes... engineering and manufacture



DECISION by PHOTOTUBE
(See contents page)

JULY
1937

Price
50 Cents

McGRAW-HILL
PUBLISHING
COMPANY, INC.

*Eastern
Air Lines*

- GO CENTRALAB ALL THE WAY



Thanks! EASTERN AIR LINES, for your gratifying answer to our questionnaire. We are proud to play our part so successfully in maintaining uninterrupted communication between these giant ships of the air and their ground stations. Eastern Air Lines remarkable record of performance is in no small measure the result of infinite attention to detail . . . and Centralab fits into that scheme with jeweled perfection. For broadcast receivers—for aviation—for replacements . . . wherever smooth reception is wanted. . . "Go Centralab all the Way."



Centralab variable resistors have been giving very satisfactory service in our ground station and aircraft applications. We find them dependable and economical for many varied applications in our communications equipment.

Don C. McRae
Supt. of Communications

Centralab controls have given excellent service under the exacting requirements of our communications service. Dependable, noise-free operation has been obtained under extreme ranges of temperature and humidity.

C. H. Bates,
Supervisor, Radio Engineering

We have found Centralab volume controls to be entirely satisfactory in aircraft and ground radio equipment. You cannot surpass them for economy and satisfactory operation.

G. E. Smith,
Asst. Supt. of Communications

Centralab
CRL

DIVISION OF GLOBE UNION INC., MILWAUKEE
Canterbury Rd. Kilbourn N. W., England 118 Ave. Ledru-Rollin, Paris

electronics

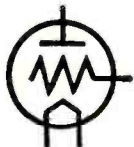

RADIO . . . COMMUNICATION AND
INDUSTRIAL APPLICATIONS OF
ELECTRON TUBES . . . DESIGN . . .
ENGINEERING . . . MANUFACTURE

HOWARD EHRLICH
Executive Vice-President

H. W. MATEER
Manager

KEITH HENNEY
Editor

DONALD G. FINK
Managing Editor

BEVERLY DUDLEY
Assistant Editor

HARRY PHILIPS
Art Director

ELECTRONICS, July 1937, Vol. 10, No. 7. Published monthly, price 50c a copy. Subscription rates—United States and possessions, Canada, Mexico and Central American countries, \$5.00 a year. All other countries, \$6.00 a year or 24 shillings. Entered as Second Class matter, August 29, 1936, at Post Office, Albany, N. Y., under the Act of March 3, 1879.
Branch Offices: 520 North Michigan Ave., Chicago; 883 Mission St., San Francisco; Aldwych House, Aldwych, London, W. C. 2; Washington; Philadelphia; Cleveland; Detroit; St. Louis; Boston; Atlanta, Ga.

Contents Copyright, 1937, by
McGraw-Hill Publishing Company, Inc.

McGRAW-HILL
PUBLISHING COMPANY, INC.

Publication Office
99-129 North Broadway, Albany, N. Y.
Editorial and Executive Offices
330 West 42nd Street, New York, N. Y.

James H. McGraw, Jr., President
Howard Ehrlich, Executive Vice President
James H. McGraw, Honorary Chairman
B. R. Putnam, Treasurer
D. C. McGraw, Secretary

Cable Address:
MCGRAWHILL, New York.
Member A.B.P. Member A.B.C.

CONTENTS, JULY, 1937

FINISH AT DETROIT FAIR GROUNDS	Cover
Where Ralph Powers' phototube camera gave decision to "Swing It," No. 8	
SUPERSONICS—A SURVEY—By Walter Mayberry	7
A review of important applications in a field full of promise	
STANDARDS IN TELEVISION—By H. M. Lewis	10
Questions concerning relations between British and American standards in television	
VOLTAGE REGULATORS USING MAGNETIC SATURATION By Kenneth Way	14
Methods for obtaining constant voltages using saturated reactors	
THE RESONOSCOPE—By Lester Holmes	17
Analyzing musical tones by tuning forks and a cathode ray oscilloscope	
AMPLIFIER MEASURING TECHNIQUE—By E. F. Kiernan	18
An outline of direct methods of measuring characteristics of a-f transformers	
PHOTOTUBE CONTROLS PUNCH PRESS—By Ralph Powers	21
Phototube protects operators of punch press, increases production, decreases insurance premiums	
PUBLIC ADDRESS AVC—By Harry Paro	24
AVC in PA systems enables speaker to exhibit wonderlust without having words missed by audience	
AVIATION BEAM SYSTEM AT INDIANAPOLIS	26
Electronics' picture record of demonstration of Lorenz blind flying system	
POWER TUBE CHARACTERISTICS—By E. L. Chaffee	30
Power tube static curves obtained by use of cathode ray tube	
MUTUAL INDUCTANCE CALCULATIONS—By Dale Pollack	31
Mutual inductance between co-axial coils in graphic form	

DEPARTMENTS

CROSSTALK	5
TUBES AT WORK	28
REFERENCE SHEET	31
BACKTALK	34
ELECTRON ART	36
QUESTIONS AND ANSWERS	48
MANUFACTURING REVIEW	54
INDEX TO ADVERTISERS	68

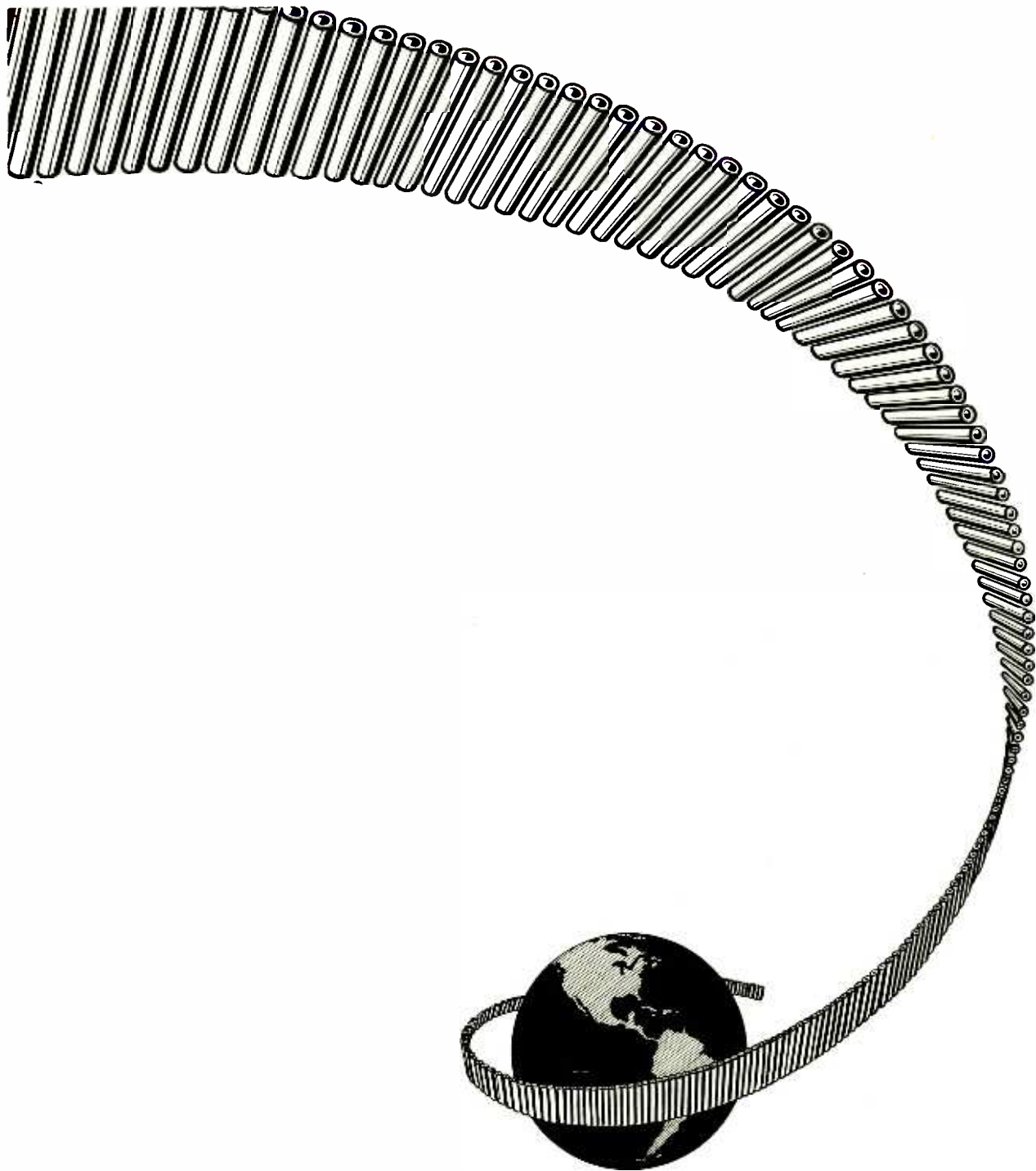

THE fact that "Superior" has turned out 32 million Cathode Sleeves since the first of the year is indicative merely of our capacity. While this may seem an impressive figure, it is important only because it represents the radio industry's penchant for seeking out a satisfactory source of supply—and then sticking to it!

SUPERIOR TUBE COMPANY, NORRISTOWN, PA.

MANUFACTURERS OF SEAMLESS AND LOCKSEAM CATHODE SLEEVES
AND FINE SEAMLESS TUBING IN VARIOUS METALS AND ALLOYS

SUPERIOR TUBING

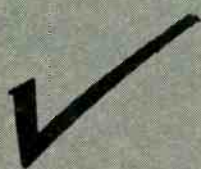

Check your knowledge of FLEXIBLE SHAFTS

Flexible shafts are, of course, known to every designing engineer—if for no other reason than their widespread and successful use on speedometers and auto radios.

But, the flexible shaft has not stood still. Important developments have been made, and many additional uses and applications have come into being.

Today the flexible shaft is worthy of *first* consideration every time a power drive or remote control problem comes up, for the very sound reason that it is the simplest means of effectively transmitting power or control movement between two points, *regardless of their relative positions.*

So check your knowledge of flexible shafts . . . and any time you want information, call on us. . . Also when you have a power drive or remote control problem let us help you work it out. . . No obligation . . . just send us the details.

The S. S. WHITE Dental Mfg. Co. INDUSTRIAL DIVISION

10 East 40th St., Room 2310E, New York, N. Y.

Partial List of S. S. WHITE Flexible Shaft Applications in the RADIO and ELECTRONICS Fields

REMOTE CONTROL SHAFTS

Auto Radios
Aircraft Radio Receivers and Transmitters
Broadcast Transmitters
Variable Frequency Crystal Holders
Radio Telephone Equipment
Aircraft Direction Finder
Aircraft Antenna Control

COUPLING SHAFTS

Electrical Instruments
Broadcast Transmitters
Auto Radio Receivers
Auto Radio Antennas
Portable Track Recorder
Auto Radio Control Panels

FLEXIBLE SHAFTS for POWER DRIVES, REMOTE CONTROLS and COUPLINGS

A MALLORY Varnished Tube Capacitor with obvious superiorities

Due to the high temperatures and humid conditions encountered in many applications, capacitors must be carefully sealed to prevent moisture loss or absorption.

Aluminum containers, rather than ordinary waxed cardboard cartons, have often been specified as a precautionary measure. The higher cost justified the results obtained.

However, the obvious superiority of the new varnished tube as designed by Mallory engineers is worthy of investigation. Many manufacturers are saving money and obtaining long trouble-free life through the adoption of this new Mallory construction.

Oven baking . . . after thorough impregnation in a special varnish . . . gives these

Mallory capacitor tubes a moisture resistance far superior to that of ordinary wax tubes.

The tubes themselves are made of paper specially selected for chemical purity and strength. High temperature sealing wax used at the ends of Mallory varnished tube capacitors adheres uniformly and tightly to the varnished interior surface.

Old style waxed tubes could not be painted as the paint would not adhere to the waxed surface. Mallory varnished tubes may be sprayed in any color by the customer at the same time the chassis is sprayed. Add this advantage to that afforded by the good hermetical seal these tubes provide . . . and you'll specify Mallory and save money.

P. R. MALLORY & CO., Inc.
INDIANAPOLIS INDIANA

Cable Address—PELMALLO

*Mallory Dry Electrolytic Capacitors are manufactured under U. S. patents 1,710,073; 1,714,191; 1,918,716, et al.



ELECTRONICS

JULY
1937



KEITH HENNEY
Editor

Crosstalk

► **SURVEY . . .** Warner & Swasey, Cleveland, recently questioned manufacturers in a wide variety of industries on the question of whether or not there was a shortage of skilled labor. 229 firms replied. 195 said "yes," 34 said "no." Types of workmen needed were machinists, tool makers, machine operators, lathe operators, boring mill operators, automatic screw machine operators and molders.

The report shows that some men trained, or to be trained in the plant, were to be found on relief rolls, and that some men on relief had been spoiled and did not care to work—but the important fact is that the type of men needed do not exist. In such a situation it seems certain that new types of control, perhaps electronics, will be developed and installed to keep machines running that might be idle because of lack of properly trained personnel.

► **LOSS . . .** America lost one of its greatest pioneers in the field of electrical science in the death of Professor Elihu Thompson, one of the founders of the General Electric Company. Alternating current transmission, arc-light illumination, resistance welding, repulsion type induction motors, oil-cooled and constant-current types of transformers, magnetic blow-out lightning arrestors and switches, fused quartz, transmission of signals without wires (10 years before Hertz), cream separators, the centrifuge—all these and other engineering and scientific devices felt his genius in the way of practical contributions.

► **Q AND A . . .** Through the courtesy of Mr. Samuel Wein (long known as "Selenium Sam" and recognized as an authority as to who did what and when in the photocell art) we are presenting typical questions asked him by

mail and are giving his answers. The editors hope that these questions will stimulate others asked of *Electronics*. Conferring with other McGraw Hill editors we discover that one of the most popular departments of an engineering paper is the question and answers. We cannot guarantee to answer questions.

► **WELL MET . . .** Two men in a restaurant, one reading *Electronics*. The other an *Electronics* subscriber expresses interest. Thus was formed the friendship and later the firm of Andrews and Perillo, designers of electrical and mechanical devices, New York. The frontispiece of June *Electronics* represented part of a shipment of phototube amplifiers made by this firm for use in South Africa. Some knotty electronic problems have been worked out by these engineers.

► **BARRIER CELL . . .** A number of diligent engineers have been assigned by motion picture equipment companies to make an intensive study of the possibility of using barrier type light sensitive cells in taking the talk off talkie films. A piece of light sensitive surface just the dimensions of the slit is backed up against the slit. The dimensions are so small there is little high-frequency loss; some engineers are working them with very little amplification; others are using a few volts in series with the cell itself.

Success may upset the emissive phototube market and price set-up.

► **RADIO WHEN YOU NEED IT . . .**

Two Oak Park, Illinois patrolmen recently met an accident in which they turned their squad car over on its side. They found themselves unhurt, but imprisoned by jammed doors, and no one in sight to give assistance. They then

thought of their radio, and were able to establish two way communication with headquarters to call help. The radio equipment was undamaged, in spite of extensive damage to the car.

► **PUBLIC INTEREST . . .** When the Communications Act of 1934 was written it stated that all stations which operated under a license must be in continuous charge of a licensed operator. There was no argument about it. That rule worked a distinct hardship on several services which are of vital importance to the communication art.

For example, Cruft Laboratory, Harvard, (and others) had been making studies of the ionosphere by transmitting signals into the upper regions and measuring the returned signals and their echoes. Automatic transmitters are used for this purpose. But unattended transmitters were illegal according to the Communications Act.

In 1934 the members of the Commission visited Cruft, saw that the transmitter was operating without benefit of an operator, advised Cruft to hire men. This would call for 4 licensed operators who would not only cost money but they would, unfortunately, have absolutely nothing to do. The FCC did not doubt the value of the research; but the law is definite. A Congressional amendment was necessary to fix up this strange situation, not only for Cruft but for other classes of service where an operator is not only unnecessary but might even be a nuisance.

The Amendment was passed by the two houses of the Congress early this year and the research will go on again after 4 years cessation. Senator Walsh, Congressman Lea, Commissioner Stewart and Mr. E. M. Webster of the FCC and Professor S. P. Simpson of the Harvard Law School all were helpful in correcting this situation. At Cruft, Professor Mimno was the leading spirit.

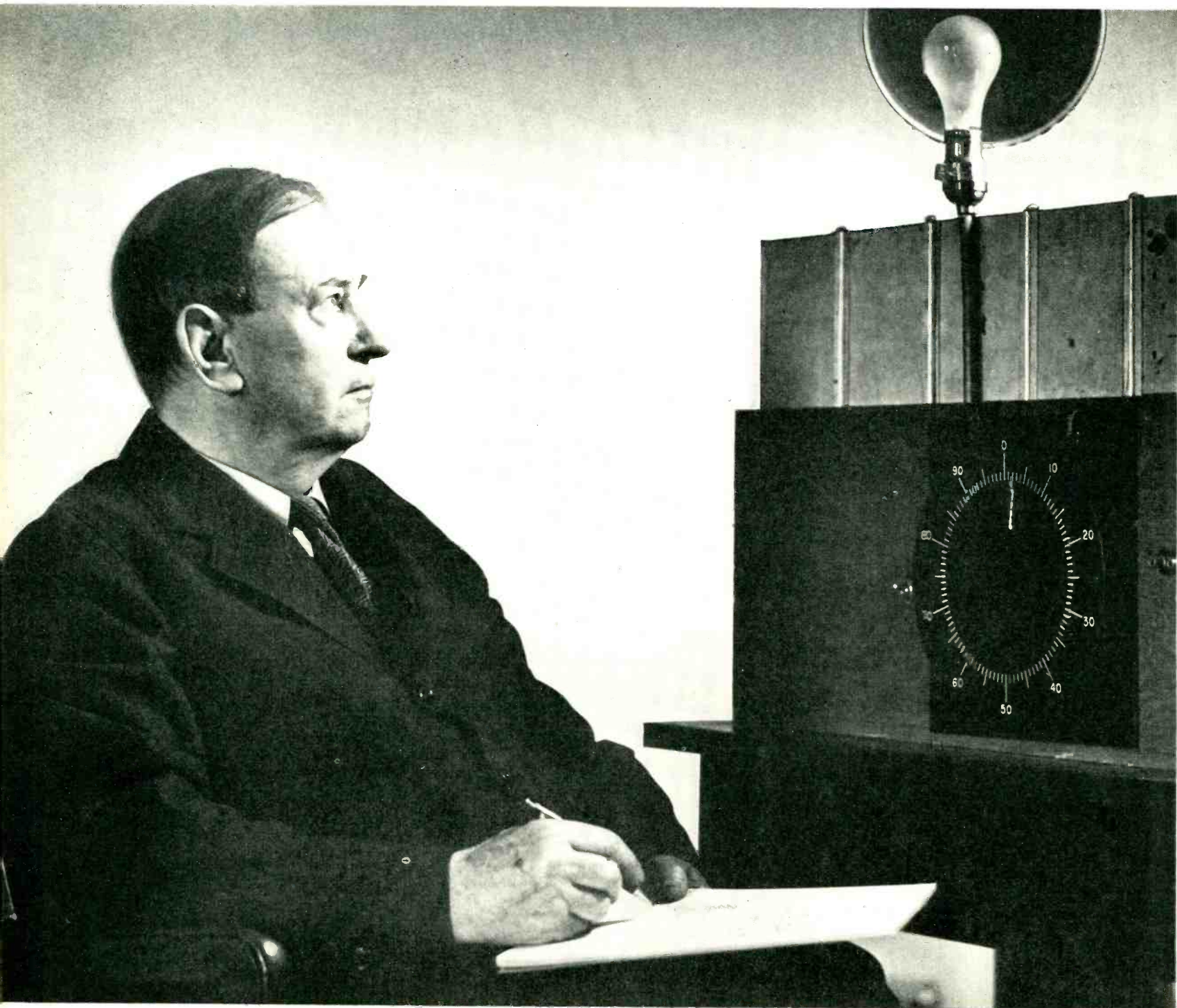

Professor GEORGE WASHINGTON PIERCE
of Cruft Laboratory, Harvard, on whose pioneering work much of
our present knowledge of supersonics is based. "G. W." has trained
many of the leading communications engineers of this generation.

Supersonics — A Survey

Increasing interest in ultra-high audio frequencies, commonly called supersonics, is evident in Electronics' editorial correspondence. This review of the art should orient the reader in a study of a scientific tool that promises much

THE purpose of this paper is to make a brief survey of what appears to be a broad and fertile field for investigation. This field is opened up by the study of the very unique and somewhat incredible effects obtained with sound waves of high frequency and intensity. These sound waves are generated by means of a conventional vacuum tube oscillator driving a quartz crystal immersed in transformer oil, turpentine, xylene or other suitable liquid as shown diagrammatically in Figure 1.

The quartz crystal when in place rests on a sheet of lead at the bottom of a dish of transformer oil. A thin sheet of brass rests on top of the crystal. The lead and brass sheets serve as electrodes and are connected to secondary terminals of a high frequency transformer.

The voltage across transformer secondary and crystal may be from 10,000 to 50,000 volts and frequencies ranging from 120,000 to 2,300,000 cps. The frequency of the oscillator is adjusted to the natural frequency of the crystal at which time the crystal will vibrate and radiate energy in the form of intense sound waves having a frequency the same as the natural frequency of the crystal.

These sound waves will be totally reflected from the surface of the oil in which the crystal is submerged and the radiation pressure exerted here will raise the oil in a mound over the crystal from which oil drops are projected. The height of the mound may be from $\frac{1}{2}$ " to 3" and the oil drops projected to a height of $\frac{1}{2}$ " to 12". The actual amplitude of the crystal is very small, approximating the order of a wave length of visible light.

The method for generating intense sound waves described briefly above is essentially the one developed by Prof. Langevin in 1917 for the purpose of submarine signalling. He

By WALTER MAYBERRY

used the Poulsen arc as a high frequency generator but its frequency instability made it impossible to keep the oscillator tuned to the natural frequency of the crystal. The vacuum tube oscillator has supplied a high frequency source of good stability and is used exclusively at the present time for this purpose. Because the coefficient of viscosity increases as the square of the frequency, 50,000 cps. is the upper practical limit for underwater signalling. In super-sonic generation, however, this limitation is not imposed, the distance between the sound radiator (the quartz plate) and the material being radiated, being relatively short.

Radiation Pressure

The radiation pressure of the sound waves as they are reflected from the free surface of the oil gives rise to the hump of oil over the crystal mentioned above. In the case of reflection from plates of metal or bottoms of flat test tubes, this pressure can be measured. Wood and Loomis¹ found the radiation pressure against a round disc 8 cm. in diameter to be 150 grams. The pressure is a maximum when the distance between the bottom of the plate and top of the crystal is a whole number of half wavelengths. When this condition holds, the reflected wave strikes the crystal when its phase is such as to be additive with the wave just leaving the crystal. By multiple reflexion then, between vibrator and plate, the amplitude rises to a very high value by reason of resonance. The pressure exerted against a plate held horizontally as it is lowered into the oil toward the crystal becomes greater periodically as the distance between plate and crystal pass through the

distances necessary for multiple reflexion. From the above statements it is seen that to get maximum energy transfer from the oil bath into some other liquid or solid immersed in the oil, the distance between the bottom of the material to be radiated and the top of crystal must be adjusted until the condition of multiple reflection is reached.

Materials for investigations placed over the crystal are subjected to complex wave patterns of radiation and in some cases violent whirling motion is imparted to a specimen. To understand clearly the reason for the complexity of the wave pattern to which the material is subjected it is necessary to digress a moment and consider the forces acting upon an oscillating quartz crystal². As is well known a natural quartz crystal has three electric axes perpendicular to the optical axis.

The crystal is cut so that one of the electric axes will be perpendicular to the plane of the crystal. If a pressure is applied to the side of the crystal corresponding to A— a negative charge will accumulate there, while correspondingly if a negative charge is applied there without pressure the crystal will contract as if the equivalent pressure had been applied there. The same hold true for positive charges on the A+ side. On the other hand, when a positive charge is placed on the negative side and a negative charge on positive side the crystal will expand. A rapid alternation of charges causes the crystal to oscillate and as a first approximation the crystal may be considered to be an oscillating rigid piston. This would be correct if the crystal were perfect and infinitely large, but with a finite crystal the forces are not symmetrical near the edges and a complex wave pattern is formed on the crystal. This can

easily be seen by first considering a point O on a crystal near the center.

If a unit negative charge is placed on the under surface with the corresponding positive charge on the upper, the crystal will tend to contract along the axis $(OA+)$ and expand along the axis $(OB-)$ and $(OC-)$. The intensities of these forces are directly proportional to the potential gradients along the respective axes. The forces along $(OB-)$ and $(OC-)$ are therefore only half as great as along $(OA-)$ since the distances through the crystal are twice as great as along $(OA-)$ (the angle between the axes being 60°). The vector resolution of the forces $(OC-)$ and $(OB-)$ along $(OA-)$ shows that they are equivalent to a force opposed to the force along $(OA-)$ and of magnitude $\frac{1}{2}(OA-)$. The vector equivalent of all three forces is therefore a single force along $(OA-)$ equal to $\frac{1}{2}$ of what that force would be if the forces along $(OC-)$ and $(OB-)$ were not present.

This symmetry does not hold however near the edges of the crystal. Consider point Q . The axis (QB) is not in the crystal at all. The resolution of the forces along $(QA-)$ and $(QC-)$ gives a force along (QX) equal to $\sqrt{3/2}(QA+)$. It is clear therefore that the pressures near the edges are not symmetrical and tend to produce distortions which travel in waves across the crystal.

A second system of forces is also acting on the crystal. As it contracts normal to the surface it expands parallel to the surface (the effect is best seen in a rectangular plate), thus the series of longitudinal waves create interference patterns with the traverse waves.

Thirdly, it has been shown that even with a perfect crystal the piezoelectric effect varies in different parts of the crystal. Dye has photographed these distortions and shows most beautiful and complex patterns which slowly drift across the plate.

Some of the interesting effects observed are described briefly below.

Physical Effects

The waves can be transmitted along a glass thread of small diameter and a meter or more in length and if the end of the thread is squeezed between finger and thumb it burns a groove into the skin. When the bottom of a tapering glass

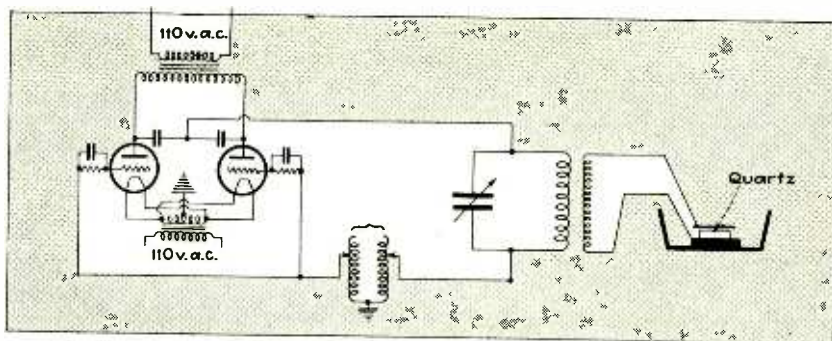

Setup for utilizing ultra sonic vibrations

rod with a sharp tip is lowered into the oil over a vibrating crystal, it will vibrate so intensely as to rapidly drill its way through wood and glass when these materials are pressed against the tip. The glass is displaced in the form of a fine powder of minute fused globules of glass.

Rather unstable emulsions are formed when the waves pass across the boundary separating such liquids as oil and water or water and mercury. In the case of mercury and water, the emulsion slowly precipitates to the bottom of the test tube at the end of 24 hours in the form of a fine powder, not metallic mercury. The author prepared a water-mercury emulsion a year ago and at the present time the precipitated powder will immediately form an emulsion upon gentle shaking. Colloidal solutions of the low melting point alloys have also been made.

In general, certain chemical reactions are accelerated and crystallizations started by these intense super-sonic vibrations. Most chemical reactions accelerated are oxidations.

A method to measure the wave length (and consequently the velocity in different materials) of these sound waves due to Wood and Loomis¹ is as follows:

A small ball of wax is stuck on the end of a glass rod held vertically over the oil (the lower end immersed). The wax melts due to heat developed by friction between vibrating rod and wax. As it slides down the rod it solidifies in rings leaving a permanent record of wave length and hence velocity. This velocity is a function of the diameter of rod and the frequency. At 285 kc. in a 6 mm. rod the velocity is 2600 meters per second but falls off to 400 meters per second in a rod 0.1 mm. diameter. These measurements are

seen to differ greatly from the known velocity of sound (audible) in glass which is about 5000 meters per second.

Because the kinematic coefficient of viscosity varies as the square of the frequency it would be expected that the heating effects in the vicinity of 400 kc. would be very pronounced. Thus a test tube filled with water and immersed in a beaker containing water and cracked ice heats rapidly when lowered over the crystal. The sound waves are thus converted into heat by absorption. The rise in temperature may be as rapid as 1° every 3 seconds.

Flocculation of Suspended Particles in a Liquid

In the case of suspensions involving particles exceeding a certain size and a specific gravity not much greater than the liquid in which they are suspended, flocculation (drawing together) occurs the moment supersonics pass through the liquid. This action is quite plain. With gas in solution, cavitating gas bubbles to which the particles stick, are forced into a clump by radiation pressure, which depends on a reasonably large surface for its action.

Biological Effects

Interest in the biological effects of very high frequency sound waves started with the investigations of Wood and Loomis¹ in 1927. Since then, these effects have been investigated more fully by a number of workers. Harvey and Loomis², 1928, devised methods for the direct observation of effects on cells under the microscope. Harvey and Loomis continued this work. Schmitt, Olson and Johnson⁴ (1928) have described methods for leading the vibrations to an isolated cell by means of a

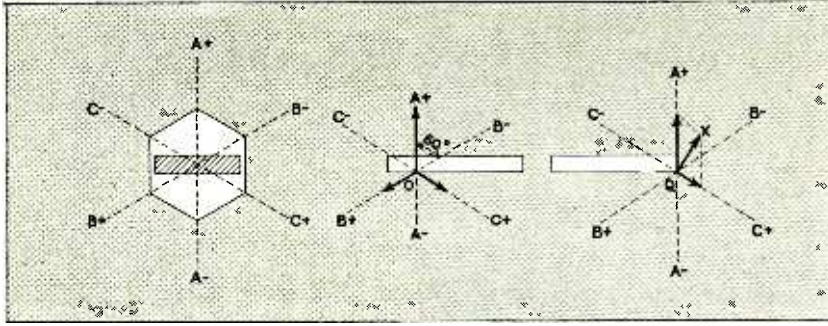

Quartz crystal cut orientations for piezoelectric effect

microneedle. Harvey and Loomis⁷ (1929) have described the destruction of luminous bacteria and Harvey⁸ (1929) the effect on muscle and nerve tissue.

The antithesis of the flocculation effect is seen in the tearing apart of small delicate structures. Filaments of living Spirogyra are torn apart and the cells burst. Small organisms such as paramecium are killed if the exposure is of sufficient duration, some being torn open. Those cells which are not thrown into nodes of the standing wave system have a better chance for survival than those that are. This doubtless accounts for the fact that all cells are not burst open.

The survival of bacteria subjected to supersonics seems to be accounted for by their small size. Due to the fact that in larger bodies the forces applied to their surfaces vary in magnitude and direction at different points they are much more susceptible to destruction. In the case of bacterium the whole body is subjected to approximately the same treatment.

In a physiological salt solution, red blood corpuscles are rapidly destroyed. Small fish and frogs are reported by Loomis to be killed by an exposure of one to two minutes. The author has been unable to visually detect any time interval between closing of plate circuit switch of oscillator and the apparent death of fish 1 inch long. However, differences of this type are unimportant because there is no recognized standard of supersonic intensity at the present time.

Mice are comparatively insensitive to treatment. A half hour exposure does not bring death although the mouse seemed badly stunned but made a quick recovery.

Pictures of the destruction of sea

urchin eggs have been taken by means of high speed microphotography and are due to Prof. E. N. Harvey. They show very rapid disintegration.

Emphasis should be placed on the fact that these results are all due to high frequency sound waves and not to the alternating electrostatic field surrounding the crystal as experiments substituting glass plates for the crystal have proven. The effects of the waves apart from slight heating are purely mechanical. This conclusion has been reached from the results of studies of a large variety of materials subjected to supersonics. The effects are the same as if the materials were rapidly bent back and forth. Estimation of the pressure changes in a fluid carrying intense supersonics gives values of the order of +20 to -20 atmospheres. Delicate structures on the outside of cells are torn off. If the cell is very small it is thrown into nodes so quickly as to escape injury. This latter difficulty will constitute the main barrier to the application of these waves to sterilization of food products. The maximum dimension of bacteria is so small relative to a wavelength of even extremely high frequency sound waves as to give a very small pressure gradient existing within the cell. The limit to which the wavelength can be shortened is determined by the difficulty of grinding quartz crystals sufficiently thin.

Professor S. N. Rzkvekin, director of a program of supersonic research at the Russian Academy of Sciences, reports the rapid growth of plants whose seeds have been subjected to these waves for short periods of time, which may open up a wide field of application. (See *Electronics*, February, 1937.)

The general physical and chem-

ical effects of supersonics may be summarized as follows:

1. *Heating of media* which absorb the waves.

2. *Movement of particles* into nodes of standing wave systems.

3. *Flocculation* (movement into large aggregates) of particles above a certain size.

4. *Dispersion* at liquid-gas and liquid-solid interfaces.

5. *Cavitation*. Expulsion of gases or vapors from solution.

6. *Compression and expansion* of media through which the sound waves pass.

7. *Acceleration* of chemical actions.

For those interested in doing experimental work the figure is a wiring diagram. The iron of the transformers should be on the side of the tube away from the tank coil and at least a foot away from the tubes. Parts can conveniently be mounted in a space 36" x 12" and should not cost more than \$80.00. The quartz crystal may be about 1 square inch in size. The oscillating circuit should be tuned to approximately the natural frequency of the crystal.

LITERATURE

- Boyle, R. W. and Lehman, J. F. *Report Canadian Research Council*, May, 1923.
 Boyle, R. W. and Froman, D. K. *Report Canadian Research Council*, June, 1923.
 Boyle, R. W. and Taylor, G. B. *Phys. Rev.*, 27:518, 1926.
 Boyle, R. W. and Taylor, G. B. *Trans. Roy. Soc. Canada*, 19:177, 1925.
 Boyle, R. W. and Lehman, J. F. *Trans. Roy. Soc. Canada*, 21:122, 1927.
 Boyle, R. W., Taylor, G. G. and Froman, D. K. *Trans. Roy. Soc. Canada*, 23:187, 1929.
 Chambers, R. and Harvey, E. N. In Press.
 Harvey, E. N. and Loomis, A. L. *Nature*, 12:622, 1928.
 Harvey, E. N., Harvey, E. N. and Loomis, A. L. *Biol. Bull.*, 55:459, 1928.
 Harvey, E. N. and Loomis, A. L. *Jour. Bacteriol.*, 17:373, 1929.
 Harvey, E. N. *Am. Jour. Physiol.*, 91:284, 1929.
 Jacobs, M. H. *Biol. Bull.*, 58:104, 1930.
 Johnson, C. H. *Am. Jour. Physiol.*, 67:356, 1929.
 Richards, W. T. and Loomis, A. L. *Jour. Am. Chem. Soc.*, 49:3086, 1927.
 Richards, W. T. *Jour. Am. Chem. Soc.*, 51:1724, 1929.
 Richards, W. T. *Proc. Nat. Acad. Sci.*, 15:310, 1929.
 Richards, W. T. and Loomis, A. L. *Proc. Nat. Acad. Sci.*, 15:587, 1929.
 Rowlands, S. *Jour. Physiol.*, 27:53, 1901.
 Schmitt, F. O., Olson, A. R. and Johnson, C. H. *Proc. Soc. Exper. Biol. and Med.*, 25:718, 1928.
 Schmitt, F. O., Johnson, C. H. and Olson, A. R. *Jour. Am. Chem. Soc.*, 51:370, 1939.
 Schmitt, F. O. *Protoplasma*, 7:332, 1929.
 Schmitt, F. O. and Uhlemeyer, B. *Proc. Soc. Exper. Biol. and Med.*, 27:626, 1930.
 Wood, R. W. and Loomis, A. L. *Phil. Mag.*, 4:417, 1927.
 Cattell, McK. and Edwards, D. J. *Am. Jour. Phys.* (XXXVI), 371, 1938.
 Ebbecke, V. *Physical Arch.*, CLVII, 79, 1914.
 Edwards, D. V. and Cattell, McK. *Am. Jour. Phys.*, XXXIV, 472, 1928.
 Johnson, E. N. *Biol. Bull.*, 59, 306, 1930.
 Harvey, E. N. and Loomis, A. L. *Science*, 72, 42, 1930.
 Harvey, E. N. *Jour. Exp. Biol.*, 8, 267, 1931.

Standards in Television

Since no action has yet been taken by the FCC on the proposed Standards submitted by the RMA last June, there remains time to consider their relationship to the British Standards. Evidence is presented herewith on three important, and disputed, items

ABOUT a year ago the Radio Manufacturers Association, through their Sub-Committee on Television, recommended certain standards for television in the United States. These standards called for a 441-line picture transmitted 30 times per second, together with other items, as reported in the July, 1936 issue of *Electronics* (page 9). To date no action has been taken on these proposals by the Federal Communications Commission. In England, however, a standard of transmission has been adopted by the government, the standard originally submitted by the Marconi-E.M.I. Company. Between the British Standards and the proposed American Standards there exist several differences which at first glance appear to be of minor consequence, but which have a great bearing on the utility of the television signal, particularly in relation to the design of television receivers. It is the purpose of this paper to consider these differences and to point out several factors which may make desirable a reconsideration of certain of the proposed American Standards.

By **H. M. LEWIS**
Hazeltine Service Corp.

The basis of scanning in the two systems is essentially the same. The British picture consists of 405 lines transmitted 25 times per second and, like the American, of two fields per frame, which are interlaced by virtue of the fact that there is an odd number of lines in the complete picture (so-called odd-line interlace). But in several other respects the two systems differ, as shown in the following table:

Item	British	American
Scanning.....	405/25, odd-line interlace.	441/30, odd-line interlace.
Polarity of transmission.....	White corresponds to an <i>increase</i> in carrier amplitude (positive transmission).	White corresponds to a <i>decrease</i> in carrier amplitude (negative transmission).
Transmission of d-c component, corresponding to background illumination.	By variation of average transmitted voltage.	Average voltage constant, d-c component transmitted by pedestal height. ¹
Synchronizing signal for each frame.	Serrated.....	Narrow vertical or serrated plus line doubling preceding serrations.
Amplitude of synchronizing signal relative to video signal.	30 per cent.....	20 per cent minimum.
Percentage of line-scanning time devoted to return "retrace" of beam.	15 per cent.....	10 per cent.

¹ The reader who is unfamiliar with terms used in television may refer to "Television Terminology," *Electronics*, June, 1937, page 14—Editor.

The three major differences are in the polarity of transmission, the method of transmitting the average brightness level (d-c component of the video signal), and in the type of frame-synchronizing signal employed. As will be shown, these three items have a great deal to do with the simplicity and reliability of television receiver design. To judge from reports of British engineers, it appears that there is serious doubt concerning the American proposals on these three items. Whether or not this criticism is jus-

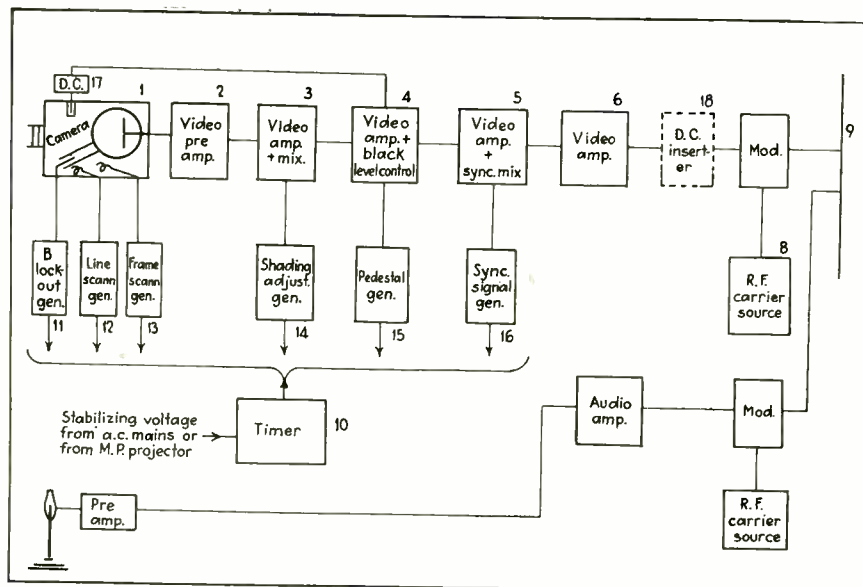

tified, it is certainly worth while to appraise the reasons given.

The elements of the television transmitter

Before considering the items of difference in detail, a short resume of the elements present in a television transmitter is in order. In Fig. 1, unit 1 is the camera containing the signal-generating tube. Following the camera are five amplifier stages (2, 3, 4, 5, and 6) which develop the modulating voltage, both in amplitude and shape suitable for applica-

Fig. 1—Elements of a typical television transmitter

tion to the modulator, 7. The carrier wave source, 8, is modulated and applied to the antenna, 9, through the modulator.

The necessity of the individual amplifier stages, 2, 3, 4, 5, and 6, arises from certain limitations of the camera tube and of the method of amplification which is used. The camera tube is a synchronously operated device, functioning under the control of scanning voltages which cause the cathode-ray beam to scan the photoelectric mosaic horizontally (line scanning) and vertically (frame scanning). During the scanning of each line from left to right, the scanning beam induces at each point on the line a voltage on the mosaic plate which is proportional to the illumination existing at that point. This video signal consists of two parts, the a-c variations which represent the changes in illumination along each line and frame, and the d-c component, which represents the average illumination of the picture. The conventional camera tube output does not contain the d.c. which is blocked by the capacity between the mosaic and the output plate. A separate photocell (17) is, therefore, used to obtain the average illumination or background. There are two general methods of transmitting the d-c component. The British method consists in varying the transmitted carrier voltage in proportion to the d-c component of the modulation. The American method consists in eliminating the d-c component from the transmitted signal (that is, transmitting with a constant average carrier voltage), and reinserting the d-c component in the receiver, by detecting the pedestal component with a peak detector and thereby obtaining a reference value of voltage which is used to set the average illumination level of the cathode-ray picture tube.

During the right-to-left motion (retrace or flyback) of the scanning beam in the camera tube, it is necessary that the beam be extinguished, otherwise the mosaic will give rise to an unwanted "ghost" image during the return trace. The mosaic type of camera tube does not perform this function, giving instead a surge of voltage during the retrace of the beam. This unwanted "kick" of voltage is removed in unit 4, the black level control, which insures that the voltage level shall correspond to

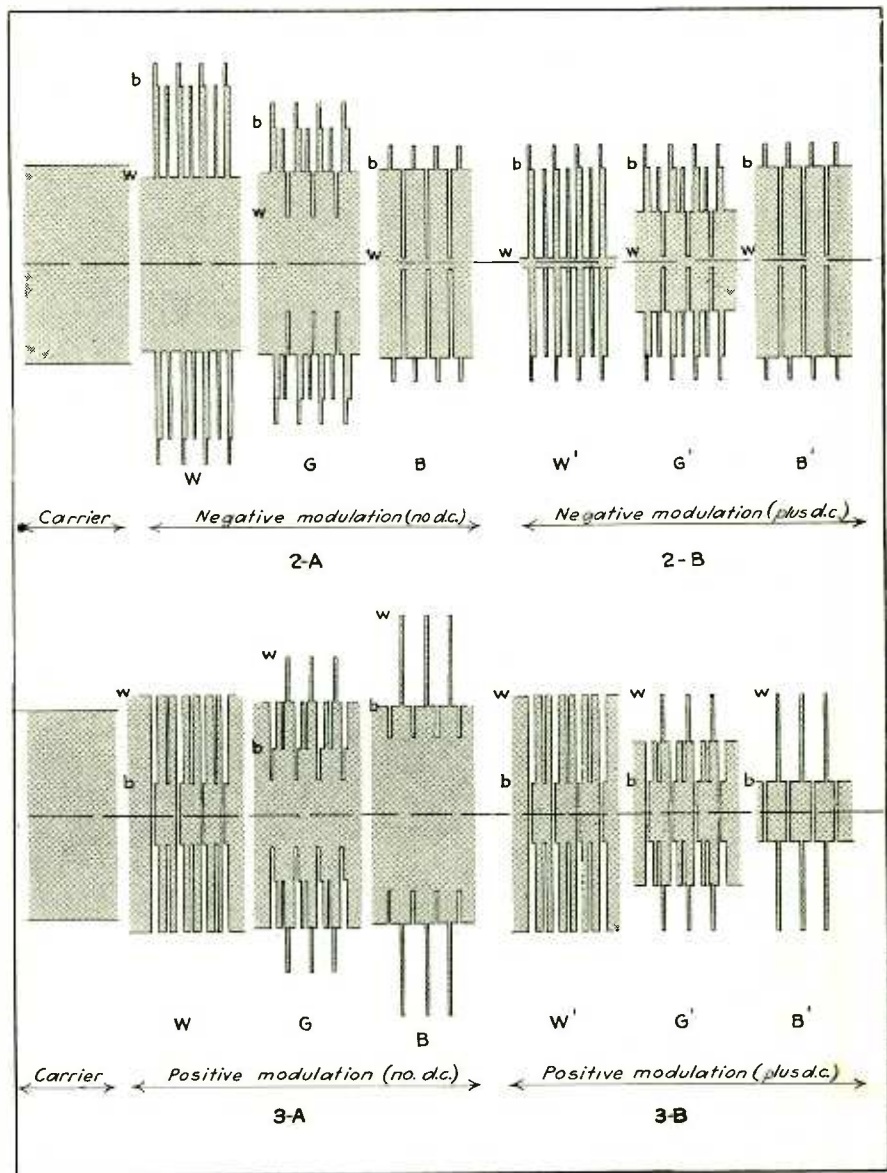

Figs. 2, 3—Comparison of r-f envelopes for positive and negative modulation, with and without d-c component. In 2-A and 3-A, the area under each envelope is the same

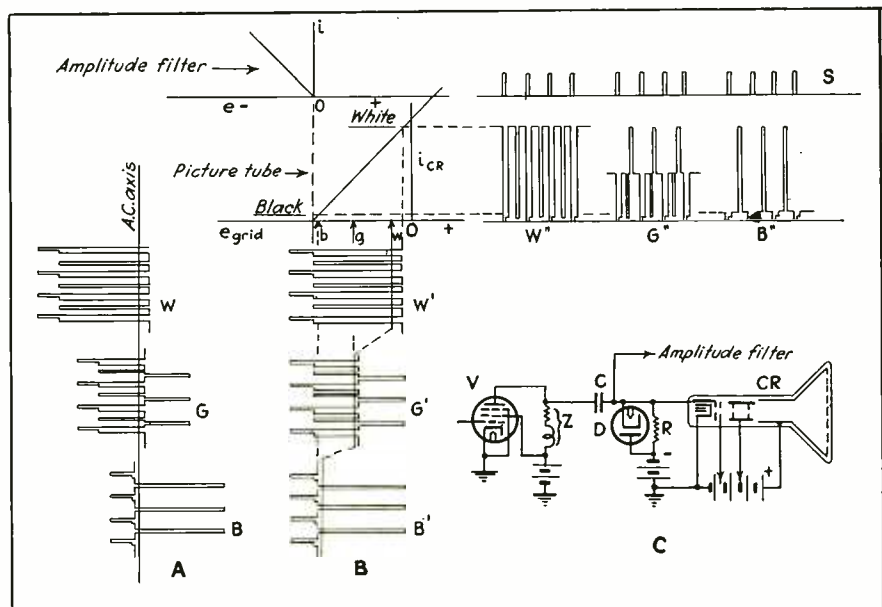

Fig. 4—Reinsertion of d-c component when not transmitted via the carrier

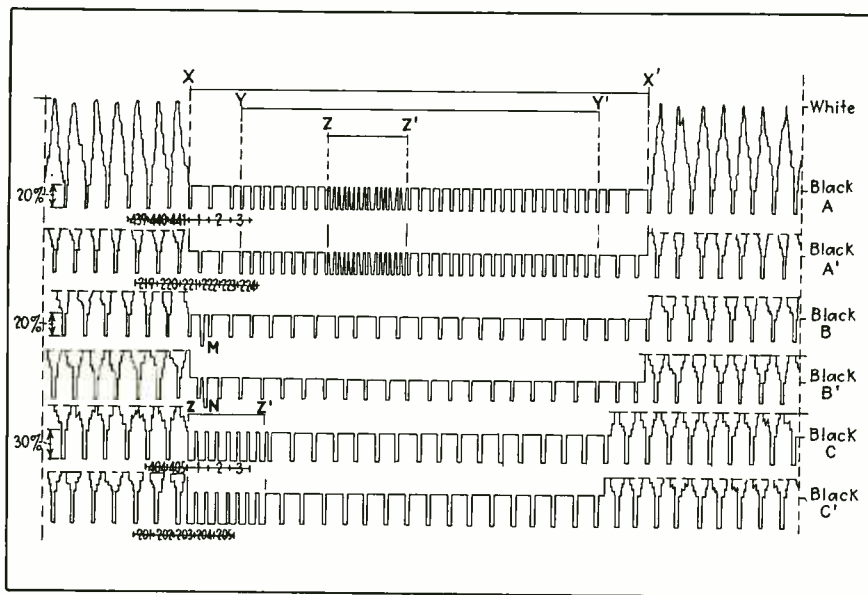

Fig. 5—Three forms of mixed signal frame-synchronizing impulses

black (or "blacker than black") during the retrace of the beam. The voltage level set by this unit, during the retrace time, is called the pedestal. Superimposed (by units 16 and 5) on the pedestal voltage, in the blacker than black direction, are the line- and frame-synchronizing impulses, which are used in the receiver to control the scanning voltages of the picture tube, so that the scanning in the receiver proceeds in synchronism with that at the transmitter.

During the scanning, the mosaic in the camera tube gives rise to voltage components which do not correspond to the illumination level, and which result in uneven shading of the received image. A special synchronous generator (shading-adjust generator, 14) adds a voltage component of the proper amplitude and shape to neutralize this effect, through the agency of the mixing amplifier, 3.

The d-c component of the video signal, which is not provided by the camera tube, is picked up by a separate illumination integrator, 17, and applied to the black level control amplifier, 4. The net result is that the signal issuing from unit 5 contains the video signal with its average d-c component in proper relation to the total amplitude of the signal. The signal contains during each retrace the pedestal voltage and synchronizing signals imposed on the pedestal. When this signal passes through the video amplifier 6, which simply increases its level, the d-c component is removed by the amplifier. Before the signal reaches the modulator the d-c component may be reinserted by

unit 18, as it is in the British system. In the American system, no attempt to reinsert the d-c component is made at the transmitter. The d-c component is reinserted after the second detector in the receiver.

In the British system the polarity of the modulator is such that the maximum carrier amplitude corresponds to the whitest part of the picture. The black pedestal level thus corresponds to a lower amplitude, and the synchronizing signals (in the blacker than black region) are at a still lower amplitude. In British practice, in fact, the synchronizing signals reduce the carrier level to zero. In the American system, on the other hand, the polarity of the modulation is negative, i.e., the blacker than black region corresponds to the maximum carrier amplitude whereas the white region corresponds to the minimum amplitude.

The Question of Polarity of Transmission

In evaluating the relative merits of positive and negative modulation, the diagrams shown in Figs. 2-A and 3-A are of value. These diagrams represent the carrier voltage applied to the antenna, for negative modulation (Fig. 2-A) and positive modulation (Fig. 3-A). Three conditions are shown. W corresponds to a vertical black bar on a white background, G to a white vertical bar and black vertical bar on a gray background, and B to a white vertical bar on a black background. The small letters w and b indicate the voltage corresponding to white and black. The average amplitude and the volt-

age difference between w and b are the same for each condition. The blacker than black region, reserved for the pedestal and synchronizing signals, is indicated in each diagram. One important difference between positive and negative modulation is the position of the synchronizing signals. In negative modulation, the synchronizing signals are the maximum parts of the carrier amplitude. Any reduction of the peak modulation capability of the transmitter thus limits the synchronizing signals and may result in loss of synchronism; likewise, any overload condition in the r-f or i-f stages of the receiver cuts off the synchronizing pulses. In positive modulation, on the other hand, the synchronizing pulses are protected from overload between the transmitter modulator and the receiver detector.

Another important difference is in the reaction to static and noise. Since this depends on the d-c transmission it will be discussed later.

Minor differences are:

(1) In positive modulation the presence of modulated-carrier frequencies produces a positive image on the cathode-ray tube.

(2) In negative modulation, curvature in the detector characteristic may correct some of the shading distortion introduced by the picture tube.

Both (1) and (2) depend on the curvature in the picture tube characteristic.

Another point has been raised in favor of negative modulation, namely, that it is an advantage to have the greatest signal energy in the synchronizing pulse in order that the picture may be synchronized on a weak signal. This is not discussed above because it appears to be unimportant. If the signal is actually weak enough for this consideration to be vital, the synchronization will be disturbed by noise interference.

The Question of Transmitting the D-C Component

The carrier representations in Figs. 2-B and 3-B show the same signals as in Figs. 2-A and 3-A except that the maximum amplitude is a constant level. The average carrier amplitude varies with the picture

content instead of remaining constant as in Figs. 2-A and 3-A. This signal, therefore, transmits the d-c component. In negative modulation (Fig. 2-B), the average power is small for the white picture (W'), average for the gray picture (G'), and great for the black picture (B'). In positive modulation (Fig. 3-B), the contrary is true, W' having the highest carrier power, G' average power, and B' the least. Fig. 2-A corresponds to the American system, Fig. 3-B to the British.

One advantage of transmitting the d-c component is the fact that the peak value of the transmitted carrier remains the same. This makes for simplicity both in transmitter design and receiver design, since amplitude overload is thereby rendered very unlikely. For the same detected voltage output, the peak power handling capacity of the transmitter output stage and the receiver i.f. system must be over 3 times as great for the waves in Fig. 2-A and 3-A as for those of 2-B and 3-B. Another advantage obtained with the d-c transmission is that the synchronizing peaks always occur on a fixed portion of the detector characteristic. Consequently they are not subject to variations due to the detector curvature. This is much more important than the fact that the synchronizing pulses may fall on a less efficient portion of the curve.

In case the d.c. is removed either in the transmitter or in a capacitance coupled video amplifier, it must be reinserted before being supplied to the amplitude filter and the picture tube. The diagrams in Fig. 4 illustrate this operation. Fig. 4-A shows the wave forms of any one of the four signals illustrated in Fig. 2 and 3 after detection and amplification. The number of amplifier stages is either odd or even depending on the polarity of the transmission and of the detector. Fig. 4-C shows one circuit which has been used to reinsert the d.c. The voltage at the plate of the last amplifier tube is as shown in Fig. 4-A, that is, the areas on either side of the axis are equal. The diode detects the pedestal peaks bringing them to a fixed voltage level, as shown in Fig. 4-B, thus reinserting the d-c component. The cathode-ray tube characteristic is shown in Fig. 4-B as a straight line. As the figure shows, the black and white portions of the signal occur at the correct

voltage to give proper picture shading. The synchronizing peaks also appear at a constant level so that they may be separated by the amplitude filter characteristic as shown at the top of Fig. 4-B.

The wave forms of Fig. 4 are ideal. The actual reinsertion of the d.c. is not performed as perfectly as the figure indicates.

A conventional a-v-c-system which operates properly on the waves of Figs. 2-A and 3-A will distort those of Fig. 2-B and 3-B. However, equally simple a-v-c circuits are available for the type of wave which transmits the d.c.

The choice between transmission or non-transmission of the d.c. resolves to:

- (A) Advantages of d.c. transmission.
 1. Less overload.
 2. Constant carrier voltage for synchronizing pulses.
- (B) Advantages of non-transmission of d.c.
 1. Less detector distortion on inward modulation.
 2. Operation of conventional a-v-c circuits.

The first advantage of the d.c. transmission seems far more important than the disadvantages.

A further comparison of Fig. 2-A, the American system, and Fig. 3-B, the British system indicates that the synchronizing signals in Fig. 3-B are much less vulnerable to interference. The scanning oscillators are sensitive to synchronizing pulses during the latter quarter of the scanning. With the system of 2-A any pulse of interference occurring in this interval which raises the signal envelope above the level b will give a false synchronizing pulse. In the system of Fig. 3-B the interfering pulse must be of approximately the right phase and amplitude to reduce the signal envelope to zero in order to provide a false synchronizing pulse. The synchronization is not disturbed if the interference is either greater or less than this value. The probability of loss of the synchronizing pulse due to interference is about the same in either system.

The final action in the receiver, after the re-insertion of the d-c com-

ponent and the separation of the synchronizing impulses from the video, is the separation of the line synchronizing impulses from the frame synchronizing impulses, which may be termed "inter-sync separation." This separation is complicated by the fact that the line synchronizing impulses must occur regularly and without interruption during the time devoted to frame synchronization. This requirement is set by the characteristics of the line oscillator. Consequently a mixed synchronizing signal containing both line and frame impulses is necessary during the frame synchronizing period. Three types of mixed signals are of practical interest; they are shown diagrammatically in Fig. 5 which consists of line drawings of the demodulated voltage, amplitude vs. time, before, during, and immediately after the frame synchronizing period. The diagrams A and A' show the first type of mixed signal, containing line synchronizing pulses of double frequency (Y-Y'), with a group of serrations in the region Z-Z'. Diagram A is at the end of one interlaced frame, A' at the end of the following interlace. It will be

(Continued on page 50)

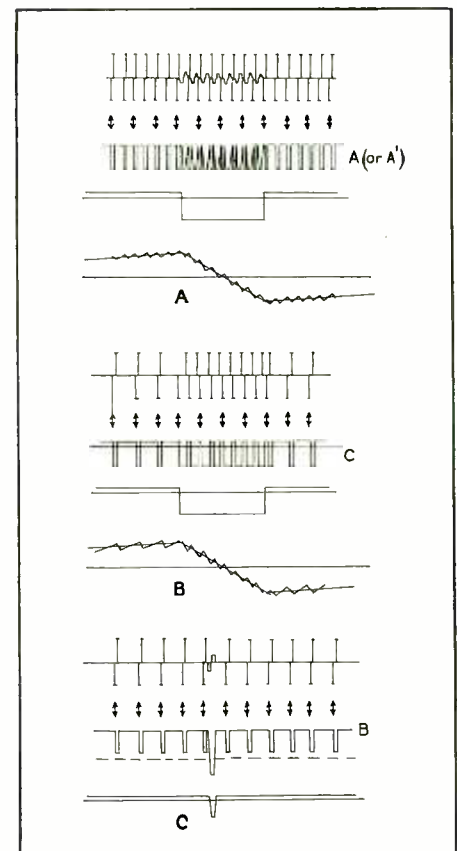

Fig. 6—Wave-forms resulting from separation of frame-sync impulses

Voltage Regulators Using Magnetic Saturation

A survey of methods for securing constant alternating voltages by means of saturated transformers and reactors useful in numerous electronic circuits

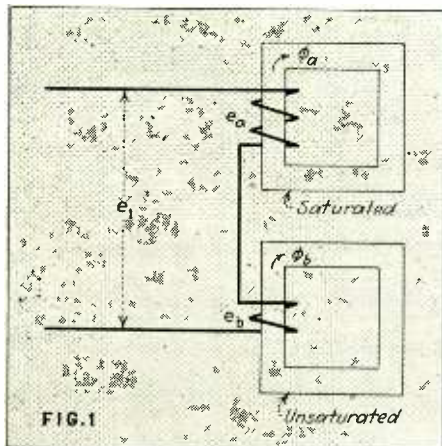

Fig. 1—Non-saturating reactor in series with a saturating reactor

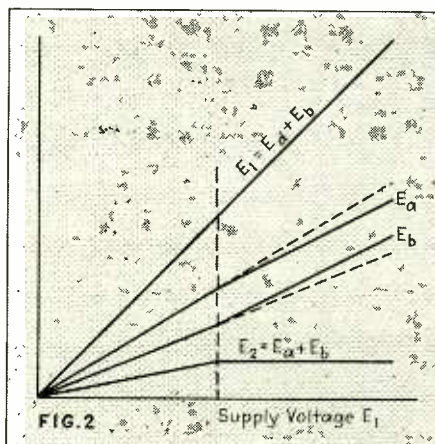

Fig. 2—Voltage relations in general saturated reactance circuit

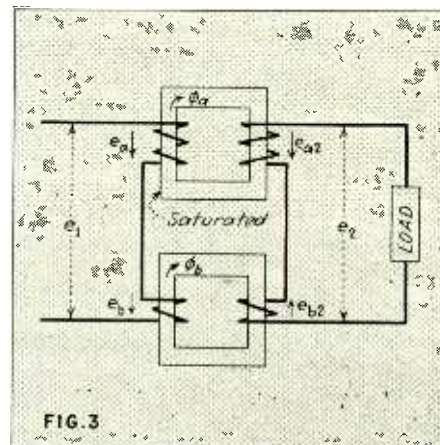

Fig. 3—Constant voltage output system using two reactances

THERE are many types of a-c voltage regulators in use at present, but not all of these are suitable for use with electronic devices. One which is especially fitted for this purpose, however, is the type using saturating magnetic paths, because in this type of regulator the action is automatic, practically instantaneous, and requires no moving parts. A regulator of this sort has been described in an article published in *Electronics*.¹ The need for this type of regulator in electronic devices was briefly summarized in this article as follows, "The accurate operation of photocells, of crystal controlled oscillators, of vacuum tube measurement circuits, and of innumerable other devices depends upon the voltages supplied to the various circuits remaining constant." Also this regulator is "—of considerable value in sound applications— and in X-ray photography—".

Various regulators of this general type have been devised and many of these have been described in an article by a German writer.² The present article is based, to a certain extent, on this article and is an attempt to assemble information

By K. J. WAY

Bell Telephone Laboratories

available on this type of regulator and also to provide an explanation of some of the more important circuits used for voltage regulation.

The circuits referred to have at least one thing in common; the circuit element upon which each of them is based is the saturating reactor, so the action of a saturating reactor will be considered first. If the voltage on an iron-core reactor is increased far enough so that the flux density rises above the knee of the saturation curve, the effective current through the reactor increases much more rapidly than the effective voltage.

This current may be used to obtain a voltage whose effective value increases more rapidly than the effective value of the supply voltage by simply connecting a resistance, a reactor, or a condenser in series with the saturating reactor. Then the voltage thus obtained may be combined with the voltage on the saturating reactor to provide an output voltage which remains constant, or can even be made to decrease, as the supply voltage increases. In one

circuit used for this purpose³, a resistance is connected in series with a saturating transformer (which is equivalent to a saturating reactor). A more interesting case, however, is that of a non-saturating reactor in series with a saturating reactor and this circuit is shown in Fig. 1.

The current in this circuit increases more rapidly than the supply voltage and the voltage across the non-saturating reactor does likewise. Hence the voltage across the saturating reactor increases less rapidly than the supply voltage. The manner in which these voltages vary when the supply voltage is increased is shown in Fig. 2 which is a qualitative picture of the operation of the circuit. The actual operation of these regulators is much too complicated to be explained very accurately in a short space. This is because they involve magnetic saturation which causes waveform distortion and makes it difficult to discuss the effective values of the waves. However, by neglecting this waveform distortion and by representing the voltage relationships in the simplest possible manner, the operation of these circuits can be explained with

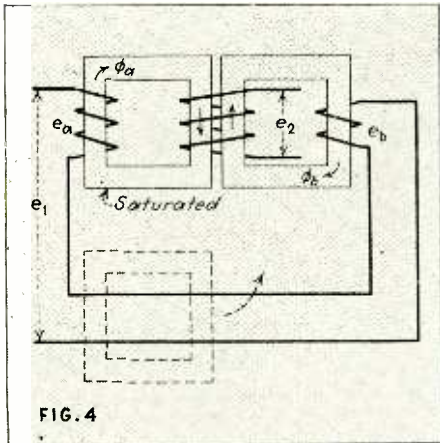

FIG. 4

Fig. 4—Use of a three-legged reactance for voltage regulation

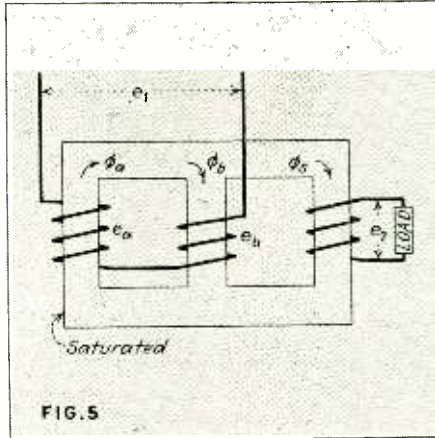

FIG. 5

Fig. 5—Rearrangement of Fig. 4 for simplification

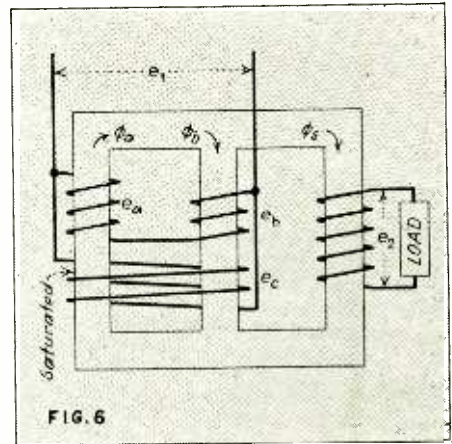

FIG. 6

Fig. 6—Additional coil overcomes leakage reactance trouble

sufficient accuracy for descriptive purposes.

Since the voltage across the saturating reactor in this circuit increases less rapidly than the supply voltage, this voltage remains more nearly constant than the supply voltage during fluctuations of the latter. Hence, to a certain extent, this circuit acts as a voltage regulator and has been used for this purpose by simply connecting the load directly across the saturating reactor.⁴

However, to make this circuit more effective, the voltages on the two reactors may be subtracted, one from the other, to obtain a constant output voltage, as shown in Fig. 2. This may be accomplished by adding secondary coils, thus making the reactors into transformers, and connecting these secondary coils with their voltages in opposite directions, as shown in Fig. 3.⁵

This is not the only method, however, for combining these voltages to obtain a constant output voltage. In another circuit used for this pur-

pose⁶, the supply voltage is added to the secondary voltages and these three voltages are so proportioned as to give a constant output voltage. In still another circuit of this sort⁷, the secondary windings are omitted and a voltage proportional to the supply voltage is subtracted from the voltage across the unsaturating reactor in order to obtain the output voltage.

One disadvantage of the voltage regulator shown in Fig. 3 is that it requires two transformer cores. In polyphase power transformers, it is possible to replace three ordinary transformers by a single transformer having a three-legged core. This suggests the possibility of using a single transformer in a similar manner in this case. If a three-legged core is used, the fluxes due to the two primary coils must be combined in the third leg. In the regulator using two cores, the secondary voltage was obtained by subtracting the voltages

on the secondary coils. Hence, in the three-legged regulator, the fluxes generating these voltages will be subtracted, as shown in Fig. 4.⁸ If the two adjacent legs in Fig. 4 are combined into one and if the legs and coils are rearranged, the regulator has the form shown in Fig. 5 above.

This circuit has one disadvantage, however, since it is possible for flux to link the primary circuit without linking the secondary circuit. In Fig. 5 the greater part of the flux circulates in the "a" and "b" legs without passing through the "s" leg. This condition is equivalent to having a large leakage reactance in the primary circuit and causes the secondary voltage to decrease rapidly when the load is increased. To remedy this condition, a coil is added as shown in Fig. 6.⁹ Its m.m.f. opposes that of the "b" coil so as to eliminate the flux in the middle leg while the core is unsaturated, but at the same time, it aids the "a" coil in producing saturation in the "a" leg.

Fig. 7—Combining primary instead of secondary coils of Fig. 3

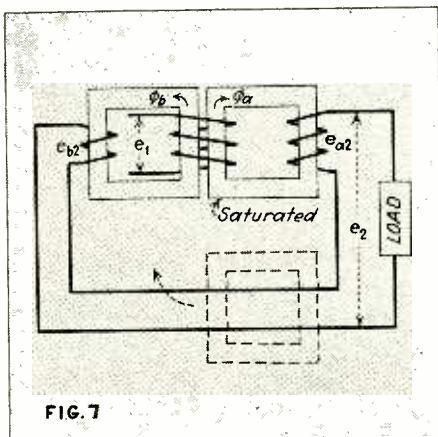

FIG. 7

Fig. 8—Change in Fig. 7 using smaller saturating core

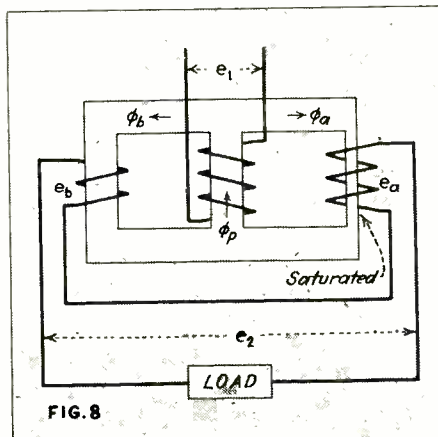

FIG. 8

Fig. 9—Circuit using autotransformer based on Fig. 8

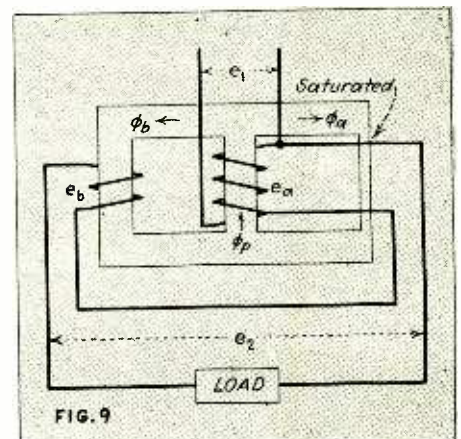

FIG. 9

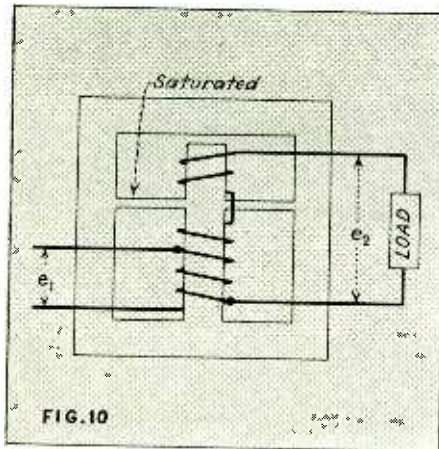

Fig. 10—Change in Fig. 9 to use shell type core

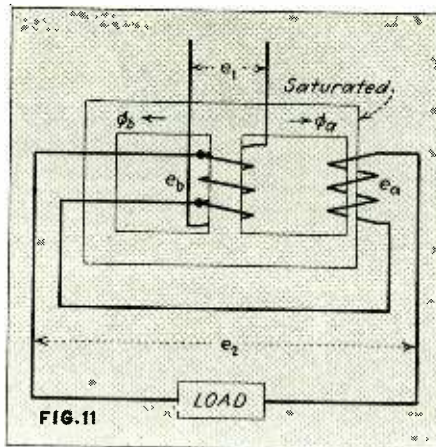

Fig. 11—Elimination of "b" instead of "a" coil of Fig. 8

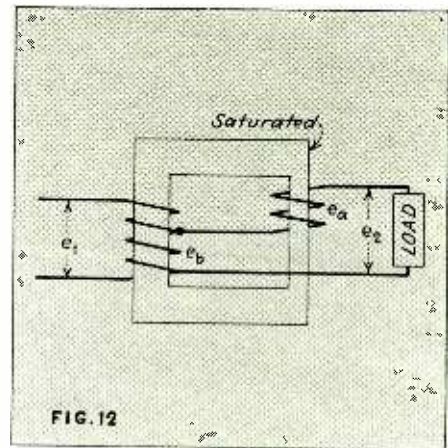

Fig. 12—Simplification making use of leakage flux

The regulator just described is only one of the several three-legged regulators which can be developed by using the circuit of Fig. 3 as a basic circuit. Referring back to Fig. 3, this circuit could have been transformed into a three-legged regulator by combining the primary coils, as shown in Fig. 7, instead of combining the secondary coils, as was done in Fig. 4. With a few changes, this circuit appears as shown in Fig. 8.¹⁰ In the original circuit of Fig. 3, the "a" core was made to saturate by making the "a" coil larger than the "b" coil. In the three-legged transformer, this method can not be used since the two primary windings are combined into one. Hence to cause saturation in the "a" leg, its cross-section is made smaller as shown in Fig. 8.

In the regulator just discussed it is possible to eliminate one of the coils and still have a device which can produce a constant output voltage. With ordinary transformers it is often possible to economize by using autotransformers in place of the usual type. Similarly, autotransformer connections can be used in voltage regulators also. In Fig. 8, the "a" coil can be replaced by an autotransformer connection as shown in Fig. 9¹¹ and by properly proportioning the windings, a constant output voltage can again be obtained.

A circuit similar to this one is shown in Fig. 10.¹² In this circuit a shell type core is used, but otherwise it is essentially the same as Fig. 9.

Instead of eliminating the "a" coil in Fig. 8, the "b" coil could have been eliminated equally well, as

may be seen in Fig. 11 above.

In a transformer of this sort involving saturation of part of the iron core, there is apt to be considerable leakage flux through the air. This complicates the design of the transformer but may be very useful in its operation as a regulator. If this leakage flux is sufficient it may be used to replace the flux in the unsaturated leg. Hence in Fig. 11 the "b" leg may be omitted, resulting in the circuit shown in Fig. 12.¹³

Use of Condenser

The regulators discussed thus far have been based on a saturating reactor in series with either a resistance or a reactor. In addition to these, there are other regulators based on a saturating reactor in series with a condenser.¹⁴ Also in many of the regulators already described, condensers have been inserted in the circuits in one place or another to improve their operation. This has been done for various purposes such as improving the voltage regulation, minimizing the change in output voltage with variations in load, and eliminating the waveform distortion of the output voltage. An example of this is the circuit of Fig. 3, for in one of the variations of this circuit,¹⁵ there is added to the saturating transformer a third coil with a condenser load. In a still different form of this circuit,¹⁶ the three coils on the saturating reactor are combined into a single coil operating as an autotransformer. In some cases, a condenser is simply placed across the line in parallel with the primary circuit of

the regulator or across the secondary in parallel with the load.

Before concluding this description of various kinds of voltage regulators, it should be explained that the order in which they have been presented does not follow the order in which they were developed. In giving a brief description of all the regulators included in this article, it has been found to be simpler to present them as though each type had been evolved from previous simpler types. However, while this may have been true in some cases, it is quite probable that in many cases, the regulators were developed, largely by cut-and-try methods, with very little knowledge of circuits previously used for the same purpose.

References

1. "Automatic Voltage Regulation." Kasson Howe, *Electronics*, May 1932, p. 164-5.
2. "Selbsttätige Strom- und Spannungs-Regler," Wilhelm Geyger, *Archiv für Technisches Messen*, Nov. and Dec. 1934, p. T147 and T162.
3. German Patent 338,677; Feb. 6, 1920.
4. U. S. Patent 1,540,307; June 2, 1925.
5. German Patent 313,300; Dec. 22, 1916.
6. German Patent 231,938; May 14, 1910.
7. U. S. Patent 1,896,995; Feb. 7, 1933.
8. U. S. Patent 1,896,316; Feb. 7, 1933.
9. U. S. Patent 1,812,299; June 30, 1931.
10. Ward Leonard Electric Co., Mount Vernon, N. Y. Also eleven other patents for somewhat similar circuits were granted to H. K. Kouyoumjian during 1931, 1932, and 1933. See also Reference No. 1.
11. German Patent 293,834; Jan. 16, 1915.
12. German Patent 307,821; Feb. 22, 1914.
13. U. S. Patent 1,893,251; Jan. 3, 1933.
14. Sola Electric Co., Chicago, Ill. See also "A Magnetically Operated A-C Voltage Control Device," J. G. Sola, *Radio Engineering*, Jan. 1931, p. 24-25.
15. "Voltage Regulating Auto-Transformer," F. Bedell and J. Kuhn, *Rev. Sci. Inst.*, Jan. 1932, p. 20-23.
16. (a) U. S. Patent 1,932,667; Oct. 31, 1933. (b) German Patent 578,321; Oct. 21, 1925 and German Patent 564,892; July 20, 1928.
17. U. S. Patent 1,942,535; Jan. 9, 1934. Also see "An Automatic Voltage Regulator," C. F. Cairns, *Proc. Radio Club of Amer.*, May 1929, p. 55-58. Also compare U. S. Patents 1,985,634 and 1,985,635; Dec. 25, 1934. Raytheon Mfg. Co., Waltham, Mass.
18. Bulletins No. DL-48-10 and DL-48-11 of Delta Mfg. Co., Cambridge, Mass. for Oct. 18, 1933. For a similar circuit, see U. S. Patent 1,967,108; July 17, 1934.

The Resonoscope

An unusual application of a cathode-ray tube for tuning musical instruments and for analyzing the contents of musical tones, useful in the manufacture of instruments

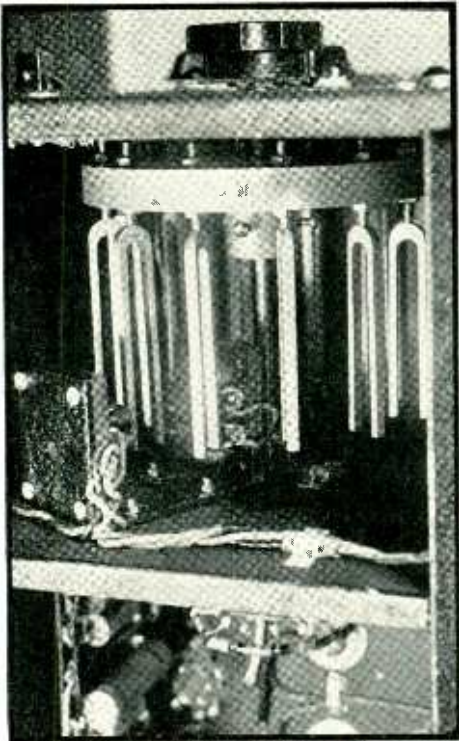

Standard-frequency tuning fork arrangement

By LESTER B. HOLMES

Dumont Laboratories
Montclair, N. J.

FOR some time, there has been an urgent demand for a device which would improve the adjustment of musical instruments in regard to pitch, tone-color, intonation, and balance. In response to this demand there has been developed an instrument known as the Resonoscope, a device developed for the purpose of tuning musical instruments visibly. It can also be used to study the wave form of the note under observation, to estimate the number of partials there are present in a single musical tone, and to balance the tone of one musical instrument with another.

The Resonoscope employs a standard 5-inch cathode ray tube with its usual power supply. There is provided a horizontal sweep of the linear type which is amplified, and which provides a full screen deflection with complete linearity. A voltage amplifier of high gain is used, in conjunction with a crystal microphone, to pick up the musical frequencies, which are fed to the vertical plates of the cathode ray tube. The high gain of this amplifier allows full-scale vertical deflection under ordinary sound intensities.

When the frequency of the horizontal sweep is exactly the same as the vertical, or any multiple of the vertical frequency, the wave form or pattern on the screen appears to stand still. If a standard frequency is applied to the grid of the oscillator of the horizontal sweep, synchronizing it to this standard frequency, it is possible to place an unknown frequency on the vertical plates and to determine whether it is of the same frequency as that of the standard.

In the Resonoscope there are twelve standard pitches used, representing the 12 notes in one octave of the chromatic scale, based on A as 440 cycles per second as a standard pitch and utilizing the tempered scale for the rest of the frequencies. This set of standard frequencies is generated by 12 electrically driven tuning forks. In the design of these frequency generators much thought was given to their stability, especially the effect of temperature or voltage variation in the electrical circuit. The tuning fork which is used was designed for a very low temperature coefficient of frequency. Under laboratory tests it showed approximately .005 per cent error per degree Fahrenheit at 440 vibrations per second. Changes in voltage, which might change the constant operating amplitude of the tuning

fork, were taken into consideration by proper design of the fork and electrical driving circuit. A voltage change of 100 volts can be made without any appreciable change in frequency. Therefore a fairly accurate standard of frequency was arrived at without a temperature control. However if a very accurate frequency precision is desired, a temperature control compartment can be added.

In order that the observer may ascertain which octave is under observation, the horizontal sweep is kept at a certain multiple of the standard so that there is a definite number of wave forms on the screen for any given octave. For example:

(Continued on page 66)

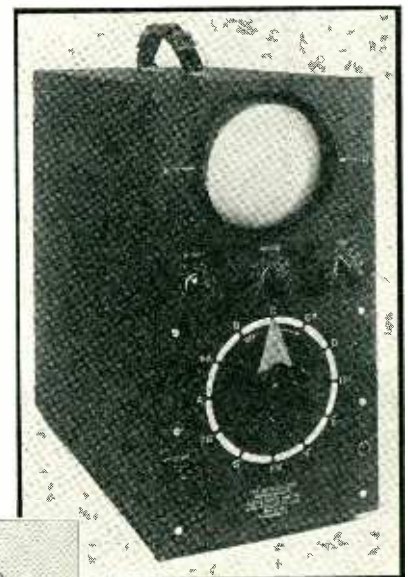

External appearance of the Resonoscope

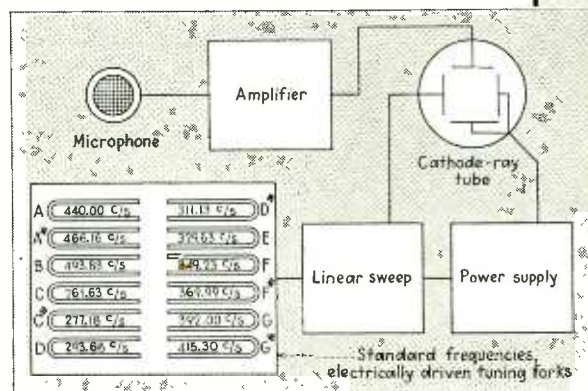

Arrangement of microphone pick-up and frequency-controlled sweep circuits

Amplifier Measuring Technique

Essential characteristics for audio transformers are discussed and a simple method of determining frequency response, power capabilities, impedance of a-f units is given

THE design of satisfactory audio frequency transformer coupled amplifiers depends upon the characteristics of the transformers as well as upon those of the tubes used in the individual stages. The tube characteristics are nearly always given by the manufacturer with sufficient completeness as to be directly useful in amplifier design. The situation with regard to the ratings and characteristics of audio transformers is not so fortunate.

The important characteristics of audio transformers are: (1) frequency response, (2) turns ratio, (3) working power level, (4) physical dimensions, (5) primary inductance, (6) insertion loss, and (7) phase shift. The frequency response is usually given by the manufacturer by means of a curve or by a statement of the deviation in decibels for a specified frequency range. The turns ratio is generally given directly, or indirectly by specifying the impedance values between which the transformer will serve as a matching device. The working power level is specified on power output and modulation transformers and on some high fidelity units, but is not as frequently specified as might be desired. The physical dimensions are usually given, but the primary inductance, insertion loss, and phase shift are seldom indicated, and for this reason these characteristics must usually be measured by the user if knowledge of them is essential for design purposes.

A more or less standard arrangement of apparatus for frequency response measurements is shown in Fig. 1. The beat frequency oscillator, suitably terminated, feeds

By E. F. KIERNAN

South Gate, Calif.

through the gain-set into the device being measured. A suitable load in the form of a non-inductive resistor is connected across the output. The oscillator output is maintained constant at some convenient level reference or zero, by means of the volume indicator. This latter device should preferably be a vacuum tube voltmeter.

To measure the gain, or amplification, the oscillator, adjusted to zero level, is set at the reference frequency. The volume indicator is switched to the load and the gain-set adjusted until the volume indicator again reads zero level. The gain in db is then read from the dials of the gain set. Data for a frequency response curve is obtained by varying the oscillator over the desired range and repeating the adjustments.

If the device being measured is designed to operate in a circuit delivering an appreciable amount of power, the above measuring proced-

ure may fail to give a true picture of the performance at rated output. The development of class AB and class B audio amplifiers wherein the d-c plate and grid currents may change several hundred percent during the passage of a signal, makes it imperative to take measurements at the rated output level. Saturation of transformer cores at high signal levels causes an increase in the harmonic distortion and a falling off in response at the low frequencies.

In Fig. 2 is shown two curves purporting to portray the response of an audio amplifier. Curve A was supplied by the manufacturer with the amplifier. Curve B was obtained by the writer from data acquired in a measuring arrangement as shown in Fig. 1. To develop the rated output required a signal input at -40 db level. The input level during the measurement, at reference frequency, was at -90 db; the V.I. reading zero level in both positions. The conditions under which curve A was obtained are not known. Opportunity was not afforded for further

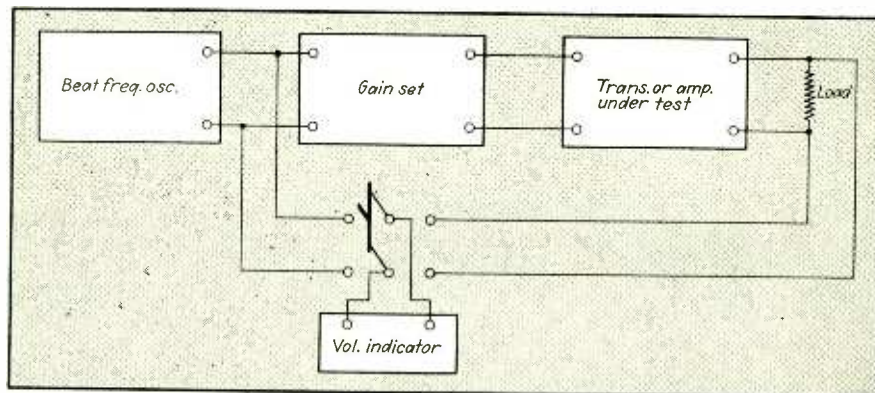

Fig. 1. Set up of laboratory equipment for determining the frequency characteristics of audio frequency amplifiers

measurements on this particular amplifier; however, at a later date development work on class B input and output transformers made available data suitable for comparison purposes.

Voltage and power transfer characteristics of the class B amplifier shown in Fig. 3 are given in the curves of Fig. 4. Curve A is the voltage transfer characteristic; curve B is the variation of power output with frequency at constant distortion. Although the voltage transfer data were obtained at a level approaching the rated output of the transformer (200 watts) the curve does not give a true picture of the performance. Curve B indicates insufficient primary inductance, due in this case to an undersized core, as shown by the falling off in power transfer at the low frequencies. The voltage transfer characteristic fails to show the terrific harmonic distortion taking place due to core saturation, as the peak amplitude of the distorted wave was approximately the same as that of a sine wave. Leakage reactance was responsible for the drooping high frequency end of curve B. These faults were overcome by increasing the core size, and by breaking the primary and secondary up into several sections each, which were wound alternately one over the other.

The use of a cathode ray oscilloscope for checking harmonic distortion is entirely practical, contrary to many opinions. This is especially true if the distortion is composed mainly of even harmonics which cause flattening of a sinusoidal signal trace. Fig. 5 is a sketch of an oscilloscope trace having 2.35 percent harmonic distortion as measured on a General Radio Type 636-A wave

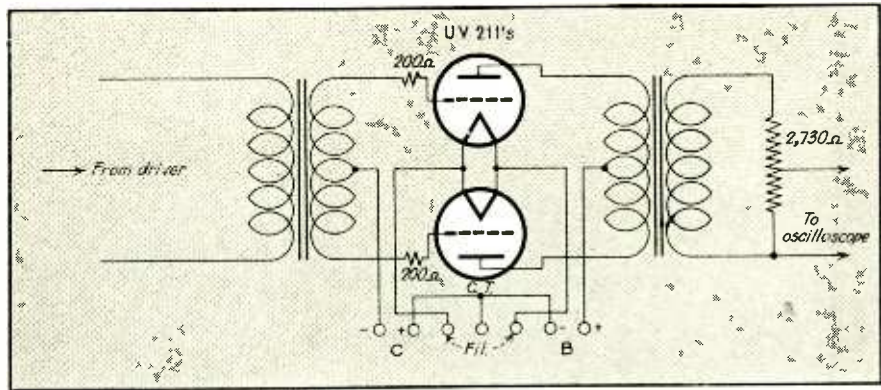

Fig. 3. A high power Class B audio amplifier push-pull circuit

analyzer. Slightly over 2 percent was due to the second harmonic, the balance to the fourth and higher. Other harmonic combinations might be more difficult to observe; however, a reference trace taken at the output of the oscillator and inscribed on a transparent mask mounted over the end of the tube will facilitate comparisons. We may expect to eventually obtain cathode ray tubes with two sets of control elements, such as are now available in Europe, which will enable the technician to observe two independent traces simultaneously.

These step-by-step methods of measurement just discussed have several disadvantages. The time required to make a frequency run is considerable and requires the services of one skilled in the reading and adjustment of the various instruments. Where a great many measurements are to be made, such as production testing, simplified equipment is demanded. Several arrangements have been used in the past, such as a manually operated stylus which traces a curve on a revolving drum driven by a motor which also drives the dial on the beat

frequency oscillator. The operator follows the movements of the output meter needle with a pointer fastened to the stylus, as the drum revolves in synchronism with the changing oscillator.¹ Another type utilizes a modulated oscillator beating against a fixed oscillator in conjunction with a cathode ray oscilloscope so as to produce an envelope on the screen which portrays the response of the equipment being measured.² An instrument has been recently placed on the market which traces the response curve directly on paper.³

Although it is generally advisable to take measurements on transformers under actual working conditions, it is possible to obtain valuable information in certain instances under simulated conditions. For instance: the leakage reactance of a class B input transformer is an important factor in determining the effective impedance inserted in series with the class B grids. The leakage reactance is difficult to evaluate; however, the arrangement of Fig. 6 can be used to obtain data to show the variation of the inserted impedance with frequency.⁴ A resistor is connected

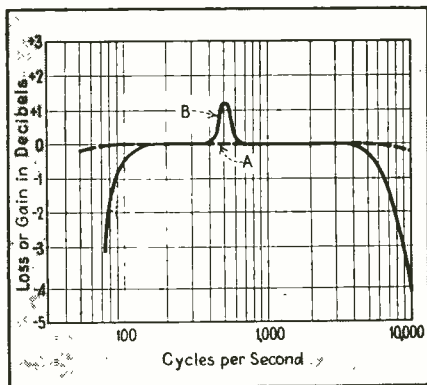

Fig. 2. Two response curves representing the same audio amplifier

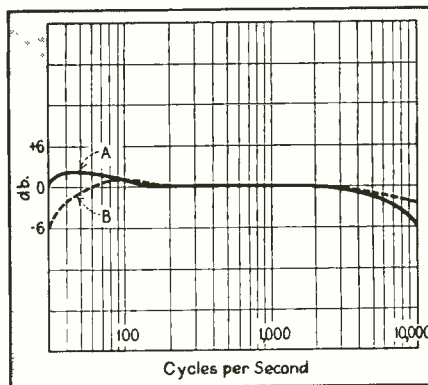

Fig. 4. Transfer characteristic (curve A) and power output

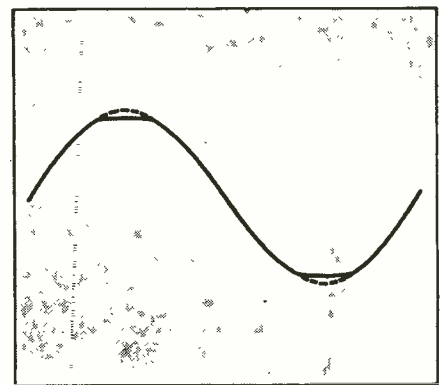

Fig. 5. Oscilloscope tracing of wave shape in amplifier

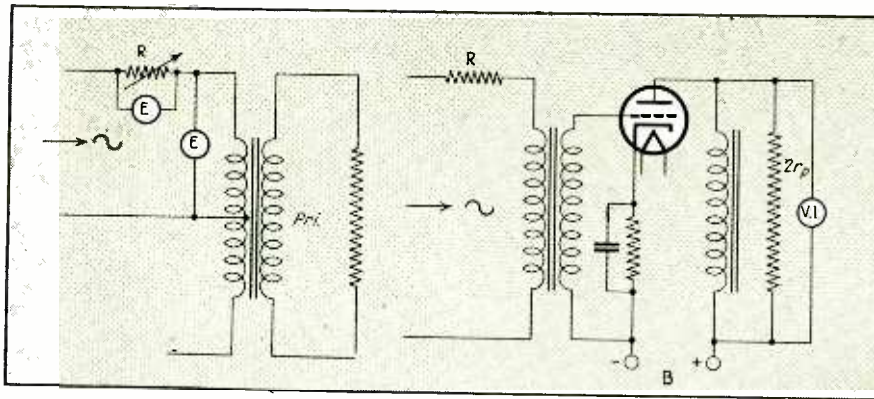

Fig. 6 (left) shows an arrangement which may be used to determine transformer impedance. Fig. 7 (right) shows a method of simulating the impedance of the tube feeding the amplifier

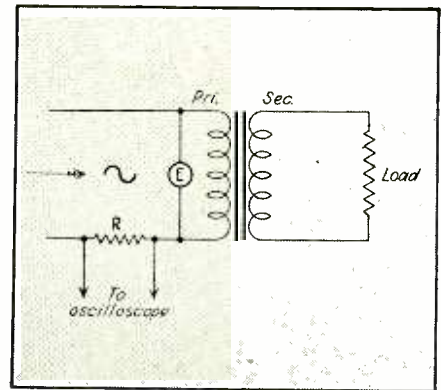

Fig. 8. Circuit for determining power handling capabilities of transformer

across the primary to simulate the plate circuit of the driver tube. Resistor R is a decade resistance box. A beat frequency oscillator together with an audio amplifier is used as a source of voltage. The decade box is adjusted until the two voltmeters read the same. The value of R is then the impedance of the half secondary at the given frequency.

When measuring the frequency response of an individual transformer designed for use in voltage amplifiers, the arrangement of Fig. 7 is used. The resistor in the primary simulates the impedance of the device out of which the transformer is to operate. The voltmeter readings are converted to db variations from the value at the reference frequency.

If the turns ratio of an audio transformer is not known but the values of the impedances between which it is designed to operate, are available, the turns ratio may be found from the relation

$$N^2 = \frac{R_s}{R_p} \quad (1)$$

If no data is obtainable the ratio may be measured by placing a known voltage of 400 cycles, or thereabouts, across the primary and measuring the secondary voltage with a vacuum tube voltmeter. The voltage ratio will very nearly equal the turns ratio.

In transformers having the windings divided into equal halves, the impedance of either half taken separately, or of the two in parallel, is equal to one fourth the value of the two in series aiding.

The power handling capabilities of a transformer may be ascertained with the arrangement of Fig. 8. The

secondary is loaded with a resistor of appropriate value. A variable source of voltage, of low frequency and good wave form, such as the commercial power line adjusted by means of a regulating transformer, is applied to the primary. The value of the highest voltage allowable across the primary without excessive distortion of the magnetizing current wave form as observed in the oscilloscope, determines the power handling capability. Knowing the turns ratio and the load resistor value, the power may be calculated from the expression

$$W = \frac{E^2}{R} \quad (2)$$

Although physical dimensions of a transformer are readily obtainable directly if not available from manufacturers' data, the winding terminal arrangement may present some difficulty if the diagram has become lost. The terminals common to any one winding may be found readily with a continuity or ohmmeter. Split windings may be phased out by placing a low value of A.C. across one section and measuring the voltage across the two sections in series, then again with one section reversed.

The primary inductance of an audio transformer is most conveniently measured by means of the Hays bridge⁵ which is arranged to pass d.c. through the winding, when necessary, during the measurement. The arrangement shown in Fig. 6 may be used to obtain an approximation from the expression

$$X_L = 2\pi fL \quad (3)$$

The accuracy is low and the result will vary with the voltage and frequency used.

Quantitative insertion loss data is seldom available; it may at times, however, be of importance. In one instance a pair of 6L6 tubes in push-pull operation, under class AB₁ conditions could not be made to deliver the 30 watts specified by the tube manufacturer. Suspecting the rating to represent an 'ideal' amplifier, a check was made of the output transformer losses as follows—the transformer turns ratio was 3.5, the r.m.s. voltage from plate to plate was 433, the secondary load was 500 ohms, the power delivered to the resistor was 25 watts. Therefore,

$$N^2 = \frac{Z_1}{Z_2} \text{ or } Z_1 = 500 \times 3.5^2 = 6125$$

$$\text{ohms (plate to plate) and } W = \frac{E^2}{R} = \frac{433^2}{6125} = 30.65 \text{ watts out of tubes.}$$

$$\text{Also } \frac{25}{30.65} = 0.815 = 0.9 \text{ db insertion loss.}$$

Phase shift is generally not apparent to the ear, but with the approach of television, which covers from the lowest audio to the lower radio frequencies, this factor will become of increasing importance.

REFERENCES

- ¹ Dickey, Edward T., "Notes on the testing of Audio Frequency Amplifiers." *Proc. I.R.E.* Aug. 1927.
- ² Diamond, H., and Webb, J. S., "The testing of Audio Frequency Transformer-Coupled Amplifiers." *Proc. I.R.E.* Sept. 1927.
- ³ *Electronics*, Feb. 1937, Page 53.
- ⁴ Barton, Loy E., "Recent Developments of the Class B Audio and Radio Frequency Amplifiers." *Proc. I.R.E.* July, 1936.
- ⁵ Terman, F. E., "Measurements in Radio Engineering."

Phototube Controls Punch Press

Protection to punch press operators afforded by phototube control. Production unaffected, insurance rates decreased by system using standard electrical and hydraulic equipment

PROTECTING punch and fabricating press operators has always been a serious problem to the safety directors of industrial plants. As production has increased, the hazard has increased,—and many safety devices have been offered. Among those most commonly used at the present time are:

(1) A system of mechanical arms and linkage so arranged, that when the press starts on its closing cycle, the mechanical arms sweep through the dangerous area of the press and knock the operator's arms or hands away from the rapidly closing dies.

(2) A system of push buttons connected in series so that all operators in both front and back of the press must keep their hands on the push buttons during the *entire* closing cycle of the press.

(3) A complicated system of straps and harnesses, which holds the operator in a fixed position. When the closing cycle of the press starts, wrist straps jerk the operator's hands away from the closing dies of the press.

These three typical types of punch press protection offer some safety for the operator, but they impede production, cause the operator to be under continual nervous strain, and in some cases injured the operators. Undoubtedly the answer to punch press operator protection is a curtain of light which can offer frictionless safety.

Presses installed in recent years have been equipped with either hydraulic or electric control of the clutch and brake. The electric or hydraulic control has supplemented the dangerous dog type clutch and, to offer greater safety, the clutch has been supplemented with an automatically energized brake, which is applied as soon as the clutch has been disengaged. Hydraulically or electrically controlled presses offer

By **RALPH A. POWERS**

*Electronic Control Corp.
Detroit, Mich.*

a most simple solution to operator safety in conjunction with a curtain of light and phototubes.

In presses that open from 12" to 18" a single beam of light will not offer the desired protection, because the operator might unconsciously avoid interception of the beam when inserting or removing stock. As a result, a continuous curtain of light, which is as high, if not higher, than the maximum opening of the press, is essential. The phototube equipment must be designed for constant operation, and with sensitivity at a point which will cause the closing dies of the press to stop within a fraction of an inch after only a partial interception of the ribbon of light.

The installation of the equipment shown was made after several experimental models had been running for almost a year.

As can be seen from the illustration, the equipment consists of: (1) A specially designed light source, (2) A system of mirrors, (3) The phototube housing, (4) The phototube amplifier.

The first light source designed for this type of equipment projected five individual beams of light approximately 2" in diameter and with $\frac{1}{2}$ " of dark space between each beam. It was felt, that, if a light source could be developed which would project a true curtain of light to completely enclose the working sides of the press, greater safety would be offered. In the illustration a card has been placed between the two

mirrors to show the virtual wall of light, which is projected by this special light source, consisting of four lenses designed and ground to give the light pattern as pictured. The light source is housed in a rugged container with the lenses and the lamps being built as a unit on $\frac{1}{4}$ " cold rolled steel so that uniform alignment of the curtain of light is maintained even though the exterior housing of the light source may be slightly damaged by careless operation or installation. The light source uses standard 50 or 32 candlepower 6-8 volt automobile headlight bulbs, operating from a self-contained transformer supplying slightly less than 5 volts to the filament of each lamp. While this under-voltage materially decreases the amount of radiation from the lamps, the life and the subsequent interval between replacement is greatly lengthened. Suitable ventilation holes have been provided in both the lower and upper portion of the housing so that ambient temperatures within the housing are kept at a safe point.

Schematic wiring diagram of control circuit for punch press. Dotted lines indicate wiring to be done by plant electricians; solid lines represent wiring within the photoelectric control unit

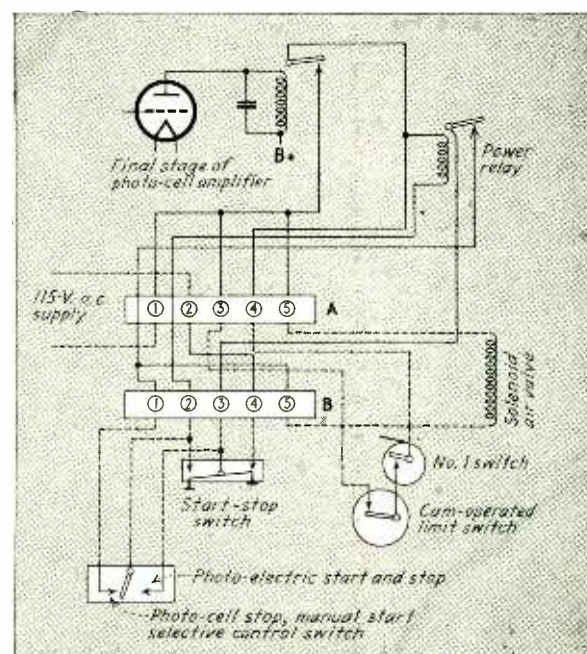

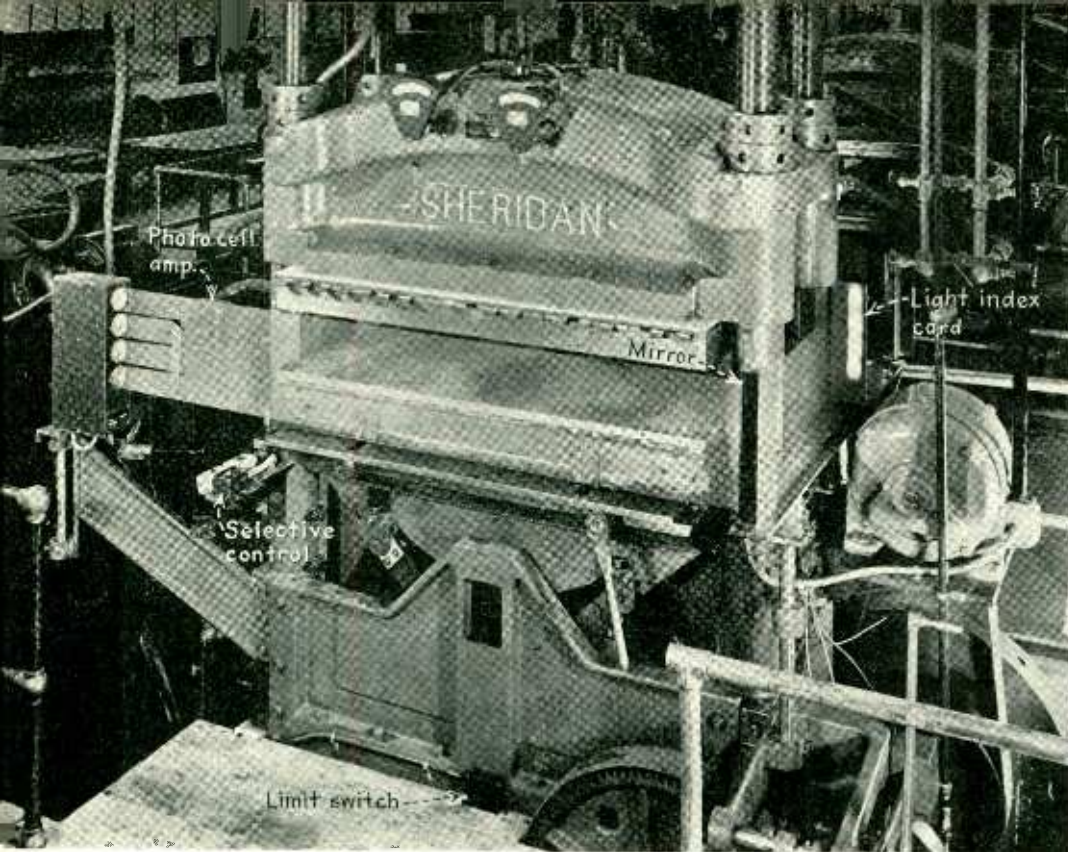

Left—General view of press with phototube safety control. Light beams pictorially exaggerated to show region of control. The phototube cell housing is at the back left corner of the press and is not visible. Below—Phototube cell housing showing condenser lenses, directional light vanes, and self contained power supply.

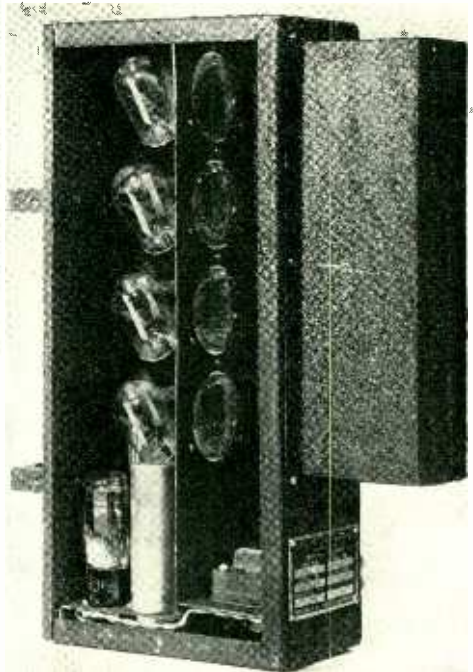

The mirrors have been mounted in a metal container, which allows angularity adjustment, providing an easy rapid method of aligning the wall of light from the light source through the two mirrors to the phototube housing. So that stray light will not interfere with persons passing behind the mirrors, metal baffles have been attached to the back side of the mirror brackets, restricting the extraneous light from other parts of the plant. The mirrors, themselves, are produced from standard back silvered plate glass, allowing periodic cleaning without injuring the reflecting medium.

The phototube housing is unique in design because the condensing lenses are arranged so that every section of the curtain of light actually impinges upon the cathode of one of the phototubes. This eliminates "dead spots" or portions of the beam of light, which could be intercepted and yet not actually cut off light from the cathodes of the phototubes. An important feature is a system of directional light vanes installed on the admittance end of the phototube housing, eliminating the necessity of making periodic sensitivity adjustments to the phototube amplifier to compensate for ever changing extraneous light values. The phototube housing contains a power pack for supplying direct current.

The phototubes are of the standard gas-filled emissive type. They

have a rated operating voltage of 90 volts and will ionize at 125 volts. With the rated 90 volts it is not unreasonable to expect upward of 35,000 hours of life with the amount of light applied under the installation conditions; but to insure a longer life the phototubes are operated at slightly less than 55 volts.

A special low capacity cable with suitable plug is used for connection of the phototube housing to the amplifying unit. The amplifying unit was designed especially for press operator protection and uses a comparatively low resistance leak on the first stage to cause immediate drop out or de-energization of the relay coil when a small portion of the light curtain is intercepted. Although the curtain of light is 13" in height and approximately 2" in thickness, the amount of light cut off by an ordinary lead pencil inserted at 90° to the axis of the beam of light, causes sufficient fall off in light intensity to drop out the relay and stop the press within $\frac{3}{8}$ " of die movement. The amplifier uses standard radio tubes arranged in a two-stage direct-coupled circuit and has a self-contained rectifier to supply d.c. to not only the amplifying tubes, but also the primary relay.

Under actual tests of standard radio tubes used in this circuit, in which the heaters are operated at approximately 10% below their rated voltage and the plate current is approximately 50% of the standard rat-

ing, an unusually long life has been experienced. The use of standard radio tubes in such an industrial application has met with favorable reception because replacements are immediately available in the most remote communities throughout the United States. These replacements may be made periodically at a cost far less than would be possible with special tubes.

The primary relay contained within the unit is of the telephone type with contact capacity rated at 75 watts non-inductive load. This relay remains energized and its contacts closed while the protecting light around the press is not obstructed. The contacts of this primary relay are used to energize a power relay with contact capacity of 1,000 watts. As can be seen from the circuit, the contacts of the power relay must be closed and the coil must be energized through the make contact of the primary relay to keep the press in operation. As a result, tube fatigue or line voltage failure would cause either or both relays

to become de-energized and thereby immediately stop the press.

To insure fool-proof operation of the safety device, the entire control equipment, as well as the phototube amplifier and the light source, was designed so that in the event of a power failure, tube fatigue, a burned out light source lamp, the relays in the amplifier would go to the de-energized position. In this position the circuit to the solenoid operated air valve is opened, allowing solenoid of the air valve to become de-energized, which turns off the air pressure and exhausts the air cylinder. Immediately the weighted arm disengages the clutch and applies the brake so that the press stops within $\frac{3}{8}$ " movement of the dies. A broken brake or the weight operated by gravity failing to perform are the only things that could fail which would impair the safety of the operators. All springs for returning air cylinders, applying brakes and disengaging the clutch, have been removed so that the entire braking and stopping mechanism of the press is dependent upon gravity.

From the accompanying circuit, showing the layout of the switches, solenoid operated air valve, and relay circuit in the photoelectric amplifier, it will be noticed that in one position the press can be arranged

so that it requires a manual operation of the switch to start the press, but that the press is automatically stopped by the interception of the light beam. In the other position of this switch, the press will function with the curtain of light actuating the automatic starting and stopping. In certain embossing operations where it is desirable to stop the press at the top of its closing cycle, the operator has merely to turn around with a new piece of unfabricated material and intercept the curtain of light as the press reaches its completed closing cycle. A slight movement out of the curtain of light allows the press to continue on its opening cycle, at the completion of which the operator steps into the light, stopping the press, inserting the piece of unfabricated material, while the other operator on the back of the press removes the completely fabricated piece. The alternative possibility of photoelectric stopping with manual starting, or both automatic starting and stopping, has permitted the use of this press for unusual types of fabrication and has increased production beyond expectations of the owners.

Aside from the photoelectric equipment, consisting of light source, two mirrors, cell housing, and amplifier, the equipment is standard electrical

and hydraulic equipment found available in any number of industrial supply houses or on the open market. The solenoid operated air valve is a standard three way valve operating directly from the 115-volt lighting line and so arranged so that the solenoid must be energized in order to allow air to pass into the air cylinder and keep the press running. The limit switch used to keep the photoelectric equipment from operating while the press is on its opening cycle is a standard limit switch which is connected mechanically to the press to operate on an adjustable cam. The switches used to select the various types of controls are standard electric switches obtainable at any industrial supply house.

The complete installation is not the combination of a series of standard light relays and standard light sources connected in such a manner to provide the desired relay operation, but special photoelectric equipment designed entirely for punch press operator's protection. The equipment has performed so satisfactorily that the owners of the few installations that have been made up to this time are now contemplating a 100% program of phototube protection for their punch and fabricating press operators—and at a future insurance premium saving.

Operator breaking light curtain when feeding punch press. Light source can be seen on opposite side of press above operator's elbow

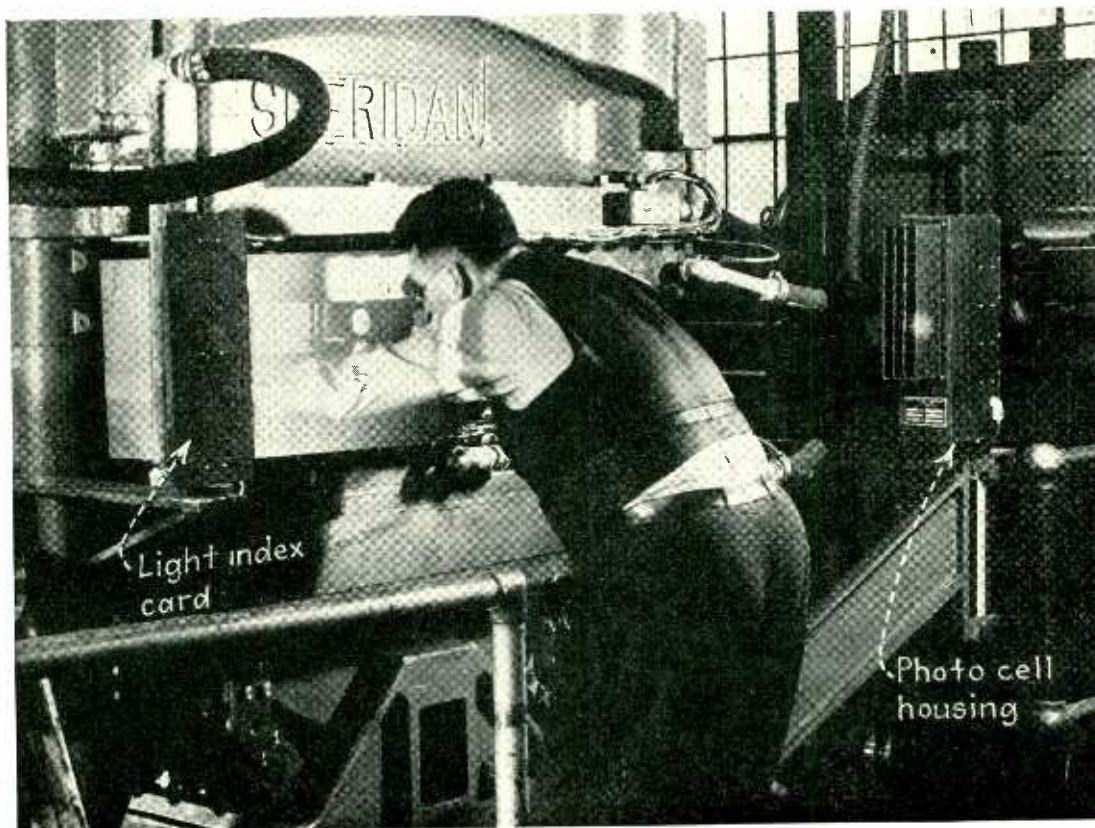

Public Address AVC

Application of automatic volume control to voice-frequency circuits enable speaker to turn his head away from a microphone without his audience losing his words. Other features of a modern PA design

PRESENT flourishing growth in the use of public address equipment is characterized by two outstanding features—on the one hand a strong demand for special facilities to meet the most diverse requirements, and on the other a strenuous insistence upon low prices. The apparent conflict can be met only by building the utmost versatility into a standard production unit.

A few of the many features required of current PA apparatus may be summarized briefly as an indication of the complexity of the problems that face the designer.

1. Sound quality better than last year's is always in demand, and is an important factor in the extensive replacement market which, today, is progressively eliminating older systems based on carbon microphones and similar obsolescent components.

2. There is a strong call for audio-frequency AVC, which permits the person using the microphone to turn his head from side to side in the manner natural to anyone addressing an audience, without extensive change in loud-speaker volume. (Nevertheless, the time constant of the AVC action must be so adjusted that normal inflection of the speaking voice is not appreciably impaired in the reproduction).

3. Automatic volume expansion (AVE) and the increased liveliness which that feature imparts to radio or recorded music, is particularly appreciated for purposes of public entertainment.

4. The same equipment is used interchangeably with microphone and with phonograph (or radio), and changeover from AVC to AVE, or vice versa, should be as quick and easy as a change of input sources.

5. Proper cueing of an entertainment program requires some form of indicator by means of which either AVC or AVE operation (or

By **HARRY PARO**
Sound Engineer
Wholesale Radio Service Company

performance without either as a standard amplifying system) can be carried out accurately at pre-determined values.

6. Best practice in public entertainment always dictates that the mechanism of the performance be concealed, or obscured so far as possible. Where controls and switches must be manipulated in view of an audience, it is desirable that these be placed in the darkest available location, but accurate operation requires that they be visible to the person using them. Self-luminous controls, with amplifier or other control panel placed back to audience, offer a satisfactory solution.

7. The wide variety of microphones now used in PA work, and the probability that that variety will increase rather than diminish in the immediate future, dictates the choice of input circuits of the greatest flexibility and of the highest possible gain.

8. Mixer facilities, permitting simultaneous use of at least two input sources, including two low-level microphones, or blending of microphone speech with recorded or radio music, is in substantially universal demand. Further, it is desirable to provide for permanent connection of more input sources than can be used at any one time, in order that others may be faded into use without interruption, or the inconvenience of changing connections or plugs.

9. The same PA amplifier is often made to serve more than one purpose. This is always true, of course, when it is used as part of rental equipment, and quite commonly the case when it is owned by its user. Reserve power is therefore advisable. The extent of reserve necessary is of

course increased if AVE is included in its circuit.

10. The same flexibility of use dictates that a PA amplifier, even when not strictly portable, shall be "semi-portable" to the extent of being as light and compact as possible.

11. Extreme fluctuations of line voltage encountered in many locations, and especially in rural and resort communities, urgently require some simple and easy means of compensation. The writer has recorded, in a resort city of a hundred thousand "floating population", line voltages running from 85 to 135 volts in a single evening. The reason, of course, is that permanent residents are comparatively few. A large part of the PA market is in just such communities.

The circuit diagram of an amplifier of very recent design in which all of the features mentioned above, and a number of others is given. It is a 60-watt unit measuring 18" by 11 $\frac{1}{4}$ " by 8 $\frac{3}{4}$ ", and weighing less than 50 pounds. Sound quality is enhanced by inclusion of reverse feedback. Harmonic distortion is 3% at 60 watts into 500 ohms—this being the rated output beyond which grid current begins to flow in the Class A output stage. Frequency range is 40 to 10,000 cycles within 3 $\frac{1}{2}$ db, rising at the upper end.

Both AVC and AVE are included. Audio-frequency AVC, it should be noted, involves problems not present in AVC applied to radio receivers, since in audio operation there is no carrier. In this amplifier the signal is split, and one part, after further amplification, is rectified and applied as control bias to a 6L7 acting as a voltage amplifier. The same bias serves either purpose, according to its polarity, and change from AVC to AVE operation is effected instantly by a small rotary switch mounted on the face of the panel.

For cued operation at pre-determined values a cathode ray indicator eye is provided, and equipped with a control that can be pre-set to close the eye at any output value between 1 and 60 watts. For example, if correct maximum volume for a given operation has been found by trial to be that which closes the eye when its control is set at Point 5, the control is so set, and the regular volume control then operated to keep the eye just closed. No accidental change of operation—such as the lecturer changing his position with reference to the microphone, or substitution of a phonograph record made at a different level—can alter the results, and the control operator is not dependent upon his judgment of the sound of a monitor speaker. A chart furnished with the amplifier indicates the wattage output that corresponds to each setting of the cathode ray eye control, when the eye just closes.

The more important controls, those that will commonly need accurate adjustment during the course of operation, are of the luminous "neodial" type, which glow with a soft neon red. They are: the cathode ray eye control, the tone control, and the two mixer-fader volume controls. Their settings are instantly visible to the operator—who may be one of the members of an orchestra—but if the amplifier is placed back-to-

audience in a reasonably dark location it will not be seen.

Any high impedance microphone can be used. Gain of the two high gain channels will vary somewhat, depending upon AVC or AVE action, but is rated at 127 db from 150,000 ohms. Condenser-velocity microphones can be interchanged with other types, such as the crystal or dynamic, by virtue of the three-terminal input jacks. The corresponding input plugs are wired to one or the other pair of terminals, according to the type of microphone used. The excitation provided for condenser-velocity microphones from the power circuits of this amplifier is substantially identical with the excitation required by the common type of caesium-gas photocells, thus adding still another point of versatility to the amplifier, which can be used without wiring changes for photocell input from talking picture equipment.

The mixer-fader facilities provide for two high-level sound sources, in addition to the two low-level sources just mentioned. These channels have a rated gain of 88 db from 150,000 ohms. The exact gain is, again, somewhat subject to the AVC-AVE action, but will in every case be ample for use with phonograph records, electric guitars, or radio tuners. Any two of the four input sources can be mixed as required,

while the other two remain connected and can be faded in, in place of one of the others, at the turn of a dial. That is, the grid potentiometers of the 6N7 permit selection of any two of the four sound sources, which are then applied to the grids of that tube, the plates of which are in common.

The power transformer, while tapped for line voltage variation, is not equipped with a tap switch. The needs of simplicity and low cost are served by using the fuse clips for this purpose. The fuse can be clipped into either of two positions, for high or for low line voltage. Where more extensive control is required, a matched auto-transformer panel, complete with voltmeter and 15-position tap switch, can be obtained at not much more than the cost of a spare kit of tubes.

The strident demand for lower costs is further met so far as possible in the pricing of the amplifier itself, which naturally can be kept down by reason of the fact that a single unit suited to many different uses is built in standard production, and not modified in any way to match the very varied purposes it is called on to serve. Other features included, such as provision of plug connections throughout and of speaker field supply, reduce costs of installation and hold down the total cost of the completed PA system.

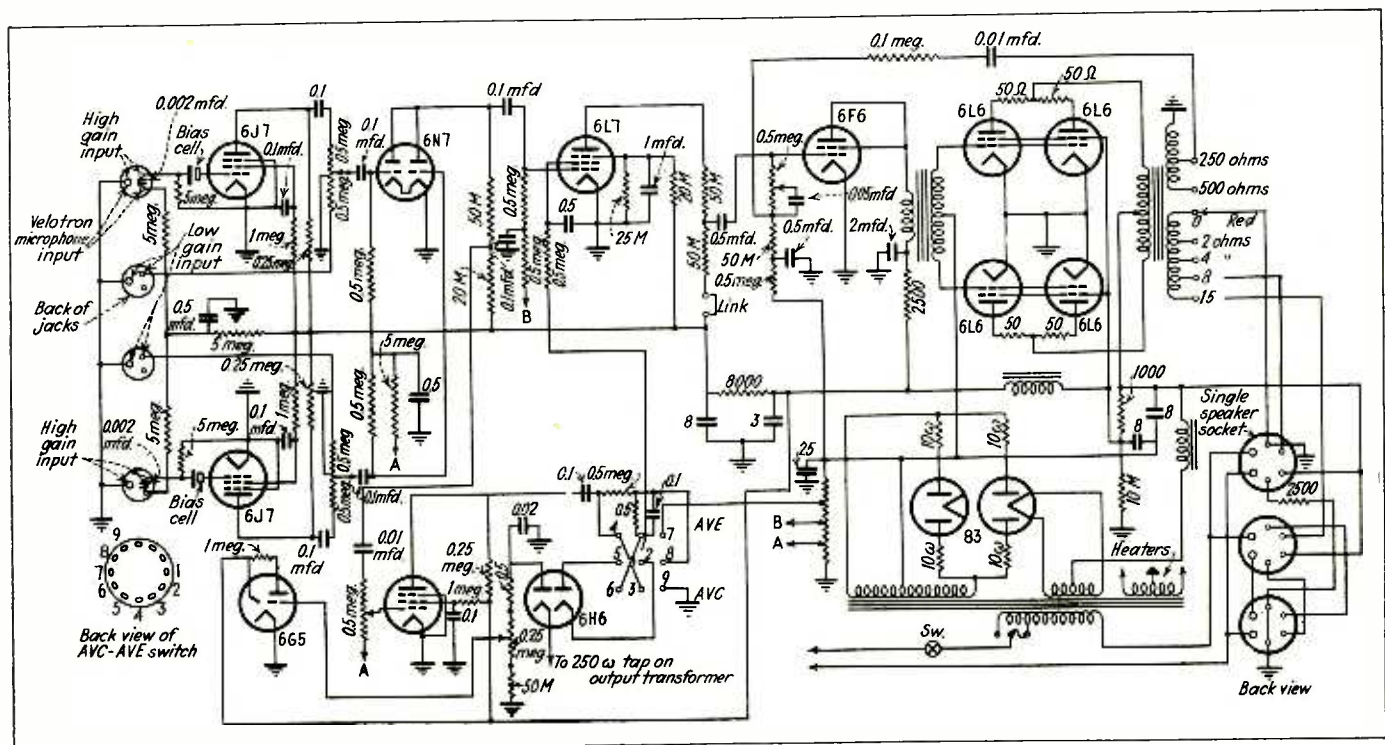

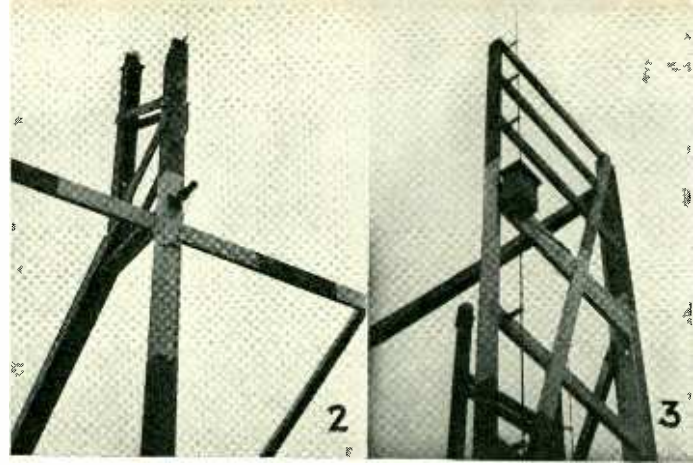
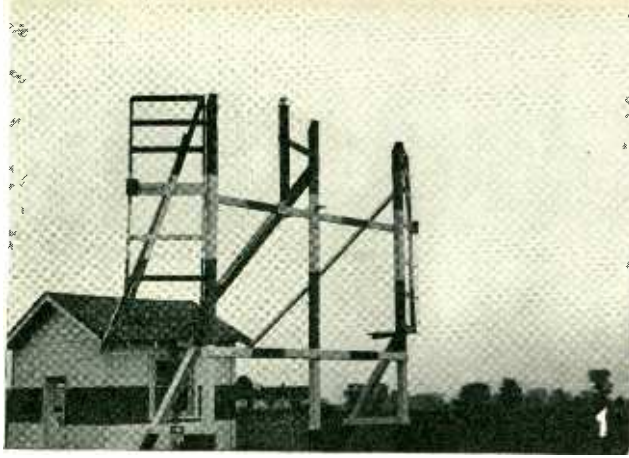

BLIND LANDING

The Lorenz—IT&T blind landing system, installed at the Indianapolis airport, recently demonstrated its ability to bring aircraft to safe landings through the most difficult weather conditions



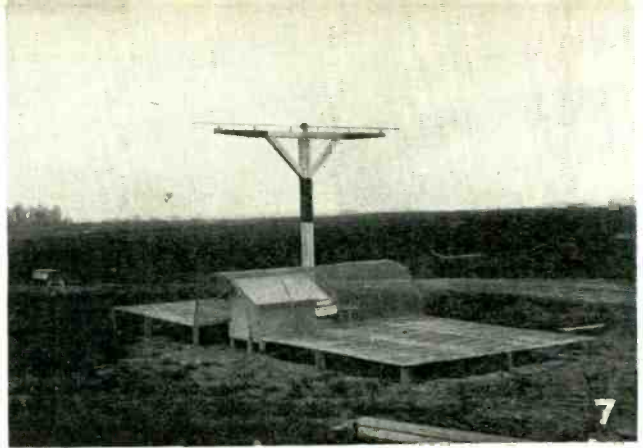

An antenna array (1) at one end of the runway, consisting of a vertical dipole (2) flanked by two reflectors (3), transmits a u-h-f beam (33.3 Mc., modulated at 1150 cps) along the runway and several miles beyond. The reflectors are not energized, but are switched by a relay (in box) to produce off-course signals, A to the right and N to the left. The array is fed by the main transmitter (4,5), crystal-controlled, 500 watt output.

The pilot picks up and follows the main beam, keeping on course by avoiding the A and N signals, either aurally or visually with the course indicator. 10,000 feet from the airport he passes over a 5-watt auxiliary transmitter or "outer marker", which directs a beam vertically upward (38 Mc., modulated with 700 cps dashes). This signal causes a light to flash on the instrument panel, (8, center) whereupon the descent to the airport is begun. At the edge of the airport, the ship passes some fifty feet above another auxiliary transmitter (6,7) the "inner marker," whose vertical 38 Mc. beam is modulated with 1700 cps dots. The pilot then sets the plane down. All this can be done in the absence of any visibility, i.e. with a hood covering the pilot's cabin.

In the control tower of the airport a monitor panel (9) indicates the proper operation of all three transmitters. The interested spectator (10) is E. G. Ports, Chief Engineer of Federal Telegraph. The inventor of the system, Dr. E. Kramer (11), of Berlin told WIRE's radio audience about it during the demonstration.

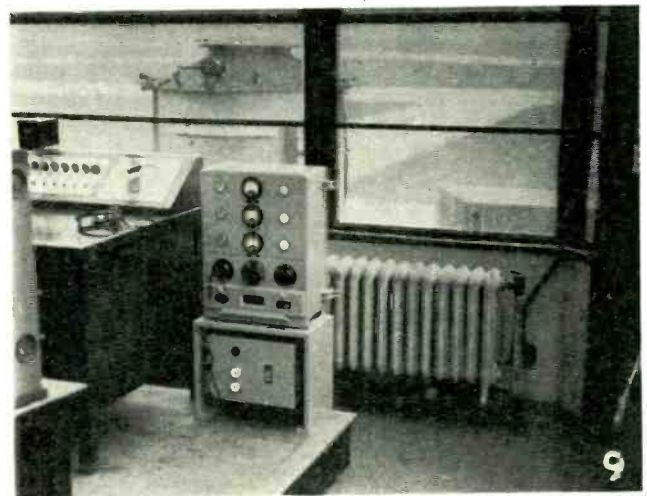
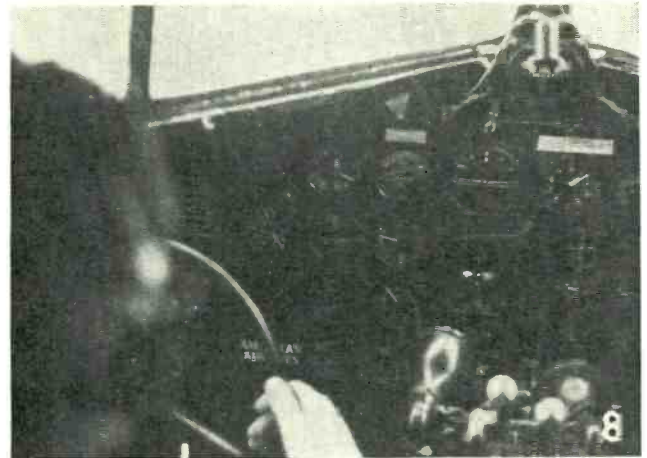

Tubes at Work

A-f-c principles applied to a telemetering aircraft compass, a self-generating transparency meter, design data for a simple u-h-f oscillator, and a light-sensitive neon-tube circuit—this month's crop of tube applications

Tube "Repeats" Aircraft Compass Bearings

AN UNUSUAL APPLICATION of electronic telemetering to aircraft navigation has been developed by a young Boston inventor, Francis West, and is being manufactured by a Boston concern. The compass, described in U. S. Patent No. 2,060,766 makes use of a magnetic compass whose readings are transferred electrically to a meter mounted in front of the pilot. The magnetic compass can be mounted anywhere in the ship, usually at the point of minimum magnetic deviation, so that its readings are accurate. The magnetic compass needle carries with it an extremely small condenser plate, while two other plates are mounted on the side of the compass bowl. The entire

bowl and its course-setting ring is rotated for a given course to the required number of degrees. When the plane is pointing in the proper direction the small movable condenser plate on the compass needle is in close proximity to the two fixed condenser plates. These condensers tune two circuits in a vacuum tube oscillator, the output of which is a direct current of one polarity when the compass swings to one side of its center position and of the opposite polarity when the compass swings to the other side. The direct current is led to a zero-center meter which is mounted in the instrument panel of the ship. When the ship pursues the course for which the compass has been adjusted the pointer of the indicator remains on zero. If the ship swings to the left the pointer also swings to the left. The operation is therefore quite similar to that of the homing compass except that the direction is controlled by a simple magnetic compass rather than by an incoming radio wave.

The unit consumes .3 ampere from a 12-volt plane battery (or .6 ampere from a 6-volt battery) and uses a single 45-volt B battery whose drain is approximately 5 milliamperes. The vacuum tube is operated at approximately $\frac{1}{2}$ of the rated capacity and has corresponding long life. By means of the sensitivity control included in the panel of the instrument, it is possible to adjust the sensitivity or speed with which the indicator needle moves so that in heavy weather erratic movements of the ship do not disturb the compass bearing. From the pilot's point of view the telemetering system offers many advantages, particularly freedom from the necessity of glancing down at a compass card and reading fine divisions to be sure that the exact course is being maintained. The vacuum tube oscillator is located underneath the compass bowl itself in the same housing, while a cable, which may be of any length, leads to the indicating meter.

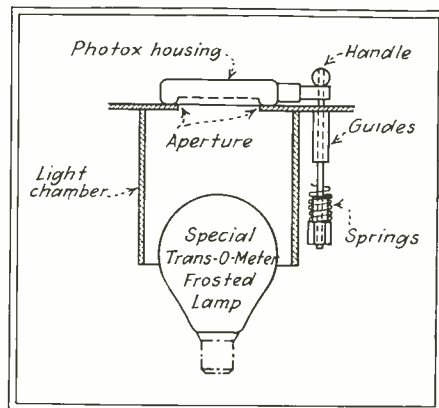

Arrangement of the transparency meter

simple design, is capable of measuring the percentage of transmittancy of any flat material. The device consists of a special standardized lamp which acts as a light source whose voltage is determined by a rheostat and voltmeter. This lamp directs its light to a photox self-generating cell, which in turn feeds a rugged microammeter. Between the lamp and the cell is an opening in front of which transparent and semi-transparent materials can be placed. The microammeter is calibrated directly in per cent from zero to 100. With the lamp shining directly on the cell, the output of the cell is adjusted so the microammeter indicates 100 per cent. Then the material is placed in front of the cell, and the degree of transparency is indicated directly on the face of the meter.

Some of the uses to which the meter are put are as follows: In paper manufacture, where the transparency of the product is of great importance, samples may be checked in a few seconds with the device. The measurement of opacity of magazine paper may similarly be measured as a test before buying or printing. Fabrics, especially of the metallic variety, can be compared in the same manner. An especially interesting application is the measurement of density of film and plate emulsions, which is of considerable importance in color photography and color printing. When the transparency of a piece of paper on which printing appears must be measured, a special mask is used which allows only the margin of the paper to appear before the cell. The arrangement of the device is shown in the diagram.

SONIC ALTIMETER



A source of high intensity sound sent from an airplane through the horn on the right is received after reflection from the ground. The delay between sending and receiving, which measures the height of the airplane, is indicated directly on a meter. Lieut. L. P. Delsasso of University of California is the inventor

Transparency Meter Tests with Photox Cell

A PORTABLE TRANSPARENCY meter, developed at the Westinghouse Laboratories in Pittsburgh, and of unusually

A 60 to 100 Megacycle Oscillator

By A. Binneweg, Jr.

OSCILLATORS FOR FREQUENCIES up to 60 Mc. usually employ a plug-in coil system, but for convenient use at frequencies higher than this a simpler clip-coil arrangement, such as is shown in the accompanying figure, is preferable. At frequencies of the order of 100 megacycles per second, the use of a variable condenser usually introduces many difficulties. The frequency-vary-

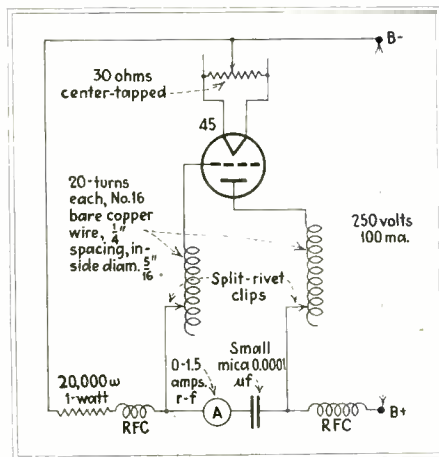

Connection diagram and construction data for Mr. Binneweg's oscillator

ing arrangement adopted by the writer consists in the use of small coils of bare copper wire, the inductance of which can be varied by means of small clips. This arrangement is the simplest and most practical the writer has found for covering the high frequency range, without use of long copper wires or rods. An oscillator constructed according to the specifications of the figure will tune between 100 and about 55 Mc., the adjustment being made by moving the clips along the coil.

Construction and Adjustments

The clips are made by soldering thin, flexible leads to small split-rivets which, when pressed into place over the wires, make almost perfect contact. The normal adjustment of the inductance coils is such that the same number of turns is included between the tube's grid terminal and the grid clip, as between the plate terminal of the tube and the plate clip. The reading of the r-f ammeter A, with 250 volts on the plate of the tube, varies from about 1 amp. at 6 Mc. to about 1.6 amp. at 90 Mc.

The value of the grid lead resistance, given as 20,000 ohms in the diagram, can be varied over wide ranges from about 10,000 to 100,000 ohms with the following results: With 250 volts on the plate, and the circuit tuned for 60 Mc., a grid lead resistance of 10,000 ohms results in an input wattage of about 15.8 watts. As the grid lead resistance is increased to

50,000 ohms, the input watts decrease to 10.9, and when the grid lead resistance is 100,000 ohms, the input wattage is 4.63 watts. Current in the oscillating circuit is 1.22 amp. at 10,000 ohms grid resistance and .61 amp. at 100,000 ohms resistance, while the grid current decreases over the same range from 11.2 to 4.0 milliamperes. The efficiency of the oscillator remains fairly constant for a wide range of these grid lead values. For best all around results, a value of about 20,000 ohms is a satisfactory compromise.

The 250 volts on the plate and a 20,000 ohm grid leak, the input watts vary from 12.3 at 56 Mc. to 18.0 at 92 Mc. The radio frequency current in the oscillating circuit is 1.14 amp. at 56 Mc. and 1.60 amp. at 92 Mc. The plate current over this range varies from 49 to 72 milliamperes.

The effect of changing the number of turns included in the grid and plate coils was investigated as follows: With ten turns in both grid and plate coils the frequency was 66.55 Mc., the input watts 14.3 and the r-f amperes 1.34. When three turns were added to the plate inductance the frequency decreased to 64 Mc., the input watts to 12.4 and the r-f amperes to 1.27. The number of grid turns was then reduced by three (making the grid turns six less than the plate turns), thus restoring the frequency to about 66.2 Mc. The input wattage was then 11.8 and the r-f current 1.30, indicating an increase in efficiency. The plate turns were then increased three and the grid turns decreased three (making a difference of twelve). The frequency was

then 65 Mc., the input power 10.5 watts and the r-f current 1.22 amperes, indicating a still further increase in efficiency. The plate current under this condition was 42 milliamperes. When the grid is given more turns than the plate coil the efficiency decreases considerably, so that when the grid has twelve more turns than the plate coil the input current is 111 milliamperes and the r-f current only 1.34 amperes. For highest efficiency, therefore, it is desirable to have a larger number of plate turns than grid turns. However, good results can be obtained over a wide range of unbalanced conditions, and the power input into a given load can be controlled readily by adjustment of the relative number of grid and plate turns. This oscillator can also be used at lower frequencies by using more turns in both grid and plate coils.

• • •

Relaxation Circuit Measures Radiant Energy

By Dr. A. Stager,
Zurich, Switzerland.

WHILE EXPERIMENTING with a neon tube relaxation oscillating circuit, the writer observed that the frequency of oscillation depends, under certain conditions, upon the character of radiation striking the neon lamp. This effect can be readily observed by arranging components as shown in the figure, in which B is a battery, P a potentiometer, R a resistor, C a condenser and

(Continued on page 52)

5-MILLION VOLT GENERATOR



Inside the towers are the motor-driven belts which carry the charge to the spherical electrodes



These towers are set up in the Palace of Discovery in the Paris Exposition. They are an electrostatic generator of the Van der Graff type, capable of generating d-c at five million volts

Power Tube Characteristics

Use of cathode ray tube is discussed in rapid method of obtaining tube static characteristics. Wide range of voltages and currents obtained without overheating

A METHOD of obtaining the static characteristic curves of a power tube using a trace on the screen of a cathode ray tube is described. The principal advantage of the method is that the portions of the curves for large values of plate and grid currents can be obtained without overheating the tube elements.

The method may be explained by referring to the diagram of connections. Adjustable alternating voltages from two transformers operating at 60 cycles, are impressed in the plate and grid circuits of the triode to be tested. Two standard resistances, R_b and R_c , of say 10 ohms, are also in the plate and grid circuits between the transformer secondary windings and the filament or cathode.

The grid circuit includes a thyatron, the grid of which is controlled by a polarizing battery and an adjustable alternating potential. This potential is generally adjusted so

By **E. L. CHAFFEE**
*Craft Laboratory
 Harvard University*

that the thyatron fires near the peak of the positive half cycle of grid circuit voltage. When the thyatron is not conducting a second battery, connected between cathode and grid through a high resistance, maintains the grid of the tube under test at a negative voltage at least as great as cut-off voltage for the highest plate potential.

The grid and plate currents remain zero almost to the middle of the positive half cycle of plate voltage. At this point the thyatron suddenly conducts and the grid voltage rises suddenly from the negative value to whatever positive value the grid transformer impresses in the circuit. The grid and plate current rise suddenly in response to the plate and grid voltages. The flow of

grid current rapidly charges the condenser C_c , shunted by resistance R_c' , resulting in a rapid recession of the grid voltage toward a negative value. The combined action of the thyatron and the grid condenser gives short pulses of plate and grid currents enabling large currents to be passed with only small average power dissipations at the electrodes. Wattmeters P_g and P_p are included in the two circuits to indicate the electrode dissipation. A condenser across the plate transformers helps to supply the sudden rush of plate current without objectionable distortion of the plate voltage wave.

The simultaneous instantaneous values of plate and grid voltages, usually the peak values, are measured by a potentiometer method at the instant of brief contact made by a commutator driven by a synchronous motor. In the same manner the instantaneous values of grid and plate currents are determined from the voltages across the resistances R_c and R_b . The direct voltages for obtaining the balances are derived from small rectifier systems indicated by the squares in the lower left portion of the figure. The d-c voltmeters indicate the magnitudes of the balance voltages. A standard Westinghouse voltmeter switch is used to throw the indicator of balance from one circuit to another.

The indicator of balance may be a galvanometer, but more rapid measurements can be made using a cathode ray tube as the indicator. A condenser C_d is charged by the unbalanced current when the commutator makes contact. This charge passes through the primary of a transformer giving a vertical deflection on the oscilloscope screen. Horizontal deflection is caused by a 60 cycle voltage. The trace on the screen when the voltages are not balanced is shown in the auxiliary picture by the dot and dash line. When the voltages are balanced the trace is a single straight line.

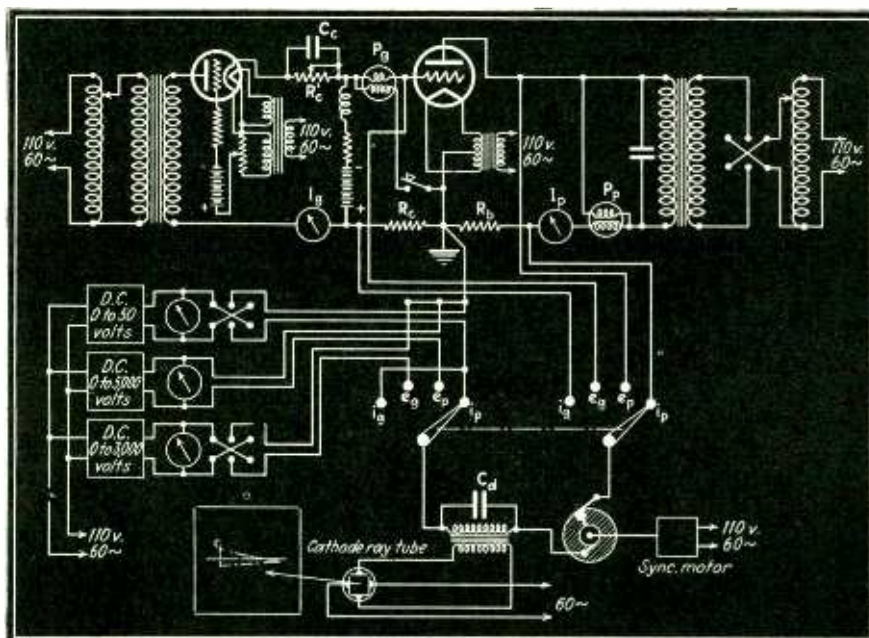

Schematic wiring diagram of cathode ray tube arrangement for measuring static characteristics of power tubes. Tube under test in center; thyatron at left

Mutual Inductance Calculations

A simplified method for performing one of the most involved calculations in coil practice, the determination of the mutual inductance between two coaxial single-layer coils in terms of their winding pitches, dimensions and separation

THE calculation of the mutual inductance between two coils always presents a problem to the engineer, the usual procedure being to measure the value experimentally. Series expressions for the calculation of mutual inductance have been available for some time, but their application is in general quite laborious. A somewhat simplified procedure has been presented by Grover¹, in which, however, some simplicity has been sacrificed in the interest of accuracy. In this reference sheet Grover's results have been further simplified and are presented in a form designed by rapid computation with satisfactory engineering precision.

By DALE POLLACK

RCA Manufacturing Co.
Camden, N. J.

same. Fill in the first column, X_n , in the proper schedule from the coil dimensions shown in Fig. 1. The second column, ρ_n^2 , is obtained from

The third column, B_n , is obtained from the curves on the reverse side. The r_n column is computed from $r_n = \sqrt{X_n^2 + A^2}$. This equation is most readily computed on a "Vector" slide rule; many engineers have pet ways of performing this operation. The last column is calculated as

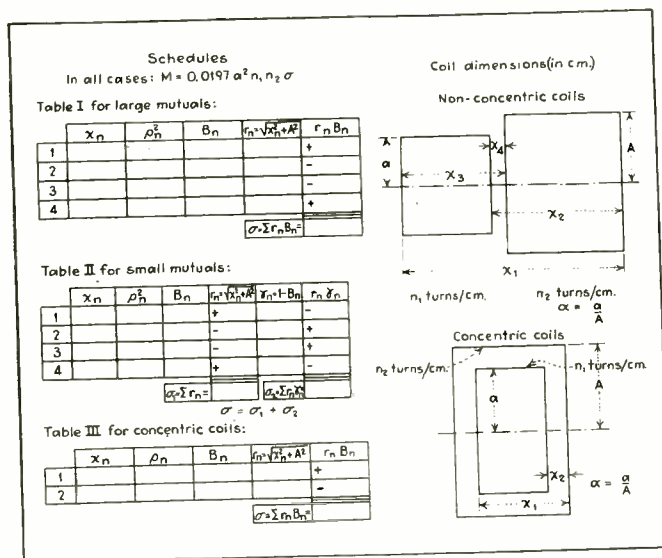

Fig. 1—Calculation schedules and coil dimensions for determining values of mutual inductance

Three tabular schedules are given for the following cases:

- I For large values of mutual
- II For small values of mutual
- III For concentric coils.

In each case the procedure is the

same. Fill in the first column, X_n , in the proper schedule from the coil dimensions shown in Fig. 1. The second column, ρ_n^2 , is obtained from the nomograph, (insert on reverse side) or from the equation given. Two sets of scales for X_n and A are given in the nomograph, but the ranges may be extended by shifting the decimal points on either set of scales by the same number of places.

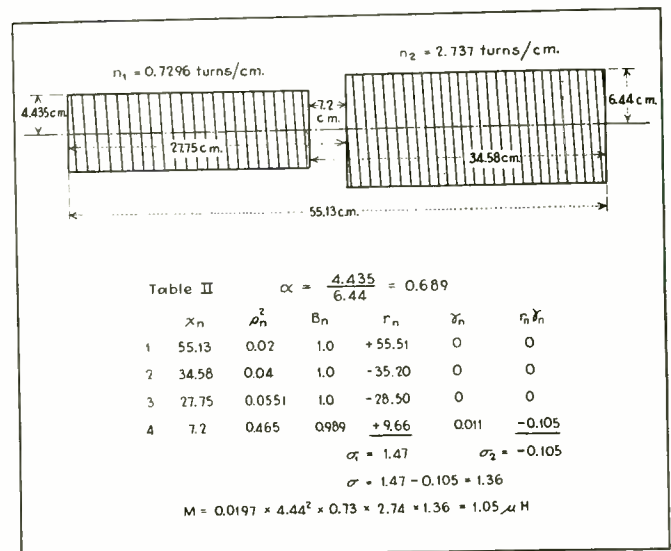

Fig. 2—Typical example of two coils whose mutual inductance is found to be 1.05 microhenries

shown. Finally, the last column (the fourth and sixth columns, in Table II) are added algebraically, taking account of the sign indicated in the column, and a value of σ is thus obtained, which is used in the equation $M = 0.0197 a^2 n_1 n_2 \sigma \mu\text{H}$. The entire calculation takes only a few minutes.

For illustration, the example in Fig. 2 is given, in which Table II is used. The calculated value, $1.05 \mu\text{h}$, is within three percent of the correct value calculated according to Grover, which is $1.0862 \mu\text{H}$.

¹ F. W. Grover, "Tables for Calculation of the Mutual Inductances of Any Two Coaxial Single-Layer Coils" *Proc. IRE*, 21, 1039, 1933.

MUTUAL INDUCTANCE CHART

By Dale Pollack

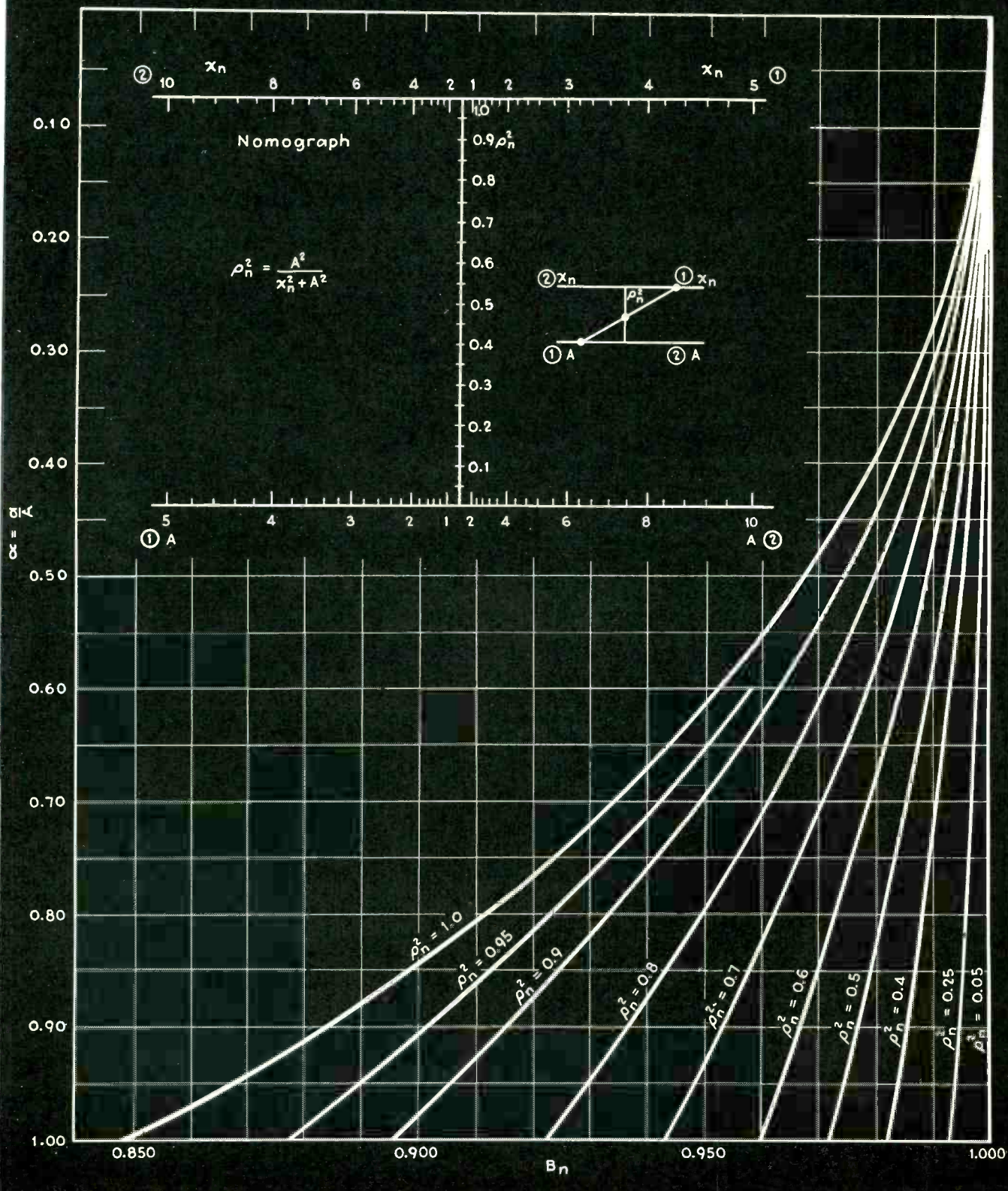



IRC
REG. U.S. PAT. OFF.

Initiative — Resourcefulness — Cooperation
to advance the interests
of the industry

INSULATED RESISTORS *Cut Costs*

TYPE MW INSULATED
POWER WIRE WOUNDS

TYPE BW LOW RANGE
INSULATED WIRE WOUNDS

TYPE BT INSULATED
METALLIZED RESISTORS

BETTER
ENGINEERING
DESIGNS

FEWER SERVICE
CALLS

QUICKER
ASSEMBLY
...Less Testing

FEWER STOCK
SIZES REQUIRED
... LESS "PAPER"
WORK

FEWER REJECTS
AT END OF
ASSEMBLY
LINE

INTERNATIONAL RESISTANCE COMPANY

401 NORTH BROAD STREET, PHILADELPHIA, PA.

Factories or Licensees in Canada, England, France, Germany, Italy, Denmark and Australia

MAKERS OF RESISTANCE UNITS OF MORE TYPES, IN MORE SHAPES, FOR
MORE APPLICATIONS THAN ANY OTHER MANUFACTURER IN THE WORLD

Backtalk

Impedance Calculation

As a result of the recent Reference Sheet dealing with slide rule impedance calculations many letters to the editor were received, indicating a far more lively interest in the subject than we had dared to hope at the time of publication. All letters dealt with alternative solutions most of which were based on the well known relation:¹

$$\sqrt{a^2 + b^2} = b \sqrt{1 + a^2/b^2}$$

In the application of this formula to the slide rule Mr. R. B. Woodhead of Montreal says: "This latter form lends itself readily to slide rule computation, particularly if b is chosen less than a. For example, in solving the 3, 4, 5, triangle, set 3 on the C scale opposite 4 on the D scale, and opposite the index on the A scale, read

$$(4/3)^2 = 1.78$$

Now move the index to $1.78 + 1 = 2.78$ on the A scale, and opposite the 3 on the C scale will be found the answer

$$3 \sqrt{(4/3)^2 + 1} = 5$$

on the D scale."

Mr. Woodhead further points out that the method may be used equally well when the hypotenuse and one side are given and the other side it to be found, in which case the 1 is subtracted from the quantity found on the A scale.

Mr. John Michael Banic, Hammond Electric Clock and Organ Co., Schiller, Ill., submits the same solution but adds the special case where B is small compared to A. Mr. Banic says: "Suppose we have such values of B and A; for example:

$$C = \sqrt{1000^2 + 2^2} = \sqrt{1,000,004}$$

The best solution for this type of problem is to use the expression:

$$C = A + B^2/2A$$

so that

$$C = 1000 + \frac{4}{2 \times 1000} = 1000.002$$

Mr. Banic gives an interesting mathematical proof of this special case, and further submits methods of evaluating

¹ See "Radio Engineering Handbook" Henney, Second Edition, Page 29.

numerous other types of problems frequently encountered.

Mr. Joseph C. Adams, of the Texas Power & Light Company, gives the same general solution of the 3, 4, and 5, triangle, and adds the very important solution for the power factor. He says: "Using the impedance $3 + j4$: the same procedure is carried out (as for $4 + j3$: Editor), giving a value of 1.777— for b^2/a^2 ; the index of the B scale being moved to 2.777—, which places the 3 of the C scale over the 5 of the D scale and gives a reading of 0.6 (60%) for the power factor on the C scale at the index of the D scale."

Mr. Walter J. Seely, Chairman of the Department of Electrical Engineering, Duke University, Durham, N. C., submitted an elaborate manual based on the relation:

$$Z = \sqrt{a^2 + b^2} = a \frac{\sqrt{1 + (a/b)^2}}{a/b} = a[f(a/b)] = aK$$

His published tables give values of K for all ratios of a/b from 1 to 10 by thousandths. Another table gives the impedance angles corresponding to the same range of values of a/b. A third table gives the decimal equivalent of minutes and seconds in terms of degrees. The tables are set up after the fashion of, and their use is similar to that of logarithm tables. In submitting them he has this to say in part: "Impedance calculations are very simple when only a few are to be made, but where thousands of computations must be made the labor involved is time consuming and fatiguing. The problem was particularly difficult in our communication work because the amount of time available to the student being limited did not permit of long and laborious calculations."

Transmission Pad Solution

Mr. R. J. Kirchner, of New York, submits a very interesting method of calculating the values of the elements of a transmission pad. In part, he says:

"Given a pad of the general form, terminated in its image impedances $Z = R$.

For a given attenuation, α (db), and for a specified terminating impedance, R, the X and Y elements of the transmis-

sion pad may be determined on a log-log slide rule as follows:

"1. With the rule normal, (indices aligned), move the glass slide from either end of the L scale, counting each integral of the L scale as two (2) db. Count from the 0 or the 10 index line, until the required attenuation, α , in db is reached. Odd db attenuations and fractions are situated between the even db attenuations represented by each integral number of the L scale.

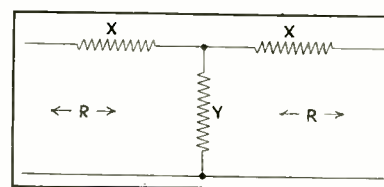

Pad solved by Mr. Kirchner

"2. Now adjust the sliding tongue of the rule so that the value of the terminating impedance, R, read on the C scale is located exactly as many units from the glass slide index line as from the end of the fixed scale D. The number of units, without regard to the scale numbers, will be the required

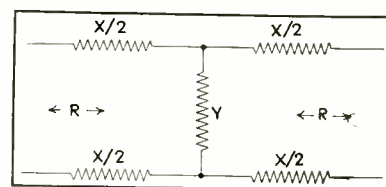

Symmetrical network

value of X for the series element of the pad.

"For the shunt element Y is determined from the product of the open and short circuit impedance of the network on an image matching basis.

$$R^2 = X^2 + 2XY$$

$$Y = \frac{R^2 - X^2}{2X} = \frac{(R-X)(R+X)}{2X}$$

"A symmetrical T network is readily transformed into a symmetrical H network as indicated below. Consider the following example: A T or H transmission pad is required to provide 5 db attenuation on an image matching basis of 600 ohms.

(Continued on page 46)

"Let's call an Instrument Specialist..."*



Build-in
WESTONS

A wide range of WESTON Instruments are now being "built-in" on machine tools, rectifiers, welding machines, radio transmitters, alarm systems, therapeutic and scientific apparatus, and wherever a close check on electrical quantities is vital to operation and control. There is also a WESTON Instrument available for your built-in requirements. Let us send full details.

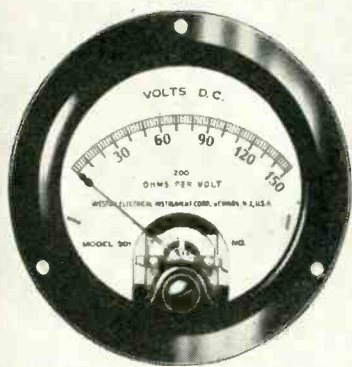

***WHENEVER ELECTRICAL QUANTITIES ARE INVOLVED, THAT MEANS THE WESTON MAN**

These days the foresighted design chief is quick to say, "Let's call an instrument *specialist*..." whenever there's a need for electrical instruments in the equipment he has on the drawing board. For when instruments are to be "designed in," rather than simply "attached to" the new model, an early error may be mighty costly to correct.

Called in at the drawing board stage, the instrument *specialist* can advise on size, shape and specifications. Where special types seem necessary, he can frequently suggest alternatives that permit less expensive standard models to be used. His counsel on instrument location may make for added dependability, safety, simplicity in assembly, or operating ease.

In the field, WESTON's sales representatives offer the same specialized knowledge that, in manufacture, has given WESTON Instruments their reputation of *proved dependability*. This knowledge is at your service when you call the WESTON man. Weston Electrical Instrument Corporation, 618 Frelinghuysen Ave., Newark, N. J.

WESTON
Instruments

THE ELECTRON ART

EACH month the world's technical literature is scanned to see what physicists and engineers are doing with tubes, for presentation in tabloid form to Electronics' readers.

Legal Aspects of Television

AN ARTICLE by Jack N. Oppenheim, entitled "Commercial Background and Legal Aspects of Television," appears in the January, 1937, issue of the *Air Law Review*, published by the New York University School of Law, Washington Square, New York City. This article deals with a brief discussion of the development of television up to the present time, both in its technical as well as in its financial aspects, and points out the various factors that led to the rise of the electrical versus the mechanical method of transmitting pictures through space. Federal regulations in other branches of communication, the relationship of television to the motion picture industry, and the regulatory problems which are likely to face the radio industry when television becomes available on a commercial scale are also treated. In view of the recent interest in the technical developments of television, "Commercial Background and Legal Aspects of Television" will probably be of interest to a number of readers of *Electronics*.

Incandescent Cathode Rectifier With Magnetic Field

IN ORDER TO PREVENT back firing in a gas or vapor rectifier with an oxide coated indirectly heated cathode the pressure must be kept low. When mercury vapor is used the vapor pressure may be reduced by lowering the temperature but below a pressure of about 1/100 mm. mercury the operating potential increases, in some cases from 12 volt to 60 volt. Low efficiency and short life owing to sputtering of the cathode are the result. A simple means of keeping the operating potential at its normal value is to apply a magnetic field between cathode and plate, according to T. Jurriaanse, Philip's Laboratory, Eindhoven. A field of 100 gauss is all that is required. The cross-section of the discharge is reduced to the cross-section of the cathode. The magnetic lines of force must connect cathode and plate; their effect is to reduce the potential drop near the cathode.—*Physica* 4. 24-28, 1937.

Atomic Investigators



The de Broglie brothers, Duke Maurice and Prince Louis Victor, who have made many important discoveries in atomic physics seen in their Paris laboratory. Prince de Broglie, (left) received the Nobel prize in physics (1929) for propounding the theory that matter consists of a series of waves as well as of corpuscles.

Characteristics of British Cathode Ray Tubes

A DOUBLE PAGE spread giving the characteristics of British cathode ray tubes was published in the April 2 issue of the *Wireless World*. This table of tube characteristics is similar in its general make-up to the characteristic data sheet published by American manufacturers for radio receiving tubes and gives the essential technical characteristics at the top half of the chart together with the socket connections on the lower half. This chart gives the characteristics of thirty different types of tubes made by Baird, Cossor, Ediswan, Ferranti, Mullard, H. M. V. and Marconi, and Standard Telephone and Cables.

Thyratron Control of Resistance Welds

THE PRINCIPAL REQUIREMENTS of resistance welding equipment and the application of thyratron tubes to assist in producing uniformly satisfactory welds are discussed in the March issue of the *General Electric Review* by Warren C. Hutchins in an article "Resistance Welding Improved by Thyratron Control".

Foreign Television Activities

FROM THE Electrical Foreign Trade Notes of the Electrical Division of the Department of Commerce we learn that the authorities of the Science Museum, South Kensington, London, with the cooperation of the British Broadcasting Corporation and the Radio Manufacturers' Association, are to hold a three months exhibition beginning in June, devoted to the history and modern developments of television. The public will be shown what television is, how it works, what is now being done and what can be done in the future. It is hoped that the exhibition will arouse interest in the subject and will convince the public that buying a television receiver is a good investment.

Through the creation of three new television centers, Soviet television will take a step forward during the coming year. The first new station to be constructed will be at Moscow and will be provided with equipment from the American market. It is anticipated that experimental operations will begin some time in May, and that the radius of this television transmitter will be 30 kilometers. It is stated that the method of transmission will employ 70,000 elements and that the pictures will be shown on a screen one meter square. Assuming unity aspect ratio this will give a definition of 265 lines.

The second center, in Leningrad, is being built entirely of Soviet materials. Forty thousand elements on a screen about the size of a postal card which from 15 to 20 people can view at one time, will form the basis of this system. The third center, in Kiev, will transmit images in 1,400 elements.

UNIFORMLY SMALL CHANGES IN ELECTRICAL CHARACTERISTICS

With

ERIE Ceramic-Sealed RESISTORS

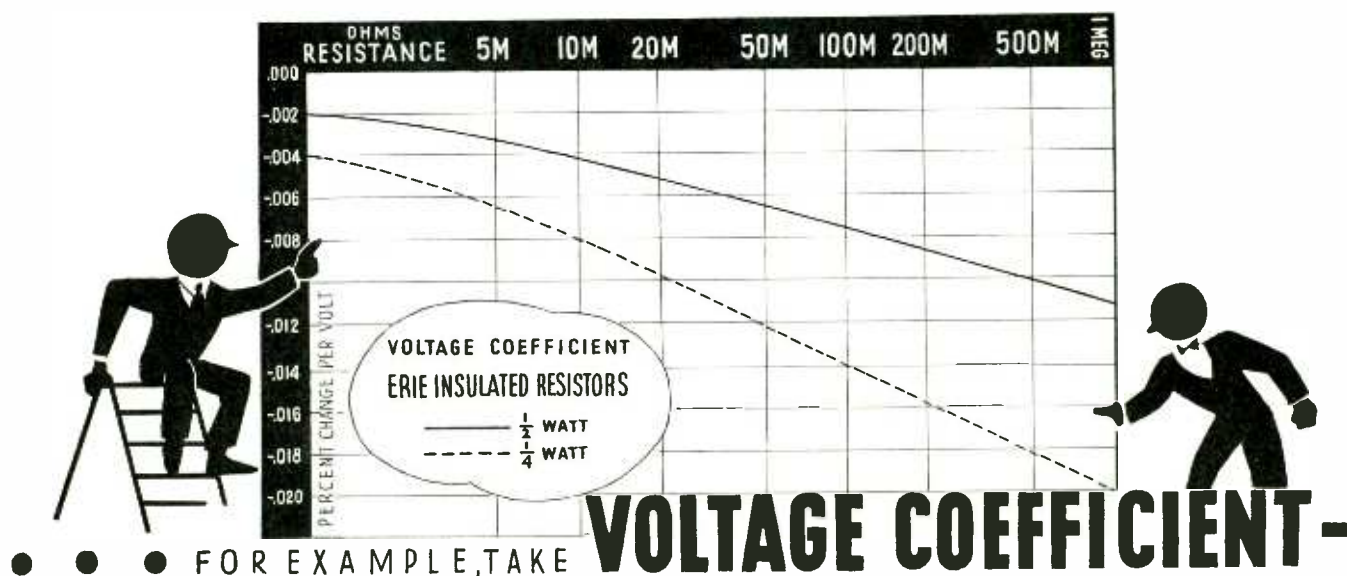

Exhaustive tests run on production samples of Erie Ceramic-Sealed Insulated Resistors show exceedingly low voltage coefficient. For example a 1,000 ohm 1/2 watt unit changes but .002% per volt, a 10,000 ohm unit drops only .0041% per volt, a 100,000 ohm resistor changes .0076% per volt, and a 1 megohm unit .011% per volt.

And take a look at the humidity and load charts at the right . . . less than 4.0% increase in resistance value after being subject to 90% relative humidity for 1,000 hours at 40°C., and only a 2.5% drop in resistance value at 100% overload after 2,000 hours.

Because of these consistently small changes in electrical characteristics, Erie Ceramic-Sealed Insulated Resistors more nearly retain their actual rated values regardless of the character of the installation.

We would like you to prove it yourself. A letter to us will bring you a generous supply of these insulated units to test in your own laboratory.

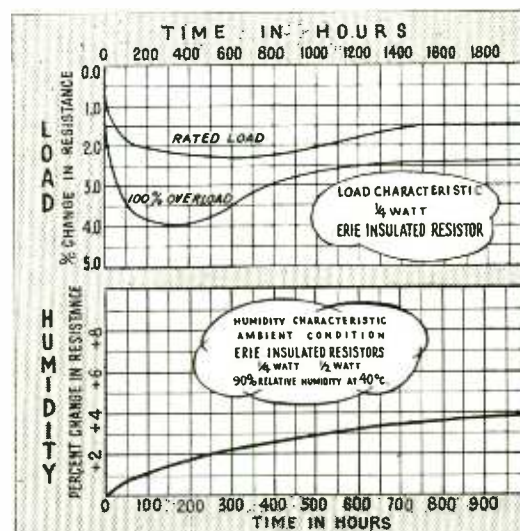

ERIE RESISTOR CORPORATION

CARBON RESISTORS AND SUPPRESSORS AUTOMATIC INJECTION MOLDING

TORONTO ERIE, PENNSYLVANIA LONDON

More and More GOOD TUBES have SPEER GRAPHITE ANODES

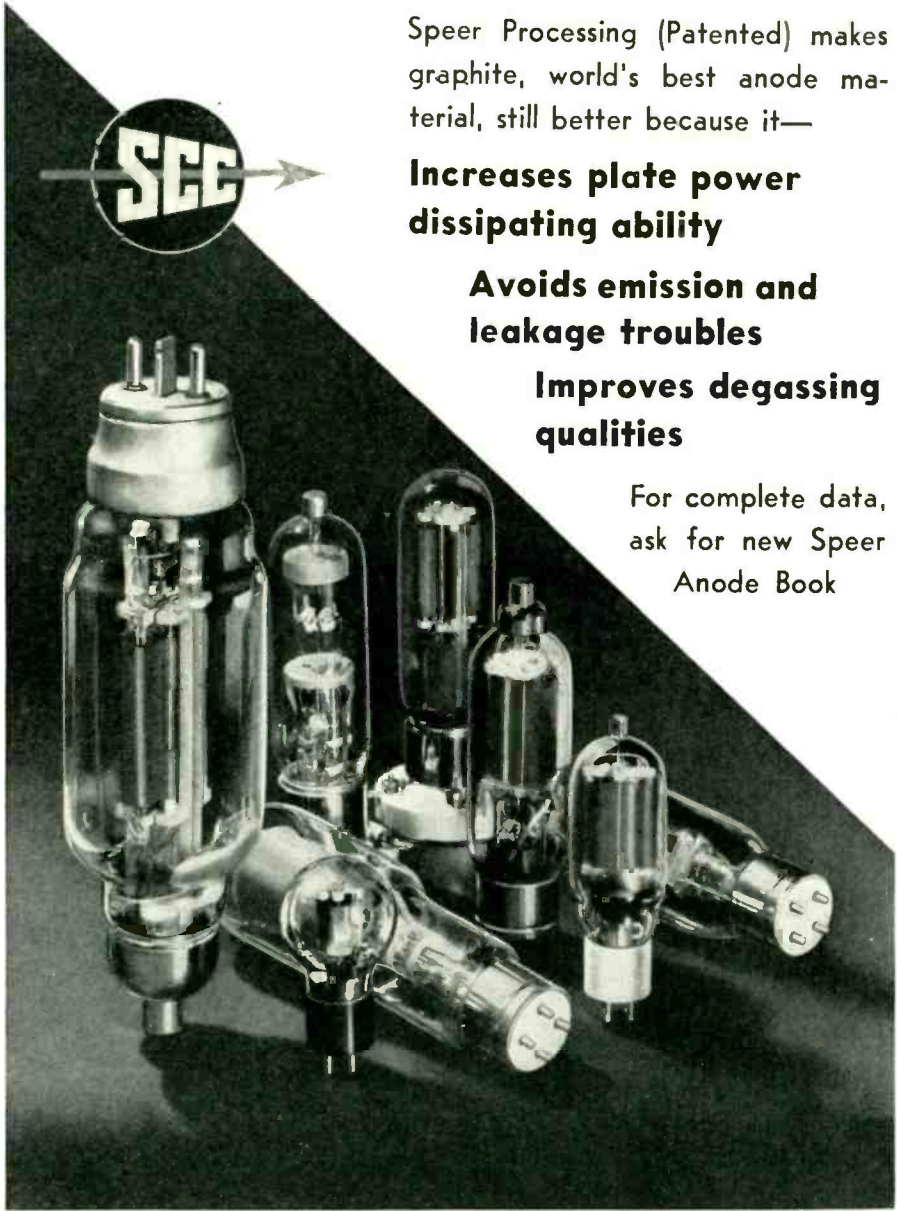

Speer Processing (Patented) makes graphite, world's best anode material, still better because it—

**Increases plate power
dissipating ability**

**Avoids emission and
leakage troubles**

**Improves degassing
qualities**

For complete data,
ask for new Speer
Anode Book

SPEER CARBON COMPANY

• ST. MARYS, PA. •

7420

U.R.S.I. — I.R.E. Meeting

A VARIETY of papers was presented at the annual joint meeting of the Institute of Radio Engineers and the American Section of the International Scientific Radio Union at Washington, D. C. on April 30. Summaries of some of the papers are given here.

Speaking on the extension of standard frequency services from WWV, Dr. J. H. Dellinger of the National Bureau of Standards announced that beginning June 1, standard frequency transmissions would be given each Tuesday and Friday on three carrier frequencies. From 10:00 to 11:30 A.M., E.S.T., emissions will be on 5,000 kc., from noon to 1:30 P.M. on 10,000 kc. and from 2:00 to 3:30, on 20,000 kc. On each Wednesday except nationally legalized holidays, an audio frequency of 1,000 cycles per second will be transmitted as modulation on the same carrier frequencies and at the same times as given above. The accuracy of the frequencies as sent from WWV will at all times be better than one part in five million. The American standard of musical pitch, 440 cycles per second for A above middle C will be broadcast as a modulation frequency every night except Saturday, Sunday, and national legal holidays. The carrier frequency will be 5,000 kc. and service will be maintained from 4:00 P.M. to 2:00 A.M. Ionosphera data and time intervals will also be transmitted from WWV.

A continuous recording, for more than a year, of the signal received at Deal, N. J., from a 150 m.c. transmitter located at Lawrenceville, N. J., has been reported by C. R. Burrows, A. Decino and L. E. Hunt of The Bell

EIFFEL TOWER AT NIGHT



Lighting arrangements of Eiffel Tower include interior flood lighting as part of the Gray Festivals of Light to be held during the Paris Exposition

July 1937 — ELECTRONICS



FEATURES

VOLTAGE RANGE: 0.1 to 150 volts in five ranges.

FREQUENCY RANGE: 20 cycles to 100 megacycles.

FREQUENCY ERRORS: Less than 1% error between 20 cycles and 50 Mc; only 3% at 100 Mc.

ACCURACY: $\pm 2\%$ of full scale.

INPUT IMPEDANCE: 5 megohms at low audio frequencies.

INPUT TERMINAL CAPACITANCE: 8 μmf .

POWER SUPPLY: 100 to 135 volts; 60, 50 or 42 cycles.

A RADICALLY NEW VACUUM-TUBE VOLTMETER

Wide Frequency and Voltage Ranges • High Accuracy • Small Frequency Error

• The General Radio Type 726-A Vacuum-Tube Voltmeter has been designed to eliminate the faults which have limited the usefulness of thermionic voltmeters in the past. This new a-c operated voltmeter is equipped with a small, bakelite-housed probe containing the entire a-c measuring circuit. The cable and indicating circuit carry direct current only. All effects of long leads are eliminated. The remarkably good frequency characteristic and range are a result of this unique design.

The instrument requires no d-c path and is insensitive to direct current. If both d-c and a-c are present in a circuit the voltmeter selects only the a-c, with no

appreciable frequency error.

A new type of voltage regulator is incorporated so that annoying zero shifts are eliminated. Constant zero reading is assured.

The meter scale with an effective length of 14 inches is essentially linear. The calibration is independent of tube characteristics to such an extent that tubes can be replaced without affecting the calibration of the instrument.

The Type 726-A Voltmeter is stocked for either 60, 50 or 42 cycle line voltage. It is equipped with line cord, pilot lamp, 6-foot probe cord and all tubes. Complete and ready for operation it is priced at \$165.00.

Write for Bulletin 152-E

GENERAL RADIO COMPANY
Cambridge, Massachusetts

MANUFACTURERS OF RADIO AND ELECTRICAL LABORATORY APPARATUS

BELIEVE IT OR NOT

WITH APOLOGIES

UTC's leadership in transformer design is substantiated by the fact that some of the largest commercial organizations turn to UTC with their special transformer problems. Some of the more interesting units recently made by UTC for such organizations are almost in the "Believe It or Not" class.



One organization* required a 60,000 AMP. transformer in a space approximately seven inch cube. Ever other supplier contacted said "Impossible."

UTC MADE IT.



One of the important elements in the "U. S. Safety in the Air" program involved a special filter for use on planes. The excessive weight of this filter made the system impractical.

UTC, however, reduced the weight from over thirty pounds to 3 1/4 POUNDS.



The use of high carrier frequencies for special communication service made necessary high power amplifier equipment for test service.

UTC designed the amplifier equipment for one organization* and supplied the audio transformers for service up to 100,000 CYCLES.



Hum pickup on portable amplifiers and pre-amplifiers was the bugaboo of one communications organization.†

They are now buying UTC because, as their Engineering Department stated, "We wouldn't have believed it possible if we hadn't actually made complete laboratory tests." The input transformers supplied to

this organization weigh only eighteen ounces, have a frequency characteristic uniform from 30 to 14,000 cycles, and a hum pickup 90 DB lower than similar units of standard construction.



A special carrier frequency problem encountered by one company,** required a high power, air-cooled, audio transformer with 30,000 VOLTS insulation and frequency response good up to 150,000 CYCLES.

A unique transformer winding licked this problem.



A complete group of speech input and remote pickup amplifiers manufactured by one company,‡ were not usable due to high hum level.

UTC suggested the use of the LS-10X (tri-alloy shield) input transformer, which eliminated the problem completely.



One of America's foremost radio comedians wanted to imitate the voice of America's foremost news announcer on his program.

The UTC 4 B sound effects filter made the job perfect.

TO OUR KNOWLEDGE

- * The largest research organization in the world.
- † Largest radio receiver organization in the world.
- ** Largest radio communications company in the world.
- ‡ Largest electrical manufacturer in the world.

Telephone Laboratories, in their paper, "Stability of 150 Mc. Waves Over a 60 Km. Path." The path which was probably representative of a common type, was 60.6 km. long and the transmitting and receiving antenna were supported at heights of 70 meters and 50 meters, respectively, above the ground. Several types of fading were identified in which the range of variations extended from less than 0.2 db to more than 20 db and the fading period ranged from the order of magnitude of a second in the case of the smaller variations to about an hour for the larger variations. The patterns produced upon the recorder by some of the rapid fading showed a symmetry about the center such as might be caused by some object moving across the transmission path.

Although there was no pronounced diurnal variation in the average field, there was a pronounced diurnal variation in the hourly fading range, the field being definitely steadier in the earlier afternoon.

These investigators are of the opinion that the same mechanism which causes the variations in the average field reported for the longer paths, might well be responsible for the variations in hourly fading range noticed over the shorter path.

Since the field is not steady, it is necessary to provide sufficient transmitter power to deliver a suitable field to the receiver during times of highest attenuation. Over this path, in order to have maintained the field strength equal to or greater than its mean value for 99% of the time during 1936, about 7 db more power would have been required. The mean value of the field strength at the receiver agrees to within 1 db of the value calculated by the level land formula previously published.

The theoretical minimum noise level of short wave receivers in the absence of any interference, the source of which is external to the receiver, was discussed by Karl G. Jansky of the Bell Telephone Laboratories in his paper, "Minimum Noise Levels Obtained on Short Wave Radio Receiving Systems." It was pointed out that the theoretical limiting noise is caused by the thermal agitation of electric charge in the first circuits of the receiver. This theoretical limit was compared with that actually measured with various antennas over a limited frequency range in the short wave spectrum. On the shorter wavelengths, the theoretical limit is never realized even in the absence of man made interference, the usable signal strength being generally limited by noise of interstellar origin.

The lowest powers measured from this noise with various antennas and for different times of day was 40.8 db below 1 microwatt which was 8.1 db above the theoretical and over 6 db above the actual noise level of the receiver. Recently, man made interference of which that caused by diathermy machines constitutes the

UNITED TRANSFORMER CORP.

72 SPRING STREET

NEW YORK, N. Y.

EXPORT DIVISION: 300 VARICK STREET NEW YORK, N. Y. CABLES: "ARLAB"



LOW-LOSS INSULATION of High Adaptability

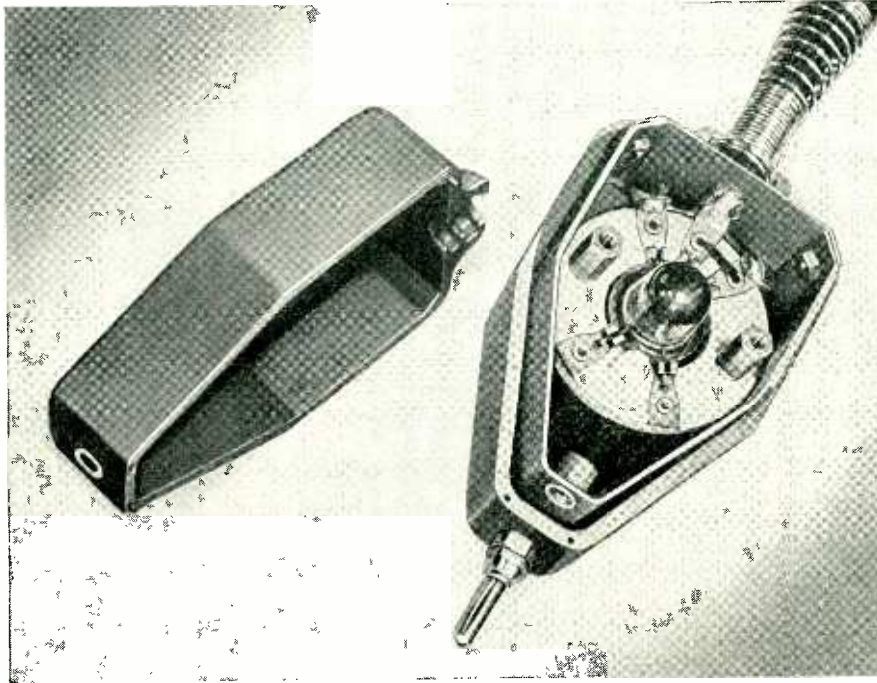

IT would be difficult to find another dielectric possessing the same freedom from power loss combined with high adaptability of design which is furnished by low-loss Bakelite Molded BM-262. This material may be formed with great accuracy into practically any shape, and often permits simplifications and improvements in the design of high-frequency instruments, parts and devices.

An interesting example of progressive design accomplished with low-loss Bakelite Molded is the

General Radio Type 726-A Vacuum Tube Voltmeter. Because the material makes possible a compact, durable probe housing of low power factor, the entire A-C measuring circuit is incorporated in the probe. Accuracy of the instrument is increased because cable and indicating circuit carry direct current only.

In addition to these advantages in dielectric and power loss characteristics and in adaptability of design, low-loss Bakelite Molded possesses other merits common to all Bakelite Materials: mechanical

strength, toughness and high resistance to moisture, oil, handling, and most chemicals and solvents.

We invite electronic engineers to consult us for complete information on the properties and uses of this material. Also write for comprehensive reference booklet 13M, "Bakelite Molded".

(Left) General Radio Vacuum Tube Voltmeter with improved probe housed in low-loss Bakelite Molded.

(Right) Compact, durable probe housing formed in two pieces from low-loss Bakelite Molded.

BAKELITE CORPORATION, 247 PARK AVENUE, NEW YORK, N.Y.
BAKELITE CORPORATION OF CANADA, LIMITED, 163 Dufferin Street, Toronto, Canada — *West Coast:* Electrical Specialty Co., Inc., 316 Eleventh Street, San Francisco, Cal.

BAKELITE

REGISTERED U. S. PAT. OFF.
The registered trade marks shown above distinguish materials manufactured by Bakelite Corporation. Under the capital "B" is the numerical sign for infinity, or unlimited quantity. It symbolizes the infinite number of present and future uses of Bakelite Corporation's products.

THE MATERIAL OF A THOUSAND USES
ELECTRONICS — July 1937

A NEW KIND OF MICROPHONE

SHURE "TRI-POLAR"



1. Uni-Directional
2. Bi-Directional
3. Non-Directional

All in this ONE
Crystal Microphone



Now, for the first time—through the new Shure "Controlled-Direction" principle—you can have *all three* basically-different kinds of Microphone response *in one unit*—instantly available through a 3-point selector switch.

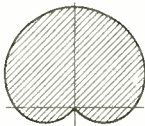

UNI-DIRECTIONAL

1. *Uni-Directional.* Wide-angle *front-side* pickup—dead at rear. Cuts out audience noise, reduces reverberation energy pickup 66%, eliminates feedback. The first economical microphone of any type to give you this feature! Output level: 63 db below 1 volt per bar.

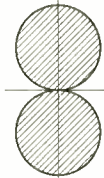

BI-DIRECTIONAL

2. *Bi-Directional.* Typical velocity characteristic with pickup from *front and back*—dead at both sides. Allows artist placement front and back, reduces reverberation energy pickup 66%, prevents feedback. The first practical crystal microphone to give you this feature! Output level: 68 db below 1 volt per bar.

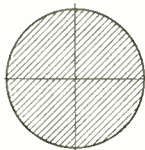

NON-DIRECTIONAL

3. *Non-Directional.* Full 360-degree *all-around* pickup for group presentations and general applications. Output level: 53 db below 1 volt per bar.

The Shure "TRI-POLAR" has a smooth wide-range frequency response from 40 to 10,000 cycles. Eliminates the need for many microphones—It is the one microphone that does everything! Rugged, light, compact—no delicate moving parts. Operates on conventional high-gain crystal amplifier without any additional transformers or accessories. Economical, too—costs but a fraction of the price of the microphones it replaces. *Model 720A available after August 1, 1937. List Price, complete with 25 feet of heavy duty cable, only..... \$39.50*

For complete information, write for Bulletin 145M.

Shure patents pending. Licensed under patents of the Brush Development Company.



SHURE BROTHERS
225 W. NURON ST., CHICAGO, U.S.A.
CABLE ADDRESS - SHUREMICRO
MICROPHONES & ACOUSTIC DEVICES



greatest part, has become so extensive that it is now the limiting noise on these wavelengths during most of the daylight hours. This interference was very bad on all the 16 meter antennas used except a rhombic directed so as to receive from a direction 50 degrees east of north. The maximum power obtained from this interference with a 16 meter $\lambda/2$ vertical antenna was 12 db above one micromicrowatt which was 61 db above the theoretical noise level of the receiver.

A substitution method for determining admittances at ultra-high frequencies, and in particular input and output admittances of vacuum tubes, was described and typical measurements were given in "Measurement of Vacuum-Tube Admittance at Ultra-High Frequencies" by Bernard Salzberg, John M. Miller, and Don G. Burnside of RCA Radiotron.

A short transmission line closed at one end and excited by an ultrahigh-frequency oscillator is shunted at the sending end by a variable capacitor and the unknown admittance. A vacuum tube indicates resonant voltage point, the unknown admittance is removed, resonance restored by the variable capacitor, and the same voltage obtained by sliding a known resistor along the line. The unknown admittance is determined by the frequency, capacitance change, and the position of the known resistor. With proper line constants, the equivalent sending-end resistance of the resistor is equal to the product of its resistance and the square of the ratio of the total line length to the distance of the resistor from the shorted end.

RADIO FREQUENCY ARCS AT PARIS EXPOSITION

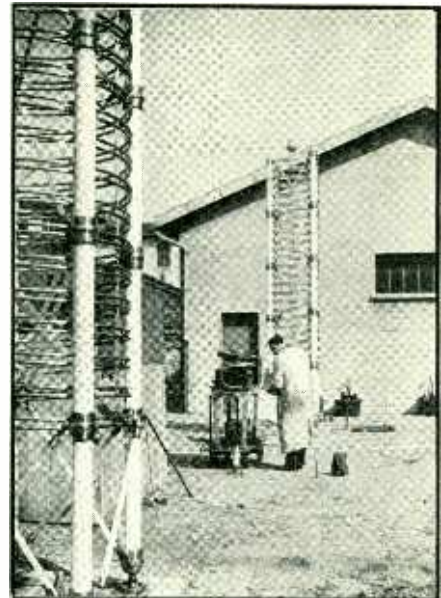

At the Palace of Electricity in the Paris Exposition, these solenoids will produce 25-foot arcs from 1500 kc. radio frequency energy

3 Audio Power Tubes *that are giving outstanding performance*

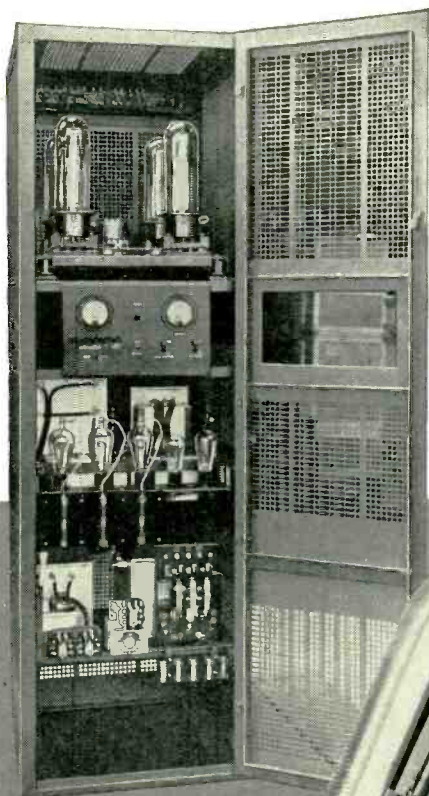

Western Electric 100 type amplifier uses four 308B tubes. Used in high powered public address systems.

The 284D is used in one of the most popular Western Electric 50 watt audio amplifiers as well as in other higher powered equipment.

The 300A is designed for high quality Class A service at comparatively low plate voltage. These tubes are used extensively in Western Electric public address and speech input amplifiers with less than 2% distortion.

The 308B was developed for use in Western Electric's high powered public address system. Four 308B's deliver 1000 watts of audio power with less than 2% distortion for average speech input levels.

For further information, write to Graybar Electric Company, Graybar Building, New York.



	284D	300A	308B
Filament Voltage.....	10	5	14 volts
Filament Current.....	3.25	1.2	6.0 amperes
Plate Voltage (Max. DC).....	1250	450	2250 volts
Plate Current DC.....	175	70	300 ma.
Mutual Conductance.....	2500	5200	7500 micromhos
Class A Output (2 Tubes).....	50	25	100 watts
Class B Output (2 Tubes).....	165		500 watts



Western Electric

Distributed by GRAYBAR Electric Co. In Canada: Northern Electric Co., Ltd.

RADIO TELEPHONE BROADCASTING EQUIPMENT



W.M. BRAND & COMPANY

268 4th Ave., New York
Chicago—217 N. Desplaines St.

Write for FULL LENGTH sample

for testing. Brand ships all orders, regardless of size, same day received.

Here is the test that proves the great tensile strength of TURBO OIL Tubing and Saturated Slewing. Take a strand of either one of these quality insulating materials and pull with all your might—it stretches then resumes its normal length and true tubular shape. You won't break it!

Prove That TURBO Can Take It!

H. F. Filament Supply for Ion Sources

A FILAMENT SUPPLY source to obviate the difficulties encountered with d.c. or a.c. sources of the usual commercial frequencies are described by J. R. Dunning and H. L. Anderson in the May issue of the *Review of Scientific Instruments* under the title "High Frequency Filament Supply for Ion Sources." Strains, resulting in distortion and displacement of the filament, are set up due to the magnetic field when filaments are heated by means of a d.c. supply. With an alternating current supply, where the frequency is not sufficiently above the natural period of the filament, vibration and eventual failure of the filament results. A simple method of overcoming these difficulties is to use a high frequency filament supply obtained by means of a power tube operating in a conventional oscillator circuit as shown in the attached figure. Using this arrangement, the authors have obtained current of the order of 100 amp. and 6 volts, using a 1 kw. air-cooled vacuum tube.

The Hartley circuit was chosen as

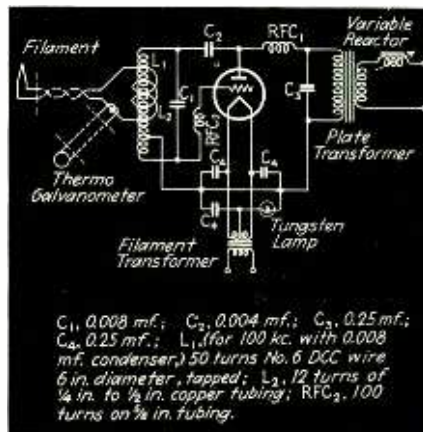

being one of the simplest to build and operate. The tube used is a 1 kw. air-cooled triode. Frequencies between 50 and 200 kc. have been found to be satisfactory for this filament supply. The power may be delivered to the filament supply by means of a twisted pair of wires or, if a more elaborate arrangement is desired, by means of a concentric tube transmission line.

The use of a tungsten filament lamp in the plate return circuit to provide grid bias to the tube tends to stabilize the output of the oscillator against line voltage variations thereby to provide a fairly constant output from the oscillator. Because of the resistance-temperature characteristic of tungsten, any tendency of the plate current to increase is counteracted by an increase of the negative bias applied to the grid. The lamp chosen should be one which will bias the tube for class B operation. The authors do not find that the selection of the

proper lamp is at all critical.

The plate is supplied from alternating current obtained from a step-up transformer and the power output from the oscillator is adjusted by varying the voltage on the primary side of the plate transformer.

Advanced Receiver Design

A PAPER DELIVERED by E. E. Beard before the New South Wales Division of the Institution of Radio Engineers, Australia, is published in the January issue of the *Radio Review of Australia* under the title "Advanced Receiver Design."

The author, who is managing director and engineer of Ace Amplifiers, Ltd., describes at some length the advantages of a triple detection type of receiver based upon the more familiar double detection or superheterodyne receiver except that two intermediate frequency amplifiers, each operating above the range of audibility, are employed. Increase in gain, without running the possibility of instability, together with increased selectivity and flexibility are claimed for this method of reception. The author has found it desirable to operate the second oscillator at a frequency just below the butt as near to the lowest frequency of the broadcast band as is possible. Under these conditions, a minimum of harmonics occur in the broadcast band. The conditions existing in Australia may make the use of such a triple detection receiver desirable, but in this country, at least in the metropolitan areas, there is no trouble at all reaching the noise level with ordinary double detection receivers.

Volume expansion in broadcast receivers is discussed under the subject of "Contrast Expansion". A simple volume expander which may be conveniently added to any existing receiver or amplifier is described by the author. In its simplest form, the method consists in connecting the field of the speaker in series with a normal output tube which is biased so that very little plate current flows, so that the field magnetism of the speaker is low. A portion of the input to the speaker transformer is then applied to a rectifier which develops a positive potential between the grid and the cathode of this tube, thus decreasing the plate current and strengthening the field of the speaker. Adequate delay to prevent distortion is caused by the inductance of the speaker field. An alternative arrangement is shown in which a triode is used as a plate detector to avoid the use of a diode rectifier. This arrangement, while effective, has the peculiarity that when signals exceed a certain value the tube commences to function as a grid leak detector and further increases in volume actually decrease the field current and limit the output from the speaker.

For assemblies as strong as these SOME PAY 2 or 3 times AS MUCH

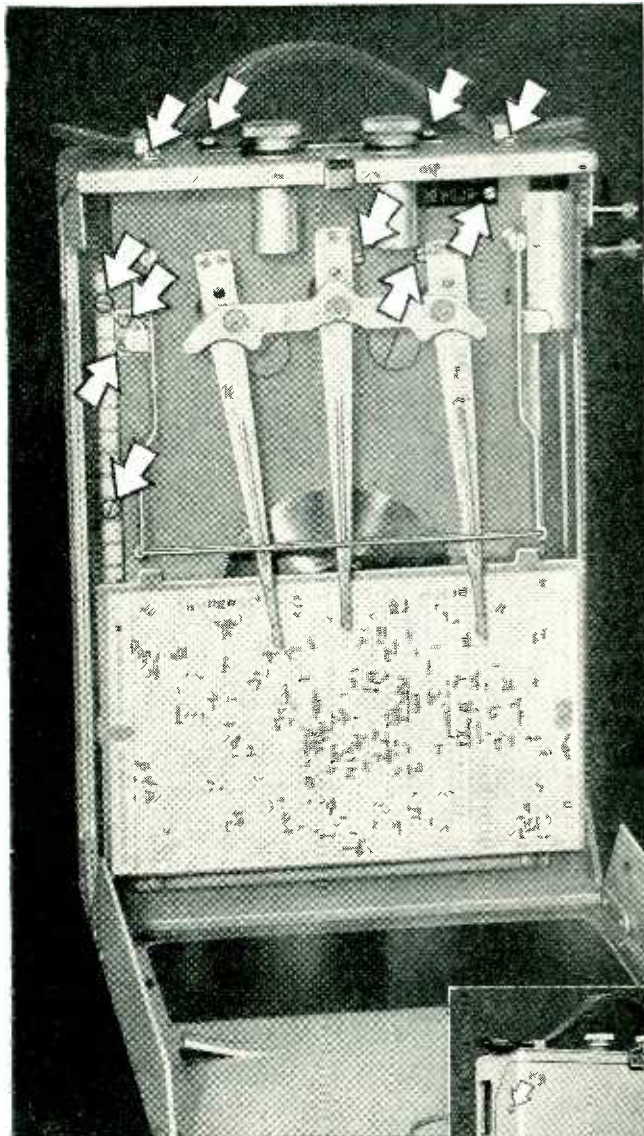

Shown here is a type R-4A Friez Recorder, size 8 1/2" x 5 1/2" x 2 1/4". In other types, made for recording only relative humidity, or temperature, or a combination of both, Hardened Self-tapping Screws are also used.

40 FASTENINGS ON FRIEZ PORTABLE RECORDERS MADE SAFE AND ECONOMICALLY

Assemblies include: attaching handle; name and specification plates; pen lifter mechanism brackets; pen lifter spring; running time electric unit; ventilating screen case latch; door latch; unbreakable window; chart storage case. Also, fastening a Bakelite cover plate to a transformer box (not shown).

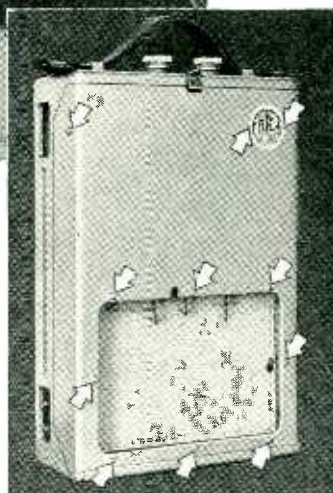

- Let a Parker-Kalon Assembly Engineer help YOU do what "FRIEZ" did... produce a better product, at lower cost.

When FRIEZ engineers tackled the job of producing a sensitive humidity-temperature-running time recording instrument that would be rugged enough for portable service in air conditioning and industrial fields, assembly methods took on new importance. Fastenings had to *stay* tight to insure permanently accurate assembly of instrument parts, and a strong and durable case. "Friez" was ready to pay a premium for maximum assembly strength. Yet, a comparison of methods showed that the simplest and cheapest means... Parker-Kalon Hardened Self-tapping Screws... actually would be the strongest, too.

K. E. Whitney, Development Engineer with Julien P. Friez & Sons, Inc., Baltimore, Md., reports: "These Screws were chosen for joining and making fastenings to the die cast aluminum parts primarily to get safe fastenings, but they give us a fine saving as well. Had we used tapped holes and machine screws the cost for fastening would have been triple present cost. Tapping the aluminum for small screws would have been a real task and lock washers would have been necessary."

Use the specialized knowledge of Parker-Kalon Assembly Engineers

Whenever assembly of metals and plastics is involved, this method that is simpler, faster, cheaper and also more secure should be considered first in designing for production. Also, it deserves serious investigation even after production has begun. To substitute these unique Screws for ordinary devices requires no radical changes. Right now, in 7 out of 10 assembly departments there are opportunities to save time, labor, money, and to improve design and product. To make sure that you are taking full advantage of this modern method, ask us to have a Parker-Kalon Assembly Engineer go over your fastening jobs with you. He will point out any chances for doing them better, at lower cost.

PARKER-KALON CORP., Varick St., New York

PARKER-KALON *Modern* FASTENING DEVICES

TYPE "Z" HEX CAP A HARDENED SELF-TAPPING SCREW FOR EVERY KIND OF ASSEMBLY TYPE "A" TYPE "U"

SOLD ONLY THROUGH RECOGNIZED DISTRIBUTORS

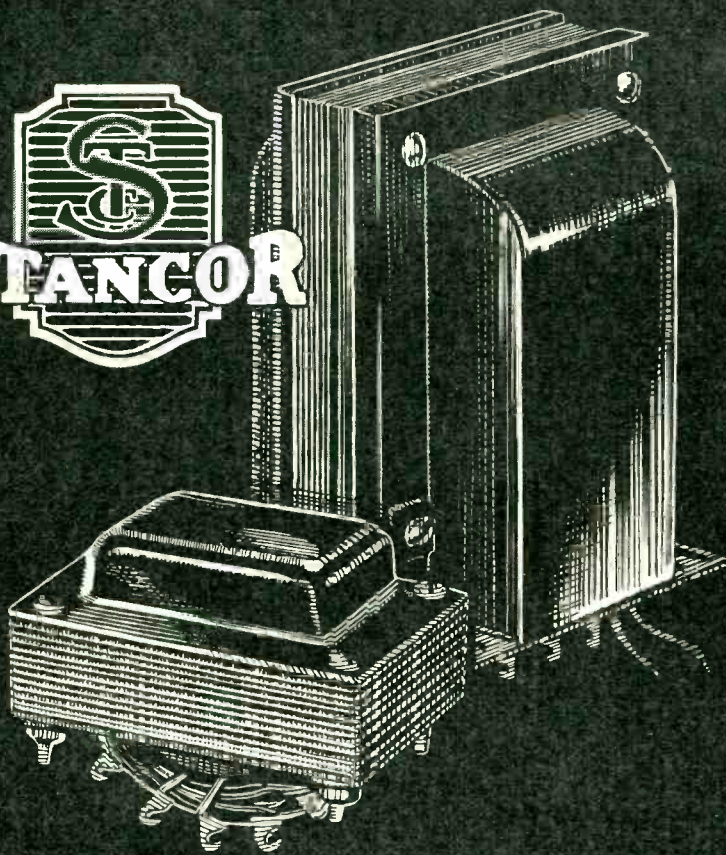

THE line of Stancor Transformers covers the whole scope of characteristics in common use. But the standard transformers of today were the laboratory transformers of yesterday . . . a large part of which were developed by Stancor engineers in cooperation with the engineering departments of manufacturers of electronic equipment of all descriptions.

YOUR TRANSFORMER PROBLEM IS OUR PROBLEM, and we will make it our business to apply our highly specialized experience and our carefully controlled manufacturing in arriving at an economical solution.

**STANDARD
TRANSFORMER
CORPORATION**

850 BLACKHAWK STREET, CHICAGO

Backtalk

(Continued from page 34)

"1. Set the glass slide index at 2.5 on the L scale (since each unit on the L scale represents 2 db), read 1.775 on the D and C scales.

"2. Move the 6.00 on the C scale (considered as 600) to the left of the glass slide index (which remains at 1.775 on the D scale) until the interval from the 6.00 on the C scale to the 1.0 on the D scale is the same number of units as from the 6.00 to the index line of the glass slider. When this occurs there are 1.675 units on each side of 6.00 or 167.5 ohms. (All on the C scale, See 432.5 opposite D scale index; equal to 600 — 167.5 and also see 767.5 on C scale on hair lines, equal to 600 + 167.5.—*Editor*). This is the value of X in the T network and $X/2 = 84$ ohms, which is used in the H network. The value of Y is the same in both the T and H networks and has the value,

$$Y = \frac{(600 - 167.5)(600 + 167.5)}{2 \times 167.5} = 988 \text{ ohms}$$

These values are in excellent agreement with the more precise values obtained in the longhand way."

Mr. Stanley Rapp of the Pacific Tel. and Tel. Co., also refers to the method mentioned above.

Mr. Verne V. Gunsolley, consulting radio engineer in Minneapolis, and whose suggestion resulted in the Reference Sheet on impedance calculations, offers the following comments on the correspondence here reviewed.

"The alternative solution offered by your correspondents was not new to me. You will recall that my suggestion was directed specifically against the particular solution in my letter of October 9th 1936."

"Of course that solution is best which is easiest to use, but quite often the ease of use depends upon the individual himself largely or what sort of crutch he is used to. Any solution that gets the same results as any other solution is equally good provided it does it as easily. For the individual who never goes beyond the vector impedance and the power factor, the algebraical solution has some advantages, and for the Mannheim type of rule it is distinctly advantageous.

"In the most general case, in any triangle, by the law of sines:

$$\frac{\sin a}{A} = \frac{\sin b}{B} = \frac{\sin c}{C}$$

In the special case of the right angled triangle, $\sin c = 1$, and we may rewrite the general case, to conform to the special case, more simply as:

$$\frac{A}{\sin a} = \frac{B}{\sin b} = C$$

"Since the slide rule is calibrated in proportion to the sines, the law of

(Continued on page 64)



**"CINCH
SOCKETS
LEAD . . ."**

Each radio tube socket shown here satisfactorily met a particular need. The most widely diversified line of sockets and plugs in America is offered by "Cinch." Thirty three different types of contacts! Each component part skillfully designed and produced to give maximum performance. Foolproof and produced to give maximum constant contact on all prongs, assembling ease, soldering accessibility, promptly delivered, "Cinch" radio tube sockets have been adopted by leading set manufacturers.

CINCH MANUFACTURING CORPORATION
 2335 WEST VAN BUREN ST. • CHICAGO, ILL.
 SUBSIDIARY: UNITED-CARR FASTENER CORPORATION, CAMBRIDGE, MASS.
 "Cinch" and Oak Radio Sockets are licensed under H. H. Eby socket patents.

in Quality

DEPENDABILITY

Service

workmanship

PERFORMANCE

Questions and Answers

EDITOR'S NOTE—The following questions and answers are taken from the correspondence of Mr. Samuel Wein of 426 Broome Street, New York City. They are but a fraction of the many queries that come to him unsolicited and unpaid for. *Electronics* will welcome similar questions and will try to publish them (and answers) as a regular feature.

A.J., Chicago.—*Earliest reference showing use of light sensitive cell for opening and subsequently closing a door by interruption of a light beam.*

[A.] William J. Hammer in his book "Radium and Other Radioactive Substances," 1903, pages 42-63, also in *Transactions A.I.E.E.*, Vol. 20 p. 582, 1903; and in the *Jour. Franklin Institute*, Vol. 155, p. 458, 1903, shows specifically the use of a selenium cell operating a relay which operated doors, window gratings, etc., by changes in light falling on the cell.

The use of an emission type of cell for this purpose is covered by U. S. Patent 1,882,152 to Kinnard and Dunlop of General Electric. An examination of the file wrapper of this patent would reveal the Examiner's citations, if any.

The operation of a relay which in turn operates any electromagnetic device by means of a barrier type of cell is more than 50 years old.

F.L., New York City.—*What kind of meter should be used with a barrier type of cell to be used as an exposure meter?*

[A.] Meters having full scale reading of 200 microamperes or less are recommended. A shunt resistor should be used to read higher values of light intensity. The device will have to be calibrated against an exposure meter or empirically for the film to be used.

M.K.L., Trenton, N. J.—*How can I measure the thickness of lacquer deposited on wire?*

[A.] The wire to be measured is held under tension to avoid slack. It is held over a slot in a diaphragm. Light is permitted to fall upon this slot under which is a cell. The difference in the cell output with and without the wire is a measure of the thickness of the wire plus lacquer. The device must be calibrated, of course.

H.A.J., Brooklyn.—*How do you close a door after it has been opened by a cell arrangement?*

[A.] All mechanical motions that have been suggested and used in door

openers have either an electrical or mechanical time delay so that the person, or object which causes the door to open has time to get through it before it automatically closes. After this time delay, the door is closed by a spring, weight, or by a motor.

A.F.S., Brooklyn.—*References on a compass using a light-sensitive cell.*

[A.] Two references are *Aviation Compass*, *Popular Mechanics*, Vol. 34, p. 840, 1920, *Electronics*, June 1933, p. 162.

W.C.F., St. Louis.—*References on making selenium cells in which a "comb" of graphite is used and on which the selenium is deposited.*

[A.] Graphite "grids" for contact with selenium films have been recommended by E.E.F. d'Albe who rubbed some graphite (soft lead pencil) over a slate surface and then polished it with a chamois skin. This he divided into two electrical portions with a sharp tool like a needle. He deposited selenium on this. An alternative method was described by F. Michelssen in German Patent 552,291, of 1931 and British Patent 337,691 of 1930. Here the glass is etched in the design (comb-like grids) and into the grooves is applied the graphite and an alloy of selenium containing tellurium is then applied and annealed.

An advantage of using graphite over metals like silver, nickel or copper is that it will not be affected by the selenium during the annealing or sensitizing process. Selenium and tellurium like sulphur form reaction products between them at the temperature of the annealing process.

In the case of selenium, a selenide is formed, for example, silver and selenium. In the case of tellurium, a telluride is formed. Platinum forms no reaction products but is expensive. Graphite is cheaper and is as useful.

Watchmaker, New York.—*Method for visibly measuring inaccuracies in watches.*

[A.] An inexpensive unit demonstrated recently consisted of a microphone picking up the sound of the watch tick. This was amplified and the output was made visible on a common neon tube. Another good indicator would be a "magic eye" used as tuning indicators in radio receivers. Each tick of the watch, or any given sum of ticks could be made to flash the neon bulb, etc.

Experimenter, Holyoke—*Wants to make a liquid light sensitive cell.*

[A.] The simplest way is to get old rectifier discs, preferably copper oxide

PROFESSIONAL SERVICES

BLILEY ELECTRIC CO.

Designers—Manufacturers
Quartz Crystals for standard or special radio frequency applications.
Inquiries Invited.
240 Union Station Bldg.
Erie, Penna.

CHARLES EISLER

EISLER ENGINEERING CO.
Consulting and Designing Engineer
Electric Welding Machines for Metal Tubes
Electric Welding Problems, High Vacuum
Compound Pumps, Soft and Hard
Glass Working Equipment, Radio and
Electronic Tube Machinery
753 So. 13th St. Newark, N. J.

ELECTRICAL TESTING LABORATORIES

Characteristics and Life Tests of Vacuum Tubes
Tests of photo cells, glow lamps, crater lamps.
Tests of electronic and optical devices.
30th Street and East End Avenue
New York, N. Y.
Phone: Butterfield 8-2600

THAD. R. GOLDSBOROUGH

REGISTERED PATENT ATTORNEY
Patent and Trademark Soliciting
Consulting Service
Patent Sale and License Negotiations
201-205 McLachlen Building
Washington, D. C.

INTERNATIONAL ELECTRONICS, INC.

CONSULTING ENGINEERS
offer designs, specifications and manufacturing instructions concerning all the new American developments in electrolytic condensers, tubes, resistors, coils and receivers. Clients all countries. No royalties. Profitable results guaranteed. Write for further information without obligation.
RESEARCH LABORATORIES
145 W. 54th Street New York, N. Y.

The Solution of Your Problem

in the field of Electronic devices may be found through enlisting the services of the Consultants whose cards appear on this page.

This is a highly specialized field and specialists are therefore better able to undertake the rapid developments necessary to keep in step with modern manufacturing progress.

(Westinghouse) which is light sensitive. Solder a stiff copper wire or rod to the disc for contact purposes. From a paint shop get some asphaltum and coat the copper side with several layers of it. See that no copper spots are visible. Allow the paint to dry over night. Support the disc in a beaker in any convenient manner so that light may get to the surface of the film of copper oxide.

Place a rod of lead in the same beaker. If lead is not obtainable use ordinary tinfoil such as is used in wrapping candy (not aluminum foil). Lead foil is placed on the back of the painted disc to avoid light reflections. Into the beaker pour a 1 per cent solution of lead nitrate (use distilled water). Lead nitrate may be obtained at any first class chemical supply house. If lead nitrate is not obtainable, a few crystals of table salt (sodium chloride) in water will produce good results.

A.C.D., Chicago.—Wants alloy that will prevent arcing and sparking at contacts.

[A.] Such alloys are made of platinum, tungsten and other elements of higher melting points. Several firms make such materials but do not reveal the constituents of the alloys. P. R. Mallory, Indianapolis, Callite Products Company, Union City, N. J., Baker & Company, Newark, N. J., make alloys of this nature. Much of the sparking can be eliminated by shunting a condenser across the contacts. Often the contacts are "made and broken" in a non-volatile oil.

H.B.S., Dayton.—Wants a relay to be used with a barrier cell, the relay not to be of the meter type.

[A.] The old fashioned coherer has been recommended to be used with these cells but little of a dependable nature has been offered to date. If the barrier cell has a battery of 2 to 6 volts in series with it, greater currents will be obtained from a given amount of illumination. Thus a less sensitive relay may be used.

Scale Maker, Toledo.—Wants a method of operating a device at a remote place when a given weight has been reached as in loading.

[A.] A capacity controlled circuit may be used. Another suggestion is to use the change in resistance of powdered copper oxide (red) when the desired pressure is applied.

B.C.D., Detroit.—Asks about relays to use in light-sensitive equipment.

[A.] There are several types of relay depending upon the amount of power to be handled. Meter type movements have been used, so that as the arm swings over its arc contact is made. These are really sensitive units, operating on microamperes. If the power to be handled is sufficient to warrant the use of a thyatron, it is advisable since it eliminates trouble with sparking, etc.

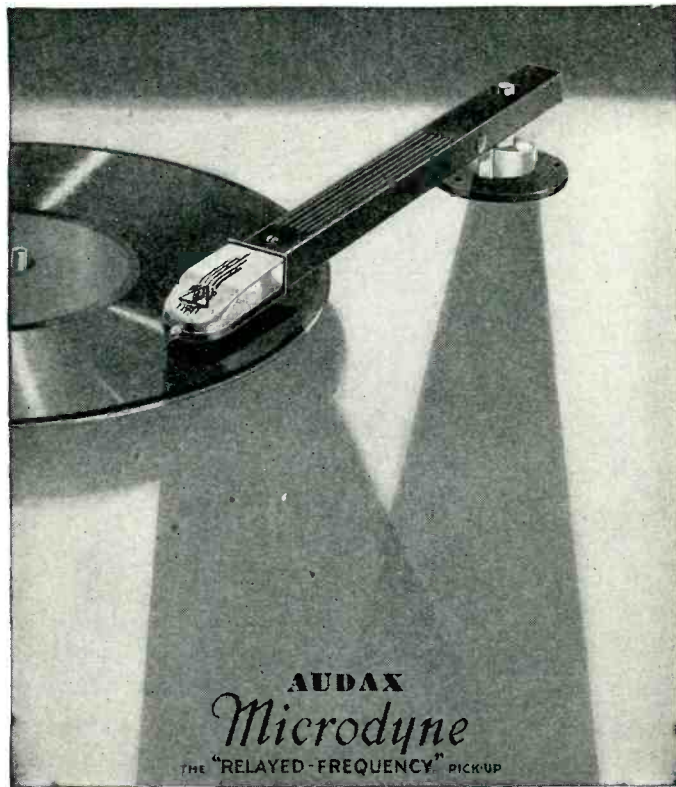

***"The Standard by Which Others
Are Judged and Valued"***

When MICRODYNE's astonishing *facsimile* performance was first demonstrated, skeptical sound experts exclaimed, "That's THE answer to the wide-range problem!" Throughout the industry spreads the fame of this inspired reproducing system that makes recording-microphone fidelity at the pick-up an accomplished fact. Not since pick-ups became commercial in 1926 has there been so startling an evolution. *Look to a leader for leadership!*

\$9.50 to \$350.00 list

A pick-up for every need from the humblest midget to the most exacting transcription requirement. Each AUDAX model delivers wider range, truer fidelity and greater stability than you can get elsewhere at the price.

CUTTERS FOR PROFESSIONAL RESULTS
IN FINE INSTANTANEOUS RECORDING

Write for your copy of "PICK-UP FACTS"

AUDAX COMPANY

500 Fifth Avenue

New York City

"Creators of High Grade Electrical and Acoustical Apparatus Since 1915"

Bill the GOAT says:

"I'm not arguing, I am just telling you something that any kid knows, —Octal base glass tubes encased in

GOAT

FORM-FITTING TUBE SHIELDS

combine the advantages of all classes of radio tubes and have the disadvantages of none."



**GOAT RADIO
TUBE PARTS, INC.**

314 Dean Street
Brooklyn, N. Y.



TELEVISION STANDARDS

(Continued from page 13)

seen that the use of the double frequency line impulses permits the occurrence of the serrations at the same time and in the same relation to the line synchronizing pulses in both odd and even frames.

Diagrams B and B' show the (narrow-vertical' type of frame synchronizing pulse, at points M and N. These impulses are of greater amplitude than the line synchronizing pulses, and hence can be separated therefrom by a properly biased vacuum tube. The narrow vertical pulses shown in the picture require that a considerable portion of the available amplitude be reserved for this purpose alone. They do give an extremely precise timing of the frame synchronization. The amplitude of both line and frame pulses may be reduced below that illustrated in the figure. The lower limit is determined by the amplitude filter characteristics. As long as the cutoff voltage levels are adjusted to pass some of the line pulses the system will operate. The danger is that the line amplitude filter may miss the line pulse entirely or may receive some of the video signal. The portion of the total voltage amplitude required for transmitting the narrow vertical synchronizing pulses is slightly greater than that required for the serrated.

The British type of frame synchronizing pulse is shown in the diagrams C and C'. Here the serrations begin at the end of each frame, and no double frequency line impulses are employed before the frame pulse occurs.

The separation of the line impulse from the frame impulses, when the latter are of the serrated type, is accomplished by integrating and differentiating circuits which consist of resistor and capacitor combinations responsive to pulses of different duration and shape. In Fig. 6 are shown the wave forms which result from the separation. The serrated sections of A or A' (Fig. 5) result in pulses like those in Fig. 6-A, those above being the result of line synchronizing differentiation, while those below are

**Buy with Confidence—
Nationwide Acceptance**

REMLER

HI-FIDELITY TRANSCRIPTION UNIT



Famous Remler quality . . . sturdily constructed with precision accuracy to stand up under the grueling test of continuous service. Improved mechanical-filter drive system provides constant speed and freedom from wow at either 33 $\frac{1}{3}$ or 78 R.P.M. FEATURES: True synchronous motor, condenser starting, mounted on rubber. Exclusive roller-bearing planetary speed reduces drive for 33 $\frac{1}{3}$ R.P.M. Speed change by simple lever. Oil-damped mechanical filter in drive shaft. Heavy 16" "flywheel" platter. High fidelity lateral pickup and

equalizer gives response within 3 db. from 45 to 6600 C.P.S. Ball-bearing mounted long radius pickup arm, with adjustable needle pressure— $\frac{1}{2}$ oz. to 6 oz.

Available in cabinet or as a unit for mounting in control table. All parts mounted in heavy cast iron framework assuring permanent alignment and simple installation. The price is unusually low. Send for complete information.

REMLER COMPANY, LTD., 19th at Bryant, San Francisco

REMLER—THE RADIO FIRM AS OLD AS RADIO

the integrated pulses due to the frame synchronizing separation. In Fig. 6-B is shown the British serration separation, while in Fig. 6-C is the narrow vertical separation.

One disadvantage of the serrated type of signal is its dependence on accurately maintained tube voltages. A slight drift in tube voltages will cause the time of tripping to be moved to another part of the integrated pulse. The integrated pulse at the bottom of Fig. 6-A is four lines in duration. The voltage which trips the scanning oscillator is substantially a horizontal line intersecting the pulse. It can be seen from the diagram that a slight vertical displacement of the line will shift the intersection in time, making the scanning oscillator start the retrace either earlier or later than the proper time.

Another disadvantage of the serrated pulse is that the timing is dependent upon an exactly equal energy content in successive groups of serrations supplied to the integrator. The serration energy may vary with picture content, etc.

In the narrow vertical type of pulse, a much greater tolerance in tube voltages is allowable before any change in the synchronizing time is discernible. This is an important point, since a relative shift in alternate frame timing of one-half a line will completely destroy the interlace, resulting in a picture of 220 lines instead of the desired 441 lines. A relative shift of only a quarter line will result in considerable loss of detail.

In conclusion it would seem that the authorities in the United States have been wise not to standardize too hastily. If a single form of mixed synchronizing signal is to be adopted it should be done with the intention of making reception simple and reliable. There is serious doubt that our proposed standard of negative modulation is correct or that the present practice of omitting the d-c component in transmission is wise. Before final standardization these three important items (polarity of modulation, method of transmitting d-c, and type of synchronizing signal) must be carefully weighed and all evidence submitted. Only by these means will the design of television receivers be simplified to the point where the public can expect steady and enjoyable pictures.



VITREOUS enamel resistors fixed, tapped and adjustable. Many varieties are available to fulfill any conceivable requirement.

Our 12 years of specialization in this field enable us to offer complete assistance in the handling of special applications.

Literature covering resistors and rheostats gladly sent upon request.

Write for further information . . . and remember the mark **HH** means reliable rheostats and resistors.

HARDWICK, HINDLE • Inc.

136 PENNINGTON ST.—NEWARK, N. J.

A TRIAL WILL CONVINCe YOU

35 Years' Experience
Insures Dependability

We Manufacture

PERMANENT MAGNETS TOOLS and DIES
METAL STAMPINGS LAMINATIONS

[Suppliers of]
ALNICO MAGNETS

**THOMAS & SKINNER
STEEL PRODUCTS CO.**

23d St. at Alford

Indianapolis, Ind.

LEACH LR RELAYS

**ALWAYS ON THE JOB GIVING
DEPENDABLE OPERATION**

The new Leach Impulse Relays make possible many new developments such as new circuits, new lock-out schemes—alarm systems and safety devices. Operation is dependable, absolutely quiet, and fast . . . time required to shift from one position to the other is approximately 1/60 second.

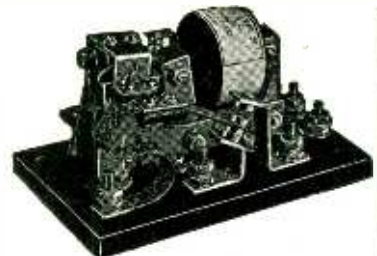

LEACH RELAY COMPANY
5915 Avalon Boulevard, Los Angeles, Calif.
15 E. 26th St., New York City

LEACH RELAY CO., 5915 AVALON BOULEVARD, LOS ANGELES, CALIF.

Please send me your new catalog. I am interested in . . . relay.

Name

Company

Address City



BRAVO, FATHER KNICKERBOCKER!

We heartily congratulate you for snapping on padlocks right and left in the burlesque world. As Aunt Agatha up in Waterbury remarked between righteous little clicks of her knitting needles "it was high time they did something about those hussies".

Our commendations, however, are tempered with selfishness. For now, when we say Somers Stands for Strip, up-and-coming radio engineers will know that because we do such a swell job of rolling light gauge metal strip our name has become synonymous with it, and they'll have nary a second thought about anything else. Remember—

"Somers Stands for Strip"
(Even if the City of New York Won't)

SOMERS BRASS COMPANY, INC.
350 Madison Avenue New York, N. Y.
Mill at Waterbury, Conn.

MONEL AND NICKEL STRIP FOR ELECTRICAL AND RADIO WORK

AUTOMATIC ELECTRIC RELAYS

A WIDE VARIETY OF TYPES FOR EVERY INDUSTRIAL USE

The Automatic Electric line of relays includes quick and delayed action types, sensitive and heavy duty types, mechanical locking types, polarized relays, etc. Available for operation on D.C. or A.C. circuits, any voltage, any contact combination. Also stepping switches, electric counters, solenoids, keys and other electrical control accessories. Write for complete illustrated catalogs.

AMERICAN AUTOMATIC ELECTRIC SALES COMPANY
1023 WEST VAN BUREN STREET CHICAGO



A NEW PERMANENT MAGNET Dynamic Speaker

A new development in a permanent magnet dynamic speaker which permits the removal of the magnet assembly from the basket, voice coil and cone assembly, without disturbing the magnet assembly, the center location of the pole piece or the strength of the magnet. Engineers and service men will readily appreciate this desirable feature in repairing and servicing this type of speaker. Present production in 5", 6 1/2" and 8" models.

ARISTON MANUFACTURING CORPORATION
4049-59 Diversey Avenue Chicago, Illinois

Tubes at Work

(Continued from page 29)

N the neon lamp. L is a source of visible light or a penetrating radiation in the ultra-violet or infra-red regions. The apparatus is placed in a dark room and the potential adjusted to the flashing point by means of the potentiometer. Under this condition the neon lamp flashes perhaps once or twice per minute. Lighting a match at a distance a few yards from the lamp will increase the flashing rate to approximately ten times per minute. Switching on an electric light of the room increases the frequency of oscil-

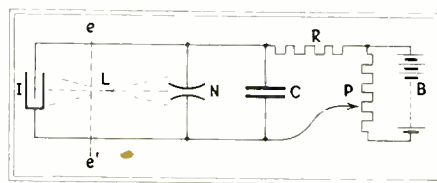

Connections of the neon radiation meter

lations to a still higher value, approximately 60 flashes per minute. In full daylight the frequency is still higher. The maximum frequency occurs at a certain light density above which the frequency begins to decrease. Typical values of the capacity and resistance used are 1 microfarad and 250,000 ohms. The relaxation characteristic shown in the diagram can be used to explain the phenomena. V_B is the potential supplied by the sliding contact of the potentiometer. V_D is the flashing potential in the dark. V_L is the flashing potential when light is striking the neon lamp, while V_E is the extinguishing potential. The decrease of flashing voltage as the illumination increases accounts for the increase in frequency, as shown by the dotted lines.

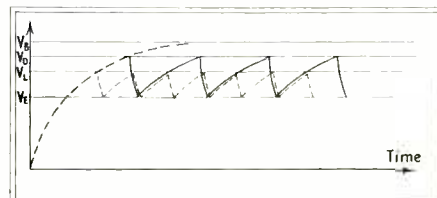

Relaxation characteristics of the radiation measuring circuit

The physical explanation of the effect is based on the presumption that the electrodes of the neon lamp, or at least parts of them are photoelectrically active. The extra electrons thereby liberated in the presence of light reduce the voltage at which flashes occur. Successful operation of the device depends, of course, on a sufficient difference between the flashing potentials

if



you are
an

**ENGINEER
EXPERIMENTER
DESIGNER**

this is YOUR catalogue—

Over 2,000 parts, designed and engineered to completion in our own plant . . . embodying the latest scientific principles of design and construction! A catalogue which furnishes at last ONE SOURCE for all those miscellaneous hardware accessories, so essential to Radio, Sound and Television. We are not jobbers but MANUFACTURERS. Special stamping assignments in metal and compositions are our speciality. Consult us freely without obligation.



American Radio Hardware Co., Inc.
476 Broadway New York City

and the extinguishing potential. If a condenser or ionization chamber is connected in parallel to the neon lamp, the frequency of oscillation can be reduced as the illumination level increases. This results from the freeing of electrons in the chamber, which reduces the resistance across the condenser. This shunt resistance increases the time necessary to bring the condenser voltage to the flashing potential value. This method is considered to be a new manner of measuring radiation and has many advantages over the more usual methods.

The output of the device can be amplified by placing a single electron tube amplifier across the neon tube or across the charging resistor. Since the currents flowing during the discharge of the condenser are very large compared with photoelectric current, the degree of necessary amplification is small.

Course in Receiver Design To be Offered by Purdue

AN ANNOUNCEMENT has been received from Professor Charles D. Aiken in charge of communication courses of Purdue University, that a course "Electrical Measurements of Radio Receiver Design" is now being offered at Purdue. The course consists of an introductory section describing the various types of receivers now in use, and stating their principles of operation. Other topics considered in the course are: Theory of Tuned Coupled Circuits, Defects in Coupled Circuit Systems, Non Linear Circuit Elements in a Radio Receiver, The Selectivity of Radio Receivers, Multi-Band Receivers, and The Audio Frequency Amplifier.

Photo Tubes Control Cocoa Refining Plant

ONE OF THE LATEST APPLICATIONS of the phototube in the food industry has recently been made in a British cocoa refining plant in connection with the feeding of each refining unit. A conveyor belt carries the cocoa nibs to the refiner where they fall into a hopper. The hopper feeds the cocoa to the rollers beneath, which break them to the proper size for the initial refining process. A photo-tube and light source are placed on opposite sides of the hopper and are so arranged that when the hopper becomes full, the light beam is interrupted, thus operating an amplifier relay and line contactors which disconnect the motor drive of the conveyor belt. As soon as the hopper has become sufficiently emptied to restore the light to the photo-cell, contact is closed, thus starting the conveyor motor. To prevent rapid switching in and out of the line contactors a delay circuit is used which does not operate until two and one-half minutes after the light has been restored.

COLLOIDAL GRAPHITE

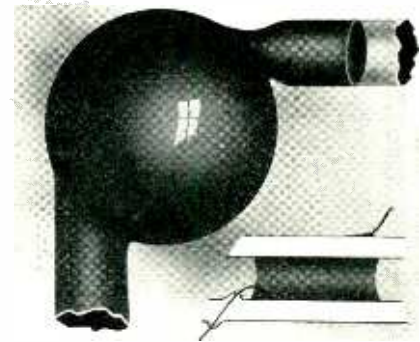

..for Useful Films

Aqueous suspensions of "dag" colloidal graphite yield highly tenacious films to a variety of substances.

These films

- Retard corrosion;
- Dry with sharp boundaries;
- Possess a high "black-body" factor;
- Are homogeneous;
- Possess a matt-like finish;
- Absorb radiation;
- Promote radiation;
- Are electrically conductive;
- Resist electron bombardment;
- Are photo-electrically poor;
- Are radio-inactive;
- Are chemically inert.

Two useful applications of such films in vacuum techniques are the formation of guard rings and the coating of complicated glass forms for shielding, "gettering" and opacity.

Ask for Bulletins B12, 171, 191,
230, A260, B260.



A DEPENDABLE POWER SUPPLY

"PINCO" Dynamotors, generators and converters produced by this pioneer manufacturer of power supply units afford the last word in this equipment for aircraft, police, marine and auto radios and public address systems. Compact and light weight. Sturdily constructed to assure long, dependable service. For complete information address

PIONEER GEN-E-MOTOR CORPORATION
Manufacturer of "PINCO" Products

Dept. No. R-4G
466 West Superior Street
CHICAGO, ILL.

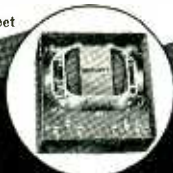

GEN-E-MOTORS

MANUFACTURING REVIEW

News

♦ B. J. Grigsby, president, announces the organization of the Elsberg Manufacturing Co., Inc., 353 West Grand Ave., Chicago. Associated with him in this new venture are Raymond J. Grigsby, vice-president, O. E. Grigsby, secretary, and H. E. Kranz, chief engineer. This company is developing and will shortly begin manufacturing a new type of slow speed high torque fractional horsepower electric motors as well as ignition devices and systems for internal combustion engines.

♦ Mr. G. M. Giannini, president of the Transducer Corp. announces that the factory which had been located at 42 West 48th St. has moved to new and larger quarters at 455 West 45th St., New York in order to accommodate increased demand for their product. In charge of activities at their new address are Mr. F. L. Lester, production engineer, and Mr. Ben Eisenberg, test and design engineer. Mr. Richard W. Carlisle, a former member of the staff of Westinghouse and RCA is serving in the capacity of design consultant.

♦ P. R. Mallory & Co., Inc., Indianapolis, announce the purchase of the assets, good will, trade mark, patents and patent rights of Electrad, Inc., New York City. Mr. L. A. de Rosa, chief engineer, and other key employees of Electrad, Inc. will join the Mallory organization. Plant and offices will be moved to Indianapolis.

♦ Officials of the National Government of China and executives of the Arcurus Radio Tube Co., Newark, N. J., concluded a contract recently naming that company as official technical advisers and counselors to assist the Republic in its program of manufacturing radio tubes. In preparation for this program, Kyi-Tsing Chu, former chief engineer of the Radio Administration, Ministry of Communications of the National Government of China, and associates representing the National Resources Commission visited various radio tube factories during the few months they have been in the United States.

♦ Herman E. Held has recently been appointed to succeed the late C. F. Henderson as manager of the San Francisco agency of the Weston Electrical Instrument Corp., with offices at 420 Market St., San Francisco.

♦ According to an announcement by E. F. Staver, Goat Radio Tube Parts, Inc. are providing additional space for the manufacture of tube parts which they supply to the independent tube manufacturers and their form-fitting tube shields used by radio receiver manufacturers.

♦ The Radiomarine Corp. of America and the American Telephone & Telegraph Co. have entered into agreement for joint participation providing radio telephone service with American vessels in the coastal and inland waters of the United States as well as those in transocean trade, according to an announcement from the Radio Corporation of America. The Bell Telephone System has been rendering shore telephone service for some time to ships suitably equipped with its marine radio telephone stations located at Boston, New York, Ocean Gate, N. J., and Miami on the east coast and Seattle, Los Angeles and San Francisco on the west coast. Through these stations and the connecting telephone land lines, the Marine Radio Telephone Service is within reach of nearly 19,000,000 Bell telephones in North America. The Radiomarine Corp. of America plans to apply for construction permits from the Federal Communications Commission to establish marine telephone postal stations on the Great Lakes and operate a service between ship and shore connecting with the telephone land line.

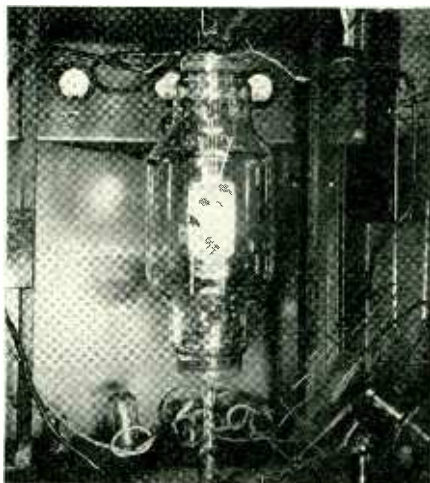

Gammatron on exhaust pump at Heintz and Kaufmann, West Coast engineers and manufacturers

♦ DeWitt C. Tanner has been made consulting patent counsel of the American Telephone & Telegraph Co. and is succeeded in his former position as general patent attorney of the Western Electric Company by Franklin T. Woodward, assistant general patent attorney, according to an announcement made June 4. Joel C. R. Palmer, patent attorney of Western Electric Co., has been appointed contract counsel of Electrical Research Products, Inc.

♦ The nine months report for the Columbia Pictures Corp. for the period ending March 27, 1937 shows a net profit, after all charges and provisions for federal income and other taxes have been made, amounting to \$1,189,354.86 which compares with \$958,578.63, reported for the nine months ended March 28, 1936. The profit for the three months ended March 27 was equivalent to \$1.61 per share.

♦ Arthur Moss, associated with Electrad, Inc. since 1923, has resigned as president of that organization and the control of Electrad, Inc. has passed to new interests. As of June 1, Mr. Moss became sales manager of the Solar Manufacturing Corp., 599 Broadway, New York City. Mr. Wickham Harter, formerly in charge of Solar sales has been promoted to the position of general sales manager.

♦ The laboratory staff of the Clough-Brengle Co., 2815 West 19th St., Chicago, has recently been augmented by the addition of Dr. Maxwell R. Krasno, formerly research physicist in the Department of Physiology of the University of Wisconsin. Dr. Krasno has specialized in the design and construction of vacuum tube devices and has done considerable development work on high fidelity phonograph and beat-frequency oscillators. He has also written a number of monographs, published by the University of Wisconsin, on the nature of cardiac potentials in physiological research. His duties with the Clough-Brengle organization will be to develop their electronic instruments.

♦ Under a contract signed June 3, all users of instantaneous recording disks manufactured by the Presto Recording Corp., 139 West 19th St., New York City will be protected by the National Patent Corp. against any damages arising from claims of patent infringement.

Literature

To make it easy to keep up to date on literature listed, *Electronics* will request manufacturers to send readers literature in which they are interested. Simply fill in the coupon on page 57.

1. **Electrical Control Equipment.** A folder showing some of the numerous electrical control products bearing the Dunco trade mark has been made available by Struthers-Dunn, Inc., 139 North Juniper St., Philadelphia, Pa.

2. **Switching Equipment.** Switching equipment for power lines is described in the March-April issue of the Delta-Star. Several new price lists have also been released by the Delta-Star Electric Co., 2400 Fulton St., Chicago, Ill., covering switching equipment.

3. **Control Switches.** A series of new catalog sheets has been issued April 15 and supersedes older material describing switches and starting devices manufactured by the Square D Co., 710 South Third St., Milwaukee, Wis.

4. **Beetleware.** "Adding Beauty of Sight to Beauty of Sound," is the name of an illustrated folder showing the application of beetleware to the manufacture of table model radio receivers. The bulletin is available from the Beetle Products Division, American Cyanamid Co., 36 Rockefeller Plaza, New York City.

5. **Brazing Alloy.** Bulletin 10 issued by Handy & Harman, 82 Fulton St., New York outlines the advantages of this company's Easy-Flo brazing alloy having a melting point of 1175 deg. F.

6. **Industrial Regulators.** Bulletin announcing the entrance of the Ideal Commutator Dresser Co., of Sycamore, Ill. into the field of regulator equipment and describing some of the advantages and uses of these regulators for automatic voltage, current and speed control, is available.

7. **Steatite Insulators.** Bulletin No. 537 published by the General Ceramics Co., 30 Rockefeller Plaza, New York City, is entitled "Standard Steatite Insulators for High Frequency Service" and gives the physical dimensions of a variety of insulator forms available from stock.

8. **Flexible Metal Tubing.** A 16-page bulletin SS-3 lists the advantages, applications, and similar information of seamless flexible metal tubing manufactured by the American Metal Hose Branch of the American Brass Co., Waterbury, Conn.

9. **Optical Equipment.** A single page folder describes a microfilm reader manufactured by the Bausch & Lomb Optical Co., Rochester, N. Y. This magnifier is intended to be used in those libraries where the material is microphotographed on standard 35 mm.

LEARADIO MOTOREEL

For Aircraft Use



Reels antenna "in and out." Remote control gives proper length of weighted antenna wire

Now A Completely Automatic Antenna Reel at Moderate Price

Ask about
the new
low-cost
radio direction
finder.

The new Learadio Motoreel for aircraft communication is completely automatic; electrically operated. Increases range and reliability of any transmitter. Simple to operate. Easily installed. Weight only 11 lbs.

Price complete, ready to install . . . **\$198.00**
With continuously variable
tuning inductance **\$223.00**
Code: "REELO"

Send for complete specifications and literature.

LEAR DEVELOPMENTS, INC.
121 West 17th Street, New York, N. Y.
Export Division: 17 State St., N.Y.C. Cable Address: Learvelops



Frequency Measuring Service



Many stations find this exact measuring service of great value for routine observation of transmitter performance and for accurately calibrating their own monitors.

MEASUREMENTS WHEN YOU NEED THEM MOST
at any hour every day in the year

R.C.A. COMMUNICATIONS, Inc.

Commercial Dept.

A RADIO CORPORATION OF AMERICA SERVICE

66 BROAD STREET

NEW YORK, N. Y.

WAXES • COMPOUNDS • VARNISHES for ELECTRICAL INSULATION

Zophar offers prompt service on Insulating Compounds for a wide variety of electrical applications, including:

... insulation for CONDENSERS, TRANSFORMERS, COILS, power packs, pot heads, sockets, wiring devices, wet and dry batteries, etc. Also WAX SATURATORS for braided wire and tape. WAXES for radio parts.

Special compounds made to your order.

ZOPHAR MILLS INC.

130-26th St.

Brooklyn, N. Y.

FOUNDED 1846

High FIDELITY

is the trend



AR43—\$75.00

• Brush sound cell construction is a "natural" for high fidelity. Faithful response over a wide frequency range is an inherent feature.



BR25—\$37.50

• When Brush microphones are rated as being flat in response, for a given frequency range, they ARE FLAT—No mechanical or electrical compensation is necessary.



B1—\$32.50

• These facts have been realized and hundreds of sound cell mikes are being used for sound level analysis and calibration purposes—Plus the thousands in "P. A." and broadcast applications.

Technical Data on request

The **BRUSH**
Development Co.
3316 Perkins Ave.
Cleveland, Ohio

motion picture film. Catalog D-221 entitled "Spectrometric Equipment" is a technical bulletin of general information concerning the use and applications of Bausch & Lomb spectrometers and associated equipment which will be found of use to the university or research laboratory worker.

10. Unitap Transformers. A single page folder describing unitap transformers (transformers having a multiple of secondary taps) is available from the B. F. Miller Co., Trenton, N. J.

11. Recording Accessories. A new price list covering recording disks, cutting and playback needles, etc., is available from the Mirror Record Corp., 58 West 25th St., New York City.

12. Transformers. A revised edition of the "T" line catalog covering audio and power components for amateur transmitter and public address systems is available from the Kenyon Transformer Co., 840 Barry St., New York City.

13. Recorder. A 4-page reprint from a magazine article entitled "Recording—New Business for the Radio Dealer," is available from the Presto Recording Corp., 139 W. 19th St., New York City.

14. Cenco News Charts. No. 14 of the *Cenco News Charts* dated May 1937 gives a considerable amount of interesting and useful information concerning some of the school and college laboratory products which are available from the Central Scientific Co., 1700 Irving Park Blvd., Chicago, Ill. One of the articles in this bulletin "Getting Closer to Atoms and Molecules," describes simple laboratory demonstration apparatus for making the effects of atoms visible. Another article entitled "Particle Sizes in Powders Found by Novel Method" outlines an interesting application of photoelectric tubes.

15. Vibration Study. Industrial bulletin under this name available from the Sundt Engineering Co., 4238 Lincoln Ave., Chicago.

16. Remote Control. Remote control for automobile radio receivers described in a bulletin of the Star Machine Manufacturers, Inc., 1371 East Gay Ave., Bronx, N. Y. Catalog No. 371.

17. Transformer Products. A loose-leaf catalog and bulletin under this title is available from the Kenyon Transformer Co., Inc., 840 Barry St., New York, N. Y.

18. Aerovox Catalog. A new catalog on condensers has recently been issued by the Aerovox Corp., 70 Washington St., Brooklyn, N. Y.

19. Power Tube. Catalog 53-57 gives technical information on Gammatron electronic products manufactured by Heintz & Kaufman, Ltd., South San Francisco, Calif.

"APIEZON"

OILS, GREASES AND WAXES

for high vacuum work have vapor pressures as low as 10^{-6} mm. of Hg, and even unmeasurable at room temperature.



THE Apiezon products which we now carry in our Philadelphia stock, include special oils for oil-diffusion vacuum pumps, and a variety of oils, greases and waxes for sealing joints and stop-cocks in high vacuum systems. Bulletin 1385-E listing physical characteristics and prices will be forwarded upon request.

JAMES G. BIDDLE CO.
ELECTRICAL AND
SCIENTIFIC INSTRUMENTS
1211-13 ARCH ST. PHILADELPHIA, PA.



VISASIG

Full Automatic Siphon
Tape Recorder

For Commercial and Amateur Use
Let Visasig solve your code reception problems

Model VI-B—records code signals from a radio receiver up to and in excess of 100 WPM. Complete as pictured above

\$69.00

Model V-4—records up to and in excess of 200 WPM. Complete

\$150.00

—Write for full particulars—
Prices FOB New York City

Universal Signal Appliances
64 West 22nd St., New York City
Department E

20. **Cable Accessories.** Cable connectors and accessories are described in Catalog No. 47-J issued by the American Phenolic Corp., 506 South Throop St., Chicago, Ill. Sockets and plugs are also listed.

21. **Tube Bulletin.** Technical bulletin on the 6B8, 6B8G, and type 15 tubes has recently been issued by the Raytheon Production Corp., 55 Chapel St., Newton, Mass.

22. **Plugs and Sockets.** A line of small plugs and sockets is described in a bulletin issued by the Cinch Manufacturing Corp., 2335 West Van Buren St., Chicago.

23. **Tubes.** Five 6.3 volt, 150 milliamperere heater tubes, 6GHG, 6L5G, 6N5, 6F7G and 6T7G are described in technical bulletin issued by the RCA Manufacturing Co., Harrison, N. J.

24. **Amber.** The properties and uses, especially the electrical uses, of amber are described in a 4-page bulletin issued by the Amber Mines, Inc., 353 5th Ave., New York City.

25. **Automobile Antennas.** Bulletins describing automobile radio antennas, together with suitable equipment for installing these devices is available from the J. F. B. Manufacturing Co., 4111 Fort Hamilton Parkway, Brooklyn, N. Y.

26. **Tuning Indicators.** A technical bulletin on a variety of electron tuning indicators is available from National Union.

27. **Intercommunicating System.** A series of intercommunicating systems, manufactured by the Remler Co., Ltd., 19th at Bryant Sts., San Francisco, Calif. is available from that company.

28. **Automatic Electronic Regulators.** Bulletins 5601 and 5602 describe two types of electronic automatic alternator voltage regulators manufactured by the Ward Leonard Electric Co., Mount Vernon, N. Y.

29. **Sylvania Tubes.** Technical bulletin covering the tubes manufactured by the Hygrade Sylvania Corp., Emporium, Pa. includes an interchangeable tube chart, tube base chart, a table of average characteristics, and technical bulletin on the type 6D7D and the 6DY5G.

30. **Intercommunicating System.** A loose-leaf catalog of the intercommunicating system manufactured by the Techna Corp., 926 Howard St., San Francisco is available from that corporation.

31. **Microphone.** A bulletin describing dynamic microphones made by the American Microphone Co., Inc., 1950 Southwestern Ave., Los Angeles, Calif. is available from this firm.

32. **Tube Base Connection.** A newly revised folder which classifies more than 400 makes and types of vacuum tubes according to their base connection has

been issued by the Weston Electrical Instrument Corp., Newark, N. J.

33. **RCA Products.** Bulletins are available from the RCA Manufacturing Co., Camden, N. J. describing piezoelectric filters for amateur work, dynamic microphones, and high fidelity measuring equipment.

34. **Oscilloscope.** A bulletin describing an oscilloscope using a 2-in. cathode ray oscillograph tube is available from the Supreme Instrument Corp., Greenwood, Miss.

35. **Continuous Furnaces.** "Making Continuous Furnaces Continuous" is the title of a folder available from the Porcelain Enamel & Manufacturing Co., Pemco & Eastern Aves., Baltimore, Md.

36. **Electrical Control Apparatus.** Catalog 4071-A deals with electrical control apparatus such as relays, stepping switches, impulse counters, etc., manufactured by the American Automatic Electric Sales Co., 1033 West Van Buren St., Chicago, Ill.

37. **Radio Hardware.** Catalog 37 describes a complete line of radio hardware for the constructor manufactured by the American Radio Hardware Co., Inc., 476 Broadway, New York City.

38. **Public Address System.** A high power public address system, especially suitable for sound coverage of large areas such as automobile raceways and aviation fields is described in a bulletin issued by the Western Electric Co., 195 Broadway, New York City. Bulletins describing the non-directional dynamic microphone type 630 A as well as the 618 A dynamic microphone and 80-A amplifier are also available.

39. **Motor Equipment.** A catalog describing motor operated industrial equipment is available from the Ideal Commutator Dresser Co., Sycamore, Ill.

..... COUPON

electronics July

Please send me the manufacturers' literature identified by the numbers circled below.

1 2 3 4 5 6 7 8 9 10 11 12 13 14
15 16 17 18 19 20 21 22 23 24 25 26 27 28
29 30 31 32 33 34 35 36 37 38 39

Name

Title

Company

Address

City

State

An Offer that has stood for 24 Years to users of Electrical Contacts

SINCE 1913 the Fansteel research laboratory has been open to users of electrical contacts. For nearly a quarter century, in good times and bad, Fansteel has maintained a staff of metallurgists and engineers whose specific function has been the study of customers' contact problem. A list of the concerns who have made use of this unique research service would constitute a Social Register of electrical manufacturers.

Tungsten, molybdenum, silver, platinum and a number of exclusive special alloys are used in the manufacture of Fansteel contacts. This wide choice of materials enables Fansteel engineers to recommend, without bias, the right contact for any electrical or mechanical condition.

We can sell you stock contacts, of course. But we would rather make a careful study of your product, backed by a series of comprehensive tests, and design contacts especially for its own particular condition.

And the best part of it all is that "custom built" Fansteel contacts usually cost no more—often less—than makeshifts.

FANSTEEL

METALLURGICAL CORPORATION
NORTH CHICAGO, ILLINOIS



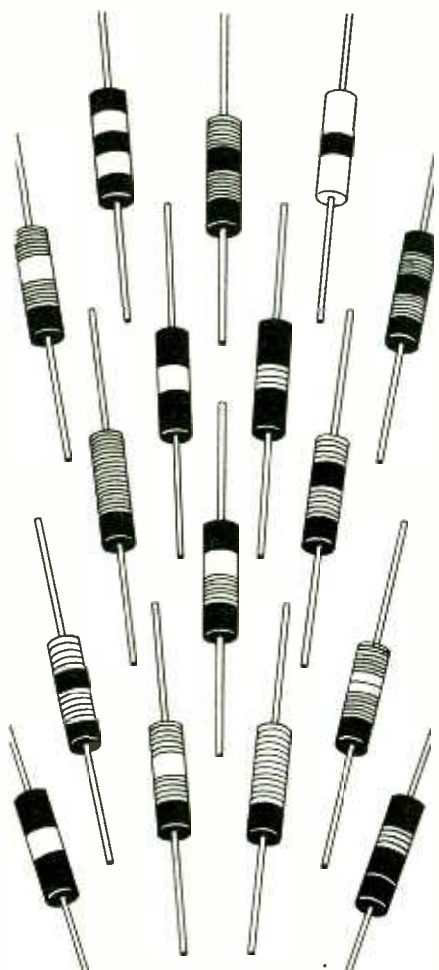

SPEER INSULATED RESISTORS

A complete range of resistance, Bakelite insulated, R.M.A. color-banded, the utmost in reliable and uniform accuracy, are products of the Speer Carbon Co., known for 29 years of pioneering and quality products. These dependable insulated resistors are standard in many of the most popular radio receiving sets on the market. They are available to you—anywhere from free samples to millions.

SPEER CARBON CO.
ST. MARYS, PA.



New Products

High Frequency Power Tube

DESCRIBED AT THE I.R.E. Convention in May, the RCA Manufacturing Co., of Harrison, N. J. announces two new water-cooled transmitting triodes designed to give high power at ultra-high frequency. Alike in fundamental design, these tubes, the 887 and the 888 feature no internal insulating material, low inter-electrode capacitances, low lead inductance, attached water jacket and high output capability. The 877 has a low amplification factor whereas

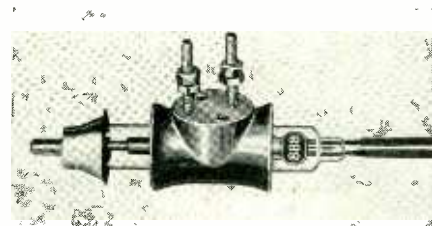

the 888 has a high μ . When used as oscillators, these tubes can be operated with a maximum power input of 1,200 watts at frequencies as high as 240 megacycles. In radio frequency amplifier service with its inherently higher efficiency at the higher frequency, either type can be used with maximum input at frequencies as high as 300 megacycles. Maximum power output is between 200 watts and 1 kilowatt, depending upon the method of operation, the plate voltage and the frequency.

...

Mobile P.A. System

A COMPACT, rugged public address system which may be used on the 110-volt a-c lines or which may be operated from a 6-volt d-c source has just been announced by the Operadio Manufacturing Co., St. Charles, Ill. The model 132-BAB uses beam power tubes and



has an output rated at 25 watts. Two 12-in. permanent magnet speakers especially designed for public address work are included with the installation. Interchangeable power packs for 6-volt or 110-volt operation are available.

For 3 AG FUSES

No. 1075

LITTELFUSE EXTRACTOR FUSE POST

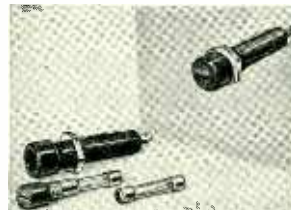

Made entirely of black Bakelite. Meets Underwriters' specifications. No parts are exposed. Safe rating 500 watts 125 or 250 volts. For panels up to 5/16". 1/2" diameter mounting hole, length 1 3/4" from front of panel; 2 1/8" overall. A superior mounting. May we sample and quote?

LITTELFUSE LABORATORIES
4242 Lincoln Ave. Chicago

Relays
made by Specialists to
suit your particular
requirements.

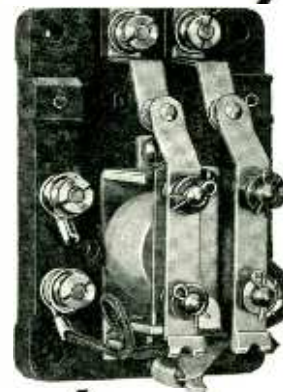

Put your problems
up to us.



STRUTHERS DUNN, Inc.
148 N. Juniper St.
Philadelphia, Pa.

Manufacturing Specialists of
Electrical Control Equipment

Dunco

Converters

A 5½ KVA. quenched spark type of converter employing a variable frequency primary excitor circuit which is tuned and capacitively coupled to a low

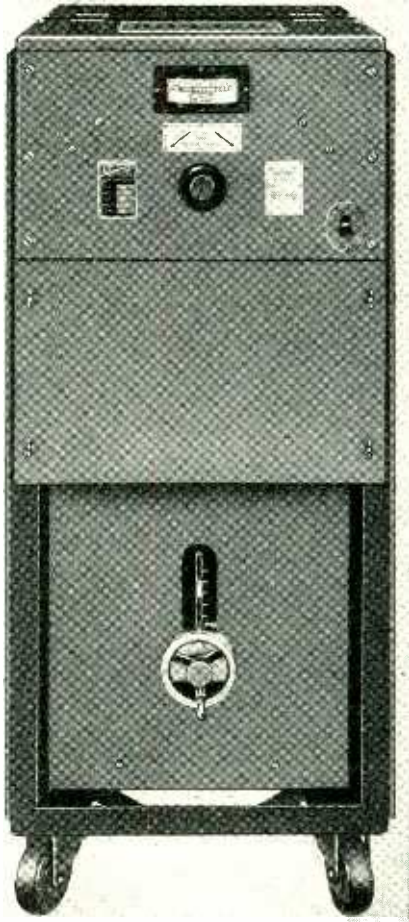

loss tank circuit is announced by the Ecco High Frequency Corp. 120 West 20th St., New York, N. Y.

Permanent Magnet Speaker

PERMANENT magnet speakers in two pieces, and available in 5 in., 6½ in. and 8 in. sizes, have been announced by the Ariston Manufacturing Co., Chicago, Ill. A feature of this speaker is that if the cone becomes damaged, it can be replaced without returning the entire unit to the factory. A closed magnetic circuit is maintained and does not need to be returned to the factory to be remagnetized.

Control Switch

A HERMETICALLY SEALED SWITCH which may be operated in any position and which is free from the deleterious effects of oil, moisture or dust, is announced by the Heineken Machinery Corp., 95 Liberty St., New York. It is possible to operate these switches above the boiling point of water without deterioration.

Non-Freezing Electrolytic Condenser

A NEW ULTRA-COMPACT, non-freezing wet electrolytic condenser is announced by the Solar Manufacturing Co., 599 Broadway, New York City. Ranges up to 8 microfarads at 500 volts peak and 38 microfarads at 100 volts peak are furnished in a can only 1 in. in diameter by 1 15/16 in. high. According to the manufacturer, temperatures as low as -20 deg. C. find these new units, (commercially known as "Minicaps") still in operative condition. The capacity of the new wet electrolytic condensers is governed largely by the peak voltage desired.

Insulated Cable

A NEW SYNTHETIC insulating compound has been recently introduced commercially by the General Electric Co. under the trade name Flamenol. While similar to rubber in its characteristics, it contains no rubber and will not support combustion. In addition to being non-combustible it is highly resistant to moisture, acid, alkalis, and oils. It has excellent aging characteristics and is mechanically strong. The properties of Flamenol are such that it can be made a very soft and flexible compound, or can be made to be one with celluloid-like rigidity. Flamenol insulated cable is recommended for power and control circuits at 600 volts and less and for operation at a maximum temperature of 60 deg. C. This cable is available in a variety of colors for circuit tracing.

Iron Core Transformers

A NEW GROUP of iron core intermediate frequency transformers is now being made by the Hammarlund Manufacturing Co., Inc., 424 West 33rd St., New York City. These new transformers provide high gain per stage, together with sharp selectivity. Finely powdered high permeability magnesium al-

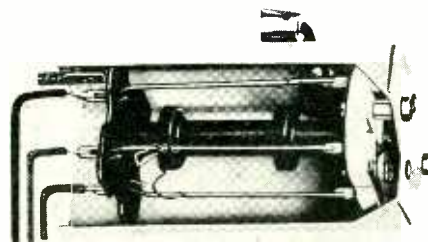

loy is used for the core permitting a great increase in inductance and a reduction in the number of winding turns with consequent reduction of eddy current losses. The overall size of these transformers is 4½ in. high by 1½ in. square. They are all tuned to 465 kilocycles.

HERE IS THE MOST
Complete
P.A. AMPLIFIER
Yet Developed

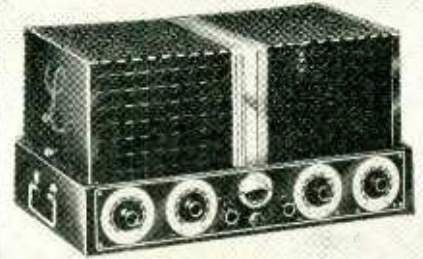

Only LAFAYETTE
OFFERS YOU THESE
20 GREAT FEATURES!

1. 60-90 Watts output; 2. Harmonic content at 60 watts, 3%; 3. Maximum gain 140 db; 4. Frequency response within 2 db-50 to 10,000 cycles; 5. Hum level-50 db below 60 watts; 6. 4 Input channels; 7. Built-in 40 watt field supply; 8. Four 6L5 tubes in output stage; 9. Semi-fixed bias supply; 10. Separate A.V.C. and A.V.E. amplifier. Instantaneous action; 11. Mixing and fading facilities; 12. Cathode-Ray "eye" output indicator; 13. Exclusive (illuminated) "Neo-Dial"; 14. New inverse feed back circuit; 15. Photo-cell and Veletron microphone supply; 16. Variable output impedances from .35 to 500 ohms; 17. 5 stages -14 tubes (all metal type); 18. Variable A.V.C. and A.V.E. control; 19. Variable Tone Control; 20. Calibrated control for Cathode-Ray output indicator.

Model 293 ADF, 60 Watt Amplifier **\$59.50**

The Lafayette line is the most complete in the world. Why not investigate the splendid values offered in our FREE catalog? There are systems and parts for every conceivable need. Special equipment made to your specifications. Mail the coupon below for your copy—it's FREE.

LAFAYETTE PRODUCTS DISTRIBUTED SOLELY BY

WHOLESALE RADIO SERVICE CO., INC.

NEW YORK, N. Y. CHICAGO, ILL.
100 SIXTH AVENUE 901 W. JACKSON BLVD.

ATLANTA, GA.
430 W. PEACHTREE ST., N. W.

BRONX, N. Y. NEWARK, N. J. JAMAICA, L. I.

WHOLESALE RADIO SERVICE CO., INC.
100 SIXTH AVENUE, NEW YORK, N. Y.

Send FREE catalog Nos. 68-1467.

Name

Address

City

**MAIL THIS COUPON NOW
FOR FREE CATALOG!**

Here It Is! THE Instrument of 1000 Uses

**HANDY
SIZE**



**Molded
Case and
Panel**

**COMPLETE
A. C. - D. C.**

**Model
666**

DEALER NET \$15.00

POCKET VOLT-OHM- MILLIAMMETER

Engineers are very enthusiastic about this pocket size instrument, sturdy and precision built. Handy for laboratory, shop or field use.

Model 666—Has 3" Sq. Triplett Rectifier Type Instrument.

A.C.-D.C. Voltage Scales Read: 10-50-250-500-1000 at 1000 ohms per volt.

D.C. Milliampere Scale Reads: 1-10-50-250.

Ohms Scales Read: Low ½-300; High 250,000. Size—3 1/8" x 5 3/4" x 2 1/4"

Black Molded Case and Panel.

Low Loss Selector Switch.

Complete with Alligator Clips, Battery and Test Leads.

Dealer Price \$15.00

A complete instrument for all servicing and other needs. Can be used for all A.C.-D.C. voltage, current and resistance analyses.

Attractive Heavy Black Leather Carrying Case with Finished Edges and Strap. Model 669, supplied extra.

Dealer Price \$3.00

WRITE FOR CATALOGUE



The Triplett Electrical Instrument Co.
234 Harmon Ave., Bluffton, Ohio

Without obligation please send me

More information on Model 666.

I am also interested in.....

Name

Address

City State

Dynamic Pickup

A NEW ELECTRODYNAMIC phonograph reproducer manufactured by the Sound Apparatus Co., 150 West 46th St., New York City offers the advantages of the electrodynamic principle in a playback for lateral cut records. This type of unit is inherently free from distortion and its constant impedance allows it to be matched to the amplifier in all frequencies. Its impedance characteristic allows sharp cut-off band controlling filters to be used between the reproducer and amplifier input and the response is practically flat from 40 to 8,000 cycles per second.

Rectifier

THE RECTIFIER, a new unit combining a 110-volt, ac transformer and a copper oxide rectifier, designed primarily to provide a 6-volt, d.c. power supply for power relay operation, has recently been introduced by the Weston Electrical Instrument Corp., Newark, N. J. Output of the transformer is



120 milliamperes continuous, or 200 milliamperes intermittent operation. The rectifier employed is of the stable copper oxide type. In addition to its use in energizing power relays, the rectifier may be used in any similar d.c. requirements where filtered current is not essential.

H F Induction Furnace

TWO NEW APPLICATIONS of induction heating are now being installed by Ajax Electrothermic Corp., Trenton, N. J. These include induction heating of tube ends prior to a series of forging operations and heating and end section of a large steel tube prior to swaging operation. The difference in the two applications is that for surface hardening a large amount of power is concentrated for a short time so that the heating is all confined to the surface of the metal which is then rapidly quenched to produce a very hard surface with a tough core. In the tube end heating application the power is not kept at such a high value, the time is extended to nearly a minute and the walls of the end of the tube are uniform in temperature at 2200 deg. F.

DU MONT Announces the new ALL-PURPOSE Five Inch OSCILLOGRAPH



TYPE 168

BECAUSE DU MONT
COMBINES CATHODE
RAY INSTRUMENT AND
TUBE DESIGN, THIS
NEW OUTSTANDING
OSCILLOGRAPH IS
MADE POSSIBLE

**RUGGED
PORTABLE
EFFICIENT
ACCURATE**

PLUS

These Important Features

- ★ A five inch new type 54-XH Du Mont Cathode Ray Tube — fine uniform focus.
- ★ Vertical plates direct, one stage or two stage amplifier, wide range.
- ★ Horizontal plates direct, one stage amplifier, or linear sweep.
- ★ High input impedance to amplifiers.
- ★ Amplified and calibrated linear sweep 15 to 30,000.
- ★ Sweep return trace eliminator.
- ★ Sweep expanding amplifier.
- ★ Complete freedom from interaction between controls.
- ★ All controls on front panel with graduated dials.
- ★ Removable calibrated celluloid scale for tube.
- ★ 400 volt power supply for amplifiers and sweep.
- ★ Separate 1100 volt rectifier for Cathode Ray Tube.
- ★ Internal or external positive synchronization.
- ★ Terminals provided for direct connection to deflection plates for D. C. and R. F. signals.

For Complete Information Write

Allen B. Du Mont Laboratories, Inc.
Upper Montclair New Jersey

HYVOL HIGH-VOLTAGE CAPACITORS



Ultra-compact, due to use of new HYVOL super-dielectric oil.

Sturdy steel container. High-tension terminals. Leak-proof.

1 to 4 mfd. 600 to 2000 v. Other sizes on special order.

A new degree of compactness, together with conservative ratings and long life, is made possible by the new HYVOL super-dielectric oil now introduced for the first time by AEROVOX.

New CATALOG: Big. Startling. 32-page book. Just issued. Write TODAY for your copy.



—LEPEL— Vacuum Testers



- Will ionize gas as low as one micron of pressure.
- Cannot puncture the glass container.
- Will operate continuously.
- Ground free and shock-proof.
- Facilitates production testing of electronic tubes and incandescent lamps. Weighs 8 ounces.

Write for Bulletin 403

LEPEL

HIGH FREQUENCY LABS., Inc.
39 West 60th St., New York City
Cable Address: LEPELSPARK

Sound Amplifier

THE "Soundmaster" reinforcing amplifying system manufactured by the Sundt Engineering Co., 4238 Lincoln Ave., Chicago, Ill. is a completely self-contained microphone - amplifier - loud-speaker system designed to meet the needs for a light, five-minute set-up unit

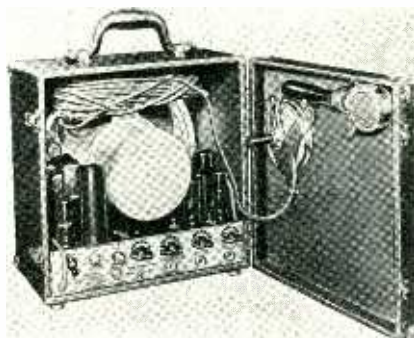

for use by public speakers, soloists, orchestras, etc. The audio power output is 12 watts, and the Soundmaster is equipped with a 12-in 15-watt speaker. It operates directly from 110 volt, 50 to 60 cycle line, but converters for battery operation can be furnished.

Hand Microphone

THE BRUNO LABORATORIES, INC., New York City, introduces their new Model HA hand Velotron microphone. It is strictly a close talking microphone and will not pick up extraneous noises. It has an output of -50 db., im-



pedance to grid, frequency response is adjustable (30 to 14,000 cps.) and requires a polarizing voltage of 150 to 350 volts. The microphone weighs 13 oz. and is finished in chrome.

Assembled Voltage Dividers

BY MEANS OF handy sectional units and the mounting base of the required length to accommodate them, it is possible to assemble voltage dividers to meet any individual need through the use of the new BYO or Build-Your-Own resistor network developed by the Clarostat Manufacturing Co., Inc., 285-7 North 6th St., Brooklyn, N. Y. Each sectional unit is a complete molded seal, metal-clad resistor with two terminals. The individual units slide into and fit snugly in the base mounting strips which assist in the conduction and radiation of heat. The individual sections may be wired in series, or may be used individually if desirable.

Compressed Gas Condenser TYPE 174

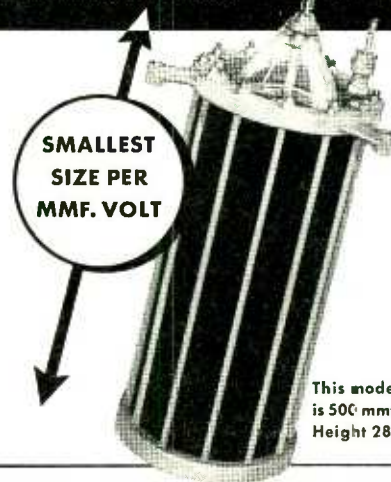

This model is 500 mmf. Height 28"

INVESTIGATE these UNIQUE compressed gas condenser ADVANTAGES

FOUR CAPACITIES: 250, 500, 1000 and 1500 mmf. TWO RATINGS . . . 40,000 and 32,000 rms working volts.

CONTROL External, continuously variable.

LOSSES Lower than equivalent air condensers.

ALSO Lower distributed inductance, complete shielding.



SOUND RECORDING EQUIPMENT



Designed, engineered and manufactured with laboratory precision by men with long recording experience who understand recording problems—these instruments will meet the most exacting professional requirements—yet they are priced within the range of every potential user.

Sturdy in construction—simple in operation—with many NEW and EXCLUSIVE mechanical and electrical features.

We invite you to consult us freely concerning your recording problems. Write for photos, including complete descriptive literature, data and prices.

Also manufacturers of the famous ALLIED blanks for instantaneous recording. Literature and price list sent upon request.

Allied Recording Products Co.
126 West 46th St., New York, N. Y.
Cable Address: Allrecord



B A R E X Embedded Getters

Our experience in specializing in the manufacture of just one product—the Embedded Getter—is illustrated by the fact that we produce more different sizes, shapes and compositions of getters than any other manufacturer in the world.

KING LABORATORIES, Inc.
205 Oneida St. Syracuse, N. Y.



The SIGMA RELAY MODEL 2-A

A 12 milliwatt semi-sensitive instrument for general electronic and industrial uses.

It embodies the following features:

Input 12 milliwatts, D.C.
Hair-spring adjustment.
Single-pole-double-throw.
Operable in any position at rated input.
Fine silver contacts control non-inductive loads up to 1½ amperes at 110 volts A.C.
Neatly housed in glass-topped dust cover.
Mounted on 5-pronged plug-in base fitting standard V.T. socket.

With coil resistances up to 2,000 ohms..... \$5.00
With higher coil resistances up to 8,000 ohms... 5.50

SIGMA INSTRUMENTS, INC.

388 Trapelo Road

Belmont, Mass.



One pair of New Series "JK" Cannon Cable Connectors (up to 37 poles) for Airplane, Radio and Signal equipment.

Coming... **COMPLETELY NEW**
line of **CANNON Plugs**
exclusively for **Airplane,
Radio and Signal Service**...
4 sizes, ranging from 4 to 37 poles!

CANNON ELECTRIC DEVELOPMENT CO.

★ 420 West Avenue 33, Los Angeles, California
★ EASTERN SALES OFFICE 220 Fifth Ave., New York, N.Y.

CANNON PLUGS



Portable Recorder

A PORTABLE RECORDER, an electric phonograph, and a sound amplifier, any one of which may be selected at will, is available in the model F automatic portable recorder manufactured by the



Vibro-Master Co., 29 West 57th St., New York, N. Y. The amplifier consists of a three-stage, high gain, wide range amplifier, using five glass metal tubes. The output stage incorporates push-pull type 45 tubes.

Panel Wiring Box

THE TECH LABORATORIES, 703 Newark Ave., Jersey City, N. J. have developed a panel wiring box which eliminates the disadvantages of the old-fashioned method of wiring such apparatus as mixer panels, switching and relay panels, amplifiers, receivers, etc. The wiring is pre-fabricated and housed in a completely shielded box which may be fastened to the panel with two machine screws. The construction is such as to have made possible substantial reduction in the capacitance to ground so that these units may be used up to the highest radio frequency. They may equally well be applied to the wiring of receivers, amplifiers, oscillators, etc.

Pick-up

THE UPKO ENGINEERING LABORATORIES, Inc., 254 Canal St., New York City announce their types M-1 and M-2 high fidelity featherweight pick-up models. These models will play all records up to 12 in. at 78 or 33 1/3 r.p.m. and are furnished with a standard im-



pedance of 10,000 ohms. Other impedance can be supplied on request. The characteristics of both of these pick-ups are identical except that the type M-2 has a volume control built in its base.

Detachable Meters

NEW, LOW COST, detachable instruments for general industrial use whose sockets may be cut into the conduit run feeding a motor or grouped in standard metal boxes to constitute a panel assembly, are announced by the Westinghouse Electric & Mfg. Co., East Pittsburgh, Pa. Advantages of the plug-in meters for industrial use include elimination of costly panels, wiring, and mounting details, flexibility through the interchanging of meters

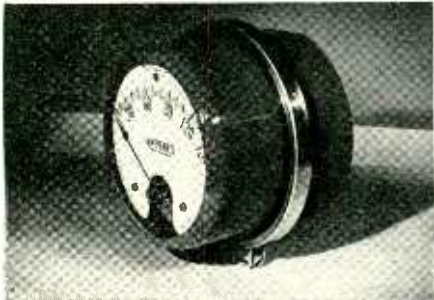

in the sockets, together with the fact that sockets can be installed and sealed off providing convenient outlets for future installation of instruments or making connections for portable analyzers or periodic testing. The detachable instrument consists of two main units, a socket or mounting device which is provided with electrical connection jaws, and the instrument mechanism mounted on a plate having electrical blades on the back and enclosed in a weatherproof housing of glass. The instrument may be of the repulsion iron vane type, the D'Arsonval type, or the dynamometer type.

Versatile Meter

THE SERIES 840 multimeter manufactured by the Precision Apparatus Corp., 821 East New York Ave., Brooklyn, N. Y. will measure voltages either a.c. or d.c., direct current, re-

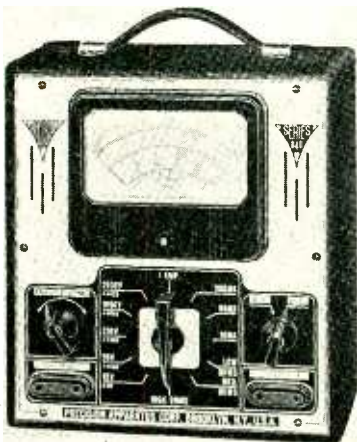

sistance and power in decibels. The meter is housed in modern bakelite square case with large window openings. Cabled wiring is used.

ANNUAL REFERENCE SHEETS SERVICE

for

ELECTRONICS SUBSCRIBERS

ELECTRONICS has received numerous requests for additional copies of the Reference Sheets that are contained each month in the publication. These requests come from subscribers who do not wish to cut their issues in order to remove the page for insertion in their loose leaf binder. Because the number of these requests are such a large proportion of our subscribers, Electronics is undertaking the additional service of supplying a complete set of these charts on an annual basis.

All Reference Sheets contained in Electronics during the calendar year will be reprinted on heavy paper, assembled and punched for the binder and sent complete to such subscribers who have placed their order at the time of publication.

Enough subscribers have indicated their intention of ordering sets to enable us to keep the price down to \$1 per set plus a small delivery charge. To such subscribers that send payment with their order, thus eliminating bookkeeping and collection expense, we will pay the delivery costs.

This service is open to bona fide subscribers at the time of publication December 1st.

Sets of charts will be printed for only the quantity of orders on hand December 1st. Delivery will be about December 15th. Placing your order with payment now will insure you a complete set of charts for the binder without further thought.

USE COUPON BELOW AND MAKE CHECKS PAYABLE TO ELECTRONICS YEARLY SERVICE

ELECTRONICS
230 W. 42nd St.
New York City

Enter my order for ELECTRONICS REFERENCE SHEETS for 1937 at \$1.00.

Here is my check. Send sheets postpaid. Bill me \$1.00 plus small delivery charge.

Name

Address

City State

THE NEW PRESTO STATIONARY RECORDER



Change speed from 78 to 33 1/3 R.P.M. in 2 seconds . . . change pitch or direction of cut in 10 seconds . . . finish one recording and start another in 15 seconds.

These are the features that busy recording studios appreciate in the new Presto stationary recorders.

Your local Presto representative will demonstrate this machine without obligation. Literature is available on request.

PRESTO RECORDING CORPORATION
143 W. 19th St., New York, N. Y.

PRESTO

RECORDING CORPORATION

New York, N. Y. • U. S. A.

For an engineering analysis of vacuum tube laws and applications, see this book

A treatment that bridges the gap between the highly mathematical tube treatise and the largely descriptive volume. It combines in a single text the basic theory underlying the operation of all types of modern vacuum tubes, both radio and industrial.

Just published

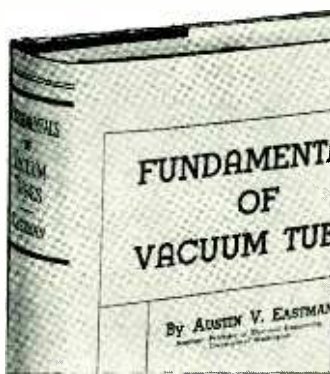

Fundamentals of Vacuum Tubes

BY AUSTIN V. EASTMAN

Assistant Professor of Electrical Engineering, University of Washington

438 pages, illustrated, \$4.00

THIS book discusses at length the principal types of vacuum tubes—high vacuum tubes, mercury-vapor tubes, photo tubes, and several special varieties—and the laws underlying each, with engineering analyses of their more important application. Such recent developments as inverse, feed-back amplifiers, beam power tubes and Ignitrons have been carefully treated. Graphical solutions for power amplifiers, both exact and approximate design procedures for Class B and C amplifiers, and harmonic analysis of output waves have also been included.

EXAMINE THIS BOOK 10 DAYS ON APPROVAL—SEND THIS COUPON
McGraw-Hill Book Co., Inc., 330 W. 42nd St., N. Y. C.

Send me Eastman—Fundamentals of Vacuum Tubes for 10 days' examination on approval. In 10 days I will send \$4.00, plus few cents postage, or return book postpaid. (Postage paid on orders accompanied by remittance.)

Name

Address City and State

Position Company L. 7-37

(Books sent on approval in U. S. and Canada only.)

BACKTALK

(Continued from page 46)

sines' becomes the 'law of angles' and we have the amazingly simple relation

$$\frac{A}{a} = \frac{B}{b} = \frac{C}{c} = C$$

where the angles a, b, and c are read on the S scale; which is just as easily used as the A or C scales. Thus suppose we have a 30, 60, 90 degree triangle in which C = 17. Set 90° on the S scale opposite 17 on the A scale, and opposite 30° on the S scale read 8.5 on the A scale for the short side, and opposite 60° on the S scale read 14.7 on the A scale for the long side. Suppose now the impedance to change at the same angle to a new value of 23. Set the 90° to 23 and take readings on the A scale opposite the given angles on the S scale, as before, and get 19.9 and 11.5.

"This method gives all the information desired in any case and so is all that is required. No new methods need to be learned and no tables are necessary. We simply make use of what we already know. Thus given the angle of lag and the branch reactance, how long would it take to find the other functions of the circuit by the algebraical method? Just try it and see. Given X = 1500, and a = 37°, then, under 1500 on the A scale set 37° on the S scale, and opposite 90° find C = 2490 and opposite the complementary angle find B = 1990.

"To find the complementary angle without even knowing what it is, merely count 37° backward from 90° on the S scale; thus 80° would be the same as -10°, 70° would be the same as -20°, and 60° would be the same as -30°. Read seven more degrees off, to the left of 60° and you have the complementary angle without giving a thought to what it is, unless you wish to, and directly above it on the B scale is the sine of the said complementary angle, which is also the cosine of the lag angle and hence the power-factor.

"Further, it so happens that the tan a, is the gain in a resonant circuit, and if we have a resonant circuit in which the branch reactance is 1500 ohms and the resistance is 4 ohms, the amplification in the tank is $\omega L/R = 1500/5 = 375$ x. To find the lag angle of a very steep triangle requires the use of the method for finding small angles given in the conventional handbooks accompanying the slide rule and deserves no special treatment. On special types of work, as in the measurement of the power factor of excellent condensers, the impedance triangle is so poorly conditioned, and the need for accuracy is so great that the slide rule often is not suited to trigonometrical solution, and sometimes not to algebraical solution. Within the limitations of the slide rule the trigonometrical solution is unlimited."

**DON'T
MISS!
THIS.**

A Story Never Told Before

Coming next month — August issue of **ELECTRONICS** — a complete story on the Engineering and Research Divisions of the **RADIO CORPORATION OF AMERICA**

HISTORY PLANT LAYOUTS PERSONNEL
ENGINEERING MANUFACTURING AND RESEARCH ORGANIZATIONS
PRODUCTS AND SERVICES PROGRAMS FOR THE FUTURE
TELEVISION FACSIMILE BROADCASTING

• • •

A fascinating engineering tour through each division

R C A MANUFACTURING COMPANY
NATIONAL BROADCASTING COMPANY
R C A COMMUNICATIONS
RADIOMARINE CORPORATION

• • •

The excellent cooperation which the editors of **ELECTRONICS** are receiving from every branch of **R C A** assures one of the most enlightening and comprehensive technical-industrial stories ever compiled.

ADVERTISING FORMS CLOSE—JULY 26

Don't Miss This!

NOTE TO ADVERTISERS—The August issue offers you a better-than-usual opportunity to broadcast your sales message to a responsive and growing audience which includes every man in every company of importance in the **ELECTRONICS** industry, and to enable you to tell your story to this influential audience at less than the cost of a postcard.

electronics

ABC A McGraw-Hill Publication ABP
330 WEST 42nd STREET, NEW YORK, N. Y.
CHICAGO • CLEVELAND • DETROIT • ST. LOUIS
PHILADELPHIA • BOSTON • SAN FRANCISCO • ATLANTA



Good tubes use

RADIO CARB A

- A carbonized nickel ribbon supplied in any width from 4" to 1/8", and in thicknesses from .020 to .004".
- Surface of uniform maximum blackness. Free from loose carbon, slivers, waves, seams, rough edges, oil and grease.
- Also bare nickel strip, filament and grid materials, made to the most critical requirements.

WILBUR B. DRIVER CO.
formerly GILBY WIRE COMPANY
 NEWARK, NEW JERSEY

Resonoscope

(Continued from page 17)

The standard for A is 440 cycles per second and the horizontal oscillator is made to sweep at 220 cycles per second, then if the musician plays a 440 note two wave forms will appear on the screen. The reason for using a sub-harmonic of the standard for the sweep is so that when the lower notes are being used the results will not be split wave-forms. One of the special features of the circuit is that the horizontal sweep is automatically changed in frequency to compensate for the change in frequency in going from one note to another. This allows the sweep circuit to be synchronized easily by the standard frequencies generated by the tuning fork.

The Resonoscope has many practical applications in the musical fields, such as, tuning musical instruments, in music education, both instrumental and vocal, and in speech departments of schools as a visual aid in training in correct enunciation, etc.

In the practical use of this instrument the operator sets the control knob to the note he wishes to tune to and this setting takes care of all the octaves of that note, the only difference being a change in the number of wave forms on the cathode ray tube screen. If the musical note under observation is sharp, or higher in frequency than the standard, the wave form will move toward the right; if it is flat, or lower in frequency than the standard, the wave form will move toward the left. This gives a direct indication whether the note is sharp or flat.

The instrument has a very important place in the research laboratory of the musical instrument manufacturer to perfect instruments and also as a solution of the commercial tuning problem as to the tuning of pianos, accordion reeds, harmonica reeds, organs, and other types of tuning that has to be done on a commercial scale in the manufacturing of musical instruments. For example—the piano factory; all pianos can be tuned by placing a magnetic pickup over the strings instead of the microphone, then the sound from the instruments being tuned will not interfere with each other and more than one can be tuned at the same time in the same room. In the manufacture of wood winds an artificial ambucher may be used with a constant pressure of air to blow the instrument and the instrument may be checked in respect to intonation and balance and every instrument turned out uniformly.

The Resonosopes may be used in schools and colleges in several departments; in the physics department for the instruction in physical sound as applied to music; in the instrumental music department as a guide for students to learn to play in perfect pitch and to determine the change in tone quality as to the method in blowing or sounding the instrument; and in the vocal department to train the student to sing in pitch and to hold long sustaining notes. If certain tones are accredited as being the fulfillment of a pleasant and perfect tone it may be photographed and kept as a reference for students to use as a guide in producing a repetition of this note. Still another valuable use is for the individual piano and organ tuner.

MICROHM WIRE WOUND RESISTORS

MICROHM WIRE WOUND RESISTORS are built on the foundation of a QUALITY PRODUCT and can be used as a component with the finest of precision instruments. Manufacturers interested in maintaining the QUALITY of their apparatus recognize this merit of QUALITY, demand and use only MICROHM WIRE WOUND RESISTORS. Precision Resistor Company manufactures a complete line of all types of wire wound resistors and is equipped to meet the most rigid specifications.

Write for catalog and prices

PRECISION RESISTOR COMPANY

332 Badger Ave. Newark, N. J.
 Manufacturers of custom built PRECISION and INDUSTRIAL WIRE WOUND RESISTORS.



TYPE R 1/2
 Watt (Actual Size) Res. 5
 to 500000 ohms.
 Accuracies as close as 1/10 of 1%.



As business paper publishers for over fifty years, McGraw-Hill is uniquely equipped to offer complete, authoritative direct mail coverage of Industry's major markets. Extreme accuracy is maintained (guaranteed to 98%) and thorough careful analysis of markets, complete classification of companies and personnel, etc., the widest possible selections are available. Send for handy reference folder "Hundreds of Thousands of Reasons Why" which describes how McGraw-Hill Lists are built and maintained.

What Fields Do You Want to Reach?

Aviation
 Bus & Electric Railways
 Civil Engineering and Construction

Administrative Executives
 Electrical Dealers & Wholesalers
 Mill Supply Houses
 Power Services
 Product Engineering & Design
 Production and Maintenance
 Radio Dealers & Wholesalers
 Radio Engineering & Design

For further details, selections from above basic classifications, counts, prices, etc., or estimates on special lists . . . ask any representative or write to



Complete Lists Covering Industry's Major Markets

SEARCHLIGHT SECTION

EMPLOYMENT : BUSINESS : OPPORTUNITIES : EQUIPMENT—USED or RESALE

UNDISPLAYED RATE:
 10 cents a word, minimum charge \$2.00.
Position Wanted, (full or part-time salaried employment only), ½ the above rates, payable in advance.
Proposals, 40 cents a line an insertion.

INFORMATION:
Box Numbers in care of our New York, Chicago or San Francisco offices count 10 words additional in undisplayed ads. Replies forwarded without extra charge.
 Discount of 10% if full payment is made in advance for four consecutive insertions of undisplayed ads (not including proposals).

DISPLAYED—RATE PER INCH
 1 inch\$6.00
 2 to 3 inches..... 5.75 an inch
 4 to 7 inches..... 5.50 an inch
 An *advertising inch* is measured vertically on one column, 3 columns—30 inches—to a page. *Contract rates on request.*

ENGINEERS WANTED

Radio Design Engineers and Radio Mechanical Engineers wanted by large radio firm in Great Lakes area. Experience on AC and Battery receiver design, or on radio dial and mechanism design required. State full details of experience and salary expected.

P-111, Electronics
 330 West 42nd St., New York City

Engineer or Physicist

with experiences in vacuum tube construction wanted as chief of a vacuum tube laboratory in Switzerland.

P-106, Electronics
 Aldwych House, Aldwych, London WC 2

POSITION VACANT

RADIO AMATEUR. Must be Electrical Engineering Graduate. Exceptional opportunity Chicago manufacturer. State age, education, experience, salary expected. P-112 Electronics, 520 No. Michigan Ave., Chicago, Ill.

POSITIONS WANTED

OPERATOR, first class radio telephone license, well rounded experience installation, and operation: 10 years broadcasting (studio, transmitter, announcing.) PW-104, Electronics, 330 West 42nd Street, New York City.

JUNIOR ENGINEER or laboratory assistant —4 years' experience design and installation of public address equipment. Desires to locate with firm offering future. PW-110, Electronics, 520 No. Michigan Ave., Chicago, Ill.

RADIO SERVICE ENGINEER—Seven years' experience, four with distributors. 25, married, will locate anywhere in U.S.A., have equipment. Capable of handling all technical and customer complaints for manufacturer or distributor. PW-113 Electronics, 330 West 42nd Street, New York City.

PATENT ATTORNEY, Radio, electrical and mechanical arts, formerly with Atwater Kent, desires full or part time position. PW-114 Electronics, 330 West 42nd Street, New York City.

MONITORING, continuity writing, directing, announcing. Also experienced in maintenance and operation of radio-telephone transmitters. Two years college and one year technical training. Age 21. Married. References. Now in Los Angeles. Will go anywhere there is opportunity to prove ability. PW-115 Electronics, 883 Mission Street, San Francisco, Calif.

New "SEARCHLIGHT" Advertisements

must be received by the 30th of the month to appear in the issue out the following month.

Address copy to the
 Departmental Advertising Staff
 Electronics

330 West 42d St., New York City

FOR SALE

REBUILT INSTRUMENTS of GUARANTEED ACCURACY

We Believe

No Instrument is BETTER than its
 CALIBRATION

Therefore

We maintain a STANDARDS laboratory, where every instrument is checked before shipment, and guaranteed to be accurate within the original makers specifications.

New Bulletin Now Ready

LOUIS J. WINSLOW
 200 Pennsylvania Ave., Hillside, N. J.

DEPENDABLE

New and Used

ELECTRONIC TUBE EQUIPMENT

A complete line of equipment for the manufacture of Radio Tubes, Neon Tubes, Incandescent Lamps, etc.

Write for Bulletin showing savings from 25 to 75%

EISLER ELECTRIC CORP.
 534 39th Street, Union City, N. J.

HIGH GRADE NEW AND USED ELECTRON TUBE EQUIPMENT

*Huge Stock of Equipment of
 Every Type and Variety*

KAHLE ENGINEERING CORPORATION
 Specialists in Equipment and Methods for the Manufacture of Neon Tubes, Radio Tubes, Incandescent Lamps, Photo Cells, X-ray Tubes, etc.
 941 DeMott St., North Bergen, N. J.

ELECTRONIC TUBE

NEW • EQUIPMENT • USED

For the manufacture of Electronic, X-Ray, Power, and Radio Tubes, Incandescent Lamps, Neon Signs, etc.

Write for full information

ELECTRONICS MACHINE CO.
 751 13th Street, Newark, N. J.

YOUR ORGANIZATION

*Is it complete?
 Are you expanding it?
 Making replacements?*

Naturally, you are anxious to secure the most suitable man or men available. You want men with the special training that will make them an asset to your organization. You can contact such men through a Position Vacant advertisement in the Searchlight Section of ELECTRONICS

REPAIRING AND FOR SALE

+ EXPERIENCE +

Eleven years of it—is our assurance that we can recondition your transmitting tubes properly and build in Long Life and Proper Characteristics.

Aircooled Tubes 100 to 1000
 watts

Watercooled 5 to 35 KW

Satisfaction Guaranteed

National Radio Tube Co., Inc.

3420 18th St. San Francisco, Calif.

Meters repaired, made more serviceable. Conversion to higher sensitivity as high as 10 microamperes for Weston type I or 24-57.

Sensitive vacuum thermo couples For Sale used Weston panel meters, Rawson microammeters, Brown pyrometers.

Reasonable Prices
Precision Electrical Instrument Co.
 561 Broadway, N. Y. C.

WANTED

WANTED TO BUY

Miniature Electrical Instruments

D.C. and A.C., Model 301 and others. State price and quantity.

W-101, Electronics
 520 No. Michigan Ave. Chicago, Ill.

CASH WAITING

We pay highest prices for your surplus laboratory equipment as meters, rheostats, bridges, decade boxes, etc. Submit your lists of what you have to offer.

AMERICAN ELECTRICAL SALES CO.
 65-67 E. 8th St. New York, N. Y.

Now you can have

Smooth Control of Voltage



for 5-Kva. loads on 230-volt
lines with Type "TH"

TRANSTAT* REGULATORS

New manufacturing facilities permit us to offer Type "TH" Transtat Regulators for larger Kva. loads. Standard single-phase units are now available for regulating up to 45 amperes throughout a range of 0 to 130 volts; also for regulating 22.5 amperes throughout a range of 0 to 260 volts. These units may be ganged for controlling voltage to three-phase loads.

The Transtat provides the ideal method for controlling voltage in alternating current circuits. It is a continuously variable auto-transformer regulator of the commutator type. Features are smooth control, high efficiency, good regulation, and moderate cost.

Send for
Bulletin
No. 1176.4.

* Patents 1,993,007 and 2,014,570; other patents pending. "Transtat" trade-mark registered U. S. Patent Office.

AMERICAN TRANSFORMER COMPANY

178 EMMET ST. NEWARK, N. J.



INDEX TO ADVERTISERS

Acheson Colloids Corp.	53
Aerovox Corp.	61
Allied Recording Products Co.	61
American Automatic Electric Co.	52
American Radio Hardware Co.	53
American Transformer Co.	68
Ariston Manufacturing Co.	52
Audak Company	49
Bakelite Corporation	41
Biddle Co., James G.	56
Brand & Co., Wm.	44
Brush Development Co.	56
Cannon Electric Development Co.	62
Centralab Div., Globe Union, Inc. Inside Front Cover	
Cinch Manufacturing Co.	47
Driver, Wilbur B., Co.	66
Dumont Laboratories, Inc., Allen B.	60
Dunn, Inc., Struthers.	58
Ecco High Frequency Corp.	68
Erie Resistor Corp.	37
Fansteel Metallurgical Corp.	57
General Radio Company.	39
Goat Radio Tube Parts, Inc.	50
Hardwick, Hindle, Inc.	51
Heintz & Kaufman, Ltd.	61
International Resistance Co.	37
King Laboratories, Inc.	62
Leach Relay Co.	51
Lear Development Co.	55
Lepel High Frequency Laboratories.	61
Little Fuse Laboratories	58
Mallory & Co., Inc., P. R.	4
Parker Kalon Corp.	45
Pioneer Gen-E-Motor Corp.	53
Precision Resistor Co.	66
Presto Recording Corporation.	64
RCA Communications, Inc.	55
RCA Manufacturing Co. Back Cover,	66
Remler Co., Ltd.	50
Shakeproof Lock Washer Co. Inside Back Cover	
Shure Brothers	42
Sigma Instruments, Inc.	62
Somers Brass Co., Inc.	52
Speer Carbon Company.	38, 58
Standard Transformer Corp.	46
Superior Tube Company.	2
Thomas & Skinner Steel Prod. Co.	51
Triplett Electrical Instrument Co.	60
United Sound Engineering	54
United Transformer Corp.	40
Universal Microphone Co.	68
Universal Signal Appliances	56
Utah Radio Products Co.	64
Western Electric Co.	43
Weston Electrical Instrument Corp.	35
White Dental Mfg. Co., S. S.	3
Wholesale Radio Service, Inc.	59
Zophar Mills, Inc.	55

Professional Services 48

SEARCHLIGHT SECTION

Classified Advertising

EMPLOYMENT	6
Wanted to purchase.	67
EQUIPMENT FOR SALE	
American Electrical Sales Co.	67
Eisler Electric Corp.	67
Electronics Machine Co.	57
Kahle Engineering Corp.	57
National Radio Tube Co., Inc.	67
Precision Electrical Instrument Co.	67
Winslow, Louis J.	67

ECCO THE MOST MODERN High Frequency Converters for BOMBARDING

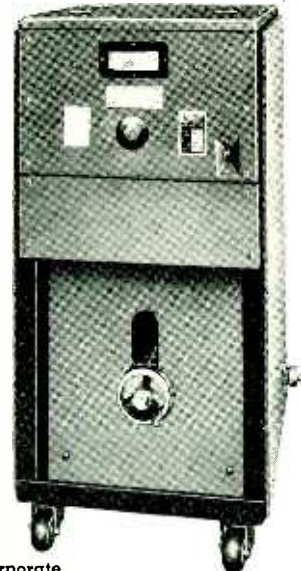

Incorporate
Straight line power output control •
High conversion efficiency • Balanced
low loss circuits • Simplicity of operation,
safety, rugged construction and many
other New and Exclusive features.

Units from 1/4 to 25 KVA Available

ECCO High Frequency Corp.
120 W. 20th Street, New York, N. Y.

HERE'S HELP

for technical
and business
men

New 1937

Catalogue of

McGRAW-HILL BOOKS



YES, this is a catalogue—but it's no ordinary one. It is a guide to stimulating, informative books by over 1200 leading minds in business, industry and research. In its 272 pages, you'll find clear, concise descriptions of more than 1500 books covering many business and technical subjects. What's your most urgent interest now? Somewhere in this big McGraw-Hill Catalogue you'll find the up-to-date books that will give the facts—experience—data—you need in solving your particular problem.

McGraw-Hill Books bring you the
experience of experts in your field

McGRAW-HILL BOOK COMPANY, INC.
330 West 42d Street, New York City

Please send me, free of charge, your 1937 Catalogue of McGraw-Hill Books. I want to know more about: (Name subjects of most interest to you.)

Name

Address

City State E. 7-37

SHAKEPROOF

THREAD-CUTTING SCREWS

THE PATENTED THREAD-CUTTING SLOT



**.. Save Time .. Cut Costs ..
Speed Up Production ...**

Shakeproof Thread-Cutting Screws tap and fasten in one operation and cut a standard machine screw thread. No special tools or changes in constructional details are necessary to take advantage of their amazing economy. Send for free demonstration kit—contains five assorted sizes and complete testing instructions. Write today!



There's no time or money wasted for separate tapping operations on modern refrigerator production lines since Shakeproof Thread-Cutting Screws have been so generally adopted by the industry.

U. S. Patent Nos. 1,862,486; 1,909,476; 1,909,477; 1,419,564; 1,782,387; 1,604,122; 1,963,800. Other Patents. Patents Pending. Foreign Patents.

Copy. 1937, Illinois Tool Works



EXTERNAL



INTERNAL

Shakeproof—the triple-action lock washer that defies vibration. Keep all connections tight—improve performance with Shakeproof—the lock washer that never lets go!

Shakeproof
LOCK WASHER CO.

Distributor of Shakeproof Products Manufactured by Illinois Tool Works
2539 N. Keeler Avenue Chicago, Illinois
In Canada: Canada Illinois Tools, Ltd., Toronto, Ontario

New Worlds to Conquer... with the **NEW RCA "888"**

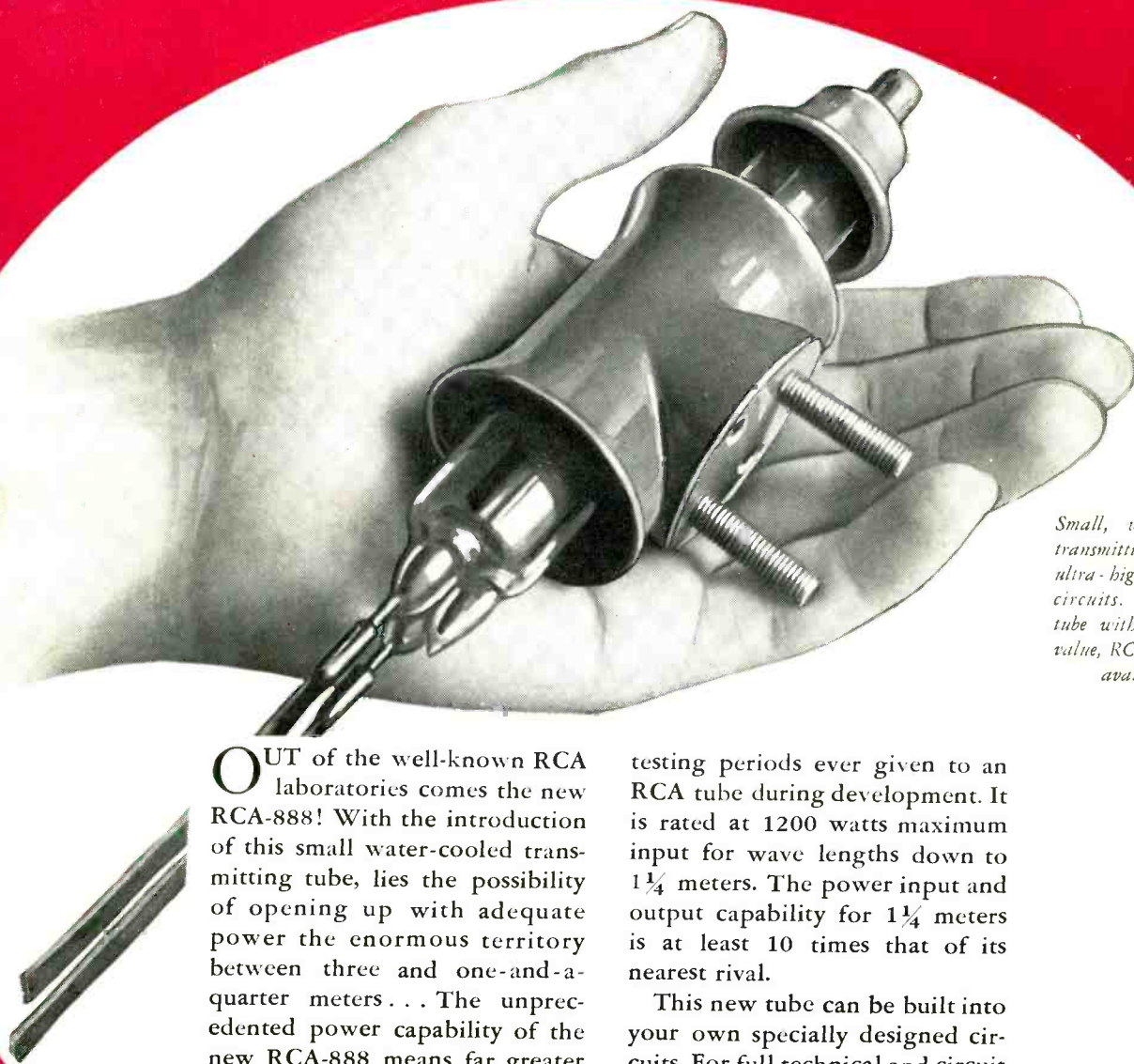

Small, water-cooled transmitting tube for ultra-high-frequency circuits. Companion tube with lower mu value, RCA-887, also available.

OUT of the well-known RCA laboratories comes the new RCA-888! With the introduction of this small water-cooled transmitting tube, lies the possibility of opening up with adequate power the enormous territory between three and one-and-a-quarter meters... The unprecedented power capability of the new RCA-888 means far greater performance and reliability in the new field of ultra-short-wave communication.

This tube has successfully undergone one of the most extensive

testing periods ever given to an RCA tube during development. It is rated at 1200 watts maximum input for wave lengths down to $1\frac{1}{4}$ meters. The power input and output capability for $1\frac{1}{4}$ meters is at least 10 times that of its nearest rival.

This new tube can be built into your own specially designed circuits. For full technical and circuit information, don't hesitate to call on RCA's skilled group of engineers. They are ready and most willing to serve you on any questions regarding the new RCA-888.



Radiotrons