

electronics

radio, sound, communications and industrial applications
of electron tubes . . . design, engineering, manufacture

STATISTICS OF THE RADIO INDUSTRY

Beat frequency
oscillators for
radio receivers

British Television
Committee
report

Electronic
arc-welding
control

RMA Engineering
Division aims

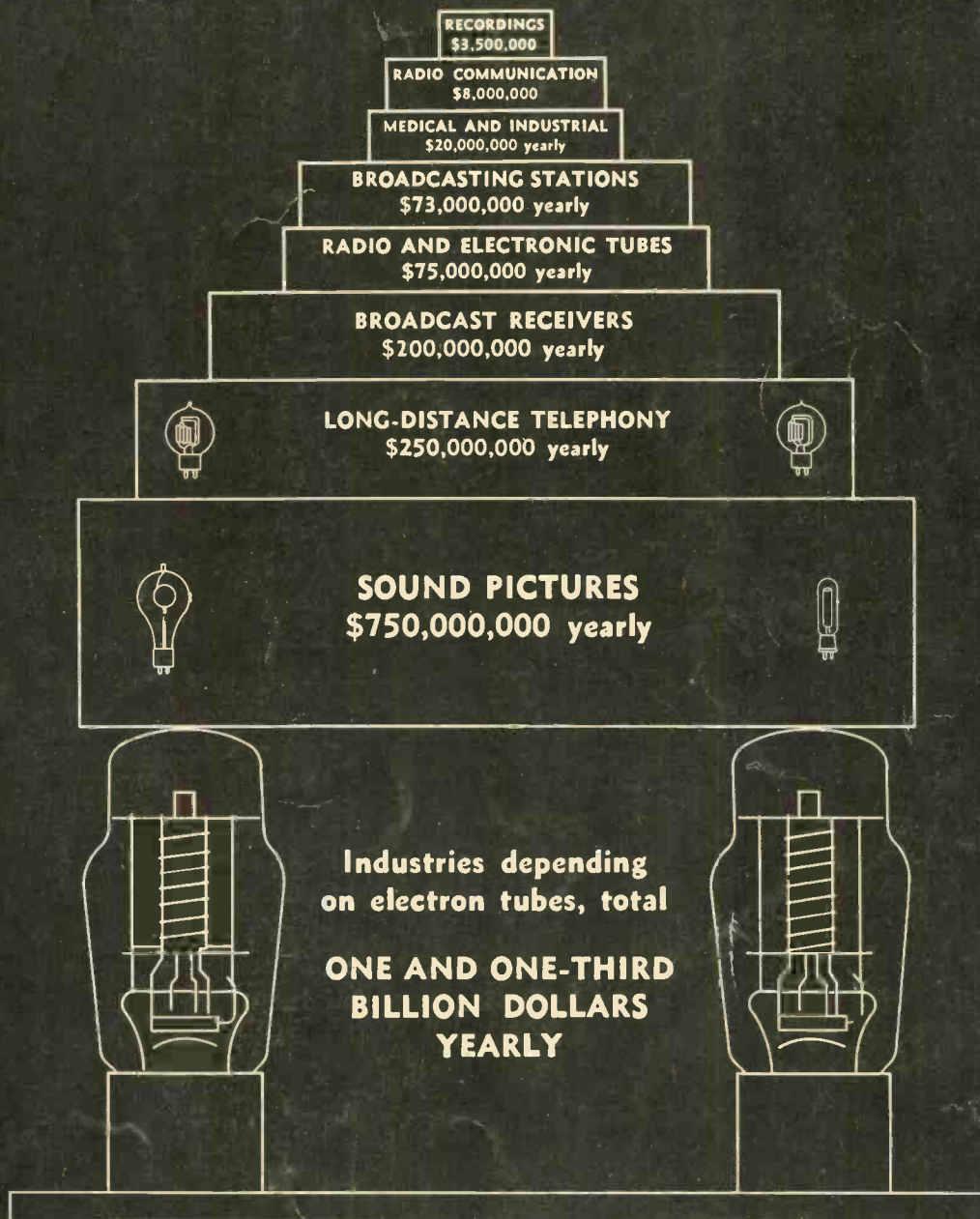

McGRAW-HILL PUBLISHING COMPANY, INC.

Price 35 Cents

MARCH 1935

EXTREME SENSITIVITY

POSITIVE MAGNETIC CONTACT

make WESTON Sensitrol Indicating

Relays ideal for many uses

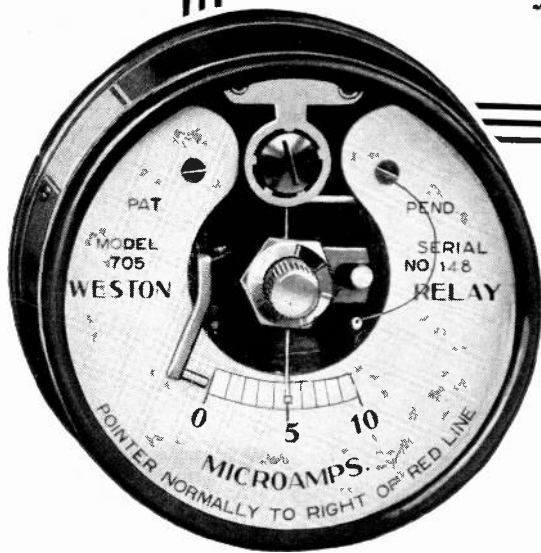

The CO alarm, shown below, recently developed for use in garages, steel mills, chemical plants, etc., employs a Weston Sensitrol Indicating Relay for indicating the CO concentration and sounding an alarm. The relay operates direct from thermocouples. (Manufacturer's name on request.)

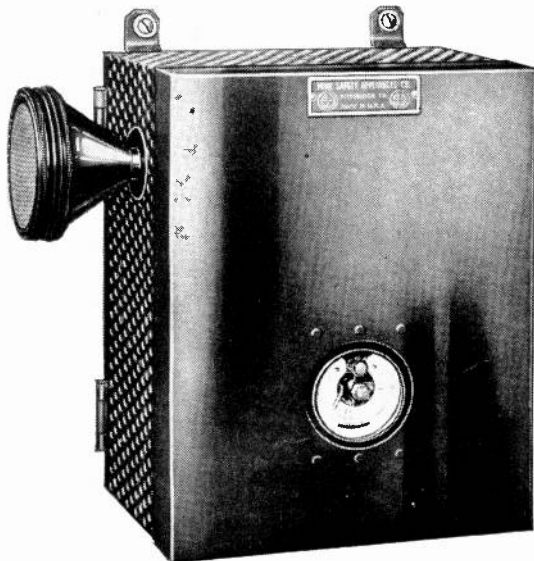

Consider the many new and exclusive features of the Weston Sensitrol Relay . . . and its almost limitless application for product and process control. Take this portable CO alarm for example:

CO present in the air is converted into CO₂. The heat liberated is measured by a thermocouple and indicated in terms of CO concentration on the Weston Sensitrol Indicating Relay. When the pointer reaches the .02% mark, the permanent magnet stationary contact pulls the pointer in and holds it tight until the contact is broken manually.

Thus the alarm continues ringing until heard and heeded.

This is but one of the many uses being found almost daily for this unique device. For the Sensitrol Relay can be made with scales of 2 microamperes or 1/2 millivolt, and handles 5 watts at 110 volts noninductive load. Its contacts are made and held magnetically which eliminates contact troubles. The scale can be calibrated for current, voltage, temperature or any other units desired.

Consider the possibilities of the Sensitrol Relay in your product, your plant, or any new development you have in mind. Let Weston engineers cooperate, or, be sure to send for full data on the Sensitrol line... Weston Electrical Instrument Corporation, 618 Frelinghuysen Avenue, Newark, New Jersey.

WESTON

Instruments



CURVILINEAR

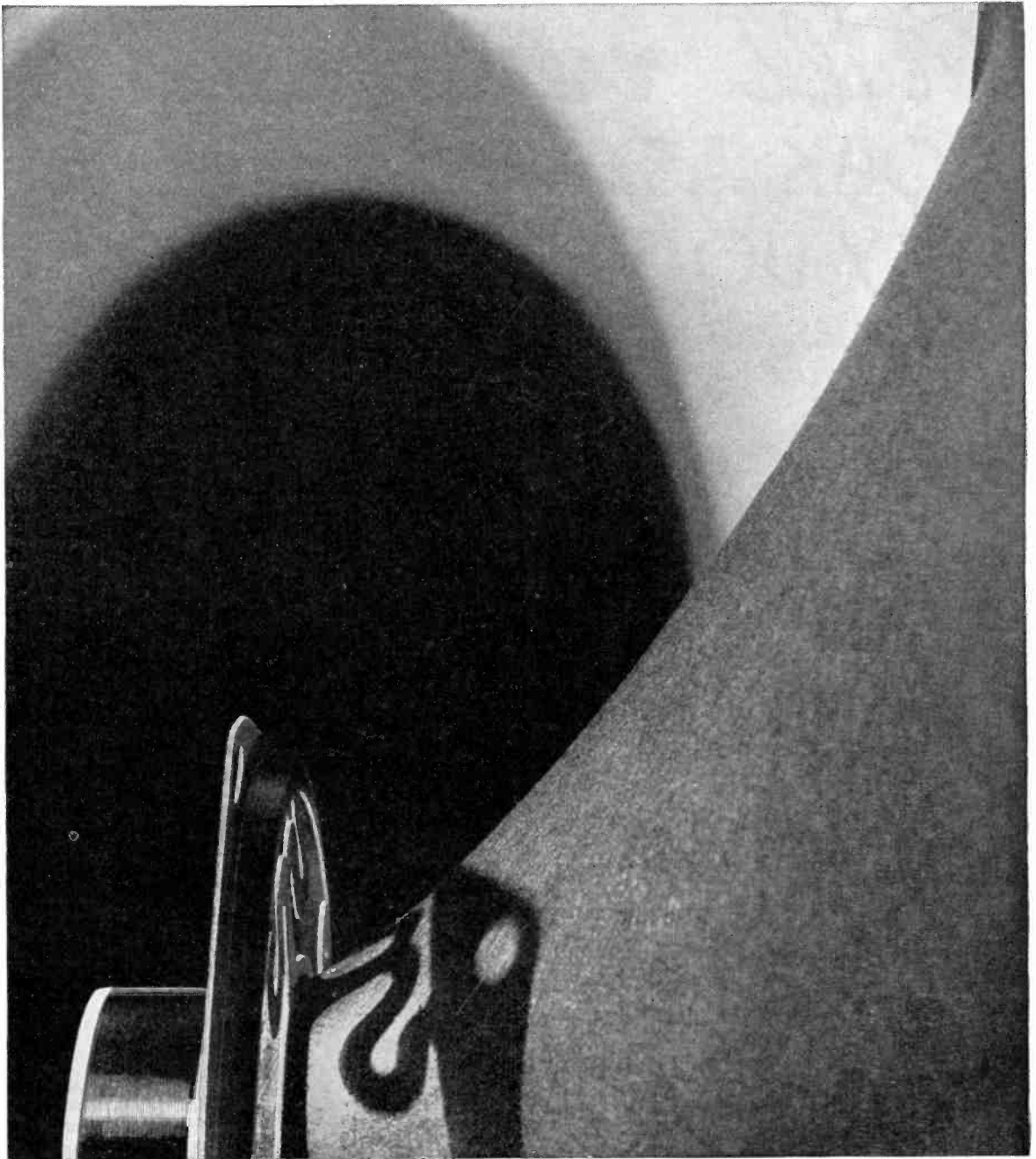

A DEFINITE ADVANCEMENT IN SPEAKER DESIGN!

MAGNAVOX engineering leads again. The Curvilinear Diaphragm is another long step towards true fidelity and realism in radio . . . another ideal of the laboratory achieved in commercial speakers. It brings a new freedom from the "loud speaker" quality of the conventional speaker . . . and a *faithfulness in reproduction far beyond* that of cone type speakers produced in the past.

Magnavox speakers equipped with the new Curvilinear Diaphragm display a sound pressure curve with less than half the deviation from linear response associated with conventional cone type reproducers. Naturally you will want to know more about this speaker design and observe its finer performance in your own laboratories. Samples and further information will be sent gladly, *without obligation*.

THE MAGNAVOX COMPANY

FORT WAYNE, INDIANA, U. S. A.

CABLE ADDRESS: "MAGNAVOX"

'INSURED'
QUALITY
THROUGH
PERSISTENT
ENGINEERING
ADVANCEMENT

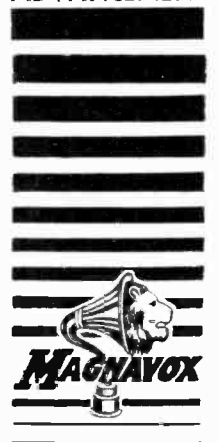

Will **YOUR RESISTORS**
 WORK AS WELL HERE AS
 THEY DO HERE

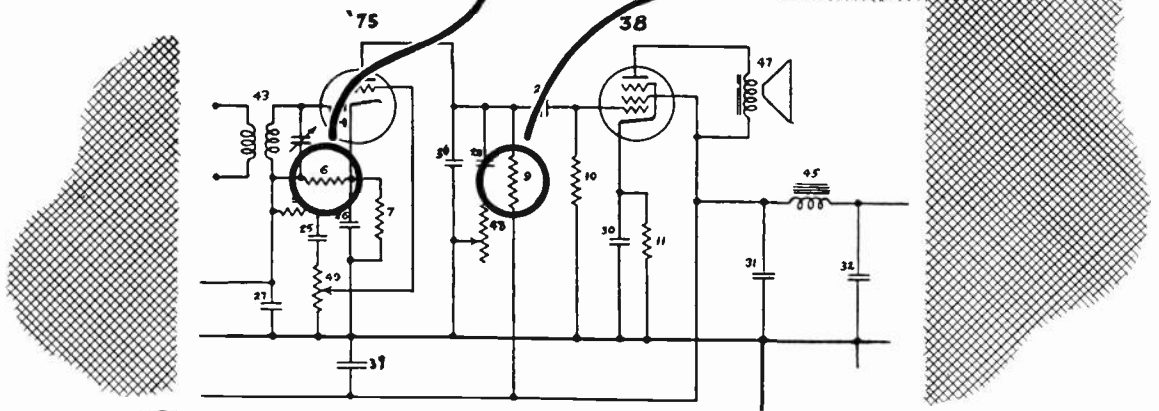

— They will
 IF THEY'RE **BALANCED**
ERIE RESISTORS

Resistors in different parts of any circuit may operate under widely varied conditions. For example, the above diagram calls for two resistors of equal resistance value—a diode resistor which carries practically no load and in which ability to resist effects of humidity is important, and a heavily loaded plate circuit resistor in which low voltage coefficient and good load characteristics are desirable.

So, unless you use resistors that are uniformly good in their electrical characteristics, you either impair the operating efficiency of your sets or keep production costs up by having to stock resistors of several nominal values in order to obtain the same actual value under different operating conditions.

Recent exhaustive tests have shown that out of seven leading competitive makes, only Erie Resistors have uniformly small changes in all their electrical characteristics. You can depend on Erie Resistors to maintain their actual ratings under any ordinary operating conditions. Switch to Erie Resistors 100% for greater efficiency and lower production costs.

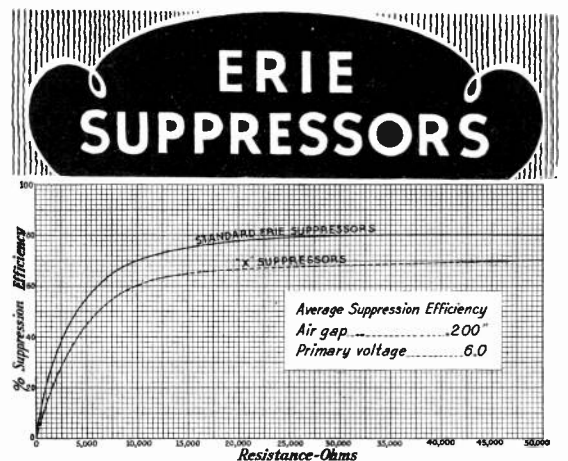

Research by Erie engineering staff definitely shows that suppressors with high voltage coefficient are correspondingly poor in suppression efficiency.

This is shown in above chart where "X" suppressors are units with high voltage coefficient. For example, a 10,000 ohm Erie Suppressor is equal in suppression efficiency to a 50,000 ohm "X" unit.

Erie Suppressors have low voltage coefficient—0.55% at 20,000 ohms. Remember this when you specify suppressors. Write today for new bulletin giving additional information on these products.

ERIE RESISTOR CORPORATION

ERIE, PA.

Factories in **ERIE, PA. - TORONTO, CANADA - LONDON, ENG.**

It cuts tube hour costs



*... and assures
Western Electric
reliability!*

The 287A is one more example of how Western Electric is constantly pioneering improved tubes that provide greater economy with traditional Western Electric reliability in operation.

This three-element mercury vapor rectifier—suitable for use as a relay or trigger action device—is an important unit of the frequency control in the 70B1 Telephotograph equipment. It is also recommended as a replacement for the 277A tube in the 1A frequency monitoring unit and all broadcasting equipment employing the 700A oscillator. The 287A's improved ability to withstand power interruptions leads to much longer operating life.

For details about Western Electric tubes, write to Graybar Electric, Graybar Building, New York—or telephone Graybar's nearest branch.

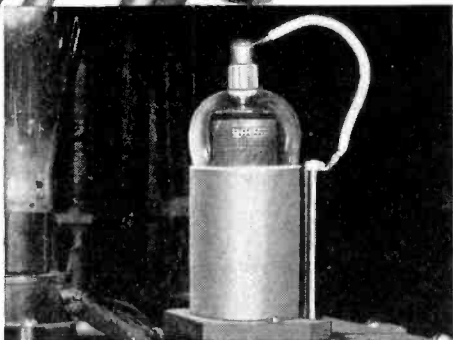

287A Rectifier Tube installed in the Western Electric 12 Type Broadcast Transmitter.

Characteristics

Filament Potential.....	2.5 Volts	Maximum Instantaneous Potential	
Nominal Filament Current.....	7.0 Amperes	between Anode and Cathode.....	2500 Volts
Approximate Anode-Cathode Potential		Safe Operating Ambient Temp. Range..	10°—50° C.
Drop when conducting.....	15 Volts	Maximum Overall Length.....	6 9/16"
Peak Plate Current.....	1.0 Ampere	Maximum Diameter.....	2 3/16"

Western Electric
RADIO TELEPHONE BROADCASTING EQUIPMENT
Distributed by GRAYBAR Electric Co. In Canada: Northern Electric Co., Ltd.

Short Wave Engineers !! . . .

Avoid Coil Absorption

Short out your unused sections with YAXLEY 1935 Switches

An outstanding new feature of Yaxley 1935 Short Wave Switches is a combination of various types of shorting rotor plates which provide a definite means of short circuiting any number of coils except the coil in use. Avoid coil absorption in *your* receivers by specifying Yaxley Switches.

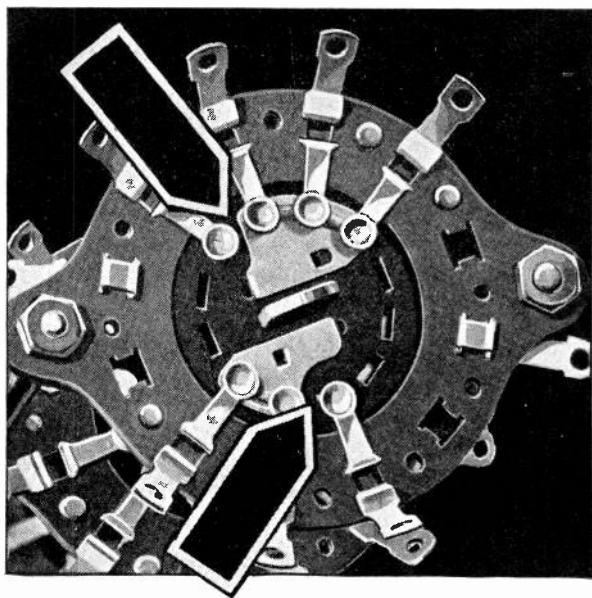

This switch provides two means of short circuiting unused coils. Note that one rotor plate short circuits two coils and the other three, adjacent to the coil in use. (Arrows designate circuits in use)

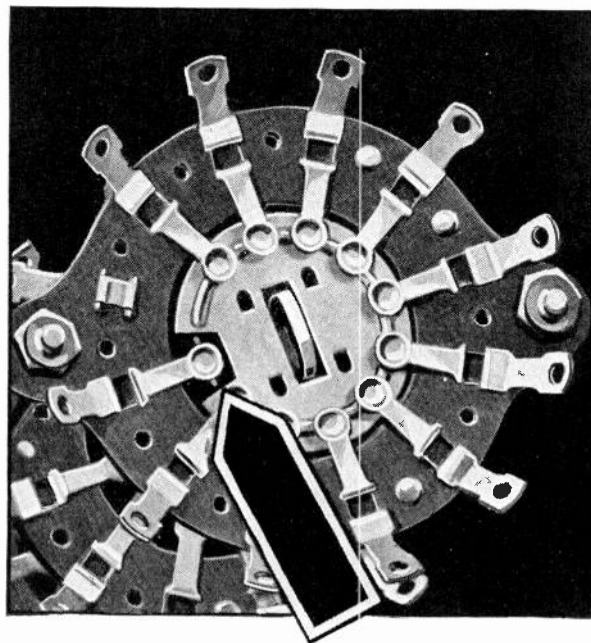

The shorting rotor plate of this switch short circuits all the coils except the coil in use. (Arrow designates circuit in use)



Other Important Features

1. Lowest contact resistance—solid silver contactors and silver plated contact terminals.
2. Lowest possible moisture absorption—insulating material of special high-grade Bakelite.
3. Low capacity.
4. Flexibility in coil and switch combinations for all circuit arrangements.

Write today for complete technical information



YAXLEY MANUFACTURING CO.
INCORPORATED
Division of P. R. Mallory & Co., Inc.
INDIANAPOLIS . . . INDIANA
Cable Address: Petmallo

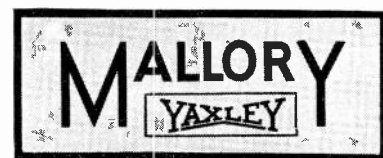

ORESTES H. CALDWELL
Editor
KEITH HENNEY, Managing Editor

HOWARD EHRLICH
Vice-President

H. W. MATEER
Manager



radio
sound
pictures
telephony
broadcasting
telegraphy
counting
grading
carrier
systems
beam
transmission
photo
cells
facsimile
electric
recording
amplifiers
phonographs
measurements
receivers
therapeutics
traffic
control
musical
instruments
machine
control
television
metering
analysis
aviation
metallurgy
beacons
compasses
automatic
processing
crime
detection
geophysics

In the air!

I NTERESTING new things are in the wind. When radio and electronic men chat informally, there is talk of some radical new developments, not yet announced, but very plausible and very significant. For example:

Pictures by "long-distance" . . . A New York daily last month published some pictures transmitted from San Francisco, explaining that these, not by AP Wirephoto, were sent by a new, relatively inexpensive process. From which one surmises that the photograph is scanned and converted to audible sound; an ordinary long-distance phone call is then put through, and in 8 to 10 minutes the picture is in the head office without costly leased wires.

Binaural recordings both in one groove . . . New realities of binaural or auditory perspective in phonographs may follow from recent experiments which show that the two slightly-different recordings may actually be cut in the single groove, one lateral, and the other vertical. Two reproducers, each free to move only in its corresponding plane, pick off the two recordings separately.

Cellophane "sound-strings" . . . An inexpensive, *continuous* sound-recording medium has long been needed. Now the Germans are trying out sensitized cellophane "string"—narrow ribbon about 2 mm wide, worked from spool to spool. Samples reaching America are surprisingly tough and injury-proof.

Light from cathode rays . . . New fluorescent materials glow with an intense cold light when bombarded with cathode rays. Perhaps here is a future new electronic illuminant, of high efficiency.

Pocket radio transceivers . . . will be tried out soon on the floor of the N. Y. Stock Exchange, enabling floor traders to keep in continuous touch with their offices, for orders and confirmations, without moving from their positions on the floor.

TOPICS without official confirmation today,—these are tips that may point to major news announcements, radical new commercial developments of tomorrow!

RADIO RECEIVER AND

All-time record in unit sales of radio sets established in 1934—exports at new peak

REACHING for new records in domestic sales of home and auto radio receivers, and attaining a new all-time high point in total set sales, as well as in exports to other lands, the American radio industry forged ahead in 1934 in a most encouraging and impressive manner. Complete statistics collected by *Electronics* and given on these pages show that nearly 4,700,000 sets were made and sold by American manufacturers during the year just past. Of these slightly over 4,000,000 went into domestic homes and automobiles, and something over 600,000 went abroad. The sum total of sets manufactured during the year is the best figure attained in any year since the birth of the industry in 1920—not excepting the momentous year of 1929.

To give life to these millions of home and auto sets, and to revitalize a few of the thousands already in service, American manufacturers made nearly 65,000,000 tubes. Of this number, almost 10,000,000 went

abroad in competition with tube manufacturers of the Continent and of Great Britain. Even our numbering system went into foreign lands, for any one who reads the foreign technical literature will find frequent mention of such tubes as the 57, the 6A7, the 43 and others. Ten million American tubes in receivers abroad, 55 million tubes in sets in this country indicate that the depleted ranks of tube manufacturers were busy in 1933 even if prices had been dropped to such a point that few, if any, admit making any money on the multitudinous transactions concomitant with distributing as many items as the sum total of tube sales figures indicates.

Curves of the industry's history show that in 1934 the unit sales price of radios turned upward again. This is not true particularly because sets cost more to build, but because the buyers bought better products; the sales of consoles compared to table models (midgets) increased. The average radio purchased in 1934 cost

the buyer \$45.50—and this included 6.5 tubes at an average price of \$1.30. Thus the manufacture and sale of radio sets produced a total retail volume of business amounting to over \$200,000,000. Tube sales amounted to \$70,000,000, and with sales of other radio apparatus brought the

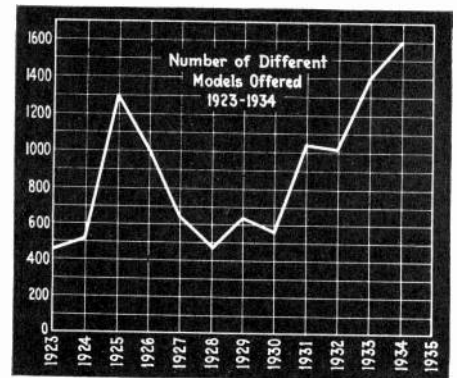

1934 hit a new high for total number of models offered for sale

total annual radio business in 1934 to approximately \$300,000,000.

It is not difficult to establish reasons for the increased sales and for the increased average retail price. During the year the all-wave sets reached new degrees of electrical efficiency, thus stimulating the old dx hunting fad. These sets are more expensive than the smaller and less complicated receivers whose tuning range is limited to the broadcast band.

All-wave sets increase program interest

Increased leisure hours have had their effect on receiver sales; and the improvement in programs offered by the broadcast stations and the extension of their services have been of major importance in selling new sets to the nation. The interest in broadcasting is at a new peak, evidenced by the unprecedented demand for time on the air. It is reported that salesmen of broadcasting time on the larger stations and chains are fighting among themselves for the next half-

THE UPWARD TREND CONTINUED DURING 1934

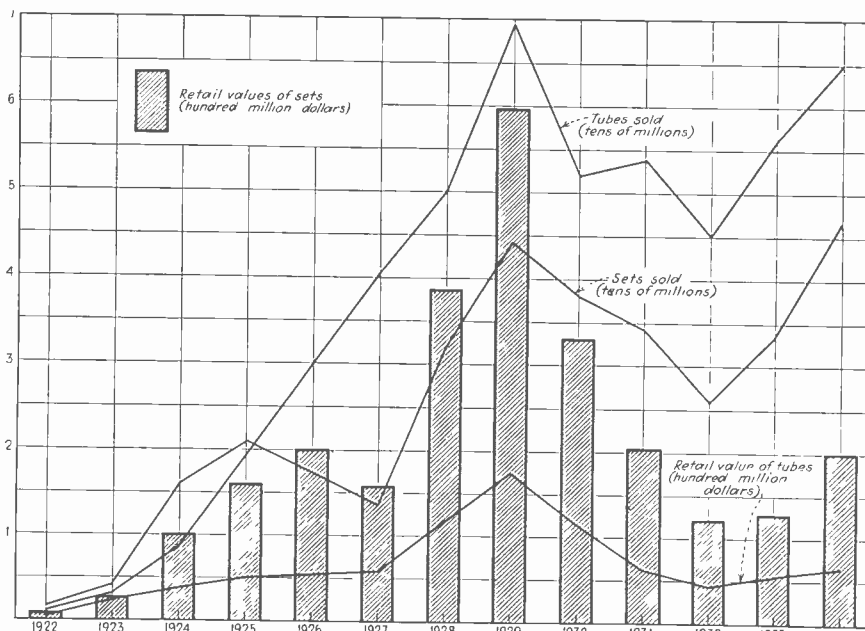

Unit sales and dollar volume of radio sets and tubes, 1923 to 1934

TUBE SALES INCREASE

Industry encouraged by higher prices compared to 1933—sales boosted by all-wave sets

hour when it will be available to sell! According to Dun & Bradstreet, October 1934 showed the highest sales in broadcast history up to that month (they may have been exceeded since), when the income was \$4,527,000, a gain of over 50 per cent over the year before. For the first ten months of 1934 total sales amounted to \$33,780,000 (major networks

ing at lower prices. The average tube price for the standard-name tubes is 96 cents; and assuming the branded tubes sold for 20 per cent off this figure an average replacement retail price of 87 cents is secured.

Why are replacement sales down? Sets sold in 1933 and 1934 used new types of tubes not likely to go bad until 1935 or later. Many of the receivers replaced old sets and took out of the market their demand for older types of tubes. The chances are, too, that many sets managed to scrape and rasp along on old tubes, not worn to the rim but approaching it asymptotically—as the engineers say.

Another encouraging note is injected into this composite picture by Dun & Bradstreet who report that failures were less in 1934. For the first eleven months of 1934 only 6 manufacturers failed with liabilities of about one-half million dollars; in 1933 there were 25 failures involving \$3,719,519. Bankruptcies among

wholesalers and retailers in 1934 dropped from 109 for 1933 to 33 for the first eleven months of 1934. The insolvents' debts, however, were about the same as in the previous year due to the failure of one large wholesaler with a \$1,000,000 default.

Automobile radios

Sales of automobile radio sets during 1934 totaled 780,000, just about duplicating the sales of auto radio in the preceding year. This was a disappointment to the industry, because it had been expected that auto-radio sales for 1934 would run well over a million sets.

This brings the number of automobile radio sets in use to a total of two million. The Automobile Chamber of Commerce estimates that there are now 22,000,000 passenger cars in use in the United States. Sales of passenger cars for 1934 totaled 2,400,000, and it is expected that 1935 sales may reach 3,000,000.

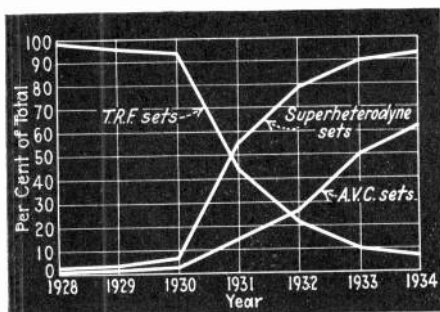

The trends in circuit design

only) or 38.8 per cent ahead of 1933, and actually 2.2 per cent ahead of 1932 when the figure reached a previous all-time high.

Better programs, the whole world to listen to, more power on broadcast stations, more leisure in which to listen, better times, government money—whatever the reasons, 1934 established new marks in number of sets made and sold, and in radio exports.

Replacement tubes sales down

The only downward pointing curve is the sale of tubes for domestic replacements. The figures shown here in tables were arrived at in the following way; data from all sources show that 6.5 tubes went into every new American radio set; 5 into each set that went abroad. Thus for initial equipment 36,240,000 tubes were required, leaving 28,642,000 tubes for replacement purposes, a smaller number than were sold in 1933 for the same purpose.

These 28,000,000 tubes may be broken down into 15,640,000 standard-name tubes, and 13,000,000 tubes which were branded-name tubes sell-

ADVERTISED PRICES HIGHER ON ALL MODELS

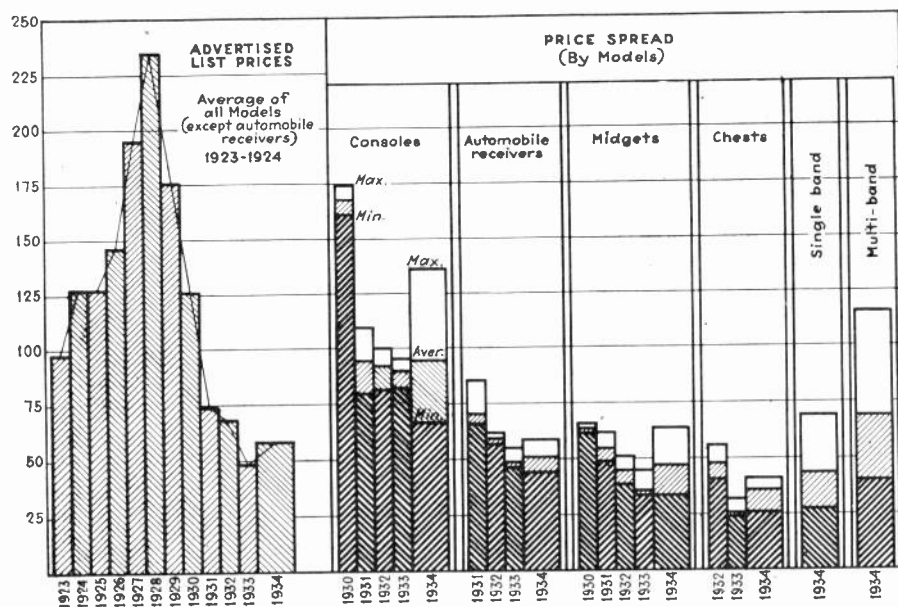

The 1934 price-spread figures are the average maximum and minimum in each manufacturer's line. For previous years, the prices are the averages of large and small manufacturers. The middle figure is the all-industry average price for each year.

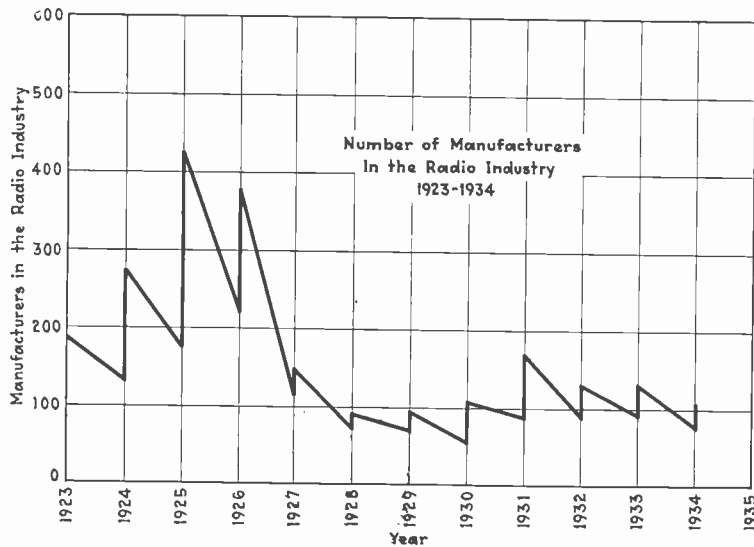

The "Ups and Downs" of the manufacturers' roster. The oblique lines represent manufacturers who went out of business. The vertical lines represent the newcomers for each year

The outlook for auto-radio sets for 1935 is about the same as for 1934, three-quarters of a million sets, with half or more of these sold to the automobile makers for initial installation when the cars are built.

Introduction of all-steel car roofs on many models for 1935 has introduced serious technical difficulties of installation, for satisfactory radio

\$8,731,179, or 54 per cent, according to Andrew W. Cruse, Chief, Electrical Equipment Division, Department of Commerce.

Overseas sales of radio equipment during the year exceeded by \$1,723,083 the former record sales of 1930, it was stated.

Exports of all classes of radio equipment during 1934 increased compared with 1933. Foreign sales of radio transmitting sets, parts and tubes were valued at \$1,090,269 compared with \$743,423 in the preceding year, an increase of 47 per cent; receiving sets were valued at \$15,338,143 against \$9,323,535, or 65 per cent; components, \$4,358,350 against \$2,783,730, or 56 per cent; receiving tubes, \$3,210,729 against \$2,623,261, or 22 per cent; loudspeakers, \$361,-

076 against \$338,055, or 7 per cent; and other accessories, \$498,331 against \$313,725, 59 per cent.

During the past few years the average unit value of radio receiving sets sold abroad from the United States has steadily decreased until 1933 when the value was recorded at \$18. This decrease, Mr. Cruse stated, has been occasioned by the increasing popularity of small receiving sets in foreign markets. All-wave sets are credited with the increase in 1934 to \$25.

The value of the export sales for the year evidences a recovery in foreign markets from the conditions which adversely affected sales abroad of American radio equipment in 1932 and 1933, according to Mr. Cruse.

While complete statistics showing the destination of exports during the year are not yet available, Mr. Cruse stated that it is quite evident that our current markets for radio equipment are in countries other than those to which such exports were consigned in the years prior to 1933.

Over 50,000 amateurs

Evidencing the ever-widening interest in amateur radio throughout the United States, its territories and possessions, records compiled by the Federal Communications Commission disclose that there were 46,390 valid amateur station licenses in existence at the close of the last fiscal year, June 30, 1934, and that this total growing at the rate of nearly 9,000 a year puts the total well above 50,000 amateurs at the beginning of 1935.

During the year 8,782 new station

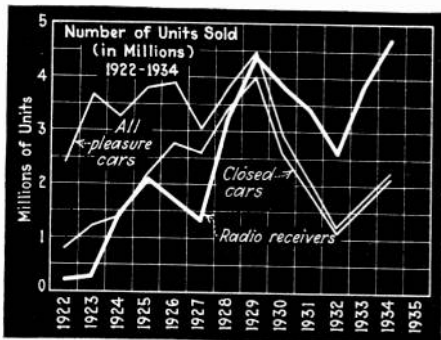

The radio industry has left the automobile industry far behind in unit sales

service. With roof antennas eliminated, it has been necessary to resort to plates hung under the car or under the running boards, and to insulated rear-bumpers serving as antennas. This all-steel construction may put a serious crimp in the use of auto-radio for 1935.

Exports of radio in 1934 establish all-time record

A new all-time record for exports of radio equipment from the United States was recorded in the calendar year 1934 when sales abroad were valued at \$24,856,898 compared with \$16,125,719 in 1933, an increase of

RECEIVING SETS—UNIT SALES—1934

Total sets sold in United States.....	4,084,000
Total sets sold abroad.....	612,000
Total sets sold.....	4,696,000
Automobile sets.....	780,000
Table models.....	2,204,000
Console models.....	1,100,000
	4,084,000

RECEIVING SETS—DOLLAR VOLUME

Total manufacturers' billings (@ 45% off list).....	\$88,623,300
Total retail value.....	200,390,000
Export sales value (612,000 sets at \$24.50).....	15,000,000
Average domestic retail price.....	45.50
(Including 6.5 tubes @ \$1.30)	
Average auto radio retail price.....	43.05
(Including 5.5 tubes @ \$1.30)	
Average table model retail price.....	34.65
(Including 5.5 tubes @ \$1.30)	
Average console model.....	67.04
(Including 8 tubes @ \$1.30)	

COMPONENTS FOR RADIO SETS

Components	Number per set				Cost per set—dollars			
	1930	1932	1933	1934	1930	1932	1933	1934
Sockets	7	8	5.25	6.25	0.35	0.176	0.136	0.162
A-f transformers.....	2	1	0.6	1.0	0.90	0.70	0.245	0.58
Power transformers.....	1	1	0.7	0.9	1.45	1.47	0.74	1.10
Power chokes.....	1	1.1	0.6	0.8	0.47	0.60	0.15	0.24
Loudspeakers.....	1	1.1	1	1.0	3.50	1.82	1.56	1.93
R-f coils.....	3	4	3	5.1	0.75	0.68	0.66	1.28*
Condensers, tuning.....	1	1	1	1.0	1.50	0.65	0.73	0.78
Condensers, by-pass.....	10	9	10	12.0	0.96	0.81	0.45	0.67
Condensers, filter.....	2	2.5	2	1.8	1.15	0.83	0.50	0.66
Resistances, fixed.....	4	10	11	12.2	0.35	0.40	0.40	0.45
Resistances, variable.....	2	2	2	2.0	0.70	0.52	0.41	0.46
Total cost per set.....					12.08	8.65	6.08	8.31

*Includes i.f. coils.

licenses were issued and there were 12,279 modifications, reissues and renewals. The figures follow:

Valid of record July 1, 1933.....	41,555
Issued during fiscal year, new and renewed	8,790
Total.....	50,345
Less cancellations	3,777
Other deletions, due to death, etc.	153
Revocations	25
Total.....	3,955

Amateurs of record close of June 30, 1934

Authorizations as amateur operators totaled 16,686; operator license endorsements for higher privileges 209; duplicates of lost or destroyed licenses 161, and special authorizations 15, making a grand total of 38,132 authorizations issued during the year, or well over 100 per day, relating to amateurs alone.

Applications for amateur operator station licenses pending July 1, 1933, were 497, while 33,184 were received during the fiscal year. Of the total, 21,672 were approved; 8,211 were returned, or referred; 3,631 applicants failed to pass required examinations.

Components prices rose slightly during the year, as might be expected from the increased cost of raw materials, higher wage scales, etc. While it is difficult to strike an average price for some components, because of the wide spread between maximum and minimum prices, the table above gives a comparison of prices with past years.

Estimates made with the aid of the Department of Commerce, indicate that the radio receiving sets in use throughout the world are apportioned among the nations of the earth as follows:

United States (21,456,000 homes with radios; 9 per cent having two or more sets).....	23,751,700
United Kingdom.....	6,124,000
Germany.....	5,424,755
Japan.....	1,739,160
France.....	1,554,295
Canada.....	1,100,000
Spain.....	700,000
Czechoslovakia.....	620,000
Argentina.....	600,000
Russia.....	600,000
Denmark.....	551,681
Austria.....	507,459
Australia.....	500,341
Other countries.....	4,000,000
Total.....	47,773,391

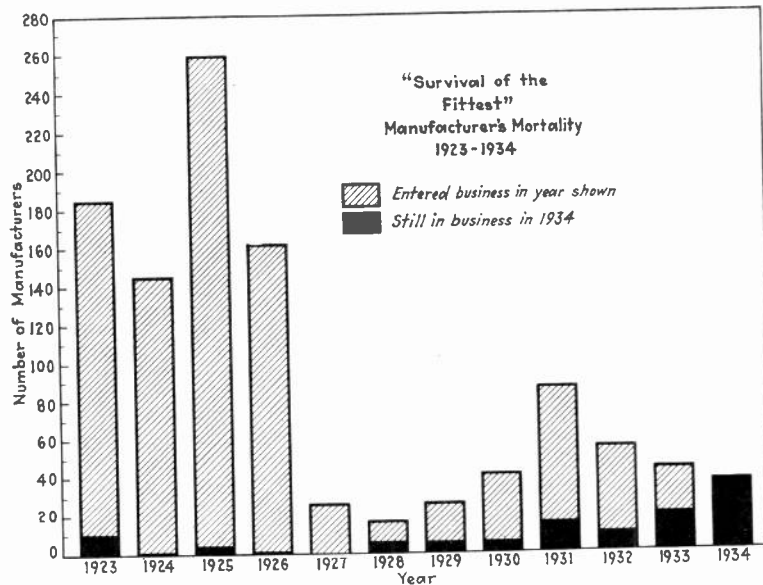

Of the total number of manufacturers which entered the radio manufacturing industry each year only the proportion shown in black still remain in business today

RECEIVING TUBES—UNIT SALES—1934

Total tubes sold in United States.....	55,192,000
Total tubes sold abroad.....	9,690,000
Total tubes sold.....	64,882,000

PRICES AND DOLLAR VOLUME

Tubes sold to set manufacturers.....	26,550,000	@ \$1.30	\$34,515,000
(Initial equipment)			
Tubes sold to foreign set manufacturers.....	3,060,000	@ \$1.30	\$3,978,000
Exports other than with sets.....	6,630,000	@ \$1.00	\$6,630,000
Replacements in United States.....	28,642,000	@ .87c	\$25,033,000
Total sales.....	64,882,000		\$70,156,000
Average retail price.....	\$1.08		

During the year 1934, radio sets and tubes were exported to five European and South American countries to the extent of over one million dollars each. These countries were Spain which purchased \$1,939,050 worth of sets and tubes; Union of South Africa, \$1,745,870; United Kingdom, \$1,235,848; Brazil, \$1,184,144; and France, \$1,092,567.

Editor's note—Several of the charts given here represent data compiled by R. H. Langley, consulting engineer, New York City, and are presented here through his courtesy. Other data are by permission of the Hazeltine Service Corp.

Text of British television report

Commission recommends immediate start of 240-line service for London area

THE BRITISH TELEVISION COMMISSION which recently visited the United States to study television progress here, has issued its official report outlining plans for the introduction of experimental television into Great Britain under the supervision of the British Broadcasting Corporation, with the following advisory commission on television:

Lord Selsdon, chairman.

Sir Frank Smith (secretary Department of Scientific and Industrial Research), who will be chairman of a technical sub-committee.

Colonel Angwin, assistant engineer-in-chief of the Post Office.

Noel Ashbridge, chief engineer B.B.C.

Vice-Admiral Sir Charles Carpendale, Controller B.B.C.

F. W. Phillips, assistant secretary of the Post Office.

An initial television broadcast transmitter is suggested for London, with a range of 25 miles in all directions. If this service proves successful, stations will be established in other centers of population, until a network of television stations has been built up. Following are excerpts from the official text of the British Television Commission's report:

WHILE low-definition has played a real part in the development of the subject, the Committee do not favor the adoption of any low-definition television for a regular public service. They are of opinion that for a satisfactory picture there should be no fewer than 240 lines a picture, with a minimum picture frequency of 25 a second. For the reception of such high-definition pictures the cathode-ray tube is now usually employed, in which the pictorial representation is brought about by a rapid transit of an electron pencil over a fluorescent screen. At present the usual size of the picture produced in this way is about 8 in. by 6 in. though the apparent size can, of course, be increased by viewing the tube with suitable magnification, but with a corresponding loss of definition. The Committee have been informed that the price to the public of a receiving set capable of producing a picture 8 in. by 6 in., with the accompanying sound transmission, would be from £50 to £80, [\$240 to \$380] but it is reasonable to assume that, in mass production, this price could be substantially reduced.

For the transmission of the complex radio signals required in television, ex-

tremely wide frequency channels are necessary, and it has long been clear that such channels are only nowadays available in the ultra-short wave-length range of under 10 meters, since all others are either unsuitable or already occupied. With these ultra-short wave-lengths the range of a sending station is practically limited to its so-called optical range, so that a number of such stations would be necessary to serve the whole country.

Television will need sound

In our opinion there will be little, if any, scope for television broadcasts unaccompanied by sound. Television is, however, a natural adjunct to sound broadcasting, and its use will make it possible for the eye as well as the ear of the listener to be reached. Associated with sound, it will greatly enhance the interest of certain of the existing types of broadcast, and will also render practicable the production of other types in which interest is more dependent upon sight than upon sound.

Nevertheless the time may come when sound broadcasting entirely unaccompanied by television will be almost as

rare as the silent cinema film is today. We think, however, that in general sound will always be the more important factor in broadcasting. Consequently the promotion of television must not be allowed to prevent the continued development of sound broadcasting.

The task of choosing a television system for a public service in this country is one of great difficulty. The system of transmission governs in a varying degree the type of set required for reception; and it is obviously desirable to guard against any monopolistic control of the manufacture of receiving sets. Further, whatever system or systems are adopted at the outset, it is imperative that nothing should be done to stifle progress or to prevent the adoption of future improvements from whatever source they may come. Moreover, the present patent position is difficult; the number of patents relating to television is very large, and in regard to many of them there are conflicting views as to their importance and validity.

New employment

At the same time it is clear from the evidence put before us that those inventors and concerns who have in the past devoted so much time and money to research and experiment in the development of television are looking—quite fairly—to recoup themselves and to gather the fruits of their labors by deriving revenue from the sale of receiving apparatus to the public, whether in sets or in parts, and whether by way of royalties paid by the manufacturers or by manufacturing themselves. It is right that this should be so, and that the growth of a new and important branch of industry capable of providing employment for a large number of workers should in every way be fostered and encouraged to develop freely and fully.



Engineers in Baird laboratory demonstrate "cine-televisor"; 30 seconds from scene to film to receiver

THE DAY HAS NOW COME—or will come this year—when in addition to listening at a turn of the switch to music and speech, it will be possible for many to see as well as to hear from their firesides what is happening at some distant point.

**SIR KINGSLEY WOOD,
Postmaster General of Great Britain.**

The ideal solution, if it were feasible, would be that, as a preliminary to the establishment of a public service, a patent pool should be formed into which all television patents should be placed, the operating authority being free to select from this pool whatever patents it desired to use for transmission and manufacturers being free to use any of the patents required for receiving sets on payment of a reasonable royalty to the pool. We have seriously considered whether we should advise you to refuse to authorize the establishment of a public service of high definition television until a comprehensive patent pool of this type had been formed, on terms considered satisfactory by the Advisory Committee. From evidence we have received, however, we are convinced that, under present conditions, when the relative value of the numerous television patents is so largely a matter of conjecture, the early formation of such a pool would present extreme difficulty.

While, however, we have been compelled to abandon the idea that the formation of a comprehensive patent pool should be a condition precedent to the establishment of a public service, *we are strongly of opinion that it is in the public interest, and in the interest of the trade itself, that such a pool should be formed.* In framing our recommendations we have kept this objective in mind; and we trust that events will shape themselves in such a way as to lead to the formation of a satisfactory patent pool at no distant date.

Baird and Marconi-E.M.I. systems

We have come to the conclusion that a start could best be made with a service of high definition television by the establishment of such a service in London. It seems probable that the London area can be covered by one transmitting station, and that two systems of television can be operated from that station. On this assumption we suggest that a start be made in such a manner as to provide an extended trial of two systems under strictly comparable conditions, by installing them side by side at a station in London where they should be used alternately—and not simultaneously for a public service.

There are two systems of high definition television—owned by Baird Tele-

vision, Limited, and Marconi-E.M.I. Television Company, Limited, respectively—which are in a relatively advanced stage of development, and have indeed been operated experimentally over wireless channels for some time past with satisfactory results. We recommend that the Baird Company be given an opportunity to supply the necessary apparatus for the operation of its system at the London station, and that the Marconi-E.M.I. Company be given a similar opportunity in respect of apparatus for the operation of its system also at that station.

In the light of the experience obtained with the first station the Advisory Committee should proceed with the planning of additional stations, until a network is gradually built up. The total number of stations and the speed at which they are provided will naturally depend upon the results obtained from the earlier stations, the popularity of the service, finance, and other factors.

Programs and cost of operation

With regard to the duration of television programs, we do not consider that it will be necessary at the outset to provide programs for many hours a day. *An hour's transmission in the*

morning or afternoon, which will give facilities for trade demonstrations, and, say, two hours in the evening will probably suffice.

We estimate that the cost of providing the London station, including all running and maintenance expenses, program costs, and amortization charges (calculated on the basis of a comparatively rapid obsolescence) for the period up to December 31, 1936 (at which date the B. B. C.'s present charter expires) will be £180,000 [\$864,000].

It must not be assumed that an accurate estimate of the cost of a number of stations can be reached by the simple process of multiplication. By far the largest factor in the above figure is the program cost. On the one hand, if the service is a success, the cost of programs will certainly rise materially, just as the cost of sound programs has risen. We have not budgeted during this early stage for a program comparable in duration, variety, or quality with existing sound programs, although the service should be amply adequate to provide interest and entertainment for the public, as well as opportunity for daily demonstrations by retailers of sets.

We feel that the development of British television, in addition to being of evident importance from the point of view of science and entertainment, and of potential importance from the angles of national defense, commerce, and communications, will also directly assist British industries.

Lastly, we are quite unable to agree that there is no urgency. On the contrary, our inquiries convince us that, apart altogether from any question of scientific prestige, *any delay would be most regrettable;* and we feel that, if our conclusions are accepted, it is most desirable that *the minimum amount of time should be lost in giving effect to our recommendations.*

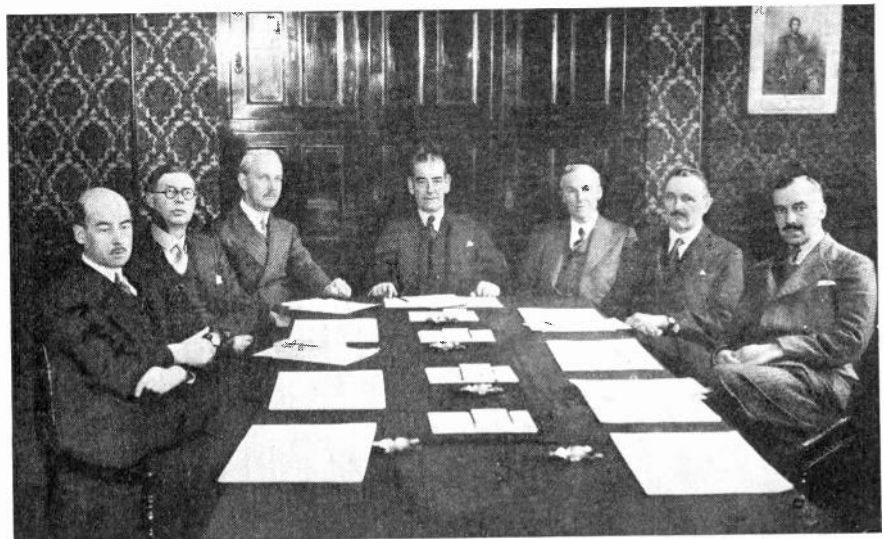

British Committee—from left to right: Noel Ashbridge, B.B.C.; C. F. Brown; Sir Frank Smith; Lord Selsdon; F. W. Phillips; Colonel Angwin; and V. Roberts

WORK OF ENGINEERING

Customer's viewpoint put paramount

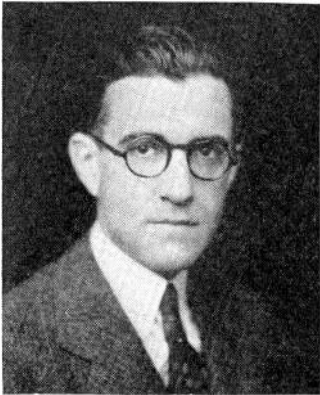

W. R. G. Baker



Virgil M. Graham

By W. R. G. BAKER

Director of Engineering, RMA

THE Engineering Division of the Radio Manufacturers Association differs from the purely technical and scientific organization in that in all of its work the *consumer's viewpoint* must be given first consideration. Therefore, the fundamental responsibility of the Engineering Division is to assist the industry in providing the consumer with a safer and better product. Next, the Engineering Division endeavors to guide, through standardization and definition, the new arts and services being developed by the industry. Finally, it provides a means of correlating and coordinating the technical effort of the industry and directing it toward the solution of problems which will result in better service to the consumer.

Problems of standardization and definition are difficult in any field, since a standard to be of any value, must be quite generally acceptable and must satisfy a number of groups who may have divergent opinions. In many instances it is probably more desirable not to attempt standardization than to so compromise the

standard set up as to make its effectiveness questionable.

Additional complications arise through the fact that the work of the division must not be at variance with technical societies, such as the Institute of Radio Engineers, and yet must satisfy the practical merchandising and business requirements of the organization of which it is a part. Furthermore, a definition may be quite acceptable to the Engineering or other divisions of RMA and yet the consumer may not accept the definition or may use the term under consideration in such a way that it has an entirely different meaning. The industry is then faced with the problem of converting the consumer or changing the terminology approved by the industry. Generally the latter is the more practical plan.

In the fields of television and facsimile the advancement is so rapid and these arts are in such a state of flux that the Division can function only to the extent that standards or definitions assist the industry in using the same language. These new arts are as yet so far from commercialization that any extensive attempt to standardize would be futile.

The Engineering Division believes that the usefulness of its standards and definitions, rather than the quantity, is a measure of its effectiveness. This Division under the guidance of the Board of Directors of RMA will continue its efforts to meet its responsibilities to the industry and the consumer.

By VIRGIL M. GRAHAM

Chairman, Standards Section, RMA

THE Engineering Division of the Radio Manufacturers Association has for the past few years carried on a portion of such standardization work as was necessary to the industry, and could only be conducted by a group so comprised in this particular field. In addition, important work along service and safety lines has been accomplished. Now under the active and progressive leadership of W. R. G. Baker as Director



J. H. Pressley
Automotive



A. F. Murray
Television



Dr. A. N. Goldsmith
Interference



L. F. Curtis
Safety

DIVISION OF R.M.A.

Wide range of committee activity

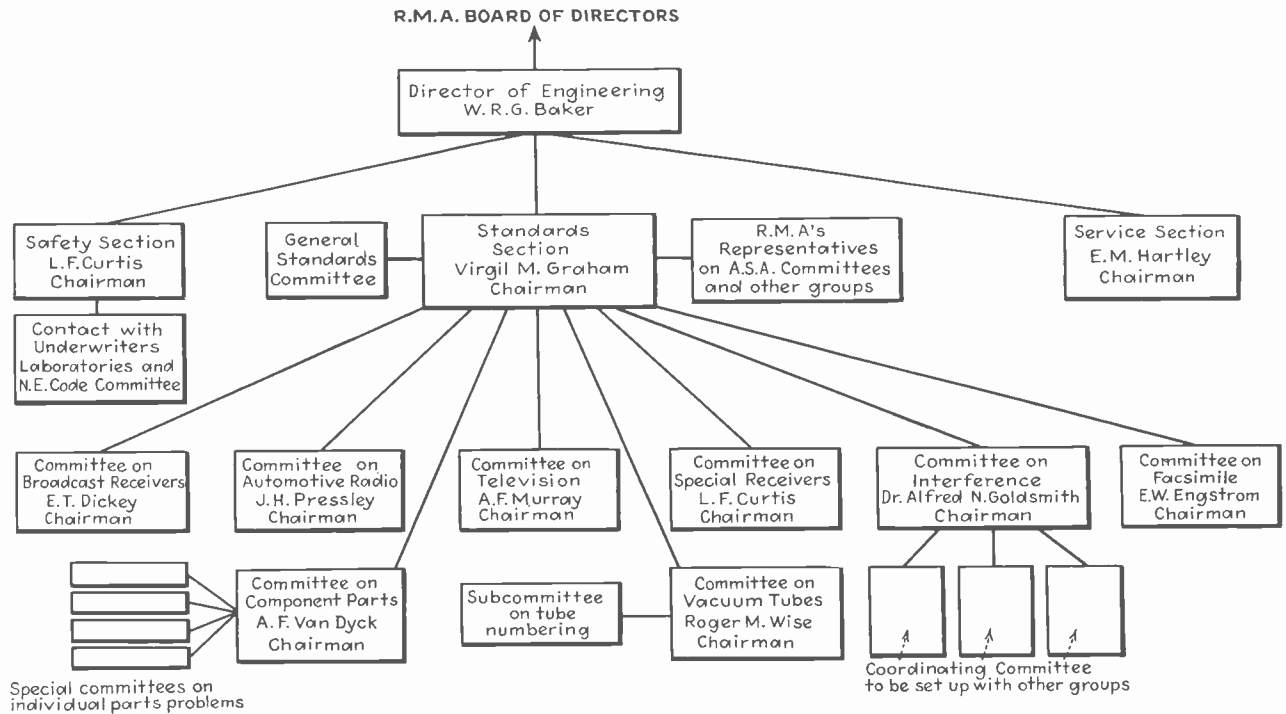

of Engineering, further work of vital importance to the industry is being undertaken, and activity on present projects is being pushed.

Before considering the outline of plans for the future work of this Division, it would be well to examine the accompanying organization chart to clarify the picture.

The Safety Section under the able chairmanship of L. F. Curtis has performed great service for the radio industry through the Industry Conferences with the Underwriters' Laboratories. These Industry Conferences are the only official contacts between the Laboratories and the manufacturers for discussing requirements on power operated receiving equipment. Recent results of Industry Conferences are a revised edition of the "Requirements on Power Operated Receiving Appliances,"

dated January, 1935, and a reconsideration of examination procedure for radio receivers. Mr. Curtis also has done much work on the radio phases involved in the latest revision of the National Electrical Safety Code.

The Service Section, of which E. M. Hartley is chairman, has done much useful work in its field, and has cooperated with the Institute of Radio Service Men in their activities. Arrangements have been made between the Service Section and the Committee on Broadcast Receivers to cooperate in clearing up some difficulties confronting service men in regard to information and instructions on receivers.

The Standards Section handles, through its technical committees, the standardization work of the Division as well as many items of engineering importance to the



Hugh Knowles
Sound equipment



E. M. Hartley
Service



Arthur Van Dyck
Component parts

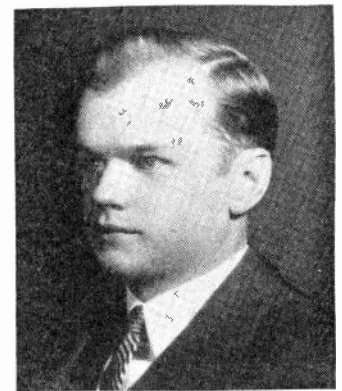

E. W. Engstrom
Facsimile

industry. Under a recently adopted new standardization procedure, the action of the General Standards Committee "in meeting" is final after the proposed standards have been circulated to the membership for comment and criticism. This arrangement prevents adoption of minority standards, due to non-return of letter ballots as in the old procedure. The general Standards Committee is composed of the chairmen of all committees in the Standards Section, with an equal number of other members representing all branches of the industry. The chairman of the Standards Section, Virgil M. Graham, acts as chairman of this committee. The results of changing from the old to the new standards procedure, while a comparatively recent action, indicates that the change will be most beneficial to the industry.

Technical chairman carry responsibility

The chairmen of the technical committees are all active and carry the responsibility of the engineering work. In some cases, sub-committees are an essential part of the committee activities, particularly where there are divergent interests headed by one main committee such as in the case of the committee on Component Parts. In the committee on Vacuum Tubes, under the direction of Roger M. Wise, the vital work of assigning tube designations is naturally of a confidential nature, and is handled by a sub-committee of one engineer from the RCA License Laboratory, pending the time when this function can be assumed by an engineering office of the RMA. Without this activity, the chaos in which the industry would be, is unthinkable.

The committee on Radio Interference, with Dr. Goldsmith as chairman, is charged with the planning of a long-range program of reduction of electrical interference with radio reception. This committee is composed of representatives of a score of interested organizations,



E. T. Dickey, *Broadcast receivers*

and will arrange for joint committees between organizations where detailed technical work is necessary. Another joint group has been functioning in a most satisfactory and useful manner for several years. This is the Joint Coordination Committee on Radio Reception of EEI, NEMA, and RMA. The foundation for the work of the committee on Interference was laid at the Conference on Reduction of Radio Interference held at the 1934 Rochester (N. Y.) Fall Meeting. At this conference, Mr. Baker expressed the responsibilities of the RMA in this work and asked the cooperation of all other interested groups.

The work of the Engineering Division on component-parts standardization until a few months ago lagged behind the other activities. However, under the chairmanship of A. F. Van Dyck, this committee has started intensive work, and results will be evident in the near future. This committee has the potentialities of saving the industry an enormous amount of money through



Roger M. Wise, *Vacuum tubes*

parts standardization, and it is the responsibility of those engaged in this work to see that the results are proportionate to the outstanding accomplishments of the parts standardization work of the Society of Automotive Engineers. One of the items now being studied is the possibility of adoption of "preferred-number" systems in sizes of such things as fixed resistors and capacitors. Another item, illustrative of the kind of work undertaken by the committee on Component Parts, is the study of sizes of containers for electrolytic capacitors with a view to reducing the number used.

The committee on Automotive Radio has in the past met jointly with the corresponding committee of the Society of Automotive Engineers, and the data resulting from the discussions have been very useful to both groups. Under the direction of J. H. Pressley, it is to be expected that this work will go forward with renewed activity. It is planned that the next joint meeting with the SAE group will be held in the early spring, and a survey of subjects for discussion is now being made.

The committees on Television and Facsimile are engaged in formulating definitions and terms, so that every one can speak the same language when these fields are opened to commercial exploitation. The new committee on Special Receivers is surveying the whole field outside of broadcast receivers to find out what the needs of technical activity are on the part of the radio industry.

The committee on Broadcast Receivers, under the guidance of E. T. Dickey, is continually working on technical problems confronting the radio manufacturers. One of the latest projects is that of obtaining data preliminary to formulation of a standard on intermediate frequencies for superheterodyne receivers.

Among other projects that are up for consideration is the revision of the Handbook of RMA Standards and Engineering Information, which must be brought up-to-date as soon as funds are available.

With the whole-hearted cooperation of the radio industry, the Engineering Division of the RMA will be worth to each individual manufacturer many times the time and money that may be spent in taking part in its activities.

GERMAN TELEVISION RECEIVERS

German television receiver with
"mirror screw" for 180-lines,
6 x 7 inch-picture

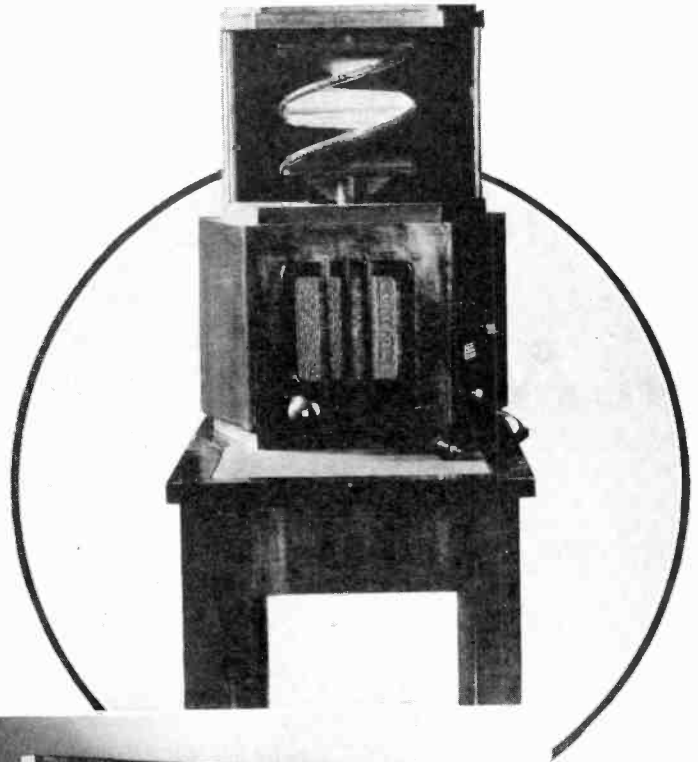

Above—Telefunken receiver
— 180 lines, image 9.0 by
10.2 inches

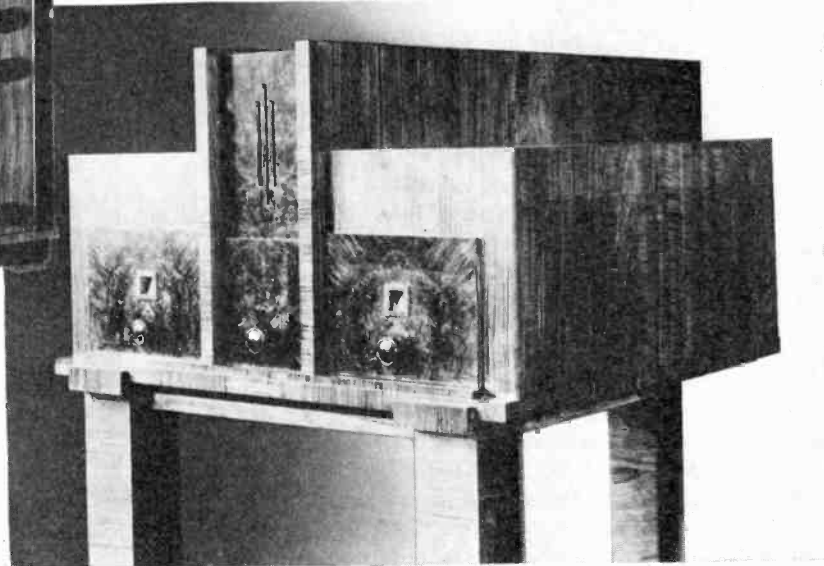

TEKADE television receiver for 180 lines. Left
switch for sound; right switch for image

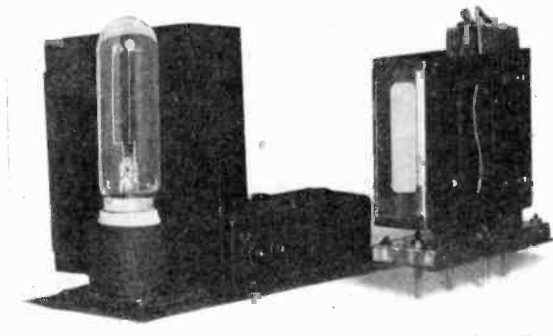

Above—Disassembled Kerr cells for
TEKADE television receiver

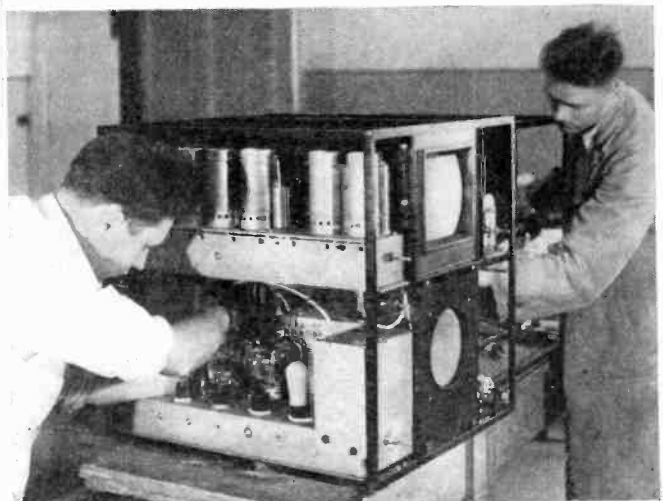

Assembling the Telefunken television
receiver

An electronic voltmeter for d-c arc welding

By W. RICHTER

*A. O. Smith Corporation
Milwaukee, Wisconsin*

IN electric arc welding the length of arc established between the electrode—either bare or covered—and the workpiece plays an important rôle in the production of uniform and satisfactory welds. The electrical characteristic indicating the length of the arc for a given type of electrode, when welding with a given amount of current, is the voltage across it. By observing this voltage it is therefore possible to compare the work of two different welders, to facilitate the training of new men or also to adjust automatic weld heads to their proper setting.

It has been found that the voltage change occurring when the arc changes from the correct to an incorrect length is rather small. A close measurement of the voltage across the arc is made difficult for two reasons. In the first place, the open circuit voltage of the welding generator is usually more than twice as high as the actual welding voltage and if it is desired to leave the instrument permanently connected across the arc it must withstand the open circuit voltage of the generator without damage. Thus we usually find a 0-100 voltmeter on the welding generators sold commercially. On the usual switchboard type of instrument with 50 scale divisions one scale division represents in this case 2 volts. If welding with 30 volts, for instance, it is obvious that the scale from at least 40 to 100 volts or 60 per cent of the total scale is entirely useless during the process of welding. The most desirable instrument would cover a smaller range, for instance, from 25 to 35 volts. In other words, it would not indicate anything below 25 volts and would reach the end of the scale at 35 volts. With 50 scale divisions we would then have an accuracy of 0.2 volts per scale division. An arrangement giving this desired result is shown in Fig. 1-a. It is only necessary to oppose the voltage to be measured by a battery of 25 volts and use a 0-10 voltmeter. It is easily seen that with an arc voltage of 25 volts the meter would indicate zero while with an arc voltage of 35 volts the meter would indicate full scale or 10 volts. With this arrangement every precaution must be taken to protect the meter from damage.

Even if these handicaps would be overcome by protec-

tive voltage relays, for instance, the result would not be very gratifying. Any oscillogram of arc welding shows that the arc voltage is fluctuating very rapidly between almost zero, which is the moment at which a globule of molten metal short circuits the arc, and a higher value. The resulting fluctuation will cover from 2 to 3 volts on a 10-volt instrument so that the increase of accuracy to .2 volt per scale division would be absolutely without any use whatsoever in the effort to determine the arc voltage more accurately. It is therefore apparent that in order to make use of the increased accuracy an instrument is needed which will indicate only the average value of this arc voltage and not follow its rapid fluctuation. In other words we must have an instrument with considerable higher damping than found in the usual commercial instruments. The instrument described in the following* fills the two conditions enumerated above without the use of any protective relays whatsoever and employs as the measuring device an inexpensive 0.5 milliamperere d-c meter. The damping of the instrument can be very easily changed to any desired value.

An electron-tube welding voltmeter

To accomplish this result the apparatus contains a vacuum tube. In the minds of most engineers vacuum tubes are characterized by their ability to follow extremely rapid fluctuations; in the present case, however, the tube is used to dampen them out. In this application use is being made of another property of a vacuum tube, namely, to indicate in its plate circuit voltage changes occurring on the grid without drawing any current, or at least only a negligible amount, from the voltage under observation and connected to the grid. The principle of the apparatus is as follows: The arc voltage or a portion of it derived from a voltage divider charges a condenser over a high resistance. Depending on the relative value of the resistance and the condenser the voltage across the condenser will follow more or less rapidly the voltage fluctuations across the arc. The voltage across the condenser is either equal or proportional to the average value of the arc voltage and the amount of damping can be changed by changing the value of the resistor or the capacity or both. The plate current of a triode can never become negative no matter how negative we make the grid of the tube. If we choose our constants, therefore, in such a manner that the lower end of the desired voltage range causes the grid of the tube to be biased to approximately the cut-off value, a further decrease in arc voltage will not cause the needle of the instrument

*Patent Applied For

VOLTAGE measurements are of great importance in rating the efficiency of arc welding apparatus. Simple meter measurements are made difficult by the varying character of the voltage and by the wide ranges to be covered. The electronic meter described herein is useful not only for welding applications but wherever average voltage values must be taken.

in the plate circuit to be deflected in the wrong direction. For the upper end of the range we can make use of the fact that the grid of a triode starts to draw current as soon as it becomes positive. We see in the diagram shown in Fig. 1 that the grid of the tube is connected to the arc voltage or a portion of it through a high resistance R_3 . If the arc voltage rises considerably, which would tend to make the grid of the tube positive, the voltage drop developed across the grid resistor R_3 due to the grid current will prevent the grid of the tube from becoming positive to any great extent. If the upper end of the desired voltage range results therefore in a grid voltage of approximately -1 volt we know that the

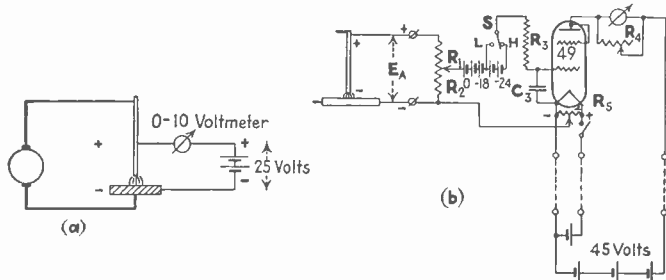

Fig. 1—(a) Simple bucking circuit for welding measurements. (b) The vacuum tube voltmeter circuit, which provides damping and which limits the range of voltage measured

amount that the pointer will go beyond full scale deflection with the application of higher voltage is very small and will not lead to any damage of the instrument. It might be asked why the upper end cannot be made to result in exactly zero grid voltage. This is not done because the small fluctuations in voltage still present on the condenser would then lead to a detector action in the tube which would result in incorrect indication.

Circuit details

The diagram of the instrument is shown in Fig. 1-b. The arc voltage E_A is connected through the terminals to the voltage divider consisting of the two resistances R_1 and R_2 . Only the portion of the voltage appearing across the resistor at R_2 acts on the instrument. The reason for this is that it was found that only a 6 volt grid change was necessary to make the plate milliammeter go over the full scale. For practical reasons it seemed undesirable to have such a small range of the instrument and it was decided to have a 12 volt arc change cause full deflection on the plate milliammeter. If the higher sensitivity is desired for special applications it can, of course, be obtained by connecting the grid to the upper end of the voltage divider or leaving the voltage divider off entirely. The decision on a twelve volt range determines the ratio of the resistor R_1 to R_2 as 1 to 1. It is easily seen that with resistors R_1 and R_2 alike a voltage change of 12 volts on the arc will produce a voltage change of 6 volts across R_2 . The grid battery "C" of a total of 24 volts serves to bring the actual grid voltage on the tube in the operating range. An adjustment of 2 volts of this voltage can be obtained by the potentiometer R_5 shunted across the filament of the tube which is a type 49. The grid battery is also tapped at -18 volts and by throwing the double throw switch S to the position L the range of the instrument can be changed. Assuming the arm of the

potentiometer R_5 to be standing in the middle and the switch S thrown to the high position it is seen that the actual grid voltage on the tube will go from -7 to -1 volt if the arc voltage changes from 32 to 44 volts. If switch S is thrown to the low position the same grid voltages will be obtained with an arc voltage of from 20 to 32 volts. The instrument covers, therefore, a total range from 20 to 44 volts in two steps. The addition of other ranges is, of course, only a matter of utilizing more taps of the C battery.

The two adjustments R_4 and R_5 made it possible to avoid the recalibration of the scale with an exchange of a tube. Thirty of these instruments had to be built and it was found possible to use identical scales on all of them and take care of the differences in the individual tubes by these two adjustments R_4 and R_5 . Thus if the mutual conductance of a particular tube was higher so that a 6 volt grid change would produce more than full scale deflection of the instrument it was only necessary to decrease the resistance R_4 until the 6 volt change produced the desired amount of meter deflection. The actual line-up on the desired points is then achieved by changing the position of potentiometer R_5 . If actual line-up was accomplished approximately one-quarter of the scale from the top and bottom values it was found that the instruments were never more than .25 volts off from the correct value. Calibration is, of course, easily achieved by putting the instrument in parallel to a precision d-c voltmeter, the latter being connected to a voltage divider across a suitable d-c source.

The photograph in Fig. 2 shows the completed instrument. The batteries are housed in a separate box which connects to the instrument proper through a plug-in arrangement. The "B" supply is a standard 45 volt battery. The "A" supply is one of the new low discharge type wet cells. Two number 6 dry cells with a suitable resistance in series can, of course, be substituted for this cell, but the voltage regulation of the wet cell is much better suited for the purpose on hand. The "C" battery is mounted in the instrument box itself and consists of a standard $22\frac{1}{2}$ volt C battery and one additional small dry cell. Since this battery does not have to carry any current it will last its shelf life. The drain on the B battery is below 5 milliamperes under which condition the battery will give many hundred hours of service. Checking of the instrument approximately twice a month showed no perceptible change in calibration.

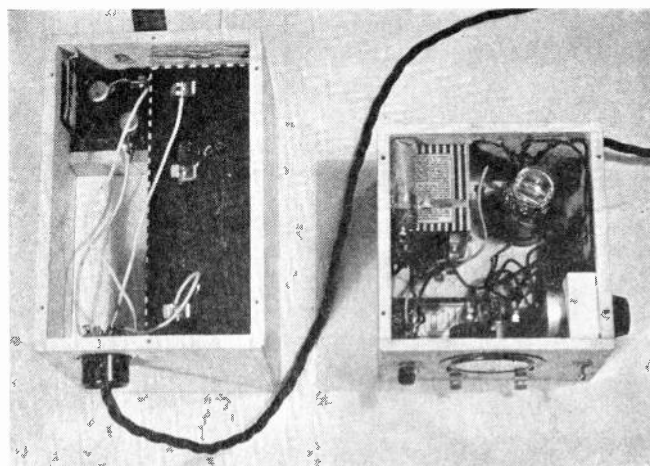

Fig. 2. The voltmeter with battery supply. A two-volt tube is used

A universal network chart

THE problems of network design which are of practical interest to the radio engineer can be classified in three divisions: the matching network (or taper pad) which matches two impedances and introduces a loss which is of secondary importance; second, the attenuation network, which is intended to introduce a fixed, known loss in the circuit and also to match the ingoing and outgoing impedances of the circuit to which it is connected; and third, the variable attenuation network which is designed to introduce a variable loss in the circuit while maintaining its terminal impedances constant. The fourth, the constant loss variable impedance type, is important only in special applications.

All of these network problems can be solved in several ways, by the use of T-pads, L-pads, π networks, both of the balanced and unbalanced variety, or by more complicated mesh networks. It is usually the wisest plan to design the simplest network which will meet the requirements of the job. And in addition, if the values of the resistors in the network can be found without long-drawn-out calculation, the design problem can be made very simple indeed. The chart on the opposite page has been designed by its author, Mr. A. James Ebel of WMT, Waterloo, Iowa, to solve all of the simpler types of network problems of the fixed-value type, and to permit the design of variable networks by a point-by-point method.

The chart is based on the fundamental theory discussed by Arthur E. Thiessen, on Page 552 of the March 1931 issue of *Electronics*.

In Fig. 1 the impedance of the generator R_G is to be matched to the impedance of the load R_L by the L-pad consisting of R_1 , the series branch, and R_2 , the shunt branch. To accomplish this match, R_1 and R_2 must have following values, which can be calculated directly from the known values of R_G and R_L :

$$R_1 = \sqrt{R_G(R_G - R_L)}$$

$$R_2 = \frac{R_G R_L}{\sqrt{R_G(R_G - R_L)}}$$

where R_G is assumed to be the larger of the impedances to be matched. For ease in computation, the ratio of the larger to the smaller impedances is introduced as:

$$r = R_G/R_L$$

Using this ratio, R_1 and R_2 can then be found in terms of their ratio to R_L , a convenient method which makes it possible to use widely varying magnitudes of R_L without the use of extended scales.

These ratios are:

$$R_1/R_L = \sqrt{r(r-1)}$$

$$R_2/R_L = \frac{r}{\sqrt{r(r-1)}}$$

By plotting the values of these ratios for different values of r , the required R_1 and R_2 for any value of R_L can be found from the graph. This has been done on the opposite page.

If n is the loss ratio (relative to a perfect matching transformer) introduced by the network, then

$$\frac{n^2 + 1}{2n} = \sqrt{R_G/R_L} = \sqrt{r}$$

From which:

$$n = \sqrt{r} + \sqrt{r-1}$$

From this relation, the loss in decibels can be given as:

$$\text{db loss} = 20 \log_{10} (\sqrt{r} + \sqrt{r-1})$$

Thus, the db loss can also be plotted as a function of r , as shown in the chart.

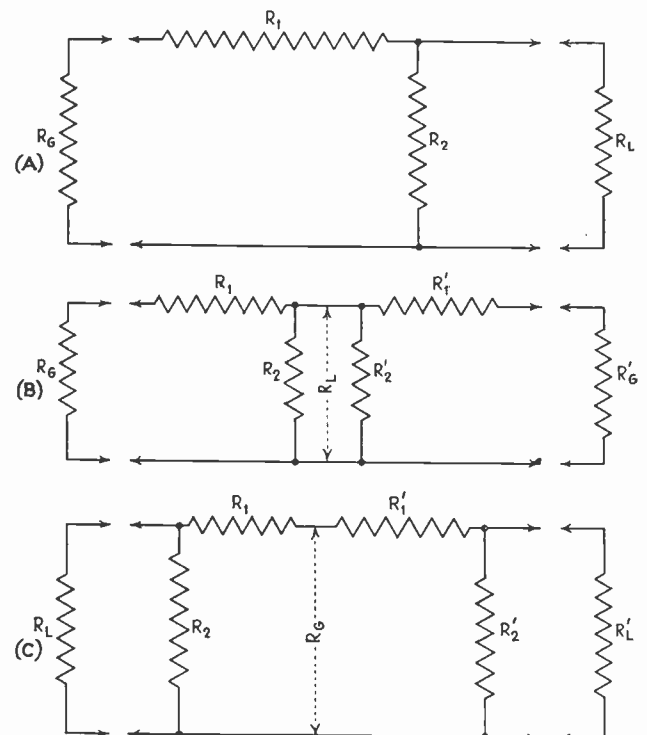
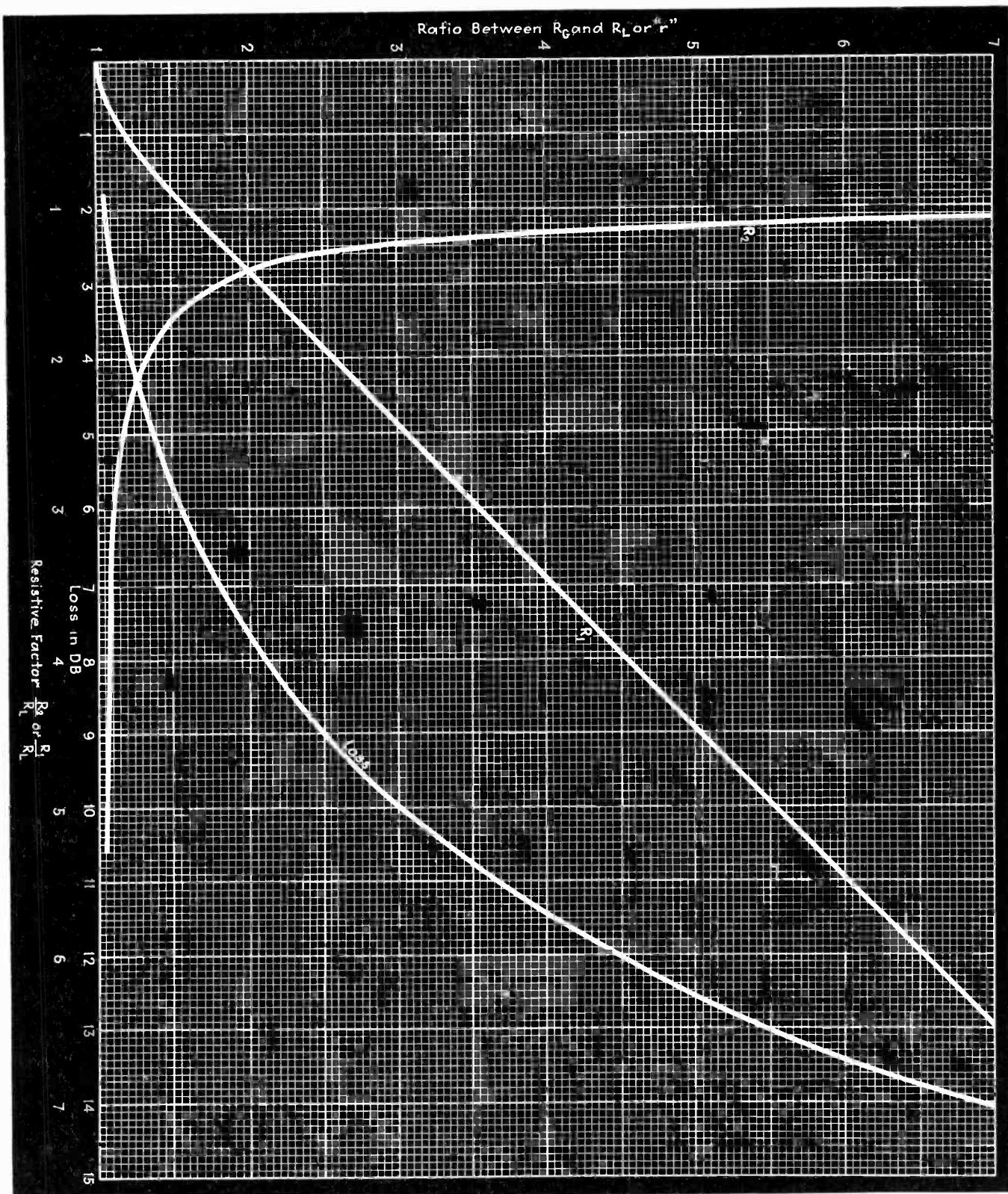

Fig. 1. The T and π pad developed from an L pad

Although the chart has been worked out on the basis of the L-type of network, T and pi-type circuits can be built up from the L-type as illustrated in the following examples, which have been compiled by the author of the chart.

I. To calculate the series and shunt branches of a taper pad matching 2,000 to 500 ohms. Since the ratio "r" in this case is 4, the abscissa shown by the chart for R_1 is 3.46 and for R_2 is 1.15 which when multiplied by R_L (500) gives 1,730 ohms for R_1 and 575 ohms for R_2 . The loss of this network, from the graph, is 11.4 db.

II. To design a 500 ohm balanced network with a loss of 20 db. Reading directly from the graph, a one to one ratio would give a zero value for R_1 , but it is still



possible to introduce a loss by tapering a network to a lower impedance and back to normal again. (See Fig. 1-B.) The loss of each half of such a combination would be half of the total loss. Therefore, calculations will be made for two 10 db taper pads to be placed "back to back." The ordinate opposite the 10 db abscissa is the ratio 3 and, since R_G is to be 500 ohms, R_L will be 500/3 or 133 ohms. From this point the procedure is the same as in Example I, the value of R_1 being found to be 326 ohms and R_2 , 163 ohms. Therefore the two series branches R_1 and R'_1 of the T pad would equal 326 ohms each and

the shunt branch would equal 163/2 or 81.5 ohms since R_2 and R'_2 are paralleled.

III. To design a 500 ohm balanced pi-network with a 20 db loss. (See Fig. 1C). Here the loss may be obtained by tapering to a higher impedance and back to normal, i.e., just the reverse of the process in Example II. Since R_L is 500 ohms in this case, it is found that for a 10 db loss or a ratio of 3 the shunt branches R_2 and R'_2 equal 500×1.2 or 600 ohms each, and the series branch being the sum of R_1 and R'_1 , equals $2 \times 500 \times 2.45$ or 2,450 ohms.

An electronics laboratory for technical students

By TRUMAN S. GRAY, Sc.D.

*Department of Electrical Engineering
Massachusetts Institute of Technology
Cambridge, Massachusetts*

ENLARGEMENT of instruction in electronics by educational institutions which train electrical engineers has become of increasing importance during the last few years. Not only in the field of communications, in which for over a decade electronic apparatus has been indispensable, but in most other branches of electrical engineering, a knowledge of the principles of the structure, operation, and utilization of electronic devices is becoming essential to the success of an engineer. This fact has been recognized and is being met in schools and colleges throughout the country. It is the purpose of this article to describe a new method of laboratory instruction in electronics used by the electrical engineering department of the Massachusetts Institute of Technology.

Laboratory methods are essential associates of textbooks or classroom processes for training in this field. The phenomena which take place inside even a simple vacuum tube are varied and complex, and their individual effect upon its electrical characteristics are not easily recognized or isolated. Classroom or textbook treatment makes plausible the main phenomena and provides a basis for calculation of their effects. However, many secondary but nevertheless important factors enter into the performance of a vacuum tube which may modify its behavior to a considerable degree. These are not easily treated in the classroom—in fact they must often be handled empirically. A sense of the relationships between the different phenomena and of their relative magnitudes is difficult to grasp. Almost the only way that students can successfully acquire this sense is by actual laboratory contact with them. In the usual laboratory practice this knowledge is imparted by measurements on commercially-built apparatus. A method of considerably greater effectiveness is to give the student the opportunity of designing, constructing, testing and utilizing his own vacuum tubes, following the guidance of the best scientific knowledge available for application to the art. This method has been introduced at the Institute.

It may be pointed out that laboratory methods of this type are in keeping with the broad objectives toward which educational work may be directed. Laboratories

in science and engineering serve not only to emphasize physical principles and to show their correlation, but to provide a place for the development of the ingenuity, skill, resourcefulness, self-reliance, initiative and experience of the student in the processes of observation and investigation. To improve these last qualities in the student (which is undoubtedly a most important objective) it is necessary that each one be allowed a maximum of freedom, consistent with his development of technique, in the choice of a laboratory project and the method of attack. The systematic, orderly assembly of standard equipment prearranged to enable the student to perform a complete prescribed experiment is to be avoided, as its use fails to fulfill one of the primary objectives of laboratory methods. This primary objective may be accomplished only in a laboratory with adequate, flexible equipment available for investigatory use in a variety of problems.

Although there can be little doubt of the effectiveness of the procedure introduced by making possible the individual design and construction of vacuum tubes, the criticism might be made that it is not practicable because the time and skill required of the students would be excessive. However, this objection has been overcome, and the results of several years' work indicate that with proper equipment and instruction the average student (having designed a tube for a particular purpose) can assemble, seal in an envelope, and evacuate a simple type of thermionic tube in the course of half a dozen hours of laboratory work. Subsequent electrical tests and comparison of the results with those obtained by other students on tubes of varied design or dimensions, together with investigation of the reasons for differences, give a comprehensive insight into the fundamental principles of vacuum tube operation.

Six operations performed

The accompanying photographs show students at work in the laboratory for tube construction. The equipment provided is of the semi-automatic type ordinarily employed by manufacturers for the experimental production of radio-receiving tubes. This eliminates the necessity on the part of the students of spending time to secure high skill in glass blowing, and enables them to devote the greater part of their time to design, assembly, and evacuation of the tubes, which are the features of engineering interest. It is significant that the equipment is not restricted to the construction of high-vacuum tubes.

TRAINING ELECTRONIC ENGINEERS

The industry has never been in greater need of well-trained electronic engineers. In this article is described a unique workshop laboratory, in which student engineers may construct tubes of their own design, including all steps from spot-welding of the elements to evacuating, basing and testing characteristics. The essential class-room instruction is thus supplemented with valuable practical training.

Models of a majority of the types of electronic devices are built by means of it with a minimum of time spent on repetitive mechanical processes.

Equipment is available to perform the six essential operations in the construction of a vacuum tube, namely, stem construction, mounting of metal parts, sealing in an envelope, evacuation, degassing and basing. For the construction of stems there is an abrasive wheel for cutting glass tubing into uniform lengths, a machine for spinning

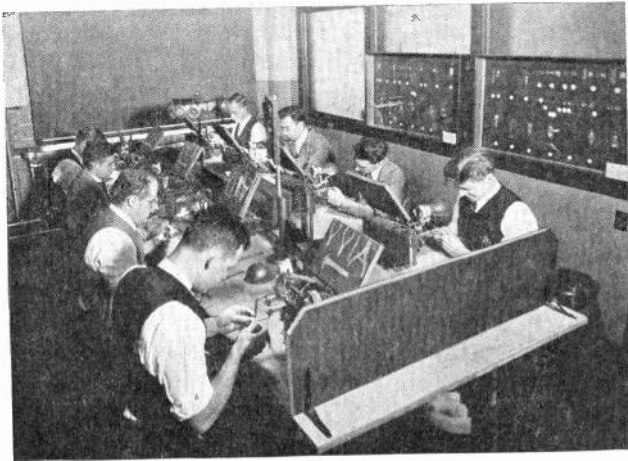

Fig. 1. Students assembling vacuum tubes of their own design. Eight spot welders and a supply of standard tube parts are available for this work

a flare on the tubing, a stem-machine for forming the glass and lead-wires together, and an annealer for cooling the finished stem slowly to eliminate objectionable strains in the glass.

The equipment for use in assembling the internal structure on the stems consists of eight electric spot-welders shown in Figure 1. A supply of standard parts is kept in a stockroom. Standard stems purchasable from manufacturers are furnished for use where possible, but special parts are made by the students as needed. In addition a grid winder, a hydrogen oven for cleaning metal parts, and a spray gun for applying experimental coatings to cathodes and filaments are available. A sealing-machine for sealing the glass envelope around the internal structure is provided, and with it is a stock of the common sizes of standard radio-receiving tube bulbs. This machine together with the remaining equipment is shown in Figure 2.

For the evacuation of tubes there are four vacuum systems. These are built for different classes of tubes. The first system is the common "trolley" type and employs rubber tubing for making the connection to the tube to be exhausted. The beginner is started on this system. After developing the ability to seal his tube directly to a glass system he may then use one of the other systems in which rubber tubing is eliminated and better vacua are obtainable. One of these systems is used for tubes requiring mercury, another for tubes requiring argon, helium, or neon, and the third for high-voltage tubes requiring a higher than usual vacuum. The students acquire a considerable skill in the scientific aspects of vacuum technique. All of the systems are equipped with rotating and diffusion pumps, with freezing traps, and with McLeod, thermocouple, or ionization gages, for measuring the pressure. The tubes may be outgassed while on the vacuum system by means of ovens for baking the glass and a high-frequency vacuum-tube oscillator (or bombardier) for heating the metal parts by

induction. Finally, a basing machine is used to bake the cement which fixes the bakelite base to the glass envelope.

The introductory experiment undertaken by all the students in the laboratory who have not previously had such experience, is the construction of a simple type of high-vacuum diode rectifier having a cylindrical anode and an axial tungsten filament. The design of the structure for assembly out of standard parts, the assembly of the filament and plate structures, the enclosure in an envelope, and the evacuation and degassing processes carried out with this tube illustrate the procedure necessary for the manufacture of most types of vacuum tubes.

Subsequently a thorough investigation of the electrical characteristics of the tube is conducted in the measurements laboratory which is fully provided with instruments and circuit equipment. This investigation is performed for the purpose of making first, an independent study of the laws of thermionic emission of electrons, and of space-charge limitation of current; second, an examination of the degree to which these phenomena are paramount in the action of the tube; and third, an observation of the typical electrical characteristics of this type of electronic device. Comparison of the experimentally determined results with data predicted by calculation from theoretical relationships developed in lectures or exhibited in textbooks and other literature show the applicability of these relationships to the scientific design of tubes, while the technique and experience acquired in the laboratory serve as a basis for further experimental investigation in the field of design and construction. The men are encouraged to devote further time in the construction and the investigation of the performance of tubes of their own design, although the study of the structure, electrical characteristics and application of some of the commercially established devices is sufficiently included in their work.

This laboratory has a triple function in the electrical

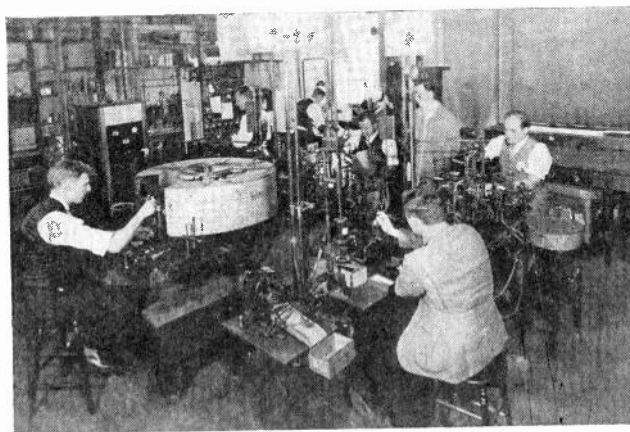

Fig. 2. In this room students have constructed almost every kind of electronic device including multi-element tubes, photocells, grid controlled mercury rectifiers, luminous tubes, and even cathode-ray oscilloscope tubes.

engineering department. In the first place, it provides an opportunity for about one hundred undergraduate students in the course of a year to learn the rudiments of vacuum-tube qualities and performances and the reasons therefor. In the second place, the laboratory provides facilities of a unique nature for graduate research by more advanced students. In the third place, it serves as a source of supply for special electronic tubes used within

[Please turn to page 89]

Beat oscillators for modern radio receivers

By ARTHUR G. MANKE

*Engineer, General Household Utilities Company
Chicago, Illinois*

THE following is presented to suggest an improved method both electrically and economically for applying the beat oscillator to a receiver having automatic volume control on all intermediate frequency amplifier tubes and obtaining an audible beat note signal at resonance for strong or weak signals. This accomplishment naturally suggests the possibility of utilizing the beat note oscillator as a means of accurately tuning a high fidelity receiver.

The beat oscillator operating in conjunction with the intermediate frequency amplifier of a superheterodyne receiver for reception of unmodulated code signals has been in use for some time. The first receivers to utilize this method of reception did not have automatic volume control and frequently utilized two stages of intermediate frequency amplification, which considerably simplified the addition of a beat frequency oscillator. In later receivers with automatic volume control on all intermediate frequency amplifier tubes, however, a careful test would reveal an inaudible beat note when the receiver was tuned to a strong signal. This condition is satisfactory where the beat oscillator is installed principally for the reception of weak signals. In the small receiver automatic volume control on all high frequency amplifier tubes is necessary, particularly where only one stage of intermediate frequency is used.

The most common method of coupling the beat oscillator to the intermediate amplifier is shown in Fig. 1. From the circuit it is evident that the strength of the beat oscillator signal applied to the second detector is dependent on the amplification of the preceding amplifier tube. Where this tube is controlled by the AVC circuit, a strong signal incoming to the receiver will reduce the amplification of this tube and, as a result, the beat signal does not function or at best very poorly. If the strength of the signal from the beat oscillator is increased to overcome this difficulty, then the beat signal is likely to operate the AVC and thereby make the receiver insensitive to very weak signals. The use of AVC with considerable delay might be used to alleviate the situation providing a proper compromise was made, so as not to impair the normal operation of the AVC system. Such a solution would of

course involve the designer in considerable difficulty and would then necessitate accurate control. A method which would be better than delayed AVC can be obtained where two intermediate frequency stages are used by simply omitting the AVC from the second amplifier tube, providing this is the receiver.

A simple and effective solution to this problem is obtained by introducing the beat oscillator signal directly into the coil which operates the diode or second detector. This is illustrated diagrammatically in Fig. 2. When the proper strength of the beat oscillator signal is introduced at this point, the beat signal operates equally well on strong or weak signals. The strength of the signal from the beat oscillator should be sufficient to draw from four to eight microamperes direct current in the diode resistor. Under these conditions, the operation of the beat oscillator will not develop sufficient AVC voltage to reduce the sensitivity of the receiver. If a diode output resistor considerably higher in resistance than 100,000 ohms is used, then the signal from the beat oscillator should be adjusted to draw proportionately less current through the diode resistor. The use of an appreciably stronger signal from the beat oscillator is not necessary, even though a stronger signal does not reduce the sensitivity of the receiver where the high frequency amplifier tubes are self biased as is usually the case. In those cases where delayed AVC is used, the maximum allowable strength of the beat oscillator will naturally be determined by the amount of delay used on the AVC diode.

The amount of stray voltage from the beat oscillator to the input of the intermediate amplifier should be small, as the amplification of this stray pick-up is dependent on the strength of the signal incoming to the receiver. The amount of stray pick-up is to a large extent dependent on the arrangement of the intermediate frequency amplifier and also whether or not a filter is used in plate supply of the oscillator. In Fig. 2, a filter is shown in the B plus lead of the last intermediate stage and this filter is effective in reducing the stray pick-up from the oscillator.

In an arrangement used by the writer considerable economy has been obtained by combining the diode intermediate frequency transformer and the beat oscillator. The primary and secondary coils of the beat oscillator are

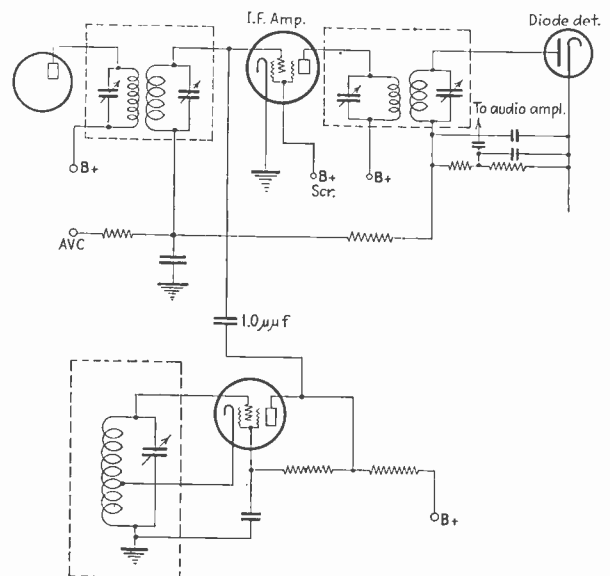

Fig. 1—Method of injecting beat frequency into i-f amplifier

placed at one end of the dowel. The grid blocking condenser of the oscillator is mounted inside the dowel. This mounting is desirable as the blocking condenser is shielded, which aids in reducing stray pick-up into the intermediate frequency amplifier. Only one can is necessary in this case to shield and house both coil assemblies.

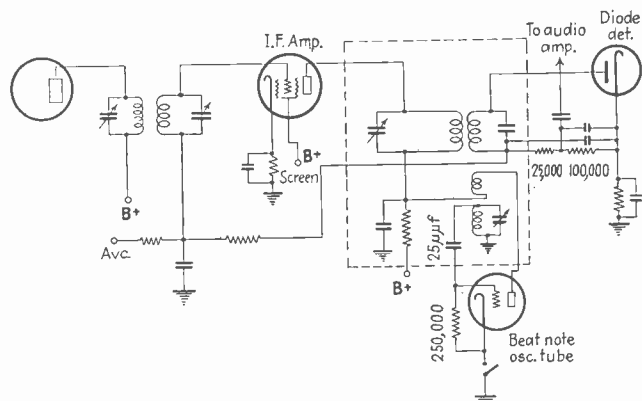

Fig. 2—Preferred circuit for receiver with beat-frequency oscillator

A trimmer near the base of the can is used to tune the beat oscillator, and a dual trimmer is used to tune both primary and secondary of the transformer. In some cases only one winding of the transformer is tuned and then only the dual trimmer is required. Where a relatively high frequency is used for the intermediate frequency amplifier, it is advantageous to use a three-coil intermediate transformer in the first stage, and in this case, both cans are identical. The trimmer near the base of the can is used to tune the plate coil of the first intermediate frequency transformer and serves to tune the secondary of the oscillator on the second or driver stage transformer.

The frequency at which the beat oscillator operates is important in this case. It is impossible to operate on the fundamental frequency of the oscillator, as this would cause serious absorption. For this reason the second or third harmonic of the oscillator is used to beat with the intermediate frequency. The use of one of the harmonics of the oscillator is advantageous in other ways. The har-

monics are weaker than the fundamental, thereby allowing the beat oscillator to operate vigorously and still the signal produced at the intermediate frequency will not be too strong. The third harmonic of the oscillator was found most desirable for the arrangement used by the writer. In this assembly, the plate coil of the intermediate transformer is adjacent to the oscillator coil which aids in reducing the oscillator voltage induced into the diode coil. Operating the oscillator at large amplitudes also aids in obtaining maximum frequency stability as all circuit constants can be chosen to favor frequency stability of the oscillator. If the beat oscillator is operated at twice the intermediate amplifier frequency, then the presence of the oscillator circuit will reduce the second harmonic which is normally present in the output of the driver stage.

Application to high fidelity receivers

The variation of oscillator frequency with line voltage becomes important in those cases where the beat oscillator is used in place of a tuning meter in a high fidelity receiver. The stability of the oscillator for line voltage variation can be appreciably increased by using a very small capacity in the oscillator blocking condenser, a high value of grid leak, and a resistance in series with the primary. The use of a good grade fixed condenser in parallel with the trimmer and moisture-proof impregnation of the oscillator coil will aid in maintaining a constant LC-product and thereby eliminate the danger of frequency shift due to temperature and humidity changes.

The use of the beat oscillator to indicate resonance will enable the operator to tune the receiver very accurately and take advantage of the maximum fidelity obtainable from the tuned circuits. On receivers having a geared pointer or a relatively large tuning dial, it would, of course, not be necessary to use the beat note signal each time a station is selected, as the exact location would soon be memorized. When receiving broadcast stations it is not necessary to switch off the beat note oscillator as the stability of the high frequency oscillator is sufficient to keep the receiver at zero beat, and this is also true of many of the short wave stations even where no particular attempt is made to stabilize the high frequency oscillator.

Students' electronics laboratory

[Continued from page 87]

the Institute in a wide variety of research projects. Many of the problems of research relating to electronics that can now be pursued effectively were previously closed to investigation because of the lack of equipment necessary to perform the constructional work quickly and with little requirement of special artisan's skill. Much of the equipment has proved to be of value in connection with investigations outside the electronics field.

Laboratory has wide scope

Electronic devices of almost endless variety involving nearly all of the important phenomena now known and used in this field may be built rapidly with this equipment. A few of the better known types of apparatus that have been constructed by students in the laboratory are thermionic rectifiers, three- and four-element amplifier tubes, photoelectric cells, cathode-ray oscillographs, gas-filled and mercury-vapor rectifiers, magnetic control tubes, grid-controlled arc rectifiers, and luminous signs.

Although small in size, the products of the laboratory illustrate the performance of the larger types of tubes, for the phenomena that take place in the usual large tubes are not far different from those that take place in some form of small tube.

That the laboratory is an effective educational method is demonstrated by the enthusiasm with which the students welcome the opportunity of designing and constructing tubes for their own investigatory laboratory problems, and by the industry with which they approach the work. It serves to stimulate and develop their initiative, spirit of industry, and resourcefulness. The laboratory is utilized to capacity a considerable part of the time. Its primary purpose is to facilitate teaching the science of the engineering applications of electronics, and it is proving competent to fulfill the purpose successfully. Many of the tubes designed are "duds," much glass is broken, and many filaments are burned out, but on the whole many lasting lessons are learned in both the science and the technique of electronics.

HIGH LIGHTS ON ELECTRONIC

Transportation noise studied by new analyzer

A NOISE ANALYZER, differing from the usual noise meter in its ability to measure separately each frequency component in a given sound, has been developed by W. O. Osbon, research engineer of the Westinghouse Electric and Manufacturing Company. The analyzer uses a modified superheterodyne principle, differing from the radio superheterodyne only in the intermediate circuit where a mechanical, rather than electrical, filter is used.

In operation the input circuit is "tuned" over the band of frequencies present in the noise spectrum. The frequency received at any one dial setting is mixed with a standard 7,000 cycle oscillator in the intermediate circuit, and the resulting beat frequency is measured in the output circuit, both as to the number of cycles per second and intensity. In this way the principle frequency components present in various types of noise may be identified, and in many cases this identification will serve to indicate the source of the noise itself. The device is capable of measuring accurately all the audible frequencies, and in addition may be used at various sound levels from the threshold of hearing to 100 decibels. The analyzer is designed for portable use, mounted in three carrying cases, with a microphone and stand. The sensitivity of the circuit is no less than that of the best laboratory devices.

A very practical application of the analyzer has been made in a recent study of the noises produced in various transportation facilities. Noises produced by

airliners, railroad coaches, Pullman cars, subway coaches, city buses, transcontinental buses, and street-cars have been analyzed, both as to total loudness and by individual frequencies. The total loudness readings, which checked studies made by the usual type of noise meter, showed that the commercial airliner ranked midway between the comparatively quiet railroad Pullman car on the one hand, and the street-car on the other.

The loudness of the individual frequencies produced by each type of conveyance, shown below, indicates the differences in the character of the noise produced by the different sources, and points the way to efficient noise reduction. That the low frequencies carry the bulk of the noise energy in each type of source is clearly apparent. The relatively large percentage of high frequencies present in the street-car noise is attributed to gear-noise, window rattle, and similar impact noises. The various peaks in each curve indicate resonance, and can be used to trace the resonating member in the source. It is anticipated that such frequency-spectrum analysis of noise sources will aid greatly in the noise-reduction programs now being carried out by governmental and commercial agencies.

Electronic sleuth for lost radium in hospitals

HOSPITALS and radiologists will be interested in a new instrument for locating lost radium preparations. A light aluminum ionization chamber, which

serves as the explorer, carried in the hand, is passed as close as possible to the space to be examined, while the operator watches the indicator in the amplifier slung by his side. This new detector is the development of Dr. L. F. Curtiss of the U. S. Bureau of Standards, and is being made by the American Instrument Company of Washington, D. C.

A trash-can can be examined for radium by merely passing the explorer around and over the can, without emptying it. A 25 mg. preparation can be detected at a distance of 7.5 feet—or 10 mg. at 3 feet distance.

Searches which required hours by the old electroscope method may be performed in a few minutes with the new instrument.

Shoal water depths by echo sounding

CAPTAIN R. S. PATTON, director, announces a recent improvement by the Coast and Geodetic Survey in the apparatus to obtain depths by echo sounding. This new equipment, now being used in surveys off the Virginia coast, takes 20 soundings a second in depths from 6 to 120 feet, with an accuracy of about one inch. At a cruising speed of ten miles per hour, a sounding is therefore obtained every ten inches along the bottom.

The instrument known as the "shoal fathometer" is a further development of the deep-water fathometer which has been used by the Coast and Geodetic Survey in hydrographic surveying for over nine years. The deep water fathometer has been of inestimable value for depths of about 15 fathoms (90 feet) to 3,000 fathoms (18,000 feet), the deepest water so far surveyed. Not built primarily for surveying, a small variation in depth indication was found in the apparatus. Having a nearly constant value, this produces a larger percentage of error in shallow water than in water of greater depths.

The general method of measuring depths by all fathometers is to produce a sound in the water at the bottom of the ship. This sound travels to the bottom and returns as an echo, picked up by a hydrophone, or electrical ear, in the bottom of the vessel. The fathometer measures precisely, and translates automatically into depth, the elapsed time from the sound production to the return of the echo, and indicates this depth by means of a neon-tube flash on a rotating disc graduated in fathoms.

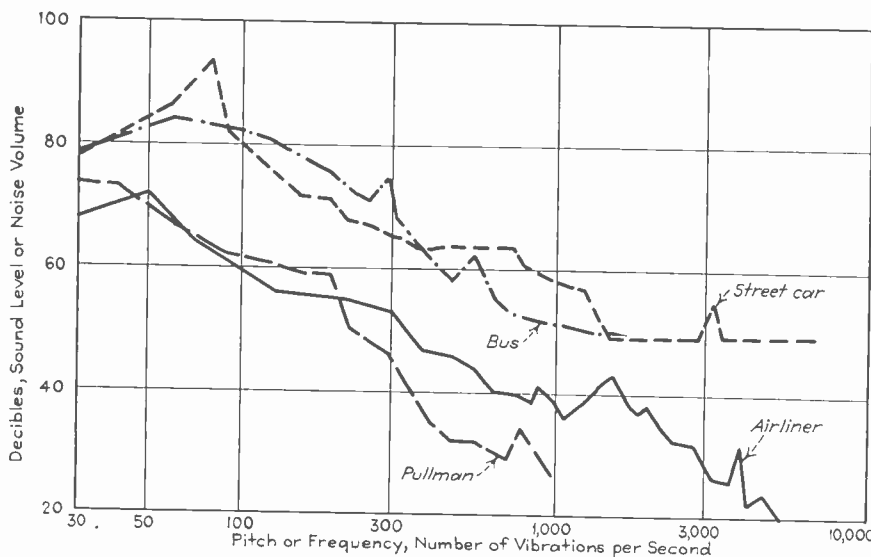

A comparison of the noise spectra produced by various transportation facilities

DEVICES IN INDUSTRY + +

Since sound in sea water has a velocity of about 4,800 feet per second, some idea may be had of the almost uncanny accuracy of the time element in

round trip. As the instrument is designed to measure this depth within one-tenth of a foot, its accuracy of measurement of time elapsed must be within four one-hundred-thousandth of a second.

In the new shoal fathometer, supersonic frequencies are used for the sound production; that is, notes produced electrically, too shrill for the human ear to detect.



Four-part sound film used for chorus instruction

THE INSTRUCTION of a group of young boys in the art of four-part choral singing is the latest application to which the photocell has been put. Colonel Richard H. Ranger, 574 Parker Street, Newark, N. J., well-known electronic engineer, has designed a four-part sound film which is used with photocell and amplifier equipment to train the young singers in the parts they are to sing in the choral arrangement. For several months a group of boys known as the Electro Choir have been practising under the direction of Colonel Ranger.

A special film is made for each selection to be sung by the choir. The film contains five sound tracks, one for the soprano, another for alto, one for tenor, one for bass and a fifth one for the complete melody. This film is made to pass five different phototubes, one for each of the five sound tracks. A light

beam shining through the film on to the photocell is modulated with the choral part of that particular track. Five amplifiers, one for each photocell, are provided, with loud speakers, switching equipment, faders, and microphones.

When the choir assembles the boy sopranos are put in one room by themselves, altos, tenors and basses each in separate rooms by themselves. Each boy is then fitted with a single earphone. Through this earphone he hears the part he is to sing, produced from the sound track of the original film. Through the other ear the boy hears the combined parts of all of the other singers. In this way he is able to balance the volume of his voice against those of the other groups, so that a uniform level of sound is produced by each of the four parts. As the boys sing their voices are picked up by four different microphones and blended in a mixing panel. Thus the complete rendition of the music is brought together finally through a loud speaker which receives the voices of all four groups.

Colonel Ranger, at the controls of the system, is able to regulate the volume of each group of boys, so that the most artistic effect is produced, and at the same time he is able to signal them if they do not perform properly through the earphones which they wear.

The boys are very enthusiastic over the entire undertaking. The parts they have to learn may be complicated, but because of the aid which they receive from the earphones on their ears, they are able to pick up the harmonic part they are to sing in a very short amount of time.

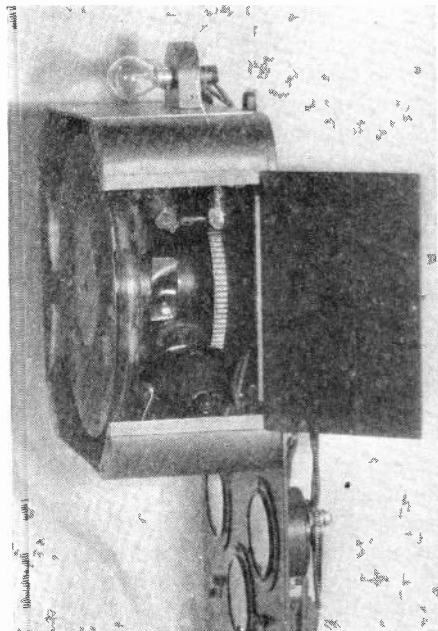

Indicator open, showing the revolving neon tube, flash of which indicates depth. At top is lamp which operates photo-tube to send out signals

this newly developed instrument, which must measure the elapsed time for the sound to travel, for example, a depth of 12 feet to the bottom and return, a total distance of but 24 feet, requiring only five one-thousandth of a second for the

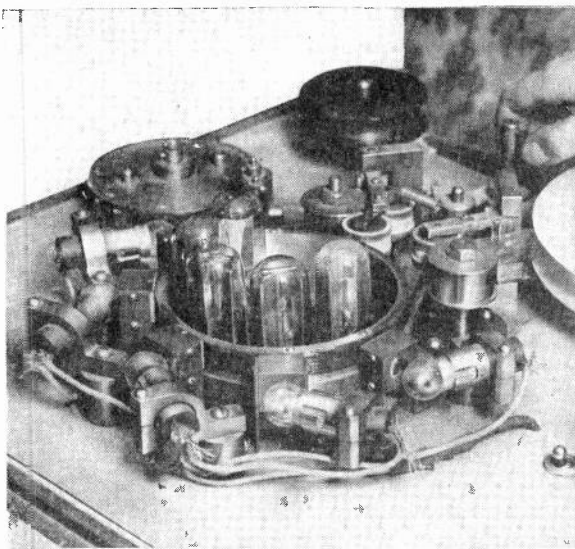

The photocells used for four-part choral instruction. The film containing sound tracks for the separate parts is scanned by individual photocells. The boys in the Electro Choir follow the music they hear in the earphones. Their voices, picked up by microphone, are blended with those of the three other groups singing the other parts

Generating sine waves with a gas discharge tube

By WINSTON E. KOCK

American-German Exchange Fellow at the Heinrich Hertz Institut für Schwingungsforschung, Berlin.

THE majority of sine wave generators now in use have various disadvantages and limitations. Vacuum tube generators have the weakness of pitch instability, whereas tuning fork generators require an extensive filter system to produce a pure sine wave. The oscillator about to be described is very simple and convenient and overcomes to a large extent the difficulties hitherto experienced.

The circuit employed is that of the inductive glow discharge oscillator¹ shown in Figure 1, and consists of the well known intermittent glow discharge circuit but with an inductance inserted in the condenser arm. Oscillations take place due to the difference between the striking and extinction potentials of the glow discharge tube. The d-c voltage supply charges the condenser C through the resistance R until the voltage across the tube reaches the ignition or striking potential. The glow discharge then takes place, and the condenser discharges through the tube until the voltage across the tube drops to the extinction potential and the glow discharge ceases. The cycle then repeats itself at a frequency determined by the constants of the circuit. With no inductance present, the frequency of intermittance is given by²

$$F = \frac{1}{RC \log \frac{E - E_e}{E - E_s}}$$

where E is the applied voltage, E_e the extinction potential and E_s the striking potential of the discharge tube.

BY USING an inductance in series with the condenser of a simple discharge-type relaxation oscillator, the voltage across the condenser can be made to approach a pure sine wave at the resonant frequency. A generator built on this principle is simple, rugged; has exceptional stability.

We can best observe the effect of the inductance by investigating the wave form of the voltage on the condenser. Figure 2 illustrates this voltage for the ordinary intermittent glow discharge. The insertion of an inductance tends to prevent the sudden changes of current in the condenser arm, and since

$$E_c = \frac{1}{C} \int i_c dt$$

the condenser voltage will likewise become smoother. Figure 2 shows this effect for various values of the d-c applied voltage. For low voltages the wave form resembles that of the case with no inductance present. However, as the voltage is increased, the frequency, also increasing, eventually approaches the resonant frequency of the oscillating circuit. The inductance and condenser begin to exert control and limit the maximum frequency to that given by:

$$F = \frac{1}{2\pi\sqrt{L'C'}}$$

where L' and C' include the effective inductance and capacity of the discharge tube. The controlling effect of the inductance and condenser is also noticed in the discharge tube current; the discharge continues throughout a larger and larger portion of the cycle as the voltage is increased. At the frequency of resonance, the discharge lasts throughout practically the entire cycle, so that even in the discharge tube a fairly sinusoidal current wave exists. The arm current is affected even more so, and the voltage across the condenser possesses a remarkable purity.

In the dynatron type of oscillator, the amplitude of the oscillations is determined by the length of the negative portion of the plate resistance curve, and the purity is

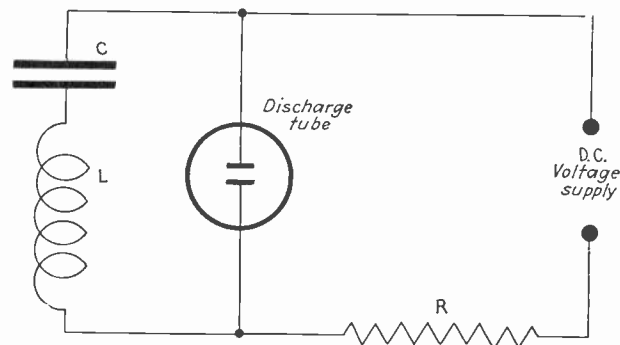

Fig. 1—Circuit diagram of the inductive glow discharge oscillator

increased by decreasing the exponential factor (and hence the amplitude) so as to decrease the damping effect on the crests of the waves. The inductive glow discharge oscillator yields, in contrast, the purest wave when operated at its maximum voltage, that is, when the output is, in general, a maximum.

Curve A, Figure 3, indicates the frequency voltage characteristics as obtained from the oscillograms in Figure 2. The flat portion of the curve can be made to correspond with any desired frequency by the proper choice of condenser and inductance. Thus curve B portrays the same characteristic except that the capacity was increased to effect a lower frequency of resonance. Frequency measurements for curve B were made with tuning

forks. An idea of how flat the characteristic becomes at resonance is obtained from Table 1. In this case, the capacity was of such a size as to effect a resonant frequency of 800 cycles.

TABLE 1

Voltage	Frequency
125	804.4
120	801.6
115	795.7

Reducing the applied voltage from 125 to 120 volts effects a frequency change of less than 3 cycles in 800. This change was measured by counting the beats between the glow discharge circuit and an 800 cycle tuning fork oscillator.

Changes in the glow lamp characteristics affect the frequency only insofar as they affect the total inductance and capacity of the circuit and for ordinary variations this is not appreciable.

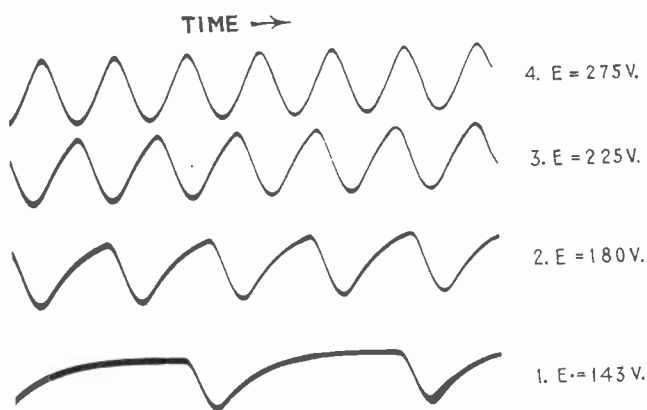

Fig. 2—Condenser voltage waveforms, for different values of d-c voltage supply. Note the approach to the sine-wave as the voltage is increased

Table 2 shows the results of a time run for a 400 cycle oscillator, also measured by the beat method.

TABLE 2

Running Time (Minutes)	Frequency
5	401.12
15	401.24
30	401.39
45	401.39
60	401.24

Even considering that the tuning fork generator was absolutely constant, the frequency variation is extremely small.

The absence of both direct and heavy alternating current in the inductance minimizes any changes in it due to heating. Changes in the series resistance affect the frequency to the same extent as do changes in the applied voltage.

Practical circuit arrangement

The most convenient method of utilizing the sinusoidal voltage present across the condenser is shown in Figure 4. Condenser C_2 blocks out the direct current component and its size depends upon the frequency range desired. For large values of C_2 , R_2 should be made large (2 to 5

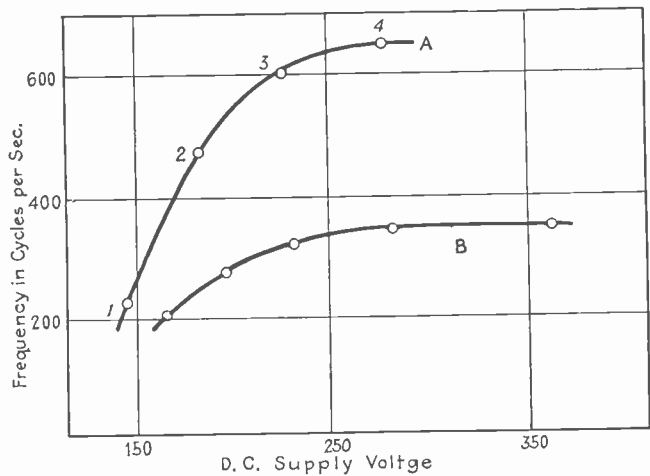

Fig. 3—Frequency-voltage characteristics Curve A is a plot of the four cases shown in figure 2. For curve B a larger condenser was used

megohms) to prevent C from affecting the frequency. The voltage R_2 is then fed directly into the grid of a suitable amplifying tube. Rectified alternating current may be used for the d-c voltage supply when maximum constancy of frequency is not essential. Even then, however, ordinary 2 to 5 per cent line voltage variations will not seriously affect the frequency as has been shown in Table 1.

For commercial glow lamps of the 110 volt type, the extinction and striking potentials lie about 10 volts apart. Although this value is reduced when discharges take place in rapid succession, there is still a considerable voltage swing on the condenser due to series resonance so that the effective voltage across R_2 is roughly 10 to 12 volts or better.

To insure maximum purity of the output wave, it is best to shield the amplifier tube from the oscillator. Due to the high harmonic content of the current in the outer branch circuit of the oscillator, the amount of pickup, even at audio frequencies, may otherwise become objectionable.

By making either the inductance or the capacity variable, a constant frequency generator of large frequency range is obtained. However, for large changes in capacity or inductance it becomes necessary to readjust the value of the applied voltage to insure that the oscillator is operating on the flat portion of the frequency-voltage curve.

¹Kock, Physics, 4, 359 (1933)
²Ryall, Jour. of Scient. Inst., 7, 177 (1930)

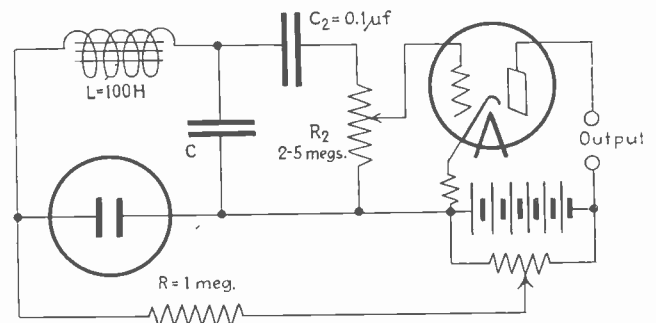

Fig. 4—Circuit diagram of the sine wave generator. For 500 cycles per second, C should be about .001 microfarads. L can be the secondary of an a-f transformer

++ NOTES ON ELECTRON

The Edgerton stroboscope in microscopic photography

THE RECENT announcement in the newspapers that the secret of the clam had been discovered, a scientific triumph of no small magnitude, referred to the discovery by Professors Jennison and Bunker of M.I.T., that the cilia (hair-like structures) of the clam membrane move with a motion not hitherto suspected. This discovery was made possible by the use of the stroboscope invented by Professor Edgerton, also of M.I.T., which permits high speed pictures to be taken under very adverse light conditions.

The microscope which views the motions to be recorded is fitted with a motion-picture camera, the film of which moves continually at a speed of about 200 inches per sec., thus permitting 200 pictures to be taken in that time. The light source underneath the specimen is an open spark gap. The intense light from the spark is used to illuminate the specimen to be examined. The light is turned on and off rapidly so that blurring of the picture does not occur. (For a complete description of the Edgerton stroboscope camera, see *ELECTRONICS*, August, 1934, page 250.)

The voltage applied to the spark gap is controlled by the circuit shown. A three-phase rectifier using mercury tubes provides a ten-ampere rectified current supply which charges a 70 microfarad condenser through the resistance shown. This condenser is charged to 1,200 volts, and discharges through a 100 ohm resistance into an 8- μ fd. condenser, which is the source of the current through the spark gap. In series with the spark gap and the 8- μ fd. condenser, is a mercury tube, containing a mercury-pool and an anode. A thyatron, operated in an impulse

amplifier circuit, discharges this mercury tube at the required rate. The excitation of the thyatron amplifier is provided by a commutator mounted on

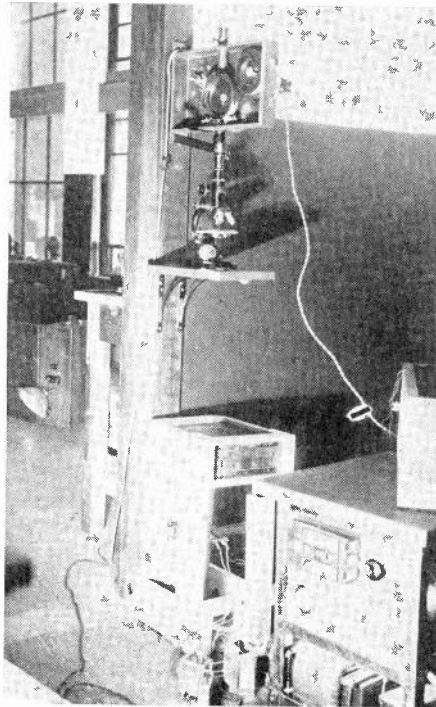

The stroboscopic camera set up for recording the motions of the clam membrane. The camera with cover removed is at the top, while the spark gap light-source and lens is in the box below

the motion picture camera, so that the commutator trips the thyatron circuit once for every picture to be taken. In this way the spark which jumps the gap is accurately controlled both in its frequency and in its time duration. High speed pictures of great sharpness and

clarity can be taken with such apparatus, and the intense light of the spark is sufficient to make high magnification possible without a dimly illuminated picture. The apparatus does not differ largely from the regulation Edgerton Stroboscope now in wide use for high speed photography work, except that the light source in this case is a spark gap, rather than the more common mercury discharge tube. The use of the spark gap provides a very compact light-source of great intensity, which is ideally suited to the requirements of microscope illumination.

High frequency compensation for high fidelity receivers

THE EXTENSION of the high frequency range of the new high fidelity receivers has brought with it a great increase in noise picked up both through the antenna and in the receiver itself. In fact many listeners prefer not to use their receivers "wide open" because of the objectionable noise which is transmitted in the high frequency range.

The suggestion has been made by Mr. Lincoln Walsh that this trouble can be overcome to a great extent by agreement of the set manufacturers to make the audio characteristic of their receivers flat only to 4,000 cycles. Above 4,000 and extending to 7,500 cycles, the characteristics should be made to slope down to a point 10 or 15 decibels lower in level. This characteristic is in fact displayed by many of the receivers on the market today. To compensate for the decreased response in the higher frequencies, the broadcast stations would have their characteristics changed so that they rise by an amount just equal to the loss of the receivers in the same range. The audio characteristics of the system are thus complementary and the response from microphone to loud speaker is flat throughout the entire range.

The objection that such a system would overload the transmitter is answered by the fact that the high frequencies present in the programs are far lower in magnitude than the low and middle frequencies. And since the average receiver of the non-high-fidelity type cuts off at about 4,000 cycles, its performance will not be affected. For such a system to be universally adopted by the receiver manufacturers would require that the idea be put into effect immediately, before many high fidelity receivers with substantially flat response

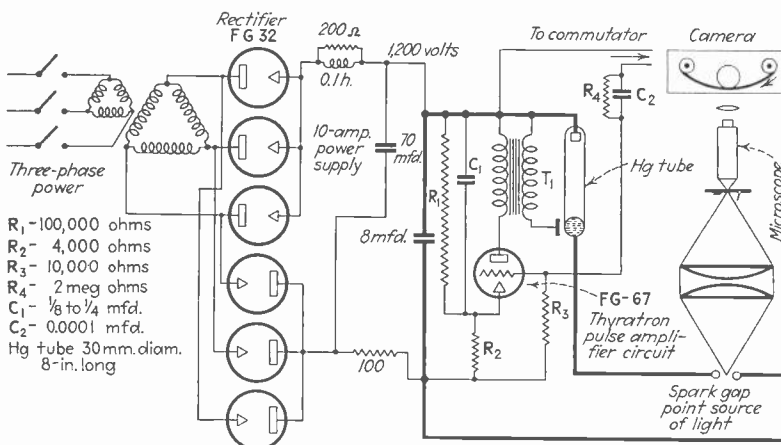

The circuit diagram of the Edgerton high speed microscope camera

TUBES AND CIRCUITS + +

are in service. These receivers, of course, would display a badly accentuated upper range if the transmitters were changed according to Mr. Walsh's plan. The suggestion is an interesting and direct way of dealing with the problem of high frequency noise in high fidelity receivers.

+

Frequency conversion characteristics

IN A STUDY made by C. A. Hultberg, of Hygrade-Sylvania the use of the 6F7 type tube as a triode-pentode converter was compared with the 6A7 type of elec-

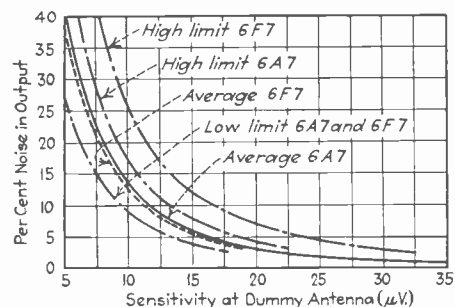

tron-coupled pentagrid converter. The illustration shows the noise introduced in the conversion process by these two tubes. It was found that the average characteristics showed practically no difference in noise between the two tubes, but the range of tube variations showed that greater noise might be expected from 6F7 type of tube.

The tubes were compared in a set-up containing a standard signal generator, a dummy antenna, a tuned input circuit, a conversion circuit, a detector and output stage, and an output meter.

+

Apparent re-activation of tubes after long rest

USERS OF 112A and 201A tubes in phototube relays have reported that after such tubes have "worn out," following several months of continuous operation, and are laid away on the shelf for a rest of a few weeks, they can be put back into the relay units, and seem to have their former vitality restored. In one case where a relay is used to control small lights burning around a country place during hours of darkness, the

112A amplifying tube operates continuously, and after service of several months loses its emission to a point where the relay will not pick up. If this fatigued 112A be then laid aside until its successor 112A reaches a similar condition, the former fatigued tube can be put back into the circuit, and will usually operate satisfactorily for several weeks, before again failing.

When report of this situation was made to E. W. Ritter, manager of the research and development laboratory of the RCA Radiotron Company, Harrison, N. J., Mr. Ritter commented as follows:

"I have made several inquiries in the Laboratory concerning the apparent re-activation or restored vitality of tubes laid aside for a period of weeks. This phenomenon has not been noticed except on photoelectric cells and I believe the explanation there is pretty generally known. It is possible for tubes to develop gas on standing idle, which for a time would aid in operation and would assist in reactivation after the tubes are put into use again. I believe this would occur only in oxide coated tubes.

"We seldom encounter a general slumping condition in the 201's and 112's during life test, that is, until the tubes have operated for 1,000 to 2,500 hours."

+

110-megacycles transmission spans 100-mile stretch

TESTS of telephone transmission on 110 megacycles, conducted by the American Radio Relay League in cooperation with the Harvard University Meteorological Observatory have shown that distances as great as 100 miles may be covered on these frequencies with low power

transmission, at least when conditions are favorable. A series of schedules on this frequency between Hartford, Conn., and Blue Hill (near Boston), Mass., showed that transmission was superior in many instances to that provided by the 56 megacycle (5 meter band) signal. Special directional antenna systems were used in this work.

+

Notes—

Radio prices are up—But in a Brooklyn plant, where an European correspondent got a job just to see how it works over here, assemblers are paid 25, 27 or 35 cents per chassis depending upon its complexity. The first day this lad put together 2 sets, the second day three, and after two weeks he could knock out 5 or 6 per day. To make any money at all, it seems that four men agree among themselves, and without the foreman's knowledge, to work together. In teams of this sort they can put together 35 to 38 sets per day. Figure it out for yourself!

Canada is in the television race—It is reported that an American television promoter, long in need of money for a working and workable system, has been subsidized by the Canadian government; that he will erect the first experimental station in Montreal by March of this year. This is to be 120 lines, mechanical scanning. An Australian buyer, in New York representing several clients, has seen a projected picture from the apparatus of this television system, 10 by 12 inches in size and is enthusiastic about its brilliance.

NEW ACORN TUBE—A PENTODE

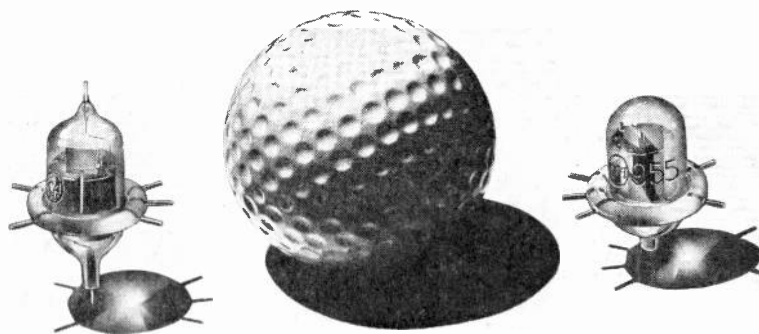

First announced at the New York I.R.E. meeting March 6, this new Radiotron will deliver a voltage amplification of 10 at 3.5 meters against 1.5 for best existing tube. Here it is compared in size with a golf ball

electronics

McGraw-Hill Publishing Company, Inc.
330 West 42d Street
New York City

ORESTES H. CALDWELL, *Editor*

KEITH HENNEY, *Managing Editor*
DONALD FINK

Vol. VIII

—MARCH 1935—

Number 3

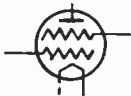

Standardize industrial tubes now!

QUICK and effective standardization is needed for industrial electronic tubes. No service which the electrical manufacturers' group can perform right now, could be more welcome than the standardization of ratings and the standardization of bases, so that purchasers can get the advantage of the conveniences and cost reductions which would follow from simplification of tube stocks.

And in the selection of tube sizes, an admirable opportunity is afforded to use the well-known schedules of "preferred numbers"—ratios of sizes, mathematically derived, which make for the greatest flexibility of use.



Glass vs. all-metal for radio tubes

WE hear many rumors that the radio receiving tube finally will throw off the last of the apron-strings that have bound it to its progenitor, the incandescent lamp, and become a metal mechanism specifically designed for its electronic function.

Nearly one billion tubes have been built so far—yet the tube's evolution away from the lamp that begot it has been painfully slow. Long the tube tenaciously held the lamp's size, the lamp's shape, the lamp's mechanical structure (until the

dome top arrived) and, to 1935, the lamp's glassy envelope.

Glass was essential in the lamp to let the light out. In the tube, quite the reverse, a metal covering had to be provided, anyway, for electromagnetic shielding. Yet so firmly established has been the precedent of glass, that fifteen years of active tube history have gone by, with glass predominant.

England had metal "catkins" two years ago. All-metal industrial tubes were introduced in America last year, although then old to Europe. Metal tubes—when they come—will merely fulfill the manifest trends of tube design for the American market.



Radio is not like safety pins

THERE are those—a few—who still fondly hope that radio will some day—preferably soon—settle down into a quiet, peaceful business, like making safety pins, with fewer annual models, fewer agencies making obsolete all products of the immediate past.

The engineers, however, who make possible an industry with an annual turnover of one-quarter billion dollars have no such illusions. They realize that radio depends upon their ability to conjure up new models and new degrees of excellence in home entertainment devices. Research men, particularly, working in the laboratory where new circuits and products originate are least inclined to look or hope for technical stability (stagnation). Says one: "The next three years will see greater change than occurred in the last five years."



Getting the tools for television

AN interesting omission from the report of the British Television Committee is any reference to "chaining" of local television transmitters by means of co-axial conductors or open-wire lines. Testimony brought forward by Lloyd Espenschied and others on this side of the

Atlantic indicates that such lines can be used to carry extremely wide bands, even up to several million cycles, well suited for television, and requiring repeaters only every fifty miles at the intensities required for television. At radio frequencies it has been found even possible to eliminate the central conductor of the pair altogether, and to depend upon the outer cylinder to guide the internal radio waves, like a separate "section of ether" cut out of space!

This co-axial conductor is certainly a new tool for television of prime importance. First the cathode-ray tube for producing the picture; then electronic scanning; and now conductors for getting far beyond the horizon. Suitable transmitters, industry enthusiasm, and money to do the job, seem to be about the only things now needed to bring television to pass.



Rating home and office appliances on noise

A VALUABLE step toward noise abatement would result from the rating of household and other appliances for noise-making—or the lack of it. Dr. E. E. Free and other groups in the Acoustic Society of America have been trying for years to get engineers and architects to do this kind of thing in specifying engines, motors, fans and similar equipment for buildings or other situations where noise would be harmful. Considerable success has followed this general effort. A large number of designing engineers now specify noise limits. Unfortunately, however, the ratings themselves have not been confirmed by independent acoustic laboratories best qualified to rate devices authoritatively. The purchasers usually write their own specifications and merely depend upon the manufacturers of the articles concerned for an unsubstantiated guarantee. If general business were in better shape undoubtedly there would be more opportunity for the use of noise meters and expert services to check such guarantees.

Any system of noise rating would be bound to involve at least slight increases in cost, although the results in "customer appeal" and purchaser satisfaction would undoubtedly offset this outlay many times.

NEWS NOTES

RMA Interference Committee meets—The first meeting of the new committee on radio interference, sponsored by the engineering division of the Radio Manufacturers Association, was scheduled to be held March 8, at the Hotel New Yorker, New York City. Dr. Alfred N. Goldsmith is chairman, and among the co-operating bodies are the Federal Communications Commission, Bureau of Standards, Canadian Department of Marine, RMA of Canada, National Electrical Manufacturers Association, Institute of Radio Engineers, Radio Wholesalers Association, American Radio Relay League, Institute of Service Men, Radio Club of America, National Association of Broadcasters, and Society of Automotive Engineers.

Motion-Picture Engineers' Convention, Hollywood, May 20 to 24—The spring convention of the Society of Motion Picture Engineers will be held at the Roosevelt Hotel, Hollywood, Calif., May 20 to 24. Nine technical sessions will be held, two in the evening, to permit members to visit the motion-picture studios which will be open for convention visitors. The banquet is scheduled for Wednesday evening, May 22. Convention arrangements are in charge of W. C. Kunzmann, G. F. Rackett, Emery Huse, Oscar F. Neu, Herbert Griffin, and J. O. Baker. The executive secretary of the S.M.P.E. is Sylvan Harris, Hotel Pennsylvania, New York City.

Acoustic Society at New York, April 29-30—The Spring meeting of the Acoustic Society of America will be held at the Hotel Roosevelt, New York City, April 29 and 30. Morning and afternoon sessions are planned for each day. On April 29 there will be a dinner at the hotel, followed by a demonstration at the Bell Laboratories, given by H. G. Knox, vice-president in charge of engineering of Electrical Research Products, Inc. Dr. Verne O. Knudsen is president, and Wallace Waterfall, Cellotex Company, 919 N. Michigan Ave., Chicago, is secretary.

Radio Engineers at Detroit July 1-3—The tenth annual convention of the Institute of Radio Engineers will be held at the Hotel Statler, Detroit, Mich., July 1, 2 and 3. Local arrangements for the convention are in charge of a committee headed by Louis H. Larime, chief engineer of Station WJDK, Detroit. National secretary of the I.R.E. is H. P. Westman, 330 W. 42nd street, New York City.

Donald Miller, I.R.E. Chicago Section secretary, 1932-1933, Western manager of *Electronics* and *Radio Retailing* and active for the past eight years in mid-Western radio activities, has been transferred to the New York office to become New York district manager of the same publications.

RADIO'S BIGGEST EXPORT YEAR

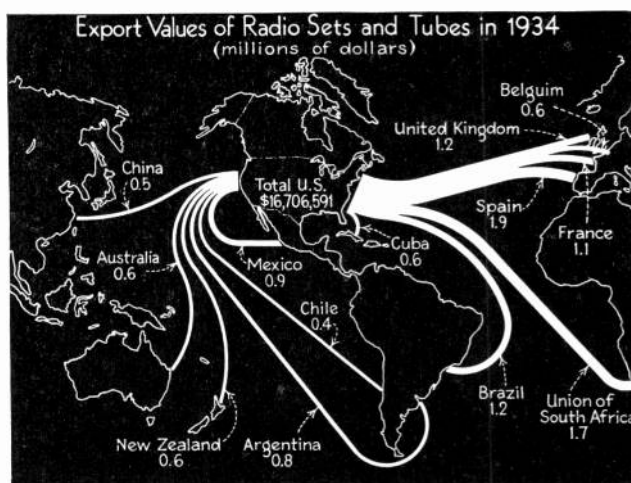

How shipments were divided among foreign countries in 1934, based upon 11-month figures, compiled by Bureau of Domestic and Foreign Commerce

A REVIEW OF THE ELECTRONIC ART HERE AND ABROAD

"Luxembourg Effect" noted in U. S. in 1919

MODULATION of one radio carrier by another has resulted in Europe on several occasions (see "The Luxembourg Effect," page 27, *Electronics*, January, 1935). Apparently, however, no report of this type of cross modulation has ever been noted in America.

The editors have received word from Mr. Robert S. Kruse that he noticed this effect in 1919 when he was engaged at the Bureau of Standards in experiments on the radio compass. According to Mr. Kruse three stations were involved: NSF, at Anacostia, 3XF, Washington and a mobile receiving station mounted in a truck. When the truck was so located that 3XF lay between it and NSF, it was observed that the spark signal of 3XF was modulating the c.w. signal of NSF. When the key was held down at NSF it was possible to tune to that station and read 3XF with its usual distinctive tone.

As soon as the effect was noted the key was locked at NSF (c. w. signal) and the power of the signal at 3XF was varied. It was found that the space modulation was very slight until the power at 3XF was sufficient to cause

audible corona of the antenna. The power was increased until the corona became visible, but beyond this point further power increase did not raise the space modulation. Mr. Kruse has suggested that perhaps the antenna voltage of the transmitter at Luxembourg was high enough on modulation peaks to cause this audible corona.

♦

Push-pull A and linear B circuits

[K. SCHMOLL, N. V. Philips, Eindhoven]. In both types of push-pull operation, A and linear B, the input waves of the two tubes are at any moment in series, but in opposite phase, while the similar output waves in the primary of the transformer are simply added through the secondary of the output transformer. When matched tubes are used, the resulting negative half-cycle accurately completes the resulting positive half cycle to form a full wave, the sum of the waves produced in tube 1 and 2. No even harmonics appear in the output, since their presence would mean a difference between positive and nega-

tive half waves. The second harmonic, the principal source of distortion cancels automatically. There are also no a-c signals flowing through the plate voltage supply and when the a-f voltages are applied to the grids over a capacity-resistance circuit, reproduction of very high quality results. The plate resistance being in series will be twice that of a single tube in both types of push-pull.

The ordinary push-pull amplifier, however, will not necessarily increase the undistorted output per tube. When, indeed, the load resistance is equal to the tube resistance to ensure maximum power output and the point forming the center of the straight-line portion of the dynamic characteristic for this load (I_p - E_g curve) is chosen as the operating point, a steady plate current i_o flows even in the absence of modulation, the potential drop E across the load being equal to that across the tube and equal to one-half the maximum available voltage. At maximum undistorted signal strength the current rises alternately to $2i_o$ and falls to nearly zero, the plate voltage varying in the opposite sense between zero and $2E$ in the load. The maximum a-c output obtainable is therefore equal to $i_o E/2$ for one tube, or at the most one-half the d-c power supplied to the tube. This yield is obtained only in theory, since it supposes the potential difference between cathode and plate to become equal to zero at the negative peak of the wave.

The tube must be so designed as to get rid of the d-c power put into the tube without undue heating even when merely the carrier is received, that is it must be designed for zero signal. The efficiency N of the tube may be stated either as N_u , the ratio of the maximum useful output $i_o E/2$ to the power supplied, so that N_u is 50%; or as N_o , the ratio of the useful output to the amount of heat which the tube must be able to dissipate in the present case N_o is also equal to 50%, that is the plate must be taken large enough to radiate this amount. In reality the complete grid swing is not obtained. For two tubes input and output have to be doubled.

As far as the circuit is concerned, linear B amplification differs from A operation mainly by the choice of the grid bias which is constant and such that the plate current is reduced to zero when no signal is received (quiescent or over-biased or AB operation). The negative half wave is practically suppressed in one of the tubes, while the positive half-wave on the grid of the second tube may produce a variation between zero and saturation current along a practically

FLEMING VALVE AT FRANKLIN INSTITUTE

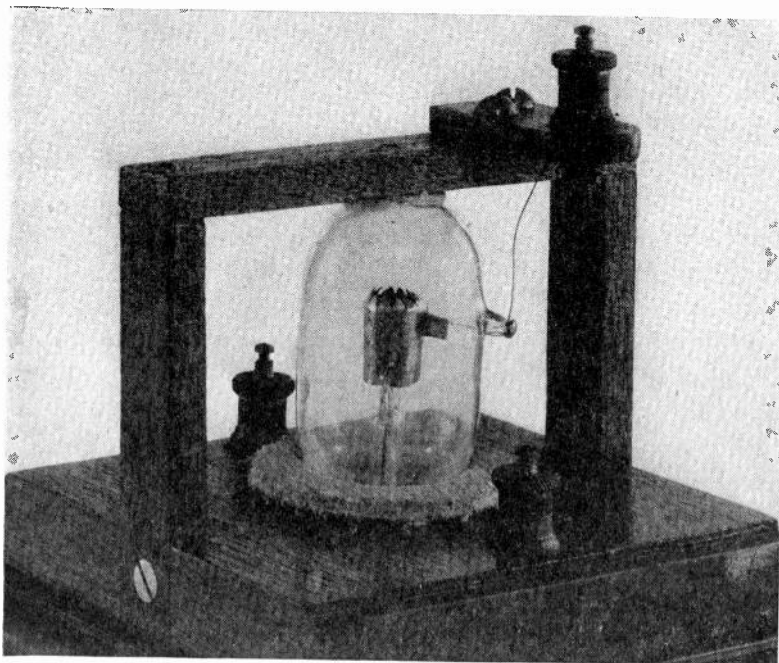

The Franklin Institute of Philadelphia has recently come into possession of this original model of the 1904 Fleming valve, accompanied by an autographed letter from Prof. Fleming in which he explains that it is one of the two original models in his possession

straight dynamic characteristic. When special output tubes with high amplification factor and low mutual conductance are used the grid bias producing zero current is itself zero so that grid current flows during the positive half-wave; in this case the preceding or driver stage must have sufficient power to make good the losses in the grid circuit.

The power put into the quiescent or linear amplifier is no longer constant. The impressed signal causes a half-wave of peak i_o to flow at a corresponding steady plate voltage E . The d-c equivalent for such a series of half-waves is equal to $w = 2 i_o E / \pi$ for both tubes, where i_o corresponds to the current which would flow if the ohmic resistance R in the input were absorbing the entire d-c potential applied to the plate. The combined useful output is again equal to $ei/2$, where $e = iR$, so that the output may be written as $i^2R/2$, or $iE_o/2$, that is it is proportional to the square of i , while the maximum combined output is equal to $N_o = i_o E / 2$. The power to be dissipated by the plate is equal to the difference between input and output, that is equal to $w = 2iE - i^2E/2i_o$. The input is proportional to i , the output proportional to i^2 , but at or near the origin smaller than the input. There arrives therefore a point where the input begins to grow less rapidly with e than the output, and where the heat to be dissipated by the plate reaches a maximum namely (as found by differentiation with respect to i) for $i = 2i_o/\pi$ so that $w = 2i_o E / \pi^2$ or practically $w = i_o E / 5$ in place of $i_o E$ as obtained in A operation.

The ratio N_1 of useful output to input is therefore equal to 78.5% while N_o the efficiency with respect to the highest plate dissipation is equal to $\pi^2/4$ or nearly 250% (since $\pi^2 = 9.8696$) against 50% for A operation. This means that small tubes can be used in B operation either for sending or receiving modulated waves. Values of N_1 between 60 and 70% are about the maximum obtained in practice without undue distortion.—*F. Techn. Monatsch.* No. 10: 389-392. 1934.

✦

German tube prices eight to ten times U. S.

EDITOR, *Electronics*:

CAN ANYONE GET into the argument (see January *Electronics*, page 27) between Dr. W. F. Ewald of Berlin, and Wm. Schrage, author of the article "German Radio Receivers" in October *Electronics*? If so, I want to take Mr. Schrage's part in the discussion regarding tube prices in Germany.

I believe it is true that, as Mr. Schrage states, radio tube prices in Germany are eight to ten times higher than in the U. S. A., despite Dr. Ewald's contention to the contrary.

When any comparison is made of German tubes valued in marks versus

United States tubes valued in dollars, the current rate of foreign exchange should be used to convert values in marks into dollars or vice versa. The exchange rate of 4.62 to the dollar Dr. Ewald uses to support his case hasn't existed for over two years. The present value of the mark is roughly U\$S .40 or 2.5 to the dollar. Therefore, the German equivalent of our 6A7, which lists at marks 18.00, is worth \$7.20 list in Germany as compared with \$1.30 in the U. S. A. The German equivalent of our type 57, listing at marks 13.50, is worth U\$S 5.40 as compared with the domestic list price of \$1.10.

Despite all this I wouldn't ask, "Why are these prices so high in Germany?" Instead, I would say, "Why are they so low in the U.S.A.?"—G. A. BODEM. *Tung-Sol Radio Tubes, Inc., Newark, N. J.*

✦

Some considerations on detectors

[P. DAVID, Chief Engineer, National Radio Laboratory, Paris.] Detection with the aid of vacuum tubes has become almost universal practice at the present time. Grid detection is often said to be more sensitive, plate detection to be more faithful owing to the absence of the shunted condenser circuit. Grid detection, however, makes the handling of strong signals difficult; it becomes necessary to use a separate tube (diode) or an additional electrode

in the same tube, one for detection, the other as grid control (binode). This system, now in popular favor, has found a rival in the cuprous oxide copper rectifier (Westector).

Any detector is required to have an infinite or at least very high resistance for negative voltages and low and if possible constant resistance for positive voltages applied at the chosen operating point. Both the semi-conducting and the vacuum tube detector give currents which (under short-circuit conditions) may be expressed as parabolic or exponential functions of the applied voltage and are therefore nearly linear above a few volts input (power detection). With ordinary a.c. both give about the same amount of rectified current; plotted as a function of the input voltage the graph shows a curvature at low signal voltages, but when a load of about 10,000 ohms is applied, then the rectified current is practically a linear function, however small the incoming voltage. It reaches about 1 mA for 30 volts. The curvature is therefore less important than might appear from theoretical considerations.

In reality, the input circuit A and the output circuit Z greatly complicate the picture in the case of modulated waves, when three frequencies are present in the detector circuit, the carrier frequency h , the audio frequency l and the direct current o , three frequencies to which A and Z , and sometimes also D , may offer entirely different impedances.

With respect to the incoming signal,

GERMAN TELEVISION WAGON

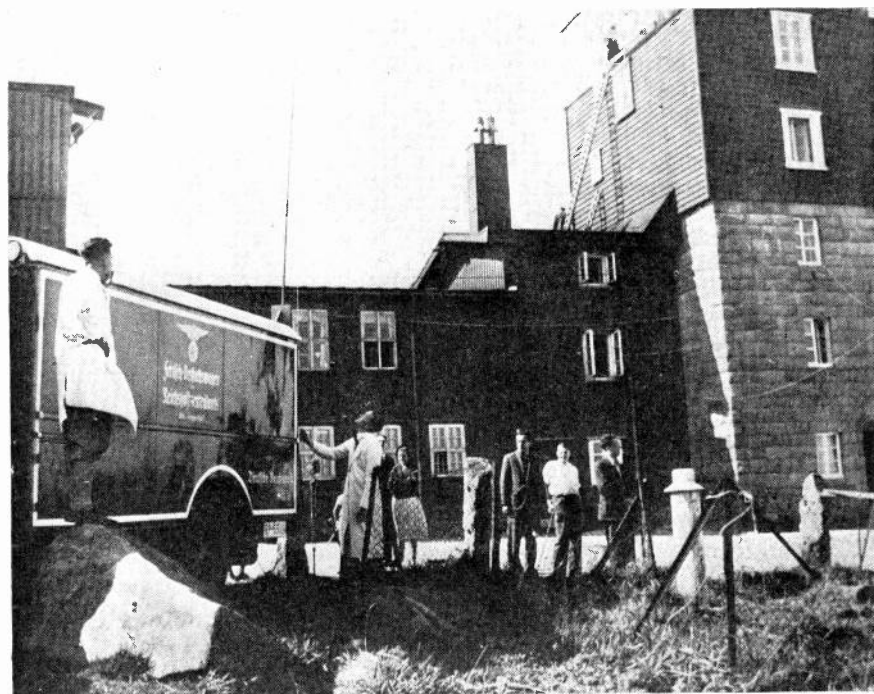

Reception from Berlin, 200 kilometers away, of 7-meter television signals was accomplished by this exploration van, proving that very short wave signals are not restricted to the optical range

the rectifier D behaves as a load converting a.c. into pulsating a.c. with respect to the rectified current, the detector behaves as a source of e.m.f. with the internal resistance D_1 , working with an external resistance R or an impedance Z .

Now the modulated high frequency wave usually comes from a tube circuit, the impedance A_h of which is therefore relatively high, 10,000 or 100,000 ohms. Hence to conserve the signal strength, it is necessary to have D_h of the detector high, if possible equal

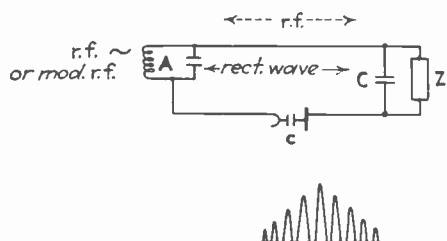

to the A_h of the source, since naturally enough the rectified voltage increases with the input voltage. It is to be expected that the detector will then also offer a high resistance to the audio frequencies. For weak signals the resistance may be taken as constant, while strong signals may displace the operating point and give a variable resistance.

Turning now to the output circuit, the fully modulated carrier wave may be considered as consisting of the sum of three high frequency waves, namely the carrier wave and the side bands, the frequencies being, h , $h + 1$ and $h - 1$. The amplitude of the side-bands is one-half of that possessed by the original audio voltage. In the rectifier the wave is converted into a d-c component and an audio frequency component. In order to get high a-f voltage, the impedance or resistance of the output circuit Z must be high, about ten times higher than D_1 , and therefore quite large. The difficulty arises, however, that in any case the output circuit must offer at the same time an easy path for the circulation of the r-f current which should suffer no weakening outside the rectifying element proper. The relatively heavy load must hence be by-passed by a condenser C of about 200 to 250 $\mu\text{mf.}$ which does not weaken the r-f voltage and does not short-circuit the a-f voltage. C must be larger than c , the natural capacity of the rectifier which produces the useful r-f potential drop; at the same time it must have a resistance much larger than D_1 with respect to audio frequencies. In practice the two requirements are often difficult to fulfill. For 5,000 cycles, a condenser of 225 $\mu\text{mf.}$ has a resistance of about 142,000 ohms, while D_1 may vary from 100,000 to 1,000,000 ohms. In traversing this high resistance the rectified current is liable to develop such a voltage drop that the operating point is shifted toward more negative values

until at the limit only the positive peaks of the incoming waves produce an output current. The current consumption is reduced, the internal resistance D_1 of the rectifier enhanced. Applied voltage and output voltage are closely proportional. The high load which is necessary thus has an influence which may outweigh the part played by the detector characteristics; it tends to render detection linear.

Regardless of the mass of theoretical details applying to particular cases, the foregoing considerations are equally valid for all kinds of detectors. Some differences between detectors must now be mentioned. The simple diode has the advantage that detection is good even at low signal voltages so that the output load may be increased to several megohms and damping greatly reduced. In ordinary grid detection the grid serves as detector as well as control grid with the result that for strong signals the rectifier current produced tends to make the grid more negative and decreases the output current unless high plate voltages are applied which may overload the tube when no signal is received. In the binode, the grid serves merely as a rectifier, the a-c output passes to a second grid, the control grid which is given a constant bias depending on the strongest signal to be handled in the set. Binodes are practically never saturated, however, so that when the signal strength exceeds the control grid bias, the volume of distorted signals may increase to large values, in contrast to grid leak detection. Plate detection suffers from the defect that the signal is amplified be-

fore being detected, and that good amplification and good detection at the same operating point are quite incompatible. It has, however, one point in its favor; it absorbs practically no signal energy.

But on the whole detectors as such are neither good nor bad; the differences lie in the suitable or unsuitable use to which they are put.—*Onde el. 13 (No. 154): 403-414. 1934.*

Magnetic materials— testing and practice

A BOOKLET entitled "Magnetic Core Materials Practice," which explains the fundamental principles of the selection of magnetic core materials, and the many tables illustrating the various properties of such material, has been issued by the Allegheny Steel Company of Brackenridge, Pa. This booklet will be distributed among the students of Electrical Engineering Departments in a large number of technical institutions, and it is intended to give these students a clear picture of the function of magnetic core materials, and to indicate the methods of selection used.

Among the curves given are permeability and magnetization curves for most of the commercially used magnetic iron and steel materials. Typical core loss characteristics of these materials are also given, together with a considerable amount of descriptive material which outlines the methods of obtaining these characteristics and how they may be used in the selection of magnetic materials for a given design.

The September, 1934 issue of *Instruments*, an article by W. R. Woodward and E. L. Furth, of the Westinghouse Company, describes the method of testing core loss in magnetic material. In this article it is pointed out that 30 per cent of the weight of almost all electrical apparatus is made up of magnetic material of one sort or another. The permeability, core loss, and exciting current values of this material are of great interest, and in production work it is necessary to continually test material for these properties. The testing equipment described in the article consists of a power supply capable of supplying the required current for the testing apparatus, an Epstein frame, the standard core loss measurement device. The complete wiring diagram is given.

The two factors which affect the accuracy of the core loss test are tied up with the generators which supply the a-c power supply of the testing device. This generator must have an accurately known reactance and an output voltage free from harmonic component. For this reason a very complicated system of power supply is essential.

SHORT-WAVE RESEARCH

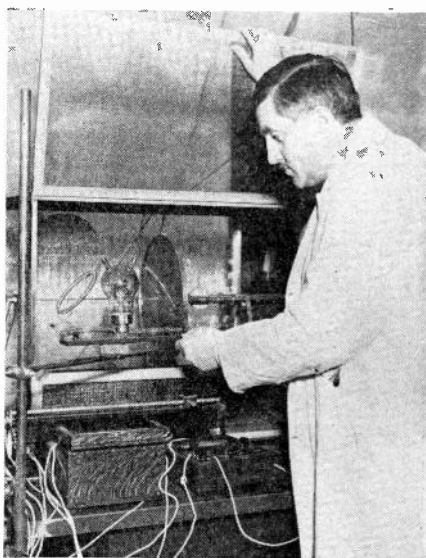

At California Institute of Technology, Dr. G. A. Potankenko uses an ultra short wave oscillator to study crystal structure

+ NEW PRODUCTS

THE MANUFACTURERS OFFER

Electronic commutator for cathode-ray tube

AN ELECTRONIC SWITCH which allows simultaneous observation of two waves on a cathode ray oscillograph is announced by the Allen B. Dumont Laboratories, Upper Montclair, N. J. The device consists of a switching tube with two amplifiers, one amplifier for each wave applied to the oscillograph. The switch operates to cut in one amplifier and then the other at such a rate that the two waves appear to be on the tube at the same time. Controls are provided on the unit for adjusting the gain of each amplifier, for varying the speed of the switching tube, for positioning the pattern on the screen and for separating the waves. The power device is operated directly from 110 volts, 60 cycle, alternating current, and lists for \$174.50. It covers a frequency range from 110 to 100,000 cycles per second and provides an amplifier gain of 50.—*Electronics.*

Phonograph oscillator

A SMALL broadcast band oscillator unit designed for use with a phonograph pick-up, has been developed by the RCA Victor Company, Camden, N. J. Known as the RK-24 phonograph oscillator, this device is actually a miniature transmitter station whose output is modulated with the current from an ordinary phonograph pick-up. The oscillator produces a signal which is received in any receiver in the ordinary manner. A 6A7 or 2A7 tube is used in the oscillator circuit, which is of the Hartley type. A tuning range from 1,400 to 1,700 kilocycles is provided, and suppressor grid modulation is used. The list price, without tube, is \$7.75.—*Electronics.*

Etched-plate electrolytic condensers

A NEW DESIGN in electrolytic condenser has been announced by The Magnavox Company, Fort Wayne, Indiana. The plates used in the condensers are etched so that the surface presents a rough rather than a smooth appearance. This increases the surface area of the plate, and therefore the effective capacity offered by it. A given capacity can thus be built into a very much smaller space,

in fact, condensers having equivalent characteristics can be built in one-third of the volume required by the more conventional type.—*Electronics.*

Illumination control relay

A NEW illumination control relay has been announced by the Weston Electrical Instrument Corporation, Newark, N. J. This relay, for both indoor and outdoor use, turns lights on and off so as to maintain a predetermined level of illumination, regardless of the time of day. The interest of plant managers, municipal and school authorities in this new device is undoubtedly a result of the nation-wide Better Light—Better Sight Campaign.

The public's quick response to this campaign has proved that sufficient il-

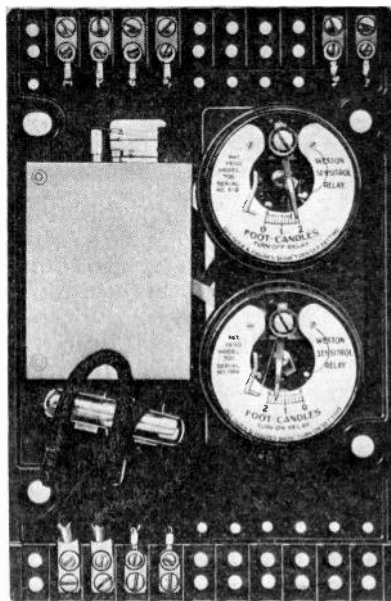

lumination has been recognized as a vital factor in industrial and social management to avoid "eye-strain," "nervous fatigue," etc.

Operation of this Model 709 illumination-control relay, is determined by the intensity of the natural light available,—not by time or the eye-sensations of an operator who performs his task after experiencing eye-fatigue. The Photronic cell, is used as the controlling element for the relay. It turns lights on at levels of natural light intensity which are insufficient for the indoor worker, or dangerous for outdoor traffic conditions. When natural light returns to adequate levels, the lights are automatically turned off, thereby eliminating waste.—*Electronics.*

Contactors

THE WARD LEONARD ELECTRIC COMPANY, Mount Vernon, N. Y., announces a line of D-C. and A-C. contactors that for several years have been used in their control assemblies and are now available as separate units.

They can be used as control contactors for motors, for disconnect purposes in conjunction with suitable auxiliary switches, for electric ovens, various other electric control applications and for special control panels.

High contact pressure with low operating and holding currents in the coil are among the features claimed for these contactors.

Auxiliary silver-to-silver contacts are furnished as standard equipment for maintaining the coil circuit when momentary push button control is used.

Additional normally open or normally closed auxiliary contacts can be furnished when required.—*Electronics.*

Electrolytic conductivity measuring instruments

A NEW SERIES of instruments which enable users to reach the upper limits of precision in measurements of electrolytic conductivity more easily, more reliably and more economically than ever before, is introduced by Leeds & Northrup Company, 4911 Stenton Avenue, Philadelphia, Pa.

The *Jones Bridge* is used for measuring electrolytic conductivity to a limit of error of 0.02 per cent, when room temperature is 20 to 30 deg. C., and relative humidity is not over 70. If calibration checks are made, overall limit of error of 0.005 per cent or better is attainable.

Oscillators, amplifiers, resistance boxes, and standard air condensers for use in conjunction with this bridge are also available.—*Electronics.*

Direction finder for aircraft radio

A NEW RADIO compass and direction finder for aircraft has been developed in the laboratories of Lear Development Company, 125 West 17th Street, New York City. The receiver weighs less than 30 lb. and is contained in a single case. It is capable of being tuned to

any Department of Commerce airway beacon signal and any standard broadcast station, in addition to being used as a radio compass on these two wavebands. Shortwave frequencies for air line and sound broadcast reception are also available.

A loop antenna and a vertical antenna are mounted on the fuselage of the ship. A visual course indicator is mounted on the instrument panel, and is used to indicate directly whether the airplane is on-course or to the left or to the right. The total weight with all equipment and accessories is 40 lb. The power supply required is a 12- or a 6-volt storage battery.—*Electronics*.

Camera for cathode-ray study

A NEW MAGAZINE type of continuous film camera, useful for all sorts of oscillographic and chronographic recording, is announced by The General Radio Company, Cambridge, Mass. When cathode-ray oscillograms either of the steady state or transient types are to be recorded, the sweep circuit of the oscillograph is not used. Instead the continuously moving film provides the time axis. The camera uses standard 35 mm. perforated films and is provided with an f/2.5 lens of 47 mm. focal length. The camera is provided with two motors, both of the series wound 115-volt type. One motor is connected directly to the take-up reel, while the other drives the film sprocket. Very uniform film speed is the result. The list price of the camera is \$495.—*Electronics*.

Solid molded adjustable resistor

THE TYPE J Bradleyometer is a new addition to the line of fixed and adjustable resistors developed by the Allen-Bradley Company, 1311 S. First Street, Milwaukee, Wis., for manufacturers of radio receivers. The Bradleyometer is

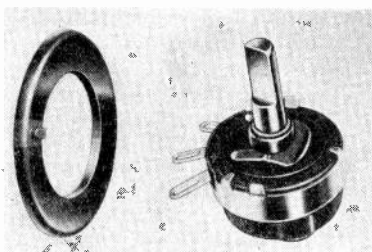

a continuously adjustable resistor for use in volume control circuits and for tone control.

The resistor unit is solid molded; long

wear does not alter its resistance. Since high humidity does not affect this resistor, the Type J Bradleyometer is adapted for auto-radio receivers and for receivers built for export.

Practically any resistance-rotation curve shape can be provided, including straight logarithmic curves, modified logarithmic, or linear resistance-rotation curves. Total resistance values can be furnished to meet practically all specifications.—*Electronics*.

Sockets for 955 acorn tube

A SOCKET made of Mycalex and intended for use with the RCA-955 acorn tube is manufactured by the Communications Engineering Company of New York City. The socket is furnished with spring clips which grip the wire terminals of the 955 tube, and is fitted

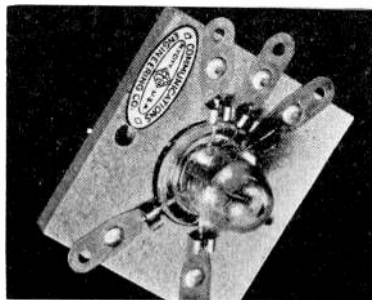

with mounting holes. Since wires cannot be soldered to the terminals of the tube without danger of cracking the seal, this socket provides a convenient method of mounting such tubes. The losses, even in ultra-high frequencies, are very small.—*Electronics*.

Inside bulb etching machine

A BULB-ETCHING machine for stamping a trade mark, monogram or rating on the inside of glass bulbs has been developed by Charles Eisler of the Eisler Engineering Co., 765 So. 13th St., Newark, N. J.

Foot-controlled and operated on an air pressure of two and one-half pounds, this machine is capable of etching from six to eight hundred bulbs an hour.

When placed on the inside surface of the bulb, the etching is protected by the glass from being rubbed or buffed off.

The machine is also adaptable to outside bulb etching, and is designed to take care of various sizes of glass bulbs commonly used in the manufacture of incandescent lamps, radio and transmission tubes, electronic tubes and similar devices.—*Electronics*.

Fluorescent compounds

THERE is now available a range of fluorescent compounds of interest to those developing television apparatus. These compounds give uniform light reflection and can be supplied to fluoresce green, yellow, orange, crucible-red, deep-red, purple-red, without discernible "after-glow," when subjected to the rays of a mercury lamp or cathode-tube. They are made by J. D. Riedel-E. de Haen, A.-G., in Germany, and are supplied in the form of fine free-flowing crystalline powders by the sole American agents, Pfaltz & Bauer, 300 Pearl Street, New York City.

Formerly it was thought desirable that fluorescent compounds for television should show a certain amount of "after-glow" in order to obviate flicker. Hence De Haen's fluorescent compounds Nos. 55, 60 and 70 have been made to emit some "after-glow."

Latterly, however, "after-glow" has been considered unnecessary, and so compounds are also produced without "after-glow." No. 60 when excited by slow cathode-ray bombardment emits an agreeable color-tone. The pictures are almost white, with sharp sepia shadows, free from flicker and, despite strong contrasts, pleasing to the eye.—*Electronics*.

Light weight aircraft transmitter

A NEW long distance telegraph transmitter weighing only 15 lb. and delivering a nominal 75 watts of continuous wave power to the antenna is announced by the Radio Division of Westinghouse Electric & Manufacturing Company, Chicopee Falls, Mass. A frequency range from 333 kilocycles to 10,000 kilocycles is provided by means of plug-in coil assemblies. This range covers marine and aviation communication bands. A 12-volt battery provides power supply through a dynamotor. Five UX-210 tubes are used, one as

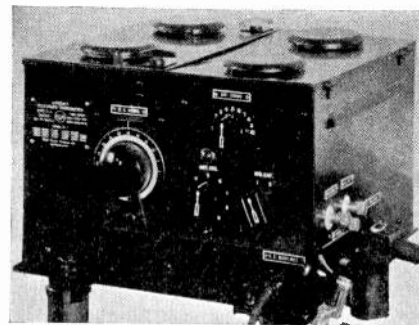

master oscillator and four as power amplifiers. The entire transmitter is mounted in a shock-proof unit which is designed to screw or bolt directly to the mounting board in the plane.—*Electronics*.

Molded resistance units

A NEW TYPE of extruded resistor (molded type) has been developed by

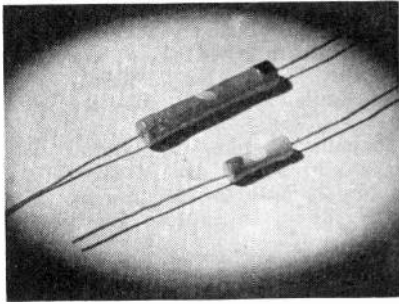

Henry L. Crowley & Company, West Orange, N. J. These resistors are said to compare in performance with wire-wound units. The entire cross section of the resistor is uniformly current-carrying, since no conducting film or coating is used. The ends of the voltage resistor are coated with metal and capped with ferrules to which are attached the usual pigtail connections. In a 1,000-hour steam box test, variations of the resistance resulting is less than 2%. The main difference between usual molded resistors and the new type lies in the use of a resistor material as the binder rather than an insulating material.—*Electronics*.

Quick-acting a-c relay

A NEW TYPE of inexpensive A.C. quick-acting relay for 50-60 cycle operation has recently been developed by Automatic Electric Company. This unit is a standard Autelco horizontal type relay, equipped with a "shading ring" which provides firm, chatterless contact closure on alternating current circuits. The relay can be furnished for operation on any current within the range from 6 to 220 volts, 50-60 cycles, and with a variety of spring combinations. Its operate and release periods are about the same as those of the corresponding D.C. relay with similar spring load. An individual slip-on cover of sheet steel, aluminum finished, can be supplied when specified.—*Electronics*.

Distortion meter

TO MEET the need for a practical instrument for the measurement of the audio harmonic content present in the output of broadcast transmitters, the Radio Research Co., Inc., 9th and Kearny Sts., N. E., Washington, D. C., announces its Type 235 distortion meter. This combines in one compact, direct-reading, rack-mounted unit everything necessary

to measure the audio harmonic content of the transmitter output. Provision is also made for checking the distortion present at any point in the audio system, thus making possible the isolation and correction of the cause of the distortion.

A built-in source of pure tone is provided for exciting the transmitter. The percentage ratio of the effective value of the combined harmonics to the fundamental is read directly on a meter graduated 0-to-10%, with a multiplier provided to extend the range to 0-to-30%. The meter can be read at values as low as 0.5%. The operation of the instrument is simple and rapid. It is entirely A.C.-operated and self-contained, no external equipment of any kind being necessary for its operation. Every effort has been made to make this equipment thoroughly practical for regular use in the broadcast station or in the laboratory where a quick, accurate means of measuring distortion is needed.—*Electronics*.

Thermal milliammeters

A SERIES of single range thermal milliammeters, suitable for measuring currents and voltages of all frequencies, has been announced by the Sensitive Research Instrument Corp., 4545 Bronx Blvd., New York, N. Y. The thermocouples used are substantially free from frequency and wave form errors. The meters are furnished with a scale $5\frac{1}{4}$ in. long, and provide an accuracy of $\frac{1}{2}$ of 1 per cent. The full scale current runs from 1.2 milliamperes to 1 amp. The list price of the 1.2 milliamperes type is \$90, while the list price of all the higher range meters is \$80. A sensitive moving coil instrument is used to indicate the direct current, produced by the thermocouple when it is heated on direct current.—*Electronics*.

Ballistic galvanometers

TWO NEW ballistic galvanometers, types 2551, D and E are offered by G-M Laboratories Inc., 1731 Belmont Avenue, Chicago. These galvanometers are of the ballistic type, and sell for \$50, without leveling base. A leveling base is available for \$9. The ballistic sensitivity of these galvanometers is .0015 microcoulombs for the 2551-D and .015 microcoulombs for the 2551-E. A complete line of laboratory apparatus including slide wire rheostats, Julius suspensions, relays and mounting brackets is offered in the October, 1934 issue of *Comments*, a house organ published by the Laboratories.—*Electronics*.

Milliometer

AN INSTRUMENT for measuring very low resistance values has been developed by the Shallcross Manufacturing Company, 700 MacDade Blvd., Collingdale, Pa. The instruments are suitable for operation by unskilled workers wherever resistances of less than 1 ohm must be measured. The value of the resistance is read directly from a meter scale, whose range can be pro-



vided for any value not greater than 10 ohms or not less than .0025 ohms. One No. 6 1.5 volt dry cell battery contained in the cabinet is used as the power supply. Accuracy is within 5% of full scale. Eight different scale ranges are available. The six-scale model lists at \$81.50, a two-scale model at \$65.—*Electronics*.

Crystal microphone

A NEW crystal microphone, capable of being mounted on a stand in suspension springs or as a hand model, has been announced by the Shure Brothers Company, manufacturers of microphones, 215 West Huron St., Chicago, Ill. Model 70H is a general purpose instrument for direct mounting on a microphone stand. Its list price is \$22.50. Suspension rings can be supplied for the Model 70H for \$1 additional. New crystal hand microphones, Model 71A without switch and Model 71AS with switch, retail for \$25 and \$26.50 respectively.

The cantilever principle is used in transferring the energy from the diaphragm to the crystal elements. The output level is considerably higher than that of non-diaphragm type crystal microphones, requiring only one additional low gain stage of amplification to give the equivalent output of a two-button microphone.—*Electronics*.

U. S. PATENTS IN THE FIELD OF ELECTRONICS

Amplification, detection, etc.

Piezo-electric patents. No. 1,974,081 to W. P. Mason, B.T.L., Inc., on a broad-band wave filter. No. 1,975,517 to A. M. Nicolson, Communication Patents Inc. on a three-phase electrical generating system. No. 1,975,603 to C. W. Hansell, RCA, on a crystal controlled oscillator with the crystal in series with a parallel tunable circuit. Similarly, No. 1,975,615 to H. O. Peterson, RCA, and No. 1,989,442 to H. E. Goldstine and J. W. Conklin, RCA, on control circuits with crystals in series with a tuned circuit. No. 1,990,822 to H. E. Goldstine, RCA, on a crystal holder.

Cathode ray tube detector. An autodyne detector circuit comprising a cathode ray tube with input circuit tuned to incoming signals and with variable feed-back from the output to the input circuit by which the tube can be made to oscillate and produce beats. C. W. Hansell, RCA No. 1,988,621.

High-frequency generator. An oscillator amplifier circuit for high frequency with network for preventing parasitics. No. 1,988,487. E. Green and F. G. Robb, RCA.

D-c a-c system. A rotatable commutator with conducting segments in pairs of successive segments, and slip rings

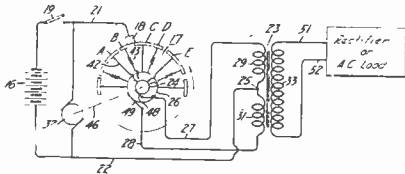

to which alternate pairs of segments are electrically connected. F. F. Hutchinson, Hutch-Gard Corp. No. 1,989,233.

Vacuum tube voltmeter. Network in the plate circuit of a tube such that no d-c potential exists at the load terminals unless a change occurs in the grid circuit. Wilson Aull, Astoria, N. Y. No. 1,989,394.

Harmonic reduction. Two tubes are connected in parallel and one of the tubes is biased to a greater extent than the other such that the harmonics appearing in the common load circuit will

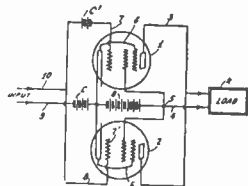

be the difference between the amounts of harmonic generated in the two tubes. R. A. Braden, RCA. No. 1,990,062.

Signal distributing system. Method of distributing programs in a metallic framework building by impressing modulated oscillations on the framework. F. Le Roy Satterlee and L. W. Kolozsy, Radio Systems, Inc. No. 1,989,466.

Interstage system. A coupling system adapted to transmit energy uniformly

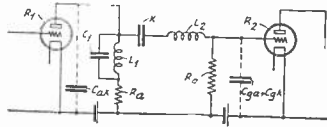

between 200 and 3,000 meters. Ludwig Babik and A. Jaumann, Siemens & Halske. No. 1,989,730.

High frequency amplifier. Two tubes coupled together by an inductance and capacity, the coupling coil having such dimensions that the inductive impedance for the lowest frequency transmitted is substantially equal to the capacitive impedance of the active parasitic capacity of the circuit for the highest frequency

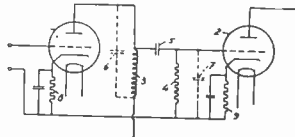

to be amplified, the resistance supplying a biasing voltage to the control electrode of the second tube being of such a value that its impedance for frequencies in the middle of the frequency range is substantially equal to the inductive impedance of the coil for the lowest and the capacitive impedance of the capacity for the highest frequency of the range. H. Stoet, The Hague, Holland. No. 1,988,987.

Wide band amplifier. In a resistance-capacitance coupled amplifier an inductance is in series with the usual coupling capacity. Shunted across this inductance is a resistance and a capacity to neutralize the phase shift caused by the capacity at lowest audio frequency

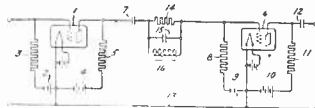

to be amplified, the entire network having inappreciable effect at both high and low frequencies. W. A. Fitch, G.E.Co. No. 1,990,781.

Amplifiers, etc. Series of patents granted to John Hays Hammond, Gloucester, Mass. No. 1,977,438; 1,977,439; 1,979,034 to 1,979,037, inclusive, on dynamic multiplier, amplifying system, monitoring system, etc.

Television, facsimile, etc.

Television system. Means for utilizing a magnetic field in a hollow two-dimensional pattern as a scanning system. L. G. Pooler, Communication Patents, Inc. No. 1,985,690. See also the following patents to the same group: No. 1,985,723 to H. C. Gillespie, synchronizing and monitoring system; 1,985,684, panoramic television system to A. M. Nicolson; No. 1,985,685, color television system, A. M. Nicolson; No. 1,985,686 on a repeater circuit using piezoelectric

elements, and No. 1,985,683 on a photo-oscillator-modulator system, also to Nicolson, Communication Patents, Inc.

Colored television. A system using several cathode ray tubes and means for giving the images produced by the tubes complementary colors and for observing simultaneously the images produced by both tubes. E. F. W. Alexander, G.E. Co. No. 1,988,931.

Facsimile system. Maurice Artzt, RCA. No. 1,988,472.

Scanning system. Apparatus including a slitted disc and a slitted drum rotating in different dimensions. H. P. Donle, Radio Inventions, Inc. No. 1,988,303.

Picture transmitting system. Otho Fulton, Bromley, England. No. 1,985,084.

Cathode ray system. Bernard Kwartin, Brooklyn, N. Y. No. 1,987,686.

Scanning system. Method for scanning a field of view in parallel elemental strips comprising means for setting up stationary light rays, two similar rows of light directing elements, etc. Frank Gray, B.T.L., Inc., No. 1,990,183. See also No. 1,990,182 to Frank Gray.

Facsimile system. Patent No. 1,985,654 filed March 26, 1934, 25 claims to W. G. H. Finch, New York, N. Y. on a facsimile system.

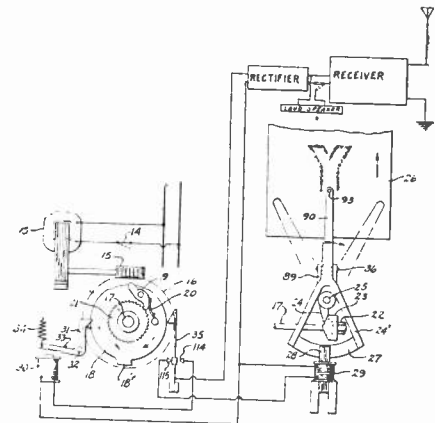

Radio circuits

Remote control devices. Patents to W. F. Cassidy, No. 1,989,739; to E. F. Nickl, No. 1,989,767; and to H. E. Repert, No. 1,989,771, all of International Communications Laboratories, Inc., on remote control devices for radio tuning.

Radio analyzer. A system for testing radio receivers, including a local power source, socket connections, etc. Ralph Stair, assigned to S. R. Winters, Washington, D. C. No. 1,990,920.

Multiple coil assembly. A switching system for a multi-wave band receiver. W. D. Loughlin, RCA. No. 1,989,205.

Vacuum tube meter. Two patents, Nos. 1,989,677 and 1,989,678 to E. L. Bowles, Watertown, Mass., on thermionic methods of measuring electrical quantities.

Long-line oscillator. A resonant transmission line several half wave lengths long coupled near its end to electrodes of the oscillator tube, the line being grounded at both its ends. C. W. Hansell. No. 1,988,622.

Electronic applications

Electrostatic generator. A movable charge-conveying medium, charge transferring means operatively related thereto, and electromagnetic means for providing continuous, steady excitation for said transferring means. Patent to Robert J. Van de Graaff, M.I.T. with 53 claims, application date Dec. 16, 1931,

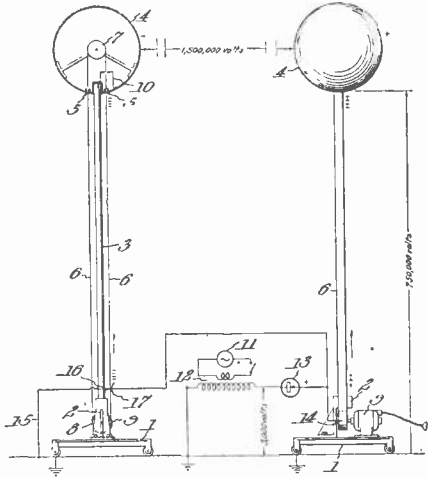

on an electrostatic high voltage generator. No. 1,991,236. See also No. 1,989,610, application date Mar. 2, 1932, to W. D. Coolidge, G.E. Co., on an electrostatic machine.

Control apparatus. Assembly of light sensitive tube and control tubes for control purposes, such as for temperature control. J. F. Kovalsky, WE&M Co. No. 1,988,658.

Gloss measurement. Apparatus for measuring the gloss of surfaces and capable of being applied directly to a sample surface. R. S. Hunter, Franklin Park, Va. No. 1,988,556.

Material testing. An electromagnet is placed in oscillating circuit in proximity to the material to be tested. W. A. Mudge and C. G. Bieber, Huntington, W. Va. No. 1,990,085.

Synthetic music. An electronic musical instrument described in *Electronics*, p. 157, May, 1934. Ivan Eremeeff, Philadelphia, Pa. No. 1,990,024.

Synchronizing system. A speed regulating device. A. Karolus Fritz Schröter and Waldemar Ilberg, R.C.A. No. 1,987,110.

Follow-up system. A. H. Mittag, G.E. Co. No. 1,982,350.

Circuit control. Method of controlling the flow of current through a gaseous electronic tube. C. Stansbury and G. C. Brown, Cutler-Hammer, Inc. No. 1,980,707.

Arc welding control. Automatic arc welding system controlled by electron tube. L. R. Smith, WE&M Co. No. 1,982,327.

Winding control. Apparatus for handling strand material, including means for winding a strand, a Wheatstone bridge, a tube, etc. G. H. Rockwood, W.E. Co. No. 1,977,697.

Machine tool control. Light sensitive method of controlling machine tool operation. D. C. Mackintosh, G.E. Co. No. 1,977,341.

Motor control. A circuit supplied with a-c frequency which varies with the speed of the motor and means for stop-

ping the flow of current through a tube when the frequency is below a given frequency. G. C. Brown, Cutler-Hammer, Inc. No. 1,983,656.

Patent Suits

1,879,863, H. A. Wheeler, Volume control; 1,755,114, L. A. Hazeltine, Unicontrol signaling system; 1,755,115, same, Variable condenser, D. C., S. D. N. Y., Doc. E 76/293, Hazeltine Corp. v. York Automatic Distributing Co., Inc. Consent order of discontinuance (notice Dec. 7, 1934).

1,755,114, L. A. Hazeltine, Unicontrol signaling system; 1,755,115, same, Variable condenser, D. C., S. D. N. Y., Doc. E 72/202, Hazeltine Corp. v. Bloomington Bros., Inc. Consent order of discontinuance (notice Dec. 11, 1934).

1,403,475, 1,403,932, 1,507,016, 1,507,017, 1,618,017, F. Lowenstein, 1,702,833, 1,811,095, Re. 18,579, filed Dec. 4, 1934, D. C., S. D. Calif. (Los Angeles), Doc. E 465-J, Radio Corp. of America, et al. v. H. C. Block (Custom Built Radio Mfg. Co.). Doc. E 466-J, Radio Corp. of America, et al. v. R. Rawlings (Rawlings Radio Co.). Patents held valid and infringed Dec. 17, 1934. Doc. E 469-H, Radio Corp. of America et al. v. J. T. Kelly, Jr. (Kelly Music Co.). Decree as above.

1,403,475, 1,403,932, 1,507,016, 1,507,017, 1,811,095 Re. 18,579, filed Dec. 4, 1934, D. C., S. D. Calif. (Los Angeles), Doc. E 468-M, Radio Corp. of America, et al. v. H. Bell Radio Mfg. Co.

1,558,437, Re. 15,278, I. Langmuir, Electrical discharge apparatus; 1,696,103, G. Seibt, Electric discharge tube; 1,852,865, C. B. Upp, Carbonized non-emissive electrode; 1,865,449, J. L. Wuertz, Thermionically inactive electrode; 1,909,051, Freeman & Wade, Thermionic vacuum tube, D. C., S. D. N. Y., Doc. E 79/109, Radio Corp. of America et al. v. Philco Radio & Television Corp. of New York. Dismissed without prejudice (notice Dec. 19, 1934).

1,354,939, H. D. Arnold, Vacuum tube device; 1,459,412, A. M. Nicholson, Thermionic translating device; 1,479,778, H. J. Van der Bijl, Vacuum tube device; 1,537,708, W. Schottky, Thermionic vacuum tube, D. C., S. D. N. Y., Doc. E 79/110, Radio Corp. of America et al. v. Philco Radio & Television Corp. of New York. Dismissed without prejudice Dec. 19, 1934.

1,403,475; 1,403,932; 1,507,016; 1,507,017; 1,618,017; 1,702,833; 1,811,095; Re. 18,579; filed Dec. 24, 1934, D. C., N. D. Ill., E. Div. Doc. 14, 252 RCA et al. v. F. M. Lund et al. (Capitol Radio Co.) Doc. 14,258, v. International Trading Corp. et al. Same, filed Dec. 4, 1934, D. C., S. D., Calif. (Los Angeles) Doc. E. 470-H, RCA et al. v. R. S. Shelley et al. (Peter Pan Radio Co.).

1,403,475; 1,403,932; 1,507,016; 1,507,017; 1,618,017; 1,702,833; 1,811,095; Re. 18,916; Filed Dec. 24, 1934, D. C., N. D., Ill., E. Div., Doc. 14,254, RCA et al. v. Arlab Mfg. Co., Doc. 14, 256, v. Levinson Radio Stores Co. et al.

1,403,475; 1,403,932; 1,618,017; 1,702,833; 1,811,095; Re. 18,579; Re. 18,916. Filed Dec. 24, 1934. RCA et al. v. A. Bloomfield (Standard Products Co.). Doc. 14, 270, RCA et al. v. J. P.

Winnecour (Economy Tire & Radio Stores). Doc. 14,266 v. Regal Radio Mfg. Co., Inc., et al. Doc. 14,268 v. Atlas Sports & Radio Co. et al.

1,403,475; 1,403,932; 1,618,017; 1,702,833; 1,811,095; filed Dec. 24, 1934, RCA v. Universal Radio Mfg. Co., Inc., et al., D. C., N. D., Ill., E. Div., Doc. 14,262.

1,403,475; 1,403,932; 1,618,018; 1,702,833; 1,811,095; Re. 18,579. Filed Dec. 24, 1934. D. C., N. D., Ill., E. Div., Doc. 14,264, RCA v. D. Krechman et al.

1,251,377; 1,297,188; 1,728,879; 1,573,374; 1,707,617; 1,795,214; 1,894,197; filed Dec. 24, 1934, D. C., N. D., Ill., E. Div., Doc. 14,255. RCA et al. v. Arla Mfg. Co. et al. Doc. 14,257, RCA et al. v. Levinson Radio Stores Co. et al. Doc. 14,261, RCA et al. v. C. A. Bloomfield (Standard Radio Products Co.). Doc. 14,263, RCA et al. v. Universal Radio Mfg. Co., Inc., et al. Doc. 14,271, RCA et al. v. J. P. Winnecour (Economy Tire & Radio Stores). Doc. 14,269, Radio Corp. of America et al. v. Atlas Sports & Radio Co. et al. Doc. 14,265, RCA et al. v. D. Krechman Radio Mfg. Co., Inc., et al.

1,855,168, C. L. Farrand, Loudspeaker, D. C. Mass., Doc. E 3774, Utah Radio Products Co. et al. v. R. T. Boudette et al. Patent held invalid; injunction on counterclaim issued Oct. 8, 1934. Plaintiffs appealed Oct. 9, 1934. (To correct notice published in 450 O. G., p. 742, formerly published as, "Injunction issued Oct. 8, 1934. Appealed Oct. 9, 1934.")

1,244,217, I. Langmuir, Electron discharge apparatus and method of operating same; 1,558,437, Re. 15,278, same, Electrical discharge apparatus; 1,855,885, A. W. Hull, Electron discharge device; 1,758,803, O. W. Pike, Vacuum tube, D. C. N. J., Doc. E 4757, General Electric Co. v. Hygrade Sylvania Corp. Consent decree Dec. 28, 1934.

1,537,708, W. Schottky, Thermionic vacuum tube; 1,696,103, G. Seibt, Electric discharge tube, filed Nov. 13, 1934, D. C. N. J., Doc. E 4754, Radio Corp. of America v. Hygrade Sylvania Corp. Consent decree Dec. 28, 1934.

Re. 17,355, W. G. Cady, Piezo-electric resonator; Re. 17,245, Re. 17,247, same, Method of maintaining electric currents of constant frequency, D. C. N. J., Doc. E 4753, Radio Corp. of America v. Hygrade Sylvania Corp. Consent decree Dec. 28, 1934.

1,879,863, H. A. Wheeler, Volume control, D. C., S. D. N. Y., Doc. E 77/152, Hazeltine Corp. v. Parmelle Transportation Co. et al. Consent order of discontinuance (notice Dec. 6, 1934). Same, D. C., E. D. N. Y., Doc. E 7163, Hazeltine Corp. v. R. E. B. Corp. Decree for defendant Dec. 11, 1934. Same, appeal filed Dec. 10, 1934, C. C. A., 2d Cir., Hazeltine Corp. v. B. Abrams et al. et al.

1,855,168, C. L. Farrand, Loudspeaker, D. C. Mass., Doc. E 3774, Utah Radio Products Co. et al. v. R. T. Boudette et al. Injunction issued Oct. 8, 1934. Appealed Oct. 9, 1934.

1,405,523, M. C. Latour, Audion or lamp relay or amplifying apparatus, D. C., S. D. N. Y., Doc. E 72/203, Latour Corp. v. Bloomington Bros., Inc. Consent order of discontinuance (notice Dec. 11, 1934).

BRITISH PATENTS

British patents are important to American readers because these disclosures often forecast corresponding U. S. patents which may not be issued until a year later.

Television

Cathode ray tubes. Fluorescent screen is formed on a flat wall to which is applied a composite lens comprising a semi-spherical part with its flat base

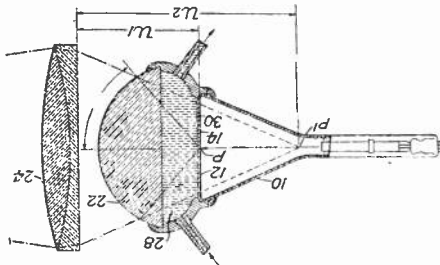

parallel to the wall, the chamber between being filled with oil which may circulate for cooling purposes. G. N. Ogloblinsky, Marconi Co. No. 417,435.

Trouble scanning system. The foreground and background actions of a composite television picture occur separately and at different points. Each are separately scanned. A. N. Goldsmith, Marconi Co. No. 417,282.

Cathode ray tube. Tube which has a photoelectrically sensitive electrode which emits photo-electrons from individual parts in dependence on the degree of illumination of those parts and which

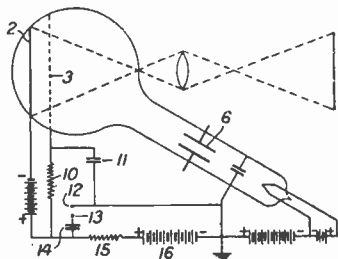

is scanned by a cathode beam; the picture to be transmitted is projected through a light-permeable anode positioned on the same side of the light-sensitive electrode as the electron gun so that the photo-electrons emitted variably obstruct the scanning ray to provide the picture signals. H. M. Dowsett, Marconi Co. No. 416,848.

Synchronizing circuit. A circuit for separating or mixing synchronizing impulses of two different frequencies in a television system comprises a Wheatstone bridge, the mixed frequencies being applied to or taken from an arm

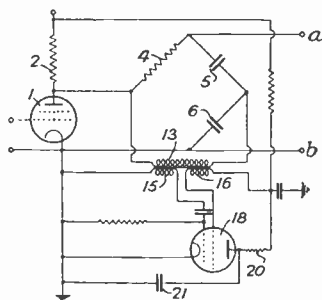

of the bridge, while the separate frequencies are taken from or applied to two conjugate diagonals. Electric & Musical Industries, Ltd. No. 416,720.

Distortion compensation. In a system in which the synchronizing signals become delayed or advanced in transmission as compared with the picture signals, means are provided for advancing or delaying the production of the synchronizing signals at the transmitter; in this way the need for a long interval between successive line-scannings is avoided. Electric & Musical Industries, Ltd. No. 415,118.

Radio circuits

Antenna transmission line. One or more radio receivers coupled to an antenna by a transmission line and a transformer with several primaries connected in series opposing relation or by a doubly resonant circuit. W. W. Macalpine, International Communications Lab. No. 415,687.

Short wave receiver. A retarding field type in which a high positive voltage is applied to the grid, and producing a direct current voltage proportional to the signal which is used to control the gain. J. J. V. Armstrong, Telefunken. No. 416,464.

Automatic volume control. The carrier frequency gain of a superheterodyne is controlled by varying the amplitude of the locally supplied oscillations produced by a dynatron. Marconi Co. No. 416,501.

Short wave system. Signaling on wave-lengths of the order of centimeters, utilizing frequency-multiplying and modulating valves in which the electron stream is subjected to a steady magnetizing-field and in which the plate, grid, and cathode-heating circuits are tuned by means of Lecher wires. N. E. Lindenblad, Marconi Co. No. 417,057.

Modulating systems. One or more rectifiers arranged in a balanced bridge circuit, the carrier voltage applied across one diagonal, and the modulated or demodulated output minus one or both of the applied voltages being taken from the other diagonal. R. J. Halsey. No. 417,251.

Automatic volume control. Selectivity of the channel through which carrier frequency energy reaches the demodulating detector is greater than that feeding the gain controlling rectifier. K. A. Chittick, Marconi Co. No. 417,284.

Directive system. An aerial system suitable for broadcasting and adapted to minimize high angle radiation comprising double radiator elements arranged on a zone of a surface of a revolution, for example, on the zone of a cone, the surface being, as a whole, substantially inclined to the vertical and the installation having a maximum diameter greater than one-quarter of the working wave-length. Telefunken. No. 417,296.

Directional antenna. To enhance the coefficient of directivity the dipole aerial is given an overall length of approximately 1.25 times the wavelength instead of the usual half-wavelength. P. S. Carter, Marconi Co. No. 416,296.

Wave change switch. Mechanical connection between bias adjustment and wave adjusting switch. Philips. No. 415,962.

Automatic volume control. Tubes in push-pull fed from a cold cathode rectifier, for example, a metal rectifier, develops an automatic-volume-control voltage. E. K. Cole, Ltd. No. 417,384.

Gas tube detector. The receipt of a signal initiates the discharge in the gaseous tube arranged to receive impulse signals. G.E. Co. No. 417,408.

Interference suppressor. Circuit between the input and the grid of the first tube in a superheterodyne receiver is

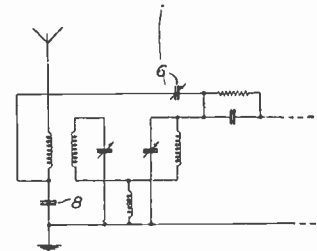

provided in addition to the normal coupling to suppress second channel interference. British Acoustic Films, Ltd. No. 417,410.

Antenna. A mast for use as an aerial is supported on insulators at three or more points with freedom of movement thereon, and is anchored to the ground within the area enclosed by the points of support. Blaw-Knox, Pittsburgh. No. 417,467.

Additional U.S. Patents

Applications to power

Speed control. Use of a controlled electric tube to supply current to a constant speed d-c motor from an a-c source. A. von Engel, WE&M Co. No. 1,985,003. See also No. 1,987,720 to S. A. Staeger, WE&M Co.

Voltage regulator. Tube method of controlling excitation from an a-c supply to a d-c motor. C. P. West, WE&M Co. No. 1,985,004.

Timing circuit. Electron tube timing circuit. H. Anschütz, G.E. Co. No. 1,985,069.

Generator. Apparatus for generating intermittent current impulses. A. Glaser, G.E. Co. No. 1,988,274.

Position control. Method for driving an object into positional agreement with a control device. M. A. Edwards, G.E. Co. Nos. 1,985,982 and 1,985,981.

Illumination control. Apparatus for controlling electric discharge lamps operated from one phase to a polyphase a-c supply. W. F. Westendorp, G.E. Co. No. 1,986,614.

Inverter. A self-excited inverting apparatus comprising a source of d-c, control tubes, etc. B. D. Bedford, G.E. Co. No. 1,986,617.

Automatic synchronizer. System for paralleling a-c sources. F. H. Gulliksen, WE&M Co. No. 1,977,384.



LEARN THE FACTS

about this New Low-loss Bakelite Molded

THE higher radio frequencies encountered in all-wave length receivers demanded insulations possessing improved electrical characteristics. To meet this need a new type of molding material has been developed in the Bakelite Laboratories which possesses exceptionally low-loss characteristics at high frequencies in addition to the other advantageous properties of standard Bakelite Molded.

Micamold, one of the manufacturers adopting this new Bakelite Molded, (XM-262) reports that they have standardized on it for "padding"

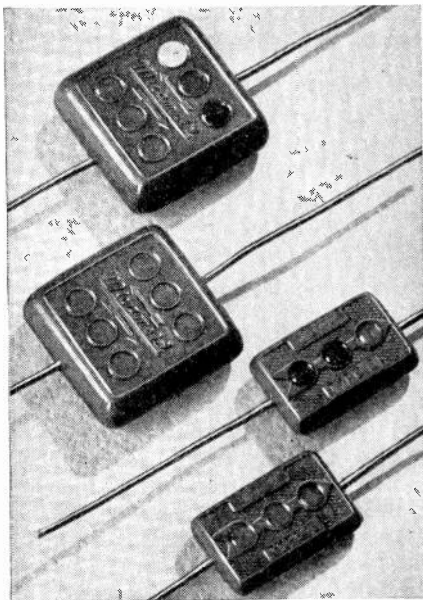

Molded Mica Condensers using low-loss Bakelite Molded XM-262. Micamold Radio Corp., Brooklyn, N. Y.

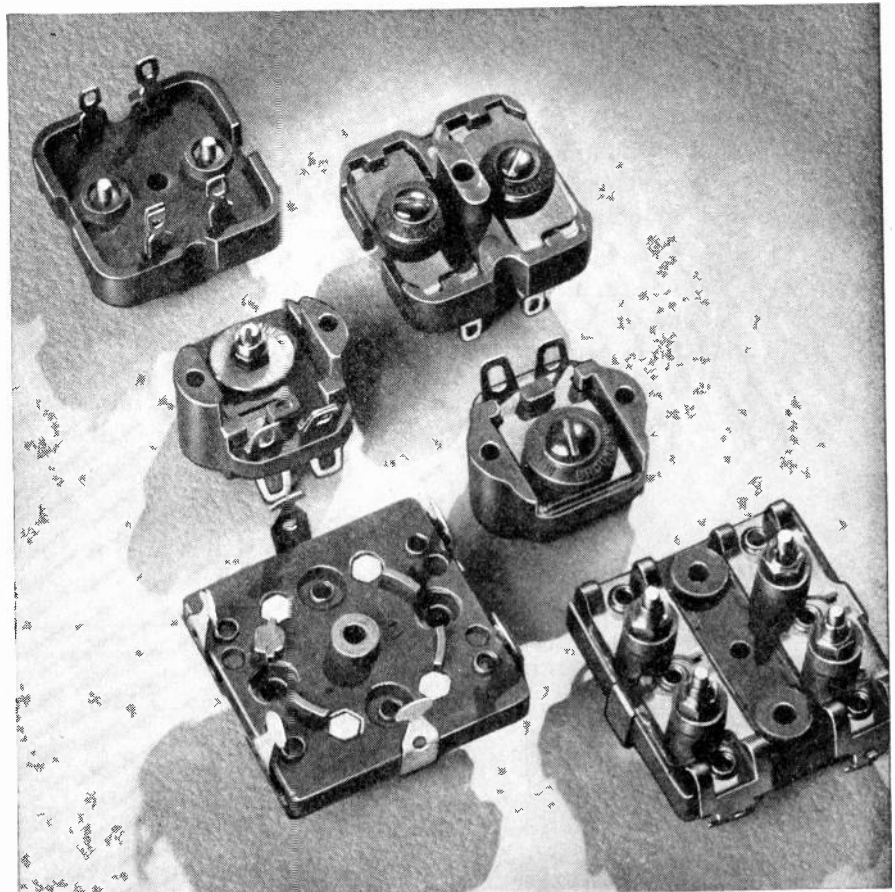

Micamold Padding Condensers with bases of low-loss Bakelite Molded XM-262. Micamold Radio Corp., Brooklyn, N. Y.

ding" and "mica" condensers for the following reasons:—

1. Low loss at high radio frequencies.
2. High surface resistivity.
3. Low moisture absorption.
4. Desirable mechanical properties.
5. Free from brittleness and breakage.
6. Adaptability to intricate and accurate forming.

This new Bakelite Molded possesses electrical characteristics com-

parable to ceramics, but unlike these it is strong, and may be formed to exceedingly accurate dimensions and shape. It may be recognized by its distinctive yellow-brown color.

We invite radio manufacturers and engineers to investigate the merits of this new Bakelite Molded, and also to write for full particulars and a copy of booklet 13M, "Bakelite Molded".

BAKELITE CORPORATION, 247 Park Avenue, New York, N. Y. 43 East Ohio Street, Chicago, Ill.
BAKELITE CORPORATION OF CANADA, LIMITED, 163 Dufferin Street, Toronto, Ontario, Canada

BAKELITE

REGISTERED TRADE MARK
The registered trade marks shown above designate material manufactured by Bakelite Corporation. Under the symbol "B" is the number of pieces and future uses of Bakelite Corporation's products.

THE MATERIAL OF A THOUSAND USES

GOAT form-fitting TUBE SHIELDS

contribute to the fine performance
of the attractive Emerson
"69" Console

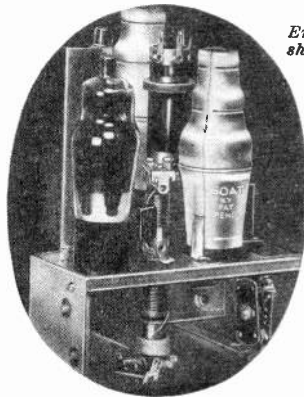

Emerson Signal Filter (in the Model "69")
showing Goat Tube Shield in place.

Emerson engineers recognize the effectiveness
of Goat Tube Shields by using them in their
model "69" chassis.

In addition, these modern shields contribute a
neat, tailored appearance—a fitting counterpart
to the beautiful console in which the chassis is
housed.



You, too, can improve performance, appearance
and profits by using Goat Form-Fitting Tube
Shields. Ask Goat for details.

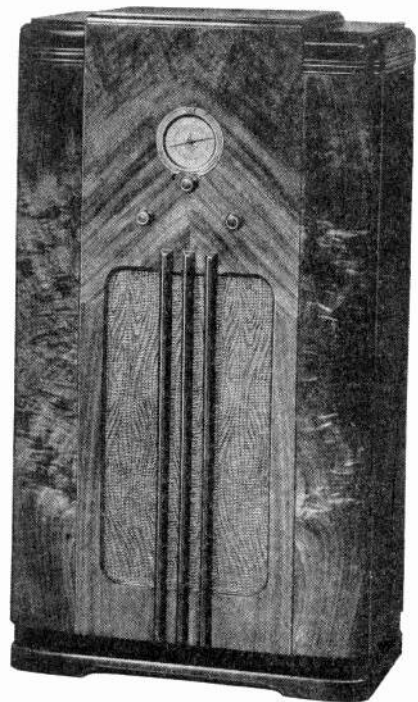

Emerson Model "69" Six-Tube Round-the-
World Superheterodyne in which Goat Form-
Fitting Tube Shields are used.

GOAT RADIO TUBE PARTS, Inc.
314 DEAN STREET
BROOKLYN, NEW YORK

Experience — which insures success to the last step in tube production



BEHIND the NEW Barex Embedded
Getter is the specialized experi-
ence of an organization whose entire
efforts are concentrated on the de-
velopment and production of just
one product—a GETTER which can
be depended on to vaporize com-
pletely, with minimum splash—a
GETTER which reduces shrinkage,
increases production and cuts costs of
both material and labor.

All these advantages are proved in the
production of manufacturers of quality
vacuum tubes. Ask us for details.

**KING LABORATORIES
INC.**

**205 ONEIDA STREET
SYRACUSE NEW YORK**

**The NEW
BAREX Embedded GETTER**

The Autelco Minor Switch

Ten Contacts—Simple, Rotary Action

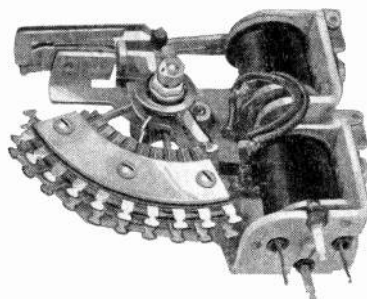

The Autelco Minor Switch can be used to select
any desired contact of a group of ten, control
being accomplished by push button, telephone
dial, etc. Switch is operated and restored by
electromagnets. One, two or three levels can be
furnished, ten contacts per level, with one, two
or three non-bridging double-spring wipers.
Arrangements can be made for operation on
from 6 volts up to 110 volts, D.C. Current car-
rying capacity per wiper, at rest—3 amperes,
D.C. or A.C.

Autelco Relays made by Automatic Electric Com-
pany, are a forty-year development embracing both
A.C. and D.C. types for every use. Send for Catalog
4016-A which gives detailed descriptive and order-
ing information. Address American Automatic
Electric Sales Company, 1033 West Van Buren St.,
Chicago, Illinois.

Automatic Electric Company
Chicago, Illinois

PROGRESS DEMANDS

... that old jobs
be done new ways

... READ
WHAT **WESTON**
HAS TO SAY ...

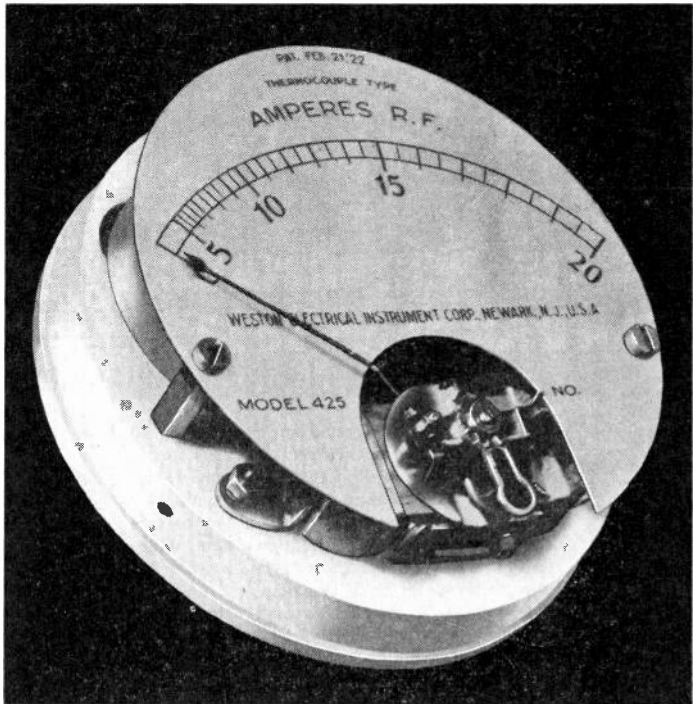

"During the past few years we have experienced a demand for thermal instruments for use on very short wave lengths and very high frequencies. Our regular instruments, with their high-grade phenol condensate bases, were not suited to this service. So much heat was developed that the bases blistered and cracked, which often resulted in burned-out instruments.

"The obvious solution was to find a new base material having a low loss factor, combined with other necessary properties. *We solved the problem by using Isolantite.*"

Isolantite Inc.

FACTORY at BELLEVILLE *New Jersey*

New York Sales Office 233 Broadway

SHAKEPROOF

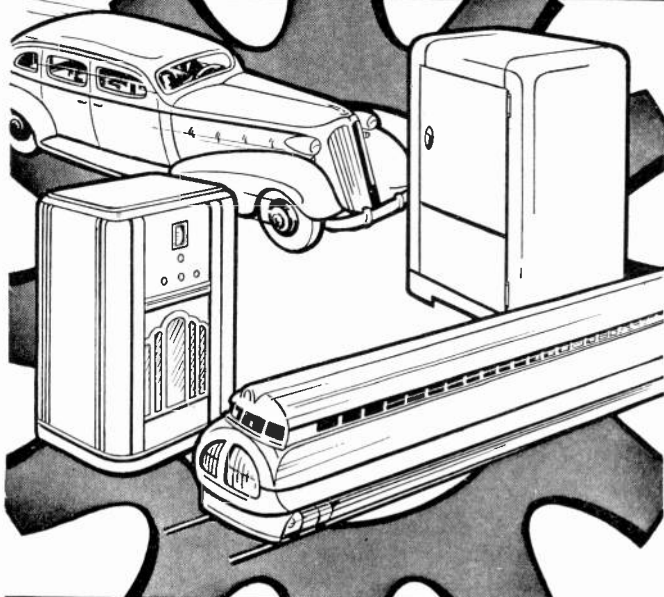

MEETS THE PERFORMANCE STANDARDS OF 1935!

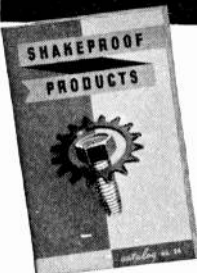

NEW CATALOG

Just off the press—our new 1935 catalog tells you how to solve your locking problems. Also illustrates and explains other patented Shakeproof products—a truly valuable book—send for your free copy today!

In every industry, engineers are striving to achieve new performance peaks. Faster speeds—greater efficiency—longer life, are some of the goals that they are trying to reach. That's why the demand for Shakeproof Lock Washers is constantly growing—the need for a tight, vibration-proof locking method is paramount. Be sure to try Shakeproof Lock Washers on your product—see how each twisted tooth forms a positive double-action lock that only applied pressure can release. Then realize that the power of this lock is multiplied by the number of teeth on the washer (from 6 to 20 times)—that's why you can depend on Shakeproof to hold each and every screw or nut absolutely tight! Send for testing samples today!



SHAKEPROOF Lock Washer Company

Distributors of Shakeproof Products
Manufactured by Illinois Tool Works

2539 N. Keeler Ave.

Chicago, Ill.

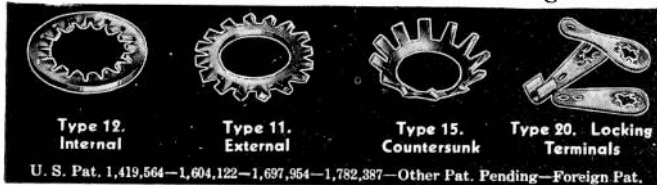

U. S. Pat. 1,419,564—1,604,122—1,697,954—1,782,387—Other Pat. Pending—Foreign Pat.

New 1935 REMLER ATTENUATORS

Endorsed by leading Broadcast Engineers

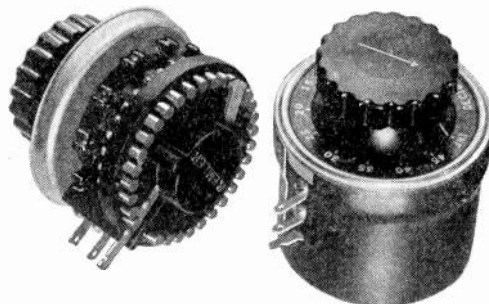

Noise, Fading and Jerkiness Eliminated

Highly recommended for broadcast apparatus, sound recording and projection equipment. Attenuation variable in 27 steps of 1 2/3 db. per step up to 45 db., fading in 3 additional increasing steps from 45 db. to infinity. Attenuation change halved as switch arm spans adjacent contacts resulting in attenuation of 5/6 db. per step. Impedance practically constant over entire range of the pad. Essentially flat frequency response.

Bakelite covered, moisture-proof bifilar windings. Handles power levels up to plus 24 db. Diameter 2 3/4"; depth back of panel 2 1/16"; mounts 2 3/8" hole or by three 6/32" screws on 1 7/16" diameter circle.

Standard impedances of 50, 200, and 500 ohms. Special values to order. LA-5 Ladder Type. Net \$10.80

Send for new Catalogue Sheets

REMLER COMPANY, Ltd.
2101 Bryant Street San Francisco, Calif.

REMLER—THE RADIO FIRM AS OLD AS RADIO

BRUSH SOUNDCELL MICROPHONES

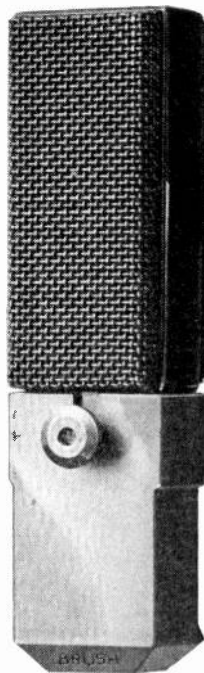

● Six models designed for various purposes—recording, reproduction and measurement of sound.

No diaphragm. No cavity resonance. No delicate adjustments or moving parts. No distortion of the wave front.

Leading manufacturers are now offering transmitting and public address equipment especially produced for use in connection with Brush Soundcell Microphones.

Illustration shows Brush Type G2S2P Microphone and socket—the most popular model for all purposes.

Write for information.

ALSO—

Brush Type T51 Tweeter for reproduction of the upper frequencies—from 3000 to 9000 cycles. No filter or field supply required.

Single unit for experimental purposes. \$7.25 postpaid in U. S.

THE BRUSH DEVELOPMENT COMPANY
E. 40th and Perkins Ave., Cleveland, Ohio

Complete · Portable · A-C Operated!



CATHODE RAY OSCILLOGRAPH

\$84⁵⁰ With RCA Tubes, Including
RCA 906 Cathode Ray Tube

Complete . . .

The RCA Cathode Ray Oscillograph, Stock No. 9545, is complete in every essential requirement for immediate use. It includes two power supplies (one for the cathode ray tube and one for the amplifier), vertical and horizontal amplifiers, saw-tooth frequency generator and six tubes, including the RCA 906 Cathode Ray Tube (3-inch).

2 Volts per Inch . . .

Through the use of two wide-frequency-range high-gain amplifiers, the sensitivity is guaranteed at 2 volts A. C. per inch for both vertical and horizontal deflection. The amplifiers have flat frequency characteristics between 20 and 90,000 cycles \pm 10 per cent.

20-15,000 Cycles . . .

A linear saw-tooth timing frequency oscillator with a special synchronizing circuit is an integral part of the RCA Oscillograph. The frequency range extends from 20 to 15,000 cycles and permits the examination of a single cycle up to 15,000 cycles or the examination of six cycles up to the limit of the amplifier—90,000 cycles. Suitable switching is provided so that either the internal timing oscillator or an external source of frequency may be connected to the plates through the amplifier. The binding posts may be connected directly to the plates for operation above 90,000 cycles.

Frequency Modulator . . .

The RCA Frequency Modulator, price \$27.50, and the RCA Test Oscillator, Type TMV-97-C, are auxiliary instruments for aligning radio circuits with the RCA Oscillograph. The Frequency Modulator is a combined motor-driven capacitor and a-c generator. The Test Oscillator has a range from 90 to 25,000 kc.

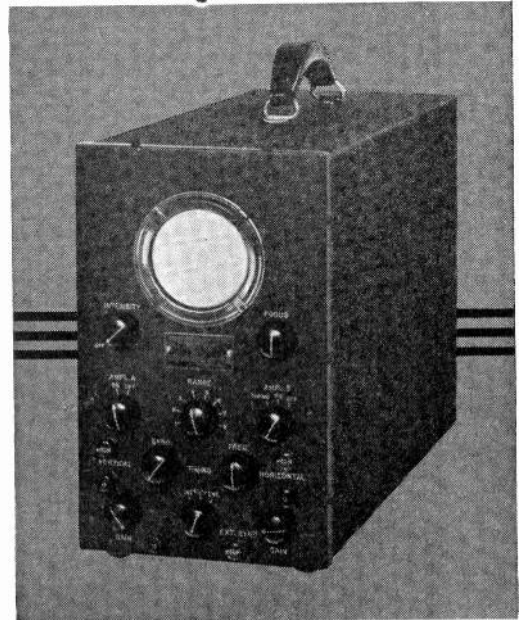

SPECIFICATIONS

TUBES—1 RCA 906, 1 RCA 879, 1 RCA 885, 1 RCA 80, 2 RCA 57. Total tubes, 6.

ACCURATE FOCUSING—Control on panel. Screwdriver adjustments for beam centering.

ILLUMINATION — Brilliant image — may be photographed with ordinary commercial camera.

SENSITIVITY—From 20 to 100,000,000 C.P.S.: 27.0 Volts R.M.S. for 1 inch deflection, 74.0 Volts R.M.S. for full screen image. From 20 to 90,000 C.P.S.: 0.7 Volts R.M.S. for 1 inch deflection, 1.9 volts R.M.S. for full screen deflection.

SWEEP CIRCUIT—Linear “saw-tooth” oscillator, adjustable from 20 to 15,000 cycles, positively synchronized with voltage under test by special circuit. Binding posts also for external synchronization.

AMPLIFIERS—Horizontal and vertical. Linear from 20 to 90,000 cycles \pm 10%. Amplifier gain is approximately 40.

NEW APPLICATIONS

The RCA Cathode Ray Oscillograph, the X-Ray of the engineer, can be used to interpret any phenomenon which can be represented electrically, as well as for the more common use of examining alternating current wave shapes, phase relations, or any intermittent electrical currents.

New applications of the Cathode Ray Oscillograph are being discovered constantly in the RCA Victor research laboratory. Correspondence regarding your possible use of the RCA Oscillograph is invited.

Write to RCA Parts Division, Camden, N. J., for Instruction Book E and treatise on Oscillographs

RCA PARTS



DIVISION

RCA MANUFACTURING CO., INC.

CAMDEN, NEW JERSEY, U. S. A.

IMPROVING ELECTRIC WAVE FILTER MEASUREMENTS

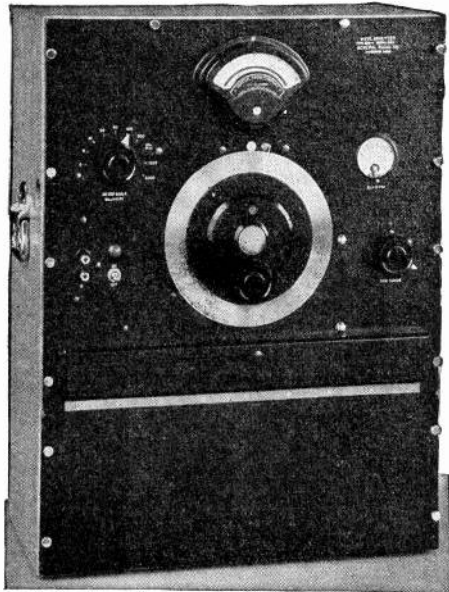

*General Radio Type 636A
Wave Analyzer*

Large errors are introduced in the measuring circuit of electric wave filters by waveform distortion and hum in the power source. These errors are of sufficient magnitude to account for the discrepancies often found between the theoretical design and the measurements on the final filter.

The usual r-m-s output voltmeter in the measuring circuit cannot discriminate between a-c supply harmonics or hum voltages and the measuring frequencies. These extraneous voltages cannot be eliminated readily. Elimination of distortion in oscillators can be carried only so far. The use of a series of filters between the power source and the measurement circuit is impracticable.

The General Radio Type 636A Wave Analyzer, when used as a selective output voltmeter in the measurement circuit, eliminates all errors due to waveform distortion and a-c hum as its selectivity is so great that it distinguishes readily between these frequencies and the measurement frequency. A frequency only 30 cycles off resonance is attenuated by 40 db and one 90 cycles off is attenuated by 60 db. This analyzer is so sensitive that no amplifier is required between the filter and the output meter.

Complete details concerning the use of the General Radio Type 636A Wave Analyzer in the measurement of filter characteristics are contained in **Bulletin EX-3503-E**, a copy of which will be sent immediately on request.

General Radio Company
30 State Street Cambridge A, Massachusetts

ELECTRICAL INSULATION



... Varnished Cloth, Tapes,
Silks and Papers



... Plates, Segments, Rings,
Tapes, Tubes, Washers



... Laminated Bakelite
Fabricated Parts, Sheets,
Rods and Tubes



... Untreated Papers, Linen
and Silk Tapes, Varnishes,
Fibre, Spaghetti Tubing,
Cotton Sleeving, etc.

RAW MICA, Uncut blocks, or cut to size.

MICA SHAPES

200 Varick Street, New York; 542 So. Dearborn Street, Chicago;
1330 Schofield Bldg., Cleveland. Branches at: Birmingham, Boston,
Cincinnati, Los Angeles, San Francisco, Seattle, Montreal, Toronto

MICA INSULATOR CO.

New Cathode Ray Oscillograph

FEATURES:

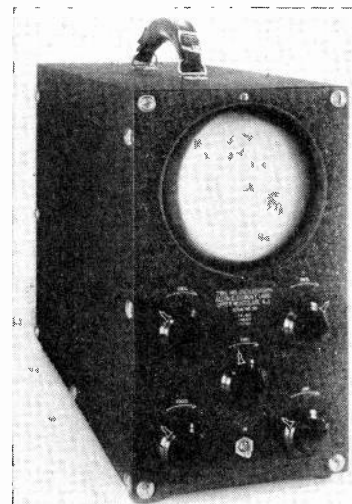

Price with 3-in. Tube..... \$99.50
Price with 5-in. Tube..... \$116.50

1. Uses either 3-in. or 5-in. diameter cathode ray tubes.
2. Dumont cathode ray tubes of the high vacuum electron lens type used having short persistence screen.
3. Design permits operation up to 100 megacycles.
4. Exclusive features incorporated in these new tubes provide highest sensitivity, mechanical strength and electrical insulation.
5. Linear sweep circuit covering audio frequency range. Controls for frequency adjustment, synchronization and sweep amplitude.
6. Two single stage amplifiers in the unit. Switching arrangement enables one stage to be used on either axis or two stages on one axis.
7. Sweep can be applied to either axis or signal directly to deflection plates without going thru amplifier.
8. Gain controls provided for each axis.
9. Patented calibrated scale so accurate quantitative measurements can be made.
10. Power supply furnishes all voltages for cathode ray tube, sweep circuit and amplifier.

ALLEN B. DUMONT LABORATORIES
UPPER MONTCLAIR, N. J.



Where you must have
NOISELESS operation
use S. S. White "NOISE TESTED" RESISTORS

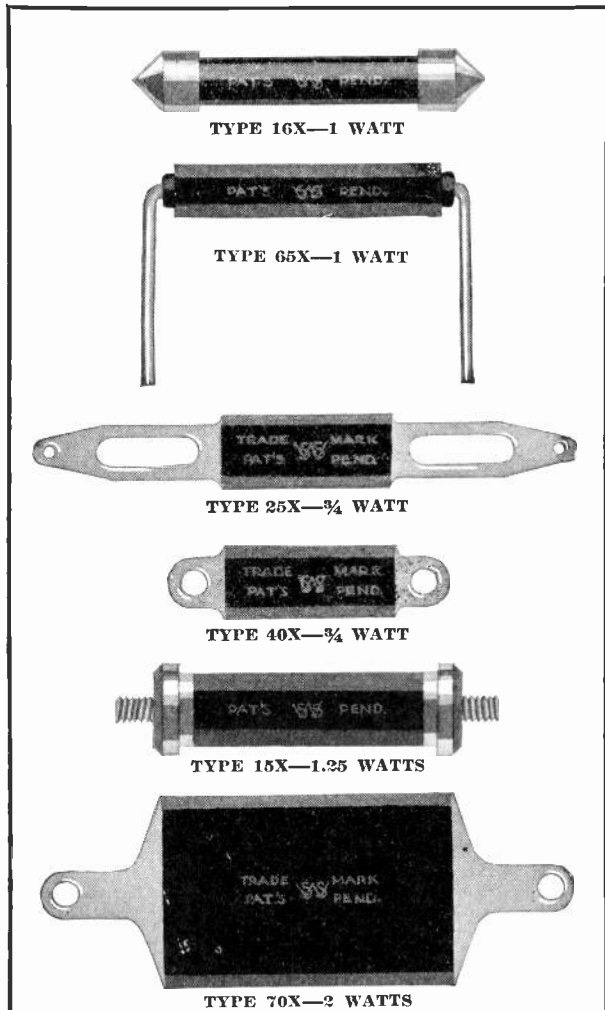

Above actual size illustrations show a few of the types available.

RESISTANCE RANGES

Commercial Field—

The standard range from 1000 ohms to 10 megohms.

Laboratory and Experimental Field—

A comprehensive assortment of unusually high values ranging from 10 megohms to 1,000,000 megohms.

If you need resistors for amplifiers, for aircraft receivers, for laboratory applications or for any other electronic equipment which must be noiseless in operation, it will pay you to use S. S. WHITE "NOISE TESTED" Resistors.

When you order noise tested resistors, each individual resistor on your order is guaranteed to meet the following exacting specification:

"For the complete audio frequency range, resistors shall have less noise than corresponds to a change in resistance of 1 part in 10,000,000."

There is a small extra charge for noise tested resistors, but this is more than offset by the assurance that every one will be noiseless, and that it will be unnecessary for you to make tests.

TRY THEM IN YOUR EQUIPMENT

That's the sure way to find out just how good these resistors are. WRITE for the descriptive circular, select the types and sizes you want and we will be glad to quote on your requirements.



The S. S. WHITE Dental Mfg. Co.
INDUSTRIAL DIVISION
 Knickerbocker Bldg.
 New York, N. Y.

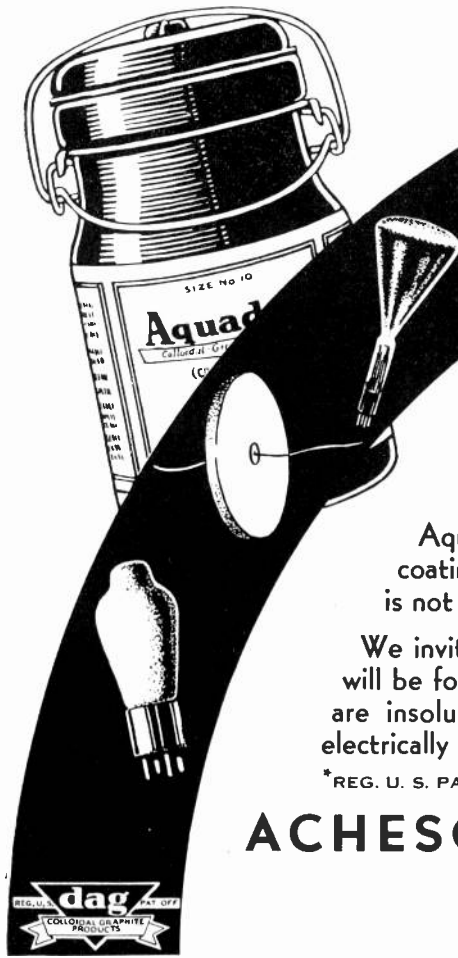

AN INVITATION TO EXPERIMENT

In the old fashioned carbon lamp, colloidal electric-furnace graphite dispersed in water, was used to cement the filaments to the "lead-in" wires. In the modern radio tube, when applied to the grid it forms dark tenacious surfaces which effectively retard secondary emission. Moreover, it finds extensive use in the efficient drawing of tungsten wire employed in the manufacture of certain lamp filaments.

Aquadag* brand colloidal-graphited water is rapidly displacing silver as a coating on the interior walls of the glass envelopes of cathode ray tubes. It is not only an easier product to apply, but adheres as well to all types of glass.

We invite your research laboratory to test this unique material and are sure it will be found valuable in problems whose solution depends upon coatings which are insoluble, non-fusible, chemically inert, electrically conducting and photo-electrically poor. For details send for Technical Bulletins Nos. C31 and D191.

*REG. U. S. PAT. OFF

ACHESON COLLOIDS CORPORATION

FOUNDED (1908) AS

ACHESON OILDAG COMPANY
PORT HURON, MICHIGAN

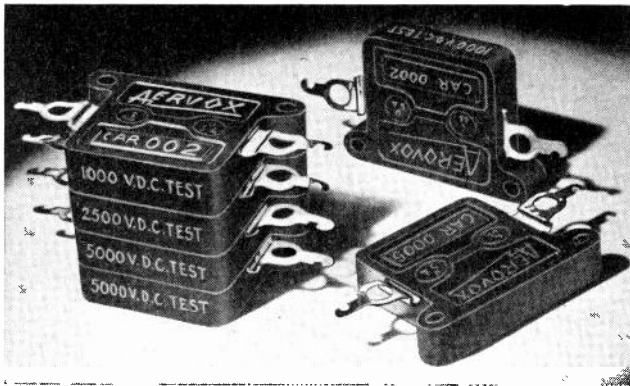

MICA CONDENSERS

Flat top and bottom for perfect stacking . . . compact assemblies or banks . . . maximum utility.

Insulated mounting holes for any mounting independent of connections. Insulated terminals for any wiring or combination of units.

Special terminals . . . no heat transfer to section when soldering. 1000, 2500, 5000 v. ratings, stamped on case.

. . . **AEROVOX Engineered**

HIGH-VOLTAGE units . . . for transmitters and electronic assemblies. Different in design . . . outstanding in advantages. Aerovox also offers midget bakelite-molded units and metal-cased units. Always the finest grade India ruby mica, special foil, genuine bakelite, generous safety factor, supreme accuracy.

Send for Data: New 1935 catalog on condensers and resistors, mailed on request. Also sample copy of Research Worker. Remember: Aerovox engineering for quality; Aerovox mass production for low prices.



AEROVOX

CORPORATION

74 Washington St. Brooklyn, N. Y.

For the Radio Engineer
For the Acoustical Engineer
For the Broadcast Engineer
For the Sound Motion Picture Engineer
etc., etc.

Applied Acoustics

The first American book to deal entirely with acoustical engineering principles. It covers the design, construction, operation and analysis of modern acoustical and electro-acoustical apparatus. Includes analysis of rooms, studios, theatres and operation of systems in modern environments and conditions. 228 Illustrations. 430 Pages. Fabrikoid. \$4.50 Postpaid.

By HARRY F. OLSON, Ph.D. and FRANK MASSA, M.Sc., Acoustical Research Engineers, RCA Victor Co., Inc.

P. BLAKISTON'S SON & CO., INC.

1012 Walnut Street, Philadelphia

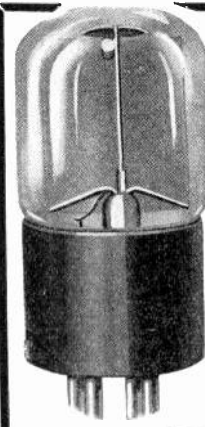

CE-2

Only one of more than thirty-five different types of CETRON photo cells manufactured by us—the most comprehensive range made today. CETRON photo cells are known for their high sensitivity, greater power and longer life.

Write today for technical folder. It is gratis.

Continental Electric Co.

First and Illinois Sts.,
St. Charles, Ill.

Cable Address: Continental

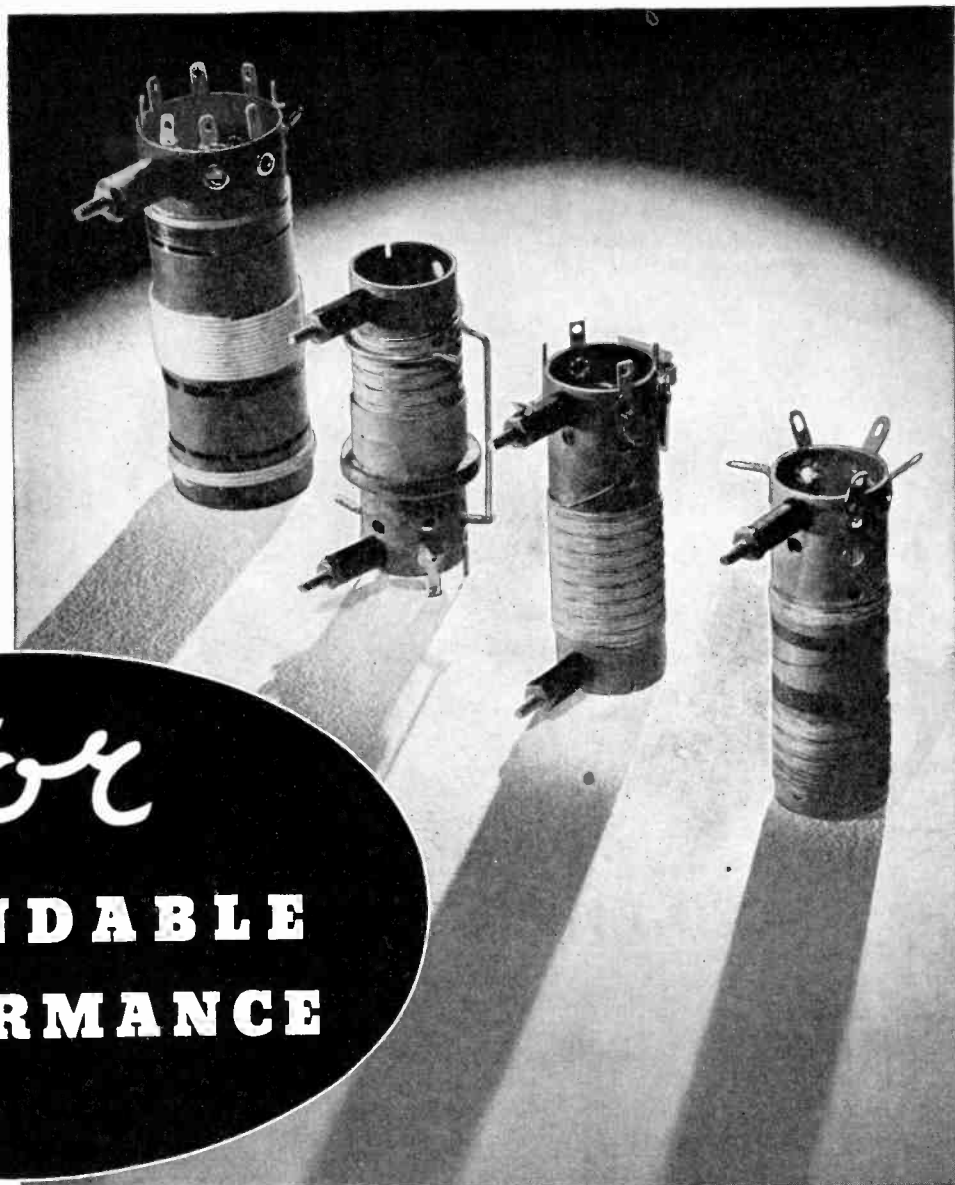

For
**DEPENDABLE
PERFORMANCE**

Use Textolite Laminated

THE coil form is the most critical factor in a short-wave radio circuit. Low dielectric losses at all degrees of humidity and a negligible change in power-factor are essential. Accuracy and permanence of dimensions are also important in order that the required inductance may be exact.

Textolite Grades No. 2008 and 2009 have been developed specially to meet these requirements. The General Manufacturing Company, Chicago, uses Textolite exclusively for the insulation of all its coil forms because it demands the highest standard of quality,

which Textolite offers. You can profit by specifying Textolite for parts requiring low dielectric losses, low moisture absorption, high surface resistivity, and ease of fabrication.



For quick and dependable service on Textolite laminated materials and fabricated parts, write to our nearest distributor: **General Laminated Products, Inc., 233 Spring Street, New York City, General Laminated Products, Inc., of Illinois, 1308 N. Halsted Street, Chicago,** or write to **Plastics Department, General Electric, West Lynn, Mass.**

942-34

GENERAL  **ELECTRIC**

Incandescent Lamp Machinery of every description

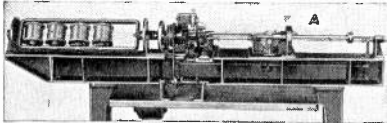
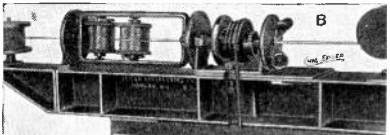
Radio Tube Machinery
Radio Tube Parts
Neon Tube Machinery
Neon Tube Parts and Supplies
Neon Tube Electrodes
Laboratory Equipment
Glass Working Machinery
Air Pressure Blowers
Ampule Exhaust Machine
Bombardiers—Radio
Bombardiers—Neon
Blast Torches
Carbonizing Machines
Electric Furnaces
Electronics Equipment
Frosting Machinery
Gas Boosters and Regulators
Gas Burners—Glass Working
Glass Apparatus
Stopcocks and Aspirators
Traps of all types
Gas Purifiers—Argon
Gas Purifiers—Nitrogen
Motorized Drives
Pumps—High Vacuum
Hooks of all kinds
Nickel Tubes—Radio
Leadwires of all kinds
Oxygen Burners—Glass Working
Gas and Air Mixers
Rubber Tubing—Vacuum
Spark Coil—Vacuum Testing
Transformers
Tungsten Wire
Copper Clad Wire
Wire Drawing Machines
Wire Cutting Machines
Wire Welding Machines
Eisler Spot Welders
Butt Welding Machines
Soldering Machines
Dental Soldering Machines
Job Spot Welding
Spot Welder Tips
Portable Spot Welders
Portable Butt Welders
Oil Burners
(Domestic and Industrial)

A—Automatic Grid Winding Machine for 4 Wire Boxed Type Grids.

B—Asbestos Core Continuous Resistance Winding Machine.

C—Strip Resistance Winder.

D—Electron Tube Butt Sealing Machine.

VACUUM AND GASEOUS TUBE PROBLEMS

Your mechanical problems will receive the prompt attention and cooperation of our engineers. If your requirements call for special machines, we shall be glad to build them to your specifications. Whatever your machinery needs are in the field of electronics, please consult

Charles Eisler

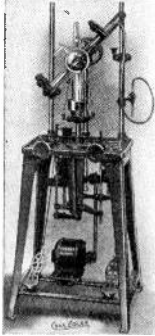

ELECTRON TUBE BUTT SEALING MACHINE

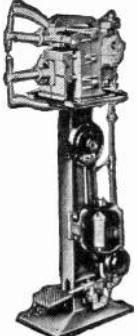

SPOT WELDERS MADE IN SIZES FROM 1/2 TO 100 K.V.A.

EISLER ENGINEERING CO. **NEWARK, N. J. U. S. A.**
751 So. 13th Street
Cable Address: Eisler, Newark, N. J.

ELMET

amp

Wires In All Sizes And Tempers

For—

- GRIDS
- SUPPORTS
- HOOKS
- HEATERS

And Other Vacuum Tube Parts

ALSO RESISTANCE WIRE FOR HIGH TEMPERATURE ELECTRIC FURNACES

WRITE FOR INFORMATION AND PRICES

AMERICAN ELECTRO METAL Corporation

LEWISTON - MAINE



A TRIAL WILL CONVINCe YOU

30 Years' Experience
Insures Dependability

We Manufacture

PERMANENT MAGNETS
METAL STAMPINGS

TOOLS and DIES
LAMINATIONS

THOMAS & SKINNER STEEL PRODUCTS CO.

23d St. at Alvord Indianapolis, Ind.



UNIVERSAL MODEL "E"

—with A.C.
Humless
Power Supply

Completely assembled—A.C. operated—ready to use Model "E" condenser microphone unit—guaranteed as silent as batteries—yet without battery expense or annoyance—Two stage amplifier with No. 230 tubes—Model B microphone with 90° swivel head; barometric adjustment; solid cast grating diaphragm protection—Frequency response from 35 to 10,000 cycles—A quality unit offered at the lowest price consistent with Universal standards.

UNIVERSAL MICROPHONE CO., Ltd.

424 Warren Lane
Inglewood, Calif., U. S. A.

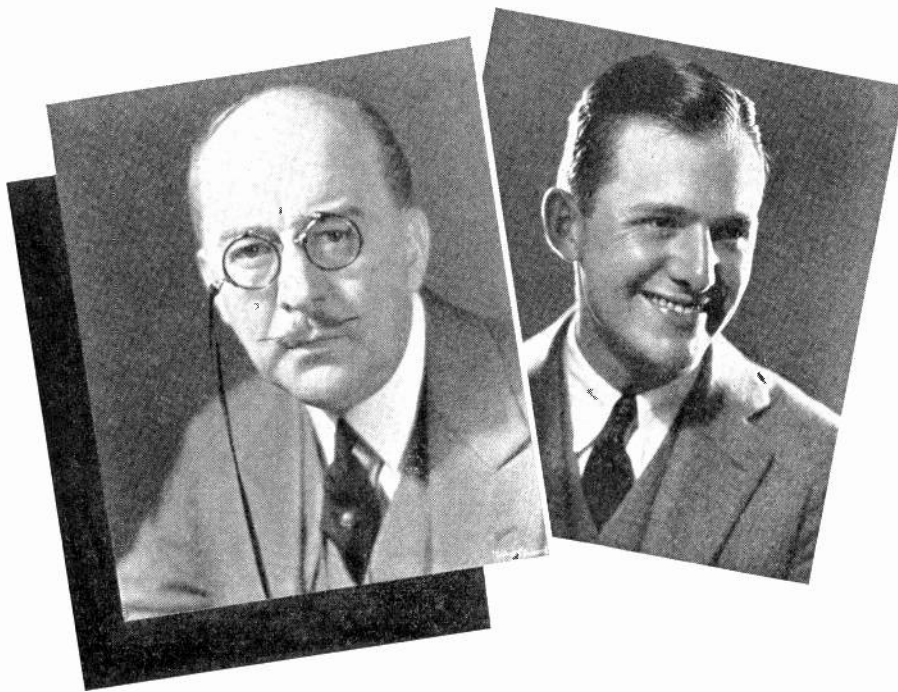

Background!

Picture two men applying for an important position. As far as you can judge by eye and ear, both seem to have about the same qualifications. But one has a very definite "something" the other lacks — a broad and successful background of experience in your particular field. His performance under fire is definitely proved. *And he is the one you choose.*

For many years the International Resistance Company has been concentrating the efforts of a large, modern organization on the manufacture of quality resistance units only. Thus IRC Resistors come to you with a background of proved performance in almost any type of application you might name.

INTERNATIONAL RESISTANCE CO.

2100 Arch St.,

Philadelphia, Pa.

TORONTO

LONDON

COPENHAGEN

MILAN

PARIS

BERLIN



POINTS YOU SHOULD KNOW



about the new STACKPOLE improved paper type radio volume and tone control FOR MODERN AUTO RADIO RECEPTION

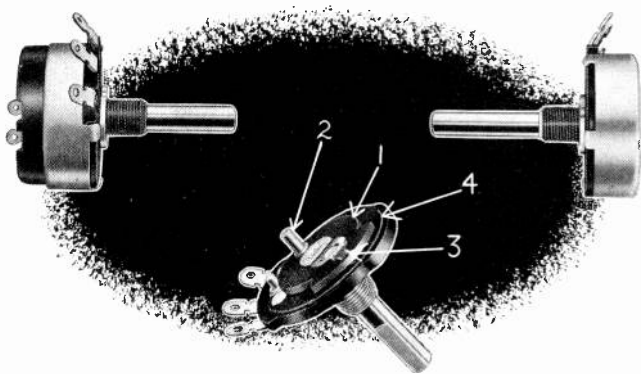

- 1 The micarta hub, which carries the contact, fully insulates the moving contact and resistance element from bushing and shaft . . . very necessary in a great number of applications.
- 2 The Switch-Operating cam, is fastened directly to the micarta hub and therefore, fully insulated from the resistance element.
- 3 The new improved spring and contact construction gives increased life and less noise. There is a true universal joint action which assures line contact with the element. Contact is pressed and polished to eliminate noise due to surface scratches on element.
- 4 New type "P" resistance element made by depositing carbon on high grade paper. Element is fired at high temperature making it permanent and unaffected by change of humidity and temperature.

This is only one of a number of new Stackpole Electrical Specialities fully described in the Stackpole Catalogue—a veritable handbook of up-to-date information for all progressive radio engineers. Send for your copy today.

STACKPOLE CARBON COMPANY
ST. MARY'S PA.

"a work we can unreservedly recommend"

—*The Electric Journal*

"excellent and authoritative"

—*Review of Scientific Instruments*

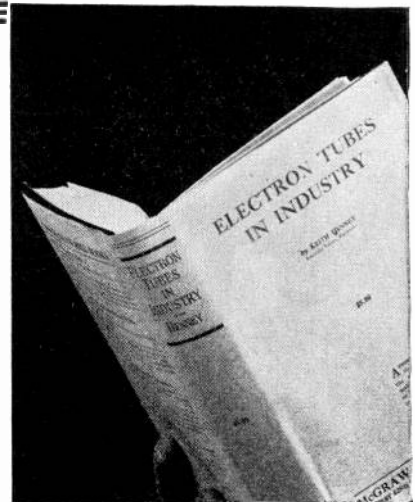

Electron Tubes in Industry

By KEITH HENNEY
Associate Editor, *Electronics*

490 pages, 6 x 9, illustrated, \$5.00

Engineers and manufacturing executives interested in cheapening or quickening industrial processes will find in this book a thorough presentation of the practical aspects of electronics—what the electron tube is doing toward making processes simpler, cheaper, safer, and in making possible new methods of control. The book describes all the various electron tubes that are useful in industrial operations.

The book is specific; it tells what is being done with tubes in industry now and how it is being done. It indicates the possibilities of the extended use of these tubes. In all possible cases the economics of such application is discussed. The book shows how much the electron tube system costs in a given instance compared with other competing systems.

Some of the Applications of Electron Tubes discussed in this book—

- | | |
|------------------------------|------------------------------|
| Vacuum tube voltmeters | Inversion (d.c. to a.c.) |
| Automatic recorders | Rectification (a.c. to d.c.) |
| Telemetering | Welding control |
| Elevator control | Illumination control |
| Color matching | High speed counting |
| Sorting and grading | Register control |
| Door openers | Paper bag manufacture |
| Voltage and speed regulation | Traffic and train control |
| Battery charging | Smoke density control |
| Viscosity tests | Thickness control |
| Precision automatic testing | Humidity control |
| Noise measurement | Chemical analysis |
| Conveyor synchronization | |

"I think that *Electron Tubes in Industry* is by far the finest thing that has ever been written on the subject. It is especially good where it relates to specific uses of tubes. The author has weeded out the theory and put the practical application into a form that will be most useful for industrial engineers who want to apply the art to their own practical purpose."

—R. D. McDILL

See this book 10 days on approval—Send this coupon

McGraw-Hill
ON-APPROVAL COUPON

McGraw-Hill Book Co., Inc., 330 West 42nd St., New York City

Send me Henney's *Electron Tubes in Industry* for 10 days' examination on approval. In 10 days I will send \$5.00, plus few cents postage and delivery, or return book postpaid. (We pay postage on orders accompanied by remittance.)

Name

Address

City and State

Position

Company L. 3-35

(Books sent on approval in U. S. and Canada only.)

A Tiny Screw but a Big trouble-saver

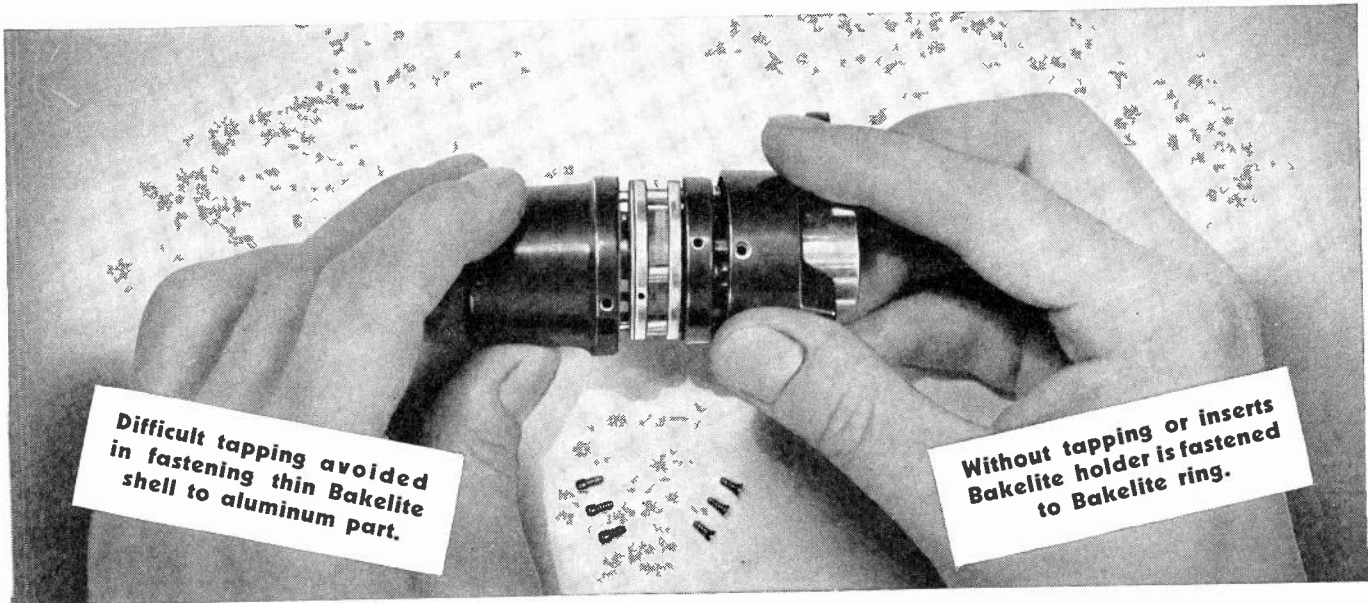
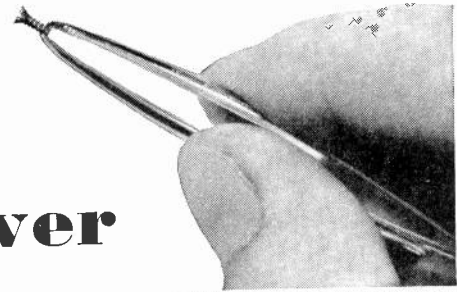

Difficult tapping avoided in fastening thin Bakelite shell to aluminum part.

Without tapping or inserts Bakelite holder is fastened to Bakelite ring.

Saves six difficult tapping operations —adds security, too, on these assemblies

A glance at the picture above will tell most any experienced production man that Eugene, Ltd. must save a good deal of trouble and expense by assembling the parts of their permanent wave steamer with Parker-Kalon Type "Z" Hardened Self-tapping Screws. To tap the six small

holes in the Bakelite and aluminum parts for machine screws would be a mean, time-consuming job. Assembly costs would be boosted still higher by tap breakage and spoilage of parts due to frequent mistapping.

In making your product, it will pay to try Self-tapping Screws wherever machine screws are used. Almost always a saving can be made and production speed increased by eliminating tapping. In small holes or shallow, bottomed holes where tapping is especially troublesome, these unique Screws will "work wonders" in cost reduction.

Hundreds of electrical parts and products are being made at lower

cost with Self-tapping Screws. In most every case they are also made better. Unbiased tests prove that these Screws actually make stronger fastenings than machine screws in either a tapped hole or a threaded metal insert.

Send a brief description of any of your assemblies that might be made with these time- and -labor- saving Screws. We'll furnish free samples for a trial with recommendations of our Assembly Engineers.

PARKER-KALON
HARDENED
Self-tapping Screws
PAT. IN U.S. AND FOREIGN COUNTRIES

Where and How to use:-

Type "Z" Hardened Self-tapping Sheet Metal Screws



For joining and making fastenings to molded, cast and laminated plastics; die castings and sheet metal. Simply turn the Screws into drilled or molded holes. Can be removed and replaced without impairing holding power.

Type "U" Hardened Metallic Drive Screws

This type of Self-tapping Screw is for making permanent fastenings to molded, cast and laminated plastics, also steel and metal castings. Just hammer the Screws into molded or drilled holes for secure fastenings.



PARKER-KALON CORPORATION, 198 Varick Street, New York, N. Y.

Please send information on Self-tapping Screws and free samples for trial on the assemblies described on attached sheet.

Name, Title
Company
Address

Parker-Kalon Products are sold only through recognized distributors

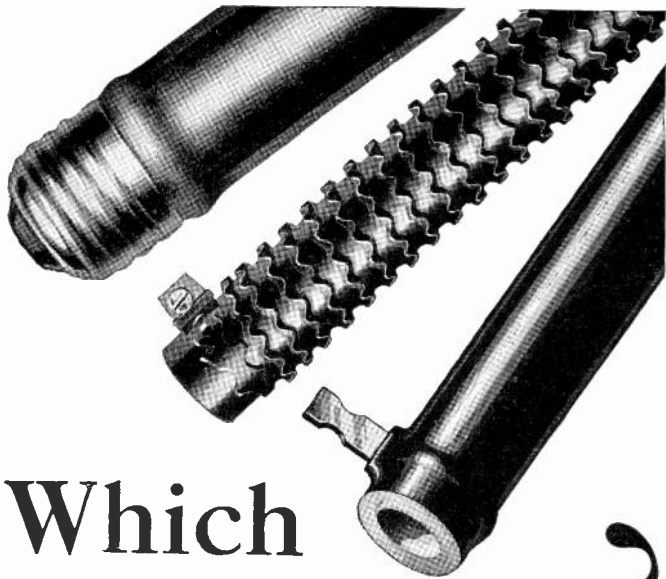

Which Resistor?

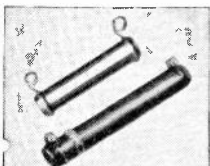

SIZES

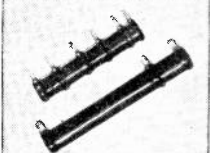

TERMINALS

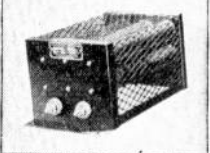

ENCLOSURES

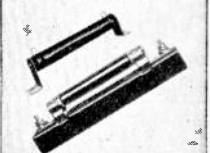

MOUNTINGS

Your resistor requirements are no more difficult to fulfill than those of more than 5000 Electrical and Industrial Engineers who are now using these bulletins as a reference guide.

Vitrohm Resistors, designed to satisfy these 5000, are available in a wide variety of sizes, ratings and terminals. Your "special" problems can be solved by these combined standard Ward Leonard Resistors.

Send for these bulletins. You will find them most useful and helpful guides in solving your resistor problems.

BULLETIN 11

Tells about Vitrohm Wire Wound Resistors, gives sizes, watt ratings.

BULLETIN 19

Describes Ward Leonard Ribflex Resistors for unusually heavy duties.

BULLETIN 25

Is a treatise of standard and special mountings and enclosures.

WARD LEONARD

RELAYS - RESISTORS - RHEOSTATS

WARD LEONARD ELECTRIC CO.
32 South Street, Mount Vernon, N. Y.

Please send me your bulletins Nos.
Name
Company
Street
City and State.....

AMERTRAN

Miniature De Luxe Audio Transformers

(Type OP)

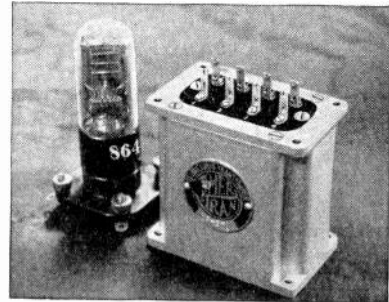

Users of high-fidelity portable amplifiers will find that AmerTran Type OP Miniature transformers will solve many of their knottiest problems. Not only are these units small in size and of light weight, but they are also high quality parts which meet broadcast station specifications.

Frequency characteristics are uniform within ± 1 dB from 30 to 12,000 cycles and all types are self-shielded electromagnetically. Windings of all transformers are in carefully balanced sections with at least four leads brought to the terminal board from each coil. All mixing, line-to-grid, and output types are equipped with a terminal from the electrostatic shield.

Mechanical specifications covering all Type OP transformers are as follows:

Base Dimensions	1-13/16" by 2-15/16"
Height of case	2-29/32"
Height over terminals	3-13/32"
Mounting dimensions	1 1/2" by 2 3/8"
Type mounting	Reversible
Metal used	Cast Aluminum
Average net weight	20 oz.
Average shipping weight	2 lbs.

The Type OP line includes 15 transformers and reactors designed to satisfy all usual requirements in portable amplifier equipment. All transformer types are \$16.50 list and reactor types are \$8.50 list. Standard trade discounts apply.

May we send our new 32-page audio bulletin which fully describes the complete AmerTran line of transformers?

AMERICAN TRANSFORMER COMPANY
Transformer Builders for More Than a Third of a Century

180 Emmet Street

Newark, N. J.



AMERTRAN TRANSFORMERS



"CINCH PROMPT DELIVERIES HAVE SAVED ME BOTH TIME AND MONEY."

"THAT'S RIGHT AND WITH THE OAK LINE WE'VE GOT MORE FEATURES TO OFFER."



ADDITION OF OAK ADDS SOCKET FEATURES

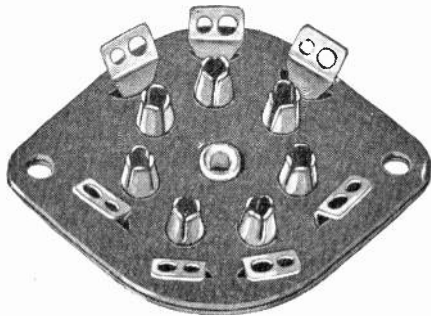

Model 33 showing 7 prong socket with No. 7 contact furnished in 4, 5, 6, and 7 prong types with full size bottom plates. Contacts designed to give utmost space between each mounting to prevent arcing and are of the "floating" type, original Cinch design.

and now **Oak** sockets are manufactured by Cinch—as well as, Oak terminal strips, dial light assemblies, screen grid caps and miscellaneous parts for the radio industry.

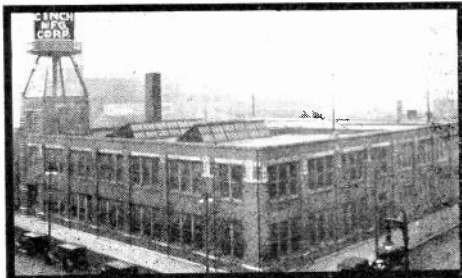

KEEPING abreast of the times with improved radio sockets—and keeping pace with the manufacturers' requirements—has put Cinch to the fore in popular use. And now with the Oak radio tube socket—and other miscellaneous parts for the radio industry—"we've got more features to offer." Cinch in acquiring the Oak rights to manufacture its sockets, terminal strips, dial light assemblies, screen grid caps, etc. has taken another forward step in the interest of those it serves.

Each day the Cinch policy, "your problems are our problems," is put to test. How easily and effectively, your problems will be met and solved, is proven in the steadily mounting demand upon the facilities of our organization. Take the example of how a plug, especially and quickly designed, "the size of a quarter" met the disagreeable situation of the engineer with the

standard size plug and no place to fit it.

And then another instance when there came the urgent request for a "plug button to fit a three-eighths hole" and how Cinch technicians avoided a costly production delay.

The quick and sure way these and many other problems have been solved recommends Cinch service.



CINCH

MANUFACTURING CORP.

2335 W. Van Buren St., Chicago, Ill.

Subsidiary of United-Carr Fastener Corp.
Cambridge, Mass.

Cinch and Oak Radio Sockets are licensed under H. H. Eby socket patents.



A better business man than his dad

THIS young man wants something. He wants it right now. And he knows that the quickest way to get it is to advertise that fact.

His dad wants *sales*. He'd like to have them *right now*, if possible. But instead of asking for orders with consistent, sales-producing advertising, he's waiting—waiting—waiting. Hoping that orders will come in of their own accord.

The pessimists are right when they say business hasn't picked up. It hasn't picked up *for them*. But their alert competitors

who are in the advertising pages asking for orders, opening doors for their salesmen, reminding their new prospects and old customers that they're still making a worthwhile product—*they'll tell you an entirely different story!*

Let the McGraw-Hill representative show you how really inexpensive it is to cover Industry's 12 major markets. A little money wisely spent in the right business papers will cover the responsive buying power throughout America's major markets. That's the way to *make* business better!

This series of "reason why" advertisements is being run to help advertising agents and advertising managers get appropriations OKed today.

McGRAW-HILL PUBLISHING COMPANY, Inc.

330 West 42nd Street, New York City

American Machinist
Aviation
Bus Transportation
Business Week

Chemical and Metallurgical
Engineering
Coal Age
Construction Methods
Electrical Merchandising

Electrical West
Electrical World
Electronics
Engineering and Mining
Journal

Engineering News-Record
Factory Management and
Maintenance
Food Industries
Metal & Mineral Markets

Power
Product Engineering
Radio Retailing
Textile World
Transit Journal

NEW A LITTLE VELOCITY

with uniform output!



Output uniform with speaker's head at any angle. Output level equal to large velocity (-88D.B.) Frequency response 60-7500 cycles. Reproduction lifelike. Eliminates audience noises. Transformer included within microphone case. Rugged construction. New chrome aluminum magnets used. Weight only 3 oz. Size 2 3/4 x 1 1/4 x 1 3/8. Write for Bulletin E.J.

AMPERITE Corporation 561 BROADWAY NEW YORK

7-POINT, Jr.

The Little Velocity by AMPERITE

ask
'em
for
more
details

OUR advertisers are really a very agreeable group — naturally, they can't always put into each advertisement all the details and information that readers want. But if you'll drop them a line, mentioning that you're a reader of *Electronics*, they'll be glad to tell you more about their products and plans.

PROFESSIONAL SERVICES

ELECTRICAL TESTING LABORATORIES

Characteristics and Life Tests of Vacuum Tubes
Tests of photocells, glow lamps, crater lamps.
Tests of electronic and optical devices.
80th Street and East End Avenue
New York, N. Y.
Phone: Butterfield 8-2600

JENKINS & ADAIR, INC.

Engineers
Designers, developers, and manufacturers of accessories and essentials for recording, broadcasting and testing at sound frequencies.
3333 Belmont Avenue, Chicago, U. S. A.
Cable Address: Jenkadair Telephone: Keystone 2130

PAUL G. WEILLER

Engineer
Consulting service, design and construction of special electronic timing devices, furnace controls, etc.
405 Lexington Ave., New York
Telephone, Van. 3-6226

PROFESSIONAL ASSISTANCE

in the solving of your most difficult problems in the highly specialized field of electronic devices is offered by consultants whose cards appear on this page.

"The Home Sweet Home Station"

RADIO STATION **W M B Q** SAYS:

Brooklyn, N. Y.

// We have been using the Bruno RV3 microphones along with units at more than twice its price and we are very well pleased with the results. We highly recommend the Bruno RV3 microphone as truly efficient in every respect.//

(signed) Paul J. Gollhofer, Chief Engineer

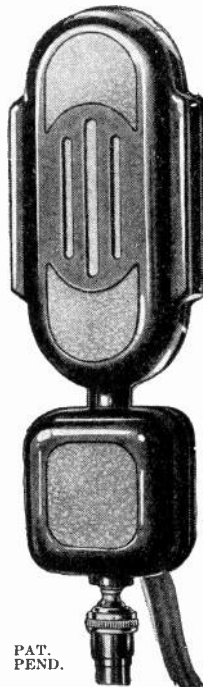

PAT. PEND.

RV 3 VELOCITY MICROPHONE

The above report is typical of the many we have received from broadcasting stations, recording studios, public address systems, etc. All are enthusiastic over the fine performance and remarkable fidelity of the RV3.

These reports lead us to believe that all claims made by Bruno for the characteristics of the RV3 are highly conservative. It also means that you can absolutely depend on the RV3 to meet or better the following guaranteed specifications:

Frequency response of 30 to 14,000 C.P.S.
Output level—69 db. (0 level — 6 m.w.)
High gain; highly directional; low feed back.

So accurate are the RV3's characteristics, that many industrial organizations use it not only as a microphone but also for the calibration of standards.

The Model RV3 features magnets of 36-42% Cobalt; pole shoes of specially treated ARMCO Alloy; ribbon of special Duralloy, specially treated and hand beaten to .0001 in.

For complete information ask for Bulletin Series "BD."

BRUNO LABORATORIES

22 W. 22nd St., New York City

Standardize

WITH

EBY

PATENTED

QUALITY

Binding Posts
Tip Jacks
Male Plugs
Female Plugs

Low-Loss Sockets
A-C Switches
Tap Switches
Terminal Strips
Short Wave Switches

Write for Latest Bulletin

HUGH H. EBY, Inc.

2066 Hunting Park Ave., PHILADELPHIA, PA.

DYNAMIC (Moving Coil) MICROPHONES

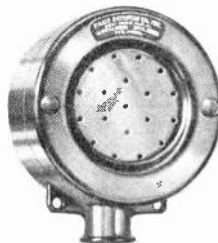

Models 6B, + 6C

GREATER SENSITIVITY

HIGHER FIDELITY

EXTREME RUGGEDNESS

LOWEST PRICE

\$33.00 AND UP

Information will be sent promptly on receipt of request on your own letter head.

RADIO RECEPTOR CO., INC. 108—7th Ave., N. Y. City
Established 1922

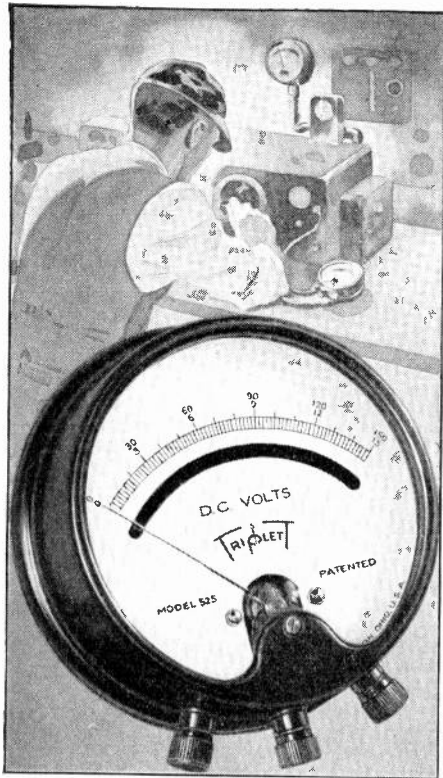

WHEN VERY ACCURATE MEASUREMENTS ARE REQUIRED

Specify **TRIPLETT**
5 INCH
Portable Instruments

LIKE the entire line of Triplett Portable Instruments, the Triplett 5-Inch Portable unit is invariably preferred by engineers, experimenters and laboratories where very accurate readings are vital. This instrument is accurate within 1%. Scales are hand drawn.

Triplett 5-inch Portable Instruments are furnished in all required ranges... with mirror scale and knife edge pointer! Marked binding posts on the lower edge of the Bakelite case afford easy lead connections. D.C. is D'Arsonval type; A.C. is the moving iron, repulsion type.

Compare this, or any other Triplett Instrument, on every essential: Advanced design... rugged, precision construction... and dependable, permanent accuracy. Prove their superiority... greater worth... and lasting satisfaction... for yourself.

Your Jobber Can Supply You

THE TRIPLETT ELECTRICAL INSTRUMENT CO.
135 Main St., Bluffton, Ohio

MAIL TODAY FOR DETAILS!

The Triplett Electrical Instrument Co.
135 Main St., Bluffton, Ohio

Send me the facts on Triplett 5-Inch Instruments.

Name

Address

City State

CONTENTS for MARCH, 1935

In the air!.....	71
Radio receiver and tube sales increase.....	72
Text of British television report.....	76
Work of Engineering Division of R.M.A.....	78
German television receivers.....	81
An electronic voltmeter for d-c arc welding.....	82
By W. RICHTER	
A universal network chart.....	84
An electronics laboratory for technical students....	86
By TRUMAN S. GRAY, Sc.D.	
Beat oscillators for modern radio receivers.....	88
By ARTHUR G. MANKE	
Highlights on electronic devices in industry.....	90
Generating sine waves with a gas discharge tube...	92
By WINSTON E. KOCK	
Notes on electron tubes and circuits.....	94
Editorials	96
A review of the electronic art.....	98
New products.....	101
U. S. patents.....	104
British patents	106

INDEX TO ADVERTISERS

This index is published as a convenience to the reader. Every care is taken to make it accurate but *Electronics* assumes no responsibility for errors or omissions.

	Page		Page
Acheson-Colloids Corp.	14	Parker-Kalon Corp.	19
Aerovox Corp.	14	Radio Receptor Co.....	23
Allen Bradley Co.	26	RCA Mfg. Co.....	11
American Electro Metal Co.....	16	RCA Radiotron Co.....	Back Cover
American Transformer Co.....	20	Remler Co., Ltd.....	10
Amperite Corp.	23	Shakeproof Lock Washer Co....	10
Automatic Elec. Co.....	8	Stackpole Carbon Co.....	18
Bakelite Corp.	7	Thomas & Skinner Steel Prod. Co.	16
Blakiston's Son & Co., P.....	14	Triplett Elec. Instr. Co.....	24
Bruno Lab's	23	Universal Microphone Co.....	16
Brush Development Co.....	10	Ward Leonard Elec. Co.....	20
Cinch Mfg. Corp.....	21	Western Electric Co.....	3
Continental Elec. Co.....	14	Weston Elec'l Instr. Co.	Inside Front Cover
Crowe Name Plate Mfg. Co.....	25	White Dental Mfg. Co., S. S.....	13
Dumont Labs., Allen B.....	12		
Eby, Inc., H. H.....	23	Professional Services	23
Eisler Eng. Co.....	16		
Erie Resistor Corp.....	2	SEARCHLIGHT SECTION	
Formica Insulation Co.	Inside Back Cover	Classified Advertising	
General Electric Co. (Textolite). 15		Employment	25
General Radio Co.....	12	EQUIPMENT FOR SALE	
Goat Radio Tube Parts, Inc.....	8	American Electrical Sales Co..	25
International Resistance Co.....	17	Eisler Engineering Co.....	25
Isolantite, Inc.	9	Kahle Engineering Co.....	25
King Laboratories	8	National Radio Tube Co.....	25
Magnavox Co.	1		
Mallory & Co., Inc., P. R.....	4		
McGraw-Hill Book Co.....	18		
Mica Insulator Co.....	12		

McGRAW-HILL PUBLISHING COMPANY, INC.,
330 WEST 42d STREET, NEW YORK, N. Y.

Branch Offices: 520 North Michigan Ave., Chicago; 883 Mission St., San Francisco; Aldwych House, Aldwych, London, W. C. 2; Washington; Philadelphia; Cleveland; Detroit; St. Louis; Boston; Greenville, S. C. James J. McGraw, Chairman of the Board; Malcolm Muir, President; James H. McGraw, Jr., Vice-President and Treasurer; Howard Ehrlich, Vice-President; B. R. Putnam, Secretary.

CROWE "MICROMASTER"

A highly successful development with exclusive features

PRECISION RECORDING CONTROLS FOR SHORT WAVE AND ULTRA SHORT WAVE RADIO RECEIVERS

A GAIN Crowe engineers have demonstrated their ability to advance the original in engineering and to increase precision and dependability.

The Micromaster has auxiliary pointer affording exact repeat indication of wave length. Stations however closely crowded may be accurately logged.

Fifteen patterns are now ready and others in course of preparation.

Scales are supplied in a wide variety and with different graduations or can be made to order to your calibration.

When fitted with 2-speed planetary drive, slow speed ratio 45 to 1; fast speed 9 to 1 in 360 degrees. Secondary pointer travels

18 times faster than double pointer.

New escutcheons are featured with either Croglas, synthetic crystal assembled on the escutcheon or convex glass crystal attached to the tuning unit with a snap ring.

Send for catalog and latest bulletins describing this new material, also other staple styles.

CROWE is also one of the oldest and largest manufacturers of Name Plates for any purpose.

WRITE FOR DETAILS.

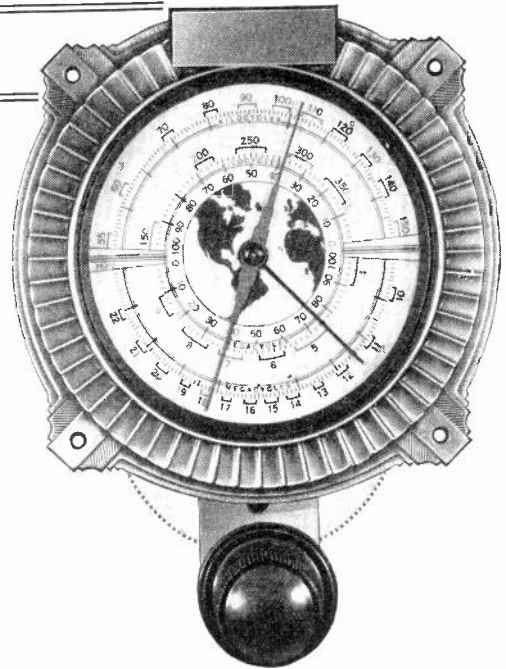

No. 192 *Micromaster*
One-Half Size—Escutcheon
No. 12590

CROWE NAME PLATE & MANUFACTURING CO.

1741 GRACE STREET, CHICAGO, ILL., U. S. A.

Searchlight Section

PATENT ATTORNEY

INVENTORS don't risk delay in protecting your ideas. Write for new FREE book "Patent Guide for the Inventor" and "Record of Invention" form. Prompt, careful, efficient service. My success built upon strength of satisfactory service to inventors located in every State in the Union. Clarence A. O'Brien, Registered Patent Attorney, 516-H Adams Building, Washington, D. C.

All types of High Grade New and Used Equipment for the manufacture of Electron Tubes.

Lowest prices on the market.

AMERICAN ELECTRICAL SALES CO.
65 East 8th St., New York, N. Y.
Cable Address: "AMELSACOMP-NEW YORK"

Reconditioning

of the Larger Type Transmitting Tubes is both Practical and Economical—we have Specialized in this work for many years and serve many Stations Regularly—Your Patronage is Also Invited.

NATIONAL RADIO TUBE CO.
INC.
3420-18th St. San Francisco, Calif.

Australian Merchant Visiting New York

The Principal of an Australian Distributing House with good credit rating will be visiting U.S.A. arriving San Francisco about 27th March.

He desires to establish contact with manufacturers (not already established in Australia) of—

Refrigerators, electric and non-electric. Radio, Accessories and Instruments (not receivers). Electric Domestic Appliances. Petrol and Air Gas Appliances and allied lines. Electrical Transcriptions and Recordings. Any other interesting or new lines.

Send full particulars to

"AUSTRALIAN MERCHANT"
care Thos. Cook & Son Ltd.

318 Stockton St., San Francisco
350 North Michigan Avenue, Chicago
587 Fifth Avenue, New York

Please write to whichever is the nearest to you of these 3 cities.

MARCH SPECIAL OFFER Tubular Furnaces

For

CARBONIZING, ANNEALING, DEGASIFYING, etc.
American Gas Furnace Co. No. 25

Complete on Stand with:

Nichrome Tube 3" o.d., 2" i.d. x 36". Water jacketed cooling chamber 19" long. Heating chamber 30" long.

Thoroughly Reconditioned Complete and Guaranteed

Special Price, \$125.00

(expires April 30, 1935)

(Only four of these on hand, subject to prior sale.)

Complete line of electrical furnaces, gas burners, vacuum pumps, and other equipment for use in the manufacture of electronic devices.

KAHLE ENGINEERING CORPORATION

350 MANHATTAN AVE.
UNION CITY, N. J.

EQUIPMENT

Air Blowers	NEW—RECONDITIONED	Flare
Vacuum Pumps	for making	Stem
Aspirators	ELECTRONIC TUBES, RADIO	Winding
Gas Boosters	TUBES, INCANDESCENT	Sealing
Spot Welders	LAMPS, NEON SIGNS	Exhaust
Gas Burners	AND SIMILAR PRODUCTS	Basing
Accessories		Machines

EISLER ENGINEERING CO.
751 So. 13th St., Newark, N. J.



The Type J Bradleyometer is made in two types: Type J is a volume control without line switch; Type JS with line switch. Both units are amazingly compact. The solid molded resistor never wears out—it never changes. The dependability is inherent.

A Compact Volume Control that is Unaffected by Wear and Extreme Humidity Changes

The small size of the new Type J Bradleyometer is creating much favorable comment among radio engineers. Never before has so reliable a volume control been made so small.

But, even more important than its small size, is the resistor construction which makes the Type J Bradleyometer impervious to moisture and, therefore, unaffected by wide changes in humidity. Hard service and long wear have no deteriorating effects upon the remarkable solid molded resistors of the Types J and JS Bradleyometers.

Since the Types J and JS units are interchangeable with others built to R. M. A. standards, every radio receiver can now be improved with these dependable volume controls. Every radio engineer should have technical data on these units. Write today.

ALLEN - BRADLEY COMPANY
110 W. Greenfield Avenue, Milwaukee, Wis.

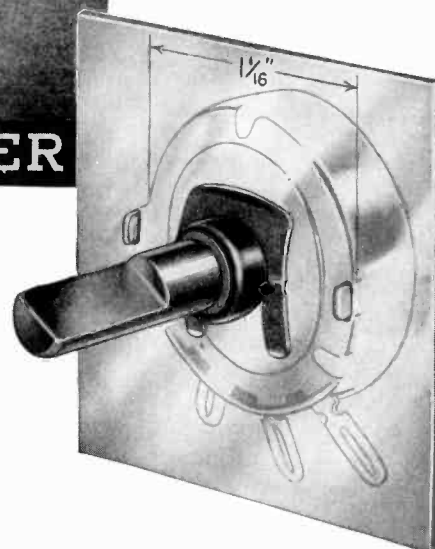

EASY TO MOUNT—The control is snapped into place on the panel with a C-washer. No threaded sleeves or nuts—no subsequent loosening.



A SOLID MOLDED RESISTOR—NOT A FILM-TYPE UNIT—The Type J resistor is homogeneous—in longitudinal section the material is varied to suit specified resistance-rotation curves. After molding, the unit cannot change. Hard service cannot alter its performance. Practically any resistance-rotation curve shape can be provided including straight logarithmic, modified logarithmic, or linear.

ALLEN-BRADLEY RADIO RESISTORS

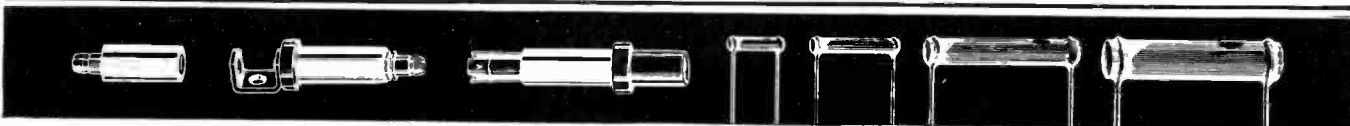

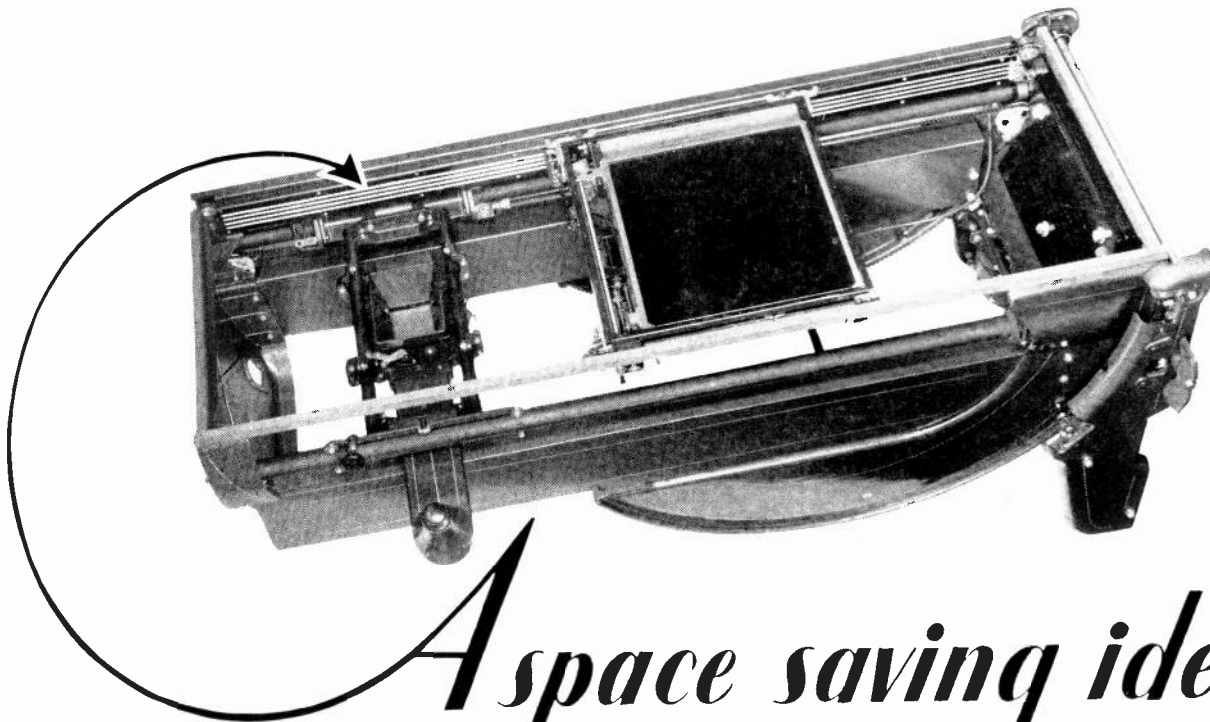

A space saving idea!

**METAL INLAYS
IN FORMICA
used for
CONDUCTORS**

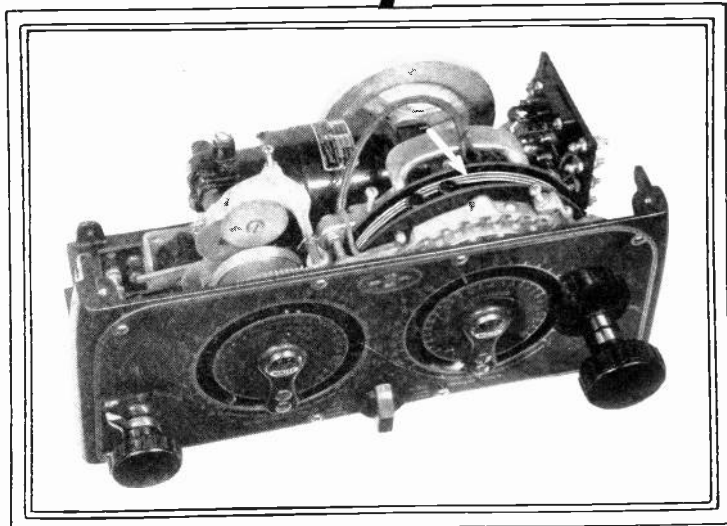

THE illustrations show how the Waite & Bartlett X-Ray Manufacturing Company of Cleveland are using Formica with metal inlays as a space saver, to carry current to moving contacts.

The Formica sheet is inlaid with a thin metal strip embedded in insulating material, and this strip acts as the conductor. On the X-Ray table it supplies current to the moving film holder. It not only saves space but supplies a type of conductor that will not be worn out by constant movement.

Space is at a premium behind the instrument panel shown in the lower picture and the conductor pressed into the Formica sheet makes more compact design possible.

Samples of Formica sheet with these pressed in conductors are yours on request.

FORMICA

THE FORMICA INSULATION CO.

4638 Spring Grove Avenue, Cincinnati, Ohio

V E R S A T I L E

D E P E N D A B L E

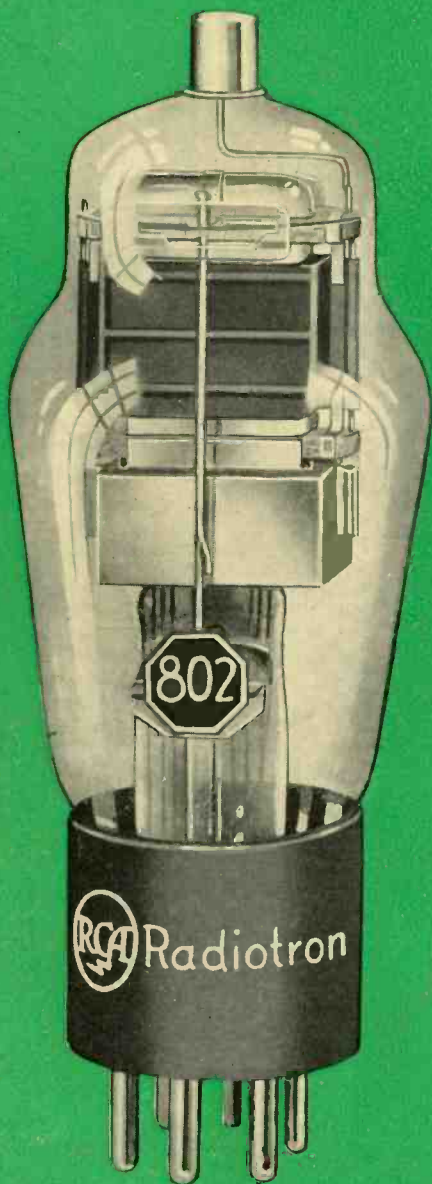

THE **NEW** **RCA-802**

R·F POWER PENTODE

Heater Voltage	6.3 volts
Heater Current	0.95 amperes
Maximum Plate Voltage	500 volts
Maximum Plate Dissipation	10 watts

RCA Radiotron is proud to introduce the new 802, which fills diversified needs for a moderate-powered pentode at a moderate price.

The applications of the RCA-802 are numerous. Some of the important uses which immediately suggest themselves are:

- (1) Straight pentode crystal oscillator
- (2) Electron-stream-coupled oscillator
- (3) Frequency multiplier (doubler, etc.)
- (4) Suppressor-modulated amplifier
- (5) Control-grid-modulated amplifier
- (6) Class C buffer-amplifier
- (7) Class C power amplifier

LIST PRICE \$3.90

Please send RCA-802 bulletin to:

Name _____

Street _____

City _____

Business Connection:

Dept. S



RADIOTRONS

RCA RADIOTRON DIVISION OF THE
RCA MANUFACTURING COMPANY, INC.
HARRISON NEW JERSEY

**For technical information on the
RCA-802 mail this coupon to RCA
Radiotron Division, Harrison, N. J.**