

# electronics

radio, sound, communications and industrial applications  
of electron tubes . . . design, engineering, manufacture

NBC's new  
Radio City  
studios

Broadcast  
system  
improvement

Remote radio  
control by the  
transmitter

IRE Fall  
Meeting report

New cathode ray  
tube design

Anodes of  
graphite



Master control board with  
pre-setting arrangements.  
New NBC studios, Radio City

McGRAW-HILL PUBLISHING COMPANY, INC.

Price 35 Cents

DECEMBER, 1933



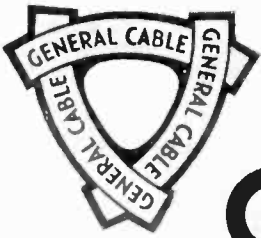

# CORD ASSEMBLIES

FOR CONSOLE,  
MANTEL, MIDGET  
AND  
AUTO RADIOS

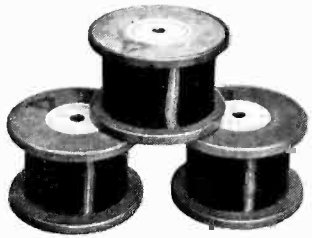
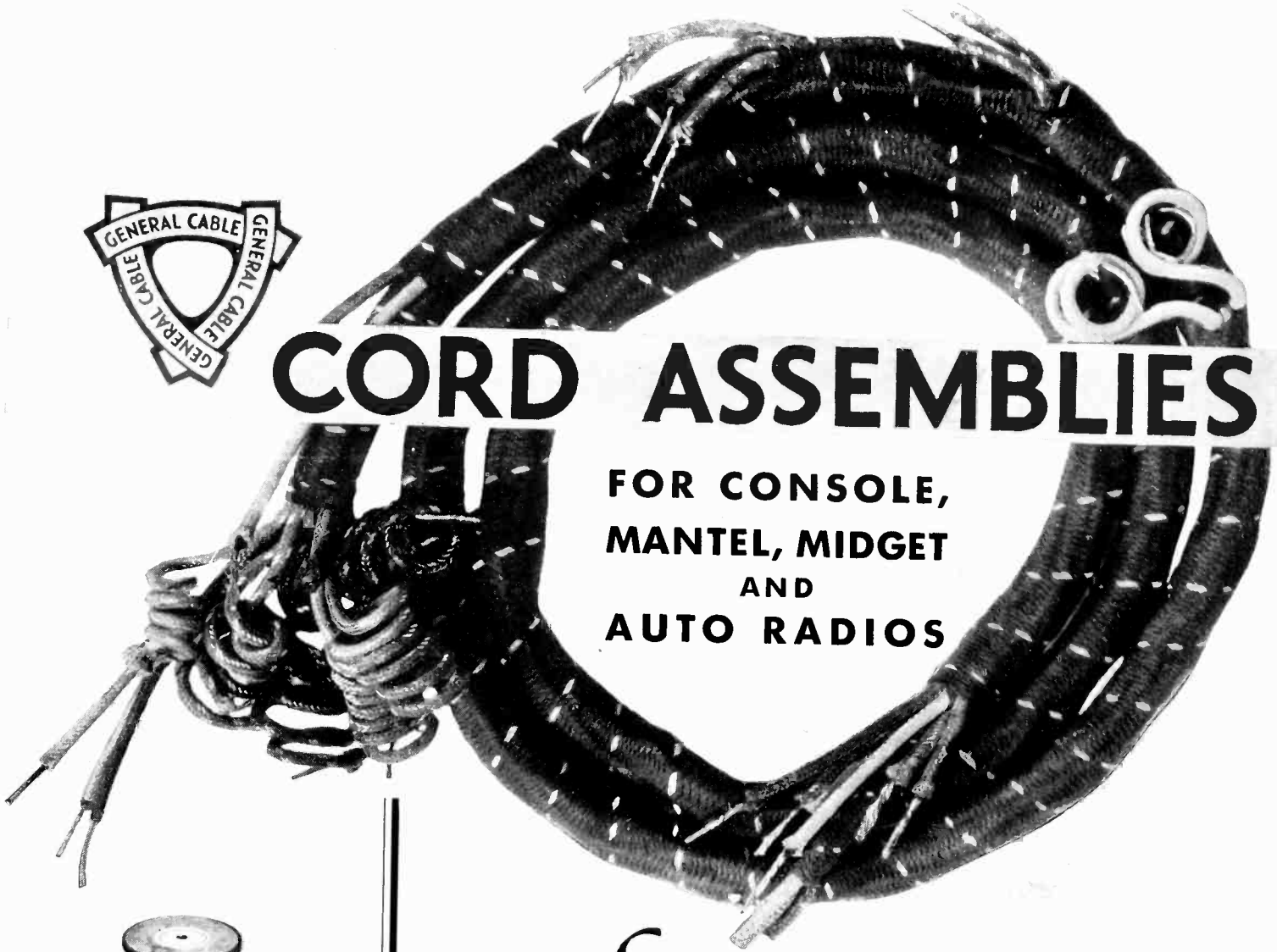

MAGNET  
WIRE

SQUARE  
FLAT OR  
ROUND

and COILS

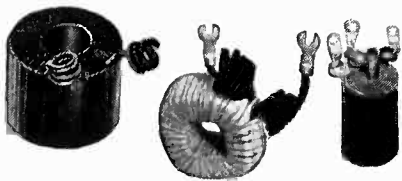

HOOK UP WIRE

Push back wire, antenna loops  
and other radio specialties.  
Profit by General Cable stand-  
ardized uniformity.

*...Engineered to the  
practical needs of service  
satisfaction...*

Take our auto radio power cable and speaker  
connection assemblies for instance: especially  
vibration resistant, fully shielded where necessary,  
and with that dead soft flexibility that makes  
a friend of the man who does the car installation  
... Here, as in all General Cable harness building,  
special inspection for soldering lug perfection aims  
to keep your assembly line moving like clockwork.

*Backed by the Service of*



**GENERAL CABLE CORPORATION**

420 LEXINGTON AVENUE, NEW YORK CITY • OFFICES IN PRINCIPAL CITIES

ELECTRONICS, December, 1933, Vol. 6, No. 12. Published monthly, price 35c. a copy. Subscription rates—United States, Mexico, and Central and South American countries, \$3.00 a year. Canada, including duty, \$3.50 a year. All other countries, \$4.00 a year or 16 shillings. Entered as second class matter April 4, 1930, at Post Office at New York, N. Y., under the Act of March 3rd, 1879. Printed in U. S. A. Cable address "McGrawhill, New York." Member of A.B.P. Member of A.B.C. Copyright 1933 by McGraw-Hill Publishing Co., Inc., 330 West 42d Street, New York, N. Y.

Printed by The Schweinler Press, N. Y.

# ✓ CHECK THESE POINTS

## ... when buying Cathode-Ray Tubes



### TYPES AVAILABLE

RCA - 903 — 9 inch screen. Electro-magnetic deflection.

LIST PRICE . . . \$120.00

RCA - 904 — 5 inch screen. Electro-static-magnetic deflection.

LIST PRICE . . . \$50.00

RCA - 905 — 5 inch screen. Electro-static deflection.

LIST PRICE . . . \$40.00

RCA - 906 — 3 inch screen. Electro-static deflection.

LIST PRICE . . . \$18.00

RCA-878—A high-voltage, high-vacuum rectifier.

LIST PRICE . . . \$11.00

RCA-885—A gaseous-type triode, suitable for sweep-circuit control.

LIST PRICE . . . \$2.00

## 1. QUALITY

RCA Cathode-Ray Tubes are manufactured to laboratory standards of precision. Comprehensive tests have demonstrated their excellent life performance.

## 2. AVAILABILITY FOR RENEWAL

The RCA Monogram is your assurance that these designs are standardized and will be available when required for renewal purposes.

RCA Radiotron Co., Inc., has recently announced four cathode-ray tubes of the hot-cathode, high-vacuum type, and two supplementary tubes for use with the cathode-ray tubes. These designs are the result of an intensive research and development program over a number of years and are carefully chosen to meet the diversified needs of oscillograph application.

### TECHNICAL INFORMATION AVAILABLE

Commercial Engineering Section,  
RCA Radiotron Co., Inc., Harrison, N. J.  
Please send me the newly prepared technical information on RCA cathode-ray tubes and supplementary types.

Name .....

Street .....

City ..... State .....



# RCA RADIOTRON CO., INC.

HARRISON      NEW JERSEY

*A Radio Corporation of America Subsidiary*

# Immediate Deliveries

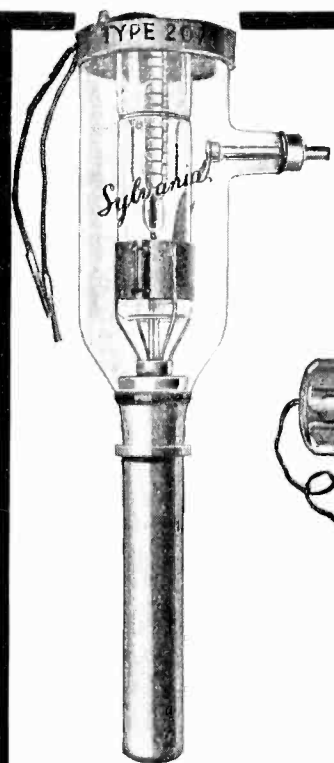

THE 207

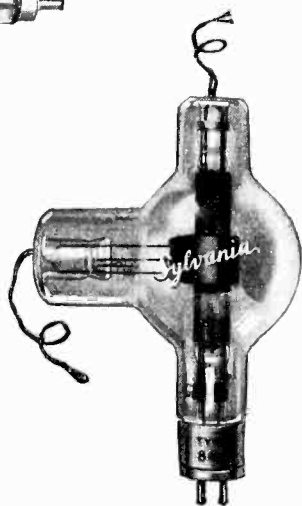

THE 860



THE 872A



THE 866

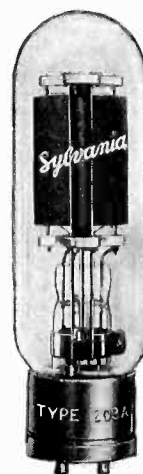

THE 203A



THE 865



THE 852



THE 849



THE 204A

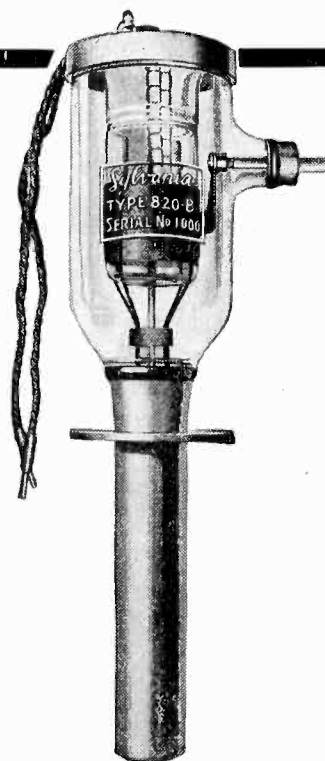

THE 820B



THE 851

ALL TYPES ILLUSTRATED IN STOCK AT THESE  
WAREHOUSE POINTS OR FACTORY:

PORTLAND, ORE.  
ATLANTA, GA.  
DENVER, COL.

CHICAGO, ILL.  
SALEM, MASS.  
DALLAS, TEX.

PHILADELPHIA, PA.  
PITTSBURGH, PA.  
LOS ANGELES, CAL.

*Sylvania*  
REGISTERED U. S. PAT. OFF.

## MODERN TRANSMITTING TUBES



THE 242A



THE 830

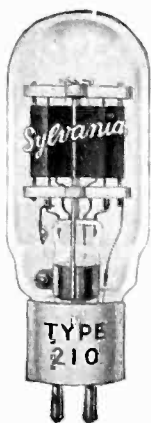

THE 210

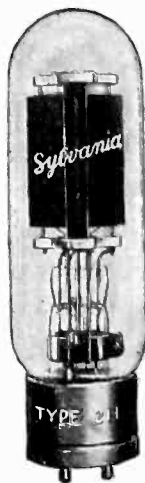

THE 211

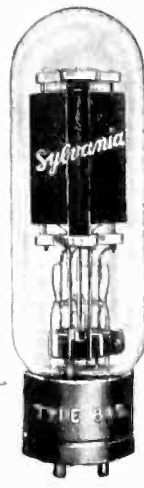

THE 845



THE 872

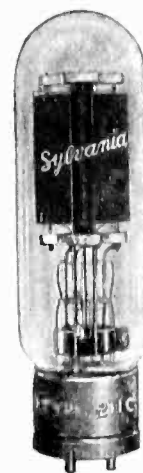

THE 211C

ALL SYLVANIA AIR-COOLED TYPES  
USE GRAPHITE ANODES



# HYGRADE SYLVANIA

*Hygrade Lamps*

# CORPORATION

*Sylvania Tubes*

## ELECTRONICS DEPARTMENT

CLIFTON, NEW JERSEY

FACTORIES:

SALEM, MASS.

EMPORIUM, PA.

ST. MARYS, PA.

CLIFTON, N. J.

# **YAXLEY** offers the largest and most complete line of switches available to the radio industry...

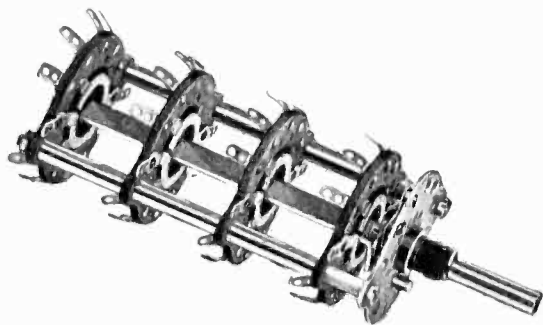

## **SHORT WAVE SWITCHES**

used by practically all manufacturers of popular 1933 receivers. Yaxley Short Wave Switches excel in flexibility in design and are particularly adaptable for all types of short wave work. They afford practically all circuit combinations and various arrangements of circuits.

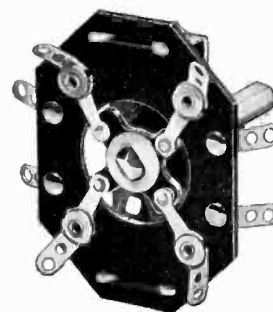

## **SELECTOR SWITCHES**

noted throughout the field for outstanding mechanical features.

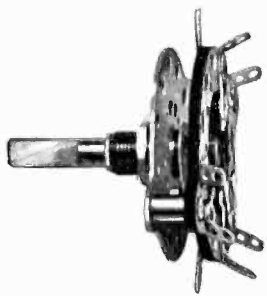

## **TAP SWITCHES**

for test equipment and laboratory purposes.

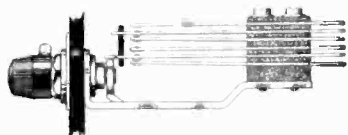

## **JACK SWITCHES**

in practically all combinations.



## **PUSH BUTTON SWITCHES**

of locking and non-locking types.

## **MULTIPLE POINT RECORDING SWITCHES**

for phonograph-radio and recording receivers.

**YAXLEY** will welcome the opportunity to co-operate in the development of the proper and most efficient switches for your new models

Executives of one large manufacturing organization recently said: "We intend to put all our switch problems up to Yaxley." We want you to feel the same way. Our engineers will gladly co-operate with your engineers at any time.



# **YAXLEY**

**YAXLEY MANUFACTURING CO.**  
INCORPORATED

# **MALLORY**

Division of P. R. Mallory & Co., Inc., INDIANAPOLIS, INDIANA

# electronics

O. H. CALDWELL  
*Editor*

KEITH HENNEY  
*Associate Editor*

McGRAW-HILL PUBLISHING COMPANY, INC.

New York, December, 1933



radio  
sound  
pictures  
telephony  
broadcasting  
telegraphy  
counting  
grading  
carrier  
systems  
beam  
transmission  
photo  
cells  
facsimile  
electric  
recording  
amplifiers  
phonographs  
measurements  
receivers  
therapeutics  
traffic  
control  
musical  
instruments  
machine  
control  
television  
metering  
analysis  
aviation  
metallurgy  
beacons  
compasses  
automatic  
processing  
crime  
detection  
geophysics

## The balance-sheet of

# TELEVISION

**I**S television ready for the public?

Put this question to the men who are in the center of television research and development today, and a wide variety of answers will be forthcoming.

Some say "Yes. Television is all ready for public exploitation." Others insist "No. Television is still in the laboratory stage. Some entirely new process will have to be discovered before television can become an entertainment art comparable even to home movies." So there you are. The experts disagree.

Let us put down the factors pro and con, in the television picture as 1934 approaches.

### *Discouraging*

Lack of detail in pictures  
High cost of television set  
Expense of tube replacements  
Small range of single transmitter  
Difficulty in "chaining" stations  
Tremendous studio expense  
Problem of who will pay for transmission

### *Encouraging*

New cathode-ray pick-up devices  
Improved cathode-ray televisior tubes  
Increased intensity of illumination  
Large projected pictures  
Wide band transmissible by new conductors (2,000,000 cycles)  
Possibility of outdoor news scenes  
Developments in ultra-short-wave apparatus

**H**ERE is much evidence of progress—yet also this testimony falls short of proving that commercial television may be expected in 1934 or 1935.

But the men who know are talking television more optimistically than ever before, and where there is such an increasing volume of smoke, there must be fire. Television may have some surprises for the conservatives before another twelve months roll around, so the television optimists insist.

# NBC'S NEW STUDIOS

Master control board; pre-set switching;  
16,000-cycle circuits; dial monitoring

**T**HE world's largest and finest radio-broadcasting studios are now in operation at Radio City, New York. Built by the National Broadcasting Company at an outlay of five million dollars, they incorporate many novel features of design and arrangement, in addition to their sheer size and completeness.

Thirty-five studios of various sizes are provided, of which sixteen went into operation in November; eleven others are yet to be electrically equipped, and eight more will be installed in the unfinished floors. The mammoth three-story auditorium studio measures 78 by 132 feet and seats 1600 people. Another large theater studio is equipped with opera chairs, stage, and a sound-insulating glass curtain which slides in from the wings, in sections. A unique four-unit "clover-leaf" studio group, provides four studios served by a central operating room glassed in on all sides. Suitable for eventual television productions, this studio group has immediate application for carrying out the English practice of setting up a broadcast with the vocalist, orchestra, speakers, etc., in different sound-proof quarters, and combining them at different levels to produce the desired ensemble effect. Several of the studios also have controllable acoustics in the form of motor-operated panels and curtains, which can be manipulated from the corresponding studio control-rooms to produce any degree of sound reflection in any part of the room.

In the general layout of the new Radio City studios, attention was given to the four different kinds of per-

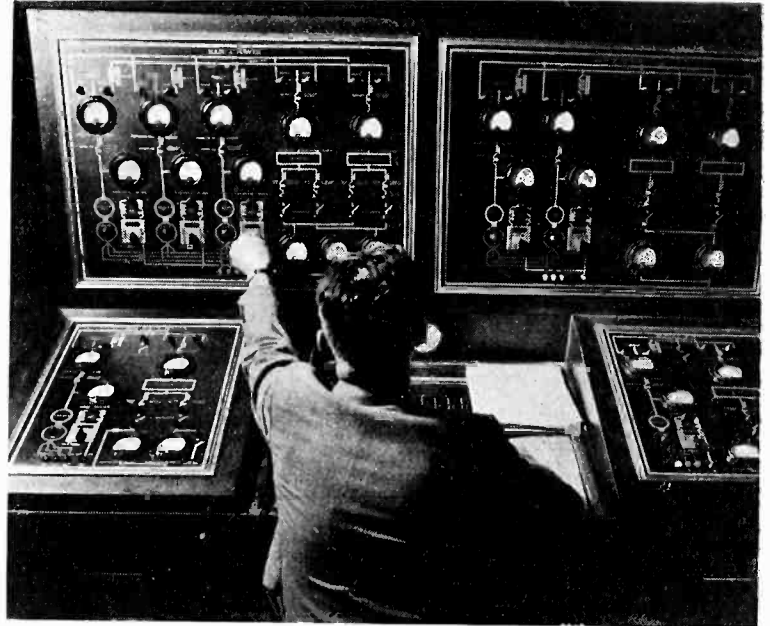

The power control desk for the new studios. Small lamps show which circuits and machines are energized

sonnel traffic which move through a large broadcast studio group:

1. The artists, speakers, performers, musicians.
2. The operating staff, announcers, production men, engineers, servicemen, etc.
3. Audiences invited to witness broadcasts.
4. Sightseers or "tourists" (who now pay 40 cents apiece to be conducted through the studios).

Accordingly the Radio City studios are so arranged that entirely separate channels and corridors are provided for these classes of traffic, so that they do not come into contact with each other. Thus there are reception rooms and lobbies for the performers and speakers, opening into the studios; while the operating staff reach the studios through corridors that interconnect with the offices. Meanwhile the public can be admitted to the large auditorium studios, and "tourists" can be conveyed through the building without directly contacting any of the working quarters, except through observation windows.

Sandwiched in between the several studio floors is the operating floor with its master control board, where are centered the operations of all interconnections between studios and lines. With two operating positions and a monitoring position, this great master control board provides for the pre-setting of connections in any combination in advance. Then at the moment of program changeover, pressure on a single button causes all the former connections to drop out and the new ones to be automatically established. This switchover can be performed from the announcer's position or from the master control board itself. A number of advance circuit arrangements can be pre-set if desired, and then

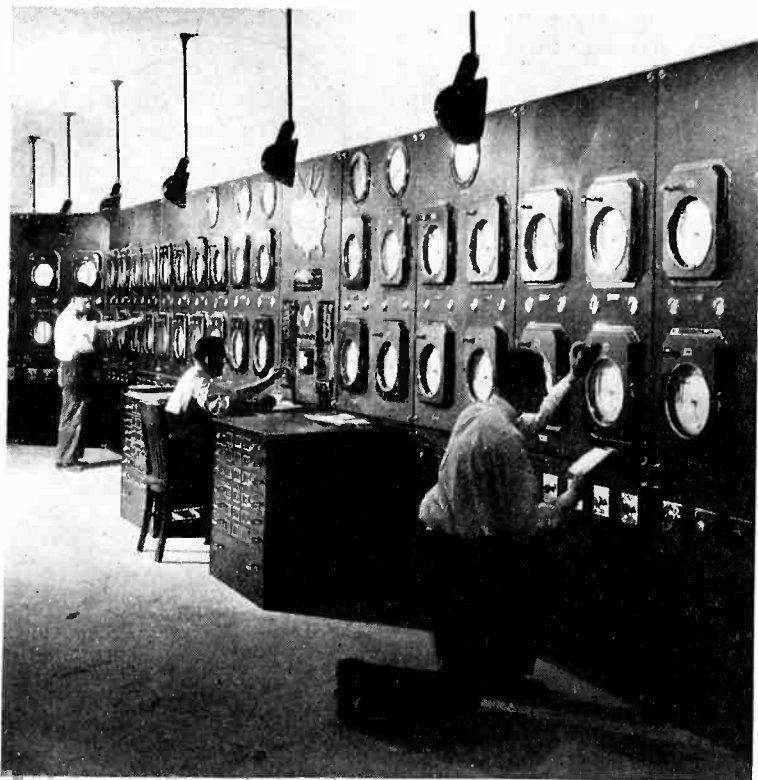

The recording thermostats for the sixty-four units of the air-conditioning system which handles 20 million cubic feet of air per hour



# IN RADIO CITY

Sound-proofing; movable acoustic panels;  
air conditioning; multiple traffic lanes

operated in succession, although ordinarily only the circuits for the following program are set up during any ordinary operating period. The elaborate flexibility of this master control scheme makes it possible to have separate studio programs feeding into the two local stations WEA and WJZ, while other studios are feeding the Red and Blue networks, and still others are transmitting auditions to out-of-town telephone circuits.

Coupled with this circuit control is the dial-controlled monitoring system operating loudspeakers in all operation centers and offices, some 120 in number. By dialing, in the same way that an automatic telephone is used, any of these offices or control rooms may listen in on any studio or audition room, on either chain, on either local NBC station direct, or on any of the principal metropolitan stations through special broadcast receivers taking their input from the air.

The necessity for the large number of studios to be installed at Radio City (35) is explained when it is realized that for every hour on the air, about seven hours of studio preparation and rehearsal are required. With two networks to keep in continuous operation, and with two local stations which sometimes have separate non-network programs, a multiplicity of studio facilities is needed. Furthermore, a variety of studio sizes must be available for the various rehearsals.

The studios contain outlets for 250 microphone connections, giving wide flexibility of microphone placement. Three-quarters of the "mikes" used are of the new velocity type, the remainder being condenser microphones. All of the circuit equipment will transmit a

full band from 30 cycles to 16,000 cycles. The loudspeakers in the control-rooms and offices reproduce up to 10,000 cycles, which may be later extended by special high-frequency units.

Some 1250 miles of wire is used in the studios alone, cut into 10,000,000 pieces, involving 20,000,000 soldered connections. Six hundred union electricians were required to complete the installation.

Elaborate precautions against the leakage of outside sound into studios, have been taken by soundproofing and acoustically treating the corridors and lobbies, the ducts for the air-conditioning system, and the vestibules between the pairs of soundproof doors entering each studio. The studios are built like "boxes within boxes," separate rooms within separate rooms, raised from the building floors by steel springs covered with felt. The studio walls make use of several inches of rockwool covered by perforated transite, which in turn is covered with decorative fabrics applied by sound-insulating glue. There are 150,000 square feet of this sound-insulating board, backed by 500,000 pounds of rockwool.

The acoustic and structural separation between studios and control rooms made it necessary to construct special triple plate glass observation windows. As many of the panes are too large to be removed for cleaning, the two intervening air-spaces between the three panes of plate-glass are hermetically sealed. To compensate for changes in barometric pressure, which would impose many tons of strain on the glass panes, a special system of valve inlets, with dustproof filters has been provided, which admit air to the internal spaces, but keep it free



A massed orchestra of 400 musicians playing in the huge auditorium studio which measures 78 by 132 feet, and seats 1,600. Three other studios each measure 50 by 80 ft. or larger

of dirt. The observation windows alone employed 8,500 sq. ft. of plate glass.

The air-conditioning plant is capable of handling 20 million cubic feet of air per hour, which completely changes the air in every studio once each eight minutes. The air-conditioning plant is built in sixty-four units, each self-controlled by a registering thermostat. All feed and exhaust air-ducts are lined and coated with rock-wool to absorb transient sounds. Stream-lined grills have been employed to reduce wind sounds to a minimum, and the air-ducts are connected to the inner studio walls by canvas hose to prevent transmission of vibrations to or from studios. The cooling tanks for the air-conditioning system are mounted on the roof of the studio section of the building.

Provision for future television broadcasting in the NBC studios, is seen in the use of special direct-current circuits for all studio lighting, although all the rest of the Radio City group is served with the usual 60-cycle alternating current. Such 60-cycle flicker would cause interference with television scanning, so direct current was used throughout the studios.

The special flush type of lighting unit used in the new studios and lobbies deserves particular notice. Prismatic glass panels control the spread of the light, to deliver uniform intensity on the working plane, and the effect is that of cheerful sunshine streaming from the ceilings, but without glare from exposed surfaces. The illumination is entirely utilitarian, no decorative color effects being attempted in the new installation.

The eight special elevators in the bank serving the NBC studios, are equipped with photo-cell safety door control, as are the fifty other elevators in the RCA building. Two beams of light projected across the threshold of each car, shine on photo-cells. If any passenger's body or clothing projects across the car doorway, intercepting

either of these beams, the door will not close and the car will not start. Even if a passenger attempts to jump between the closing doors, his interception of the light-beam will effect instant reversal of the door mechanism, opening the doors wide, automatically, and preventing any possible accident.

Every care has been taken to insure the continued operation of the studio equipment in the face of accident. For example, the interconnecting-rack room on the operating floor to which are brought all circuits from the control board, studios, relay panels, etc., is built as an air-tight enclosure, provided with automatic carbon-dioxide guns, which in case of fire fill the room with inert gas, smothering out any fire.

In the same way, storage-battery protection is afforded against interruption of power supply. The battery capacity will take care of all operating needs for forty-eight hours, supplying both the 400-volt B battery and the 14-volt A bus.

The electrical and audio equipment for the new Radio City studios is estimated to have cost about two million dollars. For the sound-insulation and acoustic treatment, air conditioning, etc., another two millions were expended. Thus with a million dollars for the eleven-story steel structure housing the studios, the total investment comes to about five millions.

The RCA Victor Company, Camden, N. J., built the electrical, radio and audio equipment. Power apparatus was furnished by the General Electric and Westinghouse companies. The Johns-Manville Company supplied the acoustic material, and Carrier Engineering Company, the air-conditioning apparatus.

The design and installation of the studios was carried out under the supervision of O. B. Hanson, engineer in charge of operation for the National Broadcasting Company.

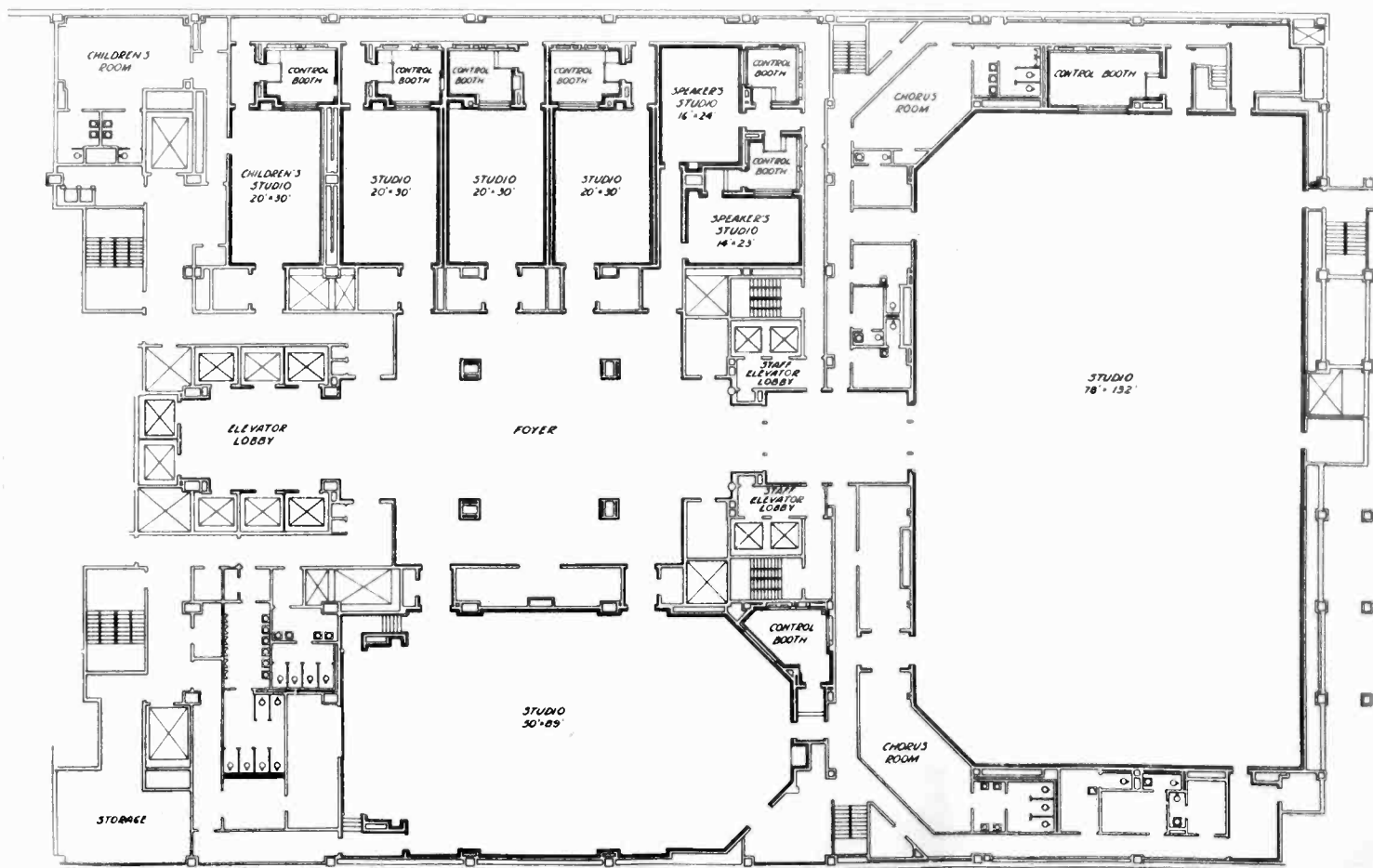

Typical studio floor layout, showing the central lobbies for performers and members of audiences; also the outer corridors by which the NBC operating staff can reach all studios and control rooms

# Controlling receivers

## from the broadcast transmitter

---

---

**T**HE desirability of some means of controlling the operation of home receiving sets from the broadcast transmitter, so as to ring a bell, light lamps, turn on the set itself, or perform some other operation, was pointed out editorially in *Electronics* for August, page 227. At that time we said:

### Why not a signal bell to call the radio listener?

Each day striking news events are inserted into the broadcast programs, changing the routine schedules. Yet unless the listener has his own radio set continuously tuned in, he misses these most thrilling features of the radio day.

Every telephone is provided with a bell to attract the user's attention. Without a bell, a telephone would be only 50 per cent as useful.

Yet the average radio receiver is like a telephone without a bell.

The listener misses some of the best things on the air, because he has no way of being notified. If there were some way of calling him to his radio set by means of a bell or a signal light, he would be able to enjoy special features. And so the public's appreciation of broadcasting generally would go up.

A low-frequency control tone on the station's carrier-wave, inaudible to the ear, but capable of operating a signal relay, might be one way to do the job.

Such a service would help popularize radio and bring the public to realize more fully the wonderful things the broadcasters provide.

Other services besides ringing a bell or lighting a lamp to summon the broadcast listener, might be performed in the same way. For example, the radio set could turn itself on to full volume when the impulse came from the broadcast transmitter.

Or by a series of tuned relays, one of a row of colored lamps might be lighted, indicating visually what kind of program was at the moment playing in the silent set—say green for dance music, purple for symphonies, yellow for children's stories, and red for political speeches!

In fact, the listener might arrange to push a button under any one of these or other headings, and then at the first program of the kind he ordered, the set would turn itself on.

Learning that engineers of the Sparks-Withington Company, Jackson, Mich., have been carrying on some experiments of this kind, in connection with the Point O' Purchase Broadcasting System, Inc., Union Guardian Building, Detroit, Mich., Captain William Sparks, president of the Sparks-Withington Company, was asked for a statement and has supplied the following report of the tests being carried on by his company.

"A radio receiver which automatically picks out the desired type of program or remains quiet until such a program comes on the air, whether it is news, market re-

ports, weather, comedy or a favorite dance orchestra, has been discussed as being a possibility of the future.

"The practicality of such a system has recently been demonstrated in a series of tests in conjunction with transmitters CKLW at Windsor, Ontario, and WABC at New York City. These tests showed that it was perfectly possible to start and stop a receiver from the transmitter without interfering with the program or producing any audible disturbance in other receivers.

"Inaudible low frequencies modulating the carrier of the transmitter at a minus 17 to minus 20 db. level were used to actuate relays in the receiver. Of course, it was necessary that that part of the receiver up to the relays be in operation at all times, only the power tubes and loudspeaker being placed in and out of operation due to the action of the relays.

"Several engineering problems had to be solved and a great many tests were run before correct operation of all the components parts could be realized. Modulating frequencies between 25 and 40 cycles were used at the transmitter. It was found that the studio-to-transmitter lines and amplifiers of most broadcasting stations are not equipped to handle these frequencies satisfactorily, and it was, therefore, necessary to place the low frequency generator directly at the transmitter.

"It was found that a separation of  $1\frac{1}{2}$  cycles between actuating frequencies was all that was required from a selectivity standpoint to operate the desired relay.

"It was at first believed that static or low frequencies of music, particularly the pipe organ, might actuate the relays since such low-level modulation at these frequencies would cause the relays to operate.

"Alloy steel reeds tuned to the different frequencies gave the required selectivity, and were equipped with contacts so that during the course of vibration a secondary circuit was closed and large amounts of power could be controlled. Selectivity of the reeds automatically produced a time delay action which prevented static and low musical notes from causing them to vibrate with sufficient intensity to close their contacts. An overloading device was provided which prevented more than a given amount of energy to be impressed upon the reeds, thereby preventing them from being shock excited sufficiently to cause operation.

"The frequency generator at the transmitter consisted primarily of toothed steel discs driven by a synchronous motor between magnetic pickups in such a manner that the teeth varied the magnetic circuit and induced the tooth frequency into the windings. Suitable electrical filters were used to keep the output free from audible harmonics of the generated frequency. Variations in the 60-cycle supply voltage frequency were, of course, reflected directly as variations in the output frequencies of the generator. However, these were found to be of an entirely tolerable magnitude.

"The receiver relay operation was smooth and completely satisfactory on signal levels between 60 microvolts and 750,000 microvolts at the receiver antenna without change or adjustment of the receiver or relays for the varying signal strengths.

"Tests over WABC were conducted during the middle of the day and during commercial programs. However, it is doubtful if anyone in the vast audience of this large transmitter other than those at the special receiver many miles away were aware that anything out of the ordinary was going on. During 'dead air' the best radio receiver would not produce an audible sound from such low level, low frequency modulation."

# RECENT ADVANCES

## IRE, RMA, NAB discuss improvement in broadcast transmission and reception

**N**OVEMBER, just closed, proved to be a busy and important month for the technical portion of the radio industry. At a well attended meeting of the New York Section of the IRE on Nov. 8, Stuart Ballantine of Boonton Research Corporation, read a paper on "High Quality Broadcast Transmission and Reception," presenting the results of a systematic two-year experimental study of the entire radio broadcast system, from microphone to loudspeaker sound field. The weaknesses of the current system were pointed out by Mr. Ballantine and definite remedies suggested in each case. The various points were clearly illustrated by a rather elaborate audible demonstration, using program material broadcast by the Columbia Broadcasting System especially for the meeting.

Almost immediately afterward the annual Fall Meeting of the Rochester Section of the IRE took place, and the subject of how to improve the entire broadcast system from microphone to loudspeaker was discussed again and, it is hoped, with some ultimate effect.

At the New York IRE meeting Mr. Ballantine, in considering the transmitting end of the system, showed wave response curves of thirty microphones of six different commercial types and presented figures showing the pro-

portions of the various types used in stations operated by the two chains. He stated that the microphone was responsible for considerable frequency distortion and one of the first steps in the improvement of the transmitting system should consist in the replacement of the older types, such as the carbon and condenser. Other defects requiring improvement are non-linearity of the modula-

### WHAT IS WRONG WITH BROADCASTING?

Lack of power to over-ride noise

Hum on transmitters; over-modulation

Bad microphones, or poor technique

Narrow frequency spacing between stations

Skipped response of average receiver

Amplifier, detector, speaker distortion

### SELECTIVITY OF MODERN RECEIVERS

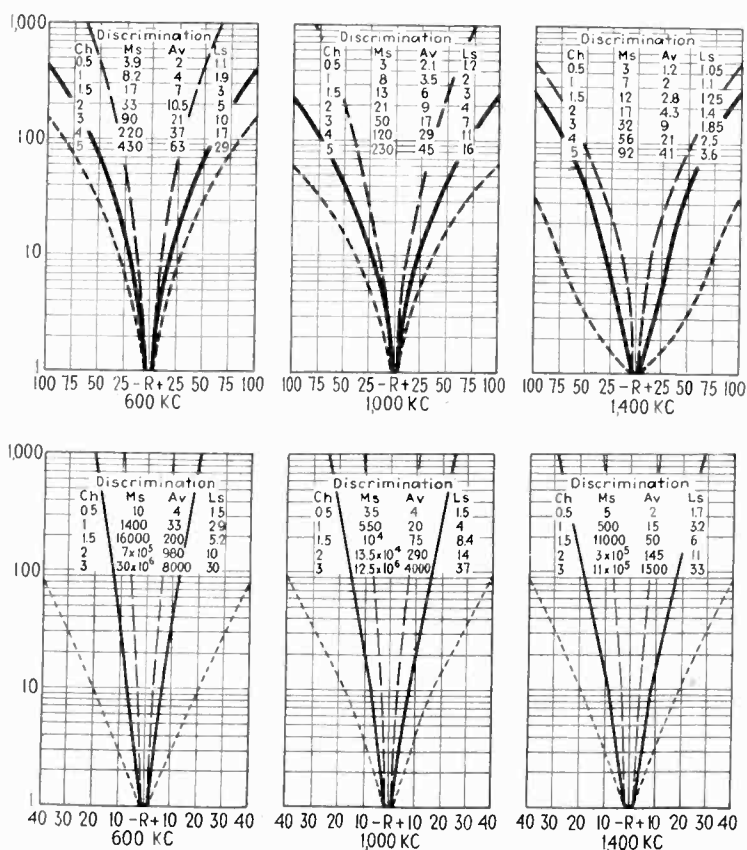

At the top are curves on TRF, supers at bottom. Maximum, average and least selectivity is shown as well as the discrimination for signals in various channels

tion characteristic, more careful monitoring to prevent over-modulation, elimination of noise, studio technique and microphone placement. The present inadequate monitoring loudspeakers used in the studios should be replaced by high-fidelity types. Mr. Ballantine also described a new automatic monitor for the prevention of over-modulation.

On the receiving side the importance of overall measurements of receivers from antenna to sound field was emphasized. The special problems associated with high-fidelity reception were discussed. Practical solutions of these problems have been incorporated in two high-fidelity receivers which have been developed in the Boonton laboratories. Among the special appliances are: anti-"monkey-chatter" filters, microphone compensators, automatic audio range control, compensator for the effect of placing the receiver in different positions in an average living room. Mr. Ballantine also emphasized the importance of regarding the room as part of the loudspeaker and showed some interesting sound-pressure records, taken with an automatic recorder, which brought out the effects of the room and of placing the receiver in rooms of different sizes and shapes.

For the demonstration a high-quality line (equalized to approximately 15,000 cycles) was run from the CBS studios on Madison Avenue to the auditorium. A special musical program, exhibiting a wide range in pitch and volume, was picked up in the CBS studios by means of a new crystal microphone having a uniform response (within 3 db) up to 15,000 cycles.

# IN THE RADIO ART

## Fall Meeting papers reveal progress in television, radio receivers, components

By means of a high-fidelity receiver tuned to WABC it was possible to compare the direct high-quality pickup through the line with the same program after being broadcast and returned to the auditorium via radio. The speaker expressed his belief that a fully equalized system good to 7,000 cycles, as represented by the radio reception from WABC, would deliver sufficient fidelity of response

### IMPROVED PROSPECT FOR HIGH FIDELITY RECEPTION

Recent events point toward a better forging of weak links in the broadcast system. These are: open discussion of present defects; demand for higher power, better transmission; suggested assignment of 20-kc. channels outside present band; interest of Edison Association in receiver safety and performance standards.

to satisfy the most critical, although the difference between this quality and full range reproduction can be recognized on direct comparison. Mr. Ballantine also showed the effect of listening to a program that had been passed through 2,000 miles of wire line. To do this he had looped back to the meeting the complete New York-Chicago-Southern Circuit of the Columbia Broadcasting System. The slight loss in high frequencies and the time delay effects were distinctly audible.

A very convincing demonstration of the distortion caused by microphones was made by switching in the studio between the crystal microphone and a commercial type of microphone in current studio use. The 10 db. rise in response above 2,000 cycles with the ordinary microphone was clearly audible.

The crackling and distortion produced by over-modulation was next demonstrated by means of a low-powered transmitter installed on the stage and modulated by the material arriving over the wire line.

One of the most interesting new devices described by the speaker was an automatic volume range compressor and expander. By means of these devices a 70 db. volume range can be automatically compressed to 35 db. for wire line transmission and automatically expanded at the other end to the original 70 db. range. Application of this technique to wide volume range and quiet phonograph recording were mentioned.

The subject of improvements to the broadcast system came up again at Rochester as the result of a paper by

Dr. A. N. Goldsmith on the conditions necessary for an increase in usable receiver fidelity. Here a number of fundamental weaknesses of the present system were pointed out and some others were added. To the fault of insufficient power to override static and noise, it was pointed out at Rochester that the level of performance attained by the better known broadcast stations was far above the average level and that the a-c hum on many carriers was making it difficult to sell receivers with good low frequency response. Measurements on stations indicated that in some cases the hum modulation amounted to several per cent of the carrier power. In general, this type of distortion is not difficult or expensive to remedy.

At a meeting of the receiver committee of the RMA Engineering Section at Rochester it was pointed out that Canada had applied to Berne for frequency assignments in the region between the present broadcast band and the ship-to-shore band (545 to 600 meters) and above the present broadcast band as well—that is the region between 1500 and 1600 kc. It was suggested that as an experiment on high fidelity broadcasting, the Federal Radio Commission and Canada give assignments for stations for these bands in 20-kc. intervals thus permitting a station to transmit 7500 cycles and leave a guard band between stations.

If such an experiment permitted radio receivers to operate successfully with a flat characteristic up to 7000

### SUPER VERSUS TRF SENSITIVITY

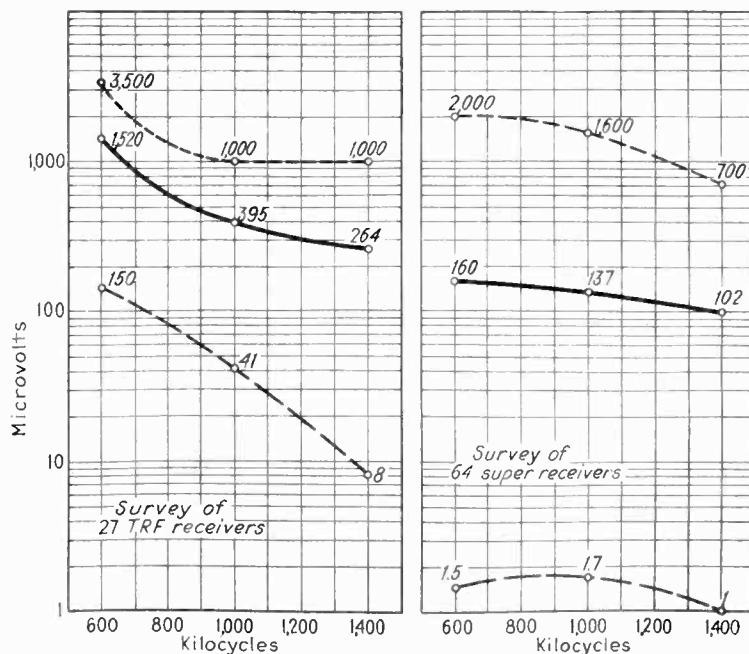

A survey of 1932-1933 receivers made for NAB, IRE, and RMA gives these sensitivity data

cycles, or higher, a precedent could be set for future extensions of the broadcast band or for a future allocation of the present channels.

At the Rochester meeting, Mr. Fred Williams, president of the RMA, pointed out to the engineers that he had long advocated the development of some visual or audible tests which a dealer could use to demonstrate clearly to a prospective customer the merits of a good receiver compared to a poor one. Engineers have felt that such tests were most difficult to make so long as it was not possible to make a receiver that was definitely superior to cheaper sets. So long as the set must cut off sharply at 5000 cycles to avoid beat note reception, and must actually cut off much before this limit to avoid crackle caused by bad modulation at the transmitter and the disturbances due to atmospherics, it is not possible to demonstrate the virtue of the high fidelity set.

If, however, a dealer could offer a radio with the fidelity and wide band demonstrated by Mr. Ballantine, and desired by all radio engineers, the argument in favor of better receivers would be won conclusively. In Mr. Williams' opinion, the advancement of the broadcast system advocated by the IRE and RMA engineers would enable a dealer to prove to his customer the skimmed quality of a skimmed price and sized receiver.

As a result of the interest shown in this subject, Dr. Goldsmith was invited to lay before the board of directors of the RMA a plan for an orderly and progressive improvement of the system. In this endeavor Dr. Goldsmith will have the aid and encouragement of the technical members of the entire industry.

Another favorable event leading to an ultimate betterment of radio receivers is the interest shown by the Association of Edison Illuminating Companies in setting standards of receiver safety and performance.

Now that the utilities are getting service calls on defective radio receivers, the Association feels it must set minimum standards for such apparatus so that its membership will be guided as to the merchandise it will offer for sale and which they will service. Electrical Testing Laboratories will set the standards, test the receivers and make lists of approved equipment.

Such standards set by an organization not interested in manufacturing radio receivers should aid in protecting the public from the shoddy and dangerous merchandise offered in quantities during the past several years.

Cooperation between this group and the RMA Standards Section might be utilized by the latter group to educate the utilities in necessity for the elimination of the

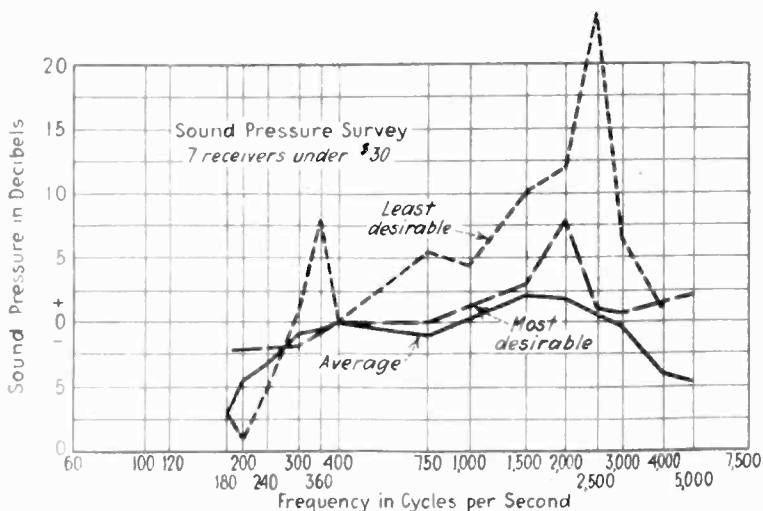

Narrow range plus non-uniform response marks the cheap, small receiver

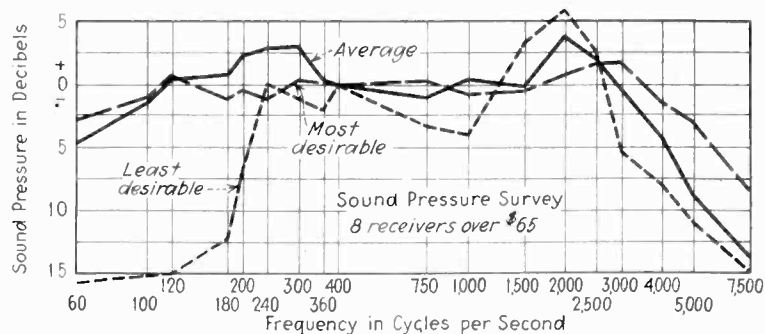

Wide-range response of the more expensive receivers

man-made static which now makes impossible the sale of high fidelity receivers except to listeners very near powerful stations.

### The Rochester papers

Among other papers presented at the Fall Meeting was a résumé by Roger Wise, chief radio engineer, Hygrade Sylvania of the improvements in tubes occurring within the past year. Mr. Wise pointed out that the mutual conductance of present type tubes was materially higher than those of a year or so ago, the average being nearer 1500 micromhos compared to the older figure of 1000. This improvement resulted from the use of better cathodes, smaller spacing and better mechanical jobs. The plate voltage limits have been increased in the case of many tubes with resultant increase in power output. Tubes which were designed for 180-volt operation are now rated at a maximum of 250 or even 300 volts. Bulb temperature and wattage dissipation had been doubled in recent years. Research on new metals and new insulators has improved the tube not only in characteristic but in life expectancy.

Tubes have been developed which will stand considerable voltage overload. For example, the first heater type tubes were sensitive to voltage variation and much trouble was experienced in locations where the line voltage varied through even fairly narrow limits. Now tubes will withstand terrific overloads. The 6.3-volt series is a good example. These tubes have good life even on 8.5 volts and in some laboratories are consistently life-tested at this voltage.

Cathode operating temperature has been reduced with corresponding increase in life. According to Mr. Wise, the power expended was formerly of the order of 25 watts per square inch of cathode area. This has been successively reduced to 18 and in some cases to 12 and 15 watts per sq.in.

Leakage currents are only 10 per cent of those experienced before circuits were devised which put a high voltage between cathode and heater. Grid and gas currents have been decreased, both factors which have improved the tube at considerable expense on the part of the tube manufacturer.

### Dynamic detection

Running true to form, Kenneth Jarvis of Zenith Radio, got off the beaten path and disclosed new and most interesting possibilities. Readers will remember that at the Fall Meeting of 1932 (See *Electronics*, December, 1932, page 368) Mr. Jarvis suggested that additional services be put in broadcast receivers, possibly operated from the broadcast station by utilizing the frequency between the carrier and the lowest audio frequency used, say between zero and 40 cycles.

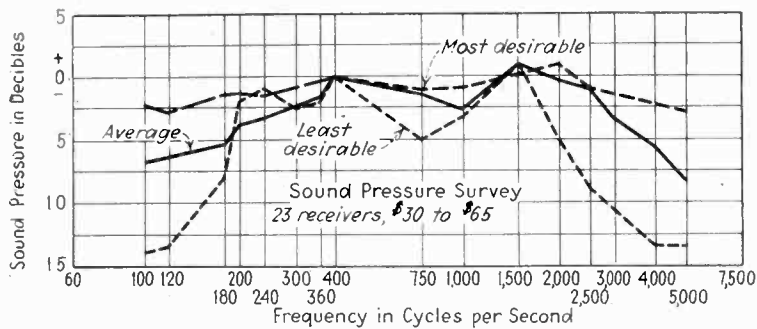

**Average priced receivers have reasonable fidelity as this NAB survey shows**

At the same time Mr. Jarvis discussed the possibility of a detector which would not only tolerate overmodulation but might enjoy it. At this year's meeting he disclosed to some extent the work he has done in this direction. He indicated how a fading carrier could be brought back to its proper strength at the receiver and thus eliminate some of the distortion resulting from selective fading.

In connection with the additional service idea, it is worth noting that facsimile systems have been developed which could get their impulses from a broadcast station without interference to the regular program, or during the night hours when the musical programs are not on the air with the result that a facsimile newspaper could be delivered to every home. The cost of such systems available at the present time is low; the quality good enough to show cartoons or advertising in addition to type.

### Receiver control from transmitter

An experiment in using the band of frequencies between the carrier and the lower limit of the audio spectrum has been tried in the Middle West. This is a system for turning on a radio set by a signal emitted by the broadcast station. This signal would be inaudible, appearing in the band below the lower limit of audibility and of very low level. This experiment (see this issue of *Electronics*, page 327) has many applications, as can be seen from the original experiment, verifying Mr. Jarvis' prognostications of a year ago.

Since these lower audio frequency circuits can be made very selective it may not be too much to expect several services in this nether audio region. Perhaps the future will see radios equipped with various buttons which, when pushed, will automatically set the receiver for the first jazz (or speech) program that comes along. Thus many of the impromptu programs of wide national or local importance which come on the air and disappear, unheard, would be called to the attention of the set owner, automatically.

Mr. Ralph Langley has suggested that a time clock in the radio could turn on the set automatically for fifteen seconds, or so, at the beginning of each quarter hour period. The set would turn itself off if the listener did not desire the program to continue. Therefore, if the broadcast station had an important message it would be delivered in this 15-second interval; the listener would hold the program as long as desired.

By this automatic system the listener would push the button for the type of program desired; when it came along the set would be turned on from the broadcast station and would continue for fifteen seconds unless the listener desired to hear the remainder of the program.

Two papers which attracted considerable attention from the engineers in attendance were given by I. G.

Maloff, RCA Victor, on television and by William S. Barden and David Grimes, RCA License Laboratory, on super-regenerative circuits. Because these papers are being prepared for publication in *Electronics*, they will not be reported in detail at the moment. Little of quantitative nature has been published on the super-regenerator since Major Armstrong's original disclosure in the *Proceedings of the IRE* in 1922. Therefore this paper giving quantitative data on the amplification possible, methods of control, the effect of varying the quenching frequency, etc., was given close attention.

The super-regenerator is a circuit of great importance now that stations are being located in the region below 10 meters wavelength. The Bayonne, N. J., police radio system installed by Radio Engineering Laboratories uses this circuit successfully on eight meters (approximately), and it is safe to assume that its use will grow rapidly.

The paper by I. G. Maloff on television problems focussed attention to the fact that the paucity of details regarding progress in the television art gives the impression that little is being done to advance the day when television will aid in bringing radio out of the red. This lack of progress is only apparent; progress continues at a rapid rate considering the tremendous problems.

Mr. Maloff's paper will be reported in greater detail in a future issue of *Electronics*. It will outline some of the problems of modulating the beam of a cathode ray tube, give concrete examples of types of tubes to be used, the amount of power necessary and methods of solution of several other important problems.

Mr. Maloff indicated that because of the difference between horizontal and vertical resolution, the band width actually required for a high-fidelity picture would not be so great as was once thought.

It seems, therefore, that the technical details of television are not too far from solution. The terminal equipment, although expensive, would become much cheaper with a volume market. On this score many pessimists still doubt the ability of a cathode ray picture to hold the attention of an audience. It may be said that many thousands of listeners follow a football game or other event with great attention; certainly the addition of sight would not detract from such entertainment.

Modern cathode ray tubes (see page 332 this issue of *Electronics*) are large in size, have great brilliance of image, are capable of a finely detailed picture, and have a long life. At present they are very expensive considered as instruments for the home, but these prices would come down if they could be made in thousand lots.

At the meeting of the television committee (RMA) a recommendation was made that the RMA encourage the Federal Radio Commission to open the band between 42 and 110 Mc. to television.

### Automobile interference problems

An excellent presentation of the entire problem of ignition interference to broadcast programs either to radios in the car or near highways was given at the Fall Meeting by L. F. Curtis, United American Bosch. The virtues of proper filtering, of shielding, and use of clean spark plugs came from the paper and from the later discussion. It was pointed out that high test gas using lead tetraethyl breaks down into various products some of which deposit on the spark gaps and lower the resistance appreciably. This lowering of resistance makes the spark suppressors installed in the car interfere with the proper functioning of the car at some speeds.

# Cathode ray tubes for oscillograph purposes

By C. W. TAYLOR, L. B. HEADRICK and  
R. T. ORTH

RCA Radiotron, Inc.,  
Harrison, N. J.

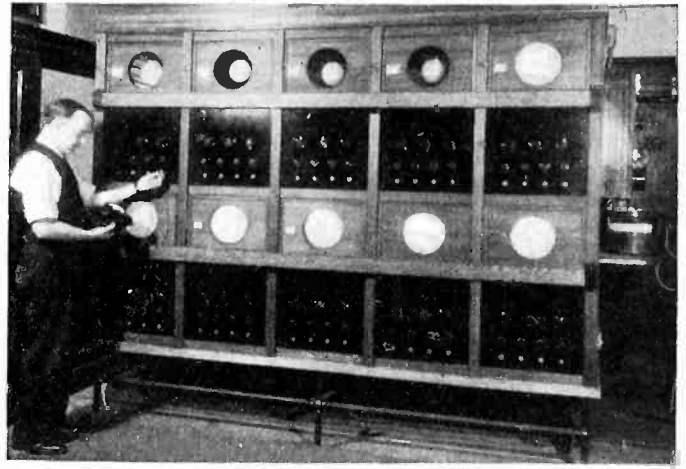

A battery of cathode ray tubes on life test

THE field of application of cathode ray oscillographs is daily being enlarged to include new uses in laboratory measurements and industrial engineering study. The common faults of cathode ray tubes have been short life, non-uniformity, insufficient brilliance of pattern, poor control of brilliance, and most of the tubes required critical adjustment and were awkward.

In studying the above difficulties, it was apparent that the choice between a high vacuum tube and an inert-gas filled tube should be given first consideration. In a gas-

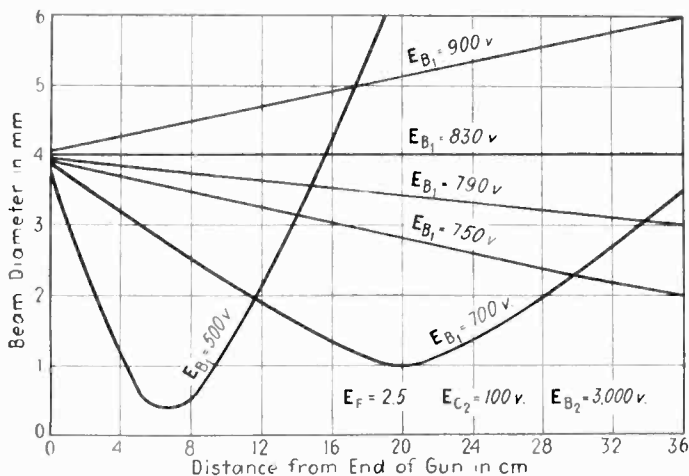

Focussing effect of the second anode voltage

filled tube, positive ion bombardment of the oxide-coated cathode shortens the life of the tube considerably. It should be mentioned also that the oxide-coated cathode is desirable because of its low-operating temperature, which reduces the possibility of any light from that source conflicting with the fluorescent pattern.

By evacuating the tube to a pressure of about  $10^{-5}$  mm. mercury, a relatively high vacuum results in which positive ion bombardment of the cathode is minimized. Gas filling presupposes the use of the gas as a focusing means to confine the beam to a narrow pencil of electrons. While the exact mechanism of gas concentration is not yet clearly understood, a review of the action has recently been given by von Ardenne.<sup>1</sup> The determining

factors, however, in forming a gas concentrated electron beam are quite clearly understood, and are outlined by E. Bruche<sup>2 & 3</sup>, as determined by the kind of gas, gas pressure, current strength, and the construction of the accelerating electrodes and the strength of the resulting field. To obtain focus in a particular tube, therefore, it is necessary to adjust the current to its critical value for the particular operating voltage conditions. This makes it difficult to control the light intensity. Again, it is difficult to manufacture gas-filled tubes because of the small amount of gas necessary to obtain gas focusing (of the order of  $10^{-3}$  mm. Hg), and because of this small amount of gas it is also difficult to keep the pressure of gas from changing during life, due to loss or addition from the glass walls or metal parts. All of these difficulties lead to the choice of a high vacuum tube. Here, however, the addition of a focusing mechanism is necessary to take the place of the gas concentration.

Either magnetic or electrostatic fields or both may be used to focus the beam of electrons to a small spot. The theory of magnetic concentration has been developed by H. Busch<sup>4 & 5</sup> and Thibaud.<sup>6</sup> The theory of electrostatic focusing has been outlined by V. K. Zworykin<sup>7</sup>; papers describing experimental work have been published by Knoll and Ruska<sup>8</sup>. To focus fast-moving electrons magnetically requires considerable power in the magnetic coil which is placed coaxially around the tube neck. Therefore it is often desirable to use electrostatic focusing, which is dependent almost solely on the ratio of voltages applied to two of the electrodes.

## Methods of deflecting the beam

The beam of electrons as accelerated out of the electron gun and focused on the screen may be deflected either by magnetic or electrostatic fields. To move the spot vertically and horizontally over the screen, it is necessary to apply two fields whose forces are at right angles. These separately applied fields of force may be magnetic, or electrostatic, or a combination of the two. It is possible to deflect in both directions magnetically with the fields applied at the same point along the electron trajectory. It is, however, more difficult to obtain a distortionless pattern with electrostatic deflection in both directions when the fields are applied at the same point, but it is quite simple to deflect first in one direction and then the other by displacing the deflection plates along the length of the bulb neck. The combination of electrostatic deflection in one direction and magnetic deflection in the other direction is often best when it is highly necessary to eliminate distortion. In combining the two methods of deflection, both fields may be applied at the



same point along the electron trajectory without any trouble from interaction between the fields. The advantages of such methods are that both the deflection plates and magnetic poles may be made small, and yet the fields are practically uniform for maximum deflection in any direction. From the tube standpoint, other effects should be mentioned in considering the modes of deflection which include spot size, defocusing of spot under deflection, distortion of pattern, and the deflection sensitivity of the tube at the operating conditions for the frequency under study.

Since these considerations are from a tube manufacturing standpoint only and since there are many secondary effects involved, they will not be discussed here. However, it is well to consider the types of deflection from an application standpoint. Electromagnetic deflection is practical up to the frequencies of  $10^4$  cycles. Electrostatic deflection is the best and simplest when frequencies above  $10^4$  cycles are being studied. However, if ultra-high frequencies of the order of magnitude of  $3 \times 10^9$  cycles are being measured, even the deflection plates may give difficulty, due to a very high frequency being applied to a relatively slowly moving electron beam. The result may be phase distortion or low or even zero deflection sensitivity. The design of a good magnetic circuit to give deflection in both directions without spot, pattern, or wave shape distortion, is difficult. Most any simple magnetic circuit may be used, however, to give good deflection in one direction, taking the usual precautions in designing any magnetic yoke with regard to soft iron and laminations and uniform field shape. In most applications, the frequency may be applied to the deflection plates and the lower-frequency timing wave may be applied through the magnets.

We shall now consider the gun. The cathode is oxide coated and of the unipotential type, heated by a non-inductive heater coil. It is surrounded by a control electrode or No. 1 grid. The amount of current drawn from the cathode is determined by the negative bias on this grid. A nominal positive potential on the No. 2 grid, or accelerating electrode, gives the emitted electrons their initial acceleration toward the screen. The field shape in this region also tends to bring the beam to focus. However, the main focusing field is between the No. 1 and No. 2 anode. The No. 2 anode is the high voltage electrode which gives the electrons their final energy for producing fluorescence of the screen. For focus, the No. 1 anode is run at between  $\frac{1}{4}$  and  $\frac{1}{5}$  of the positive potential on the high voltage electrode. For a particular gun structure, the ratio of anode voltages for focus remains constant independent of their magnitude. Briefly, the path of the electrons from cathode to fluorescent screens is initially convergent through the control electrode, passing through a focus in the region of the accelerating electrode. From here, they diverge to the main focusing field, where they are again made to converge, but this time at a point on the fluorescent screen. Those electrons which are too divergent to be focused by the main focus field are stopped by a beam-defining aperture in the No. 1 anode. In some gun structures, the accelerating electrode is omitted, and in this case, the No. 1 anode provides the initial accelerating and focusing field for the electron beam.<sup>9</sup>

The following general facts and data on high vacuum, electrostatically focused cathode ray tubes employing willemite screens may be of value to those contemplating their use:

1. All tubes should be shielded from extraneous fields,

such as the earth's magnetic field, which may cause deflection of the spot away from the axis of the tube. An iron or steel box open at one end, through which the bulb screen may project, is usually sufficient. This box should be electrically connected to ground.

2. The tube may be operated either with the cathode grounded and the No. 2 anode and deflection plates above ground, or with the latter grounded and the cathode and other electrodes below ground. If operated with the cathode below ground potential, care should be exercised in insulating the heater from ground as well as the other gun electrodes.

3. Since the size of a focused spot is almost directly proportional to the square root of the current in the beam, where extremely accurate measurements are being made it is well to reduce the beam current to the minimum, depending upon requirements of pattern brilliance.

4. The screen brilliance is affected by the fluorescent screen efficiency and by watts input to the screen. Since the light output increases with No. 2 anode voltage, it would seem wise to run this potential up to the maximum rating for the tube; from the standpoint of deflection sensitivity, however, the reverse is true and a compromise must be effected.

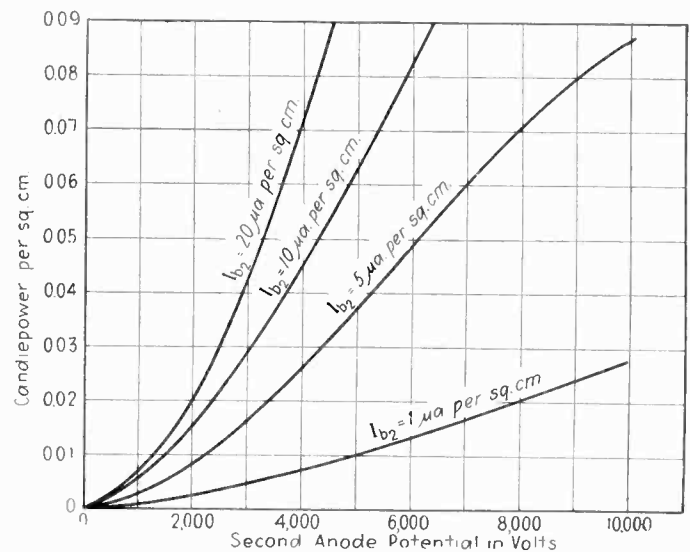

Average fluorescent screen characteristics

5. Electrostatic deflection sensitivity for a particular pair of deflection plates is inversely proportional to the No. 2 anode potential. The sensitivity is usually expressed in mm. deflection of the spot on the screen per volt impressed across the deflection plates.

6. Magnetic deflection sensitivity for a particular tube with a particular magnetic circuit is inversely proportional to the square root of the No. 2 anode potential. The magnetic deflection sensitivity is usually expressed in mm. deflection of the spot on the screen per gauss of magnetic field intensity. Since magnetic deflection sensitivity is dependent upon the external magnetic circuit and its position along the neck of the tube, the following expression is given to aid in the design and placing of the magnetic circuit:

$$\text{Magnetic Sensitivity} = \frac{d}{H} = \sqrt{\frac{e}{2E_{b2}m}} \left( X_1 X_2 + \frac{X_1^2}{2} \right)$$

$d$  = deflection in centimeters

$H$  = deflection field intensity in gauss

$X_1$  = length of pole pieces in cms

$X_2$  = distance from poles to screen in cms

$E_{b2}$  = second anode potential in stat-volts (1 stat volt = 300 practical volts)

[Please turn to page 339]

# HIGH LIGHTS ON ELECTRONIC

## Skylights controlled for uniform illumination

THE NEW FEDERAL POST OFFICE at High Point, N. C., is equipped with skylight louvres which are motor-controlled from photocells so that a uniform intensity of light is maintained throughout the day, on the working plane in the mail-sorting room, in spite of changes in natural lighting or the position of the sun.

The principal photocell unit is located on the roof, facing north, and serves to open the louvres wide as long as there is light in the sky. Other photocells control the banks of shutters, to deliver uniform intensity in front of the sorting racks. The installation has not yet been turned over by the contractors, and full information is not available. It seems likely from the improved working conditions obtained by photocells in this installation, that similar light-controlled shutters may be installed in many other post offices throughout the country.

## Amplified voice of law makes motorists beware

BY DR. E. E. FREE

HOW RADIO HAS PROVIDED a "loud voice of the law" in Wichita, Kansas, to supplement its proverbial long arm is described by Mr. Harry Barsantee in a recent announcement of the National Safety Council, of Chicago. In one of the Wichita police trucks Police Lieutenant Ray Ashworth has mounted a microphone, an amplifier and a powerful loudspeaker. The microphone hangs just beside the officer driving the truck, so that whatever he speaks into it may be boomed out with the voice of a thousand traffic officers from the loudspeaker atop the truck. Persons attempting to cross the street contrary to traffic regulations, motorists about to make a wrong turn at a corner, truck drivers preparing to park illegally and similar would-be violators of regulations are likely at any moment to hear a stentorian voice call their attention and the attention of every bystander within a block or two, to the errors about to be committed. The officer in the police truck, cruising somewhere in the neighborhood, has noticed what was about to happen and has spoken the necessary warning into his microphone. Mr. Barsantee reports that results have been most salutary not only in stopping the individual violations thus called to

public attention but in making all users of the streets more careful for fear that the accusing voice of the law is somewhere about. At fires, parades and similar occasions the outfit also has proved its value in handling crowds issuing instructions to officers and the like.

## A photo-cell thermometer

THE ACCOMPANYING SKETCH illustrates an application of a photo-cell extending an idea which appeared in the March, 1933, issue of *Electronics*. Two beams of light instead of one are employed in this apparatus.

Such a split-beam is useful in experimental work where the temperature change between two points is to be timed with a stop watch. When the

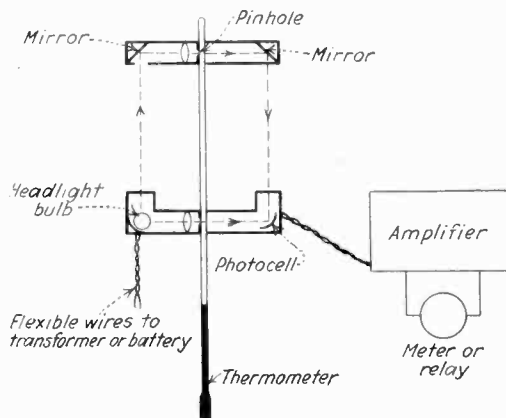

A double light-beam method of noting thermometer changes for accurate timing

mercury column intercepts the first beam, the pointer of the meter will deflect; when it passes through the second beam the pointer will deflect still further; to zero, if the cell is connected in the usual manner. It is more convenient to watch the meter for the decreases in the current than it is to decide with the eye when the mercury column passes a given point, even though a lens may be used.

Referring to the drawing, we see that there are two light heads on the thermometer. The lower one houses an intense source of light, which in this case is a double-filament headlight bulb, tilted so the maximum amount of light will be transmitted to the photo-cell which is housed in the same unit. Both filaments of the bulb are used at the same time. The photo-cell is also tilted to receive both of the beams of light, one through a pinhole, similar to the pinhole in the upper light unit, and the other by the reflected route.

The upper light head merely guides the vertical ray of light through the

second pinhole. Both light units are adjustable up and down. The meter may be replaced by a relay to enable the apparatus to be used as a thermostatic control. The relay may be used also to actuate a clockwork timer, in case the time of the passage of the mercury column between the two light beams is excessively long.

If the thermometer be replaced by a liquid gauge containing a suitable float, the split beam system may be used to regulate the levels of liquids. Once the apparatus is in use, other applications will suggest themselves.

## Light levels demonstrated by sound changes

IN CONNECTION WITH HIS LOCAL campaign for better lighting, J. E. North, manager of the Electrical League of Cleveland, wanted some way to demonstrate changes in lighting levels when different sizes of lamps are switched on.

The volume level of a radio set was finally selected as the means of showing this change. Accordingly a photocell was installed in the light of the lamps to be demonstrated. This photocell controls a relay which switches the radio set on loud or soft.

With a 25-watt lamp turned on, the radio set plays faintly and indistinctly, and it is pointed out that reading by such a light is similarly unsatisfactory. But when a 100-watt lamp is lighted, the increased light flux causes the photocell to switch on the radio receiver to loud clear tones, with every instrument clearly heard, comparable to the clear, distinct and easy vision possible with plenty of light.

Visitors to the Electrical League's showrooms in the Builders Exchange Building, Cleveland, can thus switch the lamps high or low, and observe how the radio music instantly follows in volume and clearness.

## Photo cells dependable over long service

FRED J. BROWN of the lighting service department of the Syracuse (N. Y.) Lighting Company, reports that for the past three to four years his organization has had three photocell control units in continuous service—two to control the illumination of gas holders and the third to turn on a flood-lighting installation. "Our experience has been almost perfect on these applications," reports Mr. Brown.

# DEVICES IN INDUSTRY + +

## Rectifier tubes supply Boston direct-current system

ELECTRONIC TUBES, HAVING NO MOVING parts, have replaced larger and bulkier rotating machinery for rectifying alternating current into direct current, in a substation of the Edison Electric Illuminating Company, Boston. Silent operation, high efficiency, and economy in floor space are made possible by the equipment.

The installation in the Salem Street substation, in downtown Boston. The equipment, designed and built by the General Electric Company, makes use of six Phanotron tubes. The electric energy from the power company's system enters the substation as 13,800-volt, three-phase, 60-cycle current, and is changed into direct current at 238 volts. The energy thus transformed is delivered to the distribution cables to supply residences, office buildings and stores.

At any point where it may be desired to establish a connecting link between the alternating current supply and the direct current distribution system, such a rectifier offers a compact, automatic substation in itself. Investment in real estate for substations, a serious consideration in congested business districts, may be greatly reduced, if not eliminated altogether. The small space required, coupled with absence of noise and vibration, sometimes objectionable characteristics of rotating equipment,

will permit these installations to be made in places heretofore not available.

The tubes now operating at Salem Street employ a metal type of construction, in that the cathodes are enclosed within a cylindrical shell of copper, thus reducing the use of glass to a minimum and resulting in a sturdy powerful tube capable of withstanding the shocks of service conditions.

Such rectifier equipment is applicable in connection with Edison three-wire systems, and in other cases where it is desired to convert alternating to direct current.

+

## Radio-acoustic sound ranging locates submarine peak

CAPTAIN R. S. PATTON, director U. S. Coast and Geodetic Survey, announces that the survey ship *Guide*, now engaged in hydrographic work off the California coast, reports the discovery of a submerged mountain lying about 52 miles southwestward from Point Sur.

This remarkable feature rises from depths of about 2,000 fathoms, and is ten miles long in a north and south direction.

If the ocean were to be drained, this formation would show up as an isolated mountain 7,500 feet in elevation. The position of the submerged peak was accurately determined by means of radio acoustic sound ranging, from stations on the California coast.

◆ ◆ ◆

## Duplicate generating sets for airfields started by cell

IN PROVIDING AIRPLANE BEACONS and landing fields with lights which come on at darkness, in remote locations where no power-supply lines exist, it is necessary to employ gas-engine-driven generating sets. The photocell must then automatically start up the engine-set and get it into operation, instead of merely switching on a local lighting circuit.

Complete starting apparatus for duplicate gas-engine sets is now being operated successfully by a Westinghouse photocell unit on the beacon near Pitcairn, Pa., on the airway to Washington. When darkness falls, the photocell first turns cranking current into the No. 1 set, turning it over for a predetermined time. If this engine does not start, the machine then switches over to the No. 2 duplicate of No. 1, and cranks it. If this also fails to start after an interval, the current is turned back to No. 1 again, and so on. Usually one or the other unit starts up promptly, and then continues to run until the photocell shuts off the circuit at dawn.

With this new photo-sensitive control starter, automatic beacon lighting can be provided anywhere, even in the most isolated regions, far from power lines.

## SELF-OPENING SHIPPING DOOR

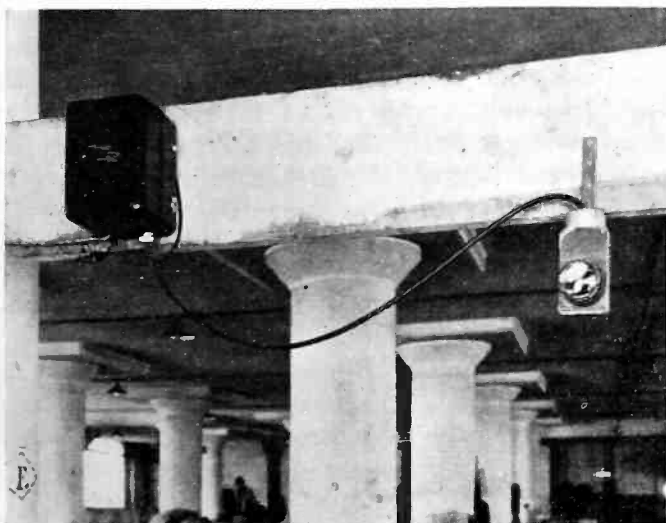

Instead of "crashing open" the doors through which hand-trucks pass, the shadow of the trucker on this ceiling photocell, opens the doors quickly and noiselessly

## TRUCKS OPEN FACTORY DOOR

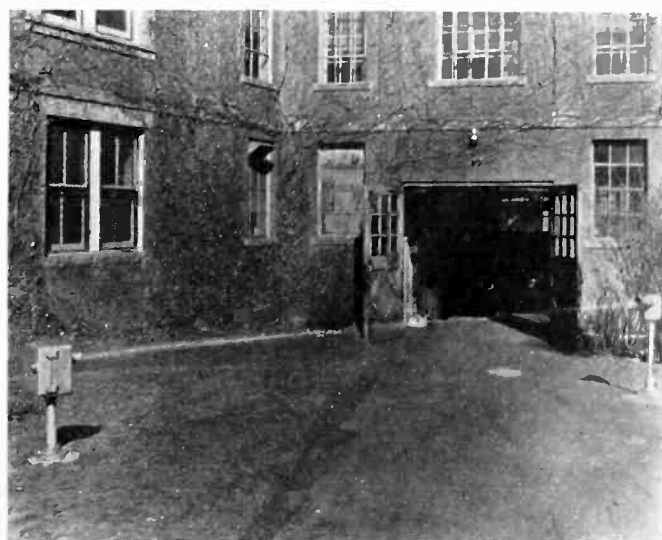

Big auto trucks used to get out of control, roll down this incline, and smash these doors of the Stanley Works, New Britain, Conn. Now a light-beam opens the doors if a truck appears

# Vacuum tube delay circuits

By M. W. MUEHTER

**M**ANY uses have been made of the fact that the charge in a condenser, and hence the voltage across it, changes slowly when appreciable resistance exists in the circuit. A good example is a delayed relay operation, particularly if the circuit must have a quick-reset feature which is difficult to attain with thermal or mechanical relays.<sup>6</sup> Introduction of large capacities in the form of electrolytic condensers has materially improved the time limits over which control is possible; application of vacuum tubes to this field has again greatly enlarged the uses of condensers shunted by resistors or in series with them.

Since the plate current of a tube can be controlled without any energy expenditure as long as the grid is kept negative with regard to the filament, the tube and the relay connected in its plate circuit will not affect the charging or discharging time of a condenser connected to its grid circuit. Under such conditions, the timing reaches a practical limit by the energy consuming insulation of the condenser itself and the associated circuit and can be made considerably longer, up to several minutes with a few microfarads. As the timing depends on the time constant  $CR$ , condensers should be used in which the ratio  $R/C$  is high, which means low leakage condensers. The actual limitation is usually given by the associated circuit, the insulation of which cannot be maintained above certain values, say 10 megohms.

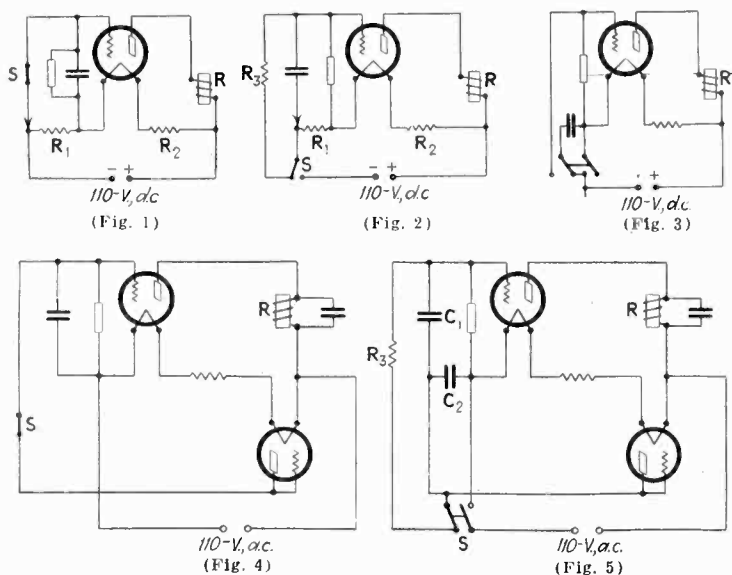

Fig. 1—Simple time delay circuit. Fig. 2—Method of saving filament life. Fig. 3—Circuit for obtaining longer delay. Fig. 4—Operation on a.c. Fig. 5—Circuit in which filaments are normally not heated

Most frequently it is desired to obtain a secondary operation after a predetermined time has elapsed since the initial operation. Figure 1 shows a simple d-c arrangement. The tube is normally heated, one of the filament series resistors supplying the plate voltage, the other keeping the condenser charged through switch  $S$ . As long as  $S$  is closed, the grid of the tube is strongly negative with regard to the filament and no plate current flows. When  $S$  is opened, the condenser slowly discharges through the shunt resistor, causing the grid to become less and less negative. At a certain negative grid voltage the relay operates. When the switch is closed again, the condenser is recharged and the grid becomes negative, causing the relay to drop back.

A disadvantage of this circuit is that the filament of the tube is always heated. The circuit in Fig. 2 avoids this. Here switch  $S$  is of the throw-over type. When  $S$  is thrown in the operated position, the tube circuit is closed and the filament heats up. The condenser is slowly charged through the grid leak. The grid potential is strongly negative at first and becomes gradually less so, until the relay operates. Resistor  $R_3$  serves to limit the arcing, when the switch is restored to normal.

By using a potentiometer instead of  $R_1$  in these two circuits and connecting  $S$  or the condenser respectively

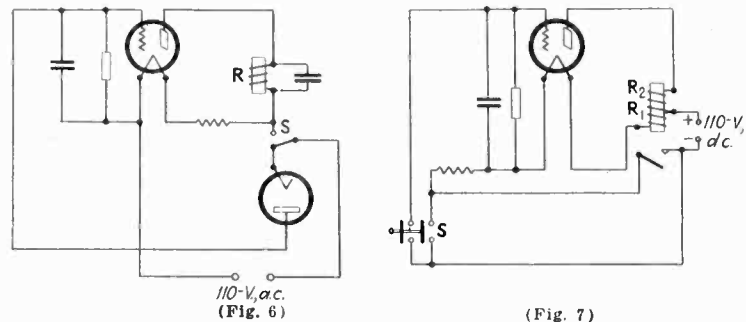

Fig. 6—Method of using glow tube for charging condenser. Fig. 7—Circuit for maintaining an operation

to the moving contact, the timing can be easily varied. Both circuits have the disadvantage that only a relatively small voltage is available for the condenser, as most of the 110 volts has to be used for the plate. In Fig. 3 the condenser is charged to 110 volts, thereby obtaining a longer delay. However, a double-pole switch  $S$  is required. Obviously the place of this switch can be taken by a set of contacts operated by another relay. When the switch is operated, the tube circuit is closed and the condenser connected to the grid circuit in such a way that the grid is negative. When the condenser has discharged through the grid leak, the relay operates.

Figure 4 shows an arrangement for a.c. Two tubes are used, one for the operation of the relay, the other to supply the charging current for the condenser. To spare a filament transformer, the filaments are operated in series with each other and a resistor on 110 volts. Both filaments are normally heated, but no current flows through the relay, as the condenser is kept negatively charged on the grid side through switch  $S$ . When  $S$  is opened, the relay operates, after the charge has dissipated.

Figure 5 illustrates another a-c circuit, where the filaments are normally not heated. When switch  $S$  is operated, current is supplied to the tubes. Condenser  $C_2$  is charged rapidly, while  $C_1$  is charged slowly through the grid leak. As the charge on  $C_1$  increases, the grid

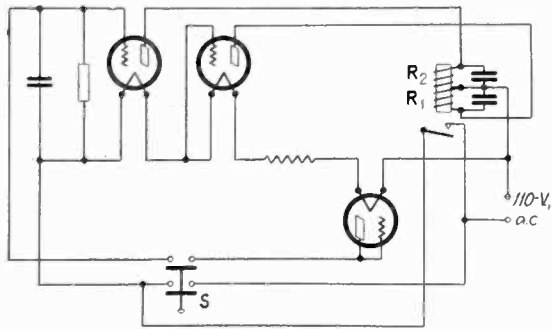

Fig. 8—Maintained circuit for a.c.

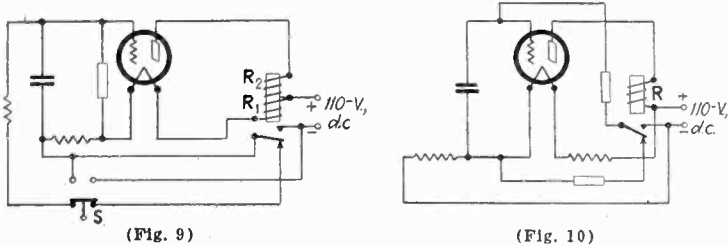

Fig. 9—Fixed duration impulse circuit. Fig. 10—Interrupter circuit

becomes less negative; finally the relay pulls up.  $C_2$  serves to maintain the negative charging potential during that part of the a-c cycle, when no current flows in the plate circuit of the charging tube.

If a glow tube is used for charging the condenser, the circuit can be so arranged, that the discharging time is utilized and the filament of the main tube is normally not heated. This is indicated by Fig. 6.

### Maintained operation

Another application frequently encountered is to maintain an operation for a predetermined time, after the starting impulse has stopped. The preceding circuits could be used for that purpose, if the operated position of the switch is used as the normal position. The relay would then be normally energized. When the switch is momentarily thrown over to the position shown, the relay drops back and remains so until the end of the predetermined time. These circuits, however, would have the disadvantage, that the tube filaments would normally be heated.

Figure 7 shows a circuit for d.c. where this is not the case; its operation is based on Fig. 1. The relay has a double winding. When the double-pole switch or push-button is operated, the filament is energized in series with relay winding  $R_1$ . A series resistor may be used in addition, if the voltage drop across  $R_1$  is not sufficient. The relay pulls up and locks the circuit in through its own contact. The second contact of the starting button charges the condenser negatively with respect to the grid, so that no plate current can flow. When the button is released, the relay stays in the operated position, until the condenser has discharged. Plate current then flows through the second relay winding opposing the first and causing the relay armature to release. The relay opens its locking circuit and restores the controlled circuits to normal.

### Fixed impulse operation

An arrangement for a.c. is indicated by Fig. 8, based on Fig. 4. Another tube is used to rectify the current for winding  $R_1$ , as otherwise no compensation of the two relay windings would be possible.

If it is desired to obtain an impulse of fixed duration regardless of the length of the initial impulse, a

circuit according to Fig. 9 may be used; it is based on Fig. 2. When  $S$  is operated the relay pulls up through winding  $R_1$  and locks in through its contact. When the condenser has been charged, winding  $R_2$  is energized, causing the relay to drop back. If, by that time, the switch should still be in the operated position, nothing further happens, until the switch is restored, discharging the condenser and making the equipment ready for the next operation. A corresponding circuit can be evolved for a.c., based on this and the preceding circuits.

### Electron-tube interrupter

An interrupter arrangement is shown in Fig. 10. Upon starting, the grid has zero potential and the relay pulls up transferring the condenser circuit to the charging position. The plate current now drops, until the relay releases, causing the condenser to discharge through its back contact. Then the relay picks up again and so forth. The timing depends on the difference of the operating and release currents of the relay, as the plate current oscillates between these two values only and never becomes zero. A corresponding circuit may be used for a.c., employing a charging tube. For very slow operation a double-tube circuit can be designed, one tube giving the delay for one half of the operation, the other for the other half, the condenser always completely charging and discharging.

### Design characteristics

The tubes best suitable for the suggested circuits are the 112A and the 230 type; the former matches better with standard relay coils, the latter has lower filament consumption (60 instead of 250 ma.).

The timing obtainable with the various circuits depends on the constancy of the supply voltage and the permissible variation in timing resulting therefrom. A higher supply voltage increases the condenser charge and would lengthen the time required for the negative grid potential to drop sufficiently, if the plate voltage would not also be higher, allowing sufficient plate current to flow at a higher negative grid potential. This has the advantage that the timing can be kept very constant even on a fluctuating line voltage. Assuming a voltage variation from 90 to 120 volts and using a 112A tube and a telephone type relay the maximum timing for Fig. 1 is about 3 seconds per megohm and microfarad with a variation of only 7% in the timing. Allowing 15%, it would be about  $4\frac{1}{2}$  sec. A less fluctuating voltage would give longer delay for the same variation and vice versa. About the same data apply to circuit No. 7. Circuits in Figs. 2 and 9, which utilize the charging time, will also give about the same timing, as long as the insulation resistance of the condenser is high with respect to the grid leak. The effective resistance in the time constant  $CR$  is the resistance resulting from connecting both in parallel, as can be derived mathematically.

With Fig. 3 the maximum timing is about  $3\frac{3}{4}$  seconds with 7% variation. To obtain this the relay has to be made less sensitive or a tap has to be made on the filament series resistor for a lower plate voltage. In the a-c circuits Figs. 4, 5, 6 and 8 the condenser is charged to the peak voltage, while the mean d-c plate voltage is 45% of the a-c voltage. The timing is about 4 seconds for 6% variation on 90/120 volts a-c, always per megohm and microfarad. If the voltage is stepped up by a transformer, which also could supply the right filament voltage, the timing could be increased.

# Graphite anodes in transmitting tubes

By D. E. REPLOGLE

Hygrade Sylvania Corporation,  
Clifton, N. J.

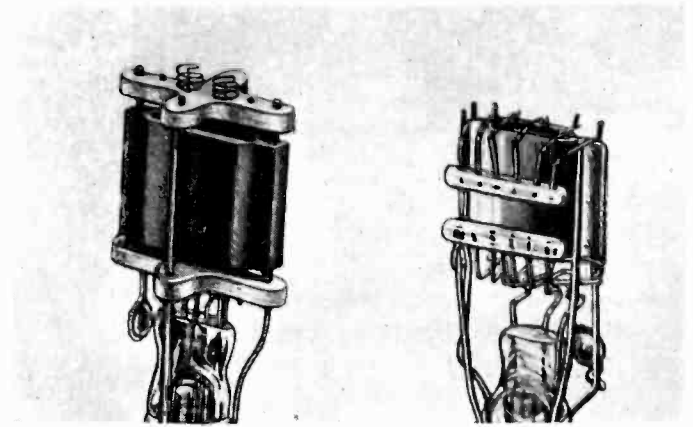

Contrast of graphite anode and conventional mount in type 211 tubes

FOR several years tube engineers have recognized the advantages of carbon for vacuum tube anodes. Witness the early attempts to use carbonized anodes in receiving tubes and the later use of carbonized nickel in receiving tubes where anode dissipation was appreciable. Carbonized metal anodes have the advantage that they will emit a greater amount of heat than any plain metal anode such as polished nickel, oxidized nickel, tantalum, molybdenum or tungsten.

Carbonized metals were impractical in transmitting tubes due to the fact that the carbonizing could not be made perfect enough to prevent the material from flaking off and depositing either on the bulb where it cut down the total heat radiation or on the filament where, due to the heat emission properties of carbon, it would cool the filament below the proper temperature and thus reduce electron emission. Furthermore, it is necessary in high powered tubes to use a metal which has a high vaporization temperature. This has restricted the metals obtainable to tantalum, molybdenum and tungsten.

Of these three metals, molybdenum has served best for anode material because it could be worked and vaporized

only at very high temperatures. It had one drawback, however—it was impossible to get perfectly homogeneous specimens of the material. Therefore, anodes were apt to warp when heated in the exhaust positions or in ordinary operation where heat might set up uneven stresses throughout the material. To overcome these troubles elaborate systems have been worked out for bracing molybdenum anodes in all power tubes of 50 watts or over. The most practical has been the "I" beam construction.

## Advantages and disadvantages of carbon anode tubes

The following advantages make transmitting tube design engineers desirous of using some form of carbon for anode construction in tubes of 50 watts or over.

1. Greater heat emission properties.
2. Homogeneous structure which does away with strains and warping during manufacturing processes.
3. Adaptability to precise machining and close tolerances.
4. High conductivity.
5. Its property of "getter action," i.e., its affinity for absorbing gases when in a proper degasified state.
6. High temperature point of vaporization.
7. Comparatively low cost.

For a number of years experiments on the use of carbon as an anode in transmitting tubes have been conducted, but the following disadvantages always prevented the making of a satisfactory tube:

1. The fact that on all machine carbon a certain amount of amorphous carbon remains on the surface of the anode which flakes off and deposits itself on the glass insulators and filament, causing the troubles mentioned above, together with providing low resistance leakage paths across insulators.
2. The giving off of gases from the anode of a transmitting tube due to the fact that the hydrocarbonates necessary in binding the carbon together break down and give off gases, shortening tube life and preventing its use at high powers.
3. The difficulty of accurately shaping large pieces of carbon for the larger transmitting tube anodes.
4. The difficulty of securing good contact between the carbon anode and the lead-in wire.

Of the above disadvantages the first two mentioned

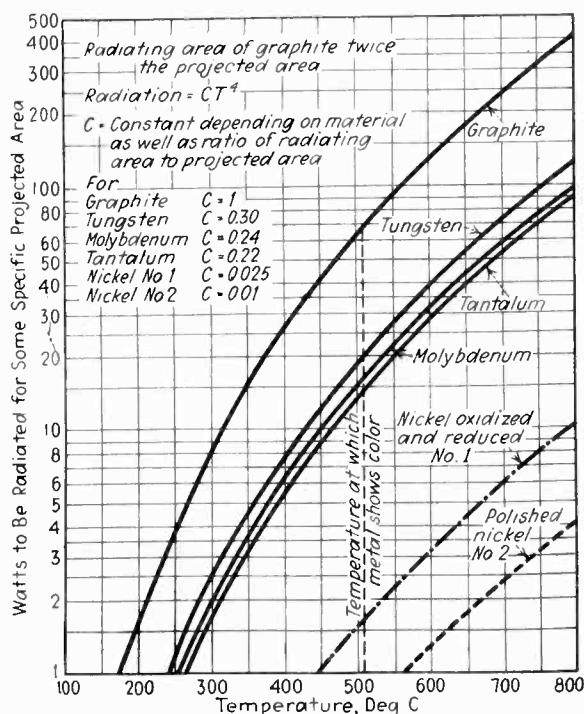

Comparative radiation of anodes made from graphite and other materials

are by far the most important, and it was necessary to evolve a process for absolutely eliminating the amorphous carbon before assembling the anodes in the tubes and of decomposing the hydrocarbonates in the binder so that the graphitized mass of the anode would emit no gases in service and permit no flaking off of the graphitized carbon.

Under the leadership of V. O. Allen a solution has been found which does just this—namely, removes all amorphous carbon from the surface of the anode and also breaks down the binder and graphitizes the carbon mass.

With this step accomplished these engineers, with the carbon manufacturers, worked out a means for machining large blocks of carbon in one piece to accurate dimensions holding a tolerance of better than 0.001 inch. This was a real achievement in that it precluded the necessity for making the anodes in pieces, with the subsequent difficulty of holding them together by rivets. These graphite anodes are held in rigid relation to the other elements by the "I" beam construction wherever possible. These "I" beams give a maximum of mechanical strength with a minimum volume of metal to be degasified.

These experiments have been so successful that carbon or graphite is used in the entire Hygrade-Sylvania line of air-cooled transmitting tubes from the small 20-watt type 210 tube to the largest air-

cooled tube, the 851, rated at 1,000 watts output.

To illustrate how graphite anode tubes increase emitting ability, a chart has been compiled showing the comparative heat radiation ability of various metals. It will be noted that at approximately 510 degrees C., all of these metals begin to show a red color. Thus, for the anode selected in this chart, the tube would dissipate 70 watts when made of graphite against 16 watts when made of molybdenum, 20 watts when made of tungsten, and 14 watts when made of tantalum. Or, considering it another way, if a tube with a molybdenum anode will dissipate 15 watts without making the plate red hot; the same tube with a graphite anode will dissipate 60 watts without heating the plate to a red color. These figures leave no doubt about the virtues of graphite.

Due to this greater heat dissipation, the internal structure of a tube is kept much cooler, and the grid and shield grid structures, which are always hard to degasify in manufacturing, are kept several degrees cooler, thereby preventing the harmful effect of secondary emission and the giving off of gases.

Further uses for this special treated graphite are becoming apparent with increased knowledge. One of the most important is the use of graphite for grid structures in water-cooled tubes where they are particularly subject to intense heat, and in special high-frequency tubes now under development which require the use of pure tungsten filaments with their attendant intense heat.

## Cathode ray tubes for oscillograph purposes

[Continued from page 333]

$$m = \text{mass of electron} = 9.02 \times 10^{-28} \text{ gms.}$$

$$e = \text{electron charge} = 1.59 \times 10^{-20} \text{ ab-coulombs}$$

From this equation, it becomes apparent that for maximum sensitivity, the poles should be placed as far from the screen as possible along the tube axis. However, the deflection field may not be applied at the No. 1 anode or closer to the cathode than the No. 1 anode without destroying the focusing mechanism. It is therefore necessary to apply the magnetic field beyond the No. 1 anode; one inch beyond is desirable to insure any stray field from penetrating within the No. 1 anode.

7. An intense beam will burn the screen if allowed to remain stationary for a short while on the fluorescent screen. An intense stationary beam may even heat the glass to red heat and puncture the bulb. It is well to have the deflection voltage applied before turning on the cathode ray beam. The cathode ray beam may be completely controlled by turning off or on the No. 2 anode voltage, or the beam intensity may be varied by varying the negative bias on the control electrode.

8. For those who contemplate using the cathode ray tube for ultra-high frequency measurements an expression for the electron velocity may be useful.

$$\text{Electron velocity} = \frac{2E_{b2} e}{m} \text{ cms. per second}$$

$$E_{b2} = \text{second anode potential in stat-volts}$$

$$e = \text{electron charge in stat-coulombs}$$

$$m = \text{mass of electron in grams.}$$

The above equation is not absolutely exact, but for electron velocities of less than 10 per cent the speed of light, the error is negligible. Since most cathode ray oscillo-

graph tube beams move more slowly than this figure, the equation may be taken without any correction.

9. For photographic work, persistence characteristics of the fluorescent screen, and spectral distribution characteristics may be of interest.

10. The fluorescent screen nearly always approximates a perfect diffusing screen which follows the cosine law for the distribution of emitted light.

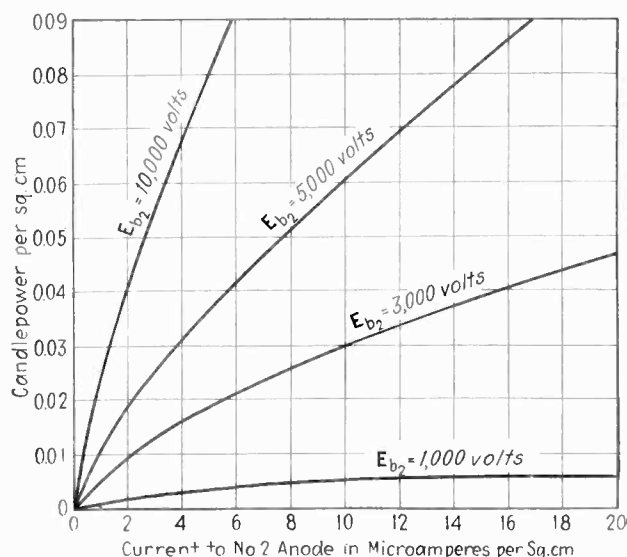

Screen candle power as a function of screen current

1. Manfred Von Ardenne, "Hochfrequenz-technik und Elektroakustik" 1932, Page 18.
2. E. Bruche, *Zeitschrift für Physik* 78, 1 and 2, Page 26.
3. E. Bruche, *Zeitschrift für Physik* 78, 3 and 4, Page 177.
4. H. Busch, *Archiv für Elektrotechnik* XVIII, 1927, Page 583.
5. H. Busch, *Ann. der Physik*, 81, 1926, Page 974.
6. Jean Thibaud, *Journal de Physique*, Vol. 10, Page 161, 1929.
7. V. K. Zworykin, *Journal of Franklin Inst.* May 1933, Page 535; also *Electronics*, Nov. 1931, Page 188.
8. Knoll and Ruska *Zeitschrift für Physik*, Vol. 78, 5 and 6 Page 318, 1932. *Ruska Zeitschrift für Physik*, Page 684, Vol. 83, 9 and 10, July 1933.
9. A typical electron-path will be found on Page 346, this issue.

# ✦ ✦ ELECTRONIC NOTES

## Improved circuits for measuring negative resistance

BY FREDERICK EMMONS TERMAN\*

THE NEED FOR A GOOD bridge circuit capable of measuring negative resistances arises in connection with the resistance neutralization method of measuring radio frequency resistance.<sup>1</sup> Several new arrangements for this purpose are shown in Fig. 1. These combine the simplicity of the Dingley bridge<sup>2</sup> together with the capacity balance feature of the Tuttle circuit,<sup>3</sup> and are thus not limited to the measurement of low resistances as Dingley's bridge is, while avoiding the complicated transformer and decimal attenuator required by Tuttle.

In practice the resistance  $R$  should not exceed several hundred ohms while  $R_s$  should be much greater than  $R_1$ . In Fig. 1 (a)  $R$  can conveniently be a single turn of resistance wire mounted on the periphery of a 6 to 8 inch disk which is rotated past a fixed contact. In the circuits shown at (b) and (c),  $R_s$  can conveniently be a 10,000-ohm tapered rheostat supplemented by one or two decades to extend the range. These decades can be made up from inexpensive wire wound resistance units since a small phase angle produces negligible error.

A practical set up for the measurement of radio-frequency resistance of

coils is shown in Fig. 2. The plate potential is adjusted so that the plate current is very small, and is usually near 45 volts. For negative resistances up to 100,000 ohms  $R_s$  is connected to tap (a) while by connecting to tap (b) a multiplying factor of 10 is obtained. Actually when the connection is made to (b) one should add 90 ohms to the results, but this is obviously negligible when the resistance being measured is above 100,000 ohms. The capacity balance is obtained by a double stator condenser made by rebuilding a two gang broadcast condenser. The oscil-

secondary of the input transformer can be avoided by using a transformer having a single secondary coil wound over the primary. By connecting the inside terminal (commonly marked C-) to the grounded side of the amplifier the inner secondary layer acts as an electrostatic shield which tests show to be just as effective as much more elaborate shielding.

The procedure for operating the circuit of Fig. 2 is as follows: The tuned circuit under test is connected across XX and adjusted to the desired frequency.  $S_2$  is then shorted, thus bypassing the measuring equipment to a-c

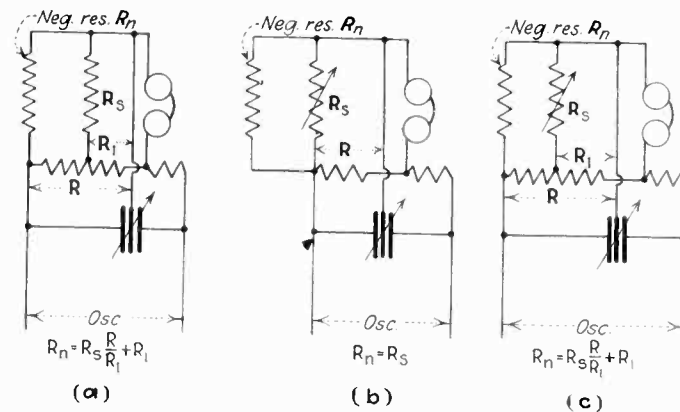

Fig. 1 — Possible methods of measuring negative resistance

lator should have a frequency of 1,000 cycles, and should be capable of developing about one volt. A two-stage amplifier, peaked at 1,000 cycles to suppress harmonics, should be used to detect balance. Troubles from electrostatic coupling between the primary and

currents without affecting the d-c voltage applied to the plate. Switch  $S_1$  is opened and the grid bias is adjusted until the tuned circuit is just on the verge of going in or out of oscillation. The oscillating condition can be tested for by means of an oscillating detector, or by watching the plate current microammeter, which always jumps slightly as oscillations start. The switch  $S_1$  is now closed while  $S_2$  is opened, after which the negative resistance is balanced on the bridge circuit. The negative resistance thus obtained is related to the tuned circuit resistance  $R_s$  by the relation  $R_n = \frac{(2\pi fL)^2}{R_s}$ . In this equation

$L$  is the inductance of the tuned circuit as measured at audio frequencies or calculated, while  $f$  is the frequency at which the circuit goes into oscillation and can be measured by means of a wavemeter or calibrated receiver. It will be noted that unlike all other methods of measuring radio-frequency resistance, no correction is necessary for stray capacities, and no delicate adjustments or special precautions are required to obtain high accuracy.

\*Stanford University.

<sup>1</sup>See Hajime Inuma, "A Method of Measuring the Radio-frequency Resistance of an Oscillatory Circuit," *Proc. I.R.E.*, vol. 18, p. 537, March, 1930.

<sup>2</sup>Edward N. Dingley, Jr., "Development of a Circuit for Measuring the Negative Resistance of Pliodynatrons," *Proc. I.R.E.*, vol. 19, p. 1948, Nov. 1931.

<sup>3</sup>W. N. Tuttle, "Dynamic Measurement of Electron Tube Coefficients," *Proc. I.R.E.*, vol. 21, p. 844, June, 1933.

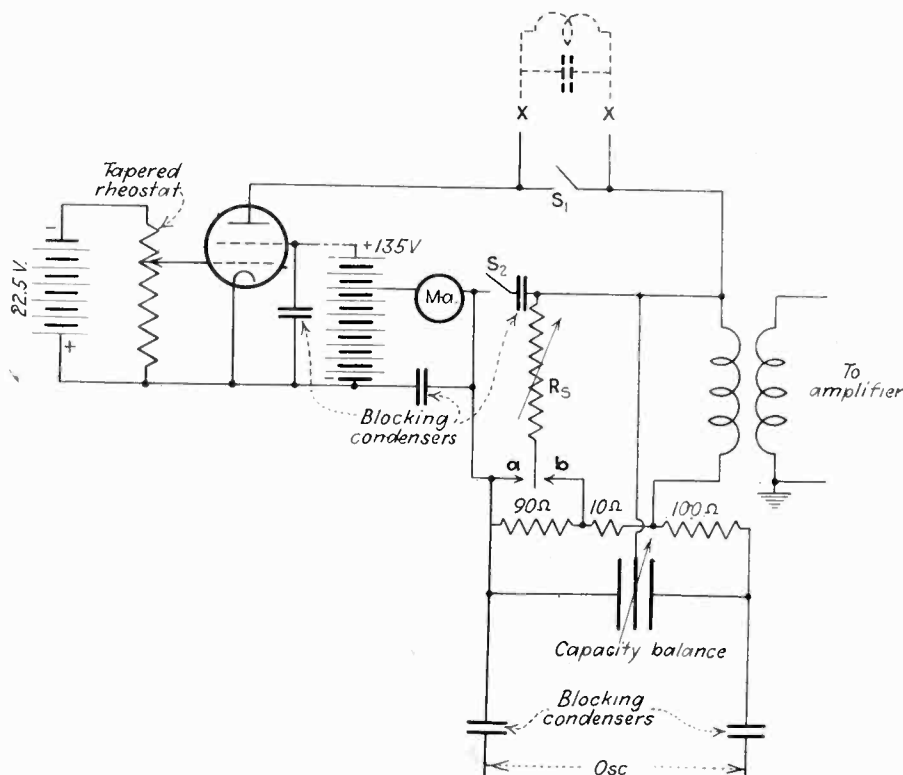

Fig. 2—Complete set-up for determining shunt resistance of an inductance-capacity circuit



# FROM THE LABORATORY ++

## Equivalent circuit for tetrodes and pentodes

By W. M. GOODHUE\*

WHEN THE TRIODE ORIGINATED, it was natural to employ a concept of a fictitious emf. in series with the load and tube impedances, because the concept of emf.'s in general arose from the consideration of power sources. However, if the series circuit is applied to many of the modern tetrodes and pentodes, the fictitious emf. becomes so large that it has no physical significance whatever, and actually becomes inconveniently large in making computations. For example, the type 57 tube has an amplification factor of approximately 1,500. Hence, with a signal of 1 volt, the fictitious emf. becomes 1,500 volts, which is far beyond any voltage which may exist in the circuits. This objection may be overcome by the use of an equivalent parallel circuit, such as is shown in the figure rather than the equivalent series circuit. Moreover, since the plate resistance is extremely high, the impedance of the load is ordinarily small in comparison. Therefore, the current may be considered as being impressed on the circuit rather than the emf.

In the figure,  $G$  is the mutual conductance of the tube;  $de_g$  the differential of impressed grid voltage;  $Z_p$  the plate impedance of the tube, and  $Z_L$  the load impedance. The load current, or plate current, due to  $de_g$  is:

$$di_p = G \frac{Z_p}{Z_p + Z_L} de_g \quad (1)$$

On the usual basis of an emf. acting on a series circuit, the plate current is

$$di_p = \frac{\mu de_g}{Z_p + Z_L} = \frac{G Z_p}{Z_p + Z_L} de_g \quad (2)$$

which is the same as equation (1).

The newer type tubes, for example, the 57 and 58, have so high a plate impedance (of the order of 1.5 megohms) that the load usually operates nearly under constant current conditions. This makes the use of the equivalent parallel circuit convenient both in viewpoint and in computation. Actually, the plate voltage is held down to reasonable values by the load impedance, and the equivalent parallel circuit expresses this condition.

As an example of the quantitative relationships for the equivalent parallel and the equivalent series circuits, consider the type 57 tube, which has a plate impedance of 1.5 megohms. Assuming a load impedance of 100,000 ohms, the fictitious impressed current is 1.23 ma. per 1-volt signal, while the actual plate current and load current are 1.15 ma.

The fictitious impressed current  $G \times de_g$  of the parallel circuit is but slightly greater than the true plate and load current,  $di_p$ , under the condition of high plate impedance. In the older series-circuit method, the fictitious impressed voltage would be 1,500 volts, whereas the true load voltage would be actually only 115 volts.

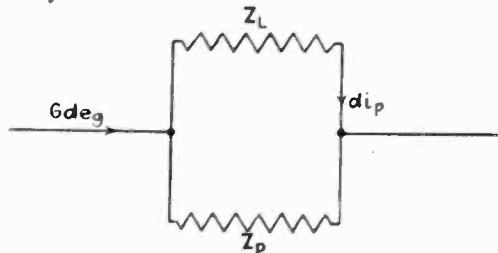

Thus, the equivalent parallel circuit is advantageous in that the fictitious impressed quantities are practically equal to the actual physical quantities. This circuit is applicable equally to ordinary triodes, although because of their low values of amplification factor, no advantage results in its use in such cases.

\*Instructor in Electrical Engineering, Harvard Engineering School, Cambridge, Mass.

## The side bands occurring in frequency modulation

E. D. SCOTT AND J. R. WOODYARD of the University of Washington, describe the Bulletin of the Engineering Experiment Station (No. 68: 5-24, 1933) experiments on frequency modulation.

In pure frequency modulation the amplitude of the wave is kept constant, but its normal frequency  $h$  is varied periodically, the amount of the variation depending on the intensity  $s$  of the sound and the period of variation being equal to the applied audio frequency  $L$ , so that the antenna current is given by an expression of the type  $I \sin(6.28 ht - sh \sin 6.28 Lt)$ . This may be written as the sum of carrier current and a large number of side bands, spaced by multiples of the modulation frequency  $L$  above and below the carrier frequency  $h$ , the amplitudes being successively proportional to the Bessel functions of successive orders  $J_0, J_1, J_2, \dots$  of  $sh/L$ . The higher orders decrease rapidly in strength. The existence of these bands was verified for the first time by using part of a Baldwin type loudspeaker as condenser plate for modulating the frequency. To separate the side bands reproduced in the receiver, a sharply tuned audio-frequency circuit was used to apply the signal to the measuring device, the incoming wave being made to beat with a separate crystal controlled oscillator. From three or four to as high as seven side bands could be isolated and measured.

## Table for solution of impedance problems

ENGINEERS WHO HAVE OCCASION to calculate the square root of the sum of the squares of two numbers, a tedious if not laborious operation, will be interested in a table of the values of  $K$  in the following equation which may be used with the slide rule to materially lessen the tedium of such calculations.

$$\sqrt{A^2 + C^2} = C \sqrt{1 + \left(\frac{A}{C}\right)^2} =$$

$$A [f(A/C)] = AK$$

The values of  $K$  for various ratios of  $A/C$  have been calculated and published in pamphlet form by W. J. Seeley, Duke University, Durham, N. C.

## A test for shorted turns

A SIMPLE METHOD OF testing bell coils and a-c. buzzer coils for shorted turns is shown in the figure as worked out by E. M. Glaser of the Pioneer Instrument Company. Quoting from Mr. Glaser "by using the test coils as oscillator inductances the bad ones are shown up by differences in excitation (grid current) or plate current. By using the coils in a dynatron oscillator circuit and shorting a coupled turn of copper strip, the differences between good and bad coils become much more obvious. The initial

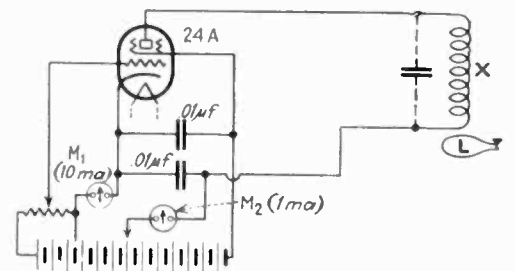

In this shorted turn tester, X is the coil under test; L is a single turn of heavy copper; M<sub>1</sub> is for initial setting to compensate for changes in voltages and M<sub>2</sub> is calibrated for test purposes.

reading of the plate milliammeter would classify the coil while the change in reading would be proportional to its figure of merit.

"These particular coils were of high impedance designed to resonate at 60 cycles with a 0.02  $\mu$ f condenser. They had been tested previously by resistance method only which had led to a high percentage of later rejects for shorted turns. By the method described the number of rejects dropped to zero." Power transformers, field coils, etc., could undoubtedly be tested in this manner.

# A Study of Litz

## wire coils—Part II

[Editor's Note—The first part of this survey of Litz wire coils by David Grimes and W. S. Barden appeared in the November issue of ELECTRONICS. This part takes up the study of typical coils of 2 mh for operation at 456 kc.]

The coils under consideration have identical inside and outside diameters, and are made of 5/40, 7/40 and 10/40 wire. Hence the 5/40 coil is the thinnest and the 10/40 is the thickest. But  $Q$  is greatest for the 5/40 coil, and least for the 10/40 coil. Now this does not mean that 5/40 is better than 7/40, and that 7/40 is better than 10/40. It does mean that the true merit of 10/40 over 5/40 cannot be realized by simply increasing the thickness of the No. 10 coil to make room for the larger 10/40 wire—which is further evidence that Litz wire standardization must regard physical size of coil as one of the premises.

Compared No. 6 (having 5/38) with No. 5 having (7/41). Physically, these two coils are nearly alike in size. 5/38 results in  $Q =$  only 48, whereas 7/41 yields  $Q = 91$ . It is evident that 7/41 is far more suitable for typical practice than is 5/38.

Comparing No. 5 (having 7/41) with No. 7 (having 10/41), the strand size is the same, the outside and inside diameters are alike, and room is made for the greater number of strands by increasing the coil thickness.  $Q$  drops from 91 to 87, but this merely means that the 10/41 wire has not been used judiciously. If that particular coil diameter be a limiting factor, 7/41 is slightly preferable to 10/41.

Compare No. 3 with No. 4. No. 3 employs 7/41 E.

System	Q	Sel.	Per Cent Improvement					
			1	2	3	4	5	6
1	102	25.5	17	9	14	14	10	17
2	98	22.5	...	...	...	...	...	...
3	96	21.5	...	...	...	...	...	...
4	92	19	0	0	0	0	0	0

Fig. 5—Actual sizes of coils made of 10/41 Litz for use at 450 kc. Selectivity at 10 kc. off resonance is given

the E meaning that enamel\* is substituted for silk as a covering on the whole wire. This wire has parallel strands, with no twists. The 7/41 E results in a slightly smaller coil than the 7/41 SS.  $Q$  is the same ( $= 87$ ) for both coils. Evidently the 7/41 E is as good or slightly better than the 7/41 SS at 450 kc.

Note that coil 10—a thin coil of 5/40, having  $Q = 90$ , compares very favorably with No. 5—a somewhat

thicker coil of somewhat less diameter wound with 7/41, having  $Q = 91$ . The indication is that 7/41 is electrically better in a typical coil than 5/40. Further data reveal the extent to which 7/41 is more worthy than 5/40. A truly rigorous result can be obtained in this instance, because 5/40 and 7/41 have very nearly the same size of wire, hence for any given physical dimensions of a coil each wire will result in the same inductance, and physical size of coil does not confuse the issue.

It is noteworthy that the best coil of the 11 in Fig. 4 is wound with 7/41 SS, and that this coil (No. 5) is a truly medium sized coil.

Interesting facts can be gleaned from a set of continuously graded coils tested at 450 kc. Consider the following data on  $\frac{5}{16}$  in. coils.

Q	Sel.	System					
		1	2	3	4	5	6
102	25.5	17	9	14	14	10	17
98	22.5	...	...	...	...	...	...
96	21.5	...	...	...	...	...	...
92	19	0	0	0	0	0	0

The coil having  $Q = 102$  has an adjacent channel selectivity  $= 25.5$  when that coil is used throughout System 1. For that coil, the gain of System 1 is 17 per cent greater than for the same system when the coil having  $Q = 92$  is used throughout that system. The row of zero's indicates the coil to which better coils are compared. For System 5 the coil having  $Q = 102$  is 10 per cent better than the coil having  $Q = 92$ , as regards gain.

Among 2-mh. coils for use at 450 kc. and wound with 10/40 SS, the least worthy coil was the thickest one having the smallest hole and the smallest outside diameter. The best coil was the thinnest having the largest outside diameter and the largest hole. Between these extremes  $Q$  ranged from 80 to 64, and adjacent channel selectivity from 13.5 to 7.5; not quite 2 to 1. For the best coil the selectivity secured was very poor compared to what can be secured at 175 kc.

On 450 kc., coils using 10/41 wire show the same characteristics—the thinnest coil being the best. The change in wire size from 40 to 41 produces a  $Q$  of 102, compared to 80. Therefore, it is easy to state that 10/41 is superior to 10/40 for 2-mh. coils worked at 450 kc.

When coils of 7/41 are compared to coils of 5/40, it is discovered that the form of the coil becomes important. Here it is not the thinnest coil that is best; it is a coil somewhat larger than the thinnest. The best 7/41 coil has  $Q$  of 96; the best 5/40 coil a  $Q$  of 90. The selectivity preference is 21.5 vs. 18.

On 260 kc. the same data hold true. Coils made from 10/41 are decidedly superior to coils of 10/40; 7/41 is slightly better than 5/40. Again form factor is of importance.

Unless coil size can be disregarded, 7/41 wire seems generally preferable to 10/41 at both 260 kc. and 450 kc.

At 175 kc., 10/41 Litz seems to be definitely out of the picture because of coil size. At 450 kc., use of 10/41 calls for thin coils of large diameter; use of 7/41 calls for thick coils of less diameter. This is of advantage in construction, because of less space in the chassis, smaller shield cans, etc.

At 260 kc. the same facts are true. If the greatest tolerable diameter is used with 10/41 coils, they do not equal in performance coils made of 7/41.

The foregoing considerations reveal that if one Litz wire were to be chosen as standard, for i-f practice, it should be 7/41 in preference to 10/41 as regards both

450 kc. and 260 kc., and, were 7/41 to be chosen in preference to any other, its performance at 175 kc. would result (generally) in a serious effect on fidelity due to side-band attenuation. Since there is a frequent desire for truly small windings, even though at a sacrifice of performance, and for i-f coils of very low cost—leading to a small amount of copper—it is important to note that 7/41 does not meet these requirements.

As an example of what can be done with poor wire, consider coil 1 (3/40 SS) a truly small coil, representing low cost on a copper basis. Its  $Q$  is 74, which renders such a coil sufficiently meritable for many cases in practice at 260 kc. as well as at 450. Due to these facts, one is inclined to reserve two, rather than one,

4 layer bank
7/41 SS
550 kc $Q=110$
1,000 " " 105
1,500 " " 90

2 layer bank
10/41 SS
550 kc $Q=122$
1,000 " " 96
1,500 " " 101

2 layer bank
10/41 SS
550 kc $Q=150$
1,000 " " 95
1,500 " " 108

2 layer bank
10/40 SS
550 kc $Q=134$
1,000 " " 108
1,500 " " 114

2 layer bank
10/41 SS
550 kc. $Q=145$
1,000 " " 120
1,500 " " 75

Fig. 6—Actual sizes of bank-wound coils used at broadcast frequencies

Litz wires to cover the general i-f requirements. Suitable wires appear to be 7/41 and 3/40, although if only one were to be chosen, the following table indicates a preference for 7/41 over 3/40, although more radio receiver manufacturers reports the use of 10/41. To this extent, physical size of coil does not appear to be highly important, at least when the choice is between two large coils, rather than between a large coil and a small coil:

Litz Wire Specif.	5	10	3	7	10	5	7	10	3
	38	38	40	40	40	41	41	41	42
Number of Mnfrs.	1	1	1	2	4	1	4	6	1

From the above data, it may be inferred that those four receiver manufacturers who use 10/40 could well add themselves to the six who use 10/41. The table shows 11 manufacturers using No. 41 wire, against 7 using No. 40. Were the 6 manufacturers who use 10/41 to add themselves to the 4 who use 7/41, they could, by proper coil design, do so without any great sacrifice of performance, and in some cases an actual improvement would be made by them in discarding 10/41 in favor of 7/41.

It appears, therefore, that if only 7/41 and 3/40 were available for i-f purposes, the Litz wire situation would be solved satisfactorily. However, there is one further influence on the choice of only three strands, and that is the effect of a broken strand. Of course strands are not supposed to break, but a broken strand in 3/40 is more

serious than a broken strand in 7/41, where there are more strands. This matter is discussed below.

The assortment of r-f coils for this study was too limited to warrant any extensive consideration of figure of merit in terms of particular uses of the coils. All inductances were substantially alike, and  $Q$  is taken as the direction (but not the extent) of the relative merit. The r-f coils comprise four typical coils, and one experimental coil of very small size. These five coils are drawn (actual size) on Fig. 6, where Litz wire data and values of  $Q$  are shown. The smallest coil—four-layer bank wound with 7/41—is more meritable (from 550 kc. to 1,500 kc.) than many solid wire r-f coils having twice the diameter and twice the length of this small coil.

At 550 kc., typical solid wire r-f coils have  $Q$ 's ranging from 70 to 100. For these coils,  $Q$  often varies less than plus or minus 30 per cent over the broadcast band. At 1,500 kc., the usual r-f selectivity is so poor that it is unimportant to compare Litz with solid wire at that end of the spectrum. A comparison shows that Litz wire is definitely advantageous at 550 kc., 10/41 being suitable at the low frequency end of the broadcast spectrum.

### Effect of broken strands

When using fine wire, *e.g.*, No. 41, it is comforting to know that a broken strand is not of great importance, particularly when there are seven or more strands. When a break occurs, it is most likely to be found at the end of the lead where a mechanical operation prepares the wire for tinning. The following table shows the percentage loss of  $Q$  due to broken strands:

Number of broken strands	I.F. Wire	Percentage loss			
		450 kc. 2 mh. 7/41	450 kc. 2 mh. 3/40	260 kc. 4 mh. 7/41	260 kc. 4 mh. 3/40
1	....	3	11	2	19
2	....	5	30	5	49
3	....	7	..	..	..
4	....	10	..	..	..
5	....	18	..	..	..
6	....	33	..	41	..

It is evident that the effect of broken strands is far less than proportional to the number of broken strands. One broken strand is of no practical importance. The above data apply to broken strands at the high end of a coil. Broken strands at the low end of a coil are found to have practically the same effect.

As a conclusion, it is fair to state that 3/40 is favorable when very *small* i-f coils are desired; 7/41 is desirable when i-f coils of medium size are in order; 10/41 is worthwhile only when *large* coils can be tolerated, at i.f.

At r.f., 7/41 and 10/41 are worthy at the low frequency end of the broadcast spectrum, but at 1,500 kc. no Litz wire tested in this study is to a worthwhile degree advantageous over solid wire.

The effect of a broken strand is unimportant when using 7/41 or 10/41, and not serious when using 3/40. A broken strand is not the equivalent of a removal of that strand. Despite the break, the strand still assists the process of conduction through the coil.

Considering both i.f. and r.f., 10/41, 7/41 and 3/40 appear to be three suitable Litz wires for general use in present-day receivers. The inclusion of 10/41, if not definitely logical at i.f. is desirable as regards r.f.

It is not important to make an extensive study of Litz wire at 175 kc. Only at high intermediate frequency—such as 450 kc. and at r.f. is Litz wire worthwhile.

\*Enamelitz, made by Acme Wire Company—editor's note.

# electronics

McGraw-Hill Publishing Company, Inc.  
330 West 42d Street  
New York City

O. H. CALDWELL, *Editor*

Volume VI —DECEMBER, 1933— Number 12

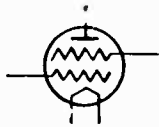

## Radio City—vast cathedral of electronics

WITH the National Broadcasting Company at last occupying its great studios at Radio City in New York, the dreams of the planners are being fulfilled to make Radio City a center for broadcasting, sound-picture, and musical entertainment for the nation.

And especially appropriate was the proposal of O. B. Hanson, engineer for NBC, to have the great reception-hall murals show *technical* features which underlie broadcasting. And appropriately occupying the place of honor at the center is a highly magnified electronic tube.

Without the tube, Radio City would be impossible. Using tubes in myriad numbers and forms, Radio City is a veritable modern cathedral of electronics.



## Privacy on the short waves

WITH the great expansion in the number of short-wave sets in the hands of the public, a new menace to the privacy of communication on these frequencies is introduced. Radio operators are required to take an oath of secrecy. But the layman who buys a short-wave set is under no such compunction. Instead, there have been cases where listeners-in on private messages have promptly communicated their "discoveries" to newspapers.

Owners of short-wave sets should be apprised of the sanctity of the communication channels.

Perhaps a tag attached to each short-wave set sold, explaining the confidential character of the frequencies about 1500 kc, would reduce disclosures, yet also increase curiosity and sales!



## The radio-press war— and facsimile

THE battle between the broadcasters and the press now breaks out on a new front—the Washington press galleries.

News men of the Columbia Broadcasting System demanded admittance to these sacred seats overlooking the halls of Congress. The committee of newspaper men in charge promptly refused them. Now the radio people will appeal directly to the House and the Senate.

The issue is of interest to *Electronics* readers because it obviously portends the day of the final break. Then the broadcasters will have to get ready with facsimile for delivering their printed programs to every home—news tabloids, too—thus opening up new markets for radio sets and for accessories that "print while you sleep."

This facsimile apparatus is all worked out—it awaits only the command to "shoot!"



## Static eliminators and higher power

MILLIONS of radio listeners still have their summer programs ruined by static. This vast portion of the public still fondly hopes that engineers will develop a workable static eliminator; forgetting, or not knowing, that the remedy is at hand. The ability to push nature's unwanted, uncontrollable noise into the background lies in lifting the heavy hand of the Federal Radio Commission off the natural enterprise of the broadcasters to increase station power.

It is futile to attempt to stay the discharges of lightning, or to turn aside the bombs thrown by the gods in their summer war maneuvers; but it is not difficult to improve reception for many of these millions now permitting their radios to gather dust until the annual static season is over.

The remedy has been known for years; and as long blindly neglected. The remedy is to increase the field strength of the station in the vicinity of the listener. It is as backward to limit the power of a station on a clear channel to 50 kw. as to limit a locomotive running on a clear track to its equivalent of a mere 67 horsepower.



## Careful engineering needed on auto-radio initial equipment

**T**HE plan to have all new automobiles initially equipped with factory-installed radio sets, has received some discouragement from the automobile dealers who sell the cars, and it now appears that this initial-equipment idea will not go ahead next season quite as fast as had been supposed, unless first-rate radio operation can be assured.

During the past year, trouble developed with some of the sets provided, and this worked to hold-up sales and payments in a way that has frightened some automobile dealers. After a month of use, the radio set would stop working, and then the purchaser would refuse to make his next payment until the radio was fixed. In this way, unsatisfactory radio operation has served to endanger the sale of the car itself. Unless competent engineering design of radio sets installed as initial equipment can be assured, car dealers who have suffered collection troubles prefer that the sets be left out altogether.

## NEWS NOTES

**Miessner piano before Radio Club, Dec. 13.** A complete technical paper on the electronic piano will be presented before the Radio Club of America at Columbia University, New York City, Dec. 13, by its inventor, Benjamin F. Miessner, of Millburn, N. J.

**Ford Exposition of Progress to feature electronic processes.** Henry Ford is expending \$300,000 on a free Exposition of Progress to be held in the great Port of Authority Building, New York City, Dec. 9 to 23. Three hundred manufacturers will co-operate, and full-scale manufacturing processes will include demonstrations of electronic-controlled welding, X-ray inspection, photocell counting and control, acoustimeter measurements, the stroboscope, and other electronic apparatus.

**States would tax broadcasting.** A general sales tax on broadcasting would be imposed under new bills introduced

before the Kansas and Missouri state legislatures, similar to the Oklahoma law which was enacted earlier this year, and is now under attack. Five per cent of gross sales would be levied.

**NAB broadcasting debate handbook ready.** "Broadcasting in the United States," a 200-page handbook presenting arguments in support of the existing system of broadcasting, is being distributed free by the National Association of Broadcasters. Press Building, Washington, D. C.

**Depreciation of broadcast stations.** The Internal Revenue Bureau at Washington is studying the rate of depreciation in value of broadcasting stations, for income-tax purposes. E. M. Elkin of KDKA, and P. G. Loucks of the Broadcasters Association, are collecting data for a meeting of interested parties.

**Sodium-vapor lighting in America.** American sodium vapor lamps are now employed for highway lighting at Port Jervis, N. Y., and Hamilton Beach, Queens, New York City (both Westinghouse), and near Schenectady, N. Y. (General Electric), according to R. D. Mailey of the General Electric Vapor Lamp Company, who demonstrated gaseous units producing 50 lumens per watt, before the N. Y. Section, A. I. E. E., Nov. 22.

**RMA Television Committee.** A special committee to confer with the Federal Radio Commission on future broadcast facilities for television, facsimile, etc., comprises Walter E. Holland of Philadelphia, chairman; J. A. Chambers of Cincinnati, chairman of engineering for the National Association of Broadcasters; Ray H. Manson of Rochester, N. Y., and Dr. W. R. G. Baker of Camden, N. J.

WOODEN TOWER, 483 FT.,  
FOR BERLIN BROADCASTER



Timber-frame towers have been used extensively in Germany. Here is construction view of the new Tegel station near Berlin, to be opened this month

# REVIEW OF ELECTRONIC LITERATURE

## HERE AND ABROAD

### Improvements in medium voltage cathode ray tube

[M. VON ARDENNE, Ardenne Laboratory] All the electrodes with the exception of the plate are made of non-magnetic material; the plate (3000 V) is slightly magnetized so as to reduce to zero the deflection caused by the earth's magnetic field. Platinum is now being used as a support for the oxide; the heating current may vary by +5 per cent without affecting the results. Origin distortion is eliminated by a clever arrangement of the deflecting plates. The four deflecting plates go to separate binding posts arranged around the plate connection in the center of the base. The luminescent material is no longer deposited upon the glass bulb and viewed from behind, but on a separate glass surface 4x4 in. placed obliquely with respect to the axis of the tube, the figures being observed from in front or projected upon a screen. Distortion that might result is corrected by having the deflecting plates form an angle with one another and the glass container free from defects. Sufficient light, about six times more than before, is obtained with the new tubes to throw an image covering  $\frac{1}{4}$  to 1 sq.m. upon a screen during lectures.—*Funkt. Monatsh.* 2: 333-340. 1933.

### Full voltage amplification with screen-grid tubes

[R. SEWIG AND W. KLEINSCHMIDT, Dresden, Institute of Technology] Full amplification of course requires high resistance in the plate circuit and the advantages of using the most recent

types of photoelectric cells, operated near saturation, are pointed out, for instance cesium vacuum cells which give saturation at 30 volts and 0.1 to 1 ma. when exposed to the light of a 40 watt lamp and represent a resistance of about 100 meg. The response is practically independent of the frequency when the capacity of the screen grid tube, cell and leads are kept below  $10\mu$  f.—*Zeits. techn. Physik* 14: 388-390. 1933.

### Push-pull grid-controlled inverter

[I. RUNGE AND H. BECKENBACH, Osram Laboratory] The mathematical discussion of the symmetrical circuit for changing d.c. into a.c. by means of grid-controlled discharge tubes (Fig. 1, *Electronics*, April, 1931, p. 581) shows that when the ohmic load is small, the condenser  $C$  can be so chosen that the fundamental frequency predominates; this is the case when the reciprocal of the inductance of the choke coil  $L$  equals the sum of four times the admittance of the condenser plus the admittance of half the transformer primary, that is  $4 p c - 1/2 p T - 1/p L$  equals zero ( $p = 6.28$  times frequency). For instance, when the load is equal to  $2.5/p L$ , the first overtone amounts to not more than 6 per cent of the amplitude of the fundamental. To approach sine curves when loads are heavy, large condensers must be used which tend to give triangular waves as soon as the load decreases and produce very high voltage. By making the condenser  $C$  progressively smaller, successive overtones are obtained in great strength. Oscillograms confirm the conclusions drawn.—*Zeits. Techn. Physik* 14: 377-385. 1933.

### Uses for the cathode-ray tube

[J. KAMMERLOHER] Synchronization is obtained by means of a condenser  $C$  charged gradually through a diode according to a logarithmic law, while the a-c potential to be studied charges at each half-wave a second condenser over

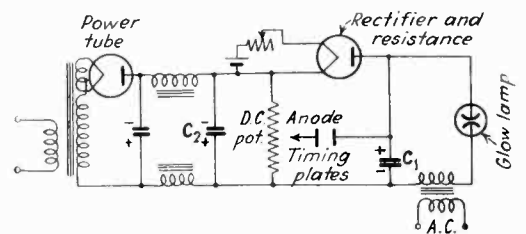

a transformer and rectifier so connected that the a-c potential determines the moment when the discharge passes through a glow lamp at each third or fourth, etc., alternation and discharges the condenser giving the time axis. One of the most important uses of this simple circuit is the study of tube characteristics at various loads by applying a-c to the properly biased grid. The grid is connected to the horizontal pair of deflecting plates and produces the horizontal or voltage axis; a pair of coils introduced into the plate circuit gives the vertical deflection so that plate current versus grid voltage curves are traced by the beam. The properties of low or high pass filters for a.f. can be studied by using the shaft of the rotor for carrying the photographic paper.—*El. Techn. Zeits.* 54: 1019-1022. 1933.

### Testing of receivers by means of resonance curves

[GUENTHER ULBRICHT, Hannover Institute of Technology] The method described by the RCA Victor Co. (Pr. I.R.E. 20:1580 — 1932) and also used by one firm in Germany is rather expensive. A simpler test is possible with the cathode ray tube replacing the oscillograph, vacuum tube voltmeter, screen and rotating mirror. The 60 cycle supply voltage is sufficiently constant to give the time axis when applied to one pair of deflecting plates the rotor plates of the oscillator are given a sinusoidal shape (figure of eight), while the stator plates are quarter circles, and the rotor is set in motion by a synchronous motor making 1,800 r.p.m. As the frequency varies as a result of this motion, the return points of the cathode ray beam trace a continuous curve, the resonance curve, of the circuit.—*Hochfr. Techn. El. Ak.* 42: 135-137. 1933.

### ELECTRON PATH IN CATHODE RAY TUBE

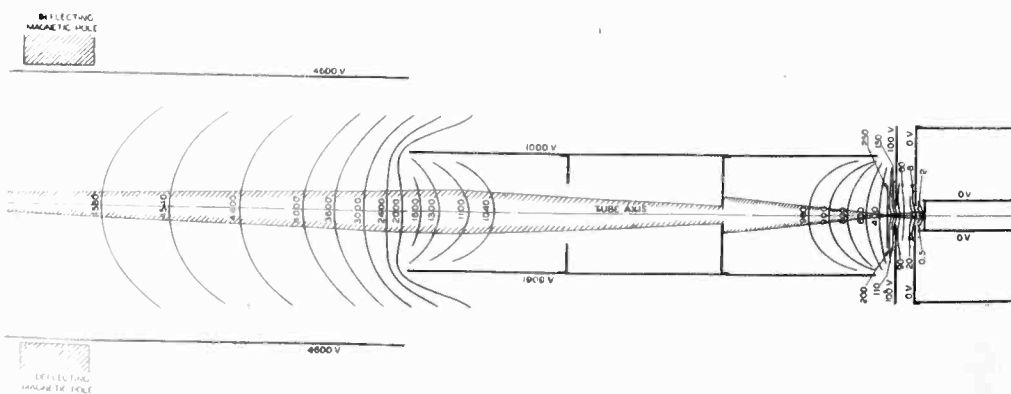

Typical electron beam outline and equipotential line plot showing focussing effect of voltages—see page 332 this issue.

## Cathode ray time axis and blocking circuits

[W. FUCHS and H. KROEMER, Aachen Institute of Technology] When transient voltage changes taking place at random are to be recorded, it is necessary to apply them to one pair of deflecting plates, to use a second pair for giving the path free to the ray within perhaps not more than one ten millionth sec. after the sudden change has set in and to produce a linear time axis with the aid of a third pair of plates. It is possible to perform the latter two tasks with a single source of voltage when a

Resistance time-axis plates of cathode ray tube

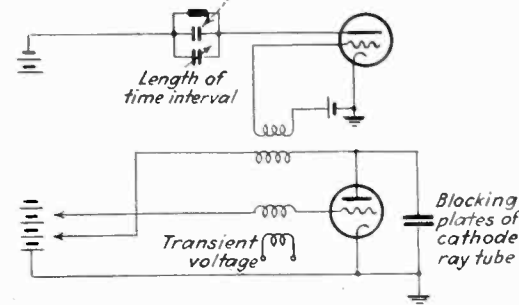

dynatron circuit is used, cathode and anode being connected to the blocking plates and the plate potential of the vacuum tube so chosen that no current flows. The appearance of the transient is made to shift the grid voltage so that the plates discharge across the tube and a wave front advances through the transformer or primary, causing the charging up of the time sweep plates. As conditions return to normal, the tube current slides along the falling characteristic and stops, and the timing plates discharge across a resistance. The device allows the study of the wave shape of broadcast waves.—*Archiv. El. Techn.* 27: 606-608. 1933.

## Television progress in Germany

[GEORG KETTE] The organizations exhibiting their receivers at the tenth annual radio show in Berlin-Witzleben were (when 90 means 90 lines, 10,800 elements 25 pictures per sec., and 180 means 180 lines, 40,000 elements, 25 pictures per sec., or frequency bands of 125,000 cycle resp. 500,000 cycles per sec.): German General Post Office: two cathode ray receivers (90 and 180); Fernsch A.G.: mirror screw (90/600/25), cathode ray (180); Telefunken: cathode ray (180); Tekade: mirror screw with glow lamp (90) and sulphide of zinc cell Loewe Radio: cathode ray (180); Mihaly (rotating mirror throwing light beam upon stationary mirror wheel (90); Von Ardenne: cathode ray transmitter of constant intensity, but variable speed. The large number of cathode ray receivers stands out. Pictures with 90 lines are suitable for tele-movies and television of single objects; 180 line pictures seem to permit the

transmission of actual scenes, but all the tests made to date depend on the transmission of the picture over wires. The intermediate-film sender has been de-

veloped further so as to give a new emulsion and exposure to the film after it has been projected.—*Ferns Tonfilm* 4: 53-61. 1933.

## BOOK REVIEW

### Electron tubes and their application —

By John H. Morecraft. Published by John Wiley & Sons, New York, 1933. (458 pages, 537 figures. Price \$4.50)

AS SUGGESTED BY THE title the book deals with the various types of electric discharge tubes, not vacuum tubes alone, which have proved to be useful in engineering. The first sixty pages show under what conditions electrons are caused to leave the inside of metallic bodies. Numerical relations are used wherever possible in order to present a concrete picture of the physical processes, and in many cases striking comparisons result which are easily imprinted upon the memory (for instance, the output of photo electrons, pp. 41-42, and later the internal resistance of vacuum tubes, p. 72). In some cases, however, the imagination has wandered too far, and the picture has become distorted; for instance, the velocity of the electrons does not vary with the temperature, as described (pp. 8, 16 and 21), but is practically the same a few hundred miles per sec., at room temperature and at white heat, a fact proven by the value of the specific heat and by the work done at the Bell Laboratories and elsewhere.

Having laid a firm basis two and

three electrode tubes are discussed. Much stress is laid on the conditions under which the triode may have a negative input resistance.

Short chapters of about twenty pages each describe hot cathode gas-filled tubes (including the cathode ray tube), photoelectric tubes (where the probable nature of Photronic cells is indicated), and special electronic devices. The actual uses to which electronic tubes are put in various fields are then mentioned. An extended discussion follows (pp. 237-408), dealing with the part which the triode plays as amplifier, oscillator, modulator and detector. The direct current, or as the author says, continuous current amplifier is given a little less than two pages. The book concludes with short sections on the uses of gas-filled three-electrode tubes, the electron tube as an electric motor and special use of electron devices.

The book ought to fulfil quite well the author's purpose to serve as a general course on electron tubes for engineering students of all branches. A point also worth mentioning is that among the 90 references to articles having appeared in various periodicals, there are 40 references to the *Proc. I.R.E.* from 1918 on, 15 to the *A.I.E.E.* for about the same length of time, 10 to the *Physical Review*, and no less than 20 to *Electronics* for the short span from April, 1930, to August, 1932.

## DIAL YOUR PROGRAM!



O. B. Hanson, NBC manager of engineering, (left) explains to R. C. Patterson, Jr., executive vice-president, the method by which any studio or station program can be dialed

# + NEW PRODUCTS

## THE MANUFACTURERS OFFER

### Mercury-contact relay

A NEW MERCURY-CONTACT RELAY for a-c operation has recently been perfected by the American Automatic Sales Company, 1033 W. Vanburen Street, Chicago, which will handle comparatively heavy currents with complete satisfaction. This relay is quick-acting, and can be equipped with either one or two mercury contacts. It can be repeatedly operated and released and will still produce "clean" makes and breaks. The same contact can be used for either making or breaking a circuit, depending

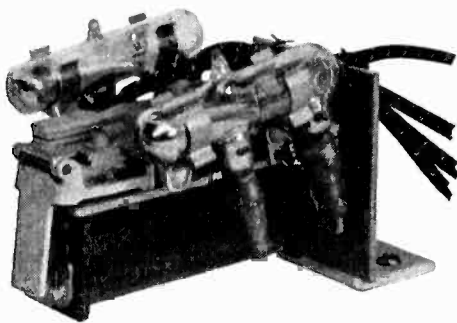

upon the setting of the support. The relay is similar to the company's d-c relays, and can be supplied either with an angle bracket or on a bakelite base with cover. It is designed to operate on 110 volts, 60 cycles, and has contact ratings for d-c or a-c non-inductive loads as follows: 25 amperes at 80 volts, 20 amperes at 120 volts and 10 amperes at 240 volts.—*Electronics*.

### Lumotrons General Scientific Corporation product

LUMOTRON PHOTO-ELECTRIC CELLS, which were described in October *Electronics*, page 290, are produced and distributed by the General Scientific Corporation, 4829 South Kedzie Ave., Chicago, successors to QRS Neon, Inc. This company also makes grid-glow tubes, television lamps, neon tubing and electrodes, animators, vacuum gauges, and optical products. Through an error in the above-mentioned item, the name of the General Scientific Corporation was incorrectly stated.

A Chicago company of somewhat similar name, also known to *Electronics* readers, is the Central Scientific Company, 460 East Ohio St., Chicago, which has been established since 1889 and which manufactures and deals in scientific apparatus, laboratory instruments, reagent chemicals and supplies. The new Cenco-Browne high-voltage elec-

trostatic generator, built by the Central Scientific Company, which produces emfs up to 750,000 volts under all conditions of temperature and humidity, was described in *Electronics*, January, 1933, page 27. Other Central Scientific Company products which have been described in *Electronics* are high-vacuum pumps, high-frequency oscillators, rheostats, and the Zeleny electroscope.—*Electronics*.

### Wire for radio tubes

KEMET LABORATORIES COMPANY, INC., 30 East 42nd St., New York City, a unit of Union Carbide and Carbon Corporation, has developed and is manufacturing and selling a new wire for use in radio tubes, which consists of an alloy of molybdenum, iron and nickel (approximately 20 per cent Mo, 20 per cent Fe and the balance largely nickel). It has good strength and ductility at ordinary temperature (tensile strength about 140,000 lb. per sq.in., and elongation about 28-30 per cent), has good winding qualities and is characterized by exceptionally high strength and stiffness at elevated temperatures. The tensile strength at 800 deg. C. (1,472 deg. F.) is approximately 60,000 lb. per sq.in. and the stiffness is comparable to that of pure molybdenum.—*Electronics*.

### 32-180-volt generator

THE PIONEER GEN-E-MOTOR CORPORATION of 1160 Chatham Court, Chicago, Ill., has just announced a new generator which provides 180 volts, d.c. from 32-volt input.

This new addition supplies "B" power from 32-volt farm light systems. Two models are available. One is complete with filter and intermediate voltage taps, which may be connected direct to any battery-operated receiver and thereby eliminate all B batteries. The

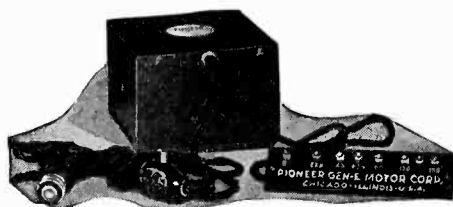

other model is supplied stripped of filter and intermediate voltage taps to meet the needs of set manufacturers who are producing radio receivers that operate direct from 32 volt farm light circuits.—*Electronics*.

### Rubber-capped plugs

DESIGNERS OF RADIO and associated apparatus of a more or less portable nature have long been in need of connector plugs that would stand up under rough use. For this purpose the Eby line of heavy duty rubber-capped plugs, when used with the newer rubber-covered cables, makes a combination which will stand the most severe usage. These plugs have been adopted by manufacturers for portable apparatus such as public-address and sound recording equipment, and are also being widely used for Automobile Radio power supply connection.

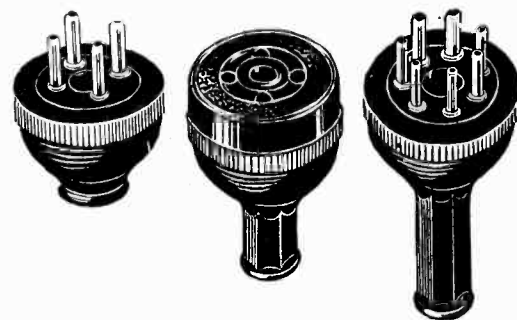

They are intended for service where moderate current carrying capacity is desired, and where voltages are not in excess of 500 volts. It is to be noted that the insulation resistance between conductors or contacts is extremely high because of the excellent insulating material used in the construction.

These plugs are supplied for four, five, six or seven-prong conductor cables in either male or female types with a selection of various styles and sizes of black rubber caps. H. H. Eby Manufacturing Company, 21st St. and Hunting Park Ave., Philadelphia, Pa.—*Electronics*.

### Multiple-coil air-core reactors

A MULTIPLE-COIL air-core reactor for laboratories and test-rooms has been developed by the Metropolitan Device Corporation, 1250 Atlantic Avenue, Brooklyn, N. Y. The coils may be connected single, in series, in parallel, or in series-parallel relation. The unit is constructed entirely of non-magnetic materials, and the coils are arranged in a relation of negligible mutual inductance. By inserting iron cores into the coil centers, the coil reactances are readily changed, or the circuit wave-shapes may be modified. The reactors may be used on single or polyphase circuits up to 440 volts.—*Electronics*.



## High-sensitivity relay

A NEW AND HIGHLY SENSITIVE relay has been announced by Ashcraft Automatic Control Company, Hollywood, Calif. This relay has a low internal resistance (100 ohms) and is sufficiently sensitive to close on the output

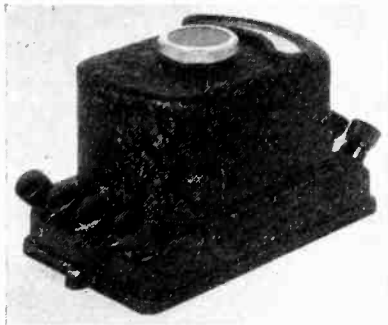

of caesium and photronic type cells. An input light intensity of  $\frac{1}{2}$  footcandle will cause the relay to close, according to the maker. Contacts carry 3 amperes at 110 volts a.c. It is said to be immune from trouble due to vibration. Relay may be set for closing its contacts for a current variation of 1 microampere to 200 microamperes. Price \$35.—*Electronics*.

+

## Electrical door-opening mechanism

AN ELECTRICAL DEVICE providing improved automatic door-opening service for garage doors has been announced by the Barber-Coleman Company, Rockford, Ill. It consists of a magnetic latch which holds the door closed until it is released by a control switch, whereupon tension in balance springs of the door pulls the latter open.—*Electronics*.

+

## Sensitive relay

PRODUCTS DEVELOPMENT COMPANY, 933 West Main-St., Louisville, Ky., is marketing the micro-relay, designed by W. Van Benschoten. In the plate circuit of an electronic tube is a normally-closed relay, which is held open by the residual value of the plate current with an unbiased grid. The controlling contacts are so wired that when they come in contact a negative bias is placed on the grid, which immediately causes the relay to close, through the fall of the plate current. This action occurs with contact resistances up to 20 megohms.

The micro-relay is of value in connection with mercury thermometers, pyrometer control, photo-cells, limit-switch applications, display advertising, etc. Price of micro-relay, a.c. and d.c. single and double poles, \$30 to \$40.—*Electronics*.

## Portable oscillator

THE NEW SERIES 31 portable DayraD test oscillator provides all frequencies from 105 to 1,650 kilocycles. Accuracy is assured by means of a transparent dial with a hair line. The instrument is thoroughly shielded and by-passed. The attenuator, separately shielded, offers signals of varying intensity necessary for the alignment and neutralization of all types of radio sets. This unit is described in Bulletin 37. The Radio Products Company, Dayton, Ohio. —*Electronics*.

+

## Transformers and chokes

FERRANTI, INC., 130 West 42d St., New York City, has just published a new 1934 catalog covering its line of transformers and chokes for use in the communication field.

During the past year more than one hundred new tubes have been released on the market, and this catalog is an attempt to cover up-to-date precision

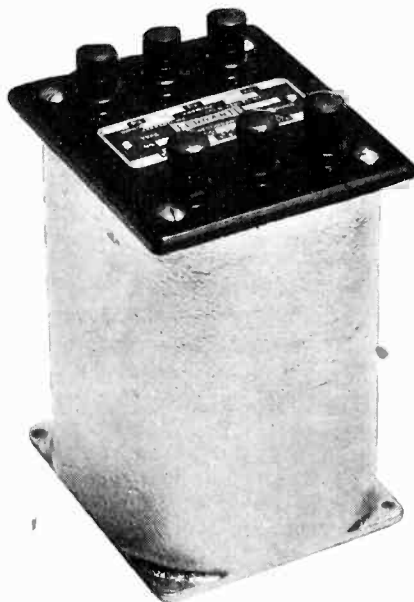

transformers for use with the more commonly used types of these new vacuum tubes.

An instance of unusual conditions which Ferranti can meet is typified by a transformer specification  $\pm 1$  db. from 30 to 25,000 cycles.

The Ferranti Company has extended its New York laboratory and engineering facilities and is now specializing in the production of quality iron-ore products.—*Electronics*.

+

## Mercury-arc switches

"NO-ARC" MERCURY TUBE SWITCHES made in 1, 2, 3 and 4 poles, each pole consisting of a mercury-tube switch with ratings of 30 amp., 125 volts; 20 amp., 250 volts, either a.c. or d.c., for controlling inductive loads, such as multiple street-lighting circuits, have been announced by the Hart Manufacturing Company, Hartford, Conn. —*Electronics*.

## Battery for 2-volt tubes

THE BURGESS BATTERY COMPANY, Freeport, Ill., announces its No. 1040 A battery especially designed for 2-volt tube radio receivers. This new A pack embodies a close-pak construction which makes it light, portable, and economical.

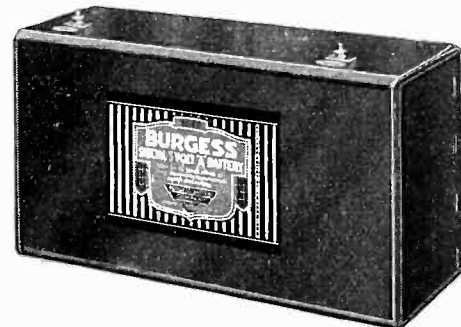

The unit will give 400 hours service at a cost of less than one cent per hour. Weight, 15 lbs.; size 12 in. by 4 in. approximately. The unit is 100 per cent dry, hermetically sealed, and requires no servicing with water or chemicals. List price, \$3.20.—*Electronics*.

+

## Laminated bakelite

INSTRUCTIONS FOR MACHINING laminated bakelite, in chart form for ready reference, are presented by the Synthane Corporation, Oaks, Pa. The various processes described for most satisfactory handling include circular sawing, band sawing, threading, milling, gear-cutting, drilling, punching, turning and boring, and the use of automatic screw machines. Details of maximum cutting speeds are given.—*Electronics*.

+

## Polarized relay

THE DUNCO POLARIZED RELAY, for operation where the direct current in the coils must be kept as low as possible, and where reversal of current reverses contacts, while deenergization of coils opens the contacts, has been produced by Struthers Dunn, Inc., 148 North Juniper St., Phila., Pa.

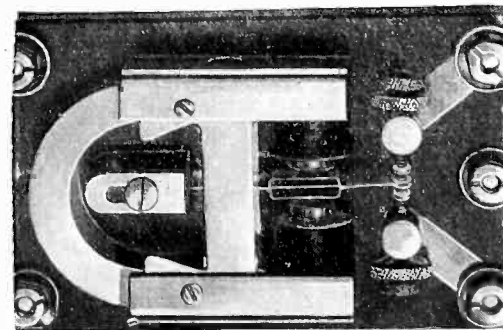

The strength of the permanent magnet used with the push-pull coils, is adjustable by means of a shunt. The contacts break 2 amp. a.c. 110 volts, or one-quarter ampere direct current, 115 volts, non-inductive load. Relays can be furnished with total coil resistance up to 6,000 ohms, and the operating power required is as low as 0.01 watt, direct current. Price \$21.—*Electronics*.

# U. S. PATENTS IN THE FIELD OF ELECTRONICS

## Radio Circuits

**Beam receiver.** Several spaced antennas; method for heterodyning the waves collected upon these antennas to a lower intermediate frequency, frequency multiplying the intermediate frequency energy to the frequency of the received wave, regeneratively amplifying said frequency multiplied energy and combining the frequency multiplied energy whereby the directive characteristic of the antenna is improved. J. Plebanski, assigned to R.C.A. No. 1,935,375.

**Antenna system.** A pair of closely spaced feeder members connected to a single receiver extending in the direction of desired communication and several antennas simultaneously coupled thereto. H. O. Peterson, R.C.A. No. 1,935,373.

**Volume control.** For circuits utilizing screen grid tubes, method of reducing volume by reducing the positive screen grid biasing potential of one or more of the tubes and simultaneously lessening the signal energy transferred. J. M. Miller, assigned to Atwater Kent Mfg. Co. No. 1,934,940.

**Communication system.** Method of radio communication which includes generating a rotary-polarized wave, receiving wave to produce a polyphase oscillating current, mixing current with a second polyphase current, and detecting the slip current thereby. R. M. Heintz, assigned to Heintz & Kaufman, Ltd. No. 1,934,924.

**Voltage converter.** Method of operating a receiver from a source of direct current by means of a vibrator, transformer and rectifier filter. R. J. Keogh, assigned to Utah Radio Products Co. No. 1,935,569. Also No. 1,935,568.

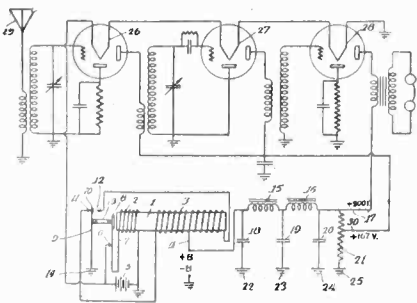

**Automatic volume control.** For use in a receiver having an r.f. amplifier, a detector, and an oscillator. The a.v.c. tube is connected to the anode circuit of the detector and a two element rectifier for impressing the voltage variations on the input electrode to control the gain. Wolfgang Kautter, assigned to Siemens & Halske. No. 1,931,660.

**Volume control.** Method for reducing the potential with respect to ground on the cathode of an amplifier as the volume of the selected incoming signal increases.

L. M. Perkins assigned to Delco-Remy Corp. Filed Aug. 15, 1929. No. 1,933,148.

**Direction finder.** Combination of a fixed beacon transmitting station, and a mobile receiving station, the beacon comprising means for transmitting waves whose instantaneous phase varies uniformly along the arc of a circle centering in the beacon and the receiver comprising phase discriminating means. P. H. Evans and J. W. Greig, assigned to B.T.L., Inc. No. 1,933,248.

**Dual-band receiver.** A t.r.f. coupling system to operate over two frequency bands, comprising a single primary winding and two secondary windings coupled thereto. The primary is shunted by a capacity of such value that the circuit is capacitively reactive to one of the frequency bands; a capacity coupling between the circuits including primary and secondary, and a switch to short-circuit one of the secondary windings to change the frequency bands. H. A. Wheeler, assigned to Hazeltine Corp. No. 1,933,402.

**Short wave system.** A beam transmitter adapted to mark out a course by emitting characteristic signals along each outer boundary comprising an oscillation generating system a directive radiating system, etc. Werner Ludenia, Berlin, assigned to Telefunken. No. 1,934,078.

**Short wave generator.** A high frequency generator of polyphase currents comprising at least three multiple discharge devices, etc. W. J. Brown, assigned to Associated Electrical Industries, Ltd., No. 1,934,523.

**Single control system.** Method of simultaneously changing the resonant points of several circuits in a heterodyne type receiver. Arthur G. D. West, Beckenham, England. No. 1,933,778.

**Diversity reception.** Method including collecting radiated energy of the same wave length at several geographically spaced points, separately amplifying and controlling each of these energies and combining them properly. Fritz Schröter and Wilhelm Runge, assigned to Telefunken. No. 1,934,211.

## Electron Tube Applications

**Train control system.** Two opposed sources of power, the voltage of one of which is determined by the speed of the train and the supplied voltage of the other of which is controlled by traffic conditions. A. G. Williamson, assigned to Union Switch & Signal Co. No. 1,933,780.

**Photographic apparatus.** Method of controlling the printing time by means of a light sensitive cell. C. M. Tuttle and D. A. Young, assigned to Eastman Kodak Co. No. 1,933,831.

**Automatic exposure system.** Method using a light sensitive cell for controlling the exposure of a film by automatically varying the intensity of the light by means of a diaphragm. G. Camilli, assigned to G. E. Co. No. 1,934,484.

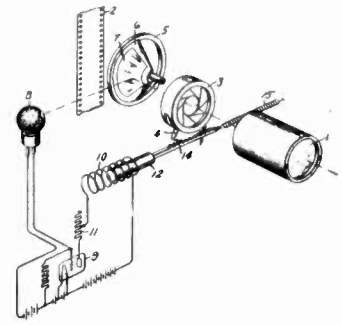

**D-C A-C system.** A vibrator-synchronous rectifier system for supplying high voltage d-c from a source of low voltage d-c. R. J. Rockwell, assigned to Crosley Radio Corp. No. 18,971.

**Translucent testers.** A device for determining the polarization effect of strains in a translucent substance such as a glass object by means of a source of polarized light, and photoelectric cell. R. S. Glasgow and A. L. d'Adrian, St. Louis, Mo. No. 1,934,187.

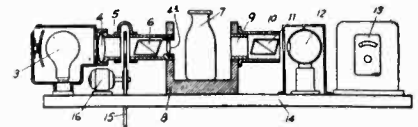

**Water softener.** Method of operating and actuating water softeners by means of photoelectric cells, etc. O. R. Sweeney and T. B. Clark, assigned to the Permutit Co. No. 1,931,968.

**Current measuring device.** Method of measuring a circuit carrying both alternating and direct current. P. F. Jackson, assigned to the Radio Products Co. No. 1,931,763.

**Deflection system.** Method for deflecting electron passage in a cathode ray tube, comprising saw-tooth voltage generating means, etc. T. Nakajima and K. Takayanagi, Japan. No. 1,933,219.

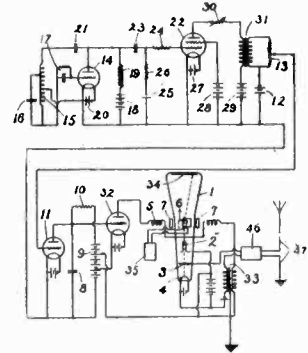

**Translating circuit.** Combination of an intermittently conductive grid controlled tube, a source of a-c for the grid circuit, a self-saturating transformer for converting a-c into a peaked wave form and rectifiers across the saturated transformer to bypass the negative half cycles of the peaked grid circuit potential. August Schmidt, Jr., assigned to G. E. Co. No. 1,935,460. See also No. 1,935,464 to C. H. Willis, assigned to G. E. Co. on a similar circuit.

**Velocity measuring apparatus.** Method of measuring the velocity of a fluid by a movable member whose vibrations are at a frequency substantially directly proportional to the velocity of the fluid and an indicating device comprising a rectifier meter. W. B. Heinz, assigned to G. E. Co. No. 1,935,445.

**Trouble detector.** A fault responsive apparatus including amplifying circuits for polyphase a-c system. Jean Fallou, assigned to G. E. Co. No. 1,935,439.

**Inverter.** Combination of a d-c supply circuit and a-c load circuit and a self-excited thermionic tube inverter. B. D. Bedford, assigned to G. E. Co. No. 1,935,431.

**Welding system.** A method of using an arc discharge device in a welding circuit for control. D. C. Prince, assigned to G. E. Co. No. 1,935,413.

**Electrical musical instrument.** Combination of a series of resilient vibrators vibrating at different periods, electro-mechanical means including a moving part connected to the vibrators, method for amplifying the impulses generated in this electro-mechanical means. V. H. Severy, assigned to Central Commercial Co. No. 1,935,215.

**Electrical sterilizing apparatus.** Method for sterilizing fluent material comprising a dielectric closed container and means for passing the material through it. K. E. Golden, assigned to Ray-dio-Ray Corp. No. 1,934,704.

## Amplification, Generation, Etc.

**Television system.** A two-way television system comprising scanning systems, receivers at each end, multiple light reflecting means, etc. H. E. Ives, assigned to B.T.L., Inc., filed Oct. 1, 1926. No. 1,932,253.

**Oscilloscope.** Cathode ray apparatus comprising a multi-vibrator having unsymmetrical plate circuits and grid-leak resistors, one of said resistors comprising a vacuum tube operated with constant plate current, and a timing wave connected across the other resistor. W. O. Osbon, assigned to W. E. & M. Co., application dated June 10, 1932. No. 1,934,322.

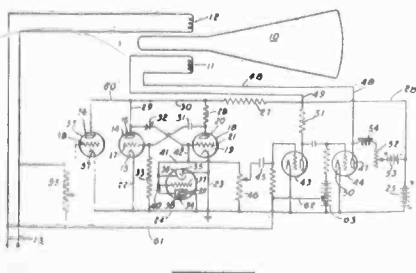

**Facsimile system.** Method of radiating heat from a point outside of the surfaces to be transmitted, collecting the heat rays and projecting the rays to a color surface. E. Wildhaber. No. 1,934,753.

**Modulating system.** Oscillations produced by a neon tube are modulated by a light sensitive cell. H. J. McCreary, assigned to Associated Electric Laboratories, Inc. No. 1,934,726.

**Detector circuit.** Method involving an auxiliary tube for securing a detector output circuit which rises rapidly at lower inputs and flattens off at higher

inputs. R. H. Galt, assigned to B.T.L., Inc. No. 1,935,316.

**Oscillation system.** A fundamental wave is supplied to the grid of a tube of a frequency which is an aliquot fraction of the desired frequency and of predetermined amplitude. Negative grid biasing voltage of such value that the constant component of the resulting control voltage is smaller than the amplitude is supplied to the grid. A tuned circuit in the output and coupled to the grid applies a compensating voltage to eliminate the action of the anode potential on the control voltage. Mauritz Vos, assigned to Ericsson. No. 1,934,574.

**Modulation system.** Patent granted to August Hund, assigned to Wired Radio. 36 Claims. Applied for May 17, 1926. Involves a modulating piezo electric crystal circuit. No. 1,933,735.

**Rectifier circuit.** Method of converting an input potential to a lower potential by connecting the potential to the plate-cathode circuit of the tube and taking out the desired potential from the grid-cathode. F. E. Terman, assigned to Wired Radio. No. 1,933,773.

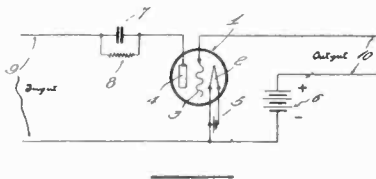

**Integrating circuit.** Electrical impulses varying in intensity are converted into impulses that are of substantially constant intensity, but which vary in duration by means of a triode, a glow discharge tube and an output relay. M. P. Hanson, assigned to Wired Radio. No. 1,933,976.

**Frequency divider.** Method of obtaining sub-multiple of an impressed frequency. W. F. Curtis, Washington, D. C. No. 1,933,970.

**Crystal control circuit.** Patent No. 1,933,967, to Albert Crosley, assigned to Wired Radio. Application filed Aug. 19, 1927.

**Frequency analyzer.** Method using several mechanical resonators having compliance couplings between to produce a beat frequency. T. M. Berry and M. S. Mead, Jr., assigned to G. E. Co. No. 1,933,306.

**Super-regenerative circuit.** Use of a glow tube for obtaining super-regenerative action. Rudolf Urtel, assigned to Telefunken. No. 1,931,950.

**Voltage regulator.** Method using a capacitive reactance and being saturated for inductive reactance to maintain voltage constant. H. A. W. Klinkhamer, assigned to R.C.A. No. 1,932,667.

**Electron coupled oscillator.** Use of a four element tube. The inner electrodes, namely, the cathode, the control grid and an inner anode are included in an oscillator circuit and an outer anode is used as an output electrode. J. B. Dow, Alexandria, Va. Application Feb. 10, 1931. No. 1,931,530.

**Volume control.** Method of controlling the transmission-frequency characteristics of an inter-stage system. S. D. Lavoie, assigned to R.C.A. No. 1,931,664.

**Frequency multiplier.** The grid of the tube is biased to the cut-off and when excited a means is provided for changing the bias in proportion to the change in the amplitude of the output current. E. Kramar and Hans Rochow, assigned to Lorenz. No. 1,931,870.

## Patent Suits

1,879,863, H. A. Wheeler, Volume control; 1,755,114, L. A. Hazeltine, Unicontrol signaling system; 1,755,115, same, Variable condenser, filed Sept. 14, 1933, D. C., S. D. N. Y., Doc. E 76/293, Hazeltine Corp. v. York Automotive Distributing Co., Inc.

1,901,735, A Crossley, Piezo electric crystal system; 1,627,958, same, Radio frequency choke coil system; 1,831,151, G. P. Walker, Temperature control system for frequency determining elements; 1,822,928, A. Hund, Piezo electric plate; 1,649,828, same, Method of preparing piezo electric plates; 1,683,093, Mirick & Crossley, Piezo electric crystal apparatus, filed Sept. 26, 1933, D. C., S. D. Ohio, W. Div., Doc. E 870, Wired Radio, Inc., v. Radio Station WFBE, Inc.

1,710,073, 1,714,191, 1,891,207, S. Ruben, Electrical condenser, filed Aug. 15, 1933, D. C., S. D. N. Y., Doc. E 76/231, Ruben Condenser Co. et al. v. Polymet Mfg. Co., Inc., et al

1,455,141, Lowell & Dunmore, Radio receiving apparatus; 1,606,212, same, Power amplifier; 1,635,117, F. W. Dunmore, Signal-receiving system, filed Aug. 17, 1933, D. C. Md., Doc. E 2193, P. D. Lowell et al. v. A. G. Triplett et al.

1,855,168, C. L. Farrand, Loud-speaker, filed Nov. 12, 1932, D. C., N. D. Ill., E. Div., Doc. 12536, Utah Radio Products Co. et al. v. Triangle Electric Co.

1,789,949, A. Georgiev, Electrolytic cell; 1,815,768, same, Electrolyte, filed Aug. 23, 1933, D. C., E. D. N. Y., Doc. E 7048, Aerovox Corp. v. McArnold Radio Corp.

1,195,632, W. C. White, Circuit connections of electron discharge apparatus; 1,239,852, F. K. Vreeland, Receiver of electrical impulses; 1,544,081, same, Transmitting intelligence by radiant energy; 1,251,377, A. W. Hull, Method of and means for obtaining constant direct current potentials; 1,297,188, I. Langmuir, System for amplifying variable currents; 1,573,374, P. A. Chamberlain, Radio condenser; 1,728,879, Rice & Kellogg, Amplifying system; 1,820,809, E. W. Kellogg, Electrical system, filed Aug. 30, 1933, D. C., S. D. N. Y., Doc. E 76/266, Radio Corp. of America et al. v. H. Antin et al. (A. H. Grebe & Co.).

1,231,764, F. Lowenstein, Telephone relay; 1,618,017, same, Wireless telegraph apparatus; 1,403,475, H. D. Arnold, Vacuum tube circuit; 1,465,332, same, Vacuum tube amplifier; 1,432,022, R. A. Heising, Circuit connection of electron discharge; 1,507,016, L. de Forest, Radio-signaling system; 1,507,017, same, Wireless telegraph and telephone system; 1,811,095, H. J. Round, Thermionic amplifier and detector; Re. 18,579, Ballantine & Hull, Demodulator and method of demodulation, filed Aug. 30, 1933, D. C., S. D. N. Y., Doc. E 76/265, Radio Corp. of America v. H. Antin et al. (A. H. Grebe & Co.).

# BRITISH PATENTS IN THE FIELD OF ELECTRONICS

## Electron Tube Application

**Statistical machine.** Cards bearing numbers are placed so that one of the first characters of the number is imaged by means of a photo-electric device, etc., to actuate registering or recording mechanism. P. W. Handel, assigned to British Thomson-Houston Co., Ltd. No. 396,504.

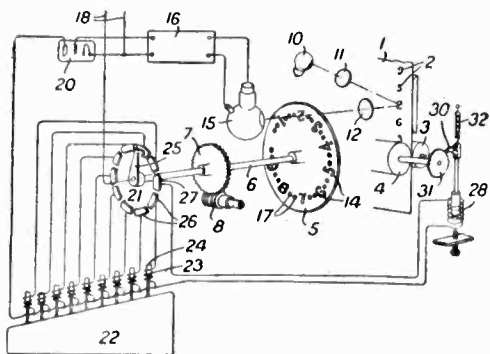

**Automatic steering apparatus.** Method of steering aircraft or other moving craft automatically in accordance with a course determined by a magnetic compass and also in accordance with signals received from a radio beacon when the craft drifts from the course. An earth inductor compass is used and gyroscopic means are provided for correcting for the vertical component of the earth's magnetic field due to tilting of the compass platform during a turn. E. F. W. Alexanderson, British Thomson-Houston Co. No. 396,547.

**Remote control.** A relay adapted to close a local circuit to sound an alarm, or to start up a machine or to control the steering gear of a moving craft in response to a wireless signal, comprises two moving systems mounted in the field of a magnet and so arranged that current supplied to a terminal flows first through a coil to a brush and then to another brush and through a second coil in the reverse direction. Any change in the strength of the current fed to the terminals moves the two coils in opposite directions, closes the contacts and energizes a buzzer. C. L. P. Dean and C. W. H. Begbie, Brighton. No. 396,753.

**Facsimile and picture transmission.** Transmission is keyed or intermittently interrupted in accordance with the picture signals to compensate at the receiver for variations in the general intensity of the signals by fading or interference. The degree of amplification of the receiver is automatically adjusted at predetermined time intervals in accordance with the intensity of the incoming signals. Lorenz. No. 396,811.

**Course indicator.** Method of maintaining an aircraft or other moving craft on a direct course toward its destination despite any tendency to drift by steering it automatically in accordance with a magnetic or gyroscopic compass associated with a directive antenna. British Thomson-Houston Co. No. 393,436.

**Railway communication.** Method of communicating to or between moving vehicles or between different parts of a train on a track by means of a high frequency transmission line alongside the track. British Thomson-Houston Co. No. 393,440.

**Arc lamp control.** Apparatus for returning a moving source of radiation such as an electrode to its correct position consisting of two thermostatic devices. Carl Zeiss. No. 393,530.

**Apparatus control.** Thermally uniting or dividing metal sheets. Radiant energy emitted by the work immediately ahead of the weld controls the process through an amplifier photocell system. J. H. Buckman and L. W. Young, Buffalo, assigned to Linde Air Products Co. No. 393,411.

**Delay circuits.** Time-lag device for keeping a door open for a predetermined time after phototube has been shaded by a passing person, etc. A charged condenser is utilized. Lyons & Co., Ltd. No. 392,928.

## Amplification Detection, Etc.

**Filter system.** A band-pass type filter structure for inter-stage coupling provided with a certain amount of feedback. Philips. No. 395,111.

**Light sensitive cell amplifier.** To minimize the effect of temperature, humidity, age, etc., on selenium and like cells, the cell is subjected to a flickering light additional to the controlling light. P. J. Heaton, London. No. 395,422.

**Inter-carrier noise suppression circuit.** A sharply tuned selective circuit for applying energy of carrier frequency to the rectifier, the output from which controls the demodulated output of the receiver so that the output is suppressed unless the voltage across the selective circuit exceeds a predetermined minimum. M. G. Nicholson, Marconi Co., Nov. 25, 1932. No. 395,569.

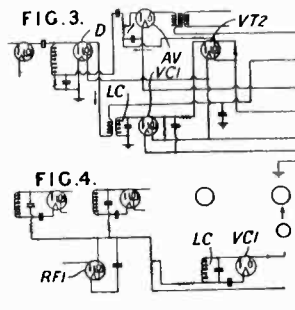

**Volume compressor.** Circuit connected in shunt to a transmission line, the impedance of which is adapted to be varied inversely as a root of the applied signal current by a control device whose output is proportional to a root of the input, and a corresponding expander for restoring the volume range comprising one or more tubes in series with the line the impedance of which is controlled by a device having a linear input-output characteristic. E.R.P.I., N. C. Norman. No. 396,046.

**Modulation system.** A radio transmitter is modulated according to an exponential curve. The demodulating characteristic of the receiver is of the same form. The advantage is that the rectified signal strength depends only on depth of modulation so that signal strength is not affected by fading. Telefunken. No. 395,840.

**Transmission line.** Used in a broadcast redistributing system in which a single aerial is coupled to a transmission line and then to several receivers. Telefunken. No. 396,008.

## TELEVISION SYSTEM

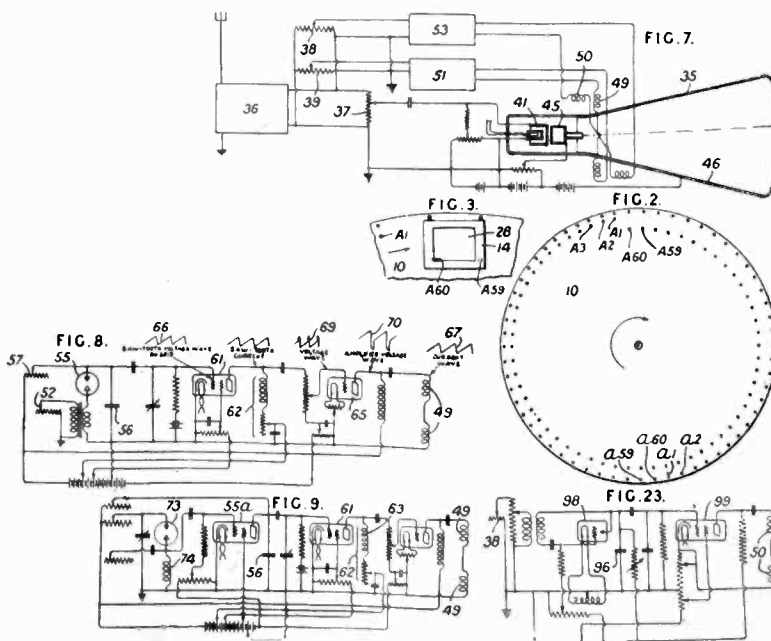

Patent granted to A. W. Vause, Marconi Company. Involves cathode ray tube, synchronizing signals developed by a Nipkow disk, etc., etc. No. 395,499

# Index to electronics—Volume VI

January to December issues, inclusive, 1933

McGraw-Hill Publishing Company

330 West 42nd Street, New York City

## Pages by Issues

January	1-30
February	31-58
March	59-86
April	87-116
May	117-146
June	147-176
July	177-206
August	207-236
September	237-264
October	265-294
November	295-322
December	323-354

(ed) Editorial \* Illustrated (N) News

## Acoustics:

Acoustically compensated volume control for radio and phonograph sets. Wolff & Cornell	*50
Perforated steel sheets pass sound waves	222
Radio acoustic ranging. Davis Belcher	*308

## Aeronautics:

Every radio station a guide for airmen	*310
Radio system for landing aircraft during fog. H. Diamond	*158

## Amplifiers:

Acoustically compensated volume control for radio and phonograph sets. Wolff & Cornell	*50
Bridge type push pull amplifiers. Leonard Tulauskas	*134
Fidelity compensation by regeneration	18
Filter type interstage amplifier coupling. W. G. Stone	*194
High gain a.c. d.c. amplifier. E. R. Meissner	*195
Push pull amplifier graphics. C. E. Kilgour	*73

Book reviews. 22, 42, 77, 101, 131, 206, 287

## Broadcasting:

Audition panel at KFWB	*221
Controlling receivers from the broadcast transmitter	*327
"Facsimile" to the aid of the broadcasters (ed)	139
550 versus 1,500 kilocycles (ed)	20
Long versus short broadcast waves	19
NBC's new Radio City studios	*324
Proper sites for broadcast stations. C. W. Horn	*66
Radio broadcast problems gather. Simplified method of modulator design. E. A. Laport	*184
Suppression of transmitter harmonics. C. G. Dietsch	*167
Time delay effects in synchronous broadcasting. C. B. Aiken	*124

## Cathode Rays:

Cathautograph: an electronic pencil. A. B. Dumont	*7
Cathode ray tubes for oscillograph purposes. R. T. Orth	*332

## Century of Progress:

Electronics at the Chicago World's Fair	*148
---	------

## Codes:

Code and the engineer	*246
NRA radio industry code	208
RMA accepts NEMA code	239
Coils, broadcast receiver. F. N. Jacob	210
Condensers, electrolytic. R. O. Lewis	*212

## Electron Tubes:

Advertising possibilities with electron tubes	133
Electronic microscope—studies of electronic emission	49
Electronic tube microscope. M. Knoll	*243
Ignition—new controlled rectifier. D. D. Knowles	*164
Radio City theaters' electron tubes	*32
Electronic periodicals	24

## Electrons:

Faster electrons	*216
------------------	------

## High Frequency:

Expanding ultra short wave radio	*266
High frequency waves kill pests in beans	193
Short waves bake crustless bread	163
Tubes to fit the wavelength. B. J. Thompson	*214

## Lights and Lighting:

Control by non-linear circuits	*19
Controlled school lighting	255
Daylight control of factory lighting saves electricity	14
Illumination control in offices	*268
Opposed photonic cells responsive independent of general illumination	44
Photocell street lighting	74
River marking lights photocell controlled	103
Sodium vapor illuminants	*189

## Measurements:

Calibration of low audio frequencies. E. R. Meissner	137
Cathode ray tubes for oscillograph purposes. R. T. Orth	*332
Cuprous-Oxide rectifier life tests	18
Frequency comparison with the cathode ray oscillograph. C. B. Fisher	*310
Low range electrostatic voltmeter. W. P. Koehel	*252
Magnetostriction oscillator	104
Measuring one billion ohms. I. J. Saxl	171
Measuring pressure and weight	103
Measuring the damping coefficient of oscillating circuits	18
Measuring the intensity of 700 Kv. X-rays	*170
New impedance measuring device. A. W. Barber	*194
Oscillator circuit measures humidity. Phantom tester. Knowles & Haller	*248
Rectifier for modulation measurements. J. L. Potter	*247
Resistance stabilized oscillators. F. E. Terman	*190
75 watt commutator type inverter. H. J. Reich	*252
Shorted turn indicator. C. G. Seright	*136
Simultaneous traces with cathode ray oscillograph. C. B. Brown	*170
Square top filters	*136
Thyratron laboratory rectifier. R. M. Kime	*219
Ultra short wave wavemeters. W. H. Moore	*311

## Music:

Controls fountains in changing colors	223
Electronic musical instruments of Europe and U. S.	*65
Transmit "auditory perspective" in music	*118
National Industrial Recovery Act—and radio	*178
New products	25, 56, 82, 111, 142, 174, 200, 231, 261, 288, 317, 348

## Noise:

Suppression of auto radio noise. Browning & Haskins	*273
---	------

## Patents:

British patents	30, 86, 116, 146, 204, 236, 294, 323, 352
U. S. patents	28, 58, 85, 114, 144, 202, 233, 264, 291, 326, 350

## Photo-Electric Cell:

Cesium-oxygen silver photo cell	49
Comparison of photocells	171

## Photo-Electric Cell—Industrial Applications:

Bar and rod heating controlled by electric eye	103
Batching of cement	*268
Color matching in automobile plant	162
Color measuring instruments. Herbert Neustadt, Jr.	*128
Control of wood pulp cooking	75
Controlling water supply	103
Counting crates on conveyors	14
Demand charges saved by cell	223
Detects smoke or fire	306
Detects turbidity in Denver water supply	*306
Directs register of cutting knife	*269
Installing photocell control. R. D. McDill	*276
Insures perfect jigsaws	*163
Laundry conveyor operated by photocell	*162
List of photocell applications	*270
Looking ahead as 1933 opens	*2
Mine doors photocell controlled	278
Muff photocell checks up theater admissions	193
Newspaper measures opacity of paper stock	14
Oil burning plant safeguarded by cell	222
Packaging machines controlled by photoelectric cell. E. L. Smith	*302
Photo-electric half-tone engraver	222
Photo-electric photometer tests air purity	45
Photo-electric U-V photometers	105
Photometry of stars by means of a photocell and a low grid current tube	49
Press stop operated by photocell	75
Reflectometer compares "amount of ink" in print	193
Rotation of frictionless meter counted	44
Safety ray elevators at Radio City	*269
Soaking pit covers operated by phototubes	306
Stroboscope inspects high speed printing	14
Stroboscopic testing of meters	15
Thermometer control by photonic cell	*74
Truck garage doors controlled by photocell	*132
Voting by means of cells	222
Web control of printing press	102
Public address at the Century of Progress	*274

## Radio:

Audio-radio increasing in 1933	*8
Back to quality in radio receivers! (ed)	106
Cabinet design. R. K. Gerth	*182

Changes in sun spot numbers 1923 to 1932 give clue to radio vagaries...	*69
Circuits for amplified automatic volume control	*16
Controlling receivers from the broadcast transmitter	*327
Dual band receiver design. Edgar Messing	*300
Electronics in resistor manufacturing. Leon Podolsky	*180
Forest fire fighting helped by radio	223
Gaseous discharge tubes for radio receiver use. J. F. Dreyer, Jr.	*40
How manufacturers can cash in on radio prosperity campaign. Earl Whitehorse	218
Inter carrier noise suppression. N. E. Wunderlich	*13
Killing weevils in wheat by short wave	75
NBC's new Radio City studios	*324
Night radio effects	194
Prices of components tend to stabilize	64
Recent advances in the radio art	*328
Reflex circuit considerations. Stinchfield & Schade	*153
Statistics of production and use	60
System for landing aircraft during fog. H. Diamond	*158
This new radio prosperity?	*296
Time to re-style radio sets is now!	*88
Trends in radio design and manufacturing	*151
When will radios be styled for sales appeal? W. D. Teague	*62
Radio City theaters' electron tubes	*32
Review of electronic literature here and abroad. 23, 54, 80, 108, 140, 198, 228, 258, 286, 314, 346	

**Sound Pictures:**

Control of sound quality in picture production. Carl Dreher	*10
Ounce crystal microphone carried on fish-pole	*102
Outdoor automobile movie	*209
"Rogue's gallery" of talking films	45

**Speakers:**

Central secretarial staff employs loudspeakers	74
Loudspeaker cost vs. quality. H. S. Knowles	*240

**Superheterodynes:**

Iron core intermediate frequency transformers. Alfred Crossley	*298
Litz wire coils for i-f and r-f transformers *303, pt. 2	*342

**Television:**

Balance sheet of television	323
Zworykin's iconoscope	*188

**Thyratron:**

As an oscillator	18
Control of welding in tube manufacture. Lord & Livingston	*186
Discharging condenser	*105
Electronic phase failure relay. Stansbury & Brown	*46
Initial impulse indicator. Livingston & Lord	*257
Kathetron. P. H. Craig	*70
Magnetic control of mercury vapor rectifier tubes. H. J. Reich	48
Single tube thyratron inverter. Livingston & Lord	*96
Thyratron controlled voltage rectifiers. H. W. Hartman	*43

**Traffic Control:**

Electric signs controlled by traffic lights	163
---	-----

**Transformers:**

Iron core intermediate frequency transformers. Alfred Crossley	*298
Litz wire coils for i-f and r-f transformers *303, pt. 2	*342
Transformers. W. J. Leidy	212

**Vacuum Tubes:**

Calculating machines and vacuum tubes	*224
Cold cathode amplifier tube. Reich & Hesselberth	*282
Combined photo and amplifier tubes. H. A. McIlvaine	*224
Detector-output tube systems. J. R. Nelson	*94
Device for temperature regulation of mercury vapor tubes. Stansbury & Brown	*104
Electron emitting alloys of nickel and barium. Randolph, Duffendack & Wolfe	*244
Emission valve modulator for superheterodynes. H. A. Wheeler	*76
Gaseous discharge tubes for radio receiver use. J. F. Dreyer, Jr.	*40
Graphite anodes in transmitting tubes. D. E. Replogle	*338

Manufacture of mercury vapor rectifier tubes. P. G. Weiller	*99
New amplifiers—detectors and rectifiers	35
New low noise vacuum tube	18
New tubes—new tube materials	93
Nickel in radio tube manufacture. A. J. Marino	*4
Role of vacuum-tubes in a tube factory. W. P. Koechel	*121
Thermionic cathodes for gas filled tubes. E. F. Lowry	*280
Thermionic tetrode voltage control	*19
Tubes with cold cathodes. August Hund	*6

**Vacuum Tubes—Applications:**

Aids in manufacturing electronic apparatus	*90
Control of temperature in crystal ovens	*253
Electron tube time-delay relay. G. C. Holloway	*220
Orientation mechanism. A. L. Rubenstein	*225
Relays for electronic devices	*36
Smoke precipitation with electronic rectifiers	254
Thyratron control of welding in tube manufacture. Lord & Livingston	*186
Vacuum tube delay circuits. M. W. Muehter	*336
Variable speed motor with vacuum tubes	*192

**X-Rays:**

Industrial X-rays for examining metals	45
--	----

**AUTHORS' INDEX**

<b>AIKEN, CHARLES B.</b> Time delay effects in synchronous broadcasting	*124
---	------

<b>BARBER, ALFRED W.</b> New impedance measuring device	*194
Belcher, Davis. Radio acoustic ranging	*308
Brown, C. B. Simultaneous traces with cathode ray oscillograph	*170
Brown, G. C. and C. Stansbury. Device for temperature regulation of mercury vapor tubes	*104
Electronic phase failure relay	*46
Browning, G. H. and Rupert Haskins. Suppression of auto radio noise	*273

<b>CORNELL, J. I., and I. WOLFF.</b> Acoustically compensated volume control	*50
Craig, Palmer H. Kathetron-control tube with external grid	*70
Crossley, Alfred. Iron core intermediate frequency transformers	*298

<b>DIAMOND, H.</b> Radio system for landing aircraft during fog	*158
Dietsch, Carl G. Suppression of transmitter harmonics	*167
Dreher, Carl. Control of sound quality in picture production	*10
Dreyer, John F. Jr. Gaseous discharge tubes for radio receiver use	*40
Duffendack, O. S., D. W. Randolph and R. A. Wolfe. Electron emitting alloys of nickel and barium	*244
Dumont, Allen B. Cathautograph; electronic pencil	*7

<b>FISHER, C. B.</b> Frequency comparison with the cathode-ray oscillograph	*310
Free, E. E. To warn truck drivers to turn out for motorists	307

<b>GERTH, RUTH KOCH.</b> Radio cabinet design	*182
---	------

<b>HALLER, C. E., and D. D. KNOWLES.</b> Phantom tester	*248
Hartman, H. W. Thyratron controlled voltage rectifier	*43
Haskins, Rupert, and G. H. Browning. Suppression of auto radio noise	*273
Hesselberth, Wilfred M., and H. J. Reich. Cold cathode amplifier tube	*282
Holloway, G. C. Electron tube time delay relay	*220
Horn, C. W. Proper sites for broadcast stations	*66
Hund, August. Tubes with cold cathodes	*6

<b>JACOB, F. N.</b> Broadcast receiver coils	210
--	-----

<b>KILGOUR, C. E.</b> Push-pull amplifier graphics	*73
Kime, R. Milford. Thyratron laboratory rectifier	*219

Knoll, M. Electronic microscope	*243
Knowles, D. D. Ignitron—a new controlled rectifier	*164
Knowles, D. D., and C. E. Haller. Phantom tester	*248
Knowles, Hugh S. Loudspeaker cost vs. quality	*240
Koechel, W. P. Low range electrostatic voltmeter	*252
Role of vacuum tubes in a tube factory	*121

<b>LAPORT, E. A.</b> Simplified method of modulator design	*184
Leidy, W. J. Transformers	*212
Lewis, R. O. Electrolytic condensers	*212
Livingston, O. W., and H. W. Lord. Initial impulse indicator	*257
Single tube thyratron inverter	*96
Thyratron control of welding in tube manufacture	*186
Lord, H. W., and O. W. Livingston. Initial impulse indicator	*257
Single tube thyratron inverter	*96
Thyratron control of welding in tube manufacture	*186
Lowry, E. F. Thermionic cathodes for gas filled tubes	*280

<b>MARINO, A. J.</b> Place of nickel in radio tube manufacture	*4
McDill, Rex D. Installing photocell control	276
McIlvaine, H. A. Combined photo and amplifier tubes	*224
Meissner, Earl K. Calibration of low audio frequencies	137
Messing, Edgar. Notes on dual band receiver designer	*300
Moore, W. H. Simple ultra short wave wavemeters	*311
Muehter, M. W. Vacuum tube delay circuits	*336

<b>NELSON, J. R.</b> Detector-output tube systems	*94
Neustadt, Herbert, Jr. Photoelectric color measuring instruments	*128

<b>ORTH, R. T.</b> Cathode ray tubes for oscillograph purposes	*332
--	------

<b>PODOLSKY, LEON.</b> Electronics in resistor manufacturing	*180
Potter, J. L. Rectifier for modulation measurements	*247

<b>RANDOLPH, D. W., O. S. DUFFENDACK and R. A. WOLFE.</b> Electron emitting alloys of nickel and barium	*244
Reich, Herbert J. Magnetic control of mercury vapor rectifier tubes	48
75-watt commutator type inverter	*252
Reich, Herbert J., and W. M. Hesselberth. Cold cathode amplifier tube	*282
Replogle, D. E. Graphite anodes in transmitting tubes	338
Rubenstein, A. L. Orientation mechanism	*225

<b>SAXL, IRVING J.</b> Measuring one billion ohms	171
Schade, O. H., and J. M. Stinchfield. Reflex circuit considerations	*153
Seright, C. G. Short turn indicator	*136
Smith, E. Lovell. Photoelectric control on packaging machines	*302
Stansbury, C., and G. C. Brown. Device for temperature regulation of mercury vapor tubes	*104
Electronic phase failure relay	*46
Stinchfield, J. M., and O. H. Schade. Reflex circuit considerations	*153
Stone, Wallace G. Filter type interstage amplifier coupling	*194

<b>TEAGUE, WALTER D.</b> When will radios be styled for sales appeal?	*62
Terman, F. E. Resistance stabilized oscillators	*190
Thompson, B. J. Tubes to fit the wavelength	*214
Tulaskas, Leonard. Bridge type push pull amplifiers	*34

<b>WEILLER, PAUL G.</b> Notes on the manufacture of mercury vapor rectifier tubes	*99
Wheeler, Harold A. Emission valve modulator for superheterodynes	*76
Whitehorse, Earl. How manufacturers can cash in on radio prosperity campaign	218
Wolfe, R. A., D. W. Randolph and O. S. Duffendack. Electron emitting alloys of nickel and barium	*244
Wolff, I., and J. I. Cornell. Acoustically compensated volume control	*50
Wunderlich, Norman E. Intercarrier noise suppression	*13

# *A big difference in size, but* **both molded complete** **in one operation**



INCREASING SALES indicate that Bakelite Molded was the logical material to use for the case of the pocket size radio receiver. It is also equally practical, and has many advantages for the cases of large size receivers. The largest shown is over 18" high, 15" wide, 9½" deep.

These large Bakelite Molded cases are not only exceptionally fine in appearance, but through having bosses, lugs and ribs formed, and metal inserts embedded during the molding operation, assembly operations become simpler and more accurate.

Another advantage of Bakelite Molded is that it lends itself equally well to both conservative and modern designs, and to the use of metal inlays. We would be glad to discuss the question of both the design and production possibilities and advantages of using Bakelite Molded for your radio receiver cases, and show you some of the things already accomplished through the use of this material.

Illustrated booklet 13M "Bakelite Molded" tells the story of the various types of Bakelite Molding Materials and their applications. Your request will bring a copy by return mail.

BAKELITE CORPORATION, 247 Park Avenue, New York, N. Y. . . . . 43 East Ohio Street, Chicago, Ill.  
 BAKELITE CORPORATION OF CANADA, LIMITED, 163 Dufferin Street, Toronto, Ontario, Canada

## BAKELITE

The registered trade marks shown above distinguish materials manufactured by Bakelite Corporation. Under the capital "B" is the numerical sign for infinity, or unlimited quantity. It symbolizes the infinite number of present and future uses of Bakelite Corporation's products.

**THE MATERIAL OF A THOUSAND USES**

# ENDURING ACCURACY

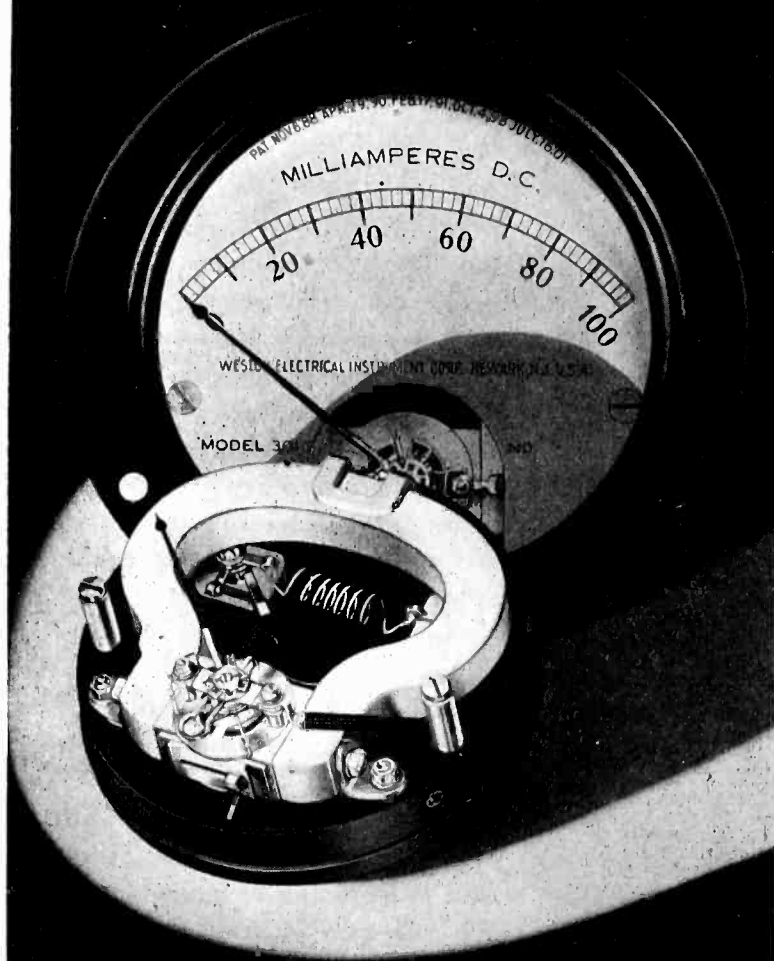

Even the smaller line of Weston Instruments embodies Weston balanced design, positive alignment of all parts to exacting tolerances and precise craftsmanship. This explains why Weston accuracy endures—why each instrument bearing the Weston name gives long, dependable service . . . WESTON ELECTRICAL INSTRUMENT CORPORATION, 618 Frelinghuysen Avenue, Newark, N. J.



## WESTON

*Radio Instruments*

## HIGH-FIDELITY SOUND REPRODUCTION

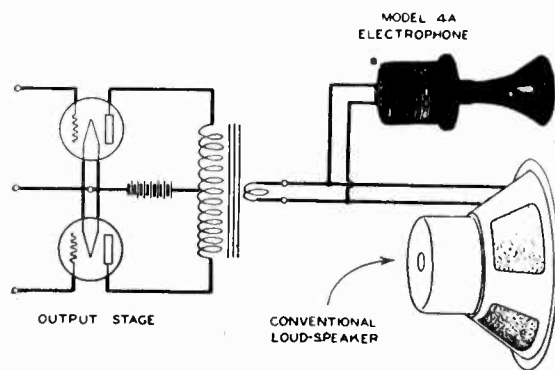

Now Simply Obtained By Adding the New Model 4A High-Frequency Electrophone To Existing Equipment.

The range of sound reproduction may be considerably extended at the high frequency end by connecting a Model 4A Electrophone unit across your present loud speaker as shown by diagram.

### NO FILTERS OR FIELD SUPPLY REQUIRED

Due to the parallel combination of capacitive reactance of the piezoelectric diaphragm employed in this unit and the inductive reactance of the low-frequency speaker the power divides naturally between the two units. No field excitation required. This results in a simplicity and saving of cost not possible with other types.

Send for Free Technical Bulletin 1K

## ELECTROPHONE CORPORATION

2019K Rittenhouse Square, Philadelphia

## Pyranol Condensers

Cornell-Dubilier pyranol-impregnated condensers are available in three standard D.C. working voltages: 1000-volt, 1 to 10 mfd.; 1500-volt, 1 to 6 mfd.; 2000-volt 1 and 2 mfd. These units feature:

- 50% reduction in cubic volume and weight over previous units, without sacrificing life.
- Non-inflammable impregnator, permitting use in hazardous locations.
- Operation at high ambient temperatures destructive to former ordinary types.
- Leakage resistance and power factor change far less at high temperatures than with other units.
- Steel containers, substantial, hermetically sealed, in standard sizes for multiple assemblies.
- And best of all, a marked reduction in price because of this newly patented impregnator!

Be sure to look further into the striking features and advantages of Cornell-Dubilier pyranol-impregnated condensers. They'll save you money and provide a better, more lasting and more economical assembly.

Write for data on pyranol-impregnated condensers as we'll send the new 1934 Cornell-Dubilier catalog covering entire line.



## CORNELL-DUBILIER CORPORATION

4377 Bronx Blvd. New York City



KENYON



PRODUCTS

# KENYON RUGGEDNESS

The superlative tone quality of KENYON Laboratory Standard Audio Components is an established fact. Such equipment is found in leading laboratories, in broadcasting stations, in recording studios, in colleges and Government departments and other places where nothing but the best will serve.

But in addition to superlative tone and initial satisfaction, there is the added feature of ruggedness. These components are more than generously designed and built—for lasting satisfaction. Which fact, in many instances, makes them the best investment in the long run.

## LABORATORY GRADE COMPONENTS



Five essential requirements of ideal audio transformer practice have been incorporated in these components—uniform response, low wave form distortion, high efficiency, effective shielding, and reliability. Unexcelled tone quality whether alone or in groups. Units housed in electrically symmetrical cases of high permeability cast iron. Cross-talk proof. Also proof against A.C. hum pickup. Electrostatic shielding in coil structure. Thoroughly impregnated and sealed in moisture-proof compound to nullify adverse climatic effects.

These components are available in a wide range of types—input, output, Class A and B, coupling, mixing, matching, filament, power, reactors, etc., for every conceivable need.

## BALANCED ASSEMBLIES

KENYON components may be readily assembled for any laboratory, recording, broadcasting, public address or other need. In addition to superlative components, KENYON engineering service also features in providing outstanding performance and satisfaction. The above assembly is a KENYON pure D.C. filament supply for horizontal mounting—typical of KENYON neatness and ruggedness.



## ADVANCED ENGINEERING AID

For over eight years KENYON research and engineering have been unstintingly devoted not only to the development of a superior line of iron-core devices, but also to the advancement of the sound reproducing art. A vast fund of experience, engineering talent and special production facilities is always at your disposal. Submit your problems to us. Let us consult with you on special designs and requirements.

## SEND FOR ENGINEERING DATA

The latest KENYON catalog—just out—contains much information on transformers and the latest amplifying art including diagrams for the use of recent tubes. Write for your copy.



KENYON TRANSFORMER CO., Inc.

122-124 Cypress Avenue - - - New York City

Here's a smart performer, the new Automatic Tom Thumb, Jr., an AC-DC, 25-60 cycle set, using 5 new-type tubes.

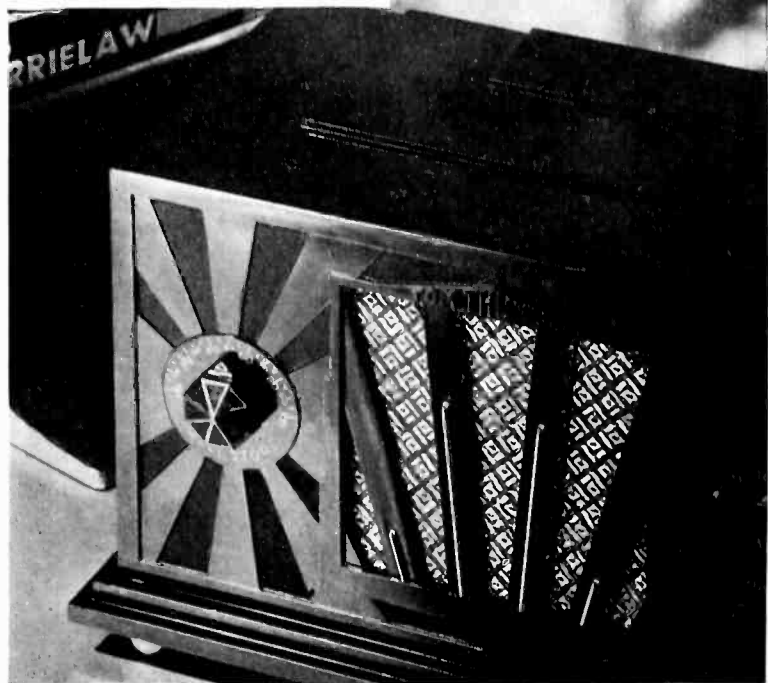

# People like them MOLDED

Planning a new midget? Tired of the over-worked shapes and styles necessary with older cabinet materials? Then mold it of Durez, the newer, smoother molding compound. Scores of new designs are possible—designs that give your set identity and sales appeal, plus production advantages.

Molded Durez cabinets are richer, glossier, smoother, free from waviness. They come from the mold completely finished, uniform, ready for assembly. They're heat and moisture proof, walls and corners are thinner, inserts automatically imbedded, and they're warp-proof, chip-proof, seamless. Smart contrasts, like black and chromium, brown and coppers, or metal or wood inlays, as well as smooth solid colors, are possible. And the more you make, the more economical they are.

We'll gladly arrange contacts with experienced designers and molders. For further details, samples, etc., write General Plastics, Inc., 1212 Walck Road, N. Tonawanda, N. Y.

# DUREZ for Smoothness

# GOAT

*form-fitting*

## TUBE SHIELDS

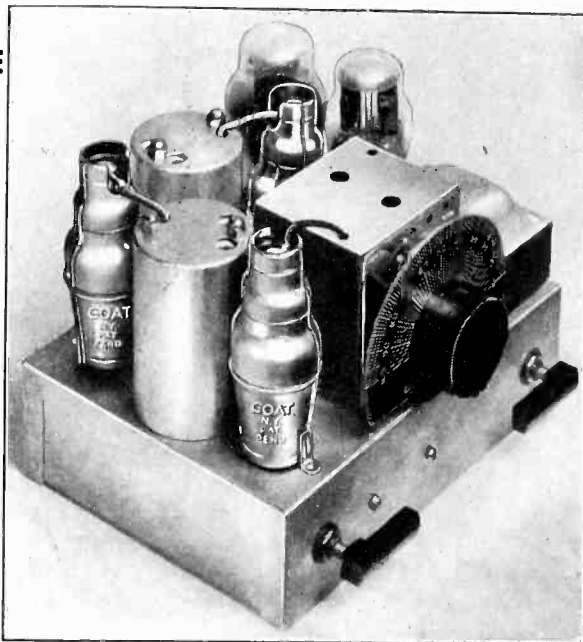

*For better protection against man-made interference in short wave and auto radio use*

**EXPOSURE** to sources of man-made interference makes the problem of shielding in auto radio design and short wave one of outstanding importance.

Goat Tube Shields are ideal for this service. They not only assure better shielding because of their close form-fitting, but effect savings in chassis size, weight and mounting. In addition they cost less to use than the old-fashioned "can" shields.

From every angle, Goat Tube Shields, available for all modern tubes, will help you improve auto radio and short-wave design and performance. Ask for full information and samples.



**GOAT**  
**RADIO TUBE PARTS**  
 INCORPORATED  
 314 Dean Street  
 BROOKLYN, N. Y.



# ENAMELITZ

Reduce manufacturing costs on I.F. and R.F. coils through the use of Enamelitz—"Litz" wire without a fabric covering.

Three Fold Savings—

1. Cost of wire
2. More coils per pound of wire
3. Less space—Greater safety

*Sample and Technical Bulletin on Request.*

### *Other Acme Wire Co. Products*

**Magnet Wire (all insulations)**

**Coils, Magnet Wire Wound**

**Varnished Insulations**

(Cambric, paper, silk, tape)

**Parvolt Condensers**

(Filter, By-pass, Power Factor Correction)

**Aerial Wire**

(Stranded and Solid—Bare or Enameled)

*For over 25 Years, suppliers to the largest radio and electrical manufacturers.*

**THE ACME WIRE CO.**

New Haven, Conn.

*You Can Depend On It*

Resinox maintains a high standard of quality which assures uniformity in molding, and enthusiastic acceptance from manufacturer and user. You can depend on Resinox for clean, uniform results . . . every time.

KEEP IN TOUCH WITH RESINOX DEVELOPMENTS

Specify

# RESINOX

Molding Resins

Molding Compounds

Laminating Varnishes

**RESINOX CORPORATION**

Subsidiary of Commercial Solvents Corporation and Corn Products Refining Company  
 230 Park Avenue, New York City

# GIANTS

in carrying capacity

# MIDGETS

in Size



## GLOBAL BRAND

### Giant-Midget Resistors

Now available, a new series of Global Resistors—Tom Thumbs in size—Goliaths as carriers.

*Glad to send samples and complete information as to sizes, wattages, etc.*

## GLOBAL CORPORATION

A Subsidiary of The Carborundum Company  
Niagara Falls, N. Y.

Manufacturers'-Type

## PADDING AND TRIMMING CONDENSERS

by HAMMARLUND

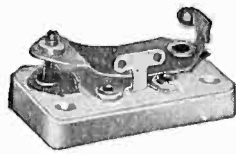

"MICS"



"BBT"

**T**HE perfected result of years of specialization on condensers for padding, trimming, aligning and compensating purposes. Standard equipment in the leading makes of receivers.

**Type "MIC":**—Made in four stock capacities (*single and dual*) from 10 mmf. to 1000 mmf. Other capacities to order. Isolantite base; phosphor bronze spring plate; mica dielectric.

**Type "BBT":**—A midget trimmer used chiefly for automobile and other small radios. Made in three capacity ranges (*single and dual*); 25 to 220 mmf. Special ranges to order. Bakelite or metal base; phosphor bronze spring plate; mica dielectric.

Write Dept. E-12 for Complete Catalog

For Better Radio  
**Hammarlund**  
PRECISION  
PRODUCTS

HAMMARLUND  
MFG. CO.,

424 W. 33rd St.,  
New York

# SHAKEPROOF

**FOUND!** *a new way to save money!*



**BUILD THE  
SHAKEPROOF  
Locking Principle  
INTO YOUR  
STANDARD PARTS**

**S**OME time ago a smart designing engineer discovered that he could save money for his firm and provide better performance for his product by incorporating the Shakeproof locking principle into certain standard parts. Since then several leading manufacturers have also taken advantage of this practical idea.

Possibly you have a part on your product where this money-saving method can be employed. If you have, you should consult Shakeproof's engineers immediately. It saves the purchase of separate lock washers because the twisted teeth are built right into the part. Each tooth bites into both nut and work and there is no possible movement of the part regardless of how great is the vibration.



"It's the Twisted Teeth that LOCK!"

Be sure to look into this new method for cutting costs—look over your product to see where it can be used and then write for a Shakeproof engineer to discuss the matter with you personally. No obligation, of course, so write us today!

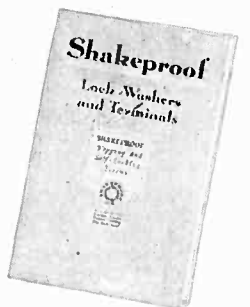

Send today for your free copy of this complete Shakeproof Catalog. Explains thoroughly the many advantages that Shakeproof offers—also shows new patented Shakeproof products.

# SHAKEPROOF Lock Washer Company

{Division of Illinois Tool Works}

2539 N. Keeler Ave.

Chicago, Ill.



Type 12.  
Internal



Type 11.  
External



Type 15.  
Countersunk



Type 20. Locking  
Terminals

U. S. Pat. 1,419,564—1,604,122—1,697,954—1,782,387—Other Pat. Pending—Foreign Pat.

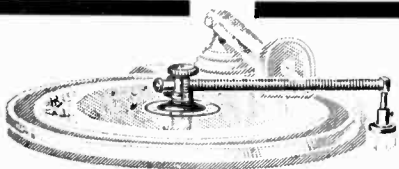

**UNIVERSAL  
Phonograph  
Recording  
Lead Screw**

For simultaneous grooving and recording—Cuts 80 lines per inch—Quick, easy installation—Machine cut gears—Accurate. Drives from center of turntable—Now offered at the extremely low price of \$10.00 List. Sold by dealers and jobbers everywhere. (Standard Discounts.)

**Double Faced, Processed Aluminum Discs**

for Phonograph Recording—either Blank or Pregrooved—Sizes, from 6 in. to 16 in. List Prices, from 30 cents up—Special Prices in Quantities. Booklet "Simplified Home Recording" sent on receipt of 10c Stamps or Coin. (Standard Discounts.)



**UNIVERSAL MICROPHONE CO., Ltd.**  
424 Warren Lane Inglewood, Calif., U. S. A.

# CANDOHMS

ARMOURED WIRE WOUND RESISTORS

## WILL LOWER YOUR COSTS

OVER SEVEN MILLION IN USE  
MAY WE SAMPLE AND QUOTE

## THE MUTER COMPANY

1255 So. Michigan Ave., Chicago

# COILS . . .

**RADIO FREQUENCY COILS:** R.F. coils for radio manufacturers. Coils manufactured with the utmost precision. Our special designed testing equipment guarantees complete accuracy.

**INTERMEDIATE FREQUENCY COILS:** I.F. coils for radio manufacturers. Our experience in supplying some of the leading manufacturers in the industry, puts us in a position to successfully serve additional clients.

**LITZ WIRE:** Special Litz wire of all sizes made to order. We have served a number of representative manufacturers with Litz wire for over four years.

**WIRE INSULATING:** We are fully equipped to handle your requirements for wire insulating on all sizes down to .0005.

Let us submit samples and quote on your requirements.

## SCIENTIFIC COIL & WIRE CO.

4348 Broadway, Chicago, Ill., U. S. A.

Telephone: Lakeview 1006

## There's a Place for You in the Parade!

Each issue of *Electronics* is a parade before an audience of 7,000—your prospects and your customers, Mr. Manufacturer. Your advertisement is *you* in that parade—a parade expected each month by 7,000 spectators, who pay a subscription price for the privilege of watching the parade. . . . Are you in the parade?

Electronics

# The mathematics you need in electrical work—

—fully covered in the  
*Palmer Home Study Course*—  
now available on easy terms



This course presents the kind of mathematics needed by the man who wants something that he can apply to the every-day problems of his job. It brings him a clear, simple and usable knowledge of the essentials of the subject—a step-by-step treatment of mathematics without needlessly involved explanations and methods.

Now you can get this well-known home-study course for 10 days' free examination and then pay at the rate of a few cents a day as you study it. Palmer, who taught in trade schools for years, built his course around the needs of practical men—used as examples the every-day problems which practical men brought to him for solution. The two books cover all the mathematics needed in every-day mechanical and engineering problems, from simple fundamentals of arithmetic to a workable knowledge of calculus. Prepared especially for home study—contain many practical problems, with answers.

### 1. Practical Mathematics for Home Study

By C. I. PALMER, Late Associate Professor of Mathematics, Armour Institute of Technology. New Second Edition, 606 pages, pocket size, flexible, 224 illustrations, \$4.00.

This book contains all that is in the four-volume series by this author, together with several new topics. This includes more than 3500 drill exercises and problems teaching the essential principles of arithmetic, geometry, algebra and trigonometry. Every man in mechanical and engineering work needs a ready and working knowledge of mathematics. Here is a handy pocket size volume that offers a practical self-instruction course.

### 2. Practical Calculus for Home Study

By C. I. PALMER, 433 pages, pocket size, flexible, 186 illustrations, \$3.00.

This book completes the course by giving a workable knowledge of calculus as used in engineering work. Almost any text or reference book on engineering subjects makes use of calculus. If you have no practical grasp of this subject, your use of these other engineering helps is hindered. Palmer says, "The subject of calculus cannot be made easy, but it can be made plain." This he has done in this book, giving a concise and understandable explanation of the mathematical method and demonstrating how it is applied in daily work.

## 10 days' examination FREE

No advance in price for installment privilege.

These are the regular, latest editions of these books. The price of the two is \$7.00, payable \$1.00 10 days after receipt of the books and \$2.00 monthly for three months—no extra charge for this easy payment plan. Also, you may examine the books 10 days free before you decide. If you have ever felt the lack of a command of practical mathematics, send the coupon below, at once, and look over the Palmer Home Study Course.



## ON-APPROVAL COUPON

McGraw-Hill Book Company, Inc.  
330 West 42d Street, New York, N. Y.

Send me the Palmer Practical Mathematics and Calculus Home Study Course (2 volumes) for 10 days' examination subject to approval or return. Within 10 days of receipt, I will send you \$1.00 plus a few cents for postage and delivery and \$2.00 monthly for 3 months thereafter, or return the books postpaid. (We pay postage on orders accompanied by remittance of first installment.)

Name .....

Address .....

City and State .....

Position .....

Company ..... F-L-12-33

(Books sent on approval in U. S. and Canada only.)

*Elastic Stop* the ideal  
adjustment nut  
for...

relays, radio  
condenser  
trimmers,  
circuit breakers,  
contactors,  
instruments, etc.

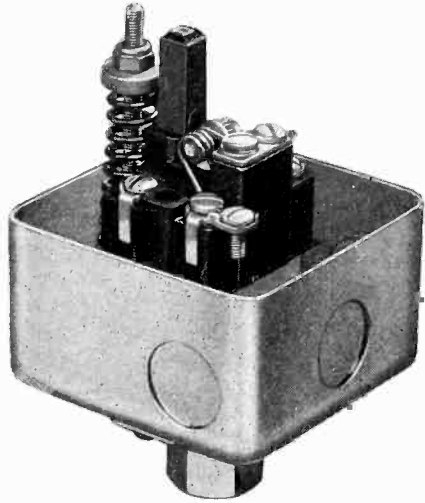

Square D pressure  
switch using brass  
No. 10/32 Elastic  
Stop Nut.

The Square D Company has standardized on Elastic Stop Nuts for their pressure switches because they maintain the spring at the calibrated adjustment even under severe vibration.

Elastic Stop Nuts can be drawn to the desired position along the bolt threads and will remain fixed at that position.

Available in brass, duraluminum and steel from No. 3/48 up.

Send for Catalogue.

**ELASTIC STOP NUT DIVISION**

A. G. A. COMPANY

ELIZABETH

NEW JERSEY

for inspection testing of

**ELECTROLYTIC  
CONDENSERS**

Fast  
Accurate  
Direct-  
Reading  
—  
A  
Complete  
Unit

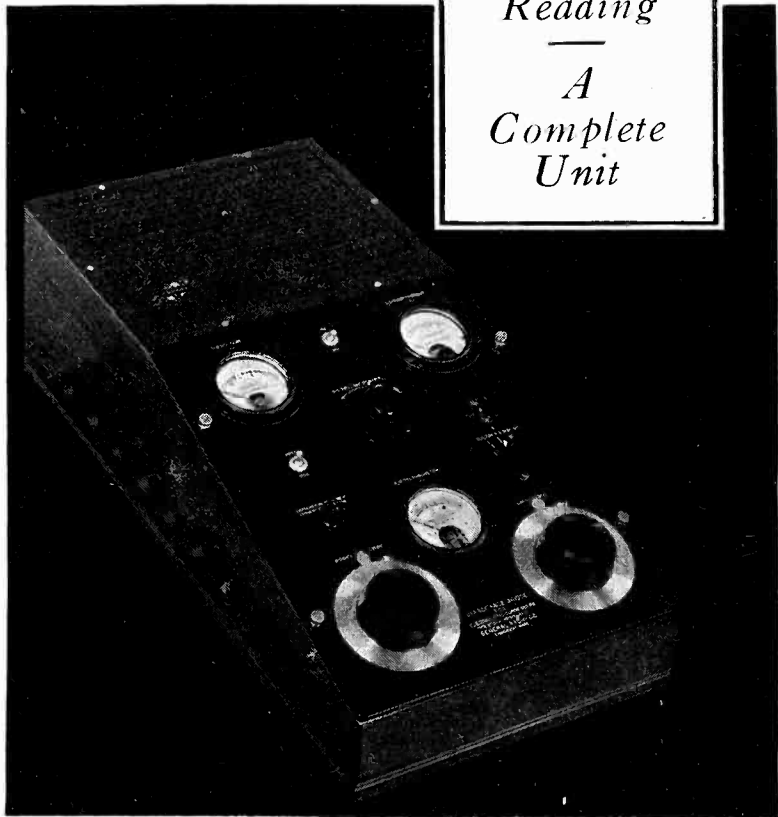

**H**ERE at last is a bridge that will measure electrolytic condensers for capacitance, power factor, and leakage current over extremely wide ranges, in the presence of a d-c polarizing voltage and a 60-cycle voltage.

It will measure capacitance over 4 decades from 0.01  $\mu$ f to 250  $\mu$ f.

It will measure power factor from 0.5% to 50%.

It will measure leakage current from 0.05 ma to 50 ma for polarizing voltages up to 600 volts.

**GET THIS BULLETIN**  
Write for a complete description in the General Radio *Experimenter* for June-July, 1933. Your copy is free for the asking. Address General Radio Company, Cambridge, Massachusetts.

The whole bridge is self-contained and ready to operate from the 110-volt, 60-cycle power supply.

**\$300**

**GENERAL RADIO**

**CONTINENTAL**  
A Dependable  
SOURCE OF SUPPLY

**SUPPRESSORS**  
New Flexo-Terminal Spark Plug Suppressor fits all cars and eliminates the need for numerous separate types. Continental Suppressors are available in all standard types and may be quickly supplied to meet any special specification. Isolantite housings, which have proven superior to any other substance under the severe heat, moisture and vibration of automobile installations, are used exclusively. Complete kits including spark plug and distributor suppressors and filter condensers are supplied for 4, 6, 8 and 12 cylinder cars.

**RESISTORS**  
Continental has specialized in the manufacture of molded resistors since the beginning of broadcasting. Today Continental design, manufacturing processes and automatic machinery are leaders in the industry. Thus Continental resistors are maintained at a standard of quality which would otherwise be prohibitive at their moderate cost. This superior quality costs you nothing extra—yet it has cut production costs for many well-known radio manufacturers. Prove these facts yourself. Get a supply of Continentals for test today!

WRITE OR WIRE FOR SAMPLES AND PRICES

**CONTINENTAL CARBON Inc.**  
13906 LORAIN AVE. • CLEVELAND, OHIO  
Canadian factory • Toronto, Ontario

# NOW = a high-powered radio engineering library

—especially selected by radio specialists of the McGraw-Hill Publications

—to give the most comprehensive, useful, authoritative coverage of radio engineering

—available at a special price and on easy terms

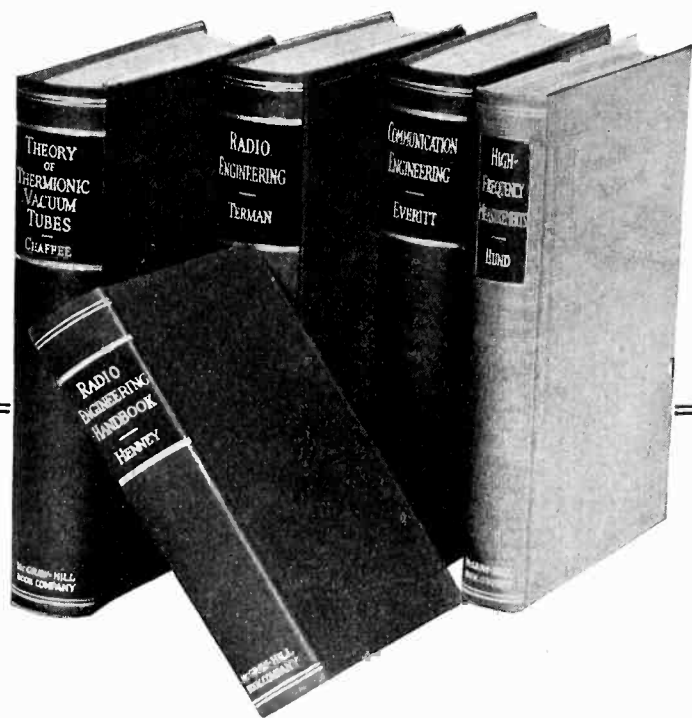

## Radio Engineering Library

5 volumes—2981 pages—nearly 2000 illustrations, \$23.50, payable \$2.50 in 10 days and \$3.00 monthly.

### What the library contains:

#### Communication Engineering

By Professor W. L. Everitt of The Ohio State University. Expository treatment of fundamentals of communication. Stresses broad principles. Covers classification of impedance elements, networks using linear bilateral impedances, networks using unilateral impedances, networks using non-linear impedances, negative resistance effects, coupling between electrical and mechanical circuits, coupling between electrical circuits and free space.

#### Radio Engineering

By Professor Frederick E. Terman of Stanford University. Comprehensive engineering treatment of important vacuum-tube and radio phenomena. Analyzes circuits and tubes and reduces them to quantitative relations predicting performance of tubes and radio apparatus with accuracy and certainty. Includes material on radio aids to navigation.

#### Theory of Thermionic Vacuum Tubes

By Professor E. Leon Chaffee of Harvard University. Comprehensive treatment of fundamentals of thermionic emission and the vacuum tube. Covers use of tube as amplifier and detector as well as its general properties. New, original material on large-signal regeneration, regeneration in coupled circuits, detection, all types of amplifiers, non-linear elements, etc.

#### High-Frequency Measurements

By August Hund. Complete, thorough reference work on measurements of high frequency. For research workers, practical designers and engineers. Presents theory and practice of measuring all manner of electrical quantities as well as present-day radio apparatus. Methods presented in a manner practical enough to meet needs of anyone interested in the increasingly important high frequency art.

#### Radio Engineering Handbook

Editor-in-chief, Keith Henney, Associate Editor of *Electronics*, assisted by staff of specialists. Handbook of radio comparable to standard handbooks in other fields of engineering. Emphasizes design area, covers everything from fundamentals to latest practical applications. Covers new tubes and circuits, Class B amplifiers, transmitters, receivers, short-wave, television, sound pictures, aircraft radio, etc.

**H**ERE is an announcement of importance to every radio engineer. These outstanding radio books, comprising a complete library of radio engineering essentials, now conveniently grouped and offered at terms that enable all to start using this library at once.

This is a real engineering library. Radio specialists of the McGraw-Hill publications selected the books for this library as those giving the most complete, dependable coverage of those facts needed by all engineers whose special fields are grounded on radio fundamentals. Covers circuit phenomena, tube theory, networks, measurements, and other subjects—gives specialized treatment of all fields of practical design and application.

These are books of recognized position in the literature—books that you will refer to and be referred to often. If you are a practical designer, researcher or engineer in any field that is based on radio, you want these books at hand for the help they can give you on hundreds of occasions, in scores of problems throughout the whole branch of radio engineering.

Space doesn't permit more than to suggest the value this library can have for you. Therefore we offer to send the entire set on approval, for your personal inspection and appraisal. If after examination you don't think these books will pay for themselves over and over as a needed and dependable reference tool in your work, return them without question. Take advantage of this offer.

### Special low price and easy terms

Bought singly, the five volumes comprising this library would cost you \$26.00. Under this offer you save \$2.50 and in addition have the privilege of paying in easy installments beginning with \$2.50, 10 days after receipt of the books, and \$3.00 monthly thereafter. Already these books are recognized as standard works that you are bound to require sooner or later. Take advantage of these convenient terms to add them to your library now.

### Examine this library 10 days—Send this coupon McGRAW-HILL ON-APPROVAL COUPON

McGraw-Hill Book Company, Inc., 330 West 42nd St., New York City  
Send me the Radio Engineers' Library, 5 volumes, for 10 days' examination on approval. Within 10 days of receipt I will send \$2.50, plus a few cents for postage and delivery, and \$3.00 monthly thereafter till \$23.50 is paid, or return the books postpaid. (We pay postage on orders accompanied by remittance of first installment.)

Name .....  
Address ..... Position .....  
City and State ..... Company .....  
(Books sent on approval in U. S. and Canada only.)

L-12-33

**makes good tubes better**



# ELMET MOLYBDENUM GRID WIRE

Start the  
New Year Right

Specify  
**ELMET**  
PRODUCTS

Its great strength -- uniform throughout every strand, is due to exceptional purity, skilled production and careful inspection. An increasing demand and capacity production is proof of ELMET SUPERIORITY.

WRITE FOR PRICES AND INFORMATION. BOX E-12

**American Electro Metal Corporation**  
LEWISTON MAINE

## A TRIAL WILL CONVINC YOU

30 Years' Experience  
Insures Dependability

We Manufacture  
**PERMANENT MAGNETS**      **TOOLS and DIES**  
**METAL STAMPINGS**      **LAMINATIONS**

## THOMAS & SKINNER STEEL PRODUCTS CO.

23d St. at Alvord

Indianapolis, Ind.



### Extreme Sensitivity

combined with a very low internal resistance of 100 ohms permits this new relay to be operated directly by the output of Caesium and Photronic type photo cells *without amplification*—operating light value is reduced to 1/2 foot candle, or 1% of that ordinarily used. Our type A Keane Cell closes contacts firmly on a variation of 1/500 foot candle. Relay may be quickly set for closing its contacts — by its own accurate scale reading—on a current variation of 1 micro-ampere to 200 micro-amperes. Positive locking contacts carry 3 amperes at 110-volts A.C. Not affected by vibration.

Price \$35.

**ASHCRAFT AUTOMATIC CONTROL  
COMPANY**  
HOLLYWOOD, CALIFORNIA

## PROFESSIONAL SERVICES

### ELECTRICAL TESTING LABORATORIES

Characteristics and  
*Life Tests of Vacuum Tubes*  
Tests of photocells, glow lamps, crater lamps.  
Tests of electronic and optical devices.  
80th Street and East End Avenue  
New York, N. Y.  
Phone: Butterfield 8-2600

### ELECTRONICS MUSIC LABS.

*Portable Electronic Organs*

for professional and broadcasting use. Equal to largest pipe organs. Qualities based on Eremeeff-Helmholtz simultaneous and Eremeeff multi-step-by-step synthesis. Mechanical and photoelectric instruments and sound on film devices.

WCAU Building, 1622 Chestnut Street,  
Philadelphia, Pa.

### JENKINS & ADAIR, INC.

*Engineers*

Designers, developers, and manufacturers of accessories and essentials for recording, broadcasting and testing at sound frequencies.

3333 Belmont Avenue, Chicago, U. S. A.  
Cable Address: Jenkadair Telephone: Keystone 2130

### RALPH H. LANGLEY, E. E.

*Licensed Professional Engineer Fellow I.R.E.*

Twenty years' experience in the Development Design, Production of Radio Transmitters and Receivers and in Radio Patents and Inventions.

BARELAY 7-0398

165 Broadway, New York

## SEARCHLIGHT SECTION

### POSITION VACANT

IMPORTANT French company manufacturing radio tubes requires an engineer who is a specialist in this line. He must have first-class references and be thoroughly familiar with the technique and manufacture of modern radio tubes. He will have charge of the technical management of such a factory. Write to: Monsieur Clement, 45 Avenue Ste-Foy, Neuilly-sur-Seine, France.

### WANTED

ANYTHING within reason that is wanted in the industry served by Electronics can be quickly located through bringing it to the attention of thousands of men whose interest is assured because this is the business paper they read.

WANTED

NEW

WANTED

### ELECTRICAL DEVICES for EUROPEAN MARKETS

desired by reputable firm, to manufacture or sell, in Europe. Only patented devices for the Radio, Electrical and Television Fields will be considered. We have a ready market for your product or patented idea.

Address

BO-56, Electronics

330 West 42d St., New York City

### NEW—RECONDITIONED—AND "AS IS" ELECTRON TUBE EQUIPMENT

DESIGNERS AND MANUFACTURERS OF MACHINERY FOR THE PRODUCTION OF ELECTRON TUBES, NEON SIGN AND INCANDESCENT LAMP EQUIPMENT, TO MEET ANY REQUIREMENT.

**EISLER ELECTRIC CORP.**

USED EQUIPMENT ALSO AVAILABLE

Advise Us of Your Needs

756 So. 13th St., Newark, N. J.

### HIGH GRADE NEW AND USED ELECTRON TUBE EQUIPMENT

Write for Bulletin Showing Savings

From 20% to 80%

**KAHLE ENGINEERING CORPORATION**

Specialists in Equipment and Methods for the Manufacture of Neon Tubes, Radio Tubes, Incandescent Lamps, Photo Cells, X-ray Tubes, etc.

350 Manhattan Ave., Union City, N. J.

All types of High Grade New and Used Equipment for the manufacture of Electron Tubes.

Lowest prices on the market.

**AMERICAN ELECTRICAL SALES CO.**

65 East 8th St., New York, N. Y.

### TORSION BALANCES

2—Roller Smith Torsion Balances for sale, in first-class condition, 1 with 200 milligram capacity, 1 with 12 milligram capacity, \$70.00 each. Also closing out many sizes of high-grade molybdenum wire.

**SHORTWAVE & TELEVISION CORP.**

70 Brookline Avenue, Boston, Mass.

# Transformers for Class B amplification in broadcast transmitters

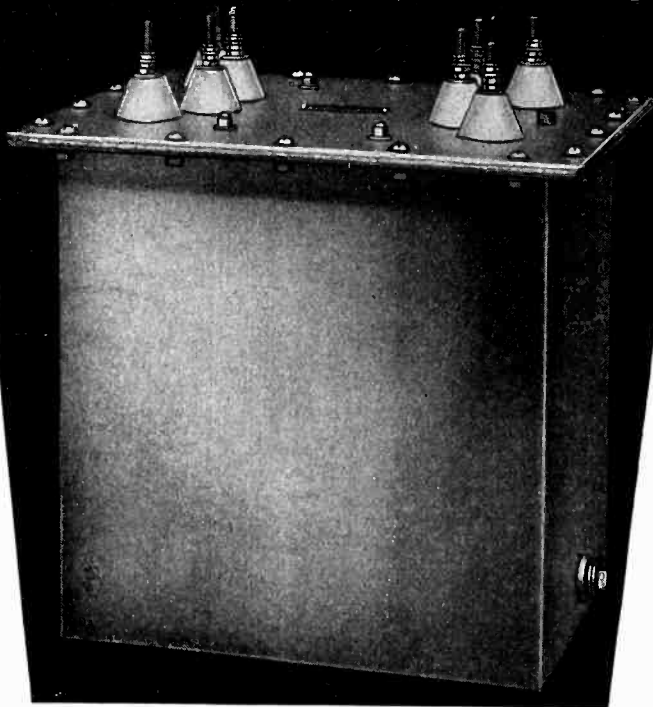

Output transformer for use between push-pull, class "B" stage using 204-type tubes and a class "C" amplifier. Operating level + 50dB; primary, 1500-1500 ohms; secondary 4750 ohms; tested at 15,000 volts; oil insulated.

FOR six months AmerTran engineers have been studying all problems associated with Class B Amplifiers. With this experience as a background a complete line of audio-frequency transformers (input and output) has been especially designed for use with tubes suitable for Class B operation.

Large output transformers for use in Class B Amplifiers of broadcast transmitters are of the design illustrated above and have the following features:

1. Oil immersed with Isolantite bushings. This permits insulation testing at a voltage which is considerably in excess of any peak which might be experienced in actual practice.
2. Welded aluminum tank provides complete r.f. shielding.
3. Wire used in primary and secondary windings is of a size which insures low d.c. resistance and ample current capacity.
4. Primary sections are balanced within 0.5% and the same phase angle exists in each section.
5. Core laminations of the best quality high-permeability alloy are operated at a low density.
6. Coil structure insures low distributed capacity, low capacity coupling, and high inductance coupling.
7. High efficiency insured by excellent regulation, constant input impedance, and unusually satisfactory frequency characteristics throughout the band of 30 to 10,000 cycles.

Complete information on transformers for use with a specific type of tube will be mailed promptly on request.

**AMERICAN TRANSFORMER COMPANY**  
176 Emmet Street Newark, N. J.

The AmerTran line includes transformers of every description for audio amplification and radio transmission.

# AMERTRAN

## Audio Transformers

# CANNON PLUGS

*Are Not Sold by the Pound!*

CANNON Cable Connectors are not just so much metal. Their undisputed supremacy and unequalled performance are the result of many factors—

- the years of "built-in" experience;
- the thousands of parts in reserve factory stock;
- the "up-and-coming" organization constantly improving design;
- the mobile factory tooled and trained for quick changes and speedy production of limited-sale items.

These factors explain the almost universal use of CANNON Plugs by those concerns that have made and are making radio history.

*A Sound System Is No Better Than the Plugs in its Cable Lines*

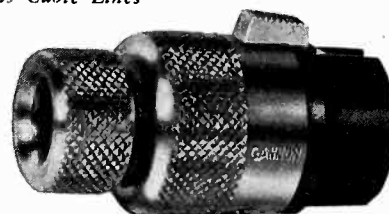

6-pole Plug 3/4 Actual Size Shows CANNON Compactness

[There is a CANNON Plug for Every Sound Equipment Need.]

**CANNON ELECTRIC DEVELOPMENT CO.**  
MANUFACTURING ENGINEERS

Main Office: 420 West Avenue 33, Los Angeles, Calif.

Eastern Sales Office: 245 Fifth Ave.,

New York, N. Y.

Representatives:



Chicago: Jenkins & Adair, Inc., 3333 Belmont Ave.  
Bombay, India: Eastern Electric & Engineering Co.,  
175 Hornby Road, Fort, Bombay, India

# REMLER ATTENUATORS

Ladder Type - - Attractively Designed

Attractively designed, new Remler Ladder Type Attenuators enhance the appearance of the panel. Precision accuracy in manufacture and critical laboratory inspection is an assurance that Remler Attenuators will meet the most exacting voice circuit requirements.

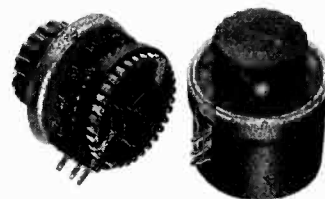

Attenuation is increased in 53 steps of 3/4 DB. each to 45 decibels. A

rising attenuation characteristic serves to completely fade the program from 45 decibels to infinity. Flat frequency characteristic from 20 to 20,000 c.p.s. Extremely low noise level. Heavy laminated wiping arm. Improved unifilar winding with finest quality silk covered resistance wire.

The unit is enclosed in an aluminum shield 2 1/8 inches deep and mounts either 2 3/8 inch hold or by means of screws through the panel.

Standard impedances of 50, 200 or 500 ohms. Special values available on order. LA-5 Ladder Type Attenuator, List price \$18.00.

Attractive discounts to Stations and other commercial users on all Remler equipment.

## TWO NEW CATALOGS

Complete with technical data, illustrations and prices, the new Remler Public Address and Remler Broadcast Equipment folders list the complete Remler line. Send for these catalogs now.

**REMLER COMPANY Ltd.**

2101 Bryant St.

San Francisco, Calif.

**REMLER—THE RADIO FIRM AS OLD AS RADIO**



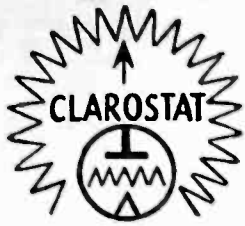

Founded  
in 1920



*Good products... like good names* ENDURE

A. T. & T.  
Atwater Kent  
Bosch  
Belmont  
C. B. S.  
Colonial  
Crosley  
Emerson  
Empire

Hammarlund  
International  
N. B. C.  
Philco  
RCA Victor  
Sparton  
Stromberg  
Texas Oil Co.  
United Air Transport

U. S. Army  
U. S. Navy  
Vacuum Oil Co.  
Wells Gardner  
Western Union  
Westinghouse  
Wurlitzer  
Zenith

Clarostat are happy to contribute to the good reputations of the above organizations. Since 1920 without outside financing or control Clarostat have been turning out quality radio and electrical components week in . . . week out.

*We solicit inquiries on mass production or special resistor problems, for radio, sound, communication or industrial application.*

**Clarostat Manufacturing Co., Inc.**

285 North 6th Street, Brooklyn, N. Y.

## INDEX TO ADVERTISERS

This index is published as a convenience to the reader. Every care is taken to make it accurate but *Electronics* assumes no responsibility for errors or omissions.

Acme Wire Co.....	8	RCA Radiotron Co., Inc.....	1
American Electro Metal Co.....	13	RCA Victor Co., Inc....	Back Cover
American Gas Accumulator Co....	11	Remler Co., Ltd.....	14
American Transformer Co.....	14	Resinox Corp.....	8
Ashcraft Automatic Control Co....	13	Scientific Coil & Wire Co.....	10
Bakelite Corp.....	5	Shakeproof Lock Washer Co....	9
Cannon Electric Development Co. 14		Thomas & Skinner.....	13
Central Radio Lab's.....	16	Universal Microphone Co., Ltd. 10	
Clarostat Mfg. Co.....	15	Western Electric Co.,	Inside Back Cover
Continental Carbon, Inc.....	11	Weston Electrical Instr. Corp... 6	
Cornell-Dubilier Corp.....	6	Yaxley Mfg. Co.....	4
Electrophone Corp.....	6		
General Cable Co. Inside Front Cover		Professional Services.....	13
General Plastics, Inc.....	7		
General Radio Co.....	11		
Globar Corp.....	9		
Goat Radio Tube Parts, Inc.....	8		
Hammarlund Mfg. Co.....	9		
Hygrade-Sylvania Corp.....	2-3		
Kenyon Transformer Co.....	7		
P. R. Mallory & Co., Inc.....	4		
McGraw-Hill Book Co.....	10-12		
Muter Co.....	10		

### SEARCHLIGHT SECTION

#### Classified Advertising

BUSINESS OPPORTUNITY	13
EMPLOYMENT	13
EQUIPMENT FOR SALE	13
American Elect. Sales Co.	13
Eisler Electric Corp.	13
Kahle Engineering Co.	13
Shortwave & Television Corp.	13

## CONTENTS for DECEMBER, 1933

The balance sheet of television.....	323
NBC's new Radio City studios.....	324
Controlling receivers from the broadcast transmitter.....	327
Recent advances in the radio art.....	328
Cathode ray tubes for oscillograph purposes.....	332
BY R. T. ORTH	
High lights on electronic devices in industry.....	334
Vacuum tube delay circuits.....	336
BY M. W. MUEHTER	
Graphite anodes in transmitting tubes.....	338
BY D. E. REPLOGLE	
Electronic notes from the laboratory.....	340
A study of Litz wire coils for i-f and r-f transformers (Part II).....	342
Editorials.....	344
News notes.....	345
Review of electronic literature here and abroad.....	346
Book review.....	347
New products.....	348
U. S. patents.....	350
British patents.....	352
Index to Volume VI (January-December, 1933).....	353

McGRAW-HILL PUBLISHING COMPANY, INC., 330 WEST 42d STREET, NEW YORK, N. Y.

Branch offices: 520 North Michigan Ave., Chicago; 883 Mission St., San Francisco; Aldwych House, Aldwych, London, W. C. 2; Washington; Philadelphia; Cleveland; Detroit; St. Louis; Boston; Greenville, S. C. James H. McGraw, Chairman of the Board; Malcolm Muir, President; James H. McGraw, Jr., Vice-President and Treasurer; Mason Britton, Vice-President; Edgar Kobak, Vice-President; H. C. Parmelee, Vice-President; Harold W. McGraw, Vice-President; B. B. Putnam, Secretary.

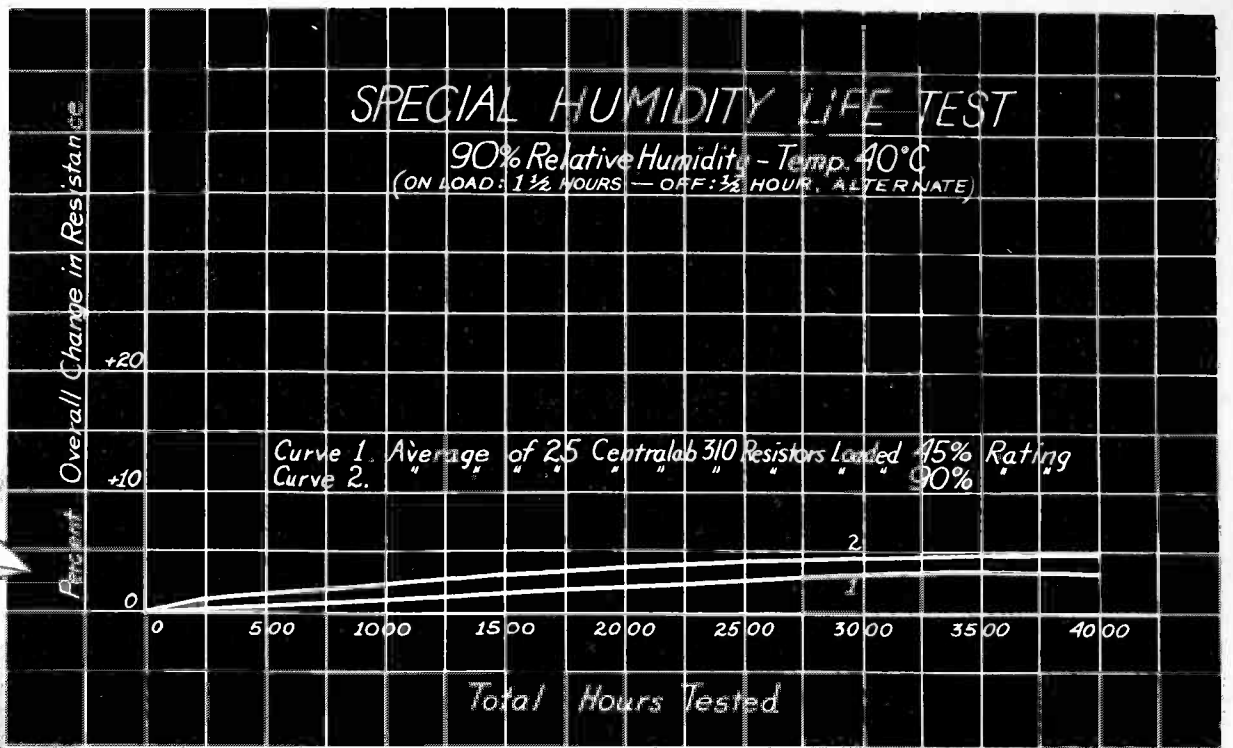

# Little DROPS OF WATER—

in the atmosphere, torrential rain storms, heavy fogs—none of these can affect the performance of a radio that is Centralab equipped. Many radio resistors fail in damp climates because the alternate heating and cooling, as the set is turned on and off, promotes moisture penetration. As a proof that Centralab Resistors are impervious to moisture under all conditions, a humidity chamber was equipped with a clock mechanism applying an intermittent load to a large number of resistors. After 4,000 hours, the equivalent of many years of radio service, the average change under this severest test of all was less than 5%.

Centralab Resistors surpass all others in performance because they are the only resistor made with solid core and integral ceramic jacket, all Baptized in Fire at 2,700° F.

Use Centralab for unfailing performance.

CENTRAL RADIO LABORATORIES . . . MILWAUKEE

**Centralab**  
 CENTRAL RADIO  LABORATORIES  
**FIXED RESISTORS**

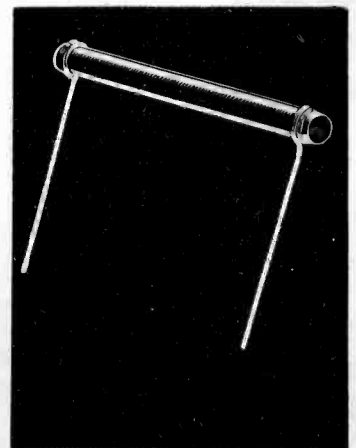

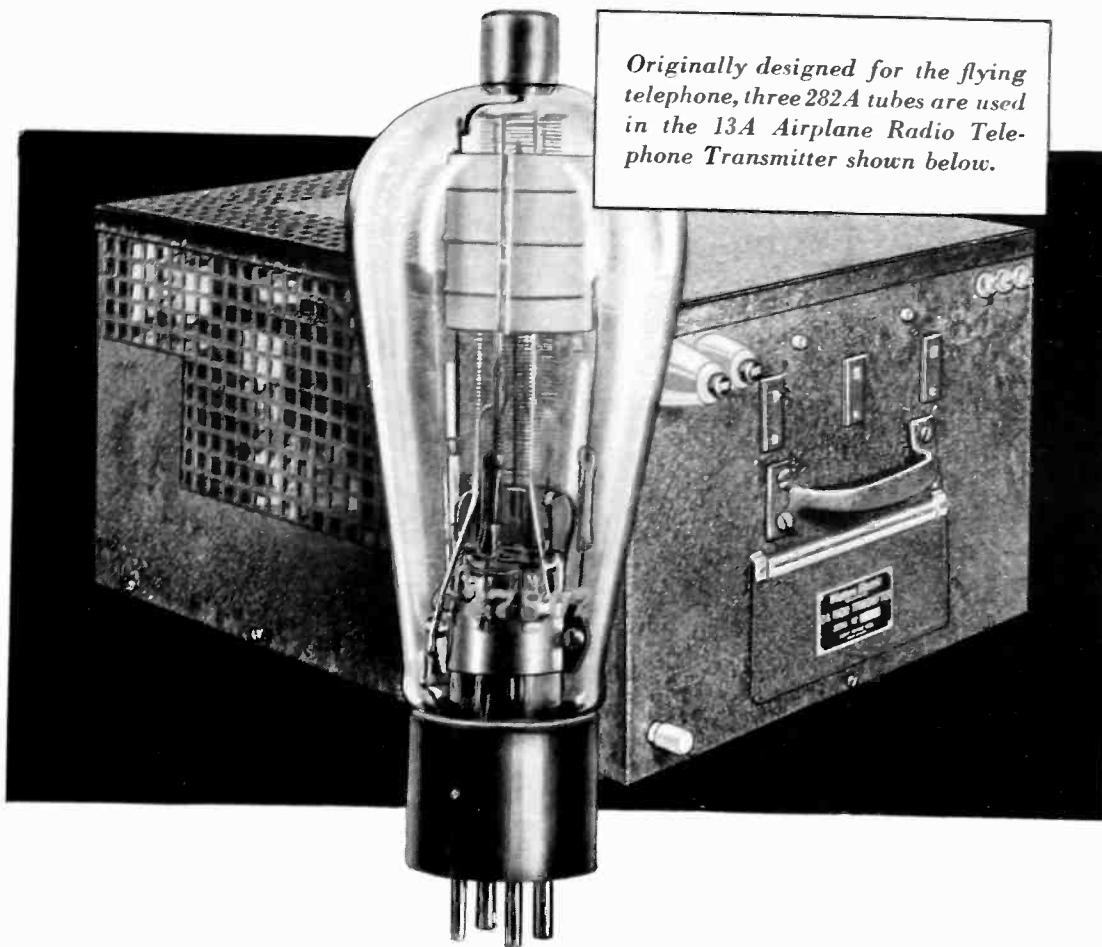

# Built for service aloft... ideal for general purposes

Western Electric's new 282A screen grid transmitting tube was designed to meet rigid specifications of flying telephone equipment. Its compactness, mechanical strength and operating dependability under varying conditions of power supply, make it an ideal tube for use in other communication systems.

Hard glass is used so that high energy dissipation and wide frequency range operation may be had without sacrifice of life. The 282A has been used in transmitters at frequencies up to 60 megacycles. Terminal arrangement insures adequate insulation under all conditions. Low internal impedance and adequate emission from thoriated tungsten filament make possible higher power output at comparatively low plate voltages.

The screen grid eliminates delicate adjustments in changing operating frequencies. Complete modulation may be accomplished with relatively low audio power by varying screen grid bias.

## Western Electric

RADIO TELEPHONE BROADCASTING EQUIPMENT

Distributed by GRAYBAR Electric Company



### Characteristics of Western Electric No. 282A Vacuum Tube:

Filament Voltage.....	10
Filament Current, Amperes.....	3
Average Plate Resistance, Ohms.....	70,000
Average Mutual Conductance, Micromhos.....	1,430
Average Amplification Factor.....	100
Approximate Direct Interelectrode Capacities:	
Plate to Control Grid.....	0.2 Mmf.
Plate to Filament and Screen Grid.....	6.8 Mmf.
Control Grid to Filament and Screen Grid.....	12.2 Mmf.
Maximum Plate Voltage, D.C.....	1,000
Maximum Plate Current, D.C. Amperes.....	0.100
Maximum Plate Dissipation, Watts.....	70
Maximum Screen Grid Potential, Volts.....	250
Maximum Screen Grid Dissipation, Watts.....	5
Maximum Overall Length.....	6-15/16"
Maximum Diameter.....	2-7/16"

GRAYBAR ELECTRIC CO. E. 12-33  
Graybar Building, New York, N. Y.

Gentlemen: Please send me full information on the Western Electric 282A Tube.

NAME.....

ADDRESS.....

CITY..... STATE.....

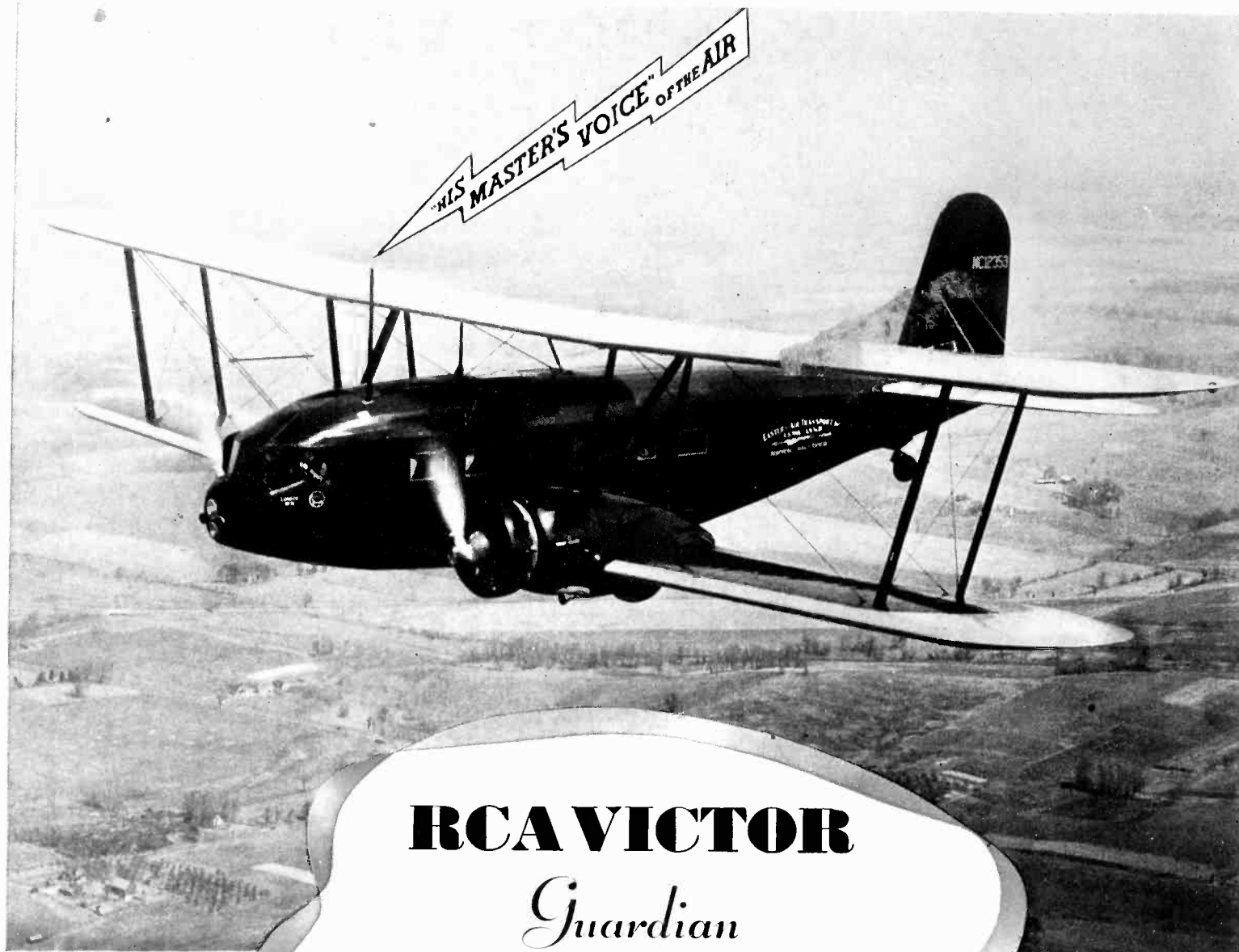

## RCA VICTOR

*Guardian  
of the Airways*



This new Condor plane operated by Eastern Air Transport Line is equipped with RCA Victor transmitter.

**P**ASSENGER planes speeding through the day . . . mail and freight planes speeding through the night — are guided on their way by Radio.

The RCA Victor trademark on radio equipment has come to mean the best... and only the best is good enough for aviation.

In every need of aviation the RCA Victor Company offers communication equip-

ment that is efficient, economical, reliable. There are many types of both transmitters and receivers for planes, as well as airport equipment. The standard of quality is that set by the world famous "Radio Headquarters".

RCA Victor is ready to build any special type of equipment to your order.

Get full details from the Aviation Radio Section.



# RCA Victor Co., Inc.

"Radio Headquarters"

Camden, New Jersey