

THE SANSUI QS-1 QUADPHONIC SYNTHESIZER®

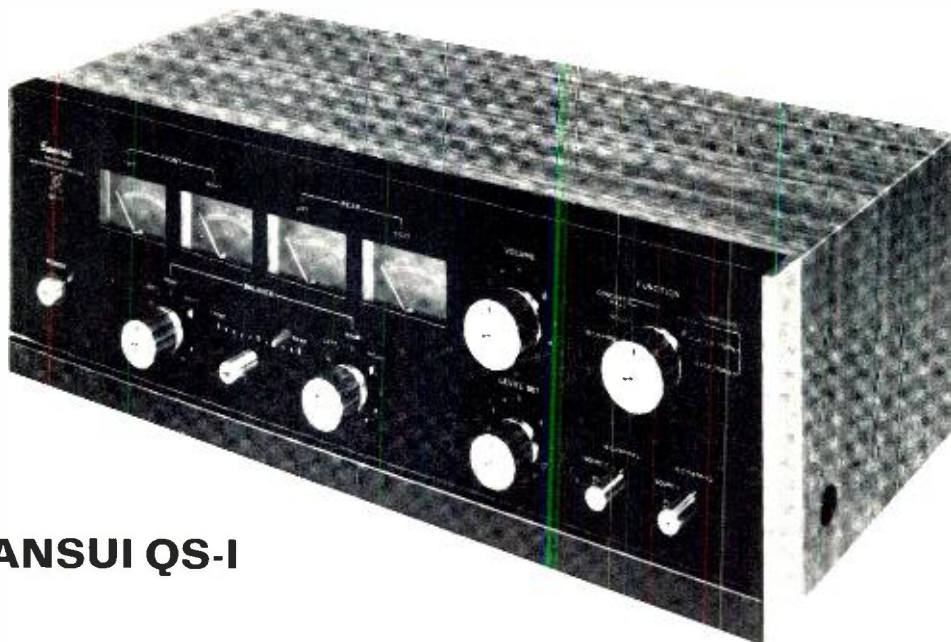

SANSUI QS-1

4-CHANNEL SOUND FROM ANY 2-CHANNEL SOURCE

Senses and recovers the ambient information hidden in your stereo discs, tapes and broadcasts

After having discovered that the ambient components of the original total sound field are already contained in hidden form, in conventional stereo records, tapes and broadcasts, Sansui engineers developed a method for sensing and recovering them. These subtle shifts and modulations, if re-introduced, breathtakingly recreate the total of the original sound as it existed in the recording or broadcast studio.

The heart of the Sansui Quadphonic Synthesizer* is a combination of a unique reproducing matrix and a phase modulator. The matrix analyzes the 2-channel information to obtain separate direct and indirect components, then redistributes these signals into a sound field consisting of four distinct sources.

This type of phase modulation of the indirect components, applied to the additional speakers, adds another important element. It sets up a complex phase interference fringe in the listening room that duplicates the multiple indirect-wave effects of the original field. The result is parallel to what would be obtained by using an infinite number of microphones in the studio (M1 through Mn in the accompanying illustration) and reproducing them through a corresponding number of channels and speakers.

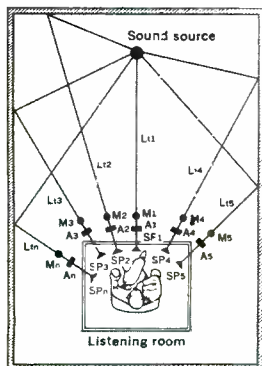
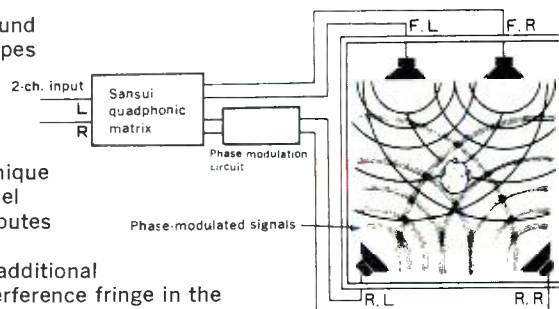

The startling, multidimensional effect goes beyond the four discrete sources used in conventional 4-channel stereo, actually enhancing the sense of spatial distribution and dramatically expanding the dynamic range. Also, the effect is evident anywhere in the listening room, not just in a limited area at the center. And that is exactly the effect obtained with live music! This phenomenon is one of the true tests of the Quadphonic system.

The Sansui Quadphonic Synthesizer QS-1 has been the talk of the recent high-fidelity shows at which it has been demonstrated throughout the country. You have to hear it yourself to believe it. And you can do that now at your Sansui dealer. Discover that you can hear four channels plus, today, with your present records and present stereo broadcasts. \$199.95.

*Patents Pending



SANSUI ELECTRONICS CORP.

Woodside, New York • Gardena, California

SANSUI ELECTRIC CO., LTD., Tokyo, Japan • Frankfurt a. M., West Germany
Electronic Distributors (Canada), British Columbia

CIRCLE NO. 124 ON READER SERVICE PAGE

Update your Radio/TV skills with these aids

Completely up-to-date, written by experts and easy to follow . . . they are "best sellers" to radio/TV technicians and amateurs alike.

COLOR-TV FIELD-SERVICE GUIDES



Invaluable for servicing Color-TV in the customer's home. Each volume contains 80 diagrams covering over 3,000 chassis . . . sensibly organized with detailed chassis layout charts on one page and specific adjustment procedures on opposite page. Indexed for instant reference.

Vol. 1 No. 20796—\$4.95
Vol. 2 No. 20807—\$4.95
Vol. 3 No. 20847—\$4.95

TRANSISTOR AUDIO AMPLIFIERS

By Jack Darr



Gives you a good, working knowledge of transistor circuits found in audio equipment of all sizes. Shows how the circuits work normally, what changes take place when trouble occurs, and how to service the solid-state equipment. An invaluable guide for all who service transistor circuits. No. 20838—\$5.50

1-2-3-4 SERVICING TRANSISTOR COLOR TV

By Forest H. Belt and Associates



Details the simple 1-2-3-4 servicing method and steps that get transistor Color-TV sets fixed easily and right every time. No. 20777—\$4.95

1-2-3-4 SERVICING AUTOMOBILE STEREO

By Forest H. Belt & Associates



Explains the simple 1-2-3-4 servicing method, shows how easy it is to apply the method to automobile stereo, fm multiplex, and tape cartridge systems. Clear, easy-to-read illustrations, charts and schematics to make servicing easy. No. 20737—\$3.95

STUDY GUIDE FOR CET EXAMINATIONS

By J. A. Wilson, CET and Dick Glass, CET



A comprehensive review of the material covered by the CET (Certified Electronics Technician) examination. It's almost a "must" for gaining a CET designation, for passing a state or local licensing exam, or as a "brush-up" in applying for a position in the electronics field. Includes question-and-answer sections and a 50-question test in each chapter. No. 20834—\$5.95

UNDERSTANDING OSCILLATORS

By Irving M. Gottlieb



What you want to know about oscillators . . . how they work, their many personalities and variations, strong and weak points, how they are used in practical applications, how to service them. A most useful text for engineers and technicians. No. 20837—\$4.50

99 ELECTRONIC PROJECTS

By Herbert Friedman



An intriguing, easy-to-follow book for hobbyists as well as those experienced in electronics. Covers sixteen groups of projects, including audio, photography, automotive, remote controls, lamp and motor control circuits, etc., many of which can be built inexpensively. No. 20818—\$3.50

101 QUESTIONS AND ANSWERS ABOUT CB ANTENNAS

By Jim Ashe



Best overall guide to the selection and installation of the proper antenna for your Citizens band radio. An ideal guide for beginners, it also answers questions about how to improve performance and range of already operating equipment and to repair and maintain CB antennas. No. 20749—\$2.95

CITIZENS BAND RADIO HANDBOOK, 4th Edition

By David E. Hicks

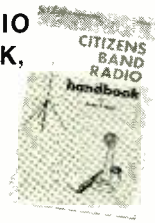

Now that two-way radio is available to any citizen, this revised edition answers the many problems and questions of all who use, or plan to use, CB equipment. Covers how to obtain a CB license, operating procedures, equipment, accessories, circuit analysis, servicing data, trouble-shooting hints, etc. No. 20839—\$4.95

SECOND-CLASS RADIOTELEPHONE LICENSE HANDBOOK, 4th Edition

By Edward M. Noll



Information needed to pass the 2nd class FCC radiotelephone exam. Questions and answers are based on the FCC exam for Elements I, II and III. Also covers communications theory and practices, solid-state two-way equipment, FCC Rules and Regulations, operating practices and procedures, reference date, etc. No. 20824—\$6.50

You'll find everything you want to know about Radio or TV in the modern Sams Technical Library. Send for our free catalog.

HOWARD W. SAMS & CO., INC.

Order from your Electronics Parts Distributor, or mail to Howard W. Sams & Co., Inc., Dept. EW081 4300 West 62nd Street, Indianapolis, Indiana 46268.

Send books checked at right. \$_____ enclosed.

Please include sales tax where applicable.

Send FREE 1971 Sams Book Catalog.

Name _____ (Please Print)

Address _____

City _____ State _____ Zip _____

- | | |
|--------------------------------|--------------------------------|
| <input type="checkbox"/> 20796 | <input type="checkbox"/> 20834 |
| <input type="checkbox"/> 20807 | <input type="checkbox"/> 20837 |
| <input type="checkbox"/> 20847 | <input type="checkbox"/> 20818 |
| <input type="checkbox"/> 20838 | <input type="checkbox"/> 20749 |
| <input type="checkbox"/> 20777 | <input type="checkbox"/> 20839 |
| <input type="checkbox"/> 20737 | <input type="checkbox"/> 20824 |

Howard W. Sams & Co., Inc.
4300 W. 62nd St., Indianapolis, Ind. 46268
August, 1971

CIRCLE NO. 125 ON READER SERVICE PAGE

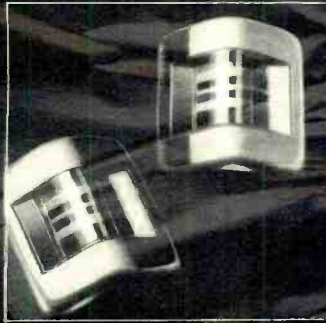

the GX generation

150,000 hours service life!

Dust Free/Wear Free/
Preeminent Recording



GX-280D



GX-220D



GX-365D

AKAI's GX-365D, GX-280D and GX-220D have formed a new GX generation. All three decks boast the AKAI-developed GX (glass and crystal ferrite) Head which is the first of its kind in the world. In conventional heads, tape dust and wear greatly reduce sound quality. But our GX Head is "dust free", "wear free" and guaranteed for over 150,000 hours of service life! In case this head should become faulty before 150,000 hours of use, it will be replaced free of charge. AKAI engineers were successful in focusing the magnetic bias field of the GX Head so that the influence of the bias is drastically lessened. A μ greater frequency response was obtained because an ideal gap width and gap depth were developed and ultra-precision processing techniques were used in the manufacture of this head.

GX-365D Professional Stereo Tape Deck

Features 3 heads, world's only automatic continuous reverse (Reverse-O-Matic), sensing tape reverse, automatic volume control (Compute-O-Matic), magnetic brake, one hysteresis synchronous 3-speed motor for capstan drive and two eddy-current outer-rotor motors for supply and take-up reel drive, and automatic stop/shut off.

GX-280D Stereo Tape Deck

Features 3 heads, one 2-speed servo-control outer-rotor motor for direct capstan drive and two eddy-current outer-rotor motors for supply and take-up reel drive, sensing tape automatic continuous reverse, automatic stop/shut off, and pause button with lock. The two 7-inch reels can be completely covered with an optional plastic dust cover.

GX-220D Stereo Tape Deck

Features 3 heads, automatic continuous reverse with sensing tape, and 3 speeds. The two 7-inch reels can be completely covered with an optional plastic dust cover.

AKAI's GX-365, GX-280 and GX-220 Stereo Tape Recorders are also available.

Audio & Video

AKAI

AKAI AMERICA, LTD.

2139 East Del Amo Boulevard/Compton,
California 90220 (213) 537-3880

Manufacturer

AKAI ELECTRIC CO., LTD.

P.O. Box 21, Tokyo International Airport, Japan

Electronics World

AUGUST 1971

VOL. 86, No. 2

Contents

Electronics World

AUGUST 1971
NO. 2



THIS MONTH'S COVER shows the Shure "Vocal Master" vocal arrangement and projection system which can be used both as a portable sound system by musical groups or artists on tour and as a "house" system for universities, night clubs, restaurants, theaters, and hotels. It provides studio-type control for vocal and instrumental balance and controls feedback. See page 27 for details.



Publisher

LAWRENCE SPORN

Editor

WM A. STOCKLIN

Technical Editor

MILTON S. SNITZER

Managing Editor

PRISCILLA B. HOEFER

Contributing Editors

WALTER H. BUCHSBAUM

Prof. ARTHUR H. SEIDMAN

FOREST H. BELT

Art Editor

RICHARD MOSS

Technical Illustrator

J. A. GOLANEK

Advertising Manager

JOSEPH E. HALLORAN

Advertising Service Manager

MARGARET DANIELLO

Associate Publisher

STANLEY NEUFELD

Group Vice President

Electronic & Photographic

FURMAN H. HEBB

August, 1971

13 Status Report on Four-Channel Stereo *Julian D. Hirsch*
Is "four-channel sound just a "gimmick?" Our skeptic has been converted and tells why he thinks it is an improvement. The Dynaco and Electro-Voice matrixing systems even enhance the sound reproduction of conventional mono and two-channel stereo discs.

27 Portable Sound Systems for Performers *Donald L. Patten*
Part 1. Microphones & Mixers
Putting together such a system is a real challenge because performers are usually loud, halls frequently have poor acoustics, and there is plenty of noise and feedback. This article tells you how you can lick these problems.

30 Recent Developments in Electronics

32 Antenna Lead-ins for TV *Forest H. Belt*

35 Electronic Typesetting *David L. Heiserman*

38 An Improved Vehicular Intrusion Alarm *Sandor Mentler*

40 Neutron Radiography for Nondestructive Testing *Harold Berger*
Details on a new testing technique, using a source of radioactive neutrons, which permits inside view of objects that would be impossible with x-rays.

42 Do We Need 4-Channel Stereo? *Frank Krausser*

45 Automatic Tint Correction in Color TV *Forest H. Belt*
Until broadcasters can keep colors correct at their end, these new circuits are just about the only way to keep colors natural on your receiver.

50 The Technician as a Mechanic *John Frye*

52 Transistor and FET Curve Tracer *Daniel Metzger*

55 NEA State Association Presidents

60 Digital Frequency Dividers for Any Ratio *Frank H. Tooker*

69 Accurate D.C.-Less Clock-Pulse Generator *Frank H. Tooker*

15 Reader Service Page

MONTHLY FEATURES

4	Coming Next Month	10	Letters
6	News Highlights	66	Books
70	New Products & Literature		

Copyright ©1971 by Ziff-Davis Publishing Company. All rights reserved

THOUSANDS OF MUSIC LOVERS PAID THE DIFFERENCE TO OWN A CROWN

Maybe they know
something you don't



There's a reason why Crown recorders cost over \$900. Why nearly every critical home music recordist hopes some day to own one. The reason is Crown's TOTAL PERFORMANCE.

Semi-professional decks may shout about a single outstanding spec, but who wants low noise at the expense of high distortion or wow and flutter? Only Crown delivers unexcelled engineering achievement in all areas of performance. Not just flat response @ ± 2 db maximum, but bandwidth wider than the entire audible spectrum. Not just low noise, but wide dynamic range for flawless piano reproduction. Plus minimal wow and flutter and the industry's lowest distortion levels.

Now couple this with Crown's famous no-compromise workmanship: Only the very finest components available. Precision handcrafting with relentless inspection. Only nine or ten moving parts for reliability. Construction "rugged enough to withstand a parachute drop." (Audio 4/68) Individual proof-of-performance guarantee. Design engineered for ten years minimum continuous service. It's a lot of work—but the result is a professional deck unparalleled in the recording industry.

Yes, Crown does cost more than any semi-pro recorder. That's the price of no-compromise TOTAL PERFORMANCE. Send for our detailed spec sheets and compare Crown with any other deck—semi-pro or professional. After all, you deserve to know what a Crown owner knows. Write Crown, Dept. EW-8 Box 1000, Elkhart, Indiana, 46514.



MADE ONLY IN AMERICA

CIRCLE NO. 142 ON READER SERVICE PAGE

Coming Next Month Special Feature Article



WHICH COMPUTER FOR THE ENGINEER/TECHNICIAN?

Although gaining acceptance, engineering computers are still a bone of contention with engineers/technicians. With a choice among desk-top, mini, and time-sharing systems, how can a man make an intelligent choice? In the first of three articles on this subject, Paul Asmus of Hewlett-Packard explains the advantages of the desk-top calculator and why this programmable unit meets needs best. The other types will be "defended" in later issues.

Hand Tools for Service & Maintenance

Have you ever used a screwdriver as a chisel or your long-nose pliers as a wrench? Almost everyone has in an emergency—but if you are an inveterate improviser, you tell the whole world that you are not a "pro." John Frye outlines both the minimum essential hand tools you'll need and the "specials" that will make your job quicker and better. Don't miss this important article on picking the right tool for your particular job.

Air-Core Coil Nomogram

If you fabricate your own coils, this handy nomogram can help since it is applicable to both hand-wound and pre-wounds.

Color-Bar Generators for Servicing

If you haven't been paying attention, you'll be both surprised and pleased by the newest models on the market. For the most part they are solid-state and a number of them have digital-IC counting circuits to assure rock-solid stability. They are compact, handy to use, and offer features to make color-TV troubleshooting a breeze. A quick-check specification chart is a useful "plus" with this article by Forest H. Belt.

All these and many more interesting and informative articles will be yours in the September issue of *ELECTRONICS WORLD* on sale August 19th.

ZIFF-DAVIS PUBLISHING COMPANY

William Ziff, President
W. Bradford Briggs, Executive Vice President
Hershel B. Sarbin, Senior Vice President and Secretary
Stanley R. Greenfield, Senior Vice President
Philip Sine, Financial Vice President and Treasurer
Walter S. Mills, Jr., Vice President, Circulation
Phillip T. Heffernan, Vice President, Marketing
Frank Pomerantz, Vice President, Creative Services
Arthur W. Butzow, Vice President, Production
Edward D. Muhlfeld, Vice President, Aviation Division
Irwin Robinson, Vice President, Travel Division
George Morrissey, Vice President
Sydney H. Rogers, Vice President

Editorial and Executive Offices
One Park Avenue
New York, New York 10016
212 679-7200

NEW YORK OFFICE
212 679-7200
Joseph E. Halloran, Adv. Mgr.

MIDWESTERN OFFICE
307 North Michigan Avenue
Chicago, Illinois 60601 312 726-0892
George B. Mannion, Jr.

WESTERN OFFICE
9025 Wilshire Boulevard
Beverly Hills, California 90211
213 CRestview 4-0265; BRadshaw 2-1151
Western Advertising Manager: Bud Dean

JAPAN James Yagi, Oji Palace Aoyama
6-25, Minami Aoyama, 6-Chome, Minato-ku
Tokyo 407-1890/6821

CIRCULATION OFFICE
P.O. Box 1093, Flushing, N.Y. 11352



Member
Audit Bureau of
Circulations

Radio & TV News • Radio News • Radio-Electronic Engineering Trademarks Reg. U.S. Pat. Off.
SUBSCRIPTION SERVICE: Forms 3579 and all subscription correspondence should be addressed to Electronics World, Circulation Department, P.O. Box 1093, Flushing, N.Y. 11352. Please allow at least eight weeks for change of address. Include your old address, as well as new—enclosing if possible an address label from a recent issue.
EDITORIAL CONTRIBUTIONS must be accompanied by return postage and will be handled with reasonable care; however publisher assumes no responsibility for return or safety of art work, photographs, or manuscripts.
ELECTRONICS WORLD (August, 1971, Vol. 86, No. 2) Published monthly at One Park Avenue, New York, New York 10016, by Ziff Davis Publishing Company—also the publishers of Airline Management, Boating, Business & Commercial Aviation, Car and Driver, Cycle, Flying, Modern Bride, Popular Electronics, Popular Photography, Skiing, Sking Area News, Skiing Trade News, Stereo Review, and Travel Weekly. One year subscription rate for U.S., U.S. Possessions, and Canada, \$7 00; all other countries, \$8 00. Second Class postage paid at New York, N.Y., and at additional mailing offices. Authorized as second class mail by the Post Office Department, Ottawa, Canada and for payment of postage in cash.

There is no substitute for training on real electronic equipment.

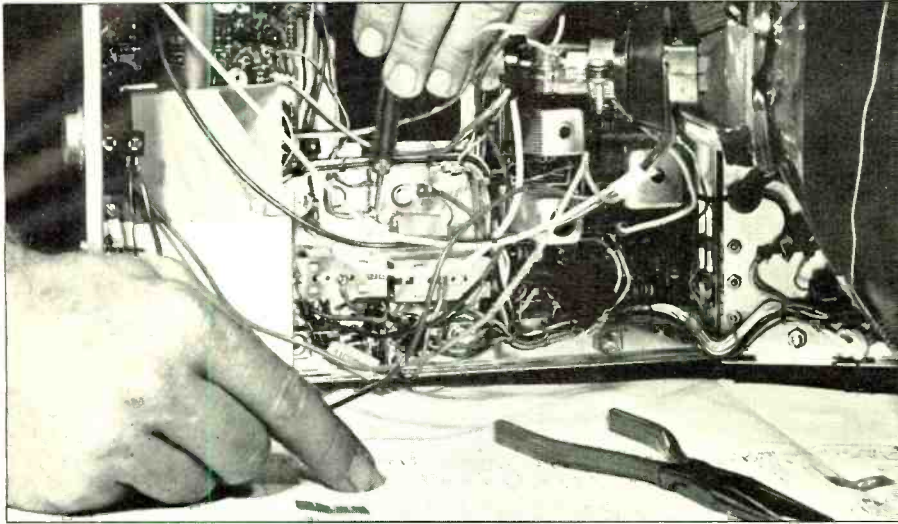

It's just as easy to train on the type of equipment technicians actually use and service.

And it's a lot more practical. Take TV Servicing, for instance.

You'll have it all over the man whose only experience has been on a TV receiver designed strictly for training purposes.

NTS Project-Method courses in Electronics combine the latest, professional equipment with easy-to-grasp lessons, texts and manuals. You build your equipment a stage at a time, and then use the equipment on projects that duplicate actual servicing problems.

It's like getting on-the-job experience at home.

Here's just some of the equipment you get to keep, and what you will learn. You'll get all the details when you receive the NTS full-color catalog.



NTS COLOR AND B&W T.V. SERVICING

You receive a color TV with many unique features, including built-in self-servicing equipment so you can make all normal test operations. You also build an AM-SW radio, solid-state radio, F.E.T. Volt-Ohmmeter, and electronic tube tester. You learn trouble-shooting, hi-fi, multiplex systems, stereo and color TV servicing.

Solid-state B&W TV 74 sq. in. picture (cabinet included)

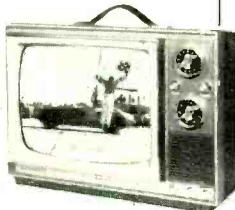

The B&W TV receiver features the latest in solid-state circuitry, making your TV training the most modern, most advanced available.

Exclusive Compu-Trainer®

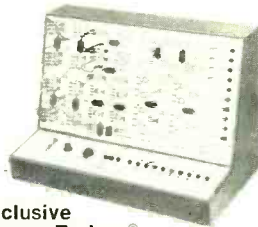

NTS ELECTRONIC & COMPUTER TECHNOLOGY

One of the 10 important kits included is this remarkable Compu-Trainer®—an NTS exclusive. It's a fully operational computer logic trainer—loaded with integrated circuits. It introduces you quickly to the how, what, and why of computers. You also receive a F.E.T. Volt-Ohmmeter and a 5" wide band oscilloscope.

Mail coupon today for free, full-color catalog that details every training program we offer. No obligation. No salesman will call.



5 watt AM transmitter receiver



NTS ELECTRONICS COMMUNICATIONS AND F.C.C.

Two exciting courses in the big-paying fields of transmitting and receiving. Either one qualifies you for your FCC First Class Radio-Telephone License. NTS trains you in Radio Fundamentals, 2-Way Radio Communications, Microwaves, Radar, Citizens Band, and more. You receive 14 kits to build: an amateur phone 6 meter VHF transmitter, plus NTS' exclusive 6 transistor solid-state radio and a fully transistorized volt-ohmmeter.

5" Oscilloscope

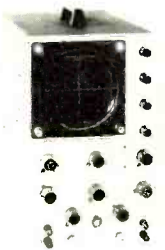

NTS INDUSTRIAL & AUTOMATION ELECTRONICS

Let NTS put you into the age of electronic controls. Systems automation is rapidly becoming the emphasis of modern industry. NTS training equipment includes a 5" wide band oscilloscope. You also get the new exclusive NTS Electro-Lab—a complete workshop. Build five industrial controls to regulate motor speed temperatures, pressure, liquid level and much more.

Please rush Free Color Catalog and Sample Lesson, plus information on course checked below. No obligation. No salesman will call.

National Technical Schools

4000 S. Figueroa St., Los Angeles, Calif. 90037

- | | |
|--|--|
| <input type="checkbox"/> Master Course in Color TV Servicing | <input type="checkbox"/> Practical Radio Servicing |
| <input type="checkbox"/> Color TV Servicing (For advanced Technicians) | <input type="checkbox"/> FCC License Course |
| <input type="checkbox"/> Master Course in B&W TV & Radio Servicing | <input type="checkbox"/> Master Course in Electronics Technology |
| <input type="checkbox"/> Master Course in Electronics Communications | <input type="checkbox"/> Industrial and Automation Electronics |
| | <input type="checkbox"/> Computer Electronics |
| | <input type="checkbox"/> Basic Electronics |
- Dept. 240-081

Name _____ Age _____

Address _____

City _____ State _____ Zip _____

- | | |
|---|---|
| <input type="checkbox"/> Check if interested in Veteran Training under new G.I. Bill. | <input type="checkbox"/> Check if interested only in Classroom Training at Los Angeles. |
|---|---|

CLASSROOM TRAINING AT LOS ANGELES

You can take classroom training at Los Angeles in sunny Southern California. NTS occupies a city block with over a million dollars in facilities devoted exclusively to technical training. Check box in coupon.

APPROVED FOR VETERANS

Accredited Member: National Association of Trade & Technical Schools; National Home Study Council.

NATIONAL TECHNICAL SCHOOLS

World-wide training since 1905

4000 S. Figueroa St., Los Angeles, Calif. 90037



NEWS HIGHLIGHTS

Unemployment Survey of Engineers Launched

A nationwide survey is being conducted by the Engineers Joint Council to determine the extent and nature of the unemployment problem facing engineers. The council recently received a \$65,000 contract from the National Science Foundation to conduct the study. The Council is querying a representative sample of 100,000 members of engineering societies as to their current employment status, thus providing the first reliable measure of both outright unemployment and the more insidious underemployment.

The Council has also recently issued its latest survey report "A Profile of the Engineering Profession." The report contains statistical data and charts showing the characteristics and occupational distribution representing 308,000 engineers. The report shows the California, at 13 percent, has the largest number of engineers of any state, followed by New York with 9 percent. Some 22 percent of all U.S. engineers are from the Middle Atlantic states. The median age of the group, which includes all engineering disciplines, is 42 with 16 years of professional experience. Almost two-thirds list themselves as supervisors. The 36-page report is available from Engineers Joint Council, Dept. P, 345 East 47th Street, New York, N.Y. 10017 at \$1.00 a copy.

Laser Safety Manual

A manual to promote safety in the classroom use of lasers, potentially hazardous light-amplifying devices, has been issued by HEW's Bureau of Radiological Health. Even relatively low-power classroom lasers, when improperly used, can cause eye damage. The manual combines discussion of laser hazard calculations, equipment features, and other safety information with a text for a short course in lasers. Included in the 117-page, illustrated volume are suggestions for laser demonstration experiments. Copies of the manual, "Laser Fundamentals and Experiments," may be purchased for \$1.25 from the Superintendent of Documents, U.S. Government Printing Office, Washington, D. C. 20402.

Color-TV Statistics

Color-TV receivers are owned by 38% of all American families according to the Bureau of Census. This is a jump from 32% in 1969. Most sets are owned by families who live in the West, residents of the suburbs of metropolitan areas, and homeowners. Their head of the household ranges in age from 25 to 54 years and the more income he has, the greater the chance that he will own a color set.

Families who have not bought a color set live mainly in the South and Northeast, in the cores of central cities, and in rural and farm areas. Their head of household is under 24 or over 35 years and his income is under \$10,000 a year. They are also mainly renters rather than homeowners. So, there are lots of people looking for a good color-TV set they can afford.

We've seen some other interesting TV statistics recently in the Television Digest Factbook. The total number of TV sets worldwide amounts to 270.5 million sets in 131 countries. The U.S. is far in the lead with 61.4 million black-and-white and 31.3 million color receivers. Next in line is the Soviet Union with 28 million black-and-white sets. Third in line is Japan with 19 million black-and-white and 5.15 million color receivers. Next in order are West Germany, Great Britain, France, Italy, and Canada.

Integrated Circuit "Real Estate"

Merle Hoover of RCA's Semiconductor Division once suggested the following notion to an EW writer. In 1969, U.S. manufacturers sold 250 million integrated circuits for a price of \$420 million. If we take as an average a square IC chip of 60 mils on a side, we come up with a total of 6250 square feet of IC's produced. This silicon "real estate" then costs \$67,000 per square foot, or nearly \$3 billion an acre! That's pretty expensive, even in these days of inflation.

News About Batteries

Scientists are working on the development of a biogalvanic battery, which uses metals and the body's oxygen and fluids to generate electricity. Workers at *ESB Inc.*'s Research Center have implanted in animals

Are You an Electronics Technician?

Want to be an Electronics Engineer?

Do You Have What It Takes to Complete Engineering Studies?

YES? Fine! But when are you going to do something about it? Grantham School of Engineering can make it happen for you.

You can earn the **accredited** Degree of Associate in Science in Electronics Engineering (the ASE), mainly by

STUDYING AT HOME

The entire educational program except for the final two weeks is conducted by correspondence. The program begins with a review of basics. Some of the main subjects covered are solid-state electronics including integrated circuits, engineering mathematics, physics, computers, network theory, engineering design, and systems analysis.

This college-level program is approved under the G.I. Bill as leading to the professional objective of **electronics engineer**, and the **degree is accredited** by the Accrediting Commission of the National Home Study Council.

Sound good? It should if you really mean business. We would be happy to send you complete information. Mail the postpaid reply coupon or write for our free booklet.

GSE

1505 N. Western Ave.
Hollywood, Calif. 90027

To Use Fold-Over Coupon:
(NO STAMP NEEDED)

Cut out entire form, then fold over at center line, and finally paste or tape the two folded parts together. Be sure your name and address are written legibly on the back. Drop in the mail TODAY; no stamp needed.

NO STAMP NEEDED; this entire fold-over coupon forms a postpaid mailing piece.

GSE

1505 N. Western Avenue
Hollywood, CA 90027

EW-8-71

I have been in electronics for ___ years. I am interested in the GSE degree program in Electronics Engineering. Please send me your free bulletin.

NAME _____ AGE _____

ADDRESS _____

CITY _____ STATE _____ ZIP _____

DO NOT CUT HERE. Fold Over, Seal & Mail. NO STAMP NEEDED.

FIRST CLASS
Permit No. 29880
Los Angeles,
Calif.

BUSINESS REPLY MAIL
No Postage Stamp Necessary If Mailed in the United States

POSTAGE WILL BE PAID BY —

GSE
Grantham School of Engineering
1505 N. Western Ave.
Hollywood, CA 90027

special platinum and magnesium or aluminum electrodes that have produced enough electricity to power a heart pacer. The electrodes are implanted under the skin in locations where there are enough body fluids and oxygen to react with the metals. Tests on humans have not been conducted as yet.

Then there is a new solid-state battery, developed by *Mallory Battery Co.*, that is small in size, highly reliable, and has an extremely long shelf life. Projected shelf life is said to be 10 years at room temperature. The anode is lithium metal and the cathode is a metal salt. The electrolyte is a lithium ion conductive, but electronically insulating solid material which serves as separator. The battery is hermetically sealed, and since there is no liquid used there is no corrosion or gassing.

On the subject of batteries, we've been seeing a number of ads in New York newspapers from one of our local optician chains. The ads, which are headed "When a mercury battery dies, it doesn't go to heaven," are a plea to users of the tiny batteries in hearing aids, camera light meters, and some watches, to bring them back to the optician's stores for "proper recycling." The ad warns about mercury pollution of seafood if the millions of mercury batteries now in use are not disposed of properly.

New Instrument Detects Fetal Life at Ten Weeks

An instrument which makes it possible to detect fetal life as early as ten weeks has been developed by *Danatron El Segundo, Calif.* Called "Echo-Tone," the unit uses the Doppler-shift principle employed in sonar equipment for underwater submarine detection. The device produces an audible signal which is proportional to the velocity of blood or tissue movement. Different velocities therefore produce different sounds which can be interpreted by the physician. The device is being used in fetal heart detection; multiple fetus detection (because of the directional nature of the sound probe); and placenta localization.

New Jersey's Assembly Halts New CATV Franchises

The N.J. Assembly has unanimously approved a one-year moratorium on local cable television franchise awards. The purpose of the moratorium was to give the Legislature time to set up new policies on the regulation of CATV. When this was written, the State Senate and the Governor had not yet acted on the moratorium but they were expected to go along with it. There have been many charges of illegal shakedowns and irregularities in the state's expanding CATV industry. A number of Trenton city officials have been indicted on charges of extorting \$50,000 from *Teleprompter Corp.*, one of the largest CATV firms.

N.Y.'s Public Service Commission Bars Picture-Telephone Test

The *N.Y. Telephone Co.* had been planning to provide picture-telephone service on an experimental basis for inter-office use in a number of businesses in the Wall St. (N.Y. City) area. The monthly rental charge would have been just under \$60 with an installation of \$50 for the service. The state's Public Service Commission turned thumbs down on the proposal, noting that the installation and maintenance would require the services of 10 employees. The PSC cited the many complaints about the poor quality of the present telephone service and declared that any diversion of company assets and resources to other than essential services, no matter how miniscule, is contrary to the commission's objectives and policies. The PSC rejected the proposal without prejudice to a refile by the phone company whenever service has improved sufficiently to warrant consideration of this new and important service offering.

CBS Grants Motorola Worldwide License for EVR Players

Motorola has been granted a worldwide non-exclusive license to manufacture and market the company's Teleplayer unit. This playback unit uses *CBS EVR* film cartridges to play back sound and pictures through one or more color-TV receivers. *Motorola* is already the exclusive manufacturing licensee of *CBS* in the United States and Canada through 1971. Soon a number of Japanese manufacturers are going to make players for the U.S. market. *Motorola* has already begun selling its player units to other licensees throughout the world in order to speed up their entry into the market, achieve early standardization, and accelerate acceptance of the EVR format.

Upcoming Electronics Show in Japan

Under the sponsorship of the Electronic Industries Association of Japan, the 1971 Japan Electronics Show will be held at the Osaka International Trade Fair Grounds from October 1 through 7. The show has been held alternately in Tokyo and Osaka each year since it was first staged in 1962. Some 290 manufacturers as well as 120 leading European and U.S. firms are expected to be represented. ▲

**"Hard work's
not enough...
you need more
education to
get ahead in
electronics"**

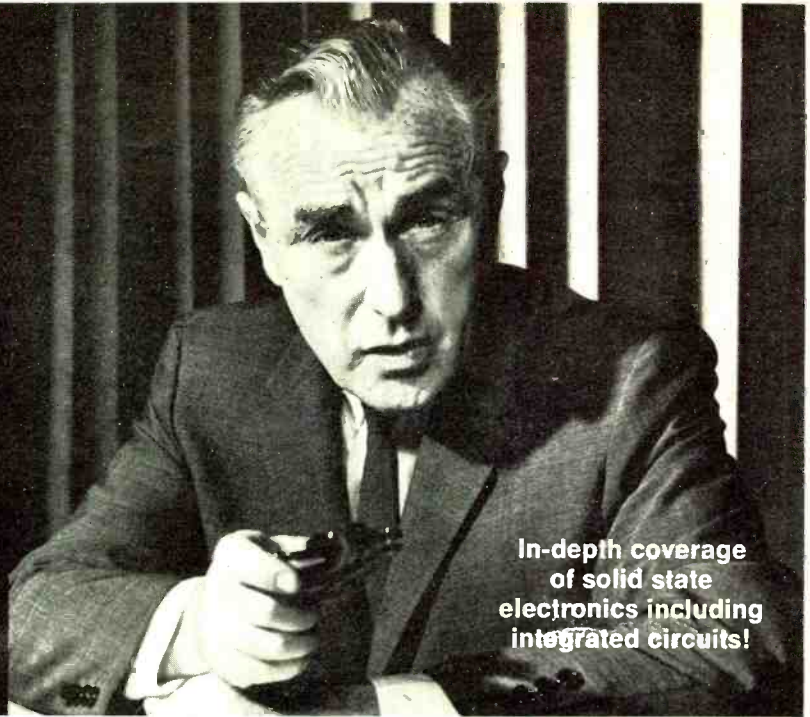

**In-depth coverage
of solid state
electronics including
integrated circuits!**

Cut along dotted line—Seal (paste or tape) and mail

Ask anyone who really knows the electronics industry. You can't hope to succeed unless you supplement your experience with specialized, up-to-date technical knowledge.

Going back to school isn't easy for a man with a full-time job and family obligations. But CREI Home Study Programs make it possible for you to get the additional education you need without attending classes. You study at home, at your own pace, on your own schedule.

CREI Programs cover all important areas of electronics including communications, automatic control, computers, even digital communications. You're sure to find a program that fits your career objectives.

FREE book gives all the facts. Mail postpaid reply coupon today or write: CREI, Dept. E1108B
3224 Sixteenth St., N.W.
Washington, D.C. 20010

Founded 1927

CREI

Accredited Member of the
National Home Study Council

**SEND FOR
FREE BOOK**

Cut out entire business reply envelope at right. Fill in coupon. Fold over, seal (paste or tape) and mail today.

NO STAMP NECESSARY.



NO STAMP NEEDED—

This entire fold-over coupon forms a postpaid envelope

Please mail me FREE book describing CREI Programs. I am employed in electronics and have a high school education.

E1108B

NAME _____ AGE _____

ADDRESS _____

CITY _____ STATE _____ ZIP _____

EMPLOYED BY _____

TYPE OF PRESENT WORK _____

I am interested in: Electronic Engineering Technology
 Space Electronics Computers Nuclear Engineering Technology
 Industrial Electronics **NEW!** Electronics Systems Engineering
 NEW! Non-Technical Course in Computer Programming

Approved for training under new G.I. Bill

Do not cut here—just fold over, seal and mail—No stamp needed

FIRST CLASS
Permit No. 288-R
Washington, D.C.

BUSINESS REPLY MAIL

No Postage Stamp Necessary If Mailed In The United States

Postage will be paid by

CREI

**CREI, A Division of the McGraw-Hill
Continuing Education Company**

3224 Sixteenth St., N.W.
Washington, D.C. 20010



ABOUT YOUR SUBSCRIPTION

Your subscription to *ELECTRONICS WORLD* is maintained on one of the world's most modern, efficient computer systems, and if you're like 99% of our subscribers you'll never have any reason to complain about your subscription service.

We have found that when complaints do arise, the majority of them occur because people have written their names or addresses differently at different times. For example, if your subscription were listed under "William Jones, Cedar Lane, Middletown, Arizona," and you were to renew it as "Bill Jones, Cedar Lane, Middletown, Arizona," our computer would think that two separate subscriptions were involved, and it would start sending you two copies of *ELECTRONICS WORLD* each month. Other examples of combinations of names that would confuse the computer would include: John Henry Smith and Henry Smith, and Mrs. Joseph Jones and Mary Jones. Minor differences in addresses can also lead to difficulties. For example, to the computer, 100 Second St. is not the same as 100 2nd St.

So, please, when you write us about your subscription, be sure to enclose the mailing label from the cover of the magazine—or else copy your name and address exactly as they appear on the mailing label. This will greatly reduce any chance of error, and we will be able to service your request much more quickly.

LETTERS

REVERBERANT SOUND

To the Editor:

I should like to correct some statements made by Don Davis in his April, 1971 article "Hi-Fi Speakers for Reverberant Sound." Mr. Davis implies that recording microphones are located at "preferred seats" in the hall when, in fact, they are usually at the front of the stage (nearer to the source of music than are most listeners). Nor do they record all relevant information in the sound reaching them; directional cues may be recorded only partially, depending on the directional response, and phase information will be lost entirely if any mixing is done.

Mr. Davis also implies that a perfect loudspeaker in a perfectly anechoic room would reproduce at the listener's ears exactly the same signal they would receive in the hall. The speaker may well reproduce precisely the signal received by the microphone, but one or two speakers in front of a listener cannot possibly create at his ears the directional distribution of sound that existed in the hall.

Finally, the primary function of the rear speakers of a 4-channel system is to reproduce the directionality of reverberation and not the correct time delays of reverberation, as suggested in the article. Also, although equalization may remove the effects of speaker/room interaction, it in no way corrects the interaction.

Although the average reader is not likely to have a truly anechoic listening room, nor is he likely to build one, there is one way in which the fidelity Mr. Davis refers to can be achieved, and that is through binaural recording. By placing two microphones exactly at the preferred seat location (often at the eardrum locations of a dummy head), and reproducing the sound with two speakers in the completely anechoic environment of a pair of headphones, superb fidelity can be achieved. However, the vast majority of home listeners spend most of their time in normal rooms, and commercial recording companies, fully aware of this, record only a fraction of the original reverberation. Therefore, for home listening on two loudspeakers, the most nearly faithful reproduction, including directional considerations, is most likely to come from loudspeakers with especially good

dispersion—quite possibly from speakers which have been deliberately designed to produce significant amounts of reverberation at all frequencies in the average home-listening room.

GERALD BLUM
Museum of Science & Hayden
Planetarium
Boston, Mass.

* * * "HI-FI STEREO AMP"

To the Editor:

I am writing to comment on the article by Walter Schopp in the January, 1971 issue of *ELECTRONICS WORLD*, "Small-Size Hi-Fi Stereo Amplifier." I'd like to call your attention to an error in the value labeled C_2 . This must be at least 100 μF if there is not to be excessive phase-shift at the low-frequency end.

Also, I am afraid many readers will be disappointed with Mr. Schopp's choice of 1000 μF for the output coupling capacitor. Used with the 8-ohm speaker, it will give a cut-off of 80 hertz rather than the 15 hertz quoted in the table. If 9000 μF is substituted, there will then be problems of power-supply hum and channel crosstalk.

Finally, the output impedance is nominally zero and not 8 ohms as shown both in the table and in the photo. It is actually between 0.1 and 0.2 ohm.

In closing, let me say that *ELECTRONIC WORLD* is not seen on British newsstands but about a dozen engineers and technicians are always pleased to read my copy. Everyone here is delighted with the magazine and hopes it will continue to enjoy popularity and success for many years to come.

JAMES G. HOLBROOK
University of Southampton
Southampton, England

* * * DYNAMIC DWELL TACH

To the Editor:

In his article "Dynamic Dwell/Tachometer" (May, 1971), the author erroneously states of conventional (collector-coupled) one-shots that "the input pulse length can be no longer than the output pulse, because the input would then tend to hold the output 'on.'"

Since there is no d.c. coupling from the output of I_3 to the input of I_4 , the



CATALOG ON REQUEST

#130 12 HOUR DIGITAL CLOCK MOVEMENTS
#131 24 HOUR DIGITAL CLOCK MOVEMENTS

TYMETER®
Time At A Glance

9:37

DIGITAL CLOCK MOVEMENTS

DIGITS RESETTABLE INDIVIDUALLY
Available in 50, 60 cy. all voltages, AC. UL approved motor, cord. One Year Guarantee.



#100-24H
24 Hour
CLOCK

Made in U.S.A.

Complete Line: Delay, Interval and Cycle Timers, Digital Computers

PENNWOOD NUMECHRON CO.
TYMETER ELECTRONICS
7749 FRANKSTOWN AVE. PITTSBURGH, PA. 15208

CIRCLE NO. 127 ON READER SERVICE PAGE

ELECTRONICS WORLD

THE MOST SPECTACULAR SOUND EXHIBITIONS of STEREO FIDELITY EVER AVAILABLE!

DEMO RECORD

Offers you a greater variety of sound than has ever before been included on a single disc.



This record is the result of two years of intensive research in the sound libraries of Deutsche Grammophon Gesellschaft, Connoisseur Society, Westminster Recording Company and Cambridge Records Incorporated. The Editors of Stereo Review have selected and edited those excerpts that best demonstrate each of the many aspects of the stereo reproduction of music. It is a series of independent demonstrations, each designed to show off one or more aspects of musical sound and its reproduction. Entirely music, the Record has been edited to provide self-sufficient capsule presentations of an enormous variety of music arranged in a contrasting and pleasing order. It includes all the basic musical and acoustical sounds that you hear when you listen to records, isolated and pointed up to give you a basis for future critical listening.

WIDE RANGE OF DEMONSTRATIONS

- Techniques of Separation & Multiple Sound Sources • Acoustic Depth • Ambiance of Concert Hall • Sharp Contrasts of Dynamics • Crescendo & Diminuendo • Very High & Very Low Pitched Musical Sounds • Polyphony (2 or more melodies at once) With Both Similar & Contrasting Instruments • Tonal Qualities of Wind, String & Percussion Instruments • Sounds of Ancient Instruments • Sounds of Oriental Instruments • Sound of Singing Voice, Both Classically Trained and Untrained • Plus a Large Sampling of Finger Snapping, Hand Clapping, Foot Stamping & Other Musical & Percussive Sounds.

13 SUPERB SELECTIONS

STRAUSS: Festive Prelude, Op. 61 (excerpt) DGG. **DEBUSSY:** Feux d'artifice (excerpt). Connoisseur Society. **BEETHOVEN:** Wellington's Victory (Battle Symphony) (excerpt from the first movement) Westminster Records. **MASSAINO:** Canzona XXXV à 16 (complete) DGG Archive. **CORRETTE:** Concerto Comique Op. 8, No. 6, "Le Plaisir des Dames" (third movement) Connoisseur Society. **KHAN:** Raga Chandranandan (excerpt) Connoisseur Society. **RODRIGO:** Concert—Serenade for Harp and Orchestra (excerpt from the first movement) DGG. **MANITAS DE PLATA:** Gypsy Rhumba (complete) Conn. Soc. **MARCELLO:** (arr. King): Psalm XVII "The Heavens are Telling" (complete) Connoisseur Society. **PRAETORIUS:** Terpsichore: La Bourrée XXXII (complete) DGG Archive. **BERG:** Wozzeck (excerpt from Act III) DGG. **BARTOK:** Sonata for two pianos and Percussion (excerpt from the first movement) Cambridge Records. **BEE-THOVEN:** Wellington's Victory (Battle Victory) (excerpt from the first movement) Westminster.

FREE Descriptive Booklet Enclosed includes discussion of the selections on the record, plus a complete description of each selection and the purpose behind its demonstration.

Only \$5.98 each

NOTE — THE STEREO DEMONSTRATION RECORD ONLY IS AVAILABLE IN YOUR CHOICE OF 33 1/3 RPM OR 45 RPM

RECORDS • Ziff-Davis Service Division
595 Broadway • New York, N.Y. 10012

My check (or money order) for \$_____ is enclosed.
Please send:

_____ Stereo Review Stereo Demonstration Records at \$5.98 each, postpaid.
Check one: 33 1/3 RPM 45 RPM

_____ Stereo Review's Binaural Demonstration Record at \$5.98 each, postpaid.
(Outside U.S.A. please send \$8.00 per record ordered.) New York State residents please add local sales tax.

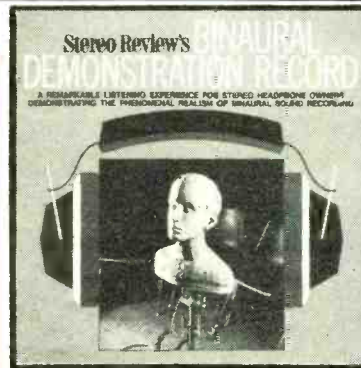

BINAURAL RECORD

Created specifically for playback thru stereo headphones, this unique record presents sound of unsurpassed realism.

Binaural recording re-creates the directions, distances, and even the elevations of sounds better than any other recording method. The super-realism of binaural recording is accomplished by recording the acoustical input for each ear separately, and then playing it back through stereo headphones. Thus the sound intended for the left ear cannot mix with the sound for the right ear, and vice versa.

Binaural recording offers the listener the identical acoustical perspective and instrument spread of the original. The sound reaching *each ear* is exactly the same as would have been heard at the live scene.

"MAX"—GENIE OF BINAURAL RECORDING. "Max," a specially constructed dummy head, cast in silicone rubber, duplicates the role of the human head as an acoustical absorber and reflector of sound. Super-precision capacitor microphones were installed in Max's ears so that each microphone would pick up exactly what each human ear would hear. The result is a demonstration of phenomenal recorded sound.

STARTLING REALITY. The Binaural Demonstration Record offers 45 minutes of sound and music of startling reality. You'll marvel at the eerie accuracy with which direction and elevation are re-created as you embark on a street tour in binaural sound—Sounds Of The City . . . Trains, Planes & Ships . . . a Basketball Game, a Street Parade, a Street Fabrication Plant, The Bird House at the Zoo—all demonstrating the incredible realism of binaural sound reproduction.

MUSIC IN BINAURAL. The musical performances presented on the Binaural Demonstration Record transport you to the concert hall for a demonstration of a wide variety of music. Selections total 23 minutes, and include examples of jazz, organ, and chamber music.

Although headphones are necessary to appreciate the near-total realism of binaural recording, the record can also be played and enjoyed on conventional stereo systems.

EW-871

Print Name _____

Address _____

City _____

State _____ Zip _____

PAYMENT MUST BE ENCLOSED WITH ORDER



Joint Venture

UNIQUE NEW WAY TO SELF EMPLOYMENT WITH EXECUTIVE LEVEL INCOME!

Get together with the world's largest electronics store chain:

\$15,000-\$20,000 GETS YOU IN BUSINESS FOR YOURSELF*

*One-time investment in physical inventory and store fixtures — no fees, no royalties, no hidden costs!

★
PROFITS
★
SECURITY
★
PRESTIGE
★

Join Allied Radio Shack in a rare opportunity to capitalize on the zooming demand for everything in consumer electronics. First in the field, we have over 950 stores nationwide but must expand to meet the growing market (\$10 billion in 1971 alone!) and need energetic men and women to operate new or existing stores. Why not be your own boss in a Joint Venture with YOUR OWN Allied Radio Shack Store? Minimum cash needed is \$15,000-\$20,000—which represents an investment in physical inventory and store fixtures—NO fees at all! You operate as a true businessman with the profit and income potential strictly up to you!

In this Joint Venture, your success is our success—50-year-old Allied Radio Shack will train you and provide the “know-how,” back you with creative merchandising, exclusive products, and the best local and national advertising in the business. You’ll sell famous products available nowhere else: Allied® and Realistic® brand audio and CB, Knight-Kit® and Science Fair® electronics and hobby kits, Archer® Antennas and Radio Shack batteries to name a few—everything priced “right” for big sales, good profits for you.

Enjoy the prestige and extra security of being associated with the Tandy Corporation (parent company of Allied Radio Shack), rated “Number One” in the nation in annual sales growth and earnings per share among firms in retailing (Forbes Magazine, 23rd Annual Report on American Industry). If you want to win with a winner and start a lucrative career today, act NOW.

CALL COLLECT OR WRITE:

A. A. Bernabei
Vice President
Allied Radio Shack
2617 West 7th St.
Fort Worth, Texas 76107
Phone (817) 336-7163.

SEND ME FULL JOINT VENTURE DETAILS		Dept. JV-15
Name	Phone	
Street		
City	State	Zip

FOREDOM MINIATURE POWER TOOLS

for the Professional Technician

Drill, grind, debur, polish, sand, cut, drive screws and nuts. No other tools can perform the range of intricate, precision operations you can do with FOREDOM.

SEND FOR COMPLETE MINIATURE POWER TOOL CATALOG 250.



THE FOREDOM ELECTRIC COMPANY
A DIVISION OF BLACKSTONE INDUSTRIES, INC.
Bethel, Connecticut 06801

one-shot responds only to a positive-going transition at the trigger input (I2) so that the output pulse duration will always be independent of the input length.

LOUIS SHAPIRO
Brooklyn, N.Y.

* * *
ERTS

To the Editor:

Your feature article in the May, 1971 issue of ELECTRONICS WORLD, “ERTS . . . Satellites to Serve Man,” is so good that it sounds as if all our scientific problems are solved. However, while I do have high hopes that the Earth Resources Technology Satellite will solve many of them, I believe the best definition we can expect will be in units of about five acres.

This, of course, means that the satellite will be most useful for regional studies and planning. What this amounts to is that we will be able to predetermine locations were conventional photographs, sensing, and ground control are most needed.

ELVIN E. BIRTH
Senior Forester
Environmental Systems Corp.
Knoxville, Tenn.

* * *
ENGINEERING CRISIS

To the Editor:

I would like to offer the following comments concerning Mr. Don Broughton's letter (May, 1971 issue of ELECTRONICS WORLD) on the subject of the engineering crisis.

First, engineers are not eligible for membership in *Phi Beta Kappa*; the engineers' honorary society is *Tau Beta Pi*.

Second, in my opinion, the purpose of an engineering education is to teach basic engineering principles and logical thought processes. From there, the engineer may continue his education in his chosen field, or not, to the extent he desires.

CHARLES E. QUENTEL
Milwaukee, Wisc.

* * *
ANNUAL INDEX

To the Editors:

I wish to know if there exists some kind of register or running list which shows the table of contents for every copy of ELECTRONICS WORLD magazine that has been published.

I would like to obtain such an index or register if one is available. Would you please inform me about the availability of such an item.

GEORGE LODADO
S. Ozone Park, N.Y.

Although we do not have lists of our tables of contents, we would certainly suggest that you check our annual indices which appear regularly in the December (occasionally January) issue.—Editor



Status Report on

Four-Channel Stereo

By JULIAN D. HIRSCH

Four-channel sound reproduction does provide sense of spaciousness—it literally immerses one in sound. Even regular mono or two-channel stereo discs are enhanced.

In recent years, a number of so-called "four-channel" recording and reproducing systems have been demonstrated, announced, or merely proposed. The public's exposure to four-channel sound, however, has been largely limited to special demonstrations held in dealer showrooms or presented at audio shows. Most of these have used four-track tape as the program source, with a repertoire tending toward flashiness (a sort of "four-channel ping-pong," in many cases).

There is no argument that tape is the medium best suited to handling four discrete channels without significant interaction or other performance compromises. Conceivably, a disc record with an ultrasonic sub-carrier, such as the JVC system, can also approach this level of performance. However, it is our belief, shared by many in the industry, that a successful four-channel medium must be completely compatible with two-channel stereo, and even with mono. This means that it should be playable on standard stereo systems with no degradation of frequency response, distortion, or separation, and should be heard on a mono system as a full mono program, again without any noticeable degradation.

This implies the ability to be transmitted by an FM station within the current FCC stereo broadcast standards. Any significant alteration of the FCC broadcast standards would be an extremely lengthy process, if indeed it could be made at all.

A family of more or less "compatible" systems has been proposed, based on matrixing operations rather than on completely separate channels. In a matrix system, the four original channels are combined, with appropriate changes of level and phase, to form two conventional stereo channels. In this form they can be recorded on standard stereo discs or two-channel tape machines, and can be transmitted over FM in a form indistinguishable from any other stereo program.

In playback, an inverse matrixing process is used. Each of the two channels is separated into two components whose

phase and magnitude are manipulated to re-create the original four-channel program. Of course, from that point onward, any four-channel system requires separate amplifiers and speakers, no matter how the signals have been processed in early stages (with one exception which we will describe shortly).

Although the various matrix systems differ among themselves in their choice of coefficients and in certain other signal-processing techniques, they are all basically compatible in the sense that a program transmitted or recorded with one system will be heard as some sort of four-channel program when played back through another system. Of course, optimum results require the use of the same signal-processing parameters in the encoding and decoding stages.

The first matrix system to be publicly announced was the so-called *Scheiber* system (see September and December 1970 issues). It differs from others in the use of a relatively complex dynamic gain-control technique to improve the four-channel separation, which is often minimal in a simple matrix system. To date, no commercial version of the *Scheiber* system has been released.

The *Dynaco* system (see October, 1970 issue) is unique in using a single two-channel amplifier to drive all four speakers, with most of the matrixing taking place in the speaker connections. It takes advantage of the presence of difference signals (L-R) in most stereo recordings to drive a single rear speaker and the sum (L+R) signal to drive a single speaker at front center. The normal L and R speakers are located at the sides of the room rather than in the usual front position.

Although specially processed records show off the *Dynaco* system to its best advantage, it frequently adds an impressive spaciousness to ordinary stereo programs. Depending on the program configuration, separation can vary from excellent to negligible (a fairly common situation with other matrix systems as well), but the ability to sample four-

channel effects with a minimum investment is certainly an attractive feature of this approach.

The Electro-Voice EVX-4

Recently, *Electro-Voice* entered the field with a system developed by Leonard Feldman, and became the first company to market a low-cost (\$59.95) decoder for home use. A much more expensive encoder is available for broadcast stations and recording studios. *Electro-Voice* has not as yet released any details on its system, and the decoder consists of little more than a single integrated circuit which offers no clues to its internal workings. A number of FM broadcast stations are presently transmitting programs through the *E-V* encoder (see "News Highlights," June, 1971 issue), so that anyone with a decoder plus an extra stereo amplifier and a pair of speakers can put it to immediate use. A few records have already been released with *E-V* encoding and more can be expected.

We have been using the Model EVX-4 decoder for some time and have made enough measurements on it to give us a fair idea of what it does and how it does it. It is a small walnut vinyl-covered box measuring $5\frac{3}{16}$ " wide \times $2\frac{1}{2}$ " high \times 7" deep and is self-powered. Normally, its two inputs come from the tape outputs of an amplifier or receiver. The front outputs (L_f and R_f) return to the amplifier tape inputs and eventually drive the front speakers (the original stereo pair). The two rear outputs (L_r and R_r) go to another stereo amplifier which drives two speakers in the left rear and right rear corners of the room. Considerable latitude in speaker placement is possible without serious effect on the final result. The amplifier gains are adjusted for front/rear balance, after which a single master gain control on the EVX-4 controls all four channels.

The tape-recorder inputs and outputs are no longer available at the amplifier, so they are duplicated on the EVX-4. A switch on its panel selects normal four-channel signal decoding or decodes the playback output of an associated tape recorder. Since the program before decoding is in conventional stereo format, any ordinary stereo tape recorder can be used to preserve an encoded broadcast which can be heard in four-channel form at a later time. A third switch position channels the recorder outputs to the front amplifier without decoding, for playing two-channel tapes.

We measured the performance of the *Electro-Voice* EVX-4 by feeding test signals to its inputs, single or in combination, and observing the phase and amplitude of the outputs at each of its terminals. With a 1000-Hz signal applied to the L input at a reference level and phase of 0 dB at 0 degrees, we measured the following outputs: L_f 0 dB at 180 degrees; R_f -14.2 dB at 180 degrees; L_r -3 dB at 180 degrees; and R_r -5 dB at 0 degrees. Similar results were obtained when driving the R input, with the numbers appropriately interchanged. They did not change measurably over the 20 Hz to 20 kHz range. Note that the phase reversal between L_r and R_r implies more amplitude separation between them than the numbers would suggest. With a

mono ($L+R$) signal applied to both inputs, the L_f and R_f outputs were each +1.5 dB at 180 degrees (a total 3-dB increase over the single-channel condition), but the two rear channels were approximately 18 dB lower in level.

Because of the complex nature of the input signal and the manner in which it affects the four outputs, it is not as easy to define "channel separation" under actual operating conditions as it would be with a two-channel stereo signal. Roughly, it can be said that the separation between the front speakers is about 14 dB, which may not sound like much but is actually sufficient for a good stereo image. The rear channels, measuring only 3 to 5 dB below the level of each front channel, are actually more distinctly separated. After all, normal stereo (as distinguished from the ping-pong variety) has considerable $L + R$ content, and the rear speakers are some 18 dB below that portion of the program, which appears between the two front speakers. This effect is striking with mono programs or voice announcements which appear in front center and are completely absent from the rear speakers.

In its other electrical parameters, the EVX-4 is essentially a non-distorting device. Its frequency response measured perfectly flat from 5 Hz to well over 20 kHz and the harmonic distortion was 0.03% at 0.1 volt, 0.125% at 1 volt, and 0.29% at 2 volts output (it is a unity gain circuit).

Although it is not really germane to our evaluation of the EVX-4, we would hazard a guess that the IC consists of four operational amplifiers, interconnected by the various feedback and matrixing resistors which establish their gains and the amount of cross-coupling between them. Presumably, *Electro-Voice* will release more data later.

How Does It Sound?

Much more important than the measurements, which served to satisfy our curiosity, was the actual performance of the EVX-4. We played all available encoded records (*Ovation* OD/1, *Crewe* CGC-1000, *Total Sound* PR/5036SD and PR/5048SD—*Enoch Light*, Project 3) as well as stereo-FM broadcasts, both encoded and normal.

On almost any type of stereo material, the EVX-4 added a sense of spaciousness that we found most pleasing. In this sense, it was not unlike the *Dynaco* system, which adds this quality to many programs. It was interesting to find that there frequently was a definite front/rear separation on ordinary stereo programs, often with a strong hint of separation between the two rear speakers as well. In fact, some normal stereo records sounded at least as good as some of the encoded records!

With the *Electro-Voice* encoded material, the effect was strongly enhanced. One was literally immersed in sound, with a sense of directionality toward the room corners (generally rather vague, however). The *E-V* system cannot hope to match the "four-way ping-pong" potential of tape and we do not feel it should be judged on that basis. It generates a sense of involvement with a sound which is so easy to accept that after a while one may be unaware of its existence. On many occasions, we switched off the rear speakers and the contrast was striking. It can only be compared to turning off most of the lights in a well-lit room after one has become adjusted to a high ambient light level.

We had been highly skeptical of early claims that four-channel sound was as much of an improvement over two channels as the latter was over mono. At this point, we are ready to eat crow. Going back to two channels after four-channel listening is like going back to mono—an intolerable prospect for a real stereo addict.

A real bonus in the situation is the fact that, even if the *Electro-Voice* system is not universally adopted, or is modified, the benefits of the EVX-4 can be realized with any stereo record or FM broadcast. We are enjoying playing some of our old, forgotten stereo discs and discovering a new dimension of sound hidden in their grooves. ▲

The *Electro-Voice* EVX-4 four-channel decoder. Heath is offering a kit version which is identical, including the IC.



Electronics World

READER SERVICE PAGE

FREE INFORMATION SERVICE!

Here's an easy and convenient way for and to get additional information about products advertised or mentioned editorially (if it has a "Reader Service Number") in this issue. Just follow the directions below . . . and the material will be sent to you promptly free of charge.

1 On coupon below, circle the number(s) that correspond(s) to the key number(s) at the bottom or next to the advertisement or editorial mention that is of interest to you. (Key numbers for advertised products also appear in the Advertisers' Index.) Print or type your name and address on the lines indicated.

2 Cut out the coupon and mail it to:
Electronics World,
P.O. Box 7842,
Philadelphia, Pa.
19101

NOTE:

If you want to write to the editors of ELECTRONICS WORLD about an article on any subject that does not have a key number, write to ELECTRONICS WORLD, One Park Avenue, New York, N.Y. 10016. Inquiries concerning circulation and subscriptions should be sent to ELECTRONICS WORLD, P.O. Box 1093, Flushing, N.Y. 11352

Electronics World

P.O. Box 7842
Philadelphia, Pa. 19101

Void 60 days after date of issue

871

1	2	3	4	5	6	7	8	9	10	11	12	13	14	15	16	17	18	19	20	21	22	23	24	25
26	27	28	29	30	31	32	33	34	35	36	37	38	39	40	41	42	43	44	45	46	47	48	49	50
51	52	53	54	55	56	57	58	59	60	61	62	63	64	65	66	67	68	69	70	71	72	73	74	75
76	77	78	79	80	81	82	83	84	85	86	87	88	89	90	91	92	93	94	95	96	97	98	99	100
101	102	103	104	105	106	107	108	109	110	111	112	113	114	115	116	117	118	119	120	121	122	123	124	125
126	127	128	129	130	131	132	133	134	135	136	137	138	139	140	141	142	143	144	145	146	147	148	149	150

Name (Print Clearly) _____ Title _____

Company Name _____

Address _____

City _____ State _____ Zip Code _____

sa

Electronics World

P.O. Box 7842
Philadelphia, Pa. 19101

Void 60 days after date of issue

871

1	2	3	4	5	6	7	8	9	10	11	12	13	14	15	16	17	18	19	20	21	22	23	24	25
26	27	28	29	30	31	32	33	34	35	36	37	38	39	40	41	42	43	44	45	46	47	48	49	50
51	52	53	54	55	56	57	58	59	60	61	62	63	64	65	66	67	68	69	70	71	72	73	74	75
76	77	78	79	80	81	82	83	84	85	86	87	88	89	90	91	92	93	94	95	96	97	98	99	100
101	102	103	104	105	106	107	108	109	110	111	112	113	114	115	116	117	118	119	120	121	122	123	124	125
126	127	128	129	130	131	132	133	134	135	136	137	138	139	140	141	142	143	144	145	146	147	148	149	150

Name (Print Clearly) _____ Title _____

Company Name _____

Address _____

City _____ State _____ Zip Code _____

sb



firsts

make learning
Electronics at home
fast and fascinating—
give you priceless
confidence.

Some NRI **firsts** in training equipment

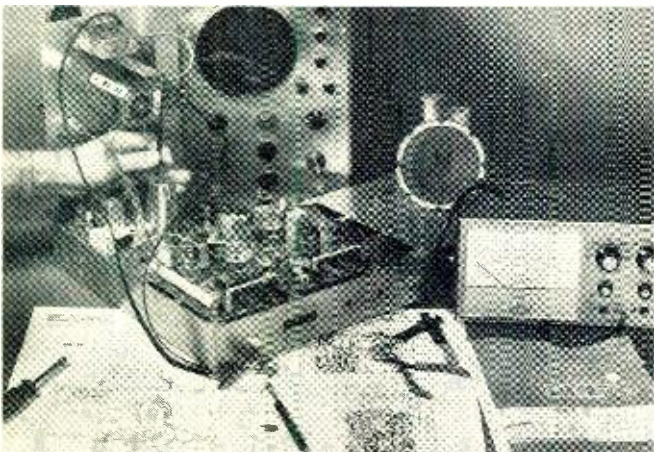

first to give you Color Television training equipment engineered specifically for education—built to fit NRI instructional material, *not* a do-it-yourself hobby kit. The end product is a superb Color TV receiver that will give you and your family years of pleasure. You “open up and explore” the functions of each color circuit as you build.



first to give you a unique, exciting digital computer *with memory* built especially for home training. You learn organization, trouble shooting, operation, programming as you build and use it. Performs the same functions as commercial computers. Lessons stress computer repair. You conduct a hundred experiments, build hundreds of circuits. A solid-state VTVM is included among ten training kits.

NRI's "discovery" method is the result of over half a century of leadership simplifying and dramatizing training at home

The FIRSTS described below are typical of NRI's half century of leadership in Electronics home training. When you enroll as an NRI student, you can be sure of gaining the in-demand technical knowledge and the priceless confidence of "hands-on" experience sought by employers in Communications, Television-Radio Servicing and Industrial and Military Electronics. Everything about NRI training is designed for your education . . . from the much-copied, educator-acclaimed Achievement Kit sent the day you enroll, to "bite-size" well-illustrated, easy to read texts programmed with designed-for-learning training equipment.

YOU GET YOUR FCC LICENSE OR YOUR MONEY BACK

There is no end of opportunity for the trained man in Electronics. You can earn \$6 or more an hour in spare time, have a business of your own or qualify quickly for career positions in business, industry, government. And if you enroll for any of five NRI courses in Communications, NRI prepares you for your FCC License exams. *You must pass* or NRI refunds your tuition in full. No school offers a more liberal money-back agreement. The full story about NRI leadership in Electronics training is in the new NRI Catalog. Mail postage-free card today. No salesman is going to call.
NATIONAL RADIO INSTITUTE, Washington, D.C. 20016

APPROVED UNDER NEW GI BILL If you have served since January 31, 1955, or are in service, check GI line on postage-free card.

designed from chassis up for your education

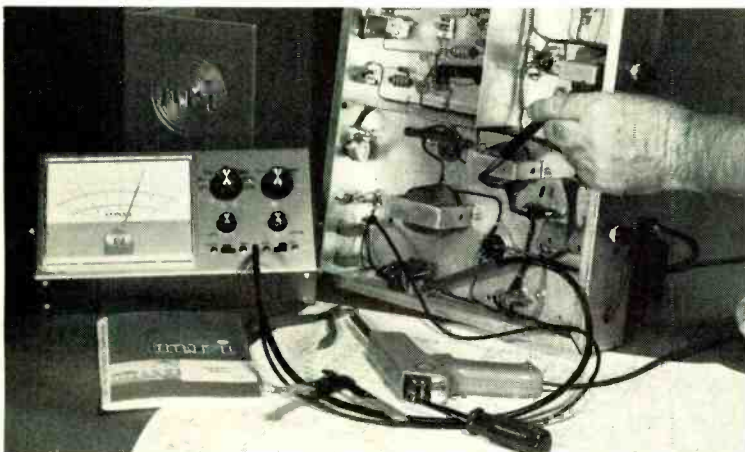

first to give you true-to-life experiences as a communications technician. Every fascinating step you take in NRI Communications training, including circuit analysis of your own 25-watt, phone/cw transmitter, is engineered to help you prove theory and later apply it on the job. Studio equipment operation and troubleshooting become a matter of easily remembered logic.



first to give you completely specialized training kits engineered for business, industrial and military Electronics. Shown above is your own training center in solid state motor control and analog computer servo-mechanisms. Telemetering circuits, solid-state multi-vibrators, and problem-solving digital computer circuits are also included in your course.



MEMOREX

Chromium dioxide cassette

An advanced cassette for specially designed

Introducing Memorex Chromium Dioxide Tape.

New Memorex Chromium Dioxide Tape has a totally different composition from conventional cassette tapes. It extends frequency response and delivers a clarity and brilliance of sound never before possible on cassette. Chromium Dioxide is so drastically different, you'll need a specially designed cassette recorder to use it.

You've probably read about conven-

tional cassette tapes that claim to be so improved it's not necessary to switch to special Chromium Dioxide equipment.

Let us simply say this:

Equipment manufacturers recognized the Chromium Dioxide breakthrough, and designed cassette recorders to take advantage of it.

Listen to a Memorex Chromium Dioxide



The tape that will change your whole opinion of cassettes.

Cassette on the new specially designed equipment. Compare it to any cassette that claims equal performance on standard equipment.

You'll find there's no comparison.

MEMOREX Recording Tape
Reproduction so true it can shatter glass.
CIRCLE NO. 130 ON READER SERVICE PAGE

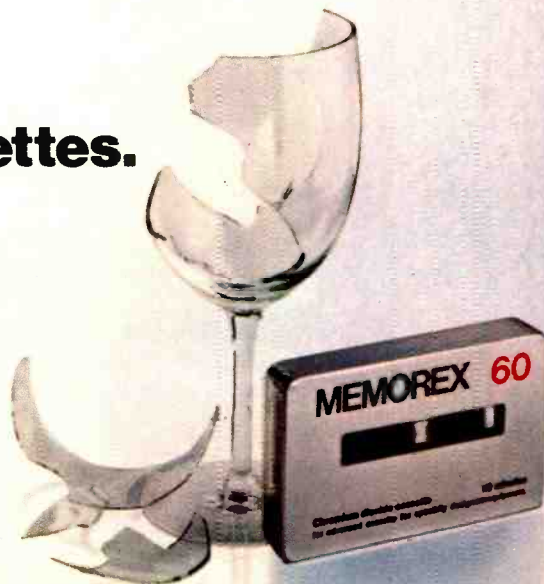

"CIE training helped pay for my new house," says Eugene Frost of Columbus, Ohio

Gene Frost was "stuck" in low-pay repair work. Then two co-workers suggested he take a CIE home-study course in electronics. Today he's living in a new house, owns two cars and a color TV set, and holds an important technical job at North American Rockwell. If you'd like to get ahead the way he did, read his inspiring story here.



IF YOU LIKE ELECTRONICS—and are trapped in a dull, low-paying job—the story of Eugene Frost's success can open your eyes to a good way to get ahead.

Back in 1957, Gene Frost was stalled in a low-pay repair job. Before that, he'd driven a cab, repaired washers, rebuilt electric motors, and been a furnace salesman. He'd turned to TV service work in hopes of a better future—but soon found he was stymied there, too.

"I'd had lots of TV training," Frost recalls today, "including numerous factory schools and a semester of advanced TV at a college in Dayton. But even so, I was stuck at \$1.50 an hour."

Gene Frost's wife recalls those days all too well. "We were living in a rented double," she says, "at \$25 a month. And there were no modern conveniences."

"We were driving a six-year-old car," adds Mr. Frost, "but we had no choice. No matter what I did, there seemed to be no way to get ahead."

Learns of CIE

Then one day at the shop, Frost got to talking with two fellow workers who were taking CIE courses... pre-

paring for better jobs by studying electronics at home in their spare time. "They were so well satisfied," Mr. Frost relates, "that I decided to try the course myself."

He was not disappointed. "The lessons," he declares, "were wonderful—well presented and easy to understand. And I liked the relationship with my instructor. He made notes on the work I sent in, giving me a clear explanation of the areas where I had problems. It was even better than taking a course in person because I had plenty of time to read over his comments."

Studies at Night

"While taking the course from CIE," Mr. Frost continues, "I kept right on with my regular job and studied at night. After graduating, I went on with my TV repair work while looking for an opening where I could put my new training to use."

His opportunity wasn't long in coming. With his CIE training, he qualified for his 2nd Class FCC License, and soon afterward passed the entrance examination at North American Rockwell. "You can imagine how I felt," says Mr. Frost. "My new job paid \$228 a month more!"

Currently, Mr. Frost reports, he's an inspector of major electronic systems, checking the work of as many as 18 men. "I don't lift anything heavier than a pencil," he says. "It's pleasant work and work that I feel is important."

Changes Standard of Living

Gene Frost's wife shares his enthusiasm. "CIE training has changed our standard of living completely," she says.

"Our new house is just one example," chimes in Mr. Frost. "We also have a color TV and two good cars instead of one old one. Now we can get out and enjoy life. Last summer we took a 5,000 mile trip through the West in our new air-conditioned Pontiac."

"No doubt about it," Gene Frost concludes. "My CIE electronics course has really paid off. Every minute and every dollar I spent on it was worth it."

Why Training is Important

Gene Frost has discovered what many others never learn until it is too late: that to get ahead in electronics today, you need to know more than soldering connections, testing circuits, and

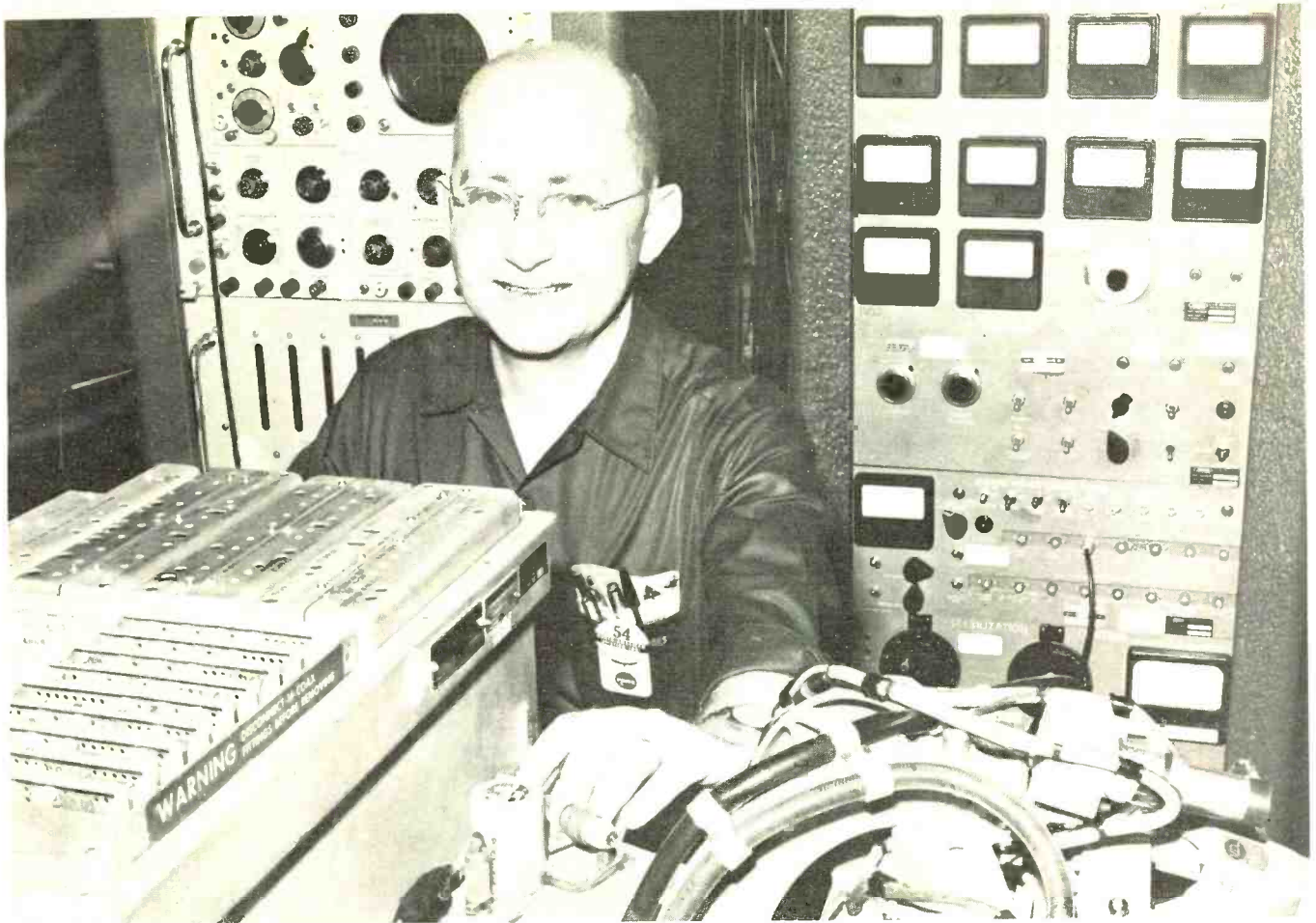

replacing components. You need to really know the fundamentals.

Without such knowledge, you're limited to "thinking with your hands" ... learning by taking things apart and putting them back together. You can never hope to be anything more than a serviceman. And in this kind of work, your pay will stay low because you're competing with every home handyman and part-time basement tinkerer.

But for men with training in the fundamentals of electronics, there are no such limitations. They think with their heads, not their hands. They're qualified for assignments that are far beyond the capacity of the "screw-driver and pliers" repairman.

The future for trained technicians is bright indeed. Thousands of men are needed in virtually every field of electronics, from 2-way mobile radio to computer testing and troubleshooting. And with demands like this, salaries have skyrocketed. Many technicians earn \$10,000, \$12,000 or more a year.

How can you get the training you need to cash in on this growing demand? Gene Frost found the answer in CIE. And so can you.

Send for Free Book

Thousands who are advancing their electronics careers started by reading our famous book, "How To Succeed In Electronics." It tells of the many electronics careers open to men with the proper training. And it tells which courses of study best prepare you for the work you want.

If you'd like to get ahead the way Gene Frost did, let us send you this 44-page book free. With it we'll

include our other helpful book, "How To Get A Commercial FCC License." Just fill out and mail the attached postpaid card.

If the card is missing, use the coupon below.

New Revised G.I. Bill Benefits:

All CIE courses are approved for full tuition reimbursement under new G.I. Bill. If you served on active duty since January 31, 1955, OR are in service now, check box on the reply card or coupon for latest G.I. Bill information.

CIE **Cleveland Institute of Electronics**
1776 East 17th Street, Cleveland, Ohio 44114

NEW

COLLEGE-LEVEL CAREER COURSE FOR MEN WITH PRIOR EXPERIENCE IN ELECTRONICS

ELECTRONICS ENGINEERING ... covers steady-state and transient network theory, solid-state physics and circuitry, pulse techniques, computer logic and mathematics through calculus. A college-level course for men already working in Electronics.

Cleveland Institute of Electronics
1776 East 17th Street, Cleveland, Ohio 44114

Please send me without cost or obligation:

1. Your 44-page book, "How To Succeed In Electronics."
2. Your book on "How To Get A Commercial FCC License."

I am especially interested in:

- | | | |
|---|---|--|
| <input type="checkbox"/> Electronics Technology | <input type="checkbox"/> Broadcast Engineering | <input type="checkbox"/> First Class FCC License |
| <input type="checkbox"/> Electronic Communications | <input type="checkbox"/> Industrial Electronics | <input type="checkbox"/> Electronics Engineering |
| <input type="checkbox"/> Electronics Technology with Laboratory | | |

Name _____ (Please Print)

Address _____

City _____ State _____ Zip _____

Veterans & Servicemen: check here for G.I. Bill information.

EW-92



NEW IR-18M solid-state 12-speed chart recorder kit

NEW GR-371MX 25" square-corner solid-state color TV kit

NEW GD-29 microwave oven kit

NEW IB-101 solid-state 15 MHz frequency counter kit

NEW IB-102 175 MHz solid-state frequency scaler kit

NEW IO-102 solid-state 5" scope kit

NEW IM-105 solid-state VOM kit

Seven new Heathkit® improvement ideas for home or shop

NEW! Heathkit IR-18M 10" chart recorder kit provides 12 different chart speeds...instant pushbutton selection from 5 sec/in. to 200 min/in. Digital logic delivers accuracy unobtainable with ordinary gear trains. Two input ranges permit accurate measurements from 0-1 & 0-10 mV full scale. Hi-Z input minimizes loading. 3-terminal floating input. Light-operated modulator eliminates problems of a mechanical chopper...operates at 240 Hz to reduce 60 Hz noise. Internal temperature-stabilized reference voltage eliminates troublesome reference battery. Coarse & Fine zero controls allow fast, accurate pen positioning. Other features: versatile pen holder that accepts virtually any writing instrument & hinged top for easy paper loading. For the best value going in a chart recorder, order your IR-18M now. Kit IR-18M, 15 lbs., **149.95***

NEW! GR-371MX 25" solid-state ultra-rectangular color TV. Check out the competition for standard features like these: 25" square corner Matrix picture tube for the biggest, brightest, sharpest color picture ever...high resolution circuitry plus adjustable video peaking...Automatic Fine Tuning...pushbutton channel advance..."Instant-On"...Automatic Chroma Control...factory assembled 3-stage solid-state IF and VHF & UHF tuners for superior reception, even under marginal conditions...adjustable noise limiting & gated AGC...adjustable tone control...hi-fi sound output to internal speaker or your hi-fi system. Plus your choice of installation in one of the three beautiful Heath cabinets or custom wall mounting capability. And the exclusive Heath self-service features let you do all normal adjustment & servicing, saving hundreds of dollars in service costs. If you want the finest, this is it...order your 371MX now. Kit GR-371MX, 125 lbs. **579.95***

NEW! GD-29 microwave oven... the most modern way to prepare food. Cooks up to 70% faster with better vitamin retention. Cooks on glass, ceramics, even paper plates. Low profile design fits under cupboards easily, yet has one of the largest oven capacities in the industry. Operates anywhere on standard 120 VAC current. Kit includes specially prepared cookbook. Kit GD-29, 97 lbs. **379.95*** Roll-around cart gives oven easy mobility, Model GDA-29-1, **24.95***

NEW! IB-102 Scaler and IB-101 Frequency Counter combination give you frequency measurement capability to 175 MHz at low, low cost. IB-101 counts from 1 Hz to over 15 MHz. Hz/kHz ranges & over-range indicator let you make an 8-digit measurement down to the

last Hz in seconds. 5-digit cold-cathode readout...extremely low input triggering...all solid-state with 26 ICs, 8 transistors. NEW IB-102 Frequency Scaler can be used with virtually any counter on the market to extend your measurement capability well into the VHF range...at a price far below the cost of a 175 MHz counter. 10:1 and 100:1 scaling ratios give resolution down to 10 Hz...1:1 ratio provides straight-thru counting for frequencies in range of counter. Exclusive Heath input circuit triggers at very low levels - at 100 MHz less than 30 mV is needed. A handy Test switch gives a quick, accurate check of proper operation. All solid-state; fully regulated supplies; convenient carrying handle/tilt stand. Extend your frequency measurement capability now with these two new kits. Kit IB-101, 7 lbs. **199.95*** Kit IB-102, 7 lbs. **99.95***

NEW! IO-102 solid-state 5" scope ideally suited for general purpose service & design work. Features wide DC-5 MHz response, 30 mV/cm sensitivity and 80 ns rise time. Switch-selected AC or DC coupling for greater versatility. Frequency-compensated 3-position attenuator. FET input provides hi-Z to minimize circuit loading. Recurrent, automatic-sweep type sweep provides five ranges from 10 Hz to 500 kHz with vernier. External horizontal and sync inputs are also provided. One volt P-P output provides an accurate comparison voltage source. Additional features include a big 5" CRT with high visibility trace; 6x10 cm ruled graticule that can be replaced with a standard camera mount; solid-state zener-regulated supplies for extra display stability and 120/240 VAC operation. An excellent all-around scope that belongs on your bench now. Kit IO-102, 29 lbs., **119.95***

NEW! IM-105 solid-state portable VOM... an extremely rugged, highly accurate, low cost meter for hundreds of applications. High impact Lexan® case and ruggedized diode & fuse protected taut-band meter movement will suffer extreme abuse and still maintain specifications. 95° wide viewing area provides high resolution. 3% DC accuracy; 4% AC accuracy; 3% DC current accuracy. Temperature compensated. 8 DCV ranges from 0.25 to 5000 V full scale...7 ACV ranges from 2.5 to 5000 V full scale...6 DC current ranges from 0.05 mA to 10 A full scale...5 ohms ranges from x1 to x10k with center scale factor of 20...5 dB ranges from -10 to +50 dB. Other features include DC polarity reversal switch; front panel thumbwheel ohms zero; self-storing handle and fast, easy assembly. A lot of meter at a little cost...that's the new IM-105. Order yours now. Kit IM-105, 7 lbs., **47.95***

See these kits at your local Heathkit Electronic Center ... or Send for Free Catalog

CALIF.: Anaheim, 330 E. Ball Road; El Cerrito, 6000 Potrero Avenue; La Mesa, 8363 Center Drive; Los Angeles, 2309 S. Flower St.; Redwood City, 2001 Middlefield Rd.; Woodland Hills, 22504 Ventura Blvd.; COLO.: Denver, 5940 W. 38th Ave.; GA.: Atlanta, 5285 Roswell Road; ILL.: Chicago, 3462-66 W. Devon Ave.; Downers Grove, 224 Ogden Ave.; MD.: Rockville, 5542 Nicholson Lane; MASS.: Wellesley, 165 Worcester St.; MICH.: Detroit, 18645 W. Eight Mile Rd.; MINN.: Hopkins, 101 Shady Oak Rd.; Mo.: St. Louis, 9296 Gravois Ave.; N.J.: Fair Lawn, 35-07 Broadway (Rte. 4); N.Y.: Jericho, L.I., 15 Jericho Turnpike; New York, 35 W. 45th Street; OHIO: Cleveland, 5444 Pearl Rd.; Woodlawn, 10133 Springfield Pike; PA.: Philadelphia, 6318 Roosevelt Blvd.; Pittsburgh, 3482 William Penn Hwy.; TEXAS: Dallas, 2715 Ross Avenue; Houston, 3705 Westheimer; WASH.: Seattle, 2221 Third Ave.; WIS.: Milwaukee, 5215 W. Fond du Lac.

Retail Heathkit Electronic Center prices slightly higher to cover shipping, local stock, consultation and demonstration facilities. Local service also available whether you purchase locally or by factory mail order.

HEATH COMPANY, Dept. 15-8
Benton Harbor, Michigan 49022



a Schlumberger company

Enclosed is \$ _____, plus shipping.
 Please send model (s) _____
 Please send FREE Heathkit Catalog. Please send Credit Application.

Name _____
Address _____
City _____ State _____ Zip _____

*Mail order prices; F.O.B. factory.
Prices & specifications subject to change without notice. CL-411



Separate microphones for each vocalist in the group permit the soundman to blend the voices properly for best mix.

Portable Sound Systems for Performers— *Part 1: Microphones & Mixers*

By DONALD L. PATTEN/Sr. Development Engr., Shure Brothers Inc.

Putting together such a system is a challenge because performers are usually loud, halls frequently have poor acoustics, and there is plenty of noise and feedback. Here's how to select, locate, and hookup mikes and mixers to overcome the problems.

In the past few years, new demands have been placed on portable sound-reinforcement systems for performing artists. These new demands include extremely high sound-pressure levels to enable the vocalist to override the amplified musical instruments called for by the modern musical repertoire. Not only are high sound-pressure levels required, but the general public has come to expect a live performance to duplicate the high quality obtainable with its home hi-fi systems. Considering that the performances heard at home are recorded under almost ideal conditions—free from such problems as acoustic feedback, background noise, and halls with poor acoustics—the live performance provides a real challenge to both performers and soundman. Even with the best available equipment, its improper use can give results that are catastrophic. Since an audience judges a performance by the quality of the sound, it is obvious that a good sound system is absolutely essential to a good performance.

The basic sound system consists of one or more microphones, microphone cables, a mixer/amplifier, speakers, and speaker cables.

Choosing Microphones

A low-impedance directional microphone of rugged construction is recommended. Low-impedance microphones

(50-250 ohms) are required to permit the use of long cables to the mixer/amplifier.

High-impedance microphones (10,000-50,000 ohms) are limited to only about 20 feet of cable because they are subject to a high-frequency roll-off, or loss of high-frequency signals in the cable. For example, consider a 30,000-ohm microphone connected to a 20-foot cable whose capacitance is 26 pF per foot. With this combination, the microphone output is attenuated by 3 dB at 10 kHz. With the same cable capacitance, but using a 150-ohm microphone, 4000 feet of cable would be required to produce the same high-frequency loss.

High-impedance microphones may be used if the mixer/amplifier is to be located on stage. This may be the case with a small group where one of the performers doubles as the soundman. Since the microphones are located close to the mixer/amplifier, 20-foot cables may be long enough. High-impedance microphone cables are susceptible to hum pickup from stage lights and other a.c.-line-operated devices and care should be taken in locating them. The use of low-impedance microphones and cables generally eliminates this problem.

The use of low-impedance microphones and long microphone cables permits the mixer/amplifier and the soundman to be located off-stage and, preferably, in the audience



Notice the large number of mikes used with this performing group. Each girl vocalist has her own mike; the pianist has a vocal mike plus another mike located below the sounding board of the piano; the guitarist also is using a vocal mike. In addition, separate mikes are used for the tambourine and tom-toms and for the bass drum. There are seven mikes in all.

area. This is the only way he can hear the performance exactly as the audience does.

Microphones are available with a number of different polar characteristics. The polar characteristic is a chart or graph of how well the microphone picks up sound from the front *versus* the sides or the back.

There are two types of microphones in general use today. One is the *omnidirectional* microphone, which picks up sound equally well from all around. The other is the *unidirectional*, sometimes referred to as the *cardioid*, microphone which picks up sounds with maximum sensitivity from the front, slightly reduced sensitivity from the sides, and rejects sounds from the rear. Of these two types, the unidirectional model is preferred for two reasons. One, the microphone is less prone to feedback because the back of the microphone can be pointed towards speakers or reflecting surfaces. Two, the microphone is sensitive to the performer and less sensitive to the audience background noises or other instrumental sounds that are coming from the sides or back of the microphone.

When selecting a unidirectional microphone, it is desirable to consider whether or not a microphone with *proximity effect* is wanted. Proximity effect is the increase in low-frequency response as the microphone is moved closer to the performer's lips.

Microphones with proximity effect increase in bass output as the microphone is brought closer to the performer's mouth. This allows the performer a great degree of control over the sound and the response by moving the micro-

Two unidirectional dynamic microphones suitable for good, portable sound-reinforcement systems. Mike at left has ball-type "pop"-filter and is characterized by proximity effect. Mike at right has integral "pop"-filter and minimized proximity effect as result of holes in handle above mounting bracket.



phone closer or farther away from him. This change in low-frequency response is desirable in many cases so that a performer can move close to the microphone and produce a deep, resonant sound when doing very soft, intimate work, and move away when this effect is not wanted. The proximity effect also aids the younger performer, giving a more resonant, mature sound to his voice. However, a few performers prefer a microphone without proximity effect. The choice is up to the performer.

From a performance standpoint, two basic microphone types are suitable for use with vocal sound systems. The dynamic type is generally preferred over the capacitor microphone because of its ruggedness and reliability. Dynamic

microphones require neither a separate amplifier nor a power supply and they are less susceptible to changes in ambient humidity and temperature. Since a portable system demands utmost reliability, the dynamic microphone is the logical choice based on dependability, ruggedness, freedom from a power supply and additional electronic circuitry.

It is important to choose a microphone that has the same frequency response from the front and sides. This feature allows the performer to turn the microphone off-axis without changing the sound quality. The only effect that should be noted is slightly reduced sensitivity.

One more consideration in choosing a microphone is the windscreen or "pop"-filter over the end of the microphone. Microphones that are used for close work by performing vocalists should have an extremely good "pop"-filter. The "pop"-filter is designed to cut down the wind or "pop" blast that comes when a "P" or other explosive-type sound is made. If you hold your hand a few inches from your mouth and make a "P" sound, a blast of air can be felt on your hand. The microphone also feels this blast of air and this creates a "popping" sound. Microphones equipped with a blast or "pop"-filter reduce or attenuate this effect. This blast sound, if not attenuated, may cause preamplifiers to overload or distort and produce an objectionable sound in the speaker system.

Microphone Phasing and Cables

The importance of the cable that is connected to the microphone should not be overlooked. Good cables and periodic cable maintenance insure reliability.

It is recommended that microphone cables be wired with 3-pin male and female Cannon-type connectors; this type of connector has proven to be rugged and reliable and requires little maintenance. The end of the cable that connects to the microphone should be wired with a female connector and the amplifier end with a male connector. By so doing every cable can be used as a microphone cable or as an extension microphone cable.

The 3-pin Cannon-type connector is designed so that pin No. 1 connects first as two mating connectors are joined together. Pin No. 1 is used as the shield or ground and therefore the shield is connected first. Because of this design feature, microphones or microphone cables may be connected to

live amplifier inputs during a setup or performance without annoying buzzes, clicks, or pops that are normally associated with open grounds. Pins 2 and 3 of the connector are wired to the two balanced conductors of the microphone cable. Consistency is important when wiring connectors to mike cables to insure compatibility and proper phase.

To test two microphones and/or their cables for proper phasing, connect them to an amplifier and then talk or sing into the two microphones while holding them three or four inches apart. The sound from the speakers should be the same when talking into either microphone or directly between them if they are in-phase with each other. If the sound drops drastically, or a dead spot is found when talking between the two microphones, one of them or its cable is out-of-phase.

To change the phase of the one microphone or cable, interchange the wires that are connected to pins 2 and 3 of the connector. All cables and microphones should be tested in this manner to insure that they are in-phase with each other. If a microphone is of different phase than other microphones, refer to the manufacturer's instructions on how to change the phase of that microphone. Some microphones are designed so that phasing changes are made by removing the male plug element in the microphone. In others, this element is cemented in place, forming a seal for the microphone to provide proper low-frequency response; removing the plug element in this type of microphone may alter or seriously affect the microphone's performance.

It should be noted that when performers are hand-holding microphones and singing and dancing with them, the cable is subjected to severe twisting, bending, or stretching. This will eventually cause the shielding inside the cable to break into many small pieces, reducing its effectiveness. Continuity of the shield may be tested with an ohmmeter. A good shield should measure no more than a few ohms. A poor shield or one that has been broken inside the cable will measure in hundreds or even thousands of ohms, and twisting or bending the cable will cause the ohmmeter reading to change. Cables in this condition should be replaced. Only high-quality, low-capacitance, two-conductor shielded cable (such as *Belden #8412, #8422*) should be used for microphone cables.

A very convenient method of running a number of microphone lines between the mixer/amplifier and the stage or performance area is to use a multiple-pair cable or a number of single cables bundled together. There are quite a few multiple-pair cables available (such as *Belden #8768* containing six pairs) which may be used for this purpose. It is suggested that each end of this cable be terminated in a junction box. Such an arrangement will reduce setup time significantly and is generally much neater than running many separate cables from the stage to the mixer. Each microphone cable should be connected to a separate mixer/amplifier input channel.

Microphone Technique

Microphone technique is extremely important in obtaining a good live performance. For example, a performer who holds a microphone at arm's length while singing in front of a band cannot expect to be heard over the instruments. The soundman will try to compensate for this poor technique by turning up the volume control until acoustic feedback is produced. Generally one of two things happens under these conditions. Either the sound of the orchestra entering the vocalist's microphone will drown out the vocalist, or the sound system's acoustic gain will be limited by feedback. To avoid these problems, the vocalist should work the microphone at a distance of one to three inches from his mouth.

By varying the distance between the microphone and his lips, it is possible to use the microphone as a very effective volume control. For soft, intimate work the microphone

should be used very close. For extremely loud passages the microphone should be backed off to a distance of several inches. By backing off the microphone in this way, the performer helps to avoid overloading the microphone preamplifier on extremely loud passages.

Some performers create "popping" sounds when working close to the microphone. This effect may be reduced by holding the microphone slightly below chin level.

Normally, it is not necessary to "mike" the instruments. However, it may be desirable to "mike" a piano or woodwind, such as the flute. In "miking" a piano, it is sometimes necessary to put the microphone inside the piano over the strings and partially close the top to avoid acoustic feedback. As an alternative, the microphone may be placed behind (on an upright) or underneath (on a grand) the sounding board. The flute or similar acoustic instruments may be picked up very effectively by playing it very close to an unused vocal microphone.

Acoustic feedback often dictates general microphone placement. But also to be considered is the rejection of unwanted loud instruments, such as drums. In the case of "miking" a flute, it may be necessary to point the back of the unidirectional microphone towards the drums in order to maintain a high signal (flute) to noise (drums) ratio.

Selecting Mixer/Amplifiers

When choosing a mixer/amplifier (which may be a single integrated unit or two separate units), a number of specifications and features should be considered. These include input impedance, input clipping level, number of input channels, individual tone controls, built-in reverberation, feedback filters, and power *vs* speaker load impedance.

The mixer/amplifier microphone inputs should be wired or connected for low-impedance microphones. If the mixer/amplifier does not have provision for low-impedance microphones, but is only wired for high-impedance types, an accessory impedance-matching transformer may be added to the input jacks to convert them to low impedance.

It is important to be aware of the microphone preamplifier input clipping level. If clipping or distortion occurs in the microphone preamplifier, this distortion will be heard in the speakers, regardless of the settings of the tone or volume controls on the mixer/amplifier. It is interesting to note that performers, when working very close to the microphone, such as with hard-rock or acid-rock program material, may produce signals in excess of the clipping level of the preamplifier. In this instance, an input attenuator will generally eliminate the distortion that would otherwise occur. Some amplifiers have an input attenuator switch built in. For those amplifiers without this feature, an in-line attenuator may be connected in the microphone cable. Some vocalists are capable of producing sound-pressure levels of approximately 130 dB SPL, at the microphone diaphragm, 10 dB above the threshold of pain! This would correspond to approximately $1/10$ th of a volt output from a low-impedance microphone. This is a case where an input attenuator

(Continued on page 65)

Close-mike technique reduces acoustic-feedback problems and increases the bass output with mikes having proximity effect.





Recent Developments in Electronics

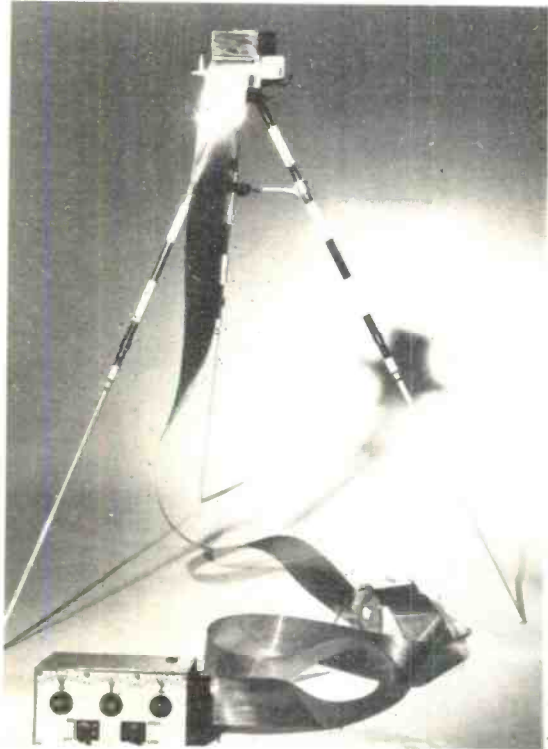

SCR Control Systems for Navy Missiles. (Top left) A modularized, completely solid-state silicon-controlled rectifier control system has been developed by GE for the Navy's Tartar Missile System. The new system replaces bulkier, heavier amplidyne control systems using vacuum tubes. The controls, servo electronics, and power amplifier used for accurately positioning the two-axis missile director are contained in a single cabinet. The design, which incorporates modern concepts in solid-state circuitry and electronics packaging, uses plug-in electronic modules which had been used in fire-control systems for the Polaris missiles aboard Navy submarines. The director is used aboard guided-missile vessels in conjunction with radar to precisely control and position data and measurement of line-of-sight rates for target tracking. The radar antenna locks on supersonic, highly maneuverable targets, while the fire-control computer provides continuous positioning data to point the radar during target tracking.

Portable Magnetometer on Moon Shows Higher Flux. (Center) Experiments performed on the Moon's magnetic field by the Apollo 14 astronauts have furnished valuable new information about that body's flux. Using a portable magnetometer to measure the magnetic fields on the lunar surface, the experiments showed a higher magnetic intensity than had been recorded on earlier space flights. Preliminary data indicated a strength in one location of about 100 gammas and about 40 in another. In one area, tests showed that the magnetic field was three times higher than similar fields revealed by instruments at the Apollo 12 landing site. While the intensity of the lunar magnetic field is slight compared to Earth's 50,000 gamma average, this new data is significant because scientists had no reason to believe the Moon had a field of this intensity. The portable device, which gets its power from a specially designed Mallory mercury battery, was built by NASA for the lunar flights.

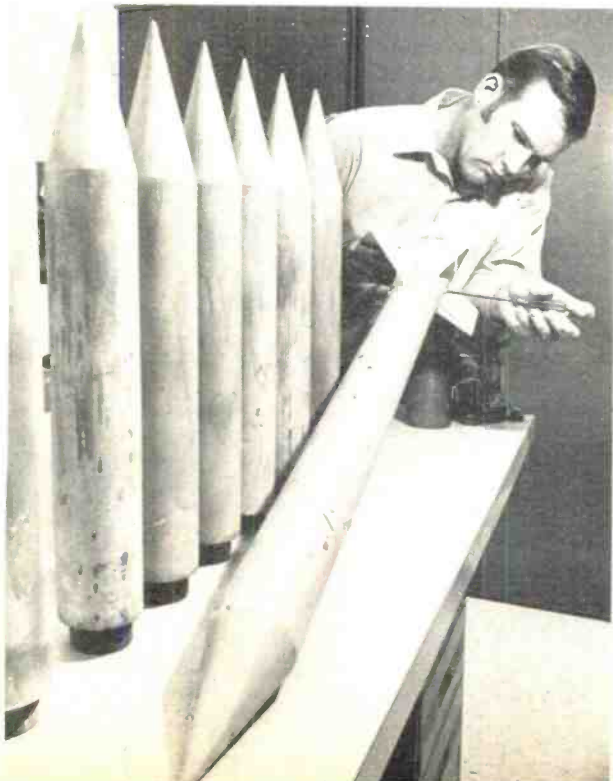

Ice Penetrometer Measures Thickness by Radio. (Below left) Experiments are being carried out at Thule, Greenland and Alert, Canada, to remotely measure ice thicknesses from the air. Dart-like projectiles are used that are dropped from an airplane. Instruments inside the projectiles register acceleration levels in the time between the impact of the penetrometers and their exit from the ice layer. This information is radioed to the aircraft, where it can be used to calculate ice thickness. Instruments within the projectiles include an accelerometer, voltage-controlled oscillator, and u.h.f. transmitter with whip antenna, all powered by a 14-volt battery. The device emits a signal of about 150 mW at a frequency of 250 MHz. Successful conclusion of the ice tests is expected to lead to development of a class of inexpensive, expendable penetrometers which can be used for sea ice research and possibly for use in selecting shipping lanes through polar regions. The tests are being carried out for the U.S. Coast Guard by Sandia Laboratories.

Computer Typesetter Inserts Pictures. (Top right) The world's first computer-based typesetting system that uses television graphics to compose words and pictures electronically into page form in less than 10 seconds has been developed. The system applies the functions of 256 television cameras to complete book-size pages from computer-programmed tapes. At an average typesetting speed of 1000 characters per second, type is set on film by area composition rather than a single line at a time as in other electronic photocomposing systems. The device, called Linotron 1010, was developed for the Air Force by CBS Laboratories and Mergenthaler Linotype Co.



New 36-Track Tape Head. (Center) A new dual-gap read-after-write digital recording head designed to record 36 separate tracks on 1-in wide tape is shown here. The head is being produced in England by Gresham Recording Heads Ltd. The high channel density is claimed to be the highest produced in Europe to date. The 36-track head is designed for operation at a tape speed of 10 inches/second. Each track head has full-width Mu-metal shields to reduce crosstalk and each winding is bifilar, making a total of 216 terminals to be connected at the rear of the head. Despite the close spacing, crosstalk figures are better than 26 dB at the rated frequency of operation. Track centers are located to within 500 microinches and each individual track height is accurate to within 0.001 inch above the head base.

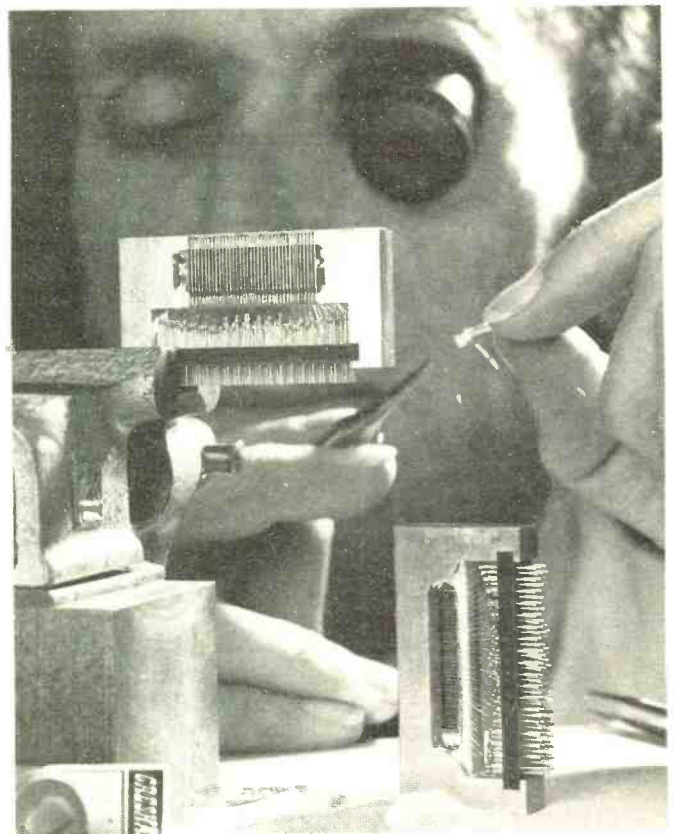

Thick-Film Modules for Color TV. (Below left) Here are closeup views at various manufacturing stages of one of the thick-film microcircuits used in some of RCA's new color-TV sets. The company uses as many as 12 separate plug-in modules, called "AccuCircuits," in six of its models. Three of the solid-state ceramic modules are used to drive the three color-TV tube guns to produce the picture on the screen. Research on thick-film modules, using DuPont metal/film compositions, was launched in 1964. The production process uses silk screening to form the thick-film circuits, kilns for firing the ceramic modules, and automated machinery linked to computers.

First TV Tube Maker in Glass Business. (Below right) RCA is in the news again this month for another development. The company has become the first domestic TV tube manufacturer to enter the glass business. At its new \$19 million plant in Circleville, Ohio, the company is pressing both glass funnels and faceplates for large-screen color-TV picture tubes. The photo shows the unload end of a giant 207-foot long oven where a worker removes hot faceplates. The newly produced faceplates are "baked" at a temperature of up to 900 degrees Fahrenheit within this oven. After their long trip, the faceplates are optically inspected and receive several checks with sophisticated measuring machines.

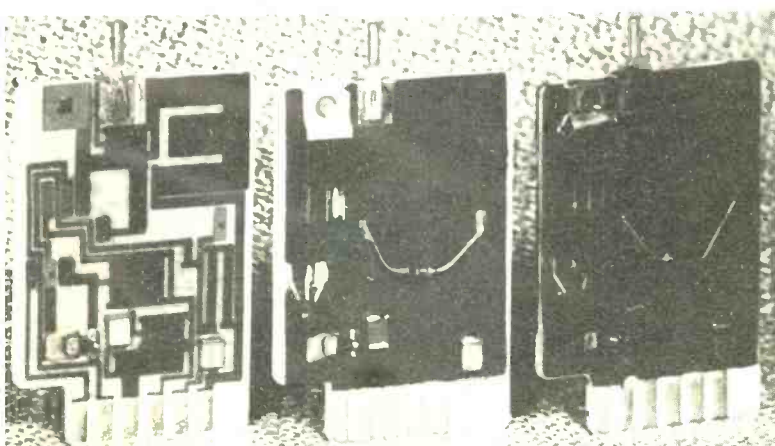

Antenna Lead-ins for TV

By FOREST H. BELT

Here's some practical help in selecting the best TV down-lead for your particular installation.

If you hear someone say that flat 300-ohm twin-lead isn't good enough for today's television-antenna installations, don't be misled. The product is as good as—or better than—it ever was. But consider these factors:

1. U.h.f. TV stations abound. Very few localities are without at least one within reception range. Line losses between antenna and receiver are much higher at u.h.f. than at v.h.f. To compensate, new lead-ins must not waste as much signal as ordinary, flat twin-lead does.

2. Color-TV is popular. More than a third of the nation's homes have color sets. These receivers, to operate best, need stronger and steadier station signals than black-and-white sets do. They need signals without ghosts, if possible. There are modern lead-ins that don't pick up extra signals on their own like ordinary twin-lead can.

3. Electrical noise and interference levels are at an all-time high. They disrupt viewing in many areas. Special lead-ins keep noise and interference blocked out better.

That's why plain 300-ohm twin-lead isn't so popular any more. Its chief attraction today is low cost. Installers can handle it easily, saving on labor. Improved plastics make it last longer than earlier versions did.

The Nature of Twin-Lead

But flat 300-ohm line loses efficiency quickly when dirt

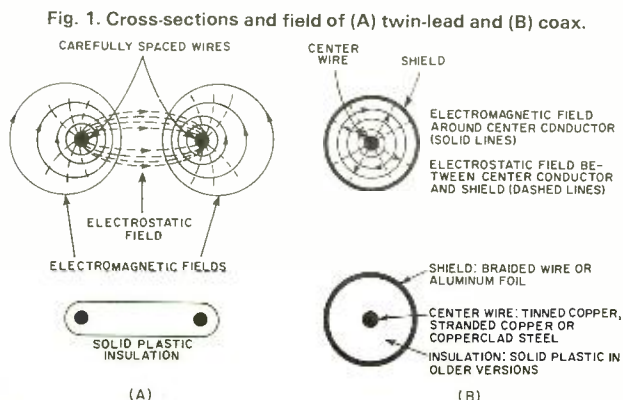

or moisture accumulates on the surface. A study of how a transmission line works will indicate why this is so.

The signals picked up by a TV antenna don't travel down the two wires as d.c. would. Instead, they are developed along the transmission line as electrostatic and electromagnetic fields, involving both the wires and the insulation between.

Take a look at the twin-lead cross-section in Fig. 1A. At any point along the transmission line there exists a field of *electrostatic* lines of force between the two conducting wires. In addition, there is an *electromagnetic* field around each wire, induced by current in the wires.

The strength of the electrostatic field depends partly on spacing of the wires, partly on the dielectric between the wires, and partly on how much signal voltage the antenna feeds the transmission line. The strength of the electromagnetic fields depends mostly on current in the wires and the dielectric surrounding the two wires.

These fields are not steady like fields caused by d.c. Since they are caused by the voltages and currents fed into the line by the antenna, the fields fluctuate at the frequencies of whatever signals are being picked up by the antenna. The magnetic fields around the wires expand and collapse millions of times per second. The electrostatic field changes strength from a few lines of flux to many and back to a few—millions of times per second. A good transmission line carries the effects of these fluctuating fields of force efficiently from antenna to receiver.

Imagine what happens when soot and other deposits from our generally polluted atmosphere settle on the plastic covering of twin-lead. The fields no longer operate in just air and plastic (both good dielectrics). Any foreign coating, in effect, interrupts the expanding and contracting lines of force, weakening them considerably. Less energy is transmitted down the line. Such losses get worse as the lead-in dielectric ages and becomes coated by atmospheric deposits.

Even more devastating is water. Being essentially conductive—or at best a much poorer dielectric than air—moisture deteriorates the fields drastically. Dirt accumulations hold moisture on the lead-in. Ice and snow keep the

fields fouled until the weather warms up. The result: spotty TV reception in damp or winter weather, even from an otherwise okay installation.

In the Round

One answer to dirt, moisture, and ice buildup is *coaxial* transmission line. The way it works is illustrated in Fig. 1B.

The *electrostatic* field develops between the center wire and the metallic shield. The efficiency of this field depends in part on the dielectric constant of the insulation between shield and center wire.

An *electromagnetic* field surrounds the center conductor. Actually, there is some magnetic field outside the shield, but its shape closely resembles the shape of the shield and therefore doesn't extend much beyond the outer sheath of plastic that protects the whole cable.

External influences don't intrude on the fields in coaxial cable like they can in twin-lead. Moisture and dirt have little effect on how well the line transfers TV signals.

Although the shield conductor is electrically exposed to r.f. noise and ghost signals, it is grounded in a proper installation and most such interference is drained off. Electrical disturbances—ignition interference, electric-motor noises, and the like—have far less effect on coax than on twin-lead. However, with home-type installations that use coax it is common to merely insert a 75-to-300-ohm matching transformer between the lead-in and the tuner. In such cases, without grounding, coax loses some of its interference protection.

The biggest drawback to ordinary coax is poor performance at u.h.f. This is particularly true of older, small-diameter RG-59/U with plastic insulation between the center wire and shield. Losses are high, up to 16 dB per 100 ft. That's just too much for most installations, even with a high-gain u.h.f. antenna delivering a hot signal. Large-diameter RG-8/U has fewer losses, but is expensive and unwieldy for home installation.

Enter, Solutions

So what's done about these problems? There's no getting around the need for a lead-in, so the answer is: better products. Here are some of today's designs. They are taking the place of old flat twin-lead and high-loss coax as lead-ins for TV.

One twin-lead version is shown in Fig. 2A. Each conductor is surrounded by foam polyethylene, and then covered by solid polyethylene much like ordinary twin-lead. A patent for this design is held by *Columbia Electronic Cables*, who markets the cable as *Durafoam #5790*; but it's available as "twin-foam" lead-in from other suppliers.

The foam dielectric has a dual advantage. Polyethylene by itself has excellent dielectric properties. When made into foam, it has the added dielectric strength of dry air held in each foam cell (the foam material is sometimes called *cellular polyethylene*).

This, in effect, helps protect the electromagnetic fields around each conductor. Dirt or moisture that could affect

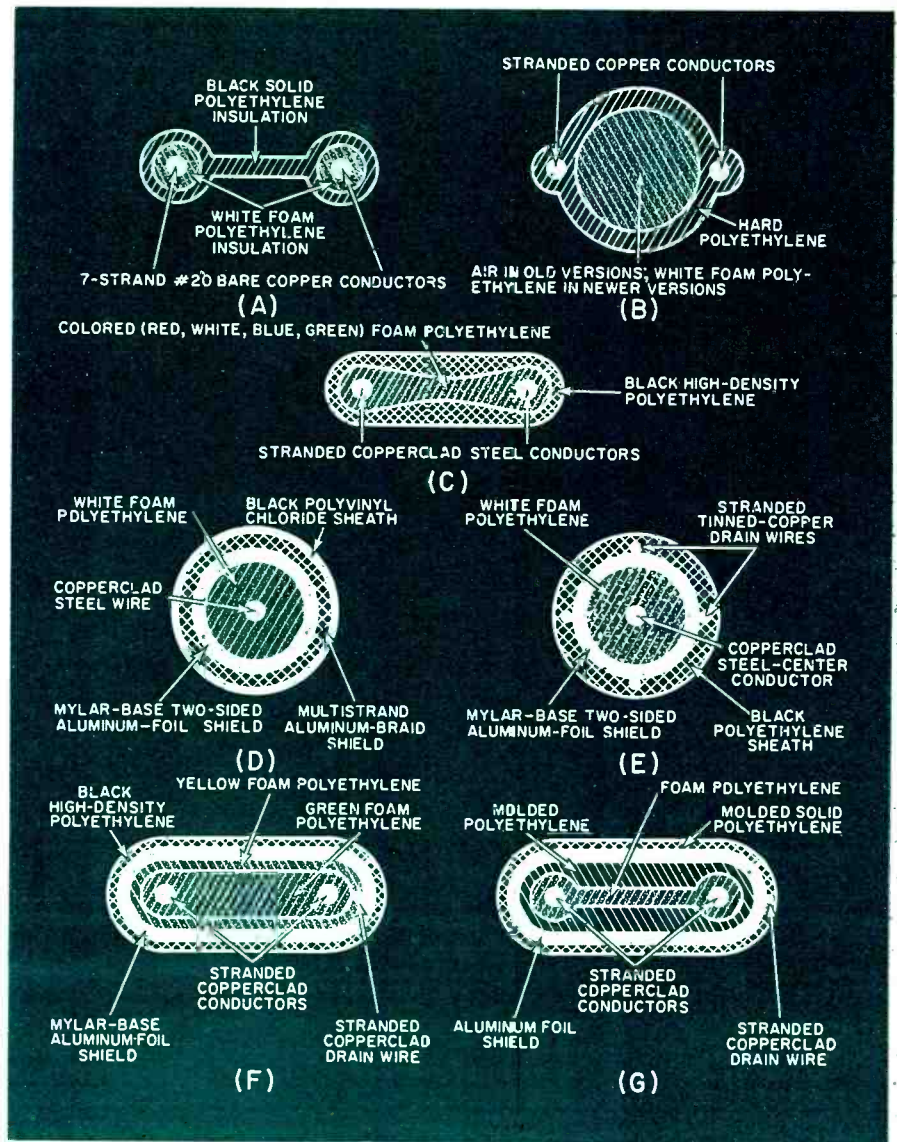

Fig. 2. Some of the newer types of TV lead-ins as described in the article.

them is kept at a distance. Changes in their surroundings have less effect than on plain twin-lead. But the added dielectric gives no protection from interference and ghost pickup.

The flat design in Fig. 2A has little effect on the electrostatic field *between* the two conductors. Under ideal conditions, losses at u.h.f. are slightly less than in flat twin-lead. With bad weather or poor installation, losses can be just as high as with plain flat lead-in. The chief advantages of this design seem to be durability and long life.

An oval design, shown in Fig. 2B, effectively protects the electrostatic fields. Any lines of force beyond the curvature of the outer skin are too weak to be bothered by dirt and moisture accumulations. In early oval lead-ins, the center was hollow, leaving mainly air as the dielectric. The trouble was, moisture got trapped inside and voided the whole purpose of making the shape oval. With advent of polyethylene foam, that problem was eliminated. Today's oval lead-ins have foam centers, giving the combined advantages of polyethylene and air as dielectrics. No moisture can collect inside.

This is an improvement over flat lead. Even with ice, attenuation of u.h.f. signals is far less. But losses build up with age. Deterioration of the thin insulation around the conductors lets losses eventually become almost as high as with flat lead. And there is still that susceptibility to r.f. noise and ghost pickup.

To combat deterioration, which is serious for lead-ins that carry u.h.f., some firms have developed what they call heavy-duty twin-lead. An example is shown in Fig. 2C.

Around and between the conductors is foam polyethylene. That's covered with a layer of high-density polyethylene. The foam layer is a better dielectric and reduces losses. The outer layer is weatherproofing, which gives durability and long life. Copperclad steel wire for the conductors adds strength to the cable.

But, still, moisture and dirt buildup can attenuate the fields enough to cut signals down almost as much as in ordinary flat lead. Indeed, some heavy-duty twin-lead shows more attenuation at u.h.f. than flat-lead. And there's no interference protection. Long life is the chief attraction of this type of line.

Shielded Versions

That business of interference rejection is important in some locales. With sensitive antennas available, coaxial cable can sometimes be used despite its losses. And, of course, modern coax designs reduce those losses. If conditions are right, the better coaxial cables are okay even for u.h.f.

Two modern coaxial cables for home-TV installation are illustrated in Figs. 2D and 2E. Both use copperclad steel center wire for strength and foam polyethylene dielectric for low loss.

Both also use a two-sided aluminum foil, which gives a double-shielding effect. The inner foil layer is next to the polyethylene foam. It "floats" electrically, being insulated from the aluminum layer on the other side of the Mylar-film base. The inner shield is thus relatively immune to the currents that can be set up in the outer shield by stray ghost or interference signals. The inner shield doesn't bother the electrostatic fields between center conductor and the grounded outer shield because the Mylar film is thin.

The *outer* foil layer in the *Jerrold* cable (Fig. 2D) is next to

a braided shield. That's typical in coax cables, except this one is made of aluminum-wire strands instead of copper. The outer foil layer of the *Columbia* wire (Fig. 2E) rests against four "drain" wires which assure continuity for grounding.

Careful construction and a foam dielectric definitely improves performance of these cables at u.h.f. They show losses rarely exceeding 8 dB at the high end of the u.h.f. band. That's better than the old large-diameter RG-8/U could boast. And it's *far* better than ordinary RG-59/U.

Under ideal conditions, twin-lead is a little better. But given moisture, dirt, and any external influence such as conduit, metal gutters, or furnace pipes, this new kind of coax outperforms the twin-lead. The coax losses aren't changed under these conditions while twin-lead losses go sky-high.

The new coax cables also have that needed protection against interference and ghost pickup. They're even better at this than older coax, because of the double shielding.

One drawback is the 75-ohm impedance of coax cable. Most TV antennas are 300 ohm balanced; so a balun transformer is needed to match them to coax lead-in. Most receiver inputs are also 300 ohm, so a matching transformer is needed at the bottom end, too. Both transformers add a loss, sometimes a couple of dB each. If the signal from the antenna isn't extra strong, or if several sets must be driven, every dB counts.

So, there's still another modern lead-in. It's *shielded twin-lead*. Two versions are shown in Figs. 2F and 2G. There's no matching problem. Impedance is 300 ohms, which matches most antennas and receivers. Losses per 100 ft at u.h.f. are almost as high as for coaxial lead, but there's no transformer loss to add.

The shielded twin-lead sold by *Saxton* (Fig. 2F) looks like multilayer heavy-duty lead-in inside. But outside the second layer of foam insulation is an aluminum-foil shield. In contact with it is a drain wire to assure shield continuity and for grounding. The whole package is then covered with a molded polyethylene sheath.

The *Belden* version (Fig. 2G) has a first layer of foam surrounding the conductors and between them, much like "twin-foam" lead-in. Over that is regular molded polyethylene insulation. Outside that is an aluminum foil shield and a molded polyethylene sheath.

Shielded twin-lead is the deluxe lead-in for today's TV installations. It handles black-and-white and color. Losses are reasonable even at u.h.f. and they're not increased by weather, poor installation, or other outside influences. The shielding minimizes ghost and interference pickup. Durability is good.

The only drawbacks seem to be cost and the fact that it takes extra installation work. That shield needs a good ground at the bottom end. The TV chassis isn't a good enough ground point, usually, and if the TV is a "hot chassis" design, it is downright dangerous. (If you must ground the chassis, insert a 0.001- μ F capacitor between the shield and the chassis. This particular precaution applies to coaxial shields or drain wires, too.)

But cost isn't very much greater than for modern coax. If what you want is the strongest, cleanest signal you can get, you'll probably buy some of the new coax or shielded twin-lead. ▲

Table 1. A listing of some of the new, improved TV lead-ins and who makes them.

MFGR.	TWIN-FOAM	FOAM TUBULAR	HEAVY-DUTY TWIN	COAXIAL	SHIELDED TWIN
Alpha Wire 711 Ledgerwood Ave. Elizabeth, N.J. 07027			5153	9820	
Amphenol Broadview III 60153			214 103	621 186	
Belden 415 S. Kilpatrick Ave. Chicago III 60644	8285	8275	9085	8228	9090
Channel Master Ellenville N.Y.	9354	9555	9566	9537	
Consolidated 1635 S. Clinton St Chicago Ill 60616	4530		4523	4582	4535
Columbia 150 Hamlet Ave. Woonsocket R.I. 02895	5790		5050	5750	
Finney (Finco) 34 W. Interstate St Bedford, Ohio 44146				CX 283 10)	
iE Mfg. 3039 W. Carroll Ave Chicago, Ill 60612	4629				4633
GC Electronics 400 S. Wymen St Rockford, Ill 61101	N4-362				
Jerrold 401 Walnut St Philadelphia Pa 19105				Coloraxial	
Saxton 215 Route 303 Congers N.Y. 10922	1037		1043	1601	1041
Winegard 3000 Kirkwood Ave Burlington, Iowa 52601				2700	

Electronic Typesetting

By DAVID L. HEISERMAN

Computers and TV-like scanning techniques are helping the publishing industry to spread the written word more quickly. Here is a description of one such system in which lines of type are photographed from screen of a CRT at typesetting speeds of up to about 1000 words per second.

Editor's Note: Our readers should have a rather special interest in this story. The actual page you are now reading as well as all the editorial pages in this publication have been produced by an electronic typesetting and page-composition system. We made the changeover effective with our last November issue. The system we use is similar to that described below in that it employs an RCA Videocomp print-out or graphic-display terminal. We use magnetic tape throughout and our Videocomp output is page-size positive film from which we make offset printing plates. However, our system is somewhat different in that it includes an IBM 360 computer and an Astrocomp system, employing an ICS input keyboard terminal and a Digital Equip. Corp. PDP-SL minicomputer. This combination provides unjustified (uneven right-hand margins) hard copy, permitting us to make corrections at that point prior to going through the entire system. This article will give our readers an idea of how electronics is being used by ELECTRONICS WORLD.

JOHANNES Gutenberg gave birth to the publishing industry when he invented the movable-type printing press. The day he set out to publish his first book, an edition of the Bible, he discovered three operational problems: setting up the type, arranging the patterns of print on each page, and running off the pages on his press. The typesetting and page-composition operations took about 5 years to complete, and it took him another 3 years to print about 200 copies of the Bible. That was in the 1450's.

More than 500 years later, the publishing industry still faces the same three-operation problems. The Industrial Revolution and 20th-century technology have, indeed, made these operations easier and much faster, but it seems that every technological improvement is soon offset by the ever-increasing demand for more printed material. As far as keeping up with demands for its products is concerned, the publishing industry is not too much better off today than it was 500 years ago.

The main problem has been that the publishing industry

has had to accept the old 3-step publishing process—type-set, compose, and print—as a fact of life. Such facts of life, however, are valid only as long as there are no innovations to make them obsolete. In the early 1960's, systems engineers found the key innovations in the forms of high-speed computers and graphic-display terminals. They saw that these two devices could merge the typesetting and page-composition operations into one, and go a long way toward bringing publishing technology up-to-date.

In 1966, RCA delivered its first electronic typesetting system using a Videocomp printer that completely automates both the typesetting and page-composition operations. Strictly speaking, the system is still a 2-step operation, but humans handle the printed material only once—the machinery does the rest of the work. There are several other similar systems on the market today (see "Electronic Type Composition" in the December, 1969 *ELECTRONICS WORLD*), but RCA was one of "the first with the most."

The Total System

The total system accepts text and special page-composition instructions from a keyboard input, and it outputs a line-by-line CRT display of the finished copy. The system requires the services of a large general-purpose computer, such as an RCA Spectra 70 or IBM 360, and a smaller, special-purpose Videocomp computer.

Using a special computer language, called PAGE-1, a copy editor makes the required composition notations on the original manuscript. A keyboard operator then types through the text, inserting the PAGE-1 notations as they occur. The keyboard digitizes all the information and records it on paper or magnetic tape.

Once all the text and composition instructions are on tape, an operator feeds it into the general-purpose computer. Using the text as "data" and the PAGE-1 notations as a "program," the computer composes the text, line-by-line and page-by-page. The composed output goes onto magnetic tape for further processing in the Videocomp unit.

This unit contains a character generator and a CRT dis-

play section. As the computer-generated text and instructions enter the unit, the finished text appears on the CRT screen one line at a time. Images on the CRT expose a continuous roll of photosensitive paper or film as it passes by. The user can employ this output material to make photocopy materials that are ready for the printing department. (See Fig. 1.)

The Input Process

Many potential customers shy away from the system as soon as they learn it has to be used in conjunction with a general-purpose computer. In many instances, this shyness isn't justified. Publishers who can afford the \$300,000-plus Videocomp unit may be doing a sufficiently brisk business to justify the services of a general-purpose computer, anyway. Moreover, the general-purpose computer does not have to be tied up with the composition operations much more than it has to be tied up with the usual accounting, administrative, and day-to-day business operations. The Videocomp system merely adds one more program to the big computer's file. The general-purpose computer doesn't have to be located in or near the editorial or printing department, either. A special line or even a time-sharing telephone line can link these departments with a remote computer.

The first step in the electronic-typesetting system involves digitizing all the text material and special editorial composition instructions. It is possible to input this information directly to the computer; but, since this is the most time-consuming part of the operation, users generally digitize the data off-line, and feed it into the computer "batch-wise." Thus the big computer isn't tied up for hours at a time while a keyboard operator types through the text and instructions.

The keyboard operator types through the text and composition instructions as if she were typing the information in one long line. The RCA system uses about 80 different characters, including capital letters, numerals, punctuation marks, and special symbols. Since the PAGE-1 composition

language consists of ordinary alphanumeric characters set off in brackets, the keyboard operator can enter the editor's composition instructions as if they were part of the main text.

The average keyboard operator can enter information at the rate of about 180 characters per minute. At this rate, it takes her about 18 hours to enter material for a typical 40,000-word novel. Publishers can cut this time to less than one working day by having three or four operators share the load at separate keyboard terminals.

No real computer work takes place at the keyboard part of the operation. The keyboard electronics merely translates each press of a key into a serialized digital word that can be impressed upon paper or magnetic tapes.

Computer Operations

The magnetic or paper tapes from the keyboard operations contain the full text and composition instructions. Since the text is in serial form at this point, the tapes also contain information regarding the proper sequence of characters and spaces. The keyboard information, however, does not indicate the precise position each character is supposed to take on a page. The main job of the general-purpose computer, then, is to tag each character code with a set of digital coordinates that indicate its position. Before the computer can assign coordinates to a character, though, it has to determine what that position is supposed to be.

A typical page of printed matter contains lines of appropriately spaced words and letters. The first part of the computer's task is to break up the continuous string of input text material into horizontal lines that will fit the page. To complicate the process, traditional page formatting demands justification of both the right- and left-hand edges of the print. This means that, except for the beginning and end of a paragraph, all the type must be blocked out so that the right- and left-hand edges line up vertically. A normal typewriter, for example, automatically justifies the left-hand edge of the print. It takes a lot of figuring—much more than most typists are willing to do—to justify the right-hand edge, too.

The computer justifies both edges of the print by counting the number of characters and spacing that might fit a line, then readjusting the number of characters and the size of the spaces to make the edges even. Sometimes this results in some rather awkward-looking spacing, so the justification part of the computer's program includes specifications for how much spacing can be tolerated without making a line of print look awkward. Whenever the computer generates a line of print that would look awkward, it switches over to a file containing the grammatical rules for hyphenating a word to be broken at the end of a line. This rule file, by the way, has to be supplemented with a 5000-word file of common exceptions to the general rules of hyphenation.

Since the computer does all the justification, there is no precise way a human operator can know exactly what part of the text will appear at the end of a page or begin the next. (By preparing the original manuscript in such a way that a close line-by-line approximation exists between the manuscript and the final typeset copy, it's possible to come quite close however.) By keeping track of the number of lines of

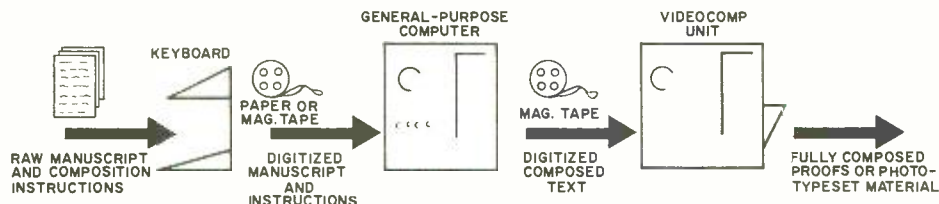
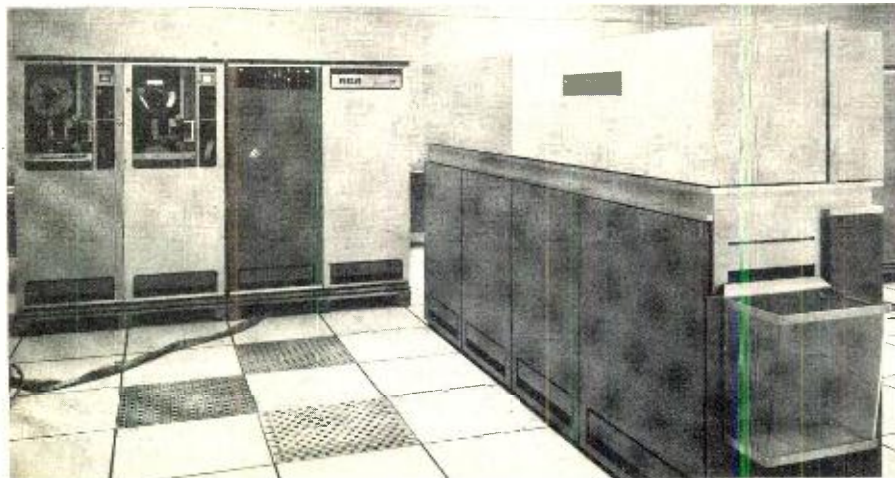

Fig. 1. The electronic typesetting and page-composition system.

Taped text information and composition instructions enter the system via the tape decks at the left. Finished photocopy appears in the basket at the right. The input keyboards and general-purpose computer are not shown here. Cost of this system runs between \$300,000 and \$500,000, depending on options.



print it generates, the computer automatically breaks off the text at the end of a page, generates a code for numbering the next page, and resumes the justification process. Whenever the editor wants a diagram or photo to appear on a page along with related text material, he uses PAGE-1 notation to tell the computer the space to be allotted to the illustration. When the computer comes across the information, it readjusts the text as much as necessary. The computer can even run a fully justified column of text around the diagram.

As far as special features such as chapter headings, footnotes, and captions are concerned, the computer takes these in its stride, too. The composition notations tell the computer the size and style of print to use in these special cases. Operations such as centering captions under a diagram are easy for the computer—it is just a matter of finding the center of the picture area, the center of the caption, and then generating an appropriate set of coordinates that line them up.

At this point in the computing operation, the part of the codes that distinguish one character from another remain essentially unchanged. The computing operations integrate the character codes with the composition codes. A 7-bit word for the keyboard character "a," for example, emerges unchanged from the general-purpose computer, but it has some new digital companions that indicate its size, shape, and position on the page. All this information, plus some signals that identify each line of print for future reference, goes onto magnetic tape.

It takes about 18 hours of keyboard time to tape the raw manuscript and PAGE-1 notations for a typical 40,000-word novel, but the general-purpose computer works out the composition codes for the same material in less than one hour.

The Printer Operation

The Videocomp printer is actually a graphic-display terminal. It accepts the prepared information from the general-purpose computer and presents the finished text on a CRT screen. A system of lenses and rollers focus the image onto either a piece of moving photosensitive paper or film, depending upon the printing technique the user desires. (See Fig. 2.)

A digital-to-analog circuit in the unit senses the coordinate information accompanying each character, and places the CRT beam into the designated position on the screen. At the same time, a character-generator circuit translates the character code into unblanking signals that intensity-modulate the beam. A vertical stroke generator, synchronized with the unblanking signal, builds up an image of the character on the screen with a resolution approaching 1800 strokes per inch. (See Fig. 3.) Depending on the size of type, up to 6000 characters per second can be set on a line width of up to 70 picas (almost 12 inches).

The character generator uses a magnetic disc or tape memory as a guide for formatting the specified font pattern for each character. Videocomp font memories can store up to eight different 80-character font designs, including modern, Old English, and script. The user, in fact, can load the font memory with any kind of conventional or custom type styles he chooses.

To keep the font memory as small as possible, all letter sizing operations take place outside the memory unit. A special circuit decodes the "size-of-type" code, and adjusts the CRT stroke length accordingly. The system can produce letters ranging from about $\frac{1}{32}$ -inch to slightly over 1 inch in height. (Character sizes of from 4 to 96 points are available. The type size you are now reading is 9 points high.)

Another circuit can alter characters extracted from the font memory to form Roman, oblique (italicized), extended, or condensed versions—all adding to the meaning and at-

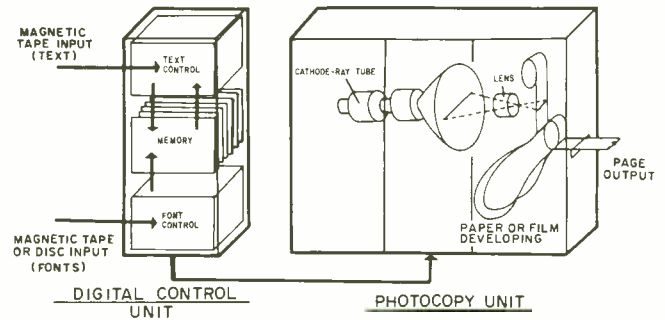

Fig. 2. Videocomp output subsystem uses a CRT printer.

tractiveness of the final copy. This circuit needs only a code word to form any one of these variations of a basic font design.

Other Capabilities of the System

Composing and phototypesetting a piece of printed material is only one function of the total system. The real pay-offs enter the picture after the main text is finished. The computer, for example, can compile a complete index, handle editorial changes with ease, and even prepare abridged versions of the original text material.

The indexing feature is so powerful that it can even index every entry of the word "and." The only problem with this feature, then, is keeping the machine from doing too much indexing. Publishers who benefit the most from the system's indexing feature are those who publish cross-indexed parts catalogues and directories. The original keyboard tape for a telephone book, for instance, can be rerun to arrange the data according to the street addresses rather than the subscribers' last names. If the publisher wants, he can run the tape again, letting the computer rearrange the same data according to the telephone numbers.

Making editorial changes in the composed manuscript is simply a matter of typing in a code designating the page and line to be changed. Following the PAGE-1 editorial (Continued on page 67)

Fig. 3. This is how the letter "a" is formed by a series of closely spaced vertical strokes. The strokes are so fine and so close together that it is impossible to distinguish them separately even under magnification. Although these strokes are shown here in black where they form the letter, the lines are intensified on the CRT face where the latter is to appear. When image is photographed, a negative is produced in which bright sections of the lines show up as black sections as shown. The bottom illustration shows the electron-beam motion in CRT. The vertical retrace lines between strokes and horizontal retrace lines between complete lines of type are, of course, completely invisible.

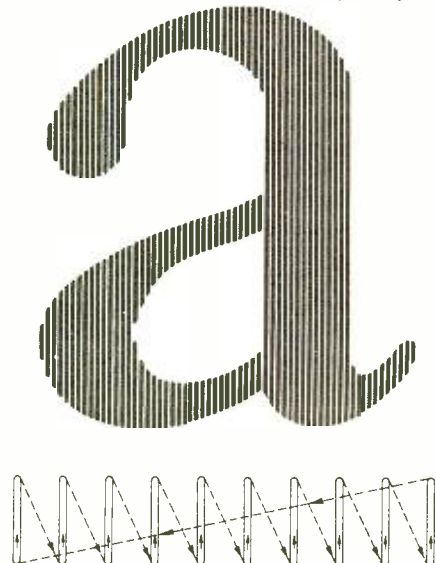

An Improved Vehicular Intrusion Alarm

By SANDOR MENTLER

Interior mounted "on-off" switch makes this alarm system virtually burglar-proof. Adjustable time-delay circuits sound horn a short time after the car door is opened.

IN 1968, over half a million automobiles were reported stolen in the United States. In addition, a large number of articles, such as tape players, high-performance engine accessories, tachometers, and other valuables were removed from cars.

These facts should indicate that a good automotive burglar alarm is a worthwhile investment. Systems available commercially for less than \$50 usually fall into one of the following three groups:

1. Alarm systems tripped by motions such as that produced by an intruder entering the car. These alarms have one serious drawback; they can be tripped accidentally by careless drivers parking their cars, youngsters sitting on the fenders, etc.

2. Alarm systems that are sensitive to ignition-switch tampering. Such systems, while protecting the vehicle, do not protect any valuables or accessories in it.

3. Alarm systems that are activated by the opening of doors, hood, or trunk lids. Systems in this group protect not only the vehicle but anything in it.

Unfortunately, devices belonging to the last group are turned on and off by means of a key-operated switch mounted on the car's exterior. This makes the system quite vulnerable.

Such a system can be greatly improved if the "on-off" switch is made accessible only from inside the car. To reach it, an intruder would have to open a door. This would acti-

vate the alarm. However, it would also be very inconvenient for the driver if the alarm went off each time he entered or left his car. This problem can be easily solved by the use of time-delay circuits. When the unit is first turned on, a delay circuit should be used to delay operation of the entire system for a few seconds to allow the driver to leave the car. For entering the car, a second time-delay circuit should be used to trigger the alarm about 5 or 10 seconds after the door is opened. This would allow ample time for the driver to turn the system off, but is too short to allow an intruder to analyze the circuit and locate the de-activating mechanism.

Over-all Operation

American-made cars are equipped with "door-jamb switches (D.J.S.) that are operated by a plunger in contact with the door. One side of the switch is grounded while the other side is connected in series with dome or courtesy lights to the positive side of the car's battery. Opening a door closes the switch, placing zero voltage across it. Closing the door opens the switch, raising the voltage across it to +12 volts. The voltage present at the D.J.S. will be used as an input signal for the system that is to be described in this article.

When the "On-Off" switch, S1 (Fig.1), is closed TD-1 is activated. At this time, however, the driver can open a door and leave his vehicle without activating the alarm because TD-2 is off (S2 is open). After the delay of a few seconds, switch S2 is closed by TD-1. If the doors are closed (D.J.S.'s open), the input to the inverter is +12 volts. Consequently, the inverter's output is at zero and TD-2 will not operate. When a door is opened (a D.J.S. closes), the inverter's output goes positive and TD-2 is activated. A few seconds later TD-2 closes switch S3, thus triggering the alarm.

Circuit Description

With Fig. 1 in mind, the circuit of Fig. 3 can be analyzed as follows: Q1 and its associated circuitry correspond to TD-1 in Fig. 1. The UJT (Q1) operates as a pulse generator. The delay between closure of S1 and the first pulse is approximated by using the equation:

Fig. 1. Block diagram of alarm system described in the article.

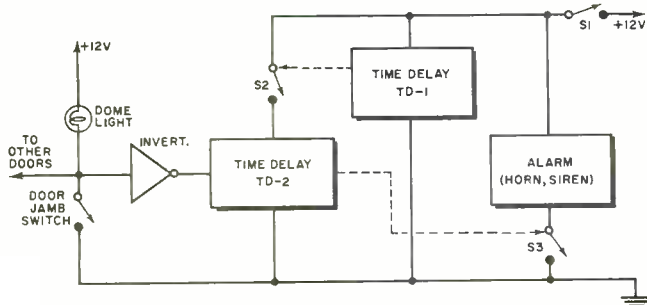

$$t = -R_1 C_1 \ln 1 - \frac{\eta R_{bb}}{R_{bb} + R_2 + R_3}$$

where:

t = delay, in seconds $\ln = \log_e$

R_{bb} = interbase resistance, in k-ohms

η = intrinsic stand-off ratio of the UJT.

R_2, R_3 in k-ohms, C_1 in μF .

For the 2N2646, η is between 0.56 and 0.75 and R_{bb} between 4.7 and 9.1k-ohms. For the values given in the circuit, the time delay will be between 12 and 22 seconds. The value of R_1 can be changed, if necessary, to adjust the timing although it should not be made larger than 800k-ohms. In practice, it was found that 15 seconds of delay allowed even a slow or elderly person to leave his car and close the door before the alarm is activated.

The function of D_1 is to ensure that the gate reverse breakdown voltage of SCR_1 is not exceeded. If an SCR other than the HEP 320 is used, R_4 can be adjusted to supply the proper triggering level.

Q_2 and Q_4 correspond to the inverter and TD-2 in Fig. 1, respectively. With the doors closed, the voltage at input terminal 1 is 12 volts, Q_2 is saturated, and SCR_2 is off. If a door is opened, input terminal 1 is grounded, Q_2 is turned off, and gate current flows through R_7 and R_8 , turning SCR_2 on.

The function of R_9 is to insure that the current through SCR_2 is larger than the holding current. With SCR_2 on, C_2 will be charged through R_{10} and R_{11} . The function of SCR_2 is to make the process irreversible: once TD-2 is in action, turning Q_2 on by closing the doors will not affect the delay circuit. When Q_4 fires it triggers SCR_3 into conduction which, in turn, triggers SCR_4 , thereby activating the alarm. SCR_4 corresponds to S_3 in Fig. 1. Its anode is connected to the horn relay, which effectively places it in series with the horn button. The function of SCR_3 is to maintain SCR_4 in the "on" condition should the horn button be depressed momentarily. Such an action would place a short across SCR_4 , tending to turn it off.

As HEP 320 (SCR_3) was found to be sensitive to dV/dt switching, the network consisting of R_{18} and C_3 was included in the circuit.

Now $dV/dt \text{ max.} = dV/dt (0) \approx 12 \text{ V} / R_{18} C_3 \approx 1 \text{ V}/\mu\text{s}$.

Q_3 and its associated circuitry form a *nor* gate. If any of the inputs is grounded, Q_3 is cut off and gate current is allowed to flow through R_{17} and D_4 to SCR_3 , turning it on. Inputs A through D are connected to door-jamb switches installed in the trunk, hood, glove compartment, etc. Existing switches can be used with no alterations, as the diodes will provide the proper isolation between the car's electrical wiring and the alarm system.

Construction and Installation

Construction is not critical and any layout can be used. The enclosure should be a metal box which would act as a heat sink for SCR_4 . After assembly, the unit can be connected to a 12-volt supply and R_1 adjusted for a delay of about 15 seconds. Next, R_{11} is adjusted for a delay of approximately 10 seconds. With shorter delays, drivers—although having enough time—have a tendency to rush into their cars to prevent the alarm system from going off.

The broken lines shown in Fig. 2

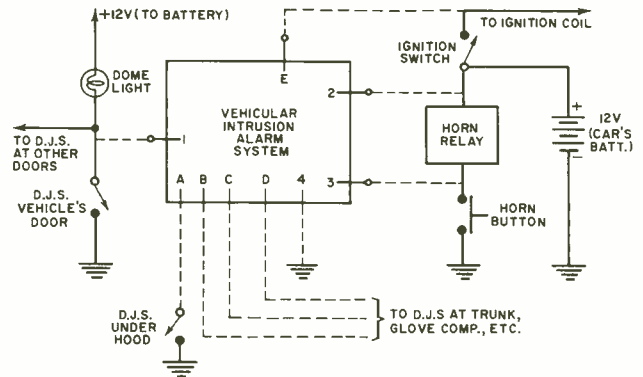

Fig. 2. Diagram indicating wiring (shown in broken lines) needed to tie alarm into the vehicle's electrical system.

represent the wiring that has to be added for tying the alarm circuit into the vehicle's electrical system.

If an alarm other than the vehicle's horn is used, it can be connected between output terminal 3 and the positive side of the battery. Load current should be limited to 5 amperes or a heavier unit must be substituted for the HEP 300 (SCR_4).

Door-jamb switches should be installed at the hood (a "must" to protect the battery and thus the alarm system) and at the trunk and glove compartments, if not already present. In convertibles, the glove compartment and ignition switch must be protected.

The alarm system is turned on by means of S_1 after the ignition switch has been turned off. Several seconds are allowed for exit. When entering the car the system must be turned off by means of S_1 within the time limit selected by the adjustment of R_{11} .

This unit represents quite a bargain for protecting hundreds or even thousands of dollars worth of equipment. ▲

Fig. 3. Parts list and schematic diagram of the vehicular intrusion alarm system. Refer to text and block diagram (Fig. 1) to determine corresponding circuit areas.

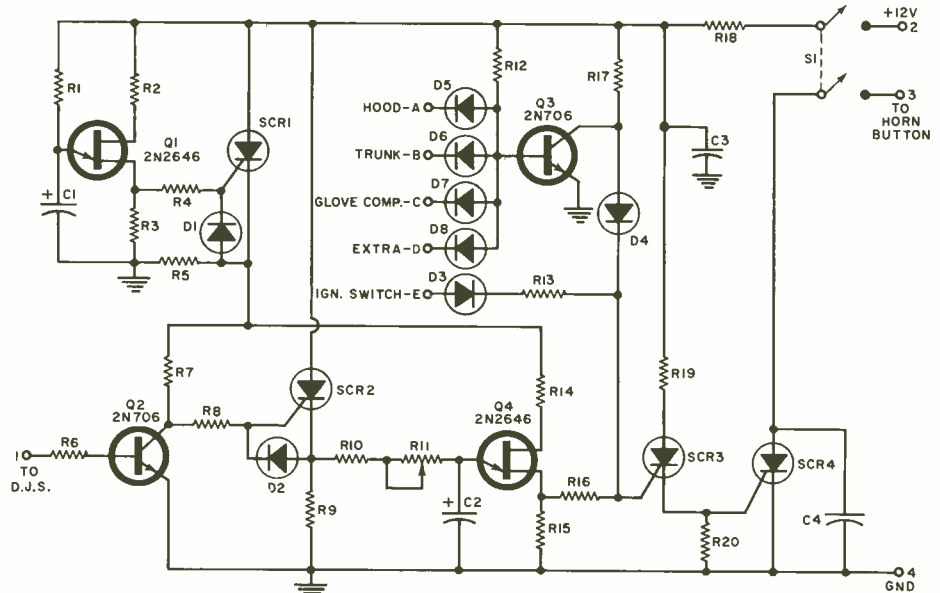

- R1—400,000 ohm, 1/4 W res.
- R2, R14—1000 ohm, 1/4 W res.
- R3—47 ohm, 1/4 W res.
- R4, R16—5000 ohm, 1/4 W res.
- R5, R9—2600 ohm, 1/4 W res.
- R6, R7, R13, R17—22,000 ohm, 1/4 W res.
- R8—10,000 ohm, 1/4 W res.
- R10—100,000 ohm, 1/4 W res.
- R11—200,000 ohm pot
- R12—47,000 ohm, 1/4 W res.
- R15—100 ohm, 1/4 W res.
- R18—47 ohm, 1/2 W res.
- R19—470 ohm, 1/2 W res. R20—2200 ohm, 1/2 W res.
- All resistors 10% tolerance.

- C1, C2—50 μF , 25 V elec. capacitor
- C3, C4—0.25 μF , 100 V Mylar capacitor
- SCR1, SCR2, SCR3—Silicon controlled rectifier (HEP 320, 2N5060)
- SCR4—Silicon controlled rectifier (HEP 300)
- D1, D2, D3, D5, D6, D7, D8—Germanium diode (1N34A or HEP 134)
- D4—Silicon diode (1N4001 or HEP 154)
- S1—D.p.d.t. switch
- Q1, Q4—Unijunction transistor (2N2646 or HEP 310)
- Q2, Q3—2N706, 2N718

Neutron Radiography

for *Nondestructive Testing*

By HAROLD BERGER, Senior Physicist, Argonne National Laboratory*

A new testing technique using a source of radioactive neutrons permits inside views of object that would be impossible with x-rays



Fig. 1. A neutron radiograph of a Masonite test object taken through 2-in.-thick lead brick. Masonite is stepped with thicknesses of 1.5, 2, and 2.5 mm, left to right. Each step has holes with diameters equal to thickness T , $2T$, and $4T$.

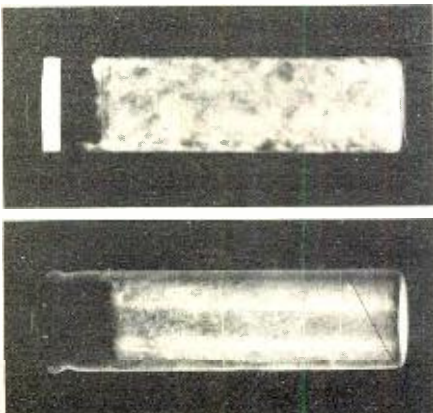

Fig. 2. Radiographs of battery using thermal neutrons at top, x-rays at bottom. Note high contrast of plastic battery cap at the top of the cell and the electrolyte mix within the cell in the top photo. The x-ray photo shows the metal casing.

Editor's Note: The world of electronics is becoming more and more aware of the value of nondestructive testing. X-ray, infrared, and ultrasonic techniques have become useful diagnostic tools that complement the normally used electrical tests. Neutron radiography supplies an additional capability to this arsenal of test methods; it should prove to be useful in a variety of inspection applications. In addition, the impact of neutron radiography on electronics is significant because of the use of electron image devices, accelerator neutron sources, and various electronic techniques. There should be an increasing awareness of neutron radiography within the field of electronics.

TO an x-radiographer, the prospects of obtaining a good radiographic image of a column of water in a lead pipe, an insulator within a metal connector, or a rubber "O"-ring in a metal valve are very poor. This is because the high x-ray energy needed to penetrate the metal goes right through the water, insulator, or rubber with minimum attenuation. The recent emergence of neutron radiography as a useful technique for nondestructive testing changes that situation. Thermal neutrons are strongly attenuated by several materials containing hydrogen, lithium, and boron; hence such materials are almost opaque to such neutrons. On the other hand, such materials as lead, bismuth, and uranium are practically transparent to thermal neutrons. Therefore, it becomes a simple matter to get a picture of

*This work was performed under the auspices of the U.S. Atomic Energy Commission.

common hydrogen-containing materials, such as plastic, wax, rubber, wood, paper, water, or other liquids, even when contained in a metal assembly.

As an example, Fig. 1 shows a thermal-neutron radiograph of a thin piece of Masonite on the source side of a 2-inch-thick lead brick. A good contrast shadow of the thin homogeneous material is obtained simply because Masonite has a high attenuation for thermal neutrons whereas the lead is essentially transparent. Of course, for an x-radiograph of the same object, the attenuation pattern would be reversed. The x-radiograph would show, primarily, the lead with little, if any, observable shadow of the Masonite.

An interesting comparison of neutron and x-radiographs of a battery is shown in Fig. 2, and several differences are apparent. A high contrast is obtained on the neutron image of the plastic battery cap and electrolyte (upper photo). The x-ray image, on the other hand, presents high contrast of the upper metal contact but the metal case tends to reduce the contrast of the internal battery details.

These examples of neutron and x-radiographs illustrate some of the possibilities for the application of neutron radiography. Let's consider the technique and its applications in the electronics field.

Radiation Sources and Detectors

The methods used to perform neutron radiography are fairly simple. The object is placed in a thermal-neutron beam in front of an image detector. The neutron beam may be obtained from a nuclear reactor, a radioactive neutron source, or an accelerator. Successful thermal-neutron radiography has been accomplished by all three sources.

The highest quality neutron radiographs have been produced by a reactor source because more neutrons are available in the thermal-energy range. More neutrons mean that collimation of the neutron beam can be tighter; therefore, the beam will be more nearly parallel and the resultant images of thick objects will be sharper. Better collimation in thermal-neutron radiography is comparable to reduced focal spot size in x-radiography.

The collimation, that is the bringing out of a beam of neutrons from a large source, is necessary for thermal-neutron radiography because there are no useful point sources of thermal or low-energy neutrons. Fortunately, the fast neutrons emitted from sources can be slowed to lower energies simply by surrounding the source with a moderator containing light material, such as water, paraffin, beryllium, or carbon.

A diagram of a simple arrangement for an accelerator source is shown in Fig. 3. In the illustration, the ion beam could be a deuteron beam, striking a tritiated target to produce neutrons by a relatively prolific and inexpensive reaction. Alternately, the center of the moderator could contain a radioactive neutron source, such as americium-241 or californium-252, or even the core of a nuclear reactor. The principle remains the same.

Detectors for thermal-neutron radiography are usually commercially available x-ray films exposed in conjunction with an intensifying screen. The common screens are neutron scintillators, or metal foils of gadolinium. The scintillators are made of a boron or lithium compound mixed with a phosphor powder, such as ZnS. Several scintillators for neutron radiography are also commercially available. Prompt *alpha* emission is produced in the lithium or boron by thermal-neutron capture; the *alpha* particle stimulates the phosphor and the resultant light exposes the film. This technique can produce very fast results. Total thermal-neutron exposures as small as a few hundred thousand neutrons/cm² produce useful images.

Somewhat better quality radiographs are normally produced by the slower techniques with gadolinium foils. Exposures may be about a hundred times higher for the metal intensifier method, but results are normally improved in

terms of less graininess and improved image sharpness. The battery neutron radiograph that is shown in Fig. 2, for example, is a good-quality radiograph obtained with a gadolinium foil.

Among other detectors for neutron radiography is a dynamic approach in which the neutron image is converted to light and then detected by a television camera. Intermediate light amplification by either a light image-intensifier tube or an integrated neutron image-intensifier tube (see Fig. 4) permits the use of an inexpensive vidicon camera. A commercially available neutron image-intensifier tube optically coupled to a vidicon camera can provide thermal-neutron images with incident intensities of about 10⁵ neutrons/cm²-second. However, for dynamic viewing at TV frame

(Continued on page 68)

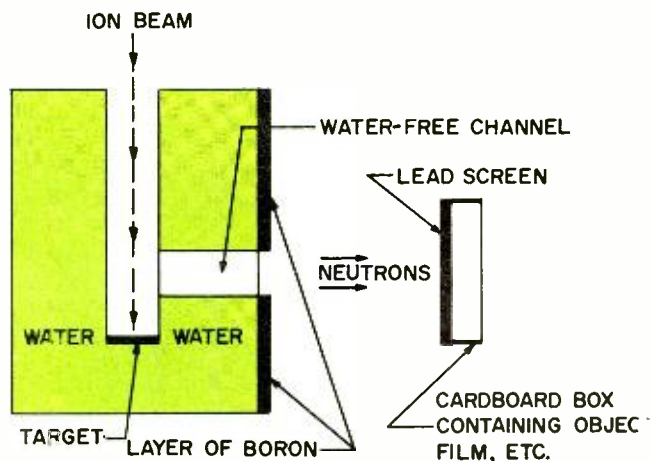

Fig. 3. An arrangement used to moderate (slow down) and collimate (form parallel paths) neutrons for radiography.

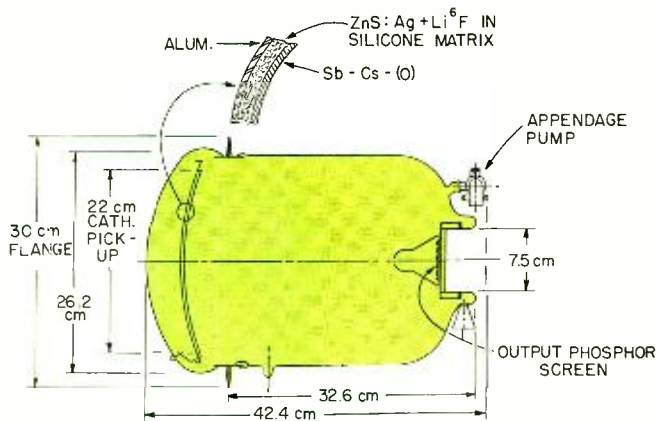
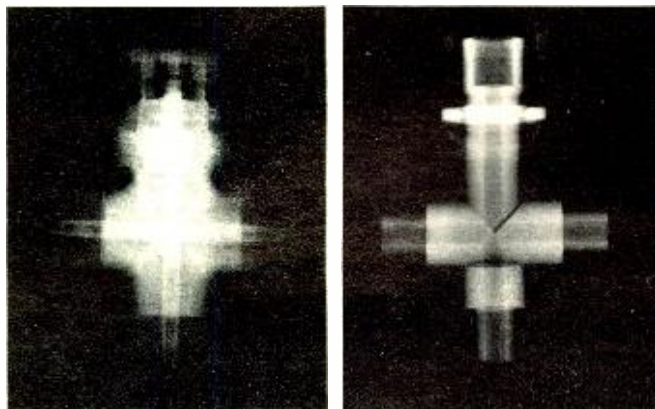

Fig. 4. Outline drawing of thermal neutron image-intensifier. Tube and detection system are made by Rauland Corp.

Fig. 5. Radiographs of BNC connector taken at Los Alamos Scientific Laboratory. Note the void in the insulation at right.



Do We Need 4-Channel Stereo?

By FRANK KRAUSSER/Chief Engineer, Fisher Radio

Yes, says our author, who shows that stereo reproduction through four channels can improve the listening experience considerably, provided certain psychoacoustic factors are taken into account.

Fig. 1. A 4-channel speaker installation and useful listening area for typical living room. Color-shaded area in center is for best ambience and front-directional reinforcement. In the crosshatched area, there is mainly front-directional reinforcement but reduced ambience information.

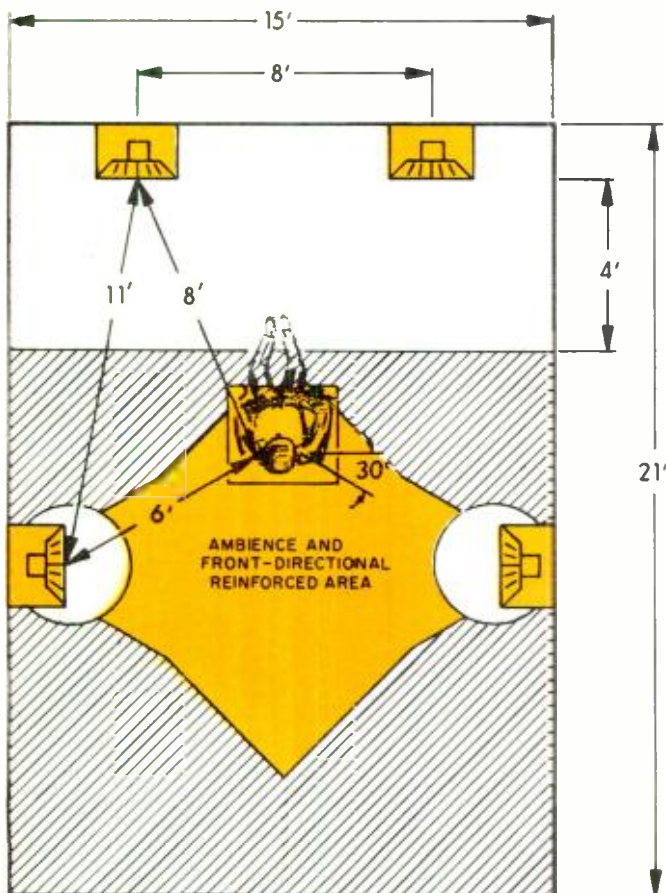

ANYONE who has the opportunity to listen both to an actual concert and a stereo reproduction on home loudspeakers is aware that the home reproduction lacks certain live qualities. Some reasons for this discrepancy include the loss of ambience content and a lack of directionality. Furthermore, in most homes, we experience a loss of low-frequency content, resulting in unsatisfactory reproduction of those instruments which are identified by their lower frequency range.

Headphones versus Speakers

Anyone listening to the same stereo recording with good headphones and with highest quality speakers has noticed that the reproduction with headphones is frequently superior. With headphones, directionality, ambience, and low-frequency content seem to come closer to the characteristics of a live concert.

Why, then, is stereo reproduction with headphones usually more lifelike than reproduction through two loudspeakers? It is evident that ambience, directionality, and low-frequency content are contained in the stereo recording, since they are available to the headphone listener. It can also be assumed that amplifiers used for headphone and speaker reproduction are of equally high quality. The only difference in the entire path between microphone and ear is the acoustical coupling from the sound transducers (speakers, headphones) to the ears.

With closely fitting headphones we have complete, direct acoustical coupling to each ear. Sound from the left headphone reaches only the left ear and sound from the right headphone is available only to the right ear. If, further, the listener at the live concert is replaced by a binaural microphone setup, the listener at home using headphones would get a closer approximation of the actual concert.

The acoustical coupling between the two loudspeakers and the listener's ears is not completely direct. The speakers are coupled to the ears via sound-pressure waves traveling through the air within the listening room. Furthermore,

each speaker is coupled in this way to both ears, not just one. Therefore, a considerable amount of material recorded in the *left* channel mainly for the *left* ear will also reach the *right* ear, and *vice versa*, resulting in reducing available channel separation with a corresponding loss of directionality.

Tests conducted by the author in a variety of living rooms indicated that we indeed have very low separation values. Values were between 4 and 12 dB, with a typical 12' × 21' living room having only 8 dB. Since other tests indicated that a minimum channel separation of 16 dB (at least around 1 kHz) is required for faithful reproduction of original material, it is apparent that 2-channel stereo reproduction in the home with speakers has its limitations with respect to directionality. There are also limitations with respect to ambience as a result of speaker placement that is used.

There are other problems encountered with speaker reproduction. Reflections from walls create acoustic holes or cancellations at frequencies below 300 Hz. Also, there is the reduction of low-frequency content below 250 Hz resulting from the elasticity (breathing) of walls, floors, ceilings, and windows. The first problem can be corrected rather simply by changing the position of the listener. The second problem is easily corrected with an inversely progressive boost of the radiated low-frequency power of the reproduced sound.

It is not as easy to re-introduce the lost directionality and ambience, but considerable improvement is possible with the help of two additional channels and speakers. However, consideration must be given to certain psychoacoustic effects. How this can be accomplished will be explained in the following paragraphs.

Psychoacoustic Effects

Hearing is governed by several related psychoacoustic effects which were studied in detail some years ago by Helmut Haas and P. Damaske.

Haas showed that, under certain conditions, one's brain accepts sounds emanating from several sources as coming from only one source whose direction is easily determined. Haas placed listeners in front of two well-separated loudspeakers which emitted short impulses of equal amplitude. He found that if the signal from one speaker were delayed between 2.5 and 20 milliseconds, the listener could detect only one speaker and hear only one impulse although both speakers were in operation. The speaker heard was the one without the time delay. Its volume appeared to be above that heard with the delayed speaker turned off. Before the listener could hear the delayed speaker, quite substantial increases of its volume (greater than 10 dB) were necessary. If the time delay were further increased above 20 ms, the listener would hear two separate impulses but experienced difficulties with respect to identification and localization of either speaker.

Haas concluded from these experiments that the brain integrates certain types of sound in steps of 20 ms. This means that indirect sound waves (reflections from walls, ceilings, furniture) are utilized by the brain to amplify the direct sound as long as they arrive at the listener's position within a certain time interval after the direct sound. That a substantial amount of indirect sound energy is used by the brain is realized when we find subjective separation values of approximately 8 dB for a typical living room, compared to the theoretically calculated values of only around 0.5 dB to 1.5 dB.

Thus far, the Haas effect has been discussed with respect to 2-channel stereo reproduction in the home. The same effect can be used to further strengthen the apparent direct sound-pressure fields and enhance the channel separation and directionality with two additional rear speakers. These should be located to the left and right of the listener

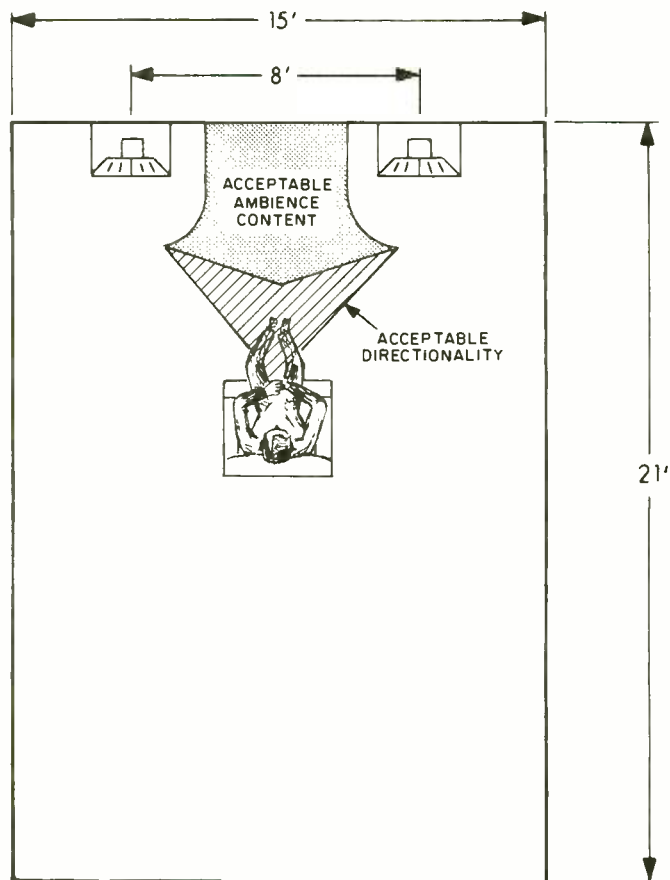

Fig. 2. Useful listening areas for 2-channel stereo setup.

and must radiate correctly delayed material related to the corresponding front speakers.

Reproduction of ambience content can also be accomplished by utilizing the two additional, rear speakers. However, optimum reproduction requires a careful choice of the location of those speakers with respect to the listener's position. P. Damaske has shown that an ambience source placed to the side of the listener is 23 dB more effective than an ambience source placed either in front of or behind the listener. This is why we have such poor ambience reproduction with speakers located in front of the listener as is the case with 2-channel stereo reproduction. We can expect the same poor ambience reproduction if we place the speakers directly behind the listener.

The ideal location for speakers for best ambience reproduction is to the sides of the listener, in line with his ears. However, we still have satisfactory ambience reproduction (3-dB loss) if the speakers are located within 30° in front and 45° to the rear of the ideal location. A speaker location somewhat to the rear is preferable since there is some music which utilizes instruments behind the listener. With this in mind, the rear speaker location was chosen to be 30° to the rear.

In order to improve and maintain directionality, it is essential that sound from the rear speakers arrive at the listener's position between 2.5 and 15 ms after the sound from the corresponding front speakers. Fifteen rather than 20 ms is used as the upper time-delay limit in order to accommodate longer transients. It is also essential that the rear speaker sound level at the listener's position not exceed the sound level of the corresponding front speaker by more than 10 dB.

Loudspeaker Spacing

Let us now apply these general rules to a 4-channel speaker installation in a typical 15' × 21' living room.

Maximum spacing between front and rear speakers,

$DFR(max)$ is dictated by three factors: (1) the time-delay differential (ΔTD) as determined by Haas-effect requirements ($\Delta TD = 15 - 2.5 = 12.5$ ms); (2) the speed of sound in air (S) which is 1.13 feet/millisecond; and (3) the minimum spacing (DX) between front speakers and edge of the useful listening area. For this example, DX was chosen to be 4 feet.

Using the above values, the maximum spacing between front and rear speakers is given by:

$$DFR(max) = \frac{\Delta TD \times S}{2} + DX = \frac{12.5 \text{ ms} \times 1.13 \text{ ft/ms}}{2} + 4 \text{ ft} = 11 \text{ ft.}$$

Fig. 1 shows one of the possible 4-channel speaker setups for the typical living room. The distance between the two front speakers is not critical and was chosen to be 8 ft. Spacing between corresponding front and rear speakers is according to the calculation—11 ft. Rear speakers are located at 30° angles behind the primary listening position.

Listening tests indicated the advisability of having equal sound levels of directional material from front and rear speakers at the primary listening position. Here, it was necessary to attenuate rear speaker output by 2.5 dB.

Keeping in mind that we can tolerate only a 10-dB increase of rear-speaker sound level before directionality reinforcement ceases, we find that the listener can approach the rear speaker to within 1.8 ft before this occurs. The total area where reinforced front directionality and good ambience reproduction is available to the listener has been indicated by the color-shaded area in Fig. 1. Within the crosshatch shaded area, the listener experiences mainly front-reinforced directionality and a reduced, though satisfactory, reproduction of ambience content.

Fig. 3. A 4-channel microphone installation within a small concert hall. Shaded area indicates living-room dimension.

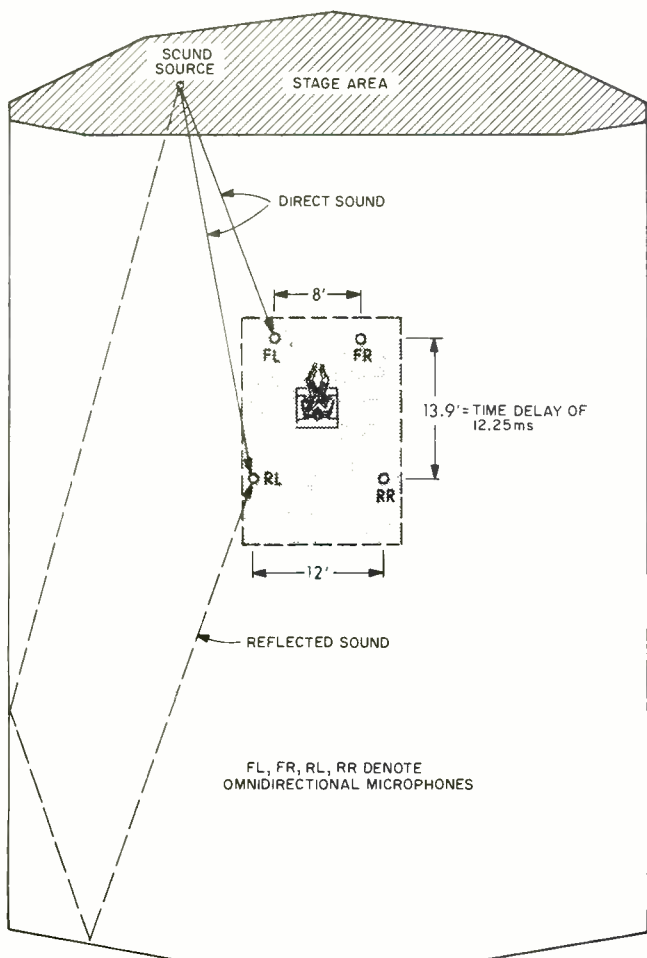

At this point it should be shown how much of an improvement of ambience reproduction we have with 4-channel as compared with 2-channel reproduction. We find that when the angle between primary listening position and either front speaker is 25° one's ear sensitivity at this angle with respect to ambience material is reduced by 10 dB. In other words, with 2-channel reproduction, we can lose up to 10 dB or 90% of the ambience content of the live concert. This compares to a loss of not more than 3 dB encountered with 4-channel reproduction. The difference between 2- and 4-channel reproduction with respect to usable listening areas is obvious if one compares Figs. 1 and 2.

It could be argued that the quality of ambience reproduction with two speakers could be somewhat improved if the speakers are designed to utilize walls to reflect strong signals. It is possible that with this type of speaker part of the reflected sound approaches the ears from a more favorable angle. In the opinion of the writer, however, there is a possibility for confusion with respect to directionality because of the very uncertain amplitude- and time-delay situation of the reflected signals.

Minimum Time Delay Between Speakers

The required minimum time delay between front and rear speakers is governed by: (1) the distance between front and rear speakers; (2) the minimum time delay $TD(min.) = 2.5$ ms as determined by the Haas effect; (3) the desire to extend the area of reinforced directionality behind the rear speakers into the full length of the listening room; and (4) the speed of sound in air (S).

The required minimum time delay $TTD(min.)$ between front and rear speakers is given by:

$$TTD(min) = \frac{DFR(max)}{S} + TD(min) = \frac{11 \text{ ft}}{1.13 \text{ ft/ms}} + 2.5 \text{ ms} = 12.25 \text{ ms.}$$

With the exception of the 4-ft distance adjoining the front speakers, this equation satisfies the time-delay requirements for the entire room. At any point within the room, sound from the front speakers will arrive first and sound from the rear speakers within the specified delay range of 2.5 to 15 ms.

There are several means available for producing the necessary time delay. A simple, but effective, method is to utilize controlled spacing between corresponding front and rear microphones during the recording session. Fig. 3 shows an example of this method. The microphones are positioned in an area that corresponds to a good seat at a live concert. Spacing between corresponding front and rear microphones is given by:

$$DM = TTD(min.) \times S = 12.25 \text{ ms} \times 1.13 \text{ ft/ms} = 13.9 \text{ ft.}$$

The spacing between the front microphones as well as between the rear microphones corresponds to the spacing of front and rear loudspeakers for the 4-channel speaker setup.

With this recording technique and the 4-channel speaker setup discussed, the good seat at a live concert is duplicated by the primary listening position shown in Fig. 1. A listener at this position will enjoy nearly the same ambience and directionality as a listener sitting in a similar position within the 4-channel microphone setup of Fig. 3. Sounds originating from the stage area, the sides, or the rear of the concert hall are reproduced with the correct directionality by the 4-channel speaker setup.

In order to take advantage of all the benefits offered by 4-channel reproduction, it is essential that the psychoacoustic factors be considered for the entire recording and playback process. This calls for standardization with respect to time delay on the part of the recording industry. Of equal importance is the education of potential users by the hi-fi industry with regard to correct speaker placement. ▲



Automatic Tint Correction in COLOR TV

BY FOREST H. BELT/Contributing Editor

Until broadcasters can keep colors correct at their end, these new receiver circuits are one way to maintain proper hues on your color set.

COLOR-TV performance is pretty good these days. But its very excellence has made one discrepancy more noticeable than ever. Call it phase error, phase/amplitude distortion, or just "blue-face/green-face syndrome," this one fault is a source of great annoyance to viewers.

The errors develop in the chain of color-TV transmission. Subjective adjustment of color cameras and monitors is part of the trouble. Technical differences in video-tape equipment contribute. Color reproduction on film varies widely. Companies are working to improve each of these factors. An inter-industry committee, the Broadcast Television Systems Committee (sponsored by the Electronic Industries Association), has investigated many approaches to eliminating these transmitted errors. But the problem has not been solved.

In the meantime viewers have become impatient. It's aggravating to have to change receiver controls every time the channel selector is turned, or a network feed stops and local programming begins, or the studio director switches from camera to camera in one program, or a filmed commercial replaces a taped program—and so on.

Receiver manufacturers have taken things into their own hands. First *Magnavox* developed an automatic tint control (a.t.c.), introduced more than two years ago. (*Editor's Note: Details of the Magnavox system appeared in the September, 1969 issue of ELECTRONICS WORLD.*) For 1971, several other color-set makers have devised some form of tint correction that works automatically. Transmitted errors that change the hue of performers' faces are to some degree overcome in the receiver.

Four of these tint-correction systems in 1971 models are: Accutint (RCA), Automatic Tint Guard or ATG (Zenith), Customatic Tint Lock (General Electric), and Electrotint (Electrohome). They're mostly in the high-end models of these brands, but look for a.t.c. systems to appear in other

models if the problem hasn't been corrected pretty soon at the broadcasting end.

RCA Accutint

This RCA tint-correction system depends on certain color-signal transmission characteristics that you may have almost forgotten if you deal only with the receiver end of color television.

Remember *I* and *Q* signals? They are the two signals that are mixed with the color subcarrier in balanced modulators to generate the chroma sidebands which then modulate the TV-station carrier. *I* and *Q* are formed by matrixing certain percentages of the *R* (red), *G* (green), and *B* (blue) signals that come from the color cameras. They are then fed

Fig. 1. Vector diagram of *I* and *Q* signals which modulate color subcarrier in balanced demodulator; these vectors represent the phases of the transmitted color sidebands.

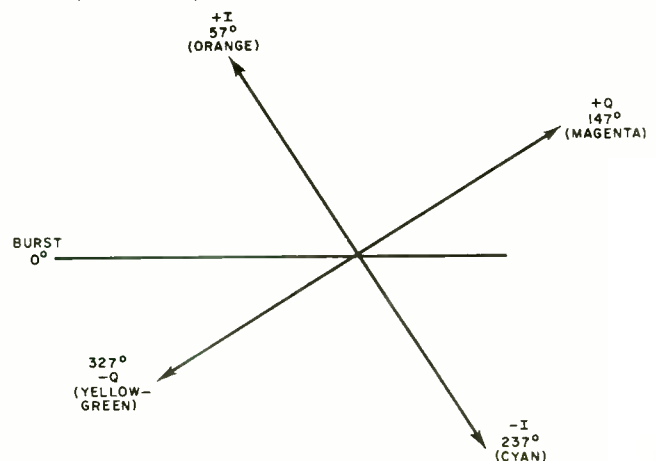

through bandwidth filters that limit Q to 0.5 MHz and I to 0.5-1.5 MHz. Their balanced modulators are phased to put the two chroma-sideband signals 90-degrees apart. Furthermore, together they are phase-rotated another 57 degrees from the reference phase of the original subcarrier.

The vector diagram of Fig. 1 shows their phase relationships. Burst, of course, is at 0 degrees—exactly in-phase with the original subcarrier. The I signal falls at 57 degrees,

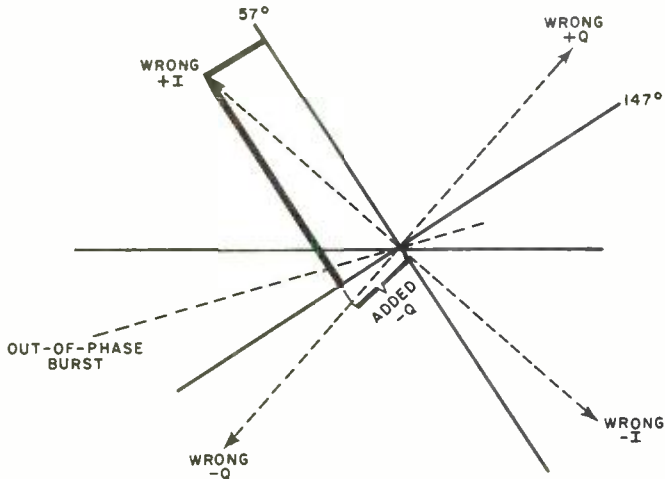

Fig. 2. If burst signal is transmitted or received in wrong phase, whole set of vectors rotates. Effect of counterclockwise rotation on I vector is same as adding $-Q$ to chroma signal. Clockwise rotation gives same effect as adding $+Q$.

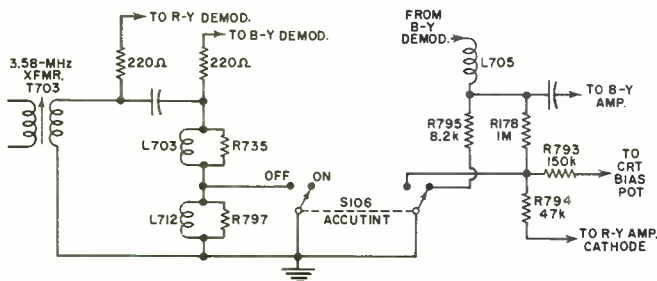

Fig. 3. Accutint in RCA color sets alters demodulation angle with one section of switch and lowers color temperature with other by reducing amount of $B-Y$ signal fed to $B-Y$ amp.

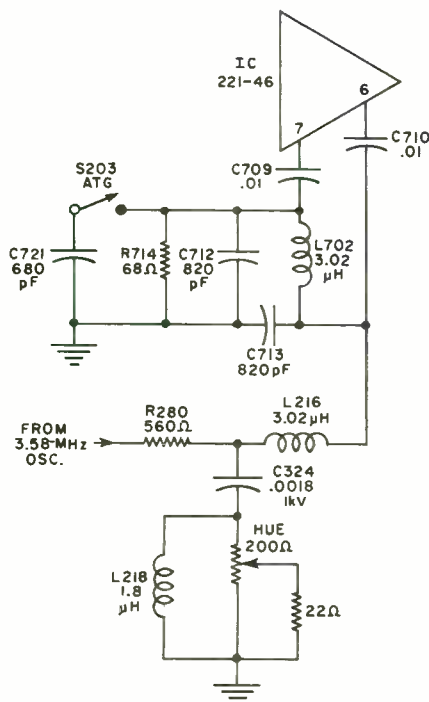

Fig. 4. Automatic Tint Guard in Zenith widens demodulation angle by insertion of capacitor in injection phase network.

the position of orange on a color-vector diagram. The $-I$ signal falls opposite the I signal, naturally, at 237 degrees; the color there is cyan. The Q signal is 90 degrees beyond the I signal, at 147 degrees, the position of magenta. And the $-Q$ signal falls at 327 degrees, just 33 degrees before the next burst signal; color there is yellow-green.

The fleshtone that is so critical to a viewer is very near the combination of R , G , B , and Y (luminance or brightness signal) that produces a pastel shade of orange. And the vector of that combination falls very near 57 degrees. Thus a correct I signal is vital to reproduction of good flesh colors.

Fleshtone is critical for four reasons: (1) The human eye is very sensitive to that part of the color spectrum. (2) Fleshtone is a known color to which the viewer can adjust the Hue control. (3) Bandwidth of the transmitted I signal is wider than the bandwidth of the Q signal, and therefore contains more color information. (4) For all those reasons, any variation of color phase near 57 degrees looks worse than a variation at some other phase angle.

Consider the burst that may be developing a phase error. Suppose burst phase is advanced a few degrees, as in Fig. 2. (All the vectors are assumed to be rotating counterclockwise.) That moves all the vectors counterclockwise that many degrees. I moves in the direction toward the normal position of $-Q$; you can say $-Q$ has been added to the I signal. Fleshtones take on a greenish cast. Were burst phase to go the other way, the vectors would rotate clockwise from normal. The effect would be the same as adding $+Q$ to the critical I signal, and fleshtones would take on a magenta or purplish cast.

You can think of any change in fleshtones as being the addition of some amount of $+Q$ or $-Q$ to the I signal that approximates flesh color. So, limit any change in either $+Q$ or $-Q$ and you limit fleshtone change.

Accutint cuts down the Q signal reproduced by the color demodulators in a receiver. Of course, modern receivers don't use I and Q demodulators. Most of them recover R and B . But I and Q are made up of portions of R and B , and the Accutint corrective circuit can operate on R and B the same as it could directly on Q .

When Accutint is working, Q output is reduced by about 50 percent. It's done by shifting $R-Y$ demodulation toward the I axis and $B-Y$ demodulation toward the $-I$ axis. Also, $B-Y$ output is cut down. The result is the same as if Q output from an $I-Q$ demodulator were cut in half.

Under that condition, signal errors that would ordinarily vary I -axis phase widely just don't have very much effect on I phase. In effect, the Accutint circuit desensitizes the demodulators in the vicinity of fleshtones. Colors there don't change much even if phase errors occur in the received color-TV signal.

One additional modification is made when Accutint is in operation. The normal cold white of the raster, at 9300 degrees Kelvin, is reduced to a warmer white, at about 6800 degrees. Less blue makes a more pleasing hue in the fleshtone range.

The circuit switching for Accutint is not at all complicated. You can see it in Fig. 3. Coil $L712$, paralleled by resistor $R797$, is switched into the coupling circuit that feeds 3.58-MHz c.w. signal into the $B-Y$ demodulator. This altered loading on burst transformer $T703$ detunes it and shifts the demodulation angle for $R-Y$ just the right amount for the Accutint angles of demodulation. Resistor $R795$ is loaded across the output of the $B-Y$ demodulator to reduce blue and lower the color temperature of the raster.

Zenith Automatic Tint Guard

This Zenith version of the tint correction operates much like that already described. Certain components are switched into the demodulators to broaden response of the color matrix. Actually, the angle between $R-Y$ and $B-Y$ demodulation vectors is widened. At the same time, green

(G-Y) output is reduced. The ATG modification in one chassis, the 12B14C52, is diagrammed in Fig. 4.

With switch S203 open, normal demodulation takes place. The 3.58-MHz c.w. signal comes through the Hue network and is phase-shifted by L216, C713, L702, C712, and R714. C709 and C710 couple the two injection signals to the integrated-circuit demodulator. With burst at 0 degrees, R-Y demodulation angle is about 74 degrees and B-Y angle is 180 degrees.

Closing the ATG switch connects 680-pF capacitor C721 between ground and the junction of R714, C712, and L702. That advances the demodulation angle of R-Y to about 66 degrees and pushes the demodulation angle of B-Y out to 195 degrees.

You can see this effect with a color-bar generator hooked up to the receiver. When ATG is turned on, the red bars move to the left almost half the width of one bar and blue bars move right about half a bar.

This has the effect of making the demodulator matrix comparatively insensitive to amplitude changes along the Q axis—which you remember is at 147 degrees, about halfway between the angles just mentioned. The effect of that kind of signal error is reduced, stabilizing the I angle and reducing fleshtone errors.

This change in demodulator matrix has another effect, too. G-Y is normally at about 285 degrees in this Zenith demodulator. The new matrixing inside the IC demodulator advances the demodulation angle of G-Y slightly, to about 280 degrees. Most important, though, the amplitude of the G-Y vector is reduced.

With both Accutint and Automatic Color Guard, viewers occasionally complain that grass and trees take on an incorrect hue. Dark greens may appear bluish and light greens may appear slightly yellowish or orangish. This characteristic must be overlooked in favor of improved fleshtones. Viewers usually are annoyed more by wrong skin colors.

GE Customatic Tint Lock

The General Electric 1971 line has a new chassis called the KE-II. It includes a tint-correction system. Fig. 5 shows the KE-II demodulator system without tint correction.

To add Tint Lock, the connection between CR703 and CR704 is broken. That's the common point where chroma sidebands from the Color control are injected to both demodulators. Separating the R-Y and B-Y demodulators makes it possible to feed the chroma sidebands to them individually.

This tells you the major difference between this tint-correction system and the ones you've already read about. The others widen the phase angle of 3.58-MHz subcarrier injection for the two demodulators, and that widens the demodulation angle. The Customatic Tint Lock instead separates the phase of chroma sidebands fed to the two demodulators. It's an entirely different approach to widening the demodulation angle.

The new circuit is shown in Fig. 6. It is inserted between the Color control and the two demodulators. There are two switches: one to bypass the correction system, and one three-position slide switch for selecting whichever demodulation angle looks best to the viewer.

The first position is 0. It is the same as with the Tint Lock switch on manual. The demodulation angle between R-Y and B-Y is 110 degrees, which is normal for this receiver.

Position 1 connects C105 and L113 into the injection paths for the color sidebands. They go through L113, L726, and L725 to the R-Y demodulator, and through C105, L728, and L727 to the B-Y demodulator. The demodulation angle between R-Y and B-Y with these components is 130 degrees.

Position 2 puts L114 in series with L113, L726, and L725, and C104 in series with C105, L728, and L727. These added inductance and capacitance values separate the chroma-

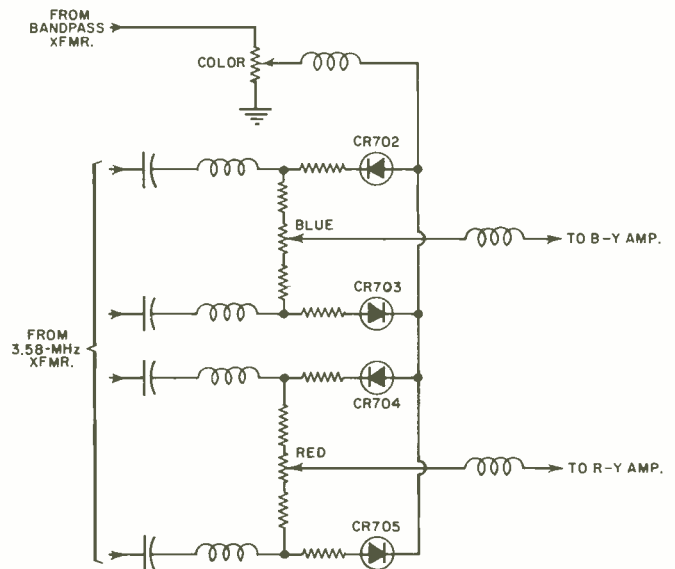

Fig. 5. Normal demodulator arrangement used in GE receiver.

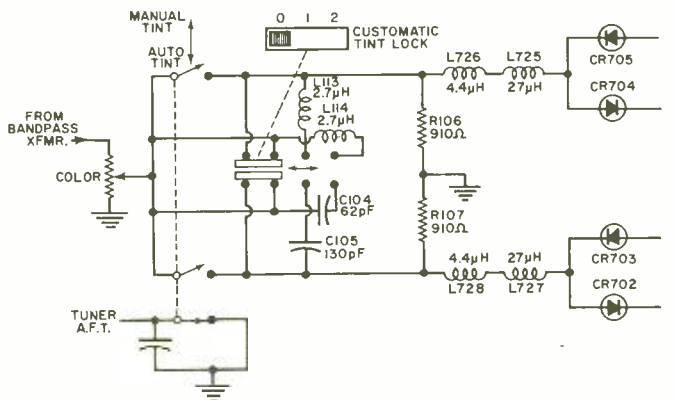

Fig. 6. Customatic Tint Lock (GE) circuits include modification of demodulators so phase-shifted chroma sidebands can be fed to them individually. Part of switch disables tuner a.f.t.

sideband injection angles even further. And that widens the demodulation angle between R-Y and B-Y to 150 degrees.

The effect of these wider demodulation angles is roughly the same as already described. If you watch their effect on the picture-tube screen with a color-bar pattern, you see the red bars move to the left and the blue bars move to the right. If you view the output of the demodulators on a vectoroscope, the R-Y vector moves counterclockwise and the B-Y vector moves clockwise. Because of the wider demodulation angle, the effects of signal errors on fleshtones are minimized.

Electrohome Electrotint

This version turns up in various chassis from Electrohome, a Canadian manufacturer that sells some color sets in the U.S. If you've read all the foregoing explanations thoroughly, the Electrotint system will seem quite simple.

Circuit operation depends on two facts. (1) R-Y is nearest the fleshtone vector and B-Y is usually a little over 90 degrees from R-Y. (2) Reducing amplitude sensitivity of the demodulators along the B-Y vector reduces the effects of any phase shift near the R-Y vector.

One version of Electrohome's Electrotint is extremely simple. It is diagrammed in Fig. 7A. A resistor and switch merely alter the gain of the B-Y color-difference amplifier. The over-all effect on maintaining fleshtones is not as great as with systems already described, but improvement is noticeable.

A second version (Fig. 7B) is more elaborate, but still

works only on the $B-Y$ axis of the demodulator vectors. A three-position switch gives the viewer some control over how insensitive the demodulator is made to phase errors near the fleshtones. The Off position leaves the $B-Y$ demodulator operating normally.

Position 1 inserts a diode and resistor between the demodulator output and ground. The cathode of the diode gets the signal. The resistor biases the diode, which then clips $-(B-Y)$ signals of high amplitude. This reduces the sensitivity of the whole demodulator system to phase errors near the fleshtone phase angle.

Position 2 keeps the diode inserted but removes the resistor. The diode alone clips out even lower amplitudes of $-(B-Y)$ signals, making the demodulator even less sensitive to fleshtone-neighborhood phase errors. This position is used only when signal errors are very bad. Other colors don't come out right when this much suppression of $-(B-Y)$ is used.

A third ElectroTint version (Fig.7C) is even more elaborate. The correction circuits operate on both $R-Y$ and $B-Y$ demodulators.

Position 1 switches diodes and resistors between ground and the outputs of both demodulators. Positive excursions of the $R-Y$ signal are reduced because the anode of that diode gets the signal. The amount of clipping is determined by bias across the two resistors. Both the $-(B-Y)$ and the $B-Y$ signals are clipped, because the diodes are connected in both polarities. Bias is set by the three resistors used with those diodes.

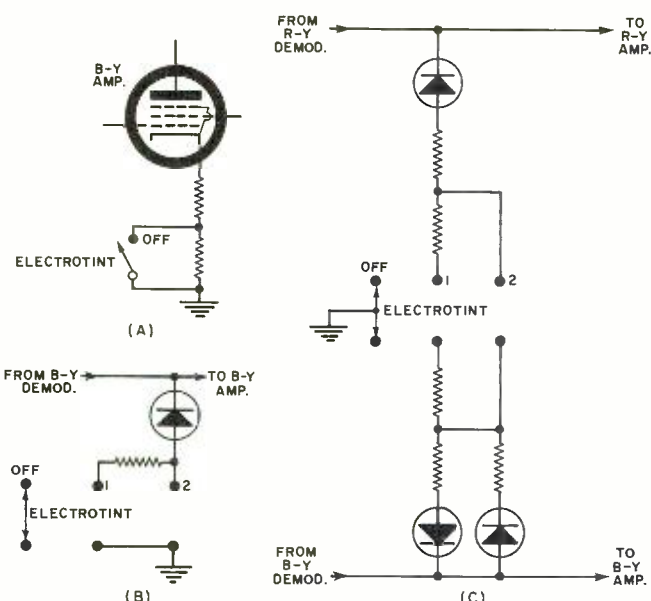
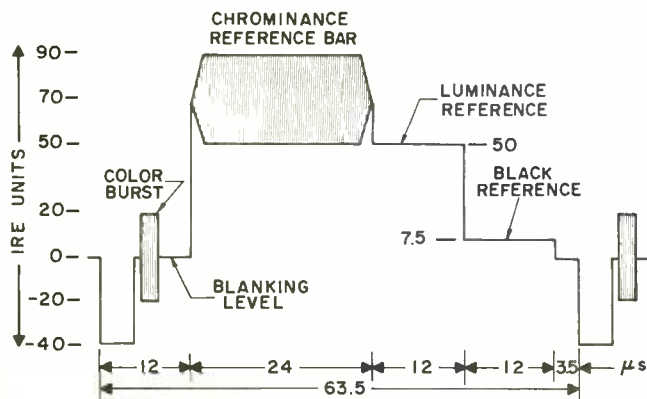

Fig. 7. Electrohome has three versions. (A) Simple reduction of the $B-Y$ amplitude. (B) Reducing $B-Y$ at either one of two levels. (C) Reducing $R-Y$, $B-Y$, and $-(B-Y)$ levels.

Fig. 8. Vertical-interval reference signal may eliminate need for any kind of automatic tint correction at receiver.



In position 2 of the switch, less bias is developed for the $R-Y$ diode, so the $R-Y$ signal is clipped at a lower amplitude level. The switch also reduces bias on both diodes for the $B-Y$ demodulator, so those signals, too, are clipped at a lower level.

Vertical Interval Reference Signals

As mentioned early in this article, a committee representing various segments of the broadcast industry is trying to overcome the need for tint-correction circuits in receivers. The answer is to correct the broadcast signal.

Two factors in the color portion of the TV broadcast signal contribute most to fleshtone errors. One is the chroma amplitude; when it changes in the vicinity of the Q axis, fleshtones are upset. The second is phase of the reference burst. If it shifts even a little, every color on the vector wheel is shifted the same amount. The eye is sensitive to fleshtone, so that's where color error is noticed first.

One suggested help is a vertical-interval reference (VIR) signal. It gives the station engineer something against which to check both chroma amplitude and burst phase. It has been tested and operating data compiled, although the final recommendation of the evaluating committee has not yet been released. The VIR signal is inserted on line 20 of the vertical blanking bar in each field or sometimes only in each alternate field. (See also "New Test Signal for Color TV" in the August, 1970 issue.)

What the VIR signal consists of is shown in Fig. 8. The diagram shows just a little more than the full line. Line 20 is inside the vertical blanking bar, so that normally the signal is not visible on the TV screen.

You can see the horizontal sync pulse going about 40 IRE units negative from zero reference (into the blacker-than-black region). It occupies about 5 microseconds of the line. Following that is the regular color-sync burst, riding early on the 7- μ s backporch of the pedestal. The pedestal is at the 0 or blanking level, whichever you want to call it.

If this were a normal line of vertical blanking, the blanking level line following the color burst would just go straight on across until next horizontal sync pulse began.

There are three elements of the VIR signal: (1) a 24-microsecond bar of chroma reference signal, 40 IRE units in amplitude and centered at 70 IRE units above zero; (2) a 12-microsecond luminance (Y) reference pedestal exactly 50 IRE units above zero reference; and (3) a 12-microsecond black-level reference pedestal exactly 7.5 IRE units above zero. The signal then drops back to blanking level or zero for the 3.5-microsecond frontporch of the next horizontal sync pulse.

The chroma reference bar comes from the origination point for the color program. It is produced by a 3.579545-MHz generator of extreme phase accuracy. A station operator checks burst phase at the output of his own transmitter against VIR chroma-bar phase. He also checks the VIR chroma-bar amplitude at the transmitter output.

If chroma amplitude has been altered, he readjusts it until the output VIR bar is 40 IRE units high. If burst phase is off, he corrects that. Eventually, automatic equipment should make these corrections at the transmitter.

He can also check luminance-level accuracy, because that too affects the colors you finally see on a receiver. Altogether, the VIR signal offers some possibility of alleviating at the transmitter the green-face/blue-face syndrome. It will depend on a continuous and dependable VIR signal being available to all stations. Probably it will have to come down the network feeds, even when there's no color program in progress. Otherwise, the change from network color to local color would still create hue problems.

If and when the VIR or some phase- and amplitude-certified system is adopted nationwide, these tint correction systems in receivers will be unnecessary. Even the manufacturers who developed the systems look forward to that. ▲

FIVE VITAL COMPONENTS

FOR KNOWLEDGE . . . FOR PROFIT . . . FOR SHEER MUSIC AND ELECTRONICS ENJOYMENT!



OUT-OF-PRINT
NO LONGER
AVAILABLE

1971 STEREO/HI-FI DIRECTORY

The complete guide to everything you need for your home music system. Everything available from all the manufacturers: amplifiers • tuners • receivers • chargers • tape machines—cartridge, cassette and reel-to-reel • speakers • cabinets • compact hi-fi systems • cartridges, arms, accessories. Picture-crammed pages and complete, accurate, reliable facts on every piece of equipment including full technical specifications, model numbers, dimensions, special features, optional accessories, manufacturers prices. If you intend to buy just one new piece of equipment this year getting hold of the 1971 Stereo/Hi-Fi Directory is your most important first step.

1971 TAPE RECORDER ANNUAL

The experts guide to getting the best use and pleasure from your tape recorder. What's available and how to choose what's best for you! WHAT TO BUY: reel-to-reel recorders, 4 and 8 track cartridge players, cassettes; HOW TO USE IT: taping off the air, tape editing, using test tapes; TAPE TACTICS: tape recorder maintenance, replacing your tape heads, using an oscilloscope — PLUS a complete Directory of Manufacturers • Glossary of Tape Recorder Terminology • fact filled Tape Recorder Directory covering Video tape recorders • Recorders, players, transports • Combination "Music Center" Machines • Raw tape • Tape accessories • Microphones—PLUS a round-up of the best pre-recorded tapes of the year!

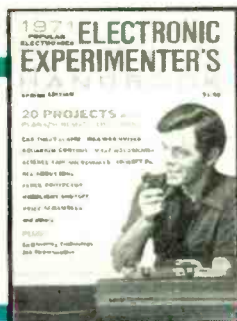

1971 ELECTRONIC EXPERIMENTER'S HANDBOOK — SPRING EDITION

20 electronics construction projects in the Spring 1971 Electronic Experimenter's Handbook. All lab-tested by the Editors, with parts list, easy "How-To-Do-It, How-It-Works" instructions—many with actual size PF foil patterns! Experimenter's Laser • Ten-Watt PA Amplifier • A Pair Of Loaded Dice • Automatic Vehicle Burglar Alarm • "No-Fooling" Fence Alarm • The Thumpa-Thumpa Box • Electric Aquarium Heater • Beginner's Signal Generator • Plus 12 others and these informative features: Caution-Laser . . . Rally Round The Reflex . . . Engineering Level Opportunities For You . . . Strange Power of Air Ions.

1971 ELECTRONIC EXPERIMENTER'S HANDBOOK — WINTER EDITION

Another big package containing more challenging, fun-to-build electronics projects. Here too, each article contains complete schematics, illustrations, parts lists and easy-to-follow instructions that guarantee results. You will build the Orb • MusicVision Light System • Simplicity + Dwell Meter • IC Frequency Standard • The Dorm Special • Pola Testers • Capacitance Meter • Squaring With An IC • All Electric Thermometer • The Tie Bookshelf Speaker • Tigers That Roar • plus 14 others—many with actual size PC foil patterns!

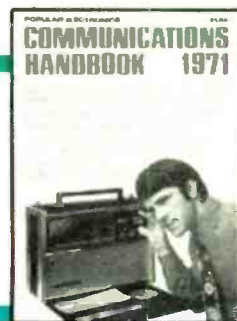
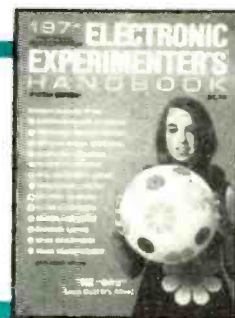

1971 COMMUNICATIONS HANDBOOK

Here's everything you want to know—need to know—about Citizens Band, Amateur Radio, Short Wave Listening. It's the world's most complete guide to communications. Fact-packed pages for the CB, SWL and HAM. Equipment buyers guide—photos—tables—charts—getting a license—ideas—tips—PLUS a special bonus listing of frequencies for all channels used by police, sheriff, fire and other public safety agencies in all states and territories and 249 cities across the country.

GET THE DELUXE LEATHERFLEX-BOUND EDITIONS FOR JUST \$3.50—POSTPAID!

These valuable annuals are also available in handsome DELUXE EDITIONS. Each volume is bound in superb leatherflex—a softly textured, gold-embossed cover which also provides rugged, lasting protection. They are truly collector's items . . . prized additions to your electronics bookshelf. And they're yours, for just \$3.50 each, postpaid. (Please allow three additional weeks for delivery.)

USE THIS COUPON TO ORDER YOUR COPIES TODAY!

ZIFF-DAVIS SERVICE DIVISION • Dept. W • 595 Broadway, New York, N.Y. 10012 EW-871

Enclosed is \$_____ Please send me the annuals I've checked below:

- 1971 Tape Recorder Annual, \$1.50
 Deluxe Edition, \$3.50
- Spring 1971 Electronic Experimenter's Handbook, \$1.50
 Deluxe Edition, \$3.50
- Winter 1971 Electronic Experimenter's Handbook, \$1.50
 Deluxe Edition, \$3.50
- 1971 Communications Handbook, \$1.50
 Deluxe Edition, \$3.50

In U.S.A. add 35c for postage and handling for each Regular Edition; Deluxe Editions are postpaid. Outside U.S.A. Regular Editions are \$2.50 each. Deluxe Editions are \$4.50 each, postpaid.

print name _____
address _____
city _____ state _____ zip _____

• PAYMENT MUST BE ENCLOSED WITH ORDER •



The Technician as a Mechanic

Mechanical skills are important to the electronics technician since he can't always choose what he will or will not service.

By **John Frye**

BARNEY had been working for three-quarters of an hour on the record changer precariously propped up on the bench with spray chemical cans. As he hunkered down for the twentieth time to observe the cycling actions of the mechanism below the motorboard, he muttered disgustedly:

"I hate fooling around with these mechanical things. I could have fixed three radios while I've been messing around trying to get unfailing precision performance out of this collection of warped pot metal and plastic. This is no job for an electronics technician."

"You think you're too good for mechanical work, maybe," Mac, his employer, suggested with disarming mildness.

"Now that you mention it, I do," Barney answered defiantly, straightening his back with his hands placed above his hip pockets. "Any ding-a-ling can work on a mechanical gadget where you can see what's wrong and needs doing. But the work for which I've been trained demands imagination coupled to a sound knowledge of electronic theory, because no one can see the tiny electrical currents I have to herd around. For me to work on mechanical things is a waste of my training. It's like putting a heart surgeon to trimming pork chops."

"The simile is clever but the argument is specious," Mac observed, grinning. "I'm not buying your innuendo that mechanical work requires less intelligence than electronic work simply because the action is easier to observe. That theory breaks down when the mechanic works on an internal combustion engine or refrigeration equipment, for he can't see what's taking place with the gases doing the work any more than you can see your electrical currents. But even when you can see the entire operation, as is the case with that record changer, you can focus on only one part of the action at a time. You need all the memory and imagination you have to keep in mind the events that precede and must follow the movement you're watching."

"You've got a point," Barney grudgingly admitted. "Working on a record player is sort of like trying to figure out a Rube Goldberg cartoon without an explanation. You have to figure it out a step at a time before you can understand everything that must occur in proper sequence from the triggering action to the conclusion. Come to think of it, I'm sure this mechanical job must take quite a bit of intelligence or I'd have had it working a long time ago. But I still don't like to work on mechanical things," he stubbornly concluded.

"I'm sure you don't, and you have lots of other technicians on your side," Mac agreed. "But let's try to see how rational this feeling really is. We've already agreed that there is no foundation to the feeling that mechanical work is somehow beneath the dignity of a technician. The fellow who comes here and works on our IBM electric typewriter is not exactly a Mortimer Snerd type. But there are other more concrete reasons for the technician's disliking mechanical work."

"Quite often the mechanical job is a dirty one involving work in awkward, cramped positions. This is usually true of

installing and servicing auto radios and of industrial electronic servicing. At least some of the work, in such cases, must be performed on location rather than at a service bench. Another reason for disliking mechanical work is that the electronics technician quite often lacks the proper mechanical tools. His thinking and interest are usually oriented more toward electronic instruments than hand tools and his money is more likely to be spent on a new digital v.t.v.m. than for a right-angle screwdriver.

"But maintaining such a negative attitude is a mistake. Some mechanical equipment almost always accompanies electronic apparatus. This is true of your record player, sound and video tape recorders, garage-door openers, SCR control equipment, electric-eye supermarket door openers, and all sorts of industrial equipment. In each case there is a close marriage between the electronic and the mechanical, and the over-all performance depends upon the proper functioning of both. As a single example, distortion in that record player can be caused by either a leaky coupling capacitor in the amplifier or a slipping motor-drive wheel. As far as the customer is concerned, he isn't interested in whether his trouble is mechanical or electronic. He just wants his record player restored to proper operation."

"RCA's ServiceAmerica policy of servicing everything electronic is forcing independents to be less choosy about what they service. Even if the independent service shop owner hates record players, garage-door openers, and tape recorders, he hardly dares turn them down. Actually, this is not all bad. There always has been good money in doing work most people dislike. That's why our garbage collector owns hundreds of acres of rich farmland."

"Yeah," Barney agreed, "and I don't remember seeing many plumbers or undertakers on welfare."

"Exactly! Really mechanical work is not so bad if you have the right equipment and the right mental attitude. Half the battle is having the right tools for the job. Trying to improvise tools leads to a loss of time, temper, knucklehead, and cabinet finish. I was strongly reminded of this not more than a week ago. I had a tape recorder in which the split plastic case was held together by two *Tru-Arc* clips—they are shaped like C-rings—slipped over split extruded bosses on the sides of the case. To get the case apart, you had to spread the ends of these clips and shove the clips out of their grooves in the bosses. Sounds easy, doesn't it? And it would have been if I had had a pair of special *Tru-Arc* pliers to slip into holes in the ends of the clips and spread them apart, but I didn't; so I tried everything in the shop before I finally bulldozed them off. It took me thirty minutes to do something that should have taken only thirty seconds because I lacked the proper tool."

"No one is going to argue with you about the necessity for having the proper tools," Barney said. "Anyone who has ever cracked a tuning slug because he used an improper tool to turn it can read you loud and clear. So can the guy who has ruined a Phillips screw head beyond all turning by using a wrong size driver or straight screwdriver on it."

"That brings up another point," Mac interrupted. "A

good mechanic respects his tools and cares for them the way a good technician respects and takes care of his instruments. Unfortunately, not all technicians have this respect for their hand tools. It makes me cringe to see a technician beating on the back end of a screwdriver he is using as a chisel or rounding off the corners of an Allen wrench trying to turn an Allen screw one size too large.

"Selecting the right tools is very important. There's no point in buying a lot of tools you don't need. The requirements of a service technician are, in the main, different from those of a carpenter, automobile mechanic, or jeweler; yet the technician may 'borrow' from the tool kit of each of these, although he may call the tool by a different name. For example, the technician's 'diagonal cutters' look suspiciously like the garage mechanic's 'cotter-key pliers,' and the 'tongue-and-groove utility pliers' of the service shop are the 'water pump pliers' of the garage.

"A good rule is to buy only the tools you know you will need and then to buy the best. Name, price, and common sense—not necessarily in that order—are the most reliable guides to quality in hand tools. For example, you may be looking at two sets of nut drivers quite far apart in price. About the only difference you can see between the cheaper set and the high-priced name brand is that the latter drivers have thinner walls and hollow shafts, while the cheaper drivers have much bulkier wrench ends and sturdy-looking solid shafts. The difference lies in the quality of the steel used in the two sets of wrenches. The thinner wrenches are actually stronger than the heavier ones. You will see the advantage of the thin-walled wrenches when you are trying to loosen a nut in a tight corner, and you will appreciate the hollow shafts when you are loosening a nut far down on a long screw, such as is often found holding a speaker in place in a wood cabinet. Finally, it's generally a good rule to stay away from 'universal tools.' They represent a compromise at best. One of the first universal tools, the monkey wrench, gave rise to the contemptuous phrase 'monkey wrench mechanic'."

"Okay," Barney said, "let's see if I understand what you're saying: You think that a good technician can and should be a good mechanic. This is necessary because almost all electronic work involves some mechanical features, even though this may be no more than the mechanical anchoring of a chassis and picture tube in a cabinet, a dial-drive mechanism, or repairing the electric clock in a clock radio. You further think my aversion to doing mechanical work is largely prejudice arising from a feeling such work is *in-*

fra dig. You believe I would do well to get over this feeling because there's good money in going after the electronic-mechanical service many others refuse to tackle. Doing mechanical work is not bad if you have the right tools."

"That's a pretty good summary," Mac applauded. "I didn't know you listened that well. However, I'd like to add a few more comments. I honestly believe you may find doing a mechanical job right takes just as much knowledge and can yield just as much satisfaction as purely electronic service. You know how you feel when you view the results of a near-perfect convergence job—there are, of course, no perfect convergence jobs. Well, I feel the same way when I put a test tape on a tape recorder I've worked on and find the tape speed is precisely on the nose with a very low wow and flutter figure. I get the same satisfaction out of seeing the sweep hand of a clock radio going around smoothly again after I have relubricated the frozen sealed-motor mechanism. And I have a sneaking hunch that child-mauled record player you've been working on will give you deep satisfaction when you have it working again. Why you may even want to specialize in changer mechanisms!"

"Don't you ever bet on it!" Barney warned as he hunkered down again and reached up to move the turntable slowly by hand. "You can brainwash me just so far, you know." ▲

BIG GAINS FORECAST FOR CCTV

BIG gains in the closed-circuit TV market, which amounted to \$90 million in 1970, have been forecast by the Industrial Studies Division of Frost & Sullivan, Inc., the New York-based technological market research organization.

Based on an annual growth rate of ten percent over the next decade, the firm foresees a \$240 million market by 1980. In its new publication, "Closed Circuit Television (CCTV) Market," the company projects sales for cameras, monitors, VTR's, and other equipment and provides detailed comparisons of view and non-view finder and vidicon, image-orthicon, and Plumbicon tube cameras. The changing sales mix between view and non-view color and black-and-white and U.S. and foreign cameras is also forecast plus a comparison of quadplex and helical scan for U.S. versus Japanese sales.

Industrial and commercial applications of CCTV systems include training, surveillance, communications, and monitoring.

Since recent FCC CATV decisions will mean more program origination using CCTV equipment, the requirements for CATV are covered and current equipment costs for large, medium, and small CCTV studios analyzed.

Further details on this report are available from the firm at 106 Fulton St., New York, N.Y. 10038. ▲

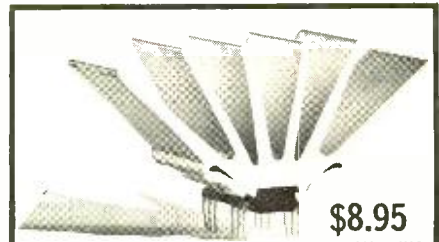

\$8.95

PLUS SHIPPING

The NEW IC-12

Nearly three years ago Sinclair introduced the IC-10, the world's first monolithic integrated circuit amplifier and preamp. IC technology has progressed rapidly and we now introduce the successor to the IC-10, the new IC-12. The IC-12 offers many advantages in terms of performance over the IC-10 and any other monolithic device in its price and power range. A minimum of external components is required, distortion remains very low, and RMS power output is improved. The IC-12 is supplied with a comprehensive applications manual and a circuit board for use in audio applications. The IC-12 may be used with batteries or with the Sinclair PZ-5 or PZ-6 power supplies.

Freq. response: 5HZ to 100KHZ ± 1 db. Depending upon external components and circuit.

THD: Typically 0.1%, less than 1% all audible frequencies up to rated output.

Power Output: 6 watts RMS into 8 ohms at 28-30 vdc.

Gain: 90 db.

Idle Current: 8 mA.

Operating Voltage: 6-30 vdc.

Noise: -70 db or better.

Heatsinking Required: None, extruded aluminum fin is integral part of design.

Package: Standard 16 Pin Dual in-line.

The IC-12 is available from authorized dealers or from Audionics, Inc.

AUDIONICS, INC.
8600 NE Sandy Blvd.
Portland, Oregon 97220

Name _____
Address _____
City _____ State _____ Zip _____

PLEASE SEND ME:

IC-12's @ \$8.95 ea. + \$1.00 shipping

PZ-5 Power Supplies @ \$13.95 + \$1.50 shipping ea.

PZ-6 Regulated Supplies @ \$23.95 + \$1.50 shipping ea.

FREE information

ew

CIRCLE NO. 149 ON READER SERVICE PAGE

GET INTO ELECTRONICS



V.T.I. training leads to success as technicians, field engineers, specialists in communications, guided missiles, computers, radar and automation. Basic & advanced courses in theory & laboratory. Electronic Engineering Technology and Electronic Technology curricula both available. Assoc. degree in 29 mos. B. S. also obtainable. G.I. approved. Graduates in all branches of electronics with major companies. Start September. February. Dorms. campus. High school graduate or equivalent. Write for catalog.

VALPARAISO TECHNICAL INSTITUTE
Dept. RD, Valparaiso, Indiana 46383

Transistor and FET Curve Tracer

Design of an adapter that permits you to display the characteristic curves of any transistor or FET on conventional scope.

By DANIEL METZGER
Asst. Prof. for Electronics Technology
Monroe County Community College, Michigan

Curve tracer adapter being used to produce family of curves on scope.

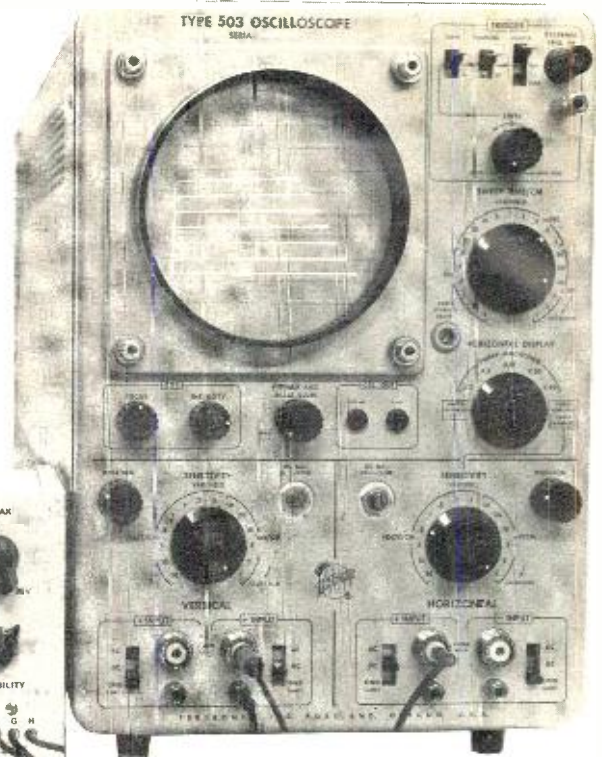
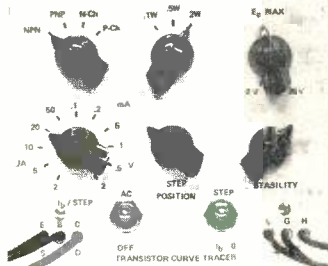

NOTHING provides more information about a transistor than its family of collector characteristic curves. Typical characteristic curves are often given in manufacturers' data sheets, but these are of limited value because transistor characteristics may vary by as much as a factor of three or four either way from unit to unit. Temperature variations also cause considerable change in transistor characteristics, especially with germanium types.

The adapter to be described will allow you to obtain an

immediate display of the characteristic curves of any transistor or FET on a conventional oscilloscope. The following are some of the uses to which the curve tracer can be put:

- Determine the a.c. and d.c. *beta*, collector-to-emitter saturation voltage, collector breakdown voltage (up to 35 volts), and dynamic collector output resistance of a transistor.
- Observe the effects of temperature on transistor characteristics, either by applying heat externally or overbiasing.

- R1—330 ohm, ½ W res.
- R2—500,000 ohm pot ("Stability" control)
- R3, R21—10,000 ohm, ½ W res.
- R4—100 ohm trimmer ("1-V Step Adj.")
- R5—33 ohm, ½ W res.
- R6—10,000 ohm trimmer ("No. of Steps")
- R7, R18—1000 ohm, ½ W res.
- R8—1800 ohm, ½ W res.
- R9—1000 ohm trimmer ("Step-Position" control)
- R10—47 ohm, ½ W res.
- R11—470 ohm, 1 W res.
- R12—2700 ohm, ½ W res.
- R13—100 ohm, 10 W res.
- R14, R16, R17, R24—100,000 ohm, ½ W res.
- R15—25,000 ohm, ½ W res. (selected, see text)
- R19—2000 ohm, ½ W res. (selected)
- R20—5000 ohm, ½ W res. (selected)
- R22—20,000 ohm, ½ W res. (selected)
- R23—50,000 ohm, ½ W res. (selected)
- R25—200,000 ohm, ½ W res. (selected)
- R26—500,000 ohm, ½ W res. (selected)
- R27—500 ohm, 2 W pot ("E_{c(max.)}" control)
- C1—0.05 μF, 200 V ceramic capacitor
- C2—0.2 μF, 200 V Mylar capacitor
- C3, C4—300 μF, 25 V elec. capacitor
- C5—500 μF, 25 V elec. capacitor
- S1—2-deck, 4-pole, 5-pos. selector sw. (3 poles, 4 pos. used) Centralab PA-1013 or equiv.
- S2—S.p. 3-pos. selector sw. (Centralab 1461 or equiv.)
- S3—2 deck, 11-pos. selector sw. (Centralab PA-1005 or equiv.)
- S4, S5—S.p.s.t. toggle sw.

Fig. 1. Schematic of tracer. Q1, Q2, and Q3 comprise staircase generator, while Q4 and Q5 form Darlington emitter-follower providing current to drive the base of the test transistor. Collector sweep voltage comes from D7-D10 full-wave bridge.

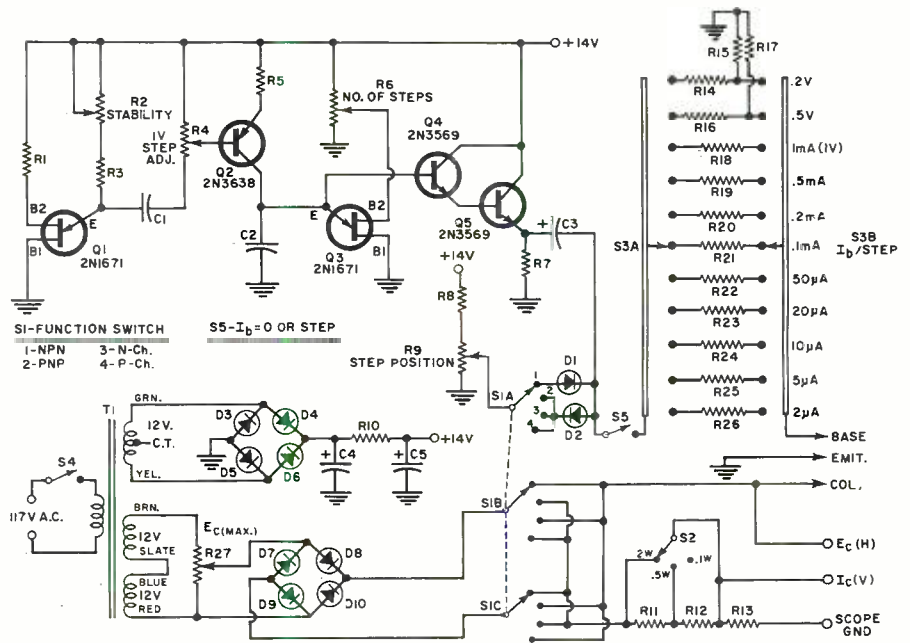

- T1—Transformer: 117 V pri.; three 12-V sec. at 0.1 A each (Stancor P-8351)
- D1-D10—Silicon diode, 100 p.i.v. (1N628 or equiv.)

- Q1, Q3—2N1671 unijunction transistor
- Q2—2N3638 "p-n-p" silicon transistor
- Q4, Q5—2N3569 "n-p-n" silicon transistor

ing the transistor and allowing it to generate its own heat.

- Observe the base-emitter input characteristics of a transistor.
- Observe the E vs I curves of diodes, zener regulators, and photocells.
- Selectively match transistors on input or output characteristics.
- Spot transistors with low breakdown or high saturation voltages as well as those with low β or high leakage; the first two tests are usually not available on meter-type transistor testers.

Circuit Description

The basic function of the adapter is to supply a continuously sweeping voltage of the proper polarity to the collector of the transistor under test, while a staircase waveform is fed through a resistor to the base to produce the "steps" of base current. A different line in the family of curves is traced at each step of the staircase. For simplicity the sweeping voltage is an unfiltered, full-wave rectified 60-Hz sine wave obtained from T1 (Fig. 1). Fig. 3 shows the relationship of the collector sweeping voltage to the base driving voltage. Although they are shown in synchronism, there is no particular need to keep them in step, since the locus of points created by the two voltages will be the same for practically any staircase repetition rate. Q1, Q2, and Q3 comprise the staircase generator, while Q4 and Q5 form a very high input impedance Darlington emitter-follower to provide the necessary current to drive the base of the test transistor without loading and consequent distortion of the staircase-generator output.

Q1 is a conventional unijunction relaxation oscillator. C1 discharges through R2 and R3 until the emitter of Q1 reaches approximately 8 to 10 volts. Q1 then fires, conducting heavily from emitter to base 1 and passing a sharp negative spike through C1 to the base of Q2. Q2 is a constant-current source which is gated on by the negative spikes. C2 receives identical current pulses from the collector of Q2 for each negative spike produced by Q1, and therefore C2

Fig. 3. Relationship of base-driving staircase to collector voltage. Upper trace, 2 volts/division; lower trace 10 volts/div.

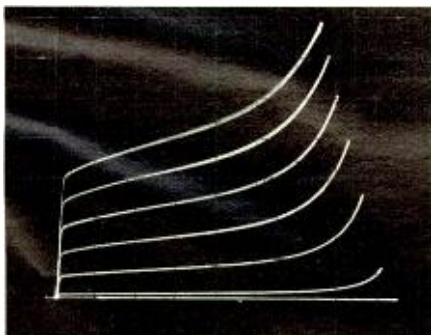
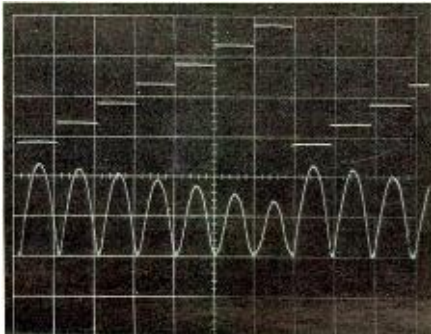

Fig. 6. Display for 2N404 germanium "p-n-p" transistor. Waveform scales are 2 V/div. horiz., 2 mA/div. vert.; $I_B = 10 \mu\text{A}/\text{step}$.

August, 1971

Fig. 4. Display for 2N3569 silicon "n-p-n" transistor. Waveform scales are 2 V/div. horiz., 2 mA/div. vert.; $I_B = 10 \mu\text{A}/\text{step}$.

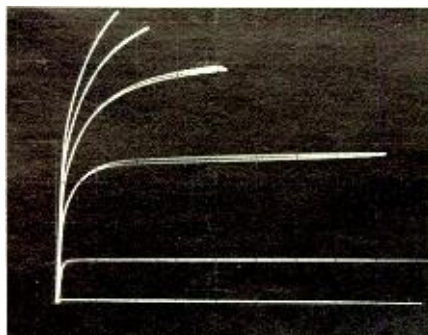
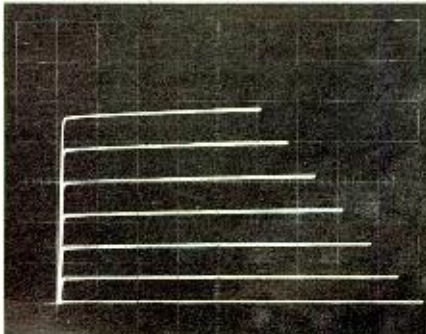

Fig. 7. Display for 2N3053 silicon "n-p-n" power transistor. The scales are 2 V/div. horiz., 20 mA/div. vert.; $I_B = 0.5 \text{ mA}/\text{step}$.

Fig. 5. Expanded detail of saturation region of 2N3569. Scales are 0.1 V/div. horiz., 1 mA/div. vert.; $I_B = 10 \mu\text{A}/\text{step}$.

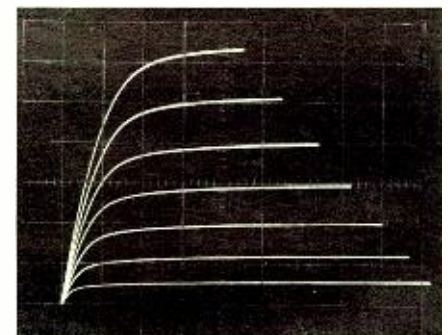
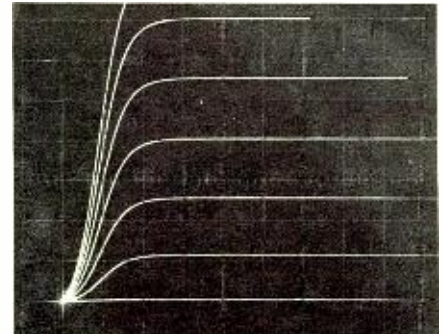

Fig. 8. Display for 2N3819 "n"-channel FET. Scales are 2 V/div. horiz., 2 mA/div. vert.; $E_{\text{gate}} = 0.5 \text{ V}/\text{step}$; 2nd line from top $E_g = 0$.

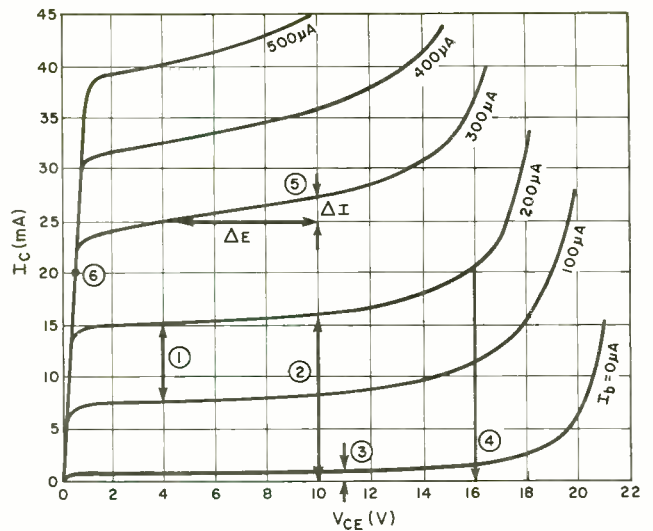

Fig. 2. Readings obtainable from characteristic curve display. (1) A.c. $\beta = \Delta I_C / \Delta I_B = (15 - 7.5 \text{ mA}) / (200 - 100 \mu\text{A}) = 75$ (at $E_C = 4 \text{ V}$, $I_C = 12 \text{ mA}$). (2) D.c. $\beta = I_C / I_B = 16 \text{ mA} / 200 \mu\text{A} = 80$ (at $E_C = 10 \text{ V}$, $I_C = 16 \text{ mA}$). (3) I_{CBO} leakage = 1 mA at 11 V. Collector cutoff current, I_{CBO} is approximately equal to I_{CEO} / β . (4) Collector-emitter breakdown voltage = 16 V (at $I_B = 200 \mu\text{A}$). (5) Collector dynamic output resistance = $\Delta E / \Delta I = 6 \text{ V} / 2.5 \text{ mA} = 2400 \text{ ohms}$ (at $E_C = 7 \text{ V}$, $I_C = 25 \text{ mA}$). The commonly given parameter $h_{OE} = \Delta I / \Delta E = 2.5 \text{ mA} / 6 \text{ V} = 416 \text{ micromhos}$. (6) Saturation voltage $V_{CE(SAT)} = 0.5 \text{ V}$ at $I_C = 20 \text{ mA}$.

charges by equal voltage steps at every spike. Q3 resets the staircase generator by discharging C2 when the voltage across it reaches the firing voltage of the unijunction.

D1 and D2 are clamping diodes which shift the d.c. level of the base-driving staircase voltage either positive or negative as required by the test transistor. R9 provides control over the d.c. level shift so that one of the staircase steps may be adjusted to a level which will give zero base current (zero gate voltage in the case of an FET test).



Close-up of the front panel of the transistor curve tracer.

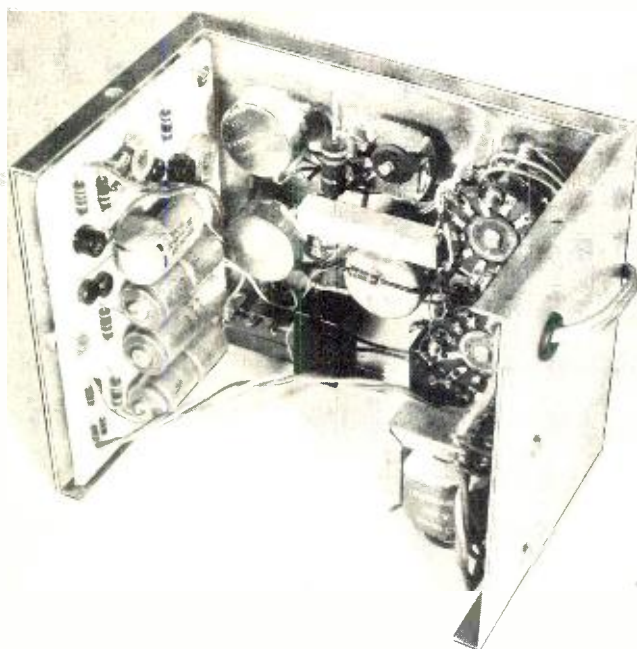

Inside view of curve tracer showing the construction details.

R_{11} , R_{12} , and R_{13} are provided in series with the collector of the test transistor to prevent damage due to excessive power dissipation. R_{13} also serves as a current-sensing resistor, providing 0.1 volt to the vertical amplifier of the oscilloscope for each milliamper of collector current.

The parts for the adapter retail cost the author about \$35, although few of them are critical and many substitutions can be made to take advantage of components already on hand. For example, nearly any unijunction transistor will do for Q_1 and Q_3 , since differences in parameters can be offset by adjustment of trimmer potentiometers R_4 and R_6 . Q_2 , Q_4 , and Q_5 should be small-signal silicon types, but there are undoubtedly hundreds of types which will work as well as the particular ones used in this unit. Similarly, diodes D_1 through D_{10} may be nearly any silicon junction type.

Resistors R_{14} through R_{26} are all standard-value components selectively picked from a junkbox for the values noted on the diagram (a high "4.7k" was used for the 5k-resistor, for example). Capacitors C_3 , C_4 , and C_5 must be several hundred μF each, but there is nothing special about the particular values shown. Capacitor C_2 is perhaps the most critical component; it must have a leakage resistance of 10

megohms or more if a clean CRT display is to be obtained.

The curve tracer is housed in a standard aluminum box with most of the electronic circuitry built on a 3" \times 5" piece of perforated breadboarding stock. Resistors R_4 and R_6 are miniature trimmers mounted directly on the board. All other variable resistors and switches are mounted on the front panel. Resistors R_{14} through R_{26} are connected directly between corresponding pins of the two decks of S_3 . In wiring the transformer secondaries, it is important that the two series windings be connected in-phase as shown in Fig. 1. Reversal of one of the secondaries would result in the voltage canceling instead of adding as desired.

Calibration and Test

Once a thorough check of the wiring has been made, the adapter is ready for test and calibration. The power supply should be checked first; 14 volts should be measured across filter capacitor C_5 and a drop of approximately 0.5 volt should appear across series resistor R_{10} . Readings which differ significantly from these norms indicate a serious malfunction which should be located before further tests are conducted.

Next, a calibrated oscilloscope should be connected to the emitter of Q_3 . If all is well, a staircase waveform will be observed. R_4 is then adjusted so that each step of the staircase represents a 1-volt increase. R_6 is adjusted to provide the desired number of steps (this will be the same as the number of trace lines in the family of curves displayed on the screen).

It is recommended that a low-power silicon $n-p-n$ transistor be used as a test transistor to gain some familiarity with the curve tracer. Set the function switch S_1 to position 1 (NPN), the power switch S_2 to .1 W, the E_C control R_{27} at midrange, the I_b /Step switch to 10 μA , the Position control R_9 full counterclockwise, the Stability control R_2 near the center of its range, and the $I_b = 0$ -Step switch S_5 to Step. It is a good idea to make these initial settings with the a.c. switch (S_4) off to avoid inadvertently applying damaging voltages to the test transistor while switching ranges.

The E_C output of the adapter is connected to the external horizontal input of the scope and the I_C output is connected to the vertical amplifier. If the scope is calibrated, the horizontal scale can be read directly in volts, while on the vertical scale each volt represents 10-mA collector current. If the scope does not have both normal and inverting inputs, you may have to settle for a display which is either upside down or backwards from the usual position, but the same information can be obtained in any case.

With S_4 "on," a characteristic-curve display should be obtained on the scope. The stability control is then adjusted to minimize the flicker of the display. The step adjust is set so that the first display line corresponds to the single line obtained when S_5 is set to $I_b = 0$. A summary of the readings which can be taken from the display is given in Fig. 2.

Junction and insulated-gate field-effect transistors may be tested by connecting the emitter, base, and collector leads to the source, gate, and drain, respectively, of the FET. If there is a fourth "substrate" lead, it should be connected with the source. S_3 must be set to one of the last three positions to provide the necessary gate-voltage steps. Again, the step-position control must be adjusted so that one of the display lines corresponds to the single line obtained when S_5 is set to $I_b = 0$.

Transistor base-emitter input characteristics, as well as characteristics for rectifier and zener diodes, photocells, and other two-lead devices can be obtained by using the "emitter" and "collector" leads only to supply a sweeping voltage. S_2 should be left on the .1-W position for such applications unless the device under test is capable of handling currents of 10 mA and above.

Typical curves produced by the instrument are shown in Figs. 3 through 8. ▲

NEA State Association Presidents

ASEA Arizona State Electronics Association
Leonard Dean, Pres., P.O. Box 11466, Phoenix, Ariz. 85017

CPEA Colorado Professional Electronic Assn.
Jim Sileo, CET, 1975 Sheridan, Denver, Colo.

CSEA California State Electronics Association
Everett Pershing, 448 N. Glenoaks Blvd, Burbank, Ca. 91502

TELSA Television Service Association of Connecticut
Saul Brown, Pres., 203 King Phillip Dr., Hartford, Conn. 06117

Television Service Dealers Assn. of Delaware
Anthony Marcozzi, Pres., 1900 W. 6th, Wilmington, Del. 19805

Florida Electronic Service Association, Inc. (not NEA member)
W. J. Co-ner, 106 E. Wright St., Pensacola, Fla.

ETA Electronic Technicians Assn. of Georgia
Jim Burgess, Pres., 2105 Evergreen Dr., Albany, Ga. 31701

IDEA Illinois Diversified Electronic Association
Bob Griffin, 208 Magnolia St., Bloomington, Ill.

IESA Indiana Electronic Service Association
Les Nesvik, 231 N. College Ave., Indianapolis, Ind.

TSA Television Service Assn. of Iowa
Wm. Gulliver, 205 E. Lincoln Way, Ames, Ia. 50010

KEA Kansas Electronics Association
Emmett Hughes, 123 W. 23rd, Hutchinson, Kan.

KETA Kentucky Electronic Technicians Assn., Inc.
Cliff Sachleben, CET, 1138 Standiford Lane, Louisville, Ky.

ETA Electronic Technicians Assn. of Louisiana
Henry C. Smith, 711 Compton, New Iberia, La. 70560

META Maryland Electronic Technicians Assn.
Jim Gilbert, County TV, 7506 Belair Rd., Baltimore, Md. 21236

TSA Television Service Assn. of Michigan
Robert Lewis, Pres., 15238 W. Warren, Dearborn, Mich. 48126

ESA St. Paul, Minn.
Don St. Claire, Pres., 450 Blair Ave., St. Paul, Minn. 55103

EST Electronic Specialist & Tech. Union of Missouri
Walter Baese, 3326 Miami, St. Louis, Mo. 63118

NESA Nebraska Electronic Service Assn., Inc.
Henry Hyde, CET, 3427 S. 42nd, Omaha, Neb. 68105

ESFETA New York
Warren Baker, Pres., 514 Second St., Albany, N. Y. 12206

TSADV
Law Russell, 254 E. Penn., Philadelphia, Pa. 19144

TSA Television Service Association of Ohio
Art Clough, CET, 31 S. Martha, Akron, Ohio 44305

OTSA Oregon Television Service Assn., Inc.
Warren Jaquenod, Pres., 177 S. 14th, Springfield, Ore.

TRI-STATE COUNCIL New Jersey, Pa., Delaware
Anthony Marcozzi, Pres., 1900 W. 6th, Wilmington, Del. 19805

TEA Texas Electronics Assn., Inc.
C.J. Rucker, 5208 Pershing, Ft. Worth, Texas 76107

VEA Virginia Electronic Assn.
Frank Blont

WSEC Washington State Electronics Council
Frank Long, Pres., 8202 Mill Plain Blvd, Vancouver

WISCONSIN
Bob Podewils, 2133 Riverside Dr., Beloit, Wis. 53511

Pres. National Electronic Associations, Inc. (NEA)
Norris Browne, CET, P.O. Box 18476, Houston, Tex. 77023

Exec. Vice-President
Dick Glass, CET, 1309 W. Market St., Indianapolis, Ind. 46222

10 CHANNELS SONAR-SCAN™ FM MONITOR RECEIVERS



EXCLUSIVE!

NOBODY CAN TOP THESE FEATURES!

- ★ PRIORITY CHANNEL—LOCKS OUT ALL OTHER SIGNALS*
- ★ CARRIER DELAY—YOU HEAR MOBILE CALLBACKS*
- ★ MANUAL SELECTICBY BY SLOW SCAN TECHNIQUE*

A proven professional performer with the most advanced technology in design, circuitry and solid state electronics assures flawless performance you can hear with extreme clarity • SONAR-SCAN will search and automatically lock a signal on any of 10 pre-programmed channels • Noise free squelch • 10 crystal controlled channels • Adjustable scan sensitivity • Narrow band operation • 117 VAC or 12 VDC, negative ground only

FR-2516 (25-50MHz) FR-2517 (150-175MHz)
Comes complete with AC and DC power cables,
mounting bracket less crystals—Crystals \$5.00 ea.

\$159⁹⁵

EXCLUSIVE WITH SONAR and PATENT PENDING*

**SONAR RADIO
CORPORATION**
73 Wortman Avenue
Brooklyn, N. Y. 1207

Send information on Model FR-2516/17
SONAR-SCAN.

Dept.
410

Name _____
Address _____
City _____ State _____ Zip _____

CIRCLE NO. 121 ON READER SERVICE PAGE

OUT-OF-PRINT
NO LONGER
AVAILABLE



STEREO/HI-FI DIRECTORY

The complete guide to everything you need for your home music system. Picture-crammed pages and complete, accurate, reliable facts on every piece of equipment. A must for everyone concerned with better listening — and sound buying.

1969 #82 \$1.25

TAPE RECORDER ANNUAL

The experts guide to getting the best use and pleasure from your tape recorder. What to buy—how to use it—tape tactics —and a round-up of the best pre-recorded tapes of the year. It's everything you want and need to know about tape recording.

1971 #19 \$1.50
1970 #99 \$1.35
1969 #81 \$1.35

Ziff-Davis Service Division—Dept. W • 595 B'way, New York, N.Y. 10012

I am enclosing \$_____ for the annuals circled below. My remittance includes an additional 35¢ per copy for postage and handling (Outside U.S.A. all magazines are \$2.50 per copy, postpaid.) EW-871

\$1.50 each 19 **\$1.35 each** 81 99 **\$1.25 each** 82

Print Name _____
Address _____
City _____ State _____ Zip _____

PAYMENT MUST BE ENCLOSED WITH ORDER

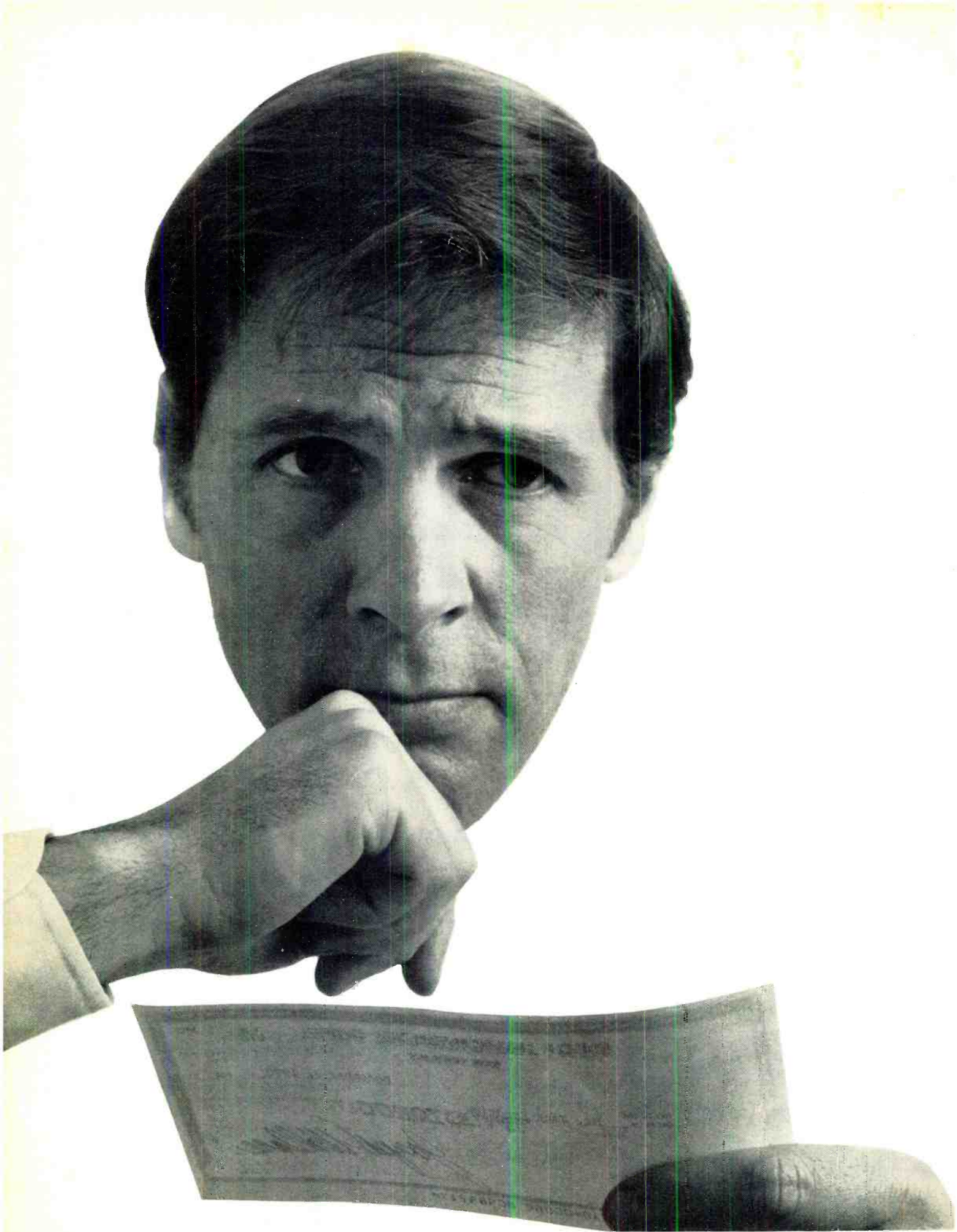

Your paycheck says a lot about you

It tells you more than how much you make. It tells you how far you've come. And if your paycheck looks very much the same as it did last year, or the year before, it simply means that *you* look very much the same as *you* did last year and the year before.

But times change, and you should be changing with them. Old dull jobs are disappearing. New exciting ones are being created. There are challenging new fields that need electronics technicians...new careers such as computers, automation, television, space electronics where the work is interesting and the earnings are greater.

RCA Institutes has one of the nation's largest and most respected home study schools devoted to electronics. They can get you started even if you've had no previous training or experience. RCA Institutes has developed a faster, easier way for you to gain the skills and the knowledge you need for a fascinating, rewarding electronics career. And you don't have to quit work and go back to school. With RCA Institutes Home Study Plan you can do

both. You set your *own* pace depending on *your* schedule.

Check over these RCA benefits:

- You get Hands-On Training—over 250 experiments and as many as 22 kits with some programs.
- You get RCA's unique "Autotext" method of learning—individual programmed instruction, the *easy, faster, simplified* way to learn!
- You get the widest choice of electronics courses and programs—everything from Electronics Fundamentals right up to Solid State Technology and Communications Electronics.
- You get a selection of low-cost tuition plans!

Sounds great, and it is! For complete information, without obligation, send in the attached postage paid card...or return the coupon below. That will say a lot about you.

Veterans: Train under new GI Bill. Accredited Member National Home Study Council. Licensed by N.Y. State—courses of study and instructional facilities approved by the State Education Department.

RCA Institutes

Home Study Dept. 240-108-0
320 West 31st Street, New York, N. Y. 10001

Please rush me FREE illustrated catalog.
I understand that I am under no obligation.

Name _____ Age _____
(please print)

Address _____

City _____ State _____ Zip _____

Veterans: Check here

If reply card
is detached—
send this
coupon today

Digital Frequency Dividers for any Ratio

By FRANK H. TOOKER

Even odd, high-division ratios, such as 11, 13 and 17, can be achieved with these useful, under-100-kHz digital circuits.

USING JK flip-flops and conventional design methods, we can set up frequency-divider circuits that will provide division ratios up to 10. Beyond this, the design of a single divider becomes too complex for convenience. Thus, some division ratios, such as 11, 13, 19, etc. are impossible to obtain. Furthermore, for those ratios which are obtainable, the use of multiple or chain dividers often results in using more JK FF's than would be needed if a more practical design method were available.

An engineering acquaintance has a solution for these problems. He simply breadboards a number of JK FF's and then interconnects them in every imaginable fashion until he gets the ratio he wants. That's one way of doing it. Aside from its unscientific nature, however, the principal difficulty with this design method is that the reliability of any such circuit is usually very much in doubt until after it has been in operation for some time.

The frequency dividers or scalars described in this article can be designed to provide any desired division ratio—any ratio at all. Ratios like 11, 13, 17, etc. are as easy to obtain as any other. These circuits use a minimum number of components for a given division ratio, they have low fan-in, no disallowed states, and they are free from exotic pulse or "blip" generation. Even more important in a number of instances, they are so easy to design that, once you are accustomed to the procedure, you can actually design one

while you are breadboarding it. The output waveform can be symmetrical if the division ratio is even.

These setups do have one disadvantage: the maximum frequency or rate of operation is about 100 kHz. This is because the circuits are asynchronous (not synchronous), *i. e.*, the input to the divider drives only the first flip-flop. The output of the first drives the input of the second, the second drives the third, and so on.

In every flip-flop, regardless of its configuration, there is a certain time delay between the application of an input and the appearance of an output. It is measured in nano-seconds (billionths of a second), and it is called the "propagation delay."

In a low-division scaler this delay is seldom of any particular consequence—but in a multi-FF asynchronous setup the delays accumulate (add one to the other), with the result that the maximum frequency or speed of operation is limited. In circuits designed for division ratios that are not strictly binary, there is an additional delay due to the method used in fixing the ratio.

All this, of course, is simply by way of explanation. The top speed of 100 kHz is adequate for a large number of applications. In many instances where this is not so, modulo-10 scalars can be used to bring the speed down to where it is within range of these dividers.

Design Principles

JK flip-flops divide in binary. Thus, division ratios of 2, 4, 8, 16, etc. are easily obtained by connecting the required number of JK FF's in an asynchronous train. The setup of Fig. 1A is a typical divide-by-4 circuit of this kind.

But suppose we want to divide by 3? Obviously, we must in some way convince the circuit of Fig. 1A that it has divided by 4 each time it reaches a count of 3. In other words, we must add a count of 1 at every third count and we must do this in a way that the result of our manipulation does not appear in evidence at the circuit's output. The setup of Fig. 1B shows a simple method by which such manipulation may be accomplished. A silver-mica capacitor, *C*, and a diode are the only additional components required.

In the circuit of Fig. 1B, a positive-going "add-control" pulse is delivered to the preclear input, *P*, of FF1 via capacitor *C* every time the \bar{Q} output of FF2 goes positive. \bar{Q} output of FF2 goes positive for the first time in each cycle of

Fig. 1. (A) Asynchronous divide-by-4 circuit. (B) Same circuit with silver-mica capacitor and diode added to provide a division ratio of 3 at the output. (C) Truth table of Fig. 1B.

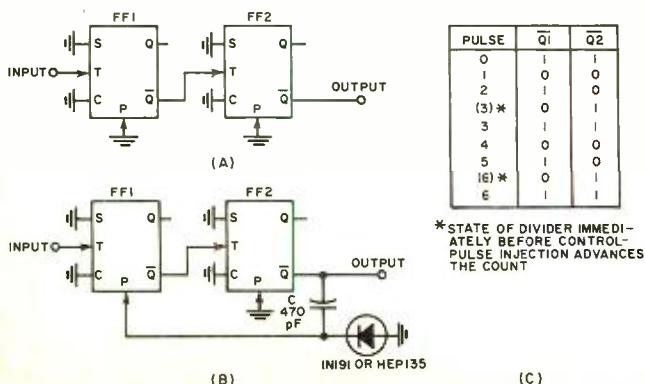

events at the third count, and the feedback to *P* of *FF1* puts in one count additionally. This count cannot appear at the output—so the setup divides by 3. The diode operates as a d. c. restorer. The truth table of Fig. 1C provides the sequence of events in detail over an interval of two cycles in the divider.

To further illustrate the design principles of these dividers, let us now assume that we need a divide-by-5 circuit. We choose a number of JK FF's that will give us the next higher binary division ratio—in this case, three JK FF's for a binary ratio of 8, as shown in Fig. 2A. Since our desired ratio is 5, the setup must add 8-5 = 3 counts at every fifth count.

The required setup is given in Fig. 2B. This time we feed an add-control pulse to the *P* input of both *FF1* and *FF2*. Feedback to *FF1* gives us a count advance of 1, and feedback to *FF2* gives us a count advance of 2. These advance values add, so we obtain our required three additional counts, and since these counts do not appear at the divider's output terminal, the circuit divides by 5.

It will be noted that, in the divider proper, we feed the \bar{Q} output of one JK FF to the *T* input of the following one. There is a very good reason for this particular connection. If we were to use the *Q* output, there is a chance that a "blip" or exotic spike pulse may appear at the divider's output every time the add-control pulse injection goes into operation. These spikes are of such short duration that they are not to be seen on the screen of any ordinary oscilloscope, but they can often raise havoc with the performance of a following digital circuit. Using the \bar{Q} output in the inter-JK FF coupling avoids this possibility. A truth table for the circuit of Fig. 2B is given in Fig. 2C.

Obtaining Symmetrical Output

It was stated earlier that symmetrical output is possible if the desired division ratio is even. Fig. 3A, the circuit of a divide-by-6 divider, shows how symmetrical output is accomplished. We divide our desired division ratio by 2, design a divider for the value thus obtained, then follow this part of the setup with a single JK FF. Thus, the setup of Fig. 3A is actually the divided-by-3 circuit of Fig. 1B followed by a further division by 2. This principle may be employed with any even division ratio to provide a symmetrical output. It is the final, single JK FF, dividing evenly by 2, that produces the symmetry.

In applications where symmetry in the output waveform is of no particular consequence, the divide-by-6 scaler in Fig. 3B may be used. This setup has no particular advantage, however, other than that which may be occasioned by convenience in the physical layout.

In the circuit of Fig. 3B, we need to advance the count by a value of 8-6 = 2, so the feedback pulse is taken only to the *P* input of *FF2*. Where these feedback values for the add-control pulse are concerned, feedback to *FF1* has a value of 1; to *FF2* a value of 2; to *FF3* a value of 4; to *FF4* a value of 8; and so on, in binary progression. The feedback values add to obtain the needed advance in the count. Feedback is never applied to the last JK FF in the string. If so doing appears to be necessary in any setup, you are attempting to use one JK FF too many.

Dividing by Any Number

The tables in Figs. 4 and 5 provide data for designing dividers or scalars having any desired division ratio. Actually, the table in Fig. 5 goes only to a division ratio of 16, but a little study of the data included here will enable the designer to extend the table to any reasonable value that may be desired.

The tables are needed only as an aid to becoming familiar with the design principles involved. Once these principles have been mastered—and they are quite simple—you can design a scaler for any desired division ratio while you are

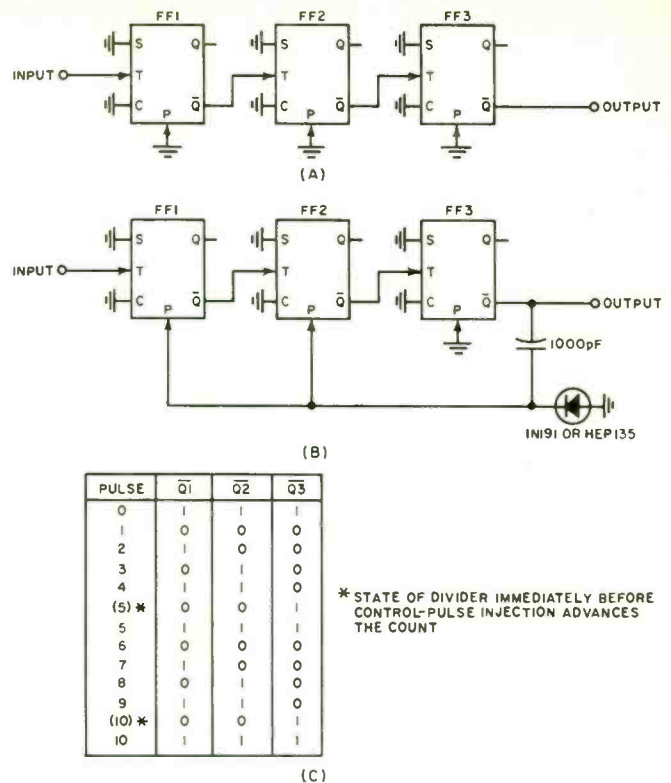

Fig. 2. (A) Asynchronous divide-by-8 circuit. (B) Same circuit with components added in order to provide the required division ratio of 5 at output. (C) The truth table of Fig. 2B.

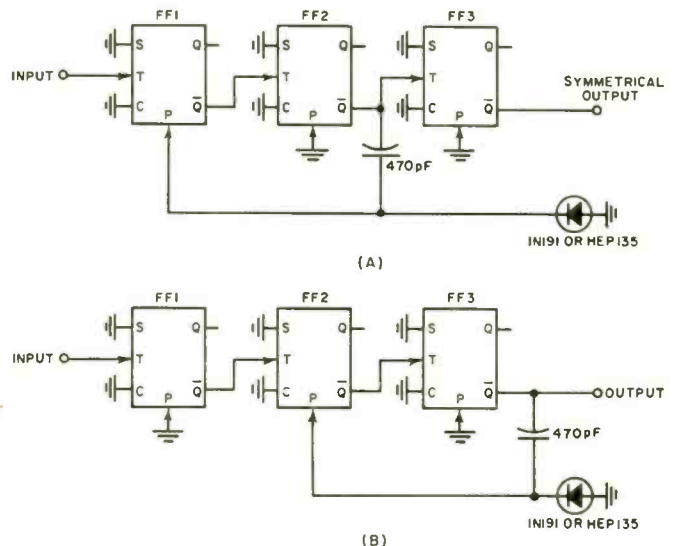

Fig. 3. (A) A divide-by-6 divider with symmetrical output. (B) A divide-by-6 divider where symmetrical output is not needed.

Fig. 4. Table giving values for designing dividers described.

NUMBER OF JK FF'S	BINARY DIVISION RATIO	ADVANCE VALUE FOR DIVIDER
1	2	1
2	4	2
3	8	4
4	16	8
5	32	16
6	64	32
7	128	64
8	256	128

Announcing the **NEW STANDARD** in Stereo Testing!

The All-New Model SR12 STEREO TEST RECORD



Whether you're an avid audiophile, a casual listener or a professional technician . . . the new MODEL SR12 will be the most important disc in your entire collection.

MODEL SR12 has been produced by Stereo Review Magazine for music lovers who want immediate answers to questions about the performance of their stereo systems and how to get the best possible sound reproduction.

It is the most complete test record of its kind — containing the widest range of checks ever included on one test disc.

Make these important stereo checks **BY EAR...** (no test instruments required)

- ▶ Frequency response—a direct warble-tone check of nineteen sections of the frequency spectrum, from 20 to 20,840 Hz, which will pinpoint any frequency response defects in your system.
- ▶ Separation—an ingenious test which indicates whether you have adequate separation for good stereo.
- ▶ Cartridge tracking—the most sophisticated tests ever devised for checking the performance of your cartridge, stylus and tone arm.
- ▶ Channel balance—two broad-band, random-noise signals which permit you to eliminate any imbalances originating in cartridge, amplifier, speakers or room acoustics.
- ▶ Hum and rumble—foolproof tests that help you evaluate the actual audible levels of rumble and hum in your system.
- ▶ Flutter—a sensitive "musical" test to check whether your turntable's flutter is low, moderate, or high.

PLUS! ● Cartridge and Speaker Phasing ● Anti-Skating Adjustment ● "Gun Shot Test" for Stereo Spread ● Multi-purpose Musician's "A" ● Equal-tempered Chromatic Octave ● Guitar-tuning Tones.

Attention Professionals Model SR12 is also designed to be used as a highly efficient design and measurement tool. Tests below have been controlled to laboratory tolerances—affording accurate numerical evaluation when used with oscilloscope, chart recorder, output meter, intermodulation-distortion meter and flutter meter.

- 1,000-Hz square waves to test transient and high-frequency response of phono pickups.
- 500 to 20,000 Hz frequency-response sweep.
- Sine-wave tone-bursts to test transient response of pickup.
- Intermodulation test using simultaneous 400-Hz and 4,000-Hz signals.
- Intermodulation sweep to show distortion caused by excessive resonances in tone arm and cartridge.
- 1,000-Hz reference tones to determine groove velocity.
- 3,000-Hz tone for flutter and speed tests.

Sample waveforms—illustrating both accurate and faulty responses are provided in the Instruction Manual for comparison with the patterns appearing on your own oscilloscope screen.

Only \$5.98

FREE Instruction Manual Includes Detailed Instructions, Charts, Tables and Diagrams

RECORDS • Ziff-Davis Service Division EW-871
595 Broadway • New York, N.Y. 10012

Please send _____ test records at \$5.98 each, **postpaid**.

My check (or money order) for \$ _____ is enclosed.
(Outside U.S.A. please send \$8.00 per record ordered.) N. Y. State residents please add local sales tax.

Print Name _____

Address _____

City _____

State _____

Zip _____

PAYMENT MUST BE ENCLOSED WITH ORDER

in the course of breadboarding it. The procedure is as follows:

1. With the desired division ratio in mind, choose a binary divider circuit having the nearest higher division ratio. Thus, for a divide-by-12 scaler, choose a binary scaler having a division ratio of 16 (four JK FF's).

2. Subtract the desired division ratio from the binary division ratio, to obtain the count-advance value. In the preceding example $16 - 12 = 4$.

3. Using the capacitor and diode setup, feed an add-control pulse to the JK-FF stage or stages providing the required count-advance value(s). In the case of the divide-by-12 scaler, this will be the third stage only. The right-hand column in Fig. 4 provides the count advance values for each stage up to 8 stages.

4. If a symmetrical output waveform is desired and the division ratio is even, divide the desired division ratio by 2, design the scaler for this half-division ratio, then follow this part of the scaler with a single JK FF, to both divide by 2 and provide the symmetry.

Amplifying the Count-Advance Pulse

The \bar{Q} output of a JK FF will drive one or two P inputs satisfactorily, but when three or four have to be driven—as is necessary in some dividers—a transistor should be added to the setup to amplify the count-advance pulse.

A typical setup of this kind—a divide-by-25 divider—is given in Fig. 6. The transistor may be any low-power silicon $n-p-n$ computer type, such as the 2N5183 or 40458, connected as a one-input gate. Note that because the transistor inverts the pulse, it is necessary to connect the base (via a 470-ohm resistor) to the Q output, rather than the \bar{Q} output, of the final JK FF. ▲

DIVISION RATIO DESIRED	NEAREST HIGHER BINARY RATIO	COUNTS TO BE ADVANCED
2 *	—	—
3	4	1
4 *	—	—
5	8	3
6	8	2
7	8	1
8 *	—	—
9	16	7
10	16	6
11	16	5
12	16	4
13	16	3
14	16	2
15	16	1
16 *	—	—

* BINARY VALUE ; NO ADVANCE IN COUNT NEEDED

Fig. 5. Values for breadboarding dividers having division ratios up to 16. For higher division ratios, extend table.

Fig. 6. A divide-by-25 circuit requires control-pulse injection at three P inputs. To make certain that an adequate control signal is available, pulse is amplified with a transistor.

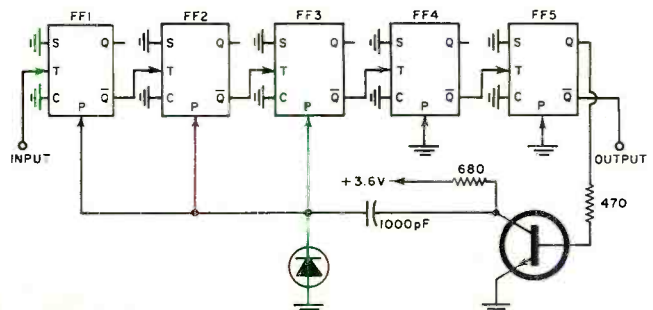

Portable Sound Systems

(Continued from page 29)

would certainly come in mighty handy.

If there is more than one vocalist, it is desirable to have a separate microphone for each performer and a mixer/amplifier with enough inputs and controls to allow individual adjustment of each mike for proper balance.

Adjustment of the individual-channel volume controls, tone controls, and master volume control—commonly referred to as "mixing"—is done by ear. Two possible situations exist which could cause problems. First, if individual volume controls are adjusted too low and the master control is set too high, output from the speakers may contain an excessive amount of hiss and noise. On the other hand, if the individual volume controls are too high and the master volume control is too low, the mixing stages ahead of the master volume control may distort and produce premature clipping, limiting the over-all output power of the amplifier with the result that full power is not obtainable. It is best to follow the amplifier manufacturer's instructions as to how to set up the volume controls. In the absence of such instructions, an audio-signal generator connected to an input channel and an oscilloscope monitoring the speaker output may be used to determine minimum volume control settings at which the power amplifier is still capable of producing full output without mixer or preamplifier clipping distortion.

It is desirable to have separate tone controls on each input channel. This permits individual tone shaping of each voice to "brighten" a flat-sounding voice or "mellow" a nasal-sounding one.

Built-in reverberation is another feature to be considered. Since much of the modern music today uses artificial reverb, both the entertainer and the audience expect this effect in a live concert. Two types of reverberation systems lend themselves to portable

sound-system use. They are the tape-loop and the coil-spring reverberation devices. The coil-spring devices are popular due to their more natural sound when reproducing the voice and freedom from the mechanical problems and frequent maintenance associated with tape-loop devices.

A number of the newer mixer/amplifiers incorporate feedback or frequency-equalizing filters that are useful in maximizing acoustic gain and minimizing acoustic feedback. While these filters are useful when the system is operated at or near the threshold of feedback, they are often misused. Feedback filters generally employ selective-frequency filtering that produces a notch or dip in frequency response over a limited frequency band with a filter depth of between 3 and 10 dB at the center frequency. These filters, when properly used, can compensate for peaks in the acoustic response of a sound system in a particular room without seriously affecting the sound. But indiscriminate use of the filters, such as turning on all the filters, can produce a frequency response with more peaks in the response than with all the filters out and may seriously affect the sound.

Proper use of filters will provide maximum acoustic gain with no apparent change in over-all sound quality. The filters are adjusted by increasing the gain until feedback is noted and the one filter that will eliminate that feedback mode is activated. Generally the first feedback pitch noted is a low-frequency one and activating the low-frequency filter may remove too much of the bass response of the over-all sound. To compensate for this lack of bass, increasing the amplifier bass controls will restore normal sound quality. Alternating back and forth between the feedback-filter adjustments and the tone controls, and increasing the volume control until feedback is again noted, a point will be reached at which two or more feedback frequencies are present at the same time. This is generally the optimum adjustment position for the tone controls and feedback filters. It should be noted that changes in location or orientation of the microphones or loudspeakers can produce drastic changes in feedback thresholds for different frequencies. It may be possible to gain additional feedback margin by repositioning the speakers and/or the microphones. After this is done, the feedback filters and tone controls should be readjusted for an optimum setting.

Next month, we will go into the problem of matching the speakers to the amplifier. We will cover the various loudspeaker types and discuss their proper placement and use.

(Concluded Next Month)

(Top) Low-impedance microphone matching transformer. (Below) In-line, low-Z mike attenuator with a 15-dB loss. This particular unit is balanced and symmetrical so it can be utilized in either direction.



CALL ME!



I'll send you 2 FREE BOOKS describing the opportunities in Electronics.

My TOLL-FREE Number is **800-321-2155**

(in Ohio, call 800-362-2105).

For details about the famous CIE home-study courses in Electronics, see our ad on page 22-25

Cleveland Institute of Electronics
1776 East 17th Street, Cleveland, Ohio 44114

CIRCLE NO. 145 ON READER SERVICE PAGE

SAVE \$240.00!



New low price on Lampkin Type 107A

**DIGITAL FREQUENCY
METER / SYNTHESIZER /
SIGNAL GENERATOR**

A money-making, time-saving, all-purpose instrument for mobile-radio maintenance.

— PLUS —

Numerous applications in educational, aerospace, industrial laboratories; in AM, FM, and TV broadcast engineering; in commercial frequency-measuring services, and many others.

PRICE \$2150.00

Write, wire, or phone — NOW!

Name _____
Address _____
City _____ State _____ Zip _____

LAMPKIN LABORATORIES, INC.
MFM Div., Bradenton, Fla. 33505

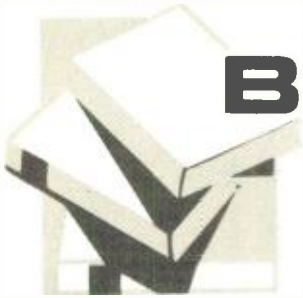

BOOKS

"HANDBOOK OF MATERIALS AND PROCESSES FOR ELECTRONICS" edited by Charles A. Harper. Published by *McGraw-Hill Book Company*, New York. 1344 pages. Price \$33.50.

This comprehensive treatment has been made possible by calling on the expertise of specialists from NASA, *Autonetics Division*, *Westinghouse*, *Republic Rubber Div.*, *RCA Labs*, *Carpenter Technology*, *Lockheed*, *Optimax*, *Rome Air Development Center*, *Allis Chalmers*, *Texas Instruments*, and *Martin Marietta*, all under the expert editorship of Charles A. Harper of *Westinghouse*.

In 15 chapters, this handbook covers plastics for electronics; laminates, reinforced plastics, and composite structures; elastomers; wires and cables; coatings for electronics; ceramics, glasses, and micas; semiconductor materials; ferrous metals; nonferrous metals; metallic and chemical finishes on metals and nonconductors; thin films; thick films; metals joining of electronic circuitry; photofabrication; and materials for the space environment. A comprehensive index makes it simple to locate exactly the information required. Copious use is made of charts, tables, line drawings, graphs, and other pertinent material. References are provided for those desiring additional information on specific topics.

"FIRST-CLASS RADIOTELEPHONE LICENSE HANDBOOK" by Edward M. Noll. Published by *Howard W. Sams & Co., Inc.*, Indianapolis. 403 pages. Price \$6.50. Soft cover.

This is a new and updated edition of a standard work that originally appeared in 1961. All of the new material included in the recently revised FCC Study Guide is covered in this edition.

The text is divided into 19 chapters, the first 13 of which contain study material related to the various phases of broadcasting, arranged according to subject matter. The next five chapters contain all of the questions (with answers) included in the Study Guide, while the final chapter presents three simulated examinations (with answers) so the student can evaluate his grasp of the subject matter.

Although the author has assumed that the reader is already holding a second-class radiotelephone license, this handbook can be used by those starting from "scratch" with the addition of study material on Elements I, II, and III. This volume covers Element IV.

Elaborately illustrated with photographs, diagrams, charts, tables, partial schematics, waveforms, and pictorials, the student using this volume as a study guide should have no trouble passing the exam for his ticket.

"BASICS OF CIRCUIT ANALYSIS FOR PRACTICING ENGINEERS" by Gordon E. Johnson. Published by *Barnes & Noble*, New York. 254 pages. Price \$4.95. Soft cover.

This is the tenth in this publisher's ongoing "professional engineering career development series" designed to keep the practicing engineer up-to-date on developments in his field. Emphasis is on practicality with a minimum of frills. Although a grasp of elementary integral calculus is required of the user, the circuit theory is developed to a level needed by the user to continue on in related fields such as electronics, pulse techniques, and feedback control theory.

There are 11 chapters covering electrical quantities, the three circuit elements, electrical and mechanical analogs, mathematics to simplify circuit analysis, the exponentially varying sinusoid, steady-state response, the step function, the Laplace transform, power, frequency response, and two port network parameters.

A good index and a listing of selected readings complete this handy, illustrated volume.

"COHERENT LIGHT" by A.F. Harvey. Published by *John Wiley & Sons, Inc.*, New York. 1283 pages. Price \$47.50.

Before tackling this monumental work, the reader is urged to sharpen his mathematical skills and spend an adequate amount of time familiarizing himself with the author's special scheme of nomenclature. Different things are meant by different type fonts and without understanding the "terminology" the reader will be in over his depth before he knows it. But once understood, the method speeds the presentation and eliminates any ambiguity regarding the specific quantity or quality to which Dr. Harvey is referring.

The author, who is with the Royal Radar Establishment at Malvern, has divided his material into 28 chapters covering fundamentals of electromagnetic radiation, optical properties of media, resonant interaction of radiation and matter, anisotropic properties of media, transmission media and components, passive resonant structures, principles of stimulated emission, population-inversion techniques, generation by free-electron techniques, paramagnetic-material lasers, gaseous-phase lasers, semiconductor lasers, construction and operation of lasers, antenna systems, external modulation and control, spatial coherence of lasers, temporal coherence of lasers, internal control of lasers, fundamental measurements of instruments, measurement techniques for materials, second-order nonlinear optics, higher-order nonlinear optics, receiver devices, receiver techniques, terrestrial propagation, intense-beam applications, processing and communication of information, and metrology and radar techniques.

It is hard to think of any topic on which an engineer would need information in this field not covered by this volume. Elaborate bibliographies accompany each chapter and a 45-page subject index allows the user to track down a specific topic for quick reference.

"STUDY GUIDE FOR CET EXAMINATIONS" by J.A. Wilson & Dick Glass. Published by *Howard W. Sams & Co., Inc.* Indianapolis. 270 pages. Price \$5.95. Soft cover.

This is a review manual for service technicians wishing to take the qualifying exam to become a Certified Electronic Technician. This is a programmed text based on sample exam questions and background material provided by the publisher's "Television Course" and "Color TV Training Manual."

A number of the sample CET Exams appeared in this magazine in the same format as they appear here—but here with greatly expanded explanations of the reasons behind the choice of correct answers. Various types of illustrative material are used to supplement the text.

"ELECTRONICS POCKET BOOK" edited by J.P. Hawker & J.A. Reddihough. Distributed by *Transatlantic Arts, Inc.*, North Village Green, Levittown, N.Y. 11756. 302 pages. Price \$6.50.

This practical little manual was designed both for reference and study purposes for those preparing for the British Electronic Servicing certificate—with concise and up-to-date information on basic circuits and techniques.

The 15 chapters range from fundamentals, through circuit elements, to counting devices and circuits, magnetic amplifiers, electronic controls and computers, installation and maintenance, and useful formulas. ▲

Electronic Typesetting

(Continued from page 37)

instructions, the computer slips in the change by recomposing the text as much as necessary. A few editorial changes frequently make it necessary to rework page numbers, index citations, and the placement of diagrams and photos. The computer and Videocomp unit can do the job readily in minutes.

Because editorial changes are so easy with electronic page-composition systems, it is now possible to update textbooks and manuals within weeks instead of the usual 6 months to a year. Telephone books and airline schedules are examples of printed materials that will soon be more up-to-date and less expensive because of total automation of page composition.

"Encyclopedia Britannica" has installed a total Videocomp system for publishing custom school texts compiled from information in its new 20-volume "Annals of America" series. A teacher can specify a certain topic, and have a text on the subject—complete with proper page numbers, table of contents, and index—within a few weeks.

RCA can already fit the Videocomp unit with a subassembly that makes it possible to reproduce line drawings as well as alphanumeric characters. The user reads the information into the system by placing a copy of the drawing over the CRT screen and placing the system into the reading mode. The CRT serves as a flying-spot scanner, and stores the graphic data, line by line, on magnetic tape. By tagging the drawing with PAGE-1 composition notations, the unit will place the drawing into the proper position on the page as it composes the rest of the text. RCA will soon announce that it can deliver another graphics subassembly unit that will be able to handle halftone illustrations as well as line drawings.

Engineers are also working on a new unit that will bypass the need for a large general-purpose computer. The user will have to trade-off some of the advantages gained by using a general-purpose machine, but the new system will make it possible for smaller publishers to boost production and reduce costs without the need for an expensive computer.

The ultimate aim of electronic page-composition technology is to integrate actual printing operations into the system. One day, Gutenberg's 3-step process will be totally automated—the raw manuscript and composition instructions will be punched into one end of the system and thousands of finished copies, ready for shipment, will appear from the other. ▲

August, 1971

*the tape that
turned the
cassette
into a
high-fidelity
medium*



**TDK SUPER DYNAMIC
(SD) TAPE**



TDK

Until TDK developed gamma ferric oxide, cassette recorders were fine for taping lectures, conferences, verbal memos and family fun—but not for serious high fidelity.

Today you can choose among high-quality stereo cassette decks.

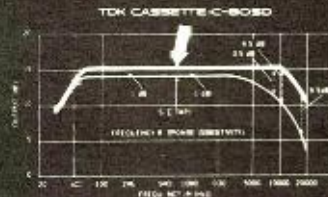

The new magnetic oxide used in TDK Super Dynamic tape distinctively differs from standard formulations in such important properties as coercive force, hysteresis-loop squareness, average particle length (only 0.4 micron!) and particle width/length ratio. These add up to meaningful performance differences: response capability from 30 to 20,000 Hz, drastically reduced background hiss, higher output level, decreased distortion and expanded dynamic range. In response alone, there's about 4 to 10 db more output in the region above 10,000 Hz—and this is immediately evident on any cassette recorder, including older types not designed for high performance. There's a difference in clarity and crispness you can hear.

Available in C60SD and C90SD lengths.

TDK ELECTRONICS CORP.
LONG ISLAND CITY, NEW YORK 11103

CIRCLE NO. 117 ON READER SERVICE PAGE

FREE

McIntosh CATALOG and FM DIRECTORY

Get all the newest and latest information on the new McIntosh Solid State equipment in the McIntosh catalog. In addition you will receive an FM station directory that covers all of North America.

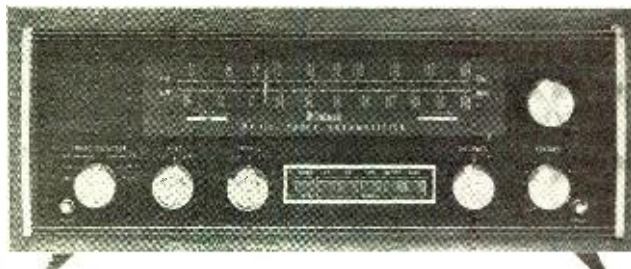

MX112
FM STEREO/AM TUNER PREAMPLIFIER
— ALL SOLID STATE

**SEND
TODAY!**

McIntosh Laboratory Inc.
2 Chambers St., Dept. 7-11-E
Binghamton, N.Y. 13903

NAME _____

ADDRESS _____

CITY _____ STATE _____ ZIP _____

CIRCLE NO. 131 ON READER SERVICE PAGE

- Increase Engine Power
- Increase Gas Mileage 10-20%
- Reduce Engine Maintenance
- Instant Starting in All Climates

V-J CAPACITIVE DISCHARGE IGNITION SYSTEM



Order Today!
\$34.95

(Easily Assembled Kit \$29.95)

- Install in 10 minutes (use original coil)
- Distributor points last lifetime of car
- Spark plugs last 3 to 10 times longer
- No changes required on timing or dwell
- EXCLUSIVE built-in switch for change from CD unit to standard ignition system while engine is running (for tune-ups, testing)
- Solid state reliability
- For 12-volt negative ground only
- 3-year guarantee

Write for Quantity Prices

V-J PRODUCTS, INC. E-8
P.O. Box 3746, Baytown, Texas 77520

Please send _____ Model J-15 Capacitive Discharge Ignition Systems

Assembled @ \$34.95 Kit Form @ \$29.95.

Enclosed is \$ _____ Ship ppd. Ship C.O.D.

Name _____

Address _____

City/State _____ Zip _____

CIRCLE NO. 118 ON READER SERVICE PAGE

Earn Your Degree
ELECTRONICS ENGINEERING

through HOME STUDY

HIGHLY EFFECTIVE HOME STUDY COURSES IN:
• Electronics Engineering Technology
• Electronics Engineering Mathematics

Earn your Associate in Science Degree in Electronics Engineering and upgrade your status and pay to the engineering level. Complete college level courses in Electronics Engineering. We're a forward looking school. Outstanding lesson material—thorough and easy to understand. Engineering taught on the basis of application and understanding rather than on the basis of memorization. Up to date in every respect. Acquire the knowledge and ability that means the difference between a low paying technician job and a high paying engineering position. Low tuition cost with low monthly payments. Free engineering placement service for our graduates. Write for free descriptive literature. Ask for bulletin J. No salesman will call on you.

COOK'S INSTITUTE
of Electronics Engineering
Forest Hill Road
P. O. Box 10634
Jackson, Miss. 39209
Established 1945
Formerly Cook's School of Electronics

CIRCLE NO. 143 ON READER SERVICE PAGE

Neutron Radiography

(Continued from page 41)

rates, one needs at least ten times this magnitude of neutron intensity for good-quality images.

The TV approach is attractive because it offers the possibility of obtaining useful images of an object in motion, and also because it would permit rapid neutron inspection of devices on a production line. Although the TV image has less contrast and spatial resolution than the x-ray film method, the basic information may suffice for many inspection problems.

Neutron radiography is now being used routinely for many inspection problems in the nuclear and aerospace industries. Radioactive materials and explosive devices account for the major efforts in the two industries, although a large variety of materials and components have been inspected by neutron radiography. On a more general basis, commercial neutron radiographic service has been available for the past several years.

In the electronics area, neutron radiography may prove to be useful for observing plastics, rubber, other insulators, or fluids in various devices. As an example, consider the object pictured in Fig. 5.

Here we have radiographs of a BNC connector. The x-radiograph at the left shows the metal components, and the interior insulators are well displayed on the neutron radiograph at the right. Together the two radiographs provide a relatively complete inspection. The break in the insulation at the crossover point, easily observed on the neutron radiograph, could be a potential failure point.

This and other examples illustrate a few specific areas in which neutron radiography could be useful as an inspec-

tion, process-control, or research and development tool. Additional application possibilities are almost unlimited.

Neutron radiographic application work presents no significant problem from the point of view of radiation hazard. Shielding of the neutron beam can be accomplished with materials such as paraffin, plastic, or water. The addition of a lead or similar shield for the gamma radiation produced in these hydrogenous materials is often also necessary. Shielding with earth or concrete blocks is very effective.

A radiation hazard unique to neutron radiography is that of radioactivity produced in the objects or detectors in the neutron beam. There is occasionally some activity produced in radiographic samples, a fact easily recognized with the use of a good radiation survey meter. On these occasions it may be necessary to allow objects to decay a few hours before they are moved out of the radiation-controlled area.

Although there is essentially no radioactivity problem with the detectors described, there are situations (such as an inspection of a radioactive object) which call for a detection method in which film is not exposed directly to the neutron beam. In that case, foils of materials, such as indium or dysprosium, are used to make a radioactive image later made visible by an autoradiograph. Such foils are primarily emitters of beta radiation, easily shielded for handling by a millimeter or so of aluminum. Although there are some radiation hazard problems with neutron radiography, they can be handled in a straightforward manner.

Several organizations offer neutron-radiographic products and services commercially. A partial listing of service organizations is given in Table 1 for those who may wish to try some sample neutron radiographs. ▲

Table 1. A partial listing of organizations offering neutron-radiography service.

Aerotest Operations¹ P.O. Box 78 San Ramon, Calif. 94583	Gulf General Atomic¹ P.O. Box 608 San Diego, Calif. 92112
Atomics International¹ P.O. Box 309 Canoga Park, Calif. 91304	High Voltage Engineering Corp.² South Bedford St. Burlington, Mass. 01803
General Electric Co.¹ Vallecitos Nuclear Center Pleasanton, Calif. 94566	Kaman Nuclear² Garden of the Gods Road Colorado Springs, Col. 80907
Greyrad Corp.¹ 12 Station Drive Princeton, N.J. 08540	Western New York Nuclear Research Center, Inc.¹ 8 Power Drive Buffalo, N.Y. 14214

Notes: ¹Reactor neutron source; ²Accelerator neutron source.

Accurate D.C.-Less Clock-Pulse Generator

By FRANK H. TOOKER

Convert 60-Hz sine waves from power line into accurate digital pulses in a simple circuit that requires no d.c.

In many sections of the country, the 60-Hz power-line frequency is held to a high order of accuracy. Thus, converted into pulses and fed into a divide-by-six scaler, it makes an excellent time base of 100-millisecond pulses for calibrating an oscilloscope screen or for use in digital circuitry.

The question is, how do we convert the sine waves of the power line to fast fall-time pulses in the simplest and most economical way? A Schmitt trigger will do it, of course, but it requires a d.c. power supply. So, in fact, does a setup of series-connected RTL inverters. The regenerative switch shown in the schematic of Fig. 1, however, converts the sine waveform directly into fast fall-time clock pulses, and it requires only the a.c. signal itself as power source.

In Fig. 1, while the sine wave at the secondary of T1 is going through its negative alternation, diode D1 conducts, charging capacitor C1. Simultaneously, the base of *n-p-n* transistor Q1 is kept negative via resistor R1. When the sine wave goes positive, the diode open-circuits, and a positive bias is thus applied to the base of Q1 via resistor R2, turning Q1 on. The regenerative switch, made up of transistors Q1 and Q2, trips into full conduction, discharging capacitor C1 rapidly through resistor R4. Following discharge, the circuit turns off, the capacitor recharges, and the cycle repeats. Discharge time, with the component values given, is less than 100 nanoseconds, thereby qualifying the signal as a clock pulse for the T-input of an RTL JK flip-flop.

Repetition rate at this point in the circuit is the same as the line frequency: 60 Hz. Peak voltage level of the pulse exceeds the requirement of a JK FT considerably, so we can decouple the pulser through a high value R5.

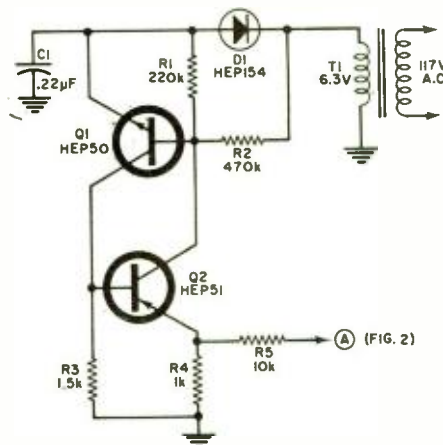
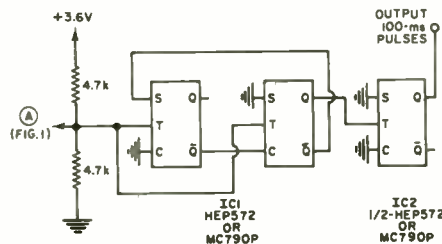

Fig. 1. Schematic of fast fall-time pulse generator requiring no d.c.

At the frequency divider (Fig. 2), a d.c. voltage divider, consisting of a pair of 4700-ohm resistors, establishes an adequate d.c. reference voltage level at the T-input of the first two JK flip-flops.

The frequency divider of Fig. 2 is conventional, dividing by 3 in the first two flip-flops and then by 2 in the last one in line, for an over-all division ratio of 6. The output waveform is symmetrical. If a 1-second pulse rate is desired, the output of this circuit may be fed into a modulo-10 minimum-hardware scaler. ▲

Fig. 2. Method of connecting pulse generator to JK flip-flop ÷ 6 scaler.



August, 1971

CALL ME!



I'll send you 2 FREE BOOKS describing the opportunities in Electronics.

My TOLL-FREE Number is
800-321-2155

(in Ohio, call 800-362-2105).

For details about the famous CIE home-study courses in Electronics, see our ad on page 22-25.

Cleveland Institute of Electronics
1776 East 17th Street, Cleveland, Ohio 44114

CIRCLE NO. 144 ON READER SERVICE PAGE

Build this magnificent Schober Theatre Organ for only

***\$1730!**



*Includes finished walnut console, Amplifier, speaker system, optional accessories extra. Only \$1256 if you build your own console.

You couldn't touch an organ like this in a store for less than \$3500—and there hasn't been a musical instrument with this vast variety of genuine Theatre Organ voices since the days of the silent movies! If you've dreamed of the grandeur of authentic big-organ sound in your own home, you won't find a more satisfying instrument anywhere—kit or no kit.

You can learn to play it. And you can build it, from Schober Kits, world famous for ease of assembly without the slightest knowledge of electronics or music, for design and parts quality from the ground up, and—above all—for the highest praise from musicians everywhere.

Send right now for your copy of the full-color Schober catalog, containing specifications of the five Schober Organ models, beginning at \$499.50. No charge, no obligation—but lots of food for a healthy musical appetite!

The Schober Organ Corp., Dept. RN-93
43 West 61st Street, New York, N.Y. 10023

Please send me Schober Organ Catalog and free 7-inch "sample" record.
 Enclosed please find \$1.00 for 12-inch L.P. record of Schober Organ music.

NAME _____

ADDRESS _____

CITY _____ STATE _____ ZIP _____

CIRCLE NO. 123 ON READER SERVICE PAGE

NEW PRODUCTS & LITERATURE

For additional information on items identified by a code number, simply fill in coupon on Reader Service Card. In those cases where code numbers are not given, may we suggest you write direct to the manufacturer on business letterhead.

COMPONENTS • TOOLS • TEST EQUIPMENT • HI-FI • AUDIO • CB • COMMUNICATIONS

A.C. REFERENCE STANDARD

The Model 510A precision a.c. voltage source can be used as either a calibration standard or as a fixed-frequency source for test applications. In



the calibration lab the unit provides an accurate reference for calibrating both true r.m.s. and average-reading a.c. voltmeters. On the production line, it can be used to verify a.c. test instrumentation and to generate a precise a.c. stimulus for circuit testing.

Output voltage of the Model 510A is 10 volts r.m.s. with an accuracy of $\pm 0.01\%$ for 30 days and $\pm 0.02\%$ for 90 days. Output current is 10 mA r.m.s., short-circuit protected. Fixed frequency output is 50 Hz to 100 kHz. Total harmonic distortion is less than 0.005%.

An optional rechargeable battery pack provides up to 12 hours of operation without a.c. line power. A d.c. reference amplifier, accurate to 15 ppm, can be used for calibration. John Fluke

Circle No. 1 on Reader Service Page

NEW ALKALINE BATTERIES

A new class of alkaline batteries, involving an entirely different internal construction from previous types, has been introduced as the Duracell Mod. I series.

According to the company, the new batteries offer increased energy density-operating life with no increase in cell size; simplified construction involving fewer parts and permitting automated assembly; and improved cell sealing for increased reliability and enhanced shelf life.

Typical increase in operating life for the Mn-1500 Mod. I over the firm's older Mn-1500 (both 1.5-V "AA" cells) at a 25-ohm load (70 degrees F continuous discharge) is 39.5 hours of service to 0.8 volt compared with 31.5 hours for the older type. Improvements range from approximately 10 to 20%, with the advantage from the new design being greater at the higher rates of current drain.

The company expects to offer these new alkaline batteries in all popular sizes for use in a wide range of battery-operated consumer goods. Mallory Battery

Circle No. 2 on Reader Service Page

AUDIO MIXER

The new "Studio MixMaster" features sound-on-sound or sound-with-sound, mix, amplify, fade, and switch facilities for both professional and home applications.

The Model 309TR Mark VI offers one to six mono inputs, up to three stereo inputs or stereo and mono combinations. It converts from one operational mode to another with fingertip-action front-panel slide switches. It also includes

individual channel gain controls, master output gain control, and right/left/both switching on each channel.

The mixer has both standard phono and phono jack inputs for each channel, four channels with full phono equalization (switchable, bass cut-off (switchable), an extra set of output jacks for convenient vu meter monitoring or headphone listening monitoring, and uses any standard input audio source—stereo or mono, tape recorders/players, high- or low-impedance microphones, tuners, etc. Switchcraft

Circle No. 3 on Reader Service Page

4-CHANNEL STEREO AMP

A four-channel, 170-watt solid-state stereo amplifier is now on the market as the LA-44.

The amplifier features separate volume controls for front left and front right, rear left and rear right; separate bass controls for front and rear; separate treble controls for front and rear; headphone jacks for front and rear channels; a "reverb" position for use with an external reverb unit to the rear channels; and THD of less than 0.8%, 100 watts r.m.s., 25 W/ch.

The LA-44 has an exclusive "composer" circuit—an electronic device which will function with any two-channel stereo source (such as records, tapes, and FM broadcasts) and which processes these two-channel signals so as to recover reflected sound components normally



masked by the so-called Haas effect, and then reproduces these reflected sounds in the rear speakers.

Power bandwidth is 15-30,000 Hz. The amplifier, which measures $13\frac{1}{2}'' \times 4'' \times 9\frac{1}{2}''$ deep, comes complete with a simulated walnut-grained metal enclosure. Lafayette

Circle No. 4 on Reader Service Page

ECONOMY CASSETTES

A new line of economy tape cassettes has just been introduced as the "Maverick" series.

The budget-priced C-30F, C-60F, and C-90F contain the company's standard quality tape. The housing is a smoky, see-through, shock-resistant plastic. Features include liners, stainless-steel pins, flanged rollers, and a spring-loaded felt pressure pad. The cassettes are packed in cardboard boxes suitable for mailing. TDK

Circle No. 5 on Reader Service Page

240-WATT STEREO RECEIVER

The Model SX-9000 is a 240-watt solid-state AM/stereo-FM receiver which includes its own reverberation amplifier. Music-power output is 240 watts total at 4 ohms. IHF sensitivity is 1.6



μV and the signal-to-noise ratio is better than 65 dB. Frequency response is 10-35,000 Hz ± 1 dB.

The receiver has inputs for two tape decks, two record players, and two microphones in addition to two auxiliary inputs so that the unit can function as a complete control for a home music entertainment center.

The microphone mixing feature permits mono or stereo recording of live performances. Tape-to-tape dubbing is facilitated by A and B tape-monitor buttons on the front panel.

The front-end uses an FET and a four-gang variable capacitor. Image rejection is 90 dB. Selectivity is enhanced by four monolithic IC's in the i.f. section, using double-tuned i.f. stages. Capture ratio is 1 dB and selectivity is 40 dB. The reverb amplifier permits adjustment of over-all sound to compensate for any acoustic condition, whether at the sound source or in the home. Pioneer

Circle No. 6 on Reader Service Page

SOUND-LEVEL CALIBRATOR

Columbia Research Laboratories, Inc., MacDade Blvd. & Bullens Lane, Woodlyn, Pa. 19094 is now marketing the Model SPC-14 sound-level calibrator which meets the requirements of the new Occupational and Health Act and Walsh-Healey Contracts Act.

The instrument is completely self-contained and solid-state and can be used for making accurate and reliable field and in-plant calibrations on various types of microphones and sound-measuring instruments.

The calibrator generates a sound-pressure level at both 100 dB and at 114 dB at the five ANSI preferred frequency levels of 125, 250, 500, 1000, and 2000 Hz, which are mandatory by law. The instrument measures 6" long by $2\frac{1}{4}''$ in diameter. The calibrator fits all $1\frac{1}{8}''$ diameter microphones but is available with adapters for $1\frac{5}{16}''$ and $5/8''$ diameter microphones.

Complete specifications are available on letterhead request.

ULTRASONIC CLEANER

A tiny ultrasonic cleaner designed especially for small parts and assemblies is now available as the Model 77. It can be used in white rooms, on electronic production lines, in labs, and in the medical, dental, and optical fields. It will clean anything that fits inside the cleaning cup and is normally cleaned in liquid.

The cleaner is of all-metal construction and operates on 117-V a.c. It has a stainless-steel cleaning cup measuring $2\frac{1}{2}''$ in diameter by $1\frac{1}{2}''$ deep. The design is solid-state. Frequency is 80 kHz. The cleaner comes complete with tweezers, cleaning brush, and sample packages of cleaning crystals for use on copper, brass, bronze, precious metals, coins, and gems. Jensen Tools

Circle No. 7 on Reader Service Page

SOUND-LEVEL METER

A completely self-contained sound-level meter that determines noise levels to provide personnel safeguards in accordance with the Walsh-Healey Act is now available as the Model SPL103.

In addition to providing rapid surveys and checks on noisy environments, the new meter protects costly equipment from malfunction and



self-destruction, by sound detection. The meter can be operated with one hand and is extremely simple to use. Measuring $10\frac{1}{2}'' \times 3\frac{3}{4}'' \times 2\frac{3}{4}''$ and weighing a total of $1\frac{1}{2}$ pounds, the instrument is powered by a 9-volt transistor battery.

The unit has A, B, and C weighted scales, plug-in detachable-type microphone, ranges from 40 to 140 dB, a push-button battery check-out, plus a fast and slow meter response option. General Scientific Equipment

Circle No. 8 on Reader Service Page

SOLID-STATE CB RADIO

A new solid-state CB two-way radio with built-in selective calling has been introduced as the Messenger 120. This unit now makes it possible for CB users to have their own private signaling systems without using external accessories.

The new reedless selective-calling circuits have locked-in code tones that respond only



when signaled by another unit equipped with the same code. According to the company, the new reedless design eliminates many of the false triggering problems of reed-type systems. With 10 codes and 23 CB channels, there is a total of 230 separate combinations available for private signaling.

With the Tone-Alert activated, the unit is completely silent, even though others are making calls on the channel. When a call comes through from one of the other units in the system, a tone sounds and a "call" signal light illuminates. If the operator wants to call the other units in his system, he simply pushes a "call" button on the front of the radio. E.F. Johnson

Circle No. 9 on Reader Service Page

INTEGRATED STEREO AMP

The Model AS-201 differential-type integrated stereo amplifier has been specifically designed for tape recording. It allows simultaneous recording and monitoring of three tape decks and has facilities for playback from five tape decks. A special differential-amplifier circuit eliminates output capacitors and the distortion they can cause.

The amplifier is rated at 100 watts (50 watts

August, 1971

Be Safe with DeltAlert The Proven Crimestopper

Everyone knows crime is increasing steadily. In fact, statistics show that one out of every six homes will be victimized this year. What can you do about it? The DeltAlert Ultrasonic Burglar Detection & Alarm System was developed to help protect you and your family. DeltAlert effectively monitors and blankets up to 300 sq. ft. of space, utilizing the sonar principle to pick up even the slightest motion. When DeltAlert is activated, horn and lights automatically begin operating. The loud ear-shattering blasts of the high intensity horn, coupled with light drives away even the boldest intruder. At home

or work, protection begins with the DeltAlert Alarm and Detection System. It's maintenance free, and to install you simply plug it in. Order yours today, and start enjoying the feeling that comes with DeltAlert protection.

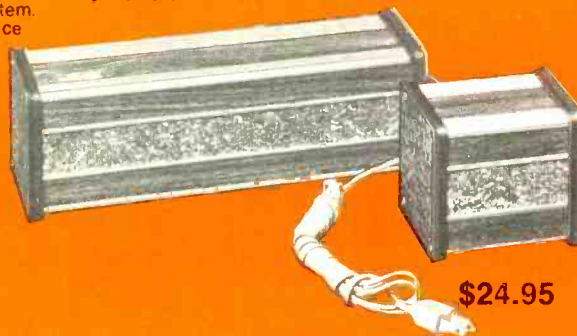

\$69.95

\$24.95

Here Are 8 Reasons to Put The Mark Ten B On Your Car

The Mark Ten B CD System with exclusive VARI SPARK[®] Circuitry will give you these substantial dollar saving advantages: 1) Eliminate 3 out of 4 tune-ups; 2) Improve combustion, reduce contaminants; 3) Install in ten minutes; 4) Instant start in all weather; 5) Dramatic increase in performance; 6) Handy switch with redundant contacts for instant return to standard ignition; 7) Two-piece housing with neoprene seals provides total dust and moisture protection; 8) Use on ANY 12-volt, negative-ground engine. Put the Mark Ten B on your car today.



It will pay for itself in dollars saved.

Mark Ten B (12v neg only) Only \$59.95 ppd.
Standard Mark Ten \$44.95 ppd.

Superior Products
At Sensible Prices

Please send me literature immediately. Enclosed is \$_____ Ship ppd. C.O.D.

Please send: DeltAlert(s) @ \$69.95 ppd.

DeltaHorn(s) @ \$24.95 ppd.

Mark Ten B @ \$59.95 ppd.

Standard Mark Ten (Assembled) @ \$44.95 ppd.

6 Volt: Neg. Ground Only Positive Ground

12 Volt: Specify Negative Ground

Standard Mark Ten (Deltakit) @ \$29.95 ppd.
(12 Volt Positive Or Negative Ground Only)

Car Year _____ Make _____

Name _____

Address _____

City/State _____

Zip _____



DELTA
PRODUCTS, INC.

P.O. Box 1147, Grand Junction, Colorado 81501, (303) 242-9000

CIRCLE NO. 140 ON READER SERVICE PAGE

71

per channel at 8 ohms and 60 watts per channel at 4 ohms, continuous sine wave) at a total harmonic distortion of under 0.5% at full-rated output.

FET's are used in the input circuits of the preamp to insure excellent sound reproduction irrespective to impedance variations at the inputs, according to the company.

The amplifier features two speaker outputs for main and remote stereo speaker systems, an instant tone-control selection switch which permits selection of flat or compensated adjustments, responsive push-button input selectors, and high and low filters. A precision 3-dB step selection tone control is employed to eliminate any tonal imbalance between channels. Teac

Circle No. 10 on Reader Service Page

FIELD-STRENGTH METER

A new solid-state portable field-strength meter capable of measuring the signal levels of all u.h.f., v.h.f., and FM channels, plus mid-band and super-band CATV channels is now available as the Model 747.

Designed for the professional TV system installer, the meter tunes from 50 to 260 MHz and 470 to 890 MHz. For ease of tuning, channel



separation is unusually wide, with all picture and sound carriers clearly marked, including mid-band and super-band carriers. Completely solid-state, the new meter is compact and balanced to hang in an easy-reading upright position from a neck strap, leaving both hands free.

The meter itself operates from four miniature 9-volt batteries. Electronic power regulation assures accuracy even as batteries age. To extend battery life, the meter is automatically turned off when the cover is closed.

Complete details are available on request. Jerrold Electronics

Circle No. 11 on Reader Service Page

V.H.F./FM RADIOTELEPHONE

The new Capri VHF provides 25 watts of maximum allowable power output and 12 channels for complete communications coverage in v.h.f./FM radiotelephone service.

Housed in a high-impact, non-corrosive case, the unit features a solid-state receiver, a crystal filter for adjacent-channel rejection, a 1-watt switch for short-range communications, plug-in transistors and fiber glass circuit boards for dependability and serviceability, integrated circuits, and a field-effect transistor. Pearce-Simpson

Circle No. 12 on Reader Service Page

RC OSCILLATOR

Combined with a Wien-bridge network, the Model ORC-27A low-frequency RC oscillator can be used for continuous frequency variation. It has coverage from 18 Hz to 200 kHz in four ranges, with a calibration accuracy of $\pm 2\%$ + 1 Hz.

A frequency dial with a scale mirror reduces



reading errors, according to the company. There are three output waveforms available for inter-modulation measurement: sine waves with a maximum output of 5 volts r.m.s.; square waves with an output voltage of 10 volts p-p minimum; and complex waves with an output voltage of 10 volts p-p minimum. Amplitude stability and distortion specifications are more than adequate for most applications, according to the maker.

The unit measures $11\frac{7}{8}$ " wide \times $7\frac{1}{16}$ " high \times $7\frac{1}{2}$ " deep. Kikusui

Circle No. 13 on Reader Service Page

HEAT-ABSORBING PASTE

Sensitive controls, fittings, gaskets, and other materials subject to damage by the heat from welding, brazing, and soldering can be protected with a new heat-absorbing paste being marketed as "ThermoTrap."

Described as a heat sink, when applied to the work surface between the area being heated and the material to be protected, the paste soaks up heat and slows heat transfer to keep heat from spreading beyond the work area. Heat-sensitive materials on the other side of the paste stay cool and safe from heat damage, according to the company.

The paste is easy to apply and adheres well to work surfaces. It is said to be odorless and harmless to skin and clothing, does not melt or run, and does not stain work surfaces. The paste can be cleaned from work surfaces with plain water or a damp cloth. Calgon

Circle No. 14 on Reader Service Page

CASSETTE TAPE DECK

The Model 201 cassette tape deck combines important characteristics of a high-performance open-reel tape recorder with the convenience of a cassette, according to its manufacturer.

It features the Dolby noise-reduction system but in addition has a heavy-duty transport mechanism and newly designed low-noise record/playback electronics. The recording meter circuitry is specially compensated to provide full indication of high-frequency signal strength while its equalization characteristic is switchable to provide for both conventional tape and the new Crolyn formulations. A separate low-noise microphone preamp is available as an accessory for those interested in making quality live recordings.

The transport uses a high-torque a.c. motor coupled through an intermediate rubber idler to an oversized balanced capstan flywheel. According to the company, in addition to low wow and flutter, the transport provides very fast wind



speeds and an accurate tape counter for easy indexing of recorded material. At the end of a cassette, the pinch roller and heads are automatically disengaged. Advent

Circle No. 15 on Reader Service Page

"INSTANT" PC BOARDS

A new way of making printed-circuit boards without artwork, photo work, chemical etching, drilling, or terminals has been introduced as "Quik-Circuits."

The sub-elements consist of pre-etched copper conductive patterns on a very thin epoxy glass board, backed by a high-strength pressure-sensitive adhesive. Sub-elements are available for all types of integrated-circuit patterns, as well as discrete components. Any combination of circuit sub-elements can be mixed on one board. The circuit boards have pre-drilled holes to match the pattern of 0.100-inch grid "P" pattern Vector board.

Interconnections are made with conductive copper tape or jumper wires. The component leads are inserted through the holes in the board, soldered in place, and the board is complete. If changes are required, the sub-elements may be repositioned any time within the first 24 hours.

A four-color brochure describing the system and the various sub-elements available will be forwarded on request. Circuit-Stik

Circle No. 16 on Reader Service Page

REVERB UNIT

The new Model 659A Reverbertron features switch selection of either remote or local operation, providing three types of reverberation control: dry, premix 1, or premix 2. It offers full-range equalization. A patented selector permits short, medium, or long decay times.

Frequency response ranges from 20 to 20,000



Hz on the dry channel (± 1 dB), compared with 50 Hz to 6 kHz on the reverberation channel with a range of adjustments to ± 15 dB. The signal-to-noise ratio is 10 dB better than the company's previous model.

The unit is effective for input levels as low as -30 dBm and output levels up to 18 dBm. The transformer-isolated input and output are 600 ohms or 150 ohm balanced or unbalanced. Fairchild Sound Equipment

Circle No. 17 on Reader Service Page

AM/STEREO-FM TUNER

The KT-7001 AM/stereo-FM tuner has been designed as a companion unit to the company's KA-7002 stereo amplifier. It features a frequency-linear-type four-gang variable capacitor and a three FET front-end. Crystal filters and four IC's in the FM i.f. stage offer wide frequency band characteristics, sharp selectivity, good capture ratio, and stable high gain, according to the manufacturer.

A push-button automatic multiplex filter eliminates noise components in the stereo sub-channel and is designed to improve the signal-to-noise ratio when the unit is tuned to a weak-signal stereo-FM station. The FM signal meter has a wide linearity range and indicates changes linear in proportion to weak signal through the strong signal. The meter can also be used as a multi-path detector by operating a push-button marked "Multipath."

FM sensitivity (IHF) is 1.5 μ V and FM frequency response is 20-15,000 Hz, +0, -1.5 dB.

Stereo separation is better than 30 dB from 20 to 15,000 Hz and better than 40 dB from 300 to 10,000 Hz. The tuner measures 16 1/4" wide x 5 1/8" high x 11" deep and weighs 18 pounds. Kenwood

Circle No. 18 on Reader Service Page

FLEXIBLE FIBERSCOPE

A high-resolution image transmitter that lets you see into remote, inaccessible illuminated areas is now available as Stock Number 60,857.

Eighteen inches long, the flexible fiberscope



has over 4000 coherent glass fibers (0.002") and is protected by semi-rigid gooseneck sheathing. To provide clear, wide sighting, its 7X magnifying eyepiece focuses from less than 1/2" from the subject to infinity.

The unit can be used to check for imperfections, fractures, and other damage in remote places or can be used to monitor hazardous processes and demonstrate fiber-optic principles. It can be used to see through pipes, tubes, or any 3/8"-plus opening. Edmund Scientific

Circle No. 19 on Reader Service Page

TAPE-TORQUE TESTER

A new precision instrument which accurately measures the torque required to wind the tape in any digital or audio cassette has been introduced as the Model M-200 Torque Tester. It is designed to aid in servicing cassette drives, incoming inspection of new cassettes, and re-inspection of used cassettes.

The unit is calibrated to display torque in gram-centimeters and ounce-inches. The user simply places a cassette on the instrument's deck and presses the "start" button. The winding torque of the cassette is continuously and dynamically indicated on the meter. Two ranges of 30 to 60 grams full-scale are provided. An 8-gram-centimeter holdback torque may be switched in and out with a lever, in accordance with ECMA and ANSI.

The instrument is powered by alkaline cells with 600-hour service life. Information Terminals

Circle No. 20 on Reader Service Page

NEW CASSETTE TAPE

Commercial quantities of Advocate's "Crolyn" cassette tape are now available for distribution. The tape uses a new type of magnetic material which is based upon a chemical particle that uses chromium rather than iron as the magnetic element in the tape coating.

Developed by DuPont, when used on cassette equipment of optimum present-day design, Crolyn tape makes the important difference between sound comparable to the better disc records and superior sound, according to the company.

The most important differences with the new tape is that beginning at about 1000 Hz and increasing as frequencies get higher (beyond audibility), Crolyn can accommodate stronger signals than conventional tape. Advent

Circle No. 21 on Reader Service Page

MANUFACTURERS' LITERATURE

POWER-SUPPLY CIRCUIT

The operation and construction of a compact, 20-volt, 3-amp regulated power supply that uses integrated circuits and a single-pass transistor

August, 1971

NEW DELUXE COLOR ORGAN CIRCUITS! UP TO 35,000 WATTS

A.P.M. SYSTEMS CORP., MANUFACTURERS OF THE FINEST COLOR ORGANS IN THE WORLD, NOW OFFER YOU THE MOST ADVANCED AND POWERFUL COLOR ORGAN CIRCUITS.

AVAILABLE IN 3 AND 4 CHANNEL KITS FEATURING:

- Solid State (easy to assemble printed circuit).
- All UL listed components.
- 3 channel circuit - 2,670 watts - easily converted to handle up to 26,250 watts.
- 4 channel circuit - 3,556 watts - easily converted to handle up to 35,000 watts.
- Electronically balanced circuitry permits one step tuning.
- Wires to any popular sound system in the same manner as a speaker.
- 2 year unconditional guarantee on all parts.
- Easy to assemble kit form.

SEND TODAY

FREE color brochure with each kit order.

A.P.M. SYSTEMS, INC.
1551 Almaden Rd.
San Jose, Calif. 95125

PLEASE RUSH ME MY A.P.M. COLOR ORGAN KIT, AS INDICATED BELOW:

Check box to indicate choice.

- 3 Channel Kit - \$37.95
 4 Channel Kit - \$54.95
 3 Channel Plans - 26,250 watts - \$2.00
 4 Channel Plans - 35,000 watts - \$2.00
 Color brochure on water swirls and living walls - \$5.00

Check one box to indicate manner of payment.

- I enclose full payment. Ship kit postpaid.
 I enclose \$5.00 deposit. Ship kit C.O.D. for balance plus postage.

Name _____

Address _____

City & State _____ Zip _____

California residents: add 5% sales tax

A.P.M. SYSTEMS, INC. Dept. M15
P.O. Box 9159, San Jose, Calif. 95117

COOPERATE WITH THE ZIP CODE PROGRAM OF THE POST OFFICE DEPARTMENT - USE ZIP CODE IN ALL ADDRESSES

ANOTHER SUPERB VALUE from Olson Electronics



ONLY \$12 DELUXE TRANSISTOR CHECKER

Compact, self-contained, self-powered dynamic transistor checker. Test may be made "in circuit" or out of circuit. Identifies and checks PNP and NPN types, plus power. Complete with instruction manual, service tips and transistor drawings.

Olson Electronics, Dept. ET,
260 S. Forge St., Akron, Ohio 44308

I enclose \$12, plus \$1 for postage and handling. Send me the TE-199 Transistor Checker.

Send me the next seven issues of the Olson Catalog, without cost or obligation. **FREE**

Name _____

Address _____

City _____

State _____ Zip _____

CIRCLE NO. 128 ON READER SERVICE PAGE

AMAZING OFFER! \$19.88

plus \$1 for shipping



BAY CAPACITIVE DISCHARGE IGNITION SYSTEM
Field-Tested for 3 Years!

Completely wired, ready-to-install (not a kit)

- Increase Engine Power
- Reduce Engine Maintenance
- Increase Gas Mileage 10-20%
- Instant Starting in All Climates
- Install in 10 minutes (use original coil)
- All American-made parts
- Solid state reliability
- Distributor points last lifetime of car
- Spark plugs last 3 to 10 times longer
- No changes required on timing or dwell
- For 12-volt negative ground systems only
- 1-year written guarantee

BAY PRODUCTS - P. O. BOX 9562, HOUSTON, TEXAS 77011 E-8

Please send _____ Model SW101 Capacitive Discharge Ignition Systems @ \$19.88. Enclosed is \$ _____ plus \$1 per unit for shipping.

Name _____

Address _____

City/State _____ Zip _____

CIRCLE NO. 116 ON READER SERVICE PAGE

are described in a 12-page application note (AN-4558).

The booklet includes circuit descriptions, performance characteristics, component specifications, and suggestions for layout and construction. Thermal-fatigue effects and safe operating conditions for power transistors are discussed from the applications standpoint and optional changes in the design outlined. RCA Commercial Engineering

Circle No. 22 on Reader Service Page

AEROSOL COOLANT DATA

A handy, fold-out booklet which describes typical thermal intermittents and how Super Frost Aid aerosol coolant can be used to locate them has just been issued.

A step-by-step service procedure is outlined that is simple to follow, definite in response, and inexpensive to use. In addition to thermal intermittents, the booklet describes how the coolant, capable of -50 degrees F, can also be used as a servicing aid for other applications, including cooling heat-sensitive components prior to soldering, preventing cold-solder joints and transformer burnout, and locating hairline cracks in PC boards. Chemtronics

Circle No. 23 on Reader Service Page

TUNER REPLACEMENTS

An 18-page tuner replacement guide and parts catalogue covering u.h.f., v.h.f., FM tuners, and tuner parts is now available for distribution. Pictured and described are channel strips for drum-type tuners; springs, clips, screws and detent balls; gears; fine-tuning gear assemblies; wafers; coils and plungers; antenna matching coils; and multi-fit tuner shafts. An antenna coil replacement guide, presented in tabular form by brand-name and original part number, is cross-referenced to replacement catalogue numbers. PTS Electronics

Circle No. 24 on Reader Service Page

STEREO TAPE CATALOGUE

A 92-page catalogue which lists stereo tapes in 8-track, cassette, open-reel, and micro-cassette formats has just been issued.

Albums are listed under the recording company and include all musical categories ranging from pop, hot rock, folk, country, Western, and operatic, to symphonic. The listings, with recording artists, then provide the catalogue numbers for the various versions available or clearly indicate when a certain recording is not available in one or more of the formats. Ampex

Circle No. 25 on Reader Service Page

LEAD-CALCIUM BATTERIES

A four-page brochure, Section 12-212A, which traces the history of lead-calcium batteries for switchgear and control, is now available. The publication compares lead-calcium battery performance with lead-antimony batteries while illustrative material is used to demonstrate the unique bottom-pour process used by the company in casting its grids to eliminate the possibility of flaws or dross that cause weak spots and reduce current-carrying capacity. C & D Batteries

Circle No. 26 on Reader Service Page

ANTENNAS & COMPONENTS

An 18-page "Home Products Catalogue" which pictures and describes an extensive line of low-noise, mast-mounted preamps; broadband amplifiers and amplified signal dividers; band separator/combiners and signal devices; matching devices and filters; u.h.f.-to-v.h.f. converters; antenna rotators; wall outlets and plugs, connectors, adapters, tools, terminations, and mast-mounting hardware; plus u.h.f./v.h.f./FM, v.h.f./FM, and u.h.f. antennas is available as No. 70-62. Blonder-Tongue

Circle No. 27 on Reader Service Page

TAPE EQUIPMENT

A new catalogue, BI 2230, covering the firm's broadcast and industrial line of professional magnetic tape equipment is now ready for distribution. It covers a complete line of recorder/

reproducers, reel and cartridge transports, amplifiers, preamps, and accessories.

The 20-page, two-color brochure gives product information, specifications, and ordering information. Telex

Circle No. 28 on Reader Service Page

INDUSTRIAL SOUND PRODUCTS

The Industrial Marketing Department of Altec Division has just issued a 16-page, two-color catalogue covering its line of industrial sound products.

The catalogue illustrates and provides basic technical information on sound equipment and the firm's "Acousta-Voicing" process for theaters, recording studios, convention centers, stadiums, airports, churches, business, and industry. The company's telephone products are included as are intercom systems for schools, hospitals, and nursing homes.

Letterhead requests to Glen W. Malme at the company address, 1515 S. Manchester Ave., Anaheim, California 92803, should include the number of the publication—AL-1712-2.

RELAYS & SWITCHES

Sigma Instruments Inc., 170 Pearl Street, Braintree, Mass. 02185 has issued a revised 20-page distributor stock catalogue of relays, reed switches, and optoelectronic components. New additions to the catalogue include dual in-line packaged and pico-type reed relays, time delay and latching relays, as well as reed triggered triacs.

All products are illustrated, dimensioned, and described. Prices are indicated for each, together with engineering considerations designed to facilitate selection.

LINEAR-DEVICE BROCHURE

National Semiconductor Corp. is now offering copies of its new brochure which covers the detailed screening and testing procedures for all standard linear devices manufactured under the firm's off-the-shelf 883 program.

The 32-page booklet covers both monolithic and hybrid linear products and describes 100% screening procedures, qualification procedures, individual-device electrical tests, burn-in circuits, critical-parameter test circuits, and connection diagrams.

For a free copy of the Linear/883 brochure, letterhead requests should be addressed to the attention of the Marketing Services Dept. of the company at 2900 Semiconductor Drive, Santa Clara, California 95051.

VOLTAGE-REGULATOR GUIDE

A handy, one-page voltage regulator guide for use in determining the correct monolithic or hybrid regulator for a specific application is now available in quantity from Teledyne Semiconductor, 1300 Terra Bella Ave., Mountain View, California 94040.

Showing a total of 15 monolithic and hybrid devices available from the company, the guide gives minimum and maximum values for both constraint and performance specifications and also lists package types available.

ROTARY SWITCHES

A comprehensive new catalogue covering standard rotary switches has been issued by Stackpole Components Company, P.O. Box 14466, Raleigh, N.C. 27610.

Included in the 12-page catalogue are complete engineering, dimension, and test data as well as prices for over 2200 standard configurations of the company's 1 $\frac{1}{8}$ " and 1 $\frac{3}{8}$ " environment-proof rotary switches.

PUSH-PULL SOLENOIDS

Detailed technical data on 65 stock model push and pull solenoids is included in catalogue C-1100 just issued by Lexed Inc., 123 Webster Street, Dayton, Ohio 45401.

There are 27 pages describing both conical and flat-face models designed for short, medium, and long-stroke requirements. Seven short and medium stroke designs ranging from $\frac{3}{4}$

inch diameter \times $\frac{1}{2}$ inch to $2\frac{1}{4}$ inch diameter \times $1\frac{1}{2}$ inches are shown. Also included are six long-stroke tubular solenoid designs ranging from $\frac{1}{2}$ inch diameter \times 1-inch to $1\frac{1}{2}$ inches diameter \times $2\frac{1}{2}$ inches.

A separate section on solenoid fundamentals covers engineering and application considerations. This section also contains several circuits and graphs to simplify calculations for special applications.

THERMISTOR DATA

Omega Engineering Inc., Box 4047, Stamford, Conn. 06907 has issued an 8-page brochure on its interchangeable curve-matched thermistors and probe assemblies.

Bulletin #8009 not only describes the company's line but includes a complete glossary of terms as well as a step-by-step procedure for designing thermistor circuits.

MINIATURE ELECTROLYTICS

The Arco/LDP Division, Pondhill Road, Great Neck, N.Y. 11022 now has available for distribution a new cross-reference guide and price book on its miniature aluminum electrolytic capacitors.

The four-page publication includes specifications on miniature Arcolytics and compares them by part number with similar products made by other capacitor firms.

SWITCH CATALOGUE

Alcoswitch, P.O. Box 1348, Lawrence, Mass. 01842 is now offering a 24-page catalogue featuring its expanding line of miniature electronic switches and keyboard assemblies.

Six lines of miniature toggles are highlighted, including the new 5-amp standard series with flat handles, 6-amp series, splashproof series, $1\frac{5}{32}$ " bushing series, locking toggles, and cylindrical-case toggle switches. Also featured are miniature rotaries, push-button, and the new rocker series.

DIGITAL VOLTMETER BOOK

A hard-bound, 395-page textbook on the theory, application, calibration, and maintenance of digital voltmeters, data acquisition, computer, and pressure systems with discussions on MOS/LSI device testing has been published by Non-Linear Systems, Inc., P.O. Box N, Del Mar, California 92014.

This complete engineering guide is divided into two parts: a textbook on the subject areas, and complete technical information on the firm's equipment and associated instrumentation.

"APPLICATION MEMOS"

Signetics Corporation, 811 E. Arques Ave., Sunnyvale, California 94086 has reprinted its 1969 handbook "Application Memos" and is offering it for distribution.

Containing approximately 400 pages, the $5\frac{1}{2}$ " \times 7" paperback handbook contains an introduction to digital logic and discusses digital considerations by family, decoding and steering, counters, shift registers and memories, interface and display elements, linear considerations, timing circuits, and parallel data handling.

PHOTO CREDITS

Page	Credit
14	Electro-Voice
27,28,29,65	Shure Bros. Inc.
30 (top)	General Electric Co.
30 (center)	Mallory Battery Co.
30 (bottom)	Sandia Laboratories
31 (top)	CBS Laboratories
31 (center)	Gresham Recording Heads Ltd.
31 (bottom left, right), 36	RCA Corp.

ELECTRONICS MARKET PLACE

COMMERCIAL RATE: For firms or individuals offering commercial products or services. \$1.00 per word (including name and address). Minimum order \$10.00. Payment must accompany copy except when ads are placed by accredited advertising agencies. Frequency discount: 5% for 6 months; 10% for 12 months paid in advance.

READER RATE: For individuals with a personal item to buy or sell. 65¢ per word (including name and address). No minimum! Payment must accompany copy.

GENERAL INFORMATION: First word in all ads set in bold caps at no extra charge. All copy subject to publisher's approval. Closing Date: 1st of the 2nd month preceding cover date (for example, March issue closes January 1st). Send order and remittance to: Hal Cymes, ELECTRONICS WORLD, One Park Avenue, New York, New York 10016.

FOR SALE

GOVERNMENT Surplus Receivers, Transmitters, Snooperscopes, Radios, Parts. Picture Catalog 25¢. Meshna, Nahant, Mass. 01908.

CONVERT any television to sensitive big-screen oscilloscope. Only minor changes required. No electronic experience necessary. Illustrated plans, \$2.00. Relco-A22, Box 10563, Houston, Texas 77018.

INVESTIGATORS, Latest Electronic Aids. Free Literature. Clifton, 11500-J NW 7th Ave., Miami, Florida 33168.

SENCORE, B & K Test Equipment Unbelievable Prices. Free Catalog and Price Sheet. Fordham Radio, 265 East 149th Street, Bronx, N.Y. 10451.

ELECTRONIC PARTS, semiconductors, kits. Free Flyer. Large catalog, \$1.00 deposit. Bigelow Electronics, Bluffton, Ohio 45817.

NEW SEMICONDUCTOR LIGHT EMITTING DIODES. Bright red lights replace light bulbs. Typical life 100 years. Operate at 1.65 volts, 50 milliamps. Order 2 for \$2.98 NOW. Data sheet and instructions included. Monsanto Company, Hobby Section, 10131 Bubb Road, Cupertino, California 95014.

ELECTRONIC COMPONENTS—Distributor prices. Free catalogue. Box 2581, El Cajon, California 92021.

ELECTRONIC Ignition. Various types. Information 10¢. Anderson Engineering, Epsom, N.H. 03239.

CONSTRUCTION PLANS: Laser . . . \$2.00. Investigation aids—2-FM microphone transmitters . . . \$1.00. FM telephone transmitter . . . \$2.00. Sound telescope . . . \$2.00. Space monitor-missile tracker . . . \$2.00. Free equipment and kit catalog. Howard, 20174 Ward, Detroit, Michigan 48235.

FREE ILLUSTRATED CATALOG!! covering wide range of low-cost stock business forms from 2-Way Radio to TV Service. Write today. Free catalog; samples, too. OEL-RICH PUBLICATIONS, 4040 N. Nashville East, Chicago, Illinois 60634.

WOULD YOU SPEND 25¢ to save \$25.00 or more? Citizens Band, AM and SSB 2-way radios, USA and export models. Send 25¢ for catalog to: BAGGY'S RADIO, 6391 Westminster Avenue, Westminster, Ca. 92683. Dealer inquiries invited.

JAPAN HONG KONG DIRECTORY. World products information. \$1.00 today. Sekai Shogyo Annai, Hillyard, Washington 99207.

TREASURE HUNTERS! Prospectors! Relco's new instruments detect buried gold, silver, coins. Kits, assembled models. Transistorized. Weighs 3 pounds. \$19.95 up. Free catalog. Relco-A22, Box 10839, Houston, Texas 77018.

RECONDITIONED Test Equipment. Reasonably priced, list available. Walter, 2697 Nickel, San Pablo, CA. 94806.

FREE CATALOG—Loads of Bargains. R.W. Electronics, 4005 West Belmont, Chicago, Illinois 60641.

BURGLAR ALARM SYSTEMS. We manufacture intruder-fire detection systems, radar and perimeter types. Accessories available. Free Literature. Inquiries for dealership and wholesale prices must be on letterhead. U.S. and Canada only. Microtech Associates, Inc., Box 10147, St. Petersburg, Florida 33733.

EUROPEAN wholesale new products catalog \$1.00 refundable. Deecow, P.O. Box 9308, North Hollywood, Calif. 91609.

SN72709N OP Amps, new, 75¢ each, allow postage. L. Jump, 3504 Lake Shore Dr., Weatherford, Texas 76086.

INTEGRATED circuits, new TTL, DTL at very competitive prices. No minimum order. Send for list. Marco Enterprises, POB 216, Dayton, Ohio 45401.

200MHZ counter, Heath \$490 . . . Regulated battery eliminator, 80 amp to 30 VDC, 220 V, 117 V conversion \$175. Tubes, magazines, details. A.C. Pedersen, E. Andover, Me. 04226.

SOLID STATE impulse relays. New surplus. Contacts: Form A (N.O.) 10 amp., 120 VAC. Control Voltage: 20-24 VDC. 60 M.A. Faston connectors, glass epoxy board. Dept. 500, 5740 N. Tripp, Chicago, Ill. 60646.

USED Equipment, RCA, Tektronix, etc. Free list. Techsystems, Box 2421, Allentown, Pa. 18001.

PLANS & KITS

INTEGRATED CIRCUIT KITS—Free Catalog. FRAZER & ASSOCIATES, 3809 Surfwood Road, Mailbu, California 90265.

CONVERT your scope. Dual trace FET switch, \$10.00. Trigger-sweep \$24.95. Kits include semiconductors, boards, instructions. Hamlin Technical Products, Box 901, Cupertino, Calif. 95014.

GOOD news for electronics component users. Integrated circuits, Assemblies, Core Memories. SN7400N—55¢. Send 10¢ for latest catalog. TRI-TEK, P.O. Box 14206, Phoenix, AZ 85031.

ELECTRONICS ENGINEERING AND INSTRUCTION

LEARN ELECTRONIC ORGAN SERVICING at home. All Makes including transistors. Experimental kit—troubleshooting. Accredited NHSC. Free Booklet. NILES BRYANT SCHOOL, 3631 Stockton, Dept. A, Sacramento, Calif. 95820.

ELECTRONICS! Associate degree—29 months. Technicians, field engineers, specialists in communications, missiles, computers, radar, automation. Start September, February. Valparaiso Technical Institute, Dept. N, Valparaiso, Indiana 46383.

WANT AN F.C.C. 1st CLASS LICENSE? WANT TO BECOME A DISC-JOCKEY? REI has a school near you VA approved call toll free: 1-800-237-2251 or write REI, 1336 Main St., Sarasota, Florida 33577. Florida Residents call: (813) 955-6922.

DEGREE in Electronics Engineering earned mostly by correspondence. Free brochure. Dept. G-9, Grantham School of Engineering, 1505 N. Western Ave., Hollywood, California 90027.

MATHEMATICS, ELECTRONICS. No contract, no obligation. Satisfaction guaranteed. Free brochure. Indiana Home Study, P.O. Box 1189, Panama City, Florida 32401.

MINIATURE RELAYS

DPDT  24 VOLTS DC
3/4" x 3/8" x 3/8"

ACTUAL SIZE

Stock No. H9130—2/\$1.00, 5/\$2.00
Printed Circuit or
Socket Mount

MOTOR SPEED & LIGHTING CONTROL

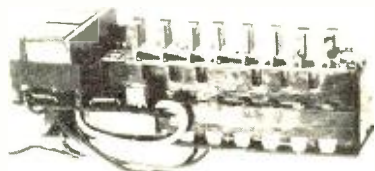

8 Push button selected controls, stop & start indicator lights. Overrun of famous blender manufacturer. Used for controlling speed of drills, saws, fans, lathes, lighting, etc. Controls up to 1500 watts. Stock No. H5002—ready to use \$3.95 ea., 2/\$7.00
Stock No. H5003—slight factory seconds, easily repaired \$2.95 ea., 2/\$5.00
Wiring diagram furnished.

COMPUTER GRADE CAPACITORS

H2049 3500 Mfd. 55 volt 4 1/4" x 1 3/4" \$.65 ea., 5/\$3.00
H2062 40,000 Mfd. 10 volt 3" x 4 1/4" Brand new \$1.25 ea., 6/\$7.00

\$1.00 FREE WITH \$10.00 ORDER
MINIMUM ORDER \$3.00

Lots of other items—send for free flier; all merchandise fully guaranteed. Please include postage; excess will be refunded.

 **DELTA ELECTRONICS CO.**
BOX 1, LYNN, MASSACHUSETTS 01903

CIRCLE NO. 141 ON READER SERVICE PAGE

LIBERTY PAYS MORE! WILL BUY FOR CASH

ALL TYPES:

- * ELECTRON TUBES
 - * SEMICONDUCTORS
 - * TEST EQUIPMENT
 - * Military Electronic Equipment
- WIRE—WRITE—PHONE COLLECT!
We pay freight on all purchases—

LIBERTY OFFERS MORE! PRESTEL FIELD STRENGTH METER

(Model 6T4G)

Only

\$129.00

F.O.B.
New York

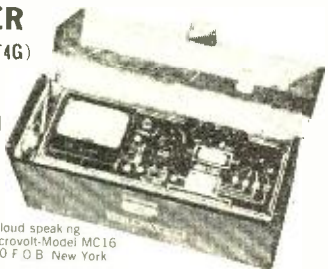

Larger, loud speaking model-2.5 microvolt-Model MC16 only \$289.00 F.O.B. New York

- * Never Anything Like It!
- * 1-Man Can Do A Better Job than 3 in the Same Time!

* **A Gold-Mine for Antenna Installers!**
Calibrated from 40 to 230, and 470 to 860 in 4 Bands Megahertz, from 10 to 50,000 Microvolts. Nothing makes it easier to properly and speedily find the correct place to install TV, FM and Communication Antennas. You can measure and hear the signals with this 4 1/2 volt battery economically powered unit.

LIBERTY ELECTRONICS, Inc.

548 Broadway, New York, New York 10012

Phone (212) 925-6000

CIRCLE NO. 132 ON READER SERVICE PAGE

IMPOSSIBLE? BARGAINS IN SURPLUS ELECTRONICS AND OPTICS

SPECIAL SALE ON DIODES AND TRANSISTORS

The recession in the electronics industry is the gain of the electronics enthusiast. Discrete components are now available at prices that are a fraction of the large volume price. Every unit listed is a brand new device, with full lead length, and in original manufacturers boxes. Guaranteed to equal or exceed manufacturers specifications.

Zener Diodes, 5% Tolerance, Mfgs. List \$1.71 each.

1N746A	3.3 Volt	1N754A	6.8 Volt
1N747A	3.6	1N755A	7.5
1N748A	3.9	1N756A	8.2
1N749A	4.3	1N757A	9.1
1N750A	4.7	1N758A	10
1N751A	5.1	1N759A	12
1N752A	5.6	14 Volt 3 Watt	
1N753A	6.2		

Specify Number: 3 for \$1.00 10 for \$2.50 100 for \$225.00
Mix or Match

TRANSISTORS

2N3055	87.5 Watt Hi-Power Silicon	\$1.25
2N242	60 Watt Germanium Hi Power	2/51.50
2N3819	N Channel FET	2 for \$1.00
2N2484	NPN Silicon Amplifier 1W, Lo Noise	2 for \$1.00
2N2907	PNP Silicon Amp-Sw. H _{ij} , 200 MC	2 for \$1.00
2N2222	NPN Silicon Amp-Sw. H _{ij} , 250 MC	3 for \$1.00
2N2369	NPN Silicon Amp-Sw H _{ij} , 500 MC	3 for \$1.00
2N2219	NPN Silicon Amp-Sw 3 W	3 for \$1.00
2N2905	PNP Silicon Amp-Sw 3 W	2 for \$1.00
NPN Silicon TO-18 Transistors marked with RCA house numbers β = 100-200, P = 0.3 Watts		
Same as Above, but 1 Watt TO-5	10 for \$1.50, 100 for \$10.00	
Same 0.3W PNP TO-18	10 for \$1.50, 100 for \$10.00	
Same 1.0W PNP TO-5	10 for \$2.00, 100 for \$15.00	

DIODES

1N4004 400 PIV, 1 A	Rectifier	5 for \$1.00
Epoxy F.W. Bridge Rectifier	400 DIV, 2 Amps	\$1.00

SURPLUS TTL INTEGRATED CIRCUITS, BRAND NEW IN ORIGINAL MANUFACTURERS CARTONS



B & F has one of the world's largest inventories of surplus integrated circuits. All are new, meeting all manufacturers original specifications, and in factory packaging. The low prices should speak for themselves. Manufactured by Texas Instruments, National, Signetics or Philco, no choice. All packages are 14/16 lead silicone Dual In Line Pak. Write for additional RTL and DTL lines not listed.

Signetics or Philco, no choice. All packages are 14/16 lead silicone Dual In Line Pak. Write for additional RTL and DTL lines not listed.

ITEMS @ 50¢

7400	Quad 2-Input NAND
7401	Quad 2-Input Open Collector NAND
7402	Quad 2-Input NOR
7404	Hex Inverter
7405	Open Collector Hex Inverter
7408	Quad 2-Input
7409	Quad 2-Input AND, Open Collector
7410	Triple 3-Input NAND
7411	Triple 3-Input AND
7420	Dual 4-Input NAND
7421	Dual 4-Input AND
7430	8-Input NAND
7440	Dual 4-Input NAND Buffer
7450	Dual 2-Wide 2-Input Expandable
7451	Dual 2-Wide 2-Input A-O-I A-O-I
7453	4-Wide Expandable 2-Input A-O-I
7454	4-Wide 2-Input A-O-I
7460	Dual 4-Input Expander

ITEMS @ \$1.00

7406	30 Volt Hex Driver Inverter
7416	15 Volt Hex Driver Inverter
7407	30 Volt Hex Driver
7417	15 Volt Hex Driver
7426	Open Collector Hi Volt NAND Quad 2-Input

ITEMS @ \$1.00 (cont.)

7470	J-K Flip-Flop
7472	J-K Master Slave Flip-Flop
7473	Dual J-K Flip-Flop
7474	Dual D Flip-Flop
7486	Quad 2-Input Exclusive OR Decoder
74121	Monostable Multivibrator (One-Shot)
74122	One Shot
8162	One Shot

ITEMS @ \$1.75

7442	BCD to Decimal Decoder
7443	Excess 3 to Decimal Decoder
7444	Excess 3 Gray to Decimal Decoder
7475	Quad Bi-Stable Latch
7480	Full Adder
7490	Decade Counter
7494	4-Bit Shift Register
7495	4-Bit Right-Left Shift Reg.
7496	5-Bit Shift Register
74151	8-Bit Data Selector with Strobe

ITEMS @ \$2.00

7448	BCD to 7 Segment Decoder Driver
7492	Divide by 12 Counter
7493	4-Bit Binary Counter
74180	8-Bit ODD-EVEN Parity Generator/Checker

ITEMS @ \$2.50

7447	BCD to 7 Segment Decoder Driver
7445	BCD to Decimal Decoder Driver
7483	4-Bit Binary Full Adder
74145	BCD to Decimal Decoder Driver

ITEMS @ \$4.00

74154	4 to 16 Line Decoder/Multiplexer
74192	Bi-Directional Counter BCD Output
74193	Bi-Directional Counter 4-Bit Binary

ITEMS @ \$10.00

7489	64 Bit Random Access Memory
7488	256-Bit Rom ASCII to EBCDIC

ITEMS @ \$3.00

7441	BCD to Decimal NIXIE Driver-Decoder
7491	8-Bit Shift Register

20% discount on all orders for 100 or more integrated circuits. All I.C.'s postpaid, with FREE air mail on orders over \$50.00. We strive to ship I.C.'s by return mail. Free data sheets on all items.

READOUTS... READOUTS... READOUTS!



7 Segment readout, lamps are 5 volts 40 milliamps. Operates directly from 7447 or 8704 integrated circuit. With connector \$6.00

- Burroughs 5441 Nixie Tube with Socket.....\$4.75
- Burroughs 5750 Nixie (wires directly into p.c.).....\$5.75
- IEE Projection Display, large easy to read numerals 0-9.....\$7.50

- 80 PAGE CATALOG - Free with any order or send \$0.25

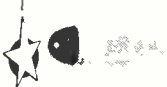

SUPER SPECIAL - TEXAS INSTRUMENTS LIGHT EMITTING DIODES (LED'S). Use as logic readouts, either on panel or right on cards. Infinite life.
2 for \$1.50 10 for \$7.00.

DECADE MODULE KITS

Seven segment readouts, with counter/decoder/driver unit. This is a nice looking seven segment numerical readout, as shown above. It is provided with a 7490 counter, 7447 decoder and printed circuit, to allow construction of a counter with a minimum of work. Units can be cascaded of course. At an unheard of low price.....\$9.75

- Same as above but with 7475 latch (option A).....\$11.75
- Same as above, but with 74192 Bi-Directional (up-down) counter (option B).....\$12.75
- Same as above, but with 74192 and 7475 latch (option C) (99% of applications do not require options, if in doubt order the basic unit)
- Nixie Output Decade Counter similar to 7 segment, but Nixie Output.....\$11.75
- Same with option (A) above.....\$12.75
- Same with option (B) above.....\$13.75
- Same with option (C) above.....\$14.75
- Lowest cost decade counter. Uses 10 incandescent bulbs, 7490 counter, 74145 decoder driver. Complete with printed circuit.....\$6.50

No options available.

LOGIC AND NIXIE POWER SUPPLIES



5 volt, 5 ampere supply 1% line, 1% load, 0.1% ripple. Built by Bluline for integrated circuit applications. Fantastic value, brand new. \$29.50

- 5 volt 3 ampere supply, with 170 volts at 50 Ma for Nixies, similar to above, except 170 volts is unregulated.\$29.50
- 5 volt 3 ampere supply, built by Powertek. Low profile for easy build-in to instruments.\$25.00

ALL ITEMS POSTAGE PAID IN THE U.S.A.

Charges Welcome: BankAmericard - Mastercharge - \$10.00 min.

B. & F. ENTERPRISES

Phone: (617) 532-2323
P.O. Box 44, Hathorne, Massachusetts 01937

CIRCLE NO. 148 ON READER SERVICE PAGE

FCC Type Exams... guaranteed to prepare you for FCC 3rd, 2nd, and 1st phone exams. 3rd class, \$7.00; 2nd class, \$12.00; 1st class, \$16.00; complete package, \$25.00. Research Company, Box 22141, Tampa, Fla. 33622.

FCC Questions on 1971 First and Second Class Exams, with answers. Guaranteed Results. \$8.95. Electronic Tutoring, Box 24190, Cleveland, Ohio 44124.

YOUR low cost ad in these columns will be read and responded to by an audience of alert electronics professionals... men who strive continually to improve their qualifications, their jobs, their homes. They'll help to improve your mail order business when they buy from you! Rates and other data are on page 75.

TUBES

TUBES, SEMICONDUCTORS, ELECTRONIC EQUIPMENT & COMPONENTS. Quality merchandise only! Serving engineers, Purchasing Agents, TV/Hi-Fi Servicemen and Hams for 20 years. Write for Catalog or call 212-WA 5-7000. BARRY ELECTRONICS, 512 Broadway, New York, N.Y. 10012.

RECEIVING & INDUSTRIAL TUBES, TRANSISTORS, All Brands—Biggest Discounts. Technicians, Hobbyists, Experimenters—Request FREE Giant Catalog and SAVE! ZALYTRON, 469 Jericho Turnpike, Mineola, N.Y. 11501.

TUBES—36¢ each. Year guarantee. Tuner Cleaner \$1.00. Free Catalog. Cornell, 4213-W University, San Diego, Calif. 92105.

SAVE money on parts and transmitting-receiving tubes, foreign-domestic. Send 25¢ for giant catalog. Refunded first order. United Radio Company, 56-E Ferry Street, Newark, N.J. 07105.

WANTED

QUICKSILVER, Platinum, Silver, Gold. Ores Analyzed. Free Circular. Mercury Terminal, Norwood, Mass. 02062.

QUICK CASH... for Electronic Tubes, Semi-conductors, Equipment (Receivers, Transmitters, Scopes, Vacuum Variables, etc.) Send lists now! Write: BARRY ELECTRONICS, 512 Broadway, New York, N.Y. 10012 (212-WA 5-7000).

CLOSEOUT! OVERHAULED & CERTIFIED COUNTERS

Solid-State 220 MHz: CMC 737CU, 7 nixies, plus 255A & B VLI1 CR tube with rectangular mask & 510 MHz: Substitute 525C for 525B, add 150.00
10 Hz-15 GHz: Read Reg. on 7 DCU's, no algebraic Beckman 7370/7580 combo.....\$750.00

1 MHz Universal, 6 DCU's, Beck. or H.P.	145.50
2 MHz Universal, 6 Nixies, Hewl-Pack	195.00
3 MHz Universal, 6 DCU's, Beckman	195.00
Solid State 5 Nixie .3 MHz, H.P. 5223L	275.00
Solid State 6 Nixie 2 MHz, H.P. 5213L	275.00
Solid State Preset & Prev. H.P. 5214L	275.00
1b 20 MHz Solid-state, Simpson #2715	250.00
2590A Hewl-Pack 13 GHz Transfer Use	420.00

BRAND-NEW SOLID-STATE SCOPE BARGAINS!

We are now the Distributor for Leader Instr. Corp. QUALITY-CONTROLLED imports. See their ad inside back cover. Warranty is 2 years on parts, 6 mos on labor. We pay the shipping to your door.

20-LB NAVY PORTABLE 4 MHZ SCOPE

AN/USM-32: 10 Hz to 4 MHz +2 lb. Line 118 v. 30. 100 Hz B.V. Lili CR tube with rectangular mask & graphic. Sensit. 40 mv rms/cm & up, and includes calibrator, 350 nsec video delay line. Input 1 mek. 28 pf. Sweep triggered by signal, 3% use/cm & up. 5 choices 2-axis Markers for exact calib. With schem. diag. & op. instruct. Good used \$129.50 (OHC at cost if desired, grtd not over \$50.)

TEK. & HEWLETT-PACKARD SCOPE BARGAINS:

See our June ad for listing. ADD: Tekt. 515A at \$395 and 543B at \$595, both exc. cond., and 661 with 451 and 573 already overhauled & calib. at only \$1090.

REDUCED SUMMER RADIO-RECEIVER PRICES:

Take advantage of the usual summer sales slump and some real good buys we made. Start a Christmas lay-away purchase if you wish... we will hold them at no charge for holding. Every receiver put through a VERY competent shop, aligned, grtd 100% perfect, and clean. SP-600-JK, double-conversion 540 KHz continuous to 54 MHz, plus crystal control, if you wish... or you'll 6 most-favorite stations. In cabinet \$299.00. Let's cabinet but with top & bottom covers. \$275.00. R390/URR, triple-conversion, 500 KHz to 32 MHz with precision digital tuning and crystal zero-beat and comparator each 100 KHz... only \$595.00 R390A/URR adds the sharper CW selectivity of mechanical filters... only \$795.00 Dual-Diversity TTY converter AN/URA-8 in very exc. cond. grtd 100% OK only \$275.00.

If you don't see it here, ask for it!

Or ask for the KIND of material you want. But don't ask for a general catalog... we believe that is nonsense in surplus... we get new things in almost every day! We ALSO BUY! So tell us what you have, condition, and your asking price.

R. E. GOODHEART CO. INC.

Box 1220-A, Beverly Hills, Calif. 90213
Phone: Area 213 272-5707

Electronics World SUBSCRIBER SERVICE

Please include an address label when writing about your subscription to help us serve you promptly. Write to: P.O. Box 1093, Flushing, N.Y. 11352

CHANGE OF ADDRESS: Please let us know you are moving at least six to eight weeks in advance. Affix magazine address label in space below and print new address in space provided. If you have a question about your subscription, attach address label to your letter.

TO SUBSCRIBE: Check these boxes: 5 years \$26 3 years \$18 1 year \$7 New Renewal

SPECIFY: Payment enclosed—You get 1 extra issue per year as a BONUS! Bill me later.

→ AFFIX LABEL →

If you have no label handy, print OLD address here.

please print

name

address

city

state

zip code

0371

please print

name

address

city

state

zip code

Add'l postage: \$1 per year outside U.S., its poss. & Can.

INTEGRATED CIRCUITS / RECTIFIERS SEMICONDUCTORS / TRIACS

BCD COUNTER KIT

Consisting of:
1-PC board 12707
2-7476 IC's
2-Silicon diodes
1-Set of instructions
When assembled by enclosed instructions, this kit will count pulses from 0-9 in BCD. These boards can be connected in series to count as high as desired. Example, two boards will count to 99, three to 999 etc. \$6.95

ER900 TRIGGER DIODES These bidirectional trigger diodes are one of the best and cheapest methods to trigger SCR's and triacs 4 \$1.00

TIS 43 GENERAL PURPOSE UNIJUNCTIONS \$1.50

2N3819 N-Channel FET's 45
2N4303 P channel FET with a GMS of 2000 ohms \$1.95

TRIACS

PRV	1A	10A	15A
100	.40	.70	1.00
200	.70	1.10	1.40
300	.90	1.35	1.80
400	1.10	1.60	2.20
500	1.50	2.00	2.60

LIGHT EMITTING DIODES (LED's)

Infra red OR visible spectrum \$1.20 ea.
Photo detectors for each \$5.80

TTL IC SERIES (DIP)

7441 BCD Decimal Decoder 2.00
7474 Dual Flip Flop85
7475 Quad Bistable Latch 1.70
7476 Dual Mast-Slave JK FF 1.00
7490 Decade Counter 1.85
7492 Divide By Twelve 1.85
7493 4 Bit Binary Counter 1.85
7481 16 bit read/write memory 1.85
Silicon Power Rectifiers

PRV	3A	30A	12A
100	.09	.30	.50
200	.16	.35	.80
400	.20	.45	1.20
600	.30	.70	1.50
800	.40	.85	1.80
1000	.55	1.10	2.20

NIXIE TUBES
Similar to Raytheon 8754, with socket & data sheet \$4.75

Terms: FOB Cambridge, Mass. Send check or Money Order. Include Postage. Average Wt. per package 1/2 lb. No C.O.D.'s. Minimum Order \$3.00. Rated companies 30 days net

DECADE COUNTER KIT

Consisting of:
1-Nixie tube & socket
1-7490
1-7475
1-7441
Specially priced at \$9.95

709C OPER AMP \$.80
SE 501 VIDEO AMP 1.00
741 OPER AMP \$1.25
723 VOLTAGE REGULATOR \$1.25

Controlled Avalanche or Epoxy Rectifiers 1 AMP.

100	.06
200	.07
400	.09
600	.11
800	.15
1000	.20

Silicon Control Rectifiers

PRV	3A	7A	20A	70A
50	.25	.28	.60	
100	.30	.38	.85	3.50
200	.50	.60	1.10	6.50
300	.60	.68	1.30	
400	.70	.75	1.50	9.50
500	.80	.85	1.70	
600	.90	1.20	1.90	11.00

Send for our Latest catalog featuring Transistors and Rectifiers; 325 Elm St., Cambridge, Mass.

OLID TATE SALES

Post Office Box 748

Somerville, Mass. 02143

Tel. (617) 547-4005

CIRCLE NO. 122 ON READER SERVICE PAGE

GREGORY ELECTRONICS

Your Best Buys In

QUALITY USED
FM 2-WAY RADIO EQUIPMENT

BIG SAVINGS ON MAMMOTH RCA EQUIPMENT PURCHASE

RCA LOW BAND

CMFT 50 27-54 MHz, 50W, Checked out, with accessories. Transistor power supply; partially transistorized receiver \$178

Same as above, but fully factory reconditioned, with new accessories \$228

RCA HIGH BAND

CMCT 30, 30W, Checked out, partially transistorized receiver, complete \$168

Same as above, 30W, but fully factory reconditioned, with new accessories \$208

CMCT60, 60 Watts \$208

Same as above, 60W, but fully factory reconditioned, with new accessories \$248

UHF 450-470 MHz CMUE 15, 12V/15W, transistor power supply with accessories \$98

Same as above, but fully factory reconditioned, with new accessories, narrow banded \$148

RCA CMU 15B 6/12 volt, 450-470 MHz less accessories \$28

accessories (sold separately) \$20

SEND FOR NEW 71½ CATALOG



**GREGORY
ELECTRONICS
CORPORATION**

249 Route 46, Saddle Brook, N. J. 07662
Phone (201) 489-9000

CIRCLE NO. 134 ON READER SERVICE PAGE

DO-IT-YOURSELF

PROFESSIONAL ELECTRONICS PROJECTS—\$1.00 up. Catalog 25¢. PARKS, Box 25665A, Seattle, Wash. 98125.

TAPE AND RECORDERS

OLD Radio Programs on tape. 6 hours for \$8.00. Catalog 50¢. Don Maris, 1926 Cherokee, Norman, Okla. 73069.

STEREO TAPE TRANSPORT—7" reel—2 speeds—pause control—made for famous manufacturer—50 to 15,000 Hz—with rec/play and erase heads, without case. Send m.o. or check for \$19.50 to Alsheimer Audio Electronics, 218 Columbia St., Utica, N.Y. 13502. \$2.50 for prepaid shipping and insurance.

STEREO TAPE RENTAL for particular people. Free catalog. Gold Coast Tape Library, Box 2262, Palm Village Station, Hialeah, Fla. 33012.

RENT 4-track open reel tapes—all major labels—3,000 different—free brochure. Stereo-Parti, 55 St. James Drive, Santa Rosa, California 95401.

BARGAIN MUSIC, Tape, Equipment Catalog 25¢. Saxitone, 1776 Columbia Road, Washington, D.C. 20009.

TRADE stereo tapes. \$1.25 each postpaid. Minimum three. Tapetrade, Box 2181, LaJolla, Calif. 92037.

VIDEO TAPE, 1 inch. x 1 mil x 1700 feet. Used. On computer reels. \$12.00 each. Lahill, P.O. Box 656, Martinsburg, W. Va. 25401.

RECORDING TAPE made by top American manufacturer, guaranteed not "seconds" or "white box;" 2400' mylar, \$2.29; 1800' mylar \$1.69; 1200' acetate \$0.79. Send for information and quantity pricing. Alsheimer Audio Electronics, 218 Columbia Street, Utica, New York 13502.

OLD Radio Programs. Catalog \$1.00 (Refundable). Radio Vault, 1533 50th SW, Wyoming, Michigan 49509.

RECORDS

POPULAR organ albums factory direct. Concert Recording, Lynwood, Calif. 90262.

CHAPEL Records Club—Free catalog. 1000 B Richmond, China Lake, Calif. 93555.

SPECIAL interest records available, produced by the editors of the world's leading special interest magazines. Send for free catalog. Record Catalog, EW, Ziff-Davis Publishing Company, One Park Ave., New York 10016.

HIGH FIDELITY

LOW, LOW quotes: all components and recorders. Hi-Fi, Roslyn, Penn. 19001.

August, 1971

HI-FI EQUIPMENT—GET Our "ROCK BOTTOM" prices on NAME BRAND amplifiers—tuners—tape-recorders—speakers FRANCHISED—60 YEARS IN BUSINESS. Write for this month's specials—NOW! Rabson's 57th St., Inc., Dept 569, 119 W. 57th St., New York, N.Y. 10019.

HI-FI components, tape recorders, sleep learning equipment, tapes. Unusual Values. Free catalog. Dressner, 1523 R Jericho Turnpike, New Hyde Park, N.Y. 11040.

DIAMOND NEEDLES and Stereo Cartridges at Discount prices for Shure, Pickering, Stanton, Empire, Grado and ADC. Send for free catalog. All merchandise brand new and factory sealed. Lyle Cartridges, Dept. E, P.O. Box 69, Kensington Station, Brooklyn, New York 11218.

GOVERNMENT SURPLUS

JEEPS Typically From \$53.90 ... Trucks from \$78.40 ... Boats, Typewriters, Airplanes, Multimeters, Oscilloscopes, Transceivers, Electronics Equipment. Wide Variety, Condition. 100,000 Bid Bargains Direct From Government Nationwide. Complete Sales Directory and Surplus Catalog \$1.00 (Deductible First \$10.00 Order.) Surplus Service, Box 820-K, Holland, Michigan 49423.

PHOTOGRAPHY—FILM, EQUIPMENT, SERVICES

SCIENCE Bargains—Request Free Giant Catalog "CJ"—148 pages—Astronomical Telescopes, Microscopes. Lenses, Binoculars, Kits, Parts, War Surplus bargains. Edmund Scientific Co., 300 Edscorp Bldg., Barrington, New Jersey 08007.



FREE Catalog of The WORLD'S FINEST GOV'T SURPLUS ELECTRONIC BARGAINS

F. M. MOTOROLA GOVERNMENT SURPLUS

	Used:	Re-Cond.:
R-394 RECEIVER 152-172 MC	\$14.95	\$22.50
T-278 TRANSMITTER 152-172 MC	18.95	24.95
R-257 RECEIVER 25-50 MC	19.95	
T-208 TRANSMITTER 25-50 MC	29.95	
CY-938 CABINET	7.95	9.95
C-847 CONTROL BOX	8.95	12.95



ALSO—Power Supplies, Amplifiers, Modules, etc.

FAIR RADIO SALES • Dept. EW, Box 1105 • Lima, Ohio 45802

CIRCLE NO. 138 ON READER SERVICE PAGE

U.S. GOV'T ELECTRONIC SURPLUS

• Nationally Known-World Famous SURPLUS CENTER offers finest, most expensive, Government Surplus electronic units and components at a fraction of their original acquisition cost.

IBM COMPUTER POWER SUPPLY

- (ITEM #22-934) -- Expensive, regulated unit. Fine for college labs, research co's, service shops, etc. Pure DC over a wide range of voltages. DC output voltages: 6, 12, 48, etc. Wide range of AC voltages available.
- Finest transformers, filters, transistor load regulation system. Independent of line voltage fluctuations. Contains five separate rectifier systems. Unit is furnished without small "regulating card" which can be easily made or can be borrowed. Data and circuit diagrams furnished. 10" x 12" x 10" (125 lbs.)



Cost Gov't Over \$500.00 **\$24.95**
ONCE-IN-A-LIFETIME SPECIAL

BURGLAR-FIRE ALARM SYSTEM



- (ITEM #1135-A) -- Final alarm system gives warning of fire or break-in. Operates on 115-AC. Control unit, 2-kilohm flash fire, 2-motors column, 3-door audio, actuator, alarm, bell, 100 ft. wire, instructions. 8 1/2" x 7 1/2" x 3" (7 lbs.)

\$29.95

STANDARD DIAL TELEPHONE

- (ITEM #715) -- Standard, commercial telephone same as used throughout U.S.A. Attractive polished black like new condition. Use as extension phone to private systems or connect several phones together for local intercom system. Full instructions are furnished. 8" x 8" x 8" lbs.



Original Cost **\$7.49**

STEP-BY-STEP TELEPHONE SWITCH

- (ITEM #7-905) -- Amazing telephone selector switch. Great experimental item. When used with two-wire telephone dial will select any number from 0 to 100. Make intercom or private system. Use to turn on remote lights, start motors, etc. Complete with contact bank. 12" x 6" x 5" (18 lbs.). Cost over \$90.00



\$6.29
• telephone dial for use with above switch. Order as (Item #700)..... **\$1.97**

MAGNETIC DIGITAL COUNTER (12 to 18-VDC)



- (ITEM #21-959) -- Use to count electrically. Use to count number of times door is opened after business is closed to show changing prices, laboratory uses, etc. Will count 1 bit each pulse and will transfer 10th count to next unit. 3 1/2" x 1 1/2" x 1 1/2" (1 1/2 lbs.)

Orig. Cost Each **\$1.99** Three **\$4.99**
Over \$19.00 For

TYPICAL BUYS FROM OUR 1971 CATALOGS

- \$ 10.00 115-Volt DPDT Relays..... **\$1.69**
- \$101.00 Regulated Transformer, Wide Range..... **\$14.91**
- \$ 15.00 20-Relay Telephone Panel..... **\$4.39**
- \$250.00 Gyroscope, Twin Rotor, 24V..... **\$9.89**

AC PROGRAM TIMING CLOCK

- (ITEM #158) -- Zenth 115-VAC unit. Use for periodic standing, work breaks, classes, turn on radio, etc. Adj. clips permit ON-OFF switching any time in 24-hour period. Also has "skip-over" feature. Can be multiple programmed. 15-comp. contacts. 8 1/2" x 8 1/2" x 4" (8 lbs.)



Cost Gov't Over \$30.00 **\$15.75**

SNAP AROUND VOLT-OHM-AMMETER



- (ITEM #21-344) -- Measures AC current without opening the line. Simply press handle and snap the probe around the conductor. Reads currents from .25 to 125-amps. Reads vol ages to 300; reads ohms up to 200. Test motors, appliances, etc. Three current ranges, two voltage ranges. With case, test leads. 7 1/2" x 3" x 1 1/2" (2 lbs.)

Res. Price **\$36.90** (2 lbs.)
Over \$50.00

SPECIAL SALE Correspondence Course In ELECTRICAL ENGINEERING



\$8.79 Prepaid in U.S.A.
\$10.79 Outside U.S.A.

- (ITEM #A180) -- Obtain technical training at low cost! Lincoln Engineering School has suspended its Correspondence Courses because of rising costs. A limited number of Electrical Engineering Courses are available, but without the examination grading service. The course consists of 15 lesson books, each with associated exams and standard answers. Book describing price saving time Experimental Laboratory Bench furnished at no extra cost.

RUNNING TIME METER



- (ITEM #2188) -- Record number of operating hours of electric lights and electrical devices such as refrigerators, furnaces, etc. Records total hours, tens and hundredths up to 9,999.99 hours. For 115-volt, 60-wattless. Size 4 1/2" x 3" x 2 1/2". Shipping weight 2 lbs.

\$4.39 Cost Over \$29.00

COMPUTER TRANSISTORS ON HEAT SINKS

IBM Computer Quality Units

- (#22-928) -- Unit consists of one 150-watt power transistor on heavy, ribbed, aluminum heat sink. Many experimental uses. (1 lb.)



Cost Gov't Over \$10.00 **\$1.99**

- (#22-915) -- Unit consists of two 150-watt power transistors, 2 pots, several diodes, capacitors, resistors, etc. on heavy, ribbed aluminum heat sinks. Ideal for use as motor speed control. (4 lbs.)



Cost Gov't Over \$35.00 **\$4.91**



ALL ITEMS SHIPPED F.O.B. LINCOLN, NEBR.
Order Direct From Ad. Money Back Guarantee.

SURPLUS CENTER

DEPT. EW 081 LINCOLN, NEBR. 68501

PERSONALS

MAKE FRIENDS WORLDWIDE through international correspondence. Illustrated brochure free. Hermes, Berlin 11, Germany.

HYPNOTISM

SLEEP Learning, Hypnotic Method. 92% effective. Details free. ASR Foundation. Box 7021 EW, HC Station, Lexington, Ky. 40502.

FREE Hypnotism, Self-Hypnosis, Sleep Learning. Catalog! Drawer H400, Ruidoso, N.M. 88345.

EDUCATIONAL OPPORTUNITIES

LEARN WHILE ASLEEP. Hypnotize! Strange catalog free. Autosuggestion, Box 24-ZD, Olympia, Washington, 98501.

INVENTIONS WANTED

PATENT Searches including maximum speed, full airmail report and closest patent copies, \$6.00. Quality searches expertly administered. Complete secrecy guaranteed. Free Invention Protection forms and "Patent Information." Write Dept. 23, Washington Patent Office Search Bureau, 711 14th Street, N.W., Washington, D.C. 20005.

MAGAZINES

OVER 2,000,000 Backdate magazines! Specify needs. Midtown, Box 917EW, Maywood, New Jersey 07607.

JAPAN PUBLICATIONS GUIDE business, pleasure, education. \$8.00. INTERCONTINENTAL, CPO 1717, Tokyo 100-91.

BUSINESS OPPORTUNITIES

FREE BOOK "999 Successful Little-Known Businesses." Work home! Plymouth 445-H, Brooklyn, N. Y. 11218.

DELUXE
MAGAZINE CASES

Designed Exclusively for
ELECTRONICS WORLD

● The ideal way to save your valuable copies, keep them well protected and make it easy for you to refer to any issue at any time. This bold new design is both decorative and attractive enough to enhance the decor of any room. Each case holds a full year's copies.

Constructed of reinforced fiberboard, these tough and durable cases are covered in a rich textured, leather-like fabric. The gold embossed back adds to its elegance and makes each case a welcome addition to your bookshelf, end table, desk—or for that matter, anywhere in your home or office.

In addition to Electronics World, cases are available for any of your favorite magazines. They're only \$3.95 each, 3 for \$11.00, 6 for \$21.00, in any combination of titles ordered. Add 50c per order for postage and handling. Outside U.S.A. add \$1.00 per case ordered.

Ziff-Davis Pub. Co., Dept. 23, 1 Park Ave., N. Y. 10016

Enclosed is \$_____. Please send Magazine Cases for the titles indicated below @ \$3.95 each, 3 for \$11.00, 6 for \$21.00. Add 50c per order for postage and handling. Outside U.S.A. add \$1.00 per case ordered.

TITLE	QUANTITY
ELECTRONICS WORLD	_____
_____	_____
_____	_____

Check One: EW-871

All Black Maroon Back • Black Sides

Print Name _____
Address _____
City _____ State _____ Zip _____

PAYMENT MUST ACCOMPANY ORDER

CLASSIFIED ADVERTISING ORDER FORM

Please refer to heading on first page of this section for complete data concerning terms, frequency discounts, closing dates, etc.

1	2	3	4	5
6	7	8	9	10
11	12	13	14	15
16	17	18	19	20
21	22	23	24	25
26	27	28	29	30
31	32	33	34	35

_____ Words { @ .65 Reader Rate } = \$ _____
{ @ \$1.00 Commercial Rate }

Insert _____ time(s) Total Enclosed \$ _____

NAME _____

ADDRESS _____

CITY _____ STATE _____ ZIP _____

SIGNATURE _____

WORD COUNT: Include name and address. Name of city (Des Moines) or of state (New York) counts as one word each. Zip Code numbers not counted. (Publisher reserves right to omit Zip Code if space does not permit.) Count each abbreviation, initial, single figure or group of figures or letters as a word. Symbols such as 35mm. COD, PO, AC, etc., count as one word. Hyphenated words count as two words. EW 8-71

I MADE \$40,000.00 YEAR by mailorder! Helped others make money! Start with \$10.00—Free proof. Torrey, Box 318-N, Ypsilanti, Mich. 48197.

\$200.00 DAILY In Your Mailbox! Your Opportunity To Do What Mailorder Experts Do. Free Details. Associates, Box 136-EW, Holland, Michigan 49423.

MAKE \$1.00 Per Sale selling engraved metal Social Security plates. Free Sales Kit. Engravingplates, Box 10460-7507, Jacksonville, Florida 32207.

FREE CATALOGS. Repair air conditioning, refrigeration. Tools, supplies, full instructions. Doolin, 2016 Canton, Dallas, Texas 75201.

JAPANESE Electronics New Products Monthly! Specimen copy \$1, deductible. Dee, P.O. Box 9308, North Hollywood, Calif. 91609.

MAILORDER! Make big money working home. Free report reveals millionaire's trade secrets! Executive (1K8), 333 North Michigan, Chicago 60601.

HIGHER INCOME, Security, Power. 256 page book reveals secrets that make men rich. Only \$2.00. Halsher Company, 11 Five Oaks, Dayton, Ohio 45405.

TREASURE FINDERS

FREE: Jetco Electronics free 24 page treasure finder catalog. Find metals, minerals, gold, silver, coins, and relics, Jetco, Box 132EW, Huntsville, Texas 77340.

RUBBER STAMPS

RUBBER Address Stamps \$2.00. Signature \$3.50. Free Catalog. Jackson's, Box 443-G, Franklin Park, Ill. 60131.

MUSICAL INSTRUMENTS

30% DISCOUNT name brand musical instruments. Free catalog. Freepoint Music, 127-L Sunrise Hwy, Freepoint, N.Y. 11520.

STAMPS

FREE! 88 DIFFERENT COUNTRIES!! An Incredible Collection of genuine postage stamps ... from Afghanistan to Zambia, all around the world! Stamps from the North and South Poles. British, French, Portuguese, Spanish Colonies. Ancient Stamps, New Issues, Airmails, Commemoratives, Moon and Outer Space Stamps—from 88 countries! Also, other exciting stamps for free examination. Buy any or none, return balance, cancel privilege any time. Plus Big Introductory Catalog. Send 10¢ for mailing. H.E. Harris, Dept. SS-12, Boston, Mass. 02117.

WOW! 110 ALL DIFFERENT GERMANY 10¢. Commemoratives, Airmails, High Values, Big Catalog, bargain lists. Also, fine stamps from our approval service, which you return without purchases and cancel service at any time. Jamestown Stamp, Dept. A81EG, Jamestown, N.Y. 14701.

FREE! BIG BARGAIN CATALOG—NEW EDITION listing thousands of bargains including U.S. & B.N.A. stamps, packets, albums, accessories and supplies. Also, fine stamps from our approval service which you may return without purchases and cancel service at any time. Jamestown Stamp, Dept. E81EG, Jamestown, N.Y. 14701.

MISCELLANEOUS

WINEMAKERS: Free illustrated catalog of yeasts, equipment. Semplex, Box 122-76, Minneapolis, Minn. 55412.

WINE Recipes and Catalog, 25¢. Country Winemaker, Box 191E, RFD 1, Mattapoisett, Mass. 02739.

AS YOU SCAN THESE COLUMNS, more than 175,000 monthly buyers of ELECTRONICS WORLD are doing the same. These men are all Electronics Professionals—individuals involved actively in electronics from a business or hobby viewpoint. Therefore, they are doubly interested in those advertisements which will enhance their careers or their leisure hours. They look to the pages of ELECTRONICS MARKET PLACE for prime sources of products and services of interest to them. They will buy from you if your advertising appears regularly in their favorite magazine. Send copy and payment now to: Hal Cymes, Classified Advertising Manager, ELECTRONICS WORLD, One Park Avenue, New York, New York 10016. REMEMBER: October issue, on sale September 21st, closes August 1st.

August, 1971

GIANT SALE ON NEW TTL TEXAS & NATIONAL ICs

Guaranteed! W/Spec Sheets
Any 3 — 10% Discount!

Type	Description	Sale
□ SN7400N	Quad NAND gate	\$.45
□ SN7401N	Open coll. out	.45
□ SN7402N	Quad NOR gate	.45
□ SN7410N	Triple 3 in. gate	.45
□ SN7420N	Dual 4 in. gate	.45
□ SN7430N	8 input gate	.45
□ SN7440N	Dual 4 in. buffer	.45
□ SN7441N	BCD-Nixie driver	1.95
□ SN7473N	Dual J-K flip flop	.88
□ SN7474N	Dual "D" flip flop	.88
□ SN7475N	Quad latch	1.95
□ SN7476N	Dual J-K flip flop	.88
□ SN7490N	Decade counter	2.25

WRITE for "IC" bargain catalog.

LIGHT EMITTING DIODES

Any 2 — 10% Discounts

□ INFRARED "LED"	\$1.45
□ INFRARED SENSOR	.88
□ VISIBLE "LED"	1.45
□ VISIBLE SENSOR	.88

*"Flame" sensitive

G-E 3.5W AUDIO "IC DIP" AMPLI

\$3.95
3 for \$10

Type PA-263, 3.5w cont. duty, 9-to-30v supply. For phono, tape, stereo.



TRIACS (THYRISTORS)

Any 3 10% Discount!

PRV	1A	3A	6A	15A	25A
50	.29	.35	.45	.55	.75
100	.35	.45	.59	.63	1.10
200	.45	.65	.85	.95	1.50
400	.95	1.25	1.50	1.75	2.50
600	1.25	1.50	1.95	2.15	2.95

10¢ Catalog on Fiber Optics, 'ICs', Semis, Parts
Terms: add postage. Rated: net 30, coll's 25%.
Phone Orders: Wakefield, Mass. (617) 245-3829
Retail: 211 Albion, St., Wakefield, Mass.

POLY PAKS P.O. BOX 942W
LYNNFIELD, MASS 01940

COUNTING SYSTEM

"DIP" COUNTING SYSTEM

□ 3-pc. kit ... \$5.95
3 KITS ... 15.00
Includes SN7490, SN7441, SN7476

NIXIE TUBE BURROUGHS

\$5.95

3 for \$15

Type B-5441, with decimals 0-9 wide angle numerals, 16 pins.

709 OP-AMP

88¢ 3 for \$ 2.25

□ Dual in line
□ TO-5 case
□ Flat pak

723 VOLTAGE REGULATOR

\$1.50

3 for \$3.75

Positive or negative, 0-to-40V, 1-watt, 150mA.

741 OP-AMP*

119 3 for \$3.45

□ Dual in line
□ TO-5 case
*709, freq. comp.

6-AMP FULL WAVE RECTIFIERS

PRV SALE

50	\$.88
100	.99
200	1.25
400	1.50
600	1.75
800	1.95
1000	2.25

DUAL 709 OP-AMP

\$1.50 3 for \$4

SPRAGUE RTL ICs

Any 3 for \$1

□ 908	Full Adder
□ 909	Buffer
□ 911	4 In. Gate
□ 912	Half Adder
□ 913	Register
□ 915	Dual 3 In. Gate

*Dual in line contains two 709's in one case.

EPOXY SILICON RECTIFIERS

PIV	1Amp	2Amp	3Amp
50	\$.05	\$.05	\$.08
100	.06	.06	.12
200	.07	.07	.15
400	.09	.09	.22
600	.12	.12	.28
800	.15	.16	.39
1000	.18	.22	.59

*microminature Any 3 — 10% Discount!

FETS, UJTs, VARACTORS, NIXIES

□ 5	Varactor diodes, 10, 20, 30, 40, 50 pc.	\$1.00
□ 1	"PUT" Programmable unijunction	1.00
□ 1	2N489 Unijunction TO-5 transistor	1.00
□ 2	2N3370 FET, N channel TO-18, metal	1.00
□ 2	2N2608 FET, P channel TO-18, metal	1.00
□ 2	2N2646 Unijunction, plastic	1.00
□ 2	2N3819 FET, N channel, plastic	1.00
□ 5	ER-900 Trigger diodes, sors, triacs	1.00
□ 2	2N3277 FET, P channel, metal TO-5	1.00

CIRCLE NO. 126 ON READER SERVICE PAGE

Genuine RCAF Watches
Gov't issue, used, guaranteed OK \$20. ea.

Projection type decimal counting units 0-9 digits. From used eqmpt. \$6 ea

SOLID STATE LAMP DRIVER completely wired with plug for use with above DCU or any similar DCU.
A \$50.00 value for only \$3.50

Wired memory from UNIVAC computer 2640 byte on plug-in board. Exlnt cond. \$10

DIP PACKAGE IC brand new 35¢ ea. or \$3.50/12. 7400-7401-7402-7410-7420-7430-7440-7451-7453-7454-7460. The following are \$2.50 ea. 7441-7475-7490-7493-74121.

FIBRE OPTICS the most comprehensive list of FO material available... face plates, jewelry, light pipes, coherent peepscope, light sources, magnifiers, circle to line converter, lamp kits. • Send for special listing.

METAL LOCATORS, become a millionaire, find jewelry, gold, silver, lost treasures. • Send for special sheet.

Send 25¢ for Surplus Catalog..
JOHN MESHNA JR. ELECTRONICS
P.O. Box 62 E. Lynn, Mass 01904

CIRCLE NO. 129 ON READER SERVICE PAGE

RECTIFIERS & TRANSISTORS

Silicon Rectifiers

PIV	25	50	100	200	400	600	800	1000	1200
1A*	.03	.04	.06	.08	.10	.14	.17	.22	
18A**	.09	.15	.19	.29	.39				
20A	.23			.59	.75	1.13	1.35	1.73	2.10
40A	.38			1.35	1.80	2.25	2.70	3.15	3.60

*Tophat. Flat-leads. **Presbtt. 3, 20, 40 Studs

Silicon Controlled Rectifiers

1500 PIV	PRV	25	50	100	200	400	600
RECT.	1A*	—	—	—	.30	.55	.85
STUD	7A	.11	.14	.20	.45	.90	1.20
1 AMP	18A**	.15	.23	.35	.60	1.10	1.40
25¢ EA.	20A	.18	.32	.45	.70	1.15	1.95

*Tophat **Presbtt. 7 & 20 Amp Stud

Germanium Power Transistors

150W-TO-3-7A
2N456A-40V-25 2N 458A- 80V-45
2N457A-60V-35 2N1021A-100V-60

Silicon Small Signal NPN, TO-5

2N696 7/\$1.00, 2N697 6/\$1.00, 2N699 5/\$1.00
2N3053 Silicon, NPN 3/\$1.00; 1N34A Diodes 100/\$2.98; 2N1142 Ger. Hi-Freq. Amplifier 3/\$1.00; Thermistor Beads, 5000 ohm or 1200 ohm—3/\$1.00; Varicaps—27, 47, or 100pf, 4V—\$1.25 ea.; P.C. Board 6" x 6" x 1/16" - 1 oz. Copper—2/98¢; Photo Cells, Herm. Glass, 5 Diff. for \$1.00; IN661 Silicon Switching 50/\$3.49—100/\$4.98; R.F. Coil Assort. 25/\$1.00, 1.C. 10-5—15/\$1.00. Epoxy Diodes, 200 MA, 3000 Piv 49¢, 6000 98¢. IN658 Silicon Computer Diode—50/\$3.49—100/\$4.98; P.C. Connector 15 Contact 2/\$1.10 Trim Pot 1K 49¢

ASSORTMENTS

Precision resistors film	50/\$1.00
Precision resistors wirewound	40/\$1.00
Ferric Chloride Etchant, 24 oz. bottle	\$1.49
Relays 6 different types	6/\$1.00
Terminal lugs, assorted	200/\$1.00
Tie lugs, assorted	50/\$1.00
Push button switches, on-off, panel	6/\$1.00
Pots, 2-4 watt, different	10/\$1.00
Electrolytic cap, 1500 MFD 25 WVDC	.98¢
2 1/4" 8 ohm speaker	80¢
Tape Recorder with speaker	\$4.95
AM Radio receiver, transmitter and oscillator	\$4.95
(Schematics included with above two items.)	
Earphone headset, 4,000 ohm	\$1.98
Output transformer primary, 150 ohm;	
see, 8 ohm	69¢ ea.
Electrolytic Caps. 25 mfd/70 VDC; 50mfd/35 VDC	49¢ ea.

Min. order \$3.00; send sufficient postage, average refunded; fully guar.; free cat. 25¢ down on COD's.

GENERAL SALES CO.

254 E. Main St. (713) 265-2369
Clute, Tex. 77331

CIRCLE NO. 136 ON READER SERVICE PAGE

KEEP PACE WITH SPACE AGE! SEE MOON SHOTS—LANDINGS, SPACE FLIGHTS, CLOSE-UP!
AMAZING SCIENCE BUYS
for FUN, STUDY or PROFIT **FREE GIANT CATALOG!**

LOW COST TREASURE FINDER



Discover the fun and profit of treasure hunting inexpensively. Light as a feather (10 oz.) solid-state metal detector finds hidden coins, jewels, precious minerals. Distinguishes minerals from metal objects. Great for school, beach, campground or backyard. Requires 9V transistor batt.—works with any common AM transistor radio thus eliminating costly extra circuitry, weight, dangling wires. Adjustable multi-purpose plastic handle reduces immediate area metal—adds to efficiency. No tuning needed.

Stock No. 71,395AK \$14.95 Ppd.

3-CHANNEL COLOR ORGAN BARGAIN!

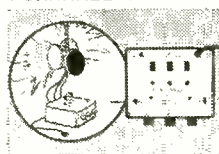

Create tremendous variety of unusual & beautiful lighting effects with this low-cost top-quality 1500-Watt unit (500 W. per channel). Compare with others selling for twice the price. Has pilot light, pilot controls and channel indicator lights. Can operate ten 150 "spot" or 200 Christmas lights. Uses reg. house current—attaches to audio source. 8/16A-type phone plug. 5 1/4" x 6 3/4" x 2 1/2". 2 1/2 lbs. Including complete instructions.

Stock No. 71,223AK \$44.50 Ppd.

ROTATING MULTI-COLORED LIGHT



Dazzling colors stream endlessly from constantly rotating light. Faceted, transparent globe has lowered drum inside with red, green, blue & yellow stars. Bulb heat rotates drum which projects flickering star patterns on walls, ceilings, etc. while individual globe facets present constantly changing array of brilliant colors. 9 3/4" star-approx. 12" high on bell-shaped base, surprising-ly light. Easily placed on table, Christmas tree or other display.

Stock No. 71,000AK \$7.00 Ppd.

SPECIAL VISUAL EFFECTS PROJECTOR SET



Dazzling, avant-garde visual effects. Fantastic variety. Incredibly beautiful. Special package offer contains all necessary apparatus. Create exciting, exploding, fiery bursts of color-like "Symphony of Spheres," "Chromatic Starbursts," "Crystal Starburst." Features 35mm 500 W. fan cooled projector—produces big image at short distance. Accepts two 9" diam. wheels (Dry Kaleidoscope & Hexidoscope), 2 cylindrical accessories (8" Colored Cloud & 3" Hexidoscope w/ six internal mirrored walls). Perfect for entertaining, parties, photography. Complete instructions.

Stock No. 71,218AK \$79.50 Ppd.

Deluxe Model No. 71,295AK (w/ Kaleidoscopic lens) \$99.50 Ppd.

BLACK-LIGHT MIGHTY MITES

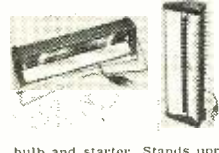

Relatively small (12") fixtures bright blacklight. Mirror-finished reflector makes instant starting. 8-watt, high-intensity bulb look like 40-watt. Up to 5,000 hours safe, low-wave (3660A) blacklight to really turn-on parties, light & theatrical shows. Psychedelic decors, holiday decorations. Shock-proof end-caps remove for safe, easy replacement of bulb and starter. Stands upright or horizontal. Alum. case.

Stock No. 71,274AK \$14.95 Ppd.

DELUXE OUTDOOR/INDOOR MODEL \$19.95 Ppd.

PSYCHEDELIC LIGHTING HANDBOOK



100 information packed pages! Fully explains latest in psychedelic lighting equipment, techniques, developments. Covers all facets of psychedelic light-show production including strobes, black lights, projectors, crystals, organic slides, mirrors, color organs, polarized color light boxes, MusicVision, etc. Shows how to "psychedelize" parties, musical groups, shows or how to set looseleaf paper punched for 3 ring binder. 8 1/2" x 11"

Stock No. 9100AK \$3.00 Ppd.

MAIL COUPON FOR GIANT FREE CATALOG

148 PAGES—1000's OF BARGAINS



Completely new 1971 edition. New items, categories, illustrations. Dozens of electrical and electromagnatic parts, accessories. Enormous selection of Astronaut, Telescopes, Microscopes, Binoculars, Magnifiers, Magnets, Lenses, Prisms. Many war surplus items; for hobbyists, experimenters, workshop. factory. Mail coupon for catalog "AK"

EDMUND SCIENTIFIC CO.
 300 EDSCORP BLDG.,
 BARRINGTON, N.J. 08007

NAME _____
 ADDRESS _____
 CITY _____
 STATE _____ ZIP _____

EMOTION METER "TESTS" YOU



Amazing lie detector type device that really works. Reveals hidden likes, dislikes. Easy to use. Sensitive and accurate. Measures changes in body resistance caused by changes in emotional state. Needle movement indicates emotional response, not whether favorable or unfavorable. Effectiveness depends on questions asked and interpretation. Unique 10-oz. set intended strictly for entertainment, education. Great fun at parties. Incls. 9V battery, compl. instrs.

Stock No. 41,422AK \$15.00 Ppd.

HELIUM BALLOONS MAKE A "BALL"



Anytime there's a balloon the air is festive. Especially when the "air" is helium; which makes a balloon perk and adventurous. Now here's 25 times the fun—25 various colored balloons of 4, 5, or 6" diameter when inflated. With them, a pressurized (300 lbs./sq. in.) can containing 25 liters of helium to share all 25. For adults or kids' parties, giveaways, bazaars or just demonstrating "lighter than air". Helium is a safe non-toxic inert gas.

Stock No. 71,289AK \$3.00 Ppd.

NEW MusicVision MINI-MODEL



Actually "see" music in dazzling action with compact, self-contained unit designed for portability. Produces fantastic patterns in beautiful color... each individual note creating its own unique, twisting, radiating shape—each shape dancing and prancing, whirling and swirling IN PERFECT TIME with the music. Features with low levels of sound at short projection distances. Perfect for window displays, rear proj. boxes, clubs, combos, parties. Stand or hang. 4 1/2 lbs. Incls. reg. 110-120V. L-Pad needed for use w/ big amplifiers.

Stock No. 71,124AK \$56.50 Ppd.

Stock No. 41,140AK (L-PAD) \$ 2.00 Ppd.

LOW COST XENON STROBE



Price breakthrough in bright, reliable electronic strobes. 50W/Second Xenon tube. Variable flash rate—60 to 500 per minute. Long life—more than 1,000,000 flashes. Printed circuit board design. Safe, durable Bakelite case. Externally mounted bulb. Piled to shelf. 8 1/4 x 3 1/2 x 7 1/4 oz. Perfect for psychedelic, stop-action lighting effects for home light shows, parties, displays.

Stock No. 71,342AK \$24.95 Ppd.

BUILD-IT-YOURSELF STROBE KIT \$19.95 Ppd.

Stock No. 71,343AK \$19.95 Ppd.

GIANT WEATHER BALLOONS



Available in big 8' and 16' diameter. Create a neighborhood sensation. Great backyard fun. Exciting beach attraction. Blow up with vacuum cleaners or auto air hose. Filled with helium (available locally) use balloons high in sky to attract crowds, advertise store sales, announce fair openings, etc. Amateur meteorologists use balloons to measure cloud heights, wind speed, temperature, pressure, humidity at various heights. Photographers can utilize for low-cost aerial photos. Made of heavy duty neoprene.

Stock No. 60,568AK 8' Diam. ... \$2.00 Ppd.

Stock No. 60,632AK 16' Diam. ... \$7.00 Ppd.

CHROMATIC "MACHINE-GUN" STROBE



Red, Green & Blue light barrage the eyeballs every 6 seconds with this low-cost top-quality mechanical strobe that can run continuously without fear of burning up. Dazzling effects over 500 ft. sq. area. Created by rotating color wheel in front of 100w. 120V reflector floodlamp (incl. elements seem to flash on & off as colors fluctuate. Turn store windows, posters, parties into flashing, pulsating productions. Convection cooled. Rugged wrinkle finish metal case. Adjustable hanger bracket. Reg. house current.

Stock No. 71,423AK (9"x9"x6") \$32.75 Ppd.

NEW \$99.50 HELIUM-NEON LASER!

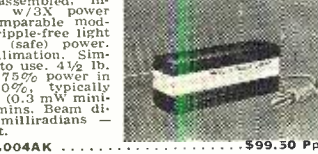

Completely assembled, instant-starting w/3X power output of comparable models. Steady, ripple-free light of moderate (safe) power. Excellent collimation. Simple and safe to use. 4 1/2 lb. unit reaches 75% power in 2 sec.; 100%, typically 0.5 milliwatt (0.3 mW minimum) in 3 mins. Beam divergence 2 milliradians—2 cms at 40ft.

Stock No. 79,004AK \$99.50 Ppd.

Stock No. 79,008AK (Single Mode) \$129.50 Ppd.

ELECTRONICS WORLD

August 1971

ADVERTISERS INDEX

R.S. No.	ADVERTISER	PAGE
	A.P.M. Systems, Inc.	73
150	Akai	2
	Allied Radio Shack	12, 63, 64
149	Audionics, Inc.	51
148	B. & F. Enterprises	76
116	Bay Products	73
	CREI A Division of the McGraw-Hill Continuing Education Company	9
146	Cleveland Institute of Electronics	22, 23, 24, 25
145	Cleveland Institute of Electronics	65
144	Cleveland Institute of Electronics	69
143	Cooks Institute of Electronics Engineering	68
142	Crown	4
141	De ta Electronics Co.	75
140	Delta Products, Inc.	71
139	Edmund Scientific Co.	80
138	Fair Radio Sales	77
137	Foredom Electric Company, The	12
136	General Sales Co.	79
	Goodheart Co., Inc., R.E.	76
135	Grantham School of Engineering ..	7
134	Gregory Electronics Corporation	77
133	Heath Company	26
	Lampkin Laboratories, Inc.	65
132	Liberty Electronics, Inc.	75
131	McIntosh Laboratory, Inc.	67
130	Memorex Recording Tape	20, 21
129	Mashna Jr., John	79
	National Radio Institute	16, 17, 18, 19
	National Technical Schools	5
128	Olson Electronics	73
127	Penwood Numechron Co.	10
126	Poly Paks	79
	RCA Institutes	56, 57, 58, 59
125	Sams & Co., Inc., Howard W.	1
124	Sansui Electronics Corp.	SECOND COVER
123	Schober Organ Corp., The	69
122	Solid State Sales	77
121	Sonar Radio Corporation	55
120	Sony Corporation of America	FOURTH COVER
	Surplus Center	78
117	TDK Electronics Corp.	67
119	Tektronix	THIRD COVER
118	V-J Products, Inc.	68
	Valparaiso Technical Institute	51
	Classified Advertising	75, 76, 77, 78, 79

EDMUND SCIENTIFIC CO. 300 EDSCORP BLDG. BARRINGTON, NEW JERSEY 08007
ORDER BY STOCK NUMBER - SEND CHECK OR MONEY ORDER - MONEY-BACK GUARANTEE
CIRCLE NO. 139 ON READER SERVICE PAGE

truly remarkable

25-MHz BANDWIDTH
DELAYING SWEEP
3% ACCURACY
10-mV SENSITIVITY
DUAL TRACE &
SIGNAL DELAY LINE
ALL FOR ONLY

\$975

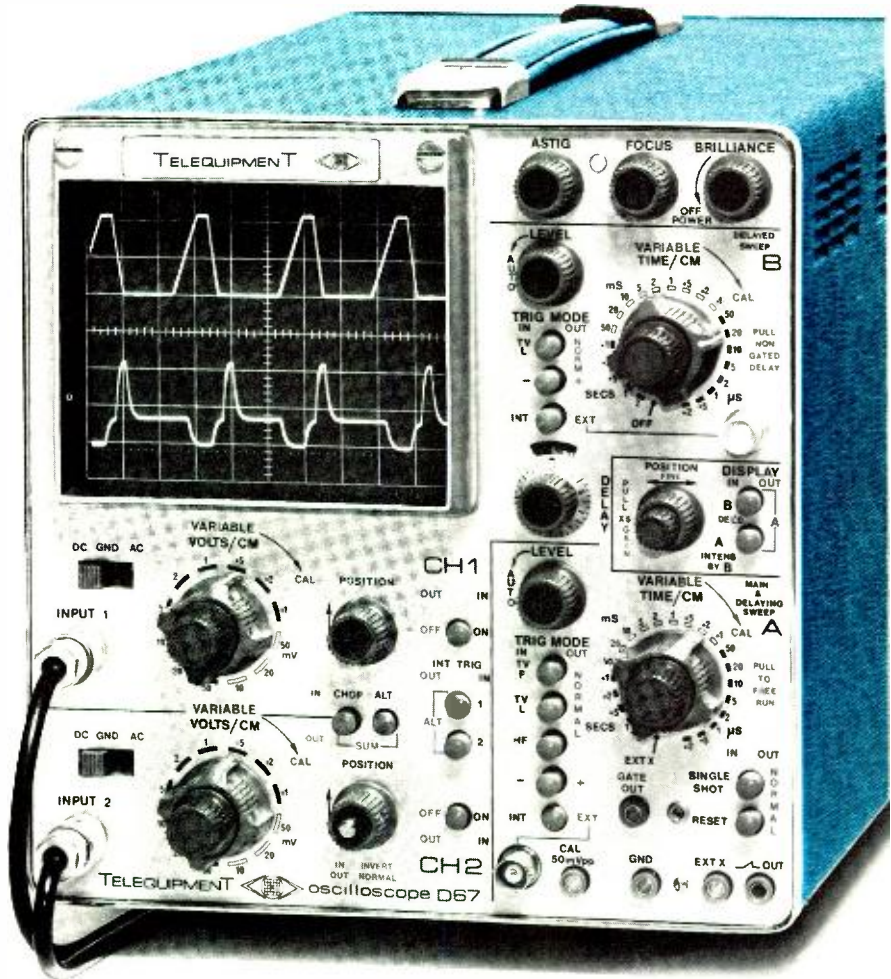

The new Telequipment D67 Oscilloscope offers the performance you have always desired at a price that is several hundred dollars lower than any other comparable model.

In addition to its impressive array of specifications, the D67 has other features not usually found in low-priced scopes: regulated power supplies, FET inputs to keep vertical trace drift to a minimum, fully solid-state design to improve reliability, transistors in sockets to make servicing easier and faster.

Bright displays are obtained by using 10-kV high voltage on the rectangular 5-inch CRT which has a big 8 x 10 cm display area.

A wide range of sweep rates from 2 s/cm to 0.2 μ s/cm (40 ns with X5 magnifier), delayed sweep, 3% accuracy and 14-ns risetime, make the D67 ideal for high

resolution analysis of pulse sequences. And if some of the pulses are jittery, that won't be a problem because the delayed sweep can be triggered. Those who have a need to view television signals will be pleased with the D67's ability to trigger at TV field and line rates. This feature allows viewing a selected line in a field.

Even if portability is not a prime consideration, you are certain to like the D67's lightweight—it weighs only 25 lbs.

Telequipment Oscilloscopes are marketed and supported in the U.S. through the Tektronix network of 57 Field Offices and 30 Service Centers. The instruments are warranted against defective parts and workmanship for one year. For more information call your nearby Tektronix field engineer or write: P. O. Box 500, Beaverton, Oregon 97005.

Telequipment Oscilloscope prices start as low as \$245.

U.S. Sales Prices FOB Beaverton, Oregon



..... a subsidiary of **TEKTRONIX®**

CIRCLE NO. 119 ON READER SERVICE PAGE

SONY® achieves true integration

In all too many transistor integrated amplifiers, the preamp stage does not quite live up to the performance of the amplifier section.

Not in Sony's new TA-1130. Thanks to an FET front end, this integrated package has a preamp stage that really does full justice to its output section.

Why FET's

For the same reason that we use them in our tuners and receivers, and in our studio professional condenser microphones; because FET's have a far wider dynamic range than ordinary transistor types.

And the preamplifier needs that range. Because it has to be sensitive enough to handle the lowest-output, moving-coil cartridges, yet still accept the highest output cartridges without overloading. (The power amp has it easier: you keep its input level fairly constant with your volume control.)

Power to Spare

But if the power amplifier doesn't need that range, it does need power. The output section of TA-1130 has it: 230 IHF watts (into 4 ohms), with continuous power rated at 65+65 watts into 8 ohms. (With all that power, we made sure that both transistor and speaker protection circuits were included.)

Nothing Stands Between You and the Sound

Both sections are powered by balanced positive *and* negative supply voltages (not just positive and ground), so there need be no coupling capacitors or interstage transformers between you and the sound.

Without them, the TA-1130 can extend its power band width down to 7 Hertz, and actually exceed its rated damping factor of 100 all the way down to 5 Hz.

An Abundance of Audiophile Conveniences

Of course, the TA-1130 has all the control facilities that you could ask for: low and high filters, tape monitor, a speaker selector, and even an Auxiliary input jack on the front panel. The selector switch is

Sony's instant-access knob-and-lever system.

There's even provision to use the TA-1130's power amp and preamp sections separately, to add equalizers, electronic cross-overs, or 4-channel adapters to your system.

In fact, you can even get the power output section separately, as the model TA-3130 basic amp. It makes a great match for our TA-2000 preamp, too.

Your Sony dealer has both models available, and at prices—\$359.50 for the TA-1130; \$239.50 for the TA-3130. Sony Corporation of America, 47-47 Van Dam Street, Long Island City, New York 11101.

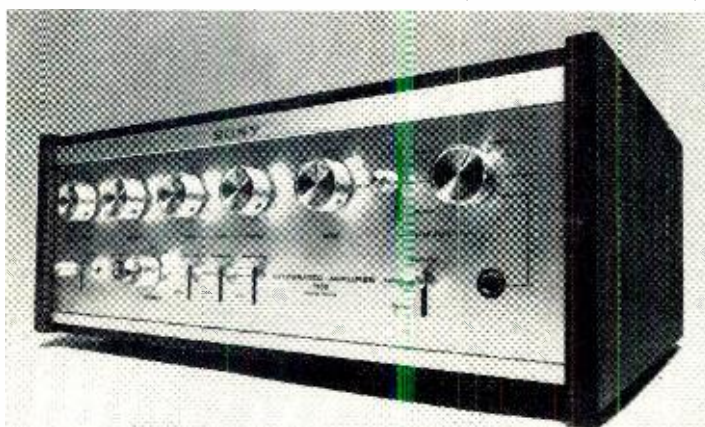

SONY® F.E.T. Amplifier